

MODEL:

# SRGROUNDPANELBC

## SmartRack® 1U Antistatic (ESD) Grounding Panel



ESD Protection



Banana Plug Compatibility



Alligator Clip Compatibility



Sturdy Steel Construction

- A** Banana Plug Connector
- B** Alligator Clip Connection Post
- C** 48-inch Ground Wires
- D** Facility Ground Connectors
- E** Mounting Brackets

Also includes mounting hardware:  
M6 cage nuts (2), M6 screws (2) and  
M6 cup washers (2).

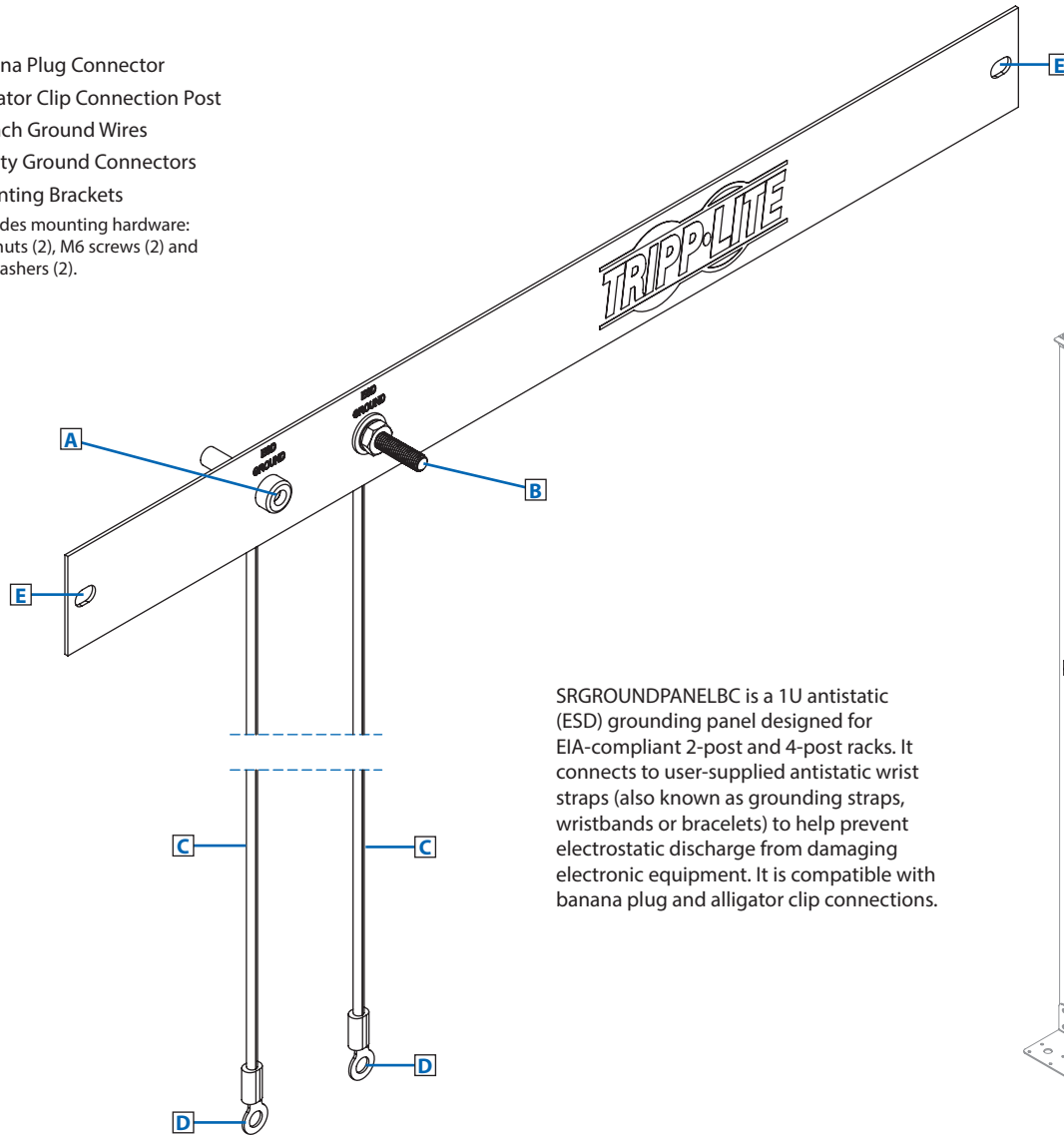

SRGROUNDPANELBC is a 1U antistatic (ESD) grounding panel designed for EIA-compliant 2-post and 4-post racks. It connects to user-supplied antistatic wrist straps (also known as grounding straps, wristbands or bracelets) to help prevent electrostatic discharge from damaging electronic equipment. It is compatible with banana plug and alligator clip connections.

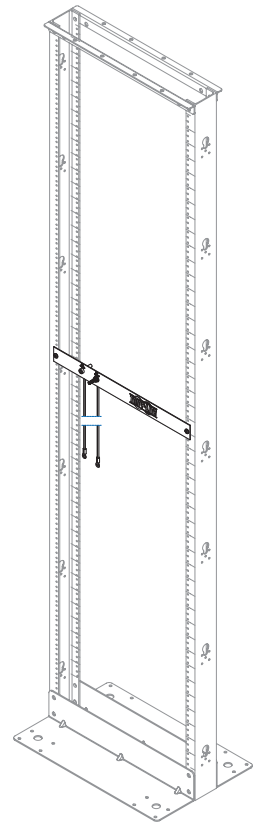

### Specifications



Model	SRGROUNDPANELBC
Unit Dimensions [H x W x D]	1.72 x 2 x 19 in. (43.7 x 50.8 x 482.6 mm)
Shipping Dimensions [H x W x D]	3 x 3 x 22 in. (77 x 77 x 560 mm)
Unit Weight	0.5 lb (0.23 kg)
Shipping Weight	1.1 lb (0.5 kg)
Standards	GOST, RoHS

SEE NEXT PAGE FOR DETAILED UNIT MEASUREMENTS



1111 W. 35th Street  
Chicago, IL 60609 USA  
773.869.1234  
tripplite.com

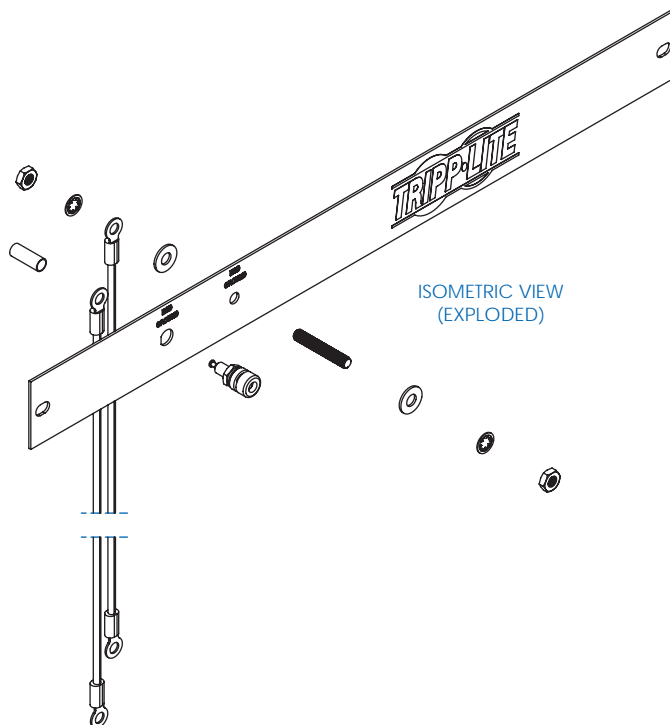
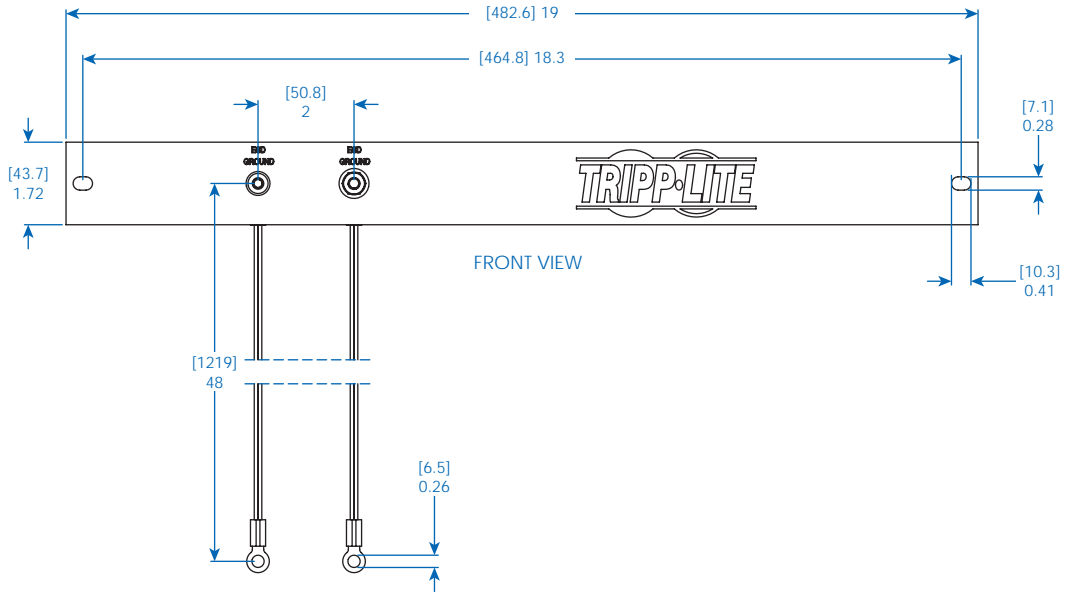
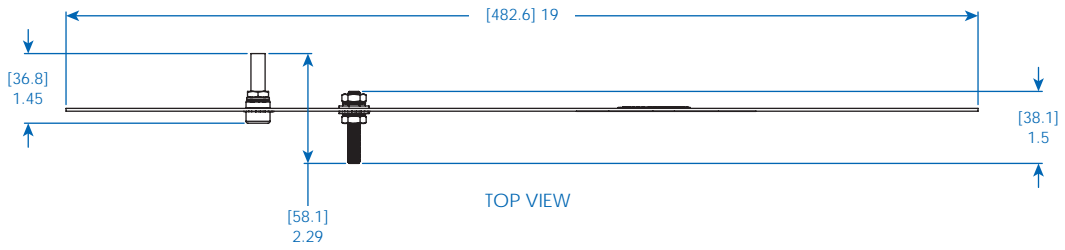

MODEL:  
**SRGROUND PANEL B.C.**



1111 W. 35th Street  
Chicago, IL 60609 USA  
773.869.1234

[triplite.com](http://triplite.com)

Dimensions: [mm] INCHES

Tripp Lite has a policy of continuous improvement. Specifications are subject to change without notice. Photos and illustrations may differ slightly from actual products.