

**SONY**

TRINITRON® COLOR VIDEO MONITOR

# **BVM-1916**

# **BVM-2016P**

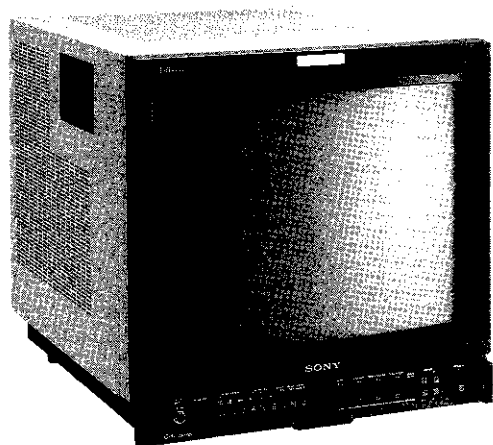

*BVM-1916*  
*CHASSIS NO. SCC-D19B-A*  
*BVM-2016P*  
*CHASSIS NO. SCC-D12B-A*



TRINITRON

**OPERATION AND MAINTENANCE MANUAL**

**2nd Edition**

**Serial No. 2000001 and Higher (BVM-1916)**

**Serial No. 2000382 and Higher (BVM-2016P)**

## For customers in the U.S.A.

This equipment has been tested and found to comply with the limits for a Class A digital device, pursuant to Part 15 of the FCC Rules. These limits are designed to provide reasonable protection against harmful interference when the equipment is operated in a commercial environment. This equipment generates, uses, and can radiate radio frequency energy and, if not installed and used in accordance with the instruction manual, may cause harmful interference to radio communications. Operation of this equipment in a residential area is likely to cause harmful interference in which case the user will be required to correct the interference at his own expense.

You are cautioned that any changes or modifications not expressly approved in this manual could void your authority to operate this equipment.

The shielded interface cable recommended in this manual must be used with this equipment in order to comply with the limits for a digital device pursuant to Subpart B of Part 15 of FCC Rules.

## For the customers in Canada

This apparatus complies with the Class A limits for radio noise emissions set out in Radio Interference Regulations.

## Pour les utilisateurs au Canada

Cet appareil est conforme aux normes Classe A pour bruits radioélectriques, spécifiés dans le Règlement sur le brouillage radioélectrique.

### SAFETY-RELATED COMPONENT WARNING!!

COMPONENTS IDENTIFIED BY SHADING AND MARK  ON THE SCHEMATIC DIAGRAMS, EXPLODED VIEWS AND IN THE PARTS LIST ARE CRITICAL TO SAFE OPERATION. REPLACE THESE COMPONENTS WITH SONY PARTS WHOSE PART NUMBERS APPEAR AS SHOWN IN THIS MANUAL OR IN SUPPLEMENTS PUBLISHED BY SONY. CIRCUIT ADJUSTMENTS THAT ARE CRITICAL TO SAFE OPERATION ARE IDENTIFIED IN THIS MANUAL. FOLLOW THESE PROCEDURES WHENEVER CRITICAL COMPONENTS ARE REPLACED OR IMPROPER OPERATION IS SUSPECTED.

#### VORSICHT!!

Hinweis für den Benutzer  
Das Gerät ist nicht für den Einsatz in Bildschirmarbeitsplätzen vorgesehen.

#### CAUTION!!

DO NOT USE THE EXTERNAL DEGAUSSER TO DEMAGNETIZE THE SCREEN.  
BE SURE TO USE THE DEGAUSS SWITCH ON THE FRONT PANEL.

### ATTENTION AU COMPOSANT AYANT RAPPORT A LA SÉCURITÉ!!

LES COMPOSANTS IDENTIFIÉS PAR UN TRAMÉ ET UNE MARQUE  SUR LES DIAGRAMMES SCHÉMATIQUES, LES VUES EXPLOSÉES ET LA LISTE DES PIÈCES SONT CRITIQUES POUR LA SÉCURITÉ DE FONCTIONNEMENT. NE REMPLACER CES COMPOSANTS QUE PAR DES PIÈCES SONY DONT LES NUMÉROS SONT DONNÉS DANS CE MANUEL OU DES SUPPLÉMENTS PUBLIÉS PAR SONY. LES RÉGLAGES DU CIRCUIT QUI SONT CRITIQUES POUR LA SÉCURITÉ DE FONCTIONNEMENT SONT IDENTIFIÉS DANS CE MANUEL. SUIVRE LES PROCÉDURES QUAND LES COMPOSANTS CRITIQUES SONT REMPLACÉS OU LE FONCTIONNEMENT IMPROPRE EST SUSPECTÉ.

#### ATTENTION!!

NE PAS UTILISER DE DÉMAGNÉTISEUR EXTERIEUR POUR DÉMAGNÉTISER L'ÉCRAN.  
UTILISER LA TOUCH DE DÉMAGNÉTISATION (DEGAUSS) SUR LA PANNEAU FRONTAL.

# TABLE OF CONTENTS

## 1. Operation

<b>1-1. Overview .....</b>	<b>1-1</b>
1-1-1. Features .....	1-1
1-1-2. Options .....	1-2
<b>1-2. Voltage Selection .....</b>	<b>1-6</b>
<b>1-3. Location and Function of Parts .....</b>	<b>1-7</b>
1-3-1. Front Panel .....	1-7
1-3-2. Rear Panel .....	1-10
1-3-3. Subcontrol Panels inside the Drawer .....	1-12
1-3-4. Switches inside the Cabinet .....	1-20
<b>1-4. Menu Operations .....</b>	<b>1-22</b>
1-4-1. Starting with the Menu Operations .....	1-22
1-4-2. Setting the Input Configuration .....	1-23
1-4-3. Presetting the Picture Levels .....	1-26
1-4-4. Selecting the White Balance .....	1-27
1-4-5. Changing and Applying the Password .....	1-30
1-4-6. Assigning the Remote Control Functions .....	1-33
1-4-7. Defining the Monitor Configuration .....	1-37
<b>1-5. Picture Adjustments .....</b>	<b>1-42</b>
1-5-1. White Balance Adjustment .....	1-42
1-5-2. Black Level Adjustment .....	1-43
<b>1-6. Specifications .....</b>	<b>1-44</b>

## 2. DISASSEMBLY

2-1. Cover Removal .....	2-1
2-2. Bezel Assembly Removal .....	2-1
2-3. Check of C Board .....	2-2
2-4. QA, QB, W and V Boards Removal .....	2-2
2-5. Open the BK Block .....	2-3
2-6. BK Board Removal .....	2-3
2-7. Check of BK Board .....	2-4
2-8. Check of EA, EB and EC Boards .....	2-4
2-9. Check of BJ Board .....	2-5
2-10. GC Board Removal .....	2-5
2-11. Power Block Assembly Removal .....	2-6
2-12. Flyback Transformer and High Voltage Block Assembly Removal .....	2-6
2-13. Picture Tube Removal .....	2-7
2-14. Control Panel Assembly Removal .....	2-7

## 3. CIRCUIT DESCRIPTION

3-1. QA, QB, BA Boards .....	3-1
3-2. BG Board .....	3-3
3-3. BH Board .....	3-5
3-4. BI Board .....	3-7
3-5. Sync Preprocessor, Pulse Generator (BJ Board) .....	3-9
3-6. BK Board .....	3-13
3-7. Beam Control Circuit (BI, BK Boards) .....	3-15
3-8. NTSC Comb Filter (BT Board) .....	3-17
3-9. NTSC Demodulator, Y Trap Circuit (BC Board) .....	3-19
3-10. PAL Demodulator, Y Trap Circuit (BD Board) .....	3-21
3-11. DA Board .....	3-23
3-12. Horizontal and Vertical Deflection Output Circuit and High Voltage Regulator Circuit (EA BLOCK) .....	3-25
3-13. H.Oscillator and H.Frequency control (DB Board) .....	3-27
3-14. High Voltage Protector Circuit, Beam Current Protector Circuit and CRT Protector Circuit (EB Board) .....	3-27
3-15. Vertical Convergence Output Circuit (EC Board) .....	3-27
3-16. Power Supply Circuit (GA, GB Boards) .....	3-29

## 4. ADJUSTMENTS

4-1.	Internal View	4-1
4-2.	Circuit Boards Location	4-2
4-3.	Quick Reference	4-3
4-4.	Sub Control Panel Location	4-4
4-5.	Setup Adjustment in Case of Picture Tube Replacement	4-5
4-6.	Safety Related Adjustments	4-11
4-7.	Circuit Adjustments	4-17

## 5. DIAGRAMS

5-1.	Block Diagram	5-1
5-2.	Frame Wiring Diagram	5-5
5-3.	Mounting and Schematic Diagrams	5-9
	TB Board	5-11
	BA Board	5-15
	BT Board	5-20
	BC Board	5-25
	BD Board	5-30
	BG Board	5-35
	BH Board	5-40
	BI Board	5-45
	BJ Board	5-50
	BK Board	5-55
	DA and DB Boards	5-60
	EA, EB, EC, C and P Boards	5-66
	GA and GB Boards	5-72
	HA, HH, HW, HX, HY, XB and Y Boards	5-78
	HZ Board	5-84
	GC, QA, QB, V and W Boards	5-90
	Z Board	5-95
5-4.	Semiconductors	5-97

## 6. EXPLODED VIEWS

6-1.	Bezel and Covers	6-1
6-2.	Picture Tube	6-2
6-3.	Chassis	6-3
6-4.	Signal Block	6-4
6-5.	Drawer Block	6-5
6-6.	Power Block	6-6

## 7. ELECTRICAL PARTS LIST

7-1



## 1-1. Overview

### 1-1-1. Features

The BVM-1916 and BVM-2016P are high-performance color video monitors designed for critical evaluation of video signals in broadcasting stations and production houses.

The BVM-1916 is the NTSC model intended for use in NTSC color standard areas and the BVM-2016P is the PAL model for the PAL color standard areas. By using optional plug-in type decoder boards, both models permit any of the NTSC, PAL, SECAM, D1 and D2 video signals to be monitored.

The other features and operations are the same.

#### **High-resolution picture**

The Fine Pitch Trinitron picture tube (0.4-mm aperture grille pitch) gives a high resolution, high contrast picture. Horizontal resolution is more than 600 TV lines at the center of the picture.

#### **Stabilized color temperature**

The incorporated beam control circuit maintains the color temperature constant for a long period of time.

#### **Picture aspect selection**

In addition to the conventional 4:3 aspect, the 16:9 aspect can be selected for monitoring the increasing number of wide-screen programs.

#### **Split screen for precise picture confirmation**

The lower half of the picture can be displayed in monochrome mode while the upper half is displayed in color mode. This facilitates confirmation of the luminance and chrominance channels, evaluation of the noise in the chrominance or luminance channel, etc.

#### **Blue-only mode for precise evaluation of noise components**

In blue-only mode, an apparent monochrome display is obtained with all three control grids driven with a blue signal. This facilitates color saturation and phase adjustments and observation of VTR noise.

#### **Easy-to-use menu operations**

The essential parameters to be preset for video monitoring can be easily set by selecting menu options displayed on the screen.

### Other features

- Picture setup function facilitating adjustment of the monitor's reference black for the black level of an incoming video signal
- Pulse cross function for simultaneous checking of the horizontal and vertical sync signals or VITS (Vertical Interval Test Signal)
- Built-in crosshatch and 100% white signal generators, facilitating monitor setup
- VITC (Vertical Interval Time Code) display possible using the optional BKM-1460 VITC adaptor
- Auto chroma/phase adjustment, automatic white balance adjustment etc. are possible using the optional BKM-2056 auto set-up adaptor.
- Precise setting of black level of the monitor, using the optional BKM-1480 black level signal generator
- A drawer containing convergence, white balance and menu controls and other function selectors
- High-performance comb filter available for the BVM-1916 as built-in standard. (For the BVM-2016P, the BKM-1422 is available as an option.)
- Auto and manual degaussing
- Three-position AFC switch
- Overdrive protection circuit to protect against picture tube damage
- EIA standard 19-inch rack mounting, using the optional BKM-2000 rack mount kit

### 1-1-2. Options

The following optional accessories are available for flexible changes and enhancement of the functions of the BVM-1916/2016P.

#### Caution

When installing the optional boards, be sure to perform the necessary settings by following the procedure mentioned in "To specify the installed optional boards" of "1-4-7. Defining the Monitor Configuration." If the settings are not correctly performed, the optional boards may not function properly.

**BKM-1410 NTSC adaptor (BC board)** [built-in standard for the BVM-1916]

Decoder board for the NTSC color system

**BKM-1411 NTSC comb adaptor (BB board)**

Comb filter board for the NTSC color system

**BKM-1412 NTSC comb adaptor (BT board)** [built-in standard for the BVM-1916]

Dynamic comb filter board for the NTSC color system

**BKM-1420 PAL adaptor (BD board)** [built-in standard for the BVM-2016P]

Decoder board for the PAL color system

**BKM-1421 PAL-M adaptor (BM board)**

Decoder board for the PAL-M color system

**BKM-1422 PAL comb adaptor (BT board)**

Comb filter board for the PAL color system

**BKM-1430 SECAM adaptor (BE board)**

Decoder board for the SECAM color system

**BKM-1440 RGB/component adaptor (BF board)**

Decoder outputs of RGB or component signals

**BKM-1460 VITC adaptor (BL board)**

Reader of Vertical Interval Time Code

**BKM-1470 safe area display (BQ board)**

For displaying the safe area

**BKM-1480 black level signal generator (BS board)**

For generating black level signals

**BKM-2000 rack mount kit**

For mounting in an EIA standard 19-inch rack

**BKM-2053 auto set-up probe**

For auto set-up operation with the BKM-2056 auto set-up adaptor

**BKM-2056 auto set-up adaptor (BN, BO and BP boards)**

For auto chroma/phase adjustment, auto white balance adjustment, and selection of color temperature

**BKM-2085-20 digital 4:2:2 serial input kit (BA3 and BV boards)**

For two serial inputs of component digital video signals

**BKM-2090-20 D-2 serial input kit (BA3 and BU boards)**

For serial input of a digital composite video signal

## Combination of the optional boards

The BVM-1916/2016P is equipped with the board compartments B1 through B5 behind the right-side panel, each of which can hold an optional board selected from the B boards listed above.

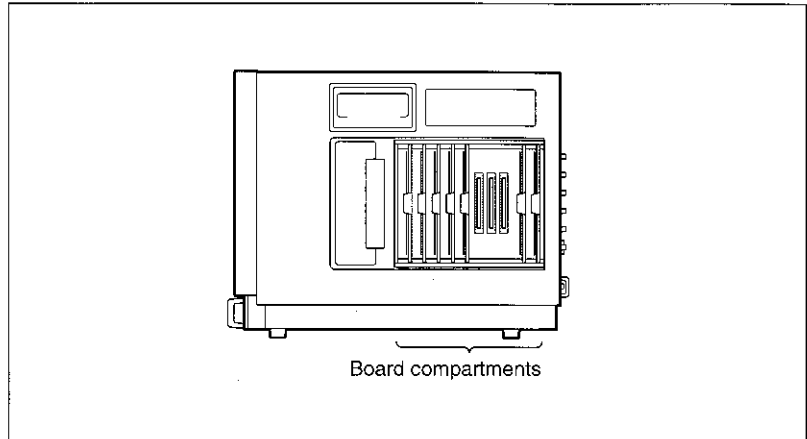

Right-side view

The BVM-1916 comes from the factory with the BT (NTSC comb adaptor) and BC (NTSC adaptor) boards installed in compartments B4 and B5.

The BVM-2016P comes from the factory with the BD (PAL adaptor) boards installed in compartment B5.

Note that the combinations of boards are limited by the allowable board assignments, as shown in the table on the next page.

Add the desired boards or replace the supplied BT, BC or BD board with optional boards, referring to the table on the next page.

### Notes

- The compartments other than B1 through B5 are reserved for the supplied BA, BG, BH, BI and BJ boards. Be sure to use these boards in the respective compartments having the same names.
- Do not leave compartment B5 empty. Be sure to insert one of the boards specified in the table on the next page. If no board is inserted, the luminance/chrominance or luminance channel will not be activated in composite signal mode.

Board assignment

Board name	Function	Compartment name				
		B5	B4	B3	B2	B1
BB (BKM-1411)	NTSC comb filter	X	○	○	○	○
BT (BKM-1412)	NTSC comb filter	○	○	○	○	○
BT (BKM-1422)	PAL comb filter	○	○	○	○	○
BC (BKM-1410)	NTSC decoder	○	○	○	○	○
BD (BKM-1420)	PAL decoder	○	○	○	○	○
BE (BKM-1430)	SECAM decoder	○	○	○	○	○
BM (BKM-1421)	PAL-M decoder	○	○	○	○	○
BF (BKM-1440)	RGB/component adaptor	X	X	○	X	X
BL (BKM-1460)	VITC reader	X	X	X	○	X
BQ (BKM-1470)	Safe area display	X	△	X	○	X
BS (BKM-1480)	Black level signal generator	○	○	○	○	○
BN, BO, BP (BKM-2056)	Auto set-up adaptor	○	○	X	X	X
BV, BA3 (BKM-2085-20)	Digital 4:2:2 serial interface	X	X	X	X	○
BU, BA3 (BKM-2090-20)	D-2 serial interface	X	X	X	X	○

○ : acceptable

× : not acceptable

△ : acceptable but the switch or control settings on the subcontrol panels cannot control the display.

**Notes**

- Do not use the BD (PAL decoder) and the BM (PAL-M decoder) boards simultaneously. This causes malfunctions of the monitor.
- Do not use the BB (NTSC comb filter) and the BT (NTSC comb filter) boards simultaneously. This causes malfunctions of the monitor.

*For details on installation and functions of the optional boards, refer to the operation and maintenance manuals of the boards.*

## 1-2. Voltage Selection

The BVM-1916 operates on 100-120 V AC and the BVM-2016P operates on 220-240 V AC.

Before connecting the unit to an AC outlet, make sure the voltage selector at the rear of your monitor is set for the appropriate voltage. If not, change the position of the selector.

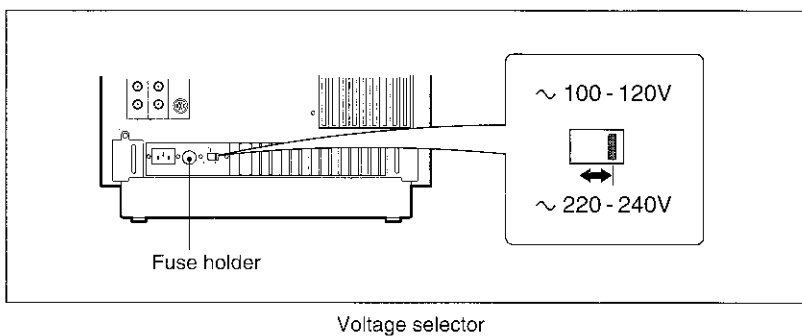

**Note**

Use a 4A/125 V fuse for the BVM-1916 (100-120 VAC) and a T2A/250V fuse for the BVM-2016P (220-240 V AC). The appropriate fuse is installed at the factory in accordance with the voltage presetting.

# 1-3. Location and Function of Parts

## 1-3-1. Front Panel

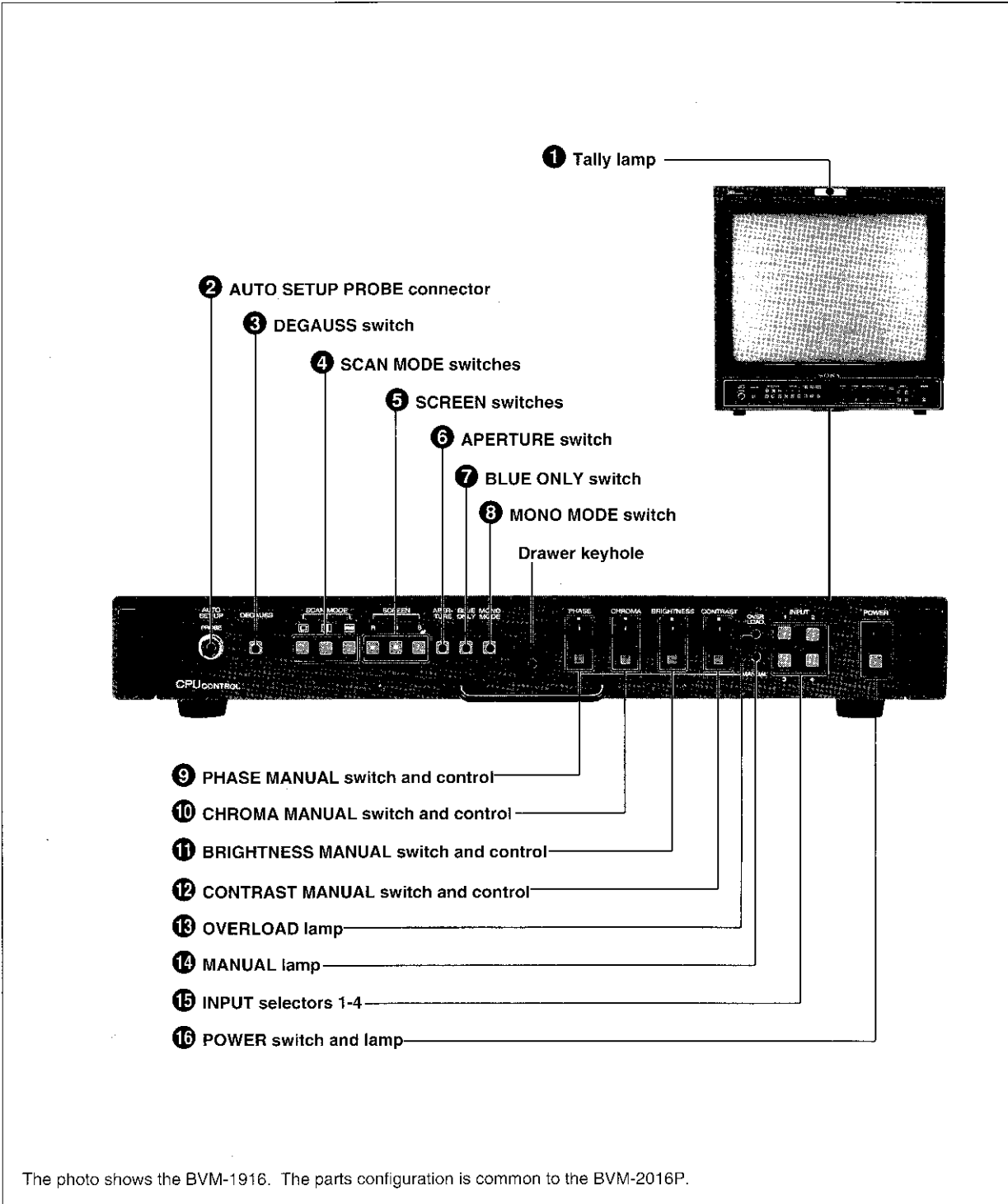

Front panel

## 1 Tally lamp

Lights when pin No. 3 and No. 8 of the REMOTE connector on the rear panel are short-circuited. The model number plate has been attached here at the factory. Replace it with one of the supplied tally number plates, as illustrated below.

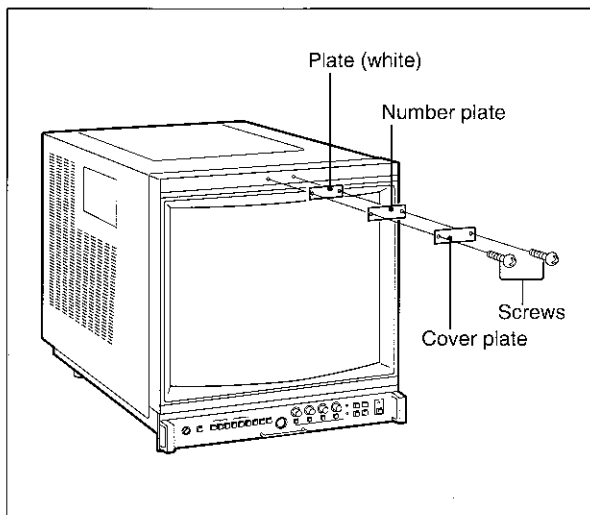

## 2 AUTO SETUP PROBE connector

Connect the optional BKM-2053 auto set-up probe for auto setup operations.

## 3 DEGAUSS switch

When the power is turned on, automatic degaussing is activated.

To demagnetize the screen manually, press this switch momentarily with the power on.



When degaussing repeatedly, wait for 5 minutes or more before pressing the switch again.

## 4 SCAN MODE switches

 (**underscan**): Depress this switch for underscanning. The display size is reduced by approximately 3% so that four corners of the raster are visible.

 (**horizontal delay**): Depress this switch to observe the horizontal sync signal in the left quarter of the screen. Picture brightness is automatically increased for easy observation.

 (**vertical delay**): Depress this switch to observe the vertical sync signal. The picture is shifted vertically and the vertical sync signal is displayed near the center of the screen. Picture brightness is automatically increased for easy observation.

- A pulse cross is displayed by depressing both the  and  switches.
- To resume normal scanning, press to release the depressed switches.

## 5 SCREEN switches

The R, G and B switches turn the red, green and blue beams respectively on and off. To turn off the beam, depress the switch. To turn it on again, press to release it.

## 6 APERTURE switch

Normally keep this switch released. A flat frequency response is obtained.

For aperture correction, depress this switch and adjust the APERTURE control inside the drawer. The boost frequency, 4.5 MHz or 6.5 MHz, can be selected with the S1 switch on the internal BG board.

With the S1 switch set at the 4.5 MHz position, the frequency response can be adjusted continuously with up to 6 dB boost at 4.5 MHz for subjective enhancement of the displayed picture.

With the S1 switch set to the 6.5 MHz position, the frequency response can be adjusted continuously with up to 6 dB boost at 6.5 MHz for compensation of aperture loss of the CRT.

## 7 BLUE ONLY switch

Normally keep this switch released. Depress this switch to turn off the red and green signals. A blue signal is displayed as an apparent monochrome picture on the screen. This facilitates CHROMA and PHASE control adjustments and observation of VTR noise.



**8 MONO MODE switch**

Normally keep this switch released (AUTO mode). Color or monochrome mode is automatically selected according to the presence or absence of color burst. Depress the switch to display color pictures in monochrome (MONO mode).

**9 PHASE MANUAL switch and control**

When this switch is in the released position, the subcarrier phase preset with the PRESETS menu operation is obtained.

To adjust the subcarrier phase manually, depress the switch and turn the control.

See "1-4-3. Presetting the Picture Levels."

**Note**

The PHASE MANUAL switch and control are disabled when the SECAM system is selected (the SECAM lamp is lit) with the SYSTEM button in the drawer, or the PAL system is selected (PAL lamp is lit) with selecting PAL D mode (the PAL S/SECAM F/COMB S lamp is not lit).

**10 CHROMA MANUAL switch and control**

When this switch is in the released position, the color saturation preset with the PRESETS menu operation is obtained.

To adjust the color saturation manually, depress the switch and turn the control.

See "1-4-3. Presetting the Picture Levels."

**11 BRIGHTNESS MANUAL switch and control**

When this switch is in the released position, the brightness preset with the PRESETS menu operation is obtained.

To adjust the brightness manually, depress the switch and turn the control.

See "1-4-3. Presetting the Picture Levels."

**12 CONTRAST MANUAL switch and control**

When this switch is in the released position, the contrast preset with the PRESETS menu operation is obtained.

To adjust the contrast manually, depress the switch and turn the control.

See "1-4-3. Presetting the Picture Levels."

**13 OVERLOAD lamp**

Lights to warn of overloading of the CRT.

**14 MANUAL lamp**

Lights when any of the four MANUAL switches 9 through 12 is depressed.

**15 INPUT selectors 1 - 4**

Select the input signal to be monitored by pressing one of these buttons.

The requirements of the input signals can be set with the CONFIGURATION buttons in the drawer and can be assigned independently to the selectors and stored in memory through the INPUT CONFIG menu operation.

See "1-4-2. Setting the Input Configuration."

**16 POWER switch and lamp**

Depress this switch to turn on the power. The lamp lights. To turn it off, press the switch again.

## 1-3-2. Rear Panel

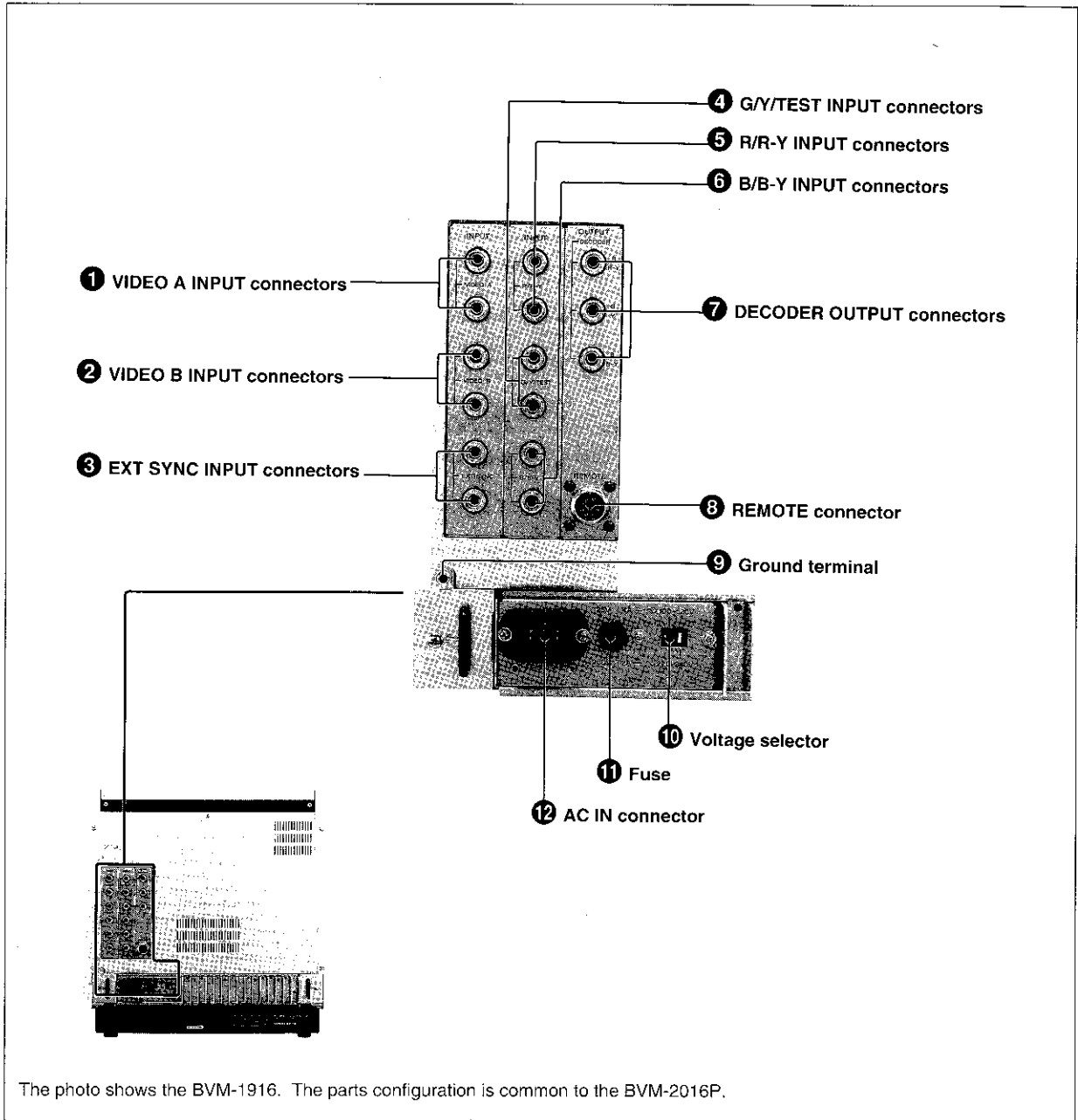

The photo shows the BVM-1916. The parts configuration is common to the BVM-2016P.

Rear panel

- 1 VIDEO A INPUT connectors (BNC)**
- 2 VIDEO B INPUT connectors (BNC)**

Input composite video signals.

Use one connector of each pair for input and the other for loop-through output.

When the loop-through output is not used, attach a 75-ohm terminator.

- 3 EXT SYNC INPUT (external sync input) connectors (BNC)**

Input a sync signal.

Use one connector for input and the other for loop-through output.

When the loop-through output is not used, attach a 75-ohm terminator.

**4 G/Y/TEST INPUT connectors (BNC)**

**5 R/R-Y INPUT connectors (BNC)**

**6 B/B-Y INPUT connectors (BNC)**

Input RGB video signals, component signals or a composite test signal. The signal format can be selected with the FORMAT button in the drawer. Use one connector of each pair for input and the other for loop-through output.

When the loop-through output is not used, attach a 75-ohm terminator.

**7 DECODER OUTPUT connectors (BNC)**

Output RGB or component (Y, R-Y, B-Y) outputs decoded from the composite (VIDEO A, VIDEO B or TEST) or component signals being displayed on the screen with the BKM-1440 RGB/component adaptor installed.

The RGB or component outputs are selected with the S1 selector on the BF board of the BKM-1440 kit.

To provide RGB output, set the S1 selector to the upper position.

To provide component output, set it to the lower position.

**Notes**

- The DECODER OUTPUT connectors do not provide the correct RGB outputs when RGB signals are displayed on the screen. To obtain the correct RGB outputs, use the loop-through outputs of the R, G and B INPUT connectors.
- The outputs obtained from noncomposite signals are also noncomposite. Supply a sync signal from the EXT SYNC INPUT connector when required.
- The output signals are affected by the CHROMA, PHASE and APERTURE controls and MATRIX switch.
- The color killer circuit is not activated for output signals.

**8 REMOTE connector**

Connect to an external control device using the supplied 10-pin connector.

To enter remote control mode, press the LOCAL/REMOTE button in the drawer so that the associated lamp lights.

The input mode and the pin assignment can be set through the REMOTE menu operation.

See "1-4-6. Assigning the Remote Control Functions."

**9 Ground terminal**

Connect to the system ground, when required.

**10 Voltage selector**

Set to 100-120 V AC for the BVM-1916 or 220-240 V AC for the BVM-2016P.

**11 Fuse**

Use a 4A fuse for the BVM-1916 or a T2A fuse for the BVM-2016P.

**12 AC IN connector**

Connect the supplied AC power cord here and secure it with the supplied cord stopper.

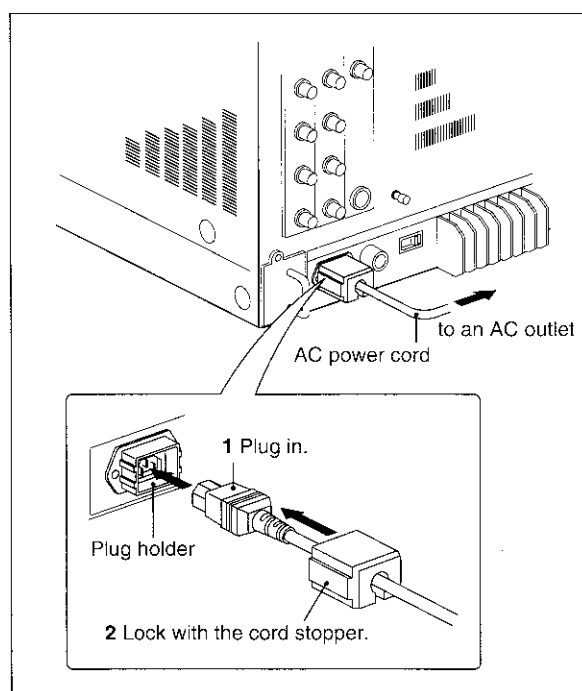

**NOTICE**

THIS NOTICE IS APPLICABLE FOR THE USA ONLY.

If shipped to the USA, use the UL LISTED power cord specified below for 220 - 240 V AC operation.

DO NOT USE ANY OTHER POWER CORD.

Plug cap	Tandem blade with ground pin
Cord	Type SJT, three 16 or 18 AWG Wires
Length	Maximum 15 feet
Rating	Minimum 10 A, 250 V AC

## 1-3-3. Subcontrol Panels inside the Drawer

Insert the supplied drawer key into the keyhole of the drawer lock, turn it 90° clockwise and pull the drawer out.

Adjust the button and controls on the subcontrol panels when the monitor is fully warmed up. Warm-up time will be at least 30 minutes after the power has been turned on.

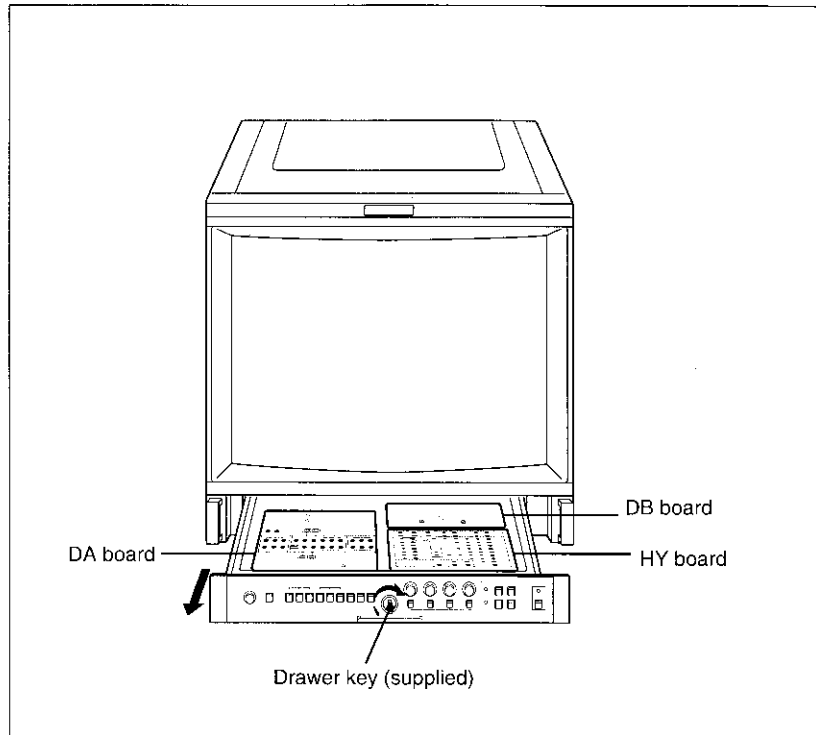

For turning the controls on the DA and DB boards, use the supplied screwdriver.

## HY board (input configuration, menu and auto setup operation section)

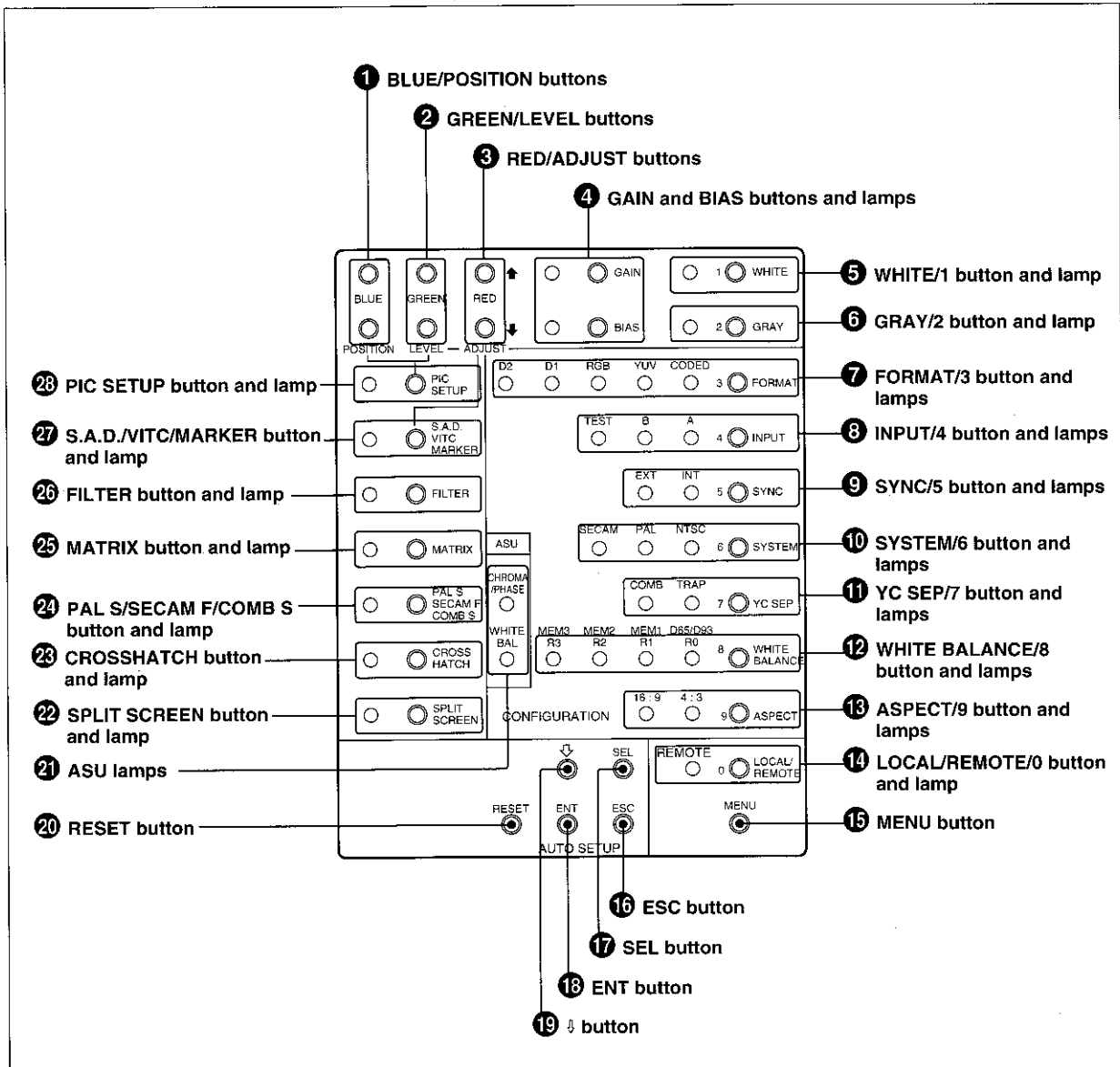

HY board

### 1 BLUE/POSITION buttons

When adjusting white balance (the GAIN or BIAS lamp is lit), use these buttons to adjust the blue signal.

When adjusting the black level (the PIC SETUP lamp is lit), use them to adjust the position of the input signal checking zone.

### 2 GREEN/LEVEL buttons

When adjusting white balance (the GAIN or BIAS lamp is lit), use these buttons to adjust the green signal.

When adjusting the black level (the PIC SETUP lamp is lit), use them to adjust the brightness of the black reference area.

### ③ RED/ADJUST buttons

When adjusting white balance (the GAIN or BIAS lamp is lit), use these button to adjust the red signal.

When the safe area is displayed (the S.A.D./VITC/MARKER lamp is lit), use them to adjust the safe area size.

### ④ GAIN and BIAS buttons and lamps

When adjusting the white balance, select the adjustment items.

**BIAS:** Adjust the white balance at the lowlight and brightness of the screen.

**GAIN:** Adjust the white balance at the highlight and contrast of the screen.

For the adjustments, use the BLUE/POSITION, GREEN/LEVEL and RED/ADJUST buttons.

### ⑤ WHITE/1 button<sup>1)</sup> and lamp

When adjusting the white balance at the highlight, press this button so that the lamp lights. The internal 100% white signal is displayed on the screen. To turn off the signal, press the button again.

### ⑥ GRAY/2 button<sup>1)</sup> and lamp

When adjusting the white balance at the lowlight, press this button so that the lamp lights. The internal gray signal is displayed on the screen. To turn off the signal, press the button again.

### ⑦ FORMAT/3 button<sup>1)</sup> and lamps

Select the signal format according to the signal to be monitored. Press this button so that the lamp of the appropriate format lights.

**CODED:** For monitoring NTSC, PAL or SECAM signal with the decoder board (BC, BD, BE or BM) installed.

**YUV:** For monitoring Y/R-Y/B-Y component signals.

**RGB:** For monitoring RGB signals.

**D-1:** For monitoring D-1 format component signals.

**D-2:** For monitoring a D-2 format composite signal.

### ⑧ INPUT/4 button<sup>1)</sup> and lamps

When monitoring a composite signal, select the input connector.

Press this button so that the lamp of the appropriate connector lights.

**A:** For monitoring the signal connected to the VIDEO A INPUT connector.

**B:** For monitoring the signal connected to the VIDEO B INPUT connector.

**TEST:** For monitoring the test signal connected to the G/Y/TEST connector.

### ⑨ SYNC/5 button<sup>1)</sup> and lamps

Select the sync mode. Press this button so that the lamp of the appropriate mode lights.

**INT (internal sync mode):** The unit operates in synchronization with the sync signal of the composite signal being displayed on the screen.

**EXT (external sync mode):** The unit operates in synchronization with the sync signal supplied from the EXT SYNC INPUT connector.

### ⑩ SYSTEM/6 button<sup>1)</sup> and lamps

When monitoring a composite signal or a signal decoded with a decoder board (BC, BD, BE or BM), select the color system according to the signal to be monitored. Press this button so that the lamp of the appropriate system lights.

**NTSC:** For monitoring a signal of the NTSC color system.

**PAL:** For monitoring a signal of the PAL color system.

**SECAM:** For monitoring a signal of the SECAM color system.

#### Note

If the decoder board for the selected color system has not been installed:

- The picture does not appear when the FILTER lamp is lit (FILTER ON).
- The picture is displayed in monochrome when the FILTER lamp is not lit (FILTER OFF).

1) These buttons also function as numeric keys when specifying the password.

See "1-4-5. Changing and Applying the Password."

**11 YC SEP(Y/C separation filter)/7 button<sup>1)</sup> and lamps**

For NTSC or PAL signal, select the filter to be used for Y/C separation. Press the button so that the lamp of the appropriate filter lights.

**COMB:** To use the comb filter with the comb filter board (BB or BT) installed.

**TRAP:** To use the built-in trap filter.

**Note**

When the appropriate comb filter board has not been installed, the trap filter is activated regardless of the setting with this button.

**12 WHITE BALANCE/8 button<sup>1)</sup> and lamps**

Select the white balance and picture levels stored in the respective registers. Press this button so that the lamp of the appropriate register lights.

At the factory, the white balance for D65 has been stored in all the registers.

**D65/D93 R0:** To use the white balance and picture levels stored in register 0.

**MEM 1 R1:** To use the white balance and picture levels stored in register 1.

**MEM 2 R2:** To use the white balance and picture levels stored in register 2.

**MEM 3 R3:** To use the white balance and picture levels stored in register 3.

*For details, see "1-4. Menu Operations."*

**13 ASPECT/9 button<sup>1)</sup> and lamps**

Select the aspect ratio of the picture to be monitored. Press this button so that the lamp of the appropriate ratio lights.

**4:3:** For the 4:3 aspect

**16:9:** For the 16:9 aspect.

**14 LOCAL/REMOTE/0 button<sup>1)</sup> and lamp**

To enable the monitor to be controlled from an external control device connected to the REMOTE connector on the rear panel, press this button so that the lamp lights (REMOTE mode). To disable the remote control (LOCAL mode), press the button again.

*For the remote control functions, see "1-4-6. Assigning the Remote Control Functions."*

**15 MENU button**

Press to initiate menu operations. The initial menu is displayed.

**16 ESC (escape) button**

Press to quit menu or auto setup operations.

**17 SEL (select) button**

Press to set the monitor to color temperature selection mode in auto setup operations. In color analyzer mode, select the memory position of the probe connected to the AUTO SETUP PROBE connector.

*For details, refer to the operation and maintenance manual of the BKM-2056 auto set-up adaptor.*

**18 ENT (enter) button**

Press to proceed to the next step during menu or auto setup operation and save the data.

**19 ↓ (cursor) button**

For selecting menu options displayed on the screen in menu or auto setup operations. Each time this button is pressed, the cursor moves downwards and, if at the bottom, jumps to the top.

**20 RESET button**

Press to reset an auto setup operation.

**21 ASU (automatic setup) lamps**

**CHROMA/PHASE:** Lights when the automatic chroma and phase adjustment is completed with AUTO CHROMA/PHASE in auto setup operations. The lamp goes off when MANUAL is selected on the SELECT MONITOR MEM menu in auto setup operations.

**WHITE BAL:** Lights when one of the color temperature to be transferred to the monitor by the auto white balance adjustment is selected on the SELECT MONITOR MEM menu in auto setup operations. When this lamp is lit, the color temperature selection on the SELECT MONITOR MEM menu can be performed using the WHITE BALANCE/8 button.

1) These buttons also function as numeric keys when specifying the password.

*See "1-4-5. Changing and Applying the Password."*

### 22 SPLIT SCREEN button and lamp

To display the lower half of the picture in monochrome mode, press this button so that the lamp lights. Press this button again to resume the normal picture.

### 23 CROSSHATCH button and lamp

To display the internal crosshatch pattern for convergence adjustment, press this button so that the lamp lights.

The crosshatch pattern is synchronized with the selected composite sync signal.

To turn off the pattern, press the button again.

### 24 PAL S/SECAM F/COMB S button and lamp

**While monitoring a PAL signal,** the demodulation mode of the the PAL system can be switched. When this button is pressed and the lamp lights, S (simple) mode is selected.

By pressing the button to turn off the lamp, D (deluxe) mode is selected.

**While monitoring a SECAM signal,** the ID signal of the the SECAM system can be switched. When this button is pressed and the lamp lights, the F (field) signal is selected. By pressing the button to turn off the lamp, the L (line) signal is selected.

**When the BKM-1412 NTSC comb filter is activated,** the comb filter mode can be switched. When this button is pressed and the lamp lights, the S (simple) comb filter is selected. By pressing the button to turn off the lamp, the D (dynamic) comb filter is selected. (When the BKM-1411 NTSC comb filter is activated, the S (simple) comb filter is always selected regardless of the button setting.)

### 25 MATRIX button and lamp

Should normally be OFF (lamp not lit).

By pressing this button so that the lamp lights (ON), the matrix circuit is activated and the chromaticity of the displayed picture more closely approximates to that of "true" NTSC phosphors.

To turn off the matrix circuit, press the button again.

### 26 FILTER button and lamp

To activate the comb or trap filter (selected with the YC SEP button) in MONO mode (MONO MODE switch on the front panel depressed), press this button so that the lamp lights.

To deactivate the filter for a wider frequency range, press the button again.

#### Note

In AUTO mode (the MONO MODE switch released), the filter is always activated for color signals regardless of the setting with this button.

### 27 S.A.D.(safe area display)/VITC/MARKER button and lamp

**When the safe area is displayed** with the BQ board (BKM-1470 safe area display) installed, the adjustment of the safe area size can be enabled.

**When the BL board (BKM-1460 VITC adaptor) has been installed,** the VITC display can be turned on and off.

### 28 PIC SETUP (picture setup) button and lamp

Use to match the black reference of the monitor with the black level of the input signal to be monitored.

By pressing this button so that the lamp lights, a vertical picture band and the black reference of the monitor are displayed on the screen for easy level comparison.

See "1-5-2. Black Level Adjustment."



## DA board

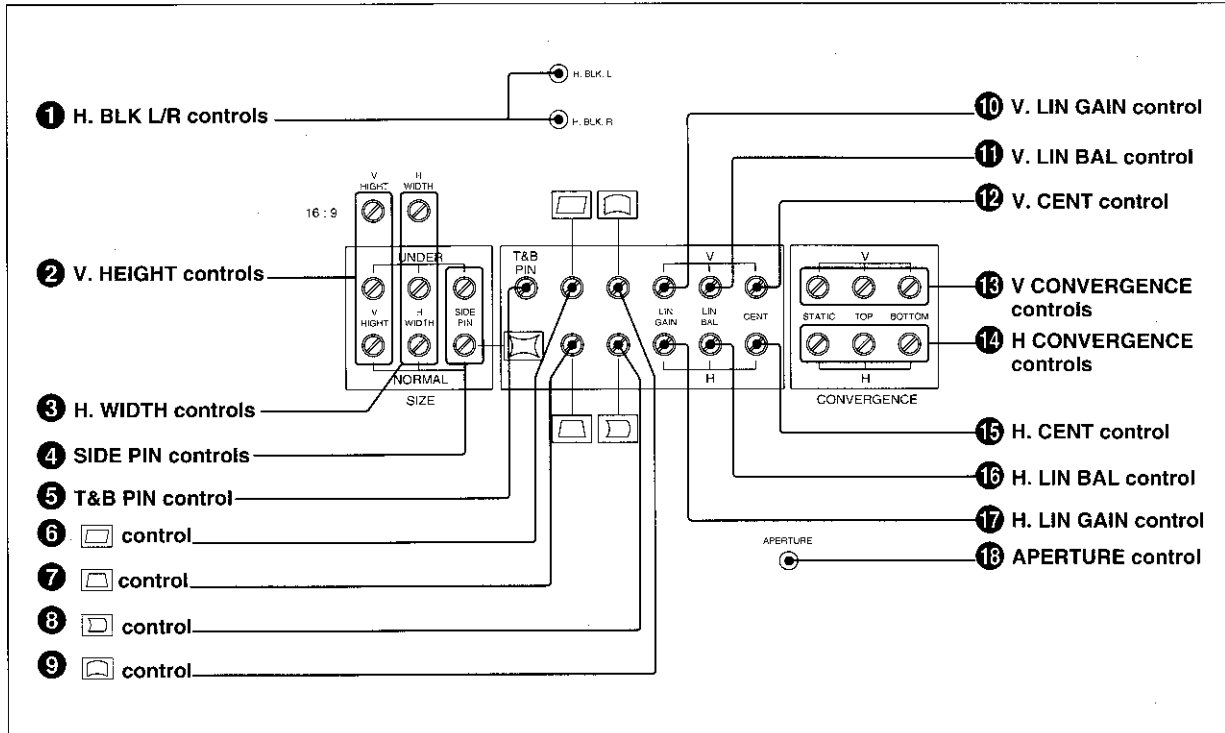

DA board

### 1 H. BLK. L/R (horizontal blanking left/right) controls

Adjust the width of the horizontal blanking at both sides of the screen.

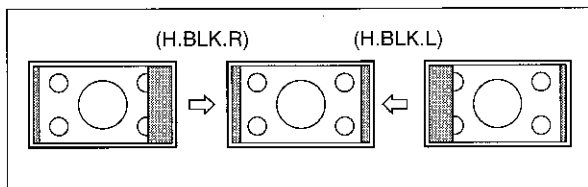

### 2 V. HEIGHT (vertical height) controls

Adjust the height of the picture. Use the NORMAL control for the 4:3-aspect normal picture, the UNDER control for the 4:3-aspect underscanned picture and the 16:9 control for the 16:9-aspect picture.

### 3 H. WIDTH (horizontal width) controls

Adjust the horizontal width of the picture. Use the NORMAL control for the 4:3-aspect normal picture, the UNDER control for the 4:3-aspect underscanned picture and the 16:9 control for the 16:9-aspect picture.

### 4 SIDE PIN (pincushion) controls

Correct the side pincushion distortion. Use the NORMAL control for the 4:3-aspect normal picture and the UNDER control for the 4:3-aspect underscanned picture.

### 5 T&B PIN (top and bottom pincushion) distortion control

Correct the top and bottom pincushion distortion.

### 6 (parallelogram distortion) control

Correct the right angled distortion of the deflection yoke.

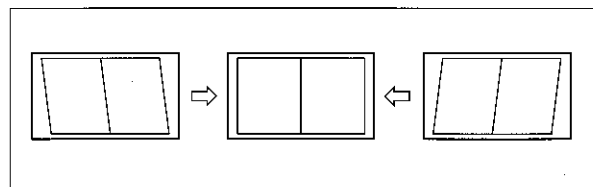

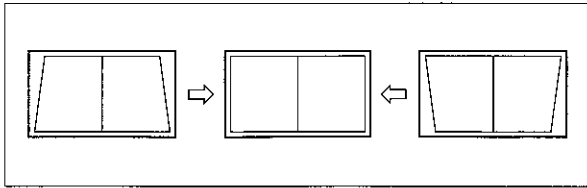

# Section 1 Operation

**7**  (side pincushion tilt) control  
Adjust the phase of the side pincushion distortion.

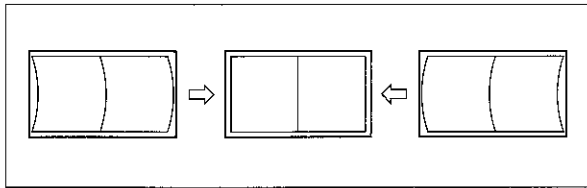

**8**  (horizontal centering linearity) control  
Adjust the horizontal linearity at the center of the picture.



**9**  (top and bottom pincushion balance) control  
Adjust the distortion at the center (X axis) of the picture.

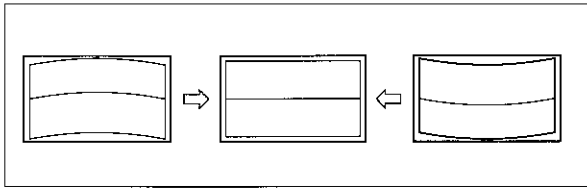

**10** **V. LIN GAIN** (vertical linearity gain) control  
Adjust the vertical linearity of the picture.

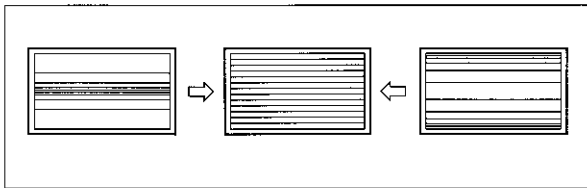

**11** **V. LIN BAL** (vertical linearity balance) control

Adjust the balance of the vertical (Y axis) linearity of the picture.

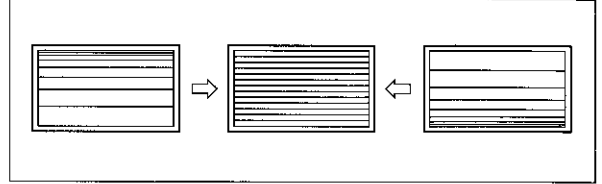

**12** **V. CENT** (vertical centering) control  
Adjust the vertical position of the picture.

**13** **V** (vertical) **CONVERGENCE** controls

**14** **H** (horizontal) **CONVERGENCE** controls

Adjust the vertical (Y axis) or horizontal (X axis) convergence of corresponding portion of the screen as follows.

	V (vertical)	H (horizontal)
STATIC		
TOP		
BOTTOM		

**15** **H. CENT** (horizontal centering) control  
Adjust the horizontal position of the picture.

**16 H. LIN BAL (horizontal linearity balance) control**

Adjust the balance of the horizontal (x axis) linearity of the picture.

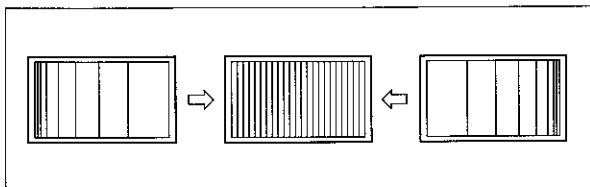

**17 H. LIN GAIN (horizontal linearity gain) control**

Adjust the horizontal linearity of the picture.

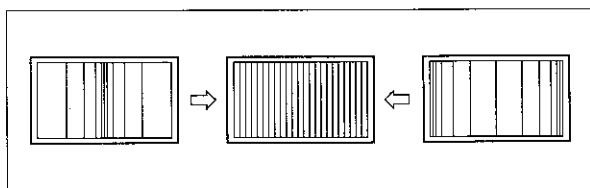

**18 APERTURE control**

Adjust the frequency response when the APERTURE switch on the front panel is depressed.

**DB board (H.V. oscillator section)**

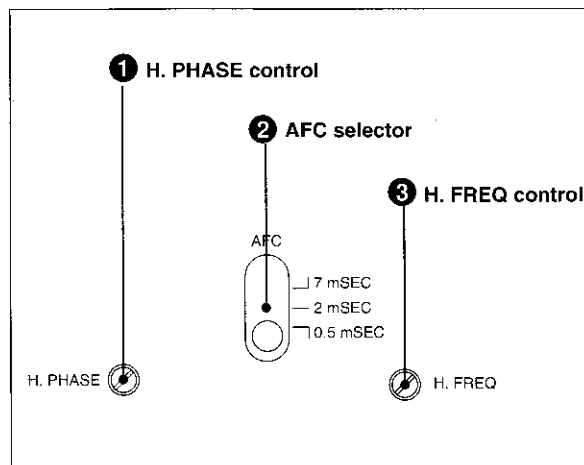

DB board

**1 H. PHASE (horizontal phase) control**  
Adjust the horizontal position of the picture.

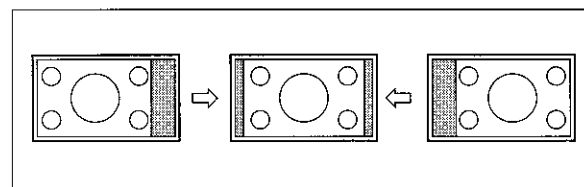

**2 AFC (automatic frequency control) selector**  
Select the AFC time constant.

- 0.5 mSEC (fast):** This mode is fast enough to compensate for VTR jitter. Set to this position to obtain a stable playback picture from a VTR.
- 2 mSEC (normal):** Normally set to this position.
- 7 mSEC (slow):** This mode is slow enough to display the time base instability introduced by mechanical jitter in the VTR playback signal.

**3 H. FREQ (oscillator) control**  
Adjust the free-run horizontal frequency.

## 1-3-4. Switches inside the Cabinet

To access to the switches on the boards inside the cabinet, see Section 2.

### BJ board

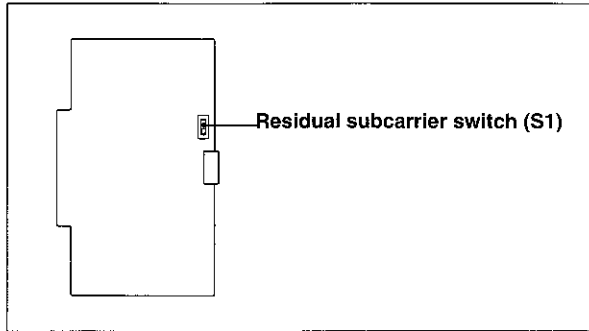

BJ board

#### Residual subcarrier switch (S1)

This switch is factory-preset to the lower position (OFF).

Normally there will be no residual subcarrier in input video signals. However, if a residual subcarrier is present, this may affect the display. Set this switch to the upper position (ON) to check if a residual subcarrier is present. If it is present in the incoming signal, color shift appears in the picture.

### BH board

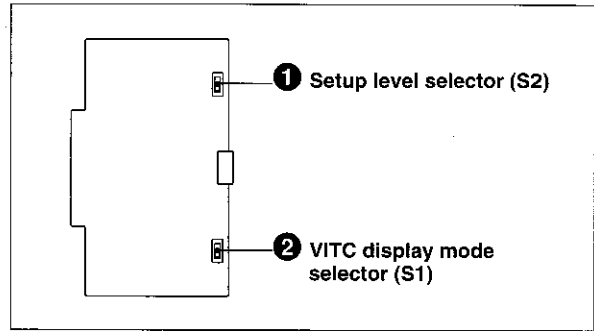

BH board

#### 1 Setup level selector (S2)

Select the setup level.

**0 IRE:** The setup level is 0%.

**AUTO:** The setup level set through the COMPONENT OFFSET or NTSC OFFSET option of the MONITOR CONFIG menu is obtained.

*See "1-4-7. Defining the Monitor Configuration."*

**7.5 IRE:** The setup level is 7.5%.

The 0% setup levels can be varied with the RV1 control and 7.5% level with the RV2 control in a range from -2.5% through +12.5%.

#### 2 VITC display mode selector (S1)

Use to invert the character and background colors for VITC display.

**Upper position:** Factory-preset position. The VITC is displayed in white characters on a black background.

**Lower position:** The VITC is displayed in black characters on a white background.

*For details, see the operation and maintenance manual of the BKM-1460 VITC adaptor.*

## BG board

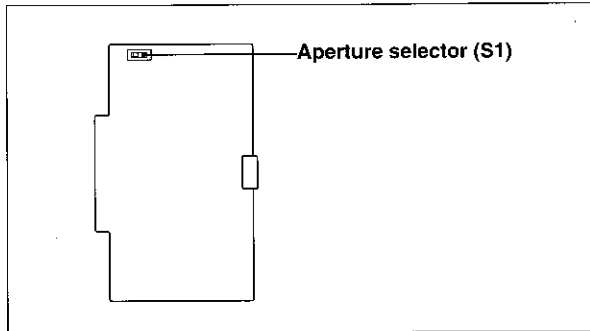

BG board

### Aperture selector (S1)

Select the boost frequency, 4.5 MHz or 6.5 MHz, for aperture correction. This selector is factory-preset to 4.5 MHz.

## QA and QB boards

The QA board is located behind the VIDEO A, VIDEO B and EXT SYNC INPUT connector panel and the QB board is located behind the R/R-Y, G/Y/TEST and B/B-Y INPUT connector panel. To access these boards, remove the INPUT connector panels, referring to Section 2.

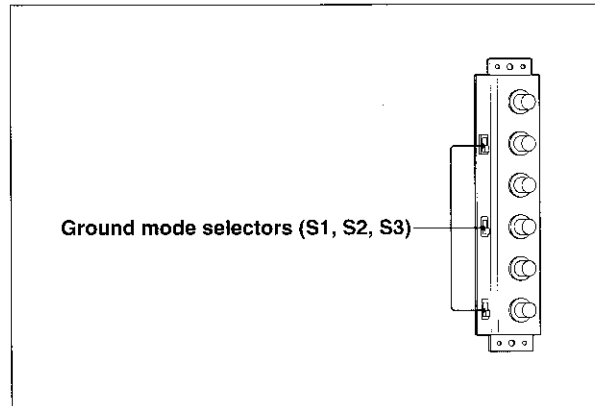

QA and QB boards

### Ground mode selectors (S1, S2, S3)

The selectors on the QA board correspond to the VIDEO A, VIDEO B or EXT SYNC INPUT connectors and those on the QB board correspond to the R/R-Y, G/Y/TEST or B/B-Y connectors, respectively.

**S (nonfloating):** Factory-preset position.

Normally keep the selectors at this position.

**F (floating):** When there is hum in the input signal to be monitored, set to this position.

Common mode noise will be rejected.



### To select a menu option

Move the cursor with the ↓ button to the line of the desired menu option and press the ENT button.  
 Pressing the ↓ button moves the cursor downward and, if at the bottom, to the top.

### To cancel the menu operation on the way

Press the ESC button.  
 At any level of the menu operations, pressing the ESC button cancels the operations without changing any data and restores normal status.

## 1-4-2. Setting the Input Configuration

At the factory, the following input signals are assigned to INPUT selectors 1 to 4 on the front panel.

Factory-set configuration

Signal	INPUT selectors			
	1	2	3	4
FORMAT	CODED	CODED	COMPONENT	RGB
INPUT	A	B	—	—
SYNC	INT	INT	INT	INT
SYSTEM <sup>a)</sup>	NTSC/PAL	NTSC/PAL	—	—
ASPECT	4 : 3	4 : 3	4 : 3	4 : 3
YC SEP <sup>b)</sup>	COMB	COMB	—	—

a) NTSC for the BVM-1916 and PAL for the BVM-2016P.

b) Only for BVM-1916. The INPUT selectors 1 and 2 on the BVM-2016P have been set to TRAP.

Using the CONFIGURATION buttons on the HY board in the drawer, these requirements of the input signals (input configuration) can be changed as desired and stored in memory through the INPUT CONFIG menu operation.

The stored configuration is always obtained when the assigned INPUT selector is pressed.

When the change is not stored through the menu operation, the input configuration returns to the previous status when another INPUT selector is pressed.

## Operation

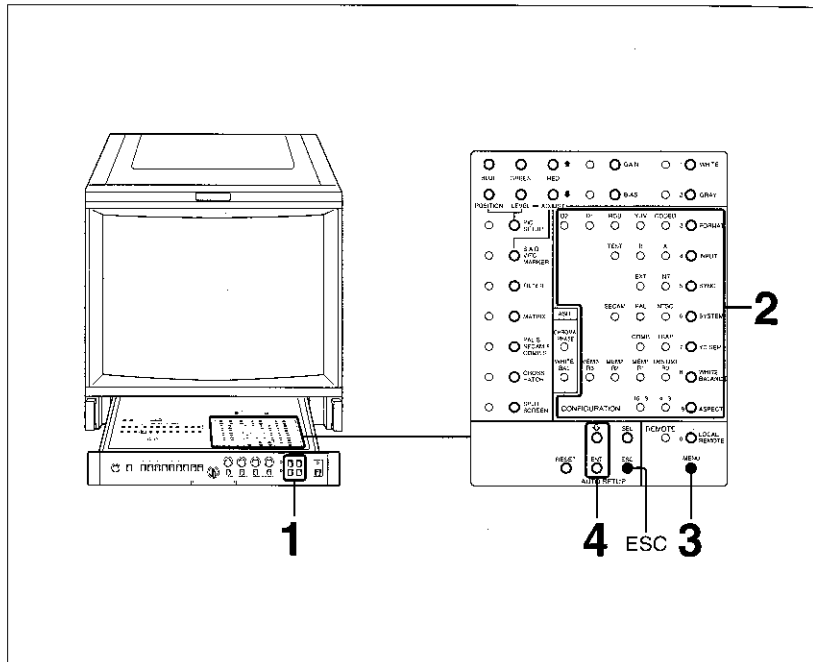

- 1** Press one of the INPUT selectors on the front panel.
- 2** Using the following COFIGURATION buttons in the drawer, set the input configuration for the INPUT selector selected in step 1. Press the buttons so that the appropriate lamps light.
  - FORMAT:** Select the signal format (CODED, YUV, RGB, D-1 or D-2).
  - INPUT:** Select the input connector A, B or TEST when you select CODED for FORMAT, or A or B when you select D-1 or D-2 for FORMAT.
  - SYNC:** Select the sync mode (INT or EXT).
  - SYSTEM:** Select the color system (NTSC, PAL or SECAM) when you select CODED or D-2 for FORMAT.
  - YC SEP:** Select the filter when you select NTSC or PAL for the color system.
  - WHITE BALANCE:** Select the register (R0, R1, R2 or R3) on which the desired white balance has been stored.  
*See "1-4-4. Selecting the White Balance."*
  - ASPECT:** Select the picture aspect (4:3 or 16:9).
- 3** When the settings are completed, press the MENU button. The initial menu is displayed.



- 
- 4** Should the cursor on the initial menu not be located at INPUT CONFIG, press the ↓ button until it returns to INPUT CONFIG, and press the ENT button.

**Note**

If the message “PLEASE ENTER PASSWORD” is displayed, enter the password.

See “1-4-5. Changing and Applying the Password.”

The input configuration set in step 2 for the INPUT selector selected in step 1 is now stored in memory.

The message “DATA SAVED” is momentarily displayed and the monitor returns to normal status.

Repeat this procedure for the other INPUT selectors as desired.

**To cancel the operation**

Press the ESC button before pressing the ENT button in step 4.

## 1-4-3. Presetting the Picture Levels

The four sets of the phase, chroma, brightness, contrast, and picture setup (black reference) levels can be set and stored in Registers R0 to R3 through the PRESETS menu operation.

### Operation

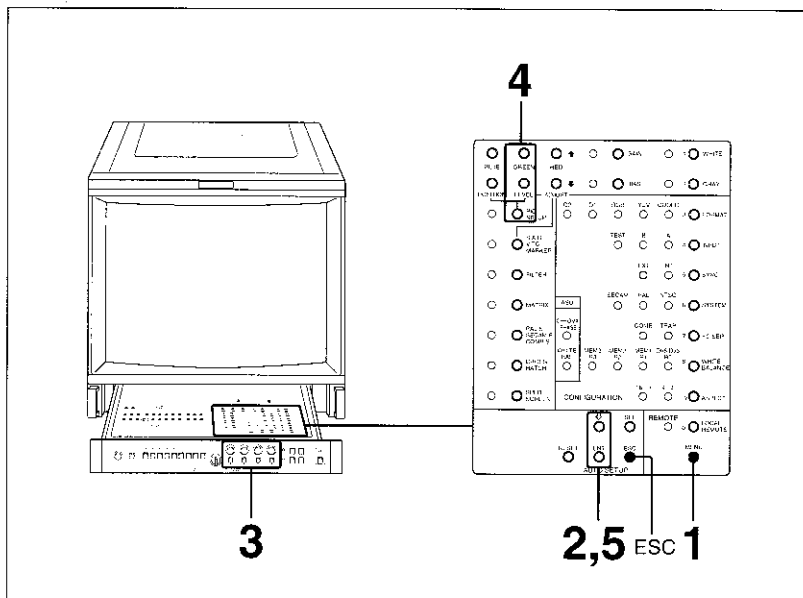

- 1** Press the MENU button.  
The initial menu is displayed.
- 2** Press the ↓ button until the cursor reaches PRESETS, then press the ENT button.  
The SAVE PRESETS menu is displayed.

SAVE PRESETS	
■	TEXT ON/OFF
	DATA REGISTER R0 *
	DATA REGISTER R1
	DATA REGISTER R2
	DATA REGISTER R3
PHASE	100 BRIGHT 100
CHROMA	100 CONTRAST 100
	PICTURE SETUP LEVEL 100
	SELECT AND PRESS ENT

An asterisk indicates the register which is currently selected with the WHITE BALANCE button. The levels stored in this register are displayed as numerical values on the lower half of the menu display.

#### Note

If the message “PLEASE ENTER PASSWORD” is displayed, enter the password.  
See “1-4-5. Changing and Applying the Password.”

- 3** Depress the PHASE, CHROMA, BRIGHTNESS and CONTRAST MANUAL switches and turn the respective controls so that the desired levels are obtained.
- 4** Press the PIC SETUP button so that the associated lamp lights and adjust the setup level for the picture by pressing the LEVEL buttons.

**Note**

The adjustments in steps 3 and 4 can be precisely performed while observing the numeric level indications (0 through 200, centering with 100) on the lower half of the menu display.

**To adjust while observing the picture on the screen**, set the cursor to TEXT ON/OFF and press the ENT button, and the SAVE PRESETS menu disappears.

For the picture setup level, follow the procedure in "1-5-2. Black Level Adjustment."

To return to the SAVE PRESETS menu, press the ENT button again.

- 5** Move the cursor to the register in which the set levels are to be stored and press the ENT button.

The levels set in steps 3 and 4 are now stored in the register selected in step 5.

The message "DATA SAVED" is momentarily displayed, and the monitor returns to normal status.

Repeat this procedure for the other registers as desired.

**To cancel the operation**

Press the ESC button before pressing the ENT button in step 5.

---

#### 1-4-4. Selecting the White Balance

The four settings for white balance can be stored in Registers R0 to R3. At the factory, the setting for D65 has been stored in all the registers

**Note**

The settings for white balance are stored in combination with the picture levels set through the PRESETS menu operation in the same Registers R0 through R3.

## Operation

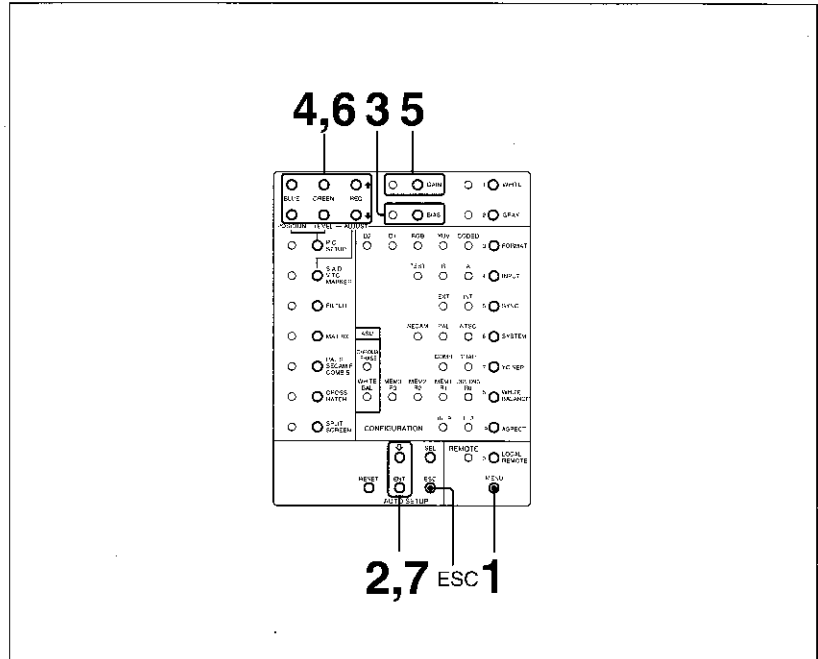

- 1** Press the MENU button.  
The initial menu is displayed.
- 2** Press the ↓ button until the cursor reaches WHITE BALANCE, then press the ENT button.  
The SAVE WHITE BALANCE menu is displayed.

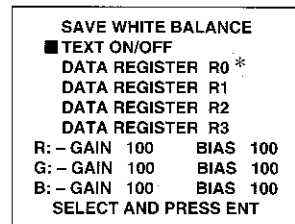

An asterisk indicates the register which is currently selected with the WHITE BALANCE button. The levels stored in this register are displayed as numerical values on the lower half of the menu display.

**Note**

If the message “PLEASE ENTER PASSWORD” is displayed, enter the password.

See “1-4-5. Changing and Applying the Password.”

- 3** Press the BIAS button.  
The associated lamp lights.
- 4** Adjust the R, G and B bias levels by pressing the RED, GREEN and BLUE buttons.
- 5** Press the GAIN button.  
The associated lamp lights.
- 6** Adjust the R, G and B signal gain levels by pressing the RED, GREEN and BLUE buttons.

**Note**

These adjustments in steps 3 through 6 can be precisely performed while observing the numeric level indications (0 through 200, centering with 100) on the lower half of the menu display.

**To adjust while observing the picture on the screen**, set the cursor to TEXT ON/OFF and press the ENT button, and the SAVE WHITE BALANCE menu disappears.

Then, adjust the white balance by following the procedure in "1-5-1. White Balance Adjustment."

To return to the SAVE WHITE BALANCE menu, press the ENT button again.

- 7** Move the cursor to the register in which the set white balance is to be stored and press the ENT button.

The white balance set in steps 3 through 6 is now stored in the register selected in step 7.

The message "DATA SAVED" is momentarily displayed, and the monitor returns to normal status.

Repeat the above procedure for the other registers as desired.

**To cancel the operation**

Press the ESC button before pressing the ENT button in step 7.

## 1-4-5. Changing and Applying the Password

The password can be specified and applied to the desired menu option to prohibit the menu settings from being changed without permission. The password can be any desired four-digit number, which is entered by using the function buttons having additional numeric indications on the HY board.

The message "PLEASE ENTER PASSWORD" is displayed when you try to select the options for which the password has been applied, from the initial menu.

If an incorrect password is entered or the password is not entered within about 5 seconds after the above message is displayed, the message "INCORRECT ENTRY" is momentarily displayed and the menu operation is canceled.

### To change the password

"9999" has been specified for the password at the factory. Change it to your desired four-digit number as follows.

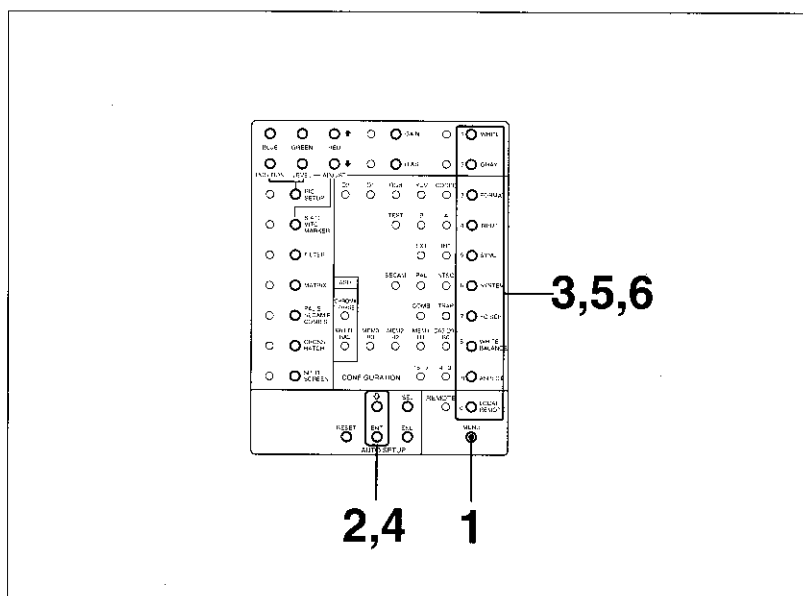

- 1 Press the MENU button.  
The initial menu is displayed.

- 2** Press the  $\downarrow$  button until the cursor reaches **PASSWORD**, then press the **ENT** button.  
The message “ENTER PASSWORD” is displayed.
- 3** Enter the current password (Factory-set: 9999).  
The **PASSWORD MENU** is displayed.

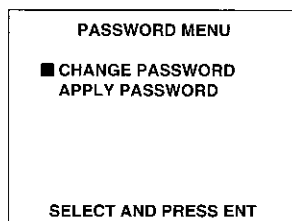

- 4** Select the **CHANGE PASSWORD** option.  
The message “ENTER NEW PASSWORD” is displayed.
- 5** Enter any desired four-digit number as your new password using the buttons labeled 0 to 9.  
The message “PLEASE RE-ENTER NEW PASSWORD TO CONFIRM” is displayed.
- 6** Enter the new password again.  
The message “PASSWORD CHANGED” is displayed and the new password is now valid.

**Note**

If an incorrect password is entered, “INCORRECT ENTRY. PASSWORD NOT CHANGED” is displayed and the menu operation is canceled.

**To cancel the operation**

Press the **ESC** button before re-entering the new password in step 6.

## To apply the password

The specified password can be activated/deactivated independently for each of the initial menu options and, with the BKM-2056 installed, the auto setup option.

- 1 Perform steps 1 through 3 mentioned in "To change the password."
- 2 By pressing the  $\downarrow$  button and then ENT button, select the APPLY PASSWORD option.  
The APPLY PASSWORD menu is displayed.

APPLY PASSWORD	
■ INPUT CONFIG	NO
WHITE BALANCE	NO
PRESETS	NO
AUTO SETUP	NO
REMOTE CONTROL	NO
MONITOR CONFIG	NO
SAVE AND APPLY	
SELECT AND PRESS ENT	

NO is displayed for each option for which the password is not activated.

YES is displayed for each option for which the password is activated.

- 3 By pressing the  $\downarrow$  button, move the cursor to the option for which the password application is to be changed.
- 4 Press the ENT button to change NO to YES or vice versa.  
(Pressing the button toggles the YES/NO setting.)

Repeat steps 3 and 4 for the other options as desired.

- 5 When the password application setting is completed, move the cursor to SAVE AND APPLY and press the ENT button.  
The message "PASSWORD APPLIED" is momentarily displayed, and the monitor returns to normal status.

## To cancel the operation

Press the ESC button before pressing the ENT button in step 5.



## 1-4-6. Assigning the Remote Control Functions

The remote control function is available either in STANDARD PARALLEL or CONFIGURE PARALLEL mode.

The mode change is achieved through the REMOTE CONTROL menu operation.

The SERIAL REMOTE option mode in the REMOTE CONTROL menu is provided for future use. If you inadvertently select it, cancel the REMOTE CONTROL menu by pressing the ESC button.

### STANDARD PARALLEL mode

The remote control function is set to the STANDARD PARALLEL mode and the following functions are assigned to the pins of the REMOTE connector at the factory.

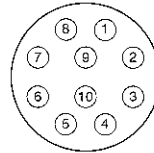

Pin assignment

Function			Pin No.						
INPUT	SYNC	MODE	1	2	3	4	5	6	7
A	INT	AUTO	O	O	-	O	-	-	-
		MONO	S	O	-	O	-	-	-
	EXT	AUTO	O	O	-	S	-	-	-
		MONO	S	O	-	S	-	-	-
B	INT	AUTO	O	S	-	O	-	-	-
		MONO	S	S	-	O	-	-	-
	EXT	AUTO	O	S	-	S	-	-	-
		MONO	S	S	-	S	-	-	-
VITC OFF			-	-	-	-	-	S	-
VITC HOLD			-	-	-	-	-	O	S
TALLY ON			-	-	S	-	-	-	-

S: Short-circuit with pin No.8  
 O: Open  
 -: Either S or O

The assigned function can be controlled by short-circuiting the corresponding pin with pin 8.

Note that pin 3 is fixed to TALLY and pin 8 is fixed to GND.

The remote control operations have priority over the respective buttons and switches of the monitor.

## CONFIGURE PARALLEL mode

The functions of the buttons or switches on the front panel or in the drawer listed below can be assigned to pins 1, 2 and 4 through 7, as desired.

### Front panel

INPUT selectors 2 to 4 (input selection)

MONO MODE switch (AUTO/MONO mode switching)

### HY board inside the drawer

WHITE button (ON/OFF)

SYNC button (INT/EXT sync mode switching)

YC SEP button (COMB/TRAP filter switching)

ASPECT button (16:9/4:3 picture aspect switching)

S.A.D./VITC/MARKER button (S.A.D. or VITC ON/OFF)

FILTER button (ON/OFF)

MATRIX button (ON/OFF)

PAL S/SECAM F/COMB S button (mode or type switching)

CROSSHATCH button (ON/OFF)

SPLIT SCREEN button (ON/OFF)

## Operation

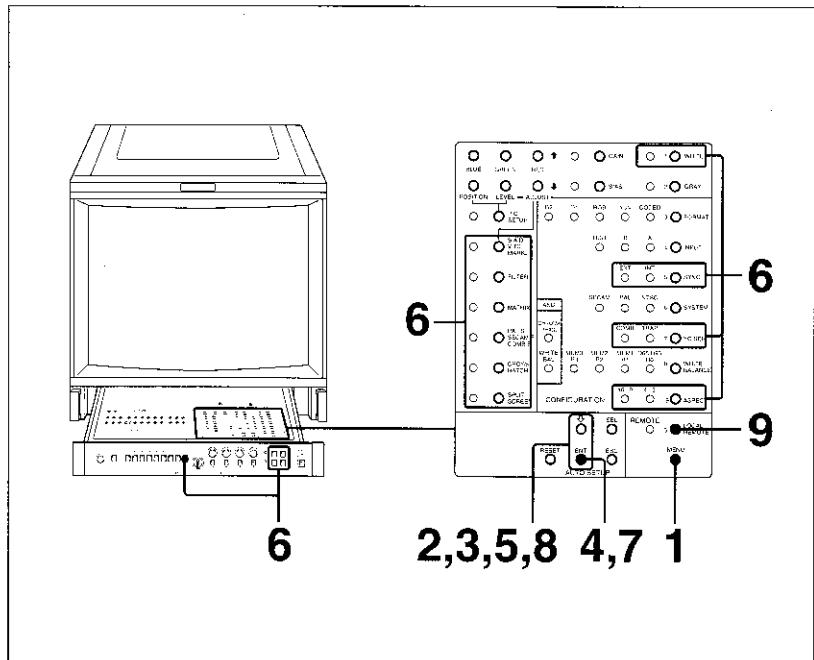

- 1 Press the MENU button to display the initial menu.

- 2 Move the cursor to REMOTE CONTROL and press the ENT button.  
The REMOTE CONTROL MENU is displayed.

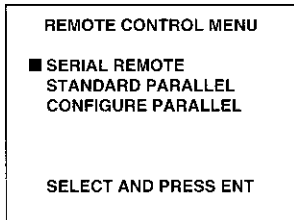

Note that SERIAL REMOTE is for future use.

- 3 **To change the pin assignment of the REMOTE connector,** move the cursor to CONFIGURE PARALLEL and press the ENT button.  
**To resume the factory-set pin assignment,** move the cursor to STANDARD PARALLEL and press the ENT button. (For the factory-set pin assignment, see page 1-33.)  
The following display appears.

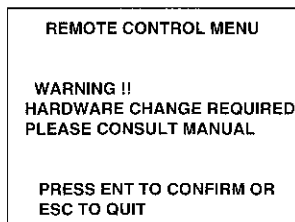

### Hardware Change

When using STANDARD PARALLEL or CONFIGURE PARALLEL mode, the 8-pin connector must be connected to HY-4 of the HY board in the drawer. Although it must have been done at the factory, make sure that the connector is connected to HY-4 properly. If not, remove the connector from HY-2 and connect it to HY-4.

- 4 Press the ENT button again to confirm the mode change in step 3. When STANDARD PARALLEL has been selected in step 3, the selected mode is now activated and the monitor returns to normal status.  
When CONFIGURE PARALLEL has been selected, the CONFIG PARALLEL REMOTE menu is displayed.

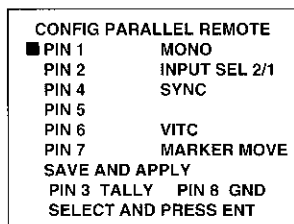

- 5 Move the cursor with the  $\downarrow$  button to the pin whose assignment is to be changed, then press the ENT button.  
The following message appears.

**CONFIG PARALLEL REMOTE**

**PLEASE SELECT FUNCTION  
TO BE APPLIED TO PIN  
AND PRESS ENT**

- 6 Press the button on the front panel or in the drawer (listed on page 1-34) whose function is to be assigned to the pin selected in step 5.
- 7 Press the ENT button.

Repeat steps 5, 6 and 7 for the other pins as desired.

- 8 When the pin assignment is completed, move the cursor to SAVE AND APPLY and press the ENT button.  
The message "DATA SAVED" is momentarily displayed, and the monitor returns to normal status.
- 9 Press the LOCAL/REMOTE button to set the monitor to the remote control mode.

### To cancel the operation

Press the ESC button before pressing the ENT button in step 8.

#### Notes

- When the INPUT selector 2, 3 or 4 is assigned to one of the REMOTE connector pins through CONFIGURE PARALLEL, the input signal for the assigned INPUT selector is selected by short-circuiting the pin to GND. In open status, the input signal of the INPUT selector 1 is selected.
- When two or more INPUT selectors are assigned to the REMOTE connector pins, be sure not to simultaneously short-circuit these pins to GND.

## 1-4-7. Defining the Monitor Configuration

In MONITOR CONFIG menu operation, the following operating conditions of the monitor can be defined.

**OPTION INSTALLATION:** To specify the installed optional boards.

**D1 CONFIGURATION:** To specify the system in which D-1 signals are to be received.

**COMPONENT OFFSET:** To set the setup level for component signals

**NTSC OFFSET:** To set the setup level for NTSC signals.

**MONITOR TYPE:** To define the model of your monitor.

In addition, all the menu options you changed can be reset to the factory-set conditions using the **RESTORE FACTORY SETUP** option.

### To start with the MONITOR CONFIG menu operation

- 1 Press the MENU button to display the initial menu.
- 2 Press the ↓ button until the cursor reaches MONITOR CONFIG, then press the ENT button.  
The MONITOR CONFIGURATION menu is displayed.

```
MONITOR CONFIGURATION
■ OPTION INSTALLATION
D1 CONFIGURATION
COMPONENT OFFSET
NTSC OFFSET
MONITOR TYPE
RESTORE FACTORY SETUP

SELECT AND PRESS ENT
```

## To specify the installed optional boards

- 1 Set the cursor to OPTION INSTALLATION on the MONITOR CONFIGURATION menu and press the ENT button. The OPTION INSTALLATION menu 1 is displayed.

OPTION INSTALLATION 1	
■ AUTO SETUP	YES
D1 OPTION	YES
D2 OPTION	YES
NTSC DECODER	YES
NTSC COMB ADP	YES
PAL DECODER	YES
PAL COMB ADP	YES
OTHER OPTIONS	
SELECT AND PRESS ENT	

- 2 By pressing the ↓ button, move the cursor to the board for which the YES/NO setting must be changed, and press the ENT button. YES must be displayed for the installed board and NO for uninstalled boards. Pressing the ENT button toggles the YES/NO setting.

Repeat step 2 for the other boards as necessary.

- 3 Move the cursor to OTHER OPTIONS and press the ENT button. The OPTION INSTALLATION menu 2 is displayed.

OPTION INSTALLATION 2	
■ PAL-M DECODER	YES
SECAM DECODER	YES
RGB/COMP O/P	YES
VITC BOARD	YES
SAFE AREA	YES
BLACK GENER	YES
OTHER OPTIONS	
SAVE AND APPLY	
SELECT AND PRESS ENT	

- 4 Set YES/NO for the boards listed in menu 2 in the same manner as with menu 1.
- 5 When the YES/NO setting is completed, move the cursor to SAVE AND APPLY and press the ENT button. The message "DATA SAVED" is momentarily displayed and the monitor returns to normal status.

## To specify the system in which D-1 signals are to be received

Before starting the following procedure, set D1 OPTION of the above OPTION INSTALLATION menu 1 to YES.

- 1 Move the cursor with the ↓ button to D1 CONFIGURATION on the MONITOR CONFIGURATION menu and press the ENT button.  
The D1 CONFIGURATION menu is displayed.

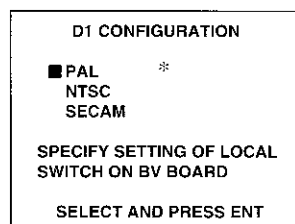

The asterisk indicates the current setting.

- 2 Move the cursor with the ↓ button to the system matching setting of the local switch on the BV board.
- 3 Press the ENT button.  
The message "DATA SAVED" is momentarily displayed and the monitor returns to normal status.

## To set the setup level for component signals

- 1 Move the cursor with the ↓ button to COMPONENT OFFSET on the MONITOR CONFIGURATION menu and press the ENT button.  
The COMPONENT OFFSET menu is displayed.

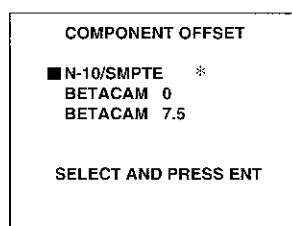

The asterisk indicates the current setting.

- 2 Move the cursor with the ↓ button to the appropriate setup level.
  - N-10/SMPTE:** When supplying the 100/0/100/0 component signals.
  - BETACAM 0:** When supplying the 100/0/75/0 component signals.
  - BETACAM 7.5:** When supplying the 100/7.5/75/7.5 component signals.

- 3 Press the ENT button.  
The message "DATA SAVED" is momentarily displayed and the monitor returns to normal status.

### To set the setup level of NTSC signals

- 1 Move the cursor with the ↓ button to NTSC OFFSET on the MONITOR CONFIGURATION menu and press the ENT button. The NTSC OFFSET menu is displayed.

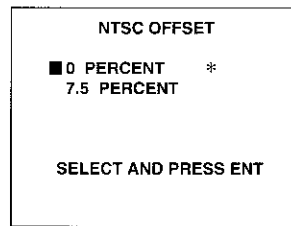

The asterisk indicates the current setting.

- 2 Move the cursor with the ↓ button to the appropriate setup level.  
**0 PERCENT:** When supplying 0 IRE NTSC signals.  
**7.5 PERCENT:** When supplying the 7.5 IRE NTSC signals.
- 3 Press the ENT button.  
The message "DATA SAVED" is momentarily displayed and the monitor returns to normal status.

### To define the model of your monitor

- 1 Move the cursor with the ↓ button to MONITOR TYPE on the MONITOR CONFIGURATION menu and press the ENT button. The MONITOR TYPE menu is displayed.

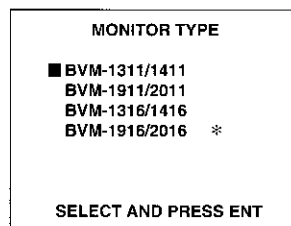

The asterisk indicates the current setting.

- 2 Move the cursor with the ↓ button to the model name of your monitor.
- 3 Press the ENT button.  
The message "DATA SAVED" is momentarily displayed and the monitor return to normal status.



## To restore the factory setup

- 1** Move the cursor with the  $\downarrow$  button to **RESTORE FACTORY SETUP** in the **MONITOR CONFIGURATION** menu and press the **ENT** button.  
The following message is displayed.

**RESTORE FACTORY SETUP**

**WARNING !!  
THIS WILL DESTROY ALL  
MANUALLY ENTERED DATA  
AND CONFIGURATIONS**

**PRESS ENT TO CONFIRM  
OR ESC TO QUIT**

- 2** Press the **ENT** button.  
All the changed menu options return to the factory-set conditions.

To cancel the restoration, press the **ESC** button before pressing the **ENT** button in step 2.

## 1-5. Picture Adjustments

### 1-5-1. White Balance Adjustment

During the adjustment, turn the red green and blue beams on and off with the SCREEN switches on the front panel as required.

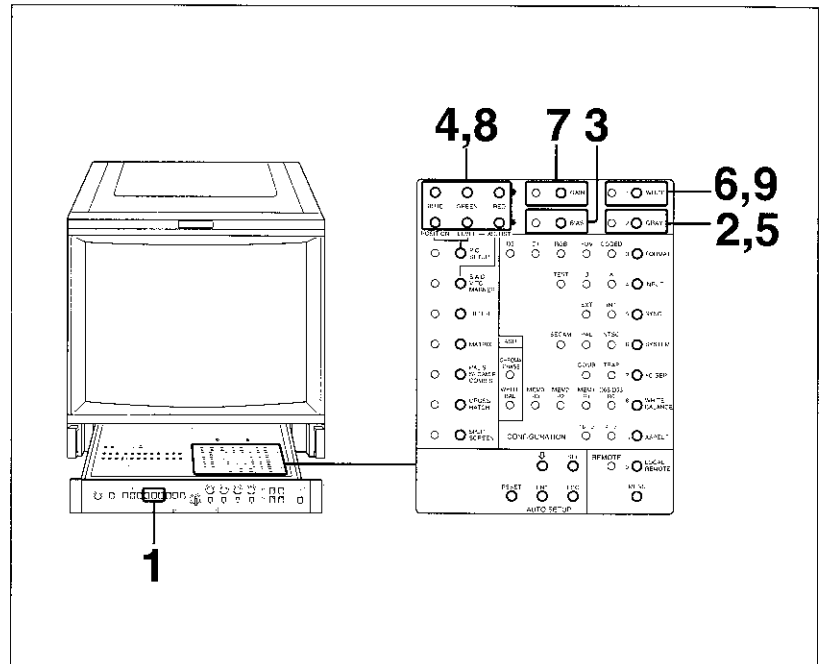

- 1** Display a test signal on the screen.
- 2** Press the GRAY button.  
The associated lamp lights and the internal gray signal is displayed on the screen.
- 3** Press the BIAS button.  
The associated lamp lights.
- 4** Adjust the white balance at the lowlight by pressing the BLUE, GREEN and RED buttons ↑ or ↓.
- 5** Press the GRAY button again.  
The associated lamp goes off and the internal gray signal disappears.
- 6** Press the WHITE button.  
The associated lamp lights and the internal 100% white signal is displayed on the screen

- 7** Press the GAIN button.  
The associated lamp lights.
- 8** Adjust the white balance at the highlight by pressing the BLUE, GREEN and RED buttons ↑ or ↓.
- 9** When the adjustment is completed, press the WHITE button so that the lamp goes off and the white signal disappears.

*For white balance adjustment using a color analyzer or equivalent, see Section 2.*

### 1-5-2. Black Level Adjustment

Match the black reference of the monitor with the black level of the input signal to be monitored.

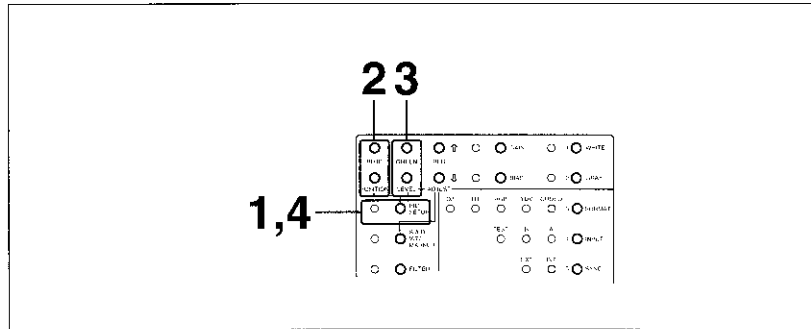

- 1** Press the PIC SETUP button.  
The associated lamp lights and a vertical picture band and the black reference of the monitor are displayed on the screen.

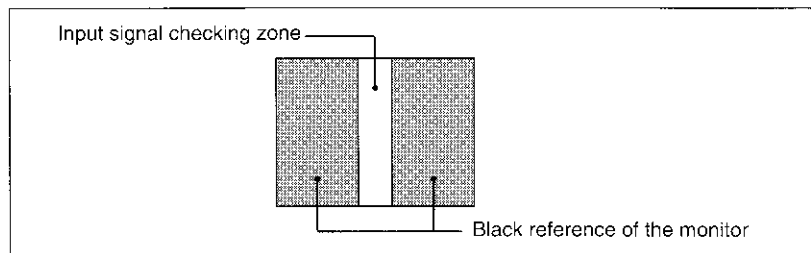

- 2** Press the POSITION buttons ↑ or ↓ to move the position of the picture band horizontally so that the black signal of the picture is located next to the black reference area.
- 3** Press the LEVEL buttons ↑ or ↓ to match the brightness of the black reference area with that of the input black signal.
- 4** Press the PIC SETUP button again.

## 1-6. Specifications

### General

System	BVM-1916: 525 lines per picture, 60 fields per second interlaced, NTSC BVM-2016P: 625 lines per picture, 50 fields per second interlaced, PAL
CRT	Fine Pitch Trinitron 0.4 mm aperture grille pitch, 90-degree deflection, 30.6 mm dia. in-line gun Effective picture size: 291 × 386 mm (h/w) (11 <sup>1</sup> / <sub>2</sub> × 15 <sup>1</sup> / <sub>4</sub> inches) 481 mm (19 inch) picture measured diagonally
Picture tube protection	EHT (Extremely High Tension) is shut off in the event of scan failure.
Warm up	30 min to meet specifications
Anode voltage	Properly adjusted HV 27 kV at zero beam current
Power consumption	Typical: 135 W Maximum: 175 W
Power requirements	BVM-1916: 100-120 V AC ±10%, 50/60 Hz BVM-2016P: 220-240 V AC ±10%, 50/60 Hz
Dimensions	448 × 455 × 584 mm (w/h/d) (17 <sup>3</sup> / <sub>4</sub> × 18 × 23 inches) including projecting parts and controls
Mass	40.3 kg (88 lb 22 oz)

### Inputs/outputs

Video inputs	BNC type (5 inputs with 5 loop-through outputs) VIDEO A/B, TEST, R/G/B: 0.7 Vp-p noncomposite video signal or 1 Vp-p composite video signal, ±6 dB positive, high-impedance Y: Composite, 1.0 Vp-p±6 dB, high-impedance R-Y/B-Y: 0.7 Vp-p±6 dB, high-impedance
Sync input	EXT SYNC: BNC type (1 input with 1 loop-through output) 1 to 8 Vp-p negative, high-impedance
Input return loss	More than 46 dB (7 MHz with 75-ohm termination)
Hum rejection	Reduced by more than 50 dB Maximum hum: Less than 4 Vrms, where hum is applied to the monitor in floating ground mode

Video outputs	DECODER OUT: BNC type (3) Output decoded signals only when BKM-1440 is installed.
Remote control	REMOTE: 10-pin connector (1)
Auto set-up	AUTO SETUP PROBE: 12-pin connector (1)

### Video signal

#### Luminance channel (RGB and composite signals)

Differential gain	Within 5% for a luminance from 0 to 103 cd/m <sup>2</sup>
Differential phase	Within 5° for a luminance from 0 to 103 cd/m <sup>2</sup>
Frequency response	Monochrome mode: 100 Hz to 6 MHz $\pm$ 1 dB (aperture correction at 0) Color mode: Trap or comb filter removes frequency in 3.58 MHz region (BVM-1916) or 4.43 MHz (BVM-2016P) region RGB mode: 100 Hz to 6 MHz $\pm$ 1 dB

#### Chrominance channel

Demodulation axis	R-Y, B-Y
Bandpass	1.3 MHz equiband
Subcarrier regeneration	$\pm$ 1° (standard input signal)
Phase control range	More than $\pm$ 15° (standard input signal)
Chroma gain control range	More than $\pm$ 6 dB

#### Chrominance/luminance

Time error	Less than 30 ns
Gain error	Less than 5%
Aperture correction	Adjustable continuously up to 6 dB boost at 4.5 MHz or 6.5 MHz (selectable)

#### DC restoration (RGB and composite signals)

Back porch type  
Back porch level: Within 1% of peak luminance, 10% to 90% (average picture level)

### Synchronization

AFC time constant	0.5 ms (fast), 2 ms (normal) or 7 ms (slow)
Line pull range/line hold range	More than $\pm$ 500 Hz at 0.5 ms time constant
Vertical blanking time	Normal: Within 1 ms Underscan: Within 0.8 ms
Horizontal retrace time	Within 10 $\mu$ s

## Picture performance

- Normal scan 5% overscan of CRT effective screen area (adjustable range more than  $\pm 15\%$ )
- Underscan 3% underscan of CRT effective screen area (adjustable range more than  $\pm 15\%$ )
- Linearity Within a central area bounded by a circle whose diameter equals the picture height, within 1% of the picture height, out of area 2%
- Color temperature D65, adjustable to other color temperatures
- Nominal chromaticity coordinates

BVM-1916: SMPTE C phosphor

	x	y
Red	0.630	0.340
Green	0.310	0.595
Blue	0.155	0.070

BVM-2016P: EBU standard phosphor

	x	y
Red	0.64	0.33
Green	0.29	0.60
Blue	0.15	0.06

- Convergence error Central area: Less than 0.5 mm  
Periphery: Less than 1.0 mm
- Calibrated contrast 103 cd/m<sup>2</sup> at peak white of standard 1 Vp-p signal
- Raster size stability Less than 1% picture height, 0% to 100% APL at 103 cd/m<sup>2</sup> peak luminance
- Scan delay Horizontal: Approx. 1/4 line  
Vertical: Approx. 1/2 field
- Resolution More than 600 TV lines (center, at 103 cd/m<sup>2</sup> luminance)

## Environment

- Operating temperature 0° C to 40° C (32° F to 104° F)
- Optimum temperature range 20° C to 30° C (68° F to 86° F)
- Humidity 0 to 90%
- Altitude Approx. 3,050 m (10,000 feet) max.

**Supplied accessories**

AC power cord (1)  
Cord stopper (1)  
Screwdriver (1)  
Drawer keys (2)  
Extension board (1)  
10-pin connector (1)  
Fuses (2)  
Tally number plates (1 set)  
Operation and maintenance manual (1)

Design and specifications are subject to change without notice.

(2)





## SECTION 2 DISASSEMBLY

### 2-1. COVER REMOVAL

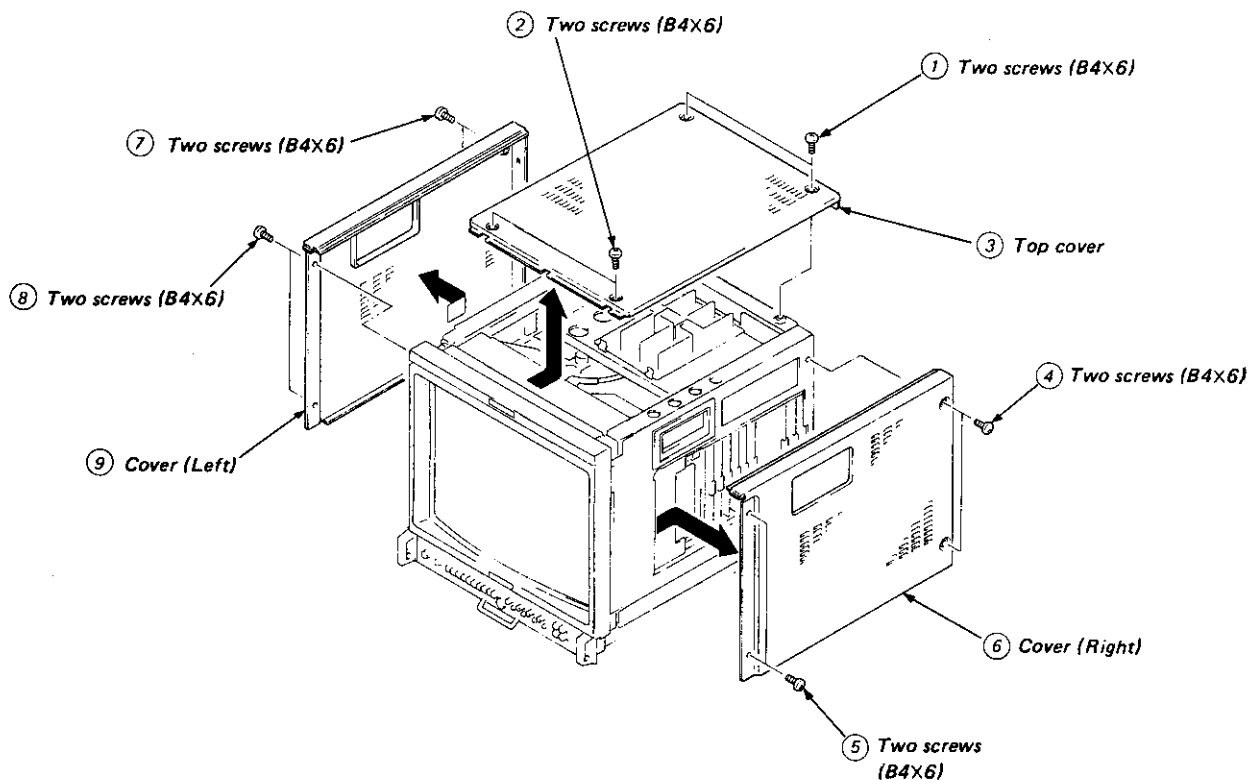

### 2-2. BEZEL ASSEMBLY REMOVAL

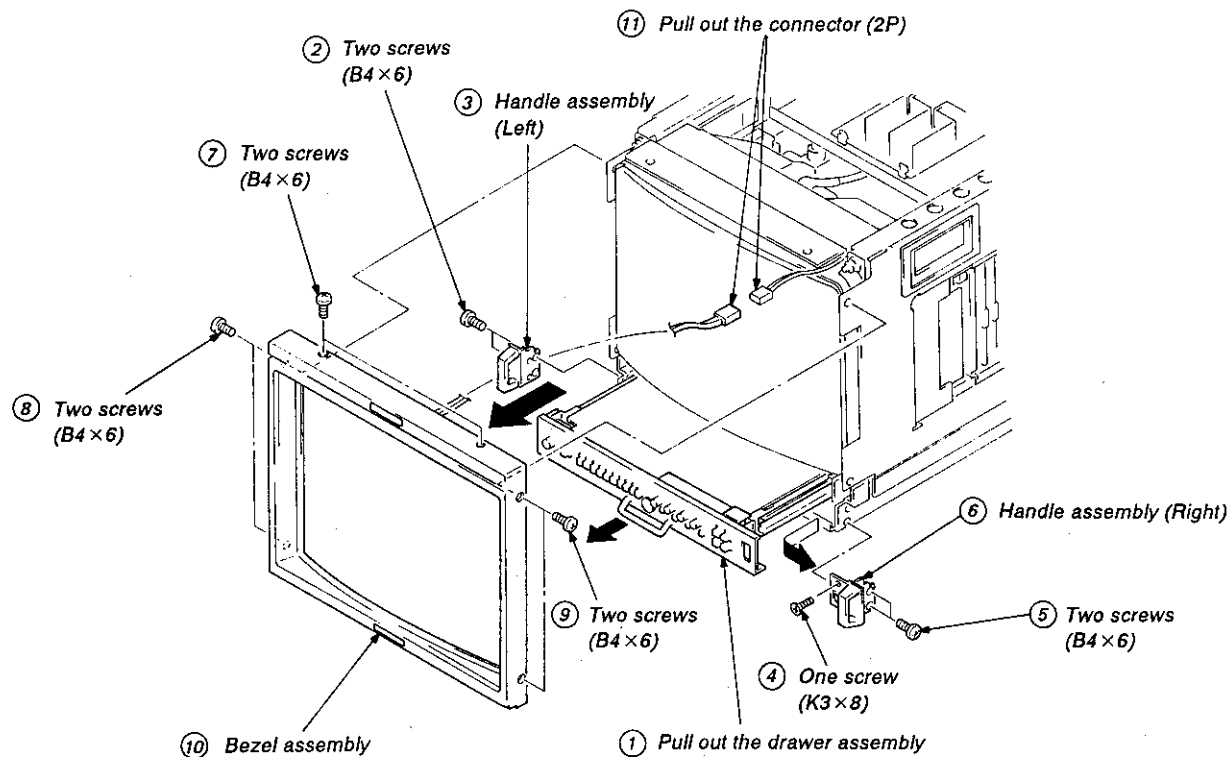

### 2-3. CHECK OF C BOARD

**Note:** Do it after removing cover (Right, Left)  
(Refer to 2-1. COVER REMOVAL)

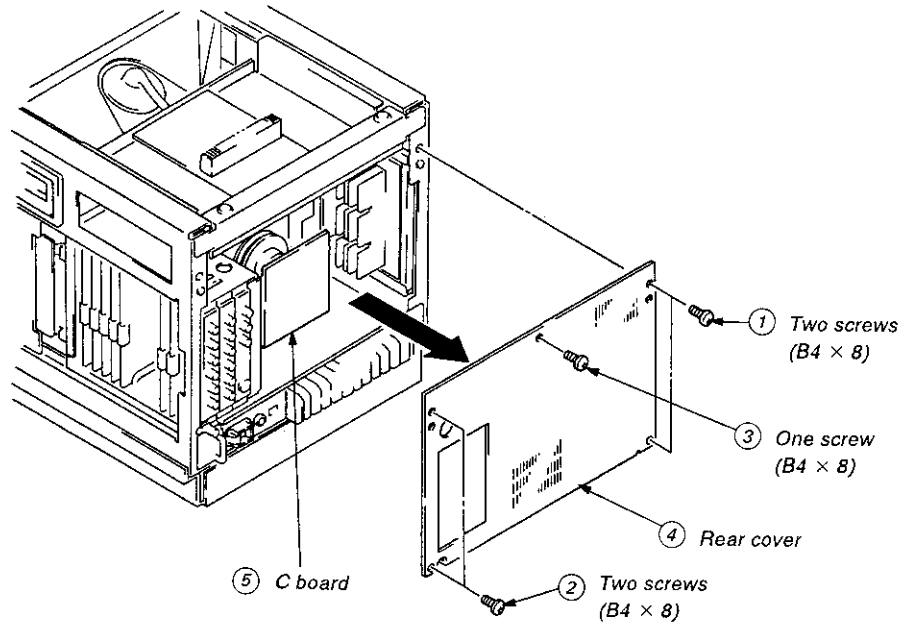

### 2-4. QA, QB, W AND V BOARDS REMOVAL

**Note:** Do it after removing rear cover.  
(Refer to 2-3. CHECK OF C BOARD)

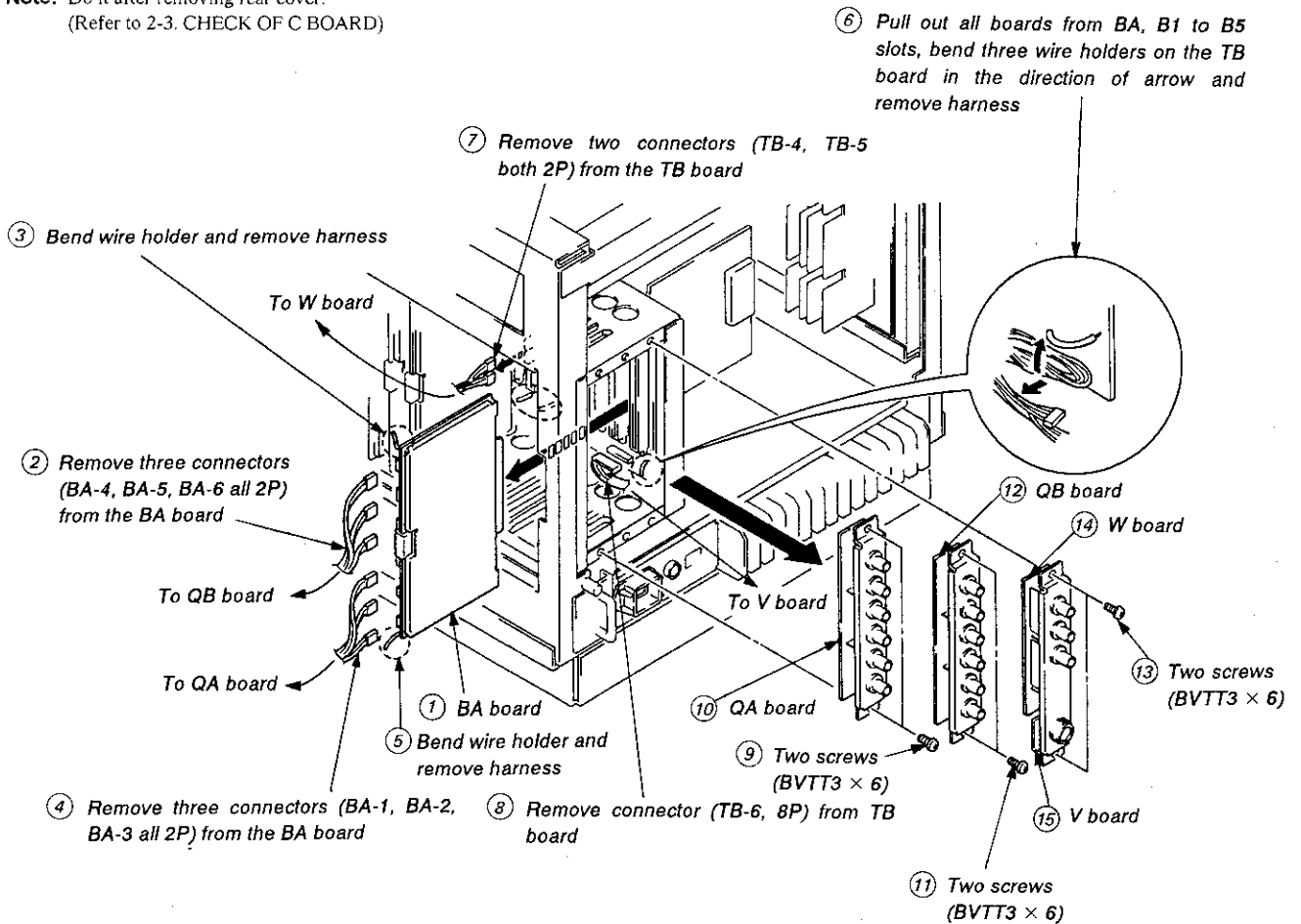

## 2-5. OPEN THE BK BLOCK

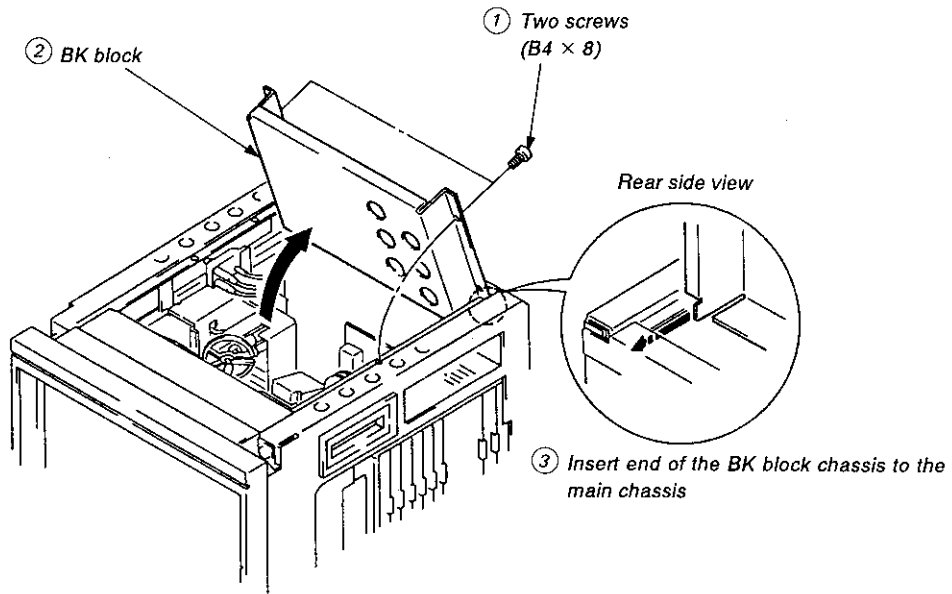

## 2-6. BK BOARD REMOVAL

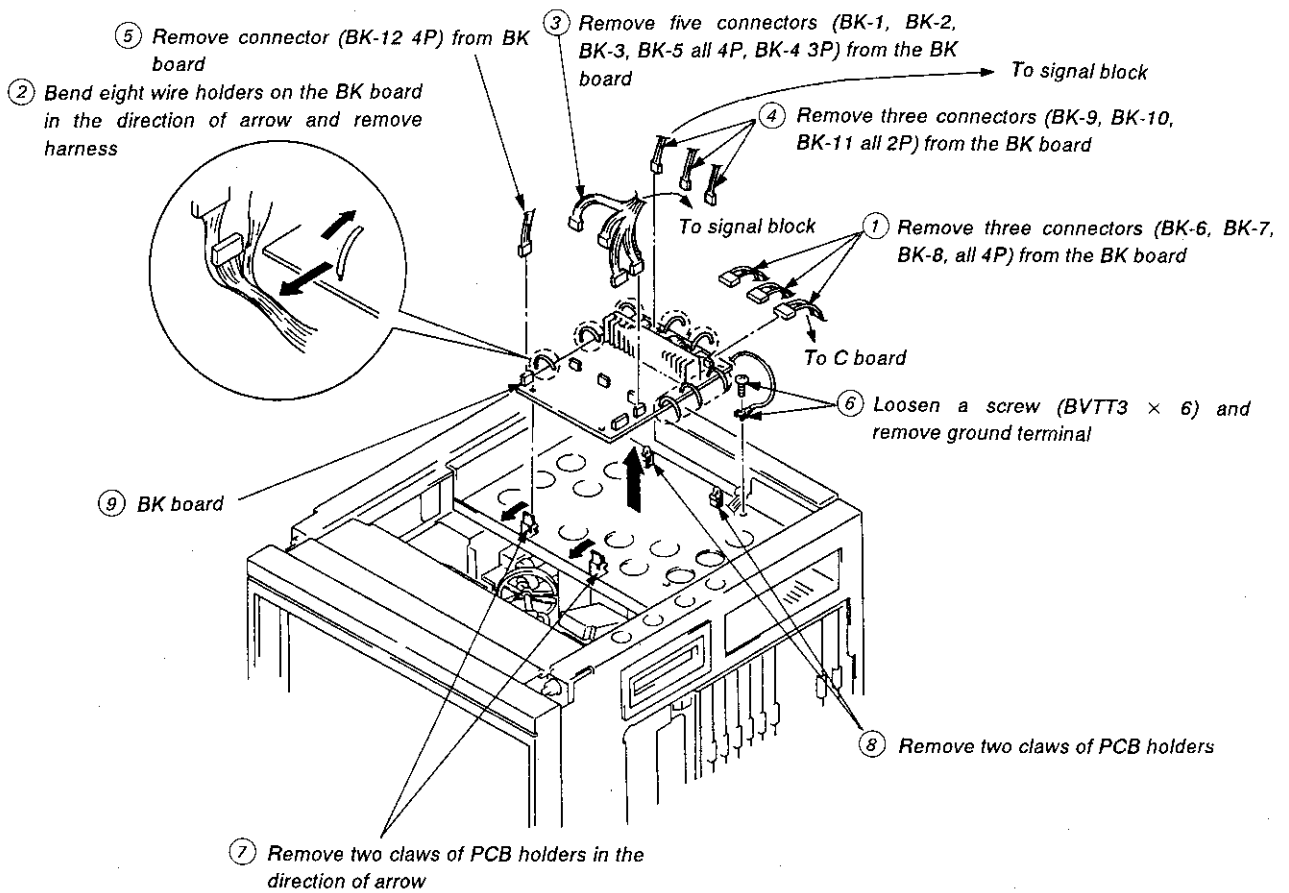

## 2-7. CHECK OF BK BOARD

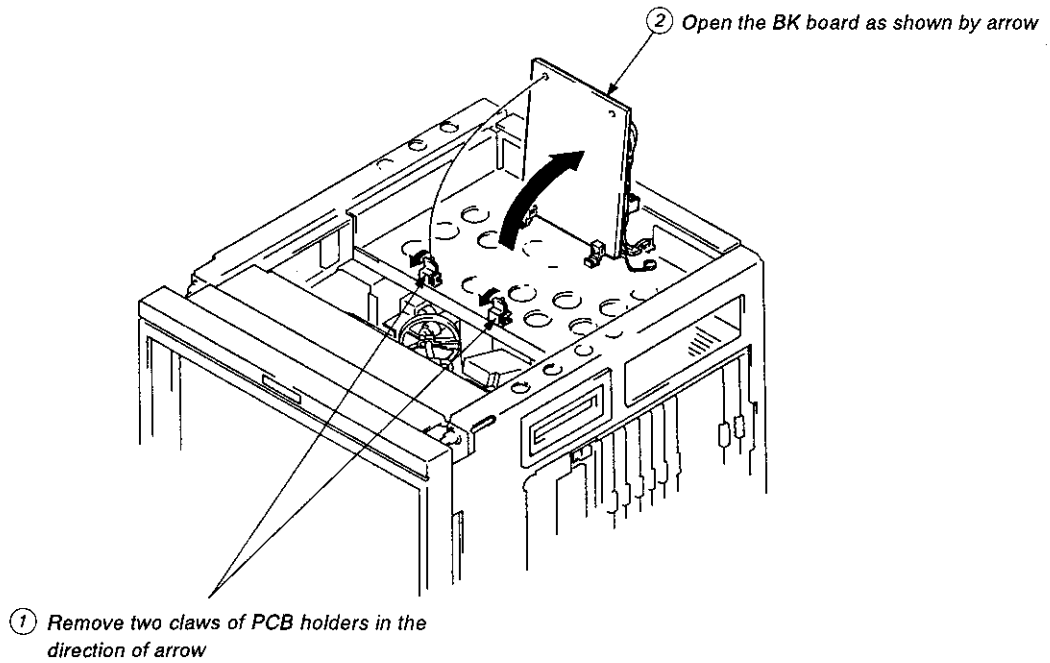

## 2-8. CHECK OF EA, EB AND EC BOARDS

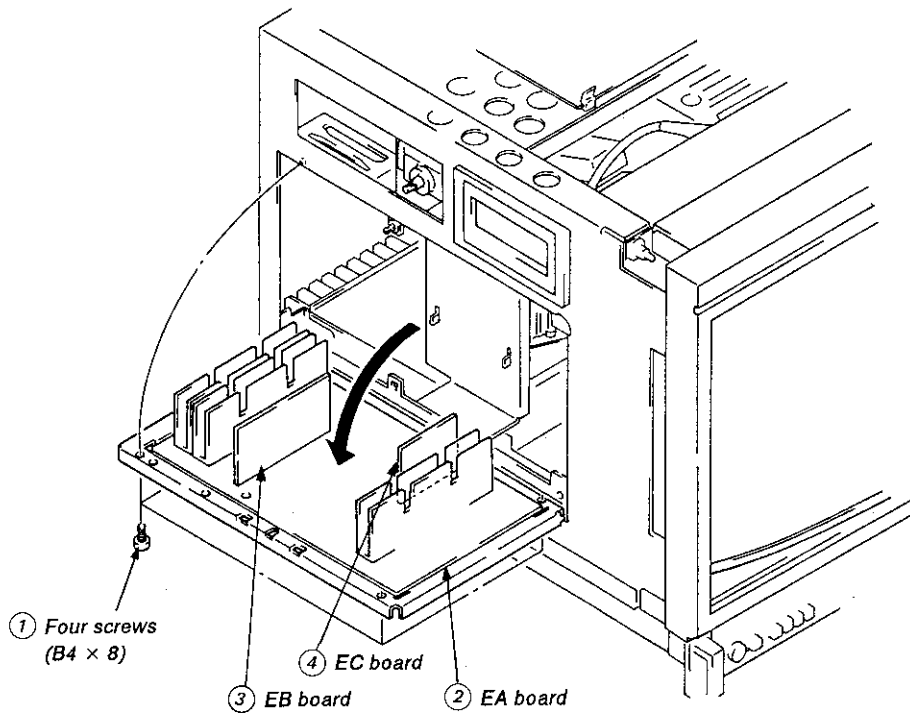

**2-9. CHECK OF BJ BOARD**

**Note:** PC board retainer is attach as anti-detach jig for the board. Remove the PC board retainer before checking.

**Note:** BA, BC, BG, BH, BI and BT boards can be checked similarly.

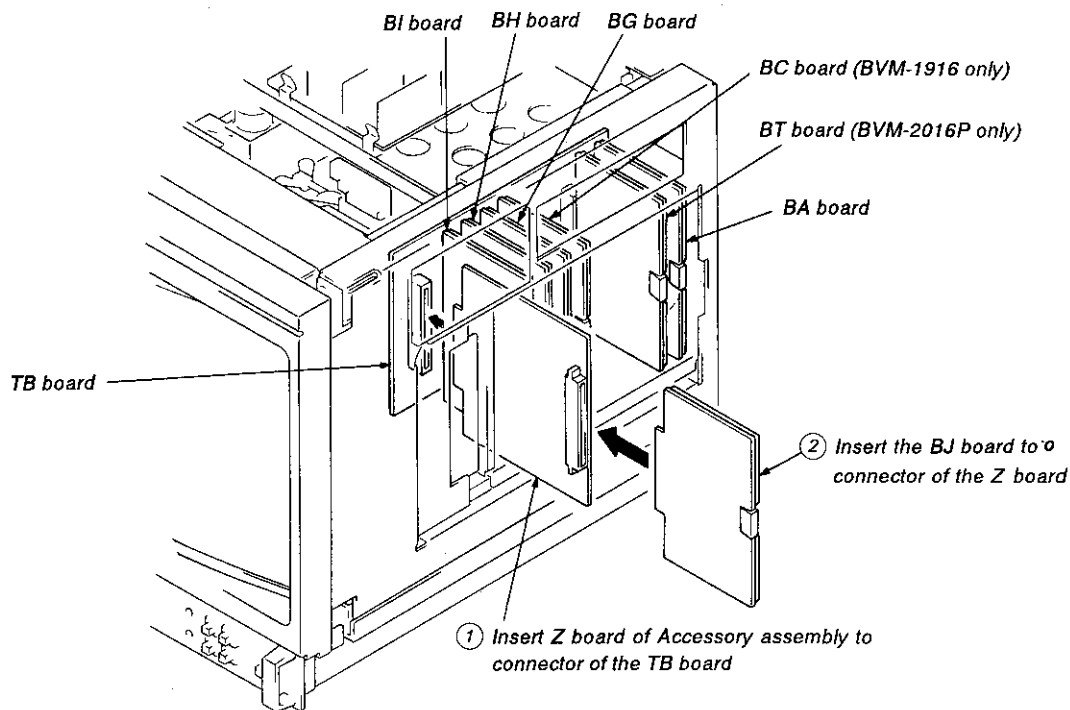

**2-10. GC BOARD REMOVAL**

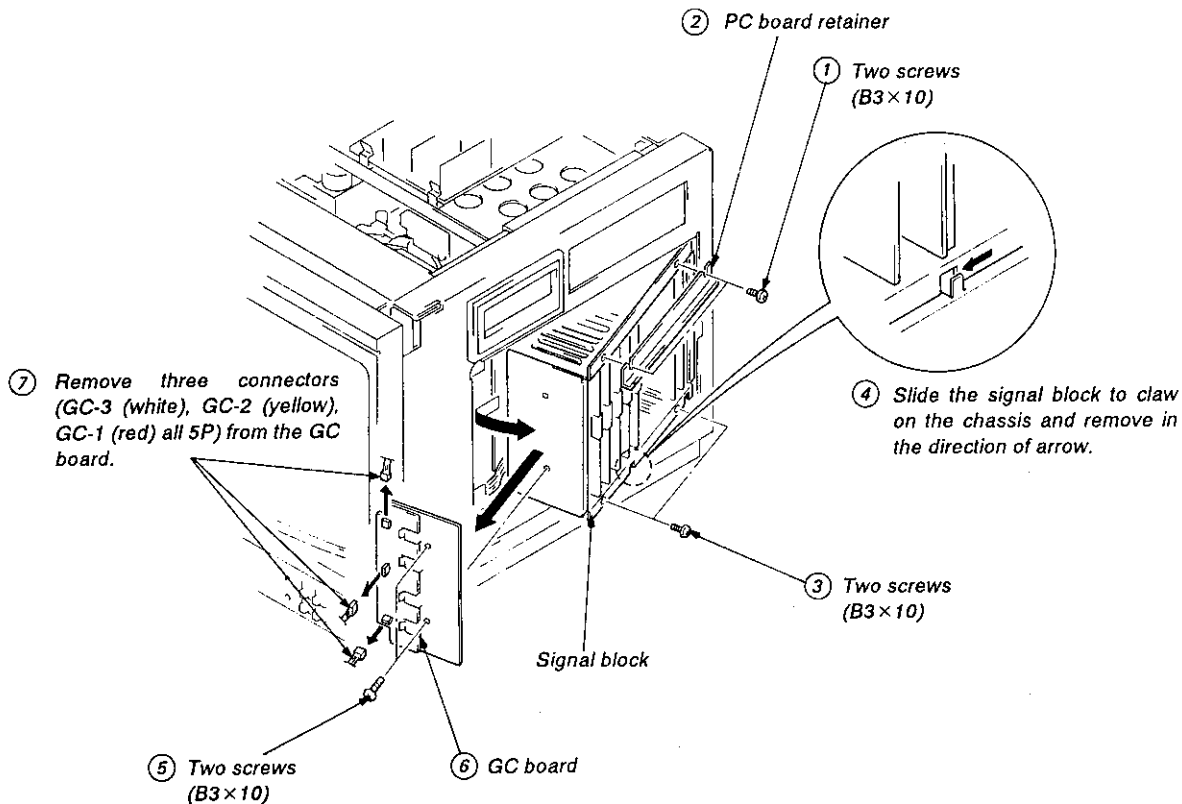

## 2-11. POWER BLOCK ASSEMBLY REMOVAL

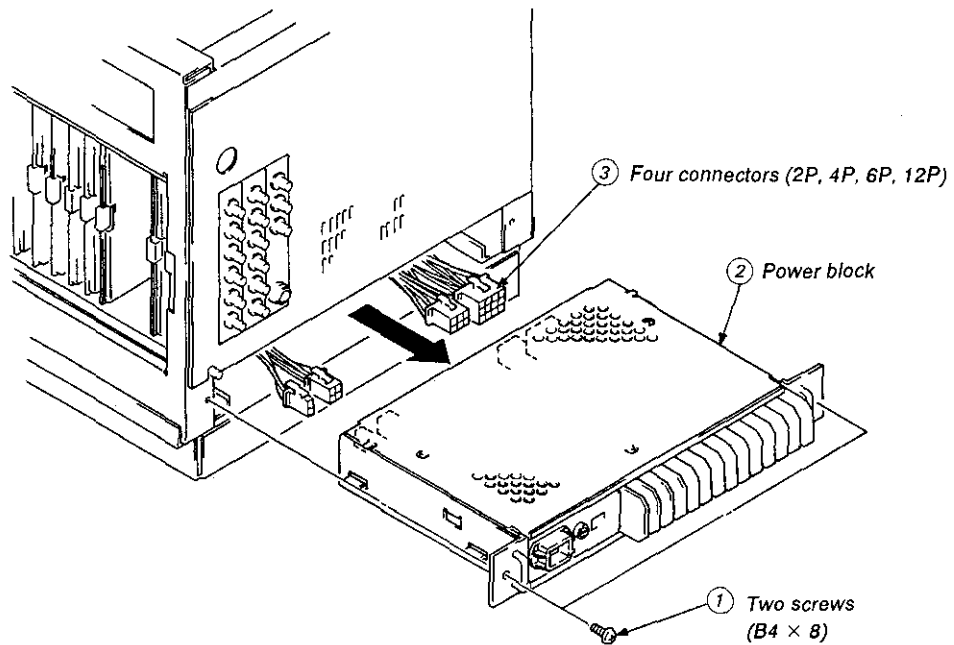

## 2-12. FLYBACK TRANSFORMER AND HIGH VOLTAGE BLOCK ASSEMBLY REMOVAL

Note: Do it after opening EA board.  
 (Refer to 2-8. CHECK OF EA, EB AND EC BOARDS)

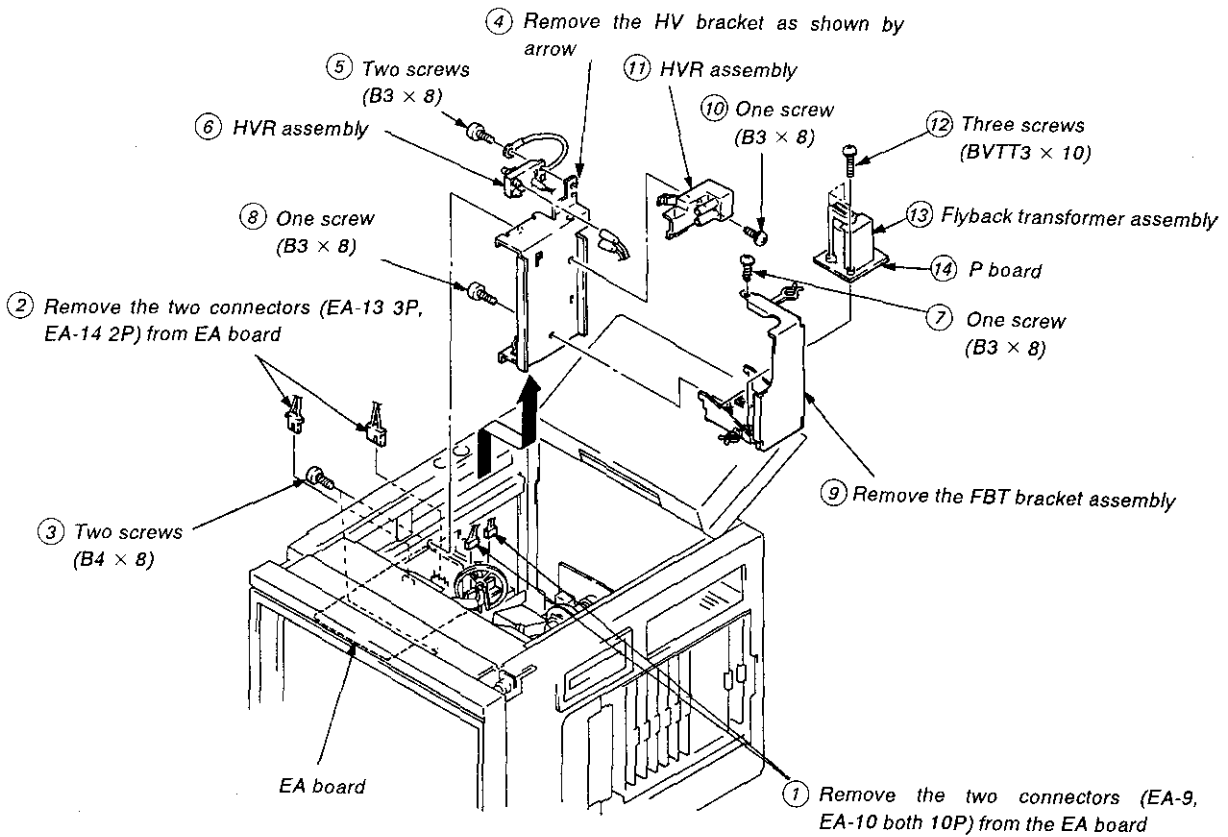

## 2-13. PICTURE TUBE REMOVAL

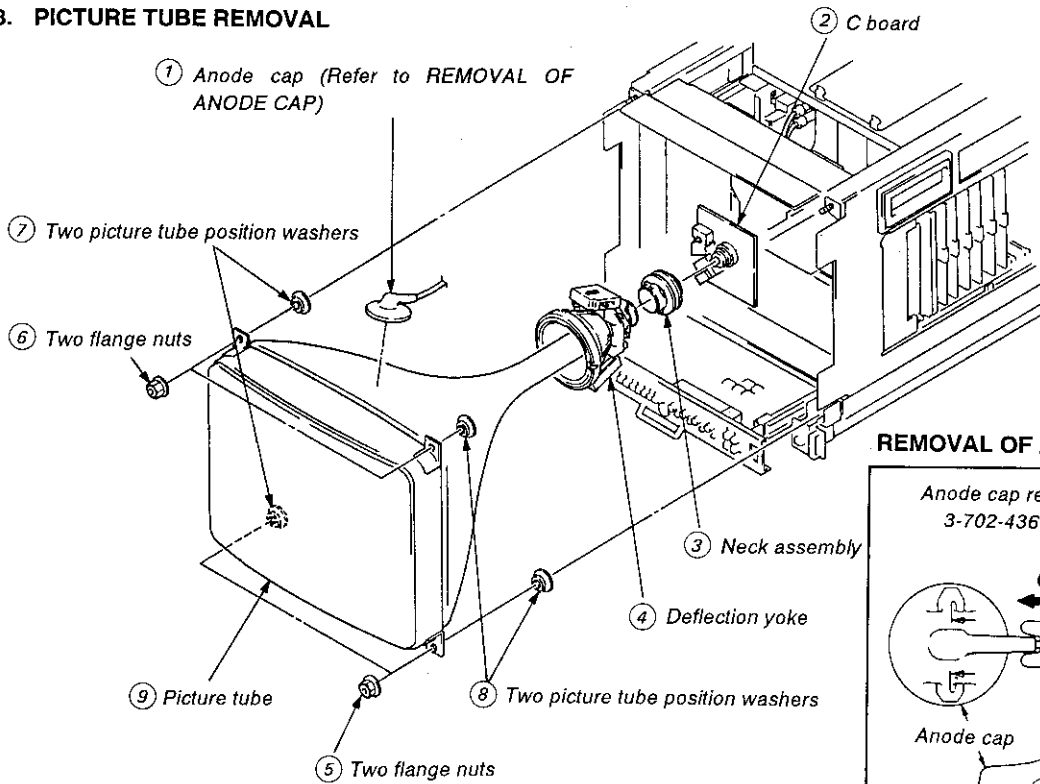

### REMOVAL OF ANODE CAP

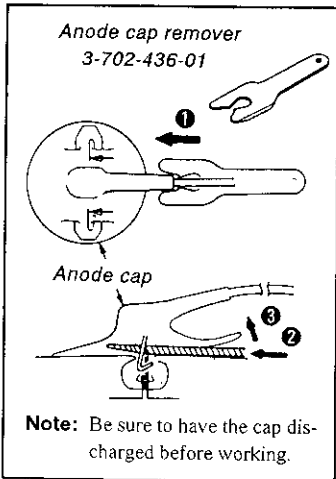

## 2-14. CONTROL PANEL ASSEMBLY REMOVAL

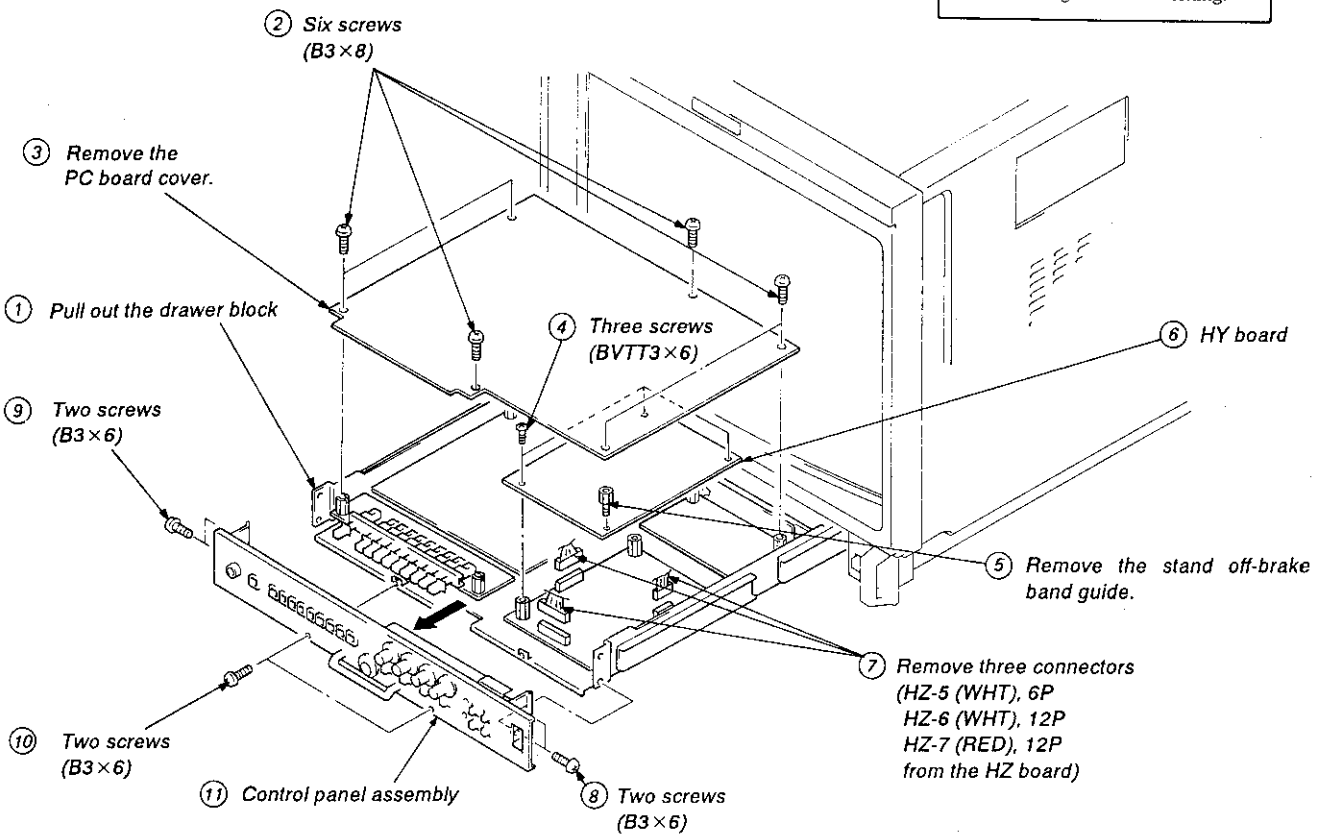





## SECTION 3 CIRCUIT DESCRIPTIONS

### 3-1. QA, QB, BA BOARDS

#### 3-1-1. Input Circuit

##### Cable Compensation (QA, QB)

CABLE COMPENSATION is composed of inductance L and capacitor C1 (Figure 1) in QA board and performs return loss compensation.

Grounding or floating in input terminal can be selected by switch S1.

On floating mode, common mode rejection can be performed. QB board also has same function.

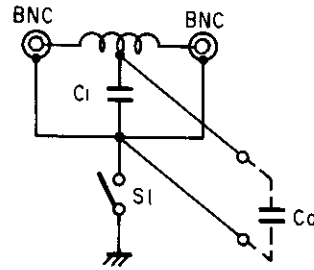

Figure 1

##### Hook Up Circuit (BA)

This circuit is composed of transistors Q101-105 and performs common mode rejection when SW S1 is selected to the floating mode.

In Figure 2, Gains of amplifier for input A and B are derived as follows.

$$A = \frac{R_c}{R_i} : \text{Gain of amplifier for input A}$$

$$B = -\frac{R_c}{R_i} : \text{Gain of amplifier for input B}$$

When input (ec + ei) is applied to input A and input (ec - ei) to input B, then output eo is

$$e_o = \frac{R_c}{R_i} (e_c + e_i) + (-\frac{R_c}{R_i}) (e_c - e_i) = 2 \frac{R_c}{R_i} e_i$$

This equation indicates that ec is eliminated and there is no common mode signal in output signal.

On hook up circuit, NF Amplifier (Negative Feedback) is used to get frequency response flat.

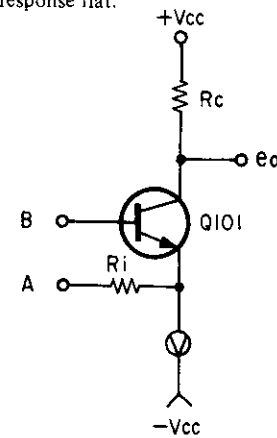

Figure 2

##### Input Select Sw, Sync Select SW (BA)

For composite video signal, VIDEO A/B/TEST mode is selected by INPUT SELECT SW (IC1). For sync signal, INT SYNC/EXT SYNC is selected by SYNC SELECT SW IC2.

#### 3-1-2. Sync AGC Circuit

This circuit is composed of following components; LPF (Low Pass Filter) (Q701), variable gain amplifier (Q702-Q705), bias control circuit (Q708-Q710), gain control circuit (Q711, 712) and amplifier (Q706, 707), Figure 3 shows block diagram of this circuit.

An inverted composite video signal or composite sync signal (eo) is derived at the collector of transistor Q707.

The bias control circuit compares maximum value of eo with base voltage of Q708 (E1) and controls bias of amplifier so that they match.

Also the gain control circuit compares pedestal level of eo with base voltage of Q711 (E2), and controls variable gain amplifier so that they match.

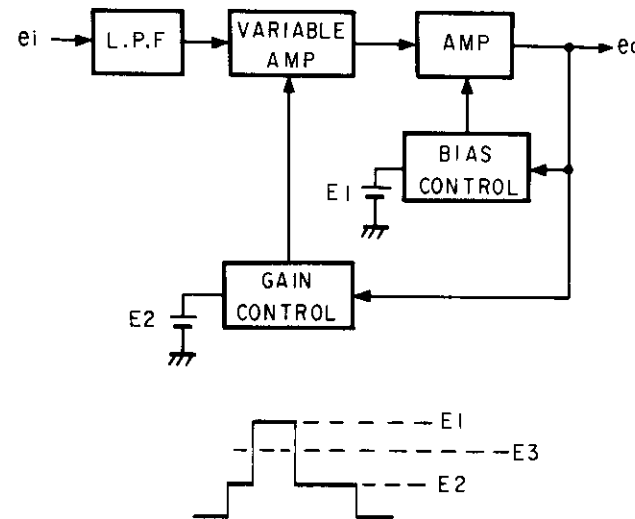

Figure 3

##### Composite Sync Separation, Vertical Sync Separation

Composite sync is separated from composite video signal or composite sync by comparing voltage eo with the base voltage of transistor Q713 (E3).

Horizontal component in composite video signal or composite sync signal is removed by LPF (Low Pass Filter, Q716) and Vertical sync is separated by transistor Q717.

### BLOCK DIAGRAM OF QA, QB, BA BOARDS

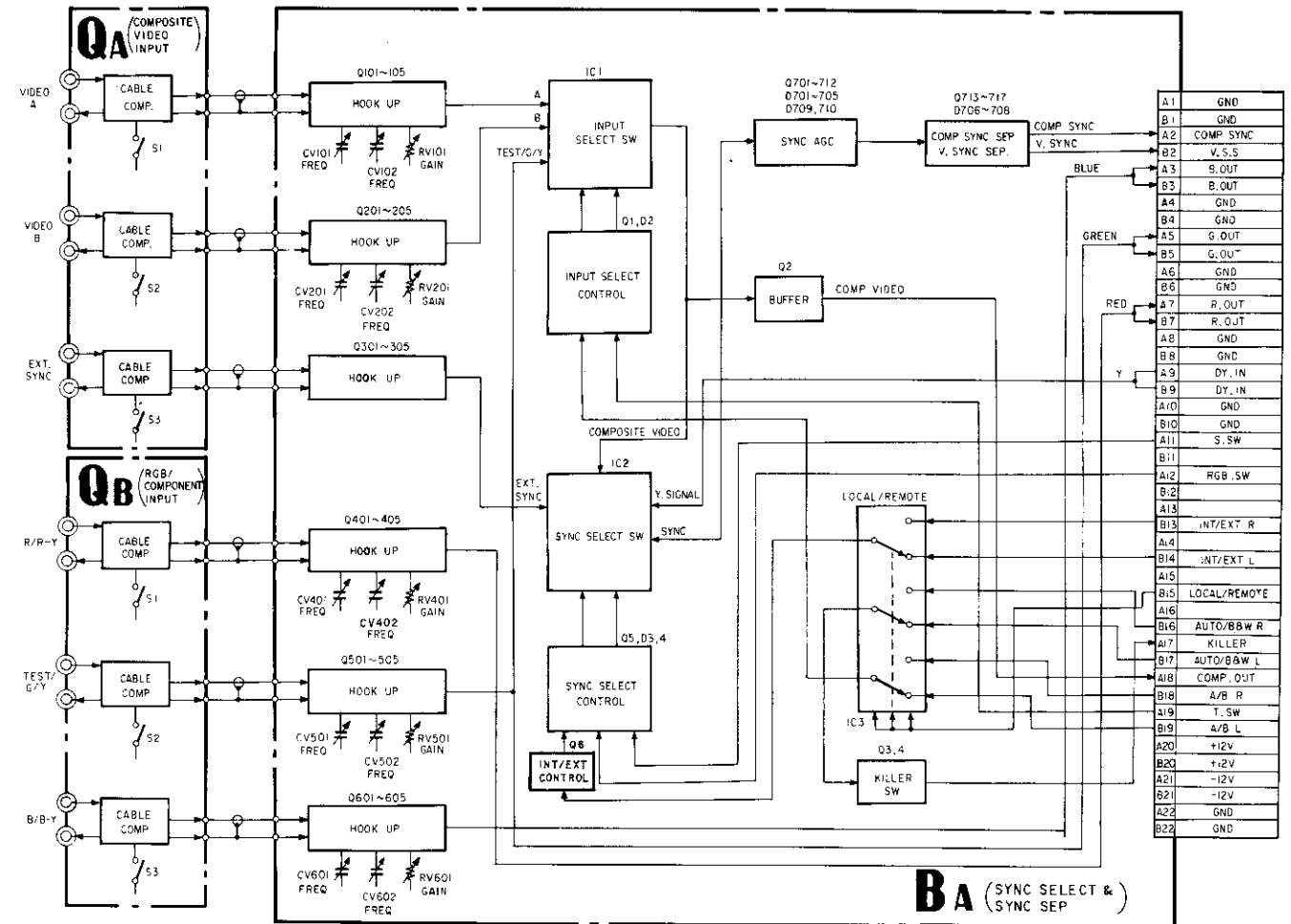

### 3-2. BG BOARD

#### 3-2-1. Luminance Signal Circuit

##### Filter SW

IC1 works as a selector switch of composite video signal or luminance signal derived from Y/C separation circuit. This IC activates by either FILTER-SW in right side drawer or killer signal.

##### Aperture Control

Aperture control circuit is composed of DL1(delay line), transistors Q5, 7, 8 and IC2. IC2 operates as a variable resistor. Resistance value between Pin ① and ③ is controlled by the potential between pin ③ and pin ④, also pin ① and pin ⑥.

Input signal:  $e_{r0}$ ,  
 Delayed signal by delay line:  $e_{r1}$   
 Second delayed signal:  $e_{r2}$

See Figure 4

$e_1$  (at base of transistor Q5) is obtained as below due to the combination of direct wave and reflected wave by DL1.

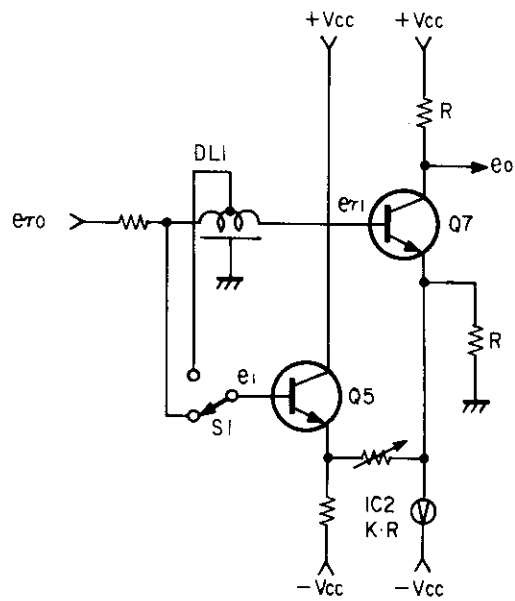

Figure 4

$$e_1 = (e_{r0} + e_{r2})/2$$

Therefore  $e_o$  is

$$e_o = \underbrace{-(e_{r1} + \frac{1}{K}(e_{r1} - \frac{1}{2}(e_{r0} + e_{r2})))}_{1st\ term} + \underbrace{\frac{1}{2}(e_{r0} + e_{r2})}_{2nd\ term}$$

K: variable constant

In the above equation, 1st term shows waveform A in Figure 5 and 2nd term shows waveform B. When K is variable, amount of pre-shoot and overshoot can be varied.

Switch S1 is used for selection of boost frequency.

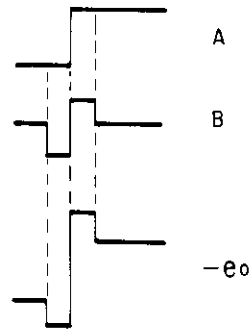

Figure 5

#### Y Delay, Y Buffer Amplifier

Y/C delay time can be matched by delay line DL2 and Y signal is amplified and fed to the next stage.

#### 3-2-2. Color Gain Control Circuit

In this section (R-Y) signal processing is described as below, but (B-Y) signal is processed by the same way as (R-Y) signal.

##### R-Y Amplifier and Clamping

The R-Y color difference signal from the decoder board is amplified at the amplifier composed of transistors Q21 and Q22 and clamped at the Horizontal Sync by transistors Q23 and IC3.

##### R-Y Gain Control Amplifier

This is a variable gain control amplifier composed of variable resistor element of IC4 and transistors Q25-Q27. Gain of this amplifier can be controlled by the color gain control voltage at the pin ⑫ of IC4.

##### AGC Pulse Generator

Generates the reference pulse for AGC (Automatic Gain Control) of color gain control circuit.

##### Gain Control Amplifier for AGC Pulse

Circuit is the same as R-Y GAIN CONTROL AMPLIFIER. Gain of this amplifier is controlled by the voltage at pin ⑧ of IC4.

##### Color Gain Control

AGC pulse, which is output signal of Gain control amplifier for AGC pulse, is clamped by IC6 (2/3) and is made sampling by IC6 (3/3). Amplitude of AGC pulse and DC voltage supplied from CHROMA control on the front panel are compared and matched by IC7 (1/2) with controlling the above gain control amplifier.

This control voltage is supplied to the control terminals of R-Y and B-Y gain control amplifiers and controls color gain.

#### 3-2-3. G-Y MATRIX amplifier

G-Y signal is obtained by matrixing R-Y signal and B-Y signal with the amplifier composed of transistors Q44 and Q45.

#### 3-2-4. NTSC MATRIX SW

NTSC MATRIX mode operation is obtained by the matrix circuit composed of resistor networks CP14-CP19, transistor Q29, Q30, Q39, Q40, Q49, Q50 and IC5. CP14-CP19 perform matrixing and IC5 works as a switch.

#### 3-2-5. COMPONENT R-Y Amplifier and Delay Circuit

R-Y signal of COMPONENT signal is compensated with amplitude, polarity and delay time to match the R-Y signal of decoder output.

### BLOCK DIAGRAM OF BG BOARD

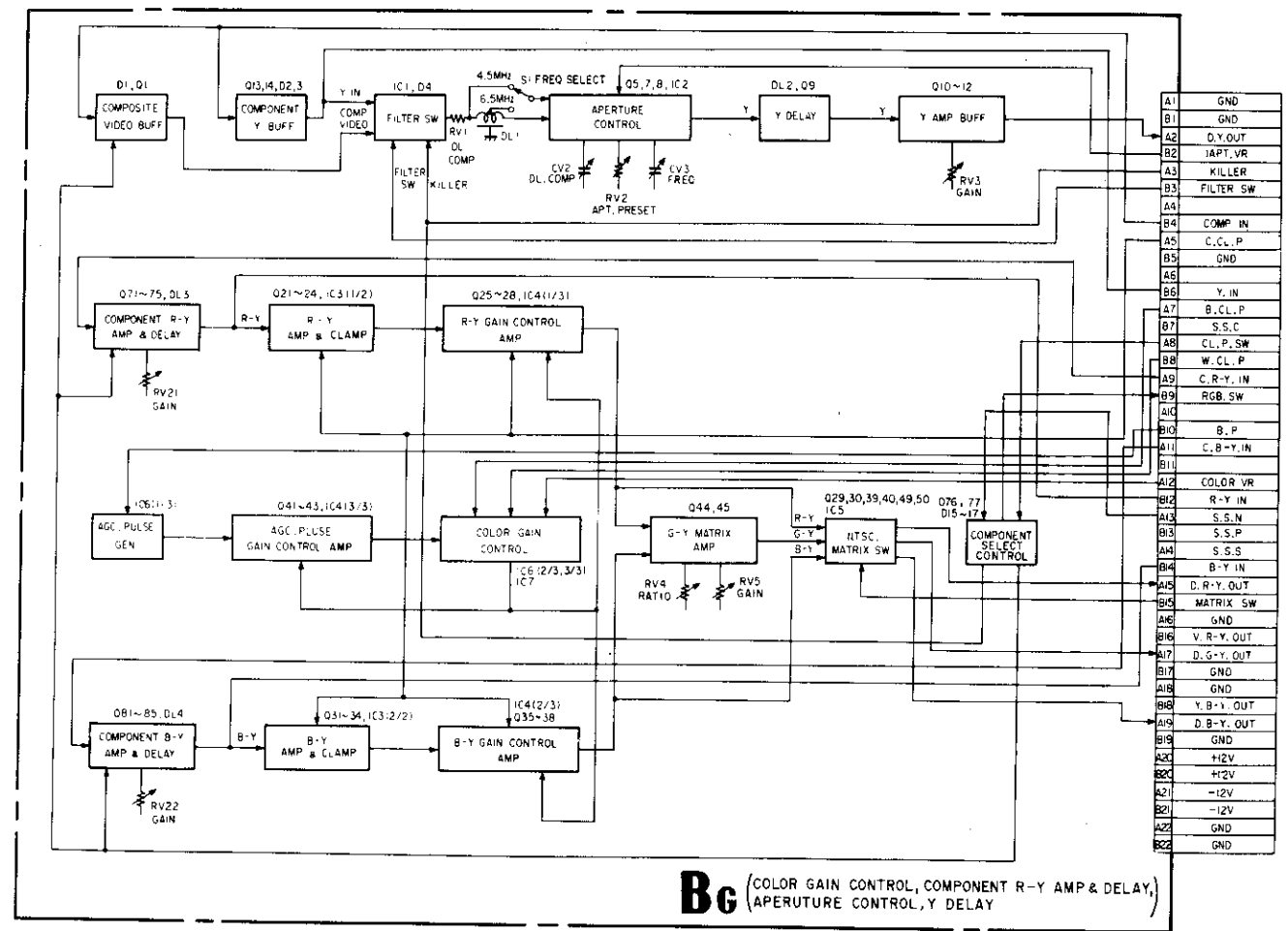

### 3-3. BH BOARD

#### 3-3-1. Switching Circuit Between Y (Luminance) Signal, Color Difference Signal and RGB Signal, AGC Pulse Insertion, Y-C Matrix

##### Switching Circuit of Y Signal, Crosshatch Signal and SET UP Signal, Buffer

Y signal, crosshatch signal and SET UP signal are selected by the switcher (IC1 (1/3) (2/3)) and selected signal is output via buffer Q1.

##### Switching Circuit of R-Y Signal, Red Signal and SET UP Signal (Same as B-Y, G-Y Signal)

R-Y signal, Red signal, SET UP signal are selected by IC2 (1/3, 2/3) and selected signal is output via buffer Q4.

##### Y Signal Screening (Same as R-Y, B-Y, and G-Y Signals)

The signal is performed SAMPLE and HOLD (S/H) at the back porch of signal by transistor Q2 and IC5 (2/2). Y screening is performed by replacing S/H output signal, by the original signal. For color difference signals screening is made at the Horizontal Sync portion.

##### Red Matrix, Blue Only SW, Buffer (Same as Green and Blue)

Red is obtained by Y-C matrix circuit composed of resistor network CP9 from color difference signals.

AGC pulse from pulse generator is inserted into Red signal for contrast control.

IC7 activates by the Blue only SW on the front panel. Blue only SW is used for the display of blue signal as a monochrome picture.

#### 3-3-2. Contrast Control, Brightness Control, Peak Limiter

##### Red Contrast, and Brightness Control Amplifier (Same as Green and Blue)

This is a variable gain control amplifier composed of variable resistor element IC101 and transistor Q102 and Q103. By controlling the voltage at pin ④ of IC101, contrast control is performed, and brightness control is done by controlling the bias voltage of transistor Q102.

##### Red limiter (Same as Green and Blue)

When excess input signal comes in, amplitude is limited by the limiter composed of transistors Q104 and Q105.

##### Red Contrast Control (Same as Green and Blue)

AGC pulse inserted in Red signal is clamped by transistor Q107 and sampled by transistor Q108.

Amplitude of above AGC pulse is compared with the reference voltage applied from CONTRAST control on the front panel in IC102 (2/2).

Contrast control is performed by controlling the gain of Red contrast brightness control amplifier so that these voltages may match.

##### Red Brightness Control (Same as Green and Blue)

The black level of Red signal is performed SAMPLE and HOLD (S/H) by transistor Q106. This S/H voltage is compared with the reference voltage applied from Brightness control on the front panel in IC102 (1/2). Brightness control is performed by controlling the bias of Red contrast Brightness control amplifier so that these voltages may match.

### BLOCK DIAGRAM OF BH BOARD

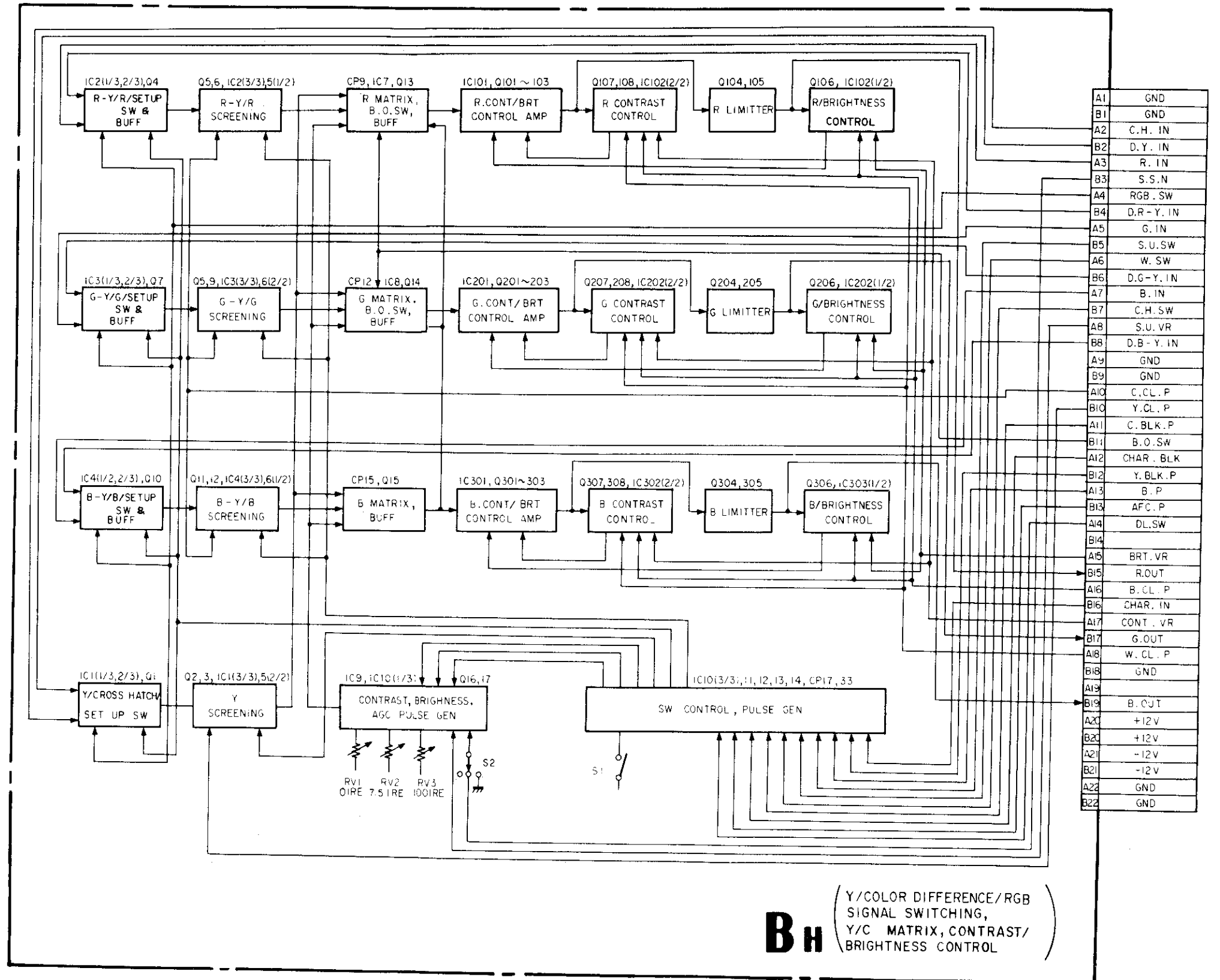

### 3-4. BI BOARD

(Same as Green and Blue)

#### 3-4-1. Red Screen SW, AGC Pulse Insertion

Red signal can be cut off by RED SCREEN SW on the front panel. Horizontal rate AGC pulse is removed and the reference pulse is inserted in the signal for the GAIN and BIAS adjustment of video output amplifier and for the beam control circuit.

#### 3-4-2. Red Limitter, Gain Bias Control Amplifier

This limiter is used for limiting the excess input level of the signal below 0V DC.

The GAIN/BIAS CONTROL amplifier is composed of variable resistor element and transistors as same as contrast control amplifier' (See section of BH board)

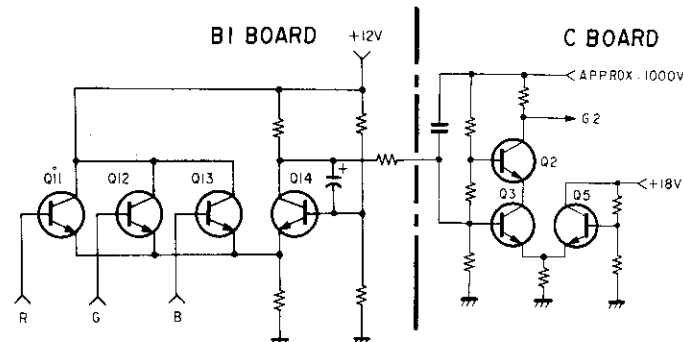
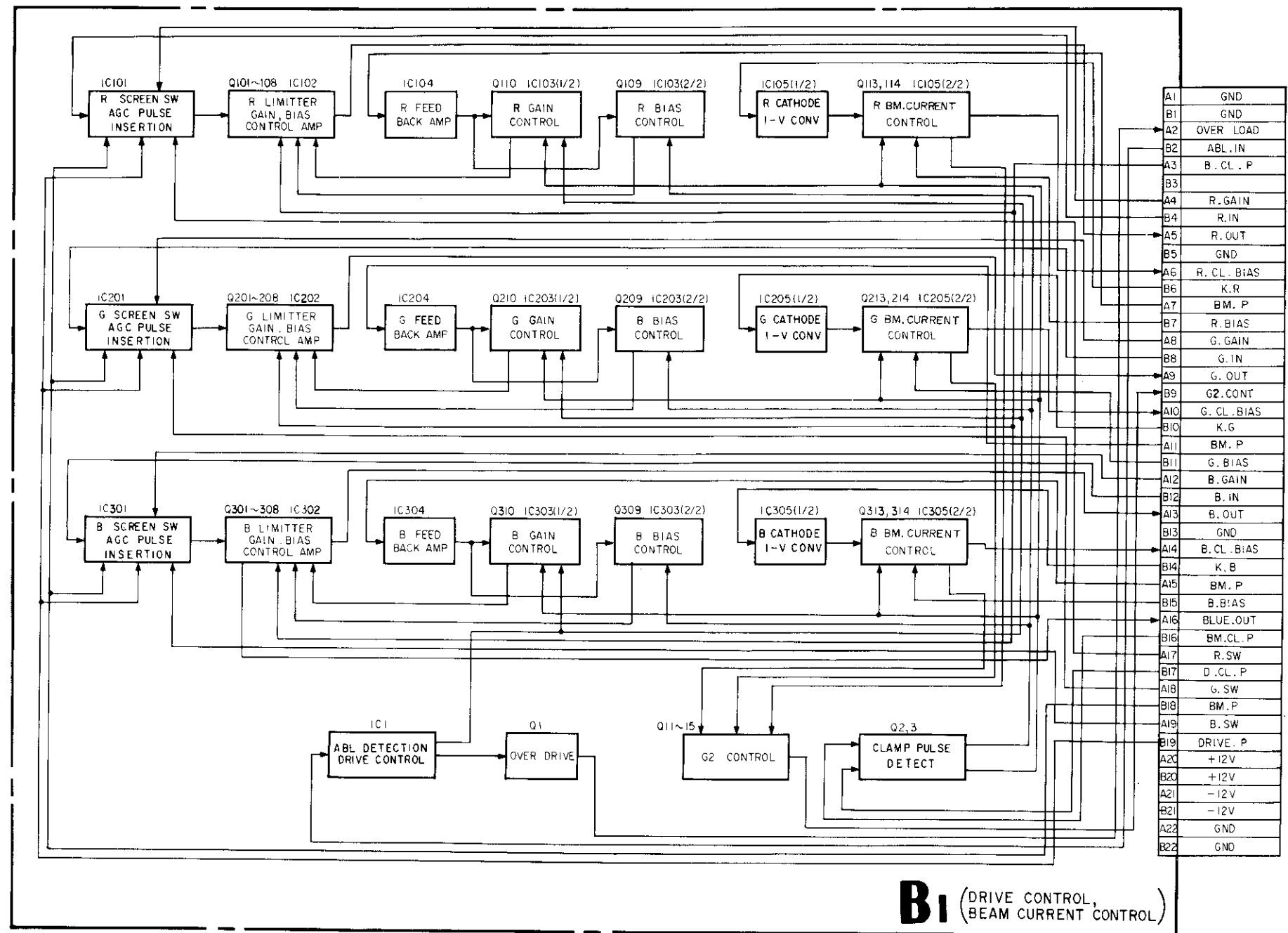

Figure 6

### BLOCK DIAGRAM OF BI BOARD



#### 3-4-3. Red Feedback Amplifier, Red Gain Control Red Bias Control Circuit

RED FEEDBACK amplifier inverts the phase of the signal derived from VIDEO OUTPUT amplifier via NF BUFF (Negative Feedback Buffer) in BK board.

The BIAS of VIDEO OUTPUT AMPLIFIER is controlled by RED BIAS CONTROL circuit so that the black level of inverted signal may be 0V DC.

(This time, black level of VIDEO OUTPUT will be -90V DC.)

RED GAIN CONTROL circuit controls the gain of VIDEO OUTPUT AMPLIFIER so that the level of the reference pulse may match to the voltage at pin ③ of IC103.

(When GAIN control (RED) in the drawer is turned, the level of the reference pulse inserted in section 1 changes. And amplitude (Gain) of Red signal changes so that the amplitude of the reference pulse derived from RED FEEDBACK amplifier may be maintained constant by GAIN CONTROL circuit.)

#### 3-4-4. Red Cathode Current Detection, Red Beam Current Control Circuit (I-V Conversion)

Refer to the BK board section of beam control circuit

#### 3-4-5. ABL Detector, Drive Control, Over Drive

The reference level of GAIN CONTROL circuit is controlled by ABL detector and DRIVE CONTROL so that the cathode current of CRT exceeds the predetermined (Preset) value to prevent damage of CRT. OVER DRIVE circuit lights up the OVER LOAD LED on the front panel for warning.

#### 3-4-6. G2 Control Circuit

Circuit diagram of G2 control circuit is shown in Figure 6.

The signal for BM. CURRENT control is fed to base of the transistor Q11 from RED BM. CURRENT control circuit. (Same as G and B)

Transistors Q11-Q13 is turned on and is compared with the reference voltage of base voltage Q14.

And this circuit drives transistor Q3, Q2 located in C board so that Transistor Q3, Q2 in C board drives G2 voltage for adjusting cut off level of CRT.

Base voltage of transistor Q14 (reference voltage) is set so that the voltage of Black level at CATHOD electrode may be +120V DC and maintain Ekco (cut off voltage) +120V constant.

### 3-5. SYNC PROCESSOR, PULSE GENERATOR (BJ BOARD)

#### 3-5-1. 1H Pulse Processing

The composite sync is separated from incoming signal at BA board. And 1H sync is made by separating V sync and equalizing pulse from composite sync.

Also H sync which has constant pulse width is made from 1H sync.

#### 3-5-2. 2fH Multivibrator

This circuit generates 2fH rate pulse from H rate flyback pulse.

#### 3-5-3. Vertical Counter

The 2fH rate pulse is counted down to generate Vertical rate trigger pulse for vertical deflection circuit.

When there is no incoming signal, trigger pulse is generated by vertical counter (384H).

When there is incoming signal with V sync, this counter circuit is reset by V sync and generates trigger pulse synchronized with V sync.

Also in order to increase stability of vertical scanning, noise gating process is made during V sync period.

#### 3-5-4. V Sync and Delay

V sync and V BLANKING pulses are generated by output trigger pulse from vertical counter.

And when V DELAY SW on the front panel is selected ON, these pulses are generated in a V/2 delayed position relative to the V sync position of incoming signal.

#### 3-5-5. Crosshatch Generator

Internal crosshatch signal is made as follows.

The vertical lines are generated by approx. 18fH rate pulses synchronized with flyback pulse.

And flyback pulse is counted down to generate horizontal lines.

#### 3-5-6. Burst Gate Pulse, Y-CLAMP Pulse, C-CLAMP Pulse Generator

The Burst Gate Pulse (B.G.P.), clamp pulse for luminance signal (Y.CL.P) and clamp pulse for color difference signal (C.CL.P) are generated from 1H sync via LCR network and transistors.

#### 3-5-7. Picture Set Up Pulse Generator

This is the gate pulse generator for picture set-up function, and consists of mono multipliers.

#### 3-5-8. Split, Y Blanking, C Blanking Pulse Generator

Y BLANKING pulse (Y BLK P) and C BLANKING pulse (C BLK P) are generated. These pulses are used for the purpose of DC restoration of color difference signal, Y signal and RGB signal. DC restoration is made by inserting the black reference signal during blanking period in the signal. Also C.BLK. pulse is mixed with vertical rate blanking signals for SPLIT display and for B/W display.

#### 3-5-9. Horizontal Rate AGC and Clamp Pulse Generator

COLOR GAIN control, CONTRAST control and BRIGHTNESS control are stabilized by insertion of reference signal and using feedback circuit. Horizontal rate BLACK pulse (B.P), BLACK CLAMP pulse (B.CL.P) and WHITE CLAMP pulse (W. CL.P) are generated here.

#### 3-5-10. Vertical Rate AGC and Clamp Pulse Generator

In this model, BEAM CONTROL circuit is used for high stability in white balance.

The reference signal is inserted in the signal for gain control circuit in video output amplifier and for beam control circuit. Vertical rate pulses are used for this purpose.

Vertical rate BEAM PULSE (BM.P) DRIVE PULSE (DRIVE.P) and BEAM CLAMP PULSE (BM.CL.P) are generated here.

#### 3-5-11. Others

Black reference is determined at the position of clamping in black reference insertion circuit for both color difference signal and RGB signal. Accordingly C.CL.P is used as clamp pulse for color difference signal processing and Y.CL.P is for RGB signal. CLAMP PULSE SELECTION SW switches C.CL.P or Y CL.P to the clamp pulse for the insertion of black reference.

BLOCK DIAGRAM OF BJ BOARD

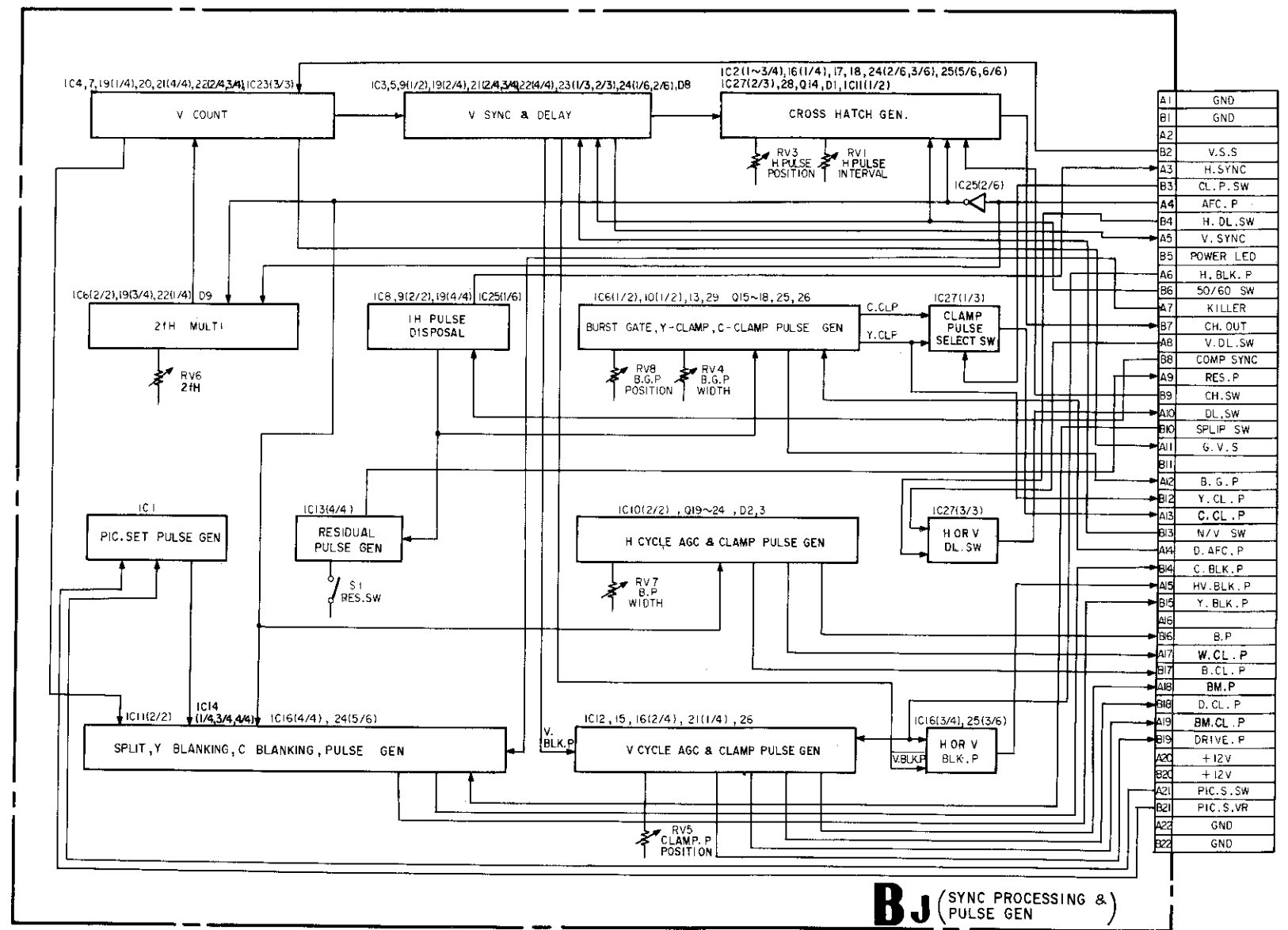

TIMING CHART OF MAJOR PULSE (BJ BOARD)

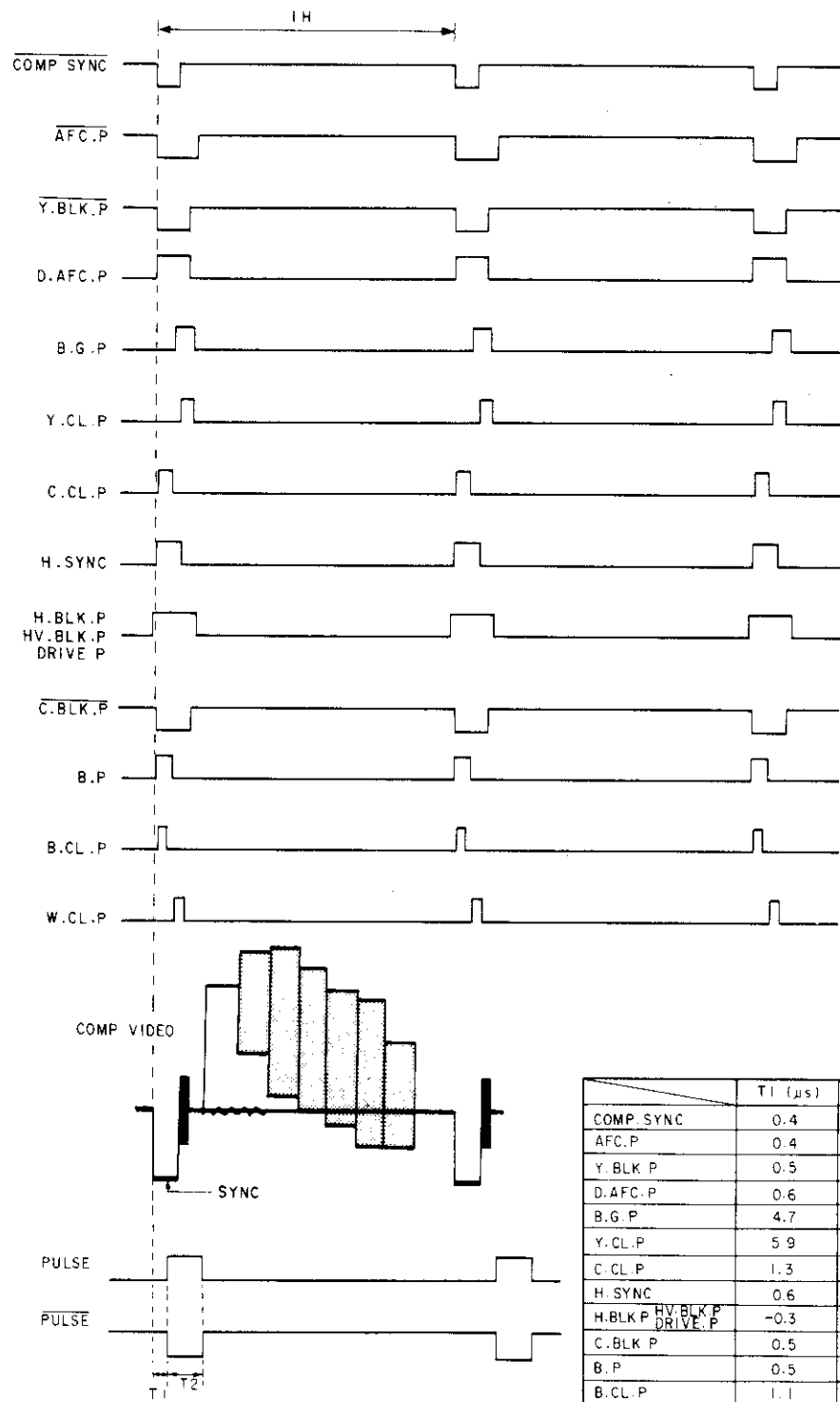

Figure 7

FIELD 1 VERTICAL BLANKING

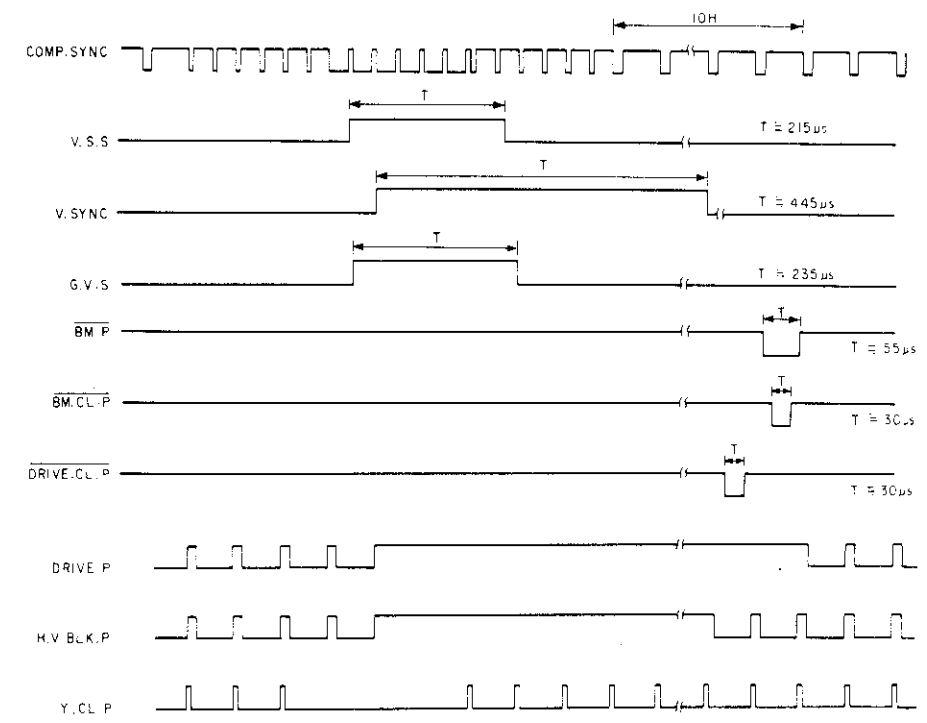

Figure 8

FIELD 2 VERTICAL BLANKING

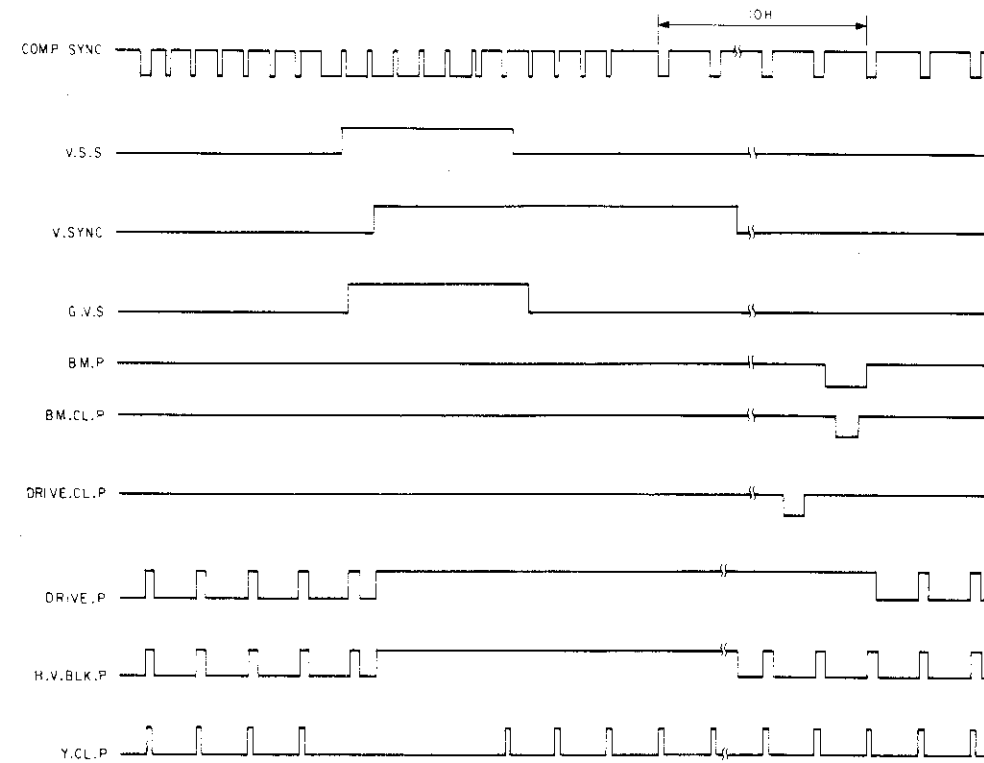

Figure 9

### 3-6. BK BOARD

Following are described about Red channel. Green and Blue channel are the SAME.

#### 3-6-1. Red Drive Amplifier, Red Buffer

This circuit drives final stage of video output amplifier. Gain is approx. 2

#### 3-6-2. Red Video Output Amplifier and Buffer

This is the final stage amplifier to obtain amplitude enough to drive cathode of CRT.

Gain is approx. 11

The amplified signal is input to the RED cathode of CRT through the next stage's buffer. At this final stage's buffer, the current source (Q107) is applied.

A B.M.P signal of positive polarity is input to the base of Q107. For this B.M.P period, Q107 is cut off, and the current is consequently not supplied to the buffer. So, the only current supplied from cathode is flown from emitter to collector of Q106 in this period.

This board outputs the Q106 collector current as K.R.

#### 3-6-3. H.V. Blanking Circuit

H.V.BLK. pulse is amplified by G1 drive circuit and it is fed to the G1 of CRT through the buffer.

BLOCK DIAGRAM OF BK BOARD

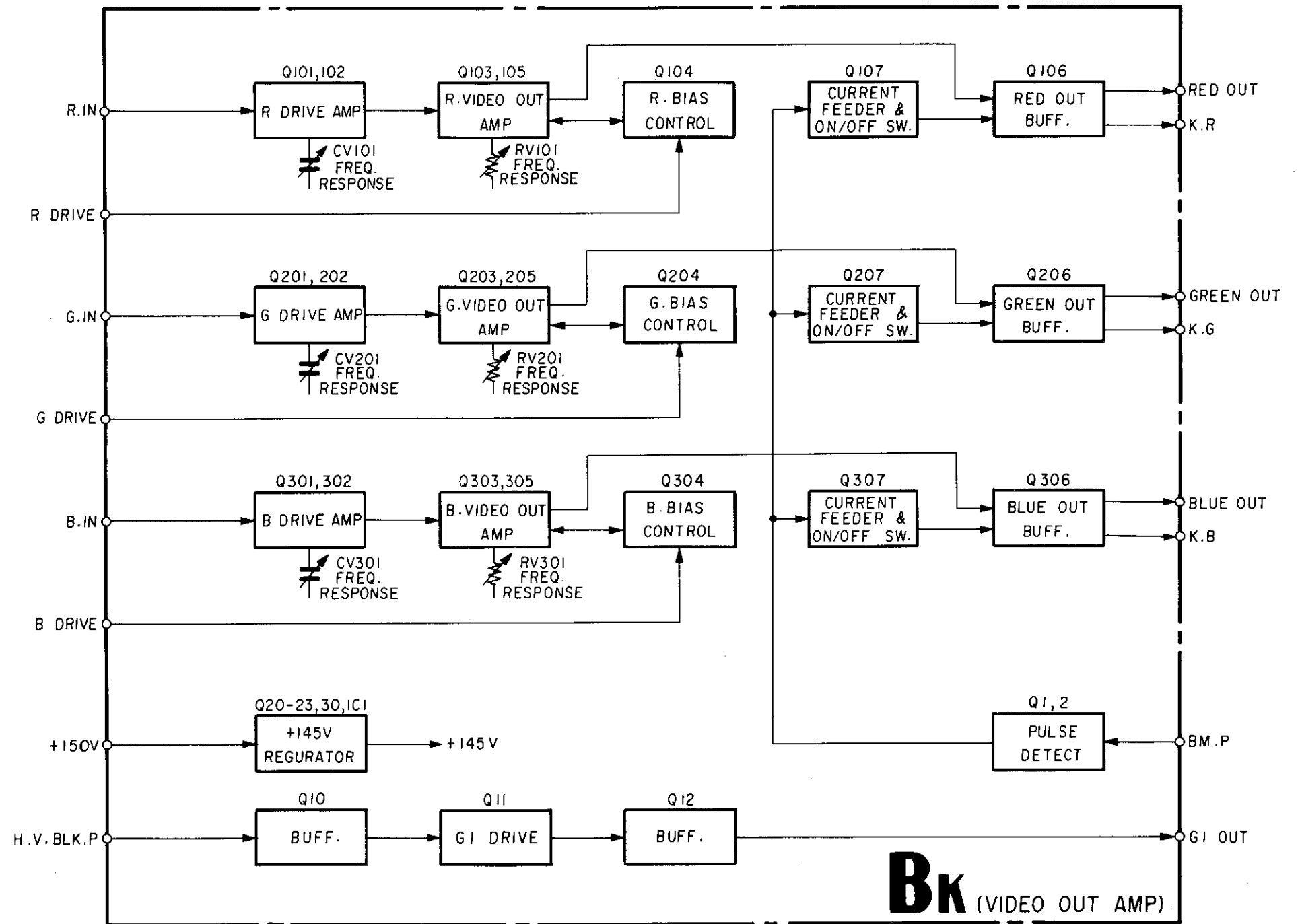

**3-7. Beam control Circuit (BI, BK BOARDS)  
(Same as Green and Blue)**

Block diagram is shown in Figure 10.

**3-7-1. Detection of Cathode Current and I-V Conversion  
(BI BOARD)**

Cathode current is detected as a voltage by using IC105 (1/2)

**3-7-2. Red BM. CURRENT Control (BI BOARD)**

BMP is inserted in the signal during vertical blanking in BI board. This BMP is detected as a cathode current and sampled by BM CLP applied to FET Q113.

This BM. CURRENT control circuit controls the base voltage of transistor Q114 so that converted voltage from cathode current and the reference voltage may match.

**3-7-3. Red Bias Control Circuit (BK BOARD)**

In the R BIAS control circuit on the BK board, emitter current of Q104 is controlled according to the variation of Q114 base voltage on the BI board.

Therefore, the base voltage of Q106 changes so that the black level of signal that is input to the cathode of CRT is controlled.

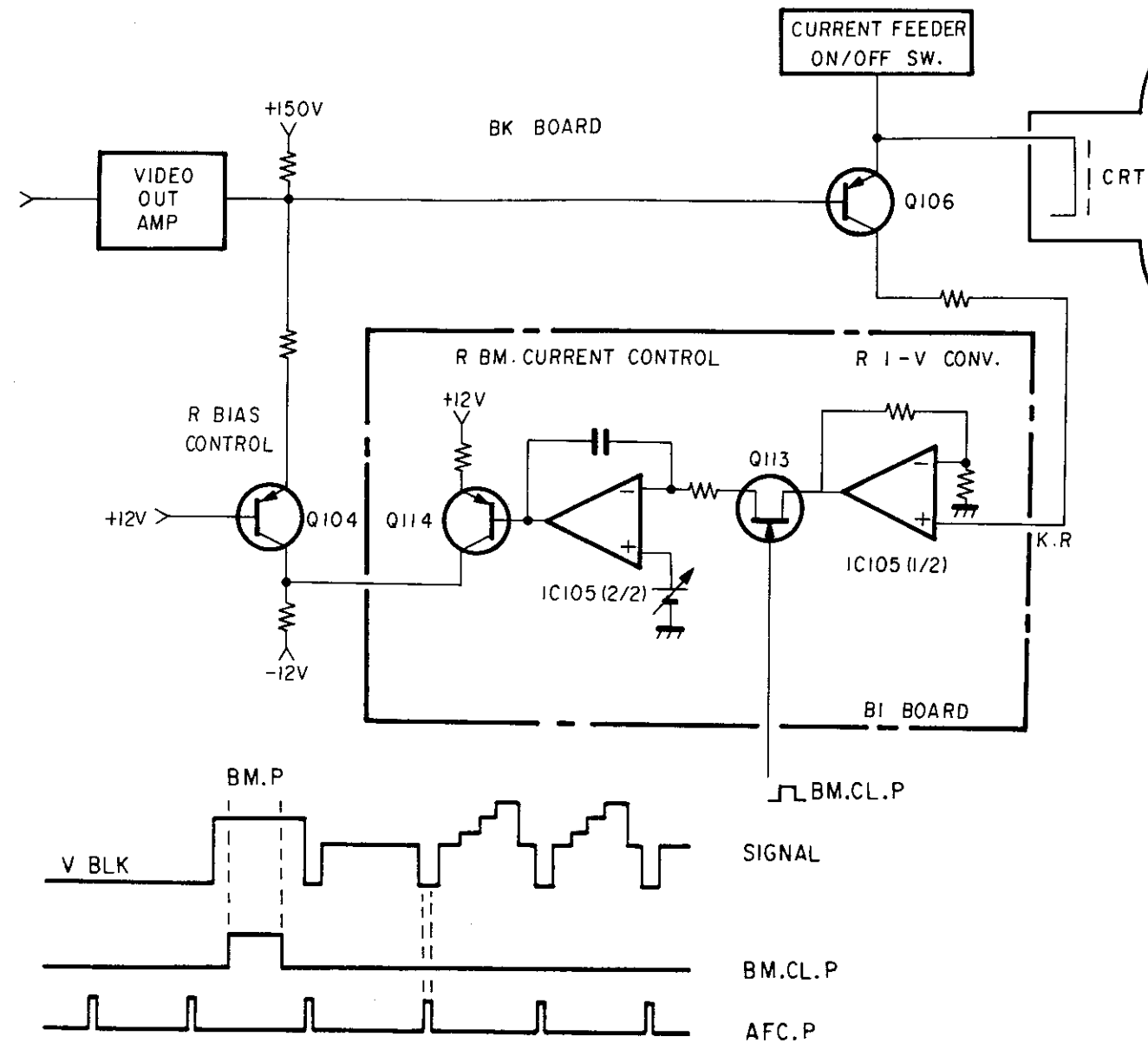



### 3-8. NTSC COMB FILTER (BT BOARD) (BVM-1916 ONLY)

#### 3-8-1. 3 Line Dynamic Comb Filter (Fig. 10)

The fed video signal is band limited by a low-pass filter. (This signal is hereinafter referred to as the OH signal.) The OH signal becomes the signal which is 1H (63.556  $\mu$ sec) delayed by the 1H delay circuit (1H delayed signal) and the signal which is 1H further delayed by the 1H delay circuit (2H delayed signal).

The OH, 1H, and 2H signals are band limited by the respective band-pass filters (center frequency: fs) for delay of  $\lambda/2$  (140 nsec). The 1H signal is further  $\lambda/2$  delayed. The OH+ $\lambda/2$ , 1H, 1H+ $\lambda/2$ , 1H+ $\lambda$  and 2H+ $\lambda/2$  (A, B, C, D and E of the block diagram) at each point are separated into chroma signals only by the correlation circuit (IC501).

The luminance signal is separated with the chroma signal subtracted from the 1H signal.

#### 3-8-2. 2 Line Sympole Comb Filter

The chroma signal is separated with the OH+ $\lambda/2$  and 1H+ $\lambda/2$  signal subtracted, and the luminance signal is separated by subtracting the chroma signal from the OH signal.

#### 3-8-3. 1H Delay Circuit (Fig. 11)

The 1H delay circuit consists of two CCD delay lines.

These CCD delay lines are used in parallel to attain 1H (63.556  $\mu$ sec) signal delay.

#### 3-8-4. Band-pass Filter (Fig. 12)

The band-pass filter consists of a delay line. It performs band limiting with the group delay kept constant.

#### 3-8-5. Correlation Circuit (IC501) (Fig. 13)

The correlation circuit consists of a limiter circuit which is common to emitters to perform separation of a chroma signal.

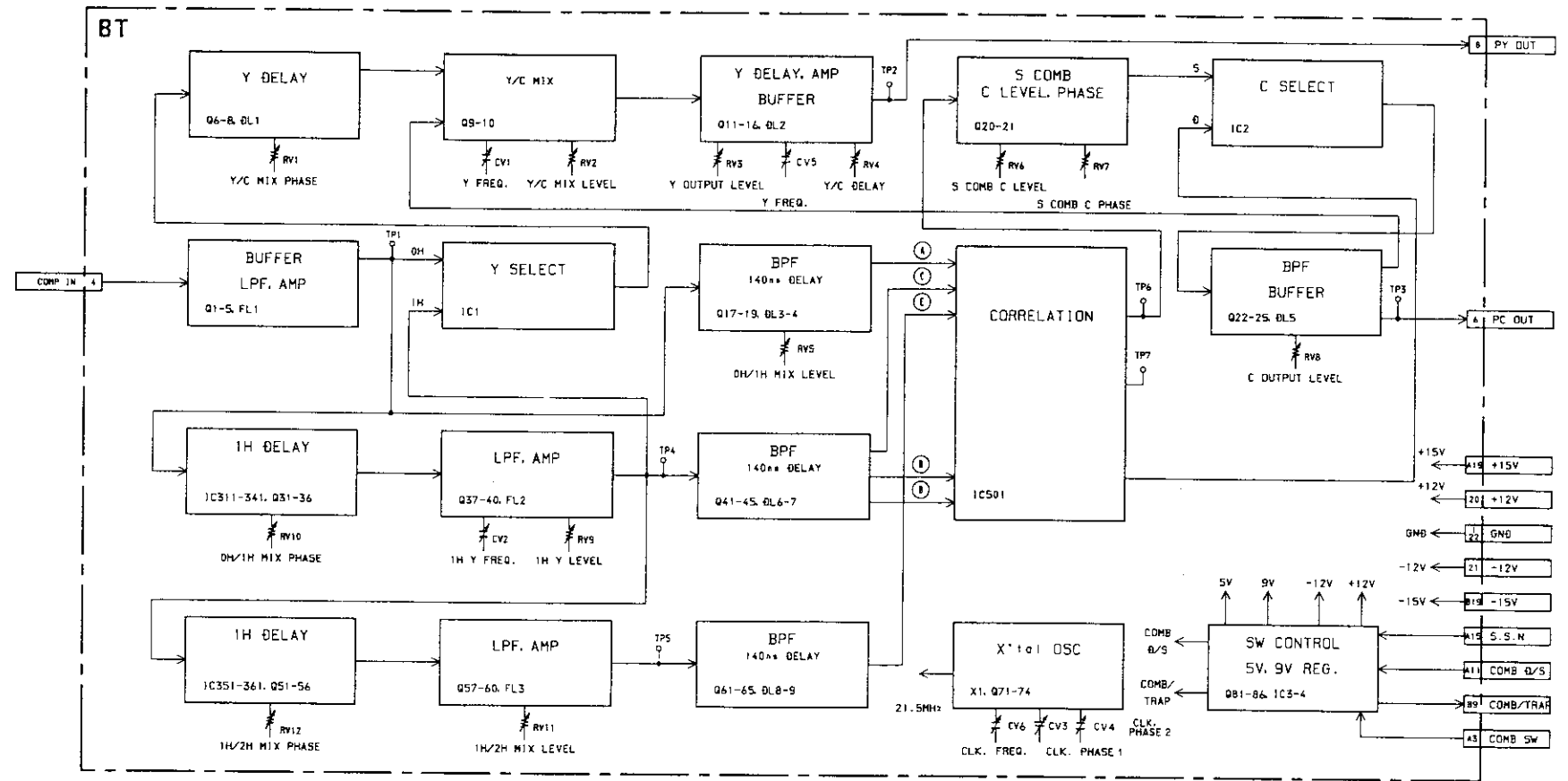

Figure 10

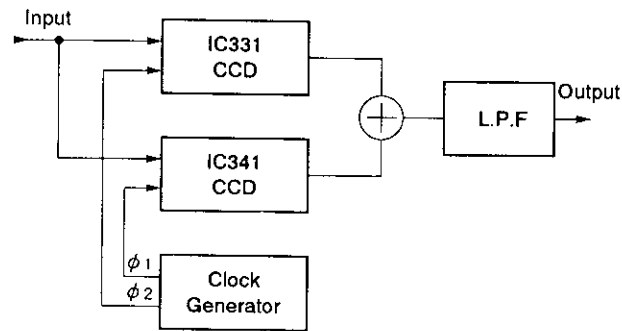

Figure 11

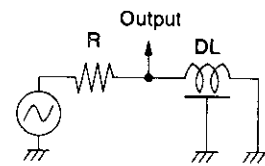

Figure 12

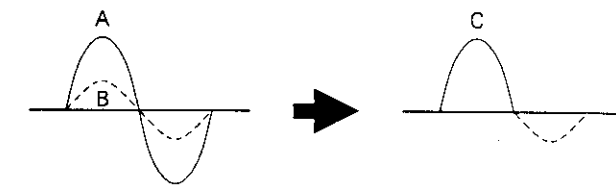
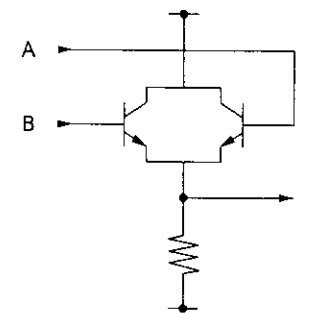

Figure 13

**(BVM-1916 ONLY)**

**3-9. NTSC DEMODULATOR, Y TRAP CIRCUIT (BC BOARD)**

The composite video signal (NTSC) supplied from BA board is fed to transistor Q1 (buffer), then is supplied to the 3.58MHz trap circuit with Y signal and to band pass filter with chrominance signal.

**3-9-1. Chroma Band Pass Filter**

The composite video signal obtained from at the emitter of transistor Q1 is fed to the Band pass filter composed of resistor R18, capacitor C7, C8, inductor L3 and transistor Q5.

The center frequency of this filter is adjusted to the subcarrier frequency (3.58MHz) by L3, and chrominance signal is derived from Q5.

This circuit selects comb filter (BB board) mode or notch filter mode by a push of button on the front panel. When comb filter mode is selected, comb switch circuit composed of transistor Q103 and Q104 activates and base voltage of Q5 goes down to -12V and Q15 is cut off and then chrominance signal (Pure C) is provided from comb filter circuit to IC2.

**3-9-2. Residual SW Circuit**

The chrominance signal derived at transistor Q5 is fed to analog switcher IC2 (Pin 7).

When switch S1 on BJ board is set to ON position, residual pulse which has almost same phase as H sync is fed to control terminal of analog switcher (pin 3) of IC2) and screening is performed during H sync period.

When switch S1 on BJ board is set to OFF position. Low level signal (0V DC) is fed to control terminal and screening action is not performed. Thus residual switch circuit does not activate.

When there is residual subcarrier in the video signal, clamp level of color difference signal changes by turning switch S1 ON/OFF and therefore residual subcarrier can be checked on the picture as a color shift.

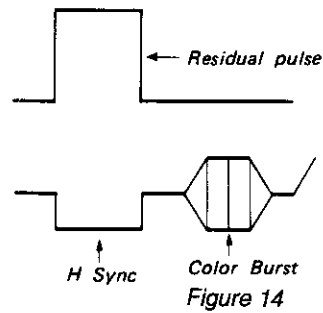

Figure 14

**3-9-3. Chroma Amplifier Circuit**

The level of chrominance signal from residual switch circuit (IC2 pin 4) is divided by resistor R85 and R86 and is fed to chroma amplifier circuit (Q6, Q7, Q8).

The gain of this amplifier is almost 1 and this amplifier has 2 outputs. They are non-inverted signal and inverted signal.

Non-inverted signal is fed to R-Y input terminal (IC1 pin 3) of demodulator and inverted signal to B-Y input terminal (IC1 pin 2).

**3-9-4. Phase Control Circuit**

The chrominance signal from residual switch is also fed to phase control circuit (Q9, Q10, Q11, Q12, D2).

In this circuit, a variable capacitance diode (D2) is used to control the phase of color burst signal.

Anode voltage of D2 is applied by variable resistor RV2 and preset adjustment of phase is made by this variable resistor.

When the PHASE control on the right side of the front panel is turned, DC level of phase control signal (board terminal A13) changes and this phase control signal is fed to the cathode of D2 via analog switcher (IC2 Pin 3). In this way, Burst phase of chrominance signal is controlled according to the DC level of the phase control signal.

Analog switcher IC3 (2/3) activates to make short-circuit between input terminal pin 13 and output terminal pin 14, only when COLOR STANDARD SELECTOR in the right side of drawer is selected to NTSC and otherwise pin 13 kept open circuit.

As above phase controlled chrominance signal is derived from emitter of transistor Q12 and burst signal in this signal is gated by IC3 (1/3). The gated burst signal is fed to the burst input terminal pin 11 of demodulator IC1.

**3-9-5. NTSC Demodulator**

Block diagram of IC1 used for NTSC demodulator is shown in Figure 15.

This IC is designed for use of NTSC demodulator.

When chrominance signal is fed to pin 1, 2 and pin 3, color burst signal to pin 11 and Burst Gate Pulse (B.G.P) to pin 13. R-Y and B-Y color difference signals are obtained at output terminals pin 21 and pin 22.

The demodulation axes of this demodulator are R-Y axis and B-Y axis. Variable capacitor CV1 is adjusted so that the phase angles between them are 90.

Local oscillator (3.58MHz) is formed by CW oscillator in IC1 connected to the terminal pin 5, 6, 7, 8 and external circuit.

The variable capacitor CV2 is adjusted so that the free run frequency may be subcarrier frequency 3.579545MHz.

Also APC (Automatic Phase Control) circuit is formed by APC section in IC1 connected to the terminal pin 9 and 10 local oscillator is controlled by APC circuit.

The color difference signals demodulated by this IC are fed to low pass filter, where high frequency component is removed, then R-Y and B-Y color difference signals are obtained.

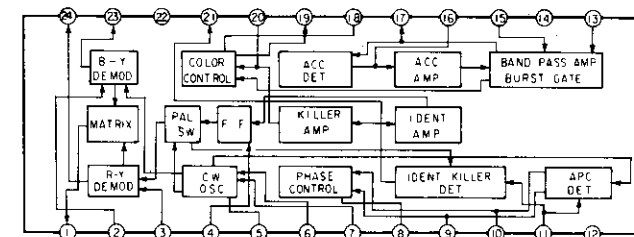

Block diagram of NTSC demodulator

Figure 15

**3-9-6. 3.58 MHz Trap Circuit, Phase Compensation, Y Delay Correction Circuit**

The composite video signal from emitter of transistor Q1 is fed to 3.58MHz trap circuit composed of resistor R5, R6, R7, capacitor C1 and inductor L1.

Adjustment of L1 is made so that the resonance frequency of this trap circuit should be subcarrier frequency.

Y (Luminance) signal removed subcarrier is obtained at output terminal of the trap circuit and is fed to the phase compensation circuit. (Transistor Q2, resistor R8, R9 R10, inductor L2 capacitor C4)

This circuit compensates phase delay of the signal at high frequency due to the trap circuit.

Y signal compensated phase delay is fed to Y-delay circuit. In this circuit Luminance/Chrominance time error is compensated by delay line.

**3-9-7. Color Standard Selector**

When NTSC system is not selected by the COLOR STANDARD SELECTOR in the right side drawer, transistor Q101 is cut off and +12V line power source is not supplied to the demodulator circuit.

**BLOCK DIAGRAM OF BC BOARD**

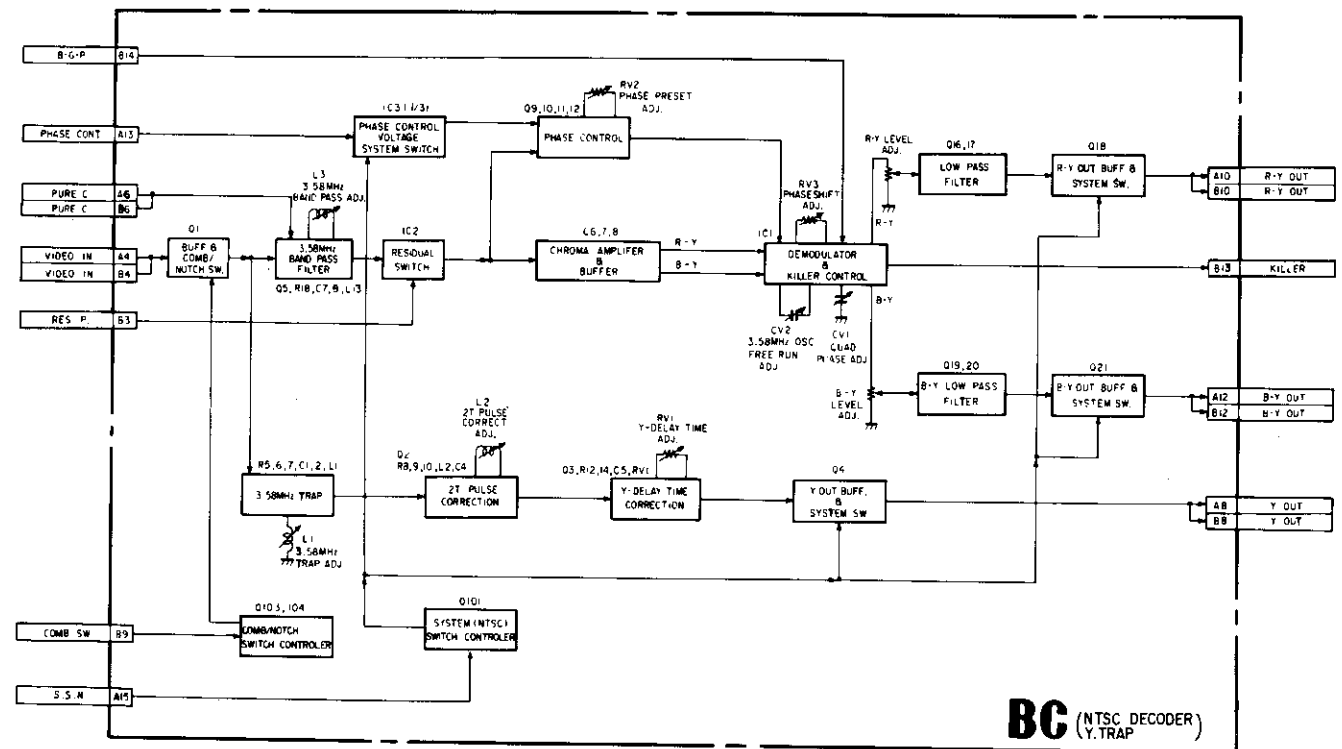

BC (NTSC DECODER) (Y TRAP)

**(BVM-2016P ONLY)**

**3-10. PAL DEMODULATOR, Y TRAP CIRCUIT  
(BO BOARD: Serial NO.2000382 and Higher)**

The composite video signal (PAL) supplied from BA board is fed to transistor Q1 (buffer), then is supplied to the 4.43 MHz trap circuit with Y signal and to band pass filter with chrominance signal.

**3-10-1. Chroma Band Pass Filter**

The composite video signal obtained from at the emitter of transistor Q1 is fed to the Band pass filter composed of resistor R12, capacitor C7, C8, inductor L3 and transistor Q5.

The center frequency of this filter is adjusted to the subcarrier frequency (4.43 MHz) by L3, and chrominance signal is derived from Q5.

**3-10-2. Residual SW Circuit**

The chrominance signal derived at transistor Q5 is fed to analog switcher IC2.

When switch S1 on BJ board is set to ON position, residual pulse which has almost same phase as H sync is fed to control terminal of analog switcher (pin ③ of IC2) and screening is performed during H sync period.

When switch S1 on BJ board is set to OFF position, Low level signal (0V DC) is fed to control terminal and screening action is not performed. Thus residual switch circuit does not activate.

When there is residual subcarrier in the video signal, clamp level of color difference signal changes by turning switch S1 ON/OFF and therefore residual subcarrier can be checked on the picture as a color shift.

**3-10-3. Chroma Amplifier Circuit**

The chrominance signal from residual switch circuit (IC2 pin ④) is fed to chroma amplifier circuit (Q17, Q36).

After the chroma signal is amplified by the inversion amplifier (gain: 1X), it is voltage divided by resistors R400 and R314 and then input to the R-Y input terminal (IC1, pin ③) and B-Y input terminal (IC1, pin ②) of the following demodulator circuit via the buffer (Q38).

**3-10-4. Phasa Control Circuit**

The chrominance signal from residual switch is also fed to phase control circuit (Q6, Q7, Q8, Q9, D10).

In this circuit, a variable capacitance diode (D10) is used to control the phase of color burst signal.

Anode voltage of D10 is applied by variable resistor RV8 and preset adjustment of phase is made by this variable resistor.

When the PHASE control on the right side of the front panel is turned, DC level of phase control signal (board terminal A13) changes and this phase control signal is fed to the cathode of D10 via analog switcher (IC5). In this way, Burst phase of chrominance signal is controlled according to the DC level of the phase control signal.

When PAL-D is selected with the PAL switch inside the right side drawer, between pins ③ and ④ of IC5 becomes conductive and phase control becomes dependent on RV7, disabling the Phase Control of the right side front panel.

Analog switcher IC5 (1/3) activates to make short-circuit between input terminal pin ③ or ⑤ and output terminal pin ④, only when COLOR STANDARD SELECTOR in the right side of drawer is selected to PAL and otherwise pin ⑨ kept open circuit.

As above phase controlled chrominance signal is derived from collector of transistor Q9 and burst signal in this signal is gated by IC6. The gated burst signal is fed to the burst input terminal pin ⑪ of demodulator IC1.

**3-10-5. PAL Demodulator**

Block diagram of IC used for PAL demodulator is shown in Figure 11. This IC is designed for use of NTSC demodulator.

When chrominance signal is fed to pin ② and pin ③, color burst signal to pin ⑪ and Burst Gate Pulse (B.G.P.) to pin ⑬. R-Y and B-Y color difference signals are obtained at output terminals pin ⑫ and pin ⑭.

The demodulation axes of this demodulator are R-Y axis and B-Y axis. Variable capacitor CV1 is adjusted so that the phase angles between them are 90°.

Local oscillator (4.43 MHz) is formed by CW oscillator in IC1 connected to the terminal pin ⑤, ⑥, ⑦, ⑧ and external circuit.

The variable capacitor CV2 is adjusted so that the free run frequency may be subcarrier frequency 4.433619 MHz.

Also APC (Automatic Phase Control) circuit is formed by APC section in IC1 connected to the terminal pin ⑨ and ⑩ local oscillator is controlled by APC circuit.

The color difference signals demodulated by this IC are fed to low pass filter, where high frequency component is removed, then R-Y and B-Y color difference signals are obtained.

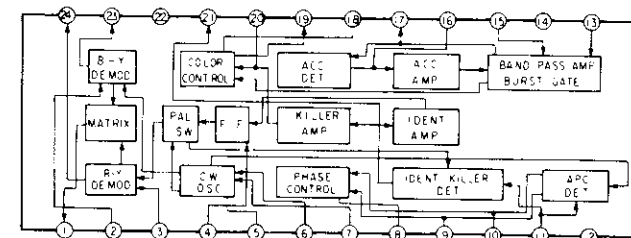

Block diagram of PAL demodulator

Figure 16

**3-10-6. PAL-D Matrix and PAL S/D Switching Circuit**

This circuit is further divided into circuits for the R-Y and B-Y signals, but the operation of both circuits is the same. So only the R-Y one will be explained.

R-Y signals input from the demodulator circuit are input to Q20 (BUFF) and Q21 (BUFF).

The signals input to Q21 are then input to pin ⑫ of the analog switcher (IC5). When PAL S has been selected, between pins ⑫ and ⑭ becomes conductive and the signals are supplied to the following circuit via Q33 (BUFF).

The signals input to Q20 are formed by IC7 and Q18. Bias is controlled by a clamp circuit and is input to pin ① of the 1H delay line (IC3). The DC level of the input is adjusted to the optimum value by using RV9.

IC3, driven by the 17.715 MHz clock signal generated by the clock generator circuit configured with X2, Q34 and Q35, delays the input signal by 1H cycle and outputs it from pin ⑤.

The high frequency component of the signal thus output is removed by the low-pass filter configured with Q40, Q22 and Q23, after which the signal is input to the following PAL-D matrix circuit.

The PAL-D matrix circuit is configured with R100, R101 and Q24. The signal that was not delayed is input through R100 while the 1H delayed signal is input through R101 at a ratio of 1/2.

The PAL-D signal added to the base of Q24 is obtained from its emitter. The signal obtained from the Q24 emitter is input to pin ⑬ of IC5. When PAL-D is selected, between pins ⑬ and ⑭ becomes conductive and the signal is supplied to the following circuit via Q33 (BUFF).

**3-10-7. 4.43 MHz Trap Circuit, Phasa Compensation, Y Delay Correction Circuit**

The composite video signal from the emitter of transistor Q1 is fed to 4.43 MHz trap circuit composed of resistor R3, R4, R5, capacitor C1, C2 and inductor L1.

Adjustment of L1 is made so that the resonance frequency of this trap circuit should be subcarrier frequency.

Y (Luminance) signal removed subcarrier is obtained at output terminal of the trap circuit and is fed to the phase compensation circuit. (Transistor Q2, resistor R6, R7, R8, inductor L2, capacitor C4)

This circuit compensates phase delay of the signal at high frequency due to the trap circuit.

Y signal compensated phase delay is fed to Y-delay circuit. In this circuit Luminance/Chrominance time error is compensated by delay line.

**3-10-8. Color Standard Selector**

When PAL system is not selected by the COLOR STANDARD SELECTOR in the right side drawer, transistor Q101, Q102 are cut off and  $\pm 12V$  line power source is not supplied to the demodulator circuit.

**BLOCK DIAGRAM OF BD (PAL) BOARD**

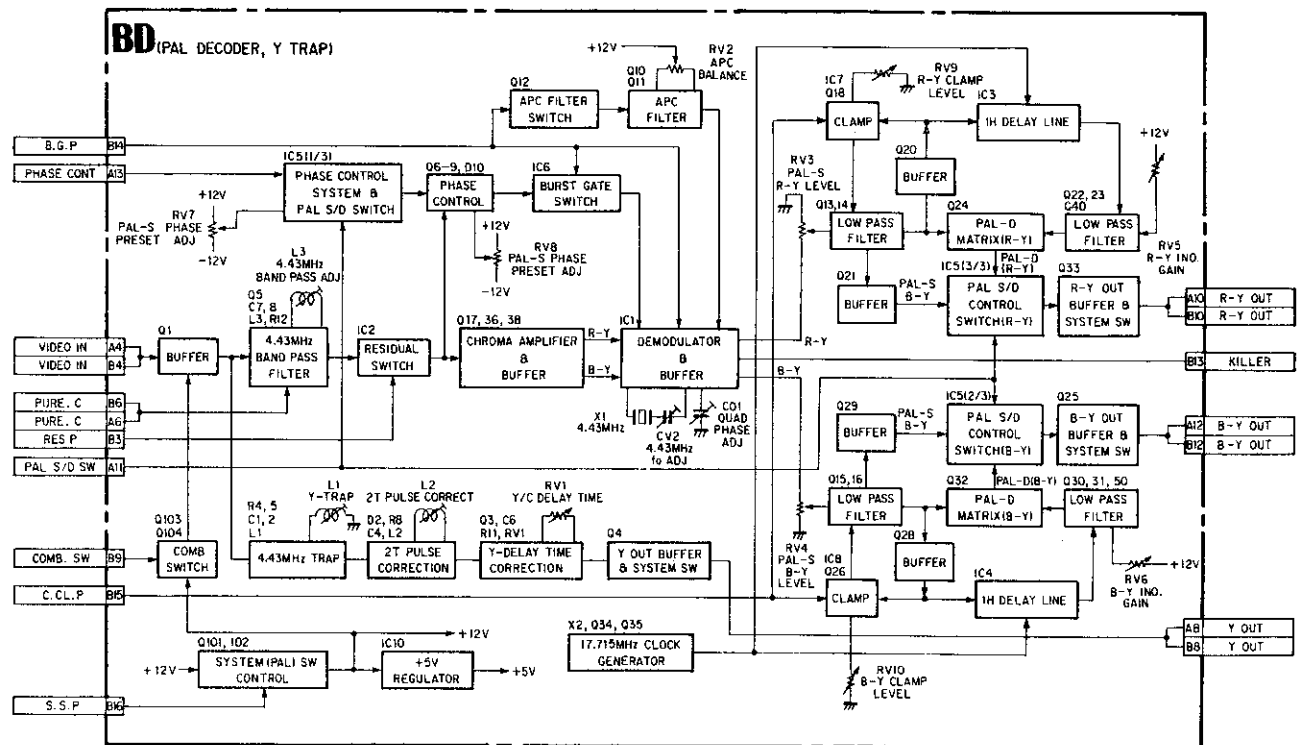

3-22

### 3-11. DA BOARD

- **Waveform Generation circuit (IC2, 7, 8, 9, 11, 18, 24, 25)**

IC2 is a waveform generator. With the input of both horizontal and vertical sync signals, this IC generates the following signals:

- H rate saw tooth waveform signal (HS)
- H rate parabolic waveform signal (HP)
- V rate saw tooth waveform signal (VS)
- V rate parabolic waveform signal (VP)
- Modulated waveform signal
- H saw × V saw (HS × VS)
- H saw × V parabola (HS × VP)
- H parabola × V saw (HP × VP)
- H parabola × V parabola (HP × VP)
- H.SW PULSE, V.SW PULSE

H.SW and V.SW pulses are those which rise just in the middle of the trace period and fall in the retrace period.

- **Scan Switching circuit (IC3, 4, 5, 6)**

In the scan switching circuit, NORMAL, UNDER or SET-UP scanning is performed.

In H.SAW GEN. circuit, the H rate saw wave is output by the integrator of IC15 using the H.SW pulses from IC2 as reset pulses. The H rate saw thus generated is delayed about 1/2H as compared with that of the IC2.

- **H.BLK. GEN., H. DRIVE GEN. circuit (IC17, 18)**

In the H.BLK GEN. circuit, the H.BLK.P required for horizontal blanking is generated from the H.SAW waveform signal which is output signal of IC13. The HV.DRIVE GEN. is the same. In the H.Delay and H.PHASE circuits, like H.BLK.GEN., the D.AFC.P is output by comparing the H.SAW output signals of IC13. Further, this circuit performs H. PHASE and H.DELAY by not changing the pulse width of D.AFC.P but changing only the position.

- **SIN. GEN., COS. GEN. circuits (IC7, 8)**

In the SIN.GEN. and COS.GEN. circuits, the SIN approximate wave is output by integrating the V rate parabola once and the COS approximate wave is output by integrating it twice.

- **H.WIDTH circuit (IC3, 11)**

In the H.WIDTH circuit, the correction waveforms such as SIDE PIN, SIDE PIN TILT, H.WIDTH, etc. are output by adding VP, VS, H. SIZE, etc. (H.WIDTH)

- **H. LIN circuit (IC13)**

In the H.LIN circuit, correction waveforms such as H.LIN.GAIN, H. LIN. BALANCE, etc are output by adding HP, HS, etc. (H.LIN)

- **V SAW circuit (IC12)**

In the V.SAW circuit, the correction waveforms such as V cycle saw wave, V.LIN. GAIN, V.LIN. BALANCE, V.GEN.T.X BOW, TOP BOTTOM PIN, etc. are output by adding VS, DC, V.SIN, VP, HS, HS × VS, etc. (V.SAW)

- **H.CENT circuit (IC16)**

In the H.CENT circuit, the correction waveforms of H.CENT, Y BOW, Y. TILT are output by adding DC, VP and VS.

- **X.CONV circuit (IC9, 14)**

In the X.CONV circuit, the correction waveform of vertical misconvergence is output by adding VP and DC which are generated separately in upper side and lower side of the picture screen.

- **Y.CONV circuit (IC9, 14, Q2)**

In the Y.CONV circuit, the correction waveform of horizontal misconvergence is output by adding VP and DC which are generated separately in upper side and lower side of the picture screen.

- **System Detector circuit (IC1, Q1)**

With the input at both horizontal and vertical sync signals IC1 distinguishes between 525/60 and 625/50.

**BLOCK DIAGRAM OF DA BOARD**

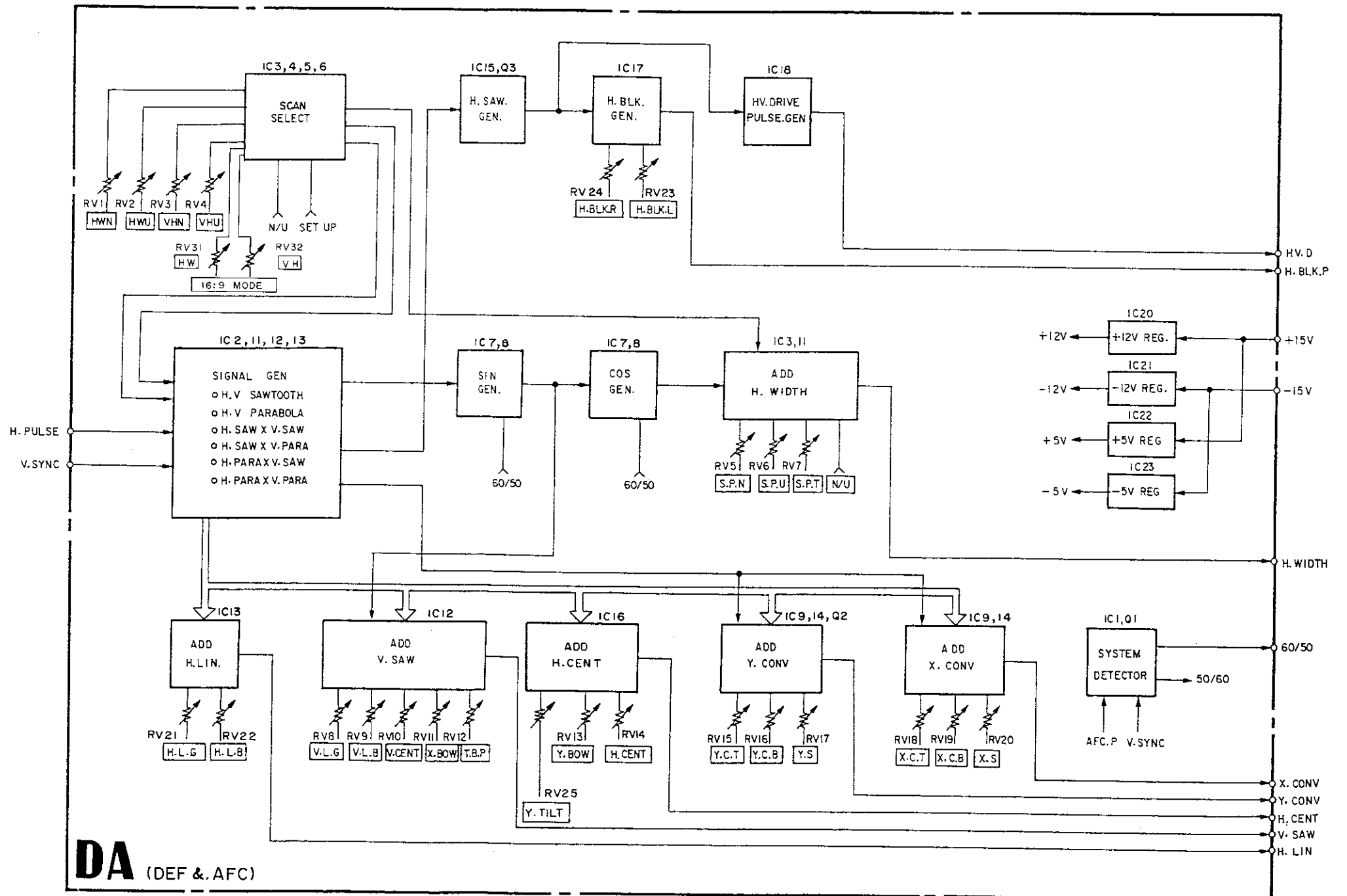

### 3-12. HORIZONTAL AND VERTICAL DEFLECTION OUTPUT CIRCUIT AND HIGH VOLTAGE REGULATOR CIRCUIT (EA BLOCK)

#### 3-12-1. Horizontal Deflection Output Circuit

The horizontal deflection output circuit controls H out of Q11, driving T2 at Q10 by the H drive pulse generated on the board DB.

The power supply circuit to H out improves the power supply efficiency using -150V and DC-DC converter with IC1 and Q7. IC1 consists of the error amplifier and the P.W.M. circuit. IC1, being supplied with the side pin-cushion correction waveform and the H. width adjusting voltage from the board DA controls the DC-DC converter output.

#### 3-12-2. H. Center Adjusting Circuit

The H. center adjusting circuit, generating a  $\pm$  power source from the secondary output of T3 (H.O.T.), flows the correction current of the horizontal center position and Y bow bend to the horizontal deflection yoke.

#### 3-12-3. H. Linearity Correction Circuit

The H. LIN. circuit amplifies the H. LIN. correction waveform generated on the board DA by the SEPP amplifiers of Q2 to Q5, and supplies these to the horizontal deflection yoke from the capacitor for S curve correction.

#### 3-12-4. Vertical Deflection Output Circuit

The vertical deflection output circuit consists of the SEPP AMP, directly connected to DC power and composed of Q201 to Q205 and the retrace pulse voltage boost-up circuit composed of Q207 and Q208.

This SEPP AMP receives, as an input the sawtooth wave voltage (added with the T&B pincushion compensating voltage and the vertical linearity compensating voltage) generated at the DA board.

Since the SEPP AMP is directly connected to the load (V.DY), the V. CENT circuit needs only DC current supplied to V sawtooth from  $\pm$  power supply. The boost-up circuit is turned on by the V.D signal and supplies energy to the output circuit during the vertical retrace period.

#### 3-12-5. High Voltage Regulator Circuit

The high voltage regulator of this unit uses the DC-DC converter type power supply circuit in order to reduce power consumption. In general, the movement of the high voltage regulator is as follows:

The high voltage regulator consists of Q16, Q18, IC3 (1/2), IC2 (IC for P.W.M. control) and HVR.

The detection voltage is obtained by directly dividing HV voltage with resistors in HVR.

IC2 compares this detection voltage with the reference voltage located outside IC2 (error amplification) and performs P.W.M. modulation. Q16 is driven by output of IC2 which is made PWM modulation and controls the voltage supplied to the FBT drive circuit (Q17, Q18, FBT).

The HV voltage is adjusted by changing the detection voltage. Since the detection voltage of HVR drops when the anode current is increasing and the high voltage drops, then the ON period of Q16 is widened.

As a result of this, as the peak current of the corrector current of Q18 increases, the energy which is stored in C68 via FBT is enlarged and the high voltage is regulated by increasing electric potential of C68.

When Q18 is turned off, a flyback pulse is generated by the synthesized resonance action by inductance of L.O.T, F.B.T and the C65, C66, C67 then, the HV voltage is generated by transferred the flyback pulse to the secondary side. (See Figure)

#### 3-12-6. CRT Heater Power Source

The CRT heater power source is supplied from the secondary winding of L.O.T.

BLOCK DIAGRAM OF EA BOARD

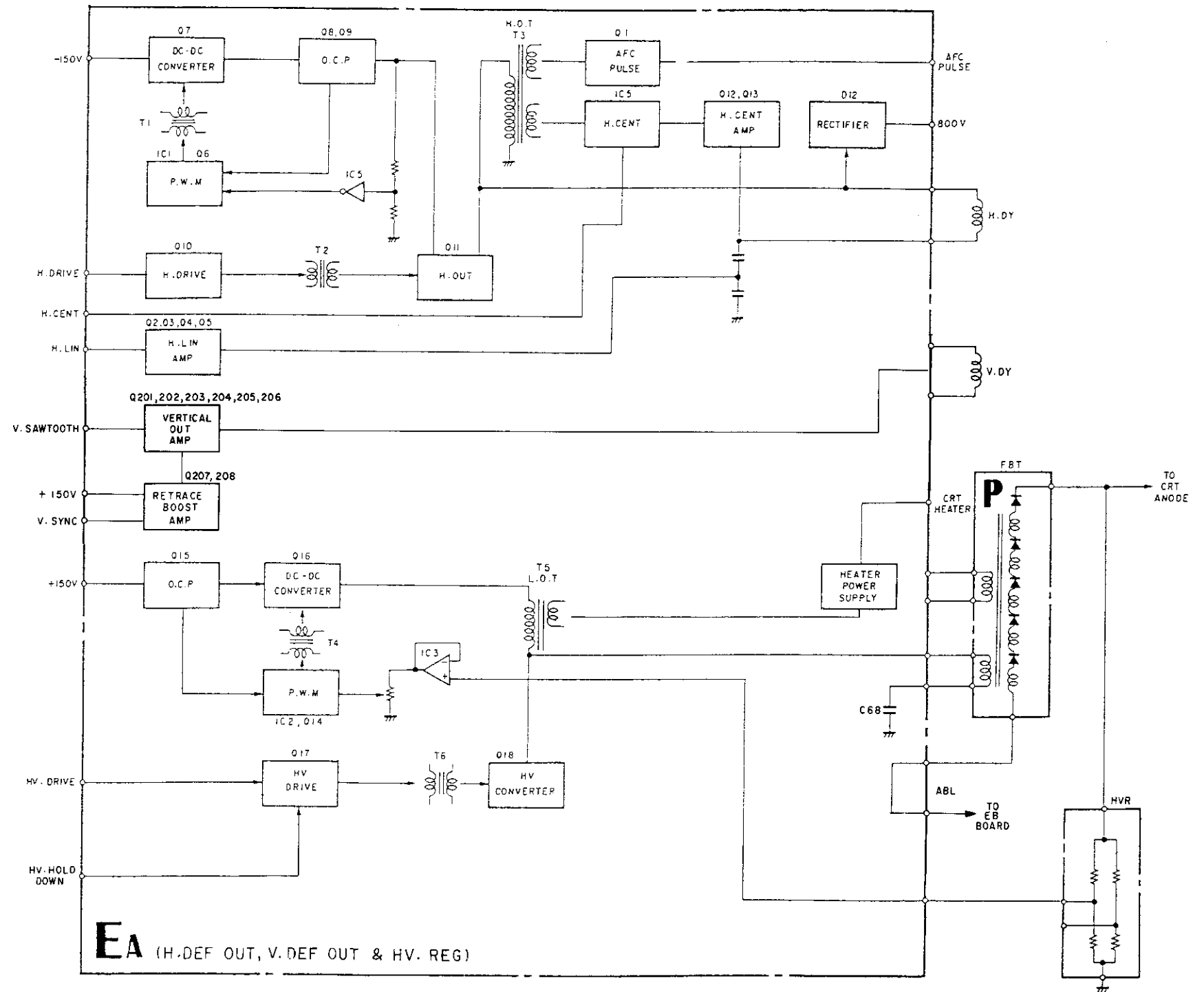

### 3-16. POWER SUPPLY CIRCUIT (GA, GB BOARDS)

#### 3-16-1. AC Power Supply, Rectifier Circuit

Voltage selector located at the rear side of the unit should be selected to the local line voltage (AC 100/120V or 220/240V). In case of AC 100/120V selected by voltage selector, rectifier D21 capacitors C80 and C81 operate as a double multiple rectifier. See Figure 17(a). In case of AC 220/240V selected by voltage selector, rectifier D21 capacitors C80 and C81 operate as a full-wave rectifier. See Figure 17(b).

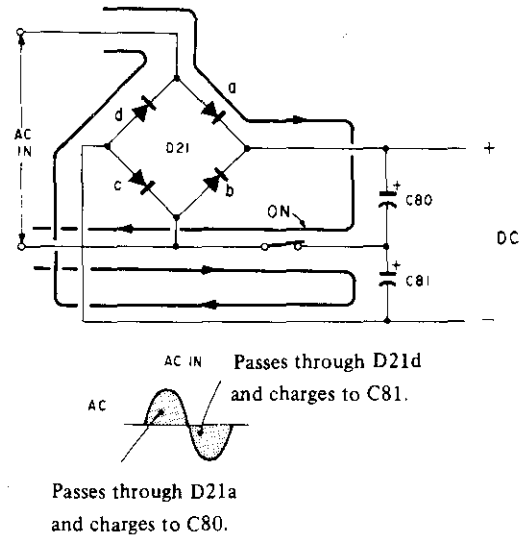

Figure 17(a)

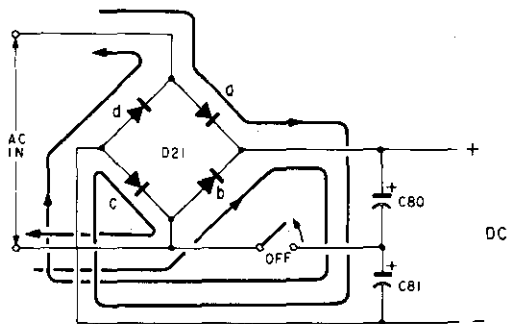

Figure 17(b)

#### 3-16-2. Degauss Circuit

There are 2 posistors (PTH1, PTH2) in the degaussing circuit. One is used for AC 100/120V operation, the other is for AC 220/240V operation, these posistors are switched by voltage selector. This degaussing circuit is turned ON and OFF by using Relay (RY1) automatically. When power is turned ON, Automatic degaussing starts to work and a few seconds later stops automatically. Also Manual degaussing is available if necessary after a few minutes power is turned on when posistor (PTH1 or PTH2) gets cool down. This manual degaussing is operated by a push of button (Degauss Switch) at the left of the front panel. When degaussing circuit starts to work, Q11 transistor turns on by time constant circuit composed of resistors R88, 91 and capacitor C74. Q11 drives Q12 transistor. Relay (RY1) is driven by Q12. Time constant circuit keeps degaussing circuit to activate for several seconds until degaussing is finished.

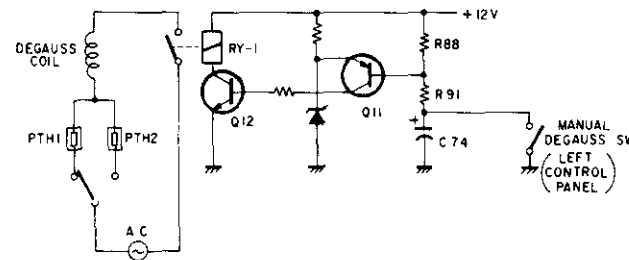

Figure 18

#### 3-16-3. Starter Circuit

Blocking oscillator composed of integrated circuit IC1 and transformer T4 operates when power is turned on. DC voltage obtained by diode D7 and capacitor C57 as a rectifier at the secondary circuit of T4 is supplied to IC2 and IC3, when AC voltage is higher than 50 ~ 70V (voltage selector at 100/120V position). Then power supply regulator starts to work and +15V line power supply is provided to IC2 and IC3 via diode D20, also voltage from T4 stops providing power supply to IC2 and IC3 because blocking oscillator is shut down by voltage generated at primary windings of SRT (Switching Regulator Transformer).

#### 3-16-4. Switching Regulator Circuit

Block diagram is shown in Figure 19. This is half bridge type of switching regulator in this model.

#### Following Description is the Theory of Half-Bridge Switching Regulator.

DC voltage  $E_{IN}$  rectified from AC voltage in AC power rectifier section is divided by capacitor C1 and C2. C1 and C2 have almost same value. Q1 (contains 2 transistors) operates as a switch driven by PWM modulated pulse via T2 (Drive Transformer). Switching current flows through primary windings of T1 (SRT) by switching transistor Q1 via T3 (Current Transformer). Thus output voltages are generated at secondary windings of T1.

#### Practical Circuit Used in this Model

There are 2 switching regulators in this power supply. One is for low voltage power supply,  $\pm 15V$ ,  $\pm 18V$  and  $+5V$ . The other is for high voltage  $\pm 150V$  power supply.

Low voltages are generated by IC2, T1, T2, T3 and Q1.  
High voltages are generated by IC3, T6, T7 and Q2

Refer to block diagram  
Current Transformer T3 and T7 detects excess current in transistor Q1 and Q2 for the protection of damage.

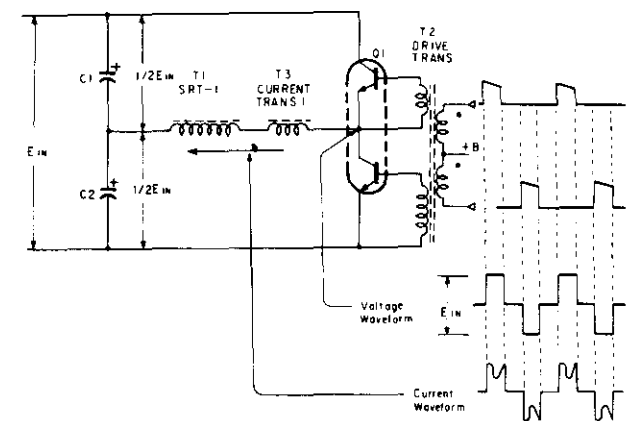
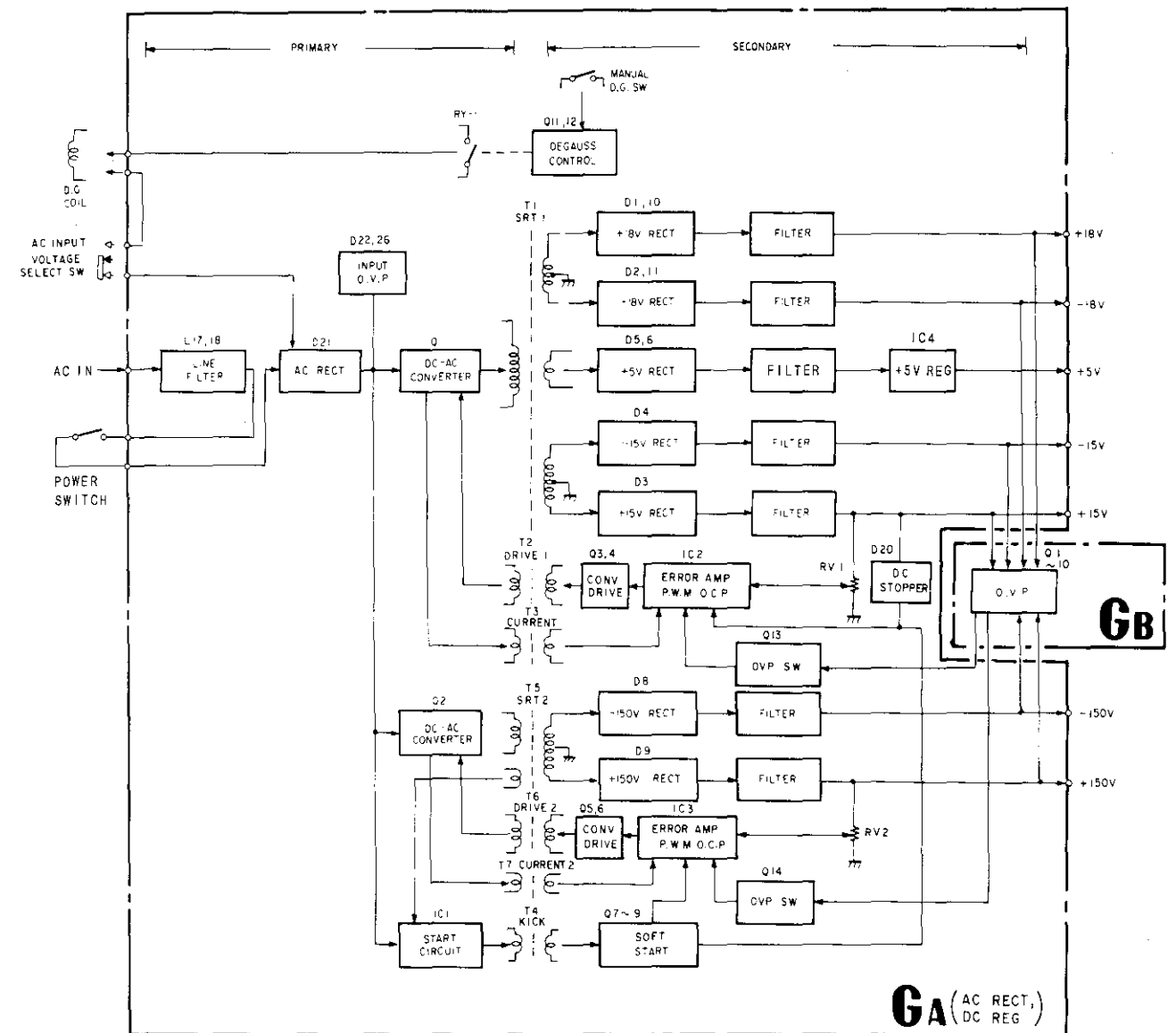

Figure 19

#### 3-16-5. Over Voltage Protector

Daughter board GB is mounted in mother board GA. GB board works for over voltage protection. When output voltage gets higher value than predetermined value, over voltage protector activates to prevent damage of unit.

### BLOCK DIAGRAM OF GA, GB BOARD



### 3-13. H. OSCILLATOR AND H.FREQUENCY CONTROL (DB BOARD)

IC204 is an IC which incorporates the H.OSC and H.AFC circuits. In this IC, the frequency and phase of H.OSC are controlled by comparing the phases of D.AFC.P and H.SYNC. This unit can vary the AFC time constant by the AFC, sw.

### 3-14. HIGH VOLTAGE PROTECTOR CIRCUIT, BEAM CURRENT PROTECTOR CIRCUIT AND CRT PROTECTOR CIRCUIT (EB BOARD)

#### 3-14-1. High Voltage Protector

The detection voltage for the high voltage protector is obtained by directly by dividing HV voltage with resistors in HVR.

For the high voltage protector circuit when this detection voltage rises more than the reference voltage by the high voltage rise output of the comparator IC4 (1/2) becomes high and the drive pulse of the high voltage converter is cut off by making D27 (SCR) gate on. Consequently, the high voltage output circuit is stopped.

#### 3-14-2. Beam Current Protector ①

The anode current is converted to the voltage by resistor R121 in which the current flows in the secondary winding of FBT.

For the high voltage current protector, when the anode current increases extraordinarily, the output of comparator IC4 (2/2) becomes high and the drive pulse of the high voltage converter is cut off by making D27 (SCR) gate on. Consequently, the high voltage output circuit is stopped.

#### 3-14-3. Beam Current Protector ②

The anode current is converted to the voltage by resistor R124 in which the current flows in the secondary winding of FBT.

For the high voltage current protector, when the anode current increases extraordinarily, the output of comparator IC6 (1/2) becomes high and the drive pulse of the high voltage converter is cut off by making D51 (SCR) gate on. Consequently, the high voltage output circuit is stopped.

#### 3-14-4. CRT Protector

The CRT protector circuit is to prevent the CRT from burning when the vertical deflection circuit is stopped by some causes.

For the CRT protector circuit, because the retrace pulse of V out disappears when the vertical deflection circuit is stopped, Q20 is turned off and the output of comparator IC6 (2/2) becomes high, then, with D27 (SCR) gated on to cut off the drive pulse of the high voltage converter circuit, the high voltage output circuit is stopped.

### 3-15. VERTICAL CONVERGENCE OUTPUT CIRCUIT (EC BOARD)

The vertical convergence output circuit drive the neck twist coil. The correction waveforms of vertical misconvergence is generated on the DA BOARD.

BLOCK DIAGRAM OF DB BOARD

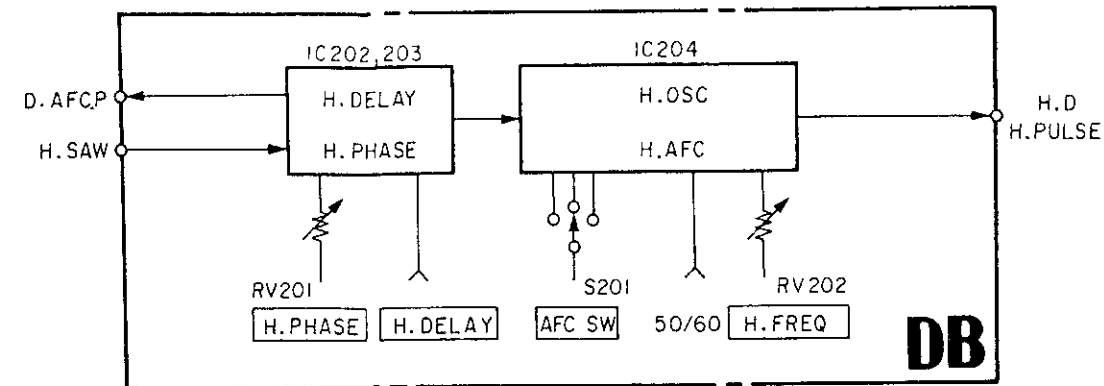

BLOCK DIAGRAM OF EB BOARD

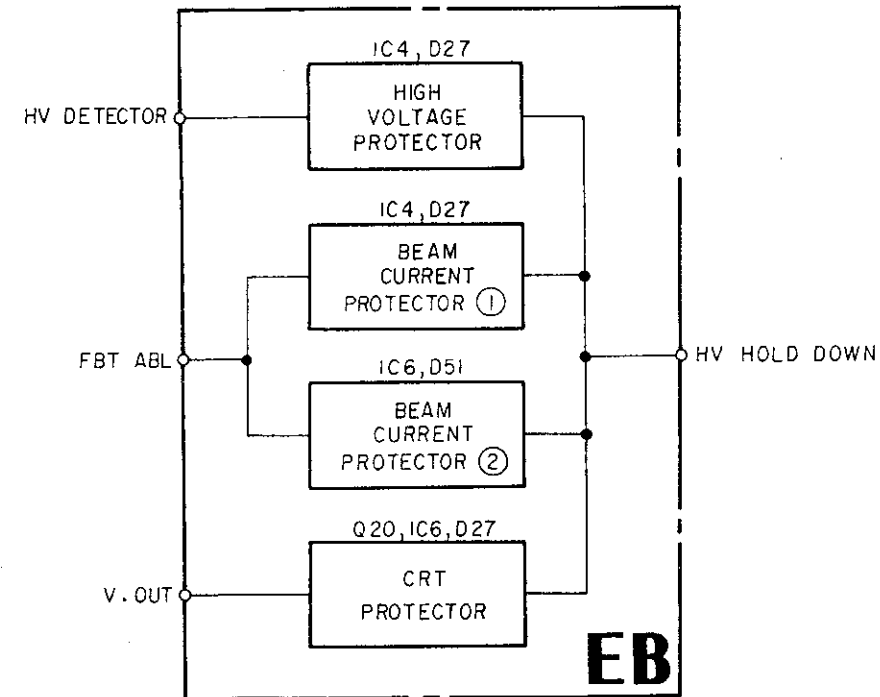

BLOCK DIAGRAM OF EC BOARD

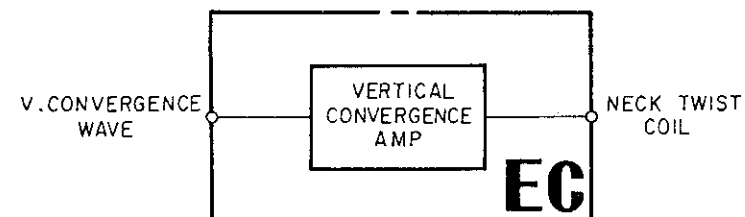





## SECTION 4 ADJUSTMENTS

### 4-1. INTERNAL VIEW

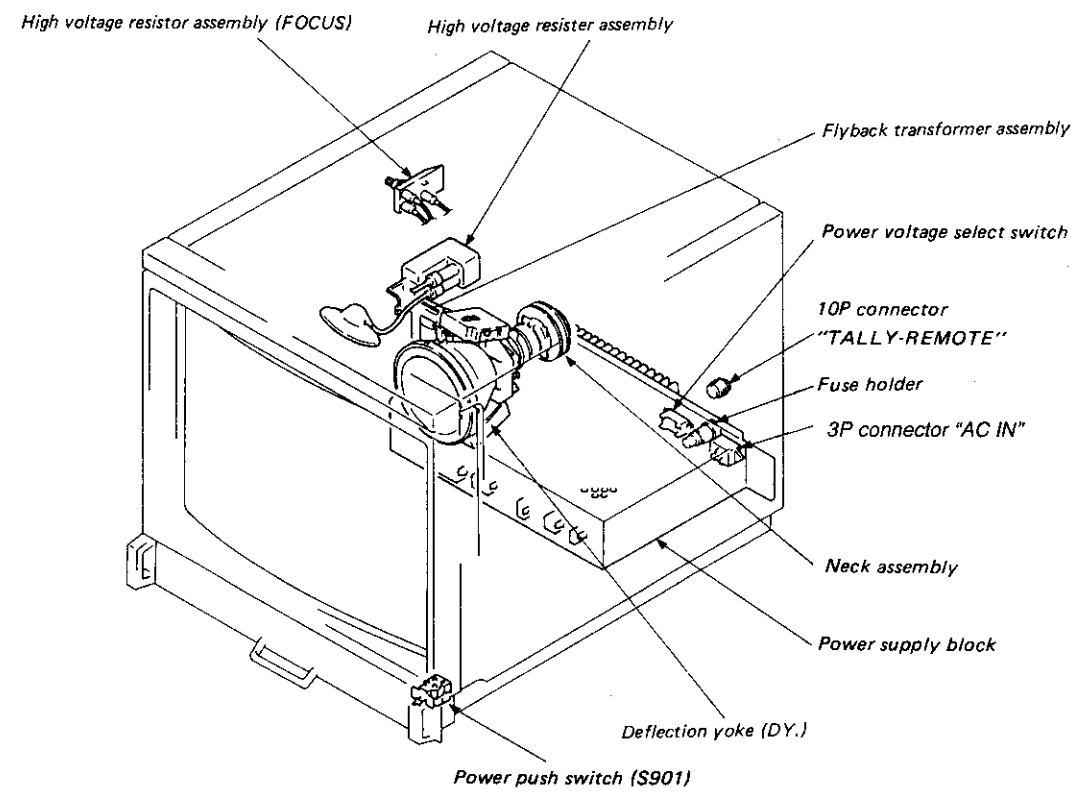

### 4-2. CIRCUIT BOARDS LOCATION

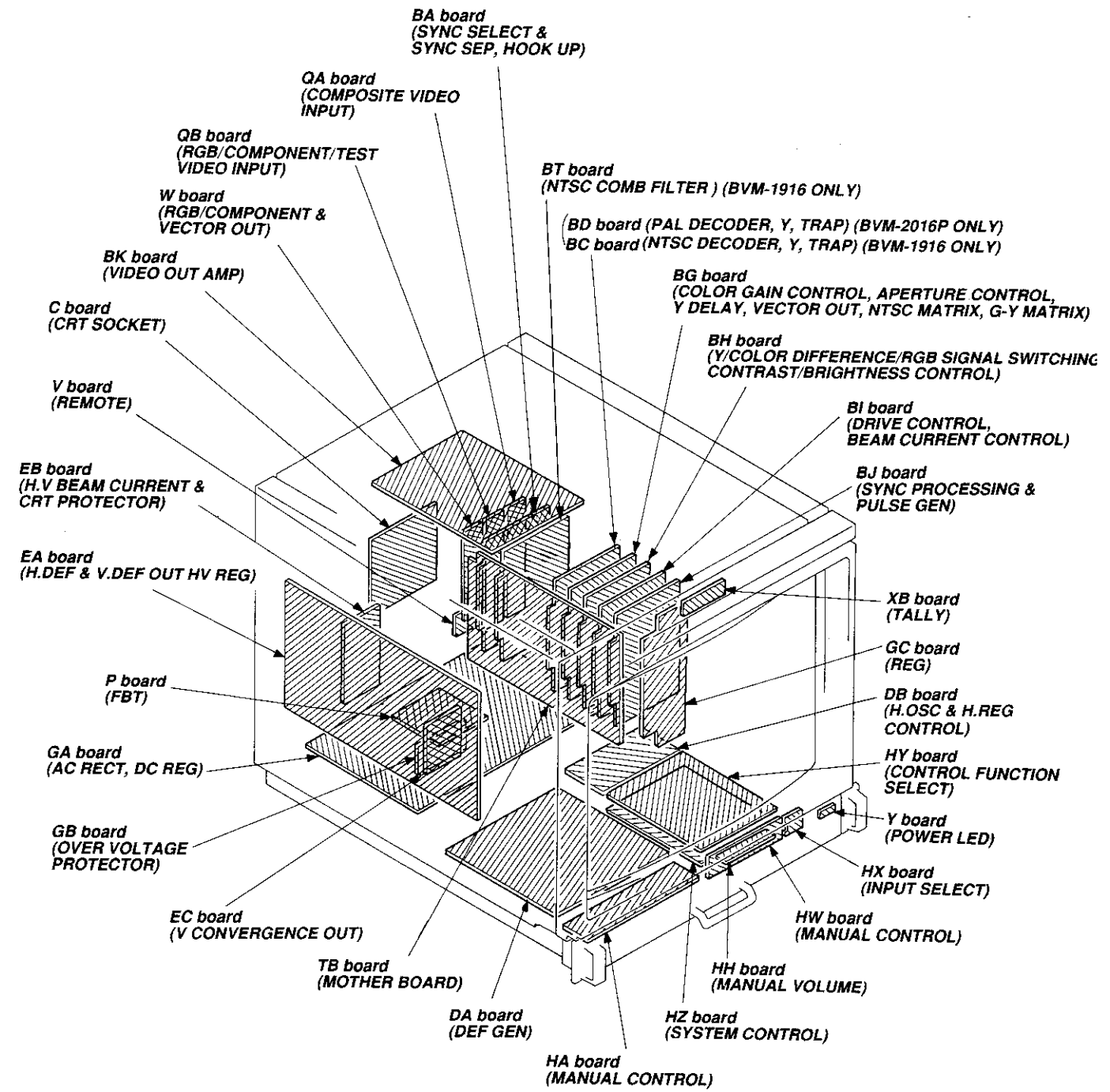

#### 4-3. QUICK REFERENCE

BOARD SECTION	BA	BC	BD	BG	BH	BI	BJ	BK	BT	C	DA
CIRCUIT DESCRIPTION	3-1	3-19	3-21	3-3	3-5	3-7 3-15	3-9	3-13 3-15	3-17	—	3-23
ADJUSTMENTS	4-21 4-25	4-31	4-61	4-21 4-27	4-21	—	4-19 4-30 4-44	4-45	4-47	—	4-76 4-79
BLOCK DIAGRAM	3-2	3-20	3-22	3-4	3-5	3-7	3-9	3-13	3-17	—	3-23
MOUNTING DIAGRAM	5-15	5-25	5-33	5-35	5-43	5-45	5-53	5-55	5-20	5-71	5-63
SCHEMATIC DIAGRAM	5-17	5-27	5-30	5-37	5-40	5-47	5-51	5-57	5-23	5-66	5-60
ELECTRICAL PARTS LIST	7-1	7-4	7-5	7-8	7-11	7-13	7-16	7-18	7-20	7-24	7-24
BOARD SECTION	DB	EA	EB	EC	GA	GB	GC	HA	HH	HW	HX
CIRCUIT DESCRIPTION	3-27	3-25	3-27	3-27	3-29	3-29	—	—	—	—	—
ADJUSTMENTS	4-79	4-14	4-15	—	4-11	—	—	—	—	—	—
BLOCK DIAGRAM	3-28	3-25	3-28	3-28	3-30	3-30	—	—	—	—	—
MOUNTING DIAGRAM	5-65	5-69	5-71	5-71	5-73	5-72	5-91	5-78	5-78	5-78	5-79
SCHEMATIC DIAGRAM	5-60	5-66	5-66	5-56	5-75	5-75	5-93	5-81	5-81	5-81	5-81
ELECTRICAL PARTS LIST	7-26	7-27	7-29	7-39	7-31	7-33	7-34	7-34	7-34	7-34	7-35
BOARD SECTION	HY	HZ	P	QA	QB	TB	V	W	XB	Y	Z
CIRCUIT DESCRIPTION	—	—	—	3-1	3-1	—	—	—	—	—	—
ADJUSTMENTS	—	—	—	—	—	—	—	—	—	—	—
BLOCK DIAGRAM	—	—	—	3-2	3-2	—	—	—	—	—	—
MOUNTING DIAGRAM	5-80	5-87	5-71	5-90	5-91	5-11	5-92	5-91	5-79	5-79	5-95
SCHEMATIC DIAGRAM	5-81	5-84	5-56	5-93	5-93	5-13	5-93	5-93	5-81	5-81	—
ELECTRICAL PARTS LIST	7-35	7-37	7-39	7-39	7-40	7-40	7-40	7-40	7-40	7-41	7-41

#### 4-4. SUB CONTROL PANEL LOCATION

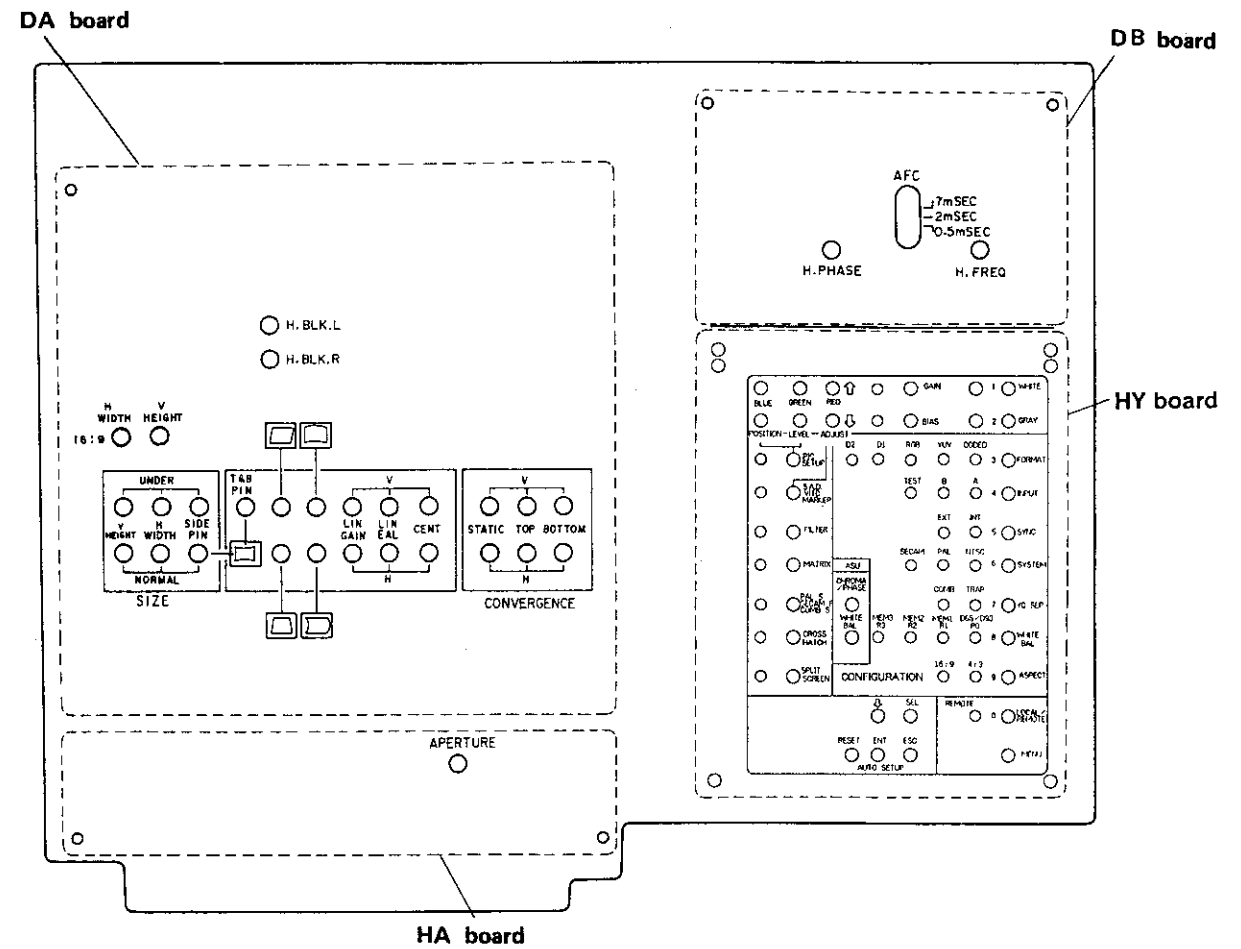

#### ADJUSTING METHOD OF DRAWER BLOCK

\* Pull out sub-control panel and press two stopper buttons to drop it 60° as shown in the figure.

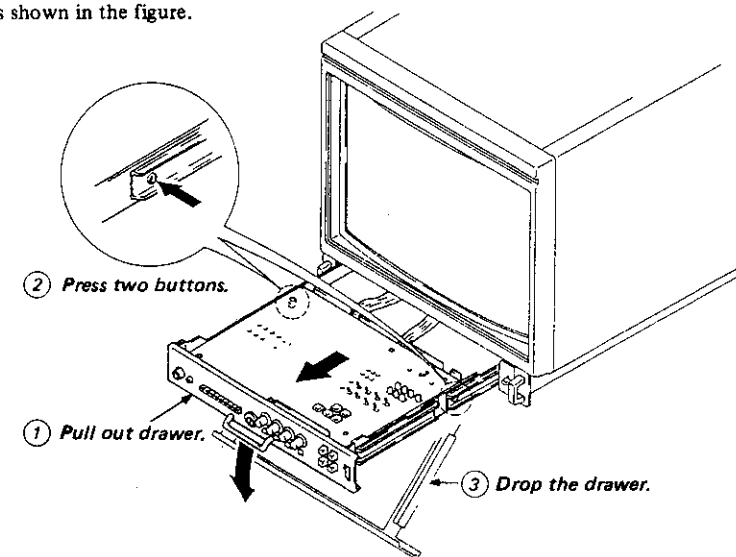

#### 4-5. SETUP ADJUSTMENT IN CASE OF PICTURE TUBE REPLACEMENT

When the picture tube has been replaced, make the following adjustments. Convergence and white balance are normally adjusted by the potentiometers on the sub control panel.

##### [Jigs Tools and Measurement Equipment Required]

1. SIGNAL GENERATOR (TEKTRONIX 1410, 1411 Series)
2. COLOR ANALYZER
3. LUMINANCE METER

##### [Landing adjustment]

1. Connect signal generator and receive a white signal.
2. Set BRIGHTNESS and CONTRAST VRs to the preset position (□).
3. Face the CRT screen toward East (or West) and press the DEGAUSS switch.
4. Set the purity control to the center as shown in Fig. 1-1.

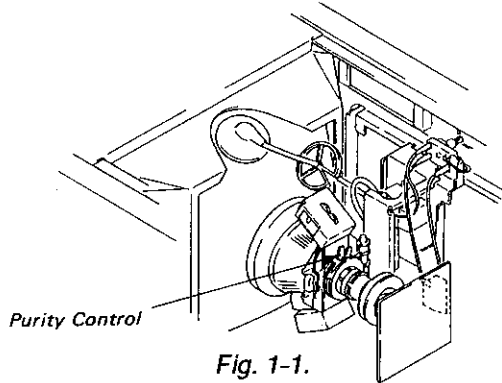

Fig. 1-1.

5. Slide DY (Deflection Yoke) as far forward as possible.
6. Set the neck assembly in the position shown in Fig. 1-2.

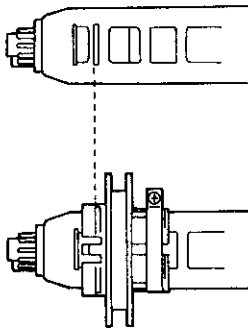

Fig. 1-2.

7. Set the screen to green only (R and B on the FRONT PANEL are in the IN position and G in the OUT position).
8. Turn purity knob as shown in Fig. 1-3 to bring the green on the center of the screen.

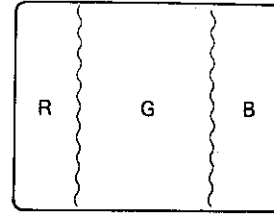

Fig. 1-3.

9. Slide DY back for uniform green raster.
10. Make the screen red only (G and B on the FRONT PANEL are in the IN position and R in the OUT position) and check landing.
11. Make the screen blue only (R and G on the FRONT PANEL are in the IN position and B in the OUT position) and check landing.
12. Adjust DY tilt and tighten DY set-screw.
13. Secure the DY with the spacers. (Fig. 1-4)

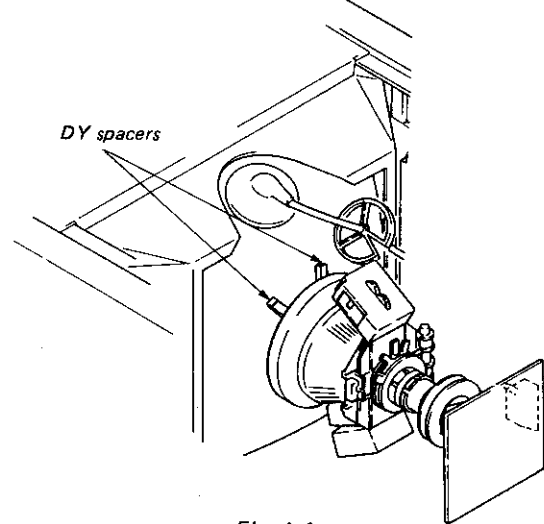
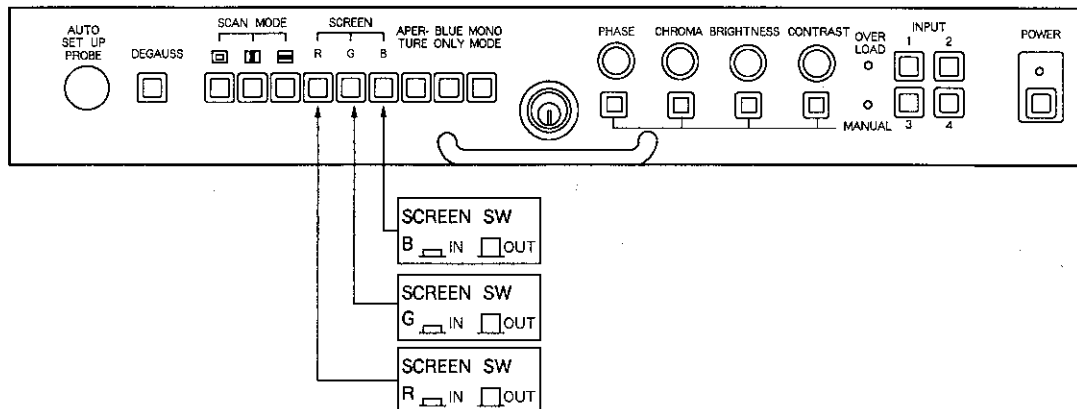

Fig. 1-4.

##### • Final check

After adjustments, check that there is no mislanding by facing the CRT towards East, West, North and South directions.

#### FRONT PANEL



**[Convergence adjustment]**

**Preparation:**

1. Connect the signal generator to receive the dot signal and crosshatch signal.
2. Adjust with CONTRAST and BRIGHTNESS controls to set to easy-to-monitor position those signals.
3. Set H.STATIC VR (RV17) on the sub control panel of DA Board to the mechanical center.

**(1) Horizontal and Vertical Static Convergence**

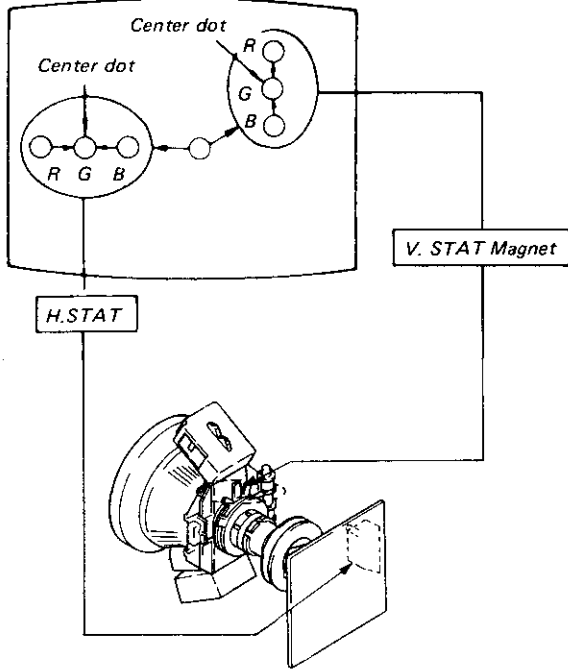
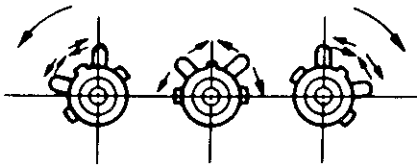
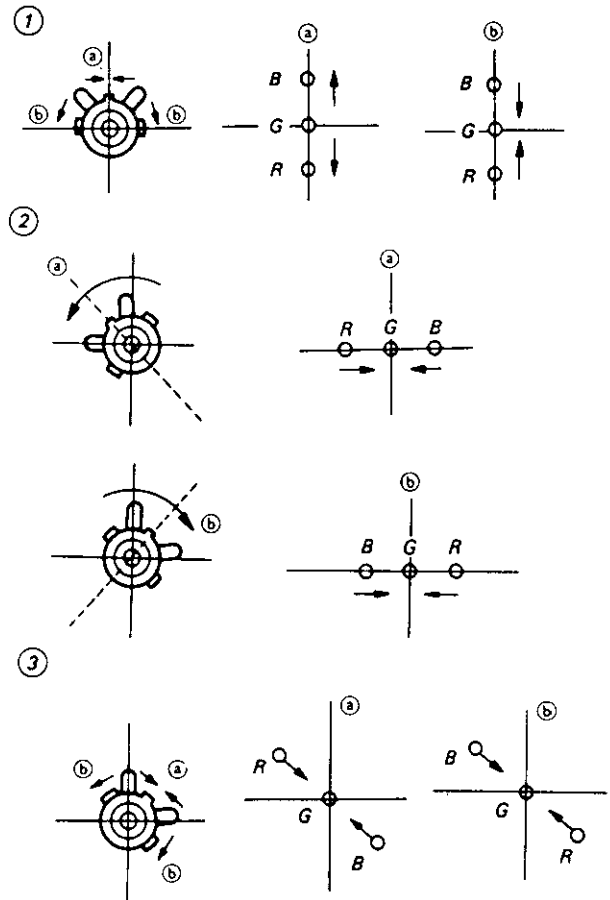

Fig. 1-5

1. Adjust H.STAT VR on the C Board to coincide red, green and blue dots on the center of screen (Horizontal movement)
  2. Adjust V. STAT magnet to coincide red, green and blue dots on the center of screen (Vertical movement)
  3. If the red, green and blue dots do not coincide on the center of screen with H. STAT VR, perform horizontal convergence adjustment using H. STAT VR and V. STAT magnet as shown below. (In this case, H. STAT VR and V. STAT magnet effect each other.)
- Tilt the V. STAT magnet and adjust static convergence to open or close the V. STAT magnet.



4. When the V. STAT magnet is moved in the direction of arrow (a) and (b), Red, Green and Blue dots move as shown below.



**• HMC and VMC correction for Hexapole Magnet.**

1. HMC (Horizontal, Mis, convergence) correction and motion of the Electron Beam with the Hexapole Magnet.

*HMC correction (A)*

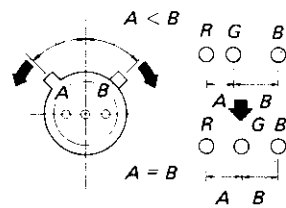

*HMC correction (B)*

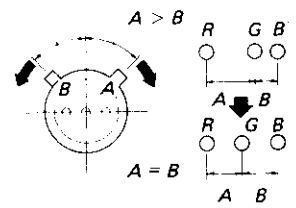

2. VMC (Vertical, Mis, convergence) correction and motion of the Electron Beam with the Hexapole Magnet.

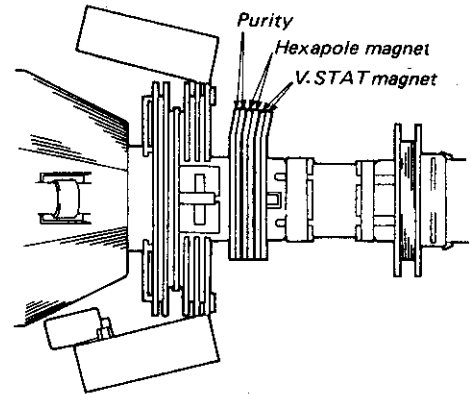
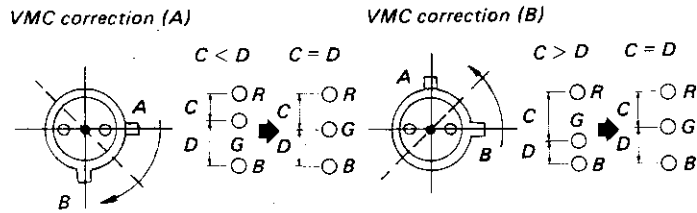

**(2) Dynamic Convergence Adjustment**

**Preparation:**

- Before starting, perform Horizontal and Vertical Static Convergence Adjustment.

1. Loosen deflection yoke screw.
2. Remove deflection yoke spacers.
3. Move the deflection yoke for best convergence as shown in Fig. 1-6.
4. Tighten the deflection yoke screw.
5. Install the deflection yoke spacers.

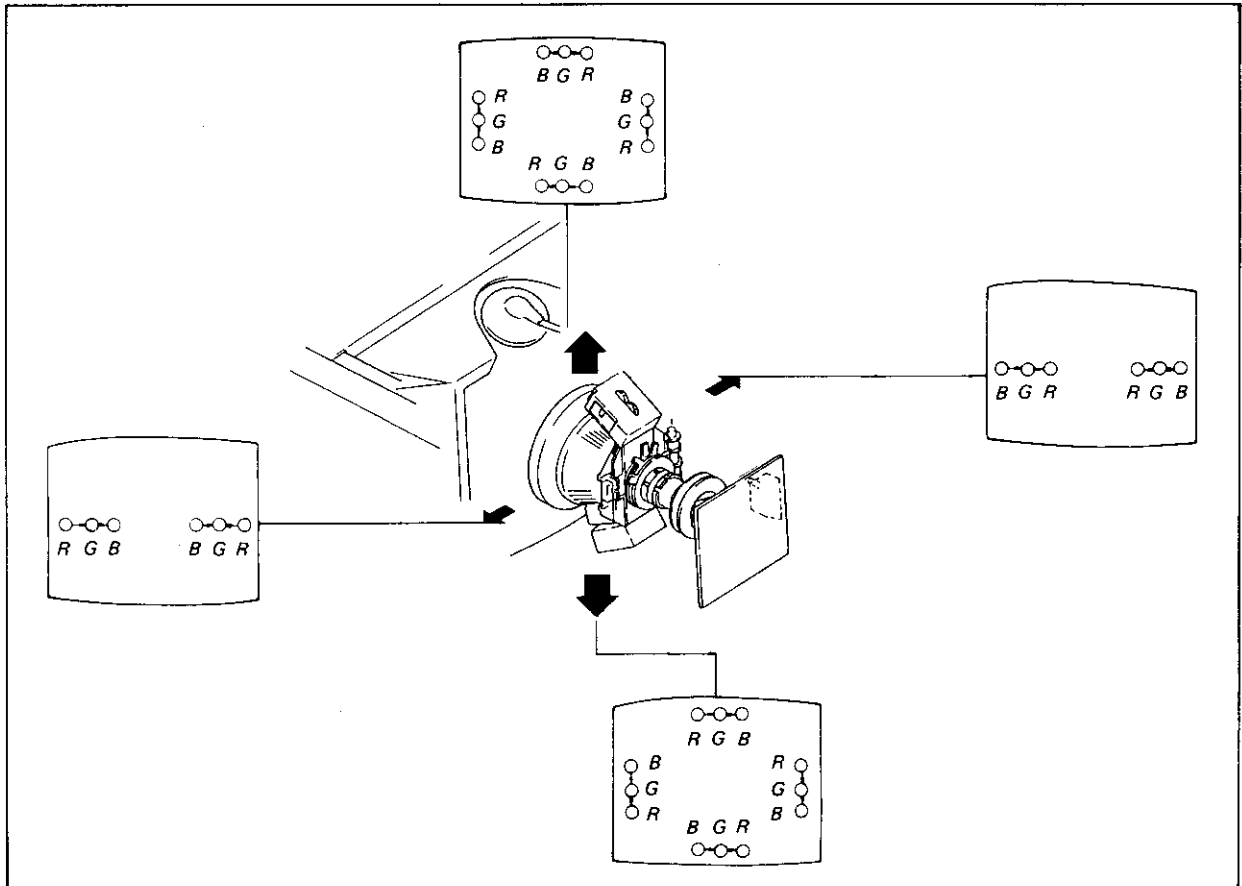
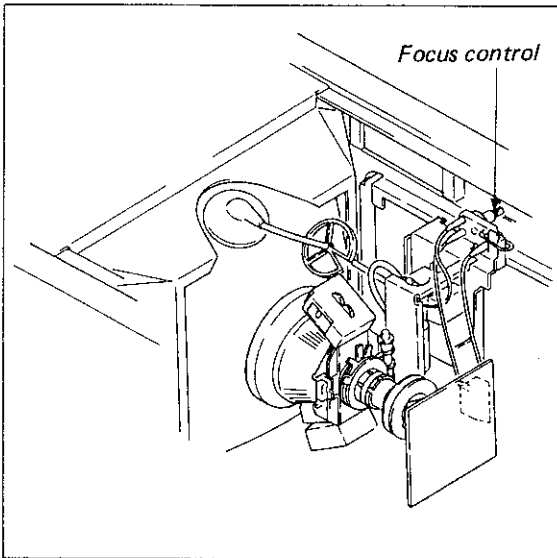
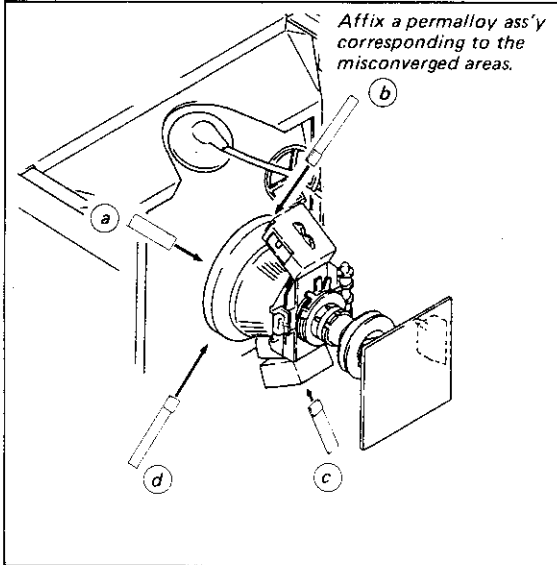
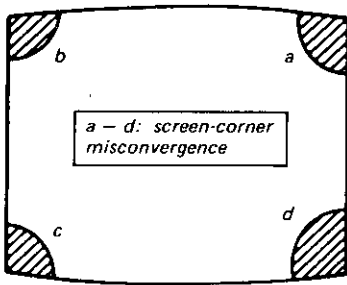

Fig. 1-6



(3) Screen-corner Convergence



[CONVERGENCE PROCESS]

1. UNDER SCAN switch ..... NOR (□)
2. Adjust the vertical static convergence with RV20 (X.S) at the sub control panel (DA board) as shown in left of Fig. 1-7.
3. Adjust the horizontal static convergence with RV17 (Y.S) at the sub control panel (DA board) as shown in right of Fig. 1-7.

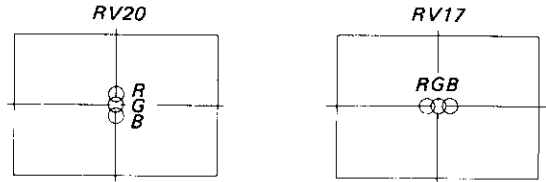

Fig. 1-7

4. Adjust the vertical convergence with RV18 (X. C. T) at the sub control panel (DA board) as shown in left upper corner of Fig. 1-8.
5. Adjust the vertical convergence with RV19 (X. C. B) at the sub control panel (DA board) as shown in left lower corner of Fig. 1-8.

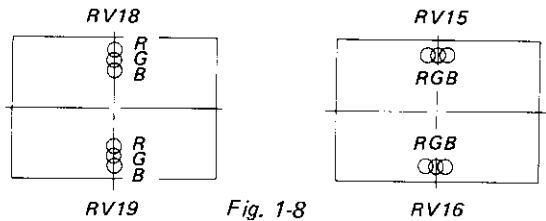

Fig. 1-8

6. Adjust the horizontal convergence with RV15 (Y.C.T) at the sub control panel (DA board) as shown in right upper corner of Fig. 1-8.
7. Adjust the horizontal convergence with RV16 (Y.C.B) at the sub control panel (DA board) as shown in right lower corner of Fig. 1-8.

Focus adjustment

1. Input a dot or cross-hatch signals.
2. Adjust the FOCUS control for best focus in the central portion of the screen.

### FRONT PANEL

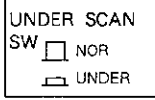
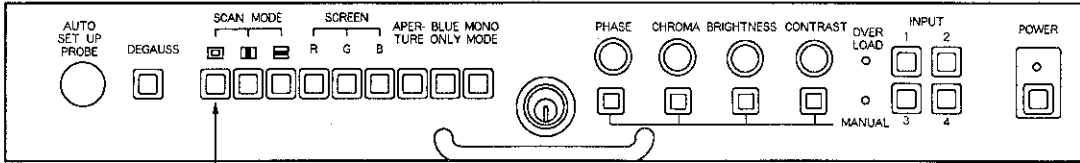

### DA board

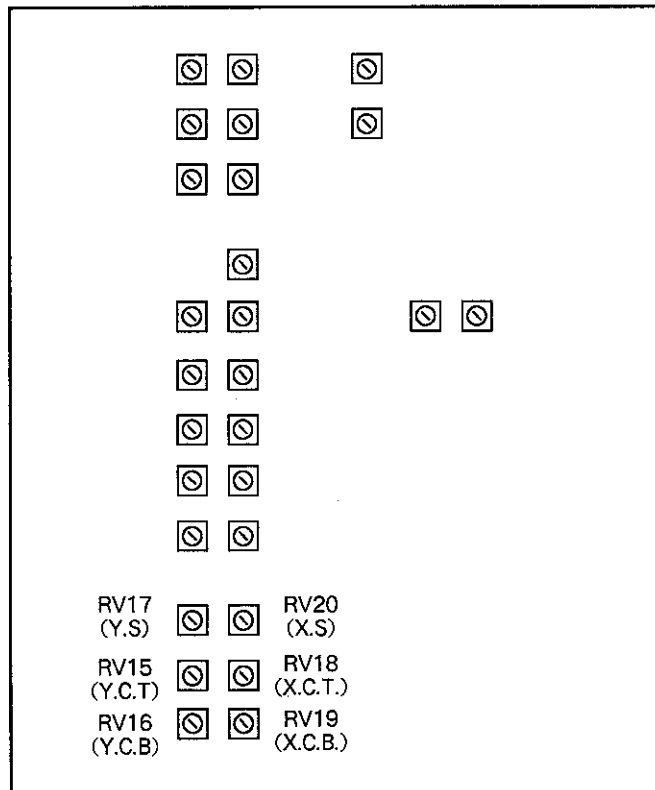

# WHITE BALANCE ADJUSTMENT

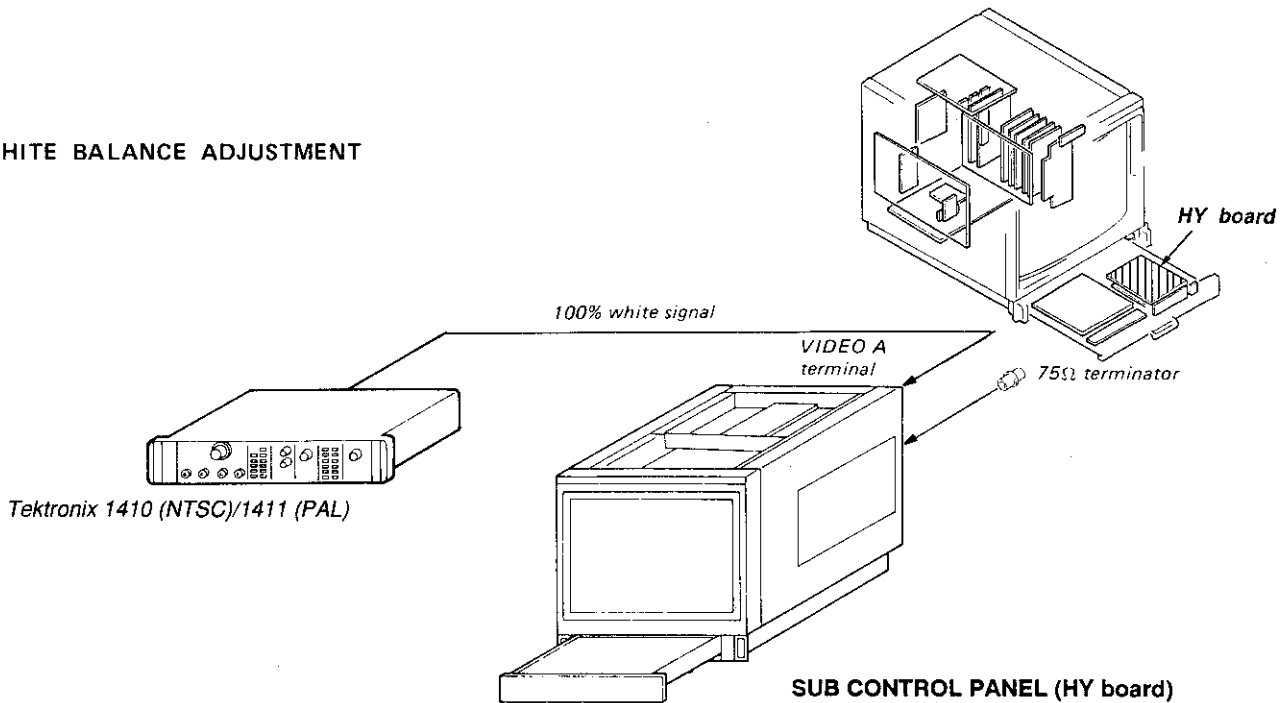

1. Input 100% white signal to VIDEO A connector.
2. Gray button ..... ON
3. BRIGHTNESS MANUAL switch ..... MANUAL. (☐)
4. CONTRAST MANUAL switch ..... MANUAL. (☐)
4. Turn BRIGHT and CONTRAST to become 100 with PRESET MENU.  
SAVE the DATA.
5. Switch off the MANUAL swithes of CONTRAST and BRIGHT.
6. Turn BIAS controls (S21:Red, S23:Green, S32:Blue) on the HY board to adjust the BRIGHTNESS to 2.8cd/m<sup>2</sup> (nit) and white balance using COLOR ANALYZER and check 2.8cd/m<sup>2</sup> (nit) by LUMINANCE METER.
7. Gray button ..... OFF
8. Turn GAIN controls (S20:Red, S22:Green, S31:Blue) on The HY board to adjust the BRIGHTNESS at HIGH LIGHT to 103cd/m<sup>2</sup> (nit) and white balance using COLOR ANALYZER and check 103cd/m<sup>2</sup> (nit) by LUMINANCE METER.
9. Repeat procedure steps 6 to 8 if necessary.
10. Save the date with SAVE WHITE BALANCE MENU.

## SUB CONTROL PANEL (HY board)

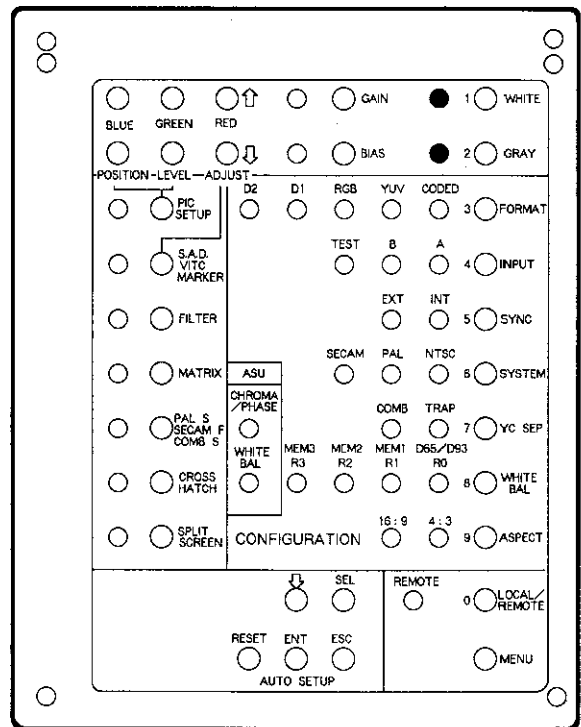

## FRONT PANEL

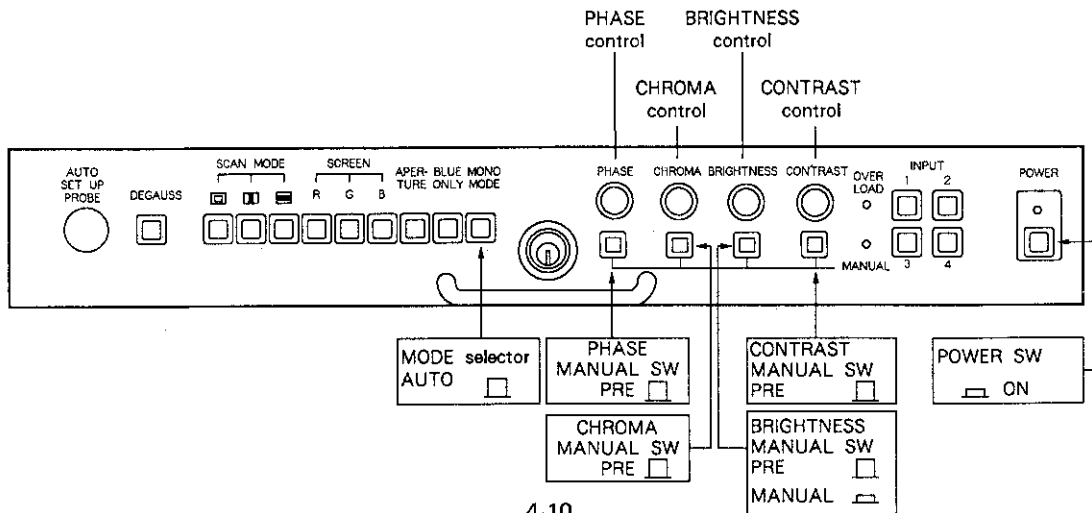



4-6. SAFETY RELATED ADJUSTMENTS

**+B PROTECTOR** (R52, R53)

When replacing the following components (marked  on the schematic diagram), make this confirmation.

- GA Board ..... Q13, Q14, R52, R53
- GB Board ..... Q3, Q4, Q5, D5, D6, D7, D8, R4, R5, R19, R20, R21, R22

It is necessary to use a digital multimeter for this confirmation.

Connect a digital multimeter to TP2 and TP3 (GND) on GA Board.

1. Receive a color bar signal and set CONTRAST and BRIGHTNESS controls to preset position. (manual button is out.)
2. Short-circuit R55 on GA board.
3. Connect a 100 kΩ variable resistor between TP4 and TP3 (GND) on GA board.
4. Turn down the 100 kΩ variable resistor gradually from maximum to minimum and confirm that voltage at TP2 drops abruptly to 0V when the digital multimeter reading reaches  $199.0 \pm 17.0V$ .
5. If step 4 isn't satisfied, select resistance values of R52 and R53 which satisfy the specifications.
6. Restore these to their original states and confirm that the voltage at TP2 is  $150.0 \pm 1.0V$ .

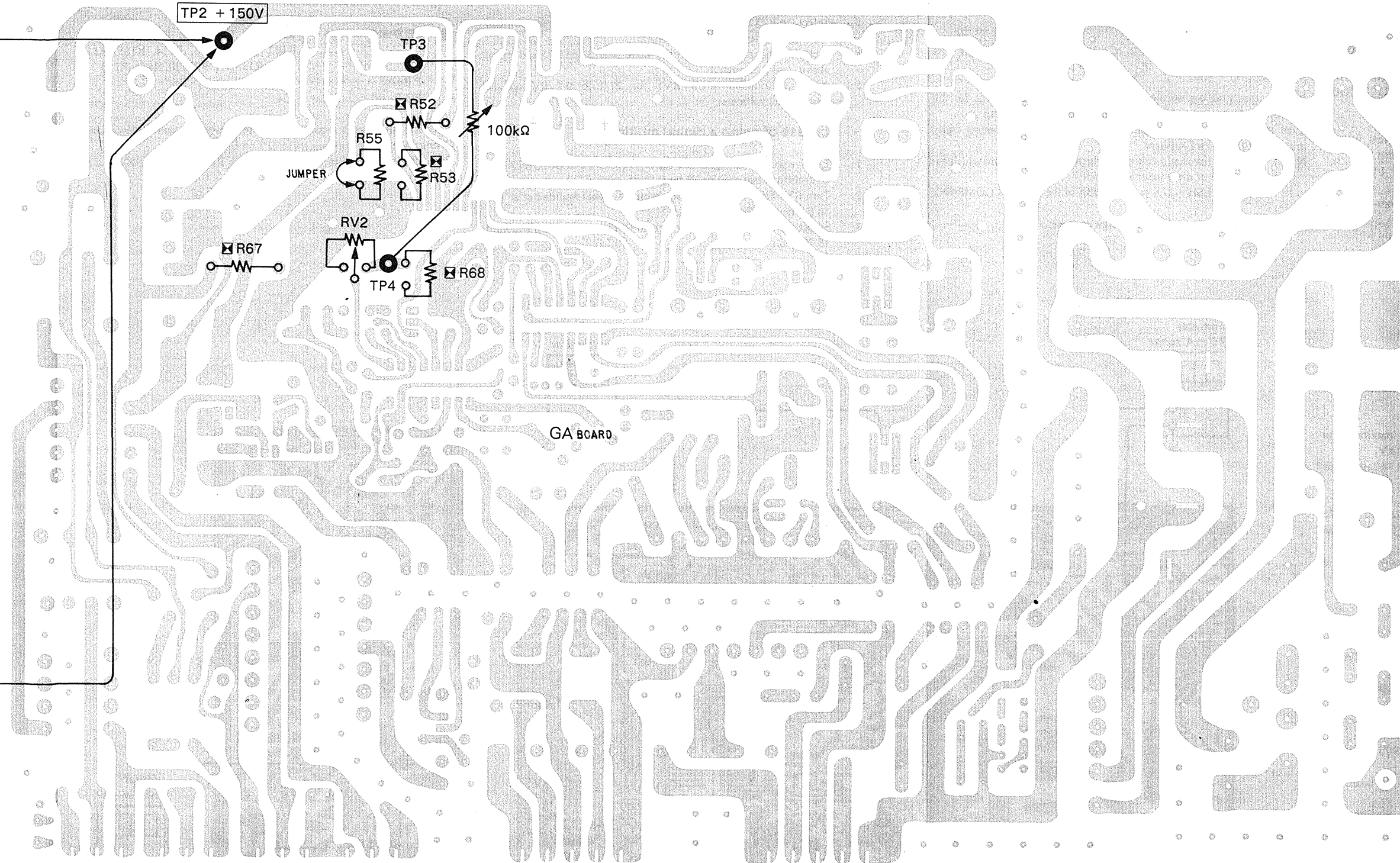
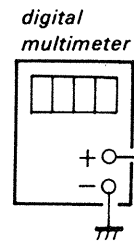

**+B MAX CONFIRMATION** (R67, R68)

When replacing the following components (marked  on the schematic diagram), make this confirmation.

- GA Board ..... IC3, C59, R67, R68, R78, RV2

It is necessary to use a digital multimeter for this confirmation.

Connect a digital multimeter to TP2 and TP3 (GND) on GA Board.

1. Receive a color bar signal and set CONTRAST and BRIGHTNESS controls to preset position. (manual button is out.)
2. Confirm that the reading on the digital multimeter is  $+165.0V \pm 13.0V$  when RV2 variable resistor is turned to fully clockwise.
3. If the specifications are not met, select resistance values for R67 and R68 which satisfy the specifications.
4. After confirmation, make the reading on the digital multimeter into  $150.0V \pm 1.0V$  by adjusting RV2 on GA Board.

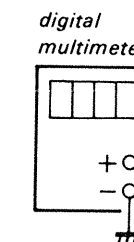

### HIGH VOLTAGE HOLD DOWN ADJUSTMENT AND CONFIRMATION

( R106, R108)

When replacing the following components (marked  on the schematic diagram), make this adjustment.

- HVR
- EB Board .....IC4, D24, D25, D27, R89, R90, R102, R103, R104, R105, R106, R107, R108, R111, R152

It is necessary to use an electrostatic voltmeter or equivalent for this adjustment. Connect the electrostatic voltmeter to the anode cap. Connect the DC current meter (3 mA range, accuracy of 1.0 class or more)

Even through an electrostatic voltmeter may not be used, connect digital multimeters to TP2 on EB Board. TP6 and TP5 (GND) on EA Board.

**Note:** Use an electrostatic voltmeter which is calibrated, and which has  $2 \times 10^9 \Omega$  or more input impedance.  
example: ESH- 27X or ESH- 23X of the SINGER COMPANY

Use a digital multimeter which has 4 digit or more.

#### In case of using electrostatic voltmeter

1. Receive a color bar signal and set CONTRAST and BRIGHTNESS controls to preset position. (Manual button is OUT  $\square$ )
2. Connect 200 k $\Omega$  variable resistor with R75 in parallel on EA Board.
3. Connect an electrostatic voltmeter to the CRT anode.
4. Turn down the variable resistor gradually from maximum to minimum until the anode voltage becomes  $29.0 \pm 0.1$  kV.
5. Select the R106 or R108 resistance so that the anode voltage drops abruptly at  $29.0 \pm 0.1$  kV.
6. Solder the selected resistor to R106 or R108.
7. Turn power on, turn down the variable resistor attached to R75 gradually from maximum to minimum and confirm that the anode voltage drops abruptly at  $29.0 \pm 0.5$  kV.
8. Remove the variable resistor and confirm that the anode voltage is  $27.0 \pm 0.1$  kV.
9. Detach the electrostatic voltmeter from the anode.

#### In case of using electrostatic voltmeter

1. Receive a color bar signal and set CONTRAST and BRIGHTNESS controls to preset position. (Manual button is OUT  $\square$ )
2. Connect the digital multimeter between TP2 on the EB board and GND.
3. Select the R106 or R108 resistance so that the digital multimeter reading becomes  $16.89 \pm 0.1V$ .
4. Connect the 200 k $\Omega$  variable resistor in parallel to R75 on the EA board.
5. Connect the digital multimeter between TP6 on the EA board and GND.
6. Turn down the variable resistor gradually from maximum to minimum and confirm that the picture disappears when voltage at TP2 goes beyond  $16.89 \pm 0.1V$ .

### HIGH VOLTAGE REGULATOR CONFIRMATION

( R73, R75)

When replacing the following components (marked  on the schematic diagram), make this adjustment.

- HVR
- EA Board .....IC2, IC3, R61, R62, R71, R72, R73, R74, R75, R88, RV1

It is necessary to use an electrostatic voltmeter or equivalent for this adjustment. Connect the electrostatic voltmeter to the anode cap. Even though an electrostatic voltmeter may not be used, connect digital multimeter to TP6 on EA Board.

**Note:** Use an electrostatic voltmeter which is calibrated, and which has  $2 \times 10^9 \Omega$  or more input impedance.  
example: ESH- 27X or ESH- 23X of the SINGER COMPANY

Use a digital multimeter which has 4 digit or more.

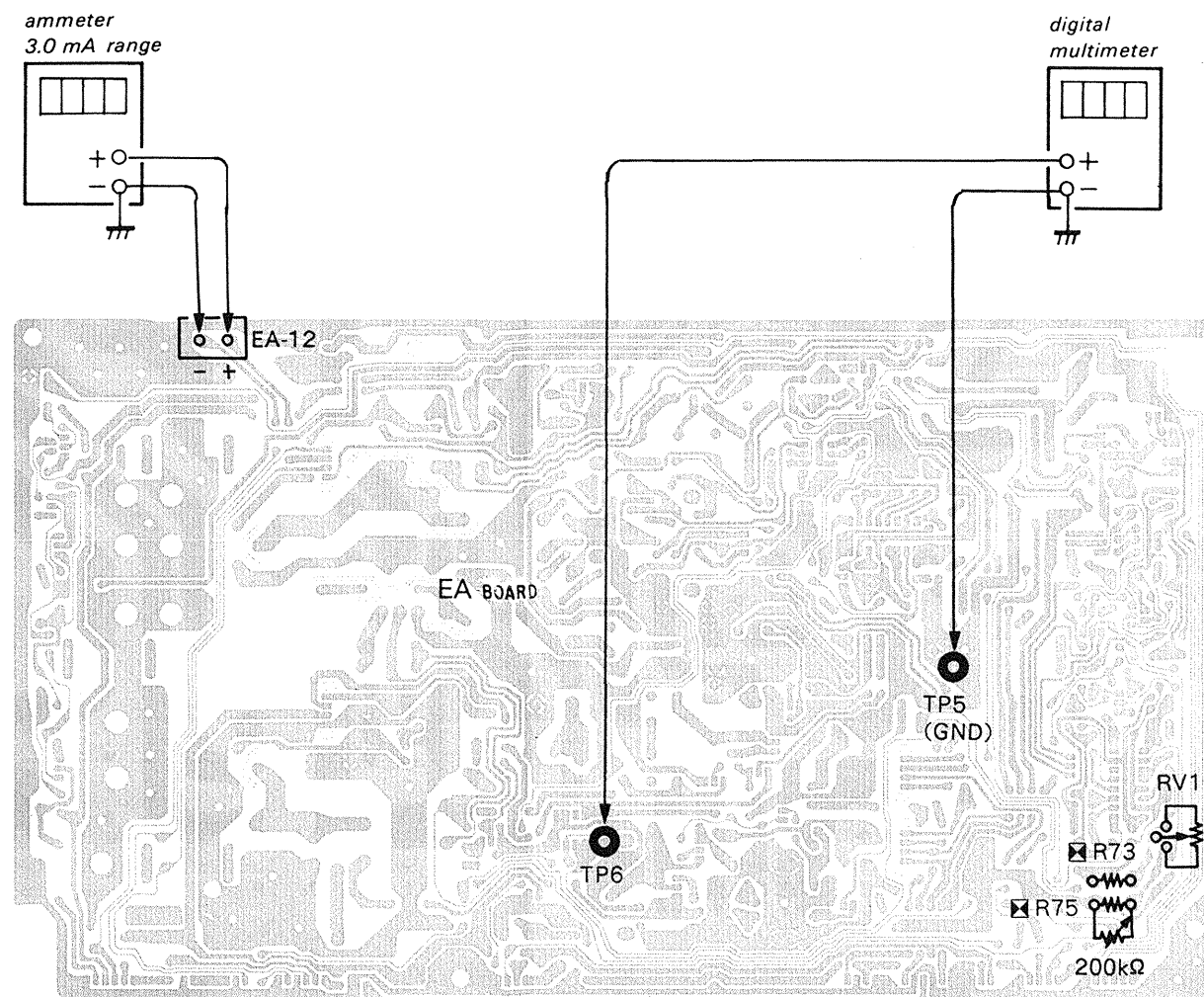

#### In case of using electrostatic voltmeter

1. Receive a color bar signal and set CONTRAST and BRIGHTNESS controls to preset position. (Manual button is out  $\square$ )
2. Turn RV1 on EA Board for a maximum reading on the electrostatic voltmeter. (Fully clockwise)
3. Select the R73 and R75 resistance so that the electrostatic voltmeter reading becomes  $27.35 \pm 0.15$  kV.
4. If step 3 is not satisfied, select the value of R73 and R75 and repeat above steps 2 through 3.
5. After confirmation adjust RV1 for  $27.0 \pm 0.1$  kV on the electrostatic voltmeter.

#### In case of using a digital multimeter

1. Receive a color bar signal and set CONTRAST and BRIGHTNESS controls to preset position. (Manual button is out  $\square$ )
2. Turn RV1 for a maximum reading on the digital multimeter at TP6 on EA Board. (Fully clockwise)
3. Select the R73 and R75 resistance so that voltage at TP6 becomes  $15.70 \pm 0.1V$ .

### BEAM CURRENT PROTECTOR 1 CONFIRMATION

( R115)

When replacing the following components (marked  on the schematic diagram), make this confirmation.

- EB Board .....IC4, D24, D26, D27, R89, R90, R102, R103, R112, R113, R114, R115, R116, R117, R118, R119, R120, R121, R153
- P Board .....FBT
- EB Board .....IC4

It is necessary to use a regulated digital multimeter for this confirmation. Connect the digital multimeters to TP1 on EB Board. Connect the current meter to EA-12. (3 mA Range, accuracy of 1.0 class or more)

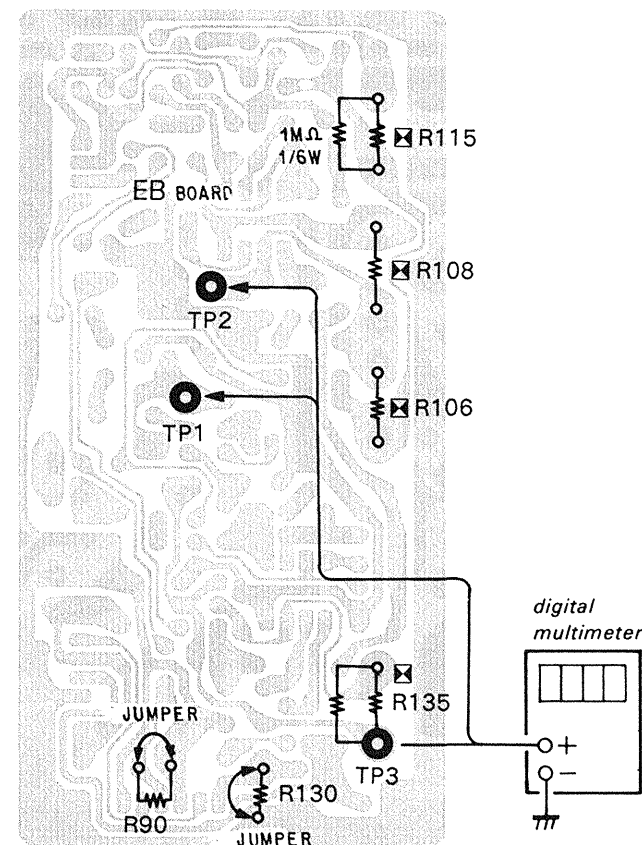

1. Receive a color bar signal.
2. Remove the EA-12 connector and connect the DC ammeter.
3. Connect the digital multimeter between TP1 on the EB board and GND.
4. Short-circuit C1 on the BI board.
5. Short-circuit R130 on the EB board.
6. Turn power on, read voltage at TP1, then proceed as follows:
  - If 32.5V or over, solder the 1 M $\Omega$  (1/6W) metal-film resistor to R115 on the EB board.
  - If less than 32.5V, open R115.
7. Turn the BRIGHTNESS and CONTRAST controls (MANUAL button is IN  $\square$ ) and confirm that the picture disappears when the DC ammeter reads  $2.0 \pm 0.4$  mA.
8. If the condition in step 7 is not satisfied, select the R115 resistance accordingly.
9. Return the EA-12 connector, C1 on the BI board and R130 on the EB Board to their initial condition.
10. Set the BRIGHTNESS and CONTRAST controls to maximum and confirm that the OVERLOAD lamp lights.

### BEAM CURRENT PROTECTOR 2 CONFIRMATION

( R135)

When replacing the following components (marked  on the schematic diagram), make this confirmation.

- EB Board .....IC6, D29, D51, R122, R123, R124, R130, R131, R132, R133, R134, R135, R136, R137, R138, R140, R141
- P Board .....FBT

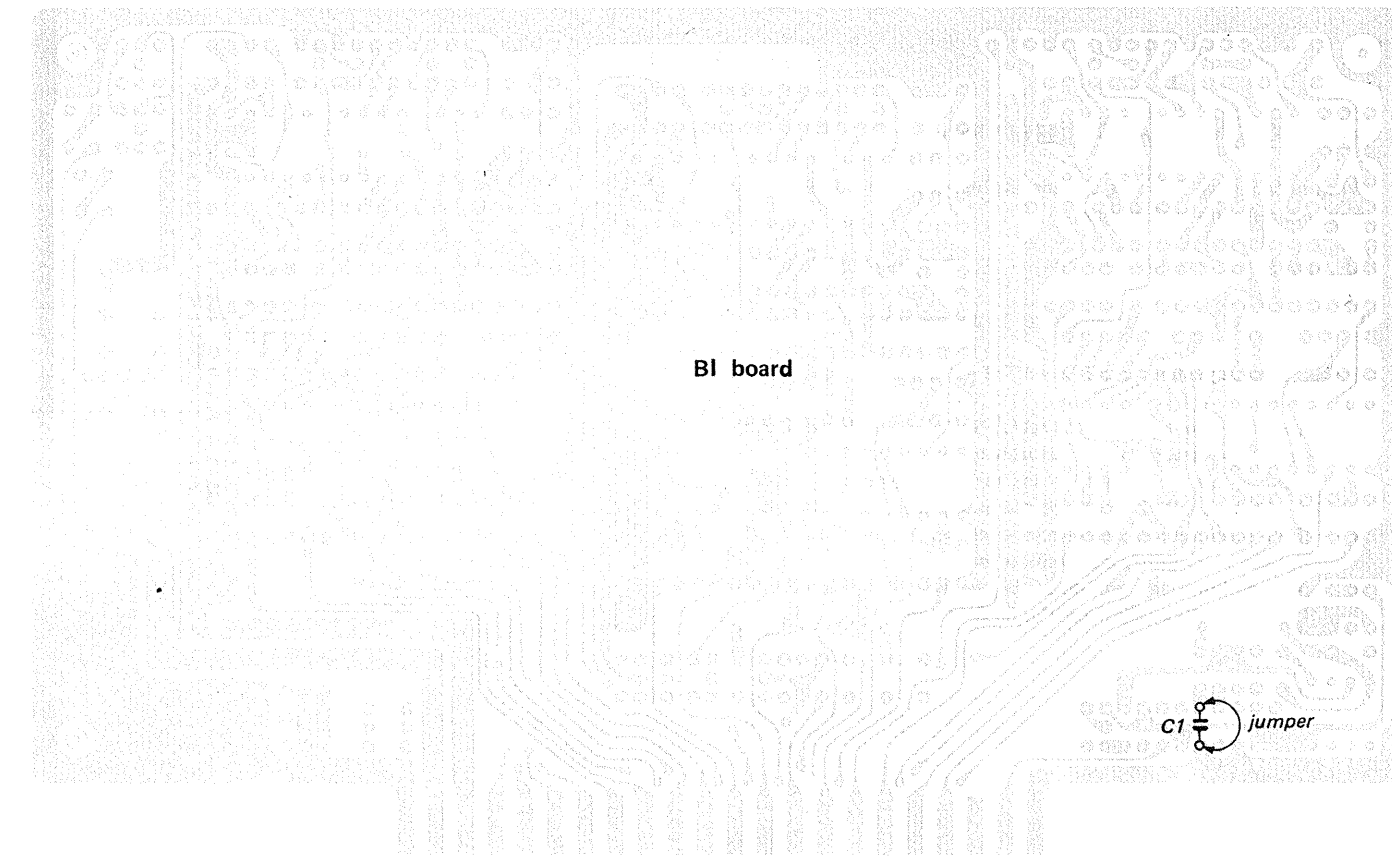

It is necessary to use a regulated digital multimeter for this confirmation. Connect the digital multimeters to TP3 on EB Board. Connect the current meter to EA-12 (3 mA Range accuracy of 1.0 class or more)

1. Receive a color bar signal.
2. Remove the EA-12 connector and connect the DC ammeter.
3. Connect the digital multimeter between TP3 on the EB board and GND.
4. Short-circuit C1 on the BI board.
5. Short-circuit R90 on the EB board.
6. Turn power on, read voltage at TP3, then proceed as follows:
  - If 32.5V or over, solder the 1 M $\Omega$  (1/6W) metal-film resistor to R135 on the EB board.
  - If less than 32.5V, open R135.
7. Turn the BRIGHTNESS and CONTRAST controls (MANUAL button is in  $\square$ ) and confirm that the picture disappears when the DC ammeter reads  $2.0 \pm 0.4$  mA.
8. If the condition in step 7 is not satisfied, select R135 resistance accordingly.
9. Return the EA-12 connector, C1 on the BI board and R90 on the EB board to their initial condition.
10. Set the BRIGHTNESS and CONTRAST controls to maximum and confirm that the OVERLOAD lamp lights.

## 4-7. CIRCUIT ADJUSTMENTS

- To make the following adjustments, unless otherwise specified, the controls knobs and switches shall be preset as described below.

### FRONT PANEL

- INPUT selector ..... 1 HX board
- CONTRAST MANUAL switch ..... PRESET
- BRIGHTNESS MANUAL switch ..... PRESET
- CHROMA MANUAL switch ..... PRESET HW board
- PHASE MANUAL switch ..... PRESET
- SCAN MODE switch HA board
  - UNDER SCAN ..... NOR
  - H. DELAY ..... NOR
  - V. DELAY ..... NOR
- SCREEN switch (R) ..... NOR
- SCREEN switch (G) ..... NOR
- SCREEN switch (B) ..... NOR
- APT switch ..... NOR
- BLUE ONLY switch ..... NOR
- MODE selector ..... AUTO

### SUB CONTROL PANEL

- FORMAT button ..... CODED HY board
- INPUT button ..... A
- SYNC button ..... INT
- COLOR SYSTEM button ..... NTSC (BVM-1916)
- ..... PAL (BVM-2016P)
- ..... COMB (BVM-1916)
- ..... TRAP (BVM-2016P)
- YC SEP button ..... COMB (BVM-1916)
- ..... D65/D93
- WHITE BALANCE button ..... D65/D93
- ASPECT button ..... 4 : 3
- PIC SETUP button ..... OFF
- SAD/VITC/MARKER button ..... OFF
- FILTER button ..... OFF
- MATRIX button ..... OFF
- PAL S/SECAM F/COMB S button ..... OFF
- CROSS HATCH button ..... OFF
- SPLIT SCREEN button ..... OFF
- WHITE button ..... OFF
- GRAY button ..... OFF
- AFC switch ..... 2m sec DA board

### SUB CONTROL PANEL (HY board)

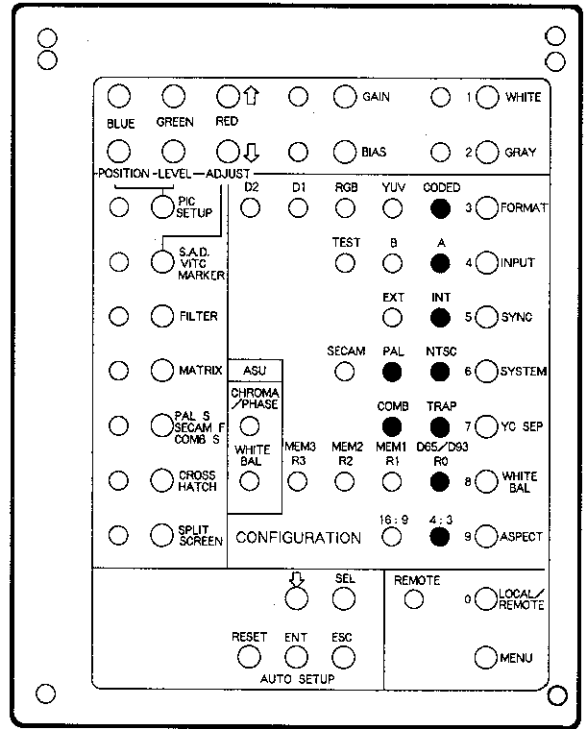

### FRONT PANEL

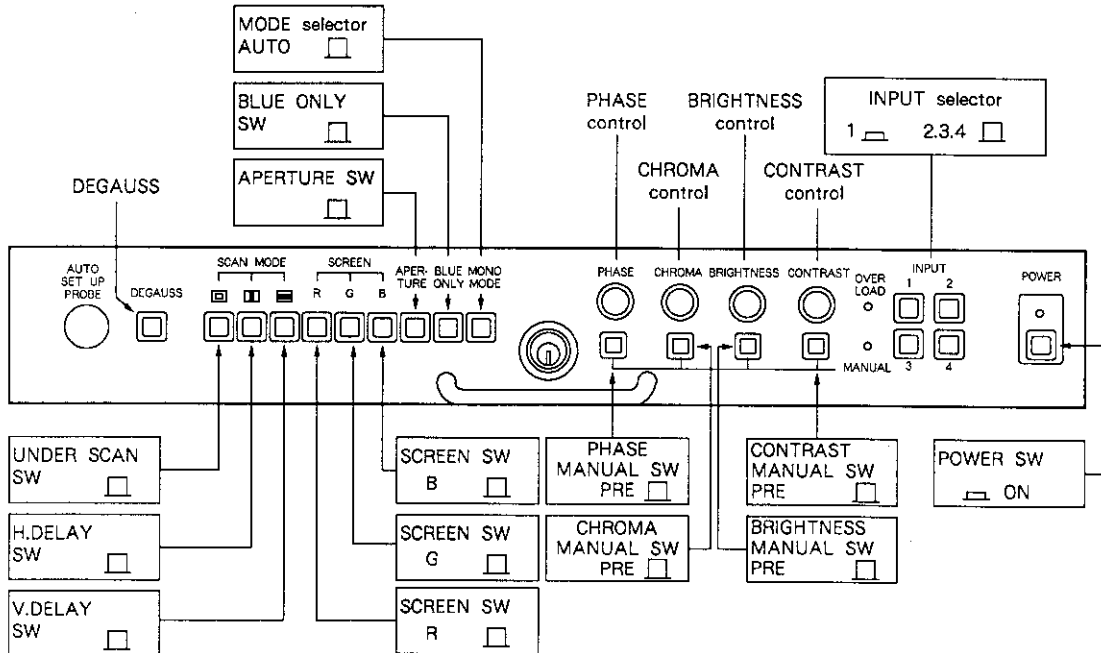

**1. SUB CHROMA, SUB PHASE ADJUSTMENT**

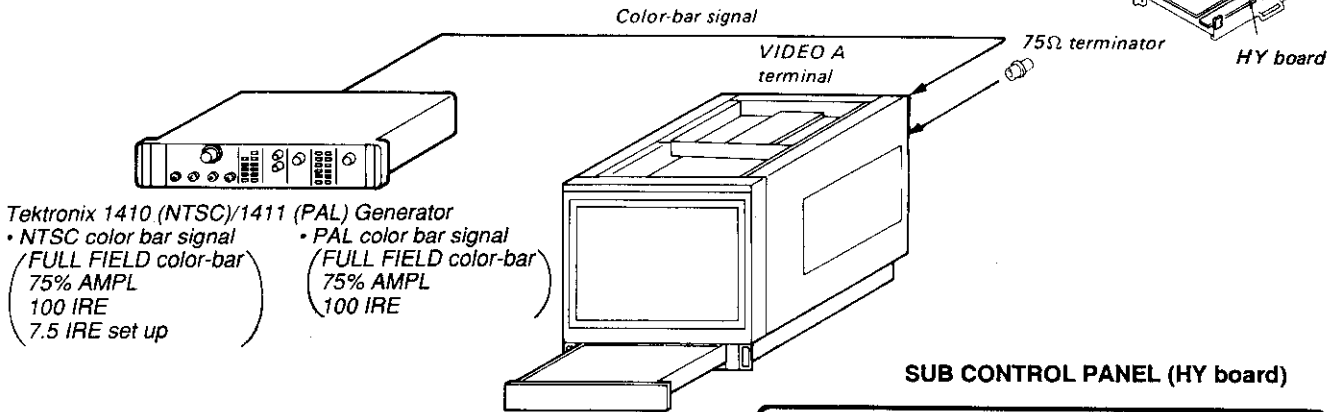
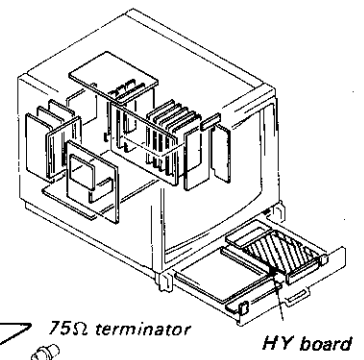

**SUB CONTROL PANEL (HY board)**

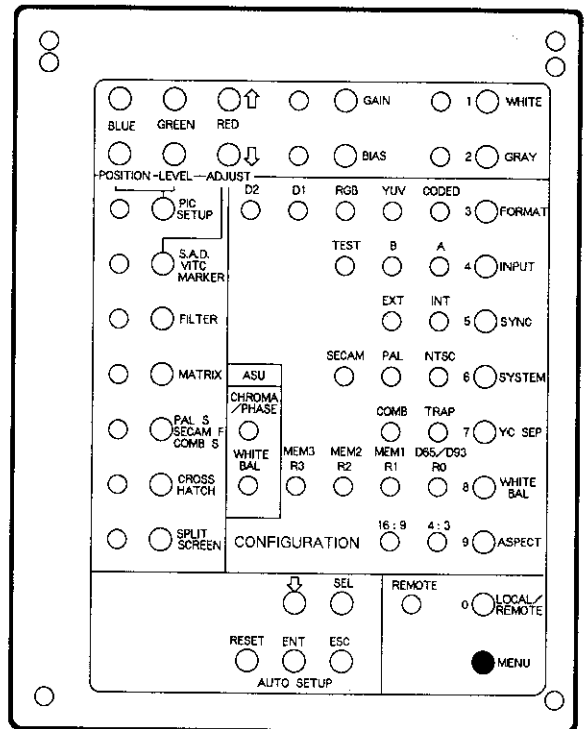

1. Press the MENU switch to select the PRESET menu.
2. CONTRAST, BRIGHT, CHROMA, PHASE MANUAL switch (FRONT PANEL).....MANUAL
3. Turn each volume control to adjust so that the value on the screen becomes 100.
4. Save the DATA.

4. ADJUSTMENTS

**FRONT PANEL**

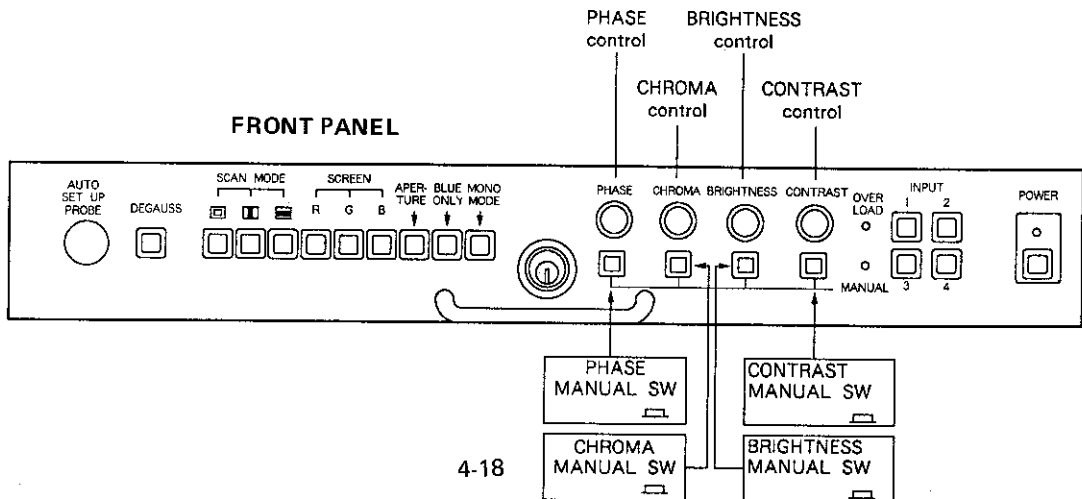

## 2. BJ Board BRT PULSE ADJUSTMENT

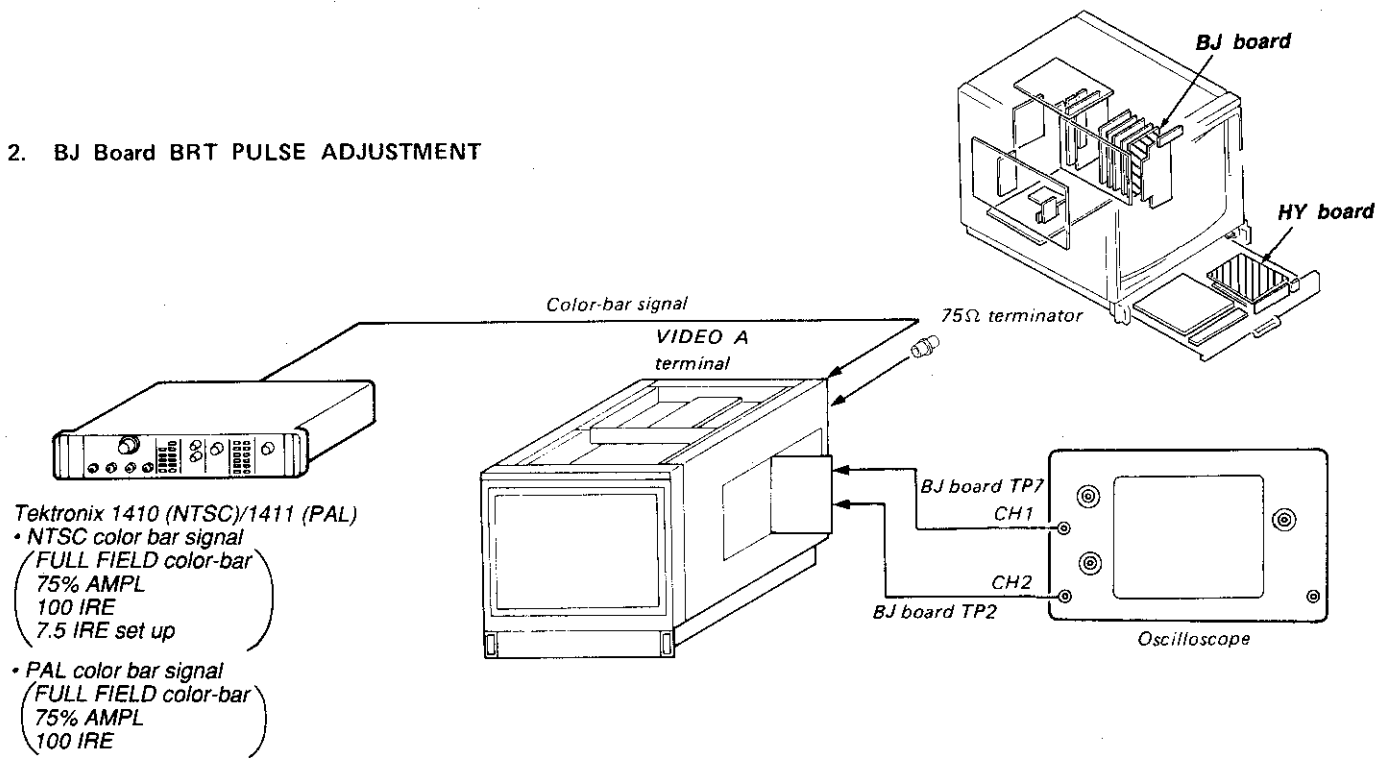

1. Input a color-bar signal to VIDEO A terminal of the set.
2. Connect an oscilloscope (CH1 probe) to the TP7 of BJ board and oscilloscope (CH2 probe) to the TP2 of BJ board.
3. Adjust RV7 to obtain the waveform on the oscilloscope as shown in Fig. 2-1.

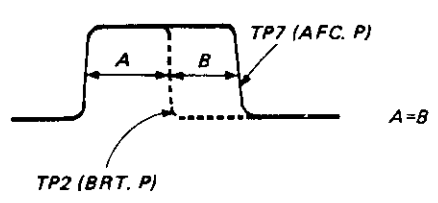
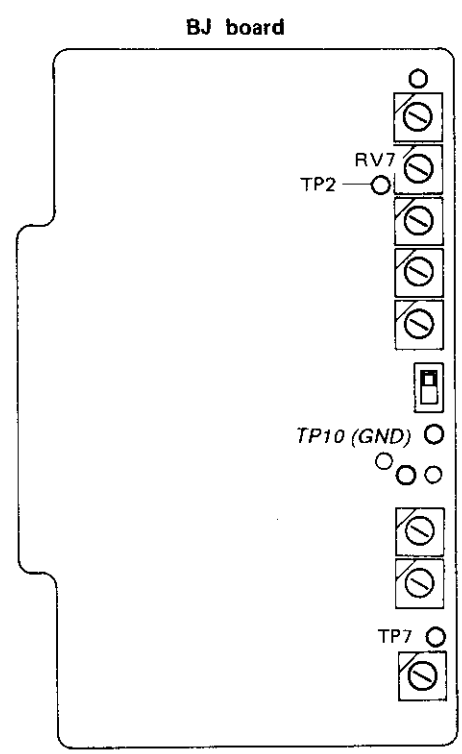
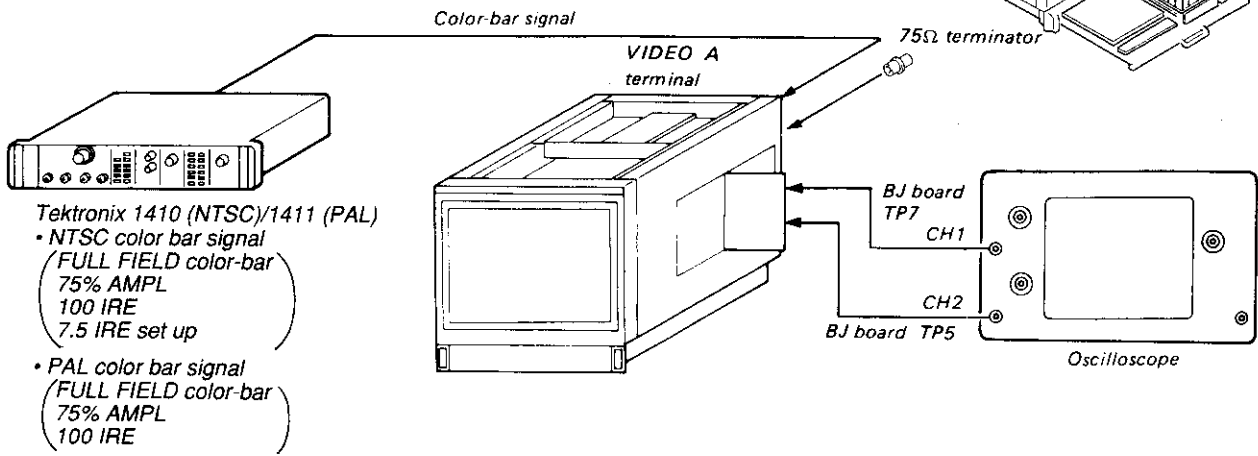
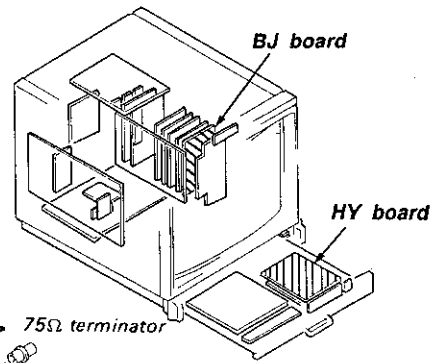

Fig. 2-1



# BJ Board SUMPLING PULSE ADJUSTMENT



1. Input a color-bar signal to VIDEO A terminal of the set.
2. Connect an osilloscope (CH 1 probe) to the TP7 of BJ board and Connect an oscilloscope (CH 2 probe) to the TP5 of BJ board.
3. Adjust RV5 to obtain the waveform on the oscilloscope as shown in Fig. 2-2.

4. ADJUSTMENTS

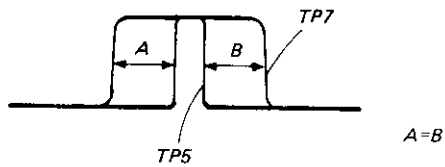
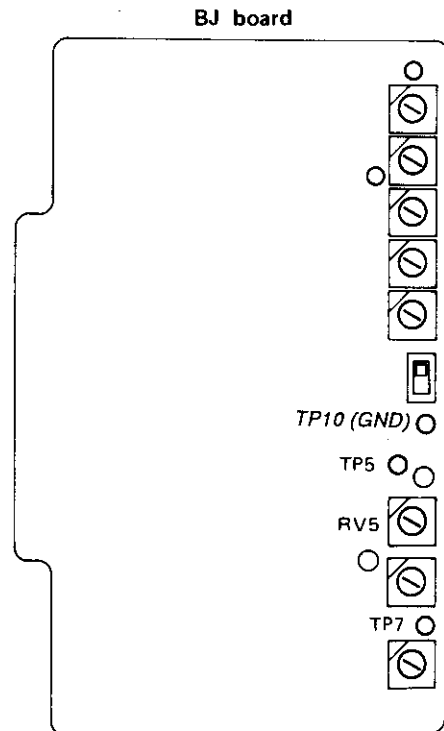
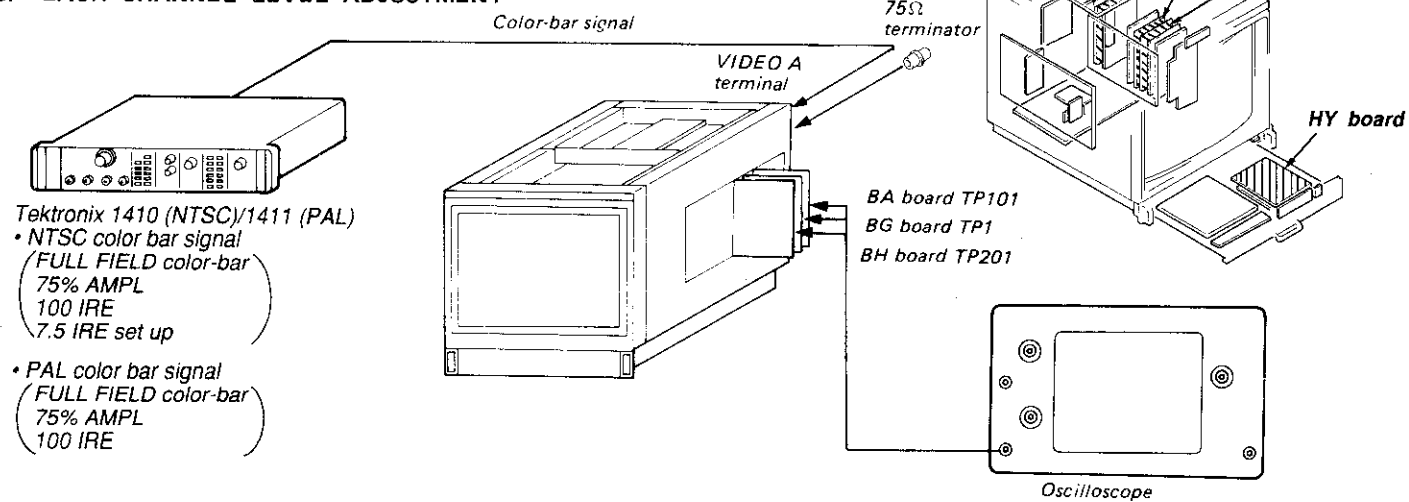

Fig. 2-2





### 3. EACH CHANNEL LEVEL ADJUSTMENT



- Tektronix 1410 (NTSC)/1411 (PAL)
- NTSC color bar signal (FULL FIELD color-bar) 75% AMPL 100 IRE 7.5 IRE set up
- PAL color bar signal (FULL FIELD color-bar) 75% AMPL 100 IRE

- FILTER button (SUB CONTROL PANEL) ..... OFF
- MODE selector (FRONT PANEL) ..... MONO
- INPUT selector (FRONT PANEL) ..... 1

#### BA board

1. Input a color-bar signal to VIDEO A terminal to the set.
2. Connect an oscilloscope to the TP101 of BA board.
3. Adjust to 1.0Vp-p with RV101 of BA board as shown in Fig. 3-1.

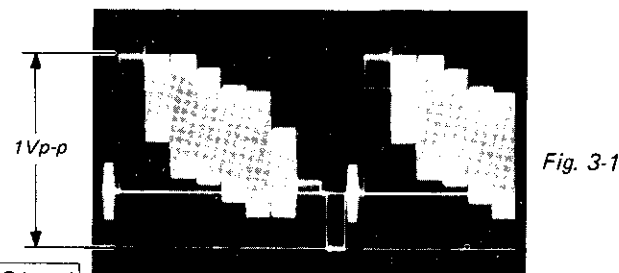

#### BG board

4. Connect an oscilloscope to the TP1 of BG board.
5. Adjust to 1.0Vp-p with RV3 of BG board as shown in Fig. 3-1.
6. Connect an oscilloscope to the TP201 of BH board.

7. Adjust FRONT BRT VR so that (A) (black level) is 0V DC as shown in Fig. 3-2.
8. Adjust FRONT CONT VR so that (B) (100% white level) is -0.7V DC as shown in Fig. 3-2.

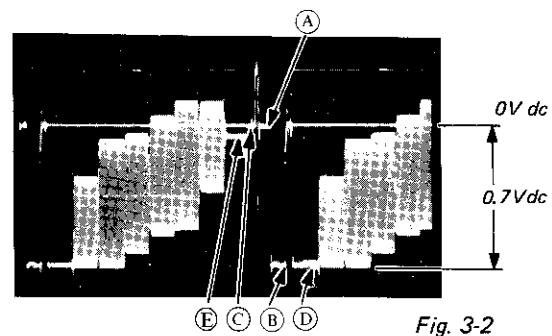

- (A) ..... Black level
- (B) ..... 100% White level
- (C) ..... 0 IRE level
- (D) ..... 100 IRE level
- (E) ..... 7.5 IRE level

#### BH board

9. S2 (BH Board) ..... 0 IRE  
Adjust RV1 of BH board so that the (C) (0 IRE level) coincides with (A) (Black level) as shown in Fig. 3-3.
10. Adjust RV3 of BH board so that the (D) (100 IRE level) coincides with (B) (100% white level) as shown in Fig. 3-3.

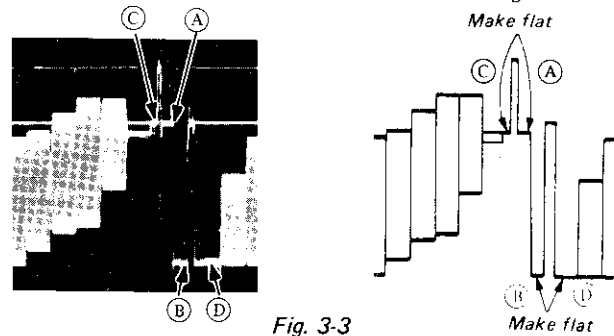

#### BH board

11. S2 (BH Board) ..... 7.5 IRE  
Adjust RV2 of BH board so that the (E) (7.5 IRE level) coincides with (A) (Black level) as shown in Fig. 3-4.
12. Set S2 (BH Board) to AUTO.

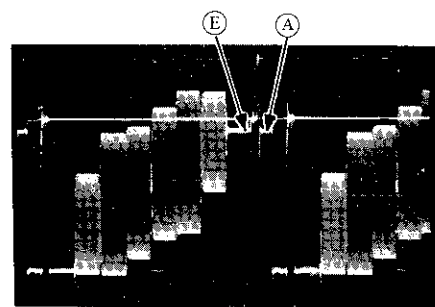
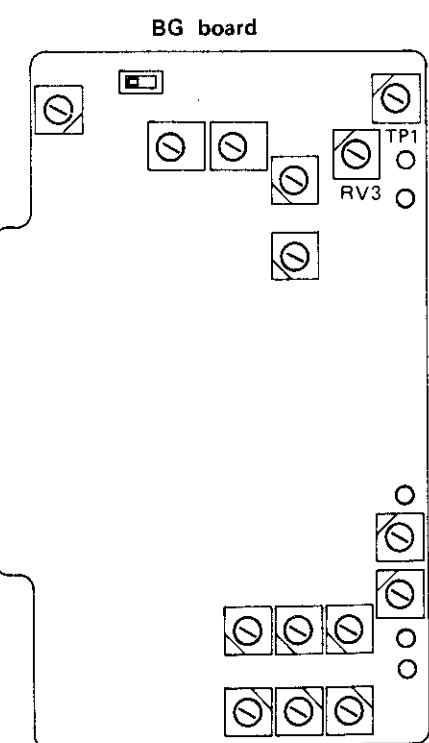
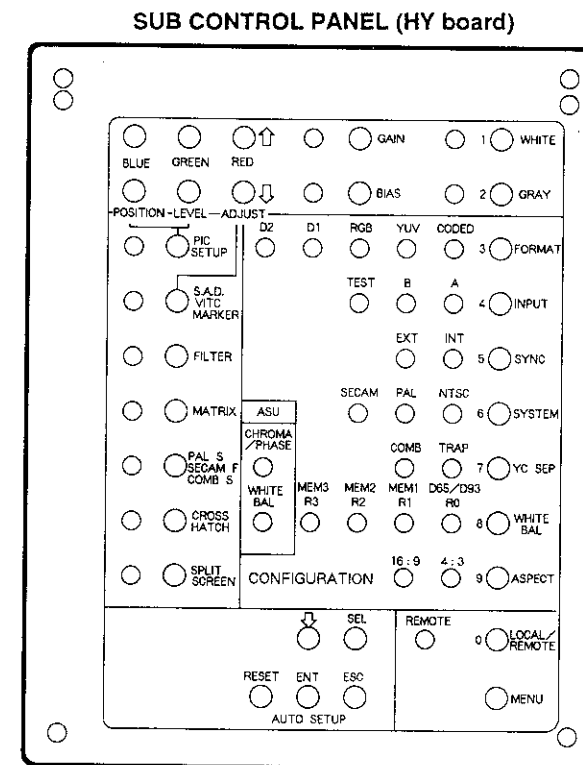
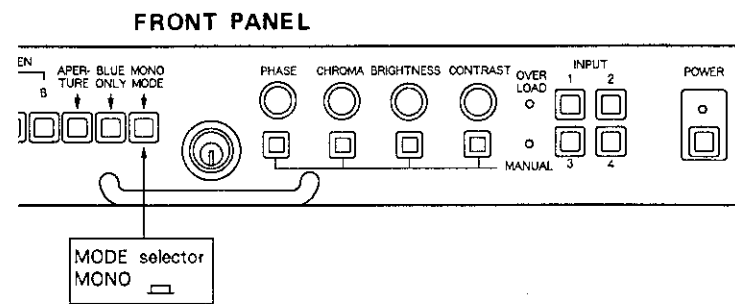
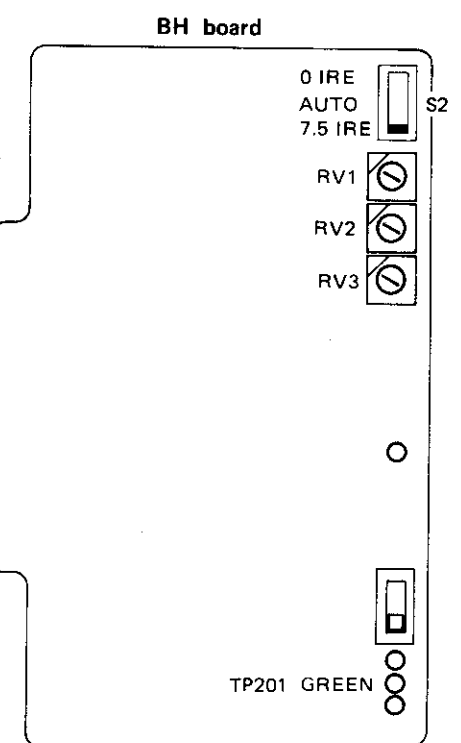
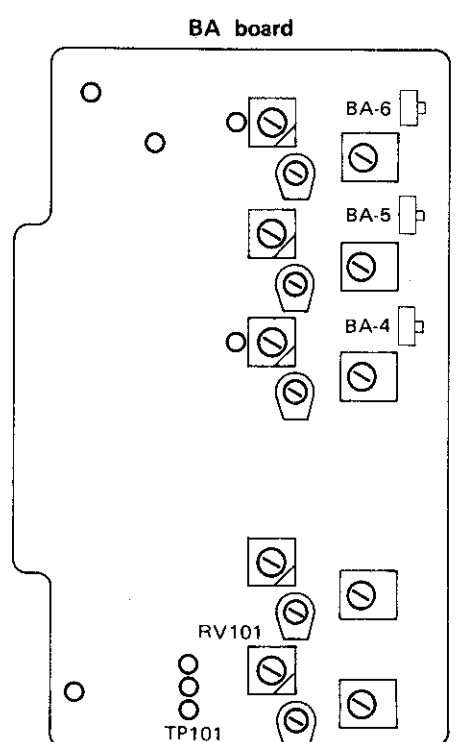

Fig. 3-4



4-22



**BA board**

13. Input a color-bar signal to RGB input terminal of the set.
  - SYNC button (SUB CONTROL PANEL).....EXT
  - FORMAT button (SUB CONTROL PANEL).....RGB

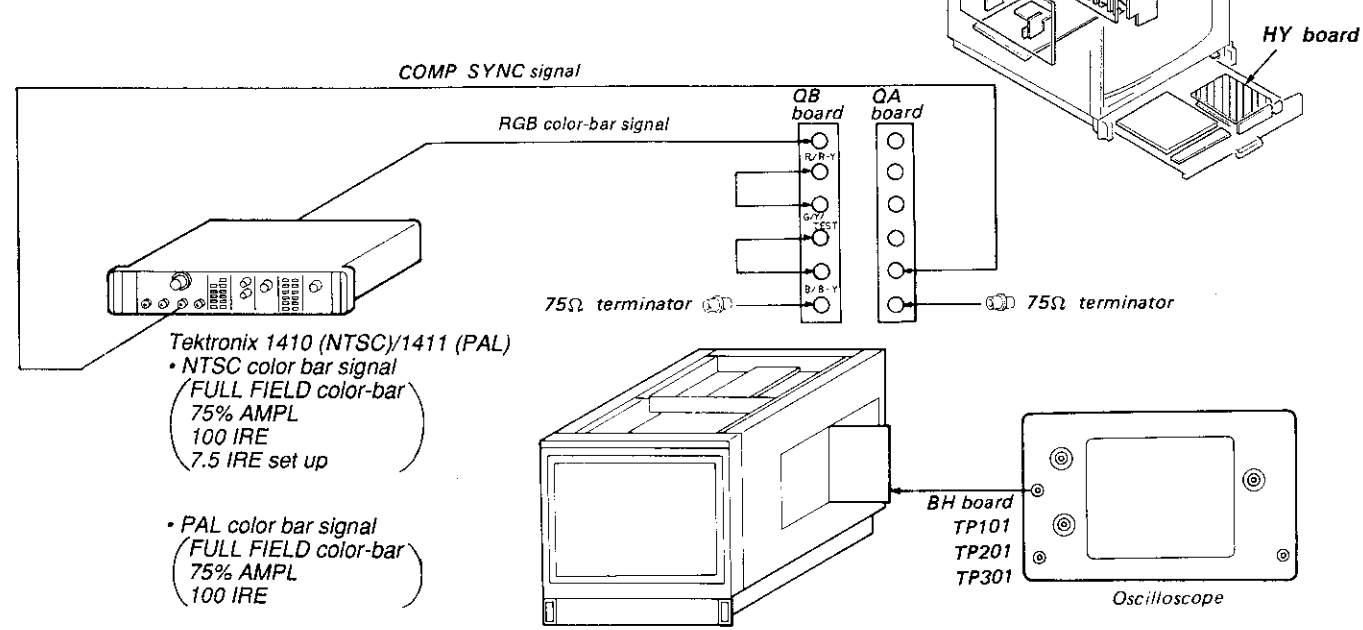

14. Connect an oscilloscope to TP101 of BH board.
15. Adjust RV401 of BA board so that the (D) (100 IRE level) coincides with (B) (100% white level) as shown in Fig. 3-5.
16. Connect an oscilloscope to TP201 of BH board.
17. Adjust RV501 of BA board so that the (D) (100 IRE level) coincides with (B) (100% white level) as shown in Fig. 3-5.
18. Connect an oscilloscope to TP101 of BH board.
19. Adjust RV601 of BA board so that the (D) (100 IRE level) coincides with (B) (100% white level) as shown in Fig. 3-5.

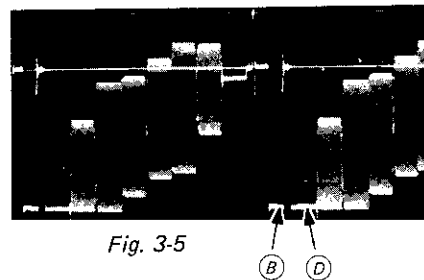

**FRONT PANEL**

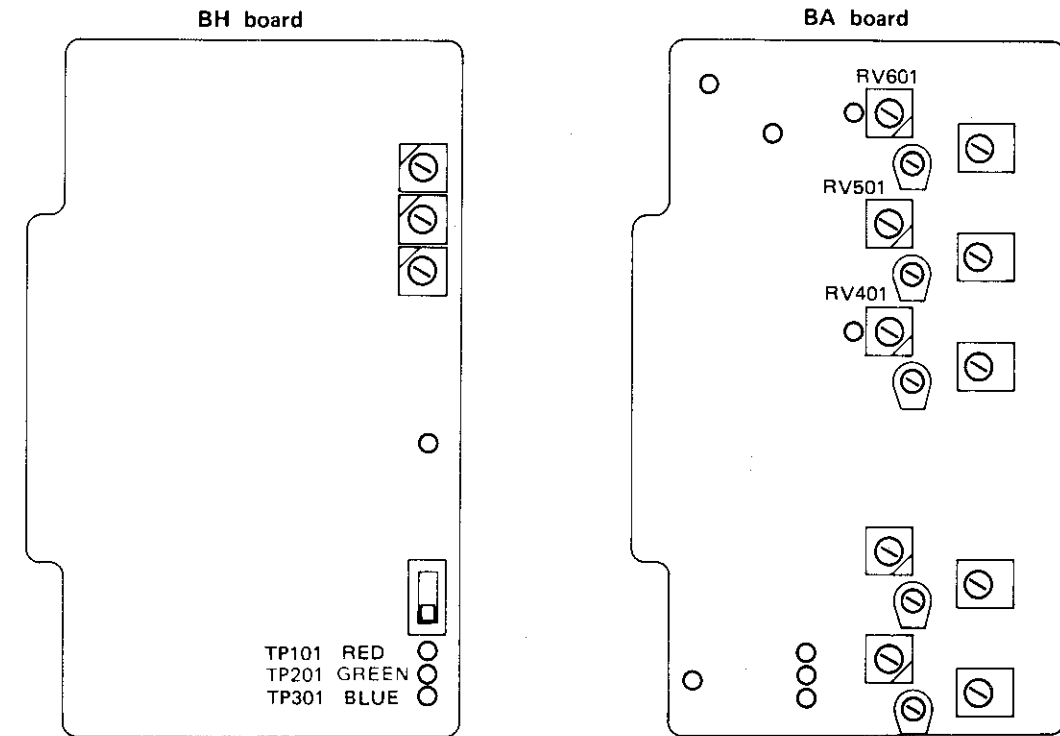
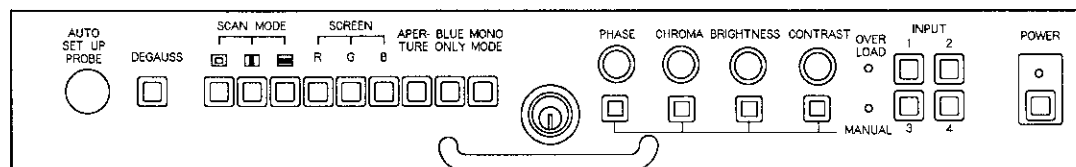

**SUB CONTROL PANEL (HY board)**

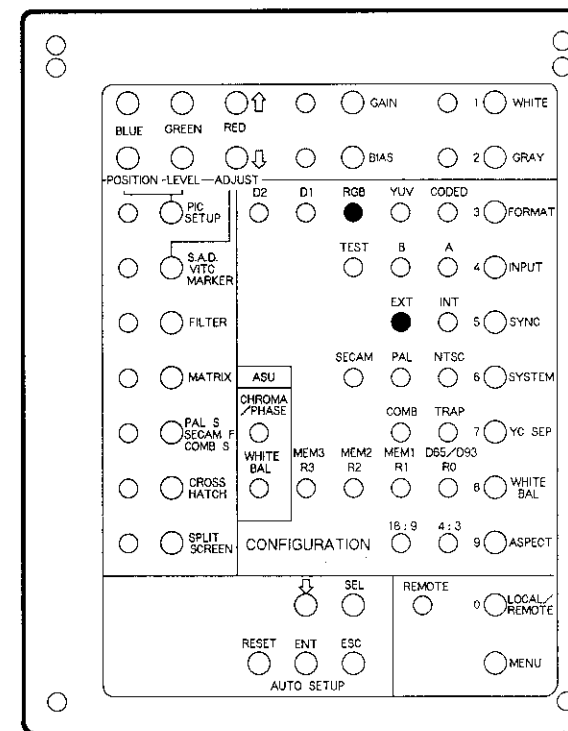



**4. BA Board INPUT CIRCUIT FREQUENCY CHARACTERISTIC ADJUSTMENT**

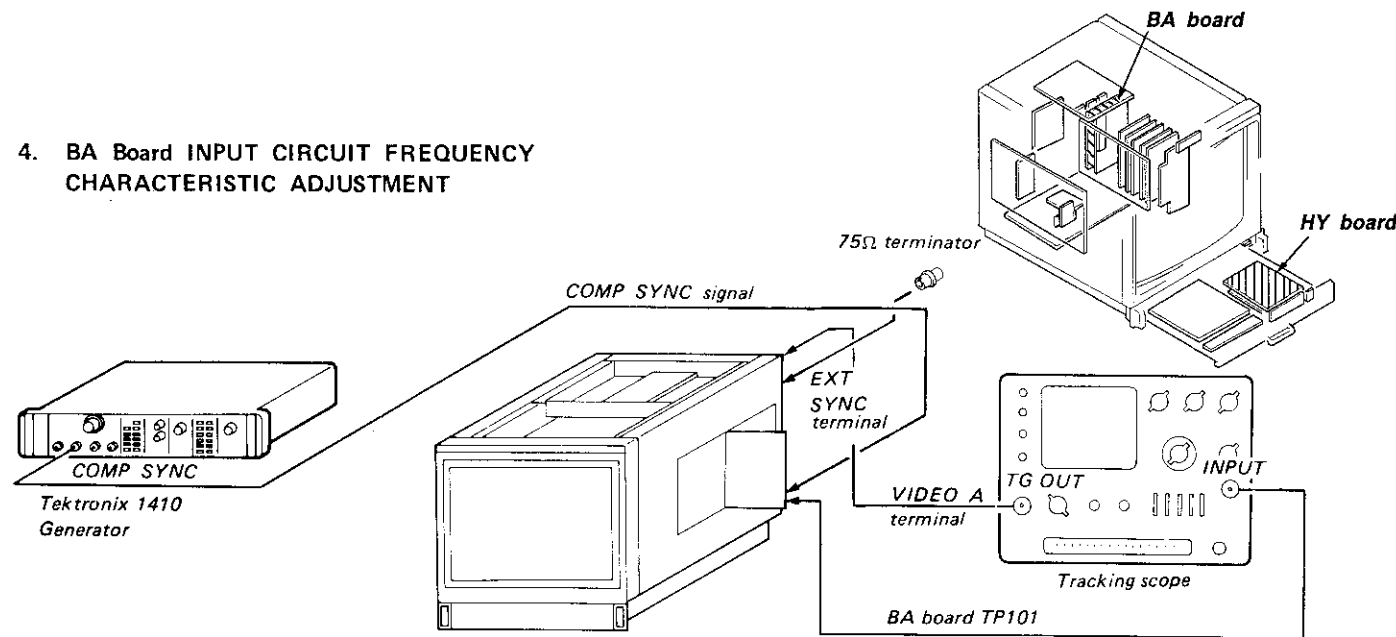

Fig. 4-1

- Complete the connection as shown in Fig 4-1.
  - FORMAT button (SUB CONTROL PANEL) ..... CODED
  - INPUT selector (FRONT PANEL) ..... 1
  - SYNC button (SUB CONTROL PANEL) ..... EXT
  - CONTRAST control (FRONT PANEL) ..... Minimum
  - BRIGHTNESS control (FRONT PANEL) ..... Minimum
- Adjust CV101 so that minimum as shown in Fig. 4-2.

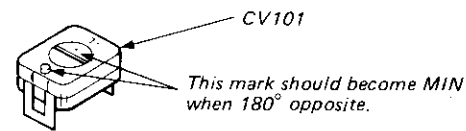

Fig. 4-2

- Adjust output waveform peak to 12MHz with CV102 of the BA board as shown in Fig. 4-3.

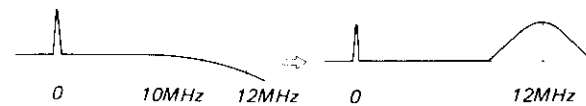

Fig. 4-3

- Adjust CV101 of the BA board so that the output waveform becomes flat in a range of 0 to 10MHz as shown in Fig. 4-4.

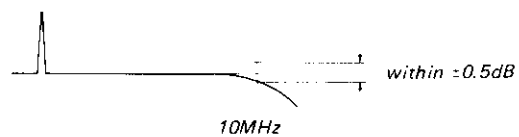
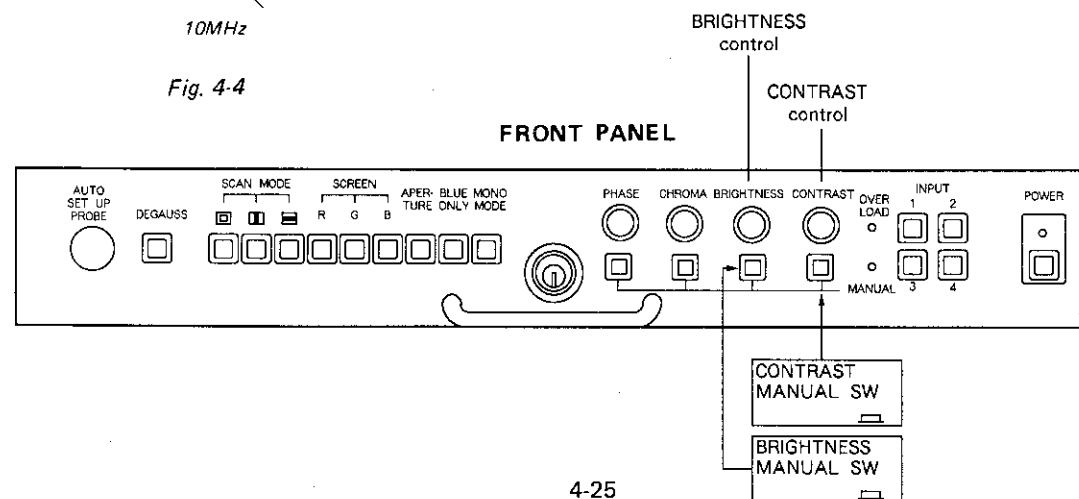

Fig. 4-4



- In the same way, perform the adjustment, under the following conditions.

INPUT	INPUT button	FORMAT button	TP (BA board)	CV (BA board)
	(SUB CONTROL PANEL)			
B	B	CODED	TP201	CV201, 202
R/R-Y		RGB	TP401	CV401, 402
G/Y/TEST		RGB	TP501	CV501, 502
B/B-Y		RGB	TP601	CV601, 602

**SUB CONTROL PANEL (HY board)**

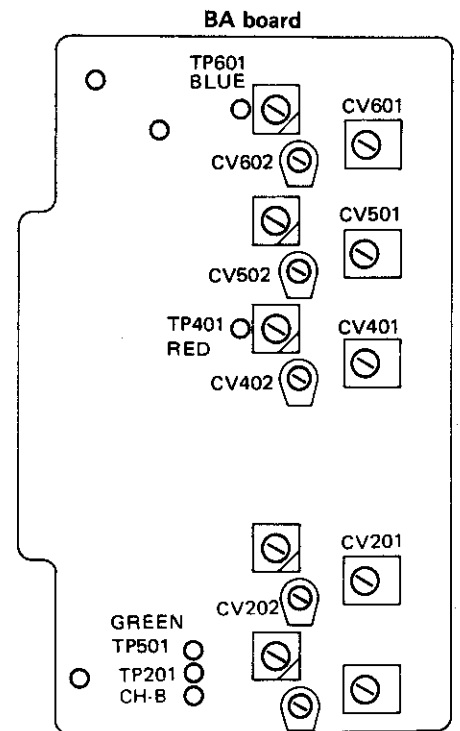
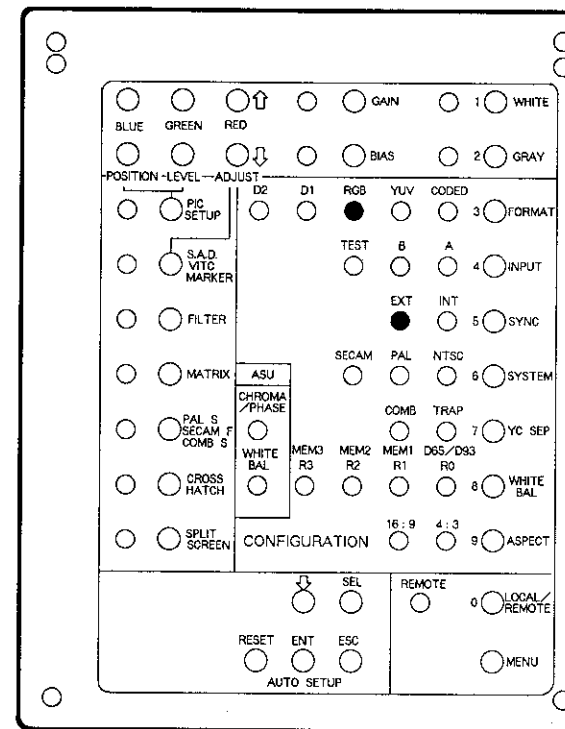

### 5. BG Board FREQUENCY CHARACTERISTIC ADJUSTMENT

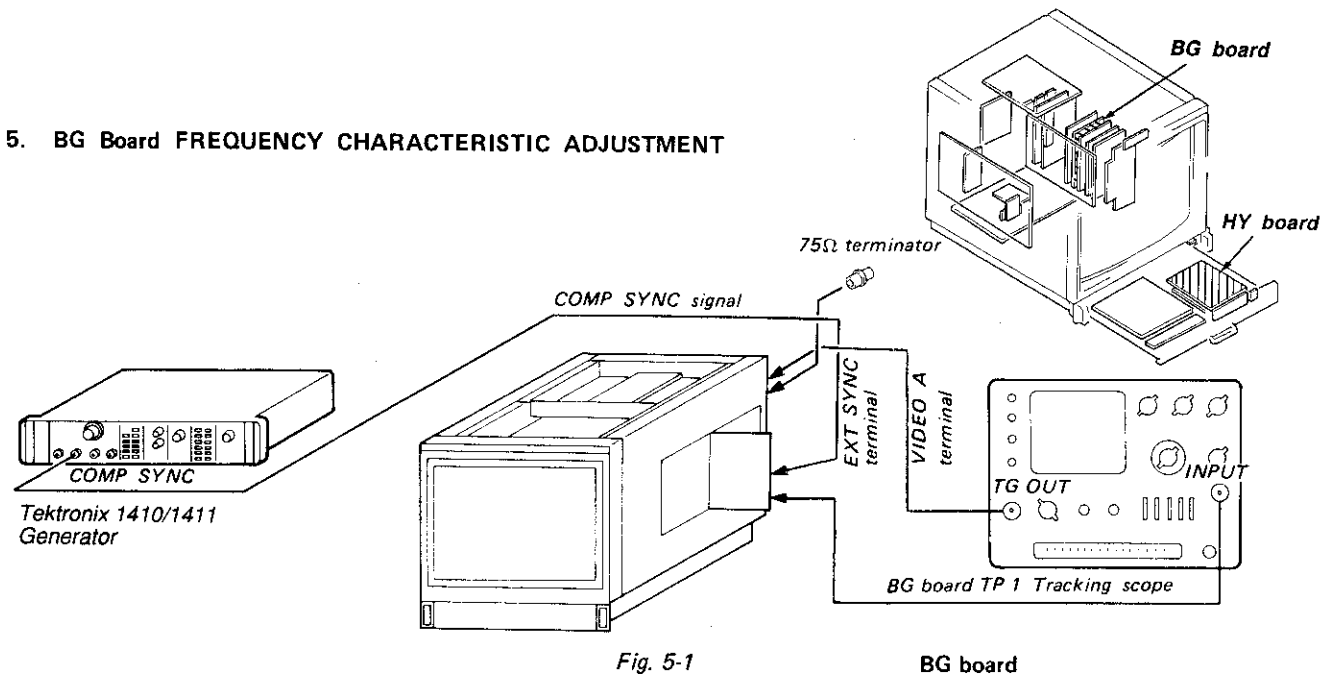

Fig. 5-1

- Complete the connection as shown in Fig 5-1.
  - SYNC button (SUB CONTROL PANEL)..... EXT
  - CONTRAST control ..... Minimum
  - BRIGHTNESS control ..... Minimum
  - S1 (BG Board) ..... 4.5MHz (4.5 6.5)

- Adjust RV1, CV2 and CV3 of the BG board so that the output waveform becomes flat in a range of 0 to 10MHz as shown in Fig. 5-2. (within 0±0.5dB)

\*Waveform movement by RV1, CV2, CV3

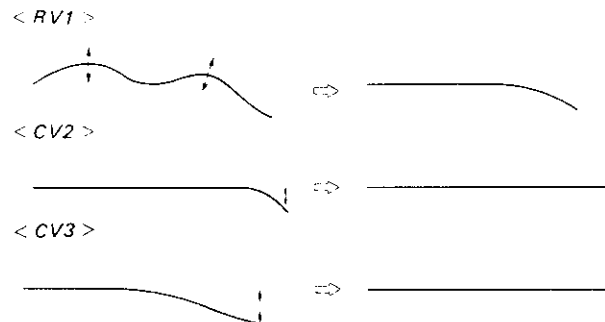
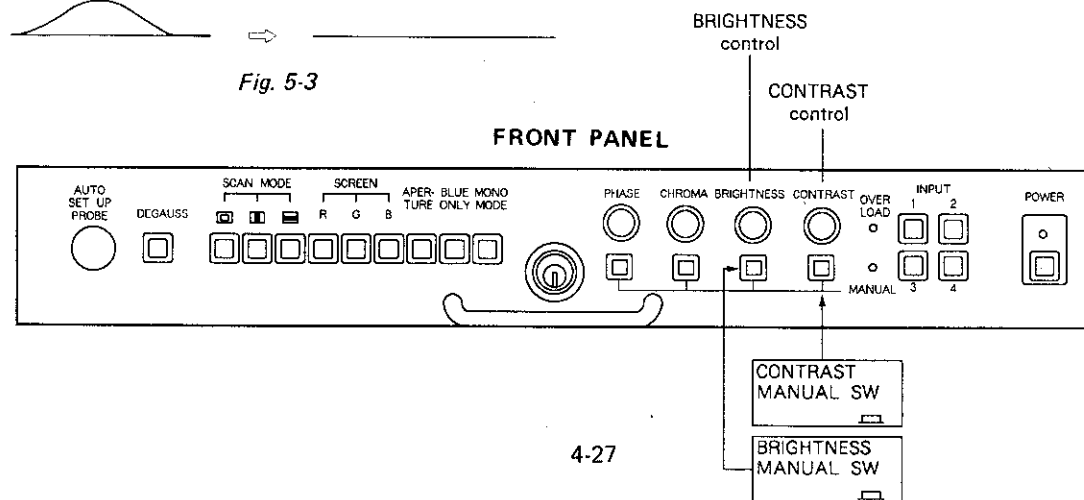

Fig. 5-2

- Adjust with RV2 (BG board) to the position in which the APT (Fig. 5-3.) begins to become effective.



Fig. 5-3



### 6. COMPONENT INPUT LEVEL ADJUSTMENT

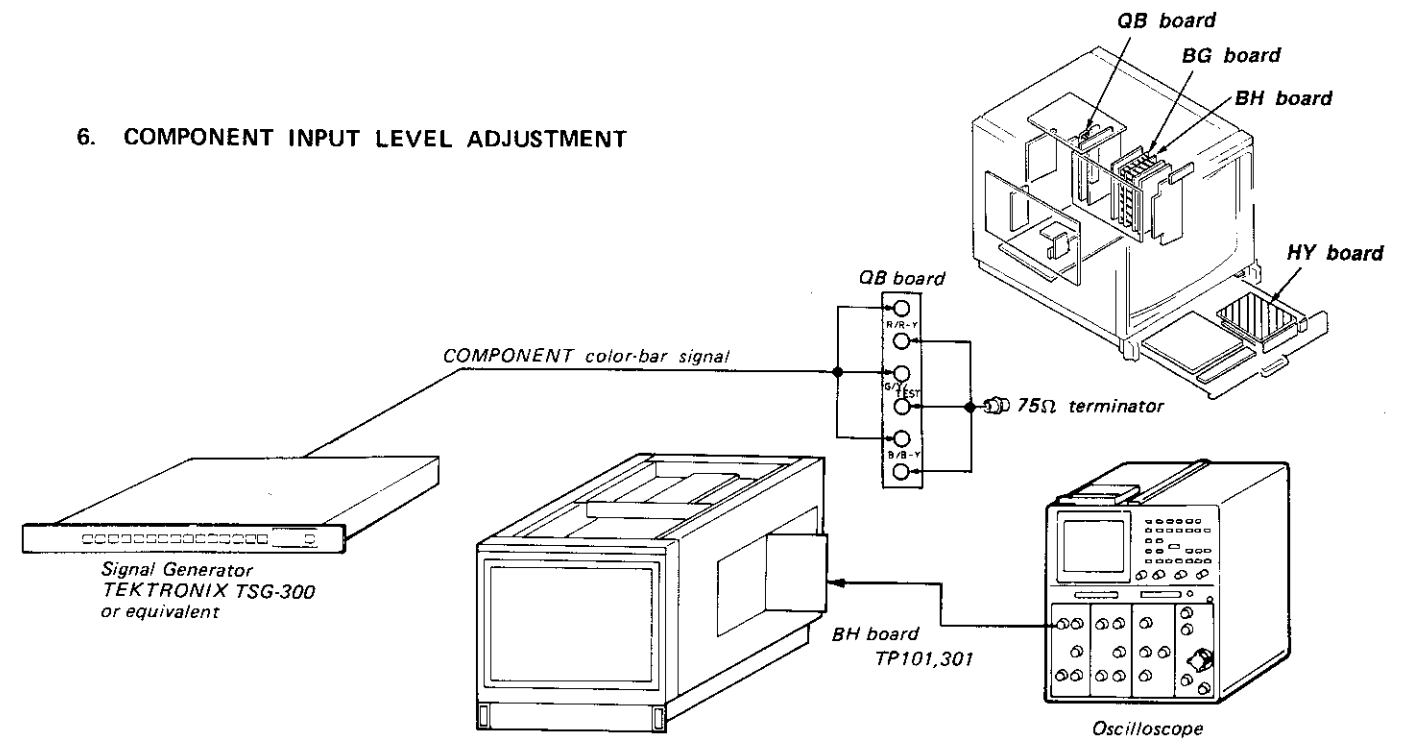

Fig. 6-1

- Complete the connections as shown in Fig. 6-1.
  - FORMAT button (SUB CONTROL PANEL)..... YUV
- Connect an oscilloscope to the TP-101 of BH board.
- Adjust RV21 of BG board so that the output waveform becomes flat. (Fig. 6-2)

- Connect an oscilloscope to the TP301 of BH board.
- Adjust RV22 of BG board so that the input waveform becomes flat. (Fig. 6-3)

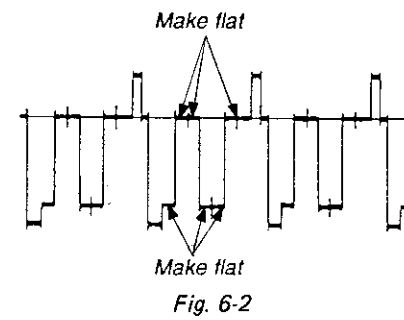

Fig. 6-2

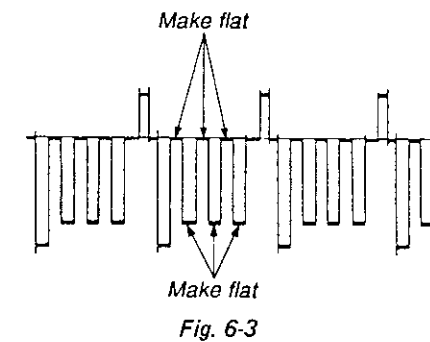
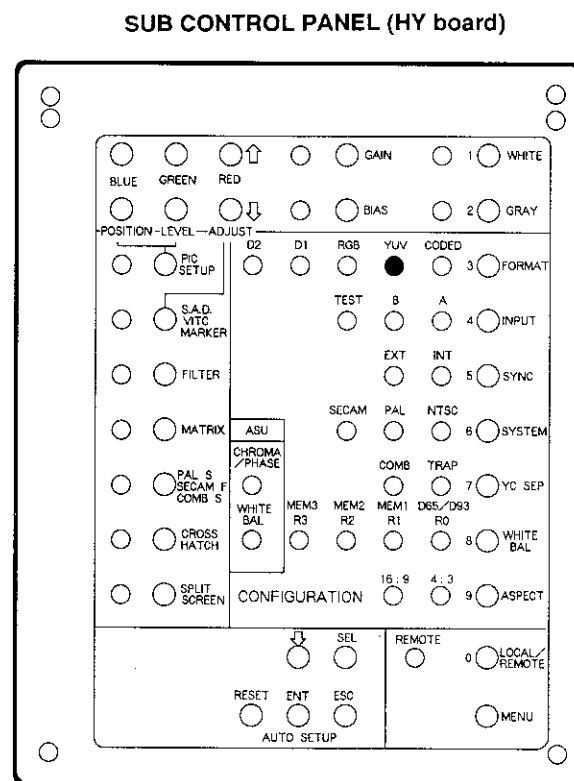
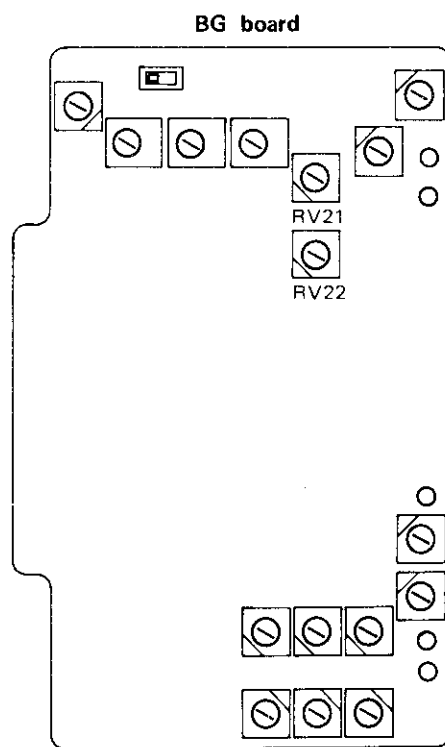
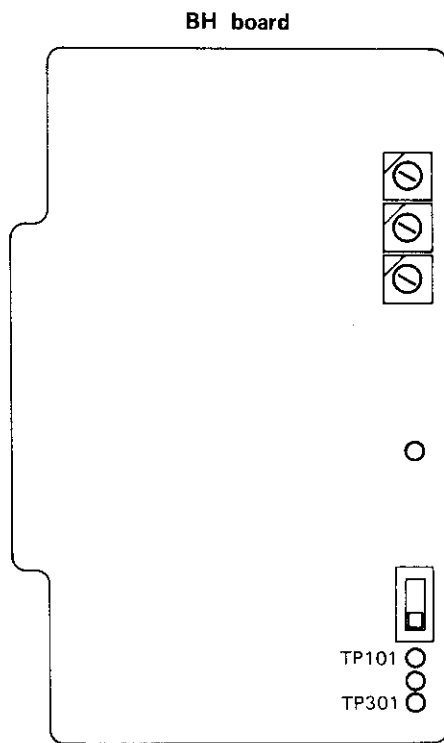
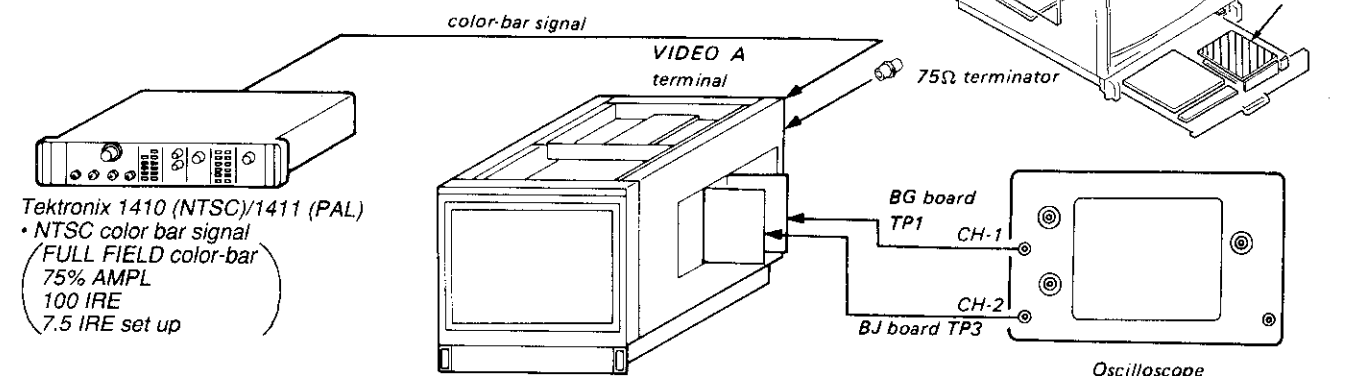

Fig. 6-3



7. BJ Board BURST GATE PULSE ADJUSTMENT



1. Input a color-bar signal to the VIDEO A terminal of the set.
2. Connect an oscilloscope (CH-1 probe) to the TP1 of BG board and connect an oscilloscope (CH-2 probe) to the TP3 of BJ board.
3. Adjust RV8 of BJ board so that the with A width is 4.3μs as shown in Fig. 7-1.

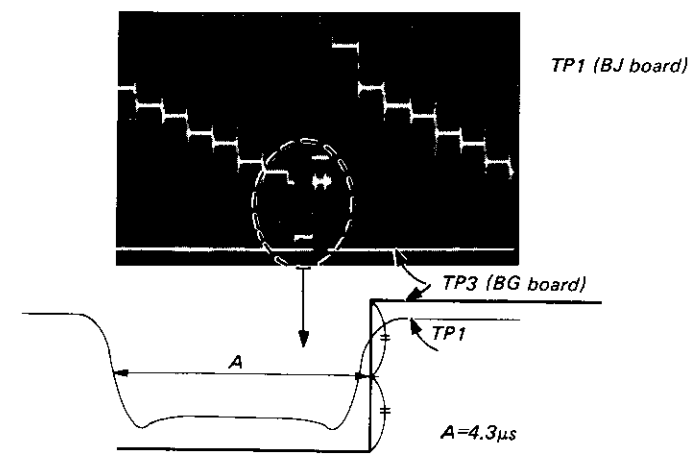

\* Adjust (A), from SYNC fall to B.G.P. (BURST GATE PULSE) rise, to 4.3μs.

Fig. 7-1

4. Adjust RV4 of BJ board so that the burst gate pulse width is 3.9 μs as shown in Fig. 7-2.

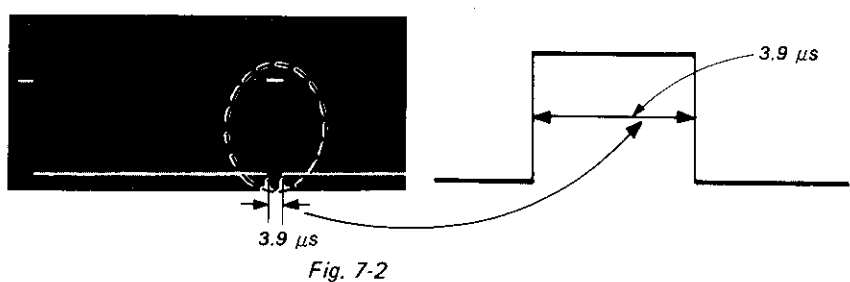
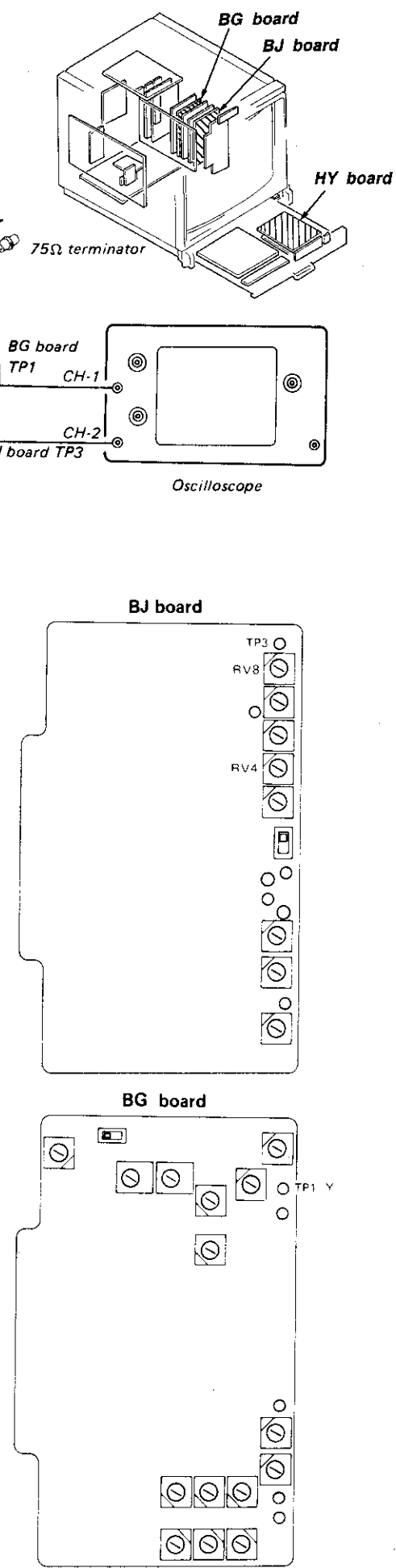
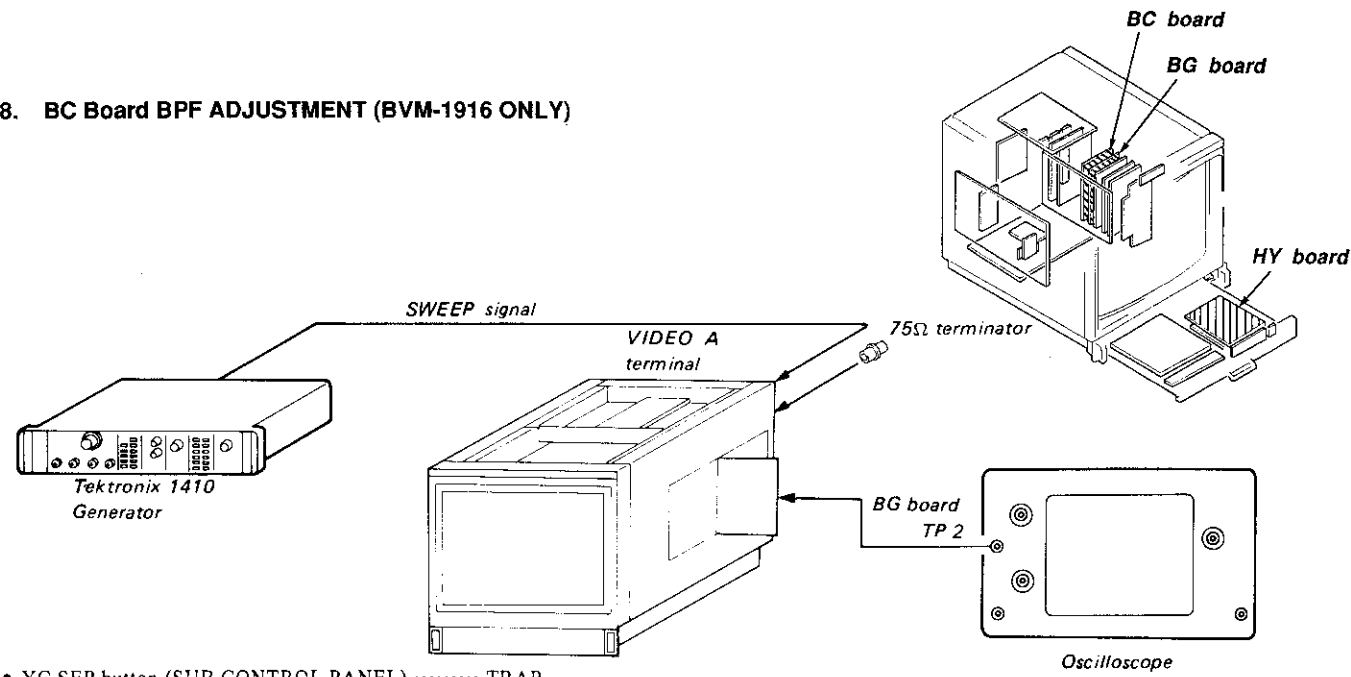

Fig. 7-2



8. BC Board BPF ADJUSTMENT (BVM-1916 ONLY)



- YC SEP button (SUB CONTROL PANEL) ..... TRAP
1. Input SWEEP signal to the VIDEO A terminal of the set.
  2. Connect an oscilloscope to the TP2 on the BG board.
  3. Make the V/dw of oscilloscope into VARIABLE, and match the upper section of waveform to 7 div as shown in Fig. 8-1.

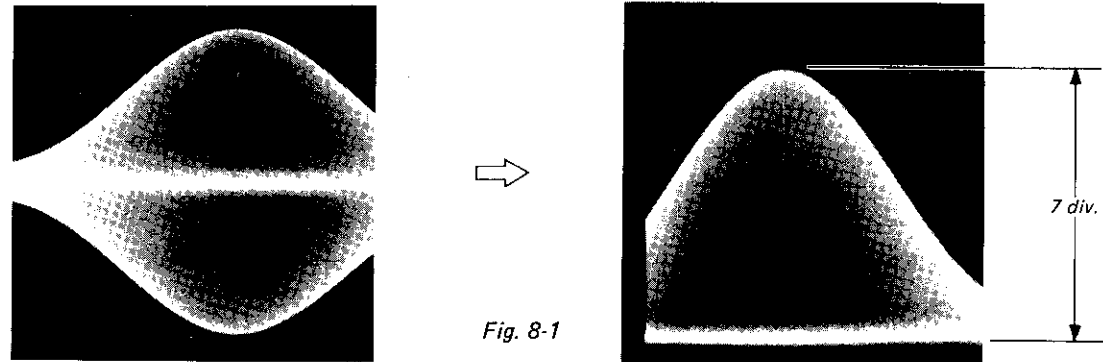

Fig. 8-1

4. Adjust L3 on the BC board so that A is equal to B as shown in Fig. 8-2.

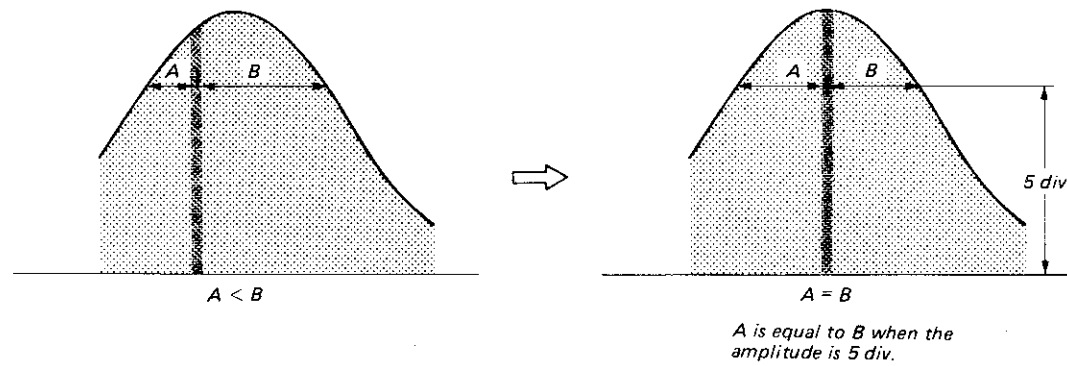
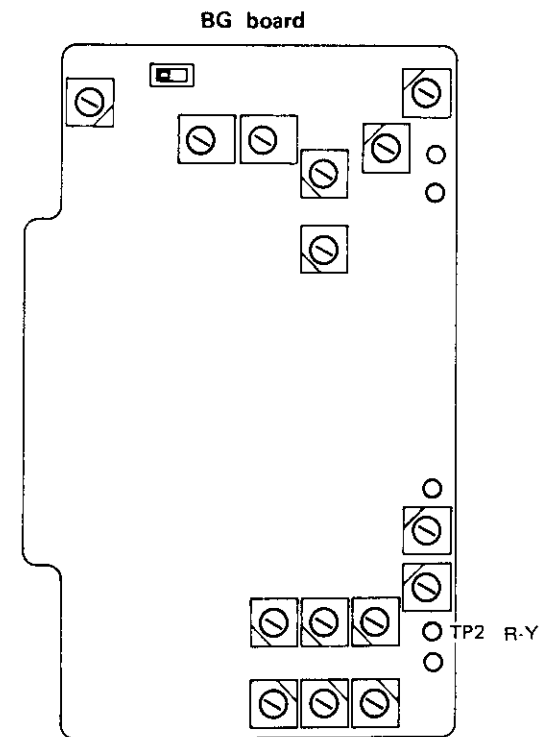
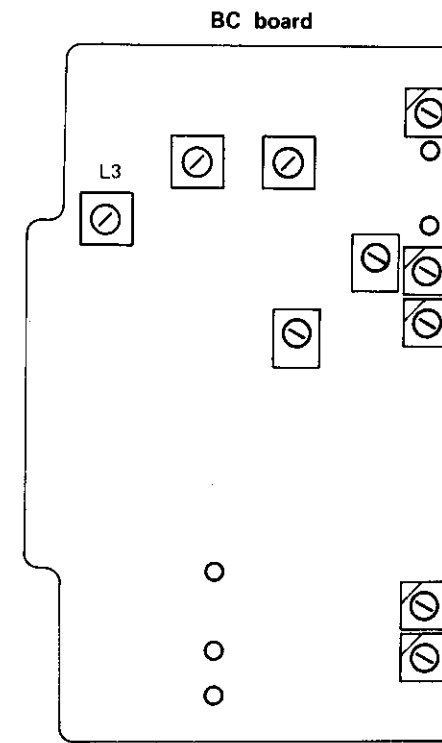
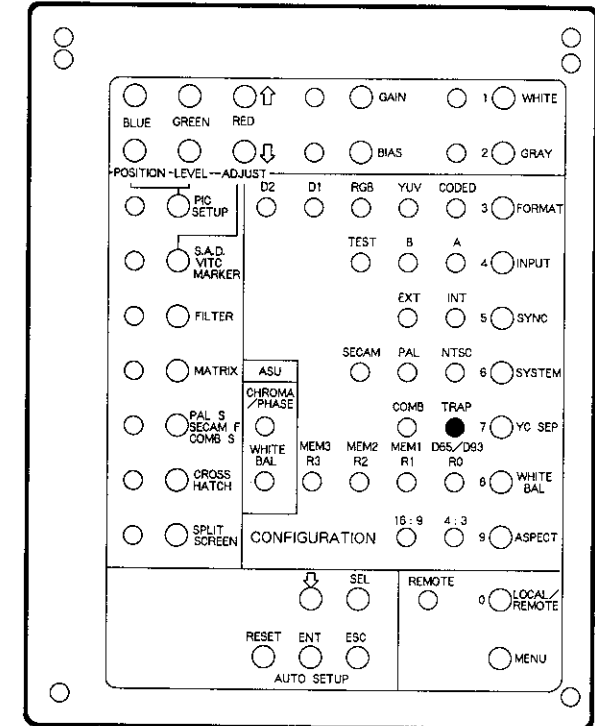

Fig. 8-2



SUB CONTROL PANEL (HY board)



### 9. BC Board PHASE SHIFT ADJUSTMENT (BVM-1916 ONLY)

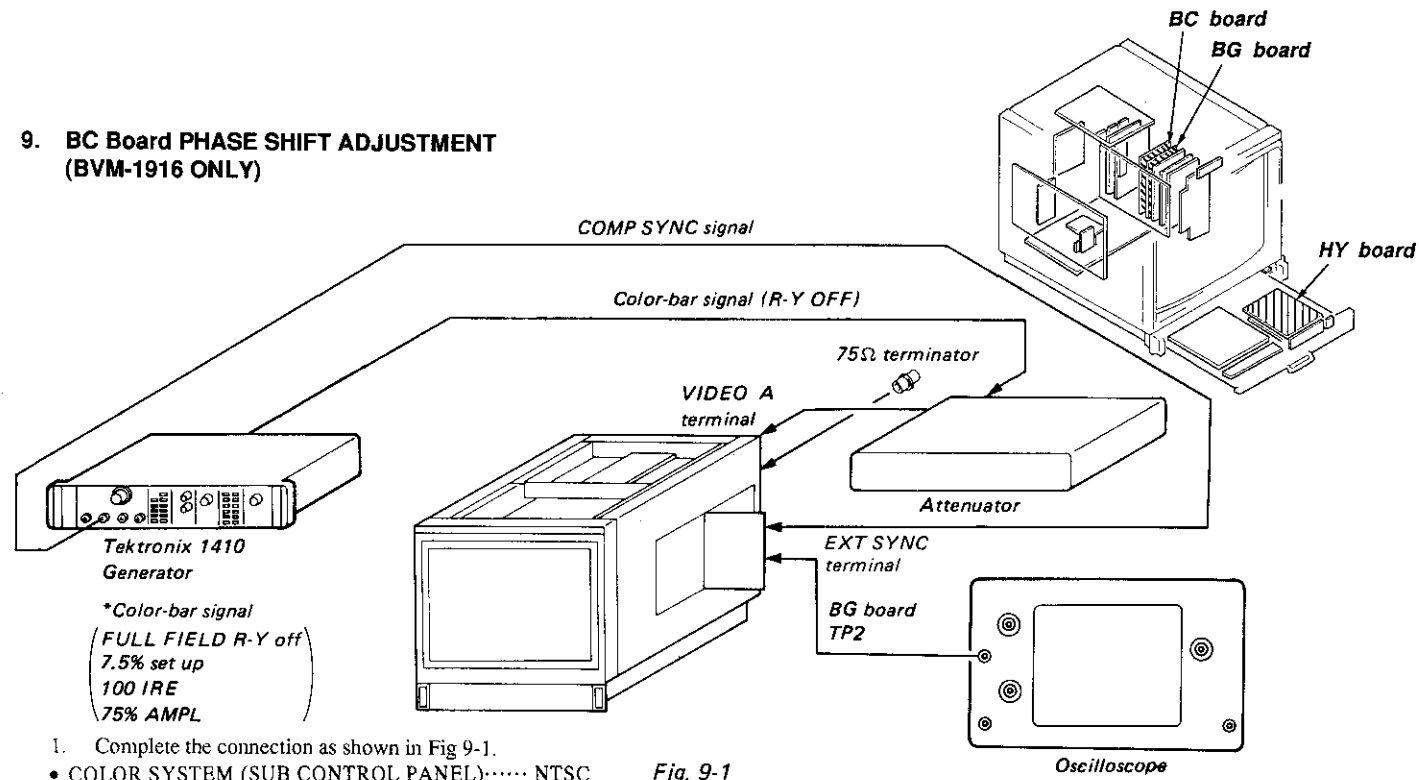

- Complete the connection as shown in Fig 9-1.
  - COLOR SYSTEM (SUB CONTROL PANEL)..... NTSC
  - FORMAT button (SUB CONTROL PANEL)..... CODED
  - YC SEP button (SUB CONTROL PANEL)..... TRAP
  - SYNC button (SUB CONTROL PANEL)..... EXT
- Connect an oscilloscope to the TP2 on the BG board.
- Make the waveform flat with the PHASE control of front panel as shown in Fig. 9-2.

Fig. 9-1

- Attenuate the signal by 10dB by using attenuator.
- Adjust RV3 on the BC board so that the output waveform becomes flat as shown in Fig. 9-2.
- Restore the attenuator to 0dB.
- Repeat the steps 3 to 5.

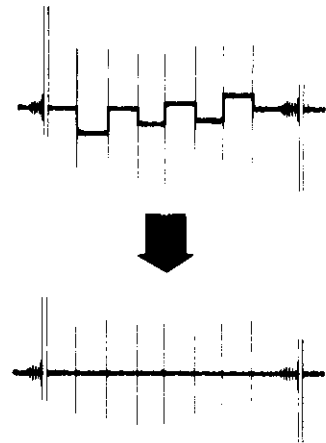
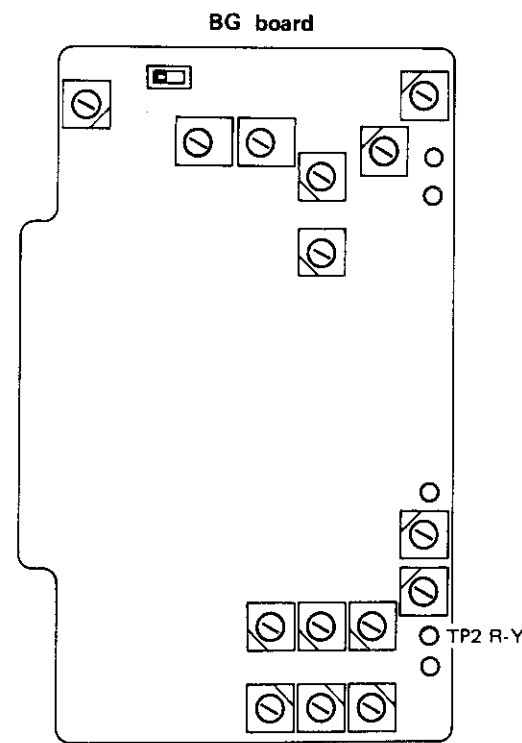
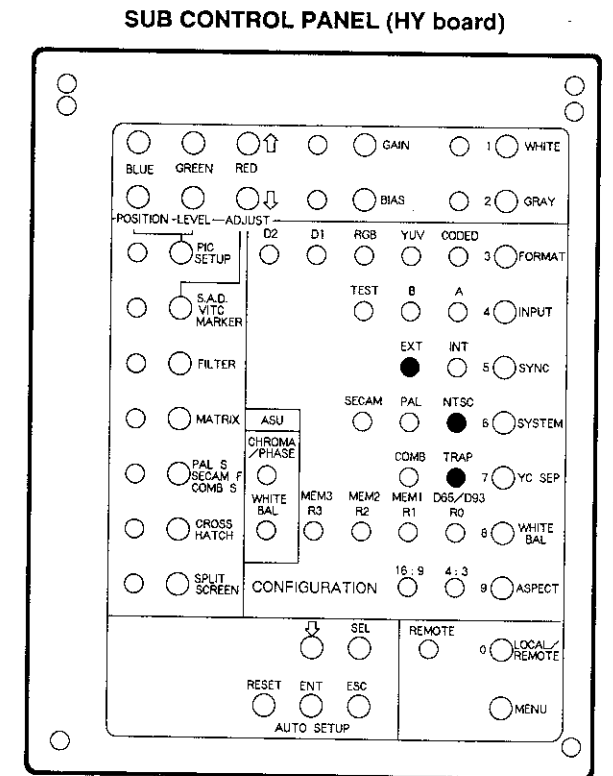
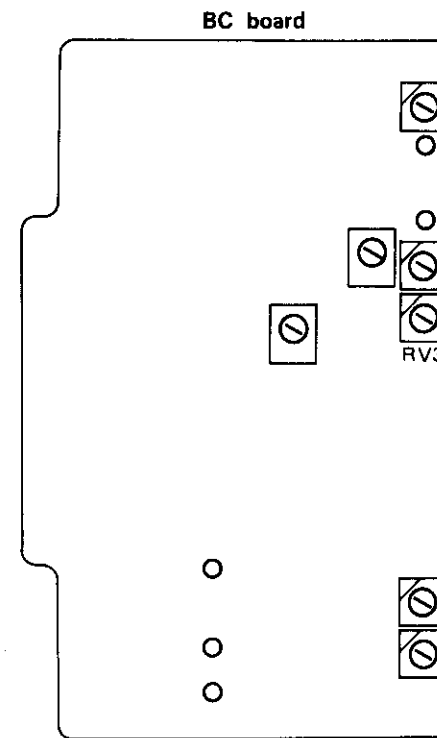
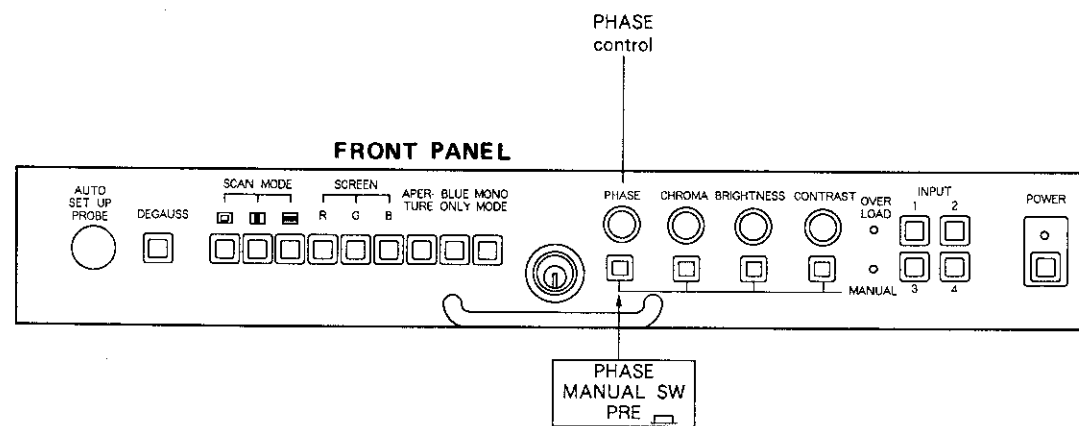
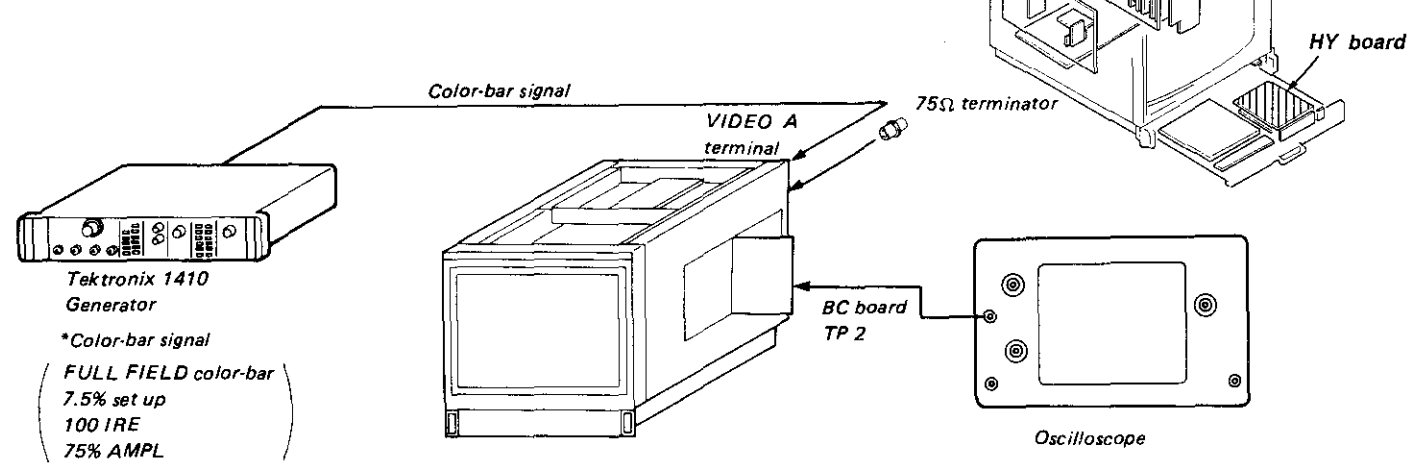

Fig. 9-2



**10. BC BOARD 3.58MHz to ADJUSTMENT (BVM-1916 ONLY)**



- YC SEP button (SUB CONTROL PANEL) ..... TRAP
1. Input color-bar signal to the VIDEO A terminal of the set.
  2. Connect an oscilloscope to the TP2 of BC board.
  3. Short-circuit between TP6 and TP7 of BC board with a jumper wire.
  4. Adjust CV2 of BC board so that the output waveform is shifted slowly as shown in Fig. 10-1.
  5. Turn off the power of this monitor, and disconnect TP6 and TP7 of BC board.

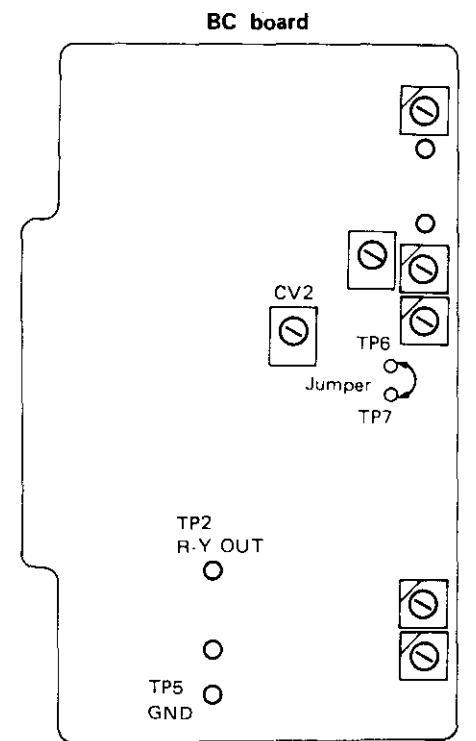
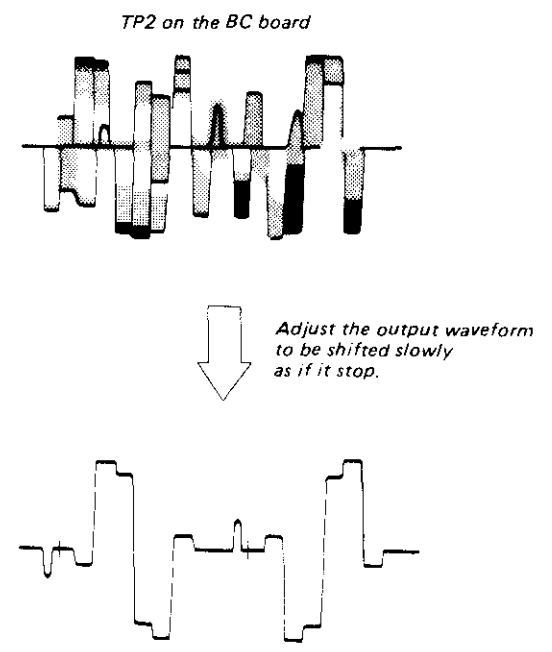
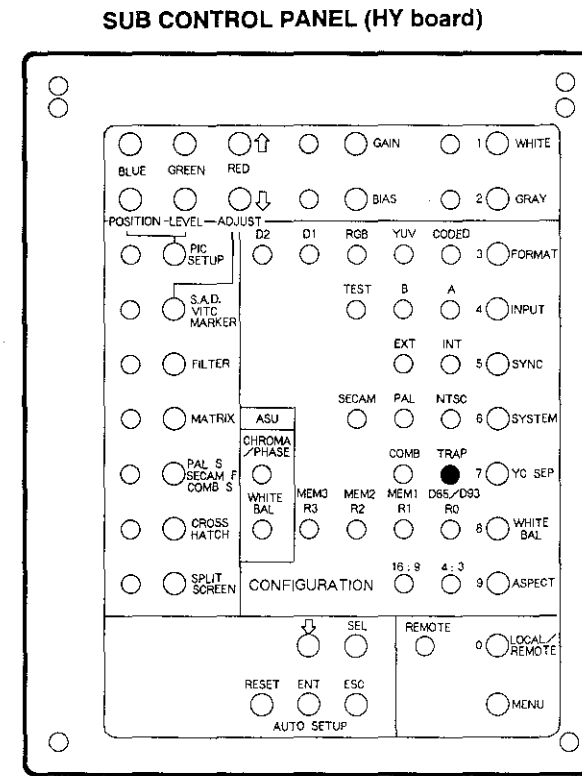
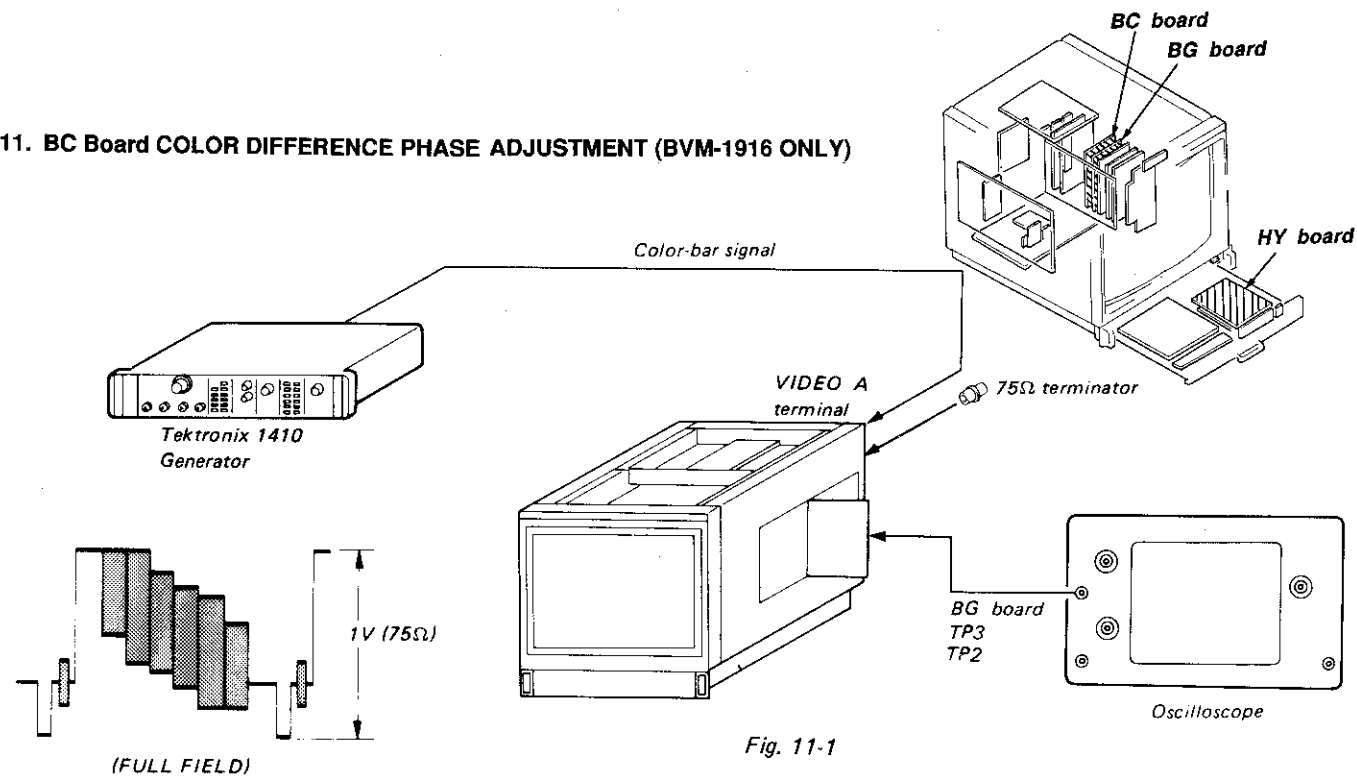

Fig. 10-1

### 11. BC Board COLOR DIFFERENCE PHASE ADJUSTMENT (BVM-1916 ONLY)



- YC SEP button (SUB CONTROL PANEL) ..... TRAP
1. Complete the connections as shown in Fig. 11-1.
  2. Turn on the power of this monitor.

#### B-Y System Adjustment

3. Connect the oscilloscope probe to TP3 on the BG board, and turn off the (B-Y) signal of the signal generator.
4. Set the oscilloscope sensitivity to 20mV/DIV, and adjust RV2 on the BC board so that the output waveform is flat. (See Fig. 11-2.)

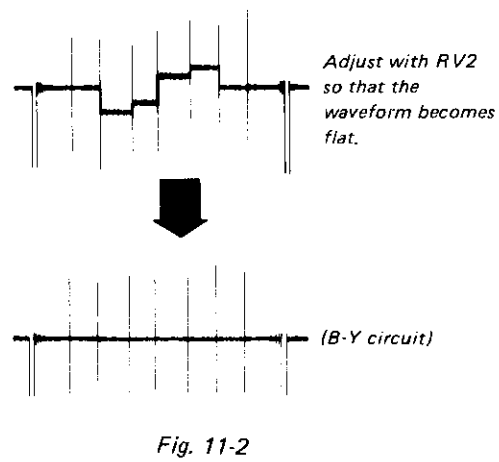

#### Quad Adjustment

5. Connect the oscilloscope probe to TP2 on the BG board. Turn on the B-Y signal of the signal generator, and turn off the (R-Y) signal. Then adjust CV1 on the BC board so that the output waveform is flat. (See Fig. 11-3)
6. Repeat the steps 3 to 6.

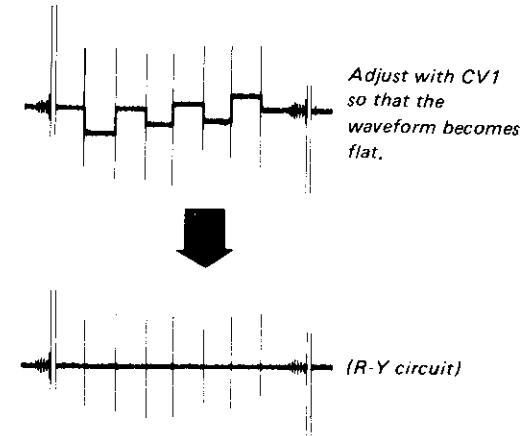

#### SUB CONTROL PANEL (HY board)

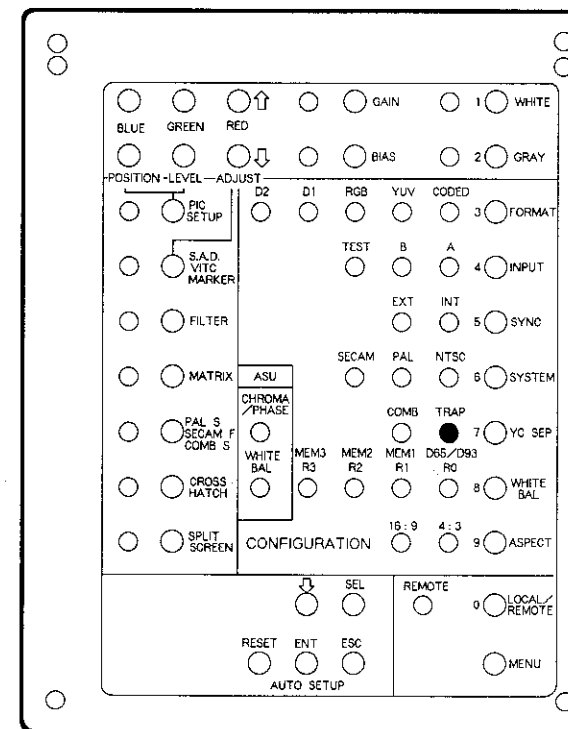

#### BC Board

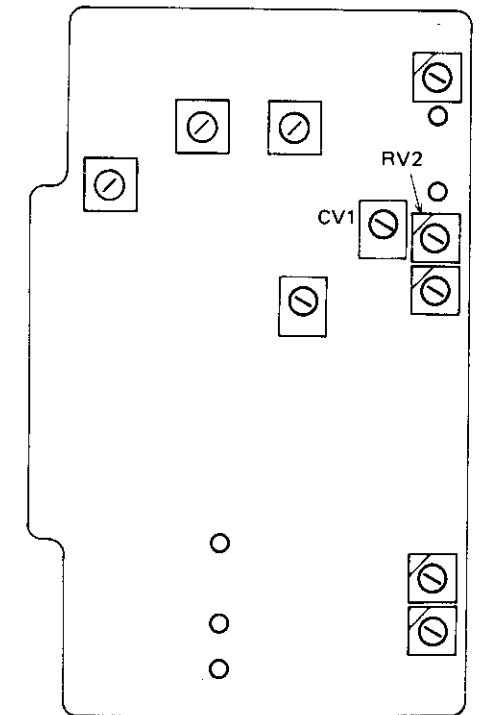

#### BG Board

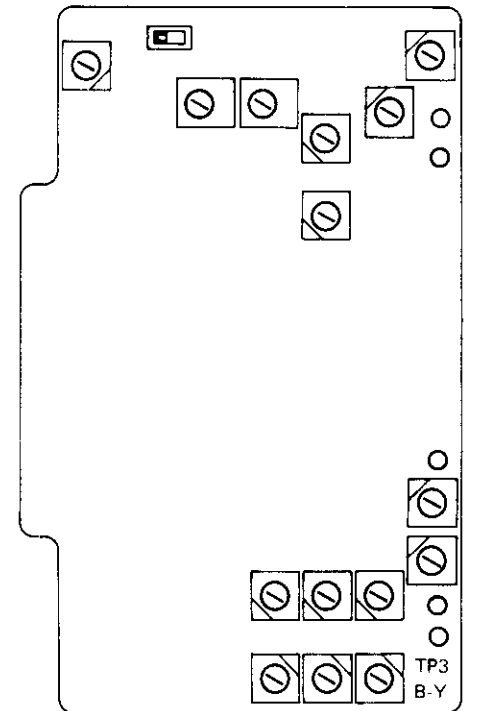

**12. BC Board COLOR DIFFERENCE LEVEL ADJUSTMENT (BVM-1916 ONLY)**

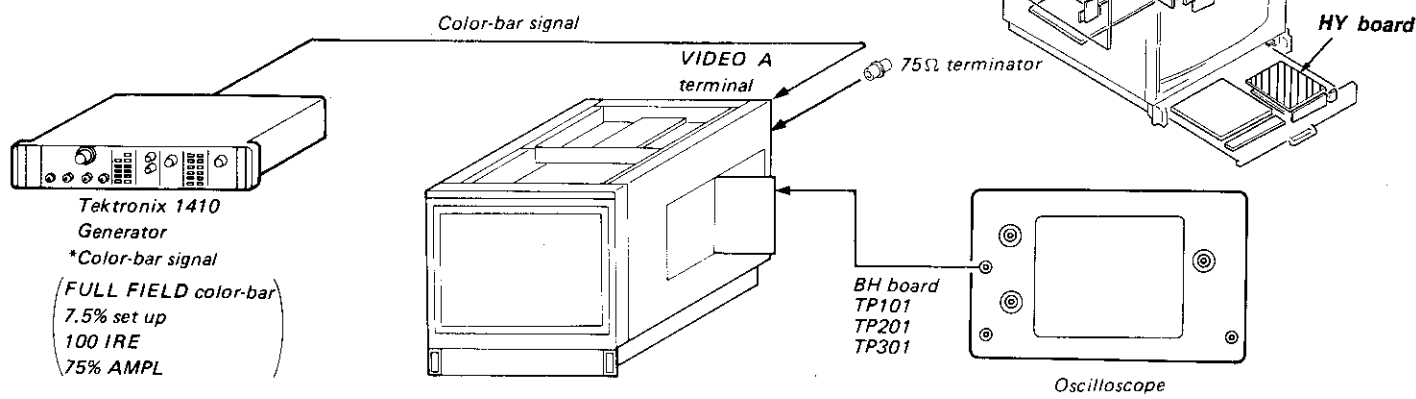

• YC SEP button (SUB CONTROL PANEL) ..... TRAP

1. Input color-bar signal to the VIDEO A terminal of the set.
2. Connect an oscilloscope to the TP101 of BH board.
3. Adjust RV4 of BC board so that the levels with  $\oplus$  is flat as shown in Fig. 12-1.

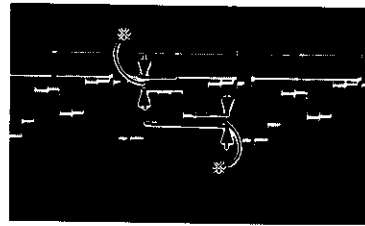

TP101 R OUT

Fig. 12-1

\* Adjust the levels with  $\oplus$  to be flat respectively using RV4 of BC board.

4. Connect an oscilloscope to the TP301 of BH board.
5. Adjust RV5 of BC board so that the output waveform as shown in Fig. 12-2.

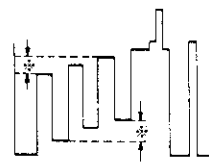

TP301 B OUT

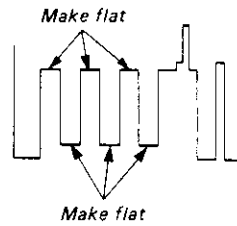
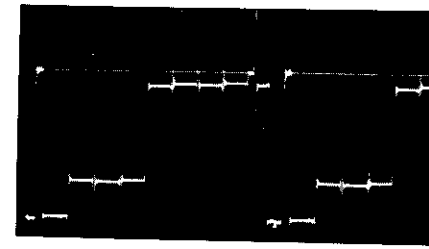

Fig. 12-2

6. Connect an oscilloscope to the TP201 of BH board.
7. Adjust RV4 and RV5 of BG board so that the INPUT waveform becomes flat as shown in Fig. 12-3.



TP201 G OUT

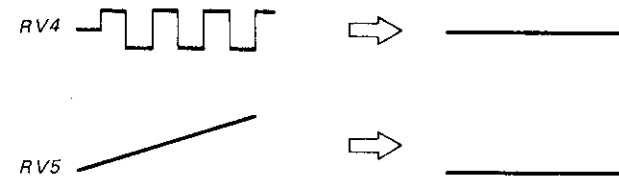
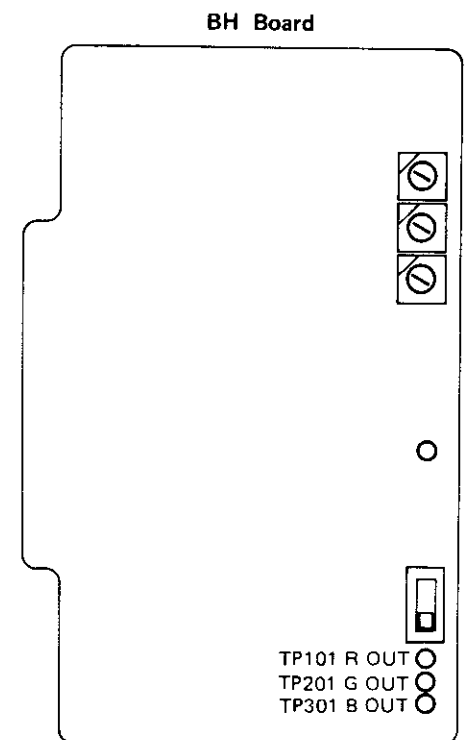
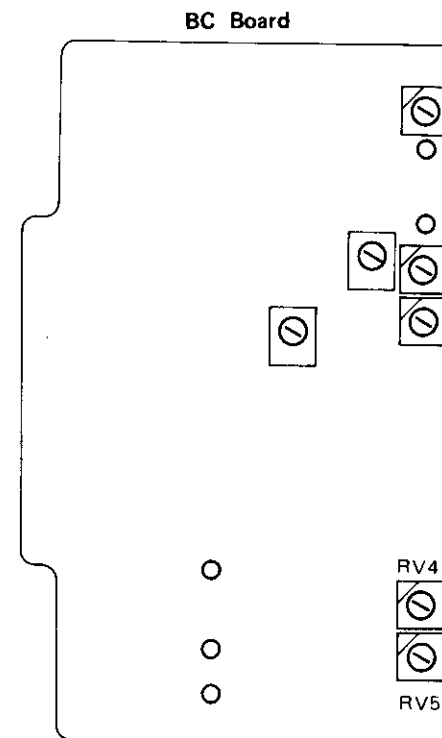
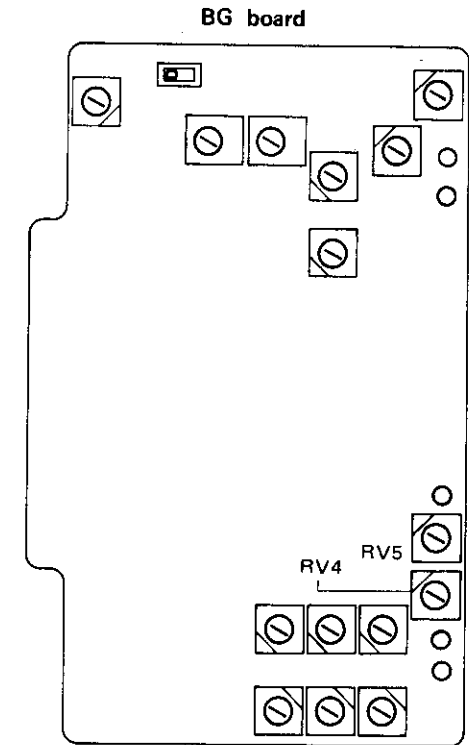
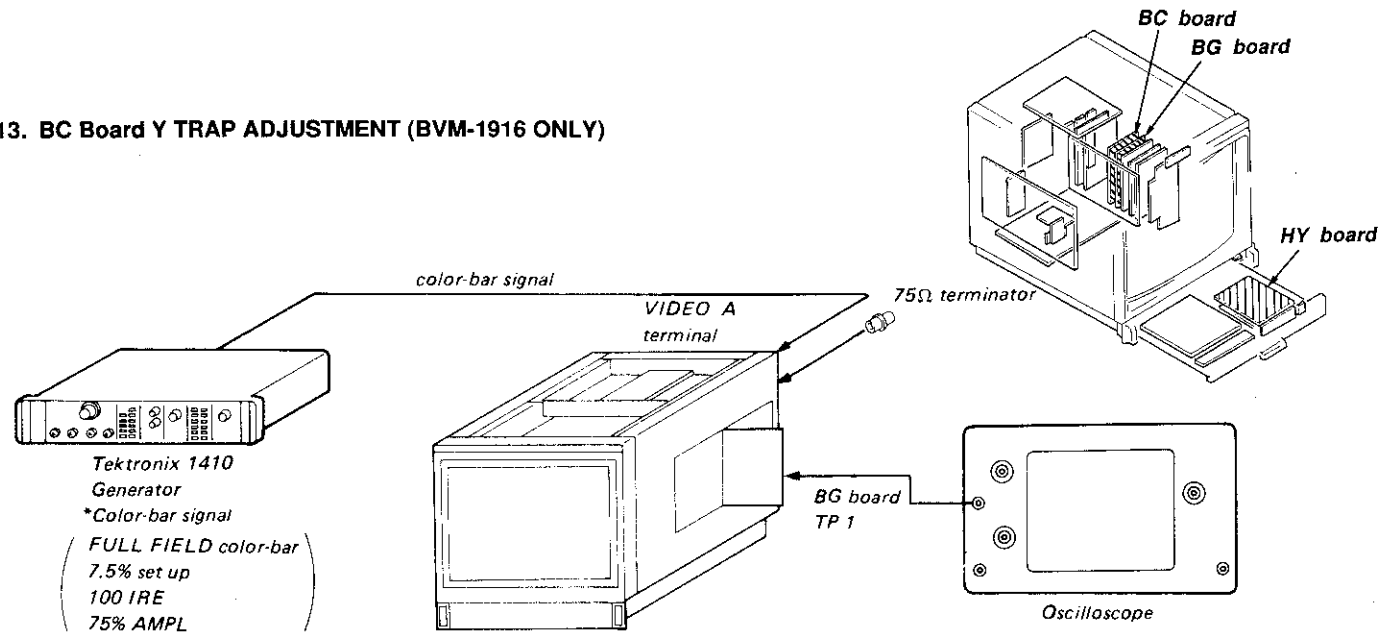

Fig. 12-3





**13. BC Board Y TRAP ADJUSTMENT (BVM-1916 ONLY)**



- COLOR SYSTEM button (SUB CONTROL PANEL)..... NTSC
  - YC SEP button (SUB CONTROL PANEL) ..... TRAP
1. Input color-bar signal to VIDEO A terminal of the set.

2. Connect an oscilloscope to the TP1 of BG board.  
 3. Adjust L1 of BC board so that 3.58MHz subcarrier is minimum as shown in Fig. 13-1.

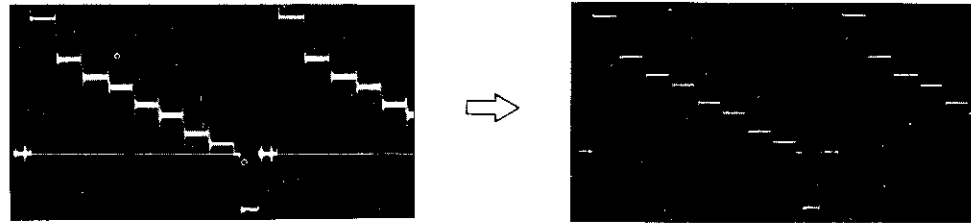
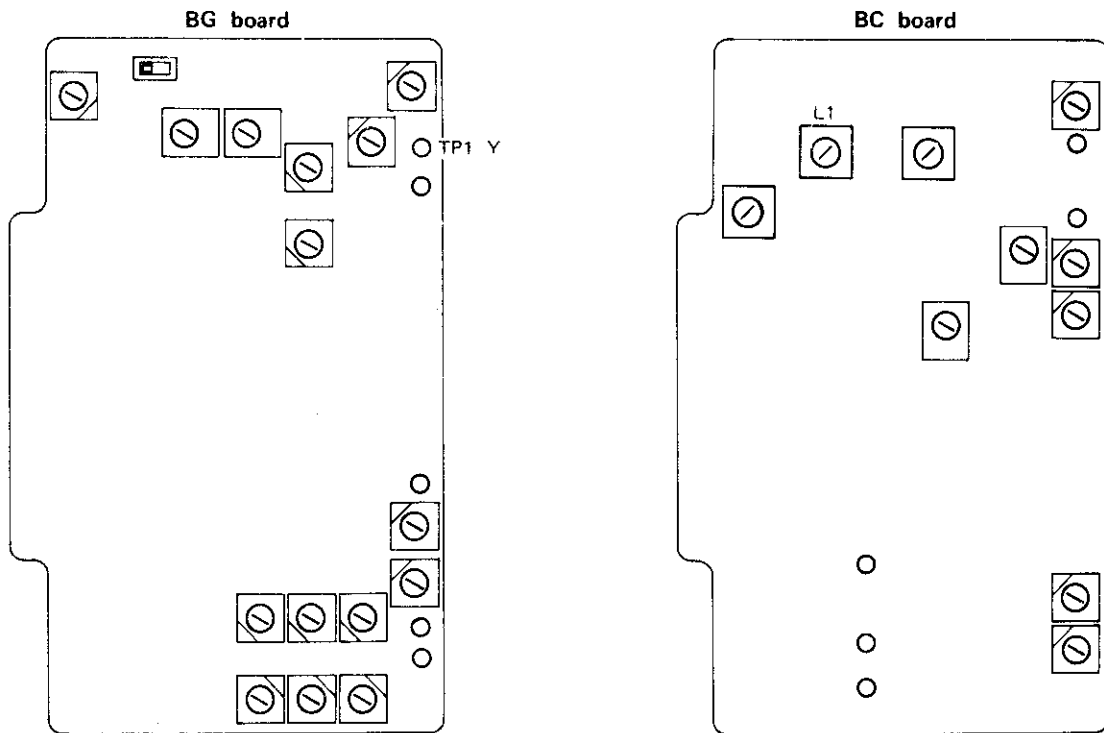
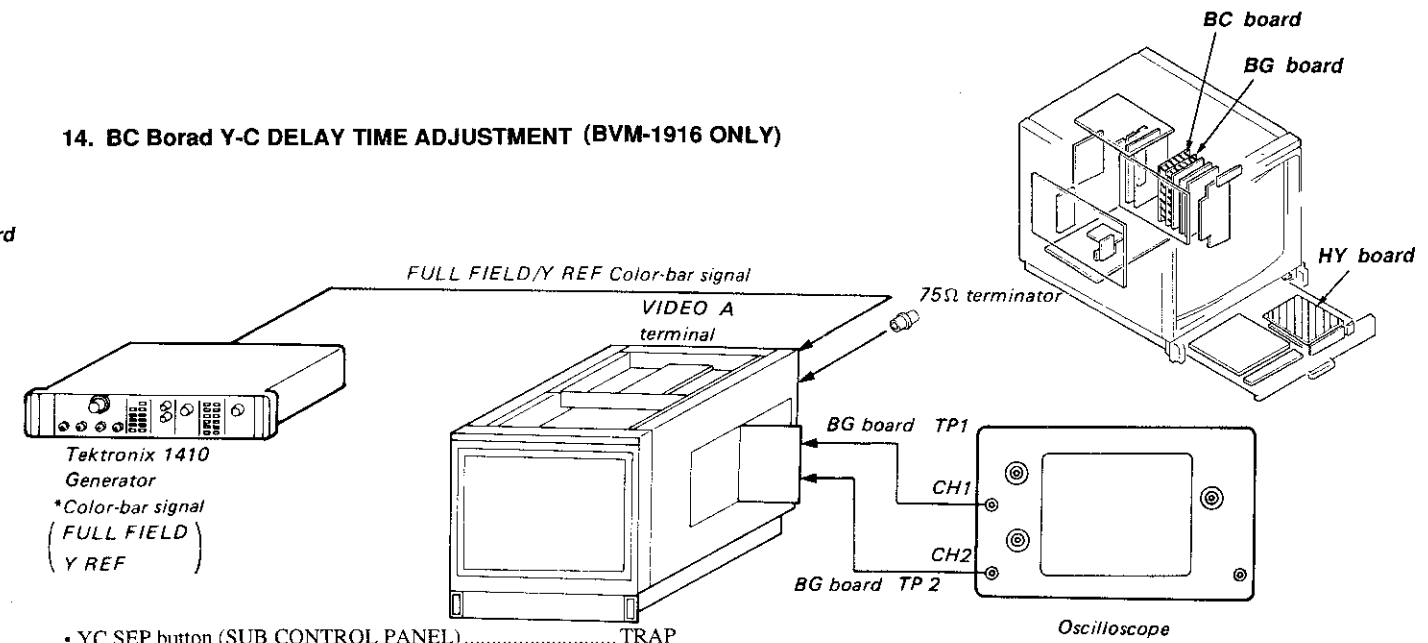

Fig. 13-1



**14. BC Board Y-C DELAY TIME ADJUSTMENT (BVM-1916 ONLY)**



- YC SEP button (SUB CONTROL PANEL)..... TRAP
1. Input color-bar signal (FULL FIELD/Y REF) to the VIDEO A terminal of the set.  
 2. Connect an oscilloscope (CH-1 probe) to the TP1 of BG board and connect an oscilloscope (CH-2 probe) to the TP2 of BG board (VERT mode of the oscilloscope is CHOP).  
 3. Adjust RV1 of BC board so that the output waveform as shown in Fig. 14-1.

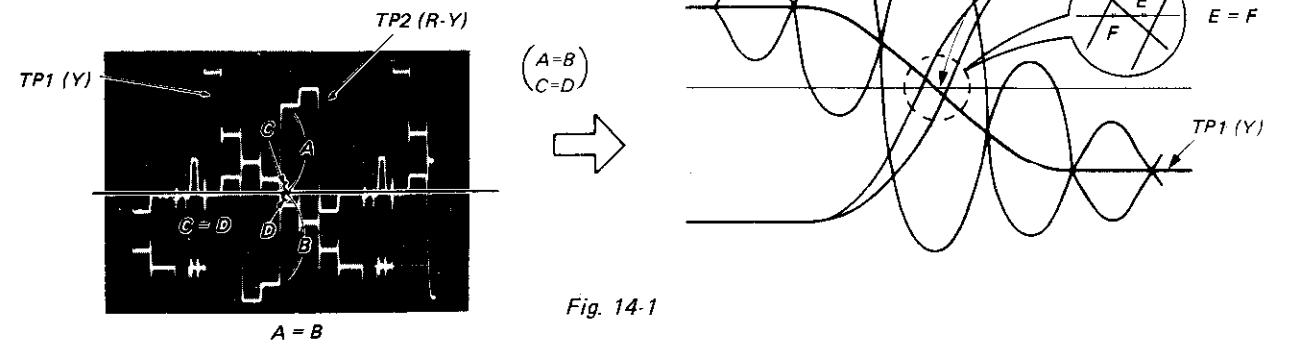
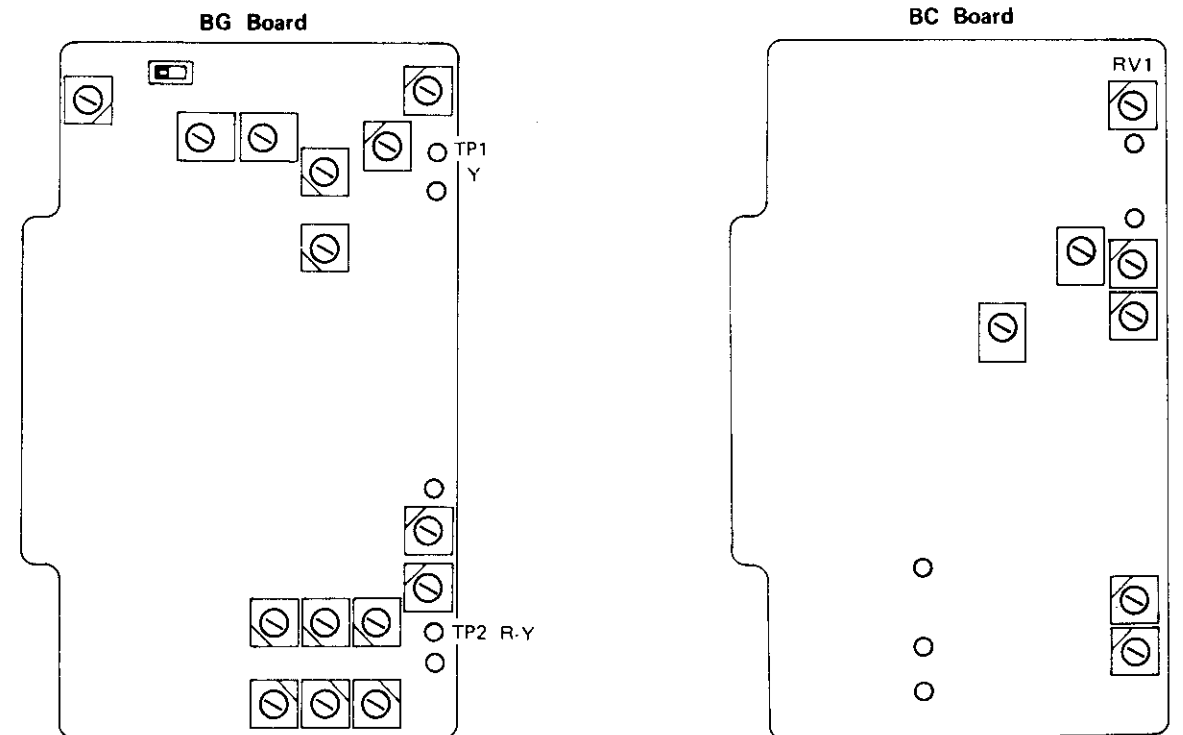
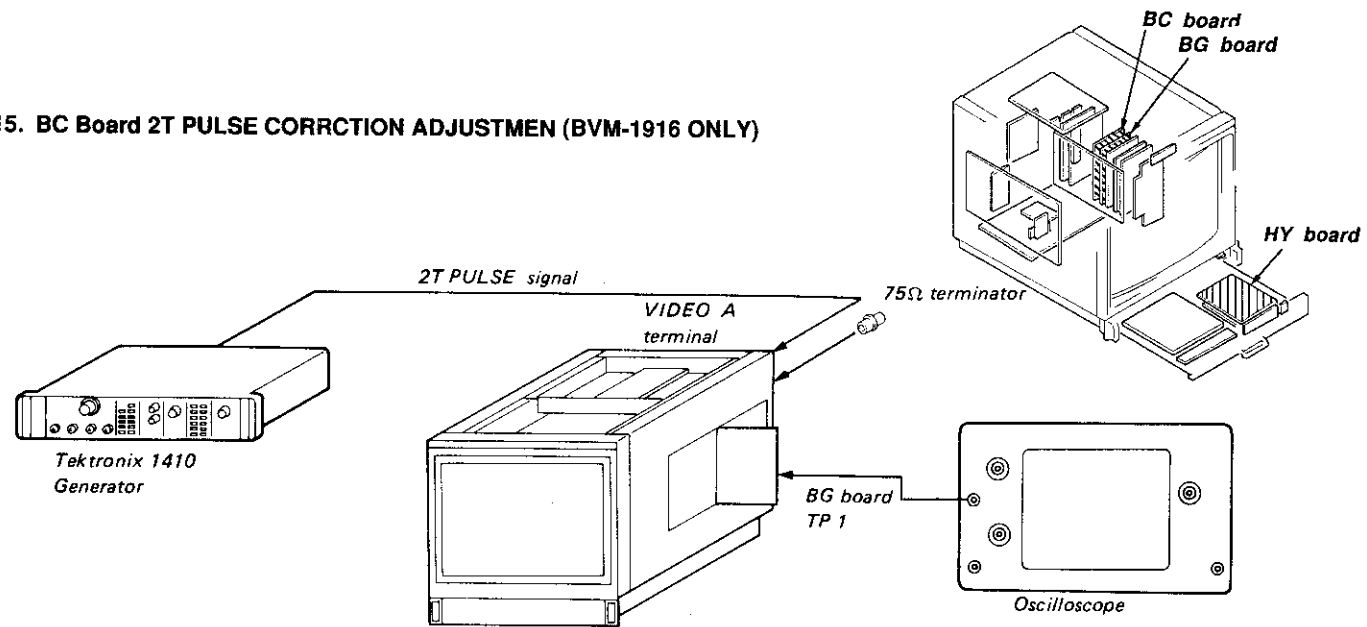

Fig. 14-1



### 15. BC Board 2T PULSE CORRECTION ADJUSTMEN (BVM-1916 ONLY)



• YC SEP button (SUB CONTROL PANEL) ..... TRAP

1. Input 2T pulse signal to VIDEO A terminal of the set.
2. Connect an oscilloscope to the TP1 of BG board.
3. Adjust L2 of BC board so that A is equal to B as shown in Fig. 15-1.
4. Change the input signal from 2T pulse to T pulse, and make sure the waveform balance is not lost extremely as shown in Fig. 15-1.

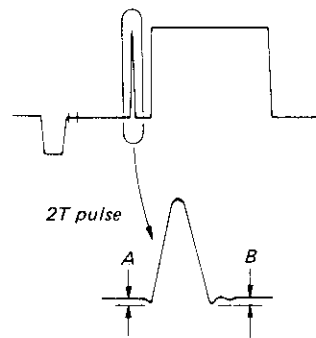

\* Adjust L2 to obtain the condition A = B.

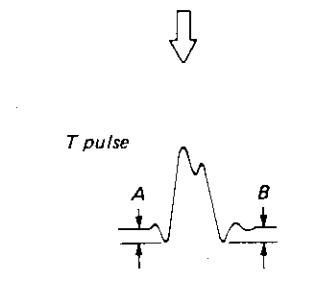
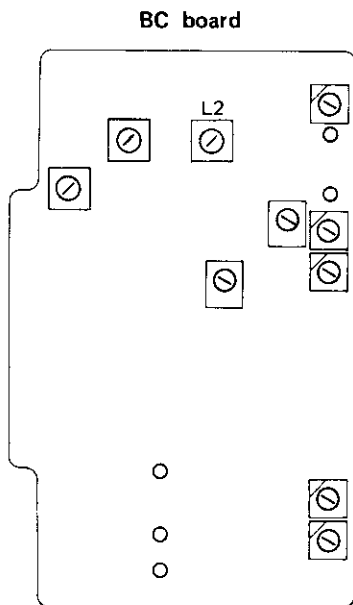

\* The waveform balance should not be lost extremely.

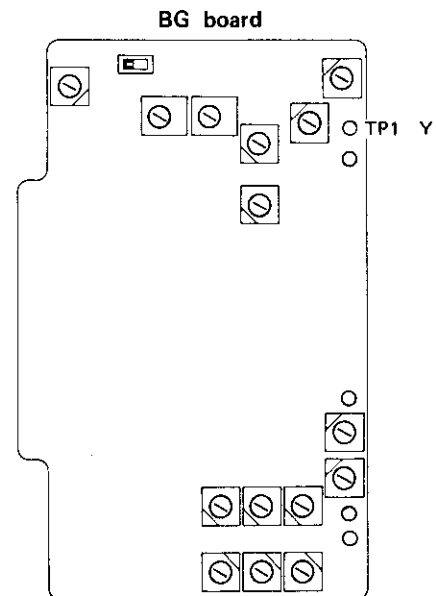
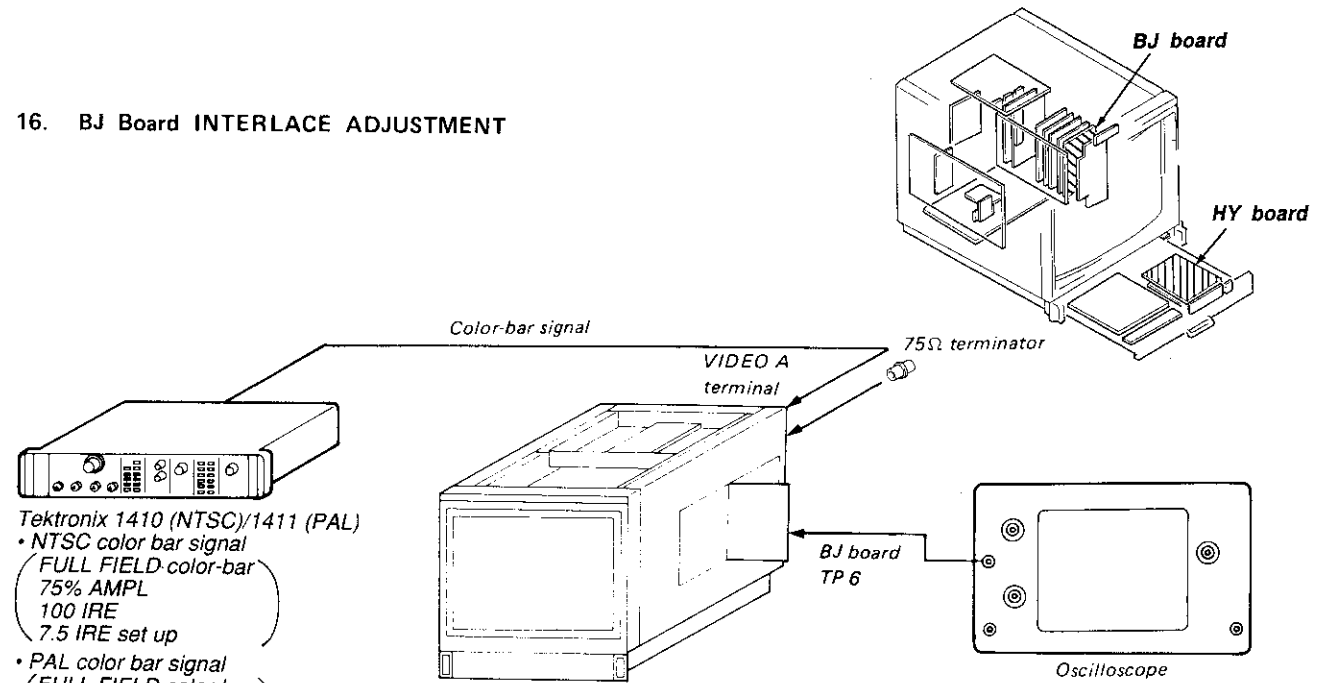

Fig. 15-1

### 16. BJ Board INTERLACE ADJUSTMENT



Tektronix 1410 (NTSC)/1411 (PAL)  
 • NTSC color bar signal  
 (FULL FIELD color-bar)  
 75% AMPL  
 100 IRE  
 7.5 IRE set up  
 • PAL color bar signal  
 (FULL FIELD color-bar)  
 75% AMPL  
 100 IRE

• YC SEP button (SUB CONTROL PANEL) ..... TRAP

1. Input color-bar signal to the VIDEO A terminal of the set.
2. Connect an oscilloscope to the TP6 on the BJ board.
3. Adjust RV6 to obtain the waveform on the oscilloscope as shown in Fig. 16-1.

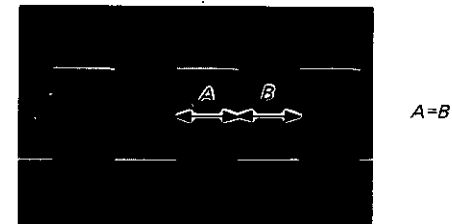
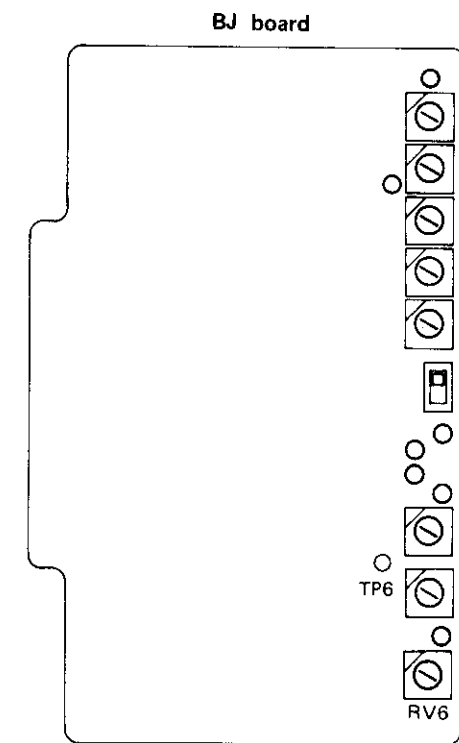
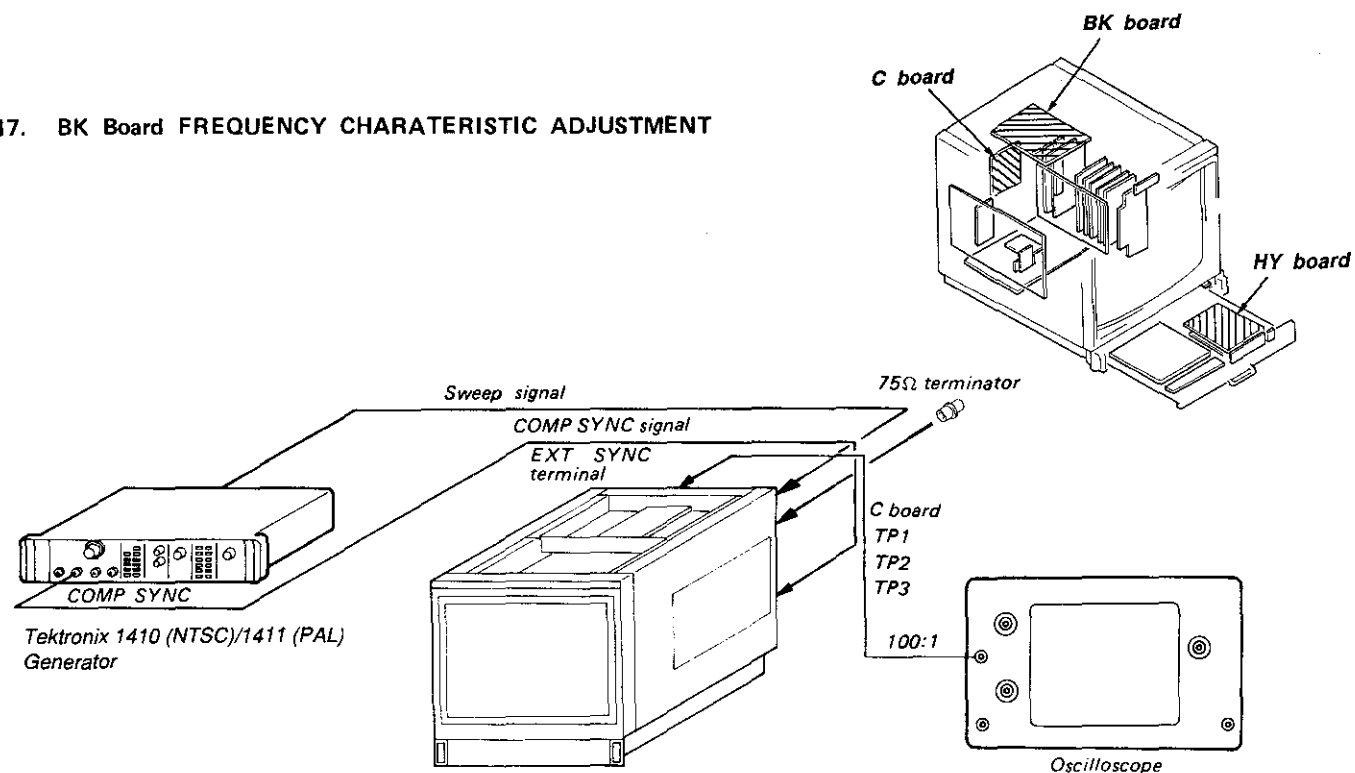

Fig. 16-1



17. BK Board FREQUENCY CHARACTERISTIC ADJUSTMENT



1. Input SWEEP signal to VIDEO A terminal of the set, and input COMP SYNC signal to EXT SYNC terminal of the set.
  - SYNC button (SUB CONTROL PANEL) ..... EXT
  - MODE selector (FRONT PANEL) ..... MONO (  )
  - FILTER button (SUB CONTROL PANEL) ... OFF
2. Connect an oscilloscope to the TP1 on the C board.  
\*Probe: 100:1
3. Adjust CV101 and RV101 on the BK board so that output waveform becomes flat in a range of 0 to 8MHz as shown in Fig. 17-1.
4. Connect an oscilloscope to the TP2 on the C board.
5. Adjust CV201 and RV201 on the BK board so that output waveform becomes flat in a range of 0 to 8MHz as shown in Fig. 17-1.
6. Connect an oscilloscope to the TP3 on the C board.
7. Adjust CV301 and RV301 on the BK board so that output waveform becomes flat in a range of 0 to 8MHz as shown in Fig. 17-1.

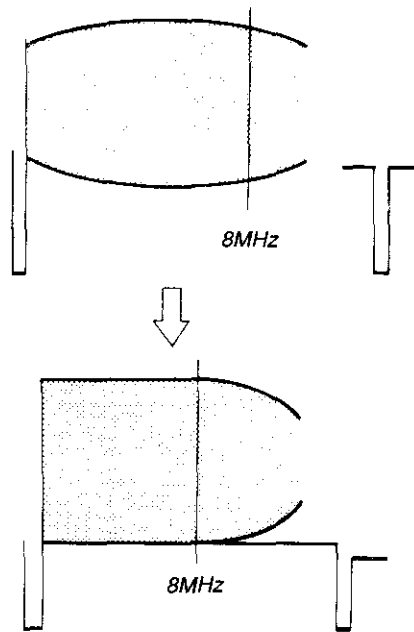
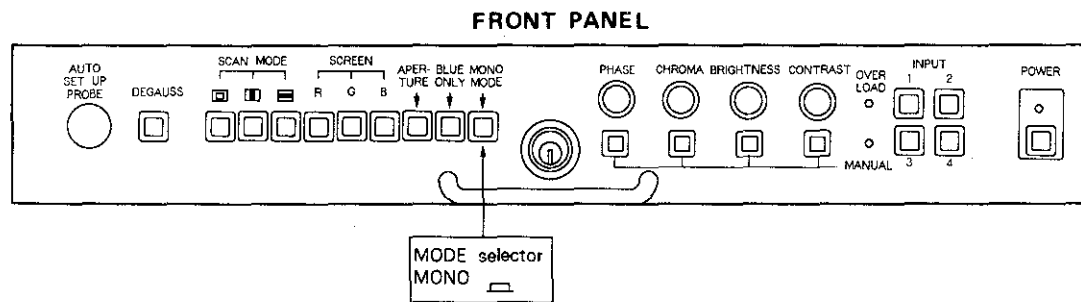
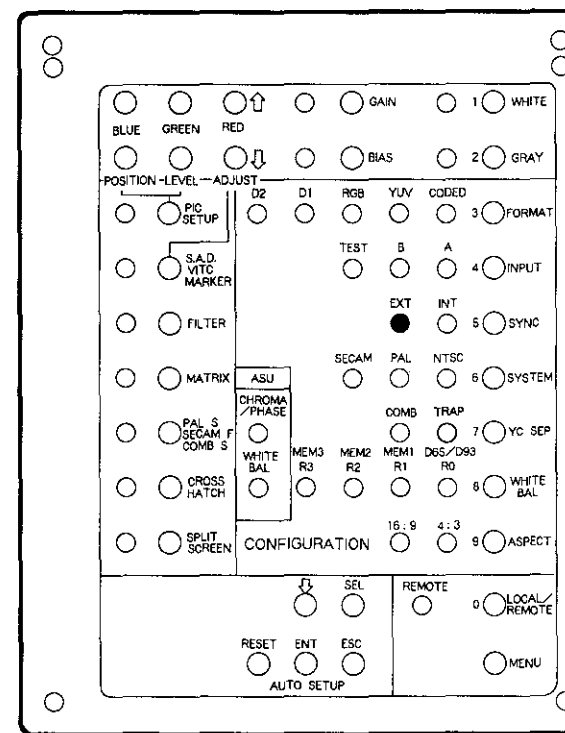

Fig. 17-1



SUB CONTROL PANEL (HY board)



C board

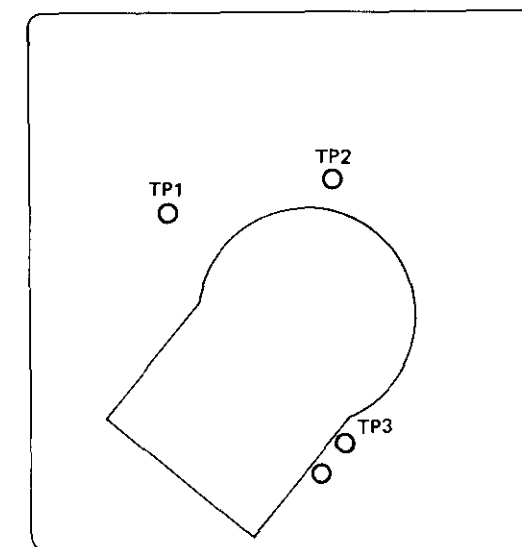

BK board

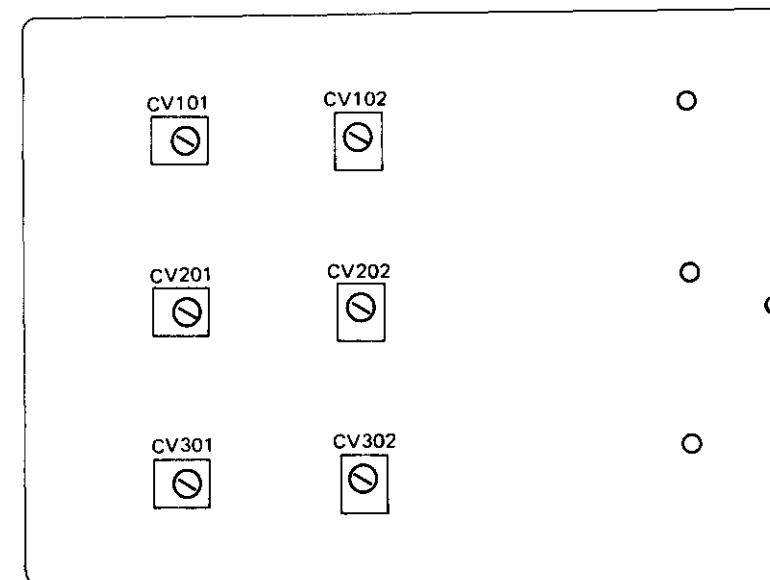

## 18. BT Board COMB FILTER ADJUSTMENT (BVM-1916 ONLY)

### 18-1. BT Board Partial Adjustment

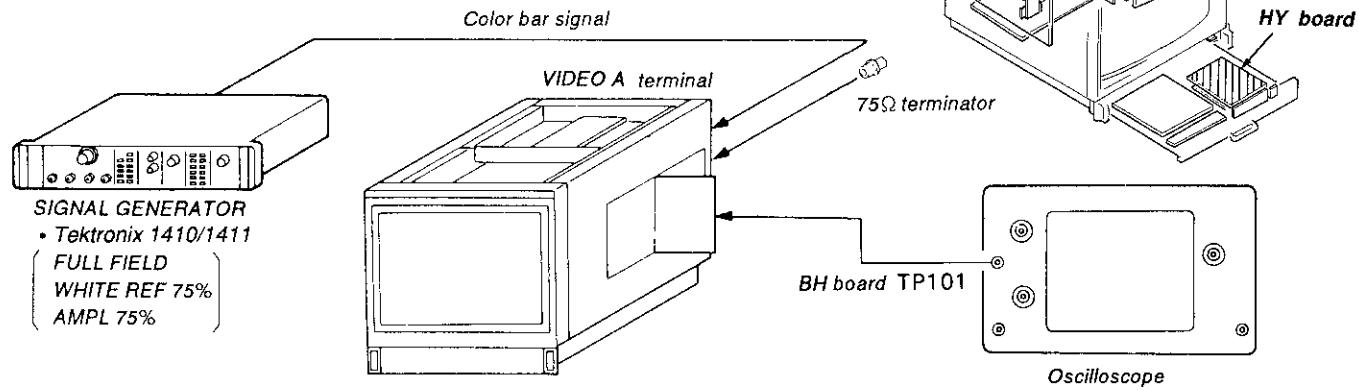

#### Luminance Level Adjustment

1. Feed a color bar signal to VIDEO A INPUT terminal of this set.
2. Set the YC SEP button on the sub control panel to TRAP position.
3. Connect the oscilloscope to TP101 (R OUT) on the BH board. (DC 0.1 V/div:H)
4. Turn the POSITION control of the oscilloscope to set the portion A (white) of Fig. 18-1 to the center of the oscilloscope.
5. Set the YC SEP button on the sub control panel to the COMB position.
6. Set the PAL S/SECAM F/COMB S button on the sub control panel to the ON.
7. Set the portion A (white) of Fig. 18-1 to the center of the oscilloscope using RV3 (luminance level) on the BT board.

#### Chroma Level Adjustment

1. Feed a color bar signal to VIDEO A INPUT terminal of this set.
2. Set the YC SEP button on the sub control panel to the TRAP position.
3. Connect the oscilloscope to TP101 on the BH board. (DC 0.1 V/div:H)
4. Turn the POSITION control of the oscilloscope to set the portion A (white) of Fig. 18-1 to the center of the oscilloscope.
5. Set the YC SEP button to the COMB position.
6. Set the PAL S/SECAM F/COMB S button on the sub control panel to the ON.
7. Set the portion B (red) of Fig. 18-1 to the center of the oscilloscope using RV8 (chroma level) on the BT board.

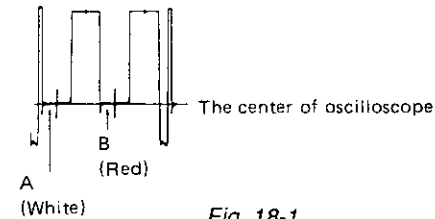

**Note:** Never attempt to turn the following parts as these cannot be easily adjusted.  
FL1, FL2, FL3, DL3, DL5, DL6, DL8

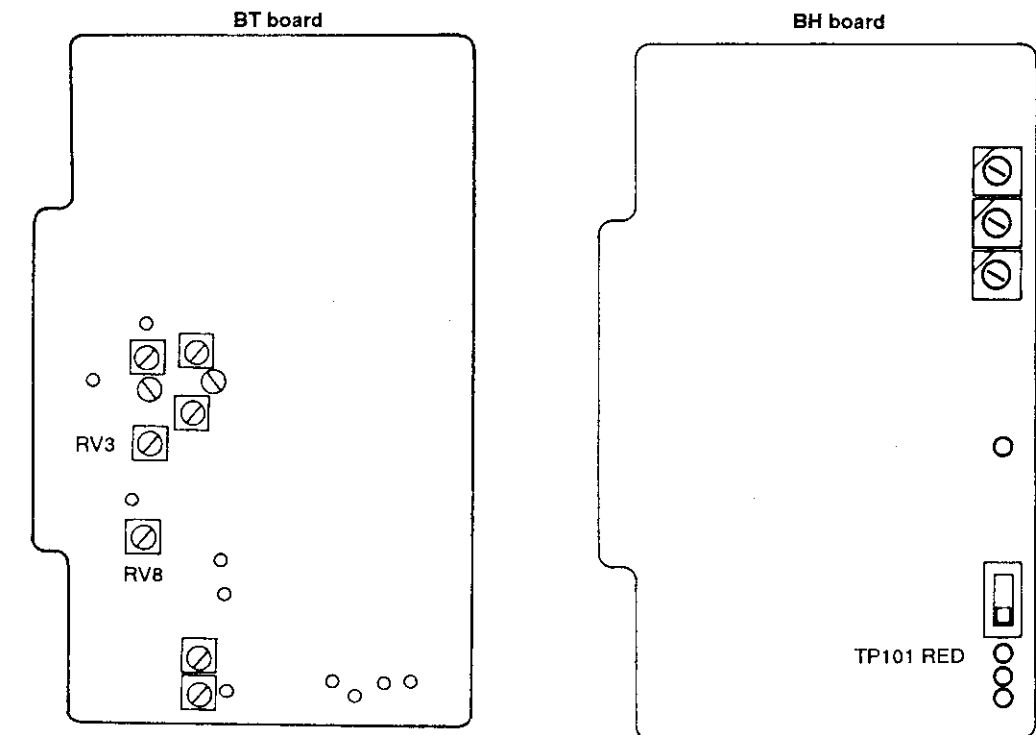
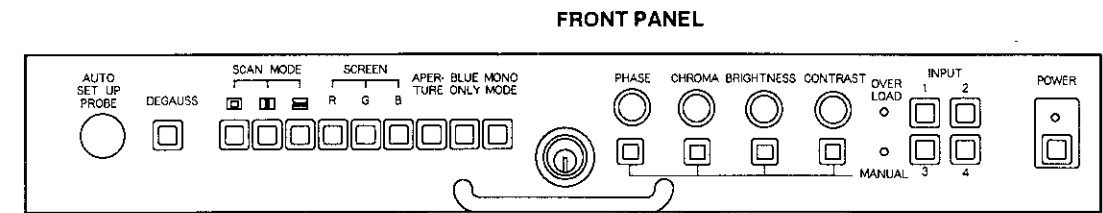

#### SUB CONTROL PANEL (HY board)

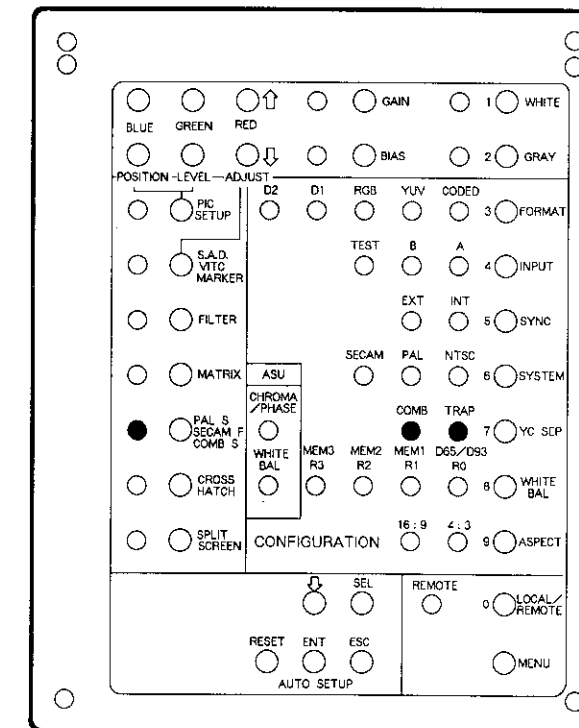

## 18-2. BT Board Total Adjustment

### 18-2-1. BT Board Luminance Level Adjustment

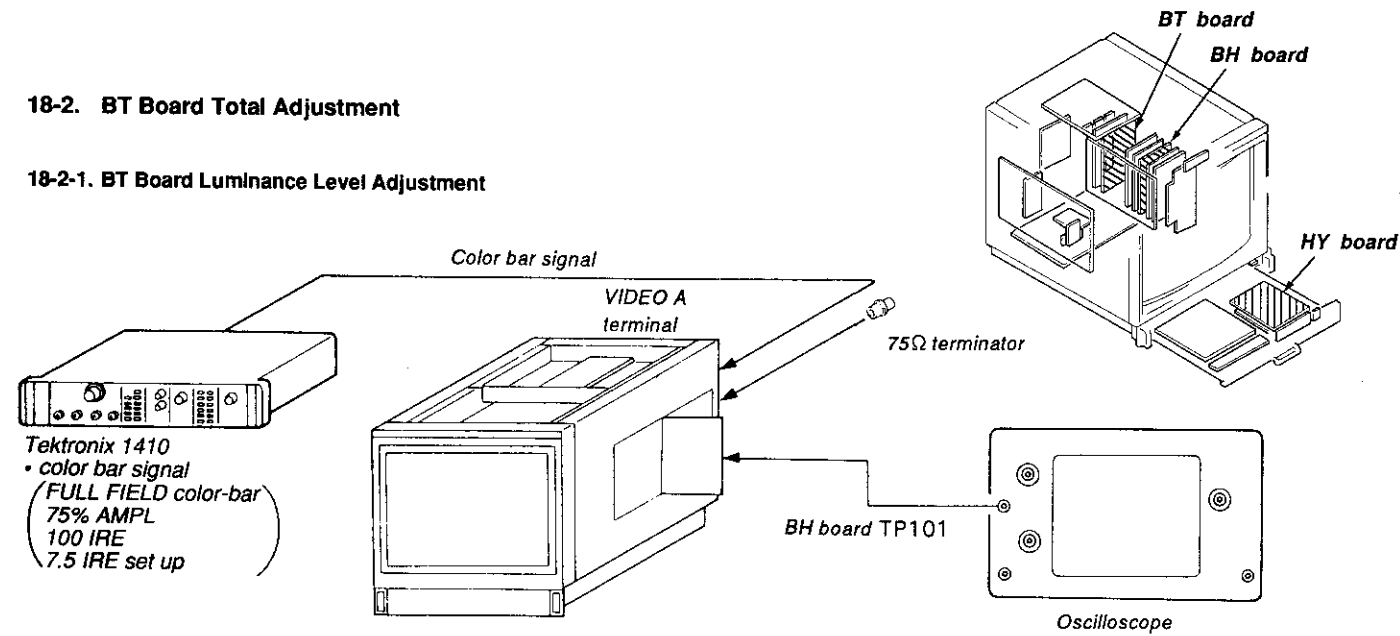

1. Feed a color bar signal to VIDEO A INPUT terminal of this set.
2. Set the YC SEP switch on the sub control panel to the TRAP position.
3. Connect the oscilloscope to TP101 (R OUT) on the BH board. (DC 0.1 V/div:H)
4. Turn the POSITION control of the oscilloscope until the portion A (white) of Fig. 18-2 is set to the center of the oscilloscope.
5. Set the YC SEP button to the COMB position.
6. Set the PAL S/SECAM F/COMB S button on the sub control panel to the ON.
7. Set the portion A (white) of Fig. 18-2 to the center of the oscilloscope using RV3 (luminance level) on the BT board.
8. Set the PAL S/SECAM F/COMB S button to the OFF.
9. Set the portion A (white) of Fig. 18-2 to the center of the oscilloscope using RV9 (1H luminance level) on the BT board.

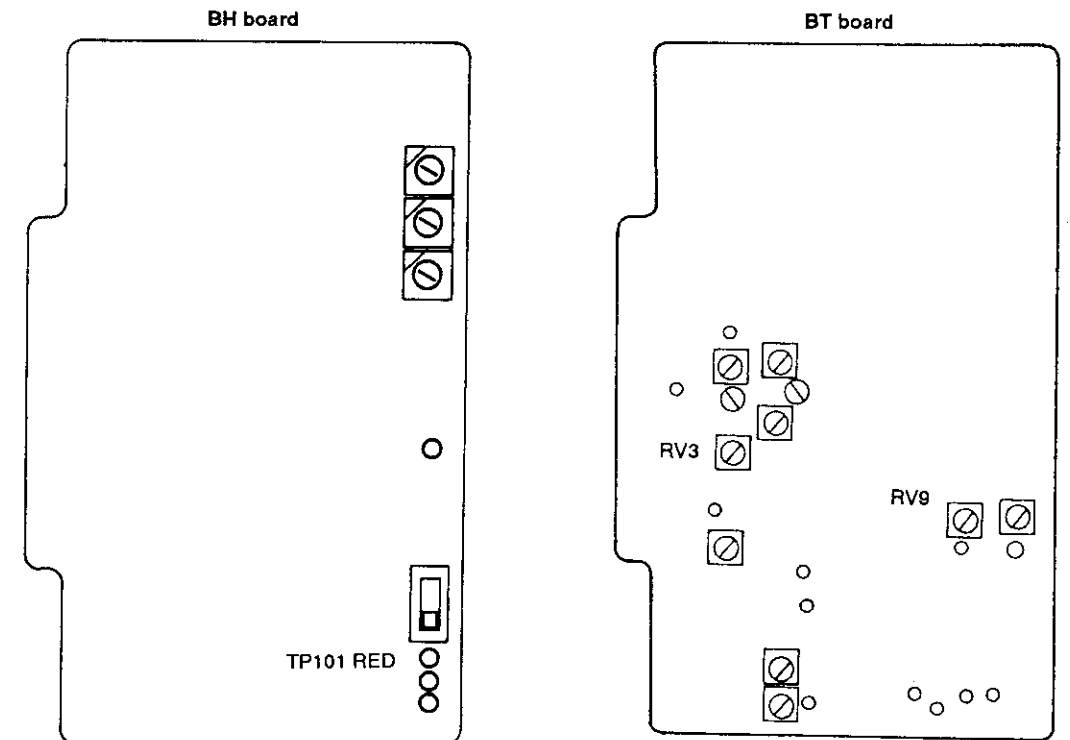
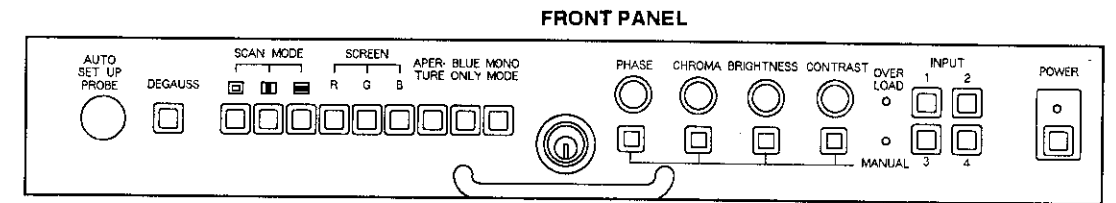
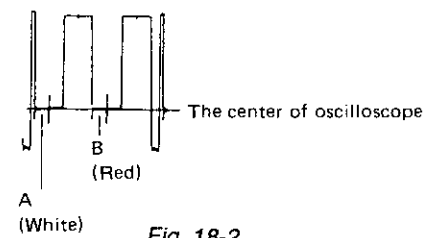

### SUB CONTROL PANEL (HY board)

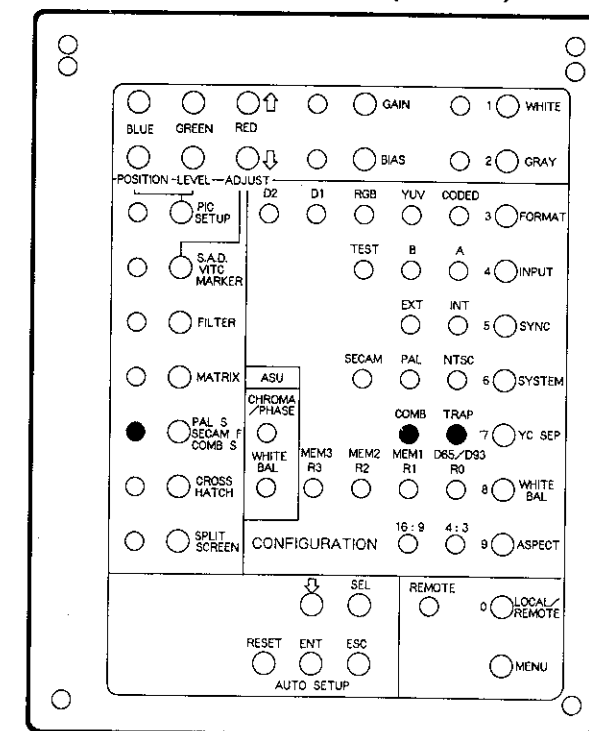

**18-2-2. BT Board Y System's Frequency Characteristics Adjustment**

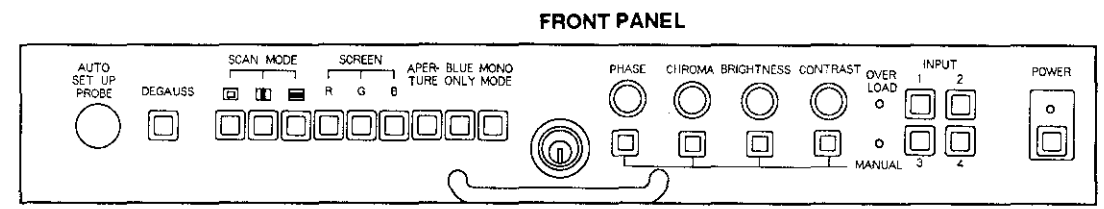
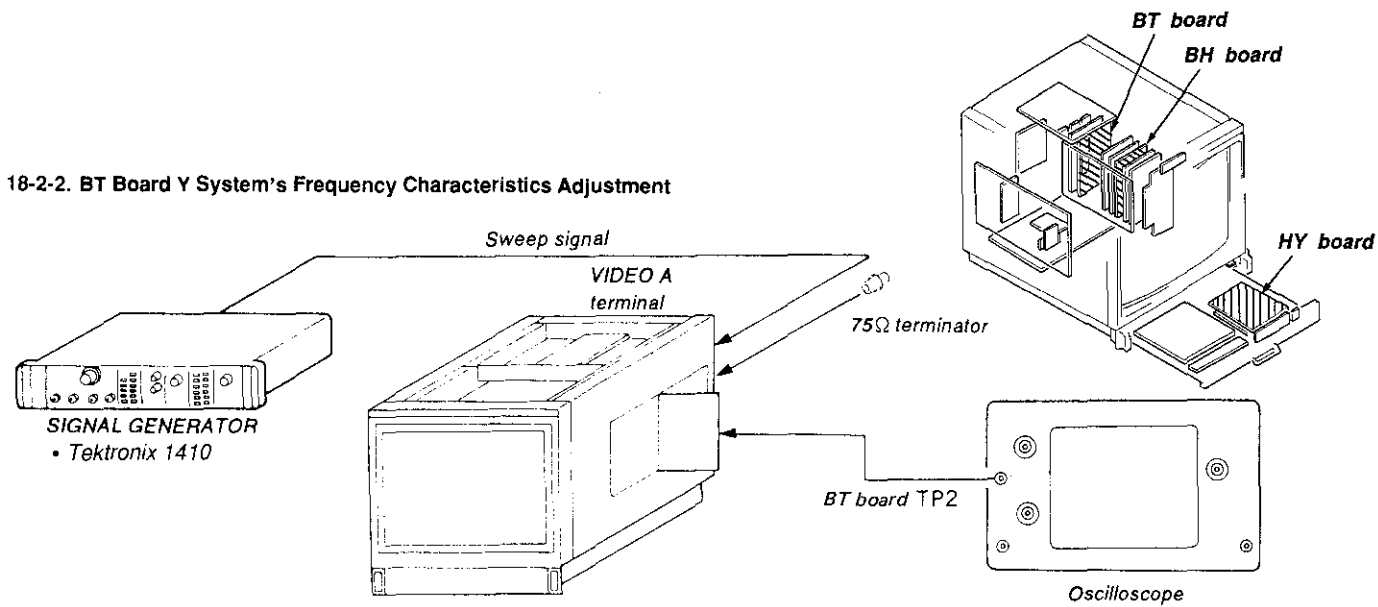

1. Feed a sweep signal to the VIDEO A INPUT terminal of this set.
2. Set the YC SEP switch on the sub control panel to the COMB position.
3. Connect the oscilloscope to TP2 on the BT board. (AC 0.1 V/div:V)
4. Set CV5 to the position as shown in Fig. 18-3.
5. Set the PAL S/SECAM F/COMB S button on the sub control panel to the ON.
6. Adjust the frequency characteristics until it is made flat using CV1 (Y FREQ) on the BT board. If it cannot be properly adjusted by using CV1, use CV5 (Y FREQ).
7. Set the PAL S/SECAM F/COMB S button to the OFF.
8. Adjust the frequency characteristics until it is made flat using CV2 (1H Y FREQ) on the BT board.
9. Set CV3 (CLK PHASE) and CV4 (CLK PHASE) on the BT board to the position as shown in Fig. 18-4.
10. Adjust the clock phase until it becomes just as shown in Fig. 18-5 using CV3.
11. If it cannot be adjusted with CV3, adjust with CV4 by returning CV3 to the position of Fig. 18-4.

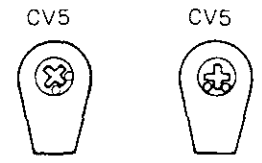

Fig. 18-3

Fig. 18-4

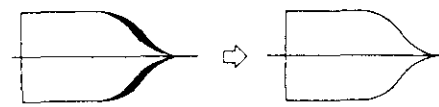
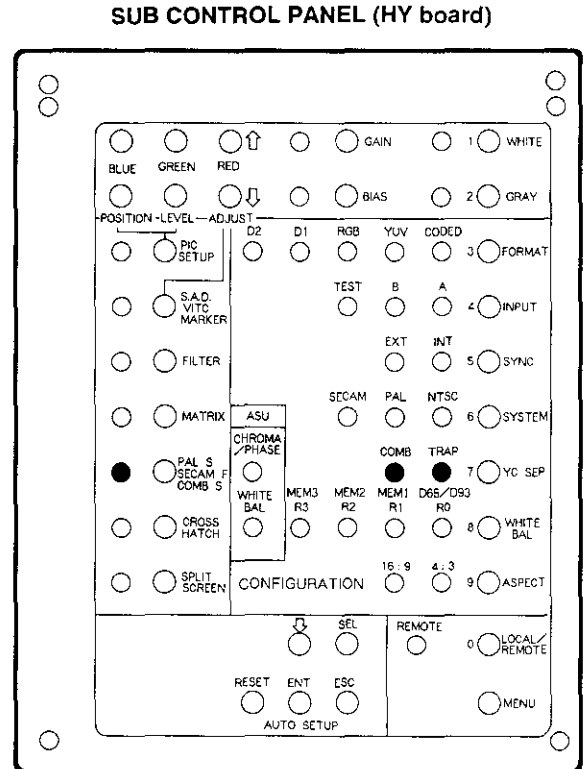
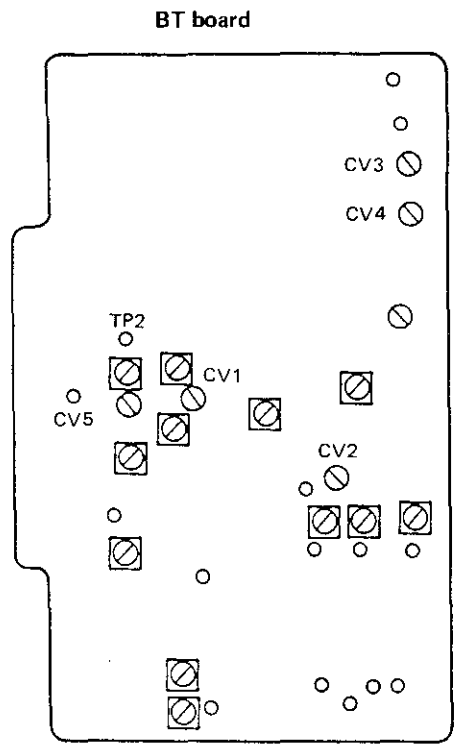
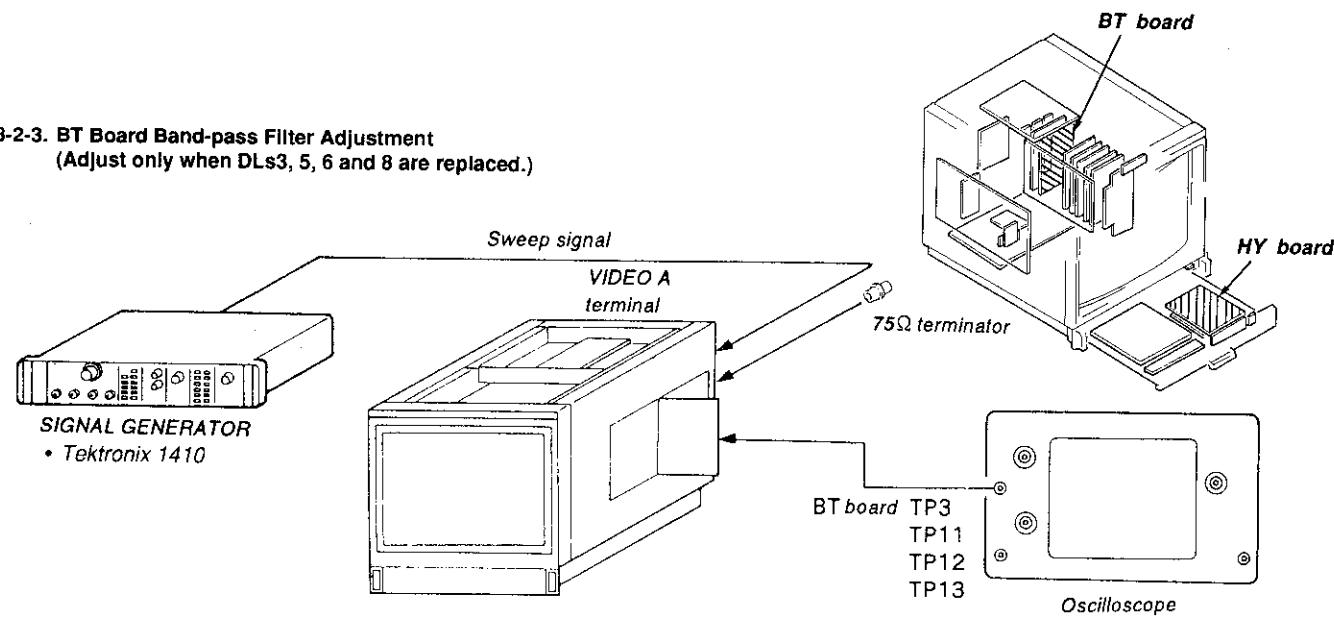

Fig. 18-5



**18-2-3. BT Board Band-pass Filter Adjustment**  
(Adjust only when DLs3, 5, 6 and 8 are replaced.)



1. Feed a sweep signal to the VIDEO A INPUT terminal of this set.
2. Set the PAL S/SECAM F/COMB S button on the front panel to the ON.
3. Connect the oscilloscope to TP11.
4. Adjust the frequency characteristics using DL3 on the BT board so that the waveform becomes symmetrical as shown in Fig. 18-5 with 3.58 MHz as center frequency.
5. Connect the oscilloscope to TP12.
6. Adjust the frequency characteristics using DL6 on the BT board so that the waveform becomes symmetrical as shown in Fig. 18-5 with 3.58 MHz as center frequency.
7. Connect the oscilloscope to TP13.
8. Adjust the frequency characteristics using DL8 on the BT board so that the waveforms becomes symmetrical as shown in Fig. 18-5 with 3.58 MHz as center frequency.
9. Connect the oscilloscope to TP3.
10. Adjust the frequency characteristics using DL5 on the BT board so that the waveforms becomes symmetrical as shown in Fig. 18-5 with 3.58 MHz as center frequency.

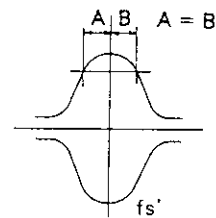
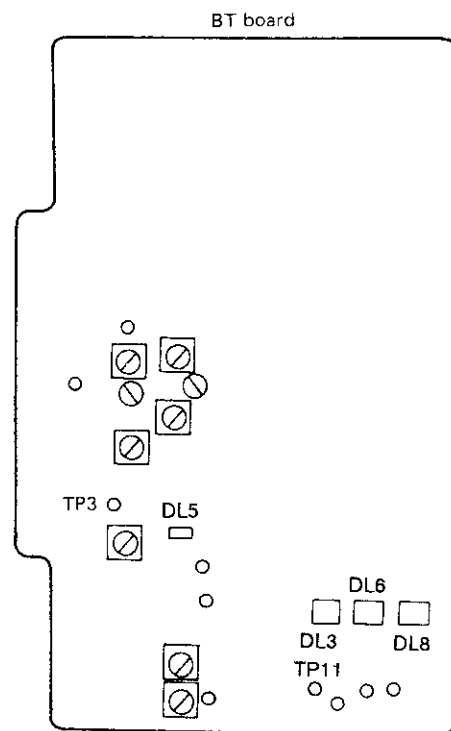
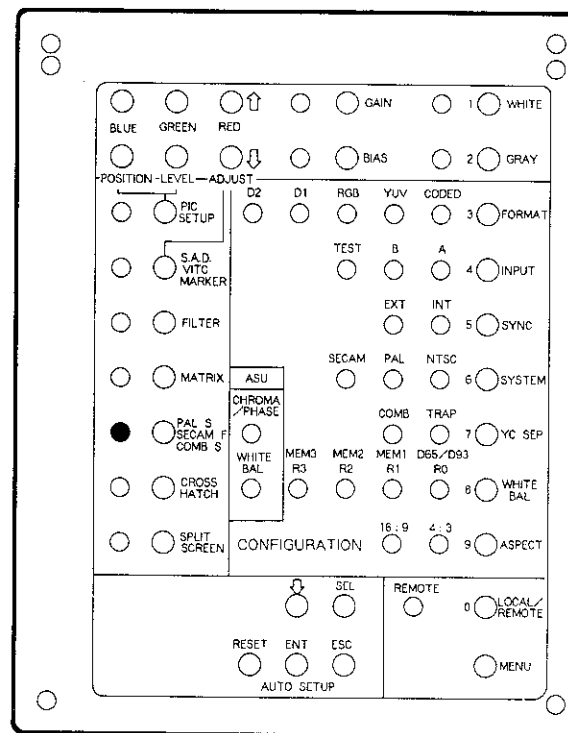

Fig. 18-6



**SUB CONTROL PANEL (HY board)**



**18-2-4. BT Board Clock to Adjustment**

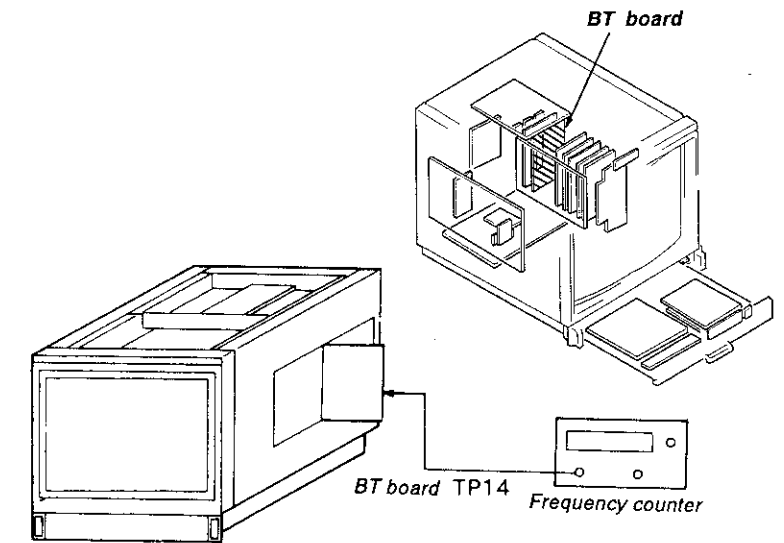

1. Connect the frequency counter to TP14.
2. Make adjustment as shown below using CV6<sup>1</sup> (CLK FREQ) on the BT board.  
• fo=21.477 MHz

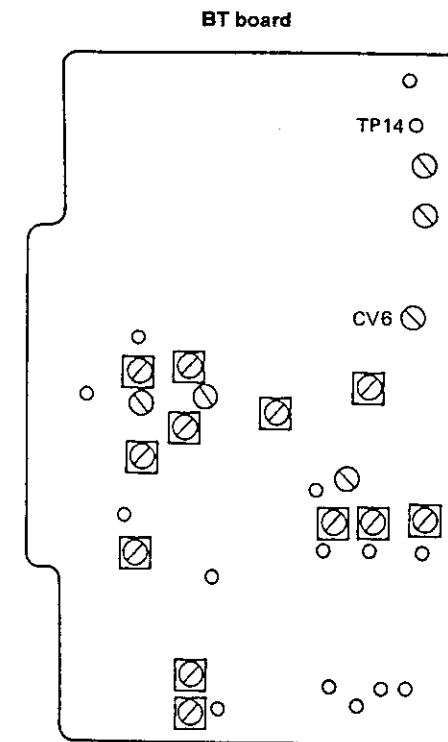

**18-2-5. BT Board 0H/1H, 1H/2H MIX Adjustment**

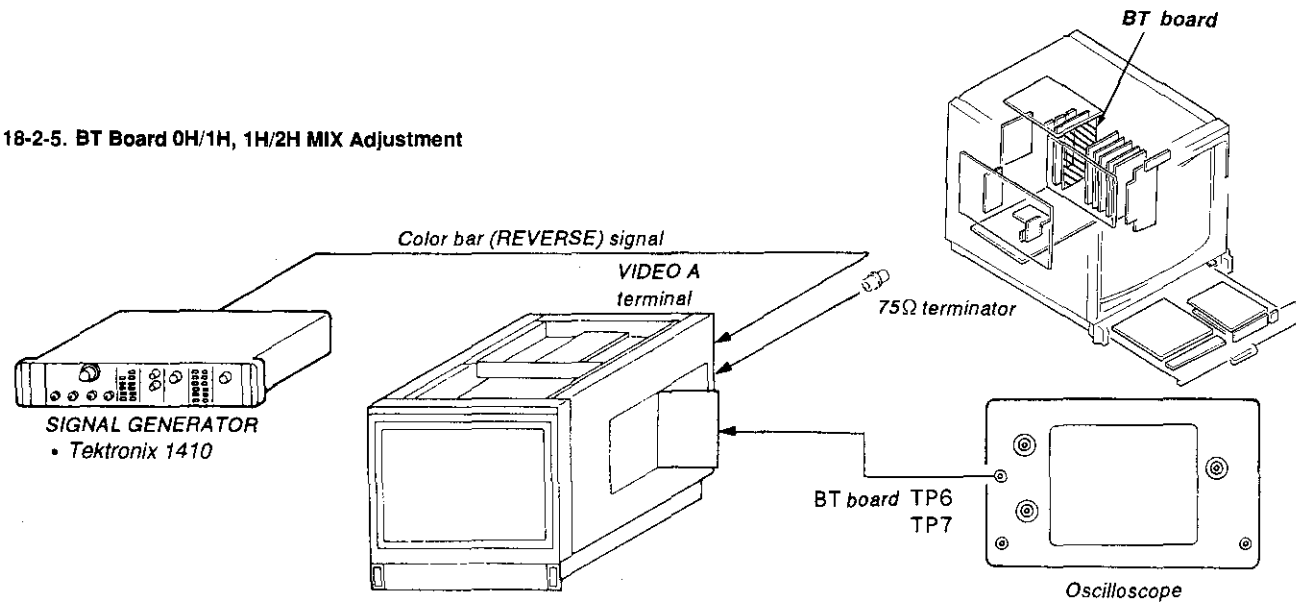

1. Feed a color bar signal (REVERSE) to the VIDEO A INPUT terminal of this set.
2. Connect the oscilloscope to TP6 to magnify the signal inverted area.
3. Turn RV5 (0H/1H MIX LEVEL) and RV10 (0H/1H MIX PHASE) on the BT board until the portion shown in Fig. 18-7 is reduced to a minimum.
4. Connect the oscilloscope to TP7.
5. Turn RV12 (1H/2H MIX PHASE) and RV11 (1H/2H MIX LEVEL) on the BT board until the portion shown in Fig. 18-7 is reduced to a minimum.

Enlarged view of inverted signal section

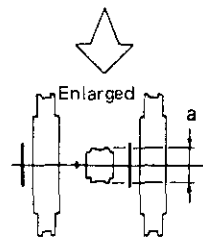
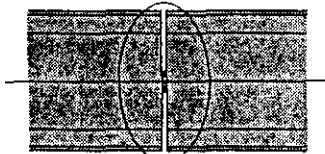
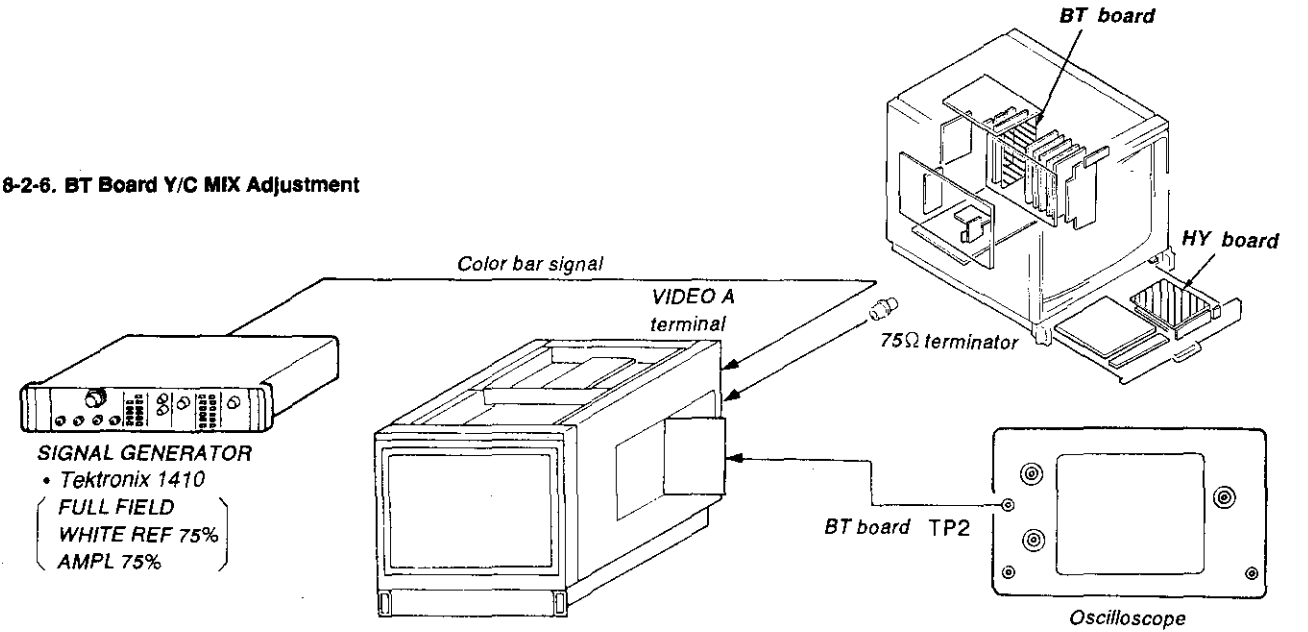

Fig. 18-7

**18-2-6. BT Board Y/C MIX Adjustment**



1. Feed a color bar signal to the VIDEO A INPUT terminal of this set.
2. Connect the oscilloscope to TP2 on the BT board.
3. Set the PAL S/SECAM F/COMB S button on the sub control panel to the OFF.
4. Turn RV1 (Y/C MIX PHASE) and RV2 (Y/C MIX LEVEL) on the BT board so that the sub-carrier level is reduced to a minimum as shown in Fig. 18-8.

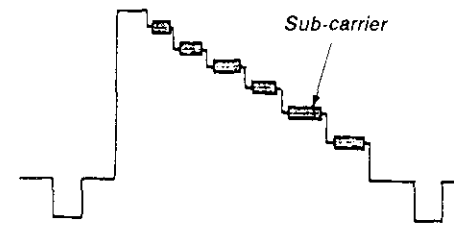
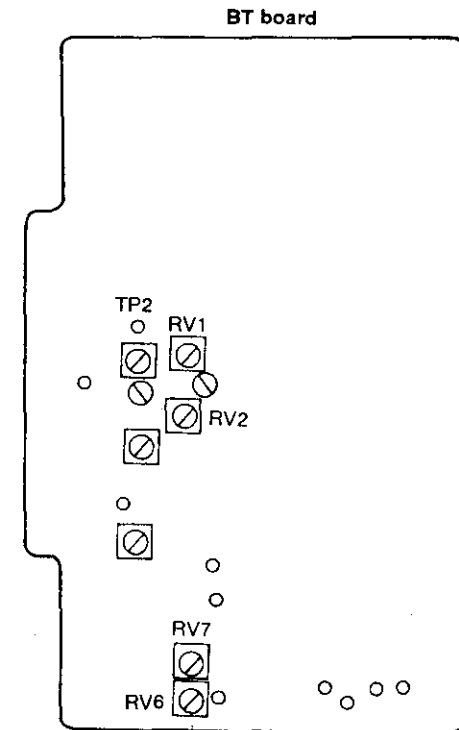
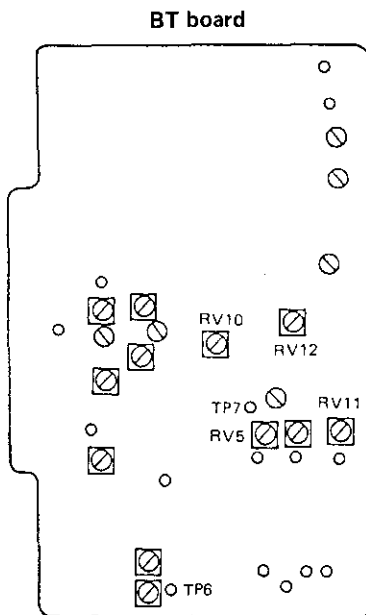
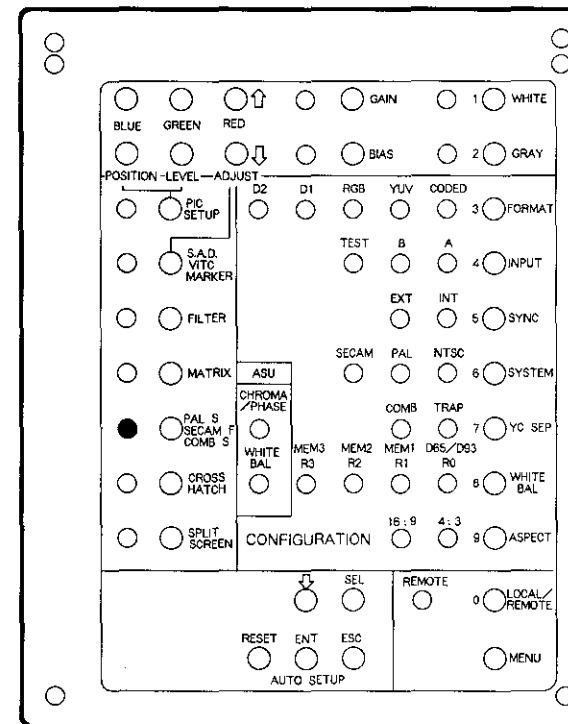

Fig. 18-8

**18-2-7. S COMB Adjustment**

1. Feed a color bar signal to the VIDEO A INPUT terminal of this set.
2. Set the PAL S/SECAM F/COMB S button on the sub control panel to the ON.
3. Connect the oscilloscope to TP2 on the BT board.
4. Turn RV6 (S COMB C Level) and RV7 (S COMB C PHASE) on the BT board so that the sub-carrier level is reduced to a minimum as shown in Fig. 18-8.

**SUB CONTROL PANEL (HY board)**





18-2-8. BT Board Chroma Level Adjustment

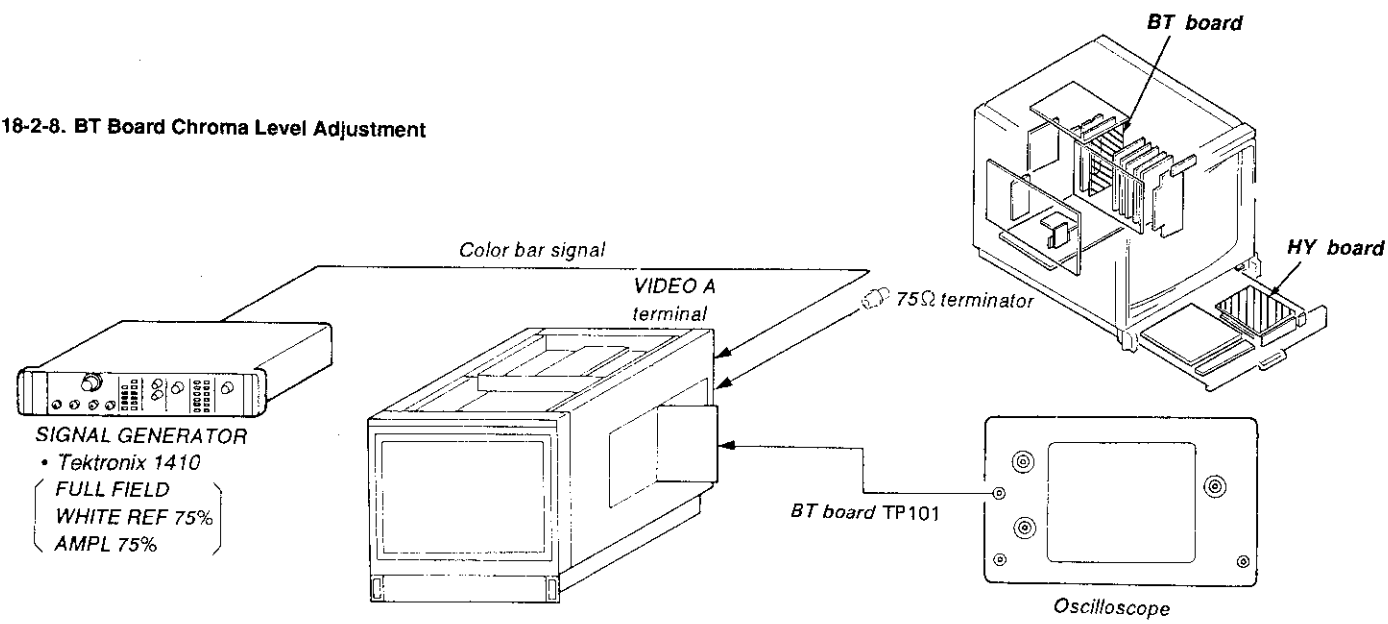

1. Feed a color bar signal to the VIDEO A INPUT terminal of this set.
2. Set the YC SEP switch on the sub control panel to the TRAP position.
3. Connect the oscilloscope to TP101 on the BT board. (DC 0.1 V/div:H)
4. Turn the POSITION control of the oscilloscope to set the portion B (red) of Fig. 18-9 to the center of the oscilloscope.
5. Set the YC SEP button to the COMB position.
6. Set the PAL S/SECAM F/COMB S button on the sub control panel to the ON.
7. Set the portion B (red) of Fig. 18-9 to the center of the oscilloscope using RV8 (C OUTPUT LEVEL) on the BT board.

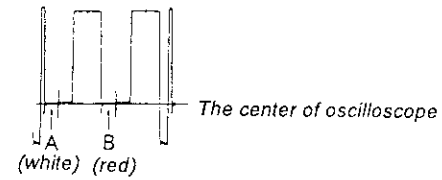
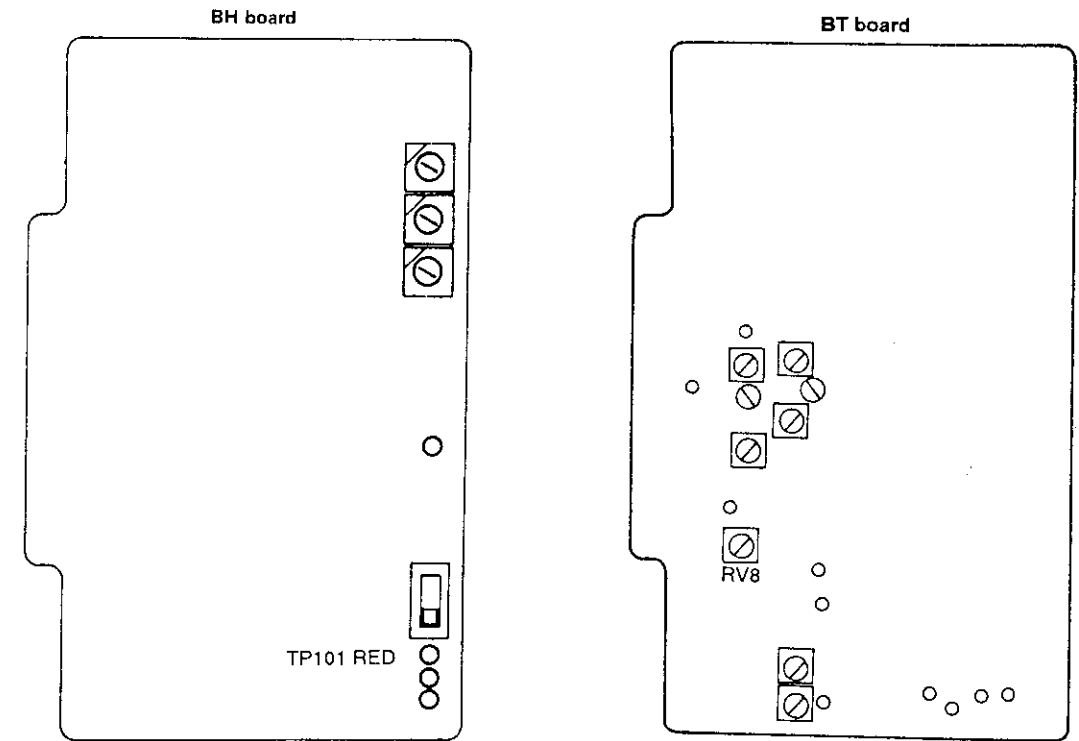
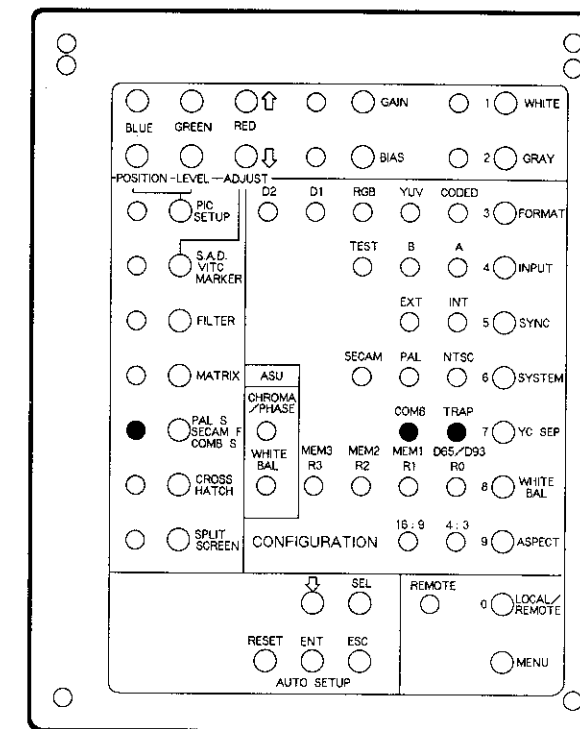

Fig. 18-9



SUB CONTROL PANEL (HY board)



18-2-9. BT Board Y/C DELAY Adjustment

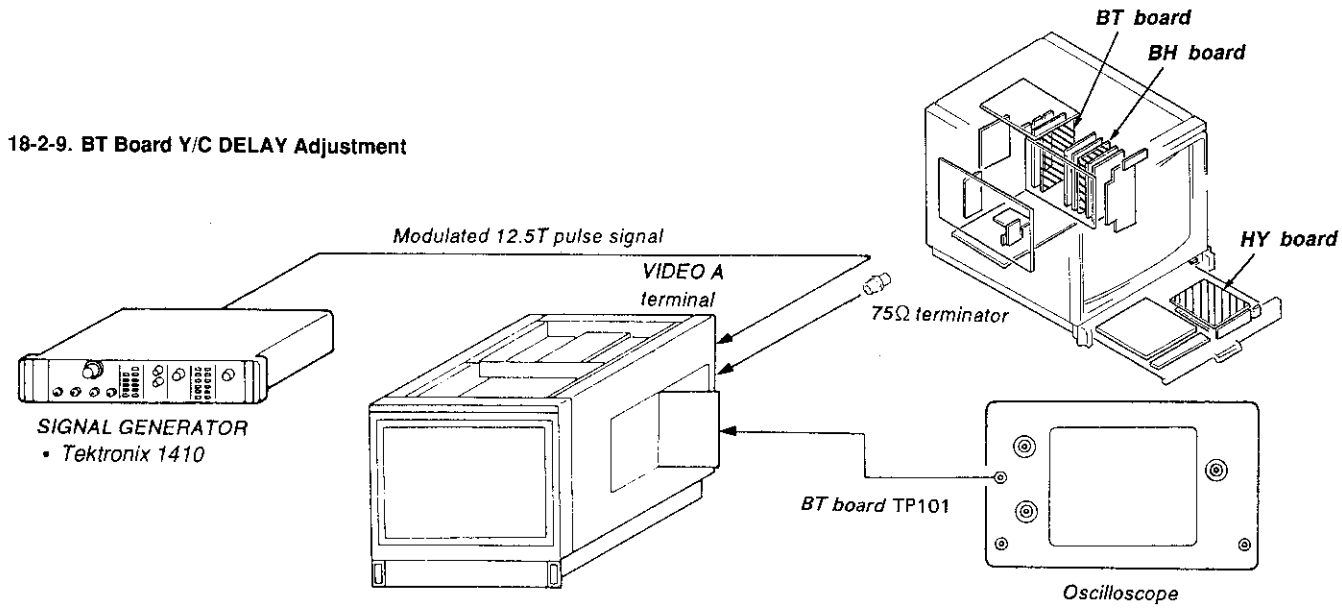

1. Feed a 12.5T pulse signal to the VIDEO A terminal of this set.
2. Set the PAL S/SECAM F/COMB S button to the ON.
3. Connect the oscilloscope to TP101 on the BH board.
4. Turn the CHROMA MANUAL control (on the front panel) until the chroma signal is adjusted as shown in Fig. 18-10.
5. After adjustment, turn RV4 (Y/C DELAY) on the BT board until the waveform is symmetrical.

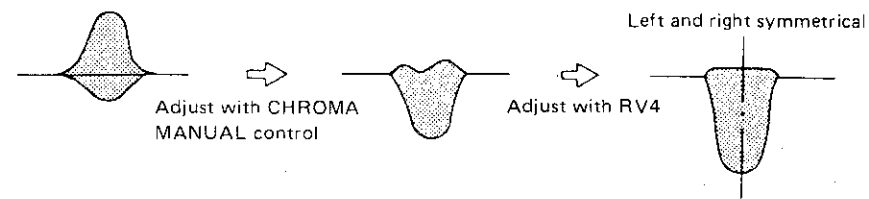
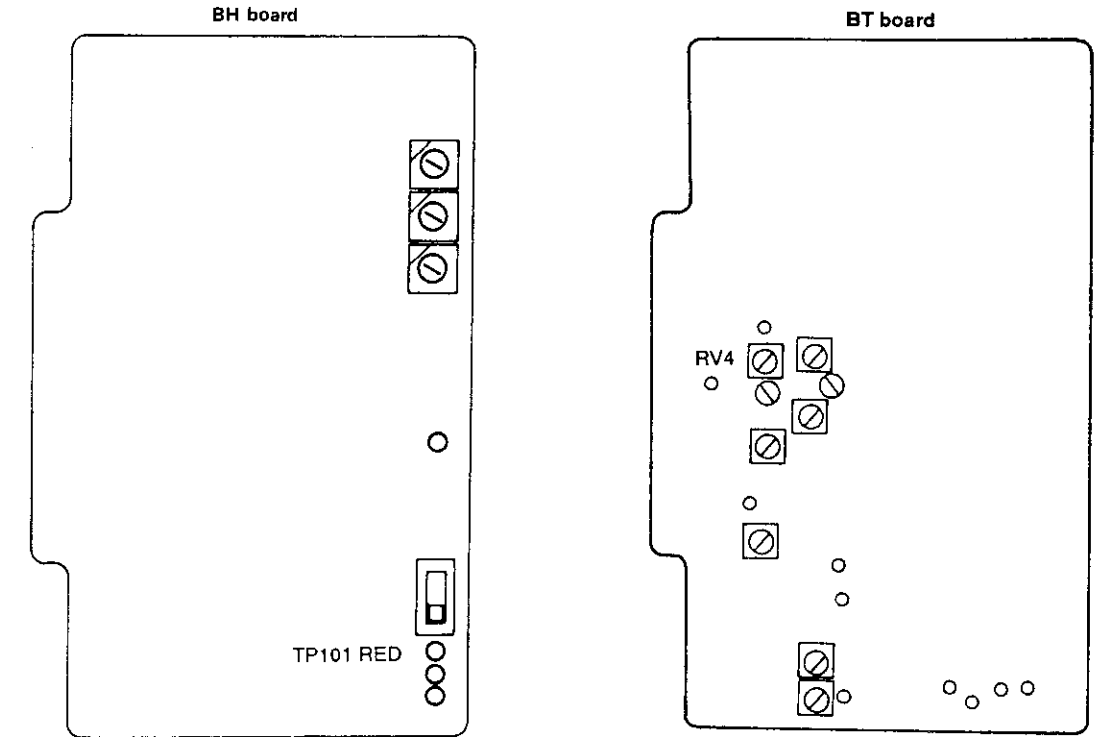
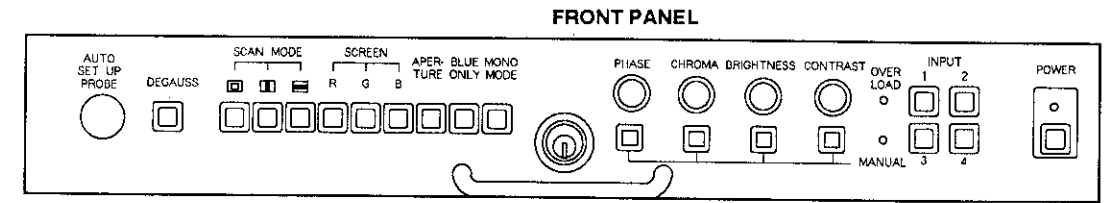
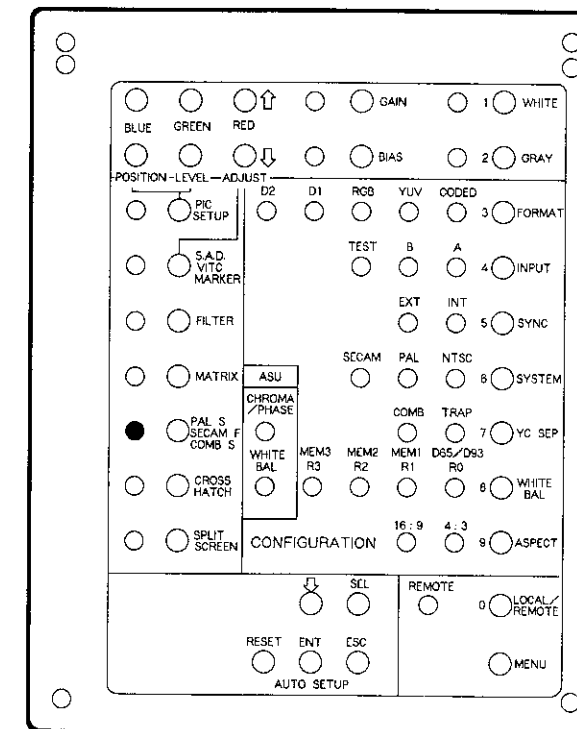

Fig. 18-10



SUB CONTROL PANEL (HY board)



**19. BD (PAL) BOARD BPF ADJUSTMENT (BVM-2016P ONLY)**

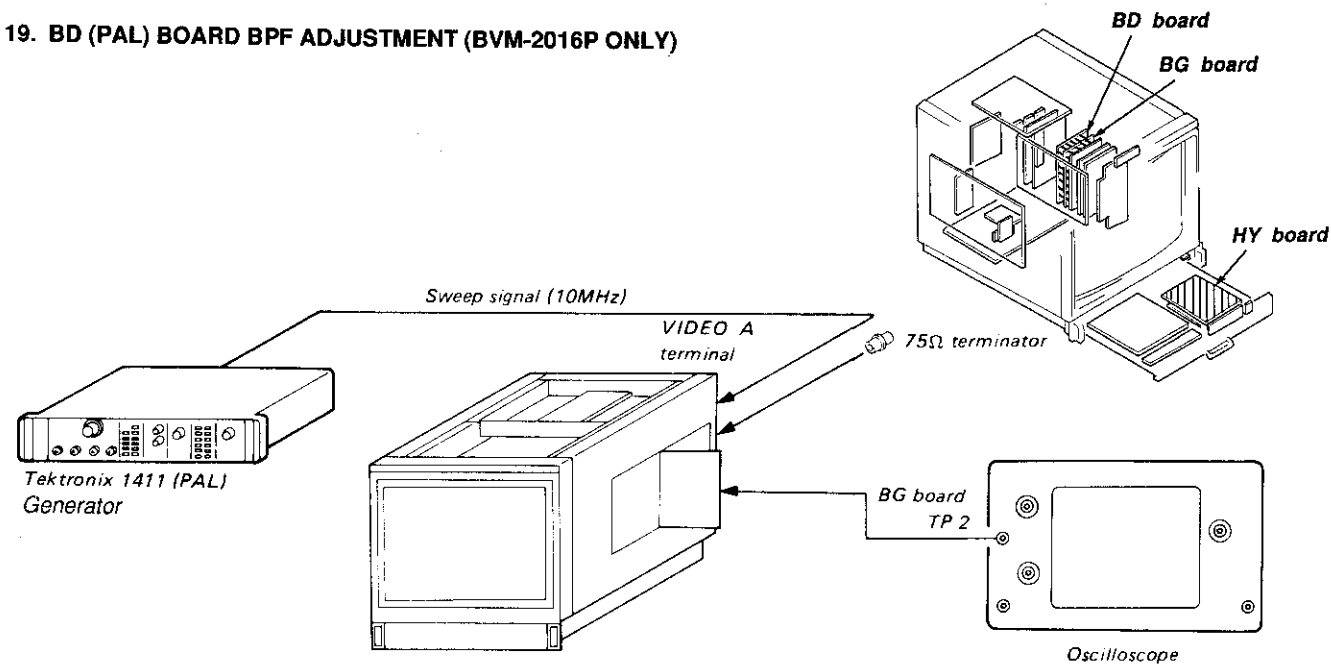

- PAL S/SECAM F/COMB S button (SUB CONTROL PANEL)..... ON
- 1. Input SWEEP signal (10MHz) to the VIDEO A terminal of the set.
- 2. Connect an oscilloscope to the TP2 on the BG board.
- 3. Make the V/div of oscilloscope into VARIABLE, and match the upper section of waveform to 7 div as shown in Fig. 19-1.

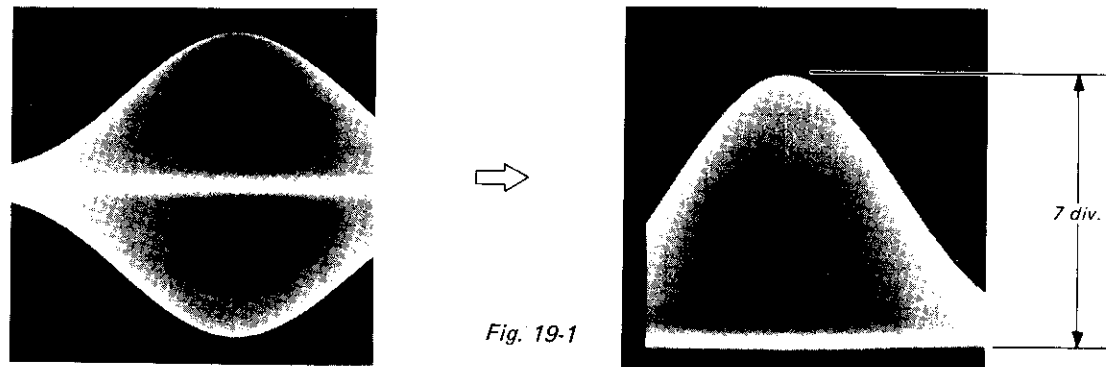

- 4. Adjust L3 on the BD board so that A is equal to B as shown in Fig. 8-2.

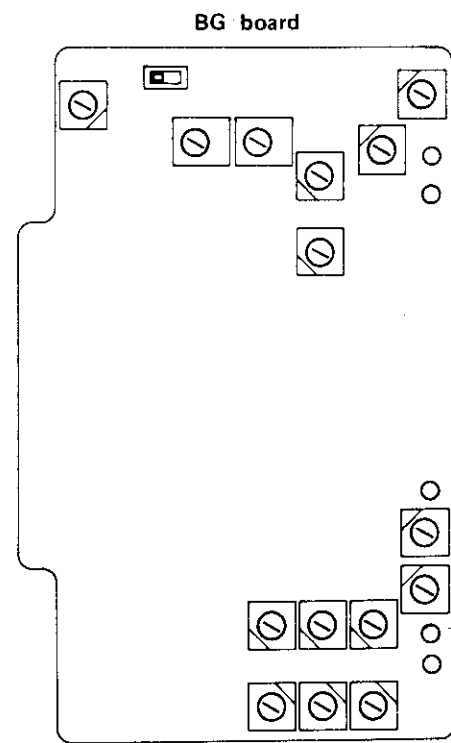
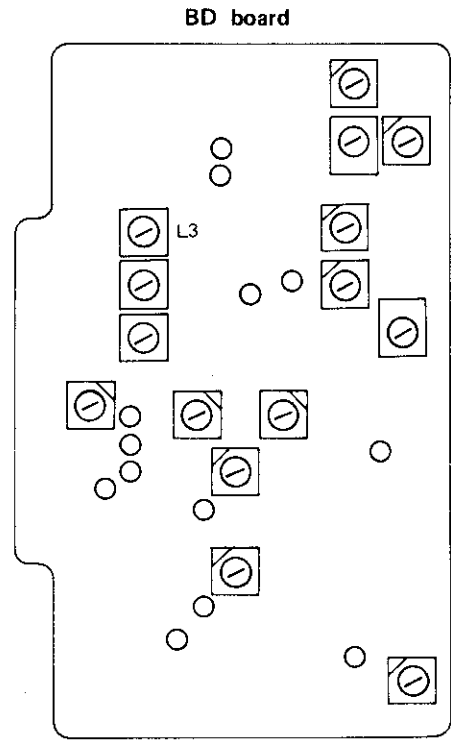
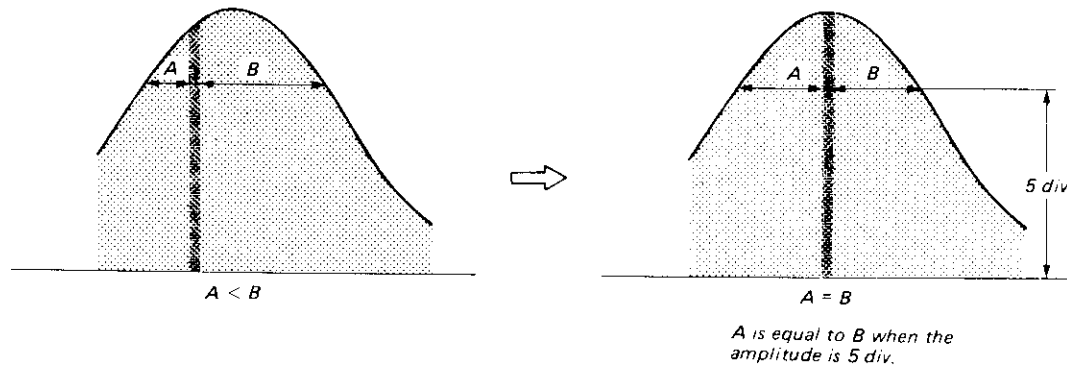

**SUB CONTROL PANEL (HY board)**

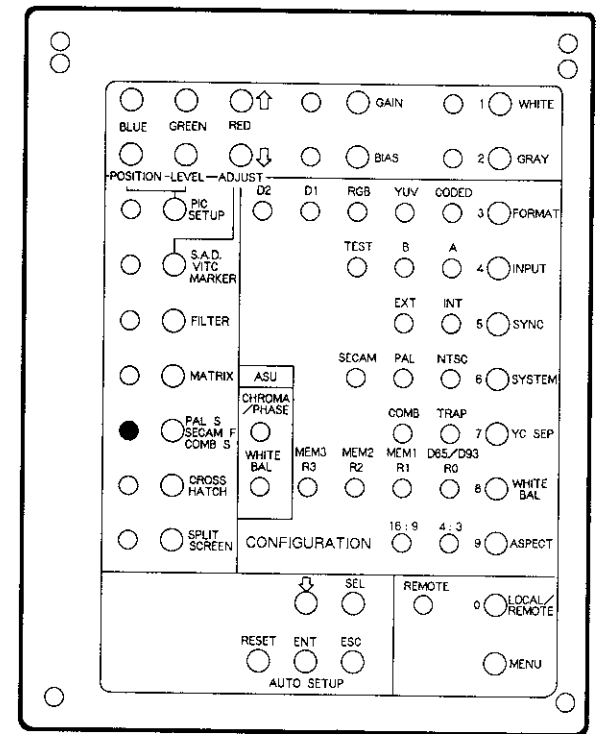

20. BD (PAL) BOARD PHASE SHIFT ADJUSTMENT (BVM-2016P ONLY)

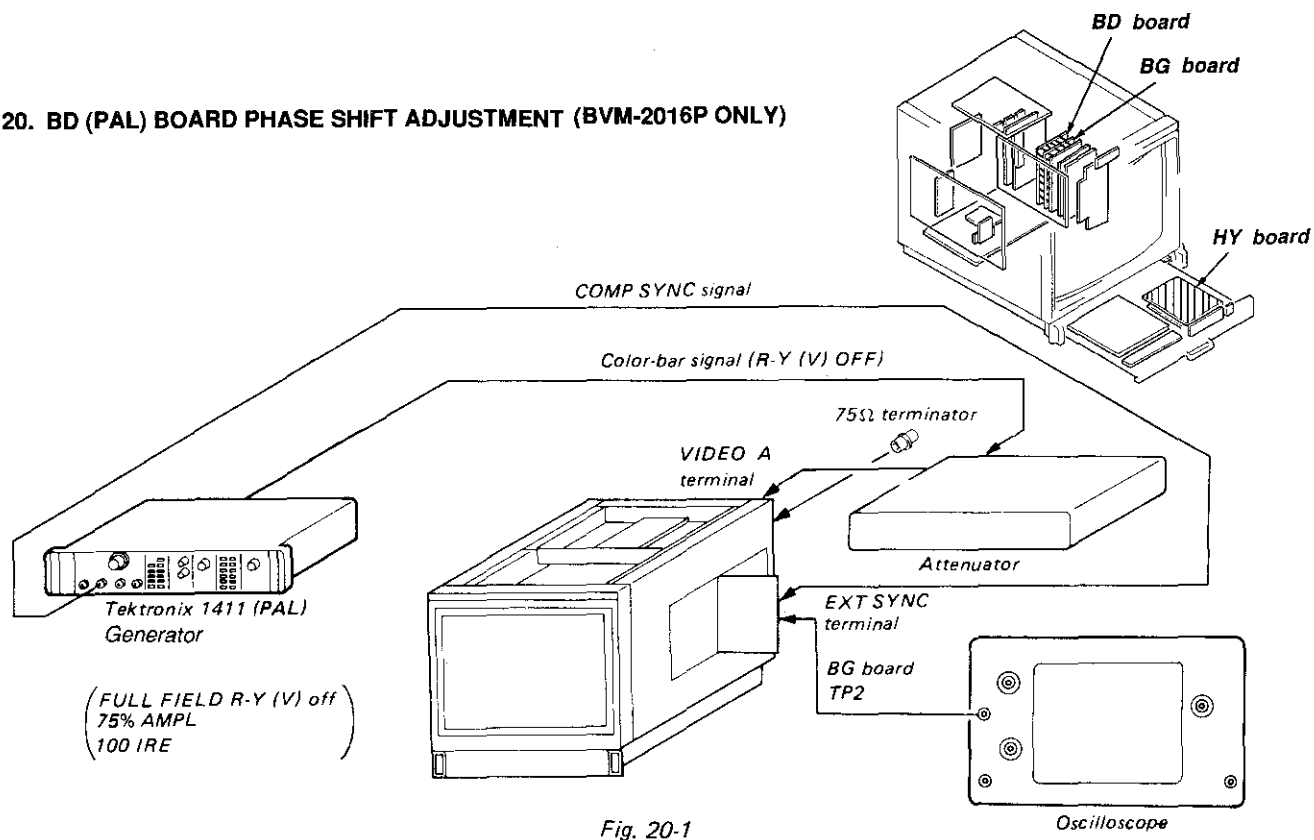

Fig. 20-1

- SYNC button (SUB CONTROL PANEL)..... EXT
- PAL S/SECAM F/COMB S button (SUB CONTROL PANEL)..... ON
- RV2 (BD BOARD).....MECHANICAL CENTER
- CV1 (BD BOARD).....MECHANICAL CENTER
- CV2 (BD BOARD).....MECHANICAL CENTER

4. Attenuate the signal by 10dB by using attenuator.
5. Adjust RV2 on the BD board so that the output waveform becomes flat as shown in Fig. 20-2.
6. Restore the attenuator to 0dB.
7. Repeat the steps 3 to 5.

1. Complete the connection as shown in Fig. 20-1.
2. Connect an oscilloscope to the TP2 on the BG board.
3. Make the waveform flat with the PHASE control of front panel (R) as shown in Fig. 20-2.

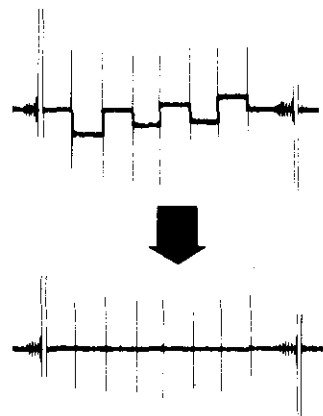
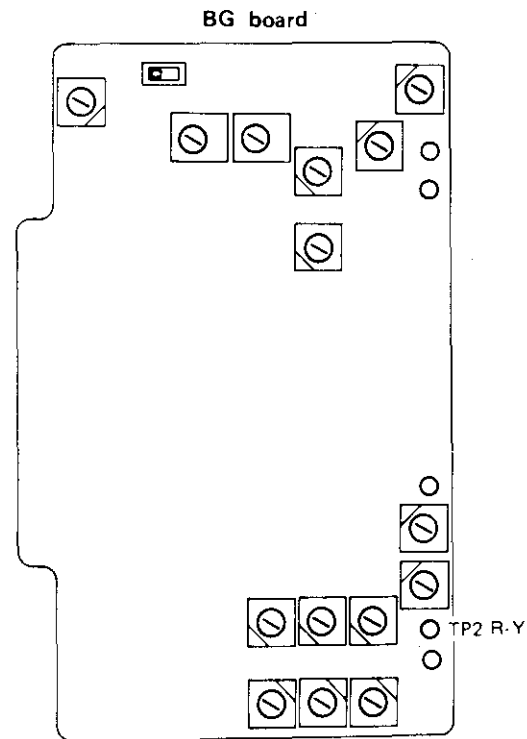
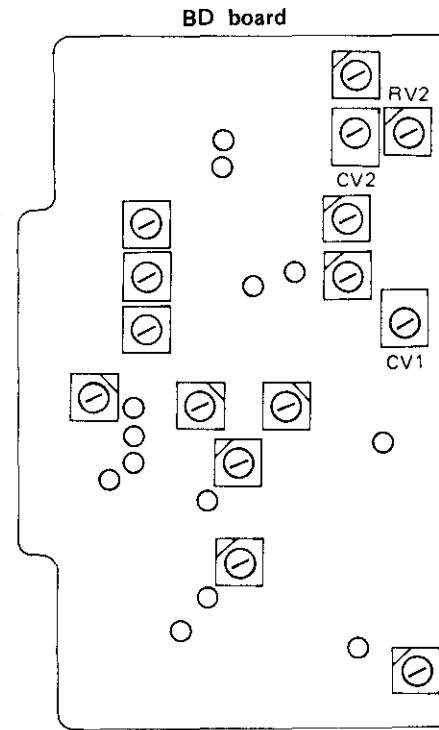
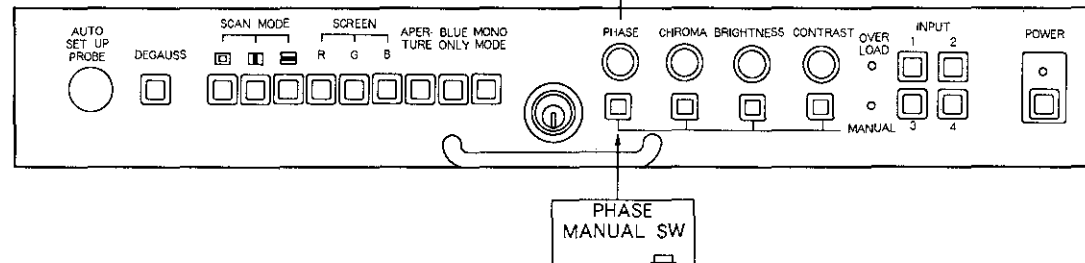
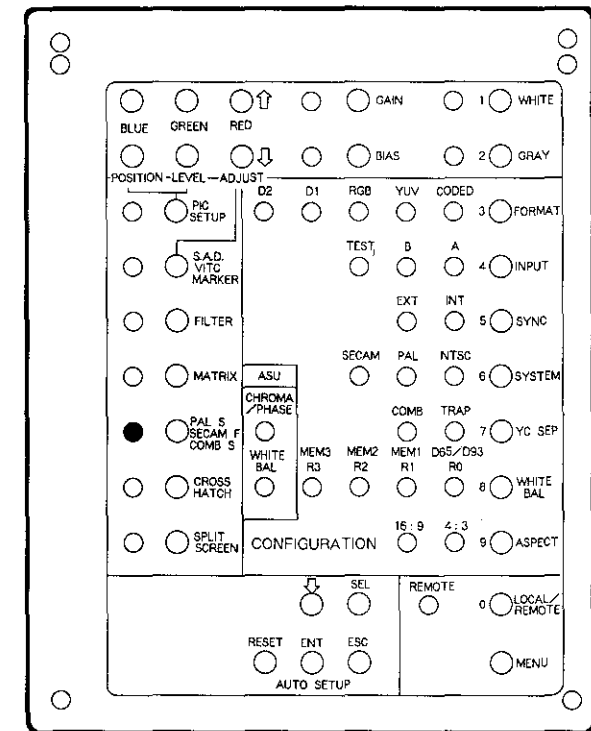

Fig. 20-2



SUB CONTROL PANEL (HY board)



**21. BD BOARD 4.43 MHz (PAL) fo ADJUSTMENT (BVM-2016P ONLY)**

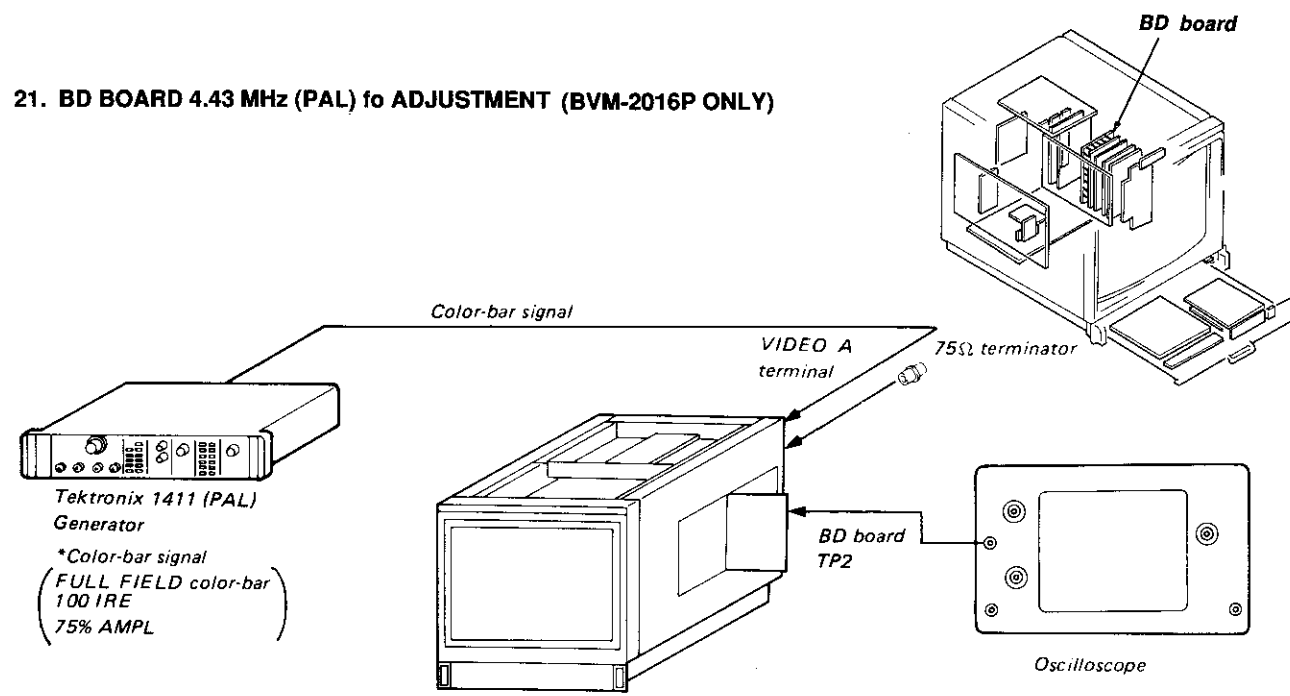

1. Input color-bar signal to the VIDEO A terminal of the set.
2. Connect an oscilloscope to the TP2 of BD board.
3. Short-circuit between TP11, 12 of BD board with a jumper wire.
4. Adjust CV2 of BD board so that the output waveform is shifted slowly as shown in Fig. 21-1.
5. Turn off the power of this monitor, and disconnect TP11, 12 of BD board.

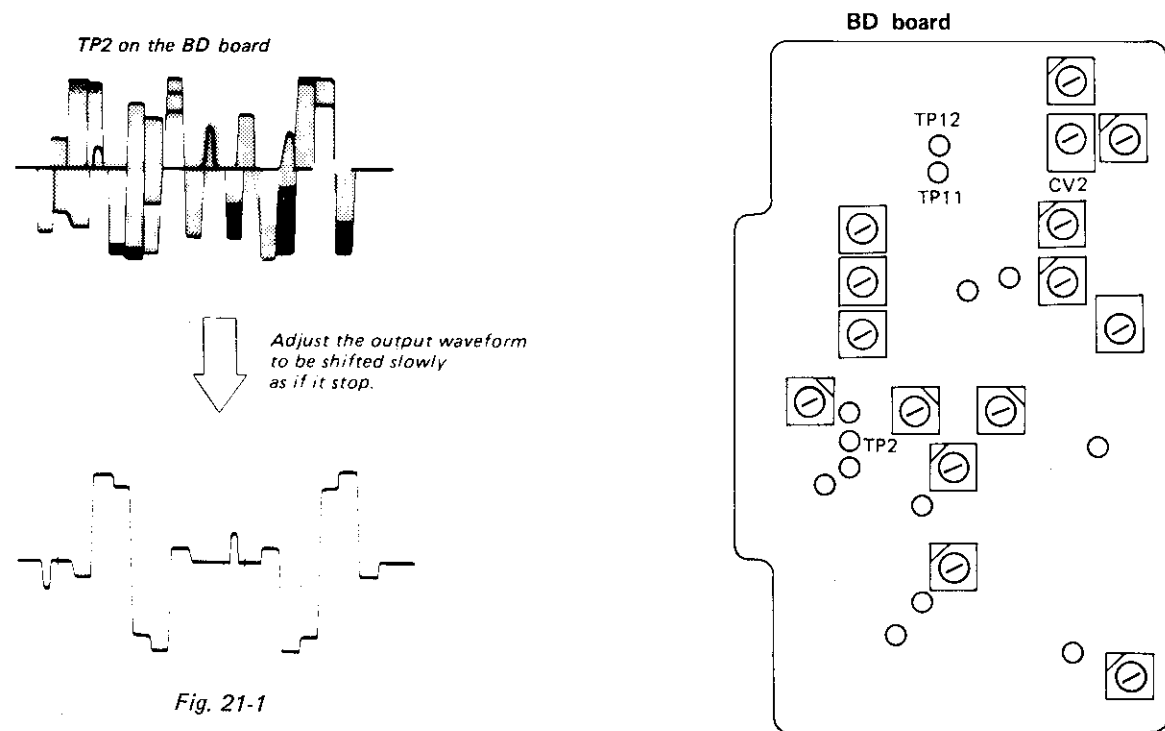

Fig. 21-1

## 22. BD BOARD (PAL) COLOR DIFFERENCE PHASE ADJUSTMENT (BVM-2016P ONLY)

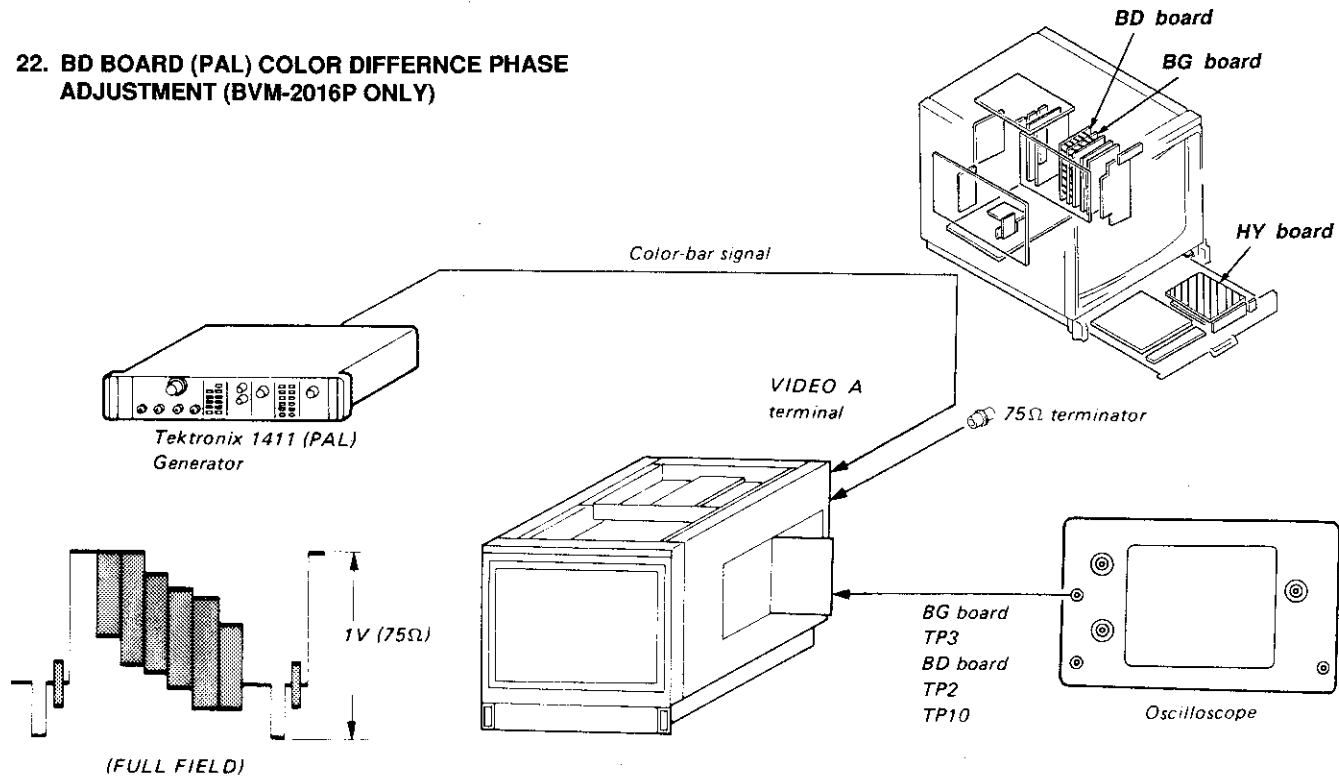

Fig. 22-1

1. Complete the connections as shown in Fig. 22-1.
2. Turn on the power of this monitor. Set the INPUT switch to the 1 position, the SYNC switch to the INT position, and the PAL S/SECAM F/COMB S button to the ON.

### B-Y System Adjustment

3. Connect the oscilloscope probe to TP3 on the BG board, and turn off the U (B-Y) signal of the signal generator.
4. Set the oscilloscope sensitivity to 20mV/DIV, and adjust RV8 on the BD board so that the output waveform is flat. (See Fig. 22-2.)

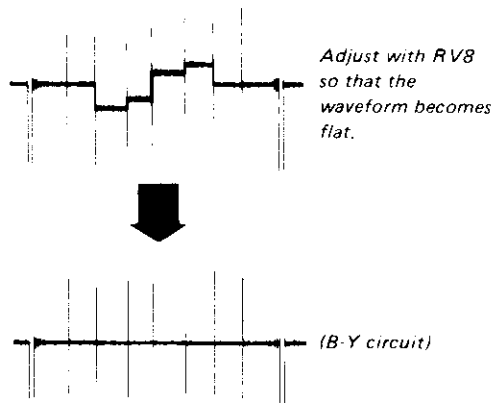
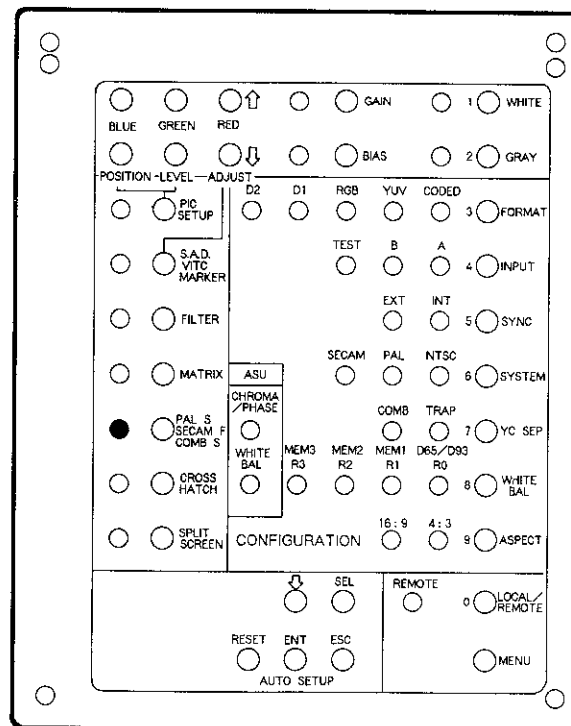

Fig. 22-2

### SUB CONTROL PANEL (HY board)



### Quad Adjustment

5. Connect the oscilloscope probe to TP on the BD board. Turn on the U signal of the signal generator, and turn off the V (R-Y) signal. Then adjust CV1 on the BD board so that the output waveform is flat. (See Fig. 22-3.)
6. Repeat the steps 3 to 6.

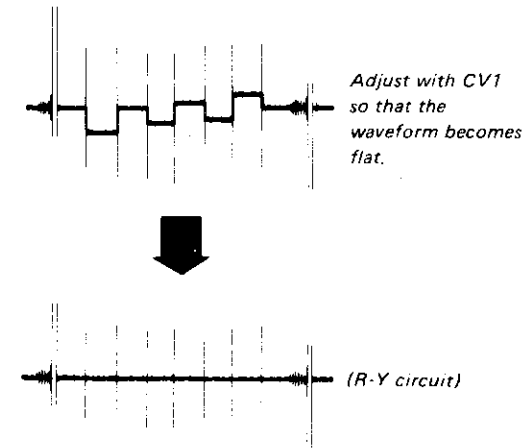
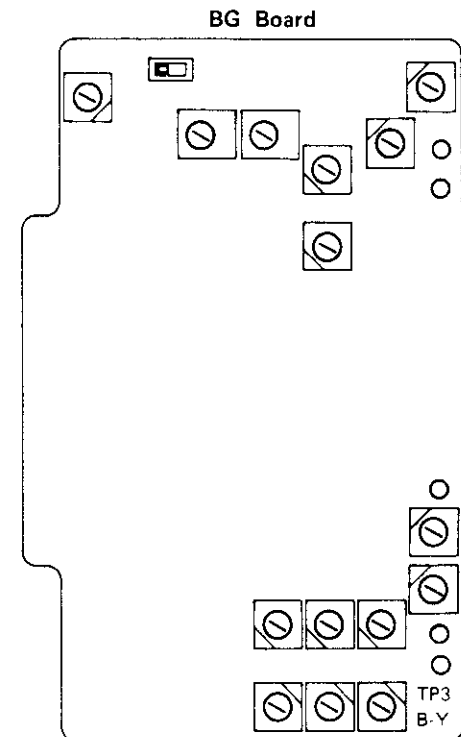
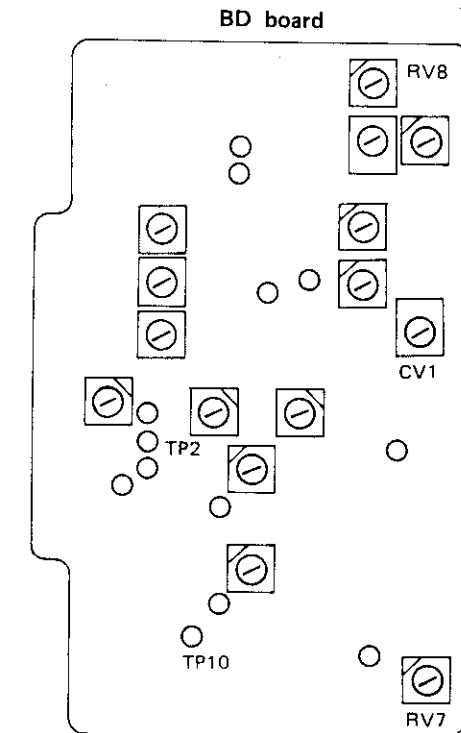

Fig. 22-3

### PAL-D Phase Adjustment

7. Set the PAL S/SECAM F/COMB S button to the OFF and turn on the V signal of the signal generator, and turn off U signal.
8. Connect the oscilloscope probe to TP10 on the BD board.
9. Adjust RV7 on the BD board so that the output waveform is flat. (See Fig. 22-2.)
10. Finally, perform the adjustments of 3 and 4 by directly mounting the BD board to the set, without using the extension board.



**23. BD BOARD (PAL) COLOR DIFFERENCE LEVEL ADJUSTMENT (BVM-2016P ONLY)**

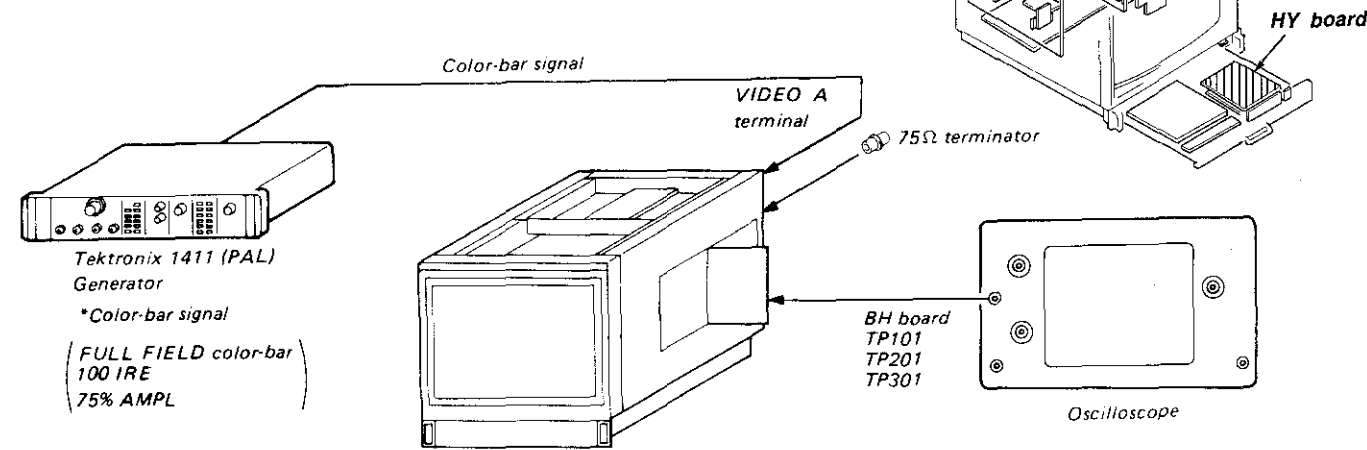

• PAL S/SECAM F/COMB S button (SUB CONTROL PANEL)..... ON

1. Input color-bar signal to the VIDEO A terminal of the set.
2. Connect an oscilloscope to the TP101 of BH board.
3. Adjust RV3 of BD or BM board so that the levels with \* is flat as shown in Fig. 23-1.

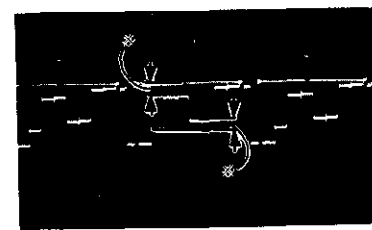

TP101 R OUT

Fig. 23-1

• Adjust the levels with \* to be flat respectively using RV3 of BD board

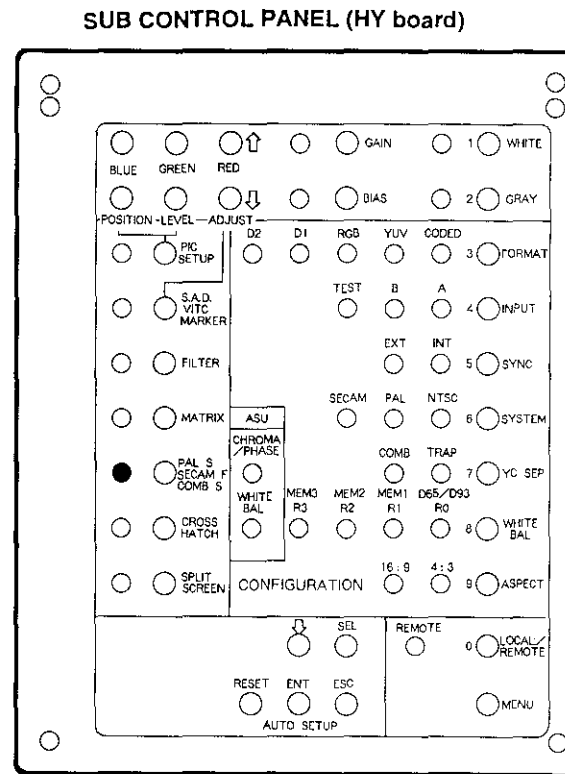

4. Connect an oscilloscope to the TP301 of BH board.
5. Adjust RV4 of BD board so that the output waveform as shown in Fig. 23-2.

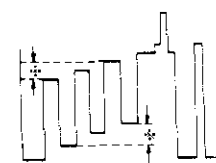

TP301 B OUT

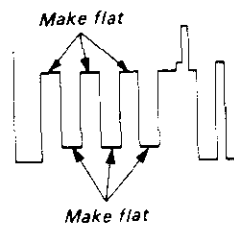
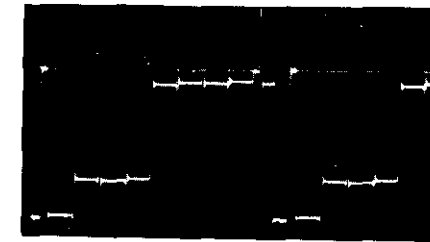

Fig. 23-2

6. Connect an oscilloscope to the TP201 of BH board.
7. Adjust RV4 and RV5 of BG board so that the INPUT waveform becomes flat as shown in Fig. 23-3.



TP201 G OUT

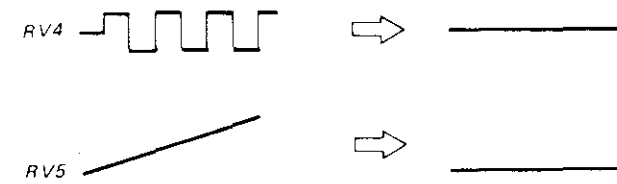
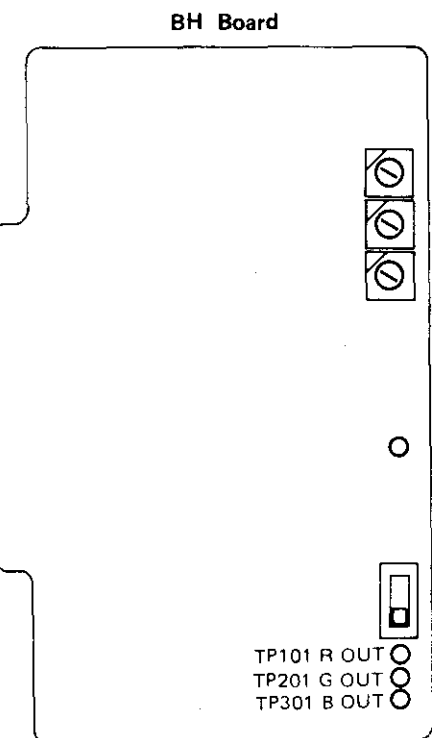
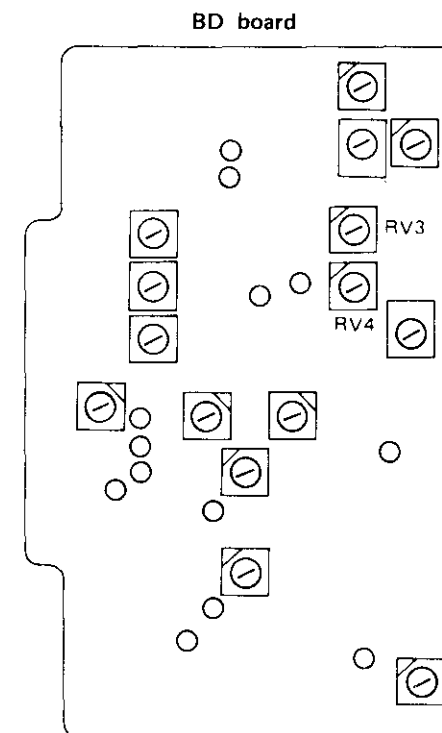
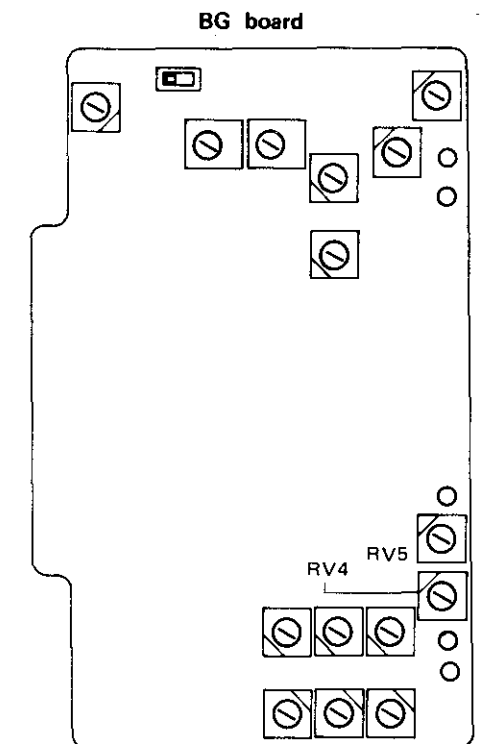
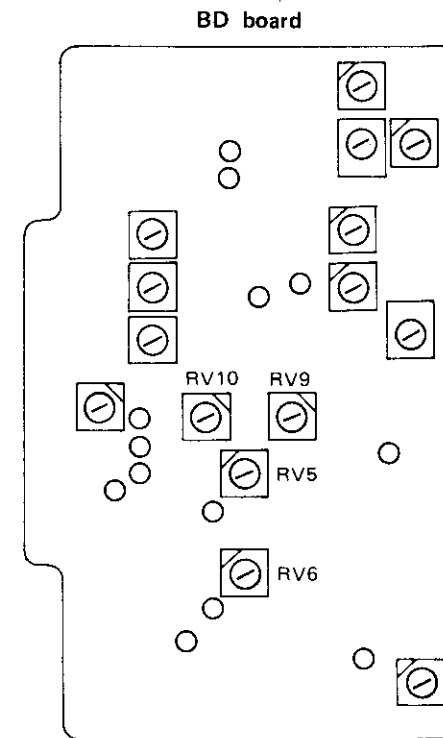
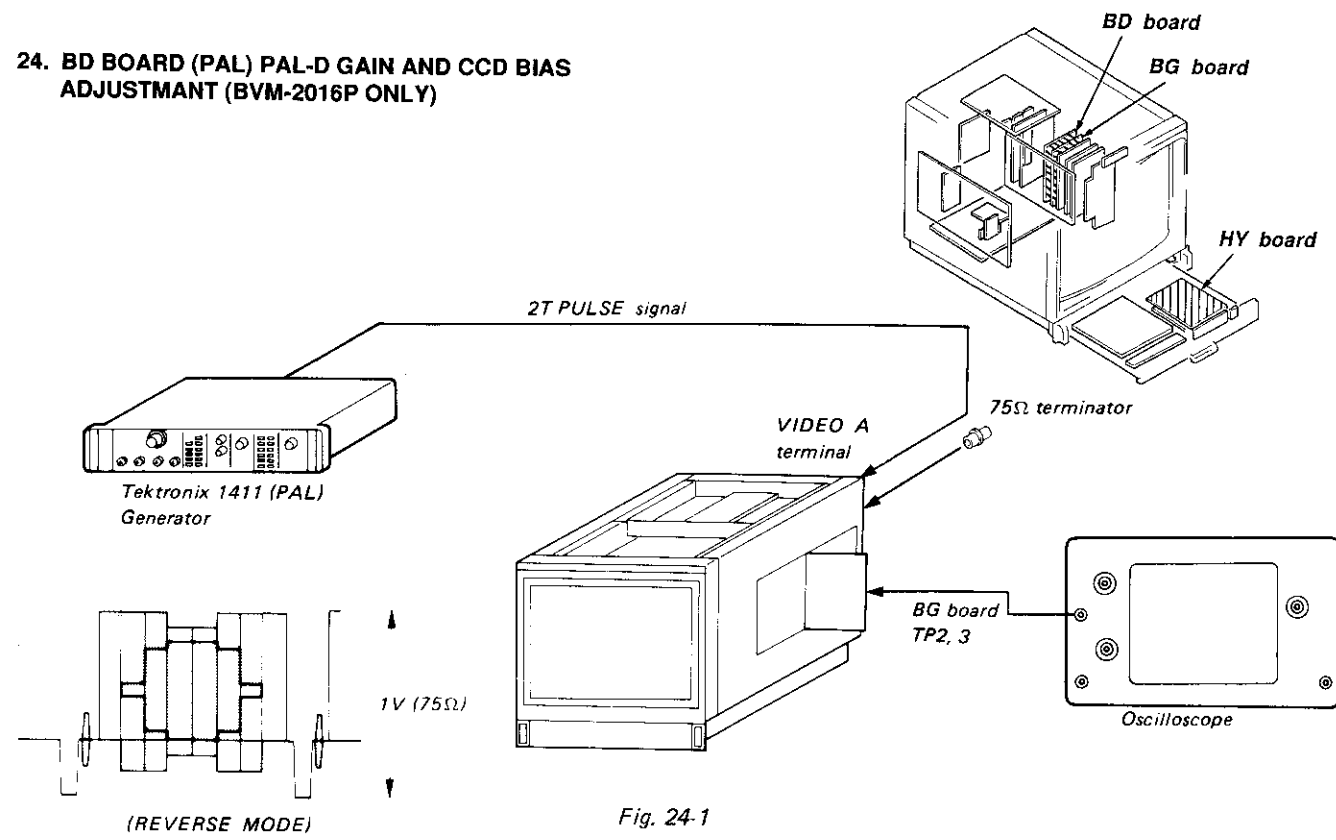

Fig. 23-3



**24. BD BOARD (PAL) PAL-D GAIN AND CCD BIAS ADJUSTMANT (BVM-2016P ONLY)**



• PAL S/SECAM F/COMB S button (SUB CONTPOL PANEL) ..... OFF

1. Complete the connection as shown in Fig. 24-1. Turn on the power of this monitor. Set the INPUT switch to the 1 position, and the SYNC switch to the INT position.
2. Connect the oscilloscope probe to TP2 on the BG board.
3. Turn RV5 and RV6 on the BD board fully clockwise.
4. By observing the waveform shown in Fig. 24-2, adjust RV9 on the BD board so that it becomes A=B.
5. Adjust RV5 on the BD board so that the waveform shown in Fig. 24-2 becomes flat.
6. Connect the probe of the oscilloscope to TP3 on the BG board and observe the section shown in Fig. 24-3.
7. Adjust RV10 on the BD board so that the waveform of the oscilloscope becomes A=B.
8. Adjust RV6 on the BD board so that the waveform shown in Fig. 24-3 becomes flat.

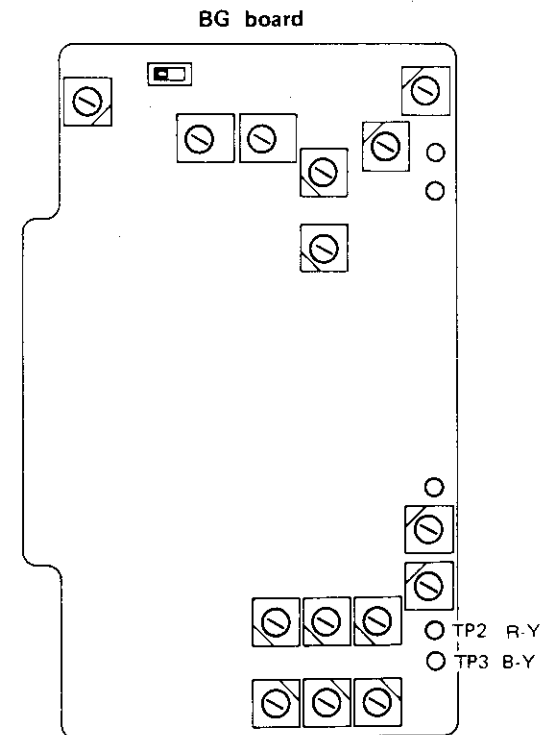
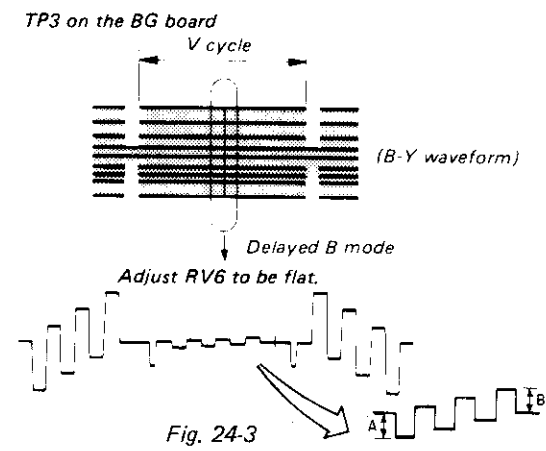
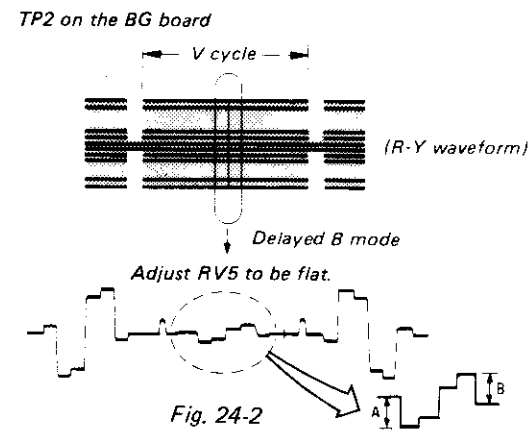



**25. BD BOARD (PAL) Y TRAP ADJUSTMENT  
(BVM-2016P ONLY)**

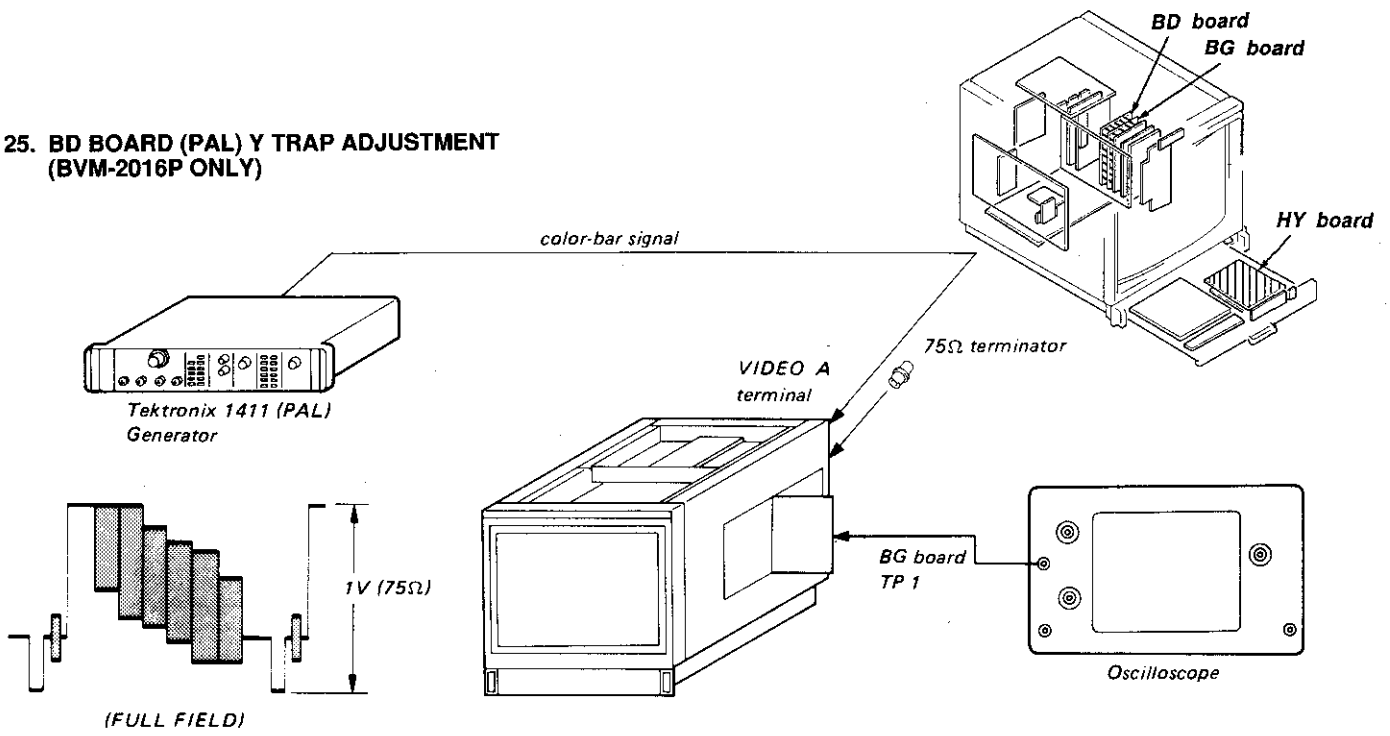

1. Input color-bar signal to VIDEO A terminal of the set.
2. Connect an oscilloscope to the TP1 of BG board.
3. Adjust L1 of BD board so that 4.43 MHz (PAL) subcarrier is minimum as shown in Fig. 25-1.

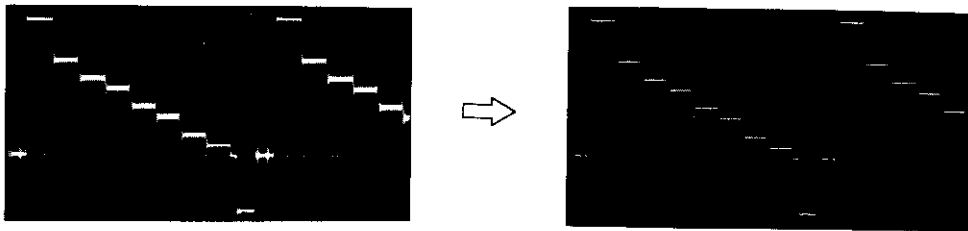
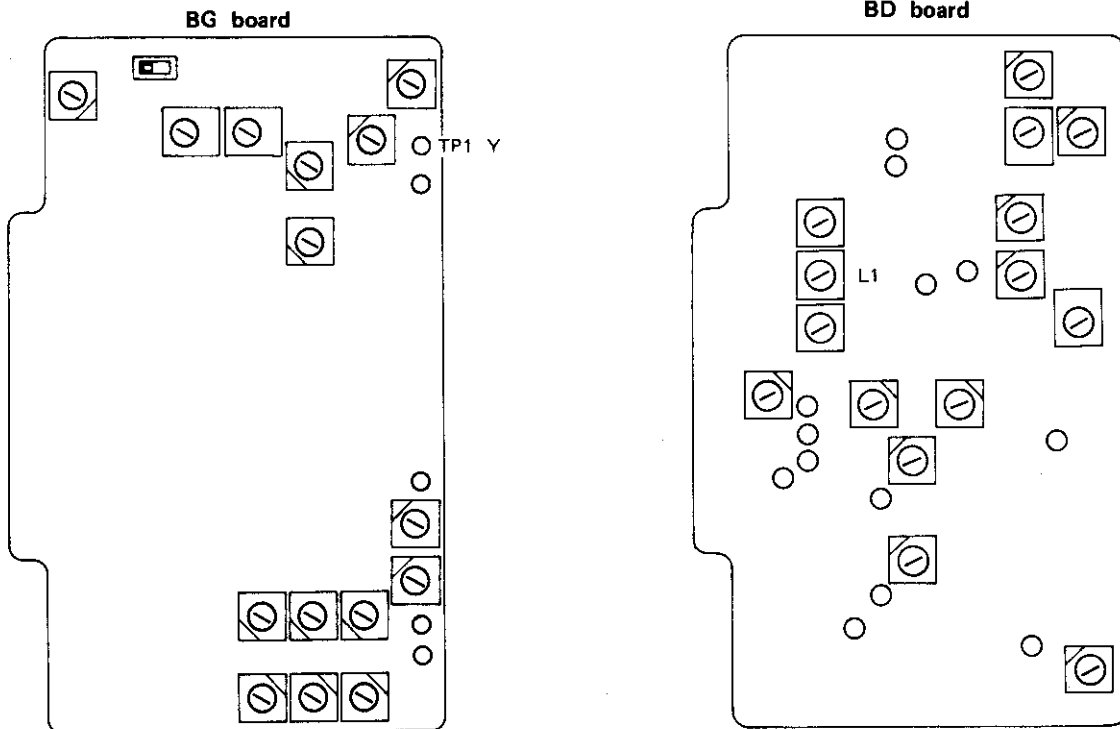
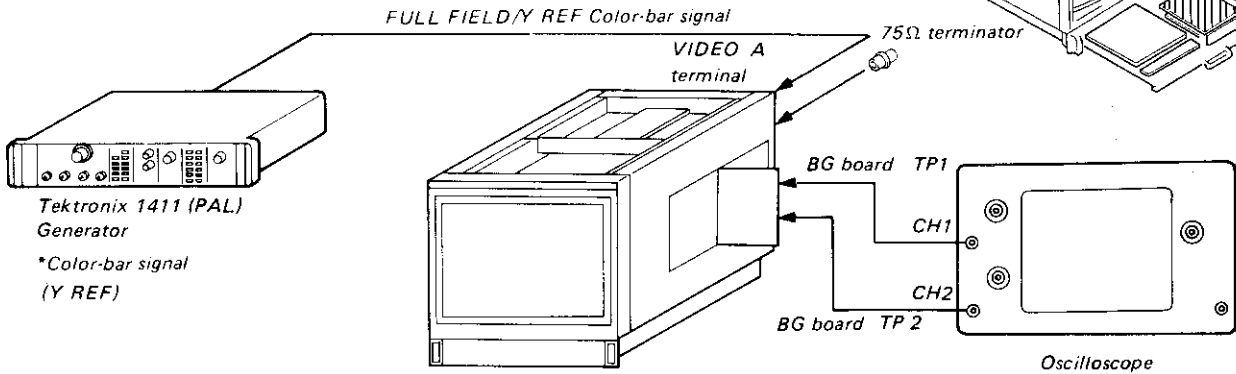
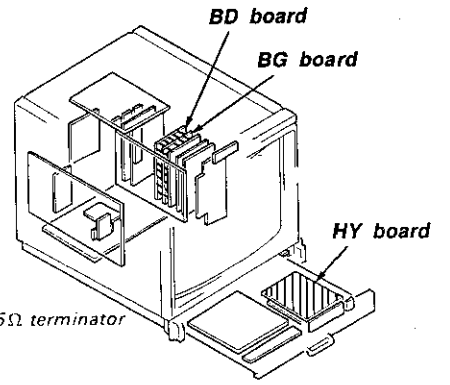

Fig. 25-1



**26. BD BOARD (PAL) DELAY TIME ADJUSTMENT (BVM-2016P ONLY)**



- PAL S/SECAM F/COMB S button (SUB CONTROL PANEL) ..... ON
1. Input color-bar signal (FULL FIELD/Y REF) to the VIDEO A terminal of the set.

2. Connect an oscilloscope (CH-1 probe) to the TP1 of BG board and connect an oscilloscope (CH-2 probe) to the TP2 of BG board (VERT mode of the oscilloscope is CHOP).
3. Adjust RV1 of BD board so that output waveform as shown in Fig. 26-1.

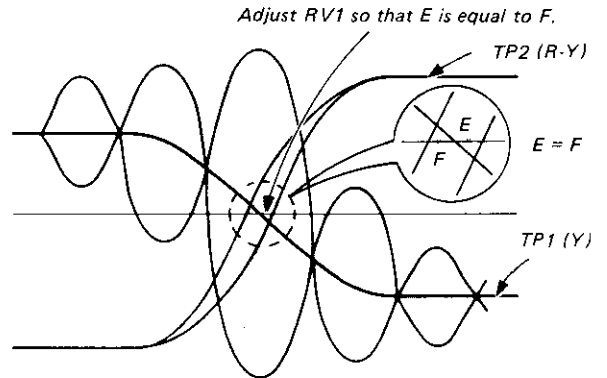
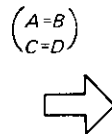
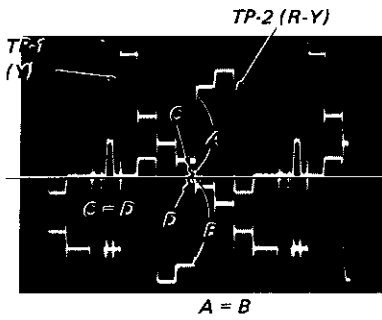
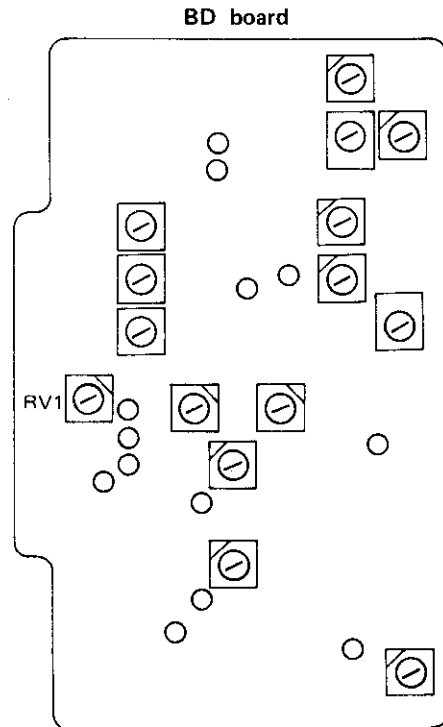
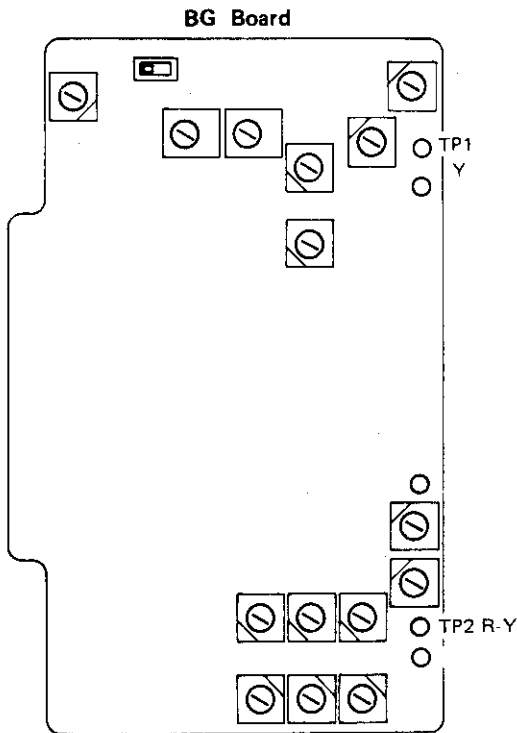
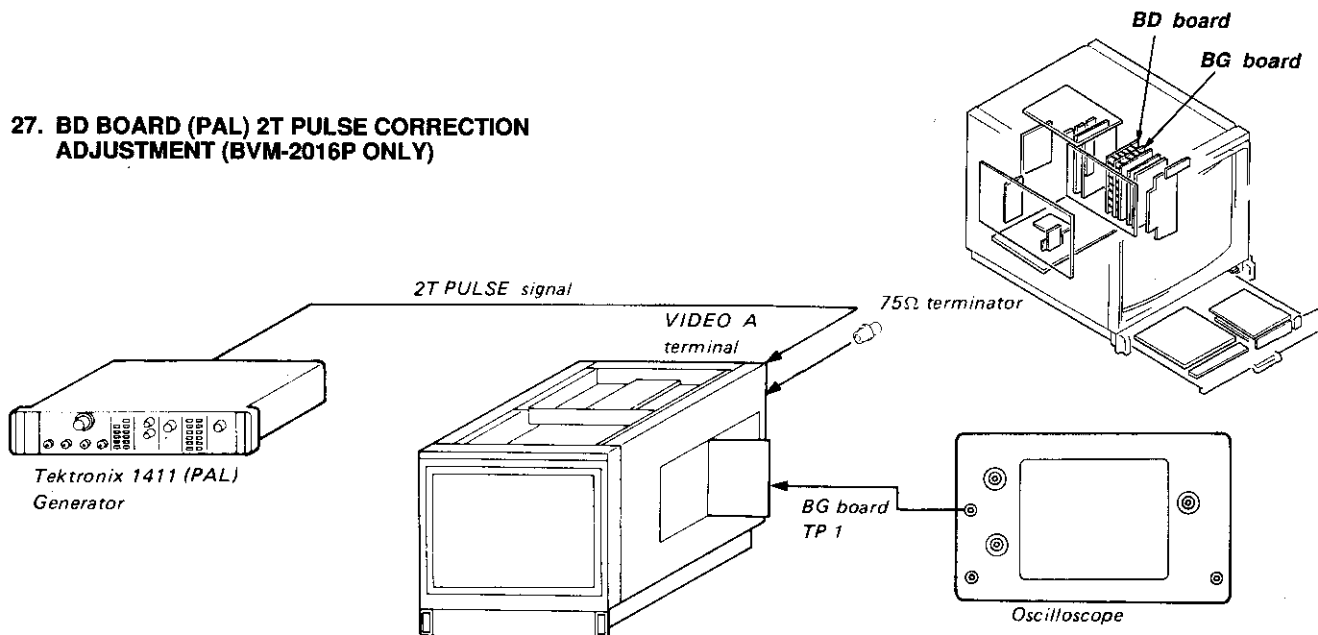

Fig. 26-1



## 27. BD BOARD (PAL) 2T PULSE CORRECTION ADJUSTMENT (BVM-2016P ONLY)



1. Input 2T pulse signal to VIDEO A terminal of the set.
2. Connect an oscilloscope to the TP1 of BG board.
3. Adjust L2 of BD or BM board so that A is equal to B as shown in Fig. 27-1.
4. Change the input signal from 2T pulse to T pulse, and make sure the waveform balance is not lost extremely as shown in Fig. 27-1.

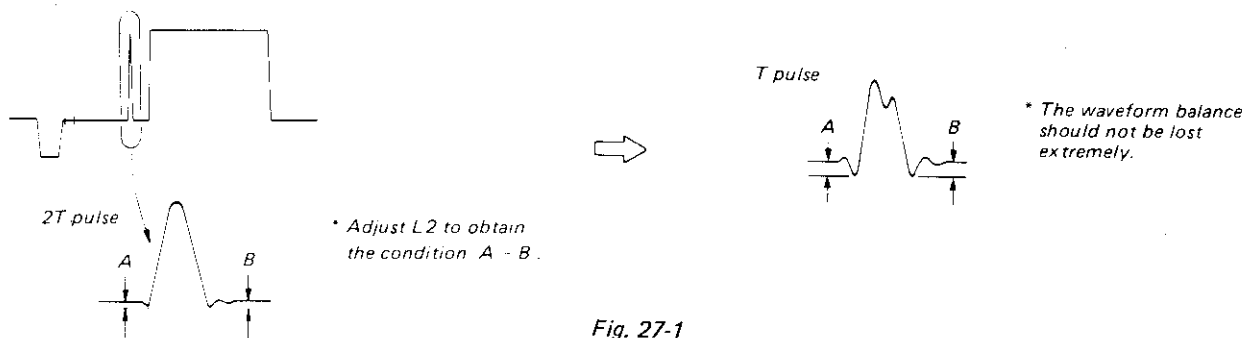
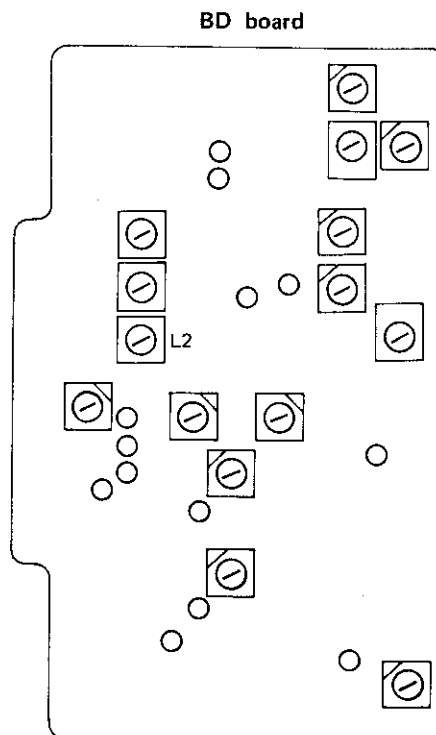
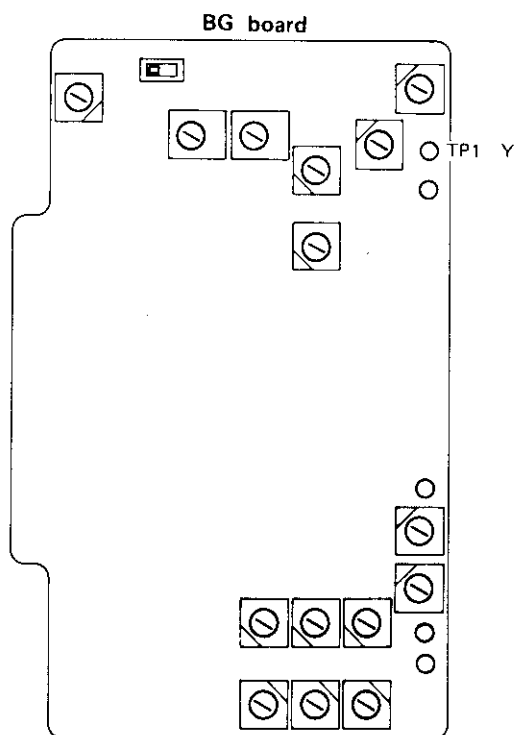
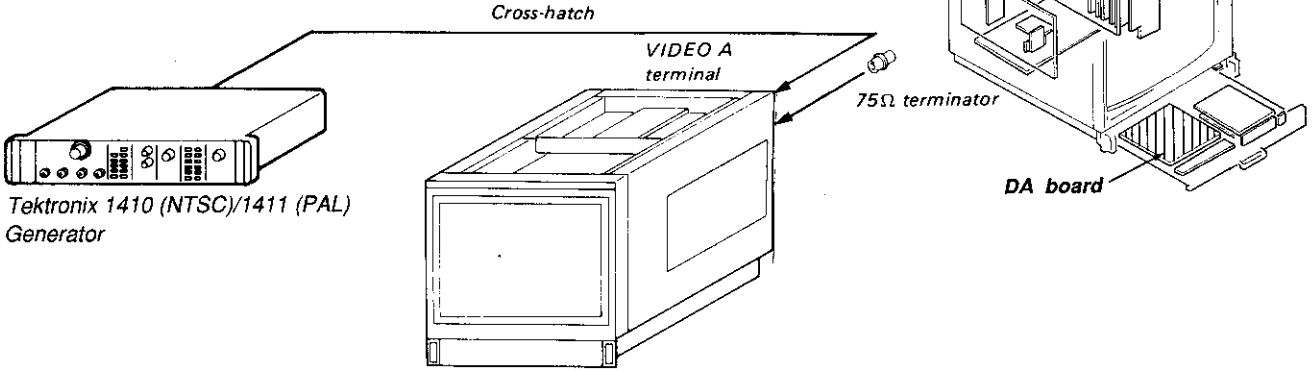

Fig. 27-1



**28. DA Board LINEARITY ADJUSTMENT**



**• Vertical Pincushion Adjustment**

1. Input only the H line of cross-hatch signal.
2. Minimize the X.BOW distortion with X.BOW (RV11) on the DA board as shown in third from the top of Fig. 28-1.
3. Minimize the T and B pincushion distortion gain with T.B.P (RV12) on the DA board as shown in second from the top of Fig. 28-1.

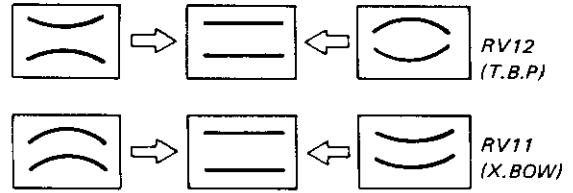

DA board Fig. 28-1

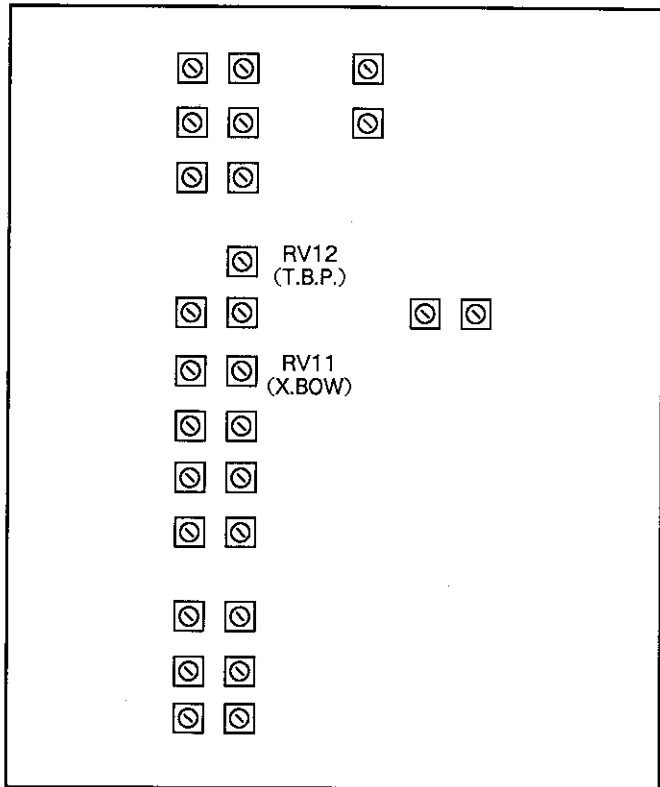

**FRONT PANEL**

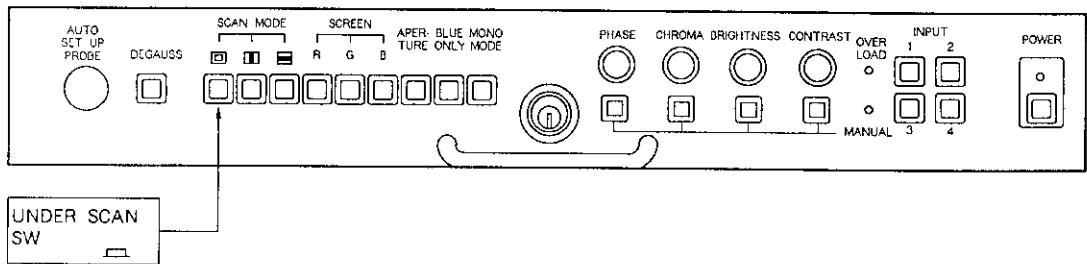

**• Vertical Lineality Adjustment**

1. Input only the H line of cross-hatch signal.
2. Adjust V center with V.CENTER (RV10) on the DA board.
3. Adjust the balance of V lineality with V.LB (RV9) on the DA board as shown in Fig. 28-2.
4. Adjust the gain of V lineality with V.LG (RV8) on the DA board as shown in Fig. 28-3.
5. Adjust the V.HEIGHT with V.H.N (RV3) on the DA board.
6. Mark tracking by repeating step 3. through 5.

RV9 ..... V LIN BALANCE

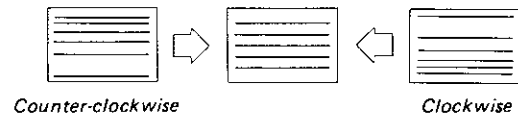

Fig. 28-2

RV8 ..... V LIN GAIN

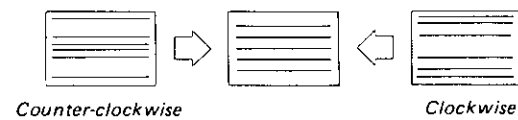

Fig. 28-3

**Side Pincushion Adjustment**

1. Input only the V line of cross-hatch signal.
2. Minimize the Y.BOW distortion with Y.BOW (RV13) on the DA board as shown in Fig. 28-7.
3. Minimize the Y.TILT distortion with Y.TILT (RV25) on the DA board as shown in Fig. 28-7.
4. Minimize the side pincushion distortion with S.P.N (RV5) on the DA board as shown in Fig. 28-4.
5. Minimize the side pincushion tilt distortion with S.P.T (RV7) on the DA board as shown in Fig. 28-5.
6. Set the SCAN selector to UNDER position.
7. Minimize the side pincushion distortion with S.P.U (RV6) on the DA board as shown in Fig. 28-4.

RV5 (S.P.N)  
RV6 (S.P.U)

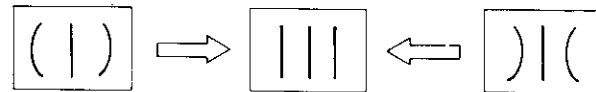

Fig. 28-4

RV7 (S.P.T)



Fig. 28-5

RV25 (Y.TILT)



Fig. 28-6

RV13 (Y.BOW)

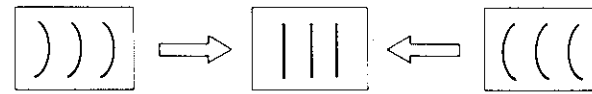

Fig. 28-7

**• Horizontal Lineality Adjustment**

1. Input only the V line of cross-hatch signal.
2. Adjust the horizontal centering with H CENTER (RV14) on the DA board.
3. Adjust the balance of H.lineality with H.L.B (RV22) on the DA board as shown in Fig. 28-8.
4. Adjust the gain of H.lineality with H.L.G (RV21) on the DA board as shown in Fig. 28-9.
5. Adjust the H.WIDTH with H.W.N (RV1) on the DA board.
6. Mark tracking by repeating step 3. through 5.
7. Set the SCAN selector to UNDER position.
8. Adjust the H.WIDTH with H.W.U (RV2) on the DA board.

RV28 (H.L.B)



Fig. 28-8

RV27 (H.L.G)

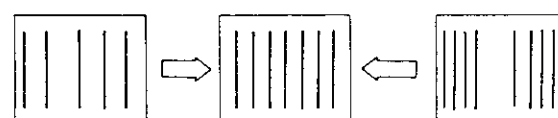
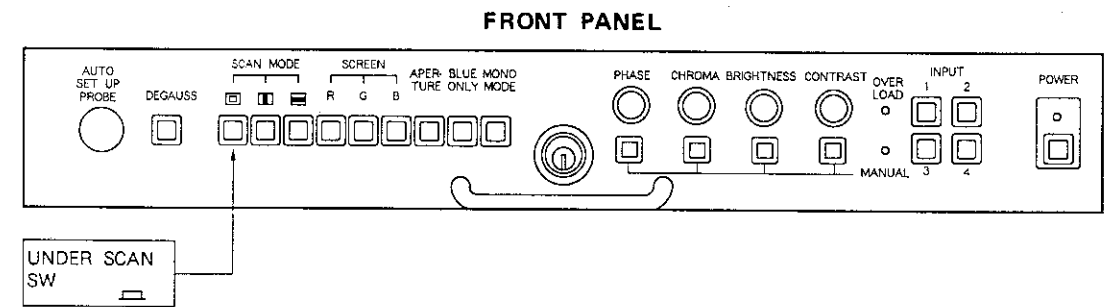
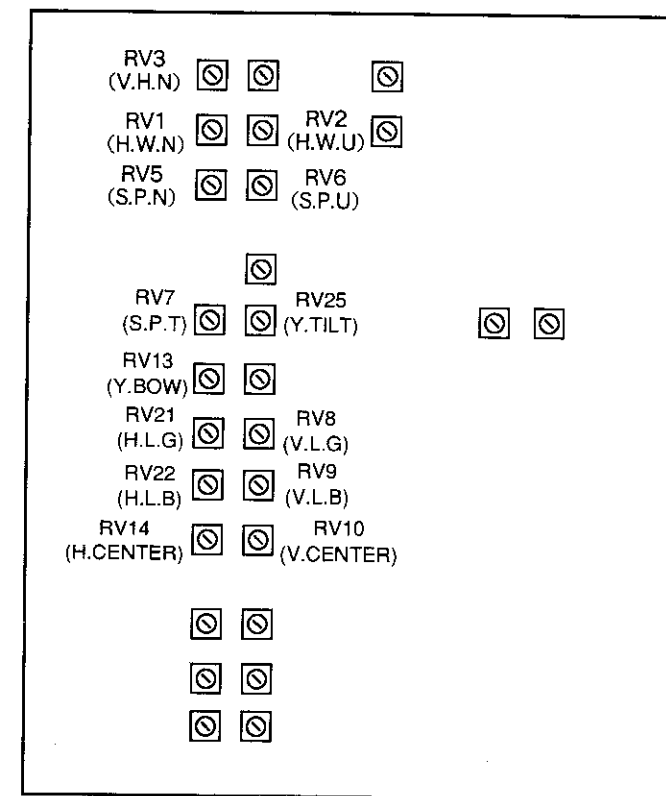

Fig. 28-9



DA board



## 29. DA, DB Board LINEARITY ADJUSTMENT

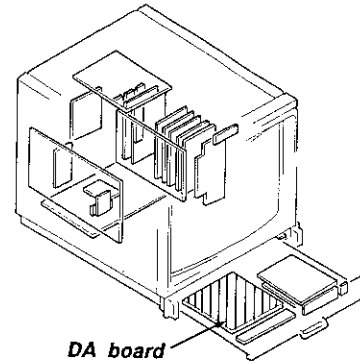
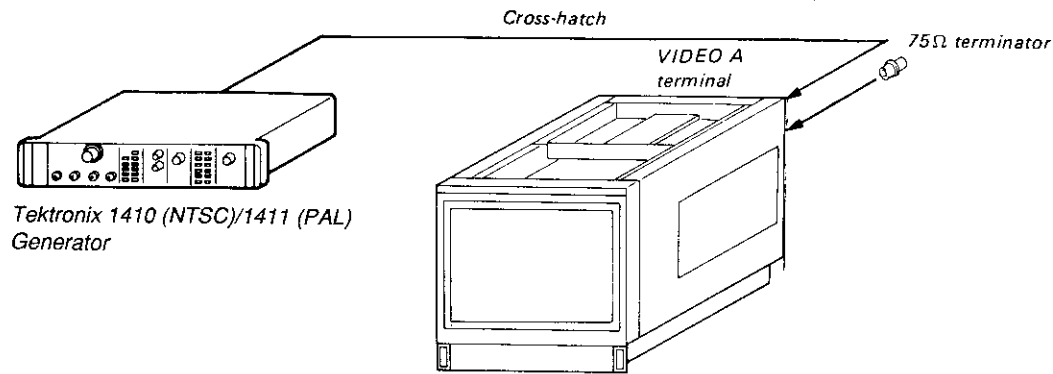

### • H.OSC Free-run Adjustment

1. Set the SYNC button to EXT.
2. Adjust H.FREQ. (RV202) on the DB board until the picture movement is still or slow.

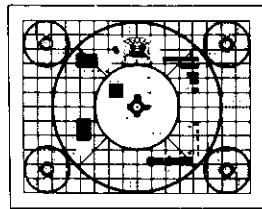

Fig. 29-1

3. Adjust H.PHASE (RV201) on the DB board for both sides of raster width without signal component coincidence.

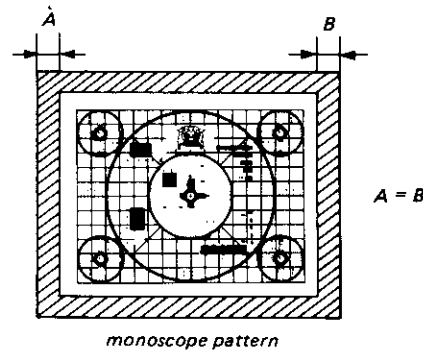

Fig. 29-3

### • Horizontal Phase and Horizontal Blanking Adjustments

1. Set the SCAN selector to UNDER position.
2. Turn the horizontal blanking controls H.BLK.R fully clockwise and H.BLK.L fully counterclockwise. (When the raster at both sides of screen are not appear completely, turn H.W.U (RV2) until obtaining the raster.)

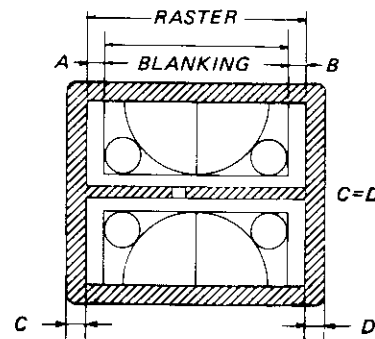

Fig. 29-2

4. Adjust H.BLK.R/H.BLK.L (RV24 and RV23) on the DA board so that the raster width without signal component become half.

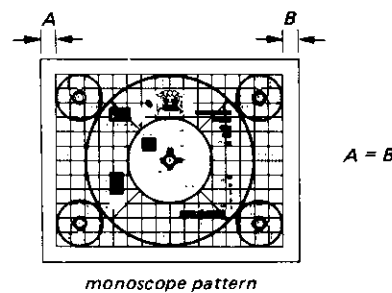
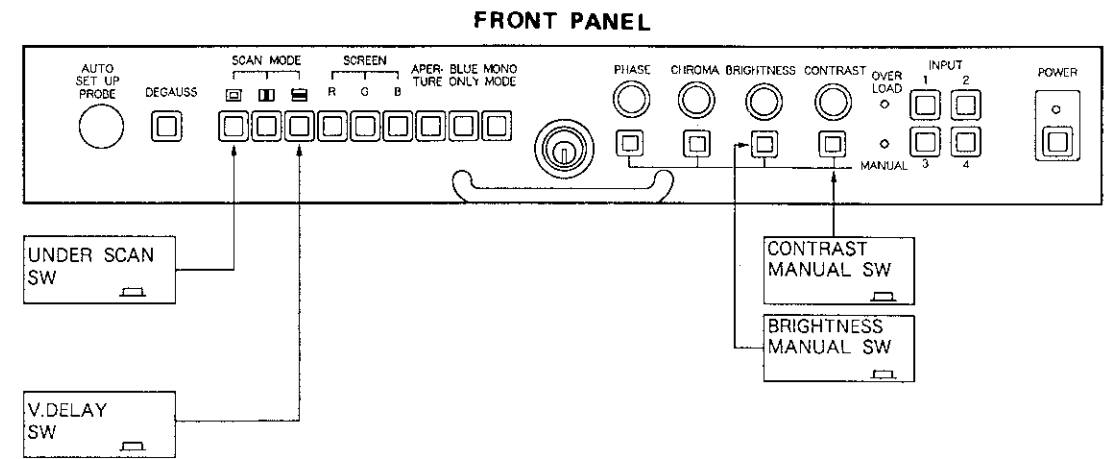
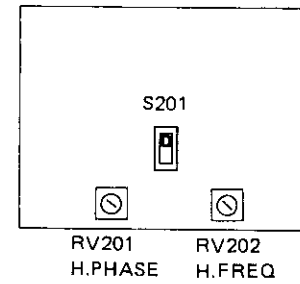

Fig. 29-4



### DB board



### DA board

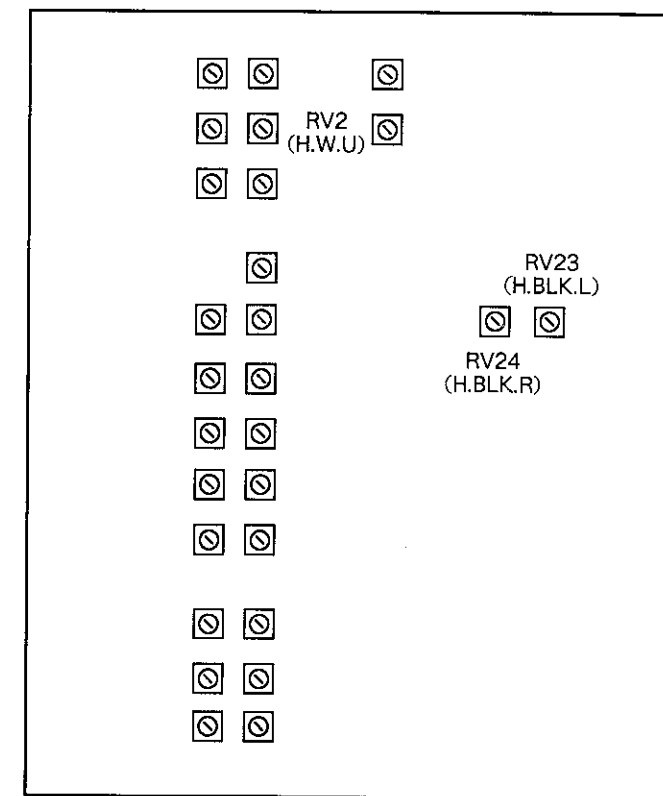

### 30. DA BOARD LINEARITY ADJUSTMENT OF 16:9 ASPECT PICTURE

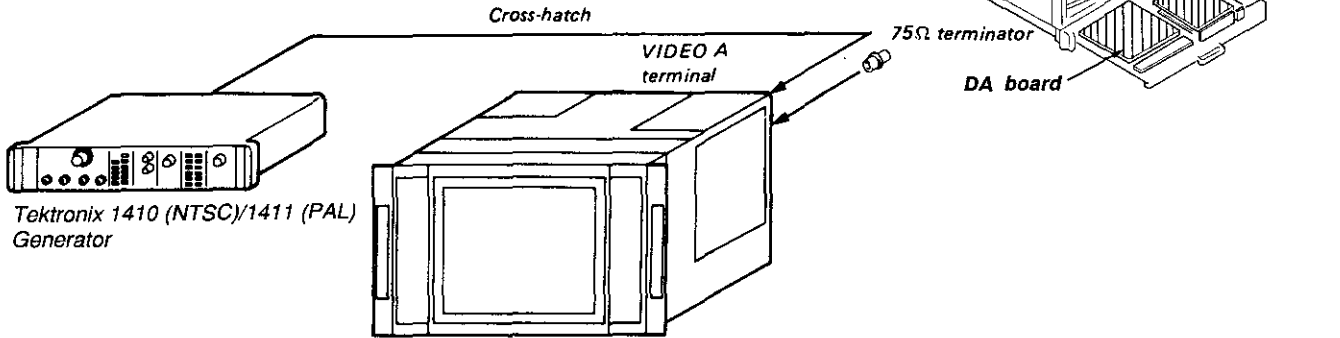

1. ASPECT button (SUB CONTROL PANEL) ..... 16:9

#### •Vertical Linearity Adjustment

1. Adjust the H. WIDTH with H. W (RV31) on the DA board.

#### •Horizontal Linearity Adjustment

1. Adjust the V. HEIGHT with V.H (RV32) on the DA board.

SUB CONTROL PANEL (HY board)

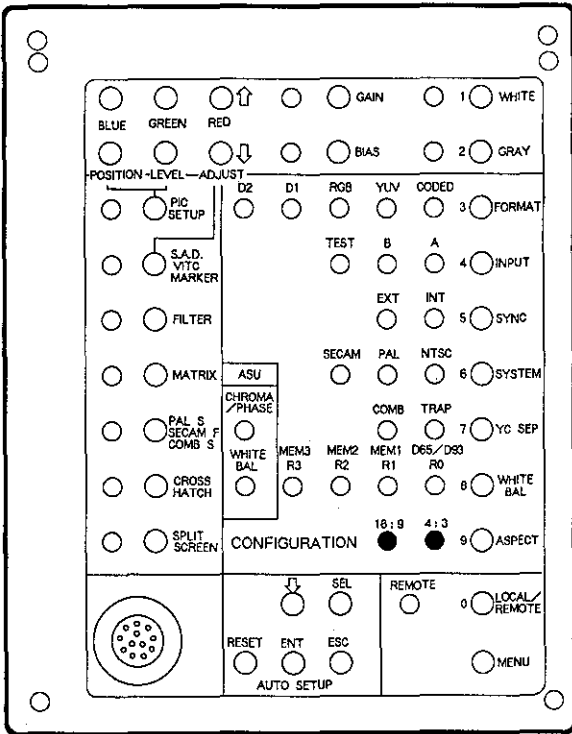

DA board

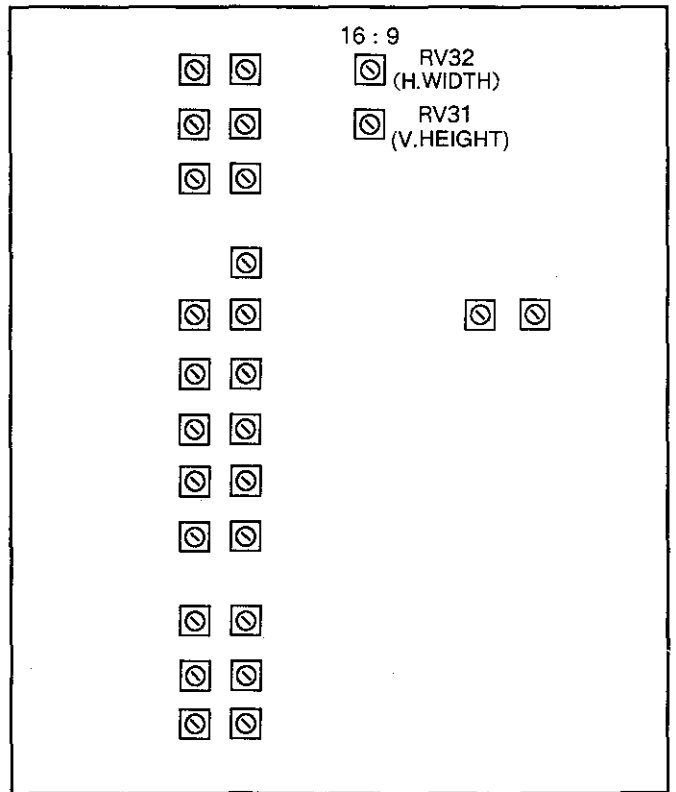





SECTION 5  
DIAGRAMS

5-1. BLOCK DIAGRAM  
SIGNAL PROCESSING BLOCK DIAGRAM

COMPOSITE VIDEO/Y

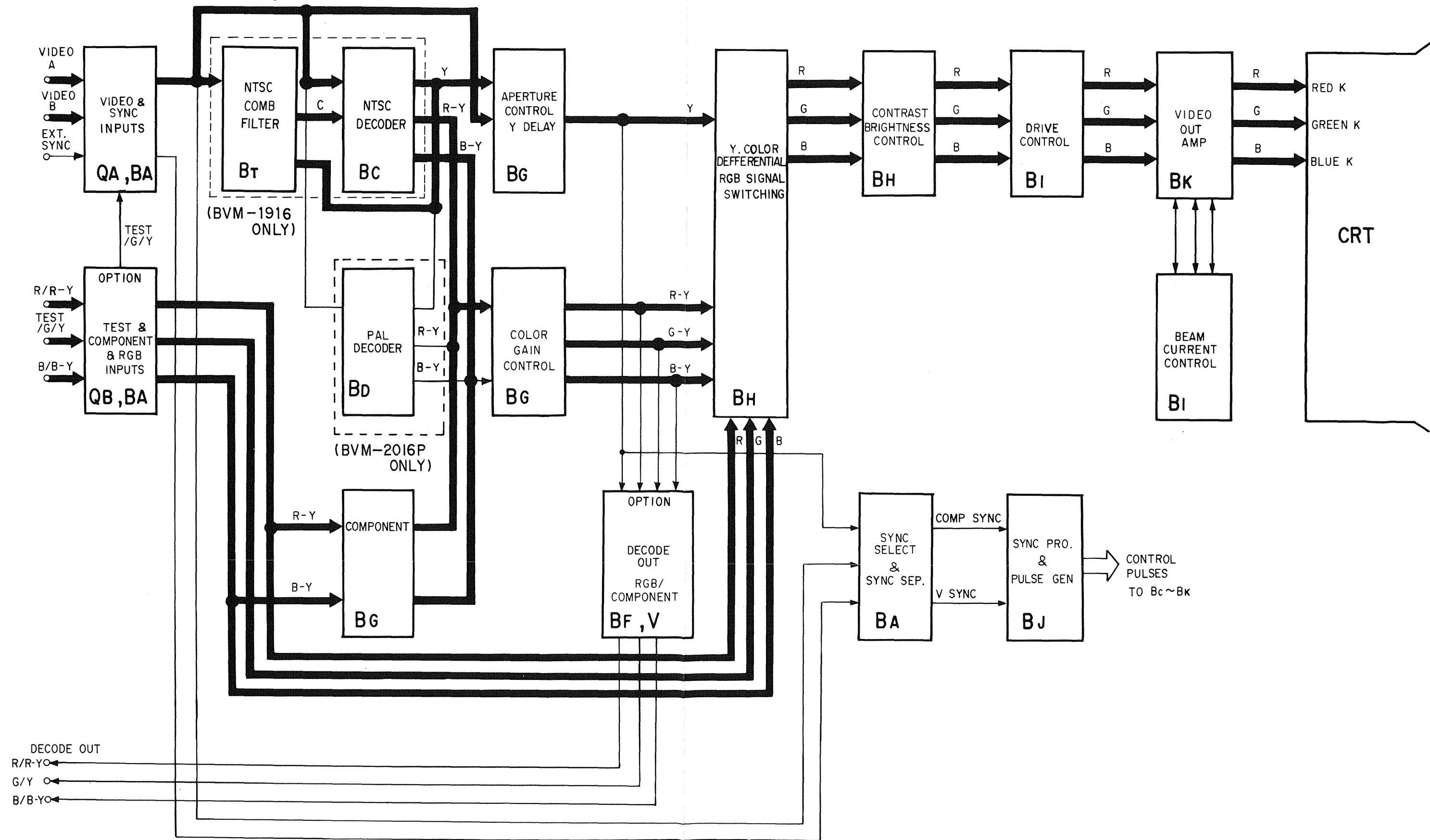

FRAME FRAME

FRAME FRAME

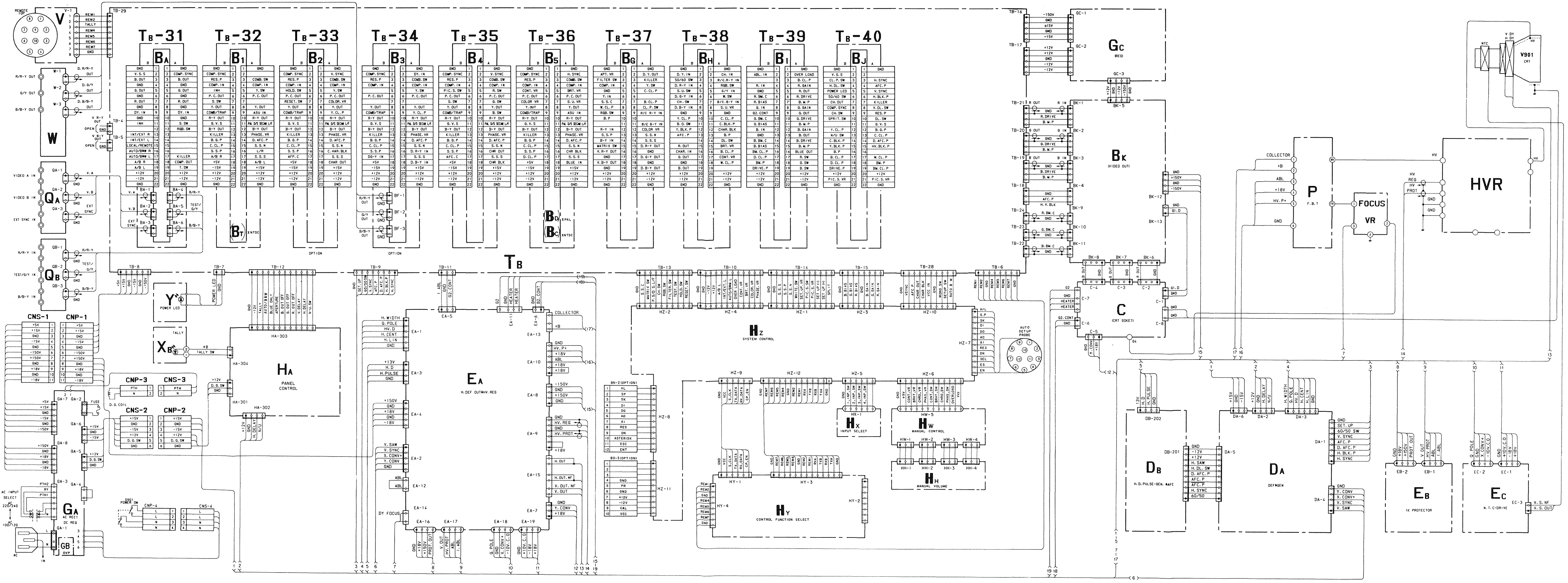

### 5-3. MOUNTING AND SCHEMATIC DIAGRAMS

#### Note:

**Note:** The components identified by shading and mark  $\Delta$  are critical for safety. Replace only with part number specified.

**Note:** Les composants identifiés par une trame et par une marque  $\Delta$  sont d'une importance critiques pour la sécurité. Ne les remplacer que par des pièce de numéro spécifié.

- All capacitors are in  $\mu\text{F}$  unless otherwise noted. p :  $\mu\text{F}$  50WV or less are not indicated except for electrolytics.
- All resistors are in ohms, 1/10W on the BT, DC, HY and HZ boards and 1/4W on the rest of the boards unless otherwise specified.

k $\Omega$  = 1000 $\Omega$ , M $\Omega$  = 1000k $\Omega$ .

- METAL FILM (:RN) resistors in 1%, 1/4 W unless otherwise specified.

$\square$  : nonflammable resistor.

$\Delta$  : internal component.

$\equiv$  : direct connection to points marked  $\equiv$  on the chassis

$\square$  : panel designation.

All variable and adjustable resistors have characteristic curve B, unless otherwise noted.

- The components identified by  $\blacksquare$  in this manual have been carefully factory-selected for each set in order to satisfy regulations regarding X-ray radiation. Should replacement be required, replace only with the value originally used.

When replacing components identified by  $\blacksquare$ , make the necessary adjustments indicated. If results do not meet the specified value, change the component identified by  $\boxtimes$  and repeat the adjustment until the specified value is achieved.

Refer to R52, R53, R67, R68, R73, R75, R106, R108, R115 and R135.

Adjust on page 4-11 ~ 4-16.

- When replacing the part in below table, be sure to perform the related adjustment.

#### Reference information

RESISTOR	: RN	METAL FILM
	: RC	SOLID
	: FPRD	NONFLAMMABLE CARBON
	: FUSE	NONFLAMMABLE FUSIBLE
	: RS	NONFLAMMABLE WIREWOUND
	: RB	NONFLAMMABLE CEMENT
COIL	: LF-8L	MICRO INDUCTOR
CAPACITOR	: TA	TANTALUM
	: PS	STYROL
	: PP	POLYPROPYLENE
	: PT	MYLAR
	: MPS	METALIZED POLYESTER
	: MPP	METALIZED POLYPROPYLENE
	: ALB	BIPOLAR
	: ALT	HIGH TEMPERATURE
	: AIR	HIGH RIPPLE

Part replaced ( $\blacksquare$ )	Adjustment ( $\boxtimes$ )
IC3, C59, R67, R68, R78, RV2 (GA board)	B+ MAX CONFIRMATION (R67, R68) Page 4-11.
Q13, Q14, R52, R53 (GA board) Q3, Q4, Q5, D5, D6, D7, D8, R4, R5, R19, R20, R21, R22 (GB board)	B+ PROTECTOR (R52, R53) Page 4-11.
IC2, IC3, R61, R62, R71, R71, R72, R73, R74, R75, R88, RV1 (EA board) HVR	HIGH VOLTAGE REGULATOR CONFIRMATION (R73, R75) Page 4-14, 15.
IC4, D24, D25, D27, R89, R90, R102, R103, R104, R105, R106, R107, R108, R111, R152 (EB board) HVR	HIGH VOLTAGE HOLD DOWN ADJUSTMENT AND CONFIRMATION (R106, R108) Page 4-14.
IC4, D24, D26, D27, R89, R90, R102, R103, R112, R113, R114, R115, R116, R117, R118, R119, R120, R121, R153 (EB board) FBT (P board)	BEAM CURRENT PROTECTOR-1 CONFIRMATION (R115) Page 4-15, 16.
IC6, D29, D51, R122, R123, R124, R130, R131, R132, R133, R134, R135, R136, R137, R138, R140, R141 (EB board) FBT (P board)	BEAM CURRENT PROTECTOR-2 CONFIRMATION (R135) Page 4-16.

$\square$  : adjustment for repair.

$\equiv$  : B+ bus.

$\equiv$  : B- bus.

○ : Circled numbers are waveform references.

Waveforms are taken with a color-bar signal input and with a 75 $\Omega$  terminator connected to an open terminal.

Switches and controls are as set as follows unless otherwise noted.

- Switches and controls are as set as follows unless otherwise noted.

#### FRONT PANEL

INPUT selector	1	HX board
CONTRAST MANUAL switch	PRESET	HW board
BRIGHTNESS MANUAL switch	PRESET	
CHROMA MANUAL switch	PRESET	
PHASE MANUAL switch	PRESET	
SCAN MODE switch		HA board
$\square$ UNDER SCAN	NOR	
$\square$ H. DELAY	NOR	
$\square$ V. DELAY	NOR	
SCREEN switch (R)	NOR	HA board
SCREEN switch (G)	NOR	
SCREEN switch (B)	NOR	
APT switch	NOR	
BLUE ONLY switch	NOR	
MODE selector	AUTO	
SUB CONTROL PANEL		
FORMAT button	CODED	
INPUT button	A	
SYNC button	INT	
COLOR SYSTEM button	NTSC (BVM-1916) PAL (BVM-2016P) CCMB (BVM-1916) TRAP (BVM-2016P)	
YC SEP button	D65/D93	
WHITE BALANCE button	4:3	HY board
ASPECT button	OFF	
PICTURE SETUP button	OFF	
SAD/VTC/WARKER button	OFF	
FILTER button	OFF	
MATRIX button	OFF	
PAL S/SECAM F/COMB S button	OFF	
CROSS HATCH button	OFF	
SPLIT SCREEN button	OFF	
WHITE button	OFF	
GRAY button	OFF	
APC switch	2m sec	DA board

#### Note:

- $\square$  : Pattern from the side which enables seeing.
- $\square$  : Pattern of the rear side.



TB board (MOTHER BOARD)

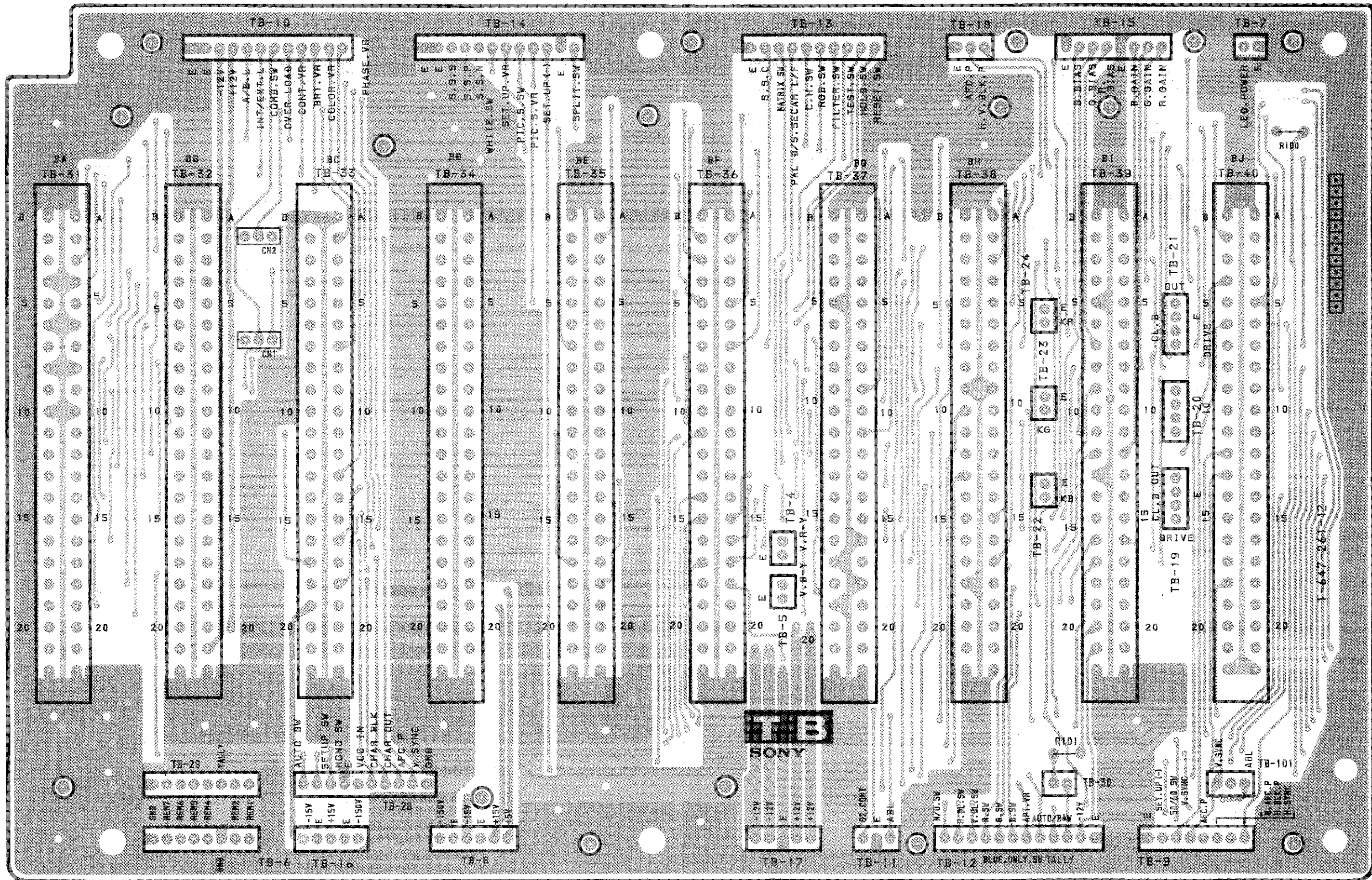

• : Pattern from the side which enables seeing.  
 • : Pattern of the rear side.

TB board (MOTHER BOARD)

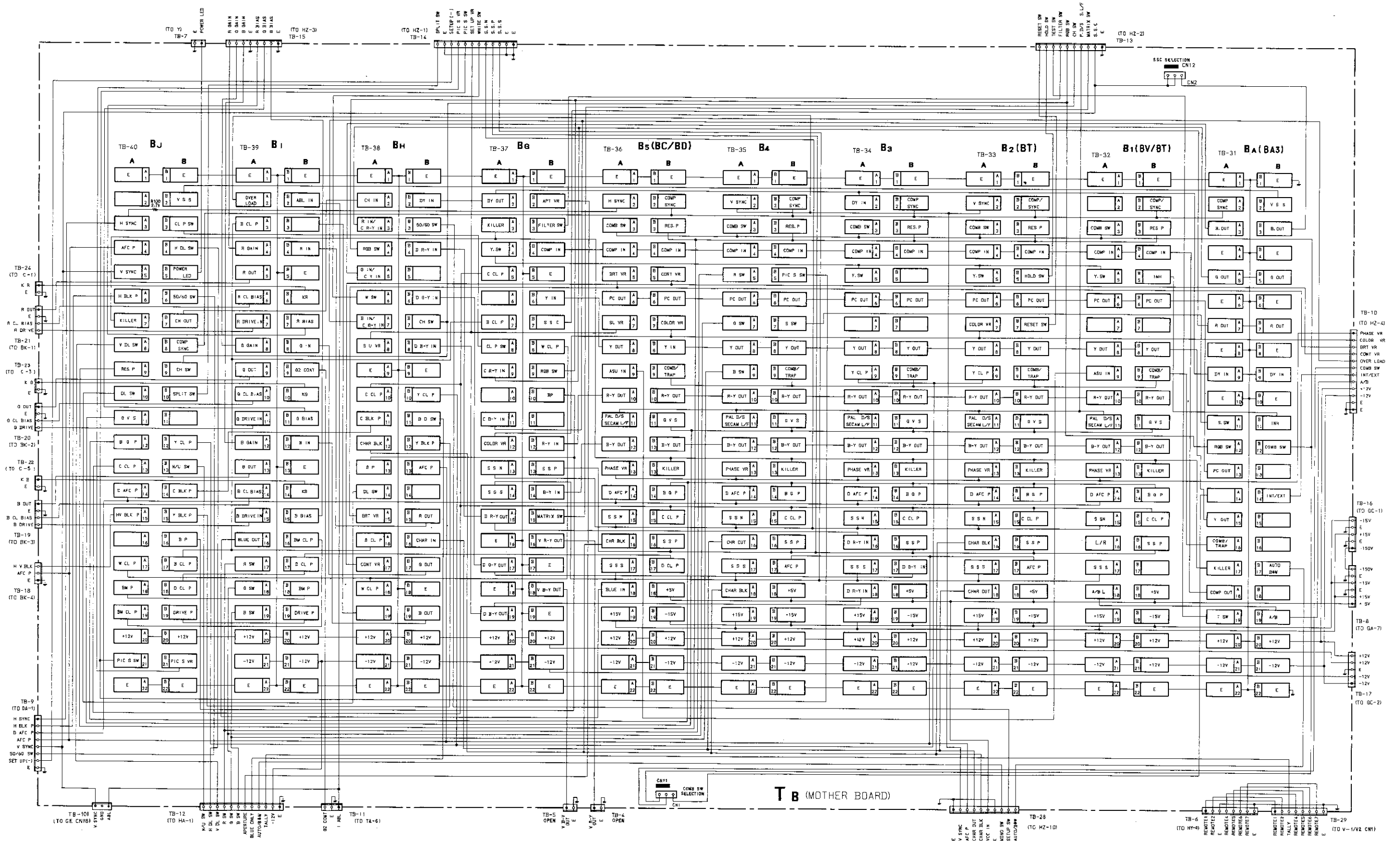

BA board (SYNC SELECT & SYNC SEP, HOOK UP)

IC	2										3				1																																	
Q	717	716	715	714	713	708	711	707	706	704	703	705	702	5	6	3	4	2	1																													
	605	604	603	602	601	505	504	503	502	501	405	404	403	402	401	305	304	303	302	301	205	204	203	202	201	105	104	103	102	101																		
D	708 707 706 703 705 710										101 709				4														2																			
TP ADJ	TP702		TP601		RV601		CV602		CV601		TP701		RV501		CV502		CV501		TR401		RV401		CV402		CV401		TP2		RV201		CV202		CV201		TP501		RV101		TP1		TP201		TPI01		CV102		CV101	

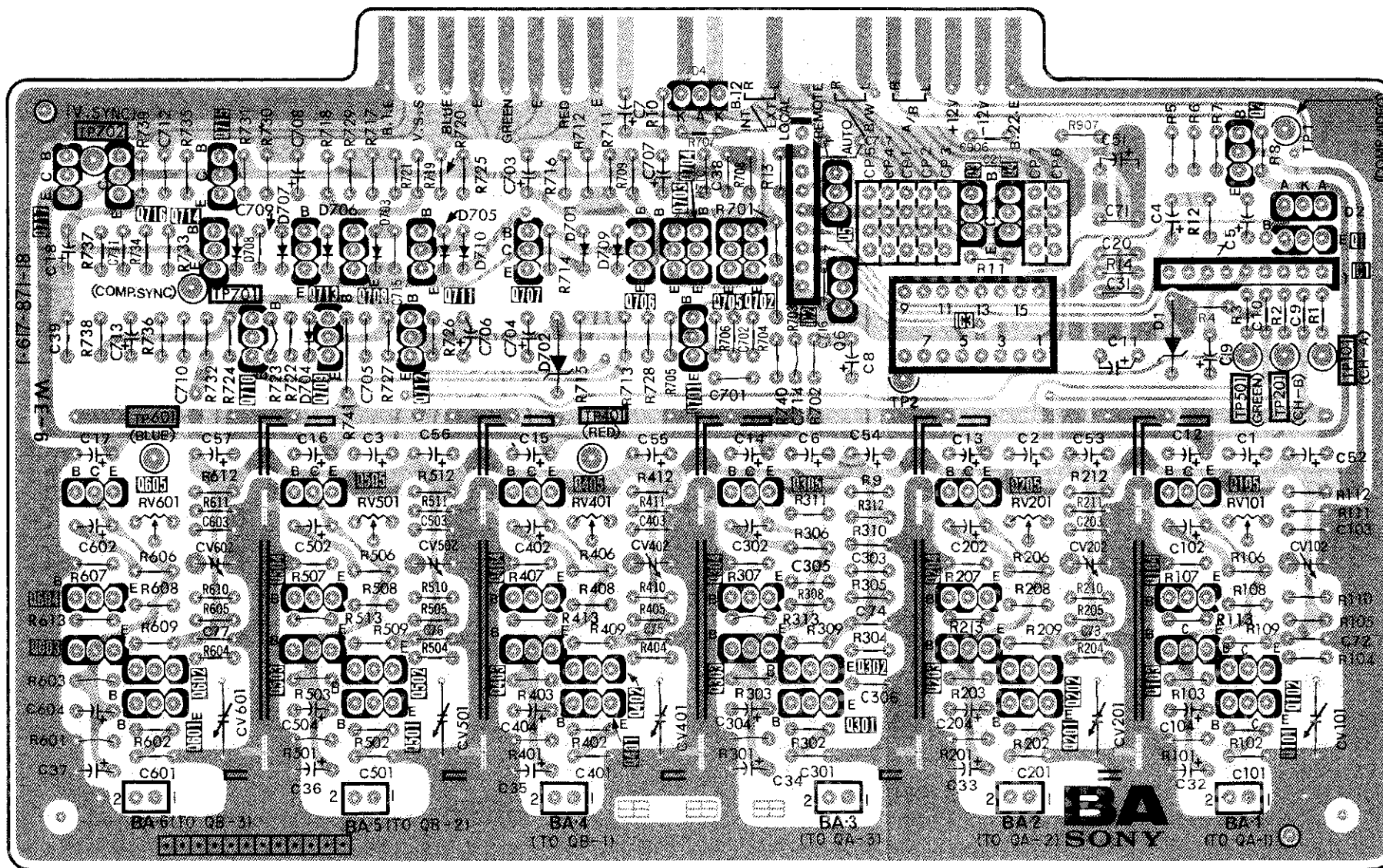

• : Pattern from the side which enables seeing.  
 • : Pattern of the rear side.



BA board (SYNC SELECT & SYNC SEP, HOOK UP)

BA BOARD

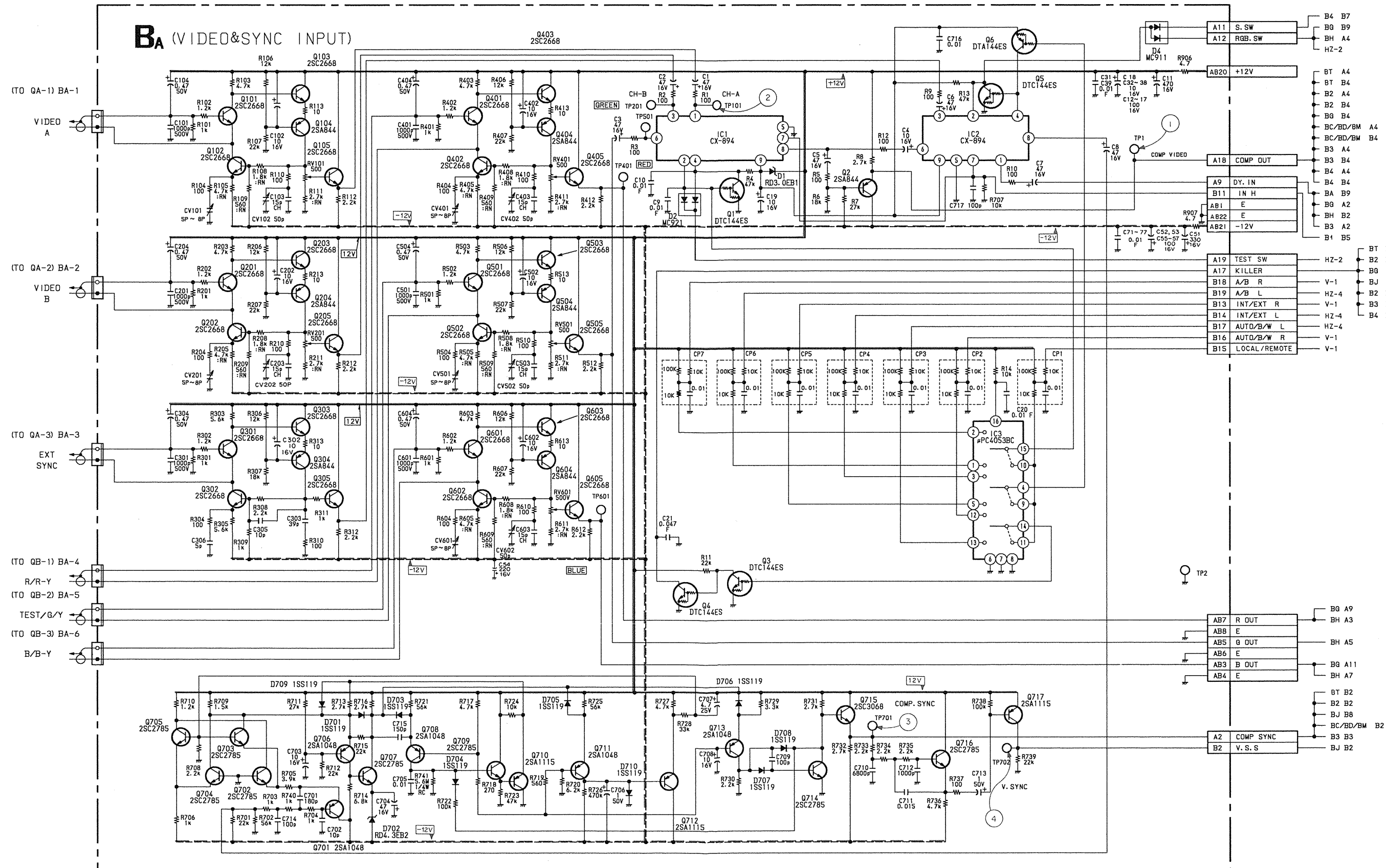

IC1	CX894	INPUT SELECT
2	CX894	SYNC SELECT
3	MC14053BCP	LOCAL/REMOTE SW
Q1	DTC144ES	INPUT SELECT CONTROL
2	2SA844	BUFF
3	DTC144ES	KILLER
4	DTC144ES	KILLER
5	DTC144ES	SYNC SELECT CONTROL
6	DTA144ES	INT/EXT CONTROL
101	2SC2668	VIDEO A AMP
102	2SC2668	VIDEO A AMP
103	2SC2668	VIDEO A AMP
104	2SA844	VIDEO A AMP
105	2SC2668	VIDEO A AMP
201	2SC2668	VIDEO B AMP
202	2SC2668	VIDEO B AMP
203	2SC2668	VIDEO B AMP
204	2SA844	VIDEO B AMP
205	2SC2668	VIDEO B AMP
301	2SC2668	EXT SYNC AMP
302	2SC2668	EXT SYNC AMP
303	2SC2668	EXT SYNC AMP
304	2SA844	EXT SYNC AMP
305	2SC2668	EXT SYNC AMP
401	2SC2668	R-Y/R AMP
402	2SC2668	R-Y/R AMP
403	2SC2668	R-Y/R AMP
404	2SA844	R-Y/R AMP
405	2SC2668	R-Y/R AMP
501	2SC2668	TEST/Y/G AMP
502	2SC2668	TEST/Y/G AMP
503	2SC2668	TEST/Y/G AMP
504	2SA844	TEST/Y/G AMP
505	2SC2668	TEST/Y/G AMP
601	2SC2668	B-Y/B AMP
602	2SC2668	B-Y/B AMP

Q603	2SC2668	B-Y/B AMP
604	2SA844	B-Y/B AMP
605	2SC2668	B-Y/B AMP
701	2SA1048	SYNC AGC
702	2SC2785	SYNC AGC
703	2SC2785	SYNC AGC
704	2SC2785	SYNC AGC
705	2SC2785	SYNC AGC
706	2SA1048	SYNC AGC
707	2SC2785	SYNC AGC
708	2SA1048	SYNC AGC
709	2SC2785	SYNC AGC
710	2SA1115	SYNC AGC
711	2SA1048	SYNC AGC
712	2SA1115	SYNC AGC
713	2SA1048	COMP SYNC SEP
714	2SC2785	COMP SYNC SEP
715	2SC3068	COMP SYNC SEP
716	2SC2785	V SYNC SEP
717	2SA1115	V SYNC SEP
D1	RD3 0E-B1	+9V REG
2	MC921	INPUT SELECT CONTROL
4	MC911	SYNC SELECT CONTROL
701	1SS119	SYNC AGC
702	RD4 3E-B2	-7.5V REG
703	1SS119	SYNC AGC
704	1SS119	SYNC AGC
705	1SS119	SYNC AGC
706	1SS119	SYNC AGC
707	1SS119	COMP SYNC SEP
708	1SS119	COMP SYNC SEP
709	1SS119	SYNC AGC
710	1SS119	SYNC AGC

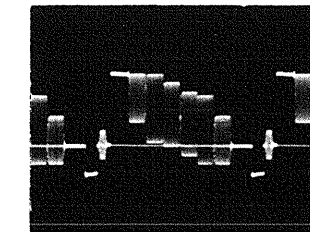

① 1Vp-p (H)  
② 1Vp-p (H)

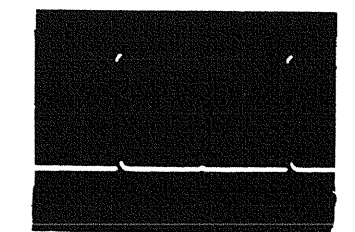

④ 12Vp-p (V)

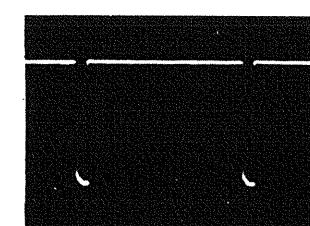

③ 12Vp-p (H)





BT BT

BT board (3 LINE DYNAMIC COMB FILTER, 2 LINE SIMPLE COMB FILTER, BPF)

(BVM-1916 ONLY)

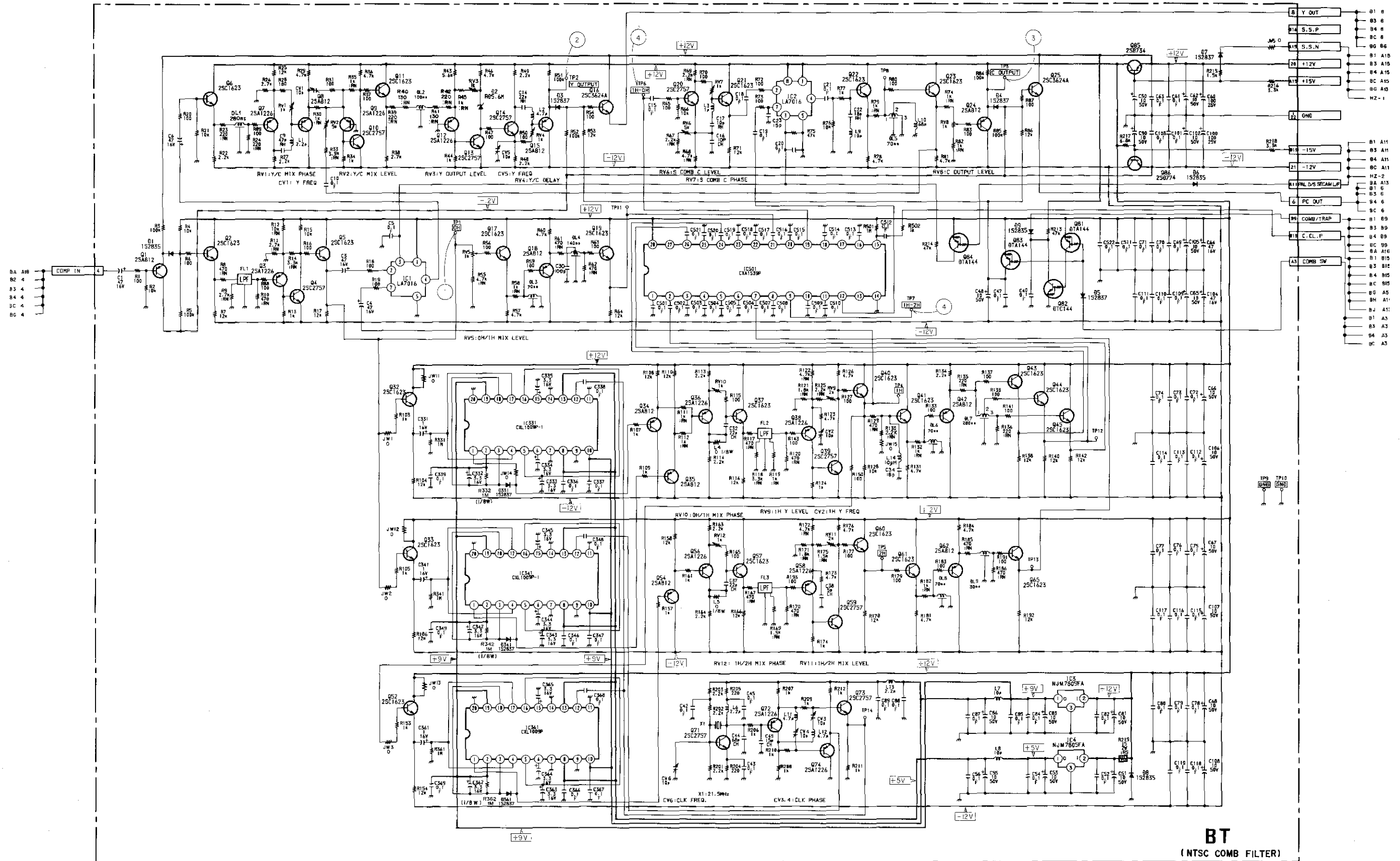

BT  
(NTSC COMB FILTER)

BC BC

BC Board (NTSC DECODER Y. TRAP)  
(BVM-1916 ONLY)

IC	1															2			3		
Q	19	20	21	16	17	18	15	14	13	12	11	10	9	7	6	8	5	4	3	2	1
D	6	5	3	7	2	4															
TP	RV5		RV4		TP7		TP6		RV3		RV2		TP4		TP1		RV1				
ADJ	TP5	TP3	TP2		CV2		CV1		TP4		TP1		RV1								

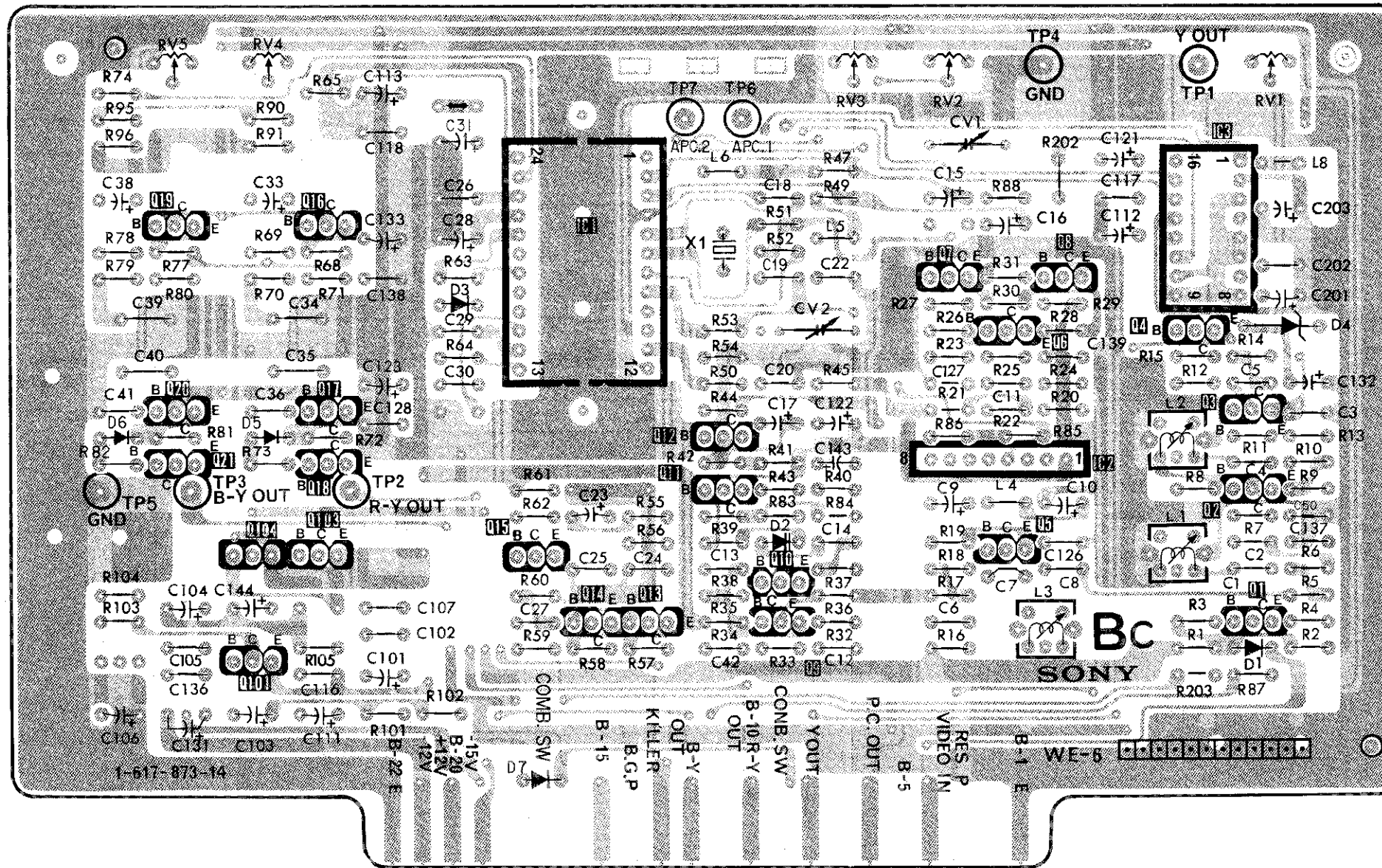

• : Pattern from the side which enables seeing.  
 ■ : Pattern of the rear side.

BC Board (NTSC DECODER Y. TRAP)  
(BVM-1916 ONLY)

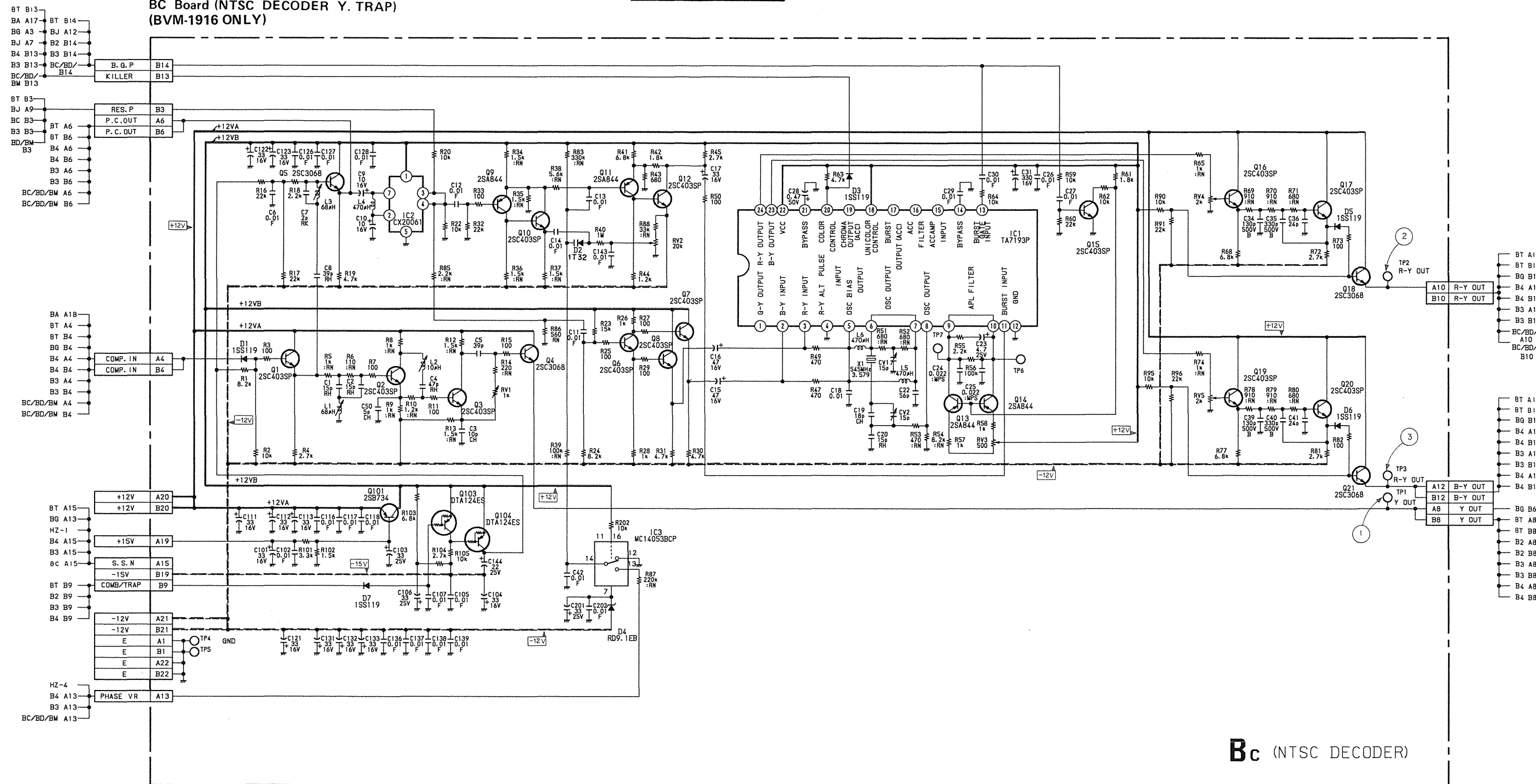

Bc (NTSC DECODER)

BC BOARD

IC1	TA7193P	DEMODULATOR
2	CX20061	RESIDUAL SWITCH
3	MC14053BCP	ANALOG SWITCH
Q1	2SC403SP	BUFF.
2	2SC403SP	ACTIVE FILTER
3	2SC403SP	Y-DELAY CORRECT
4	2SC3068	BUFF.
5	2SC3068	BUFF.
6	2SC403SP	AMP.
7	2SC403SP	BUFF.
8	2SC403SP	BUFF.
9	2SA844	PHASE CONTROL
10	2SC403SP	PHASE CONTROL
11	2SA844	PHASE CONTROL
12	2SC403SP	PHASE CONTROL
13	2SA844	APL FILTER

14	2SA844	APL FILTER
15	2SC403SP	APL FILTER
16	2SC403SP	LOW PASS FILTER
17	2SC403SP	LOW PASS FILTER
18	2SC3068	BUFF.
19	2SC403SP	LOW PASS FILTER
20	2SC403SP	LOW PASS FILTER
21	2SC3068	BUFF.
101	2SB734	SYSTEM SW.
103	DTA124ES	COMB. SWITCH
104	DTA124ES	COMB. SWITCH
D1	1SS119	SYSTEM SWITCH
2	1T32	PHASE CONTROL
3	1SS119	KILLER SWITCH
4	RD9.1EB3	SWITCH BIAS.
5	1SS119	SYSTEM SWITCH
6	1SS119	SYSTEM SWITCH
7	1SS119	PROTECTOR

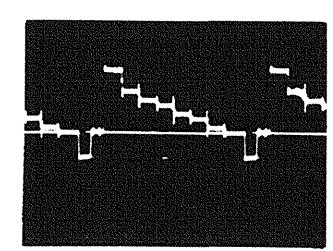

① 1Vp-p (H)

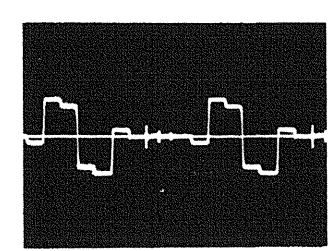

② 0.3Vp-p (H)

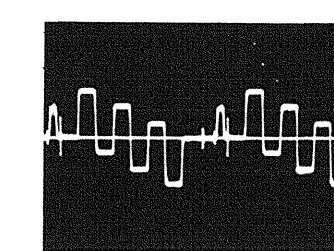

③ 0.36 Vp-p (H)

BD board (PAL DECODER Y. TRAP)  
(BVM-2016P ONLY : Serial No. 2000382 and Higher)

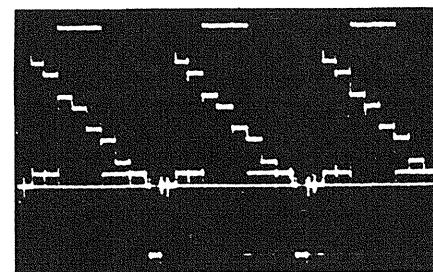

① 1Vp-p (H)

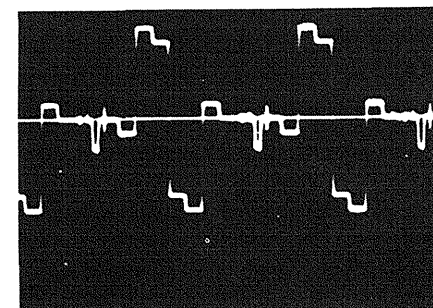

② 0.3Vp-p (H)

④ 0.32Vp-p (H)

③ 0.32Vp-p (H)

⑤ 0.36Vp-p (H)

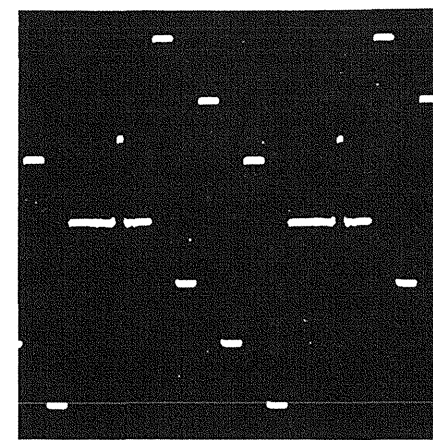

⑥ 0.38Vp-p (H)

⑧ 0.39Vp-p (H)

⑦ 0.38Vp-p (H)

⑨ 0.42Vp-p (H)



⑩ 0.26Vp-p (H)

⑪ 0.26Vp-p (H)

IC1	TA7193P	PAL DEMODULATOR
2	LA7016	RESIDUAL SWITCH
3	CXL5506P	1H DELAY LINE
4	CXL5506P	1H DELAY LINE
5	MPD4053BC	ANALOG SWITCHER
6	LA7016	BURST GATE
7	NJM4558D	R-Y CLAMP
8	NJM4558D	B-Y CLAMP
10	NJM78L05A	+5V REG
Q1	2SC403SP	BUFFER
2	2SC403SP	ACTIVE FILTER
3	2SC403SP	Y-DELAY CORRECTER
4	2SC3068	BUFFER
5	2SC3068	BUFFER
6	2SA844-D	PHASE CONTROLLER
7	2SC403SP	PHSAE CONTROLLER
8	2SA844-D	PHASE CONT. AMP.
9	2SC403SP	PHASE CONT. AMP.
10	2SA1175	APL FILTER
11	2SA1175	APL FILTER
12	2SC403SP	APL FILTER SWITCH
13	2SC403SP	R-Y L.P.F
14	2SC403SP	R-Y L.P.F
15	2SC403SP	B-Y L.P.F
16	2SC403SP	B-Y L.P.F
17	2SP403SP	AMPLIFIER
18	2SK381-A	R-Y CLAMP
20	2SA1175	BUFFER
21	2SC403SP	BUFFER
22	2SC403SP	CCD OUT L.P.F
23	2SA844-D	CCD OUT L.P.F.
24	2SC403SP	BUFFER
25	2SC3068	BUFFER
26	2SK381-A	B-Y CLAMP
28	2SA1175	BUFFER
29	2SC403SP	BUFFER
30	2SC403SP	CCD OUT L.P.F
31	2SA844-D	CCD OUT L.P.F.
32	2SC403SP	BUFFER
33	2SC3068	BUFFER
34	2SC403SP	CCD CLOCK GEN
35	2SA844-D	CCD CLOCK GEN
36	2SC403SP	BUFFER
38	2SC403SP	BUFFER
40	2SC403SP	CCD OUT L.P.F
50	2SC403SP	CCD OUT L.P.F
101	2SB734	SYSTEM SWITCH
102	2SD789	SYSTEM SWITCH
103	DTA124ES	COMB. SWITCH
104	DTA124ES	COMB. SWITCH
D1	1SS119	SYSTEM SWITCH
2	1SS119	COMB. SWITCH
5	RD9.1EB2	SWITCH BIAS
6	1SS119	KILLER SWITCH
10	1T25	PHASE CONTROL
11	1SS119	PAL S/D SWITCH
12	RD12EB2	PHASE SWITCH
13	RD12EB2	SYSTEM SWITCH
16	1SS119	COMB SW
201	1SS119	PROTECTOR
202	1SS119	PROTECTOR

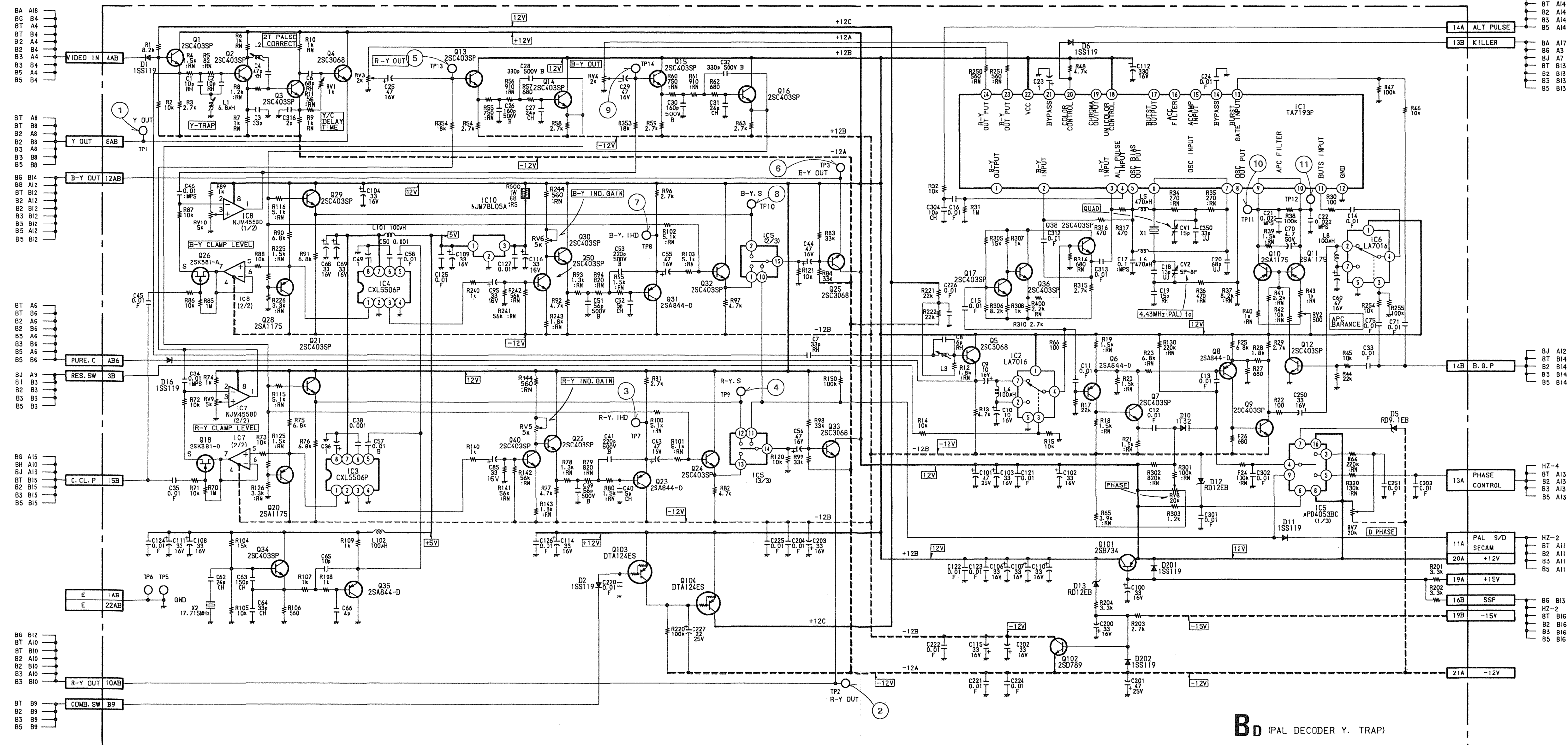

BD (PAL DECODER Y. TRAP)



BD BD

BD board (PAL DECODER Y.TRAP)  
 (BVM-2016P ONLY : Serial No. 2000382 and Higher)

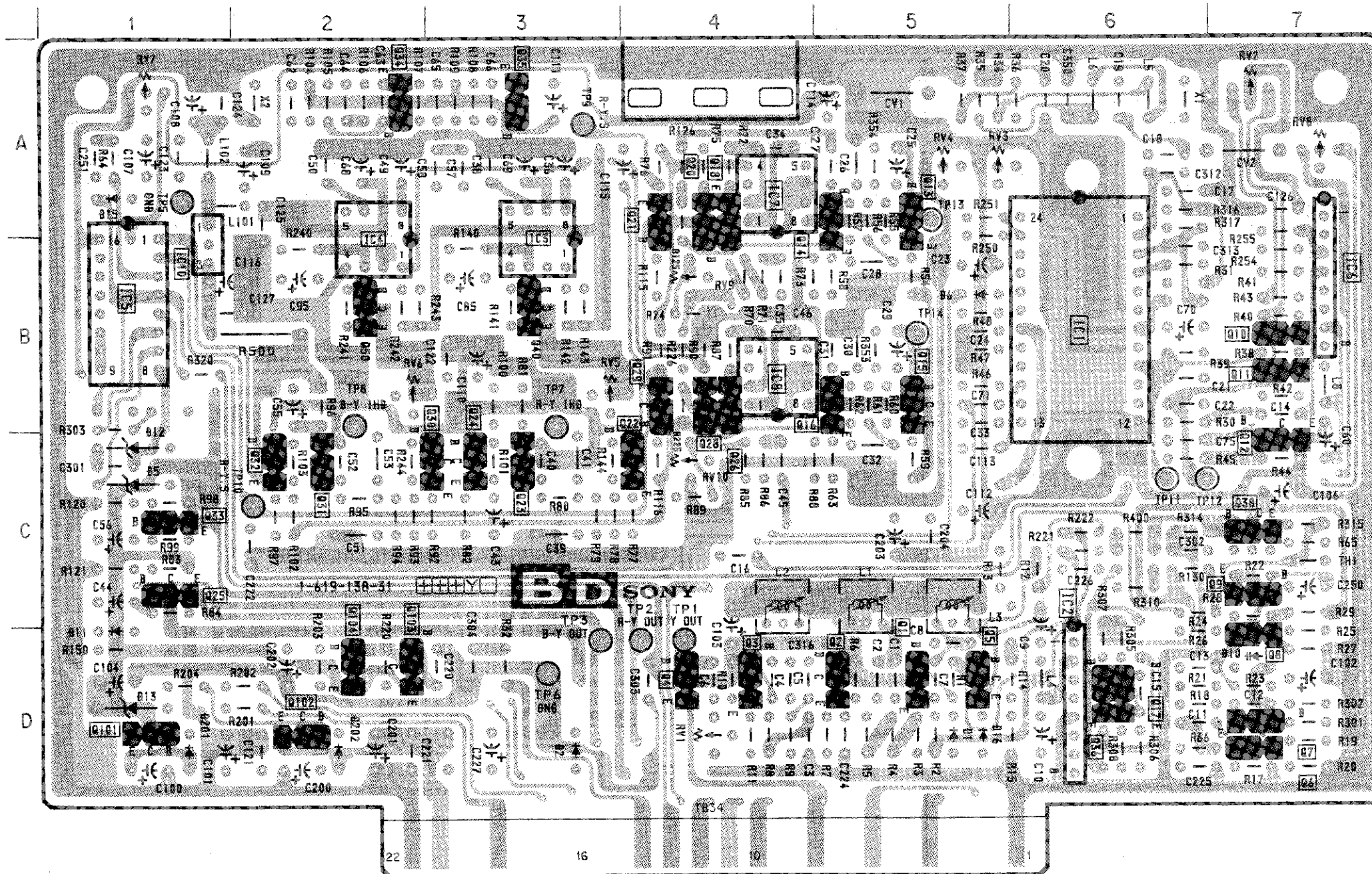

IC		DIODE	
IC1	B-6	D1	D-5
IC2	C-6	D2	D-3
IC3	B-3	D5	C-1
IC4	B-2	D6	B-5
IC5	B-1	D10	D-7
IC6	B-7	D11	D-1
IC7	A-4	D12	C-1
IC8	B-4	D13	D-1
IC10	B-1	D16	D-5
TRANSISTOR		D201	D-1
		D202	D-2
		TRIMMER	
Q1	D-5	Q2	D-5
Q3	D-4	Q4	D-4
Q5	D-7	Q6	D-7
Q7	D-7	Q8	D-7
Q9	C-7	Q10	B-7
Q11	B-7	Q12	C-7
Q13	A-5	Q14	B-4
Q15	B-5	Q16	B-4
Q17	D-6	Q18	A-4
Q20	A-4	Q21	A-4
Q22	B-4	Q23	C-3
Q24	B-3	Q25	C-1
Q26	C-4	Q28	C-4
Q29	B-4	Q30	B-3
Q31	C-2	Q32	C-2
Q33	C-1	Q34	A-2
Q35	A-3	Q36	D-6
Q38	C-7	Q40	B-3
Q50	B-2	Q101	D-1
Q102	D-2	Q103	C-2
Q104	C-2		
		VARIABLE RESISTOR	
CV1	A-5	CV2	A-7
		TEST POINT	
TP1	C-4	TP2	C-4
TP3	D-3	TP5	A-1
TP6	D-3	TP7	B-3
TP8	B-2	TP9	A-3
TP10	C-2	TP11	C-6
TP12	C-6	TP13	A-5
TP14	B-5		

• : Pattern from the side which enables scoring.  
 • : Pattern of the rear side.

BG BG

BG board (COLOR GAIN CONTROL, COMPONENT R-Y AMP & DELAY, APERTURE CONTROL, Y, DELAY, NTSC MATRIX SW, G-Y MATRIX AMP)

IC	1	3 4	6	7	5				
Q	5 8 10 11 12	7 9	72 71 73 74 75	13 14 16 76 77 82 81 83 84 85	21 22 23 24 25 26 27 28 41	34 33 35 36 37 38 42 43	40 50 30	29 49	45 44
D		17 6	1 7 2	15 16	5				
TP ADJ	RV1	CV2 CV3 RV3	RV21 TPI TP4	RV22	TP5 RV5	RV4	RV11 RV12 RV13 TP2	TP3	RV14 RV15 RV16

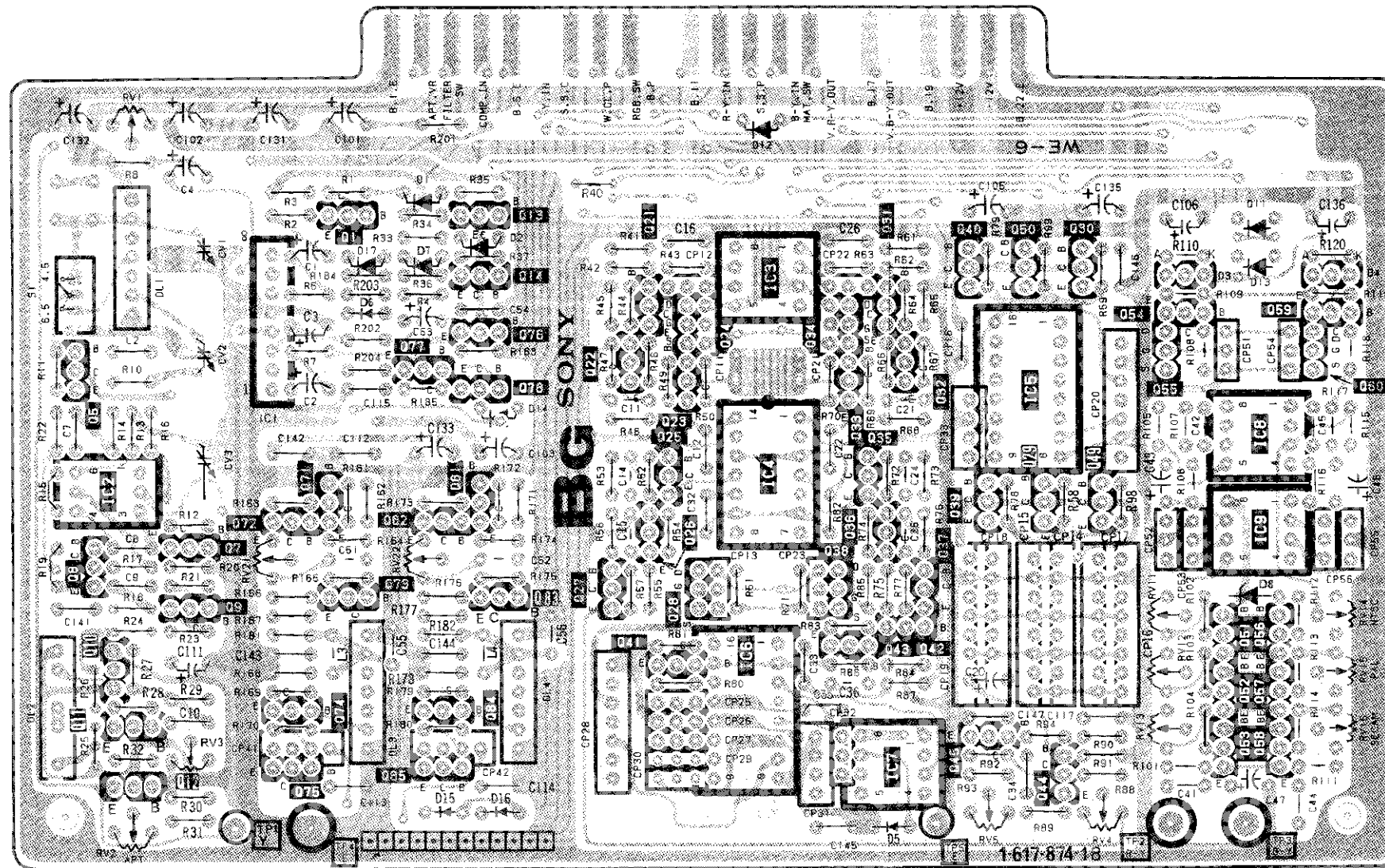

- : Pattern from the side which enables seeing.
- : Pattern of the rear side.

BG board (COLOR GAIN CONTROL, COMPONENT R-Y AMP & DELAY, APERUTURE CONTROL, Y, DELAY, NTSC MATRIX SW, G-Y MATRIX AMP)

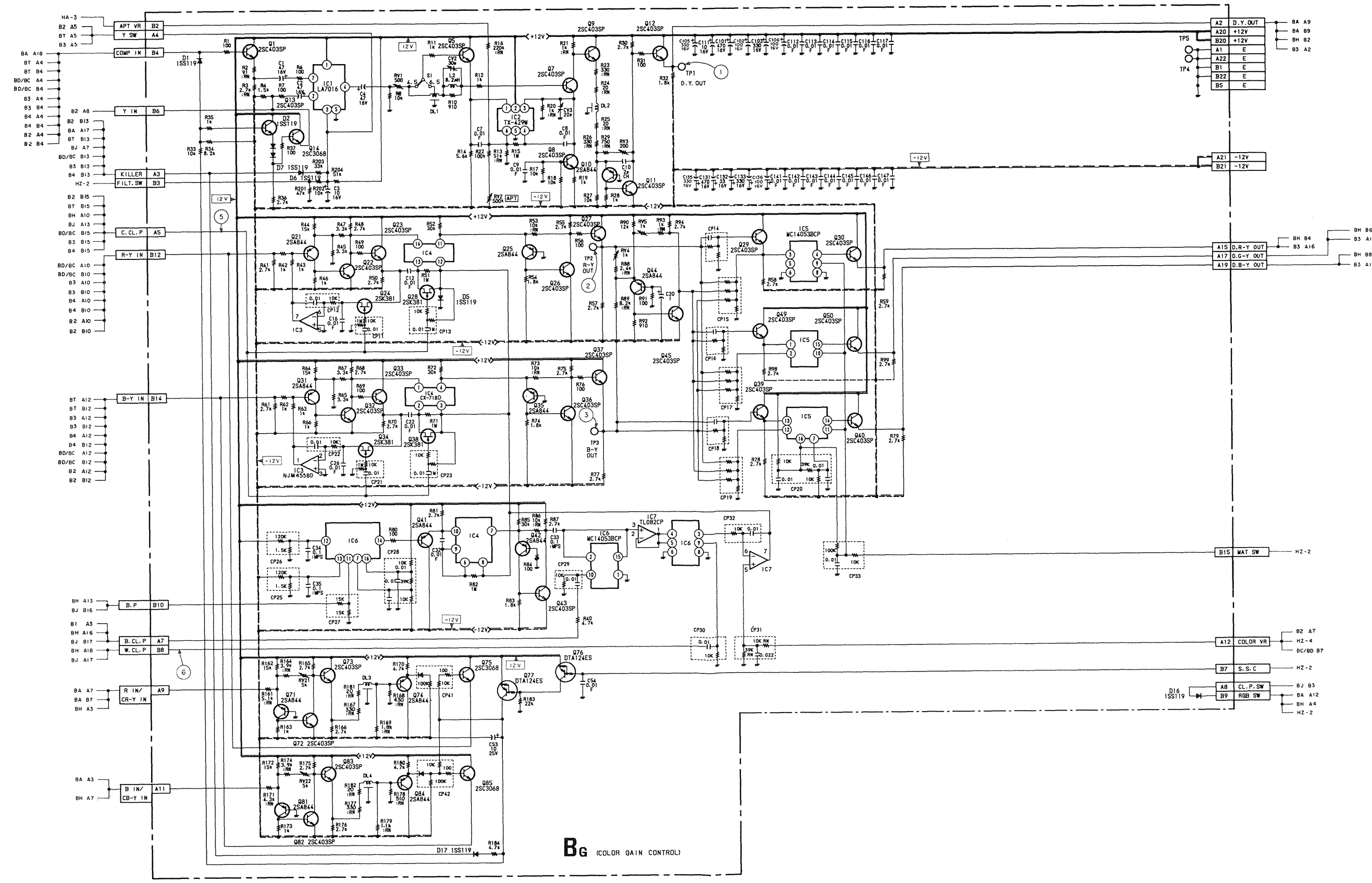

B<sub>G</sub> (COLOR GAIN CONTROL)

BG BOARD

IC1	LA7016	FILTER SW
2	TX-429M	APERTURE
3	NJM4558D	COLOR DIFFERENCE CLAMP
4	CX-718D	CHROMA CONTROL
5	MC14053BCP	MATRIX SW
6	MC14053BCP	CHROMA CONTROL
7	TL082CP	CHROMA CONTROL
8	TL082CP	VECTOR OUTPUT
9	TL082CP	VECTOR OUTPUT
Q1	2SC403SP	BUFF
5	2SC403SP	APERTURE
7	2SC403SP	APERTURE
8	2SC403SP	APERTURE
9	2SC403SP	Y DELAY
10	2SA844	Y AMP
11	2SC403SP	Y AMP
12	2SC403SP	Y AMP
13	2SC403SP	BUFF
14	2SC3068	BUFF
21	2SA844	R-Y AMP
22	2SC403SP	R-Y AMP
23	2SC403SP	R-Y CLAMP
24	2SK381	R-Y CLAMP
25	2SA844	R-Y CHROMA CONTROL
26	2SC403SP	R-Y CHROMA CONTROL
27	2SC403SP	R-Y CHROMA CONTROL
28	2SK381	R-Y CHROMA CONTROL
29	2SC403SP	R-Y BUFF
30	2SC403SP	R-Y BUFF
31	2SA844	B-Y AMP
32	2SC403SP	B-Y AMP
33	2SC403SP	B-Y CLAMP
34	2SK381	B-Y CLAMP
35	2SA844	B-Y CHROMA CONTROL
36	2SC403SP	B-Y CHROMA CONTROL
37	2SC403SP	B-Y CHROMA CONTROL
38	2SK381	B-Y CHROMA CONTROL
39	2SC403SP	B-Y BUFF
40	2SC403SP	B-Y BUFF
41	2SA844	CHROMA CONTROL
42	2SA844	CHROMA CONTROL
43	2SC403SP	CHROMA CONTROL

Q44	2SA844	CHROMA CONTROL
45	2SC403SP	CHROMA CONTROL
49	2SC403SP	G-Y BUFF
50	2SC403SP	G-Y BUFF
51	DTA124ES	GAIN CHANGE SW
52	DTA124ES	GAIN CHANGE SW
53	DTA124ES	GAIN CHANGE SW
54	2SC403SP	R-Y BUFF
55	2SK381	R-Y CLAMP
56	DTA124ES	GAIN CHANGE SW
57	DTA124ES	GAIN CHANGE SW
58	DTA124ES	GAIN CHANGE SW
59	2SC403SP	B-Y BUFF
60	2SK381	B-Y CLAMP
71	2SA844	R-Y AMP
72	2SC403SP	R-Y AMP
73	2SC403SP	R-Y AMP
74	2SA844	R-Y DELAY
75	2SC3068	R-Y BUFF
76	DTA124ES	COMPONENT SW
77	DTA124ES	COMPONENT SW
78	DTC144ES	COMPONENT SW
81	2SA844	B-Y AMP
82	2SC403SP	B-Y AMP
83	2SC403SP	B-Y AMP
84	2SA844	B-Y DELAY
85	2SC3068	B-Y BUFF
D1	1SS119	COMPONENT SW
2	1SS119	DC SHIFT SW
3	MC932	PROTECT
4	MC932	PROTECT
5	1SS119	PROTECT
6	1SS119	DC SHIFT
7	1SS119	FILTER SW
8	RO6 2E-B2	+6V REG
11	1SS119	GAIN CHANGE SW
12	1SS119	GAIN CHANGE SW
13	1SS119	GAIN CHANGE SW
14	1SS119	GAIN CHANGE SW
16	1SS119	R.G.B. SW
17	1SS119	KILLER

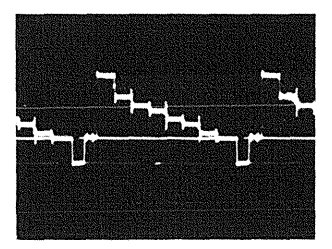

① 1.0Vp-p (H)

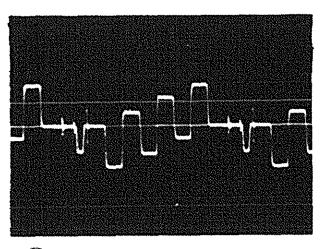

③ 1.7Vp-p (H)

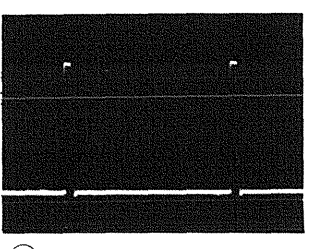

⑤ 4.8Vp-p (H)

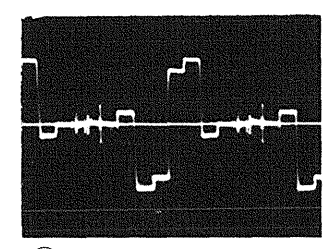

② 1.4Vp-p (H)

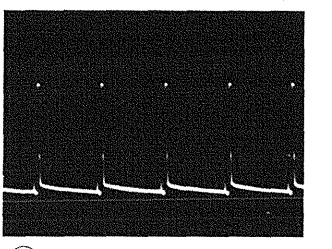

⑥ 12Vp-p (H)



BH BOARD

IC1(1/3)	TC4053BP	COMPOSITE/R.G.B. CHANGE SW
(2/3)		SET UP & CROSS HATCH SW
(3/3)		SCREENING SW
2(1/3)	TC4053BP	COMPOSITE/R.G.B. CHANGE SW
(2/3)		SET UP SW
(3/3)		SCREENING SW
3(1/3)	TC4053BP	COMPOSITE/R.G.B. CHANGE SW
(2/3)		SET UP SW
(3/3)		SCREENING SW
4(1/3)	TC4053BP	COMPOSITE/R.G.B. CHANGE SW
(2/3)		SET UP SW
(3/3)		SCREENING SW
5	NJM4558S	SAMPLE HOLD
6	NJM4558S	SAMPLE HOLD
7	LA7016	BLUE ONLY SW
8	LA7016	BLUE ONLY SW
9	MC14053BCP	AGC PULSE, SET UP, WHITE, VITC INSERT GEN
10(1/2)	MC14053BCP	AGC PULSE, SET UP, WHITE, VITC INSERT GEN
(2/2)		COLOR DIFFERENCE & R.G.B. SCREENING PULSE GEN
11(1/4)	MC14081BCP	AGC PULSE, SET UP, WHITE, VITC INSERT GEN
(2/4)		COLOR DIFFERENCE & R.G.B. SCREENING PULSE GEN
(4/4)		Y SCREENING PULSE GEN
12	MC14081BCP	AGC PULSE, SET UP, WHITE, VITC INSERT GEN
13	MC14001BCP	AGC PULSE, SET UP, WHITE, VITC INSERT GEN
14	TC4030BP	AGC PULSE, SET UP, WHITE, VITC INSERT GEN
101	TX-429M	R CONTRAST CONTROL
102	TL082CP	R CONTRAST & BRIGHT CONTROL
201	TX-429M	G CONTRAST CONTROL
202	TL082CP	G CONTRAST & BRIGHT CONTROL
301	TX-429M	B CONTRAST CONTROL
302	TL082CP	B CONTRAST & BRIGHT CONTROL
Q1	2SC403SP	Y BUFF
2	2SK523	Y SAMPLE HOLD
3	2SA844	Y BUFF
4	2SC403SP	R-Y/R BUFF

Q5	2SK523	R-Y/Y SAMPLE HOLD
6	2SA844	R-Y/R BUFF
7	2SC403SP	G-Y/R BUFF
8	2SK523	G-Y/Y SAMPLE HOLD
9	2SA844	G-Y/G BUFF
10	2SC403SP	B-Y/B BUFF
11	2SK523	B-Y/B SAMPLE HOLD
12	2SA844	B-Y/B BUFF
13	2SA844	R BUFF
14	2SA844	G BUFF
15	2SA844	B BUFF
16	2SC3068	AGC PULSE BUFF
101	2SK381	R CONTRAST CONTROL
102	2SA844	R AMP
103	2SC403SP	R AMP
104	2SC403SP	R LIMITER
105	2SC403SP	R LIMITER
106	2SK381	R BRIGHT CONTROL
107	2SK381	R CONTRAST CONTROL
108	2SK381	R CONTRAST CONTROL
201	2SK381	G CONTRAST CONTROL
202	2SA844	G AMP
203	2SC403SP	G AMP
204	2SC403SP	G LIMITER
205	2SC403SP	G LIMITER
206	2SK381	G BRIGHT CONTROL
207	2SK381	G CONTRAST CONTROL
208	2SK381	G CONTRAST CONTROL
301	2SK381	B CONTRAST CONTROL
302	2SA844	B AMP
303	2SC403SP	B AMP
304	2SC403SP	B LIMITER
305	2SC403SP	B LIMITER
306	2SK381	B BRIGHT CONTROL
307	2SK381	B CONTRAST CONTROL
308	2SK381	B CONTRAST CONTROL
D1	1SS119	R LIMITER
101	1SS119	R PROTECT
102	1SS119	R PROTECT
201	1SS119	G LIMITER
202	1SS119	G PROTECT
301	1SS119	B LIMITER
302	1SS119	B PROTECT

BH board (Y/COLOR DIFFERENCE/RGB SIGNAL SWITCHING, Y-C MATRIX, CONTRAST/BRIGHTNESS CONTROL)

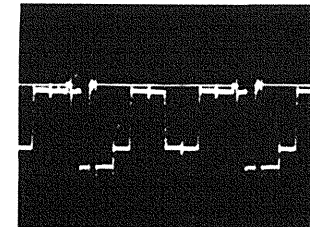
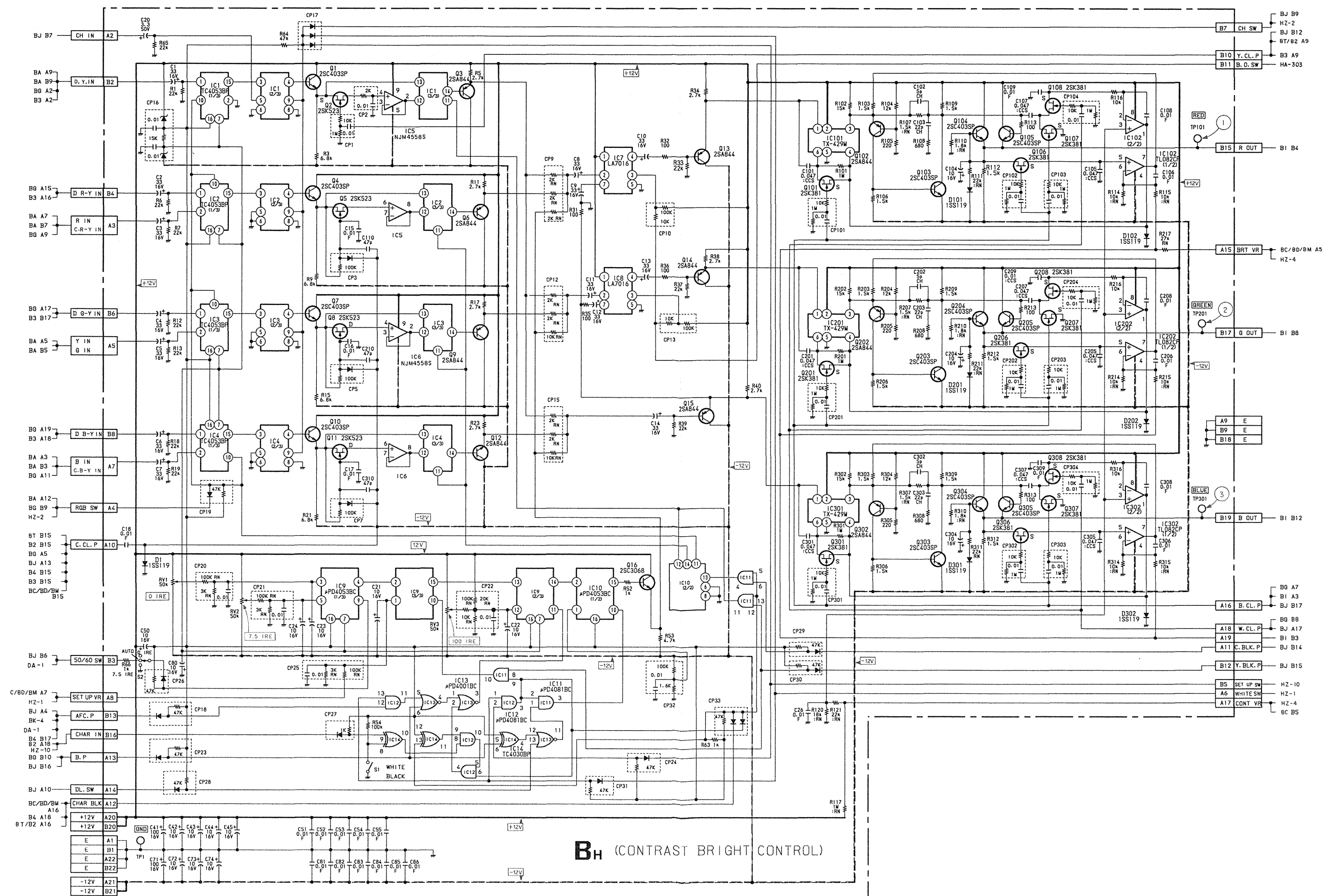

① 1.2Vp-p (H)

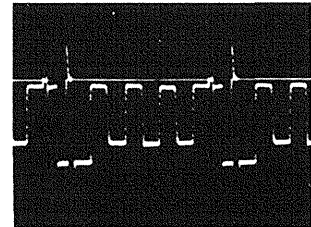

③ 1.2Vp-p (H)

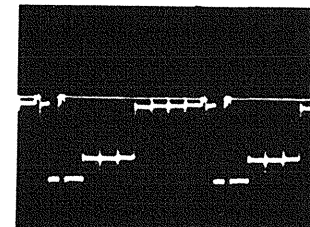

② 1.2Vp-p (H)

BH (CONTRAST BRIGHT CONTROL)

5. DIAGRAMS



**BH BH**

BH board (Y/COLOR DIFFERENCE/RGB SIGNAL SWITCHING, Y-C MATRIX, CONTRAST/BRIGHTNESS CONTROL)

IC		9 4 3 2 1		10 6 5		11 8 7		12 301 201 101	13	14 304 305 204 205		102 306 307 308 206 207 208 106 107 108
Q		10 7 4 1		12 11 8 9 6 5 2 3		16 15 14 13						
D								302 202 102		301 201		
TP ADJ		RV1 RV2 RV3					TP1					TP201 TP101 TP301

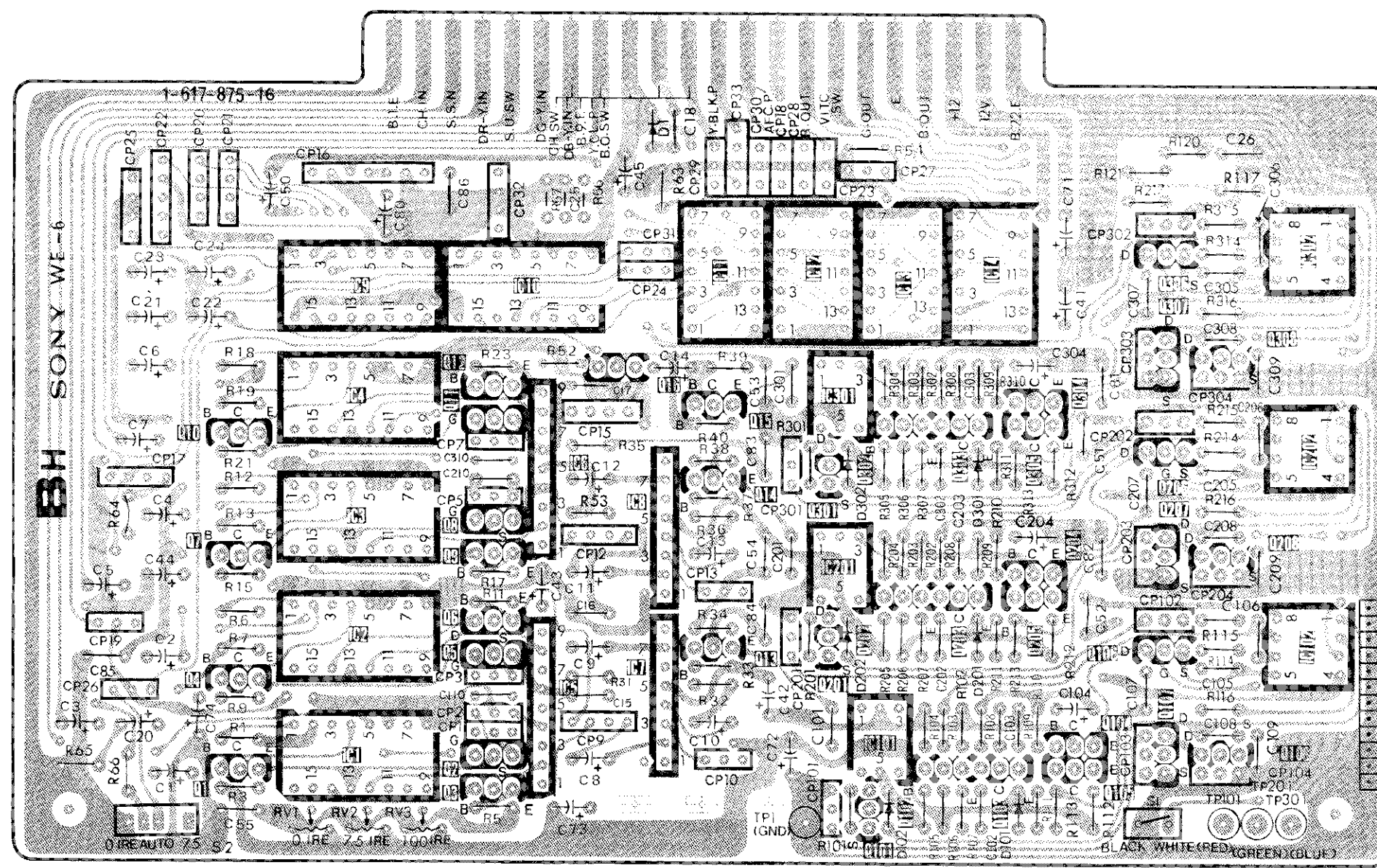

BI board (DRIVE CONTROL, BEAM CURRENT CONTROL)

IC	101	105	201	205	301	305
Q	102 103 106	108 107 109	202 203 206 201 205	208 207 209	302 303 306 301 305	304 307 309
D	5	7 4 1 2 6	102 104 103 101	105	202 204 203 201	205 302 304 303 305
TP	I					

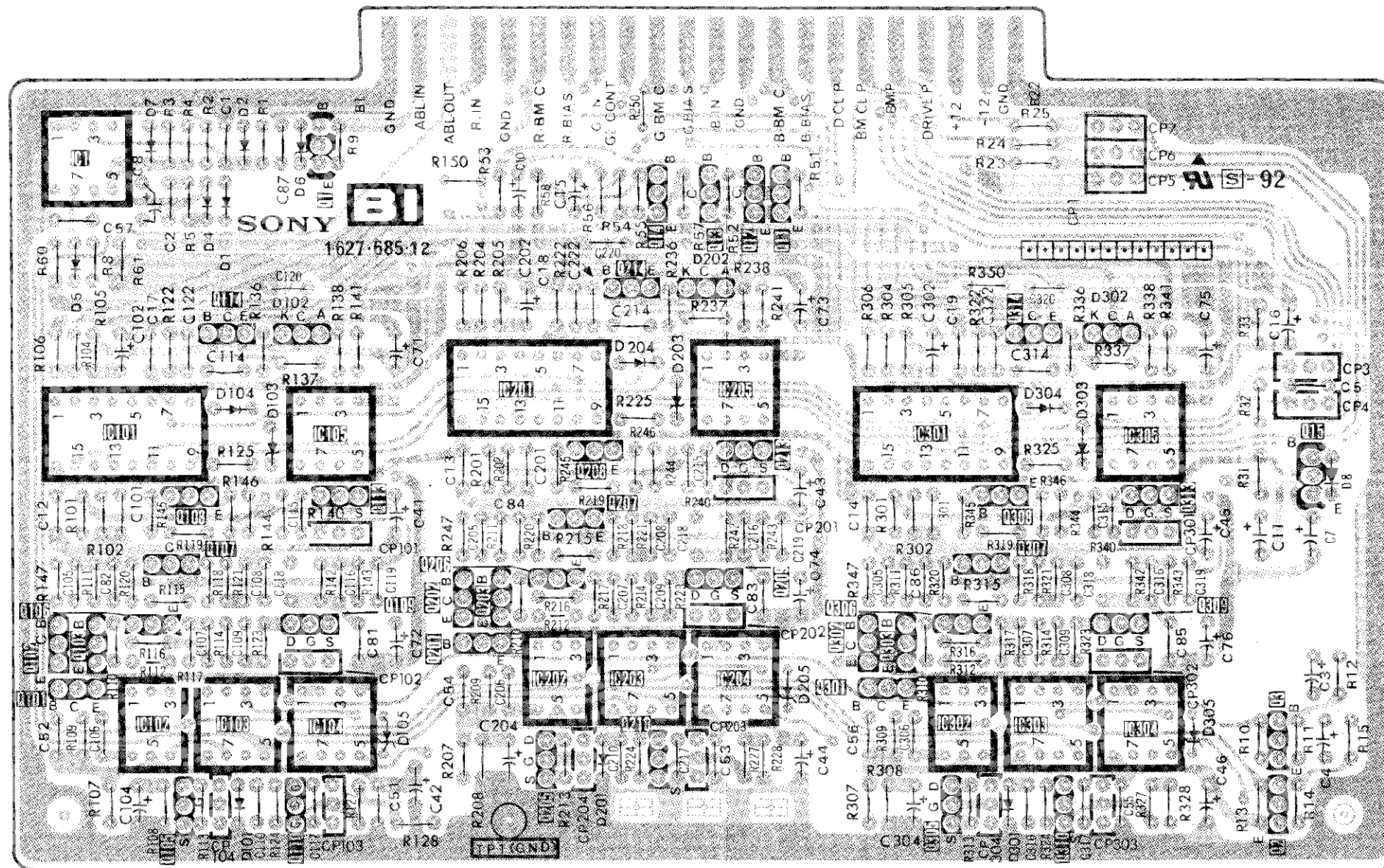

- : Pattern from the side which enables se
- : Pattern of the rear side.

BI BI

BI

BI board (DRIVE CONTROL, BEAM CURRENT CONTROL)

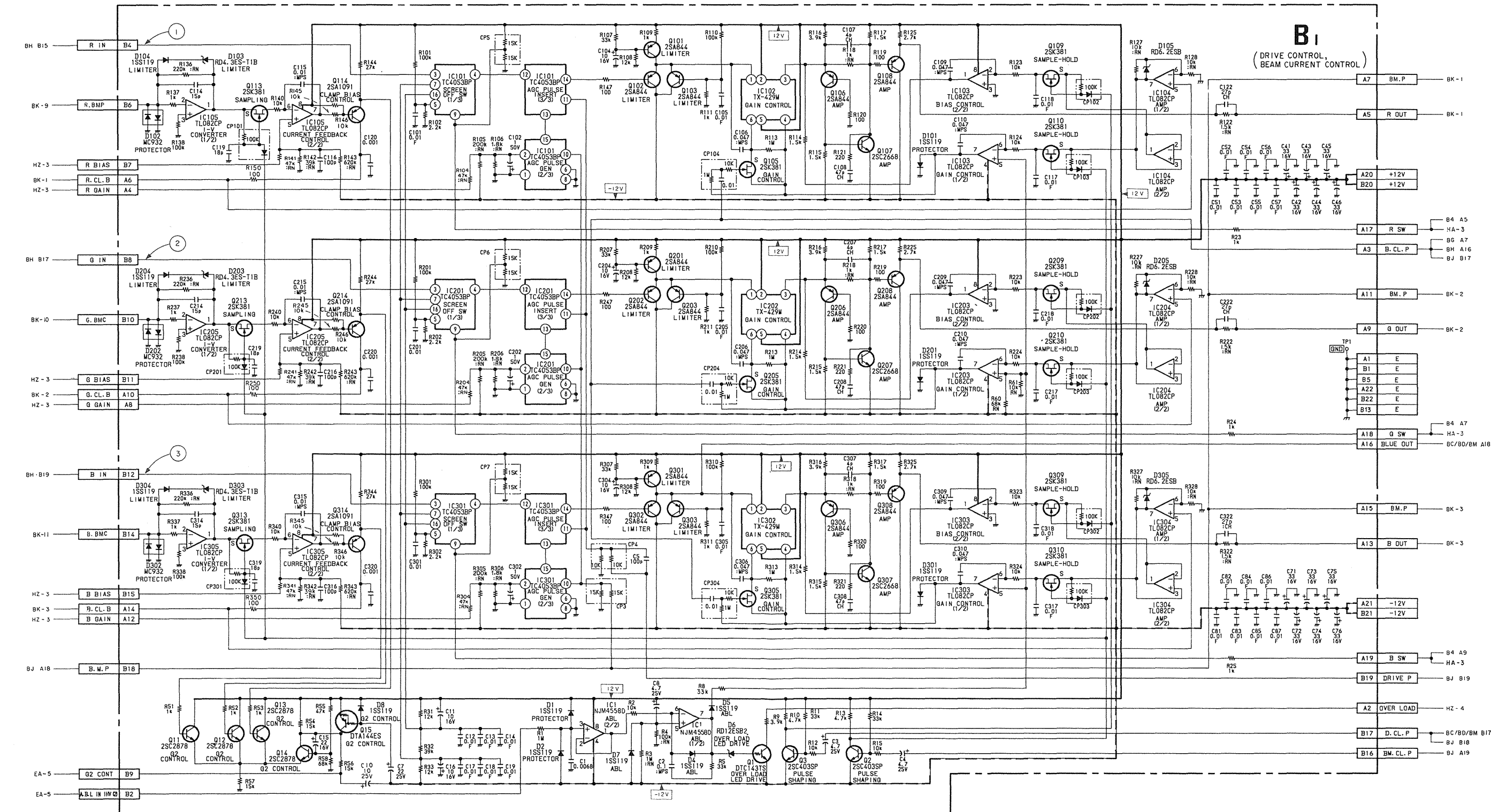

BI BOARD

IC1	NJM4558D	ABL
101(1/3)		SCREEN OFF SW
(2/3)	TC4053BP	AGC PULSE GEN
(3/3)		AGC PULSE INSERT
102	TX-429M	GAIN CONTROL
103(1/2)	TL082CP	GAIN CONTROL
(2/2)		BIAS CONTROL
104	TL082CP	AMP
105(1/2)	TL082CP	I-V CONVERTER
(2/2)		CURRENT FEEDBACK CONTROL
201(1/3)		SCREEN OFF SW
(2/3)	TC4053BP	AGC PULSE GEN
(3/3)		AGC PULSE INSERT
202	TX-429M	GAIN CONTROL
203(1/2)	TL082CP	GAIN CONTROL
(2/2)		BIAS CONTROL
204	TL082CP	AMP
205(1/2)	TL082CP	I-V CONVERTER
(2/2)		CURRENT FEEDBACK CONTROL
301(1/3)		SCREEN OFF SW
(2/3)	TC4053BP	AGC PULSE GEN
(3/3)		AGC PULSE INSERT
302	TX-429M	GAIN CONTROL
303(1/2)	TL082CP	GAIN CONTROL
(2/2)		BIAS CONTROL
304	TL082CP	AMP
305(1/2)	TL082CP	I-V CONVERTER
(2/2)		CURRENT FEEDBACK CONTROL

Q110	2SK381	SAMPLE-HOLD
113	2SK381	SAMPLING
114	2SA1091	CLAMP BIAS CONTROL
201	2SA844	LIMITER
202	2SA844	LIMITER
203	2SA844	LIMITER
205	2SK381	GAIN CONTROL
206	2SA844	AMP
207	2SC2668	AMP
208	2SA844	AMP
209	2SK381	SAMPLE-HOLD
210	2SK381	SAMPLE-HOLD
213	2SK381	SAMPLING
214	2SA1091	CLAMP BIAS CONTROL
301	2SA844	LIMITER
302	2SA844	LIMITER
303	2SA844	LIMITER
305	2SK381	GAIN CONTROL
306	2SA844	AMP
307	2SC2668	AMP
308	2SA844	AMP
309	2SK381	SAMPLE-HOLD
310	2SK381	SAMPLE-HOLD
313	2SK381	SAMPLING
314	2SA1091	CLAMP BIAS CONTROL

D1	1SS119	PROTECTOR
2	1SS119	PROTECTOR
4	1SS119	ABL
5	1SS119	ABL
6	RD12ESB2	OVER LOAD LED DRIVE
7	1SS119	ABL
8	1SS119	G2 CONTROL
101	1SS119	PROTECTOR
102	HC932	PROTECTOR
103	RD4.3ES-T1B	LIMITER
104	1SS119	LIMITER
105	2SA844	LIMITER
106	2SA844	LIMITER
107	2SK381	GAIN CONTROL
108	2SA844	AMP
109	2SK381	SAMPLE-HOLD

D205	RD6.2ESB	LIMITER
301	1SS119	PROTECTOR
302	HC932	PROTECTOR
303	RD4.3ES-T1B	LIMITER
304	1SS119	LIMITER
D305	RD6.2ESB	LIMITER

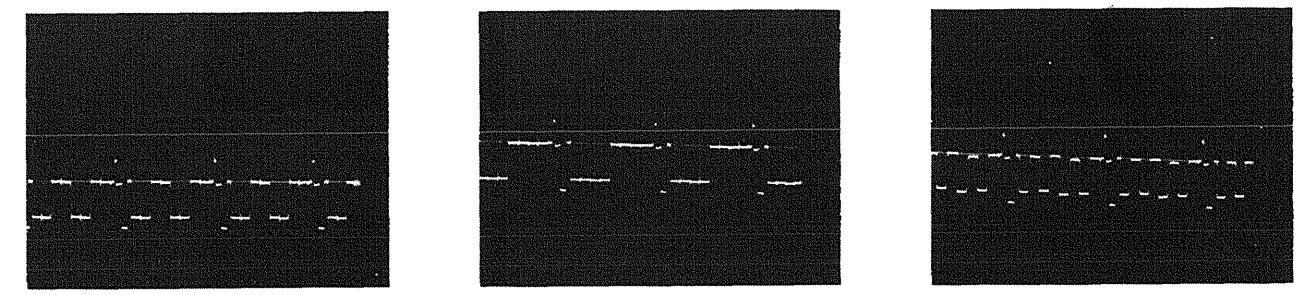

① 1.2 Vp-p(H)      ② 1.2 Vp-p(H)      ③ 1.2 Vp-p(H)

5. DIAGRAMS









BK board (VIDEO OUT AMP)

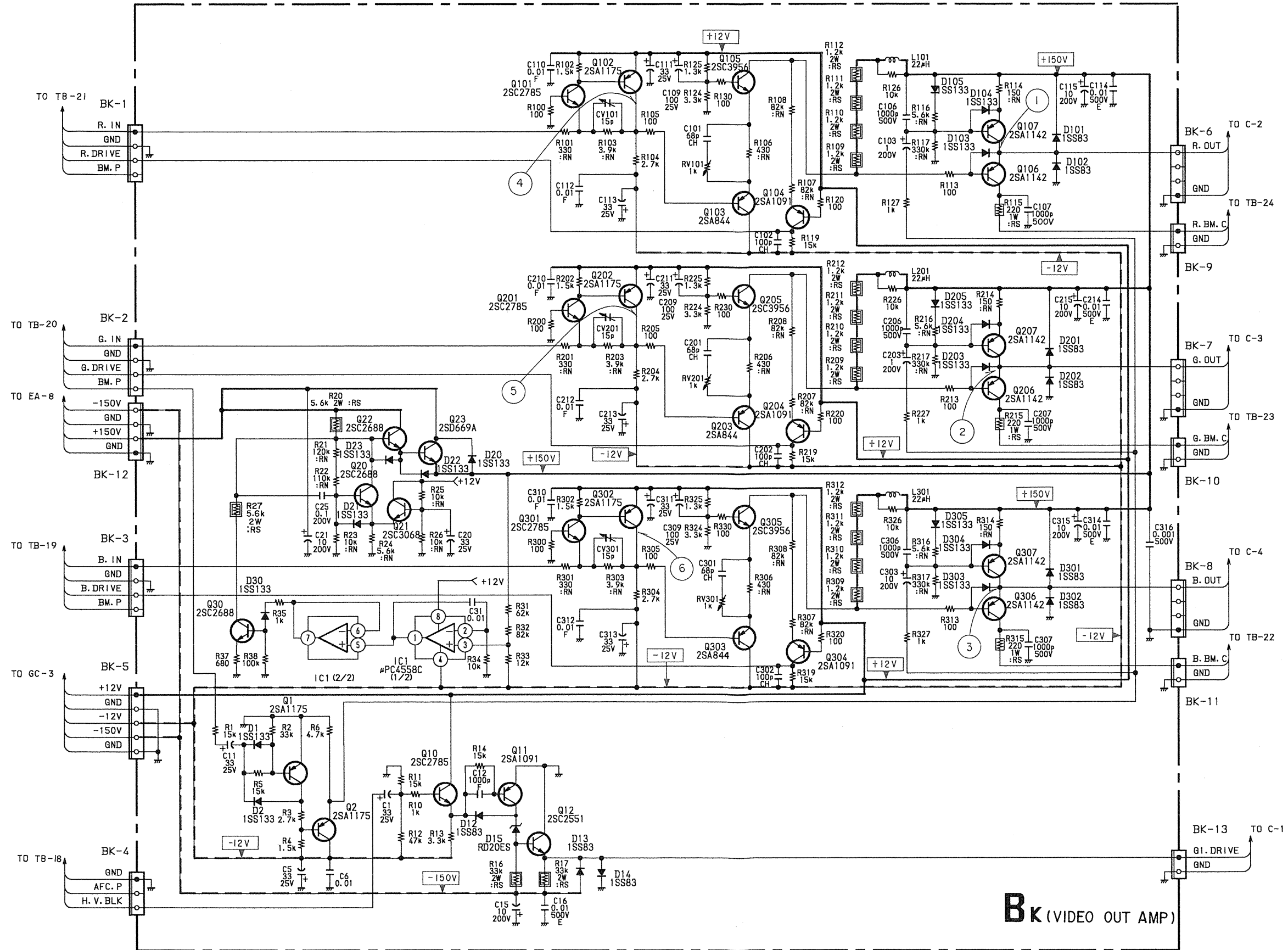

BK (VIDEO OUT AMP)

BK BOARD

IC1	UPC4558C	LIPPLE FILTER
Q1	2SA1175	INVERTER
2	2SA1175	BUFF.
10	2SC2785	BUFF.
11	2SA1091	BUFF.
12	2SC2351	BUFF.
20	2SC2688	LIPPLE FILTER
21	2SC3068	LIPPLE FILTER
22	2SC2688	LIPPLE FILTER
23	2SD669A	LIPPLE FILTER
30	2SC2688	LIPPLE FILTER
101	2SC2785	R-PRE AMP.
102	2SA1175	R-PRE AMP.
103	2SA844	BUFF.
104	2SA1091	BUFF.
105	2SC3956	BUFF.
106	2SA1142	R-VIDEO OUT
107	2SA1142	R-VIDEO OUT
201	2SC2785	G-PRE AMP.
202	2SA1175	G-PRE AMP.
203	2SA844	BUFF.
204	2SA1091	BUFF.
205	2SC3956	BUFF.
206	2SA1142	G-VIDEO OUT
207	2SA1142	G-VIDEO OUT
301	2SC2785	B-PRE AMP.
302	2SA1175	B-PRE AMP.
303	2SA844	BUFF.
304	2SA1091	BUFF.
305	2SC3956	BUFF.
306	2SA1142	B-VIDEO OUT
307	2SA1142	B-VIDEO OUT
D1	1SS133	INVERTER
2	1SS133	INVERTER
12	1SS83	PROTECTOR
13	1SS83	BIAS
14	1SS83	PROTECTOR
15	RD20ES-TB	BIAS
20	1SS133	PROTECTOR
21	1SS133	PROTECTOR
22	1SS133	PROTECTOR
23	1SS133	PROTECTOR
30	1SS133	PROTECTOR
101	1SS83	PROTECTOR
102	1SS83	PROTECTOR
103	1SS133	PROTECTOR
104	1SS133	PROTECTOR
105	1SS133	BIAS
201	1SS83	PROTECTOR
202	1SS83	PROTECTOR
203	1SS133	PROTECTOR
204	1SS133	PROTECTOR
205	1SS133	BIAS
301	1SS83	PROTECTOR
302	1SS83	PROTECTOR
303	1SS133	PROTECTOR
304	1SS133	PROTECTOR
305	1SS133	BIAS

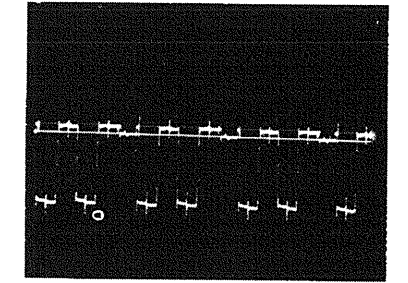

① 30 Vp-p(H)

④ 3 Vp-p(H)

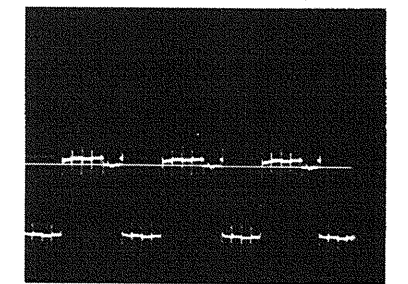

② 35 Vp-p(H)

⑤ 3.5 Vp-p(H)

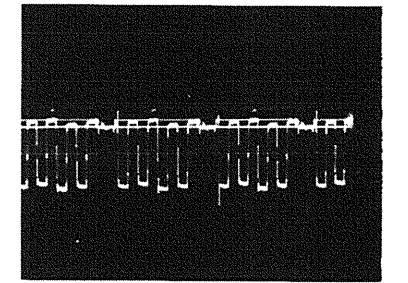

③ 30 Vp-p(H)

⑥ 3 Vp-p(H)



DA Board (DEF GEN)  
DB Board (H.OSC & H.REG CONTROL)

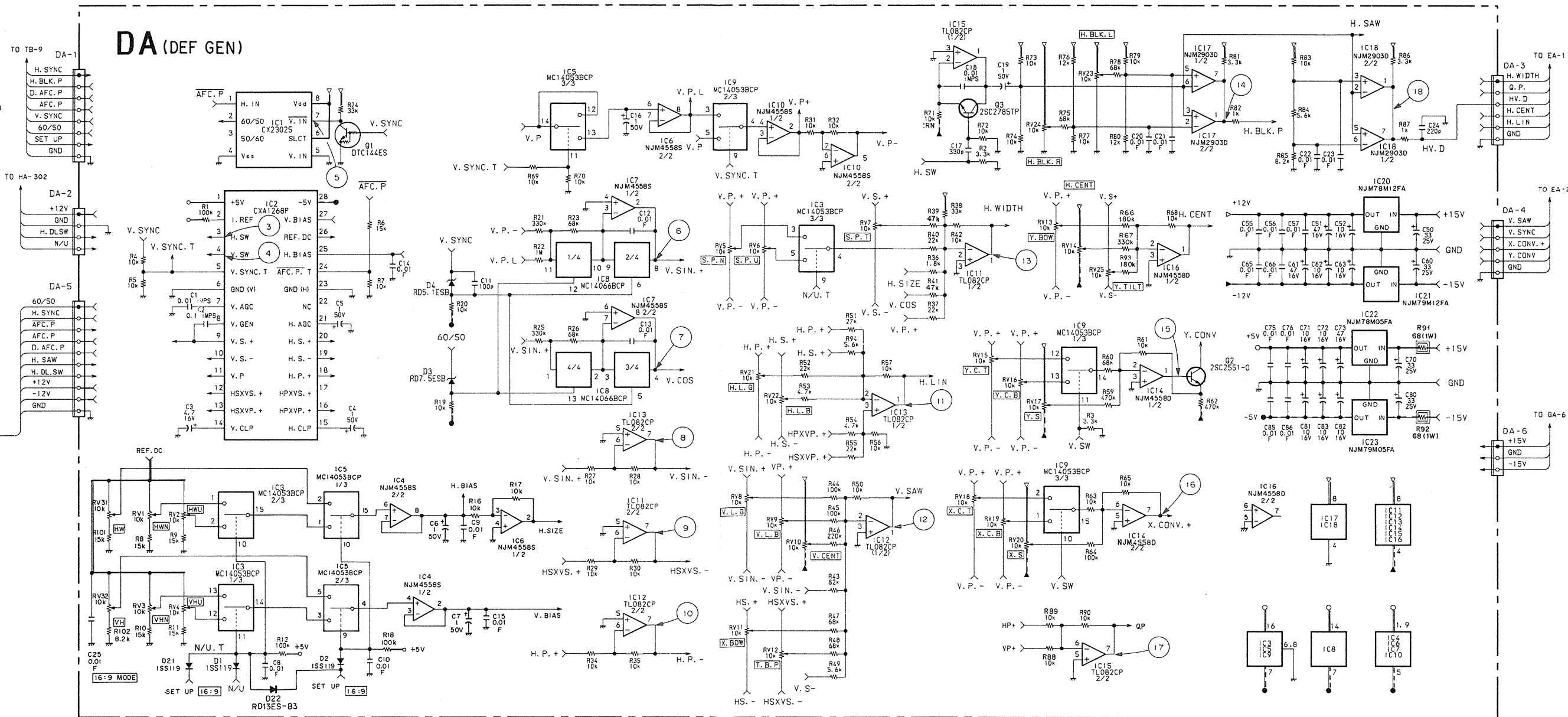
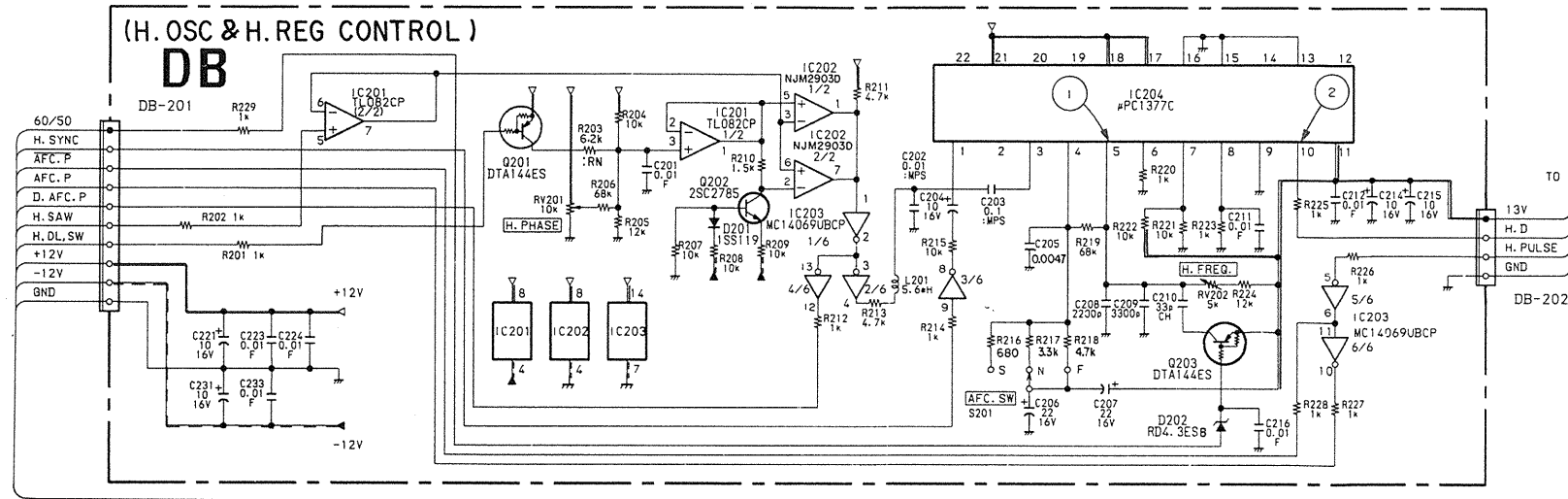

5. DIAGRAMS

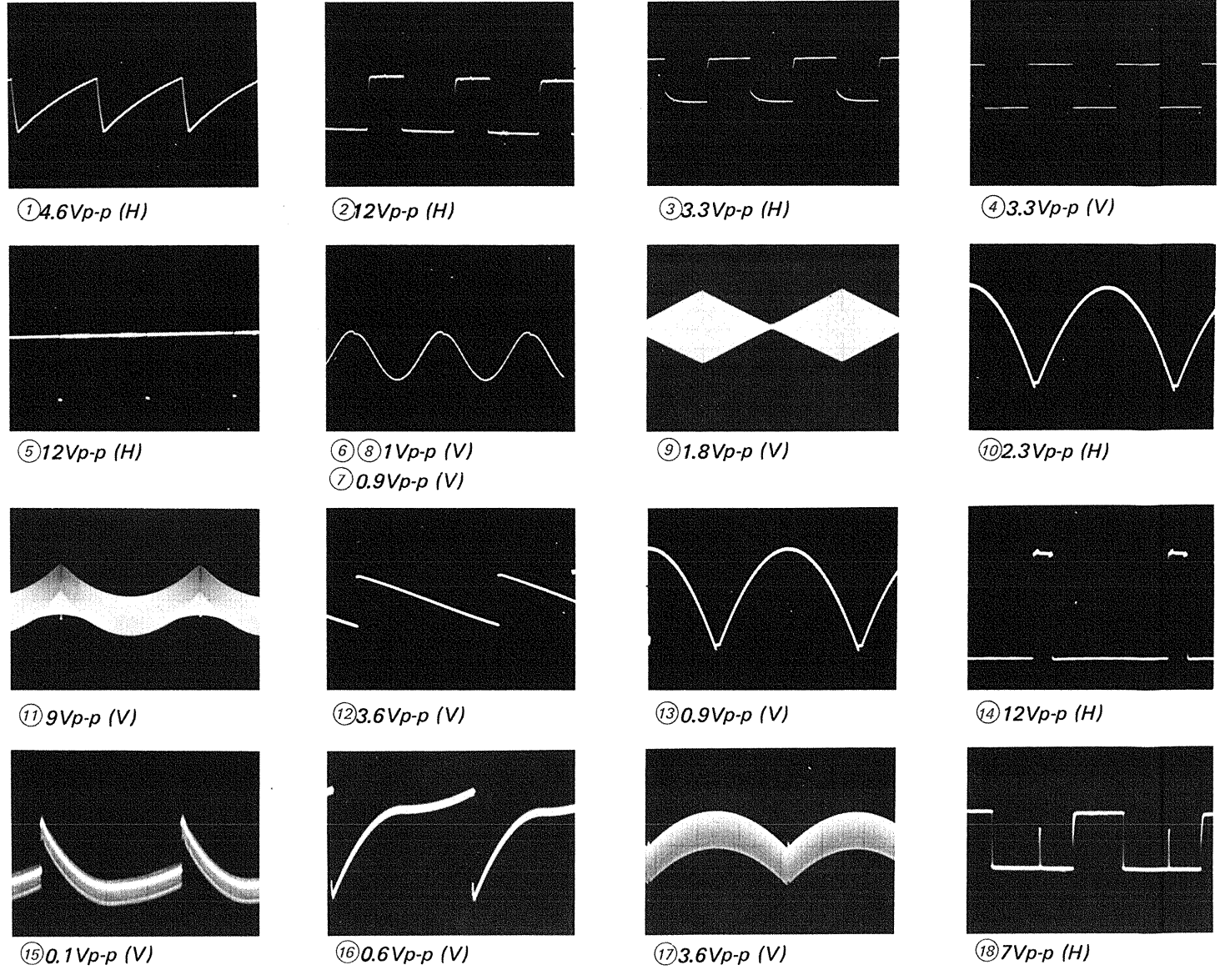



IC	Q	D	RV
		2	
		21	
			22
22, 23			
18, 20, 21			6
			23
15, 16, 17			
			24
			32, 31
14, 13, 12, 11			
			5
			1
			2
			3
			19, 10, 11, 6 18, 9, 25, 2 20, 8, 12, 4
			16, 14, 13, 5 15, 22, 7, 1 17, 21
			3
9, 8			
			2
			3
10			
			4
			7

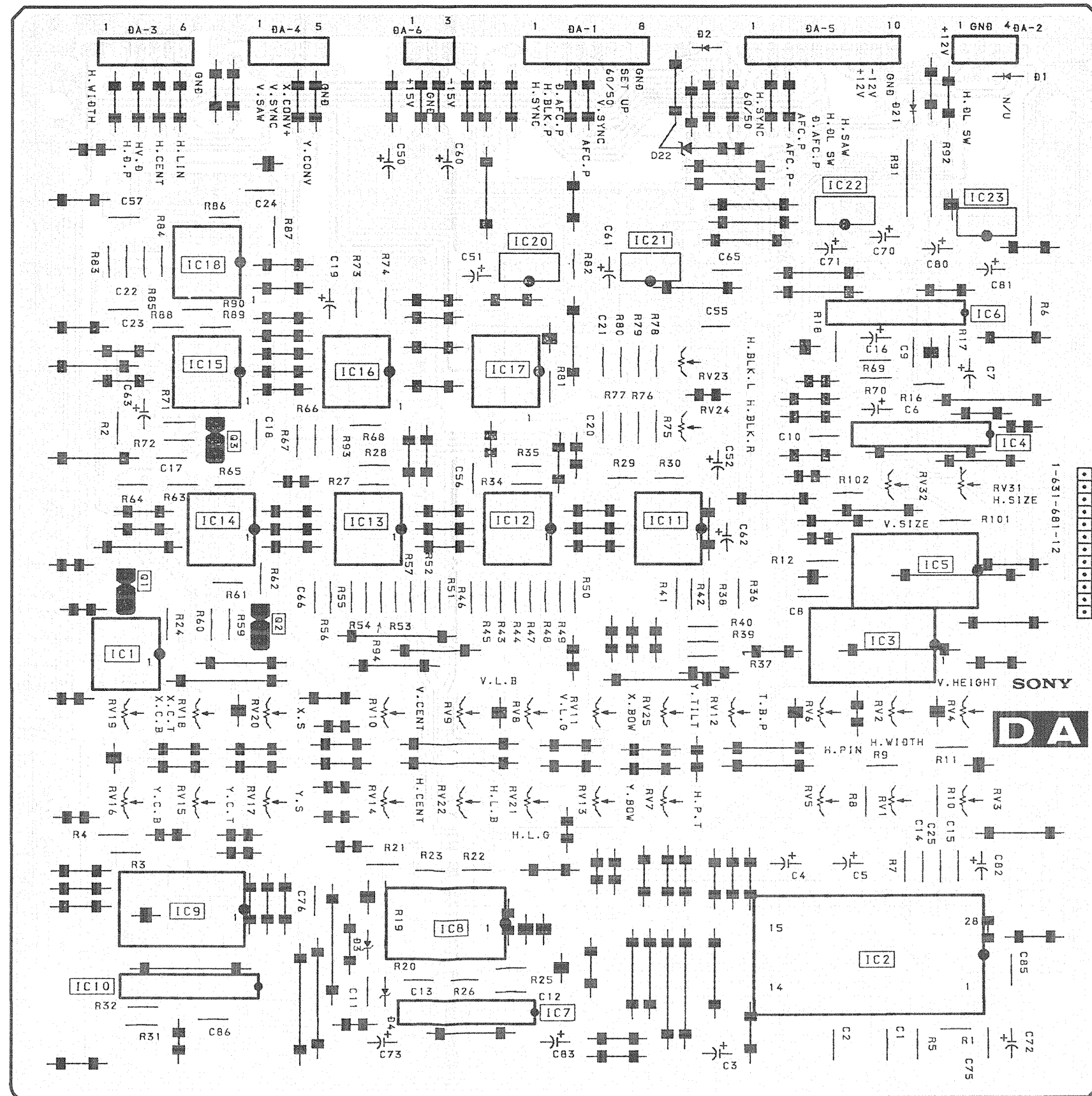

DB board (H.OSC & H.REG CONTROL)

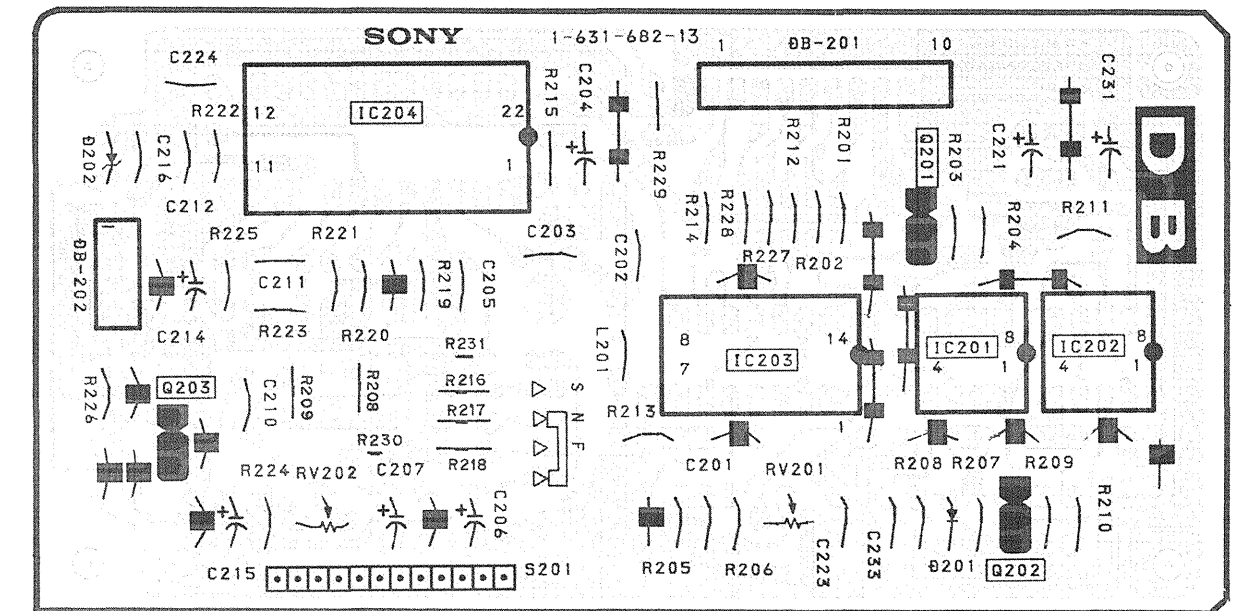

DA board

IC	Part Number	Function
1	CX23025	SYSTEM DETECTOR
2	CXA1268P	SIGNAL GEN.
3	MC14053BCP	SCAN SELECT/ADD H.WIDTH
4	NJM4558S	SCAN SELECT/ADD H.WIDTH
5	MC14053BCP	SCAN SELECT/ADD H.WIDTH
6	NJM4558S	SCAN SELECT/ADD H.WIDTH
7	NJM4558S	SIN GEN./COS GEN.
8	MC14066BCP	SIN GEN./COS GEN.
9	MC14053BCP	ADD Y.CONV/ADD X.CONV
10	NJM4558S	SIGNAL GEN.
11	TL082CP	SIGNAL GEN./ADD H.WIDTH
12	TL082CP	SIGNAL GEN./ADD V.SAW
13	TL082CP	SIGNAL GEN./ADD H.LIN.
14	NJM4558D	ADD Y CONV/ADD X.CONV
15	TL082CP	H.SAW.GEN.
16	NJM4558D	ADD H.CENT
17	NJM2903D	H. BLK GEN.
18	NJM2903D	H.V DRIVE PULSE GEN.
20	NJM78M12FA	+12V REG
21	NJM79M12FA	-12V REG
22	NJM78M05FA	+5V REG
23	NJM79M05FA	-5V REG
Q		
1	DTC144ES	SYSTEM DETECTOR
2	2SC2551	ADD Y CONV
3	2SC2785	H.SAW.GEN.
D		
1	1SS119	SCAN SELECT
2	1SS119	SCAN SELECT
3	RD7.5ES-B	LIMITER
4	RD5.1ES-B	LIMITER
21	1SS119	SCAN SELECT
22	RD13ES-B3	SCAN SELECT

DB board

IC	Part Number	Function
IC 201	TL082CP	H DELAY/H PHASE
IC 202	NJM2903D	H DELAY/H PHASE
IC 203	MC14069UBCP	H DELAY/H PHASE
IC 204	UPC1377C	H OSC/H AFC
Q		
Q 201	DTA144ES	H.PHASE
Q 202	2SC2785	H.PHASE
Q 203	DTA144ES	SYSTEM DETECTOR/AFC
D		
D 201	1SS119	H. PHASE
D 202	RD4.3ES-B1	SYSTEM DETECTOR/AFC

EA, EB, EC, C, P

EA, EB, EC, C, P EA, EB, EC, C, P

EA board (H.DEF & V.DEF OUT, HV REG)  
 EB board (H.V , BEAM CURRENT & CRT PROTECTOR)  
 EC board (V CONVERGENCE OUT)  
 C board (CRT SOCKET)  
 P board (FBT)

EA board

IC	1	FA5301P	P.W.M CONTROL
	2	FA5301P	P.W.M CONTROL
	3	TL082CP	BUFF/COMPARATOR
	5	uPC458D	H.CENT
O	1	2SA1175	AFC PULSE
	2	2SA979	H.LIN AMP
	3	2SD669A-C	H.LIN AMP
	4	2SD1137	H.LIN AMP
	5	2SB860	H.LIN AMP
	6	2SC2688	P.W.M DRIVE
	7	2SC2542	P.W.M OUT
	8	2SC2551	O.C.P
	9	2SA1175	O.C.P
	10	2SC2688	H.DRIVE
	11	2SD1399	H.OUT
	12	2SD1134	H.CENT AMP
	13	2SB858	H.CENT AMP
	14	2SC2688	P.W.M
	15	2SA1091	O.C.P
	16	2SC2542	DC DC CONVERTER
	17	2SC2688	HV DRIVE
	18	2SD1399	HV CONVERTER
	19	2SA1175	AFC.PULSE
	201	2SA979	V.OUT AMP
	202	2SC3209	V.OUT AMP
	203	2SA1091-0	V.OUT AMP
	204	2SC2551	V.OUT AMP
	205	2SA1306B-0	V.OUT AMP
	206	2SC3298B	V.OUT AMP
	207	2SB861	RETRACE BOOST AMP
	208	2SC2551	RETRACE BOOST AMP
D	1	RD12ES-B	BIAS
	3	1SS119	BIAS
	4	1SS119	BIAS
	5	RH-1A	H.DRIVE
	6	CR02AM-4	PROTECTOR
	7	RH-1A	DC DC CONV
	8	ERD28-04S	DC DC CONV
	9	RH-1A	H.P. RECT
	10	RH-1A	H.P. RECT
	12	V11N	RECT
	13	RH-1A	HV CONV
	14	RH-1A	DC-DC CONV
	15	RH-1A	DC-DC CONV
	16	RH-1A	HV CONV
	28	1SS119	PROTECTOR
	30	1SS119	PROTECTOR
	32	RH-1A	PROTECTOR
	33	RH-1A	PROTECTOR
	35	1SS119	PROTECTOR
	37	1SS119	BIAS
	38	1SS119	BIAS
	39	RD12ES B	BIAS
	40	RD18ES-B2	PROTECTOR
	41	RD3.3ES-B2	PROTECTOR
	42	RH-1A	RECT
	50	CR02AM-4	PROTECTOR
	201	GP080	RETRACE BOOST SW
	202	GP080	RETRACE BOOST SW
	203	1SS119	BIAS
	204	1SS119	BIAS
	205	1SS119	BIAS
	206	1SS119	PROTECTOR

EB board

IC	4	NJM2903D	HV PROT/BEAM CURRENT PROT1
	6	NJM2903D	CRT PROT/BEAM CURRENT PROT2
O	20	2SC2785	CTR PROT
D	19	1SS119	PROTECTOR
	20	1SS119	MIXER
	24	UPC574J	32V REG
	25	1SS119	MIXER
	26	1SS119	MIXER
	27	CR02AM-4	PROTECTOR
	29	UPC574J	32V REG
	36	1SS119	PROTECTOR
	51	CR02AM-4	PROTECTOR

EC board

IC	201	uPC458D	V CONV AMP
O	210	2SC2785	V CONV AMP
	211	2SA1175	V CONV AMP
D	210	1SS119	PROTECTOR
	211	1SS119	PROTECTOR
	212	1SS119	BIAS
	213	1SS119	BIAS

C board

O	1	2SC3675	V CON DRIVE
	2	2SC3675	G2 CONT
	3	2SC2551	G2 CONT
	4	2SC2785	G2 CONT
D	1	1SS119	PROTECTOR
	3	1SS119	PROTECTOR
	4	1SS119	PROTECTOR
	5	1SS119	PROTECTOR

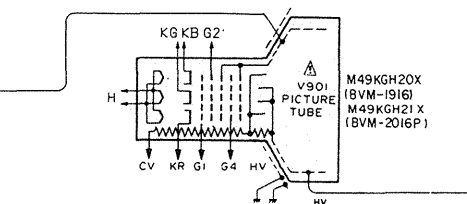
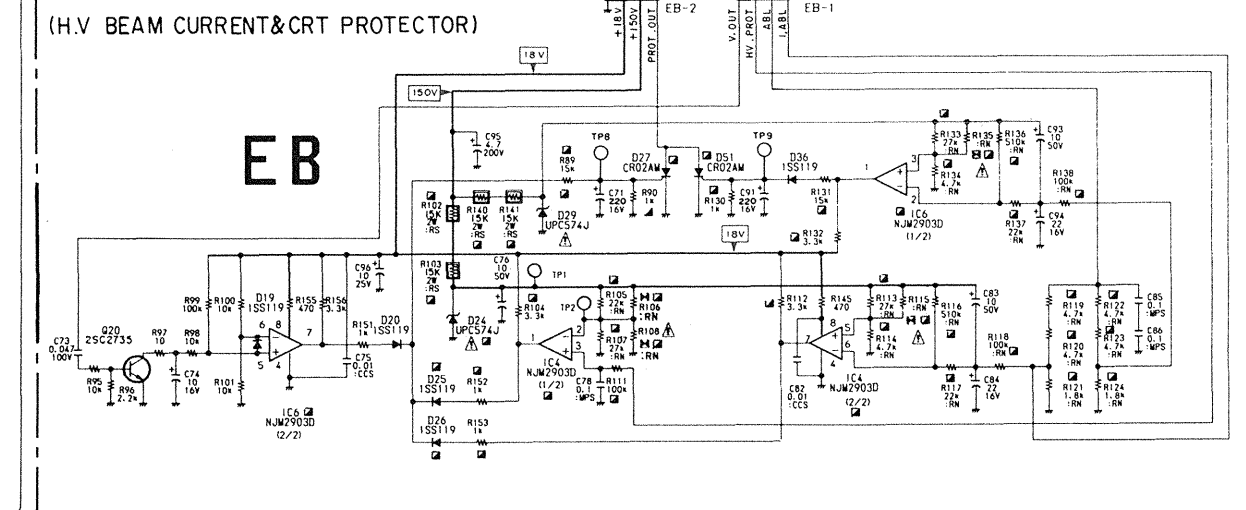
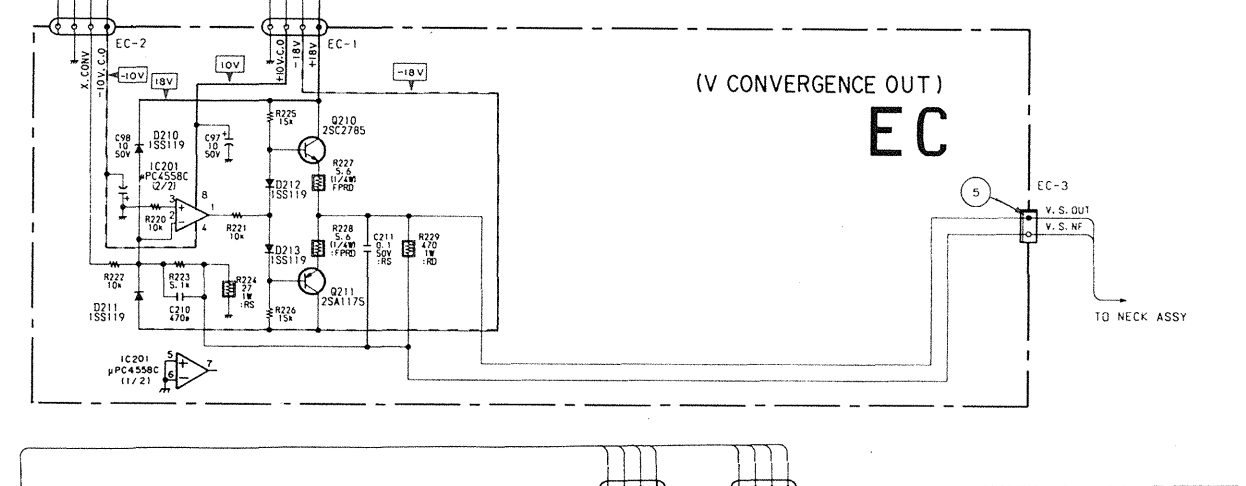
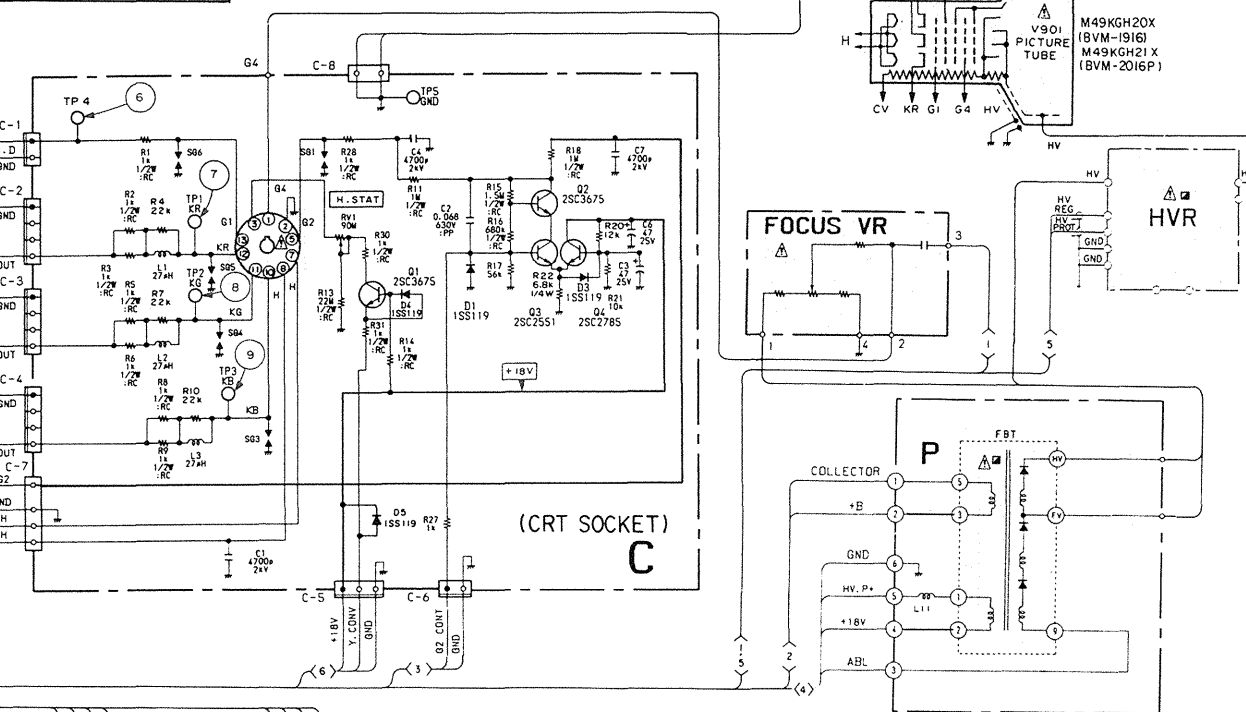
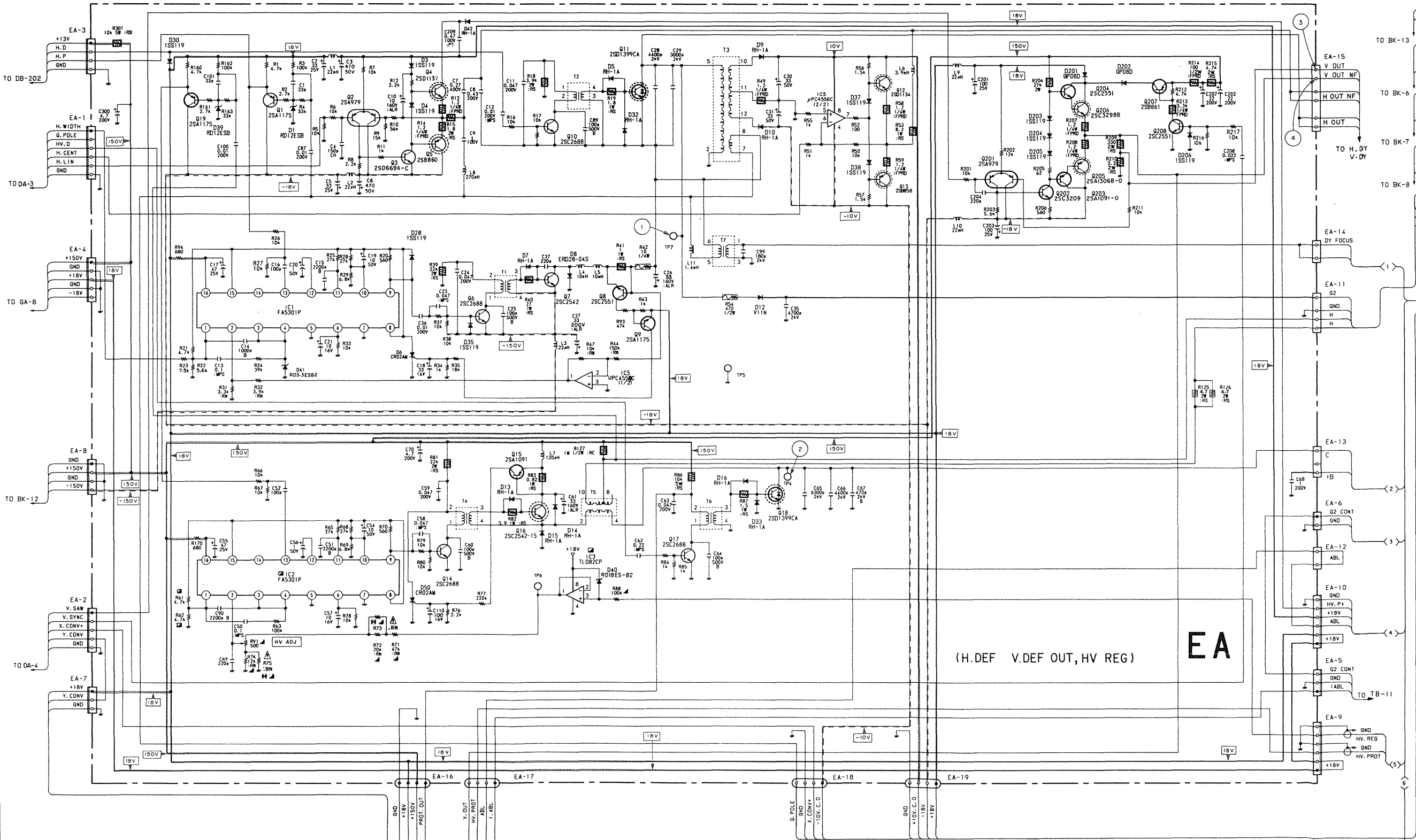



EA board (H.DEF & V DEF OUT, HV.REG)

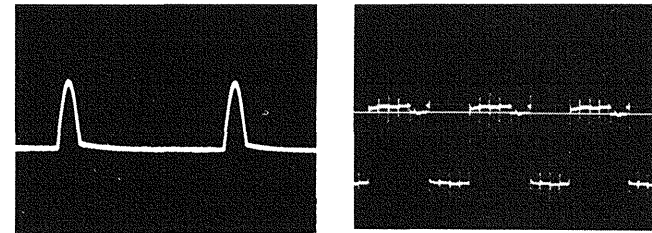

1 760Vp-p (H)  
2 840Vp-p (H)

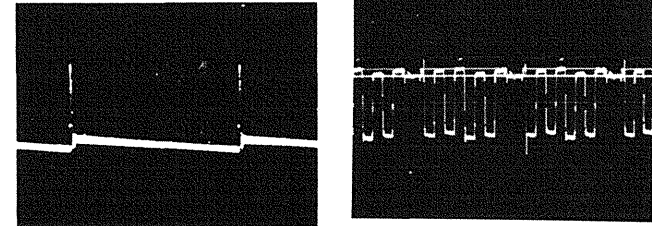

3 110 Vp-p (V)  
4 3.6Vp-p (V)

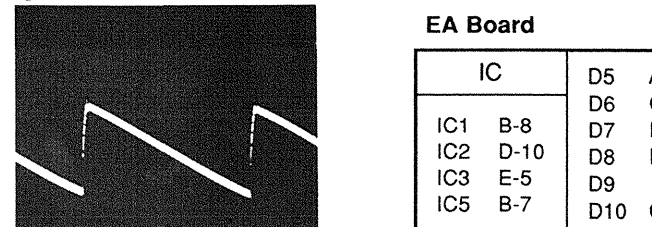

5 0.5Vp-p (V)  
6 124Vp-p (H)

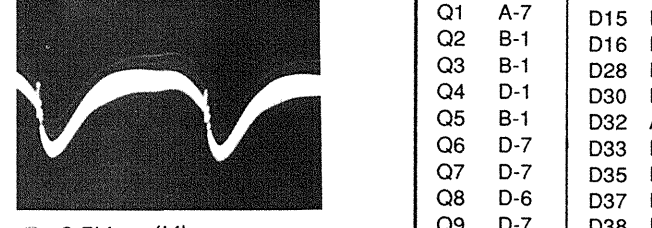

7 76Vp-p (H)  
8 54Vp-p (H)

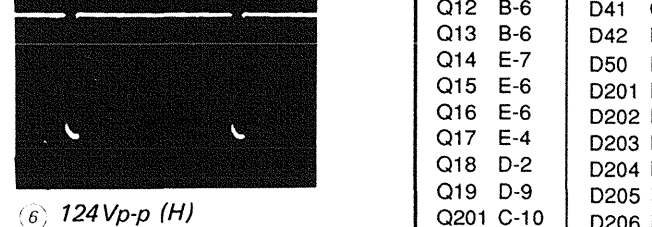

9 60Vp-p (H)

EA Board

IC	D5 A-4
IC1 B-8	D6 C-7
IC2 D-10	D7 D-6
IC3 E-5	D8 D-6
IC5 B-7	D9 B-5
	D10 C-5
TRANSISTOR	D12 C-4
Q1 A-7	D13 E-6
Q2 B-1	D14 E-6
Q3 B-1	D15 E-6
Q4 D-1	D16 D-3
Q5 B-1	D28 B-7
Q6 D-7	D30 F-5
Q7 D-7	D32 A-5
Q8 D-6	D33 D-3
Q9 D-7	D35 D-7
Q10 A-5	D37 B-6
Q11 B-2	D38 B-6
Q12 B-6	D39 C-10
Q13 B-6	D40 E-5
Q14 E-7	D41 C-8
Q15 E-6	D42 E-1
Q16 E-6	D50 D-7
Q17 E-4	D201 B-10
Q18 D-2	D202 B-9
Q19 D-9	D203 B-10
Q201 C-10	D204 B-10
Q202 C-9	D205 B-10
Q203 C-9	D206 B-10
Q204 B-9	VARIABLE RESISTOR
Q205 D-9	RV1 E-10
Q206 B-9	TEST POINT
Q207 A-9	TP4 E-3
Q208 A-10	TP5 C-8
DIODE	TP6 E-5
D1 A-7	TP7 B-3
D3 D-1	
D4 C-1	

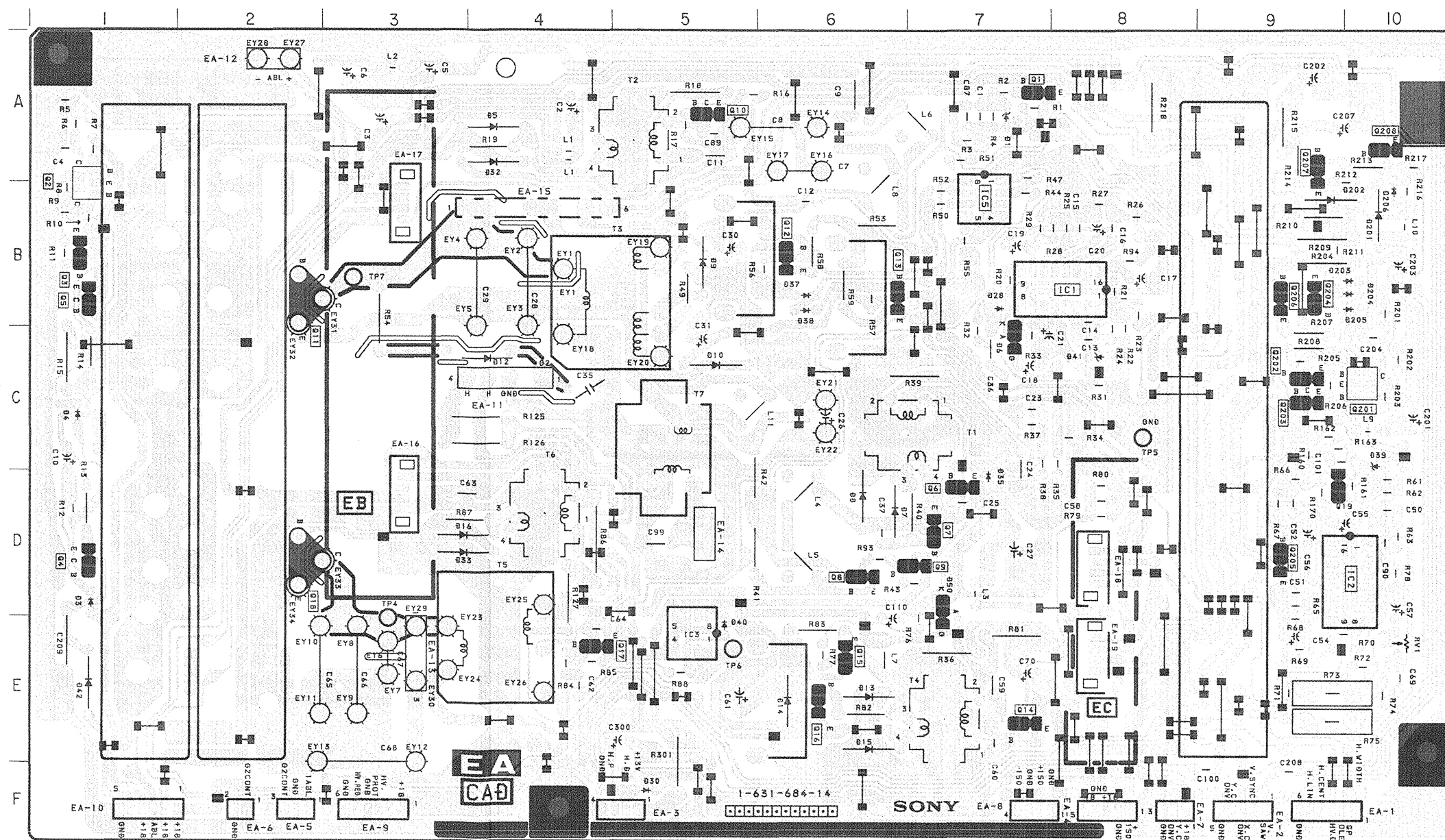

EB board (H.V, BEAM CURRENT & CRT PROTECTOR)

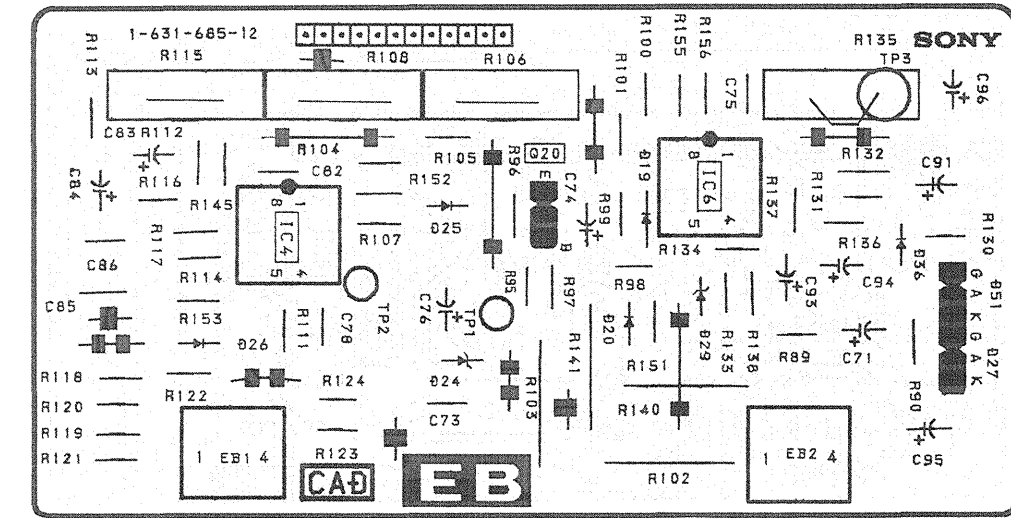

C board (CRT SOCKET)

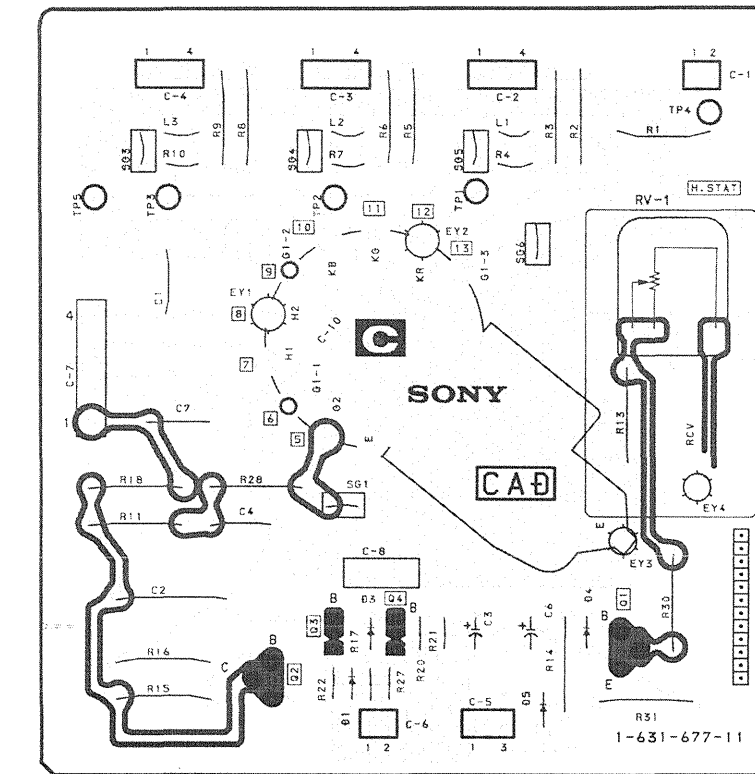

EC board (V CONVERGENCE OUT)

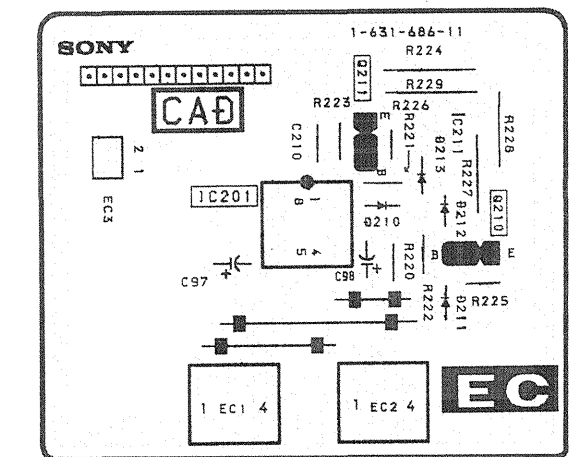

P board (FBT)

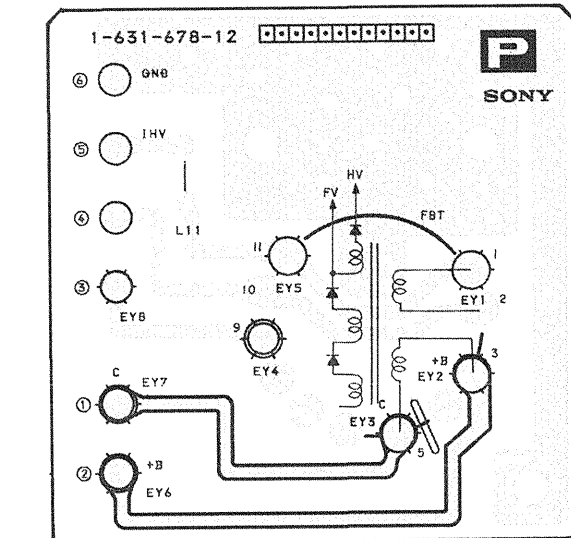



GB board (OVER VOLTAGE PROTECTOR)

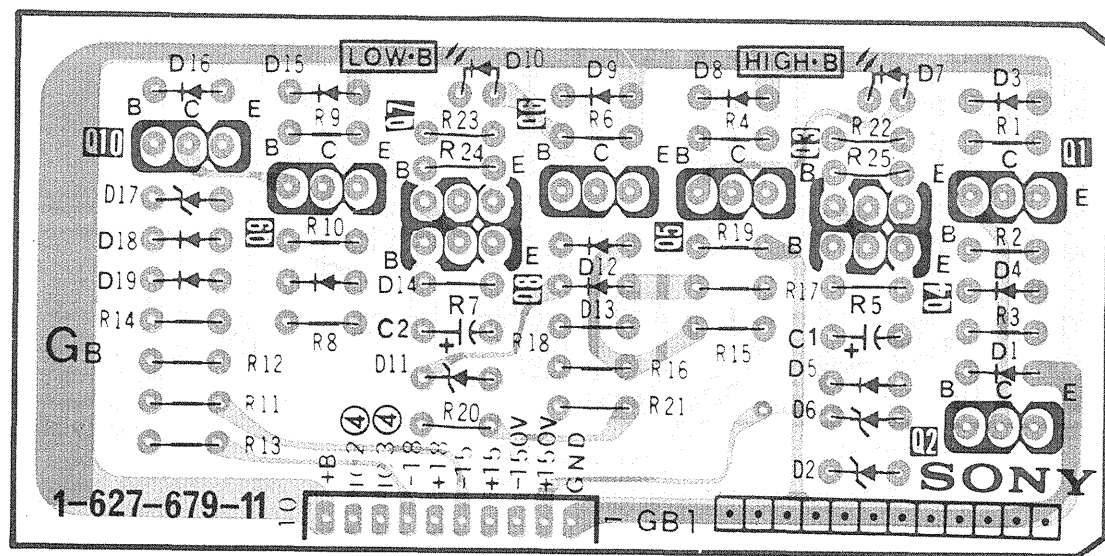

GA board (AC RECT, DC REG)

IC	Q	D	ADJ-TP
		23 25	TP2
		11	TP3
4		12	
			RV1
		21	
		13	RV2 TP4 TP5
2		14	
3			TP1
		20	
	7	3	
	9	6	
	8	14	
		4	
		7	
		31,32	
		29	
		30	
		26	
1			
		28	
		3	
		4	
	2	9	8

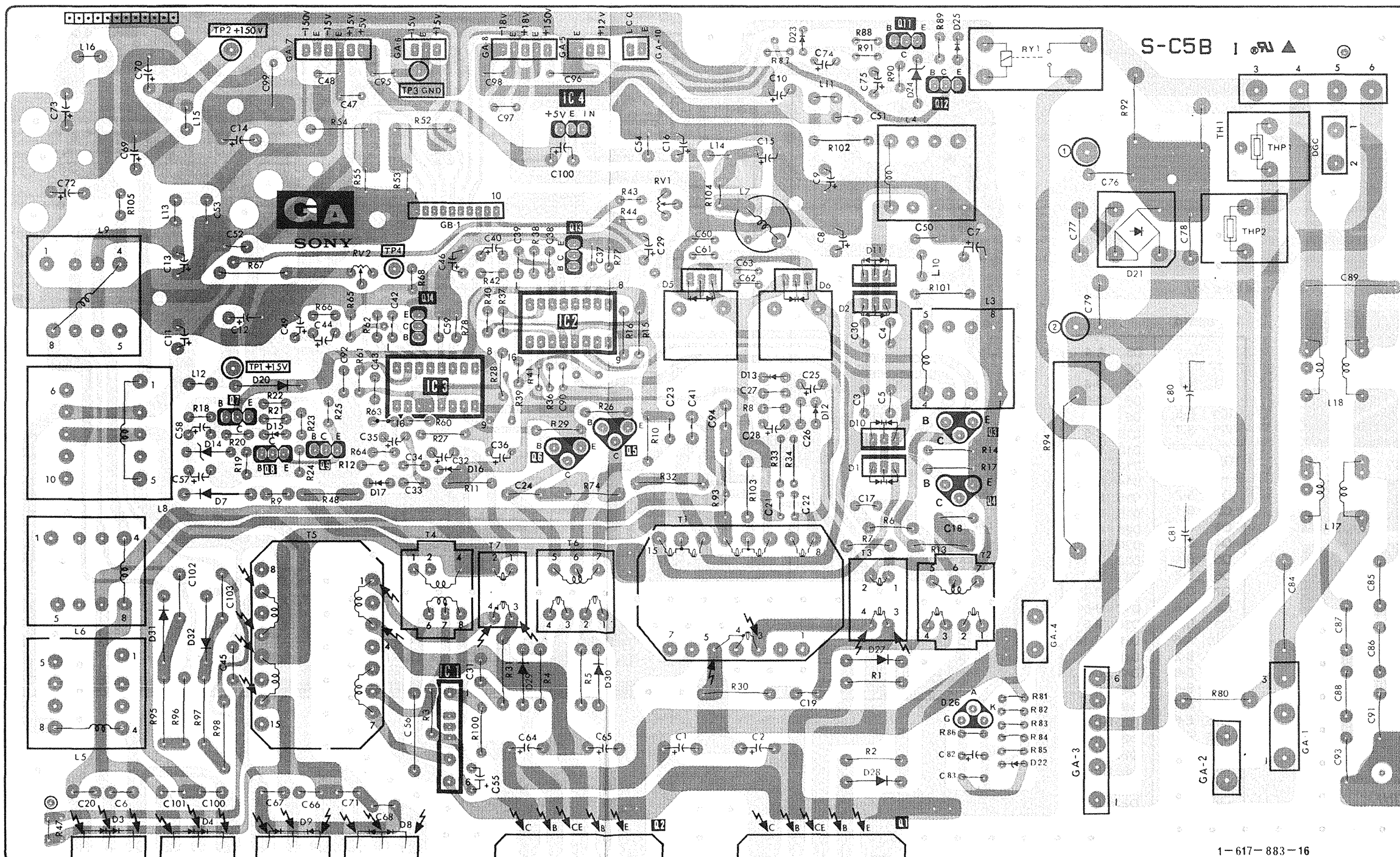

• : Pattern from the side which enables seeing  
 • : Pattern of the rear side.

GA board (AC RECT, DC REG)  
GB board (OVER VOLTAGE PROTECTOR)

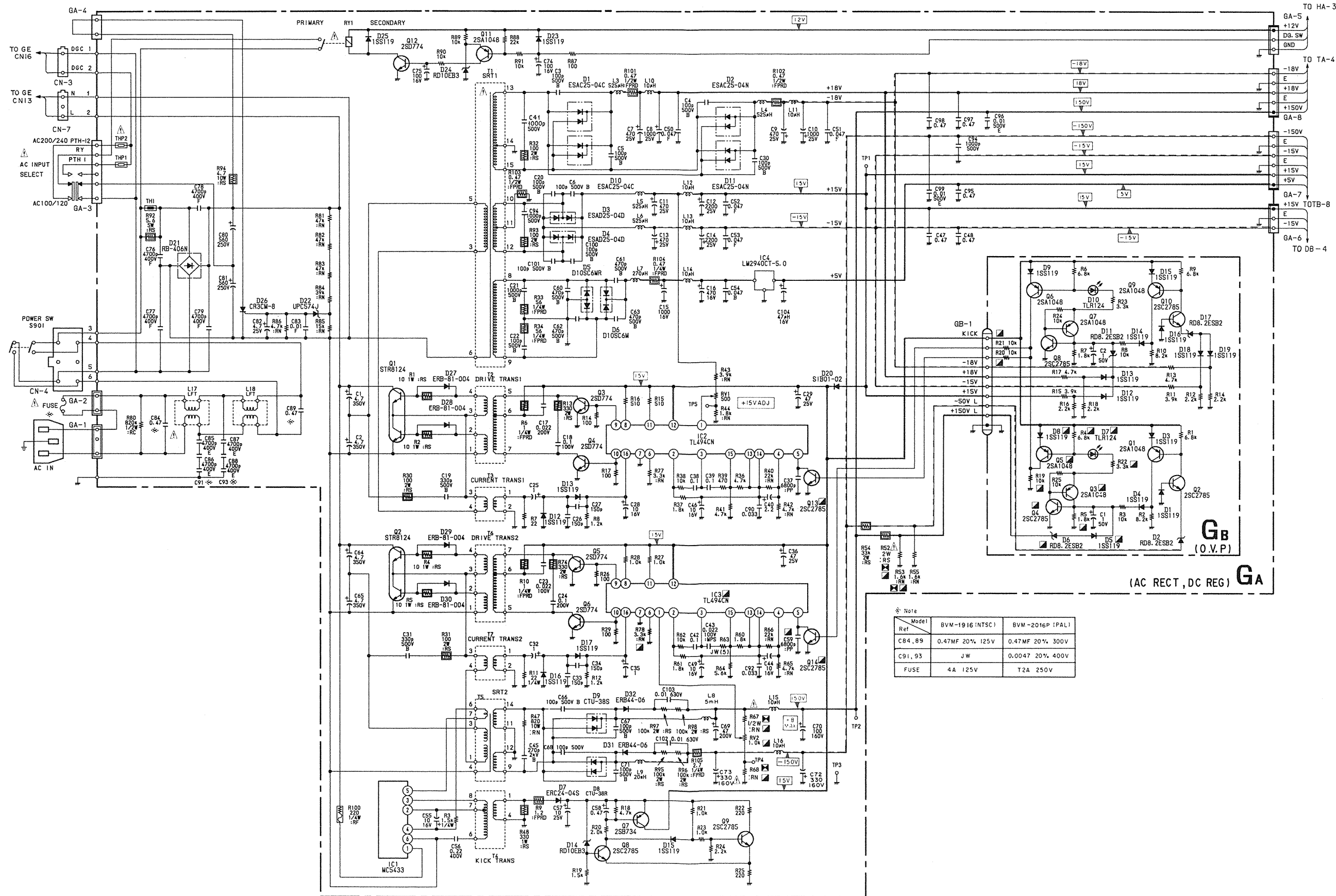

Note

Ref	Model	BVM-1916 (NTSC)	BVM-2016P (PAL)
C84, 89		0.47MF 20% 125V	0.47MF 20% 300V
C91, 93		JW	0.0047 20% 400V
FUSE		4A 125V	T2A 250V

GA BOARD

IC1	MCS433	STARTER
2	TL494CN	DC REG
3	TL494CN	DC REG
4	LM2940CT-5.0	+5V REG
Q1	STR8124	DC-DC CONV.
2	STR8124	DC-DC CONV.
3	2SD774	CONV. DRIVE
4	2SD774	CONV. DRIVE
5	2SD774	CONV. DRIVE
6	2SD774	CONV. DRIVE
7	2SB734	SOFT. START
8	2SC2785	SOFT. START
9	2SC2785	SOFT. START
11	2SA1048	D.G. CONTROL
12	2SD774	D.G. CONTROL
13	2SC2785	O.V.P SW
14	2SC2785	O.V.P SW
D1	1SS119	PROTECTOR
2	RD8.2ES-T1B2	REFERENCE
3	1SS119	PROTECTOR
4	1SS119	MIX.
5	1SS119	MIX.
6	RD8.2ES-T1B2	REFERENCE
7	TLR124	O.V.P INDICATE
8	1SS119	PROTECTOR
9	1SS119	PROTECTOR
10	TLR124	O.V.P INDICATE
11	RD8.2ES-T1B2	REFERENCE
12	1SS119	MIX.
13	1SS119	MIX.
14	1SS119	MIX.
15	1SS119	PROTECTOR
16	1SS119	PROTECTOR
17	RD8.2ES-T1B2	REFERENCE
18	1SS119	MIX.
19	1SS119	MIX.
D1	ESAC25-04C	+18V RECT
2	ESAC25-04N	-18V RECT
3	ESAD25-04D	+15V RECT
4	ESAD25-04D	-15V RECT
5	D10SC6MR	+5V RECT
6	D10SC6MR	+5V RECT
7	ERC24-04S	START. RECT
8	CTU-38S	-150V RECT
9	CTU-38S	+150V RECT
10	ESAC25-04C	+18V RECT
11	ESAC25-04N	-18V RECT
12	1SS119	O.C.P RECT
13	1SS119	O.C.P RECT
14	RD10EB3T	STARTER
15	1SS119	STARTER
16	1SS119	O.C.P RECT
17	1SS119	O.C.P RECT
20	SIB01-02	DC. STOPPER
21	RB406N	AC RECT
22	UPC574J	O.V.P
23	1SS119	DISCHARGE
24	RD10EB3T	+10V REG
25	1SS119	SW PROTECT
26	CR3CM-8	O.V.P
27	ERB81-004	CONV. DRIVE
28	ERB81-004	CONV. DRIVE
29	ERB81-004	CONV. DRIVE
30	ERB81-004	CONV. DRIVE
31	ERB44-06	
32	ERB44-06	

GB BOARD

Q1	2SA1048	O.V.P (-150V)
2	2SC2785	O.V.P (-150V)
3	2SA1048	O.V.P (+150V)
4	2SC2785	O.V.P (+150V)
5	2SA1048	O.V.P (+150V)
6	2SA1048	O.V.P (+15V)
7	2SA1048	O.V.P (+15V)
8	2SC2785	O.V.P (+15V)
9	2SA1048	O.V.P (-15V)
10	2SC2785	O.V.P (-15V)
D1	1SS119	PROTECTOR
2	RD8.2ES-T1B2	REFERENCE
3	1SS119	PROTECTOR
4	1SS119	MIX.
5	1SS119	MIX.
6	RD8.2ES-T1B2	REFERENCE
7	TLR124	O.V.P INDICATE
8	1SS119	PROTECTOR
9	1SS119	PROTECTOR
10	TLR124	O.V.P INDICATE
11	RD8.2ES-T1B2	REFERENCE
12	1SS119	MIX.
13	1SS119	MIX.
14	1SS119	MIX.
15	1SS119	PROTECTOR
16	1SS119	PROTECTOR
17	RD8.2ES-T1B2	REFERENCE
18	1SS119	MIX.
19	1SS119	MIX.



HA, HH, HW, HX, HY, XB, Y

HA, HH, HW, HX, HY, XB, Y HA, HH, HW, HX, HY, XB, Y

HW board (MANUAL CONTROL)

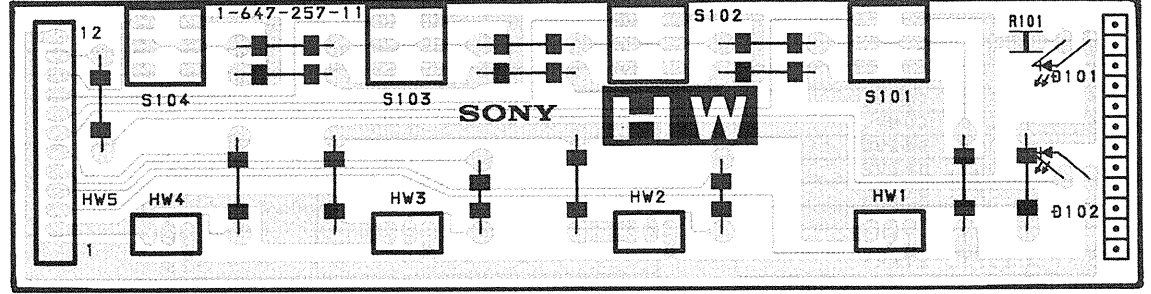

HX board (INPUT SELECT)

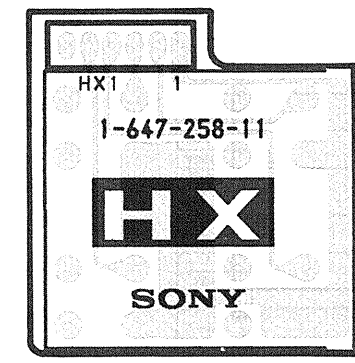

HH board (MANUAL VOLUME)



XB board (TALLY)

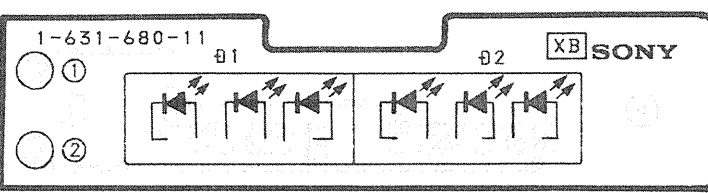

HA board (PANEL CONTROL)

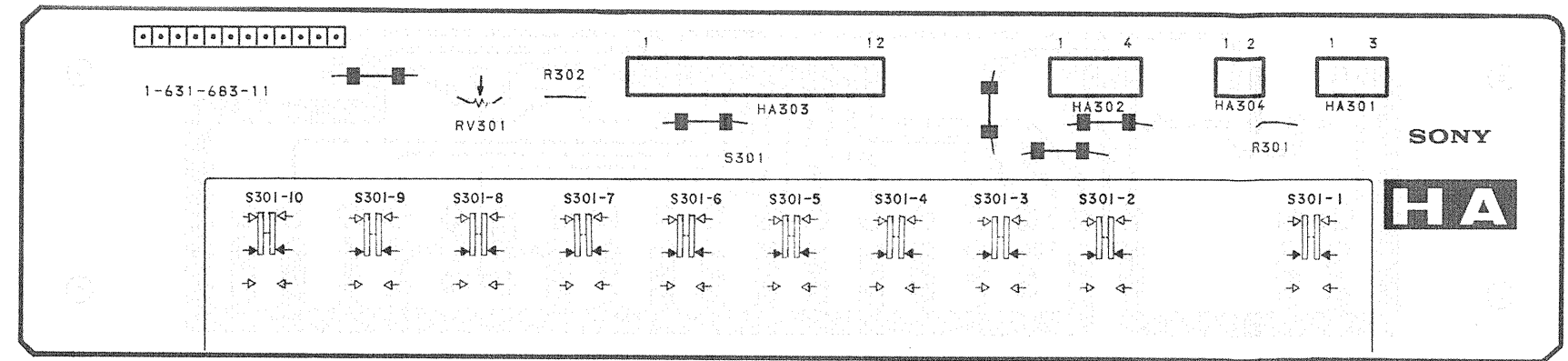

HY board (CONTROL FUNCTION SELECT)

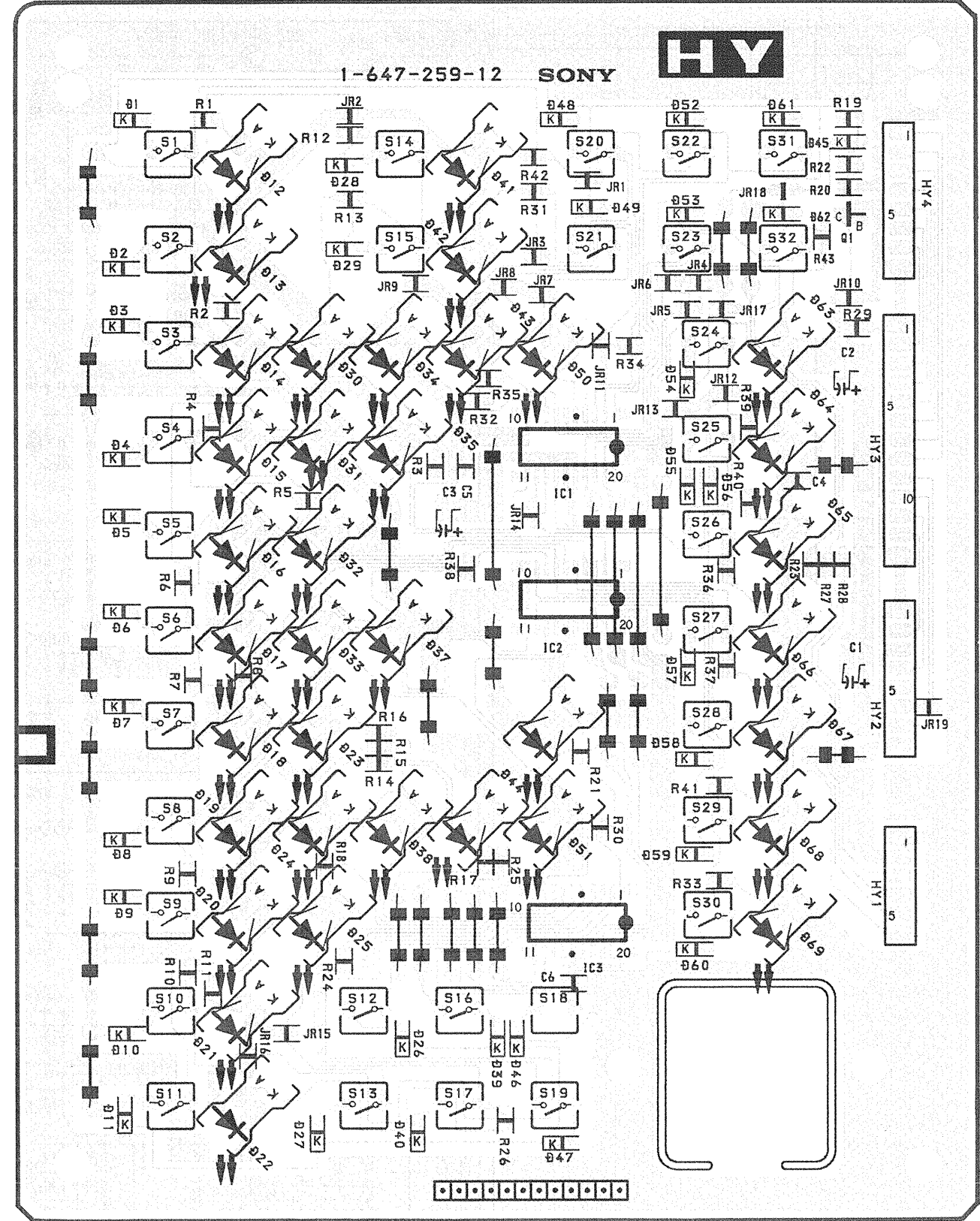

Y board (POWER LED)

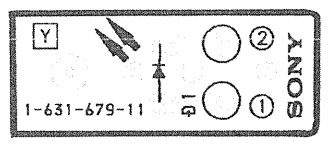

5. DIAGRAMS



HZ board (SYSTEM CONTROL)

HZ BOARD

IC 1	SN75176BP	RECEIVER
2	SN75176BP	TRANSMITTER
3	X25040P	NV RAM
4	PST529C	RESET
5	TL082M	OP AMP
6	uPD6142G-101	ON SCREEN D
7	TC74HCT02AF	NOR GATE
8	TC74HCT32AF	OR GATE
9	TC74HCT04AF	INVERTOR
10	TL082M	SAMPLE HOLD
11	TC74HCT139AF	DECODER
12	MC14051BF	DE-MULTIPLEXER
13	CXD10950	I/O EXPANDER
14	TL082M	SAMPLE HOLD
15	TC74HC299AF	SHIFT REGISTER
16	MC14051BF	DE-MULTIPLEXER
17	TC74HCT02AF	NOR GATE
18	TL082M	SAMPLE HOLD
19	TL082M	SAMPLE HOLD
20	DAC8043GP	D/A CONNECTOR
21	REF02EZ	REF. VOLTAGE
22	TL082M	SAMPLE HOLD
23	TL082M	SAMPLE HOLD
24	HD6475368-BVM1.20	CPU
0 2	DTC144EK	OUTPUT BUFFER
3	DTC144EK	OUTPUT BUFFER
4	DTC144EK	OUTPUT BUFFER
5	DTC144EK	OUTPUT BUFFER
6	DTC144EK	OUTPUT BUFFER
7	DTC144EK	OUTPUT BUFFER
8	DTC144EK	OUTPUT BUFFER
9	DTC144EK	OUTPUT BUFFER
10	DTC144EK	OUTPUT BUFFER
11	DTC144EK	OUTPUT BUFFER
12	DTC144EK	OUTPUT BUFFER
13	DTC144EK	OUTPUT BUFFER
14	DTC144EK	OUTPUT BUFFER
15	DTC144EK	OUTPUT BUFFER
16	DTC144EK	OUTPUT BUFFER
17	DTC144EK	OUTPUT BUFFER
18	DTC144EK	OUTPUT BUFFER
19	2SA1226	OUTPUT BUFFER
20	DTC144EK	OUTPUT BUFFER
21	DTC144EK	OUTPUT BUFFER
22	DTC144EK	OUTPUT BUFFER
23	DTC144EK	OUTPUT BUFFER
24	DTC144EK	OUTPUT BUFFER
25	DTC144EK	OUTPUT BUFFER
26	DTC144EK	OUTPUT BUFFER
27	DTC144EK	OUTPUT BUFFER
28	DTA144EK	OUTPUT BUFFER
29	DTC144EK	OUTPUT BUFFER
30	2SA1226	OUTPUT BUFFER
900	2SC2351	OUTPUT BUFFER
901	2SC1623	OUTPUT BUFFER
902	DTC144EK	OUTPUT BUFFER
903	DTC144EK	OUTPUT BUFFER
D 1	RDS.6ES-T1B	PROTECTION
2	RDS.6ES-T1B	PROTECTION
3	RDS.6ES-T1B	PROTECTION
4	RDS.6ES-T1B	PROTECTION
5	RDS.6ES-T1B	PROTECTION
6	RDS.6ES-T1B	PROTECTION
7	RDS.6ES-T1B	PROTECTION
8	RDS.6ES-T1B	PROTECTION
9	RDS.6ES-T1B	PROTECTION
10	RDS.6ES-T1B	PROTECTION
11	RDS.6ES-T1B	PROTECTION
12	RDS.6ES-T1B	PROTECTION
13	RDS.6ES-T1B	PROTECTION
14	RDS.6ES-T1B	PROTECTION
15	RDS.6ES-T1B	PROTECTION
16	RD15M-T1B	PROTECTION
17	1S2835	SWITCH
18	1S2837	SWITCH
19	1S2837	SWITCH
21	RD7.5M-T1B2	-7.5V REG
22	RD7.5M-T1B2	+7.5V REG

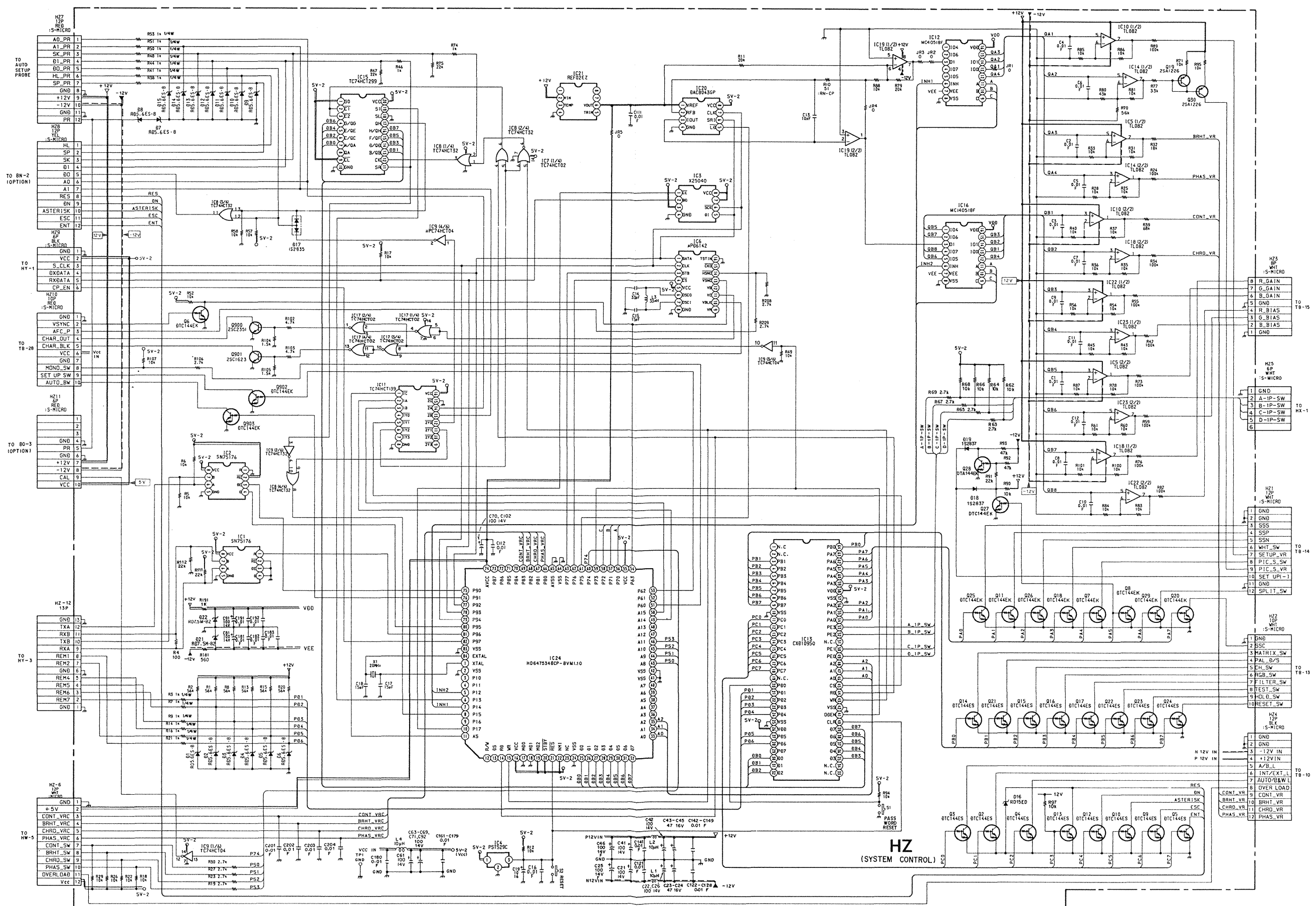

5. DIAGRAMS



HZ HZ

HZ

HZ board (SYSTEM CONTROL)

- CONDUCTOR SIDE -

IC	Q	D,TP
16	23 16 22 15 14 9 10 13 17 21 29 8 7 18 26 11 25	16
13		
12 19		
21 20		15 14 13 12 11 10 9
3		7 8
24		6 5 4 3 2 1
4	903 6 900 901 902	17
		TPI

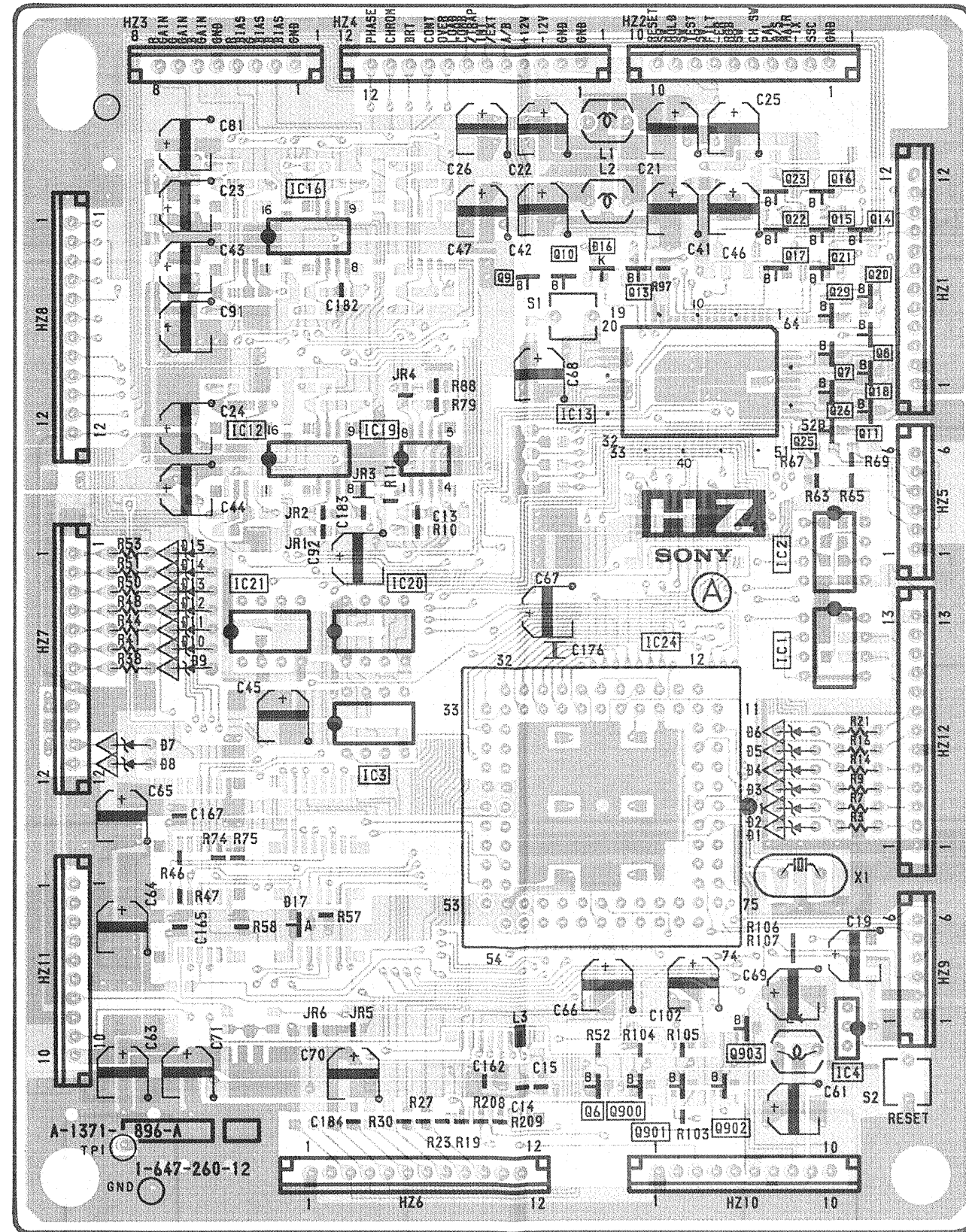

- COMPONENT SIDE -

IC	Q	D, TP
23 22 18	28, 27 30 4 2 3 24 19 12 5	18 19 21 22
14 10 5		
2 15		15 14 13 12 11 10 9
1	20 21	7 8
3		6 5 4 3 2 1
24	11 7	20
8 9		TPI
4	17 6	

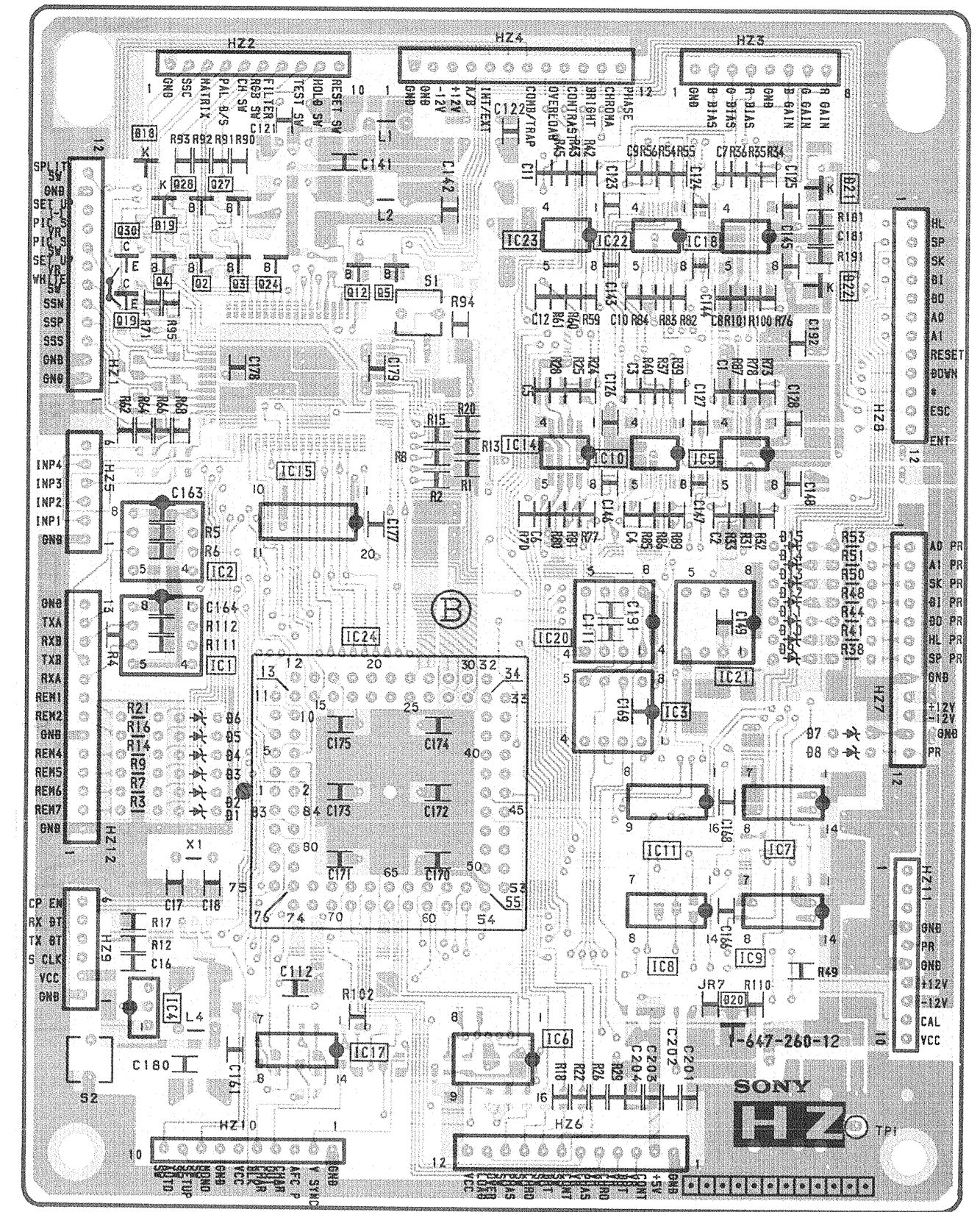

• : Pattern from the side which enables seeing.  
• : Pattern of the rear side.

QA board (COMPOSITE VIDEO INPUT)

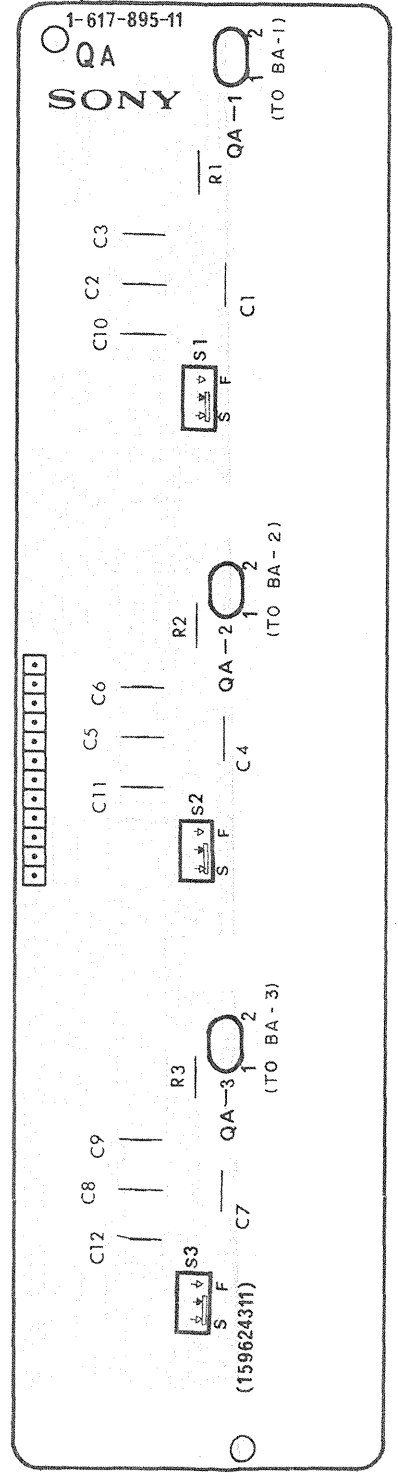

W board (RGB/COMPONENT OUT)

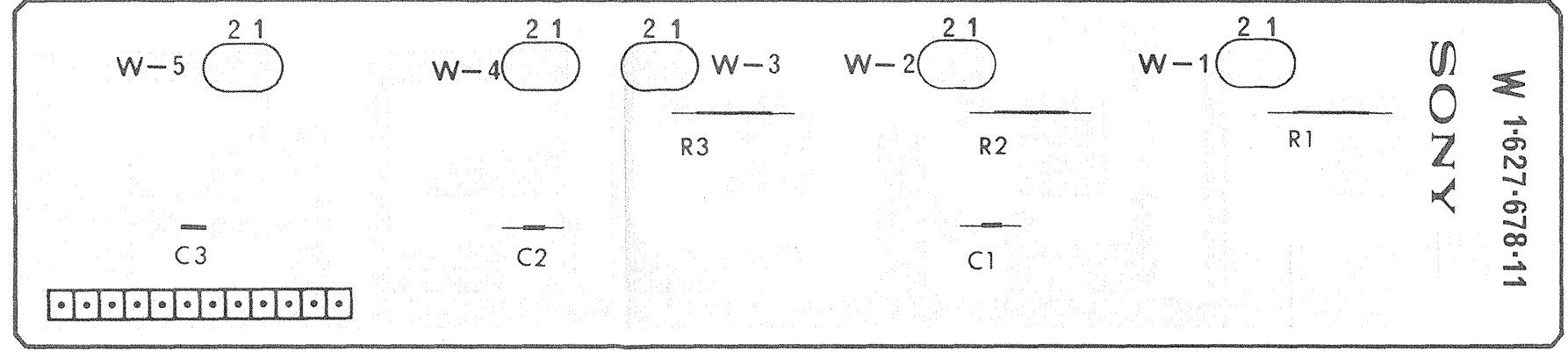

QB board (RGB/COMPONENT INPUT)

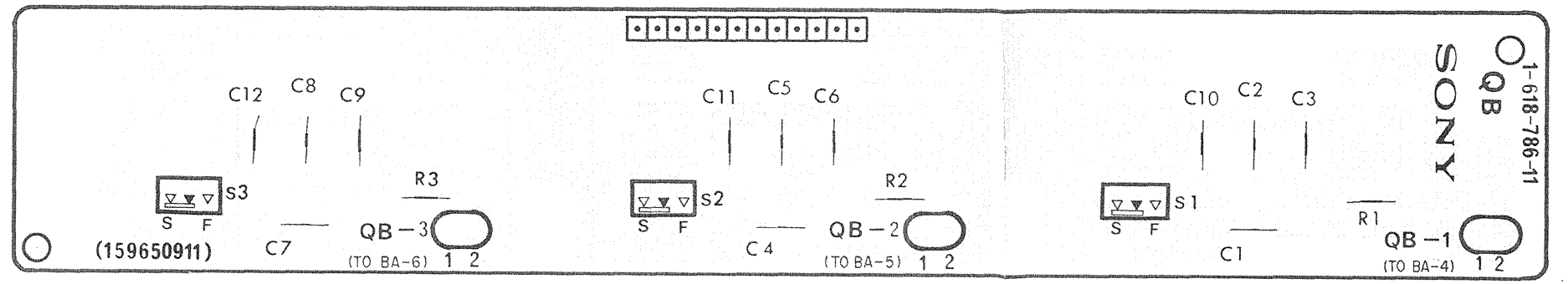

V board (REMOTE)

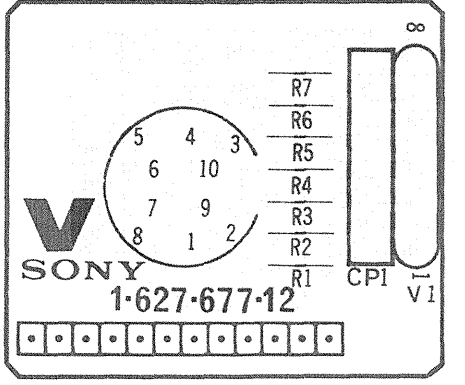

GC board (REG)

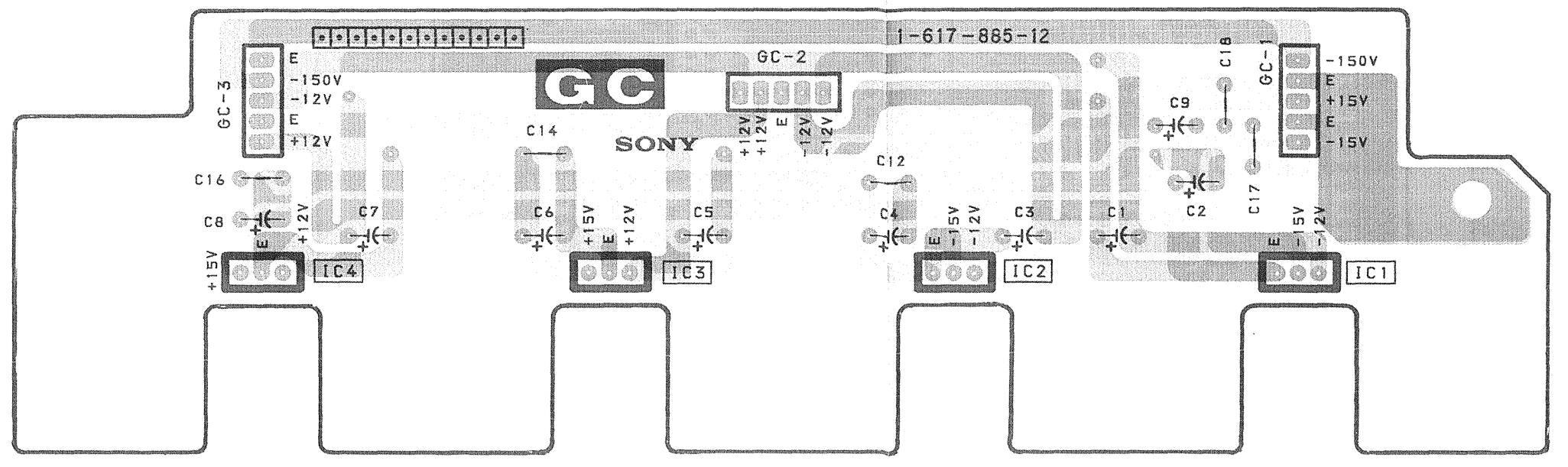

5. DIAGRAMS

• : Pattern from the side which enables seeing  
• : Pattern of the rear side.

# GC, QA, QB, V, W GC, QA, QB, V, W

GC board (REG) QA board (COMPOSITE VIDEO INPUT) QB board (RGB/COMPONENT INPUT)  
V board (REMOTE) W board (RGB/COMPONENT OUT)

GC BOARD

IC 1	μPC7912H	-12V REG
2	μPC7912H	-12V REG
3	μPC2412HF	+12V REG
4	μPC2412HF	+12V REG

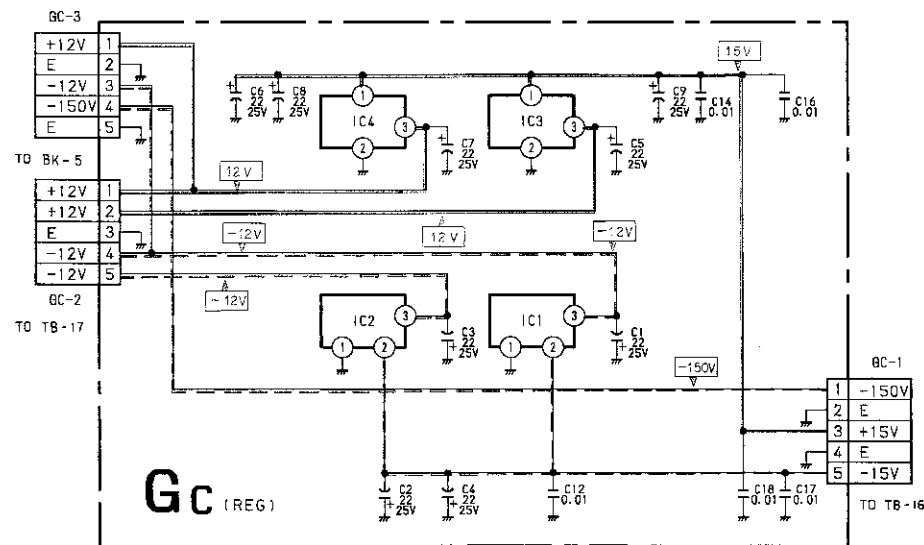
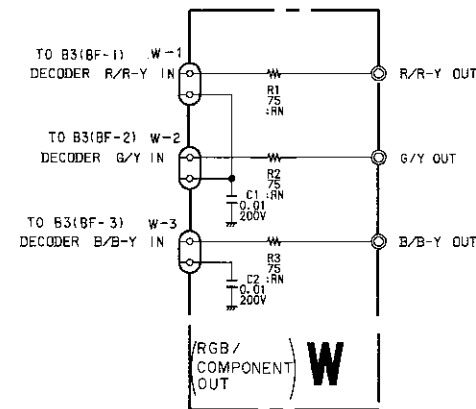
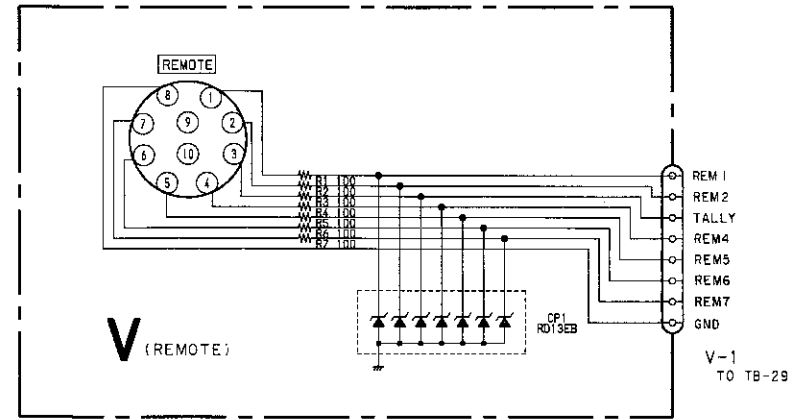
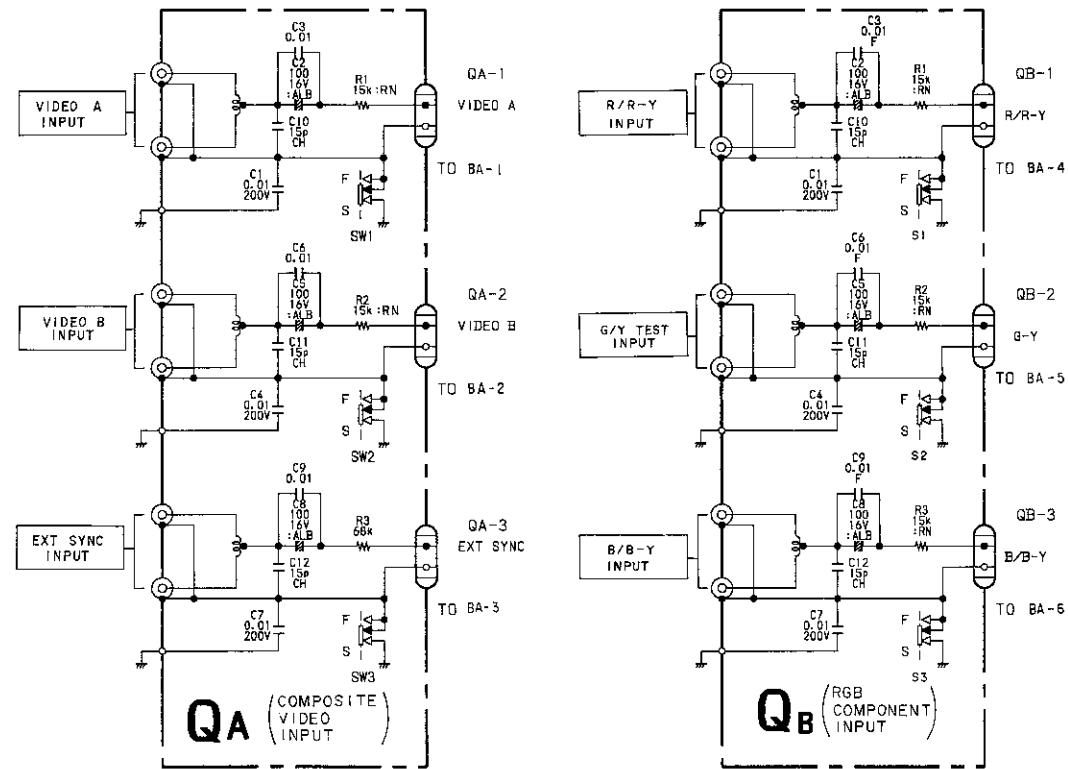



Z Z

Z board (EXTENSION BOARD)

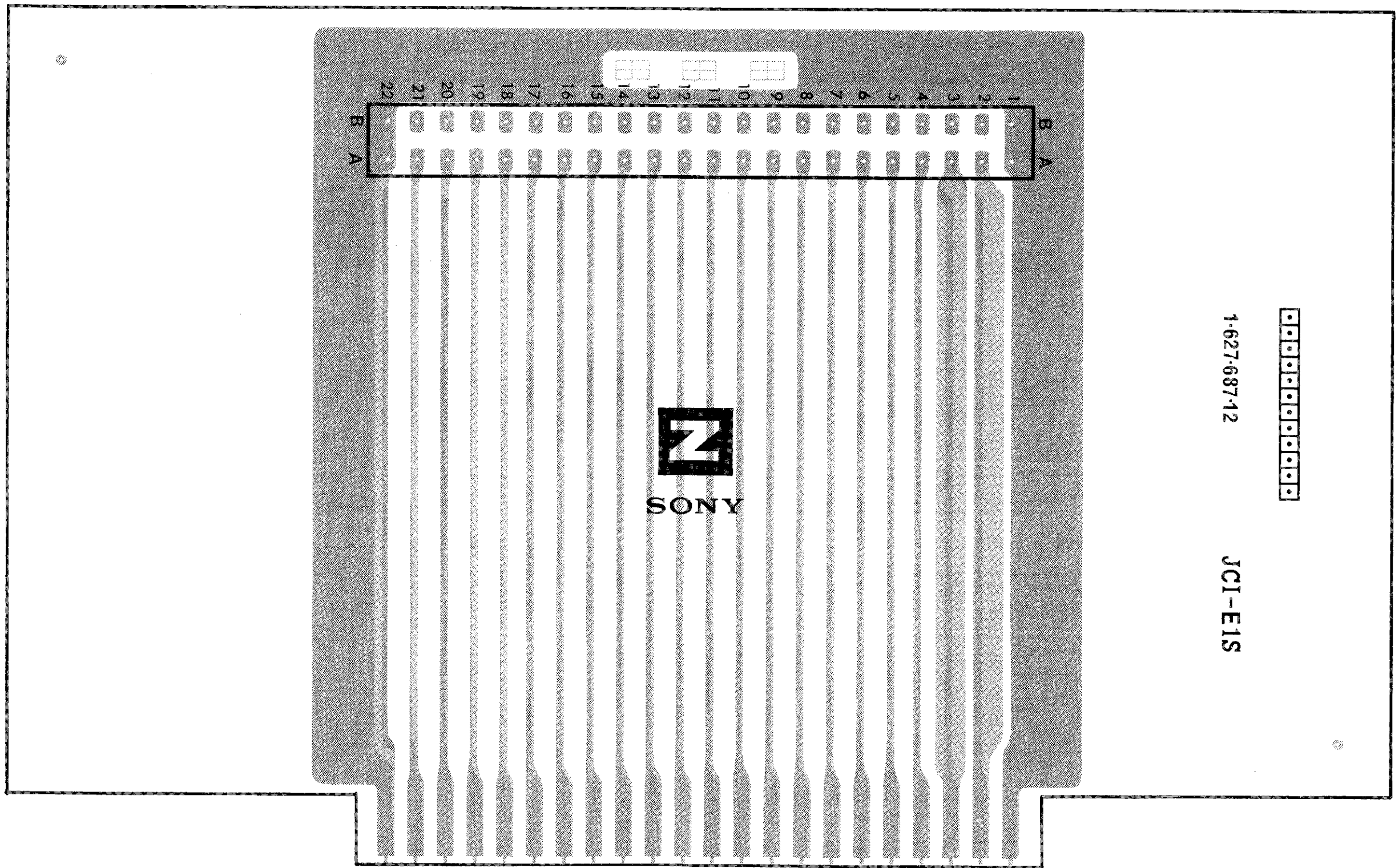

• : Pattern from the side which enables seeing.  
• : Pattern of the rear side.

## 5-4. SEMICONDUCTORS

**CX-158 (SONY)**  
HORIZONTAL DEFLECTION OSCILLATOR/FREQUENCY LIMITER  
— TOP VIEW —

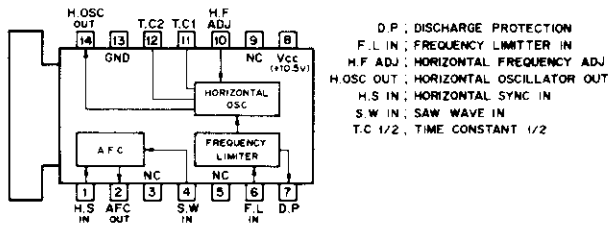

**CX-718D (SONY)**  
SRG FET IC  
— TOP VIEW —

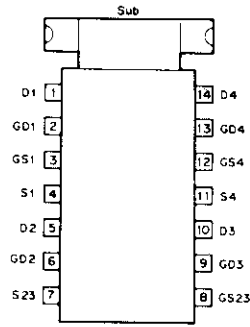

**CX20061 (SONY)**  
ANALOG SWITCH  
— SIDE VIEW —

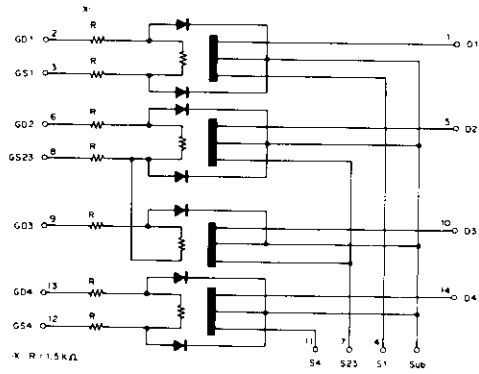
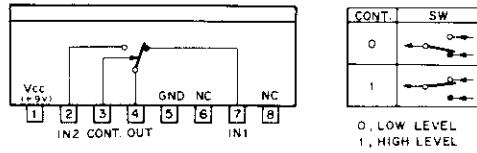

**CX23025 (SONY)**  
C-MOS TV-VTR SYNC SIGNAL DISCRIMINATOR  
— TOP VIEW —

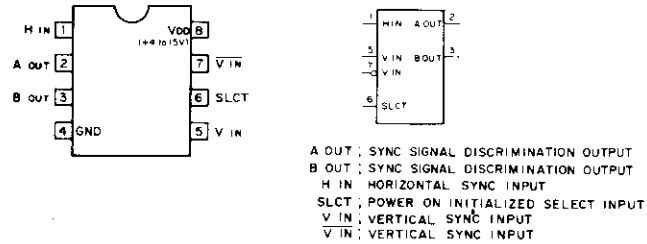

POWER ON INITIALIZED

SLCT INPUT	A OUTPUT	B OUTPUT
1	0	1
0	1	0

DISCRIMINATION

V SYNC INPUT FREQUENCY	A	B
50Hz	0	1
60Hz	1	0

0, LOW LEVEL  
1, HIGH LEVEL

**CX894 (SONY)**  
3 INPUT SWITCH  
— SIDE VIEW —

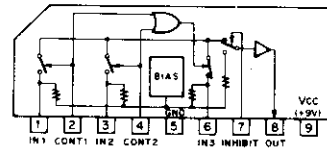

**CX7991 (SONY)**  
C-MOS 12-BIT SERIAL TO PARALLEL CONVERTER  
— TOP VIEW —

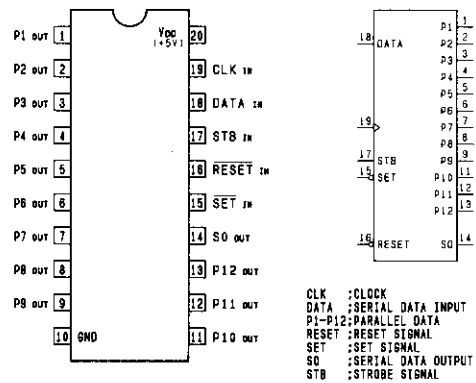

**CXA1539P**

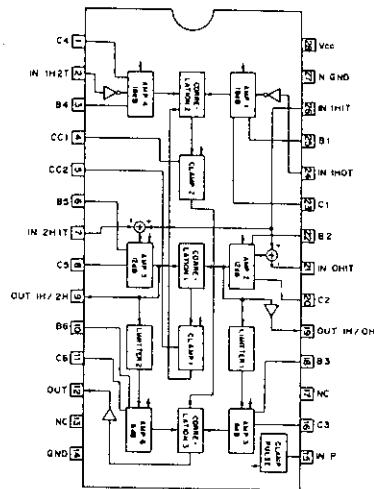

CXD1095Q (SONY) FLAT PACKAGE  
C-MOS I/O PORT EXPANDER  
— TOP VIEW —

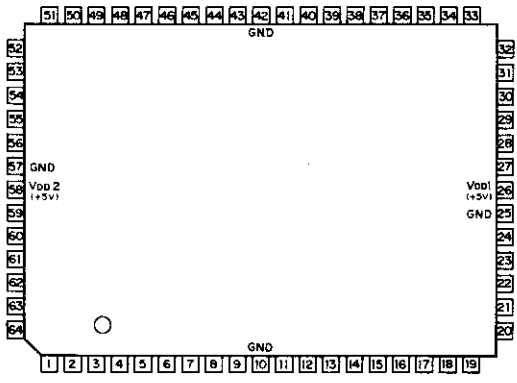

PIN NO.	IN	OUT	SYMBOL	PIN NO.	IN	OUT	SYMBOL	PIN NO.	IN	OUT	SYMBOL	PIN NO.	IN	OUT	SYMBOL
1			NC	17			PC6	33			NC	49			PX0
2			NC	18			PC7	34			NC	50			PX1
3			PB1	19			NC	35			D3	51			NC
4			PB2	20			PDO	36			D4	52			PX2
5			PB3	21			PD1	37			D5	53			PX3
6			PB4	22			PD2	38			D6	54			PA0
7			PB5	23			PD3	39			D7	55			PA1
8			PB6	24			PD4	40			CLR	56			PA2
9			PB7	25			GND	41			RST	57			GND
10			GND	26			Vdd2(+5V)	42			GND	58			Vdd2(+5V)
11			PC0	27			PD5	43			WR	59			PA3
12			PC1	28			PD6	44			RD	60			PA4
13			PC2	29			PD7	45			CS	61			PA5
14			PC3	30			D0	46			AO	62			PA6
15			PC4	31			D1	47			A1	63			PA7
16			PC5	32			D2	48			A2	64			PB0

CXL1009P (SONY)  
C-MOS CCD SIGNAL PROCESSOR FOR TBC  
— TOP VIEW —

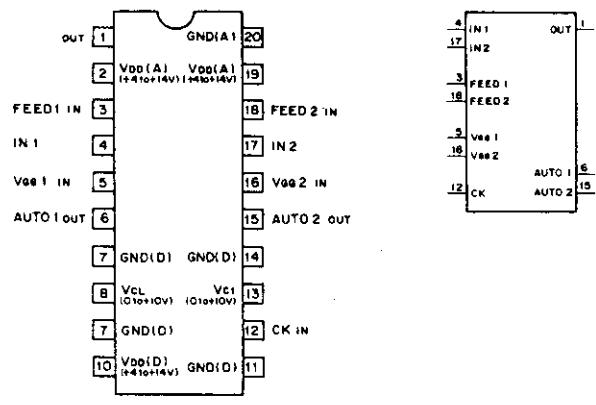

OUT ; OUT PUT  
FEED 1/2 IN ; FEEDBACK INPUT 1/2  
IN 1/2 ; INPUT 1/2  
Vdd 1/2 IN ; GATE INPUT 1/2  
AUTO 1/2 OUT ; AUTO BIAS OUTPUT 1/2  
CK IN ; CLOCK INPUT  
VCL ; POWER SUPPLY 2(DIGITAL)  
Vdd(A)/(I/D) ; POWER SUPPLY 1(ANALOG)/(DIGITAL)  
GND(A)/(I/D) ; GROUND(ANALOG)/(DIGITAL)

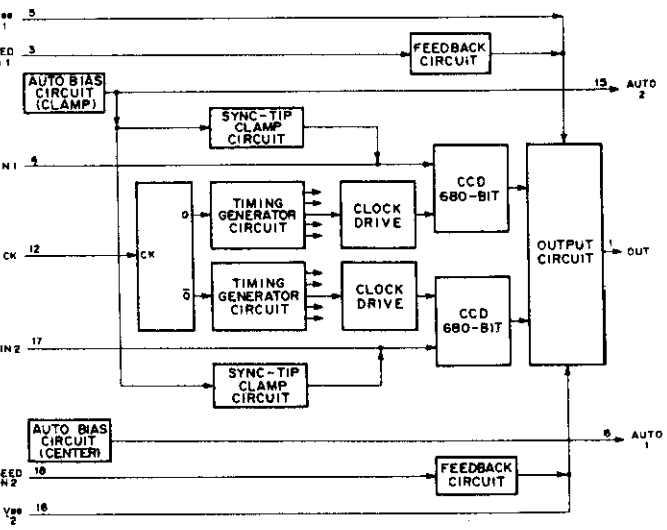

5. DIAGRAMS

CS	RD	WR	A2	A1	AO	MODE
0	0	1	0	0	0	PORT A → DATA BUS
0	0	1	0	0	1	PORT B → DATA BUS
0	0	1	0	1	0	PORT C → DATA BUS
0	0	1	0	1	1	PORT D → DATA BUS
0	0	1	1	0	0	PORT X → DATA BUS
0	0	1	1	0	1	---
0	0	1	1	1	0	---
0	0	1	1	1	1	---
0	1	0	0	0	0	DATA BUS → PORT A
0	1	0	0	0	1	DATA BUS → PORT B
0	1	0	0	1	0	DATA BUS → PORT C
0	1	0	0	1	1	DATA BUS → PORT D
0	1	0	1	0	0	DATA BUS → PORT X
0	1	0	1	0	1	---
0	1	0	1	1	0	DATA BUS → CTL REG. 1
0	1	0	1	1	1	DATA BUS → CTL REG. 2
1	X	X	X	X	X	DATA BUS ; HI-Z

0; LOW LEVEL  
1; HIGH LEVEL  
X; DON'T CARE  
HI-Z; HIGH IMPEDANCE

DO-D7; DATA BUS INPUTS/OUTPUTS  
CS; CHIP SELECT INPUT  
RD; READ STROBE INPUT  
WR; WRITE STROBE INPUT  
AO-A2; ADDRESS INPUT  
RST; RESET INPUT  
CLR; CLEAR INPUT

PA0-PA7; PORT A INPUTS/OUTPUTS  
PB0-PB7; PORT B INPUTS/OUTPUTS  
PC0-PC7; PORT C INPUTS/OUTPUTS  
PD0-PD7; PORT D INPUTS/OUTPUTS  
PX0-PX3; PORT X INPUTS/OUTPUTS

DAC8043GP (PMI)  
CMOS 12-BIT SERIAL INPUT D/A CONVERTER  
- TOP VIEW -

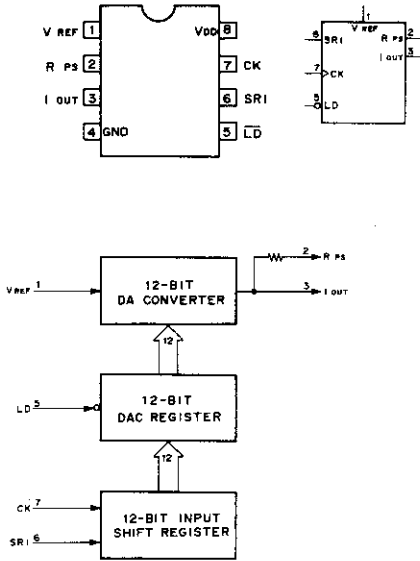

HD14011BP (HITACHI)  
MC14011BCP (MOTOROLA)  
TC4011BP (TOSHIBA)  
uPD4011BC (NEC)  
CMOS 2-INPUT NAND GATE  
- TOP VIEW -

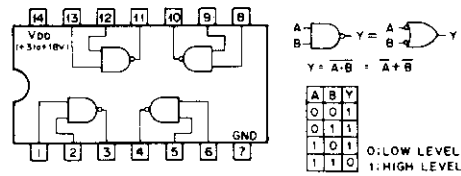

HD14538BP (HITACHI)  
CMOS DUAL RETRIGGERABLE NON-RETRIGGERABLE  
MONOSTABLE MULTIVIBRATOR  
- TOP VIEW -

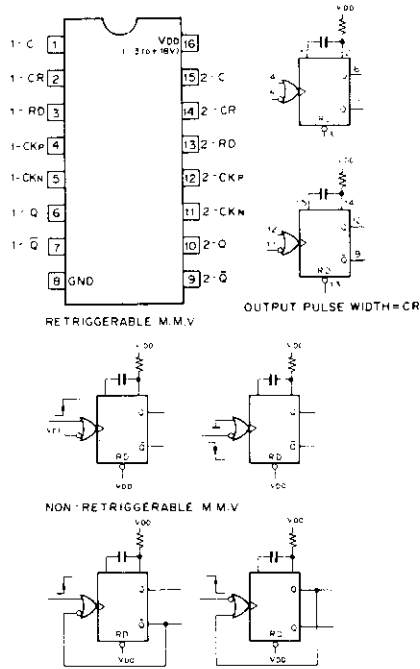

LA7016 (SANYO)  
ELECTRONIC SWITCH  
- SIDE VIEW -

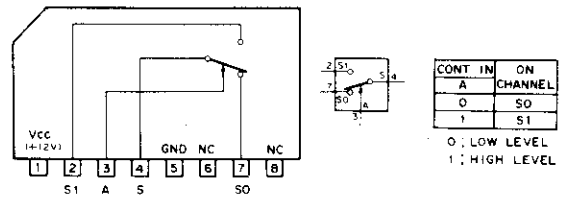

LM7812CT  
POSITIVE VOLTAGE REGULATOR (500mA)  
- FRONT VIEW -

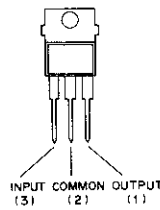

LM7912CT (NS) - 12V  
NEGATIVE VOLTAGE REGULATOR  
- FRONT VIEW -

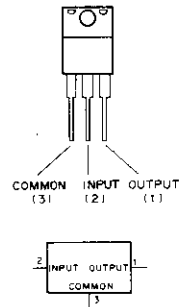

MC14001BCP (MOTOROLA)  
uPD4001BC (NEC)  
CMOS 2-INPUT NOR GATE  
- TOP VIEW -

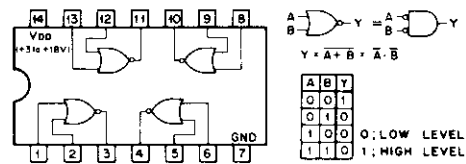

MC14023BCP (MOTOROLA)  
TC4023BP (TOSHIBA)  
CMOS 3-INPUT NAND GATE  
- TOP VIEW -

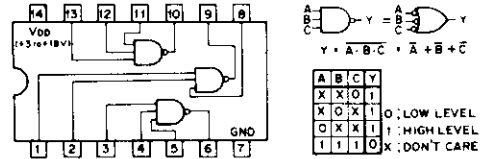

**MBB4027B (FUJITSU)**  
 TC504027BP (TOSHIBA)  
 C-MOS J-K MASTER SLAVE FLIP-FLOP WITH DIRECT SET/RESET  
 - TOP VIEW -

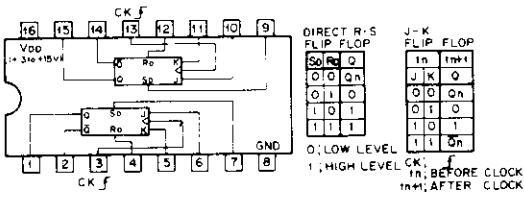

**MC14027BCP (MOTOROLA)**  
 C-MOS J-K MASTER SLAVE FLIP-FLOP WITH DIRECT SET/RESET  
 - TOP VIEW -

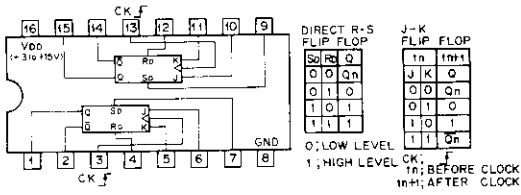

**MC14051BF**  
 C-MOS 8-CHANNEL MULTIPLEXER/DEMULTIPLEXER  
 - TOP VIEW -

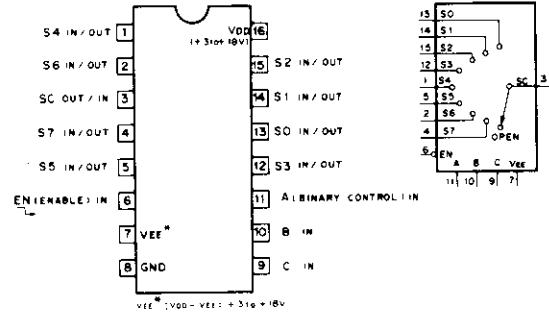

**MC14053BCP (MOTOROLA)**  
 TC4053BP  
 TC4053BPHB (TOSHIBA)  
 μPC4053BC  
 C-MOS 2-CHANNEL MULTIPLEXER/DEMULTIPLEXER  
 - TOP VIEW -

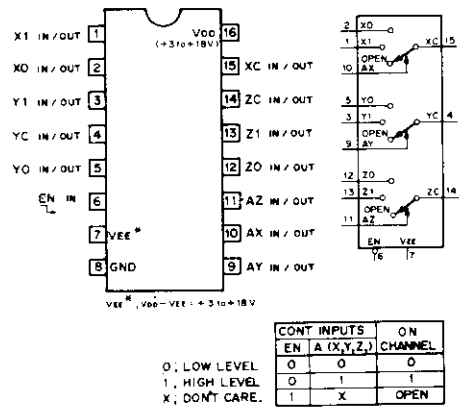

**MC14040BCP (MOTOROLA)**  
 TC4040BP (TOSHIBA)  
 C-MOS 12-STAGE RIPPLE CARRY BINARY COUNTER-DRIVER  
 - TOP VIEW -

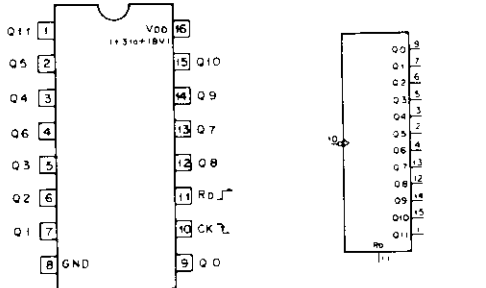

**MC14066BCP**  
 C-MOS BILATERAL ANALOG SWITCH  
 - TOP VIEW -

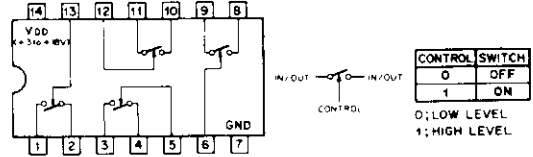

**MC14069UBCP**  
 uPD4069UBC (NEC)  
 - TOP VIEW -

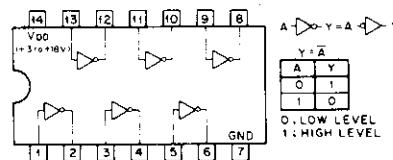



MC14071BCP (MOTOROLA)  
TC4071BP (TOSHIBA)  
μPD4071BC (NEC)  
C-MOS 2-INPUT OR GATE  
— TOP VIEW —

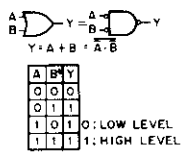
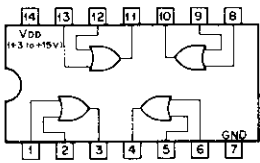

MC14520BCP (MOTOROLA)  
TC4520BP (TOSHIBA)  
C-MOS DUAL 4-BIT BINARY UP COUNTER  
— TOP VIEW —

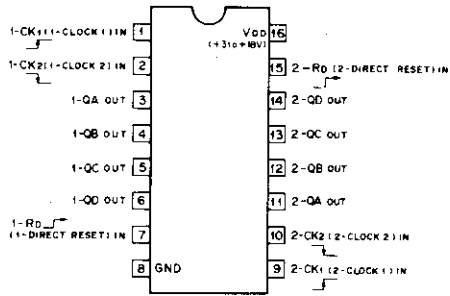

STATE	0	1	2	3	4	5	6	7	8	9	10	11	12	13	14	15
0	0	0	0	0	0	0	0	0	0	0	0	0	0	0	0	0
1	0	0	0	0	1	0	0	0	0	0	0	0	0	0	0	0
2	0	0	0	1	0	0	0	0	0	0	0	0	0	0	0	0
3	0	0	1	0	0	0	0	0	0	0	0	0	0	0	0	0
4	0	1	0	0	0	0	0	0	0	0	0	0	0	0	0	0
5	0	1	0	1	0	0	0	0	0	0	0	0	0	0	0	0
6	0	1	1	0	0	0	0	0	0	0	0	0	0	0	0	0
7	0	1	1	1	0	0	0	0	0	0	0	0	0	0	0	0
8	1	0	0	0	0	0	0	0	0	0	0	0	0	0	0	0
9	1	0	0	1	0	0	0	0	0	0	0	0	0	0	0	0
10	1	0	1	0	0	0	0	0	0	0	0	0	0	0	0	0
11	1	0	1	1	0	0	0	0	0	0	0	0	0	0	0	0
12	1	1	0	0	0	0	0	0	0	0	0	0	0	0	0	0
13	1	1	0	1	0	0	0	0	0	0	0	0	0	0	0	0
14	1	1	1	0	0	0	0	0	0	0	0	0	0	0	0	0
15	1	1	1	1	0	0	0	0	0	0	0	0	0	0	0	0

0: LOW LEVEL  
1: HIGH LEVEL  
X: DON'T CARE

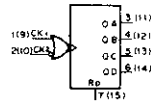

CK1	CK2	R0	ACTION
↑	↑	0	INCREMENT COUNTER
↓	↓	0	INCREMENT COUNTER
↑	X	0	NO CHANGE
X	↑	0	NO CHANGE
↑	↑	0	NO CHANGE
↑	↑	1	NO CHANGE
X	X	1	QA THRU QD = 0

MC14073BCP (MOTOROLA)  
TC4073BP (TOSHIBA)  
C-MOS 3-INPUT POSITIVE AND GATE  
— TOP VIEW —

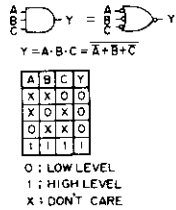
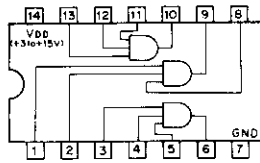

MC14081BCP (MOTOROLA)  
TC4081BP (TOSHIBA)  
μPD4081BC (NEC)  
C-MOS 2-INPUT AND GATE  
— TOP VIEW —

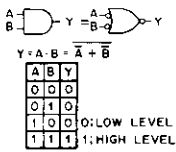
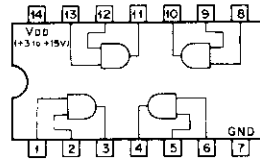

NJM082M (JRC) FLAT PACKAGE  
μPC4082C  
OPERATIONAL AMPLIFIER  
(JFET INPUT)  
— TOP VIEW —

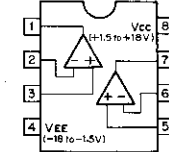

MC14175BCP (MOTOROLA)  
C-MOS DECADE COUNTER/DIVIDER  
— TOP VIEW —

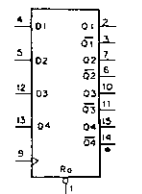
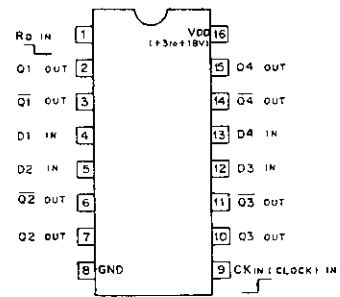

CK	D	Rd	Q	Q
↑	0	1	0	1
↑	1	1	1	0
↑	X	1	Q0	Q0
X	X	0	0	1

0: LOW LEVEL  
1: HIGH LEVEL  
X: DON'T CARE

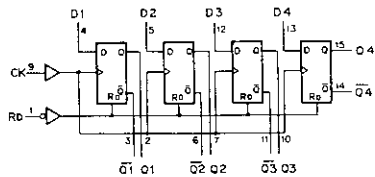

NJM2903D (JRC)  
VOLTAGE COMPARATOR  
— TOP VIEW —

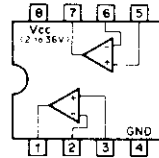

NJM4558S (JRC)  
HIGH PERFORMANCE DUAL OPERATIONAL AMPLIFIER  
— SIDE VIEW —

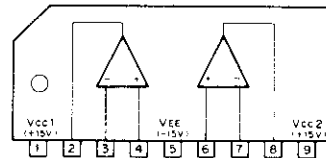

NJM4558D (JRC)  
 uPC4558C (NEC)  
 uPC4553C  
 OPERATIONAL AMPLIFIER  
 - TOP VIEW -

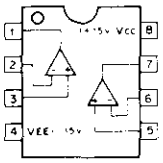

NJM7805FA  
 NJM7809FA  
 NJM7812FA  
 POSITIVE VOLTAGE REGULATOR (1A)  
 - SIDE VIEW -

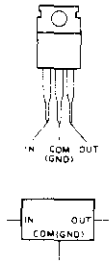

NJM78L05A (JRC) + 5V (100mA)  
 POSITIVE VOLTAGE REGULATOR

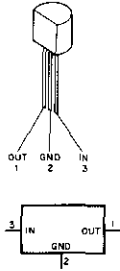

PST529C (MITSUMI)  $V_s = 4.5V$   
 VOLTAGE DETECTOR, SYSTEM RESET  
 (MITSUMI)

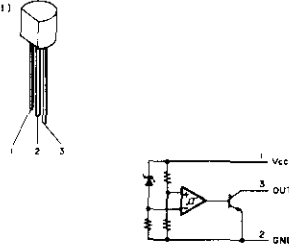

NJM78M05FA (JRC) + 5V  
 NJM78M12FA (JRC) + 12V  
 POSITIVE VOLTAGE REGULATOR  
 - FRONT VIEW -

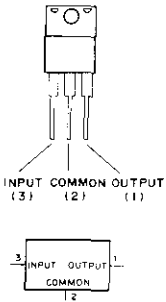

REF-02EZ (PMI)  
 REFERENCE/TEMPERATURE TRANSDUCER  
 - TOP VIEW -

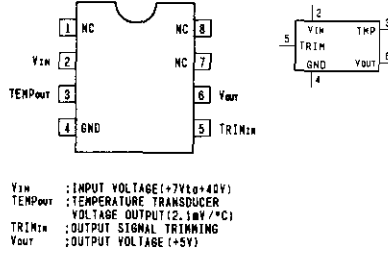

$V_{In}$  : INPUT VOLTAGE (+7V to +40V)  
 $TEMP_{out}$  : TEMPERATURE TRANSDUCER  
 VOLTAGE OUTPUT (2.5mV/°C)  
 $TRIM_{In}$  : OUTPUT SIGNAL TRIMMING  
 $V_{out}$  : OUTPUT VOLTAGE (+5V)

SN75176BP (TI)  
 TTL-DIFFERENTIAL BUS TRANSCEIVER  
 - TOP VIEW -

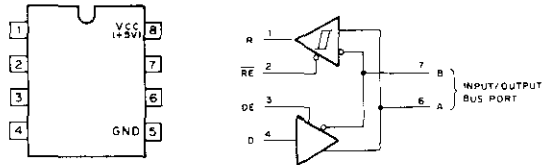

FUNCTION TABLE

- DRIVER -

INPUT	ENABLE	OUTPUT	
D	OE	A	B
1	1	1	0
0	1	0	1
X	0	HI-Z	HI-Z

- RECEIVER -

DIFFERENTIAL INPUTS		ENABLE	OUTPUT
A	B	RE	R
$V_{io} > 0.2V$	0	1	1
$-0.2V < V_{io} < 0.2V$	0	0	?
$V_{io} < -0.2V$	0	0	0
X	X	1	HI-Z

1 : HIGH LEVEL  
 0 : LOW LEVEL  
 X : DON'T CARE  
 HI-Z : HIGH IMPEDANCE  
 ? : INDETERMINATE

NJM79M05FA (JRC) - 5V  
 NJM79M12FA (JRC) - 12V  
 NEGATIVE VOLTAGE REGULATOR  
 - FRONT VIEW -

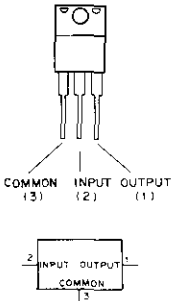

TA7812S  
 POSITIVE VOLTAGE REGULATOR (0.5A)  
 - SIDE VIEW -

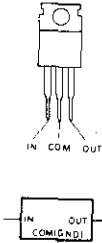

TA7193P (TOSHIBA)  
TV CHROMA PROCESS (PAL)  
- TOP VIEW -

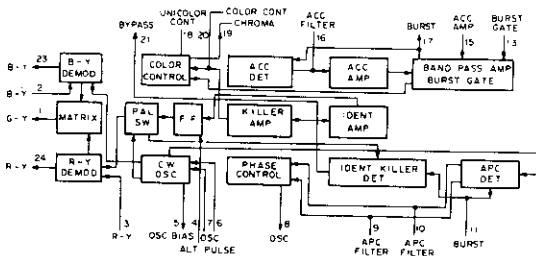
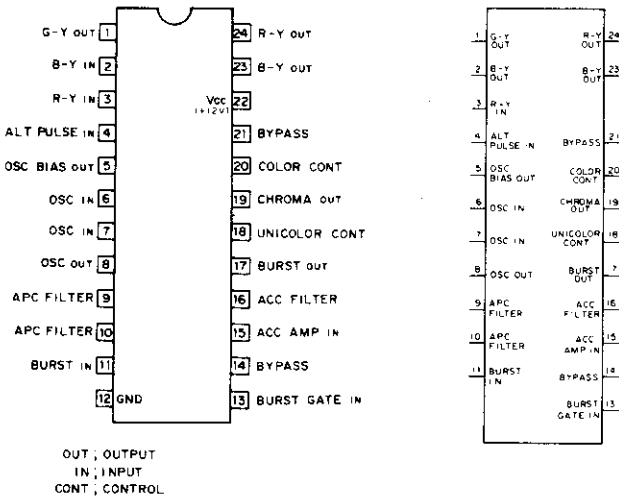

TC4030BP (TOSHIBA)  
TC4030BPHB (TOSHIBA)  
CMOS EXCLUSIVE OR GATE  
- TOP VIEW -

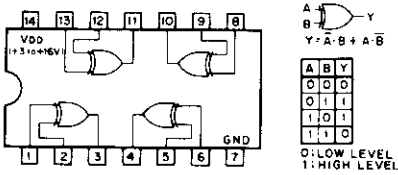

TC4066BPHB (TOSHIBA)  
CMOS QUAD BILATERAL ANALOG SWITCHES  
- TOP VIEW -

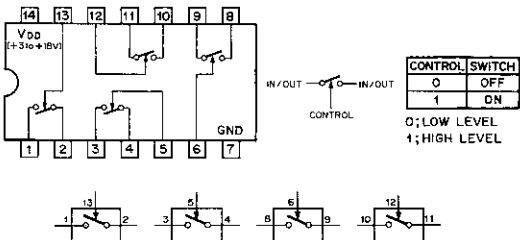

TC4069BP (TOSHIBA)  
CMOS INVERTER  
- TOP VIEW -

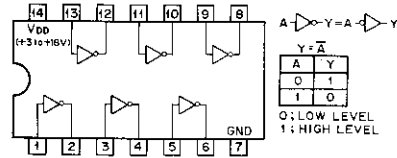

TC74HC299AF  
TTL 8-BIT UNIVERSAL SHIFT/STORAGE REGISTER  
- TOP VIEW -

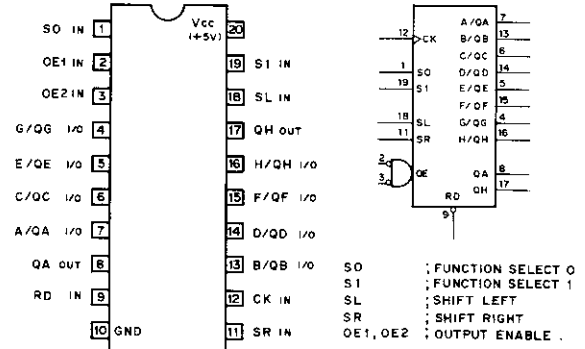

MODE	INPUTS								INPUTS/OUTPUTS								OUTPUTS		
	RD	CK	SO	S1	OE1	OE2	SL	SR	A	B	C	D	E	F	G	H	QA	QH	
CLEAR	0	X	0	X	0	0	X	X	0	0	0	0	0	0	0	0	0	0	0
HOLD	1	X	0	0	0	0	X	X	QA	QB	QC	QD	QE	QF	QG	QH	QA	QH	
SHIFT RIGHT	1	J	1	0	0	0	X	0	QA	QB	QC	QD	QE	QF	QG	QH	QA	QH	
SHIFT LEFT	1	J	0	1	0	0	0	1	QB	QC	QD	QE	QF	QG	QH	1	QB	1	
LOAD	1	J	1	1	X	X	X	X	0	0	0	0	0	0	0	0	0	0	
OUTPUT ENABLE	X	X	X	X	1	X	X	X	HIGH-IMPEDANCE (INTERNAL LOGIC IS NOT AFFECTED)								QA	QH	

0...h: The level of the steady-state input at inputs A through H respectively  
0; LOW LEVEL  
1; HIGH LEVEL  
X; DON'T CARE

TC74HCT139AF  
TTL 2-TO-4-LINE DECODER/DEMULTEPLEXER  
- TOP VIEW -

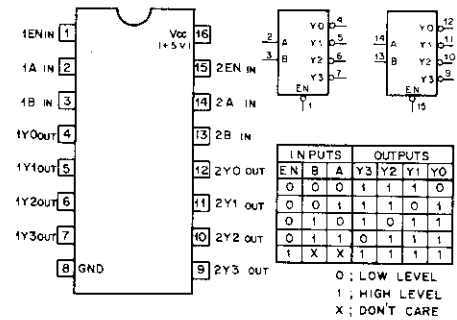

5. DIAGRAMS

TC74HCT02AF (TOSHIBA) FLAT PACKAGE  
 CMOS QUAD 2-INPUT NOR GATES  
 - TOP VIEW -

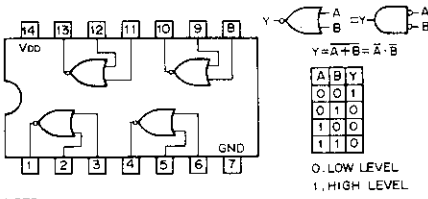

NOTE:

TYPE	V <sub>DD</sub>
TC74AC02F	+2 to +5.5V
74ACT02SJ	+4.5 to +5.5V
TC74ACT02F	+2 to +6V
OTHER TYPES	+2 to +6V

TC74HCT04AF (TOSHIBA) FLAT PACKAGE

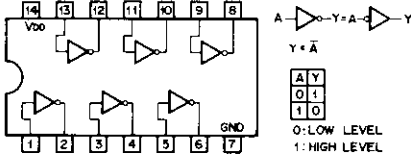

NOTE:

TYPE	V <sub>DD</sub>
74HCT04 TYPE	+5V
TC74AC04 TYPE	+2 to +5.5V
74ACT04 TYPE	+4.5 to +5.5V
OTHER TYPES	+2 to +6V

TC74HCT32AF  
 TTL 2-INPUT POSITIVE-OR GATE  
 - TOP VIEW -

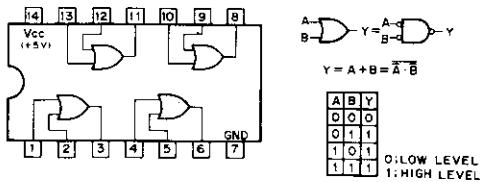

TL494CN (TI)  
 PWM POWER CONTROL  
 - TOP VIEW -

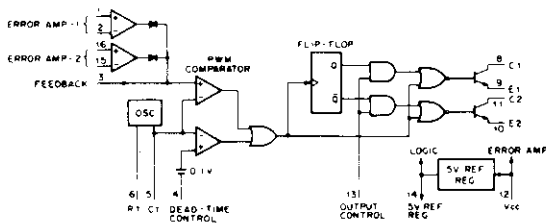
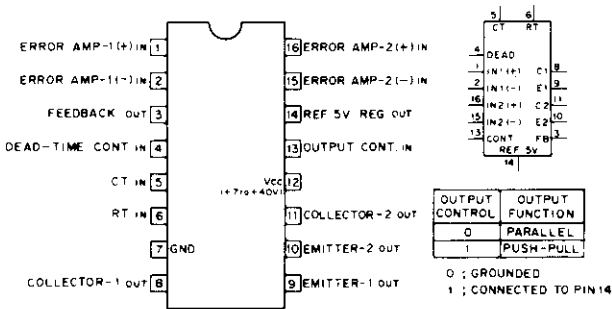

TL082ACP  
 TL082CP  
 TL082M  
 OPERATIONAL AMPLIFIER  
 (J FET-INPUT)  
 - TOP VIEW -

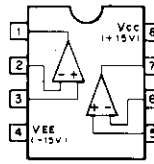

CXL5506P

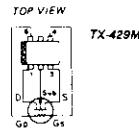
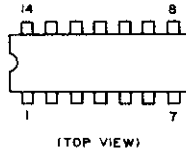

UPC1377C (NEC)  
 SYNCHRONIZATION SIGNAL PROCESSOR OF COLOR TV  
 - TOP VIEW -

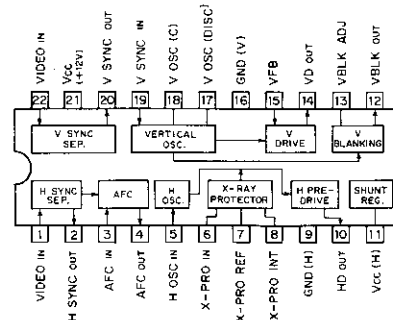

- AFC IN ; INPUT OF AFC DETECTOR
- AFC OUT ; OUTPUT OF AFC DETECTOR
- GND(H) ; GROUND OF HORIZONTAL PART
- GND(V) ; GROUND OF VERTICAL PART
- HD OUT ; OUTPUT OF HORIZONTAL PULSE
- HOSC IN ; INPUT OF HORIZONTAL OSCILLATION
- HSYNC OUT ; OUTPUT OF SYNCHRONIZATION SIGNAL SEPARATOR
- VBK OUT ; OUTPUT OF VERTICAL BLANKING PULSE
- VBKADJ ; VERTICAL BLANKING PULSE DURATION ADJUST
- VCC ; VCC OF VERTICAL PART
- VCC(H) ; VCC OF HORIZONTAL PART
- VD OUT ; OUTPUT OF VERTICAL AMPLIFIER
- VFB ; VERTICAL FEEDBACK
- VIDEO IN ; INPUT OF HORIZONTAL/VERTICAL SYNCHRONIZATION SIGNAL SEPARATOR
- VOSC(C) ; VERTICAL OSCILLATION (CHARGE)
- VOSC(DISC) ; VERTICAL OSCILLATION (DISCHARGE)
- VSYNC IN ; INPUT OF VERTICAL SYNCHRONIZATION SIGNAL
- VSYNC OUT ; OUTPUT OF VERTICAL SYNCHRONIZATION SIGNAL SEPARATOR
- X-PRO IN ; INPUT OF X-RAY PROTECTOR
- X-PRO INT ; INTEGRATION CIRCUIT OF X-RAY PROTECTOR
- X-PRO REF ; REFERENCE OF X-RAY PROTECTOR

UPC7812H (NEC) +12V  
POSITIVE VOLTAGE REGULATOR (1A)  
- SIDE VIEW -

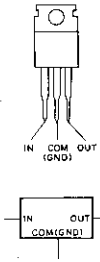

uPC7912H (NEC)  
NEGATIVE VOLTAGE REGULATOR (1A)  
- SIDE VIEW -

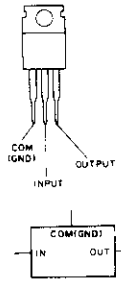

OUTPUT VOLTAGE	AN79???	FS79???	uA79???	uPC79???	MC79???
-2V					MC7902CT
-5V	AN7905	FS7905	uA7905UC	uPC7905H	MC7905CT
-5.2V					MC7905.2CT
-6V	AN7906		uA7906UC		MC7906CT
-7V	AN7907				
-8V	AN7908		uA7908UC	uPC7908H	MC7908CT
-9V	AN7909				
-10V	AN7910				
-12V	AN7912		uA7912UC	uPC7912H	MC7912CT
-15V	AN7915		uA7915UC	uPC7915H	MC7915CT
-18V	AN7918		uA7918UC	uPC7918H	MC7918CT
-20V	AN7920				
-24V	AN7924		uA7924UC	uPC7924H	MC7924CT

UPD6142G-101 (NEC) FLAT PACKAGE  
CMOS 8-BIT SERIAL INPUT CHARACTER DISPLAY  
- TOP VIEW -

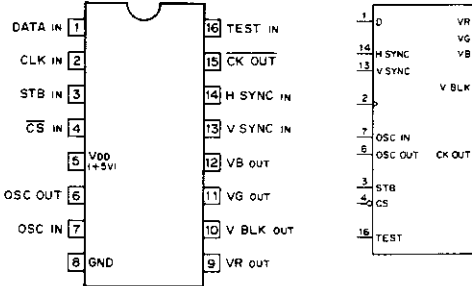

D: DATA INPUT  
CK OUT: EQUAL TO OUTPUT OF OSC OUT  
CLK: CLOCK INPUT  
CS: CHIP SELECT INPUT  
H SYNC: H SYNC INPUT  
OSC IN, OUT: EXTERNAL TERMINAL FOR OSC  
STB: STROBE INPUT  
TEST: TEST CLOCK INPUT  
VB: BLUE CHARACTER DATA OUTPUT  
V BLK: V BLANKING OUTPUT  
VG: GREEN CHARACTER DATA OUTPUT  
VR: RED CHARACTER DATA OUTPUT  
V SYNC: V SYNC INPUT

uPD4053BC (NEC)  
C-MOS TRIPLE 2-CHANNEL ANALOG MULTIPLEXERS/DEMULTIPLEXERS  
- TOP VIEW -

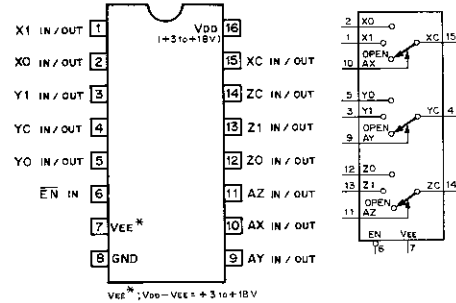

VEE\*: VDD - VEE = +3 to +18V

CONT. INPUTS	ON CHANNEL	
EN	A (X,Y,Z)	CHANNEL
0	0	0
0	1	1
1	X	OPEN

0: LOW LEVEL  
1: HIGH LEVEL  
X: DON'T CARE.

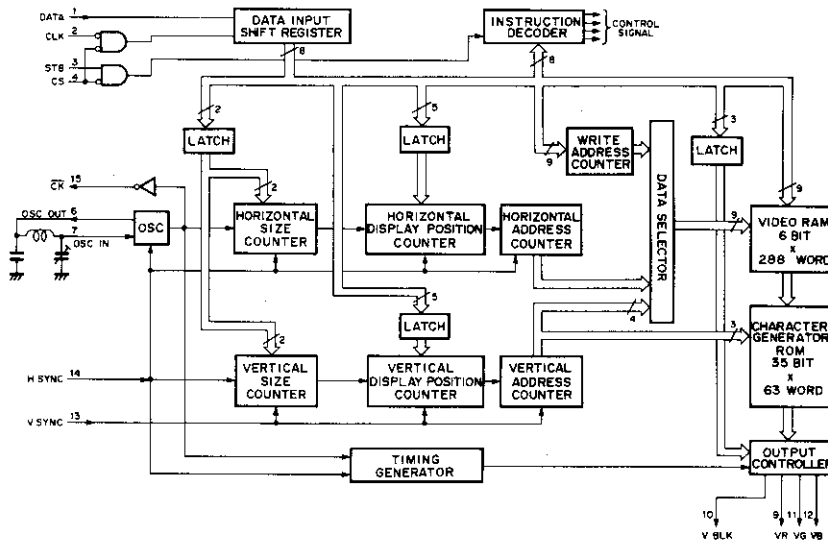

CXA1268P

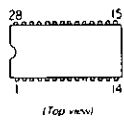

2SA979  
2SA1306



2SD789



10E2  
GP08D  
RD10EB  
RD12EB  
RD12ES  
RD20ES  
RD3.0EB  
RD3.0ES  
RD4.3EB  
RD4.3ES  
RD5.1ES  
RD5.6EB  
RD5.6ES  
RD6.2ES  
RD7.5ES  
RD8.2ES  
RD9.1EB  
RD9.1ES  
RU-3AM

ERB44-06  
ERB81-004  
ERD28-04S  
ERD28-08S  
RH-1A  
SIB01-02

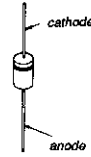

MC921

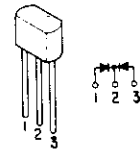

uPC574J



2SA1048  
2SA1115  
2SC2688  
2SC403SP  
DTA124ES  
DTA144ES  
DTC143TS  
DTC144ES  
XDA124ES  
XDA144ES  
XDC144ES

2SD1137

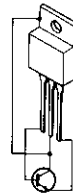

ESAC25-04C

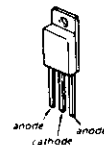

MC932

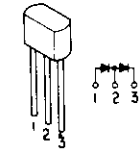

X25040

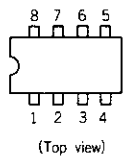

2SK381

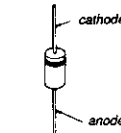

ESAC25-04C

ESAC25-04N



RB406N



2SA473  
2SB858  
2SB860  
2SB861  
2SC3675  
2SD1134

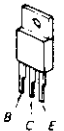

2SA1142



2SK523

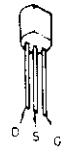

1T25

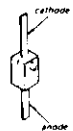

ESAC31-02D

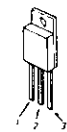

RD5.6M  
RD7.5M



5. DIAGRAMS

2SA812  
2SA1162  
2SA1226  
2SC1623  
2SC2757  
2SC3624A  
DTA144EK  
DTC144EK



2SA1175  
2SC2785



1S2835  
1S2836  
1S2837  
MA152WK



CR02AM-4  
CR02AM-8



LT-9220H

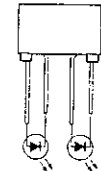

S3WB60Z

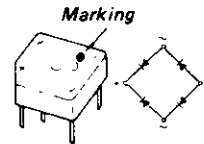

2SA844  
2SA893A  
2SA1091  
2SC1890A  
2SC2551  
2SC2878  
2SC3068



2SC3298  
2SD669A



1SS119  
1SS83  
WG713A

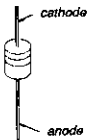

CR3CM-8

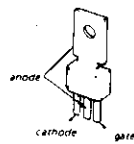

MA110

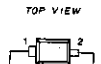

GL3HYB  
TLG124A  
TLR124  
TLY124

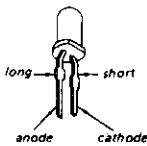

2SB734  
2SD774



CTU-38R  
CTU-38S

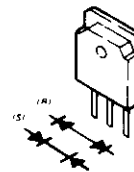

MC911

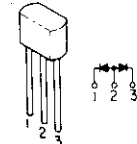

V11N



## SECTION 6 EXPLODED VIEWS

**NOTE:**

- Items with no part number and no description are not stocked because they are seldom required for routine service.
- The construction parts of an assembled part are indicated with a collation number in the remark column.

- Items marked " \* " are not stocked since they are seldom required for routine service. Some delay should be anticipated when ordering these items.

The components identified by shading and mark are critical for safety. Replace only with part number specified.

Les composants identifiés par une trame et une marque sont critiques pour la sécurité. Ne les remplacer que par une pièce portant le numéro spécifié.

### 6-1. BEZEL AND COVERS

- : BVTT3×6      7-685-871-01
- : B4×8        7-682-561-04
- ▲ : B4×6        7-682-560-09
- △ : B4×6        7-682-560-04

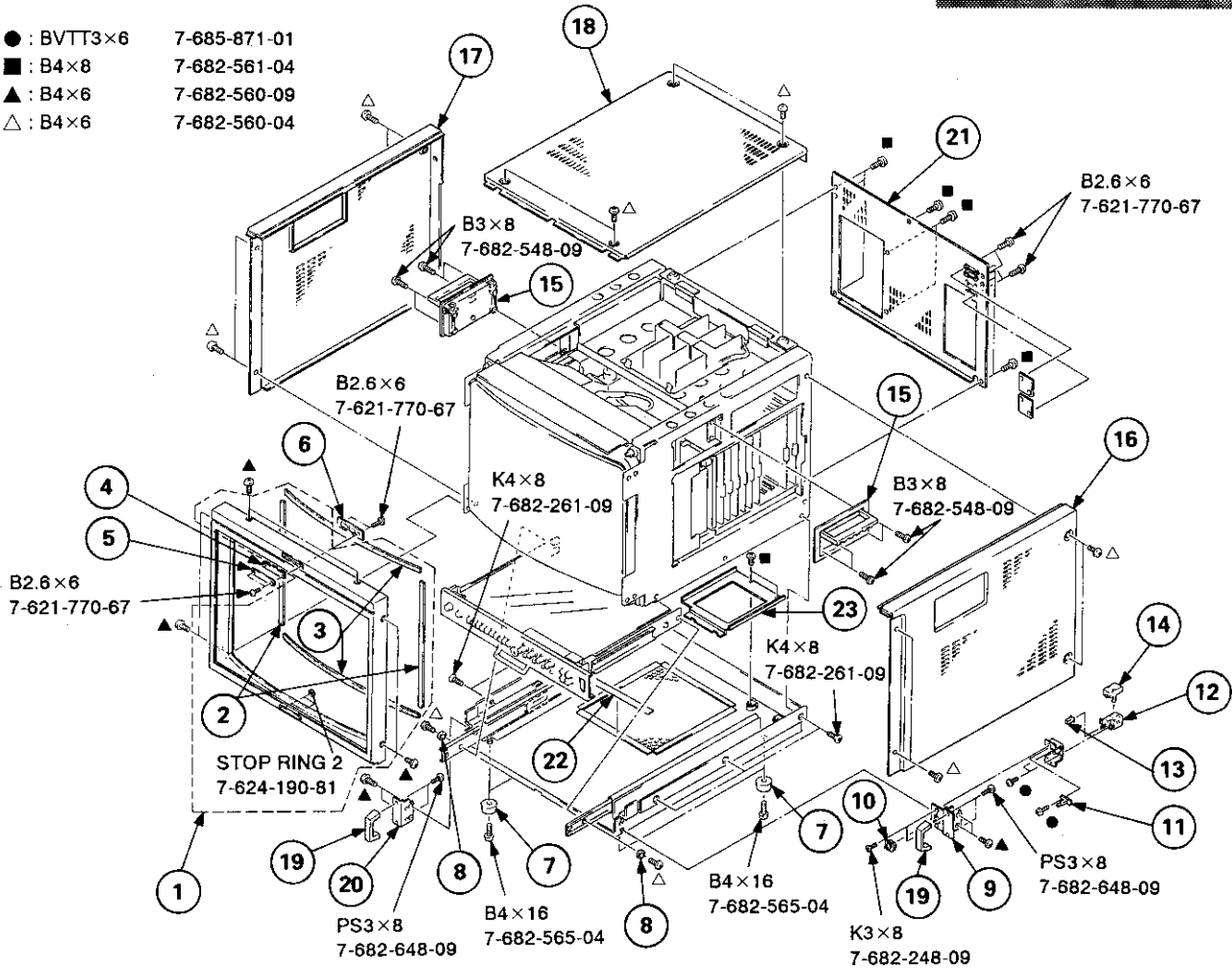

REF.NO.	PART NO.	DESCRIPTION	REMARK	REF.NO.	PART NO.	DESCRIPTION	REMARK
1	X-4379-412-1	BEZEL ASSY	2,3	11	*1-631-679-11	Y BOARD	
2	4-308-878-XX	CUSHION (B), BEZEL		12	▲.1-571-877-12	SWITCH, PUSH (AC POWER)	
3	4-308-878-XX	CUSHION (A), CRT		13	4-374-839-01	BUTTON (A)	
4	*4-386-839-01	PLATE, TALLY		14	*4-393-095-01	COVER, POWER SWITCH	
5	*4-386-840-01	PLATE (B), TALLY		15	X-3642-018-0	HANDLE ASSY	
6	*1-631-680-11	XB BOARD		16	*4-386-832-01	COVER (RIGHT)	
7	X-483-620-29	FOOT		17	*4-386-833-01	COVER (LEFT)	
8	*4-379-499-01	SPACER		18	*4-386-831-01	COVER (UPPER)	
9	*X-4379-408-1	PANEL ASSY, POWER SWITCH		19	*4-353-706-00	HANDLE	
10	4-379-423-11	ESCUTCHEON (A)		20	*4-386-808-01	BRACKET (LEFT), HANDLE	
				21	*4-391-239-01	COVER, REAR	
				22	4-372-556-01	SHEET, BLOTTING	
				23	4-386-814-03	BRACKET, POWER	

# 6-2. PICTURE TUBE

□ : B3×10 7-682-549-04

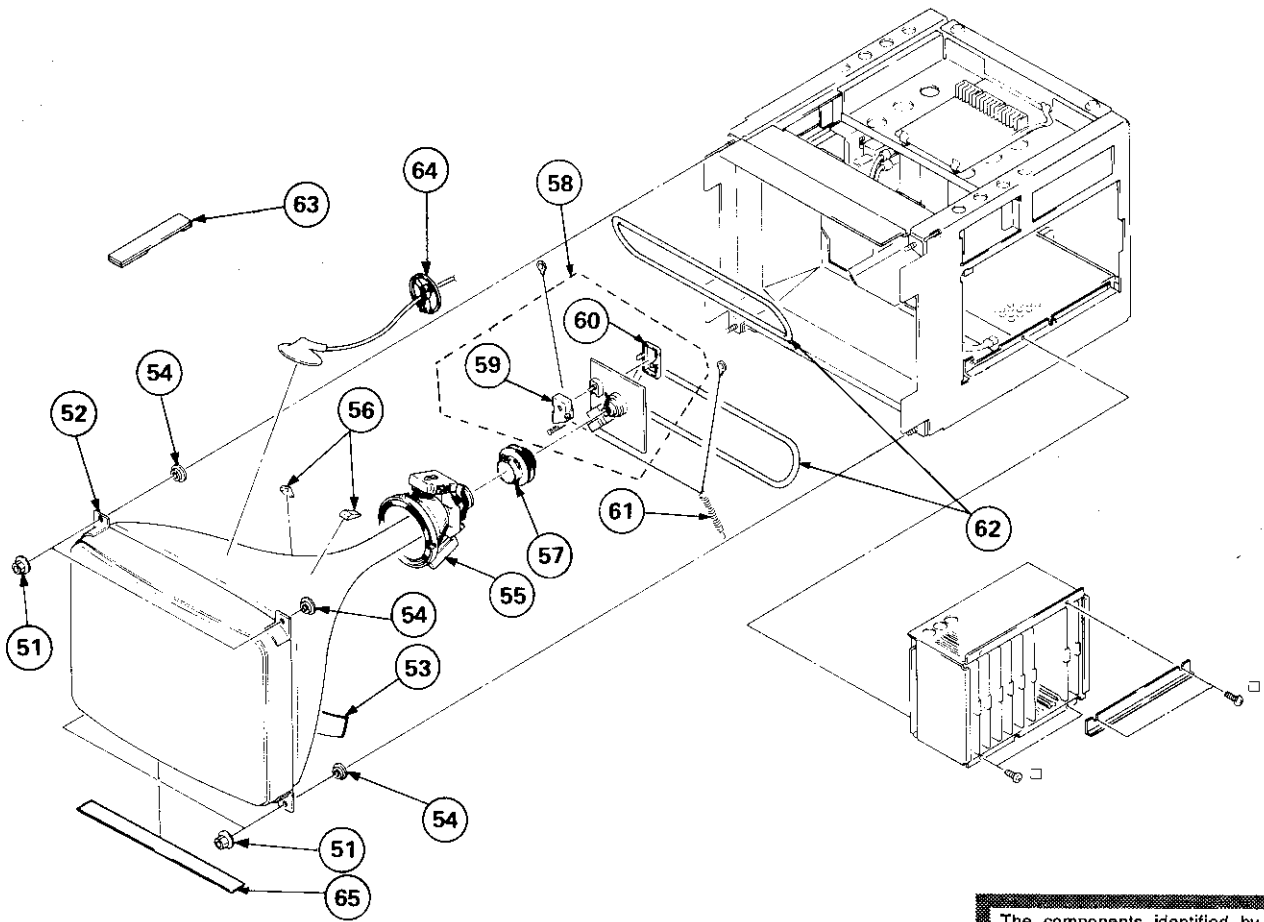

6. EXPLODED VIEWS

The components identified by shading and mark  $\Delta$  are critical for safety. Replace only with part number specified.

Les composants identifiés par une trame et une marque  $\Delta$  sont critiques pour la sécurité. Ne les remplacer que par une pièce portant le numéro spécifié.

REF.NO.	PART NO.	DESCRIPTION	REMARK	REF.NO.	PART NO.	DESCRIPTION	REMARK
51	4-306-034-00	FLANGE NUT, (B) 5MM		60	*4-379-160-01	COVER (REAR LID), CV	
52	$\Delta$ 8-736-121-05	CRT (M49KGH21X) (BYM-2016P ONLY)		61	4-303-774-XX	SPRING	
	$\Delta$ 8-736-123-05	CRT (M49KGH20X) (BYM-1916 ONLY)		62	$\Delta$ 1-426-460-11	COIL, DEMAGNETIZATION	
53	3-831-441-11	CLOTH, BLOTTING		63	X-4309-608-0	PERMALLOY ASSY, CONVERGENCE	
54	4-348-567-00	WASHER, CRT POSITION		64	*3-704-372-01	HOLDER, HV CABLE	
55	$\Delta$ 1-451-349-22	DEFLECTION YOKE (Y20FZA)		65	4-385-725-01	SHEET, BLOTTING	
56	3-703-003-00	SPACER, DY					
57	$\Delta$ 1-452-337-22	NECK ASSY, CRT (NA304)					
58	*A-1331-020-A	C BOARD, COMPLETE	59, 60				
59	*4-379-167-01	COVER (MAIN), CV					



### 6-3. CHASSIS

- : BVTT3×6      7-685-871-01
- : B4×8        7-682-561-04
- : B3×10       7-682-549-04

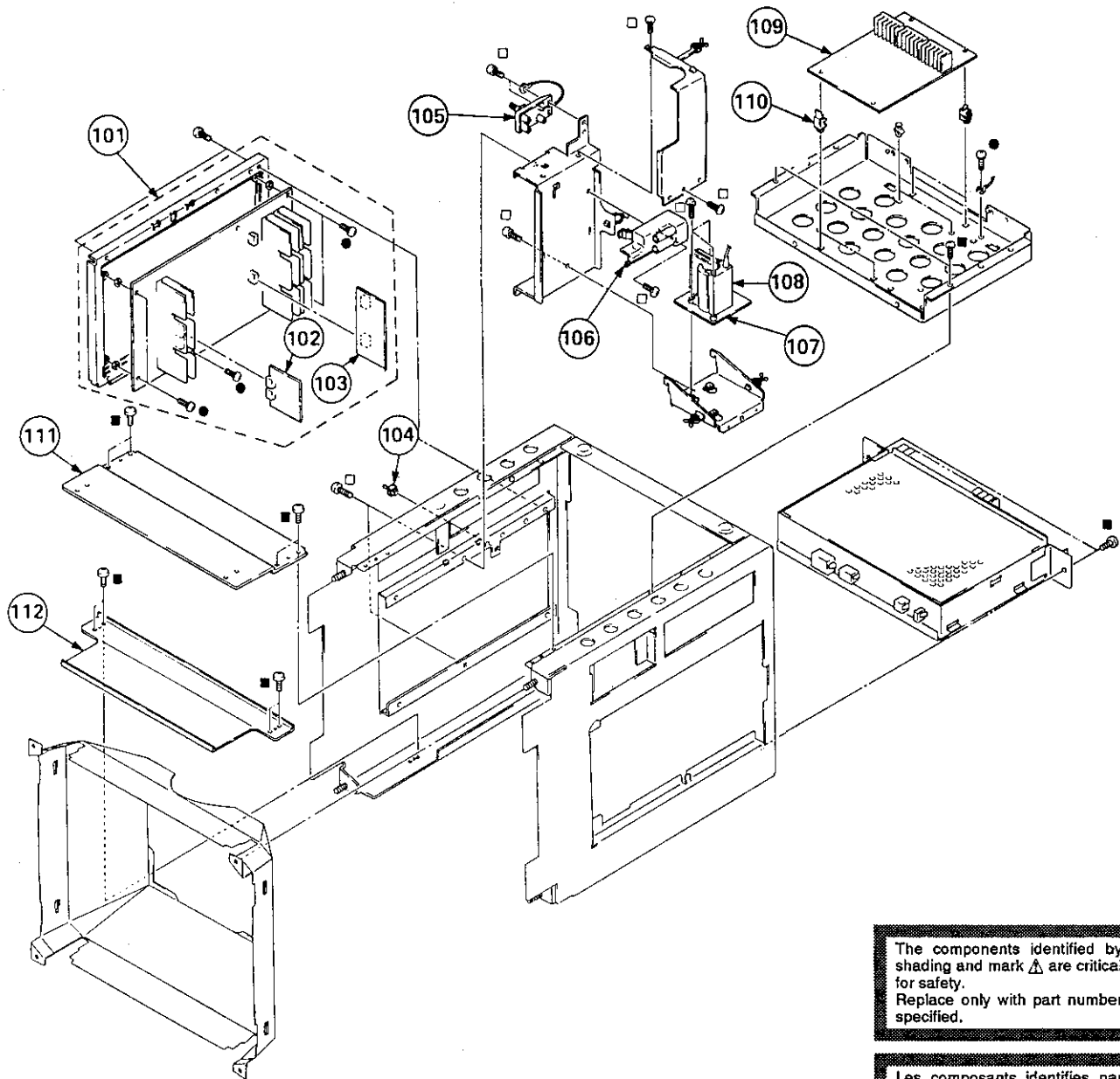

The components identified by shading and mark  $\Delta$  are critical for safety. Replace only with part number specified.

Les composants identifiés par une trame et une marque  $\Delta$  sont critiques pour la sécurité. Ne les remplacer que par une pièce portant le numéro spécifié.

REF. NO.	PART NO.	DESCRIPTION	REMARK	REF. NO.	PART NO.	DESCRIPTION	REMARK
101	*A-1345-881-A	EA BOARD, COMPLETE		102, 103	106 $\Delta$ .1-238-301-12	RESISTOR ASSY, HIGH-VOLTAGE	
102	*1-631-686-11	EC BOARD			107 *1-631-678-11	P BOARD	
103	*1-631-685-11	EB BOARD			108 $\Delta$ .1-439-382-21	TRANSFORMER ASSY, FLYBACK	
104	*4-303-473-00	SUPPORT, PC			109 *A-1135-523-A	BK BOARD, COMPLETE	
105	$\Delta$ .1-237-165-13	RESISTOR ASSY, HIGH-VOLTAGE			110 *3-703-141-00	HOLDER, PCB	
					111 *4-386-819-02	STAY, FRONT	
					112 *4-391-234-03	STAY, UNDER	

### 6-4. SIGNAL BLOCK

- : BVTT3×6    7-685-871-01
- : BVTT3×6    7-682-547-09
- : B3×10     7-682-549-04

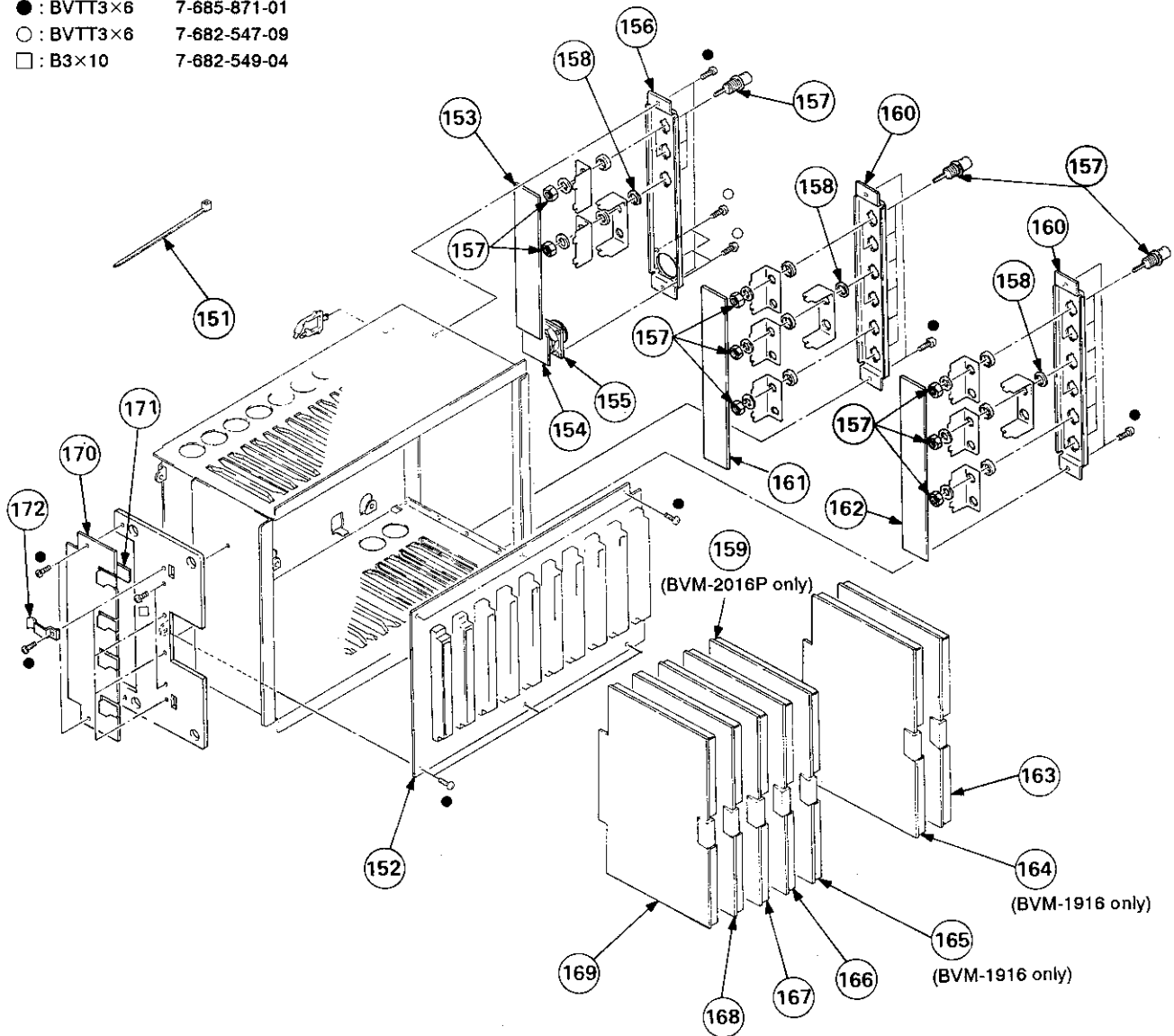

6. EXPLODED VIEWS

REF. NO.	PART NO.	DESCRIPTION	REMARK	REF. NO.	PART NO.	DESCRIPTION	REMARK
151	*3-337-402-01	BAND, BINDING		161	*1-618-786-11	QB BOARD	
152	*A-1390-344-A	TB BOARD, COMPLETE		162	*1-617-895-11	QA BOARD	
153	*1-627-678-11	W BOARD		163	*A-1135-355-A	BA BOARD, COMPLETE	
154	*1-627-677-11	V BOARD		164	*A-1135-606-B	BT BOARD, COMPLETE (BVM-1916 ONLY)	
155	1-563-265-11	CONNECTOR, MULTIPLE 10P		165	*A-1135-357-A	BC BOARD, COMPLETE (BVM-1916 ONLY)	
156	*4-391-220-01	PANEL (C), CONNECTOR		166	*A-1135-537-A	BG BOARD, COMPLETE	
157	1-565-791-11	CONNECTOR, BNC 1P		167	*A-1135-359-A	BH BOARD, COMPLETE	
158	*4-379-404-01	INSULATOR, BNC		168	*A-1135-591-A	BI BOARD, COMPLETE	
159	*A-1135-391-A	BD BOARD, COMPLETE (BVM-2016P ONLY)		169	*A-1135-361-A	BJ BOARD, COMPLETE	
160	*4-379-439-01	PANEL (A), CONNECTOR		170	*1-617-885-11	GC BOARD	
				171	4-370-970-01	SPACER, TR	
				172	*4-363-404-00	HOLDER, IC	

# 6-5. DRAWER BLOCK

● : BVTT3×6 7-685-871-01

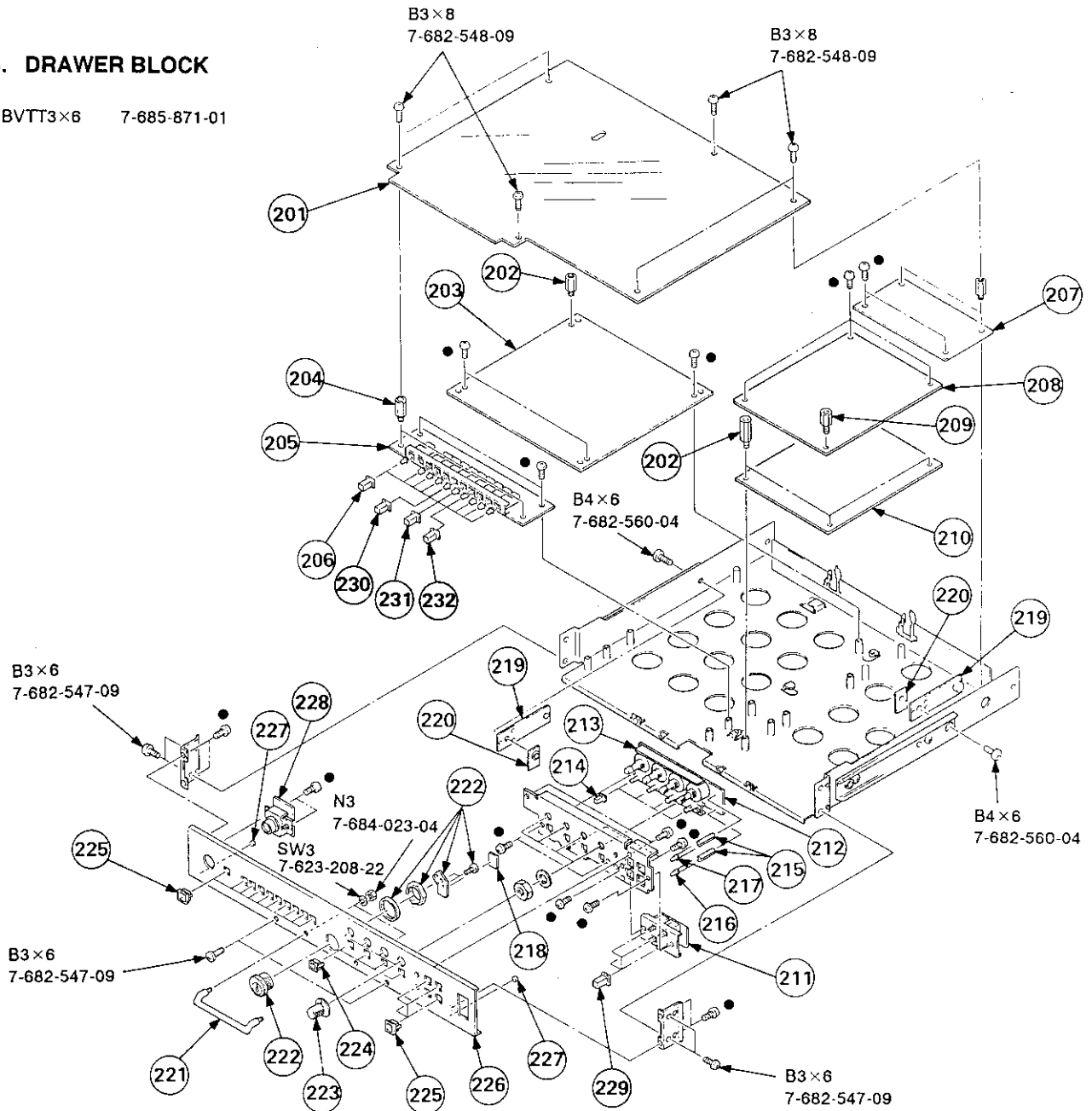

6. EXPLODED VIEWS

REF.NO.	PART NO.	DESCRIPTION	REMARK	REF.NO.	PART NO.	DESCRIPTION	REMARK
201	*4-040-631-01	COVER, PCB		216	8-719-812-42	DIODE TLY124	
202	*2-264-136-00	SUPPORT, SWITCH, PUSH BUTTON		217	8-719-812-41	DIODE TLR124	
203	*A-1345-882-B	DA BOARD, COMPLETE		218	4-337-209-11	PROTECTOR, SCRATCH	
204	3-897-313-01	BOSS (17.2), RELAY		219	*X-4379-407-1	STOPPER ASSY	
205	*1-631-683-11	HA BOARD		220	*4-386-844-01	NUT, PLATE	
206	4-374-839-21	BUTTON (A)		221	4-386-802-01	HANDLE, DRAWER	
207	*A-1345-884-A	DB BOARD, COMPLETE		222	4-378-917-01	LOCK, CYLINDER	
208	A-1371-895-A	HY BOARD, COMPLETE		223	X-3673-635-0	KNOB (1) ASSY, CONTROL	
209	*3-711-018-01	STAND OFF-BRAKE BAND GUIDE		224	4-379-424-11	ESCUTCHEON (B)	
210	A-1375-121-A	HZ BOARD, COMPLETE		225	4-379-423-11	ESCUTCHEON (A)	
211	*1-647-258-11	HX BOARD		226	4-386-822-21	PANEL, CONTROL	
212	*1-647-257-11	HW BOARD		227	4-911-672-01	FELT, COVER	
213	*1-627-682-11	HH BOARD		228	1-941-422-15	CONNECTOR ASSY (ROUND TYPE) 12P	
214	4-379-422-11	BUTTON (B)		229	4-039-982-01	BUTTON (U)	
215	*4-026-910-00	HOLDER, LED		230	4-374-839-31	BUTTON (A) (R)	
				231	4-374-839-41	BUTTON (A) (G)	
				232	4-374-839-51	BUTTON (A) (B)	

## 6-6. POWER BLOCK

● : BVTT3×6 7-685-871-01

6. EXPLODED VIEWS

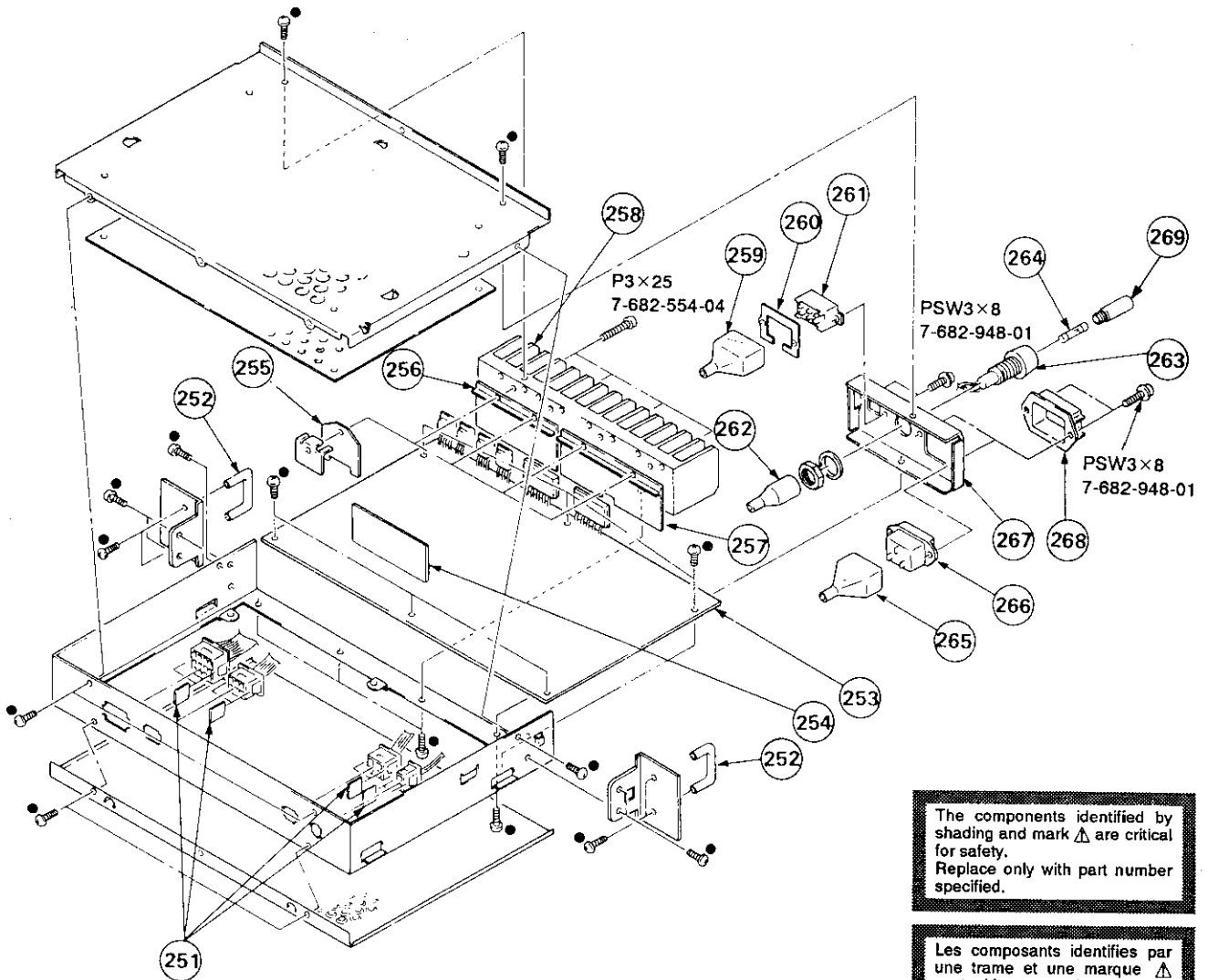

The components identified by shading and mark  $\Delta$  are critical for safety. Replace only with part number specified.

Les composants identifiés par une trame et une marque  $\Delta$  sont critiques pour la sécurité. Ne les remplacer que par une pièce portant le numéro spécifié.

REF. NO.	PART NO.	DESCRIPTION	REMARK	REF. NO.	PART NO.	DESCRIPTION	REMARK
251	3-675-469-00	SPACER, SOLENOID		260	*4-379-409-01	NUT, PLATE	
252	4-379-421-01	HANDLE, DRAWER		261	$\Delta$ 1-570-173-22	SWITCH, VOLTAGE CHANGE	
253	*A-1316-089-A	GA BOARD, COMPLETE (BVM-1916 ONLY)	254	262	*4-393-031-01	COVER, FUSE HOLDER	
254	*A-1316-090-A	GA BOARD, COMPLETE (BVM-2016P ONLY)	254	263	$\Delta$ 1-533-167-21	HOLDER, FUSE	
	*1-627-679-11	GB BOARD		264	$\Delta$ 1-532-746-11	FUSE, GLASS TUBE (4.0A/125V) (BVM-1916 ONLY)	
					$\Delta$ 1-532-203-11	FUSE, TIME-LAG (2.0A/250V) (BVM-2016P ONLY)	
255	*4-379-408-01	INSULATOR (G3)		265	*4-601-466-11	COVER, 3P INLET	
256	4-379-410-01	SPACER (G2), POLISHING		266	$\Delta$ 1-580-375-11	INLET, 3P	
257	4-379-403-01	SPACER (G1), POLISHING		267	*4-379-430-01	PANEL, POWER	
258	*4-347-706-02	HEAT SINK (TR)		268	2-990-241-02	HOLDER (A), PLUG	
259	*4-371-879-02	COVER, AC SELECT		269	$\Delta$ 1-533-168-21	HOLDER, FUSE	

# SECTION 7 ELECTRICAL PARTS LIST

BA

**NOTE:**

The components identified by shading and mark **▲** are critical for safety. Replace only with part number specified.

Les composants identifiés par une trame et une marque **▲** sont critiques pour la sécurité. Ne les remplacer que par une pièce portant le numéro spécifié.

- Items marked "\*" are not stocked since they are seldom required for routine service. Some delay should be anticipated when ordering these items.
- All variable and adjustable resistors have characteristic curve B, unless otherwise noted.

When indicating parts by reference number, please include the board name.

- RESISTORS**
- All resistors are in ohms
  - F: nonflammable

- CAPACITORS**
- MF:  $\mu$ F, PF:  $\mu$ F
- COILS**
- MMH: mH, UH:  $\mu$ H
  - The components identified by **■** in this manual have been carefully factory-selected for each set in order to satisfy regulations regarding X-ray radiation. Should replacement be required, replace only with the value originally used.

REF. NO.	PART NO.	DESCRIPTION	REMARK	REF. NO.	PART NO.	DESCRIPTION	REMARK
	*A-1135-355-A	BA BOARD, COMPLETE *****		C34	1-126-964-11	ELECT 10MF 20%	16V
	*4-353-708-00	HOOK, FINGER		C35	1-126-964-11	ELECT 10MF 20%	16V
	7-682-547-09	SCREW +BVT 3X6 (S)		C36	1-126-964-11	ELECT 10MF 20%	16V
		<CONNECTOR>		C37	1-126-964-11	ELECT 10MF 20%	16V
BA1	*1-566-054-11	PIN, CONNECTOR 2P		C38	1-126-964-11	ELECT 10MF 20%	16V
BA2	*1-566-054-11	PIN, CONNECTOR 2P		C39	1-101-004-00	CERAMIC 0.01MF	50V
BA3	*1-566-054-11	PIN, CONNECTOR 2P		C51	1-124-119-00	ELECT 330MF 20%	16V
BA4	*1-566-054-11	PIN, CONNECTOR 2P		C52	1-126-101-11	ELECT 100MF 20%	16V
BA5	*1-566-054-11	PIN, CONNECTOR 2P		C53	1-126-101-11	ELECT 100MF 20%	16V
		<COMPOSITION CIRCUIT BLOCK>		C54	1-124-120-11	ELECT 220MF 20%	16V
BA6	*1-566-054-11	PIN, CONNECTOR 2P		C55	1-126-101-11	ELECT 100MF 20%	16V
		<COMPOSITION CIRCUIT BLOCK>		C56	1-126-101-11	ELECT 100MF 20%	16V
CP1	1-233-030-11	COMPOSITION CIRCUIT BLOCK		C57	1-126-101-11	ELECT 100MF 20%	16V
CP2	1-233-030-11	COMPOSITION CIRCUIT BLOCK		C71	1-101-004-00	CERAMIC 0.01MF	50V
CP3	1-233-030-11	COMPOSITION CIRCUIT BLOCK		C72	1-101-004-00	CERAMIC 0.01MF	50V
CP4	1-233-030-11	COMPOSITION CIRCUIT BLOCK		C73	1-101-004-00	CERAMIC 0.01MF	50V
CP5	1-233-030-11	COMPOSITION CIRCUIT BLOCK		C74	1-101-004-00	CERAMIC 0.01MF	50V
		<CAPACITOR>		C75	1-101-004-00	CERAMIC 0.01MF	50V
CP6	1-233-030-11	COMPOSITION CIRCUIT BLOCK		C76	1-101-004-00	CERAMIC 0.01MF	50V
CP7	1-233-030-11	COMPOSITION CIRCUIT BLOCK		C77	1-101-004-00	CERAMIC 0.01MF	50V
		<CAPACITOR>		C101	1-102-038-00	CERAMIC 0.001MF	500V
C1	1-126-967-11	ELECT 47MF 20%	16V	C102	1-126-964-11	ELECT 10MF 20%	16V
C2	1-126-967-11	ELECT 47MF 20%	16V	C103	1-102-951-00	CERAMIC 15PF 5%	50V
C3	1-126-967-11	ELECT 47MF 20%	16V	C104	1-124-902-00	ELECT 0.47MF 20%	50V
C4	1-126-964-11	ELECT 10MF 20%	16V	C201	1-102-038-00	CERAMIC 0.001MF	500V
C5	1-126-967-11	ELECT 47MF 20%	16V	C202	1-126-964-11	ELECT 10MF 20%	16V
C6	1-126-967-11	ELECT 47MF 20%	16V	C203	1-102-951-00	CERAMIC 15PF 5%	50V
C7	1-126-967-11	ELECT 47MF 20%	16V	C204	1-124-902-00	ELECT 0.47MF 20%	50V
C8	1-126-967-11	ELECT 47MF 20%	16V	C301	1-102-038-00	CERAMIC 0.001MF	500V
C9	1-101-004-00	CERAMIC 0.01MF	50V	C302	1-126-964-11	ELECT 10MF 20%	16V
C10	1-101-004-00	CERAMIC 0.01MF	50V	C303	1-102-965-00	CERAMIC 39PF 5%	50V
C11	1-126-103-11	ELECT 470MF 20%	16V	C304	1-124-902-00	ELECT 0.47MF 20%	50V
C12	1-126-101-11	ELECT 100MF 20%	16V	C305	1-102-947-00	CERAMIC 10PF 0.5PF	50V
C13	1-126-101-11	ELECT 100MF 20%	16V	C306	1-102-942-00	CERAMIC 5PF 1PF	50V
C14	1-126-101-11	ELECT 100MF 20%	16V	C401	1-102-038-00	CERAMIC 0.001MF	500V
C15	1-126-101-11	ELECT 100MF 20%	16V	C402	1-126-964-11	ELECT 10MF 20%	16V
C16	1-126-101-11	ELECT 100MF 20%	16V	C403	1-102-951-00	CERAMIC 15PF 5%	50V
C17	1-126-101-11	ELECT 100MF 20%	16V	C404	1-124-902-00	ELECT 0.47MF 20%	50V
C18	1-126-964-11	ELECT 10MF 20%	16V	C501	1-102-038-00	CERAMIC 0.001MF	500V
C19	1-126-964-11	ELECT 10MF 20%	16V	C502	1-126-964-11	ELECT 10MF 20%	16V
C20	1-101-004-00	CERAMIC 0.01MF	50V	C503	1-102-951-00	CERAMIC 15PF 5%	50V
C21	1-101-006-00	CERAMIC 0.047MF	50V	C504	1-124-902-00	ELECT 0.47MF 20%	50V
C31	1-101-004-00	CERAMIC 0.01MF	50V	C601	1-102-038-00	CERAMIC 0.001MF	500V
C32	1-126-964-11	ELECT 10MF 20%	16V	C602	1-126-964-11	ELECT 10MF 20%	16V
C33	1-126-964-11	ELECT 10MF 20%	16V	C603	1-102-951-00	CERAMIC 15PF 5%	50V
		<CAPACITOR>		C604	1-124-902-00	ELECT 0.47MF 20%	50V
		<CAPACITOR>		C701	1-102-976-00	CERAMIC 180PF 5%	50V
		<CAPACITOR>		C702	1-102-947-00	CERAMIC 10PF 0.5PF	50V
		<CAPACITOR>		C703	1-126-964-11	ELECT 10MF 20%	16V
		<CAPACITOR>		C704	1-126-967-11	ELECT 47MF 20%	16V
		<CAPACITOR>		C705	1-136-153-00	FILM 0.01MF 5%	50V

7. ELECTRICAL PARTS LIST



BA

7. ELECTRICAL PARTS LIST

REF. NO.	PART NO.	DESCRIPTION	REMARK	REF. NO.	PART NO.	DESCRIPTION	REMARK
C706	1-124-903-11	ELECT	1MF	20%	50V		
C707	1-124-927-11	ELECT	4.7MF	20%	25V		
C708	1-126-964-11	ELECT	10MF	20%	16V		
C709	1-102-973-00	CERAMIC	100PF	5%	50V		
C710	1-130-481-00	MYLAR	0.0068MF	5%	50V		
C711	1-136-155-00	FILM	0.015MF	5%	50V		
C712	1-130-471-00	MYLAR	0.001MF	5%	50V		
C713	1-124-903-11	ELECT	1MF	20%	50V		
C714	1-102-973-00	CERAMIC	100PF	5%	50V		
C715	1-101-361-00	CERAMIC	150PF	5%	50V		
C716	1-136-153-00	FILM	0.01MF	5%	50V		
C717	1-102-973-00	CERAMIC	100PF	5%	50V		
<TRIMMER>							
CV101	1-141-179-12	CAP, VAR, TRIMMER (5-8P)					
CV102	1-141-260-00	TRIMAR, CERAMIC (50P)					
CV201	1-141-179-12	CAP, VAR, TRIMMER (5-8P)					
CV202	1-141-260-00	TRIMAR, CERAMIC (50P)					
CV401	1-141-179-12	CAP, VAR, TRIMMER (5-8P)					
CV402	1-141-260-00	TRIMAR, CERAMIC (50P)					
CV501	1-141-179-12	CAP, VAR, TRIMMER (5-8P)					
CV502	1-141-260-00	TRIMAR, CERAMIC (50P)					
CV601	1-141-179-12	CAP, VAR, TRIMMER (5-8P)					
CV602	1-141-260-00	TRIMAR, CERAMIC (50P)					
<DIODE>							
D1	8-719-109-63	DIODE RD3.0ESB2					
D2	8-719-000-06	DIODE MC921					
D4	8-719-000-04	DIODE MC911					
D701	8-719-911-19	DIODE 1SS119					
D702	8-719-109-75	DIODE RD4.3ESB2					
D703	8-719-911-19	DIODE 1SS119					
D704	8-719-911-19	DIODE 1SS119					
D705	8-719-911-19	DIODE 1SS119					
D706	8-719-911-19	DIODE 1SS119					
D707	8-719-911-19	DIODE 1SS119					
D708	8-719-911-19	DIODE 1SS119					
D709	8-719-911-19	DIODE 1SS119					
D710	8-719-911-19	DIODE 1SS119					
<IC>							
IC1	8-759-208-94	IC CX-894					
IC2	8-759-208-94	IC CX-894					
IC3	8-759-140-53	IC UPD4053BC					
<TRANSISTOR>							
Q1	8-729-900-89	TRANSISTOR DTC144ES					
Q2	8-729-384-48	TRANSISTOR 2SA844-E					
Q3	8-729-900-89	TRANSISTOR DTC144ES					
Q4	8-729-900-89	TRANSISTOR DTC144ES					
Q5	8-729-900-89	TRANSISTOR DTC144ES					
Q6	8-729-900-65	TRANSISTOR DTA144ES					
Q101	8-729-266-82	TRANSISTOR 2SC2668-0					
Q102	8-729-266-82	TRANSISTOR 2SC2668-0					
Q103	8-729-266-82	TRANSISTOR 2SC2668-0					
Q104	8-729-384-48	TRANSISTOR 2SA844-E					
Q105	8-729-266-82	TRANSISTOR 2SC2668-0					
Q201	8-729-266-82	TRANSISTOR 2SC2668-0					
Q202	8-729-266-82	TRANSISTOR 2SC2668-0					
Q203	8-729-266-82	TRANSISTOR 2SC2668-0					
Q204	8-729-384-48	TRANSISTOR 2SA844-E					
Q205	8-729-266-82	TRANSISTOR 2SC2668-0					
Q301	8-729-266-82	TRANSISTOR 2SC2668-0					
Q302	8-729-266-82	TRANSISTOR 2SC2668-0					
Q303	8-729-266-82	TRANSISTOR 2SC2668-0					
Q304	8-729-384-48	TRANSISTOR 2SA844-E					
Q305	8-729-266-82	TRANSISTOR 2SC2668-0					
Q401	8-729-266-82	TRANSISTOR 2SC2668-0					
Q402	8-729-266-82	TRANSISTOR 2SC2668-0					
Q403	8-729-266-82	TRANSISTOR 2SC2668-0					
Q404	8-729-384-48	TRANSISTOR 2SA844-E					
Q405	8-729-266-82	TRANSISTOR 2SC2668-0					
Q501	8-729-266-82	TRANSISTOR 2SC2668-0					
Q502	8-729-266-82	TRANSISTOR 2SC2668-0					
Q503	8-729-266-82	TRANSISTOR 2SC2668-0					
Q504	8-729-384-48	TRANSISTOR 2SA844-E					
Q505	8-729-266-82	TRANSISTOR 2SC2668-0					
Q601	8-729-266-82	TRANSISTOR 2SC2668-0					
Q602	8-729-266-82	TRANSISTOR 2SC2668-0					
Q603	8-729-266-82	TRANSISTOR 2SC2668-0					
Q604	8-729-384-48	TRANSISTOR 2SA844-E					
Q605	8-729-266-82	TRANSISTOR 2SC2668-0					
Q701	8-729-119-76	TRANSISTOR 2SA1175-HFE					
Q702	8-729-119-78	TRANSISTOR 2SC2785-HFE					
Q703	8-729-119-78	TRANSISTOR 2SC2785-HFE					
Q704	8-729-119-78	TRANSISTOR 2SC2785-HFE					
Q705	8-729-119-78	TRANSISTOR 2SC2785-HFE					
Q706	8-729-119-76	TRANSISTOR 2SA1175-HFE					
Q707	8-729-119-78	TRANSISTOR 2SC2785-HFE					
Q708	8-729-119-76	TRANSISTOR 2SA1175-HFE					
Q709	8-729-119-78	TRANSISTOR 2SC2785-HFE					
Q710	8-729-119-76	TRANSISTOR 2SA1175-HFE					
Q711	8-729-119-76	TRANSISTOR 2SA1175-HFE					
Q712	8-729-119-76	TRANSISTOR 2SA1175-HFE					
Q713	8-729-119-76	TRANSISTOR 2SA1175-HFE					
Q714	8-729-119-78	TRANSISTOR 2SC2785-HFE					
Q715	8-729-800-10	TRANSISTOR 2SC3068					
Q716	8-729-119-78	TRANSISTOR 2SC2785-HFE					
Q717	8-729-119-76	TRANSISTOR 2SA1175-HFE					
<RESISTOR>							
R1	1-247-807-31	CARBON	100	5%	1/4W		
R2	1-247-807-31	CARBON	100	5%	1/4W		
R3	1-247-807-31	CARBON	100	5%	1/4W		
R4	1-249-437-11	CARBON	47K	5%	1/4W		
R5	1-247-807-31	CARBON	100	5%	1/4W		
R6	1-249-432-11	CARBON	18K	5%	1/4W		
R7	1-249-434-11	CARBON	27K	5%	1/4W		
R8	1-249-422-11	CARBON	2.7K	5%	1/4W		
R9	1-247-807-31	CARBON	100	5%	1/4W		
R10	1-247-807-31	CARBON	100	5%	1/4W		
R11	1-249-433-11	CARBON	22K	5%	1/4W		
R12	1-247-807-31	CARBON	100	5%	1/4W		
R13	1-249-437-11	CARBON	47K	5%	1/4W		
R14	1-249-429-11	CARBON	10K	5%	1/4W		
R101	1-249-417-11	CARBON	1K	5%	1/4W		
R102	1-249-418-11	CARBON	1.2K	5%	1/4W		
R103	1-249-425-11	CARBON	4.7K	5%	1/4W		
R104	1-247-807-31	CARBON	100	5%	1/4W		
R105	1-215-437-00	METAL	4.7K	1%	1/4W		
R106	1-249-430-11	CARBON	12K	5%	1/4W		
R107	1-249-433-11	CARBON	22K	5%	1/4W		
R108	1-215-427-00	METAL	1.8K	1%	1/4W		

REF. NO.	PART NO.	DESCRIPTION	REMARK
R109	1-215-415-00	METAL	560 1% 1/4W
R110	1-247-807-31	CARBON	100 5% 1/4W
R111	1-215-431-00	METAL	2.7K 1% 1/4W
R112	1-249-421-11	CARBON	2.2K 5% 1/4W
R113	1-249-393-11	CARBON	10 5% 1/4W
R201	1-249-417-11	CARBON	1K 5% 1/4W
R202	1-249-418-11	CARBON	1.2K 5% 1/4W
R203	1-249-425-11	CARBON	4.7K 5% 1/4W
R204	1-247-807-31	CARBON	100 5% 1/4W
R205	1-215-437-00	METAL	4.7K 1% 1/4W
R206	1-249-430-11	CARBON	12K 5% 1/4W
R207	1-249-433-11	CARBON	22K 5% 1/4W
R208	1-215-427-00	METAL	1.8K 1% 1/4W
R209	1-215-415-00	METAL	560 1% 1/4W
R210	1-247-807-31	CARBON	100 5% 1/4W
R211	1-215-431-00	METAL	2.7K 1% 1/4W
R212	1-249-421-11	CARBON	2.2K 5% 1/4W
R213	1-249-393-11	CARBON	10 5% 1/4W
R301	1-249-417-11	CARBON	1K 5% 1/4W
R302	1-249-418-11	CARBON	1.2K 5% 1/4W
R303	1-249-426-11	CARBON	5.6K 5% 1/4W
R304	1-247-807-31	CARBON	100 5% 1/4W
R305	1-249-426-11	CARBON	5.6K 5% 1/4W
R306	1-249-430-11	CARBON	12K 5% 1/4W
R307	1-249-432-11	CARBON	18K 5% 1/4W
R308	1-249-421-11	CARBON	2.2K 5% 1/4W
R309	1-249-417-11	CARBON	1K 5% 1/4W
R310	1-247-807-31	CARBON	100 5% 1/4W
R311	1-249-417-11	CARBON	1K 5% 1/4W
R312	1-249-421-11	CARBON	2.2K 5% 1/4W
R313	1-249-393-11	CARBON	10 5% 1/4W
R401	1-249-417-11	CARBON	1K 5% 1/4W
R402	1-249-418-11	CARBON	1.2K 5% 1/4W
R403	1-249-425-11	CARBON	4.7K 5% 1/4W
R404	1-247-807-31	CARBON	100 5% 1/4W
R405	1-215-437-00	METAL	4.7K 1% 1/4W
R406	1-249-430-11	CARBON	12K 5% 1/4W
R407	1-249-433-11	CARBON	22K 5% 1/4W
R408	1-215-427-00	METAL	1.8K 1% 1/4W
R409	1-215-415-00	METAL	560 1% 1/4W
R410	1-247-807-31	CARBON	100 5% 1/4W
R411	1-215-431-00	METAL	2.7K 1% 1/4W
R412	1-249-421-11	CARBON	2.2K 5% 1/4W
R413	1-249-393-11	CARBON	10 5% 1/4W
R501	1-249-417-11	CARBON	1K 5% 1/4W
R502	1-249-418-11	CARBON	1.2K 5% 1/4W
R503	1-249-425-11	CARBON	4.7K 5% 1/4W
R504	1-247-807-31	CARBON	100 5% 1/4W
R505	1-215-437-00	METAL	4.7K 1% 1/4W
R506	1-249-430-11	CARBON	12K 5% 1/4W
R507	1-249-433-11	CARBON	22K 5% 1/4W
R508	1-215-427-00	METAL	1.8K 1% 1/4W
R509	1-215-415-00	METAL	560 1% 1/4W
R510	1-247-807-31	CARBON	100 5% 1/4W
R511	1-215-431-00	METAL	2.7K 1% 1/4W
R512	1-249-421-11	CARBON	2.2K 5% 1/4W
R513	1-249-393-11	CARBON	10 5% 1/4W
R601	1-249-417-11	CARBON	1K 5% 1/4W
R602	1-249-418-11	CARBON	1.2K 5% 1/4W
R603	1-249-425-11	CARBON	4.7K 5% 1/4W
R604	1-247-807-31	CARBON	100 5% 1/4W
R605	1-215-437-00	METAL	4.7K 1% 1/4W
R606	1-249-430-11	CARBON	12K 5% 1/4W
R607	1-249-433-11	CARBON	22K 5% 1/4W

REF. NO.	PART NO.	DESCRIPTION	REMARK
R608	1-215-427-00	METAL	1.8K 1% 1/4W
R609	1-215-415-00	METAL	560 1% 1/4W
R610	1-247-807-31	CARBON	100 5% 1/4W
R611	1-215-431-00	METAL	2.7K 1% 1/4W
R612	1-249-421-11	CARBON	2.2K 5% 1/4W
R613	1-249-393-11	CARBON	10 5% 1/4W
R701	1-249-433-11	CARBON	22K 5% 1/4W
R702	1-249-438-11	CARBON	56K 5% 1/4W
R703	1-249-417-11	CARBON	1K 5% 1/4W
R704	1-249-417-11	CARBON	1K 5% 1/4W
R705	1-249-424-11	CARBON	3.9K 5% 1/4W
R706	1-249-417-11	CARBON	1K 5% 1/4W
R707	1-249-429-11	CARBON	10K 5% 1/4W
R708	1-249-421-11	CARBON	2.2K 5% 1/4W
R709	1-249-419-11	CARBON	1.5K 5% 1/4W
R710	1-249-418-11	CARBON	1.2K 5% 1/4W
R711	1-249-434-11	CARBON	27K 5% 1/4W
R712	1-249-433-11	CARBON	22K 5% 1/4W
R713	1-249-422-11	CARBON	2.7K 5% 1/4W
R714	1-249-427-11	CARBON	6.8K 5% 1/4W
R715	1-249-433-11	CARBON	22K 5% 1/4W
R716	1-249-422-11	CARBON	2.7K 5% 1/4W
R717	1-249-425-11	CARBON	4.7K 5% 1/4W
R718	1-249-410-11	CARBON	270 5% 1/4W
R719	1-249-414-11	CARBON	560 5% 1/4W
R720	1-247-850-11	CARBON	6.2K 5% 1/4W
R721	1-249-438-11	CARBON	56K 5% 1/4W
R722	1-249-441-11	CARBON	100K 5% 1/4W
R723	1-249-437-11	CARBON	47K 5% 1/4W
R724	1-249-429-11	CARBON	10K 5% 1/4W
R725	1-249-438-11	CARBON	56K 5% 1/4W
R726	1-247-895-00	CARBON	470K 5% 1/4W
R727	1-249-425-11	CARBON	4.7K 5% 1/4W
R728	1-249-435-11	CARBON	33K 5% 1/4W
R729	1-249-423-11	CARBON	3.3K 5% 1/4W
R730	1-249-421-11	CARBON	2.2K 5% 1/4W
R731	1-249-422-11	CARBON	2.7K 5% 1/4W
R732	1-249-422-11	CARBON	2.7K 5% 1/4W
R733	1-249-421-11	CARBON	2.2K 5% 1/4W
R734	1-249-421-11	CARBON	2.2K 5% 1/4W
R735	1-249-421-11	CARBON	2.2K 5% 1/4W
R736	1-249-425-11	CARBON	4.7K 5% 1/4W
R737	1-247-807-31	CARBON	100 5% 1/4W
R738	1-249-441-11	CARBON	100K 5% 1/4W
R739	1-249-433-11	CARBON	22K 5% 1/4W
R740	1-249-417-11	CARBON	1K 5% 1/4W
R741	1-202-473-00	SOLID	5.6M 5% 1/4W
R906	1-249-389-11	CARBON	4.7 5% 1/4W
R907	1-249-389-11	CARBON	4.7 5% 1/4W

<VARIABLE RESISTOR>

RV101	1-237-514-21	RES, ADJ, CERMET 500
RV201	1-237-514-21	RES, ADJ, CERMET 500
RV401	1-237-514-21	RES, ADJ, CERMET 500
RV501	1-237-514-21	RES, ADJ, CERMET 500
RV601	1-237-514-21	RES, ADJ, CERMET 500

\*\*\*\*\*

7. ELECTRICAL PARTS LIST



REF. NO.	PART NO.	DESCRIPTION	REMARK	REF. NO.	PART NO.	DESCRIPTION	REMARK
*A-1135-357-A		BC BOARD, COMPLETE (BVM-1916 ONLY) *****		C132	1-104-792-51	ELECT 33MF	20% 16V
				C133	1-104-792-51	ELECT 33MF	20% 16V
*4-353-708-00		HOOK, FINGER		C136	1-101-004-00	CERAMIC 0.01MF	50V
7-682-950-01		SCREW +PSW 3X12		C137	1-101-004-00	CERAMIC 0.01MF	50V
7-682-547-09		SCREW +BVTT 3X6		C138	1-101-004-00	CERAMIC 0.01MF	50V
				C139	1-101-004-00	CERAMIC 0.01MF	50V
				C143	1-101-004-00	CERAMIC 0.01MF	50V
		<CAPACITOR>		C144	1-124-916-11	ELECT 22MF	20% 25V
C1	1-102-951-00	CERAMIC 15PF	5% 50V	C201	1-126-966-11	ELECT 33MF	20% 25V
C2	1-102-951-00	CERAMIC 15PF	5% 50V	C202	1-101-004-00	CERAMIC 0.01MF	50V
C3	1-102-947-00	CERAMIC 10PF	0.5PF 50V			<TRIMMER>	
C4	1-101-880-00	CERAMIC 47PF	5% 50V	CV1	1-141-171-00	CAP, TRIMMER 15P	
C5	1-102-965-00	CERAMIC 39PF	5% 50V	CV2	1-141-171-00	CAP, TRIMMER 15P	
C6	1-101-004-00	CERAMIC 0.01MF	50V			<DIODE>	
C7	1-102-935-00	CERAMIC 2PF	0.25PF 50V	D1	8-719-911-19	DIODE 1SS119	
C8	1-101-361-00	CERAMIC 39PF	5% 50V	D2	8-719-949-46	DIODE 1T32	
C9	1-126-964-11	ELECT 10MF	20% 16V	D3	8-719-911-19	DIODE 1SS119	
C10	1-126-964-11	ELECT 10MF	20% 16V	D4	8-719-110-13	DIODE RD9.1ESB2	
C11	1-101-004-00	CERAMIC 0.01MF	50V	D5	8-719-911-19	DIODE 1SS119	
C12	1-101-004-00	CERAMIC 0.01MF	50V	D6	8-719-911-19	DIODE 1SS119	
C13	1-101-004-00	CERAMIC 0.01MF	50V	D7	8-719-911-19	DIODE 1SS119	
C14	1-101-004-00	CERAMIC 0.01MF	50V			<IC>	
C15	1-126-967-11	ELECT 47MF	20% 16V	IC1	8-759-204-21	IC TA7193P	
C16	1-126-967-11	ELECT 47MF	20% 16V	IC2	8-752-006-12	IC CX20061	
C17	1-104-792-51	ELECT 33MF	20% 16V	IC3	8-759-140-53	IC UPD4053BC	
C18	1-101-004-00	CERAMIC 0.01MF	50V			<COIL>	
C19	1-102-953-00	CERAMIC 18PF	5% 50V	L1	1-408-533-00	COIL, VARIABLE	
C20	1-102-951-00	CERAMIC 15PF	5% 50V	L2	1-408-513-00	COIL (VARIABLE)	
C22	1-101-884-00	CERAMIC 56PF	5% 50V	L3	1-408-533-00	COIL, VARIABLE	
C23	1-247-927-11	ELECT 4.7MF	20% 25V	L4	1-408-429-00	INDUCTOR 470UH	
C24	1-136-157-00	FILM 0.022MF	5% 50V	L5	1-408-429-00	INDUCTOR 470UH	
C25	1-136-157-00	FILM 0.022MF	5% 50V	L6	1-408-429-00	INDUCTOR 470UH	
C26	1-101-004-00	CERAMIC 0.01MF	50V			<TRANSISTOR>	
C27	1-101-004-00	CERAMIC 0.01MF	50V	Q1	8-729-119-78	TRANSISTOR 2SC2785-HFE	
C28	1-124-902-00	ELECT 0.47MF	20% 50V	Q2	8-729-119-78	TRANSISTOR 2SC2785-HFE	
C29	1-101-004-00	CERAMIC 0.01MF	50V	Q3	8-729-119-78	TRANSISTOR 2SC2785-HFE	
C30	1-101-004-00	CERAMIC 0.01MF	50V	Q4	8-729-800-10	TRANSISTOR 2SC3068	
C31	1-124-119-00	ELECT 330MF	20% 16V	Q5	8-729-800-10	TRANSISTOR 2SC3068	
C34	1-109-676-00	MICA 130PF	1% 500V	Q6	8-729-119-78	TRANSISTOR 2SC2785-HFE	
C35	1-109-631-00	MICA 330PF	1% 500V	Q7	8-729-119-78	TRANSISTOR 2SC2785-HFE	
C36	1-102-960-00	CERAMIC 24PF	5% 50V	Q8	8-729-119-78	TRANSISTOR 2SC2785-HFE	
C39	1-109-676-00	MICA 130PF	1% 500V	Q9	8-729-384-48	TRANSISTOR 2SA844-E	
C40	1-109-631-00	MICA 330PF	1% 500V	Q10	8-729-119-78	TRANSISTOR 2SC2785-HFE	
C41	1-102-960-00	CERAMIC 24PF	5% 50V	Q11	8-729-384-48	TRANSISTOR 2SA844-E	
C42	1-101-004-00	CERAMIC 0.01MF	50V	Q12	8-729-119-78	TRANSISTOR 2SC2785-HFE	
C50	1-102-942-00	CERAMIC 5PF	0.5PF 50V	Q13	8-729-384-48	TRANSISTOR 2SA844-E	
C101	1-104-792-51	ELECT 33MF	20% 16V	Q14	8-729-384-48	TRANSISTOR 2SA844-E	
C102	1-101-004-00	CERAMIC 0.01MF	50V	Q15	8-729-119-78	TRANSISTOR 2SC2785-HFE	
C103	1-126-966-11	ELECT 33MF	20% 25V	Q16	8-729-119-78	TRANSISTOR 2SC2785-HFE	
C104	1-104-792-51	ELECT 33MF	20% 16V	Q17	8-729-119-78	TRANSISTOR 2SC2785-HFE	
C105	1-101-004-00	CERAMIC 0.01MF	50V	Q18	8-729-800-10	TRANSISTOR 2SC3068	
C106	1-126-966-11	ELECT 33MF	20% 25V	Q19	8-729-119-78	TRANSISTOR 2SC2785-HFE	
C107	1-101-004-00	CERAMIC 0.01MF	50V	Q20	8-729-119-78	TRANSISTOR 2SC2785-HFE	
C111	1-104-792-51	ELECT 33MF	20% 16V	Q21	8-729-800-10	TRANSISTOR 2SC3068	
C112	1-104-792-51	ELECT 33MF	20% 16V	Q101	8-729-140-97	TRANSISTOR 2SB734-34	
C113	1-104-792-51	ELECT 33MF	20% 16V				
C116	1-101-004-00	CERAMIC 0.01MF	50V				
C117	1-101-004-00	CERAMIC 0.01MF	50V				
C118	1-101-004-00	CERAMIC 0.01MF	50V				
C121	1-104-792-51	ELECT 33MF	20% 16V				
C122	1-104-792-51	ELECT 33MF	20% 16V				
C123	1-104-792-51	ELECT 33MF	20% 16V				
C126	1-101-004-00	CERAMIC 0.01MF	50V				
C127	1-101-004-00	CERAMIC 0.01MF	50V				
C128	1-101-004-00	CERAMIC 0.01MF	50V				
C131	1-104-792-51	ELECT 33MF	20% 16V				



REF. NO.	PART NO.	DESCRIPTION	REMARK
Q103	8-729-900-63	TRANSISTOR DTA124ES	
Q104	8-729-900-63	TRANSISTOR DTA124ES	
<RESISTOR>			
R1	1-249-428-11	CARBON	8.2K 5% 1/4W
R2	1-249-429-11	CARBON	10K 5% 1/4W
R3	1-247-807-31	CARBON	100 5% 1/4W
R4	1-249-422-11	CARBON	2.7K 5% 1/4W
R5	1-215-421-00	METAL	1K 1% 1/4W
R6	1-215-398-00	METAL	110 1% 1/4W
R7	1-247-807-31	CARBON	100 5% 1/4W
R8	1-215-421-00	METAL	1K 1% 1/4W
R9	1-215-421-00	METAL	1K 1% 1/4W
R10	1-215-423-00	METAL	1.2K 1% 1/4W
R11	1-247-807-31	CARBON	100 5% 1/4W
R12	1-215-425-00	METAL	1.5K 1% 1/4W
R13	1-215-425-00	METAL	1.5K 1% 1/4W
R14	1-215-405-00	METAL	220 1% 1/4W
R15	1-247-807-31	CARBON	100 5% 1/4W
R16	1-249-433-11	CARBON	22K 5% 1/4W
R17	1-249-433-11	CARBON	22K 5% 1/4W
R18	1-249-421-11	CARBON	2.2K 5% 1/4W
R19	1-249-425-11	CARBON	4.7K 5% 1/4W
R20	1-249-429-11	CARBON	10K 5% 1/4W
R22	1-249-429-11	CARBON	10K 5% 1/4W
R23	1-249-431-11	CARBON	15K 5% 1/4W
R24	1-249-428-11	CARBON	8.2K 5% 1/4W
R25	1-247-807-31	CARBON	100 5% 1/4W
R26	1-249-417-11	CARBON	1K 5% 1/4W
R27	1-247-807-31	CARBON	100 5% 1/4W
R28	1-249-417-11	CARBON	1K 5% 1/4W
R29	1-247-807-31	CARBON	100 5% 1/4W
R30	1-249-425-11	CARBON	4.7K 5% 1/4W
R31	1-249-425-11	CARBON	4.7K 5% 1/4W
R32	1-249-433-11	CARBON	22K 5% 1/4W
R33	1-247-807-31	CARBON	100 5% 1/4W
R34	1-215-425-00	METAL	1.5K 1% 1/4W
R35	1-215-425-00	METAL	1.5K 1% 1/4W
R36	1-215-425-00	METAL	1.5K 1% 1/4W
R37	1-215-425-00	METAL	1.5K 1% 1/4W
R38	1-215-439-00	METAL	5.6K 1% 1/4W
R39	1-215-469-00	METAL	100K 1% 1/4W
R40	1-247-903-91	CARBON	1M 5% 1/4W
R41	1-249-427-11	CARBON	6.8K 5% 1/4W
R42	1-249-420-11	CARBON	1.8K 5% 1/4W
R43	1-249-415-11	CARBON	680 5% 1/4W
R44	1-249-418-11	CARBON	1.2K 5% 1/4W
R45	1-249-422-11	CARBON	2.7K 5% 1/4W
R47	1-249-413-11	CARBON	470 5% 1/4W
R49	1-249-413-11	CARBON	470 5% 1/4W
R50	1-247-807-31	CARBON	100 5% 1/4W
R51	1-215-417-00	METAL	680 1% 1/4W
R52	1-215-417-00	METAL	680 1% 1/4W
R53	1-215-413-00	METAL	470 1% 1/4W
R54	1-215-443-00	METAL	8.2K 1% 1/4W
R55	1-249-421-11	CARBON	2.2K 5% 1/4W
R56	1-249-441-11	CARBON	100K 5% 1/4W
R57	1-249-417-11	CARBON	1K 5% 1/4W
R58	1-249-417-11	CARBON	1K 5% 1/4W
R59	1-249-429-11	CARBON	10K 5% 1/4W
R60	1-249-433-11	CARBON	22K 5% 1/4W
R61	1-249-420-11	CARBON	1.8K 5% 1/4W
R62	1-249-429-11	CARBON	10K 5% 1/4W

REF. NO.	PART NO.	DESCRIPTION	REMARK
R63	1-249-425-11	CARBON	4.7K 5% 1/4W
R64	1-249-429-11	CARBON	10K 5% 1/4W
R65	1-215-421-00	METAL	1K 1% 1/4W
R68	1-249-427-11	CARBON	6.8K 5% 1/4W
R69	1-215-420-00	METAL	910 1% 1/4W
R70	1-215-420-00	METAL	910 1% 1/4W
R71	1-215-417-00	METAL	680 1% 1/4W
R72	1-249-422-11	CARBON	2.7K 5% 1/4W
R73	1-247-807-31	CARBON	100 5% 1/4W
R74	1-215-421-00	METAL	1K 1% 1/4W
R77	1-249-427-11	CARBON	6.8K 5% 1/4W
R78	1-215-420-00	METAL	910 1% 1/4W
R79	1-215-420-00	METAL	910 1% 1/4W
R80	1-215-417-00	METAL	680 1% 1/4W
R81	1-249-422-11	CARBON	2.7K 5% 1/4W
R82	1-247-807-31	CARBON	100 5% 1/4W
R83	1-215-481-00	METAL	330K 1% 1/4W
R85	1-215-429-00	METAL	2.2K 1% 1/4W
R86	1-215-415-00	METAL	560 1% 1/4W
R87	1-215-477-00	METAL	220K 1% 1/4W
R88	1-215-457-00	METAL	33K 1% 1/4W
R90	1-249-429-11	CARBON	10K 5% 1/4W
R91	1-249-433-11	CARBON	22K 5% 1/4W
R95	1-249-429-11	CARBON	10K 5% 1/4W
R96	1-249-433-11	CARBON	22K 5% 1/4W
R101	1-249-423-11	CARBON	3.3K 5% 1/4W
R102	1-249-419-11	CARBON	1.5K 5% 1/4W
R103	1-249-427-11	CARBON	6.8K 5% 1/4W
R104	1-249-422-11	CARBON	2.7K 5% 1/4W
R105	1-249-429-11	CARBON	10K 5% 1/4W
R202	1-249-429-11	CARBON	10K 5% 1/4W
<VARIABLE RESISTOR>			
RV1	1-237-500-21	RES. ADJ. CERMET	1K
RV2	1-237-504-21	RES. ADJ. CERMET	20K
RV3	1-237-499-21	RES. ADJ. CERMET	500
RV4	1-237-501-21	RES. ADJ. CERMET	2K
RV5	1-237-501-21	RES. ADJ. CERMET	2K
<CRYSTAL>			
X1	1-567-505-11	OSCILLATOR, CRYSTAL	
*****			
*A-1135-391-A BD BOARD, COMPLETE			
*****			
*4-353-708-00 HOOK, FINGER			
<CAPACITOR>			
C1	1-102-947-00	CERAMIC	10PF 0.5PF 50V
C2	1-102-947-00	CERAMIC	10PF 0.5PF 50V
C3	1-102-963-00	CERAMIC	33PF 5% 50V
C4	1-101-880-00	CERAMIC	47PF 5% 50V
C6	1-101-888-00	CERAMIC	68PF 5% 50V
C7	1-102-963-00	CERAMIC	33PF 5% 50V
C8	1-102-943-00	CERAMIC	6PF 0.5PF 50V
C9	1-126-964-11	ELECT	10MF 20% 16V
C10	1-126-964-11	ELECT	10MF 20% 16V
C11	1-101-004-00	CERAMIC	0.01MF 50V
C12	1-101-004-00	CERAMIC	0.01MF 50V
C13	1-101-004-00	CERAMIC	0.01MF 50V
C14	1-101-004-00	CERAMIC	0.01MF 50V
C15	1-101-004-00	CERAMIC	0.01MF 50V
C16	1-101-004-00	CERAMIC	0.01MF 50V

7. ELECTRICAL PARTS LIST



BD

REF. NO.	PART NO.	DESCRIPTION	REMARK	REF. NO.	PART NO.	DESCRIPTION	REMARK
C17	1-136-165-00	FILM	0.1MF 5% 50V	C226	1-101-004-00	CERAMIC	0.01MF 50V
C18	1-102-950-00	CERAMIC	13PF 5% 50V	C227	1-124-916-11	ELECT	22MF 20% 25V
C19	1-102-951-00	CERAMIC	15PF 5% 50V	C250	1-104-792-51	ELECT	33MF 20% 16V
C20	1-101-888-00	CERAMIC	68PF 5% 50V	C251	1-101-004-00	CERAMIC	0.01MF 50V
C21	1-163-157-00	FILM	0.022MF 5% 50V	C301	1-101-004-00	CERAMIC	0.01MF 50V
C22	1-163-157-00	FILM	0.022MF 5% 50V	C302	1-101-004-00	CERAMIC	0.01MF 50V
C23	1-124-903-11	ELECT	1MF 20% 50V	C303	1-101-004-00	CERAMIC	0.01MF 50V
C24	1-101-004-00	CERAMIC	0.01MF 50V	C304	1-102-947-00	CERAMIC	10PF 0.5PF 50V
C25	1-126-967-11	ELECT	47MF 20% 16V	C312	1-101-004-00	CERAMIC	0.01MF 50V
C26	1-109-628-00	MICA	160PF 1% 500V	C313	1-101-004-00	CERAMIC	0.01MF 50V
C27	1-102-960-00	CERAMIC	24PF 5% 50V	C316	1-102-935-00	CERAMIC	2PF 0.25PF 50V
C28	1-109-631-00	MICA	330PF 1% 500V	C350	1-102-963-00	CERAMIC	33PF 5% 50V
C29	1-126-967-11	ELECT	47MF 20% 16V	<TRIMMER>			
C30	1-109-628-00	MICA	160PF 1% 500V	CV1	1-141-171-00	CAP, TRIMMER	15P
C31	1-102-960-00	CERAMIC	24PF 5% 50V	CV2	1-141-179-12	CAP, VAR, TRIMMER	
C32	1-109-631-00	MICA	330PF 1% 500V	<DIODE>			
C33	1-101-004-00	CERAMIC	0.01MF 50V	D1	8-719-911-19	DIODE	1SS119
C34	1-136-153-00	FILM	0.01MF 5% 50V	D2	8-719-911-19	DIODE	1SS119
C35	1-101-004-00	CERAMIC	0.01MF 50V	D5	8-719-910-13	DIODE	RD9.1ESB2
C36	1-124-903-00	ELECT	1MF 20% 50V	D6	8-719-911-19	DIODE	1SS119
C38	1-102-074-00	CERAMIC	0.001MF 10% 50V	D10	8-719-949-46	DIODE	1T32
C39	1-109-667-11	MICA	56PF 1% 500V	D11	8-719-911-19	DIODE	1SS119
C40	1-102-942-00	CERAMIC	5PF 0.5PF 50V	D12	8-719-110-31	DIODE	RD12ESB2
C41	1-109-621-00	MICA	220PF 1% 500V	D13	8-719-110-31	DIODE	RD12ESB2
C43	1-126-967-11	ELECT	47MF 20% 16V	D16	8-719-911-19	DIODE	1SS119
C44	1-126-967-11	ELECT	47MF 20% 16V	D201	8-719-911-19	DIODE	1SS119
C45	1-101-004-00	CERAMIC	0.01MF 50V	D202	8-719-911-19	DIODE	1SS119
C46	1-136-153-00	FILM	0.01MF 5% 50V	<IC>			
C49	1-124-903-00	ELECT	1MF 20% 50V	IC1	8-759-204-21	IC	TA7193P
C50	1-102-074-00	CERAMIC	0.001MF 10% 50V	IC2	8-759-800-81	IC	LA7016
C51	1-109-667-11	MICA	56PF 1% 500V	IC3	8-752-340-28	IC	CXL5506P
C52	1-102-942-00	CERAMIC	5PF 0.5PF 50V	IC4	*1-526-652-21	SOCKET, IC	<DP> 8P; IC3
C53	1-109-621-00	MICA	220PF 1% 500V	IC4	8-752-340-28	IC	CXL5506P
C55	1-126-967-11	ELECT	47MF 20% 16V	IC4	*1-526-652-21	SOCKET, IC	<DP> 8P; IC4
C56	1-126-967-11	ELECT	47MF 20% 16V	IC5	8-759-140-53	IC	UPD4053BC
C57	1-101-004-00	CERAMIC	0.01MF 50V	IC6	8-759-800-81	IC	LA7016
C58	1-101-004-00	CERAMIC	0.01MF 50V	IC7	8-759-145-58	IC	UPC4558C
C60	1-126-967-11	ELECT	47MF 20% 16V	IC8	8-759-145-58	IC	UPC4558C
C62	1-102-960-00	CERAMIC	24PF 5% 50V	IC10	8-759-708-05	IC	NJM78L05A
C63	1-101-361-00	CERAMIC	150PF 5% 50V	<COIL>			
C64	1-102-518-11	CERAMIC	33PF 5% 50V	L1	1-408-533-00	COIL, VARIABLE	
C65	1-102-947-00	CERAMIC	10PF 0.5PF 50V	L2	1-408-532-00	COIL, VARIABLE	
C66	1-102-937-00	CERAMIC	4PF 0.25PF 50V	L3	1-408-514-11	COIL (VARIABLE)	
C68	1-104-792-51	ELECT	33MF 20% 16V	L4	1-408-421-00	INDUCTOR	100UH
C69	1-104-792-51	ELECT	33MF 20% 16V	L5	1-408-429-00	INDUCTOR	470UH
C70	1-124-927-11	ELECT	4.7MF 20% 50V	L6	1-408-429-00	INDUCTOR	470UH
C71	1-101-004-00	CERAMIC	0.01MF 50V	L8	1-408-421-00	INDUCTOR	100UH
C75	1-101-004-00	CERAMIC	0.01MF 50V	L101	1-408-421-00	INDUCTOR	100UH
C85	1-104-792-51	ELECT	33MF 20% 16V	L102	1-408-421-00	INDUCTOR	100UH
C95	1-104-792-51	ELECT	33MF 20% 16V	<TRANSISTOR>			
C100	1-104-792-51	ELECT	33MF 20% 16V	Q1	8-729-119-78	TRANSISTOR	2SC2785-HFE
C101	1-126-967-11	ELECT	47MF 20% 25V	Q2	8-729-119-78	TRANSISTOR	2SC2785-HFE
C102	1-104-792-51	ELECT	33MF 20% 16V	Q3	8-729-119-78	TRANSISTOR	2SC2785-HFE
C103	1-104-792-51	ELECT	33MF 20% 16V	Q4	8-729-800-10	TRANSISTOR	2SC3068
C104	1-104-792-51	ELECT	33MF 20% 16V				
C106	1-104-792-51	ELECT	33MF 20% 16V				
C107	1-104-792-51	ELECT	33MF 20% 16V				
C108	1-104-792-51	ELECT	33MF 20% 16V				
C109	1-104-792-51	ELECT	33MF 20% 16V				
C110	1-104-792-51	ELECT	33MF 20% 16V				
C224	1-101-004-00	CERAMIC	0.01MF 50V				
C225	1-101-004-00	CERAMIC	0.01MF 50V				

7. ELECTRICAL PARTS LIST

REF. NO.	PART NO.	DESCRIPTION	REMARK
Q5	8-729-800-10	TRANSISTOR 2SC3068	
Q6	8-729-384-48	TRANSISTOR 2SA844	
Q7	8-729-119-78	TRANSISTOR 2SC2785-HFE	
Q8	8-729-384-48	TRANSISTOR 2SA844	
Q9	8-729-119-78	TRANSISTOR 2SC2785-HFE	
Q10	8-729-119-76	TRANSISTOR 2SA1175-HFE	
Q11	8-729-119-76	TRANSISTOR 2SA1175-HFE	
Q12	8-729-119-78	TRANSISTOR 2SC2785-HFE	
Q13	8-729-119-78	TRANSISTOR 2SC2785-HFE	
Q14	8-729-119-78	TRANSISTOR 2SC2785-HFE	
Q15	8-729-119-78	TRANSISTOR 2SC2785-HFE	
Q16	8-729-119-78	TRANSISTOR 2SC2785-HFE	
Q17	8-729-119-78	TRANSISTOR 2SC2785-HFE	
Q18	8-729-600-19	TRANSISTOR 2SK381-A	
Q20	8-729-119-76	TRANSISTOR 2SA1175-HFE	
Q21	8-729-119-78	TRANSISTOR 2SC2785-HFE	
Q22	8-729-119-78	TRANSISTOR 2SC2785-HFE	
Q23	8-729-384-48	TRANSISTOR 2SA844	
Q24	8-729-119-78	TRANSISTOR 2SC2785-HFE	
Q25	8-729-800-10	TRANSISTOR 2SC3068	
Q26	8-729-600-19	TRANSISTOR 2SK381-A	
Q28	8-729-119-76	TRANSISTOR 2SA1175-HFE	
Q29	8-729-119-78	TRANSISTOR 2SC2785-HFE	
Q30	8-729-119-78	TRANSISTOR 2SC2785-HFE	
Q31	8-729-384-48	TRANSISTOR 2SA844	
Q32	8-729-119-78	TRANSISTOR 2SC2785-HFE	
Q33	8-729-800-10	TRANSISTOR 2SC3068	
Q34	8-729-119-78	TRANSISTOR 2SC2785-HFE	
Q35	8-729-384-48	TRANSISTOR 2SA844	
Q36	8-729-119-78	TRANSISTOR 2SC2785-HFE	
Q38	8-729-119-78	TRANSISTOR 2SC2785-HFE	
Q40	8-729-119-78	TRANSISTOR 2SC2785-HFE	
Q50	8-729-119-78	TRANSISTOR 2SC2785-HFE	
Q101	8-729-140-97	TRANSISTOR 2SB734-34	
Q102	8-729-320-62	TRANSISTOR 2SD789-34	
Q103	8-729-900-63	TRANSISTOR DTA124ES	
Q104	8-729-900-63	TRANSISTOR DTA124ES	
<RESISTOR>			
R1	1-249-428-11	CARBON 8.2K 5%	1/4W
R2	1-249-429-11	CARBON 10K 5%	1/4W
R3	1-249-422-11	CARBON 2.7K 5%	1/4W
R4	1-215-425-00	METAL 1.5K 1%	1/4W
R5	1-215-395-00	METAL 82 1%	1/4W
R6	1-215-421-00	METAL 1K 1%	1/4W
R7	1-215-421-00	METAL 1K 1%	1/4W
R8	1-215-423-00	METAL 1.2K 1%	1/4W
R9	1-215-421-00	METAL 1K 1%	1/4W
R10	1-215-421-00	METAL 1K 1%	1/4W
R11	1-215-391-00	METAL 56 1%	1/4W
R12	1-215-427-00	METAL 1.8K 1%	1/4W
R13	1-249-425-11	CARBON 4.7K 5%	1/4W
R14	1-249-429-11	CARBON 10K 5%	1/4W
R15	1-249-429-11	CARBON 10K 5%	1/4W
R17	1-249-433-11	CARBON 22K 5%	1/4W
R18	1-215-425-00	METAL 1.5K 1%	1/4W
R19	1-215-425-00	METAL 1.5K 1%	1/4W
R20	1-215-425-00	METAL 1.5K 1%	1/4W
R21	1-215-425-00	METAL 1.5K 1%	1/4W

REF. NO.	PART NO.	DESCRIPTION	REMARK
R22	1-247-807-31	CARBON 100 5%	1/4W
R23	1-215-441-00	METAL 6.8K 1%	1/4W
R24	1-215-469-00	METAL 100K 1%	1/4W
R25	1-249-427-11	CARBON 6.8K 5%	1/4W
R26	1-249-415-11	CARBON 680 5%	1/4W
R27	1-249-415-11	CARBON 680 5%	1/4W
R28	1-249-420-11	CARBON 1.8K 5%	1/4W
R29	1-249-422-11	CARBON 2.7K 5%	1/4W
R30	1-247-807-11	CARBON 100 5%	1/4W
R31	1-247-903-31	CARBON 1M 5%	1/4W
R32	1-249-429-11	CARBON 10K 5%	1/4W
R34	1-215-407-00	METAL 270 1%	1/4W
R35	1-215-407-00	METAL 270 1%	1/4W
R36	1-215-413-00	METAL 470 1%	1/4W
R37	1-215-443-00	METAL 8.2K 1%	1/4W
R38	1-249-441-11	CARBON 100K 5%	1/4W
R39	1-215-425-00	METAL 1.5K 1%	1/4W
R40	1-215-421-00	METAL 1K 1%	1/4W
R41	1-215-429-00	METAL 2.2K 1%	1/4W
R42	1-215-445-00	METAL 10K 1%	1/4W
R43	1-215-421-00	METAL 1K 1%	1/4W
R44	1-249-433-11	CARBON 22K 5%	1/4W
R45	1-249-429-11	CARBON 10K 5%	1/4W
R46	1-249-429-11	CARBON 10K 5%	1/4W
R47	1-249-441-11	CARBON 100K 5%	1/4W
R48	1-249-425-11	CARBON 4.7K 5%	1/4W
R54	1-249-422-11	CARBON 2.7K 5%	1/4W
R55	1-215-418-00	METAL 750 1%	1/4W
R56	1-215-420-00	METAL 910 1%	1/4W
R57	1-249-415-11	CARBON 680 5%	1/4W
R58	1-249-422-11	CARBON 2.7K 5%	1/4W
R59	1-249-422-11	CARBON 2.7K 5%	1/4W
R60	1-215-418-00	METAL 750 1%	1/4W
R61	1-215-420-00	METAL 910 1%	1/4W
R62	1-249-415-11	CARBON 680 5%	1/4W
R63	1-249-422-11	CARBON 2.7K 5%	1/4W
R64	1-215-477-11	METAL 220K 1%	1/4W
R65	1-215-435-00	METAL 3.9K 1%	1/4W
R66	1-247-807-31	CARBON 100 5%	1/4W
R70	1-247-903-00	CARBON 1M 5%	1/4W
R71	1-249-429-11	CARBON 10K 5%	1/4W
R72	1-249-429-11	CARBON 10K 5%	1/4W
R73	1-249-429-11	CARBON 10K 5%	1/4W
R74	1-249-417-11	CARBON 1K 5%	1/4W
R75	1-249-427-11	CARBON 6.8K 5%	1/4W
R76	1-249-427-11	CARBON 6.8K 5%	1/4W
R77	1-249-425-11	CARBON 4.7K 5%	1/4W
R78	1-215-424-00	METAL 1.3K 1%	1/4W
R79	1-215-419-00	METAL 820 1%	1/4W
R80	1-215-425-00	METAL 1.5K 1%	1/4W
R81	1-249-422-11	CARBON 2.7K 5%	1/4W
R82	1-249-425-11	CARBON 4.7K 5%	1/4W
R83	1-249-435-11	CARBON 33K 5%	1/4W
R84	1-249-435-11	CARBON 33K 5%	1/4W
R85	1-247-903-00	CARBON 1M 5%	1/4W
R86	1-249-429-11	CARBON 10K 5%	1/4W
R87	1-249-429-11	CARBON 10K 5%	1/4W
R88	1-249-429-11	CARBON 10K 5%	1/4W
R89	1-249-417-11	CARBON 1K 5%	1/4W
R90	1-249-427-11	CARBON 6.8K 5%	1/4W
R91	1-249-427-11	CARBON 6.8K 5%	1/4W
R92	1-249-425-11	CARBON 4.7K 5%	1/4W



REF. NO.	PART NO.	DESCRIPTION	REMARK
R93	1-215-424-00	METAL	1.3K 1% 1/4W
R94	1-215-419-00	METAL	820 1% 1/4W
R95	1-215-425-00	METAL	1.5K 1% 1/4W
R96	1-249-422-11	CARBON	2.7K 5% 1/4W
R97	1-249-425-11	CARBON	4.7K 5% 1/4W
R98	1-249-435-11	CARBON	33K 5% 1/4W
R99	1-249-435-11	CARBON	33K 5% 1/4W
R100	1-215-438-00	METAL	5.1K 1% 1/4W
R101	1-215-438-00	METAL	5.1K 1% 1/4W
R102	1-215-438-00	METAL	5.1K 1% 1/4W
R103	1-215-438-00	METAL	5.1K 1% 1/4W
R104	1-249-431-11	CARBON	15K 5% 1/4W
R105	1-249-429-11	CARBON	10K 5% 1/4W
R106	1-249-414-11	CARBON	560 5% 1/4W
R107	1-249-417-11	CARBON	1K 5% 1/4W
R108	1-249-417-11	CARBON	1K 5% 1/4W
R109	1-249-417-11	CARBON	1K 5% 1/4W
R115	1-215-438-00	METAL	5.1K 1% 1/4W
R116	1-215-438-00	METAL	5.1K 1% 1/4W
R120	1-249-429-11	CARBON	10K 5% 1/4W
R121	1-249-429-11	CARBON	10K 5% 1/4W
R125	1-215-425-00	METAL	1.5K 1% 1/4W
R126	1-215-433-00	METAL	3.3K 1% 1/4W
R130	1-215-477-00	METAL	220K 1% 1/4W
R140	1-249-417-11	CARBON	1K 5% 1/4W
R141	1-215-463-00	METAL	56K 1% 1/4W
R142	1-215-463-00	METAL	56K 1% 1/4W
R143	1-215-427-00	METAL	1.8K 1% 1/4W
R144	1-215-415-00	METAL	560 1% 1/4W
R150	1-249-441-11	CARBON	100K 5% 1/4W
R201	1-249-423-11	CARBON	3.3K 5% 1/4W
R202	1-249-423-11	CARBON	3.3K 5% 1/4W
R203	1-249-422-11	CARBON	2.7K 5% 1/4W
R204	1-249-423-11	CARBON	3.3K 5% 1/4W
R220	1-249-441-11	CARBON	100K 5% 1/4W
R221	1-249-433-11	CARBON	22K 5% 1/4W
R222	1-249-433-11	CARBON	22K 5% 1/4W
R225	1-215-425-00	METAL	1.5K 1% 1/4W
R226	1-215-433-00	METAL	3.3K 1% 1/4W
R240	1-249-417-11	CARBON	1K 5% 1/4W
R241	1-215-463-00	METAL	56K 1% 1/4W
R242	1-215-463-00	METAL	56K 1% 1/4W
R243	1-215-427-00	METAL	1.8K 1% 1/4W
R244	1-215-415-00	METAL	560 1% 1/4W
R250	1-215-415-00	METAL	560 1% 1/4W
R251	1-215-415-00	METAL	560 1% 1/4W
R254	1-249-429-11	CARBON	10K 5% 1/4W
R255	1-249-441-11	CARBON	100K 5% 1/4W
R301	1-215-469-00	METAL	100K 1% 1/4W
R302	1-215-491-00	METAL	820K 1% 1/4W
R303	1-249-418-11	CARBON	1.2K 5% 1/4W
R305	1-249-431-11	CARBON	15K 5% 1/4W
R306	1-249-428-11	CARBON	8.2K 5% 1/4W
R307	1-249-417-11	CARBON	1K 5% 1/4W
R308	1-249-417-11	CARBON	1K 5% 1/4W
R310	1-249-422-11	CARBON	2.7K 5% 1/4W
R314	1-215-417-00	METAL	680 1% 1/4W
R315	1-249-422-11	CARBON	2.7K 5% 1/4W
R316	1-249-413-11	CARBON	470 5% 1/4W
R317	1-249-413-11	CARBON	470 5% 1/4W

7. ELECTRICAL PARTS LIST

REF. NO.	PART NO.	DESCRIPTION	REMARK
R320	1-215-472-00	METAL	130K 1% 1/4W
R353	1-249-432-11	CARBON	18K 5% 1/4W
R354	1-249-432-11	CARBON	18K 5% 1/4W
R400	1-215-429-00	METAL	2.2K 1% 1/4W
R500	1-215-862-11	METAL OXIDE	68 5% 1W F
<VARIABLE RESISTOR>			
RV1	1-237-515-21	RES, ADJ, CERMET	1K
RV2	1-238-783-11	RES, ADJ, CERMET	500
RV3	1-238-785-21	RES, ADJ, CERMET	2K
RV4	1-238-785-21	RES, ADJ, CERMET	2K
RV5	1-238-801-11	RES, ADJ, CERMET	5K
RV6	1-238-801-11	RES, ADJ, CERMET	5K
RV7	1-238-788-11	RES, ADJ, CERMET	20K
RV8	1-238-788-11	RES, ADJ, CERMET	20K
RV9	1-237-517-21	RES, ADJ, CERMET	5K
RV10	1-237-517-21	RES, ADJ, CERMET	5K
<CRYSTAL>			
X1	1-567-504-11	OSCILLATOR, CRYSTAL	
X2	1-760-461-11	VIBRATOR, CRYSTAL	
*****			
		*A-1135-537-A	BG BOARD, COMPLETE
*****			
		*4-353-708-00	HOOK, FINGER
		7-682-547-09	SCREW +BVTT 3X6 (S)
<CAPACITOR>			
C1	1-126-967-11	ELECT	47MF 20% 16V
C2	1-126-967-11	ELECT	47MF 20% 16V
C3	1-126-964-11	ELECT	10MF 20% 16V
C4	1-126-967-11	ELECT	47MF 20% 16V
C7	1-101-004-00	CERAMIC	0.01MF 50V
C8	1-101-004-00	CERAMIC	0.01MF 50V
C9	1-101-004-00	CERAMIC	0.01MF 50V
C10	1-102-935-00	CERAMIC	2PF 0.25PF 50V
C12	1-101-004-00	CERAMIC	0.01MF 50V
C16	1-101-004-00	CERAMIC	0.01MF 50V
C20	1-124-903-11	ELECT	1MF 20% 50V
C22	1-101-004-00	CERAMIC	0.01MF 50V
C26	1-101-004-00	CERAMIC	0.01MF 50V
C32	1-101-004-00	CERAMIC	0.01MF 50V
C33	1-136-165-00	FILM	0.1MF 5% 50V
C34	1-136-165-00	FILM	0.1MF 5% 50V
C35	1-136-165-00	FILM	0.1MF 5% 50V
C53	1-124-915-11	ELECT	10MF 20% 25V
C54	1-101-004-00	CERAMIC	0.01MF 50V
C101	1-126-103-11	ELECT	470MF 20% 16V
C102	1-126-101-11	ELECT	100MF 20% 16V
C103	1-124-119-00	ELECT	330MF 20% 16V
C105	1-124-119-00	ELECT	330MF 20% 16V
C106	1-126-101-11	ELECT	100MF 20% 16V
C111	1-126-964-11	ELECT	10MF 20% 16V
C112	1-101-004-00	CERAMIC	0.01MF 50V
C113	1-101-004-00	CERAMIC	0.01MF 50V
C114	1-101-004-00	CERAMIC	0.01MF 50V
C115	1-101-004-00	CERAMIC	0.01MF 50V
C116	1-101-004-00	CERAMIC	0.01MF 50V



REF. NO.	PART NO.	DESCRIPTION	REMARK	REF. NO.	PART NO.	DESCRIPTION	REMARK
C117	1-101-004-00	CERAMIC	0.01MF				50V
C131	1-126-103-11	ELECT	470MF				20% 16V
C132	1-126-101-11	ELECT	100MF				20% 16V
C133	1-124-119-00	ELECT	330MF				20% 16V
C135	1-124-119-00	ELECT	330MF				20% 16V
C136	1-126-101-11	ELECT	100MF				20% 16V
C141	1-101-004-00	CERAMIC	0.01MF				50V
C142	1-101-004-00	CERAMIC	0.01MF				50V
C143	1-101-004-00	CERAMIC	0.01MF				50V
C144	1-101-004-00	CERAMIC	0.01MF				50V
C145	1-101-004-00	CERAMIC	0.01MF				50V
C146	1-101-004-00	CERAMIC	0.01MF				50V
C147	1-101-004-00	CERAMIC	0.01MF				50V
<COMPOSITION CIRCUIT BLOCK>							
CP11	1-232-726-11	COMPOSITION	CIRCUIT	BLOCK			
CP12	1-232-728-11	COMPOSITION	CIRCUIT	BLOCK			
CP13	1-232-726-11	COMPOSITION	CIRCUIT	BLOCK			
CP14	1-233-018-11	COMPOSITION	CIRCUIT	BLOCK			
CP15	1-233-019-11	COMPOSITION	CIRCUIT	BLOCK			
CP16	1-233-031-11	COMPOSITION	CIRCUIT	BLOCK			
CP17	1-233-032-11	COMPOSITION	CIRCUIT	BLOCK			
CP18	1-233-013-11	COMPOSITION	CIRCUIT	BLOCK			
CP19	1-233-017-11	COMPOSITION	CIRCUIT	BLOCK			
CP20	1-232-752-11	COMPOSITION	CIRCUIT	BLOCK			
CP21	1-232-726-11	COMPOSITION	CIRCUIT	BLOCK			
CP22	1-232-728-11	COMPOSITION	CIRCUIT	BLOCK			
CP23	1-232-726-11	COMPOSITION	CIRCUIT	BLOCK			
CP25	1-232-730-11	COMPOSITION	CIRCUIT	BLOCK			
CP26	1-232-730-11	COMPOSITION	CIRCUIT	BLOCK			
CP27	1-231-765-00	COMPOSITION	CIRCUIT	BLOCK			
CP28	1-232-752-11	COMPOSITION	CIRCUIT	BLOCK			
CP29	1-232-728-11	COMPOSITION	CIRCUIT	BLOCK			
CP30	1-232-728-11	COMPOSITION	CIRCUIT	BLOCK			
CP31	1-232-734-11	COMPOSITION	CIRCUIT	BLOCK			
CP32	1-232-728-11	COMPOSITION	CIRCUIT	BLOCK			
CP33	1-232-738-11	COMPOSITION	CIRCUIT	BLOCK			
CP41	1-233-014-11	COMPOSITION	CIRCUIT	BLOCK			
CP42	1-233-014-11	COMPOSITION	CIRCUIT	BLOCK			
<TRIMMER>							
CV2	1-141-181-11	CAP, TRIMMER					
CV3	1-141-171-00	CAP, TRIMMER	20P				
<DIODE>							
D1	8-719-911-19	DIODE	1SS119				
D2	8-719-911-19	DIODE	1SS119				
D5	8-719-911-19	DIODE	1SS119				
D6	8-719-911-19	DIODE	1SS119				
D7	8-719-911-19	DIODE	1SS119				
D16	8-719-911-19	DIODE	1SS119				
D17	8-719-911-19	DIODE	1SS119				
<DELAY LINE>							
DL1	1-415-477-11	DELAY LINE					
DL2	1-415-458-11	DELAY LINE					
DL3	1-406-769-11	DELAY LINE					
DL4	1-406-769-11	DELAY LINE					
<IC>							
IC1	8-759-800-81	IC	LA7016				
IC2	8-766-001-49	TRANSISTOR	TX-429M				
IC3	8-759-145-58	IC	UPC4558C				
IC4	8-757-182-14	IC	CX-718D-1				
IC5	8-759-140-53	IC	UPD4053BC				
IC6	8-759-140-53	IC	UPD4053BC				
IC7	8-759-503-91	IC	TLO82ACP				
<COIL>							
L2	1-408-408-00	INDUCTOR			8.2UH		
<TRANSISTOR>							
Q1	8-729-119-78	TRANSISTOR	2SC2785-HFE				
Q5	8-729-119-78	TRANSISTOR	2SC2785-HFE				
Q7	8-729-119-78	TRANSISTOR	2SC2785-HFE				
Q8	8-729-119-78	TRANSISTOR	2SC2785-HFE				
Q9	8-729-119-78	TRANSISTOR	2SC2785-HFE				
Q10	8-729-384-48	TRANSISTOR	2SA844-E				
Q11	8-729-119-78	TRANSISTOR	2SC2785-HFE				
Q12	8-729-119-78	TRANSISTOR	2SC2785-HFE				
Q13	8-729-119-78	TRANSISTOR	2SC2785-HFE				
Q14	8-729-800-10	TRANSISTOR	2SC3068				
Q21	8-729-384-48	TRANSISTOR	2SA844-E				
Q22	8-729-119-78	TRANSISTOR	2SC2785-HFE				
Q23	8-729-119-78	TRANSISTOR	2SC2785-HFE				
Q24	8-729-600-19	TRANSISTOR	2SK381-A				
Q25	8-729-384-48	TRANSISTOR	2SA844-E				
Q26	8-729-119-78	TRANSISTOR	2SC2785-HFE				
Q27	8-729-119-78	TRANSISTOR	2SC2785-HFE				
Q28	8-729-600-19	TRANSISTOR	2SK381-A				
Q29	8-729-119-78	TRANSISTOR	2SC2785-HFE				
Q30	8-729-119-78	TRANSISTOR	2SC2785-HFE				
Q31	8-729-384-48	TRANSISTOR	2SA844-E				
Q32	8-729-119-78	TRANSISTOR	2SC2785-HFE				
Q33	8-729-119-78	TRANSISTOR	2SC2785-HFE				
Q34	8-729-600-19	TRANSISTOR	2SK381-A				
Q35	8-729-384-48	TRANSISTOR	2SA844-E				
Q36	8-729-119-78	TRANSISTOR	2SC2785-HFE				
Q37	8-729-119-78	TRANSISTOR	2SC2785-HFE				
Q38	8-729-600-19	TRANSISTOR	2SK381-A				
Q39	8-729-119-78	TRANSISTOR	2SC2785-HFE				
Q40	8-729-119-78	TRANSISTOR	2SC2785-HFE				
Q41	8-729-384-48	TRANSISTOR	2SA844-E				
Q42	8-729-384-48	TRANSISTOR	2SA844-E				
Q43	8-729-119-78	TRANSISTOR	2SC2785-HFE				
Q44	8-729-384-48	TRANSISTOR	2SA844-E				
Q45	8-729-119-78	TRANSISTOR	2SC2785-HFE				
Q49	8-729-119-78	TRANSISTOR	2SC2785-HFE				
Q50	8-729-119-78	TRANSISTOR	2SC2785-HFE				
Q71	8-729-384-48	TRANSISTOR	2SA844-E				
Q72	8-729-119-78	TRANSISTOR	2SC2785-HFE				
Q73	8-729-119-78	TRANSISTOR	2SC2785-HFE				
Q74	8-729-384-48	TRANSISTOR	2SA844-E				
Q75	8-729-800-10	TRANSISTOR	2SC3068				
Q76	8-729-900-63	TRANSISTOR	DTA124ES				
Q77	8-729-900-63	TRANSISTOR	DTA124ES				
Q81	8-729-384-48	TRANSISTOR	2SA844-E				
Q82	8-729-119-78	TRANSISTOR	2SC2785-HFE				
Q83	8-729-119-78	TRANSISTOR	2SC2785-HFE				
Q84	8-729-384-48	TRANSISTOR	2SA844-E				
Q85	8-729-800-10	TRANSISTOR	2SC3068				

7. ELECTRICAL PARTS LIST



REF. NO.	PART NO.	DESCRIPTION	REMARK	REF. NO.	PART NO.	DESCRIPTION	REMARK
<RESISTOR>							
R1	1-217-807-31	CARBON	100 5% 1/4W	R66	1-249-417-11	CARBON	1K 5% 1/4W
R2	1-215-396-00	METAL	91 1% 1/4W	R67	1-249-423-11	CARBON	3.3K 5% 1/4W
R3	1-215-431-00	METAL	2.7K 1% 1/4W	R68	1-249-422-11	CARBON	2.7K 5% 1/4W
R4	1-249-419-11	CARBON	1.5K 5% 1/4W	R69	1-217-807-31	CARBON	100 5% 1/4W
R6	1-217-807-31	CARBON	100 5% 1/4W	R70	1-249-422-11	CARBON	2.7K 5% 1/4W
R7	1-217-807-31	CARBON	100 5% 1/4W	R71	1-247-903-00	CARBON	1M 5% 1/4W
R8	1-249-429-11	CARBON	10K 5% 1/4W	R72	1-247-866-11	CARBON	30K 5% 1/4W
R10	1-247-830-11	CARBON	910 5% 1/4W	R73	1-215-445-00	METAL	10K 1% 1/4W
R11	1-249-417-11	CARBON	1K 5% 1/4W	R74	1-249-420-11	CARBON	1.8K 5% 1/4W
R12	1-249-417-11	CARBON	1K 5% 1/4W	R75	1-249-422-11	CARBON	2.7K 5% 1/4W
R13	1-215-462-00	METAL	51K 1% 1/4W	R76	1-217-807-31	CARBON	100 5% 1/4W
R14	1-249-426-11	CARBON	5.6K 5% 1/4W	R77	1-249-422-11	CARBON	2.7K 5% 1/4W
R15	1-247-903-00	CARBON	1M 5% 1/4W	R78	1-249-422-11	CARBON	2.7K 5% 1/4W
R16	1-215-477-00	METAL	220K 1% 1/4W	R79	1-249-422-11	CARBON	2.7K 5% 1/4W
R17	1-249-429-11	CARBON	10K 5% 1/4W	R80	1-217-807-31	CARBON	100 5% 1/4W
R18	1-249-429-11	CARBON	10K 5% 1/4W	R81	1-249-422-11	CARBON	2.7K 5% 1/4W
R19	1-249-417-11	CARBON	1K 5% 1/4W	R82	1-247-903-00	CARBON	1M 5% 1/4W
R20	1-215-421-00	METAL	1K 1% 1/4W	R83	1-249-420-11	CARBON	1.8K 5% 1/4W
R21	1-215-421-00	METAL	1K 1% 1/4W	R84	1-217-807-31	CARBON	100 5% 1/4W
R22	1-249-441-11	CARBON	100K 5% 1/4W	R85	1-247-866-11	CARBON	30K 5% 1/4W
R23	1-215-409-00	METAL	330 1% 1/4W	R86	1-215-445-00	METAL	10K 1% 1/4W
R24	1-215-380-00	METAL	20 1% 1/4W	R87	1-249-422-11	CARBON	2.7K 5% 1/4W
R25	1-215-380-00	METAL	20 1% 1/4W	R88	1-215-430-00	METAL	2.4K 1% 1/4W
R26	1-215-409-00	METAL	330 1% 1/4W	R89	1-215-443-00	METAL	8.2K 1% 1/4W
R27	1-249-429-11	CARBON	10K 5% 1/4W	R90	1-249-430-11	CARBON	12K 5% 1/4W
R28	1-249-417-11	CARBON	1K 5% 1/4W	R91	1-217-807-31	CARBON	100 5% 1/4W
R29	1-215-418-00	METAL	750 1% 1/4W	R92	1-247-830-11	CARBON	910 5% 1/4W
R30	1-249-422-11	CARBON	2.7K 5% 1/4W	R93	1-215-421-00	METAL	1K 1% 1/4W
R31	1-217-807-31	CARBON	100 5% 1/4W	R94	1-249-422-11	CARBON	2.7K 5% 1/4W
R32	1-249-420-11	CARBON	1.8K 5% 1/4W	R98	1-249-422-11	CARBON	2.7K 5% 1/4W
R33	1-249-429-11	CARBON	10K 5% 1/4W	R99	1-249-422-11	CARBON	2.7K 5% 1/4W
R34	1-249-428-11	CARBON	8.2K 5% 1/4W	R161	1-215-438-00	METAL	5.1K 1% 1/4W
R35	1-249-417-11	CARBON	1K 5% 1/4W	R162	1-249-431-11	CARBON	15K 5% 1/4W
R36	1-249-422-11	CARBON	2.7K 5% 1/4W	R163	1-249-417-11	CARBON	1K 5% 1/4W
R37	1-217-807-31	CARBON	100 5% 1/4W	R164	1-215-435-00	METAL	3.9K 1% 1/4W
R40	1-249-425-11	CARBON	4.7K 5% 1/4W	R165	1-249-422-11	CARBON	2.7K 5% 1/4W
R41	1-249-422-11	CARBON	2.7K 5% 1/4W	R166	1-249-422-11	CARBON	2.7K 5% 1/4W
R42	1-249-417-11	CARBON	1K 5% 1/4W	R167	1-215-409-00	METAL	330 1% 1/4W
R43	1-249-417-11	CARBON	1K 5% 1/4W	R168	1-215-412-00	METAL	430 1% 1/4W
R44	1-249-431-11	CARBON	15K 5% 1/4W	R169	1-215-427-00	METAL	1.8K 1% 1/4W
R45	1-249-423-11	CARBON	3.3K 5% 1/4W	R170	1-249-425-11	CARBON	4.7K 5% 1/4W
R46	1-249-417-11	CARBON	1K 5% 1/4W	R171	1-215-436-00	METAL	4.3K 1% 1/4W
R47	1-249-423-11	CARBON	3.3K 5% 1/4W	R172	1-249-431-11	CARBON	15K 5% 1/4W
R48	1-249-422-11	CARBON	2.7K 5% 1/4W	R173	1-249-417-11	CARBON	1K 5% 1/4W
R49	1-217-807-31	CARBON	100 5% 1/4W	R174	1-215-435-00	METAL	3.9K 1% 1/4W
R50	1-249-422-11	CARBON	2.7K 5% 1/4W	R175	1-249-422-11	CARBON	2.7K 5% 1/4W
R51	1-247-903-00	CARBON	1M 5% 1/4W	R176	1-249-422-11	CARBON	2.7K 5% 1/4W
R52	1-247-866-11	CARBON	30K 5% 1/4W	R177	1-215-409-00	METAL	330 1% 1/4W
R53	1-215-445-00	METAL	10K 1% 1/4W	R178	1-215-414-00	METAL	510 1% 1/4W
R54	1-249-420-11	CARBON	1.8K 5% 1/4W	R179	1-215-422-00	METAL	1.1K 1% 1/4W
R55	1-249-422-11	CARBON	2.7K 5% 1/4W	R180	1-249-425-11	CARBON	4.7K 5% 1/4W
R56	1-217-807-31	CARBON	100 5% 1/4W	R181	1-215-380-00	METAL	20 1% 1/4W
R57	1-249-422-11	CARBON	2.7K 5% 1/4W	R182	1-215-380-00	METAL	20 1% 1/4W
R58	1-249-422-11	CARBON	2.7K 5% 1/4W	R183	1-249-433-11	CARBON	22K 5% 1/4W
R59	1-249-422-11	CARBON	2.7K 5% 1/4W	R184	1-249-425-11	CARBON	4.7K 5% 1/4W
R61	1-249-422-11	CARBON	2.7K 5% 1/4W	R201	1-249-437-11	CARBON	47K 5% 1/4W
R62	1-249-417-11	CARBON	1K 5% 1/4W	R202	1-249-429-11	CARBON	10K 5% 1/4W
R63	1-249-417-11	CARBON	1K 5% 1/4W	R203	1-249-435-11	CARBON	33K 5% 1/4W
R64	1-249-431-11	CARBON	15K 5% 1/4W	R204	1-247-872-11	CARBON	51K 5% 1/4W
R65	1-249-423-11	CARBON	3.3K 5% 1/4W				
				<VARIABLE RESISTOR>			
				RV1	1-237-514-21	RES, ADJ, CERMET 500	
				RV2	1-237-508-21	RES, ADJ, CERMET 500K	

REF. NO.	PART NO.	DESCRIPTION	REMARK	REF. NO.	PART NO.	DESCRIPTION	REMARK
RV3	1-237-498-21	RES. ADJ. CERMET 200		C86	1-101-004-00	CERAMIC	0.01MF 50V
RV4	1-237-500-21	RES. ADJ. CERMET 1K		C101	1-161-021-11	CERAMIC	0.047MF 10% 25V
RV5	1-237-500-21	RES. ADJ. CERMET 1K		C102	1-102-942-00	CERAMIC	5PF 0.5PF 50V
RV21	1-237-517-21	RES. ADJ. CERMET 5K		C103	1-102-959-00	CERAMIC	22PF 5% 50V
RV22	1-237-517-21	RES. ADJ. CERMET 5K		C104	1-126-964-11	ELECT	10MF 20% 16V
<SWITCH>				C105	1-161-021-11	CERAMIC	0.047MF 10% 25V
S1	1-570-857-11	SWITCH, SLIDE		C106	1-101-004-00	CERAMIC	0.01MF 50V
*****				C107	1-161-021-11	CERAMIC	0.047MF 10% 25V
*A-1135-359-A	BH BOARD, COMPLETE	*****		C108	1-101-004-00	CERAMIC	0.01MF 50V
*4-353-708-00	HOOK, FINGER			C109	1-101-004-00	CERAMIC	0.01MF 50V
7-682-547-09	SCREW +BVTT 3X6 (S)			C110	1-101-880-00	CERAMIC	47PF 5% 50V
<CAPACITOR>				C201	1-161-021-11	CERAMIC	0.047MF 10% 25V
C1	1-104-792-51	ELECT	33MF 20% 16V	C202	1-102-942-00	CERAMIC	5PF 0.5PF 50V
C2	1-104-792-51	ELECT	33MF 20% 16V	C203	1-102-959-00	CERAMIC	22PF 5% 50V
C3	1-104-792-51	ELECT	33MF 20% 16V	C204	1-126-964-11	ELECT	10MF 20% 16V
C4	1-104-792-51	ELECT	33MF 20% 16V	C205	1-161-021-11	CERAMIC	0.047MF 10% 25V
C5	1-104-792-51	ELECT	33MF 20% 16V	C206	1-101-004-00	CERAMIC	0.01MF 50V
C6	1-104-792-51	ELECT	33MF 20% 16V	C207	1-161-021-11	CERAMIC	0.047MF 10% 25V
C7	1-104-792-51	ELECT	33MF 20% 16V	C208	1-101-004-00	CERAMIC	0.01MF 50V
C8	1-104-792-51	ELECT	33MF 20% 16V	C209	1-101-004-00	CERAMIC	0.01MF 50V
C9	1-104-792-51	ELECT	33MF 20% 16V	C210	1-101-880-00	CERAMIC	47PF 5% 50V
C10	1-104-792-51	ELECT	33MF 20% 16V	C301	1-161-021-11	CERAMIC	0.047MF 10% 25V
C11	1-104-792-51	ELECT	33MF 20% 16V	C302	1-102-942-00	CERAMIC	5PF 0.5PF 50V
C12	1-104-792-51	ELECT	33MF 20% 16V	C303	1-102-959-00	CERAMIC	22PF 5% 50V
C13	1-104-792-51	ELECT	33MF 20% 16V	C304	1-126-964-11	ELECT	10MF 20% 16V
C14	1-104-792-51	ELECT	33MF 20% 16V	C305	1-161-021-11	CERAMIC	0.047MF 10% 25V
C15	1-101-004-00	CERAMIC	0.01MF 50V	C306	1-101-004-00	CERAMIC	0.01MF 50V
C16	1-101-004-00	CERAMIC	0.01MF 50V	C307	1-161-021-11	CERAMIC	0.047MF 10% 25V
C17	1-101-004-00	CERAMIC	0.01MF 50V	C308	1-101-004-00	CERAMIC	0.01MF 50V
C18	1-101-004-00	CERAMIC	0.01MF 50V	C309	1-101-004-00	CERAMIC	0.01MF 50V
C20	1-126-111-11	ELECT	3.3MF 20% 50V	C310	1-101-880-00	CERAMIC	47PF 5% 50V
C21	1-126-964-11	ELECT	10MF 20% 16V	<COMPOSITION CIRCUIT BLOCK>			
C22	1-126-964-11	ELECT	10MF 20% 16V	CP1	1-232-726-11	COMPOSITION CIRCUIT BLOCK	
C23	1-126-964-11	ELECT	10MF 20% 16V	CP2	1-232-727-11	COMPOSITION CIRCUIT BLOCK	
C24	1-126-964-11	ELECT	10MF 20% 16V	CP3	1-233-012-11	COMPOSITION CIRCUIT BLOCK	
C26	1-101-004-00	CERAMIC	0.01MF 50V	CP5	1-233-012-11	COMPOSITION CIRCUIT BLOCK	
C41	1-124-119-00	ELECT	330MF 20% 16V	CP7	1-233-012-11	COMPOSITION CIRCUIT BLOCK	
C42	1-124-119-00	ELECT	330MF 20% 16V	CP9	1-232-735-11	COMPOSITION CIRCUIT BLOCK	
C43	1-124-119-00	ELECT	330MF 20% 16V	CP10	1-231-760-00	COMPOSITION CIRCUIT BLOCK	
C44	1-126-964-11	ELECT	10MF 20% 16V	CP12	1-232-735-11	COMPOSITION CIRCUIT BLOCK	
C45	1-126-964-11	ELECT	10MF 20% 16V	CP13	1-231-760-00	COMPOSITION CIRCUIT BLOCK	
C50	1-126-964-11	ELECT	10MF 20% 16V	CP15	1-232-735-11	COMPOSITION CIRCUIT BLOCK	
C51	1-101-004-00	CERAMIC	0.01MF 50V	CP16	1-232-749-11	COMPOSITION CIRCUIT BLOCK	
C52	1-101-004-00	CERAMIC	0.01MF 50V	CP17	1-232-096-00	COMPOSITION CIRCUIT BLOCK	
C53	1-101-004-00	CERAMIC	0.01MF 50V	CP18	1-233-011-11	COMPOSITION CIRCUIT BLOCK	
C54	1-101-004-00	CERAMIC	0.01MF 50V	CP19	1-233-011-11	COMPOSITION CIRCUIT BLOCK	
C55	1-101-004-00	CERAMIC	0.01MF 50V	CP20	1-232-736-11	COMPOSITION CIRCUIT BLOCK	
C71	1-124-119-00	ELECT	330MF 20% 16V	CP21	1-232-736-11	COMPOSITION CIRCUIT BLOCK	
C72	1-124-119-00	ELECT	330MF 20% 16V	CP22	1-232-745-11	COMPOSITION CIRCUIT BLOCK	
C73	1-124-119-00	ELECT	330MF 20% 16V	CP23	1-233-011-11	COMPOSITION CIRCUIT BLOCK	
C74	1-126-964-11	ELECT	10MF 20% 16V	CP24	1-233-011-11	COMPOSITION CIRCUIT BLOCK	
C80	1-126-964-11	ELECT	10MF 20% 16V	CP25	1-233-144-11	COMPOSITION CIRCUIT BLOCK	
C81	1-101-004-00	CERAMIC	0.01MF 50V	CP26	1-233-011-11	COMPOSITION CIRCUIT BLOCK	
C82	1-101-004-00	CERAMIC	0.01MF 50V	CP27	1-232-177-00	COMPOSITION CIRCUIT BLOCK	
C83	1-101-004-00	CERAMIC	0.01MF 50V	CP28	1-233-011-11	COMPOSITION CIRCUIT BLOCK	
C84	1-101-004-00	CERAMIC	0.01MF 50V	CP29	1-233-011-11	COMPOSITION CIRCUIT BLOCK	
C85	1-101-004-00	CERAMIC	0.01MF 50V	CP30	1-233-011-11	COMPOSITION CIRCUIT BLOCK	
				CP31	1-233-011-11	COMPOSITION CIRCUIT BLOCK	
				CP32	1-232-737-11	COMPOSITION CIRCUIT BLOCK	
				CP33	1-231-938-00	COMPOSITION CIRCUIT BLOCK	
				CP101	1-232-726-11	COMPOSITION CIRCUIT BLOCK	
				CP102	1-232-726-11	COMPOSITION CIRCUIT BLOCK	

7. ELECTRICAL PARTS LIST







REF.NO.	PART NO.	DESCRIPTION	REMARK	REF.NO.	PART NO.	DESCRIPTION	REMARK
R109	1-249-419-11	CARBON	1.5K 5% 1/4W	C1	1-130-481-00	MYLAR	0.0068MF 5% 50V
R110	1-215-427-00	METAL	1.8K 1% 1/4W	C2	1-136-165-00	FILM	0.1MF 5% 50V
R111	1-215-453-00	METAL	22K 1% 1/4W	C3	1-124-927-11	ELECT	4.7MF 20% 25V
R112	1-249-419-11	CARBON	1.5K 5% 1/4W	C4	1-124-927-11	ELECT	4.7MF 20% 25V
R113	1-247-807-31	CARBON	100 5% 1/4W	C5	1-102-973-00	CERAMIC	100PF 5% 50V
R114	1-215-445-00	METAL	10K 1% 1/4W	C7	1-124-916-11	ELECT	22MF 20% 25V
R115	1-215-445-00	METAL	10K 1% 1/4W	C8	1-124-927-11	ELECT	4.7MF 20% 25V
R116	1-249-429-11	CARBON	10K 5% 1/4W	C10	1-124-915-11	ELECT	10MF 20% 50V
R117	1-215-493-00	METAL	1M 1% 1/4W	C11	1-126-964-11	ELECT	10MF 20% 50V
R120	1-215-451-00	METAL	18K 1% 1/4W	C12	1-101-004-00	CERAMIC	0.01MF 50V
R121	1-215-453-00	METAL	22K 1% 1/4W	C13	1-101-004-00	CERAMIC	0.01MF 50V
R201	1-247-903-91	CARBON	1M 5% 1/4W	C14	1-101-004-00	CERAMIC	0.01MF 50V
R202	1-249-431-11	CARBON	15K 5% 1/4W	C15	1-126-233-11	ELECT	22MF 20% 16V
R203	1-249-419-11	CARBON	1.5K 5% 1/4W	C16	1-126-964-11	ELECT	10MF 20% 16V
R204	1-249-430-11	CARBON	12K 5% 1/4W	C17	1-101-004-00	CERAMIC	0.01MF 50V
R205	1-249-409-11	CARBON	220 5% 1/4W	C18	1-101-004-00	CERAMIC	0.01MF 50V
R206	1-249-419-11	CARBON	1.5K 5% 1/4W	C19	1-101-004-00	CERAMIC	0.01MF 50V
R207	1-215-425-00	METAL	1.5K 1% 1/4W	C41	1-104-792-51	ELECT	33MF 20% 16V
R208	1-249-415-11	CARBON	680 5% 1/4W	C42	1-104-792-51	ELECT	33MF 20% 16V
R209	1-249-419-11	CARBON	1.5K 5% 1/4W	C43	1-104-792-51	ELECT	33MF 20% 16V
R210	1-215-427-00	METAL	1.8K 1% 1/4W	C44	1-104-792-51	ELECT	33MF 20% 16V
R211	1-215-453-00	METAL	22K 1% 1/4W	C45	1-104-792-51	ELECT	33MF 20% 16V
R212	1-249-419-11	CARBON	1.5K 5% 1/4W	C46	1-104-792-51	ELECT	33MF 20% 16V
R213	1-247-807-31	CARBON	100 5% 1/4W	C51	1-101-004-00	CERAMIC	0.01MF 50V
R214	1-215-445-00	METAL	10K 1% 1/4W	C52	1-101-004-00	CERAMIC	0.01MF 50V
R215	1-215-445-00	METAL	10K 1% 1/4W	C53	1-101-004-00	CERAMIC	0.01MF 50V
R216	1-249-429-11	CARBON	10K 5% 1/4W	C54	1-101-004-00	CERAMIC	0.01MF 50V
R217	1-215-455-00	METAL	27K 1% 1/4W	C55	1-101-004-00	CERAMIC	0.01MF 50V
R301	1-247-903-00	CARBON	1M 5% 1/4W	C56	1-101-004-00	CERAMIC	0.01MF 50V
R302	1-249-431-11	CARBON	15K 5% 1/4W	C57	1-101-004-00	CERAMIC	0.01MF 50V
R303	1-249-419-11	CARBON	1.5K 5% 1/4W	C71	1-104-792-51	ELECT	33MF 20% 16V
R304	1-249-430-11	CARBON	12K 5% 1/4W	C72	1-104-792-51	ELECT	33MF 20% 16V
R305	1-249-409-11	CARBON	220 5% 1/4W	C73	1-104-792-51	ELECT	33MF 20% 16V
R306	1-249-419-11	CARBON	1.5K 5% 1/4W	C74	1-104-792-51	ELECT	33MF 20% 16V
R307	1-215-425-00	METAL	1.5K 1% 1/4W	C75	1-104-792-51	ELECT	33MF 20% 16V
R308	1-249-415-11	CARBON	680 5% 1/4W	C76	1-104-792-51	ELECT	33MF 20% 16V
R309	1-249-419-11	CARBON	1.5K 5% 1/4W	C81	1-101-004-00	CERAMIC	0.01MF 50V
R310	1-215-427-00	METAL	1.8K 1% 1/4W	C82	1-101-004-00	CERAMIC	0.01MF 50V
R311	1-215-453-00	METAL	22K 1% 1/4W	C83	1-101-004-00	CERAMIC	0.01MF 50V
R312	1-249-419-11	CARBON	1.5K 5% 1/4W	C84	1-101-004-00	CERAMIC	0.01MF 50V
R313	1-247-807-31	CARBON	100 5% 1/4W	C85	1-101-004-00	CERAMIC	0.01MF 50V
R314	1-215-445-00	METAL	10K 1% 1/4W	C86	1-101-004-00	CERAMIC	0.01MF 50V
R315	1-215-445-00	METAL	10K 1% 1/4W	C87	1-101-004-00	CERAMIC	0.01MF 50V
R316	1-249-429-11	CARBON	10K 5% 1/4W	C101	1-101-004-00	CERAMIC	0.01MF 50V
		<VARIABLE RESISTOR>		C102	1-124-903-11	ELECT	1MF 20% 50V
RV1	1-237-505-21	RES, ADJ, CERMET 50K		C104	1-126-964-11	ELECT	10MF 20% 16V
RV2	1-237-505-21	RES, ADJ, CERMET 50K		C105	1-101-004-00	CERAMIC	0.01MF 50V
RV3	1-237-505-21	RES, ADJ, CERMET 50K		C106	1-136-161-00	FILM	0.047MF 5% 50V
		<SWITCH>		C107	1-102-937-00	CERAMIC	4PF 0.25PF 50V
S1	1-570-857-11	SWITCH, SLIDE		C108	1-101-880-00	CERAMIC	47PF 5% 50V
S2	1-570-851-11	SWITCH, SLIDE		C109	1-136-161-00	FILM	0.047MF 5% 50V
		*****		C110	1-136-161-00	FILM	0.047MF 5% 50V
		*A-1135-591-A BI BOARD, COMPLETE		C114	1-102-951-00	CERAMIC	15PF 5% 50V
		*****		C115	1-136-153-00	FILM	0.01MF 5% 50V
		*4-353-708-00 HOOK, FINGER		C116	1-102-973-00	CERAMIC	100PF 5% 50V
		7-682-547-09 SCREW +BVTT 3X6 (S)		C117	1-101-004-00	CERAMIC	0.01MF 50V
		<CAPACITOR>		C118	1-101-004-00	CERAMIC	0.01MF 50V
				C119	1-102-953-00	CERAMIC	18PF 5% 50V
				C120	1-102-973-00	CERAMIC	100PF 5% 50V
				C122	1-102-961-00	CERAMIC	27PF 5% 50V
				C201	1-101-004-00	CERAMIC	0.01MF 50V
				C202	1-124-903-11	ELECT	1MF 20% 50V
				C204	1-126-964-11	ELECT	10MF 20% 16V

7. ELECTRICAL PARTS LIST

REF. NO.	PART NO.	DESCRIPTION	REMARK	REF. NO.	PART NO.	DESCRIPTION	REMARK
C205	1-101-004-00	CERAMIC	0.01MF	50V			
C206	1-136-161-00	FILM	0.047MF	5%	50V		
C207	1-102-937-00	CERAMIC	4PF	0.25PF	50V		
C208	1-101-880-00	CERAMIC	47PF	5%	50V		
C209	1-136-161-00	FILM	0.047MF	5%	50V		
C210	1-136-161-00	FILM	0.047MF	5%	50V		
C214	1-102-951-00	CERAMIC	15PF	5%	50V		
C215	1-136-153-00	FILM	0.01MF	5%	50V		
C216	1-102-973-00	CERAMIC	100PF	5%	50V		
C217	1-101-004-00	CERAMIC	0.01MF		50V		
C218	1-101-004-00	CERAMIC	0.01MF		50V		
C219	1-102-953-00	CERAMIC	18PF	5%	50V		
C220	1-102-973-00	CERAMIC	100PF	5%	50V		
C222	1-102-961-00	CERAMIC	27PF	5%	50V		
C301	1-101-004-00	CERAMIC	0.01MF		50V		
C302	1-124-903-11	ELECT	1MF	20%	50V		
C304	1-126-964-11	ELECT	10MF	20%	16V		
C305	1-101-004-00	CERAMIC	0.01MF		50V		
C306	1-136-161-00	FILM	0.047MF	5%	50V		
C307	1-102-937-00	CERAMIC	4PF	0.25PF	50V		
C308	1-101-880-00	CERAMIC	47PF	5%	50V		
C309	1-136-161-00	FILM	0.047MF	5%	50V		
C310	1-136-161-00	FILM	0.047MF	5%	50V		
C314	1-102-951-00	CERAMIC	15PF	5%	50V		
C315	1-136-153-00	FILM	0.01MF	5%	50V		
C316	1-102-973-00	CERAMIC	100PF	5%	50V		
C317	1-101-004-00	CERAMIC	0.01MF		50V		
C318	1-101-004-00	CERAMIC	0.01MF		50V		
C319	1-102-953-00	CERAMIC	18PF	5%	50V		
C320	1-102-973-00	CERAMIC	100PF	5%	50V		
C322	1-102-961-00	CERAMIC	27PF	5%	50V		
<COMPOSITION CIRCUIT BLOCK>							
CP3	1-231-765-00	COMPOSITION CIRCUIT BLOCK					
CP4	1-231-765-00	COMPOSITION CIRCUIT BLOCK					
CP5	1-231-765-00	COMPOSITION CIRCUIT BLOCK					
CP6	1-231-765-00	COMPOSITION CIRCUIT BLOCK					
CP7	1-231-765-00	COMPOSITION CIRCUIT BLOCK					
CP101	1-233-012-11	COMPOSITION CIRCUIT BLOCK					
CP102	1-233-012-11	COMPOSITION CIRCUIT BLOCK					
CP103	1-233-012-11	COMPOSITION CIRCUIT BLOCK					
CP104	1-232-726-11	COMPOSITION CIRCUIT BLOCK					
CP201	1-233-012-11	COMPOSITION CIRCUIT BLOCK					
CP202	1-233-012-11	COMPOSITION CIRCUIT BLOCK					
CP203	1-233-012-11	COMPOSITION CIRCUIT BLOCK					
CP204	1-232-726-11	COMPOSITION CIRCUIT BLOCK					
CP301	1-233-012-11	COMPOSITION CIRCUIT BLOCK					
CP302	1-233-012-11	COMPOSITION CIRCUIT BLOCK					
CP303	1-233-012-11	COMPOSITION CIRCUIT BLOCK					
CP304	1-232-726-11	COMPOSITION CIRCUIT BLOCK					
<DIODE>							
D1	8-719-911-19	DIODE 1SS119					
D2	8-719-911-19	DIODE 1SS119					
D4	8-719-911-19	DIODE 1SS119					
D5	8-719-911-19	DIODE 1SS119					
D6	8-719-110-31	DIODE RD12ESB2					
D7	8-719-911-19	DIODE 1SS119					
D8	8-719-911-19	DIODE 1SS119					
D101	8-719-911-19	DIODE 1SS119					
D102	8-719-016-42	DIODE MC932					
D103	8-719-109-74	DIODE RD4.3ESB1					
D104	8-719-911-19	DIODE 1SS119					
D105	8-719-109-93	DIODE RD6.2ESB2					
D201	8-719-911-19	DIODE 1SS119					
D202	8-719-016-42	DIODE MC932					
D203	8-719-109-74	DIODE RD4.3ESB1					
D204	8-719-911-19	DIODE 1SS119					
D205	8-719-109-93	DIODE RD6.2ESB2					
D301	8-719-911-19	DIODE 1SS119					
D302	8-719-016-42	DIODE MC932					
D303	8-719-109-74	DIODE RD4.3ESB1					
D304	8-719-911-19	DIODE 1SS119					
D305	8-719-109-93	DIODE RD6.2ESB2					
<IC>							
IC1	8-759-145-58	IC UPC4558C					
IC101	8-759-140-53	IC UPD4053BC					
IC102	8-766-001-49	TRANSISTOR TX-429M					
IC103	8-759-503-91	IC TL082ACP					
IC104	8-759-503-91	IC TL082ACP					
IC105	8-759-503-91	IC TL082ACP					
IC201	8-759-140-53	IC UPD4053BC					
IC202	8-766-001-49	TRANSISTOR TX-429M					
IC203	8-759-503-91	IC TL082ACP					
IC204	8-759-503-91	IC TL082ACP					
IC205	8-759-503-91	IC TL082ACP					
IC301	8-759-140-53	IC UPD4053BC					
IC302	8-766-001-49	TRANSISTOR TX-429M					
IC303	8-759-503-91	IC TL082ACP					
IC304	8-759-503-91	IC TL082ACP					
IC305	8-759-503-91	IC TL082ACP					
<TRANSISTOR>							
Q1	8-729-900-74	TRANSISTOR DTC143TS					
Q2	8-729-119-78	TRANSISTOR 2SC2785-HFE					
Q3	8-729-119-78	TRANSISTOR 2SC2785-HFE					
Q11	8-729-231-55	TRANSISTOR 2SC2878-AB					
Q12	8-729-231-55	TRANSISTOR 2SC2878-AB					
Q13	8-729-231-55	TRANSISTOR 2SC2878-AB					
Q14	8-729-231-55	TRANSISTOR 2SC2878-AB					
Q15	8-729-900-65	TRANSISTOR DTA144ES					
Q101	8-729-384-48	TRANSISTOR 2SA844					
Q102	8-729-384-48	TRANSISTOR 2SA844					
Q103	8-729-384-48	TRANSISTOR 2SA844					
Q105	8-729-600-19	TRANSISTOR 2SK381-A					
Q106	8-729-384-48	TRANSISTOR 2SA844					
Q107	8-729-266-82	TRANSISTOR 2SC2668-0					
Q108	8-729-384-48	TRANSISTOR 2SA844					
Q109	8-729-600-19	TRANSISTOR 2SK381-A					
Q110	8-729-600-19	TRANSISTOR 2SK381-A					
Q113	8-729-600-19	TRANSISTOR 2SK381-A					
Q114	8-729-200-17	TRANSISTOR 2SA1091-0					
Q201	8-729-384-48	TRANSISTOR 2SA844					
Q202	8-729-384-48	TRANSISTOR 2SA844					
Q203	8-729-384-48	TRANSISTOR 2SA844					
Q205	8-729-600-19	TRANSISTOR 2SK381-A					
Q206	8-729-384-48	TRANSISTOR 2SA844					
Q207	8-729-266-82	TRANSISTOR 2SC2668-0					
Q208	8-729-384-48	TRANSISTOR 2SA844					
Q209	8-729-600-19	TRANSISTOR 2SK381-A					
Q210	8-729-600-19	TRANSISTOR 2SK381-A					
Q213	8-729-600-19	TRANSISTOR 2SK381-A					





REF. NO.	PART NO.	DESCRIPTION	REMARK	REF. NO.	PART NO.	DESCRIPTION	REMARK
R311	1-249-417-11	CARBON	1K 5% 1/4W	C35	1-130-471-00	MYLAR	0.001MF 5% 50V
R313	1-247-903-91	CARBON	1M 5% 1/4W	C36	1-102-824-00	CERAMIC	470PF 5% 50V
R314	1-249-419-11	CARBON	1.5K 5% 1/4W	C37	1-124-903-11	ELECT	1MF 20% 50V
R315	1-249-419-11	CARBON	1.5K 5% 1/4W	C38	1-101-004-00	CERAMIC	0.01MF 50V
R316	1-249-424-11	CARBON	3.9K 5% 1/4W	C39	1-101-004-00	CERAMIC	0.01MF 50V
R317	1-249-419-11	CARBON	1.5K 5% 1/4W	C40	1-102-074-00	CERAMIC	0.001MF 10% 50V
R318	1-215-421-00	METAL	1K 1% 1/4W	C61	1-101-888-00	CERAMIC	68PF 5% 50V
R319	1-247-807-31	CARBON	100 5% 1/4W	C62	1-101-880-00	CERAMIC	47PF 5% 50V
R320	1-247-807-31	CARBON	100 5% 1/4W	C63	1-101-888-00	CERAMIC	68PF 5% 50V
R321	1-249-409-11	CARBON	220 5% 1/4W	C64	1-101-880-00	CERAMIC	47PF 5% 50V
R322	1-215-425-00	METAL	1.5K 1% 1/4W	C65	1-102-820-00	CERAMIC	330PF 5% 50V
R323	1-249-429-11	CARBON	10K 5% 1/4W	C66	1-101-004-00	CERAMIC	0.01MF 50V
R324	1-249-429-11	CARBON	10K 5% 1/4W	C67	1-101-880-00	CERAMIC	47PF 5% 50V
R325	1-249-422-11	CARBON	2.7K 5% 1/4W	C100	1-126-967-11	ELECT	47MF 20% 16V
R327	1-215-445-00	METAL	10K 1% 1/4W	C102	1-104-792-51	ELECT	33MF 20% 16V
R328	1-215-445-00	METAL	10K 1% 1/4W	C106	1-101-004-00	CERAMIC	0.01MF 50V
R336	1-215-477-00	METAL	220K 1% 1/4W	C108	1-104-792-51	ELECT	33MF 20% 16V
R337	1-249-417-11	CARBON	1K 5% 1/4W	C109	1-101-004-00	CERAMIC	0.01MF 50V
R338	1-249-441-11	CARBON	100K 5% 1/4W	C110	1-101-004-00	CERAMIC	0.01MF 50V
R340	1-249-429-11	CARBON	10K 5% 1/4W	C111	1-101-004-00	CERAMIC	0.01MF 50V
R341	1-215-461-00	METAL	47K 1% 1/4W	C112	1-101-004-00	CERAMIC	0.01MF 50V
R342	1-215-459-00	METAL	39K 1% 1/4W	C113	1-101-004-00	CERAMIC	0.01MF 50V
R343	1-215-488-00	METAL	620K 1% 1/4W	C114	1-126-964-11	ELECT	10MF 20% 16V
R344	1-249-434-11	CARBON	27K 5% 1/4W	C115	1-101-004-00	CERAMIC	0.01MF 50V
R345	1-249-429-11	CARBON	10K 5% 1/4W	C116	1-101-004-00	CERAMIC	0.01MF 50V
R346	1-249-429-11	CARBON	10K 5% 1/4W	C117	1-101-004-00	CERAMIC	0.01MF 50V
R347	1-247-807-31	CARBON	100 5% 1/4W	C118	1-126-964-11	ELECT	10MF 20% 16V
R350	1-247-807-31	CARBON	100 5% 1/4W	C120	1-101-004-00	CERAMIC	0.01MF 50V
				C121	1-101-004-00	CERAMIC	0.01MF 50V
*****							
	*A-1135-361-A	BJ BOARD, COMPLETE		C122	1-101-004-00	CERAMIC	0.01MF 50V
		*****		C130	1-104-792-51	ELECT	33MF 20% 16V
	*4-353-708-00	HOOK, FINGER		<COMPOSITION CIRCUIT BLOCK>			
	7-682-547-09	SCREW +BVTT 3X6 (S)		CP1	1-232-738-11	COMPOSITION CIRCUIT BLOCK	
				CP2	1-232-738-11	COMPOSITION CIRCUIT BLOCK	
				CP3	1-232-738-11	COMPOSITION CIRCUIT BLOCK	
				CP4	1-232-738-11	COMPOSITION CIRCUIT BLOCK	
				CP5	1-232-738-11	COMPOSITION CIRCUIT BLOCK	
				<DIODE>			
				D1	8-719-911-19	DIODE 1SS119	
				D2	8-719-911-19	DIODE 1SS119	
				D3	8-719-911-19	DIODE 1SS119	
				D7	8-719-911-19	DIODE 1SS119	
				D8	8-719-911-19	DIODE 1SS119	
				D9	8-719-911-19	DIODE 1SS119	
				D11	8-719-016-42	DIODE MC932	
				<IC>			
				IC1	8-759-345-38	IC HD14538BP	
				IC2	8-759-040-01	IC MC14001BCP	
				IC3	8-759-240-40	IC TC4040BP	
				IC4	8-759-240-40	IC TC4040BP	
				IC5	8-759-000-35	IC MC14027BCP	
				IC6	8-759-000-35	IC MC14027BCP	
				IC7	8-759-000-35	IC MC14027BCP	
				IC8	8-759-000-35	IC MC14027BCP	
				IC9	8-759-000-35	IC MC14027BCP	
				IC10	8-759-345-38	IC HD14538BP	
				IC11	8-759-345-38	IC HD14538BP	
				IC12	8-759-345-38	IC HD14538BP	

7. ELECTRICAL PARTS LIST

REF. NO.	PART NO.	DESCRIPTION	REMARK	REF. NO.	PART NO.	DESCRIPTION	REMARK
IC13	8-759-040-01	IC MC14001BCP		R56	1-249-434-11	CARBON 27K 5%	1/4W
IC14	8-759-040-01	IC MC14001BCP		R57	1-249-422-11	CARBON 2.7K 5%	1/4W
IC15	8-759-240-71	IC TC4071BP		R58	1-249-425-11	CARBON 4.7K 5%	1/4W
IC16	8-759-140-11	IC UPD4011BC		R59	1-247-836-11	CARBON 1.6K 5%	1/4W
IC17	8-759-140-11	IC UPD4011BC		R60	1-249-427-11	CARBON 6.8K 5%	1/4W
IC18	8-759-000-32	IC MC14023BCP		R61	1-215-449-00	METAL 15K 1%	1/4W
IC19	8-759-240-81	IC TC4081BP		R62	1-249-433-11	CARBON 22K 5%	1/4W
IC20	8-759-240-81	IC TC4081BP		R63	1-249-425-11	CARBON 4.7K 5%	1/4W
IC21	8-759-240-71	IC TC4071BP		R64	1-249-425-11	CARBON 4.7K 5%	1/4W
IC22	8-759-240-71	IC TC4071BP		R65	1-249-417-11	CARBON 1K 5%	1/4W
IC23	8-759-040-73	IC TC4073BP		R66	1-249-430-11	CARBON 12K 5%	1/4W
IC24	8-759-240-69	IC TC4069UBP		R67	1-249-425-11	CARBON 4.7K 5%	1/4W
IC25	8-759-240-69	IC TC4069UBP		R68	1-249-433-11	CARBON 22K 5%	1/4W
IC26	8-759-041-75	IC MC14175BCP		R69	1-249-425-11	CARBON 4.7K 5%	1/4W
IC27	8-759-140-53	IC UPD4053BC		R70	1-249-417-11	CARBON 1K 5%	1/4W
IC28	8-759-208-04	IC TC4520BPHB		R71	1-249-430-11	CARBON 12K 5%	1/4W
IC29	8-759-345-38	IC HD14538BP		R72	1-249-433-11	CARBON 22K 5%	1/4W
		<COIL>		R74	1-249-430-11	CARBON 12K 5%	1/4W
L1	1-408-098-00	INDUCTOR 560UH		R75	1-249-422-11	CARBON 2.7K 5%	1/4W
L2	1-408-098-00	INDUCTOR 560UH		R76	1-215-463-00	METAL 56K 1%	1/4W
L3	1-407-715-11	INDUCTOR 680UH		R77	1-215-475-00	METAL 180K 1%	1/4W
		<TRANSISTOR>		R78	1-215-439-00	METAL 5.6K 1%	1/4W
Q14	8-729-119-78	TRANSISTOR 2SC2785-HFE		R79	1-249-425-11	CARBON 4.7K 5%	1/4W
Q15	8-729-119-78	TRANSISTOR 2SC2785-HFE		R80	1-249-433-11	CARBON 22K 5%	1/4W
Q16	8-729-119-78	TRANSISTOR 2SC2785-HFE		R81	1-249-425-11	CARBON 4.7K 5%	1/4W
Q17	8-729-119-78	TRANSISTOR 2SC2785-HFE		R82	1-249-415-11	CARBON 680 5%	1/4W
Q18	8-729-119-78	TRANSISTOR 2SC2785-HFE		R83	1-249-417-11	CARBON 1K 5%	1/4W
Q19	8-729-119-76	TRANSISTOR 2SA1175-HFE		R85	1-249-430-11	CARBON 12K 5%	1/4W
Q20	8-729-119-78	TRANSISTOR 2SC2785-HFE		R87	1-249-422-11	CARBON 2.7K 5%	1/4W
Q21	8-729-119-78	TRANSISTOR 2SC2785-HFE		R89	1-247-887-00	CARBON 220K 5%	1/4W
Q22	8-729-119-78	TRANSISTOR 2SC2785-HFE		R90	1-249-441-11	CARBON 100K 5%	1/4W
Q23	8-729-119-76	TRANSISTOR 2SA1175-HFE		R91	1-249-441-11	CARBON 100K 5%	1/4W
Q24	8-729-119-78	TRANSISTOR 2SC2785-HFE		R92	1-249-441-11	CARBON 100K 5%	1/4W
Q25	8-729-119-78	TRANSISTOR 2SC2785-HFE		R93	1-249-429-11	CARBON 10K 5%	1/4W
Q26	8-729-119-78	TRANSISTOR 2SC2785-HFE		R94	1-249-429-11	CARBON 10K 5%	1/4W
		<RESISTOR>		R95	1-249-441-11	CARBON 100K 5%	1/4W
R2	1-215-439-00	METAL 5.6K 1%	1/4W	R96	1-249-417-11	CARBON 1K 5%	1/4W
R3	1-249-422-11	CARBON 2.7K 5%	1/4W	R100	1-249-423-11	CARBON 3.3K 5%	1/4W
R4	1-215-449-00	METAL 15K 1%	1/4W	R111	1-249-427-11	CARBON 6.8K 5%	1/4W
R5	1-249-441-11	CARBON 100K 5%	1/4W	R112	1-249-429-11	CARBON 10K 5%	1/4W
R6	1-249-425-11	CARBON 4.7K 5%	1/4W	R113	1-249-429-11	CARBON 10K 5%	1/4W
R7	1-215-439-00	METAL 5.6K 1%	1/4W	R114	1-249-422-11	CARBON 2.7K 5%	1/4W
R37	1-249-441-11	CARBON 100K 5%	1/4W	R115	1-249-419-11	CARBON 1.5K 5%	1/4W
R38	1-215-454-00	METAL 24K 1%	1/4W	R116	1-249-427-11	CARBON 6.8K 5%	1/4W
R39	1-249-422-11	CARBON 2.7K 5%	1/4W	R117	1-249-429-11	CARBON 10K 5%	1/4W
R42	1-249-433-11	CARBON 22K 5%	1/4W	R118	1-249-429-11	CARBON 10K 5%	1/4W
R43	1-247-876-11	CARBON 75K 5%	1/4W	R119	1-249-422-11	CARBON 2.7K 5%	1/4W
R44	1-249-429-11	CARBON 10K 5%	1/4W	R120	1-249-419-11	CARBON 1.5K 5%	1/4W
R45	1-249-441-11	CARBON 100K 5%	1/4W	R121	1-249-417-11	CARBON 1K 5%	1/4W
R46	1-249-441-11	CARBON 100K 5%	1/4W	R122	1-249-417-11	CARBON 1K 5%	1/4W
R47	1-247-862-11	CARBON 20K 5%	1/4W	R123	1-249-413-11	CARBON 470 5%	1/4W
R48	1-215-467-00	METAL 82K 1%	1/4W	R124	1-249-417-11	CARBON 1K 5%	1/4W
R49	1-249-422-11	CARBON 2.7K 5%	1/4W	R125	1-249-417-11	CARBON 1K 5%	1/4W
R50	1-215-469-00	METAL 100K 1%	1/4W	R126	1-249-417-11	CARBON 1K 5%	1/4W
R51	1-215-445-00	METAL 10K 1%	1/4W	R127	1-249-417-11	CARBON 1K 5%	1/4W
R52	1-247-885-00	CARBON 180K 5%	1/4W	R128	1-249-417-11	CARBON 1K 5%	1/4W
R53	1-215-449-00	METAL 15K 1%	1/4W	R129	1-249-417-11	CARBON 1K 5%	1/4W
R54	1-249-422-11	CARBON 2.7K 5%	1/4W				
		<VARIABLE RESISTOR>		RV1	1-237-504-21	RES, ADJ, CERMET 20K	
				RV3	1-237-504-21	RES, ADJ, CERMET 20K	
				RV4	1-237-503-21	RES, ADJ, CERMET 10K	
				RV5	1-237-506-21	RES, ADJ, CERMET 100K	

7. ELECTRICAL PARTS LIST



REF. NO.	PART NO.	DESCRIPTION	REMARK	REF. NO.	PART NO.	DESCRIPTION	REMARK
RV6	1-237-505-21	RES, ADJ, CERMET 50K		C211	1-124-482-11	ELECT 33MF	20% 25V
RV7	1-237-504-21	RES, ADJ, CERMET 20K		C212	1-101-004-00	CERAMIC 0.01MF	50V
RV8	1-237-504-21	RES, ADJ, CERMET 20K		C213	1-124-482-11	ELECT 33MF	20% 25V
RV9	1-237-505-21	RES, ADJ, CERMET 50K		C214	1-102-050-00	CERAMIC 0.01MF	99% 500V
<SWITCH>				C215	1-123-939-00	ELECT 10MF	20% 200V
S1	1-570-857-11	SWITCH, SLIDE		C301	1-102-525-11	CERAMIC 68PF	5% 50V
*****				C302	1-102-973-00	CERAMIC 100PF	5% 50V
*A-1135-523-A	BK BOARD, COMPLETE			C303	1-124-341-00	ELECT 1MF	20% 200V
*****				C306	1-102-038-00	CERAMIC 0.001MF	500V
*4-353-770-00	HEAT SINK (TYPE 220)			C307	1-102-038-00	CERAMIC 0.001MF	500V
7-682-948-01	SCREW +PSW 3X8			C309	1-124-478-11	ELECT 100MF	20% 25V
7-682-548-04	SCREW +BVT 3X8 (S)			C310	1-101-004-00	CERAMIC 0.01MF	50V
<CONNECTOR>				C311	1-124-482-11	ELECT 33MF	20% 25V
BK1	*1-566-056-11	PIN, CONNECTOR 4P		C312	1-101-004-00	CERAMIC 0.01MF	50V
BK2	*1-566-056-11	PIN, CONNECTOR 4P		C313	1-124-482-11	ELECT 33MF	20% 25V
BK3	*1-566-056-11	PIN, CONNECTOR 4P		C314	1-102-050-00	CERAMIC 0.01MF	99% 500V
BK4	*1-566-055-11	PIN, CONNECTOR 3P		C315	1-123-939-00	ELECT 10MF	20% 200V
BK5	*1-566-057-11	PIN, CONNECTOR 5P		C316	1-102-038-00	CERAMIC 0.001MF	500V
BK6	*1-566-043-11	PIN, CONNECTOR 4P		<TRIMMER>			
BK7	*1-566-043-11	PIN, CONNECTOR 4P		CV101	1-141-171-00	CAP, TRIMMER 15P	
BK8	*1-566-043-11	PIN, CONNECTOR 4P		CV201	1-141-171-00	CAP, TRIMMER 15P	
BK9	*1-566-054-11	PIN, CONNECTOR 2P		CV301	1-141-171-00	CAP, TRIMMER 15P	
BK10	*1-566-054-11	PIN, CONNECTOR 2P		<DIODE>			
BK11	*1-566-054-11	PIN, CONNECTOR 2P		D1	8-719-911-19	DIODE 1SS119	
BK12	*1-566-056-11	PIN, CONNECTOR 4P		D2	8-719-911-19	DIODE 1SS119	
BK13	*1-566-054-11	PIN, CONNECTOR 2P		D12	8-719-901-83	DIODE 1SS83	
<CAPACITOR>				D13	8-719-901-83	DIODE 1SS83	
C1	1-124-482-11	ELECT 33MF	20% 25V	D14	8-719-901-83	DIODE 1SS83	
C5	1-124-482-11	ELECT 33MF	20% 25V	D15	8-719-110-53	DIODE RD20ESB2	
C6	1-101-004-00	CERAMIC 0.01MF	50V	D20	8-719-911-19	DIODE 1SS119	
C11	1-124-482-11	ELECT 33MF	20% 25V	D21	8-719-911-19	DIODE 1SS119	
C12	1-101-001-00	CERAMIC 0.001MF	50V	D22	8-719-911-19	DIODE 1SS119	
C15	1-123-939-00	ELECT 10MF	20% 200V	D23	8-719-911-19	DIODE 1SS119	
C16	1-102-050-00	CERAMIC 0.01MF	99% 500V	D30	8-719-911-19	DIODE 1SS119	
C20	1-124-482-11	ELECT 33MF	20% 25V	D101	8-719-901-83	DIODE 1SS83	
C21	1-123-939-00	ELECT 10MF	20% 200V	D102	8-719-901-83	DIODE 1SS83	
C25	1-108-704-11	NYLAR 0.1MF	10% 200V	D103	8-719-911-19	DIODE 1SS119	
C31	1-136-153-00	FILM 0.01MF	5% 50V	D104	8-719-911-19	DIODE 1SS119	
C101	1-102-525-11	CERAMIC 68PF	5% 50V	D105	8-719-911-19	DIODE 1SS119	
C102	1-102-973-00	CERAMIC 100PF	5% 50V	D201	8-719-901-83	DIODE 1SS83	
C103	1-124-341-00	ELECT 1MF	20% 200V	D202	8-719-901-83	DIODE 1SS83	
C106	1-102-038-00	CERAMIC 0.001MF	500V	D203	8-719-911-19	DIODE 1SS119	
C107	1-102-038-00	CERAMIC 0.001MF	500V	D204	8-719-911-19	DIODE 1SS119	
C109	1-124-478-11	ELECT 100MF	20% 25V	D205	8-719-911-19	DIODE 1SS119	
C110	1-101-004-00	CERAMIC 0.01MF	50V	D301	8-719-901-83	DIODE 1SS83	
C111	1-124-482-11	ELECT 33MF	20% 25V	D302	8-719-901-83	DIODE 1SS83	
C112	1-101-004-00	CERAMIC 0.01MF	50V	D303	8-719-911-19	DIODE 1SS119	
C113	1-124-482-11	ELECT 33MF	20% 25V	D304	8-719-911-19	DIODE 1SS119	
C114	1-102-050-00	CERAMIC 0.01MF	99% 500V	D305	8-719-911-19	DIODE 1SS119	
C115	1-123-939-00	ELECT 10MF	20% 200V	<IC>			
C201	1-102-525-11	CERAMIC 68PF	5% 50V	IC1	8-759-145-58	IC UPC4558C	
C202	1-102-973-00	CERAMIC 100PF	5% 50V	<COIL>			
C203	1-124-341-00	ELECT 1MF	20% 200V	L101	1-408-413-00	INDUCTOR 22UH	
C206	1-102-038-00	CERAMIC 0.001MF	500V	L201	1-408-413-00	INDUCTOR 22UH	
C207	1-102-038-00	CERAMIC 0.001MF	500V	L301	1-408-413-00	INDUCTOR 22UH	
C209	1-124-478-11	ELECT 100MF	20% 25V				
C210	1-101-004-00	CERAMIC 0.01MF	50V				

7. ELECTRICAL PARTS LIST



REF. NO.	PART NO.	DESCRIPTION	REMARK
<TRANSISTOR>			
Q1	8-729-119-76	TRANSISTOR 2SA1175-HFE	
Q2	8-729-119-76	TRANSISTOR 2SA1175-HFE	
Q10	8-729-119-78	TRANSISTOR 2SC2785-HFE	
Q11	8-729-200-17	TRANSISTOR 2SA1091-0	
Q12	8-729-255-12	TRANSISTOR 2SC2551-0	
Q20	8-729-119-80	TRANSISTOR 2SC2688-LK	
Q21	8-729-800-10	TRANSISTOR 2SC3068	
Q22	8-729-119-80	TRANSISTOR 2SC2688-LK	
Q23	8-729-306-92	TRANSISTOR 2SD669A-C	
Q23H	*4-363-146-00	HEAT SINK, V.OUT	
Q23S	4-370-970-01	SPACER, TR	
Q30	8-729-119-80	TRANSISTOR 2SC2688-LK	
Q101	8-729-119-78	TRANSISTOR 2SC2785-HFE	
Q102	8-729-119-76	TRANSISTOR 2SA1175-HFE	
Q103	8-729-384-48	TRANSISTOR 2SA844-E	
Q104	8-729-200-17	TRANSISTOR 2SA1091-0	
Q105	8-729-822-47	TRANSISTOR 2SC3956-E	
Q105H	*4-363-146-00	HEAT SINK, V.OUT	
Q105S	4-370-970-01	SPACER, TR	
Q106	8-729-802-71	TRANSISTOR 2SA1407-D	
Q106S	4-370-970-01	SPACER, TR	
Q107	8-729-802-71	TRANSISTOR 2SA1407-D	
Q107S	4-370-970-01	SPACER, TR	
Q201	8-729-119-78	TRANSISTOR 2SC2785-HFE	
Q202	8-729-119-76	TRANSISTOR 2SA1175-HFE	
Q203	8-729-384-48	TRANSISTOR 2SA844-E	
Q204	8-729-200-17	TRANSISTOR 2SA1091-0	
Q205	8-729-822-47	TRANSISTOR 2SC3956-E	
Q205H	*4-363-146-00	HEAT SINK, V.OUT	
Q205S	4-370-970-01	SPACER, TR	
Q206	8-729-802-71	TRANSISTOR 2SA1407-D	
Q206S	4-370-970-01	SPACER, TR	
Q207	8-729-802-71	TRANSISTOR 2SA1407-D	
Q207S	4-370-970-01	SPACER, TR	
Q301	8-729-119-78	TRANSISTOR 2SC2785-HFE	
Q302	8-729-119-76	TRANSISTOR 2SA1175-HFE	
Q303	8-729-384-48	TRANSISTOR 2SA844-E	
Q304	8-729-200-17	TRANSISTOR 2SA1091-0	
Q305	8-729-822-47	TRANSISTOR 2SC3956-E	
Q305H	*4-363-146-00	HEAT SINK, V.OUT	
Q305S	4-370-970-01	SPACER, TR	
Q306	8-729-802-71	TRANSISTOR 2SA1407-D	
Q306S	4-370-970-01	SPACER, TR	
Q307	8-729-802-71	TRANSISTOR 2SA1407-D	
Q307S	4-370-970-01	SPACER, TR	
<RESISTOR>			
R1	1-249-431-11	CARBON 15K 5%	1/4W
R2	1-249-435-11	CARBON 33K 5%	1/4W
R3	1-249-422-11	CARBON 2.7K 5%	1/4W
R4	1-249-419-11	CARBON 1.5K 5%	1/4W
R5	1-249-431-11	CARBON 15K 5%	1/4W
R6	1-249-425-11	CARBON 4.7K 5%	1/4W
R10	1-249-417-11	CARBON 1K 5%	1/4W
R11	1-249-431-11	CARBON 15K 5%	1/4W
R12	1-249-437-11	CARBON 47K 5%	1/4W
R13	1-249-423-11	CARBON 3.3K 5%	1/4W
R14	1-249-431-11	CARBON 15K 5%	1/4W
R16	1-215-901-00	METAL OXIDE 33K 5%	2W F
R17	1-215-901-00	METAL OXIDE 33K 5%	2W F

REF. NO.	PART NO.	DESCRIPTION	REMARK
R20	1-216-461-00	METAL OXIDE 5.6K 5%	2W F
R21	1-215-471-00	METAL 120K 1%	1/4W
R22	1-215-470-00	METAL 110K 1%	1/4W
R23	1-215-445-00	METAL 10K 1%	1/4W
R24	1-215-439-00	METAL 5.6K 1%	1/4W
R25	1-215-445-00	METAL 10K 1%	1/4W
R26	1-215-445-00	METAL 10K 1%	1/4W
R27	1-216-461-00	METAL OXIDE 5.6K 5%	2W F
R31	1-247-874-11	CARBON 62K 5%	1/4W
R32	1-249-440-11	CARBON 82K 5%	1/4W
R33	1-249-430-11	CARBON 12K 5%	1/4W
R34	1-249-429-11	CARBON 10K 5%	1/4W
R35	1-249-417-11	CARBON 1K 5%	1/4W
R37	1-249-415-11	CARBON 680 5%	1/4W
R38	1-249-441-11	CARBON 100K 5%	1/4W
R100	1-247-807-31	CARBON 100 5%	1/4W
R101	1-215-409-00	METAL 330 1%	1/4W
R102	1-249-419-11	CARBON 1.5K 5%	1/4W
R103	1-215-435-00	METAL 3.9K 1%	1/4W
R104	1-249-422-11	CARBON 2.7K 5%	1/4W
R105	1-247-807-31	CARBON 100 5%	1/4W
R106	1-215-412-00	METAL 430 1%	1/4W
R107	1-215-467-00	METAL 82K 1%	1/4W
R108	1-215-467-00	METAL 82K 1%	1/4W
R109	1-216-457-00	METAL OXIDE 1.2K 5%	2W F
R110	1-216-457-00	METAL OXIDE 1.2K 5%	2W F
R111	1-216-457-00	METAL OXIDE 1.2K 5%	2W F
R112	1-216-457-00	METAL OXIDE 1.2K 5%	2W F
R113	1-247-807-31	CARBON 100 5%	1/4W
R114	1-215-401-11	METAL 150 1%	1/4W
R115	1-215-865-11	METAL OXIDE 220 5%	1W F
R116	1-215-439-00	METAL 5.6K 1%	1/4W
R117	1-215-481-00	METAL 330K 1%	1/4W
R119	1-249-431-11	CARBON 15K 5%	1/4W
R120	1-247-807-31	CARBON 100 5%	1/4W
R124	1-249-423-11	CARBON 3.3K 5%	1/4W
R125	1-247-834-11	CARBON 1.3K 5%	1/4W
R126	1-249-429-11	CARBON 10K 5%	1/4W
R127	1-249-417-11	CARBON 1K 5%	1/4W
R130	1-247-807-31	CARBON 100 5%	1/4W
R200	1-247-807-31	CARBON 100 5%	1/4W
R201	1-215-409-00	METAL 330 1%	1/4W
R202	1-249-419-11	CARBON 1.5K 5%	1/4W
R203	1-215-435-00	METAL 3.9K 1%	1/4W
R204	1-249-422-11	CARBON 2.7K 5%	1/4W
R205	1-247-807-31	CARBON 100 5%	1/4W
R206	1-215-412-00	METAL 430 1%	1/4W
R207	1-215-467-00	METAL 82K 1%	1/4W
R208	1-215-467-00	METAL 82K 1%	1/4W
R209	1-216-457-00	METAL OXIDE 1.2K 5%	2W F
R210	1-216-457-00	METAL OXIDE 1.2K 5%	2W F
R211	1-216-457-00	METAL OXIDE 1.2K 5%	2W F
R212	1-216-457-00	METAL OXIDE 1.2K 5%	2W F
R213	1-247-807-31	CARBON 100 5%	1/4W
R214	1-215-401-11	METAL 150 1%	1/4W
R215	1-215-865-11	METAL OXIDE 220 5%	1W F
R216	1-215-439-00	METAL 5.6K 1%	1/4W
R217	1-215-481-00	METAL 330K 1%	1/4W
R219	1-249-431-11	CARBON 15K 5%	1/4W
R220	1-247-807-31	CARBON 100 5%	1/4W
R224	1-249-423-11	CARBON 3.3K 5%	1/4W
R225	1-247-834-11	CARBON 1.3K 5%	1/4W
R226	1-249-429-11	CARBON 10K 5%	1/4W

7. ELECTRICAL PARTS LIST





REF. NO.	PART NO.	DESCRIPTION	REMARK	REF. NO.	PART NO.	DESCRIPTION	REMARK
R227	1-249-417-11	CARBON	1K 5% 1/4W	C38	1-163-222-11	CERAMIC CHIP 5PF	0.25PF 50V
R230	1-247-807-31	CARBON	100 5% 1/4W	C40	1-163-038-00	CERAMIC CHIP 0.1MF	25V
R300	1-247-807-31	CARBON	100 5% 1/4W	C42	1-163-038-00	CERAMIC CHIP 0.1MF	25V
R301	1-215-409-00	METAL	330 1% 1/4W	C43	1-163-038-00	CERAMIC CHIP 0.1MF	25V
R302	1-249-419-11	CARBON	1.5K 5% 1/4W	C44	1-163-113-00	CERAMIC CHIP 68PF	5% 50V
R303	1-215-435-00	METAL	3.9K 1% 1/4W	C45	1-163-038-00	CERAMIC CHIP 0.1MF	25V
R304	1-249-422-11	CARBON	2.7K 5% 1/4W	C47	1-163-038-00	CERAMIC CHIP 0.1MF	25V
R305	1-247-807-31	CARBON	100 5% 1/4W	C48	1-124-907-11	ELECT 10MF	20% 50V
R306	1-215-412-00	METAL	430 1% 1/4W	C49	1-163-097-00	CERAMIC CHIP 15PF	5% 50V
R307	1-215-467-00	METAL	82K 1% 1/4W	C50	1-124-907-11	ELECT 10MF	20% 50V
R308	1-215-467-00	METAL	82K 1% 1/4W	C51	1-124-667-11	ELECT 10MF	20% 50V
R309	1-216-457-00	METAL OXIDE	1.2K 5% 2W	C52	1-163-038-00	CERAMIC CHIP 0.1MF	25V
R310	1-216-457-00	METAL OXIDE	1.2K 5% 2W	C53	1-124-667-11	ELECT 10MF	20% 50V
R311	1-216-457-00	METAL OXIDE	1.2K 5% 2W	C54	1-163-038-00	CERAMIC CHIP 0.1MF	25V
R312	1-216-457-00	METAL OXIDE	1.2K 5% 2W	C55	1-124-667-11	ELECT 10MF	20% 50V
R313	1-247-807-31	CARBON	100 5% 1/4W	C56	1-163-038-00	CERAMIC CHIP 0.1MF	25V
R314	1-215-401-11	METAL	150 1% 1/4W	C60	1-124-478-11	ELECT 100MF	20% 25V
R315	1-215-865-11	METAL OXIDE	220 5% 1W	C61	1-163-038-00	CERAMIC CHIP 0.1MF	25V
R316	1-215-439-00	METAL	5.6K 1% 1/4W	C62	1-124-907-11	ELECT 10MF	20% 50V
R317	1-215-481-00	METAL	330K 1% 1/4W	C63	1-163-038-00	CERAMIC CHIP 0.1MF	25V
R319	1-249-431-11	CARBON	15K 5% 1/4W	C64	1-124-477-11	ELECT 47MF	20% 16V
R320	1-247-807-31	CARBON	100 5% 1/4W	C65	1-124-907-11	ELECT 10MF	20% 50V
R324	1-249-423-11	CARBON	3.3K 5% 1/4W	C66	1-124-907-11	ELECT 10MF	20% 50V
R325	1-247-834-11	CARBON	1.3K 5% 1/4W	C67	1-124-907-11	ELECT 10MF	20% 50V
R326	1-249-429-11	CARBON	10K 5% 1/4W	C68	1-124-907-11	ELECT 10MF	20% 50V
R327	1-249-417-11	CARBON	1K 5% 1/4W	C69	1-163-038-00	CERAMIC CHIP 0.1MF	25V
R330	1-247-807-31	CARBON	100 5% 1/4W	C70	1-163-038-00	CERAMIC CHIP 0.1MF	25V
<VARIABLE RESISTOR>				C71	1-163-038-00	CERAMIC CHIP 0.1MF	25V
RV101	1-237-515-21	RES, ADJ, CERMET 1K		C72	1-163-038-00	CERAMIC CHIP 0.1MF	25V
RV201	1-237-515-21	RES, ADJ, CERMET 1K		C73	1-163-038-00	CERAMIC CHIP 0.1MF	25V
RV301	1-237-515-21	RES, ADJ, CERMET 1K		C74	1-163-038-00	CERAMIC CHIP 0.1MF	25V
*****				C75	1-163-038-00	CERAMIC CHIP 0.1MF	25V
*A-1135-606-B	BT BOARD, COMPLETE (BVM-1916 ONLY)			C76	1-163-038-00	CERAMIC CHIP 0.1MF	25V
*****				C77	1-163-038-00	CERAMIC CHIP 0.1MF	25V
*4-353-708-00	HOOK, FINGER			C78	1-163-038-00	CERAMIC CHIP 0.1MF	25V
7-682-547-09	SCREW +BVT 3X6 (S)			C79	1-163-038-00	CERAMIC CHIP 0.1MF	25V
*****				C80	1-163-038-00	CERAMIC CHIP 0.1MF	25V
<CAPACITOR>				C81	1-124-667-11	ELECT 10MF	20% 50V
C1	1-124-477-11	ELECT	47MF 20% 16V	C82	1-163-038-00	CERAMIC CHIP 0.1MF	25V
C3	1-124-477-11	ELECT	47MF 20% 16V	C83	1-124-667-11	ELECT 10MF	20% 50V
C4	1-124-477-11	ELECT	47MF 20% 16V	C84	1-163-038-00	CERAMIC CHIP 0.1MF	25V
C5	1-163-038-00	CERAMIC CHIP	0.1MF 25V	C85	1-163-038-00	CERAMIC CHIP 0.1MF	25V
C6	1-124-477-11	ELECT	47MF 20% 16V	C86	1-124-667-11	ELECT 10MF	20% 50V
C9	1-163-369-11	CERAMIC CHIP	47PF 5% 50V	C87	1-163-038-00	CERAMIC CHIP 0.1MF	25V
C10	1-163-038-00	CERAMIC CHIP	0.1MF 25V	C88	1-163-038-00	CERAMIC CHIP 0.1MF	25V
C14	1-163-101-00	CERAMIC CHIP	22PF 5% 50V	C89	1-163-038-00	CERAMIC CHIP 0.1MF	25V
C15	1-163-038-00	CERAMIC CHIP	0.1MF 25V	C90	1-124-907-11	ELECT 10MF	20% 50V
C16	1-163-227-11	CERAMIC CHIP	10PF 0.5PF 50V	C100	1-124-478-11	ELECT 100MF	20% 25V
C17	1-163-093-00	CERAMIC CHIP	10PF 5% 50V	C101	1-163-038-00	CERAMIC CHIP 0.1MF	25V
C18	1-163-038-00	CERAMIC CHIP	0.1MF 25V	C102	1-124-907-11	ELECT 10MF	20% 50V
C19	1-163-038-00	CERAMIC CHIP	0.1MF 25V	C103	1-163-038-00	CERAMIC CHIP 0.1MF	25V
C20	1-163-038-00	CERAMIC CHIP	0.1MF 25V	C104	1-124-477-11	ELECT 47MF	20% 16V
C21	1-163-038-00	CERAMIC CHIP	0.1MF 25V	C105	1-124-907-11	ELECT 10MF	20% 50V
C22	1-163-099-00	CERAMIC CHIP	18PF 5% 50V	C106	1-124-907-11	ELECT 10MF	20% 50V
C23	1-163-097-00	CERAMIC CHIP	15PF 5% 50V	C107	1-124-907-11	ELECT 10MF	20% 50V
C30	1-163-251-11	CERAMIC CHIP	100PF 5% 50V	C108	1-124-907-11	ELECT 10MF	20% 50V
C32	1-163-235-11	CERAMIC CHIP	22PF 5% 50V	C109	1-163-038-00	CERAMIC CHIP 0.1MF	25V
C34	1-163-099-00	CERAMIC CHIP	18PF 5% 50V	C110	1-163-038-00	CERAMIC CHIP 0.1MF	25V
C37	1-163-235-11	CERAMIC CHIP	22PF 5% 50V	C111	1-163-038-00	CERAMIC CHIP 0.1MF	25V
				C112	1-163-038-00	CERAMIC CHIP 0.1MF	25V
				C113	1-163-038-00	CERAMIC CHIP 0.1MF	25V
				C114	1-163-038-00	CERAMIC CHIP 0.1MF	25V
				C115	1-163-038-00	CERAMIC CHIP 0.1MF	25V
				C116	1-163-038-00	CERAMIC CHIP 0.1MF	25V

7. ELECTRICAL PARTS LIST



REF. NO.	PART NO.	DESCRIPTION	REMARK	REF. NO.	PART NO.	DESCRIPTION	REMARK
C117	1-163-038-00	CERAMIC CHIP 0.1MF	25V				
C118	1-163-038-00	CERAMIC CHIP 0.1MF	25V				
C119	1-163-038-00	CERAMIC CHIP 0.1MF	25V				
C331	1-135-091-00	TANTAL. CHIP 1MF	20% 16V				
C332	1-135-092-21	TANTAL. CHIP 3.3MF	20% 16V				
C333	1-135-092-21	TANTAL. CHIP 3.3MF	20% 16V				
C334	1-135-092-21	TANTAL. CHIP 3.3MF	20% 16V				
C335	1-135-092-21	TANTAL. CHIP 3.3MF	20% 16V				
C336	1-163-038-00	CERAMIC CHIP 0.1MF	25V				
C337	1-163-038-00	CERAMIC CHIP 0.1MF	25V				
C338	1-163-038-00	CERAMIC CHIP 0.1MF	25V				
C339	1-163-038-00	CERAMIC CHIP 0.1MF	25V				
C341	1-135-091-00	TANTAL. CHIP 1MF	20% 16V				
C342	1-135-092-21	TANTAL. CHIP 3.3MF	20% 16V				
C343	1-135-092-21	TANTAL. CHIP 3.3MF	20% 16V				
C344	1-135-092-21	TANTAL. CHIP 3.3MF	20% 16V				
C345	1-135-092-21	TANTAL. CHIP 3.3MF	20% 16V				
C346	1-163-038-00	CERAMIC CHIP 0.1MF	25V				
C347	1-163-038-00	CERAMIC CHIP 0.1MF	25V				
C348	1-163-038-00	CERAMIC CHIP 0.1MF	25V				
C349	1-163-038-00	CERAMIC CHIP 0.1MF	25V				
C361	1-135-091-00	TANTAL. CHIP 1MF	20% 16V				
C362	1-135-092-21	TANTAL. CHIP 3.3MF	20% 16V				
C363	1-135-092-21	TANTAL. CHIP 3.3MF	20% 16V				
C364	1-135-092-21	TANTAL. CHIP 3.3MF	20% 16V				
C365	1-135-092-21	TANTAL. CHIP 3.3MF	20% 16V				
C366	1-163-038-00	CERAMIC CHIP 0.1MF	25V				
C367	1-163-038-00	CERAMIC CHIP 0.1MF	25V				
C368	1-163-038-00	CERAMIC CHIP 0.1MF	25V				
C369	1-163-038-00	CERAMIC CHIP 0.1MF	25V				
C501	1-163-038-00	CERAMIC CHIP 0.1MF	25V				
C502	1-163-038-00	CERAMIC CHIP 0.1MF	25V				
C503	1-163-038-00	CERAMIC CHIP 0.1MF	25V				
C504	1-163-038-00	CERAMIC CHIP 0.1MF	25V				
C505	1-163-038-00	CERAMIC CHIP 0.1MF	25V				
C506	1-163-038-00	CERAMIC CHIP 0.1MF	25V				
C507	1-163-038-00	CERAMIC CHIP 0.1MF	25V				
C508	1-163-038-00	CERAMIC CHIP 0.1MF	25V				
C509	1-163-038-00	CERAMIC CHIP 0.1MF	25V				
C510	1-163-038-00	CERAMIC CHIP 0.1MF	25V				
C511	1-163-038-00	CERAMIC CHIP 0.1MF	25V				
C512	1-163-038-00	CERAMIC CHIP 0.1MF	25V				
C513	1-163-038-00	CERAMIC CHIP 0.1MF	25V				
C514	1-163-038-00	CERAMIC CHIP 0.1MF	25V				
C515	1-163-038-00	CERAMIC CHIP 0.1MF	25V				
C516	1-163-038-00	CERAMIC CHIP 0.1MF	25V				
C517	1-163-038-00	CERAMIC CHIP 0.1MF	25V				
C518	1-163-038-00	CERAMIC CHIP 0.1MF	25V				
C519	1-163-038-00	CERAMIC CHIP 0.1MF	25V				
C520	1-163-038-00	CERAMIC CHIP 0.1MF	25V				
C521	1-163-038-00	CERAMIC CHIP 0.1MF	25V				
C522	1-163-038-00	CERAMIC CHIP 0.1MF	25V				
<TRIMMER>							
CV1	1-141-304-21	TRIMMER, CERAMIC					
CV2	1-141-304-21	TRIMMER, CERAMIC					
CV3	1-141-304-21	TRIMMER, CERAMIC					
CV4	1-141-304-21	TRIMMER, CERAMIC					
CV5	1-141-304-21	TRIMMER, CERAMIC					
CV6	1-141-304-21	TRIMMER, CERAMIC					
<DIODE>							
				D1	8-719-104-34	DIODE 1S2836	
				D2	8-719-105-91	DIODE RD5.6M-B2	
				D3	8-719-801-78	DIODE 1SS184	
				D4	8-719-801-78	DIODE 1SS184	
				D5	8-719-801-78	DIODE 1SS184	
				D6	8-719-104-34	DIODE 1S2836	
				D7	8-719-801-78	DIODE 1SS184	
				D8	8-719-104-34	DIODE 1S2836	
				D9	8-719-104-34	DIODE 1S2836	
				D331	8-719-801-78	DIODE 1SS184	
				D341	8-719-801-78	DIODE 1SS184	
				D361	8-719-801-78	DIODE 1SS184	
<DELAY LINE>							
				DL1	1-415-348-21	DELAY LINE	
				DL2	1-415-477-11	DELAY LINE	
				DL3	1-415-700-11	DELAY LINE	
				DL4	1-415-654-12	DELAY LINE	
				DL5	1-415-700-11	DELAY LINE	
				DL6	1-415-700-11	DELAY LINE	
				DL7	1-415-348-21	DELAY LINE	
				DL8	1-415-700-11	DELAY LINE	
				DL9	1-415-727-11	DELAY LINE	
<FILTER>							
				FL1	1-236-562-11	FILTER, LOW PASS	
				FL2	1-236-561-11	FILTER, LOW PASS	
				FL3	1-236-732-11	FILTER, LOW PASS	
<IC>							
				IC1	8-759-800-81	IC LA7016	
				IC2	8-759-800-81	IC LA7016	
				IC3	8-759-701-78	IC NJM7809FA	
				IC4	8-759-701-75	IC NJM7805FA	
				IC331	8-752-334-78	IC CXL1009P-1	
				IC341	8-752-334-78	IC CXL1009P-1	
				IC361	8-752-330-14	IC CXL1009P	
				IC501	8-752-053-68	IC CXA1539P	
<IC SOCKET>							
				ICS331*1-526-656-00	SOCKET, IC (DP) 20P		
				ICS341*1-526-656-00	SOCKET, IC (DP) 20P		
				ICS361*1-526-656-00	SOCKET, IC (DP) 20P		
				ICS501*1-526-659-00	SOCKET, IC (DP) 28P		
<COIL>							
				L1	1-410-196-11	INDUCTOR CHIP 2.2UH	
				L2	1-410-200-31	INDUCTOR CHIP 4.7UH	
				L3	1-410-192-51	INDUCTOR CHIP 1UH	
				L4	1-216-296-00	METAL GLAZE 0 5% 1/8W	
				L5	1-216-296-00	METAL GLAZE 0 5% 1/8W	
				L6	1-410-196-11	INDUCTOR CHIP 2.2UH	
				L7	1-410-470-11	INDUCTOR 10UH	
				L8	1-410-470-11	INDUCTOR 10UH	
				L9	1-410-204-31	INDUCTOR CHIP 10UH	
				L10	1-408-419-00	INDUCTOR 68UH	
				L11	1-410-200-31	INDUCTOR CHIP 4.7UH	
				L12	1-410-200-31	INDUCTOR CHIP 4.7UH	
				L13	1-410-196-11	INDUCTOR CHIP 2.2UH	

7. ELECTRICAL PARTS LIST



BT

REF. NO.	PART NO.	DESCRIPTION	REMARK	REF. NO.	PART NO.	DESCRIPTION	REMARK
L14	1-410-204-31	INDUCTOR CHIP 10UH					
L15	1-410-216-31	INDUCTOR CHIP 100UH					
<TRANSISTOR>				<RESISTOR>			
Q1	8-729-216-22	TRANSISTOR 2SA1162-G		JW1	1-216-295-00	METAL GLAZE 0 5% 1/10W	
Q2	8-729-120-28	TRANSISTOR 2SC1623-L5L6		JW2	1-216-295-00	METAL GLAZE 0 5% 1/10W	
Q3	8-729-122-63	TRANSISTOR 2SA1226-E4		JW3	1-216-295-00	METAL GLAZE 0 5% 1/10W	
Q4	8-729-175-72	TRANSISTOR 2SC2757-T33		JW5	1-216-295-00	METAL GLAZE 0 5% 1/10W	
Q5	8-729-120-28	TRANSISTOR 2SC1623-L5L6		JW11	1-216-295-00	METAL GLAZE 0 5% 1/10W	
Q6	8-729-120-28	TRANSISTOR 2SC1623-L5L6		JW12	1-216-295-00	METAL GLAZE 0 5% 1/10W	
Q7	8-729-122-63	TRANSISTOR 2SA1226-E4		JW13	1-216-295-00	METAL GLAZE 0 5% 1/10W	
Q8	8-729-216-22	TRANSISTOR 2SA1162-G		JW14	1-216-295-00	METAL GLAZE 0 5% 1/10W	
Q9	8-729-122-63	TRANSISTOR 2SA1226-E4		JW15	1-216-295-00	METAL GLAZE 0 5% 1/10W	
Q10	8-729-175-72	TRANSISTOR 2SC2757-T33		R1	1-216-025-00	METAL GLAZE 100 5% 1/10W	
Q11	8-729-120-28	TRANSISTOR 2SC1623-L5L6		R2	1-216-073-00	METAL GLAZE 10K 5% 1/10W	
Q12	8-729-122-63	TRANSISTOR 2SA1226-E4		R3	1-216-097-00	METAL GLAZE 100K 5% 1/10W	
Q13	8-729-175-72	TRANSISTOR 2SC2757-T33		R4	1-216-073-00	METAL GLAZE 10K 5% 1/10W	
Q14	8-729-175-72	TRANSISTOR 2SC2757-T33		R5	1-216-097-00	METAL GLAZE 100K 5% 1/10W	
Q15	8-729-216-22	TRANSISTOR 2SA1162-G		R6	1-216-025-00	METAL GLAZE 100 5% 1/10W	
Q16	8-729-422-29	TRANSISTOR 2SD601A-S		R7	1-216-075-00	METAL GLAZE 12K 5% 1/10W	
Q17	8-729-120-28	TRANSISTOR 2SC1623-L5L6		R8	1-216-643-11	METAL CHIP 470 0.50% 1/10W	
Q18	8-729-216-22	TRANSISTOR 2SA1162-G		R9	1-216-661-11	METAL CHIP 2.7K 0.50% 1/10W	
Q19	8-729-120-28	TRANSISTOR 2SC1623-L5L6		R10	1-216-643-11	METAL CHIP 470 0.50% 1/10W	
Q20	8-729-175-72	TRANSISTOR 2SC2757-T33		R11	1-216-661-11	METAL CHIP 2.7K 0.50% 1/10W	
Q21	8-729-120-28	TRANSISTOR 2SC1623-L5L6		R12	1-216-675-11	METAL CHIP 10K 0.50% 1/10W	
Q22	8-729-120-28	TRANSISTOR 2SC1623-L5L6		R13	1-216-049-00	METAL GLAZE 1K 5% 1/10W	
Q23	8-729-120-28	TRANSISTOR 2SC1623-L5L6		R14	1-216-663-11	METAL CHIP 3.3K 0.50% 1/10W	
Q24	8-729-216-22	TRANSISTOR 2SA1162-G		R15	1-216-073-00	METAL GLAZE 10K 5% 1/10W	
Q25	8-729-422-29	TRANSISTOR 2SD601A-S		R16	1-216-025-00	METAL GLAZE 100 5% 1/10W	
Q32	8-729-120-28	TRANSISTOR 2SC1623-L5L6		R17	1-216-075-00	METAL GLAZE 12K 5% 1/10W	
Q33	8-729-120-28	TRANSISTOR 2SC1623-L5L6		R18	1-216-025-00	METAL GLAZE 100 5% 1/10W	
Q34	8-729-216-22	TRANSISTOR 2SA1162-G		R19	1-216-025-00	METAL GLAZE 100 5% 1/10W	
Q35	8-729-216-22	TRANSISTOR 2SA1162-G		R20	1-216-025-00	METAL GLAZE 100 5% 1/10W	
Q36	8-729-122-63	TRANSISTOR 2SA1226-E4		R21	1-216-073-00	METAL GLAZE 10K 5% 1/10W	
Q37	8-729-120-28	TRANSISTOR 2SC1623-L5L6		R22	1-216-057-00	METAL GLAZE 2.2K 5% 1/10W	
Q38	8-729-122-63	TRANSISTOR 2SA1226-E4		R23	1-216-635-11	METAL CHIP 220 0.50% 1/10W	
Q39	8-729-175-72	TRANSISTOR 2SC2757-T33		R24	1-216-635-11	METAL CHIP 220 0.50% 1/10W	
Q40	8-729-120-28	TRANSISTOR 2SC1623-L5L6		R25	1-216-075-00	METAL GLAZE 12K 5% 1/10W	
Q41	8-729-120-28	TRANSISTOR 2SC1623-L5L6		R26	1-216-059-00	METAL GLAZE 2.7K 5% 1/10W	
Q42	8-729-216-22	TRANSISTOR 2SA1162-G		R27	1-216-057-00	METAL GLAZE 2.2K 5% 1/10W	
Q43	8-729-120-28	TRANSISTOR 2SC1623-L5L6		R28	1-216-025-00	METAL GLAZE 100 5% 1/10W	
Q44	8-729-120-28	TRANSISTOR 2SC1623-L5L6		R29	1-216-065-00	METAL GLAZE 4.7K 5% 1/10W	
Q45	8-729-120-28	TRANSISTOR 2SC1623-L5L6		R30	1-216-651-11	METAL CHIP 1K 0.50% 1/10W	
Q52	8-729-120-28	TRANSISTOR 2SC1623-L5L6		R31	1-216-025-00	METAL GLAZE 100 5% 1/10W	
Q54	8-729-216-22	TRANSISTOR 2SA1162-G		R33	1-216-665-11	METAL CHIP 3.9K 0.50% 1/10W	
Q56	8-729-122-63	TRANSISTOR 2SA1226-E4		R34	1-216-049-00	METAL GLAZE 1K 5% 1/10W	
Q57	8-729-120-28	TRANSISTOR 2SC1623-L5L6		R35	1-216-651-11	METAL CHIP 1K 0.50% 1/10W	
Q58	8-729-122-63	TRANSISTOR 2SA1226-E4		R36	1-216-065-00	METAL GLAZE 4.7K 5% 1/10W	
Q59	8-729-175-72	TRANSISTOR 2SC2757-T33		R37	1-216-025-00	METAL GLAZE 100 5% 1/10W	
Q60	8-729-120-28	TRANSISTOR 2SC1623-L5L6		R38	1-216-059-00	METAL GLAZE 2.7K 5% 1/10W	
Q61	8-729-120-28	TRANSISTOR 2SC1623-L5L6		R39	1-216-635-11	METAL CHIP 220 0.50% 1/10W	
Q62	8-729-216-22	TRANSISTOR 2SA1162-G		R40	1-216-630-11	METAL CHIP 130 0.50% 1/10W	
Q65	8-729-120-28	TRANSISTOR 2SC1623-L5L6		R41	1-216-630-11	METAL CHIP 130 0.50% 1/10W	
Q71	8-729-175-72	TRANSISTOR 2SC2757-T33		R42	1-216-635-11	METAL CHIP 220 0.50% 1/10W	
Q72	8-729-122-63	TRANSISTOR 2SA1226-E4		R43	1-216-067-00	METAL GLAZE 5.6K 5% 1/10W	
Q73	8-729-175-72	TRANSISTOR 2SC2757-T33		R44	1-216-049-00	METAL GLAZE 1K 5% 1/10W	
Q74	8-729-122-63	TRANSISTOR 2SA1226-E4		R45	1-216-651-11	METAL CHIP 1K 0.50% 1/10W	
Q81	8-729-901-06	TRANSISTOR DTA144EK		R46	1-216-065-00	METAL GLAZE 4.7K 5% 1/10W	
Q82	8-729-901-01	TRANSISTOR DTC144EK		R47	1-216-025-00	METAL GLAZE 100 5% 1/10W	
Q83	8-729-901-06	TRANSISTOR DTA144EK		R48	1-216-057-00	METAL GLAZE 2.2K 5% 1/10W	
Q84	8-729-901-06	TRANSISTOR DTA144EK		R49	1-216-057-00	METAL GLAZE 2.2K 5% 1/10W	
Q85	8-729-140-97	TRANSISTOR 2SB734-34		R50	1-216-025-00	METAL GLAZE 100 5% 1/10W	
Q86	8-729-140-96	TRANSISTOR 2SD774-34		R51	1-216-097-00	METAL GLAZE 100K 5% 1/10W	
				R52	1-216-097-00	METAL GLAZE 100K 5% 1/10W	

7. ELECTRICAL PARTS LIST



REF. NO.	PART NO.	DESCRIPTION	REMARK	REF. NO.	PART NO.	DESCRIPTION	REMARK
R53	1-216-075-00	METAL GLAZE	12K 5% 1/10W	R130	1-216-659-11	METAL CHIP	2.2K 0.50% 1/10W
R54	1-216-025-00	METAL GLAZE	100 5% 1/10W	R131	1-216-065-00	METAL GLAZE	4.7K 5% 1/10W
R55	1-216-667-11	METAL CHIP	4.7K 0.50% 1/10W	R132	1-216-651-11	METAL CHIP	1K 0.50% 1/10W
R56	1-216-025-00	METAL GLAZE	100 5% 1/10W	R133	1-216-025-00	METAL GLAZE	100 5% 1/10W
R57	1-216-065-00	METAL GLAZE	4.7K 5% 1/10W	R134	1-216-057-00	METAL GLAZE	2.2K 5% 1/10W
R58	1-216-651-11	METAL CHIP	1K 0.50% 1/10W	R135	1-216-635-11	METAL CHIP	220 0.50% 1/10W
R59	1-216-025-00	METAL GLAZE	100 5% 1/10W	R136	1-216-635-11	METAL CHIP	220 0.50% 1/10W
R60	1-216-065-00	METAL GLAZE	4.7K 5% 1/10W	R137	1-216-025-00	METAL GLAZE	100 5% 1/10W
R61	1-216-643-11	METAL CHIP	470 0.50% 1/10W	R138	1-216-075-00	METAL GLAZE	12K 5% 1/10W
R62	1-216-643-11	METAL CHIP	470 0.50% 1/10W	R139	1-216-025-00	METAL GLAZE	100 5% 1/10W
R63	1-216-025-00	METAL GLAZE	100 5% 1/10W	R140	1-216-075-00	METAL GLAZE	12K 5% 1/10W
R64	1-216-075-00	METAL GLAZE	12K 5% 1/10W	R141	1-216-025-00	METAL GLAZE	100 5% 1/10W
R65	1-216-025-00	METAL GLAZE	100 5% 1/10W	R142	1-216-075-00	METAL GLAZE	12K 5% 1/10W
R66	1-216-073-00	METAL GLAZE	10K 5% 1/10W	R143	1-216-025-00	METAL GLAZE	100 5% 1/10W
R67	1-216-659-11	METAL CHIP	2.2K 0.50% 1/10W	R150	1-216-025-00	METAL GLAZE	100 5% 1/10W
R68	1-216-667-11	METAL CHIP	4.7K 0.50% 1/10W	R153	1-216-049-00	METAL GLAZE	1K 5% 1/10W
R69	1-216-659-11	METAL CHIP	2.2K 0.50% 1/10W	R154	1-216-075-00	METAL GLAZE	12K 5% 1/10W
R70	1-216-025-00	METAL GLAZE	100 5% 1/10W	R157	1-216-049-00	METAL GLAZE	1K 5% 1/10W
R71	1-216-075-00	METAL GLAZE	12K 5% 1/10W	R158	1-216-075-00	METAL GLAZE	12K 5% 1/10W
R72	1-216-025-00	METAL GLAZE	100 5% 1/10W	R161	1-216-049-00	METAL GLAZE	1K 5% 1/10W
R73	1-216-643-11	METAL CHIP	470 0.50% 1/10W	R163	1-216-057-00	METAL GLAZE	2.2K 5% 1/10W
R74	1-216-651-11	METAL CHIP	1K 0.50% 1/10W	R164	1-216-057-00	METAL GLAZE	2.2K 5% 1/10W
R75	1-216-089-00	METAL GLAZE	47K 5% 1/10W	R165	1-216-025-00	METAL GLAZE	100 5% 1/10W
R76	1-216-073-00	METAL GLAZE	10K 5% 1/10W	R166	1-216-075-00	METAL GLAZE	12K 5% 1/10W
R77	1-216-049-00	METAL GLAZE	1K 5% 1/10W	R167	1-216-643-11	METAL CHIP	470 0.50% 1/10W
R78	1-216-065-00	METAL GLAZE	4.7K 5% 1/10W	R169	1-216-655-11	METAL CHIP	1.5K 0.50% 1/10W
R79	1-216-651-11	METAL CHIP	1K 0.50% 1/10W	R170	1-216-643-11	METAL CHIP	470 0.50% 1/10W
R80	1-216-025-00	METAL GLAZE	100 5% 1/10W	R171	1-216-657-11	METAL CHIP	1.8K 0.50% 1/10W
R81	1-216-065-00	METAL GLAZE	4.7K 5% 1/10W	R172	1-216-667-11	METAL CHIP	4.7K 0.50% 1/10W
R82	1-216-651-11	METAL CHIP	1K 0.50% 1/10W	R173	1-216-065-00	METAL GLAZE	4.7K 5% 1/10W
R83	1-216-025-00	METAL GLAZE	100 5% 1/10W	R174	1-216-049-00	METAL GLAZE	1K 5% 1/10W
R84	1-216-097-00	METAL GLAZE	100K 5% 1/10W	R175	1-216-655-11	METAL CHIP	1.5K 0.50% 1/10W
R85	1-216-097-00	METAL GLAZE	100K 5% 1/10W	R176	1-216-065-00	METAL GLAZE	4.7K 5% 1/10W
R86	1-216-075-00	METAL GLAZE	12K 5% 1/10W	R177	1-216-025-00	METAL GLAZE	100 5% 1/10W
R87	1-216-025-00	METAL GLAZE	100 5% 1/10W	R178	1-216-075-00	METAL GLAZE	12K 5% 1/10W
R88	1-216-025-00	METAL GLAZE	100 5% 1/10W	R179	1-216-025-00	METAL GLAZE	100 5% 1/10W
R89	1-216-025-00	METAL GLAZE	100 5% 1/10W	R181	1-216-065-00	METAL GLAZE	4.7K 5% 1/10W
R103	1-216-049-00	METAL GLAZE	1K 5% 1/10W	R182	1-216-651-11	METAL CHIP	1K 0.50% 1/10W
R104	1-216-075-00	METAL GLAZE	12K 5% 1/10W	R183	1-216-025-00	METAL GLAZE	100 5% 1/10W
R105	1-216-049-00	METAL GLAZE	1K 5% 1/10W	R184	1-216-065-00	METAL GLAZE	4.7K 5% 1/10W
R106	1-216-075-00	METAL GLAZE	12K 5% 1/10W	R185	1-216-643-11	METAL CHIP	470 0.50% 1/10W
R107	1-216-049-00	METAL GLAZE	1K 5% 1/10W	R186	1-216-643-11	METAL CHIP	470 0.50% 1/10W
R108	1-216-075-00	METAL GLAZE	12K 5% 1/10W	R191	1-216-025-00	METAL GLAZE	100 5% 1/10W
R109	1-216-049-00	METAL GLAZE	1K 5% 1/10W	R192	1-216-075-00	METAL GLAZE	12K 5% 1/10W
R110	1-216-075-00	METAL GLAZE	12K 5% 1/10W	R193	1-216-025-00	METAL GLAZE	100 5% 1/10W
R111	1-216-651-11	METAL CHIP	1K 0.50% 1/10W	R201	1-216-057-00	METAL GLAZE	2.2K 5% 1/10W
R112	1-216-651-11	METAL CHIP	1K 0.50% 1/10W	R202	1-216-057-00	METAL GLAZE	2.2K 5% 1/10W
R113	1-216-057-00	METAL GLAZE	2.2K 5% 1/10W	R203	1-216-057-00	METAL GLAZE	2.2K 5% 1/10W
R114	1-216-057-00	METAL GLAZE	2.2K 5% 1/10W	R204	1-216-033-00	METAL GLAZE	220 5% 1/10W
R115	1-216-025-00	METAL GLAZE	100 5% 1/10W	R205	1-216-033-00	METAL GLAZE	220 5% 1/10W
R116	1-216-075-00	METAL GLAZE	12K 5% 1/10W	R206	1-216-049-00	METAL GLAZE	1K 5% 1/10W
R117	1-216-643-11	METAL CHIP	470 0.50% 1/10W	R207	1-216-049-00	METAL GLAZE	1K 5% 1/10W
R118	1-216-663-11	METAL CHIP	3.3K 0.50% 1/10W	R208	1-216-049-00	METAL GLAZE	1K 5% 1/10W
R119	1-216-651-11	METAL CHIP	1K 0.50% 1/10W	R209	1-216-049-00	METAL GLAZE	1K 5% 1/10W
R120	1-216-643-11	METAL CHIP	470 0.50% 1/10W	R210	1-216-049-00	METAL GLAZE	1K 5% 1/10W
R121	1-216-657-11	METAL CHIP	1.8K 0.50% 1/10W	R211	1-216-049-00	METAL GLAZE	1K 5% 1/10W
R122	1-216-667-11	METAL CHIP	4.7K 0.50% 1/10W	R212	1-216-049-00	METAL GLAZE	1K 5% 1/10W
R123	1-216-065-00	METAL GLAZE	4.7K 5% 1/10W	R213	1-216-089-00	METAL GLAZE	47K 5% 1/10W
R124	1-216-049-00	METAL GLAZE	1K 5% 1/10W	R214	1-216-089-00	METAL GLAZE	47K 5% 1/10W
R125	1-216-659-11	METAL CHIP	2.2K 0.50% 1/10W	R215	1-216-053-00	METAL GLAZE	1.5K 5% 1/10W
R126	1-216-065-00	METAL GLAZE	4.7K 5% 1/10W	R216	1-216-061-00	METAL GLAZE	3.3K 5% 1/10W
R127	1-216-025-00	METAL GLAZE	100 5% 1/10W	R217	1-216-069-00	METAL GLAZE	6.8K 5% 1/10W
R128	1-216-073-00	METAL GLAZE	10K 5% 1/10W	R218	1-216-061-00	METAL GLAZE	3.3K 5% 1/10W
R129	1-216-643-11	METAL CHIP	470 0.50% 1/10W				

7. ELECTRICAL PARTS LIST



Les composants identifiés par une trame et une marque **▲** sont critiques pour la sécurité. Ne les remplacer que par une pièce portant le numéro spécifié.

The components identified by shading and mark **▲** are critical for safety. Replace only with part number specified.

REF. NO.	PART NO.	DESCRIPTION	REMARK
R219	1-215-881-11	METAL OXIDE 15 5%	2W F
R331	1-216-121-00	METAL GLAZE 1M 5%	1/10W
R332	1-216-270-00	METAL GLAZE 1M 5%	1/8W
R341	1-216-121-00	METAL GLAZE 1M 5%	1/10W
R342	1-216-270-00	METAL GLAZE 1M 5%	1/8W
R361	1-216-121-00	METAL GLAZE 1M 5%	1/10W
R362	1-216-270-00	METAL GLAZE 1M 5%	1/8W
R501	1-216-121-00	METAL GLAZE 1M 5%	1/10W
R502	1-216-049-00	METAL GLAZE 1K 5%	1/10W
<VARIABLE RESISTOR>			
RV1	1-237-515-21	RES, ADJ, CERMET 1K	
RV2	1-237-517-21	RES, ADJ, CERMET 5K	
RV3	1-237-515-21	RES, ADJ, CERMET 1K	
RV4	1-237-515-21	RES, ADJ, CERMET 1K	
RV5	1-237-515-21	RES, ADJ, CERMET 1K	
RV6	1-237-517-21	RES, ADJ, CERMET 5K	
RV7	1-237-515-21	RES, ADJ, CERMET 1K	
RV8	1-237-515-21	RES, ADJ, CERMET 1K	
RV9	1-237-516-21	RES, ADJ, CERMET 2K	
RV10	1-237-515-21	RES, ADJ, CERMET 1K	
RV11	1-237-516-21	RES, ADJ, CERMET 2K	
RV12	1-237-515-21	RES, ADJ, CERMET 1K	
<CRYSTAL>			
X1	1-567-790-11	VIBRATOR, CRYSTAL	
*****			
	*A-1331-020-A	C BOARD, COMPLETE	*****
	*1-508-766-00	PIN, CONNECTOR (5MM PITCH) 4P	
	*1-508-786-00	PIN, CONNECTOR (5MM PITCH) 2P	
	▲ 1-526-798-37	SOCKET, CRT	
	*1-566-054-11	PIN, CONNECTOR 2P	
	*1-566-055-11	PIN, CONNECTOR 3P	
	*1-566-056-11	PIN, CONNECTOR 4P	
	*4-379-160-01	COVER (REAR LID), CV	
	*4-379-167-01	COVER (MAIN), CV	
<CAPACITOR>			
C1	1-162-114-00	CERAMIC 0.0047MF	2KV
C2	1-129-724-00	FILM 0.068MF	10% 630V
C3	1-126-967-11	ELECT 47MF	20% 25V
C4	1-162-114-00	CERAMIC 0.0047MF	2KV
C6	1-126-967-11	ELECT 47MF	20% 25V
C7	1-162-114-00	CERAMIC 0.0047MF	2KV
<DIODE>			
D1	8-719-911-19	DIODE 1SS119	
D3	8-719-911-19	DIODE 1SS119	
D4	8-719-911-19	DIODE 1SS119	
D5	8-719-911-19	DIODE 1SS119	
<COIL>			
L1	1-408-414-00	INDUCTOR 27UH	
L2	1-408-414-00	INDUCTOR 27UH	
L3	1-408-414-00	INDUCTOR 27UH	

7. ELECTRICAL PARTS LIST

REF. NO.	PART NO.	DESCRIPTION	REMARK
<TRANSISTOR>			
Q1	8-729-804-48	TRANSISTOR 2SC3675	
Q2	8-729-804-48	TRANSISTOR 2SC3675	
Q3	8-729-255-12	TRANSISTOR 2SC2551-0	
Q4	8-729-119-78	TRANSISTOR 2SC2785-HFE	
<RESISTOR>			
R1	1-202-818-00	SOLID 1K 10%	1/2W
R2	1-202-818-00	SOLID 1K 10%	1/2W
R3	1-202-818-00	SOLID 1K 10%	1/2W
R4	1-249-433-11	CARBON 22K 5%	1/4W
R5	1-202-818-00	SOLID 1K 10%	1/2W
R6	1-202-818-00	SOLID 1K 10%	1/2W
R7	1-249-433-11	CARBON 22K 5%	1/4W
R8	1-202-818-00	SOLID 1K 10%	1/2W
R9	1-202-818-00	SOLID 1K 10%	1/2W
R10	1-249-433-11	CARBON 22K 5%	1/4W
R11	1-202-719-00	SOLID 1M 10%	1/2W
R13	1-202-735-00	SOLID 22M 10%	1/2W
R14	1-202-818-00	SOLID 1K 10%	1/2W
R15	1-202-721-00	SOLID 1.5M 10%	1/2W
R16	1-202-848-00	SOLID 680K 10%	1/2W
R17	1-249-438-11	CARBON 56K 5%	1/4W
R18	1-202-719-00	SOLID 1M 10%	1/2W
R20	1-249-430-11	CARBON 12K 5%	1/4W
R21	1-249-429-11	CARBON 10K 5%	1/4W
R22	1-249-427-11	CARBON 6.8K 5%	1/4W
R27	1-249-417-11	CARBON 1K 5%	1/4W
R28	1-202-818-00	SOLID 1K 10%	1/2W
R30	1-202-818-00	SOLID 1K 10%	1/2W
R31	1-202-818-00	SOLID 1K 10%	1/2W
<VARIABLE RESISTOR>			
RV1	1-230-798-11	RES, ADJ, METAL GLAZE 90M	
<SPARK GAP>			
SG1	1-519-422-11	GAP, SPARK	
SG3	1-519-422-11	GAP, SPARK	
SG4	1-519-422-11	GAP, SPARK	
SG5	1-519-422-11	GAP, SPARK	
SG6	1-519-422-11	GAP, SPARK	
*****			
	*A-1345-882-B	DA BOARD, COMPLETE	*****
	*1-566-055-11	PIN, CONNECTOR 3P	
	*1-566-056-11	PIN, CONNECTOR 4P	
	*1-566-057-11	PIN, CONNECTOR 5P	
	*1-566-058-11	PIN, CONNECTOR 6P	
	*1-566-060-11	PIN, CONNECTOR 8P	
	*1-566-062-11	PIN, CONNECTOR 10P	
<CAPACITOR>			
C1	1-136-153-00	FILM 0.01MF	5% 50V
C2	1-136-165-00	FILM 0.1MF	5% 50V
C3	1-126-163-11	ELECT 4.7MF	20% 16V
C4	1-126-160-11	ELECT 1MF	20% 50V
C5	1-126-160-11	ELECT 1MF	20% 50V
C6	1-126-160-11	ELECT 1MF	20% 50V



REF. NO.	PART NO.	DESCRIPTION	REMARK
R48	1-249-439-11	CARBON 68K 5%	1/4W
R49	1-249-426-11	CARBON 5.6K 5%	1/4W
R50	1-249-429-11	CARBON 10K 5%	1/4W
R51	1-249-434-11	CARBON 27K 5%	1/4W
R52	1-249-433-11	CARBON 22K 5%	1/4W
R53	1-249-425-11	CARBON 4.7K 5%	1/4W
R54	1-249-425-11	CARBON 4.7K 5%	1/4W
R55	1-249-433-11	CARBON 22K 5%	1/4W
R56	1-249-429-11	CARBON 10K 5%	1/4W
R57	1-249-429-11	CARBON 10K 5%	1/4W
R59	1-247-895-00	CARBON 470K 5%	1/4W
R60	1-249-439-11	CARBON 68K 5%	1/4W
R61	1-249-429-11	CARBON 10K 5%	1/4W
R62	1-247-895-00	CARBON 470K 5%	1/4W
R63	1-249-429-11	CARBON 10K 5%	1/4W
R64	1-249-441-11	CARBON 100K 5%	1/4W
R65	1-249-429-11	CARBON 10K 5%	1/4W
R66	1-247-885-00	CARBON 180K 5%	1/4W
R67	1-247-891-00	CARBON 330K 5%	1/4W
R68	1-249-429-11	CARBON 10K 5%	1/4W
R69	1-249-429-11	CARBON 10K 5%	1/4W
R70	1-249-429-11	CARBON 10K 5%	1/4W
R71	1-215-445-00	METAL 10K 1%	1/4W
R72	1-249-429-11	CARBON 10K 5%	1/4W
R73	1-249-429-11	CARBON 10K 5%	1/4W
R74	1-249-429-11	CARBON 10K 5%	1/4W
R75	1-249-439-11	CARBON 68K 5%	1/4W
R76	1-249-430-11	CARBON 12K 5%	1/4W
R77	1-249-429-11	CARBON 10K 5%	1/4W
R78	1-249-439-11	CARBON 68K 5%	1/4W
R79	1-249-429-11	CARBON 10K 5%	1/4W
R80	1-249-430-11	CARBON 12K 5%	1/4W
R81	1-249-423-11	CARBON 3.3K 5%	1/4W
R82	1-249-417-11	CARBON 1K 5%	1/4W
R83	1-249-429-11	CARBON 10K 5%	1/4W
R84	1-249-426-11	CARBON 5.6K 5%	1/4W
R85	1-249-428-11	CARBON 8.2K 5%	1/4W
R86	1-249-423-11	CARBON 3.3K 5%	1/4W
R87	1-249-417-11	CARBON 1K 5%	1/4W
R88	1-249-429-11	CARBON 10K 5%	1/4W
R89	1-249-429-11	CARBON 10K 5%	1/4W
R90	1-249-429-11	CARBON 10K 5%	1/4W
R91	1-215-862-11	METAL OXIDE 68 5%	1W F
R92	1-215-862-11	METAL OXIDE 68 5%	1W F
R93	1-247-885-00	CARBON 180K 5%	1/4W
R94	1-249-426-11	CARBON 5.6K 5%	1/4W
R101	1-249-431-11	CARBON 15K 5%	1/4W
R102	1-249-428-11	CARBON 8.2K 5%	1/4W
<VARIABLE RESISTOR>			
RV1	1-237-518-21	RES, ADJ, CERMET 10K	
RV2	1-237-518-21	RES, ADJ, CERMET 10K	
RV3	1-237-518-21	RES, ADJ, CERMET 10K	
RV4	1-237-518-21	RES, ADJ, CERMET 10K	
RV5	1-237-518-21	RES, ADJ, CERMET 10K	
RV6	1-237-518-21	RES, ADJ, CERMET 10K	
RV7	1-237-518-21	RES, ADJ, CERMET 10K	
RV8	1-237-518-21	RES, ADJ, CERMET 10K	
RV9	1-237-518-21	RES, ADJ, CERMET 10K	
RV10	1-237-518-21	RES, ADJ, CERMET 10K	
RV11	1-237-518-21	RES, ADJ, CERMET 10K	
RV12	1-237-518-21	RES, ADJ, CERMET 10K	
RV13	1-237-518-21	RES, ADJ, CERMET 10K	

7. ELECTRICAL PARTS LIST

REF. NO.	PART NO.	DESCRIPTION	REMARK
RV14	1-237-518-21	RES, ADJ, CERMET 10K	
RV15	1-237-518-21	RES, ADJ, CERMET 10K	
RV16	1-237-518-21	RES, ADJ, CERMET 10K	
RV17	1-237-518-21	RES, ADJ, CERMET 10K	
RV18	1-237-518-21	RES, ADJ, CERMET 10K	
RV19	1-237-518-21	RES, ADJ, CERMET 10K	
RV20	1-237-518-21	RES, ADJ, CERMET 10K	
RV21	1-237-518-21	RES, ADJ, CERMET 10K	
RV22	1-237-518-21	RES, ADJ, CERMET 10K	
RV23	1-237-518-21	RES, ADJ, CERMET 10K	
RV24	1-237-518-21	RES, ADJ, CERMET 10K	
RV25	1-237-518-21	RES, ADJ, CERMET 10K	
RV31	1-237-518-21	RES, ADJ, CERMET 10K	
RV32	1-237-518-21	RES, ADJ, CERMET 10K	
*****			
*A-1345-884-A DB BOARD, COMPLETE			
*****			
*1-566-056-11 PIN, CONNECTOR 4P			
*1-566-062-11 PIN, CONNECTOR 10P			
<CAPACITOR>			
C201	1-101-004-00	CERAMIC 0.01MF	50V
C202	1-136-153-00	FILM 0.01MF	5% 50V
C203	1-136-165-00	FILM 0.1MF	5% 50V
C204	1-126-157-11	ELECT 10MF	20% 16V
C205	1-130-479-00	MYLAR 0.0047MF	5% 50V
C206	1-124-234-00	ELECT 22MF	20% 16V
C207	1-124-234-00	ELECT 22MF	20% 16V
C208	1-130-475-00	MYLAR 0.0022MF	5% 50V
C209	1-130-477-00	FILM 0.0033MF	5% 50V
C210	1-102-518-11	CERAMIC 33PF	5% 50V
C211	1-101-004-00	CERAMIC 0.01MF	50V
C212	1-101-004-00	CERAMIC 0.01MF	50V
C214	1-126-157-11	ELECT 10MF	20% 16V
C215	1-126-157-11	ELECT 10MF	20% 16V
C216	1-101-004-00	CERAMIC 0.01MF	50V
C221	1-126-157-11	ELECT 10MF	20% 16V
C223	1-101-004-00	CERAMIC 0.01MF	50V
C224	1-101-004-00	CERAMIC 0.01MF	50V
C231	1-126-157-11	ELECT 10MF	20% 16V
C233	1-101-004-00	CERAMIC 0.01MF	50V
<DIODE>			
D201	8-719-911-19	DIODE 1SS119	
D202	8-719-109-74	DIODE RD4.3ESB1	
<IC>			
IC201	8-759-503-91	IC TL082ACP	
IC202	8-759-729-03	IC NJM2903D	
IC203	8-759-240-69	IC TC4069UBP	
IC204	8-759-100-60	IC UPC1377C	
<COIL>			
L201	1-410-068-11	INDUCTOR 5.6MMH	
<TRANSISTOR>			
Q201	8-729-900-65	TRANSISTOR DTA144ES	

REF. NO.	PART NO.	DESCRIPTION	REMARK
Q202	8-729-119-78	TRANSISTOR 2SC2785-HFE	
Q203	8-729-900-65	TRANSISTOR DTA144ES	
<RESISTOR>			
R201	1-249-417-11	CARBON 1K 5% 1/4W	
R202	1-249-417-11	CARBON 1K 5% 1/4W	
R203	1-215-440-00	METAL 6.2K 1% 1/4W	
R204	1-249-429-11	CARBON 10K 5% 1/4W	
R205	1-249-430-11	CARBON 12K 5% 1/4W	
R206	1-249-439-11	CARBON 68K 5% 1/4W	
R207	1-249-429-11	CARBON 10K 5% 1/4W	
R208	1-249-429-11	CARBON 10K 5% 1/4W	
R209	1-249-429-11	CARBON 10K 5% 1/4W	
R210	1-249-419-11	CARBON 1.5K 5% 1/4W	
R211	1-249-425-11	CARBON 4.7K 5% 1/4W	
R212	1-249-417-11	CARBON 1K 5% 1/4W	
R213	1-249-425-11	CARBON 4.7K 5% 1/4W	
R214	1-249-417-11	CARBON 1K 5% 1/4W	
R215	1-249-429-11	CARBON 10K 5% 1/4W	
R216	1-249-415-11	CARBON 680 5% 1/4W	
R217	1-249-423-11	CARBON 3.3K 5% 1/4W	
R218	1-249-425-11	CARBON 4.7K 5% 1/4W	
R219	1-249-439-11	CARBON 68K 5% 1/4W	
R220	1-249-417-11	CARBON 1K 5% 1/4W	
R221	1-249-429-11	CARBON 10K 5% 1/4W	
R222	1-249-429-11	CARBON 10K 5% 1/4W	
R223	1-249-417-11	CARBON 1K 5% 1/4W	
R224	1-249-430-11	CARBON 12K 5% 1/4W	
R225	1-249-417-11	CARBON 1K 5% 1/4W	
R226	1-249-417-11	CARBON 1K 5% 1/4W	
R227	1-249-417-11	CARBON 1K 5% 1/4W	
R228	1-249-417-11	CARBON 1K 5% 1/4W	
R229	1-249-417-11	CARBON 1K 5% 1/4W	
<VARIABLE RESISTOR>			
RV201	1-237-518-21	RES, ADJ, CERMET 10K	
RV202	1-237-517-21	RES, ADJ, CERMET 5K	
<SWITCH>			
S201	1-571-908-11	SWITCH, SLIDE	
*****			
*A-1345-881-A	EA BOARD, COMPLETE	*****	
*1-508-765-00	PIN, CONNECTOR (5MM PITCH) 3P		
*1-508-766-00	PIN, CONNECTOR (5MM PITCH) 4P		
*1-508-786-00	PIN, CONNECTOR (5MM PITCH) 2P		
*1-565-495-11	CONNECTOR, BOARD TO BOARD 4P		
*1-566-054-11	PIN, CONNECTOR 2P		
*1-566-041-11	PIN, CONNECTOR 2P		
*1-566-055-11	PIN, CONNECTOR 3P		
*1-566-056-11	PIN, CONNECTOR 4P		
*1-566-057-11	PIN, CONNECTOR 5P		
*1-566-058-11	PIN, CONNECTOR 6P		
*1-568-536-11	PLUG (MINIATURE DY) 6P		
*4-309-378-00	SPACER		
*4-043-154-01	HOLDER, IC		
*4-381-904-01	SPRING (C)		
*4-381-907-01	INSULATOR (A)		
*4-381-908-01	INSULATOR (B)		
7-682-547-09	SCREW +BVTT 3X6 (S)		

REF. NO.	PART NO.	DESCRIPTION	REMARK
<CAPACITOR>			
C1	1-102-963-00	CERAMIC 33PF 5% 50V	
C2	1-124-482-11	ELECT 33MF 20% 25V	
C3	1-126-329-11	ELECT 470MF 20% 50V	
C4	1-101-361-00	CERAMIC 150PF 5% 50V	
C5	1-124-482-11	ELECT 33MF 20% 25V	
C6	1-126-329-11	ELECT 470MF 20% 50V	
C7	1-136-121-00	FILM 0.27MF 5% 400V	
C8	1-136-108-00	FILM 0.43MF 5% 200V	
C9	1-130-789-00	FILM 1MF 5% 100V	
C10	1-104-965-11	ELECT 10MF 20% 160V	
C11	1-108-700-11	MYLAR 0.047MF 10% 200V	
C12	1-108-692-11	MYLAR 0.01MF 10% 200V	
C13	1-136-165-00	FILM 0.1MF 5% 50V	
C14	1-102-074-00	CERAMIC 0.001MF 10% 50V	
C15	1-102-121-00	CERAMIC 0.0022MF 10% 50V	
C16	1-102-973-00	CERAMIC 100PF 5% 50V	
C17	1-124-477-11	ELECT 47MF 20% 25V	
C18	1-104-792-51	ELECT 33MF 20% 16V	
C19	1-124-907-11	ELECT 10MF 20% 50V	
C20	1-124-903-11	ELECT 1MF 20% 50V	
C21	1-126-964-11	ELECT 10MF 20% 16V	
C23	1-136-161-00	FILM 0.047MF 5% 50V	
C24	1-108-700-11	MYLAR 0.047MF 10% 200V	
C25	1-162-117-00	CERAMIC 100PF 10% 500V	
C26	1-123-024-21	ELECT 33MF 160V	
C27	1-123-949-00	ELECT 33MF 20% 200V	
C28	1-136-069-00	FILM 0.0044MF 3% 2KV	
C29	1-136-066-00	FILM 0.0033MF 3% 2KV	
C30	1-124-512-11	ELECT 33MF 20% 50V	
C31	1-124-512-11	ELECT 33MF 20% 50V	
C35	1-162-114-00	CERAMIC 0.0047MF 2KV	
C36	1-108-692-11	MYLAR 0.01MF 10% 200V	
C37	1-102-978-00	CERAMIC 220PF 5% 50V	
C50	1-136-165-00	FILM 0.1MF 5% 50V	
C51	1-102-121-00	CERAMIC 0.0022MF 10% 50V	
C52	1-102-973-00	CERAMIC 100PF 5% 50V	
C54	1-124-907-11	ELECT 10MF 20% 50V	
C55	1-124-477-11	ELECT 47MF 20% 25V	
C56	1-124-903-11	ELECT 1MF 20% 50V	
C57	1-126-964-11	ELECT 10MF 20% 16V	
C58	1-136-161-00	FILM 0.047MF 5% 50V	
C59	1-108-700-11	MYLAR 0.047MF 10% 200V	
C60	1-162-117-00	CERAMIC 100PF 10% 500V	
C61	1-123-024-21	ELECT 33MF 160V	
C62	1-136-169-00	FILM 0.22MF 5% 50V	
C63	1-108-700-11	MYLAR 0.047MF 10% 200V	
C64	1-162-117-00	CERAMIC 100PF 10% 500V	
C65	1-136-072-00	FILM 0.0063MF 3% 2KV	
C66	1-136-069-00	FILM 0.0044MF 3% 2KV	
C67	1-162-134-11	CERAMIC 470PF 10% 2KV	
C68	1-136-111-00	FILM 1MF 5% 200V	
C69	1-102-978-00	CERAMIC 220PF 5% 50V	
C70	1-124-666-11	ELECT 4.7MF 20% 200V	
C87	1-108-692-11	MYLAR 0.01MF 10% 200V	
C89	1-162-117-00	CERAMIC 100PF 10% 500V	
C90	1-102-121-00	CERAMIC 0.0022MF 10% 50V	
C99	1-162-130-11	CERAMIC 180PF 10% 2KV	
C100	1-108-692-11	MYLAR 0.01MF 10% 200V	
C101	1-102-963-00	CERAMIC 33PF 5% 50V	
C110	1-126-101-11	ELECT 100MF 20% 16V	

7. ELECTRICAL PARTS LIST

EA

REF. NO.	PART NO.	DESCRIPTION	REMARK	REF. NO.	PART NO.	DESCRIPTION	REMARK
C201	1-124-478-11	ELECT	100MF	20%	25V		
C202	1-124-340-00	ELECT	22MF	20%	200V		
C203	1-124-478-11	ELECT	100MF	20%	25V		
C204	1-102-978-00	CERAMIC	220PF	5%	50V		
C207	1-124-340-00	ELECT	22MF	20%	200V		
C208	1-136-157-00	FILM	0.022MF	5%	50V		
C209	1-108-646-00	MYLAR	0.47MF	10%	100V		
C300	1-124-666-11	ELECT	4.7MF	20%	200V		
<DIODE>							
D1	8-719-110-31	DIODE RD12ESB2					
D3	8-719-911-19	DIODE 1SS119					
D4	8-719-911-19	DIODE 1SS119					
D5	8-719-300-76	DIODE RH-1A					
D6	8-719-000-28	THYRISTOR CRO2AM-8					
D7	8-719-300-76	DIODE RH-1A					
D8	8-719-928-08	DIODE ERD28-08S					
D9	8-719-300-76	DIODE RH-1A					
D10	8-719-300-76	DIODE RH-1A					
D12	8-719-901-19	DIODE V11N					
D13	8-719-300-76	DIODE RH-1A					
D14	8-719-300-76	DIODE RH-1A					
D15	8-719-300-76	DIODE RH-1A					
D16	8-719-300-76	DIODE RH-1A					
D28	8-719-911-19	DIODE 1SS119					
D30	8-719-911-19	DIODE 1SS119					
D32	8-719-300-76	DIODE RH-1A					
D33	8-719-300-76	DIODE RH-1A					
D35	8-719-911-19	DIODE 1SS119					
D37	8-719-911-19	DIODE 1SS119					
D38	8-719-911-19	DIODE 1SS119					
D39	8-719-110-31	DIODE RD12ESB2					
D40	8-719-110-49	DIODE RD18ES-B2					
D41	8-719-109-66	DIODE RD3.3ESB2					
D42	8-719-300-76	DIODE RH-1A					
D50	8-719-000-28	THYRISTOR CRO2AM-8					
D201	8-719-908-03	DIODE GP08D					
D202	8-719-908-03	DIODE GP08D					
D203	8-719-911-19	DIODE 1SS119					
D204	8-719-911-19	DIODE 1SS119					
D205	8-719-911-19	DIODE 1SS119					
D206	8-719-911-19	DIODE 1SS119					
<CONNECTOR>							
EA3	*1-566-056-11	PIN, CONNECTOR 4P					
EA7	*1-566-055-11	PIN, CONNECTOR 3P					
EA10	*1-566-058-11	PIN, CONNECTOR 6P					
EA16	*1-565-495-11	CONNECTOR, BOARD TO BOARD 4P					
EA17	*1-565-495-11	CONNECTOR, BOARD TO BOARD 4P					
EA18	*1-565-495-11	CONNECTOR, BOARD TO BOARD 4P					
EA19	*1-565-495-11	CONNECTOR, BOARD TO BOARD 4P					
<IC>							
IC1	8-759-947-49	IC FA5301P					
IC2	8-759-947-49	IC FA5301P					
IC3	8-759-503-91	IC TLO82ACP					
IC5	8-759-145-58	IC UPC4558C					
<COIL>							
L1	1-459-433-00	COIL (WITH CORE)					
L2	1-459-433-00	COIL (WITH CORE)					
L3	1-459-433-00	COIL (WITH CORE)					
L4	1-459-111-00	COIL, DRAM CORE (CDI)					
L5	1-459-111-00	COIL, DRAM CORE (CDI)					
L6	1-459-087-00	COIL, HCC DUST CORE 3.9MMH					
L7	1-459-215-00	COIL (WITH CORE)					
L8	1-459-207-00	COIL, CORE					
L9	1-459-433-00	COIL (WITH CORE)					
L10	1-459-433-00	COIL (WITH CORE)					
L11	1-459-123-00	COIL, DUST CORE (PAC)					
<TRANSISTOR>							
Q1	8-729-119-76	TRANSISTOR 2SA1175-HFE					
Q2	8-729-697-92	TRANSISTOR 2SA979-G					
Q3	8-729-306-92	TRANSISTOR 2SD669A-C					
Q4	8-729-208-71	TRANSISTOR 2SC3298B-0					
Q5	8-729-385-82	TRANSISTOR 2SB858-C					
Q6	8-729-119-80	TRANSISTOR 2SC2688-LK					
Q7	8-729-906-53	TRANSISTOR 2SC2542-15					
Q8	8-729-255-12	TRANSISTOR 2SC2551-0					
Q9	8-729-119-76	TRANSISTOR 2SA1175-HFE					
Q10	8-729-119-80	TRANSISTOR 2SC2688-LK					
Q11	8-729-800-80	TRANSISTOR 2SD1399-CA					
Q12	8-729-313-42	TRANSISTOR 2SD1134-C					
Q13	8-729-385-82	TRANSISTOR 2SB858-C					
Q14	8-729-119-80	TRANSISTOR 2SC2688-LK					
Q15	8-729-200-17	TRANSISTOR 2SA1091-0					
Q16	8-729-906-53	TRANSISTOR 2SC2542-15					
Q17	8-729-119-80	TRANSISTOR 2SC2688-LK					
Q18	8-729-800-80	TRANSISTOR 2SD1399-CA					
Q19	8-729-119-76	TRANSISTOR 2SA1175-HFE					
Q201	8-729-697-92	TRANSISTOR 2SA979-G					
Q202	8-729-140-96	TRANSISTOR 2SD774-34					
Q203	8-729-200-17	TRANSISTOR 2SA1091-0					
Q204	8-729-255-12	TRANSISTOR 2SC2551-0					
Q205	8-729-017-05	TRANSISTOR 2SA1837					
Q206	8-729-208-71	TRANSISTOR 2SC3298B-0					
Q207	8-729-386-12	TRANSISTOR 2SB861-C					
Q208	8-729-255-12	TRANSISTOR 2SC2551-0					
<CONNECTOR>							
R73	*1-506-371-00	PIN, CONNECTOR 2P					
R75	*1-506-371-00	PIN, CONNECTOR 2P					
<RESISTOR>							
R1	1-249-425-11	CARBON	4.7K	5%	1/4W		
R2	1-249-422-11	CARBON	2.7K	5%	1/4W		
R3	1-249-441-11	CARBON	100K	5%	1/4W		
R4	1-249-435-11	CARBON	33K	5%	1/4W		
R5	1-249-429-11	CARBON	10K	5%	1/4W		
R6	1-249-429-11	CARBON	10K	5%	1/4W		
R7	1-249-429-11	CARBON	10K	5%	1/4W		
R8	1-249-421-11	CARBON	2.2K	5%	1/4W		
R9	1-249-431-11	CARBON	15K	5%	1/4W		
R10	1-249-438-11	CARBON	56K	5%	1/4W		
R11	1-249-417-11	CARBON	1K	5%	1/4W		
R12	1-249-421-11	CARBON	2.2K	5%	1/4W		
R13	1-249-448-11	CARBON	1.2	5%	1/4W	F	
R14	1-249-448-11	CARBON	1.2	5%	1/4W	F	
R15	1-216-372-11	METAL OXIDE	1.8	5%	2W	F	

7. ELECTRICAL PARTS LIST



The components identified by shading and mark **Δ** are critical for safety. Replace only with part number specified.

Les composants identifiés par une trame et une marque **Δ** sont critiques pour la sécurité. Ne les remplacer que par une pièce portant le numéro spécifié.

The components identified by **■** in this manual have been carefully factory-selected for each set in order to satisfy regulations regarding X-ray radiation. Should replacement be required, replace only with the value originally used.

**EA EB**

REF. NO.	PART NO.	DESCRIPTION	REMARK	REF. NO.	PART NO.	DESCRIPTION	REMARK
R16	1-249-429-11	CARBON	10K 5% 1/4W	R87	1-216-351-00	METAL OXIDE	1.5 5% 1W F
R17	1-249-429-11	CARBON	10K 5% 1/4W	R88	1-249-441-11	CARBON	100K 5% 1/4W
R18	1-216-460-11	METAL OXIDE	3.9K 5% 2W	R93	1-249-437-11	CARBON	47K 5% 1/4W
R19	1-216-352-11	METAL OXIDE	1.8 5% 1W F	R94	1-249-415-11	CARBON	680 5% 1/4W
R20	1-249-414-11	CARBON	560 5% 1/4W	R125	1-216-377-11	METAL OXIDE	4.7 5% 2W F
R21	1-249-425-11	CARBON	4.7K 5% 1/4W	R126	1-216-377-11	METAL OXIDE	4.7 5% 2W F
R22	1-249-426-11	CARBON	5.6K 5% 1/4W	R127	1-202-719-00	SOLID	1M 10% 1/2W
R23	1-247-852-11	CARBON	7.5K 5% 1/4W	R160	1-249-425-11	CARBON	4.7K 5% 1/4W
R24	1-249-436-11	CARBON	39K 5% 1/4W	R161	1-249-422-11	CARBON	2.7K 5% 1/4W
R25	1-249-434-11	CARBON	27K 5% 1/4W	R162	1-249-441-11	CARBON	100K 5% 1/4W
R26	1-249-429-11	CARBON	10K 5% 1/4W	R163	1-249-435-11	CARBON	33K 5% 1/4W
R27	1-249-429-11	CARBON	10K 5% 1/4W	R170	1-249-415-11	CARBON	680 5% 1/4W
R28	1-249-434-11	CARBON	27K 5% 1/4W	R201	1-249-429-11	CARBON	10K 5% 1/4W
R29	1-249-427-11	CARBON	6.8K 5% 1/4W	R202	1-249-430-11	CARBON	12K 5% 1/4W
R31	1-215-433-00	METAL	3.3K 1% 1/4W	R203	1-249-426-11	CARBON	5.6K 5% 1/4W
R32	1-215-435-00	METAL	3.9K 1% 1/4W	R204	1-216-465-11	METAL OXIDE	27K 5% 2W F
R33	1-249-429-11	CARBON	10K 5% 1/4W	R205	1-247-802-11	CARBON	62 5% 1/4W
R34	1-249-417-11	CARBON	1K 5% 1/4W	R206	1-249-414-11	CARBON	560 5% 1/4W
R35	1-249-432-11	CARBON	18K 5% 1/4W	R207	1-249-382-11	CARBON	1.2 5% 1/4W F
R37	1-249-429-11	CARBON	10K 5% 1/4W	R208	1-249-382-11	CARBON	1.2 5% 1/4W F
R38	1-249-429-11	CARBON	10K 5% 1/4W	R209	1-215-889-00	METAL OXIDE	330 5% 2W F
R39	1-215-900-11	METAL OXIDE	22K 5% 2W F	R210	1-216-375-00	METAL OXIDE	3.3 5% 2W F
R40	1-216-423-11	METAL OXIDE	27 5% 1W F	R211	1-249-429-11	CARBON	10K 5% 1/4W
R41	1-216-349-00	METAL OXIDE	1 5% 1W F	R212	1-249-425-11	CARBON	4.7K 5% 1/4W
R42	1-212-857-00	FUSIBLE	10 5% 1/4W F	R213	1-247-719-11	CARBON	3.3K 5% 1/4W F
R43	1-249-417-11	CARBON	1K 5% 1/4W	R214	1-247-739-11	CARBON	100 5% 1/2W F
R44	1-215-473-00	METAL	150K 1% 1/4W	R215	1-215-896-00	METAL OXIDE	4.7K 5% 2W F
R47	1-215-445-00	METAL	10K 1% 1/4W	R216	1-249-429-11	CARBON	10K 5% 1/4W
R49	1-249-448-11	CARBON	1.2 5% 1/4W F	R217	1-249-429-11	CARBON	10K 5% 1/4W
R50	1-249-429-11	CARBON	10K 5% 1/4W	R301	1-215-948-00	WIREWOUND	10K 10% 5W F
R51	1-249-417-11	CARBON	1K 5% 1/4W			<VARIABLE RESISTOR>	
R52	1-247-807-31	CARBON	100 5% 1/4W	RV1	1-237-514-21	RES, ADJ, CERMET 500	
R53	1-216-360-11	METAL OXIDE	8.2 5% 1W F			<TRANSFORMER>	
R54	1-212-998-00	FUSIBLE	470 5% 1/2W F	T1	1-437-078-00	TRANSFORMER, HORIZONTAL DRIVE	
R55	1-249-417-11	CARBON	1K 5% 1/4W	T2	1-437-078-00	TRANSFORMER, HORIZONTAL DRIVE	
R56	1-249-419-11	CARBON	1.5K 5% 1/4W	T3	1-439-383-11	HOT	
R57	1-249-419-11	CARBON	1.5K 5% 1/4W	T4	1-437-078-00	TRANSFORMER, HORIZONTAL DRIVE	
R58	1-249-448-11	CARBON	1.2 5% 1/4W F	T5	1-439-384-11	LOT	
R59	1-249-448-11	CARBON	1.2 5% 1/4W F	T6	1-437-078-00	TRANSFORMER, HORIZONTAL DRIVE	
R61	1-249-425-11	CARBON	4.7K 5% 1/4W	T7	1-407-849-00	TRANSFORMER, D.F	
R62	1-249-425-11	CARBON	4.7K 5% 1/4W			*****	
R63	1-249-441-11	CARBON	100K 5% 1/4W	*1-631-685-11	EB BOARD	*****	
R65	1-249-434-11	CARBON	27K 5% 1/4W	*1-565-480-11	CONNECTOR, BOARD TO BOARD 4P		
R66	1-249-429-11	CARBON	10K 5% 1/4W			<CAPACITOR>	
R67	1-249-429-11	CARBON	10K 5% 1/4W	C71	1-124-120-11	ELECT	220MF 20% 16V
R68	1-249-434-11	CARBON	27K 5% 1/4W	C73	1-108-634-11	MYLAR	0.047MF 10% 100V
R69	1-249-427-11	CARBON	6.8K 5% 1/4W	C74	1-126-964-11	ELECT	10MF 20% 16V
R70	1-249-414-11	CARBON	560 5% 1/4W	C75	1-161-051-00	CERAMIC	0.01MF 10% 50V
R71	1-215-461-00	METAL	47K 1% 1/4W	C76	1-124-667-11	ELECT	10MF 20% 50V
R72	1-215-452-00	METAL	20K 1% 1/4W	C78	1-136-165-00	FILM	0.1MF 5% 50V
■R73	Δ 1-215-447-00	METAL	1/4W	C82	1-161-051-00	CERAMIC	0.01MF 10% 50V
R74		METAL	12K 1% 1/4W	C83	1-124-907-11	ELECT	10MF 20% 50V
■R75	Δ 1-249-421-11	METAL	1/4W	C84	1-126-233-11	ELECT	22MF 20% 16V
R76		CARBON	2.2K 5% 1/4W	C85	1-136-165-00	FILM	0.1MF 5% 50V
R77	1-247-887-00	CARBON	220K 5% 1/4W				
R78	1-249-429-11	CARBON	10K 5% 1/4W				
R79	1-249-429-11	CARBON	10K 5% 1/4W				
R80	1-249-429-11	CARBON	10K 5% 1/4W				
R81	1-215-900-11	METAL OXIDE	22K 5% 2W F				
R82	1-216-356-00	METAL OXIDE	3.9 5% 1W F				
R83	1-216-348-00	METAL OXIDE	0.82 5% 1W F				
R84	1-249-417-11	CARBON	1K 5% 1/4W				
R85	1-249-417-11	CARBON	1K 5% 1/4W				
R86	1-215-948-00	METAL OXIDE	10K 5% 5W F				

7. ELECTRICAL PARTS LIST



**EB EC**

The components identified by **■** in this manual have been carefully factory-selected for each set in order to satisfy regulations regarding X-ray radiation. Should replacement be required, replace only with the value originally used.

Les composants identifiés par une trame et une marque **▲** sont critiques pour la sécurité. Ne les remplacer que par une pièce portant le numéro spécifique.

The components identified by shading and mark **▲** are critical for safety. Replace only with part number specified.

REF. NO.	PART NO.	DESCRIPTION	REMARK	REF. NO.	PART NO.	DESCRIPTION	REMARK
C86	1-136-165-00	FILM	0.1MF 5%	50V	R117	1-215-453-00	METAL 22K 1% 1/4W
C91	1-124-120-11	ELECT	220MF 20%	16V	R118	1-215-469-00	METAL 100K 1% 1/4W
C93	1-124-907-11	ELECT	10MF 20%	50V	R119	1-215-437-00	METAL 4.7K 1% 1/4W
C94	1-126-233-11	ELECT	22MF 20%	16V	R120	1-215-437-00	METAL 4.7K 1% 1/4W
C95	1-124-666-11	ELECT	4.7MF 20%	200V	R121	1-215-427-00	METAL 1.8K 1% 1/4W
C96	1-124-915-11	ELECT	10MF 20%	25V	R122	1-215-437-00	METAL 4.7K 1% 1/4W
<DIODE>							
D19	8-719-911-19	DIODE 1SS119			R123	1-215-437-00	METAL 4.7K 1% 1/4W
D20	8-719-911-19	DIODE 1SS119			R124	1-215-427-00	METAL 1.8K 1% 1/4W
D24	▲ 8-759-157-40	IC UPC574J			R130	1-249-417-11	CARBON 1K 5% 1/4W
D25	8-719-911-19	DIODE 1SS119			R131	1-249-431-11	CARBON 15K 5% 1/4W
D26	8-719-911-19	DIODE 1SS119			R132	1-249-423-11	CARBON 3.3K 5% 1/4W
D27	8-719-000-28	THYRISTOR CRO2AM-8			R133	1-215-455-00	METAL 27K 1% 1/4W
D29	▲ 8-759-157-40	IC UPC574J			R134	1-215-437-00	METAL 4.7K 1% 1/4W
D36	8-719-911-19	DIODE 1SS119			■ R135	▲ METAL	1/4W
D51	8-719-000-28	THYRISTOR CRO2AM-8			R136	1-215-486-00	METAL 510K 1% 1/4W
<CONNECTOR>							
EB1	*1-565-480-11	CONNECTOR, BOARD TO BOARD 4P			R137	1-215-453-00	METAL 22K 1% 1/4W
EB2	*1-565-480-11	CONNECTOR, BOARD TO BOARD 4P			R138	1-215-469-00	METAL 100K 1% 1/4W
<IC>							
IC4	8-759-729-03	IC NJM2903D			R140	1-215-899-11	METAL OXIDE 15K 5% 2W F
IC6	8-759-729-03	IC NJM2903D			R141	1-215-899-11	METAL OXIDE 15K 5% 2W F
<TRANSISTOR>							
Q20	8-729-119-78	TRANSISTOR 2SC2785-HFE			R145	1-249-413-11	CARBON 470 5% 1/4W
<CONNECTOR>							
R106	*1-506-371-00	PIN, CONNECTOR 2P			R151	1-249-417-11	CARBON 1K 5% 1/4W
R108	*1-506-371-00	PIN, CONNECTOR 2P			R152	1-249-417-11	CARBON 1K 5% 1/4W
R115	*1-506-371-00	PIN, CONNECTOR 2P			R153	1-249-417-11	CARBON 1K 5% 1/4W
R135	*1-506-371-00	PIN, CONNECTOR 2P			R155	1-249-413-11	CARBON 470 5% 1/4W
<RESISTOR>							
R89	1-249-431-11	CARBON 15K 5%	1/4W		R156	1-249-423-11	CARBON 3.3K 5% 1/4W
R90	1-249-417-11	CARBON 1K 5%	1/4W		*****		
R95	1-249-429-11	CARBON 10K 5%	1/4W		*1-631-686-11	EC BOARD	*****
R96	1-249-421-11	CARBON 2.2K 5%	1/4W		*1-565-480-11	CONNECTOR, BOARD TO BOARD 4P	
R97	1-249-393-11	CARBON 10 5%	1/4W		*1-566-041-11	PIN, CONNECTOR 2P	
R98	1-249-429-11	CARBON 10K 5%	1/4W		<CAPACITOR>		
R99	1-249-441-11	CARBON 100K 5%	1/4W		C97	1-124-907-11	ELECT 10MF 20% 50V
R100	1-249-429-11	CARBON 10K 5%	1/4W		C98	1-124-907-11	ELECT 10MF 20% 50V
R101	1-249-429-11	CARBON 10K 5%	1/4W		C210	1-102-824-00	CERAMIC 470PF 5% 50V
R102	1-215-899-11	METAL OXIDE 15K 5%	2W F		C211	1-136-165-00	FILM 0.1MF 5% 50V
R103	1-215-899-11	METAL OXIDE 15K 5%	2W F		<DIODE>		
R104	1-249-423-11	CARBON 3.3K 5%	1/4W		D210	8-719-911-19	DIODE 1SS119
R105	1-215-453-00	METAL 22K 1%	1/4W		D211	8-719-911-19	DIODE 1SS119
■ R106	▲ METAL		1/4W		D212	8-719-911-19	DIODE 1SS119
R107	1-215-455-00	METAL 27K 1%	1/4W		D213	8-719-911-19	DIODE 1SS119
■ R108	▲ METAL		1/4W		<CONNECTOR>		
R111	1-249-441-11	CARBON 100K 5%	1/4W		EC1	*1-565-480-11	CONNECTOR, BOARD TO BOARD 4P
R112	1-249-423-11	CARBON 3.3K 5%	1/4W		EC2	*1-565-480-11	CONNECTOR, BOARD TO BOARD 4P
R113	1-215-455-00	METAL 27K 1%	1/4W		<IC>		
R114	1-215-437-00	METAL 4.7K 1%	1/4W		IC201	8-759-145-58	IC UPC4558C
■ R115	▲ METAL		1/4W		<TRANSISTOR>		
R116	1-215-486-00	METAL 510K 1%	1/4W		Q210	8-729-119-78	TRANSISTOR 2SC2785-HFE
					Q211	8-729-119-76	TRANSISTOR 2SA1175-HFE
<RESISTOR>							
R220	1-249-429-11	CARBON 10K 5%	1/4W				

7. ELECTRICAL PARTS LIST

The components identified by shading and mark **▲** are critical for safety. Replace only with part number specified.

Les composants identifiés par une trame et une marque **▲** sont critiques pour la sécurité. Ne les remplacer que par une pièce portant le numéro spécifié.



REF. NO.	PART NO.	DESCRIPTION	REMARK	REF. NO.	PART NO.	DESCRIPTION	REMARK
R221	1-249-429-11	CARBON 10K 5% 1/4W		C19	1-102-030-00	CERAMIC 330PF 10% 500V	
R222	1-249-429-11	CARBON 10K 5% 1/4W		C20	1-162-117-00	CERAMIC 100PF 10% 500V	
R223	1-247-848-11	CARBON 5.1K 5% 1/4W		C21	1-102-038-00	CERAMIC 0.001MF 500V	
R224	1-216-423-11	METAL OXIDE 27 5% 1W F		C22	1-162-117-00	CERAMIC 100PF 10% 500V	
R225	1-249-431-11	CARBON 15K 5% 1/4W		C23	1-106-375-12	MYLAR 0.022MF 10% 100V	
R226	1-249-431-11	CARBON 15K 5% 1/4W		C24	1-108-704-11	MYLAR 0.1MF 10% 200V	
R227	1-249-456-11	CARBON 5.6 5% 1/4W F		C25	1-124-903-11	ELECT 1MF 20% 50V	
R228	1-249-456-11	CARBON 5.6 5% 1/4W F		C26	1-101-361-00	CERAMIC 150PF 5% 50V	
R229	1-215-867-00	METAL OXIDE 470 5% 1W F		C27	1-101-361-00	CERAMIC 150PF 5% 50V	
*****				C28	1-126-964-11	ELECT 10MF 20% 16V	
*A-1316-089-A	GA BOARD, COMPLETE (BVM-1916 ONLY)			C29	1-126-967-11	ELECT 47MF 20% 25V	
*A-1316-090-A	GA BOARD, COMPLETE (BVM-2016P ONLY)			C30	1-162-117-00	CERAMIC 100PF 10% 500V	
	*****			C31	1-102-030-00	CERAMIC 330PF 10% 500V	
	(INCLUDING GB BOARD)			C32	1-124-903-11	ELECT 1MF 20% 50V	
▲ 1-533-167-21	HOLDER, FUSE			C33	1-101-361-00	CERAMIC 150PF 5% 50V	
▲ 1-533-168-21	HOLDER, FUSE			C34	1-101-361-00	CERAMIC 150PF 5% 50V	
▲ 1-570-173-22	SWITCH, VOLTAGE CHANGE			C35	1-124-903-11	ELECT 1MF 20% 50V	
▲ 1-580-375-11	INLET 3P			C36	1-126-967-11	ELECT 47MF 20% 25V	
2-990-241-02	HOLDER (A), PLUG			C37	1-130-734-00	FILM 0.0068MF 5% 50V	
*3-337-402-01	BAND, BINDING			C38	1-136-165-00	FILM 0.1MF 5% 50V	
*4-347-706-00	HEAT SINK (TR)			C39	1-136-165-00	FILM 0.1MF 5% 50V	
*4-371-879-02	COVER, AC SELECT			C40	1-124-925-11	ELECT 2.2MF 20% 50V	
4-379-403-01	SPACER (G1), POLISHING			C41	1-102-038-00	CERAMIC 0.001MF 500V	
*4-379-408-01	INSULATOR (G3)			C42	1-136-165-00	FILM 0.1MF 5% 50V	
*4-379-409-01	NUT, PLATE			C43	1-136-165-00	FILM 0.1MF 5% 50V	
4-379-410-01	SPACER (G2), POLISHING			C44	1-126-966-11	ELECT 10MF 20% 16V	
*4-379-430-01	PANEL, POWER			C45	1-162-132-00	CERAMIC 270PF 10% 2KV	
*4-386-847-01	HEAT SINK (S.R.T)			C46	1-126-964-11	ELECT 10MF 20% 16V	
*4-386-848-01	BAND (S.R.T)			C47	1-136-173-00	FILM 0.47MF 5% 50V	
*4-393-031-01	COVER, FUSE HOLDER			C48	1-136-173-00	FILM 0.47MF 5% 50V	
*4-601-466-11	COVER, 3P INLET			C49	1-126-964-11	ELECT 10MF 20% 16V	
7-432-114-11	SCREW, LOCK			C50	1-101-006-00	CERAMIC 0.047MF 50V	
7-682-150-01	SCREW +P 3X12			C51	1-101-006-00	CERAMIC 0.047MF 50V	
7-682-552-04	SCREW +P 3X16			C52	1-101-006-00	CERAMIC 0.047MF 50V	
7-682-554-04	SCREW +P 3X25			C53	1-101-006-00	CERAMIC 0.047MF 50V	
7-682-560-04	SCREW +P 4X6			C54	1-101-006-00	CERAMIC 0.047MF 50V	
7-682-247-04	SCREW +K 3X6			C55	1-126-964-11	ELECT 10MF 20% 16V	
7-682-547-04	SCREW +B 3X6			C56	1-136-201-11	FILM 0.22MF 5% 400V	
7-682-948-01	SCREW +PSW 3X8			C57	1-124-915-11	ELECT 10MF 20% 25V	
7-685-646-79	SCREW +BVTP 3X8 TYPE2 IT-3			C58	1-124-902-00	ELECT 0.47MF 20% 50V	
7-682-547-09	SCREW +BVTT 3X6 (S)			C59	1-130-734-00	FILM 0.0068MF 5% 50V	
	<CAPACITOR>			C60	1-102-228-00	CERAMIC 470PF 10% 500V	
C1	1-124-024-00	ELECT 4.7MF 20% 350V		C61	1-102-228-00	CERAMIC 470PF 10% 500V	
C2	1-124-024-00	ELECT 4.7MF 20% 350V		C62	1-102-228-00	CERAMIC 470PF 10% 500V	
C3	1-162-117-00	CERAMIC 100PF 10% 500V		C63	1-102-228-00	CERAMIC 470PF 10% 500V	
C4	1-162-117-00	CERAMIC 100PF 10% 500V		C64	1-124-024-00	ELECT 4.7MF 20% 350V	
C5	1-162-117-00	CERAMIC 100PF 10% 500V		C65	1-124-024-00	ELECT 4.7MF 20% 350V	
C6	1-162-117-00	CERAMIC 100PF 10% 500V		C66	1-162-117-00	CERAMIC 100PF 10% 500V	
C7	1-126-104-11	ELECT 470MF 20% 25V		C67	1-162-117-00	CERAMIC 100PF 10% 500V	
C8	1-126-105-11	ELECT 1000MF 20% 25V		C68	1-162-117-00	CERAMIC 100PF 10% 500V	
C9	1-126-104-11	ELECT 470MF 20% 25V		C69	1-124-562-11	ELECT 47MF 20% 200V	
C10	1-126-105-11	ELECT 1000MF 20% 25V		C70	1-124-171-00	ELECT 100MF 20% 160V	
C11	1-126-104-11	ELECT 470MF 20% 25V		C71	1-162-117-00	CERAMIC 100PF 10% 500V	
C12	1-124-602-00	ELECT 2200MF 20% 25V		C72	1-107-948-11	ELECT 330MF 20% 160V	
C13	1-126-104-11	ELECT 470MF 20% 25V		C73	1-107-948-11	ELECT 330MF 20% 160V	
C14	1-124-602-00	ELECT 2200MF 20% 25V		C74	1-104-665-11	ELECT 100MF 20% 16V	
C15	1-126-183-11	ELECT 1000MF 20% 16V		C75	1-104-665-11	ELECT 100MF 20% 16V	
C16	1-126-103-11	ELECT 470MF 20% 16V		C76	▲ 1-161-953-52	CERAMIC 0.0047MF 20% 400V	
C17	1-106-375-12	MYLAR 0.022MF 10% 200V		C77	▲ 1-161-953-52	CERAMIC 0.0047MF 20% 400V	
C18	1-108-638-11	MYLAR 0.1MF 10% 100V		C78	1-162-599-12	CERAMIC 0.0047MF 20% 400V	
				C79	1-162-599-12	CERAMIC 0.0047MF 20% 400V	
				C80	1-125-658-11	ELECT 560MF 20% 250V	
				C81	1-125-658-11	ELECT 560MF 20% 250V	

7. ELECTRICAL PARTS LIST

GA

Les composants identifiés par une trame et une marque  $\Delta$  sont critiques pour la sécurité. Ne les remplacer que par une pièce portant le numéro spécifique.

The components identified by shading and mark  $\Delta$  are critical for safety. Replace only with part number specified.

REF. NO.	PART NO.	DESCRIPTION	REMARK	REF. NO.	PART NO.	DESCRIPTION	REMARK
C82	1-124-927-11	ELECT	4.7MF 20% 25V	GA1	1-506-348-XX	PIN, CONNECTOR 3P	
C83	1-101-004-00	CERAMIC	0.01MF 50V	GA2	*1-506-371-00	PIN, CONNECTOR 2P	
C84	$\Delta$ 1-136-311-51	FILM	0.47MF 20% 125V (BVM-1916 ONLY)	GA3	*1-508-768-00	PIN, CONNECTOR (5MM PITCH) 6P	
	$\Delta$ 1-136-311-61	FILM	0.47MF 20% 300V (BVM-2016P ONLY)	GA4	*1-508-786-00	PIN, CONNECTOR (5MM PITCH) 2P	
C85	$\Delta$ 1-162-578-51	CERAMIC	0.0047MF 20% 400V	GA5	*1-566-055-11	PIN, CONNECTOR 3P	
C86	$\Delta$ 1-162-578-51	CERAMIC	0.0047MF 20% 400V	GA6	*1-566-055-11	PIN, CONNECTOR 3P	
C87	$\Delta$ 1-162-578-51	CERAMIC	0.0047MF 20% 400V	GA7	*1-566-058-11	PIN, CONNECTOR 6P	
C88	$\Delta$ 1-162-578-51	CERAMIC	0.0047MF 20% 400V	GA8	*1-566-057-11	PIN, CONNECTOR 5P	
C89	$\Delta$ 1-136-311-51	FILM	0.47MF 20% 125V (BVM-1916 ONLY)			<IC>	
	$\Delta$ 1-136-311-61	FILM	0.47MF 20% 300V (BVM-2016P ONLY)	IC1	1-806-805-11	IC MC5433	
C90	1-136-159-00	FILM	0.033MF 5% 50V	IC2	8-759-904-94	IC TL494CN	
C91	1-162-599-12	CERAMIC	0.0047MF 20% 400V (BVM-2016P ONLY)	IC3	8-759-904-94	IC TL494CN	
C92	1-136-159-00	FILM	0.033MF 5% 50V	IC4	8-759-925-54	IC $\mu$ PC2405HF	
C93	1-162-599-12	CERAMIC	0.0047MF 20% 400V (BVM-2016P ONLY)			<COIL>	
C94	1-102-038-00	CERAMIC	0.001MF 500V	L3	1-459-643-11	COIL, CHOKE 525UH	
C95	1-136-173-00	FILM	0.47MF 5% 50V	L4	1-459-643-11	COIL, CHOKE 525UH	
C96	1-102-050-00	CERAMIC	0.01MF 99% 500V	L5	1-459-643-11	COIL, CHOKE 525UH	
C97	1-136-173-00	FILM	0.47MF 5% 50V	L6	1-459-643-11	COIL, CHOKE 525UH	
C98	1-136-173-00	FILM	0.47MF 5% 50V	L7	1-459-207-00	COIL, CORE	
C99	1-102-050-00	CERAMIC	0.01MF 99% 500V	L8	1-403-581-11	COIL, CHOKE 5MMH	
C100	1-162-117-00	CERAMIC	100PF 10% 500V	L9	1-459-645-11	COIL, CHOKE 20MMH	
C101	1-162-117-00	CERAMIC	100PF 10% 500V	L10	1-421-329-00	COIL, CHOKE	
C102	1-136-601-11	FILM	0.01MF 5% 630V	L11	1-421-329-00	COIL, CHOKE	
C103	1-136-601-11	FILM	0.01MF 5% 630V	L12	1-421-329-00	COIL, CHOKE	
C104	1-124-477-11	ELECT	47MF 20% 16V	L13	1-421-329-00	COIL, CHOKE	
		<DIODE>		L14	1-421-329-00	COIL, CHOKE	
D1	8-719-912-51	DIODE ESAC25-04C		L15	1-421-329-00	COIL, CHOKE	
D2	8-719-918-73	DIODE ESAC25-04N		L16	1-421-329-00	COIL, CHOKE	
D3	8-719-901-73	DIODE ESAD25-04D		L17	$\Delta$ 1-421-590-11	TRANSFORMER, LINE FILTER (BVM-1916 ONLY)	
D4	8-719-901-73	DIODE ESAD25-04D			$\Delta$ 1-423-937-11	TRANSFORMER, LINE FILTER (LFT) (BVM-2016P ONLY)	
D5	8-719-988-31	DIODE D10SC6MR		L18	$\Delta$ 1-421-590-11	TRANSFORMER, LINE FILTER (BVM-1916 ONLY)	
D6	8-719-510-09	DIODE D10SC6M			$\Delta$ 1-423-937-11	TRANSFORMER, LINE FILTER (BVM-2016P ONLY)	
D7	8-719-300-33	DIODE RU-3AM				<TRANSISTOR>	
D8	8-719-300-52	DIODE CTU-38R		Q1	8-729-301-76	TRANSISTOR STR8124-R	
D9	8-719-300-53	DIODE CTU-38S		Q2	8-729-301-76	TRANSISTOR STR8124-R	
D10	8-719-912-51	DIODE ESAC25-04C		Q3	8-729-140-96	TRANSISTOR 2SD774-34	
D11	8-719-918-73	DIODE ESAC25-04N		Q4	8-729-140-96	TRANSISTOR 2SD774-34	
D12	8-719-911-19	DIODE 1SS119		Q5	8-729-140-96	TRANSISTOR 2SD774-34	
D13	8-719-911-19	DIODE 1SS119		Q6	8-729-140-96	TRANSISTOR 2SD774-34	
D14	8-719-100-58	DIODE RD10EB3		Q7	8-729-140-97	TRANSISTOR 2SB734-34	
D15	8-719-911-19	DIODE 1SS119		Q8	8-729-119-78	TRANSISTOR 2SC2785-HFE	
D16	8-719-911-19	DIODE 1SS119		Q9	8-729-119-78	TRANSISTOR 2SC2785-HFE	
D17	8-719-911-19	DIODE 1SS119		Q11	8-729-119-76	TRANSISTOR 2SA1175-HFE	
D20	8-719-200-02	DIODE 10E-2		Q12	8-729-140-96	TRANSISTOR 2SD774-34	
D21	$\Delta$ 8-719-300-07	DIODE RB406N		Q13	8-729-119-78	TRANSISTOR 2SC2785-HFE	
D22	8-759-157-40	IC UPC574J		Q14	8-729-119-78	TRANSISTOR 2SC2785-HFE	
D23	8-719-911-19	DIODE 1SS119				<RESISTOR>	
D24	8-719-100-58	DIODE RD10EB3		R1	1-215-857-11	METAL OXIDE 10 5% 1W F	
D25	8-719-911-19	DIODE 1SS119		R2	1-215-857-11	METAL OXIDE 10 5% 1W F	
D26	8-719-003-08	THYRISTOR CR3CM-8		R3	1-247-715-11	CARBON 1.5K 5% 1/4W	
D27	8-719-982-04	DIODE ERB81-004		R4	1-215-857-11	METAL OXIDE 10 5% 1W F	
D28	8-719-982-04	DIODE ERB81-004		R5	1-215-857-11	METAL OXIDE 10 5% 1W F	
D29	8-719-982-04	DIODE ERB81-004		R6	1-249-447-11	CARBON 1 5% 1/4W F	
D30	8-719-982-04	DIODE ERB81-004		R7	1-247-692-11	CARBON 22 5% 1/4W	
D31	8-719-300-33	DIODE RU-3AM		R8	1-249-418-11	CARBON 1.2K 5% 1/4W	
D32	8-719-300-33	DIODE RU-3AM		R9	1-249-382-11	CARBON 1.2 5% 1/4W F	
		<CONNECTOR>		R10	1-249-447-11	CARBON 1 5% 1/4W F	
				R11	1-247-692-11	CARBON 22 5% 1/4W	

The components identified by shading and mark **Δ** are critical for safety. Replace only with part number specified.

Les composants identifiés par une trame et une marque **Δ** sont critiques pour la sécurité. Ne les remplacer que par une pièce portant le numéro spécifié.

The components identified by **■** in this manual have been carefully factory-selected for each set in order to satisfy regulations regarding X-ray radiation. Should replacement be required, replace only with the value originally used.

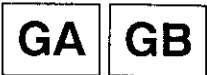

REF. NO.	PART NO.	DESCRIPTION	REMARK
R12	1-249-418-11	CARBON 1.2K 5% 1/4W	
R13	1-215-889-00	METAL OXIDE 330 5% 2W	F
R14	1-247-700-11	CARBON 100 5% 1/4W	
R15	1-247-709-11	CARBON 510 5% 1/4W	
R16	1-247-709-11	CARBON 510 5% 1/4W	
R17	1-247-700-11	CARBON 100 5% 1/4W	
R18	1-249-425-11	CARBON 4.7K 5% 1/4W	
R19	1-249-419-11	CARBON 1.5K 5% 1/4W	
R20	1-247-838-00	CARBON 2K 5% 1/4W	
R21	1-249-417-11	CARBON 1K 5% 1/4W	
R22	1-249-409-11	CARBON 220 5% 1/4W	
R23	1-249-417-11	CARBON 1K 5% 1/4W	
R24	1-249-421-11	CARBON 2.2K 5% 1/4W	
R25	1-249-409-11	CARBON 220 5% 1/4W	
R26	1-247-700-11	CARBON 100 5% 1/4W	
R27	1-247-713-11	CARBON 1K 5% 1/4W	
R28	1-247-713-11	CARBON 1K 5% 1/4W	
R29	1-247-700-11	CARBON 100 5% 1/4W	
R30	1-215-886-11	METAL OXIDE 100 5% 2W	F
R31	1-215-886-11	METAL OXIDE 100 5% 2W	F
R32	1-215-886-11	METAL OXIDE 100 5% 2W	F
R33	1-247-697-11	CARBON 56 5% 1/4W	F
R34	1-247-697-11	CARBON 56 5% 1/4W	F
R36	1-249-425-11	CARBON 4.7K 5% 1/4W	
R37	1-249-420-11	CARBON 1.8K 5% 1/4W	
R38	1-249-429-11	CARBON 10K 5% 1/4W	
R39	1-249-413-11	CARBON 470 5% 1/4W	
R40	1-215-453-00	METAL 22K 1% 1/4W	
R41	1-249-425-11	CARBON 4.7K 5% 1/4W	
R42	1-215-437-00	METAL 4.7K 1% 1/4W	
R43	1-215-435-00	METAL 3.9K 1% 1/4W	
R44	1-215-427-00	METAL 1.8K 1% 1/4W	
R47	1-216-995-11	METAL 820 1% 10W	
R48	1-215-866-11	METAL OXIDE 330 5% 1W	F
■R52	Δ	METAL OXIDE 2W	F
■R53	Δ	METAL 1/4W	
R54	1-215-901-00	METAL OXIDE 33K 5% 2W	F
R55	1-215-426-00	METAL 1.6K 1% 1/4W	
R60	1-249-420-11	CARBON 1.8K 5% 1/4W	
R61	1-249-420-11	CARBON 1.8K 5% 1/4W	
R62	1-249-429-11	CARBON 10K 5% 1/4W	
R64	1-249-426-11	CARBON 5.6K 5% 1/4W	
R65	1-215-437-00	METAL 4.7K 1% 1/4W	
R66	1-215-453-00	METAL 22K 1% 1/4W	
■R67	Δ	METAL 1/2W	
■R68	Δ	METAL 1/4W	
R74	1-215-889-00	METAL OXIDE 330 5% 2W	F
R77	1-215-433-00	METAL 3.3K 1% 1/4W	
R78	1-215-433-00	METAL 3.3K 1% 1/4W	
R80	Δ 1-202-643-35	SOLID 820K 10% 1/2W	
R81	1-215-461-00	METAL 47K 1% 1/4W	
R82	1-215-461-00	METAL 47K 1% 1/4W	
R83	1-215-461-00	METAL 47K 1% 1/4W	
R84	1-215-459-00	METAL 39K 1% 1/4W	
R85	1-215-449-00	METAL 15K 1% 1/4W	
R86	1-215-437-00	METAL 4.7K 1% 1/4W	
R87	1-247-807-31	CARBON 100 5% 1/4W	
R88	1-249-433-11	CARBON 22K 5% 1/4W	
R89	1-249-429-11	CARBON 10K 5% 1/4W	
R90	1-249-429-11	CARBON 10K 5% 1/4W	
R91	1-249-429-11	CARBON 10K 5% 1/4W	
R92	Δ 1-217-295-11	WIREWOUND 5.6 10% 5W	F
R93	1-215-886-11	METAL OXIDE 100 5% 2W	F
R94	1-205-538-00	WIREWOUND 4.7 10% 10W	
R95	1-215-904-11	METAL OXIDE 100K 5% 2W	F

REF. NO.	PART NO.	DESCRIPTION	REMARK
R96	1-215-904-11	METAL OXIDE 100K 5% 2W	F
R97	1-215-904-11	METAL OXIDE 100K 5% 2W	F
R98	1-215-904-11	METAL OXIDE 100K 5% 2W	F
R100	1-212-889-00	FUSIBLE 220 5% 1/4W	F
R101	1-249-470-11	CARBON 0.47 5% 1/2W	F
R102	1-249-470-11	CARBON 0.47 5% 1/2W	F
R103	1-249-470-11	CARBON 0.47 5% 1/2W	F
R104	1-249-377-11	CARBON 0.47 5% 1/4W	F
R105	1-249-386-11	CARBON 2.7 5% 1/4W	F
<VARIABLE RESISTOR>			
RV1	1-237-514-21	RES. ADJ. CERMET 500	
RV2	1-237-515-21	RES. ADJ. CERMET 1K	
<RELAY>			
RY1	Δ 1-515-805-11	RELAY, POWER	
<TRANSFORMER>			
T1	Δ 1-448-433-11	TRANSFORMER, CONVERTER (S.R.T)	
T2	Δ 1-447-106-11	TRANSFORMER, DRIVE	
T3	Δ 1-421-624-12	TRANSFORMER, CURRENT	
T4	Δ 1-447-426-12	TRANSFORMER, CONVERTER	
T5	Δ 1-448-432-12	TRANSFORMER, CONVERTER (S.R.T)	
T6	Δ 1-447-106-11	TRANSFORMER, DRIVE	
T7	Δ 1-421-624-12	TRANSFORMER, CURRENT	
<THERMISTOR>			
TH1	Δ 1-809-531-11	THERMISTOR, POWER	
THP1	Δ 1-806-387-12	THERMISTOR (POSITIVE)	
THP2	Δ 1-800-686-33	THERMISTOR (POSITIVE)	
*****			
*1-627-679-11 GB BOARD			
*****			
<CAPACITOR>			
C1	1-124-903-11	ELECT 1MF 20% 50V	
C2	1-124-903-11	ELECT 1MF 20% 50V	
<DIODE>			
D1	8-719-911-19	DIODE 1SS119	
D2	8-719-110-08	DIODE RD8.2ESB2	
D3	8-719-911-19	DIODE 1SS119	
D4	8-719-911-19	DIODE 1SS119	
D5	8-719-911-19	DIODE 1SS119	
D6	8-719-110-08	DIODE RD8.2ESB2	
D7	8-719-812-41	DIODE TLR124	
D8	8-719-911-19	DIODE 1SS119	
D9	8-719-911-19	DIODE 1SS119	
D10	8-719-812-41	DIODE TLR124	
D11	8-719-110-08	DIODE RD8.2ESB2	
D12	8-719-911-19	DIODE 1SS119	
D13	8-719-911-19	DIODE 1SS119	
D14	8-719-911-19	DIODE 1SS119	
D15	8-719-911-19	DIODE 1SS119	
D16	8-719-911-19	DIODE 1SS119	
D17	8-719-110-08	DIODE RD8.2ESB2	
D18	8-719-911-19	DIODE 1SS119	
D19	8-719-911-19	DIODE 1SS119	

7. ELECTRICAL PARTS LIST

GB	GC	HA	HH	HW
----	----	----	----	----

REF. NO. PART NO. DESCRIPTION

<CONNECTOR>

GA1 \*1-506-603-11 PLUG, L TYPE (2.0MM PITCH) 10P

<TRANSISTOR>

Q1 8-729-119-76 TRANSISTOR 2SA1175-HFE  
 Q2 8-729-119-78 TRANSISTOR 2SC2785-HFE  
 Q3 8-729-119-76 TRANSISTOR 2SA1175-HFE  
 Q4 8-729-119-78 TRANSISTOR 2SC2785-HFE  
 Q5 8-729-119-76 TRANSISTOR 2SA1175-HFE  
 Q6 8-729-119-76 TRANSISTOR 2SA1175-HFE  
 Q7 8-729-119-78 TRANSISTOR 2SA1175-HFE  
 Q8 8-729-119-78 TRANSISTOR 2SC2785-HFE  
 Q9 8-729-119-76 TRANSISTOR 2SA1175-HFE  
 Q10 8-729-119-78 TRANSISTOR 2SC2785-HFE

<RESISTOR>

R1 1-249-427-11 CARBON 6.8K 5% 1/4W  
 R2 1-249-428-11 CARBON 8.2K 5% 1/4W  
 R3 1-249-429-11 CARBON 10K 5% 1/4W  
 R4 1-249-427-11 CARBON 6.8K 5% 1/4W  
 R5 1-249-420-11 CARBON 1.8K 5% 1/4W  
 R6 1-249-427-11 CARBON 6.8K 5% 1/4W  
 R7 1-249-420-11 CARBON 1.8K 5% 1/4W  
 R8 1-249-429-11 CARBON 10K 5% 1/4W  
 R9 1-249-427-11 CARBON 6.8K 5% 1/4W  
 R10 1-249-428-11 CARBON 8.2K 5% 1/4W  
 R11 1-249-424-11 CARBON 3.9K 5% 1/4W  
 R12 1-249-421-11 CARBON 2.2K 5% 1/4W  
 R13 1-249-425-11 CARBON 4.7K 5% 1/4W  
 R14 1-249-421-11 CARBON 2.2K 5% 1/4W  
 R15 1-249-424-11 CARBON 3.9K 5% 1/4W  
 R16 1-249-421-11 CARBON 2.2K 5% 1/4W  
 R17 1-249-425-11 CARBON 4.7K 5% 1/4W  
 R18 1-249-421-11 CARBON 2.2K 5% 1/4W  
 R19 1-249-429-11 CARBON 10K 5% 1/4W  
 R20 1-249-429-11 CARBON 10K 5% 1/4W  
 R21 1-249-429-11 CARBON 10K 5% 1/4W  
 R22 1-249-423-11 CARBON 3.3K 5% 1/4W  
 R23 1-249-423-11 CARBON 3.3K 5% 1/4W  
 R24 1-249-429-11 CARBON 10K 5% 1/4W  
 R25 1-249-429-11 CARBON 10K 5% 1/4W

\*1-617-885-11 GC BOARD  
 \*\*\*\*\*

<CAPACITOR>

C1 1-124-916-11 ELECT 22MF 20% 25V  
 C2 1-124-916-11 ELECT 22MF 20% 25V  
 C3 1-124-916-11 ELECT 22MF 20% 25V  
 C4 1-124-916-11 ELECT 22MF 20% 25V  
 C5 1-124-916-11 ELECT 22MF 20% 25V  
 C6 1-124-916-11 ELECT 22MF 20% 25V  
 C7 1-124-916-11 ELECT 22MF 20% 25V  
 C8 1-124-916-11 ELECT 22MF 20% 25V  
 C9 1-124-916-11 ELECT 22MF 20% 25V  
 C12 1-101-004-00 CERAMIC 0.01MF 50V  
 C14 1-101-004-00 CERAMIC 0.01MF 50V  
 C16 1-101-004-00 CERAMIC 0.01MF 50V  
 C17 1-101-004-00 CERAMIC 0.01MF 50V  
 C18 1-101-004-00 CERAMIC 0.01MF 50V

REMARK REF. NO. PART NO. DESCRIPTION

<CONNECTOR>

GC1 \*1-566-044-11 PIN, CONNECTOR 5P  
 GC2 \*1-566-057-11 PIN, CONNECTOR 5P  
 GC3 \*1-566-044-11 PIN, CONNECTOR 5P

<IC>

IC1 8-759-012-71 IC MC7912CT  
 IC2 8-759-012-71 IC MC7912CT  
 IC3 8-759-146-55 IC  $\mu$ PC2412HF  
 IC4 8-759-146-55 IC  $\mu$ PC2412HF

\*1-631-683-11 HA BOARD  
 \*\*\*\*\*

<CONNECTOR>

HA301 \*1-566-055-11 PIN, CONNECTOR 3P  
 HA302 \*1-566-056-11 PIN, CONNECTOR 4P  
 HA303 \*1-566-064-11 PIN, CONNECTOR 12P  
 HA304 \*1-566-054-11 PIN, CONNECTOR 2P

<RESISTOR>

R301 1-247-814-11 CARBON 200 5% 1/4W  
 R302 1-215-469-00 METAL 100K 1% 1/4W

<VARIABLE RESISTOR>

RV301 1-237-519-21 RES, ADJ, CERMET 20K

<SWITCH>

S301 1-570-565-11 SWITCH, PUSH (10 KEY)

\*1-627-682-11 HH BOARD  
 \*\*\*\*\*

\*1-566-614-11 PLUG (L TYPE) 3P

<VARIABLE RESISTOR>

RV1 1-238-332-11 RES, VAR, CARBON 20K  
 RV2 1-238-332-11 RES, VAR, CARBON 20K  
 RV3 1-238-332-11 RES, VAR, CARBON 20K  
 RV4 1-238-332-11 RES, VAR, CARBON 20K

\*1-647-257-11 HW BOARD  
 \*\*\*\*\*

7-682-547-09 SCREW +BVTT 3X6 (S)

<HOLDER>

D1 \*4-026-910-00 HOLDER, LED  
 D2 \*4-026-910-00 HOLDER, LED

<DIODE>

D101 8-719-812-42 DIODE TLY124  
 D102 8-719-812-41 DIODE TLR124

7. ELECTRICAL PARTS LIST

REF. NO.	PART NO.	DESCRIPTION	REMARK	REF. NO.	PART NO.	DESCRIPTION	REMARK
		<RESISTOR>					
R101	1-216-065-00	METAL GLAZE 4.7K 5% 1/10W		D23	8-719-812-42 *4-374-937-01	DIODE TLY124 HOLDER, LED; D23	
		<SWITCH>		D24	8-719-812-42 *4-374-937-01	DIODE TLY124 HOLDER, LED; D24	
S101	1-570-566-11	SWITCH, PUSH (4 KEY)		D25	8-719-812-42 *4-374-937-01	DIODE TLY124 HOLDER, LED; D25	
*****							
	*1-647-258-11	HX BOARD *****		D26	8-719-404-46	DIODE MA110	
		<SWITCH>		D27	8-719-404-46	DIODE MA110	
S1	1-692-470-11	SWITCH, PUSH (4 KEY)		D28	8-719-404-46	DIODE MA110	
*****							
	A-1371-895-A	HY BOARD, COMPLETE *****		D29	8-719-404-46	DIODE MA110	
		<CAPACITOR>		D30	8-719-812-42 *4-374-937-01	DIODE TLY124 HOLDER, LED; D30	
C1	1-124-584-00	ELECT 100MF 20% 10V		D31	8-719-812-42 *4-374-937-01	DIODE TLY124 HOLDER, LED; D31	
C2	1-124-584-00	ELECT 100MF 20% 10V		D32	8-719-812-42 *4-374-937-01	DIODE TLY124 HOLDER, LED; D32	
C3	1-124-584-00	ELECT 100MF 20% 10V		D33	8-719-812-42 *4-374-937-01	DIODE TLY124 HOLDER, LED; D33	
C4	1-163-031-11	CERAMIC CHIP 0.01MF 50V		D34	8-719-812-42 *4-374-937-01	DIODE TLY124 HOLDER, LED; D34	
C5	1-163-031-11	CERAMIC CHIP 0.01MF 50V		D35	8-719-812-42 *4-374-937-01	DIODE TLY124 HOLDER, LED; D35	
C6	1-163-031-11	CERAMIC CHIP 0.01MF 50V		D36	8-719-812-42 *4-374-937-01	DIODE TLY124 HOLDER, LED; D36	
		<DIODE>		D37	8-719-812-42 *4-374-937-01	DIODE TLY124 HOLDER, LED; D37	
D1	8-719-404-46	DIODE MA110		D38	8-719-812-42 *4-374-937-01	DIODE TLY124 HOLDER, LED; D38	
D2	8-719-404-46	DIODE MA110		D39	8-719-404-46	DIODE MA110	
D3	8-719-404-46	DIODE MA110		D40	8-719-404-46	DIODE MA110	
D4	8-719-404-46	DIODE MA110		D41	8-719-812-42 *4-374-937-01	DIODE TLY124 HOLDER, LED; D41	
D5	8-719-404-46	DIODE MA110		D42	8-719-812-42 *4-374-937-01	DIODE TLY124 HOLDER, LED; D42	
D6	8-719-404-46	DIODE MA110		D43	8-719-812-42 *4-374-937-01	DIODE TLY124 HOLDER, LED; D43	
D7	8-719-404-46	DIODE MA110		D44	8-719-812-42 *4-374-937-01	DIODE TLY124 HOLDER, LED; D44	
D8	8-719-404-46	DIODE MA110		D45	8-719-404-46	DIODE MA110	
D9	8-719-404-46	DIODE MA110		D46	8-719-404-46	DIODE MA110	
D10	8-719-404-46	DIODE MA110		D47	8-719-404-46	DIODE MA110	
D11	8-719-404-46	DIODE MA110		D48	8-719-404-46	DIODE MA110	
D12	8-719-812-42 *4-374-937-01	DIODE TLY124 HOLDER, LED; D12		D49	8-719-404-46	DIODE MA110	
D13	8-719-812-42 *4-374-937-01	DIODE TLY124 HOLDER, LED; D13		D50	8-719-812-42 *4-374-937-01	DIODE TLY124 HOLDER, LED; D50	
D14	8-719-812-42 *4-374-937-01	DIODE TLY124 HOLDER, LED; D14		D51	8-719-812-42 *4-374-937-01	DIODE TLY124 HOLDER, LED; D51	
D15	8-719-812-42 *4-374-937-01	DIODE TLY124 HOLDER, LED; D15		D52	8-719-404-46	DIODE MA110	
D16	8-719-812-42 *4-374-937-01	DIODE TLY124 HOLDER, LED; D16		D53	8-719-404-46	DIODE MA110	
D17	8-719-812-42 *4-374-937-01	DIODE TLY124 HOLDER, LED; D17		D54	8-719-404-46	DIODE MA110	
D18	8-719-812-42 *4-374-937-01	DIODE TLY124 HOLDER, LED; D18		D55	8-719-404-46	DIODE MA110	
D19	8-719-812-42 *4-374-937-01	DIODE TLY124 HOLDER, LED; D19		D56	8-719-404-46	DIODE MA110	
D20	8-719-812-42 *4-374-937-01	DIODE TLY124 HOLDER, LED; D20		D57	8-719-404-46	DIODE MA110	
D21	8-719-812-42 *4-374-937-01	DIODE TLY124 HOLDER, LED; D21		D58	8-719-404-46	DIODE MA110	
				D59	8-719-404-46	DIODE MA110	
				D60	8-719-404-46	DIODE MA110	
				D61	8-719-404-46	DIODE MA110	
				D62	8-719-404-46	DIODE MA110	
				D63	8-719-812-42 *4-374-937-01	DIODE TLY124 HOLDER, LED; D63	
				D64	8-719-812-42 *4-374-937-01	DIODE TLY124 HOLDER, LED; D64	
				D65	8-719-812-42 *4-374-937-01	DIODE TLY124 HOLDER, LED; D65	

7. ELECTRICAL PARTS LIST





REF. NO.	PART NO.	DESCRIPTION	REMARK	REF. NO.	PART NO.	DESCRIPTION	REMARK
D66	8-719-812-42	DIODE TLY124		R19	1-216-045-00	METAL GLAZE 680 5%	1/10W
	*4-374-937-01	HOLDER, LED; D66		R20	1-216-033-00	METAL GLAZE 220 5%	1/10W
D67	8-719-812-42	DIODE TLY124		R21	1-216-043-00	METAL GLAZE 560 5%	1/10W
	*4-374-937-01	HOLDER, LED; D67		R22	1-216-033-00	METAL GLAZE 220 5%	1/10W
D68	8-719-812-42	DIODE TLY124		R23	1-216-295-00	METAL GLAZE 0 5%	1/10W
	*4-374-937-01	HOLDER, LED; D68		R24	1-216-043-00	METAL GLAZE 560 5%	1/10W
D69	8-719-812-42	DIODE TLY124		R25	1-216-043-00	METAL GLAZE 560 5%	1/10W
	*4-374-937-01	HOLDER, LED; D69		R26	1-216-043-00	METAL GLAZE 560 5%	1/10W
		<CONNECTOR>		R27	1-216-049-00	METAL GLAZE 1K 5%	1/10W
HY1	*1-566-045-11	PIN, CONNECTOR 6P		R28	1-216-049-00	METAL GLAZE 1K 5%	1/10W
HY2	*1-566-047-11	PIN, CONNECTOR 8P		R29	1-216-049-00	METAL GLAZE 1K 5%	1/10W
HY3	*1-566-052-11	PIN, CONNECTOR 13P		R30	1-216-043-00	METAL GLAZE 560 5%	1/10W
HY4	*1-566-047-11	PIN, CONNECTOR 8P		R31	1-216-043-00	METAL GLAZE 560 5%	1/10W
		<IC>		R32	1-216-043-00	METAL GLAZE 560 5%	1/10W
IC1	8-757-991-00	IC CX-7991		R33	1-216-043-00	METAL GLAZE 560 5%	1/10W
IC2	8-757-991-00	IC CX-7991		R34	1-216-043-00	METAL GLAZE 560 5%	1/10W
IC3	8-757-991-00	IC CX-7991		R35	1-216-043-00	METAL GLAZE 560 5%	1/10W
		<TRANSISTOR>		R36	1-216-043-00	METAL GLAZE 560 5%	1/10W
Q1	8-729-422-29	TRANSISTOR 2SD601A-S		R37	1-216-043-00	METAL GLAZE 560 5%	1/10W
		<RESISTOR>		R38	1-216-043-00	METAL GLAZE 560 5%	1/10W
JR1	1-216-295-00	METAL GLAZE 0 5%	1/10W	R39	1-216-043-00	METAL GLAZE 560 5%	1/10W
JR2	1-216-295-00	METAL GLAZE 0 5%	1/10W	R40	1-216-043-00	METAL GLAZE 560 5%	1/10W
JR3	1-216-295-00	METAL GLAZE 0 5%	1/10W	R41	1-216-043-00	METAL GLAZE 560 5%	1/10W
JR4	1-216-049-00	METAL GLAZE 1K 5%	1/10W	R42	1-216-043-00	METAL GLAZE 560 5%	1/10W
JR5	1-216-295-00	METAL GLAZE 0 5%	1/10W	R43	1-216-043-00	METAL GLAZE 560 5%	1/10W
JR6	1-216-295-00	METAL GLAZE 0 5%	1/10W			<SWITCH>	
JR7	1-216-295-00	METAL GLAZE 0 5%	1/10W	S1	1-572-482-11	SWITCH, KEY BOARD (1 KEY)	
JR8	1-216-295-00	METAL GLAZE 0 5%	1/10W	S2	1-572-482-11	SWITCH, KEY BOARD (1 KEY)	
JR9	1-216-295-00	METAL GLAZE 0 5%	1/10W	S3	1-572-482-11	SWITCH, KEY BOARD (1 KEY)	
JR10	1-216-295-00	METAL GLAZE 0 5%	1/10W	S4	1-572-482-11	SWITCH, KEY BOARD (1 KEY)	
JR11	1-216-295-00	METAL GLAZE 0 5%	1/10W	S5	1-572-482-11	SWITCH, KEY BOARD (1 KEY)	
JR12	1-216-295-00	METAL GLAZE 0 5%	1/10W	S6	1-572-482-11	SWITCH, KEY BOARD (1 KEY)	
JR13	1-216-295-00	METAL GLAZE 0 5%	1/10W	S7	1-572-482-11	SWITCH, KEY BOARD (1 KEY)	
JR14	1-216-295-00	METAL GLAZE 0 5%	1/10W	S8	1-572-482-11	SWITCH, KEY BOARD (1 KEY)	
JR15	1-216-295-00	METAL GLAZE 0 5%	1/10W	S9	1-572-482-11	SWITCH, KEY BOARD (1 KEY)	
JR16	1-216-295-00	METAL GLAZE 0 5%	1/10W	S10	1-572-482-11	SWITCH, KEY BOARD (1 KEY)	
JR17	1-216-295-00	METAL GLAZE 0 5%	1/10W	S11	1-572-482-11	SWITCH, KEY BOARD (1 KEY)	
JR18	1-216-295-00	METAL GLAZE 0 5%	1/10W	S12	1-572-482-11	SWITCH, KEY BOARD (1 KEY)	
JR19	1-216-295-00	METAL GLAZE 0 5%	1/10W	S13	1-572-482-11	SWITCH, KEY BOARD (1 KEY)	
R1	1-216-043-00	METAL GLAZE 560 5%	1/10W	S14	1-572-482-11	SWITCH, KEY BOARD (1 KEY)	
R2	1-216-043-00	METAL GLAZE 560 5%	1/10W	S15	1-572-482-11	SWITCH, KEY BOARD (1 KEY)	
R3	1-216-043-00	METAL GLAZE 560 5%	1/10W	S16	1-572-482-11	SWITCH, KEY BOARD (1 KEY)	
R4	1-216-043-00	METAL GLAZE 560 5%	1/10W	S17	1-572-482-11	SWITCH, KEY BOARD (1 KEY)	
R5	1-216-043-00	METAL GLAZE 560 5%	1/10W	S18	1-572-482-11	SWITCH, KEY BOARD (1 KEY)	
R6	1-216-043-00	METAL GLAZE 560 5%	1/10W	S19	1-572-482-11	SWITCH, KEY BOARD (1 KEY)	
R7	1-216-043-00	METAL GLAZE 560 5%	1/10W	S20	1-572-482-11	SWITCH, KEY BOARD (1 KEY)	
R8	1-216-043-00	METAL GLAZE 560 5%	1/10W	S21	1-572-482-11	SWITCH, KEY BOARD (1 KEY)	
R9	1-216-043-00	METAL GLAZE 560 5%	1/10W	S22	1-572-482-11	SWITCH, KEY BOARD (1 KEY)	
R10	1-216-043-00	METAL GLAZE 560 5%	1/10W	S23	1-572-482-11	SWITCH, KEY BOARD (1 KEY)	
R11	1-216-043-00	METAL GLAZE 560 5%	1/10W	S24	1-572-482-11	SWITCH, KEY BOARD (1 KEY)	
R12	1-216-043-00	METAL GLAZE 560 5%	1/10W	S25	1-572-482-11	SWITCH, KEY BOARD (1 KEY)	
R13	1-216-043-00	METAL GLAZE 560 5%	1/10W	S26	1-572-482-11	SWITCH, KEY BOARD (1 KEY)	
R14	1-216-043-00	METAL GLAZE 560 5%	1/10W	S27	1-572-482-11	SWITCH, KEY BOARD (1 KEY)	
R15	1-216-043-00	METAL GLAZE 560 5%	1/10W	S28	1-572-482-11	SWITCH, KEY BOARD (1 KEY)	
R16	1-216-043-00	METAL GLAZE 560 5%	1/10W	S29	1-572-482-11	SWITCH, KEY BOARD (1 KEY)	
R17	1-216-043-00	METAL GLAZE 560 5%	1/10W	S30	1-572-482-11	SWITCH, KEY BOARD (1 KEY)	
R18	1-216-043-00	METAL GLAZE 560 5%	1/10W	S31	1-572-482-11	SWITCH, KEY BOARD (1 KEY)	
				S32	1-572-482-11	SWITCH, KEY BOARD (1 KEY)	
				*****			

7. ELECTRICAL PARTS LIST







REF.NO.	PART NO.	DESCRIPTION	REMARK	REF.NO.	PART NO.	DESCRIPTION	REMARK
	A-1375-121-A	HZ BOARD, COMPLETE *****		C144	1-163-031-11	CERAMIC CHIP 0.01MF	50V
		<CAPACITOR>		C145	1-163-031-11	CERAMIC CHIP 0.01MF	50V
C1	1-163-031-11	CERAMIC CHIP 0.01MF	50V	C146	1-163-031-11	CERAMIC CHIP 0.01MF	50V
C2	1-163-031-11	CERAMIC CHIP 0.01MF	50V	C147	1-163-031-11	CERAMIC CHIP 0.01MF	50V
C3	1-163-031-11	CERAMIC CHIP 0.01MF	50V	C148	1-163-031-11	CERAMIC CHIP 0.01MF	50V
C4	1-163-031-11	CERAMIC CHIP 0.01MF	50V	C149	1-163-031-11	CERAMIC CHIP 0.01MF	50V
C5	1-163-031-11	CERAMIC CHIP 0.01MF	50V	C150	1-136-161-00	FILM 0.047MF	5% 50V
C6	1-163-031-11	CERAMIC CHIP 0.01MF	50V	C161	1-163-031-11	CERAMIC CHIP 0.01MF	50V
C7	1-163-031-11	CERAMIC CHIP 0.01MF	50V	C162	1-163-031-11	CERAMIC CHIP 0.01MF	50V
C8	1-163-031-11	CERAMIC CHIP 0.01MF	50V	C163	1-163-031-11	CERAMIC CHIP 0.01MF	50V
C9	1-163-031-11	CERAMIC CHIP 0.01MF	50V	C164	1-163-031-11	CERAMIC CHIP 0.01MF	50V
C10	1-163-031-11	CERAMIC CHIP 0.01MF	50V	C165	1-163-031-11	CERAMIC CHIP 0.01MF	50V
C11	1-163-031-11	CERAMIC CHIP 0.01MF	50V	C166	1-163-031-11	CERAMIC CHIP 0.01MF	50V
C12	1-163-031-11	CERAMIC CHIP 0.01MF	50V	C167	1-163-031-11	CERAMIC CHIP 0.01MF	50V
C13	1-163-227-11	CERAMIC CHIP 10PF	0.5PF 50V	C168	1-163-031-11	CERAMIC CHIP 0.01MF	50V
C14	1-163-239-11	CERAMIC CHIP 33PF	5% 50V	C169	1-163-031-11	CERAMIC CHIP 0.01MF	50V
C15	1-163-097-00	CERAMIC CHIP 15PF	5% 50V	C170	1-163-031-11	CERAMIC CHIP 0.01MF	50V
C16	1-163-031-11	CERAMIC CHIP 0.01MF	50V	C171	1-163-031-11	CERAMIC CHIP 0.01MF	50V
C17	1-163-097-00	CERAMIC CHIP 15PF	5% 50V	C172	1-163-031-11	CERAMIC CHIP 0.01MF	50V
C18	1-163-097-00	CERAMIC CHIP 15PF	5% 50V	C173	1-163-031-11	CERAMIC CHIP 0.01MF	50V
C19	1-124-779-00	ELECT CHIP 10MF	20% 16V	C174	1-163-031-11	CERAMIC CHIP 0.01MF	50V
C21	1-126-769-21	ELECT CHIP 100MF	20% 14V	C175	1-163-031-11	CERAMIC CHIP 0.01MF	50V
C22	1-126-769-21	ELECT CHIP 100MF	20% 14V	C176	1-163-031-11	CERAMIC CHIP 0.01MF	50V
C23	1-126-204-11	ELECT CHIP 47MF	20% 16V	C177	1-163-031-11	CERAMIC CHIP 0.01MF	50V
C24	1-126-204-11	ELECT CHIP 47MF	20% 16V	C178	1-163-031-11	CERAMIC CHIP 0.01MF	50V
C25	1-126-769-21	ELECT CHIP 100MF	20% 14V	C179	1-163-031-11	CERAMIC CHIP 0.01MF	50V
C26	1-126-769-21	ELECT CHIP 100MF	20% 14V	C180	1-163-031-11	CERAMIC CHIP 0.01MF	50V
C41	1-126-769-21	ELECT CHIP 100MF	20% 14V	C181	1-163-031-11	CERAMIC CHIP 0.01MF	50V
C42	1-126-769-21	ELECT CHIP 100MF	20% 14V	C182	1-163-031-11	CERAMIC CHIP 0.01MF	50V
C43	1-126-204-11	ELECT CHIP 47MF	20% 16V	C183	1-163-031-11	CERAMIC CHIP 0.01MF	50V
C44	1-126-204-11	ELECT CHIP 47MF	20% 16V	C191	1-163-031-11	CERAMIC CHIP 0.01MF	50V
C45	1-126-204-11	ELECT CHIP 47MF	20% 16V	C192	1-163-031-11	CERAMIC CHIP 0.01MF	50V
C46	1-126-769-21	ELECT CHIP 100MF	20% 14V	C201	1-163-031-11	CERAMIC CHIP 0.01MF	50V
C47	1-126-769-21	ELECT CHIP 100MF	20% 14V	C202	1-163-031-11	CERAMIC CHIP 0.01MF	50V
C61	1-126-769-21	ELECT CHIP 100MF	20% 14V	C203	1-163-031-11	CERAMIC CHIP 0.01MF	50V
C63	1-126-769-21	ELECT CHIP 100MF	20% 14V	C204	1-163-031-11	CERAMIC CHIP 0.01MF	50V
C64	1-126-769-21	ELECT CHIP 100MF	20% 14V			<DIODE>	
C65	1-126-769-21	ELECT CHIP 100MF	20% 14V	D1	8-719-109-88	DIODE RD5.6ESB1	
C66	1-126-769-21	ELECT CHIP 100MF	20% 14V	D2	8-719-109-88	DIODE RD5.6ESB1	
C67	1-126-769-21	ELECT CHIP 100MF	20% 14V	D3	8-719-109-88	DIODE RD5.6ESB1	
C68	1-126-769-21	ELECT CHIP 100MF	20% 14V	D4	8-719-109-88	DIODE RD5.6ESB1	
C69	1-126-769-21	ELECT CHIP 100MF	20% 14V	D5	8-719-109-88	DIODE RD5.6ESB1	
C70	1-126-769-21	ELECT CHIP 100MF	20% 14V	D6	8-719-109-88	DIODE RD5.6ESB1	
C71	1-126-769-21	ELECT CHIP 100MF	20% 14V	D7	8-719-109-88	DIODE RD5.6ESB1	
C81	1-126-769-21	ELECT CHIP 100MF	20% 14V	D8	8-719-109-88	DIODE RD5.6ESB1	
C91	1-126-769-21	ELECT CHIP 100MF	20% 14V	D9	8-719-109-88	DIODE RD5.6ESB1	
C92	1-126-769-21	ELECT CHIP 100MF	20% 14V	D10	8-719-109-88	DIODE RD5.6ESB1	
C102	1-126-769-21	ELECT CHIP 100MF	20% 14V	D11	8-719-109-88	DIODE RD5.6ESB1	
C111	1-163-031-11	CERAMIC CHIP 0.01MF	50V	D12	8-719-109-88	DIODE RD5.6ESB1	
C112	1-163-031-11	CERAMIC CHIP 0.01MF	50V	D13	8-719-109-88	DIODE RD5.6ESB1	
C121	1-163-031-11	CERAMIC CHIP 0.01MF	50V	D14	8-719-109-88	DIODE RD5.6ESB1	
C122	1-163-031-11	CERAMIC CHIP 0.01MF	50V	D15	8-719-109-88	DIODE RD5.6ESB1	
C123	1-163-031-11	CERAMIC CHIP 0.01MF	50V	D16	8-719-106-88	DIODE RD15M-B1	
C124	1-163-031-11	CERAMIC CHIP 0.01MF	50V	D17	8-719-104-34	DIODE 1S2836	
C125	1-163-031-11	CERAMIC CHIP 0.01MF	50V	D18	8-719-801-78	DIODE 1SS184	
C126	1-163-031-11	CERAMIC CHIP 0.01MF	50V	D19	8-719-801-78	DIODE 1SS184	
C127	1-163-031-11	CERAMIC CHIP 0.01MF	50V	D21	8-719-106-23	DIODE RD7.5M-B2	
C128	1-163-031-11	CERAMIC CHIP 0.01MF	50V	D22	8-719-106-23	DIODE RD7.5M-B2	
C129	1-136-161-00	FILM 0.047MF	5% 50V			<CONNECTOR>	
C141	1-163-031-11	CERAMIC CHIP 0.01MF	50V	HZ1	*1-566-064-11	PIN, CONNECTOR 12P	
C142	1-163-031-11	CERAMIC CHIP 0.01MF	50V	HZ2	*1-566-062-11	PIN, CONNECTOR 10P	
C143	1-163-031-11	CERAMIC CHIP 0.01MF	50V	HZ3	*1-566-060-11	PIN, CONNECTOR 8P	

7. ELECTRICAL PARTS LIST



REF. NO.	PART NO.	DESCRIPTION	REMARK	REF. NO.	PART NO.	DESCRIPTION	REMARK
HZ4	*1-566-064-11	PIN, CONNECTOR 12P		Q16	8-729-901-01	TRANSISTOR DTC144EK	
HZ5	*1-566-058-11	PIN, CONNECTOR 6P		Q17	8-729-901-01	TRANSISTOR DTC144EK	
HZ6	*1-566-064-11	PIN, CONNECTOR 12P		Q18	8-729-901-01	TRANSISTOR DTC144EK	
HZ7	*1-566-064-11	PIN, CONNECTOR 12P		Q19	8-729-122-63	TRANSISTOR 2SA1226-E4	
HZ8	*1-566-064-11	PIN, CONNECTOR 12P		Q20	8-729-901-01	TRANSISTOR DTC144EK	
				Q21	8-729-901-01	TRANSISTOR DTC144EK	
HZ9	*1-566-058-11	PIN, CONNECTOR 6P		Q22	8-729-901-01	TRANSISTOR DTC144EK	
HZ10	*1-566-062-11	PIN, CONNECTOR 10P		Q23	8-729-901-01	TRANSISTOR DTC144EK	
HZ11	*1-566-062-11	PIN, CONNECTOR 10P		Q24	8-729-901-01	TRANSISTOR DTC144EK	
HZ12	*1-566-065-11	PIN, CONNECTOR 13P		Q25	8-729-901-01	TRANSISTOR DTC144EK	
				Q26	8-729-901-01	TRANSISTOR DTC144EK	
		<IC>		Q27	8-729-901-01	TRANSISTOR DTC144EK	
IC1	8-759-939-25	IC SN75176BP		Q28	8-729-901-06	TRANSISTOR DTA144EK	
IC2	8-759-939-25	IC SN75176BP		Q29	8-729-901-01	TRANSISTOR DTC144EK	
IC3	8-759-164-54	IC X2504D		Q30	8-729-122-63	TRANSISTOR 2SA1226-E4	
IC4	8-759-995-76	IC P5T529C		Q900	8-729-101-11	TRANSISTOR 2SC2351-R2R3	
IC5	8-759-981-48	IC TL082M		Q901	8-729-120-28	TRANSISTOR 2SC1623-L5L6	
IC6	8-759-112-72	IC UPD6142G-101		Q902	8-729-901-01	TRANSISTOR DTC144EK	
IC7	8-759-239-88	IC TC74HCT02AF		Q903	8-729-901-01	TRANSISTOR DTC144EK	
IC8	8-759-240-03	IC TC74HCT32AF					
IC9	8-759-233-66	IC TC74HCT04AF					
IC10	8-759-981-48	IC TL082M					
						<RESISTOR>	
IC11	8-759-240-65	IC TC74HCT139AF		JR1	1-216-295-00	METAL GLAZE 0 5% 1/10W	
IC12	8-759-009-05	IC MC14051BF		JR2	1-216-295-00	METAL GLAZE 0 5% 1/10W	
IC13	8-759-938-68	IC CXD1095Q		JR3	1-216-295-00	METAL GLAZE 0 5% 1/10W	
IC14	8-759-981-48	IC TL082M		JR4	1-216-295-00	METAL GLAZE 0 5% 1/10W	
IC15	8-759-238-69	IC TC74HC299AF-TP1		JR5	1-216-295-00	METAL GLAZE 0 5% 1/10W	
IC16	8-759-009-05	IC MC14051BF		R1	1-216-091-00	METAL GLAZE 56K 5% 1/10W	
IC17	8-759-239-88	IC TC74HCT02AF		R2	1-216-091-00	METAL GLAZE 56K 5% 1/10W	
IC18	8-759-981-48	IC TL082M		R3	1-249-417-11	CARBON 1K 5% 1/4W	
IC19	8-759-981-48	IC TL082M		R4	1-216-025-00	METAL GLAZE 100 5% 1/10W	
IC20	8-759-518-73	IC DAC8043GP		R5	1-216-073-00	METAL GLAZE 10K 5% 1/10W	
IC21	8-759-518-76	IC REF02EZ		R6	1-216-073-00	METAL GLAZE 10K 5% 1/10W	
IC22	8-759-981-48	IC TL082M		R7	1-249-417-11	CARBON 1K 5% 1/4W	
IC23	8-759-981-48	IC TL082M		R8	1-216-091-00	METAL GLAZE 56K 5% 1/10W	
IC24	8-759-255-38	IC HD6475368-BVM1.20		R9	1-249-417-11	CARBON 1K 5% 1/4W	
				R10	1-216-620-11	METAL CHIP 51 0.50% 1/10W	
		<IC SOCKET>		R11	1-216-080-00	METAL GLAZE 20K 5% 1/10W	
ICS3	1-526-652-21	SOCKET, IC (DP) 8P		R12	1-216-073-00	METAL GLAZE 10K 5% 1/10W	
ICS24	1-540-069-11	SOCKET, IC (IC113) 84P		R13	1-216-091-00	METAL GLAZE 56K 5% 1/10W	
				R14	1-249-417-11	CARBON 1K 5% 1/4W	
				R15	1-216-091-00	METAL GLAZE 56K 5% 1/10W	
		<COIL>		R16	1-249-417-11	CARBON 1K 5% 1/4W	
L1	1-408-409-00	INDUCTOR 10UH		R17	1-216-073-00	METAL GLAZE 10K 5% 1/10W	
L2	1-408-409-00	INDUCTOR 10UH		R18	1-216-073-00	METAL GLAZE 10K 5% 1/10W	
L3	1-410-210-21	INDUCTOR CHIP 33UH		R19	1-216-059-00	METAL GLAZE 2.7K 5% 1/10W	
L4	1-408-409-00	INDUCTOR 10UH		R20	1-216-091-00	METAL GLAZE 56K 5% 1/10W	
				R21	1-249-417-11	CARBON 1K 5% 1/4W	
				R22	1-216-073-00	METAL GLAZE 10K 5% 1/10W	
		<TRANSISTOR>		R23	1-216-059-00	METAL GLAZE 2.7K 5% 1/10W	
Q2	8-729-901-01	TRANSISTOR DTC144EK		R24	1-216-097-00	METAL GLAZE 100K 5% 1/10W	
Q3	8-729-901-01	TRANSISTOR DTC144EK		R25	1-216-073-00	METAL GLAZE 10K 5% 1/10W	
Q4	8-729-901-01	TRANSISTOR DTC144EK		R26	1-216-073-00	METAL GLAZE 10K 5% 1/10W	
Q5	8-729-901-01	TRANSISTOR DTC144EK		R27	1-216-059-00	METAL GLAZE 2.7K 5% 1/10W	
Q6	8-729-901-01	TRANSISTOR DTC144EK		R28	1-216-073-00	METAL GLAZE 10K 5% 1/10W	
Q7	8-729-901-01	TRANSISTOR DTC144EK		R29	1-216-073-00	METAL GLAZE 10K 5% 1/10W	
Q8	8-729-901-01	TRANSISTOR DTC144EK		R30	1-216-059-00	METAL GLAZE 2.7K 5% 1/10W	
Q9	8-729-901-01	TRANSISTOR DTC144EK		R31	1-216-073-00	METAL GLAZE 10K 5% 1/10W	
Q10	8-729-901-01	TRANSISTOR DTC144EK		R32	1-216-079-00	METAL GLAZE 18K 5% 1/10W	
Q11	8-729-901-01	TRANSISTOR DTC144EK		R33	1-216-073-00	METAL GLAZE 10K 5% 1/10W	
Q12	8-729-901-01	TRANSISTOR DTC144EK		R34	1-216-097-00	METAL GLAZE 100K 5% 1/10W	
Q13	8-729-901-01	TRANSISTOR DTC144EK		R35	1-216-073-00	METAL GLAZE 10K 5% 1/10W	
Q14	8-729-901-01	TRANSISTOR DTC144EK		R36	1-216-073-00	METAL GLAZE 10K 5% 1/10W	
Q15	8-729-901-01	TRANSISTOR DTC144EK					

The components identified by shading and mark  $\Delta$  are critical for safety. Replace only with part number specified.

Les composants identifiés par une trame et une marque  $\Delta$  sont critiques pour la sécurité. Ne les remplacer que par une pièce portant le numéro spécifié.



REF. NO.	PART NO.	DESCRIPTION	REMARK
R37	1-216-073-00	METAL GLAZE	10K 5% 1/10W
R38	1-249-417-11	CARBON	1K 5% 1/4W
R39	1-216-093-00	METAL GLAZE	68K 5% 1/10W
R40	1-216-073-00	METAL GLAZE	10K 5% 1/10W
R41	1-249-417-11	CARBON	1K 5% 1/4W
R42	1-216-097-00	METAL GLAZE	100K 5% 1/10W
R43	1-216-073-00	METAL GLAZE	10K 5% 1/10W
R44	1-249-417-11	CARBON	1K 5% 1/4W
R45	1-216-073-00	METAL GLAZE	10K 5% 1/10W
R46	1-216-049-00	METAL GLAZE	1K 5% 1/10W
R47	1-216-081-00	METAL GLAZE	22K 5% 1/10W
R48	1-249-417-11	CARBON	1K 5% 1/4W
R49	1-216-073-00	METAL GLAZE	10K 5% 1/10W
R50	1-249-417-11	CARBON	1K 5% 1/4W
R51	1-249-417-11	CARBON	1K 5% 1/4W
R52	1-216-073-00	METAL GLAZE	10K 5% 1/10W
R53	1-249-417-11	CARBON	1K 5% 1/4W
R54	1-216-073-00	METAL GLAZE	10K 5% 1/10W
R55	1-216-097-00	METAL GLAZE	100K 5% 1/10W
R56	1-216-073-00	METAL GLAZE	10K 5% 1/10W
R57	1-216-073-00	METAL GLAZE	10K 5% 1/10W
R58	1-216-073-00	METAL GLAZE	10K 5% 1/10W
R59	1-216-097-00	METAL GLAZE	100K 5% 1/10W
R60	1-216-073-00	METAL GLAZE	10K 5% 1/10W
R61	1-216-073-00	METAL GLAZE	10K 5% 1/10W
R62	1-216-073-00	METAL GLAZE	10K 5% 1/10W
R63	1-216-059-00	METAL GLAZE	2.7K 5% 1/10W
R64	1-216-073-00	METAL GLAZE	10K 5% 1/10W
R65	1-216-059-00	METAL GLAZE	2.7K 5% 1/10W
R66	1-216-073-00	METAL GLAZE	10K 5% 1/10W
R67	1-216-059-00	METAL GLAZE	2.7K 5% 1/10W
R68	1-216-073-00	METAL GLAZE	10K 5% 1/10W
R69	1-216-059-00	METAL GLAZE	2.7K 5% 1/10W
R70	1-216-091-00	METAL GLAZE	56K 5% 1/10W
R71	1-216-073-00	METAL GLAZE	10K 5% 1/10W
R73	1-216-097-00	METAL GLAZE	100K 5% 1/10W
R74	1-216-049-00	METAL GLAZE	1K 5% 1/10W
R75	1-216-081-00	METAL GLAZE	22K 5% 1/10W
R76	1-216-097-00	METAL GLAZE	100K 5% 1/10W
R77	1-216-085-00	METAL GLAZE	33K 5% 1/10W
R78	1-216-073-00	METAL GLAZE	10K 5% 1/10W
R79	1-216-080-00	METAL GLAZE	20K 5% 1/10W
R80	1-216-088-00	METAL GLAZE	43K 5% 1/10W
R81	1-216-073-00	METAL GLAZE	10K 5% 1/10W
R82	1-216-097-00	METAL GLAZE	100K 5% 1/10W
R83	1-216-073-00	METAL GLAZE	10K 5% 1/10W
R84	1-216-073-00	METAL GLAZE	10K 5% 1/10W
R85	1-216-073-00	METAL GLAZE	10K 5% 1/10W
R86	1-216-073-00	METAL GLAZE	10K 5% 1/10W
R87	1-216-073-00	METAL GLAZE	10K 5% 1/10W
R88	1-216-073-00	METAL GLAZE	10K 5% 1/10W
R89	1-216-097-00	METAL GLAZE	100K 5% 1/10W
R90	1-216-073-00	METAL GLAZE	10K 5% 1/10W
R91	1-216-081-00	METAL GLAZE	22K 5% 1/10W
R92	1-216-089-00	METAL GLAZE	47K 5% 1/10W
R93	1-216-089-00	METAL GLAZE	47K 5% 1/10W
R94	1-216-073-00	METAL GLAZE	10K 5% 1/10W
R95	1-216-073-00	METAL GLAZE	10K 5% 1/10W
R100	1-216-073-00	METAL GLAZE	10K 5% 1/10W
R101	1-216-073-00	METAL GLAZE	10K 5% 1/10W
R102	1-216-065-00	METAL GLAZE	4.7K 5% 1/10W
R103	1-216-065-00	METAL GLAZE	4.7K 5% 1/10W
R104	1-216-053-00	METAL GLAZE	1.5K 5% 1/10W
R105	1-216-053-00	METAL GLAZE	1.5K 5% 1/10W

REF. NO.	PART NO.	DESCRIPTION	REMARK
R106	1-216-059-00	METAL GLAZE	2.7K 5% 1/10W
R107	1-216-073-00	METAL GLAZE	10K 5% 1/10W
R111	1-216-081-00	METAL GLAZE	22K 5% 1/10W
R112	1-216-081-00	METAL GLAZE	22K 5% 1/10W
R181	1-216-043-00	METAL GLAZE	560 5% 1/10W
R191	1-216-049-00	METAL GLAZE	1K 5% 1/10W
R208	1-216-059-00	METAL GLAZE	2.7K 5% 1/10W
R209	1-216-059-00	METAL GLAZE	2.7K 5% 1/10W
<SWITCH>			
S1	1-572-482-11	SWITCH, KEY BOARD (1 KEY)	
S2	1-572-482-11	SWITCH, KEY BOARD (1 KEY)	
<CRYSTAL>			
X1	1-577-121-11	VIBRATOR, CRYSTAL	
*****			
*1-631-678-11 P BOARD *****			
$\Delta$ 1-439-382-21 TRANSFORMER ASSY, FLYBACK			
<COIL>			
L11	1-459-215-00	COIL (WITH CORE)	
*****			
*1-617-895-11 QA BOARD *****			
<CAPACITOR>			
C1	1-108-692-11	MYLAR	0.01MF 10% 200V
C2	1-126-235-11	ELECT	100NF 20% 16V
C3	1-101-004-00	CERAMIC	0.01MF 50V
C4	1-108-692-11	MYLAR	0.01MF 10% 200V
C5	1-126-235-11	ELECT	100MF 20% 16V
C6	1-101-004-00	CERAMIC	0.01MF 50V
C7	1-108-692-11	MYLAR	0.01MF 10% 200V
C8	1-126-235-11	ELECT	100MF 20% 16V
C9	1-101-004-00	CERAMIC	0.01MF 50V
C10	1-102-951-00	CERAMIC	15PF 5% 50V
C11	1-102-951-00	CERAMIC	15PF 5% 50V
C12	1-102-951-00	CERAMIC	15PF 5% 50V
<RESISTOR>			
R1	1-215-449-00	METAL	15K 1% 1/4W
R2	1-215-449-00	METAL	15K 1% 1/4W
R3	1-249-439-11	CARBON	68K 5% 1/4W
<SWITCH>			
S1	1-570-857-11	SWITCH, SLIDE	
S2	1-570-857-11	SWITCH, SLIDE	
S3	1-570-857-11	SWITCH, SLIDE	
*****			

7. ELECTRICAL PARTS LIST

**QB TB V W XB**

REF. NO. PART NO. DESCRIPTION REMARK REF. NO. PART NO. DESCRIPTION REMARK

\*1-618-786-11 QB BOARD  
\*\*\*\*\*

<CAPACITOR>

C1	1-108-692-11	MYLAR	0.01MF	10%	200V
C2	1-126-235-11	ELECT	100MF	20%	16V
C3	1-101-004-00	CERAMIC	0.01MF		50V
C4	1-108-692-11	MYLAR	0.01MF	10%	200V
C5	1-126-235-11	ELECT	100MF	20%	16V
C6	1-101-004-00	CERAMIC	0.01MF		50V
C7	1-108-692-11	MYLAR	0.01MF	10%	200V
C8	1-126-235-11	ELECT	100MF	20%	16V
C9	1-101-004-00	CERAMIC	0.01MF		50V
C10	1-102-951-00	CERAMIC	15PF	5%	50V
C11	1-102-951-00	CERAMIC	15PF	5%	50V
C12	1-102-951-00	CERAMIC	15PF	5%	50V

<RESISTOR>

R1	1-215-449-00	METAL	15K	1%	1/4W
R2	1-215-449-00	METAL	15K	1%	1/4W
R3	1-215-449-00	METAL	15K	1%	1/4W

<SWITCH>

S1	1-570-857-11	SWITCH, SLIDE			
S2	1-570-857-11	SWITCH, SLIDE			
S3	1-570-857-11	SWITCH, SLIDE			

\*\*\*\*\*

\*A-1390-344-A TB BOARD, COMPLETE  
\*\*\*\*\*

<CONNECTOR>

CN1	*1-564-431-11	POST, CONNECTOR 3P			
CN2	*1-564-431-11	POST, CONNECTOR 3P			
CN11	*1-561-724-00	SOCKET, CONNECTOR 2P			
CN12	*1-561-724-00	SOCKET, CONNECTOR 2P			

<RESISTOR>

R100	1-249-422-11	CARBON	2.7K	5%	1/4W
R101	1-249-413-11	CARBON	470	5%	1/4W

<CONNECTOR>

TB4	*1-566-054-11	PIN, CONNECTOR 2P			
TB5	*1-566-054-11	PIN, CONNECTOR 2P			
TB6	*1-566-060-11	PIN, CONNECTOR 8P			
TB7	*1-566-054-11	PIN, CONNECTOR 2P			
TB8	*1-566-058-11	PIN, CONNECTOR 6P			
TB9	*1-566-060-11	PIN, CONNECTOR 8P			
TB10	*1-566-064-11	PIN, CONNECTOR 12P			
TB11	*1-566-055-11	PIN, CONNECTOR 3P			
TB12	*1-566-064-11	PIN, CONNECTOR 12P			
TB13	*1-566-062-11	PIN, CONNECTOR 10P			
TB14	*1-566-064-11	PIN, CONNECTOR 12P			
TB15	*1-566-060-11	PIN, CONNECTOR 8P			
TB16	*1-566-057-11	PIN, CONNECTOR 5P			
TB17	*1-566-057-11	PIN, CONNECTOR 5P			
TB18	*1-566-055-11	PIN, CONNECTOR 3P			
TB19	*1-566-056-11	PIN, CONNECTOR 4P			
TB20	*1-566-056-11	PIN, CONNECTOR 4P			

TB21	*1-566-056-11	PIN, CONNECTOR 4P			
TB22	*1-566-054-11	PIN, CONNECTOR 2P			
TB23	*1-566-054-11	PIN, CONNECTOR 2P			
TB24	*1-566-054-11	PIN, CONNECTOR 2P			
TB28	*1-566-062-11	PIN, CONNECTOR 10P			
TB29	*1-566-060-11	PIN, CONNECTOR 8P			
TB30	*1-566-054-11	PIN, CONNECTOR 2P			
TB31	*1-561-337-00	CONNECTOR, MULTI			
TB32	*1-561-337-00	CONNECTOR, MULTI			
TB33	*1-561-337-00	CONNECTOR, MULTI			
TB34	*1-561-337-00	CONNECTOR, MULTI			
TB35	*1-561-337-00	CONNECTOR, MULTI			
TB36	*1-561-337-00	CONNECTOR, MULTI			
TB37	*1-561-337-00	CONNECTOR, MULTI			
TB38	*1-561-337-00	CONNECTOR, MULTI			
TB39	*1-561-337-00	CONNECTOR, MULTI			
TB40	*1-561-337-00	CONNECTOR, MULTI			

\*\*\*\*\*

\*1-627-677-11 V BOARD  
\*\*\*\*\*

1-563-265-11 CONNECTOR, MULTIPLE 10P

<COMPOSITION CIRCUIT BLOCK>

CP1 1-232-350-11 COMPOSITION CIRCUIT BLOCK

<RESISTOR>

R1	1-247-807-31	CARBON	100	5%	1/4W
R2	1-247-807-31	CARBON	100	5%	1/4W
R3	1-247-807-31	CARBON	100	5%	1/4W
R4	1-247-807-31	CARBON	100	5%	1/4W
R5	1-247-807-31	CARBON	100	5%	1/4W
R6	1-247-807-31	CARBON	100	5%	1/4W
R7	1-247-807-31	CARBON	100	5%	1/4W

\*\*\*\*\*

\*1-627-678-11 W BOARD  
\*\*\*\*\*

<CAPACITOR>

C1	1-108-692-11	MYLAR	0.01MF	10%	200V
C2	1-108-692-11	MYLAR	0.01MF	10%	200V

<RESISTOR>

R1	1-214-702-00	METAL	75	1%	1/4W
R2	1-214-702-00	METAL	75	1%	1/4W
R3	1-214-702-00	METAL	75	1%	1/4W

\*\*\*\*\*

\*1-631-680-11 XB BOARD  
\*\*\*\*\*

<DIODE>

D1	8-719-901-49	DIODE LT-9010H			
D2	8-719-901-49	DIODE LT-9010H			

\*\*\*\*\*

7. ELECTRICAL PARTS LIST

The components identified by shading and mark  $\Delta$  are critical for safety. Replace only with part number specified.

Les composants identifiés par une trame et une marque  $\Delta$  sont critiques pour la sécurité. Ne les remplacer que par une pièce portant le numéro spécifié.

Y Z

REF. NO.	PART NO.	DESCRIPTION	REMARK
	*1-631-679-11	Y BOARD *****	
		<DIODE>	
D1	8-719-812-43	DIODE TLG124A	
*****			
	*1-627-687-11	Z BOARD *****	
	*1-561-337-21	CONNECTOR, MULTI	
*****			
		MISCELLANEOUS *****	
	$\Delta$ 1-237-165-13	RESISTOR ASSY, HIGH-VOLTAGE	
	$\Delta$ 1-238-301-12	RESISTOR ASSY, HIGH-VOLTAGE	
	$\Delta$ 1-426-460-11	COIL, DEMAGNETIZATION	
	$\Delta$ 1-451-349-22	DEFLECTION YOKE (Y20FZA)	
	$\Delta$ 1-452-337-22	NECK ASSY, CRT (NA304)	
	$\Delta$ 1-532-203-11	FUSE, TIME-LAG (2.0A/250V) (BVM-2016P ONLY)	
	$\Delta$ 1-532-746-11	FUSE, GLASS TUBE (4.0A/125V) (BVM-1916 ONLY)	
	1-565-791-11	CONNECTOR, BNC 1P	
	$\Delta$ 1-571-877-12	SWITCH, PUSH (AC POWER)	
	1-941-422-15	CONNECTOR ASSY (ROUND TYPE) 12P	
	$\Delta$ 8-736-121-05	CRT (M49KGH21X) (BVM-2016P ONLY)	
	$\Delta$ 8-736-123-05	CRT (M49KGH20X) (BVM-1916 ONLY)	
*****			
		ACCESSORIES & PACKING MATERIALS *****	
PART NO.	DESCRIPTION	REMARK	
$\Delta$ 1-532-203-11	FUSE, TIME-LAG (2.0A/250V)		
$\Delta$ 1-532-746-11	FUSE, GLASS TUBE (4.0A/125V)		
$\Delta$ 1-551-812-11	CORD, POWER (7.0A/125V) (BVM-1916 ONLY)		
1-560-776-00	SOCKET, CONNECTOR 10P		
$\Delta$ 1-590-151-11	CORD SET, POWER (10.0A/250V) (BVM-2016P ONLY)		
2-990-242-01	HOLDER (B), PLUG (BVM-1916 ONLY)		
*3-170-078-01	HOLDER (B), PLUG (BVM-2016P ONLY)		
4-040-435-11	MANUAL, O&M		
*4-361-988-02	BAG, PROTECTION (BVM-1916 ONLY)		
4-378-901-01	KEY		
4-386-841-01	LABEL, TALLY NUMBER		
4-386-841-11	LABEL, TALLY NUMBER		
*4-386-858-01	CUSHION (UPPER)		
*4-386-875-01	CUSHION (FRONT LOWER)		
*4-386-876-01	CUSHION (REAR LOWER)		
*4-040-404-01	INDIVIDUAL CARTON (BVM-2016P ONLY)		
*4-391-252-01	INDIVIDUAL CARTON (BVM-1916 ONLY)		
*4-361-988-02	BAG, PROTECTION (BVM-2016P ONLY)		
7-700-731-03	DRIVER, VR ADJUSTMENT		

7. ELECTRICAL PARTS LIST





## **CONFIDENTIAL**

The material contained in this manual consists of information that is the property of Sony Corporation and is intended solely for use by the purchasers of the equipment described in this manual.

Sony Corporation expressly prohibits the duplication of any portion of this manual or the use thereof for any purpose other than the operation or maintenance of the equipment described in this manual without the express written permission of Sony Corporation.

## **CONFIDENTIEL**

Le matériel contenu dans ce manuel consiste en informations qui sont la propriété de Sony Corporation et sont destinées exclusivement à l'usage des acquéreurs de l'équipement décrit dans ce manuel.

Sony Corporation interdit formellement la copie de quelque partie que ce soit de ce manuel ou son emploi pour tout autre but que des opérations ou entretiens de l'équipement à moins d'une permission écrite de Sony Corporation.

## **VERTRAULICH**

Das in dieser Anleitung enthaltene Material besteht aus Informationen, die Eigentum der Sony Corporation sind, und ausschließlich zum Gebrauch durch den Käufer der in dieser Anleitung beschriebenen Ausrüstung bestimmt sind.

Die Sony Corporation untersagt ausdrücklich die Vervielfältigung jeglicher Teile dieser Anleitung oder den Gebrauch derselben für irgendeinen anderen Zweck als die Bedienung oder Wartung der in dieser Anleitung beschriebenen Ausrüstung ohne ausdrückliche schriftliche Erlaubnis der Sony Corporation.

9-978-341-11

**Sony Corporation**  
B&I Systems Company

**English**  
95DZ09044-1  
Printed in Belgium 6402  
©1995.4