

PB2000-910403  
NTSB/AAR-00/03  
DCA96MA070

# NATIONAL TRANSPORTATION SAFETY BOARD

WASHINGTON, D.C. 20594

## AIRCRAFT ACCIDENT REPORT

In-flight Breakup Over the Atlantic Ocean  
Trans World Airlines Flight 800  
Boeing 747-131, N93119  
Near East Moriches, New York  
July 17, 1996

**DISTRIBUTION STATEMENT A**  
Approved for Public Release  
Distribution Unlimited

20010406 094

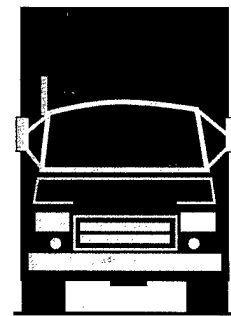
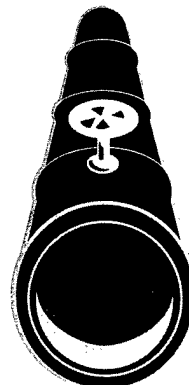
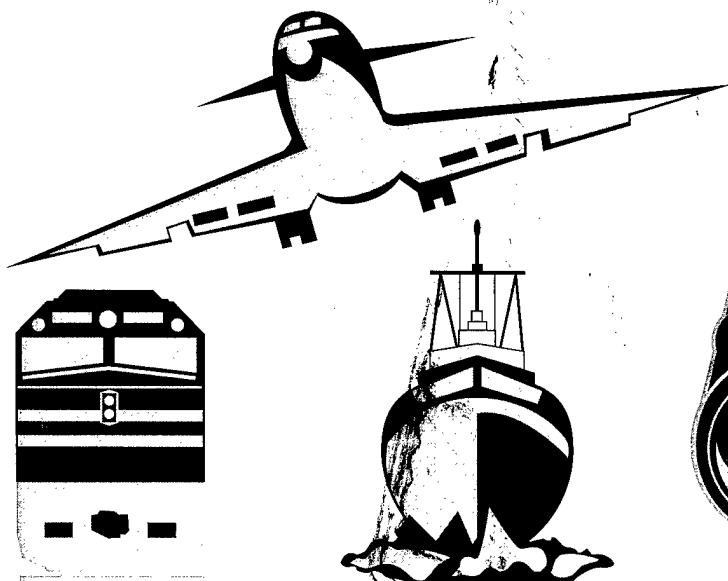

6788G

# **Aircraft Accident Report**

---

**In-flight Breakup Over The Atlantic Ocean  
Trans World Airlines Flight 800  
Boeing 747-131, N93119  
Near East Moriches, New York  
July 17, 1996**

**NTSB/AAR-00/03  
DCA96MA070  
PB2000-910403  
Notation 6788G  
Adopted August 23, 2000**



**National Transportation Safety Board  
490 L'Enfant Plaza, S.W.  
Washington, D.C. 20594**

**National Transportation Safety Board. 2000. *In-flight Breakup Over The Atlantic Ocean, Trans World Airlines Flight 800, Boeing 747-131, N93119, Near East Moriches, New York, July 17, 1996. Aircraft Accident Report NTSB/AAR-00/03. Washington, DC.***

**Abstract:** This report explains the accident involving Trans World Airlines, Inc. flight 800, which experienced an in-flight breakup and then crashed into the Atlantic Ocean near East Moriches, New York, on July 17, 1996. Safety issues in the report focus on fuel tank flammability, fuel tank ignition sources, design and certification standards, and the maintenance and aging of aircraft systems. Safety recommendations concerning these issues are addressed to the Federal Aviation Administration.

The National Transportation Safety Board is an independent Federal agency dedicated to promoting aviation, railroad, highway, marine, pipeline, and hazardous materials safety. Established in 1967, the agency is mandated by Congress through the Independent Safety Board Act of 1974 to investigate transportation accidents, determine the probable causes of the accidents, issue safety recommendations, study transportation safety issues, and evaluate the safety effectiveness of government agencies involved in transportation. The Safety Board makes public its actions and decisions through accident reports, safety studies, special investigation reports, safety recommendations, and statistical reviews.

Recent publications are available in their entirety on the Web at <<http://www.nts.gov>>. Other information about available publications also may be obtained from the Web site or by contacting:

**National Transportation Safety Board  
Public Inquiries Section, RE-51  
490 L'Enfant Plaza, S.W.  
Washington, D.C. 20594  
(800) 877-6799 or (202) 314-6551**

Safety Board publications may be purchased, by individual copy or by subscription, from the National Technical Information Service. To purchase this publication, order report number **PB2000-910403** from:

**National Technical Information Service  
5285 Port Royal Road  
Springfield, Virginia 22161  
(800) 553-6847 or (703) 605-6000**

*The Independent Safety Board Act, as codified at 49 U.S.C. Section 1154(b), precludes the admission into evidence or use of Board reports related to an incident or accident in a civil action for damages resulting from a matter mentioned in the report.*



1.11.1	Cockpit Voice Recorder	58
1.11.1.1	Sound Spectrum Study	59
1.11.1.2	Cockpit Voice Recorder-Related Airplane Tests	60
1.11.2	Flight Data Recorder	61
1.12	Wreckage Recovery and Documentation Information	62
1.12.1	Wreckage Recovered from the Red Zone	69
1.12.2	Wreckage Recovered from the Yellow Zone	70
1.12.3	Wreckage Recovered from the Green Zone	71
1.12.4	Engines	74
1.12.5	Center Wing Fuel Tank Pumps and Other Components	75
1.12.6	Air Conditioning Equipment	77
1.12.6.1	Brown Splatter Material on Air Conditioning Ducts	78
1.12.7	Recovered Electrical Components/Wiring	79
1.13	Medical and Pathological Information	84
1.14	Fire/Explosion	85
1.15	Survival Aspects	86
1.16	Tests and Research	87
1.16.1	Radar Data Information	87
1.16.1.1	Information Regarding Certain Primary Radar Targets Recorded by the Islip, New York, Radar Site	89
1.16.2	Trajectory and Main Wreckage Flightpath Studies	94
1.16.2.1	Trajectory Study Description and Results	94
1.16.2.2	Main Wreckage Flightpath Study Description and Results	95
1.16.3	Sequencing Study Information	100
1.16.3.1	Two- and Three-Dimensional Reconstructions	101
1.16.3.2	Airplane Breakup Sequencing Study Information	103
1.16.4	Additional Metallurgical, Material, and Structural Testing and Information	112
1.16.4.1	Metallurgical Examination of Several Small Holes in the Accident Airplane's Structure	112
1.16.4.2	Metallurgical Examination of Fatigue Cracking	114
1.16.4.3	Metallurgical Examination of the Fuselage Joint Between Sections 41 and 42	116
1.16.4.4	Metallurgical Examination of the Forward Cargo Door	116
1.16.4.5	Metallurgical Examination of Nose Landing Gear Doors and Surrounding Structure	117
1.16.4.6	Examination of Brown Splatter Material	117
1.16.4.7	Examination of Red/Brown-Shaded Substance Found on Passenger Seats	118
1.16.4.8	Examination of Explosive Residue	118
1.16.4.8.1	FAA Studies on the Effects of Sea Water on Explosive Residue Contamination	119
1.16.4.9	Wing Center Section and Center Wing Fuel Tank Structural Response and Failure Information	119
1.16.5	Jet A Fuel Vapor and Fuel Tank Research and Testing	120
1.16.5.1	Testing Conducted to Identify the Conditions that Existed in the Accident Airplane at the Time of the Accident	124
1.16.5.1.1	747 Flight Tests at JFK	124
1.16.5.1.1.1	Fuel Vapor Sampling and Analysis from 747 Flight Tests at JFK—Desert Research Institute	129
1.16.5.1.2	Testing of Fuel Samples from TWA Flight 881 (Arriving at JFK from Athens, Greece)	130

1.16.5.2	Laboratory Testing of Jet A Fuels—California Institute of Technology . . . . .	131
1.16.5.3	Jet Fuel Vapor Chemistry—University of Nevada . . . . .	133
1.16.5.4	Quarter-Scale Center Wing Fuel Tank Model Combustion Experiments— California Institute of Technology	134
1.16.5.5	Computational Research of Center Wing Fuel Tank Combustion . . . . .	136
1.16.5.5.1	Study of Computer Model Calculations of Full-Scale Center Wing Fuel Tank Combustion . . . . .	137
1.16.5.6	Bruntingthorpe Full-Scale Center Wing Fuel Tank Explosion Tests . . . . .	139
1.16.5.7	Boeing/U.S. Air Force E-4B Center Wing Fuel Tank Fuel Heating Study . . . . .	140
1.16.6	Potential Ignition Source Research and Testing . . . . .	142
1.16.6.1	Arcing Information . . . . .	143
1.16.6.2	Wire Short-Circuit Characteristics and Protection . . . . .	143
1.16.6.2.1	Circuit Breaker Protection Information . . . . .	148
1.16.6.3	Aging Effects on Material Properties of Wires . . . . .	151
1.16.6.3.1	Previous Reports about Wire Degradation and Aging . . . . .	156
1.16.6.4	Electromagnetic Interference. . . . .	159
1.16.6.4.1	Electromagnetic Interference from External Sources. . . . .	159
1.16.6.4.1.1	NASA's Report Regarding Electromagnetic Interference from External Sources. . . . .	161
1.16.6.4.2	Electromagnetic Interference from Internal Sources . . . . .	161
1.16.6.4.2.1	Electromagnetic Interference from Personal Electronic Devices On Board TWA Flight 800 . . . . .	163
1.16.6.5	Boeing's Center Wing Fuel Tank Ignition Fault Tree Analysis Computations. . . . .	164
1.16.6.5.1	Other Fault Tree Analysis Information. . . . .	169
1.16.6.6	Compensator Probe Testing at the FAA's William J. Hughes Technical Center . . . . .	170
1.16.6.7	Fuel Pump Tests (Motor Cavity Explosions) . . . . .	170
1.16.6.8	Electrostatic Research . . . . .	172
1.16.6.9	Sulfide-Deposit Tests and Research . . . . .	173
1.16.6.10	Auto Ignition and Hot Surface Ignition Information. . . . .	176
1.16.6.11	Meteorite Strike Information. . . . .	177
1.17	Operational and Management Information . . . . .	178
1.17.1	Trans World Airlines, Inc. . . . .	178
1.17.2	FAA Oversight of TWA Maintenance. . . . .	178
1.18	Additional Information . . . . .	179
1.18.1	Accident Record and History of Fuel Tank Fires/Explosions on Airplanes . . . . .	179
1.18.2	Information Regarding Electrical/Wiring Anomalies on Airplanes . . . . .	181
1.18.2.1	Accidents, Incidents, and Events Involving Electrical/Wiring Components . .	181
1.18.2.2	Previous Safety Board Safety Recommendations Regarding Electrical Components. . . . .	186
1.18.2.3	Inspection of Wiring in Several Transport-Category Airplanes . . . . .	188
1.18.2.4	Boeing Service Letter Regarding Inspection of Wiring on High-Time 747 Airplanes (747-SL-20-048, Dated January 25, 1995) . . . . .	192
1.18.2.5	Wiring Inspection Methods . . . . .	194
1.18.3	Safety Recommendations and Responses and Actions Resulting From the TWA Flight 800 Accident . . . . .	196
1.18.3.1	December 13, 1996, Safety Recommendations Regarding Fuel Tank Flammability (Safety Recommendations A-96-174 through -177). . . . .	196

1.18.3.2	February 18, 1997, Safety Recommendation Regarding the Handling and Placement of Explosive Training Aids (Safety Recommendation A-97-11) . . .	204
1.18.3.3	April 7, 1998, Safety Recommendations Regarding Fuel Quantity Indication System Wiring and Components (Safety Recommendations A-98-34 through -39) . . . . .	205
1.18.3.4	Actions Resulting From the TWA Flight 800 Accident . . . . .	212
1.18.3.4.1	Airworthiness Directives . . . . .	212
1.18.3.4.2	Aviation Rulemaking Advisory Committee/Fuel Tank Harmonization Working Group . . . . .	215
1.18.3.4.3	Notice of Proposed Rulemaking 99-18 (Fuel Tank System Design Review, Flammability Reduction, and Maintenance/Inspection Requirements). . . . .	217
1.18.3.4.4	FAA's Aging Transport Non-Structural Systems Plan . . . . .	226
1.18.4	Witness Information . . . . .	229
1.18.4.1	General Witness Information . . . . .	229
1.18.4.2	Witness Document Issues . . . . .	233
1.18.4.3	Research Regarding Accuracy of Witness Memory . . . . .	237
1.18.4.3.1	Perception and Storing Information in Memory . . . . .	237
1.18.4.3.2	Retrieving Information from Memory . . . . .	239
1.18.4.3.2.1	Postevent Information . . . . .	241
1.18.4.4	Witnesses of Special Interest . . . . .	242
1.18.4.5	Witness Line-of-sight Study . . . . .	247
1.18.4.6	Central Intelligence Agency Review of the Witness Data . . . . .	248
1.18.4.7	Missile-Related Information . . . . .	250
1.18.4.7.1	Missile Visibility Study . . . . .	254
<b>2.</b>	<b>Analysis . . . . .</b>	<b>256</b>
2.1	General . . . . .	256
2.2	The Accident Sequence . . . . .	256
2.2.1	The In-Flight Breakup . . . . .	256
2.2.1.1	Consideration of a Structural Failure and Decompression . . . . .	257
2.2.1.2	Consideration of a High-Energy Explosive Device Detonation (Bomb or Missile Warhead) . . . . .	257
2.2.1.3	Consideration of a Fuel/Air Explosion in the Center Wing Fuel Tank . . . . .	259
2.2.2	Reported Witness Observations . . . . .	262
2.2.2.1	Potential Explanations for Reported Witness Observations . . . . .	262
2.2.2.1.1	Anomalous Witness Accounts . . . . .	265
2.2.2.1.1.1	Issues Associated with Interviewing and Documentation . . . . .	266
2.2.2.1.1.2	Issues Associated with Witness Perception and Memory . . . . .	267
2.2.2.2	Conclusion Regarding Reported Witness Observations . . . . .	269
2.2.3	Cause of the In-Flight Breakup . . . . .	271
2.3	Evaluation of Potential Ignition Sources . . . . .	271
2.3.1	Possible Ignition Sources Unrelated to the Fuel Quantity Indication System . . . . .	271
2.3.1.1	Lightning Strike . . . . .	272
2.3.1.2	Meteorite Strike . . . . .	272
2.3.1.3	Missile Fragment . . . . .	272
2.3.1.4	Small Explosive Charge . . . . .	273
2.3.1.5	Auto Ignition or Hot Surface Ignition . . . . .	274
2.3.1.6	Fire Migration Through the Vent System . . . . .	275
2.3.1.7	Uncontained Engine Failure or Turbine Burst . . . . .	276

2.3.1.8	Malfunctioning Jettison/Override Pump	276
2.3.1.9	Malfunctioning Scavenge Pump	277
2.3.1.10	Static Electricity	278
2.3.1.11	Conclusion Regarding Ignition Sources Unrelated to the Fuel Quantity Indication System	279
2.3.2	Introduction of Ignition Energy Through the Fuel Quantity Indication System	279
2.3.2.1	Transfer of Energy to the Fuel Quantity Indication System Wiring Outside the Center Wing Tank	279
2.3.2.1.1	Electromagnetic Interference	279
2.3.2.1.2	Short Circuiting	281
2.3.2.1.2.1	Possible Short-Circuit Energy Transfer Mechanisms	281
2.3.2.1.2.2	Adequacy of Existing Circuit Protection Systems	283
2.3.2.1.2.2.1	Circuit Breakers	284
2.3.2.1.2.2.2	Electrical Resistors	285
2.3.2.1.2.2.3	Shielding and Physical Separation of Wires	285
2.3.2.1.2.2.4	Transient Suppression Devices	286
2.3.2.1.2.3	Factors Suggesting the Likelihood that a Short-Circuit Event Occurred on TWA Flight 800	288
2.3.2.2	Release of Ignition Energy Inside the Center Wing Fuel Tank	290
2.3.2.2.1	Arcing	290
2.3.2.2.2	Resistance Heating	291
2.3.2.2.3	Silver-Sulfide Deposits on Fuel Quantity Indication System Wiring and Components	291
2.3.2.2.3.1	Elimination of Silver-Sulfide Deposits Inside Fuel Tanks	292
2.3.2.2.4	Ignition Location Inside the Center Wing Fuel Tank	293
2.3.2.3	Possible Ignition Scenario for TWA Flight 800 Explosion	294
2.4	Fuel Tank Design and Certification Standards	294
2.4.1	Preclusion of Ignition Sources in Fuel Tanks	294
2.4.2	Preclusion of Flammable Fuel/Air Vapor in Fuel Tanks	298
2.5	Maintenance and Aging Issues	302
<b>3.</b>	<b>Conclusions</b>	<b>306</b>
3.1	Findings	306
3.2	Probable Cause	308
<b>4.</b>	<b>Recommendations</b>	<b>309</b>
4.1	New Recommendations	309
4.2	Previously Issued Recommendations Resulting From This Accident Investigation	310
4.3	Previously Issued Recommendations Classified in This Report	312
<b>5.</b>	<b>Appendixes</b>	<b>313</b>
	Appendix A: Investigation and Hearing	313
	Appendix B: Cockpit Voice Recorder Transcript	315
	Appendix C: Search and Recovery Information	363
	Appendix D: Document Management Tags Database Information	369
	Appendix E: Accident Airplane Maintenance Records	372
	Appendix F: Sooting and Fracture Diagrams	377
	Appendix G: Fuel Tank Explosions/Fires—Civilian and Military Aircraft	412
	<b>Glossary of Terms</b>	<b>417</b>



## Figures

1. Three views of the 747-100 airplane . . . . .	8
2. Location of some body stations and waterlines in the 747. . . . .	9
3a. Location of fuselage sections 41, 42, and 44 . . . . .	10
3b. Location of fuselage sections 46 and 48 . . . . .	11
4a. A cross-section of the 747-100 wing center section . . . . .	13
4b. Another cross-section of the 747-100 wing center section . . . . .	14
5. The 747-100 aerodynamic fairings . . . . .	15
6. A schematic diagram of the 747-100's air conditioning system . . . . .	18
7. Top and side views of the 747-100's wing center section and air conditioning system . . . . .	19
8. Underside view of the 747-100's wing center section and air conditioning system . . . . .	20
9. The air conditioning ducts around the 747-100's center wing fuel tank . . . . .	21
10. Diagram of a BMS13-42A Poly-X wire . . . . .	24
11. A schematic diagram of the 747-100 fuel tank arrangement . . . . .	27
12. A layout of a typical 747-100 center wing fuel tank and left wing fuel tank vent system . . . . .	29
13. A 747 pressure fueling flow diagram . . . . .	30
14. A diagram of the 747 pressure fueling system components . . . . .	32
15. Diagrams of a fuel quantity probe and a compensator . . . . .	35
16. The fuel quantity probe and compensator locations in the 747's center wing fuel tank . . . . .	36
17. A schematic diagram of the 747-100's fuel quantity indication system wiring, fuel flow wiring, cockpit voice recorder wiring, and other wiring information . . . . .	38
18. Locations of the wire raceways in the 747-100. . . . .	39
19. A schematic diagram of the fuel pump locations in the 747. . . . .	41
20. A diagram of the 747-100 interior. . . . .	53
21. The wreckage location relative to the airplane's flightpath, JFK, and Long Island. . . . .	64
22a. Map showing the locations of the red, yellow, and green zones. . . . .	66
22b. A 747, color-coded to indicate the debris fields from which corresponding wreckage was recovered . . . . .	67
22c. The accident airplane's flightpath, color-coded to indicate the debris fields from which corresponding wreckage was recovered. . . . .	68
23. A diagram of a jettison/override fuel pump . . . . .	76
24. A photograph showing wreckage recovered with tangled and damaged wires attached . . . . .	80
25. Radar data showing vehicle and/or object tracks within 10 nm of TWA flight 800 just before the accident . . . . .	90
26. Primary radar returns that appeared near the accident airplane after 2031:12 . . . . .	91

27. Sequence of eight primary radar returns recorded by the Islip, New York, radar site about the time of the accident . . . . .	92
28a. Roll angle for nose off at 2031:15.2 cases . . . . .	98
28b. Map view of nose off at 2031:15.2 cases . . . . .	98
28c. Altitude for nose off at 2031:15.2 cases . . . . .	99
28d. East position for nose off at 2031:15.2 cases . . . . .	99
28e. North position for nose off at 2031:15.2 cases . . . . .	100
29. A photograph of the right side of the large three-dimensional reconstruction, with the support scaffolding visible . . . . .	102
30. A schematic drawing of the lower portion of the fuselage skin in the area forward of the front spar . . . . .	105
31. Diagram showing the approximate shape of the upper skin panel stiffener and its location before being struck by SWB3 as the beam rotated forward . . . . .	107
32. A flow chart of the fuel-related research conducted to support this investigation . . . . .	121
33. Side view, top view, and three-dimensional view of wing center section/center wing fuel tank bays . . . . .	127
34. A trip-curve chart for a typical circuit breaker (excerpted from Texas Instruments Klixon® specification) . . . . .	149
35a. Sample origination locations for the 747 manufactured in 1970 . . . . .	152
35b. Sample origination locations for the DC-10 manufactured in 1973 . . . . .	152
35c. Sample origination locations for the 747 manufactured in 1973 . . . . .	153
36. Chart showing the percent probability of failure of Kapton wiring in different locations in the P-3 airplane . . . . .	158
37. A diagram of a scavenge pump . . . . .	171
38. Diagram showing the areas typically inspected on 747 airplanes. . . . .	190
39. A chart showing the 737 fuel pump conduit wear rate that was identified by the FAA during representative 500 wire inspections . . . . .	214
40. Map showing the witness locations and the location of the accident site. . . . .	231
41. A map showing the debris zones and the positions of the five witnesses of special interest. . . . .	244
42. Map of sight lines plotted for 11 witnesses . . . . .	249
43. Diagram of warhead detonation fragment pattern. . . . .	253
44. Diagram showing airplane and missile launch site locations that could result in missile selfdestruct within 40 feet of the plane . . . . .	254
45. A graphical illustration of the equidistance tendency . . . . .	268
46. Diagram of the center wing tank fuel quantity indication system wiring on the 747 and its common connectors . . . . .	282
47. A time line of salvage operation events . . . . .	366
Sooting and fracture diagrams . . . . .	378-411

## Tables

1. Injury chart. . . . .	4
2. TWA's fueling records, indicating TWA flight 800's fuel loading when it prepared to depart JFK . . . . .	43
3. Winds aloft measured by a weather balloon launched from Upton, New York . . . . .	57
4. A time line of simulation scenarios. . . . .	97
5. 747-100 wing center section/center wing fuel tank SWBs and spars failure strengths . . . . .	120
6. A summary of the maximum and minimum recorded ullage temperatures at 13,700 feet msl during the emulation flight test . . . . .	128
7. Fuel/air mass ratios and ullage temperatures measured at the bay 2 sampling port during the TWA flight emulation flight test. . . . .	130
8. Results of wet short-circuit tests conducted by Lectromec . . . . .	146
9. The origin and potential environmental exposures of test samples. . . . .	151
10. Several fault tree analysis basic elements, as identified in Boeing's fault tree analysis report, with their failure rates, exposure times, and calculated event probability. . . . .	166
11. Some of the basic elements of Boeing's fault tree analysis, showing the differences between the data presented in Boeing's graphical and tabular representations. . . . .	167

## Abbreviations

<b>AAIB</b>	Air Accidents Investigation Branch (British)
<b>a.c.</b>	alternating current
<b>AC</b>	advisory circular
<b>ACAP</b>	Aviation Consumer Action Project
<b>ACM</b>	air cycle machine
<b>AD</b>	airworthiness directive
<b>AFCB</b>	arc-fault circuit breaker
<b>AFM</b>	aircraft flight manual
<b>AFRL</b>	U.S. Air Force Research Laboratory
<b>AIDS</b>	airborne integrated data system
<b>ALPA</b>	Air Line Pilots Association
<b>amp</b>	ampere
<b>AOA</b>	angle-of-attack
<b>API (2003)</b>	American Petroleum Institute (Recommended Practice 2003)
<b>APU</b>	auxiliary power unit
<b>ARAC</b>	Aviation Rulemaking Advisory Committee
<b>ARTCC</b>	air route traffic control center
<b>AS</b>	aircraft service (check)
<b>ASB</b>	alert service bulletin
<b>ASR</b>	airport surveillance radar
<b>ATA</b>	Air Transport Association of America
<b>ATC</b>	air traffic control
<b>ATE</b>	automated test equipment
<b>ATF</b>	Bureau of Alcohol, Tobacco, and Firearms
<b>ATP</b>	airline transport pilot
<b>ATSRAC</b>	Aging Transport Systems Rulemaking Advisory Committee
<b>AWIGG</b>	Aircraft Wiring and Inert Gas Generator
<b>BL</b>	butt line
<b>BMS</b>	Boeing Material Specification
<b>CAM</b>	cockpit area microphone
<b>CAMI</b>	Civil Aeromedical Institute (Federal Aviation Administration)

---

<b>CDG</b>	Charles DeGaulle International Airport (Paris, France)
<b>CDL</b>	Combustion Dynamics Limited
<b>CEU</b>	central electronics unit
<b>CFR</b>	<i>Code of Federal Regulations</i>
<b>c.g.</b>	center of gravity
<b>CHDO</b>	Certificate Holding District Office
<b>CIA</b>	Central Intelligence Agency
<b>CIT</b>	California Institute of Technology
<b>CMR</b>	Christian Michelsen Research
<b>CVR</b>	cockpit voice recorder
<b>CWT</b>	center wing fuel tank
<b>d.c.</b>	direct current
<b>DERA</b>	Defense Evaluation and Research Agency (British)
<b>DGAC</b>	Direction Generale de L'Aviation Civile
<b>DNA</b>	deoxyribonucleic acid
<b>DoD</b>	Department of Defense
<b>DRI</b>	Desert Research Institute
<b>EDS</b>	energy dispersive spectroscopy
<b>E/E</b>	electrical/electronics
<b>EME</b>	electromagnetic environment
<b>EMI</b>	electromagnetic interference
<b>EPR</b>	engine pressure ratio
<b>F</b>	Fahrenheit
<b>FAA</b>	Federal Aviation Administration
<b>FARs</b>	<i>Federal Aviation Regulations</i>
<b>FBI</b>	Federal Bureau of Investigation
<b>FDR</b>	flight data recorder
<b>FMEA</b>	failure modes and effects analysis
<b>FOK</b>	Francis S. Gabreski Airport (Westhampton Beach, New York)
<b>fps</b>	feet per second
<b>FQIS</b>	fuel quantity indication system
<b>FR</b>	<i>Federal Register</i>
<b>FTHWG</b>	Fuel Tank Harmonization Working Group

---

<b>GPS</b>	global positioning system
<b>HF</b>	high frequency
<b>Hg</b>	mercury
<b>HIRF</b>	high-intensity radiated fields
<b>HP</b>	High Performance
<b>HPC</b>	high-pressure compressor
<b>HSSM</b>	Hamilton Standard Service Manual
<b>Hz</b>	hertz (cycles per second)
<b>IAM</b>	International Association of Machinists, Aerospace Workers, and Flight Attendants
<b>IOE</b>	initial operating experience
<b>J</b>	joule
<b>JAA</b>	Joint Aviation Authorities
<b>JFK</b>	John F. Kennedy International Airport (New York, New York)
<b>JSC</b>	Joint Spectrum Center (DoD)
<b>kJ</b>	kilojoule
<b>kW</b>	kilowatt
<b>LaRC</b>	Langley Research Center
<b>LBL</b>	left butt line
<b>LFL</b>	lower flammability limit
<b>LLS</b>	laser line-scanning
<b>LPC</b>	low-pressure compressor
<b>MAC</b>	mean aerodynamic chord
<b>MHz</b>	megahertz
<b>MIE</b>	minimum ignition energy
<b>mil</b>	one-thousandth of an inch
<b>mJ</b>	millijoule
<b>mm</b>	millimeter
<b>MO</b>	modification order
<b>MSFC</b>	George C. Marshall Space Flight Center
<b>MSIC</b>	Missile and Space Intelligence Center (Defense Intelligence Agency)

---

<b>msl</b>	mean sea level
<b>NaCl</b>	saline-water electrolyte solution
<b>NAFI</b>	U.S. Naval Avionics Facility
<b>NASA</b>	National Aeronautics and Space Administration
<b>NASIP</b>	National Aviation Safety Inspection Program
<b>NAWC-AD</b>	Naval Air Warfare Center—Aircraft Division
<b>NAWC-WD</b>	Naval Air Warfare Center—Weapons Division
<b>nm</b>	nautical mile
<b>NOAA</b>	National Oceanic and Atmospheric Administration
<b>NPRM</b>	notice of proposed rulemaking
<b>NRC</b>	Nuclear Regulatory Commission
<b>NRL</b>	Naval Research Laboratory
<b>NYANG</b>	New York Air National Guard
<b>PED</b>	personal electronic device
<b>PETN</b>	pentaerythritol tetranitrate
<b>PI</b>	production illustration (Boeing's)
<b>PMI</b>	principal maintenance inspector
<b>P/N</b>	part number
<b>PPM</b>	partial program manager
<b>PS</b>	periodic service (check)
<b>psi</b>	(pressure expressed in) pounds per square inch
<b>PTFE</b>	polytetrafluoroethylene
<b>P&amp;W</b>	Pratt & Whitney
<b>RADES</b>	Radar Evaluation Squadron
<b>RBL</b>	right butt line
<b>RDX</b>	cyclotrimethylenetrinitramine
<b>RF</b>	radio frequency
<b>ROV</b>	remote-operated vehicle
<b>SAE</b>	Society of Automotive Engineers
<b>SB</b>	service bulletin
<b>SDR</b>	service difficulty report
<b>SEM</b>	scanning electron microscope
<b>SFAR</b>	Special Federal Aviation Regulation
<b>SL</b>	service letter

---

<b>S/N</b>	serial number
<b>SNL</b>	Sandia National Laboratories
<b>SS</b>	station service (check)
<b>SSS</b>	side-scan sonar
<b>STA</b>	body station
<b>STC</b>	supplemental type certificate
<b>STP</b>	surge tank protection
<b>SUPSALV</b>	Supervisor of Salvage and Diving
<b>SURVIAC</b>	Survivability/Vulnerability Information Analysis Center
<b>SWB</b>	spanwise beam
<b>SWPM</b>	Standard Wiring Practices Manual (Boeing)
<b>TC</b>	type certificate
<b>TCS</b>	time control service (check)
<b>TDR</b>	time-domain reflectometry
<b>TRU</b>	transformer-rectifier unit
<b>TSD</b>	transient suppression device
<b>TWA</b>	Trans World Airlines, Inc.
<b>UDRI</b>	University of Dayton Research Institute
<b>UL</b>	Underwriters Laboratories, Inc.
<b>USAF</b>	U.S. Air Force
<b>USCG</b>	U.S. Coast Guard
<b>UV</b>	ultraviolet ray
<b>VHF</b>	very high frequency
<b>V/m</b>	volt/meter
<b>VSCU</b>	video system control unit
<b>VSO</b>	volumetric shutoff
<b>WCS</b>	wing center section
<b>WHCASS</b>	White House Commission on Aviation Safety and Security
<b>WL</b>	body waterline
<b>WS</b>	wing station
<b>WSSIWG</b>	Wire System Safety Interagency Working Group
<b>XL-ETFE</b>	cross-linked ethylenetetrafluoroethylene



## Executive Summary

On July 17, 1996, about 2031 eastern daylight time, Trans World Airlines, Inc. (TWA) flight 800, a Boeing 747-131, N93119, crashed in the Atlantic Ocean near East Moriches, New York. TWA flight 800 was operating under the provisions of 14 *Code of Federal Regulations* Part 121 as a scheduled international passenger flight from John F. Kennedy International Airport (JFK), New York, New York, to Charles DeGaulle International Airport, Paris, France. The flight departed JFK about 2019, with 2 pilots, 2 flight engineers, 14 flight attendants, and 212 passengers on board. All 230 people on board were killed, and the airplane was destroyed. Visual meteorological conditions prevailed for the flight, which operated on an instrument flight rules flight plan.

The National Transportation Safety Board determines that the probable cause of the TWA flight 800 accident was an explosion of the center wing fuel tank (CWT), resulting from ignition of the flammable fuel/air mixture in the tank. The source of ignition energy for the explosion could not be determined with certainty, but, of the sources evaluated by the investigation, the most likely was a short circuit outside of the CWT that allowed excessive voltage to enter it through electrical wiring associated with the fuel quantity indication system.

Contributing factors to the accident were the design and certification concept that fuel tank explosions could be prevented solely by precluding all ignition sources and the design and certification of the Boeing 747 with heat sources located beneath the CWT with no means to reduce the heat transferred into the CWT or to render the fuel vapor in the tank nonflammable.

The safety issues in this report focus on fuel tank flammability, fuel tank ignition sources, design and certification standards, and the maintenance and aging of aircraft systems. Safety recommendations concerning these issues are addressed to the Federal Aviation Administration.

# 1. Factual Information

## 1.1 History of Flight

On July 17, 1996, about 2031 eastern daylight time,<sup>1</sup> Trans World Airlines, Inc. (TWA) flight 800, a Boeing 747-131 (747), N93119, crashed in the Atlantic Ocean near East Moriches, New York. TWA flight 800 was operating under the provisions of 14 *Code of Federal Regulations* (CFR) Part 121 as a scheduled international passenger flight from John F. Kennedy International Airport (JFK), New York, New York, to Charles DeGaulle International Airport (CDG), Paris, France. The flight departed JFK about 2019, with 2 pilots, 2 flight engineers, 14 flight attendants, and 212 passengers on board. All 230 people on board were killed, and the airplane was destroyed. Visual meteorological conditions prevailed for the flight, which operated on an instrument flight rules flight plan.

On the day of the accident, the accident airplane departed Athens, Greece, as TWA flight 881 about 0537, landed at JFK about 1631, and arrived at terminal 5, gate 27, about 1638. The flight crew that had flown the accident airplane from Athens, Greece, to JFK told National Transportation Safety Board investigators that it did not observe any operational abnormalities during that flight. A scheduled flight crew change occurred at JFK. The accident airplane was refueled at JFK<sup>2</sup> and remained at gate 27 with the auxiliary power unit (APU) and two of its three air conditioning packs operating (for about 2 1/2 hours) until it departed as TWA flight 800.

According to company records, flight 800 was to be the first leg of a scheduled 3-day trip sequence for the four flight crewmembers. A captain occupied the left front seat, a captain/check airman occupied the right front seat, a flight engineer occupied the right aft seat (flight engineer position), and a flight engineer/check airman occupied the left aft seat (cockpit jump seat).<sup>3</sup> TWA flight 800 was scheduled to depart JFK for CDG about 1900; however, the flight was delayed because of a disabled piece of ground equipment<sup>4</sup> and concerns about a suspected passenger/baggage mismatch. According to the cockpit voice recorder (CVR),<sup>5</sup> at 1959:44, gate agent personnel advised the flight

---

<sup>1</sup> Unless otherwise indicated, all times are eastern daylight time, based on a 24-hour clock.

<sup>2</sup> For additional information regarding TWA flight 881 flight crew statements about the airplane's fuel load during that flight, refueling difficulties at JFK, and the fuel on board the accident airplane when it departed JFK, see section 1.6.

<sup>3</sup> The flight engineer was receiving initial operating experience (IOE) training during the accident flight.

<sup>4</sup> A disabled fleet service vehicle was blocking the accident airplane at the gate, and there was a delay obtaining the proper equipment to tow the fleet service vehicle.

<sup>5</sup> See appendix B for a complete transcript of the CVR. The local (eastern daylight) time reference was established by correlating the last seven very high frequency (VHF) radio transmissions made by the pilots of TWA flight 800 and recorded by the flight data recorder (FDR) microphone keying parameter with the CVR and the Boston Air Route Traffic Control Center (ARTCC). The correlation points all agreed within 1 second.

crew that, although a passenger's bag had been pulled because they suspected that it was unattended, they subsequently confirmed that "the passenger was on board the whole time." The CVR recorded the sound of the cockpit door closing at 1959:59, and the flight crew of TWA flight 800 continued to prepare for departure.

TWA flight 800 was pushed back from the gate about 2002. According to the CVR, between 2005 and 2007:46, the flight crew started the Nos. 1, 2, and 4 engines and completed the after-start checklist. At 2007:52, the captain/check airman advised the JFK gate hold controller that TWA flight 800 was "ready to taxi." About 2008, the flight crew received taxi instructions from air traffic control (ATC) and began to taxi to runway 22 right (22R), the departure runway. While the airplane was taxiing (about 2014), the CVR recorded the flight crew starting the No. 3 engine and conducting the delayed engine-start and taxi checklists.

At 2017:18, the CVR recorded ATC stating, "TWA 800 heavy caution wake turbulence from a 757, runway 22R, taxi into position and hold." The CVR transcript indicated that the captain/check airman acknowledged the ATC clearance and that the airplane was taxied into position on the departure runway.<sup>6</sup> At 2018:21, ATC advised the pilots of TWA flight 800 that the wind was out of 240° at 8 knots and cleared flight 800 for takeoff on runway 22R. The CVR recorded the flight crew conducting the before-takeoff checklist and the sound of increasing engine noise; FDR and CVR information indicated that the airplane became airborne about 2019.

During the accident airplane's departure from JFK, the pilots of TWA flight 800 received a series of (generally increasing) altitude assignments and heading changes from New York Terminal Radar Approach Control and Boston ARTCC controllers. At 2025:41, Boston ARTCC advised the pilots to "climb and maintain [19,000 feet] and expedite through [15,000 feet]"; the pilots acknowledged the instructions at 2025:47. According to the CVR, at 2026:24, Boston ARTCC amended TWA flight 800's altitude clearance, advising the pilots to maintain 13,000 feet mean sea level (msl). At 2027:47, the CVR recorded the sound of the altitude alert tone, and the FDR data indicated that the airplane reached its assigned altitude.

At 2029:15, the CVR recorded the captain stating, "Look at that crazy fuel flow indicator there on number four...see that?"<sup>7</sup> At 2030:15, Boston ARTCC advised, "TWA 800 climb and maintain [15,000 feet msl]." The CVR recorded the captain stating, "climb thrust," and the captain/check airman acknowledging the ATC clearance at 2030:18. At 2030:25, the captain repeated, "climb thrust," and at 2030:35, the flight engineer responded, "power's set." The CVR recording of the next 30 seconds from the cockpit area microphone (CAM)<sup>8</sup> includes the following sounds:

---

<sup>6</sup> Review of the ATC and CVR transcripts from the accident flight indicated that the captain (left front seat) was performing the pilot-flying duties, while the captain/check airman (right front seat, identified as the "first officer" in the CVR transcript) was performing the radio communications and other pilot-not-flying duties during the departure.

<sup>7</sup> For additional information regarding the fuel flow sensing and indication system on the 747-100, see section 1.6.2.3.

- a sound similar to a mechanical movement in the cockpit (at 2030:42),
- an unintelligible word (at 2031:03), and
- sounds similar to recording tape damage noise (at 2031:05).<sup>9</sup>

At 2031:12, the CVR recording ended. A sound spectrum study of the information recorded by the CVR revealed that twice within the last second of the CVR recording (about 0.73 and 0.68 seconds before the recording stopped), the captain's channel recorded harmonic tones at the 400 Hertz<sup>10</sup> (Hz) frequency, but it did not record other electrical system background noise that it had recorded previously throughout the recording. These other electrical system background noises were recorded on the other CVR channels without interruption.<sup>11</sup> The CVR then recorded a "very loud sound" for a fraction of a second (0.117 second) on all channels immediately before the recording ended. The accident airplane's last recorded radar<sup>12</sup> transponder return occurred at 2031:12, and a review of the FDR data indicated that the FDR lost power at 2031:12.

According to the Boston ARTCC transcript, at 2031:50, the captain of an Eastwind Airlines Boeing 737 (Stinger Bee flight 507) reported that he "just saw an explosion out here." About 10 seconds later, the captain of Stinger Bee flight 507 further advised, "we just saw an explosion up ahead of us here...about 16,000 feet or something like that, it just went down into the water."<sup>13</sup> Subsequently, many ATC facilities in the New York/Long Island area received reports of an explosion from other pilots operating in the area.

Many witnesses in the vicinity of the accident at the time that it occurred stated that they saw and/or heard explosions, accompanied by a large fireball over the ocean, and observed debris, some of which was burning, falling to the water. According to witness documents, about one-third of these witnesses reported that they observed a streak of light, resembling a flare, moving upward in the sky to the point where a large fireball appeared. Several witnesses reported seeing this fireball split into two fireballs as it descended toward the water.<sup>14</sup>

---

<sup>8</sup> The audio information recorded by the CAM includes audio (airborne) sounds and vibrations picked up by the fuselage-mounted microphone.

<sup>9</sup> Subsequent examination of the CVR tape indicated that these sounds were likely the result of water damage to the tape head. Because of the position of the tape on the reels, the portion of the tape that contained sounds from the last seconds before the CVR stopped recording was exposed to water after the accident.

<sup>10</sup> A Hz is a unit of frequency equal to 1 cycle per second.

<sup>11</sup> The Safety Board's CVR sound spectrum study revealed no other such changes or other unusual electrical occurrences on the 31-minute 30-second recording. See section 1.11.1.1 for a detailed discussion of the results of the sound spectrum study and other CVR-related testing, including how the CVR system installed on the 747 would respond to various types of explosive events.

<sup>12</sup> Examination of radar data indicated that the accident airplane's last radar transponder return was recorded by the Federal Aviation Administration's (FAA) radar site at Trevoise, Pennsylvania. For additional information regarding radar information, see section 1.16.1.

<sup>13</sup> Radar data and ATC records indicated that Stinger Bee flight 507 was about 20 to 25 miles northeast of TWA flight 800, on a southwesterly heading.

<sup>14</sup> For additional information regarding witness reports, including that of the pilot of Stinger Bee flight 507, see section 1.18.4.

Pieces of the airplane wreckage were discovered floating on and beneath the surface of the Atlantic Ocean about 8 miles south of East Moriches, New York. The main wreckage was found on the ocean floor, between 40° 37' 42" and 40° 40' 12" north latitude and 72° 40' 48" and 72° 35' 38" west longitude. The accident occurred in dusk lighting conditions.

## 1.2 Injuries to Persons

Table 1. Injury chart.

Injuries	Flight Crew	Cabin Crew	Passengers	Other	Total
Fatal	4	14	212	0	230
Serious	0	0	0	0	0
Minor	0	0	0	0	0
None	0	0	0	0	0
Total	4	14	212	0	230

## 1.3 Damage to Aircraft

The airplane was destroyed by the explosion, breakup and impact forces, and fire. According to insurance company records, the airplane was valued at \$11 million.

## 1.4 Other Damage

No structures on the ground were damaged.

## 1.5 Personnel Information

The Safety Board reviewed the flight crew's flight- and duty-time limits and rest records and found no evidence that they were not within the limits established by Federal regulations. The cabin crew comprised 14 flight attendants.

### 1.5.1 The Captain (Left Front Seat)

The captain, age 58, was hired by TWA on May 20, 1965. He held airline transport pilot (ATP) certificate No. 1453736 with multiengine land and instrument ratings. The captain's most recent FAA first-class airman medical certificate was issued on March 22, 1996, and contained the limitation that he possess glasses for near vision.

The captain's first assignment with TWA was as a first officer on the Convair 880. He subsequently served as first officer and captain on the Boeing 707 (707) and Lockheed 1011 before transitioning to the 747. He received a 747 type rating on February 19, 1990, and began 747 captain upgrade training on May 21, 1996; the captain's most recent proficiency check was satisfactorily completed on June 19, 1996. According to TWA records, at the time of the accident, the captain had flown approximately 18,800 total flight hours, including 5,490 hours in the 747.

### **1.5.2 The Captain/Check Airman (Right Front Seat)**

The captain/check airman, age 57, was hired by TWA on April 13, 1964. He held ATP certificate No. 1475512 with single-engine land, multiengine land, and instrument ratings. The captain/check airman's most recent FAA first-class airman medical certificate was issued on April 15, 1996, with no restrictions or limitations.

The captain/check airman's first assignment with TWA was as a first officer on the Convair 880. He subsequently served as flight crewmember on the 707, Boeing 727, and Lockheed 1011 before transitioning to the 747. He received a 747 type rating on December 30, 1974, and qualified as a 747 check airman on May 3, 1993. According to TWA records, at the time of the accident, the captain/check airman had flown approximately 17,000 total flight hours, including 4,700 hours in the 747.

### **1.5.3 The Flight Engineer (Right Aft/Flight Engineer's Seat)**

The flight engineer trainee, age 24, was hired by TWA on June 22, 1996. He held flight engineer-turbo jet-powered certificate No. 306804492. The flight engineer trainee's most recent FAA first-class airman medical certificate was issued on December 12, 1995, with no restrictions or limitations.

The flight engineer trainee was hired by TWA as a 747 flight engineer, and the accident flight was the sixth leg of his IOE training. According to TWA records, at the time of the accident, the flight engineer trainee had flown approximately 2,520 total flight hours, including about 30 hours as flight engineer trainee in the 747.

### **1.5.4 The Flight Engineer/Check Airman (Left Aft/Cockpit Jump Seat)**

The flight engineer/check airman, age 62, was hired by TWA on February 26, 1966. He held ATP certificate No. 1409009 and flight engineer-turbo jet-powered certificate No. 1694661. The flight engineer/check airman's most recent FAA first-class airman medical certificate was issued on July 17, 1996, and contained the limitation that he wear glasses for near and distant vision.

The flight engineer/check airman's first assignment with TWA was as a flight engineer on the Lockheed Constellation 749, 749A, and 1049G model airplanes. In

February 1967, he upgraded to the first officer position on these model airplanes. On November 19, 1986, the flight engineer/check airman received a 747 type rating. He subsequently performed 747 first officer and captain duties until he turned 60 on July 2, 1993, at which time, he became a flight engineer on the 747 rather than retire.<sup>15</sup> According to TWA records, at the time of the accident, the flight engineer/check airman had about 3,047 hours of flight engineer experience, including 2,397 hours as flight engineer on the 747.

## 1.6 Airplane Information

The accident airplane, N93119, a 747-100 series airplane (model 747-131),<sup>16</sup> serial number (S/N) 20083, was manufactured by Boeing in July 1971 and purchased new by TWA. The airplane was added to TWA's operating certificate on October 27, 1971, and, except for a 1-year period,<sup>17</sup> was operated by TWA in commercial transport service until the accident occurred. According to TWA records, the accident airplane had 93,303 total hours of operation (16,869 flight cycles)<sup>18</sup> at the time of the accident.<sup>19</sup> The 747-100 is a low-wing, transport-category airplane that is about 225 feet long and 63 feet high (from the ground to the top of the vertical stabilizer), with a wingspan of about 195 feet. The 747-100 can carry about 430 passengers and cargo. Figure 1 shows three views of the 747-100 airplane.

The accident airplane was equipped with four Pratt & Whitney (P&W) JT9D-7AH turbofan engines. Company maintenance records indicated that the No. 1 (outboard left) engine, S/N 662209, was installed on the accident airplane on December 31, 1995, and had operated about 47,989 hours since new; the No. 2 (inboard left) engine, S/N 662593, was installed on the accident airplane on December 6, 1995, and had operated about 80,884 hours since new; the No. 3 (inboard right) engine, S/N 662426, was installed on the accident airplane on June 18, 1996, and had operated about 80,336 hours since new;

---

<sup>15</sup> *Federal Aviation Regulations* (FARs) stipulate a mandatory retirement age of 60 for air carrier captains and first officers; however, they allow continued airman activity in other areas, including the flight engineer position.

<sup>16</sup> The 747-100 series airplane is one of several 747 models. Other 747 models include the -200, -300, -SP, and -SR (collectively referred to as the "Classic") series airplanes, and the -400. The military uses derivatives of the 747, which are identified as the E-4B and VC-25.

<sup>17</sup> On December 15, 1975, the accident airplane was ferried to the Boeing Military Aircraft Company in Wichita, Kansas, to be prepared for sale to the Government of Iran. According to the Airclaims Limited database, the accident airplane was sold to the Iranian Air Force in December 1975; however, the airplane was not delivered to Iran and was returned to TWA's operating certificate on December 16, 1976. Maintenance records indicated that the airplane had been operated about 7 hours with four landings between December 1975 and December 1976. (See Maintenance Records Group Chairman's Factual Report, dated October 8, 1997, for a list of the modifications and inspections accomplished in preparation for the sale of the airplane.)

<sup>18</sup> A flight cycle is one complete takeoff and landing sequence.

<sup>19</sup> According to a Boeing AERO magazine article, the minimum design service objective for 747 series airplanes was 20,000 flights, 60,000 hours, and 20 years.

and the No. 4 (outboard right) engine, S/N 662463, was installed on the accident airplane on May 11, 1996, and had operated about 77,061 hours since new.

According to TWA's dispatch documents for the accident flight, the airplane's takeoff weight was calculated to be 590,441 pounds,<sup>20</sup> including 19,751 pounds of cargo (6,062 pounds of cargo in the forward cargo compartment and 13,689 pounds of cargo in the aft and bulk cargo compartments)<sup>21</sup> and 176,600 pounds of fuel. TWA dispatch records and load information recorded by the CVR indicated that there were 29 passengers in the first-class cabin, 183 passengers in the coach cabin, and 18 crewmembers (4 flight crewmembers and 14 cabin crewmembers) on board the airplane. The dispatch documents indicated that the airplane's takeoff center of gravity (c.g.) was calculated to be 18.4 percent of the mean aerodynamic chord (MAC), and the takeoff horizontal stabilizer trim setting was 6.1 units nose up.

### 1.6.1 Boeing 747—General Description/Information

The 747-100 fuselage comprises five major sections (referred to in Boeing manuals as sections 41 [the forward section], 42, 44, 46, and 48 [the tail section]) and consists of the external skin, internal circumferential frames, and longitudinal (fore-aft) stiffening members, called stringers.<sup>22</sup> For ease of reference, in the airplane's documentation, Boeing divided the airplane into reference planes, which are designated as body stations (STA),<sup>23</sup> body waterlines (WL),<sup>24</sup> and butt lines (BL).<sup>25</sup> The locations of various components and fuselage areas in 747s are measured in inches from fixed points of reference. Figure 2 shows the locations of some STAs and WLs. Figures 3a and 3b show the locations of numerous STAs and other fuselage areas, including fuselage sections, doors, and wheel wells.

<sup>20</sup> The maximum certificated takeoff gross weight for the accident airplane was 734,000 pounds.

<sup>21</sup> According to Boeing documents, the aft cargo compartment consists of an aft containerized cargo/baggage compartment and a (farther aft) bulk cargo compartment, which have separate doors and are separated by compartment divider nets. TWA's dispatch records use the term "rear cargo compartment" to describe the aft containerized cargo/baggage compartment and "aft cargo compartment" to describe the bulk cargo compartment. These dispatch documents specified that the "rear cargo compartment" contained 12,428 pounds of cargo and that the "aft cargo compartment" contained 1,261 pounds of cargo.

<sup>22</sup> The 747-100 wings also contain stringers, which extend from the wing root to the wing tip, to support and reinforce the wing skin.

<sup>23</sup> A STA is a longitudinal point along an airplane's fuselage, identified numerically by its distance in inches from a reference point. In a classic 747, this point is 90 inches forward of the airplane's nose.

<sup>24</sup> A WL is a horizontal point along an airplane's fuselage, identified numerically by its distance in inches from a parallel imaginary plane (WL 0.00) located 91 inches below the lowest body surface.

<sup>25</sup> A BL number refers to a lateral fuselage location and reflects the number of inches the location is right or left of the airplane's centerline.



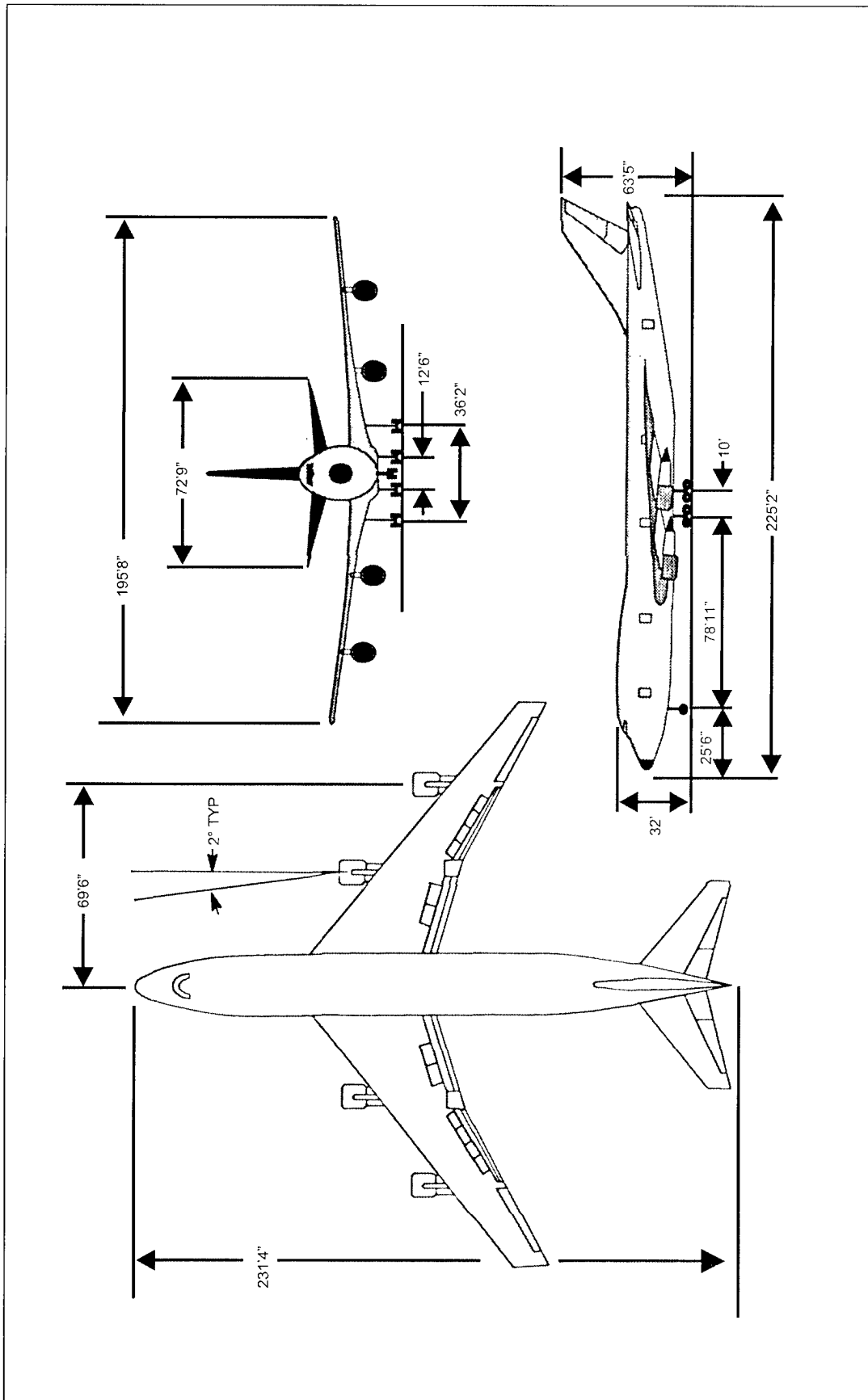

Figure 1. Three views of the 747-100 airplane.

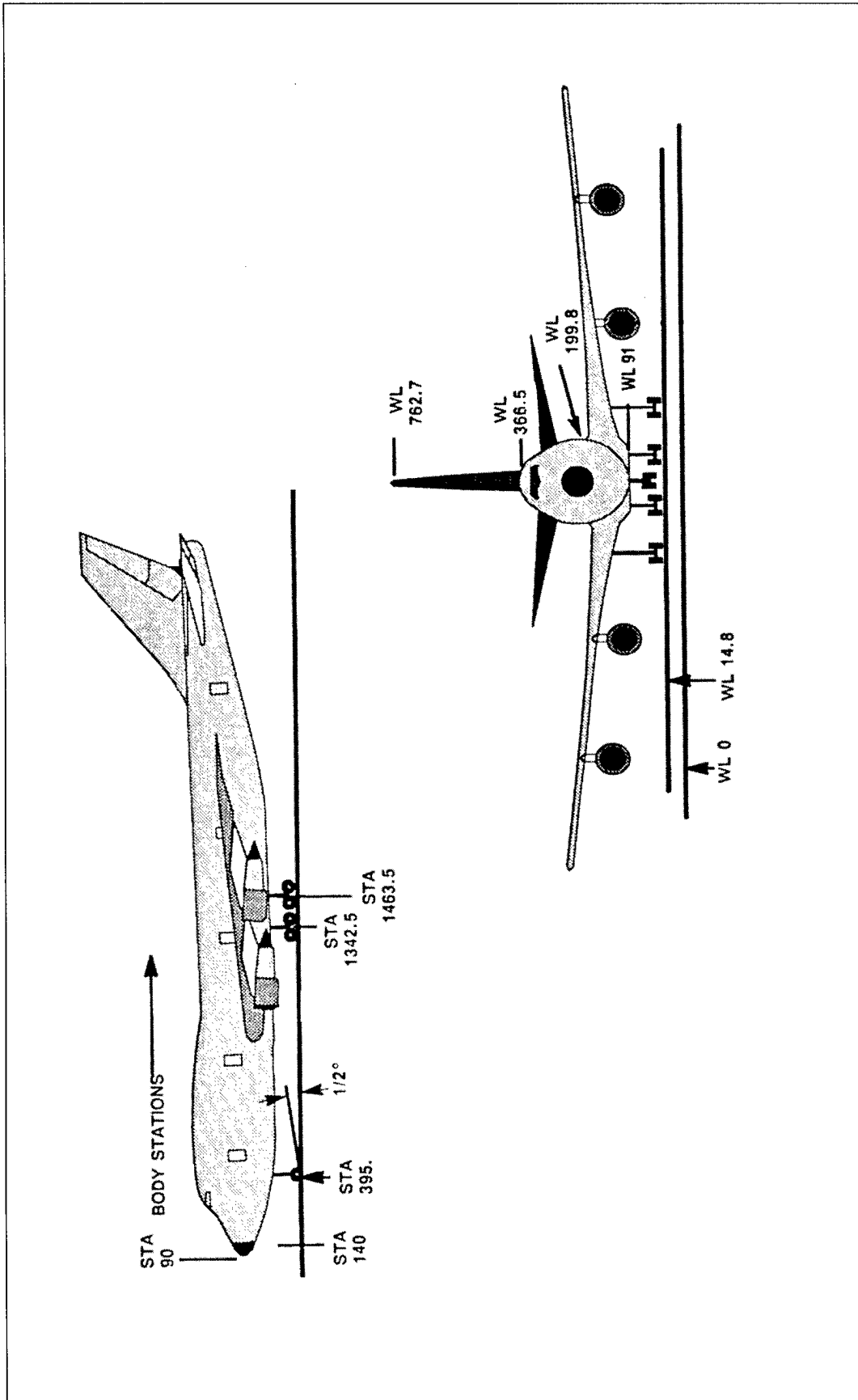

Figure 2. Location of some body stations and waterlines in the 747.

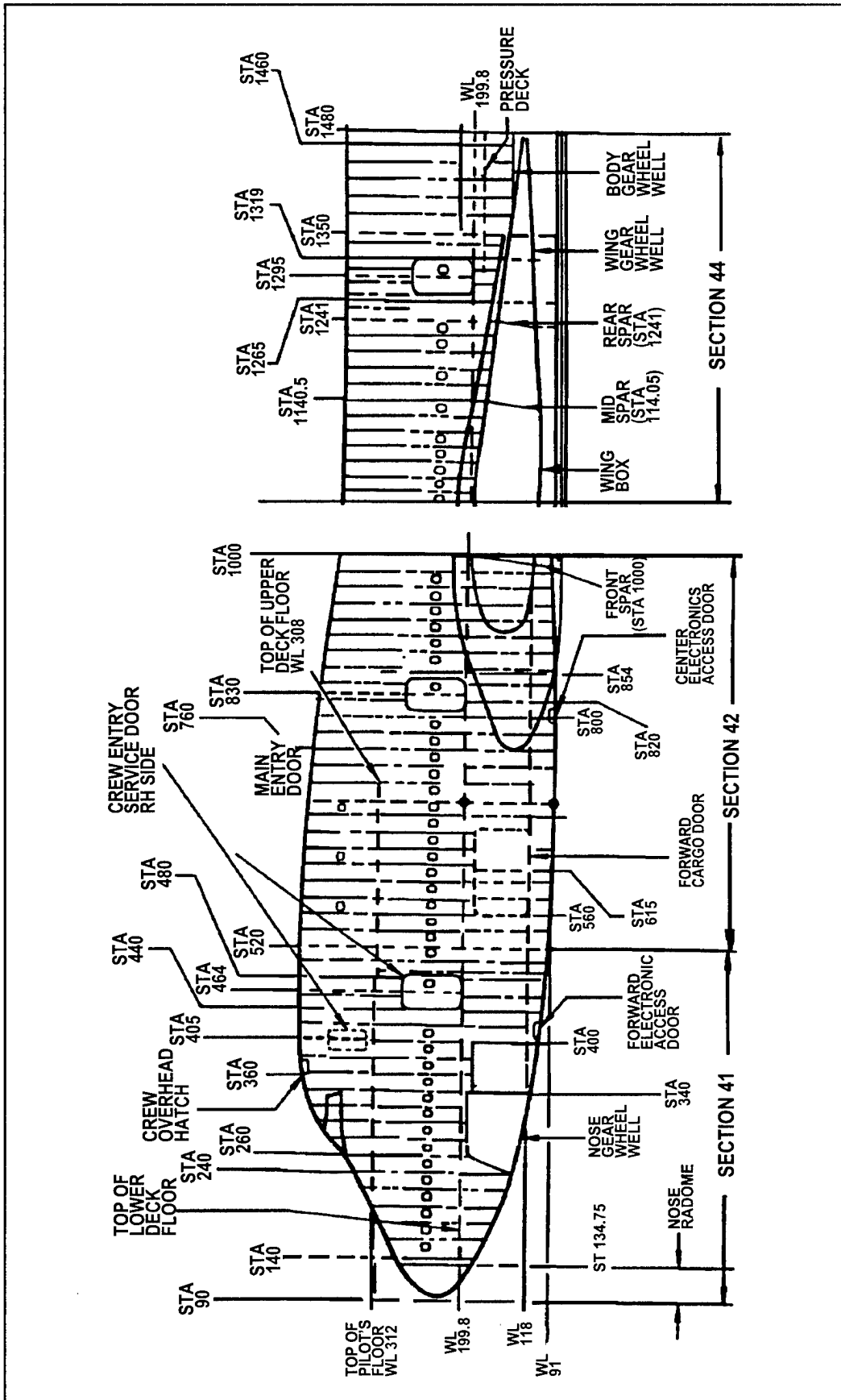

Figure 3a. Location of fuselage sections 41, 42, and 44.

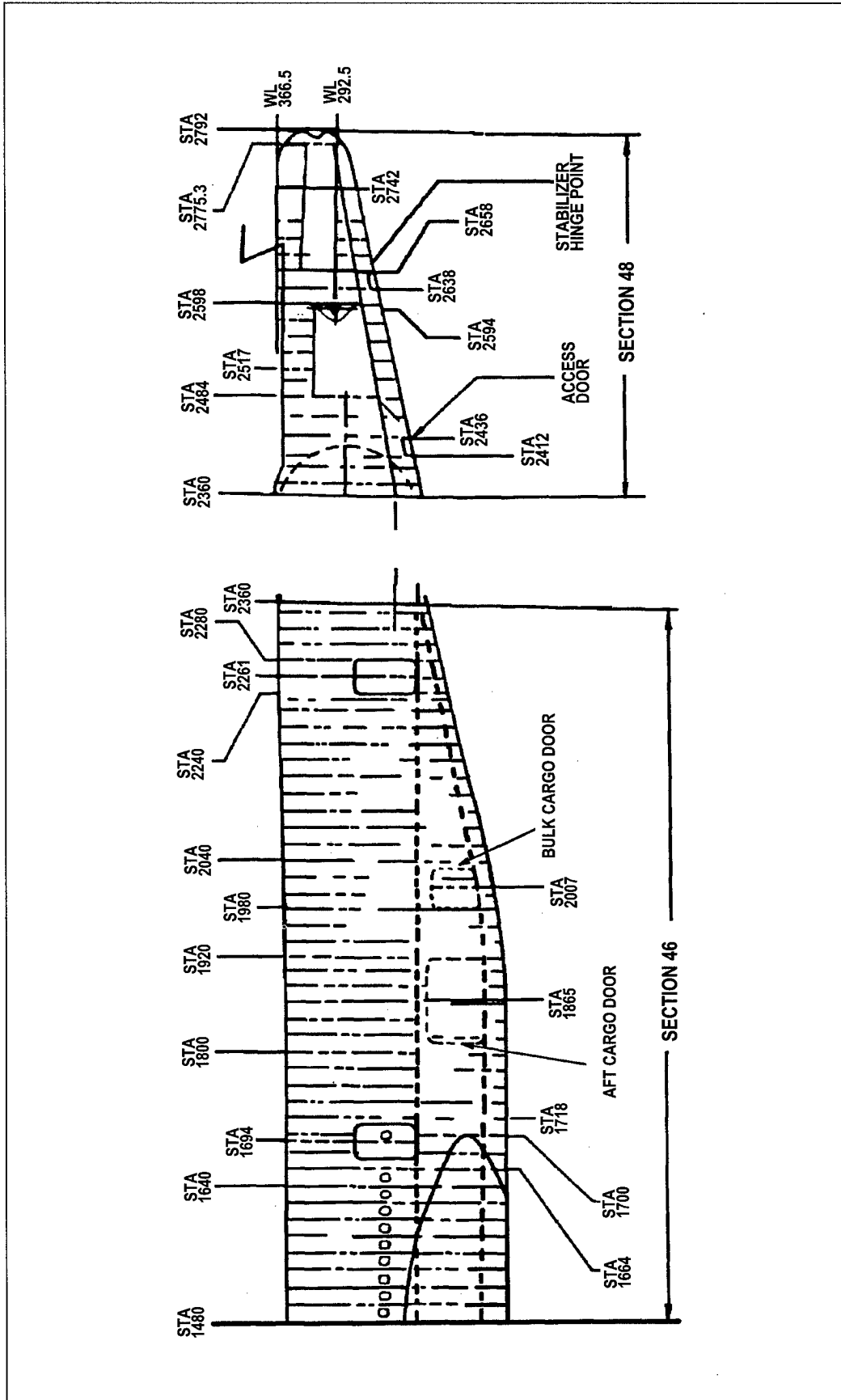

Figure 3b. Location of fuselage sections 46 and 48.

The vertical and horizontal stabilizers intersect the tail section of the fuselage between STAs 2220 and 2590. The wing leading edges intersect the fuselage (with a sweepback angle of  $37\ 1/2^\circ$ ) just aft of STA 900, and the trailing edge is located just forward of STA 1480. The wing front, mid, and rear spars extend through the wing center section (WCS)<sup>26</sup> between the right and left wings at STAs 1000, 1140.5, and 1241, respectively (see figures 3a, 4a, and 4b). The fuselage is nearly circular in cross-section where it intersects the front spar at the ring chord.<sup>27</sup> The bottom of this portion of the fuselage is also attached to the lower end of the keel beam (see figure 4a), which is a box-shaped, load-bearing structure located along the airplane's centerline that extends from the aft wall of the forward cargo compartment<sup>28</sup> (STA 1000) through the main and body landing gear compartments to the forward wall of the aft cargo compartment (STA 1480). (Figure 4a shows the keel beam structure and locations of WCS lateral beams/spars, and the ring chord.) The portion of the airplane below the WCS is contained within an aerodynamic fairing<sup>29</sup> that blends into the wing leading edge. Figure 5 shows the 747-100 aerodynamic fairings.

#### 1.6.1.1 747-100 Wing Center Section and Center Wing Fuel Tank Description

The 747-100's WCS is located aft of the forward cargo compartment and forward of the main landing gear bay in the lower fuselage. Like the cargo compartments, the WCS is below the main cabin floor. The WCS is about 21 feet wide, 20 feet long, and varies in height from about 4 1/2 to 6 feet (with the shortest height located at the aft end). The WCS is framed by the front and rear wing spars and the side-of-body ribs that separate the WCS from the inboard wing fuel tanks. The upper and lower skin panels separate the WCS from the passenger cabin floor (which is located above the WCS and supported by longitudinal floor beams) and the airplane's heat exchanger/air conditioning equipment (which is located beneath the WCS),<sup>30</sup> respectively. According to Boeing, the WCS carries the wing bending forces through the airplane and supports the fuselage during flight.

---

<sup>26</sup> The WCS is a large structural box located in the 747 lower fuselage between the wings and comprises the center wing fuel tank (CWT) and a dry bay directly forward of the CWT. For additional information regarding the WCS and CWT, see section 1.6.1.1. (Note: The CWT is called the wing center tank in some documents.)

<sup>27</sup> A chord is an angle member that attaches two other pieces together, usually at an angle of about  $90^\circ$ . The ring chord is an angle member that attaches the bottom of the forward fuselage section to the front side of the lower-pressure bulkhead and the front spar.

<sup>28</sup> As previously discussed, the 747 has a forward and an aft cargo compartment, each located in the lower portion of the fuselage, below the main cabin floor.

<sup>29</sup> The fairings are composite material shaped around the fuselage and wings to make the airplane more aerodynamic.

<sup>30</sup> For further details about the airplane's heat exchanger/air conditioning equipment (air conditioning packs), see section 1.6.1.2.

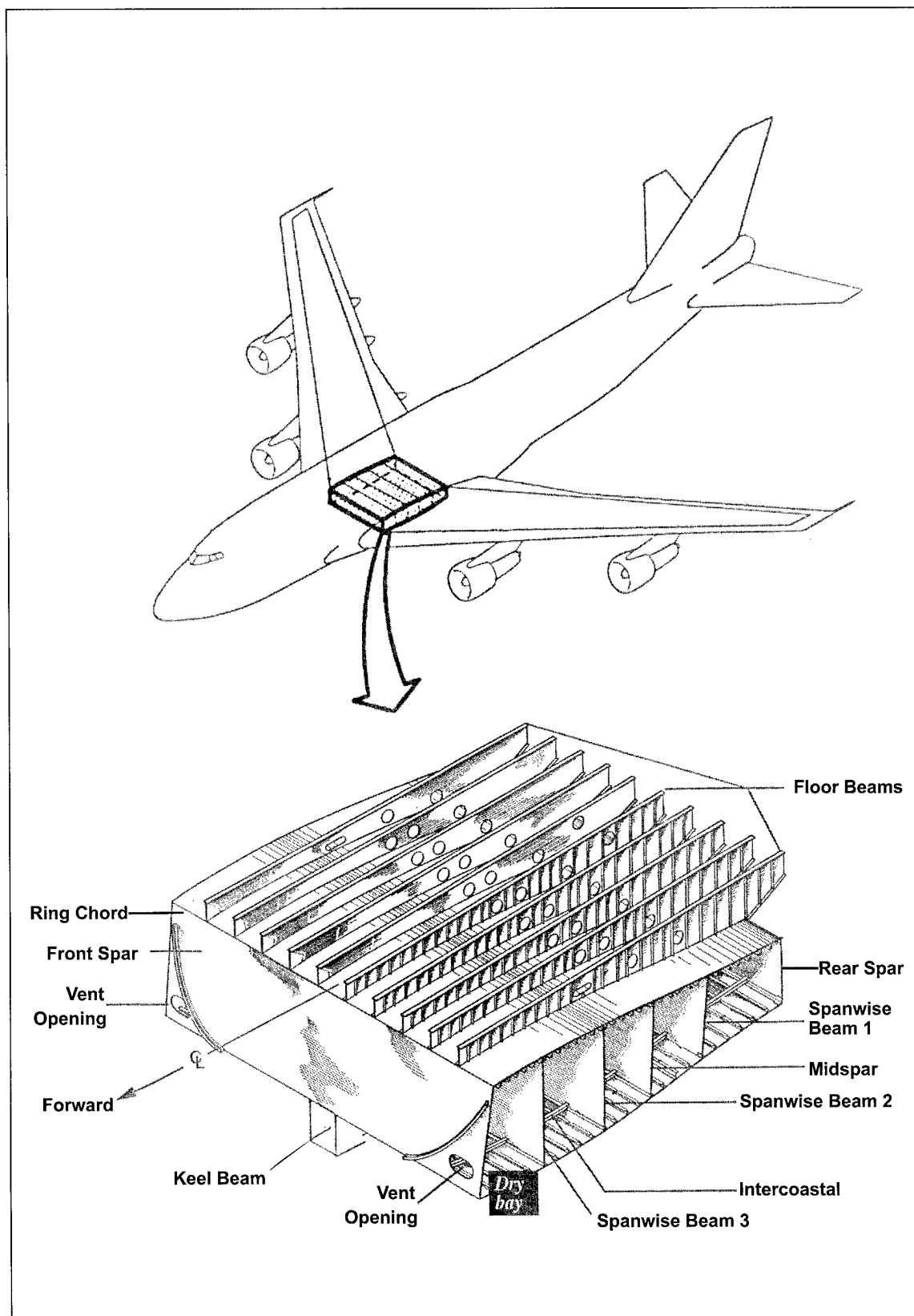

Figure 4a. A cross-section of the 747-100 wing center section.

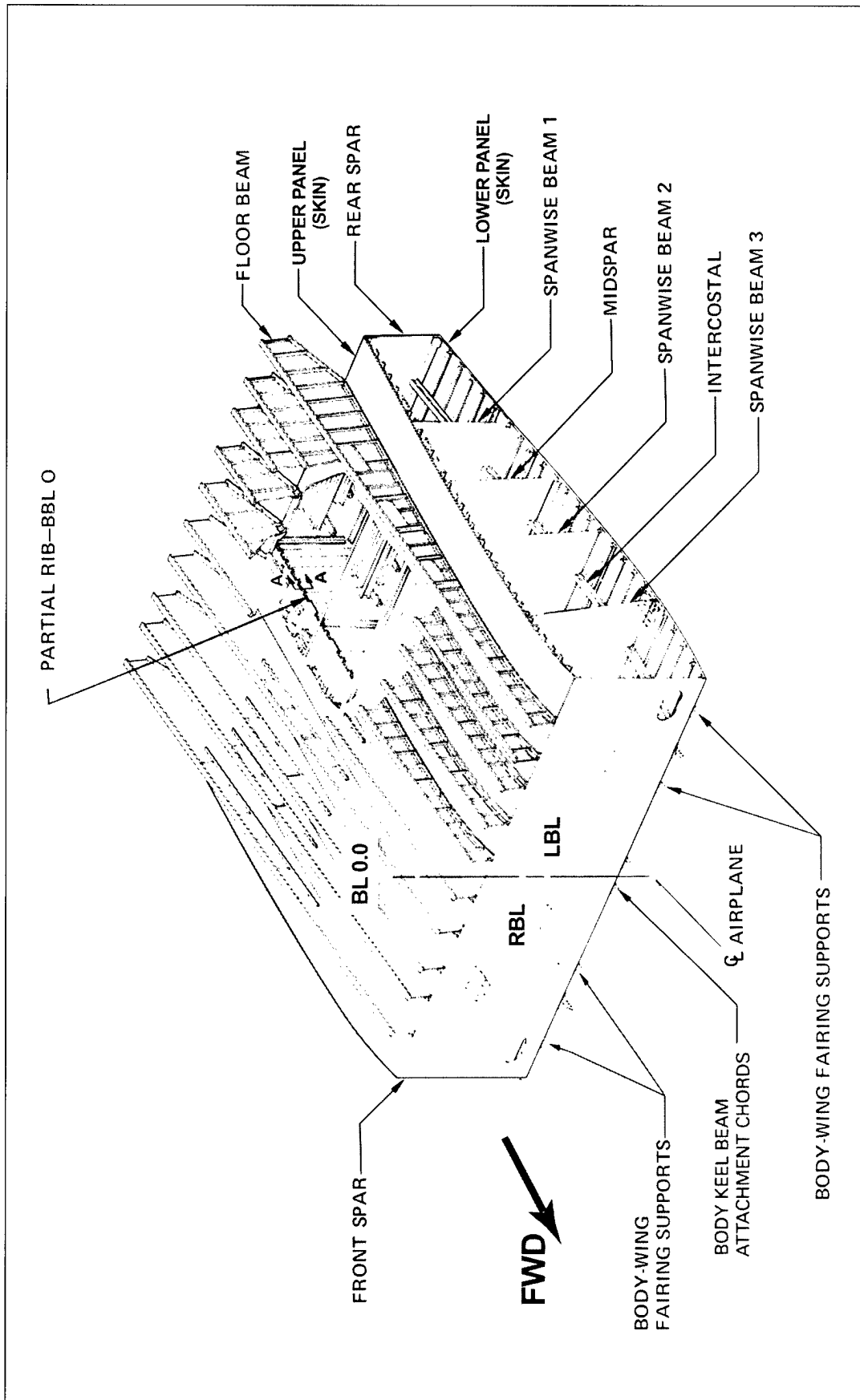

Figure 4b. Another cross-section of the 747-100 wing center section.

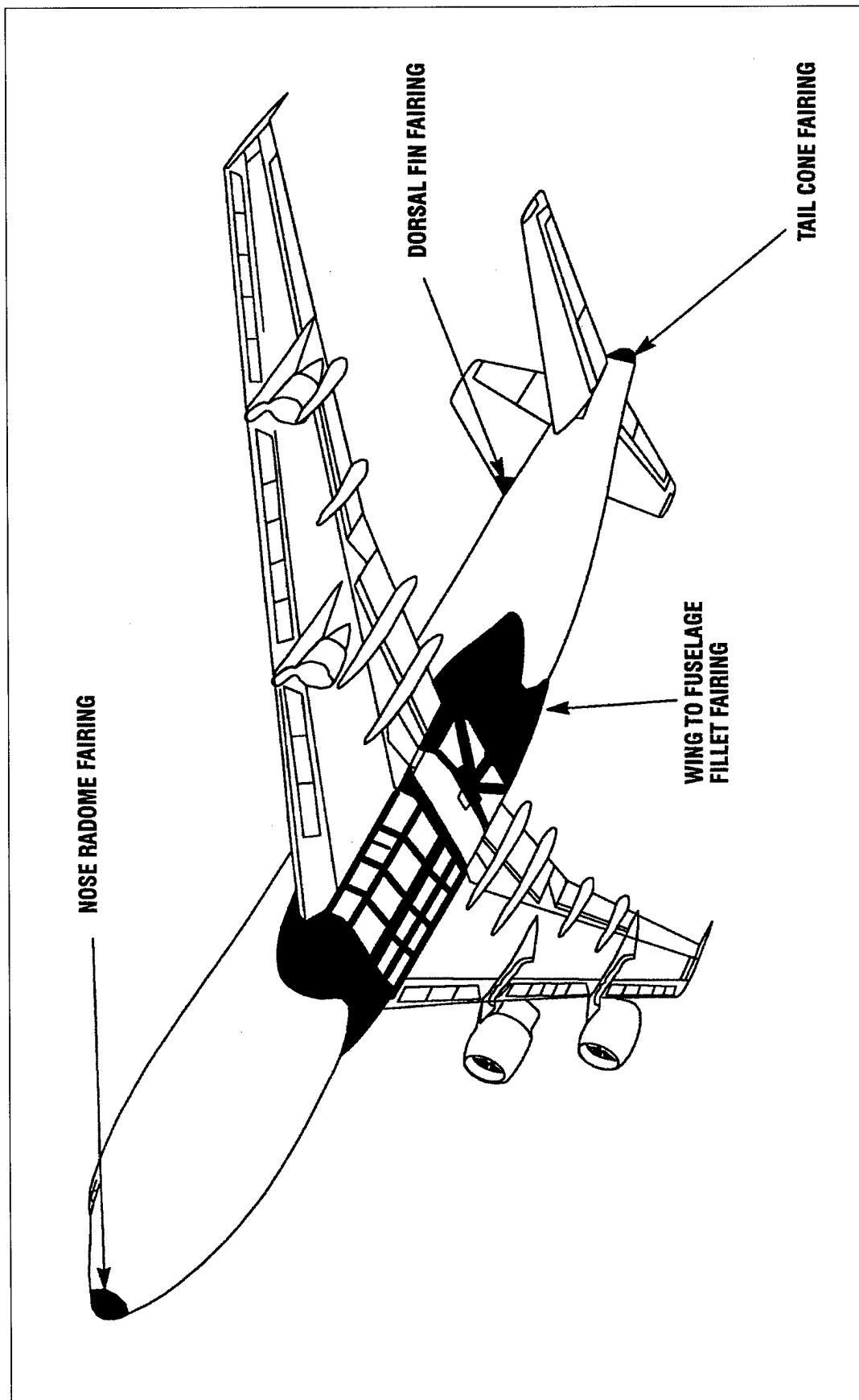

Figure 5. The 747-100 aerodynamic fairings.



The WCS is divided laterally into compartments by six beams, including (from farthest aft to forward) the rear spar, spanwise beam (SWB)1, the mid spar, SWB2, SWB3, and the front spar (see figures 4a and 4b). In addition, a partial longitudinal rib divides the WCS along the airplane's centerline (BL 0) between the mid and rear spars. The WCS compartments located between the rear spar and SWB3 comprise the CWT. In the 747-100, the compartment between SWB3 and the front spar is a dry bay that is not intended to contain fuel.<sup>31</sup> SWBs 1 and 2, the partial ribs, and the mid spar in the CWT contain a number of cutouts and vent holes to allow air or fuel to move between the various bays and electrical tubing/conduit<sup>32</sup> to pass through. In addition, the SWBs and mid spar contain maintenance access doors, which are attached with removable fasteners. SWB2 also contains a manufacturing access door, which was permanently fastened in place during completion of the manufacturing process. The CWT is sealed from the outside atmosphere except for two vent stringers that connect the CWT to vents in the surge tanks at each of the two wing tips. The WCS dry bay is vented to the atmosphere through two openings in the front spar (see figure 4a).

Attached to the bottom of the WCS is the keel beam (see figures 4a and 10), which provides longitudinal strength to the airplane. The keel beam contains two vertical webs (located at left BL [LBL] 9 and right BL [RBL] 9), a heavy chord along its lower edge, a smaller chord along its upper edge, and various stiffeners. The keel beam upper chord is attached to the WCS lower skin panel by a series of aluminum bolts/rivets forward of the mid spar and by titanium bolts aft of the mid spar. Additionally, the keel beam upper chord is attached to each WCS lateral beam (front spar, SWB3, SWB2, mid spar, SWB1, and rear spar) by steel tension bolts.

#### 1.6.1.2 747-100 Air Conditioning Equipment Description

The 747-100 air conditioning system comprises three air conditioning packs, manufactured by Hamilton Standard, that reduce the temperature and pressure of hot bleed air from one or more of the airplane's engines, the APU, or the high-pressure ground power carts during ground operations<sup>33</sup> to provide environmental control (pressurization, ventilation, and temperature) to the cockpit and the main cabin. (Figure 6 is a schematic diagram of the 747-100 air conditioning system.) The air conditioning packs are located in an enclosed area (the air conditioning pack bay) under the WCS in the following locations: pack No. 1 is located to the left of the keel beam (beneath the forward left portion of the CWT); pack No. 2 is located immediately aft of pack No. 1; and pack No. 3

---

<sup>31</sup> The compartment between SWB3 and the front spar was originally equipped with a bladder cell for water and plumbing to inject that water into the engines to increase engine thrust on takeoff. When the original engines were replaced with higher thrust engines, water for water injection was not needed, and the compartment between SWB3 and the front spar was converted to a dry bay. The accident airplane's water system had been deactivated, and the bladder cell and plumbing had been removed. In some later models of the 747 and in the military (E-4B) version, this dry bay has been modified to carry fuel.

<sup>32</sup> An electrical conduit is a rigid tube that contains electrical wires.

<sup>33</sup> According to postaccident interviews with TWA ground operations personnel, while the accident airplane was on the ground at JFK, two of the three air conditioning packs were operated (powered by the APU) in accordance with TWA procedures.

is located adjacent to pack No. 1 (beneath the forward right portion of the CWT) on the right side of the keel beam (see figures 7 and 8).

Each air conditioning pack includes the following major components:

- A pack control valve, which controls the volume of air supplied to its respective pack (and bleed trim system).<sup>34</sup>
- Dual heat exchangers—all air going through the air conditioning pack must pass through both the primary and secondary heat exchangers. Heat exchanger cooling air is provided by ram air in flight and the air cycle machine (ACM) fan on the ground. When minimum cooling is required, ram air passing through the primary and secondary heat exchangers provides sufficient cooling and the ACM is bypassed.
- An ACM, which consists of a fan, compressor, expansion turbine, and bypass valve. When partially cooled air from the heat exchangers requires additional cooling, the bypass valve closes and the air is routed through the ACM expansion turbine for maximum cooling.

The air conditioning packs remove heat from the engine bleed air through the primary and secondary heat exchangers (with excess heat exhausted into the air conditioning pack bay through a set of louvers that are flush with the lower fairings). After conditioned air leaves each of the air conditioning packs,<sup>35</sup> it is routed through ductwork to the aft side of the rear spar, then along the aft side of the rear spar (through the main landing gear wheel well) upward until it reaches the top of the CWT. The conditioned air is then routed forward between the upper skin of the WCS and the main cabin floor into a common plenum located above the CWT.<sup>36</sup> The conditioned air then branches off to vertical risers in the airplane's side walls and ascends to the air distribution/exchange system for the pressurized portion of the fuselage above the main cabin ceiling. (Figure 9 shows the air conditioning ducts around the CWT.) Temperature and pressure sensors located throughout the system relay information to gauges in the cockpit, permitting the flight crew to monitor the performance and operation of the air conditioning packs.

---

<sup>34</sup> Some of the high-temperature engine bleed air from the air conditioning pack inlet is diverted to the air conditioning ducts on top of the WCS upper skin, where it is mixed with the conditioned air on demand to increase the temperature of the air provided to the zone being adjusted. This diverted air is termed "bleed trim" air.

<sup>35</sup> According to the Boeing 747 Operations and Maintenance Manuals, the air conditioning pack outlet temperatures typically range from between 35° to 160° Fahrenheit (F).

<sup>36</sup> The 747-100 cockpit/cabin has four air conditioning zones for which the flight and cabin crewmembers can select independent temperatures. The three air conditioning packs then deliver air to the plenum that has been cooled to the temperature required by the zone with the greatest cooling demand; temperatures within the other zones can be adjusted independently by adding engine bleed trim air.

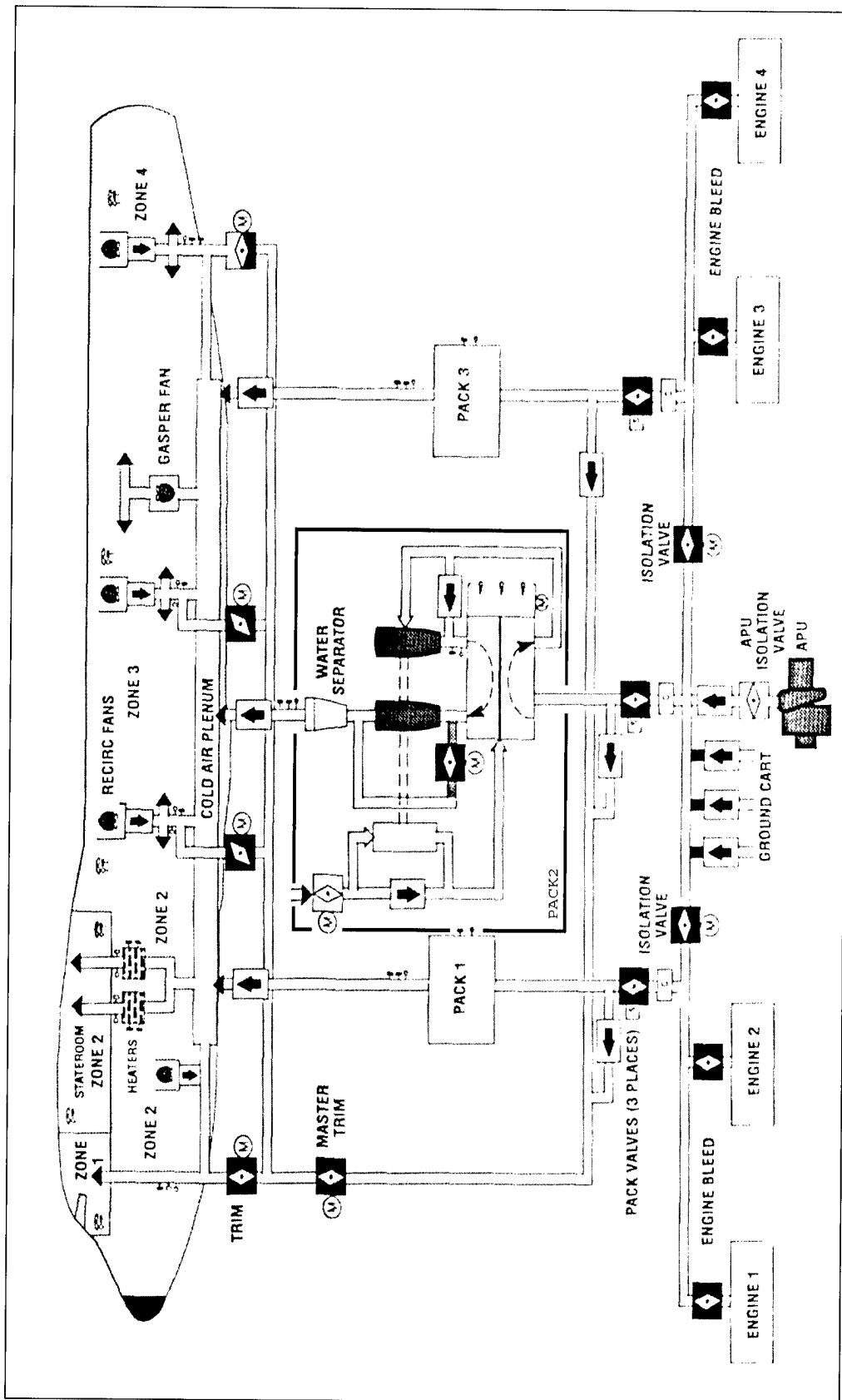

Figure 6. A schematic diagram of the 747-100's air conditioning system.

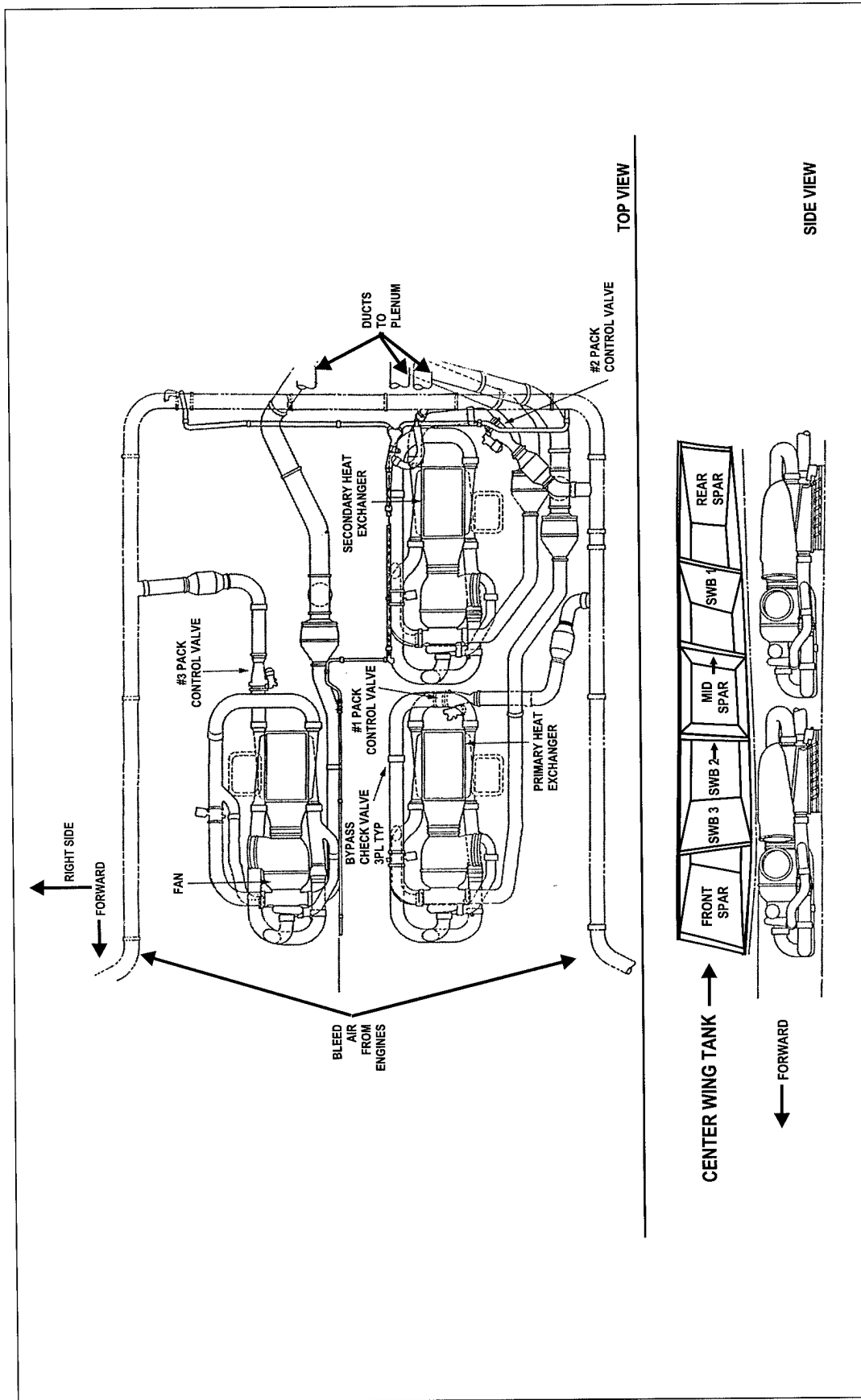

Figure 7. Top and side views of the 747-100's wing center section and air conditioning system.

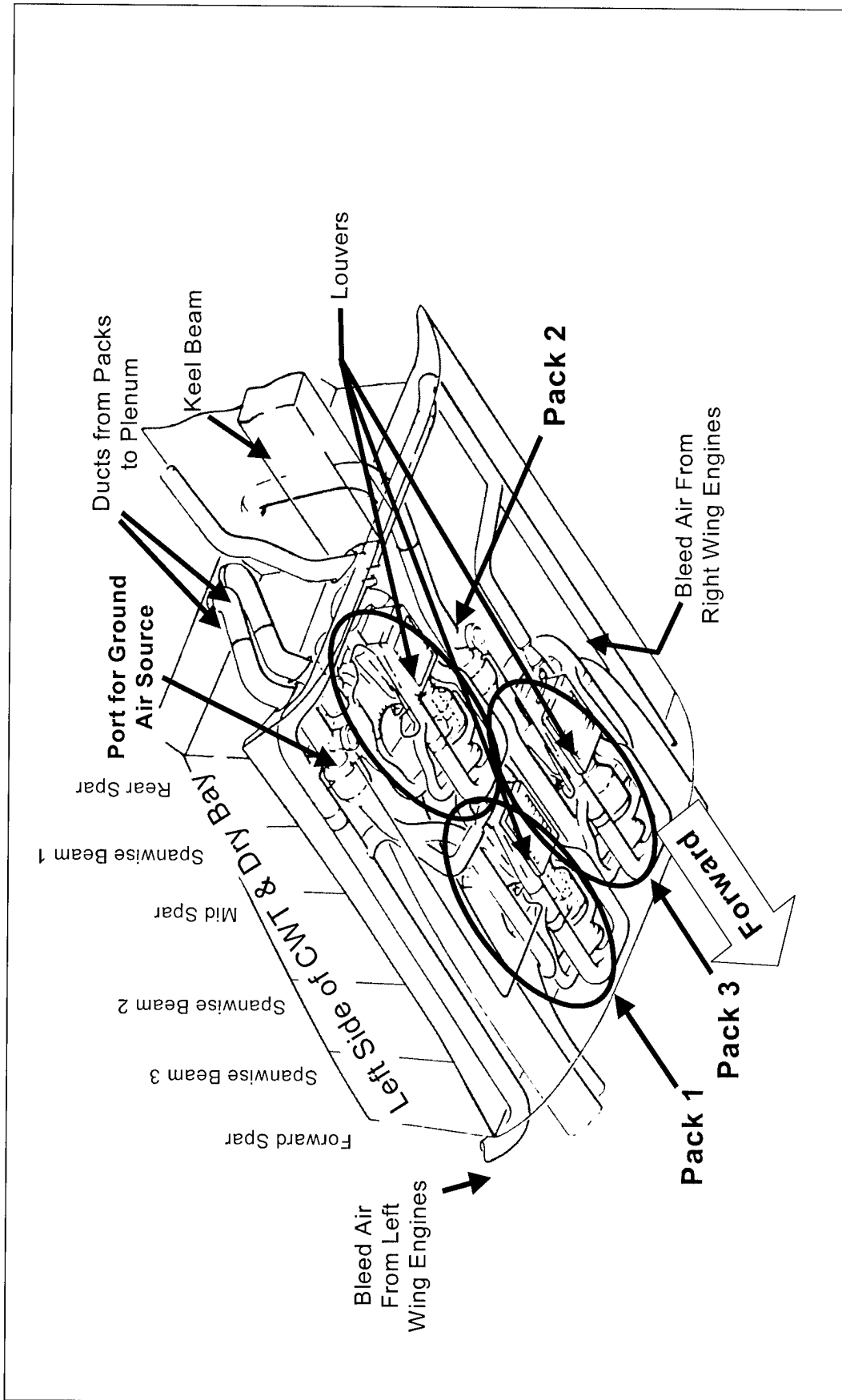

Figure 8. Underside view of the 747-100's wing center section and air conditioning system.

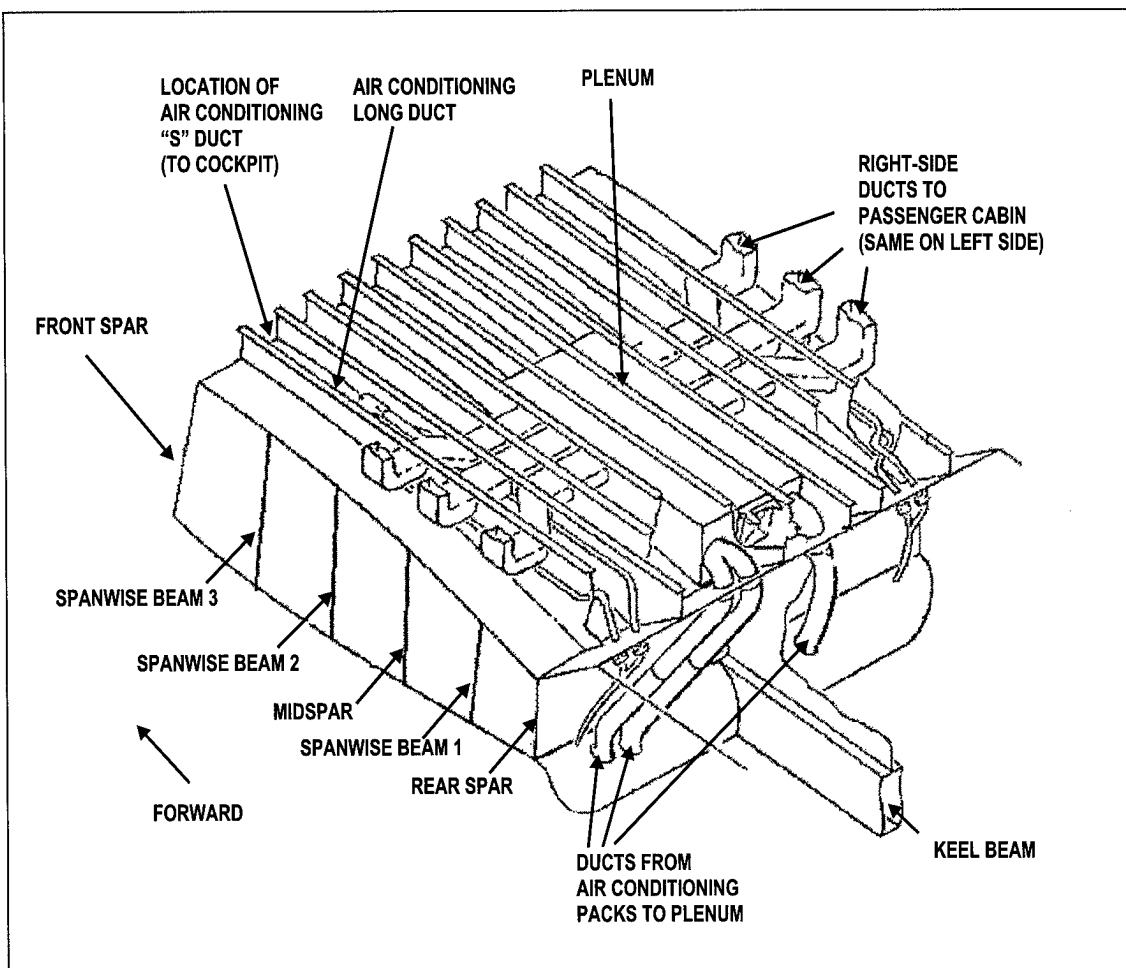

Figure 9. The air conditioning ducts around the 747-100's center wing fuel tank.

### 1.6.1.3 747-100 Electrical and Wiring Information

#### 1.6.1.3.1 747-100 Electrical Information

The accident airplane's electrical system consists of four engine-driven generators (one per engine) and one APU-driven generator,<sup>37</sup> all of which are capable of providing 115/200-volt,<sup>38</sup> three-phase, 400-Hz alternating current (a.c.). These generators are driven by a constant-speed drive located on the engine/APU gearbox, as applicable. Two 36-ampere (amp)<sup>39</sup>-hour nickel cadmium batteries provide 24-volt backup direct current (d.c.) power and APU start power and electrical bus<sup>40</sup> and switching logic for power

<sup>37</sup> A second APU-driven generator is optional and is installed in some 747-100 airplanes.

<sup>38</sup> A volt is the basic unit of measurement of electromagnetic force (the force that causes electrons to flow through a conductor of specified resistance).

<sup>39</sup> An amp is the basic unit of measurement of electric current flow.

<sup>40</sup> An electrical bus is a power distribution point to which a number of circuits may be connected. It often consists of a solid metal strip in which a number of terminals are installed; however, it can also consist of a section of wire from which power is distributed to other wires/circuits.

distribution. An inverter<sup>41</sup> provides power from the batteries to flight critical equipment when primary a.c. power is not available. The airplane also has receptacles for external a.c. power. The APU generator control unit functions as an a.c. external power monitor and prevents abnormal power from an external source from entering the airplane.

During normal operation, the four engine-driven generators supply power to four main a.c. buses. The generators are synchronized and connected together by the closing bus tie<sup>42</sup> and split bus breakers.<sup>43</sup> The galley power distribution system obtains primary 115/200-volt a.c. power from the four engine-driven generators. Step-down transformers<sup>44</sup> are used to convert some of the primary 115/200-volt a.c. power to 28-volt a.c. power, which is then distributed to various instruments and most nongalley airplane lighting systems by four main a.c. load buses. Five separate 75-amp transformer-rectifier units (TRU), which are connected to each other through isolation relays, convert the a.c. power to 28-volt d.c. power, which is used for control circuits and various d.c. components throughout the airplane.

#### 1.6.1.3.2 747 Wiring Information—General and Specific to Accident Airplane

Boeing's general design and performance requirements for wires installed in the 747 (as outlined in its Drawing 60B40037) states the following:

all parts specified in this drawing shall provide 30,000 hours of continuous trouble-free operation when exposed to...ambient temperature extremes ranging from a low of -65° to 250° F and combined with: 1) altitudes ranging from 1,000 feet below sea level to 50,000 feet above sea level, 2) vibration as defined in D6-13014 'Model 747 Equipment Vibration Test Requirements; Area 7, Category A,' 3) relative humidity varying from 0 to 100 percent, and 4) exterior contamination in the form of moisture, dust, sand, and metallic particles.

Boeing's definition of moisture includes salt water; Skydrol 500 A hydraulic fluid, as described in Boeing Document D6-1100; hydraulic fluid conforming to MIL-H-5606;<sup>45</sup> aviation lubricating oil conforming to MIL-L-7808; and jet fuels conforming to MIL-J-5624, D1655-59, P&WA 522, or caustic cleaning fluid.

Early production 747s were manufactured using Boeing Material Specifications (BMS)13-38 or BMS13-39 wiring for all nonfuel tank applications; however, Boeing

---

<sup>41</sup> According to the FAA Airframe & Powerplant Mechanics General Handbook, Advisory Circular (AC) 65-9, an inverter is a mechanical or electronic device used to convert d.c. power to a.c. power, which is then used "mainly for instruments, radio, radar, lighting, and other accessories."

<sup>42</sup> A closing bus tie is used to electrically connect two or more electrical buses.

<sup>43</sup> The split bus breaker is a manually operated circuit breaker used to separate the a.c. power distribution system (which normally operates with the four a.c. buses joined together as one electrical power bus) into two separate a.c. buses.

<sup>44</sup> A step-down transformer is used to reduce higher-voltage a.c. power for use in airplane systems that require lower voltages.

<sup>45</sup> The designation "MIL" is used to identify components and parts manufactured to the standards described in Department of Defense (DoD) documents known as Military Standards. MIL parts are commonly used in civilian transport airplanes.

adopted the use of BMS13-42 wiring on July 30, 1969. BMS13-42 wiring is an aliphatic polyimide (also termed "alkane-imide") insulated wire, also known by the trade name Poly-X,<sup>46</sup> and was manufactured by Raychem.<sup>47</sup> Boeing's Manufacturing Development Report 6-27037, dated April 5, 1970, stated, "Employment of the new wire was designated...because its thinner insulation provided a potential weight saving of approximately 400 to 600 pounds per airplane over that achieved with the existing BMS13-38 and BMS13-39 wire."

On April 13, 1970, Boeing's 747 material specification for Poly-X wire of the BMS13-42/8 type used in nonfuel quantity indication system wire bundles was revised slightly to specify the use of BMS13-42A.<sup>48</sup> BMS13-42A Poly-X wire consists of three layers of modified alkane-imide polymer coating (0.015 inch minimum thickness) over a tin-coated copper core conductor and inner and outer layers of primary insulation (0.009 inch minimum thickness). Boeing's material specification for this type of wire states that "a coating of modified imide polymer shall be applied over the insulation. This coating shall be continuous and free from cracks, splits, blisters, and other defects when examined without the aid of magnification."<sup>49</sup> Figure 10 shows a BMS13-42A Poly-X wire, with typical markings specified by Boeing.

A wire type table contained in the FAA's Aging Non-Structural Systems Program documentation indicated that the use of Poly-X wire was discontinued in 747 production in 1975.<sup>50</sup> According to FAA records, Boeing used MIL-W-81044/20 (also identified by Boeing as BMS13-42C and -42D and known by the trade name Stilan) in 747 production between 1975 and 1979. The records indicate that Boeing has used cross-linked ethylenetetrafluoroethylene (XL-ETFE, per MIL-W-22759; also identified by Boeing as BMS13-48 and known by the trade name Tefzel)<sup>51</sup> in 747 production in various applications since 1979. However, the records also show that Boeing used MIL-W-81381 (also identified by Boeing as BMS13-51 and known by the trade name Kapton)<sup>52</sup> in 747 production between 1985 and 1993. Most of the wiring in the accident airplane was BMS13-42A Poly-X wiring and was stamped with a green "42A," although other types of

---

<sup>46</sup> The term "Poly-X" also applies to BMS13-42A, an aliphatic polyimide insulated wire with a thicker external coating (on some larger diameter wires) than BMS13-42. For simplicity, in this report, the term "Poly-X" will be used to indicate BMS13-42/42A wiring in general. Where it is appropriate, the report will refer specifically to either BMS13-42 or BMS13-42A Poly-X.

<sup>47</sup> Although Raychem stopped manufacturing Poly-X wire in 1975, the current Boeing Standard Wiring Practices Manual (SWPM), 20-00-13, table III, page 96, continues to specify Poly-X as an approved alternative material for use.

<sup>48</sup> BMS13-42 was still used in woven sleeves and other protected applications.

<sup>49</sup> Boeing required specialized tools for use with Poly-X wiring and warned that use of other tools "will result in...damage to conductor or insulation." For additional information regarding the condition of the wiring recovered from the accident airplane and wiring in other inspected airplanes, see section 1.18.2.

<sup>50</sup> According to the FAA's Aging Non-Structural Systems Program documentation, "airplane manufacturers typically continue to use existing stock until it is exhausted, [and as a result, some material] changeovers may have taken considerable time. Thus, trying to determine the wire type installed based on the date of manufacture of an airplane is not necessarily accurate."

<sup>51</sup> For simplicity, in this report, XL-ETFE will be used to indicate cross-linked ETFE, per MIL-W-22759.



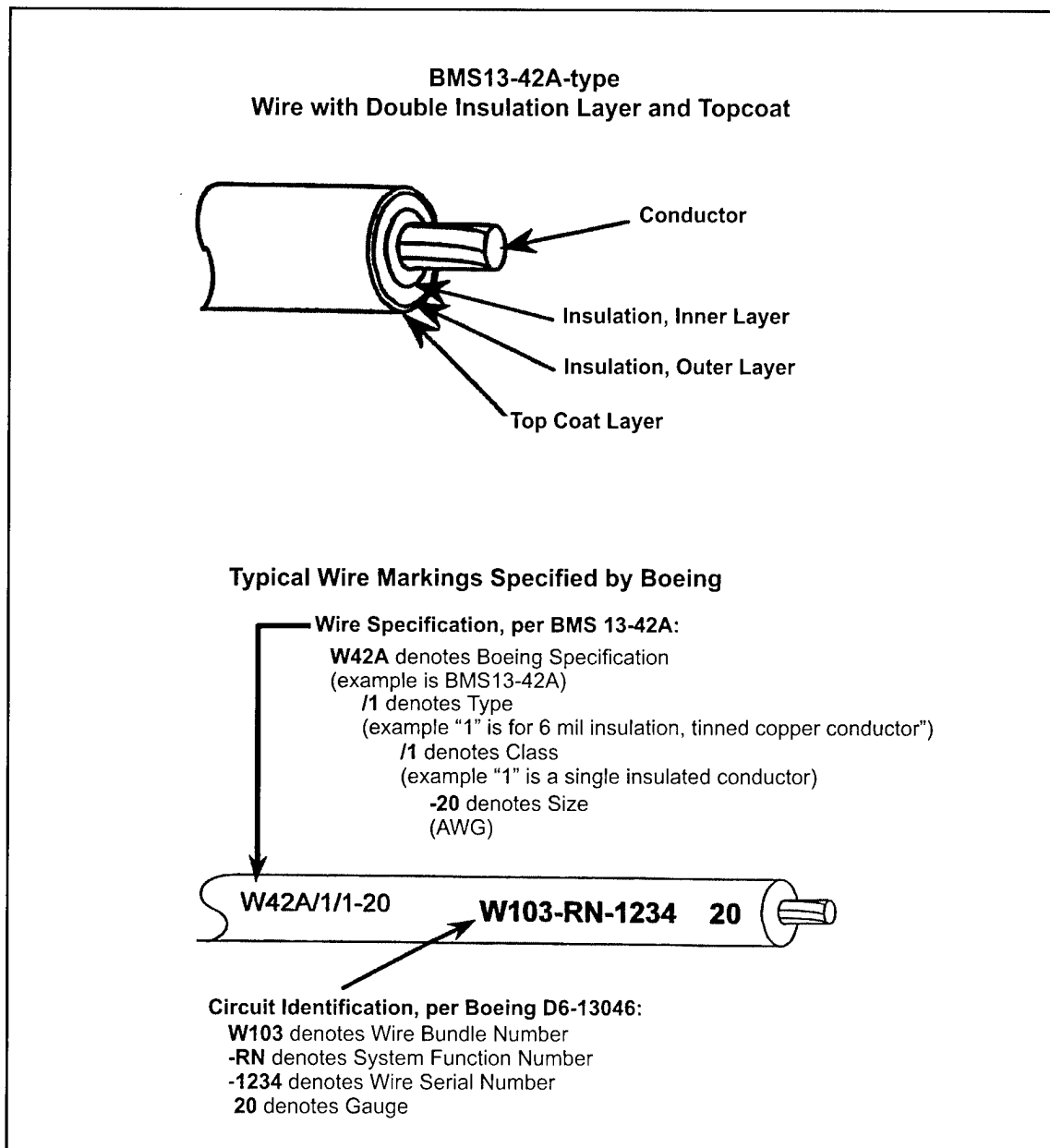

**Figure 10.** Diagram of a BMS13-42A Poly-X wire.

wire were specified and recovered. For example, the fuel quantity indication system (FQIS) wiring used in the fuel tanks was polytetrafluoroethylene (PTFE), per MIL-W-16878, which is also known by the trade name Teflon.<sup>53</sup>

<sup>52</sup> For simplicity, in this report, the trade name Kapton (a du Pont trade name for a material that has multiple applications) will be used to indicate MIL-W-81381 wire. During an April 1999 presentation, du Pont showed that this type of wire had good abrasion/cut-through (resistance), low-smoke/nonflame, and weight and space characteristics. Du Pont indicated that its limitations were arc-track resistance and flexibility.

<sup>53</sup> According to Boeing's 747 specifications, PTFE (or Teflon) has been used for FQIS wiring in fuel tanks and between the CWT and gauges at the flight engineer station in the cockpit. For simplicity, in this report, the trade name Teflon will be used to indicate PTFE wiring, per MIL-W-16878.

### 1.6.1.3.3 Separation of 747 Wire Circuits

The Safety Board's review of FAA regulations revealed that the FARs do not contain specific guidance regarding separation of electrical circuits/wiring. However, 14 CFR Section 25.1309 states that "[t]he airplane systems and associated components, considered separately and in relation to other systems, must be designed so that...the occurrence of any failure condition which would prevent the continued safe flight and landing of the airplane is extremely improbable."<sup>54</sup>

Boeing Document D6-24391, "Criteria for Separation of Critical Electric Circuits," dated March 17, 1970, provided guidelines for separation that Boeing deemed necessary for isolation of critical systems. These guidelines were applicable to "any electrical equipment or system for which the proper functioning is considered essential to safe operation" in all Boeing commercial airplanes at that time, including the 747-100 airplane. The document stated that the "object of the circuit separation is to prevent hazardous malfunctions or simultaneous loss of redundant power supplies or redundant equipment functions due to failures such as: 1) fire or damage to any wire bundle, 2) loss of any single connector, 3) fire in a junction box, or 4) engine turbine burst."

D6-24391 listed the circuits to separate in each major airplane system, the reasons for the separation, and the methods to be used for the separation. For those systems designated as protected (such as fire warning and protection system wiring, wiring to individual fuel pumps, and individual engine installation circuits), Boeing specified separation distances of at least 1/4 inch in pressurized areas and at least 1/2 inch in unpressurized areas.<sup>55</sup> According to Boeing's SWPM, where such separation is not possible because of space or other constraints, separation by an insulation material (as described in the SWPM) or by a fusible link circuit breaker is required.

Although D6-24391 and Boeing's SWPM indicated that wiring to individual fuel pumps needed to be protected by separation, no special separation was required for other FQIS and fuel system wiring, including the fuel quantity probes and interconnecting wiring and the fuel quantity gauges. However, Boeing incorporated an electromagnetic interference (EMI) shield on the FQIS wire bundle between the flight engineer's panel and the CWT on 747s produced after line number 243 (the accident airplane was line number 164).<sup>56</sup>

---

<sup>54</sup> For more information about 14 CFR Section 25.1309, see section 1.16.6.5.

<sup>55</sup> In a May 25, 1999, letter to the Safety Board, Boeing indicated that it had conducted a series of tests during the design and certification of the 747 in 1969 and 1970, and again in 1980, that indicated that wire bundles separated by a minimum 1/4-inch air gap from a failed bundle will not sustain damage that compromises the electrical integrity of the wire bundle.

<sup>56</sup> According to a May 26, 1998, letter to the FAA, Boeing stated that the shielding was added "due to fluctuating indication caused by EMI." EMI is further discussed in section 1.16.6.4 of this report.

The Safety Board's review of other manufacturers' separation standards revealed the following:

- In Douglas Aircraft Company<sup>57</sup> specification WZZ-7002, Douglas specified that wiring for protected systems (including FQIS and other fuel system wiring, fire warning system wiring, primary generator feeder cables, and electro-explosive devices) must be isolated by at least 3 inches from other electrical wiring. Further, Douglas specified that the routing of such wires must be continuous from the tank to the cockpit gauge, with no connectors<sup>58</sup> shared with other systems.
- In a November 2, 1998, letter to the Safety Board, Airbus stated that “the design aim for AIRBUS aircraft has been for all in-tank wiring to be segregated from power sources. As such, electrical segregation exists on all aircraft together with physical segregation from 115-volt power wiring. We have found an exception with some fuel [quantity] sense wiring in A300 and A310 [airplanes] where wiring runs locally in the same routes as 115-volt wiring. This point is under review...”

## 1.6.2 747-100 Fuel System Description

The 747-100's fuel system consists of seven fuel tanks (three in each wing and one in the CWT), an engine crossfeed system (manifold and valves),<sup>59</sup> a fueling station on the left wing, a fuel jettison system, and a surge tank in each wing tip. The fuel tanks include the inboard and outboard main tanks and a reserve tank in each wing and the CWT (which occupies most of the WCS in the fuselage). According to Boeing, the wing fuel tank capacities for the 747-100 are as follows: reserve tanks—3,350 pounds (500 gallons) each; outboard main tanks—29,614 pounds (4,420 gallons) each; inboard main tanks—82,008 pounds (12,240 gallons) each; and the CWT—86,363 pounds (12,890 gallons). Figure 11 is a schematic diagram of the 747-100 fuel tank arrangement.

The left and right wing fuel tanks are formed by sealing the internal wing structure so that the front and rear spars define the forward and aft limits of the tanks, respectively. The left and right wings also contain dry bays, which are located outboard of the reserve wing tanks. As previously discussed, the forward and aft limits of the CWT are defined by SWB3 and the rear spar, respectively; the space between SWB3 and the front spar in the WCS is a dry bay. A sump drain is located near the lowest point of each of the seven fuel tanks.

---

<sup>57</sup> Douglas Aircraft Company merged with Boeing and is now the Douglas Products Division of the Boeing Commercial Airplane Group.

<sup>58</sup> A connector is a device that permits in-line connection(s) between one or more wires for a continuous electrical path(s) at a location where the wires may be disconnected and reconnected without mismatching circuits. Typical multicontact electrical connectors are assembled from two subassemblies, the plug and the receptacle, which mate to connect wires with pin and socket contacts.

<sup>59</sup> The fuel crossfeed system permits the transfer of fuel from any fuel tank to any engine; however, it does not permit the transfer of fuel from one fuel tank to another fuel tank.

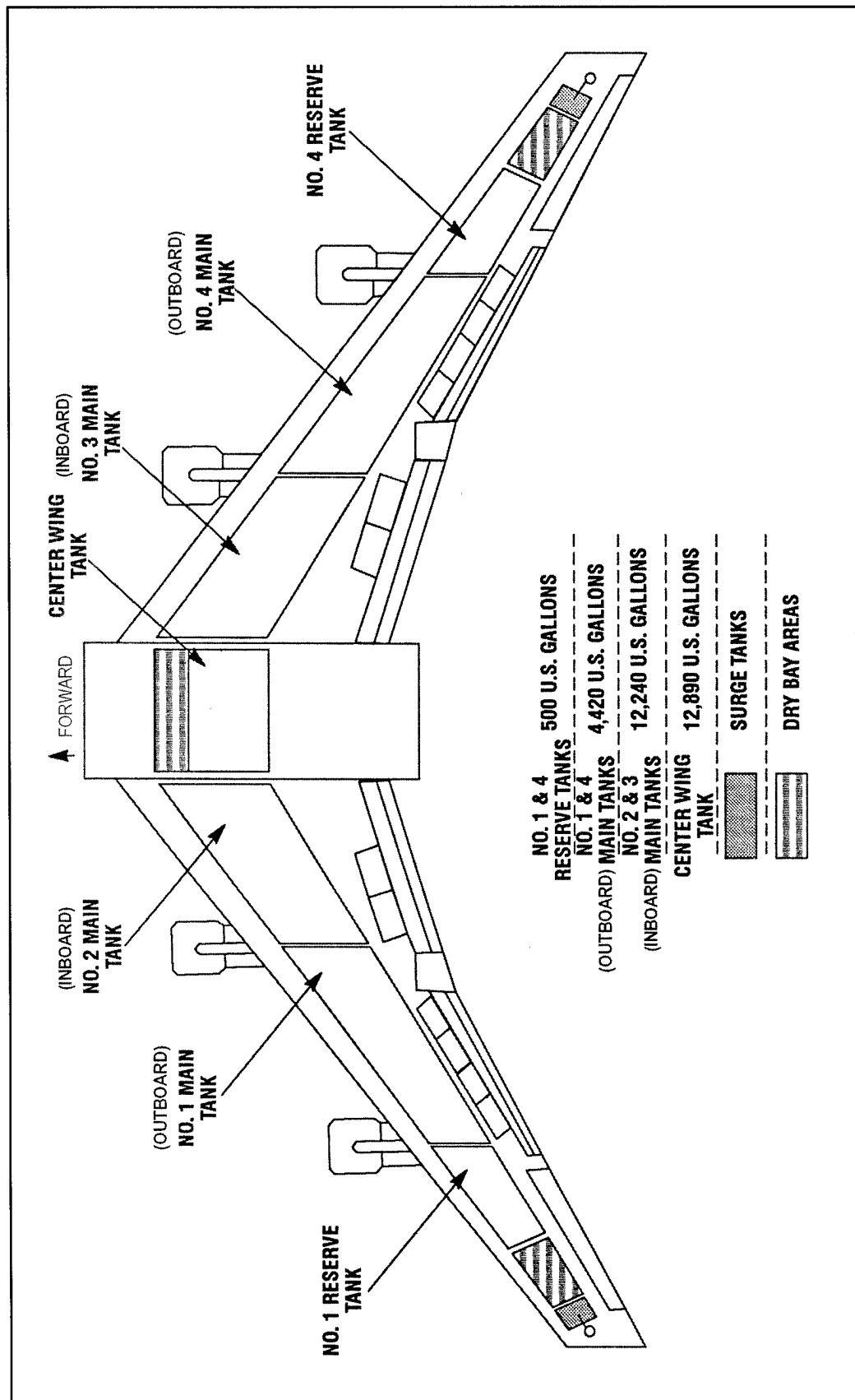

Figure 11. A schematic diagram of the 747-100 fuel tank arrangement.

Each wing also contains a surge tank, located outboard of the dry bays. The surge tanks in the wing tips act as reservoirs (vent collector tanks) if the other fuel tanks are overfilled. The top of each fuel tank is vented to outside atmosphere. The vent system consists of continuous hollow spaces inside box-shaped stringers attached to the interior side of the upper skins of the wing and CWT. These vent stringers are routed outboard from the top of each fuel tank in the wings to the surge tank tip of that wing. The CWT is vented directly to the surge tanks in both wings. To complete the venting system path to outside atmosphere, a single tube connects the outboard side of each surge tank with the outside atmosphere at the lower wing tip surface.<sup>60</sup> Figure 12 shows a typical 747-100 CWT and left wing fuel tank vent system layout. The right wing fuel tank vent system layout is similar.

To protect against the propagation of a flame from the surge tank to any of the other fuel tanks through the vent system,<sup>61</sup> the 747-100 surge tank overboard vents are equipped with a surge tank protection (STP) system. The STP system consists of an optical photocell located in each overboard vent designed to trigger the discharge of Halon (a fire extinguishing agent) into the surge tank when a flame or bright light source<sup>62</sup> is sensed in that overboard vent. Discharge of the extinguishing agent is designed to occur about 1 millisecond after the photocell senses a flame.

The 747-100 uses a pressure fueling system to distribute fuel under pressure from a fueling station in the left wing<sup>63</sup> to all of the fuel tanks through a crossover manifold, the main distribution manifold,<sup>64</sup> and refuel valves (one each at the reserve and outboard fuel tanks and two each at the inboard fuel tanks and the CWT). The fueling station is equipped with two fueling receptacles coupled together and connected to the crossover manifold, which extends through the outboard fuel tank to the main distribution manifold. In addition, a fueling control panel is located in the lower leading edge of the left wing, near the fueling station where ground service hoses connect to the refueling ports. Figure 13 shows the 747 pressure fueling flow diagram, excerpted from Boeing's 747 Maintenance Manual.

---

<sup>60</sup> According to Boeing, the vents are sized to permit passage of fuel if an overfill situation occurs during ground refueling. This design criterion requires a larger vent cross-section area than would be required to provide air pressure equalization alone.

<sup>61</sup> Flames entering fuel tanks through the vent system was a factor in the December 8, 1963, accident following a lightning strike on a Pan Am Boeing 707 in Elkton, Maryland, and in the November 23, 1964, accident involving a TWA 707 in Rome, Italy.

<sup>62</sup> According to a representative from Fenwal Safety Systems (the manufacturer of the STP system), the system has been triggered by lightning, flamefronts, and even bright flashlights (used by mechanics during maintenance or by pilots during preflight inspections).

<sup>63</sup> Although the accident airplane only had a fueling station on the left wing, at the time of its manufacture, an optional right wing fueling station was available and installed on some 747s.

<sup>64</sup> The main distribution manifold, which extends through the length of the wing, terminating at a fixed jettison nozzle on the wing trailing edge near each wing tip, is also used as the fuel jettison manifold. Fuel can only be jettisoned from the inboard main tanks and the CWT.

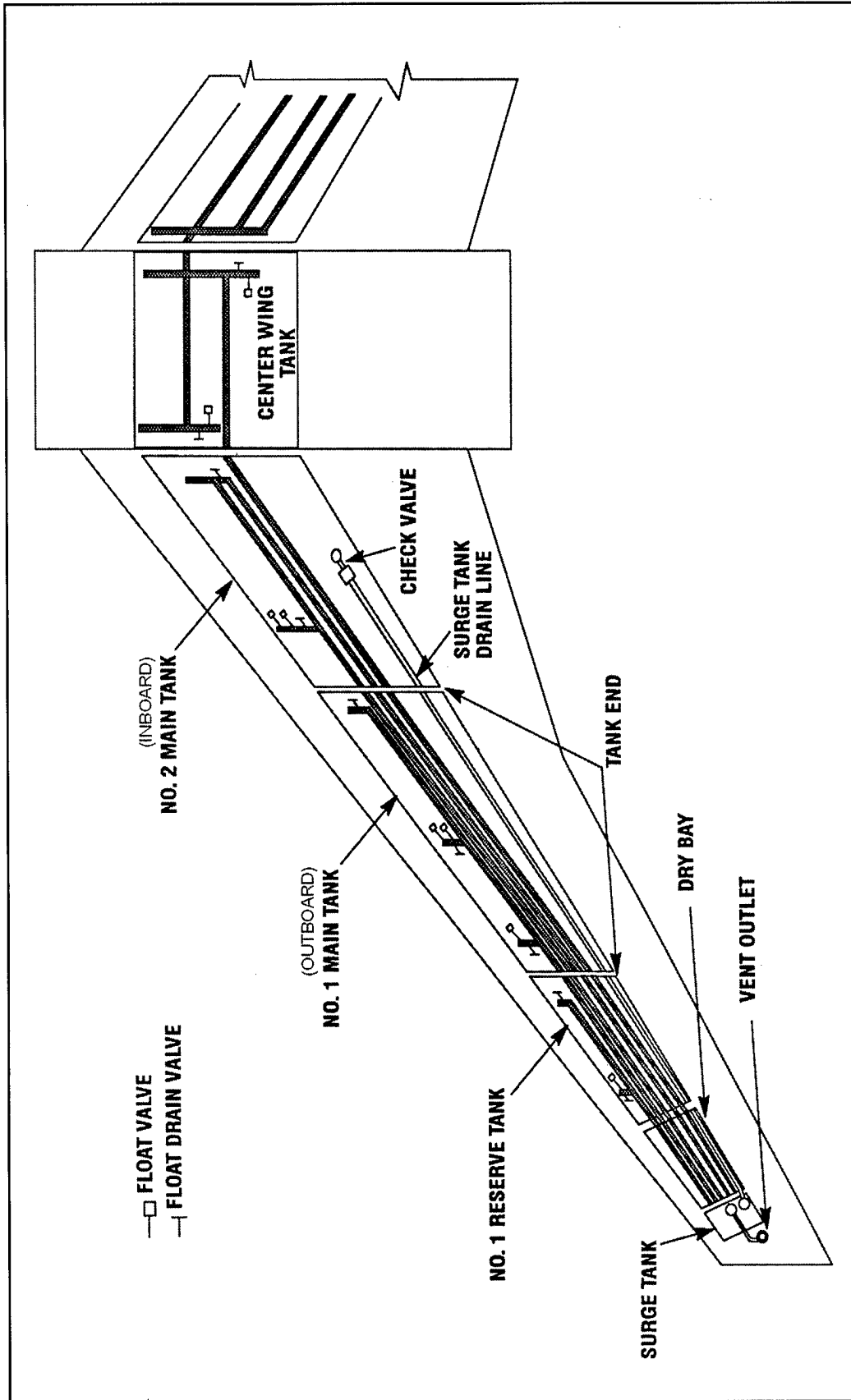

Figure 12. A layout of a typical 747-100 center wing fuel tank and left wing fuel tank vent system.

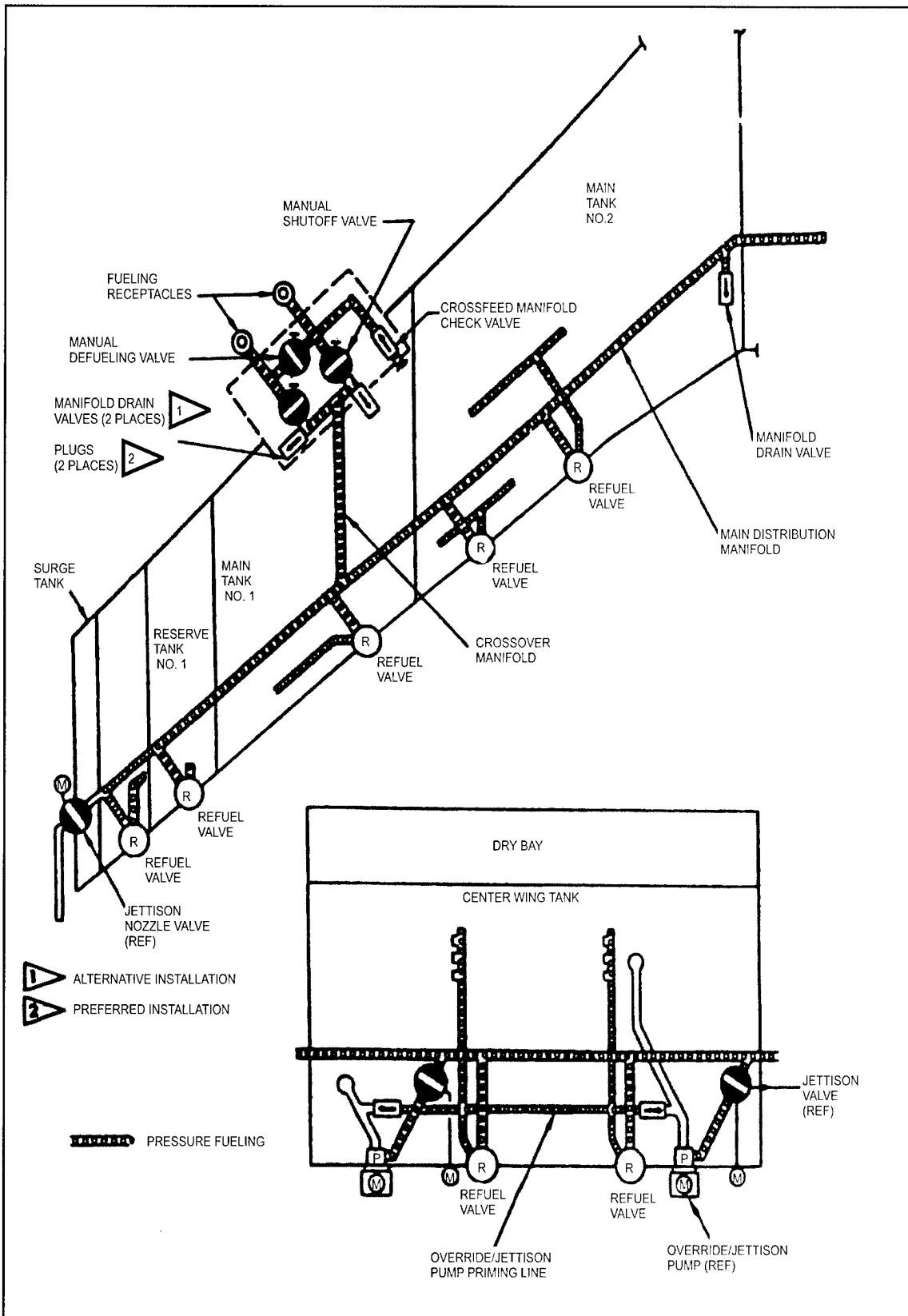

Figure 13. A 747 pressure fueling flow diagram.

The wing refueling control panel contains fuel quantity indicators,<sup>65</sup> refuel valve control switches, valve position indicator lights, a refuel power switch, and a test switch and indicators for the volumetric shutoff (VSO) control. (Figure 14 shows the pressure fueling system components.) The VSO control unit can be set to automatically close the refuel valves when a preselected amount of fuel is loaded. The preselected amount of fuel can range in the tanks from any partial quantity to full fuel tanks.<sup>66</sup> Refueling can also be controlled by ground personnel, who can close the refueling valve manually when the fuel quantity indicator shows that the desired quantity of fuel is on board the airplane. The VSO will also shut the valves when fuel enters the surge tanks if a fuel tank is overfilled.

### 1.6.2.1 Fuel Quantity Indication System Components and Wiring Information

The amount of fuel in each of the 747-100's seven fuel tanks is measured by a set of FQIS probes and compensators,<sup>67</sup> with the number of fuel quantity probes and compensators differing for each tank. The 747-100 has 65 fuel quantity probes and 13 fuel quantity compensators. The fuel quantity probes are positioned as follows: 4 each in the Nos. 1 and 4 reserve fuel tanks; 13 each in the Nos. 1 and 4 main fuel tanks; 12 each in the Nos. 2 and 3 main fuel tanks; and 7 in the CWT. The fuel quantity compensators, located near the low point of each fuel tank, are positioned as follows: two in the No. 1 reserve tank; one in the No. 4 reserve tank; one in each surge tank; two each in the Nos. 1 and 4 main fuel tanks; two in the No. 2 main fuel tank; one in the No. 3 main fuel tank; and

---

<sup>65</sup> The fuel quantity indicators at the wing refueling control panel are repeater type indicators; they share information with corresponding primary indicators on the flight engineer's lower instrument panel for display in the cockpit. For additional information regarding FQIS components/indicators, see section 1.6.2.1.

<sup>66</sup> While the accident airplane was being fueled at JFK, the fuel system's automatic VSO activated before the fuel tanks were full. According to postaccident interviews, a TWA mechanic examined the fuel system and "[overrode] the system, pull[ed the] volumetric [shutoff valve or VSO] fuse and an overflow circuit breaker." After the fueller finished fueling the airplane manually, the TWA mechanic reset the fuse and circuit breaker. According to the fueller and TWA maintenance personnel, activation of the VSO is a common occurrence. According to maintenance records, the accident airplane had numerous VSO-related maintenance writeups during the weeks before the accident. For additional information about the accident airplane's previous refueling difficulties, see section 1.6.3.

<sup>67</sup> The 747-100 FQIS measures changes in the capacitance of tubular fuel quantity probes located in each fuel tank for the display of fuel quantity on cockpit indicators and on repeater indicators located at the refueling station in the left wing. The system is also connected to systems that require fuel quantity information, including the gross weight/total fuel weight indicator, airborne integrated data system (AIDS), and VSO (ground refueling) systems. Fuel quantity probes are components of the FQIS, a set of which is positioned in each of an airplane's fuel tanks to measure the quantity of fuel in each tank through a range of levels within the tank. Fuel quantity compensators are used in the FQIS and VSO systems. For FQIS applications, compensators are used to compensate for variations in the electrical properties (the dielectric constant) of fuel, which vary from one type of fuel to another (and even within the same type of fuel, depending on the "batch" and the age of the fuel) to ensure consistent fuel quantity indications. About 90 percent of the 747-100, -200, and -300 series airplanes are equipped with FQIS components manufactured by Honeywell Corporation; the remaining 10 percent of the 747-100, -200, and -300 series airplanes and all 747-400 airplanes have been retrofitted with FQIS components manufactured by BFGoodrich Aerospace Corporation (formerly Simmonds Precision) or Smiths Industries.



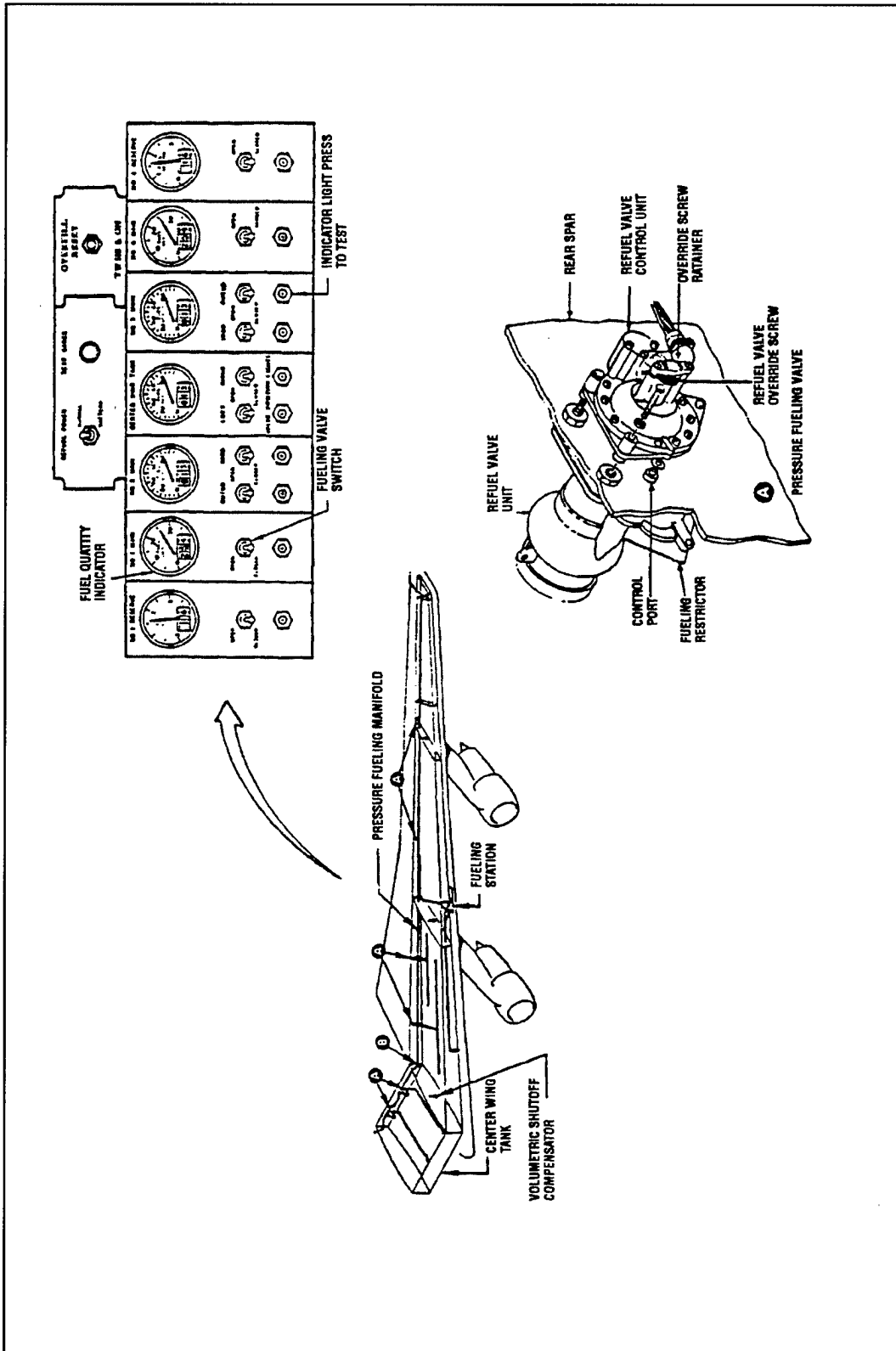

Figure 14. A diagram of the 747 pressure fueling system components.

one in the CWT. Figure 15 shows a fuel quantity probe and a compensator. Figure 16 shows the fuel quantity probe and compensator locations in the CWT.

The fuel quantity probes in the 747-100 fuel tank contain two metallic electrodes, which are assembled as inner and outer tubes and are oriented vertically within the probe. A hard plastic terminal block is located near the top of the fuel quantity probe for wiring connections, and two brackets mount the probes vertically in the fuel tank. The diameter of the inner electrode varies, based on the contours of the fuel tank, and the length of each fuel quantity probe is determined by the height of the fuel tank at that location. Because the capacitance<sup>68</sup> of air is different than that of fuel, capacitance values for each fuel quantity probe are different when air, instead of fuel, fills the gap between the inner and outer tubes. Thus, the capacitance of the fuel quantity probe varies linearly, depending on the depth of fuel in the tank.

The fuel quantity compensators in the 747-100 fuel tank contain three metallic electrodes, an external mounting tube, a hard plastic terminal block near the top of the mounting tube for wiring connections, and two mounting clamps. A fuel's density (and, therefore, its dielectric constant) changes with temperature and other variables; the compensators provide a "0" reference for the FQIS. Therefore, the fuel quantity compensators are mounted at the lowest point in the fuel tank so that they remain in contact with fuel until the tank is almost empty.

The fuel quantity probes and compensators in the 747-100 fuel tanks are connected in series by wires, and the entire set is then connected to a fuel quantity gauge on the flight engineer's panel in the cockpit. The cockpit fuel quantity gauge generates an electrical voltage, and the resulting electrical capacitance between the probes' inner and outer tubes is measured. The measurements of fuel in the gaps between the tubes are summed, and the amount is calibrated so that the flight engineer's fuel quantity gauge indicates the weight of the remaining fuel instead of the capacitance. (Weight is the common measurement for fuel quantity in transport airplanes.) A gauge at the left wing pressure refueling control panel repeats at the cockpit display.

Although most of the wiring for the accident airplane was BMS13-42A Poly-X, the wiring used for the 747 FQIS wires in the fuel tanks and from the CWT to a wire splice located behind the flight engineer's panel was silver-plated copper wiring with Teflon insulation. Specifically, Teflon wires were routed from the fuel quantity probes and compensators in the fuel tanks, through the interior of the fuel tank supported by numerous nylon clips, to the electrical connector located on the aft side of the rear wing spar for the CWT and on the forward side of the forward wing spar for the main fuel tanks. Outside of the fuel tanks, FQIS wires were routed from the connectors on the wing spars to a splice located near each of the fuel quantity indicators (one for each fuel tank) located on the flight engineer's panel in the cockpit,<sup>69</sup> then to the fuel quantity totalizer indicator and the VSO unit.<sup>70</sup> Seven fuel quantity repeater gauges are mounted at the left wing refueling panel;<sup>71</sup> wires to these gauges are routed through the wing fuel tanks from the

<sup>68</sup> Capacitance is the property of conductors separated by a dielectric material (for example air or fuel) that permits the storage of electricity when potential differences exist between conductors.

cockpit gauges. The only electrical wiring/components located inside the 747 CWT (or any 747 fuel tanks) are those associated with the FQIS (including the ground refueling system).<sup>72</sup> According to representatives from Honeywell and Boeing, electrical power is supplied to the FQIS components through the cockpit fuel gauges and is intended to be limited to 0.02 millijoule (mJ).<sup>73</sup>

Wiring diagrams for the 747 indicate that FQIS and fuel flow indication wire bundles<sup>74</sup> were routed along common raceways<sup>75</sup> from the flight engineer station to the electrical equipment compartment located between the nose landing gear wheel well and the forward cargo compartment. The diagrams also show that the left wing and CWT FQIS wires were routed in a raceway with a wire bundle containing wires leading to the CVR for part of their path through the upper left fuselage and adjacent to a wire bundle containing wires leading to the right main wing fuel tank for part of their path behind the flight engineer station (upper right fuselage). Additionally, the diagrams indicate that, if Boeing's PI 61B70103<sup>76</sup> were followed for the accident airplane,<sup>77</sup> the left wing FQIS wires would have been corouted in a raceway with wires from other systems (such as lights) that were bundled with both the CVR and the No. 4 fuel flow indicator wires for a portion of their paths. Further, the wiring diagrams show that the right wing FQIS wires were routed to a connection at the T347 terminal strip in the CWT. Figure 17 is a

---

<sup>69</sup> The primary indicators convert fuel quantity probe and compensator capacitance into dial and counter indications of fuel quantity. Each primary indicator has two variable resistor adjustment shafts for calibrating the indicator so that it displays the proper zero and full indications for empty and full fuel quantity probe values.

<sup>70</sup> The fuel quantity totalizer indicator (termed the "gross weight/total fuel weight indicator" in the TWA 747 Operations Manual) is a dual-counter display device located on the flight engineer's panel. It converts signals from the seven primary fuel quantity indicators into an indication of total fuel weight, which is displayed on the lower of the two counters. The second counter display indicates the airplane's gross weight.

<sup>71</sup> Each repeater indicator converts a signal from the associated primary indicator into a duplicate indication of fuel quantity. The repeater indicators are used for refueling operations and are deenergized whenever the door to the refueling panel is closed. Each repeater indicator has two variable resistor adjustment shafts for calibrating the indicator so that it displays the proper zero and full indications for empty and full fuel quantity probe values.

<sup>72</sup> Although the fuel pump motor cavities contain wiring, they are separated from the CWT by flame suppression passages and other parts.

<sup>73</sup> A joule (J) is a unit of measurement of electrical work or energy; 1 J is the amount of work done by 1 watt of power in 1 second. The power supplied to the FQIS components through the cockpit fuel gauge (0.02 mJ) is about 10 percent of the minimum ignition energy (MIE) requirement (0.25 mJ) for hydrocarbon fuels, referenced by the American Petroleum Institute Recommended Practice 2003 (API 2003), "Protection Against Ignitions Arising out of Static, Lightning, and Stray Currents," fifth edition, December 1991.

<sup>74</sup> The Boeing SWPM refers to wires that are tied in a group as a "harness"; the TWA Master Wire Bundle Document and Boeing production illustrations (PI) refer to wires that are tied in a group as a "bundle." In this report, the term "bundle" will be used to refer to wires that are tied in a group, except where a reference source is being quoted.

<sup>75</sup> "Raceway" is the term used for areas in the 747 where wire bundles are grouped into a common route.

<sup>76</sup> The most recent revision to PI 61B70103 was dated November 10, 1971.

<sup>77</sup> According to an October 13, 1999, letter from Boeing, the original wiring installation diagram had been superseded by a more direct wiring path for the No. 4 fuel flow indicator wires when the accident airplane was manufactured. No documentation of this change was provided. The actual wiring route of the No. 4 fuel flow indicator wires in the accident airplane could not be determined.

Note :

Style of wire attachments shown are typical and not specific to any probe or compensator.

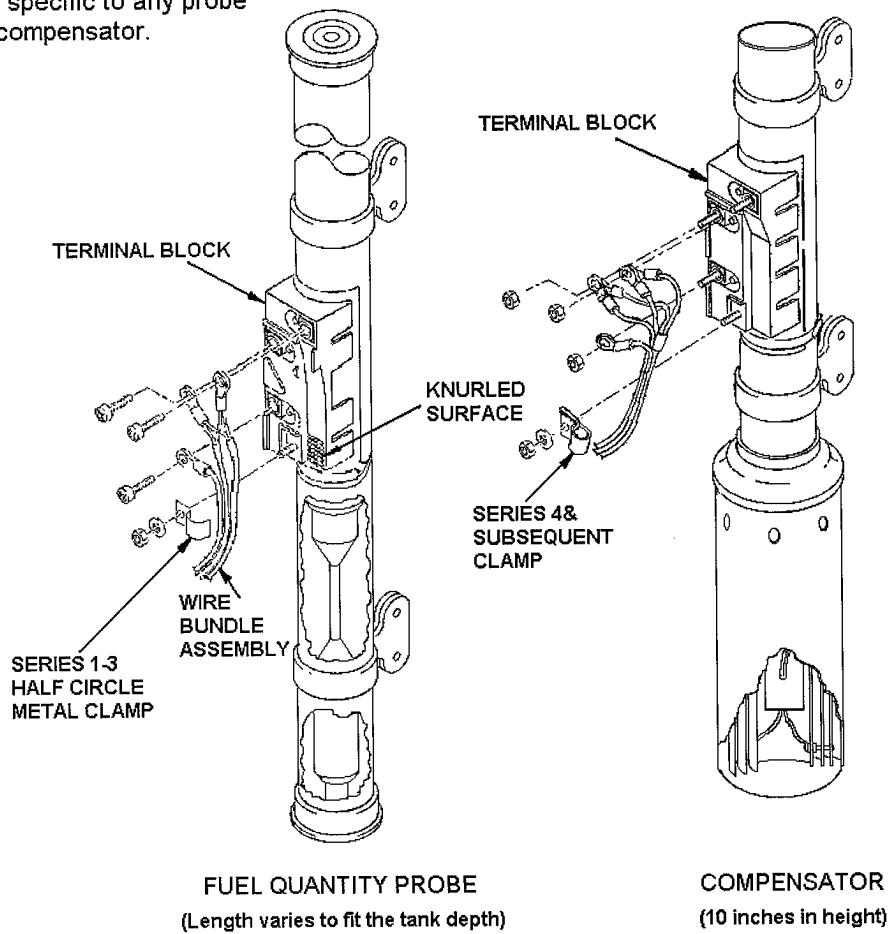

Figure 15. Diagrams of a fuel quantity probe and a compensator.

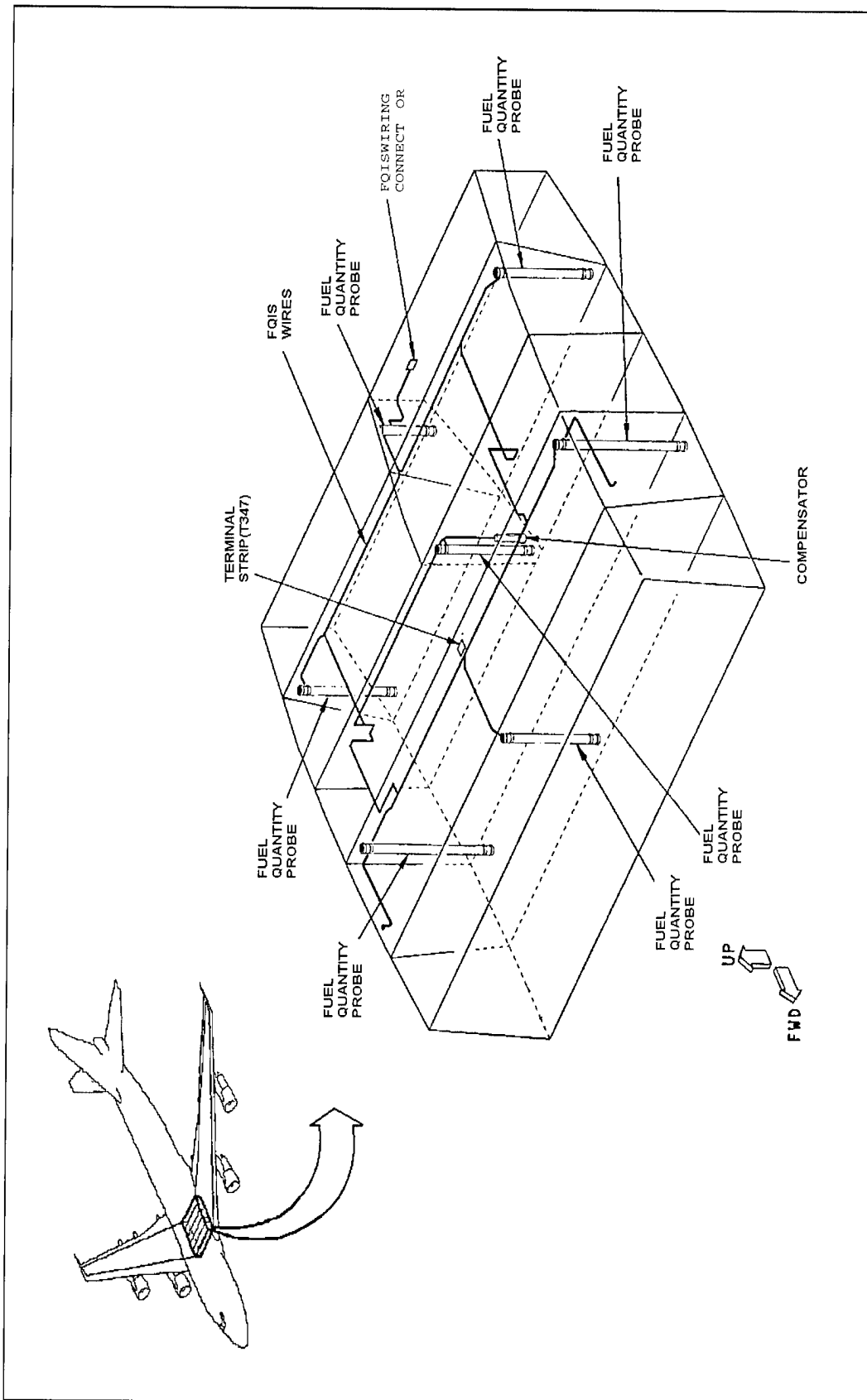

Figure 16. The fuel quantity probe and compensator locations in the 747's center wing fuel tank.

schematic diagram of the FQIS wiring, fuel flow wiring, CVR wiring, and other wiring information from the 747-100, and figure 18 shows the locations of the wire raceways in the 747-100.

Boeing's PIs also indicated that the CWT FQIS wires were routed from the front of the airplane to the CWT, VSO, totalizer, and the AIDS in and next to bundles carrying numerous other power and signal wires. Although most airplane systems operated on 115-volt power, the Safety Board's review of wiring in other airplanes<sup>78</sup> indicated that the FQIS and engine fuel flow wire bundles are routed near, and occasionally bundled with, wires that provide 350-volt a.c. power to the cabin fluorescent lights.<sup>79</sup>

According to TWA, the fuel quantity probes and compensators (and most other electrical and fuel system components, including wiring and connectors) are condition-monitored items, which means that they are removed and replaced only when inoperative. Unless a malfunction of the FQIS requires unscheduled maintenance, the units are inspected only during the scheduled D check.<sup>80</sup> According to TWA maintenance records, the fuel quantity probes and compensators installed in the accident airplane's fuel tanks were the original units installed when the airplane was manufactured in 1971, except for four of the fuel quantity probes in fuel tank No. 1, which records indicate were replaced during a 5B check in September 1987.<sup>81</sup>

### 1.6.2.2 747-100 Fuel Pump System Description

The 747-100 has 16 fuel pumps, including 4 fuel boost pumps in each wing (2 per engine),<sup>82</sup> 2 fuel jettison/override pumps in each wing,<sup>83</sup> 2 fuel jettison/override pumps in

---

<sup>78</sup> For more information about the Safety Board's review of wiring in other airplanes, see section 1.18.2.

<sup>79</sup> Although the Safety Board is not aware of instances in which FQIS wires shared connectors with wires carrying more than 115 volts, Boeing specifications permit FQIS wiring to be mixed in common connectors with airplane system wires carrying up to 350 volts.

<sup>80</sup> For additional information regarding the scheduled D check, see section 1.6.3.1.

<sup>81</sup> Although there was no maintenance record indicating that any other fuel quantity probes or compensators had been replaced, an April 20, 1993, maintenance record indicated that maintenance was conducted to correct fuel quantity discrepancies in the No. 1 main fuel tank; this maintenance record showed capacitance measurements for each No. 1 main fuel tank probe. There was no record of probe removal with this maintenance action. According to the Maintenance Records Group report, a review of maintenance records from other TWA airplanes indicated that malfunctioning probes were removed and sent to the overhaul shop for cleaning.

<sup>82</sup> Fuel boost pumps move fuel from the fuel tanks to the engines or the APU.

<sup>83</sup> The jettison/override pumps have two uses in the 747, one of which is to jettison fuel from the airplane when this function is selected at the flight engineer station. The jettison/override pumps also provide fuel to the engine manifolds at a higher pressure than the fuel boost pumps; thus, fuel pressure from the jettison/override pumps in the CWT closes the main fuel tank check valves, ensuring that the fuel from the CWT is consumed before the fuel in the main wing fuel tanks.



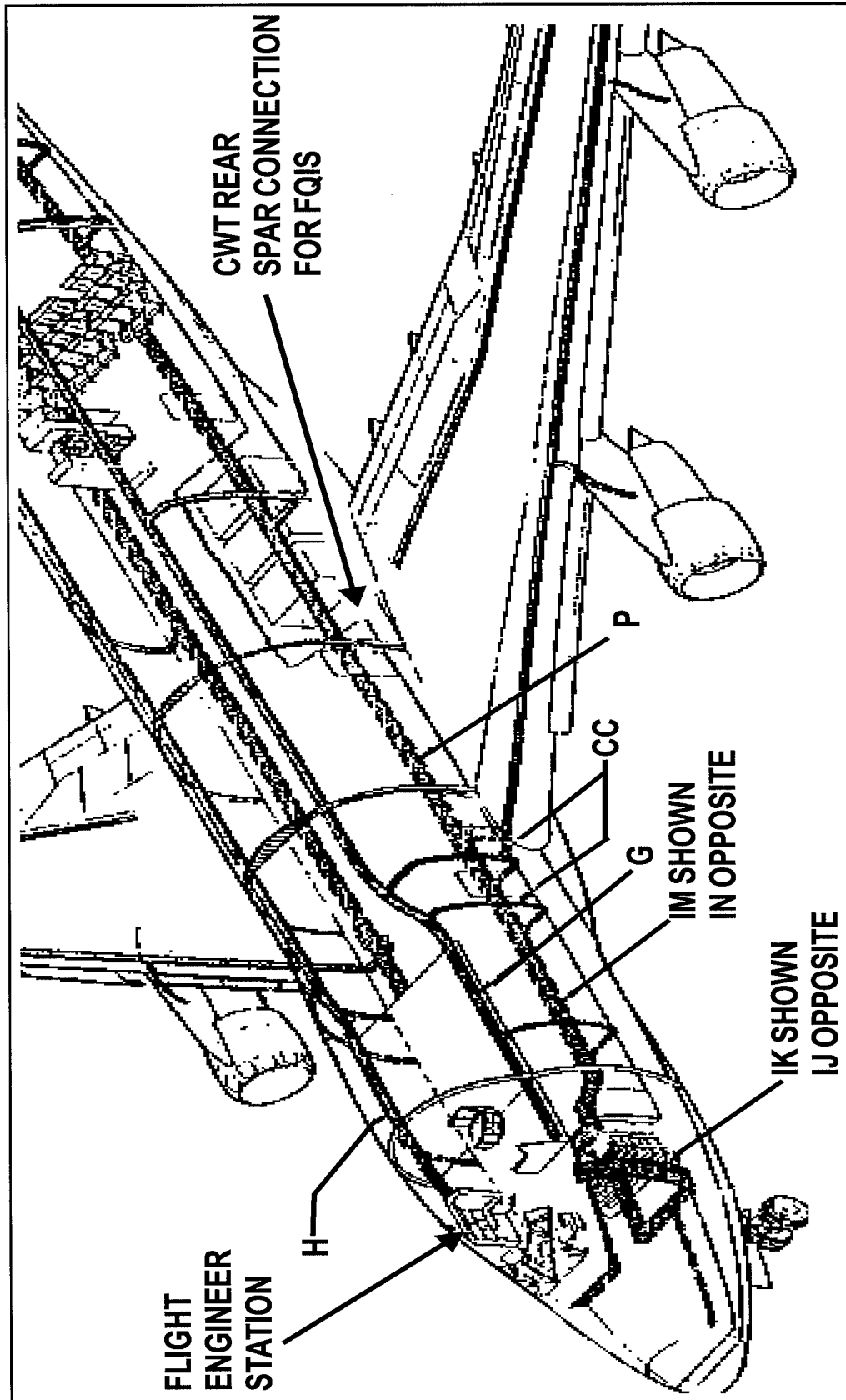

Figure 18. Locations of the wire raceways in the 747-100.



the CWT, 1 fuel scavenge pump in the CWT,<sup>84</sup> and an APU d.c. fuel pump in the left wing. (Figure 19 is a schematic diagram of the fuel pump locations in the 747.) The fuel scavenge pump, APU fuel pump, and fuel boost pumps are condition-monitored items. According to TWA maintenance records, TWA established a hard-time life limit of 9,000 hours for the fuel jettison/override pumps.<sup>85</sup>

According to TWA, the company's maintenance facility in Kansas City, Missouri, conducted all 747 fuel pump overhauls and repairs in accordance with the manufacturer's overhaul manuals and (as in the case of the jettison/override pump's 9,000-hour hard-time limit) specifications established by TWA's engineers and accepted by the FAA. Examination of the maintenance history of the fuel pumps installed in the accident airplane's CWT at the time of the accident revealed the following:

- Fuel scavenge pump, CWT—S/N M285; this pump's most recent overhaul was signed off on October 18, 1994, and the unit passed a functional test on October 20, 1994. The pump was installed on the accident airplane on April 22, 1996. At the time of the accident, the pump had accumulated 1,040 flight hours since overhaul.
- Jettison/override pump, CWT—S/N 690469A; this pump's most recent overhaul was signed off on March 14, 1996, and the unit passed a functional test on March 18, 1996. The pump was installed on the accident airplane on March 27, 1996. At the time of the accident, the pump had accumulated 1,270 flight hours since overhaul and had an estimated (9,000-hour) removal date of February 10, 1998.
- Jettison/override pump, CWT—S/N 690394; this pump's most recent overhaul was signed off on December 6, 1994, and the unit passed a functional test on December 8, 1994. The pump was installed on the accident airplane on May 15, 1995. At the time of the accident, the pump had accumulated 4,412 flight hours since overhaul and had an estimated (9,000-hour) removal date of June 24, 1997.

---

<sup>84</sup> The scavenge pump is designed to remove the last amounts of usable fuel from the CWT and pump it into the left inboard (No. 2) fuel tank. The intake opening for this pump is located very close to the bottom of the tank between the mid spar and SWB2. Although the scavenge pump removes fuel that is unobtainable by the jettison/override pumps, a small amount of residual fuel will remain in the fuel tank that the scavenge pump is not able to remove (unusable fuel). In the 747 CWT, the jettison/override and scavenge pumps are mounted on the rear spar such that the pump motor is external to the tank but contains fuel-cooled windings. Fuel for cooling is supplied to the windings through a small-diameter tube in series with a check valve, both of which are intended to suppress flames. The pumps also contain a thermal fuse designed to open at less than 400° F.

<sup>85</sup> More than 17 years before the accident, TWA established the hard-time limit to reduce the number of unscheduled removals, after the company determined that the mean time between unscheduled removals for the pumps was 11,352 hours. The 9,000-hour scheduled removal occurs at every second C check and at every D check. For more information about C and D checks, see section 1.6.3.1.

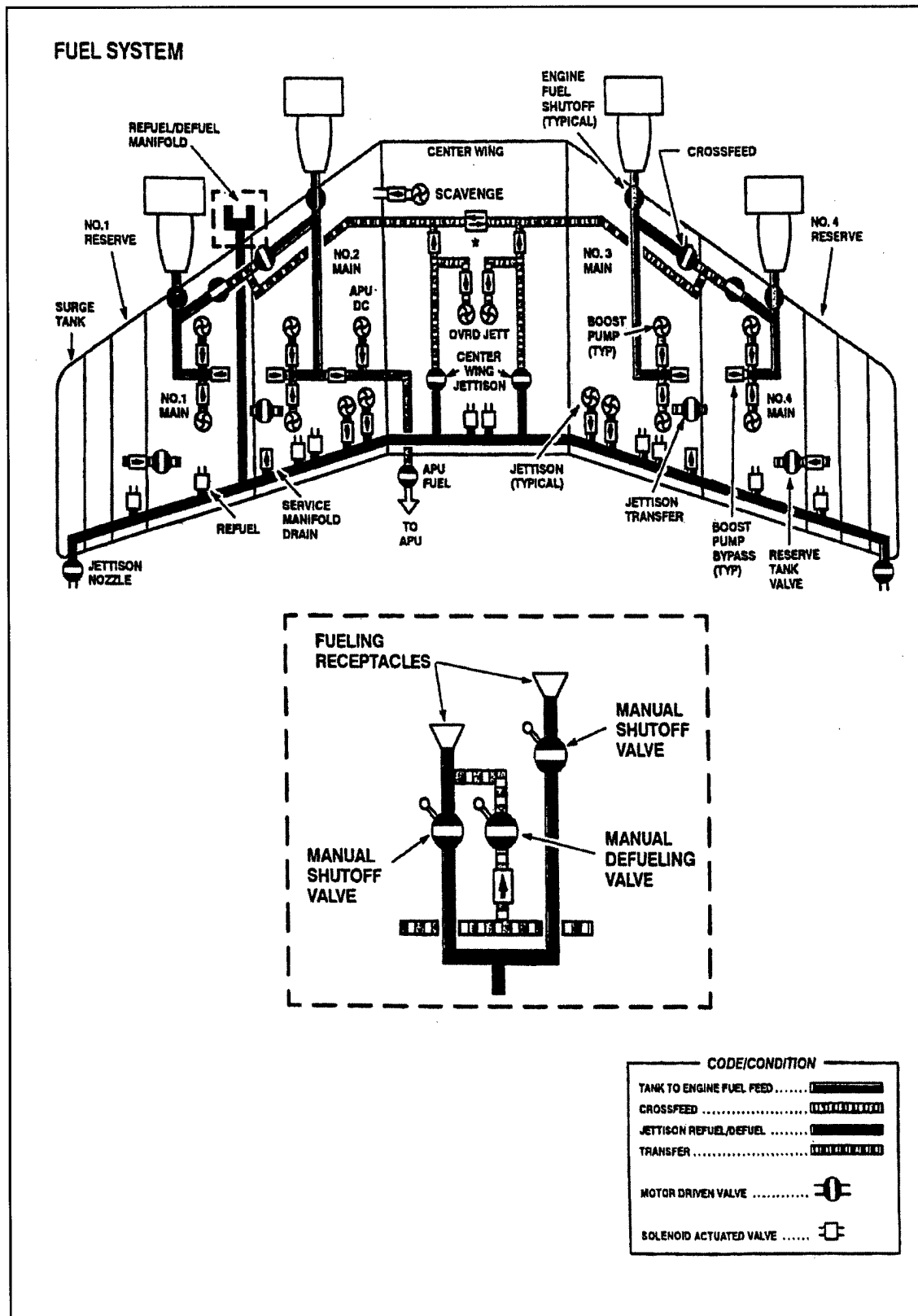

Figure 19. A schematic diagram of the fuel pump locations in the 747.

### 1.6.2.3 747-100 Fuel Flow Indication Information

According to TWA's Maintenance Manual, the 747-100 has a fuel flow sensor/transmitter mounted on each of the airplane's four engines. Fuel flowing through each sensor/transmitter turns an impeller; information regarding the rotational speed of the impeller is transmitted and displayed in the cockpit to indicate the fuel flow. Other major components of the indication system are a fuel flow computer located adjacent to the VSO computer in the electrical/electronics (E/E) bay, a fuel flow indicator located near the fuel quantity indicators at the flight engineer station, and a repeater indicator located in the cockpit near the center of the forward instrument panel.

The fuel flow components are connected by wires that are routed from the engines to the main fuselage through raceways along the forward wing spars. The wires are then routed forward through the fuselage, in raceways beneath the cabin floor, to the computer in the E/E, then along the fuselage frame at STA 360, and upward to the flight engineer's station. The wires routed from the fuel flow and VSO computers to the cockpit are tied into larger bundles that include wires from other systems (including cabin lighting wires, which carry voltage as high as 350-volts a.c.).<sup>86</sup> Figure 17 shows the routing of fuel flow wires through the 747-100.

In a May 2, 2000, letter, Boeing stated that the following are possible causes for an erratic fuel flow indication (as referenced in the CVR—see section 1.1 or appendix B) in a 747-100:

1. The aircraft transmitters had low-speed motors, and the motor drive circuitry in the signal conditioner was failing;
2. Significant contamination was present in the affected transmitter;
3. There was a fault in the signal circuitry; or
4. There was a fault in the indicator.

Further, with regard to the fuel flow meters in the 747-100, Boeing's letter stated that "the portion of the mechanism which is in fuel is lubricated by fuel. The motor has sealed bearings, which [are removed and replaced only when inoperative], not on a schedule."

### 1.6.2.4 TWA Flight 800 Fueling Information

TWA's fueling records indicated that the accident airplane was refueled at Athens and that its fuel load for the trip to JFK included a full CWT. TWA's records further indicated that upon arrival at JFK, the accident airplane's CWT contained about 300 pounds of fuel; when the airplane was refueled at JFK, no additional fuel was added to the CWT.<sup>87</sup> According to TWA's fueling records, the accident airplane was fueled at

---

<sup>86</sup> Three hundred fifty volts is the root mean square voltage (average amplitude) of the 400-Hz electric waves in the cabin lighting circuit's wires. The peak voltage of a 350-volt a.c. circuit is slightly more than 450 volts.

JFK using the underwing pressure method. Table 2 shows TWA's fueling records, which indicate TWA flight 800's fuel loading when it prepared to depart JFK.

**Table 2.** TWA's fueling records, indicating TWA flight 800's fuel loading when it prepared to depart JFK.

Fuel Tank	Indicated Fuel Load Before Fueling (pounds)	Indicated Fuel Load After Fueling (pounds)
No. 1 Reserve	0	3,400
No. 1 Main	5,400	24,600
No. 2 Main	5,300	62,900
CWT	300	300 <sup>a</sup>
No. 3 Main	6,900	62,700
No. 4 Main	6,300	24,600
No. 4 Reserve	0	3,300
<b>Total</b>	<b>24,200</b>	<b>181,800</b>

<sup>a</sup> The cockpit indicator has an analog scale and a digital (rotating drum) scale. When the digital display indicates 300 pounds, the analog needle would indicate near "0."

On the basis of the airplane's dispatch fuel load information and performance data, the Safety Board calculated that the fuel on board the airplane at takeoff was about 176,600 pounds (consistent with TWA's dispatch records) and at the time of the accident was about 165,000 pounds.

## 1.6.3 Maintenance Information

### 1.6.3.1 TWA's 747 Maintenance Inspection Program

During its investigation of the TWA flight 800 accident, the Safety Board reviewed TWA's maintenance program and maintenance recordkeeping procedures and conducted a detailed examination of the accident airplane's maintenance records. The Board's review of TWA's FAA-accepted continuous airworthiness maintenance inspection program for its 747 fleet revealed that it included the following inspections and intervals:

<sup>87</sup> During postaccident interviews, the flight engineer from the Athens-JFK flight (TWA flight 881) told Safety Board investigators that all of the usable fuel in the CWT was used during the flight to JFK and that the fuel pumps appeared to work normally. He stated that he did not observe any change in the CWT fuel quantity indication after the usable fuel was consumed. (According to Boeing, the CWT capacity includes 50 gallons [300 pounds] of unusable fuel.)

- Periodic service (PS) inspection—includes the cockpit and cabin, airplane exterior, and a final check. Accomplished at scheduled layovers of 6 hours or more at stations staffed by TWA mechanics, or every other operating day maximum, unless a higher maintenance level is accomplished. The accident airplane's most recent PS was accomplished on July 17, 1996, at JFK before the departure of TWA flight 800.
- Aircraft service (AS) inspection—includes all PS items, plus routine AS inspection items (including checks for cockpit and cabin; exterior fuselage, wings, gear, and empennage; engines and struts; oil, hydraulic fluid, and water servicing; and fuel tank sumping), which are identified as AS-1 through AS-6. AS-1 through AS-6 are accomplished in sequence at intervals not to exceed 100 hours of airplane time in service, until a time control service (TCS) inspection is accomplished. The accident airplane's most recent AS inspection (an AS-1 inspection) was accomplished on July 13, 1996, at JFK, at an airplane total flight time of 93,253 hours.
- TCS inspection—includes, to a greater degree and depth than the AS inspection, the following: the cockpit and cabin; exterior fuselage, wings, gear, and empennage; engines and struts; oil, hydraulic fluid, and water servicing; and fuel tank sumping. TCS inspections are accomplished at intervals not to exceed 1,200 hours of airplane time in service. The accident airplane's most recent TCS was accomplished on April 15, 1996, at JFK, at an airplane total flight time of 92,231 hours.
- Station service (SS) inspection—interim cabin refurbishment program with limited external airplane inspection. SS inspections are accomplished at intervals not to exceed 800 hours of airplane time in service. The accident airplane's most recent SS inspection was accomplished on May 11, 1996, at JFK, at an airplane total flight time of 92,466 hours.<sup>88</sup>
- C inspection—includes checks of the integrity and airworthiness of the airframe, fluid quantities, security of components, operational checks, overhaul of specified components, the accomplishment of principal structure elements per the structural inspection program, and the Corrosion Prevention and Control Program. The C check consists of three blocks designated as 1E, 2E, and 3E, accomplished in sequence at intervals not to exceed 13 months. The accident airplane's most recent C inspection (3E) was accomplished on November 6, 1995, at an airplane total flight time of 91,084 hours.

---

<sup>88</sup> Although the SS inspection was to be accomplished at intervals not to exceed 800 hours of airplane time in service, on July 12, 1996, the FAA had granted TWA a one-time 100-hour extension to this interval for the accident airplane. Thus, the accident airplane's next SS was due within 900 hours of the previous SS inspection.

- D inspection—a more in-depth inspection of the structure and systems than the C inspection to ensure the integrity and airworthiness of the airframe, fluid quantities, security of components, operational checks, and overhaul of specified components. D inspections are accomplished at intervals not to exceed 4 years. The accident airplane's most recent D inspection was accomplished on December 14, 1992, at an airplane total flight time of 80,267 hours. The routine work is accomplished as defined in TWA's Operations Specifications Manual, TWA's approved engineering reports, structural inspection programs and documents approved for control of repair, overhaul, parts replacement, periodic inspections, and routine checks.

#### 1.6.3.1.1 TWA's General Inspection Policies

According to the TWA General Policies and Procedures Manual, dated May 15, 1994, TWA had the following three levels of airplane and powerplant inspection:

- A. Visual Inspection: Visual airframe and power plant inspection constitutes a check of visible or exposed areas, usually external, as specified on the appropriate inspection forms. A visual inspection may include those items which are partially hidden, plus those that might be readily accessible through quick access panels.
- B. Detailed Inspection: A detailed inspection is covered by two complementary inspection concepts—the area concept and the specific item concept.

Area Concept—The area inspection concept constitutes a very detailed inspection of the designated area, including, but not limited to structures, tubing, cables, wiring and any units exposed or visible through routine open up. Normal assistance to visual inspection will be used as required and may consist of mirrors, magnifying glasses, dye penetrant checks or specialized non-destructive test equipment where applicable.

Specific Item Concept—The specific item concept is a very detailed inspection of a specific item as detailed on the work forms or by inspection supervision. It is limited to the defined item(s) and does not cover the associated area.

- C. Final Inspection: Upon completion of all maintenance and service work at [C inspection] and higher maintenance as outlined on the appropriate maintenance work forms, the airframe and powerplant shall be given a final check by an inspector.

The airframe final inspection is intended as a visual safety check to ensure that all access covers, inspection doors, and panels are installed; that tools, rags, loose hardware, etc., have been removed from the cabin, cockpit, cargo compartments, wheel wells, and engine inlets; and that all loose equipment and furnishings have been properly stowed.

The Safety Board's review of TWA maintenance documents indicated that inspection of the 747 CWT was to be accomplished by an area concept-type of detailed inspection. The manual did not specifically define the area to be inspected, nor did it provide specific inspection instructions for the various compartments of the CWT or the various components within the CWT, such as FQIS wiring, connectors, and probes.

### 1.6.3.1.2 TWA and Boeing Wiring Inspection Guidance

The Safety Board's Maintenance Records Group asked TWA and Boeing personnel to describe any procedures and guidance that they provided to maintenance personnel regarding the protection of wire bundles in 747s while maintenance was being accomplished near them. Boeing had published general inspection guidelines, which advised operators to assess the existing condition of wires and use good judgment and common sense during maintenance to prevent injury and damage. Boeing's guidance indicated that wire bundles and equipment should be moved to avoid unnecessary damage when any type of repair is being accomplished in the area. According to Boeing Service Letter (SL) 747-SL-20-048, dated January 25, 1995, "As a general rule, wiring that is left undisturbed will have less degradation than wiring that is reworked. As wiring and components become more brittle with age this effect becomes more pronounced." Boeing had also issued Service Bulletin (SB) 747-53-2272, "Fuselage—Nose Section 41 Body Frame Structural Replacement and Reinforcement," which advised operators to "[f]abricate a suitable work platform as required to protect wire bundles." According to Boeing engineers,<sup>89</sup> most operators cover nearby wire bundles with bubble wrap or tape a clean cloth over the bundle while making repairs in the area.

At the Safety Board's request, TWA provided the Maintenance Records Group with a copy of its Boeing Commercial Jet Standard Overhaul Practices Manual (most recently revised in September 1997), which TWA indicated it had developed based on Boeing documents. Chapter 20 of this manual included guidance regarding the following: repair and replacement procedures for metal and electrical work, inspection procedures, cleaning procedures, finishing procedures, installation procedures, specifications, and materials. According to TWA, these subjects were also addressed in its maintenance classroom training sessions, and maintenance/fleet service personnel were expected to use general housekeeping procedures in performing their duties. TWA personnel indicated that the company did not have a written policy concerning the use of protective covers over or around wire bundles when performing metal work near the wire bundles; instead, maintenance personnel were expected to determine (on a case-by-case basis) whether a protective covering was necessary and whether the wire bundle needed to be moved to accomplish a maintenance task.

### 1.6.3.2 Accident Airplane's Maintenance Information

Investigators reviewed the following records for the accident airplane: aircraft maintenance logs for the accident airplane from December 1992 to the accident date; C inspection routine and nonroutine work cards from June 3, 1986, to November 6, 1995 (the most recent C inspection); D inspection routine and nonroutine work cards from February 8, 1986, to December 11, 1992 (the most recent D inspection);<sup>90</sup> engineering maintenance liaison records; and all records regarding airworthiness directives (AD), SBs, and modification orders (MO)<sup>91</sup> for the accident airplane. TWA maintenance records indicated that the company had complied with all applicable FAA ADs,<sup>92</sup> accomplished all

---

<sup>89</sup> Similar information was also obtained in writing from TWA personnel.

scheduled maintenance items, and maintained its continuous airworthiness maintenance program on the accident airplane.

The Safety Board's examination of the accident airplane's maintenance records revealed that the airplane had experienced several intermittent problems during fueling operations in the 2 years before the accident, including one that occurred before the accident airplane departed JFK. After the accident, a TWA mechanic advised the Board that while the accident airplane was being fueled at JFK for TWA flight 800, the fuel system shut down. The mechanic reported that the VSO fuse and an overflow circuit breaker<sup>93</sup> were pulled and the pressure fueling process was continued. After the airplane was fueled, the mechanic reset the fuse and circuit breaker.<sup>94</sup>

In addition to the refueling difficulties noted, the Safety Board's review of the accident airplane's maintenance records revealed three logbook entries regarding fuel leaks during the preceding 2 years. The Board also noted 25 maintenance logbook entries regarding fuel flow; fuel gauge indications, inaccuracies, and fluctuations; and inoperable fuel system equipment. Appendix E contains descriptions of the fueling discrepancies observed and the resultant maintenance actions.

#### **1.6.3.2.1 Airworthiness Directives and Service Bulletins Applicable to 747 Fuel Pumps and Related Wiring**

FAA AD 79-06-02, effective April 19, 1979, required compliance with Boeing Alert Service Bulletin (ASB) 747-28-A2092, dated February 12, 1979, which recommended a one-time main fuel tank pump wiring inspection, repair, and modification to preclude electrical arcing<sup>95</sup> into the Nos. 2 and 3 main fuel tanks.<sup>96</sup> The AD described a

<sup>90</sup> According to TWA personnel, in accordance with the company's FAA-accepted maintenance recordkeeping program, TWA retains its aircraft maintenance logs for 30 months, its C inspection routine and nonroutine work cards for 10 years, and its D inspection routine and nonroutine work cards for 25 years. (The FAA requires operators to retain inspection records until the next similar inspection or higher-level inspection occurs.)

<sup>91</sup> MOs authorize the expenditure of funds and accomplishment of physical changes to an airplane or components, one-time inspections and their resulting rework, and special scheduled work beyond normal overhaul or maintenance. They also authorize funds for associated tooling, outside services, and initial spares. MOs may be used to authorize service evaluations for the improvements in performance of TWA airplanes, installation of new equipment, and extension of service life of airplanes and engine accessories and components.

<sup>92</sup> See section 1.6.3.2.1 for information regarding ADs and SBs for the 747 fuel pumps and FQIS wiring and section 1.6.3.2.2 for information regarding ADs and SBs for 747 structural inspections.

<sup>93</sup> A circuit breaker is a mechanical device designed to open a circuit (stop the current flow) when the current flow within that circuit exceeds a set limit for a length of time.

<sup>94</sup> The TWA 747 Maintenance Manual states that if dispatch timing precludes repair of a malfunctioning VSO control unit, "the shutoff system can be disabled by removing the fuse in the VSO control unit in the right main equipment center on shelf E3. This permits operation of the refuel valves and fuel quantity indicators, but disables the automatic VSO control unit. The fuel level shutoff must be controlled by the individual refuel valve switches for all tanks."

<sup>95</sup> Arcing is defined by Underwriters Laboratories, Inc. (UL), as "a luminous discharge of electricity across an insulating medium." The electrical discharge of an arc can involve temperatures of several thousand degrees Celsius. For additional information regarding arcing, see section 1.16.6.1.



method of alleviating wire chafing that involved installing a double layer of Teflon sleeves<sup>97</sup> over the wiring where it was routed within the fuel tanks. TWA maintenance records indicated that the AD was accomplished on the accident airplane on June 6, 1979.<sup>98</sup>

On August 3, 1995, Boeing issued ASB 747-28-A2194, "Fuel-Distribution-Fuel Boost and Override/Jettison Pumps-Inspection." The ASB stated that operators had removed eight fuel pumps from service that had fuel leaks at the pump/wire bundle interface and recommended that all operators test the resistance on each 747 boost and jettison/override pump "at the next opportunity," replacing those that did not pass the insulation check. The SB stated the following:

after a long time, water can get inside the potting of the wire terminal assembly and cause corrosion. The corrosion in the wire terminal assembly can cause arcing between the power pins and the pump case. The arcing causes thermal expansion of the materials inside the cap. This expansion causes failure of the cap attachment flange or the attaching screws and a subsequent fuel leak.

According to TWA maintenance personnel, at the time of the accident, ASB 747-28-A2194 had not been accomplished on the accident airplane because the FAA had subsequently issued Notice of Proposed Rulemaking (NPRM) 96-NM-57-AD, which proposed an AD that would "require repetitive visual inspections to detect discrepancies of the wire terminal assembly, electrical connector, and wire insulation on the fuel pump; and replacement of the fuel pump with a new fuel pump, if necessary" and "repetitive insulation resistance test of the fuel pump wiring." The resultant AD (AD 97-03-17) became effective on March 14, 1997, and TWA's corresponding MO (72F57) was finalized on April 1, 1997.

### **1.6.3.2.2 Airworthiness Directives and Service Bulletins Applicable to 747 Structural Inspections**

#### Nose Section (Section 41)—Internal Inspections

On January 31, 1986, the FAA issued AD 86-03-51, which required structural inspection of the nose section (section 41) on certain 747 airplanes, including the accident airplane, "to prevent sudden decompression of the fuselage." On February 14, 1986, Boeing issued SB 747-53A2265, "Fuselage-Nose Section 41-Body Frame Structure Inspections and Crack Repairs," which provided additional information regarding inspection and repair of this area.<sup>99</sup> According to the SB, "numerous body frame and other internal structure cracks in the upper deck, main deck and lower lobe of the [nose section],

---

<sup>96</sup> These fuel pumps are located in the outboard end of fuel tank Nos. 2 and 3 and draw fuel from the lowest points of fuel tank Nos. 1 and 4.

<sup>97</sup> A sleeve is a woven or flexible jacket that protects electrical wiring.

<sup>98</sup> AD 79-06-02 (and postaccident superseding ADs) are discussed further in section 1.18.3.4.

<sup>99</sup> At the time of the accident, eight revisions to SB 747-53A2265 had been issued. The most recent revision was issued on April 14, 1994, and specified that all frame cracks must be repaired before further flight.

were reported by several operators on a number of airplanes with 7,000 to 20,002 flight cycles....The body internal structure cracking is attributed to cabin pressure cyclic loading." The SB further stated that continued operation with undetected or unrepaired frame cracks "may cause two or more adjacent frames to crack through near the same stringer, which could lead to extensive body skin cracking and rapid cabin decompression." Therefore, the SB recommended inspections of the affected area to be accomplished within specified flight cycle limits, with repairs as needed, and repeat inspections at intervals not to exceed 3,000 flight cycles.<sup>100</sup> The Safety Board's review of TWA's maintenance records indicated that the accident airplane was inspected in accordance with SB 747-53A2265 on May 8, 1986.

On December 15, 1986, the FAA issued AD 86-23-06, which superseded AD 86-03-51 and required repetitive inspections of several areas in the 747 nose section. TWA maintenance records indicated that the company accomplished the resulting initial inspection on the accident airplane on April 15, 1988. On June 24, 1991, the FAA issued AD 91-11-01, which superseded AD 86-23-06 and required several repetitive inspections in accordance with Boeing SB 747-53A2265 to detect and repair body frame and other internal structure cracks and possible adjacent skin cracks in the 747 nose section. AD 91-11-01 further stated, "installation of new and improved body frame structure in accordance with FAA approved procedures or Boeing SB 747-53-2272, dated January 12, 1987...is considered terminating action for the repetitive inspections required by this AD for the structure (considered to be stringers, clips and skin associated with the frame)." Boeing SB 747-53-2272, "Fuselage-Nose Section 41-Body Frame Structure Replacement and Reinforcement," stated, in part, "fabricate a suitable work platform as required to protect any wire bundles disconnected in the upper deck area between STA 420 and 520."

According to TWA maintenance records, an MO was written to direct and schedule accomplishment of SB 747-53-2272. In accordance with this MO, the work platform structure was fabricated on 17 of TWA's 747s, including the accident airplane, terminating the need for the repetitive inspections required by AD 91-11-01. The MO also directed modifications in accordance with Boeing's Document D6-35999, "Aging Airplane SB Structural Modification Program-Model 747," dated March 1989, which required replacement of trailing edge flap tracks, reinforcement of the APU cutout, installation of a splice strap at the STA 1241 bulkhead, and modification of longitudinal floor beams.

#### Sections 42 and 46 Lower Lobe—Internal Inspections

On September 17, 1986, the FAA issued AD 86-18-01, requiring 747 operators to inspect STAs 540 to 760 and 1820 to 1900 and stringers S-35 to S-42 on the left side of the airplane "to detect cracking of body frame structure in the lower lobe (sections 42 and 46) of the fuselage." AD 86-18-01 applied, in part, to all 747 series airplanes listed in Boeing ASB 747-53A2237, Revision 1, dated March 28, 1986, which included the accident airplane. According to TWA maintenance records, the accident airplane was inspected in

---

<sup>100</sup> The SB indicated that operators should reduce the repeat inspection interval to 2,000 flight cycles on airplanes with more than 20,000 flight cycles.

accordance with AD 86-18-01 on November 19, 1991, and the next repetitive inspection was due on November 19, 1996.

#### Nose Section (Section 41)—External Inspections

On January 22, 1991, the FAA issued AD 90-26-10, requiring 747 operators to conduct external inspections of the fuselage skin from STA 220 to 520 and between stringers S-6 and S-14 on both sides of the airplane “to prevent rapid decompression of the airplane.” Inspections were to be accomplished in accordance with Boeing ASB 747-53A2321, dated October 31, 1989, and repeated thereafter at intervals not to exceed 2,000 flight cycles. The AD required detected cracks to be repaired “prior to further flight.” According to TWA maintenance records, the accident airplane was inspected in accordance with AD 90-26-10 on November 6, 1995, and the next repetitive inspection was due on October 20, 1998.

#### **1.6.3.2.3 Maintenance Accomplished Near Fuel Quantity Indication System Wiring in the Accident Airplane**

The Safety Board’s review of TWA’s maintenance records for the accident airplane revealed several instances in which repairs and other maintenance items were accomplished near the FQIS wiring paths during the 10-year period that preceded the accident, including the following:

- In February 1986, during an inspection, a new forward cargo compartment fitting was installed between the upper front spar chord and the cabin floor at STA 1000, LBL 9. In addition, maintenance personnel cleaned the “exposed areas of all E1, E2, and E3 equipment shelves, wire bundles and terminal strips” and the wiring outboard of (behind) the flight engineer’s panel in the cockpit and removed metal shavings from the interior of the P-6 panel and the right-side body landing gear wheel well (STAs 1350 to 1394). (The fuel flow computer and VSO unit were located in the E3 equipment rack.)
- In May 1986, during escape light path modification maintenance, a clamp was installed on the right sidewall just above the main deck floor level in the forward E/E compartment, securing a wire bundle, and a crack in the left-side bulkhead at STA 440 was repaired. (The wire bundle that contained the fuel flow computer and VSO unit wires was routed down the side of the airplane from the flight engineer’s position along STA 360, then turned aft beneath the floor, passing through this area.)
- In April 1987, during an inspection, TWA maintenance personnel replaced two cracked stringers and repaired a cracked former flange between STAs 420 and 460. Additionally, maintenance records from this visit indicated that debris (including dirt, metal shavings/cuttings, and loose hardware) was cleaned from the E/E compartments, and several loose/unclamped wires/wire bundles were secured. (As previously indicated, the fuel flow computer and VSO unit were located in the E3 equipment rack, and associated FQIS-related wiring is routed through this area, between E3 and STA 360.)

- In September 1988, during a C inspection, TWA maintenance personnel observed evidence of electrical arcing at the cannon plug for the service carts in galley C; two electrical cords were removed and replaced. Galley C is located in the center of the airplane, just aft of the L2/R2 main cabin doors, between STAs 850 and 880. Figure 20 is a diagram of the 747-100 interior. (The CWT FQIS wire bundles [W480] were routed in a raceway beneath the floorboards slightly aft of galley C.)
- In November 1988, during a D inspection, TWA maintenance personnel removed numerous floor and wall panels located between STAs 360 and 1265 so that "metal work" repairs could be accomplished. (The areas addressed during these repairs contained FQIS-related wire bundles that are routed forward from the CWT rear spar, past the aft edge of galley C, to the fuel flow computer and VSO unit.)
- In October 1990, during an inspection, TWA maintenance personnel observed corrosion at STA 1241, LBL 57, removed the corroded metal, and repaired the area. Subsequently, TWA maintenance personnel reinstalled wire bundles and the wire bundle tray (which had been removed to gain access to the canted pressure bulkhead) under the floor at STA 1241, LBL 70, after "metal work" was completed. (W480 FQIS wires passed above and beneath this repair area.)
- In December 1991, during an inspection, TWA maintenance personnel repositioned the wiring on the rear of the cockpit fuel quantity panel. (These wire bundles included both power wires and FQIS circuit wires from each fuel tank, including the CWT.)
- In December 1992, during a D inspection, the last of several tasks required by a 747 structural modification program mandated by AD 90-06-06 was accomplished. These tasks generated several nonroutine work cards, which indicated that corrosion and cracks were found, and repairs were accomplished in accordance with maintenance manual instructions. Several of these work cards indicated that wire bundles and ducting were removed to gain access to repair areas and reinstalled upon completion of repairs. Numerous wire bundle clamps were found deteriorated and were replaced. At STA 920, a wire bundle that was chafing was repositioned. (The work cards were not specific as to which wire bundles were removed. The CWT FQIS wire bundle [W480] is routed laterally along the floorbeam<sup>101</sup> at STA 920 [crossing wires in the raceway], en route to the cockpit.)
- On May 24, 1994, during scheduled ground maintenance at JFK (to perform a cabin seating reconfiguration), the left potable water bottle cap burst and separated from the cap attachment ring, resulting in damage to the area above and around the potable water bottles. The CWT FQIS wire bundle was routed through the area just outboard of the potable water compressor. According to maintenance records, corrective actions included the following:

---

<sup>101</sup> Although the floorbeams above the WCS are oriented longitudinally, floorboards in the rest of the airplane are oriented laterally.

The potable water bottle air compressor pressure switch and connector, water system pressure relief valve, plus 3 feet of associated wiring were removed from the airplane for testing.<sup>102</sup> The air compressor pressure switch was reinstalled, and the connector and relief valve were replaced.

Both potable water bottles were removed, and the area, including the bulkhead aft of the bottles, was inspected. Most of the potable water bottles' support rods and fittings were broken and/or bent and were replaced or repaired. The potable water bottles were replaced with serviceable potable water bottles.

Several damaged ceiling and floor panels, baggage restraint bars, passenger service units, and trim panels were observed near seat rows 19 through 22, seats 4, 5, 6, and 7, and were removed and replaced. At STA 980, the floor beam above the left potable water bottle was removed, repaired, and reinstalled. The ceiling support in the forward cargo compartment was bent at LBL 24 between STAs 960 and 980, and the floor support was bent and cracked at STA 984, between LBL 12 and LBL 32; both supports were removed, repaired, and reinstalled.

Wire bundles forward and aft of STA 970 were removed from the support clamps for sheet metal repair (forward and above the potable water bottle area) and were resecured upon repair completion. The wire bundle for the potable water bottle air compressor was disconnected just forward of the compressor during repairs, and was reconnected and secured after the metal repairs were completed.

The forward cargo compartment between STAs 980 and 1000 was cleaned of water, dirt, and debris.

- In November 1995, TWA maintenance personnel accomplished AD 89-12-07, "Overwing Center Section Cavity Drain Inspection," during which the main cabin floor panels were removed to expose the STA 1240 cavity drain. (The FQIS wire bundle that was routed from the cockpit to the CWT is located beneath the floorboards near this work.)

During its examination of recovered wreckage, the Safety Board found evidence of repairs accomplished near FQIS wire routing areas for which no associated maintenance records were found. For example, wires carrying FQIS signals to the upper deck AIDS unit were routed across the top of the airplane through an area where replacement fasteners and differences in paint were observed. The interior of the airplane skin in this area had a note, handwritten in green paint, that stated, "OCT 1, 1992 1:47 AM." The Maintenance Records Group did not find a maintenance record that it could associate with this handwritten note.

---

<sup>102</sup> As a result of this potable water bottle event and subsequent tests, on May 31, 1994, Boeing advised TWA to replace the tested relief valve with a different part number (P/N) pressure relief valve. On October 27, 1994, Boeing issued SB 747-38A2105, which advised all 747 operators (line numbers 1 through 1,013) to replace the potable water system pressure relief valve at the earliest opportunity. On June 23, 1995, the FAA issued AD 95-11-03, which required replacement of the potable water system pressure relief valve.

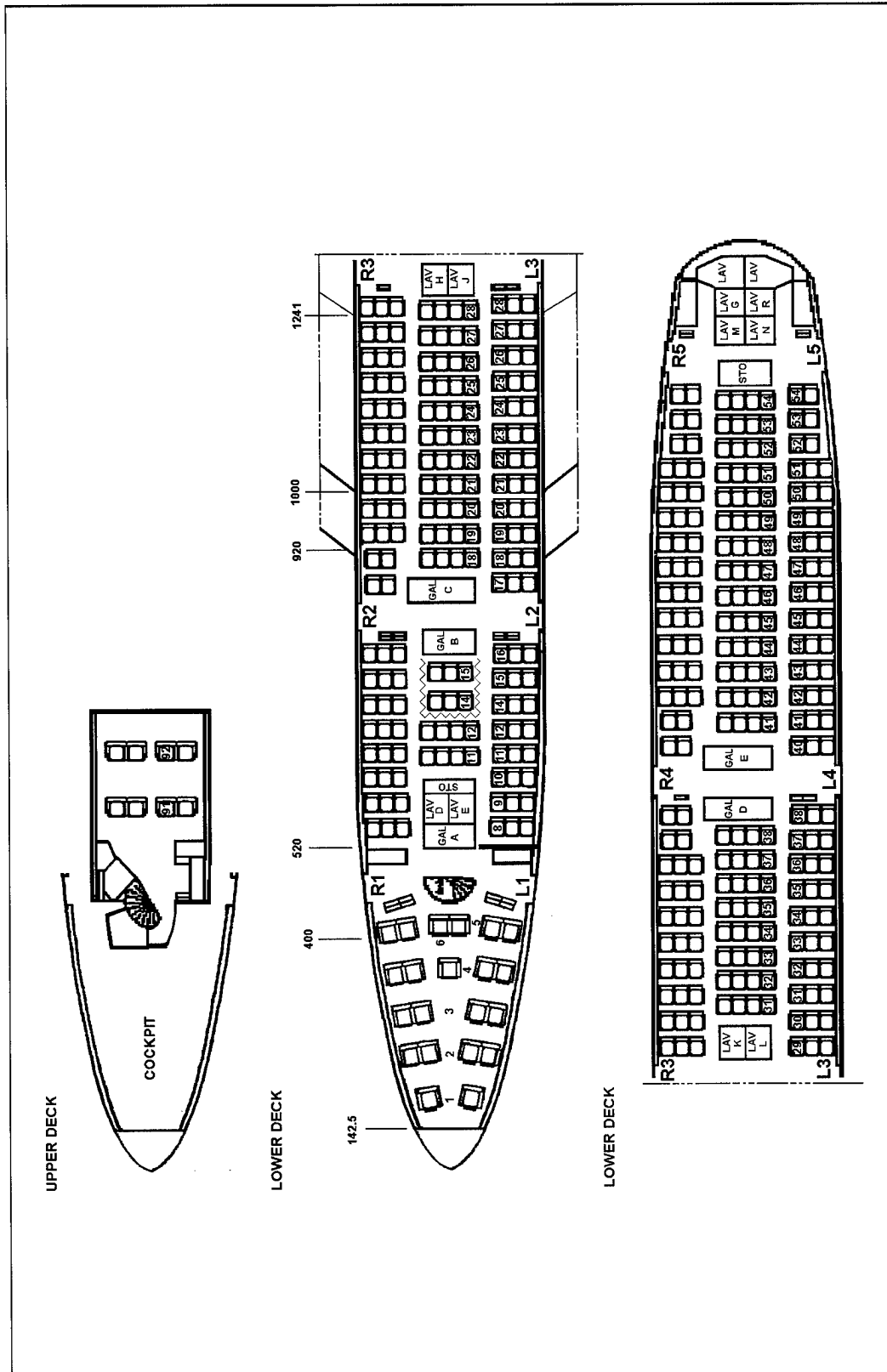

Figure 20. A diagram of the 747-100 interior.

#### 1.6.3.2.4 TWA Flight 800 Predeparture Maintenance Information

The flight and cabin crew of TWA flight 881 (the accident airplane's inbound flight segment, from Athens, Greece, to JFK) entered several maintenance writeups in the logbook, which were addressed by TWA maintenance personnel at JFK before TWA flight 800 departed. These writeups included the following:

- The Nos. 1 and 2 engines exceeded the exhaust gas temperature limits of 925° F for 2 seconds. The overtemperature was caused by an unanticipated rapid spool-up of the engines during takeoff out of Athens. Maintenance personnel checked the inlet and exhaust on both engines, and no abnormalities were found.
- A deferred item from July 7, 1996, indicated that maintenance personnel had to physically check the No. 3 engine oil quantity because of an oil quantity gauge discrepancy. The No. 3 engine oil tank was checked and serviced with oil. No malfunctions were found.
- The splash guard in the aft upper deck lavatory was missing. Maintenance personnel reset the splash pan.
- The drain in galley C had leaked, and the surrounding area of the floor was soaked. Maintenance personnel cleared an obstruction from the drain.
- The No. 1 engine pressure ratio (EPR)<sup>103</sup> indicator was sticking. Maintenance personnel replaced the EPR module.

As previously indicated, maintenance personnel also accomplished a PS inspection and checked the landing gear tire pressure before the accident airplane departed JFK. The most recent TWA All Open Item Work Sheet for the accident airplane indicated that the following maintenance items had been deferred:

- A June 9, 1996, maintenance logbook entry indicated that a 30-inch crack was observed in the fiberglass panel on the underside of the left wing, between the fuselage and the wing landing gear at the trailing edge, forward of the flap. Maintenance personnel performed a repair,<sup>104</sup> however, the item remained open until a new panel could be produced and installed.
- A June 30, 1996, maintenance logbook entry indicated that a tear was observed in the arm rest cover at row 31, seat 7. The item was deferred with a note that stated that the entire seat should be recovered.
- A July 4, 1996, maintenance logbook entry indicated that the rear attachment on the left-side canoe fairing for the No. 2 trailing edge flap was broken. The fairing was removed, flap carriage was reported to be otherwise normal, and

---

<sup>103</sup> EPR is a measurement of the engine's power output as a ratio of total pressure of the gases in the exhaust pipe divided by the total pressure of the air entering the engine inlet.

<sup>104</sup> This time-limited repair would typically have been considered an airworthy repair until the airplane's next scheduled higher maintenance check; in the case of the accident airplane, this would have been a D check scheduled for December 1996/January 1997. However, TWA had scheduled the panel for replacement when the new panel was available, at the next SS inspection.

replacement of the fairing was deferred on the basis of the Minimum Equipment and Dispatch Procedures, Configuration Deviation List. The following operational stipulations were associated with this deferment: (1) for takeoff, reduce runway zero wind and climb limit weights 2,700 pounds; (2) for landing, reduce critical temperature 1° F. A placard listing these limitations was affixed in the cockpit.

- A July 5, 1996, maintenance logbook entry described spots on the upper deck carpets. The item was deferred because there was insufficient time to perform the corrective action.
- A July 7, 1996, maintenance logbook entry indicated that the No. 3 engine failed to go into reverse thrust and that the thrust reverser lever interlock failed to release. Maintenance personnel were unable to complete the repair because they did not have the necessary cables in stock. The item was deferred until July 17, 1996, when a mechanic was scheduled to install the cables while the airplane was on the ground at JFK. However, the mechanic told Safety Board investigators that he was unable to complete the repair before the airplane's scheduled departure, so he mechanically locked the thrust reverser in the forward position, and the item was again deferred for 10 days. The Minimum Equipment and Dispatch Procedures indicated that the flight crew must be notified, associated systems for stopping the airplane must be operational, and affected systems must be placarded "INOP." Records indicated that these procedures were followed.
- A July 7, 1996, maintenance logbook entry indicated that maintenance personnel replenished the oil supply in the No. 3 engine, after which the flight engineer's oil quantity gauge indicated that the engine contained 4 quarts of oil. After the engine was started, the flight engineer's No. 3 oil quantity gauge indicated 2.3 quarts. The flight engineer's oil quantity gauge was placarded "INOP," and the item was deferred. TWA's minimum equipment and dispatch procedures indicate that the items must be repaired within 10 calendar days. The procedures state that "one (oil quantity gauge) may be inoperative if it is verified before each takeoff that the oil tank is filled to the maximum recommended capacity; there is no evidence of above normal oil consumption or leakage; and oil pressure indicating, low oil pressure warning, and oil temperature indicating systems operate normally and are monitored." The affected gauge (flight engineer's panel) was to be placarded "INOP." Before the departure of TWA flight 800, these procedures were signed off as accomplished.
- A July 11, 1996, maintenance logbook entry indicated that the drain in galley C was clogged and drained very slowly. Maintenance personnel cleared the drain and signed off the maintenance item. However, a July 12, 1996, maintenance logbook entry indicated that the drain was still clogged. Maintenance personnel again cleared the drain, blew air through the line, and signed off the maintenance item. Later that day, at JFK, a logbook entry indicated that the drain was still clogged; however, because maintenance personnel did not have time to address the item, it was deferred.



- A July 15, 1996, maintenance logbook entry indicated that the No. 3 left leading edge flap amber (cautionary) light illuminated when the leading edge flaps were in the retracted position. The item was deferred because maintenance personnel did not have time to complete the task. The Minimum Equipment and Dispatch Procedures indicated that the affected lights must be placarded "INOP" and that the item must be repaired within 10 calendar days.
- A July 15, 1996, maintenance logbook entry indicated that the R3 door emergency chute pressure gauge was not visible. Maintenance personnel deferred the item, indicating that the emergency chute cover needed to be "reworked."
- A July 17, 1996, maintenance logbook entry indicated that the captain's weather radar display was inoperative, indicating no range markings or antenna sweeps. The item was deferred. The Minimum Equipment and Dispatch Procedures indicated that the indicator must be placarded "INOP" and that the item must be repaired within 10 calendar days.

## 1.7 Meteorological Information

The surface weather observation taken about 1951 at JFK on July 17, 1996, located 52 nautical miles (nm) west of the accident site, stated the following:

Winds 220° at 8 knots; visibility 10 miles; clouds at 6,000 feet scattered, ceiling 7,000 feet broken, 9,000 feet broken; temperature 82° F; dew point 70° F; altimeter setting 30.07 inches of Hg [mercury]; wind shift 1906; rain began 1918 and ended 1929; precipitation 0.00 inch between 1927 and 1951.

The surface weather observation taken about 2051 at JFK stated the following:

Winds 240° at 9 knots; visibility 10 miles; few clouds at 10,000 feet; temperature 80° F; dew point 69° F; altimeter setting 30.08 inches of Hg.

The surface weather observation taken about 1945 at Francis S. Gabreski Airport (FOK) Westhampton Beach, New York, located 12 nm north of the accident site (the nearest reporting station to the accident site), stated the following:

Winds 240° at 4 knots; visibility 4 miles; haze; clouds at 6,000 feet scattered; temperature 73° F; dew point 66° F; altimeter setting 30.08 inches of Hg; total sky cover 3/8.

The surface weather observation taken about 2045 at FOK stated the following:

Winds calm; visibility 6 miles; haze; clouds at 6,000 feet scattered; temperature 72° F; dew point 66° F; altimeter setting 30.09 inches of Hg; total sky cover 3/8.

The winds aloft measured by a weather balloon launched from Upton, New York, on July 17, 1996, about 2000, are shown in table 3. (Upton is located about 15 nm from the accident site.)

**Table 3.** Winds aloft measured by a weather balloon launched from Upton, New York.

Altitude (feet msl)	Wind Direction (degrees)	Wind Speed (knots)
1,000	270	12
2,000	280	14
3,000	285	17
4,000	290	17
5,000	303	19
6,000	310	19
7,000	315	17
8,000	320	16
9,000	330	12
10,000	335	12
11,000	320	12
12,000	295	16
13,000	290	16
14,000	300	17
15,000	303	19
16,000	305	21
17,000	315	29
18,000	315	33

These numbers were used during the Safety Board's trajectory study.<sup>105</sup> Review of the meteorological data revealed no record of significant meteorological conditions in the area or at the time of the accident.

## 1.8 Aids to Navigation

No difficulties with the navigational aids were known or reported.

## 1.9 Communications

No difficulties with communications were known or reported.

<sup>105</sup> For additional information regarding the trajectory study, see section 1.16.2.1.

## 1.10 Airport Information

JFK is located 1/2 mile southeast of the New York City limits and has an airport elevation of 13 feet. The airport has five runways. Runway 14/32 is 2,560 feet long and 75 feet wide; runway 13R/31L is 14,592 feet long and 150 feet wide; runway 13L/31R is 10,000 feet long and 150 feet wide; runway 4R/22L is 8,400 feet long and 150 feet wide; and runway 4L/22R is 11,351 feet long and 150 feet wide. The accident airplane departed from runway 22R.

## 1.11 Flight Recorders

The two flight recorders on the accident airplane had been mounted in the aft fuselage, above and aft of the L5 door. According to wiring diagrams and maintenance documents and personnel, 115-volt a.c. power (provided by the engine-driven generators) was routed to the recorders through wiring along the upper right side of the passenger cabin from the a.c. essential bus/flight engineer panel. The recorder signal wires were routed along the upper left side of the passenger cabin. The recorders were recovered from the Atlantic Ocean by surface-supplied U.S. Navy divers operating from the U.S.S. Grasp on the evening of July 24, 1996. They were immediately packed in water to prevent/delay the onset of corrosion and shipped to the Safety Board's laboratory in Washington, D.C., for readout.

### 1.11.1 Cockpit Voice Recorder

The CVR installed on the accident airplane was a Fairchild model A-100.<sup>106</sup> Although the CVR unit exhibited external and internal structural damage and the recording medium (magnetic tape) was wet (which, as noted in section 1.1, resulted in sounds similar to recording tape damage noise to be recorded at 2031:05), the tape was otherwise in good condition, and the quality of the recording was good.<sup>107</sup> The CVR recording consisted of four channels of audio information: one channel contained audio information recorded by the CAM, and the other three channels contained audio information recorded through the radio/intercom selector panels at the captain, first officer, and flight engineer positions. The accident airplane was not equipped with noise-activated ("hot") microphones at the flight crew positions (nor was it required to be so equipped). Therefore, the audio information recorded at the flight crew positions consisted of air-to-ground communication and navigation radio audio information and did not include flight crew conversations and sounds in the cockpit. However, depending on

---

<sup>106</sup> The CVR identification plate and S/N were missing and were not recovered.

<sup>107</sup> The Safety Board uses the following categories to classify the levels of CVR recording quality: excellent, good, fair, poor, and unusable. A good recording is one in which most of the crew conversations can be accurately and easily understood. The transcript that is developed may indicate several words or phrases that are not intelligible. Any loss in the transcript can be attributed to minor technical deficiencies or momentary dropouts in the recording system or to a large number of simultaneous cockpit/radio transmissions that obscure each other.

their nature and volume, these sounds could be recorded by the CAM. The cessation of the CVR recording at 2031:12 was consistent with the loss of electrical power to the recorder. A transcript was prepared of the entire 31-minute 30-second recording. See appendix B for a complete transcript of the CVR recording.

### 1.11.1.1 Sound Spectrum Study

The Safety Board further examined the audio information recorded by the four CVR channels using a sound spectrum analyzer (which provides a visual presentation of the frequency of the sound signals) and a computer signal analyzer (which allows analysis of the analog wave form and frequency content of the sounds and provides detailed timing information of the events).<sup>108</sup> Examination of the CVR sound spectrum information indicated that throughout most of the accident flight, all of the CVR flight crew position channels recorded an electrical background noise that consisted primarily of a 400-Hz frequency electrical system power “hum,” with harmonic tones<sup>109</sup> at multiples of up to 13 times the 400-Hz frequency.<sup>110</sup> However, 0.73 and 0.68 seconds before the CVR recording stopped, there were brief (2 microseconds) changes in the electrical system background noise hum recorded by the captain’s position CVR channel. The harmonic tones of multiples greater than 800 Hz were not recorded (were “dropped out”), whereas the 400-Hz electrical background noise was still recorded on the captain’s position channel. There was no evidence of any other power disturbances on any channel of the CVR recording.

The Safety Board contracted with the Naval Air Warfare Center-Aircraft Division (NAWC-AD), Patuxent River, Maryland, to measure the voltage harmonics of the captain’s CVR channel under various electrical load conditions.<sup>111</sup> According to the NAWC-AD report,<sup>112</sup> the baseline total harmonic distortion<sup>113</sup> of the voltages measured at the captain’s CVR channel input was approximately 33 percent. The NAWC-AD testing indicated that application of an electrical load resulted in a reduction in the total harmonic distortion voltages measured at the captain’s CVR channel. The electrical load adjustment

---

<sup>108</sup> For additional details and graphs, see Sound Spectrum Group Chairman’s Factual Report, dated November 15, 1997.

<sup>109</sup> Most noises, including electrically generated tones, are made up of a fundamental frequency (in this case, 400 Hz) and multiples of that fundamental frequency, which are known as harmonic tones.

<sup>110</sup> The CVR wiring is routed from the cockpit to the tail of the airplane with numerous wires and cables that are powered by the airplane’s 115-volt (400-Hz) electrical system, which results in the CVR recording a 400-Hz background noise. Most airplanes’ a.c. electrical systems operate on a 400-Hz frequency; this background noise hum is a common feature on CVRs.

<sup>111</sup> The Safety Board also contracted with the NAWC-AD to determine whether electrical power transients could induce sufficient energy into the FQIS wiring through capacitive and inductive coupling to ignite fuel in a 747-100’s CWT. For additional information regarding these tests, see section 1.16.6.4.2.

<sup>112</sup> See NAWC-AD Report No. NAWCADPAX/TR-2000/33, *Boeing 747-100 Fuel Quantity Indication System (FQIS) Susceptibility to Induced Energy from Capacitive and Inductive Cable Coupling*, dated June 12, 2000.

<sup>113</sup> Total harmonic distortion is used to compare an electrical waveform to a pure sine-wave, expressed as a percentage of pure sine-wave voltage output. A total harmonic distortion score of 0 percent is the equivalent of a perfect sine-wave and indicates no harmonic distortion.

required to attain the minimum value of total harmonic distortion voltages observed in the NAWC-AD tests (less than 12 percent) occurred under the following conditions: immediately after closing all generator circuit breakers; when the circuit breaker for TRU 2 was opened; when the essential power selector was switched to either electrical bus 1, 2, or 3; and when all six TRU circuit breakers were opened.

As previously discussed in section 1.1, the CVR recorded an event (a “very loud sound”) that was about 40 percent louder than the previous signals during the last few tenths of a second of the CVR recording, which continued until the CVR recording abruptly stopped.<sup>114</sup> This event was recorded by all four CVR channels; however, examination revealed that the very loud sound was recorded by the captain’s position channel 7.25 microseconds before it was recorded by the other three channels.

### 1.11.1.2 Cockpit Voice Recorder-Related Airplane Tests

The Safety Board documented the CVR’s response to various types of explosive events during a series of controlled tests on a decommissioned 747-100 airplane.<sup>115</sup> The test series included the following conditions: detonation of four simultaneous explosions in four different cargo container locations on board the pressurized airplane, controlled high explosive detonations at various locations inside and outside the unpressurized fuselage, and 15 fuel/air mixture explosions at various locations on board the unpressurized airplane. The fuel/air mixture explosion tests included one test in which a known fuel/air mixture was exploded in the airplane’s CWT.<sup>116</sup>

Sound spectrum analysis plots from these airplane tests were compared with those from the TWA flight 800 CVR recording. For further comparisons, the Safety Board plotted the CVR recordings from other known in-flight explosions/breakups (such as Pan Am flight 103, a 747-100 airplane that crashed at Lockerbie, Scotland, after a bomb on board exploded;<sup>117</sup> an Air India 747-100 that crashed in the Atlantic Ocean southwest of Ireland after a bomb on board exploded;<sup>118</sup> and United flight 811, a 747-100 that lost its forward cargo door in flight.<sup>119</sup> The Board also plotted the CVR recording from a Philippine Airlines 737-300 that experienced a fuel/air mixture explosion in the CWT as it

---

<sup>114</sup> This sound cannot be discerned simply by listening to the CVR but was identified through the sound spectrum study; therefore, it is not indicated in the CVR transcript.

<sup>115</sup> This airplane was obtained by the FAA and the British Civil Aeronautic Administration to conduct explosive hardening trials on cargo containers. The airplane fuselage was structurally intact, with all exterior doors and windows in place; therefore, it could be pressurized. However, the airplane’s engines, the cabin interior, and the cockpit instruments had been removed. For the Safety Board’s tests, the airplane was equipped with additional instrumentation (including multiaxis accelerometers, pressure sensors, flash or detonation sensors, cabin microphones, and CAMs) and several CVRs, one of which approximately duplicated the CAM and recorders that were installed on TWA flight 800.

<sup>116</sup> For the CWT fuel/air mixture explosion test, additional instrumentation was added to record the acceleration, pressures, and the gas mixture inside the tank. For additional information regarding these tests, see section 1.16.5.6.

<sup>117</sup> See Air Accidents Investigation Branch. 1990. *Report on the Accident to Boeing 747-121, N739PA at Lockerbie, Dumfriesshire, Scotland, on 21 December 1988*. Aircraft Accident Report 2/90.

<sup>118</sup> See Report of the Court Investigating. February 26, 1986. *Accident to Air India Boeing 747 Aircraft VT-EFO, “Kanishka” on 23 June 1985*. Honorable Mr. Justice B. N. Kirpal, Judge, High Court of Delhi.

was being pushed back from the gate at Ninoy Aquino International Airport, Manila, Philippines, on May 11, 1990.<sup>120</sup>

The CVRs recovered from these airplanes all recorded very loud sound events just before they stopped recording. The sound signatures from these events were compared with the sound signatures recorded at the end of the TWA flight 800 CVR recording. Generally, the sound signatures could be characterized based on how quickly the loud noise event rose from the background noise (rise time), the duration of the loud noise event, and how quickly the loud noise event decreased (fall time).<sup>121</sup> The TWA flight 800 CVR recorded noise characteristics that were most similar to those recorded by the CVRs on board the United flight 811 and Philippine Airlines airplanes. The loud noise events recorded by these three CVRs were characterized by longer rise times, durations, and fall times than the loud noises recorded by the CVRs on board the Pan Am and Air India airplanes; the Pan Am and Air India CVR recordings exhibited very fast rise times, very short durations, and very fast fall times. The TWA flight 800 CVR was the only CVR that recorded the change in the airplane's electrical system background noise described in section 1.11.1.1.

### 1.11.2 Flight Data Recorder

The FDR was a Sundstrand model UFDR, S/N 10291, which recorded 18 parameters of airplane flight information on a 1/4-inch magnetic 8-track tape capable of retaining 25 hours of data. The accident airplane's FDR system included a data acquisition unit, which gathered and converted analog flight information to digital data for transmission to the central electronics unit (CEU). The CEU provided a serial binary data stream to the FDR. The 18 recorded parameters included time (Greenwich mean time), pressure altitude, indicated airspeed, magnetic heading, vertical acceleration, longitudinal acceleration, angle-of-attack (AOA), pitch attitude, roll attitude, pitch trim (stabilizer) position, aileron position (sensed at the right inboard aileron), elevator position (sensed on right and left sides), rudder position (sensed for upper and lower panels), flap position (sensed for inboard and outboard flaps on both wings), leading edge devices (sensed for each device—four on each wing), EPR for all four engines, thrust reverser position for all four engines, and VHF microphone keying.

Although the FDR exhibited external and internal impact and water damage, the crash enclosure and recording medium were intact and yielded data of good quality. Examination of the recorded data indicated that although the FDR operated normally until

---

<sup>119</sup> See National Transportation Safety Board. 1990. *United Airlines Flight 811, Boeing 747-122, N4713U, Honolulu, Hawaii, February 24, 1989*. Aircraft Accident Report NTSB/AAR-90/01. Washington, DC.

<sup>120</sup> The Safety Board assisted in the Philippine Government's investigation of this accident. Damage to float switch wiring and a defective fuel quantity sensor were identified as possible sources of ignition; however, a definitive ignition source was not confirmed. For information about the safety recommendations that resulted from this investigation, see section 1.18.1.

<sup>121</sup> The amplitude of the noise was not a reliable means of comparison because these noise events typically overloaded the CVR recording system when they occurred.

it stopped recording at the time of the power loss, some parameters recorded anomalous or erratic values. The following parameters contained frequent data anomalies recorded during the accident and previous flights:

- Aileron position – Recorded values were noisy and erratic.
- Thrust reverser engine No. 3 – During the landing at JFK that preceded the accident, the “transit” indication was displayed while the other three engines indicated a “deployed” condition. (The thrust reverser on engine No. 3 had been mechanically locked in the retracted position by maintenance personnel at JFK before TWA flight 800 departed on the day of the accident. Corrective maintenance was deferred for up to 10 days.)
- Altitude (coarse) – Indicated erroneous altitude values and was unusable.
- Altitude (fine) – Occasionally displayed noisy values.
- Leading edge flap left No. 3 – With the flaps retracted, the “transit” indication remained on. With the flaps extended, the “transit” condition indicated “extended.” The maintenance log contained the following entry: “July 15th, 3L LE flap amber [light] stays on with LE flaps up and retracted electrically. [Forward] panel lights ops check ok.”
- Indicated airspeed – The recorded values were occasionally erratic.

Examination of the FDR data indicated that the data recorded during the accident airplane’s approach and landing at JFK before the accident flight (as TWA flight 881) did not reveal any anomalous airplane or flight conditions. During the first 12 1/2 minutes of the accident flight (from the start of the takeoff roll until 2031:12, when the recording stopped abruptly), the FDR operated continuously and recorded data consistent with a normal departure and climb. The data indicated that the airplane was in a wings-level climb, and the vertical and longitudinal acceleration forces were consistent with normal airplane loads when the recording stopped. Examination of the FDR data revealed that the interruption of the recording at 2031:12 was consistent with the loss of electrical power to the recorder.<sup>122</sup>

## 1.12 Wreckage Recovery and Documentation Information

Pieces of the wreckage were distributed along a northeasterly<sup>123</sup> path about 4 miles long by 3 1/2 miles wide in the Atlantic Ocean off the coast of Long Island. (Figure 21 shows the wreckage location relative to the airplane’s flightpath, JFK, and Long Island.)

---

<sup>122</sup> For additional information, see Flight Data Recorder Group Chairman’s Factual Report (Revision 1), Flight Data Recorder Group Chairman’s Factual Report—Addendum I, and Flight Data Recorder Group Chairman’s Factual Report—Addendum II, all of which are dated February 15, 2000.

<sup>123</sup> At the last point of radar contact, the airplane’s true course was about 75°; the wreckage was generally oriented along a path of about 60° from that last point of radar contact.

The first priority of the early search and recovery efforts was the recovery of victims; wreckage recovery was the second priority.<sup>124</sup>

Throughout most of the search and recovery operation, remote-operated vehicles (ROV), SSS, and laser line-scanning equipment were used to search existing underwater debris fields. This equipment was also used to explore areas outside existing debris fields that might contain victims and wreckage and to videotape the wreckage and ocean floor. Scuba divers and ROVs were used to recover victims and wreckage. In the late stages of wreckage recovery, scallop trawlers were used to recover pieces of wreckage that had become embedded in the ocean floor. (Search and recovery efforts are described in detail in appendix C.)

When pieces of wreckage were recovered, they were typically tagged and numbered according to their wreckage recovery location. Although most tagged pieces of wreckage were tagged on the ship as they were recovered, it occasionally became necessary to cut or separate objects (previously tagged as a whole) into more than one piece. Additionally, some objects were extracted from an entangled group of debris (recovered and tagged as a unit); in some cases, pieces were received in a bag, net, or box full of other items with one tag assigned to the container. Finally, some parts simply broke during handling/transport, leaving some parts untagged. In all of these situations, the recovery position information on the ship tag from the original object or group of objects was transferred to the hangar tag(s) assigned to the separated object(s). The documentation/tagging process is described in detail in appendix D.<sup>125</sup>

Pieces of wreckage were then typically transported by boat to shore through the Shinnecock Inlet, where they were loaded onto trucks and transported to leased hangar space at the former Grumman Aircraft facility in Calverton, New York.<sup>126</sup> Upon arrival at the hangar, investigators worked to identify and document the pieces of wreckage.

---

<sup>124</sup> Very few pieces of wreckage were recovered during the first 2 days after the accident; those that were recovered during this time were found floating on the ocean's surface. Several days of side-scan sonar (SSS) searching preceded the underwater wreckage recovery operations.

<sup>125</sup> During the wreckage recovery phase, an extensive database of recovery information was created. This database contained a variety of information collected during the search and recovery operation, including recovery position data for thousands of parts. Extensive efforts involving representatives from the parties to the investigation were undertaken to cross-check and validate the information in this database. Nonetheless, not all of the recovery positions listed in the database are known with the same degree of certainty. A detailed Data Management Report was prepared to fully document this issue and to ensure proper use of the database. When used in accordance with the provisions of this report, the tags database provides a highly accurate source of recovery data. Recovery position data from the tags database were used in the trajectory study and were mentioned in the Sequencing Group's study report. Safety Board investigators audited the recovery data used in the trajectory and sequencing studies to confirm the quality of the data extracted from the tags database. This validation work confirmed that the data were used appropriately in both of these studies. For additional information regarding the tags database, see appendix D or the Data Management Report, dated November 17, 1997.

<sup>126</sup> Although almost all of the recovered wreckage was transported by boat to shore through the Shinnecock Inlet, during the first few days of recovery, some recovered wreckage was transported to shore through the Moriches Inlet. Additionally, some pieces of wreckage were flown from the ships to the hangar at Calverton.



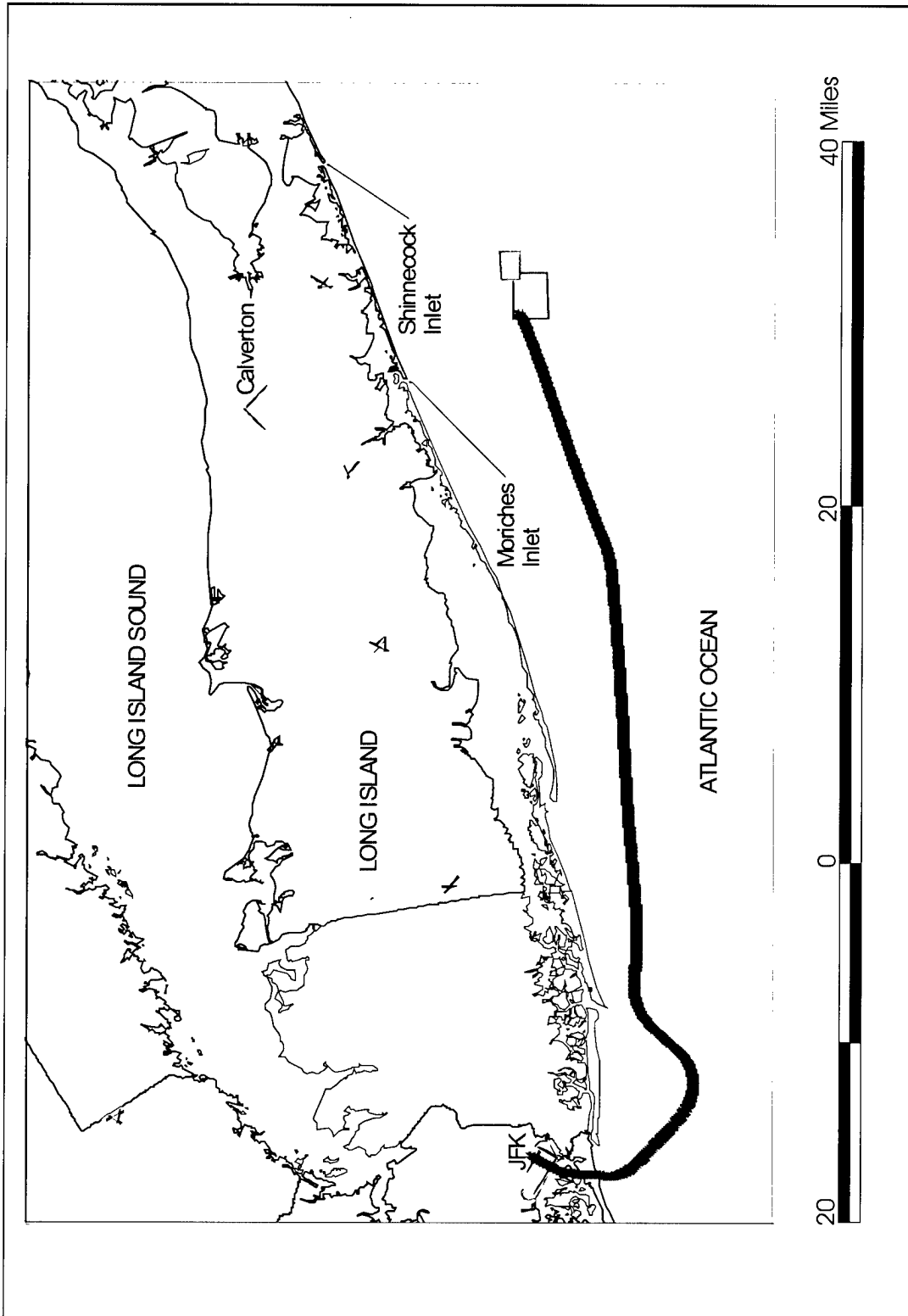

Figure 21. The wreckage location relative to the airline's flightpath, JFK, and Long Island.

The recovery effort took more than 10 months and involved personnel and equipment from multiple agencies and companies. Most of the examination, documentation, and (where pertinent) reconstruction of the recovered pieces of wreckage were completed within 1 year of the accident. However, some wreckage examination was ongoing until mid-2000.

More than 95 percent of the accident airplane wreckage was eventually recovered. Throughout the wreckage recovery and documentation processes, fire and explosives experts and/or metallurgists from the Safety Board, DoD, Federal Bureau of Investigation (FBI), Bureau of Alcohol, Tobacco, and Firearms (ATF), FAA, and parties to the investigation thoroughly examined all recovered pieces of the wreckage for evidence of damage characteristic of a bomb,<sup>127</sup> missile, or high-order explosive (such as hot-particle penetration, pitting, petalling, hot-gas erosion of metal, high degree of fragmentation, hole penetration from outside to inside).<sup>128</sup> No evidence of such damage was found. Where areas of small missing pieces of the airplane were observed in the reconstructions, pieces of wreckage that would have been adjacent to or nearby those areas were reexamined closely. These adjacent or nearby pieces of wreckage contained no evidence of damage from a bomb, high-order explosive (bomb or missile warhead), or from missile warhead entry or detonation.

As previously noted, a few pieces of the airplane structure were recovered floating in the water. The most prominent of these pieces was a very large portion of the right wing, from just outboard of the outboard engine to the wing tip. However, most of the pieces of airplane wreckage were recovered from the ocean floor, predominantly in three identified debris fields labeled by investigators the red, yellow, and green zones, from farthest west to farthest east, respectively. (Figure 22a shows the location of the three debris zones and the Long Island shoreline. Figures 22b and 22c show a 747 and the accident airplane's flightpath, respectively, color-coded to indicate the debris fields from which corresponding wreckage was recovered.) The following subsections provide a general description of the pieces of wreckage (and their major characteristics) recovered from each zone. Additionally, these subsections describe the recovered condition of the accident airplane's engines, CWT fuel pumps and other CWT components, the air conditioning equipment, and the electrical components and wiring. Details of damage and specific characteristics of the various structural pieces are given, as necessary, to support the discussion of the breakup sequence in section 1.16.3. See appendix F for fire damage<sup>129</sup> and soot deposit diagrams for recovered pieces of wreckage from the wings, aft fuselage, CWT, and other selected areas. For additional information, see Fire and Explosion Group Chairman's Factual Report, dated August 22, 1997.

---

<sup>127</sup> For the purposes of this report, the term "bomb" means an explosive device designed to release destructive material at high velocity upon detonation, but does not include an explosive device designed only to set off a small charge of sufficient strength to penetrate the fuel tank and ignite explosive vapors.

<sup>128</sup> Several factors led to speculation that the accident might have been caused by a bomb or missile strike, including heightened safety and security concerns because of the 1996 Olympics then being held in the United States, the fact that TWA flight 800 was an international flight, and the sudden and catastrophic nature of the in-flight breakup.

<sup>129</sup> During the hours after the accident, there were numerous fuel-fed fires on the surface of the water around debris in the green zone. Thus, some of the fire damage and soot deposits found on pieces of wreckage discovered in the green zone may have occurred postimpact.

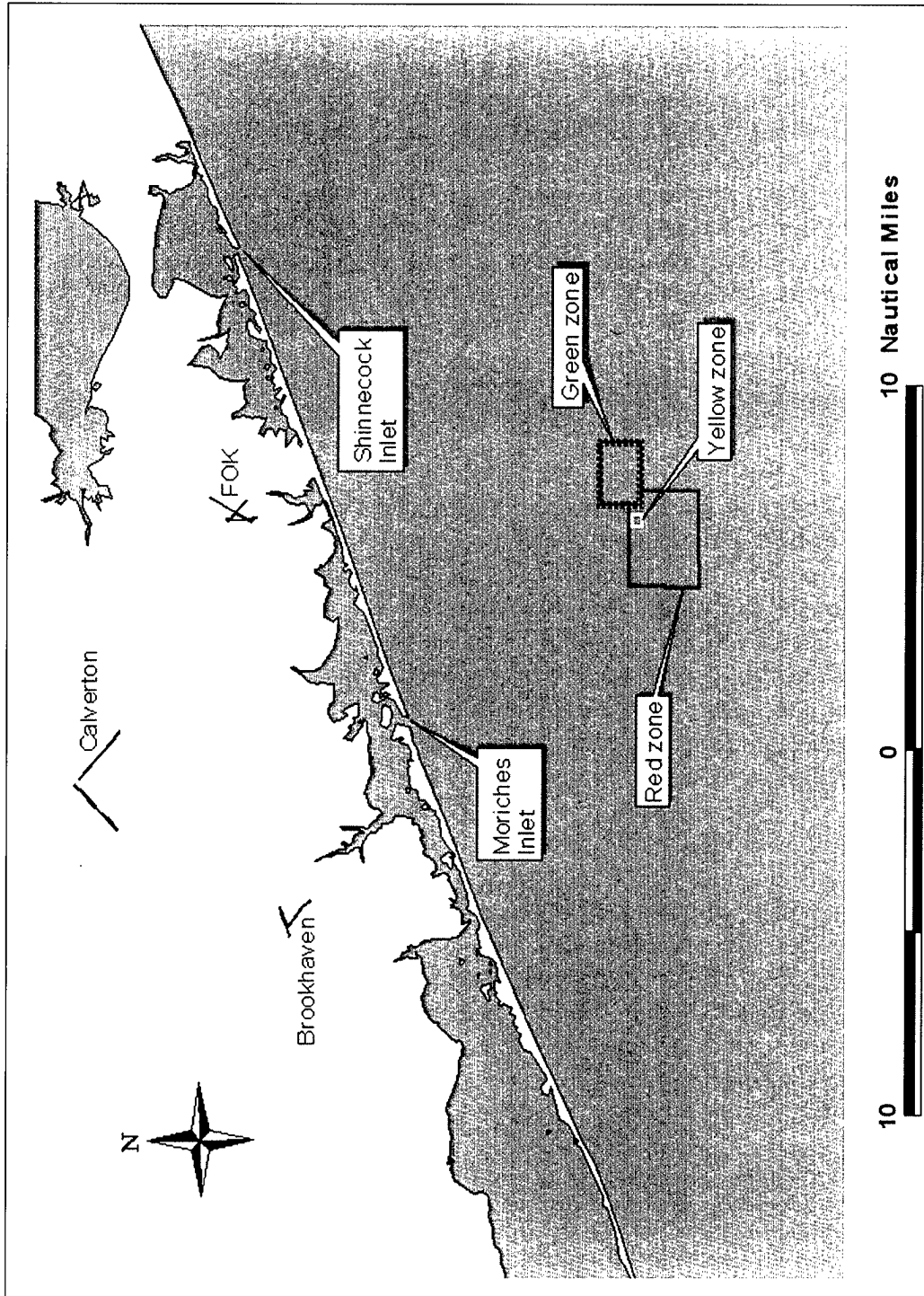

Figure 22a. Map showing the locations of the red, yellow, and green zones.

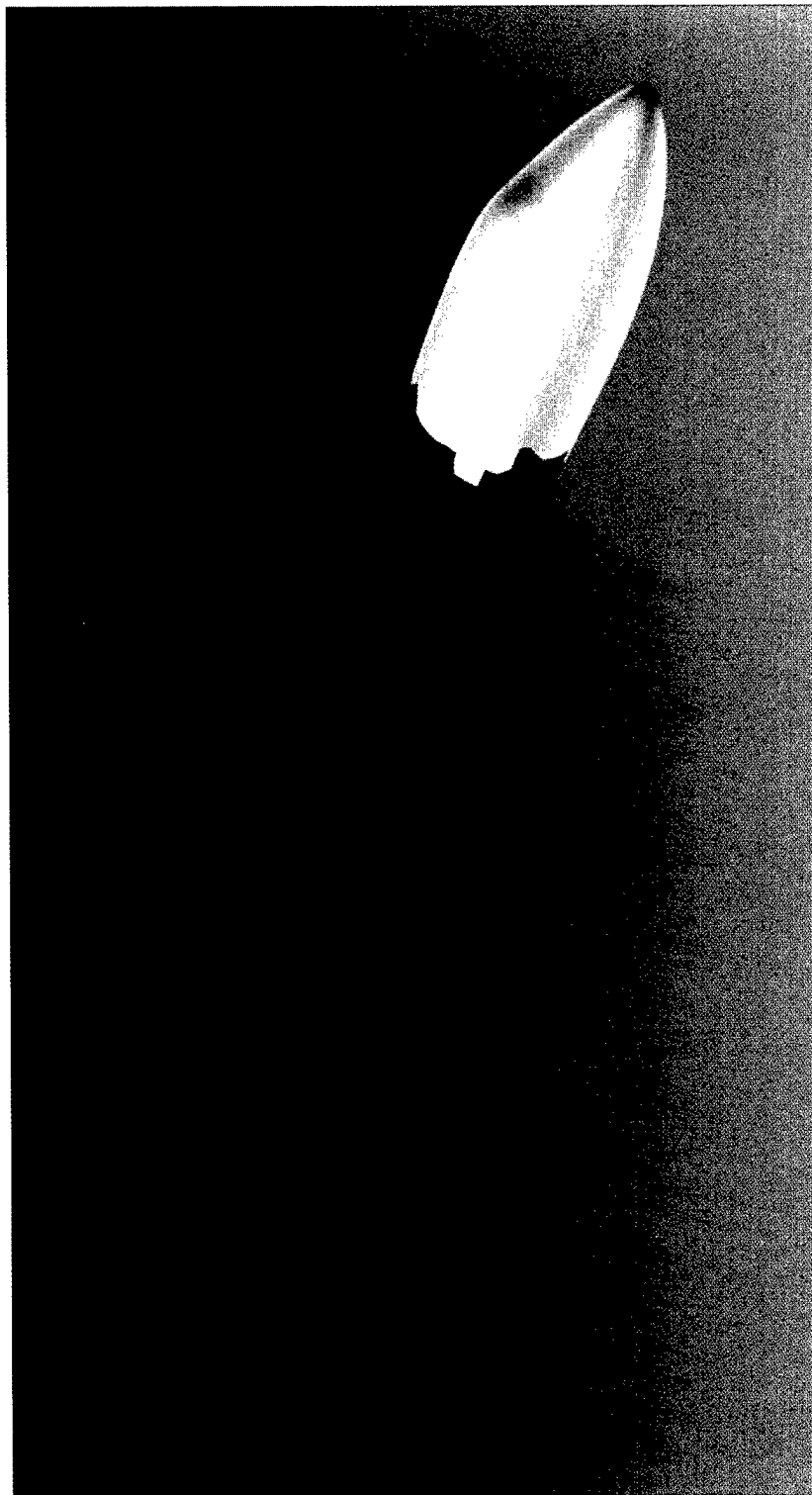
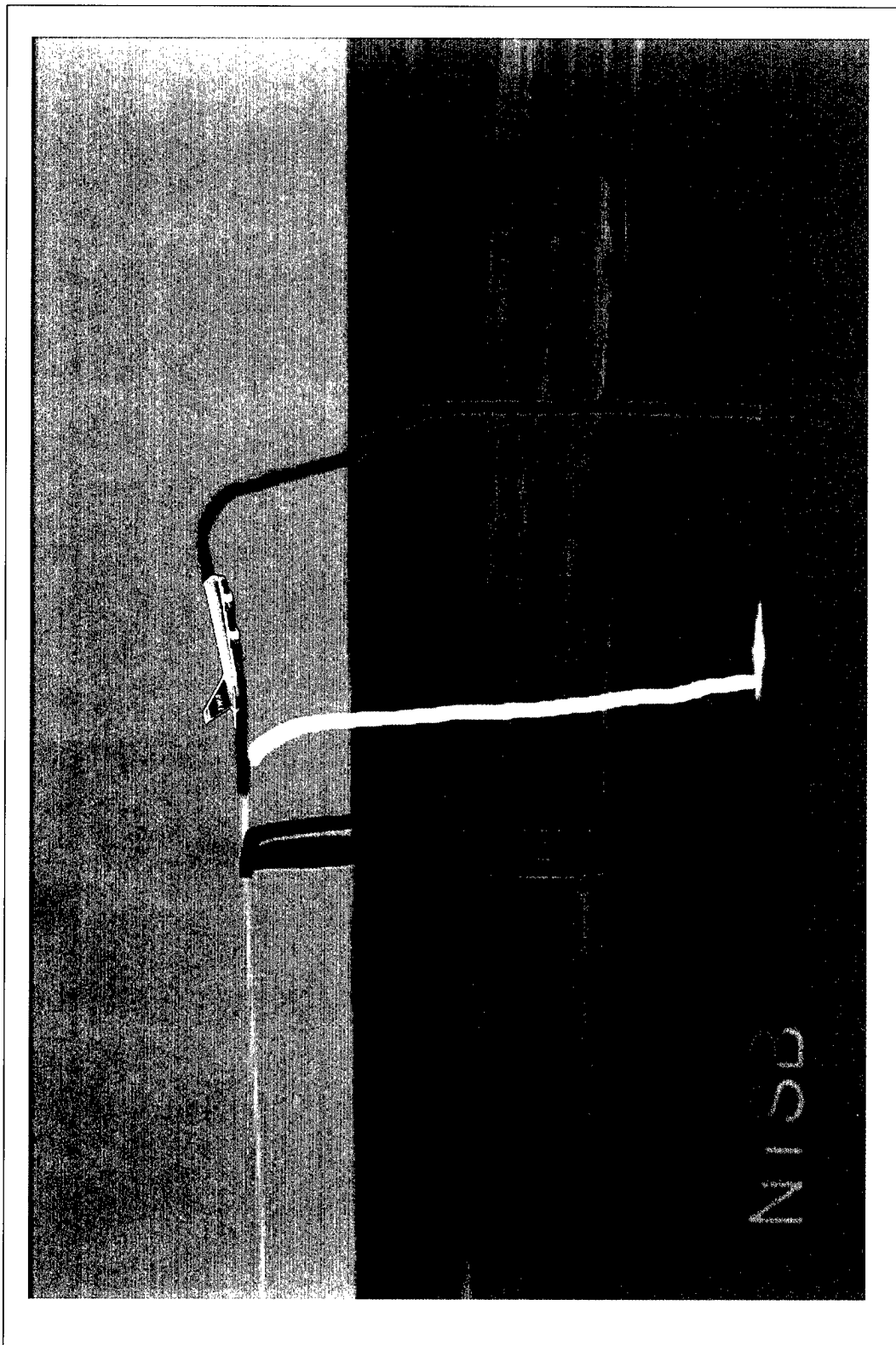

Figure 22b. A 747, color-coded to indicate the debris fields from which corresponding wreckage was recovered.



**Figure 22c.** The accident airplane's flightpath, color-coded to indicate the debris fields from which corresponding wreckage was recovered.

### 1.12.1 Wreckage Recovered from the Red Zone

The red zone was the largest of the three zones and was located farthest west (closest to JFK) in the wreckage distribution. Pieces recovered from the red zone generally included pieces from between about fuselage STA 840 and about fuselage STA 1000 (the aft portion of section 42—see figure 3a for station references); the structure from the aft end of the forward cargo compartment; and pieces from the WCS, including most of the front spar, a large portion of SWB3, and the manufacturing access door from SWB2. Other pieces of wreckage recovered from the red zone included three of the four nose landing gear doors (the fourth nose landing gear door was located in the yellow zone),<sup>130</sup> the forward portion of the keel beam, main cabin floor beams, flooring material from above the WCS, galley C, several passenger seats, two cargo containers, and the two forward air conditioning packs<sup>131</sup> (packs 1 and 3—pack 2 was recovered from the green zone).<sup>132</sup>

None of the pieces of wreckage recovered from the red zone exhibited crushing damage<sup>133</sup> as severe as that found on many pieces of the structure recovered from the yellow and green zones.<sup>134</sup> In addition, although some of the pieces recovered from the red zone contained light soot deposits, none of the pieces contained moderate or heavy soot deposits or any other evidence of exposure to fire. Specifically, no fire damage was observed on the forward portion of the keel beam, air conditioning pack debris, and the fairing material located beneath the CWT.

Two of the four cargo containers that had been loaded in the accident airplane's forward cargo compartment (those located on the left side of the forward cargo compartment) were recovered from the red zone. The sides of these two containers were largely intact, and the damage observed was consistent with water impact. Examination of the forward cargo compartment containers and recovered portions of the forward cargo compartment and forward cargo compartment equipment (including the potable water bottles, floor tracks, cargo container stops)<sup>135</sup> revealed no evidence of preimpact damage to the forward cargo compartment ceiling and/or wiring routed along the ceiling.<sup>136</sup> There was no evidence that the potable water bottles had contacted the cargo containers, and all

<sup>130</sup> For more information about the yellow zone, see section 1.12.2.

<sup>131</sup> For specific descriptions of the air conditioning packs, see section 1.12.6.

<sup>132</sup> According to wreckage recovery documentation, some of the earliest red zone pieces recovered were LF14A and RF1 (pieces of fuselage from the CWT area, left and right sides, respectively), which were recovered on July 24, 1996; CW504 (piece of the front spar), which was recovered on August 7, 1996; and RF35 (piece of right-side fuselage near CWT), which was recovered on August 14, 1996. Many of the pieces recovered from the red zone were recovered several weeks after the accident. For more information about the green zone, see section 1.12.3.

<sup>133</sup> See section 1.16.3 for a discussion of the significance of crushing damage.

<sup>134</sup> See sections 1.12.2 and 1.12.3, respectively.

<sup>135</sup> The floor tracks and the track support structure from the front of the forward cargo compartment were not recovered.

<sup>136</sup> FQIS wiring clips (without FQIS wires) were located along the cargo compartment ceiling at the aft end of the forward cargo compartment.

recovered cargo container stops were found intact and affixed to their respective cargo compartment floor tracks.

### 1.12.2 Wreckage Recovered from the Yellow Zone

The yellow zone was the smallest of the three zones and was contained within the red zone on its northeastern side (see figure 22a). This zone contained pieces of the airplane's forward fuselage, from about STA 840 to the nose of the airplane (STA 90). The wreckage recovered from the yellow zone included nearly all of fuselage section 41 (the nose section) and the forward portions of fuselage section 42. Overall examination of the fuselage pieces recovered from the yellow zone revealed severe crushing damage that extended from the left-side main cabin floor (about 3 feet below the left-side main cabin windows), across the bottom of the fuselage, and to just above the right-side main cabin windows. Pieces of fuselage structure from the top of this portion of the fuselage were found broken into pieces much larger than those from the bottom.

Pieces of wreckage recovered from the yellow zone did not exhibit any evidence of soot deposits or fire or heat damage. No evidence of foreign-object impact to the cockpit windows was found. The two cargo containers that had been loaded on the right side of the accident airplane's forward cargo compartment were recovered from the yellow zone. These containers were more fragmented than the two left-side containers.<sup>137</sup>

Examination of cockpit components recovered in the yellow zone revealed that the altimeters at the captain and first officer positions (which are powered by engine-driven generators on different wings) displayed 13,820 and 13,800 feet, respectively. The clocks at the captain and first officer positions (which are independently set and powered by the airplane battery in the cockpit) stopped at 2031:30 and 2031:20, respectively.

The fuel quantity gauges at the flight engineer position indicated the following fuel quantities: 3,100 pounds in the No. 1 reserve fuel tank; 22,200 pounds in the No. 1 main fuel tank; 57,500 pounds in the No. 2 main fuel tank; 640 pounds in the CWT (indicated by both the electrical and mechanical gauge mechanisms);<sup>138</sup> 60,100 pounds in the No. 3 main fuel tank; 27,300 pounds in the No. 4 main fuel tank; and 3,300 pounds in the No. 4 reserve fuel tank. The fuel-used indicators for the Nos. 1, 2, 3, and 4 engines showed 2,680; 2,710; 23,570;<sup>139</sup> and 2,830 pounds, respectively. The fuel quantity totalizer

---

<sup>137</sup> For more information, see section 1.12.1.

<sup>138</sup> TWA flight 800 dispatch paperwork indicated that the CWT contained 300 pounds of fuel. This reading, which would have been recorded by the ground refueler at JFK, would have been obtained from a repeater gauge at the left wing refueling station; the repeater gauge would register the same quantity as the cockpit gauge. The difference between the 300- and 640-pound readings exceeded the accuracy tolerance allowed by the manufacturer and recorded during certification tests. Tests conducted by the Safety Board during this investigation showed that the application of power to a wire leading to the fuel quantity gauge could cause the digital display to change at a rate of about 1,000 pounds per second (direction and rate of change varied, depending on which wires were shorted). According to circuit breaker trip curve data (see figure 34 in section 1.16.6.2.1), more than 1,000 percent of the rated current could pass through a properly functioning circuit breaker in 0.34 second, indicating that the digital display could change by several hundred pounds in less time than is required to trip the circuit breaker.

indicator<sup>140</sup> indicated a gross weight of between 587,000 and 588,000 pounds and a total fuel-on-board weight of between 169,000 and 170,000 pounds.

The Nos. 1, 2, and 3 crossfeed valve switches were found in the "On" (open) positions, and the No. 4 crossfeed valve switch was found in the "Off" (closed) position.<sup>141</sup> The Nos. 1, 2, and 3 engine fuel flow indicators showed zero fuel flow, whereas the No. 4 engine fuel flow indicator showed 900 pounds per hour.

The Safety Board examined the recovered caution and warning lightbulb indicators<sup>142</sup> for indications of a preaccident malfunction. Lightbulb filaments were examined with 10 X or 15 X monocular microscope magnification or with a variable (75 X maximum magnification) binocular microscope. These examinations revealed that most of the lightbulb filaments, whether intact or broken, exhibited no evidence of distortion or stretching of the filament or individual coils.

The cabin zone temperature control panel (which is located at the flight engineer's position) was severely damaged. The temperature control for Zone 1 was found in the "Cool" position (the coolest setting of the temperature controls). The trim valve indicator for Zone 2 (see figure 6) was found at the "Mid-Heat" position (the warmest setting of the temperature controls). The instrument panel was broken and bent where the air conditioning pack selector switches should have been attached, and the pack selector switches were attached by their respective wire bundles. All three switches were bent upward toward the 12 o'clock position.

Although postaccident examination revealed that the cockpit flap control lever was located between the 10° and 20° extended positions, physical damage to recovered leading and trailing edge flap components indicated that the flaps were in the retracted positions at the time of water impact. The landing gear handle in the cockpit was in the center position, marked "Off," and physical damage indicated that the landing gear was retracted at the time of water impact. The pitch-trim jackscrew was found about 3/4 up from the bottom of the jackscrew (10 screw threads visible above the carriage, 35 threads visible below), which, according to Boeing, is consistent with a climb-trim position.

### 1.12.3 Wreckage Recovered from the Green Zone

The green zone was located farthest east (farthest from JFK) in the wreckage distribution. Most of the airplane wreckage was recovered from this zone, including most of the pieces of both wings, all four engines, and the fuselage aft of about STA 1000

---

<sup>139</sup> The fuel-used indicator for the No. 3 engine was heavily damaged.

<sup>140</sup> As previously indicated, the TWA 747 Operations Manual describes this flight engineer station indicator as a gross weight/total fuel weight indicator.

<sup>141</sup> Although individual switch positions throughout the cockpit wreckage were documented, most of the switches were not locked in position, and many had strands of wire wrapped around the switch toggle.

<sup>142</sup> Many of the caution and warning lightbulb indicators were not recovered, and some of those that were recovered were badly damaged. Loss of power can also affect filament analysis. See Systems Group Chairman's Factual Report, dated November 17, 1997, for detailed information.



(fuselage sections 44, 46, and 48—see figures 3a and 3b for reference). In addition, some pieces from the aft portion of fuselage section 42 were recovered from the green zone. The green zone also contained most of the WCS/CWT, including all recovered pieces from the rear spar, SWB1, the mid spar, SWB2 (except the SWB2 manufacturing access door, which was recovered from the red zone), and the upper and lower skin panels of the WCS. Portions of SWB3 and the front spar were also recovered from the green zone, as were the aft portion of the keel beam, the aft air conditioning pack, the main landing gear, and the tail section.

Examination revealed that some pieces of wreckage recovered from the green zone exhibited heavy soot deposits and severe heat damage. Fire and heat damage (including blackened structure, melted wiring and aluminum materials, and burned composite materials) and heavy soot deposits were found on the following: some pieces from the aft CWT; floor beams and some of the passenger seats located just aft of the CWT rear spar; the portion of the fuselage above the right wing root, including the airplane's external skin, parts of the right wing (including the front spar), and portions of the left wing outboard of the No. 1 engine.<sup>143</sup> Appendix F contains soot deposit/fracture diagrams for the WCS, wings, and fuselage.

The fire damage was particularly severe on a portion of the right-side fuselage structure that remained attached to the inboard section of the right wing (including the fuselage area surrounding the R3 cabin door, located just above the right wing root). Heavy soot deposits were found on the top surface of the right wing. The R3 cabin door, which had separated from the fuselage and was recovered separately, exhibited fire and heat damage and soot deposits on the inside and outside surfaces with some areas of melted-through aluminum. Portions of the door normally shielded by the door frame and portions of the door frame normally shielded by the door also exhibited heavy soot deposits. In addition, severe fire damage was observed on the left side of SWB2, large portions of which appeared to have been melted away.

Examination of the WCS upper skin panel pieces revealed that pieces from the forward left side of the panel exhibited no soot deposits, whereas pieces from the right side of the upper skin panel exhibited moderate to heavy soot deposits. Inspection of pieces of the WCS lower skin panel and the aft portion of the keel beam revealed substantial deformation and some soot deposits. Specifically, most of the lower surface of the WCS lower skin panel exhibited widespread moderate to heavy soot deposits, with the soot accumulation generally heavier on the right side; most of the upper surface of the lower skin panel exhibited light soot deposits, with localized areas of heavy soot deposits.

Most right and left wing wreckage pieces, including the wing tip antennas, were recovered from the green zone, although some small internal pieces of the left wing were recovered from the red zone during trawling operations (late in the recovery process), and some pieces of the right and left wings, including the outboard portion of the right wing, were found floating (early in the recovery process) and were not associated with a specific

---

<sup>143</sup> The fire and heat damage observed outboard of the No. 1 engine on the left wing is discussed further later in this section.

debris zone. The wing landing gear and engines were not attached to the wings when they were recovered. Most pieces of the right and left wing flight control surfaces (including leading and trailing edge flaps, ailerons, and spoilers) were recovered from the green zone<sup>144</sup> and exhibited general impact damage. Many portions of the trailing edge flaps, ailerons, and spoilers and some portions of the leading edge flaps exhibited fire damage and soot deposits.

The outboard sections of both wings had separated from their respective wings just outside of the outboard engines, near wing station 1224. Both separated outboard wing sections were recovered relatively intact; they were about 29 feet long and extended from about wing station (WS) 1224 to the wing tip.

Examination of pieces of the right wing revealed the presence of soot deposits in the fuel tank vent stringers in the right wing structure, the separated outboard portion of the wing, and in the surge tank in the wing tip. Heavier soot deposits were observed on the outboard portions of the attached wing structure, while the separated outboard portion of the right wing and the vent stringers closer to the right wing root contained light soot deposits. Additionally, fire (heat) damage was observed on the upper skin of the right wing section outboard of the No. 4 engine to the location where the most-outboard portion of the wing separated. No fire (heat) damage was observed on the separated outboard portion of the right wing.

Most of the left wing stringers (including vent stringers) between the left side-of-body rib and WS 1224 had separated from the upper and lower skin pieces; these stringers were bent and curled in various directions. The left wing outboard of the No. 1 engine was fragmented and was recovered in many pieces. The most-outboard piece of the left wing that was recovered was a piece of the left wing tip that included the top and bottom wing surface near the surge tank. Light soot deposits were observed on the interior of this piece of wreckage, near the front spar and on the lower surface of the surge tank, near the vent stringer. The fracture surfaces in these areas did not contain soot deposits. Additionally, a relatively large piece of the lower left wing surface from just outboard of the No. 1 engine was recovered; although the internal and fracture surfaces on this piece were clean, light soot deposits were observed on its external surface. The lower surface of the left wing contained soot deposits, with moderate to heavy soot deposits just inboard of the bottom fairing. The upper surface of the left wing was mostly free of soot. The upper skin of the inboard section of the left wing was fractured into numerous pieces, whereas most of the lower skin on the inboard portion of the left wing was recovered in larger pieces.

Fuselage section 44 is located above the wings and extends from the front spar to the aft end of the wheel wells (STA 1480). The 16 main landing gear tires were recovered from the green zone and examined at the hangar in Calverton. All of the tires were found burst with evidence of external forces and exhibited cuts and gouges that were consistent with the recovered wheel well wreckage. No evidence of internally generated failures associated with heat was found on any of the tires.<sup>145</sup>

---

<sup>144</sup> Some pieces of flight control surfaces were recovered floating on the ocean's surface and were not associated with a specific debris zone.

All seven cargo containers that had been loaded in the accident airplane's aft container cargo compartment were recovered from the green zone and were severely damaged in a manner consistent with impact forces. Six of these seven cargo containers were constructed of aluminum and exhibited a similar degree and nature of damage. The seventh cargo container was constructed of fiberglass-reinforced plastic, instead of aluminum, and was shattered.

Fuselage section 46 extends between STA 1480 and 2360. The recovered pieces of the fuselage from this section exhibited a fragmentation pattern similar to that observed on the forward portion of the fuselage, which was recovered in the yellow zone. The upper fuselage structure in this section was found broken into relatively large pieces, while the lower fuselage structure (below the window belt on the right side of the fuselage and below stringers 28 to 31 on the left side of the fuselage) was fragmented into smaller pieces. Most upper fuselage skin pieces were totally or partially separated from the frames and stringers. The lower fuselage pieces exhibited inboard bulging in the skin bays (the area between adjacent stringers and frames), with stringers broken or damaged at most frame stations.

Fuselage section 48 broke into large sections, the majority of which did not exhibit substantial compression damage. Minimal evidence of soot deposits or heat damage was found on pieces of wreckage from the aft portion of sections 46 and 48.

### 1.12.4 Engines

The four engines were found in the green zone separated from the wings. The No. 1 engine had crushing damage along the bottom of the nacelle and the low-pressure compressor (LPC), high-pressure compressor (HPC), and diffuser cases; the No. 2 engine had crushing damage along the right side of the nacelle and the LPC, HPC, and diffuser cases; the No. 3 engine inlet and fan blades were crushed rearward, and the LPC and HPC cases had crushing damage from the front and along the bottom; and the No. 4 engine inlet was crushed rearward, the LPC and HPC cases were crushed axially from the front and inward from the right side, and the diffuser case was crushed along the right side. All of the fan cases and cowls were separated from their respective engines. All engine thrust reversers were also separated from their respective engines; however, examination of the recovered thrust reverser actuators showed that the drive mechanisms were at the head end of the jackscrew, consistent with a thrust reverser stowed position at the time of impact.

The Safety Board's disassembly and examination of the four engines revealed LPC damage consistent with a minimal amount of low-pressure rotor rotation (if any) at the time of impact and HPC damage consistent with some high-pressure rotor rotation at the time of impact. No evidence of uncontainment, case rupture, fire, penetration of an object from outside into the engine, or preimpact damage was found in any of the engines.

---

<sup>145</sup> Although there was no evidence of heat-related damage, investigators observed marks on the surfaces of the four tires mounted on the left wing main landing gear that were not seen on the other tires. (In their stowed positions, these tires would have been located just aft of the CWT.) These marks appeared similar to light soot deposits on the rubber material and exhibited no evidence of exposure to sustained heat or fire.

Additionally, the Board's examination of the APU revealed no evidence of uncontainment, case rupture, fire, penetration of an object from outside into the APU, or preimpact damage.<sup>146</sup>

### 1.12.5 Center Wing Fuel Tank Pumps and Other Components

Both jettison/override pumps from the CWT were recovered, examined, and tested. The jettison/override pumps were impact damaged (especially at the aft ends, where they had been attached to the rear spar), but exhibited no evidence of electrical shorts, arcing, preimpact breaching of the housing, or discoloration of the pump shaft. (Figure 23 is a diagram of a jettison/override fuel pump.) Examination revealed that the jettison/override pumps' thermal fuses and flame arrestor tubes were intact and exhibited no evidence of thermal or flame exposure. The CWT jettison/override pump motors exhibited no evidence of heat-related discoloration; the motor windings were the same tan color as those from the wing fuel tanks. (A similar jettison/override pump was heated in a laboratory test until the thermal fuse melted at slightly less than 400° F, and the motor windings were subsequently found to have darkened substantially.)

The CWT jettison/override pump control switches in the recovered cockpit wreckage were found in the "Off" position. Investigators examined the possibility that any one or all of these switch positions might have been altered during the accident sequence. Unlike the scavenge pump switch (which was recovered damaged in the "Off" position), the jettison/override switches did not have a locking feature, and the recovered switch positions could not be positively related to a preimpact position. The jettison/override switch base damage was consistent with the toggle switch being in the position to which it was spring-loaded and not at the "Off" position. However, according to TWA procedures, with only unusable fuel remaining in the CWT, these pump switches should have been off at the time of the accident. Further, the CVR did not record any comments regarding activation of these pumps.

Although the general condition of the left CWT jettison/override pump was clean, two pieces of a clear, soft, rubberlike foreign material were found on the outside diameter of the motor/impeller housing. Infrared examination by the National Aeronautics and Space Administration (NASA) determined that the material was a silicone-based substance. Additionally, the right jettison/override pump exhibited evidence of rubbing between the impeller edges and adjacent housing surfaces. Overhaul records from Crane Company, Hydro-Aire, Inc. (the pump manufacturer), described similar damage in other pumps and attributed it to worn shaft bearings.<sup>147</sup>

<sup>146</sup> For additional information, see Powerplants Group Chairman's Factual Report, dated February 25, 1997.

<sup>147</sup> Similar, but extensively deeper rubbing damage was found in jettison/override pumps in the Philippine Airlines 737 that had a CWT explosion on May 11, 1990. The Safety Board conducted tests for 2 weeks to determine whether galling between aluminum surfaces within the pump could have ignited flammable vapors. The investigative group was not able to ignite flammable vapors by impeller rubbing or by other types of contact between internal fuel pump components.

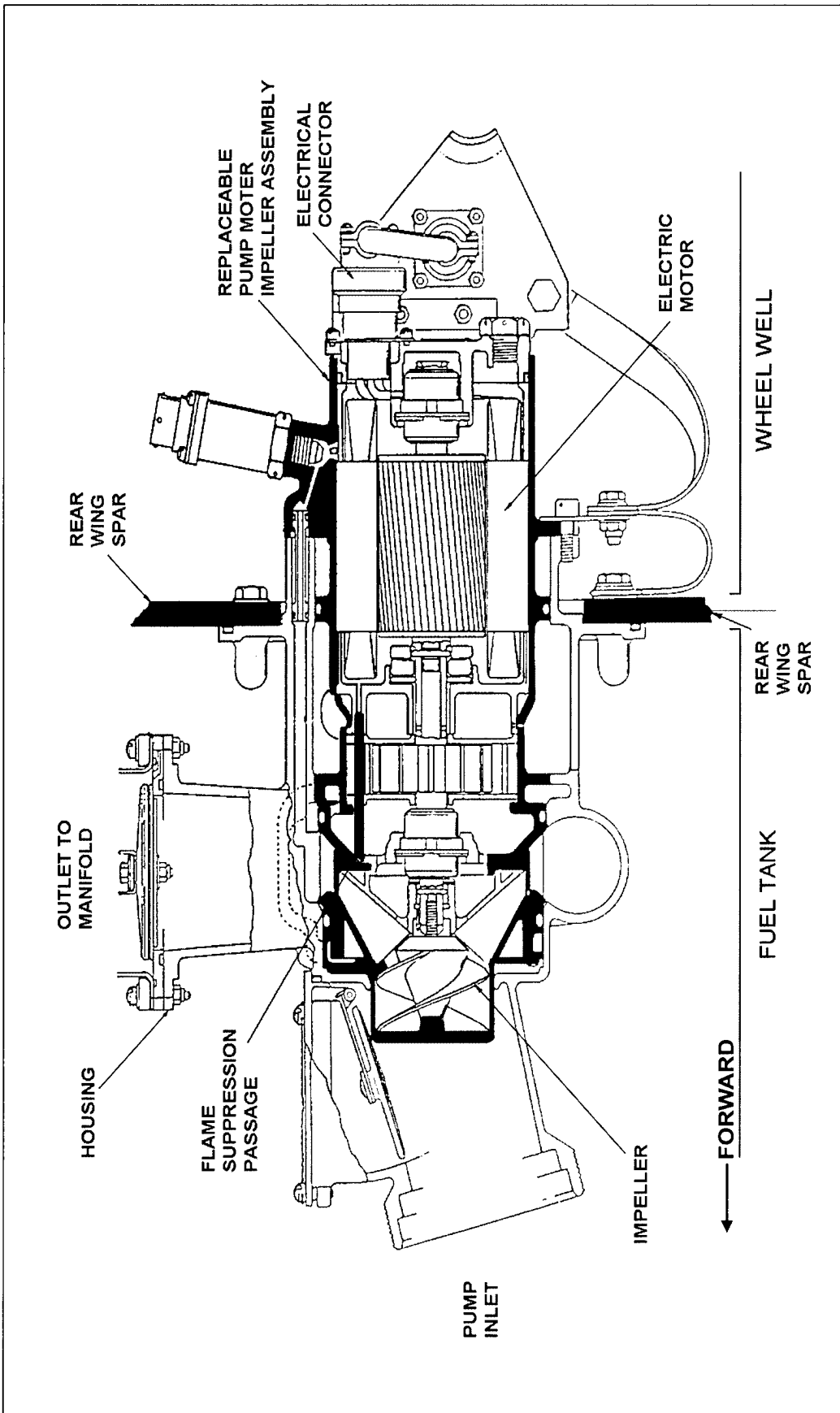

Figure 23. A diagram of a jettison/override fuel pump.

The CWT scavenge pump motor and impeller were not recovered. However, examination of the recovered fragments of related components, including the flange/spacer that was mounted between the scavenge pump and the rear spar, did not reveal evidence that the scavenge pump could have been an ignition source. Examination of the rear spar where the flange would have been mounted revealed a flange-shaped clean area, surrounded by an area of heavy sooting, with evidence of heat damage. There were no soot or fire patterns emanating from the scavenge pump mounting hole in the rear spar, and there was no indication that the heat detectors in the main landing gear wheel well had detected heat.

A 10 3/4-inch-long section of fuel tube assembly with a P/N unique to the CWT scavenge pump pick-up tube was recovered. According to an installation drawing, the tube assembly would have been installed near an opening in the mid spar. Although the outside of the tube contained soot deposits, the internal surfaces had a slightly golden color, similar to the anodize finish seen on other fuel tubing. No evidence of soot deposits or flame flow patterns were observed in the tube that could be related to an ignition source.

### 1.12.6 Air Conditioning Equipment

Air conditioning packs 1 and 3 (the forward-most air conditioning packs) were recovered from the red zone, and pack 2 was recovered from the green zone. Examination of recovered pieces of the three conditioned air systems revealed that numerous ducts and the heat exchanger headers exhibited flattening on the upper surfaces. However, there was no evidence of preimpact leaks that may have abnormally heated the CWT or of an uncontained rotor burst from the ACMs. Disassembly of the ACMs revealed no evidence of preimpact rotational scoring in housing areas adjacent to the impellers. Where the ducting that routed conditioned air from the air conditioning packs to the plenum was found broken or ripped, no localized color changes were observed on the ducting or adjacent materials. Where breaks occurred in heat-affected weld zones on this ducting, the Safety Board's metallurgists found no evidence of fatigue failures.

Some of the titanium ducts that transport hot bleed air from the engine(s) or APU to the air conditioning packs were examined in the Safety Board's Materials Laboratory and found to contain preexisting cracks. According to Boeing, the blue coloration on the exterior surface of the ducts and on the preexisting crack areas indicated that the fractures existed when the ducts were stress relieved during manufacture. On some of the duct fractures, the preexisting cracks extended all the way through the duct wall thickness. The circumferential length of these cracks ranged from between 0.1 to 0.5 inch. There was no evidence that the cracks that extended through the duct wall had extended around the circumference of a duct before the accident.

The turbine bypass valves for the three air conditioning packs were positioned about 10° from the fully closed position. The two recovered ram air inlet doors were found in the fully open position, and the two recovered ram exit actuators were found in the fully retracted (door open) position. According to the Hamilton Standard Service Manual

(HSSM), these positions indicated that the three air conditioning packs were operating to cool the airplane cabin. The recovered flow control valves were found in the closed position. According to the HSSM, a spring would move the flow control valve to the closed position if it did not have positive pneumatic pressure.

In the 747-100, some conditioned air is moved forward from the air duct/plenum chamber (which is located above the WCS and beneath the cabin floor) through what investigators referred to as “the air conditioning long duct,” which begins about STA 1000 (above the front spar) and continues to about STA 1080 (between SWB3 and SWB2). The forward portion of the air conditioning long duct had broken, and three pieces (totaling about 67 inches in length) were recovered and examined. Most of the polyurethane insulation that normally surrounds the air conditioning long duct was missing from these pieces.

#### **1.12.6.1 Brown Splatter Material on Air Conditioning Ducts**

The forward-most piece of the air conditioning long duct was about 14 inches long and exhibited little evidence of fire or heat damage. There was brown splatter material on the outside of the left and lower duct surfaces and on the inside lower surface, extending 3 inches forward from the aft end of this piece of duct. The splatter material continued across the aft fracture surface. The middle piece was about 28 inches long (with the aft end extending to above SWB3) and contained some soot deposits. Brown splatter material extended aft from the forward end of this piece as follows: about 6 inches aft on the right-side inside duct surface, about 12 inches aft on the inside lower surface, and about 16 inches aft (intermittently) on the left-side inside duct surface. The aft-most piece was about 25 inches long and contained darker soot deposits than the middle piece. Brown splatter material extended aft about 4 inches from the forward end on the inside surface of this piece. Some brown splatter material was observed on the inside upper and lower surfaces at the aft end of this piece of duct; the splatter material on the inside upper surface extended forward 8 to 10 inches in spots.

At its forward end (above the front spar), the air conditioning long duct connects to what investigators called the S duct, which curves upward and outboard from the long duct. The aft portion of the S duct, extending 21 inches forward of the air conditioning long duct, was recovered and examined. The polyurethane insulation surrounding the recovered portion of the S duct was damaged and, in some places, missing. In areas where the insulation was missing, the duct appeared to have been scraped. The forward end of the recovered S duct piece was split longitudinally, and the inside surface of the duct exhibited numerous brown splatter material. Similar brown splatter material was also observed on the air conditioning long duct, the left side of the forward upper WCS and the front spar, and on some cabin passenger seats located above and/or forward of the WCS.

The brown splatter material on the upper WCS extended aft along the air conditioning long duct to the point where it met the trim air “Y” inlet. At that location, the insulated metal trim air pipe is attached to the air conditioning long duct by a connector. Examination of the recovered trim air pipe revealed that a portion of the connector was

still attached to the end of the pipe, and no evidence of an overheated condition was found.<sup>148</sup>

### 1.12.7 Recovered Electrical Components/Wiring

The Safety Board thoroughly examined all recovered and identified electrical and FQIS components and wiring (including connections, repairs, bundling, bundle fragments, various loose wires).<sup>149</sup> Almost every piece of recovered wire exhibited damage, including numerous cracks in the insulation (many of which penetrated to the core conductors), extensive abrasions, twists, and cuts; further, salt deposits were found on insulation and on copper where insulation had been breached. (Figure 24 shows wreckage recovered with tangled and damaged wires attached.) Some of the recovered wiring exhibited evidence of electrical arcing; however, there was no evidence of electrical arcing to recovered CWT FQIS wiring (about half of the CWT FQIS wiring was recovered and identified). Microscopic examination (up to 70 X) revealed that the ends of most wires were necked or sheared. Blackened insulation was observed on many wires; however, many of these wires had been routed through the burned areas of the fuselage and right wing root. Figure 18 in section 1.6.1.3 is a general illustration of 747 wire raceways between the cockpit and the aft fuselage, taken from TWA's Electrical/Electronic Wiring Raceway Identification [91-00-00].

Most of the wiring recovered from the accident airplane was found separated from its mounting structure. Some wire fragments in the wings remained attached to the wing structure by production clips, and other wires got tangled with structural wreckage. The majority of the forward fuselage wiring was received at the hangar in Calverton in two sections. Both of these sections were tangled with other debris, which included structural materials and other electrical components; one section included material from the cockpit and upper deck, whereas the other section included material mostly from the E/E bay that had been located between the nose landing gear wheel well and forward cargo compartment.

Because the right side (the flight engineer's side) of the accident airplane's forward fuselage (including the wiring and electrical/FQIS components in that area) was severely fragmented, recovery and documentation of all of the electrical and FQIS components and airplane wiring from that area were not possible. Recovered electrical components from the flight engineer station included the CWT fuel panel (including the quantity gauge and fuel flow indicators), the FQIS wiring connector at the flight engineer station, the resistor installed between the FQIS wire and the attached AIDS wiring,<sup>150</sup> and most circuit breakers (most of which were broken).

---

<sup>148</sup> For additional information regarding the brown splatter material, see section 1.16.4.6.

<sup>149</sup> For additional information regarding wiring in transport-category airplanes, see section 1.18.2.

<sup>150</sup> Resistors are used in circuits to limit the amount of current (amperage), and thus power, that can pass through them. According to Boeing, protective resistors connected to 747 CWT FQIS wiring (including the fuel quantity gauges, VSO unit, AIDS, and fuel quantity totalizer gauge) limit the amperage from an internal short circuit to about 1 milliamp.



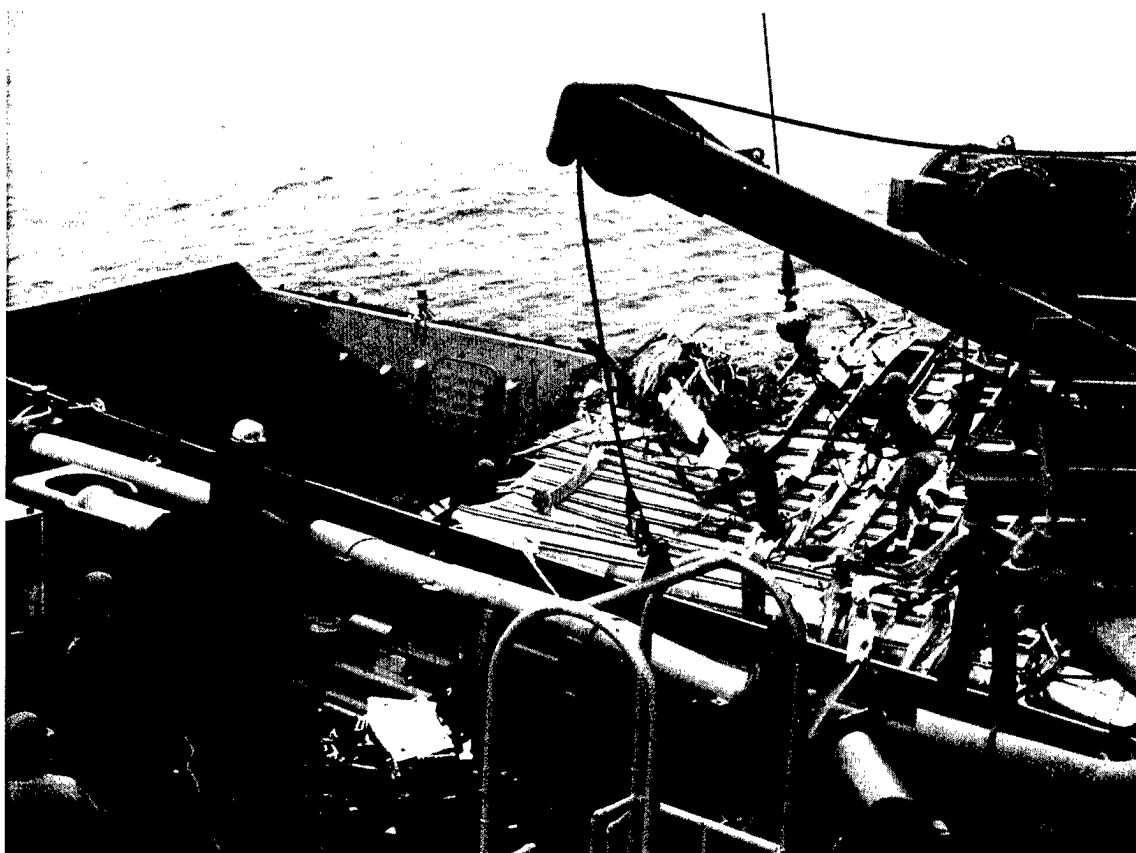

**Figure 24.** A photograph showing wreckage recovered with tangled and damaged wires attached.

Some wiring from the upper left fuselage aft side of the cockpit was recovered in loose fragments, whereas other wiring from this area was recovered tangled with structural debris. The upper deck electronics rack (E11) was recovered as an independent piece of wreckage, with fragments of wire bundles attached. No evidence of fire damage or soot deposits was observed on the recovered forward fuselage electrical components or wiring.

The BMS13-42A Poly-X wire from the accident airplane was stiff and inflexible, whereas recovered Teflon wires (used in the accident airplane's fuel tanks) and samples of BMS13-42A Poly-X wire obtained from a retired 747 (N93117) were supple and pliable. Recovered wiring from the area near the CWT was tangled and exhibited fire damage and soot deposits. About half of the original FQIS wires (as shown in Boeing's 747-100 engineering and production records) were recovered and identified. Although no evidence of arcing was observed on any of the recovered components connected to the CWT FQIS (the fuel quantity indicator, totalizer gauge, AIDS, VSO, and left wing refueling station), examination of other FQIS wires and wires routed adjacent to the FQIS wires revealed possible evidence of arcing in several locations. For example, examination of the recovered wiring and wreckage from the right wing revealed evidence of arcing on

generator cables routed with a wire bundle in the leading edge of the right wing, near the wing root. The right wing front spar was fractured and exhibited evidence of heat damage in the area. The wire bundles had melded into a mass that included wires leading to the right main wing tank (No. 4) fuel flow gauge and also included right wing FQIS wiring that would have been routed through the right wing fuel tanks to a common connection with the CWT FQIS at terminal strip T347.

In addition, two non-FQIS wires that would have been corouted in the same raceway with the CWT FQIS were found with possible arcing or heat damage at STA 955.<sup>151</sup> Copper strands on these two wires had melted and rehardened. The wire bundle fragment had fire damage. None of the adjacent wires in this section of the raceway, including some recovered FQIS wiring, exhibited the same melting/resolidification; however, some FQIS wiring from this area was not recovered.<sup>152</sup>

Fragments from all seven of the CWT fuel quantity probes were recovered; two of these fuel quantity probe fragments contained pieces of their respective terminal blocks. Examination of the recovered terminal block fragments revealed that they exhibited characteristics of the Honeywell Series 4 and subsequent terminal blocks (for example, smooth [unknurlled] surface areas and a nylon strain relief clamp instead of a metal clamp).<sup>153</sup>

An intact compensator was recovered still attached to fuel tank structure from the No. 4 reserve fuel tank; the compensator and fuel tank structure exhibited evidence of fire damage. In addition, a large fragment of another compensator, exhibiting evidence of heat and fire damage, was recovered. This compensator fragment had no identification markings that would associate it with a specific fuel tank; however, the only pieces of fuel tank structure near compensator installations that exhibited evidence of fire damage were from the No. 4 reserve fuel tank and the CWT. Further examination of this compensator fragment revealed that electrical parts inside the attached support tube had soot deposits and exhibited evidence of melting and resolidification and blackening at the bottom edges

---

<sup>151</sup> Maintenance records revealed that several repairs had been conducted in this area, including structural repairs from a burst potable water tank and numerous other floor repairs. Metal shavings were found adhered to recovered fragments of a floor beam from STA 920, within 2 inches of where the CWT FQIS wiring would have been routed in the raceway.

<sup>152</sup> Another location in which evidence of possible arcing might have been observed involved three left wing FQIS wires from a bundle near STA 510. Investigators located a note, written by a member of the Systems Group, which indicated that he observed evidence of "arching (sic)" on the FQIS wires. (The 747-100 CWT FQIS is not isolated from left wing FQIS wiring; during postaccident evaluation of wiring paths on a retired 747, an electrical signal placed on the CWT FQIS wiring was also detected on wiring from the left wing FQIS wiring.) However, subsequent attempts to locate the relevant portion of this wire bundle to confirm this observation were not successful, and some Systems Group members did not recall seeing any such evidence of arcing. (Some other Systems Group members did recall seeing evidence of arcing.) Some parties to the investigation did not believe that this note should be considered significant evidence of arcing.

<sup>153</sup> Honeywell Series 1 to 3 fuel quantity probe terminal blocks had knurled surfaces (relatively sharp pointed cones in the hard plastic) that resulted in sharp edges resembling saw teeth at the terminal block edges. Honeywell Series 4 (and subsequent series) fuel quantity probe terminal blocks did not have these knurled surfaces. Additionally, wires were attached to Series 1 to 3 fuel quantity probe terminal blocks with metal clamps, whereas wires were attached to Series 4 fuel quantity probe terminal blocks with nylon-lined clamps.

of the plastic parts. The soot deposits exhibited an upward flow pattern and were located at the lowest edges of a plastic sleeve that covers a wire shielding connection, two plastic insulators on connectors, and the plastic lead wire support. The general features of each plastic part did not appear to have been molten, and away from the blackened edges each part retained its color. (Recovery records indicated that this intact compensator and the compensator fragment were recovered from the green zone.)

Investigators found that Boeing and TWA wiring documents for the accident airplane did not show all of the wires that were recovered.<sup>154</sup> Additionally, examination of wire configurations in the accident airplane revealed that they did not match those shown in Boeing's technical diagrams. For example, Boeing's PI 61B70126 showed separated wire bundles in a tray located above the CWT. Portions of these bundles recovered from the accident airplane's wreckage were found twisted in a single mass of wires, with no evidence that they had been separated into wire bundles as illustrated in Boeing's PI. Further, the Safety Board's examination of this area of wiring in other 747s (N93117 and N93105), including some operated by TWA, revealed that the wires were apparently not bundled as shown in the PI but were randomly laid in trays.<sup>155</sup>

Examination revealed black spots on crimped FQIS wire connectors, including one on a damaged fuel probe from the accident airplane's CWT. (During the Safety Board's participation in the investigation of a May 1976 Iranian Air Force 747 crash near Madrid, Spain, investigators observed a similar black spot on a wire located adjacent to the site of this crimped wire connector.)<sup>156</sup> X-ray energy dispersive spectroscopy (EDS) examination of the black spot revealed that it contained copper, sulfur, and trace amounts of silver.<sup>157</sup> According to fuel experts at the U.S. Air Force (USAF) Research Laboratory (AFRL) at Wright Patterson Air Force Base, this residue was similar to silver-sulfide deposits<sup>158</sup> that they observed during previous examinations of fuel probes from military airplanes.

The Safety Board's examination of wiring from the accident airplane revealed evidence of damage to electrical insulation on wires that had been attached to FQIS fuel quantity probe terminal blocks. Sulfide deposits were found on some exposed conductors. Much of the damage, which included exposed conductors, was not visible until the wiring was removed from the fuel quantity probe terminal blocks for inspection.<sup>159</sup>

---

<sup>154</sup> Investigators recovered unmarked wiring, which was not shown on the Boeing or TWA documents.

<sup>155</sup> For additional information about the Safety Board's inspections of other airplanes, see section 1.18.2.

<sup>156</sup> See National Transportation Safety Board. 1978. *Special Investigation Report – Wing Failure of Boeing 747-131, Near Madrid, Spain, May 9, 1976*. NTSB/AAR-78/12. Washington, DC.

<sup>157</sup> For the purposes of this report, deposits containing copper, sulfur, and silver will be called silver-sulfide deposits. Silver-plated copper wiring is used in the 747 FQIS. Sulfur is commonly contained in jet fuel. In April 1998, Boeing provided the Safety Board with laboratory reports and other documents that described the presence of sulfur in turbine fuel as early as September 1970 (Budd, B. J. and Sanger, R. P. *Silver Corrosion by Aviation Turbine Fuel*. Institute of Petroleum.).

<sup>158</sup> For additional information regarding sulfide deposits, see section 1.16.6.9.

<sup>159</sup> Similar damage was observed on several other 747 airplanes during postaccident inspections. Some of the exposed core conductors apparently resulted from cold flow (migration or displacement) of the Teflon insulation material, whereas others were apparently the result of mechanical damage.

Additionally, investigators noted that various methods had been used to route wires to and secure them at the fuel quantity probe terminal blocks. In general, two different types of fuel quantity probe terminal blocks were recovered in the accident airplane wreckage—those with knurled surfaces and those without knurled surfaces. (See figure 15.) Investigators observed instances in which adjacent FQIS insulation had been breached near the knurled area of some terminal blocks. Honeywell documents (the Component Maintenance Manual and Overhaul Manual) indicated that both terminal block designs were in service at the time that the accident airplane was manufactured. According to an October 27, 1997, letter from Boeing, “[a] production change was made at Boeing that installed the Series 4 probes in line number 65 and on. [The accident airplane] was line number 164 and was delivered 10/27/71, so it is improbable that it was delivered with Series 3 terminal block probes.”

Examination of the recovered FQIS wires revealed wires that had been repaired for damage that existed before the accident, evidenced in some cases by splices of various types. Several wire repairs were also found that did not comply with standards for repairs or installations used by Boeing or TWA, including the following:<sup>160</sup>

- An oversized strain relief clamp was used on the terminal block of the compensator in the No. 1 fuel tank. The cable harness passing through the clamp was wrapped around to pass through the clamp twice and still was not firmly secured. Chafing was observed on some wires.
- Numerous wire splices were covered by a plastic insulating sleeve over metal barrels, such that the ends of the wire splices were open, with no other wrapping. These wire splices were noted at locations throughout the airplane (including areas exposed to fluid contamination, such as above the potable water tanks on the front spar) and occasionally showed evidence of corrosion.
- Several wire bundles contained numerous wire splices on adjacent wires at the same location. Boeing’s SWPM recommended that wire splices be separated by a minimum of 0.25 inch, and Boeing SL 747-SL-20-048, dated January 25, 1995, stated that “[wire s]plices should be staggered throughout the bundle, this reduces the potential for wire-to-wire chafing and bundle interference.”
- The connector pins in the recovered fuel totalizer gauge contained excessive solder, which appeared to have inadvertently joined connecting pins/wires from the right wing main fuel tank and CWT FQIS. The excessive solder had cracked between the connecting pins.<sup>161</sup>

---

<sup>160</sup> During accident-related inspections of other transport-category airplanes, the Safety Board observed conditions and repairs similar to these in a variety of other airplanes operated by different airlines. For additional information, see section 1.18.2. Also see Systems Group Chairman’s Factual Report, dated November 17, 1997; Systems Group Chairman’s Factual Report—Addendum for Aircraft Wire Inspections and Historical Reports, dated July 28, 1999; and System Group Chairman’s Factual Report—Addendum for Fuel Quantity Indicators, dated February 5, 2000.

<sup>161</sup> Although the cause of the cracking in the solder is unknown, postaccident tests conducted at Honeywell (the manufacturer of the fuel totalizer gauge) revealed that when slightly more than 270 volts was applied to one of the connecting pins, electrical energy would cross the crack in the solder.

## 1.13 Medical and Pathological Information

The bodies of 99 of the 230 airplane occupants were recovered from the surface of the ocean by various civilian, military, and police vessels during the first 24 hours after the accident. U.S. Navy and local police divers discovered most of the remaining victims during the next 3 months; however, some remains were recovered during the trawling operations (the final stage of search and recovery operations, which continued until April 30, 1997). The last recovered human remains were retrieved by a fishing trawler on May 22, 1997. In most cases, when victims were recovered, they were transferred from the dive boats and/or salvage ships to a Suffolk County Police Department boat and transported to the Suffolk County Medical Examiner's Office in Hauppauge, New York.<sup>162</sup> In some cases, victims were transported to shore by helicopter.

Most identifications of occupants were accomplished through the use of fingerprints or dental records. However, in 29 cases, neither of these methods was successful; these cases required the use of deoxyribonucleic acid (DNA) protocols or forensic radiography as the primary means of identification. (Nineteen occupants were identified solely by DNA, and 10 were identified by forensic radiography, either by the medical examiner or the Armed Forces Institute of Pathology.)

Toxicological samples (muscle tissue) from the captain (left front seat), the flight engineer trainee, and the check flight engineer were sent to the FAA's Civil Aeromedical Institute (CAMI) in Oklahoma City, Oklahoma, for examination. Suitable toxicological specimens were not available for the captain/check airman (right front seat). The toxicological results for all submitted specimens were negative for all drugs of abuse<sup>163</sup> and for prescription and over-the-counter medications. CAMI's toxicological report indicated that the presence of small amounts of alcohol in some of the specimens was most likely "from postmortem ethanol production" caused by decomposition.

During the investigation of the accident, the Medical Forensic Group, which included medical/forensic experts from the USAF, the U.S. Navy, the U.S. Army (retired), the FBI, the Safety Board, and the Suffolk County Police Department, was formed to review the available medical and forensic documentation for evidence that an explosive device (bomb or missile) had detonated near any passenger or crewmember. The review revealed no localized areas of damage or injuries in the airplane.<sup>164</sup> In addition, investigators used biomechanical analysis and correlated medical and forensic data with passenger seat assignments<sup>165</sup> and recovered seat damage (422 of the 455 seats on the

---

<sup>162</sup> A temporary morgue at the U.S. Coast Guard (USCG) station at East Moriches was used during the first several weeks of the investigation. The remains of the occupants of TWA flight 800 that were recovered subsequently were transported to the Suffolk County Medical Examiner's Office in Hauppauge, New York, for identification and examination.

<sup>163</sup> The five drugs of abuse tested in postaccident analysis are marijuana, cocaine, opiates, phensylidine, and amphetamines.

<sup>164</sup> If an explosive device had detonated inside the airplane, localized areas of damage/injuries would be expected.

airplane were recovered) to reconstruct injury events as they occurred during the explosion, breakup, and water impact of the accident airplane.

A Medical Forensic Investigation Analysis Report, dated January 28, 1999, and prepared for the Department of Justice/FBI by a medical/forensic expert,<sup>166</sup> concluded the following:

- Exhaustive analysis of all available medical data on the victims of TWA Flight 800 by an experienced team of forensic pathologists, biomechanicists and criminal investigators failed to find any evidence that any victim was directly exposed to a bomb blast or missile warhead detonation. This finding makes it highly unlikely that a localized explosion occurred within the passenger cabin of TWA Flight 800.
- All injuries found in the victims were consistent with severe in-flight break up and subsequent water impact.
- Injury and burn patterns to the victims as well as some body locations suggest that there was a severe break up of the passenger cabin early in the crash sequence.
- Fire propagated in the [cabin zone located above the CWT] after most occupants [of this section] had been ejected. The small number of passengers with burn injuries exhibited only superficial burns consistent with exposure to a flash flamefront.

## 1.14 Fire/Explosion

Physical evidence indicated that an overpressure event<sup>167</sup> occurred in the airplane's CWT.<sup>168</sup> During the resultant airplane breakup, additional fires occurred. Witness documents<sup>169</sup> and physical evidence also indicated that, after the wreckage impacted the water, fuel on the water's surface continued to burn for several hours.

Subsequent examination of the recovered airplane wreckage revealed that significant fire damage was observed only in specific areas, including components from within the CWT, floor beams and some of the passenger seats that had been located above and just aft of the WCS, the portion of the fuselage adjacent to and above the right wing

---

<sup>165</sup> The Safety Board notes that passenger seat assignments may not reflect the seats actually used by all passengers. The accident flight was not a full flight, and passengers may have moved during the ground delay at JFK.

<sup>166</sup> Shanahan, Dennis F., M.D., M.P.H., Colonel, U.S. Army, Medical Corps (retired). For additional information, see Dr. Shanahan's complete report and the Medical Forensic Group Chairman's Factual Report, dated October 17, 1997.

<sup>167</sup> In this report, the Safety Board uses the term "overpressure event" to connote an event in which the pressure in the CWT is increased in a relatively short time to a level at which the structural integrity of the CWT was compromised.

<sup>168</sup> For breakup sequence information, see section 1.16.3.2

<sup>169</sup> For additional information regarding witnesses and witness documents, see section 1.18.4.

root, portions of the right wing, and portions of the left wing outboard of the No. 1 engine. Soot deposits on the fuselage aft of the front spar were only observed on the external fuselage skin; however, heavy soot deposits were observed on the aft portion of the keel beam.<sup>170</sup>

Additional fire and explosion information is contained in other sections of this report, as pertinent. For example, section 1.12 contains descriptions of the fire, heat, and soot damage observed on recovered wreckage. Additionally, sections 1.16.1, 1.16.2, and 1.16.3 contain radar, trajectory study, and sequencing study information, respectively, regarding the airplane's breakup. Also, sections 1.16.5 and 1.16.6 contain additional information regarding heat- and fire-related damage/evidence, research into the fuel/air mixture on board the accident airplane at the time of the accident, the characteristics and combustion behaviors of Jet A vapors,<sup>171</sup> and research and testing to identify the potential ignition location. See appendix F for documentation of soot patterns on pieces of wreckage and appendix G for a list of other fire/explosion-related airplane accidents.

## 1.15 Survival Aspects

Although individuals in various civilian, military, and police vessels reached the accident site and initiated a search for survivors within minutes of the initial water impact, no survivors were located. The accident was not survivable.<sup>172</sup>

---

<sup>170</sup> For more detailed information regarding fire and explosion damage, see Fire and Explosion Group Chairman's Factual Report, dated August 22, 1997. Also, see Fire and Explosion Group Chairman's Factual Report—Appendixes I and II (Sooting/Fracture Diagrams).

<sup>171</sup> Jet A fuel is a kerosene fuel used in civilian turbine engine airplanes. It is composed of a mixture of more than 100 distinct types of hydrocarbon molecules; the precise composition often varies between refinery and by season. Jet A fuel is specified to have a minimum flash point of 100° F. Jet A-1 is a similar fuel, but has a slightly lower freezing point. Although Jet A fuel is available in some other countries, it is used primarily in the United States.

<sup>172</sup> Although some of the accident airplane occupants may not have received injuries that were instantaneously fatal, all occupants received fatal injuries; therefore, the accident was considered non-survivable. Sufficient remains were recovered of 202 of the 230 occupants for investigators to make a determination of the level of severity of the injuries received. The following severity criteria was used: severe trauma was defined as "trauma that resulted in instantaneously fatal injuries"; moderate trauma was defined as "trauma that resulted in fatal injuries that could not be determined with certainty to be instantaneously fatal"; and minimal trauma was defined as "trauma in which fatal injuries were present, but not considered instantaneously fatal." On the basis of these criteria, investigators determined that 183 of the 202 occupants received severe trauma injuries, 15 of the 202 occupants received moderate trauma injuries, and 4 of the 202 occupants received minimal trauma injuries. Occupants identified as receiving minimal trauma injuries were all assigned to seats in zone C of the airplane passenger cabin; two of these four occupants were recovered from the surface of the ocean during the first hours after the accident.

## 1.16 Tests and Research

### 1.16.1 Radar Data Information

The Safety Board reviewed radar data obtained from the FAA (long-range and airport surveillance radar [ASR]), military, and private sites for evidence of a missile or a midair collision. Additionally, the Board used radar information, where possible, to locate and track pieces of the airplane as they fell to the water, to help define the path of the airplane wreckage. The Board used long-range radar data recorded at FAA radar sites at Trevoise, Pennsylvania; Riverhead, New York; and North Truro, Massachusetts. The long-range radar systems at each of these sites are capable of recording data within about a 200-nm radius of the site and completing a 360° sweep about every 12 seconds.<sup>173</sup> In addition, the Board used ASR data from five FAA radar sites, which are located at the following airports: JFK; Newark International Airport, Newark, New Jersey; Long Island MacArthur Airport, Islip, New York; Westchester County Airport, White Plains, New York; and Stewart International Airport, Newburgh, New York. Each ASR site is capable of recording data within about 60-nm radius of the site and completing a 360° sweep about every 4.7 seconds. The Board also reviewed radar data recorded at the Sikorsky Aircraft plant in Stratford, Connecticut. These radar data were fed into the Sikorsky plant from the FAA's Riverhead, New York, radar site and from Sikorsky's own radar site in Shelton, Connecticut. The Sikorsky radar site is capable of recording data within about a 60-nm radius of the site and completing a 360° sweep about every 4 seconds.

At the Safety Board's request, recorded radar data were also obtained from the sites of the USAF's 84th Radar Evaluation Squadron (84 RADES). The 84 RADES uses the same long-range antennas as the FAA (at Trevoise, Riverhead, and North Truro) to gather the raw radar returns. However, the USAF had modified the radar system at North Truro and used its own processing software, which allowed the 84 RADES to estimate the altitude of primary targets.<sup>174</sup> The North Truro radar system recorded a primary target at a location that was consistent with the trajectory of the accident airplane just after the last transponder return from the accident airplane was recorded; this target had an estimated altitude of 14,400 feet. Because of accuracy limitations,<sup>175</sup> this radar data could not be used to determine whether the accident airplane climbed after the nose separated. (Many of the subsequent primary returns recorded a value of 102,000 feet, which, according to the 84 RADES, is a flag denoting that the radar was unable to estimate the height of the target even though a position was determined.)

---

<sup>173</sup> The data recorded at these three radar sites were fed to Boston, New York, and Washington, D.C., ARTCCs; to U.S. Navy sites; and to a private site operated by Sikorsky Aircraft.

<sup>174</sup> At the time of the TWA flight 800 accident, only the North Truro radar system had been modified to record altitude data for primary returns.

<sup>175</sup> The published accuracy for the recorded altitude values is +/- 3,000 feet; however, the error can increase significantly when the range of the radar target increases beyond 100 nm, as was the case with the accident airplane. According to the 84 RADES, the height estimations of higher targets (that is, 20,000 feet msl and above) were more accurate than the recorded height estimations of targets near the accident airplane's altitude.



Recorded radar data from ground-based radar antenna sites can be either primary or secondary in nature. A primary radar target is recorded when a primary radar signal reflects off of an object's surface and returns to the site for processing and display. Primary radar returns contain no identification or altitude information. A secondary radar target is produced when a radar signal is detected by an airplane's transponder,<sup>176</sup> which transmits a coded message in response to interrogation by a ground-based transmitter. Secondary radar returns contain airplane identification and altitude data. All radars reviewed by the Safety Board during this investigation were transmitting and recording primary and secondary data, except the Sikorsky radar, which transmitted and recorded secondary data only.

Although radar used in ATC is intended to display returns from airplane surfaces, unassociated primary radar returns (those that are not associated with any airplane track) are common and can be caused by other surfaces, such as trucks, boats, buildings, weather, flocks of birds, smoke, temperature inversions, and ground/sea clutter. According to FAA Order 6300.13, "Radar Systems Optimization and Flight Inspection Handbook," chapter 3, paragraph 24, dated March 10, 1992, "[t]errain, fixed structures, and surface traffic within line-of-sight range of the ASR antenna system reflect radar energy which can degrade performance of the system. Such reflections can produce...false target displays."

Using the recorded radar data, the Safety Board was able to track TWA flight 800's secondary radar returns from the time that the airplane departed JFK (about 2019) until the time that the airplane's last secondary radar return was recorded (2031:12). The radar data review also revealed multiple sets of primary and secondary radar returns from other airplanes/objects in the area as the accident airplane climbed after takeoff and at the time of the accident.

Examination of the radar data showed the following vehicle and/or object tracks within 10 nm of TWA flight 800 just before the accident (see figure 25):

- A U.S. Navy P-3 antisubmarine airplane was less than 3 nm south-southwest of TWA flight 800 at an altitude of about 20,000 feet msl,<sup>177</sup> moving to the southwest at more than 250 knots ground speed.
- USAir (now USAirways) flight 217 was about 3 nm south-southwest of TWA flight 800, descending through an altitude of about 21,700 feet msl and moving northward.

---

<sup>176</sup> A transponder is the airborne receiver/transmitter portion of a radar system that responds to interrogation signals received from ground-based equipment.

<sup>177</sup> Most of the radar returns for the P-3 were primary radar returns because its transponder was malfunctioning such that secondary signals were available intermittently. During postaccident interviews, Boston ARTCC personnel stated that they were actively monitoring the P-3's primary radar returns, despite the malfunctioning transponder. According to ATC transcripts and postaccident interviews with the P-3 flight crew, the P-3 was at an assigned altitude of 20,000 feet msl when the accident occurred. Further, one secondary radar return with the P-3's assigned transponder beacon code was identified among the primary returns along the P-3's flightpath, and the 84 RADES primary altitude data showed that the P-3 was about 20,000 feet msl.

- TWA flight 900 was about 9 nm west of TWA flight 800 at an altitude of about 19,000 feet msl, moving to the east-northeast.
- An unidentified (primary radar) track was recorded less than 3 nm south-southeast of TWA flight 800, moving southwest about 30 knots ground speed, consistent with the speed of a boat.
- An unidentified (primary radar) track was recorded about 5 nm west of TWA flight 800, moving east-southeast about 15 knots ground speed, consistent with the speed of a boat.
- An unidentified (primary radar) track was recorded about 5 nm west-northwest of TWA flight 800, moving to the south-southwest about 12 knots ground speed, consistent with the speed of a boat.
- An unidentified (primary radar) track was recorded about 6 nm northwest of TWA flight 800, moving to the southeast about 20 knots ground speed, consistent with the speed of a boat.

The radar data also showed several isolated primary returns not associated with any track. (As previously noted, primary radar returns are often recorded from surfaces other than airplane surfaces.)

The Safety Board's examination of all of the available radar data revealed no sequence of primary or secondary radar returns that intersected TWA flight 800's position at any time, nor did it reveal any radar returns consistent with a missile or other projectile traveling toward the accident airplane. No secondary radar returns were received from TWA flight 800 after 2031:12; however, after 2031:12, numerous new primary radar returns appeared near the accident airplane's last recorded radar position, some of which were visible for up to 20 minutes after the last secondary radar return was received from the accident airplane. The primary radar returns that appeared near the accident airplane after 2031:12 were recorded largely in two areas of dense concentration, located about 1 to 1 1/2 miles east-northeast and 1 1/2 to 2 1/2 miles northeast of the last secondary radar return, respectively (see figure 26).

#### **1.16.1.1 Information Regarding Certain Primary Radar Targets Recorded by the Islip, New York, Radar Site**

The Islip, New York, radar data showed one particular sequence of eight primary radar returns about the time of the accident (see figure 27) that warranted further review. On the basis of the times of and distances between these primary radar returns, the target appeared to be moving away from TWA flight 800's position at a ground speed of more than 400 knots. The first of the eight radar returns was recorded at 2030:15, more than 6 nm southeast of the accident airplane. The last of these returns was recorded at 2031:30 (18 seconds after TWA flight 800's last secondary return), about 15 miles southeast of TWA flight 800.





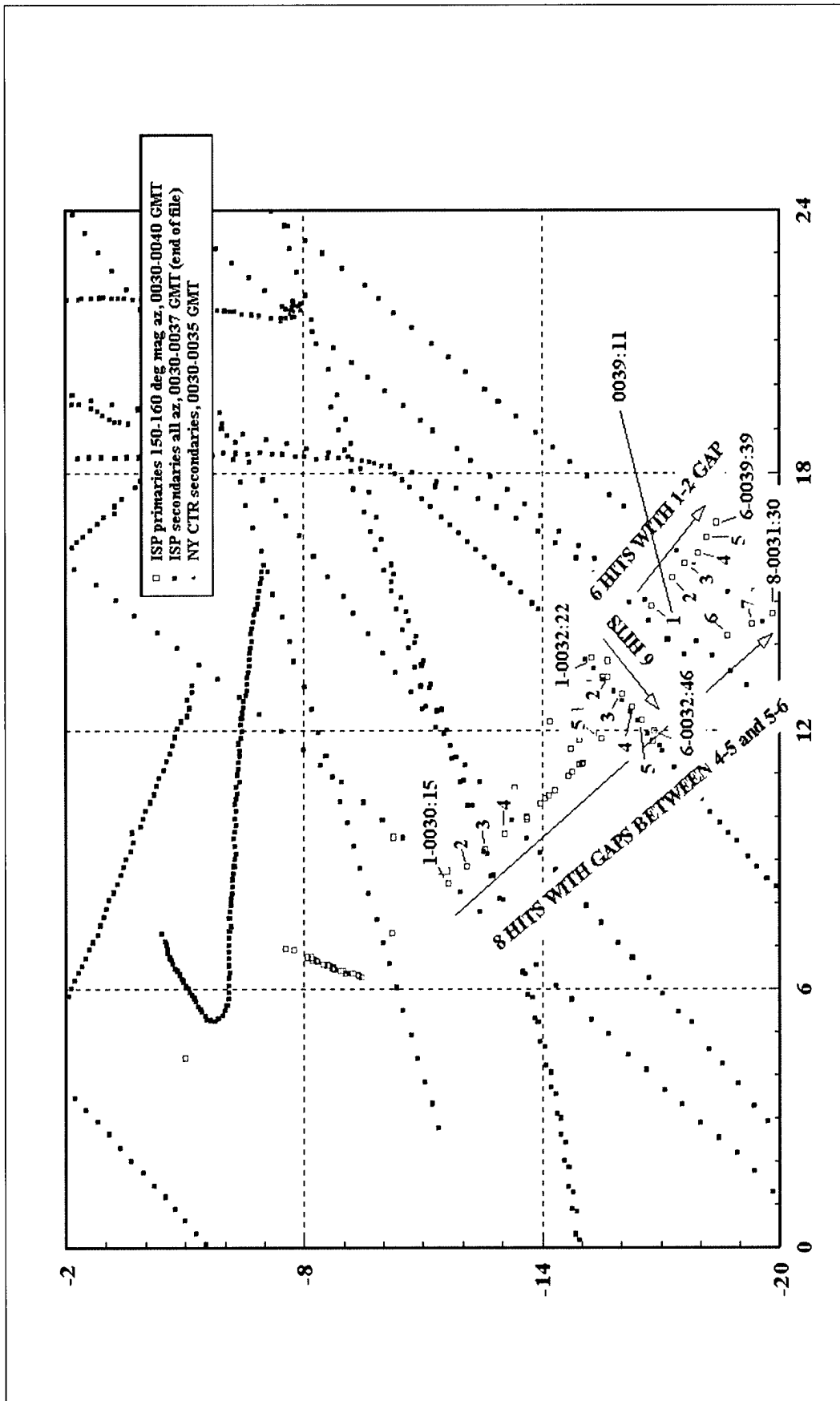

Figure 27. Sequence of eight primary radar returns recorded by the Islip, New York, radar site about the time of the accident.

Although most of the radar systems from which the Safety Board obtained data were capable of recording radar targets in the geographic area in which these primary radar returns were recorded, this sequence of eight primary radar returns was only observed in the data from the Islip radar site. Further examination of the returns recorded in that geographic area by the Islip site between about 2030 and 2040 revealed two additional sequences of primary radar tracks with apparent ground speeds greater than 300 knots. One of these sequences indicated a radar target movement away from TWA flight 800 to the southeast, whereas the other sequence indicated a target movement away from TWA flight 800 to the southwest.

In all three cases, the sequences of primary radar targets appeared with no radar track leading to them and disappeared after four to eight intermittent returns. The returns in each of these sequences were irregularly spaced and had varying signal strengths. The azimuth of each of the sequences was  $150^{\circ}$  to  $160^{\circ}$  relative to the radar, and there were no primary or secondary tracks leading to or away from them. None of the three sequences intersected TWA flight 800's position at any time.

Investigators learned from air traffic controllers and radar technicians that ground or building reflections of primary radar returns from airplanes flying in one geographic area can cause "false primary" targets to be recorded as though the airplanes were flying in another geographic area. FAA documentation and review of the area around the Islip radar site showed numerous buildings and structures that could create such reflections. Investigators identified commercial airplanes traveling through other areas within the coverage of the Islip radar at the same time that the three sequences of primary radar returns were recorded; these airplanes had similar ground speeds to those indicated by and flightpaths that were not inconsistent with the three sequences of primary radar returns.

During its investigation of this accident, the Safety Board became aware of several allegations of potentially suspicious radar targets, including the following: (1) that the Islip primary radar data showed evidence of groups of military surface targets converging in a suspicious manner in an area around the accident site and (2) that a southwesterly bound 30-knot primary track just south-southeast of the accident site was involved in foul play, as evidenced by its failure to divert from its course and assist with the search and rescue operations.

With regard to the first of these radar targets, the Safety Board examined the U.S. military records for the time of the accident, which showed that there were no military surface vessels within 15 nm of the accident site at the time of the accident. In addition, the U.S. military "Warning and Restricted Areas Information Log" dated July 17 and 18, 1996, indicated that all warning areas in the area of the accident were available on July 17, 1996, for concurrent use by nonmilitary aircraft (not scheduled for exclusive military use) except for the following:

- Air operations were scheduled in warning area W-387A/B (closest point about 160 nm south of the accident site) between 2030 and 2230.
- Air operations were scheduled in warning area W-107 (closest point about 60 nm south of the accident site) between 1330 and 1600.

With regard to the second potentially suspicious radar target, the Safety Board reviewed the 30-knot primary target recorded by the Islip radar site on the night of the accident to determine why it did not divert from its course and proceed to the area where the TWA flight 800 wreckage had fallen. The Board's examination of radar data showed that at the time of the last TWA flight 800 secondary return (2031:12), the 30-knot target was about 3 nm south-southeast of TWA flight 800 and headed south-southwest. On the basis of the target's position relative to TWA flight 800 and the likely forward-looking perspective of the target's occupant(s), the occupants would not have been in a position to observe the accident airplane's breakup and/or subsequent explosions/fireball(s). Additionally, it is unlikely that the occupants would have been able to hear the TWA flight 800 event over the sound of its engines and the ambient noise associated with the hull's displacement of water. Further, if the occupants were in an enclosed bridge or cabin, the chance of seeing or hearing the TWA flight 800 event would be even further diminished. Further, the Board reviewed the Islip radar data for other similar summer days and nights in 1999 (3 years after the accident) and found numerous slow offshore primary tracks consistent with those found at the time of the accident. The Board's review indicated that such tracks were consistent with normal commercial fishing, recreational, and/or cargo vessel traffic.

## 1.16.2 Trajectory and Main Wreckage Flightpath Studies

### 1.16.2.1 Trajectory Study Description and Results

During its investigation of the TWA flight 800 accident, the Safety Board conducted a trajectory study in which it used the known winds aloft and the weights and estimated aerodynamic characteristics of selected pieces of wreckage<sup>178</sup> to help predict the likely timing of those pieces' separation from the airplane and their motion during the subsequent descent to the water. The results of the trajectory study were used in combination with other information, such as radar data, wreckage recovery locations, and the metallurgical experts' examination of the wreckage reconstruction, to help determine the sequence<sup>179</sup> of the airplane's structural breakup.

A ballistic object's<sup>180</sup> trajectory is determined by its ballistic coefficient, which is the weight of an object divided by the product of its drag coefficient multiplied by its area.<sup>181</sup> Thus, a foam ball (which has a very low ballistic coefficient) would fall slowly when released from an initial point in space, moving almost exclusively with the wind to its ground location. In contrast, a bowling ball (which has a high ballistic coefficient) would fall rapidly when released from an initial point, with very little displacement resulting from the wind.

---

<sup>178</sup> The trajectory study concentrated on items recovered from the red zone, the westernmost search area along the wreckage path.

<sup>179</sup> For further information about the Safety Board's sequencing study, see section 1.16.3.2.

<sup>180</sup> For the purposes of this report, a ballistic object is one that has no stable lift.

<sup>181</sup> For specific information regarding individual objects' ballistic coefficients, see the Trajectory Study Group Chairman's report, "Trajectory Study, Supporting Material," dated October 14, 1997.

The Safety Board used time-step simulation<sup>182</sup> to calculate the paths of selected pieces of wreckage from the airplane's position at the time of the initial event (based on FDR data) to that object's recovery location.<sup>183</sup> The Board used its BREAKUP computer program<sup>184</sup> to determine the trajectories of pieces of wreckage that had separated from the airplane.<sup>185</sup> The program begins with the pieces of wreckage at an altitude and airspeed consistent with the airplane's last recorded FDR data, then predicts the movement of those pieces through the air, and generates coordinates for the impact location of these pieces of wreckage.<sup>186</sup>

In general, the trajectory study indicated that pieces of wreckage recovered from the red zone departed the airplane during the first few seconds after the initial event, followed shortly thereafter by the separation of the forward fuselage (recovered from the yellow zone). As outlined in the following section, the remainder of the airplane flew for a time in crippled flight and did not exhibit ballistic behavior until about 40 seconds after the initial event (when the WCS failed); pieces of wreckage from this portion of the airplane were recovered from the green zone. In general, the results obtained in the trajectory study were consistent with other evidence, including the Metallurgy Structures/Sequencing Group's (Sequencing Group) findings regarding the airplane's breakup.<sup>187</sup> However, the trajectory study's results for two wreckage pieces (RF35 and CW504)<sup>188</sup> suggested that these pieces separated before the airplane's last secondary radar return, which was not consistent with other (CVR, FDR, radar data, and sequencing study) evidence. The Safety Board's trajectory study indicated that these pieces of wreckage did not behave ballistically.<sup>189</sup>

### 1.16.2.2 Main Wreckage Flightpath Study Description and Results

The Safety Board conducted a series of computer simulations to examine the flightpath of the main portion of the fuselage (including the wings, most of the WCS, aft

---

<sup>182</sup> Time-step simulation calculates a new position, velocity, flightpath angle, etc. for each piece of wreckage using accelerations calculated for the previous iteration.

<sup>183</sup> According to Oceaneering personnel, the documented wreckage recovery locations were estimated to be accurate to within 100 meters. However, the accuracy of documented recovery locations varied depending on recovery platform and global positioning system (GPS) equipment type and wreckage type. (Some small pieces were collected in baskets and then lifted to the ship; only the basket location was documented.)

<sup>184</sup> The BREAKUP computer program is a FORTRAN program developed at the Safety Board that, given an initial position and velocity vector, calculates the time history of the trajectory of a piece of wreckage (defined by its drag and weight).

<sup>185</sup> The winds used in the trajectory study were interpolated from upper air data measured by a radiosonde balloon launched from Upton, New York, on July 17, 1996, at 1934 (see table 3 in section 1.7).

<sup>186</sup> For more details regarding this process, see the Trajectory Study Group Chairman's report, "Trajectory Study," dated October 14, 1997.

<sup>187</sup> For more information, see 1.16.3.2.

<sup>188</sup> For additional information regarding CW504 and RF35, see the Trajectory Study Group Chairman's report, "Trajectory Study," dated October 14, 1997. Also, see the Data Management Group Chairman's report, "Data Management Report," dated November 17, 1997.

<sup>189</sup> See the trajectory study for possible explanations for this nonballistic behavior.



fuselage, and empennage) after the forward fuselage separated. Investigators configured the Board's workstation-based flight simulation computer program to enable simulations that would reflect the thrust, mass, and longitudinal aerodynamic characteristics of an intact 747-100, based on Boeing's 747-100 engineering data. Then, investigators modified the engineering code so that the simulation would reflect the aerodynamic and mass property changes that Boeing estimated would have occurred when the forward fuselage separated.<sup>190</sup>

The separation of the forward fuselage would result in significant changes to the weight and balance and aerodynamic characteristics of the airplane, substantially modifying its flight characteristics. Boeing's engineers estimated that the airplane's c.g. would move aft from 21.1 to 57.8 percent MAC; the airplane's total weight would decrease by almost 80,000 pounds; and the airplane's moments of inertia would decrease significantly when the forward fuselage separated. Further, the aerodynamic loads that would normally result from air impacting and flowing over the smooth forward fuselage would be replaced by the loads created by air impacting and flowing over the blunt open fuselage, which would result in increased drag and altered airflow across the inboard sections of the wings. When the predicted weight and balance changes were considered with the predicted aerodynamic effects, an initial net nose-up pitching movement was indicated.

After the Safety Board's flight simulation computer program had been modified to account for the changes in the 747-100's mass and aerodynamic characteristics, investigators conducted simulations to identify the airplane's motion during the seconds before and after the separation of the forward fuselage. The simulation "airplane" was positioned at the altitude, airspeed, and pitch angles last recorded by the FDR and then flown through the loss of forward fuselage without further flight control input. The modified mass and aerodynamic characteristics were applied to the remaining fuselage until it began to break up,<sup>191</sup> after which the remaining pieces of wreckage exhibited ballistic behavior. Because investigators could not positively determine engine power settings after the FDR stopped recording, the Board performed simulations using each of the following engine power settings: (1) the accident airplane's last recorded power setting (climb power), (2) engine power off, and (3) full engine power. The results of these simulations indicated that variations in engine power would not have significantly affected the path of the crippled airplane.

Rather than develop a simulation for all combinations of aerodynamic characteristics, the Safety Board bracketed the estimated range of effects by conducting a "fast" simulation (using maximum nose-down pitching moment and minimum drag and lift coefficients), a "slow" simulation (using minimum nose-down pitching moment and maximum drag and lift coefficients), and an "intermediate" simulation (using midrange

---

<sup>190</sup> Because it is not possible (with existing technology) to precisely quantify these changes, Boeing's engineers estimated a range of values for the airplane's aerodynamic characteristics after the forward fuselage separated.

<sup>191</sup> Physical evidence described in the sequencing report (see section 1.16.3.2) indicates that the wings failed and separated outboard of the outboard engines followed by failure of the WCS adjacent to the left wing.

data). Further, the Board varied the timing of the forward fuselage separation, conducting simulations with nose departure times at the beginning, middle, and end of the 4-second interval indicated for possible forward fuselage separation by the trajectory study. Table 4 shows scenarios involved in the simulations.

**Table 4.** A time line of simulation scenarios.

Clock Time(s)	Event
2031:12	Initial event
2031:15.2, 2031:17.2, 2031:19.2	Forward fuselage separation
2031:46	Wing tip failure
2031:50	WCS failure adjacent to left wing

The Safety Board's simulations indicated that the longitudinal response of the airplane to the loss of the forward fuselage (with no flight control input) was to climb to above 16,000 feet msl. However, the airplane's lateral response to the loss of the forward fuselage (with no flight control input) was less clear. Evaluation of primary radar return data (from radar sites at White Plains, Islip, and JFK) indicated that after the initial event, the main portion of the airplane may have turned north after the forward fuselage separated and then turned south toward the main wreckage recovery site in the green zone. However, there was considerable scatter in the radar data after the in-flight breakup, and the recorded radar tracks differed, such that data from the Islip and White Plains radar sites indicated a more pronounced turn to the north followed by a turn back south, while data from the JFK radar site indicated a much straighter path to the wreckage site.

Simulations were run using bank angle inputs to match the radar data. The slow and intermediate simulations that used a nose departure time at the beginning of this interval did not match the radar data, nor did any of the simulations that used a nose departure time at the end of this interval. The fast simulation that used a nose departure time at the beginning of the interval could provide close matches with data from all three radar sites with different bank angle inputs. Simulations with a nose departure time in the middle of the interval did not match the Islip and White Plains radar points; however, intermediate and fast simulations with a nose departure time in the middle of the interval matched the JFK radar data. (See figures 28a through 28e.) The Safety Board's simulations indicated that the maximum altitudes that might have been reached by the TWA flight 800 aft fuselage after separation of the nose section ranged between 15,537 and 16,678 feet msl.

In addition to the uncertainties caused by radar track variation, radar data scatter, and imprecise aerodynamic characteristics previously discussed, there are uncertainties in the timing and physics of the final breakup that affect the final seconds of the simulations. The timing of the wing tip and WCS failure were based largely on witness statements;<sup>192</sup> therefore, they are not precise to the second. Further, the change in aerodynamics caused by the wing tip failure at a high AOA is uncertain, as is the effective ballistic coefficient of the main body after the WCS failure.

<sup>192</sup> For more information, see section 1.18.4 and appendix H.

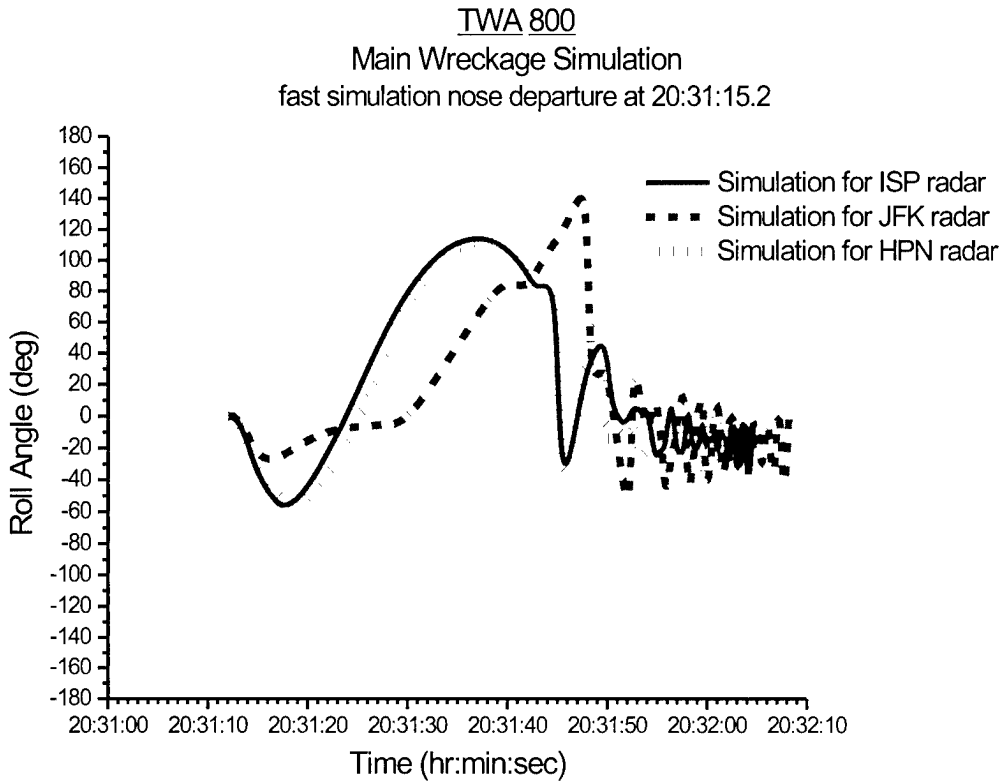

Figure 28a. Roll angle for nose off at 2031:15.2 cases.

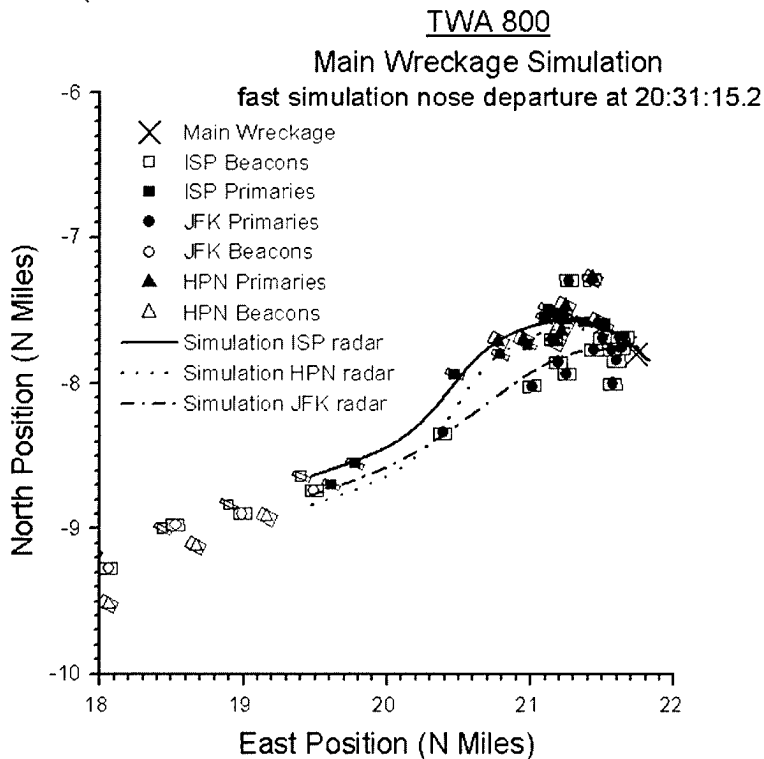

Figure 28b. Map view of nose off at 2031:15.2 cases.

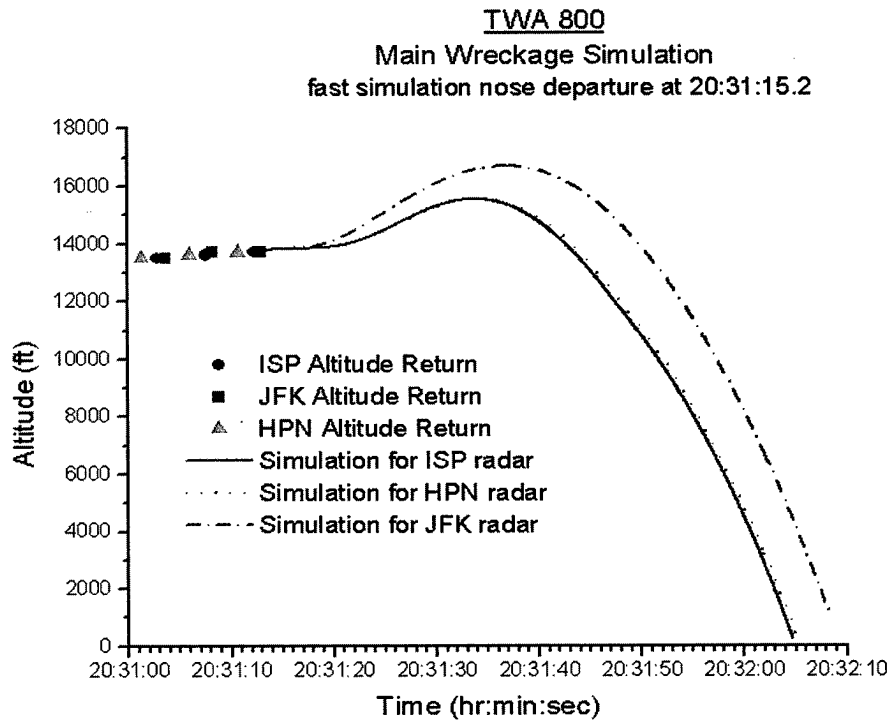

Figure 28c. Altitude for nose off at 2031:15.2 cases.

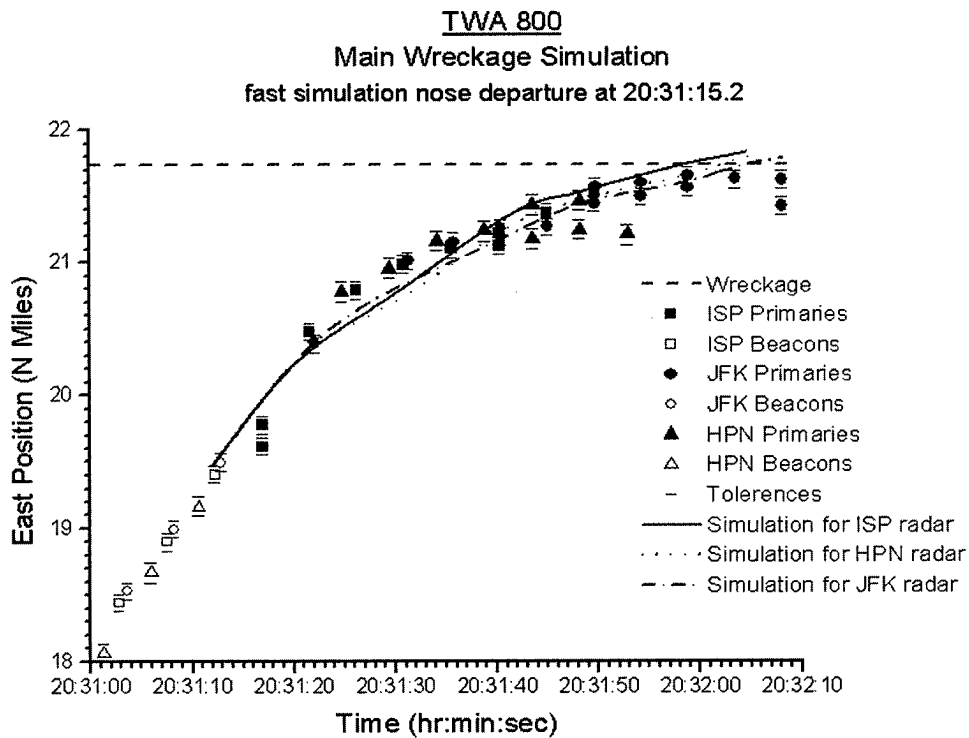
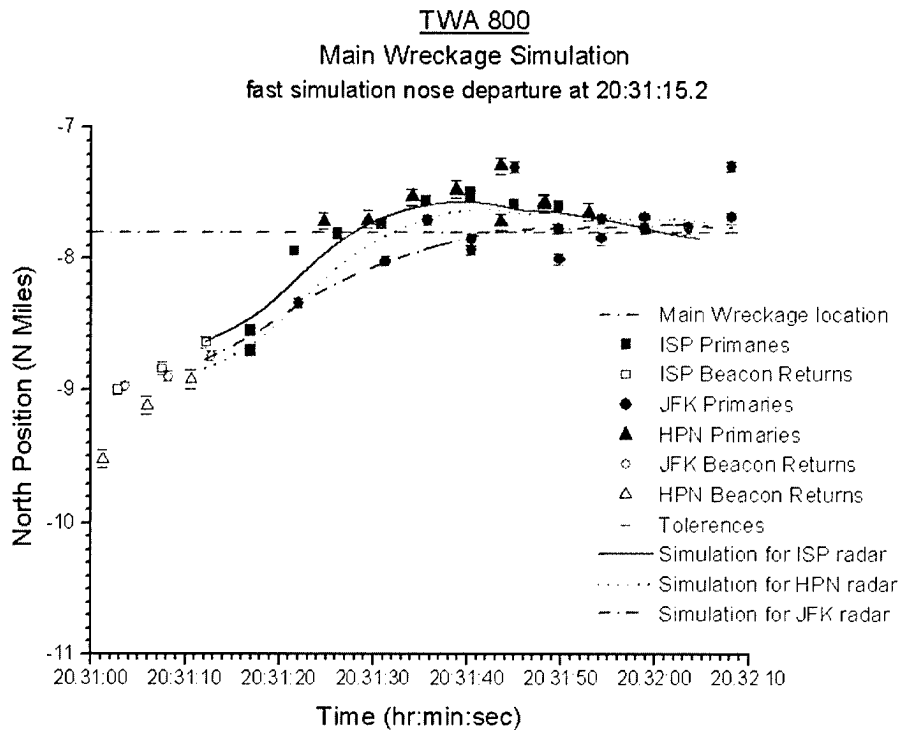

Figure 28d. East position for nose off at 2031:15.2 cases.



**Figure 28e.** North position for nose off at 2031:15.2 cases.

### 1.16.3 Sequencing Study Information

In December 1996, the Safety Board formed the Sequencing Group, which comprised Safety Board investigators and representatives from the parties to the investigation, to evaluate the sequence of the airplane's structural breakup and correlate and compare proposed accident scenarios with the structural observations. To this end, the Sequencing Group examined individual pieces of the recovered structure, two-dimensional reconstructions or layouts of sections of the airplane, and various-sized three-dimensional reconstructions of portions of the airplane.<sup>193</sup> The Sequencing Group also evaluated the relationship of the location of pieces of wreckage at the time of recovery<sup>194</sup> to differences in fire effects (soot deposits on surfaces and fractures, changes in electrical conductivity) noted on pieces that are normally mated or adjacent to each other. The following subsections discuss the two- and three-dimensional reconstructions of the recovered airplane wreckage, the Sequencing Group's examinations of the wreckage, and the accident airplane's breakup sequence identified by the Sequencing Group.

<sup>193</sup> For additional information regarding the reconstructions, see the Reconstruction Group Chairman's Factual Report, dated October 7, 1997; the Medical Forensic Group Chairman's Factual Report, dated October 17, 1997; and the Fire and Explosion Group Chairman's Factual Report, dated August 22, 1997.

<sup>194</sup> For descriptions of most of the pieces of wreckage found in the red, yellow, or green zones, see sections 1.12.1, 1.12.2, and 1.12.3.

### 1.16.3.1 Two- and Three-Dimensional Reconstructions

Several two-dimensional grids were marked on the hangar floor in Calverton, corresponding to Boeing's drawings of the 747's various major structures and components (fuselage, right and left wing structures, cabin interior [including seats, galleys, and lavatories], empennage, landing gear, and WCS). After the individual pieces of wreckage were identified and placed in the appropriate location on the corresponding grid, the structure was examined by the Sequencing Group.

Between August 1996 and January 1997, the WCS/CWT was reconstructed in the following three separate small three-dimensional mockups: (1) the rear spar, SWB1, mid spar, SWB2, SWB3, centerline rib, and the WCS upper panel; (2) the front spar, forward lower panel pieces, keel beam, and adjacent fuselage pieces; and (3) the remaining WCS lower panel. Investigators also assembled separate three-dimensional reconstructions of the forward and aft cargo compartments, air conditioning packs, underwing fairing, nose landing gear wheel well, fragments of fuel tank assemblies and components, and the cockpit instrument panels. These three-dimensional reconstructions were assembled informally, with investigators grouping various combinations of parts, in an attempt to understand spatial relationships between damaged components. Additional documentation of individual components and pieces of wreckage was conducted while the pieces were in these reconstructions.

In the spring of 1997, investigators assembled a 93-foot-long, three-dimensional reconstruction of the center portion of the airplane's fuselage (from about STA 520 to about STA 1632, including the CWT, the main landing gear bay, the surrounding fuselage, and the furthest inboard pieces of the wings) in the hangar in Calverton.<sup>195</sup> Pieces from smaller three-dimensional reconstructions were incorporated into the large three-dimensional reconstruction. Additionally, the Airplane Interior Documentation Group inventoried, examined, and identified all recovered airplane interior components and (where possible) placed those interior parts in the interior of the 93-foot long, three-dimensional reconstruction. This larger three-dimensional reconstruction of the center portion of the fuselage provided the Sequencing Group with useful information about damage patterns and failure sequences. (Figure 29 is a photograph of the right side of the large three-dimensional reconstruction, with the support scaffolding visible.) Examination of the 93-foot long, three-dimensional reconstruction revealed that the largest area of unrecovered or unidentified fuselage structure in the vicinity of the CWT was about 1 square foot. However, the underlying structural pieces (stringers and/or frames) were recovered in each area of missing fuselage and revealed no evidence of through penetration.

---

<sup>195</sup> In December 1996, the Safety Board contracted with Wiss, Janney, Elstner, and Associates, Inc., to design, fabricate, and assemble the required framework, devise the means by which the various pieces of airplane wreckage could be attached to the framework, and connect the pieces of airplane wreckage to the framework. Some truss fabrication and erection tasks were subcontracted to Syracuse Rigging, and steel fabrication was performed by Delhi Steel Corporation. The reconstruction of this portion of the airplane occurred between February and late May 1997.

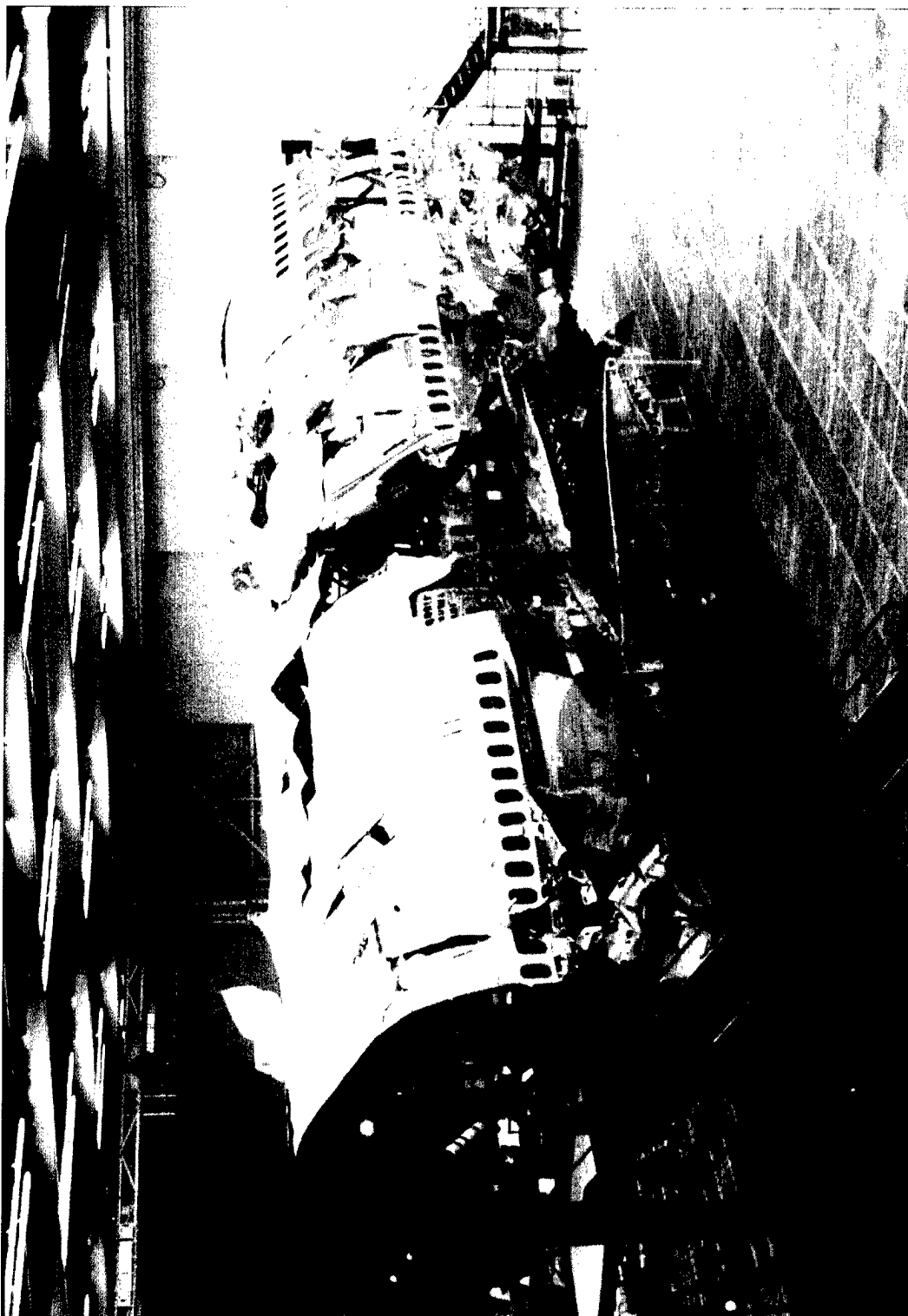

**Figure 29.** A photograph of the right side of the large three-dimensional reconstruction, with the support scaffolding visible.

### 1.16.3.2 Airplane Breakup Sequencing Study Information

As previously discussed, pieces of the forward portion of the WCS (including some pieces from the CWT) and the fuselage directly forward of the wing front spar were recovered from the red zone and (consistent with the Safety Board's trajectory study) were, therefore, among the first pieces to separate from the airplane. Pieces of wreckage from forward of about STA 840 were found primarily in the yellow zone. Further, most of the remainder of the airplane (including the wings, major portions of the WCS, the aft fuselage, and the empennage) was found in a relatively small area in the green zone, indicating that this portion of the airplane remained intact for some time after the separation of the forward fuselage section.

The Sequencing Group also conducted detailed visual examinations, occasionally with magnifications up to 30 X, of the separated structure, with primary emphasis on the WCS and fuselage pieces recovered from the red zone. Fracture directions, deformations associated with pieces adjacent to the fractures, and witness marks were evaluated on many of these pieces of wreckage. The group determined fracture directions based on visible fracture features that indicated local fracture propagation direction (such as chevron marks and river patterns [a series of small steps in a fracture that indicate the local direction of crack propagation]), the presence of branching cracks, and rivet-to-rivet fracture features.<sup>196</sup> Deformation associated with a fracture indicated how the pieces on each side of the fracture were moving relative to each other as the fracture occurred.<sup>197</sup> Witness marks demonstrated the direction of motion of the structure as it separated and deformed. All of these evaluations provided the Sequencing Group with information about initial areas of separation. The Sequencing Group also used stress analysis<sup>198</sup> to reinforce that the proposed scenarios for the breakup sequence were consistent with structural properties and expected failure modes.<sup>199</sup>

---

<sup>196</sup> Rivet-to-rivet fracture direction was determined by identifying a smaller crack that usually initiated from a rivet hole in front of the main (larger) crack and then turned to meet the main crack. With fractures thus divided into longer and shorter legs between rivet holes, the longer leg would indicate the primary direction of fracture propagation.

<sup>197</sup> Fuselage skin fractures that did not contain out-of-plane deformation were classified by the Sequencing Group as "having occurred earlier in the sequence because these fractures must have occurred while the associated fuselage pieces were still aligned with each other nearly in the correct position." Fuselage skin fractures that did contain out-of-plane deformation (either bending or tearing) were classified by the group as "having occurred later in the sequence because the associated pieces of fuselage must have been out of alignment with each other before the fracture occurred." Fuselage skin fractures along a row of rivet holes that were consistent with in-plane loading (hoop or longitudinal tension with the possible presence of in-plane shear) were classified by the group as "having occurred earlier in the breakup sequence than fractures with out-of-plane bending or shear deformation."

<sup>198</sup> Stress analysis is the science of using calculations to estimate stress. Inputs into the calculations include information on, for example, material properties, component dimensions, structural conditions, and load amounts and directions.

<sup>199</sup> In addition, Boeing calculated failure strengths for the various CWT components (spars and beams) and the pressures at which the CWT components would fail and provided the results to the Safety Board. For more information about these calculated failure strengths and pressures, see section 1.16.4.9.



The Sequencing Group examined portions of the structure in great detail and then developed localized sequence segments based on the observable features in each portion. The group agreed that any proposed sequence for an individual portion of the structure had to comport with the general breakup sequence indicated by the overall recovered structure, including the early separation of forward portions of the WCS and a ring of fuselage material from forward of the WCS. Individual sequence segments were combined, until a cohesive and comprehensive breakup sequence, consistent with the overall body of evidence, was generated.

The detailed examinations of the fuselage red zone pieces are an example of how these examinations were successful in determining an important segment of the breakup sequence. Figure 30 shows a schematic drawing of the lower portion of the fuselage skin in the area forward of the front spar. In this figure, the earlier fuselage skin fractures have been highlighted, and arrows have been added to indicate the direction of cracking in these earlier fractures. Of all of the fuselage fractures examined, only a limited number (all of which were on pieces recovered from the red zone) could be classified as earlier fractures (that is, consistent with in-plane loading). Further detailed examination of the rivet-to-rivet fracture pattern in these earlier fuselage fractures generated information on crack propagation directions and indicated that the earliest fracturing was of the lower fuselage, beginning at the front spar of the WCS. (The methodology used to determine the sequence of fracture in the fuselage red zone pieces was typical of the approach used for the entire airplane structure.)

On the bases of its detailed examination of the recovered airplane structure (which, as previously indicated, considered fracture features and other physical evidence, recovery locations, etc.),<sup>200</sup> the Sequencing Group determined that the initial failure of the airplane structure was the spanwise fracture of SWB3 at its upper chord. The sequencing report identified an overpressure event within the CWT as the cause of the fracture of SWB3. According to Boeing's calculations, SWB3 is the weakest of the boundary members of the CWT and would be the first member expected to fail as pressure within the tank increased. As discussed in the next several paragraphs, evidence of the overpressure event within the CWT was apparent in the upward lifting of the center of the CWT upper skin as SWB3 failed at its upper chord, in the subsequent forward rotation of SWB3, and in the forward bowing of the front spar as it fractured.

As the upper portion of SWB3 rotated forward, hinging on the still-attached lower chord, the upper chord impacted the aft side of the upper skin panel stiffener immediately forward of SWB3. (Figure 31 shows the approximate shape of this stiffener and its location before being struck by SWB3 as the beam rotated forward.) A geometrical layout of SWB3 and the upper and lower skin panels indicates that the forward rotation of SWB3 about its lower chord would result in an impact on the vertical flange of the stringer about 1.8 inches above the lower edge of the stringer (assuming no relative motion between the upper skin panel and SWB3). However, in the center of this stiffener, a witness mark was

---

<sup>200</sup> See Metallurgy/Structures Sequencing Group Chairman's Factual Report Sequencing Study, dated April 8, 1997.

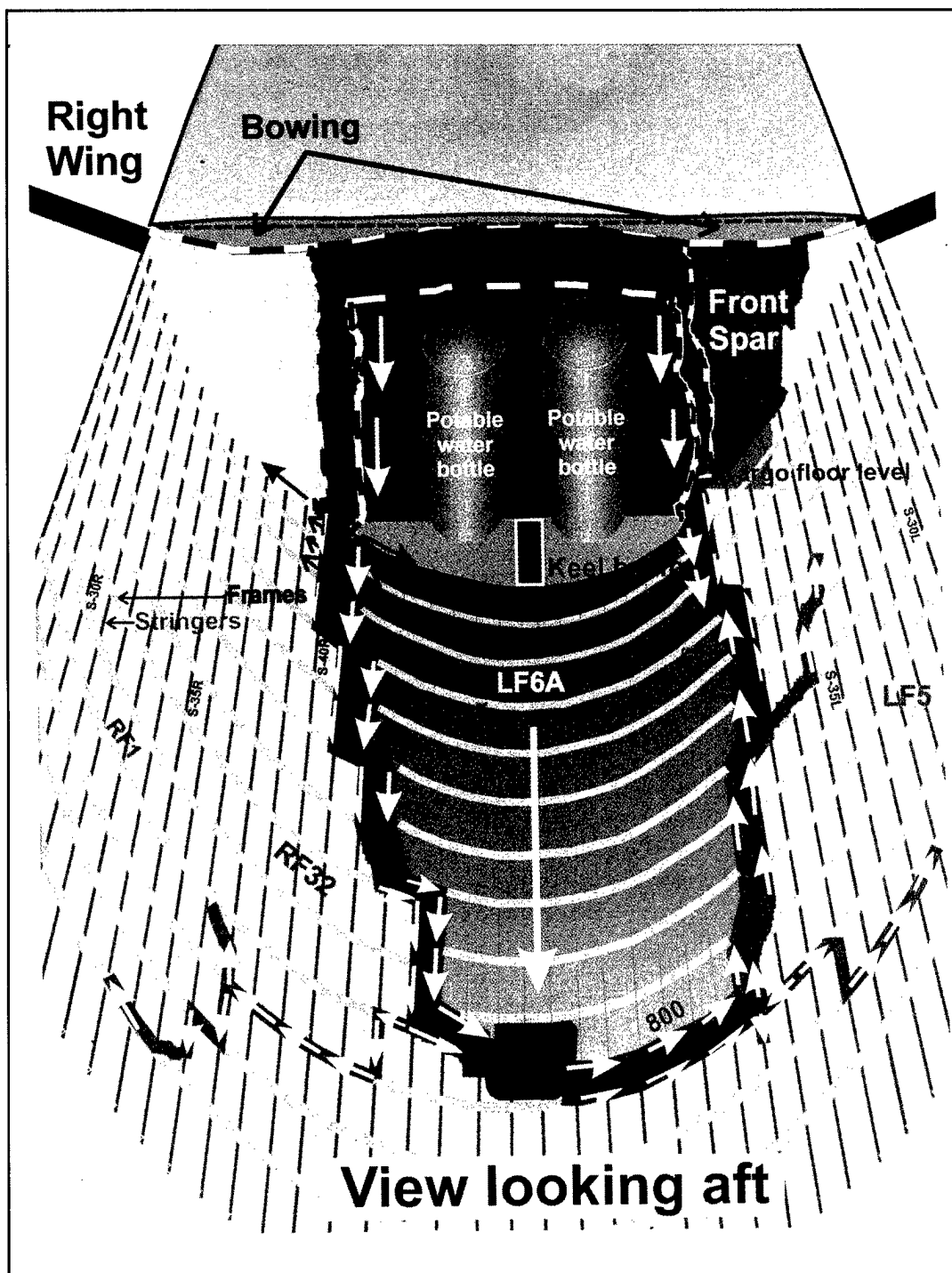

Figure 30. A schematic drawing of the lower portion of the fuselage skin in the area

noted at a distance of only 0.9 inch above the lower edge of the stringer. The difference between these values represents an upward vertical displacement of 0.9 inch between the upper and lower skin panels along the airplane's centerline when SWB3 impacted the stringer. The distance of the witness mark from the bottom of the stringer's vertical flange gradually increased at positions further outboard, indicating lesser amounts of upward vertical displacement outboard of the centerline. According to the sequencing study, the location of the marks left on the stiffener by SWB3 indicate that the upper skin of the CWT was likely bowed upward, apparently also as a result of an overpressure event within the CWT.

Continued forward and downward rotation of the top of SWB3 caused the upper end of SWB3 to impact the stiffeners on the aft surface of the front spar about 12 inches below the upper skin panel. This impact left a distinct set of marks on the front spar and initiated multiple failures near the top of that spar. (Figure 31 also shows the approximate orientation between the front spar and SWB3 as the aft side of the front spar was impacted by the upper end of SWB3.) Geometric evaluation and physical evidence indicated that the front spar was intact and in place when it was contacted by the upper end of SWB3. (The location of these SWB3 impact marks on the front spar was a major factor in the Sequencing Group's determination that fracture of the upper portion of SWB3 was the initial failure in the airplane structure.)

According to the sequencing study, impact of SWB3 with the aft side of the front spar severely damaged the front spar stiffeners and initiated fractures in the front spar's upper chord. Overpressure escaping from the CWT caused the front spar to bulge forward as it failed along the upper chord; this bulging resulted in two forward-protruding lobes on the front spar, one on each side of the spar centerline. The sequencing report attributed the formation of the two lobes to the inertial resistance provided by the two potable water bottles attached to the center of the forward side of the front spar. These bottles were full when the airplane left JFK, and their combined weight was more than 3,000 pounds. As the front spar bulged forward, fractures developed near the center of each of the two lobes. In addition, the front spar was further damaged when portions of SWB3 penetrated the aft side of the front spar as SWB3 continued to rotate forward and down.

The Sequencing Group determined that the upper chord of the front spar then completely separated from the WCS upper skin panel, and the overpressure within the CWT forced the WCS lower skin panel and the forward end of the keel beam downward. Stress analysis performed as a part of the sequencing study showed that the continuing downward keel beam motion increased the stresses in the ring chord and fuselage skin adjacent to the front spar. The front spar stiffener at LBL 18 was not bent as far forward as the others, indicating that there was limited forward rotation of the front spar in this area before the ring chord separated at the bottom of the stiffener. Fractures on the right side of the front spar continued into the lower pressure bulkhead,<sup>201</sup> then continued through the ring chord and into the fuselage skin just in front of the front spar, at stringer 40 right (see figure 30).

---

<sup>201</sup> The lower pressure bulkhead extends between the lower chord of the front spar and the ring chord.

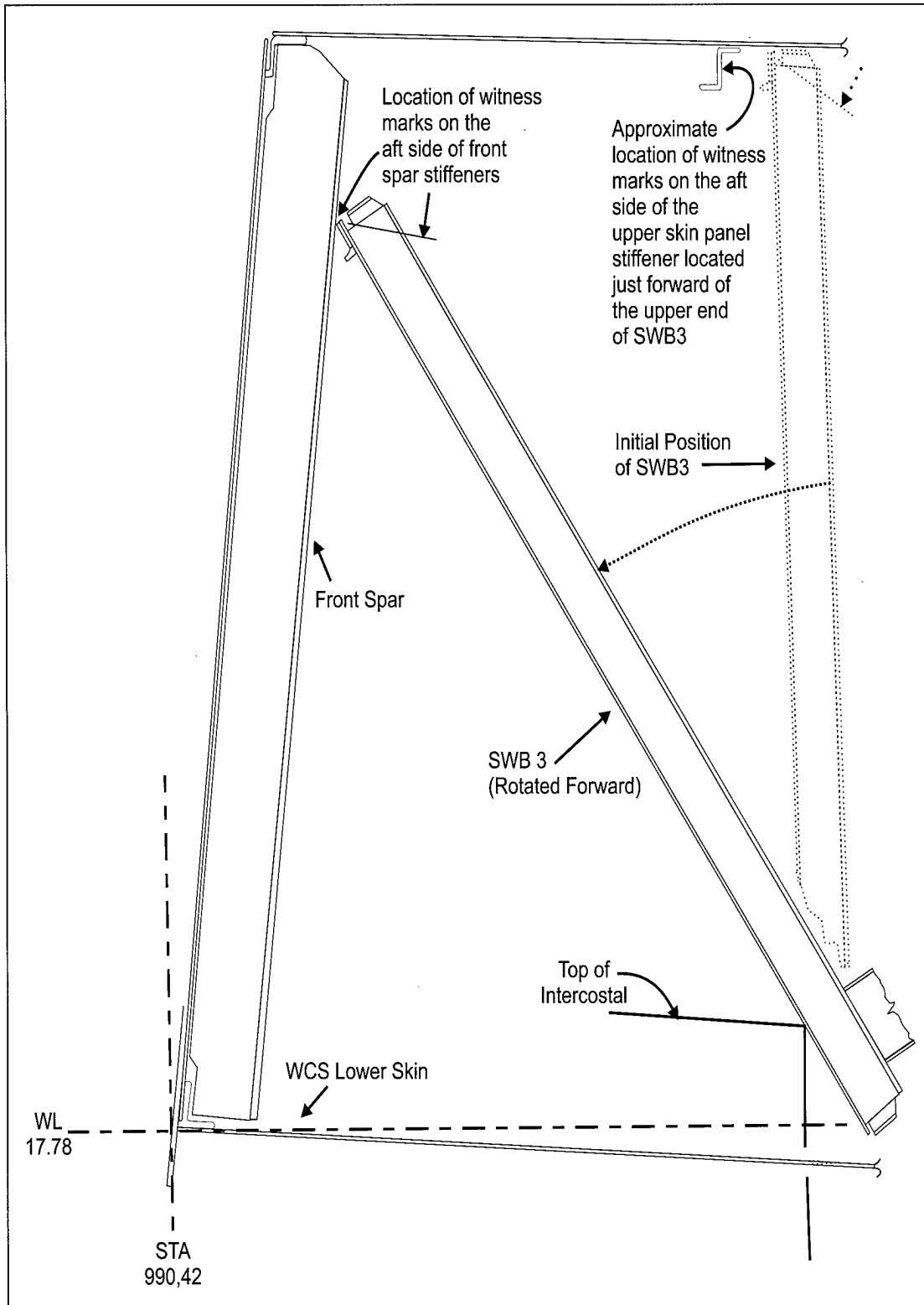

**Figure 31.** Diagram showing the approximate shape of the upper skin panel stiffener and its location before being struck by SWB3 as the beam rotated forward.

On the basis of cracking directions of the fuselage skin, the Sequencing Group determined that the initial fuselage skin cracking (at stringer 40 right just forward of the front spar, about STA 1000) propagated forward and toward the bottom center of the airplane, then continued circumferentially in both directions and back toward the front spar on the lower left side. This fuselage cracking then quickly progressed<sup>202</sup> around three sides of a large piece of fuselage belly structure (subsequently identified primarily as piece LF6A). See figure 30 for a diagram of this cracking in the fuselage; piece LF6A is located in the center of this figure.

According to the sequencing study, the combined load of normal cabin pressurization and vented overpressure from the CWT/WCS generated a downward force on this large section of the fuselage belly structure and resulted in additional downward loading on the keel beam. Stress analysis showed that these loads were sufficient to cause separation of the forward portion of the keel beam from the WCS lower skin panel and then to cause the keel beam to fracture about 22 inches aft of the mid spar. The report indicated that when the large piece of fuselage belly structure (primarily piece LF6A) separated, a large opening in the bottom of the fuselage resulted. Pieces from the WCS (primarily pieces from SWB3, the front spar, and the manufacturing access door from SWB2) exited the airplane through this large opening.

As previously discussed, SWB2 contains a removable maintenance access door (located just to the left of the SWB2 centerline) and a “permanently” sealed manufacturing access door (located just to the right of the SWB2 centerline). The Sequencing Group noted that the manufacturing access door (with an attached piece of the web of SWB2) was recovered from the red zone and identified the following three possible reasons for the separation of this door early in the accident sequence: (1) internal pressure generated as a part of the initial overpressure event created a load that resulted in the separation of the door; (2) the downward movement of the forward portion of the keel beam as it separated from the lower surface of the WCS created a downward loading on SWB2, resulting in separation of the door; or (3) a combination of (1) and (2).

The sequencing study indicated that, as the belly structure separated, adjacent pieces of the remaining fuselage skin and structure continued to crack and tear. Nearly symmetric pieces of fuselage skin above the right side and left side of the large hole in the belly separated from the rest of the airplane in an outward, upward, and aft direction. A curl of metal was created on both of these two pieces at the final point of separation (the upper aft corner). After these pieces of fuselage skin separated, the hole in the fuselage extended across the entire bottom of the airplane between the main cabin window belts.

According to the Sequencing Group, as the airplane continued to depressurize through the large hole in its underside, the nose of the airplane began to bend down,

---

<sup>202</sup> Although the Sequencing Group did not determine specific timing for the events that it identified, explosive decompression testing showed that normal cabin pressure differentials would cause this type of crack in the fuselage skin to propagate in fractions of a second. (The experts involved in Fire and Explosion Group testing calculated that this fuselage cracking occurred in about 24 milliseconds.) In addition to normal cabin pressurization loads, the accident airplane’s fuselage structure was subjected to loads from the venting of the WCS overpressure.

creating compression stresses, in the window belts above the hole. The window belts collapsed from these compression stresses and compression buckling spread upward toward the crown of the airplane, where evidence of tension failure was found. Subsequently, pieces of fuselage skin began to separate from right to left across the top of the airplane; some of these pieces had curls similar to the two symmetric curls below the window belt. This loss of fuselage structure around the airplane's circumference forward of the WCS resulted in the separation of the airplane's forward fuselage from the remainder of the airplane, which included most of the WCS, the wings, the aft fuselage, and the empennage.

According to the Sequencing Group, fire damage and soot deposit patterns on recovered wreckage indicated that some areas of fire existed on the main portion of the airplane as it continued in crippled flight after the loss of the forward fuselage.<sup>203</sup> The study indicated that, after some period of crippled flight (about 34 seconds, based on information from witness documents), the right and left wings outboard of the outboard engines failed in upward bending overload. Next, the WCS failed in upward bending adjacent to the left wing. (The upper skin panel buckled in compression, and the lower skin panel failed in tension.) The compression buckling in the left side of the WCS upper skin panel continued aft through the left side of the horizontal pressure deck above the wing landing gear wheel well and into the body landing gear wheel well. The main landing gear beam was separated in upward bending below this area of compression buckling (about LBL 75), consistent with the upward bending failure of the WCS.

The Sequencing Group determined that the external and internal soot deposit patterns revealed a distinct difference between structure that separated with the left wing (as a result of the upward bending failure of the WCS) and the remainder of the airplane. Lack of soot deposits on the large fuselage piece above the left wing and other fuselage pieces from the crown of the airplane indicated that these pieces separated with the left wing. A review of soot deposit patterns, fracture characteristics, and interface of the rear spar with upper and lower skin panels (see the earlier discussion in this section regarding evidence from the reconstruction of the remaining WCS upper panel) indicated that the pickle fork fitting<sup>204</sup> on the left side of the rear spar remained attached to the left wing's lower chord and that the portion of the rear spar located to the right of LBL 21.5 remained attached to the right wing. Soot deposit patterns on the remaining right wing and aft fuselage pieces indicated that these pieces of the airplane remained together for some time after the left wing separated. However, damage characteristics and differences in soot deposit patterns indicated that the remaining aft fuselage separated from the right wing in stages.<sup>205</sup>

The sequencing study stated that upward crushing damage found on the lower portion of the aft fuselage (aft of about STA 1480) indicated that most of this portion of

---

<sup>203</sup> This information is also consistent with observations recorded in witness documents (see section 1.18.4) and the Fire and Explosion Group Chairman's Factual Report, dated August 22, 1997.

<sup>204</sup> The rear spar body bulkhead is commonly termed the "pickle fork fitting." The pickle fork fitting is a complex machined forging that provides one of the primary vertical load paths connecting the spars of the outboard wings and the WCS to the fuselage structure.

the fuselage struck the water as a large single piece. On the basis of the location of the crushing damage, the Sequencing Group determined that the aft portion of the fuselage was rolled slightly to the right and relatively flat when it impacted the water. Similar crushing damage was found on the lower portion of the fuselage on the nose section (forward of about STA 840). The location of the crushing damage indicated that this portion of the airplane was rolled about 45° to the right when it impacted the water. As previously discussed, severe crushing damage was not found on any of the pieces found in the red zone.

According to the sequencing study, some aft fuselage pieces and wheel well structure (including the aft portion of the keel beam, the right main landing gear beam, and the right portion of the STA 1350 bulkhead) remained with the right wing for a period of time,<sup>206</sup> accumulating additional soot from a fire source on the right wing, after the separation of the fuselage aft of STA 1480. Several right-side fuselage pieces contained heavy soot deposits and fire damage, indicating that they remained attached to the right wing during an intense fire. A right-side fuselage piece that was recovered attached to the right wing was severely burned.

According to the sequencing study, severe fire damage on many portions of the WCS that were not recovered from the red zone (including the far right side of SWB3, the right two-thirds of SWB2, the right portion of the WCS upper skin panel, and the rear spar near BL 0) indicated that these areas remained attached to the right wing during the most intense fire. Although very heavy soot deposit and severe fire damage were noted on the exterior surfaces of the right rear portion of the WCS, the interior surfaces in this area (including the aft portion of the right side-of-body rib) did not contain fire damage or soot

---

<sup>205</sup> Before, during, and after the Sequencing Group's study of the airplane's breakup sequence, Boeing conducted separate analyses of several portions of the breakup sequence using a computer model of the 747-100 fuselage from STA 540 to 1480, which included most of the WCS box. The computer model was adapted to simulate the failure of SWB3 and the front spar as described in the previous section. For the purposes of these analyses, a sustained overpressure of 25 pounds per square inch (psi) was assumed in the WCS. According to Boeing, it used 25 psi because it was somewhat higher than the pressure at which Boeing personnel would expect the SWBs to fail (see section 1.16.4.9). The fuselage was pressurized to 4 psi cabin pressure differential.

Boeing also performed wing bending moment analyses to determine the effects of the separation of the forward section of the fuselage. These analyses assumed that the aft fuselage and wings would pitch up as a result of the sudden aft movement of the c.g. Boeing's analyses showed that at a high AOA and a 5.5 to 6 G load factor, the wing tips would fail, and the WCS would continue to carry the predicted loads. When the aerodynamic loading assumptions in the analyses were modified to account for the wing tip separation, the simulation showed that an additional 1 G increase in load factor would result in buckling (and ultimate failure) of the upper skin panel of the WCS, consistent with the upward bending failure of the WCS described by the Sequencing Group. According to Boeing's wing bending analyses (wing tip on and wing tip off), SWB2 must have been sufficiently intact (after separation of the forward fuselage) to provide substantial support to the WCS upper skin panel.

According to a January 20, 2000, letter from Boeing, its computer modeling and wing bending moment analyses did not reveal any inconsistencies with the basic findings described in the Safety Board's sequencing report.

<sup>206</sup> The Sequencing Group was unable determine how long each of these pieces remained with the right wing as the pieces of wreckage fell to the water.

deposits. The Sequencing Group determined that this was evidence that the right rear portion of the WCS remained largely intact until water impact.

The sequencing study established that the most intense fire effects were limited to the right wing, portions of the WCS, and a limited amount of fuselage structure above the right wing and that the most likely source of fuel for this fire was the right wing inboard fuel tank. Many of the fractures from the portion of the airplane with the most intense fire effects did not contain soot deposits, indicating that significant breakup damage occurred as the intensely fire-damaged structure impacted the water.

In summary, according to the sequencing study report, the breakup sequence was as follows:

- An overpressure within the CWT initiated a failure at the top of SWB3.
- The top of SWB3 rotated forward and down and impacted the aft side of the front spar.
- The front spar bulged forward in two lobes, one on each side of the potable water bottles mounted in the center of the forward side of the front spar.
- Cracking on the right side of the front spar progressed downward, through the lower-pressure bulkhead and ring chord, and entered the fuselage.
- Fuselage cracking propagated dynamically around a large piece of belly structure, which separated, creating a hole through which WCS structure was ejected from the airplane.
- The forward portion of the keel beam was peeled off of the lower surface of the WCS, and the keel beam separated in two pieces aft of the mid spar.
- Fuselage pieces on each side of the hole in the belly structure began to separate upward, outward, and aft.
- The window belts above the hole in the lower fuselage buckled, and this compression buckling spread toward the top of the airplane.
- Pieces of fuselage separated across the top of the airplane, thereby completely separating the forward fuselage from the remainder of the airplane.
- The main portion of the airplane (including the wings, most of the WCS, and the aft fuselage) continued in crippled flight for a period of time.
- The wing tips separated at the outboard engines.
- The WCS separated adjacent to the left wing.
- The fuselage aft of STA 1480 separated from the remainder of the WCS and the right wing.
- Other structure separated from the right wing and remaining portion of the WCS.

The Sequencing Group also examined the reconstructed portion of the airplane in areas where structure appeared to be missing. For example, an apparent hole (2 to 3 feet long with about a 5 feet circumference) was visible in the fuselage structure above the



main portion of the pickle fork fitting at the upper left rear corner of the WCS. However, the Sequencing Group's report indicated that examination of the fuselage skin surrounding the apparent hole revealed that most, if not all, of the fuselage skin that appeared to be missing was present in folded skin attached to adjacent structure. All of the structural pieces in the vicinity of this "hole" were recovered from the green zone, indicating that none of the pieces from this area separated early in the breakup sequence. The Sequencing Group determined that the features of the apparent hole were consistent with the compression buckling failure of the left side of the WCS associated with the loss of the left wing later in the breakup sequence. The Sequencing Group report did not associate any of the apparent large holes in the structure with the initiation of the airplane breakup. In addition, the sequencing study report stated that "one noteworthy aspect of the structural breakup characteristic is the exceptional degree of symmetry between right and left sides. Starting with SWB3 and forward in the sequence there is the suggestion of a very uniform driving force."

#### **1.16.4 Additional Metallurgical, Material, and Structural Testing and Information**

##### **1.16.4.1 Metallurgical Examination of Several Small Holes in the Accident Airplane's Structure**

The Safety Board examined the recovered wreckage for evidence that the airplane's breakup was initiated by penetration of the CWT by a small, high-velocity fragment (generated, for example, by explosion of a missile warhead near the airplane or of a high-energy explosive within the airplane). Members of the Structures Group identified 196 relatively small holes in the accident airplane's structure that they considered to be in an appropriate location and of an appropriate size and shape to have resulted from such a fragment. These holes were then examined in detail by Safety Board metallurgists and others to determine if they had characteristics of high-velocity penetrations.

At the Safety Board's request, Boeing created test plates with a variety of high- and low-velocity penetration characteristics, which were then compared with the holes in the accident airplane wreckage. To produce these test plates, Boeing personnel fired fragments of various sizes and materials (to simulate missile warhead fragments) at target plates of various thicknesses and materials (corresponding to those found in the accident airplane's WCS).

Boeing also measured each fragment's velocity when it impacted the test plate. Examination of the holes and impact marks on the test plates revealed that holes resulting from high- and low-velocity penetrations each had distinctive damage characteristics. The approximate impact velocity at which the features transitioned from high- to low-velocity (as defined below) was a function of the thickness of the impacted material and the size and material of the impacting fragments. For example, it was determined that 1/4-inch to 3/8-inch steel cubes impacting a 0.10-inch-thick aluminum plate would produce low-velocity characteristics at impact speeds less than or equal to 1,000 feet per second

(fps) and would produce high-velocity characteristics at impact speeds greater than or equal to 1,500 fps. Characteristics of high-velocity penetrations were as follows:

- **Splashback**—high-velocity penetrations caused material around the perimeter of the hole on the entry side of the plate to deform in the direction opposite to the motion of the penetrating fragment. This feature occurred for high-velocity impacts regardless of whether they resulted in full penetration, partial penetration, or just impact marks.
- **Exit deformation or breakout**—similar to splashback but on the exit side of the test plate. Passage of the fragment through the test plate generated local deformation or shear breakout of material around the hole.
- **Hole wall characteristics**—high-velocity penetrations created hole walls that exhibited melted and resolidified material adjacent to the entry side (including transferred material from the penetrating fragment), severe shear deformation, and multiple shear cracks.
- **Overall deformation**—high-velocity penetrations did not produce significant overall membrane deformation in the direction of motion of the penetrating fragment.

Characteristics of low-velocity penetrations were as follows:

- **Splashback**—low-velocity penetrations did not cause splashback.
- **Hole wall characteristics**—low-velocity penetrations created hole walls that appeared to be generated by fracture of the test plates, resulting in elongated ductile dimples throughout the entire thickness of the plate. No melting was found on the low-velocity holes.
- **Overall deformation**—low-velocity penetrations produced more overall membrane deformation in the direction of motion of the penetrating fragment.

An initial evaluation showed that many of the holes in the recovered airplane wreckage were obvious penetrations from the inside of the structure outward, contained substantial deformation adjacent to them, and generally had some amount of impact damage associated with them consistent with low-velocity penetration by a structural member. Other holes were actually tears or penetrations in the structure with minimal associated missing material. On the basis of these observations, all but 25 of the 196 holes were determined not to have characteristics of high-velocity penetration. The Safety Board's more detailed examinations of the remaining 25 holes revealed that 23 of the holes—all associated with the WCS—did exhibit characteristics of low-velocity penetration. These holes exhibited no evidence of splashback, and significant deformation was observed in the surrounding material.

Only two holes had any characteristics of high-velocity penetration, and these holes also exhibited some low-velocity penetration characteristics. Both holes were about 3/16 inch in diameter and were located in the horizontal pressure deck above the main landing gear bay (aft of the WCS/CWT). The hole in piece LF137 was located in the pressure deck at STA 1457 and LBL 110. The chipped-out metal on the lower surface of

and the exit deformation associated with this hole were consistent with penetration by a fragment moving downward and slightly aft. The hole in piece RF60 was located in the pressure deck at STA 1452 and LBL 62. The chipped-out metal on the lower surface of and the exit deformation associated with this hole were consistent with penetration by a fragment moving downward and slightly inboard. Both holes exhibited the following features:

- lack of overall deformation in the sheets around the holes;
- no splashback;
- chipped-out metal on the lower surface of the sheets on one side of the holes; and
- smooth hole walls, generally perpendicular to the surface, with some exit deformation on the lower surfaces.

Because these holes contained features characteristic of both low-velocity holes (no splashback) and high-velocity holes (lack of overall deformation), it was difficult to determine the likely impact velocity in that area. However, on the basis of the direction of the penetrations and their locations relative to each other, it was determined that the penetrating objects for the two holes did not originate from a common point, nor did they originate from a point outside the airplane.

A portion of piece LF137 that contained one of the holes was cut from the piece and sent to the Safety Board's Materials Laboratory for further examination.<sup>207</sup> A bench binocular microscopic examination (using magnifications of up to 70 X) of this portion of piece LF137 revealed a crescent of deformed material on the upper surface of the piece, adjacent to one side of the hole. The hole was slightly elongated in the direction of the crescent; the hole diameter at the crescent was 0.19 inch, whereas the perpendicular diameter was 0.17 inch. Examination of the hole using a scanning electron microscope (SEM) revealed that much of the hole wall was covered by deposits that were mostly composed of mud-covered oxides. Portions of the hole with fewer deposits within the deformed crescent exhibited parallel lines consistent with metal deformation smearing. EDS examination of various areas on the removed piece generated spectra typical of 7075-T6 aluminum alloy,<sup>208</sup> the specified material for the piece. In some places, spectra showed traces of oxygen, sulfur, and chlorine. No evidence of melted and resolidified metal was noted on any portion of the hole wall.

#### 1.16.4.2 Metallurgical Examination of Fatigue Cracking

During their examination of the recovered pieces of the WCS, investigators observed evidence of several fatigue cracks.<sup>209</sup> All of the fatigue cracks detected during structural examinations were evaluated by the Sequencing Group as a part of the

---

<sup>207</sup> The hole in piece RF60 was directly adjacent to the steel framework supporting the reconstructed airplane and was much more difficult to cut out without removing the entire piece. Therefore, because the holes in pieces RF60 and LF137 were so similar in appearance, only the hole in LF137 was examined in the laboratory.

<sup>208</sup> 7075-T6 is an aluminum alloy with primary alloying elements of zinc, magnesium, and copper.

determination of the breakup sequence. Small preexisting fatigue cracks were observed in the front spar vertical stiffener shear ties at RBL 83.24 (lower), RBL 75.92 (upper and lower), LBL 75.92 (upper and lower), and LBL 83.24 (lower). These cracks were all located in the shear tie radius near the base of the leg that attaches to the vertical stiffener near the aft edge and had a maximum length of 0.20 inch. These shear ties are subject to inspection per Boeing SB 747-57-2249.<sup>210</sup>

Small fatigue cracks were also found in the shear tie of the LBL 75.92 and LBL 33.99 longitudinal floorbeams where they intersected the front spar upper chord at STA 1000.<sup>211</sup> The LBL 75.92 shear tie had a 0.15-inch fatigue crack emanating from the aft side of the bolt hole and a possible 0.125-inch fatigue crack emanating from the forward side of the hole. The LBL 33.99 shear tie had a 0.25-inch fatigue crack emanating from the forward side of the bolt hole.

Additionally, fatigue cracks were found in the lower chord of the front spar. The cracks were in the horizontal leg of the chord and initiated from the chord's fillet radius just outboard of the underwing longeron splice fittings at both RBL and LBL 80. The fatigue crack at RBL 80 was about 1.2 inches long and about 0.10 inch deep, whereas the fatigue crack at LBL 80 was about 1.45 inches long and about 0.12 inch deep (about 1/3 of the chord's thickness).

This region of the accident airplane had been modified in 1982 (in accordance with SB 747-53-2064, which addressed adjacent ring chord cracking) by incorporating two fittings on the WCS lower skin panel and a corresponding double fitting on the fuselage skin. These fittings are adjacent to the underwing longeron splice fitting and provide an alternate load path for the longeron forward/aft loads. The sequencing report noted that the postmodification configuration was very stiff and significantly limited further deflection; without continued deflection, fatigue crack growth cannot continue. Therefore, the Sequencing Group determined that the fatigue cracking observed in the recovered pieces of the accident airplane existed before these fittings were installed. The Sequencing Group further noted that the propagation of the overstress fracture through the fillet radius during the overpressure event coincidentally exposed these two areas of localized, preexisting fatigue cracking in the front spar lower chord.

---

<sup>209</sup> Although the accident airplane's structure contained minimal preexisting corrosion damage, the Sequencing Group's study indicated that this damage would not have affected the breakup of the airplane. Further, the Sequencing Group determined that none of the small fatigue cracks that were found on some parts of the airplane (as discussed in this section) had coalesced into a propagating crack that could have led to the in-flight breakup.

<sup>210</sup> According to Boeing personnel, the company has received reports from 747 operators observing cracks ranging from 0.50 to 1.5 inches long without complete part failure.

<sup>211</sup> According to the sequencing report, the front spar upper chord at STA 1000 is a secondary attachment for the floor structure and was not involved in carrying primary airframe loads.

### 1.16.4.3 Metallurgical Examination of the Fuselage Joint Between Sections 41 and 42

The Safety Board was aware of concern about possible assembly problems with the fuselage joint between sections 41 and 42 (which extend forward and aft, respectively, from STA 520) on 747s<sup>212</sup> and considered the possibility that a failure at this joint might have occurred, initiating the breakup sequence. This joint area was wholly contained within the forward fuselage section that the Sequencing Group identified as having separated from the airplane early in the breakup sequence.

Overall examination of the forward portion of the airplane showed that sections 41 and 42 exhibited uniform crushing damage that extended across the bottom of the fuselage from about 3 feet below the left-side main cabin windows (S-39L) to above the right-side main cabin windows (S-14R). This damage was consistent with this section of the airplane impacting the water intact in a right-wing-low attitude. The structures examination also revealed that portions of the joint between sections 41 and 42 were separated during the water impact, whereas some portions remained intact.<sup>213</sup> The portions of the STA 520 joint that separated were examined for evidence of preexisting fatigue or other preexisting damage. The Safety Board's examination of this joint revealed that all fractures were typical of overstress separations, with no evidence of fatigue, fretting, or significant corrosion.

### 1.16.4.4 Metallurgical Examination of the Forward Cargo Door

The Safety Board also considered the possibility that the forward cargo door (the forward edge of which is located several feet aft of STA 520 on the lower right side of the fuselage) separated from the accident airplane in flight and that this separation initiated the breakup sequence. The Board examined the pieces of the forward cargo door, which were recovered from the yellow zone. All eight of the latching cams at the bottom of the door were recovered attached to pieces of the lower end of the door and were in the latched position. Additionally, the latching cams and pieces of the cargo door remained attached to the pins along the lower door sill. The hinge at the top of the door was broken into several pieces, but the hinge pin still held the various pieces of the hinge together. There was no evidence to suggest that this hinge separated. The forward cargo door exhibited severe crushing deformation and fragmentation, very similar to damage observed on the adjacent fuselage structure.

---

<sup>212</sup> In conversations with Safety Board staff, Boeing personnel indicated that because the shape and size of the ends of sections 41 and 42 could vary during the manufacturing process, extra effort was sometimes required to fit these sections exactly together.

<sup>213</sup> The fuselage joint between sections 41 and 42 was not separated across the top of the airplane (between S-2L and S-5R) or along portions of the right and left sides (between S-18L and S-39L, S-44L and S-47L, S-19R and S-28R, and S-40R and S-45R).

#### 1.16.4.5 Metallurgical Examination of Nose Landing Gear Doors and Surrounding Structure

The left aft nose landing gear door was heavily damaged in a manner consistent with other parts recovered from the yellow zone and with many other pieces from the forward portion of the fuselage. However, the right and left forward and the right aft nose landing gear doors exhibited relatively little damage and were recovered from the red zone with other airplane pieces that the sequencing report indicated had separated early in the breakup sequence. Further, the hinges from some of these doors appeared to have overtravel damage, indicating that the doors may have been forced inward. After careful examination of the nose landing gear doors and pieces of the surrounding structure, the Sequencing Group determined that the doors did not overtravel inward a significant amount and that the apparent overtravel damage to the hinges could have occurred after the doors opened or separated. Subsequent teardown inspection of the nose landing gear door actuator revealed that the actuator's locking mechanism was not damaged and was within specifications, consistent with the Sequencing Group's failure scenario that the nose landing gear doors may have opened during the initial stages of the breakup and then been torn off by exposure to the air stream.<sup>214</sup>

#### 1.16.4.6 Examination of Brown Splatter Material

As previously discussed, parts of the WCS and portions of the cabin interior above and forward of the WCS were found to have splatterlike deposits of a dark brown rubbery (spongy) material. The highest concentration of these deposits appeared on the top surface of the WCS near a long duct that was fastened to the top surface of the CWT. Samples of this brown splatter material were examined, the features of the deposits were recorded in detail, and their composition and physical characteristics were determined by chemical analyses. At the Safety Board's request, several independent laboratories performed analyses on this splatter material.<sup>215</sup>

Chemical analyses by the laboratories were consistent and showed that the dark brown splatter material was consistent with a polyurethane elastomer. This material was consistent with the flexible polyurethane material with which the long air conditioning duct located above the CWT was insulated. However, microscopic examination of the splatter material showed that some of the deposits were not uniform and had fiberlike materials embedded in the dark material. According to the splatter report, the other embedded materials or fibers were consistent with a "Nylon™ 6 series. The discolored fiber...appeared to be a fibrous material much like Azlon."<sup>216</sup> Examination of a long air

---

<sup>214</sup> Cable and hydraulic lines for the nose landing gear control system are routed through the CWT area. It is likely that these systems would be disrupted early in the airplane's break up sequence, resulting in a loss of hydraulic power.

<sup>215</sup> For additional information about the splatter material, splatter pattern and chemical analyses, see Factual Report on Splatter Deposits, dated October 2000.

<sup>216</sup> According to the Federal Trade Commission, Azlon is a generic name for a manufactured fiber in which the fiber-forming substance is composed of any regenerated naturally occurring protein (for instance, proteins from corn, peanuts, and milk have been used in such manufacturing applications). Azlon is commonly used in airplane carpeting and seat fabrics.

conditioning duct removed from the same area on a 747 airplane of similar age revealed the presence of similar fibers adhering to the outside surface of the duct. These fibers were determined to be consistent with the fibers in the carpeting and seat fabrics from that airplane.

#### **1.16.4.7 Examination of Red/Brown-Shaded Substance Found on Passenger Seats**

During the Safety Board's examination of recovered wreckage, investigators observed red/brown-shaded substances on several damaged passenger seats. These substances appeared as a thin coating, which covered the surfaces of interior components of the seatbacks. Specifically, these substances were found on the forward face (inside) of the plastic seatback, on the backward face (backside) of the metal seatback frame, and on the plasticized foam strips used to attach these components together. Examination revealed that similar-looking substances were found in other seatbacks throughout the airplane, many of which did not exhibit thermal and/or significant mechanical damage. According to Weber,<sup>217</sup> the location and appearance of the red/brown-shaded substance was consistent with an adhesive used in the construction of the seats. Subsequent laboratory testing at NASA of several samples of the substance taken from the seatbacks identified these substances as being consistent with adhesives.<sup>218</sup>

#### **1.16.4.8 Examination of Explosive Residue**

Examination of recovered wreckage revealed trace amounts of explosive residue on three samples of material from three separate locations in the airplane wreckage. These material samples were submitted to the FBI's laboratory in Washington, D.C., with many other material samples for analysis. The pieces on which these traces were found were described by the FBI as a piece of canvaslike material and two pieces of floor panel; however, the exact locations of the traces were not documented. According to the FBI's laboratory report,<sup>219</sup> analysis of each of the three material samples revealed that they contained traces of different explosives: one contained cyclotrimethylenetrinitramine (RDX), one contained nitroglycerin, and one contained a combination of RDX and pentaerythritol tetranitrate (PETN).

Subsequent investigation revealed that the accident airplane had been used for a dog-training explosive detection exercise at St. Louis-Lambert International Airport (STL), St. Louis, Missouri, on June 10, 1996. During that exercise, an airport police officer placed five training aids containing explosives (one of which was cracked and could have released small amounts of explosives) in various locations inside the passenger cabin. Training aids were placed in the following locations: (1) in row 1, in the center armrest compartment separating seats 1 and 2; (2) in a small closet at the rear of the upper

---

<sup>217</sup> Weber is the manufacturer of the seats located in the passenger cabin region located above the CWT, in zone C.

<sup>218</sup> For further information, see the Factual Report on Red/Brown-Shaded Substance Found on Passenger Seats, dated October 2000.

<sup>219</sup> See FBI file No. 265A-NY-259028, dated March 4, 1997.

deck; (3) in row 10, inside the rear pouch of the seat back in front of seat 9; (4) in row 20, in the overhead compartment above seats 1 and 2; and (5) beside exit door R3 (see figure 20 in section 1.6.3.2 for an airplane diagram).<sup>220</sup>

#### **1.16.4.8.1 FAA Studies on the Effects of Sea Water on Explosive Residue Contamination**

FAA personnel at the FAA's William J. Hughes Technical Center in Atlantic City, New Jersey, conducted tests to study the effects of sea water on cloth and aluminum airplane parts that had been exposed to explosives contamination.<sup>221</sup> Pieces of aluminum from the wing of a commercial airplane and pieces of airplane seat covers were contaminated with explosive residue by manually deposited explosives and by exposure to an actual explosion and were then immersed in sea water. In both cases, when the cloth and aluminum airplane parts were examined after 2 days of immersion in sea water, the explosive residues were completely dissipated. The FAA's report concluded, "our experiments have shown that their [sic] is very little likelihood that blast deposited explosive materials remain very long on cloth or aluminum aircraft parts after immersion in [sea water]." The FAA attributed this, in part, to the explosive residues being "somewhat soluble in [sea water]."

#### **1.16.4.9 Wing Center Section and Center Wing Fuel Tank Structural Response and Failure Information**

Boeing performed structural response calculations to determine the failure pressures and response frequency<sup>222</sup> for the beams and spars in the WCS/CWT.<sup>223</sup> On the basis of their calculations, Boeing engineers generated a range of pressure differentials required to fail these members.<sup>224</sup> The failure pressure differentials for the SWBs and spars of the WCS/CWT are summarized in table 5. The "minimum" pressure column in the table corresponds to the "minimum initial failure strength" determined by conventional stress analysis methods used in commercial airplane design to ensure that minimum strength will always exceed regulatory requirement. The "maximum" pressure column in the table corresponds to the "estimated maximum initial failure strength" determined by using detailed finite element computer models.

---

<sup>220</sup> For additional information, see the Hazardous Materials—Security Group Chairman's Factual Report, dated April 27, 1999.

<sup>221</sup> For additional information, see the FAA's report, "Immersion Studies of Aircraft Parts Exposed to Plastic Explosives," which is appended to the Safety Board's Hazardous Materials—Security Group Chairman's Factual Report.

<sup>222</sup> Frequency analysis of the structural members indicated that these members would respond statically to the rates of pressure differences generated by the combustion processes.

<sup>223</sup> Because nobody has tested a WCS to failure, the failure strengths predicted by Boeing were based entirely on traditional analytic methods and numerical computations.

<sup>224</sup> See Safety Board Memorandum to the TWA docket, "Boeing Submission," dated June 5, 2000. In addition to the assumptions identified in the memorandum, it should be noted that the failure pressures that were calculated do not account for progressive failures in which the failure pressure for a beam may be decreased because of failure or damage of a neighboring beam.



**Table 5.** 747-100 wing center section/center wing fuel tank SWBs and spars failure strengths.

Component	Minimum (psi)	Maximum (psi)
Front spar	20	25 to 30
SWB3	20	25
SWB2	20	30 to 35
Mid spar	20	35 to 40
SWB1	25	45 to 50
Rear spar	30	45 to 50

### 1.16.5 Jet A Fuel Vapor and Fuel Tank Research and Testing

During its investigation of the TWA flight 800 accident, the Safety Board was hampered by the lack of available pertinent research data regarding the flammability and other characteristics of Jet A fuel and its behavior in airplane fuel tanks. In an attempt to develop data that would be useful in the investigation, the Board assembled a team that included the most renowned experts in the combustion and fuel-related fields and, with the help of these experts, developed and implemented a research program. The objectives of this research program were to (1) develop an understanding of the thermal and vapor environment within the 747 CWT; (2) determine the chemical and physical properties, flammability, and combustion behavior of Jet A fuel; and (3) develop computer models of the combustion process within the 747 CWT to assist in the determination of the ignition location. The researchers performed laboratory experiments, scale-model tests, and numerical simulations to examine the explosion of Jet A fuel/air vapor under conditions similar to those that existed within TWA flight 800's CWT at the time of the accident. Specifically, the researchers wanted to identify the flammability limits and combustion behavior of Jet A fuel and the propagation of flames through the compartments within the CWT structure. Figure 32 shows a flow chart of the fuel-related research conducted to support this investigation.

The FAA has certificated commercial jet airplanes based on the assumption that fuel tanks are considered to always be flammable and has required manufacturers to demonstrate that any energy inside the tank would be below the MIE for Jet A vapors to ensure safe operation of the airplane. However, at the time of this accident, specific information about fuel tank flammability and Jet A thermochemistry was largely unavailable. The research conducted during this investigation enabled analysis of the flammability of aircraft fuel tanks and provided a scientific basis for evaluating methods of reducing fuel tank flammability, as identified in safety recommendations previously issued to the FAA.<sup>225</sup>

<sup>225</sup> For more information about these safety recommendations, see section 1.18.3.

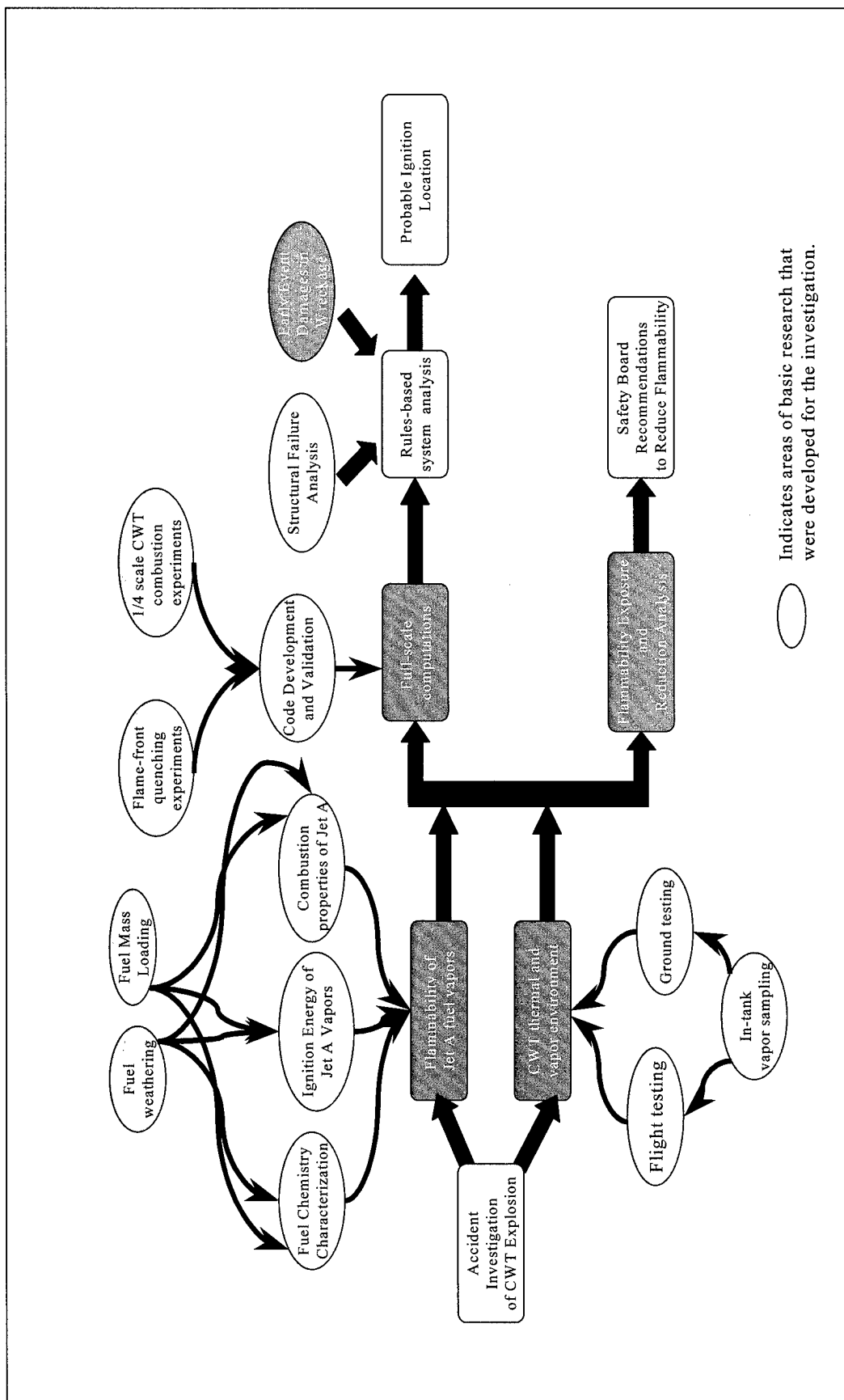

Figure 32. A flow chart of the fuel-related research conducted to support this investigation.

The research associated with this accident investigation included the use of standardized tests, engineering models, state-of-the-art scientific techniques, development of new methods, and extension of existing methods. For example, the research team adapted numerical tools and developed computational models for use in full-scale simulations of 747 CWT combustion that explored the effects of various parameters and assumptions (such as ignition locations within the CWT). Additionally, a computational rules-based analysis method was developed to compare the simulations against the observed damage to the recovered wreckage. (The goal of this computational effort was to narrow down the number of probable ignition source locations within the CWT.)<sup>226</sup>

Flight and ground tests were performed to determine, as accurately as possible, the thermal and vapor conditions that were present inside the accident airplane's CWT at the time of the accident. These tests, in part, identified specific conditions present in the accident airplane's CWT (temperature, altitude [pressure], mass loading,<sup>227</sup> and weathering)<sup>228</sup> considered important in identifying the behavior of the combustion that took place within the accident airplane's CWT. Using this information, all subsequent analyses and tests were focused on conditions that best approximated those of the accident airplane at the time of the accident.

Analysis of the fundamental chemical and physical properties of Jet A liquid and vapor, calculation of vapor pressure, and molecular weight produced information that was then used to predict fuel vapor concentrations in the accident airplane's CWT at the time of the accident. On the basis of hundreds of tests, conducted over a wide range of conditions, the research team was able to identify the conditions (ignition energies, fuel/air mixtures) under which Jet A fuel combustion could occur and to quantify the behavior (flame speeds and peak pressures) that would likely result from such combustion.

Two independent computer models, using different numerical codes (selected to complement each other), were developed to predict the propagation of combustion in a scale model and full-scale model of the 747 CWT. Hundreds of computer simulations were performed to develop and validate the models. The results of the tests conducted with the models showed the pressure differences that developed across the structural members that divide the 747 CWT into compartments. These models were then used to make calculations of Jet A combustion in a full-scale CWT geometry, for many different combustion scenarios.

---

<sup>226</sup> The research efforts and their results are discussed further in subsections of this section. Additionally, the research efforts were extensively documented in a series of reports that were submitted to the Safety Board and are available in the public docket for this accident investigation. See subsections for specific report references.

<sup>227</sup> Fuel mass loading refers to the measure of the amount of fuel relative to the entire volume of its container.

<sup>228</sup> Weathering is the change in a liquid fuel chemical composition as a result of exposure to environmental conditions. An example involves heating and pressure changes to a vented aircraft fuel tank, where preferential evaporation of the lower molecular weight components of the jet fuel occurs, resulting in a redistribution of the chemical composition of the remaining liquid fuel.

Scale-model experiments were also used to validate the numerical analyses and to demonstrate the propagation of an explosion in a multicompartiment fuel tank. During the scale-model testing, quenching<sup>229</sup> was identified as an issue because of the complex nature of the CWT. As a result, additional experiments and engineering modeling were accomplished to address the issue of quenching.

Ultimately, the results of the computer model research were used in an attempt to identify the location of probable ignition within the CWT. That effort required the use of physical evidence, data, and estimates derived from the investigation despite substantial uncertainties and possible interpretative bias. To address these issues, a quantitative technique based on statistical reasoning, called a rules-based analysis method, was developed.

Before the rules-based analysis could be used to compare the results of the numerical simulations of the explosion process with the observations of damage to the airplane and estimates of structural responses within the 747 CWT, it was necessary to identify the damages that resulted from the initial combustion event. Because damages observed in the wreckage could have been caused by the initial overpressure event, the subsequent in-flight breakup, impact with the ocean, and/or fire, it was necessary to develop a consensus as to which damages resulted from the initial combustion event. Thus, Safety Board investigators and Boeing engineers identified these initial damages and assigned levels of confidence to each; these damages and levels of confidence were then coded into the rules-based analysis method. Additionally, Safety Board investigators and Boeing engineers estimated the pressures at which various CWT structural members would fail and assigned levels of certainty to each. (These uncertainties existed because a CWT had never been tested to failure. As a result, Boeing's estimates provided a range of estimated failure pressures.)

Through incorporation of numerical simulations, observed damages, and structural failure analysis, the rules-based analysis method provided an indication of how consistent each numerical scenario was with the observable damage to the wreckage and provided investigators with a means of comparing and evaluating each possible ignition source location within the CWT. Further, the rules-based analysis resulted in a scientifically based, quantitative method of analyzing the CWT combustion event in general.

The following subsections describe the ground and flight tests, vapor sampling, Jet A fuel and vapor experiments, 1/4- and full-scale model tests, computer modeling, and the rules-based analysis method in greater detail. Additionally, sections 1.16.5.6 and 1.16.5.7 describe the full-scale 747 CWT explosion test conducted in Leicestershire, England, and the Boeing/USAF E-4B CWT fuel heating study, respectively.

---

<sup>229</sup> Quenching is the extinguishment of a combustion flamefront; often as a result of decreased temperature or propagation through a passageway, such as an orifice or a vent.

### 1.16.5.1 Testing Conducted to Identify the Conditions that Existed in the Accident Airplane at the Time of the Accident

#### 1.16.5.1.1 747 Flight Tests at JFK

In mid-July 1997, the Safety Board conducted a series of flight tests<sup>230</sup> to obtain data regarding the operating temperatures, pressures, and accelerations within and around a 747-100 series airplane's CWT under conditions similar to those that existed on TWA flight 800. The airplane used for these flight tests was a 747-121 leased from Evergreen Airlines.<sup>231</sup>

The Safety Board determined the type and location of additional sensors and instrumentation to be installed and developed the flight test procedures for its series of flight tests, with input from parties to the investigation. Additional instrumentation was installed in the test airplane (by Boeing)<sup>232</sup> to measure the following: CWT ullage and fuel temperatures at 48 locations,<sup>233</sup> internal and external CWT surface temperatures at 42 locations, air conditioning pack bay temperatures at 20 locations (beneath the CWT), air conditioning pack surface temperatures at 13 locations,<sup>234</sup> vibration measurements of the CWT lower skin panel,<sup>235</sup> and EMI data. In addition, temperature sensors were installed in the No. 3 fuel tank at each vent and near the high point of each fuel pump power conduit, on the inside surface of the top wing skin in the No. 3 fuel tank vent

---

<sup>230</sup> In total, nine flight tests were conducted. Six flight tests were performed by the Safety Board and are documented in the Flight Test Group Chairman's Factual Report, dated November 19, 1997. The remaining three flight tests were performed by Boeing and FAA personnel. The purpose of these three flight tests was to examine the effects of certain hardware modifications on heating in fuel tanks; the data from these flights are considered proprietary.

<sup>231</sup> The 747-100 series included the -121 variant used in these flight tests and the -131 variant (the accident airplane). According to Boeing, the fuel systems in these two 747 variants are the same, except for the method of vent stringer flame protection—the accident airplane had an STP system (which was developed by Boeing for TWA after a TWA 707 fuel tank explosion in Rome, Italy), whereas the flight test airplane used a flame suppression canister. The 747-121 test airplane was flown by Boeing pilots under an experimental airworthiness certificate during the flight tests. In addition to the Boeing flight crew, the Safety Board's Flight Test Group Chairman and Program Test Director and Boeing's Test Director, Flight Analysis Engineer, and Flight Instrumentation Engineer were on board the airplane for all flight tests. For those tests during which vapor sampling was accomplished, a vapor sampling operator was also on board the airplane. Evergreen Airlines staff were used for mechanical dispatch, maintenance, operations, and ground support for the flight tests.

<sup>232</sup> For additional information regarding instrumentation, see the Flight Test Group Chairman's reports (Exhibit 23B), "Flight Test Plan" and (Exhibit 23E) "Test Item Requirements List (TIRL), Instrumentation Locations and Flight Test Schedule," dated November 19, 1997.

<sup>233</sup> Each fuel bay was instrumented individually to identify temperature variations throughout the CWT.

<sup>234</sup> Temperature sensors were placed in the following locations on each air conditioning pack: on the engine bleed air duct near the flow control valve, at the water separator outlet, on the top of the heat exchanger inlet, and on the top of the compressor outlet. In addition, a temperature sensor was placed on the side support housing and on the heat exchanger exhaust louver.

<sup>235</sup> It was postulated that the CWT might have been exposed to sufficient vibration to result in very small droplets of the remaining CWT fuel becoming airborne (known as lofting), resulting in a more flammable fuel/air mixture in the CWT. Examination of the vibration measurement data revealed that the CWT lower skin panel was not subject to vibration of the energy or frequency that would be necessary to produce fuel lofting.

stringer, and in the surge tanks (at four locations in the right surge tank and at three locations in the left surge tank).

Evergreen Airlines provided ballast weight and arranged fueling such that the airplane's weight and balance, dispatch fuel load, and takeoff fuel load matched those of TWA flight 800, as closely as possible, for test flights in which duplication of conditions was required. The Jet A fuel loaded in the CWT during the flight tests was originally loaded on an Olympic Airways 747 in Athens, Greece, and flown to JFK on a regular service flight, similar to the flight flown by the accident airplane before the accident flight. The fuel was purchased from Olympic Airways, unloaded from the Olympic Airways 747 CWT into a fuel truck, then loaded into the flight test airplane CWT before the first test flight. Six Safety Board flight tests were conducted with multiple variations in aircraft operations. One of these six tests, the TWA flight 800 emulation flight test, was designed to replicate the configuration, ground operation, and flight profile of the accident airplane as closely as possible. The following is an explanation of this flight test:<sup>236</sup>

- TWA Flight 800 Emulation Flight Test—During this flight test, the pilots attempted to duplicate TWA flight 800's preflight actions/operations, takeoff, and ascent as closely as possible. The flight test airplane took off within 1 minute of the time of day that the accident airplane took off, 2 days before the 1-year anniversary of the accident flight. Slight variations from the TWA flight 800 climb profile were necessary to comply with ATC instructions; however, the overall climb profile matched that of the accident airplane within 1,000 feet, elapsed times within 1 minute, and airspeeds within 20 knots throughout the climb.
- The flight test airplane's CWT contained 50 gallons of Jet A fuel (obtained from the Olympic Airways 747 from Athens, Greece),<sup>237</sup> and the main wing fuel tanks were refueled at JFK to approximate TWA flight 800's fuel loads. During the refueling, the outside air temperature (measured on the tarmac near the airplane) was 88° F.<sup>238</sup> The temperature of the fuel loaded on the airplane ranged from 88° to 91° F. Air conditioning pack Nos. 1 and 3 were operated at the "full-cold" setting for about 2 3/4 hours before the flight test pilots began to start the airplane's engines. The airplane began to taxi for takeoff about 1957 and took off about 2021. The air conditioning packs were turned off for takeoff, and all three air conditioning packs were started after takeoff (in accordance with TWA procedures) and remained operational for the remainder of the flight. As the airplane climbed through 10,000 feet msl, the pilots initiated a crossfeed procedure outlined in the TWA Flight Handbook for fuel management. During the next 5 minutes, fuel tank No. 3 provided fuel to the

<sup>236</sup> As previously stated, additional information regarding the other five flight tests is included in the Flight Test Group Chairman's Factual Report, dated November 19, 1997.

<sup>237</sup> Fuel from the Olympic Airways 747 CWT was used so that vapor samples taken from the test airplane's CWT during the flight tests would more closely represent the weathered fuel in the accident airplane's CWT. This fuel was tested after the flight test; its flash point was determined to be 116° F.

<sup>238</sup> Meteorological records indicate that the temperature at JFK when the accident airplane departed was 82° F.

Nos. 1, 2, and 3 engines with both No. 3 boost pumps operating, while fuel tank No. 4 provided fuel to the No. 4 engine with both No. 4 boost pumps operating. For the remainder of the flight, the pilots performed the fuel management procedures described in the TWA Flight Handbook. The pilots flew the ascent profile recorded by the accident airplane's FDR (as closely as possible) until the airplane passed through 13,700 feet msl, then continued to climb at a constant rate. The airplane leveled off at 19,000 feet msl and remained there for about 2 hours before it returned to JFK about 2241. Three CWT fuel/air vapor samples were taken during this flight test (during taxi for takeoff and as the airplane climbed through 10,400 and 14,200 feet msl).

Examination of the temperature data collected during the emulation flight test indicated that the highest ullage temperature measured within the CWT was 145° F and that it occurred in the left mid bay just before the airplane began to taxi for takeoff. Examination of the temperature data also indicated that the highest ullage temperature measured at 13,700 feet msl was 127° F and that it occurred in the left mid bay (see figure 33). Table 6 shows the maximum and minimum recorded ullage temperatures at 13,700 feet msl during the emulation flight test.<sup>239</sup>

The Safety Board also measured the ambient air and component surface temperatures within the air conditioning pack bay. At the time that the flight test airplane was pushed back from the gate (after operating on the ground for 2 3/4 hours with the Nos. 1 and 3<sup>240</sup> air conditioning packs operating), air conditioning pack component surface temperatures ranged from 250° to 350° F, and ambient air temperatures within the pack bay ranged from 148° to 228° F.<sup>241</sup>

---

<sup>239</sup> Temperature sensors were located in the middle of each bay at three height locations: 3 inches below the top of the CWT (upper CWT), 3 inches above the bottom of the CWT (lower CWT), and halfway between the top and bottom of the CWT. Bays 1 and 2 also had temperature sensors located 3 inches in from the left sidewall and 3 inches in from the right sidewall, at the same height locations.

<sup>240</sup> These are the farthest forward air conditioning packs, mounted just aft of the front spar on either side of the keel beam.

<sup>241</sup> These temperature ranges reflect variations in the temperature sensor's proximity to the operating air conditioning components. For example, the temperatures measured near the bleed air inlets to air conditioning pack Nos. 1 and 3 were at the high end of the range, whereas temperatures measured near the bleed air inlets to air conditioning pack No. 2 were at the lower end of the range, and the temperatures measured at the compressor outlets for air conditioning pack Nos. 1 and 3 were in the low- to mid-temperature range. After the airplane became airborne, these temperatures decreased, but not significantly enough to rapidly change the temperatures within the CWT.

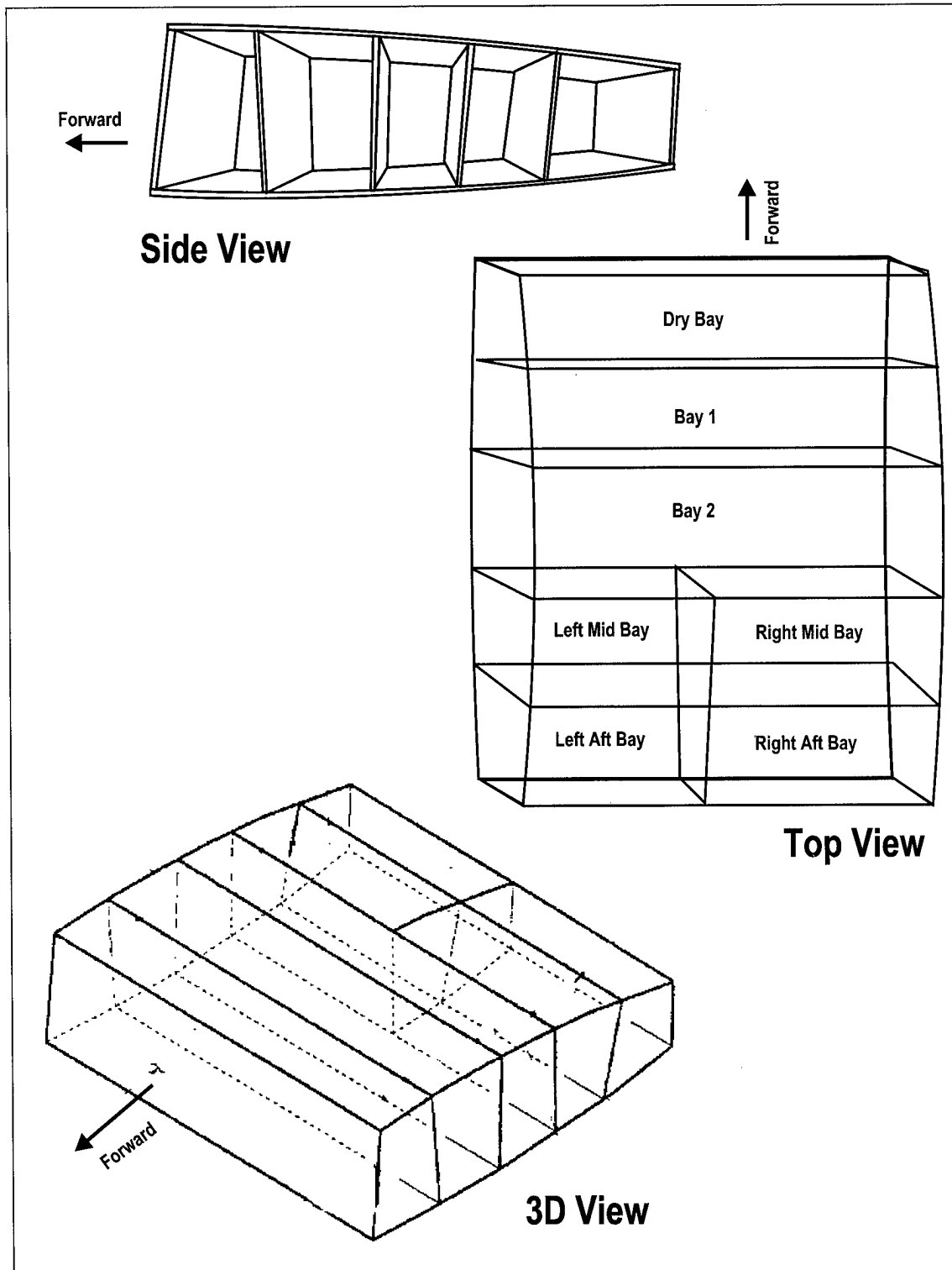

**Figure 33.** Side view, top view, and three-dimensional view of wing center section/center wing fuel tank bays.



**Table 6.** A summary of the maximum and minimum recorded ullage temperatures at 13,700 feet msl during the emulation flight test.

Ullage Bay Location	Maximum Temperature in ° F (including temperature sensor height location)	Minimum Temperature in ° F (including temperature sensor height location)
Bay 1 <sup>a</sup> —Center	117 (lower CWT)	114 (upper CWT)
Bay 1—Left side	111 (lower CWT)	107 (lower CWT)
Bay 1—Right side	110 (lower CWT)	101 (upper CWT)
Bay 2 <sup>b</sup> —Center	120 (lower CWT)	117 (upper CWT)
Bay 2—Left side	110 (lower CWT)	102 (upper CWT)
Bay 2—Right side	109 (lower CWT)	102 (upper CWT)
Left Mid Bay	127 (lower CWT)	114 (upper CWT)
Right Mid Bay	114 (lower CWT)	106 (upper CWT)
Left Aft Bay	120 (lower CWT)	113 (upper CWT)
Right Aft Bay	112 (lower CWT)	103 (upper CWT)

<sup>a</sup> In this section, the term “bay 1” refers to the fuel bay between SWB3 and SWB2.

<sup>b</sup> In this section, the term “bay 2” refers to the fuel bay between SWB2 and the mid spar.

As previously discussed, the CWT is configured within the airframe such that the air conditioning packs are located in an enclosed bay, directly below and very near<sup>242</sup> the bottom surface of the CWT.<sup>243</sup> Because of the high temperatures at which the air conditioning packs operate, the ambient air temperature within the pack bay increases when the air conditioning packs are operated. As a result of these elevated temperatures, heat in the pack bay is transferred into the CWT through its bottom surface. Some of this heat is transferred out of the CWT (for example, into the wing main fuel tanks or the main landing gear wheel well), and some of it remains in the CWT. This heat flow results in a significant increase in the temperature of the CWT fuel and ullage, which was shown in table 6. The temperature variations within the CWT are illustrative of this heat flow. In general, the hotter temperatures in the CWT ullage were located in the lower, center portions of the CWT (nearest the heat source), whereas cooler temperatures were measured around the sides and top of the CWT (where heat was transferred out of the CWT).

Examination of the temperatures measured in the surge tanks, vent stringers, and the No. 3 fuel tank during the TWA flight 800 emulation flight test indicated that these temperatures were about the same or slightly warmer than the outside air temperature during the ground portion of the flight test (airplane temperatures of 85° to 90° F versus

<sup>242</sup> The air conditioning packs' distance from the bottom of the CWT varies from about 2 to about 12 inches. See figure 7 for a side-view diagram of the air conditioning packs/CWT.

<sup>243</sup> The air conditioning packs are also located under the CWT in other Boeing and Airbus airplanes; however, in some Airbus airplanes, the air conditioning pack bays are ventilated. In contrast, in the DC-10, MD-11, and L-1011 series airplanes, the air conditioning packs are located in the nose, and in the Fokker F-100 and MD-80 airplanes, the air conditioning packs are located in the tail.

outside air temperatures of 82° to 88° F [depending on the time and location of the temperature reading]). As the test airplane's altitude increased after takeoff, the temperatures measured in the surge tanks, vent stringers, and No. 3 fuel tank decreased. When the TWA flight 800 emulation flight test climbed through 13,800 feet, the temperatures in the surge tank and vent stringers had decreased to 68° F, whereas the temperatures measured in the No. 3 fuel tank had decreased to 65° to 75° F (depending on the temperature sensor location).<sup>244</sup>

#### 1.16.5.1.1.1 Fuel Vapor Sampling and Analysis from 747 Flight Tests at JFK—Desert Research Institute

Personnel from the Desert Research Institute (DRI), Boeing, and the Safety Board designed a vapor sampling system, which was installed and functionally tested on the flight test airplane before the first test flight.<sup>245</sup> The sampling system consisted of preevacuated, 1-liter stainless steel sampling bottles,<sup>246</sup> which were plumbed through a central manifold and mounted in the airplane's forward cargo compartment. A stainless steel sampling tube extended from the manifold in the forward cargo compartment through the front spar and an access panel on SWB3. This sampling tube had an outside diameter of 1/8 inch, was 25 feet long, and terminated with an open end located about 12 inches aft of SWB3 within bay 2 (about 30 inches above the bottom of the tank and 35 inches left of the CWT centerline), where the fuel vapor samples were drawn. Vapor samples were collected during taxi and as the airplane climbed through about 10,000 and 14,000 feet msl during the emulation flight test. The vapor sample bottles were subsequently transported to DRI, where scientists measured the vapor samples for hydrocarbon fuel concentrations.

Review of the data obtained from the emulation flight test revealed that the CWT vapor samples had fuel/air mass ratios<sup>247</sup> of 0.034, 0.046, and 0.054 on the ground during taxi and as the airplane climbed through about 10,000 and 14,000 feet msl (see table 7). According to scientific literature<sup>248</sup> and tests conducted by experts at the California Institute of Technology (CIT), the lower flammability limit (LFL) of Jet A fuel is at a fuel/air mass ratio of 0.032 to 0.038.<sup>249</sup>

<sup>244</sup> For additional information regarding the flight test results, see *Flight Test Results: TWA 800 Emulation Flight* (Exhibit 23F).

<sup>245</sup> For additional information regarding the vapor sampling mechanism and the handling and testing of the vapor samples collected, see the Flight Test Group Chairman's Factual Report, dated November 19, 1997. Also, see the DRI report, "Sampling and Analysis of Vapors from the Center Wing Tank of a Test Boeing 747-100 Aircraft," dated November 1997.

<sup>246</sup> Two sampling bottles were used for each vapor sample acquisition. One bottle was used to purge the sampling line and manifold, and the other, subsequently, was used to collect a valid vapor sample.

<sup>247</sup> The fuel/air mass ratio is a measure of the mass of fuel in a mixture divided by the mass of the air in that mixture. In the context of this flight test sample, it is a measure of the mass of the fuel in the ullage divided by the mass of the air in the ullage.

<sup>248</sup> Nestor, L. 1967. *Investigation of Turbine Fuel Flammability within Aircraft Fuel Tanks*. Final Report DS-67-7. Naval Air Propulsion Test Center, Naval Base, Philadelphia, Pennsylvania. Also, Shepherd, J. E.; Nuyt, C. D.; and Lee, J. J. 2000. *Flashpoint and Chemical Composition of Aviation Kerosene (Jet A)*. Graduate Aeronautical Laboratories, CIT. Explosion Dynamics Report FM99-4.

**Table 7.** Fuel/air mass ratios and ullage temperatures measured at the bay 2 sampling port during the TWA flight emulation flight test.

Sample	Temperature of Ullage at Sample Location in ° F	Fuel/air Mass Ratio
Emulation flight test, taxi	123	0.034
Emulation flight test, about 10,000 feet msl	115	0.046
Emulation flight test, about 14,000 feet msl	117	0.054

During subsequent flight tests, investigators collected additional vapor samples from the CWT ullage. The fuel in the CWT was not consumed, nor was the CWT refueled during the series of flight tests in which vapor samples were collected. Examination of the series of vapor samples showed that the vapor composition gradually changed through a process known as fuel weathering. Subsequent flash point testing (conducted at CIT)<sup>250</sup> of liquid fuel samples collected at each flight test did not indicate a significant change in flash point (less than 3° F) as the fuel weathered during the series of flight tests.

#### 1.16.5.1.2 Testing of Fuel Samples from TWA Flight 881 (Arriving at JFK from Athens, Greece)

On October 1, 1996, a fuel sample (about 50 milliliters) was obtained from the CWT of a TWA 747 that had just arrived at JFK from Athens, Greece, as TWA flight 881. Because TWA flight 881's CWT had been refueled in Athens and was believed to have encountered conditions (flight profile, thermal environment, and weathering) similar to those encountered by the accident airplane during its flight from Athens to JFK (before it departed as TWA flight 800), the Safety Board considered this fuel sample to be representative of the fuel in the accident airplane's CWT when the overpressure event occurred. This fuel sample was taken to Saybolt International's laboratories for standardized fuel testing. The flash point of this fuel was measured at 114° F, and it was noted that the sample contained an antistatic additive that resulted in the sample having 90 picosiemens/meter electrical conductivity.<sup>251</sup>

<sup>249</sup> From May 29 to 31, 1998, Boeing performed additional ground tests, with technical support from the Safety Board, to investigate the 747-100 CWT thermal and vapor environment. These tests were conducted at Pinal Air Park in Marana, Arizona, using a 747-100 series airplane leased from Evergreen Airlines and were similar in scope to the JFK flight tests conducted by the Safety Board. Testing was performed in a hot ambient environment (outside air temperatures above 95° F), with all three of the airplane's air conditioning packs operating. The tests were conducted in the following conditions: (1) a nearly empty fuel load in the CWT (50 gallons, similar to TWA 800), with uninsulated air conditioning packs; (2) 50 gallons of fuel in the CWT, with thermally insulated air conditioning packs; and (3) 12,000 pounds of fuel in the CWT, with uninsulated air conditioning packs. Temperature and vapor measurements of the CWT indicated that a flammable condition existed during ground operations during each of the three tests. For additional information, see *Summary Data Report: B-747-100 Center Wing Tank Ground Testing at Marana, Arizona*, dated January 20, 2000.

<sup>250</sup> Shepherd, Nuyt, and Lee.

### 1.16.5.2 Laboratory Testing of Jet A Fuels—California Institute of Technology

A review of Jet A combustion data available when the TWA flight 800 accident occurred revealed that insufficient research data were available to adequately address the specific issues germane to the characteristics of a CWT explosion.<sup>252</sup> Therefore, the Safety Board contracted with explosion dynamics experts at the CIT Graduate Aerodynamics Laboratory to conduct a comprehensive experimental and analytical investigation of the combustion behavior of Jet A fuel. This included flammability research to identify conditions under which Jet A fuel/air mixtures are flammable and combustion research to determine the characteristics (for example, explosion peak pressures and flame speeds) of Jet A fuel combustion. The issues of ignition energy, temperature, altitude (pressure), mass loading, weathering, and fuel chemistry<sup>253</sup> were investigated because of their criticality to the explosion of the CWT.

The flammability research focused on defining the conditions at which Jet A fuel vapor was found to be flammable.<sup>254</sup> A precision test fixture was developed to generate fuel vapors over a large range of temperature and pressure conditions, and an electronic spark system was developed to ignite the vapors while accurately measuring the ignition energy supplied. Hundreds of tests were performed<sup>255</sup> to determine the flammability limits of the fuel vapor, as a function of ignition energy, fuel temperature, pressure (to simulate altitude), fuel mass loading, and fuel weathering. The test conditions were selected to

---

<sup>251</sup> Electrical conductivity for fuel is the ability of the fuel to dissipate a static charge, and the unit of measure is picosiemens per meter. For additional information regarding the results of fuel tests conducted during this investigation, see Powerplants Group Chairman's Factual Report, dated February 25, 1997. This fuel sample was also analyzed for chemical composition. For additional information, see the University of Nevada report, "Sampling and Analysis of Vapors from the Center Tank of a Test Boeing 747-100 Aircraft," dated November 1997.

<sup>252</sup> According to the experts at CIT, the Jet A flammability data at the time of the accident included limited data on flammability properties found in the industry standard references (Kuchta, J. M. et. al. 1985. *Aircraft Mishap Fire Pattern Investigations*. Final Report APWAL-TR-85-2057. Aero Propulsion Laboratory.; and Zabetakis, M. G. 1965. *Flammability Characteristics of Combustible Gases and Vapors*. Bulletin 627. Bureau of Mines.), much of which was without direct attribution. However, the CIT experts indicated that much of the Jet A flammability data that existed at the time of the accident appeared to have been derived from the following three technical reports: Nestor; Ott, E. 1970. *Effects of Fuel Slosh and Vibration on the Flammability Hazards of Hydrocarbon Turbine Fuels within Aircraft Fuel Tanks*. Technical Report AFAPL-TR-70-65. Fire Protection Branch of the Fuels and Lubrication Division. Wright Patterson Air Force Base, Ohio; and Kosvic et. al. 1971. *Analysis of Aircraft Fuel Tank Fire and Explosion Hazards*. Technical Report AFAPL-TR-71-07. Air Force Aero Propulsion Laboratory, Wright Patterson Air Force Base, Ohio.

<sup>253</sup> Fuel chemistry variations commonly result from different formulations of Jet A fuel and can be affected by variations in fuel supply, fuel supplier, fuel handling, and/or mass loading.

<sup>254</sup> For additional information regarding these tests, see CIT/Graduate Aeronautical Laboratory. 1999. *Spark Ignition Energy Measurements in Jet A*. Explosion Dynamics Laboratory Report FM97-9. Also, see CIT/Graduate Aeronautical Laboratory. 2000. *Spark Ignition Measurements in Jet A: Part II*. Explosion Dynamics Laboratory Report FM99-7.

<sup>255</sup> Initially, these tests were performed using single component hydrocarbon fuels (methane and propane) to validate the experimental procedures and test results when compared to previously published research on these fuels. However, subsequent tests were performed using Jet A fuel/fuel vapors.

thoroughly document Jet A fuel vapors' characteristics under conditions that were determined to have existed in the accident airplane.

The explosion dynamics experts at CIT also conducted research to determine the combustion characteristics of Jet A fuel and how those characteristics are affected by different fuel temperatures, pressures (simulating different altitudes), fuel mass loading, fuel batch source, and fuel weathering.<sup>256</sup> Combustion characterization required hundreds of experiments<sup>257</sup> of the ignition of Jet A fuel vapors in various size test vessels. Measurements of pressure histories and explosion peak pressures were made during tests conducted under a multitude of conditions. Flame speeds were calculated over the range of conditions. The flame speeds and explosion peak pressures were compared to theoretical calculations under ideal conditions. The resultant information allowed researchers to make more accurate theoretical calculations of the combustion of Jet A fuel under nonidealized conditions. Additionally, this information was critical to the development of computer models of Jet A combustion within the CWT.<sup>258</sup>

Upon completion of the tests and research, the experts evaluated the applicability of the data acquired in relation to the TWA flight 800 accident conditions. The conclusions specific to the accident conditions were based on the examination of a similar flash point Jet A fuel, at a temperature range of 104° to 122° F at 13,800 feet msl, with a fuel mass loading equivalent to 50 gallons in the CWT. The explosion dynamics experts from CIT and the Safety Board determined the following:

- The flammability limits of Jet A fuel are variable and depend (at least) on ignition energy level, temperature, pressure, and mass loading. The magnitude of the ignition energy of the fuel vapor for the accident airplane's conditions (50 gallons of Jet A fuel in the CWT at a pressure equivalent to 13,800 feet msl) is estimated to vary from 0.5 J at 104° F to less than 0.5 mJ at 122° F.
- At 13,800 feet msl, with fuel mass loading conditions simulating those of the accident airplane, Jet A fuel<sup>259</sup> vapors could be ignited at temperatures as low as 96.4° F.
- Published research involving pure hydrocarbon fuels<sup>260</sup> estimated the LFL of these fuels at sea level to be a fuel/air mass ratio of 0.036 to 0.041. Published research involving Jet A fuels<sup>261</sup> estimated the LFL for Jet A to be a fuel/air

---

<sup>256</sup> For additional information regarding this research, see *Jet A Explosions—Experiments: Laboratory Testing*, dated November 21, 1997.

<sup>257</sup> Similar to the previously discussed flammability research, initial tests were performed using single component hydrocarbon fuels for validation purposes, with subsequent tests performed using Jet A fuel/fuel vapors.

<sup>258</sup> For more information, see section I.16.5.5.

<sup>259</sup> The fuel used in this test was obtained from the Los Angeles International Airport (LAX), Los Angeles, California, and was determined to have a flash point of 116.6° F. As previously indicated, on the basis of tests conducted on fuel obtained from the same fuel source in Athens, Greece, the fuel on board the accident airplane was determined to have a flash point of 114° F.

<sup>260</sup> Kuchta. (The data were taken at sea level.)

<sup>261</sup> Nestor.

mass ratio of 0.032 to 0.035, for pressure between 0.4 and 1.0 atmospheres. Although the LFL was not explicitly tested for during CIT's research, the lowest fuel/air mass ratio ignited was calculated at 0.038 at 13,800 feet msl, using 80 J spark energy.

- Most existing Jet A vapor pressure data are highly contradictory and based on correlations rather than measurements. Vapor pressure varies between fuel batches, and measurements can easily be contaminated by dissolved air. The vapor pressure measurements obtained in the CIT research and the fuel vapor characterization made by Woodrow<sup>262</sup> represent a significant portion of the available Jet A vapor pressure and chemical composition data.
- Simulating the altitude and fuel mass loading conditions of TWA flight 800 in a laboratory test cell, explosion peak pressures of Jet A vapors were measured at 39.2 psi (at 104° F) and 52.2 psi (at 122° F) above ambient pressure at 13,800 feet (8.6 psi).
- Ignition of Jet A vapors (at sea level) can occur at temperatures significantly below their flash point temperatures. A survey of Jet A fuels used in the current research indicated that fuel/air mass ratios calculated at the flash point temperature range from 0.0354 to 0.0488, which indicates that the flash point temperature of the fuel would be higher than its temperature at the LFL. Therefore, flash point temperatures are not a reliable guide for assessing the explosion hazards of Jet A fuels. Flammability tests in vessels or tubes with the appropriate mass loading factor, ignition source, test and analysis procedures, and instrumentation must be used to determine flammability limits.

### 1.16.5.3 Jet Fuel Vapor Chemistry—University of Nevada

The Safety Board contracted with the University of Nevada's Center for Environmental Sciences and Engineering to analyze the properties of Jet A fuel vapor.<sup>263</sup> The objective of these analyses was to characterize fuel vapor chemistry and determine the vapor concentrations (fuel/air mass ratios) generated by jet fuels under various conditions. Many different sources of Jet A fuel were tested over a range of temperatures and fuel mass loadings, encompassing the conditions that existed when the TWA flight 800 accident occurred. These analyses were also able to quantify the effects of fuel weathering and altitude on fuel vapor concentrations. One analysis was made of Jet A fuel obtained from Athens, Greece, shortly after the TWA flight 800 accident.<sup>264</sup> This analysis showed that for the temperature range (104° to 122° F) and fuel mass loading in the accident airplane's CWT at the time of the accident, the fuel/air mass ratios were between 0.036 and 0.066.

---

<sup>262</sup> Woodrow, J. and Seiber, J. 1997. *The Laboratory Characterization of Jet Fuel under Simulated Flight Conditions*. Center for Environmental Sciences and Engineering. University of Nevada. Reno, Nevada.

<sup>263</sup> Woodrow and Seiber.

<sup>264</sup> As stated previously in section 1.16.5.1.2, this fuel came from TWA flight 881 and was believed to most closely represent the fuel within the accident airplane's CWT at the time of the accident.

#### 1.16.5.4 Quarter-Scale Center Wing Fuel Tank Model Combustion Experiments—California Institute of Technology

The Jet A explosion tests discussed in section 1.16.5.2 were conducted in laboratory explosion chambers. The Safety Board determined that it also needed to investigate the phenomena associated with flame propagation in multicompartment, interconnected, and vented tanks representative of the accident airplane's CWT. The Board contracted with CIT and Applied Research Associates to conduct a comprehensive series of combustion tests using a 1/4-scale model of the CWT. The objectives for these tests were to (1) provide a definitive set of combustion data for the development and validation of computer code models<sup>265</sup> of the combustion process within the CWT and (2) demonstrate the combustion of Jet A fuel vapor at the temperature, pressure (altitude), and fuel mass loading present in the accident airplane at the time of the accident in a simplified yet representative CWT model.

Accordingly, the explosion dynamics experts at CIT designed an experimental test program in which a CWT model was constructed with length, width, and height measurements that were roughly one-fourth the size of a full-size 747-100 CWT.<sup>266</sup> (The 1/4-scale CWT model was 5 feet long and wide and 1 1/2 feet high.) The 1/4-scale model was constructed with a steel top and bottom, removable steel partitions, and transparent high-strength plastic (Lexan) sides, which enabled observation of the combustion event. Later modifications to the model included temperature and pressure controls, which allowed researchers to simulate the temperature and altitude of the accident airplane's CWT.<sup>267</sup> The model was instrumented with pressure and temperature gauges, and an external camera system was incorporated to view the combustion event.

Seventy-two tests were conducted, in three separate test phases, over a 2-year period. The initial phase of testing was conducted using a simulant fuel.<sup>268</sup> The second and third phases of testing were conducted using Jet A fuel. Variations in model configurations, ignition locations, and fuel vapor conditions were examined. Because the primary intent of these tests was to provide a validation database for computer model

---

<sup>265</sup> For a description of the computational modeling effort, see section 1.16.5.5.

<sup>266</sup> This size difference results in the volume of the model tank being one sixty-fourth that of the full-scale CWT. For additional information, see CIT/Graduate Aeronautical Laboratory. 1997. *Jet A Explosions – Field Test Plan, 1/4-Scale Experiments*. Explosion Dynamics Laboratory Report FM97-17.

<sup>267</sup> For additional information regarding these tests, see CIT/Graduate Aeronautical Laboratory. 2000. *Results of 1/4-Scale Experiments—Vapor Simulant and Liquid Jet A Tests*. Explosion Dynamics Laboratory Report FM98-6. Also, see CIT/Graduate Aeronautical Laboratory. 2000. *1/4-Scale Testing, Part II—Simulant Repeatability Series, Jet A Vapor and Quenching*. Explosion Dynamics Laboratory Report FM99-7.

<sup>268</sup> The simulant fuel (1.4 percent propane, 7 percent hydrogen, and 91.6 percent air) was developed and used in this test series to permit the observation of multicompartment fuel vapor explosions at the local ambient temperature and pressure conditions of the test site (near Denver, Colorado), simulating the combustion behavior of the Jet A fuel vapor in the accident airplane's CWT at the conditions that existed at the time of the accident. Using the simulant fuel greatly reduced the experimental effort required (compared to using Jet A fuel). Using Jet A fuel during the second and third phases of tests required significant modifications to the test model to elevate the temperature to between 104° and 122° F at a reduced pressure equivalent to an altitude of 13,800 feet msl.

development (which required that the essential physical phenomena of the CWT combustion event be represented), researchers did not require experimental duplication of all of the conditions on board the accident airplane. Important distinctions between the 1/4-scale test model and the full-scale CWT and the limitations of the testing were the following:

- The complexities of the full-scale CWT were simplified in the 1/4-scale model. The features believed to be most significant—bay volumes and lengths and vent and passageway areas—were scaled from the full-scale CWT, with some simplifications. For example, variations in tank height and the finer geometric details of stiffeners and stringers were not included in the model.
- It is not clear if the results of the 1/4-scale model testing can scale directly to replicate full-scale results. The effects of scaling on some features (such as flow turbulence and flame quenching) are not well understood.
- The effects of temperature and fuel vapor concentration variations within a single bay and between bays could not be examined in this limited experimental program.<sup>269</sup>
- Other simplifications of the 1/4-scale model included the even distribution of fuel between the bays and a smooth floor geometry. Thus, the role of liquid layer participation may not be accurately demonstrated.
- The testing did not attempt to simulate partition failures, representative of full-scale CWT structural dynamic behavior during the combustion event, and the effects of such failures upon the combustion dynamics.

Because of the differences between the 1/4-scale test model and the full-scale CWT, the interpretations that could be made by directly comparing these experimental results to a full-scale explosion were limited. Within these limitations, however, analysis of the experimental results led the researchers to reach the following conclusions regarding direct application of the 1/4-scale test results to TWA flight 800:

- Jet A fuel ignited and combusted during every test using conditions approximating those that existed in the accident airplane's CWT at the time of the accident.

---

<sup>269</sup> Temperature and vapor concentration variations within a single bay and between bays were observed in the JFK flight test results. Subsequent ground tests were conducted in Marana, Arizona, in which CWT temperatures and vapor concentrations were measured with higher resolutions than those measured during the JFK flight tests. These tests confirmed the existence of temperature and vapor concentration variations within a single bay and between bays. For additional information, see Summary Data Report: B-747-100 Center Wing Tank Ground Testing at Marana, Arizona, dated January 20, 2000, and the Flight Test Group Chairman's Factual Report, dated November 19, 1997.



- The ignition of Jet A fuel in one bay of the 1/4-scale model resulted in transmission of the flame through the bay passageways and vent stringers and ignition in neighboring bays, illustrating the behavior of multicompartment flame propagation.<sup>270</sup> Flamefront quenching was also observed to be a characteristic of flame propagation.
- After the combustion flamefront propagated from the ignition bay to a neighboring bay, the combustion process dramatically accelerated, allowing explosion pressures to increase rapidly.
- In certain tests, pressure levels in bay 1 (the bay between SWB2 and SWB3) of the 1/4-scale model exceeded those needed to fail SWB3 (as indicated by Boeing's structural analysis of the full-scale geometry).<sup>271</sup>

#### 1.16.5.5 Computational Research of Center Wing Fuel Tank Combustion

The Safety Board contracted with two research laboratories—Sandia National Laboratories (SNL) and Christian Michelsen Research (CMR)—to develop computer code models of the combustion process that occurs in a 747 CWT. Both research laboratories had extensive experience in large-scale explosion modeling and possessed existing combustion codes that could be applied to the task of modeling the CWT combustion process.

This research was intended to develop computer models capable of generating accurate solutions for different full-scale CWT combustion scenarios.<sup>272</sup> Rules-based analysis,<sup>273</sup> which compared the results from each computer solution to the physical evidence, was then to be applied to these computer solutions to determine the probability that a particular combustion scenario might have occurred in the accident airplane. The Safety Board hoped that research involving this combination of computer modeling and rules-based analysis would indicate the most probable ignition source for the CWT overpressure event.

The combustion model development was conducted concurrently by the two laboratories for 2 years. During this period, model development was continually being validated using the data generated in the 1/4-scale experimental test program. Additionally, because each computer model used a different approach toward calculating the combustion process, the researchers were able to develop and verify their work in conjunction with each other.<sup>274</sup>

During the initial development stages, both research laboratories produced computer models of the 1/4-scale CWT geometry and provided solutions using both the

---

<sup>270</sup> Multicompartment flamefront propagation refers to the progression of a flamefront through the fuel/air vapor space within and between fuel tank compartments.

<sup>271</sup> For more information, see section 1.16.4.9.

<sup>272</sup> Each scenario represents a unique combination of ignition location, ullage temperature, and structural failure timing, for which a computer solution was calculated.

<sup>273</sup> For additional information regarding the rules-based analysis, see section 1.16.5.5.1.

simulant and Jet A fuel. Subsequently, auxiliary computer models and supplemental experimental tests were conducted to refine the accuracy of certain characteristics of the Jet A combustion process. The most significant of these involved the issue of modeling flamefront quenching through compartment passageways. Considerable effort was spent on this issue, and a simple, limited model was developed to describe this behavior.

In the final developmental stages, each computer model was revised to model the full-scale CWT geometry. Two full-scale calculations were performed using the SNL model, and 32 full-scale calculations were conducted using the CMR model. On the basis of their analysis of the full-scale computer modeling calculation results, the experts from both research laboratories concluded the following:

- The combustion behaviors of multicompartiment flame propagation exhibited in the full-scale model calculations were consistent with those observed in the 1/4-scale modeling tests.
- During some scenarios, the pressures developed in bay 1 exceeded the pressure required to fail SWB3.<sup>275</sup>
- In all of the computer solutions, conditions were calculated that indicated that quenching could have occurred in some of the vents and passageways of the full-scale CWT geometry (which has 89 intercompartment passageways connecting the 6 fuel bays and 2 vent stringers connecting the CWT to the wing tip vents).
- Incorporating the effects of quenching in the calculations appeared to significantly affect the differential pressure histories that developed across the internal CWT structural members. This resulted in the solutions having an enhanced sensitivity to ignition location.

Because the full-scale computer modeling results indicated that the conditions for flamefront quenching appeared to exist, and because this behavior affects the development of compartment pressures, the ability to accurately predict quenching was very important. However, because the research data regarding the quenching phenomena are limited, a complete understanding of quenching behavior was not possible, and the issue of quenching remains unresolved.

#### **1.16.5.5.1 Study of Computer Model Calculations of Full-Scale Center Wing Fuel Tank Combustion**

The Safety Board contracted with Combustion Dynamics, Limited (CDL) to evaluate the consistency between the computer calculations of the full-scale CWT combustion model and other information and evidence obtained during the investigation.

---

<sup>274</sup> The code used by SNL determines pressure histories from global mass, momentum, and energy balances. Flame propagation is represented as a moving interface that separates the burned and unburned gases. The CMR model uses a finite volume technique for solving the mass, momentum, energy, and kinetic turbulent energy production and dissipation. This model follows the motion of the flamefront, separating burned and unburned gases.

<sup>275</sup> For more information about the pressures required to fail SWB3, see section 1.16.4.9.

The Board hoped that by conducting this evaluation for each computer model solution or scenario (each involving a different combination of ignition location within the CWT, ullage temperature, and timing of structural failure), it would be possible to narrow the number of probable ignition location(s) within the CWT. CDL used the rules-based analysis to evaluate this consistency.<sup>276</sup>

As previously discussed, the rules-based analysis required the development of the following areas of the investigation:

- identification of damage (or nondamage) observed in the recovered CWT wreckage that could be attributed to an early event in the breakup sequence,<sup>277</sup> such as the failure of SWB3 in the forward direction and the rupture and forward deflection of the SWB2 manufacturing access door; and
- mechanical failure analysis of the CWT structural members, which defined a range of pressure differentials that could cause failure of each of the CWT SWBs and spars.<sup>278</sup>

Using information from these areas, the rules-based analysis developed probabilities of damage/failure events for the actual (observed in wreckage) and simulated (calculated by the computer) events. These probabilities were then used to develop a consistency estimate, which was an indication of how consistent an observed failure/damage was with the computer model's calculations for that failure/damage (for example, pressure differential across that panel). The consistency estimates for each individual failure/damage event were then combined to produce an overall consistency estimate, which would indicate the overall agreement between that computer scenario's combination of events and the total of the observed damages.

The rules-based analysis was used to examine each of the 32 scenarios of full-scale CWT calculations provided by the CMR model. The results showed a positive overall consistency value between each scenario that was modeled and the observed damages. Although scenarios involving certain ignition locations produced results with higher consistency estimates than scenarios involving other ignition locations, none of the differences in consistency estimates were high enough to permit a determination of the most probable ignition location with a high degree of confidence. The experts at CDL attributed this to the uncertainties associated with the full-scale model calculations,<sup>279</sup> the limited amount of airplane damage that could conclusively be considered the result of early events,<sup>280</sup> and the difficulties involved in determining the failure modes and failure pressure loads of the complex geometries of the CWT structural members (even with full

---

<sup>276</sup> For additional information, see Thibault, P. 2000. *Evaluation of Explosion Scenarios*. Combustion Dynamics, Limited. Report CDL-1010.

<sup>277</sup> The early event damage considered in this study/evaluation included damage caused by the CWT overpressure event and did not include damage caused by the subsequent in-flight breakup of the airplane, fire, or water impact.

<sup>278</sup> For more information, see section 1.16.4.9 and Safety Board Memorandum to the TWA flight 800 Docket, "Boeing Submission," dated June 5, 2000.

<sup>279</sup> For more information about the full-scale model calculations, see section 1.16.5.5.

utilization of modern computer resources). Therefore, the rules-based analysis did not provide a definitive determination regarding the probability that any given location within the CWT was the ignition location. However, the rules-based analysis did reveal that the pressure differentials produced by an internal fuel/air explosion were consistent with the overall level of damage observed in the CWT. Further, the experts at CDL indicated that this conclusion was supported by a simple analysis based on the peak pressures that were experimentally observed for the combustion of Jet A fuel/air mixtures at the (temperature, pressure, and mass loading) conditions that existed in TWA flight 800's CWT at the time of the accident.

#### 1.16.5.6 Bruntingthorpe Full-Scale Center Wing Fuel Tank Explosion Tests

Between July 28 and August 2, 1997, the Safety Board, with the assistance of the British Defense Evaluation and Research Agency (DERA), conducted a CWT fuel/air explosion test by igniting a propane/air mixture in the CWT of an out-of-service 747 located at Bruntingthorpe Airfield, Leicestershire, England. The Board also detonated explosive charges at different locations inside and outside of the CWT and documented the resulting damage.<sup>281</sup> Examination of the damage indicated that when metal of the same type and thickness as the CWT walls was penetrated by a small charge, there was petalling of the surface on which the charge was placed, pitting on the adjacent surfaces, and visible hot gas washing damage in the surrounding area.

Documentation of the damage (direct and collateral) patterns was conducted as a group activity, with the involvement of technical representatives from several parties to the investigation, including Boeing and TWA. The tests enabled the Safety Board to examine the explosion, deformation, and failure processes (crack paths and failure sequences) produced by the ignition of a fuel/air mixture within the CWT and detonation of explosive charges.

It was not possible for the tests (nor was it intended) to exactly reproduce the explosion of TWA flight 800's CWT.<sup>282</sup> However, weight was added to the test airplane to simulate some of the loads on the accident airplane as closely as possible. For example, water was added to the main wing fuel tanks to reproduce the accident airplanes' fuel loads, the potable water bottles forward of the front spar were filled with water, and sandbags were placed in some of the passenger seats over the WCS. (The Safety Board

---

<sup>280</sup> Although nearly all of the wreckage has been recovered and, where pertinent, reconstructed, much of the early event-related damage was altered or affected by the events following the overpressure event, including the in-flight breakup of the airplane, water impact, fire, and handling during the recovery efforts.

<sup>281</sup> Each of the explosive charges used PE4, a type of plastic explosive using RDX combined with a plasticizer. In some cases, the charge was coupled with various amounts of bare shot.

<sup>282</sup> For example, it was not possible to simulate the atmospheric pressure, load factors, and/or slipstream encountered by the accident airplane in flight at nearly 14,000 feet msl nor was it possible to pressurize the fuselage. As a result of damage from the explosive charge testing (which had taken place previously), the test airplane exhibited significant damage to the aft fuselage beginning with the STA 1480 bulkhead; missing sidewall panels, ceilings (including overhead bins), windows, and doors (including the cockpit door and several main cabin doors); and damage to many other doors (including the forward cargo door) that precluded closing or latching those doors. However, the airplane's CWT and wing structure were repaired, as necessary.

notes that, despite these adjustments, the loading of the test airplane was significantly different from that of the accident airplane. These differences made a direct comparison of the results of the fuel/air explosion of the CWT in the test airplane with the results of the fuel/air explosion in the accident airplane of limited use.)

Portions of the cabin floor structure on the test airplane were modified to accommodate test hardware and instrumentation.<sup>283</sup> The openings in the CWT tank (including the tank vents to the wings) were hermetically sealed, and a predetermined amount of propane<sup>284</sup> was loaded in the CWT to approximate the amount of fuel vapor in the accident airplane's CWT at the time of the explosion.

The propane/air mixture in the test airplane's CWT was ignited by detonating an explosive device located on the right side of the rear spar (about RBL 82). According to the DERA report, this detonation "triggered a major event or events in the [CWT]....a relatively slow deflagration was evident from the audible output accompanied by a limited flash, visible externally. Deformation and holing of the fuselage roof was obvious, even from a distance."

Safety Board investigators and representatives from DERA and several parties to the investigation examined the postexplosion damage to the test airplane and developed a summary of the failure sequence that they believed showed the progression of the overpressure resulting from the propagation of the propane/air explosion. The Board observed that the test parameters used resulted in a significantly more dynamic and destructive explosion within the test airplane's CWT than was indicated by the accident airplane's wreckage.<sup>285</sup> (The catastrophic nature of the damage to the test airplane indicated that if such an event occurred in flight, it would likely result in the airplane instantaneously separating into four major components: left wing, right wing, forward fuselage, and aft fuselage.)

#### **1.16.5.7 Boeing/U.S. Air Force E-4B Center Wing Fuel Tank Fuel Heating Study**

In March 1999, the USAF Safety Center, Directorate of Engineering and Technical Services advised the Safety Board of a USAF E-4B fuel tank heating study that had been conducted by Boeing for the USAF from 1979 to 1980.<sup>286</sup> The E-4B is a military variant of the commercial 747, manufactured by Boeing, which has a larger CWT fuel capacity

---

<sup>283</sup> Test hardware and instrumentation installed for the tests included pressure, flamefront propagation, and propane/air concentration sensors throughout the CWT; accelerometers in the passenger seats above the fuel tank to measure the acceleration forces applied to the seats; a CAM; cockpit and airplane skin accelerometers; and various pressure gauges in the passenger cabin to obtain complete CVR documentation of the effects of the explosion. Associated cables and connectors were located within the CWT bays where necessary.

<sup>284</sup> A propane/air mixture was used because it was very portable and would stay in the vapor state for the period of time needed for the test, despite the cold climate.

<sup>285</sup> For example, on the test airplane, the force of the explosion shattered SWB3 into a large number of small pieces, which were propelled forward, whereas on the accident airplane, SWB3 initially only fractured at its upper chord and then rotated forward into the front spar.

than the 747-100.<sup>287</sup> The E-4B is also equipped with a 4th air conditioning pack beneath the CWT.

According to the Boeing study, the E-4B fuel heating study resulted from USAF concerns that CWT fuel temperatures could exceed the maximum allowable fuel temperature (a limit imposed for fuel pump performance, not flammability). Boeing's study indicated that these concerns were based on the USAF's finding<sup>288</sup> CWT temperatures in excess of the allowable limit. The study also stated that the USAF's concern regarding the potential problem of high fuel temperatures was supported by "reports of a Japan Airlines commercial aircraft operating out of Hawaii that was experiencing loss of CWT fuel feed during the ascent to altitude." Boeing's study stated that the purpose of the study was, in part, "the identification of aircraft operational procedures and hardware modifications which will extend the duration of aircraft operation before a [CWT] overheat condition occurs."

Boeing's study analyzed CWT temperatures during extended periods of ground operation in extreme (hot, humid) environmental conditions. The study included an experimental phase, during which fuel temperatures in the CWT were measured, and an analytic phase, during which computer modeling was used to predict CWT temperatures under various conditions. CWT fuel temperatures exceeding the allowable limit were measured during the experimental phase and were predicted under certain operating conditions by the computer models used in the analytic phase. The study also determined that although the increase in CWT fuel temperatures was the net effect of several heat sources and sinks, "the major heat load appears to be due to the high temperatures in the air conditioning equipment [bay]."

As a result of this experimental and analytic work, the Boeing study proposed manipulating CWT fuel loads/initial fuel temperatures and ground operation with the air conditioning pack doors open as operational methods to reduce CWT temperatures. The Boeing study also concluded that thermal insulation should be installed between the air conditioning packs and the CWT in the air conditioning pack bay and included

---

<sup>286</sup> The report, "Center Wing Tank Fuel Heating Study," was prepared by Boeing for the USAF, was, Document No. D226-20582-1. Boeing personnel associated with the TWA flight 800 investigation indicated that they did not become aware of this study until late in the investigation because the study pertained to the military variant of the 747 and did not focus directly on flammability. Thus, they were not able to provide the Safety Board (or the FAA or 747 operators) with the potentially relevant information about 747 CWT overheating and corrective measures during the early stages of the investigation. According to Boeing, as a result of this event, the company revised its procedures such that all company reports and resources (military and/or civilian) are now electronically accessible through key-word searches. Further, Boeing has reported that its accident investigation procedures have been revised and now include the ability to electronically search the company's technical documents.

<sup>287</sup> The E-4B has a CWT capacity of 110,812 pounds (about 17,000 gallons of Jet A at 6.51 pounds per gallon). This CWT capacity is equivalent to that of a 747-200 (and subsequent 747) model airplanes. The CWT capacity for the 747-100 is 12,890 gallons. According to Boeing, the increased CWT capacity in the E-4B/747-200 models was created by using the area between SWB3 and the front spar as a fuel bay, not as a dry bay, as it was used on 747-100s.

<sup>288</sup> For additional information regarding USAF testing, see *IOT and E Environmental Testing at Howard Air Force Base*. January 1979.

preliminary designs for the installation of thermal insulation. Further, the Boeing study discussed several possible methods that would provide an insulating air layer between the air conditioning pack bay components and the CWT, including baffling of the air conditioning pack bay (also termed “directed” ventilation)<sup>289</sup> and general forced air conditioning pack bay ventilation (using either an outside air source or recirculating air conditioning pack bay air).

### 1.16.6 Potential Ignition Source Research and Testing

During its investigation of the TWA flight 800 accident, the Safety Board evaluated numerous potential ignition sources of the fuel vapor within the CWT, including those in which the energy entered the CWT through the FQIS wiring<sup>290</sup> and those in which the energy entered the CWT through other mechanisms. Potential ignition sources in which the energy may have entered the CWT through the FQIS included radiated electromagnetic energy from transmitters outside the airplane that coupled to FQIS wiring; a transfer of electromagnetic force from personal electronic devices (PED) or other potential emitters within the airplane to the FQIS wiring; a transient voltage/current spike from wiring associated with other, higher-voltage aircraft systems induced onto corouted FQIS wiring; or a transfer of voltage from a short circuit from wires carrying higher voltage to adjacent wires carrying lower voltages, including the FQIS wires (this short circuit could occur if the insulation covering the conductors is compromised or through a bridge created by contaminants, such as metal shavings or fluid).

Other potential ignition mechanisms (those not related to the FQIS) examined by the Safety Board included a lightning or meteorite strike; a missile fragment; a small explosive charge placed on or in the CWT; auto ignition or hot surface ignition,<sup>291</sup> resulting from elevated temperatures (caused by either engine bleed air leaks, a fire in the main landing gear wheel well, or a fire in the air conditioning pack bay beneath the CWT);<sup>292</sup> a fire migrating from another fuel tank through the vent (stringer) system; an uncontained engine failure or a turbine burst in an air conditioning pack; a malfunctioning jettison/override pump; a malfunctioning CWT scavenge pump; and static electricity.

---

<sup>289</sup> A concept similar to baffling/directed ventilation is used on Airbus A300, A310, A319, A320, and A321 airplanes.

<sup>290</sup> According to the FAA’s Aging Non-Structural Systems Research Plan, electrical failures can occur in the following ways: (1) interruption of current in a circuit (also called an open circuit), which the FAA considered the “most benign failure mode...[although they] may result in more serious failure in some other part of the electrical system”; (2) a bolted short circuit, which will generally trip the airplane’s thermal circuit breakers and prevent their reset; (3) an intermittent short circuit—the FAA indicated that “a high frequency of intermittent failure may eventually lead to serious consequences either by the more critical failure of components or by a more critical failure of the interconnect system (e.g., electrical arcing)”; (4) an intermittent instantaneous discharge (arcing), which the FAA indicated may be “the most serious failure mode for electrical...components”; and (5) degraded shielding, which the FAA indicated may result in “the introduction of undesirable noise or electrical energy with potential adverse affects to the safety of the systems.”

<sup>291</sup> For additional information regarding auto ignition and hot surface ignition, see section 1.16.6.10.

<sup>292</sup> The Safety Board is aware of at least one report of fuel leaking into the air conditioning pack bay in a 747.

### 1.16.6.1 Arcing Information

As previously indicated, electrical arcing is defined (in an article published by UL) as "a luminous discharge of electricity across an insulating medium." UL indicated the following:

The electrical discharge of an arc can involve temperatures of several thousand degrees Celsius. In determining the heating effects of an arc, the classical Joule heating equation involving current squared multiplied by resistance ( $I^2R$ ), however, does not fully explain the heating effects. Although the total power dissipated in the arc is equal to the total voltage drop in the arc multiplied by the arc current, power dissipation is not uniform throughout the arc.

In general, arcing can be divided into two categories: (1) non-contact arcing, and (2) contact arcing.

Non-contact arcing is arcing that does not require direct physical contact between the conductors or "electrodes" where the arcing is taking place. Two types of non-contact arcing involving lower voltages are: a) arcing between conductors separated by insulation that occurs across the surface of the insulation, and b) arcing between conductors separated by pyrolyzed (carbonized) insulation.

With arcing between conductors separated by insulation, the mechanism of initiating an arc between stationary conductors separated by insulation will depend on the type and geometry of the conductors and insulation between them. In the case of typical air clearances found in an electrical residential distribution system, many kilovolts may be required to initiate arcing.

With arcing between conductors separated by carbonized insulation, also known as an "arc-tracking event," arcing can occur at normal operational voltages. The resulting fault-current causes the carbon path to open and an arc is established similar to parting the conductors, as with contact arcing. Carbonized insulation between opposite polarity conductors or between a line-voltage conductor and ground can lead to an across-the-line arcing fault or a line-to-ground arcing fault.

Contact arcing is arcing that involves direct or indirect physical contact between the conductors, known as electrodes, where the arcing is taking place, such as arcing between closing or parting conductors making or breaking a circuit. With this type of arcing, the arc initiation mechanism involves a hot point (essentially from  $I^2R$  heating) at the last point of contact when a circuit is being interrupted (i.e., conductors initially in contact are parting), or at the first point of contact where a circuit is being established (i.e., conductors that are initially separated and subsequently come into contact).

Contact arcing is associated with normal operational arcing that occurs with any kind of air-gap type electrical switching device. Properly designed switching devices are capable of withstanding such arcing without excessive contact damage or generation of excessive heat. Contact arcing may also be associated with arcing faults due to the unintentional creation or interruption of current.

### 1.16.6.2 Wire Short-Circuit Characteristics and Protection

The contamination observed by investigators on the wiring recovered from the accident airplane prompted the Safety Board to contract with Lectromechanical Design



Company (Lectromec) to conduct laboratory research into the short-circuit behaviors of the following commonly used aircraft wiring: BMS13-42 and -42A Poly-X wires and Kapton wires.<sup>293</sup> The Poly-X wires used for these tests were the most pliable (best case) samples obtained from a retired 747 (N93117) that was manufactured in 1971 and retired after 25 years in service, whereas the Kapton wires used for these tests were obtained from a reel of new wire.<sup>294</sup>

According to the Lectromec report, “Electrical Arcing of Aged Aircraft Wiring,” three types of tests were conducted: wet short-circuit tests in which a 1 percent saline-water electrolyte solution (NaCl)<sup>295</sup> or lavatory fluid was used as a conductor; dry short-circuit tests in which metal shavings (steel and/or aluminum)<sup>296</sup> were used as conductors; and dry abrasion tests in which metal shavings were placed between oscillating wires. In all test cases, the test wire bundles were connected to a generator that provided three-phase, 400-Hz power at 120-volt a.c., in a circuit with 7.5- or 10-amp circuit breakers and a 1-ohm<sup>297</sup> resistor.<sup>298</sup> Lectromec’s report indicated that during these tests, three categories of electrical activity were observed—scintillations, flashing, and strong arcing—which it described as follows:

- Scintillations are high-frequency, micro-discharges that appeared as pinpoints of light that flickered at the edge of cracks in the wiring insulation. Scintillations did not result in circuit breakers opening;<sup>299</sup> however, during more lively scintillations, an electrical buzzing or crackling sound could be heard, and char, or soot, formed on the wire (and adjacent wires) over time. Lectromec was not equipped to accurately measure the small amounts of energy in these scintillations.

---

<sup>293</sup> Poly-X wires were tested more extensively than the Kapton wires. For additional information regarding Kapton and/or Poly-X wiring, see section 1.6.1.3.2 and the Systems Group Chairman’s Factual Report—Addendum for Electrical Wiring Information, dated February 10, 2000. Additionally, Poly-X and Kapton wires are compared in the U.S. Naval Avionics Facility (NAFI) report NAFI-TR-2210, dated October 19, 1977, which is discussed further in section 1.16.6.3.1.

<sup>294</sup> The types of wires used for individual tests are indicated in the individual test results discussions and/or tables. As previously discussed, BMS13-42 and -42A Poly-X wires are basically the same except for the thickness of the external coat (insulation); the BMS13-42 Poly-X used in these tests had an insulation thickness of about 7 (one thousandth of an inch) mil, whereas the BMS13-42A Poly-X tested had an insulation thickness of about 11 mil. The Kapton wire used in these tests had an insulation thickness of about 8 to 9 mil. For additional information regarding these types of wires, see Systems Group Chairman’s Factual Report—Addendum for Electrical Short Circuit/Arcing of Aged Aircraft Wiring, dated October 7, 1999, and section 1.6.1.3.2.

<sup>295</sup> These tests were conducted to Society of Automotive Engineers (SAE) test standard AS4373 4.5.9 (Method 509) with variations, such as the use of lavatory fluid as an electrolyte.

<sup>296</sup> The metal shavings used in these tests were produced using a 3/16-inch drill bit. The steel shavings tended to be longer and stronger than the aluminum alloy shavings.

<sup>297</sup> An ohm is the unit of resistance of an electrical conductor, at which the fall of potential is 1 volt when the current is 1 amp.

<sup>298</sup> Although in this case a resistor was used to simulate the resistance associated with a long run of wire, typically resistors are used in circuits to limit the amount of current (amperage), and thus power, that can pass through it.

<sup>299</sup> For additional information regarding circuit breakers, see section 1.16.6.2.1.

- Flashing is an arcing discharge, seen as a single flash of light with an accompanying popping sound that usually occurred after a test sample had been scintillating for some time. Rapid, repeated flashing could continue for several seconds (but not for extended periods of time) and was followed by periods of dormancy. Typically, 2 to 4 J of electrical energy were transferred between the source and the target wire, although electrical energy transfers as high as 90 J were observed. In an April 20, 2000, letter to the Safety Board, Lectromec stated that the peak power available to the victim wire during a 3/4-millisecond flashing event was 1.3 kilowatts (kW), with a possible energy dissipation of 400 mJ. During one series of flashing events, Lectromec measured 8.25 J of energy available in less than 20 milliseconds. Flashing did not cause the 10-amp circuit breakers protecting the circuit to open,<sup>300</sup> but did result in erosion of insulation and conductors in the wire and adjacent wires over time.
- Strong arcing is an arcing discharge that could continue for hundreds of cycles, typically involving 5 kilojoules (kJ) of electrical energy and that could cause significant collateral damage to the insulation of adjacent wires. Strong arcing events often, but not always, resulted in the interruption of power when the circuit breakers opened (“tripped”). Strong arcing was observed in one of three tests involving a BMS13-42 Poly-X wire that had a relatively thin layer of insulation (about 7 mil). Tests involving BMS13-42A Poly-X wiring did not result in the strong arcing that was observed in wet-short testing of Kapton or BMS13-42 Poly-X.<sup>301</sup>

According to the report, most of the flashing and strong arcing that occurred varied widely in intensity and range. In addition, the discharges were observed to be directional (not a ball-shaped discharge), with sufficient directionality that they missed an adjacent piece of aluminum in some tests.

### Wet Short-Circuit Tests

The wet short-circuit tests involved a bundle of seven wires, five of which were attached to the generator and were considered “active,” whereas the other two wires in the bundle were not attached to the generator and were considered “passive.” The wire bundle was suspended horizontally in a test chamber, with both ends secured to stable platforms. The insulation on two active wires at the top of the bundle had been intentionally damaged (cut or sliced) circumferentially, exposing the conductors. The cuts in the two wires were placed in the bundle such that the cuts were separated by about 6 millimeters (mm). Then, with the generator providing 120-volt a.c. power, separate tests were conducted with electrolyte solutions of 1 percent NaCl solution or lavatory waste water dripped on the wires such that the fluids landed between the cuts in the wire insulation at a rate of 6 to

<sup>300</sup> According to a circuit breaker manufacturer, if the current in a circuit rises abruptly (within a few milliseconds), it can exceed the rated current by more than 1,000 percent before the circuit breaker trips.

<sup>301</sup> Lectromec noted that the strong arcing of BMS13-42 Poly-X was not as energetic as the strong arcing exhibited by the Kapton.

10 drops per minute. The experiment was allowed to run for up to 25 minutes or until a circuit breaker tripped. In some cases circuit breakers were reset and, the test continued.<sup>302</sup> Table 8 shows the results of the wet short-circuit tests conducted by Lectromec.

**Table 8.** Results of wet short-circuit tests conducted by Lectromec.

Type of Wire	Electrolyte	Duration	Qualitative Description of Visual Effect	No. of Circuit Breakers that Tripped	Length of Damage/Char Buildup
Poly-X (BMS13-42A)	1 percent NaCl	20 minutes	Some intense flashing	0	1/2 inch
	1 percent NaCl	25 minutes	Some intense flashing	0	5/8 inch
	Lavatory fluid	10 minutes	Some intense flashing	0	1/4 inch
	Lavatory fluid	16 minutes	Some intense flashing	0	3/8 inch
Poly-X (BMS13-42)	1 percent NaCl	5 minutes	Some intense flashing	0	1/2 inch
	1 percent NaCl	Less than 1/2 minute	Some intense flashing	0	1/4 inch
	1 percent NaCl	About 3 minutes	Strong arcing	1 (reset, then 3)	1/2 inch
Kapton	1 percent NaCl	About 1.5 minutes	Strong arcing	3 (reset)	2 inches
	1 percent NaCl	Less than 1/2 minute	Strong arcing	3 (no reset)	7/8 inch

According to the Lectromec report, during these tests, scintillations were generally visible soon after the tests were started. During the tests in which flashing occurred, flashing events frequently repeated at various intervals (ranging from several flashes per second to more than 1 minute apart) throughout the test. Oscillogram measurements indicated that the peak electrical energy dissipation (about 90 J, with power peaks between 3 and 6 kW)<sup>303</sup> during these flashing events occurred during a test in which a wet-short was initiated by dripping lavatory fluid onto Poly-X (BMS13-42A) wiring. The estimated peak electrical energy dissipated before the circuit breakers tripped during the tests in which strong arcing was observed was about 2 kJ.

<sup>302</sup> The 25-minute limit was selected because it exceeded the length of the accident airplane's flight; most of the tests also exceeded the 2 1/2-minute interval between the CVR-recorded comment regarding the "crazy fuel flow" and the explosion. In one undocumented wet short-circuit test, the test continued with some intense flashing observed for more than 8 hours without tripping a circuit breaker. This test was eventually terminated at the end of the Lectromec work day.

<sup>303</sup> Oscillogram measurements taken during one of the pretests indicated that current peaks of 75 amps occurred and more than 350 J of electrical energy was dissipated. Subsequent examination of the wire bundle revealed about 1/4 inch of damage and a char buildup around the cut in the insulation; both conductors were still intact.

Lectromec also conducted wet dielectric tests<sup>304</sup> on the wires after seven of the wet short-circuit tests to determine whether the wires that had not been intentionally cut had been damaged. Multiple wires within the bundle failed six of the seven wet dielectric tests.

### **Metal Shaving Abrasion Tests (Dry)**

Most of the metal shaving abrasion tests were conducted in two experimental configurations<sup>305</sup>—two tests were conducted with the wire bundle secured to surfaces such that the bundle had a 90°-angle bend in it, and four tests were conducted with wires in a common bundle, aligned longitudinally with each other. In both configurations, one of the surfaces to which the wires were attached was stable, and the other surface was movable. The movable surface was attached to an “oscillator,” which had a 1/2-inch movement stroke. When activated, the oscillator moved the wires to which it was attached.

The two 90°-angle metal shaving abrasion tests were conducted with a seven-wire bundle and a metal shaving at least 0.5 inch long woven between the wires (one bundle had a steel shaving, the other had an aluminum shaving). The bundles were secured to a stationary platform at one end and to a movable bar at the other end, in a manner that resulted in a 2-inch radius, 90° bend in the wire bundle. The linear motion of the oscillator caused the wires in the bundle to squeeze together with the metal shaving and then relax repeatedly. These tests were run concurrently, for 19 1/4 hours, with no electrical events (that is, scintillations, flashing, or arcing) observed and no circuit breakers tripped. Post-test examination revealed some damage to the wires. Damage observed where the shavings had been woven into the wire bundles appeared to be mostly superficial damage to the insulation topcoat (with the steel shaving resulting in slightly more damage). Lectromec reported that the damage resulting from the flexing and moving of the 25+ year-old wires in the bundles was more severe, including broken and cracked wires, with exposed conductors in both bundles; these wires subsequently failed wet dielectric tests.

During the four longitudinal metal shaving abrasion tests, two identical wire bundles (four wires in each) were secured together with nylon ties along their midsections, and several metal shavings were placed between the two bundles. Both ends of one of the bundles were then secured to a stationary platform, while the ends of the other bundle were secured to a movable bar. The results of these tests varied from cases in which the

---

<sup>304</sup> Wet dielectric tests provide an indication of the integrity of a wire's insulation. These tests were conducted by placing individual wires in a water bath with both ends out of the water, then applying 1,000-volt d.c. to the wire conductor while the water bath was grounded. If a current was measured in the circuit, it was an indication that the wire had short-circuited through its insulation to the water bath, and the wire failed the test.

<sup>305</sup> Several different configurations of drill shaving abrasion tests were considered and tried before Lectromec decided to use the two configurations described in this section. Lectromec reported that during these early trial tests, the shape and size of drill shavings had a significant effect on the test results. For example, in most cases thin aluminum shavings often broke apart and fell out of the wire bundles and did not interact with individual wires, whereas larger metal shavings resulted in the tripping of circuit breakers. Further, thin metal shavings often acted as fuses and evaporated after carrying an initial current between wires (thus ending the short-circuit condition), whereas shavings with relatively large cross-sections could support a larger current without evaporating.

wire bundle shed the metal shavings without a short circuit, to others in which the metal shavings cut through the insulation, exposed the conductor, and caused a transfer of energy to occur. For example, one 2.5-millisecond pulse melted the metal shaving without tripping circuit breakers, whereas another test resulted in prolonged flashing events with power peaks of greater than 10 kW, damaging all the wires in the test bundle. Post-test examination of the wires revealed that bundles containing aluminum alloy shavings were less damaged by contact with the shavings than those containing steel shavings. However, as with the 90°-angle metal shaving abrasion tests, movement of these wires resulted in cracked and damaged wires that subsequently failed wet dielectric tests. Examination revealed that cracks had appeared in the insulation. No circuit breakers were tripped during these tests.

### **Dry Short-Circuit Tests, with Metal Shavings**

Eight tests were conducted to document the dry short-circuit capability of the metal shavings when a Poly-X wire's conductor was exposed. In these tests, two of seven wires in a bundle were cut circumferentially (about 1 mm wide) to a depth that exposed the conductor, placed on opposite sides of the bundle, and positioned so that the exposed conductor was visible. Aluminum or steel metal shavings of various thicknesses were then woven through the bundles so that they touched both of the exposed conductors. The bundles were then suspended horizontally in the test chamber and attached to the generator, and 120-volt a.c. power was applied.

According to the Lectromec report, all but one of these tests resulted in short flashes of various intensity, none of which tripped a circuit breaker. Strong arcing was not observed in any of the eight tests of Poly-X wire, but one test with a steel shaving resulted in what Lectromec described as an "intense flash." During four of the tests, a visible flash was observed and then the sample became dormant (no current flow was measured). In these four cases, minimal or no damage was observed to the wire insulation; all (non-predamaged) wires passed wet dielectric tests after these tests. However, the other three dry short-circuit tests resulted in flashing events of longer duration and in additional damage to adjacent wires after the flash/arc event. After three of the eight tests, several (one to five) non-predamaged wires failed wet dielectric tests. Oscillogram measurements indicated that the peak current during these tests was 140 amps and that the peak electrical energy dissipated was 18 J.

#### **1.16.6.2.1 Circuit Breaker Protection Information**

According to the USAF Aircraft Mishap Investigation Handbook for Electronic Hardware, the typical thermal circuit breaker contains a bimetallic strip and two electrical contacts (one of which is spring-loaded) in a circuit. When the circuit is heated, the electrical contacts heat the bimetallic strip, causing it to bend. The amount of bending is a function of the amount of heat, which is dependent on the time and amount of current flowing through the circuit. When the heat exceeds a preset amount, the bending of the bimetallic strip causes the release of the spring-loaded contacts to open the circuit. The circuit can be opened or reset by manually pulling or pushing on the circuit breaker button, respectively. The position of the button denotes the state of the circuit breaker. Figure 34

shows a “trip-curve” chart for a typical circuit breaker (excerpted from Texas Instruments Klixon® specification), which depicts the relationship between the amount of current that can pass through a circuit breaker and the amount of time until the circuit breaker opens.

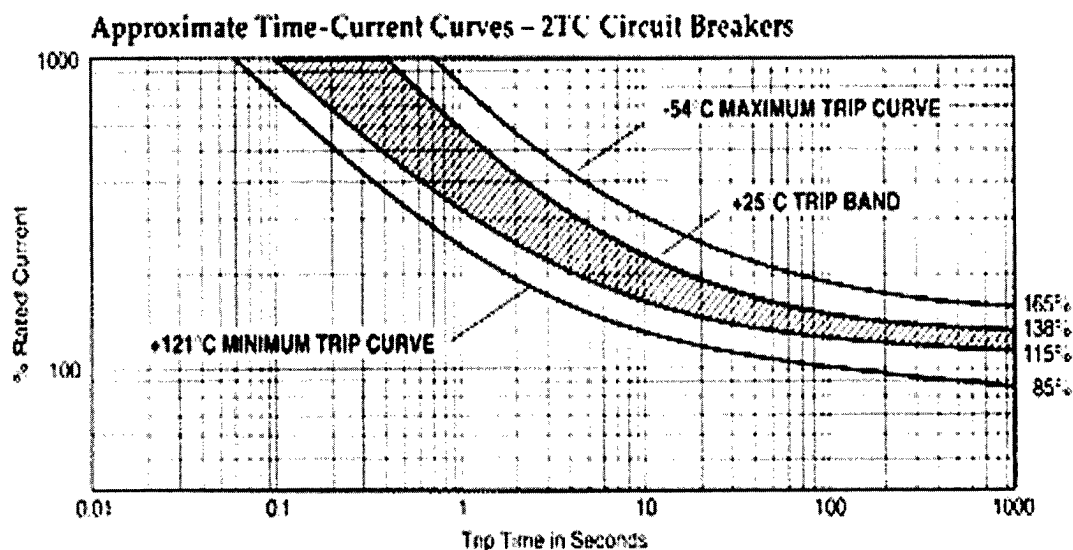

**Figure 34.** A trip-curve chart for a typical circuit breaker (excerpted from Texas Instruments Klixon® specification).

The USAF handbook also describes typical circuit breaker failure modes, including welding and erosion/wear of the electrical contacts, material transfer, overcurrent, and contamination. Further, the handbook states that “the mechanical structures have changed over many years; therefore, age is also a factor.”

Boeing Document D6-40359 describes a study, “Impact of Electrical Overloads on Wire and...Circuit Breakers Used on 707, 727, and 737 Airplanes,” dated February 2, 1972. The document stated that “early in 1971, [an air carrier] reported a failure of a...circuit breaker. As a result of this failure and subsequent investigations, there has been consideration given to the need for electrically checking all [similar] circuit breakers which are in service.” The document further stated that circuit breakers that have been in service “could not reasonably be expected to meet the overload current versus trip time calibration curves of a new breaker” and contained a description of how the bimetallic strips may lose integrity and degrade with exposure to high internal temperatures.

Subsequently, Boeing studied about 1,200 circuit breakers that had been removed from service during a fleetwide survey<sup>306</sup> and found that “initial results of on-board testing showed that 72 percent of all breakers tested satisfied the procurement specifications.” Further laboratory testing of the 28 percent that did not meet procurement specifications

revealed that an additional 9 percent of the circuit breakers originally tested (for a total of 81 percent) satisfied the procurement specifications, despite initial results indicating that they did not. Boeing speculated that the test equipment and methods used during the initial tests might have resulted in erroneous failure indications for the 9 percent. Further, Boeing speculated that the test equipment and methods used in the initial tests might have damaged circuit breakers within the remaining 19 percent that did not satisfy procurement specifications. After Boeing revised the pass-fail criteria and retested the circuit breakers, test results showed that 99.2 percent of the tested circuit breakers could function in time to protect the wires.

After a European 757 experienced an arc-tracking event in Kapton wiring on May 10, 1985, Boeing investigated methods to protect against arc-tracking events. Boeing document D045Y41102TR, "270 [volt d.c.] Wet Dielectric Arc Tracking Tests," described development of a 270-volt-d.c. trip curve that would provide protection equivalent to that provided by a thermal circuit breaker with an a.c. power source. Boeing found that starting loads and in-rush current required circuit protection levels to be set higher than the rating of available circuit breakers.

Boeing discovered that the trip characteristics to interrupt arc-tracking events below the 1,000 percent (rated) current level of d.c. circuits were the same as those of a.c. circuit breakers.<sup>307</sup> Therefore, Boeing designed an electronic circuit breaker to eliminate the arcing problems associated with d.c. switches. However, Boeing also found that application of 270-volt d.c. electricity to 115/200-volt a.c. circuit breakers resulted in the melting of the breaker contacts.

To offer additional protection to electrical circuits against the unwanted effects of electrical arcing, nonaerospace manufacturers have begun incorporating arc-fault detection technology into products known as arc-fault circuit breakers (AFCB, also known as arc-fault circuit interruptors). According to UL,<sup>308</sup> an AFCB is a device intended to reduce the number of arcing-fault fires by opening the electrical circuit when an arc fault is detected. An AFCB differs from a typical thermal-based circuit breaker in that the AFCB has complex electronic circuitry that can identify specific characteristics or signatures of the current or voltage waveform that are unique to electrical arcing. In 1998, in conjunction with the National Electrical Manufacturing Association, UL began working with manufacturers and other interested parties to form an Industry Advisory Group to develop a standard for safety for AFCB products. In February 1999, UL published the First Edition of the Standard for Safety for Arc-Fault Circuit Interruptors. The USAF, FAA, and Boeing have been working to develop AFCBs for aerospace use, but no AFCBs are currently certificated for use in airplanes.

---

<sup>306</sup> The 1,200 circuit breakers were removed from 50 airplanes and were considered representative of the circuit breakers in the fleet.

<sup>307</sup> Current may briefly exceed 1,000 percent, as shown in figure 34.

<sup>308</sup> This paragraph is reprinted with the permission of UL, from "AFC[B]s Show Promise to Save Lives by Preventing Electrical Fires." 1999. *On the Mark*, Vol. 5. No. 3-4.

### 1.16.6.3 Aging Effects on Material Properties of Wires

To better understand the condition of wiring in aging transport-category airplanes, the Safety Board contracted with Raytheon Systems Company (Raytheon) to test aged wire samples to the specifications for newly manufactured wire of that type. The aged wire samples were similar in age and type to the wiring on TWA flight 800 and were obtained from three recently (not more than 6 months before the wire samples were obtained) retired airplanes—two 747s, one manufactured in 1970 and the other in 1973, and a Douglas DC-10 manufactured in 1973.<sup>309</sup> The wire samples ranged in length from 1 foot to more than 26 feet and in size from small, partial bundles with just a few wires to large bundles with many wires. The samples were taken from pressurized fuselage locations, most of which were relatively protected from traffic, exposure to light, or other potential environmental stresses. Figures 35a, 35b, and 35c show the sample origination locations for the 747 manufactured in 1970, the DC-10, and the 747 manufactured in 1973, respectively. Table 9 further describes the origin and potential environmental exposure of each sample.

**Table 9.** The origin and potential environmental exposures of test samples.

Aircraft	Sample	Origin of Wire	Potential Environmental Exposure
747, Delivered 1973	Samples 1, 2, 3, and 4	Flight engineer's panel in cockpit	Possible ultraviolet (UV) ray exposure
	Sample 5	STA 380, right side of flight crew exit door	Possible UV ray exposure
	Sample 6	STA 1438, directly beneath floor panel of seats 37A, B, and C	Benign
	Sample 7	Just forward of the CWT on the right side	Benign
DC-10, Delivered 1973	Samples 1 and 3	Cockpit overhead center panel	Hot, dry, no UV ray exposure
	Sample 2	STA 770, a 12-foot long section from above the R2 door	Benign
	Sample 6	Not marked	Not known
	Sample 7	Underneath flooring in cockpit	Benign
	Sample 8	STA 919 to 1570, on the right side, overhead R2 door	Elevated temperatures
747, Delivered 1971	Sample 1	Forward cargo compartment	Benign

<sup>309</sup> According to the Raytheon report, the wires tested were "essentially identical." Raytheon described all of the tested wires as tin-coated copper conductors with a dual layer of cross-linked extruded alkane-imide polymer insulation and a topcoat or Poly-X type wire. There was only one manufacturer (Raychem) qualified to produce wire for either the Boeing or MIL specifications during the wire usage period. When Raychem stopped producing this wire type in 1977, the associated MIL specification was cancelled.



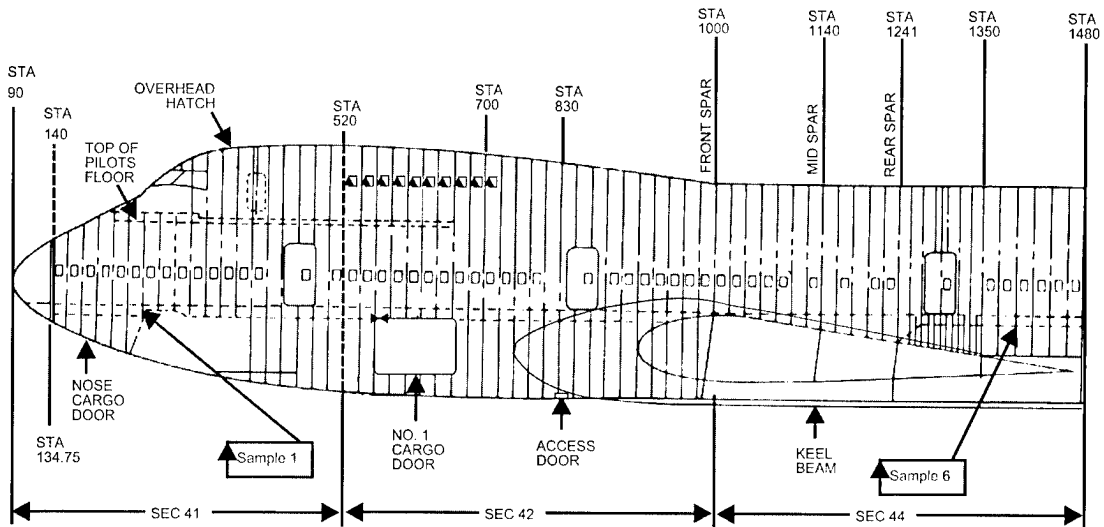

Figure 35a. Sample origination locations for the 747 manufactured in 1970.

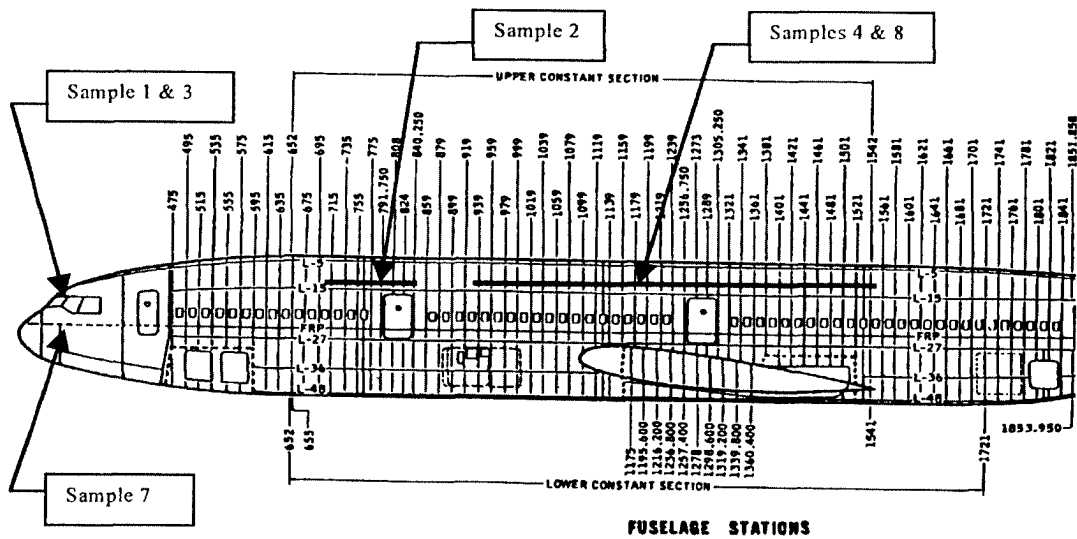
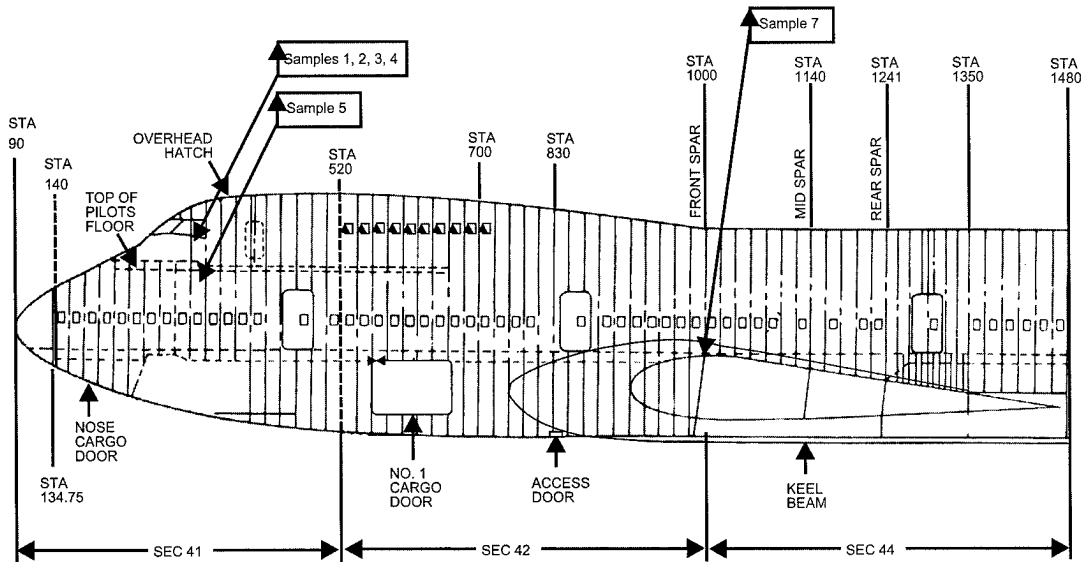

Figure 35b. Sample origination locations for the DC-10 manufactured in 1973.



**Figure 35c.** Sample origination locations for the 747 manufactured in 1973.

In addition to visual examinations, Raytheon tested the wire samples against the following performance requirements for new wire:

- Mechanical and electrical tests, including concentricity tests (to measure the thickness of the insulation layers and the overall sample geometry), dielectric tests (to determine the integrity of wire insulation), insulation resistance tests (to measure the electrical resistance that the insulation imparts between the conductor and ground), insulation tensile strength and elongation tests (to identify materials that have weakened because of thermal breakdown, UV degradation, or other mechanisms), and notch sensitivity tests (to measure the ability of a wire insulation to resist the propagation of a nick or cut through the insulation layers to the conductor).
- Thermal tests, including blocking tests (to ensure that the insulation does not adhere to itself after heating), low-temperature (cold-bend) tests (to ensure that the wire retains physical and electrical integrity through mechanical and electrical stress at the temperature extremes), shrinkage tests (to indicate whether the wire insulation is physically and dimensionally stable when exposed to short-term high temperature), thermal shock tests (to measure an insulation's ability to resist shrinkage and expansion following several thermal cycles to temperature extremes), and wrapback tests (to evaluate the wire's ability to withstand thermal stress while under mechanical stress).

- Thermal aging tests, including accelerated aging tests (to evaluate a wire's ability to withstand a higher temperature under mechanical stress for a short period of time), lifecycle tests (to evaluate a wire's ability to withstand slightly elevated temperatures under mechanical stress for a longer exposure time), and electrical integrity tests (to evaluate a wire's electrical integrity during forced hydrolysis and mechanical properties and electrical integrity during heat aging).

According to the Raytheon report, in general, the wire samples obtained from the three airplanes appeared to be in similar, "generally decent" condition; however, the condition and performance of the specific wire samples varied within and across the airplanes. Raytheon's report indicated that visual examination of the wire samples revealed a variety of conditions: the presence of debris, such as lint and small chips, paint residue, and possibly foam or adhesive residue; contamination by what appeared to be oil or grease and a dark brown film; mechanical damage, such as insulation cracking, indentations caused by tight clamps or nylon tie wraps, abrasion of the insulation, and various nicks and cuts; and deep hot-stamp marking, which resulted in cracking of the insulation. The wire insulation was also observed to be brittle in all cases, and, in some cases, the outer layers cracked as a result of routine handling in the laboratory. About 20 percent of the wires received with damage failed in dielectric testing, indicating that the wires' insulation did not meet the integrity requirements for new wire and that fluid could reach core conductors.

Further, although the wire samples met most of the performance requirements for new wire when subjected to tests for insulation resistance, notch sensitivity, blocking, cold-bend shrinkage, thermal shock, and accelerated aging, problems/failures were noted during concentricity, elongation, dielectric, and lifecycle tests. For example, the Raytheon report indicated that several wire samples from different airplanes failed concentricity tests, "indicating that the insulation was degrading with layer separation." Additionally, in several cases the elongation of the outer insulation was extremely low, indicating that "the wire became more brittle with age....None of the wire samples tested passed the lifecycle test, indicating that the long-term life of all samples may be limited. Additional thermal life testing...showed that the samples had some limited life remaining before beginning to fail physically and electrically."

The Raytheon report included the following conclusions:

1. Most wire samples tested had definitely aged as indicated by the outer jacket [insulation layer] failures in accelerated aging and lifecycle.
2. The inner insulation continued to provide electrical integrity, as it was designed to do, although the outer jacket [insulation layer] was losing its ability to mechanically protect the wire. [See figure 10.]
3. The wire submitted for testing would be expected to perform adequately in the short term, provided there was no added stress beyond what it had experienced.

4. The weak point in this wire type appears to be the lack of ability to maintain physical and electrical integrity during extended elevated thermal exposure with mechanical stress. As the wire ages, there is an increased risk of dielectric problems [breakdown of wire insulation integrity], mechanical damage and loss of electrical integrity.
5. No wire was submitted that was exposed to high levels of environmental exposure (such as wires from wheel wells, wing leading edges, etc.). Wire from these areas, would be expected to perform worse than the wire submitted. [See figures 35a, 35b, and 35c for sample locations.]

Investigators found original Boeing markings (such as green W42A lettering) on the recovered wiring for most of the accident airplane's systems,<sup>310</sup> and many of the recovered FQIS wiring throughout the airplane had the darkened appearance of similar wire materials found in similar-aged airplanes. (As previously stated, the accident airplane had 93,303 total hours of operation at the time of the accident.)

Raytheon found wires other than Kapton and single- and dual-layer insulation Poly-X in the sample wire bundles that it examined. These wires were insulated with single- and dual-layer Teflon and cross-linked polyalkene/polyvinylidene fluoride (an earlier type of wire that had been manufactured per MIL-W-81044/9).<sup>311</sup> The Safety Board extended its contract with Raytheon to include testing of these additional three wire types and some various connectors found with the wire samples.<sup>312</sup>

As with the previous wire tests, Raytheon tested these materials to the acceptance standards for new material. Raytheon indicated that although the wire samples were in "generally decent condition for having 25 years service life, there were problems evident during the inspection and performance testing."<sup>313</sup> Although these wire samples passed most of the tests to which they were subjected, test failures were found. For example, the wire sample with a single layer of Teflon insulation exhibited two dielectric failures, the wire sample with a dual layer of Teflon of insulation failed the low-temperature (cold-bend) tests, and the MIL-W-81044/9 wire sample failed the low-temperature (cold-bend) and lifecycle tests. Specifically, Raytheon's report regarding the second set of wire tests concluded the following:

- The three wire types evaluated have degraded in different manners during service life.

---

<sup>310</sup> TWA personnel installed some galley, lighting, and navigation/communication avionics wiring shortly after the airline took possession of the airplane and again during a modification in 1992.

<sup>311</sup> A few short lengths of another wire (BMS13-38) were also found, but insufficient wire was available for testing. According to a Raychem technical paper presented at the 18th International Wire and Cable Symposium in Atlantic City, New Jersey, from December 3 to 5, 1969, Poly-X wire provided improved mechanical strength and fluid resistance at elevated temperatures, whereas "some of the newer hydraulic fluids attacked the MIL-W-81044 wires at elevated temperatures."

<sup>312</sup> For additional information, see Systems Group Chairman's Factual Report—Addendum for Aging Aircraft Wire Testing by Raytheon, Report 2, dated January 28, 2000.

<sup>313</sup> Although Raytheon's statement indicated that the wire samples had 25 years of service life, some of the wires tested had not been available for use for that long.

- Single layer BMS13-48 [XL-ETFE, such as Tefzel] type wire developed dielectric failures, possibly due to the thinner wall thickness providing less mechanical protection to the wire.
- Dual layer BMS13-48 [XL-ETFE, such as Tefzel] type wire passed dielectric tests without failures, but the outer layer has lost strength and flexibility as evidenced by the results of tensile, elongation, and low temperature cold bend tests.
- Dual layer MIL-W-81044/9 type wire failed two tests. The outer layer cracked during the low-temperature cold bend test even though retaining electrical integrity. The wire failed lifecycle tests, indicating that the wire has aged significantly and has limited additional life.
- The BMS13-48 [XL-ETFE, such as Tefzel] wire appeared to be in better physical shape than the [BMS13-42 Poly-X] wire tested [previously].
- None of the wire samples tested had been exposed to high levels of environmental stresses. Wire from areas exposed to high levels of environmental stress (such as wires in landing gear wheel wells, wing leading edges, etc.) would be expected to perform worse than the wire submitted.
- The connectors from all three aircraft showed signs of aging, such as the presence of corrosion and hardening grommets.
- Connectors from all three aircraft passed dielectric testing indicating they insulated the contacts from each other and the shell, but several of the connectors did not have the ability to have maintenance performed on the connectors. Contacts were not retained, grommets began to crumble, and some contacts were not removable.

#### 1.16.6.3.1 Previous Reports about Wire Degradation and Aging

In May 1976, Boeing published document D6-42974, "Investigation of Wire on Wire Abrasion Testing," in which it documented the wear characteristics for several wire types. The results indicated that the resistance of the tested wire types was rated as follows, from best to worst: BMS 13-51 (Kapton), BMS13-13 (PVC Nylon), BMS13-42C (Stilan), BMS13-31 (mineral-filled PTFE), BMS13-48 (Tefzel), and BMS13-42A/B (Poly-X). Boeing's report stated that "the results are more or less as would be expected and agree with predictions based on in-service experience by Boeing and others and with other evaluations of these wires."

Reports from NAFI noted that Poly-X was adopted for use on January 2, 1970, because MIL-W-81044/16 and /18 were phased out. Poly-X was first installed in the F-4N Phantom II, and the first wire insulation malfunctions were recorded in September 1975.<sup>314</sup> The NAFI report also stated that failures of Poly-X in F-14 aircraft had been reported about 3 years after installation. On the basis of its observations of Poly-X failures, NAFI established that the time to field failures for Poly-X in U.S. Navy

---

<sup>314</sup> For additional information, see U.S. Naval Avionics Facility. 1977. *Investigation of Poly-X Wire Deterioration on F-4N Aircraft*. NAFI Report No. 01-76, NARF-NORIS.

operations was between 3 and 5 years in service.<sup>315</sup> Additional laboratory tests conducted by NAFI and historical evidence indicated that Poly-X wires aged 2.3 to 7 times faster than Kapton. The NAFI report stated, "if it is assumed that there is reasonable correlation between laboratory tests and service experience, then Kapton-insulated wire may fail after 7-21 years of service. The use of milder cleaning compounds...should extend the service life of the installation."

After the NAFI reports were published and the U.S. Navy switched to milder cleaning compounds, the military, the aviation industry, and Boeing continued to study the wire-aging process. A 1997 Lectromec report<sup>316</sup> documented the aging of Kapton wire insulation in various locations in U.S. Navy P-3 airplanes. This report indicated that wire insulation in areas exposed to sunlight and moisture could reach the end of its service life (chemically) within 1 year, whereas wire insulation in protected areas in the same airplane could survive for up to 10 years. Figure 36 shows the percent probability of failure of Kapton wiring in different locations in the P-3 airplane.

The Safety Board also found that Boeing documented and described cracked wire insulation in SL 747-SL-20-048, issued January 25, 1995. Boeing described "the virtue of a wire by wire inspection" of wing leading edge and engine strut areas. However, the SL also stated that "Boeing generally does not recommend special wiring inspections unless a fault is experienced or an area is disturbed for other reasons."

---

<sup>315</sup> The Safety Board notes that airplanes flown by the U.S. Navy may experience environmental conditions to which civilian airplanes may not be subjected, including continuous operations in humid salt-air environments and frequent washings with acidic cleaning solutions. Further, wires in the wing-fold area (which are nonexistent on civilian airplanes) were often exposed to more vibration and environmental conditions (such as sunlight, wind, rain) than wiring in a like location on a civilian airplane.

<sup>316</sup> For additional information, see the following Lectromec reports/papers: *Aging Measurements of Operating Aircraft Wiring; Implications for Specification Writing and Aircraft Reliability*, dated July 10, 1997; and *Description of Lectromec WIDAS Aging Support Program*, dated November 11, 1998. Also, see Eaton, D. R. and Bruning, A. 1999. *Economic Aircraft Wire Maintenance, Inspection and Repair: Performance Implications*.

	Years				
	1	2	5	10	20
Location	Percentage of Failures				
Bomb Bay	0	0	0	24	33
Wing, Outboard Trailing Edge	0	0	0	28	53
Galley/Aft Cabin	0	0	0	41	61
Wing Center Leading Edge	0	0	15	23	30
Forward Electrical Load Center	0	0	24	35	48
Avionics Bay C1	0	0	43	57	68
Wing Inboard/Ro Leading Edge	15	20	32	46	60
Avionics Bay H1	21	23	40	46	78
Hydraulic Service Center Under De	20	26	39	56	64
Main Wheel Well	38	42	50	72	100
Nose Wheel Well	31	57	89	100	100
Wing Center Trailing Edge	0	74	91	100	100

**Figure 36.** Chart showing the percent probability of failure of Kapton wiring in different locations in the P-3 airplane.

#### 1.16.6.4 Electromagnetic Interference

##### 1.16.6.4.1 Electromagnetic Interference from External Sources

The Safety Board requested that the DoD Joint Spectrum Center (JSC) conduct research into and calculate the electromagnetic environment (EME) in which TWA flight 800 was likely to have been operating at the time of the accident (that is, the electromagnetic field strength from the external emitters to which the airplane was exposed during its flight). Fixed and mobile radio frequency (RF) emitters<sup>317</sup> in the TWA flight 800 environment were identified. Ground-based emitters with frequency assignments<sup>318</sup> for the eastern United States (as identified in the JSC-maintained frequency assignment databases) comprised the fixed emitters. These ground-based emitters included the following equipment types: ASR, air route surveillance radar, airport surface detection equipment, military navigation radar, weather radar, terminal Doppler weather radar, long-range tracking radar, U.S. Navy radar shore installations, space object tracking radar, over-the-horizon radar, and research and development emitters.<sup>319</sup> The RF equipment on board air and sea platforms near TWA flight 800 (as identified by the Safety Board, FAA, U.S. Navy, USCG, and Air National Guard records) comprised the mobile emitters.

After the RF characteristics of the fixed and mobile emitters were collected, the electrical field strengths and energy densities these emitters could generate at the accident airplane's position and altitude were calculated for the time of its last secondary radar return. The calculations were based in part on the emitter's distance from that location and the propagation path losses associated with those distances. The JSC report indicated that the following assumptions were used in calculating the potential electric field strengths at the TWA flight 800 location:

All fixed and mobile transmitters were assumed to be emitting except commercial airline high frequency (HF) communication...equipment. Commercial airline HF [communication] equipment are typically not employed when...VHF air traffic control is available.<sup>320</sup> Military HF [communication] transmitters were assumed to be active at the time of the accident.

In calculating the peak and average electric field strengths generated at TWA flight 800, maximum values of peak power, duty cycle, and antenna mainbeam gain were assumed. Where the duty cycles of pulsed emitters were unavailable,

---

<sup>317</sup> According to an April 13, 2000, letter from the JSC, emitters are "pulsed sources of low duty cycle and narrow antenna beamwidths."

<sup>318</sup> The agencies responsible for ensuring that there are no conflicts between different emitters (the Federal Communications Commission for civilian emitters, the JSC for military emitters) assign frequencies that can be used for various functions.

<sup>319</sup> Although television, radio, and cellular telephone ground emitters also contribute to the EME, the electromagnetic field strengths and energy densities generated by these emitters are significantly weaker than the other emitters considered during this research.

<sup>320</sup> Because commercial airline HF equipment is typically not used and to limit the scope of the JSC analysis, it was assumed that this equipment was not emitting at the time of the accident.



the JSC compared combinations of pulsewidths and pulse repetition rates to determine the highest duty cycle.

The avionics on board USAir[ways] flight 217 [located about 2.5 nm southwest of TWA flight 800 at 17,000 feet msl] were assumed to be representative of the commercial aircraft in the vicinity of TWA flight 800. Since USAir[ways] flight 217 was the closest commercial aircraft to TWA flight 800, the electric field strength predictions due to the emitters on board USAir[ways] flight 217 were assumed to represent the worst case for the EME due to commercial aircraft emitters.

[To reduce the size of the list of emitters to be further analyzed,] a peak electric field strength of 1 volt/meter (V/m) at the accident location was selected as a conservative threshold for the minimum field strength that needed to be considered.<sup>[321]</sup>

The JSC report stated that when it included terrain and antenna pattern data in its electric field strength calculations, it identified 40 fixed ground-based emitters that had the potential to generate peak electric field strengths greater than 1 V/m at the accident location. Two of the 40 fixed ground-based emitters were identified as having the potential to generate an average electrical field strength<sup>322</sup> greater than 1 V/m at the accident location: the Westford, Massachusetts, tracking radar and the Brookhaven, New York, weather radar emitters. According to the JSC report, its calculations revealed that no mobile emitters, shipboard or airborne, could generate average electric field strengths greater than 1 V/m. The JSC report further stated, “although many classified emitters were identified in the environment, none of them were close enough or powerful enough to generate peak or average electric field strengths greater than 1 V/m.”

The energy density values (in mJ/m<sup>2</sup>) were calculated to help relate the field strength values to units which the investigators could more readily compare with the MIE. According to the April 13, 2000, letter from the JSC, it is possible for the energy density from emitters to overlap in time and space, having an additive effect on the energy density available at that time and space. However, according to JSC, the probability of the energy density from any two emitters to precisely overlap in time and space at the accident site was less than  $1.85 \times 10^{-4}$  and would result in an energy density increase (for the highest energy density emitter) from 0.013 mJ/m<sup>2</sup> to 0.02 mJ/m<sup>2</sup>. Further, the likelihood of additional emitters overlapping in time and space at the accident site decreased exponentially with each additional emitter. For example, the calculated probability of 3 dominant emitters overlapping in time and space at the accident site was  $7.1 \times 10^{-9}$  (with a resultant energy density increase to 0.024 mJ/m<sup>2</sup>), whereas the probability of 11 dominant emitters overlapping in time and space at the accident site was less than  $1.1 \times 10^{-83}$  (with a resultant energy density increase to 0.043 mJ/m<sup>2</sup>).

---

<sup>321</sup> The 1 V/m threshold was used based on the judgement of JSC engineers that there was no way to induce an explosion in the CWT with field strengths under that level. Subsequent NASA Langley Research Center (LaRC) research confirmed this engineering judgement (see section 1.16.6.4.1.1).

<sup>322</sup> Average field strengths are the ones that would better create the energy required to create a spark. The peak field strengths exist for such a short period of time (microseconds) that there is not enough time to affect wires in a way that would create a spark with enough energy to ignite a fuel/air mixture.

#### 1.16.6.4.1.1 NASA's Report Regarding Electromagnetic Interference from External Sources

At the Safety Board's request, NASA's LaRC conducted tests (using the data developed by the JSC) to determine the worst-case energy levels from external RF transmitters that could be induced to fuel tank FQIS components. To this end, LaRC researchers developed and validated a new computer code that was used to predict the passenger cabin shielding effectiveness and to model signal-to-wire coupling within the cabin.<sup>323</sup> The researchers used a dominant external emitter identified by JSC<sup>324</sup> as the input signal for their computer code. The LaRC report indicates the following:

the maximum available energy inside the TWA 800 passenger cabin from any identified dominant emitter was determined to be less than 0.1 [mJ], which is below estimates of the minimum ignition energy required for ignition of Jet A fuel vapor. Energy coupled to aircraft wiring within the passenger cabin will be several orders of magnitude (approximately  $10^{-4}$  times) less than this.

#### 1.16.6.4.2 Electromagnetic Interference from Internal Sources

The Safety Board contracted with the NAWC-AD to measure the voltage harmonics on the captain's channel of the CVR<sup>325</sup> and determine if electrical power transients could induce sufficient energy into the FQIS wiring through capacitive and inductive cable coupling to ignite fuel in a 747-100 airplane's CWT.<sup>326</sup> In November 1999, NAWC-AD conducted electrical ground tests at AAR Aircraft Services, Inc.'s, facilities in Roswell, New Mexico.

The tests in Roswell, New Mexico, were inspired by laboratory tests conducted at Boeing in 1997,<sup>327</sup> which created transient voltages in CWT FQIS wires by switching on and off the power (simulating large power relays or motor loads) in wires that had been laid parallel to the CWT bundle. The tests induced up to 0.6 mJ of energy into a CWT harness, exceeding Boeing's specification of 0.02 mJ and the MIE of 0.25 mJ referenced

---

<sup>323</sup> Note: The EMI would be induced on wires outside the CWT, and the energy would then be transferred into the CWT.

<sup>324</sup> The JSC identified the dominant external emitter as the Brookhaven, New York, weather radar and an airborne radar emitter as a close second. The emitter used by the LaRC researchers was the search radar at Riverhead, New York, which had the third highest field intensity levels. This emitter was used to allow for a decreased computation time for the numerical computer code developed by LaRC. Even at this lower frequency, the calculations required 182 central processing unit hours to complete. To perform the calculations using the dominant emitter would have taken on the order of 14,000 central processing unit hours.

<sup>325</sup> For more information, see section 1.11.1.1.

<sup>326</sup> For the purposes of this investigation, the Safety Board examined the effects of EMI as a potential ignition source for the CWT overpressure event. The Board did not examine the potential effects that EMI might have on an airplane's navigation/communication systems.

<sup>327</sup> These tests were described by a Boeing engineer during his testimony at the Safety Board's public hearing in December 1997. They are also discussed in the FAA's NPRM 97-NM-272-AD and in Boeing's May 26, 1998, comments on that NPRM.

in API 2003. The tests were conducted using maximum source voltages of 800 volts with resultant voltage transients in excess of 1,000 volts.<sup>328</sup>

The Safety Board contracted with NAWC-AD to conduct tests similar to those conducted by Boeing, except that they were to be conducted on an airplane using actual airplane systems to generate the switching transients. To prepare for these tests, NAWC-AD and Safety Board personnel examined and analyzed Boeing drawings and documents and examined more than 900 wires from systems in a 747-100 to determine the electrical loads (components) to which they were attached and to determine which of these loads would have the highest potential for coupling energy to CWT FQIS wiring if their wires were corouted. The wires connected to loads with the highest coupling potential were repositioned within wire bundles/trays so that they were adjacent to the FQIS wiring<sup>329</sup> to provide a “worst-case” routing situation.

Because the CWT access doors in the 747-100 did not provide adequate access for instrumentation for these tests, the researchers used a surrogate CWT<sup>330</sup> that provided better instrumentation access. The surrogate CWT was positioned on the ground by the test airplane’s main landing gear, and the airplane’s FQIS wiring was disconnected from the airplane’s CWT and connected to the surrogate CWT. The airplane’s systems were powered using engine-driven generators, and the FQIS was energized.<sup>331</sup> Voltage and current measurements were taken at fuel probes in the surrogate CWT as the airplane systems’ electrical loads were cycled. Additional measurements were taken with conductive debris (a few strands of aluminum wool) placed either across terminals of a fuel probe or from a terminal of a fuel probe to the simulated CWT to create and calculate the energy dissipation through the debris. According to the NAWC-AD report,<sup>332</sup> the maximum energy calculated for a transient through conductive debris (a few strands of aluminum wool) was 0.125 mJ.

---

<sup>328</sup> The 800 volts were much higher than the 25 to 125 volts found in wiring corouted with the 747 FQIS wiring system; however, it prompted further tests.

<sup>329</sup> The wires for the high coupling potential loads were only moved to be adjacent to the FQIS wiring when they were corouted in the same bundle or tray. In portions of their runs where the two sets of wires were not corouted, they were not moved.

<sup>330</sup> According to a NASA report, although the surrogate tank had a similar overall volume to the 747-100 CWT, the surrogate tank had different overall dimensions, was made of steel (not aluminum), and was not divided into bays like the CWT.

<sup>331</sup> To avoid igniting fuel in the airplane’s wing tanks during these tests, nitrogen gas was continuously pumped into the on-board fuel tanks through the pressure-refueling receptacle on the left wing. The inertness of the on-board tanks was continuously monitored throughout the tests by measuring the oxygen content from the outflow vents at the tip of each wing.

<sup>332</sup> See Naval Air Warfare Center–Aircraft Division. 2000. *Boeing 747-100 Fuel Quantity Indication System (FQIS) Susceptibility to Induced Energy from Capacitive and Inductive Cable Coupling*. NAWCADPAX/TR-2000/33.

#### 1.16.6.4.2.1 Electromagnetic Interference from Personal Electronic Devices On Board TWA Flight 800

The Safety Board was aware of cases in which signals from PEDs reportedly adversely affected airplane systems.<sup>333</sup> Therefore, to determine whether EMI from PEDs on board the accident airplane may have been involved in this accident, it requested that scientists at NASA LaRC evaluate the effects of signals from PEDs on board the airplane (such as laptop computers, video games, AM/FM and other handheld [CB, police, fire, business, maritime] radios, tape players, compact disc players, cellular telephones, garage door openers, remote control toys, and pagers) on airplane wiring. The report noted the following:

[the electromagnetic] environment [created by a transmitter] is highly dependent upon distance from the transmitter. This relationship changes as the inverse of the distance squared ( $1/R^2$ ). For example, if you move from 1 meter to 100 meters away, the available power [from a transmitter] is reduced by 10,000. Alternatively, it can be demonstrated that a portable radio transmitting about 5 watts may generate field levels in excess of 100 Volts/meter very close to its antenna...[PEDs] are typically operated over a wide range of frequencies and power levels, and can often be set to radiate continuously. When used inside an aircraft, PEDs can be placed very close to aircraft wiring, and their emissions are not subject to airframe attenuation as [external sources are].

The NASA LaRC research into the effect of PEDs on the FQIS system was designed to study whether a typical portable device could possibly create an ionization event (spark) or excessive heating, if all available power is applied directly to the FQIS wiring. To support this effort, LaRC researchers performed the following analysis and experimental testing:

- determined the worst-case electromagnetic threat that could have been created by commercially available PEDs in terms of power and frequency;
- determined the electrical characteristics of the CWT and FQIS wiring in a retired 747-100 airplane;
- removed the fuel probes and FQIS wiring from a retired 747-100 airplane, installed them in a laboratory test chamber, and conducted tests to determine the RF power required to achieve a spark or excessive heating of the laboratory installation;
- determined scaling factors required to compare the laboratory with the airplane FQIS installations; and
- assessed existing guidelines and references for understanding how continuous RF signals may impart sufficient energy to ignite fuel vapors.

<sup>333</sup> For example, a June 29, 1998, NASA Aviation Safety Reporting System report (98-30/10-2) cited anomalous displays on navigation instruments at both pilot positions of a DC-9 during the approach to landing. The report indicated that after landing, a flight attendant reported that a passenger "received a pager call while the airplane was on base leg, and refused to turn it off."

The NASA LaRC report concluded that the strongest electrical signal that could be coupled to the FQIS from PEDs in the passenger cabin and then cause a spark in the CWT was about 1.5 watts (about one-tenth of the minimum power level required to induce a spark from the FQIS).<sup>334</sup> This was obtained during laboratory testing by applying a simulated intermittent fault (an arc-gap between the FQIS components and a ground lead)<sup>335</sup> at a worst-case location for voltage enhancements. Without an intermittent fault, no detectable discharge event was observed, even when applying more than 10 watts of RF power. The report further stated that the worst-case coupling from PEDs in the passenger cabin would be coupled to the FQIS wires, not directly to the tank volume. Although the FQIS coupled power levels predicted to result from a PED signal vary as a function of emitter frequency, LaRC researchers reported that the maximum predicted power level was about 0.06 watt.

#### **1.16.6.5 Boeing's Center Wing Fuel Tank Ignition Fault Tree Analysis<sup>336</sup> Computations**

Although the FAA regulations regarding the certification of new airplanes in December 1969, when the 747-100 airplanes were certificated, did not require manufacturers to conduct a quantitative evaluation of probability levels for system failures, the FAA currently does require manufacturers to perform such an evaluation for certification. The regulatory guidelines addressing quantitative evaluation of failure modes were adopted in April 1970 as amendment 25-23 to 14 CFR Part 25; the quantitative evaluation procedures were subsequently detailed in AC 25.1309-1A. The probability levels are described in terms of the consequences of minor, major, and catastrophic failures. For example, Section 25.1309 states the following:

(b) The airplane systems and associated components, considered separately and in relation to other systems, must be designed so that—

(1) the occurrence of any failure condition which would prevent the continued safe flight and landing of the airplane is extremely improbable....<sup>337</sup>

<sup>334</sup> For these tests, the NASA LaRC researchers were limited by their laboratory equipment to using continuous wave signals instead of pulsed signals. Power measurements were used to characterize continuous wave signals, and they were proportional to energy measurements over the short term. Energy measurements from continuous wave signals were a function of how long the signal was maintained and would not have represented the conditions present during the accident.

<sup>335</sup> A ground connects electrical circuits to a large common conductor considered to be at zero electrical potential (such as the earth or, in the case of an airplane, the skin of the airplane and then overboard to the atmosphere).

<sup>336</sup> A fault tree analysis is designed to examine an end event through consideration of assumed precipitating events. Each of these precipitating events is in turn broken down until a level is attained in which no additional precipitating events will occur. The total of all of the events and the way in which they are tied together creates the fault tree analysis.

<sup>337</sup> AC 25.1309-1A defines the term "extremely improbable" failure conditions as conditions that are "so unlikely that they are not anticipated to occur during the entire operational life of all airplanes of one type." These type of conditions are further defined as "those having a probability on the order of  $1 \times 10^{-9}$  or less" for each flight hour based on a flight of mean duration for the airplane type.

(d) Compliance with the requirements of paragraph (b) of this section must be shown by analysis, and where necessary, by appropriate ground, flight, or simulator tests. The analysis must consider—

- (1) Possible modes of failure, including malfunctions and damage from external sources;
- (2) The probability of multiple failures and undetected failures;
- (3) The resulting effects on the airplane and occupants, considering the stage of flight and operating conditions, and
- (4) The crew warning cues, corrective action required, and the capability of detecting faults.

Similarly, Section 25.901(c) requires the following:

[f]or each powerplant and auxiliary power unit installation [including the fuel tank system], it must be established that no single failure or malfunction or probable combination of failures will jeopardize the safe operation of the airplane except that the failure of structural elements need not be considered if the probability of such failure is extremely remote.

Although no fault tree analysis report was required (nor was one conducted) for the accident airplane's certification, as part of its involvement in the Safety Board's investigation of the TWA flight 800 accident, Boeing developed and submitted a CWT ignition fault tree analysis report on November 25, 1996; this report was subsequently revised on December 20, 1996.<sup>338</sup> The assumptions made in developing Boeing's fault tree analysis report included the following:

- Only events considered germane to the TWA event were quantified.
- Aircraft was assumed to be in climb/cruise configuration.
- The CWT FQIS worked normally on the previous flight.
- The delivery schedule of this report required that many of the failure rates developed for events in this report be subjectively established. Using the qualitative criteria contained in...AC 1309-1A as shown below, best engineering judgement used qualitative risk assessment and then assigned [the following] quantitative values: probable =  $1 \times 10^{-05}$ ; improbable =  $1 \times 10^{-06}$  to  $1 \times 10^{-09}$ ; and extremely improbable =  $1 \times 10^{-10}$ .
- Quantitative rates assigned were the result of experience with [the] system and discussion with subject matter specialists.
- Failure rates will be reviewed for refinement as the final fault tree is constructed.<sup>339</sup>
- Air conditioning packs were...intact at impact.

<sup>338</sup> For additional information, see Systems Group Chairman's Factual Report—Addendum for Fault Tree Data, dated May 19, 2000.

<sup>339</sup> After the December 1996 revision, no further fault tree analysis reports were received from Boeing.

- A combustible fuel/air mixture existed in all fuel tank air spaces as modeled.
- Scavenge pump switch was turned off at the time of the event.

Boeing's CWT ignition fault tree analysis report identified the ignition of the CWT as the top-level failure mode, and the impact of all lower-level elements that compose the tree was evaluated using mathematical probability relationships. The fault tree analysis was constructed downward from the top-level event by progressively determining the conditions required for each lower-level event. Eventually, the tree reached a level where an event had no preceding events; this event was termed a "basic element." Boeing's CWT fault tree analysis report identified 167 basic elements. According to Boeing, each basic element was assigned a failure rate and an exposure time (the maximum time presumed by Boeing that the condition could go undetected) based on either in-service data or engineering estimates. These failure rates and exposure times were combined to produce a probability of failure for each element, using the following formula: probability of failure =  $1 \times e^{-(\text{failure rate} \times \text{exposure time})}$ . Some of the basic elements identified in Boeing's fault tree analysis report are shown (with their failure rates, exposure times, and calculated event probability) in table 10.

**Table 10.** Several fault tree analysis basic elements, as identified in Boeing's fault tree analysis report, with their failure rates, exposure times, and calculated event probability.

Basic Element	Failure Rate (events/hour)	Exposure Time (hours)	Basic Element Probability
Fuel/air mixture in CWT will support explosion	N/A	N/A	$1 \times 10^{-00}$
Metallic object capable of creating spark in CWT	$1 \times 10^{-06}$	8.0	$8 \times 10^{-06}$
Tank sealant decays, resulting in exposed metal surface	$1 \times 10^{-07}$	8.0	$8 \times 10^{-07}$
Electrical faults in surge tank	$1 \times 10^{-07}$	8.0	$8 \times 10^{-07}$
Fire propagates from surge tank to CWT	$1 \times 10^{-06}$	8.0	$8 \times 10^{-06}$
Conductive material bridging terminals	$3.55 \times 10^{-07}$	8.0	$2.64 \times 10^{-06}$
Unique wire-to-wire faults route to FQIS leads in right wing	$2.44 \times 10^{-07}$	8.0	$1.95 \times 10^{-06}$
Fuel probe contacts CWT structure	$3.55 \times 10^{-07}$	8.0	$2.84 \times 10^{-06}$
Unique wire-to-wire faults route to FQIS leads in left wing	$2.44 \times 10^{-07}$	8.0	$1.95 \times 10^{-06}$
Fire propagates from WCS dry bay to CWT	$1 \times 10^{-05}$	8.0	$8 \times 10^{-05}$
Combustible fuel/air mixture in air conditioning pack bay	N/A	N/A	$1 \times 10^{-00}$
Explosion-proofed equipment does not operate as designed	$1 \times 10^{-08}$	60000	$6 \times 10^{-01}$
Fire propagates from air conditioning pack bay to WCS dry bay	$1 \times 10^{-05}$	8.0	$8 \times 10^{-05}$
Fuel leak to air conditioning pack bay	$1 \times 10^{-05}$	8.0	$8 \times 10^{-05}$
VSO unit internal fault results in power to FQIS lead	$1.4 \times 10^{-07}$	8.0	$1.12 \times 10^{-06}$
FQIS wiring fault produces ignition source in main tank	$1 \times 10^{-6}$	8.0	$8 \times 10^{-06}$

Boeing's fault tree analysis report contained a graphical representation of the fault tree and a table showing the failure rates and exposure times for the fault tree's basic elements. During its review of the fault tree analysis report, the Safety Board noted that, in some cases, the information in the graphical representation of the fault tree did not agree with the information in the table. For some elements, the disagreement was several orders of a magnitude. According to Boeing's graphical representation, the probability of an ignition event in the CWT (the top-level failure mode) was  $8.45 \times 10^{-11}$ . Although Boeing did not calculate the top-level failure mode probability using the table values, when Safety Board investigators substituted the table values into the appropriate positions in the fault tree and completed the calculations, the table values showed that the probability of an ignition event in the CWT was  $1.46 \times 10^{-5}$ . Table 11 shows the differences between the data presented by Boeing in a graph and a table for of the some basic elements of its fault tree analysis.

**Table 11.** Some of the basic elements of Boeing's fault tree analysis, showing the differences between the data presented in Boeing's graphical and tabular representations.

Description	Failure rate (graphical)	Failure rate (tabular)	Exposure time (graphical)	Exposure time (tabular)	Probability of failure (graphical)	Probability of failure (tabular)
Optimum air gap exists	$4 \times 10^{-07}$	$4 \times 10^{-07}$	0.22	8	$8.8 \times 10^{-08}$	$3.2 \times 10^{-06}$
Optimum air gap exists <sup>a</sup>	$4 \times 10^{-07}$	$4 \times 10^{-07}$	0.22	0.2	$8 \times 10^{-08}$	$8 \times 10^{-08}$
Leak through side-of-body rib from web fatigue crack	$7.69 \times 10^{-07}$	$1 \times 10^{-05}$	8	8	$6.15 \times 10^{-06}$	$8 \times 10^{-05}$
Air gap to ground exists	$4 \times 10^{-07}$	N/A	0.22	N/A	$8 \times 10^{-08}$	$1 \times 10^{-00}$
Scavenge pump deterioration or pump wear results in loss of protection	$3.4 \times 10^{-08}$	$6.9 \times 10^{-07}$	8	8	$2.72 \times 10^{-07}$	$5.52 \times 10^{-06}$
Foreign object provides ground in CWT	N/A	N/A	N/A	N/A	$1 \times 10^{-06}$	$1 \times 10^{-00}$
Current limit circuit failure (no indication)	$1.1 \times 10^{-07}$	$8 \times 10^{-07}$	8	8	$8.8 \times 10^{-07}$	$6.4 \times 10^{-06}$
Circuit breaker fails closed	$4.76 \times 10^{-06}$	$4.76 \times 10^{-06}$	60000	60000	$2.86 \times 10^{-01}$	$2.48 \times 10^{-01}$
Short to power on lead in wire bundle	$2.44 \times 10^{-08}$	$4.07 \times 10^{-08}$	8	8	$1.95 \times 10^{-07}$	$3.26 \times 10^{-07}$
Wire-to-wire short	$4.07 \times 10^{-09}$	$2.44 \times 10^{-07}$	8	8	$3.26 \times 10^{-08}$	$1.95 \times 10^{-06}$
Sufficient energy created to ignite fuel/air mixture	$1 \times 10^{-07}$	$1 \times 10^{-05}$	8	8	$8 \times 10^{-07}$	$8 \times 10^{-05}$



**Table 11.** Some of the basic elements of Boeing's fault tree analysis, showing the differences between the data presented in Boeing's graphical and tabular representations.

Tank sealant decays, exposing metal	$1 \times 10^{-07}$	$1 \times 10^{-06}$	8	8	$8 \times 10^{-07}$	$8 \times 10^{-06}$
Scavenge pump burnthrough results in ignition source	$1.15 \times 10^{-08}$	$1 \times 10^{-07}$	8	8	$9.2 \times 10^{-08}$	$8 \times 10^{-07}$
Scavenge pump internal friction results in ignition source	$3.45 \times 10^{-07}$	$2 \times 10^{-06}$	8	8	$2.76 \times 10^{-06}$	$1.6 \times 10^{-05}$

<sup>a</sup>. This event was listed in the fault tree two separate times with different values.

Because of these inconsistencies in Boeing's fault tree analysis report, because of other questions the Safety Board had regarding the detailed information used to construct the fault tree,<sup>340</sup> and because the fault tree did not reflect the findings of the ongoing investigation, on June 4, 1998, the Board requested that Boeing further review and revise the fault tree analysis report, as necessary. On July 29, 1998, Boeing responded and indicated the following, stating that although the Board was correct in some of its points:

we [Boeing] do not believe that revising the [fault tree analysis] by incorporating new data or changing the probability numbers will help identify new areas to inspect or help identify the cause of the accident. We believe it would be more productive to continue the various inspection and modification programs that are presently underway.

The Safety Board subsequently asked NASA's George C. Marshall Space Flight Center (MSFC) to review Boeing's fault tree analysis report and the Board's concerns. In a November 25, 1998, letter, NASA MSFC personnel stated the following:

Many of the probabilities, failure rates, and/or exposure times were much lower than would reasonably be expected. The probability of occurrence should be higher and/or exposure times should be longer on many of the basic events...Based on our evaluation of the tree and the information provided by the [Safety Board], the subject fault tree analysis quantification cannot stand up to peer review and should not be viewed as realistic. It should be noted that the logic of the tree could not be fully evaluated since we did not have access to the engineering drawings and schematics of the system. However, based on previous systems experience, we would expect the tree to be constructed differently.

NASA MSFC personnel further indicated that the exposure time numbers used in Boeing's fault tree analysis report appeared to be overly optimistic and that the use of more realistic numbers would result in an increased probability of a top-level failure.

<sup>340</sup> For example, the Safety Board questioned the exposure times listed for some of the basic elements in Boeing's fault tree analysis report. According to Boeing, most of the items listed in tables 8 and 9 had exposure times of 0.22 to 8 hours; however, the Board notes that some of these items would likely go undiscovered until heavy maintenance inspections (a potential exposure time of more than 2,000 hours), whereas others might never be detected during the life of the airplane.

In its submission, Boeing stated that, because the fault tree analysis was developed only to support the accident investigation, it did not go through the “iterative review process with the FAA normally associated with certification of a system, nor were the underlying [failure modes and effects analyses] FMEAs developed that normally would be the source of data to build the [fault tree analysis].”

#### 1.16.6.5.1 Other Fault Tree Analysis Information

During its evaluation of the FMEA/fault tree process for this investigation, the Safety Board noted several other accidents/incidents in which failures occurred that either had not been anticipated or had not been perceived as catastrophic and, therefore, had not been appropriately addressed in the manufacturer’s fault tree analysis. For example, after a series of accidents and incidents in the 1990s involving uncommanded rudder movements on 737s, the Board recommended that the FAA convene an engineering test and review board to evaluate the 737 rudder system.<sup>341</sup> The resultant engineering test and review board, which convened in 1999, identified catastrophic failure modes that had not been identified through the FMEA and fault tree analyses submitted by Boeing in 1997 in connection with certification of the 737-NG airplanes. The recent in-flight failure of a horizontal stabilizer actuator on an Alaska Airlines MD-80 may be another example of a failure that was not anticipated through the FMEA/fault tree analysis process.<sup>342</sup>

Further, the Safety Board observed that fault tree analyses used in noncommercial aviation industries do not always anticipate every failure. As evidenced by the Space Shuttle Challenger disaster, even systems that have undergone NASA’s failure analysis review can experience unexpected failure modes. In addition, the nuclear power accident that occurred on March 28, 1979, at the Three Mile Island nuclear power plant near Harrisburg, Pennsylvania, was attributed to a series of unanticipated failures that were, therefore, not considered during development. According to the October 30, 1979, “Report of the President’s Commission on the Accident at Three Mile Island,” the valve failure that initiated the accident sequence was not detected by the operators in the control room, who relied on the indicator light indicating that the valve had closed as intended. The operators did not heed other indications that the valve had not closed. The report stated, “Prior to [the Three Mile Island accident], the NRC [Nuclear Regulatory Commission] had paid insufficient attention to [loss of coolant accidents] of this size and the probability of their occurrence in licensing reviews.” Similarly, the NRC’s January 1980 “Report to the Commissioners and to the Public” noted the following:

---

<sup>341</sup> For additional information, see National Transportation Safety Board. 1999. *Uncontrolled Descent and Collision with Terrain, USAir Flight 427, Boeing 737-300, N513AU, near Aliquippa, Pennsylvania, September 8, 1994*. NTSB/AAR-99/01. Washington, DC.

<sup>342</sup> The investigation of the January 31, 2000, Alaska Airlines flight 261 accident is still ongoing (as of the date of report publication).

The greatest risk of an accident comes not from the design basis accidents...but from small loss of coolant accidents and relatively routine transients compounded by multiple failures or human error, having a higher probability of occurring than a large pipe break. These types of potential accident sources have, however, been all but ignored by the NRC in the regulatory review process.

#### **1.16.6.6 Compensator Probe Testing at the FAA's William J. Hughes Technical Center**

During June/July 1999, the Safety Board conducted a series of tests at the FAA's William J. Hughes Technical Center, in Atlantic City, New Jersey, to determine the physical effects that the ignition and explosion of Jet A fuel vapor would have on a CWT compensator probe assembly.<sup>343</sup> Specifically, the tests were designed to correlate observed damage to the compensator lead wire assemblies to the location of an ignition source in Jet A vapor. To accomplish this goal, the tests were conducted with four different ignition source locations.

Video documentation of the tests showed that it was possible for a combustion flamefront to traverse the interior of the compensator. After the tests, the test compensators were compared with the recovered TWA flight 800 compensator. In many instances, evidence of thermal damage (including soot deposits to lead wires and lead wire guides and slight melting of the lead wire guide) was observed after the tests. However, in all cases, the thermal damage observed on the test compensators was much less severe than that observed on the recovered TWA flight 800 compensator lead wire assembly.

#### **1.16.6.7 Fuel Pump Tests (Motor Cavity Explosions)**

The Safety Board's review of the scavenge pump design revealed that the scavenge pump motor was mounted on the aft surface of the rear spar (external to the CWT, in the main landing gear wheel well) but contained fuel-cooled windings. Fuel supplied to cool the windings passed through a flame suppression system consisting of a small-diameter tube in series with a check valve. Further, the scavenge pump contained a thermal fuse designed to open at less than 400° F. (The review indicated that the scavenge pump had satisfactorily completed qualification tests during which the pump was operated without cooling fuel until the thermal fuse opened. The Board's review of qualification test results and service records revealed no evidence of fuel vapor igniting inside or outside the scavenge pump motor.)

During its investigation of the TWA flight 800 accident, the Safety Board conducted tests to determine the explosion-proof characteristics of an old and a new scavenge pump with intact flame arrestor tubes and check valves. When vapors in the motor housings of both the old and new scavenge pumps were ignited, no sparks or flames escaped from the pump motor to ignite the explosive atmosphere in the representative laboratory fuel tank adjacent to the pump. Further, the scavenge pumps successfully

---

<sup>343</sup> For additional information, see the FAA's Summary Data Report: Investigation of the Effects of Combustion on a Fuel Quantity Indicating System Fuel Compensator Probe, dated January 19, 2000.

contained multiple explosions that were intentionally ignited within the pump motor cavity, preventing the ignition from transferring to the fuel tank. (Figure 37 is a diagram of a scavenge pump.) Because the Board became aware of instances in which the flame arrestor tube was broken or missing, investigators also conducted a series of tests to determine whether the scavenge pump motor housing would contain explosions with only one of the flame suppression system components (either the flame arrestor tube or the check valve) functioning. In all tests, the scavenge pump housing contained the explosions, and the explosive atmosphere surrounding the test pump did not ignite.

During its postaccident examination of other transport-category airplanes, the Safety Board observed that components in the electrical connector on a scavenge pump in a retired 747 were deteriorated. (Boeing ASBs 747-28A2194 and 747-28A0043, both dated January 18, 1996, "encouraged" operators to inspect for degradation in connectors.) Investigators observed that several scavenge pump electrical connectors had been manufactured of a material that degraded with long-term exposure to fuel. Boeing provided the Board with a service history for the 747 scavenge pump for the 10 years preceding the accident. When queried about the brevity of this history, Boeing indicated that most operators did not return the scavenge pumps to the manufacturer for overhaul.

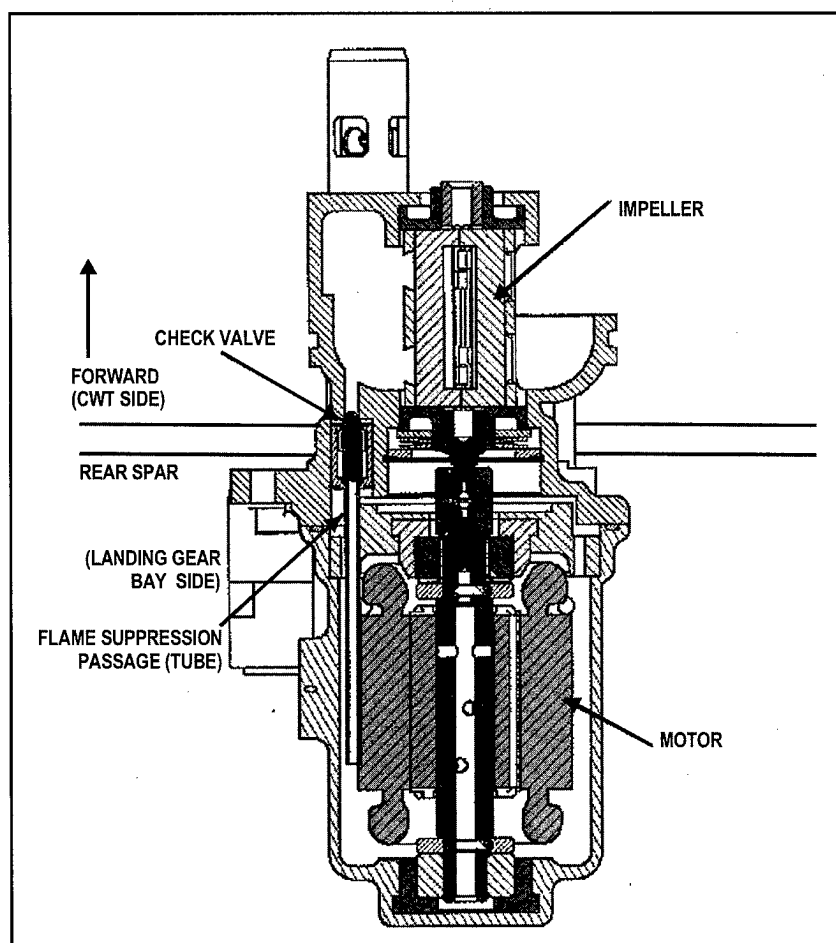

Figure 37. A diagram of a scavenge pump.

As a result of these findings, Boeing issued ASB 747-28A2206, dated September 25, 1997, and AD 97-25-06, effective December 16, 1997. AD 97-25-06 contained the following summary:

The actions specified in this AD are intended to prevent potential failures within the electrical motor assembly of the scavenge pump, which could result in leakage of fuel from an electrical connector into the main landing gear well, or electrical arcing within the scavenge pump motor; those conditions could result in a fuel fire in the wheel well.

The AD required disconnection of the electrical connector, a one-time inspection to identify the P/N of the electrical connector, and possible scavenge pump replacement. The FAA subsequently received a report about damage to the internal wiring of a scavenge pump after a replacement connector was found to have a longer backshell component. (The longer backshell provided insufficient clearance for parts inside the pump, which could cause arcing in the motor and fuel leakage into the wheel well.) As a result, Boeing issued ASB 747-28A2215, dated May 14, 1998, which called for another one-time inspection of the scavenge pump motor-impeller P/Ns, with part replacement if necessary. The FAA made this action mandatory by releasing AD 98-14-17, effective July 23, 1998.

#### 1.16.6.8 Electrostatic Research

Electrostatic hazards have been recognized for many years and have resulted in numerous publications, including the previously discussed API 2003 and the FAA Aircraft Lightning Protection Handbook, DOT/FAA/CT-89/222.<sup>344</sup> The Safety Board contracted with the AFRL at Wright Patterson Air Force Base and the Naval Research Laboratory (NRL) to conduct research into fuels, fuel additives, and electrostatic charging of fuels. The AFRL tests revealed that, of the various items tested, Teflon-cushioned wire clamps (known as Adel clamps)<sup>345</sup> were most susceptible to electrostatic charging and achieved the highest voltage potentials. These clamps, which are used to hold tubing in the CWT, are among those parts in the CWT that are electrically isolated (unbonded).<sup>346</sup> (Safety Board investigators documented more than 30 megohms of resistance between fuel tube couplings on the test airplane, as well as between isolated metal clamps and the fuel tubes that the clamps were mounted on, indicating inadequate bonding.)

---

<sup>344</sup> On page 198, illustration 7.27, the FAA's lightning protection guidance indicates that unbonded clamps could present an ignition hazard if a lightning strike occurred.

<sup>345</sup> Teflon-cushioned, or Adel, wire clamps are used with other hardware (such as screws, washers, and nuts) to secure electrical wires and tubing.

<sup>346</sup> Certification standards require that "major components" of the powerplant installation be electrically bonded to the other parts of the airplane. (For more information about certification requirements, see 14 CFR 25.901[b][4].) According to a June 2, 2000, letter, to the Safety Board Boeing design practices permit parts that are less than 3 inches in any direction (including some types of clamps and connectors installed in fuel tanks) to be electrically unbonded, presumably because such parts are not believed to have enough capacitance to retain hazardous levels of static electricity under expected operating conditions. Boeing 747 fuel tank assembly drawings show Adel clamp installations in which the clamp does not have a grounding strap.

Testing demonstrated that when the electrically isolated Adel clamp was exposed to a fuel spray or drip, an electrical charge was created on the clamp. The fuel spray or drip replicated a pressurized fuel leak. Fuel spraying or dripping onto clamps that were not thoroughly wet (thus, not permitting the fuel to create a wet path to the ground through antistatic additives) created higher voltage potentials than spraying or dripping onto clamps that were thoroughly wet. However, the highest voltage potential attained in testing was 650 volts, which would produce a discharge energy of only 0.0095 mJ. Voltage potentials of 1,150 volts were produced in tests using fuel of a higher conductivity than that in the accident airplane's CWT, which could produce a discharge energy of 0.030 mJ.<sup>347</sup>

The Safety Board learned that Boeing had accumulated almost 5 J of energy on clamps during tests that followed two explosions in Boeing 727 fuel tanks during ground refueling at Minneapolis, Minnesota, in 1970.<sup>348</sup> Subsequently, research conducted by NRL personnel also found that the Adel clamp retained up to 5,800 volts (capable of producing 0.84 mJ in a spark) when exposed to a fast drip of fuel containing commercially unavailable additives. However, to obtain a discharge exceeding the MIE of Jet A fuel vapor from a charged, isolated Adel clamp, the fuel used in the tests had to contain high-conductivity additives that are no longer manufactured and not available in fuel from JFK or the Athens airport at the time of the accident.

#### 1.16.6.9 Sulfide-Deposit Tests and Research

Safety Board investigators found dark deposits on FQIS fuel quantity probes, compensators, and wiring that had been recovered from various fuel tanks in the accident airplane and in similar locations in three other airplanes that were inspected during this investigation (N93105, N93117, and F-BPVE [all 747s]). The Board's examination of several of these deposits using an SEM identified copper, silver (silver-plated copper wiring is used in fuel tanks), and sulfur (a contaminant in jet fuel), a combination also known as silver-sulfides.<sup>349</sup>

The Safety Board became aware that the AFRL fuel specialists had conducted research on similar deposits in the late 1980s/early 1990s. According to the AFRL specialists, the silver-sulfide deposits on components from the accident airplane were similar to deposits that they had identified previously on fuel quantity probes in military airplanes. For example, in 1990, silver-sulfide deposits were observed on a fuel quantity probe from a USAF trainer in 1990. During electrical bench tests involving this probe,

<sup>347</sup> Although voltage potentials of more than 5,000 volts were obtained in some laboratory tests, these tests simulated extreme worst-case ground refueling conditions and did not use materials or fuel that would have been present on the accident airplane.

<sup>348</sup> The Aviation Rulemaking Advisory Committee (ARAC) Fuel Tank Harmonization Working Group (FTHWG) and API 2003 cite several previous fuel tank explosions that were believed to have been caused by static electricity.

<sup>349</sup> Although for the purposes of this report, these deposits will be called silver-sulfide deposits, they are sometimes referred to as "copper sulfide deposits," "sulfides," or "sulfidation." According to a 1991 Boeing engineering report, silver should never contact sulfur-containing liquids because of its susceptibility to sulfidation.

flammable vapor ignited when voltages higher than those encountered during normal fuel system operation were applied. The AFRL research indicated that these deposits could break down and result in arcing when exposed to a 170-volt pulse. Further, the AFRL fuel specialists noted that the silver-sulfide deposits were semiconductive and, thus, gradually reduced insulation resistance between electrical connections. The AFRL report concluded that the accumulation of silver-sulfide deposits “is most likely the result of a long-term degradation or corrosion process...[and that] as the probes age, more probe failures [calibration errors] can be expected.”<sup>350</sup>

As a result of Safety Board requests<sup>351</sup> for any documents pertaining to silver or copper sulfides, on April 23, 1998, Boeing provided the Board with several documents, including the following:

- Boeing Materials Technology Engineering Report MS21053, dated June 17, 1988, that described the examinations of arcing damage in 18 fuel pumps. One of the 18 fuel pumps exhibited evidence of arcing at the location of sulfide deposits (the other 17 were too badly damaged to identify the origin of arcing).
- Boeing Analytical Engineering Report 2-5323-WP-91-97, dated March 20, 1991, that described Boeing’s examination of sulfide deposits on a harness from a fuel quantity indicator from the right wing tank of a 757. The fuel quantity indicator had a documented history of irregularities after only 750 hours in service. The report noted “it is readily observed...that the...contaminant has migrated up into the...connector even after only 750 hours in service.”
- A Parker Berteau Aerospace memorandum, dated August 18, 1992, which documented sulfide deposits on FQIS components removed from DC-10 airplanes.
- Boeing Laboratory Report 9-5576-P+CA-025P, dated March 30, 1993, that described sulfide deposits on electrical hardware from the fuel tanks of 737, 747, and DC-10 airplanes.
- Boeing Laboratory Report 9-5576-P+CA-025P1, dated April 29, 1993, that also described sulfide deposits on electrical hardware from the fuel tanks of 737, 747, and DC-10 airplanes and included two additional reports (obtained through a literature search): *Silver Corrosion by Aviation Turbine Fuel*, dated September 1970, written at the Journal of the Institute of Petroleum; and *Copper and Silver Corrosion by Aviation Turbine Fuels*, dated April 22, 1973, written at the Indian Institute of Petroleum.
- Boeing Analytical Engineering Report 9-5576-WP-97-272, dated August 5, 1997, that described electrical tests of FQIS parts containing sulfide deposits.

---

<sup>350</sup> See Slenski, George. 1990. *Analysis of Trainer Aircraft Fuel Probes I. U.S. Air Force Research Laboratory*. Materials Integrity Branch, Systems Support Division, Materials Directorate.

<sup>351</sup> The Safety Board requested the above-mentioned information from Boeing in letters dated December 19, 1997, and March 6, 1998.

At the Safety Board's request, AFRL specialists at the Wright Laboratory further examined the deposits on numerous parts from the accident airplane (including fuel quantity probe units and an FQIS compensator fragment) and other airplanes in which similar deposits were observed on fuel system components.

In May 1998, the Safety Board became aware of a similar deposit found on a Tower Air 747 CWT T347 terminal strip.<sup>352</sup> According to Tower Air management, maintenance personnel had been troubleshooting refueling problems (including premature and delayed refueling shutoff) and problems with FQIS wiring when they observed the deposits on the terminal strip and removed it. The Board subsequently requested that several independent laboratories examine and test the deposits on the terminal strip. In response to the Board's request, the AFRL in Dayton, Ohio, tested the electrical resistance of and documented the deposits; Evans-East Laboratories in Plainsboro, New Jersey, tested the chemical properties of the deposits in greater depth; and the AFRL/University of Dayton Research Institute (UDRI) documented the deposits' reaction to electrical loads. In addition, tests conducted at the AFRL Electronic Failure Analysis Laboratory and the Fuels Branch Laboratory used a portion of the Tower Air T347 terminal strip to observe and document the deposits' breakdown in the presence of flammable jet fuel vapor.

The results of this research, described in reports from Evans-East Laboratories<sup>353</sup> and the AFRL/UDRI,<sup>354</sup> revealed that these silver-sulfide deposits accumulate over time<sup>355</sup> as a result of exposure to jet fuel (and jet fuel vapor), which contains sulfur.<sup>356</sup> These deposits were typically found on FQIS wire at terminations and where damaged insulation resulting in exposed wire conductor. Additionally, AFRL was able to ignite lighter fluid using a sulfide deposit sample from the Tower Air T347 terminal strip. Additionally, during tests conducted at UDRI, researchers were readily able to create numerous sulfide deposits in a laboratory setting. According to UDRI, this research indicated that increased temperatures enhanced the formation of silver-sulfide deposits and that fuel washing could slow the accumulation of these deposits.

---

<sup>352</sup> Of the many FQIS components with sulfide deposits from other airplanes examined during this investigation, the two that had been removed from the airplane because of FQIS anomalies were both 747 CWT T347 terminal strips.

<sup>353</sup> For additional information, see the Evans-East Laboratories reports dated April 22, 1998, and April 24, 1998.

<sup>354</sup> For additional information, see the following AFRL reports: AFRL/MLSA 99-2, dated January 26, 1999; AFRL/MLSA 99-33, dated June 21, 1999; and AFRL/MLSA 99-68, dated October 18, 1999. Additionally, an earlier AFRL report (WL/MLS 97-102) documented residues on FQIS components from the accident airplane (see Systems Group Chairman's Factual Report, dated November 17, 1997).

<sup>355</sup> UDRI research revealed that the time required for sulfide deposits to accumulate can vary considerably and is related to factors, such as sulfur content of the fuel, temperature.

<sup>356</sup> Where wiring is connected to a fuel quantity probe in a 747-100 fuel tank (for example, at the terminal block connectors), the silver-plated copper conductor of the connected wire is exposed to fuel and fuel vapor. (The FQIS design for all 747 Classic series airplanes results in exposed conductors at terminal blocks.)



During FAA-sponsored tests conducted in response to Safety Recommendation A-98-37 (issued as a result of this accident), researchers at the University of Arizona also used the method developed by UDRI to create silver-sulfide deposits in a laboratory. During subsequent tests, these deposits served as an ignition mechanism for Jet A fuel vapor. The results of these tests were discussed at a November 9, 1999, meeting involving FAA, Safety Board, and industry personnel. According to University of Arizona personnel, the formation of sulfur-containing conductive deposits from Jet A fuel on silver wire occurred with both a.c. and d.c. current. Additional tests in this area are ongoing.<sup>357</sup>

According to a BFGoodrich representative at the November 9, 1999, meeting, on the basis of the AFRL findings in the early 1990s, BFGoodrich had developed a means of improving the accuracy and reliability of FQIS wiring used in military applications through design changes that began in 1993 and involved the use of (1) nickel-plated wire, (2) gold-plated ring connectors, (3) sealant in shrink tubes, and (4) separate inner and outer layers of shrink tube. The BFGoodrich representative stated that previously reported inaccuracies in the FQIS had largely resulted from current leakages through the sulfide deposits and that the design changes resulted in a large reduction in reported FQIS problems.<sup>358</sup>

According to Boeing personnel, Boeing uses nickel-plated, instead of silver-plated, wiring in its newly manufactured 777 and 737-NG airplanes. However, in a December 7, 1999, letter, Boeing indicated that “overall, the wholesale replacement of FQIS bundles in the tank is not recommended.”

#### **1.16.6.10 Auto Ignition and Hot Surface Ignition Information**

The Safety Board considered the possibility that elevated temperatures within the CWT (resulting from engine bleed air leaks, a fire in the main landing gear wheel well, or a fire in the air conditioning pack bay) increased the temperature of the fuel/fuel vapor or the CWT structure/components to a sufficiently high temperature to result in ignition. This ignition could occur as a result of ignition mechanisms known as hot surface ignition and auto ignition.

Hot surface ignition of Jet A fuel can result when a very high temperature surface comes into contact with fuel or fuel vapor and is highly dependent upon many factors, including the geometric aspects of the hot surface and the environmental conditions affecting the fuel/fuel vapor. Existing research<sup>359</sup> indicates that hot surface ignition of fuels similar to Jet A can occur at temperatures ranging between 900° and 1,300° F.<sup>360</sup>

---

<sup>357</sup> For information about Safety Board recommendations regarding sulfide deposits, see section 1.18.3.

<sup>358</sup> In a January 20, 2000, letter to the Safety Board, Boeing indicated that at least two additional companies were manufacturing wire harnesses that have terminations resistant to sulfidation.

<sup>359</sup> Kuchta.

<sup>360</sup> If an individual hot spot within the CWT were to reach temperatures between 900° and 1,300° F, it is likely that the CWT surface in this area would also have been this hot. These temperatures are at or near the melting temperature of the CWT's aluminum skin (aluminum softens/melts at 800° to 1,200° F, depending on the specific aluminum alloy).

Tests conducted by Boeing indicated that strands of steel wool can be ignited by as little as 32 milliamps from a 25-volt 400-cycle a.c. source.

Auto ignition of Jet A fuel can result when a large volume of fuel/air vapor is sufficiently elevated in temperature for ignition to occur without direct contact with an ignition source (such as a spark, arc, hot surface, or hot filament). Auto ignition is also highly dependent on many factors, including the size of the heated volume and container and environmental conditions affecting the vapor. The lowest temperature that can result in auto ignition is called the auto ignition temperature. Existing research indicates that the auto ignition temperature for Jet A fuel vapor at sea level is about 460° F. The auto ignition temperature tends to increase as the altitude increases.

Data provided by Boeing indicated that multiple engine malfunctions (concurrent failures of the (1) engine bleed air pressure relief valve, (2) precooler cooling airflow control valves, and (3) pylon shutoff and regulating valve would be required) could result in bleed air temperatures above 800° F at the engines. The failures required to produce such excessive bleed air temperatures would have resulted in an engine malfunction warning, and the excessive bleed air temperatures would have been sensed by temperature sensors installed inside and outside of bleed air ducts, resulting in cockpit warnings. Further, according to engineering data from Hamilton Standard (the manufacturer of the air conditioning system) and Boeing, the combination of failures required to produce such elevated temperatures would have resulted in overpressure leading to an air conditioning duct burst.<sup>361</sup>

The FAA's certification regulations regarding fuel tank temperatures (Section 25.981) state the following:

- The highest temperature allowing a safe margin below the lowest expected auto ignition temperature of the fuel in the fuel tanks must be determined.
- No temperature at any place inside any fuel tank where fuel ignition is possible may exceed the temperature determined under paragraph (a) of this section. This must be shown under all probable operating, failure, and malfunction conditions of any component whose operation, failure, or malfunction could increase the temperature inside the tank.

#### 1.16.6.11 Meteorite Strike Information

During the evenings after the TWA flight 800 accident, many meteorites were observed in the northeastern United States. Therefore, the Safety Board considered the possibility that TWA flight 800 was struck by a meteorite, which then caused the CWT explosion. The Board consulted an expert in the study of meteorites, a professor from the University of Pittsburgh's Department of Geology and Planetary Science, to evaluate the possibility of a meteorite hitting an airplane.<sup>362</sup> According to the professor's testimony,

---

<sup>361</sup> Examination of the recovered wreckage revealed no evidence of damage that would have resulted from such extreme temperatures. Further, the CVR did not record any audible cockpit warning or any flight crew discussion that would indicate that such a condition existed in the accident airplane.

knowing the frequency with which meteorites have struck cars and dwellings over the past several decades, and based on a comparison of estimates of (1) the area of the earth's surface represented by cars and dwellings with (2) the area of the earth's surface represented by airplanes in the air at any given time, he calculated that a meteorite could be expected to strike an aircraft once every 59,000 to 77,000 years.

## **1.17 Operational and Management Information**

### **1.17.1 Trans World Airlines, Inc.**

TWA holds an air carrier certificate, No. TWAA017A, and is authorized to conduct operations in accordance with 14 CFR Part 121 as a domestic and flag air carrier. TWA's main maintenance facility and maintenance overhaul facility is located at the Kansas City International Airport (MCI), Kansas City, Missouri. Additionally, at the time of the accident, TWA maintained major station maintenance bases that serviced the 747 at JFK; LAX; MCI; STL; and San Francisco International Airport, San Francisco, California. TWA's main operations base is located at STL. TWA conducts flight crew training at its facilities at STL, JFK, and LAX.

### **1.17.2 FAA Oversight of TWA Maintenance**

The FAA principal maintenance inspector (PMI) assigned to the TWA certificate at the time of the accident was located at the Certificate Holding District Office (CHDO) in Kansas City, Missouri. He was hired by the FAA in July 1988 and was initially assigned as a partial program manager (PPM) for TWA's 747, 757, and 767 fleets. The PMI was an Assistant PMI for TWA for 2 years before he was assigned to the PMI position in 1990. He stated that he had no certificate oversight responsibilities other than TWA and that he had an assistant PMI and four PPMs to assist him with the oversight of the TWA certificate.

According to the PMI, he had adequate staffing for the oversight of TWA's maintenance operations and did not have any concerns about the company's maintenance program. He stated that TWA personnel were receptive to feedback and made corrections in a timely manner when discrepancies were identified. TWA's most recent National Aviation Safety Inspection Program (NASIP) was conducted in September and October 1995. The TWA NASIP involved airworthiness inspectors from Kansas City, Missouri, who traveled to other TWA maintenance facilities to accomplish their assignments. In addition, geographic inspectors in Atlanta, Georgia; Dallas/Fort Worth, Texas; and Salt Lake City, Utah, assisted in ramp inspections. The Safety Board's review of the NASIP inspection's airworthiness findings revealed that none of the findings

---

<sup>362</sup> During his testimony at the Safety Board's public hearing for TWA flight 800, the professor defined a meteor as a "visual phenomenon caused by a body plunging through the atmosphere. You don't see the body itself, you see the glow of compressed air and ionized gases in front of the meteorite," and a meteorite as a "chunk of silicate rock or nickel-iron alloy, believed to originate in the asteroid zone of the solar system."

pertained to 747-100 fuel systems, fuel tanks, wiring, or structural inspections. (The accident airplane was not inspected during the NASIP.) The National Program Tracking and Reporting Subsystem indicated, with regard to the listed airworthiness items, that TWA corrected the items. In all cases, the Flight Standards CHDO concurred with TWA's actions to correct the findings.

## 1.18 Additional Information

### 1.18.1 Accident Record and History of Fuel Tank Fires/Explosions on Airplanes

The Safety Board has participated in the investigation of several aviation accidents/incidents involving fuel tank explosions. According to a list prepared by the FAA, since 1959 there have been at least 26 documented fuel tank explosions/fires in military and civilian transport-category airplanes (including TWA flight 800). Appendix G lists these fuel tank explosions/fires, several of which are discussed in greater detail in this section.<sup>363</sup>

The Safety Board conducted a special investigation of the May 9, 1976, accident involving an Iranian Air Force 747-131, as it approached Madrid, Spain, following a flight from Iran. All 17 people on board the airplane were killed, and the airplane was destroyed. Witnesses reported seeing lightning strike the left wing, followed by fire, explosion, and separation of the outboard wing before the airplane crashed. Examination of the wreckage revealed evidence of an explosion that originated in at least one of the left wing fuel tanks near a fuel valve installation. The airplane's fuel tanks contained a mixture of JP-4 and Jet A fuel.<sup>364</sup> The Board's report noted that almost all of the electrical current of a lightning strike would have been conducted through the aluminum structure around the ullage<sup>365</sup> but discussed how some energy might have entered the fuel tanks.<sup>366</sup> Although the Board's report did not identify a specific point of ignition within the tank, it noted that discharges

<sup>363</sup> Although not listed in appendix G, the Safety Board is also aware of an in-flight fuel tank explosion in a wing tank on a U.S. Navy C-130 that occurred on January 15, 1972, near Cambridge, Maryland. The U.S. Navy's investigation concluded that "an arc occurred in the fuel tank airspace from either...the #10 fuel quantity probe to an unknown ground...[or] from [chafing of] the coax[ial] cable in the immediate vicinity of the #10 fuel quantity probe to an unknown ground."

<sup>364</sup> Although the Safety Board's report indicated that the airplane's fuel tanks contained a mixture of JP-4 and Jet A fuel, it is likely that the airplane's fuel tanks actually contained a mixture of JP-4 and Jet A-1 fuel. Jet A-1 fuel is commonly used by air carriers throughout the world, and Jet A has relatively limited availability outside the United States.

<sup>365</sup> The Safety Board did not determine the probable cause of this foreign accident because it had no statutory authority to do so. However, several hypotheses addressing the sequence of events and possible causes of the accident were presented in the Board's report. Further, in a February 13, 1979, memorandum, the FAA stated, in part, "[the Safety Board's report indicated] that 'energy levels required to produce a spark will not necessarily damage metal or leave marks'...The enclosed photographs show the localized burned and melted portions of the plastic sleeves of the compensator wiring harness....In view of the fact that flammable vapors can be ignited by very low electrical energy which is less than that required to produce any physical evidence and in consideration of the internal condition of the compensator, we suggest that a careful review should be given of the compensator as a possible ignition source."

could produce sufficient electrical energy to ignite the fuel/air mixture and that energy levels required to produce a spark will not necessarily damage metal or leave marks at the point of ignition. Upward flowing burn patterns were observed on the compensator that the FAA considered a potential ignition source for the surge tank fire.<sup>367</sup>

The Safety Board also assisted in the investigation of the crash of Avianca flight 203, a 727, on November 27, 1989, which killed all 107 people on board the airplane. The airplane had departed Bogota, Colombia, about 5 minutes before the crash. Examination of the wreckage revealed that a small bomb placed under a passenger seat, above the CWT, had exploded.<sup>368</sup> According to the Colombian Government's report regarding this accident, the bomb explosion itself did not compromise the structural integrity of the airplane; however, the explosion punctured the CWT and ignited the Jet A fuel/air vapor<sup>369</sup> in the ullage, resulting in the destruction of the airplane.

The Safety Board also participated in the investigation of a May 11, 1990, accident, involving a Philippine Airlines 737-300 at Ninoy Aquino International Airport, Manila, Philippines, in which the Jet A fuel/air mixture in the CWT exploded as the airplane was being pushed back from the gate. Of the 120 people on board the airplane, 8 were killed, and 30 were seriously injured. As a result of this accident, the Safety Board issued Safety Recommendations A-90-100 through -103 to the FAA. In its safety recommendation letter, the Board noted that the exact source of ignition had not been established. However, lightning damage and damaged FQIS wires were found. The Board stated that "it is possible that the combination of a faulty float switch and damaged wires providing a continuous power supply to the float switch may have caused an electrical arc or overheating of the switch leading to the ignition of the center fuel tank vapor."

---

<sup>366</sup> Additional information regarding the amount of energy from lightning that might reach conductive components in fuel tanks is contained in Lightning Protection Handbooks published by the FAA and NASA.

<sup>367</sup> The damage was described in an undated FAA memo as follows: "localized burned and melted portions of the plastic sleeves of the compensator wiring harness where the black unshielded leadwire joins the HI Z leadwire. This is the same area where flashover to the HI Z terminal was observed at 6.9 kilovolts during voltage breakdown tests on new compensators....Evidence of arcing was difficult to detect following these tests. It may be noted in the photographs that the bottom edge of the leadwire plastic support is also burned and that a side of the plastic sleeve around the HI Z and black leadwires is not burned. This type of localized damage tends to indicate that a brief flame stream could have been initiated at the lug end of the HI Z leadwire which was directed upward through the compensator as the unit is mounted in the surge tank."

<sup>368</sup> Evidence of a bomb explosion included deformation of materials away from a location at the height of the passenger seat pan, hot-gas pitting damage on multiple pieces of wreckage that formed a pattern radiating from the same location (including into the CWT), punctures radiating from the same location, and shrapnel. Further, according to the FBI's laboratory report, No. 91204034 S YQ YB/91207052 S YQ YB, dated January 30, 1990, chemical analysis of a piece of wreckage from the right side of the CWT identified the presence of RDX and PETN high explosive. These two explosives comprise about 86 percent of the composition of SEMTEX, which is a rubberlike material manufactured by Synthesia Corporation of Semtin, Czechoslovakia, primarily for use in mining and other civil engineering activities. According to the FBI, SEMTEX has been used by criminal and terrorist elements in Europe since 1966. (SEMTEX was identified as the material used in the bomb placed on Pan Am flight 103. For additional information, see section 1.11.1.2.)

<sup>369</sup> As indicated with regard to the Iranian Air Force 747, because Jet A fuel has limited availability outside the United States and because Jet A-1 is commonly available outside of the United States, it is likely that this airplane's fuel tanks contained Jet A-1 fuel.

Safety Recommendations A-90-100 through -102 addressed the inspection of float switch wiring on 737-300, -400, and -500 airplanes, the inspection of other wiring bundles on all 14 CFR Part 121 airplanes, and the development and utilization of testing techniques to detect defective float switches (with a requirement to replace all defective units). On the basis of the FAA's responses indicating that it intended to take no action on these recommendations, the Safety Board classified all three safety recommendations "Closed—Unacceptable Action" on March 24, 1992. The Board also recommended, in Safety Recommendation A-90-103, that the FAA conduct a detailed engineering design review and testing of the fuel pumps used in the 737-300, -400, and -500 to verify that overheating and interference between the rotating components of the pump and its case will not cause a fire hazard (tests should be conducted with the jet fuel at its flash point). The Board determined that subsequent testing and research conducted by the FAA satisfied the intent of this recommendation and classified it "Closed—Acceptable Alternate Action" on March 24, 1992.

## **1.18.2 Information Regarding Electrical/Wiring Anomalies on Airplanes**

### **1.18.2.1 Accidents, Incidents, and Events Involving Electrical/Wiring Components**

During its investigation of the TWA flight 800 accident, the Safety Board examined its aviation accident/incident database for records of previous accidents and incidents involving transport-category airplanes in which the Board had used the words "wire" or "wiring" in the probable cause. In addition, the Safety Board reviewed other available records involving wiring- and/or fire/smoke-related air carrier events, including the following:

- Boeing laboratory reports, SBs, and SLs;
- AFRL reports;
- Safety Board preliminary, airworthiness factual, and accident brief reports;
- AIR 2000 air safety reports;
- British Air Accidents Investigation Branch (AAIB) reports;
- FAA service difficulty reports (SDR);<sup>370</sup> and
- a Civil Aviation Administration of China investigation report.

The results of these reviews are discussed in this section.

#### **Wiring-Related Accidents/Incidents**

In an October 21, 1996, fax, the Civil Aviation Authority of Singapore described an event that occurred on October 12, 1996, in which an operator reported that arcing in a wire bundle on a 747-200 cargo airplane had resulted in a fire at the aft bulkhead of the forward cargo compartment about STA 1000. The airplane was undergoing maintenance at the time of the fire, and subsequent inspection revealed damage to wire bundles W834,

W846, W1524, and W370; the insulation blanket; the aft bulkhead of the forward cargo compartment; and (possibly) the CWT sealant. The operator removed the affected components from the airplane and shipped them to Boeing for examination and evaluation. A December 16, 1996, letter from Boeing stated that “X-ray microanalysis and chemical identification of the damaged wire suggest that the insulation of the wire was damaged and that arcing had occurred between the damaged wires or that arcing between the damaged wires and ground had occurred.”

The Safety Board’s database research revealed 15 Board-investigated air carrier accidents/incidents that occurred between 1983 and 1999 in which wiring was a factor in the probable cause. These events occurred on a wide variety of airplane types/manufacturers (including a 727, two 737s, a 747, a 767, a DC-8, a DC-9, an MD-88, three DC-10s, an L-1011, an A320, a DeHavilland DHC-8, and an ATR) and various air carriers. A review of these records indicated the following anomalous electrical/wiring conditions:

- On May 27, 1983, near Kansas City, Missouri, a wire bundle behind the L-1011’s flight engineer’s panel electrically short-circuited—the flight engineer extinguished the resultant fire with a portable fire extinguisher. Smoke in the cockpit abated naturally.
- On October 7, 1983, at Juneau, Alaska, a taxi light switch on the departing 727-247 series airplane failed and burned the insulation on an adjacent wire.
- On May 17, 1984, near Minneapolis, Minnesota, the first officer on a DC-10 observed sparks and smoke from the left-side panel. Cockpit lights were turned off, and the smoke dissipated. Subsequent inspection revealed that a wire bundle located between the center of the instrument panel and a fluorescent light beneath the first officer’s glare shield exhibited evidence of fire damage. This wire bundle was stretched tightly across a sharp metal edge on the side of the fluorescent light. Insulation and a fabric sleeve around the wires were burned, exposing the wires. Investigation revealed that the wire bundle was removed and reinstalled 4 days before the event.

---

<sup>370</sup> Although the FAA collects a significant amount of data about mechanical failures through its SDR program, the Safety Board has noted that these data are often incomplete. In a June 3, 1993, letter to the FAA, the Board stated that “the SDR program is often used during aviation accident/incident investigations to research the history of aircraft failures, malfunctions, and defects. However, attempts to effectively use the SDR database in recent Safety Board investigations have revealed that the current program is incomplete and of limited value in identifying service defect histories because many reportable service difficulties are not reported to the FAA.” In the same letter, the Board issued Safety Recommendations A-93-61 through -63 to the FAA, which proposed changes to improve the SDR program. On August 4, 1995, the FAA issued NPRM 95-12, “Operational and Structural Difficulty Reports,” proposing to revise the reporting requirements, but no final rule was ever issued. In subsequent investigations, the Board continued to find incomplete information in searches of the SDR database and on January 9, 1998, issued Safety Recommendation A-97-125, which asked the FAA to modify the SDR reporting system so that it would contain more complete and accurate information about component failures. On April 15, 1999, the FAA agreed that improved reporting was needed and published a supplemental NPRM to update the proposed changes. On October 26, 1999, Safety Recommendations A-93-61 and A-97-125 were classified “Open—Acceptable Response,” pending issuance of the final rule. The FAA issued the final rule on September 15, 2000.

- On October 5, 1986, at Seattle, Washington, the internal power feeder cables on a DC-10 short-circuited and melted during an attempt to apply ground power to the airplane. According to the Safety Board's report, the investigation revealed "poor workmanship" in a modification installation.
- On July 12, 1987, near Boston, Massachusetts, faulty wiring in the throttle quadrant of the 767 airplane resulted in an uncommanded go-around.
- On March 30, 1988, at Boston, Massachusetts, a loosened battery ground connection on a DC-10 airplane resulted in an electrical arc and ignition of pooled fuel in the center accessory compartment. There was fire damage to the compartment, wires, and insulation blanket.
- On April 15, 1988, near Seattle, Washington, an electrical wire in the DHC-8 airplane chafed against a hydraulic line and arced, resulting in a hydraulic fluid leak, a subsequent fire, and hydraulic system failure.
- On December 30, 1989, at Tucson, Arizona, a 737 experienced an in-flight fire and loss of hydraulic power. Inspection revealed that an electrical wire chafed against a hydraulic line; the wire arced, resulting in a hole in the hydraulic line and a hydraulic fluid leak. Subsequent arcing ignited the leaking fluid, resulting in a fire and loss of hydraulic power.
- On November 13, 1991, near Toledo, Ohio, damaged wires in the DC-8 airplane wire bundle resulted in a faulty indication that the main cargo door was closed and locked. The main cargo door subsequently opened in flight.
- On November 20, 1991, while departing Atlanta, Georgia, a passenger on board the MD-88 observed fire coming from the right-side overhead compartment. Subsequent inspection revealed that a damaged cannon plug connector adjacent to a cabin overhead light assembly resulted in an electrical short circuit.
- On January 3, 1992, near Denver, Colorado, the flight crew on a 737 noted an "electrical-type" burning odor, followed by a loud arcing sound and a small fire at the flight deck aft overhead panel. The flight crew reported that it easily extinguished the fire. Subsequent inspection revealed that a wire bundle chafed against the cockpit door frame and short-circuited, resulting in electrical arcing and the small fire. This wire bundle was not shielded or anchored to protect against chafing, as was the other wire bundle routed through this compartment.
- On February 25, 1994, the flight crew on the ATR observed smoke in the cockpit during descent near Mosinee, Wisconsin. Subsequent inspection revealed that a push-button selector indicator switch in the cockpit had melted and resolidified, and adjacent wiring exhibited evidence of heat damage. Records indicated previous malfunctions associated with water/fluid contamination near the switches, and the manufacturer had issued two SBs addressing the problem.



- On March 18, 1996, near Detroit, Michigan, the flight crew on the Airbus A320 airplane received a series of elevator/pitch-related computer fault messages. Subsequent inspection revealed an intermittent fault in the elevator servo controller electrovalve coil and a defective diode in an electronic module for one of the stabilizer actuators.
- On July 5, 1997, near Flint, Michigan, the DC-9 flight crew observed smoke beneath the instrument panel glareshield. Subsequent inspection revealed burned wiring and a charred position light switch behind the cockpit instrument panel/glareshield. Further examination revealed an electrical short in the left wing tip oscillating position light autotransformer.
- On May 18, 1998, near Minneapolis, Minnesota, the 747 flight crew experienced several uncommanded “kicks” of the yaw damper while troubleshooting a fire warning indication. The flight crew disengaged the yaw damper but continued to experience uncommanded “kicks,” although they were less severe. Subsequent inspection revealed that a VHF transceiver coax connector located near the yaw damper control box was not properly shielded, resulting in EMI with the yaw damper system.

#### **FAA Service Difficulty Report Data Regarding Wiring and/or Fire/Smoke-Related Events**

The Safety Board also searched the FAA’s SDR database for wiring and/or fire/smoke-related events involving 747s and found 21 events.<sup>371</sup> These events are summarized in the SDRs as follows:

- Electrical fire in a galley. Investigation revealed that the source of the fire was damaged wires in a coffeemaker. (FAA control No. 00013, December 21, 1986.)
- Electrical fire started in a passenger entertainment control box near the R4 door. (FAA control No. 00030, June 12, 1987.)
- Thirteen burned wires in a 6- by 8-inch area at the cabin floor line were found at STA 1200. Circuit breaker for pallet drive wheels tripped. (FAA control No. 00029, December 2, 1988.)
- Electrical fire from an electrical short circuit in a galley. (FAA control No. 00119, February 2, 1990.)
- Electrical fire below aft galley personnel elevator. (FAA control No. 0008, October 29, 1990.)
- Electrical fire in the upper control module of the first-class galley. Found a split capacitor in the oven controller. (FAA control No. 00135, December 21, 1990.)

---

<sup>371</sup> This list does not include events involving light ballasts, failures to light sockets, reseated electrical connectors that cleared faults, and secondary damage to wires caused by failure of other components.

- The No. 2 leading edge device position switch was short-circuited to the ground, resulting in a malfunction indication (amber light) in the cockpit. (FAA control No. 0015, March 15, 1996.)
- R4 door emergency lights were inoperative because of loose wiring on a cannon plug at the battery charging unit. (FAA control No. 00466, April 5, 1996.)
- R4 and L2 emergency lights were inoperative. Maintenance actions included repairs to the emergency light pin and wiring. (FAA control No. 00199, June 20, 1996.)<sup>372</sup>
- The No. 3 engine fire loop wires were worn through at the hydraulic box forward bracket. (FAA control No. 00263, August 8, 1996.)
- During a daily check, maintenance personnel found zone E right-side emergency path light inoperative. Replaced fuse and repaired chafed wire. (FAA control No. 00572, August 15, 1996.)
- Left main landing gear microswitch wires were chafed, resulting in cockpit indication that the left landing gear was down and locked when the landing gear was retracted. (FAA control No. 00662, August 15, 1996.)
- During a daily check, maintenance personnel found two lavatory smoke detectors inoperative. Found and repaired broken wiring. (FAA control No. 00621, August 15, 1996.)
- Floor emergency lights inoperative on the left side of the cabin at seat rows 51 to 66 and on the right side of the cabin at seat rows 35 to 43. Secured emergency light wiring. (FAA control No. 00112, August 29, 1996.)
- During a daily check, maintenance personnel found 5L emergency light inoperative. Repaired wiring. (FAA control No. 00760, August 29, 1996.)
- A wire short circuited to the ground and resulted in inoperative upper deck floor evacuation lights. (FAA control No. 00525, September 5, 1996.)
- Electrical arcing sounds and sparks were observed near the overhead passenger service unit at seat 4B. Examination revealed that the wiring harness that runs parallel with the sidewall light assembly above 4A and B was burned. (FAA control No. 00231, September 5, 1996.)
- During a daily check, maintenance personnel found No. 2L (main entry door) upper light inoperative. Found chafed wire at bustle light connector. (FAA control No. 00405, September 12, 1996.)
- Disconnected wiring resulted in inoperative floor evacuation path emergency lights from cabin seat row 3 to 27. Maintenance personnel reconnected wiring and installed light assembly. (FAA control No. 00633, September 19, 1996.)

---

<sup>372</sup> Maintenance records indicated that this SDR pertained to repairs performed on the accident airplane. The repaired wire was part of a bundle that branched off from a larger bundle that included CWT and left wing FQIS wires leading to the upper deck AIDS unit and also contained high-voltage wiring for lighting. Because condensation is a common problem in transport airplanes, the 747 design includes drip shields to protect critical elements (including cockpit wiring) from condensation.

- Electrical arcing and smoke were observed from work light wiring for a galley coffeemaker. (FAA control No. 00668, September 26, 1996.)
- Floor evacuation path light wiring short-circuited near cabin seat 50H. (FAA control No. 00747, October 10, 1996.)

### 1.18.2.2 Previous Safety Board Safety Recommendations Regarding Electrical Components

The Safety Board reviewed its safety recommendation database for recommendations that involved electrical components by searching for key words, such as “breaker,” “circuit,” “circuitry,” “electrical,” “wire,” and “wiring.” The safety recommendations identified in the Board’s review were evaluated, and several nonpertinent recommendations were eliminated.<sup>373</sup> This section discusses the pertinent safety recommendations.

On January 12, 1967, the Safety Board issued Safety Recommendation A-67-003 to the FAA, which addressed electrical cockpit heaters and related circuitry in Convair 340, 440, and 580 model airplanes. The safety recommendation letter indicated that “while examining the aircraft, loose nuts, screws, drill shavings, and trash were found inside the circuit breaker panel compartment.” The FAA responded in a February 2, 1967, letter that “to preclude accumulation of trash and unwanted items in the circuit breaker panel compartment, Allegheny Airlines is in the process of issuing an inspection card calling for vacuuming this compartment each 300 hours.” On January 1, 1975, the Safety Board classified Safety Recommendation A-67-003 “Closed—Acceptable Action.”

On June 2, 1983, an in-flight fire occurred on board a McDonnell Douglas DC-9-32, operated as Air Canada flight 797, and, after an emergency landing, the cabin interior continued to burn. Five crewmembers and 19 passengers were able to evacuate the burning airplane; the remaining 23 passengers died in the fire. On July 19, 1983, the Safety Board issued Safety Recommendation A-83-047, which recommended that the FAA require the inspection and periodic reinspection of the lavatory flush pump motors and associated wiring; Safety Recommendation A-83-048, which recommended that the FAA develop a procedure to inspect lavatory flush pump motors; and Safety Recommendation A-83-049, which recommended that the FAA require bulletins for frequent removal of waste from lavatories, “which gives sufficient emphasis to areas susceptible to the accumulation of fluids in the vicinity of wire harnesses and other electrical components which can cause corrosion.” On June 12, 1984, the Safety Board classified Safety Recommendation A-83-049 “Closed—Acceptable Action.” On November 17, 1986, the Safety Board classified Safety Recommendations A-83-047 and -048 “Closed—Acceptable Alternate Action.”<sup>374</sup>

On June 27, 1988, the Safety Board issued Safety Recommendation A-88-064, which recommended that the FAA conduct a directed safety investigation to determine the

---

<sup>373</sup> Nonpertinent safety recommendations included those in which the electrical component key words were only indirectly referenced in the discussion of other systems (for example, circuit breakers were referenced in a safety recommendation regarding CVRs).

reliability of circuit breakers and the mechanisms by which failures internal to the circuit breakers can disable operating systems and to identify appropriate corrective actions, as necessary. The FAA agreed with the intent of the recommendation and reported that an examination had been made. On October 24, 1989, the Safety Board classified Safety Recommendation A-88-064 "Closed—Acceptable Alternate Action."

On August 8, 1990, the Safety Board issued Safety Recommendation A-90-102, which recommended that the FAA issue an AD "applicable to all 14 CFR Part 121 airplanes to require, at the next scheduled maintenance inspection, an inspection of the wires in wire bundles in the wings where additional wiring has been added since the airplane was manufactured. The inspection should be directed to the determination of insulation damage where the bundle is under clamps and inside vapor seals and pressure seals." The FAA refused to issue the recommended ADs and cited the Boeing 737 Maintenance Planning Document, which recommended a zonal visual inspection of the interior CWT that would include wires and wire bundles at every 7C check (approximately 21,000 flight hours). On March 24, 1992, the Safety Board classified Safety Recommendation A-90-102 "Closed—Unacceptable Action."

On August 14, 1991, the Safety Board issued Safety Recommendation A-91-070, which recommended that the FAA require "specific quality control and inspection procedures for wire bundle installations on transport-category aircraft to verify proper bend radii, chafe protection, and routing practices by aircraft manufacturers during fabrication and by airlines during maintenance operations that expose wire bundles." The FAA agreed with the intent of this safety recommendation and required the recommended quality control and inspection procedures. On February 10, 1994, the Safety Board classified Safety Recommendation A-91-070 "Closed—Acceptable Action."

Also on August 14, 1991, the Safety Board issued Safety Recommendation A-91-071, which recommended that the FAA "notify...[PMIs] and operators of transport-category aircraft of the fire hazard posed by accumulations of lint and other debris on wire bundles." The FAA subsequently issued Handbook Bulletin 91-15, "Origin & Propagation of Inaccessible Aircraft Fire Under In-Flight Airflow Conditions," and recommended that PMIs ensure that operators of transport-category airplanes clean wiring in inaccessible areas. On October 20, 1992, the Safety Board classified Safety Recommendation A-91-071 "Closed—Acceptable Action."

On April 9, 1992, the Safety Board issued Safety Recommendation A-92-021, which recommended that the FAA "require that the electrical actuating systems for nonplug cargo doors on transport-category aircraft provide for the removal of all electrical power from circuits on the door after closing (except for any indicating circuit power necessary to provide positive indication that the door is properly latched and locked) to eliminate the possibility of uncommanded actuator movements caused by wiring short

---

<sup>374</sup> On May 10, 1985, lavatory fluid was found to have contaminated the wire bundles near improper (deep) hot-stamp markings, resulting in an in-flight fire aboard a Monarch Airlines 757. Additionally, on October 22, 1995, lavatory fluid-contaminated electrical components (specifically a connector in the yaw damper circuit) resulted in uncommanded roll/yaw oscillations in a 737.

circuits.” The FAA agreed with the intent of this safety recommendation and required that all such electrical power be removed before taxi. On August 10, 1993, the Safety Board classified Safety Recommendation A-92-021 “Closed—Acceptable Alternate Action.”

### 1.18.2.3 Inspection of Wiring in Several Transport-Category Airplanes

Postaccident inspection of recovered wiring from the accident airplane and other transport-category airplanes revealed numerous notable conditions in both older and newer transport-category airplanes, including damage to wire insulations, fluid stains on wires, and metal shavings resting on and between wires in wire bundles. The Safety Board is aware of several prior incidents that resulted from short circuits apparently caused by contaminants. For example, after a January 9, 1998, short-circuit incident aboard a United Airlines 767, copper conductors from wires within the damaged wire bundle were found with melted aluminum (consistent with metal shavings found immediately beneath the wire bundle), indicating that a metal shaving acted as a bridge to form a short circuit. Another example is the October 22, 1995, incident involving roll/yaw oscillations on a 737 near Manchester, England. The incident was attributed to a short circuit in the rudder circuitry resulting from lavatory fluid bridging the pins within an electrical conductor. Additional similar incidents are described in the Systems Group Chairman’s Factual Report—Addendum for Aircraft Wire Inspections and Historical Reports, including the following: a July 19, 1997, incident involving a Lufthansa 747 (after circuit breakers opened while on approach to JFK, drill shavings were found in an area of burned and damaged wiring in the front cargo hold) and a May 10, 1985, incident involving a Monarch Airlines 757 (after generators tripped and smoke appeared in flight, lavatory fluid was found on a burned area of a wire bundle, and insulation was found damaged by out-of-tolerance hot-stamp markings).<sup>375</sup>

In connection with the TWA flight 800 investigation, the Safety Board examined the wiring in 25 transport-category airplanes that had been maintained by various air carriers. The inspected airplanes included 18 Boeing airplanes (13 747-100, -200, and -300 “Classic” series airplanes;<sup>376</sup> a 747-400; 2 737s; a 757; and a 767), 4 Douglas airplanes (a DC-9-30, an MD-90, and 2 MD-11s), 2 Lockheed L-1011s, and an Airbus A300. The airplanes examined ranged in age from new (not yet delivered to the operator) to 28 years old (retired by the operator) and in total flight time from 4 to 102,712 hours.

The Safety Board used manufacturer and air carrier wiring diagrams as references during its inspections of these airplanes. Although different airplane types and series were inspected, the same general areas were inspected in each airplane when accessible. These areas included the main electrical equipment center,<sup>377</sup> circuit breaker panels, the area behind the flight engineer’s panel and forward of the cockpit escape door, the area near the

---

<sup>375</sup> Additional cases in which contamination was found are discussed later in this section and in sections 1.18.2.1 and 1.18.2.2.

<sup>376</sup> The airplanes examined were from various sources. The investigative group agreed that the general condition (extent of contamination and workmanship) of the wiring observed in airplanes of a given operator was similar to that of other operators’ airplanes with similar flight times.

water bottles in the forward cargo compartment, and the pressure seal-to-wing wire route.<sup>378</sup> Figure 38 shows the areas typically inspected on 747 airplanes.

Metal debris was observed on or near the wire bundles of all airplanes except for one new 737, which was only examined by investigators for about 10 minutes. A 9-month-old airplane had light lint “fuzz” beginning to accumulate on wires behind an avionics rack. Additionally, accumulations of foreign materials were observed on and between wires/wire bundles in many of the airplanes in many locations. The foreign materials included lint (fiber and dust particles), metal shavings, hardware (washers, screws, rivets [drilled and undrilled]), structural corrosion preventive compound, blue and brown fluid stains, paint, and pieces of paper. Wire insulation was damaged and/or cut where metal debris was found between individual wires within a wire bundle. In some cases, the core conductors of the wires were exposed to the grounded shielding of other wires. Wire bundles in wheel wells were typically black and oily, and fluid was found on wires located near hydraulic actuators in wings; grease was found on wires near flap actuators and on landing gear struts. Wire bundles were found adhered into solid, stiff masses with additional wires strapped to the outside of the existing bundle. The inspections also revealed crumbled rubber cushions in clamps, cracked O-rings, kinked wires, and wires with cracked and/or chafed insulation.

Further, investigators identified several instances in which the wires and/or wire bundle routing, clamping, and/or tension in various series 747 airplanes did not appear to be in accordance with Boeing’s 747 manuals or PIs. For example, in some airplanes, parallel small wire bundles were tied into larger wire bundles differently than shown in the PIs. Additionally, in some airplanes, wires were stretched tightly between clamps and rubbed/chafed against clamps, other brackets, and around bends. This rubbing/chafing often resulted in abraded wire insulation. In one airplane, three blackened rub marks were found on two wire bundles. In one 747, a set of twisted wires in a woven jacket (similar to that used for FQIS wires) had chafed through the jacket, wire topcoat, and into the base of the insulation. Further, in other inspected airplanes, wires/wire bundles that were supposed to be segregated in separate parallel bundles (according to Boeing 747 PIs) were in contact with each other.

---

<sup>377</sup> The term “main electrical equipment center” is used in Boeing’s 747 Systems Handbook to refer to a compartment located aft of the nose landing gear bay that contains avionics and electrical distribution components. Although Boeing describes similar compartments in its airplanes by various terms, they are generally referred to as “E/E bays.”

<sup>378</sup> For detailed information regarding the individual airplane inspections, see Systems Group Chairman’s Factual Report—Addendum for Aircraft Wire Inspections and Historical Reports, dated July 28, 1999.

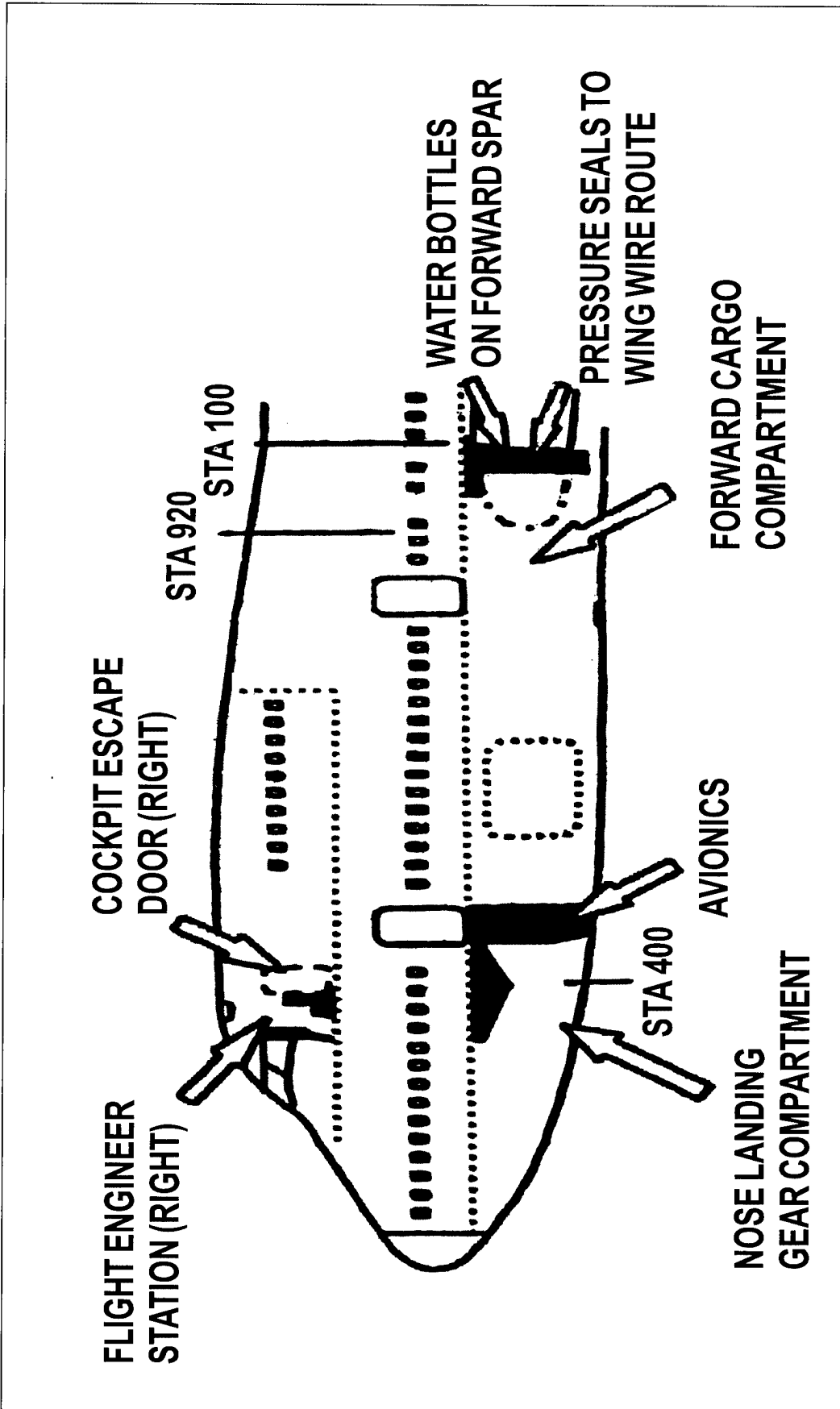

Figure 38. Diagram showing the areas typically inspected on 747 airplanes.

In one airplane (its last known flight was in January 1997), wires in the raceway over the CWT were not bundled (as indicated by Boeing's PIs) but were randomly laid in a tray, such that individual wires crossed from one side of the tray to the other. Higher-voltage generator and galley power cables were clamped to the adjacent structure (not routed in the tray). Inspection of the inside of this airplane's CWT revealed the following: the scavenge pump inlet screen contained a nearly 1-inch-long uninsulated wire fragment, a vertically routed FQIS wire was chafed where it contacted a horizontal structural flange, and a horizontally routed FQIS wire was chafed where it contacted a vertical row of rivets between two supporting clamps. Examination of this airplane's CWT fuel quantity probes by the AFRL experts revealed sulfide deposits on the bare wire ends and terminal sleeves, and some of the wires were loose under the clamps; two of the wires exhibited striation marks that resembled jaw marks of a wire stripping tool.

Five of the 25 airplanes inspected by Safety Board and other investigators during this investigation exhibited signs of fire and heat damage, as evidenced by the following:

- In the 767 E/E bay near the galley chiller unit, investigators observed melted and resolidified wires, charred insulation and burned foam, black and crispy wire insulation adjacent to a woven fabric sleeve around a small wire bundle, and copper balls consistent with arcing on wires more than 1 inch from wires exposed through melted holes in wire insulation. Additionally, an AAIB inspector was in the compartment when the mechanic applied electrical power to the airplane during the inspection, and the wiring aft of the galley chiller began to arc.<sup>379</sup> (Investigation revealed that the galley chiller had been replaced the previous day. Water was found on a thermal insulation blanket beneath the galley chiller and wire bundle. Metal shavings, coins, screws, copper wire, locking wire, plastic cable ties, and dust/dirt were also found on or beneath wire bundles.)
- In one of the L-1011's mid-electronics-service-center,<sup>380</sup> two wire bundles of about 3-inch diameter were found burned. Examination of the area revealed blue-fluid stains and dust accumulations on wire bundles and generator feeder cables. In the burned area of the bundles, melted and resolidified copper provided evidence of wire-to-wire arcing; there was no evidence of arcing to other structure or areas.<sup>381</sup>

---

<sup>379</sup> After this incident, the FAA issued AD 98-07-26, which required 767 operators to inspect the airplanes' wiring and to wrap the wires for additional protection. The FAA indicated that its examinations of 150 other 767 airplanes revealed similar damage to wiring near the galley chillers in 13 of the airplanes.

<sup>380</sup> Lockheed uses the term "mid-electronics-service-center" to describe an area located forward of the forward wing spar, beneath the aft edge of the 2L lavatory in the cabin. As noted previously, Boeing refers to similar areas in its airplanes as "E/E bays."

<sup>381</sup> After this damage was found, the operator inspected the remainder of its L-1011 fleet (35 airplanes). The operator reported the following findings: 5 airplanes exhibited evidence of blue-fluid contamination of wires in the inspection area; 11 airplanes exhibited "some signs of feeder to bundle rubbing" in the inspection area; 17 airplanes "demonstrated excessive dirt and dust" in the inspection area; and 13 airplanes had metal shavings and/or paper debris in the inspection area. Further, the operator reported that it was aware of three or four previous occurrences involving blue-fluid contamination of wire bundles below the midlavatories on its L-1011s.



- Examination of the video system control unit (VSCU) near one of the MD-11's R2 door revealed melted and resolidified plastic and a low-resistance path between pins in the cannon plug electrical connector that had been attached to the unit. Teardown of the VSCU revealed liquid stains on the top and bottom surfaces of internal circuit boards. The manufacturer stated that the circuit connected 115-volt a.c. power to circuits designed for 28 volts or less.
- Beneath the other MD-11's floorboards (between STAs 1661 and 1681), a metalized mylar insulation blanket (a 60 inch X 20 inch area) was burned/partially burned. Detailed examination of this area revealed that a wiring harness containing 20-gauge insulated wire was routed across the frame at STA 1681. One wire was separated, and seven other wires exhibited damaged and chafed insulation where they contacted the frame. A 1 1/4-inch hole in the insulation blanket was located beneath the chafed wire bundle.
- Behind the circuit breaker panel to the right of the flight engineer's station on the other L-1011, an Adel clamp and circuit breaker exhibited evidence of thermal damage (blackening). One circuit breaker (CB 3F1) was found popped, and the circuit breaker's post appeared to have arced to an Adel wiring clamp that held a bundle of wires. Maintenance personnel noted that the wire stand-off associated with this Adel clamp was about 1/8 inch long. They indicated that the wire bundle worked its way close to the circuit breaker lug until the Adel clamp contacted the lug and shorted.

#### **1.18.2.4 Boeing Service Letter Regarding Inspection of Wiring on High-Time 747 Airplanes (747-SL-20-048, Dated January 25, 1995)**

Boeing indicated that after being “requested by operators to provide guidance on areas of wiring that warrant special attention on high time 747 airplanes,” it inspected several high-time 747 airplanes. On the basis of these inspections, on January 25, 1995, Boeing issued SL 747-SL-20-048, which stated that “overall, Boeing has found that most airplane wiring exceeds the economic design goal of the airplane.”<sup>382</sup> Further, the SL stated that Boeing “believe[d] that the wiring on high time 747 airplanes is holding up exceptionally well,” and noted that “[w]iring damage is hard to predict but some areas of wiring experience degradation more frequently.” Boeing indicated that it considered “the principal causes of wiring degradation” to be vibration (and vibration in conjunction with other factors), maintenance (proper and improper),<sup>383</sup> indirect damage (damage resulting

<sup>382</sup> Boeing indicated that the 747's economic design goal was 50,000 flight hours; however, it noted that many in-service 747s significantly exceed (in some cases, more than double) this flight time. (According to Airclaims, as of November 30, 1999, 469 of the 747s operated worldwide had more than 50,000 hours, including 14 with more than 100,000 hours. Airclaims data indicated that 154 of the 747s operated at that time by U.S.-based operators had more than 50,000 hours, including 3 with more than 100,000 hours.) Although Boeing indicated that the 747's economic design goal was 50,000 flight hours, Boeing's design documentation for the electrical system indicated that the design goal of electrical system components was “30,000 hours of continuous trouble-free operation.”

<sup>383</sup> SL 747-SL-20-048 noted that although improper maintenance can contribute to long-term wiring problems and wiring degradation, even proper maintenance can disturb wiring, resulting in increased degradation. According to Boeing, “as wiring and components become more brittle with age this effect becomes more pronounced.”

from events not directly related to wiring, such as pneumatic duct ruptures), chemical contamination,<sup>384</sup> and heat.<sup>385</sup>

SL 747-SL-20-048 stated that operators should be particularly attentive to the following areas during wiring inspections:

- Clamping points—damaged clamps, clamp cushion migration, or improper clamp installations can aggravate wire chafing.
- Connectors—worn seals, missing seal plugs or dummy contacts, or lateral pressure on connector grommets can compromise connector integrity and allow contamination to enter the connector, resulting in corrosion or grommet degradation.
- Terminations—terminal lugs and wire splices are susceptible to mechanical damage, corrosion, heat damage, and chemical contamination. Also, the buildup and nut torque on large-gauge wire studs are critical to their performance.
- Backshells<sup>386</sup>—wires may break at backshells because of excessive flexing, static pressure, or missing build up.
- Sleeves and conduits—damage to sleeving and conduits, if not corrected, will often lead to wire damage.

SL 747-SL-20-048 also stated that a special inspection of high-time 747 airplane wiring should include the following areas: wings, engine and nacelle, landing gear, electrical panels, and power feeders. Boeing noted that the wings, engine and nacelle areas, and landing gear are high vibration areas. The SL further stated that “the wing leading edge and pylons are...difficult environment[s] for wiring installations” and, in attachment 2 to 747-SL-20-048, Boeing indicated that it could “see the virtue of a wire by wire inspection” of these areas. The attachment described such an inspection as follows:

Wiring is released, cleaned, bundle clamps...and bundle ties removed. However, environmentally sealed and potted installations and wiring in conduit should be left undisturbed unless damage is suspected. Wiring should be closely inspected for damage from vibration and exposure to environmental damage. Wire bundles are separated to allow inspection of individual wires.

---

<sup>384</sup> SL 747-SL-20-048 stated that “certain chemicals commonly found in an air carrier operating environment (for example, hydraulic, cleaning, corrosion-inhibiting, and/or deicing fluids) can result in wiring component degradation.”

<sup>385</sup> According to Boeing, wiring that was not designed for high temperatures will degrade more rapidly when exposed to heat. SL 747-SL-20-048 stated that exposure to even low levels of heat can degrade wiring over long periods of time.

<sup>386</sup> A backshell is a mechanical component that provides protection and support for wires attaching to an electrical connector, relieving strain from the electrical pins to which the wires attach.

### 1.18.2.5 Wiring Inspection Methods

Currently, aircraft wiring is usually visually inspected during an air carrier's detailed inspection of the area through which it is routed.<sup>387</sup> This method of wire inspection requires a visible defect to develop before detection is possible. However, as previously stated, a large portion of an airplane's electrical wiring is not readily visible (and, therefore, not readily inspectable) because it is bundled with dozens of other wires (of which, only the portions of the wires on the surface of the bundles would be visible) or blocked from view by other structures or components (including other wire bundles, airframe structure, and avionics or other system components). Other obstructions to visual inspection of wires include protective sleeves installed on wires, clamps, potting material or sealant, and limited viewing angles because of confined inspection areas.

Although many wire defects may be difficult or impossible to detect through visual inspection alone, automated test equipment (ATE) inspection systems are available to supplement visual inspections. These systems include electrical continuity or resistance tests, insulation resistance and capacitance tests, and time-domain reflectometry (TDR).<sup>388</sup> According to the manufacturers, ATE inspection systems would be capable of quick, thorough, and reliable inspections of electrical system components, such as wiring and connectors, on commercial airplanes. ATE inspection systems can be connected to an airplane's electrical system through electrical connectors to perform a series of computerized inspections of every wire within a bundle—even those that would not be visible to the human eye. ATE inspection systems could be used to establish baseline properties of individual wires within a wire bundle and to detect any differences in the properties of those wires (possible indications of the presence of short circuits, chafing, abrasions, cuts, or cracks in the insulation) during subsequent inspections. Using ATE inspection systems would allow air carriers to evaluate the condition of electrical wiring and detect defects before they become visually apparent and cause an electrical malfunction. Further, the location of the degradation could be determined from these test sets, which would allow specific repairs to be performed before failures (such as electrical arcing) could occur (known as proactive inspection).

However, ATE inspection systems have some limitations and disadvantages, including equipment cost, size, and weight; the need for specially trained test equipment personnel and numerous cables long enough to attach the ATE to the airplane at the furthest ends of individual circuits; unique electrical connectors that must mate with connectors in the airplanes to be tested;<sup>389</sup> and preprogrammed software requirements. According to observers, the time required to set up the test equipment, then disconnect the test equipment and reinstall airplane components that had been removed for access to connectors, exceeded the time it took to run the test.

---

<sup>387</sup> For a description of TWA's general inspection procedures, see section 1.6.3.1.1.

<sup>388</sup> TDR is an ATE inspection technique that involves injecting small electrical pulses into each wire and then measuring the reflected energy.

<sup>389</sup> There are numerous electrical connectors available to manufacturers and operators, and the specific connectors used may vary from airplane to airplane and within an airplane, making it difficult to match with ATE connectors.

The Safety Board has learned that since the TWA flight 800 accident, the FAA, U.S. Navy, and USAF have (independently and jointly) conducted research into ATE aircraft wiring inspection systems/techniques. These research efforts include the following:

- Through the Aging Transport Systems Rulemaking Advisory Committee (ATSRAC),<sup>390</sup> the FAA has tested/evaluated ATE systems from several manufacturers at the FAA's Validation Center (SNL) in Albuquerque, New Mexico. Recent evaluation of an ATE system revealed that interpretation of the test results could result in the identification of many wiring faults, by type and location that were not visually observable. However, a trained system operator was required to differentiate installation characteristics (such as clamps and other structure adjacent to wires) from defects. The FAA concluded that further research should be initiated to optimize the test systems for commercial aircraft use and to develop appropriate acceptance and failure criteria for the electrical properties of a wire.
- The U.S. Navy contracted with Lectromec to compare visual wire inspections with an electronic wire inspection technique. According to the resultant report (Report N193-RPT14MY9), during the inspections of U.S. Navy P-3 airplanes, visual inspections detected only 25 to 39 percent of the defects that were subsequently identified using the electronic inspection technique.
- The U.S. Navy has been developing an aircraft wiring system with embedded diagnostic and prognostic capabilities (on board ATE), which is known as smart wire.
- The U.S. Navy has initiated the Aircraft Wiring and Inert Gas Generator (AWIGG) Group and has hosted a series of meetings in which Government and industry representatives discuss AWIGG-related problems and solutions. Many ATE system manufacturers have provided presentations regarding ATE products and developments.
- The USAF AFRL has been conducting research into ATE systems and has issued Small Business Innovation Research contracts to fund ATE research and development.<sup>391</sup> The FAA and the USAF's Office of Productivity, Reliability, Availability, and Maintainability are jointly sponsoring an effort to enhance ATE inspection systems currently being developed.

Additionally, in June 2000, the White House Office of Science and Technology organized a Wire System Safety Interagency Working Group (WSSIWG) to examine the condition of wires (and other interconnections) in various transportation and industry modes<sup>392</sup> and to evaluate wire inspection/maintenance methods that may help maintain safe conditions. The WSSIWG provides an opportunity for discussion and sharing of

---

<sup>390</sup> For additional information regarding the ATSRAC, see section 1.18.3.4.4.

<sup>391</sup> According to an AFRL representative, studies of USAF wire failures and inspection techniques indicated that maintenance/inspection personnel did not always use ATE inspection methods because of their limitations. As a result, the USAF has been seeking more user-friendly ATE inspection techniques.

information among representatives from agencies with a wide range of possibly unrelated uses for wire.

### **1.18.3 Safety Recommendations and Responses and Actions Resulting From the TWA Flight 800 Accident**

#### **1.18.3.1 December 13, 1996, Safety Recommendations Regarding Fuel Tank Flammability (Safety Recommendations A-96-174 through -177)**

During its investigation of the TWA flight 800 accident, the Safety Board became concerned about the operation of transport-category airplanes with potentially explosive fuel/air mixtures in the fuel tanks, noting that this was inconsistent with the basic tenet of transport aircraft design that no single-point failure should prevent continued safe flight. As a result of its concerns, the Safety Board issued Safety Recommendations A-96-174 through -177 to the FAA on December 13, 1996.

Safety Recommendations A-96-174 and -175<sup>393</sup> asked the FAA to

Require the development and implementation of design or operational changes that will preclude the operation of transport-category airplanes with explosive fuel/air mixtures in the fuel tanks:

(a) Significant consideration should be given to the development of airplane design modifications, such as nitrogen-inerting systems<sup>[394]</sup> and the addition of insulation between heat-generating equipment and fuel tanks. Appropriate modifications should apply to newly certificated airplanes and, where feasible, to existing airplanes. (A-96-174)

(b) Pending implementation of design modifications, require modifications in operational procedures to reduce the potential for explosive fuel/air mixtures in the fuel tanks of transport-category aircraft. In the 747, consideration should be given to refueling the...CWT before flight whenever possible from cooler ground fuel tanks, proper monitoring and management of the CWT fuel temperature, and maintaining an appropriate minimum fuel quantity in the CWT. (A-96-175)

In its February 18, 1997, response, the FAA stated that these safety recommendations proposed major changes in the requirements for fuel tank design and fuel management on transport-category airplanes. The FAA noted that (as previously discussed) existing airworthiness standards assume that fuel vapor in the tank is flammable and that design requirements dictate eliminating potential fuel tank ignition sources. The FAA stated that controlling the flammability characteristics of fuel vapor in airplane fuel tanks would require a major change in design concept and that to control fuel temperatures to the extent necessary to ensure that the fuel tank vapor is nonflammable

---

<sup>392</sup> For example, the WSSIWG includes representatives from the FAA, U.S. Navy, USAF, NRC, and Department of Commerce (National Institute of Standards and Technology).

<sup>393</sup> Safety Recommendation A-96-175 was designated "Urgent."

<sup>394</sup> Fuel tank inerting involves using inert gases in fuel tanks to lower the potential for explosions.

under all operating conditions would be a major task with significant economic implications. The FAA indicated that to evaluate these safety recommendations adequately, it would solicit public comments regarding the technological practicality and economic reasonableness of the Safety Board's recommendations. A notice to solicit public comment was published on April 3, 1997, in 62 *Federal Register* (FR) 16013. Comments were required to be submitted to the FAA by August 1, 1997.<sup>395</sup>

In a June 27, 1997, letter, the FAA stated that it shared the Safety Board's goal of minimizing the risk of fuel tank explosions and believed that reducing fuel volatility and ignition sources was the most promising path to this objective. However, the FAA indicated that more research on the chemistry of fuel vapor and the energy needed to ignite the vapor and additional flight tests to obtain data on fuel and vapor temperatures were needed to determine the best actions to be taken. The FAA also stated that it was pursuing an aggressive program to further minimize ignition sources within fuel tanks, including providing ground-fault protection to wires in fuel tanks and more focused maintenance programs for fuel tank components.

On July 1, 1997, the Safety Board advised the FAA that Safety Recommendation A-96-174 addressed the current FAA policy of preventing fuel tank explosions by eliminating ignition sources because this policy has not been 100 percent effective. The Board's letter further noted that it is unlikely that TWA flight 800 would have experienced the catastrophic explosion and breakup if the CWT had not contained explosive fuel/air vapor. The Board indicated its belief that it is unacceptable to allow explosive fuel/air vapor to exist in fuel tanks of passenger-carrying aircraft. The Board stated that, although it was concerned about the length of time it took for the FAA to publish the request for comments, it recognized the value in the FAA seeking and evaluating input from the industry before mandating policy change that could require significant modifications to aircraft designs. Therefore, Safety Recommendation A-96-174 was classified "Open—Acceptable Response."

Regarding Safety Recommendation A-96-175, the Safety Board noted that it called for operational changes that could be instituted quickly and that neither limiting air conditioning use on the ground nor reappportioning initial fuel loading to the CWT from the wing tanks would require the purchase of additional equipment or fuel. The Board

---

<sup>395</sup> According to this notice to solicit public comment, the FAA had initiated research into the feasibility of nitrogen inerting as a method of "reducing the likelihood of fuel tank explosion due to post crash ground fire" in 1969. This research involved the installation and use of a nitrogen inerting system in a DC-9. The FAA concluded that although "the system provided adequate inerting of the fuel tanks...the costs of such a system were shown to outweigh the benefits at that time." The notice to solicit public comment also cited Safety Recommendation A-71-59, which was issued by the Safety Board in 1971 as a result of an accident in New Haven, Connecticut, in which 27 of 28 airplane occupants survived the initial ground impact but died as a result of the postcrash fire/explosion. Safety Recommendation A-71-59 urged the FAA to "require fuel system fire safety devices which will be effective in prevention and control of both in flight and postcrash fuel system fires and explosions." On November 13, 1985, Safety Recommendation A-71-59 was classified "Closed—Acceptable Action."

The notice to solicit public comment also stated that the military has used nitrogen inerting systems in C-5 and C-17 military transport-category airplanes, the F-22 fighter, and the V-22 tiltrotor. The military also uses foam filler explosion suppression systems in several of its airplanes.

noted that, although reducing fuel tank temperatures by only a few degrees may seem insignificant, incremental reductions of fuel/air temperatures could keep them below the lower explosive limits of the fuel. Because the FAA had not initiated any immediate action in response to Safety Recommendation A-96-175, it was classified "Open—Unacceptable Response."

In a December 3, 1997, letter, the FAA stated that it had received 976 pages of comments from 340 commenters regarding the Safety Board's recommendations in response to its notice to solicit public comment. The FAA indicated that comments from the public generally expressed a concern that action be taken to improve safety, whereas industry comments focused on the technical merits and costs associated with implementing the recommendations. The FAA noted that commenters did not agree on the reliability of possible long-term methods of reducing or eliminating explosive fuel/air mixtures or on the weight and cost implications. The FAA indicated that it intended to establish an ARAC working group<sup>396</sup> to evaluate both reducing or eliminating explosive fuel/air vapors and potential ignition sources within airplane fuel tanks and to identify specific methods to implement improvements in transport airplane fuel tank safety for the current and future fleet. The FAA stated that the ARAC working group would be given 6 months to provide the FAA with a report describing all technical issues and specific solutions.

Regarding short-term methods of reducing exposure time to explosive fuel/air mixtures, the FAA stated that its analysis indicated that loading cool fuel into the CWT and controlling the use of the air conditioning packs on the ground would have little effect on the overall level of exposure to operation with explosive fuel/air mixtures and that it did not see a significant safety benefit from adding fuel to the CWT when it would normally be empty. However, the FAA stated that removing heat from the pack bay through dedicated ventilation, coupled with insulating the tank from heat sources, may significantly reduce the exposure to operation with explosive fuel/air mixtures. The FAA indicated that design modifications, such as insulation or inerting, were among the long-term solutions that would be evaluated by the ARAC working group.

The FAA also stated that, in the short-term, it would further reduce the likelihood of fuel tank explosions by the following actions:

- proposing to require periodic inspections of 747 fuel tanks and equipment inside fuel tanks;
- continuing to correct design or maintenance-related deficiencies in 747 fuel tanks that may lead to ignition sources being present; and

---

<sup>396</sup> The FAA stated that the ARAC working group would be composed of industry experts, as well as a number of passenger, union, and public interest group members.

- proposing to require, for the fleet of all large air transport airplanes, that (1) each type certificate holder develop a fuel tank maintenance and inspection program, (2) each operator have an FAA-approved fuel system maintenance program, (3) original certification compliance findings be reviewed to revalidate that failures within the fuel system will not result in ignition sources, and (4) operation of electrically driven fuel pumps in fuel tanks with adjacent heat sources be prohibited when the pump inlet is not fully submerged in liquid fuel, unless a flame arrestor is installed in the fuel pump inlet line.

In a March 3, 1998, letter, the FAA indicated that the notice to establish the new ARAC working group (the FTHWG) was published in the FR on January 23, 1998. The notice gave the FTHWG until July 23, 1998, to provide the FAA with a technical report.<sup>397</sup> The FAA further noted that Safety Board-sponsored testing at CIT indicated that reducing the temperature of the fuel in the CWT significantly increased the energy level required to ignite the fuel and that this information conflicted with industry-standard data traditionally used by the military and the FAA in establishing the flammability of vapors within fuel tanks. The FAA stated that it had established a team of fuel experts to review all available data on the relationship of fuel temperature to MIE and that a report of the team's conclusions and recommendations was expected by the end of March 1998. The FAA further stated that, upon review of that report, it intended to reevaluate whether a significant safety improvement could be achieved through practical changes in fuel loading and fuel usage procedures.

The FAA also reported on the status of the short-term actions (outlined in its December 3, 1997, letter) to reduce the likelihood of fuel tank explosions. Specifically, in addition to several planned actions, the FAA stated that it had already completed the following actions:

- Issued AD 97-26-07, effective December 29, 1997. (superseding AD 96-26-06), which required a repetitive inspection of Teflon sleeves that protect wiring to the outboard main tank boost pumps on all 747 series airplanes. (The FAA noted that similar AD action was planned for 767 series airplanes.)
- Issued NPRM 97-NM-272-AD on November 26, 1997, which proposed to require modification of 747 FQIS wiring to incorporate separation, shielding, and/or electrical transient suppression features to prevent electrical signals with excessive energy from entering the fuel tanks. (The FAA noted that a similar NPRM was being developed for FQIS wiring on 737s.)

In a September 21, 1999, response, the Safety Board expressed concern that in the 2 1/2 years since the safety recommendations were issued, no design modifications to airplanes had been made. Noting that the FAA had taken no action toward implementing Safety Recommendation A-96-174, and it appeared that no action was contemplated, the

---

<sup>397</sup> For additional information regarding the FTHWG's technical report, conclusions, and recommendations, see section 1.18.3.4.2.



Board classified the recommendation “Open—Unacceptable Response.” With regard to short-term actions, the Board noted that its July 1997 flight tests had demonstrated that the potential flammability of vapors in CWTs could be reduced through fuel management and limiting the use of air conditioning packs. The Board stated that, although the overall reduction in flammability was not as great as originally thought, the reductions represented a safety improvement that could be achieved at minimal cost and in a very short time. Because the FAA had not taken any action directly responding to Safety Recommendation A-96-175 in nearly 3 years, the Board classified it “Open—Unacceptable Response.”

In a November 3, 1999, letter, the FAA noted that the FTHWG, whose report had been issued on July 23, 1998, concluded that reducing flammability in all fuel tanks to the level of wing tanks on most airplanes (which the FTHWG calculated to be approximately 7 percent of the fleetwide operational time) as a worthwhile goal. After evaluating various design concepts, the FTHWG concluded that retrofitting the existing fleet was not currently feasible but that changes could be made for new airplane designs that would reduce the flammability of CWTs. The FAA stated that it may not agree with everything contained in the FTHWG’s report<sup>398</sup> but that it did agree with the conclusion that further study is needed to determine if a method can be shown to be feasible that would eliminate or reduce the flammability of fuel tanks on in-service airplanes. The FAA indicated that it had therefore initiated studies of directed ventilation and ground-based inerting methods and that, after equipment requirements for ground-based inerting had been determined, it intended to task the ARAC to perform a detailed study of inerting options.

The FAA also stated that, on the basis of conclusions of a team of fuel experts and the FTHWG, it had determined that the information available still showed that there was no significant safety benefit from adding fuel to 747 CWTs. However, the FAA indicated that it was continuing to take short-term actions to reduce the likelihood of fuel tank explosions by proposing airworthiness actions to correct any design or maintenance-related deficiencies in fuel tank systems that may lead to an ignition source being present.

In a May 17, 2000, letter, the FAA indicated that it was continuing to make progress toward taking action to significantly reduce the exposure of transport-category airplane fuel tanks to flammable vapors in both newly certificated and existing airplanes and that methods under evaluation were cooling of the CWT using directed ventilation and fuel tank inerting using on-board nitrogen or ground-based nitrogen sources. According to the FAA, initial temperature data provided by airplane manufacturers indicated that directed ventilation systems would not reduce the temperature of heated CWTs as much as previously expected or predicted in the FTHWG’s report. However, the FAA stated that it would reach a final conclusion after it received additional temperature data.

---

<sup>398</sup> During a February 29, 2000, meeting with Safety Board staff, FAA staff indicated that the FAA did not intend to endorse the FTHWG’s proposed exposure criteria of 7 percent and would convene another ARAC to study methods of protecting fuel tank vapors. The tasking for this ARAC was published in the FR on July 14, 2000.

The FAA also stated that its study indicated that the cost to implement ground-based inerting was significantly less than the FTHWG's estimate. The FAA's analysis indicated that ground-based inerting would reduce the fleetwide average flammability exposure for affected CWTs to approximately 2 percent. The FAA indicated that it planned to conduct ground and flight tests to determine how long ground-based inerting would remain effective during flight and whether vent system modifications would be required to ensure its effectiveness. The FAA stated that these tests and its ground-based inerting report would be completed by mid-2000. The FAA further stated that a new ARAC working group would be established to perform a detailed study of ground-based inerting and on-board inerting methods for in-service, newly manufactured, and newly designed airplanes and to develop further data required for the FAA to determine if a method of inerting fuel tanks could be practical for these airplanes. The FAA also stated that on October 29, 1999, it had proposed regulatory changes (in NPRM 99-18)<sup>399</sup> that would require minimizing the flammability of fuel tanks in newly designed transport-category airplanes. The FAA stated that the proposed regulation was intended as a short-term measure to require that fuel tanks are not heated and that they cool to below the ignition temperature at a rate equivalent to that of a wing tank.

With regard to operational procedures, the FAA stated that, in response to recent suggestions from Safety Board staff, it had evaluated the use of ground sources for conditioned air instead of using the airplane's air conditioning packs and had determined that this would provide a greater reduction in the exposure of those CWTs to flammable vapors than adding cooler fuel to the CWT before flight. The FAA further stated that its analysis indicated that the use of ground-conditioned air on days when temperatures exceeded 60° F<sup>400</sup> would reduce the exposure from approximately 35 percent<sup>401</sup> to approximately 25 percent, whereas adding cooler fuel to the CWT would result in a reduction to only approximately 30 percent. The FAA also determined that a combination of refueling the CWT with cooler fuel and using ground-conditioned air did not result in any additional reduction in exposure to flammability. The FAA noted that a May 5, 2000, Boeing SL, dated May 5, 2000, recommended that operators use ground-conditioned air when available and practical and when ambient ground temperatures are greater than 60° F and that they evaluate opening the pack bay doors to provide additional ventilation. The FAA stated that it would issue an information bulletin to FAA representatives assigned to each air carrier encouraging the application of the Boeing SL.

Safety Recommendations A-96-174 and -175 and their current classifications are discussed further in section 2.4 of this report.

---

<sup>399</sup> For additional information about NPRM 99-18, see section 1.18.3.4.3.

<sup>400</sup> The FAA stated that analysis showed that using ground-conditioned air would provide little or no reduction in CWT flammability, which would already be low, when ambient temperatures are below 60° F.

<sup>401</sup> Although the FTHWG had estimated that CWTs with air conditioning packs located beneath them would be flammable an average of 30 percent of the fleetwide operational time, the FAA's estimate of 35 percent was based on an analysis that considered the results of research completed after the FTHWG.

Safety Recommendation A-96-176 asked the FAA to

Require that the 747 Flight Handbooks of TWA and other operators of 747s and other aircraft in which fuel tank temperature cannot be determined by flight crews be immediately revised to reflect the increases in...CWT fuel temperatures found by flight tests, including operational procedures to reduce the potential for exceeding CWT temperature limits.

(Although the FAA's February 18 and June 27, 1997, letters referenced Safety Recommendations A-96-174 through -177, they did not specifically address Safety Recommendation A-96-176.)

In its July 1, 1997, letter to the FAA, the Safety Board noted that correcting these and similar flight handbook errors would not have required a delay while the FAA sought public comment. Accordingly, Safety Recommendation A-96-176 was classified "Open—Unacceptable Response."

In its December 3, 1997, letter, the FAA acknowledged that the Safety Board's flight tests had shown that it was possible for the temperature of the fuel in the CWTs of Boeing 747s to rise significantly during extended periods of air conditioning pack operation on the ground. However, the FAA stated that it had not required that such information be provided to operators in the FAA-approved aircraft flight manual (AFM) and that the information in the Boeing 747 TWA Flight Handbook is considered by the FAA to be advisory only.

The FAA also noted (in its December 3, 1997, and March 3, 1998, letters) that the fuel tank temperature limits given in the FAA-approved AFM for the Boeing 747 were intended to prevent freezing of the fuel and to ensure that the fuel feed system will perform in hot weather without any anomalous operation caused by excessive fuel vapor/liquid ratios within the fuel feed system, not to preclude operation of the airplane with a flammable fuel/air mixture in the fuel tanks.

In a September 21, 1999, letter, the Safety Board noted that the information in the TWA 747 Flight Handbook about temperature limits was incorrect in that it states that air conditioning pack operation can elevate the CWT temperature by 10° to 20° F, whereas flight tests found increases from the baseline fuel tank temperature of 40° to 60° F during air conditioning pack operation. Because the FAA had taken no action directly responding to Safety Recommendation A-96-176, it was again classified "Open—Unacceptable Response."

In its May 17, 2000, letter, the FAA noted that TWA no longer operates 747s and that the TWA flight handbooks that were the subject of this recommendation are no longer active. According to the FAA, Boeing had reviewed its flight and operations manuals and polled operators regarding the content of their flight handbooks and determined that none of those documents provided CWT temperature correction information for flight crews.<sup>402</sup> On the basis of this information, in an August 3, 2000, letter, the Safety Board classified Safety Recommendation A-96-176 "Closed—No Longer Applicable."

Safety Recommendation A-96-177 asked the FAA to

Require modification of the...[CWT] of 747 airplanes and the fuel tanks of other airplanes that are located near heat sources to incorporate temperature probes and cockpit fuel tank temperature displays to permit determination of fuel tank temperatures.

(Although the FAA's February 18 and June 27, 1997, letters referenced Safety Recommendations A-96-174 through -177, they did not specifically address Safety Recommendation A-96-177.)

In its July 1, 1997, letter to the FAA, the Safety Board noted that without temperature probes and indicators, 747 flight crews could not be alerted to hazardous temperatures in the CWT. The Board stated that these changes, if implemented, would allow flight crews to reduce exposure to high CWT temperatures and that neither change would have significant economic impact. Although the Board expressed concern about the length of time it took the FAA to publish its request for comments on the Board's recommendations, it recognized the value in seeking and evaluating input from the industry. Accordingly, Safety Recommendation A-96-177 was classified "Open—Acceptable Response."

As previously discussed, in its December 3, 1997, letter, the FAA stated that the purpose of the fuel tank temperature limits in Boeing's AFM was not for the management of fuel tank temperature to preclude the presence of a flammable mixture in the fuel tank ullage and that it considered the current tank temperature indication scheme used on transport-category airplanes to be adequate for the purposes for which it was intended. The FAA indicated that comments on this recommendation from industry, operators, and manufacturers questioned the usefulness of providing such information to flight crews. On the basis of those comments, the FAA indicated that the management of fuel tank temperature on existing airplane configurations through the creation of a tank temperature "red-line" associated with tank flammability is not considered to be practical. It also noted that the addition of another set of electrical components and wiring inside the fuel tank would create another possible source of tank ignition.

In a March 3, 1998, letter, the FAA stated that, as additional technical data and information were developed through the ongoing activities (including the FTHWG and Safety Board-sponsored fuel research at CIT), it would further evaluate the need to take the specific actions identified by the Board in Safety Recommendation A-96-177. In its September 21, 1999, letter, the Safety Board stated that, because the FAA had taken no action to implement Safety Recommendation A-96-177, it was classified "Open—Unacceptable Response."

In a November 3, 1999, letter, the FAA indicated that the work of the FTHWG and researchers at CIT was complete. The FAA stated that it had concluded that no practical

---

<sup>402</sup> Boeing found that one non-U.S. operator had a note similar to the one found in the TWA Flight Handbook, and it requested that the operator remove that note.

means of reducing fuel temperatures in fuel tanks existed but that, as stated in response to Safety Recommendation A-96-174, it had begun studies of directed ventilation methods to determine if they could be effective in cooling CWTs and be feasible for retrofit on the existing fleet of transport-category airplanes. The FAA stated that it would reevaluate this recommendation after the conclusion of the studies of methods that could significantly reduce the flammability of fuel tanks.

The FAA stated that, although certain military airplanes incorporate fuel temperature indications with cockpit temperature displays for each tank, those displays are not used to determine fuel tank flammability; instead, they are used to monitor fuel tank temperatures during extended ground operation to ensure that the fuel temperatures in the main fuel tanks (wing tanks) do not rise to a range that would cause degraded fuel pump performance or pump cavitation when the engines are operating at high thrust levels that require high fuel flow from the fuel pumps. The FAA reiterated its belief that no benefit would be gained from additional fuel tank temperature probes.

In its May 17, 2000, letter, the FAA stated that its evaluations of directed ventilation and fuel tank inerting systems indicated that flight crews would not require CWT temperature information in connection with those methods of controlling flammability. Further, the FAA stated that the use of ground-conditioned air would not require that information either.

In an August 3, 2000, letter, the Safety Board agreed that using these methods to reduce flammability could obviate flight crews needing fuel tank temperature information but noted that neither directed ventilation nor fuel tank inerting systems are currently in use and, although a Boeing SL recommends the use of ground-conditioned air when available, it is not required. Accordingly, pending implementation of adequate methods for reducing fuel tank flammability or for determining fuel tank temperatures, Safety Recommendation A-96-176 was classified "Open—Unacceptable Response."

### **1.18.3.2 February 18, 1997, Safety Recommendation Regarding the Handling and Placement of Explosive Training Aids (Safety Recommendation A-97-11)**

During the TWA flight 800 investigation, the Safety Board became aware that on June 10, 1996, a dog handler, working under the auspices of the FAA's Explosives Detection Canine Team Program, had spilled trace amounts of explosives while placing training aids on board the accident airplane during a proficiency training exercise. As a result of this finding, on February 18, 1997, the Board issued Safety Recommendation A-97-11, which asked the FAA to

Develop and implement procedures, including a checklist of safety-related items, for the handling and placement of explosive training aids by K-9 explosives detection teams to prevent contamination of aircraft and airport facilities and to ensure an effective K-9 explosives detection program.

In its April 18, 1997, February 9 and December 14, 1998, letters, the FAA stated that it had developed several initiatives to safeguard and account for canine explosives training aids used by participants in the FAA's Explosives Detection Canine Team Program. For example, the FAA indicated that on May 19, 1997, it initiated a national database to record explosives training conducted on aircraft. In addition, during August and September 1997 and January 1998, the FAA provided updated and detailed training for all FAA canine coordinators regarding proper safe handling, storage, and accountability for explosives training aids. The FAA's letter further stated that it procured explosives magazines approved by the ATF for each of the FAA's Explosives Detection Canine Team Program participants. According to the FAA, these magazines are secured with two high-security locks and provide a greater degree of security while reducing contamination problems.

The FAA also indicated that it had developed procedures for the use of barrier material(s) to prevent leaving explosives residues on surface areas when placing explosives training aids on aircraft or within the airport environment. In addition, the FAA developed an Explosives Detection Canine Team Training Log (in lieu of the checklist suggested in Safety Recommendation A-97-11) to aid in monitoring training requirements by requiring documentation of the type and number of training aids used and verification that the training aids were removed from the aircraft/airport environment. Further, the FAA's letter indicated that on October 28, 1998, FAA staff briefed the Safety Board on the contents of the FAA Explosives Detection Canine Team Program Standard Operating Practices and explained how the procedures described therein addressed the intent of Safety Recommendation A-97-11.

On February 8, 1999, the Safety Board responded that, because the FAA's actions satisfied the intent of Safety Recommendation A-97-11, it was classified "Closed—Acceptable Action."

### **1.18.3.3 April 7, 1998, Safety Recommendations Regarding Fuel Quantity Indication System Wiring and Components (Safety Recommendations A-98-34 through -39)**

As a result of its concerns about the potential for excessive energy to enter airplane fuel tanks through the FQIS and result in possible fuel tank ignition sources, the Safety Board issued Safety Recommendations A-98-34 through -39 on April 7, 1998.

Safety Recommendation A-98-34 asked the FAA to

Issue, as soon as possible, an...[AD] to require a detailed inspection of... [FQIS] wiring in Boeing 747-100, -200, and -300 series airplane fuel tanks for damage and the replacement or the repair of any wires found to be damaged. Wires on Honeywell Series 1-3 probes and compensators should be removed for examination.

Safety Recommendation A-98-35 asked the FAA to

Issue an...[AD] to require the earliest possible replacement of the Honeywell Corporation Series 1-3 terminal blocks used on Boeing 747 fuel probes with terminal blocks that do not have knurled surfaces or sharp edges that may damage...[FQIS] wiring.

In a June 10, 1998, letter, the FAA stated that Boeing had issued SB 747-28-2205, Revision 1, calling for inspections and testing to verify that the wiring, tubing, and component installations inside the CWT are in satisfactory condition and electrically bonded to the airplane structure. The FAA indicated that Boeing had also issued SBs calling for the replacement of Series 1-3 probes with Series 4 or later probes (SB 747-28-A2208) and installation of a flame arrestor in the inlet line of the electrical motor-operated scavenge pump located in the CWT (SB 747-28-A2210). The FAA stated that it would issue an NPRM proposing to require compliance with these SBs, including a requirement to replace CWT fuel probes at a specified period of time.

On July 24, 1998, the FAA issued NPRM 98-NM-163-AD, which proposed to require compliance with SBs 747-28-2205, Revision 1, and 747-28-A2208 and to require replacement of FQIS components within 20 years of manufacture. In a February 9, 1999, letter, the Safety Board stated that it did not believe the referenced Boeing SBs contained sufficiently detailed instructions to ensure that the inspections were adequately thorough. For example, the Board noted that, although much of the damage it observed during its airplane wiring inspections was not visible until wiring was removed from its installation, the SBs did not specify the removal of wires for inspection. The Board further noted that the SBs did not address the issue of migration (cold-flow) of insulation material or the presence of localized blackening on the wire surfaces, which might indicate breaches in the insulation and, thus arcing, inside the tank. This, in turn, could ignite the flammable fuel vapors.<sup>403</sup> The Board also noted that the FAA had provided no statistical basis for its proposed requirement to replace FQIS components within 20 years of their manufacture. Therefore, pending information from the FAA indicating that adequate and thorough inspections would be required and described and demonstrating the appropriateness of a 20-year service life for FQIS components, Safety Recommendation A-98-34 was classified "Open—Unacceptable Response." Pending final rulemaking to remove Series 1-3 terminal blocks (which have knurled surfaces) from the 747 fuel tanks within 2 years of the AD's effective date, Safety Recommendation A-98-35 was classified "Open—Acceptable Response."

In a November 3, 1999, letter, the FAA acknowledged the Safety Board's concern about hidden damage to wires going undetected during inspections but expressed concerns that the removal and replacement process might cause additional wire damage. The FAA stated that it believed that "inspections that minimize the amount of disturbance of wiring are the best compromise between the risks associated with wire removal and hidden damage." The FAA indicated that it believed that the in-tank inspections and

<sup>403</sup> Conductors exposed as a result of migration or displacement of the wire insulation (cold-flow) was one of the suspected ignition mechanisms for the 1990 Philippine Airlines 737 CWT explosion.

modifications (including the replacement of FQIS probes with knurled surfaces or sharp edges) required by AD 99-08-02 R1,<sup>404</sup> issued on June 29, 1999, in combination with the shielding/separation of FQIS wiring outside the fuel tanks required by AD 98-20-40<sup>405</sup> would provide the level of safety intended by Safety Recommendation A-98-34. The FAA also stated that, on October 26, 1999, it issued a Special Federal Aviation Regulation (SFAR),<sup>406</sup> which proposed to require a design review revalidating the fuel tank system designs to ensure that failures could not create ignition sources within the fuel tanks and to require manufacturers to design specific fuel tank maintenance and inspection programs to ensure the continued safety of fuel tank systems.<sup>407</sup>

Regarding the proposed 20-year life limit for FQIS components, the FAA agreed that there was little technical basis for the selection of that life limit and stated that it had hoped to gather additional information on an appropriate life limit through the NPRM comment process. However, on the basis of the comments that it had received, the FAA determined that additional study of sulfide deposits was necessary before any life limit could be imposed.

On the basis of the FAA's actions, in an August 3, 2000, letter, the Safety Board classified Safety Recommendations A-98-34 and -35 "Closed—Acceptable Action."

Safety Recommendation A-98-36 asked the FAA to

Conduct a survey of...[FQIS] probes and wires in Boeing 747s equipped with systems other than Honeywell Series 1-3 probes and compensators and in other model airplanes that are used in Title 14...[CFR] Part 121 service to determine whether potential fuel tank ignition sources exist that are similar to those found in the Boeing 747. The survey should include removing wires from fuel probes and examining the wires for damage. Repair or replacement procedures for any damaged wires that are found should be developed.

---

<sup>404</sup> In response to AD 99-08-02 R1, on June 27, 1997, Boeing issued SB 747-28-2205, which described fuel tank inspection procedures for 747 operators. Eight of the nine inspection tasks described involved visual inspections, and none of the inspection tasks required removal of wiring from fuel quantity probes or compensators. (During this investigation, Safety Board investigators repeatedly found that it was not possible to detect damage on the concealed side of wiring.) On September 25, 1997, Boeing issued a Notice of Status Change for SB 747-28-2205. And on October 27, 1997, Boeing notified 747 operators by telex (M-7220-970-1725) that it was developing a new SB that would provide operators with details regarding the inspection of 747 fuel quantity probes and FQIS wires. In an October 30, 1997, letter to the Board, Boeing indicated that the new SB would require the removal of wiring from terminal blocks for inspection, replacement of Series 1-3 fuel quantity probes, reporting of damage found at Series 4 and subsequent fuel quantity probes, replacement of certain CWT FQIS wire harnesses, inspection for proper wire routing and existing damage, establishment of an electrical resistance check of very low voltage, and establishment of standards for permissible FQIS repairs.

<sup>405</sup> AD 98-20-40 is discussed further in connection with Safety Recommendation A-98-98.

<sup>406</sup> For more information about the proposed SFAR, which was issued as part of NPRM 99-18, see section 1.18.3.4.3.

<sup>407</sup> The FAA reiterated these actions in its May 17, 2000, letter.



In its June 10, 1998, letter, the FAA indicated that it was working with an industry team to develop plans to survey the condition of fuel tank systems on large transport-category airplanes and that the survey would include a review of historical data, including maintenance data. The FAA stated that the industry team had indicated that although it did not intend to remove wiring from FQIS probes (for fear of causing damage that would go undetected), FQIS wires in fuel tanks would be inspected for damage from chafing and abrasion under the clamps. The FAA indicated that it would review the industry team's plans for the survey, evaluate the benefit of removing wires from fuel probes, and monitor the results of the inspections. The FAA further indicated that it planned to issue an NPRM proposing an SFAR that would require a design review of the fuel tank system in all large transport-category airplane fleets.

In its February 9, 1999, response, the Safety Board expressed its concern that the industry team did not intend to remove the FQIS wires to avoid the potential for undetected damage to the wiring. The Board emphasized that in several cases its staff detected damage to 747 wire insulation only after the wires were removed from their installed locations; the damage subsequently observed included compression ruptures, cold-flow, chafes, and cuts. The Board urged the FAA to reconsider the benefits of removing the wiring from the fuel probes to allow a thorough inspection for damage. Pending the results of the FAA's inspections and the issuance of the SFAR, Safety Recommendation A-98-36 was classified "Open—Acceptable Response."

In a November 3, 1999, response to the Safety Board, the FAA indicated that although the manufacturers' instructions for the surveys of FQIS wiring in transport-category airplanes did not include removal of FQIS wiring, all FQIS wires in fuel tanks would be visually inspected for damage from chafing, abrasion under clamps, etc. The FAA further stated that it did not see a need to mandate removal of FQIS wires in airplanes other than 747s with FQIS probes that have knurled surfaces or sharp edges. The FAA indicated that it would continue to monitor the industry team's findings and evaluate the need for future actions.

In November 3, 1999, and May 17, 2000, letters, the FAA noted that on October 26, 1999, it had issued the planned SFAR, which proposed a design review to revalidate the fuel tank system designs to ensure that failures could not create ignition sources within the fuel tanks.<sup>408</sup>

In an August 3, 2000, letter, the Safety Board stated that, pending completion of the inspections currently in progress and the proposed fault tolerance evaluation and the implementation of the maintenance programs that will result from the SFAR, Safety Recommendation A-98-36 was classified "Open—Acceptable Response."

---

<sup>408</sup> For further details about the SFAR, see section 1.18.3.4.3.

Safety Recommendation A-98-37 asked the FAA to

Require research into copper-sulfide deposits on...[FQIS] parts in fuel tanks to determine the levels of deposits that may be hazardous, how to inspect and clean the deposits, and when to replace the components.

In its June 10, 1998, response, the FAA indicated that it was establishing a fuel tank system copper-sulfide research program, which it intended to conduct in partnership with the DoD. The FAA stated that the research program would address the identification of the conditions required for film deposit formation, determination of film properties, and diagnostics and film deposit removal.

In February 9, 1999, letter, the Safety Board stated that it supported the FAA's plan and provided the FAA with information gathered during the TWA flight 800 investigation that might be useful to its research. Pending further information about the FAA's current and planned actions, Safety Recommendation A-98-37 was classified "Open—Acceptable Response."

In a November 3, 1999, letter, the FAA indicated that in April 1999, it had initiated a research program (through the FAA Aviation Assurance Center of Excellence Program) into the effects of sulfur-compound deposits on fuel system components. Participants in the research program included the FAA, Boeing, BFGoodrich, Arizona State University, and the UDRI. The Safety Board attended meetings as an observer and provided information pertaining to sulfides that was obtained during the TWA flight 800 investigation. The FAA indicated that it expected a report from the research team by the end of January 2000.

In its May 17, 2000, letter, the FAA stated that it was continuing to make progress in understanding copper-sulfur and silver-sulfur deposits and the potential hazards that they may cause. The FAA indicated that the researchers had grown deposits in a laboratory but had not found indications of significant deposits occurring in in-service airplanes to compare with the laboratory-grown deposits. The FAA indicated that the research program had been extended so that the team could complete its evaluation.

Safety Recommendation A-98-37 and its current classification are further discussed in section 2.3.2.2.3.1 of this report.

Safety Recommendation A-98-38 asked the FAA to

Require in Boeing 747 airplanes, and in other airplanes with...[FQIS] wire installations that are corouted with wires that may be powered, the physical separation and electrical shielding of FQIS wires to the maximum extent possible.

Safety Recommendation A-98-39 asked the FAA to

Require, in all applicable transport airplane fuel tanks,...[STPs] to prevent electrical power surges from entering fuel tanks through...[FQIS] wires.

In its June 10, 1998, letter, the FAA stated that NPRM 97-NM-272, issued on November 26, 1997, proposed to adopt an AD applicable to 747-100, -200, -300, -SP, and -SR airplanes which would require installation of electrical transient suppression devices (TSD) and/or the installation of shielding and separation of the electrical wiring of the FQIS located outside the fuel tanks. The FAA stated that it also issued a similar NPRM (98-NM-50-AD) applicable to 737-100, -200, -300, -400, and -500 series airplanes. Regarding other transport-category airplanes, the FAA indicated that the team developed to work on the fuel tank design review SFAR was developing advisory material for conducting the design reviews, which would include information on the use of wire separation and electrical shielding and/or TSDs to protect the FQIS wiring inside fuel tanks when applicable to the different airplane designs.

In its February 9, 1999, response, the Safety Board noted that on September 30, 1998, the FAA issued AD 98-20-40, which required the installation of shielding and separation of the electrical wiring of the FQIS wiring located outside the fuel tanks in 747 airplanes. In addition, the Board acknowledged the FAA's NPRM proposing a similar AD applicable to 737s. However, the Board expressed concern that the degree of separation required by AD 98-20-40 might not adequately protect fuel tanks from FQIS wiring deficiencies that might allow excessive energy into the tanks. The Board stated that information from several investigations indicated that Boeing's minimum separation standard of 1/4<sup>409</sup> inch might be insufficient. For example, as previously discussed, when the Board assisted in the AAIB's investigation of a January 9, 1998, wiring fire on board a United Airlines 767, investigators found insulation melted away from wires located more than 1 inch from the location of the electrical arc. Balls of copper were found embedded into insulation and other materials. The Board expressed a similar concern about adequate separation of FQIS wiring in other large transport-category airplanes, including the Airbus 300 and 310 airplanes, in which powered cables and FQIS wiring are also corouted.

The Safety Board also noted that, although the NPRM preceding AD 98-20-40 had proposed a requirement for installation of electrical TSDs, the AD did not require such devices. The Board stated that it did not believe that wire separation and shielding alone would protect against the entry of power from sources attached to FQIS wires. The Board noted that, for example, in a 747, 115-volt a.c. power and FQIS circuits are contained in common electrical connectors at the fuel gauges and in other components, such as the VSO. The Board stated that surge suppression systems would protect against damage that could affect numerous wires at once and against unforeseen circumstances. Pending receipt of further details regarding the wiring separation that would be accomplished by AD 98-20-40 and planned activities for other airplane models, Safety Recommendation

---

<sup>409</sup> The Safety Board cited the lesser of Boeing's required separation distances—1/4 inch in pressurized areas and 1/2 inch in unpressurized areas.

A-98-38 was classified "Open—Acceptable Response." However, noting that the FAA had apparently decided against TSDs in AD-98-20-40, Safety Recommendation A-98-39 was classified "Open—Unacceptable Response."

In its November 3, 1999, and May 17, 2000, letters to the Safety Board, the FAA acknowledged that, although the NPRM that led to AD 98-20-40 proposed TSDs as an optional or additional requirement to the shielding and separation requirement, that requirement was not included in the AD. The FAA stated that, when the AD was issued, it had determined that TSD technology was not fully developed for application to in-service airplanes and that wire separation and shielding could provide the required level of protection. However, the FAA indicated that it had since determined that either separation and shielding or TSD technology, executed properly, will adequately ensure that high-energy signals are not introduced on wiring inside fuel tanks. The FAA further stated that, to comply with the ADs,<sup>410</sup> the design must include separation and shielding of wires between FQIS components and separation of the connectors to the components and circuits inside the components.

The FAA stated that it was also evaluating the acceptability of TSD technology and, although the evaluations of proposed designs were not complete, it indicated that TSDs could be used to meet the intent of the ADs. However, the requirements for approval of a design using TSD technology would include demonstrating that the device would limit the transfer of electrical energy and power through the wires that enter a fuel tank to intrinsically safe levels (that is, limit to less than spark energy and filament heating energy limits that could create an ignition spark or a hot surface ignition source in a piece of wire, such as a strand of steel wool, which could short between FQIS circuits in the tanks).<sup>411</sup> For other transport-category airplanes with FQIS, the FAA stated that draft AC 25.981.1X, prepared as guidance material for compliance with the fuel tank design SFAR, included information on the design and maintenance lessons learned in connection with the TWA flight 800 investigation and described the use of wire separation and shielding, or TSD technology, to protect FQIS wiring from short-circuits to other system wiring and other failures and malfunctions that could induce high electrical energy on FQIS wires that enter fuel tanks.

Safety Recommendations A-98-38 and -39 and their current classifications are further discussed in sections 2.3.2.1.2.2.3 and 2.3.2.1.2.2.4 of this report, respectively.

---

<sup>410</sup> The FAA also noted that a similar AD, requiring separation and shielding of FQIS wires and circuits on 737s, was issued on January 26, 1999.

<sup>411</sup> For additional information, see Federal Aviation Administration. 2000. *FQIS Transient Suppression Device/Unit for Installation on Boeing Model 747-100, -200, -300, SP, and SR Series Airplane*. Issue Paper P-1. Washington, DC. This issue paper stated that the FAA would require "no single failure, or combination of failures not shown to be extremely improbable [not anticipated to occur during the entire operational life of all airplanes of that type], will allow 200 microjoules and/or 30 milliamps, or greater, into the fuel tank assuming the conditions for spark energy or filament heating exist."

### 1.18.3.4 Actions Resulting From the TWA Flight 800 Accident

#### 1.18.3.4.1 Airworthiness Directives

As part of the TWA flight 800 investigation, the FAA examined earlier ADs for issues that might potentially have been related to the accident. This examination revealed that (as previously discussed) on March 8, 1979, the FAA issued AD 79-05-04, which required (among other actions) inspections of wires in main fuel tanks on a limited number of 747 airplanes, with installation of Teflon sleeves on the effected wires (in accordance with Boeing ASB 747-28A2091) required to terminate repeat inspections. AD 79-05-04 was issued as a result of the FAA's investigation of a report that fuel pump wires in an aluminum conduit that was routed through the fuel tank from a wing spar to a fuel pump had chafed through the insulation, resulting in electrical arcing. The arcing from the chafed wire to the conduit created a hole; however, the arcing did not result in fire or explosion because of the level of the fuel. After the FAA issued AD 79-05-04, an FAA fleetwide survey indicated that wires in these conduits were chafing against the conduit and that up to 80 percent of the total insulation thickness was missing on numerous wires in many airplanes. On the basis of these findings, on March 19, 1979, the FAA issued AD 79-06-02, which made the inspections and possible replacement actions applicable to other airplanes.

During the investigation of the TWA flight 800 accident, the FAA determined that an environment conducive to vibration existed in the conduit and wire bundles of the fuel boost pumps and the auxiliary fuel tank jettison pumps, which could cause abrasion of the Teflon sleeving and subsequent abrasion of the wires in the bundles. Thus, on January 21, 1997, the FAA issued AD 96-26-06, which required the removal of wires from conduits in all 747s' Nos. 1 and 4 main fuel tanks and inspections and replacement of damaged sleeving or wires. The FAA superseded AD 96-26-06 with AD 97-26-07 (applicable to all 747 airplanes) on December 29, 1997. AD 97-26-07 required the inspection of the auxiliary fuel tank jettison pumps as well as of the wiring and Teflon sleeves in conduit for the Nos. 1 and 4 main fuel tanks.

After these ADs were issued, the FAA became aware of "severe wear" of the fuel boost pump wiring in two model 737-200 airplanes that had accumulated 54,000 and 67,000 total flight hours, respectively. Additionally, the FAA received a report about pin-sized holes in the conduit of a 737-200 that had 75,000 total flight hours. As a result of these reports, on April 24, 1998, Boeing issued ASB 737-28A1120, which described procedures for removal of the 737 fuel boost pump wiring and inspection or replacement (with the addition of Teflon sleeves) of that wiring. Further, the FAA issued Telegraphic AD T98-10-51, which required removal of the 737 fuel boost pump wiring and inspection or replacement (with the addition of Teflon sleeves) of that wiring and was applicable to 737-100, -200, -300, -400, and -500 airplanes with more than 50,000 flight hours.

After it received additional reports and information about arcing on boost pump wiring on airplanes of various ages and flight-hour accumulation, the FAA issued the following ADs to revise the pertinent requirements: (1) AD T98-11-51, which broadened the inspection requirements outlined in AD T98-10-51 to include wires in 737 wing

conduits, on May 10, 1998; (2) AD 98-11-52, which revised the flight-hour requirement outlined in AD T98-11-51 to include airplanes with more than 40,000 flight hours, on June 24, 1998; and (3) AD 99-21-15, which further revised the flight-hour requirement outlined in AD T98-11-51 to include airplanes with more than 20,000 flight hours, on October 8, 1999. Figure 39 shows the 737 fuel pump conduit wear rate that was identified by the FAA during representative 500 wire inspections.<sup>412</sup> Similar data for 747 inspection results were not released.

The FAA also received a report of corrosion on bonding jumper wires located within a concentrated area in the wing fuel tanks on an in-service Airbus A300. Further inspections of other Airbus model airplanes did not reveal similar extensive corrosion or damage to bonding jumper wires; however, they did reveal evidence of the accumulation of deposits composed of copper, sulfur, and silver (also known as silver-sulfide deposits) around the outer braid of some jumper wires. Tests conducted by the manufacturer showed that these deposits did not affect the bonding function of the leads. Airbus has developed a one-time inspection SB for its airplanes to determine the extent of the silver-sulfide deposits and to ensure that the level of jumper wire damage found on the A300 is not widespread.

On November 26, 1997, the FAA issued NPRM 97-NM-272-AD, which proposed a requirement for operators of 747-100, -200, and -300 airplanes to install components for the suppression of electrical transients and/or the installation of shielding and separation of FQIS wiring from other airplane system wiring. On September 23, 1998, the FAA issued AD 98-20-40, which required the installation of shielding and separation of the FQIS wiring on 747-100, -200, and -300 airplanes. This action was intended to preclude high levels of electrical energy from entering the airplane fuel tank wiring because of EMI or electrical short circuits. (On April 14, 1998, the FAA issued NPRM 98-NM-50-AD, which proposed a similar requirement for 737-100, -200, -300, -400, and -500 airplanes; the resultant AD 99-03-04 was issued on January 26, 1999.) According to the FAA, the FQIS wiring in all later model 737s and 747s has wire separation and fault isolation features that may meet the intent of these ADs. Rulemaking currently under consideration (Docket No. 99-18, discussed later in this section) will require evaluation of the more recent designs.

On March 30, 1998, the FAA received reports of three instances of electrical arcing within fuel pumps installed in Lockheed L-1011 fuel tanks. In one case, the electrical arc had resulted (as previously mentioned) in a hole in the side of the pump. According to the FAA's AD-related text, "the internal electrical failures in the wing fuel tank fuel boost pumps could result in either electrical arcing or localized overheating, which could breach the protective housing and expose it to fuel vapors and consequent potential fire or explosion in the wing fuel tank." On April 3, 1998, the FAA issued emergency AD 98-08-09, which required that fuel be carried in the fuel tanks to cover the fuel pumps thereby precluding ignition of vapors within the fuel tank (by this mechanism) until a corrective action was developed.

<sup>412</sup> For additional information, see the FAA's Web site at <<http://www.faa.gov/apa/737iu.htm>>.

## Wear Rate Found by 737 Fuel Pump Conduit Wire Inspections

Upper Line Denotes Exposed Conductor,  
Lower Line Denotes 50% Insulation Wear

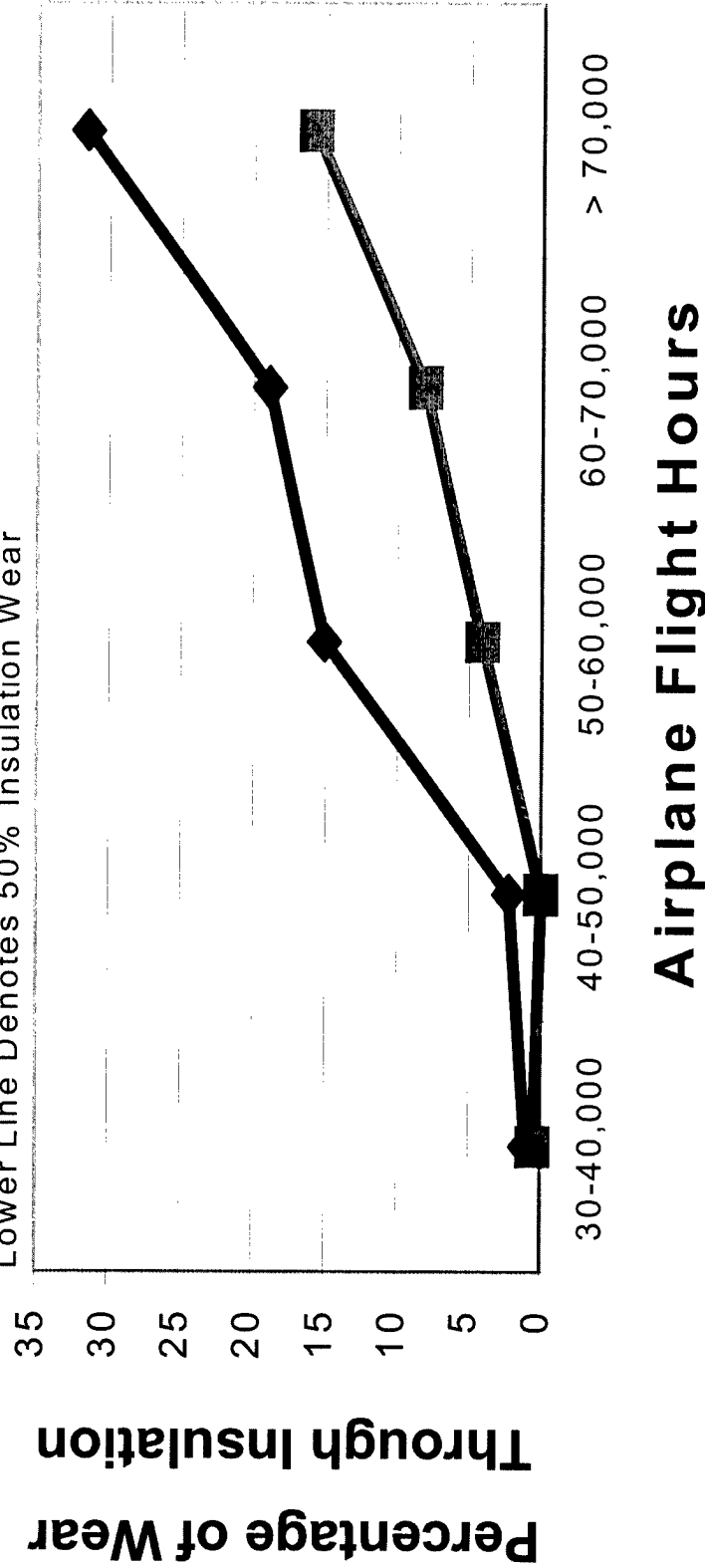

**Figure 39.** A chart showing the 737 fuel pump conduit wear rate that was identified by the FAA during representative 500 wire inspections.

The Direction Generale de L'Aviation Civile (DGAC) received three reports of CWT pumps in Airbus A300s with cracked canister legs caused by fatigue. In one case, this led to separation of the pump canister from its lower housing. As a result of these events, on November 30, 1998, the DGAC issued French Telegraphic AD T98-476-272(B), which required inspection and possible replacement of the fuel pumps on Airbus A300-B4-600R and A300-F4-600R airplanes. T98-476-272(B) stated that the cracked canister legs could result in loss of flame trap capability and could provide an ignition source in the CWT. As a result of the DGAC action, the FAA issued AD T98-25-93 on December 7, 1998, requiring similar action.

The FAA became aware of another unanticipated fuel tank system failure condition as a result of reported incidents involving 767 airplanes in which parts from fuel pump assemblies contacted the rotating fuel pump impeller. In two reported cases, objects from a broken fuel pump inlet diffuser assembly were ingested into the fuel pump, causing damage to the pump impeller and pump housing. Because this condition could have resulted in sparks or hot debris in the presence of fuel vapor, the FAA issued AD 97-19-15, which required revision of the 767 AFM to include procedures to switch off the fuel pumps when the CWT is nearly empty. According to the FAA, the intent of this action is to maintain liquid fuel over the pump inlet so that any debris generated by a failed fuel pump would not come into contact with fuel vapors.

#### **1.18.3.4.2 Aviation Rulemaking Advisory Committee/Fuel Tank Harmonization Working Group**

On April 3, 1997, the FAA published a notice in the FR that requested comments about the Safety Board's Safety Recommendations A-96-174 through -177 regarding reduced flammability. As previously discussed, on the basis of its review of comments that it had received, the FAA determined that additional information was needed before it would initiate rulemaking action to address the Board's recommendations. Therefore, on January 23, 1998, the FAA established an ARAC working group, the FTHWG, which was tasked with gathering the information needed. Representatives from the Aerospace Industries Association, Air Transport Association of America (ATA), International Air Transport Association, European Association of Aerospace Industries, Air Line Pilots Association, API, General Aviation Manufacturers Association, Joint Aviation Authorities (JAA), Aviation Consumer Action Project (ACAP), and FAA were involved in the FTHWG.

The FTHWG was tasked with recommending regulatory changes that would "eliminate or significantly reduce the hazards associated with explosive vapors in transport-category airplane fuel tanks [of]...new type designs, in-production airplanes and the existing fleet." Its objectives included the following: (1) analyze the history of the world transport-category aircraft fleet, the safety status of the existing fleet, various means of reducing exposure to flammable fuel vapors, and the means to eliminate the resultant hazard if ignition does occur; (2) recommend regulatory text for new rulemaking aimed at controlling flammability of fuel vapors in fuel tanks; and (3) assess the cost benefit of those means.



On July 23, 1998, the FTHWG submitted its final report to the FAA. The report indicated that the FTHWG's studies showed that flammability exposure varied across airplane types and depended on fuel tank location. According to the report, some fuel tanks already have a low exposure to flammable conditions. For example, the FTHWG calculated that wing tanks are flammable approximately 7 percent of the fleetwide operational time. Further, results from the FTHWG's thermal analysis indicated that the flammability exposure for fuel tanks that were not adjacent to such heat sources approximated that of wing tanks, whereas CWTs heated by air conditioning equipment located beneath them are flammable an average of 30 percent of the fleetwide operating time.<sup>413</sup> The FTHWG concluded that the safety record of wing tanks was adequate and if the same level could be achieved in all CWTs, an adequate overall safety objective would be achieved. Accordingly, reducing flammability in all fuel tanks to the level of the wing tanks on most airplanes was seen by the FTHWG as a worthwhile goal. Various possible means to achieve this goal were evaluated for technical and economic merits, and the FTHWG reached the following conclusions:

- Techniques to reduce or eliminate heat input to the tanks from nearby heat sources were evaluated. Of these techniques, directed ventilation and relocation of the significant heat sources reduce the exposure to an acceptable level. However, relocation is only feasible for new airplane designs. Directed ventilation for in-service aircraft is estimated to have an overall cost of \$3.5 billion over a 10-year period.
- To reach the goal by changing fuel properties, a minimum flash point specification of 140° F would be required. A change of this magnitude falls outside of the current experience base and may require engine re-design/re-qualification. The overall fuel manufacturing cost increase for a 10-year period is estimated at \$15 billion in the USA and \$60 billion for the rest of the world and could result in a significant shortfall of jet fuel.
- Techniques such as on board fuel tank inerting or installation of foam in the tanks would also achieve the goal, but at a cost estimated to be at least \$20 billion over the next 10 years and would be very difficult to retrofit in current airplanes. Ground inerting, wherein specific tanks are made inert before flight, at specific airports, is an option that needs future study to determine; (a) the logistical costs of such a system, and (b) if retrofit installation of the distribution system internal to the airplane could be achieved in a cost effective manner.
- The Working Group considered several concepts that were determined to be insufficiently advanced technically at this time, for transport airplane fuel tank use. These included ullage sweeping and explosion suppression systems.

---

<sup>413</sup> As previously discussed, the FAA subsequently determined that 35 percent was a more accurate estimate.

The FTHWG made the following recommendations to the FAA and JAA:

- Adopt the proposed new regulatory action on new aircraft designs that would limit the development of flammable conditions in the fuel tanks, based on the intended fuel types, to less than 7 percent of the expected fleet operational time, or provide means to mitigate the effects of an ignition of fuel vapors within fuel tanks such that any damage caused by an ignition will not prevent continued safe flight and landing.
- Continue to investigate means to achieve a cost-effective reduction in flammability exposure for the in-service fleet and newly manufactured aircraft.
- Pursue the studies associated with directed ventilation and ground-based inerting systems to improve their cost effectiveness.
- If a practical means of achieving a cost effective reduction in flammability exposure can be found for the in-service fleet, either at the level specified in the rule or at some intermediate level (recommendations 2 and 3 above), consider application of that solution, in combination with other actions (e.g., SFAR).
- If a practical means of achieving a cost effective reduction in flammability exposure can be found for newly manufactured aircraft, either at the level specified in the rule or at some intermediate level (recommendations 2 and 3 above), consider application of that solution, in combination with other actions (e.g., SFAR).<sup>[414]</sup>

#### **1.18.3.4.3 Notice of Proposed Rulemaking 99-18 (Fuel Tank System Design Review, Flammability Reduction, and Maintenance/Inspection Requirements)**

On October 29, 1999, the FAA published NPRM No. 99-18,<sup>415</sup> "Transport Airplane Fuel Tank System Design Review, Flammability Reduction, and Maintenance and Inspection Requirements." The NPRM indicated that the TWA flight 800 accident and resulting Safety Board recommendations had prompted the FAA to examine the

---

<sup>414</sup> One FTHWG representative, the representative from the ACAP, submitted a letter, dated July 23, 1998, expressing his dissenting view regarding the final report and recommendations prepared by the FTHWG. He stated, in part, "I opposed acceptance of the Report and its recommendations (a) because some of its key factual findings regarding costs of fixing the problem are unsupported and apparently flawed, (b) because its recommended rule changes are wholly inadequate to eliminate or significantly reduce the risk of fuel tank explosions and fires in the near or mid-term future, and (c) because I strongly disagree with the policy position...that a cost benefit analysis which found that doing nothing for the existing air carrier fleet would cause the equivalent of three TWA 800 disasters over ten years..." was acceptable.

In his letter, the ACAP representative further indicated that the ARAC/FTHWG found that a significant danger exists for fuel tank explosions, especially for CWTs with adjacent heat sources. He stated that the ARAC/FTHWG's final report indicated that "the best available technology to eliminate the risk of fuel tank explosions is in flight nitrogen inerting which regardless of the ignition source virtually eliminates the risk and has been successfully used for years on military [transport airplanes]...."

<sup>415</sup> For additional information, see NPRM, "Transport Airplane Fuel Tank System Design Review, Flammability Reduction, and Maintenance and Inspection Requirements." Notice No. 99-18. 64 FR 586644 (October 29, 1999).

underlying safety issues surrounding fuel tank explosions, the adequacy of existing regulations, the service history of airplanes certificated to those regulations, and existing fuel system maintenance practices. The NPRM proposed to amend the current regulations to address prevention of ignition sources and minimization of flammable vapors in fuel tanks in future airplane designs.

### **Prevention of Ignition Sources**

According to NPRM 99-18, the regulatory authorities and aviation industry have always presumed that a flammable fuel/air mixture exists in fuel tanks at all times and have adopted the philosophy that the best way to ensure airplane fuel tank safety is to preclude ignition sources within fuel tanks. This philosophy has been based on the application of fail-safe design requirements to the airplane fuel tank system to preclude ignition sources from being present in fuel tanks when component failures, malfunctions, or lightning encounters occur. The NPRM noted that airplane fail-safe requirements are provided in 14 CFR Sections 25.901 (c) and 25.1309<sup>416</sup> and that, in general, the FAA's policy has been to require applicants to assume the presence of foreseeable latent (undetected) failure conditions when demonstrating that subsequent single failures will not jeopardize the safe operation of the airplane. However, the NPRM noted that the requirements of these sections "have not been consistently applied and documented when showing that ignition sources are precluded from transport category airplane fuel tanks."

The FAA also reviewed SDRs for the transport-category airplane fleet, evaluated the certification and design practices used on previously certificated airplanes, initiated an inspection of fuel tanks on existing 747 airplanes, and evaluated the results of an industry-led inspection of a representative sampling of transport-category airplanes. The FAA indicated that inspections revealed debris (including lockwire, rivets, and metal shavings) within the fuel tanks and in scavenge pumps of in-service 747 airplanes. Further, the FAA observed corrosion and damage to insulation on FQIS probe wiring on six out of eight probes removed from in-service airplanes. Inspection of fuel tank system components from out-of-service 747 airplanes revealed damaged (worn, chafed) wiring and a buildup of conductive sulfide deposits on the FQIS wiring.<sup>417</sup> On the basis of its work, the FAA identified the following conditions as possible contributors to the development of ignition sources within the fuel tanks: aging of fuel tank system components, contamination (debris), corrosion of components, and sulfide deposits on components.

NPRM 99-18 noted that the intent of existing inspection and maintenance programs is to ensure that the inherent level of safety that was originally designed into the system is maintained. The NPRM further noted that historically, FAA-required inspection programs for fuel tank systems included operational checks, functional checks following

---

<sup>416</sup> These sections are quoted in section 1.16.6.5, in connection with Boeing's CWT ignition fault tree analysis and report.

<sup>417</sup> As previously discussed, tests conducted by the Safety Board during this investigation indicated that conductive deposits or damaged wiring may result in a location where arcing could occur if high-power electrical energy was transmitted to the FQIS wiring from another airplane source.

maintenance actions, overhaul of certain components to prevent dispatch delays, and general zonal visual inspections conducted concurrently with other maintenance actions. However, the NPRM noted that specific maintenance instructions to detect and correct conditions that degrade fail-safe capabilities had not been deemed necessary because it had been assumed that the original fail-safe capabilities would not be degraded in service.

NPRM 99-18 stated that typical transport-category airplane fuel tank systems are designed with redundancy and fault indication features such that single component failures do not result in any significant reduction in safety. Therefore, fuel tank systems historically have not had any life-limited components or specific detailed inspection requirements, unless mandated by an AD. Most of the components are inspected "on condition," meaning that some test, check, or other inspection is performed to determine continued serviceability, and maintenance is performed only if the inspection identifies a condition requiring correction. Visual inspection of fuel tank system components is by far the predominant method of inspection for components such as boost pumps, fuel lines, couplings, wiring. Typically these inspections are conducted concurrently with zonal inspections or internal or external fuel tank structural inspections. These inspections normally do not provide information regarding the continued serviceability of components within the fuel tank system unless the visual inspection indicates a potential problem area. For example, certain degraded fuel tank system conditions, such as worn wiring routed through conduit to fuel pumps, debris inside fuel pumps, corrosion to bonding wire interfaces, would not be detected without dedicated intrusive inspections that are much more extensive than those normally conducted.<sup>418</sup>

After its review of the 747 design, the FAA determined that during initial certification of the fuel tank system, the degree of tank contamination and the significance of certain failure modes of fuel tank system components had not been considered to the extent that recent events/service experience indicated was needed. For example, during initial certification, the manufacturer had demonstrated that the FQIS had been shown to preclude arcing if FQIS wiring came in contact with the highest electrical voltage produced on the airplane in the absence of contamination. However, testing conducted during this investigation has shown that if contamination, such as conductive debris (for example, lockwire, nuts, bolts, steel wool, corrosion, sulfide deposits, and metal filings), is located within gaps in the fuel probe, the voltage needed to create an arc is within values that could result from an electrical short-circuit or current induced in the FQIS probe wiring by adjacent wiring. According to NPRM 99-18, "if any of these anomalies were combined with a subsequent failure within the electrical system that creates an electrical short, or if [high-intensity radiated fields, or HIRF] or electrical current flow in adjacent wiring induces EMI voltage in the FQIS wiring, sufficient energy could enter the fuel tank and cause an ignition source within the tank."

On the basis of its review of SDRs and accident and incident reports, the FAA identified numerous fuel tank system design features, malfunctions, failures, and

<sup>418</sup> For more information regarding TWA's visual inspections, see section 1.6.3.1.1.

maintenance-related actions that would result in a degradation of the systems' safety features, including the following:

#### Fuel pump-related items

- ingestion of components (the pump inlet check valve or the pump inducer) in the pump impeller, resulting in debris in the fuel tank;
- stator winding failures during operation of the fuel pump, resulting in arcing through the fuel pump housing;
- inappropriate wrapping of the fuel pump windings, resulting in deactivation of the pump's thermal protective features;
- absence of cooling port tubes between the pump assembly and the pump motor (has occurred as a result of improper fuel pump overhaul);
- extended fuel pump operation in empty fuel tanks (dry-running fuel pumps);
- use of steel impellers that could produce sparks if debris enters the fuel pump;
- exposure of electrical connections within the fuel pump housing with inadequate clearance to the fuel pump cover, resulting in arcing;
- internal wires contacting the pump rotating group, energizing the rotor and causing arcing at the impeller/adaptor interfaces;
- poor bonding of components to structure and/or across component interfaces;
- insufficient ground fault current protection capability;

#### Wiring inside fuel tanks

- chafing/wearing of Teflon sleeve and wire insulation, allowing arcing through metallic conduits into fuel tanks;

#### Fuel pump connectors

- electrical arcing at connections within electrical connectors because of bent pins or corrosion;
- corrosion of electrical connectors in the fuel pump motor, resulting in fuel leakage and subsequent fuel-fed fire outside the fuel tank and electrical arcing through the connector housing (outside the fuel tank);
- improper materials in connector design;

#### FQIS wiring

- degradation of wire insulation (cracking), corrosion, and sulfide deposits at electrical connectors;
- unshielded FQIS wires routed in wire bundles with high-voltage wires.

FQIS probes

- corrosion and sulfide deposits, resulting in reduced breakdown voltage in FQIS wiring;
- terminal block wiring clamp features at electrical connections on fuel probes, damaging wire insulation;
- contamination in fuel tanks, causing reduced arc path between FQIS probe walls;

Bonding straps

- corrosion to bonding straps;
- loose or improperly grounded attachment points;
- static bonds on fuel tank system plumbing connections inside the fuel tank worn by wing movement and/or corrosion;

Electrostatic charge

- use of nonconductive reticulated polyurethane foam that holds electrostatic charge buildup; and
- spraying of fuel into fuel tanks through inappropriately designed refueling nozzles or pump cooling flow return methods.

NPRM 99-18 stated that the FAA's "review of service history, design features, and maintenance instructions of the transport airplane fleet indicated that aging of fuel tank system components and unforeseen fuel tank system failures and malfunctions have become a safety issue for the fleet of turbine-powered transport category airplanes."

NPRM 99-18 proposed an SFAR that would require transport-category airplane type certificate (TC) holders for transport-category airplanes and holders of supplemental type certificates (STC) that affect the transport-category airplane's fuel system<sup>419</sup> to conduct a safety review of the fuel tank system designed to show that fuel tank fires or explosions will not occur. Specifically, the TC or STC holder would be required to determine whether the fuel system design meets the existing requirements of 14 CFR Section 25.901<sup>420</sup> and the requirements of Section 25.981(a) and (b), which would include several provisions added by the NPRM. If the design does not meet these requirements,

---

<sup>419</sup> The proposed rule would apply to airplanes that had TCs issued after January 1, 1958, and that have a certificated passenger capacity of at least 30 people or payloads of 7,500 pounds or more and proposed a 12-month compliance period for the review and an 18-month compliance period for the maintenance and inspection instructions development. The FAA has determined that 35 TCs and 168 STCs would need a fuel tank system design assessment.

<sup>420</sup> Section 25.901 requires, in part, that major components of airplane powerplant installations (including fuel tanks) be electrically bonded to the other parts of the airplane and that for each powerplant installation, no single failure or malfunction or probable combination of failures will jeopardize the safe operation of the airplane.

the SFAR would require the TC or STC holder to develop the necessary corrective design changes.

As previously discussed, Section 25.981 currently requires that “a safe margin” exist between the temperature at any place inside a fuel tank where fuel ignition is possible and the lowest expected auto ignition temperature of the fuel in the fuel tank. NPRM 99-18 proposed to revise Section 25.981 so that subsection (a) would prohibit an ignition source from being present at any point in the fuel tank system “where catastrophic failure could occur due to ignition of fuel or vapors.” The new rule would require that this be shown by demonstrating (1) compliance with the existing requirement regarding auto ignition temperature and (2) that an ignition source in the fuel tank system could not result from any single failure, from any single failure in combination with any latent failure condition not shown to be extremely remote, or from any combination of failures not shown to be extremely improbable.<sup>421</sup> The revised Section 25.981 would also require, in subsection (b), that critical design configuration control limitations, inspections, or other procedures be established as necessary to prevent development of ignition sources.

According to NPRM 99-18, the TC and STC design approval holder would be expected to do the following to comply with the SFAR:

develop a failure modes and effects analysis (FMEA) for all components in the fuel tank system. Analysis of the FMEA would then be used to determine whether single failures, alone or in combination with foreseeable latent failures, could cause an ignition source to exist in a fuel tank. A subsequent quantitative fault tree analysis should then be developed to determine whether combinations of failures expected to occur in the life of the affected fleet could cause an ignition source to exist in a fuel system.<sup>422</sup>

The SFAR would also require TC and STC holders to develop all maintenance and inspection instructions necessary to maintain the design features required to preclude the existence or development of an ignition source within the fuel tank system.<sup>423</sup> According to NPRM 99-18, the FAA anticipates that the safety review would identify critical areas of the fuel tank and other related systems that would require maintenance actions to account for the effects of aging, wear, corrosion, and possible contamination of the fuel tank system. The NPRM noted, for example, that service history indicates that copper-sulfide

---

<sup>421</sup> According to the NPRM, for the purposes of the new rule, extremely remote failure conditions are those not anticipated to occur to each airplane during its total life but that may occur a few times when considering the total operational life of all airplanes of the type. Extremely improbable failure conditions are those not anticipated to occur during the entire operational life of all airplanes of one type.

<sup>422</sup> The Safety Board identified numerous potential ignition hazards (including, but not limited to, aging components, contamination and corrosion of components, and sulfide deposits on components) during the TWA flight 800 investigation. The NPRM stated that these failure conditions and any other foreseeable failures should be assumed when performing the FMEA analysis. However, the NPRM indicated that uncontained engine failures; terrorist actions, such as bombs; and the effects of postcrash or other fires from outside the tank would be outside the purview of the proposed FMEAs.

<sup>423</sup> The SFAR also states that “no person may operate a turbine-powered transport category aircraft...unless instructions for maintenance and inspection of the fuel tank system are incorporated into its inspection program.”

deposits may form on fuel tank components and that this could degrade the intended design capabilities by providing a possible arcing mechanism. Therefore, the NPRM noted that it might be necessary to provide maintenance instructions to identify and eliminate such deposits.

### **Minimizing Development of Flammable Vapors in Fuel Tanks**

NPRM 99-18 noted that, in addition to its review of potential fuel tank ignition sources, the FAA had "undertaken a parallel effort to address the threat of fuel tank explosions by eliminating or significantly reducing the presence of explosive fuel air mixtures within fuel tanks of new type designs, in-production [airplanes], and the existing fleet of transport airplanes." According to the NPRM, the FAA agreed with the intent of the regulatory text recommended by the FTHWG. However, because no economic evaluation had been completed to determine if practical means were available to reduce the exposure below the 7 percent of fleetwide operational time proposed by the FTHWG, the NPRM stated that the FAA was proposing a more objective regulation intended to minimize exposure to operation with flammable conditions in fuel tanks.

NPRM 99-18 proposed to add a new subsection (c) to 14 CFR Section 25.981, which would require that fuel tank installations in newly designed airplanes include a means to minimize the development of flammable vapors in fuel tanks, or to mitigate the effects of an ignition of fuel vapors within fuel tanks, such that no damage caused by an ignition will prevent continued safe flight and landing. According to the NPRM, the proposal was not intended to prevent the development of flammable vapors because total prevention has not been found to be feasible; instead, the proposal is intended as an interim measure to preclude, in new designs, the use of design methods that result in a relatively high likelihood that flammable vapors will develop in fuel tanks. (The NPRM noted that certain design methods, such as the location of air conditioning packs directly below a fuel tank without provisions to reduce transfer of heat from the packs to the tank, increase the likelihood that flammable vapors will develop in fuel tanks.) The NPRM further stated that the intent of the proposal is to require that fuel tanks are not heated and that they cool at a rate equivalent to that of a wing tank in the transport-category airplane being evaluated.

### **Draft Advisory Circulars**

In connection with regulatory changes proposed in NPRM 99-18, on January 12, 2000, the FAA issued two draft ACs. FAA Draft AC 25.981-1X, "Fuel Tank Ignition Source Prevention Guidelines," "provides guidance for demonstrating compliance with the [proposed] certification requirements for prevention of ignition sources within the fuel tanks of transport category airplanes." The draft AC states that "[p]rior to conducting a fuel system safety assessment, each applicant should assemble and review relevant lessons learned from their previous products, their suppliers, and any other available sources, to assist in identifying any unforeseen failures, wear, or other conditions that could result in an ignition source."<sup>424</sup> The draft AC provides detailed guidance about potential fuel tank ignition sources, accepted design practices, ignition source failure analysis, electrical sources, friction sparks, surface ignition, and instructions for continued airworthiness.



Further, the draft AC states that the ignition source failure analyses required by the proposed SFAR

are intended to address system failures that may result in the presence of an ignition source in the fuel tanks. These regulations are not intended to address failures or conditions that could lead to ignition of fuel vapors from such sources as uncontained engine debris, external fires following engine separation or failure, damage resulting from explosive materials, such as bombs, or post crash fire heating of tank surfaces or propagation of fire through the airplane vent system into the fuel tanks. These hazards are addressed by other regulations.

FAA Draft AC 25.981-2X, "Fuel Tank Flammability Minimization," "provides information and guidance concerning compliance with the [proposed] airworthiness standards for transport category airplanes pertaining to minimizing the formation or mitigation of hazards from flammable fuel air mixtures within fuel tanks." The draft AC reiterates, as noted in NPRM 99-18, that the intent of the proposed regulation is to require that the exposure to formation or presence of flammable vapors is equivalent to that of an unheated wing tank in the transport-category airplane being evaluated. The draft AC contains detailed guidance about methods for minimizing fuel tank flammability and acceptable means to mitigate the effects of an explosion.

#### **Safety Board Comments on NPRM 99-18**

In a March 23, 2000, letter, the Safety Board submitted its comments on NPRM 99-18. The Board stated that it generally supported the proposed regulatory changes but urged the FAA to give further consideration to some issues. Specifically, with regard to the proposed requirement for FMEAs, the letter stated that the "Safety Board generally supports the intent of the SFAR in requiring an FMEA analysis, but is concerned about the construction of the FMEAs, as well as the thoroughness and integrity of the data that will be used." The Board cited the concerns expressed by Safety Board investigators and NASA specialists about the Boeing fault tree analysis report submitted to the Board in connection with the TWA flight 800 investigation.<sup>425</sup> The Board further stated the following:

the Safety Board's concerns about the FMEAs are amplified by the fact that no single source exists for reliable and comprehensive data on component failures or malfunctions. Because the calculations in an FMEA are based on failure rates, incomplete or inappropriate failure data can skew the results of an examination. The Board is aware that service history data maintained by manufacturers do not capture data from all operators. Further, the Board has found that the amount of data provided by the manufacturers of replacement component parts sometimes greatly exceeds the data provided by the aircraft manufacturers (possibly because replacement parts suppliers can sell parts directly to operators and repair facilities). Although the FAA collects a significant amount of data about mechanical failures through its Service Difficulty Report (SDR) program, even

---

<sup>424</sup> The draft AC also states that "service history has shown that ignition sources have developed in airplane fuel tanks due to unforeseen failure modes or factors that were not considered at the time of original certification of the airplane, including sparks, or hot surfaces within the fuel tanks."

<sup>425</sup> For more information about this fault tree analysis report, see section 1.16.6.5.

these data are incomplete.<sup>426</sup> Other sources of potentially relevant data are the service histories maintained by the military of its variants of commercial airliners and the Board's accident and incident investigation database; however, neither of these sources provides complete data either.

Further, the many affected TC and STC holders (some of which are not the original designers or manufacturers) may have varying levels of experience with developing FMEAs. In addition, the Safety Board is concerned that engineers working for TC and STC holders may not recognize the existence or significance of certain hazards and that potentially competing interests may affect the quality and thoroughness of some FMEAs. In cases in which the TC or STC holder no longer exists, FAA personnel with varying levels of skill and experience may have to conduct the FMEAs. Finally, the Board is concerned that the FAA may have an insufficient number of staff who are trained to properly evaluate an FMEA.

Therefore, to ensure the integrity and effectiveness of the fuel tank system safety review, the Safety Board urges the FAA to develop and provide adequate standards and criteria to guide the development of the FMEAs and fault tree analyses. In particular, because there is no single comprehensive collection system that contains data on the failure of airplane components and because of the inadequacies that exist in each source of data, those guidelines should specify that the data used for the FMEAs must be collected from all available sources, including operators, manufacturers, and appropriate government agencies.

The FAA needs to provide adequate oversight and auditing of the FMEA analysis results to ensure their technical accuracy and integrity. In particular, such oversight and auditing should include a review of the data sources used to ensure that all available and appropriate sources of failure data have been taken into account. FAA oversight and auditing can also provide a method to identify potential deficiencies in the FMEAs that might be overlooked or not recognized by engineers and designated engineering representatives who work with these systems on a daily basis.

Regarding the proposed requirement for maintenance and inspection instructions, the Safety Board indicated that it

strongly endorses continuing airworthiness through improvements to maintenance, inspection, and minimum equipment lists. However, given the very general nature of some current inspection criteria pertaining to fuel tank safety (as documented by the FAA in its Transport Non-Structural Systems Plan), the Board is concerned that the instructions resulting from the SFAR requirement may be similarly broad and, therefore, potentially ineffective. Many potential ignition sources (such as hidden cracks in wiring, sulfide deposits, and use of inappropriate materials) may not be apparent during a general visual inspection. Therefore, the Board urges the FAA to ensure that the maintenance and inspection instructions developed as a result of this SFAR are detailed and specific enough to provide mechanics with useful inspection criteria and to ensure that they are properly trained about how to effectively carry out those instructions, including a requirement for a detailed inspection of each component in any area that may be exposed to fuel or fuel vapors.

---

<sup>426</sup> For additional information regarding the Safety Board's concerns about and recommendations made pertaining to the SDR program, see section 1.18.2.1.

Regarding the regulatory proposal to minimize development of flammable fuel vapors in new designs, the Safety Board indicated that it was “concerned that the NPRM does not propose any regulatory changes that address fuel tank flammability in current designs and in the existing fleet” and that “[t]his is especially disturbing because some operational measures (such as limiting the on-ground operating time of air conditioning packs and substituting a ground-based cool air supply and cooling or ventilating the pack bay) that can reduce current levels of flammable vapors could be accomplished immediately.” The Board stated that it was “aware that the FAA is conducting research into on-ground fuel tank inerting systems for the existing fleet,<sup>[427]</sup> and that because] the Board believes that fuel tank inerting is a promising, near-term method that could dramatically reduce fuel tank flammability in the existing fleet, it strongly supports the FAA’s continued work in this regard and looks forward to regulatory implementation.”

Finally, the Safety Board stated the following:

[a]lthough FAA staff have indicated to Safety Board staff that the FAA does not intend to endorse the FTHWG’s proposed exposure criteria [of 7 percent of the fleet operational time], the Board nonetheless wishes to register its concerns about those criteria. Because it is a fleetwide average, it does not account for increased risks that may exist at specific locations, during certain time periods, or for certain flights.<sup>[428]</sup> In addition, the premise that transport airplane fuel tanks located in the wings have an acceptable safety record is unacceptable because wing fuel tanks have exploded.<sup>[429]</sup> The Safety Board believes that the goal should be to completely eliminate the development of flammable vapors in fuel tanks to the greatest extent technically feasible (such as would result from the use of on-ground inerting systems).

#### 1.18.3.4.4 FAA’s Aging Transport Non-Structural Systems Plan

On July 25, 1996, White House Commission on Aviation Safety and Security (WHCASS) was chartered. The WHCASS subsequently recommended that the FAA expand its aging aircraft program to cover nonstructural systems by (1) conducting full and complete teardowns of selected aircraft scheduled to go out of service, (2) establishing a “lead-the-fleet” research program, (3) expanding the FAA-DoD-NASA cooperative aging aircraft program, (4) expanding programs of the Airworthiness Assurance Working Group to include nonstructural components, and (5) encouraging the development of modern technical means to ensure and predict the continued airworthiness of aging nonstructural systems.

---

<sup>427</sup> The Safety Board noted that the FAA is also engaged in research regarding on-board inerting systems for future designs.

<sup>428</sup> The Safety Board noted that of the 16 fuel tank explosions documented by the ARAC, 11 occurred in the months of May, June, and July, and only 2 occurred outside of warm climates or summer months. Further, short flights in warm climates can have a dramatically higher exposure time than the fleetwide average. For these flights, attempting to reduce the flammability of CWTs to the level of wing tanks would be of little benefit.

<sup>429</sup> For example, as previously indicated, the Board noted that wing tank explosions caused the May 9, 1976, accident involving a 747 operated by the Iranian Air Force near Madrid, Spain, and the January 15, 1972, accident involving a U.S. Navy C-130 near Cambridge, Maryland.

The FAA participated in the Safety Board's inspections of 26 airplanes in January 1998, then inspected additional airplanes by the end of March 1998. The FAA's examinations revealed deterioration of wiring components (wires, bundles, connectors, grounds, clamps, shielding), contamination of wire bundles with excessive dust and fluids, cracking of outer layers of multilayer insulation, ground terminals with resistance measurements outside specifications, corrosion on connector pins, and improper wire installations/repairs. The FAA also found that aging wire becomes stiff and easily cracked; wire bundles are often difficult to inspect; and contamination of wire bundles with metal shavings during maintenance is a common occurrence. In response to these findings and the WHCASS's recommendation, in July 1998, the FAA issued the Aging Transport Non-Structural Systems Plan.

The FAA's plan concluded that current maintenance practices do not adequately address wiring components; inspection criteria are too general (for example, "perform a general visual inspection"); unacceptable conditions are not described in sufficient detail; repair instructions/data are hard to locate and extract from Boeing's SWPM, as currently presented; wire replacement criteria may not be adequate; and current incident/maintenance reporting procedures do not allow for easy identification of failures.

The FAA then identified the following tasks:

- establish an Aging Transport Systems Oversight Committee to coordinate the various aging systems initiatives within the FAA;
- conduct an in-depth review of the aging transport fleet (including service history) and make model-specific safety recommendations related to airplane systems;
- enhance airplane maintenance to better address aging airplane systems;
- improve inspection criteria for wiring (need more complete descriptions of undesirable conditions);
- define acceptance criteria for corrosion on flight control actuators, associated linkages, and hydraulic fittings;
- revise [Maintenance Symposium Group] MSG-3 process to address catastrophic events associated with wire failures as MSG-3 review items and identify maintenance tasks/intervals to address;
- establish a means to minimize contamination of wiring from metal shavings (vacuuming is not sufficient, can cause shorting of wires and failure of electrical systems, may become a serious problem for new airplanes where 0.008-inch insulation thickness wire is used versus 0.020-inch insulation in current aging airplanes);
- review inspection/repair training to ensure it adequately addresses recognition and repair of aging wiring components;
- develop guidance material to address electromagnetic compatibility, lightning, and HIRF protection in maintenance programs;
- review and update Chapter 20 of manufacturer's standard practices of wiring;

- add aging systems tasks to the aging airplane research program, determine if a service life for airplane wire is appropriate, establish condition of aging wiring components and validate the adequacy of visual inspections, develop nondestructive testing tools for inspection of wiring systems,<sup>430</sup> establish aging effects on lightning and HIRF protection systems, develop arc fault circuit breaker, and perform destructive testing of flight control linkages;
- improve reporting of accident/incident and maintenance actions involving wiring system components (wires, connectors, wire shields, grounds, circuit breakers), urge ATA to establish appropriate codes, improve formats, add data to National Aviation Safety Data Analysis Center databases, and recommend that aging components removed during maintenance be examined for safety implication of failure;
- evaluate the need for additional maintenance of transport-category airplane fuel system wiring and address any unsafe conditions, review fleetwide service problems to identify any unsafe fuel system wiring conditions, and develop an SFAR to address fuel system wiring design and maintenance practices; and
- improve wiring installation drawings and instructions for continuing airworthiness, task SAE to write an aviation recommended practice to define best practices for modification of existing wiring on transport-category airplanes, develop training aids in wiring installation practices for certification engineers and designees, develop job aid for certification engineers and designees to use in evaluation of adequacy of wire systems installation drawings and instructions for continuing airworthiness.

In November 1998, the FAA established the ATSRAC, and on January 19, 1999, defined its charter in FAA Order 1110.127. According to the charter, the ATSRAC's task is to propose FARs revisions and associated guidance material as appropriate to ensure that nonstructural systems in transport-category airplanes are designed, maintained, and modified in a way that ensures their continued operational safety throughout the service life of the airplanes. Its duties are to recommend standardization clarification and to upgrade regulations, standards, and procedures related to aging systems as necessary to institutionalize lessons learned from aging systems review and recommend mandatory retroactive rules (ADs) to ensure safety of the transport-category airplane fleet.

On January 11, 1999, the FAA issued "Terms of Reference," which identified the following five major tasks for the ATSRAC: (1) conduct an in-depth survey of the condition of aging transport-category airplane fleetwide systems and propose model-specific safety recommendations related to airplane systems that will eliminate or significantly reduce the hazards associated with the types of age-related degradation

---

<sup>430</sup> In this regard, the FAA plan noted that "[w]ire is difficult to inspect in several areas of the airplane due to inaccessibility. Wire inside conduits is not inspectable by visual means. These difficulties, associated with the inspection of aging wiring bundles and connectors, can be overcome by the development and use of non-destructive testing tools to assess the state of the wiring in an airplane. The FAA will explore what tools already exist for these purposes. Where tools do not exist, promising technologies will be explored for adoption to the problems associated with inspection of aging wiring systems."

displayed by the fleet; (2) review the service history, manufacturer's SBs and SLs, and applicable ADs for the aging transport-category airplane fleet and identify information that pertains to aging systems for possible mandatory action; (3) improve general maintenance criteria for airplane systems to ensure that aging systems-related problems are identified and corrected; (4) review, update, and simplify manufacturer's standard practices for wiring; and (5) review air carrier and repair station training programs for nonstructural systems inspection and repair to ensure that they adequately address aging wiring system components and other nonstructural systems.

In connection with improvement of maintenance criteria, the FAA noted that "maintenance procedures currently in use in the air transport industry may not adequately or proactively address aging non-structural systems." The FAA specified several subtasks associated with this task, including defining improved inspection criteria for wiring, connectors, and associated components; defining practices to eliminate wire bundle contamination (with metal shavings, fluids, or other damaging materials) during maintenance; defining acceptance criteria for corrosion of systems components; and proposing a process to ensure that components removed during maintenance are examined for safety implications of the observed failures and the results are tracked to the original service problem.

## **1.18.4 Witness Information**

### **1.18.4.1 General Witness Information**

In the days immediately following the accident, the Safety Board announced its intention to form a Witness Group to interview witnesses to the accident. However, the Board deferred to the concerns expressed by Federal criminal investigators regarding the need for confidential treatment of eyewitness information while the criminal investigation was ongoing. Hence, the Board did not initially share witness information with private sector parties and did not use its party system to conduct witness interviews in its traditional fashion. Instead, a Safety Board investigator reviewed FBI interview notes and briefed other Board investigators on their contents.

In November 1996, the FBI agreed to provide the Safety Board with access to witness documents in which personally identifying information had been blacked-out (redacted). A Witness Group was formed to review these documents and conduct a limited number of witness interviews in cooperation with the FBI.<sup>431</sup> Upon completion of these interviews and the group's review of the redacted witness documents, this Witness Group was disbanded.

The FBI concluded its active criminal investigation of the crash in November 1997,<sup>432</sup> and in April 1998, it provided redacted witness documents<sup>433</sup> to Safety Board investigators. The Board formed a second Witness Group to study the documents

---

<sup>431</sup> The Safety Board intended to present information about the witnesses at its December 1997 public hearing; however, the FBI objected, and the Board did not address this topic at its hearing.

and prepare them for inclusion in the public docket. (Unless otherwise specified, all subsequent references to the “Witness Group” are to the second Witness Group.)

The witness documents were summaries of information<sup>434</sup> collected by FBI agents during interviews with potential witnesses. The Witness Group determined that the documents contained 736 witness accounts.<sup>435</sup> Because group members believed that it was not necessary and because of the amount of time that had elapsed (about 21 months) when the Safety Board received information about the identity of the witnesses,<sup>436</sup> the Witness Group chose not to reinterview most of the witnesses;<sup>437</sup> instead, the group chose to rely on the original FBI documents as the best available evidence of the observations initially reported by the witnesses.

According to these documents, 670 witnesses reported seeing something that the Witness Group determined was probably related to the accident, and nearly 250 reported hearing something that was determined to be likely related to the accident.<sup>438</sup> Figure 40 is a map that shows the witness locations and the location of the accident site.

The Witness Group determined that of the 736 witnesses, 239 were sound witnesses,<sup>439</sup> 179 were sight and sound witnesses, 258 were streak-of-light<sup>440</sup> witnesses,

---

<sup>432</sup> Although the FBI ceased its active investigative efforts in November 1997, it indicated that it remained prepared to resume the investigation at any time, should information indicate that such resumption was warranted.

<sup>433</sup> The FBI provided the Safety Board with witness documents that the Board could release in the public docket; to this end, FBI personnel removed personal information that would have identified the witnesses from the documents. For additional information, see the Witness Group Chairman’s Factual Report, dated February 9, 2000.

<sup>434</sup> The FBI stated that no verbatim records of the witness interviews were produced. The summaries provided to the Safety Board were generally written in the words of the agents who conducted the interviews and not necessarily in the words of the witnesses themselves. Witnesses were not asked to review or correct the documents.

<sup>435</sup> A witness was defined by the Witness Group as “anyone who reported hearing a sound and/or seeing an event or object or objects (including smoke or fire) in the sky in the general vicinity of the accident site, on July 17, 1996, at the approximate time of the accident.”

<sup>436</sup> Research indicates that the most accurate witness information is obtained immediately after an event is observed. See section 1.18.4.3 for additional information regarding the effects of time on witness recollections.

<sup>437</sup> One exception was the captain of Eastwind flight 507, who, because of his vantage point relative to TWA flight 800 and his experience as an airline pilot, was reinterviewed by the Witness Group on March 25, 1999.

<sup>438</sup> For additional information, see the Witness Group study report, dated February 9, 2000.

<sup>439</sup> The documents for these witnesses reported that they heard sounds such as a boom, a roar, or a thunderlike rumble. Two hundred seventy-five of the witness documents pertaining to the 670 sight witnesses did not mention hearing any sounds, and 216 of the remaining sight witnesses did not hear anything that the Witness Group judged to be related to the accident.

<sup>440</sup> The Witness Group defined a streak of light as “an object moving in the sky that could be variously described in witness documents as a point of light, fireworks, a flare, a shooting star, or something similar.” The definition noted that a streak of light was usually described as ascending, but could also be described as arcing over and/or descending. The Witness Group agreed that the streak of light definition must not meet the definition of a fireball and that it must precede any report of a fireball by that witness.

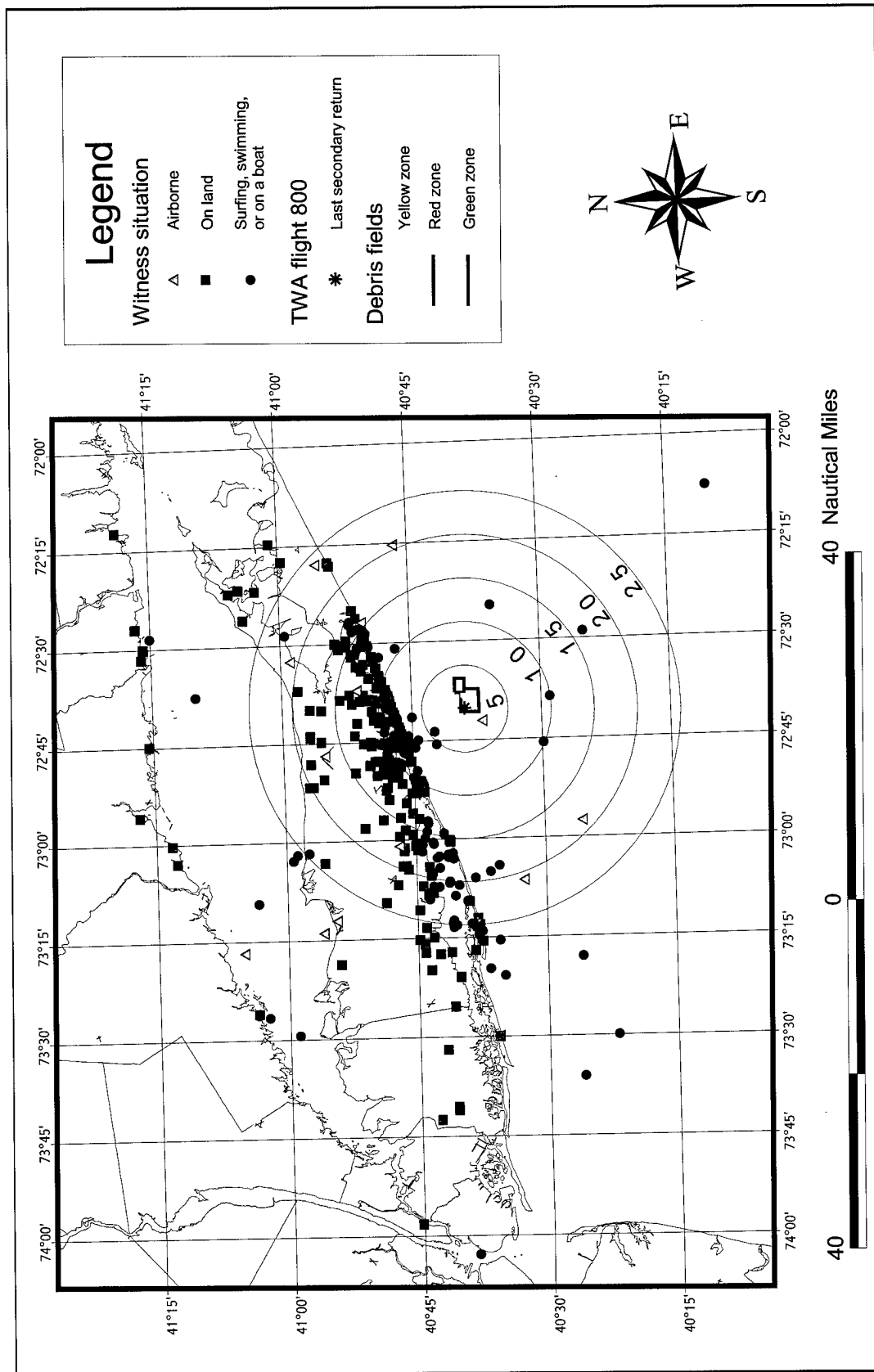

Figure 40. Map showing the witness locations and the location of the accident site.



and 599 were fireball witnesses. Of the 258 streak-of-light witnesses, 38 reported that the streak was ascending vertically or nearly so,<sup>441</sup> 18 indicated that it originated from the surface of the earth, and 7 reported that it originated at the horizon.<sup>442</sup> Of the 599 fireball witnesses, 264 reported seeing the fireball originate, 200 reported seeing the fireball split into two fireballs, and 217 reported observing the fireball hit the surface of the water (or disappear below the horizon). In addition, 210 witnesses reported seeing both a fireball and a streak of light.

Sufficient information was present in the materials provided by the FBI for the Witness Group to plot the reported position (approximate latitude and longitude) of 591 witnesses and the situation (land, sea, or air) of 699 witnesses.<sup>443</sup> Of the 591 witnesses whose reported positions were plotted, seven were positioned within 5-nm ground distance of the last secondary radar return from TWA flight 800. About 200 witnesses were positioned between 5- and 10-nm ground distance of the last secondary radar return. More than 200 witnesses were positioned between 10- and 15-nm ground distance of the last secondary radar return. About 80 witnesses were positioned between 15- and 20-nm ground distance of the last secondary radar return. Nearly 100 witnesses were positioned more than 20-nm ground distance from the last secondary radar return.

Of the 699 witnesses whose witness documents contained sufficient information to determine their reported situation at the time of the accident,<sup>444</sup> 460 were on land, 202 were on or in the water, and 37 were in aircraft. Most of the witnesses on land were outside, and most of the witnesses on the water were in boats. Of the 460 witnesses on land, 172 reported seeing a streak of light,<sup>445</sup> and 365 reported seeing a fireball (122 of these witnesses reported seeing the fireball split into two fireballs during its descent).

---

<sup>441</sup> The Witness Group determined that of the 220 streak-of-light witnesses who did not characterize the motion of the streak as vertical or nearly so, 126 provided some information about the lateral motion of the streak. Of these, 45 witnesses reported that the streak moved to the east, 23 reported that it moved to the west, 18 reported that it moved to the south, and 4 reported that it moved to the north. Thirty-six of the streak-of-light accounts contained no information about the direction of travel.

<sup>442</sup> Some of the 38 witnesses who reported the streak ascending vertically or nearly so may also have reported that it originated from the surface of the earth or from the horizon. Thirteen of these 38 witnesses were in vehicles (including boats), and one was paddling a surfboard at the time of the reported observation. A total of 56 witnesses reported seeing a streak of light ascending vertically or nearly so and/or a streak of light that originated from the surface of the earth or the horizon.

<sup>443</sup> Six calculations were made for each of the witnesses for whom a position could be determined: ground distance, slant range, elevation angle, initial azimuth, final azimuth, and sound time. Ground distance was defined as "the linear distance in feet along the surface from the witness's location to the surface of the water directly under the last secondary radar return for flight 800." Slant range was defined as "the elevated distance in feet from the witness's position and the position of flight 800 at altitude at the time of the last secondary radar return, calculated using ground distance and the airplane's altitude." Elevation angle was defined as "the angle in degrees formed from the witness's line of sight to flight 800." The initial azimuth was defined as "the bearing (in degrees true) from the witness to the accident airplane at the time of the last secondary radar return." The final azimuth was defined as "the bearing in degrees true from the witness to a point in the northeast corner of the debris field." The sound time was defined as "the approximate time required for sound to travel to the witness from flight 800's position at the time of the last secondary radar return."

<sup>444</sup> The witness document(s) for 2 of the 258 streak-of-light witnesses, 15 of the 599 fireball witnesses, and 1 of the 200 witnesses that reported seeing the fireball split in two did not contain sufficient information to determine that witness's situation at the time of the accident.

About one-third of the witnesses on land reported hearing something related to the accident. Of the 202 witnesses who were on or in the water, 78 reported seeing a streak of light, and 182 reported seeing a fireball (61 of whom reported seeing the fireball split). About 25 percent of those witnesses on or near the water reported hearing something related to the accident. All of the 37 airborne witnesses reported seeing a fireball (16 of whom reported seeing the fireball split in two), and 6 of the 37 reported seeing a streak of light.

A witness document pertaining to a professional fisherman who, according to the document, had been fishing in the area of the accident for about 5 or 6 months preceding the accident, indicated that there had been "a lot of flare activity" in the area during that time. A document pertaining to another witness, who was on board a USCG cutter that responded to the accident, indicated that by the time the cutter arrived at the accident site about 30 minutes after the accident, "fishing boats in the area had already begun to set off flares."<sup>446</sup>

The Witness Group reached 17 conclusions, including the following:

- The streak of light reported by many (of the 258 streak-of-light witnesses) may have been the accident airplane during some stage of its flight<sup>447</sup> before the fireball developed. Most of the streak-of-light accounts are generally consistent with the calculated flightpath of the accident airplane; however, 38 witnesses described a streak of light rising straight up or nearly so. These 38 witness accounts seem to be inconsistent with the calculated flightpath of the accident airplane.
- The descending fireball (observed by 599 witnesses) was the accident airplane. In all likelihood, the witnesses who watched this fireball split were observing the final stages of the structural breakup of the aircraft.

#### 1.18.4.2 Witness Document Issues

According to the Witness Group study report, the Witness Group identified several aspects of the witness documents that made it difficult to extract accurate and reliable information from them, including possible interviewer and/or interviewee bias (for example, the assumption that a missile was used against the airplane), potentially flawed

---

<sup>445</sup> The 38 witnesses who characterized the motion of the streak of light as vertical or nearly so were found to be widely dispersed throughout Long Island. The closest of these witnesses was situated about 7.8-nm slant range from TWA flight 800, and the farthest was about 47-nm slant range from TWA flight 800.

<sup>446</sup> For more information about this witness document, see section 1.18.4.4.

<sup>447</sup> Central Intelligence Agency (CIA) analysts, who initially evaluated certain witness information provided by the FBI, also concluded that the majority of the witness observations must have occurred well after the initial explosion and, consequently, none of those observations could have been of a missile that caused the explosion. The CIA analysts concluded that the remaining eyewitness accounts described events fully consistent with observations expected if only the aircraft in various stages of crippled flight were being observed. The CIA analysts concluded that there was absolutely no evidence that a missile was employed to shoot down TWA flight 800.

distance and direction information, multiple witness reports summarized in a single account, recording of witness speculations and conclusions, imprecise or vague language, conflicting information, and errors concerning the origin of the streak of light.

According to an FBI Special Agent involved with the FBI's earlier criminal investigation who met with the Witness Group on September 30, 1998,<sup>448</sup> the FBI initially suspected that a missile might have been used against TWA flight 800; therefore, FBI agents tended to use the witness documents to capture information that appeared relevant to its criminal investigation involving a missile rather than to record a complete accounting of the events described by the witness. In addition, missile experts were present at some interviews. According to the Special Agent, FBI agents were provided with suggested interview questions pertaining to missiles. These questions, which were included in the documents provided by the FBI pertaining to Witness 32 (and which the Special Agent indicated were asked in several cases), included the following:

- "How long did the missile fly?"
- "What does the terrain around the launch sight look like? Were scorch marks visible?"
- "Where was the sun in relation to the aircraft and the missile launch point?"

The Witness Group study report cited the presence of missile experts and questions such as these as potential sources of interviewer or interviewee bias that could influence the outcome of the interview. Other examples of possible interviewer/interviewee bias cited in the Witness Group study report included the following:

- According to a witness document, a witness located about 10.4-nm slant range from TWA flight 800<sup>449</sup> described an ascending red ball. The document further states, "Upon impact, [witness' name redacted] observed a large fireball." Neither the witness document nor the attached interview notes<sup>450</sup> stated that the witness saw anything other than the red ball in the sky; thus, it is unclear what the "impact" mentioned in the document is. Although this incongruity could be because of other reasons, the witness appears to have described an ascending red ball and a large fireball, which the interviewer related using the word "impact." It is also possible that the witness used the word "impact," but the original interview notes used to generate the witness document do not contain the word "impact."

---

<sup>448</sup> On September 30, 1998, an FBI agent who had been substantially involved in the FBI's missile investigation met with the Witness Group to discuss the witness-related processes used by the FBI during this investigation.

<sup>449</sup> For more information about individual witnesses, see the Witness Group study report, which contains witness numbers that can be correlated to witness documents.

<sup>450</sup> Interview notes were not available for most witness documents.

- Two other witnesses (both of whom were 8.2-nm slant range from TWA flight 800), described seeing a flarelike object but, according to the document, “they did not see what [the] flare struck, but it exploded in air into a large orange fireball.” This characterization may suggest that the interviewer and/or the interviewees believed that the flarelike object was a missile, which must have struck something.

According to the Witness Group study report, some witness documents noted that witnesses acknowledged that they did not realize that they had observed an airplane accident until they saw media accounts of the accident, and some documents specifically stated that witnesses made conclusions about what they observed after learning about the accident in the media. For example, one document stated that a witness (located about 13.2-nm slant range from TWA flight 800) did not think anything about his observation until he learned about the TWA flight 800 accident while watching the evening news. Another document indicated that a witness located 31-nm slant range from TWA flight 800 concluded that he had observed a missile after hearing news accounts about the crash. The Witness Group study report noted that media coverage about the crash and the associated criminal investigation might have led to bias on the part of some interviewees.<sup>451</sup>

Examination of the witness documents also indicated that distance estimates and direction of travel information varied considerably. For example, two witnesses who were in the same location observing the accident described seeing an ascending flarelike object. One witness estimated that the flarelike object was about 30 miles away, whereas the other witness estimated that it was 5 or 6 miles away. (Subsequent calculations indicated that the accident site was located about 26 statute miles ground distance away from their location.) Additionally, in general, there were notable variations in the witness accounts regarding the direction of motion of the streak of light—as mentioned in section 1.18.4.1, 38 documents reported that the streak of light moved vertically, 45 reported that it moved to the east, 23 reported that it moved to the west, 18 reported that it moved to the south, and 4 reported that it moved to the north. (Thirty-six witness documents that reported a streak of light did not contain information about the direction of travel.)

Combined accounts (multiple witness reports summarized in a single document or series of documents) presented another challenge. Although the Witness Group assigned witness numbers to each witness identified in the documents, it was not always possible to attribute specific observations to specific individual witnesses. The accounts of witnesses who were interviewed in small groups, and especially married couples, were often reported as if each person saw, remembered, and reported exactly the same events.

The Witness Group also determined that some documents included speculation and conclusions about what witnesses observed without stating what the witness reported observing. For example, one witness document stated, “He saw what he thought at the

---

<sup>451</sup> It is also noteworthy that the documents recording the initial interviews of some witnesses, who have since indicated that they believe a missile was used against the airplane, did not indicate that the witnesses initially reported seeing a missile.

time to be a large bright flare in the sky.” In this case, a description of exactly what the witness observed was not provided, nor were other details, such as whether the flare was moving, ascending, or descending, and if so, at what speed. The document only states what the witness, located about 14.8-nm slant range from TWA flight 800, *thought* he was observing.

The Witness Group study report also noted that some witness documents contained imprecise language. For example, one witness document stated that the witness reported seeing fire falling from the sky and “when it hit the water, approximately 8 to 10 seconds later, there was a big explosion,” without clarifying whether the 8 to 10 seconds referred to the amount of time between when the witness first saw the fire and when it hit the water or between when the fire hit the water and the explosion. Another witness document stated that the witness “only saw the object ascending for a split second when he observed an orange or light colored object ascending from the southwest direction. He stated it ascended for approximately five seconds,” without resolving whether the witness observed one or two objects and whether it (or they) ascended for a split second or 5 seconds. In addition, documentation pertaining to some witnesses was internally inconsistent. For example, one witness document indicated that the witness “observed what appeared to be a USCG flare” and also that “he observed what he thought was a shooting star.” Further, the document refers to the object as “the missile.”

The Witness Group study report determined that the witness documents indicated that at least three witnesses characterized the origin of the streak of light differently over two interviews. One witness document, based on a July 22, 1996, interview, stated that a witness who was located about 22.3-nm slant range from TWA flight 800 observed a flare rise straight up from the ocean. FBI agents reinterviewed this witness on June 26, 1997, and the witness document based on that interview stated that the witness first observed the flare about 15° to 20° above the horizon. Another witness (located about 14.7-nm slant range from TWA flight 800) also characterized the origin of the streak of light differently in two interviews. The witness document based on a July 23, 1996, FBI interview reported that the witness saw a flare come from the water, whereas the witness document based on an FBI interview conducted on July 15, 1997, reported that the witness saw a flare begin ascending from 3 inches above the horizon. A third witness, interviewed by the FBI on July 23, 1996, reported seeing “what appeared to be cheap fireworks coming off the beach.” The witness document based on a second FBI interview with this witness, conducted on July 29, 1996, reported that the witness observed “a white light that was traveling skyward from the ground.”<sup>452</sup> During subsequent interviews, this witness stated that when he first observed the white light it was in the sky just above a house.

---

<sup>452</sup> During an April 30, 1999, briefing for the Witness Group, CIA analysts said that during a careful reinterview by FBI agents, it became clear that the firework-like streak was in midflight when it was first observed by this witness. The Safety Board received no documentation concerning this interview from the FBI.

### 1.18.4.3 Research Regarding Accuracy of Witness Memory

Research into human memory and its accuracy has demonstrated that human memory is subject to error and that these errors occur for a variety of reasons.<sup>453</sup> Further, people tend to be unaware of their memory errors and may be overconfident in the accuracy of their memories,<sup>454</sup> and this confidence may increase over time.<sup>455</sup> The Safety Board's own investigative experience has confirmed that witness reports are often inconsistent with the known facts or with other witnesses' reports of the same events.<sup>456</sup>

#### 1.18.4.3.1 Perception and Storing Information in Memory

People use their eyes, ears, and other sensory organs to take in information from the environment; however, the raw data from the sensory organs are "processed," or acted on, by the brain before people become aware of what their organs have sensed.<sup>457</sup> The brain receives and rapidly processes the sensory information such as light or sound that is detected by the sensory organs.<sup>458</sup> This processing occurs involuntarily<sup>459</sup> and results in the mental representation of sensation, which is called perception.<sup>460</sup> In other words, the brain forms perceptions from raw sensory data (for example, the brain perceives music or words from sound energy). This processing is necessary because it filters and organizes the many sights and sounds that people are exposed to into useful auditory and visual images. However, because perception is not perfectly faithful to reality, people are subject to illusions.<sup>461</sup>

---

<sup>453</sup> Roediger, R. 1996. "Memory Illusions." *Journal of Memory and Language*. Vol. 35. p. 76-100.

<sup>454</sup> Lindsay, R. C.; Wells, G. L.; and Rumpel, C. M. 1981. "Can People Detect Eyewitness Identification Accuracy Within and Across Situations?" *Journal of Applied Psychology*. Vol. 67. p. 79-89.

<sup>455</sup> Woocher, F. D. 1977. "Did Your Eyes Deceive You? Expert Psychological Testimony on the Unreliability of Eyewitness Identification." *Stanford Law Review*. Vol. 29. p. 969-1,030.

<sup>456</sup> For example, following the June 6, 1971, midair collision of a DC-9 with a Marine Corps F-4B, some witnesses reported having seen the F-4B doing rolls and circling the area, although a surviving occupant of the F-4B indicated that the only roll was performed at 15,500 feet, too far away to have been observed by ground witnesses. (See NTSB/AAR-72/26.) Also, following the September 6, 1985, crash of Midwest Express Airlines flight 105, a pilot witness reported seeing the airplane pitch up 20°, then down 12°, and back up 20°, although the FDR data indicated no such pitch changes. (See NTSB/AAR-87/01.) In addition, after the August 31, 1988, crash of Delta Airlines flight 1141 at Dallas Fort Worth International Airport, a passenger on board the airplane stated that he saw the flaps extended, although the physical evidence from the wreckage and airplane performance studies demonstrated, and the Board concluded, that the wing flaps and slats had not been extended. (See NTSB/AAR-89/04.) Similarly, following the August 16, 1987, crash of Northwest Airlines flight 255 at Detroit, Michigan, two pilot-rated witnesses reported seeing the flaps extended, although the FDR indicated, and the Board concluded, that the flaps and slats were not extended. (See NTSB/AAR-88/05.)

<sup>457</sup> Coren, S. and Ward, L. M. 1994. *Sensation and Perception*. Harcourt Brace College Publishers. Fort Worth, Texas.

<sup>458</sup> Goldstein, E. B. 1989. *Sensation and Perception*. Wadsworth Publishing. Belmont, California.

<sup>459</sup> Treisman, A. 1986. "Features and Objects in Visual Processing." *Scientific American*. Vol. 255. p. 114-125.

<sup>460</sup> Goldstein.

<sup>461</sup> Coren and Ward.

### Perception of distance and motion

The visual image sensed by the eye is two dimensional, but the brain uses a variety of cues to perceive depth and distance.<sup>462</sup> These cues include information from binocular disparity (the phenomenon that different views of the world are seen by each of a person's two eyes) and the perception of perspective and texture gradients, which are present in any feature-rich visual scene (such as looking down a busy city block).<sup>463</sup> In the absence of such depth-perception cues (for example, when looking across a desert or out over a large body of water), people cannot judge distance accurately, and an object viewed under such circumstances usually appears to be closer to the observer than it actually is.<sup>464</sup> Further, in the absence of depth perception cues, if structures, trees, or other objects are present near an observers' line of sight to a critical object, people tend to perceive the critical object and the intervening objects as equally distant from the observer.<sup>465</sup> For example, a distant tall building viewed along with several closer small buildings will appear to be located about the same distance from the observer as the short buildings. This illusion has been termed the equidistance tendency.<sup>466</sup>

Research also indicated that, if the critical object is in motion, the equidistance tendency can also have the effect of exaggerating the perceived motion of the object. Further, any motion of the observer's head may result in concurrent motion of the critical object. Under viewing conditions that cause the critical object to appear closer to the observer than it actually is, the critical object will appear to move in the same direction as the observer's head moves.<sup>467</sup> The closer the object appears to the observer, the greater the amount of apparent motion.<sup>468</sup> In other words, the perceptual error magnifies any concurrent motion of the object caused by motion of the observer's head. Further, if the critical object is actually in motion, the apparent motion that results from movement of the observer's head may enhance, cancel out, or even reverse the motion of the critical object.<sup>469</sup>

### Storing information in memory

Researchers of human memory have recognized that in addition to memory for specific events (episodic memory), human memory also contains memories that are not

---

<sup>462</sup> Bruce, V. and Green, P. R. 1992. *Visual Perception: Physiology, Psychology and Ecology*. Lawrence Erlbaum. London, England.

<sup>463</sup> Goldstein.

<sup>464</sup> Gogel, W. C. 1963. "The Visual Perception of Size and Distance." *Vision Research*. Vol. 3. p. 101-120.

<sup>465</sup> Gogel, W. C. 1965. "Equidistance Tendency and Its Consequences." *Psychological Bulletin*. Vol. 64. p. 153-163.

<sup>466</sup> Gogel.

<sup>467</sup> Gogel, W. C. and Tietz, J. D. 1973. "Absolute Motion Parallax and the Specific Distance Tendency." *Perception and Psychophysics*. Vol. 13. p. 284-302.

<sup>468</sup> Gogel, W. C. and Tietz, J. D. 1977. "Eye Fixation and Attention as Modifiers of Perceived Distance." *Perception and Motor Skills*. Vol. 45. p. 343-362.

<sup>469</sup> Gogel, W. C. 1990. "A Theory of Phenomenal Geometry and Its Applications." *Perception and Psychophysics*. Vol. 48. p. 105-123.

associated with specific events and places (semantic memory).<sup>470</sup> These semantic memories include generic information about the concepts that underlie everyday activities. Humans use elements of semantic memory in an attempt to understand sensory input.<sup>471</sup> This may occur without the observer's awareness.<sup>472</sup> For example, someone reading a newspaper does not carefully decipher the features of each letter to discover the words that they form. Rather, the reader's knowledge of the subject matter and experience with the language helps him or her anticipate the words and their meanings; this speeds reading and allows it to become an almost automatic task.

Perception of events is driven by context cues and the observer's experience and expectations,<sup>473</sup> including semantic memory. This results in a fairly immediate interpretation of the event. Thus, what is stored in memory about an event includes fragments of the event itself and elements of interpretation.<sup>474</sup>

#### 1.18.4.3.2 Retrieving Information from Memory

According to I. E. Hyman, a psychologist, "People do not simply retrieve a memory and replay the experience—memory is not like a videotape. Instead people combine...knowledge from various sources with their own personal experiences...to create memories."<sup>475</sup> Hyman has indicated that all memories are constructions. Research has also shown that memories may correctly convey the gist of an event or a conversation; however, some of the reported details are likely to be inaccurate and may reflect the witness's own beliefs or expectations about the event witnessed.<sup>476</sup> Further, vivid and confidently held memories of important events can change over time.<sup>477</sup>

Hyman has identified several types of memory errors, such as conjunction errors, memory intrusions, time slice errors, and postevent information errors.<sup>478</sup> Conjunction

---

<sup>470</sup> Tulving, E. 1972. "Episodic and Semantic Memory." *Organization of Memory*. Academic Press. New York, New York.

<sup>471</sup> Spiro, R. J. 1975. *Inferential Reconstruction for Memory for Connected Discourse*. Tech. Report No. 2. Laboratory for Cognitive Studies in Education, University of Illinois. Urbana, Illinois.

<sup>472</sup> Schneider, W. and Shiffrin, R. M. 1977. "Controlled and Automatic Human Information Processing I: Detection, Search and Attention." *Psychological Review*. Vol. 84. p. 1-66.

<sup>473</sup> Lindsay, P. H. and Norman, D. A. 1972. *Human Information Processing*. Academic Press. New York, New York.

<sup>474</sup> Rumelhart, D. E., and Ortony, A. 1977. "The Representation of Knowledge in Memory." *Schooling and the Acquisition of Knowledge*. Lawrence Erlbaum Associates. Hillsdale, New Jersey.

<sup>475</sup> Hyman, I. E. 1999. "Creating False Autobiographical Memories: Why People Believe Their Memory Errors." *Ecological Approaches to Cognition: Essays in Honor of Ulrich Neisser*. Lawrence Erlbaum Associates. Hillsdale, New Jersey.

<sup>476</sup> Neisser, U. 1981. "John Dean's Memory." *Cognition*. Vol. 9. p. 1-22. Also, Hyman, I. E. and Neisser, U. 1992. "The Role of the Self in Recollections of a Seminar." *Journal of Narrative and Life History*. Vol. 2. p. 81-103.

<sup>477</sup> Neisser, U. and Harsch, N. 1992. "Phantom Flashbacks: False Recollections of Hearing the News about Challenger." *Affect and Accuracy in Recall: Studies of "Flashbulb" Memories*. Cambridge University Press. New York, New York.

<sup>478</sup> Hyman refers to postevent information errors as "misinformation errors."



errors occur when a witness blends information from different events into a single memory. Memory intrusions (inclusion of specific information that was not originally present) occur when people incorporate their general knowledge and experiences into their memories and tend to occur in situations in which the recall of details is required or expected.<sup>479</sup> Time slice errors occur when people are asked to recall information about an event, but they erroneously recall information about an event that took place at a different time.<sup>480</sup> In other words, they recall something that may be a true event, but something that occurred before or after the event in question. Postevent information errors occur when people receive some postevent information about an event that they have observed and then later report the information as if they actually experienced it.<sup>481</sup>

Hyman has proposed three conditions that must exist for memory errors to occur: witnesses must (1) believe that the event is plausible, (2) construct an image of the event, and (3) believe that the event is a memory of something that they actually observed.<sup>482</sup> A plausible event is one that the witness believes could have actually occurred. For example, research has demonstrated that people form false memories only when they consider them to be plausible.<sup>483</sup> As further discussed below, the more reliable or knowledgeable that the witness believes the source of a suggested event is, the more likely the witness is to believe that the event is plausible.

Hyman has indicated that plausible information only becomes a false memory if witnesses construct a mental image of it. Other research supports the concept that imagining an event increases the chances of witnesses erroneously claiming that they recall it actually occurring.<sup>484</sup> In fact, Hyman believes that almost any activity that causes people to think about, imagine, or discuss events will lead to construction of images and, thus, memories.

Finally, Hyman notes that for a false memory to occur, the witness must begin to believe that the event is a memory of something that he or she actually observed. In other words, the witness must misattribute the source of the incorrect information. Researchers

---

<sup>479</sup> Hyman, I. E. and Rubin, D. C. 1990. "Memorabilia: A Naturalistic Study of Long-term Memory." *Memory and Cognition*. Vol. 18. p. 205-214.

<sup>480</sup> Brewer, W. F. 1988. "Memory for Randomly-selected Autobiographical Events." *Remembering Reconsidered: Ecological and Traditional Approaches to the Study of Memory*. Cambridge University Press. New York, New York.

<sup>481</sup> Belli, R. F. 1989. "Influences of Misleading Postevent Information: Misinformation Interference and Acceptance." *Journal of Experimental Psychology: General*. Vol. 118. p. 72-85; Loftus, E. F. 1979. "The Malleability of Human Memory." *American Scientist*. Vol. 67. p. 312-320; Loftus, E. F. 1979. "Mental Morphosis: Alterations in Memory Produced by the Bonding of New Information to Old." *Attention and Performance IX*. Lawrence Erlbaum Associates. Hillsdale, New Jersey. p. 417-434; and Loftus, E. L. and Loftus, G. R. 1980. "On the Permanency of Stored Information in the Human Brain." *American Psychologist*. Vol. 35. p. 409-420.

<sup>482</sup> Hyman. 1999.

<sup>483</sup> Hyman, I. E. and Pentland, J. 1995. "Guided Imagery and the Creation of False Childhood Memories." *Journal of Memory and Language*. Vol. 35. p. 101-117.

<sup>484</sup> Goff, L. M. and Roediger, H. L. 1996. "Imagination Inflation: Multiple Imaginings Can Lead to False Recollection of One's Actions." Paper presented at the 37th annual meeting of the Psychonomic Society. Chicago, Illinois.

have demonstrated that people also often misattribute the source of information that they have learned.<sup>485</sup> That is, they may recall a particular piece of information, but not the source of that information. For example, someone may read about an event in a newspaper and also hear about it on television. Later, he or she may correctly recall details about the event, but incorrectly recall from which source he or she learned the details. Researchers have termed such events "source monitoring errors," and research has shown that eyewitness susceptibility to postevent information errors may result in part from source monitoring errors.<sup>486</sup> It has also been demonstrated that even when witnesses may be able to accurately attribute information to a particular source (such as an interviewer or a television news report), unless carefully questioned about the source of the information, they may still report the information as if it had been personally observed.<sup>487</sup>

#### 1.18.4.3.2.1 Postevent Information

Postevent information can be acquired in a variety of ways, including from interviewers during official questioning, other witnesses, media information, and even from the witness's own thoughts as he or she "replays" the event in memory. Research has shown that an interviewer's phrasing of questions can have a considerable effect on the information elicited from people.<sup>488</sup> For example, the use of a definite article versus an indefinite article in questioning (that is, "Did you see the broken headlight?" versus "Did you see a broken headlight?") is sufficient to increase the likelihood of a positive report.<sup>489</sup> In another example, researchers found that people's estimates of speed were affected by substituting different verbs (for example, "contacted," "bumped," and "smashed") for the word "hit" in the question "How fast were the cars going when they hit each other?"<sup>490</sup>

Researchers have also found that a witnesses' perception of the level of knowledge or credibility of the interviewer affects their susceptibility to postevent information. Witnesses who are asked a biased question by an interviewer whom they believe is knowledgeable about the event are more likely to give an incorrect answer than (1) witnesses who are asked a biased question by an interviewer whom they believe to be naïve or (2) witnesses who are asked unbiased questions.<sup>491</sup> Smith and Ellsworth conducted a study in which participants viewed a videotape of a simulated bank robbery

---

<sup>485</sup> Johnson, M. K.; Hashtroudi, S.; and Lindsay, D. S. 1993. "Source Monitoring." *Psychological Bulletin*. Vol. 114. p. 3-28.

<sup>486</sup> Lindsay, D. S. and Johnson, M. K. 1989. "The Eyewitness Suggestibility Effect and Memory for Source." *Memory and Cognition*. Vol. 17. p. 349-358.

<sup>487</sup> Lindsay and Johnson.

<sup>488</sup> Horgarth, R. M. (Ed.) 1982. *Question Framing and Response Consistency*. Jossey-Bass. San Francisco, California.

<sup>489</sup> Loftus, E. F., and Zanni, G. 1975. "Eyewitness Testimony: The Influence of the Wording of a Question." *Bulletin of the Psychonomic Society*. Vol. 5. p. 86-88.

<sup>490</sup> Loftus, E. F. and Palmer, J. P. 1974. "Reconstruction of Automobile Destruction: An example of the Interaction Between Language and Memory." *Journal of Verbal Learning and Verbal Behavior*. Vol. 13. p. 585-589.

<sup>491</sup> Smith, V. L. and Ellsworth, P. C. 1987. "The Social Psychology of Eyewitness Accuracy: Misleading Questions and Communicator Expertise." *Journal of Applied Psychology*. Vol. 72(2). p. 294-300.

committed by more than one perpetrator.<sup>492</sup> The participants who were asked, "What did the other guy's gun look like?" by a knowledgeable interviewer (one they who knew had seen the videotape) in reference to an unarmed perpetrator were much more likely to report a nonexistent gun than those participants who were asked the same question by a naïve interviewer (one who they believed had not seen the videotape), or those who were asked, "Did the other guy have a gun?" (regardless of the assumed/presumed knowledge status of the interviewer).

In addition to information provided by interviewers, research has shown that people will incorporate false information provided by other witnesses on a later recall test of details about a written story.<sup>493</sup> It has also been demonstrated that people may incorporate details provided by others into their own descriptions of human faces.<sup>494</sup> Research has also documented that, in a group interview about an event that the entire group has observed, if misinformation is reported as a memory by a member of the group, the likelihood is increased that others will also report this false information as if they had also witnessed it.<sup>495</sup> This research also showed that if an interviewer claims that other witnesses to the same event (who are not present at the interview) have reported that a given detail was part of the event, the witness being questioned is more likely to report having seen the same detail, even though the detail was not part of the event.

The effect of subsequent repeated testing of the memories of subjects who were exposed to misleading postevent information has also been studied. Research has demonstrated that if witnesses reported the misinformation on the first test, they were likely to repeat the misinformation on a second test.<sup>496</sup> This, and other research<sup>497</sup> appears to show that repeated retrieval increases the probability of creating false memories. Researchers have also found that likelihood of false memory creation is increased when the postevent information is presented in multiple forms (reading, hearing, or seeing the information).<sup>498</sup>

#### 1.18.4.4 Witnesses of Special Interest

Because of their unique vantage points and/or the level of precision and detail provided in the documentation pertaining to these witnesses, the following five witnesses

---

<sup>492</sup> Smith and Ellsworth.

<sup>493</sup> Betz, A. L.; Skowronski, J. J.; and Ostrum, T. M. 1996. "Shared Realities: Social Influence and Stimulus Memories." *Social Cognition*. Vol. 14. p. 113-140.

<sup>494</sup> Loftus, E. F. and Green, E. 1980. "Warning: Even Memory for Faces May be Contagious." *Law and Human Behavior*. Vol. 4. p. 323-334.

<sup>495</sup> Shaw, J. S.; Garven, S.; and Wood, J. M. 1997. "Co-witness Information Can Have Immediate Effects on Eyewitness Memory Reports." *Law and Human Behavior*. Vol. 21. p. 503-523.

<sup>496</sup> Roediger, H. L. et. al. 1996. "Misinformation Effects in Recall: Creating False Memories Through Repeated Retrieval." *Journal of Memory and Language*. Vol. 35. p. 300-318.

<sup>497</sup> Mitchell, K. J. and Zaragoza, M. S. 1996. "Repeated Exposure to Suggestion and False Memory: The Role of Contextual Variability." *Journal of Memory and Language*. Vol. 35. p. 246-260.

<sup>498</sup> Mitchell and Zaragoza.

have generated special interest. Figure 41 is a map showing the debris zones and the position of these five witnesses.

### **The pilot of Eastwind Airlines flight 507**

According to radar data, about the time of the last secondary radar return from TWA flight 800, Eastwind flight 507 was located about 24 nm northeast of TWA flight 800's location at an altitude of about 15,400 feet.<sup>499</sup> According to a statement that he prepared on the night of the accident, the captain of Eastwind flight 507 reported seeing what looked like an off-colored "landing light" that at first he thought might be an engine fire.<sup>500</sup> He subsequently identified the "landing light" as an airplane that he needed to monitor. According to documents pertaining to an interview the day after the accident, the captain of Eastwind flight 507 estimated that he observed the airplane for about 2 to 3 minutes.<sup>501</sup> To signal the flight crew of the other aircraft that they were in sight, the Eastwind captain switched on his own landing lights. As he flicked on his own landing lights, the aircraft that he had been watching "exploded into a very large ball of flames."<sup>502</sup> According to the statement that he prepared on the evening of the accident, "[a]lmost immediately two flaming objects, with flames trailing about 4,000 feet behind them, fell out of the bottom of the ball of flame."

At 2031:50, the captain of Eastwind flight 507 reported to Boston ARTCC Sardi Sector, "we just saw an explosion out here stinger bee five oh seven." At 2037:20, he further reported, "ah yes sir it just blew up in the air and then we saw two fireballs go down to the to the water...also ah there seemed to be a light...I thought it was a landing light...and it was coming right at us at about I don't know about fifteen thousand feet or something like that and I pushed on my landing lights ah you know so I saw him and then it blew."<sup>503</sup> In the written statement that he made on the night of the accident, the captain of Eastwind flight 507 stated that he immediately called ATC after seeing the "explosion." However, during an interview on March 25, 1999, he told Safety Board investigators that after seeing the explosion, he paused for about 10 seconds before reporting the explosion to ATC.

In the statement that he made on the night of the accident, the captain of Eastwind flight 507 also indicated that "prior to the explosion I did not see any missile, air to air or

---

<sup>499</sup> For each of the pilot witnesses mentioned in this section, the Safety Board used radar data to determine positions and altitudes for witness aircraft relative to the last secondary radar return received from TWA flight 800.

<sup>500</sup> He indicated that he dismissed this possibility because he saw no smoke trail.

<sup>501</sup> In a transcribed interview by the Safety Board's Witness Group conducted about 3 years after the accident, the witness indicated that he watched the light "on and off for over two minutes, minimum but I probably had seen him [the light] for over five minutes."

<sup>502</sup> The captain indicated that the explosion occurred below his airplane at an altitude he estimated to be between about 13,000 and 15,000 feet msl.

<sup>503</sup> The captain of Eastwind flight 507 was the first airborne witness to report seeing the accident to the air traffic controller at the Boston ARTCC.

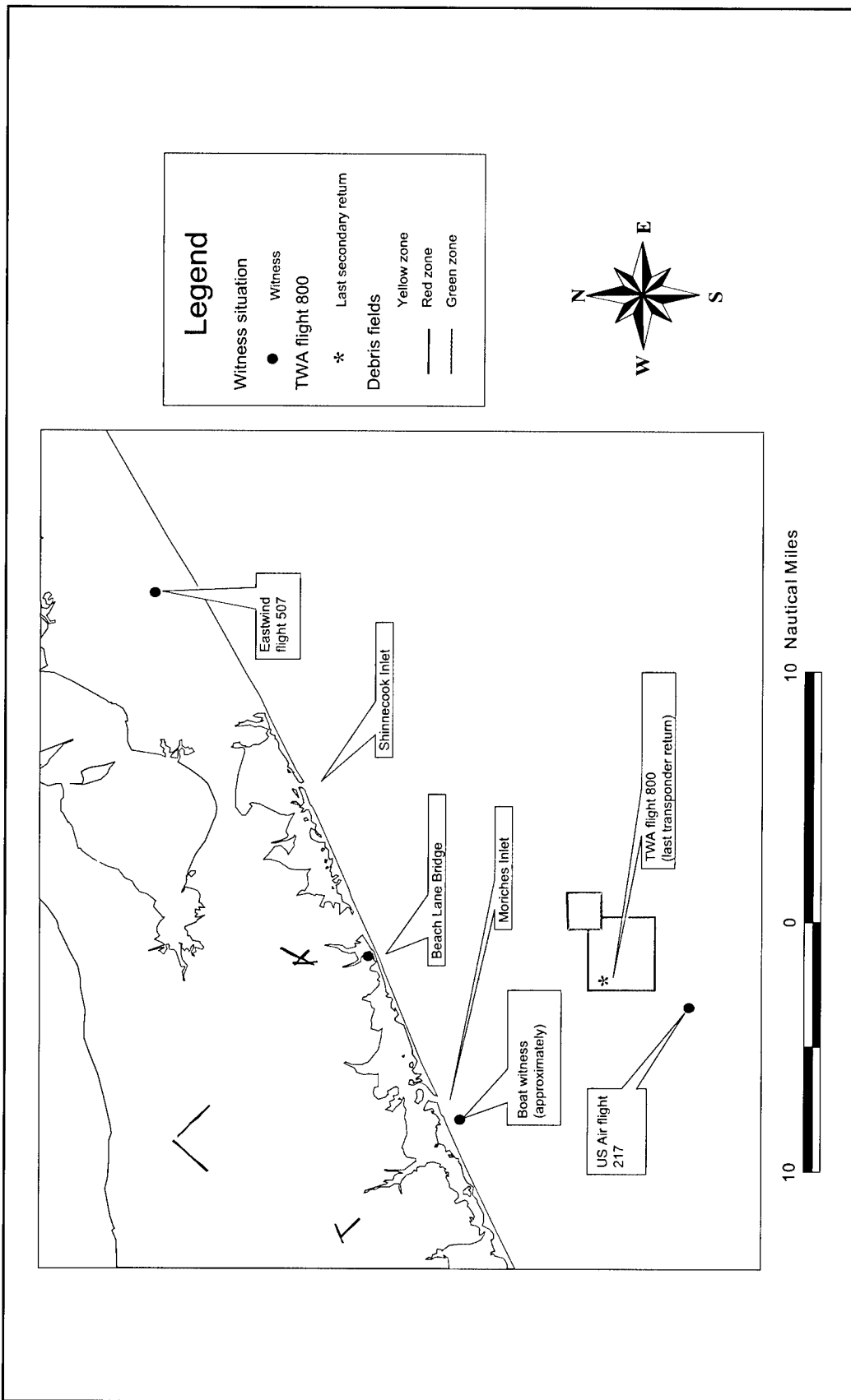

Figure 41. A map showing the debris zones and the positions of the five witnesses of special interest.

ground to air..." The pilot stated in a subsequent interview with the Safety Board that he did not see anything coming up at or hitting the other airplane.

### **The witnesses in the HH-60 helicopter**

Crewmembers (the pilot, copilot, and flight engineer) in a New York Air National Guard (NYANG) HH-60 helicopter, who at the time of the accident were performing instrument approaches about 11 nm from where the main portion of the wreckage fell into the ocean, were interviewed by the FBI shortly after the accident. According to documentation of those interviews, the pilot of the NYANG helicopter stated that he first observed a red streak of light moving very fast from right to left<sup>504</sup> and that it was traveling in a gradually descending arc—almost horizontally. He stated that he observed the streak for about 1 to 2 seconds after which he saw an explosion. He described the streak as having the trajectory and image of a shooting star. In an interview with the Safety Board's initial Witness Group (conducted on January 11, 1997), he indicated that he observed a red-orange streak of light moving horizontally for about 3 to 5 seconds in a gradually descending arc that he described as a "gentle descending trajectory"—similar to a shooting star. He then saw what he described as an explosion, followed 1 to 2 seconds later by a second and possibly a third explosion.<sup>505</sup> He stated that he then saw a fireball, which he described as "four times the size of the sun," that hit the ocean's surface about 10 seconds after he first saw the fireball.<sup>506</sup> The HH-60 pilot indicated that the fireball followed the same trajectory as the streak. According to the witness documents, the pilot stated that he had no idea what it was and that he never saw anything that he identified as an airplane.

The witness documents indicated that the copilot and flight engineer from the HH-60 stated that their first observation of the event was of flaming debris at an estimated altitude of 4,000 to 5,000 feet and that this flaming debris hit the water about 8 seconds after they first spotted it. According to the witness documents, the copilot stated that, although he did not remember it on the evening of the accident, the next day he remembered seeing an object streaking from his left to his right just before the appearance of the fireball. He characterized this object as being like an "incendiary device" or a "pyrotechnic." He stated that he then saw a succession of three explosions, each longer than the last.

### **The streak-of-light witness aboard USAirways flight 217<sup>507</sup>**

Witness documents pertaining to interviews with a passenger seated in a window seat on the right side of USAirways flight 217 (which was flying on a generally northerly

---

<sup>504</sup> During his interview with the initial witness group, the pilot of the NYANG helicopter told investigators that the helicopter was on a heading of 238°.

<sup>505</sup> The witness described the explosions as being "like flak...a hard explosion."

<sup>506</sup> During questioning about a missile by TWA's representative to the Safety Board's initial Witness Group, the pilot stated, "and when I looked up at this thing in the air, nothing said 'missile.'" However, in subsequent statements to the media, the pilot has stated that he saw an "ordnance explosion" and that he believed that a missile was used against the airplane.

heading about 2.5 nm southwest of and about 8,000 feet above TWA flight 800 at the time of the last secondary radar return) indicated that he “observed some blinking lights on a small plane flying underneath the [USAirways flight 217] aircraft...[and] approximately 15-20 seconds later, he observed a light which appeared to be a ‘flare’” for about 10 seconds moving from right to left. According to the witness documents, the witness “then observed an initial small explosion in the same area that he last observed the flare. Within a second later, the small explosion turned into a large explosion” and then a descending fireball.

Safety Board investigators used radar data to determine that the “small plane” seen passing underneath USAirways flight 217 by this witness was a U.S. Navy P-3 Orion.<sup>508</sup> According to radar data and a visibility study done by Safety Board investigators, the P-3 would have passed under USAirways flight 217 and out of view of the witness about 1 to 1 1/2 seconds before the end of the FDR data and the last radar transponder return from TWA flight 800 (that is, about the time of the explosion in the CWT). The radar data and visibility study also indicated that TWA flight 800 would not have been visible to passengers seated on the right side of USAirways flight 217 when the CWT overpressure event occurred.<sup>509</sup>

#### **The witness on the Beach Lane Bridge in Westhampton Beach, New York**

Witness documents pertaining to a witness who was standing on a bridge on Beach Lane over Quantuck Canal in Westhampton Beach, New York (9.6-nm slant range from the position of TWA flight 800’s last secondary radar return), stated that he saw “a white light that was traveling skyward from the ground at approximately a 40° angle.” He stated that it looked like “cheap fireworks” or a meteor that went up and “‘arched over’ and disappeared,” traveling in a south/southeasterly direction. However, in subsequent interviews this witness apparently acknowledged that he did not see the light originate at the surface of the earth because the light appeared in the sky above the house.<sup>510</sup>

The witness documents further indicated that the witness reported that he first saw the light above the fourth or fifth house<sup>511</sup> west of the bridge on the south side of Dune Road and that the light was visible for about 15 seconds. He said that 2 or 3 seconds after

---

<sup>507</sup> There were six additional witnesses aboard USAirways flight 217, five of whom were seated on the right side of the airplane. (It could not be determined where the sixth witness was seated.) None of these witnesses was classified by the Witness Group as having reported seeing a streak of light, but the documents indicated that all of these witnesses reported seeing a large fireball on the right side of USAirways flight 217. The document pertaining to one of these witnesses (who was seated in seat 6F) stated that before the witness saw a fireball, he saw an aircraft that “had what he took to be its landing lights on, and [he] could observe cabin lights on the vessel.” According to the document, the witness reported watching the airplane with “cabin lights” for 30 to 40 seconds, then seeing it bank to the left. The document then states, “The aircraft exploded and a large round orange fireball appeared.” The document contains no mention of any other light in the sky.

<sup>508</sup> The CIA reached the same conclusion.

<sup>509</sup> For additional information regarding the radar data and visibility study, see Witnesses 4–Witness Visibility Study, dated June 22, 2000, and Witnesses 4–Viewing Angles Study, dated July 7, 2000.

<sup>510</sup> When asked how high above the house the light was, the witness indicated that, if one were to imagine a flag pole on top of the house, the light would have appeared at the top of the flag pole.

the white light disappeared he saw an orange fireball and "the fireball descended at approximately a 30° angle and left a fire trail burning behind it." The witness reported that he saw the fireball descend behind the second house on the south side of Dune Road west of the public parking lot and, seconds after first observing the fireball, he felt and heard an explosion followed by three others.

The Safety Board obtained aerial imagery of the bridge and the houses and used it to draw sight lines. A sight line drawn from the witness position through the fourth or fifth house intersected the flightpath of TWA flight 800 near the last transponder return from the accident airplane. A sight line drawn from the witness position through the second house intersected the green zone near where the aft fuselage was recovered.

### **The witnesses on a boat near Great Gun Beach**

Witness documents indicated that three witnesses were fishing in a boat about 1 to 1 1/2 miles<sup>512</sup> from the shoreline (about 6 1/2 to 7 1/2 nm from the accident site). One of those witnesses stated that he looked up and observed a faint yellow object, which he thought might possibly be a meteor. This witness directed the attention of his companions to the object. He stated that it looked like a "shooting star" moving in a downward, 45° sloping arc and that it that grew larger and brighter. He stated that he then heard a "rushing roar" type of sound and at that moment realized that he was watching an airplane and that he saw one wing separate from the fuselage and remaining wing<sup>513</sup> at the same time as he heard and felt<sup>514</sup> an explosion. The witness reported, "It [the airplane] had rolled over onto its left side, and seemed to be hooking northward and downward." He stated that he then saw what he believed was the right wing separate from the fuselage. The other two witnesses in the boat reported that, before the object broke apart, it seemed to turn toward the north. One of the other two witnesses estimated that he observed part of the object separate from the remainder about 8 seconds after he first sighted the light. (The witness who saw the "shooting star" estimated that he began observing it before his companions saw it.)

#### **1.18.4.5 Witness Line-of-sight Study**

A line-of-sight study was conducted by the Suffolk County Police Department's Marine Bureau to determine the geographical area from which witnesses reported seeing a flarelike object.<sup>515</sup> The study was accomplished between July 20 and 30, 1996, during FBI reinterviews of several witnesses who reported seeing a streak of light or flarelike object

---

<sup>511</sup> The witness document pertaining to a July 23, 1996, FBI interview states that the witness stated that he "saw what appeared to be cheap fireworks coming off the beach about 4 or 5 houses west of the bridge." A document pertaining to a more detailed FBI interview on July 29, 1996, states that the "white light came in to view just above the roof top of the fourth house west of the public parking area on Dune Road."

<sup>512</sup> In one document of an interview with the witness who first saw the object, the witness estimated that he was about 1 1/2 miles from the shoreline. In a second document, the witness stated that he was about 1 mile offshore.

<sup>513</sup> The witness stated that he saw the right wing separate from the fuselage; however, the Sequencing Group determined that the left wing separated from the fuselage and right wing.

<sup>514</sup> He reported that he felt a concussion on his chest at the same time as he saw the wing separate.



on the evening of July 17, 1996. During these reinterviews, the witnesses were taken to the locations from which they made their observations. The position (latitude and longitude) of each witness and the horizontal direction (azimuth) were recorded for each witness location to the area where he or she observed the streak of light or flarelike object.<sup>516</sup> Data from witnesses who could describe their positions and their observations of the flarelike object relative to fixed reference points (such as a flagpole or a building) were recorded and then plotted on a map of the accident debris fields. Lines depicting the azimuth from the witness's position to the area that the witness reported seeing the streak of light or flarelike object were also drawn.

The line-of-sight study determined the latitude and longitude of two points at which the sight lines appeared to intersect (according to the Suffolk County Police Department's Marine Bureau) and recommended that the FBI search a 1-nm area around these points for evidence of a missile.<sup>517</sup> Safety Board investigators also plotted these data, developed a sight line plot map using computer map-making software, and determined that 7 of the 11 sight lines intersected the green zone debris field and that two passed just north of it. Figure 42 shows a map of the sight lines plotted for 11 of the witnesses.

#### 1.18.4.6 Central Intelligence Agency Review of the Witness Data

Early in the investigation, at the FBI's request, the CIA reviewed data regarding the TWA flight 800 accident (including witness reports and information; FDR, CVR, ATC, and radar data; and infrared sensor information from a U.S. satellite) to determine if the streak of light reported by many of the witnesses might have been a missile. The CIA's video<sup>518</sup> stated that "not surprisingly, most eyewitnesses saw only the most conspicuous segment of the disaster—the fire trail and cascade of flames in the 10 to 15 seconds before the aircraft hit the water."

The CIA video indicated that because "sound from the aircraft's explosion took more than 40 seconds to reach each of the 58 eyewitnesses [that they evaluated<sup>519</sup>] who reported hearing sounds associated with the disaster. Therefore, any events eyewitnesses reported seeing at about the time they heard the first sound took place well after the explosion." The CIA video concluded that "most [witnesses] describe observations made only during the final moments of the disaster—well after the aircraft exploded....To date, there is no evidence that anyone saw a missile shoot down TWA flight 800."

---

<sup>515</sup> The FBI requested this study as part of its investigation of the possibility that a missile had been used against the accident airplane.

<sup>516</sup> A Garmin Model 45 GPS receiver was used to determine position (in degrees, minutes, and seconds), and a hand-held magnetic compass was used to determine azimuth (in magnetic degrees).

<sup>517</sup> These two locations were well within the undersea area covered by the 9-month search and recovery operation that concluded in April/May 1997. (See appendix C for information regarding the search and recovery operation.)

<sup>518</sup> For additional information, see the CIA video, "TWA Flight 800: What did the witnesses see?," first shown at the November 18, 1997, FBI press conference.

<sup>519</sup> The FBI provided the CIA with only some of the witness documents that were later provided to the Safety Board.

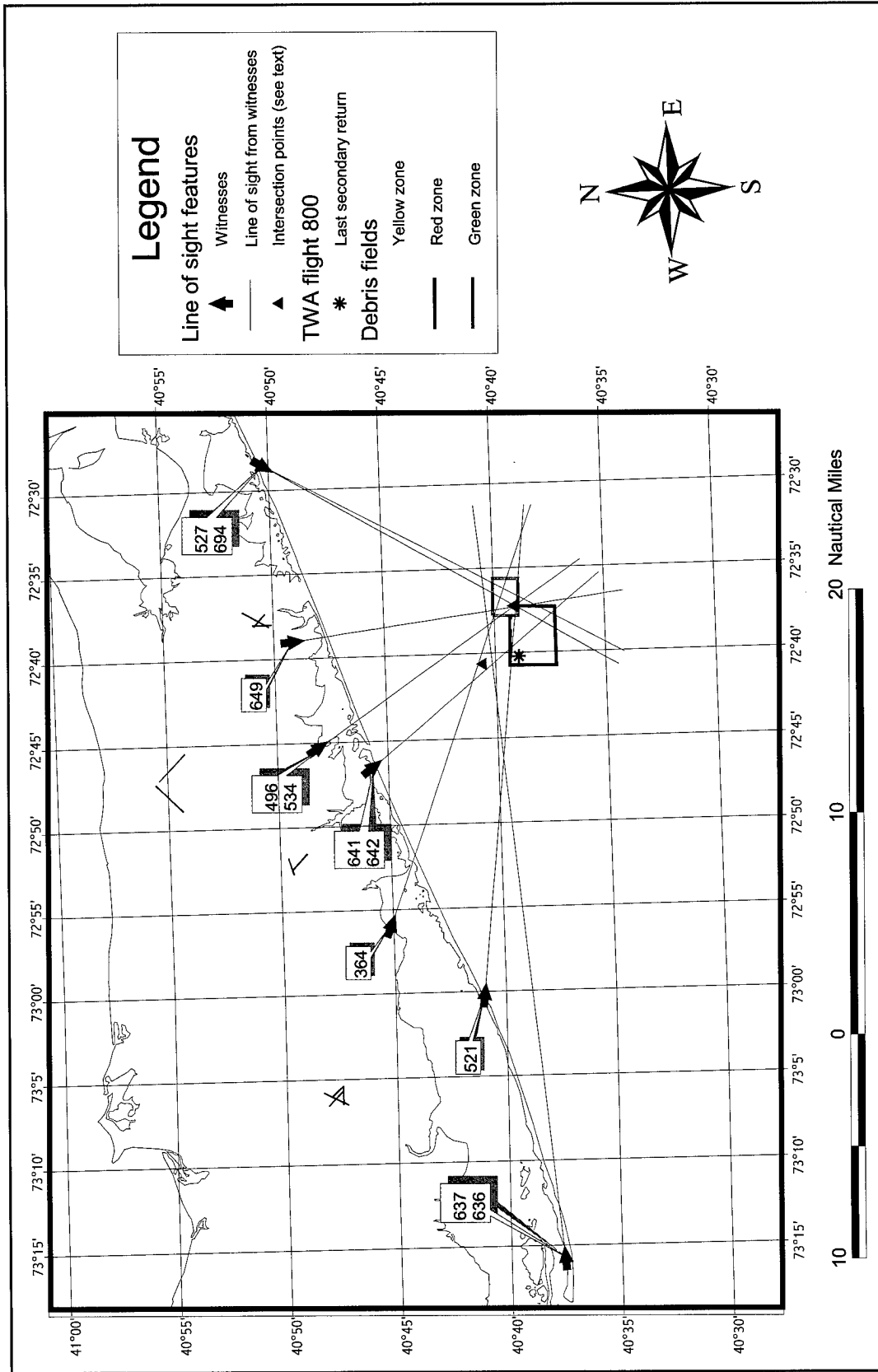

Figure 42. Map of sight lines plotted for 11 witnesses.

#### 1.18.4.7 Missile-Related Information

At the Safety Board's request, the Naval Air Warfare Center—Weapons Division (NAWC-WD) at China Lake, California, provided assistance in identifying possible missile impact damage on the accident airplane wreckage. NAWC-WD experts conducted detailed examinations of the recovered wreckage and reconstructions and analyzed other data to evaluate the possibility that a shoulder-launched missile destroyed the airplane.<sup>520</sup>

According to a ballistics/warhead testing expert from the NAWC-WD, if a missile<sup>521</sup> with a live warhead impacted the airplane and detonated, the wreckage would likely have exhibited extensive damage to the impact area from the initial penetration of the missile and the subsequent dispersion of high-velocity postdetonation fragments. He described the following four regions<sup>522</sup> of warhead damage as being typical for nearly all missile warheads:

- The first region, which is in the immediate vicinity of the detonation, is characterized by complete removal of the structure...due to weakening by fragment penetrations and dislocation by the blast pressure wave.
- The second region contains numerous high-velocity<sup>523</sup> fragment penetrations, soot residue from the explosive, and may exhibit distortion, but not widespread removal, of structure...due to the pressure wave.
- The third region contains more widely spaced high-velocity fragment penetrations, usually with little evidence of sooting or pressure wave damage.
- The fourth region contains only occasional high- and low-velocity fragment penetrations.

---

<sup>520</sup> For detailed information, see the NAWC-WD report, "TWA Flight 800 Missile Impact Analysis," dated December 1997.

<sup>521</sup> The expert considered it most likely that, if a missile were involved in the TWA flight 800 accident, it would be a shoulder-launched missile (a Man Portables Air Defense System) because (1) shoulder-launched missiles are available and are effective terrorist weapons and (2) larger surface-to-air and air-to-air missile systems are expensive, require training and equipment not readily available, and leave clearly identifiable evidence over larger areas of the target than shoulder-launched systems.

<sup>522</sup> According to the NAWC-WD expert, these regions did not have distinct boundaries between each other, and overlapping of characteristic damage between regions is common.

<sup>523</sup> The expert defined high-velocity as "in excess of around 4,000 feet per second" and indicated that holes resulting from high-velocity penetrations would be "visually quite different from low-velocity impacts."

According to the NAWC-WD ballistics/warhead testing expert, although some types of damage inflicted by warheads can be caused by other events<sup>524</sup>

high-velocity fragment penetrations are unique to explosive events and give investigators a conclusive method of identifying these encounters when they occur. Previous testing on both commercial and military aircraft has shown that even with small shoulder-launched weapons, high-velocity fragmentation damage to the aircraft will exist over large areas of the target....Based on previous testing performed by the military and [FAA], it is inconceivable that a warhead could have detonated in or near the fuselage without leaving evidence of high-velocity fragmentation damage somewhere on the recovered wreckage.

NAWC-WD also performed infrared signature measurements of 747s on approach to a commercial airport to identify the most likely tracking points for a shoulder-launched missile. According to the NAWC-WD report, infrared seekers on shoulder-launched missiles typically aim for hot spots, such as engine exhausts or inlets. The NAWC-WD infrared measurements showed that the four engines and the underside of the fuselage where the air conditioning pack bay is located (under the CWT) were the "hot spots" on the 747. The NAWC-WD report indicated that its experts observed no evidence of high-velocity fragmentation damage on the accident airplane. Specifically, the report indicated that no such damage was observed on the accident airplane's engines or air conditioning pack components.

The NAWC-WD report concluded the following:

No conclusive evidence of missile impacts exists on any of the recovered wreckage of TWA flight 800. No evidence of high-velocity fragment impacts exists, which indicates a live warhead did not detonate within or near the exterior of the aircraft....The possibility that a shoulder-launched missile was launched at TWA flight 800, failed to intercept it, self-destructed in close proximity,<sup>525</sup> and initiated the breakup of the aircraft is highly improbable."

The Safety Board used missile performance data provided by NAWC-WD, warhead detonation data from the Defense Intelligence Agency's Missile and Space Intelligence Center (MSIC), and damage tolerance data from the Survivability/Vulnerability Information Analysis Center (SURVIAC) in a computer simulation study to further evaluate the possibility that a shoulder-launched missile aimed at the accident airplane did not reach its target but selfdestructed at a point close enough for a fragment to enter the CWT.<sup>526</sup>

According to the Safety Board's study, for missile selfdestruction to be a possible source of CWT ignition for TWA flight 800, the missile must be (1) close enough at detonation for a fragment to enter the CWT, (2) oriented such that the fragmentation

---

<sup>524</sup> For example, soot deposits may be caused by a fuel-fed fire, and low-velocity penetrations may be caused by ground/water impacts.

<sup>525</sup> According to missile warhead experts, shoulder-launched missiles will selfdestruct their warheads about 15 to 17 seconds after they are launched if they do not reach a target.

<sup>526</sup> For additional information, see Missile Self Destruct Performance Study, dated April 13, 2000.

pattern intersects the CWT, and (3) far enough away at detonation that the airplane was not peppered with holes.<sup>527</sup>

In an effort to bracket the possible missile performance range, NAWC-WD provided the Safety Board with data for a low-performance and a high-performance missile.<sup>528</sup> According to NAWC-WD personnel, a typical missile flight would consist of about 8 seconds of engine burn (7.8 and 8.4 seconds for the two missiles the Board received data for) followed by a high-speed coast of about 7 to 9 seconds to selfdestruction if no target has been hit. During the 15- to 17-second flight, the missile would track to a heat source on the airplane.

According to the MSIC, warhead detonation typically results in about 1,000 fragments of various sizes, with an average mass of less than 10 grains (0.0229 ounce), and a mass as large as 40 grains (0.0916 ounce) in the pattern shown in figure 43. MSIC reported that warhead fragments could have an initial velocity of up to 9,000 fps. Data obtained from the SURVIAC indicated that 10- and 40-grain fragments would require velocities of 3,500 fps and 2,000 fps, respectively, to penetrate the CWT if they impacted the bottom of the CWT at a right angle. Using the initial speed and speed decay rate for the warhead fragments, the Safety Board calculated that a detonation would have to occur 40 feet or less below the airplane's CWT for a fragment to retain sufficient velocity to penetrate the CWT.

SURVIAC's data indicated that an even greater velocity would be required for a fragment to penetrate the CWT if it struck the bottom of the CWT at an angle. For example, a 40-grain fragment impacting the CWT at a 60° angle would require a velocity of more than 4,500 fps to penetrate the bottom of the tank. Using the initial speed and speed decay rate for the warhead fragments, the Safety Board calculated that a detonation would have to occur within 17 feet of the airplane's CWT for a fragment to retain sufficient velocity to penetrate the CWT at a 60° angle. Further, SURVIAC data showed that a fragment loses both velocity and mass when it must pass through other layers of material (such as metal or fiberglass) before penetrating the component of interest (in this case, the CWT). Additionally, when the fragment speed decay rate was adjusted to represent a fragment passing through Jet A fuel, calculations indicated that the fragment would slow from 9,000 fps to 2,000 fps in less than 1 inch. The Board notes that, regardless of where the detonation occurred, a missile fragment would have had to have penetrated multiple layers of material to enter the CWT.

---

<sup>527</sup> As previously discussed, examination of the wreckage revealed only two holes in the horizontal pressure deck (above the left side of the wing landing gear bay) that contained some features of both high-velocity and low-velocity penetrations. However, the features of these penetrations indicated that they were made by objects coming from different directions; therefore, it is not likely that they originated from a common location. Moreover, the physical features of both holes indicated they were made by objects traveling from inside the airplane out, rather than the reverse.

<sup>528</sup> Because of the sensitive nature of the data, the missiles for which data were provided were not identified.

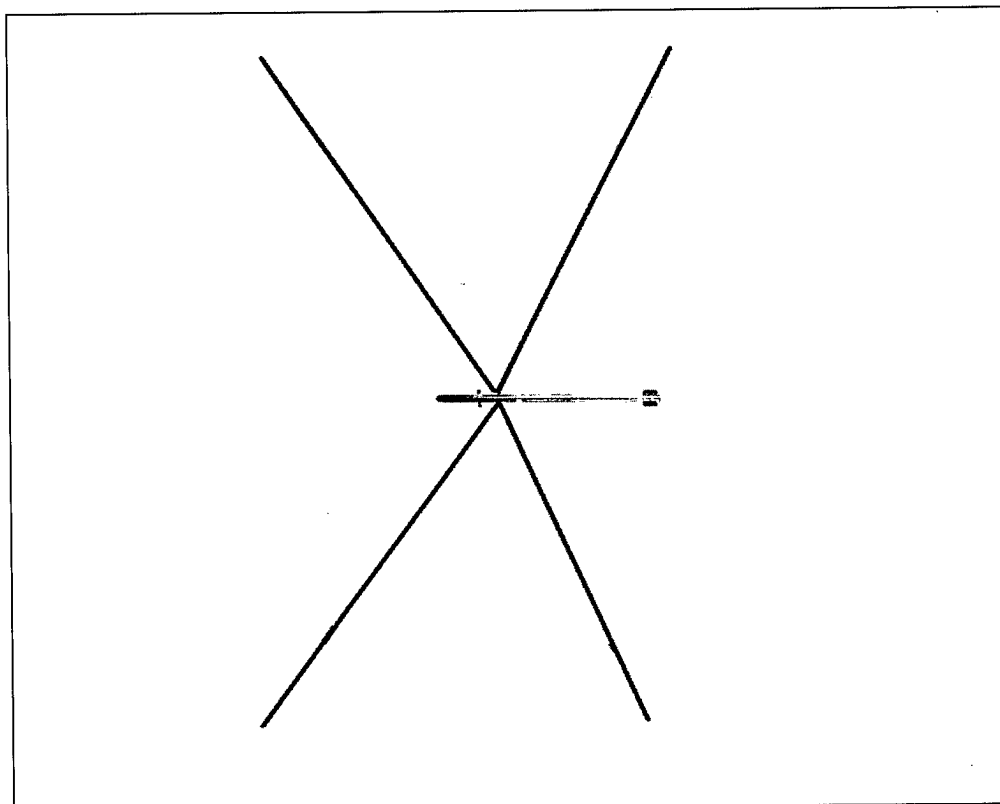

**Figure 43.** Diagram of warhead detonation fragment pattern.

The Safety Board's computer simulations (using this missile performance data and taking into account the winds at the time of the accident) showed that the locations on the surface from which a missile launched at TWA flight 800 would result in selfdestruction within 40 feet of the airplane were extremely limited. Figure 44 shows airplane locations at which, if a high-performance missile were launched at the airplane, the missile would selfdestruct within 40 feet of the airplane. Note that, at the scale shown, the launch area that would result in a selfdestruction within 40 feet of the airplane is not as wide as the line showing the 15-second perimeter in this figure.

Simulations further showed that, because of the pattern in which missile fragments are dispersed after selfdestruction (see figure 43), launches from many of these positions would result in no fragments having a trajectory that would result in penetration of the CWT. For example, because of the nature of missile guidance, a launch from most positions on the perimeter shown in figure 44 would result in the missile catching the aircraft from behind. The area in front of the missile is not in the fragment dispersal area.

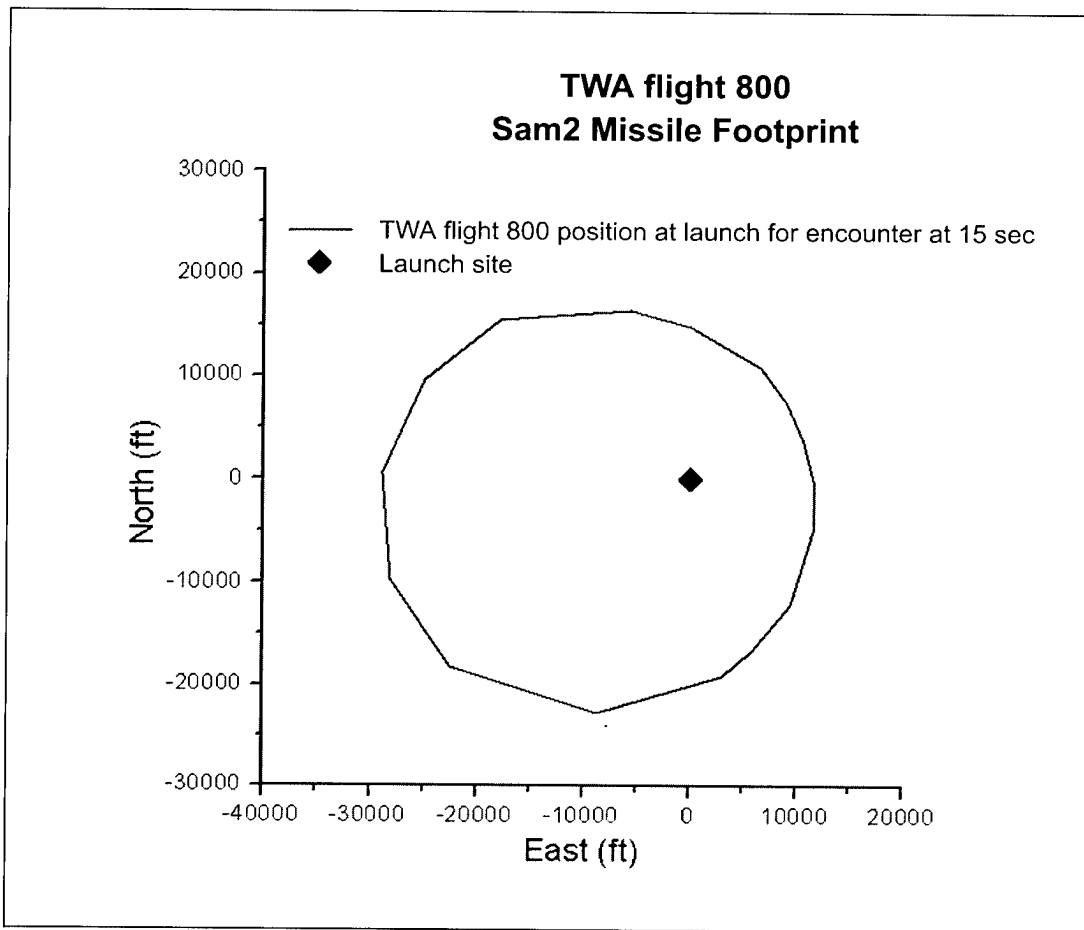

**Figure 44.** Diagram showing airplane and missile launch site locations that could result in missile selfdestruct within 40 feet of the plane.

#### 1.18.4.7.1 Missile Visibility Study

On the basis of performance data for a fairly high-performance, shoulder-launched missile, to collide with TWA flight 800, a hypothetical missile would have had to have been launched between about 4.5 nm and 11 nm from shore. Safety Board investigators consulted with missile experts in U.S. intelligence and defense communities to determine if the launch and flight signatures of a shoulder-fired missile would be detectable at those distances. Weapons systems experts indicated that there were no data available on which to base an answer to this question. Consequently, the Board conducted (and videotaped) missile visibility tests on April 28, 2000, at Eglin Air Force Base, Fort Walton Beach, Florida, to determine if observers could see and describe the characteristics of a missile launch.

The missiles were launched just after sunset on April 28, 2000, when the surface weather conditions and the position of the sun were similar to the conditions on Long Island at the time of the accident. Observer groups were positioned every 2 nm from the launch point out to 14 nm.<sup>529</sup> The observers were told where to look, and they listened to the launch countdowns via handheld radios. Although nine countdowns were

accomplished, only three missiles were launched. The observers did not know which countdowns would lead to launches and which would not. Statements and other information were obtained from the observers between countdowns.

The three missile launches were easily detected by all of the observers. There were four false alarms (reports of something moving in the sky after a countdown that was *not* followed by a missile launch). According to the observers, the launched missiles appeared as a bright light or flame rising from the surface. The observers also indicated that the light was only visible during the (about 7 to 8 second) burn, and then they observed nothing until the missile selfdestructed about 7 to 8 seconds later.<sup>530</sup> Observers who reported seeing the missile selfdestruct described it as an abrupt flash of light. Some of the closest observers reported hearing a muffled boom about 20 to 30 seconds after they observed the flash of light. All observers reported that they were unable to see the body of the missile from any range.<sup>531</sup>

---

<sup>529</sup> The observers who were positioned 14 nm from the launch site were originally positioned closer to the missile launch site (12 nm out), with instructions to move farther out for subsequent launches if the missile was visible from the closer position during the first observed launch. Thus, the lighting conditions for the tests during which these witnesses were positioned 14 nm from the launch site were darker than in earlier tests. For the first launch, which was conducted under lighting conditions that were comparable to those that existed at the time of the TWA flight 800 accident, no observers were positioned farther than 12 nm from the launch site.

<sup>530</sup> Not all observers reported observing the missile selfdestruct. For example, during the first launch, five of the six observers positioned within 6 nm of the launch site reported observing the missile selfdestruct. None of the observers positioned more than 6 nm from the launch site reported observing the missile selfdestruct.

<sup>531</sup> For the second launch, one observer at 10 nm replied, "maybe," when asked if he saw the missile body. He answered negatively for the other two launches, including the first launch, which was conducted under lighting conditions comparable to those that existed at the time of the TWA flight 800 accident.



## 2. Analysis

### 2.1 General

The flight crew was properly certificated and qualified and had received the training and off-duty time prescribed by Federal regulations. No evidence indicated any preexisting medical or behavioral conditions that might have adversely affected the flight crew's performance during the accident flight.

The airplane was certificated, equipped, and dispatched in accordance with Federal regulations and approved TWA procedures. (Maintenance issues relating to airplane wiring are discussed in section 2.5.)

At the time of the accident, there were light winds and scattered clouds in the area, but there were no significant meteorological conditions that might have disrupted the flight.

### 2.2 The Accident Sequence

#### 2.2.1 The In-Flight Breakup

On July 17, 1996, about 2019, TWA flight 800 took off from John F. Kennedy International Airport (JFK), New York, New York, destined for Charles DeGaulle International Airport, Paris, France. The airplane climbed over the Atlantic Ocean without incident and leveled off at its assigned altitude of 13,000 feet about 2027. At 2030:18, in response to an air traffic control (ATC) instruction to climb to 15,000 feet, the flight crew increased the airplane's engine thrust. The airplane was ascending through 13,760 feet at 2031:12 when both the cockpit voice recorder (CVR) and the flight data recorder ceased recording without warning.

Many witnesses in the area of the accident at the time that it occurred reported that they saw and/or heard an explosion, accompanied by a fireball over the ocean, and observed debris falling to the water. These witness reports and the widespread distribution of the wreckage indicated that TWA flight 800 had experienced a catastrophic in-flight structural breakup. In addition, a noise recorded on the CVR in the last few tenths of a second before the CVR recording stopped was similar to the last noises heard on CVR recordings from other airplanes that had experienced structural breakups (including fuel tank explosions).<sup>532</sup> On the basis of this initial information, investigators considered several possible causes for TWA flight 800's in-flight structural breakup: a structural failure and decompression; detonation of a high-energy explosive device, such as a bomb

---

<sup>532</sup> For more information about CVR-related tests, see section 1.11.1.2.

exploding inside the airplane or a missile warhead exploding upon impact with the airplane; and a fuel/air explosion in the center wing fuel tank (CWT).

### **2.2.1.1 Consideration of a Structural Failure and Decompression**

Close examination of the wreckage revealed no evidence of preexisting airplane structural faults (such as fatigue, corrosion, or mechanical damage) that could have contributed to the in-flight breakup. The examination revealed that the structure did have minimal preexisting corrosion damage, none of which could have led to or affected the breakup of the airplane. Small fatigue cracks were found in some parts of the airplane, including in the lower chord of the front spar and in the shear ties for the floor beams and stiffeners at the front spar; however, none of these cracks had coalesced into a propagating crack that could have led to the in-flight breakup. Further, although the joint between fuselage sections 41 and 42 on some 747s purportedly had been subject to manufacturing assembly problems, there was no evidence that it had separated in any locations before impact.

It was also suggested that the breakup could have been initiated by the in-flight separation of the forward cargo door. However, all eight of the latching cams along the bottom of the door (and some pieces of the cargo door itself) remained attached to the pins along the lower door sill, and there were no indications of preimpact failure of the hinge at the top of the door. This evidence indicates that the door was closed and locked at impact. Further, deformation and fracture patterns on the door matched damage to the adjacent fuselage structure, confirming that the door was in the closed position at the time of impact. Therefore, the Safety Board concludes that the in-flight breakup of TWA flight 800 was not initiated by a preexisting condition resulting in a structural failure and decompression.

### **2.2.1.2 Consideration of a High-Energy Explosive Device Detonation (Bomb or Missile Warhead)**

Several factors led to speculation that the accident might have been caused by a bomb or missile strike. These factors included heightened safety and security concerns because of the 1996 Olympics then being held in the United States, the fact that TWA flight 800 was an international flight, and the sudden and catastrophic nature of the in-flight breakup. In addition, numerous witnesses to the accident reported seeing a streak of light and then a fireball, which some people believed represented a missile destroying the airplane.<sup>533</sup> Further, some anomalous primary radar targets were recorded by the Islip, New York, radar site in the general vicinity of TWA flight 800 at the time of the accident that apparently could not be explained.<sup>534</sup> Accordingly, the Safety Board considered the possibility that a bomb<sup>535</sup> exploded inside the airplane or that a missile warhead from a shoulder-launched missile exploded upon impact with the airplane.<sup>536</sup>

Testing performed by the Federal Bureau of Investigation (FBI) found trace amounts of explosives on three separate pieces of airplane wreckage (described by the FBI

---

<sup>533</sup> For more information about these witness reports, see section 2.2.2.

as a piece of canvaslike material and two pieces of floor panel). However, none of the damage characteristics typically associated with a high-energy explosion of a bomb or missile warhead (such as severe pitting, cratering, petalling, or hot gas washing) were found on any portion of the recovered airplane structure, including the pieces on which the trace amounts of explosives were found. Only about 5 percent of the airplane's fuselage was not recovered, and none of the areas of missing fuselage were large enough to have encompassed all of the damage that would have been caused by the detonation of a bomb or missile. Although several large holes are visible in the reconstructed portion of the airplane fuselage, almost all of the structure that originally filled in these holes is attached to the remaining structure but is folded either inward or outward. No area of structure in the reconstructed portion of the airplane contained any unexplained holes large enough to represent the entry point of a missile.<sup>537</sup> Further, the victims' remains showed no evidence of injuries that could have been caused by high-energy explosives,<sup>538</sup> nor was there any damage to the airplane seats and other interior components consistent with a high-energy explosion.

Investigators considered several scenarios to determine how the trace amounts of explosive residue might have gotten on the wreckage from the accident airplane. Trace amounts of explosive residue could have been transferred to the contaminated pieces from the military personnel (and their associated clothing, boots, and equipment) that were on

---

<sup>534</sup> Investigators closely evaluated three sequences of primary radar returns recorded by the Islip radar site around the time of the accident (from about 1 minute before the accident to 9 minutes after), which appear to show three targets moving at 300 to 400 knots ground speed about 10 nautical miles (nm) southwest of the accident. None of the three sequences intersected TWA flight 800's position at any time, and all of them were moving away from the accident airplane. For each of these three sequences of primary returns, investigators found that the signal strengths varied randomly from very high to very low, the azimuth was always 150° to 160° relative to the radar, and there were no primary or secondary tracks leading to or away from them. Further, Islip was the only radar site out of six primary radar sites covering this airspace that recorded these primary returns. Investigators learned from air traffic controllers and radar technicians that ground or building reflections of primary radar returns from aircraft flying in one geographic area can cause "false primary" targets to be recorded as though the aircraft were flying in another geographic area. Numerous buildings and structures in the area around the Islip radar site could have created such reflections. Investigators identified commercial airplanes traveling through other areas within the coverage of the Islip radar at the same time that the three sequences of primary returns were recorded; these airplanes had similar ground speeds and flightpaths as the three sequences of primary radar returns. These findings indicate that the three sequences of 300 to 400 knot primary radar returns recorded by the Islip radar site between about 2030 and 2040 do not represent unexplained objects (such as a missile) but, rather, represent false or reflected returns from actual aircraft in other geographic areas.

<sup>535</sup> For the purposes of this discussion, the term "bomb" means an explosive device designed to release destructive material at high velocity upon detonation. The term does not refer to an explosive device designed only to set off a small charge of sufficient strength to penetrate the fuel tank and ignite explosive vapors. The possibility that such a device might have ignited the fuel/air vapor in the CWT is discussed in section 2.2.1.2.

<sup>536</sup> The possibility that the CWT was ignited by a missile fragment from a missile warhead that exploded at a sufficient distance from the airplane such that most of the other fragments would not have caused the type of damage typically left by an exploding missile warhead is discussed in section 2.3.1.3.

<sup>537</sup> The largest missing area in the portion of the airplane fuselage recovered from the red zone (where the first pieces to depart the airplane would have landed) was about 1 square foot. A missile warhead is about 3 inches in diameter; however, the underlying structural pieces (stringers and/or frames) in each of the areas of missing fuselage showed no signs of penetration by a missile warhead.

board the accident airplane when it was used to transport troops during the Gulf War in 1991. In addition, explosives were placed and then removed from several locations in the accident airplane during a dog-training explosive detection exercise about 1 month before the accident.<sup>539</sup>

However, testing by the Federal Aviation Administration's (FAA) Technical Center indicated that residues of explosives found on the accident airplane would dissipate completely after 2 days of immersion in sea water.<sup>540</sup> Very few pieces of airplane wreckage were recovered during the first 2 days after the accident, and those pieces that were recovered were found floating on the ocean's surface; several days of side-scan sonar searching preceded any underwater wreckage recovery operations. Therefore, it is very likely that the pieces on which the explosive residues were found were immersed in ocean water for considerably more than 2 days before they were recovered.

Thus, it is quite possible that the trace amounts of explosive residue detected on wreckage pieces from the accident airplane were not present before the airplane entered the water but, rather, were deposited during or after recovery operations. The military personnel, ships, and ground vehicles used during the recovery operations had come into frequent previous contact with explosives. Trace amounts of those substances could have been transferred from the surfaces of the ships or ground vehicles, or from clothing and boots of military personnel, onto wreckage pieces during the recovery operations or through subsequent contact with the pieces in the airplane hangar where the airplane wreckage was later assembled and laid out.

Despite being unable to determine the exact source of the trace amounts of explosive residue found on the wreckage, the lack of any corroborating evidence associated with a high-energy explosion indicates that these trace amounts did not result from the detonation of a high-energy explosive device on TWA flight 800. Accordingly, the Safety Board concludes that the in-flight breakup of TWA flight 800 was not initiated by a bomb or a missile strike.

### **2.2.1.3 Consideration of a Fuel/Air Explosion in the Center Wing Fuel Tank**

It was clear from the wreckage recovery locations that the first pieces to depart the airplane were from the area in and around the airplane's wing center section (WCS),

---

<sup>538</sup> According to a medical/forensic analysis report prepared for the Department of Justice/FBI by a medical/forensic expert, all injuries were consistent with a severe in-flight breakup and subsequent water impact.

<sup>539</sup> During that exercise, an airport police officer placed five training aids containing explosives (one of which was cracked and could have released small amounts of explosives) in various locations inside the passenger cabin. The officer's activities were limited to the forward portion (forward of row 30) of the airplane. Training aids were placed in the following five locations: (1) in row 1, in the center armrest compartment separating seats 1 and 2; (2) in a small closet at the rear of the upper deck; (3) in row 10, inside the rear pouch of the seatback in front of seat 9; (4) in row 20, in the overhead compartment above seats 1 and 2; and (5) beside exit door R3.

<sup>540</sup> The testing included both cloth and aluminum airplane pieces that were contaminated by manually deposited explosives and by exposure to an actual explosion. In both cases, no trace of explosives remained after 2 days of immersion in sea water.

which includes the CWT, and, therefore, that the breakup must have initiated in this area. Specifically, wreckage found in the red zone (the wreckage zone closest to JFK along the airplane's flightpath and, therefore, containing the earliest pieces to depart the airplane) consisted primarily of pieces from the WCS front spar and spanwise beam (SWB) 3, the manufacturing access door from SWB2,<sup>541</sup> the two forward air conditioning packs, large pieces of a ring of fuselage structure just in front of the wing front spar, and main cabin floor beams and flooring material from above the WCS and from the fuselage in front of the WCS. None of these pieces showed evidence of prolonged fire exposure. (There was insufficient fuel in the CWT for its destruction to have resulted in a significant fire.)<sup>542</sup> However, some pieces were lightly sooted, indicating that there was some fire associated with the initial event in this area.

As discussed in section 1.16.3, the Metallurgy Structures/Sequencing Group's sequencing study concluded (in part because pieces from inside the CWT were among the first pieces to depart the airplane) that the initial event in the breakup sequence was an overpressure event<sup>543</sup> within the CWT and that the earliest piece of the airplane to be disturbed was SWB3. Specifically, the Sequencing Group concluded that SWB3 fractured at its upper end and that overpressure within the CWT caused it to rotate forward about its lower end. As the upper end of SWB3 rotated forward, it impacted the aft surface of the front spar, leaving distinct witness marks across most of the front spar. Analysis of the wreckage further indicated that when SWB3 impacted the front spar, it initiated multiple fractures along the upper chord of the front spar. Overpressure escaping from the CWT caused the front spar to bulge forward on either side of the two potable water bottles attached next to each other at the center of the front spar. The upper end of the front spar then completely separated from the upper skin of the WCS. After the upper end of the front spar was completely separated from the upper skin, the overpressure remaining within the CWT forced the WCS lower skin and the forward end of the keel beam downward. Downward loading of the forward end of the keel beam greatly increased the stress in the ring chord and in the fuselage skin adjacent to the front spar.

As the keel beam was forced downward, cracking propagated down through the lower pressure bulkhead and ring chord and immediately entered the fuselage skin at stringer 40 right. This initial fuselage skin crack at stringer 40 right propagated forward at an angle to the left (toward the bottom center of the airplane), then branched circumferentially left and right, and then (from the left branch) propagated back toward the front spar on the lower left side. Thus, at this point, the fuselage skin had cracked

---

<sup>541</sup> The remainder of SWB2 was found in the green zone (the wreckage zone farthest from JFK along the airplane's flightpath, and, therefore, containing the last pieces to depart the airplane). The manufacturing door was only lightly sooted, whereas the sooting on the remainder of SWB2 was moderate to heavy, indicating that the remaining portion of the WCS was subjected to a more substantial fire after the early departure of the manufacturing door.

<sup>542</sup> Therefore, the large "fireball" described by some witnesses could not have been caused by the initial destruction of the CWT. For additional discussion about the nature of the reported fireball, see section 2.2.2.1.

<sup>543</sup> As previously mentioned, the Sequencing Group defined an overpressure event as "one that would create sufficient pressure in a relatively short time to a level at which the structural integrity of the CWT is compromised."

around three sides of a large piece of fuselage structure (including the piece identified after recovery operations as "LF6A"); only the side adjacent to the lower pressure bulkhead (beneath the front spar) remained attached to the other structure.

Downward loading (from normal cabin pressurization and vented CWT overpressure) on this weakened fuselage piece was transmitted to the forward end of the keel beam, which caused it to separate from the WCS lower skin panel and fracture about 22 inches aft of the mid spar. The separation of the large piece of fuselage created a large opening in the fuselage, just forward of the front spar, through which pieces of the front spar, SWB3, and the manufacturing access door from SWB2 exited the airplane. (The apparent forward and upward motion of the manufacturing access door after it separated from SWB2 at its lower edge indicates that, at that time, the pressure on the aft surface of the door was greater than on the forward surface, consistent with venting of the overpressure forward of SWB2 through the large opening in the bottom of the fuselage.) The sequencing study determined that the breakup sequence was initiated by an overpressure inside the CWT. Because there was no evidence that a high-energy explosive device detonated in this (or any other) area of the airplane, this overpressure could only have been caused by a fuel/air explosion in the CWT.

Safety Board flight tests that recreated, to the extent possible, the conditions experienced by the accident airplane indicated that fuel vapor temperatures within the CWT at the time of the accident ranged from 101° to 127° F. Further, Safety Board-sponsored testing at the CIT showed that Jet A fuel vapors under conditions simulating the pressure, altitude, and fuel mass loading of TWA flight 800 are flammable at these temperatures and at those as low as 96.4° F. Therefore, the Safety Board concludes that the fuel/air vapor in the ullage of TWA flight 800's CWT was flammable at the time of the accident.

Early in the investigation, questions were raised about whether a Jet A fuel/air explosion in the CWT, without any additional forces, could generate sufficient pressure to break apart the fuel tank and lead to the destruction of the airplane. This issue was explored in July and August 1997 when, as part of a series of tests using an out-of-service 747 at Bruntingthorpe Airfield, Leicestershire, England, investigators simulated a fuel/air explosion in the CWT by igniting a propane/air mixture. Evaluation of the resulting damage indicated that the tank structure failed as a result of overpressure. The Safety Board recognizes that the test conditions at Bruntingthorpe were not fully comparable to the conditions that existed on TWA flight 800 at the time of the accident;<sup>544</sup> however, previous fuel/air explosions in the CWTs of commercial airliners that had used Jet A fuel (such as the November 1989 accident involving a 727 operated by Avianca and the May 1990 accident involving a 737 operated by Philippine Airlines) confirm that a CWT explosion involving Jet A fuel can break apart the fuel tank and lead to the destruction of an airplane.

---

<sup>544</sup> For example, those tests were conducted near sea level (rather than at 13,800 feet altitude), did not account for the effects of aerodynamic loads and pressurization on the accident airplane, used a small charge as an ignition source, and used a propane/air mixture as a surrogate for Jet A fuel, which released more energy than the mixture in TWA flight 800's CWT.

Further, in the laboratory testing at CIT simulating the altitude, temperature, and fuel mass loading conditions of TWA flight 800, peak pressures of 39.2 to 52.2 pounds per square inch (psi) (above ambient pressure)<sup>545</sup> were measured from the combustion of a fuel/air mixture similar to the one that existed in the CWT of TWA flight 800. These pressures exceed the structural limitations of SWB3 (which, according to Boeing, will fail when subjected to a pressure differential of between 20 to 25 psi) and, therefore, would be sufficient to initiate failure of the CWT structure. Finally, analysis of the results of computer modeling of combustion in a full-scale CWT under conditions simulating those of TWA flight 800 indicated that a localized ignition of the flammable vapor could have generated pressure levels that, based upon structural failure analysis, would cause the damages observed in the wreckage of the accident airplane's CWT. Accordingly, the Safety Board concludes that a fuel/air explosion in the CWT of TWA flight 800 would have been capable of generating sufficient internal pressure to break apart the tank.

## 2.2.2 Reported Witness Observations

As discussed in section 2.2.1.2, the physical evidence indicated that a missile did not strike the airplane.<sup>546</sup> However, numerous witnesses in the vicinity of the accident reported seeing a streak of light<sup>547</sup> before the appearance of a fireball.<sup>548</sup> There was intense public interest in these witness reports and much speculation that the reported streak of light was a missile that eventually struck TWA flight 800, causing the airplane to explode.<sup>549</sup> However, because the physical evidence indicates that a missile did not strike the airplane, the witnesses must have been observing something other than a missile. In an attempt to determine what these witnesses were observing, Safety Board investigators studied all of the witness accounts in the context of the other information gathered during this investigation.

### 2.2.2.1 Potential Explanations for Reported Witness Observations

The Witness Group concluded that the streak of light reported by witnesses might have been the accident airplane during some stage of its flight before the fireball developed, noting that most of the 258 streak-of-light accounts were generally consistent with the calculated flightpath of the accident airplane after the CWT explosion. The group

---

<sup>545</sup> At 13,800 feet, the ambient pressure would have been 8.6 psi. The dry bay area in front of SWB3 is unpressurized and, therefore, at ambient pressure.

<sup>546</sup> As will be discussed in section 2.3.1.3, a scenario in which the vapor in the CWT was ignited by a missile warhead fragment is also very unlikely.

<sup>547</sup> According to the witness documents provided to the Safety Board by the FBI, 258 of the 736 witnesses described seeing (about the time of the accident) a streak of light, a flarelike object, or fireworks in the sky. These and similarly described observations were referred to by the Witness Group as a "streak of light." For more information about witness observations, see section 1.18.4.

<sup>548</sup> Of the 736 witnesses, 599 reported seeing a descending fireball; 200 of those reported seeing the fireball split into two fireballs before hitting the surface of the water.

<sup>549</sup> The witnesses who reported observing a streak of light were the only witnesses who described seeing something that could have been consistent with a missile. None of the documents pertaining to the other witnesses provided any information suggestive of a missile.

also determined that the descending fireball observed by 599 witnesses was the accident airplane and that the 200 witnesses who reported seeing the fireball split into two fireballs were observing the final stages of the structural breakup of the airplane.

On the basis of computer simulations and witness information, the Safety Board determined that the entire breakup sequence of the airplane (from the time of the CWT explosion until the time that the aft portion of the airplane impacted the water) lasted about 47 to 54 seconds. The sequencing study established that the nose portion of the airplane separated from the remainder of the airplane after the initial explosion in the CWT. Computer simulations indicated that this occurred about 3 to 5 seconds after the initial explosion.<sup>550</sup> Computer simulations based on radar data, trajectory calculations, and airplane performance factors indicate that after the separation of the nose portion, the remainder of the airplane (including much of the WCS, the wings, the aft fuselage, and the tail) continued in crippled flight and pitched up while rolling to the left (north), ascended from 13,800 to about 15,000 or 16,000 feet,<sup>551</sup> and then rolled into a descending turn to the right (south). It is likely that, after the nose portion separated from the aft fuselage, a fuel-fed fire within the breached CWT (or any other fire that might have existed, such as from fuel that might have been leaking at the wing roots) would have been visible to witnesses from some distance and was likely the streak of light reported by many of the witnesses.

It is also likely, based on the wreckage, computer simulations, and witness documents, that shortly after the descending turn to the right, the outboard left and right wings simultaneously separated at the outboard engines in upward bending. (The recovery positions of the antennas from the wing tips confirm that the outboard portions of the wings separated from the airplane significantly after the nose portion.) The separation of the outboard portions of the wings probably precipitated fuel-fed fires at both outboard main wing tanks and most likely was the beginning of the developing fireball described by witnesses. This fireball probably began to develop about 34 seconds after the CWT explosion.<sup>552</sup>

On the basis of witness documents, the sequencing study, and computer simulations, shortly after the outboard portion of the wings separated, the WCS separated adjacent to the left wing, causing the left wing to separate from what remained of the airplane structure. These failures would have resulted in the continuing development of a

---

<sup>550</sup> The Safety Board's computer simulations using airplane performance data indicated that the nose could have separated from 3.23 to 5.25 seconds after the initial event. (See Main Wreckage Flight Path Study.) The Safety Board also conducted a trajectory study to calculate how long after the initial event the nose separated from the airplane. However, because of the uncertainties inherent in such a study (for example, the effect of winds and ocean currents), this time could not be precisely determined. Results of the study initially indicated that the nose separation could have occurred from 3.9 to 7.5 seconds after the initial event. Additional computer simulations conducted after the trajectory study indicated that poor matches with known radar and wreckage location data were obtained with scenarios in which the nose separated more than 5 seconds after the initial event. Therefore, the nose separation most likely occurred from about 3 to 5 seconds after the initial event.

<sup>551</sup> Computer simulations indicated that the maximum altitude that the accident airplane's aft portion could have ascended after the separation of the nose portion ranged from 15,537 to 16,678 feet. See addendums 1 and 2 to the Main Wreckage Flight Path Study.



larger fuel-fed fireball.<sup>553</sup> The development of a severe fire associated with what remained of the airplane (portions of the WCS, the right wing, and a few pieces of attached fuselage) after the separation of the burning left wing is probably what witnesses reported as a “splitting” of the fireball.

Several witnesses have become prominent because of their unique vantage points and/or the level of precision and detail provided in their accounts.<sup>554</sup> Advocates of the missile-attack scenario have asserted that some of these witnesses observed a missile. However, as further explained below, analysis of these witnesses’ reported observations demonstrated that those observations are not consistent with their having observed a missile attack on TWA flight 800. Rather, they are consistent with these witnesses having observed some part of the in-flight fire and breakup sequence after the CWT explosion.

For a missile to have initiated the TWA flight 800 breakup sequence, it would have had to have been fired at least 41 to 49 seconds before the initial development of a fireball.<sup>555</sup> However, the pilot of the HH-60 helicopter indicated that he saw a fireball developing just 1 to 5 seconds after he first saw the streak of light.<sup>556</sup> Therefore, he must have been observing the late stages of the airplane’s breakup and not a missile attack.<sup>557</sup> The captain of Eastwind Airlines flight 507 also could not have seen a missile attack because the explosion that he reported having seen occurred about 34 seconds after the CWT explosion. Therefore, he must have seen the development of the fireball, not the earlier CWT explosion. Further, the Eastwind captain stated that he did not see a missile or anything coming up at or hitting the airplane. The CWT explosion also occurred before the time that the passenger aboard USAir flight 217<sup>558</sup> reported seeing a “flare.”<sup>559</sup> In fact, TWA flight 800 was not in this witness’s field of view at the time of the CWT explosion. Therefore, this flare could not have been a missile attacking TWA flight 800; however, this witness’s description is consistent with his having observed burning fuel from the accident airplane (in crippled flight) and the airplane’s subsequent breakup after the CWT explosion.

---

<sup>552</sup> The captain of Eastwind flight 507 reported to the Boston Air Route Traffic Control Center that he saw an explosion (at 2031:50, about 38 seconds after TWA flight 800 lost power [2031:12] as a result of the explosion in the CWT). Assuming it took about 4 seconds for the captain to realize that he saw an explosion, confer with the first officer, and contact ATC, it follows that he first saw the developing fireball about 34 seconds after the explosion. Four seconds is a compromise between what the pilot first reported on the night of the accident (that he called ATC “immediately”) and what he stated to Safety Board investigators almost 3 years later (that he waited about 10 seconds before calling ATC) that favors his initial impression but provides adequate response time.

<sup>553</sup> Many witness accounts describe a fireball developing after the streak of light arched over and began to descend. Analysis of the witness accounts suggests that the occurrence of this fireball was not a discrete event, but a transition from a streak of light to a fireball that occurred over a relatively brief period.

<sup>554</sup> For more information about these witness accounts, see section 1.18.4.4.

<sup>555</sup> This would comprise a 7- to 15-second missile flight plus about 34 seconds from the time of the CWT explosion to the outboard wing separations.

<sup>556</sup> Although the Safety Board recognizes that witnesses frequently provide inaccurate estimates of time, the Board considers it highly unlikely that the HH-60 pilot would have reported seeing the streak of light for only 1 to 5 seconds if he had actually seen the streak of light for 41 to 49 seconds.

<sup>557</sup> In addition, the HH-60 pilot stated that the fireball followed the same trajectory as the streak, which is consistent with the streak and the fireball both representing the airplane.

The witnesses on the boat near Great Gun Beach were close enough to the accident airplane, with an unobstructed view, to have seen a missile if one had been launched. However, they did not describe a sequence of events consistent with a missile attack. Rather, their observations of the northward turn and wing separation are consistent with their having seen the accident airplane after the CWT explosion. The reported observations of the witness on the Beach Lane Bridge are also fully consistent with his having seen the accident airplane from about the time of the CWT explosion until the aft portion of the airplane descended into the green zone. Further, he did not describe a sequence of events consistent with a missile strike. Most notably, this witness did not describe any abrupt change in the streak of light's speed or direction, which likely would have been evident if a missile strike had occurred.

### 2.2.2.1.1 Anomalous Witness Accounts

Although most of the observations reported in the witness documents are consistent with the witnesses having observed some portion of the airplane's crippled flight and breakup sequence,<sup>560</sup> the Safety Board recognizes that a small percentage of the reported witness observations cannot be explained so readily. The Witness Group noted that documents pertaining to 38 witnesses described a streak of light ascending vertically, or nearly so, and that these accounts seem to be inconsistent with the accident airplane's calculated flightpath. The Board recognizes that, in addition to these reports, 18 witnesses reported seeing a streak of light that originated at the surface or from the horizon, which also does not appear to be consistent with the airplane's calculated flightpath and other known aspects of the accident sequence. In an attempt to reconcile these 56 witness accounts with the calculated accident sequence, the Board considered the effect of potential deficiencies in the interviewing and documentation process and of errors in witness memory and/or perception.

---

<sup>558</sup> As noted in section 1.18.4.4, there were six additional witnesses aboard USAir flight 217, one of whom (seated in seat 6F) stated that he saw an aircraft that "had what he took to be its landing lights on, and [he] could observe cabin lights on the vessel." According to the document, the witness reported watching the airplane with "cabin lights" for 30 to 40 seconds, then seeing it bank to the left. The document then states, "the aircraft exploded and a large round orange fireball appeared." The document contains no mention of any other light in the sky. Because the CWT explosion aboard TWA flight 800 (and the subsequent loss of electrical power) would have occurred before TWA flight 800 could have been visible to the witness seated in seat 6F, the passenger in seat 6F could not have seen TWA flight 800's cabin lights, nor could he have witnessed any missile attack. Further, his observations are consistent with his having observed the accident airplane in crippled flight and its subsequent breakup after the CWT explosion.

<sup>559</sup> The witness reported seeing the flare about 15 to 20 seconds after he saw a small airplane, which had to have been the U.S. Navy P-3 Orion, pass under his airplane. The P-3 passed under USAir flight 217 about the time of the CWT explosion; therefore, if a hypothetical missile or warhead fragment had struck TWA flight 800, it would have had to have been fired about 7 to 15 seconds before the witness reported seeing the flare.

<sup>560</sup> This is consistent with the results of the FBI-sponsored line-of-sight study in which a Deputy Inspector from the Suffolk County Marine Bureau drew a line of sight from the location of 11 witnesses through a fixed reference point where they each reported having seen a streak of light. (See figure 42.) The sight lines for 7 of the 11 witnesses studied intersected the green zone (and two passed just north of it), where the main portion of the wreckage was recovered from the ocean. These sight lines are consistent with these witnesses observing only the last portion of crippled flight.

### 2.2.2.1.1.1 Issues Associated with Interviewing and Documentation

It should be noted that almost all of the witness interviews were conducted by the FBI during its criminal investigation primarily to determine whether a missile had been used against TWA flight 800.<sup>561</sup> The Safety Board is aware that FBI agents generally did not record all of the information provided by witnesses but, rather, focused on information that might have been relevant to the possibility that a missile was used against TWA flight 800.<sup>562</sup> This focus is evident in some of the suggested interview questions provided by the FBI to its agents, which include assumptions about a missile attack.<sup>563</sup> Research has shown that how interview questions are phrased can have a considerable effect on the information elicited during an interview.<sup>564</sup> Research has also shown that other types of word choices can affect the answers to questions.<sup>565</sup>

Further, witnesses who believe that their interviewer is knowledgeable about the event in question are more likely to be influenced by such suggestive questioning than those who do not think that their interviewer is knowledgeable. Some witnesses may have believed that the FBI agents were more knowledgeable than they actually were about whether a missile was used against TWA flight 800. This may have been especially true during those interviews in which Department of Defense (DoD) missile experts were present. Therefore, the scope and phrasing of the FBI agents' questions and possible witnesses' beliefs that the agents were more knowledgeable about the event than they actually were (each of which could have suggested the possibility of a missile) could have biased the interviewees answers to some questions.<sup>566</sup>

---

<sup>561</sup> As noted in section 1.18.4.1, because of the amount of time that had elapsed by the time the Safety Board received information about the identity of the witnesses, the Witness Group chose not to reinterview most of the witnesses; instead, the group chose to rely on the original FBI documents as the best available evidence of the observations initially reported by the witnesses.

<sup>562</sup> During a September 30, 1998, meeting with the Witness Group, an FBI agent who had been involved with the FBI's earlier criminal investigation indicated that, because of suspicions that a missile might have been used against TWA flight 800, FBI agents frequently did not record a complete account of the visual and aural events described by the witnesses but, rather, concentrated on information that appeared relevant to its criminal investigation.

<sup>563</sup> For example, some of the suggested interview questions included the following: "How long did the missile fly?"; "What does the terrain around the launch site look like?"; and "Where was the sun in relation to the aircraft and the missile launch point?". For more information about other possible sources of interviewer or interviewee bias, see section 1.18.4.2.

<sup>564</sup> For example, the use of a definite article (for example, "did you see the broken headlight?") instead of an indefinite article (for example, "did you see a broken headlight?") is sufficient to increase the likelihood of a positive answer. For more information about this research and other issues associated with the accuracy of witness memory, see section 1.18.4.3.

<sup>565</sup> For example, substantially differing answers were received to the question "how fast were the cars going when they hit each other?" when the word "hit" was replaced with "contacted," "bumped," or "smashed."

<sup>566</sup> For example, one witness described the streak of light as "going straight up, not zig zag." It is possible that this witness and others may have used the term "straight up" to denote the absence of obvious course corrections in response to interviewer questions about such corrections, not to indicate that the streak of light was ascending vertically.

It is also possible that some of the witnesses who were classified “streak-of-light witnesses” by the Witness Group did not, in fact, report observing a streak of light. For example, a witness may only have observed a fireball falling from the sky; however, because of deficiencies inherent in the documentation process, the description recorded in the witness document may have met the Witness Group’s definition of a streak of light. (The potential for inaccurate witness classification is illustrated by the fact that at least three streak-of-light witnesses explained during reinterviews by the FBI or media that, contrary to what was reported in connection with their earlier interview, they did not observe the streak of light originate at the surface of the earth.)<sup>567</sup>

In addition, the Witness Group identified several other issues that made it difficult to extract accurate and reliable information from the witness documents, including potentially flawed distance and direction information, multiple witness reports summarized in a single account, recording of witness speculations and conclusions, imprecise or vague language, conflicting information, and errors concerning the origin of the streak of light.<sup>568</sup>

#### **2.2.2.1.1.2 Issues Associated with Witness Perception and Memory**

##### **Perception<sup>569</sup>**

It is possible that, from some witnesses’ locations, the burning airplane might have appeared to be rising vertically. Specifically, some witnesses who were standing on Long Island looking to the southwest would have been in a position to see the airplane coming nearly directly toward them, which could have resulted in the appearance of a rising (perhaps even near-vertical to some witnesses) flightpath for a portion of the time that the airplane was in crippled flight. Because of the angle at which these witnesses were positioned, any fire coming from the CWT could have appeared to them as a streak of light moving vertically.

It should also be noted that witnesses observing the accident from Long Island would have been viewing it against a featureless background and, therefore, would have had few, if any, depth perception cues. Consequently, because of the tendency to perceive more distant objects as being about the same distance away as intervening objects (the equidistance tendency), the streak of light could have appeared closer to them than it actually was. The equidistance tendency is illustrated in figure 45, which depicts a person at point “c” observing an object at point “a” that appears at point “b” at the same perceptual distance as an intervening building at point “d.”

This phenomenon possibly explains why the witness on the Beach Lane Bridge stated that the streak of light came into his view just above the roof of a house and why he reported that it appeared to have originated on the beach just beyond that house. For some observers, the equidistance tendency would have caused the streak of light to appear lower

---

<sup>567</sup> For further information about these three witnesses, see section 1.18.4.2.

<sup>568</sup> For more information about these issues, see section 1.18.4.2.

<sup>569</sup> For more information about perception of distance and motion, see section 1.18.4.3.1.

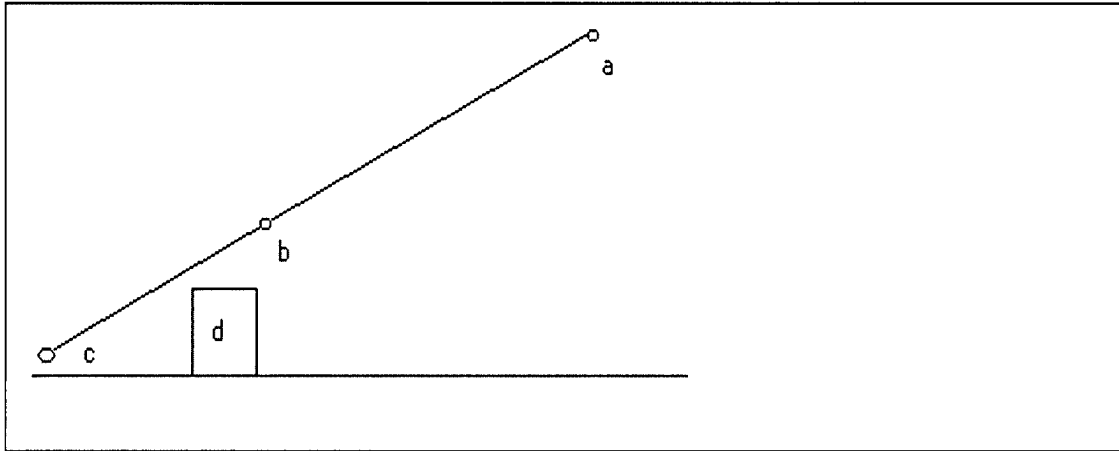

**Figure 45.** A graphical illustration of the equidistance tendency.

in the sky than it actually was, which explains why the streak of light may have been reported by some witnesses as having originated at the surface of the earth. It should be noted that almost all of the witnesses who reported that the streak of light originated at the surface viewed the streak of light on the far side of intervening terrain features, such as houses or the barrier island. These witnesses would have perceived the streak of light to be about the same distance as the intervening object because the elevation angle of the object would have been perceptually reduced.

Further, if an observer views an object for which few or no depth perception cues are available, the motion of the observer's head will cause the observer to perceive the object moving concurrently with the observer's head. At the time of the reported observations, 13 of the 38 witnesses who reported that the streak of light ascended vertically or nearly so were in vehicles (including boats) and one of the witnesses was paddling a surfboard. Other witnesses may also have been moving. The effect of the concurrent motion of the observer's head and the observed object would have caused the streak of light to appear to have been moving differently than it was actually moving, and this effect could have caused the streak of light to have appeared to rise vertically or nearly so. The closer that the streak of light appeared to a given witness, the greater the apparent motion of the streak of light to that witness.

Further, the airplane's relatively low elevation above the horizon<sup>570</sup> could have led many witnesses to believe that they were observing a flare or fireworks. (As discussed previously, because of the absence of depth perception cues, witnesses who saw the airplane in crippled flight could not be expected to provide good information about how far away it was or its direction of travel.)<sup>571</sup> As discussed in section 1.18.4.3, a witness's perception of events is driven by context cues, experience, and expectations. The fact that it was July (a month often associated with fireworks) and that several flares had been launched in the area during the week preceding the accident could have led witnesses to

<sup>570</sup> For example, to witnesses located 10 nm, 15 nm, or 20 nm (slant range) from the accident airplane, the airplane would appear about 13.1°, 8.7°, and 6.5°, respectively, above the horizon.

believe that they were seeing a flare or fireworks, which could also have led witnesses to believe, and subsequently report, that what they observed had originated from the surface, even though they did not actually see the object's origination point. It is also possible that some of these witnesses may have actually observed one or more of the flares launched from boats in the area shortly after the wreckage impacted the water to direct attention to the accident site.<sup>572</sup>

### Memory<sup>573</sup>

Research has shown that a person may unintentionally, and without awareness, create an inaccurate memory because of exposure to postevent information provided by other witnesses or media reports or because of expectations and beliefs. If misinformation is received from one of these sources, there is an increased likelihood that this misinformation will be assimilated and reported by the witness as a memory. Some witnesses' recollections might have been influenced by exposure to other witnesses' accounts; being interviewed together; engaging in conversations with other people; or hearing, watching, or reading media accounts of the crash (which included interviews with eyewitnesses and speculation about a missile strike.)<sup>574</sup> In this regard, it is noteworthy that the documents recording the initial interviews of some witnesses did not indicate that these witnesses initially reported seeing a missile; however, these same witnesses have since indicated that they believe that a missile was used against TWA flight 800. Research has also shown that a witness's confidence in the accuracy of his or her memory (even when it is inaccurate) increases over time and with repeated retrieval, which possibly explains why some witnesses displayed a high level of confidence in the accuracy of their reported observations.

#### 2.2.2.2 Conclusion Regarding Reported Witness Observations

Given the potential deficiencies in the witness documents, the potential inaccuracies in witnesses' recollections, and the large number of witnesses whose observations were documented and studied in this case, the Safety Board did not expect all of the documented witness observations to be consistent with one another. Therefore, the

---

<sup>571</sup> This is illustrated by the variation in the witness accounts regarding the direction of the motion of the streak of light (38 reported that it moved vertically; 45 reported that it moved to the east; 23 reported that it moved to the west; 18 reported that it moved to the south; and 4 reported that it moved to the north. Thirty-six of the streak-of-light accounts contained no information about the direction of the motion of the streak of light).

<sup>572</sup> Although flares were launched after the accident sequence (and, therefore, would have appeared after the fireball), witnesses who also reported seeing a fireball may have recalled seeing the streak of light (flare) before the fireball because their memories of the accident sequence were influenced by postevent information provided by media reports or other witnesses or by other factors. (As discussed in section 1.18.4.3.2, research has shown that when asked to recall information about an event, people sometimes recall information about an event that occurred at a different time than the event about which they are questioned.)

<sup>573</sup> For more information about storing information in and retrieving it from memory, see sections 1.18.4.3.1 and 1.18.4.3.2.

<sup>574</sup> Many witnesses acknowledged that they did not even know that they had observed an airplane accident until after seeing media accounts of the accident.

Board did not view these apparently anomalous witness reports as persuasive evidence that some witnesses might have observed a missile.

Investigators determined that if witnesses had observed an actual missile attack on TWA flight 800 (beginning about the time that an airborne missile would have become visible to the time that the wreckage from TWA flight 800 fell into the ocean), they would have seen the following: (1) a light (the burning of the missile motor) ascending very rapidly and steeply for about 8 seconds (this rapidly moving light, which would have been visible for at least 12 nm<sup>575</sup> from the launch point, would not descend like a firework or flare); (2) the light disappearing<sup>576</sup> for up to about 7 seconds;<sup>577</sup> (3) upon a missile (or warhead fragment) striking the airplane and igniting the fuel/air vapor in the CWT, another light (flames coming from the CWT), moving considerably slower and more laterally than the first light (although ascending somewhat for a short time), for about 30 seconds; (4) this light descending while simultaneously developing into a fireball falling toward the ocean. It is noteworthy that none of the witness documents included a description of such a scenario.

Therefore, the Safety Board concludes that the witness observations of a streak of light were not related to a missile and that the streak of light reported by most of these witnesses was burning fuel from the accident airplane in crippled flight during some portion of the postexplosion, preimpact breakup sequence.<sup>578</sup> The Board further concludes that the witnesses' observations of one or more fireballs were of the airplane's burning wreckage falling toward the ocean.

---

<sup>575</sup> Although during some of the missile visibility tests the light from the burning missile motor was visible to witnesses who were positioned up to 14 nm from the launch point, the lighting conditions during those tests were darker than in earlier tests and, therefore, were not comparable to the lighting conditions at the time of the TWA flight 800 accident. For the tests conducted under lighting conditions that were comparable to those that existed at the time of the TWA flight 800 accident, no witnesses were positioned farther than 12 nm away from the launch site.

<sup>576</sup> The Safety Board's missile visibility tests indicated that, after completion of the motor burn, observers saw no visible evidence of the missile until it self-destructed.

<sup>577</sup> Because of the distance from which a hypothetical missile would likely have been launched, most direct-strike scenarios and any self-destruct scenario (for further discussion of a missile self-destruct scenario, see section 2.3.1.3) would require that the missile travel about 7 seconds in "coast" mode; therefore the missile would have been invisible before striking the airplane. Only if a missile had been launched from almost directly underneath the accident airplane (as close to vertically as possible) would the "coast" time have been significantly reduced or eliminated.

<sup>578</sup> Central Intelligence Agency (CIA) analysts, who initially evaluated witness information provided by the FBI, also concluded that the majority of the witness observations must have occurred well after the initial explosion and, consequently, that none of those observations could have been of a missile causing the explosion. The CIA analysts concluded that the remaining witness accounts described events fully consistent with observations expected if only the airplane were being observed in various stages of crippled flight. The CIA analysts concluded that there was absolutely no evidence that a missile was employed to shoot down TWA flight 800.

### 2.2.3 Cause of the In-Flight Breakup

On the basis of the accident airplane's breakup sequence; wreckage damage characteristics; scientific tests and research on fuels, fuel tank explosions, and the conditions in the CWT at the time of the accident; and analysis of witness information, the Safety Board concludes that the TWA flight 800 in-flight breakup was initiated by a fuel/air explosion in the CWT.

## 2.3 Evaluation of Potential Ignition Sources

In an attempt to determine what ignited the flammable fuel/air vapor in the CWT and caused the explosion, investigators evaluated numerous potential ignition sources. Possible ignition source scenarios fell generally into two main categories: (1) energy entered the CWT by way of fuel quantity indication system (FQIS) wiring (discussed in section 2.3.2) or (2) energy entered the CWT by other means (discussed in section 2.3.1).

The minimum ignition energy (MIE) for Jet A fuel has been generally accepted to be about 0.25 millijoule (mJ)<sup>579</sup> based on testing done by the American Petroleum Institute (API) and is documented in API Recommended Practice 2003 (API 2003), "Protection Against Ignitions Arising out of Static, Lightning, and Stray Currents," fifth edition, December 1991. However, laboratory testing conducted at CIT using fuel similar to that used on the accident flight indicated that the energy needed to ignite Jet A fuel at an altitude of 13,800 feet ranged from 0.5 mJ (at 122° F) to 500 mJ (at 104° F). Therefore, this higher range of ignition energies was used as a reference for evaluating whether a particular potential ignition source could have ignited the fuel/air vapor in TWA flight 800's CWT. However, investigators also considered the lower, generally accepted, MIE of 0.25 mJ to be relevant in evaluating whether a potential ignition source might pose an ignition hazard in other airplanes under different circumstances (for example, at different altitudes and temperatures).

### 2.3.1 Possible Ignition Sources Unrelated to the Fuel Quantity Indication System

The Safety Board evaluated numerous potential ignition sources that could have ignited the fuel/air vapor in TWA flight 800's CWT. Among the potential ignition sources considered by investigators that were unrelated to the FQIS were the following: a lightning or meteorite strike; a missile fragment; a small explosive charge placed on the CWT; auto ignition or hot surface ignition, resulting from elevated temperatures produced by sources external to the CWT; a fire migrating to the CWT from another fuel tank via the vent (stringer) system; an uncontained engine failure or a turbine burst in the air conditioning packs beneath the CWT; a malfunctioning CWT jettison/override pump; a malfunctioning CWT scavenge pump; and static electricity.

---

<sup>579</sup> A mJ is one-thousandth of a joule (J), which is a measurement of electrical energy (1 J is the work done by 1 watt in 1 second).



### 2.3.1.1 Lightning Strike

No witnesses reported that lightning struck the accident airplane or that lightning was in the area of TWA flight 800 at the time of the accident. Further, recorded meteorological data indicated no atmospheric disturbances in the area of TWA flight 800 at the time of the accident. Therefore, it is very unlikely that a lightning strike ignited the fuel/air vapor in the CWT.

### 2.3.1.2 Meteorite Strike

An expert in the study of meteorites testified at the Safety Board's public hearing that no report exists of a meteorite ever having struck an airplane. He testified that, given the known frequency with which meteorites have struck cars and dwellings over the past several decades and based on a comparison of estimates of (1) the area of the earth's surface represented by cars and dwellings with (2) the area of the earth's surface represented by airplanes in the air at any given time, he calculated that a meteorite could be expected to strike an aircraft once every 59,000 to 77,000 years. Further, none of the holes in the CWT or fuselage structure exhibited characteristics of high-velocity penetration through the exterior (such as outward metal deformation around the perimeter of the entry and exit sides of the hole, lack of overall deformation, and distinctive features of the hole wall surface) that would be expected from a meteorite strike.<sup>580</sup> Therefore, it is very unlikely that a meteorite ignited the fuel/air vapor in the CWT.

### 2.3.1.3 Missile Fragment

Although, as discussed in section 2.2.1.2, a missile-strike scenario was not supported by the physical evidence, investigators considered whether a missile might have self-destructed close enough to TWA flight 800 for a missile fragment to have entered the CWT and ignited the fuel/air vapor, yet far enough away that it would not have left any damage features characteristic of a missile strike. According to missile performance data provided to the Safety Board by the Naval Air Warfare Center—Weapons Division (NAWC-WD), Survivability/Vulnerability Information Analysis Center, and Missile and Space Intelligence Center (MSIC), the warhead from a shoulder-launched missile will self-destruct about 15 seconds after launch if no target has been hit,<sup>581</sup> and missile warhead fragments are always dispersed in a predictable fragmentation pattern. Using the initial speed and decay rate for the missile warhead fragments, the Board calculated that a detonation would have to occur within 40 feet of an airplane for a fragment traveling perpendicular to the CWT to retain sufficient velocity to penetrate the CWT. In the case of a fragment traveling at an angle to the CWT, a detonation would have to occur even closer to the airplane.

---

<sup>580</sup> Two holes in the horizontal pressure deck (above the left side of the wing landing gear bay) contained some features of both high-velocity and low-velocity penetrations. However, the physical features of both holes indicated that they were made by objects traveling from inside the airplane out, rather than the reverse. Therefore, neither hole could have been made by a meteorite.

<sup>581</sup> The exact number of seconds after launch that a missile warhead will self-destruct varies slightly, depending on the type of missile. The Safety Board's analysis of the likelihood of this scenario would apply equally to missiles with a slightly longer or shorter self-destruct range.

The Safety Board's computer simulations using this missile performance data, which took into account the winds at the time of the accident, showed that the number of locations on the surface (all of which were on water) from which a missile launched at TWA flight 800 could have resulted in selfdestruction within 40 feet of the airplane were extremely limited. Simulations further showed that, because of the pattern in which missile warhead fragments are dispersed after selfdestruction, launches from many, if not most, of these positions would not result in fragments with a proximity and orientation sufficient to penetrate the CWT. Further, simulations also showed that a missile launch from one of the few sites that could potentially have resulted in a detonation at the proximity and orientation for a fragment to penetrate the tank and ignite the fuel/air vapor would have resulted in numerous fragments impacting the surrounding airplane structure with sufficient force to leave distinctive impact marks.<sup>582</sup> No such impact marks were found on the accident airplane's wreckage.

In addition, a missile fragment would have had to penetrate multiple layers of material to enter the CWT, and, although some areas of fuselage skin and CWT structure are missing, possible straight-line entry paths were extremely limited. Further, as previously mentioned, none of the holes in the CWT or fuselage structure exhibited characteristics of high-velocity penetration through the exterior that would have resulted from a missile fragment.<sup>583</sup> Therefore, it is very unlikely that a missile warhead selfdestructed at a distance close enough to the accident airplane that at least one fragment could have entered the CWT with sufficient force and velocity to have ignited the fuel/air vapor in the CWT, yet far enough from the airplane that almost none of the remaining fragments impacted its structure.<sup>584</sup>

#### 2.3.1.4 Small Explosive Charge

Another potential ignition source that investigators considered was the detonation of a small explosive charge<sup>585</sup> that had been placed on the CWT that could have breached the fuel tank and ignited the flammable fuel/air vapor. However, testing by the Safety Board and the British Defense Evaluation and Research Agency in August 1997 at Bruntingthorpe Airfield, Leicestershire England, demonstrated that when metal of the

<sup>582</sup> According to data from MSIC, upon detonation a warhead will release about 1,000 fragments of varying sizes, up to 40 grains (equivalent to 0.0916 ounce).

<sup>583</sup> The features of the two holes in the horizontal pressure deck that displayed some features of high-velocity penetration indicated that they were made by objects coming from different directions; therefore, it is not likely that they originated from a common location. Further, as previously mentioned, the physical features of both holes indicated that they were made by objects traveling from inside the airplane out, rather than the reverse. Therefore, neither hole supports a scenario in which the fuel/air vapor in the CWT was ignited by the entry of a missile fragment.

<sup>584</sup> A study by the NAWC-WD for the DoD's Office of Special Technology also concluded that the probability of such a scenario was "extremely low." According to the report, "[f]or a missile shooter to launch the weapon, the weapon to fly at the target, the target to be just beyond the kinematic envelope of the weapon, the warhead to be properly positioned at self-destruct, and one of the very few heavy fragments to impact in an area to penetrate the thick wing skin with enough residual energy to initiate an explosion is stretching credulity to the point that this scenario must be considered a low-priority area of concern."

<sup>585</sup> A small explosive charge is a minimal amount of a highly explosive material (such as a plastic explosive) detonated by a fusing device.

same type and thickness as the CWT walls was penetrated by a small charge, there was petalling of the surface on which the charge was placed, pitting on the adjacent surfaces, and visible hot gas washing damage in the surrounding area. As discussed in section 2.2.1.2, none of these damage characteristics were found on the recovered CWT wreckage, and none of the areas of missing skin were large enough to represent the damage that would have been caused by the detonation of a small explosive charge. Therefore, it is very unlikely that a small explosive charge detonated on the CWT, breached the fuel tank, and ignited the fuel/air vapor.

### 2.3.1.5 Auto Ignition or Hot Surface Ignition

Investigators also evaluated whether the surface of the CWT might have been heated to a high enough temperature to have caused ignition of the fuel/air vapor inside the tank as a result of auto ignition<sup>586</sup> or hot surface ignition.<sup>587</sup> Investigators considered whether an external mechanism, such as a bleed air leak near the CWT, a fire in the air conditioning pack bay beneath the CWT, or a fire in the main landing gear wheel well, could have raised a large volume of the CWT ullage above the auto ignition temperature or caused a localized hot spot on the interior of the CWT skin that could have reached hot surface ignition temperatures.

However, a scenario in which a significant portion of the CWT volume was heated to auto ignition temperatures was not considered a credible possibility because the amount of heat that would have been necessary to raise the temperature of the entire (or at least most of the) CWT to 460° F or more would have almost certainly left significant evidence of thermal damage on the CWT.<sup>588</sup> Further, for a hot spot approaching hot surface ignition temperatures (900° to 1,300° F) to have developed on the inside surface of the CWT, the temperature on the outside surface would have had to have been at least as high as these temperatures. However, these temperatures are near the softening and melting temperatures of the CWT's aluminum skin; therefore, the CWT would have shown evidence of having been heated to these temperatures. As further discussed below, no evidence was found that indicated that the CWT reached auto ignition or hot surface ignition temperatures.

Analysis of Boeing data indicates that multiple engine malfunctions could produce bleed air temperatures above 800° F at the engines. However, the accident airplane's

---

<sup>586</sup> Auto ignition can occur when a large volume of Jet A fuel/air vapor is sufficiently elevated in temperature without direct contact with an ignition source, such as a spark, arc, or hot surface or filament. Auto ignition is highly dependent upon many factors, including the size of the heated volume and container and other environmental conditions that affect fuel vapor. Existing research indicates that the auto ignition temperature at sea level for Jet A fuel is about 460° F. Auto ignition temperature increases as the altitude increases.

<sup>587</sup> Hot surface ignition can occur when a very high temperature surface comes into contact with Jet A fuel or fuel/air vapor. Hot surface ignition is highly dependent upon many factors, including the geometric aspects of the hot surface and other environmental conditions that affect fuel and fuel/air vapor. Existing research indicates that hot surface ignition temperatures at sea level for fuels similar to Jet A range from 900° to 1,300° F. Hot surface ignition temperature increases as the altitude increases.

<sup>588</sup> Knowledge of the CWT thermodynamic environment, derived in part from the JFK flight tests and the Marana, Arizona, ground tests, indicates that such temperatures would most likely not be reached.

engines, all of which were recovered and extensively examined, showed no evidence of any failure or malfunction. Further, engineering data from Hamilton Standard (the manufacturer of the air conditioning system) and Boeing indicated that the combination of failures required to produce such elevated bleed air temperatures<sup>589</sup> would also have caused an overpressure leading to an air conditioning duct burst. However, the reconstructed air conditioning packs showed no evidence of leakage in the packs or ducts. In addition, no discussion of an overheat or other warning<sup>590</sup> was recorded by the CVR, which would be expected if excessive bleed air temperatures or any other failure occurred, especially with two flight engineers in the cockpit.<sup>591</sup>

Investigators also considered whether a fuel leak from the CWT or the inboard fuel tanks onto the hot air conditioning packs beneath the CWT could have caused a fire in the pack bay or main landing gear wheel well and subsequent auto ignition or hot surface ignition of the fuel/air vapor in the CWT. (The Safety Board is aware of at least one report of fuel leaking into the air conditioning pack bay in a 747.) However, no fire damage was observed on the first two packs (and surrounding material) to depart the airplane (those found in the red zone),<sup>592</sup> nor on the fairings from underneath the packs, which would be expected if the packs had been exposed to a fire of sufficient heat and intensity to have raised a large volume of the temperature inside the CWT to 460° F or to have heated a spot on the interior surface to more than 900° F. Although there was fire damage to the wheel well, the burning and soot in that area had a flow pattern that could be traced from the fuel tank to the wheel well, indicating that the fire in the CWT preceded the fire in the wheel well. Further, the tires from the wheel well showed only limited localized heat damage, contrary to what would be expected if they had been exposed to a fire of sufficient heat and intensity to have raised a large volume of the temperature inside the CWT to 460° F or to have heated a spot on the interior surface to more than 900° F. Therefore, it is very unlikely that the fuel/air vapor in the CWT ignited as a result of either auto ignition or hot surface ignition caused by elevated temperatures produced by sources external to the CWT.

### 2.3.1.6 Fire Migration Through the Vent System

Because the fuel vent system on the 747 permits communication between fuel tanks, investigators considered the possibility that a fire originating in one of the other fuel tanks might have entered the CWT through the fuel vent system. However, the fuel vent system's design is such that if a flame had propagated through the vent system, it would

---

<sup>589</sup> Concurrent failures of the (1) engine bleed air pressure relief valve, (2) precooler cooling airflow control valves, and (3) pylon shutoff and regulating valve would be required.

<sup>590</sup> The failures required to produce such excessive bleed air temperatures would have activated engine malfunction and excessive bleed air temperature warnings from sensors installed both inside and outside the bleed air ducts.

<sup>591</sup> It is evident from the captain's remark on the CVR about the "crazy" No. 4 fuel flow that the flight crew was attentive to the gauges and other indications on the instrument panel.

<sup>592</sup> The third pack, which was recovered from the green zone, had fire damage. However, this damage was likely the result of the severe fire(s) that affected the WCS and surrounding structure during the remainder of the breakup sequence, most notably after the separation of the left wing.

have had to have traveled through the wing tip surge tank to meet the vents from the other fuel tanks. The surge tank overboard vents are equipped with a surge tank protection (STP) system, which includes a photocell in each overboard vent designed to trigger the discharge of Halon (a fire extinguishing agent) into the surge tank when a flame or bright light source is sensed at an overboard vent. The accident airplane's Halon bottles were found undischarged.<sup>593</sup> More importantly, temperature measurements taken during the 1997 flight tests at JFK showed that at 13,800 feet, the fuel/air vapor in the section of the vent system leading to the wing tips would have cooled to the point that it could not sustain a flame. Therefore, it is very unlikely that a fire originating in another fuel tank migrated through the fuel vent system to the CWT and ignited the fuel/air vapor.

### **2.3.1.7 Uncontained Engine Failure or Turbine Burst**

Investigators also considered the possibility that an uncontained engine failure or a turbine burst in the air conditioning packs beneath the CWT caused debris to enter the tank with sufficient velocity to ignite the vapors. However, the engines and reconstructed packs showed no evidence of an uncontained engine failure or turbine burst. Therefore, it is very unlikely that an uncontained engine failure or a turbine burst in the air conditioning packs ignited the fuel/air vapor in the CWT.

### **2.3.1.8 Malfunctioning Jettison/Override Pump**

Investigators also considered the possibility that a jettison/override pump malfunction produced a spark that ignited the fuel/air vapor in the CWT. Both pumps from the CWT were recovered and tested. One pump had evidence that indicated that the impeller had contacted the impeller housing. However, tests conducted in connection with the investigation of the May 11, 1990, accident involving a CWT explosion on a Philippine Airlines 737 indicated that galling of the aluminum impeller against the impeller housing would not result in ignition of flammable vapor. The other pump showed no evidence of any malfunction or overheating that could have caused the vapor in the pump to ignite.

There were no comments or sounds on the CVR indicating that the pumps were used (and there would have been no reason for them to have been used because there was no usable fuel in the CWT). However, even if the pumps were used and a pump motor had malfunctioned or overheated, this would not likely have ignited the fuel/air vapor in the CWT because of the flame suppression system incorporated into the pump design. When vapors in the motor housings of both an old and a new scavenge pump (which have a flame suppression system similar to that in the jettison/override pumps) were ignited in postaccident testing, the test pump flame suppression systems consistently functioned as designed and prevented sparks or flames from escaping from the pump motors and igniting flammable vapors outside the pumps. (In some tests, even after investigators

---

<sup>593</sup> It should be noted that the STP system is designed, and the Halon bottles are configured, to protect against flames entering the airplane from the outside. Therefore, even though the passage of a flame through the surge tank would likely have triggered discharge of the Halon, the flames would not likely have been extinguished by the Halon.

removed part of the flame suppression system to simulate conditions found in some malfunctioning pumps,<sup>594</sup> the remaining parts of the system still prevented ignition of the surrounding flammable vapor.) Further, in previous instances in which arcing has occurred in jettison/override pump motors, the flame suppression system has prevented a flame from entering the fuel tank and igniting the fuel/air vapor.<sup>595</sup> Therefore, it is very unlikely that a jettison/override pump malfunction ignited the fuel/air vapor in the CWT.

### 2.3.1.9 Malfunctioning Scavenge Pump

Investigators also considered the possibility that a scavenge pump malfunction could have produced the ignition energy for the CWT explosion. The motor and impeller were not recovered and, therefore, could not be examined for signs of fire or overheating. However, the recovered control switch had damage indicating that it was in the "Off" position at impact, suggesting that the pump was not operating at the time of the explosion and, therefore, could not have provided an ignition source. However, even if the pump had been on<sup>596</sup> and a flame had developed inside the pump's motor housing, it is still unlikely that the flame could have entered the tank.<sup>597</sup>

Although examination of a section from the recovered scavenge pump inlet tube (which draws fuel from the CWT into the pump) revealed some darkened areas on the tube, there was insufficient evidence to determine whether this damage occurred as part of the initial event or later in the accident sequence. However, as previously discussed, when vapors in the motor housings of both an old and a new scavenge pump were ignited in postaccident testing, the test pump flame suppression systems consistently functioned as designed and prevented sparks or flames from escaping from the pump motors and igniting flammable vapors outside the pumps.

Examination also found no evidence of extreme localized overheating (such as heat damage or discoloration to the flange/spacer between the pump and the rear spar or splatter on surrounding structure from a hole arced through the motor housing), which could have resulted in ignition of the fuel/air vapor inside the CWT. Therefore, although a CWT scavenge pump malfunction could not be entirely ruled out as a possible ignition source for the CWT explosion, there is no evidence that such a malfunction ignited the fuel/air vapor in the CWT.

---

<sup>594</sup> The flame suppression system consists of a small-diameter tube in series with a check valve. Tests were run with one or the other component removed.

<sup>595</sup> For example, 18 jettison/override pumps that had experienced arcing in the motor were examined by Boeing for evidence of sulfide deposits. (See Systems Group Chairman's Factual Report Addendum, "Deposits on Fuel Tank Electrical Components.") None of these pumps had ignited the vapor in the pump.

<sup>596</sup> Investigators recognized the possibility that the switch might have moved to the "Off" position sometime during the breakup sequence. However, there were no comments on the CVR indicating that the flight crew was activating the CWT scavenge pump. Such an action would have been highly unusual given that the tank was not in use and, therefore, would likely have generated some comment from one or both of the flight engineers.

<sup>597</sup> The scavenge pump motor is mounted on the outside of the CWT, on the aft of the rear spar, and cooling fuel is drawn from the tank through small-diameter tubes.

### 2.3.1.10 Static Electricity

Investigators also theorized that electrically isolated parts in the CWT<sup>598</sup> could become so highly charged from static electricity (generated by fuel striking the part or from fuel moving through the fuel lines) that a discharge between such a part and a nearby grounded fuel tank component could create a spark of sufficient energy to ignite the fuel/air vapor in the tank. The Safety Board contracted with the U.S. Air Force (USAF) Research Laboratory (AFRL) at the Wright Patterson Air Force Base and with the Naval Research Laboratory to conduct tests to assess the electrostatic charging capabilities of several electrically isolated components commonly found in aircraft fuel systems. This testing revealed that unbonded Teflon-cushioned wire clamps (found in the 747 CWT and inboard main fuel tanks) were particularly susceptible to electrostatic charging. However, the highest voltage potential attained in testing that used fuel similar to that used on the accident flight was 650 volts, which it was estimated would produce a discharge energy of only about 0.0095 mJ.<sup>599</sup> Even assuming that the clamp could attain a voltage of 1,150 volts (which was produced in tests using fuel of a higher conductivity than the fuel in the CWT on TWA flight 800), the highest discharge energy that voltage could produce was estimated to be about 0.030 mJ, which is still well below the 0.25 mJ MIE for Jet A fuel vapor. Therefore, on the basis of the evidence from the TWA flight 800 investigation and research and testing to date, it is very unlikely that static electricity ignited the fuel/air vapor in the CWT. Nonetheless, the Board recognizes that the discharge of static electricity has resulted in prior fuel tank explosions<sup>600</sup> and cannot rule out the possibility that, under some conditions, static electricity could produce sufficient energy to ignite the flammable vapor in a fuel tank.

The findings from this investigation raised concerns regarding the adequacy of bonding protection against high-energy discharges, such as from lightning (or perhaps from refueling). The Safety Board is concerned about the Boeing design practice that permits parts that are less than 3 inches long in any direction (including some types of clamps and connectors installed in fuel tanks) to be electrically unbonded. Tests conducted by Boeing after two fuel tank explosions in 1970 found that a single unbonded clamp could store up to 5 mJ of energy during the increased fuel flow rates associated with ground refueling.<sup>601</sup> Further, according to the FAA's Aircraft Lightning Protection Handbook, unbonded clamps could present an ignition hazard in the event of a lightning

---

<sup>598</sup> Certification standards only require that "major components" of the powerplant installation be electrically bonded to the other parts of the airplane. See 14 *Code of Federal Regulations* (CFR) 25.901(b)(4). According to a June 2, 2000, letter to the Safety Boeing, Boeing design practices permit parts that are less than 3 inches long in any direction (including some types of clamps and connectors installed in fuel tanks) to be electrically unbonded, presumably because such parts are not believed to have enough capacitance to retain hazardous levels of static electricity under expected operating conditions.

<sup>599</sup> A volt is the basic unit of measurement of electromotive force (the force that causes electrons to flow through a conductor). As previously mentioned, a J is a measurement of electrical work or energy. Power (watts or J/seconds) is related to voltage through  $V^2/R$ , or the square of the voltage divided by the resistance, measured in ohms.

<sup>600</sup> The July 23, 1998, report of the Aviation Rulemaking Advisory Committee (ARAC) Fuel Tank Harmonization Working Group (FTHWG) and API 2003 cite several previous fuel tank explosions believed to have been caused by static electricity.

strike. The Safety Board concludes that Boeing's design practice that permits parts less than 3 inches long in any direction to be electrically unbonded may not provide adequate protection against potential ignition hazards created by static electricity or electricity generated by lightning. Because the Board is concerned that other manufacturers' design practices may not be adequate, the Safety Board believes that the FAA should examine manufacturers' design practices with regard to bonding of components inside fuel tanks and require changes in those practices, as necessary, to eliminate potential ignition hazards.

### **2.3.1.11 Conclusion Regarding Ignition Sources Unrelated to the Fuel Quantity Indication System**

In summary, the Safety Board concludes that it is very unlikely that the flammable fuel/air vapor in the CWT on TWA flight 800 was ignited by a lightning or meteorite strike; a missile fragment; a small explosive charge placed on the CWT; auto ignition or hot surface ignition, resulting from elevated temperatures produced by sources external to the CWT; a fire migrating to the CWT from another fuel tank via the vent (stringer) system; an uncontained engine failure or a turbine burst in the air conditioning packs beneath the CWT; a malfunctioning CWT jettison/override pump; a malfunctioning CWT scavenge pump; or static electricity.

## **2.3.2 Introduction of Ignition Energy Through the Fuel Quantity Indication System**

The only electrical wiring located inside the CWT is the wiring associated with the FQIS.<sup>602</sup> According to Boeing design specifications, the voltage to the FQIS wiring is limited so that it cannot discharge energy in excess of 0.02 mJ. Therefore, for the FQIS to have played a role in igniting the flammable fuel/air vapor in the CWT, the following two events would have had to have occurred: (1) a transfer of a higher-than-intended voltage onto FQIS wiring from a power source outside of the fuel tank and (2) the release of the energy from that FQIS wiring into the inside of the tank in a way that could ignite the fuel/air vapor in the tank.

### **2.3.2.1 Transfer of Energy to the Fuel Quantity Indication System Wiring Outside the Center Wing Tank**

#### **2.3.2.1.1 Electromagnetic Interference**

Investigators examined several possible ways by which energy (from either outside or inside the airplane) might have been transferred to the FQIS by electromagnetic interference (EMI). One possibility explored was that radiated electromagnetic energy

---

<sup>601</sup> These test results were reported to the FAA during a March 11, 1971, meeting regarding electrostatics during refueling and were summarized in a March 16, 1971, FAA memorandum that documented the results of that meeting.

<sup>602</sup> Although the fuel pump motor cavities contain wiring, they are separated from the CWT by flame suppression passages and other parts.



from radio frequency (RF) transmitters outside the airplane could couple to FQIS wiring. However, the National Aeronautics and Space Administration's (NASA) Langley Research Center (LaRC) study of the RF sources present in the electromagnetic environment (EME) at the time of the TWA flight 800 accident concluded that, even assuming that the highest possible electromagnetic signal levels were being emitted by these sources at the time of the accident, the maximum available energy inside the airplane (but not on the wires) from these signal levels would be less than 0.1 mJ. The study further noted that any such energy that coupled to aircraft wiring inside the airplane would be several orders of magnitude less than 0.1 mJ. Therefore, although it is conceivable that under different circumstances a significantly stronger EME than was present at the time of the TWA flight 800 accident might present an ignition hazard, the Safety Board concludes that EMI from RF sources external to TWA flight 800 did not produce enough energy to ignite the fuel/air vapor in the CWT.

The Safety Board also considered the possibility that power was transferred from personal electronic devices (PED) to the FQIS wiring. Therefore, at the Board's request, NASA LaRC scientists also studied the electromagnetic force that could be generated by PEDs. The study found that the strongest electrical signal that could be coupled to the FQIS wiring from PEDs was about one-tenth of the minimum power level required in laboratory tests to induce a spark from the FQIS by applying a simulated arc gap.<sup>603</sup> Therefore, the Safety Board concludes that EMI from PEDs played no role in igniting the fuel/air vapor in TWA flight 800's CWT.

Finally, the Safety Board examined the possibility that a transient voltage/current spike from wiring associated with higher-voltage aircraft systems could be induced onto corroded FQIS wiring. Early in the investigation during laboratory tests, Boeing was able to induce transient voltages in excess of 1,000 volts (estimated to be capable of producing 0.6 mJ of energy) in FQIS wiring. However, these tests did not accurately represent the voltage sources that would exist in an actual airplane. More comprehensive testing was conducted by the Naval Air Warfare Center—Aircraft Division on an airplane using actual airplane systems, in which transient voltages were created in an energized FQIS by switching the power to the aircraft systems on and off. In those tests, the maximum energy released by FQIS wiring inside the fuel tank when a discharge mechanism was provided (by placing conductive debris across FQIS fuel probe terminals) was 0.125 mJ. This is significantly less than the 0.5 to 500 mJ that would have been needed to ignite the Jet A fuel/air vapor in TWA flight 800's CWT and only half of the generally accepted MIE level for Jet A fuel (0.25 mJ). Therefore, the Safety Board concludes that it is unlikely that EMI from aircraft system wiring played a role in igniting the fuel/air vapor in TWA flight 800's CWT.

---

<sup>603</sup> One watt was required to induce a spark during laboratory tests.

### 2.3.2.1.2 Short Circuiting

#### 2.3.2.1.2.1 Possible Short-Circuit Energy Transfer Mechanisms

Excess voltage from a short circuit can be transferred from wires carrying higher voltage to wires carrying lower voltage if the wires are near each other. Wires carrying high voltage can be placed near FQIS wires both in common wire bundles and at connectors in various locations. The investigation found that Boeing design specifications permit FQIS wiring to be bundled with, or routed next to, higher-voltage airplane system wires, some carrying as much as 350 volts.<sup>604</sup> In addition, Safety Board examinations of other transport-category airplanes, including several 747s, found that high-voltage wires can be corouted with FQIS wires in ways that do not comply with the manufacturer's production illustrations (PI) and/or are not consistent with the guidance in Boeing's Standard Wiring Practices Manual (SWPM). These noncompliant wiring configurations can be installed at the time of manufacture or during subsequent maintenance activities.

The CWT FQIS wiring in the 747 terminates at common connectors with the fuel quantity indicator, the totalizer gauge, the airborne integrated data system (AIDS), the volumetric shutoff (VSO), and the left wing refueling station; each of these connectors also includes terminating wires from circuits that carry 115 volts.<sup>605</sup> (See figure 46.) Short circuits in connectors have caused incidents in the past. For example, an October 22, 1995, incident involving roll/yaw oscillations on a 737 near Manchester, England, was attributed to a short circuit in the rudder circuitry of the incident airplane that resulted from lavatory fluid bridging the pins within an electrical conductor.

A short circuit can occur if the wire's internal conductors are accessible/exposed and there is either (1) direct contact between the conductors or (2) a bridge between the conductors, created by contaminants, such as metal shavings or fluid.<sup>606</sup> Conductors inside electrical connectors are, of necessity, always accessible (because a connector is designed to join wires in a continuous electrical path), and conductors outside connectors can become exposed as a result of cracking or other damage to wire insulation. The investigation found that damaged and/or contaminated wire insulation is widespread in older transport-category airplanes and also exists in new airplanes. Specifically, Safety Board examinations of wiring on 26 airplanes of varying ages (ranging from new to

---

<sup>604</sup> Most airplane systems carry 115 volts, but in the Safety Board's examinations of numerous transport-category airplanes, lighting circuits of 192 and 350 volts were found in bundles that also contained wiring associated with the FQIS. Even higher voltage wires exist in these airplanes (such as for strobe lights, fluorescent lighting starting circuits, and radios), but none were found routed with FQIS wires.

<sup>605</sup> Although the Safety Board is not aware of FQIS wires sharing connectors with wires carrying more than 115 volts, Boeing specifications also permit FQIS wiring to be mixed in common connectors with airplane system wires carrying up to 350 volts.

<sup>606</sup> Testing conducted for the Safety Board by Lectromec demonstrated that current peaks of more than 100 amperes (amp), which released 2 to 4 J of energy (of which about 400 mJ could be transferred to a victim wire), could be produced on wires protected by 10-amp circuit breakers when short circuits were created by dripping either water or lavatory fluid onto damaged wires. (For more information about this testing, see section 1.16.6.2.)

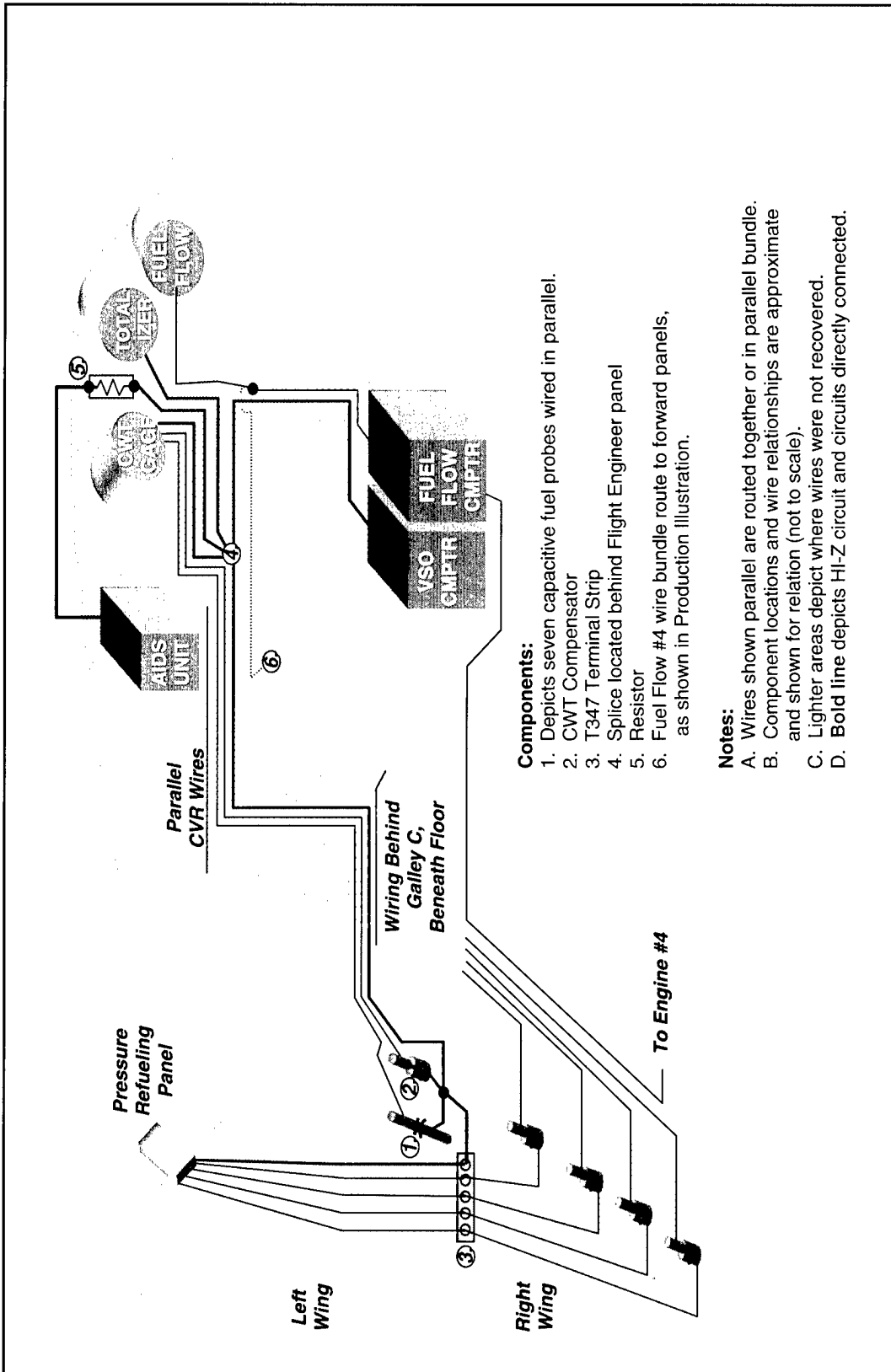

Figure 46. Diagram of the center wing tank fuel quantity indication system wiring on the 747 and its common connectors.

28 years old) revealed that all of the older airplanes exhibited numerous examples of mechanically damaged, chafed, cracked, and contaminated wires. The examinations also found sharp-edged metal drill shavings (which can damage wire insulation), fluid stains, and other potentially hazardous material in or near the aircraft wiring of old and new airplanes.

The Safety Board is aware of several incidents that resulted from short circuits apparently created by contaminants.<sup>607</sup> In addition, Board-sponsored testing at Lectromec showed that contaminants, such as water, lavatory fluid, and metal shavings, can create a mechanism that can allow energy to inadvertently transfer between wires with cracked or damaged insulation. The tests demonstrated that fluids could migrate between wires with cracked or damaged insulation, reaching copper conductors at the sites of existing insulation damage, and become a mechanism for the intermittent transfer of short bursts of energy (referred to by Lectromec as "flashing" or "scintillations") for as long as 25 minutes without tripping circuit breakers. Further, the tests revealed that metal shavings could cut through insulation and unintentionally transfer energy from one wire to another wire in a bundle (or at a connector) when the shavings contacted two bare conductors.

Finally, in addition to the possibility of a short circuit to the CWT's FQIS wiring, there are several ways in which a short circuit to FQIS wires associated with fuel tanks other than the CWT could transfer energy to the CWT. First, in the totalizer gauge on the accident airplane, the wires attached to the connector pins for the right wing main tank FQIS and the CWT FQIS had been improperly soldered together and had subsequently cracked apart. During examination of the gauge at Honeywell, it was determined that electrical energy would cross the crack in the solder between the connector pins when slightly more than 270 volts (less than is used in lighting circuits) was applied to one of the pins.<sup>608</sup> Second, the routing of the right wing FQIS wires to a connection in the CWT (at terminal strip T347)<sup>609</sup> created another possible mechanism by which a short circuit from a higher-voltage wire in the right wing FQIS wiring could have carried excessive voltage to the CWT. A third way in which excess energy from another tank's FQIS wiring could enter the CWT was demonstrated during postaccident evaluation of wiring paths on a retired 747; an electrical signal that was placed on the CWT FQIS wiring was also detected on wiring from the left wing FQIS, indicating that the two sets of wiring were not electrically isolated. Thus, a short circuit from a higher-voltage wire to left wing FQIS wiring could result in excess energy being transferred to the CWT.

#### **2.3.2.1.2.2 Adequacy of Existing Circuit Protection Systems**

As previously discussed, short circuits can transfer energy from higher-voltage wires to lower-voltage FQIS wires and become a potential fuel tank ignition hazard. More

---

<sup>607</sup> For more information about these incidents, see section 1.18.2.3.

<sup>608</sup> Although no 270-volt circuits were identified in the wings of any airplanes examined, the PIs for the accident airplane showed right wing FQIS wires were routed through the fuselage in bundles that contained 350-volt lighting circuits.

<sup>609</sup> This same terminal strip installation was found to have sulfide deposits in two other 747s.

commonly, short circuits can cause sparks that can ignite lint or other flammable materials and cause secondary damage to other aircraft system wires. To minimize or eliminate the damage caused by short circuits, wiring circuits can be protected by one or more of the following methods: (1) circuit breakers (either the standard, thermally activated type or the recently developed processor-based arc-fault circuit breakers [AFCB]); (2) electrical resistors; (3) shielding and/or physical separation of wires; and (4) transient suppression devices (TSD), such as surge protection systems. The Safety Board evaluated each of these methods to determine whether they could provide adequate protection to FQIS wiring circuits by preventing short circuits to those wires from becoming potential fuel tank ignition hazards.

### 2.3.2.1.2.2.1 Circuit Breakers

The design of thermally activated circuit breakers permits higher-than-desired current to pass through the wire during normal operation before sufficient heat is generated to interrupt the circuit (trip the circuit breaker). The level of heat required to trip the circuit breaker is a function of not only amperage and voltage, but also the duration of the event. Thus, higher-than-desired current may flow through the wire, intermittently, for long periods of time without tripping the circuit breaker. As previously mentioned, testing conducted for the Safety Board by Lectromec demonstrated that current peaks of more than 100 amps, which released 2 to 4 J of energy<sup>610</sup> (of which about 400 mJ could be transferred to a victim wire), could be produced on wires protected by 10-amp circuit breakers when short circuits were created by dripping either water or lavatory fluid onto damaged wires. Further, intermittent short circuits existed for as long as 25 minutes without tripping circuit breakers. Therefore, because the energy levels transmitted during these types of electrical activity are high enough to ignite flammable fuel/air vapor in a fuel tank, thermally activated circuit breakers cannot be relied upon to prevent short circuits to FQIS wires from becoming potential fuel tank ignition hazards.

The Safety Board is aware that the FAA and industry have been working to develop processor-based AFCBs that would trip the circuit breaker within the first milliseconds of a higher-than-desired energy transfer. Such protection systems would represent an improvement over thermally activated circuit breakers because they would minimize the amount of time that current would be permitted to flow through a short circuit (such as occurs in arc-tracking) and, therefore, also minimize the amount of fire and system damage following a short-circuit event. Therefore, the Board supports the continuation of efforts to develop this technology and will follow those efforts with interest. However, the Board remains concerned that even the short duration of time that energy is permitted to transfer by such systems might still allow the transfer of enough energy to FQIS wiring to ignite flammable fuel/air vapor in a fuel tank. Therefore, it is unclear whether processor-based AFCBs could adequately prevent short circuits to FQIS wiring from becoming potential fuel tank ignition hazards.

---

<sup>610</sup> On one occasion, 90 J were released during a 40-millisecond succession of flashes.

### 2.3.2.1.2.2.2 Electrical Resistors

A resistor limits the amount of current (amperage), and thus power, that can pass through it. According to Boeing, protective resistors in the components connected to 747 CWT FQIS wiring (fuel quantity gauges, the VSO unit, AIDs, and fuel quantity totalizer gauge) limit the amperage from an internal short circuit to about 1 milliamp. Therefore, although each of those components includes a 115-volt circuit, the amount of energy transferred to the CWT FQIS wiring as a result of an internal short circuit would be too small to ignite the fuel/air vapor in the CWT. However, as previously discussed, there are many ways in which a short circuit outside of these components could transfer energy to FQIS wiring. Because resistors are designed to limit current with a known voltage, they are not appropriate devices to prevent short circuits to FQIS wiring from a variety of possible voltage sources.

### 2.3.2.1.2.2.3 Shielding and Physical Separation of Wires

As discussed in the Safety Board's April 7, 1998, safety recommendation letter to the FAA, shielding and physical separation of FQIS wires from other wires can be an effective means of preventing the transfer of potentially hazardous levels of energy to FQIS wires from higher-voltage wiring. In that letter, the Board issued Safety Recommendation A-98-38, which asked the FAA to

Require in Boeing 747 airplanes, and in other airplanes with FQIS wire installations that are corouted with wires that may be powered, the physical separation and electrical shielding of FQIS wires to the maximum extent possible.

In response, the FAA initiated two notice of proposed rulemakings (NPRM) that subsequently led to the issuance of airworthiness directives (AD) to require shielding and separation of FQIS wiring on 747 and 737 airplanes.<sup>611</sup> Regarding other airplane types, the FAA indicated that advisory material being developed in connection with the fuel tank design reviews proposed in NPRM 99-18<sup>612</sup> would include information "describing the use of wire separation and electrical shielding to protect FQIS wiring from short circuits...and other failures and malfunctions that could induce high electrical energy on FQIS wires that enter fuel tanks." In its February 9, 1999, response, the Safety Board expressed concern about the adequacy of Boeing's wire separation standard (discussed further below) and stated that, pending receipt of further details regarding this separation standard and planned activities for other airplane models, Safety Recommendation A-98-38 was classified "Open—Acceptable Response."

Although airplane manufacturers generally provide protection for certain critical electrical circuits, there is no FAA regulation that specifies wire separation criteria or identifies which circuits must be protected. In their evaluation of the adequacy of the wire

<sup>611</sup> The NPRMs proposed the installation of TSDs as an optional or additional requirement. Although the final ADs did not include TSDs as an alternative, the FAA indicated in correspondence related to Safety Recommendation A-98-39 that it will nonetheless permit TSDs as an alternate means of compliance.

<sup>612</sup> For more information about this NPRM, see section 1.18.3.4.3.

separation that would be required by the two ADs, Safety Board investigators reviewed the general wire separation standards and practices of several airplane manufacturers and found that these standards are not uniform. For example, Douglas Aircraft Company specified that wiring for certain systems (including FQIS and other fuel system wiring, fire warning system wiring, primary generator feeder cables, and electro-explosive devices) must be separated by at least 3 inches from other electrical wiring. In contrast, Boeing specifications do not require protection for some of the systems specified by Douglas (such as the FQIS), and, for those systems that are designated as protected, the required separation distance is only 1/4 inch in pressurized areas and 1/2 inch in unpressurized areas.

The potential for short circuits to damage nearby wiring (more than 1 1/2 inches away) has been documented in Safety Board investigations of numerous accidents and incidents.<sup>613</sup> The Safety Board concludes that existing standards for wire separation may not provide adequate protection against damage from short circuits. Therefore, the Safety Board believes that the FAA should review the design specifications for aircraft wiring systems of all U.S.-certified aircraft and (1) identify which systems are critical to safety and (2) require revisions, as necessary, to ensure that adequate separation is provided for the wiring related to those critical systems.

#### **2.3.2.1.2.2.4 Transient Suppression Devices**

TSDs limit the amount of energy or current that can pass through them to a predetermined amount. In its April 7, 1998, safety recommendation letter to the FAA, the Safety Board indicated that, because of the number of potential latent ignition sources in fuel tanks, the many means by which energy can be introduced into FQIS wires, and the difficulty of achieving complete wire separation and shielding in in-service airplanes, TSDs (referred to in that letter as "surge protection systems") may be the most effective method of preventing FQIS wiring from becoming an ignition source. The Board noted that if such devices were installed where FQIS wires enter fuel tanks, they could provide added protection against excessive power surges in the FQIS system, regardless of origin. Accordingly, the Board issued Safety Recommendation A-98-39, which asked the FAA to

Require, in all applicable transport airplane fuel tanks, surge protection systems to prevent electrical power surges from entering fuel tanks through FQIS wires.

In its June 10, 1998, response, the FAA indicated that it had issued NPRMs proposing to require, on 747s and 737s, installation of TSDs and/or installation of wire shielding and separation of the electrical wiring of the FQIS located outside of the fuel tanks. In its February 9, 1999, response, the Safety Board stated that wire shielding and

---

<sup>613</sup> For example, during postincident inspection of a shorted wire bundle after a January 9, 1998, incident aboard a United Airlines 767 en route from Zurich, Switzerland, to Washington Dulles International Airport in which the flight crew made a precautionary landing at London Heathrow International Airport after experiencing multiple display errors and tripped circuit breakers, power was inadvertently reapplied and arcing resumed, but it did not trip any additional circuit breakers. However, this event damaged dozens of wires, some more than 1 1/2 inches away, and also burned printed circuit tracks from cards located in another section of the electronics compartment.

separation alone could not protect against the entry of power from sources attached to FQIS wires and noted that FQIS wires share common connections with some higher-voltage circuits. The Board urged the FAA to reconsider its response to this safety recommendation. On the basis of the FAA's decision not to require TSDs, the Board classified A-98-39 "Open—Unacceptable Response."

In its November 3, 1999, and May 17, 2000, letters, the FAA indicated that on the basis of comments received on the NPRM, it had initially determined that TSD technology was not sufficiently developed for application to in-service airplanes and that wire separation and shielding provided a better design solution for protection of FQIS wiring. The FAA also stated that the requirement for separation and shielding of electrical circuits would apply to all portions of the circuit (including those portions within connectors and components).

Regarding the reliability of TSDs, the FAA indicated in its November 3, 1999, letter that it had been particularly concerned about comments that it had received on the NPRM regarding the potential for latent failure modes and the introduction of error in fuel quantity indications. However, the FAA further stated that several manufacturers had subsequently expressed interest in developing TSD technology as a possible alternate means of compliance with the ADs and that approval of TSDs would be considered. The FAA indicated that it had started determining appropriate requirements for such approval. The FAA further indicated that it did not plan to propose a requirement for both circuit separation and shielding and the installation of TSDs and that it believed either design, executed properly, would adequately ensure that high-energy signals are not introduced on wiring inside fuel tanks.

In its May 17, 2000, letter to the Safety Board, the FAA stated that the requirements for approval of a TSD design will include demonstrating that the device will limit the transfer of energy and power through the wires that enter a fuel tank to intrinsically safe levels (limited to less than spark energy and filament heating limits that could create an ignition spark or a hot surface ignition source in a fuel tank). According to the FAA,<sup>614</sup> in connection with approving TSDs as an alternate means of compliance, it will be assumed that failure of the TSD will result in catastrophic consequences. Therefore, it appears that for a TSD design to receive approval, it would have to be shown that the possibility of any such failure is extremely improbable, as defined in Advisory Circular (AC) 1309-1A.

As will be discussed in section 2.4.2, the FAA has initiated rulemaking to require minimizing fuel tank flammability in newly designed airplanes and is evaluating methods to reduce flammability in existing designs. If flammability in existing and future transport-category airplanes were eliminated or reduced (to the maximum extent technologically feasible), the Safety Board would agree with the FAA that either TSDs or separation and shielding, if executed properly, will provide adequate protection against introduction of excess energy to wiring inside fuel tanks.<sup>615</sup> Therefore, pending the timely completion of

<sup>614</sup> See Issue Paper P-1, "FQIS Transient Suppression Device/Unit for Installation on Boeing Model 747-100, -200, SP and SR Series Airplanes," dated January 13, 2000.



the FAA's actions to eliminate or reduce (to the maximum extent technologically feasible) flammability, Safety Recommendations A-98-38 and -39 are classified "Open—Acceptable Response."

### **2.3.2.1.2.3 Factors Suggesting the Likelihood that a Short-Circuit Event Occurred on TWA Flight 800**

Much of the insulation on the wiring recovered from the accident airplane was cracked or otherwise damaged, often exposing the inner conductor. When powered, such damaged wires would be vulnerable to short-circuiting. Although some of the damage to the accident airplane's wiring insulation probably occurred as a result of the accident or search and recovery operations, the degraded condition of wiring insulation found during inspections of other transport-category airplanes of about the same age as the accident airplane (and representing numerous different operators) suggests that at least some of the damage to the wiring insulation on the accident airplane very likely existed before the accident. Given what was found during the inspections of other airplanes, it is also likely that metal shavings and other contaminants were interspersed with the wiring system on the accident airplane before the accident.

Evidence of arcing was found on generator cables routed with wires in the leading edge of the right wing, near the wing root. Although this arcing damage might have been caused by the breaking of the forward wing spar and subsequent fuel fire, it is possible that it could also have been caused before the explosion. Because this wire bundle included wires leading to the right main wing tank (No. 4) fuel flow gauge and right wing FQIS wiring that would have been routed to a connection in the CWT at terminal strip T347, a short circuit in this bundle could have carried excessive energy into the CWT FQIS.

In addition, two non-FQIS wires at body station (STA) 955, which would have been corouted in the same raceway as CWT FQIS wiring, were found with possible arcing damage.<sup>615</sup> (Although the FQIS wiring recovered from this area did not contain evidence of arcing, it should be noted that some of the FQIS wiring from this area was not recovered.) These wires were located near structural repairs from a burst potable water tank and numerous other floor repairs. These repairs could have disturbed nearby wires, cracking or otherwise damaging the wire insulation, and could also have generated metal shavings. In fact, metal drill shavings were found adhered to fragments of a floor beam from STA 920, within 2 inches of where the CWT FQIS wiring would have been routed. This area was also near galley C, which was the site of numerous reported leaks in the 2 weeks preceding the accident. Leakage from this area could have dripped onto electrical

---

<sup>615</sup> The Safety Board recognizes that some FQIS technologies currently in development do not rely on wiring inside fuel tanks. Instead, the sensors for such systems utilize fiber-optics, sonics, and other underlying mechanisms. No additional protection (TSDs or separation and shielding of wires) would be required to prevent energy from entering fuel tanks so equipped.

<sup>616</sup> Copper strands on these two wires had melted and rehardened with molten/resolidified ends. Although it is possible that this damage could have been caused by the postexplosion fire, investigators considered it unlikely that only two wires from this raceway would have sustained such damage if the entire area had been exposed to fire.

wiring located immediately beneath the galley floor and caused a short circuit that affected the CWT FQIS wiring.

Repairs to the area around the upper deck flight attendant lighting panel could also have created conditions conducive to short-circuiting. A lighting wire and pin in that panel had been repaired on June 20, 1996, about a month before the accident. Although no evidence of arcing was found on the repaired wire, during the repair other wires bundled with it might well have been moved. The repaired wire was part of a bundle that branched off from a larger bundle that contained CWT and left wing FQIS<sup>617</sup> wires that led to the upper deck AIDS unit and also contained high-voltage wiring for lighting; thus, manipulation of wires during the repair could have resulted in movement and cracking of these wires. In addition, there was evidence of extensive structural repairs in this area, and the cabin interior had been altered, both of which could have disturbed these wires and introduced metal shavings, possibly damaging the wire insulation. Further, condensation, which is common in transport-category airplanes,<sup>618</sup> could have provided a mechanism for short-circuiting of such damaged wires when powered. Finally, in addition to being bundled with FQIS wires, the lighting wires were also bundled with CVR wires and No. 4 fuel flow wires along some portions of their path. Therefore, a short circuit involving these lighting wires could also explain the electrical anomalies indicated on the CVR recording and the No. 4 fuel flow indicator.

Although no evidence of arcing was found in any of the components connected to the CWT FQIS (the fuel quantity indicator, totalizer gauge, AIDS, VSO unit, and left wing refueling station), investigators considered the possibility that a short circuit in one of those components could have been a source of excess voltage transferred to the CWT FQIS wiring. The interior of each of these components contained numerous complex wiring and circuit assemblies that could have obscured evidence of a short circuit. Further, it is also possible that a short circuit at lower power or through moisture could occur without leaving evidence of arcing.<sup>619</sup> Therefore, there were several possible locations at which a short circuit of higher-voltage wiring could have affected the CWT FQIS wires in the accident airplane.

Further, as noted previously, there are several indications that possible anomalous electrical events occurred in the airplane just before the explosion. First, the captain's CVR channel recording has two "dropouts" of background power harmonics, indicating some type of electrical anomaly, less than a second before the CVR lost power.<sup>620</sup> Second, captain's comments about a "crazy" No. 4 (right outboard engine) fuel flow indicator were

---

<sup>617</sup> As previously noted, FQIS wiring from wing tanks is not electrically isolated from the CWT FQIS wires and, therefore, energy resulting from a short circuit to any of those FQIS wires could potentially reach the CWT.

<sup>618</sup> The 747 design includes drip shields between the upper deck and cockpit to protect critical elements (including the cockpit wiring) from condensation.

<sup>619</sup> For more information about arcing, see section 1.16.6.2.

<sup>620</sup> The continuation of the 400- and 800-Hz signals through these two periods indicate that the CVR was functioning and that the dropouts were not the result of damage to the recording. Safety Board testing found that power interruptions on adjacent circuits could result in acoustical indications on the CVR.

recorded on the CVR about 2 1/2 minutes before it lost power, which also suggests that some type of electrical anomaly occurred that affected that wiring. And third, the recovered CWT fuel quantity gauge from the cockpit displayed a reading of 640 pounds, which does not agree with the quantity recorded by the ground refueler (300 pounds).<sup>621</sup> Safety Board testing showed that applying power to a wire leading to the fuel quantity gauge can cause the digital display to change by several hundred pounds in less time than is required to trip the circuit breaker. This suggests that an electrical anomaly might have affected the reading of the cockpit gauge (accounting for the discrepancy).

These electrical anomalies were not necessarily related to the same event. However, it is possible that one or more of these anomalies were a manifestation of an electrical event that resulted in excess voltage being transferred to the CWT FQIS wiring. On the basis of this and the other evidence previously discussed, the Safety Board concludes that a short circuit producing excess voltage that was transferred to the CWT FQIS wiring is the most likely source of ignition energy for the TWA flight 800 CWT explosion.

### **2.3.2.2 Release of Ignition Energy Inside the Center Wing Fuel Tank**

#### **2.3.2.2.1 Arcing**

Exposed conductors on FQIS wiring (caused by either mechanical damage or cold-flow)<sup>622</sup> within a fuel tank could provide a mechanism that would lead to arcing inside the tank, which in turn could ignite the flammable fuel/air vapor.<sup>623</sup> (This was one of the suspected ignition mechanisms for the 1990 Philippine Airlines 737 CWT explosion and the 1972 Navy C-130 fuel tank explosion.) Very little (about 4 feet) of the CWT FQIS wiring from the accident airplane was recovered, and, therefore, the degree to which the wiring in the tank might have been damaged before the accident could not be assessed. However, investigators found preaccident damage, including exposed conductors,<sup>624</sup> on some of the recovered FQIS wiring from inside TWA flight 800's wing tanks, and damaged FQIS wiring was found inside the CWTs of several of the other 747 airplanes examined by the Safety Board.<sup>625</sup> In addition, the presence of a conductive material, such as metal drill shavings or safety wire (both of which were found in the fuel

---

<sup>621</sup> There is evidence that the cockpit gauge indicated 300 pounds while the airplane was on the ground; the figure recorded by the ground refueler (300 pounds) would have been taken from a "repeater" gauge at the refueling station, which registers the same quantity as the cockpit gauge. The difference between this and the 640-pound indication at the time of the accident exceeded the accuracy tolerance allowed by the manufacturer and the error recorded during certification tests. Further, the 640-pound indication was found in both the electrical and mechanical gauge mechanisms, which also suggests that the indication may not have been attributable to an error in the gauge.

<sup>622</sup> Cold-flow refers to migration or displacement of wire insulation.

<sup>623</sup> Investigators also theorized that arcing might occur if a loosely connected FQIS probe intermittently contacted structure inside the fuel tank. However, no loose fuel probes were found during FAA-required postaccident inspections of 747s for loose fuel probes, and there was no evidence in the recovered wreckage from the accident airplane to support this theory.

<sup>624</sup> Some of the exposed core conductors resulted from cold-flow of the polytetrafluoroethylene insulation material, and others apparently resulted from improper maintenance. Sulfide deposits were found on some exposed conductors, indicating that the damage existed before the accident.

tanks of other airplanes), could have provided a mechanism that would lead to arcing of FQIS components. Although no clear evidence of arcing was found inside TWA flight 800's CWT, fire damage along the route of the FQIS wiring was severe enough that it likely would have obscured any such evidence.

### 2.3.2.2.2 Resistance Heating

Another potential source of ignition energy is resistance heating, which could have resulted from a thin filament<sup>626</sup> being heated through contact with a wire, probe, or compensator exposed to excess voltage.<sup>627</sup> Although no clear evidence of a filament ignition was found inside TWA flight 800's CWT, such evidence could also have been physically lost or obscured by fire damage.

### 2.3.2.2.3 Silver-Sulfide Deposits on Fuel Quantity Indication System Wiring and Components

Research and testing conducted during this investigation found that silver-coated copper parts inside fuel tanks, such as those used in the FQIS, can develop silver-sulfide deposits<sup>628</sup> that are semiconductive and, therefore, can reduce the resistance between electrical connections and permit arcing. Such deposits can become a potential ignition mechanism inside a fuel tank.<sup>629</sup>

Silver-sulfide deposits were found on FQIS probes, compensators, and wiring from the accident airplane. Similar deposits have been discovered on FQIS parts from other airplanes, both military and civilian (including other 747s). Research by the Safety Board, the FAA, and the AFRL has found that deposits accumulate over time as a result of the part's exposure to jet fuel and fuel vapors, which contain sulfur. (It should be noted that the FQIS design for the 747 classic includes exposed conductors at terminal blocks.) In addition, laboratory research by the University of Dayton Research Institute conducted as a result of this investigation found that increased temperatures enhanced the formation of silver-sulfide deposits and that fuel washing could slow the accumulation of these deposits. This finding is significant with regard to CWTs because they are less frequently

<sup>625</sup> This damage was discussed in the Safety Board's April 7, 1998, safety recommendation letter to the FAA.

<sup>626</sup> A filament is a slender wire, such as that found inside an electric light bulb.

<sup>627</sup> For example, testing by Boeing indicated that steel wool can be ignited by as little as 32 milliamps from a 25-volt 400-cycle alternating current source. (The Boeing data did not include variables required to calculate energy [J] from the voltage value that was provided.)

<sup>628</sup> These deposits are sometimes also referred to as "copper-sulfide deposits," "sulfides," or "sulfidation."

<sup>629</sup> Ignition of vapors in an AFRL trainer fuel probe in 1990 during electrical bench tests (when test voltages higher than normal fuel system voltages were applied) was attributed by the AFRL to sulfide deposits. Subsequent AFRL testing for the Safety Board indicated that the deposits could break down and result in arcing when exposed to a 170-volt pulse. Also, during the investigation of the TWA flight 800 accident, the Board became aware that in 1988, Boeing found evidence of silver-sulfide deposits at the location of arcing in 18 fuel pump motors. In addition, during FAA-sponsored testing at Arizona State University in connection with this investigation, application of direct current voltage to silver-sulfide deposits created in a laboratory ignited Jet A fuel vapors.

filled with fuel to the top than wing tanks, and, therefore, the terminal block at the top of the CWT fuel probes is less often covered by fuel (which would subject it to fuel washing) than would be the case in a wing tank.<sup>630</sup>

The AFRL concluded that the accumulation of silver-sulfide deposits “is most likely the result of a long-term degradation or corrosion process...[and that] as the probes age, more probe failures [calibration errors] can be expected.” However, the problem is not solely limited to older airplanes; silver-sulfide deposits that were significant enough to cause FQIS anomalies<sup>631</sup> were found in a 757 airplane with only 750 hours.<sup>632</sup>

The existence of silver-sulfide deposits on FQIS components from both the accident airplane and numerous other airplanes raises the possibility that sulfide deposits could have provided an energy release mechanism at the point of ignition in the CWT. The accident airplane’s recent maintenance history, which indicates FQIS anomalies, is consistent with silver-sulfide deposits interfering with FQIS operation. Accordingly, sulfide deposits were considered as a possible ignition mechanism for the TWA flight 800 CWT explosion.

#### **2.3.2.2.3.1 Elimination of Silver-Sulfide Deposits Inside Fuel Tanks**

In response to AFRL’s findings from the 1990 vapor ignition incident, BFGoodrich eliminated the use of silver-plated components in the FQIS and began using nickel-plated wire, gold-plated ring connectors, and sealant. Those improved components have been used in military airplanes since about 1993. According to BFGoodrich, since that time, there has been a large reduction in the FQIS anomalies that had been associated with silver-sulfide deposits (such as FQIS inaccuracies). Although a Boeing 1991 engineering report indicated that silver should never contact sulfur-containing liquids because of the susceptibility to sulfidation, and Boeing uses nickel-plated (instead of silver-plated) wiring in its newly manufactured 777 and 737-NG airplanes, Boeing indicated in a December 7, 1999, letter to the Safety Board that it does not recommend replacing silver-plated FQIS components in existing airplanes.

In an April 7, 1998, letter to the FAA, the Safety Board expressed concern that sulfide deposits on FQIS wires could become an ignition source in fuel tanks and issued Safety Recommendation A-98-37, which asked the FAA to

Require research into copper-sulfide deposits on FQIS parts in fuel tanks to determine the levels of deposits that may be hazardous, how to inspect and clean the deposits, and when to replace the components.

---

<sup>630</sup> Only two of the many FQIS components from other airplanes examined during this investigation that contained silver-sulfide deposits had been removed from the airplane because of FQIS anomalies; both were terminal strips from the top of 747 CWTs.

<sup>631</sup> Research by BFGoodrich, an FQIS manufacturer, conducted after the AFRL vapor ignition incident in 1990 found that silver-sulfide deposits could permit leakage of electrical currents and, therefore, cause FQIS anomalies.

<sup>632</sup> For more information about sulfide deposit tests, see section 1.16.6.9.

In response to this recommendation, the FAA convened a team of specialists from Government, academia, and industry to conduct research. According to the FAA's May 17, 2000, response to the Safety Board, the team has studied the properties of sulfide deposits created in a laboratory environment but has not found indications of significant levels of deposits occurring in in-service airplanes for comparison. The FAA indicated that the research program had been extended from its original 12-month timeframe so that the team could complete its evaluation.

The FAA indicated in NPRM 99-18 that it anticipates that the proposed fuel tank safety review will identify critical areas of the fuel tank system that will require maintenance actions to account for the effects of aging, wear, corrosion, and possible contamination of the fuel system. Specifically, the FAA noted that it might be necessary to provide maintenance instructions to identify and eliminate silver-sulfide deposits.<sup>633</sup>

The Safety Board concludes that silver-sulfide deposits on FQIS components inside fuel tanks pose a risk for ignition of flammable fuel/air vapor. Although precluding operations with flammable fuel/air vapor (as recommended in Safety Recommendation A-96-174) would eliminate this risk, flammable fuel/air vapors will not likely be eliminated in all fuel tanks or during all phases of flight. Therefore, although the Board is pleased that the FAA is continuing to support research into sulfide deposits, the Safety Board believes that the FAA should require the development and implementation of corrective actions to eliminate the ignition risk posed by silver-sulfide deposits on FQIS components inside fuel tanks. The Safety Board classifies Safety Recommendation A-98-37 "Closed—Acceptable Action—Superseded."

#### **2.3.2.2.4 Ignition Location Inside the Center Wing Fuel Tank**

The Safety Board contracted with two research laboratories, Sandia National Laboratory and Christian Michelsen Research, to develop computer modeling in an attempt to determine potential ignition locations. However, because of considerable uncertainties in some aspects of the methodology, the results of that modeling could not be used to determine the most likely ignition location.<sup>634</sup>

Nonetheless, investigators examined all of the recovered CWT FQIS components, which included portions of all seven fuel probes, one complete terminal block and one partial terminal block, and the compensator.<sup>635</sup> None of the recovered probes or terminal blocks exhibited any noteworthy signs of damage. However, several plastic parts inside the compensator's innermost tube were found burned, with an apparent upward-flowing burn pattern, which investigators hypothesized could indicate that a fire initiated inside the

<sup>633</sup> In NPRM 98-NM-163-AD, the FAA proposed that silver-plated copper FQIS wiring in 747 CWTs be replaced with nickel-plated copper FQIS wiring within 20 years of the airplane's manufacture. Although the FAA acknowledged that there was little technical basis for this time limit, and the proposed replacement requirement was not included in the final rule (AD 98-08-02), the Safety Board is concerned that this proposal indicates a belief on the part of the FAA that silver-sulfide deposits do not pose a significant risk for airplanes less than 20 years old. As discussed in section 2.3.2.2.3, potentially hazardous deposits can accumulate in younger airplanes as well as on older airplanes, and such deposits can pose a significant risk.

<sup>634</sup> For more information about the computer modeling, see section 1.16.5.5.

compensator. Similar burn patterns<sup>636</sup> were observed on the compensator believed by the FAA to be the ignition source for the surge tank fire in the 747 that experienced a fuel tank explosion in May 1976 near Madrid, Spain.<sup>637</sup> (Although the Safety Board discounted the compensator as an ignition source in its October 1978 report of the Madrid accident, a different conclusion might have been warranted<sup>638</sup> given what is now known about sulfides and other ignition-related phenomenon.) However, there was insufficient evidence to conclude that the damage to the CWT compensator occurred before the explosion, and, therefore, no determination could be reached regarding the likelihood that the compensator was the ignition location.

### 2.3.2.3 Possible Ignition Scenario for TWA Flight 800 Explosion

Therefore, the Safety Board concludes that the ignition energy for the CWT explosion most likely entered the CWT through the FQIS wiring, and, although it is possible that the release of ignition energy inside the CWT was facilitated by the existence of silver-sulfide deposits on an FQIS component, neither the energy release mechanism nor the location of the ignition inside the CWT could be determined from the available evidence.

## 2.4 Fuel Tank Design and Certification Standards

### 2.4.1 Preclusion of Ignition Sources in Fuel Tanks

As previously discussed, a fuel tank explosion requires both a flammable fuel/air mixture and an ignition source. For purposes of certification, the FAA and transport-category airplane manufacturers have historically assumed that a flammable fuel/air mixture exists in fuel tanks at all times and have attempted to preclude fuel tank explosions by eliminating ignition sources in fuel tanks.<sup>639</sup> This philosophy is reflected in NPRM 99-18, which proposes to require (1) substantiation that no ignition sources will exist in fuel tanks and (2) development of maintenance and inspection criteria to ensure

---

<sup>635</sup> Although the burned compensator did not have any marks identifying it as being from the CWT, it was identified as such by process of elimination. Only one fuel tank other than the CWT (reserve tank No. 4) showed any evidence of fire in the vicinity of a compensator; the compensator from this tank was positively identified by unique characteristics. Therefore, the burned compensator apparently came from the CWT.

<sup>636</sup> For more information about these burn patterns, see section 1.18.1.

<sup>637</sup> Although the ignition energy for that explosion is believed to have come from a lightning strike, the energy would still have had to find a release mechanism inside the tank.

<sup>638</sup> The Safety Board explained its determination that “fuel did not ignite” at the compensator by noting that “[t]ests showed that it took more voltage to spark the probe than would conceivably be induced in its wiring [and that] microscopic examination found no evidence of sparking.” However, as was pointed out in an undated FAA memo commenting on the Board report, the report also recognized that “energy levels required to produce a spark will not necessarily damage metal or leave marks” and that “a spark [of] ... sufficient energy to ignite the fuel... will not necessarily leave physical evidence.”

<sup>639</sup> As stated in the FAA’s January 12, 2000, Draft AC 25.981-1X, “Fuel Tank Ignition Source Prevention Guidelines,” “[d]ue to the difficulty in predicting fuel tank flammability, the FAA has always assumed that a flammable fuel air mixture exists in airplane fuel tanks and has required that no ignition sources be present.”

that the level of safety originally designed into the fuel tank system is maintained.<sup>640</sup> The proposed rules would require affected type certificate and supplemental type certificate holders to create a failure modes and effects analysis (FMEA) for all components in the fuel tank system and use the resulting data to develop a quantitative fault tree analysis to determine whether combinations of failures expected to occur in the life of the fleet could cause an ignition source to exist in a fuel system. In the NPRM, the FAA indicated that these analyses should conform to the structured requirements of 14 CFR Sections 25.901(c) and 25.1309, which the FAA acknowledged "have not been consistently applied and documented when showing that ignition sources are precluded from transport category airplane fuel tanks."<sup>641</sup>

The Safety Board recognizes that FMEAs and fault tree analyses provide a structured and systematic method for identifying and evaluating the potential risk that might be posed by failure modes and, therefore, that they can be a useful part of the certification process. However, the Board is concerned that undue reliance is being placed on such analyses as proof that ignition sources have been precluded. As further discussed below, there are several reasons why such analyses may be unreliable.

Unrealistic or otherwise flawed data can be used to develop fault tree analyses. This problem was demonstrated during this investigation by a CWT ignition fault tree analysis that was developed by Boeing at the Safety Board's request (but that was not required to be and was not submitted as part of the FAA certification process). The exposure times and failure rates appeared to be too low for some events, resulting in overly optimistic probability data. Failure analysis specialists at NASA, who reviewed the fault tree analysis at the Board's request, stated the following in a November 25, 1998, letter:

Many of the probabilities, failure rates, and/or exposure times were much lower than would reasonably be expected. The probability of occurrence should be higher and/or exposure times should be longer on many of the basic events....Based on our evaluation of the tree and the information provided by the [Safety Board], the subject fault tree analysis quantification cannot stand up to peer review and should not be viewed as realistic. It should be noted that the logic of the tree could not be fully evaluated since we did not have access to the engineering drawings and schematics of the system. However, based on previous systems experience, we would expect the tree to be constructed differently.

Further, Safety Board staff noted that the two formats in which the data were presented (graphical and tabular) indicated different levels of risk for an ignition source (which was identified as the top-level failure mode); one form indicated that the risk of a CWT explosion was within acceptable limits (that is, it was extremely improbable, as

---

<sup>640</sup> The NPRM also addresses flammability reduction in newly designed airplanes; however, it does not address flammability in current designs.

<sup>641</sup> These regulations require the applicant to show (using a quantitative evaluation) that no failure or probable combination of failures will prevent continued safe flight and landing. For more details about these requirements, see section 1.16.6.5.



defined in AC 1309-1A), and the other indicated that the risk of a CWT explosion was not within acceptable limits.<sup>642</sup>

In its submission, Boeing indicated that, because the fault tree analysis was developed only to support the accident investigation, it did not go through the “iterative review process with the FAA normally associated with certification of a system, nor were the underlying FMEAs developed that normally would be the source of data to build the [fault tree analysis].” The Safety Board recognizes that the data submitted by Boeing to the Board in connection with this investigation might not have been submitted to, or accepted by, the FAA during the certification process. However, it is unclear whether the problems identified by the Board and NASA would have been avoided or corrected during that process, since Boeing was aware that the information it was supplying to the Board would be used as part of the TWA flight 800 investigation. In any event, the questionable data used by Boeing in its CWT ignition fault tree analysis raises concerns that similarly questionable data may have been used to develop other fault tree analyses that have been submitted to and accepted by the FAA in connection with aircraft certifications. The adequacy of fault tree analyses submitted in connection with aircraft certification was not examined as part of the TWA flight 800 accident investigation. However, this issue will be addressed in the Board’s upcoming safety study on aircraft certification.

Contributing to the possibility that FMEAs and fault tree analyses will be based on inaccurate data and, therefore, will not accurately depict all possible failure modes and their probability of occurrence is the fact that no single source exists for reliable and comprehensive data on component failures or malfunctions. Because the calculations in an FMEA are based (in part) on failure rates, incomplete or inappropriate failure data can significantly skew the results of an examination. The Safety Board is aware that service history data maintained by manufacturers do not include data from all operators. Further, the Board has found that the amount of data provided by the manufacturers of replacement component parts sometimes greatly exceeds the data provided by the aircraft manufacturers (possibly because replacement part suppliers can sell parts directly to operators and repair facilities). Although the FAA collects a significant amount of data about mechanical failures through its Service Difficulty Report (SDR) program, even these data are incomplete.<sup>643</sup> Other sources of potentially relevant data are the service histories maintained by the military of its variants of commercial airliners and the Board’s accident and incident investigation database; however, neither of these sources provides complete data either.

Even a well-constructed FMEA or fault tree analysis that incorporates the most complete and accurate data available will be unreliable to some extent because it is not possible to predict all failure modes or to accurately determine their probability of occurrence. As demonstrated by the series of accidents and incidents involving uncommanded rudder movements on 737s and the recent horizontal stabilizer trim system failure on a McDonald Douglas MD-83, unanticipated failure modes in aircraft systems

---

<sup>642</sup> For more information about Boeing’s CWT ignition fault tree analysis, see section 1.16.6.5.

<sup>643</sup> For more information about concerns regarding and actions taken to address problems with the SDR program, see section 1.18.2.1.

can and do occur. The FAA has acknowledged that “ignition sources have developed in airplane fuel tanks due to unforeseen failure modes or factors that were not considered at the time of original certification of the airplane.”<sup>644</sup> Similarly, the engineering and test evaluation board that was convened in 1999, which was in response to a Safety Board recommendation, to evaluate the 737 rudder system identified catastrophic failure modes that had not been identified through the FMEA and fault tree analyses submitted in 1997 in connection with certification of the 737-NG airplanes. As evidenced by the Space Shuttle disaster, even systems that have undergone the rigorous and highly respected NASA failure analysis reviews can experience unexpected failure modes. Similarly, the March 28, 1979, nuclear power accident at the Three Mile Island nuclear power plant near Harrisburg, Pennsylvania, was attributed to a series of failures that were not anticipated by the Nuclear Regulatory Commission and, therefore, not considered during development.<sup>645</sup>

In addition, FMEAs are sometimes intentionally constructed to exclude certain failure modes. The FAA acknowledged in draft AC 25-981-1X that the fuel tank ignition FMEAs proposed in NPRM 99-18 are not intended to consider all potential ignition sources. Ignition sources that are outside the purview of the proposed FMEAs include uncontained engine failure debris; terrorist actions, such as bombs; and the effects of postcrash or other fires outside the tank (including the propagation of fire through the airplane vent system).

Finally, to the extent that the prevention of failure modes are dependent on adequate maintenance and inspection of systems and components, the premise that maintenance and inspection programs will prevent failures is also inherently flawed. Many potentially hazardous conditions in aircraft electrical wiring and related fuel system components (such as worn wiring or exposed conductors obscured by clamps or other wires, debris inside fuel pumps, and hidden silver-sulfide deposits) are not easily detected by visual inspection, which is currently the primary method for inspecting such components. Other potentially hazardous conditions (such as metal shavings or other debris) may be perceived by maintenance personnel as commonplace and, therefore, insignificant. Consequently, necessary maintenance and/or replacement of some components—upon which a favorable risk assessment may have been based—may not occur.

Therefore, although FMEAs and fault tree analyses focused on eliminating ignition sources are important and necessary parts of the design and certification process, the Safety Board concludes that they should not be relied upon as the sole means of demonstrating that an airplane’s fuel tank system is not likely to experience a catastrophic failure. The Safety Board further concludes that a fuel tank design and certification philosophy that relies solely on the elimination of all ignition sources, while accepting the

---

<sup>644</sup> FAA Draft AC 25.981-1X, “Fuel Tank Ignition Source Prevention Guidelines,” dated January 12, 2000. Similarly, the FAA acknowledged in NPRM 99-18 that the TWA flight 800 accident investigation has led to the discovery of numerous previously unforeseen failure modes that could result in fuel tank ignition and that were not considered in connection with the 747 original certification.

<sup>645</sup> For more information about the Three Mile Island accident, see section 1.16.6.5.1.

existence of fuel tank flammability, is fundamentally flawed because experience has demonstrated that all possible ignition sources cannot be predicted and reliably eliminated.

The design and certification of the 737 rudder system and the MD-80 stabilizer trim system may have been similarly flawed because both of these systems have experienced unanticipated catastrophic failures<sup>646</sup> as a result of failure modes that appear to have been unforeseen. The flawed 737 rudder system design and the potentially flawed MD-80 horizontal stabilizer design would have been precluded by a certification approach that required a reliable independent means for overcoming or counteracting the catastrophic effects of a failure, even if the probability of the catastrophic failure mode is calculated to be extremely improbable. (This issue will be further addressed in the Safety Board's upcoming safety study on aircraft certification.) In the case of fuel tank safety, such redundant protection could be achieved by requiring, in addition to the preclusion of ignition sources, the preclusion of a flammable fuel/air mixture. The Safety Board concludes that operating transport-category airplanes with flammable fuel/air mixtures in fuel tanks presents an avoidable risk of an explosion.<sup>647</sup>

#### 2.4.2 Preclusion of Flammable Fuel/Air Vapor in Fuel Tanks

A major reason for the flammability of the fuel/air vapor in the CWT on the 747 (and similarly designed airplanes)<sup>648</sup> is the large amount of heat generated by the air conditioning packs located directly below the tank, which significantly elevates the temperatures in the pack bay. Heat from the pack bay can transfer to the CWT through the bottom of the tank and cause temperatures to rise above the lower flammability limit.<sup>649</sup> Therefore, the 747 (and other similarly designed airplanes) may operate a significant portion of the time with a flammable fuel/air mixture.<sup>650</sup> Under these circumstances, a single ignition source could cause an explosion and destroy the airplane.

---

<sup>646</sup> In the case of the 737, the catastrophic failures were uncommanded rudder movements; in the case of the MD-80, they were uncommanded horizontal stabilizer movements.

<sup>647</sup> The FAA and the aviation industry have also recognized that there is a safety benefit in reducing the degree of fuel tank flammability. For example, after several fuel tank explosions in the 1970s, the use of JP-4 fuel in civil transport-category aircraft was discontinued in favor of Jet A fuel, which is less flammable. Further, in NPRM 99-18, the FAA proposed regulatory changes aimed at minimizing the development of flammable fuel/air mixtures in newly designed airplanes. However, as further discussed in section 2.4.1.2, no regulatory action has yet been taken to address the flammability of fuel tanks in the existing fleet and in current designs.

<sup>648</sup> The air conditioning packs are also located under the CWT in several Boeing and Airbus airplanes; however, in some Airbus airplanes the pack bays are ventilated. In contrast, in the DC-10, MD-11, and L 1011, the packs are located in the nose; in the MD-80, packs are located in the tail.

<sup>649</sup> Further, as shown in the Safety Board's July 1997 flight tests at JFK, ullage temperatures are highest at the bottom and center of the CWT (nearest the heat source) and become cooler in the regions around the side and top of the CWT (where the heat leaves the tank).

In its December 13, 1996, letter to the FAA, the Safety Board stated that the existence of a flammable fuel/air mixture in transport-category airplane fuel tanks was inconsistent with the basic tenet of transport-aircraft design that no single-point failure should prevent continued safe flight and landing. Because of its concerns, the Board issued Safety Recommendations A-96-174 and -175, which asked the FAA to

Require the development and implementation of design or operational changes that will preclude the operation of transport-category airplanes with explosive fuel/air mixtures in the fuel tanks:

(a) Significant consideration should be given to the development of airplane design modifications, such as nitrogen-inerting systems and the addition of insulation between heat-generating equipment and fuel tanks. Appropriate modifications should apply to newly certificated airplanes and, where feasible, to existing airplanes. (A-96-174)

(b) Pending implementation of design modifications, require modifications in operational procedures to reduce the potential for explosive fuel/air mixtures in the fuel tanks of transport-category aircraft. In the 747, consideration should be given to refueling the CWT before flight whenever possible from cooler ground fuel tanks, proper monitoring and management of the CWT fuel temperature, and maintaining an appropriate minimum fuel quantity in the CWT. (A-96-175)

Initially, the FAA did not agree with the Safety Board that such changes were necessary to address fuel tank flammability, and in its early responses relating to Safety Recommendations A-96-174 and -175 (dated February 18, 1997, and June 28, 1997), it indicated that it was focusing its efforts on eliminating ignition sources. However, in October 1999, the FAA stated in NPRM 99-18 that it was undertaking a "parallel effort to address the threat of fuel tank explosions by eliminating or significantly reducing the presence of explosive fuel/air mixtures within the fuel tanks in new type designs, in production, and the existing fleet of transport airplanes." The FAA further acknowledged in the NPRM that the placement of air conditioning packs under fuel tanks "without provisions to reduce transfer of heat from the packs to the tank" is the primary reason for elevated temperatures in those fuel tanks and indicated that one purpose of the proposed rule changes (to "minimize" the flammability of fuel tanks in newly designed aircraft) is "to preclude the future use of such design practices." In the NPRM, the FAA also recognized that airplanes without heat sources adjacent to fuel tanks have significantly reduced levels of flammability exposure (5 percent of the fleet operational time) when

---

<sup>650</sup> It should be noted that the potential for 747 CWT overheating and methods for mitigating against it were studied by Boeing and documented in a 1980 Fuel Tank Heating Study prepared for the USAF in connection with the E-4B, a military variant of the 747. According to Boeing, its personnel associated with the TWA flight 800 investigation did not become aware of the report until late in the investigation. The Safety Board recognizes that the military variant of the 747 is not directly comparable to the civilian 747 and that the focus of that study was fuel pump functionality, not flammability. Nonetheless, it is unfortunate that potentially relevant information about 747 CWT overheating and corrective measures was not provided to the FAA or to 747 operators earlier. According to Boeing, all of its company reports and resources are now electronically accessible through key-word searches, and its accident investigation processes have been revised and now include the ability to electronically search the company's technical documents.

compared with airplanes that have heat sources adjacent to fuel tanks (30 percent of the fleet operational time).<sup>651</sup>

The Safety Board is pleased that the FAA agrees that the heat generated by the packs located under the CWT significantly increases the flammability exposure in the CWT. Further, the Safety Board concludes that the placement of heat-generating equipment under a fuel tank containing Jet A fuel can unnecessarily increase the amount of time that the airplane is operating with a flammable fuel/air mixture unless measures are in place to either (1) prevent the heat from entering the CWT or (2) eliminate the flammable vapors inside the CWT.

Although the Safety Board supports the FAA's efforts to address fuel tank flammability in new designs, the Board is concerned about the FAA's apparent premise that minimizing, rather than eliminating, fuel tank flammability is an acceptable goal. The ARAC working group (the FTHWG) established to advise the FAA in its rulemaking efforts concluded that the safety record of fuel tanks located in the wings (which the FTHWG calculated were flammable about 7 percent of the fleet operational time) was adequate and that if the same level of safety could be achieved in CWTs, the overall safety objective could be achieved. Thus, the FTHWG proposed limiting the exposure to flammable conditions in all fuel tanks to less than 7 percent of the expected fleet operational time.

FAA staff indicated during meetings with Safety Board staff on February 29, 2000, that the FAA did not intend to endorse the FTHWG's proposed 7 percent exposure criteria. However, the FAA's draft guidance<sup>652</sup> concerning compliance with the proposed new requirement to minimize fuel tank flammability reflects exposure criteria that are tied to the exposure of wing tanks; these criteria are reiterated in the FAA's May 17, 2000, letter to the Board describing its actions in response to several safety recommendations, including A-96-174 and -175. The draft guidance states that "the intent of the regulation is to require that the exposure to formation or presence of flammable vapors is equivalent to that of an unheated wing tank in the transport airplane being evaluated," which, as previously mentioned, the FTHWG calculated to be about 7 percent of the fleet operational time.

The Safety Board registered two concerns about such exposure criteria in its comments on NPRM 99-18. First, the Board stated that because the exposure criteria is based on a fleetwide average, it does not account for increased risks that may exist at specific locations, during certain time periods, or for certain flights.<sup>653</sup> Second, the Board

---

<sup>651</sup> The FAA amended this estimate (of how much of the fleet operational time CWTs are flammable) to 35 percent in its May 17, 2000, letter to the Safety Board, based on its analysis of recent flammability research.

<sup>652</sup> FAA Draft AC 25.981-2X, "Fuel Tank Flammability Minimization," dated January 12, 2000.

<sup>653</sup> The Safety Board notes that of the 16 fuel tank explosions documented by the FTHWG, 11 occurred in the months of May, June, and July, and only 2 occurred outside of warm climates or summer months. Further, short flights in warm climates can have a dramatically higher exposure time than the fleetwide average. For these flights, attempting to reduce the fleetwide flammability of CWTs to the level of wing tanks would be of little benefit.

questioned the premise that transport-category airplane wing fuel tanks have an acceptable safety record, noting that wing fuel tanks have exploded. The Board also stated that the goal should be to completely eliminate the development of flammable vapors in fuel tanks to the greatest extent technically feasible (such as would result from the use of inerting systems).

In addition, the Safety Board is even more concerned that NPRM 99-18 did not propose any regulatory changes that address fuel tank flammability in current designs and in the existing fleet. This is especially disturbing because some operational measures that can reduce current levels of flammable vapors (such as limiting the on-ground operating time of air conditioning packs and instead using a ground-based cool air supply and cooling or ventilating the pack bay) could be accomplished immediately.

The FAA indicated in its May 17, 2000, letter to the Safety Board that it is evaluating methods for reducing flammability in both future and existing designs, including directed ventilation and on-board or ground-based fuel tank nitrogen inerting systems. However, according to the FAA, fuel tank temperature data provided (to date) by airplane manufacturers in response to its request indicate that directed ventilation systems would not reduce the temperature of heated CWTs as much as predicted by the FTHWG. The FAA indicated that it would not reach a final decision regarding the benefits of this design change until it had received and evaluated all of the requested fuel tank temperature data.

With regard to fuel tank inerting, the FAA letter stated that its research on ground-based inerting indicated that the costs associated with the needed ground equipment are significantly less than what was estimated by the FTHWG and, further, that analysis indicated that ground-based inerting would reduce the fleetwide average flammability exposure for affected CWTs to about 2 percent. The FAA indicated that it planned to conduct ground and flight tests to determine how long ground-based inerting would remain effective during flight and whether vent system modifications would be required to ensure its effectiveness. The FAA stated that it is also establishing an ARAC working group to gather additional data on the practicality of both ground-based and on-board inerting methods.

In addition, the FAA indicated that it is evaluating the use of ground sources for conditioned air (instead of using the air conditioning packs) as an additional measure to reduce the flammability of CWTs in existing designs and the current fleet. According to the FAA, use of ground sources on days when the temperature exceeds 60° F would reduce the fleetwide flammability of CWTs from about 35 percent to about 25 percent. The FAA stated that a Boeing service letter (SL) recommends that operators use ground sources for conditioned air when available and practical and that it intends to encourage operators to follow this recommendation. The Safety Board is pleased by the significant reduction in flammability that can be achieved by using ground sources for conditioned air and notes that a requirement that such sources be used seems to be a logical step toward satisfying the intent of Safety Recommendation A-96-175.

Although the use of ground sources for conditioned air can provide meaningful short-term benefits, fuel tank inerting appears to be a more promising, near-term method that could even more dramatically reduce fuel tank flammability in the existing fleet.<sup>654</sup> Thus, the Safety Board is pleased that the FAA has recently begun to aggressively study this method. However, given that 3 1/2 years have passed since the Board recommended that the FAA give significant consideration to the issue of fuel tank inerting as a means of precluding the operation of transport-category airplanes with flammable vapors in the fuel tanks, and given the nature of the results that have been achieved by prior ARACs (particularly the FTHWG)<sup>655</sup> the Board is concerned that the FAA has chosen to address this issue by forming another ARAC working group to review and advise the FAA regarding the practicality of fuel tank inerting methods. The Board strongly encourages the FAA to consider a broader range of inerting technologies<sup>656</sup> and expedite the pace of its research and rulemaking initiatives with regard to fuel tank inerting. However, based on the FAA's recent input to the Board, and pending additional expedited action with regard to fuel tank inerting, Safety Recommendations A-96-174 and -175 are classified "Open—Acceptable Response."

## 2.5 Maintenance and Aging Issues

As previously discussed, no evidence was found that preexisting airplane fatigue or corrosion contributed to the accident.<sup>657</sup> Although small fatigue cracks were found in the lower chord of the front spar and in shear ties for the floor beams and stiffeners at the front spar, they would not have degraded the capability of the front spar to react to wing bending loads as a part of the WCS, nor would they have affected the pattern or severity of the airplane's structural breakup. These fatigue cracks appear to have been exposed by fractures generated by the forces associated with the overpressure event within the CWT and by the continued breakup of the airplane. No fatigue cracking was associated with the initial failure of the CWT at the upper end of SWB3.

However, several potentially unsafe conditions were found in and near the electrical wiring from the accident airplane, including cracked wire insulation, metal

---

<sup>654</sup> The Safety Board recognizes that fuel tank flammability can be counteracted in a number of different ways. However, inerting appears to be the most direct and effective method because it does not require monitoring or predicting temperatures inside the fuel tank.

<sup>655</sup> The FTHWG was tasked with recommending regulatory changes that would "eliminate or significantly reduce the hazards associated with explosive vapors in transport category airplane fuel tanks [of]...new type designs, in-production airplanes and the existing fleet." 63 *Federal Register* 3614 (January 23, 1998). However, its final report recommended regulatory changes only with regard to flammability reduction in new aircraft designs and also recommended further study of methods for flammability reduction in the existing fleet and current designs. Further, as previously discussed, the Safety Board disagreed with the FTHWG conclusion that the safety record of wing fuel tanks was adequate and that the FAA should strive for a similar safety record for fuel tanks adjacent to heat sources.

<sup>656</sup> For example, the FAA should research the effectiveness of inerting gases other than nitrogen and various methods of gas storage, delivery, and availability.

<sup>657</sup> For more information about preexisting fatigue and corrosion in the accident airplane, see section 2.2.1.1.

shavings adhered to a floor beam along which FQIS wires would have been routed,<sup>658</sup> other debris, and sulfide deposits. In addition, as previously mentioned, evidence of several repairs that did not comply with the guidelines in Boeing's SWPM were found on the accident airplane. Noncompliant repairs included the use of an oversized strain relief clamp on the terminal block of the No. 1 fuel tank compensator, which did not adequately secure the wires; numerous open-ended (rather than sealed) wire splices, which exposed conductors to possible water contamination; several wire bundles containing numerous wire splices on adjacent wires at the same location; and excessive solder on the connector pins inside the fuel totalizer gauge, which had connected the pins/wires from the right wing main fuel tank and the CWT FQIS.

Although some of these conditions may suggest the need for improved maintenance, the Safety Board found that deterioration, damage, and contamination of aircraft wiring and related components, and noncompliant repairs, such as those found on the accident airplane, were common in the airline transport-category airplanes of numerous operators (especially in the older airplanes) inspected in connection with this accident investigation.<sup>659</sup> Therefore, the Safety Board concludes that the condition of the wiring system in the accident airplane was not atypical for an airplane of its age and that the airplane was maintained in accordance with prevailing industry practices.

Nonetheless, the Safety Board was concerned about the damage and contamination found on electrical wiring and components during its examinations of transport-category airplanes, including the accident airplane. These conditions were especially disturbing because it was apparent from those examinations that a large portion of aircraft wiring is difficult, if not impossible, to inspect and/or test because of its inaccessibility (as a result of being confined in wire bundles or blocked by other obstructions). Moreover, the general nature of current visual wiring inspection criteria is such that wire damage or other potentially unsafe conditions may not be detected even on visible and accessible portions of aircraft wiring. The Safety Board concludes that, until recently, insufficient attention has been paid to the condition of aircraft electrical wiring, resulting in potential safety hazards.

However, this accident investigation has resulted in a heightened awareness of the importance of maintaining the integrity of aircraft wiring, and the FAA has now recognized that current maintenance practices may not adequately or proactively address aging nonstructural systems. In its July 1998 Aging Transport Non-Structural Systems Plan (which was developed after the FAA received the recommendation of the White House Commission on Aviation Safety and Security and had participated in Safety Board airplane inspections), the FAA described the results of its evaluation of five

---

<sup>658</sup> The presence of metal shavings is consistent with maintenance records that described compressed air being used to blow metal shavings off avionics units. (For more information about the accident airplane's maintenance records, see section 1.6.3.2.)

<sup>659</sup> The widespread existence of such conditions was also corroborated by Boeing's SL 747-SL-20-048 (January 25, 1995), which detailed similar conditions found in numerous 747s. In that SL, Boeing also stated that it "believe[d] that the wiring on high time 747 airplanes is holding up exceptionally well" and noted that "[w]iring damage is hard to predict but some areas of wiring experience degradation more frequently."



transport-category airplanes deemed representative of the "aging" fleet of transport-category airplanes. The FAA found conditions similar to those found by the Board during airplane inspections in connection with this investigation, including deterioration of wiring and related components; stiff and easily cracked wire; contamination of wire bundles with metal shavings, dust, and fluids; cracked insulation; corrosion on connector pins; and improper wire installation and repairs. The FAA also found, as had Board investigators, that wires contained in wire bundles could be difficult to inspect.

The FAA concluded that current maintenance practices do not adequately address wiring components, wire inspection criteria are too general, unacceptable conditions are not described in sufficient detail, repair instructions and data are difficult to extract from SWPMs, wire replacement criteria may not be adequate, and current incident/maintenance reporting procedures do not allow for easy identification of failures. The Safety Board concurs with these conclusions. The FAA's plan also detailed several tasks and associated subtasks aimed at correcting these problems, including improving wiring inspection criteria and providing more detailed descriptions of undesirable conditions; improving inspector training to ensure that it adequately addresses the recognition and repair of aging wiring components; and developing methods for nondestructive testing of wiring.<sup>660</sup>

To assist in addressing these problems, the FAA established the Aging Transport Systems Rulemaking Advisory Committee (ATSRAC), the activities of which the Safety Board has been following with great interest. The Board is encouraged that other Government agencies, including the U.S. Navy and USAF, have increased their research into aging aircraft systems and shared the resulting information and reports with the FAA and that the White House has formed a Wire Safety Research interagency working group. Although the FAA's research is scheduled to continue into future fiscal years, the ATSRAC charter will expire in January 2001, unless it is extended. In light of the short time remaining for the completion of the ATSRAC's work, the Board is concerned that the ATSRAC's final report and recommendations may not fully and adequately address all of the issues identified in the Aging Transport Non-Structural Systems Plan.

The Safety Board supports the FAA's ongoing efforts to address the maintenance/aging issues identified by the Aging Transport Non-Structural Systems Plan and will continue to follow the activities of the ATSRAC and other Government and industry initiatives related to aircraft maintenance and aging problems. The Safety Board concludes that the issues defined in the FAA's Aging Transport Non-Structural Systems Plan are important safety issues that must be fully addressed through appropriate changes, including rulemaking. Therefore, the Safety Board believes that the FAA should, regardless of the scope of the ATSRAC's eventual recommendations, address (through rulemaking or other means) all of the issues identified in the Aging Transport Non-Structural Systems Plan, including the need for improved training of maintenance

---

<sup>660</sup> The Safety Board has participated in demonstration tests of automated test equipment in which faults were detected that could not be visually seen. Lectromec documented similar results during inspections of five U.S. Navy P-3 airplanes, finding that visual inspections revealed only 25 to 39 percent of the defects found by electrical inspections. For more information about these inspections, see section 1.18.2.5.

personnel to ensure adequate recognition and repair of potentially unsafe wiring conditions; the need for improved documentation and reporting of potentially unsafe electrical wiring conditions; and the need to incorporate the use of new technology, such as AFCBs and automated wire test equipment. To determine whether adequate progress is being made in these areas, the Safety Board believes that, within 90 days, the FAA should brief the Safety Board on the status of its efforts to address all of the issues identified in the Aging Transport Non-Structural Systems Plan.

## 3. Conclusions

### 3.1 Findings

1. The flight crew was properly certificated and qualified and had received the training and off-duty time prescribed by Federal regulations. No evidence indicated any preexisting medical or behavioral conditions that might have adversely affected the flight crew's performance during the accident flight.
2. The airplane was certificated, equipped, and dispatched in accordance with Federal regulations and approved TWA procedures.
3. At the time of the accident, there were light winds and scattered clouds in the area, but there were no significant meteorological conditions that might have disrupted the flight.
4. The in-flight breakup of TWA flight 800 was not initiated by a preexisting condition resulting in a structural failure and decompression.
5. The in-flight breakup of TWA flight 800 was not initiated by a bomb or a missile strike.
6. The fuel/air vapor in the ullage of TWA flight 800's center wing fuel tank was flammable at the time of the accident.
7. A fuel/air explosion in the center wing fuel tank of TWA flight 800 would have been capable of generating sufficient internal pressure to break apart the tank.
8. The witness observations of a streak of light were not related to a missile, and the streak of light reported by most of these witnesses was burning fuel from the accident airplane in crippled flight during some portion of the postexplosion preimpact breakup sequence. The witnesses' observations of one or more fireballs were of the airplane's burning wreckage falling toward the ocean.
9. The TWA flight 800 in-flight breakup was initiated by a fuel/air explosion in the center wing fuel tank.
10. Boeing's design practice that permits parts less than 3 inches long in any direction to be electrically unbonded may not provide adequate protection against potential ignition hazards created by static electricity generated by lightning or other high-energy discharges.

11. It is very unlikely that the flammable fuel/air vapor in the center wing fuel tank (CWT) on TWA flight 800 was ignited by a lightning or meteor strike; a missile fragment; a small explosive charge placed on the CWT; auto ignition or hot surface ignition, resulting from elevated temperatures produced by sources external to the CWT; a fire migrating to the CWT from another fuel tank via the vent (stringer) system; an uncontained engine failure or a turbine burst in the air conditioning packs beneath the CWT; a malfunctioning CWT jettison/override pump; a malfunctioning CWT scavenge pump; or static electricity.
12. Electromagnetic interference from radio frequency sources external to TWA flight 800 did not produce enough energy to ignite the fuel/air vapor in the center wing fuel tank.
13. Electromagnetic interference from personal electronic devices played no role in igniting the fuel/air vapor in TWA flight 800's center wing fuel tank.
14. It is unlikely that electromagnetic interference from aircraft system wiring played a role in igniting the fuel/air vapor in TWA flight 800's center wing fuel tank.
15. Existing standards for wire separation may not provide adequate protection against damage from short circuits.
16. A short circuit producing excess voltage that was transferred to the center wing tank (CWT) fuel quantity indication system wiring is the most likely source of ignition energy for the TWA flight 800 CWT explosion.
17. Silver-sulfide deposits on fuel quantity indication system components inside fuel tanks pose a risk for ignition of flammable fuel/air vapor.
18. The ignition energy for the center wing fuel tank (CWT) explosion most likely entered the CWT through the fuel quantity indication system (FQIS) wiring, and, although it is possible that the release of ignition energy inside the CWT was facilitated by the existence of silver-sulfide deposits on an FQIS component, neither the energy release mechanism nor the location of the ignition inside the CWT could be determined from the available evidence.
19. Failure modes and effects analyses and fault tree analyses should not be relied upon as the sole means of demonstrating that an airplane's fuel tank system is not likely to experience a catastrophic failure.
20. A fuel tank design and certification philosophy that relies solely on the elimination of all ignition sources, while accepting the existence of fuel tank flammability, is fundamentally flawed because experience has demonstrated that all possible ignition sources cannot be predicted and reliably eliminated.
21. Operating transport-category airplanes with flammable fuel/air mixtures in fuel tanks presents an avoidable risk of an explosion.

22. The placement of heat-generating equipment under a fuel tank containing Jet A fuel can unnecessarily increase the amount of time that the airplane is operating with a flammable fuel/air mixture unless measures are in place to either (1) prevent the heat from entering the center wing fuel tank (CWT) or (2) eliminate the flammable vapor inside the CWT.
23. The condition of the wiring system in the accident airplane was not atypical for an airplane of its age, and the airplane was maintained in accordance with prevailing accepted industry practices.
24. Until recently, insufficient attention has been paid to the condition of aircraft electrical wiring, resulting in potential safety hazards.
25. The issues defined in the Federal Aviation Administration's Aging Transport Non-Structural Systems Plan are important safety issues that must be fully addressed through appropriate changes, including rulemaking.

### **3.2 Probable Cause**

The National Transportation Safety Board determines that the probable cause of the TWA flight 800 accident was an explosion of the center wing fuel tank (CWT), resulting from ignition of the flammable fuel/air mixture in the tank. The source of ignition energy for the explosion could not be determined with certainty, but, of the sources evaluated by the investigation, the most likely was a short circuit outside of the CWT that allowed excessive voltage to enter it through electrical wiring associated with the fuel quantity indication system.

Contributing factors to the accident were the design and certification concept that fuel tank explosions could be prevented solely by precluding all ignition sources and the design and certification of the Boeing 747 with heat sources located beneath the CWT with no means to reduce the heat transferred into the CWT or to render the fuel vapor in the tank nonflammable.

## 4. Recommendations

### 4.1 New Recommendations

As a result of the investigation of the TWA flight 800 accident, the National Transportation Safety Board makes the following recommendations to the Federal Aviation Administration (FAA):

Examine manufacturers' design practices with regard to bonding of components inside fuel tanks and require changes in those practices, as necessary, to eliminate potential ignition hazards. (A-00-105)

Review the design specifications for aircraft wiring systems of all U.S.-certified aircraft and (1) identify which systems are critical to safety and (2) require revisions, as necessary, to ensure that adequate separation is provided for the wiring related to those critical systems. (A-00-106)

Require the development and implementation of corrective actions to eliminate the ignition risk posed by silver-sulfide deposits on fuel quantity indication system components inside fuel tanks. (A-00-107)

Regardless of the scope of the Aging Transport Systems Rulemaking Advisory Committee's eventual recommendations, address (through rulemaking or other means) all of the issues identified in the Aging Transport Non-Structural Systems Plan, including

- the need for improved training of maintenance personnel to ensure adequate recognition and repair of potentially unsafe wiring conditions;
- the need for improved documentation and reporting of potentially unsafe electrical wiring conditions; and
- the need to incorporate the use of new technology, such as arc-fault circuit breakers and automated wire test equipment.

To determine whether adequate progress is being made in these areas, the Safety Board believes that, within 90 days, the Federal Aviation Administration should brief the Safety Board on the status of its efforts to address all of the issues identified in the Aging Transport Non-Structural Systems Plan. (A-00-108)

## 4.2 Previously Issued Recommendations Resulting From This Accident Investigation

As a result of the TWA flight 800 accident investigation, the Safety Board issued the following safety recommendations to the FAA on December 13, 1996:

Require the development and implementation of design or operational changes that will preclude the operation of transport-category airplanes with explosive fuel/air mixtures in the fuel tanks:

(a) Significant consideration should be given to the development of airplane design modifications, such as nitrogen-inerting systems and the addition of insulation between heat-generating equipment and fuel tanks. Appropriate modifications should apply to newly certificated airplanes and, where feasible, to existing airplanes. (A-96-174)

(b) Pending implementation of design modifications, require modifications in operational procedures to reduce the potential for explosive fuel/air mixtures in the fuel tanks of transport-category aircraft. In the 747, consideration should be given to refueling the center wing fuel tank (CWT) before flight whenever possible from cooler ground fuel tanks, proper monitoring and management of the CWT fuel temperature, and maintaining an appropriate minimum fuel quantity in the CWT. (A-96-175)

Require that the 747 Flight Handbooks of TWA and other operators of 747s and other aircraft in which fuel tank temperature cannot be determined by flight crews be immediately revised to reflect the increases in center wing fuel tank (CWT) fuel temperatures found by flight tests, including operational procedures to reduce the potential for exceeding CWT temperature limits. (A-96-176)

Require modification of the center wing fuel tank of 747 airplanes and the fuel tanks of other airplanes that are located near heat sources to incorporate temperature probes and cockpit fuel tank temperature displays to permit determination of fuel tank temperatures. (A-96-177)

As a result this accident investigation, the Safety Board also issued the following recommendation to the FAA on February 18, 1997:

Develop and implement procedures, including a checklist of safety-related items, for the handling and placement of explosive training aids by K-9 explosives detection teams to prevent contamination of aircraft and airport facilities and to ensure an effective K-9 explosives detection program. (A-97-11)

As a result of this accident investigation, the Safety Board also issued the following recommendations to the FAA on April 7, 1998:

Issue, as soon as possible, an airworthiness directive to require a detailed inspection of fuel quantity indication system wiring in Boeing 747-100, -200, and -300 series airplane fuel tanks for damage, and the replacement or the repair of any wires found to be damaged. Wires on Honeywell Series 1-3 probes and compensators should be removed for examination. (A-98-34)

Issue an airworthiness directive to require the earliest possible replacement of the Honeywell Corporation Series 1-3 terminal blocks used on Boeing 747 fuel probes with terminal blocks that do not have knurled surfaces or sharp edges that may damage fuel quantity indication system wiring. (A-98-35)

Conduct a survey of fuel quantity indication systems probes and wires in Boeing 747s equipped with systems other than Honeywell Series 1-3 probes and compensators and in other model airplanes that are used in Title 14 *Code of Federal Regulations* Part 121 service to determine whether potential fuel tank ignition sources exist that are similar to those found in the 747. The survey should include removing wires from fuel probes and examining the wires for damage. Repair or replacement procedures for any damaged wires that are found should be developed. (A-98-36)

Require research into copper-sulfide deposits on fuel quantity indication system parts in fuel tanks to determine the levels of deposits that may be hazardous, how to inspect and clean the deposits, and when to replace the components. (A-98-37)

Require in Boeing 747 airplanes, and in other airplanes with fuel quantity indication system (FQIS) wire installations that are corouted with wires that may be powered, the physical separation and electrical shielding of FQIS wires to the maximum extent possible. (A-98-38)

Require, in all applicable transport airplane fuel tanks, surge protection systems to prevent electrical power surges from entering fuel tanks through fuel quantity indication system wires. (A-98-39)

For additional information about these recommendations, see section 1.18.3 of this report.



### 4.3 Previously Issued Recommendations Classified in This Report

The following previously issued recommendations are classified in this report:<sup>661</sup>

- Safety Recommendation A-96-174 (previously classified “Open—Unacceptable Response”) is classified “Open—Acceptable Response” in section 2.4.2 of this report.
- Safety Recommendation A-96-175 (previously classified “Open—Unacceptable Response”) is classified “Open—Acceptable Response” in section 2.4.2 of this report.
- Safety Recommendation A-98-37 (previously classified “Open—Acceptable Response”) is classified “Closed—Acceptable Action—Superseded” in section 2.3.2.2.3.1 of this report.
- Safety Recommendation A-98-38 (previously classified “Open—Acceptable Response”) is again classified “Open—Acceptable Response” in section 2.3.2.1.2.2.3 of this report.
- Safety Recommendation A-98-39 (previously classified “Open—Unacceptable Response”) is classified “Open—Acceptable Response” in section 2.3.2.1.2.2.4 of this report.

#### BY THE NATIONAL TRANSPORTATION SAFETY BOARD

**James E. Hall**  
Chairman

**John A. Hammerschmidt**  
Member

**John J. Goglia**  
Member

**George W. Black, Jr.**  
Member

**Carol J. Carmody**  
Member

**Adopted August 23, 2000**

---

<sup>661</sup> For the text of these recommendations, see section 4.2.

## 5. Appendixes

### Appendix A Investigation and Hearing

#### Investigation

The National Transportation Safety Board was initially notified of this accident about 2050 eastern daylight time on July 17, 1996. A full go-team was assembled in Washington, D.C., and arrived on scene early the next morning; investigators from the Safety Board's regional office in Parsippany, New Jersey, went immediately to the scene of the accident. The go-team was accompanied by the Safety Board Vice Chairman and representatives from the Safety Board's Office of Government and Public Affairs.

The following investigative groups were formed during the course of this investigation: Systems, Structures, Maintenance Records, Airplane Interior Documentation, Witness, Metallurgy Structures/Sequencing, Medical Forensic, Fire and Explosion, Powerplants, Air Traffic Control, Operations, Aircraft Performance, Airport Security, Reconstruction, Hazardous Materials—Security, and Flight Test. Specialists were also assigned to stand by in the Safety Board laboratories for the cockpit voice recorder and flight data recorder.

Parties to the investigation were the Federal Aviation Administration (FAA); the Boeing Commercial Airplane Group; Trans World Airlines, Inc. (TWA); the International Association of Mechanists, Aerospace Workers, and Flight Attendants (IAM); the Air Line Pilots Association (ALPA); the National Air Traffic Controllers Association; Pratt & Whitney; Honeywell; and the Crane Company, Hydro-Aire, Inc. (For information about agencies and companies that assisted during the search and recovery operation, see appendix C.)

Additionally, representatives from France's Bureau Enquetes Accidents, the United Kingdom's Air Accidents Investigation Branch, and Australia's Bureau of Air Safety Investigations participated in the investigation as observers, in accordance with the provisions of Annex 13 to the Convention on International Civil Aviation. In addition, representatives from Canada's Transportation Safety Board and International Civil Aviation Organization, Singapore's Civil Aviation Authority, and Russia's Interstate Aviation Committee observed portions of the investigation.

## Public Hearing

A public hearing was conducted for this accident from December 8 through 12, 1997, in Baltimore, Maryland. Chairman Jim Hall presided over the hearing. Parties to the public hearing were the FAA; Boeing; TWA; IAM; ALPA; Honeywell; and the Crane Company, Hydro-Aire.

## Appendix B

### Cockpit Voice Recorder Transcript

The following is a transcript of the Fairchild A-100 cockpit voice recorder (CVR) installed on the accident airplane. Only radio transmissions to and from the accident airplane were transcribed. The CVR transcript reflects the 31 minutes and 30 seconds before power was lost to the CVR. All times are eastern daylight time, based on a 24-hour clock.

Transcript of a Fairchild Model A-100 Cockpit Voice Recorder S/N UNK which was removed from a Trans World Airlines, Inc., Boeing Commerical Aircraft Co. B747-100 N93119, which was involved in an inflight accident on July 17, 1996 approximately 10 miles south of East Moriches, New York.

#### LEGEND

<b>RDO</b>	<b>Radio transmission from accident aircraft</b>
<b>CAM</b>	<b>Cockpit Area Microphone sound or source</b>
<b>INT</b>	<b>Aircraft flight/ground intercom sound or source</b>
<b>-1</b>	<b>Voice identified as Captain (left seat)</b>
<b>-2</b>	<b>Voice identified as First Officer (right seat)</b>
<b>-3</b>	<b>Voice identified as Second Officer</b>
<b>-4</b>	<b>Voice identified as Instructor Flight Engineer</b>
<b>-5</b>	<b>Voice identified as gate agent personnel</b>
<b>-6</b>	<b>Voice identified as male aircraft ground personnel</b>
<b>-?</b>	<b>Voice unidentified</b>
<b>TWR</b>	<b>JFK Local Controller (tower)</b>
<b>GND</b>	<b>JFK Ground Controller</b>
<b>DEP</b>	<b>New York Radar Departure Controller</b>
<b>FIC</b>	<b>TWA Flight Information Controller</b>
<b>GH</b>	<b>Kennedy Gate Hold Controller</b>
<b>CTR</b>	<b>Boston ARTCC Controller (center)</b>
<b>LOAD</b>	<b>TWA passenger/freight load Controller</b>
<b>ATIS</b>	<b>Kennedy automated terminal information service</b>
<b>UNK</b>	<b>Unknown source</b>
<b>*</b>	<b>Unintelligible word</b>
<b>@</b>	<b>Nonpertinent word</b>
<b>#</b>	<b>Expletive deleted</b>

%	Break in continuity
()	Questionable text
(( ))	Editorial insertion
-	Pause

Note: All times are expressed in Eastern Daylight Savings time. Only radio transmissions to and from the accident aircraft were transcribed.

### CVR Quality Rating Scale

The levels of recording quality are characterized by the following traits of the cockpit voice recorder information:

<b>Excellent Quality</b>	Virtually all of the crew conversations could be accurately and easily understood. The transcript that was developed may indicate only one or two words that were not intelligible. Any loss in the transcript is usually attributed to simultaneous cockpit/radio transmissions that obscure each other.
<b>Good Quality</b>	Most of the crew conversations could be accurately and easily understood. The transcript that was developed may indicate several words or phrases that were not intelligible. Any loss in the transcript can be attributed to minor technical deficiencies or momentary dropouts in the recording system or to a large number of simultaneous cockpit/radio transmissions that obscure each other.
<b>Fair Quality</b>	The majority of the crew conversations were intelligible. The transcript that was developed may indicate passages where conversations were unintelligible or fragmented. This type of recording is usually caused by cockpit noise that obscures portions of the voice signals or by a minor electrical or mechanical failure of the CVR system that distorts or obscures the audio information.
<b>Poor Quality</b>	Extraordinary means had to be used to make some of the crew conversations intelligible. The transcript that was developed may indicate fragmented phrases and conversations and may indicate extensive passages where conversations were missing or unintelligible. This type of recording is usually caused by a combination of a high cockpit noise level with a low voice signal (poor signal-to-noise ratio) or by a mechanical or electrical failure of the CVR system that severely distorts or obscures the audio information.
<b>Unusable</b>	Crew conversations may be discerned, but neither ordinary nor extraordinary means made it possible to develop a meaningful transcript of the conversations. This type of recording is usually caused by an almost total mechanical or electrical failure of the CVR system.

AIR-GROUND COMMUNICATIONCONTENTTIME and SOURCEINTRA-COCKPIT COMMUNICATIONCONTENTTIME and SOURCE

1959: 40	Start of recording.
1959: 41 CAM-?	got it.
1959: 42 CAM-?	an agent comin'.
1959: 43 CAM-?	yeah right.
1959: 44 CAM- 5	passenger's bag pulled, the passenger was on board the whole time.
1959: 49 CAM- 5	all right.
1959: 50 CAM-1	is the bags back on?
1959: 52 CAM- 5	huh?
1959: 53 CAM-?	yes.

AIR-GROUND COMMUNICATIONCONTENTTIME and SOURCEINTRA-COCKPIT COMMUNICATIONCONTENTTIME and SOURCE

1959: 53  
CAM- 1 yeah he was on the whole time.

1959: 54  
CAM- 1 okay.

1959: 56  
CAM- 4 are we reconciled?

1959: 56  
CAM-? let's go.

1959: 58  
CAM-? push.

1959: 59  
CAM (( sound similar to cockpit door closing)).

2000: 01  
CAM- 1 we won't bother telling them that.

2000: 03  
CAM-? nope.

2000: 04  
CAM- 1 you don't mind, huh?

2000: 11  
CAM- 3 we'd have a mutiny back there.



AIR-GROUND COMMUNICATION

<u>TIME and SOURCE</u>	<u>CONTENT</u>
2000: 14 CAM- 4	now the lavatories are full.
2000: 15 CAM- 1	okay, well she said she'd call me as soon as they ah --.
2000: 16 CAM- 3	probably have to get the ATIS now, huh?
2000: 18 CAM- 2	don't don't ah let them do their job Ralph they'll tell you when they're seated.
2000: 22 ATIS	-- visibility greater than one zero ceiling better than five thousand temperature two eight due point two one altimeter three zero zero seven approach in use VOR DME runway two two left departure runway runway two two right and southwest departures runway three one left from intersection of kilo kilo all pilot are require to read back all runway hold short instructions in interest of noise abatement please use the assigned runway advise you have tango Kennedy airport information tango two three five one Zulu weather wind two two zero eight visibility --.
2000: 36 CAM- 3	all door lights are out.
2000: 37 CAM- 1	thank you.

INTRA-COCKPIT COMMUNICATION

<u>TIME and SOURCE</u>	<u>CONTENT</u>
2000: 14 CAM- 4	now the lavatories are full.
2000: 15 CAM- 1	okay, well she said she'd call me as soon as they ah --.
2000: 16 CAM- 3	probably have to get the ATIS now, huh?
2000: 18 CAM- 2	don't don't ah let them do their job Ralph they'll tell you when they're seated.
2000: 22 ATIS	-- visibility greater than one zero ceiling better than five thousand temperature two eight due point two one altimeter three zero zero seven approach in use VOR DME runway two two left departure runway runway two two right and southwest departures runway three one left from intersection of kilo kilo all pilot are require to read back all runway hold short instructions in interest of noise abatement please use the assigned runway advise you have tango Kennedy airport information tango two three five one Zulu weather wind two two zero eight visibility --.
2000: 36 CAM- 3	all door lights are out.
2000: 37 CAM- 1	thank you.

<u>INTRA-COCKPIT COMMUNICATION</u>		<u>AIR-GROUND COMMUNICATION</u>	
<u>TIME and SOURCE</u>	<u>CONTENT</u>	<u>TIME and SOURCE</u>	<u>CONTENT</u>
2000: 53 CAM- 2	tango.	2001: 02 INT- 6	cockpit ground.
		2001: 05 INT- 1	hello ground
		2001: 06 INT- 6	all right every thing is shut down here you should have all doo lights out and when you have clearance you can release the brakes.
		2001: 13 INT- 1	yeah we'll get the clearance we're waitin' on all the people to sit down I'll be back with ya in just a second.
2001: 18 CAM	(( sound of cabin chime)).	2000: 40 INT- 6	okay we're standing by.
2001: 23 CAM- 3	hello darling.		
2001: 24 CAM- 3	everybody seated thanks.		

AIR-GROUND COMMUNICATION

TIME and SOURCE	CONTENT
2001: 25 CAM- 1	amazing.
2001: 26 CAM- 3	everybody's seated.
2001: 27 CAM- 1	do we have push back clearance to move?
2001: 28 CAM- 3	we're we're we cleared to push from FIC or -.
2001: 30 CAM- 1	no not yet.
2001: 31 CAM- 2	you have to call them.
2001: 32 RDO- 3	FIC TWA eight hundred gate twenty seven.
2001: 37 FIC	TWA eight hundred?
2001: 38 RDO- 3	yeah we're ready to push.

INTRA-COCKPIT COMMUNICATION

TIME and SOURCE	CONTENT
2001: 25 CAM- 1	amazing.
2001: 26 CAM- 3	everybody's seated.
2001: 27 CAM- 1	do we have push back clearance to move?
2001: 28 CAM- 3	we're we're we cleared to push from FIC or -.
2001: 30 CAM- 1	no not yet.
2001: 31 CAM- 2	you have to call them.
2001: 32 RDO- 3	FIC TWA eight hundred gate twenty seven.
2001: 37 FIC	TWA eight hundred?
2001: 38 RDO- 3	yeah we're ready to push.

<u>INTRA-COCKPIT COMMUNICATION</u>		<u>AIR-GROUND COMMUNICATION</u>	
<u>TIME and SOURCE</u>	<u>CONTENT</u>	<u>TIME and SOURCE</u>	<u>CONTENT</u>
2001: 39 CAM	(( sound of electric seat adjustment)).	2001: 42 FIC	TWA eight hundred you're cleared to push gate twenty seven.
2001: 46 CAM- 2	cleared to push.		
2001: 47 CAM- 1	cleared to push.	2001: 48 RDO- 3	cleared to to push eight hundred.
		2001: 50 INT- 1	okay ground we are cleared to push yeah well wait a minute hang on a minute.
2001: 53 CAM- 1	did they say everybody was seated yeah they did.		
2001: 54 CAM- 3	yes.	2001: 58 INT- 1	okay, we're cleared to push sorry.

AIR-GROUND COMMUNICATION

TIME and SOURCE                      CONTENT

2001: 57  
INT- 6                      brakes released please.

2001: 59  
INT- 1                      beacon on brakes released.

2002: 00  
INT- 6                      thank you.

INTRA-COCKPIT COMMUNICATION

TIME and SOURCE                      CONTENT

2001: 58  
CAM                      (( sound similar to parking brake being released)).

2002: 02  
CAM- 2                      you got something else to do Ralph.

2002: 05  
CAM- 1                      number one ADP-.

2002: 06  
CAM- 2                      there you go.

2002: 07  
CAM- 1                      and the electric.

2002: 08  
CAM- 2                      it's a command.

2002: 09  
CAM- 1                      electric's on.

AIR- GROUND COMMUNICATION

<u>TIME and SOURCE</u>	<u>CONTENT</u>
2002: 10 CAM- 2	right.
2002: 10 CAM- 2	that's a command.
2002: 11 CAM- 1	command.
2049: 27 CAM- 1	number one ADP on and the electric.
2002: 16 CAM- 2	before you release the brakes.
2002: 22 CAM-?	*
2002: 27 CAM- 2	block's at oh two I assume.
2002: 29 CAM- 3	I'm showin' oh two out. is that what you want?
2002: 32 CAM- 2	that's fine.

INTRA- COCKPIT COMMUNICATION

<u>TIME and SOURCE</u>	<u>CONTENT</u>
2002: 10 CAM- 2	right.
2002: 10 CAM- 2	that's a command.
2002: 11 CAM- 1	command.
2049: 27 CAM- 1	number one ADP on and the electric.
2002: 16 CAM- 2	before you release the brakes.
2002: 22 CAM-?	*
2002: 27 CAM- 2	block's at oh two I assume.
2002: 29 CAM- 3	I'm showin' oh two out. is that what you want?
2002: 32 CAM- 2	that's fine.

AIR-GROUND COMMUNICATION

<u>TIME and SOURCE</u>	<u>CONTENT</u>
2002: 33 CAM- 1	yeah.
2002: 34 CAM- 2	that's fine.
2002: 35 CAM- 1	okay.
2002: 38 CAM- 2	that's a minute over kill.
2002: 40 CAM- 1	yeah well that was because they weren't seated they probably had people standing up and they were *.
2002: 46 CAM- 2	* down.
2002: 48 CAM- 2	exactly.
2002: 50 CAM- 1	you can bet on it.
2002: 54 CAM- 1	I still think I'm sittin' too high in this thing.

INTRA-COCKPIT COMMUNICATION

<u>TIME and SOURCE</u>	<u>CONTENT</u>
2002: 33 CAM- 1	yeah.
2002: 34 CAM- 2	that's fine.
2002: 35 CAM- 1	okay.
2002: 38 CAM- 2	that's a minute over kill.
2002: 40 CAM- 1	yeah well that was because they weren't seated they probably had people standing up and they were *.
2002: 46 CAM- 2	* down.
2002: 48 CAM- 2	exactly.
2002: 50 CAM- 1	you can bet on it.
2002: 54 CAM- 1	I still think I'm sittin' too high in this thing.

<u>INTRA-COCKPIT COMMUNICATION</u>		<u>AIR-GROUND COMMUNICATION</u>	
<u>TIME and SOURCE</u>	<u>CONTENT</u>	<u>TIME and SOURCE</u>	<u>CONTENT</u>
2003: 11 CAM- 1	somebody calling us .	2003: 10 FIC	eight hundred.
		2003: 12 RDO- 3	go ahead.
		2003: 13 FIC	tell your mechanic to pull you back push you back far enough so we can get an arrival into your gate.
		2003: 18 RDO- 3	okay.
		2003: 21 INT- 1	and ah ground FIC wants you to push us back far enough so they can bring somebody in our gate.
		2003: 27 INT- 6	okay we'll do that.
		2003: 30 INT- 1	thank you.
2003: 32 CAM-?	* where's this thing.		



AIR-GROUND COMMUNICATION

<u>TIME and SOURCE</u>	<u>CONTENT</u>
2004: 07 CAM- 1	ah there's that ah new airplane.
2004: 10 CAM- 2	one twenty nine yes sir.
2004: 43 INT- 6	okay this looks far enough.
2004: 45 INT- 1	okay if you say so.
2004: 47 INT- 6	brakes parked please.
2004: 50 INT- 1	brakes parked.
2004: 51 INT- 6	thank you cleared to turn your engines.
2004: 54 INT- 1	okay we'll turn one two and four today.
2004: 56 INT- 6	(( sound of two mike clicks)).

INTRA- COCKPIT COMMUNICATION

<u>TIME and SOURCE</u>	<u>CONTENT</u>
2004: 07 CAM- 1	ah there's that ah new airplane.
2004: 10 CAM- 2	one twenty nine yes sir.
2004: 48 CAM	(( sound of parking brake being set)).

AIR-GROUND COMMUNICATION

TIME and  
SOURCE

CONTENT

INTRA- COCKPIT COMMUNICATION

TIME and  
SOURCE

CONTENT

2004: 59 CAM- 1	turn one please.
2005: 12 CAM- 2	(( sound of cough)).
2005: 19 CAM- 1	contact.
2005: 22 CAM- 2	you got N- 1?
2005: 26 CAM- 1	I do now.
2005: 27 CAM- 2	you do now.
2005: 29 CAM- 3	four fifty.
2005: 30 CAM- 1	it bobbed but not much.
2005: 42 CAM- 1	and turn two please.

AIR-GROUND COMMUNICATION

TIME and SOURCE  
CONTENT

INTRA-COCKPIT COMMUNICATION

TIME and SOURCE  
CONTENT

2005: 44  
CAM- 4 \*\*\*.

2006: 00  
CAM- 1 N- one.

2006: 01  
CAM- 3 turning.

2006: 04  
CAM- 1 two.

2006: 07  
CAM- 3 four hundred.

2006: 24  
CAM- 1 turn four.

2006: 25  
INT- 1 turning four.

2006: 27  
INT- 6 \* four.

2006: 45  
CAM- 1 contact.

2006: 51  
CAM- 3 four hundred.

<u>INTRA-COCKPIT COMMUNICATION</u>		<u>AIR-GROUND COMMUNICATION</u>	
<u>TIME and SOURCE</u>	<u>CONTENT</u>	<u>TIME and SOURCE</u>	<u>CONTENT</u>
2007: 13 CAM- 1	okay and after start checklist when you have a moment.	2006: 56 INT- 1	disconnect ground equipment stand by for hand signals thank you.
2007: 14 CAM	(( sound of momentary power interruption to the CVR)).	2006: 58 INT- 6	okay.
2007: 15 CAM	(( sound of altitude alert tone)).		
2007: 20 CAM- 3	stand by.		
2007: 29 CAM- 1	after start.		
2007: 30 CAM- 3	after start checklist. flight recorder?		
2007: 33 CAM- 1	on.		

AIR-GROUND COMMUNICATION

<u>TIME and SOURCE</u>	<u>CONTENT</u>
2007: 34 CAM- 3	start switches?
2007: 35 CAM- 1	off.
2007: 36 CAM- 3	beacon lights?
2007: 37 CAM- 1	are on.
2007: 38 CAM- 3	brake pressure?
2007: 41 CAM- 1	checked.
2007: 42 CAM- 3	start levers?
2007: 44 CAM- 1	idle detent.
2007: 45 CAM- 3	engine anti- ice?
2007: 46 CAM- 1	off.

INTRA-COCKPIT COMMUNICATION

<u>TIME and SOURCE</u>	<u>CONTENT</u>
2007: 34 CAM- 3	start switches?
2007: 35 CAM- 1	off.
2007: 36 CAM- 3	beacon lights?
2007: 37 CAM- 1	are on.
2007: 38 CAM- 3	brake pressure?
2007: 41 CAM- 1	checked.
2007: 42 CAM- 3	start levers?
2007: 44 CAM- 1	idle detent.
2007: 45 CAM- 3	engine anti- ice?
2007: 46 CAM- 1	off.

<u>INTRA- COCKPIT COMMUNICATION</u>		<u>AIR- GROUND COMMUNICATION</u>	
<u>TIME and SOURCE</u>	<u>CONTENT</u>	<u>TIME and SOURCE</u>	<u>CONTENT</u>
2007: 50 CAM- 1	you need to get taxi clearance.	2007: 52 RDO- 2	Kennedy gate hold TWA's eight hundred heavy we're life guard ah we're ready to taxi out delta alpha with tango.
2008: 04 CAM- 3	after start checklist complete.	2008: 01 GH	TWA eight hundred all right contact ground one two one point niner for the taxi inform them that you are lifeguard.
		2008: 07 RDO- 2	roger.
		2008: 13 RDO- 2	Kennedy ground TWA's eight hundred heavy lifeguard comin' out delta alpha with tango.
		2008: 19 GND	ah TWA eight hundred heavy ah you're a life guard today?
		2008: 24 RDO- 2	yes sir.

<u>INTRA-COCKPIT COMMUNICATION</u>		<u>AIR-GROUND COMMUNICATION</u>	
<u>TIME and SOURCE</u>	<u>CONTENT</u>	<u>TIME and SOURCE</u>	<u>CONTENT</u>
2008: 25 GND		2008: 25 GND	you know every day you come out and we don't know that you're a lifeguard and then you tell us you are and ah if you could tell company to ah you know ah put that in their flight plan ah it would help us out alot.
2008: 38 RDO- 2		2008: 38 RDO- 2	TWA's eight hundred understand I don't think they knew it either until the last minute.
2008: 41 GND		2008: 41 GND	all right TWA eight hundred taxi right on alpha and hold short of echo.
2008: 47 RDO- 2		2008: 47 RDO- 2	TWA's eight hundred right alpha hold short of echo.
2008: 49 RDO- 3		2008: 49 RDO- 3	and a load TWA eight hundred.
2008: 52 CAM- 1	right on alpha and hold short of echo.		
2008: 53 CAM- 1	clear right?		
2008: 54 CAM- 2	clear right.		

AIR-GROUND COMMUNICATION

TIME and SOURCE                      CONTENT

2008: 55 CAM	(( sound of parking break being released)).	
2008: 57 CAM- 2	clear left.	
		2009: 05 RDO- 3                      and load TWA eight hundred.
		2009: 07 LOAD                      eight hundred stand by.
2009: 19 CAM- 2	watch number one it's too high.	
2009: 26 CAM- 1	forty five percent.	
2009: 28 CAM- 1	you got a guy over there.	
2009: 30 CAM- 2	yup.	
2009: 34 CAM- 1	right on alpha huh?	
		2009: 36 LOAD                      eight hundred ready to copy?

INTRA- COCKPIT COMMUNICATION

TIME and SOURCE                      CONTENT



<u>INTRA-COCKPIT COMMUNICATION</u>		<u>AIR-GROUND COMMUNICATION</u>	
<u>TIME and SOURCE</u>	<u>CONTENT</u>	<u>TIME and SOURCE</u>	<u>CONTENT</u>
2009: 41 CAM- 1	clear.	2009: 37 RDO- 3	ready to copy.
2009: 42 CAM- 2	yeah.	2009: 38 LOAD	on board twenty nine up front one eight three in the rear takeoff fuel is one seven six decimal six your gross takeoff weight is five nine zero seven seven one trim six decimal one and no reported GSI's. copy?
2009: 43 CAM- 2	keep it comin'.		
2009: 51 CAM- 1	does he look clear?		
2009: 52 CAM- 2	yup it's no problem.	2009: 56 RDO- 3	okay twenty nine in the front one eighty three in the back one seven six decimal six on the fuel five nine zero decimal seven seven one on the takeoff weight six point one on the trim and no GSIs TWA eight hundred out.

<u>INTRA-COCKPIT COMMUNICATION</u>		<u>AIR-GROUND COMMUNICATION</u>	
<u>TIME and SOURCE</u>	<u>CONTENT</u>	<u>TIME and SOURCE</u>	<u>CONTENT</u>
2010: 01 CAM- 1	one two three --.		
2010: 09 CAM- 1	ya think he's gunna try and get us out being a lifeguard?	2010: 10 LOAD	okay read back. * both times?
		2010: 12 RDO- 3	yeah we're out at ah zero zero zero two and ah expecting off here probably about ah thirty five.
2010: 15 CAM- 2	I think he just * .		
2010: 19 CAM- 2	that's your undershoot problem huh.		
2010: 21 CAM- 1 ?	* it is	2010: 24 LOAD	copy zero two and three five have a good flight eight hundred.
		2010: 25 RDO- 3	see ya.

<u>INTRA-COCKPIT COMMUNICATION</u>		<u>AIR-GROUND COMMUNICATION</u>	
<u>TIME and SOURCE</u>	<u>CONTENT</u>	<u>TIME and SOURCE</u>	<u>CONTENT</u>
2010: 26 CAM- 1	how's that look?		
2010: 27 CAM- 2	better.		
2010: 50 CAM- 3	six point one on the trim.		
2010: 53 CAM- 2	okay set up here.		
2011: 58 CAM- 1	well we lost a little bit of weight huh? payload.	2012: 04 GND	TWA eight hundred make a left turn on um taxi way echo behind Carnival and hold short of runway three one right and you can monitor tower now on one two three point niner.
		2012: 17 RDO- 2	TWA's eight hundred heavy left echo hold short of three one right over to the tower, bye.
2012: 24 CAM- 1	left on echo behind carnival hold short of three one right.		
2012: 35 CAM- 2	(( sound of cough)).		

AIR-GROUND COMMUNICATION

<u>TIME and SOURCE</u>	<u>CONTENT</u>
2012: 38 CAM	(( sound of parking brake release)).
2012: 41 CAM- 2	can I have the weight slip if you are done with it, Ollie?
2013: 22 CAM- 2	notice that's going to be an undershoot too.
2013: 24 CAM- 1	what's that?
2013: 25 CAM- 2	good.
2013: 27 CAM- 1	well then someone's given me the wrong poop cause I was tryin' to turn like on the L ten eleven they said I was over- turning.
2013: 33 CAM- 2	ah.
2013: 38 CAM- 1	how much past center then?
2013: 40 CAM- 2	nose wheel is back by the emergency exit door. right?

INTRA- COCKPIT COMMUNICATION

<u>TIME and SOURCE</u>	<u>CONTENT</u>
2012: 38 CAM	(( sound of parking brake release)).
2012: 41 CAM- 2	can I have the weight slip if you are done with it, Ollie?
2013: 22 CAM- 2	notice that's going to be an undershoot too.
2013: 24 CAM- 1	what's that?
2013: 25 CAM- 2	good.
2013: 27 CAM- 1	well then someone's given me the wrong poop cause I was tryin' to turn like on the L ten eleven they said I was over- turning.
2013: 33 CAM- 2	ah.
2013: 38 CAM- 1	how much past center then?
2013: 40 CAM- 2	nose wheel is back by the emergency exit door. right?

<u>INTRA-COCKPIT COMMUNICATION</u>		<u>AIR-GROUND COMMUNICATION</u>	
<u>TIME and SOURCE</u>	<u>CONTENT</u>	<u>TIME and SOURCE</u>	<u>CONTENT</u>
2013: 42 CAM- 1	right, right.	2013: 41 TWR	and lifeguard TWA eight hundred heavy Kennedy tower good evening you with me?
2013: 45 CAM-?	(sound of cough).		
2013: 46 CAM- 2	so you really can't start the turn until the nose wheel is past there the center taxi line and whatever it takes as far as -.		
2013: 54 CAM- 1	the angle but *.		
2013: 56 CAM- 2	as far as comin' out with the main gear you just want to play with it a little bit a few times to find out.		
2014: 04 CAM- 1	okay.		
2014: 07 CAM- 2	but that first turn would have been a very dirty *.		
2014: 10 CAM- 1	*.		

<u>INTRA-COCKPIT COMMUNICATION</u>		<u>AIR-GROUND COMMUNICATION</u>	
<u>TIME and SOURCE</u>	<u>CONTENT</u>	<u>TIME and SOURCE</u>	<u>CONTENT</u>
2014: 11 CAM- 2	there's no way you could - .	2014: 12 TWR	TWA eight hundred heavy lifeguard Kennedy tower.
		2014: 13 RDO- 2	TWA's eight hundred heavy lifeguard go ahead.
		2014: 16 TWR	I'm gunna put you behind British Airways so the company heavy seven six knows to follow you so make a right on the runway a left at Zulu alpha and follow British.
		2014: 23 RDO- 2	TWA eight hundred heavy okay right on ah thirty one ah correction thirteen left and follow British.
2014: 29 CAM- 1	start the number three motor.		
2014: 31 CAM- 2	let's.		
2014: 33 CAM- 2	start taxi.		

AIR-GROUND COMMUNICATIONINTRA-COCKPIT COMMUNICATION

<u>TIME and SOURCE</u>	<u>CONTENT</u>	<u>TIME and SOURCE</u>	<u>CONTENT</u>
2014: 36 CAM- 1	okay.		
2014: 37 CAM- 2	are you ready?		
2014: 37 CAM- 3	okay.		
2014: 43 CAM- 2	just let me have one engine.		
2014: 39 CAM- 3	there you go.		
2014: 40 CAM-?	if you need it.		
2014: 41 CAM- 3	all right we got enough pressure.		
2014: 42 CAM- 2	okay here we go I'll get the engine for ya.		
2014: 53 CAM- 2	watch your feet just steer it.		
2014: 56 CAM- 2	just leave 'em alone for a little bit.		

AIR-GROUND COMMUNICATION

TIME and  
SOURCE                      CONTENT

INTRA-COCKPIT COMMUNICATION

TIME and  
SOURCE                      CONTENT

2014: 58  
CAM- 1                      you want number three back?

2014: 59  
CAM- 2                      yup.

2015: 01  
CAM- 2                      don't touch the engines.

2015: 02  
CAM- 1                      okay.

2015: 04  
CAM- 2                      start lever.

2015: 08  
CAM- 3                      four hundred.

2015: 23  
CAM- 2                      okay you can have 'em now.

2015: 29  
CAM- 2                      here you got no problems.

2015: 33  
CAM- 1                      delayed engine -.



AIR-GROUND COMMUNICATION

<u>TIME and SOURCE</u>	<u>CONTENT</u>
2015: 34 CAM- 2	wide runway you don't need to worry about it.
2015: 36 CAM- 1	yeah delayed engine start.
2015: 39 CAM- 3	delayed engine start checklist. start switches?
2015: 42 CAM- 1	off.
2015: 43 CAM- 3	start levers?
2015: 45 CAM- 1	idle detent.
2015: 47 CAM- 3	engine anti- ice?
2015: 47 CAM- 1	off.
2015: 51 CAM- 3	delayed engine start checklist is complete.
2015: 53 CAM- 1	taxi checklist.

INTRA- COCKPIT COMMUNICATION

<u>TIME and SOURCE</u>	<u>CONTENT</u>
2015: 34 CAM- 2	wide runway you don't need to worry about it.
2015: 36 CAM- 1	yeah delayed engine start.
2015: 39 CAM- 3	delayed engine start checklist. start switches?
2015: 42 CAM- 1	off.
2015: 43 CAM- 3	start levers?
2015: 45 CAM- 1	idle detent.
2015: 47 CAM- 3	engine anti- ice?
2015: 47 CAM- 1	off.
2015: 51 CAM- 3	delayed engine start checklist is complete.
2015: 53 CAM- 1	taxi checklist.

AIR-GROUND COMMUNICATION

<u>TIME and SOURCE</u>	<u>CONTENT</u>
2015: 55 CAM- 3	taxi checklist. Flaps and runway?
2015: 58 CAM- 1	flaps are ten and green for runway two two right Kennedy.
2016: 04 CAM- 3	ten eight green two two right Kennedy. take off data EPR and airspeed bugs?
2016: 08 CAM- 1	five hundred and ninety thousand seven seventy one takeoff EPR's set at point three three three bugs set and cross checked at one fifty three.
2016: 16 CAM- 2	set and cross checked.
2016: 17 CAM- 3	stabilizer trim?
2016: 18 CAM- 1	is set at six point one.
2016: 21 CAM- 3	probe heat?

INTRA- COCKPIT COMMUNICATION

<u>TIME and SOURCE</u>	<u>CONTENT</u>
2015: 55 CAM- 3	taxi checklist. Flaps and runway?
2015: 58 CAM- 1	flaps are ten and green for runway two two right Kennedy.
2016: 04 CAM- 3	ten eight green two two right Kennedy. take off data EPR and airspeed bugs?
2016: 08 CAM- 1	five hundred and ninety thousand seven seventy one takeoff EPR's set at point three three three bugs set and cross checked at one fifty three.
2016: 16 CAM- 2	set and cross checked.
2016: 17 CAM- 3	stabilizer trim?
2016: 18 CAM- 1	is set at six point one.
2016: 21 CAM- 3	probe heat?

AIR-GROUND COMMUNICATIONCONTENTTIME and SOURCEINTRA-COCKPIT COMMUNICATIONCONTENTTIME and SOURCE

2016: 22 CAM- 1	on.
2016: 23 CAM- 3	flight controls
2016: 25 CAM- 1	checked.
2016: 26 CAM- 3	auto- brakes?
2016: 28 CAM- 1	armed.
2016: 29 CAM- 2	now you can start it.
2016: 31 CAM- 3	yaw dampers?
2016: 32 CAM- 1	on.
2016: 34 CAM- 2	wrong answer checked.
2016: 35 CAM- 1	checked.

AIR-GROUND COMMUNICATIONCONTENTTIME and SOURCEINTRA-COCKPIT COMMUNICATIONCONTENTTIME and SOURCE

2016: 37 CAM- 2	right here don't roll out start rollin' out you're beside the line.01
2016: 43 CAM- 3	seat belt shoulder harnesses?
2016: 44 CAM- 1	checked.
2016: 51 CAM- 1	okay gentlemen standard TWA crew coordination you call out eighty Vee one Vee R please.
2016: 58 CAM- 2	that's the first officers -.
2017: 00 CAM- 1	we're going to fly headings, huh.
2017: 02 CAM- 2	I say that's standard first officer duties.
2017: 06 CAM- 1	well.
2017: 07 CAM- 3	taxi checklist is complete.

<u>INTRA-COCKPIT COMMUNICATION</u>		<u>AIR-GROUND COMMUNICATION</u>	
<u>TIME and SOURCE</u>	<u>CONTENT</u>	<u>TIME and SOURCE</u>	<u>CONTENT</u>
2017: 08 CAM- 1	two hundred five degree on the heading five thousand.		
2017: 10 CAM- 2	that's it.		
2017: 18		TWR	TWA eight hundred heavy caution wake turbulence from a seven fifty seven runway two two right taxi into position and hold.
		2017: 24 RDO- 2	TWA's eight hundred heavy lifeguard position and hold two two right.
2017: 28 CAM- 1	position and hold two two right.		
2017: 31 CAM- 1	will you alert the cabin please.		
2017: 40 CAM- 3	flight attendants please be seated for takeoff.		
2017: 55 CAM- 4	****.		
2018: 03 CAM- 2	now that's better.		

<u>INTRA-COCKPIT COMMUNICATION</u>		<u>AIR-GROUND COMMUNICATION</u>	
<u>TIME and SOURCE</u>	<u>CONTENT</u>	<u>TIME and SOURCE</u>	<u>CONTENT</u>
2018: 04 CAM- 3	now it's coming on *		
2018: 06 CAM- 1	I'll just extend it out to that line.		
2018: 07 CAM- 3	* sure *		
2018: 09 CAM- 2	yeah that's one of the ways you test yourself too is whether when you get rolled out is the whole airplane longitudinally lined up.		
2018: 15 CAM- 1	yeah.	2018: 21 TWR	TWA eight hundred heavy lifeguard wind's two four zero at eigh runway two two right cleared for takeoff.
2018: 31 CAM- 1	before takeoff checklist.	2018: 27 RDO- 2	TWA's eight hundred heavy lifeguard cleared for takeoff two two right.
2018: 33 CAM- 3	before takeoff checklist. icing considerations?		

AIR-GROUND COMMUNICATION

<u>TIME and SOURCE</u>	<u>CONTENT</u>
2018: 34 CAM- 1	checked.
2018: 35 CAM- 3	cabin alert?
2018: 36 CAM- 1	checked.
2018: 36 CAM- 3	transponder?
2018: 37 CAM- 1	that's checked.
2018: 39 CAM- 3	ignition?
2018: 40 CAM	(( sound of click)).
2018: 41 CAM- 1	flight start.
2018: 42 CAM- 3	body gear steering?

INTRA-COCKPIT COMMUNICATION

<u>TIME and SOURCE</u>	<u>CONTENT</u>
2018: 34 CAM- 1	checked.
2018: 35 CAM- 3	cabin alert?
2018: 36 CAM- 1	checked.
2018: 36 CAM- 3	transponder?
2018: 37 CAM- 1	that's checked.
2018: 39 CAM- 3	ignition?
2018: 40 CAM	(( sound of click)).
2018: 41 CAM- 1	flight start.
2018: 42 CAM- 3	body gear steering?

AIR-GROUND COMMUNICATION

TIME and SOURCE  
CONTENT

INTRA-COCKPIT COMMUNICATION

TIME and SOURCE  
CONTENT

2018: 43 CAM- 1	disarmed.
2018: 44 CAM- 2	clocks.
2018: 46 CAM- 3	before takeoff checklist is complete.
2018: 48 CAM- 1	thank you.
2018: 49 CAM- 4	get right up in there.
2018: 51 CAM	(( sound of increasing engine noise)).
2018: 59 CAM- 1	trim throttles.
2019: 14 CAM- 2	eighty knots.
2019: 23 CAM- 2	Vee one.
2019: 35 CAM- 2	Vee R.



<u>INTRA-COCKPIT COMMUNICATION</u>		<u>AIR-GROUND COMMUNICATION</u>	
<u>TIME and SOURCE</u>	<u>CONTENT</u>	<u>TIME and SOURCE</u>	<u>CONTENT</u>
2019: 41 CAM	(( sound of two clicks)).		
2019: 43 CAM- 1	gear up.		
2019: 44 CAM- 2	gear up.		
		2020: 00 TWR	TWA eight hundred heavy contact New York departure one three five point nine good evening.
		2020: 05 RDO- 2	TWA's eight hundred heavy good night.
		2020: 14 RDO- 2	Kennedy departure TWA's eight hundred heavy lifeguard leaving nine hundred climbing five thousand.
		2020: 19 DEP	lifeguard TWA eight hundred heavy New York departure radar contact climb and maintain one one thousand.
		2020: 24 RDO- 2	TWA's eight hundred heavy climb and maintain one one thousand.

<u>INTRA-COCKPIT COMMUNICATION</u>		<u>AIR-GROUND COMMUNICATION</u>	
<u>TIME and SOURCE</u>	<u>CONTENT</u>	<u>TIME and SOURCE</u>	<u>CONTENT</u>
2020: 29 CAM- 1	climb to one thousand and maintain.	2020: 44 DEP	TWA eight hundred heavy turn left heading one five zero.
2020: 47 CAM- 1	left to one five zero.	2020: 48 RDO- 2	TWA's eight hundred heavy turn left heading one five zero.
2020: 51 CAM- 1	flaps five.		
2020: 53 CAM- 2	flaps five.		
2021: 11 CAM- 1	flaps one.		
2021: 12 CAM- 2	flaps one.		
2021: 26 CAM- 1	flaps up.		
2021: 29 CAM- 2	say what?		

<u>INTRA-COCKPIT COMMUNICATION</u>		<u>AIR-GROUND COMMUNICATION</u>	
<u>TIME and SOURCE</u>	<u>CONTENT</u>	<u>TIME and SOURCE</u>	<u>CONTENT</u>
2021: 29 CAM- 1	flaps up.		
2021: 30 CAM- 2	flaps up.		
2021: 48 CAM- 1	climb thrust.		
		2022: 01 DEP	TWA lifeguard TWA eight hundred heavy turn left heading zero seven zero.
		2022: 07 RDO- 2	TWA's lifeguard eight hundred heavy turn left heading zero seven zero.
2022: 11 CAM- 1	left zero seven zero.		
		2022: 29 DEP	TWA eight hundred heavy or lifeguard TWA eight hundred heavy turn left heading zero five zero vector climbin' around traffic.
		2022: 35 RDO- 2	TWA's eight hundred heavy turn left heading zero five zero.

<u>INTRA-COCKPIT COMMUNICATION</u>		<u>AIR-GROUND COMMUNICATION</u>	
<u>TIME and SOURCE</u>	<u>CONTENT</u>	<u>TIME and SOURCE</u>	<u>CONTENT</u>
2022: 41 CAM- 1	left zero five zero climb vector.	2022: 44 DEP	TWA eight hundred heavy the traffic in the turn will be three o'clock and five miles northeast bound four thousand nor- is a company seven two five five in trail will be a Saab-Fairchild when you're out of five I'll have on course.
2022: 58 CAM- 1	he's at three o'clock?	2022: 54 RDO- 2	TWA's eight hundred heavy understand.
2023: 00 CAM- 2	yeah.		
2023: 02 CAM- 2	that's the problem.	2023: 19 DEP	TWA eight hundred heavy direct Betty resume own navigation.
2023: 26 CAM- 1	direct Betty and our own nav.	2023: 22 RDO- 2	TWA's eight hundred heavy direct Betty own navigation.

<u>INTRA-COCKPIT COMMUNICATION</u>		<u>AIR-GROUND COMMUNICATION</u>	
<u>TIME and SOURCE</u>	<u>CONTENT</u>	<u>TIME and SOURCE</u>	<u>CONTENT</u>
2019: 52 CAM- 1	that's alive.		
2023: 37 DEP		2023: 37 DEP	TWA lifeguard TWA eight hundred heavy contact Boston one three two point three.
2023: 38 CAM- 2	huh.		
2023: 39 CAM- 1	direct Betty. correct?		
2024: 00 CAM- 1	*	2023: 42 RDO- 2	TWA's eight hundred heavy ah say again the frequency.
		2023: 44 DEP	one three two point three.
2024: 01 CAM	(( sound of noise of recording tape)).	2023: 46 RDO- 2	TWA's eight hundred heavy good day.

<u>INTRA-COCKPIT COMMUNICATION</u>		<u>AIR-GROUND COMMUNICATION</u>	
<u>TIME and SOURCE</u>	<u>CONTENT</u>	<u>TIME and SOURCE</u>	<u>CONTENT</u>
2024: 30 CAM- 1	seems like a home sick angel here (* / awesome).		
2024: 36 CAM- 2	it's bleeding off airspeed that's why.		
2024: 38 CAM- 1	yeah *.	2024: 41.7 RDO- 2	New York center TWA's lifeguard eight hundred heavy eight thousand two hundred climbing one one thousand.
		2024: 48 CTR	TWA eight hundred Boston center roger climb and maintain one three thousand.
		2024: 53.4 RDO- 2	TWA's eight hundred heavy climb and maintain one three thousand.
2024: 57 CAM- 1	climb and maintain one three thousand.	2025: 31 CTR	TWA eight hundred what's your rate of climb?
		2025: 34.5 RDO- 2	TWA's eight hundred heavy ah about two thousand feet a minute here until accelerating out of ten thousand.

<u>INTRA-COCKPIT COMMUNICATION</u>		<u>AIR-GROUND COMMUNICATION</u>	
<u>TIME and SOURCE</u>	<u>CONTENT</u>	<u>TIME and SOURCE</u>	<u>CONTENT</u>
2025: 53 CAM- 1	climb to one nine zero expedite through one five thousand.	2025: 41 CTR	roger sir climb and maintain flight level one niner zero and expedite through fifteen.
2025: 57 CAM- 3	pressurization checks.	2025: 47.1 RDO- 2	TWA's eight hundred heavy climb and maintain one niner zero and expedite through one five thousand.
2025: 59 CAM- 3	(takeoff) thrust go on cross feed?		
2026: 02 CAM-?	ah.		
2026: 04 CAM- 1	yeah.		
2026: 07 CAM- 3	I'll leave that on for just a little bit.		
2026: 12 CAM- 3	is that right?		

<u>INTRA-COCKPIT COMMUNICATION</u>		<u>AIR-GROUND COMMUNICATION</u>	
<u>TIME and SOURCE</u>	<u>CONTENT</u>	<u>TIME and SOURCE</u>	<u>CONTENT</u>
2026: 13 CAM- 4	yes.		
2026: 29 CAM- 1	thirteen thousand.	2026: 24 CTR	TWA eight hundred amend the altitude maintain ah one three thousand thirteen thousand only for now.
2026: 35 CAM- 1	stop climb at one three thousand.	2026: 30.3 RDO- 2	TWA's eight hundred heavy okay stop climb at one three thousand.
2026: 51 CAM- 1	*		
2026: 59 CAM- 2	twelve for thirteen.		
2027: 35 CAM	(( sound of click)).		
2027: 47 CAM	(( sound of altitude alert tone)).		



<u>TIME and SOURCE</u>	<u>CONTENT</u>	<u>TIME and SOURCE</u>	<u>CONTENT</u>
	<u>INTRA- COCKPIT COMMUNICATION</u>		<u>AIR- GROUND COMMUNICATION</u>
2029: 15 CAM- 1	look at that crazy fuel flow indicator there on number four.	2028: 13 CTR	TWA eight hundred you have traffic at one o'clock and ah seven miles south bound a thousand foot above you he's ah Beech nineteen hundred.
		2028: 20.6 RDO- 2	TWA's ah eight hundred heavy ah no contact.
		2028: 22.5 RDO- 3	FIC TWA eight hundred.
		2028: 25 FIC	TWA eight hundred.
		2028: 25.7 RDO- 3	Eight hundred with an off report ah plane number one seven one one nine we're out at zero zero zero two, and we're off at zero zero one nine, fuel one seven nine decimal zero, estimating Charles De' Gaul at zero six two eight.
		2028: 42 FIC	TWA eight eight hundred got it all.
		2028: 44.8 RDO- 3	Thank you.

<u>INTRA-COCKPIT COMMUNICATION</u>		<u>AIR-GROUND COMMUNICATION</u>	
<u>TIME and SOURCE</u>	<u>CONTENT</u>	<u>TIME and SOURCE</u>	<u>CONTENT</u>
2029: 23 CAM- 1	see that.		
2029: 35 CAM- 1	some where in here I better trim this thing (in/up).		
2029: 39 CAM- 2	huh?		
2029: 39 CAM- 1	some place in here I better find out where this thing's trimmed.	2030: 15 CTR	TWA eight hundred climb and maintain one five thousand.
2030: 18 CAM- 1	climb thrust.	2030: 19.2 RDO- 2	TWA's eight hundred heavy climb and maintain one five thousand leaving one three thousand.
2030: 24 CAM- 1	Ollie.		
2030: 24 CAM- 3	huh.		

AIR-GROUND COMMUNICATIONINTRA-COCKPIT COMMUNICATION

<u>TIME and SOURCE</u>	<u>CONTENT</u>	<u>TIME and SOURCE</u>	<u>CONTENT</u>
2030: 25 CAM- 1	climb thrust.		
2030: 28 CAM- 1	climb to one five thousand.		
2030: 35 CAM- 3	power's set.		
2030: 42 CAM	(( sound similar to a mechanical movement in cockpit))		
2031: 03 CAM	*		
2031: 05 CAM	(( sounds similar to recording tape damage noise)).		
2031: 12	end of recording.		

## Appendix C

### Search and Recovery Information

#### Search and Recovery

Agencies and companies with personnel and equipment that responded promptly to the accident and reported to the crash site and/or staging areas and/or provided long-term assistance during the search and recovery operation included most of the parties to the investigation and the following: Federal Bureau of Investigation (FBI),<sup>662</sup> Bureau of Alcohol, Tobacco, and Firearms; U.S. Coast Guard (USCG) (including its Underwater Search and Survey Divisions); U.S. Navy (and its contractor, Oceaneering Advanced Technologies, Inc., and subcontractor, Science Applications International Corporation); New York Air National Guard; New York State Army National Guard, 106<sup>th</sup> Air Rescue Wing; National Oceanic and Atmospheric Administration (NOAA); New York State Emergency Management Office; New York State Division of State Police; New York City Police and Fire Departments; Suffolk County Police and Sheriff's Departments, Medical Examiner, and Fire, Rescue, and Emergency Services; Nassau County Police Department; Southampton Police Department; East Moriches Fire Department; and American Underwater Search and Survey Ltd.

During the first several hours after the accident, many private citizens and military and police personnel went to the crash site in boats to search for possible survivors.<sup>663</sup> The first responders reported that many pieces of wreckage (some quite large, including the right wing tip) were found floating in or near areas of fuel-fed fires, making recovery difficult. Although many first responders reported that they observed numerous pieces of wreckage sink beneath the water's surface, several pieces of wreckage were recovered from the water's surface during the 24-hour period after the accident.<sup>664</sup>

Because the Moriches Inlet was the closest inlet to the accident site (about 8 miles), throughout the night of July 17, boats traveled from the accident site to the USCG station at East Moriches, New York, with human remains and airplane debris. This station became the hub for staging and coordinating the search and recovery efforts almost immediately after the accident occurred. On July 18, 1996, the Safety Board, with other involved agencies, established a biohazard containment procedure for the search and recovery operation. The Suffolk County Medical Examiner established a temporary

---

<sup>662</sup> Because of the possibility that the TWA flight 800 accident was the result of a terrorist or criminal act, the FBI was involved in the investigation from July 17, 1996, until November 18, 1997, at which time, it determined that a terrorist or criminal act most likely did not cause the accident and withdrew from active involvement in the investigation.

<sup>663</sup> For additional information regarding the survival aspects of this accident, see section 1.15.

<sup>664</sup> The first responders' attempts to recover wreckage were limited by the presence of fuel-fed fires, the equipment available, and the size of some pieces of wreckage. For example, the crew of the USCG vessel *Juniper*, a 225-foot cutter/buoy tender, tried to recover the right wing tip, but the crane on board the boat was too short.

morgue at the East Moriches location.<sup>665</sup> A staging area for the ship-shore-hangar transfer of recovered airplane wreckage and debris was established at the USCG station at Shinnecock Inlet, New York (about 18 miles northeast of the debris fields).<sup>666</sup> Figures 21 and 22 in section 1.12 show the accident airplane's approximate flightpath, the Moriches and Shinnecock Inlets, and the three major identified debris fields.

On July 18, 1996, the Safety Board requested the U.S. Navy's assistance in the underwater search and recovery of the victims, the flight data recorder (FDR) and cockpit voice recorder (CVR), and the airplane wreckage.<sup>667</sup> Also on July 18, teams of scuba divers from state and local police departments began operations to recover victims and debris. SUPSALV coordinated with the NOAA vessel *Rude* (which arrived on scene on the night of the accident)<sup>668</sup> to use its side-scan sonar (SSS) to locate victims and wreckage on the ocean floor and to help target scuba divers' efforts until additional U.S. Navy personnel and equipment arrived. SUPSALV also contracted for the services of the commercial vessel *Pirouette*, which arrived on scene on the evening of July 19, 1996. On July 20, 1996, the *Pirouette* (supplied with U.S. Navy-owned equipment, including an SSS system, a towed-pinger locator, and a mini-remote operated vehicle [ROV]) joined the *Rude* in its efforts to locate victims and the FDR and CVR (which, as previously indicated, were recovered on July 24) and to map the underwater debris fields.

On July 21, the U.S. Navy's Explosive Ordnance Disposal and mobile diving units of the Atlantic Fleet arrived, providing additional scuba divers, surface support personnel, and the equipment and logistical support necessary for establishing a fully operational shore-based command, communication, and control center and dive station at the East Moriches location. The shore-based scuba diving operation used small watercraft to transport scuba divers from the U.S. Navy and local police departments between the shore-based dive station and the dive locations. Because this process was recognized as cumbersome and time-consuming (in part because of the distances involved), ocean-based diving stations were established when the necessary support equipment arrived at the site about a week after the accident.

---

<sup>665</sup> A more permanent morgue operation was subsequently established at the Suffolk County Medical Examiner's Office in Hauppauge, New York.

<sup>666</sup> The Shinnecock Inlet location was chosen for transfer of recovered airplane wreckage and debris instead of the Moriches Inlet because the Shinnecock Inlet is wider and, thus, has significantly calmer water, facilitating the passage of boats loaded with wreckage.

<sup>667</sup> The Safety Board has had a memorandum of understanding with the U.S. Navy regarding wreckage recovery for many years and has requested the U.S. Navy's assistance during several investigations, including the United Airlines flight 811 accident on February 24, 1989, involving the in-flight separation of a cargo door on a Boeing 747-122 near Honolulu, Hawaii. Additionally, the U.S. Navy was involved in the search and recovery efforts for the Air India Airlines 747 that crashed in the Atlantic Ocean off the coast of Ireland in June 1985; the space shuttle Challenger in 1986; the South African Airways flight 295 747-200B airplane that crashed 130 miles northeast of Mauritius in November 1987; and the Birgenair 757 that crashed off the coast of the Dominican Republic in February 1996. U.S. Navy Supervisor of Salvage and Diving's (SUPSALV) testimony during the Board's December 1997 TWA flight 800 public hearing indicated that, on average, the U.S. Navy recovers about one military airplane from the ocean every 3 weeks.

<sup>668</sup> The *Rude* is an oceangoing research vessel that responded from Newport, Rhode Island, on the night of the accident to assist in the search for possible survivors and the early recovery efforts. The *Rude* continued to assist in search and recovery efforts until it departed the area on August 1, 1996.

By the end of July, two U.S. Navy salvage ships (the U.S.S. *Grasp* and U.S.S. *Grapple*) had reported to the accident site and were providing ocean-based stations for surface-supplied scuba diving and ROV operations. The U.S.S. *Grasp* was moored over the major area of airplane debris in the green zone, and the U.S.S. *Grapple* was moored over the major area of airplane debris in the yellow zone.<sup>669</sup> These ships were equipped with high-capacity cranes for lifting large pieces of debris from the water. Two U.S. Navy support vessels, the U.S.S. *Oak Hill* and U.S.S. *Trenton*, provided logistical support (berthing, dining, and medical) for scuba divers operating from the U.S.S. *Grapple* and U.S.S. *Grasp*, as well as a landing/docking area for the helicopters and amphibious watercraft engaged in the transportation of debris, personnel, and supplies. (Figure 47 shows a time line of salvage operation events, excerpted from the U.S. Navy's report.)<sup>670</sup>

Throughout most of the search and recovery operation, ROV, SSS, and laser line-scanning (LLS) equipment were used to search existing debris fields. This equipment was also used to explore areas outside existing debris fields that might contain victims and wreckage and to videotape the wreckage and ocean floor. Scuba divers and ROVs were used to systematically recover victims and wreckage.

### Recovery Procedures

Small pieces of wreckage and debris were placed in bags and carried to the ocean surface by divers or placed in salvage baskets and lifted to the ocean surface by an amphibious tugboat or a salvage ship. (The ROVs performed some limited recovery tasks. The larger ROV could grip larger objects and perform some rigging tasks with its two sophisticated manipulator arms; however, the mini-ROVs could only retrieve small objects with their simple manipulators.) Larger items were rigged with lifting straps by divers and lifted by the tugboat (or, in the case of two very large pieces, the ship). Although some particularly small and/or potentially important pieces of wreckage were transported to shore by helicopter, most of the wreckage was transported to shore on the amphibious tugboats. Some very large pieces (including an 80-foot-long section of the right wing) had to be cut into smaller sections before they could fit on the amphibious tugs for the move to shore and in the trucks for the move to a storage/reconstruction facility. (The Safety Board leased a hangar at the former Grumman Aircraft facility in Calverton, New York, to be used for wreckage storage, examination, and reconstruction; this facility became the command center and headquarters for the investigation.)

---

<sup>669</sup> All other scuba diving (red zone and other areas of debris) was accomplished by mobile scuba diving teams operating from small boats.

<sup>670</sup> U.S. Navy. 1998. *U.S. Navy Salvage Report TWA Flight 800*. Report S0300-BZ-RPT-010, 0910-LP-015-6130.

**FLIGHT 800 SALVAGE OPERATIONS TIME LINE OF EVENTS**

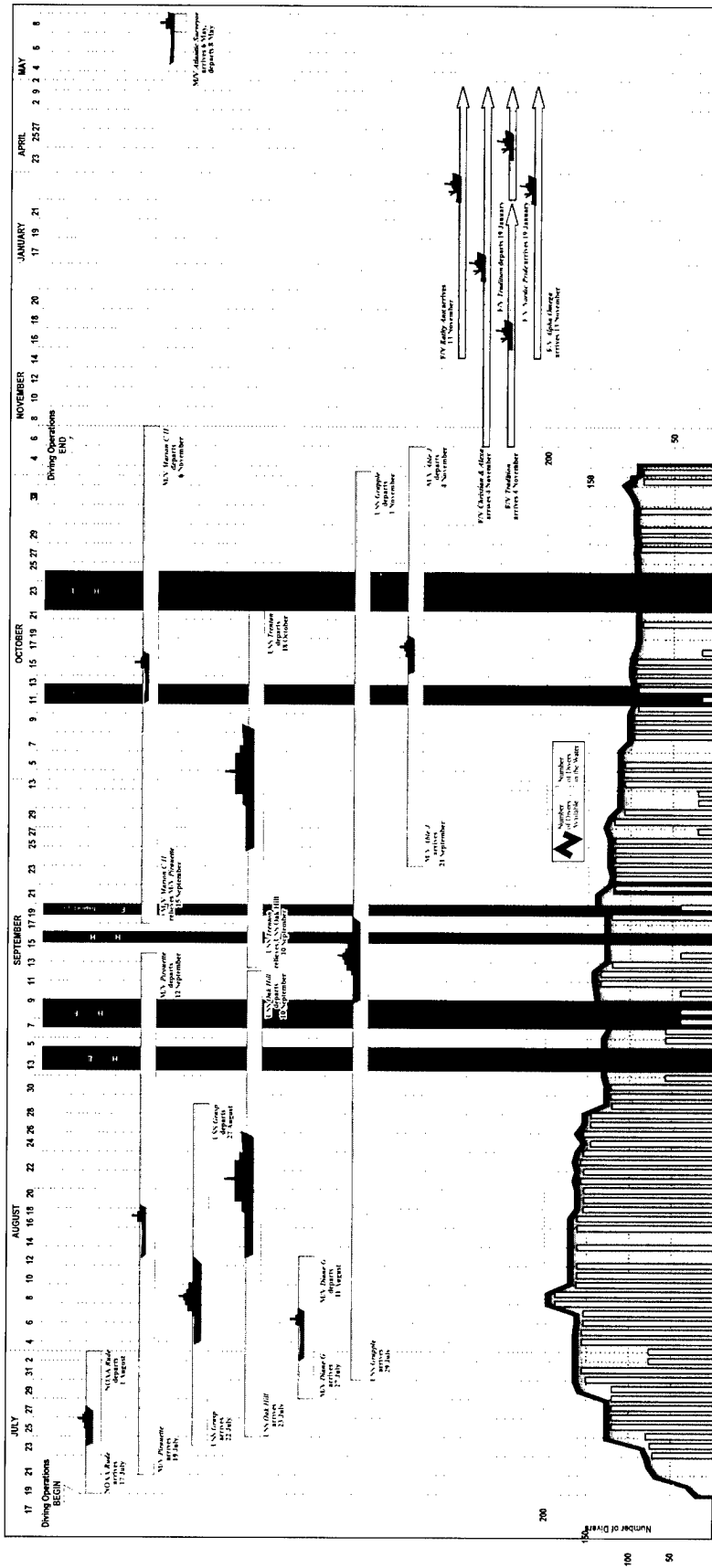

Figure 47. A time line of salvage operation events.

When the amphibious tugboats arrived at Shinnecock Inlet with wreckage, New York State Army National Guard and/or local police personnel used a mobile crane to transfer wreckage from the tugboats to 18-wheeled open bed trucks, which then transported the wreckage to the hangar at Calverton.<sup>671</sup> Safety Board and FBI personnel were present to observe all wreckage transfers to preserve the evidentiary value of the wreckage. Also, to ensure that wreckage recovery locations were accurately tracked, the amphibious tugboats and trucks/trailers were searched for any dropped debris after each trip.

### U.S. Navy Salvage Report Information

The U.S. Navy's report, which documented the TWA flight 800 search and recovery efforts, indicated that the search and recovery operation occurred in the following three phases: (1) a period of intense activity, from July 17 to the end of August 1996; (2) a period of sustained effort, from September 1 to November 2, 1996; and (3) trawling operations, from November 4, 1996, to April 28, 1997.

According to the U.S. Navy report, the period of intense activity primarily involved recovering victims and those pieces of the airplane seen as critical to the investigation. These efforts included a thorough mapping of the debris on the ocean floor and required the almost continual use of ROVs, SSS, LLS equipment, and scuba divers. During the month of August, an average of 153 divers were available; on 26 days in August, all available divers were used. By the end of August, 211 victims had been recovered and identified. According to the U.S. Navy report, "two events marked the end of the period of intense activity and the beginning of the period of sustained effort. The first was the [August 27] departure...of the *Grasp* and the 25 divers that she carried. The second was the occurrence of heavy weather, much of it the result of Atlantic hurricanes, that made diving operations impossible on more than half of the days in September."<sup>672</sup>

The period of sustained effort involved the continued use of ROVs, SSS, LLS equipment, and scuba divers to recover the remaining victims and as much of the airplane as possible. In part because of inclement weather, the pace of the recovery operations moderated during this period. High swells and currents from Hurricane Edouard and other storms that affected the area during these months caused significant shifting of the wreckage and sand, requiring debris fields to be remapped. According to the U.S. Navy report, the period of sustained effort was "characterized by the steady and thorough exploitation of the debris fields. [SSS] was used to expand existing debris fields, make more detailed searches of existing debris fields, and explore areas that might contain debris. Divers and ROVs were used to systematically remove all of the debris from one

<sup>671</sup> The New York State Army National Guard provided 12 tractors and 10 trailers to transport wreckage to the hangar at Calverton.

<sup>672</sup> With the onset of autumn, severe weather became an increasingly significant operational factor in the search and recovery efforts. Five major storm systems affected the search and recovery operations in varying degrees: Hurricane Edouard (August 19 to September 3), Hurricane Fran (August 23 to September 8), Hurricane Hortense (September 3 to 16), Hurricane Josephine (October 4 to 8), and Hurricane Lili (October 14 to 27).



debris field before moving on to the next.” The last search and recovery-related SSS and scuba diving operations occurred on October 13 and November 2, respectively. By November 2, about 95 percent of the airplane wreckage had been recovered.

At the Safety Board’s request, the U.S. Navy proposed many options for the third phase of the recovery operation.<sup>673</sup> After reviewing the options, the Board chose trawling for the third phase because it provided an optimal combination of expected effectiveness, cost, environmental impact, and suitability for winter operations. Trawling operations involved the use of five commercial trawlers, under contract to the U.S. Navy, to scrape up layers of silt to recover pieces of wreckage that had become embedded in the ocean floor. Trawl lines several miles long were carefully laid out to cover the entire area being trawled, criss-crossing the debris fields, and the Board monitored and prioritized the trawling areas carefully. The scallop trawlers then moved along the trawl lines at 2 to 3 knots, towing 15-foot-wide nets on each side of the ship. After the trawler completed each pass along a trawl line, the nets were brought aboard and emptied; all natural materials were discarded; and all man-made objects were retained, documented, and transported to shore on small boats. Successive trawler sweeps were made to cover the gap between the two nets, and each area was reswept until no new material was recovered (some lines in the red zone were swept more than 10 times). When material recovered by the trawlers reached shore, it was examined by Safety Board personnel, who separated the airplane debris from other objects.

The trawling operation was complicated by the presence of a submerged trans-Atlantic telephone cable inside the northern boundary of the trawling area. To avoid snagging or otherwise damaging the telephone cable, the commercial scallop trawlers did not trawl within 200 yards of the cable; however, the area within 200 yards of the cable was thoroughly inspected and documented by an AT&T ROV and was declared clear of airplane debris.

Trawling operations ended on April 28, 1997, because successive trawling sweeps turned up no additional debris. Between April 30 and May 18, 1997, a U.S. Navy ROV was used to make a final inspection of the wreckage recovery area. The ROV made 85 dives after the trawling operations ceased, locating only one small piece of additional wreckage; therefore (with the concurrence of the Safety Board and the FBI), trawling and other search and recovery efforts were formally terminated on May 18, 1997. The trawling operation recovered pieces of the airplane that amounted to about 1 to 2 percent of its structure.

---

<sup>673</sup> Proposed options for the third phase of the recovery operation included trawling, the development of a rake attachment for ROVs, the use of a suction dredge, lift excavation, and the continued employment of scuba divers.

## Appendix D

### Document Management Tags Database Information

Pieces of wreckage were tagged with color-coded and numbered tags that corresponded to the debris field from which they were recovered. The color-coded tags were usually attached to items promptly upon recovery and before items were transported to the hangar; however, in some cases, items were not tagged until they arrived at the hangar.<sup>674</sup> A data management team consisting of Safety Board investigators, party representatives, and representatives from the Navy and its contractor Oceaneering Advanced Technology, Inc.,<sup>675</sup> compiled a database from wreckage logs completed when recovered items were tagged. Subsequently, the team cross-checked the information in this database against all available sources of recovery information, including diver logs, ship records, photographs, videotapes, target assignments, FBI evidence records, and identification of parts made by investigative team members, to ensure that the most valid information was contained in the tags database system.

Of the 3,168 recovered items that received color-coded identification tags on the ships, 645 items were recovered from the red zone, 462 items were recovered from the yellow zone, and 1,885 items were recovered from the green zone. In addition, 176 items were recovered from other locations (orange), were found floating (blue), or were recovered from unknown locations (white).<sup>676</sup> Additionally, 1,444 recovered items arrived (or were discovered) at the hangar without tags. Of the 1,444 hangar tags, 1,210 were assigned to items recovered during the dive operation, and 234 were assigned to items recovered during the trawling operation.<sup>677</sup> Untagged pieces were tagged, if necessary.

When each piece of wreckage arrived at the hangar in Calverton, it was examined by members of the Structures Group, who, when possible, identified the portion of the airplane from which the wreckage piece had originated. A log number was generated for

---

<sup>674</sup> Although most pieces of wreckage were ship-tagged, during salvage and reconstruction efforts it occasionally became necessary to cut or separate objects (previously tagged as a whole) into more than one piece, leaving some untagged portions. Additionally, some objects were extracted from an entangled group of debris (recovered and tagged as a unit); in some cases, pieces were received in a bag, net, or box full of other items with one tag assigned to the container. Finally, some parts simply broke during handling/transport, leaving some parts untagged. In all of these situations, the recovery position information on the ship tag from the original object or group of objects was transferred to the hangar tag(s) assigned to the separated object(s). All large and small pieces of wreckage that were identifiable and considered significant were tagged.

<sup>675</sup> Representatives from the Federal Bureau of Investigation (FBI) and the Structures and Airplane Interior Documentation Groups also participated in this effort at various times, as needed.

<sup>676</sup> Some floating and/or washed ashore items received blue tags, and others received white tags.

<sup>677</sup> Tags that were color coded to reflect the debris zones (red, yellow, or green) were assigned to trawled items based on the zone in which the item was recovered. Color-coded tags were also assigned to the remaining 1,210 items tagged in the hangar. Of these, 145 corresponded to the known recovery zone, and the remaining 1,065 were assigned color-coded tags based on the probable recovery zone, which was identified by cross-referencing the FBI lot number of the previously untagged item with the ship-tagged items in the same lot.

the pieces that could be structurally identified, and pieces were further examined, sketched, and photographed, as appropriate. Log numbers were written on the piece of wreckage and on a separate tag that was attached to the piece. Log number classifications subdivided the wreckage into 12 subgroups and used the following nomenclature (XX denotes the number assigned to an individual piece):

LF-XX	Left fuselage
RF-XX	Right fuselage
LW-XX	Left wing
RW-XX	Right wing
H-XX	Horizontal stabilizer (both sides)
LE-XX	Left elevator
RE-XX	Right elevator
V-XX	Vertical stabilizer
R-XX	Rudder
CW-1XX	Wing center section (WCS)—upper skin
CW-2XX	WCS—lower skin
CW-3XX	WCS—right side-of-body rib
CW-4XX	WCS—left side-of-body rib
CW-5XX	WCS—front spar
CW-6XX	WCS—spanwise beam (SWB) 3
CW-7XX	WCS—SWB2
CW-8XX	WCS—mid spar
CW-9XX	WCS—SWB1
CW-10XX	WCS—rear spar
CW-11XX	WCS—butt line zero rib
FBM-XX	Floor beam
LG-XX	Landing gear

This wreckage documentation was maintained in a massive database that was cross-referenced by investigative groups during the investigation. This database contained details related to each piece, such as recovery location, extent and type of damage, photographs, sketches, and Boeing's engineering drawings depicting the part's location on the airplane.

### Migration of TWA Flight 800 Debris

During the first few days of recovery efforts, investigators used ocean current data to predict where pieces of wreckage would have come to rest on the ocean floor. After confirming wreckage locations through the use of side-scan sonar (SSS) equipment,

investigators and recovery crews were able to focus their recovery efforts productively. Pieces of wreckage important to the investigation (sequencing and trajectory efforts) were located and recovered during the first month after the accident in the positions initially identified by SSS equipment. However, as recovery efforts continued, it was necessary to expand the area searched by the SSS equipment, in part, because ocean currents resulted in the continual shifting of the sediment on the ocean floor and migration (and/or concealment) of pieces of wreckage.<sup>678</sup>

---

<sup>678</sup> Although the positions of heavier pieces of wreckage would be less affected by ocean currents than those of lighter pieces, such items would be subject to concealment by shifting sediment on the ocean floor.

## Appendix E

### Accident Airplane Maintenance Records

The National Transportation Safety Board's review of the accident airplane's maintenance records revealed numerous fuel system-related maintenance writeups during the 2 years before the accident. The accident airplane's maintenance records described the following discrepancies, which occurred during refueling, and the resultant maintenance actions:

- Nonroutine Maintenance Record—December 16, 1995. The airplane would not accept fuel. The volumetric control was replaced, and the system operation checked normal.
- Nonroutine Maintenance Record—April 21, 1996. The airplane would not accept fuel. The four main fuel tanks were pressure-fueled. A followup check indicated that the system operated normally during ground fueling.
- Aircraft Maintenance Log—April 28, 1996. The airplane's wing refueling valves closed continuously for no apparent reason. The fueler was able to fuel by moving the fuel switch back and forth between the normal and battery positions. The connector at the fueling panel was cleaned, and the anomaly was listed on the Open Item Work Sheet to correct, as required.
- Aircraft Maintenance Log—April 30, 1996. The airplane's fueling system shut down, and the airplane would not accept fuel. The item was deferred until May 1, 1996, when the fueling panel magnet was replaced, and the system operation checked normal.
- Aircraft Maintenance Log—May 2, 1996. (This writeup references the April 30, 1996, logbook entry above.) The airplane's No. 4 main fuel gauge volumetric switch shut off at "22.4," and the volumetric switch in the main electrical service bay shut off all the fueling valves at the under-wing fueling station. The item was deferred until May 5, 1996, when the R118 ground handling No. 2 relay was replaced because there was "no power at B2 terminal, and only 19 vdc [volts direct current] on the external power output." The system operation checked normal.
- Nonroutine Maintenance Record—May 15, 1996. The fuse and fuse holder were missing from the volumetric controller. Both fuses were replaced.
- Nonroutine Maintenance Record—May 23, 1996. The airplane would not accept fuel. The fueling panel magnet was replaced, the panel was secured, and the system operation checked normal.
- Nonroutine Maintenance Record—June 4, 1996. The airplane's fueling system shut down while fueling. The volumetric switch and valves were cycled several times, and the system subsequently checked normal. When the

auto-fuel shut off about 80,000 to 85,000 pounds, the overfill circuit breaker was pulled to continue fueling. Maintenance personnel suspected that the No. 1 reserve or main refuel valve was not shutting completely.

- Aircraft Maintenance Log—July 7, 1996. All fuel valves shut off during fueling and did not open electrically. The surge tank was sumped; all of the valves then operated normally.

The accident airplane's three logbook entries regarding fuel leaks indicated the following:

- Aircraft Maintenance Log—September 23, 1995. During the preflight walk-around inspection, the flight engineer observed fuel dripping from the left wing dump chute while fueling was in progress. The drip stopped when fueling was terminated. The aircraft maintenance log entry contained the following engineering note: "this is an abnormal condition, possible dump valve problem. Pressure fuel system." No further leaks were noted.
- Nonroutine Maintenance Record—June 18, 1996. The No. 3 engine was removed because of an overtemperature, and a replacement engine was installed. The maintenance record indicated that maintenance personnel checked the operation of the cross-feed valve as part of the replacement engine installation in accordance with the maintenance manual instructions. During this procedure, an eight drop-per-minute leak was noted at the fuel shut-off valve. The logbook entry indicated that this leakage was within the limits specified in the maintenance manual, which states that leakage cannot exceed 20 drops per minute.
- Aircraft Maintenance Log—July 10, 1996. A small amount of fuel was found dripping from the flap assembly on the left wing behind the No. 2 engine. Maintenance personnel tightened the No. 1 main control fueling valve core mounting screws; no further leaks were noted.

The following text describes the 25 logbook entries regarding fuel flow; fuel gauge indications, inaccuracies, and fluctuations; and inoperable fuel system equipment and the corrective actions taken:

- Aircraft Maintenance Log—July 9, 1994. The "total fuel indication drums hang up and rotate along with the gross weight drums when gross weight is adjusted with set knob." The item was deferred until July 12, 1994, when the fuel totalizer indicator was replaced and the system was calibrated in accordance with the maintenance manual; the system subsequently passed a functional test.

- Aircraft Maintenance Log—July 30, 1994. The flight engineer's No. 2 engine fuel flow read higher than the other engines. A cross-feed check with the fuel used indicator and a quantity decrease confirmed a high fuel flow. All other engine parameters were normal. The fuel flow power supply was replaced, and the system passed a functional test.
- Aircraft Maintenance Log—August 1, 1994. Repeat of July 30, 1994, writeup. The item was deferred until August 3, 1995, when the No. 1 engine fuel flow transmitter was removed and replaced. The engine was run and fuel flow transmitter operation appeared normal; no leaks were noted.
- Aircraft Maintenance Log—August 4, 1994. The No. 1 reserve fuel tank lost fuel during flight. Maintenance personnel checked under the wing and the fuel transfer valve for leaks; none were found. The fuel quantity gauge reading matched the drip stick quantity indication. The fuel tank sumps were drained.
- Aircraft Maintenance Log—August 10, 1994. The No. 1 reserve fuel tank lost fuel during flight. The fuel tank sumps were drained, and the fuel quantity gauge reading matched the drip stick quantity indication. The item was deferred until August 18, 1994, when the No. 1 reserve fuel tank successfully completed an operational check.
- Aircraft Maintenance Log—November 21, 1994. The No. 1 reserve fuel quantity indicator was inoperative. The indicator connector was cleaned and reseated, and the indicator operation checked normal.
- Aircraft Maintenance Log—February 3, 1995. The fuel totalizer indication was inaccurate. The ramp indicator indicated 241,200 pounds of fuel on board, and the fuel totalizer indicated 246,700 pounds. Maintenance personnel indicated that fuel totals were within maintenance manual limits.
- Aircraft Maintenance Log—February 3, 1995 (after another flight). The fuel totalizer indication was inaccurate. The ramp indicator indicated 187,500 pounds of fuel on board, and the fuel totalizer indicated 191,400 pounds. During flight, the totalizer indication was consistent with the total of the individual gauge quantity indications. The item was deferred until February 5, 1995, when the totalizer was recalibrated in accordance with the maintenance manual procedures, and its operation checked normal.
- Aircraft Maintenance Log—February 11, 1995. The captain's No. 2 fuel flow indication was inaccurate (high). The fuel used indication was high from engine start until takeoff. Maintenance personnel tested the fuel flow module, and its operation checked normal.
- Aircraft Maintenance Log—April 28, 1995. The fuel temperature indication was lower than the actual temperature in all positions (15° low on Nos. 1, 3, and 4 engines; 20° low on No. 2 engine). The item was deferred until April 29, 1995, when the fuel temperature indicator was removed and replaced.

- Aircraft Maintenance Log—May 5, 1995. The fuel temperature indication for engine No. 2 was higher than the actual temperature. The item was deferred until May 6, 1995, when the fuel temperature bulb was removed and replaced.
- Aircraft Maintenance Log—May 18, 1995. The gross weight/total fuel weight indication was inaccurate. This gauge indicated 1,500 pounds less than the sum of the individual tank gauges. The item was deferred until May 21, 1995, when the indicator checked within maintenance manual limits.
- Aircraft Maintenance Log—July 20, 1995. The No. 1 main fuel tank quantity indicator was inaccurate. The item was deferred until August 5, 1995, when the No. 1 main fuel tank quantity indicator was removed and replaced. Full and empty capacitance was checked, and the indicator and totalizer were calibrated per maintenance manual references. All of the systems checked normal.
- Aircraft Maintenance Log—August 3, 1995. An engineering note stated that the No. 1 fuel gauge should be placarded inoperative because of an “existing fuel problem. Suspect possibility of fuel siphoning from the number 1 tank (when boost pumps are off) into fuel manifold.” No external fuel leaks were noted, and no transfer of fuel occurred when the fuel manifolds were pressurized. Engine fuel burn appeared normal. The item was closed out on August 21, 1995.
- Aircraft Maintenance Log—August 4, 1995. An engineering note stated that the center wing fuel tank (CWT) fuel quantity indicator showed 1,300 pounds when the analog fuel quantity needle indicated that the tank was empty. The item was deferred until August 5, 1995, when the CWT fuel quantity indicator was removed and replaced. Full and empty capacitance was checked, and the indicator and totalizer were calibrated per maintenance manual references. All of the systems checked normal.
- Aircraft Maintenance Log—August 15, 1995. The flight engineer’s fuel flow indicator was inoperative. Examination revealed no problems with the fuel or the forward panel fuel flow indicator. The No. 4 fuel flow indicator was removed and replaced, and the system checked normal.
- Aircraft Maintenance Log—August 23, 1995. The flight engineer’s No. 4 fuel flow indicator stuck at 7,900 pounds. The pilot’s fuel flow gauges were normal. The item was deferred until August 24, 1995, when the fuel flow indicator was removed and replaced.
- Aircraft Maintenance Log—October 9, 1995. An engineering note indicated that the wing quantity gauges and the flight engineer’s fuel quantity gauges were to be checked against the actual fuel quantity before the airplane was fueled because of fuel quantity discrepancies. According to the note, all operations checked normal.
- Nonroutine Maintenance Record—December 1, 1995. The No. 1 engine fuel flow indicator was inoperative. Maintenance personnel checked the fuel flow, and all operations checked normal.



- Aircraft Maintenance Log—December 4, 1995. The flight engineer's No. 1 engine fuel flow indicator was inoperative. The fuel flow indicator was replaced, the No. 1 fuel flow transmitter connector was cleaned, and the indicator appeared to operate normally.
- Aircraft Maintenance Log—December 17, 1995. The No. 4 reserve fuel tank quantity indicator was inoperative. The item was deferred until December 17, 1995, when the wing and cockpit indicators were replaced. The cockpit and wing indicators' full and empty indications were calibrated, and volumetric operations checked normal.
- Aircraft Maintenance Log—December 17, 1995. The CWT fuel quantity gauge indication was erratic and fluctuated between 0 and 2,000 pounds when the CWT was empty. The indicator calibration full/empty volumetric totalizer was replaced, and the gauge appeared to operate normally.
- Aircraft Maintenance Log—December 28, 1995. The No. 1 engine fuel flow indication fluctuated. The item was deferred until January 1, 1996, when a byte check was performed on the fuel flow amperage.
- Aircraft Maintenance Log—April 27, 1996. The No. 1 engine fuel flow numerals indicated 10,000 pounds per hour above the pointer value. The fuel used and pilot's gauges appeared to indicate normally. The No. 1 engine fuel flow indicator was replaced and appeared to operate normally.
- Aircraft Maintenance Log—May 13, 1996. Both of the No. 4 engine fuel flow indicators were pegged high and inoperative. The item was deferred until May 15, 1996, when maintenance personnel performed a byte check on the electronic unit. All tests were passed, and maintenance personnel suspected wiring. On May 16, 1996, maintenance personnel cleaned and secured the fuel flow transmitter connector with no improvement noted. On May 18, 1996, maintenance personnel replaced the No. 4 transmitter, and the engine fuel flow operation checked normal.

## **Appendix F**

### **Sooting and Fracture Diagrams**

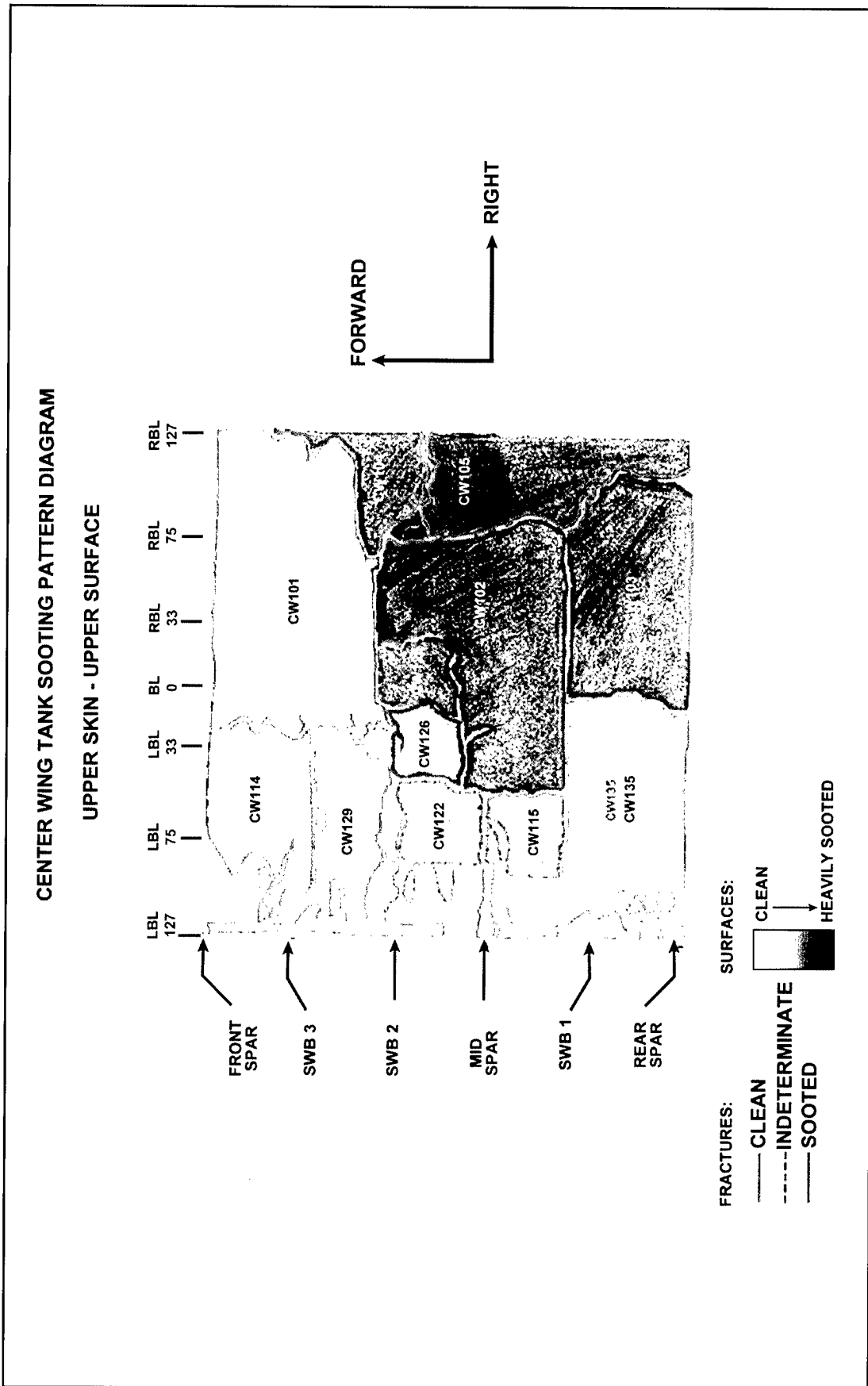

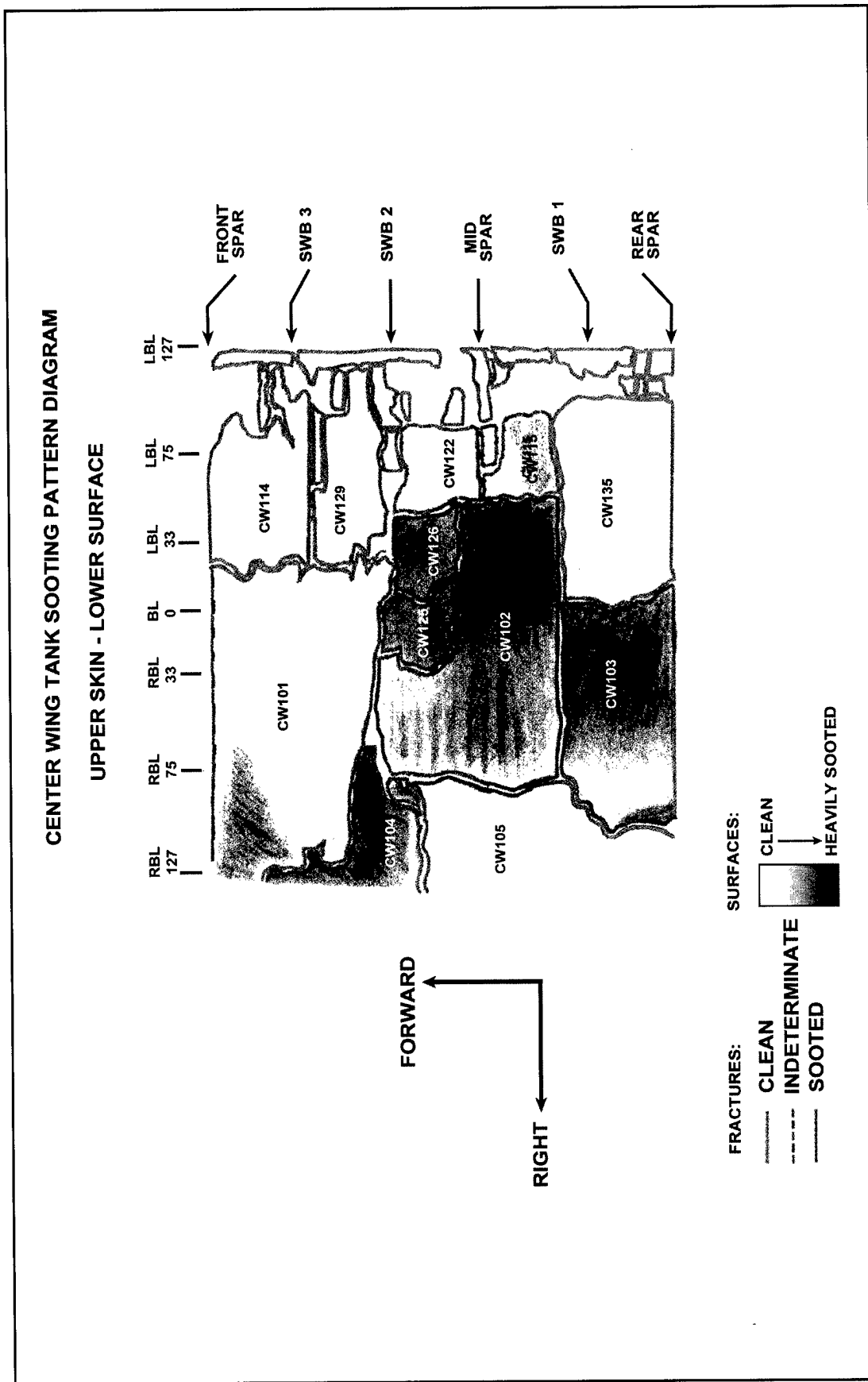



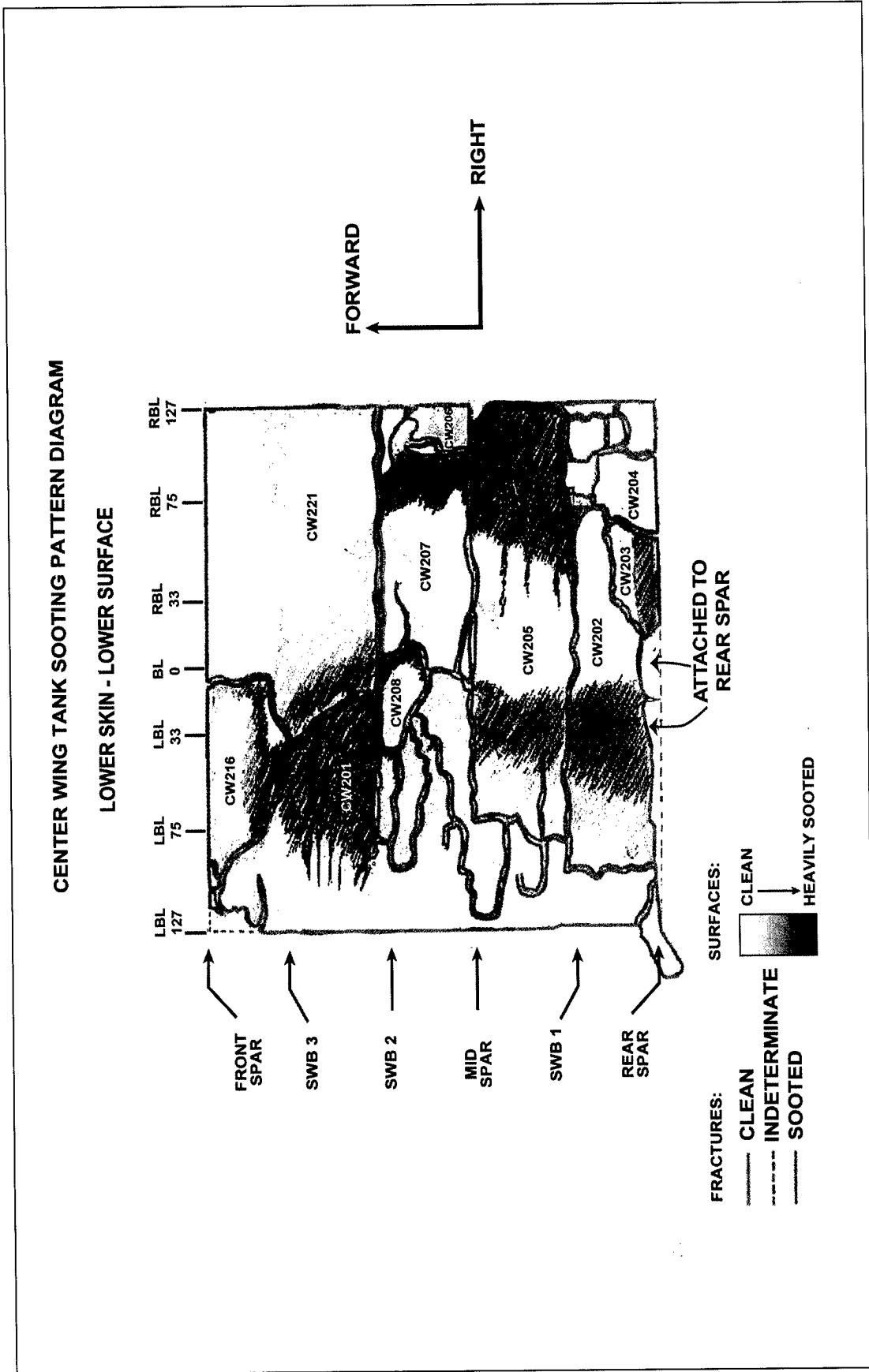

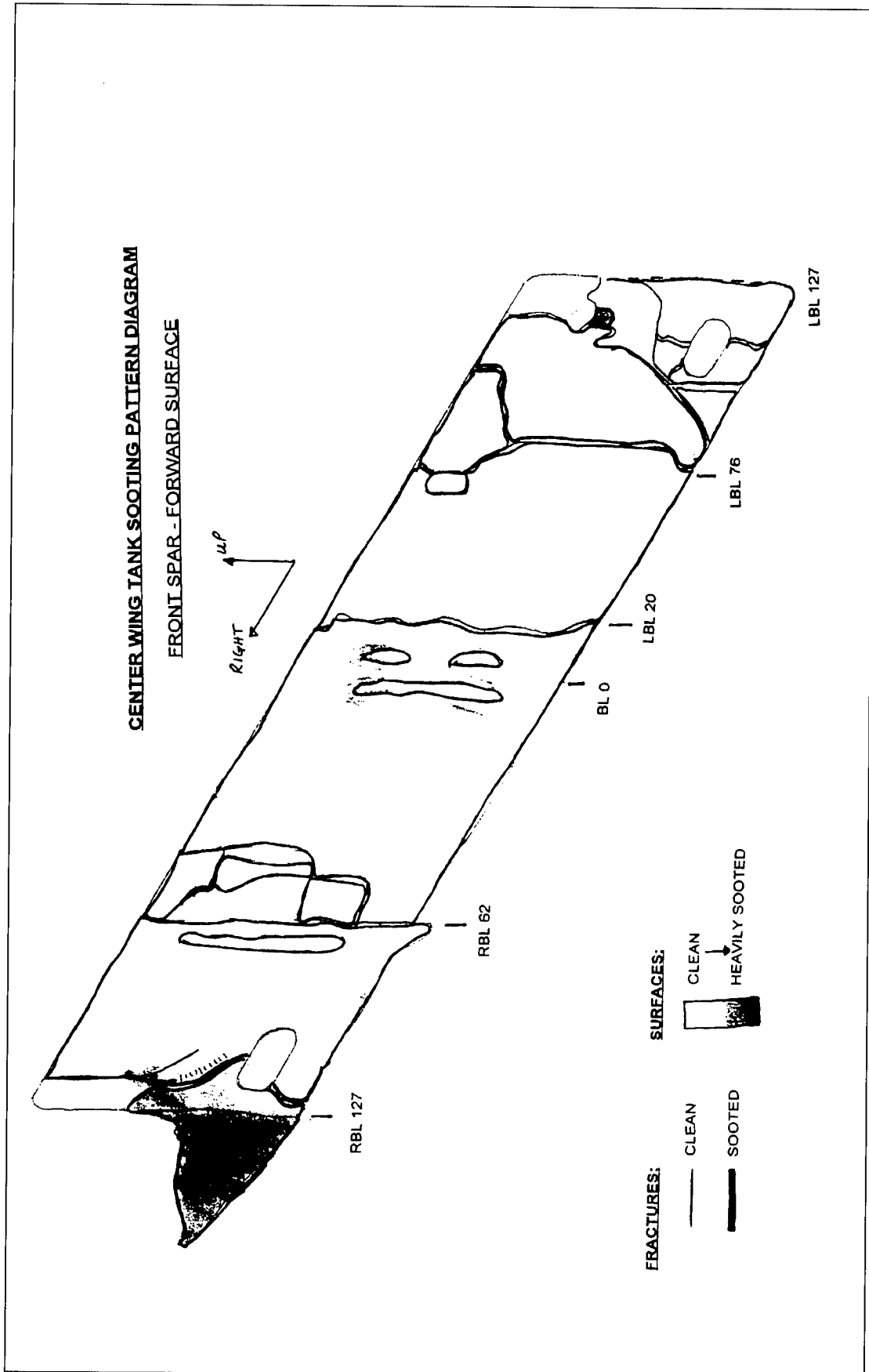

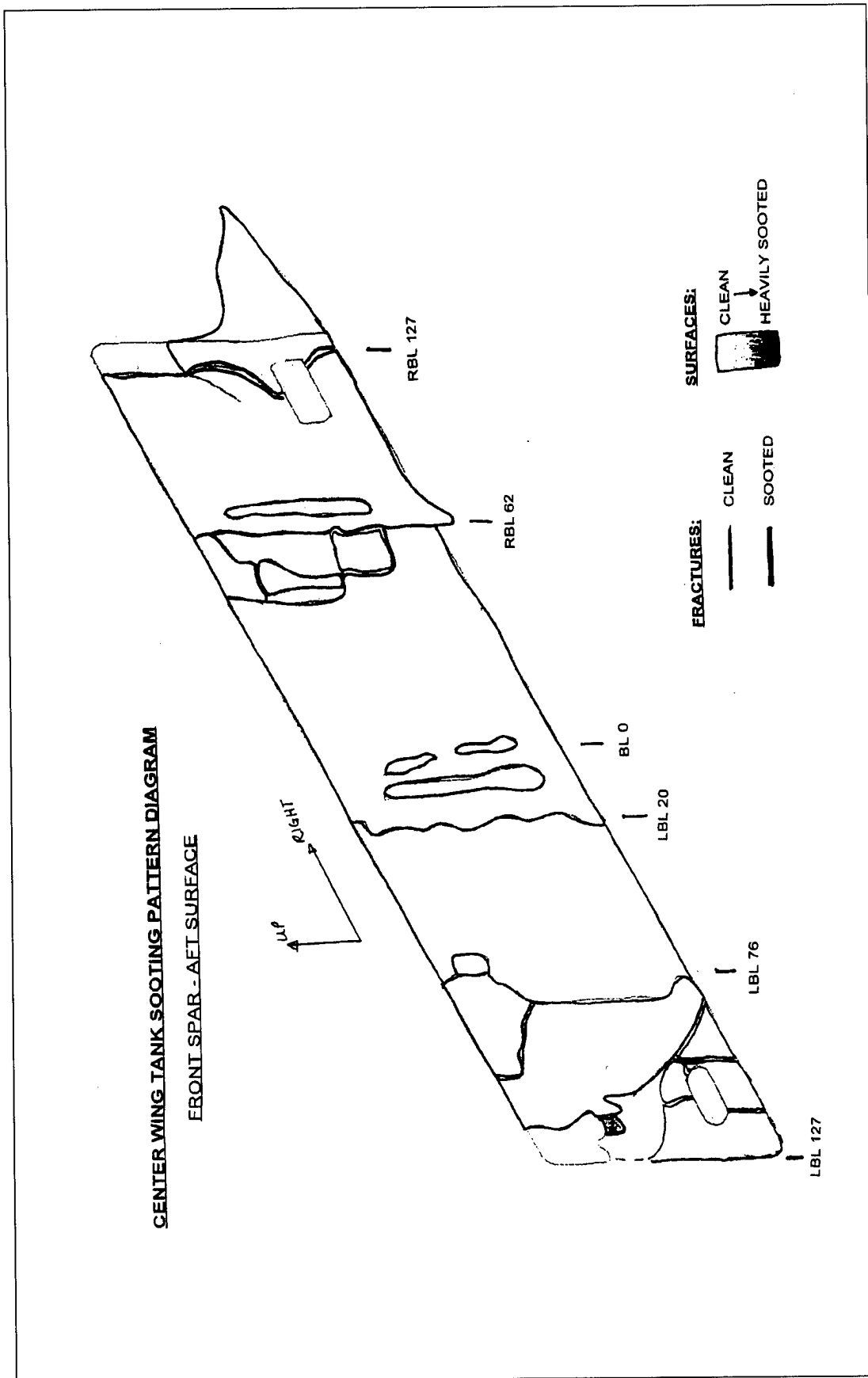



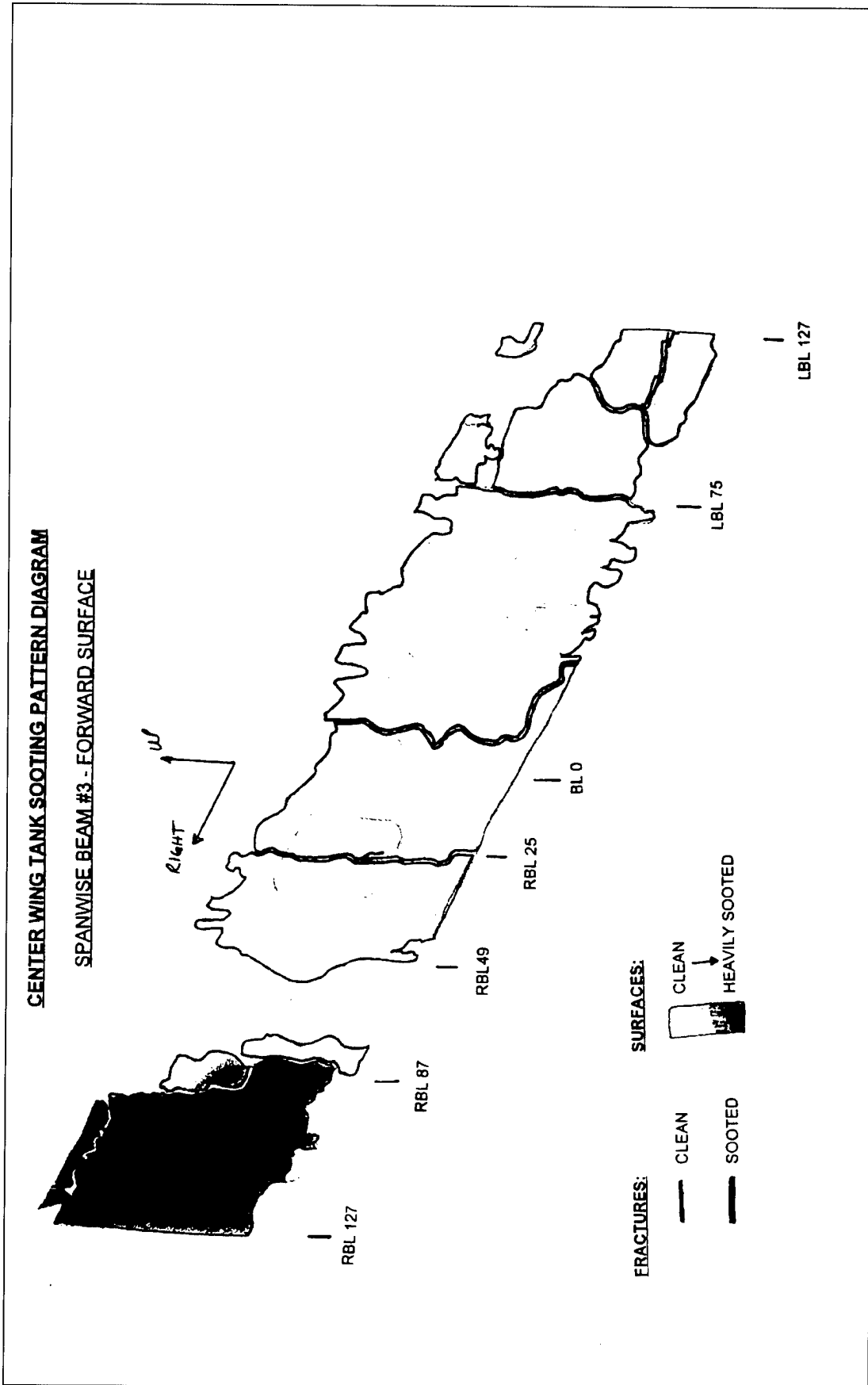

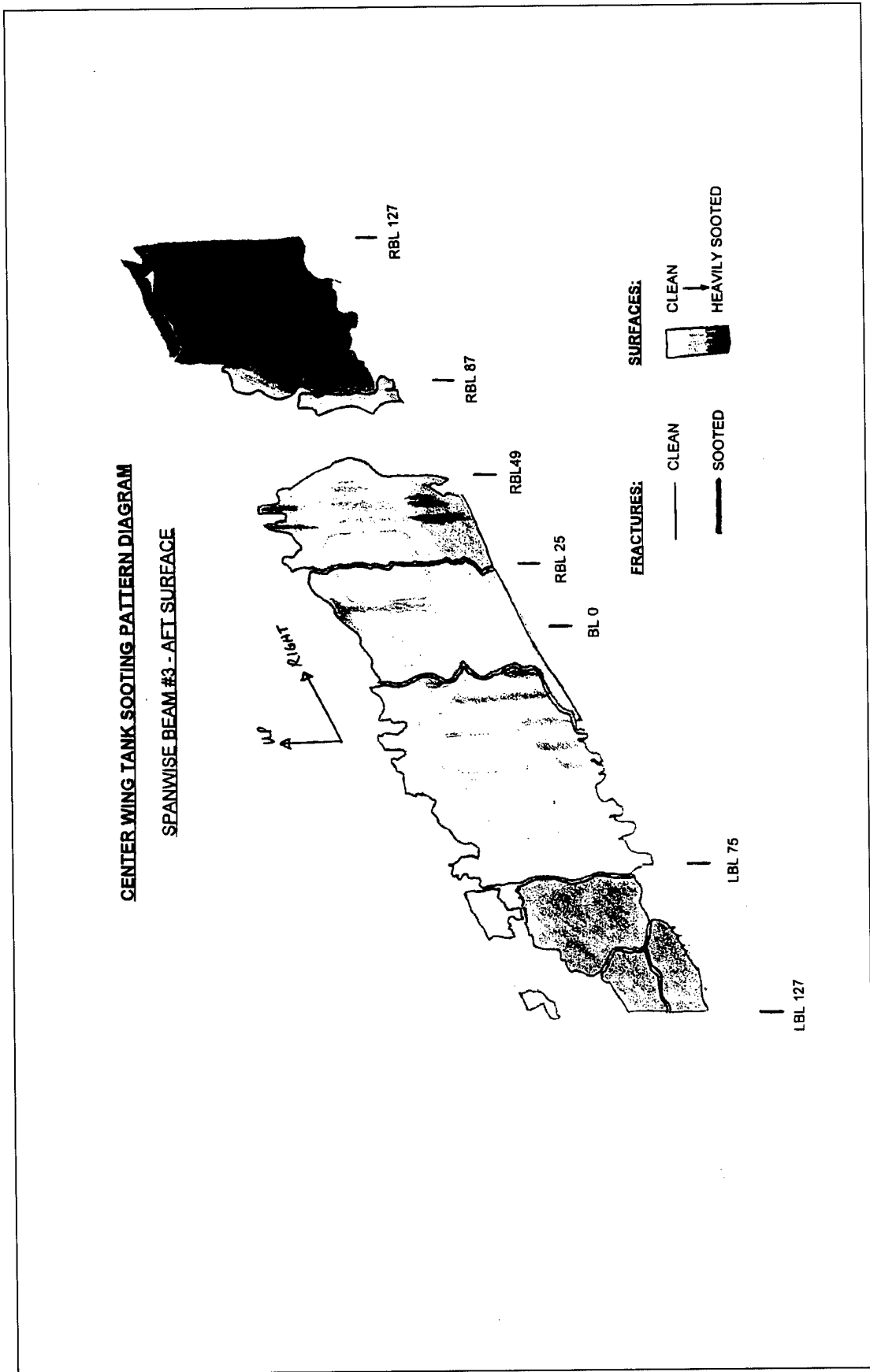

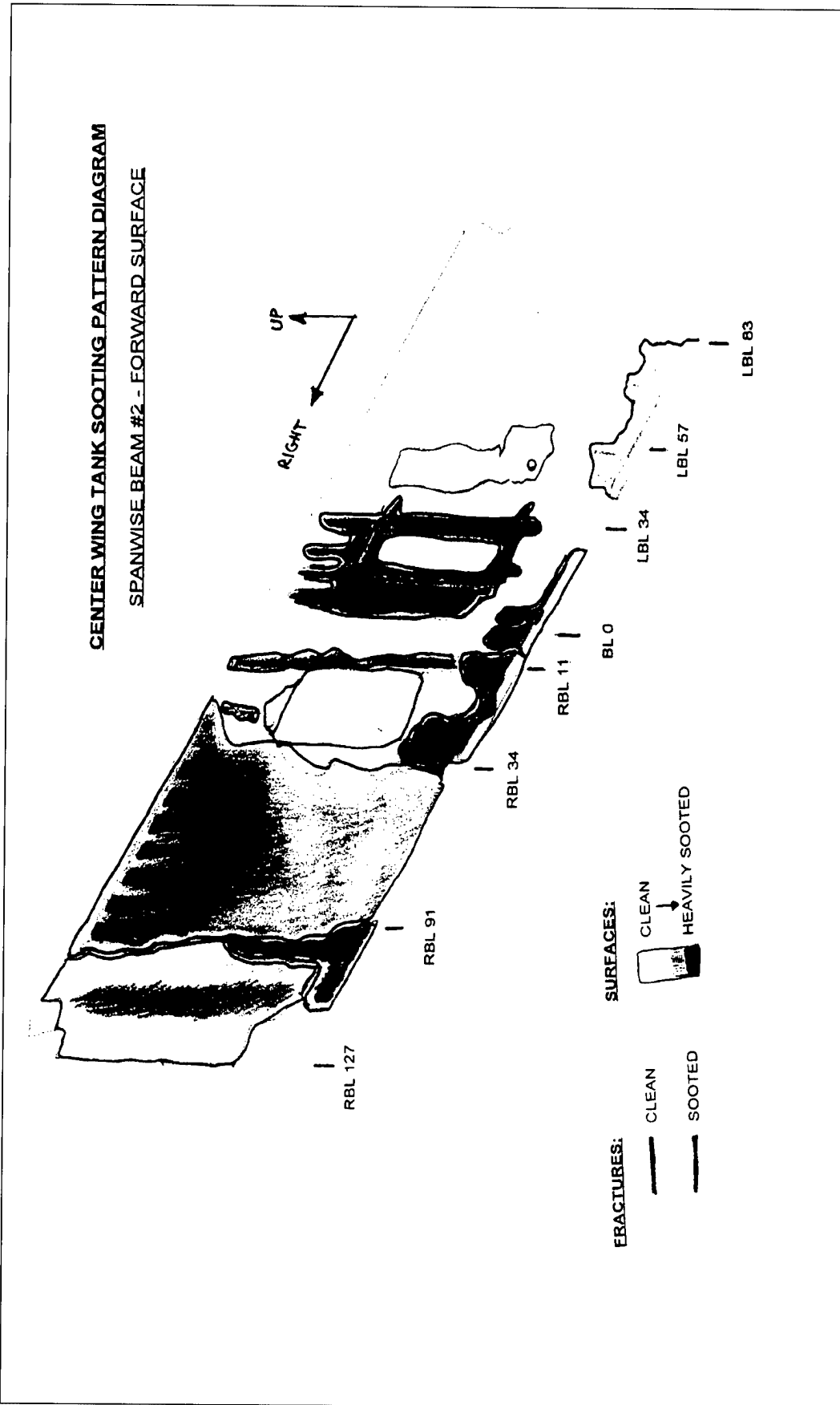

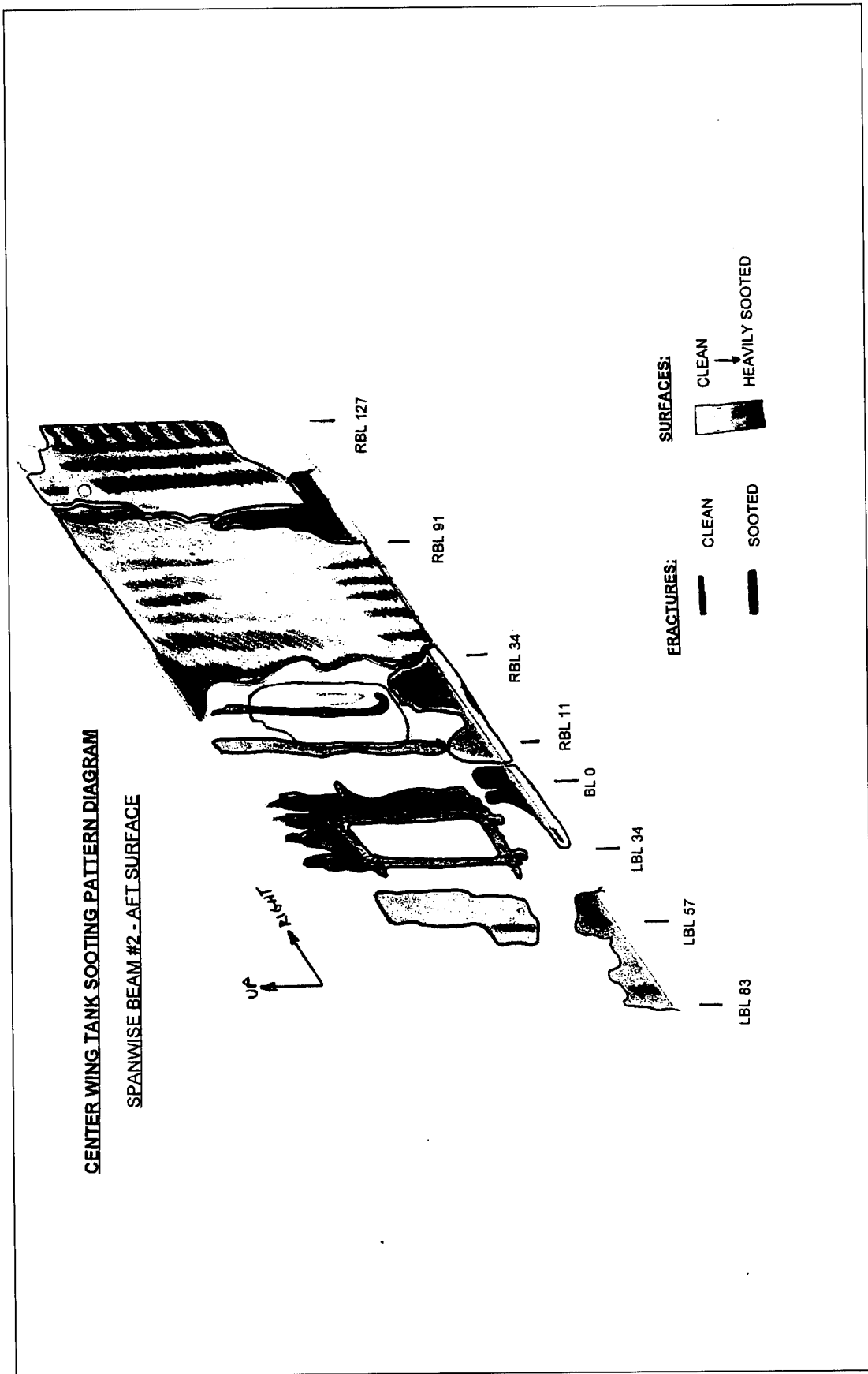

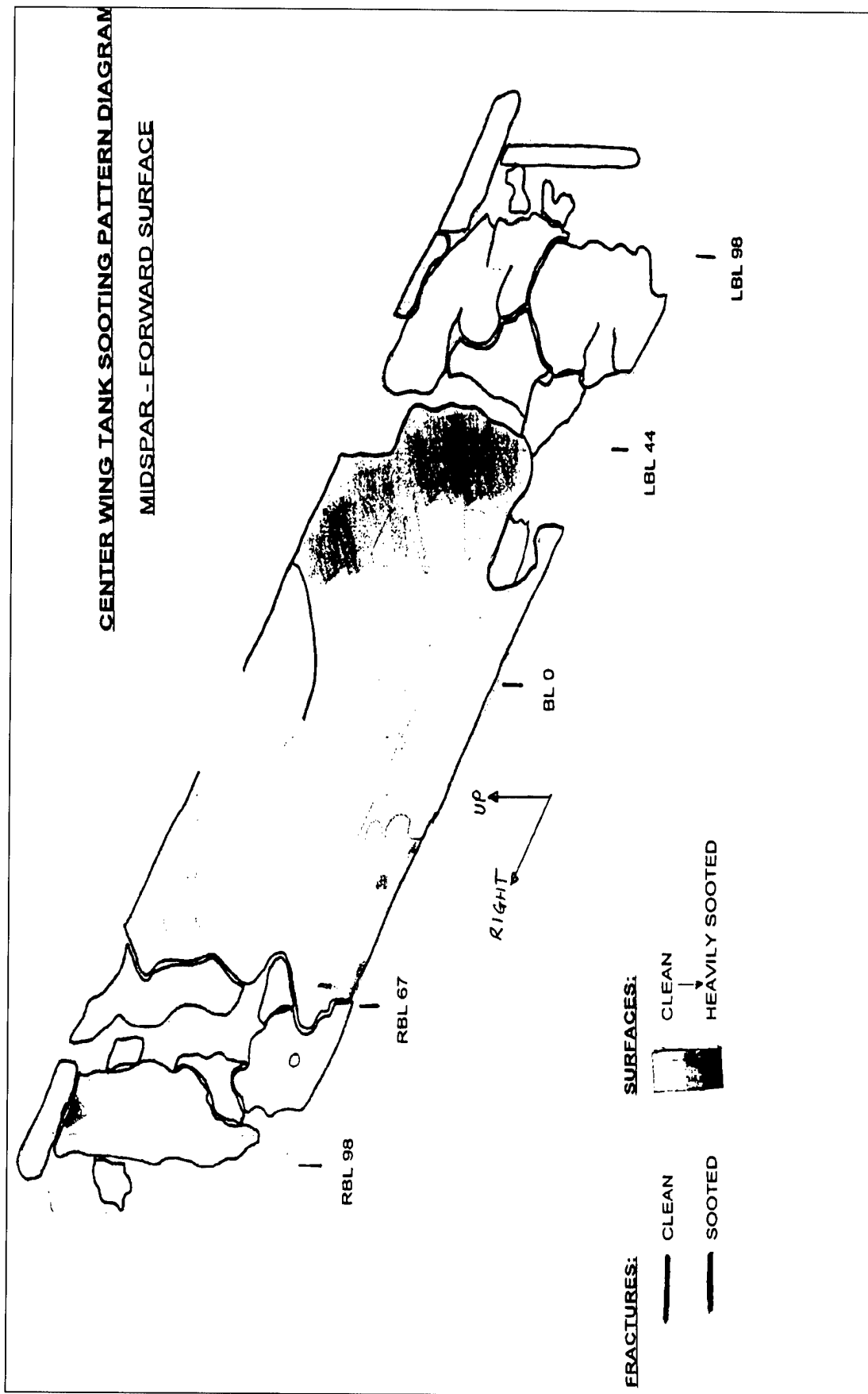

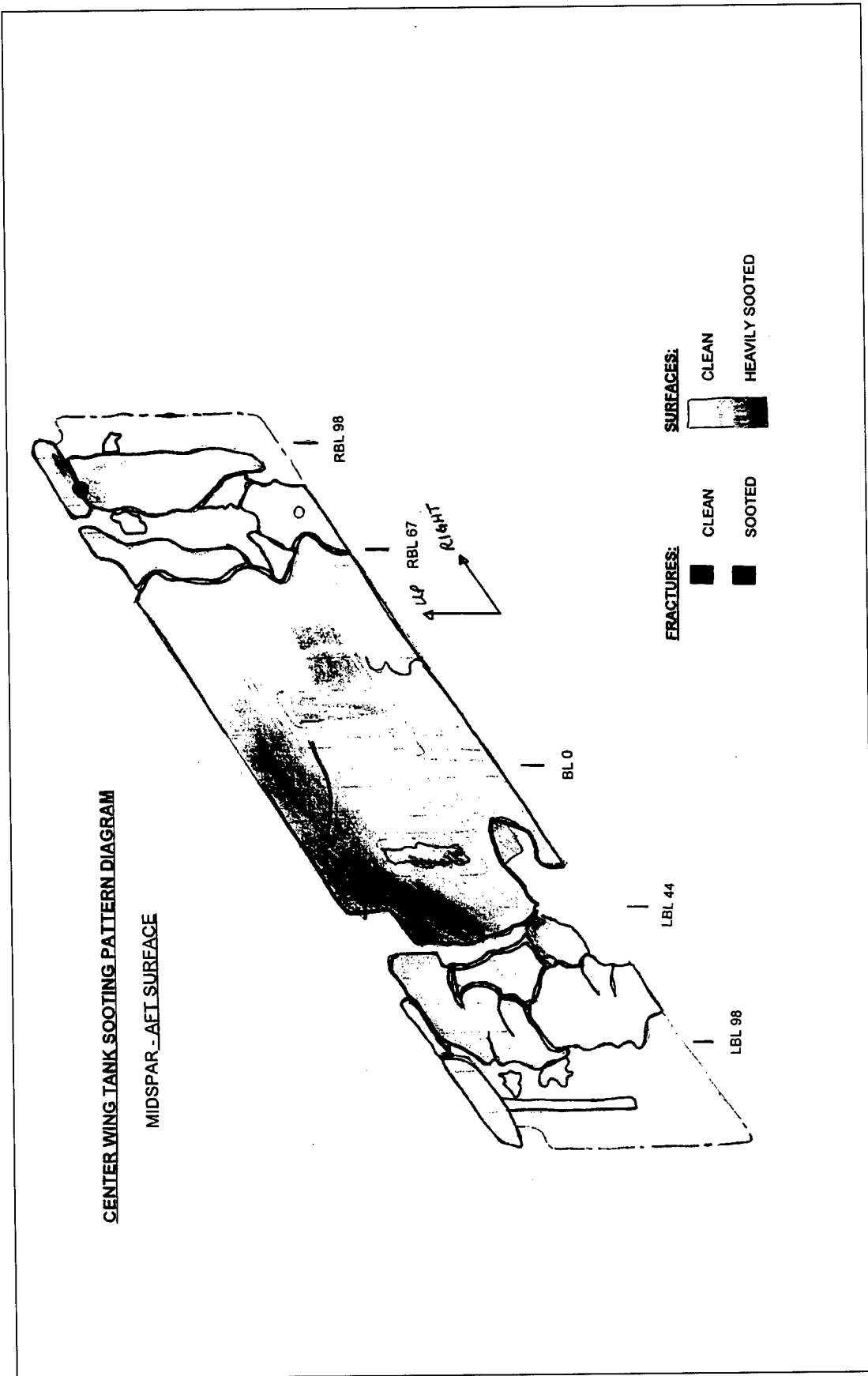

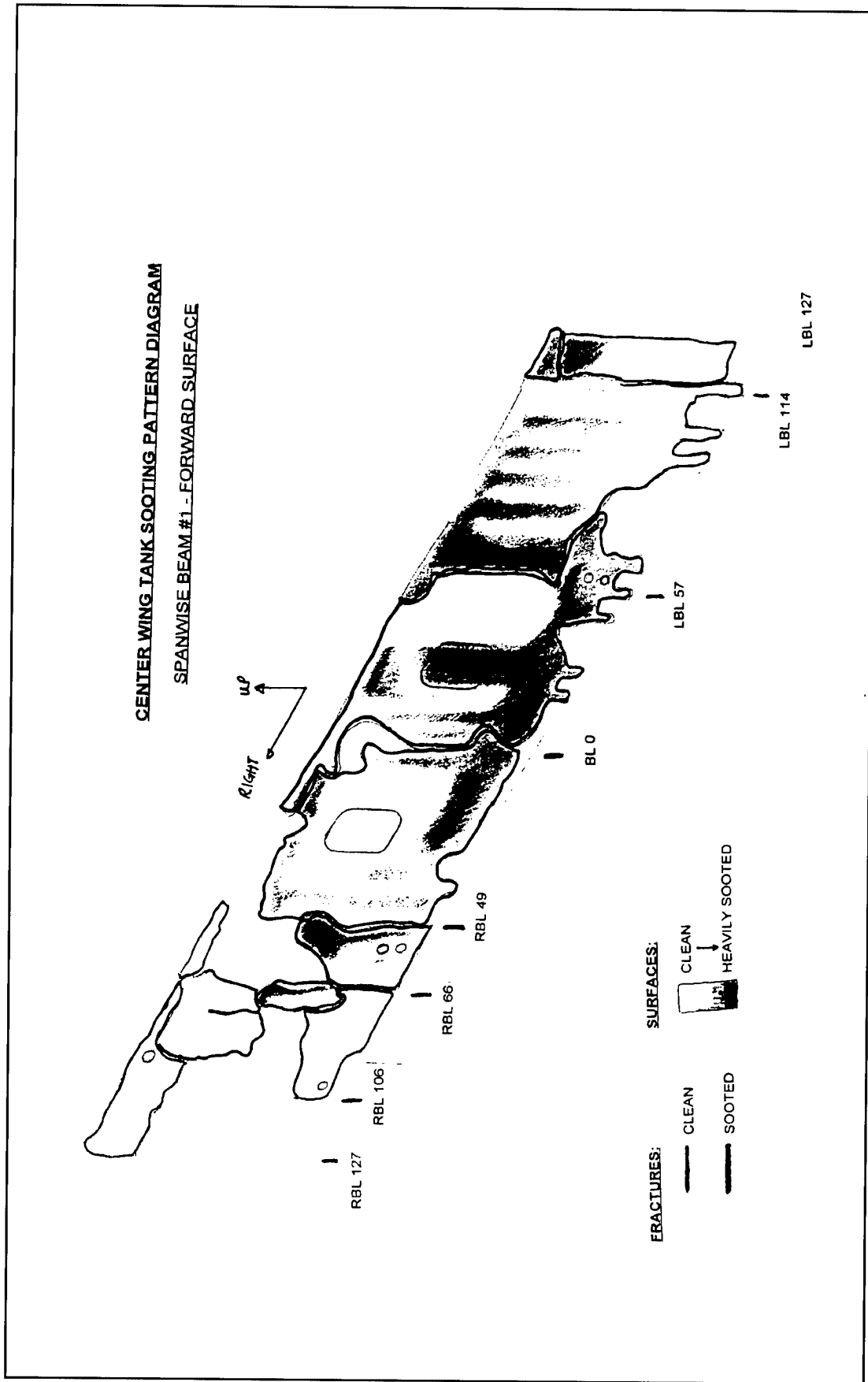

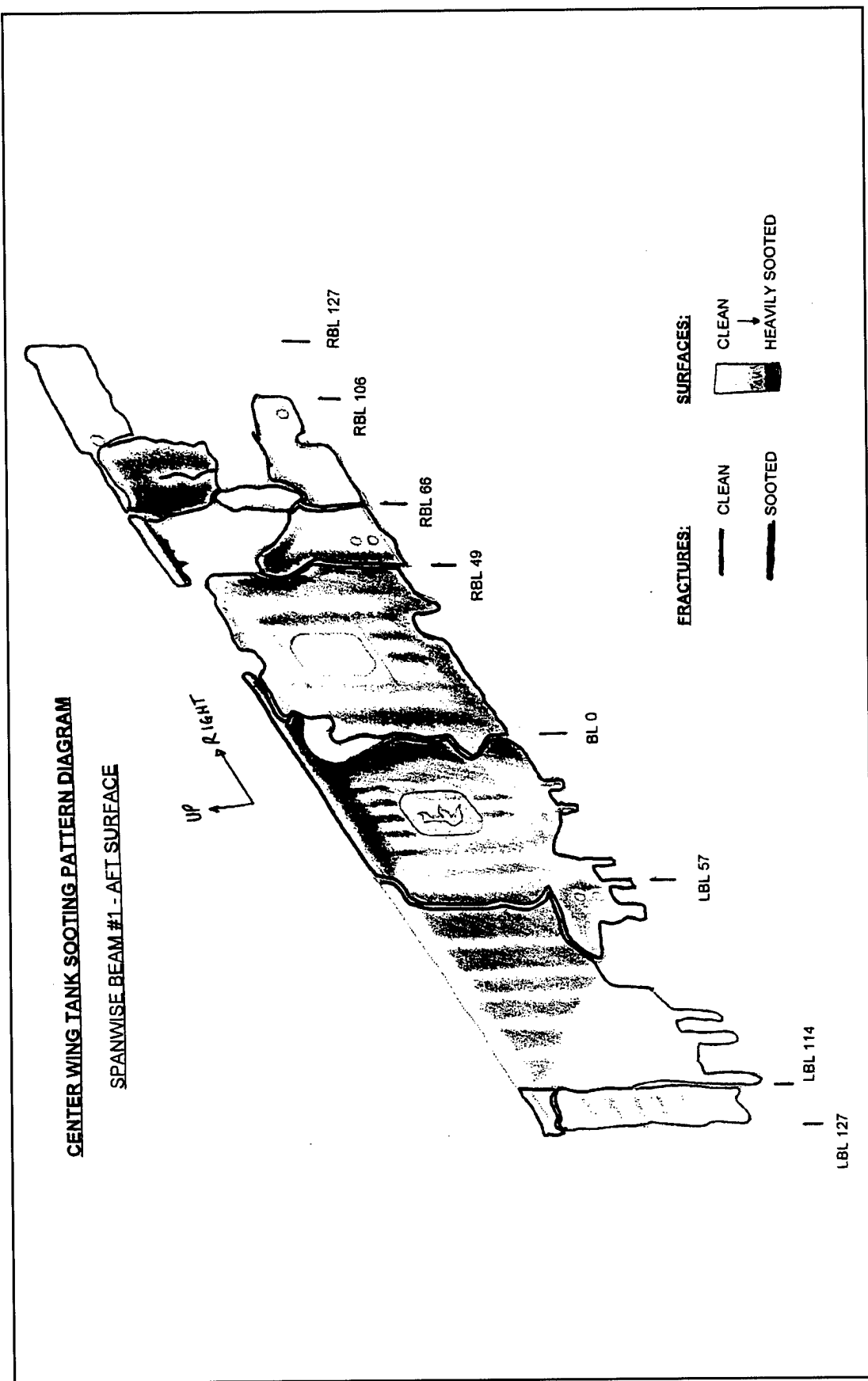



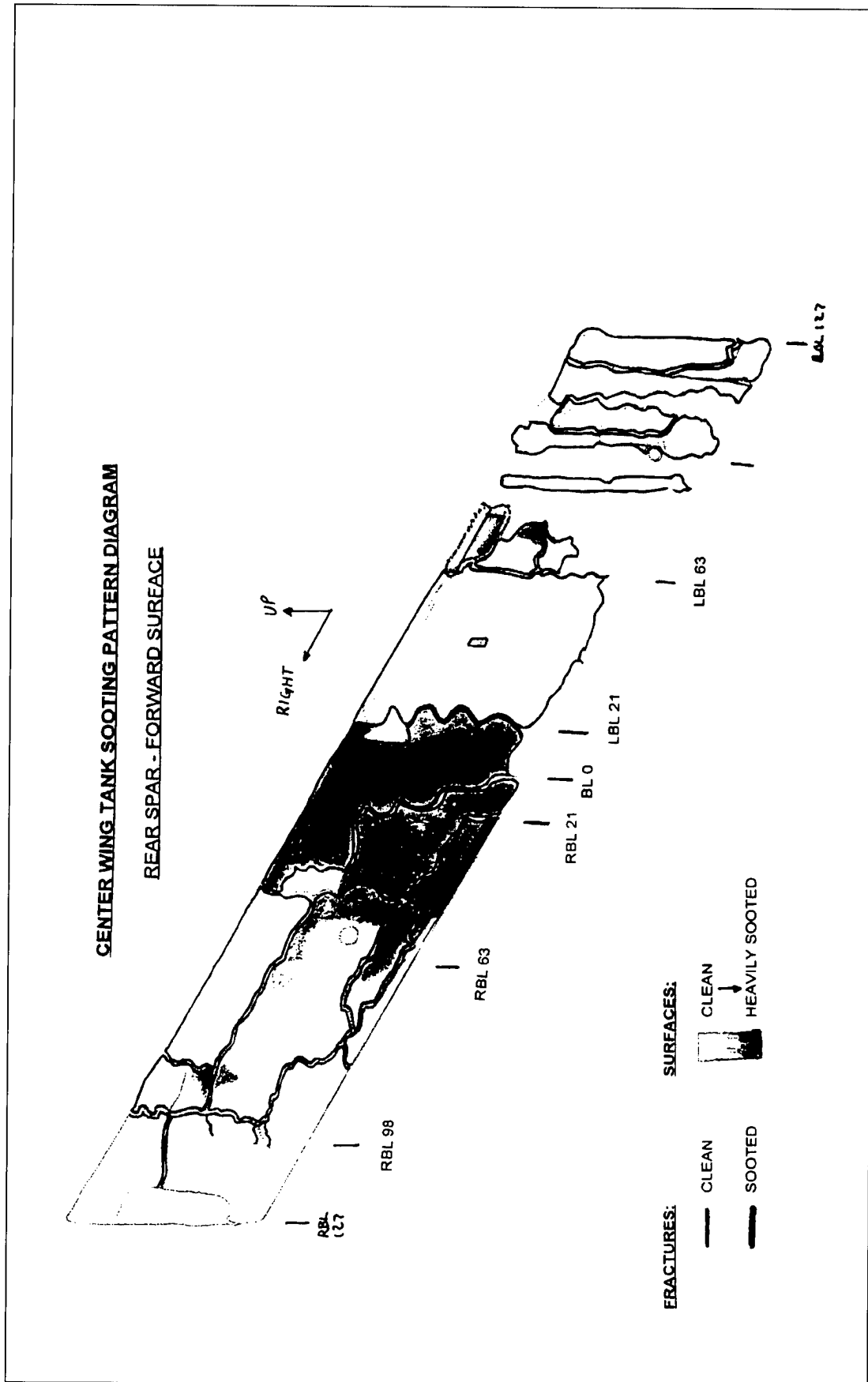

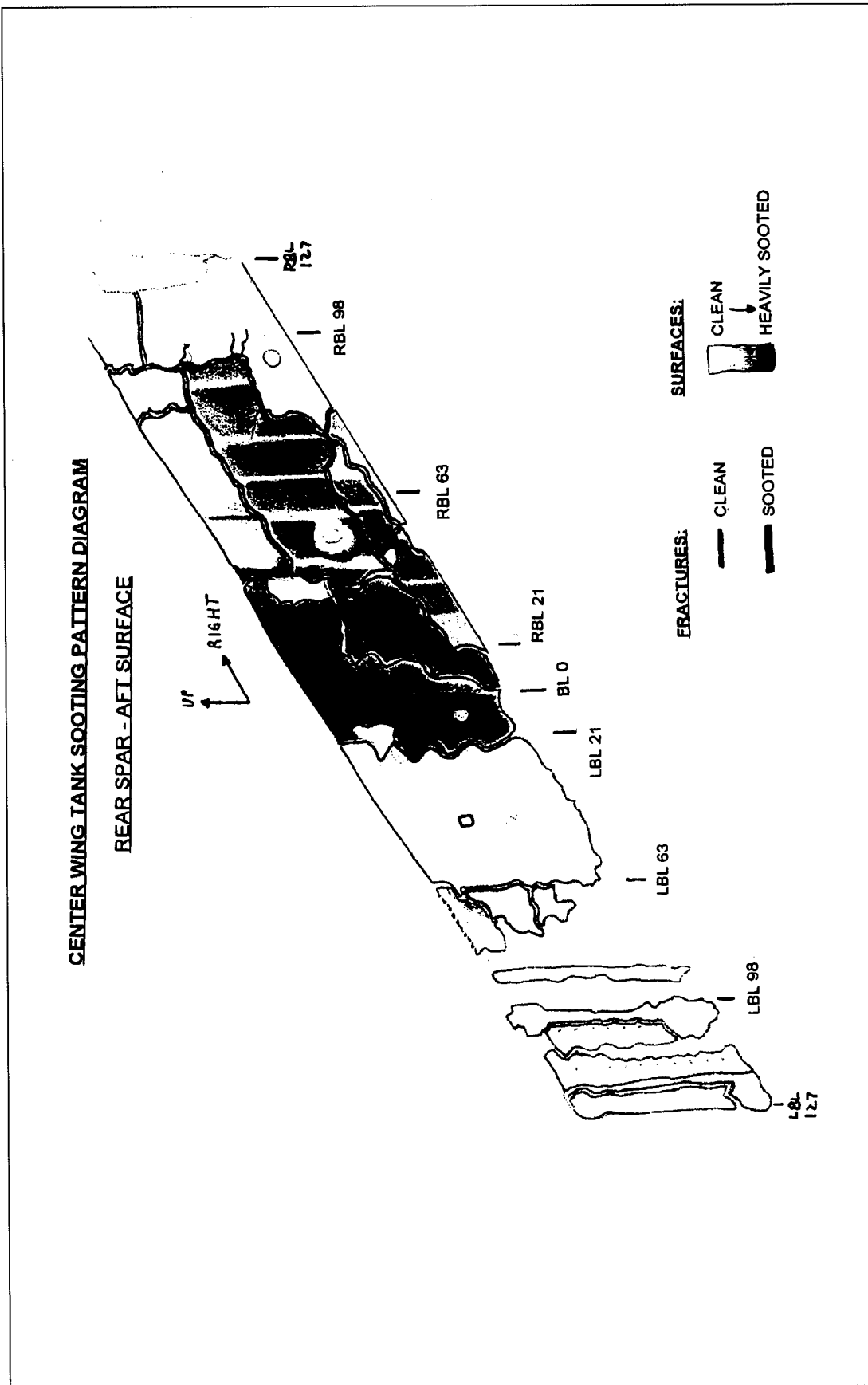

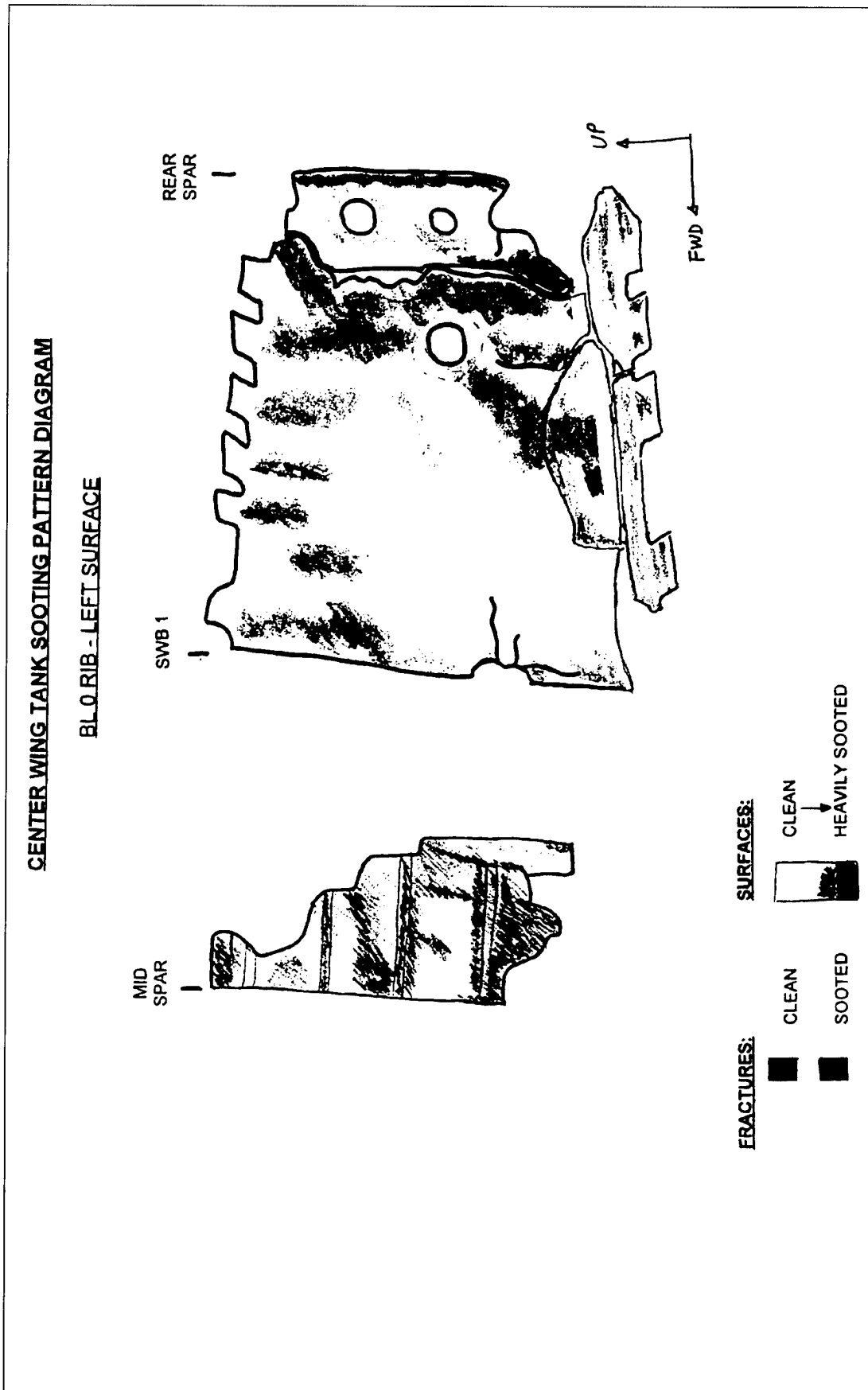

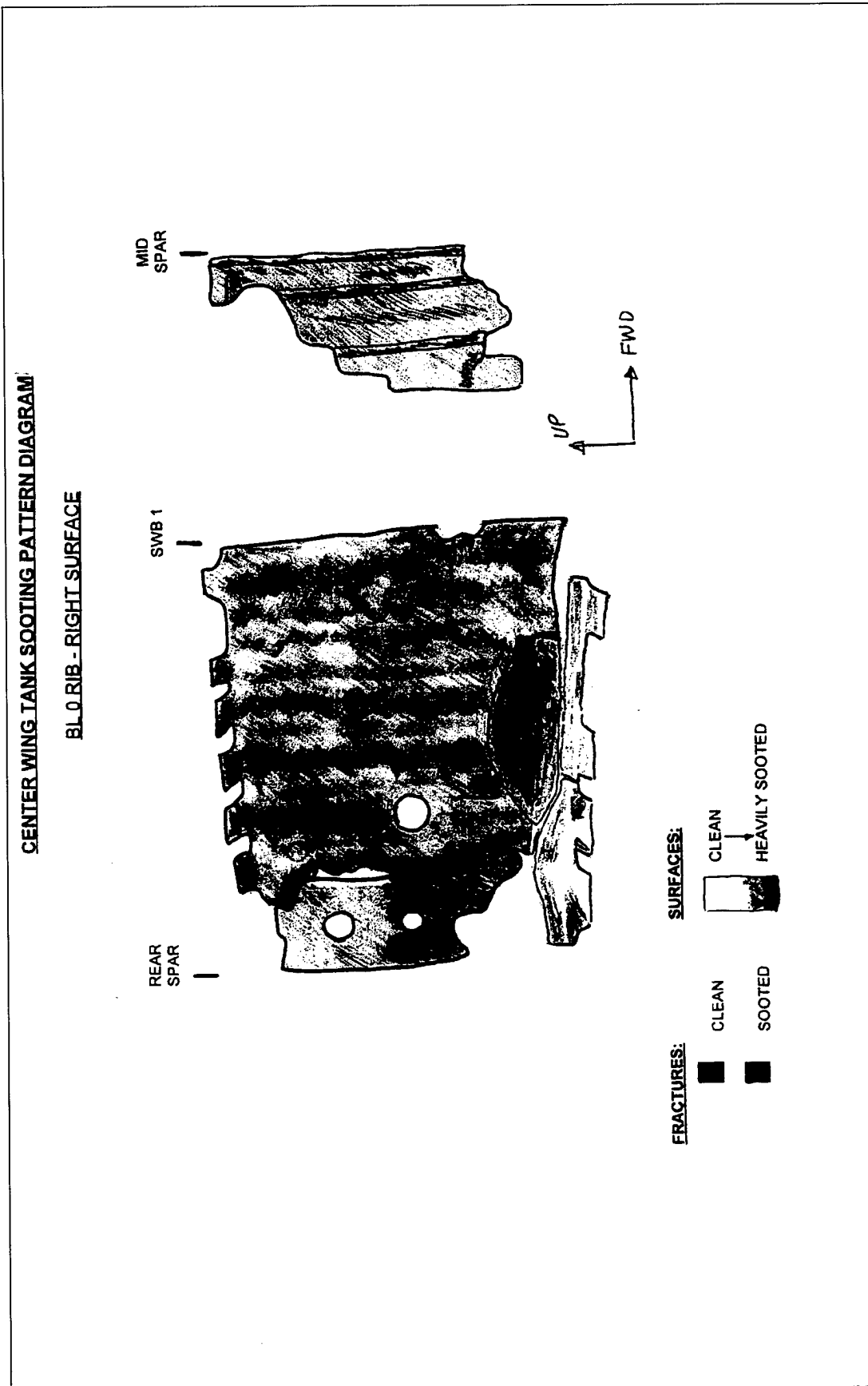

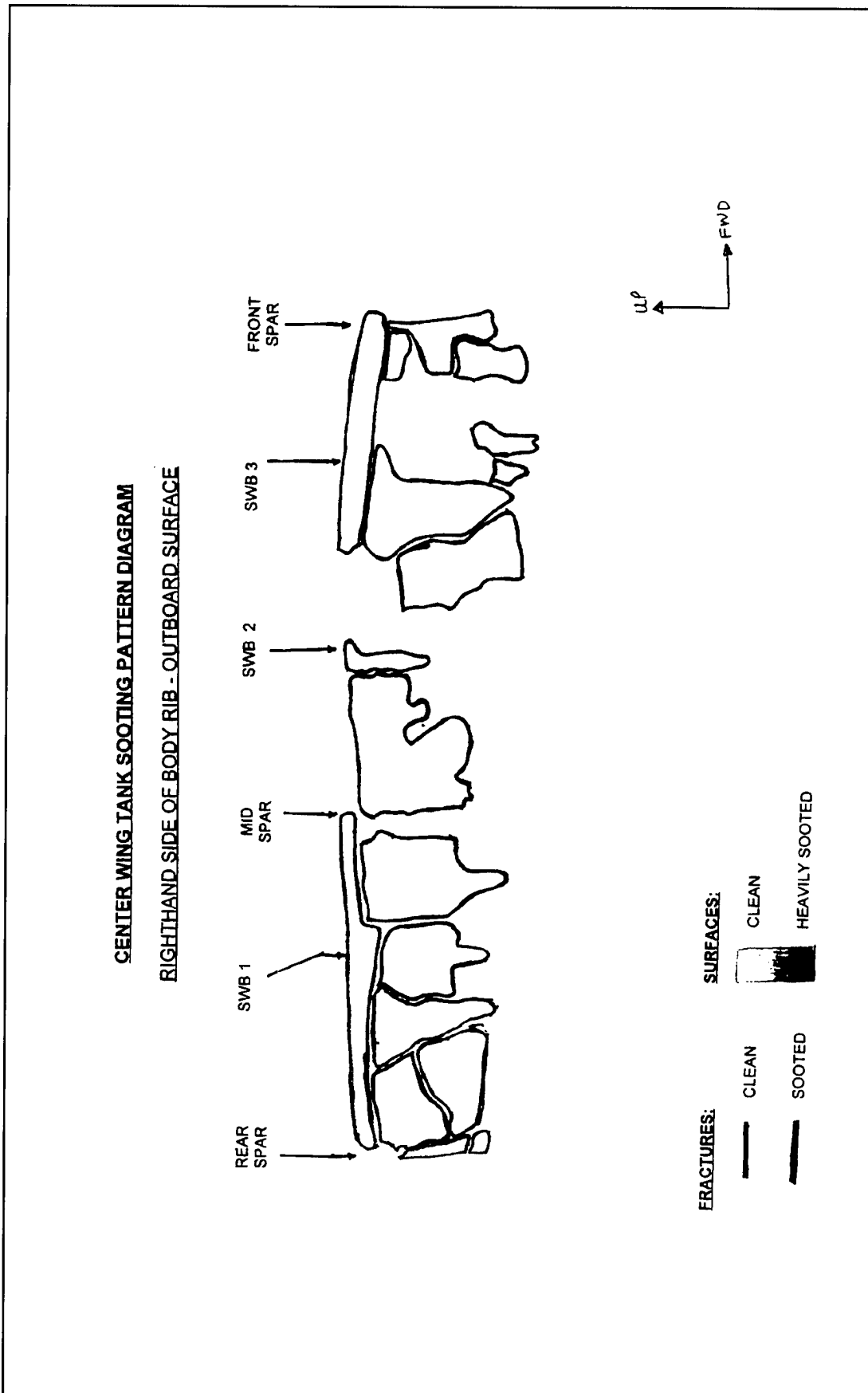

**CENTER WING TANK SOOTING PATTERN DIAGRAM**  
**RIGHTHAND SIDE OF BODY RIB - INBOARD SURFACE**

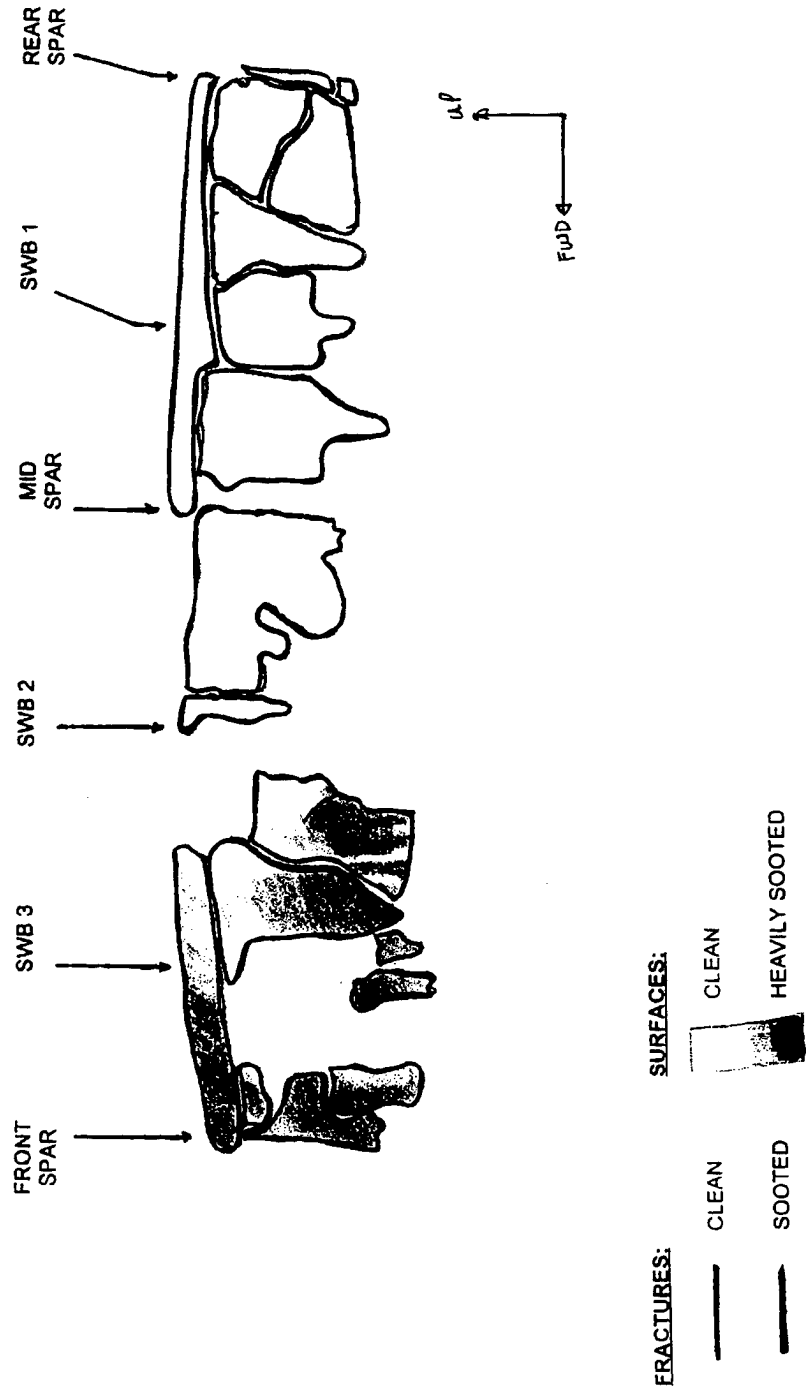

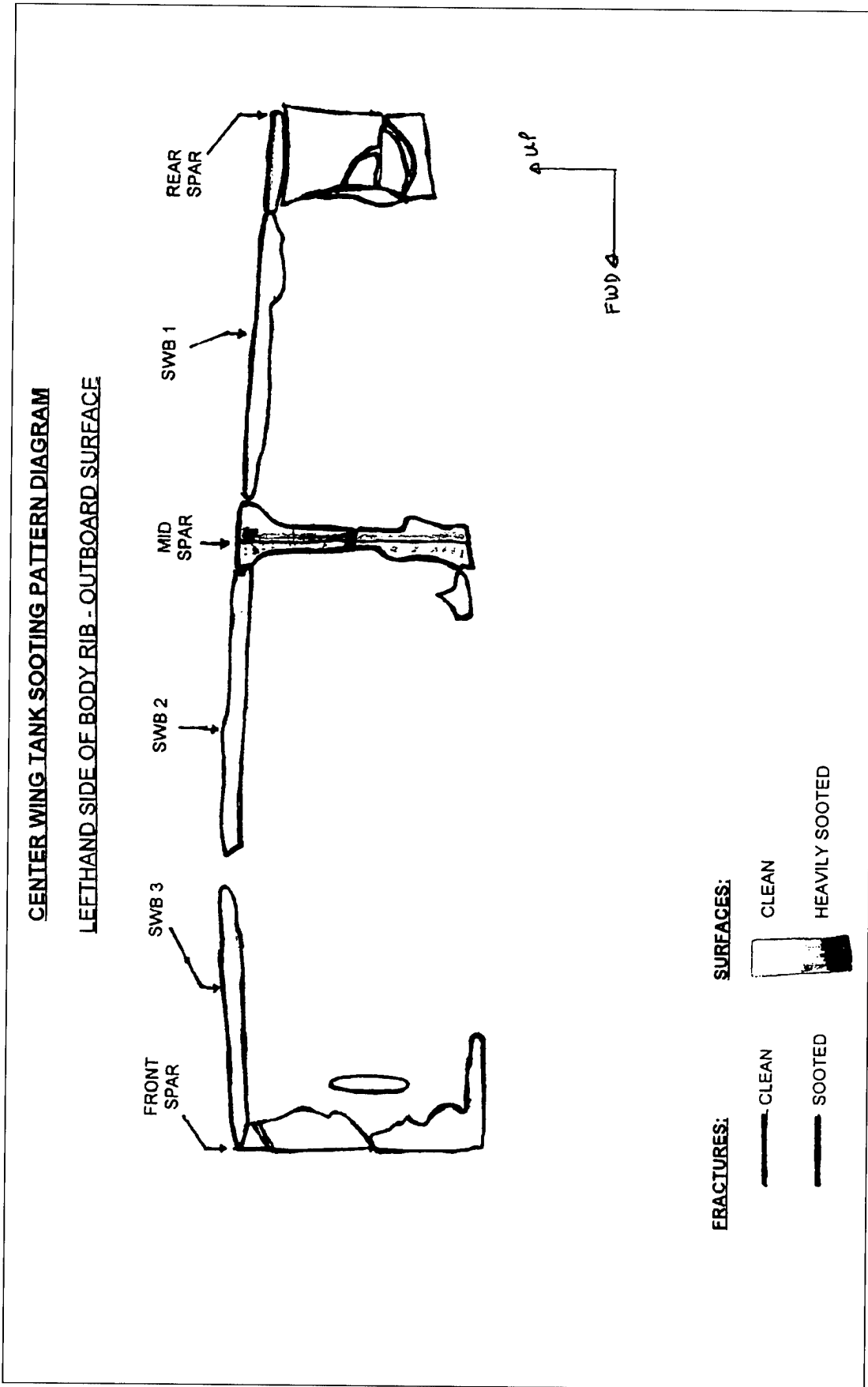

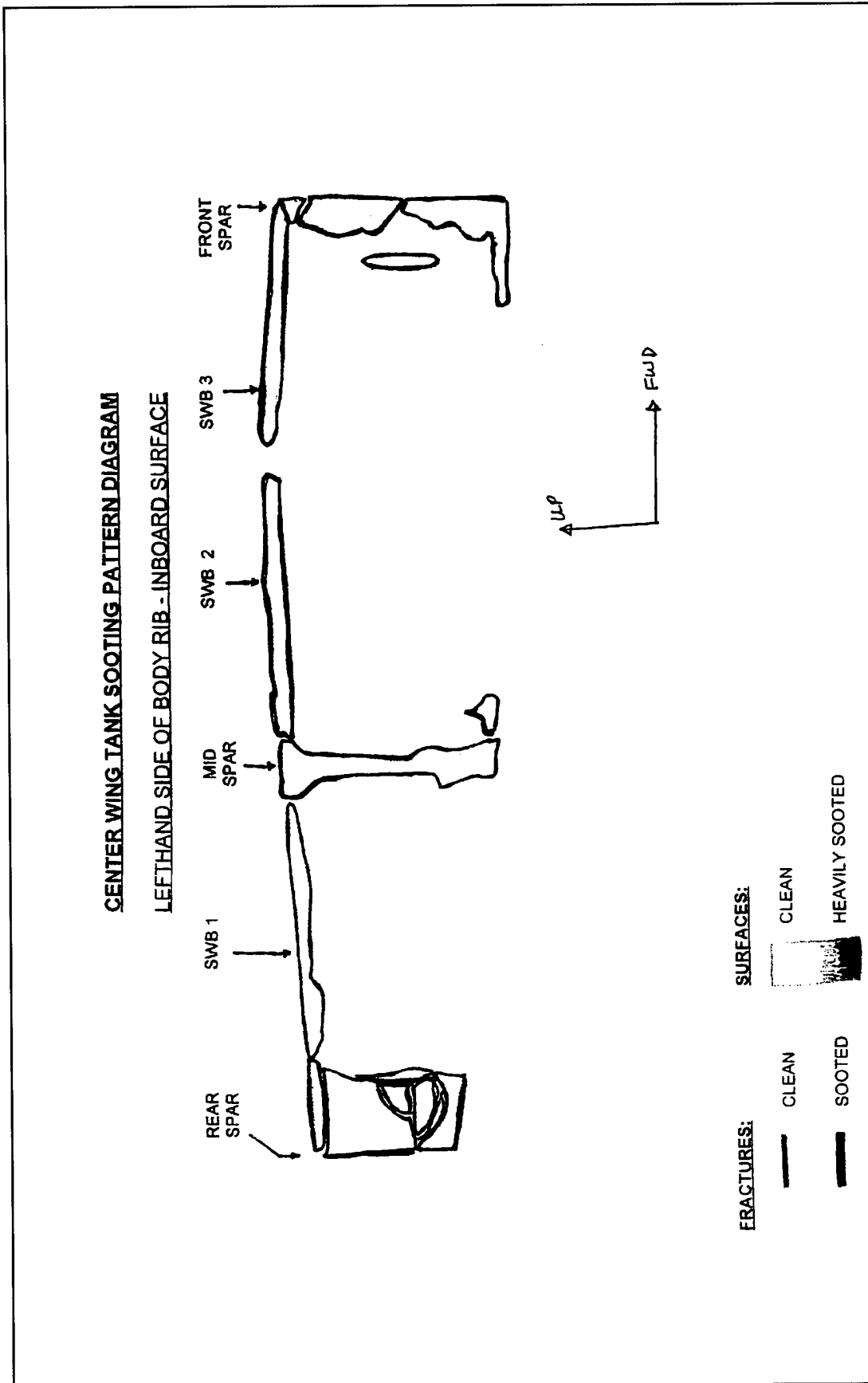



**RIGHT WING SOOTING PATTERN DIAGRAM**

UPPER SKIN - EXTERNAL SURFACE

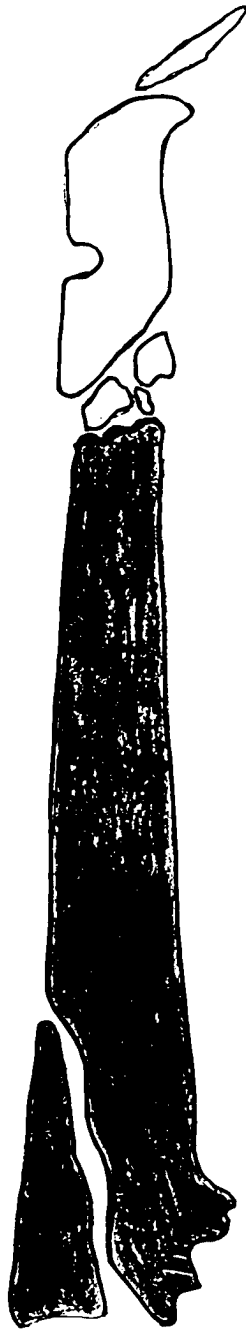

FRACTURES:

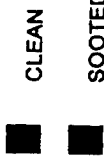

SURFACES:

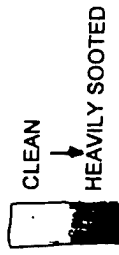

LOWER SKIN - EXTERNAL SURFACE

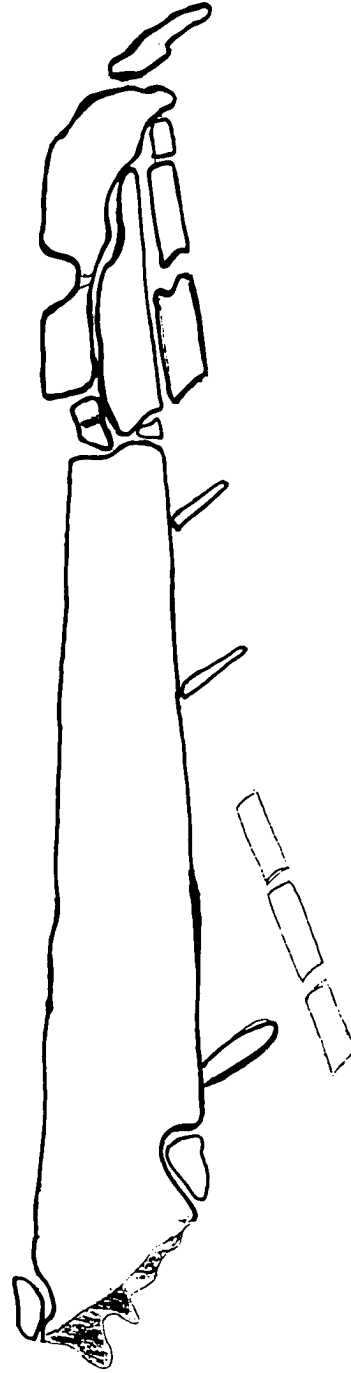

**RIGHT WING SOOTING PATTERN DIAGRAM**

**UPPER SKIN - INTERNAL SURFACE**

Note: See Vent Stringer  
soot diagram for details  
of vent stringer sooting.

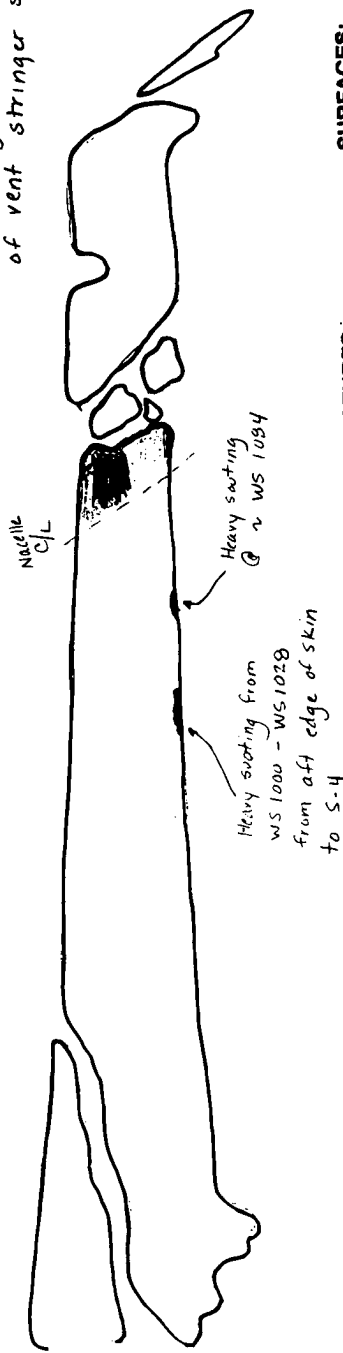

**FRACTURES:**

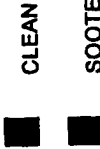

**SURFACES:**

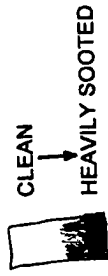

**LOWER SKIN - INTERNAL SURFACE**

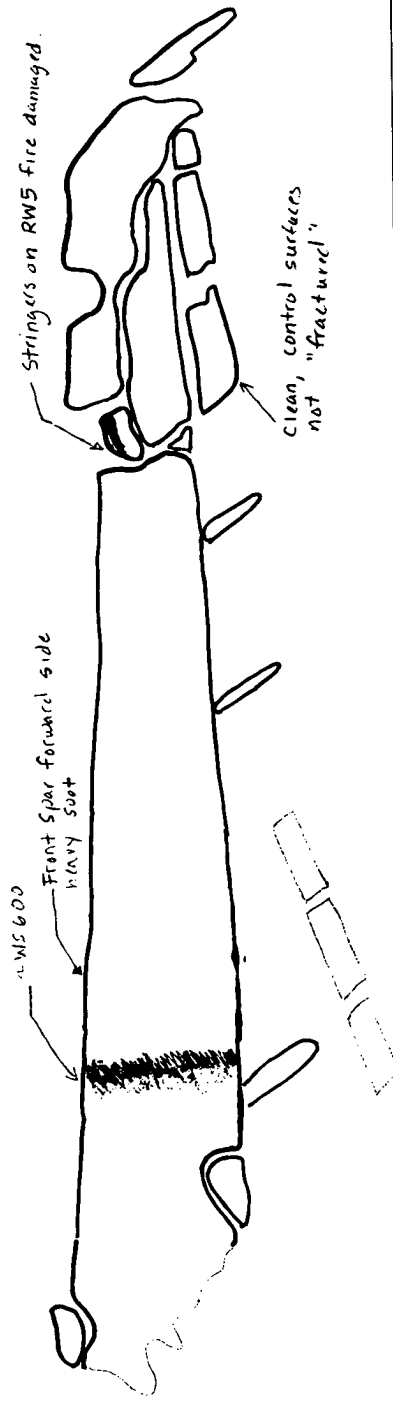

Clean, control surfaces  
not, "fractured"

**LEFT WING SOOTING PATTERN DIAGRAM**

**UPPER SKIN - EXTERNAL SURFACE**

NOTE: Many small pieces of the upper skin are not shown on the diagram.

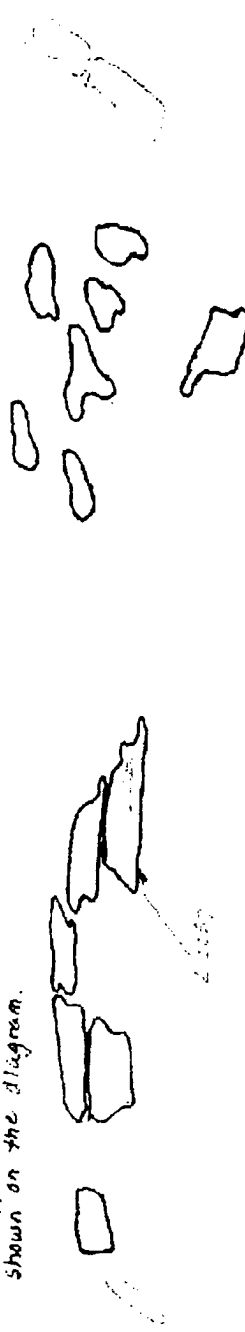

**LOWER SKIN - EXTERNAL SURFACE**

NOTE: With the exception of the piece noted, of the external surface of the upper skin is clean. The control surfaces do show sooting and fire damage to the composite parts.

**FRACURES:**

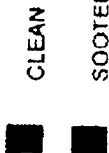

**SURFACES:**

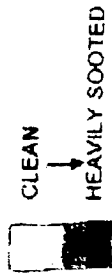

LEFT WING SOOTING PATTERN DIAGRAM

UPPER SKIN - INTERNAL SURFACE



NOTE: Many small pieces of the upper skin are not shown on the diagram.



NOTE: With the exception of the piece noted, the upper surface of the control surfaces is clean. Sooting and fire damage to the composite parts.

NOTE: SEE Vent stringer soot diagram for details of vent stringer sooting.

LOWER SKIN - INTERNAL SURFACE

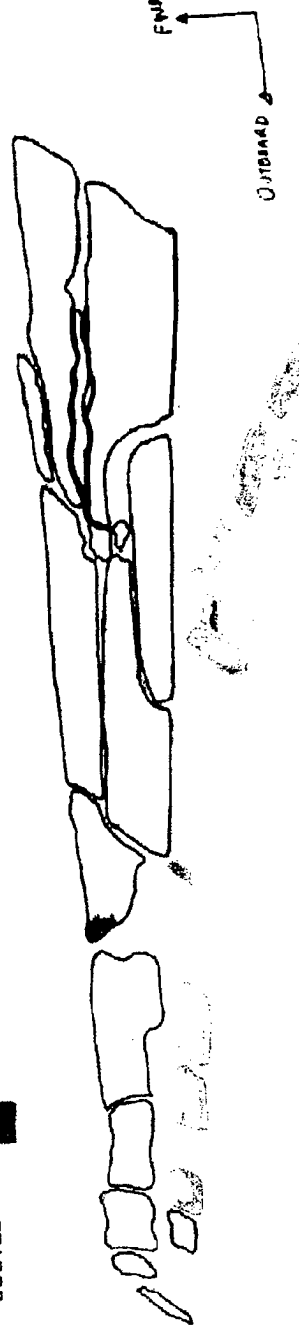

FRACTURES:

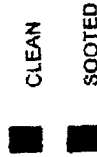



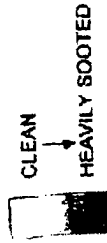

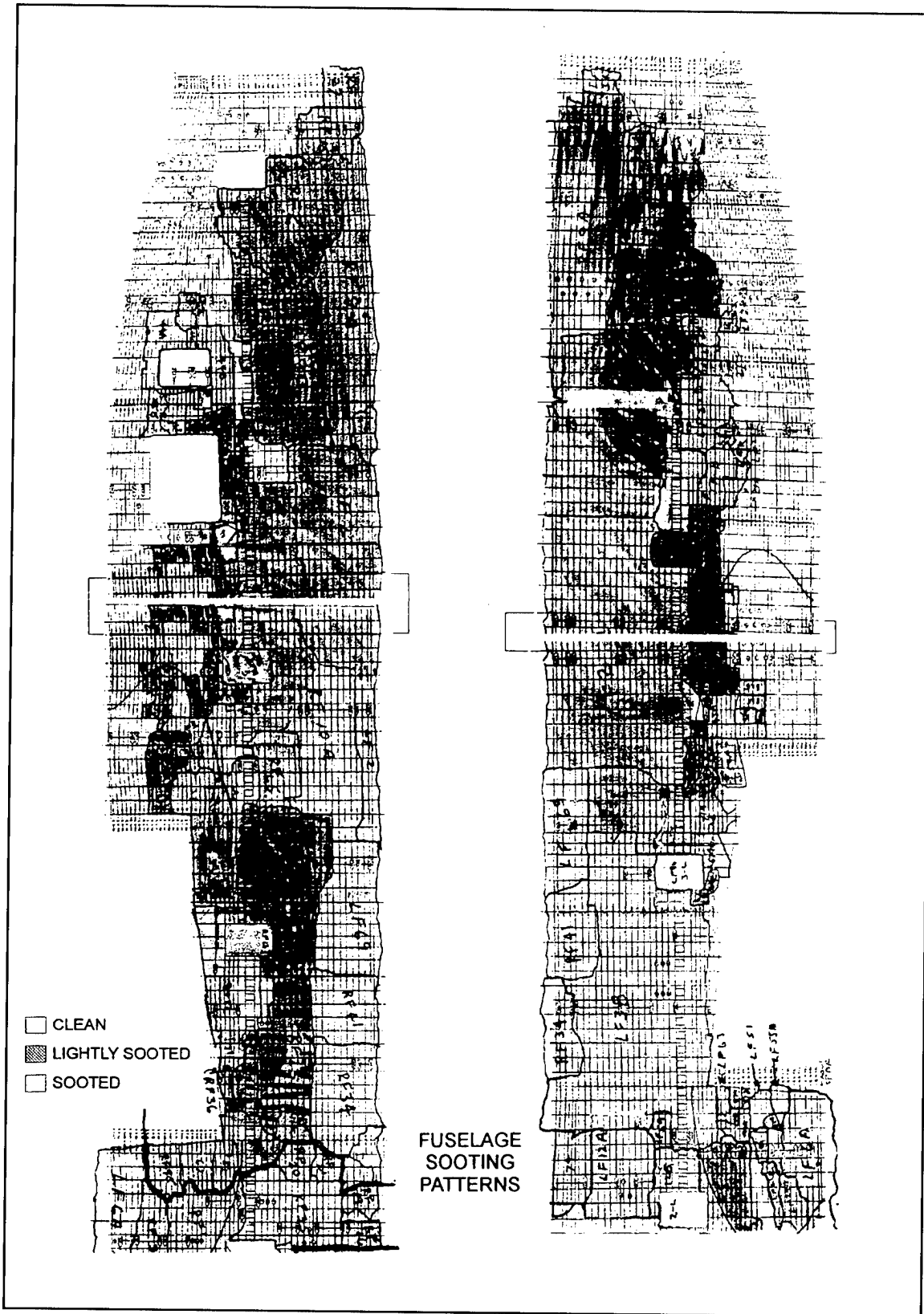
SURFACES:





Fuselage sooting diagrams

-  No sooting evident
-  Light sooting
-  Moderate sooting
-  Heavy sooting

Surveyed panels are all recovered from the Green debris field and are located from approximately STA 910 to STA 1600.

Aft of STA 1600, no sooting is evident internally. On the exterior, there is light to moderate sooting extending aft along the entire length of the fuselage from approximately the main deck window belt on the RHS to approximately S-8 on the LHS

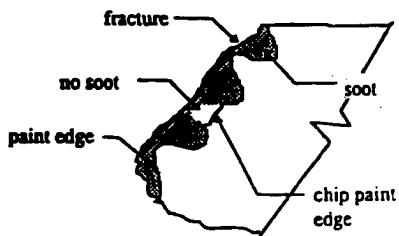
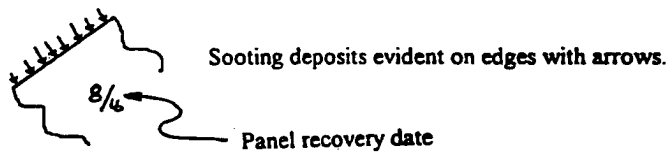

Determination primarily made by examining external paint failures near the fracture edge. Soot deposits remain on underlying paint when the top layer peels near fracture.



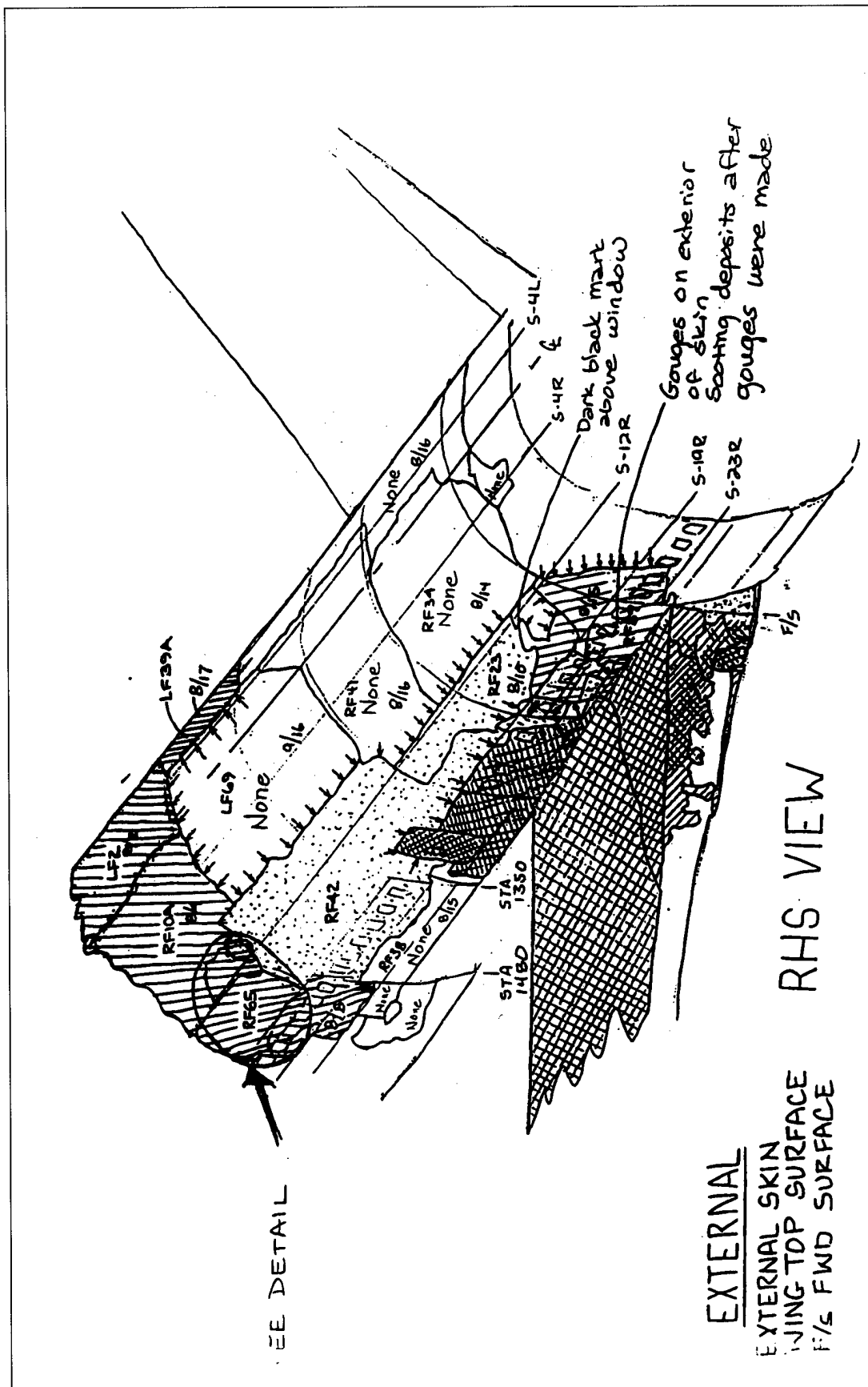



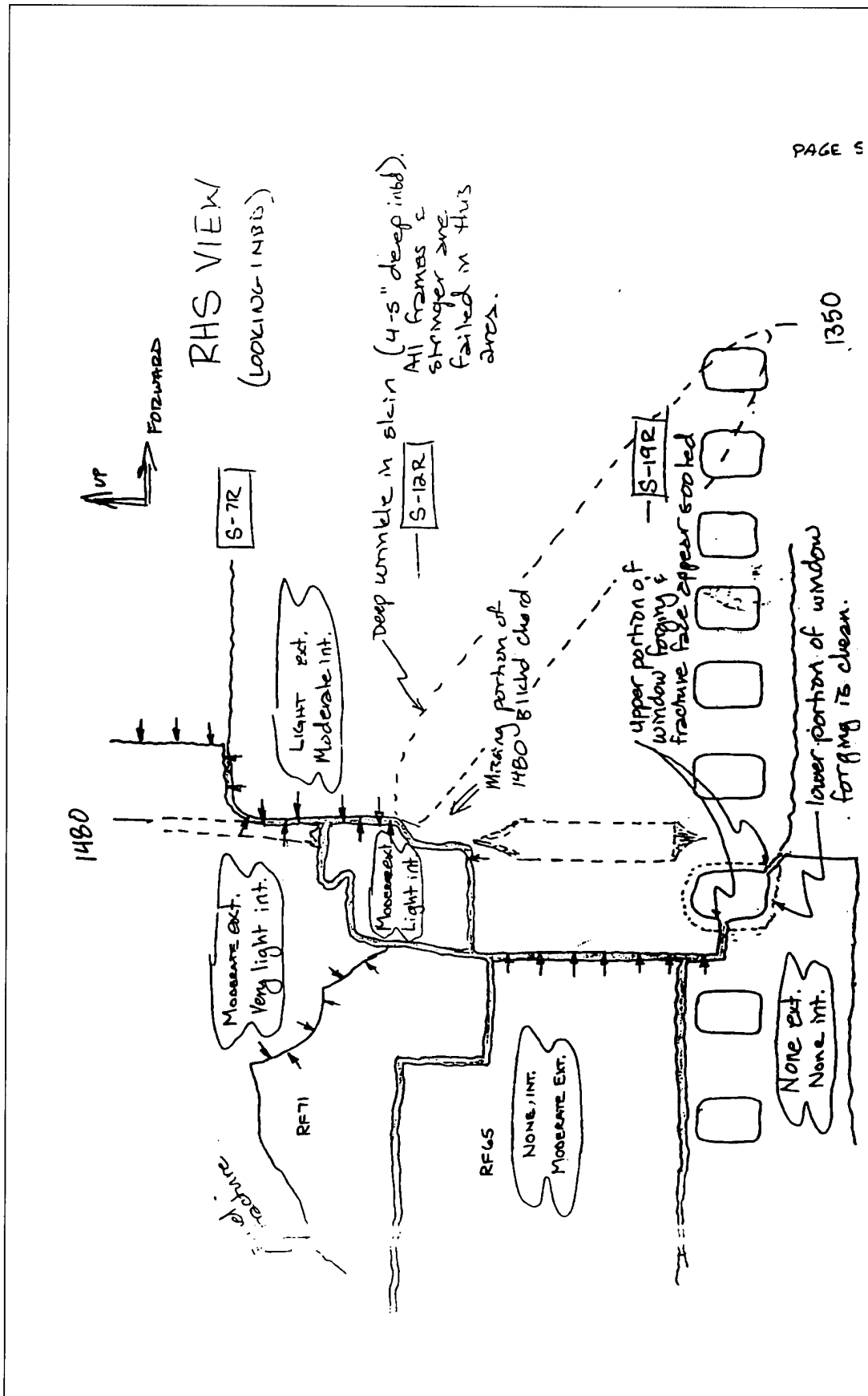

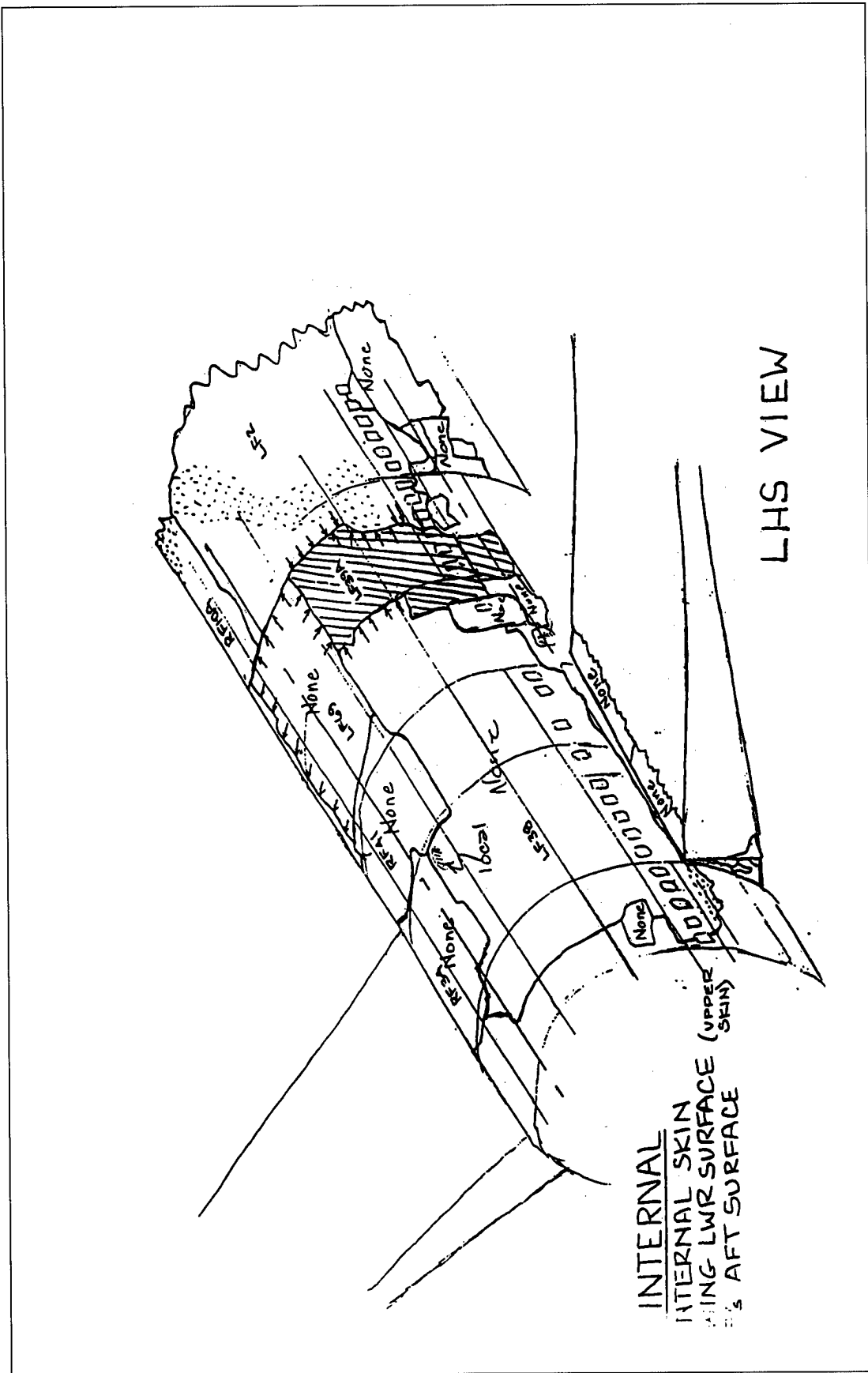

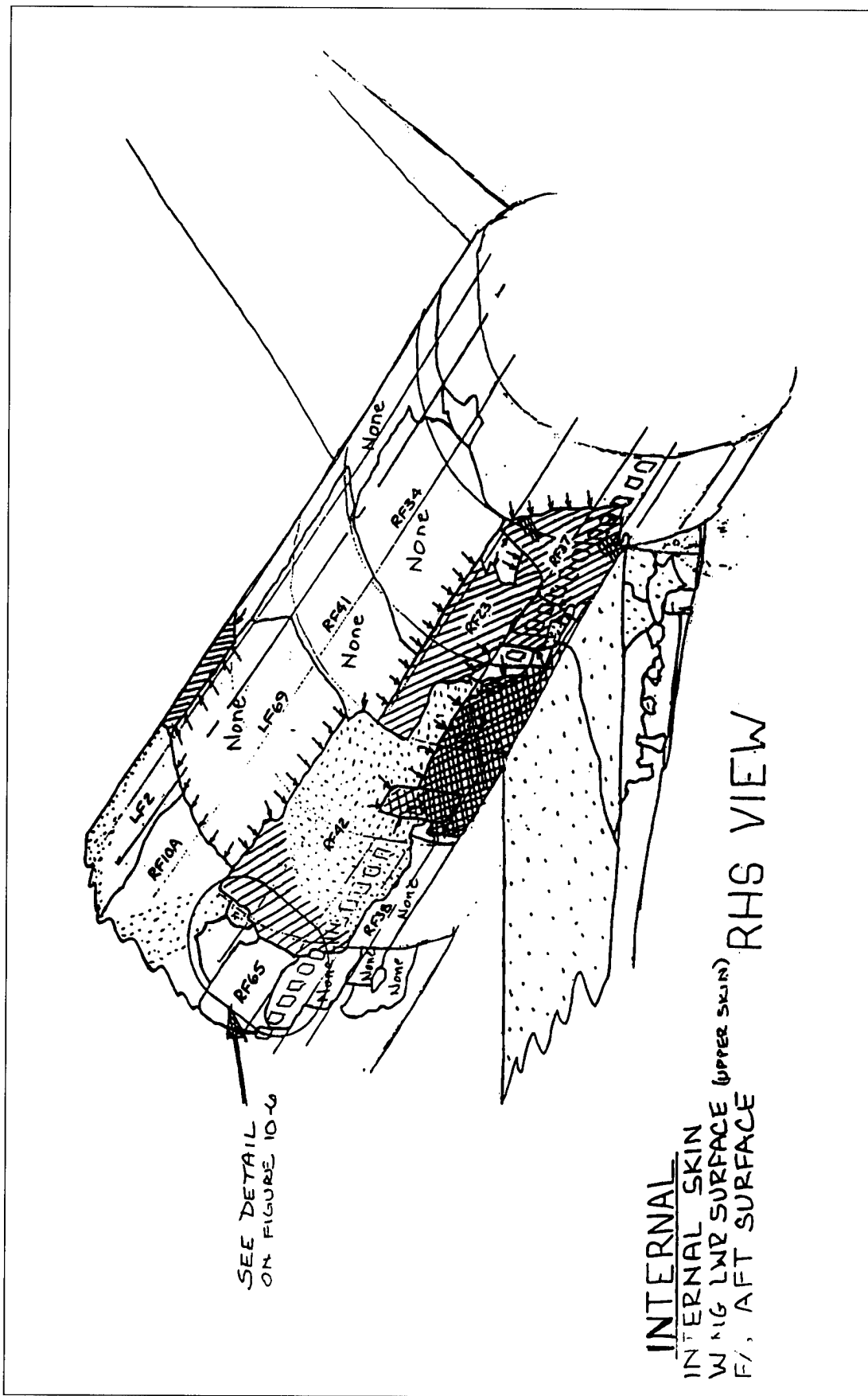



## **Appendix G**

### **Fuel Tank Explosions/Fires—Civilian and Military Aircraft**

FUEL TANK EXPLOSIONS/FIRES --  
CIVILIAN AIRCRAFT

Model	Operator/ Location	Year	Fatal	Hull loss	Fuel type	Benefit	Phase of operation	Description/Cause
B707	OSO	1959	4	Yes	UNK	Yes	Flight	Lightning, in flight explosion.
B707	Elkton	1963	81	Yes	JP-4	Yes	Flight	#4 Engine fire heated wing upper surface above 900°F-- Partially full fuel tank exploded resulting in loss of 21 ft of wing. Landed safely.
B707	San Francisco	1965	0	Yes	Jet A	Possible	Flight	
B727	Southern Air Tr.	1964	1	No	Jet A	No	Ground maintenance	While purging center tank for entry, static discharge from CO2 Firex Nozzle to center tank access door caused wing tank explosion.
B727	Minneapolis	1968	0	No	Jet A	Yes	Ground refueling	Electrostatic Charge--Ground refueling system found as source of charging-- minor damage to wing structure group. Equipment and airplane refueling system design standards have eliminated recurrence.
B727	Minneapolis	1971	0	No	Jet A	Yes	Ground refueling	See Above.
DC-8	Toronto Canada	1970	106	Yes	JP-4	Yes	Flight	Spoiler deployed. Possible fuel tank explosion during go-around following ground impact during attempted landing.
DC-8	Travis AFB	1974	1	Yes	JP-4	No	Ground	World Airways DC-8 inboard main tank, exploded and burned at Travis AFB during maintenance. Open fuel cell, mechanic forced circuit breaker in.
DC-9	Air Canada	1982	0	Yes	Jet A-1	Possible	Ground maintenance	During maintenance center wing fuel tank exploded. Dry running of pumps suspected cause.

Be 400	Jackson, MS	1989	0	No	JP-4/Jet A	Yes	Ground Refueling	
								During refueling of auxiliary tank ignition occurred. Tank remained intact but fuel leakage occurred. Electrostatic charge discharge from polyurethane foam source of ignition.
B727	Avionca	1989	107	Yes	Jet A	Possible	Climb	Bomb located over center wing fuel tank. Inerting benefit unknown.
B737	Philippine Airlines 1990	8		Yes	Jet A	Yes	Taxi	Not determined -- empty center wing fuel tank explosion.
B747	TWA 800	1996	230	Yes	Jet A	Yes	Climb	Unknown -- empty center wing fuel tank explosion.

**FUEL TANK EXPLOSIONS/FIRES --  
MILITARY AIRCRAFT (NON-COMBAT)**

Model	Operator/ location	Year	Fatal loss	Hull type	Fuel Benefit	Phase of operation	Cause
B-52	Loring AFB Maine	1970 July	0	JP-4	Yes	Maintenance	Most likely ignition source traced to arcing or overheating of fuel pump shaft or fuel quantity probe.
B707	Spain	1971 June	Yes	JP-4	Yes	Decent, 17K	In-flight explosion of #1 main tank. USAF determined chafing of boost pump wires located in conduits as possible ignition source
B-52H	Minot AFB, ND	1975 Nov	0	JP-4	Yes	Maintenance	Prior to body tank refueling, exploded after midnight while on ramp. No specific evidence but suspected fuel pump locknut rotor ignition source
B747	Iranian Fuel Tanker	1976	7	JP-4	Yes	Decent 8K	Lightning--wing tank.
KC-135Q	Plattsburg AFB, NY	1980 Feb	Yes	JP-4	Yes	Refueling	Aft body tank, faulty fuel probe found as problem.
B-52G	Robins AFB, GA	1980 Aug	Yes	JP-4	Yes	Maintenance	While transferring fuel from body tanks to wing tanks the empty mid body tank exploded. Investigation showed electrical arcing occurred in the mid body boost pump due to mis-positioned phase lead wire inside the pump.
KC-135A	Near Chicago	1982 March	Yes	JP-4	Yes	Descent, 12K	Forward body tank exploded, initial cause listed as VHF antenna.
B-52G	Grand Forks AFB ND	1983 Jan	Yes	JP-4	Yes	Maintenance	While troubleshooting a fuel transfer malfunction, center wing tank exploded due to an electrical fault associated with the EMI filter on a valve.
KC-135A	Altus AFB, OK	1987 Feb	Yes	JP-4	Yes	Landing roll out	During landing roll out an explosion and fire occurred following copilot transmission on UHF radio. The



B-52H	Swayer AFB, MI	1988 Dec	Yes	Yes	JP-4	Yes	Touch and go	UHF wire run near the right aft wing root in the fuselage was melted due to an electrical fault. Fuel vapors in the area of the aft body tank were ignited
KC-135A	Loring AFB Maine	1989 Sept	Yes	Yes	JP-4	Yes	Parked	At 20 feet AGL while landing, the empty aft body tank exploded. Pump operating in the aft body tank was cause. Evidence of arcing a overheat was found.
KC-135A	Loring AFB Maine	1989 Oct	Yes	Yes	JP-4	Yes	In flight	During system flight shut down, explosion in the aft fuselage tank occurred. Source of ignition was believed to be a hydraulically driven fuel pump mounted inside the aft body fuel tank.
KC-135R	Mitchell Field	1993 Dec	Yes	Yes	JP-4	Yes	Maintenance	Explosion in the pattern aft body fuel tank caused hull loss. Aft body hydraulically driven fuel pump implicated as source of ignition.

Mitchell Field, Milwaukee, WI

## Glossary of Terms

**Air conditioning pack:** An assembly of air conditioning system components that reduces the temperature and pressure of hot bleed air that is then routed to pressurized areas of the cockpit, cabin, and cargo compartments to provide environmental control (pressurization, ventilation, and temperature). The bleed air source can be any one or a combination of the following: engines, auxiliary power unit (APU), or ground air connections.

**Air cycle machine (ACM):** An assembly in the air conditioning system that includes components such as a fan and compressor. When partially cooled air from the heat exchangers requires additional cooling, the air is routed through the ACM expansion turbine for maximum cooling.

**Alternating current (a.c.):** An electric current that periodically changes in direction and constantly changes in magnitude.

**Ampere (amp):** The basic unit of measurement of electric current flow.

**Arcing:** Arcing is defined by Underwriters Laboratories, Inc., as a luminous discharge of electricity across an insulating medium. The electrical discharge of an arc can involve temperatures of several thousand degrees Celsius.

**Auto ignition:** Spontaneous ignition of a fuel/air vapor when it is sufficiently elevated in temperature for ignition to occur without direct contact with an ignition source, such as a spark, arc, or hot surface or filament. Auto ignition is highly dependent upon many factors, including the size of the heated volume and container and other environmental conditions that affect fuel vapor. Existing research indicates that the auto ignition temperature for Jet A fuel/air vapor at sea level is about 460° Fahrenheit (F). Auto ignition temperature increases as the altitude increases.

**Ballistic coefficient:** The weight of an object divided by the product of its drag coefficient multiplied by its area, used to determine the motion of an object in an atmospheric environment.

**Bleed air:** The hot pressurized air ducted from an airplane's engines, APU, or a ground source for use by other airplane systems (such as pressurization and air conditioning).

**Body station (STA):** A longitudinal point along an airplane's fuselage, identified numerically by its distance in inches from a reference point. In a classic 747, this point is 90 inches forward of the airplane's nose.

**Bomb:** (as used in this report) An explosive device designed to release destructive material at high velocity upon detonation, as distinguished from a small explosive charge.

**Bonding:** Connecting components to maintain them at a common electric potential.

**Boost pump:** (as used in this report) A pump mounted in the wing fuel tanks designed to move fuel from certain wing tanks to the engines.

**Capacitance:** The property of conductors separated by a dielectric material (for example, air or fuel) that permits the storage of electricity when potential differences exist between conductors.

**Center wing fuel tank (CWT):** A fuel tank that, in the 747-100 series, is located in the wing center section (WCS), between the rear spar and spanwise beam (SWB) 3 and that has a Jet A fuel capacity of 86,363 pounds (12,890 gallons). (See wing center section.)

**Conductivity:** A measure of the extent to which a material is capable of conducting an electric current. (See ohm.)

**Connector:** (as used in this report) A device that makes an in-line connection(s) between one or more wires for a continuous electrical path(s) at a location where the wires are subject to being disconnected and reconnected without mismatching circuits. Typical military-specification multicontact electrical connectors are assembled from two subassemblies, the plug and receptacle, which mate to connect wires with pin and socket contacts.

**Contact:** (as used in this report) A device within an electrical connector used to provide the electrical path joining two individual wires.

**Coupling:** Transferring energy between elements or circuits of an electrical system.

**Current:** The movement of electricity (the flow of electrons) through a conductor. Measured in amps.

**Dielectric:** A nonconductor of electricity.

**Direct current:** An electric current that flows continuously in one direction.

**Dry bay:** A compartment in the WCS that is not intended to contain fuel. In the 747-100, a dry bay is located between SWB3 and the forward spar.

**Electromagnetic environment (EME):** The total of all electromagnetic fields and the associated frequencies, power levels, and polarizations in a given or defined region. The EME consists of natural and manufactured sources of electromagnetic energy.

**Electromagnetic interference:** (as used in this report) Electromagnetic energy from a source either internal or external to an aircraft that imposes greater-than-intended voltage on an electrical system.

**Energy:** The capacity for doing work. It may exist in potential, kinetic, thermal, electrical, chemical, nuclear, or other forms and be transformed from one form to another. Electromagnetic energy is expressed in units of work, such as joules (J) or kilowatt-hours.

**Explosion:** (as used in this report) The sudden and rapid escape of gases from a confined space, accompanied by high temperatures, violent shock, and loud noise.

**Extremely improbable failure condition:** As defined in Federal Aviation Administration Advisory Circular (AC) 25.1309-1A, a condition so unlikely that it is not anticipated to occur during the entire operational life of all airplanes of one type and that has a probability of occurrence on the order of  $1 \times 10^{-9}$  or less each flight hour, based on a flight of mean duration for the airplane type.

**Failure modes and effects analysis:** A structured and systematic analytical method for identifying potential failure modes of a component or system and for evaluating the potential risk(s) that might be posed by various failure modes.

**Fault tree analysis:** An analysis designed to examine an end event through consideration of assumed precipitating events. Each of these precipitating events is in turn broken down until a level is attained in which no additional precipitating events will occur. The total of all of the events and the way in which they are tied together creates the fault tree analysis.

**Fireball:** (as defined by the TWA flight 800 investigation's Witness Group) One or more downward-moving ball(s) of fire in the sky. According to the Witness Group's definition, it could be characterized (by witnesses) as either stationary or descending; however, to meet the group's definition of a fireball, it must not have been reported to have appeared in the sky after the termination of a streak of light (if such a streak were reported). It could not have been an ascending object or an object that met the group's definition of a streak of light.

**Flash point:** The minimum temperature at sea level at which a liquid fuel vaporizes sufficiently to form an ignitable mixture with air (when exposed to an open flame), as determined by a standardized test procedure.

**Flashing:** (as used in this report) A category of electrical activity observed during short-circuit tests conducted by Lectromechanical Design Company (Lectromec) as a part of the TWA flight 800 accident investigation, characterized by an arcing discharge seen as a single flash of light with an accompanying popping sound.

**Fuel mass loading:** A measure of the amount of fuel relative to the entire volume of its container.

**Fuel quantity indication system (FQIS):** In the 747-100, a system that measures changes in the capacitance of tubular probes located in each fuel tank for the display of fuel quantity on cockpit gauges and on repeater gauges located at the fueling station in the left wing. The system is also connected to systems that require fuel quantity information,

including the gross weight/total fuel weight indicator, airborne integrated data acquisition, and the volumetric shutoff ([VSO] ground refueling) systems.

**Fuel quantity compensator:** A component used in the FQIS or VSO system to compensate for variations in the dielectric constant of fuel, which varies from one type of fuel to another (and even within the same type of fuel, depending on the "batch" and age of the fuel) to ensure consistent fuel quantity indications. There is at least one compensator in each fuel tank.

**Fuel quantity probe:** A component of the FQIS, a set of which is positioned in each of an airplane's fuel tanks, used to measure the quantity of fuel in each tank through a range of levels within the tank. The 747-100 may have 65 or more fuel quantity probes positioned within the 7 fuel tanks.

**Fuel washing:** Motion of fuel over a part, which can lead to electrostatic charge accumulation or removal of contaminants (such as sulfides).

**Green zone:** One of three debris fields, labeled during the TWA flight 800 accident investigation, from which the accident airplane's wreckage was recovered. This zone was located farthest east (farthest from John F. Kennedy International Airport [JFK]) in the wreckage distribution. This zone contained pieces of wreckage from both wings and most of the aft portions of the fuselage, including the following: both wings; all four engines; pieces of SWB1, SWB2, mid spar, and rear spar; the aft portion of the keel beam; the main landing gear; and the tail section.

**Grounding:** Connecting electrical circuits to a large common conductor considered to be at zero electrical potential such as the earth or, in the case of an airplane, the skin of the airplane, which is at a fixed electrical potential.

**Heat exchangers:** (as used in this report) Devices in the 747-100 used to initially cool the heated bleed air coming from the engines located within the air conditioning pack bay under the CWT.

**High-intensity radiated fields:** High-power electromagnetic fields that exist in a defined environment, particularly in the vicinity of high-power radar sites, broadcast antennas, and other high-power radio frequency sources.

**Hot surface ignition:** A phenomenon in which a very high temperature surface comes into contact with fuel or fuel vapor that results in ignition. Hot surface ignition is highly dependent upon many factors, including the geometric aspects of the hot surface and other environmental conditions that affect fuel and fuel vapor. Existing research indicates that hot surface ignition temperatures at sea level for fuels similar to Jet A range from 900° to 1,300° F. The hot surface ignition temperature increases as the altitude increases.

**Ignition energy:** The quantity of heat or electrical energy that must be absorbed by a fuel/air vapor mixture in a finite volume to generate a propagating flame. Commonly measured as the energy provided by a small (millimeter size) spark.

**Impeller:** A blade on a rotating part in an air compressor or fuel pump.

**Improbable failure condition:** As defined in AC 25.1309-1A, a condition not anticipated to occur during the entire operational life of a single random airplane; however, it may occur occasionally during the entire operational life of all airplanes of one type. It has the probability of occurrence on the order of  $1 \times 10^{-5}$  or less, but greater than on the order of  $1 \times 10^{-9}$  each flight hour, based on a flight of mean duration for the airplane type.

**Jet A fuel:** A kerosene fuel used in civilian turbine engine airplanes. Jet A fuel is composed of a mixture of more than 100 distinct types of hydrocarbon molecules; the precise composition often varies between refinery and by season. Jet A fuel is specified to have a minimum flash point of 100° F. Jet A-1 is a similar fuel, but has a slightly lower freezing point. Although Jet A fuel is available in some other countries, it is used primarily in the United States.

**Jettison/override pump:** In the 747, a fuel pump that has two uses, one of which is to jettison fuel overboard when this function is selected at the flight engineering station. The pump is also designed to provide fuel to the engine manifolds at a higher pressure than the boost pumps, which are located in the wing fuel tanks. Two CWT jettison/override pumps are mounted on the rear spar of the CWT, and pressure from these pumps closes the main tank check valves, resulting in the use of fuel from the CWT before that of fuel from the wing tanks.

**Joule (J):** A unit of measurement of electrical work or energy; 1 J is the amount of work done by 1 watt of power in 1 second.

**Keel beam:** A box-shaped, load-bearing structure located along the airplane's centerline that extends from the aft wall of the forward cargo compartment below the WCS and through the main and body landing gear compartments to the forward wall of the aft cargo compartment. The CWT is located above the keel beam.

**Kilojoule (kJ):** A unit of measurement equaling 1,000 J.

**Lower flammability limit:** The lowest temperature that will provide a sufficient concentration of fuel vapor to propagate a flame.

**Millijoule (mJ):** A unit of measurement equaling one-thousandth of a J.

**Minimum ignition energy (MIE):** The minimum quantity of heat or electrical energy that must be absorbed by an optimal fuel/air vapor mixture in a finite volume to generate a propagating flame. The MIE for Jet A fuel is generally accepted to be about 0.25 mJ.

**Ohm:** The unit of resistance of an electrical conductor, at which the fall of potential is 1 volt when the current is 1 amp. (See resistance.)

**Overpressure event:** (as used in this report) An event in which the pressure in the CWT is increased in a relatively short time to a level at which the structural integrity of the CWT is compromised.

**Power:** The time rate of energy transfer; the practical unit of measurement is 1 watt. (See watt.)

**Primary radar target:** A radar target produced when a radar signal reflects off of an object's surface and returns to a ground-based radar antenna/site for processing and display.

**Quenching:** The extinguishment of a combustion flamefront; often as a result of decreased temperature or propagation through a passageway, such as an orifice or a vent.

**Raceway:** A term used to refer to areas within the 747 where wire bundles are grouped into a common route.

**Red zone:** One of three debris fields, labeled during the TWA flight 800 accident investigation, from which the accident airplane's wreckage was recovered. This zone was located farthest west (closest to JFK) in the wreckage distribution. A relatively small amount of widely dispersed debris was recovered from the red zone, including the following: pieces from the WCS front spar and SWB3, the manufacturing access door from SWB2, pieces of the fuselage from STA 840 and STA 1000, main cabin floor beams and flooring material from above and in front of the WCS area, and the two forward air conditioning packs. (See figure 3a.)

**Resistance:** The property of a conductor that tends to restrict the flow of an electric current. (See ohm.)

**Ring chord:** An angle member that attaches the bottom of the forward fuselage section to the front side of the lower pressure bulkhead and the front spar.

**Scavenge pump:** (as used in this report) A small fuel pump designed to remove the last amounts of accessible fuel from the lowest point of a 747 CWT and discharge the fuel into the left inboard fuel tank. Although the scavenge pump removes fuel not accessible by the jettison/override pumps, a small amount of residual fuel will remain in the fuel tank that the scavenge pump is not able to remove.

**Scintillation:** (as used in this report) A category of electrical activity observed during short-circuit tests conducted by Lectromec as a part of the TWA flight 800 accident investigation, characterized by a high frequency micro-discharge that usually results in the formation of char or soot on a wire (and adjacent wires) over time.

**Secondary radar target:** A radar target produced when a radar signal is detected by an airplane's transponder, which transmits a coded message in response to interrogation by a ground-based transmitter.

**Shielding:** (as used in this report) Metal covers placed around electric wires and electronic devices to prevent the intrusion of external electrostatic and electromagnetic fields.

**Short circuit:** An unintended current path between conductors. Short circuits can occur either directly, if the protective insulation covering between internal conductors in each wire is compromised and there is direct contact between the conductors, or through a "bridge" created by contaminants, such as metal shavings or fluid.

**Sleeve (wire):** A woven or flexible jacket that protects electrical wiring.

**Small explosive charge:** A minimal amount of a highly explosive material (such as a plastic explosive) detonated by a fusing device.

**Spanwise beam 1:** One of the lateral beams in the CWT that divides it into compartments and supports the structure of the WCS. SWB1 is located between the mid and rear spars.

**Spanwise beam 2:** One of the lateral beams in the CWT that divides it into compartments and supports the structure of the WCS. SWB2 is located between the mid spar and SWB3.

**Spanwise beam 3:** One of the lateral beams in the CWT that divides it into compartments and supports the structure of the WCS. SWB3 is located between SWB2 and the front spar.

**Spar:** A beam that extends laterally through the WCS into the outboard wing structure. The 747-100 has front, mid, and rear spars.

**Splice (wire):** (as used in this report) A fixed connection of two electrical wires. Splices can be made by various methods, such as soldering wires together or with crimped metal barrels, and are typically covered by insulating material.

**Streak of light:** (as defined by the TWA flight 800 investigation's Witness Group) An object moving in the sky that could be variously described in witness documents as a point of light, fireworks, a flare, a shooting star, or something similar, which was usually described as ascending, but could also be described as arcing over and/or descending.

**Streak-of-light witness:** (as defined by the TWA flight 800 investigation's Witness Group) Any witness who reported seeing an airplane in the general vicinity of a streak of light at the same time that the streak of light was visible (around the time and vicinity of the TWA flight 800 accident). (See witness.)



**Stringer:** A stiffening member found in the 747-100's fuselage and wings that helps to support and reinforce the structure.

**Strong arcing:** (as used in this report) A category of electrical activity observed during short-circuit tests conducted by Lectromec as a part of the TWA flight 800 accident investigation, characterized by an arcing discharge that could continue for hundreds of cycles, typically involving 5 kJ of electrical energy.

**Surge tank protection system:** A system to detect and extinguish fire that consists of a series of optical photocells that trigger the discharge of Halon (a fire extinguishing agent) into the surge tank when a flame or bright light source is sensed in the surge tank. Discharge of the extinguishing agent is designed to occur about 1 millisecond after the photocell senses a flame.

**Transient suppression device:** An electrical device that limits the amount of energy or current that can pass through it to a predetermined amount.

**Transient voltage:** A temporary voltage surge or excursion; for example, that which occurs when first turning an electrical system on.

**Transponder:** The airborne receiver/transmitter portion of a radar system that responds to interrogation signals received from ground-based equipment.

**Ullage:** The space in a fuel containing tank not occupied by liquid fuel.

**Upper flammability limit:** The maximum temperature at which a concentration of fuel vapor will propagate a flame.

**Volt:** The basic unit of measurement of electromotive force (the force that causes electrons to flow through a conductor). One volt is the electromotive force required to cause current to flow at the rate of 1 amp through a resistance of 1 ohm. One volt equals 1 amp times 1 ohm.

**Watt:** The basic unit of measurement of power. In electrical application, 1 watt equals 1 volt times 1 amp. (See power.)

**Weathering:** The change in a liquid fuel chemical composition as a result of exposure to environmental conditions. An example involves heating and pressure changes to a vented aircraft fuel tank, where preferential evaporation of the lower molecular weight components of the jet fuel occurs, resulting in a redistribution of the chemical composition of the remaining liquid fuel.

**Wing center section:** A large structural box located aft of the forward cargo compartment and forward of the main landing gear bay in the lower fuselage between the wings, which comprises the CWT and a dry bay directly forward of the CWT. (See center wing fuel tank.)

**Witness:** (as defined by the TWA flight 800 investigation's Witness Group) Anyone who reported hearing a sound and/or seeing an event or object or objects (including smoke or fire) in the sky around the time and vicinity of the TWA flight 800 accident. According to the Witness Group's definition, it must have been likely that the sound or object observed was related to the crash, and the report must not have been a secondhand account.

**Yellow zone:** One of three debris fields, labeled during the TWA flight 800 accident investigation, from which the accident airplane's wreckage was recovered. This zone was the smallest of the three zones and was contained within the red zone on its northeastern side and located in a small concentrated area. This zone contained wreckage from the forward portion of the fuselage, from STA 90 (the nose of the airplane) to STA 840, including the cockpit, section 41, and the forward portions of section 42. (See figure 3a.) This wreckage was found relatively intact.