

Technical Report

Operations
Charioteer, Musketeer, Touchstone,
Cornerstone, Aqueduct, Sculpin and Julin

Tests

MILL YARD, DIAMOND BEECH, MIGHTY OAK, MIDDLE NOTE
MISSION GHOST, MISSION CYBER, MISTY ECHO, DISKO ELM,
MINERAL QUARRY, DISTANT ZENITH, DIAMOND FORTUNE,
And HUNTERS TROPHY

9 October 1985 - 18 September 1992

Approved for public release; distribution is unlimited.



Technical Report
May 1999

Prepared for:
Defense Threat Reduction Agency
45045 Aviation Drive
Dulles, VA 20166-7517

DSWA IACRO-97-3020

Carole R. Schoengold

20000209 094

Prepared by: Bechtel Nevada
P.O. Box 98521
Las Vegas, NV 89193-8521

United States Underground Nuclear Weapons Tests
Underground Nuclear Test Personnel Review

DTIC QUALITY INSPECTED 1

DESTRUCTION NOTICE:

Destroy this report when it is no longer needed. Do not return to sender.

PLEASE NOTIFY THE DEFENSE THREAT REDUC-
TION AGENCY, ATTN: ADP, 45045 AVIATION DRIVE,
DULLES, VA 20166-7517, IF YOUR ADDRESS IS
INCORRECT, IF YOU WISH IT DELETED FROM THE
DISTRIBUTION LIST, OR IF THE ADDRESSEE IS NO
LONGER EMPLOYED BY YOUR ORGANIZATION.

DISTRIBUTION LIST UPDATE

This mailer is provided to enable DTRA to maintain current distribution lists for reports. (We would appreciate you providing the requested information.)

- Add the individual listed to your distribution list.
- Delete the cited organization/individual.
- Change of address.

Note:

Please return the mailing label from the document so that any additions, changes, corrections or deletions can be made easily. For distribution cancellation or more information call DTRA/ADM (703) 325-1036.

NAME: _____

ORGANIZATION: _____

OLD ADDRESS

NEW ADDRESS

TELEPHONE NUMBER: () _____

DTRA PUBLICATION NUMBER/TITLE

CHANGES/DELETIONS/ADDITIONS, etc.)
(Attach Sheet if more Space is Required)

DTRA or other GOVERNMENT CONTRACT NUMBER: _____

CERTIFICATION of NEED-TO-KNOW BY GOVERNMENT SPONSOR (if other than DTRA):

SPONSORING ORGANIZATION: _____

CONTRACTING OFFICER or REPRESENTATIVE: _____

SIGNATURE: _____

CUT HERE AND RETURN

DEFENSE THREAT REDUCTION AGENCY
ATTN: ADM
45045 AVIATION DRIVE
DULLES, VA 20166-7517

DEFENSE THREAT REDUCTION AGENCY
ATTN: ADM
6810 TELEGRAPH ROAD
ALEXANDRIA, VA 22310-3398

REPORT DOCUMENTATION PAGE

Form Approved
OMB No. 0704-0188

Public reporting burden for this collection of information is estimated to average 1 hour per response, including the time for reviewing instructions, searching existing data sources, gathering and maintaining the data needed, and completing and reviewing the collection of information. Send comments regarding this burden estimate or any other aspect of this collection of information, including suggestions for reducing this burden, to Washington Headquarters Services, Directorate for Information Operations and Reports, 1215 Jefferson Davis Highway, Suite 1204, Arlington, VA 22202-4302, and to the Office of Management and Budget, Paperwork Reduction Project (0704-0188), Washington, DC 20503.

1. AGENCY USE ONLY (Leave blank)	2. REPORT DATE May 1999	3. REPORT TYPE AND DATES COVERED Technical 851009-920918	
4. TITLE AND SUBTITLE Operations Charioteer, Musketeer, Touchstone, Cornerstone, Aqueduct, Sculpin, and Julin Tests MILL YARD, DIAMOND BEECH, MIGHTY OAK, MIDDLE NOTE, MISSION GHOST, MISSION CYBER, MISTY ECHO, DISKO ELM, MINERAL QUARRY, DISTANT ZENITH, DIAMOND FORTUNE, AND HUNTERS TROPHY		5. FUNDING NUMBERS C-DSWA IACRO-97-3020	
6. AUTHOR(S) Carole R. Schoengold			
7. PERFORMING ORGANIZATION NAME(S) AND ADDRESS(ES) Bechtel Nevada P.O. Box 98521 Las Vegas, NV 89193-8521		8. PERFORMING ORGANIZATION REPORT NUMBER	
9. SPONSORING/MONITORING AGENCY NAME(S) AND ADDRESS(ES) Defense Special Weapons Agency 6801 Telegraph Road Alexandria, VA 22310-3398 ESN/Schaeffer		10. SPONSORING/MONITORING AGENCY REPORT NUMBER DSWA-6328F	
11. SUPPLEMENTARY NOTES N/A			
12a. DISTRIBUTION/AVAILABILITY STATEMENT Approved for public release; distribution is unlimited.		12b. DISTRIBUTION CODE	
13. ABSTRACT (Maximum 200 words) This report is a personnel-oriented history of DoD participation in underground nuclear weapons testing up to and during Operations Charioteer, Musketeer, Touchstone, Cornerstone, Aqueduct, Sculpin, and Julin; Tests MILL YARD, DIAMOND BEECH, MIGHTY OAK, MIDDLE NOTE, MISSION GHOST, MISSION CYBER, MISTY ECHO, DISKO ELM, MINERAL QUARRY, DISTANT ZENITH, DIAMOND FORTUNE, and HUNTERS TROPHY, 9 October 1985 to 18 September 1992. It is the ninth in a series of historical reports which includes all DoD underground nuclear test participation from 1962 forward. In addition to these historical reports, a restricted distribution report (consisting of several volumes) identifies all DoD and DoD-affiliated participants, military, civilian, and DoD contractors, in both DoD and DOE tests, and lists their individual dose data.			
14. SUBJECT TERMS Defense Special Weapons Agency (DSWA) Centers for Disease Control (CDC) Underground Nuclear Test Personnel Review (UNTPR)		15. NUMBER OF PAGES	
		16. PRICE CODE	
17. SECURITY CLASSIFICATION OF REPORT UNCLASSIFIED	18. SECURITY CLASSIFICATION OF THIS PAGE UNCLASSIFIED	19. SECURITY CLASSIFICATION OF ABSTRACT UNCLASSIFIED	20. LIMITATION OF ABSTRACT SAR

UNCLASSIFIED

SECURITY CLASSIFICATION OF THIS PAGE

CLASSIFIED BY:

N/A since Unclassified

DECLASSIFY ON:

N/A since Unclassified

14. SUBJECT TERMS (Continued)

Nevada Test Site (NTS)
Underground Tests (UGT)
Charioteer
Musketeer
Touchstone
Cornerstone
Aqueduct
Sculpin
Julin
MILL YARD
DIAMOND BEECH

MIGHTY OAK
MIDDLE NOTE
MISSION GHOST
MISSION CYBER
MISTY ECHO
DISKO ELM
MINERAL QUARRY
DISTANT ZENITH
DIAMOND FORTUNE
HUNTERS TROPHY

SECURITY CLASSIFICATION OF THIS PAGE

UNCLASSIFIED

SUMMARY

Twelve Department of Defense (DoD)-sponsored underground nuclear tests were conducted at the Nevada Test Site (NTS) from 9 October 1985 through 18 September 1992 to study weapons effects. All twelve were tunnel tests using the three-nested containment vessel concept. Eight of the tests were radiation-effects tests using the horizontal line-of-sight (HLOS) configuration. These tests were DIAMOND BEECH, MIGHTY OAK, MIDDLE NOTE, MISSION CYBER, DISKO ELM, MINERAL QUARRY, DISTANT ZENITH, and HUNTERS TROPHY. The other four, MILL YARD, MISSION GHOST, MISTY ECHO, and DIAMOND FORTUNE tests were blast, shock, and radiation-effects tests conducted in a hemispherical-type cavity design configuration.

Most of these tests released some radioactive effluent during their posttest operational period. All releases of radioactive effluent detected from any of the tests were either the result of controlled releases (planned releases where effluent was filtered before being released through the tunnel ventilation system) or of operational gas sampling releases (which were planned releases where most of the effluent was filtered). The only test from which effluent was detected offsite (i.e., off the NTS Test Range Complex) was the MIGHTY OAK test. All effluent releases from the other tests were detected onsite only.

As recorded on Area Access Registers, 14,147 individual entries to radiation exclusion (radex) areas were made after the above DoD tests. Of this number, 1042 were made by DoD-affiliated personnel (military, DoD civilian, and DoD contractor). The remainder were made by the Department of Energy (DOE)¹ and other government-agency and contractor personnel.

¹ DOE's predecessors were the Atomic Energy Commission (AEC), 1 January 1947 to 19 January 1975; and the Energy Research and Development Administration (ERDA), 19 January 1975 to 1 October 1977.

The average gamma radiation exposure per entry for all participants was 1.5 milliroentgen (mR). The average gamma radiation exposure per entry for DoD-affiliated participants was 2.2 mR. The maximum exposure of a non-DoD participant during an entry was 3.2 R. The maximum exposure of a DoD-affiliated participant was 625 mR. These maximum exposures occurred during the MIGHTY OAK test.

The following table summarizes pertinent test data.

Table S-1. Department of Defense-sponsored underground nuclear tests
9 October 1985 - 18 September 1992.

OPERATION	CHARIOTEER			MUSKETEER			TOUCHSTONE			CORNERSTONE			AQUEDUCT		SCULPIN		JULIN	
	MILL YARD	DIAMOND BEECH	MIGHTY OAK	MIDDLE NOTE	MISSION GHOST	MISSION CYBER	MISTY ECHO	DISKO ELM	MINERAL QUARRY	DISTANT ZENITH	DIAMOND FORTUNE	HUNTERS TROPHY	TEST DATE	YIELD ²	TEST DATE	YIELD ²		
TEST																		
DATE	9 Oct 1985	9 Oct 1985	10 Apr 1986	18 Mar 1987	20 June 1987	2 Dec 1987	10 Dec 1988	14 Sept 1989	25 July 1990	19 Sept 1991	30 Apr 1992	18 Sept 1992						
LOCAL TIME (hours)	1340 PDT	1620 PDT	0608 PST	1028 PST	0900 PDT	0830 PST	1230 PST	0800 PDT	0800 PDT	0930 PDT	0930 PDT	1000 PDT						
NTS LOCATION	U12n.20	U12n.19	U12t.08	U12n.21	U12t.09	U12p.02	U12n.23	U12p.03	U12n.22	U12p.04	U12p.05	U12n.24						
TYPE	Tunnel	Tunnel	Tunnel	Tunnel	Tunnel	Tunnel	Tunnel	Tunnel	Tunnel	Tunnel	Tunnel	Tunnel						
PURPOSE	Weapons Effects	Weapons Effects	Weapons Effects	Weapons Effects	Weapons Effects	Weapons Effects	Weapons Effects	Weapons Effects	Weapons Effects	Weapons Effects	Weapons Effects	Weapons Effects						
DEPTH (ft)	1,230	1,325	1,294	1,309	1,054	899	1,313	857	1,278	865	776	1,264						
YIELD ²	Low	Low	Low	Low	Low	Low	Low	Low	Low	Low	Low	Low						

² Low indicates less than 20 kilotons.

PREFACE

The United States Government conducted 194 nuclear device tests from 1945 through 1958 during atmospheric test series at sites in the United States and in the Atlantic and Pacific Oceans. The U.S. Army's Manhattan Engineer District (MED) implemented the testing program in 1945. In 1947 its functions were assumed by the Armed Forces Special Weapons Project (AFSWP) and the Atomic Energy Commission which administered the program from 1947 until testing was suspended by the United States on 1 November 1958.

Of the 194 nuclear device tests conducted, 161 were for weapons-related or for weapons-effects purposes, and 33 were safety experiments. An additional 24 nuclear experiments were conducted from December 1954 to February 1956 in Nevada. These experiments were physics studies using small quantities of fissionable material and conventional explosives.

President Eisenhower had proposed that test ban negotiations begin on 31 October 1958, and had pledged a one-year moratorium on United States testing to commence after the negotiations began. The Conference on Discontinuance of Nuclear Weapons Tests began at Geneva on 31 October 1958, the U.S. moratorium began on 1 November, and the AEC detected the final Soviet nuclear test of their fall series on 3 November 1958. Negotiations continued until May 1960 without final agreement. No nuclear tests were conducted by either nation until 1 September 1961 when the Soviet Union resumed nuclear testing in the atmosphere. The United States began a series of underground tests in Nevada on 15 September 1961, and U.S. atmospheric tests were resumed on 25 April 1962 in the Pacific.

The United States conducted five tests in Nevada during July 1962, that were either atmospheric, surface, or crater tests. The last U.S. atmospheric nuclear test in the Pacific was conducted on 4 November 1962. The Limited Test Ban Treaty (LTBT), that prohibited tests in the atmosphere, in outer space, and underwater, was signed in Moscow on 5 August 1963. From the resumption of United

States atmospheric testing on 25 April 1962 until the last atmospheric test on 4 November 1962, 41 tests (i.e., 40 weapons-related and weapons-effects tests and one Plowshare crater test) were conducted as part of the Pacific and Nevada atmospheric test operations. The underground tests, which resumed on 15 September 1961, have continued on a year-round basis through the period of this report.

In 1977, 15 years after atmospheric testing stopped, the Center for Disease Control (CDC)³ noted a possible leukemia cluster within the group of soldiers who were assigned to the Nevada Test Site during the SMOKY test, one of the Nevada tests in the 1957 PLUMBBOB series. After that CDC report, the Veterans Administration (VA) received a number of claims for medical benefits filed by former military personnel who believed their health may have been affected by their participation in the nuclear weapons testing program.

In late 1977, the DoD began a study to provide data for both the CDC and the VA on radiation exposures of DoD military and civilian participants in atmospheric nuclear testing. That study has progressed to the point where a number of reports describing DoD participation in atmospheric tests have been published by the Defense Nuclear Agency (DNA), now the Defense Special Weapons Agency (DSWA)⁴, as the Executive Agent for the DoD.

On 20 June 1979, the United States Senate Committee on Veterans Affairs began hearings on Veterans Claims for Disabilities from Nuclear Weapons Testing. In addition to requesting and receiving information on DoD personnel participation and radiation exposures during atmospheric testing, the Chairman of the Senate Committee

³ The Center for Disease Control was part of the Department of Health, Education and Welfare (now the Department of Health and Human Services).

⁴ The Defense Nuclear Agency became the Defense Special Weapons Agency on 1 July 1996.

expressed concern regarding exposures of DoD participants in DoD-sponsored and DOE-sponsored underground tests.

The Chairman requested and received information from the Director, DNA, in an exchange of letters through 15 October 1979 regarding research on underground testing radiation exposures. In early 1980, the DNA initiated a program to acquire and consolidate underground testing radiation exposure data in a set of published reports similar to the program then under way on atmospheric testing data. This report is the ninth in a series regarding participation and radiation exposures of DoD military and civilian participants in underground nuclear tests.

SERIES OF REPORTS.

Most reports in this series discuss DoD-sponsored underground tests in chronological order, after presenting introductory and general information. The reports discuss all underground tests identified as DoD-sponsored in United States Nuclear Tests (DOE/NV-209), published by the DOE Nevada Operations Office (DOE/NV), Office of External Affairs.

One report (DNA 6326F) discusses general participation of DoD personnel in DOE-sponsored⁵ underground tests, with specific information on those tests that released radioactive effluent or where exposures of DoD personnel were involved.

A separate set of volumes (comprising one report) is a census of DoD personnel who participated in DOE and DoD underground nuclear

⁵ For readability and ease of understanding, Sections 1 and 2 of this volume will use the acronym "DOE" to discuss the general responsibilities and procedures applicable to DOE and each of its predecessor agencies. Any activity that is tied to a specific time period will be discussed using the acronym of the agency in control during that period (e.g., safety experiments were conducted only during the era of the AEC).

tests and their radiation exposure data. Distribution of this report is limited by provisions of the Privacy Act.

METHODS AND SOURCES USED TO PREPARE THE VOLUMES.

Information for these reports was obtained from several locations. Classified documents were researched at Headquarters/DNA (HQ/DNA) in Washington, D.C. Additional documents were researched at Field Command/DNA (FC/DNA), the Air Force Weapons Laboratory (AFWL) Technical Library (now a part of the Air Force Laboratory), Sandia National Laboratories (SNL) in Albuquerque, New Mexico, and Lawrence Livermore National Laboratory (LLNL) in Livermore, California. Most of the radiation measurement data were obtained at DOE/NV, and its prime support contractor, Reynolds Electrical & Engineering Company, Inc. (REECo)⁶, both in Las Vegas, Nevada.

Unclassified records were used to document underground testing activities when possible, but, when necessary, unclassified information was extracted from classified documents. Both unclassified and classified documents (with unclassified titles) are cited in the Reference Section at the end of each report. Locations of the referenced documents are also shown. Copies of most of the unclassified references have been entered into the document collection of the Coordination and Information Center (CIC), a DOE contractor-operated facility located in Las Vegas, Nevada.

Radiation measurements, exposure data, test data, and offsite reports generally are maintained in hard copy or on microfilm at the REECo facilities, or as original documents at the Federal Archives and Records Center, Laguna Niguel, California. The Master File of all available personnel exposure data for nuclear testing programs on the continent and in the Pacific from 1945 to the present is maintained by REECo for DoD and DOE.

⁶ Bechtel Nevada became the prime support contractor on 1 January 1996.

ORGANIZATION OF THIS VOLUME.

A summary of this volume appears before this Preface and includes general objectives of the tests, characteristics of each test, and data regarding DoD participants and their radiation exposures.

Section 1, "Introduction," following this Preface and the Table of Contents, discusses the historical background, underground testing objectives, DoD and DOE organizational responsibilities, and locations of NTS underground testing areas.

Section 2, "Underground Testing Procedures," explains the basic mechanics of underground testing, including containment problems and procedures, emplacement types, diagnostic techniques, the purpose of effects experiments, tunnel and drilling area access requirements, radiological safety procedures, telemetered measurements of radiation levels, and air support requirements.

A section on each test discussed in this volume follows in chronological order. Each test section contains a test summary, a discussion of preparations and test operations, an explanation of safety procedures implemented, and listings of monitoring, sampling, and exposure results.

A reference section and appendices to the text follow the test sections. These include Sources of Information (Appendix A), a Glossary of Terms (Appendix B), a list of Abbreviations and Acronyms (Appendix C), applicable DOE Nevada Test Site Standard Operating Procedures (Appendices D-F), and a Sandia Laboratories, Albuquerque Tunnel Reentry Procedure (Appendix G).

TABLE OF CONTENTS

Section	Page
SUMMARY	iii
PREFACE	vi
FIGURES	xxii
TABLES	xxviii
1 INTRODUCTION	1
1.1 HISTORICAL BACKGROUND	1
1.2 UNDERGROUND TESTING OBJECTIVES	2
1.3 DOD TESTING ORGANIZATIONS AND RESPONSIBILITIES	4
1.3.1 Defense Nuclear Agency	4
1.3.2 Air Force Support	10
1.3.3 DOE-DoD Relationships	12
1.4 DOE ORGANIZATIONS, CONTRACTORS, AND RESPONSIBILITIES	17
1.4.1 Atomic Energy Commission	17
1.4.2 Nevada Test Organization	19
1.4.3 NTO Radiological Safety	21
1.4.4 NTS Scientific Users	21
1.4.5 Test Support Organizations	23
1.5 NEVADA TEST SITE	24
2 UNDERGROUND TESTING PROCEDURES	29
2.1 CONTAINMENT PROBLEMS AND PROCEDURES	29
2.1.1 Vertical Shaft Containment	30
2.1.2 Tunnel Containment	31
2.1.3 Containment Evaluation Panel	35

TABLE OF CONTENTS (Continued)

Section	Page
2.1.4 Test Controller's Advisory Panel	37
2.1.5 Effluent Release Procedures	40
2.2 EMPLACEMENT TYPES	43
2.2.1 Vertical Shaft Emplacement	43
2.2.2 Tunnel Emplacement	46
2.3 DIAGNOSTIC TECHNIQUES	50
2.3.1 Radiation Measurements	50
2.3.2 Radiochemical Measurements	50
2.4 EFFECTS EXPERIMENTS	51
2.5 TUNNEL AND DRILLING AREA ACCESS REQUIREMENTS . .	52
2.5.1 Tunnel Access Control	53
2.5.2 Drilling Area Access Control	55
2.6 INDUSTRIAL SAFETY CONSIDERATIONS	56
2.7 RADIOLOGICAL SAFETY PROCEDURES	59
2.7.1 The U.S. Department of Energy, Nevada Test Site - Standard Operating Procedures (NTS SOP 5401 and 5402)	59
2.7.2 The Standard Operating Procedures for the Health Protection Department, REECo	60
2.7.3 Implementation of Radiological Procedures	60
2.7.4 Additional Methods Used to Control Radex Areas	69
2.8 TELEMETERED MEASUREMENTS OF RADIATION LEVELS . .	70

TABLE OF CONTENTS (Continued)

Section	Page
2.8.1 Telemetry System in Use	71
2.8.2 Remote Area Radiation Detection Monitoring Support	74
2.9 AIR SUPPORT REQUIREMENTS	78
2.9.1 Changes in Air Support Requirements . . .	78
2.9.2 Radsafe Support for Indian Springs Air Force Auxiliary Field Personnel . . .	79
2.9.3 Radsafe Support for Helicopters	80
3 MILL YARD AND DIAMOND BEECH TESTS	82
3.1 TEST SUMMARY	82
3.2 PRETEST ACTIVITIES	84
3.2.1 Responsibilities	84
3.2.2 Planning and Preparations	85
3.3 TEST-DAY ACTIVITIES	103
3.3.1 Pretest Activities	103
3.3.2 Test Area Monitoring	104
3.3.3 Initial Surface Radiation Surveys and Recovery Activities	105
3.4 POSTTEST ACTIVITIES	105
3.4.1 Tunnel Reentry Activities	105
3.4.2 Posttest Mining and Drilling	108
3.4.3 Industrial Safety	110
3.5 RESULTS AND CONCLUSIONS	111

TABLE OF CONTENTS (Continued)

Section	Page
4	MIGHTY OAK TEST 115
	4.1 TEST SUMMARY 115
	4.2 PRETEST ACTIVITIES 115
	4.2.1 Responsibilities 115
	4.2.2 Planning and Preparations 117
	4.3 TEST-DAY ACTIVITIES 130
	4.3.1 Pretest Activities 130
	4.3.2 Test Area Monitoring 130
	4.3.3 Initial Surface Radiation Surveys 131
	4.4 POSTTEST ACTIVITIES 132
	4.4.1 Tunnel Reentry Activities 132
	4.4.2 Posttest Tunnel Rehabilitation, Mining, and Recoveries 133
	4.4.3 Industrial Safety 137
	4.5 RESULTS AND CONCLUSIONS 138
5	MIDDLE NOTE TEST 140
	5.1 TEST SUMMARY 140
	5.2 PRETEST ACTIVITIES 140
	5.2.1 Responsibilities 140
	5.2.2 Planning and Preparations 142
	5.3 TEST-DAY ACTIVITIES 155

TABLE OF CONTENTS (Continued)

Section	Page
5.3.1 Pretest Activities	155
5.3.2 Test Area Monitoring	156
5.3.3 Initial Surface Radiation Surveys	156
5.4 POSTTEST ACTIVITIES	157
5.4.1 Tunnel Reentry Activities	157
5.4.2 Posttest Mining and Drilling	159
5.4.3 Industrial Safety	160
5.5 RESULTS AND CONCLUSIONS	161
6 MISSION GHOST TEST	163
6.1 TEST SUMMARY	163
6.2 PRETEST ACTIVITIES	163
6.2.1 Responsibilities	163
6.2.2 Planning and Preparations	165
6.3 TEST-DAY ACTIVITIES	176
6.3.1 Pretest Activities	176
6.3.2 Test Area Monitoring	177
6.3.3 Initial Surface Radiation Surveys	177
6.4 POSTTEST ACTIVITIES	177
6.4.1 Tunnel Reentry Activities	177
6.4.2 Posttest Mining and Drilling	178
6.4.3 Industrial Safety	180
6.5 RESULTS AND CONCLUSIONS	181

TABLE OF CONTENTS (Continued)

Section	Page
7	MISSION CYBER TEST 184
7.1	TEST SUMMARY 184
7.2	PRETEST ACTIVITIES 184
7.2.1	Responsibilities 184
7.2.2	Planning and Preparations 186
7.3	TEST-DAY ACTIVITIES 198
7.3.1	Pretest Activities 198
7.3.2	Test Area Monitoring 199
7.3.3	Initial Surface Radiation Surveys 199
7.4	POSTTEST ACTIVITIES 200
7.4.1	Tunnel Reentry Activities 200
7.4.2	Posttest Mining and Drilling 201
7.4.3	Industrial Safety 203
7.5	RESULTS AND CONCLUSIONS 204
8	MISTY ECHO TEST 206
8.1	TEST SUMMARY 206
8.2	PRETEST ACTIVITIES 206
8.2.1	Responsibilities 206
8.2.2	Planning and Preparations 208
8.3	TEST-DAY ACTIVITIES 220
8.3.1	Pretest Activities 220
8.3.2	Test Area Monitoring 221
8.3.3	Initial Surface Radiation Survey 221

TABLE OF CONTENTS (Continued)

Section	Page
8.4 POSTTEST ACTIVITIES	222
8.4.1 Tunnel Reentry Activities	222
8.4.2 Posttest Mining and Drilling	223
8.4.3 Industrial Safety	224
8.5 RESULTS AND CONCLUSIONS	225
9 DISKO ELM TEST	228
9.1 TEST SUMMARY	228
9.2 PRETEST ACTIVITIES	228
9.2.1 Responsibilities	228
9.2.2 Planning and Preparations	230
9.3 TEST-DAY ACTIVITIES	242
9.3.1 Pretest Activities	242
9.3.2 Test Area Monitoring	243
9.3.3 Initial Surface Radiation Surveys	243
9.4 POSTTEST ACTIVITIES	244
9.4.1 Tunnel Reentry Activities	244
9.4.2 Posttest Mining and Drilling	246
9.4.3 Industrial Safety	248
9.5 RESULTS AND CONCLUSIONS	249
10 MINERAL QUARRY TEST	252
10.1 TEST SUMMARY	252
10.2 PRETEST ACTIVITIES	252

TABLE OF CONTENTS (Continued)

Section	Page
10.2.1 Responsibilities	252
10.2.2 Planning and Preparations	254
10.3 TEST-DAY ACTIVITIES	267
10.3.1 Pretest Activities	267
10.3.2 Test Area Monitoring	267
10.3.3 Initial Surface Radiation Surveys	268
10.4 POSTTEST ACTIVITIES	268
10.4.1 Tunnel Reentry Activities	268
10.4.2 Posttest Mining and Drilling	271
10.4.3 Industrial Safety	271
10.5 RESULTS AND CONCLUSIONS	272
11 DISTANT ZENITH TEST	275
11.1 TEST SUMMARY	275
11.2 PRETEST ACTIVITIES	275
11.2.1 Responsibilities	275
11.2.2 Planning and Preparations	277
11.3 TEST-DAY ACTIVITIES	291
11.3.1 Pretest Activities	291
11.3.2 Test Area Monitoring	291
11.3.3 Initial Surface Radiation Surveys	292
11.4 POSTTEST ACTIVITIES	292

TABLE OF CONTENTS (Continued)

Section	Page
11.4.1 Tunnel Reentry Activities	292
11.4.2 Posttest Mining and Drilling	295
11.4.3 Industrial Safety	296
11.5 RESULTS AND CONCLUSIONS	297
12 DIAMOND FORTUNE TEST	300
12.1 TEST SUMMARY	300
12.2 PRETEST ACTIVITIES	300
12.2.1 Responsibilities	300
12.2.2 Planning and Preparations	302
12.3 TEST-DAY ACTIVITIES	316
12.3.1 Pretest Activities	316
12.3.2 Test Area Monitoring	316
12.3.3 Initial Surface Radiation Surveys	317
12.4 POSTTEST ACTIVITIES	318
12.4.1 Tunnel Reentry Activities	318
12.4.2 Posttest Mining and Drilling	319
12.4.3 Industrial Safety	320
12.5 RESULTS AND CONCLUSIONS	321
13 HUNTERS TROPHY TEST	324
13.1 TEST SUMMARY	324
13.2 PRETEST ACTIVITIES	324

TABLE OF CONTENTS (Continued)

Section	Page
13.2.1 Responsibilities	324
13.2.2 Planning and Preparations	326
13.3 TEST-DAY ACTIVITIES	338
13.3.1 Pretest Activities	338
13.3.2 Test Area Monitoring	339
11.3.3 Initial Surface Radiation Surveys	339
13.4 POSTTEST ACTIVITIES	340
13.4.1 Tunnel Reentry Activities	340
13.4.2 Posttest Mining and Drilling	342
13.4.3 Industrial Safety	343
13.5 RESULTS AND CONCLUSIONS	344
14 REFERENCES	346
 Appendix	
A SOURCES OF INFORMATION	A-1
B GLOSSARY OF TERMS	B-1
C ABBREVIATIONS AND ACRONYMS	C-1
D U.S. DEPARTMENT OF ENERGY STANDARD OPERATING PROCEDURE CHAPTER 1102 - THE NUCLEAR TEST ORGANIZATION	D-1
E U.S. DEPARTMENT OF ENERGY STANDARD OPERATING PROCEDURE CHAPTER 5402 RADIOLOGICAL SAFETY	E-1

TABLE OF CONTENTS (Continued)

Section	Page
F U.S. DEPARTMENT OF ENERGY STANDARD OPERATING PROCEDURE CHAPTER 5401 ENVIRONMENT, SAFETY, AND HEALTH COORDINATION RESPONSIBILITY	F-1
G GENERAL TUNNEL REENTRY PROCEDURES FOR DEFENSE NUCLEAR AGENCY AND SANDIA LABORATORIES NUCLEAR TESTS	G-1

FIGURES

Figure		Page
1-1	Federal government structure for continental nuclear tests (1985-1992)	5
1-2	Partial organization chart of Field Command, Defense Nuclear Agency (1992)	9
1-3	Nuclear Test Organization (1992)	20
1-4	Nellis Air Force Range and the NTS	26
1-5	Nevada Test Site	27
2-1	A typical subsidence crater	45
2-2	Vertical LOS pipe configuration	47
2-3	Horizontal LOS pipe configuration	49
2-4	Portal of a typical DoD tunnel complex	58
2-5	NTS combination personnel dosimeter and security credential holder (1979-1986)	63
2-6	Panasonic personnel dosimeter and security credential holder	65
2-7	Panasonic TLD components	66
2-8	Track etch neutron dosimeter packet	67
2-9	Track etch neutron dosimeter components	68
2-10	Neher-White RAM probe	72

FIGURES (Continued)

Figure		Page
2-11	RAMS readout console	73
2-12	Typical remote radiation detection monitoring system for shaft-type emplacement site	75
2-13	Typical permanently established remote radiation detection stations operated continuously throughout the NTS	76
3-1	MILL YARD and DIAMOND BEECH tests - tunnel layout . .	83
3-2	MILL YARD and DIAMOND BEECH tests - tunnel facilities layout	86
3-3	MILL YARD test - support equipment installation . . .	88
3-4	MILL YARD test - support equipment installation (Continued)	89
3-5	MILL YARD test - stemming plan	91
3-6	DIAMOND BEECH test - stemming plan	93
3-7	MILL YARD and DIAMOND BEECH tests - surface RAMS . .	99
3-8	MILL YARD and DIAMOND BEECH tests - underground RAMS	100
3-9	MILL YARD and DIAMOND BEECH tests - underground RAMS U12n.19/U12n.20 complex	101
3-10	MILL YARD test - underground diagnostic RAMS	102
4-1	MIGHTY OAK test - tunnel layout	116

FIGURES (Continued)

Figure		Page
4-2	MIGHTY OAK test - tunnel facilities layout	119
4-3	MIGHTY OAK test - stemming plan	120
4-4	MIGHTY OAK test - surface RAMS	127
4-5	MIGHTY OAK test - underground RAMS	128
4-6	MIGHTY OAK test - underground RAMS and reentry drifts, U12t.08 complex	129
5-1	MIDDLE NOTE test - tunnel layout	141
5-2	MIDDLE NOTE test - tunnel facilities layout	143
5-3	MIDDLE NOTE test - stemming plan	145
5-4	MIDDLE NOTE test - surface RAMS	152
5-5	MIDDLE NOTE test - underground RAMS	153
5-6	MIDDLE NOTE test - underground RAMS U12n.21 complex .	154
6-1	MISSION GHOST test - tunnel layout	164
6-2	MISSION GHOST test - tunnel facilities layout	166
6-3	MISSION GHOST test - stemming plan	168
6-4	MISSION GHOST test - surface RAMS	173
6-5	MISSION GHOST test - underground RAMS	174

FIGURES (Continued)

Figure		Page
6-6	MISSION GHOST test - underground RAMS U12t.09 complex	175
7-1	MISSION CYBER test - tunnel layout	185
7-2	MISSION CYBER test - tunnel facilities layout	187
7-3	MISSION CYBER test - stemming plan	189
7-4	MISSION CYBER test - surface RAMS	195
7-5	MISSION CYBER test - underground RAMS	196
7-6	MISSION CYBER test - underground RAMS U12p.02 complex	197
8-1	MISTY ECHO test - tunnel layout	207
8-2	MISTY ECHO test - tunnel facilities layout	209
8-3	MISTY ECHO test - view of cavity	211
8-4	MISTY ECHO test - stemming plan	212
8-5	MISTY ECHO test - surface RAMS	218
8-6	MISTY ECHO test - underground RAMS	219
9-1	DISKO ELM test - tunnel layout	229
9-2	DISKO ELM test - tunnel facilities layout	231
9-3	DISKO ELM test - stemming plan	233

FIGURES (Continued)

Figure		Page
9-4	DISKO ELM test - surface RAMS	239
9-5	DISKO ELM test - underground RAMS	240
9-6	DISKO ELM test - underground RAMS U12p.03 complex	241
10-1	MINERAL QUARRY test - tunnel layout	253
10-2	MINERAL QUARRY test - tunnel facilities layout	256
10-3	MINERAL QUARRY test - stemming plan	257
10-4	MINERAL QUARRY test - surface RAMS	264
10-5	MINERAL QUARRY test - underground RAMS	265
10-6	MINERAL QUARRY test - underground RAMS U12n.22 complex	266
11-1	DISTANT ZENITH test - tunnel layout	276
11-2	DISTANT ZENITH test - helium-filled mylar bag emplaced in drift	278
11-3	DISTANT ZENITH test - facility drift and alcove protection plug locations	280
11-4	DISTANT ZENITH test - stemming plan	282
11-5	DISTANT ZENITH test - surface RAMS	288
11-6	DISTANT ZENITH test - underground RAMS	289

FIGURES (Continued)

Figure		Page
11-7	DISTANT ZENITH test - underground RAMS U12p.04 complex	290
12-1	DIAMOND FORTUNE test - tunnel layout	301
12-2	DIAMOND FORTUNE test - mylar bag emplacement in the cavity	303
12-3	DIAMOND FORTUNE test - drift complex layout	305
12-4	DIAMOND FORTUNE test - stemming plan	307
12-5	DIAMOND FORTUNE test - surface RAMS	313
12-6	DIAMOND FORTUNE test - underground RAMS	314
12-7	DIAMOND FORTUNE test - underground RAMS U12p.05 complex	315
13-1	HUNTERS TROPHY test - tunnel layout	325
13-2	HUNTERS TROPHY test - drift complex layout	327
13-3	HUNTERS TROPHY test - stemming plan	329
13-4	HUNTERS TROPHY test - surface RAMS	335
13-5	HUNTERS TROPHY test - underground RAMS	336
13-6	HUNTERS TROPHY test - underground RAMS U12n.24 complex	337

TABLES

Table		Page
S-1	Department of Defense-sponsored underground nuclear tests - 09 October 1985 through 18 September 1992 . . .	v
2-1	Department of Defense-sponsored underground nuclear tests - 09 October 1985 through 18 September 1992 . . .	44
2-2	NTS permanent RAMS	77
2-3	NTS satellite stations	78
3-1	MILL YARD and DIAMOND BEECH tests RAMS unit locations 09 October 1985 - surface	96
3-2	MILL YARD and DIAMOND BEECH tests RAMS unit locations 09 October 1985 - underground	97
4-1	MIGHTY OAK test RAMS unit locations 10 April 1986 - surface	124
4-2	MIGHTY OAK test RAMS unit locations 10 April 1986 - underground	125
5-1	MIDDLE NOTE test RAMS unit locations 18 March 1987 - surface	149
5-2	MIDDLE NOTE test RAMS unit locations 18 March 1987 - underground	150
6-1	MISSION GHOST test RAMS unit locations 20 June 1987 - surface	171
6-2	MISSION GHOST test RAMS unit locations 20 June 1987 - underground	172

TABLES (Continued)

Table		Page
7-1	MISSION CYBER test RAMS unit locations 02 December 1987 - surface	192
7-2	MISSION CYBER test RAMS unit locations 02 December 1987 - underground	193
8-1	MISTY ECHO test RAMS unit locations 10 December 1988 - surface	215
8-2	MISTY ECHO test RAMS unit locations 10 December 1988 - underground	216
9-1	DISKO ELM test RAMS unit locations 14 September 1989 - surface	236
9-2	DISKO ELM test RAMS unit locations 14 September 1989 - underground	237
10-1	MINERAL QUARRY test RAMS unit locations 25 July 1990 - surface	261
10-2	MINERAL QUARRY test RAMS unit locations 25 July 1990 - underground	262
11-1	DISTANT ZENITH test RAMS unit locations 19 September 1991 - surface	285
11-2	DISTANT ZENITH test RAMS unit locations 19 September 1991 - underground	286
12-1	DIAMOND FORTUNE test RAMS unit locations 30 April 1992 - surface	310

TABLES (Continued)

Table		Page
12-2	DIAMOND FORTUNE test RAMS unit locations 30 April 1992 - underground	311
13-1	HUNTERS TROPHY test RAMS unit locations 19 September 1992 - surface	332
13-2	HUNTERS TROPHY test RAMS unit locations 19 September 1992 - underground	333

SECTION 1

INTRODUCTION

The first United States nuclear detonation designed to be contained underground was the RAINIER tunnel test. The test was conducted by the University of California Radiation Laboratory (UCRL) for the AEC at the NTS on 19 September 1957. This was a weapons-related experiment with a relatively low yield of 1.7 kilotons (kt). The second tunnel test, also conducted at NTS by UCRL for the AEC, was a safety experiment detonated on 22 February 1958. This experiment, the VENUS test, resulted in a yield of less than one ton. These two tunnel tests and five additional safety experiments, with yields ranging from zero to 115 tons, were the beginning of the United States underground nuclear testing program, the only type of nuclear detonation testing permitted by treaty from August 1963 through the end of the testing period in September 1992. The first DoD-sponsored underground nuclear weapons-effects test was the 5.7 kt HARD HAT test conducted by the Defense Atomic Support Agency (DASA) on 15 February 1962 at NTS.

1.1 HISTORICAL BACKGROUND.

While technical conferences between the United States and the Soviet Union on banning nuclear detonation tests continued, and concern regarding further increases in worldwide fallout mounted, a number of nuclear tests were conducted underground during 1957-1958 in Nevada. Prior to the United States testing moratorium of 1 November 1958, a total of nine safety experiments in shafts, six safety experiments in tunnels, and five weapons-related tests in tunnels were conducted by user laboratories. During this period, the technology to achieve complete containment of radioactive products had not been developed. Reduction of fallout and operational convenience were the prime motivations for underground testing. Thus, radioactive products from several of these tests were not completely contained underground. Contain-

ment of nuclear detonations was a new scientific and engineering challenge. Understanding and solving the majority of containment problems would require years of underground testing experience.

When the United States resumed testing on 15 September 1961, the first 32 on-continent tests were conducted underground, including a cratering experiment, DANNY BOY on 5 March 1962, with the device emplaced 110 feet below the surface. The resultant crater from this weapons-effects test was 84 feet deep. Then the Operation Dominic series began in the Pacific, and the Operation Sunbeam series was conducted simultaneously with underground testing at NTS during 1962. During the Operation Dominic series, five DoD high-altitude weapons-effects tests were conducted as Operation Fishbowl. These series of tests comprised the last atmospheric nuclear detonations by the United States.

The commitment of the United States to reduce levels of worldwide fallout by refraining from conducting nuclear tests in the atmosphere, in outer space, and underwater was finalized when the LTBT with the Soviet Union was signed on 5 August 1963. With the signing of the Threshold Ban Treaty in 1974 and the Peaceful Nuclear Explosions Treaty in 1976, the United States and the Soviet Union agreed to limit the design yield of underground tests to 150 kt. While these treaties were not ratified by the United States until September 1990, both governments adhered to their maximum yield limitations. (The delay in ratifying was ultimately resolved by U.S./Soviet protocols agreed to on 1 June 1990.)

1.2 UNDERGROUND TESTING OBJECTIVES.

The majority of United States underground tests have been for weapons-related purposes. New designs were tested to improve efficiency and deliverability characteristics of nuclear explosive devices before they entered the military stockpile as components of nuclear weapons.

In addition to weapons-related tests, safety experiments with nuclear devices also were conducted by user laboratories. These were experiments designed to confirm that a nuclear explosion will not occur in case of an accidental detonation of the explosive associated with the device during transportation, handling, or storage of weapons.

Nuclear weapons-effects tests (NWET) sponsored by DoD were conducted to determine the vulnerability or survivability of military systems or components when exposed to one or more effects of a nuclear detonation. The nuclear devices for these tests were provided by DOE weapons-development laboratories and were designed to be similar to the actual nuclear components used in nuclear weapons. Actual weapon configurations were only used in a few tests. Military systems, structures, materials, electronics experiments, and other related experiments were provided by DoD and DOE agencies. Many of these tests were complex and involved greater numbers of participants than other categories of tests previously mentioned. Personnel from DNA, other government organizations, user laboratories and contractors, and DoD contractor agencies were involved.

Some tests were designed to study the response of hardened structures to shock waves generated by nuclear detonations. Many tests were designed to study the response of military components to effects of radiation produced by nuclear weapons. Such tests required a direct line-of-sight between the nuclear device and the experiments. Many of the radiation-effects tests required the simulation of high-altitude (up to exoatmospheric) conditions. These tests involved installation of experiments inside large steel line-of-sight (LOS) pipes, hundreds of feet long and usually 12 to 24 feet in diameter. Large vacuum pumps were used to reduce pressure inside the pipes to the desired level.

The DoD weapons-effects tests conducted during Operation Charioteer (MILL YARD, 9 October 1985; DIAMOND BEECH, 9 October 1985; and MIGHTY OAK, 10 April 1986), Operation Musketeer (MIDDLE NOTE, 18 March 1987; and MISSION GHOST, 20 June 1987), Operation Touch-

stone (MISSION CYBER, 2 December 1987), Operation Cornerstone (MISTY ECHO, 10 December 1988; and DISKO ELM, 14 September 1989), Operation Aqueduct (MINERAL QUARRY, 25 JULY 1990), Operation Sculpin (DISTANT ZENITH, 19 September 1991), and Operation Julin (DIAMOND FORTUNE, 30 April 1992; and HUNTERS TROPHY, 18 September 1992) are discussed in this volume.

1.3 DOD TESTING ORGANIZATIONS AND RESPONSIBILITIES.

Administering the underground nuclear testing program was a joint DOE-DoD responsibility. The similar nature of the DOE and DoD organizational structure, during the period of this report, is shown in Figure 1-1.

1.3.1 Defense Nuclear Agency.

The HQ/DNA (now DSWA), located near Washington, D.C., is composed of personnel from each of the Armed Services and civilian DoD employees. It was originally established as the Armed Forces Special Weapons Project (AFSWP) to assume the military functions of the Manhattan Engineer District (MED). This action was initiated through issuance of a joint Army-Navy memorandum, dated 29 January 1947, that was retroactive to 1 January 1947 (when the Atomic Energy Commission was activated). The responsibility for DoD nuclear weapons-effects testing was assigned to AFSWP. The National Security Act of 1947 had become law when the Secretary of Defense issued a memorandum on 21 October 1947 to the three Service secretaries reconfirming the previous directive of 29 January, and thus, AFSWP officially represented all of the services. AFSWP was charged with providing nuclear weapons support to the Army, Navy, and Air Force. As originally chartered, AFSWP was directly responsible to each of the three Service chiefs. In 1951, the Air Force Special Weapons Center (AFSWC), located at Kirtland Air Force Base (KAFB), Albuquerque, New Mexico, was assigned the responsibility by DoD to provide specific support to the AEC for continental nuclear testing (see Section

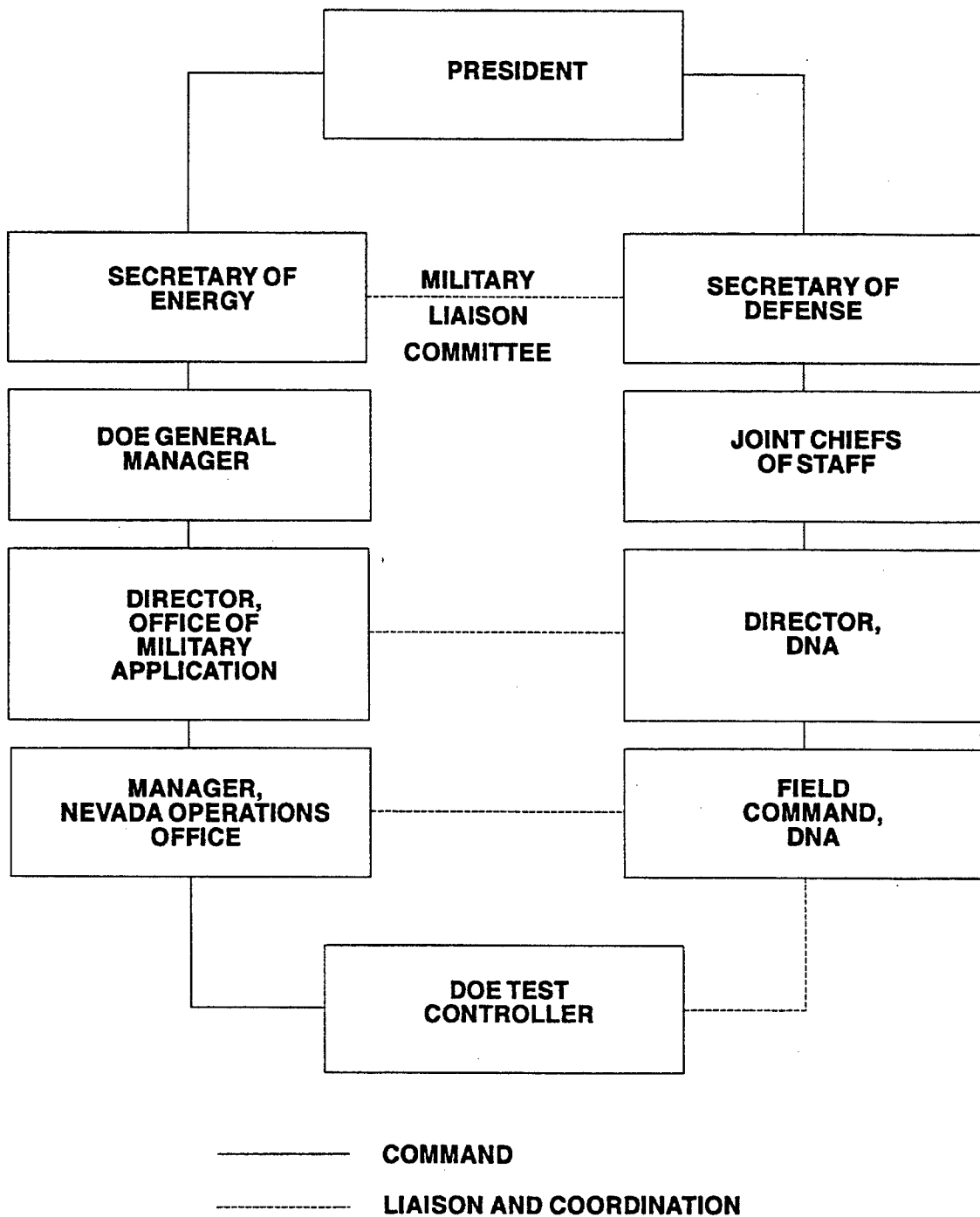

Figure 1-1. Federal government structure for continental nuclear tests (1985-1992).

1.3.2). This command was not directly related to AFSWP; however, the two organizations coordinated several support tasks.

By issuance of General Order No. 2, Headquarters, DASA (HQ/DASA), dated 6 May 1959, AFSWP became DASA. Under its new charter, DASA was responsible to the Secretary of Defense through the Joint Chiefs of Staff (JCS).

DASA's five major areas of responsibility for the DoD included:

1. Staff assistance to the Office of the Secretary of Defense, through the JCS.
2. Research in weapons effects.
3. Atomic tests.
4. Weapons-related tests.
5. Assistance to the Services.

Responsibilities of HQ/DASA included providing consolidated management and direction for the DoD nuclear weapons-effects testing program. Technical direction and management of field operations for DoD nuclear weapons-effects testing activities were delegated to Field Command, DASA (FC/DASA), located at Sandia Base, now KAFB in Albuquerque, New Mexico. From 6 May 1959 until 1 July 1964 the Weapons Effects Test Group (WETG) of FC/DASA was responsible for nuclear weapons-effects testing and seismic detection research (VELA-UNIFORM) for the Director, DASA. This organization maintained close liaison with the AEC/Nevada Operations Office (NVOO). Personnel from FC/DASA became the military members of the joint AEC-DoD testing organization at the NTS and other continental United States test locations. Participation of DoD agencies and their contractors in nuclear field tests was coordinated and supported by FC/DASA. On 1 July 1964, the testing organization in Albuquerque was designated as the Weapons Test Division (WTD), a Division of HQ/DASA. On 1 August 1966, WTD's name was changed to Test Command, DASA (TC/DASA), and it became a

separate command under HQ/DASA, remaining in Albuquerque. The responsibility for technical direction and management of field operations for nuclear effects tests remained in effect during these changes in organization. During this period, WTD and TC/DASA maintained an engineering and support branch (designated the Nevada Branch) at the NTS and a liaison office at AEC/NVOO. The Nevada Branch maintained liaison with AEC/NVOO and supervised FC/DASA activities at NTS. On 12 May 1970, the Commander, FC/DASA, assumed additional command of TC/DASA.

On 29 March 1971 (effective 1 July 1971), the Deputy Secretary of Defense directed the reorganization of DASA as a result of cut-backs recommended by the "Blue Ribbon Panel" survey of agency activities. In his Executive Memorandum, DASA was retained as a defense agency under the new title, "Defense Nuclear Agency." Also on 1 July 1971, FC/DASA was redesignated as FC/DNA, and TC/DASA became TC/DNA. While the responsibilities and manning levels at Field Command were reduced during this transition, Test Command remained essentially the same.

On 1 January 1972, TC/DNA was discontinued and personnel were transferred to FC/DNA. The responsibility for technical direction and management of field operations for nuclear weapons-effects tests were transferred to the newly formed Test Directorate (Field Command Test, FCT), of FC/DNA. The Nevada Branch of TC/DASA was changed to the Test Construction Division of the Test Directorate (FCTC), and the responsibility for the liaison office at AEC/NVOO was transferred to FCTC. In 1975 a Containment Division was added to Test Directorate to plan and supervise the containment research program for DNA. In 1982 the Test Directorate Safety Engineer was added as a separate office.

On 11 May 1987, HQ/DNA was reorganized consistent with recommendations of the Johnson Panel. By authority of HQ/DNA letter "Transfer of Test Directorate Field Command Functions and Responsibilities to HQ/DNA," dated 11 May 1987, Test Directorate, FC/DNA was deactivated and its functions and responsibilities were placed directly under Test Directorate, HQ/DNA. A DNA Nevada Operations

Office (TDNV) was established in Nevada to centralize underground nuclear test planning and execution functions, and a New Mexico Operations Office (TDNM) was established to conduct high explosive and aboveground radiation simulation tests.

On 18 September 1987, The Office of Test Science & Technology (TDTT) was created from the old Technical Directors Division. The new TDTT consisted of these three divisions: Underground Test Technology (TTUT), Simulation Technology (TTST), and Test Technology (TTTT).

The TDNV consisted of these five divisions: Construction Engineering (NVCE), that provided field and mechanical engineering support for DNA activities at the NTS; Technical Engineering (NVTE), that provided continuity and consulting; Containment & Geotechnical (NVCG), that was responsible for containment technology; Underground Test Operations (NVTO), that was responsible for overall planning and execution of underground nuclear tests; and Test Support (NVTS), that provided administration and logical support.

On 21 August 1990, TDNV reorganized and consolidated into four divisions with the elimination of NVTE, and its functions consolidated under NVCE. In addition, NVTO took the responsibilities for Supply and Transportation (TOST) and Administration and Security (TOAS) from the former NVTS division that was replaced by the Technical Compliance Division (NVTC), while the NVCG remained the same.

Then on 1 July 1992, with a reorganization at DNA, TDNV was reorganized and put under the responsibility of Field Command, and thus became FCNV. The new FCNV had five divisions: the four discussed above remained and Test Verification Operations (NVTV) was added. Figure 1-2 shows the FCNV organizational structure.

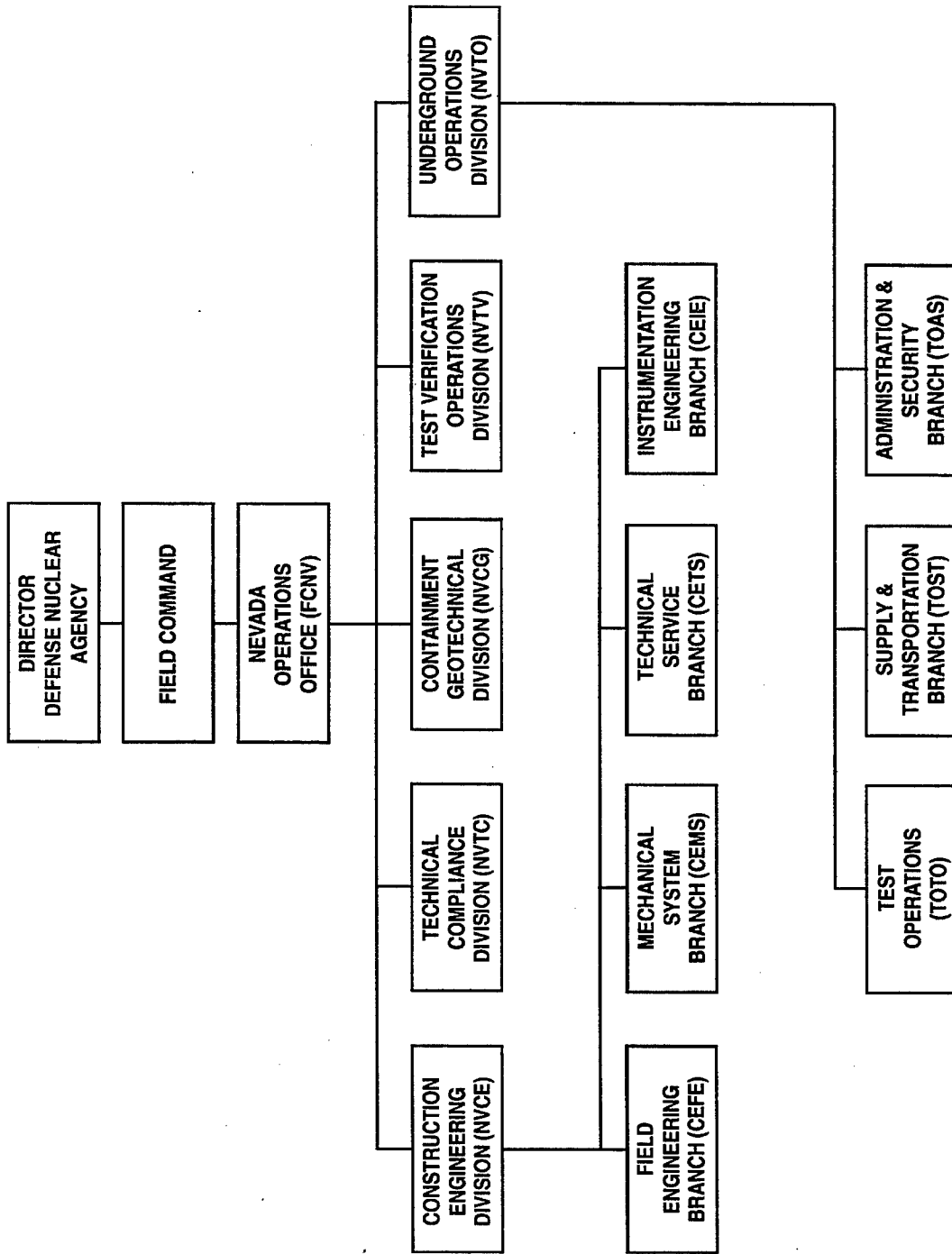

Figure 1-2. Partial organization chart of Field Command, Defense Nuclear Agency (1992).

1.3.2 Air Force Support.

Until 1 July 1974, AFSWC provided air support to the Nevada Test Site Organization (NTSO) during nuclear tests at the NTS. Detachment 1 of the 4900th Test Group provided aircraft for shuttle service between KAFB, Albuquerque, New Mexico, and Indian Springs Air Force Auxiliary Field (ISAFAF) in Nevada. They also provided aircraft and crews to perform low-altitude cloud tracking, radio relay support, and courier missions. On 1 July 1974, AFSWC's air support responsibility, along with Detachment 1, 4900th Test Group, was transferred to the 57th Fighter Weapons Wing (FWW), Tactical Air Command (TAC), at Nellis Air Force Base (NAFB), Nevada. AFSWC continued to support the Air Force's nuclear research and development (R&D) mission until 1 April 1976 when it was deactivated. The nuclear R&D mission was transferred to the Air Force Weapons Laboratory (AFWL), KAFB, New Mexico. Detachment 1 remained at ISAFAF and continued to provide support to the NTS. However, personnel, aircraft, equipment, and supplies became the responsibility of the 57th FWW. Support was formalized by Inter-service Support Agreements (ISA) between the Tactical Fighter Weapons Center (as represented by the 57th FWW) and FC/DNA, acting as the agent of the Departments of Defense and Energy for receiving aeronautical support at NTS. On 1 November 1983, Detachment 1, 4900th Test Group was deactivated and replaced by the 4460th Helicopter Squadron (HS) that was activated at ISAFAF. The 4460th was the largest helicopter unit in TAC with six UH-1N helicopters and 77 authorized personnel. Operations provided by the 4460th HS through September 1987 were as follows:

- A. Weekly perimeter security flights and a D-2 airborne inspection of perimeter gates. (The term D-day is used to designate the day on which a test takes place; therefore D-x or D+x indicates the number of days before or after the day a test is executed. The terms H-x and H+x are used to denote the number of hours before or after a test.)

- B. An airborne security inspection of pre-closed areas on D-1.
- C. A D-day airborne safety inspection and Test Controller standby mission to be flown prior to H-11 hours and to cover the downwind area for personnel and livestock locations. (The standby portion of this mission was for rapid evacuation of personnel and/or reentry of scientific personnel, if necessary.)
- D. A D-day helicopter airborne closed-circuit television mission to provide a stable platform for both television and color photography coverage of surface ground zero at zero time.
- E. A D-day helicopter cloud surveillance to provide initial data for immediate "onsite" decisions regarding safeguard actions. (Not to be considered as "cloud tracking.")
- F. Damage survey flights, as required, and other support flights as requested by the Test Controller and as operationally feasible by the 57th FWW Deputy Commander for Operations.
- G. Normal technical support and laboratory photography flights, as required, including survey of preshot, postshot, and new construction areas.
- H. An airborne security inspection to cover the NTS boundary, checking the locked barricades, and looking for areas where intruders might have gained access to the NTS unobserved.
- I. Operational orientation tours and management surveillance flights as requested by higher headquarters of either activity.

On 1 October 1987, after Field Command's Test Directorate functions had been transferred to HQ/DNA, air support for DoD underground tests at the NTS was transferred from Detachment 1, 57th FWW, NAFB (stationed at ISAFAB) to DOE. The ISA between FC/DNA and the Tactical Fighter Weapons Center was amended and that portion governing air support was deleted. A new "Management Agreement" between DOE/NV and DNA, that covered air support, was initiated. This agreement stated that DNA would fund the procurement and lease of test support aircraft and the associated operation and personnel necessary to provide air support or fund and arrange necessary military aircraft support. The DOE/NV would determine test support requirements and obtain support aircraft and personnel, and would submit budget requirements for such support to DNA. During 1987, helicopter support (aircraft and pilots) for DoD underground nuclear tests at NTS was provided by EG&G. REECO provided monitors and equipment; one monitor for the closed-circuit television mission aircraft that covered the GZ area, one for the TC/security standby aircraft, and two for the cloud tracking aircraft. This aircraft and personnel support provided by EG&G was continued through the completion of underground testing in September 1992.

1.3.3 DOE-DoD Relationships.

DoD was responsible for establishing criteria for nuclear weapons, developing and producing delivery systems, developing nuclear weapons plans and forces, providing defense against nuclear attack, and obtaining nuclear weapons-effects data through DNA. DOE was responsible for research, development, production, and supply of nuclear weapons to the Armed Forces in quantities and types specified by the JCS. Quantities and types of weapons were described in the Nuclear Weapons Stockpile Memorandum, signed by the Secretary of Defense and Secretary of Energy or his alternate and approved by the President. DOE, in association with DoD, was also responsible for providing field nuclear test facilities in the continental United States and islands in the Pacific.

The principal points of field coordination between DoD and DOE were at DOE/NV in Las Vegas and at NTS. From the beginning of the DoD underground nuclear weapons-effects test program (the first test was HARD HAT in February 1962) through the period covered by this report, Field Command (or Test Command) was the fielding agency for DoD-DNA and served as the primary point of contact with the Nevada office of the DOE. DOE/NV represented DOE in the field for all continental tests. The DOE nuclear weapons-development laboratories fielded underground tests as part of the weapons-development program. DNA fielded underground tests at NTS to obtain weapons-effects data. Because the NTS was a DOE installation, the Manager, NV, was responsible for all operations there.

For each DoD-sponsored test, HQ/DNA coordinated requirements with the military services. Requirements for testing to determine the nuclear vulnerability or hardening of military systems or components were submitted by these organizations. As part of long-range underground nuclear weapons-effects test planning, HQ/DNA developed a schedule of specific tests designed to satisfy military requirements. One or more of the DoD agencies were cosponsors and usually active participants in each DoD underground test. Many of the nuclear weapons-effects tests also included active participation by one or more of the DOE laboratories in vulnerability/survivability experiments for nuclear warheads, warhead electrical systems, and limited-life components (LLC). The initial approval of DoD experiments and the selection of the nuclear source (device) for each test were accomplished at the HQ/DNA level. A request for the appropriate nuclear device and associated support was forwarded by HQ/DNA to the Director, Division of Military Application, DOE. The DOE assigned one or more of the weapons-development laboratories to provide the device support.

Following initial planning, the responsibility for detailed planning, engineering, fielding, execution, and reporting was assigned to the TDDT. They formed a Test Group staff for each test. The Technical Director (normally a military officer assigned to TDDT or AFWL), the Test Group Director (TGD), and other

members of the staff were appointed by HQ/DNA. The Test Group Engineer normally was selected from NVCE, of the TDNV.

The Test Group staff developed detailed test plans and schedules. Engineering and construction plans were developed by the TDNV and coordinated with the Nuclear Test Organization⁷ (NTO). Final engineering designs were developed by DOE contractors, Holmes & Narver, Inc. (H&N), and/or Fenix & Scisson, Inc. (F&S). In November 1990, this function was assumed by a new DOE contractor, Raytheon Services Nevada (RSN). Engineering drawings were approved by TDNV and NTO prior to actual construction. Construction was performed by the principal DOE support contractor, REECo. TDNV and members of the Test Group staff monitored construction activities. The DNA Test Group staff coordinated development of technical experiments and initiated action to obtain required support equipment (e.g., steel LOS pipe and mechanical closures). The Test Group staff reviewed the technical support requirements submitted by experimenter agencies and submitted consolidated requirements to the DOE/NV that, in turn, advised the NTO of future requirements.

During the construction phase, the NVCG began collecting containment-related information. During drilling or mining operations, rock cores were analyzed for bulk density, moisture content, grain density, porosity, unconfined compressive strength, triaxial compression (for a variety of confining pressures), ultrasonic shear and compressive wave velocities, carbon dioxide content, presence of clay that could swell, and other features. This testing was conducted for DNA primarily by Terra Tek, a DNA contractor located in Salt Lake City, Utah, as part of the DNA containment-research program. Some testing was also done by the H&N (after November 1990, RSN) Testing Laboratory at the NTS.

⁷ Assumed some of the functions of the Nevada Test Site Organization (NTSO) in 1982, but should not be confused with the Nevada Test Site Office and its functions in 1992.

Geologic features of the tunnels were examined and mapped as construction progressed, usually by a DOE contractor. Several months prior to the planned test, NVCG prepared a prospectus that contained a detailed description of the containment features of the testbed, site geologic information, types and locations of mechanical closures, details of containment plugs, analytical calculations, and related test history. This document was reviewed by Containment Evaluation Panel (CEP; see Section 2.1.3) members and formally presented by DNA to the CEP for categorization.

The DNA Test Group staff normally moved to NTS a few months prior to the planned test execution date (three to six months depending on the complexity of the test). Prior to arrival of DoD experimenter personnel, the Nevada Operations Office, in conjunction with the Test Group staff, made arrangements to provide required instrumentation and recording facilities, office space and equipment, communications equipment, vehicles, photography, and other support items. Housing and food services for DoD personnel at NTS were provided by REECo. Upon arrival at NTS, DoD personnel were briefed on safety and security by the Test Group staff and other DoD and DOE personnel. These briefings included radiation safety control policies, procedures, and equipment. Experimenter agencies were provided with copies of HQ/DNA security and safety plans.

Under the supervision of the Test Group staff, experimenter personnel installed experiments and checked out instrumentation cables and recording systems. A series of electrical dry runs were conducted from the participating (user) laboratory control room and DNA monitoring room at the Control Point (CP) complex (see Section 1.5) to determine that all signals and remotely controlled equipment were functioning properly. After all systems were declared ready, permission was requested from the DOE to install the nuclear device. Installation and check out were conducted by the participating device-development laboratory with DOE security safeguarding the device and other classified materi-

als. The next activities consisted of placing stemming materials in preplanned locations and checking all containment features.

The DOE/NV Test Controller was in charge of the entire test operation from the day that programmatic authority for the test was approved. When the Test Controller was satisfied that all conditions, as prescribed in written procedures and as approved by the detonation authority, were satisfactory to detonate the device, he gave permission to the user laboratory to arm the device and initiate the final countdown.

The Test Controller and his staff, supported by NVCG and TDNV personnel at the CP, monitored the countdown, detonation, and posttest response of remotely operated radiation monitoring equipment. When released by the Test Controller, the reentry teams composed of TDNV personnel and REECO Radiological Safety (Radsafe) and Industrial Hygiene personnel, entered the area to monitor for radiation and other safety hazards. After assurance that reentry could be accomplished, the Test Controller released selected experimenters to collect recorded data from the portal recording areas. All of these operations were conducted in accordance with postshot plans developed by the DOE Test Controller staff, the DoD Test Group staff, and TDNV personnel, unless posttest conditions required modifications.

For tunnel tests, initial reentry into the tunnel was authorized by the DOE Test Controller after it was determined that conditions were safe for reentry operations. Tunnel reentry was controlled by TDNV personnel with assistance from SNL health physicists, REECO Radsafe personnel, and REECO construction personnel. After the tunnel was declared safe for experiment recovery, the Test Group staff assumed control of the area. Based on REECO Radsafe monitoring data, DNA personnel determined when it was safe to remove the experiments. Experimenters then removed experiments for analysis and documentation of results.

1.4 DOE ORGANIZATIONS, CONTRACTORS, AND RESPONSIBILITIES.

1.4.1 Atomic Energy Commission.

The AEC was created by the Atomic Energy Act of 1946 in July, the same month the JCS were conducting Operation Crossroads with assistance from the U.S. Army's MED. On 1 January 1947, the MED was deactivated and the AEC and AFSWP assumed its functions. The Atomic Energy Act was revised in 1954 and has been amended extensively since.

The AEC established headquarters (AEC/HQ) offices in Washington, D.C., and operations offices in areas that were centers of AEC operations. In areas of lesser activity, area offices, branch offices, and field offices were established. The Director of the Division of Military Application (DMA) in AEC/HQ was delegated responsibility for the nuclear-weapons development and testing program. The Director of DMA was always a flag officer from one of the armed forces, as specified by the Atomic Energy Act of 1954, and he was an Assistant General Manager in the AEC organization.

In 1951, the Director of DMA designated and delegated his responsibility for conduct of on-continent tests to the Test Manager of the AEC Santa Fe Operations Office (SFOO) near Los Alamos Scientific Laboratory. Later in 1951, SFOO was moved to Albuquerque. With delegated authority from the Director of DMA, the Manager, SFOO, designated Test Managers for on-continent tests. The same authority applied when SFOO became the Albuquerque Operations Office (ALOO) in 1956. The AEC Las Vegas Field Office (LVFO), established in 1951, managed the Nevada Test Site (called the Nevada Proving Ground from 1952 to 1955) for the Test Manager. LVFO became a Branch Office in 1955, an Area Office in 1960, and the Nevada Operations Office (NVOO, later shortened to NV) in 1962, with the Manager, NVOO, or his representative designated as Test Manager. In 1972, the Test Manager became the Test Controller.

In 1977, DMA was changed to the Office of Military Applications (OMA). The OMA initiated the chain of authority and approval for detonating each nuclear device by requesting that each user laboratory and DNA submit proposed test programs to OMA. This request was made in the spring of each year for tests to be conducted in the next fiscal year. The OMA consolidated proposed test programs, developed a test program proposal while consulting with DoD, and generated a program approval request. The OMA then presented the proposed test program to the National Security Council (NSC) Ad Hoc Committee on Nuclear Testing. Chaired by the NSC, this committee included representatives of the DoD, JCS, Department of State, Arms Control and Disarmament Agency, Office of Management and Budget, Office of Science and Technology, and Central Intelligence Agency. After incorporating informal committee comments, OMA forwarded the proposed program from the Secretary of Energy to the President through the NSC. The NSC solicited and incorporated formal comments in its recommendation to the President.

Test program approvals were requested at six-month intervals. Approval of tests for the first six months was received at the beginning of each fiscal year. The process was repeated six months later for tests in the last half of the fiscal year. Presidential approvals were signed by the Assistant to the President for National Security Affairs. Subsequently, test program authority messages were sent from the Director OMA to the user laboratories, DNA, and DOE/NV.

Authority to detonate each nuclear device was handled separately and individually. The technical content of detonation authority requests originated in presentations to the CEP by the user laboratory or DNA. Based on categorizations by the CEP and the Nuclear Explosive Safety Study (NESS), the Manager, NV, requested detonation authority from OMA. Required information in each request included statements on compliance with treaties, environmental impact, public announcement plans, test program authority, the NESS report, and any other particularly noteworthy aspects of

the test. After OMA and additional DOE reviews, the Manager, NV, was notified of detonation authority approval.

1.4.2 Nevada Test Organization.

As stated in the Nuclear Test Organization (NTO) Standard Operating Procedure, (SOP), NTS SOP 1102, Appendix D⁸), the NTO included DOE, DoD, user laboratory, contractor, agency, and organizational personnel who participated in or provided support for test operations at the NTS. The Manager, NV, headed the NTO and appointed the Test Controller who was assigned full responsibility for the safe conduct of each nuclear test. (See Figure 1-3.) The Test Controller was supported by the NTO, which was a continuing task organization whose composition could be readily changed in response to the needs and technical objectives of each test.

The Continental Test Organization (CTO)⁹ was part of the original NTSO. However, it was disestablished on 1 August 1962, with its responsibilities (e.g., Military Deputy to the Manager, NVOO) being assumed by WETG, FC/DASA, WTD/DASA, TC/DASA, and subsequently by Test Directorate, FC/DNA. During the 1982-85 period, covered by the previous Underground Nuclear Test Personnel Review (UNTPR) report DNA 6327F), the Deputy for Military Matters position was deleted from the NTO organization chart. Responsibilities of that position for coordinating DoD programs and support to the NTO were transferred to the Test Construction Division (now TDNV).

⁸ DOE NTS SOP 1102 superseded DOE NTS SOP 0101 and several earlier versions of NTS SOP 1102. This SOP, dated 29 July 1992, was in effect when the last nuclear test was conducted at the NTS.

⁹ See DNA 6320F, Operations Nougat and Whetstone, for additional information.

UNITED STATES DEPARTMENT OF ENERGY NUCLEAR TEST ORGANIZATION

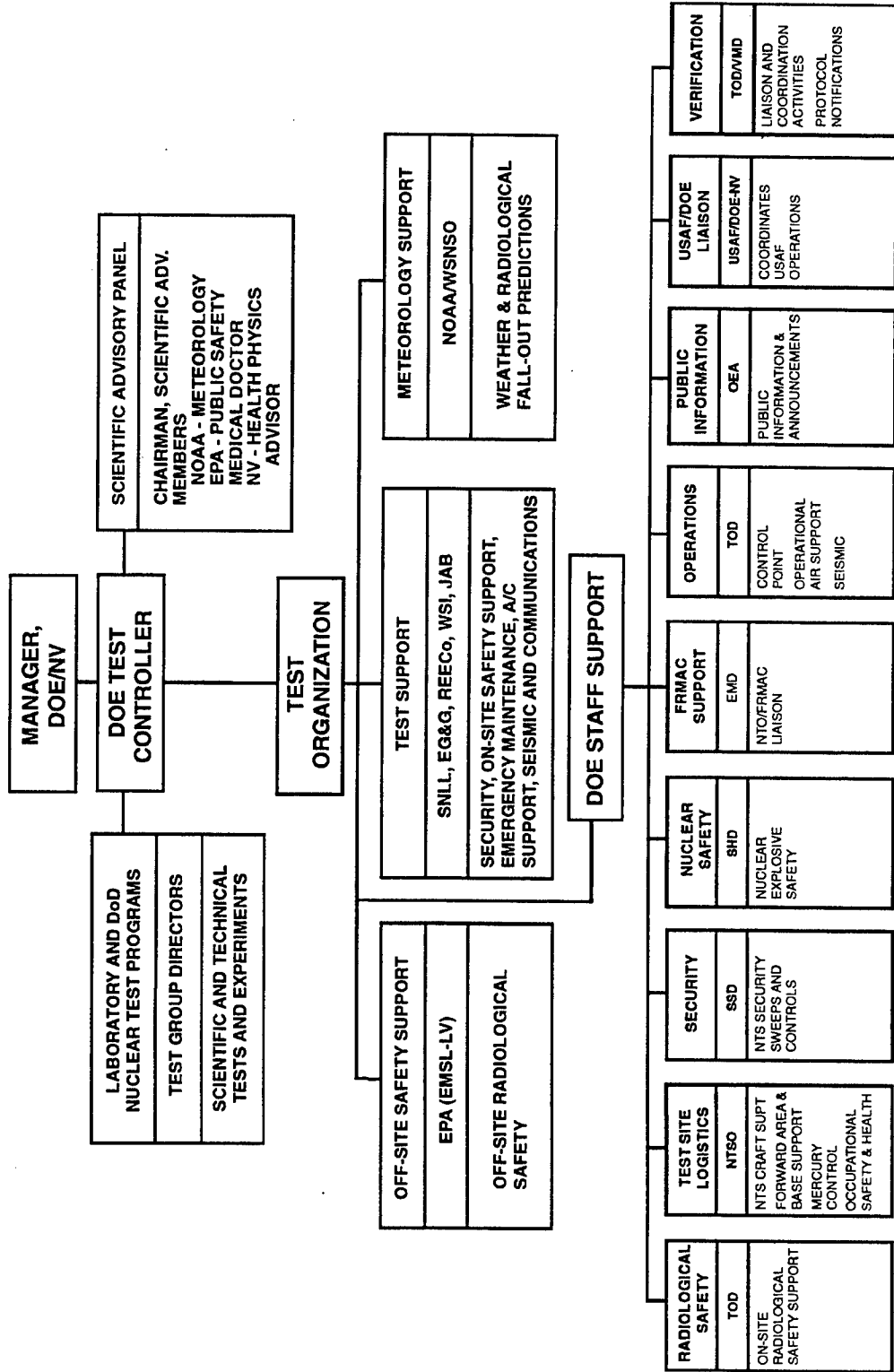

Figure 1-3. Nuclear Test Organization (1992).

1.4.3 NTO Radiological Safety.

The Test Controller was responsible for protection of participating personnel and offsite populations from radiation hazards associated with activities conducted at NTS. By mutual agreement between the Test Controller and a scientific user (see Section 1.4.4), control of radiation safety within the area assigned for a particular activity was delegated to the user's TGD during the period of time when such control could have had a direct bearing on the success or failure of the scientific program.

The onsite radiological safety support contractor (REEC Co Radsafe) was responsible to the Director, Test Operations Division, for both routine and test radiological safety coordination onsite as stated in Appendix E, DOE NTS SOP 5402¹⁰, "Radiological Safety." During tests, the Test Manager, NV, delegated control of all radiological safety and environmental protection activities within assigned areas or facilities to the user TGD. When this occurred, each Radsafe coordinator was responsible to the TGD through his radiological safety organization for support in his test area.

The U.S. Environmental Protection Agency (EPA) was responsible to the Test Controller for operation of the offsite radiological safety program.

1.4.4 NTS Scientific Users.

The NTS scientific users were DNA (for nuclear weapons effects) and the development laboratories Los Alamos National Laboratory (LANL), Lawrence Livermore National Laboratory (LLNL), and Sandia National Laboratories (SNL). LANL and LLNL were primarily involved in weapons-development testing while SNL conducted a limited number of weapons-effects tests and supported weapons

¹⁰ DOE NTS SOP 5402, dated 13 January 1992, superseded DOE NTS SOP 0524 and earlier versions of NTS SOP 5402. This SOP was in effect when the last nuclear test was conducted at NTS.

development tests. A brief description of these laboratories follows:

- A. LANL was established early in 1943 as Los Alamos, Project Y, of the MED for the specific purpose of developing an atomic bomb. Los Alamos scientists supervised the test detonation of the world's first atomic weapon in July 1945 at the Trinity site in New Mexico. Los Alamos became Los Alamos Scientific Laboratory (LASL) in January 1947 when the AEC and AFSWP were activated to replace the MED. LASL was renamed LANL on 29 December 1979 when Congress passed a bill changing LASL, LLL, and SLA to national laboratories. The Laboratory's continuing assignment was to conceive, design, test, and develop nuclear components of atomic weapons. The contract under which LANL performed work for DOE was administered first by the AEC's Santa Fe Operations Office and later by the Albuquerque Operations Office. The laboratory is operated by the University of California.

- B. LLNL (originally the University of California Radiation Laboratory [UCRL], then the Lawrence Radiation Laboratory [LRL], the Lawrence Livermore Laboratory [LLL], and finally LLNL) was established as a second DOE weapons laboratory at Livermore, California, in 1952. The Laboratory's responsibilities were parallel to those of LANL. Devices developed by LLNL first were tested in Nevada in 1953, and LLNL-developed devices have been tested in each Continental and Pacific series since. The contract under which LLNL performed work for DOE was administered by their San Francisco Operations Office. This Laboratory is also operated by the University of California.

- C. SNL has also undergone several name changes; it was established in 1945 as Z Division of Los Alamos. In April 1948, it was named Sandia Laboratory, Branch of Los Alamos Scientific Laboratory; and in November 1949 it assumed its identity as a full-fledged weapons research

institution operated by Sandia Corporation (SC), a non-profit subsidiary of Western Electric. In May 1956 it was renamed Sandia Laboratory, Albuquerque (SLA) adding a Livermore Branch in March 1956 (to provide closer support to LLL). SLA also began operation of the ballistics test facilities for the AEC at the Tonopah Ballistics Range (now Tonopah Test Range) in September 1956. In 1969, the name was changed to Sandia Laboratories (SL), and in 1979 it was changed to Sandia National Laboratories. SNL's role has been to conceive, design, test, and develop the non-nuclear components of atomic weapons and perform other work in related fields.

1.4.5 Test Support Organizations.

In keeping with its policy, DOE used private contractors for maintenance, operations, and construction (including military and civil defense construction) at the NTS. Nevada Operations Office personnel administered all housekeeping, construction, and related services activity, but the implementation of these functions was performed by contractors. Major support contractors were the following:

- A. REECo was the principal DOE operational and support contractor for the NTS, providing electrical and architectural engineering, state-of-the-art large-diameter and conventional shaft drilling, heavy-duty construction and excavation, mining and tunneling, occupational safety and fire protection, radiological safety, toxic and explosive gas monitoring, communications and electronics, power distribution, occupational medicine, and other support functions. REECo maintained offices in Las Vegas and extensive facilities necessary to operate at NTS.
- B. Edgerton, Germeshausen & Grier, Inc., (renamed EG&G, Inc. in 1966) was the principal technical contractor, providing control point functions such as timing and firing, and diagnostic functions such as scientific photography

and measurement of detonation characteristics. In addition, EG&G personnel manned the DoD monitor room. EG&G support facilities were maintained in Las Vegas and at NTS.

- C. H&N performed architect/engineer services for the NTS and was the principal support contractor for DOE's off-continent operations. H&N had a home office in the Los Angeles area and also maintained offices in Las Vegas and at NTS.
- D. F&S was a consultant architect/engineer for drilling and mining operations in connection with underground nuclear testing since 1963. The company was involved in design of many underground structures and in the field of deep, large-diameter hole drilling. Las Vegas Branch activity was conducted from offices in Las Vegas and Mercury, Nevada.
- E. RSN was awarded the DOE contract for services formerly performed by H&N and assumed those functions in November 1990. RSN had previously purchased F&S and combined those contractor functions under RSN.

Numerous other contractors performed various construction and other support functions for DOE and DoD.

1.5 NEVADA TEST SITE.

An on-continent location was selected for conducting nuclear weapons tests. Construction began at what was called the Nevada Test Site in December 1950, and testing began in January 1951. The name was changed to the Nevada Proving Grounds (NPG) in March 1952 and again changed to the Nevada Test Site on 31 December 1954.

The original boundaries were expanded as new testing areas and projects were added. Figure 1-4 shows the present NTS location bounded on three sides by the Nellis Air Force Range. The NTS encompasses about 1,350 square miles. This testing location was selected for both safety and security reasons. The arid climate, lack of industrialization, and exclusion of the public from the Nellis Air Force Range resulted in a very low population density in the area around NTS:

The only paved roads within the NTS and Nellis Air Force Range complex were those constructed by the government for access purposes. NTS testing areas were physically protected by surrounding rugged topography. The few mountain passes and dry washes where four-wheel drive vehicles might enter were posted with warning signs and barricades. NTS security force personnel patrolled perimeter and barricade areas in aircraft and vehicles. Thus, unauthorized entry to NTS was difficult, and the possibility of a member of the public inadvertently entering an NTS testing area was extremely remote.

Figure 1-5 shows the NTS, its various area designations, and the locations of the 12 tests covered by this volume. In a location designation such as "U12n.07" the "U" signifies an underground location, "12" identifies the area at NTS, "n" denotes the tunnel, and "07" indicates the drift number.

A low mountain range separates the base camp, Mercury, from the location of early AEC and DoD atmospheric tests at Frenchman Flat in Area 5. This area was also later used for DoD underground testing. The elevation of Frenchman Dry Lake in the middle of the Flat is about 3,100 feet.

A mountain pass separates Frenchman Flat from Yucca Flat testing areas. The pass overlooks both Frenchman and Yucca Flats and contains the CP complex of buildings including Control Point 1 (CP-1) and Control Point 9 (CP-9) where timing and firing for most underground nuclear tests were performed, and Control Point 2 (CP-2) where radiological safety support was based.

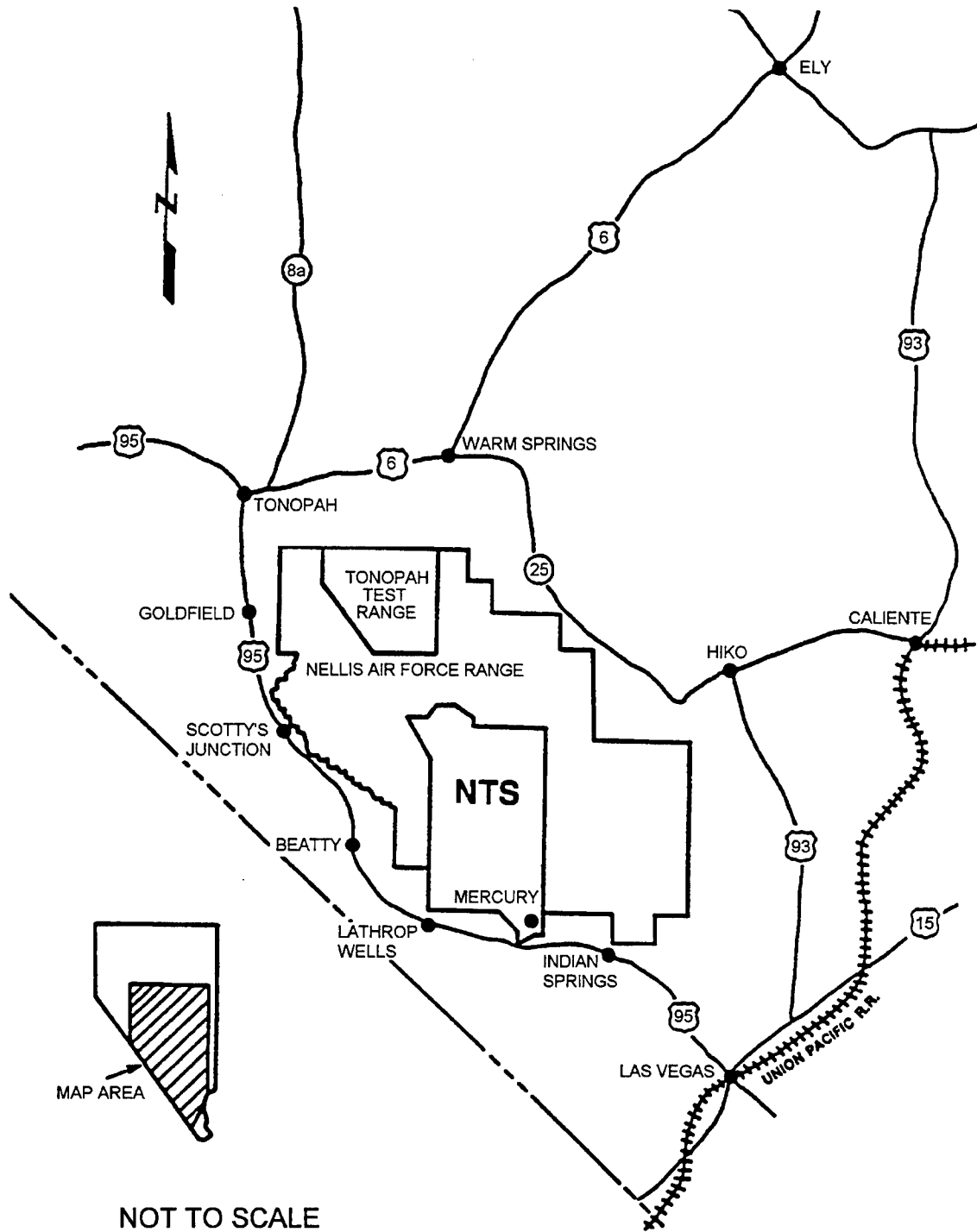

Figure 1-4. Nellis Air Force Range and the NTS.

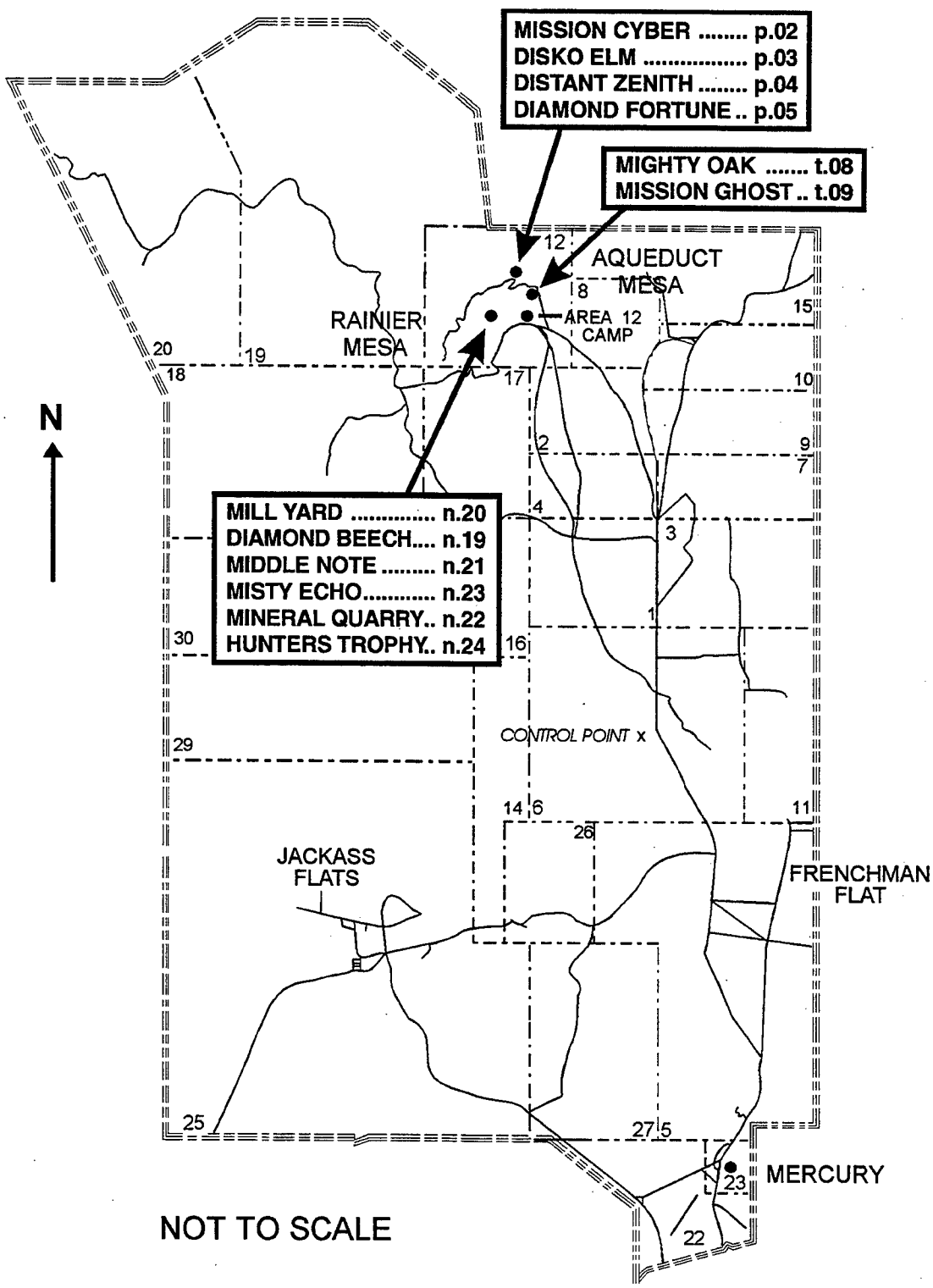

Figure 1-5. Nevada Test Site.

Yucca Flat testing areas include Areas 1, 2, 3, 4, 6, 7, 8, 9, and 10. Underground tests were conducted in some of these areas and generally were shaft emplacement types. The elevation of Yucca Dry Lake at the south end of Yucca Flat is about 4,300 feet. To the west of Yucca Flat is the Area 18 testing location. Some DoD atmospheric tests were conducted in Area 18, and one DoD cratering test, DANNY BOY, was conducted on Buckboard Mesa in this area at an elevation of about 5,500 feet. The northern part of Area 16 and all of Area 17 are mostly mountainous regions and are located between Yucca Flat and Area 18. The single Area 16 tunnel complex (at an elevation of about 5,400 feet) was a DoD underground testing location.

Rainier Mesa is in Area 12, northwest of Yucca Flat. The top of the Mesa is at an elevation of about 7,500 feet. All DoD tunnel emplacement tests on NTS that were not in the Area 16 tunnel complex or the Area 15 shaft and tunnel complex were in Rainier Mesa and adjoining Aqueduct Mesa. The major Rainier Mesa tunnel complexes were B, E, G, and N tunnels. Portions of the T tunnel and all of the P tunnel complexes were constructed in the adjoining Aqueduct Mesa.

Area 15 is in the foothills at the north end of Yucca Flat. The deeper of the two access shafts drops 1,500 feet below the surface elevation of 5,100 feet. There were three tests conducted in Area 15, all sponsored by DoD. HARD HAT and TINY TOT were discussed in DNA Report 6320F, Operations Nougat and Whetstone, while PILE DRIVER was discussed in DNA Report 6321F, Operations Flintlock and Latchkey.

SECTION 2

UNDERGROUND TESTING PROCEDURES

Underground tests conducted at the NTS prior to 1962 were contained, weapons-related experiments (including the safety tests). These tests were controlled by the AEC and conducted by LASL or LLL. Experience gained in the area of underground radioactivity containment during these tests provided the basic concepts for development of containment plans for DoD/DNA-sponsored underground nuclear weapons-effects tests which followed. These DoD tests were generally more complex than earlier AEC tests and required the development of new containment concepts and hardware.

A primary consideration in all underground tests was the safety of test participants and the general public, especially regarding exposures to radioactive materials. This chapter discusses, in general terms, containment problems and procedures, types of emplacement, diagnostic techniques, effects experiments, area access requirements, industrial and radiological safety, radiation measuring systems, and air support requirements.

2.1 CONTAINMENT PROBLEMS AND PROCEDURES.

Completely containing radioactive material underground while accomplishing diagnostic measurements and effects experiments proved to be a major scientific and engineering challenge. Original efforts considered only detonation containment in competent rock formations. It was necessary to modify the original efforts to consider zones of weakness in rock caused by faults and containment failures resulting from diagnostic and experiment structures. Under certain conditions, particularly the presence of clay or a high water content in rock near the detonation point, residual stress could be lower, allowing a stronger-than-normal shock wave that could adversely affect containment. Some containment failures were partially attributable to additional overpressure from secondary gas expansion (i.e., steam pressure). The

major containment features and problems that evolved are discussed below.

2.1.1 Vertical Shaft Containment.

Some of the first shaft safety experiments were in unstemmed shafts with concrete plugs penetrated by cable and instrumentation holes. When nuclear yields were produced, these emplacements did not completely contain the debris. The first method used to fully contain nuclear detonations in shafts was stemming (i.e., filling the shaft with aggregate and sand after device emplacement).

Keyed concrete plugs at different depths in the shaft stemming sometimes were used. The shaft diameter was enlarged at the plug construction location so the poured concrete plug would key into the ground surrounding the shaft and provide more strength against containment failure. Combinations of concrete and epoxy were used later, and epoxy replaced concrete as a plug material for some shaft emplacements.

Radiochemical sampling pipes, LOS pipes, and other openings in stemming and plug containment features had to be closed rapidly after detonation to prevent venting of radioactive effluent to the atmosphere. Closure systems driven by high explosives, springs, or hydraulics were developed to seal the openings. After some of these early systems did not prevent releases of effluent to the atmosphere, use of openings to the surface for diagnostic or experiment purposes was discontinued for several years until technology improved.

Some scientific and other cables from the device emplacement to the surface were another source of containment problems. While these cables could be embedded in concrete and epoxy, which helped prevent leakage along the outside of the cables, radioactive gases under high pressure could travel along the inside of cables. The inner conductors of high frequency coaxial cables were hollow copper tubes whose inner openings were an inch or more in diameter providing easy flow paths for gas. This problem was solved by

using solid dielectric cables and factory-certified gas-tight cables and fittings. Another solution was to embed the inner components of these cables in epoxy or other materials at appropriate locations (e.g., in concrete plugs) using a technique known as gas blocking.

Many containment problems were caused by unanticipated geologic and hydrologic conditions at particular test locations. Even careful and rigorous calculations, engineering, construction, and preparations were inadequate in the presence of unsuitable geologic settings.

Another similar problem was the presence of higher-than-anticipated water content in rock formations surrounding or near the detonation point. This problem caused greater shock transmission plus secondary gas expansion when the water turned to steam. In addition, presence of sufficient iron in the test configuration caused the disassociation of water with subsequent greater secondary gas expansion from hydrogen gas. A result was much higher and longer sustained pressure from the detonation point toward the surface and the possibility of subsequent failure of geologic or constructed containment features.

Recognizing and understanding geologic and hydrologic conditions at each test location was necessary before these containment problems could be solved. As additional information became available through drilling and intensive geologic studies, these problems were lessened by investigations of proposed detonation locations and application of detailed site-selection criteria.

2.1.2 Tunnel Containment.

As with shaft detonations, containment methods used for tunnel tests were designed keeping the basic characteristics of a nuclear detonation in mind. Tunnel configurations were constructed with device emplacements strategically located to cause sealing of the access tunnel by force of the detonation. Additional containment features were used to contain radioactive debris.

One of the original user laboratory stemming configurations consisted of one or more sandbag plugs installed a short distance from the projected self-sealing location toward the tunnel entrance (i.e., the portal). Two plugs, each about 60 feet long, were a typical installation. The sandbag plugs were later changed to solid sand backfill plugs extending several hundred feet from the device location. In many cases, the sand stemming had short sections of air voids between the plugs. Closer to the portal, a keyed concrete plug with a metal blast door was constructed. The blast door was designed to contain any gases (with pressure up to 75 pounds per square inch [psi]) that might penetrate the sandbag plugs.

Also as with shaft detonations, the unknown presence of undesirable geologic and hydrologic conditions sometimes caused venting of radioactive effluent either through the overburden (i.e., the ground above the tunnel) to the surface, through fissures opened between the detonation point and the main tunnel, or through the plugs and blast door to the main tunnel vent holes and portal. More substantial containment features evolved as containment problems became better understood and tunnel tests became more complex.

The first horizontal line-of-sight (HLOS) DoD tunnel test was MARSHMALLOW in 1962. Stemming for that test consisted of four sandbag plugs extending out to a distance of a few hundred feet from the nuclear device (similar to earlier AEC tunnel tests). A Gas Seal Door (GSD) (i.e., a blast door) was installed in the main access drift. The next DoD tunnel test, GUMDROP (1965), used sand backfill (with a few air gaps) out to a few hundred feet. As DoD tunnel testing continued, sand plugs were gradually replaced with various grout mixtures. Some grout mixtures were designed to match the strength and shock propagation of the native tunnel material (usually ash-fall tuff) while other grout mixtures were designed to be weaker and form a solid stemming plug shortly after device detonation.

Also, as tunnel testing continued, the GSD no longer was used as a containment device. It was replaced by strong concrete plugs 10 to 20 feet thick, referred to as Overburden Plugs (OBPs) and later renamed Drift Protection Plugs (DPPs) and Gas Seal Plugs (GSPs). In addition, other plugs were used to protect tunnel facilities (i.e., Facilities DPPs [FDPPs] and Alcove Protection Plugs [APPs]). These plugs were keyed into the tunnel wall and some were designed to withstand overpressures up to 1,000 psi and temperatures up to 1,000°F. Some of the plugs were penetrated with electrical cables and steel pipes, and a small access hatch was constructed. All of these penetrations were gas sealed (or capped) to provide protection against possible gas seepage through the plug.

Use of HLOS pipes in tunnel tests necessitated development of additional closure systems. The HLOS pipe tunnel and its access tunnels generally were separated from the main tunnel by one or more concrete plugs. The closure systems primarily were for protection of the experiments inside the HLOS pipe, but some were also considered useful features for the formation of a stemming plug.

The tunnel volume outside the pipe was stemmed using grout and/or concrete, while the experiments inside the HLOS pipe were protected by mechanical closure systems. Several types of mechanical closures were used, including compressed gas-driven gates that closed off the HLOS pipe from the detonation within a small fraction of a second after detonation time. Another type of mechanical closure was the tunnel and pipe seal (TAPS) unit, first used on the DOOR MIST test. The TAPS was a heavy steel door that was released at shot time and fell to the closed position in less than one second.

In 1972 DNA developed a containment concept that was to become the standard for future underground nuclear tests. This concept became known as the nested or three-vessel containment concept. While exact containment features varied for each test, the following provides a general description of the three-vessel concept:

Vessel I was the stemmed area. Almost all of the open tunnel volume surrounding the working point (WP), including the main and access drift, were filled with rock-matching grout (RMG) while some areas further from the WP (in both the bypass and LOS drifts) were filled with superlean grout (SLG). The remainder of the main and bypass drifts out to the end of the stemming, and also the Mechanical Auxiliary Closure (MAC) and Gas Seal Auxiliary Closure (GSAC) access drifts, were filled with high-strength grout (HSG), or concrete. The MAC, GSAC, and TAPS units themselves were normally surrounded with structural concrete. In some cases specific mixtures of grout were used; i.e., SLG and HSG, or HSG with high-strength groutcrete or concrete. Steel stemming bulkheads were used to seal off sections of the drift allowing it to be filled one section at a time. All voids were completely filled by pressure grouting at the back or top of the drift. High-stress valves were installed in all lines which penetrated the stemmed area, and all cables were gas blocked by using standard DNA gas-blocking procedures. Vertical cable holes were typically stemmed with RMG above the tunnel floor followed by cement grout, epoxy, and coarse stemming material.

Vessel II consisted of the various DPPs. Several massive containment structures consisting of reinforced concrete plugs, designed to withstand pressures of 1000 psi and temperatures of 1,000°F, were installed in the tunnel complex as a backup in the event that the drifts failed to stem properly or that radioactive material seeped through the stemmed areas. Typical of these plugs were the DPPs, each of which was reusable. All mechanical penetrations through the containment had valves or seals that met or exceeded the containment criteria of the structures themselves. The DPP was a high-strength concrete plug keyed into the tunnel rock (normally filled with HSG during button-up activities).

Vessel III was that portion of the tunnel main drift protected by a Gas Seal Plug (GSP) and GSD. The GSP sealed the entire tunnel and was designed to withstand pressures of 500 psi and temperatures of 500°F. Penetrations of the GSP were sealed using the same techniques as the DPP. The GSP contained a trainway that

would normally remain open until tunnel button-up occurred prior to test detonation. The steel GSD, on the portal side of the GSP, was installed in a reinforced concrete plug which was keyed into the rock. The GSD was closed during button-up activities, and a 10 psi pressure was applied between it and the GSP as additional reassurance against low-pressure leaks.

2.1.3 Containment Evaluation Panel.

Because containment problems were particularly difficult to solve, the AEC began to change its emphasis on conditions under which nuclear detonations should be conducted. Another reason for the change of emphasis was that the LTBT required that radioactive fallout be confined within the borders of the sponsoring country.

The Manager, AEC/NVOO had primary responsibility for the underground containment of radioactivity from underground tests. Containment of the DoD-sponsored tests was a joint effort on the part of AEC, DoD, and contractor scientists and engineers. To carry out this responsibility, AEC/NVOO established a Test Evaluation Panel (TEP) on 17 December 1963 to review plans for each test as presented by user testing organizations for each test program. The chairman of this panel represented the Manager, NVOO, and membership consisted of two representatives (one voting member plus an alternate) from each of the user testing organizations (LASL, LLL, SLA, and FC/DNA) plus specialists from contractor and other government organizations such as the U.S. Geological Survey (USGS). Other AEC/NVOO contractor personnel were available to present information in their areas of expertise (e.g., mining and drilling operations).

On 19 March 1971, testing was suspended because containment failure had caused serious venting of a laboratory-sponsored test (BANE BERRY). During this time the TEP, under a formal charter, was changed to the Containment Evaluation Panel (CEP). The CEP, as an independent agent, evaluated the containment design of each proposed nuclear test, assuring that all relevant data available for proper evaluation were considered. They were instructed to

give increased emphasis to containment of radioactive materials. The panel membership was enlarged by the addition of a hydrologist, a geologist with expertise in underground nuclear phenomenology (both nominated by their respective organizations and approved by the Manager, NVOO), and consultants representing additional areas of expertise. These permanent advisors were representatives of the EPA, the National Oceanic and Atmospheric Administration Air Resources Laboratory (NOAA/ARL), and REECO. Each underground testing organization was represented as before.

Prior to a formal meeting of the CEP, each user planning a nuclear test prepared documents (i.e., a prospectus) describing its proposed tests with particular emphasis on containment considerations, and submitted these documents to each panel member for review. This information then was presented by the users to the CEP, generally at the following meeting. Details of the containment plan were reviewed and compared to previous successful experiences. Each CEP member (or alternate) was requested to submit a written statement describing the details considered favorable or unfavorable to achieve successful containment.

During the period covered by this report, evaluations to estimate the probability of successful containment conformed to specific guidance from OMA at HQ/DOE. Each CEP member used this guidance to categorize each test as one of the following:

CATEGORY A

Considering all containment features and appropriate historical, empirical, and analytical data, the best judgment of the member indicates a very high confidence in successful containment.

CATEGORY B

Considering all containment features and appropriate historical, empirical, and analytical data, the best judgment of the member indicates a lesser but still adequate degree of confidence in successful containment.

CATEGORY C

Considering all containment features and appropriate historical, empirical, and analytical data, the best judgment of the member indicates some doubt that successful containment will be achieved.

UNABLE TO CATEGORIZE

The Manager, NV, was advised of the findings of the evaluation in order to provide a basis on which to request detonation authority. He forwarded a written report on each CEP meeting, containing the statements of each voting member and consultant, to HQ/DOE for review and recommendations for approval to execute each test. The detonation authority request package also included the chairman's summary, the prospectus, and a transmittal letter with other pertinent test data, such as approval dates.

2.1.4 Test Controller's Advisory Panel.

Careful consideration of each test by the CEP to avoid releases of radioactive effluent to the atmosphere was followed by additional precautions prior to test execution. If an unanticipated release of effluent from an underground detonation occurred, it was necessary to ensure protection of onsite participants and the offsite population. The Test Controller's Advisory Panel was composed of a scientific advisor and representatives from each organization which could contribute information to this protection goal.

This panel met at several readiness briefings in advance of each test and in the Control Room prior to and during execution of each test. Two CEP members acted as advisors to the Test Controller's Advisory Panel to recommend if the as-built containment features for the test were acceptable or whether the plans should be referred back to the entire CEP. The D-1 Containment Briefing provided a technical review of the as-built containment features and deviations from the plan presented to the CEP. Panel members briefed the Test Controller's representative on other aspects of

test activities and meteorological conditions which he considered in his decision on whether a test should be conducted. Information presented by the panel included the status of test participants in the test area. Permission to arm and detonate the nuclear device was not given until all participants (other than those at approved manned stations) were clear of the controlled test area.

Weather conditions were considered in detail. Wind speeds and directions at increasing altitudes above the ground were measured with weather balloons at stations around NTS, both preceding and during each test. Measurements were used to calculate and present information on where an unanticipated release of effluent might be transported off the NTS and what the levels of radiation might be in the predicted effluent cloud.

Actual locations of population centers, general location of each dairy cow herd, and numbers of people at ranches and mines in the projected direction of the effluent cloud were identified and evaluated. EPA personnel in the offsite areas notified mining people to be above ground for safety purposes at the anticipated detonation time of tests which might cause a ground control hazard. This information and numbers of people who might need to be advised to stay under cover or be evacuated were presented for consideration. EPA personnel started offsite air samplers and placed radiation dosimeters in offsite locations before detonation time. Readiness information included capability for advising state officials to institute a milk diversion program if cattle, feed, or milk might become contaminated, and to replace milk and dry feed for localized family dairy cows.

The status of standby aircraft for effluent cloud sampling and tracking capability was presented. Communications between offsite weather stations and EPA personnel were checked to ensure proper operation.

Radsafe personnel onsite ensured that remote radiation monitoring stations in the test area and in other NTS areas were functional.

Data from these stations, the weather stations, offsite EPA personnel, and personnel clearing the test area were displayed in the Control Room for continual visual examination by the Test Controller and the Advisory Panel. In addition, closed-circuit television cameras were operational on the ground and in helicopters in the test area to detect any visual indications of possible effluent release and provide capability for immediate response action by the Test Controller and the Advisory Panel members.

If the Test Controller decided that the projected effluent direction was close to populated areas, or weather conditions were not stable enough to determine the direction of any released effluent after detonation, the approval to arm and detonate was not given. The test was either postponed for another day or placed on hold until conditions were favorable.

Conditions were considered favorable when the following situations existed: (1) the projected effluent direction was toward sparsely populated areas; (2) weather conditions were relatively stable; (3) EPA personnel could contact the few residents in the projected effluent direction and advise them to take protective actions; and (4) the impact on the milk supply from dairy cattle would be minimal. In addition, all essential equipment, personnel, and procedures were required to be in readiness status or activated before permission to arm and detonate was given.

Permission to arm usually was given at least two hours before a scheduled detonation to allow time for arming, securing of the test configuration and containment systems, and departure of the arming party from the test area. The detonation, however, could be delayed at any moment up to detonation time, or postponed until another day or time when conditions might be more favorable.

The Test Controller and the Advisory Panel received information, watched visual displays, and communicated with their field personnel up to and after detonation for a sufficient time to ensure that venting had not occurred. Remote radiation detection instru-

ment readings and closed-circuit television of the test area were monitored to detect any indication of effluent release.

When all other indications of venting were negative and the Test Controller decided personnel could approach the test location, (i.e., subsidence craters had formed for shaft detonations, and cavity collapse had occurred for tunnel emplacements, as indicated by geophones) initial radiation survey teams entered the test area to ensure that effluent had not been released or that any radiation levels were low enough for experiment data recovery to begin. For tunnel tests, reentry of the tunnel itself (after initial survey of the surface areas, recovery of data, and approval by the DOE Test Controller) was a matter for separate and careful consideration by the Test Group Director and radiological safety personnel.

2.1.5 Effluent Release Procedures.

If radioactive effluent was released from an underground test, established procedures were initiated in accordance with guidelines set forth in DOE NTS SOP 5402, "Radiological Safety" (see Appendix E), and DOE NTS SOP 5401, "Environment, Safety, and Health Coordination Responsibility" (see Appendix F). Immediately upon detection of possible venting and effluent release after a detonation, the following procedures were initiated:

- A. For some tests, Radsafe survey teams were at manned stations in the test area. These teams were released to make radiation measurements to be used in determining direction and radiation levels of radioactive effluent.
- B. Aircraft were standing by to sample and track the effluent. Data reported were further used to refine information on effluent direction and radioactivity concentrations.
- C. EPA monitors in offsite areas, previously stationed in the projected path of any released effluent, were advised

of actual effluent direction and radioactivity measurement data and directed to move sampling and dosimeter equipment, perform ground radiation surveys, and notify residents and workers in the effluent path of any necessary precautionary measures, such as remaining in buildings or evacuating the area temporarily.

- D. Capabilities were held in readiness to advise state officials to implement a milk diversion program. If this was necessary, Nevada and neighboring state officials could be advised to impound and replace milk supplies possibly contaminated through the cattle feed pathway, and hold impounded milk for the decay of probable contaminants (radioiodines) before using it for other purposes. On a localized basis, EPA personnel were ready to replace family dairy cow milk with fresh milk, and analyze milk for concentrations of specific radionuclides. Dry feed supplies also could be replaced for family dairy cattle if required.

- E. Capabilities were in readiness for thyroid monitoring of offsite individuals possibly exposed to radioiodines from the effluent. These mobile monitoring stations could be used in the offsite areas for screening measurements to determine if any offsite residents or workers experienced iodine uptake and should be transported to Las Vegas facilities for more precise thyroid measurements and dose assignment.

Each of the above procedures was established to avoid or minimize exposure of the offsite population and maintain any such exposures below the radiation protection standards for individuals and population groups in uncontrolled areas.

While the above procedures were initiated, additional onsite procedures also were implemented. Radsafe survey teams, when released by the Test Controller, surveyed the test area in sufficient detail to plot gamma radiation isointensity lines on NTS

maps and provide specific intensity measurements at experiment stations on the surface and at other locations of interest. These data were used by the Test Controller in releasing personnel to enter radiation areas in the controlled area and by the Test Group Director in determining when surveys of his immediate test area and recoveries of experiment data could be accomplished. These decisions were based on calculations of personnel gamma radiation doses from survey data, radiation intensities at recovery locations, and estimated times in the area. The purpose was to reduce potential safety and health risks and to maintain occupational radiation exposures as low as reasonably achievable.

Some tunnel tests that did not result in venting of radioactive effluent to the atmosphere did have a failure of the containment system within the tunnel. High radiation levels then existed in locations where reentry personnel needed to enter to accomplish data recovery. Procedures developed to minimize exposures of reentry and recovery personnel included the placement of remote radiation detectors located at strategic tunnel complex locations, remote tunnel atmosphere samplers that removed tunnel air to locations outside the tunnel for analysis, and tunnel air filters that would allow controlled purging of tunnels before reentry with only controlled gaseous radionuclide releases to the atmosphere.

Remote monitoring and sampling equipment provided information on radiation levels, toxic gases, and explosive mixtures necessary to determine whether tunnel ventilation should be accomplished before reentry. Tunnel ventilation filters stopped particulate radioactivity, and activated charcoal in the filters absorbed most of the radioiodines, thus allowing primarily only radionuclides of the noble gases, such as xenon, to be released to the atmosphere. (Exposure to radionuclides of the noble gases is far less hazardous than exposure to other fission products.) Release of this radioactive material to the atmosphere in a gradual, highly-controlled manner during tunnel ventilation to protect reentry personnel was subject to approval of the Test Controller.

2.2 EMBLACEMENT TYPES.

The DoD conducted 12 underground tests that are discussed in this report. Table 2-1 lists the tests and pertinent data. All 12 DoD tests conducted during Operations Charioteer, Musketeer, Touchstone, Cornerstone, Aqueduct, Sculpin, and Julin were tunnel tests. Both tunnel and shaft emplacement types are discussed in this section. An emplacement type not discussed in this report was one that resulted in the excavating or ejecting of material from the ground surface to form a crater (see Crater Experiment in the Glossary of Terms).

2.2.1 Vertical Shaft Emplacement.

A vertical shaft nuclear detonation was intended to be contained underground. The shaft was usually drilled, but sometimes mined, and it may have been lined with a steel casing or have been uncased. The nuclear device was emplaced at a depth calculated to contain the explosion. At detonation, a cavity was formed by vaporized and melted rock. Pressure from the hot gases in the cavity held surrounding broken rock in place until the cavity volume cooled sufficiently to decrease pressure. As broken rock fell into the cavity formed by the detonation, a chimney was formed. If the chimney of falling rock reached the surface, a subsidence crater was formed. Figure 2-1 shows a typical subsidence crater.

If a device was placed too deeply in the alluvium of Frenchman or Yucca Flat for the detonation yield, or the depth was correct but the yield was much less than anticipated, a subsidence crater might not form (i.e., the chimney might not reach the surface). This was a problem during early years of underground testing when it was necessary to move drilling rigs into subsidence craters soon after tests for cavity sample recovery purposes. If a subsidence crater did not form, drilling rigs could not be moved to the surface ground zero (SGZ). When directional drilling from outside the crater was implemented, lack of a subsidence crater in alluvium became less of a problem. Experience gained with depth

Table 2-1. Department of Defense-sponsored underground nuclear tests
9 October 1985 - 18 September 1992.

OPERATION	CHARIOTEER			MUSKETEER		TOUCHSTONE	CORNERSTONE		AQUEDUCT	SCULPIN	JULIN	
	MILL YARD	DIAMOND BEECH	MIGHTY OAK	MIDDLE NOTE	MISSION GHOST	MISSION CYBER	MISTY ECHO	DISKO ELM	MINERAL QUARRY	DISTANT ZENITH	DIAMOND FORTUNE	HUNTERS TROPHY
DATE	9 Oct 1985	9 Oct 1985	10 Apr 1986	18 Mar 1987	20 June 1987	2 Dec 1987	10 Dec 1988	14 Sept 1989	25 July 1990	19 Sept 1991	30 Apr 1992	18 Sept 1992
LOCAL TIME (hours)	1340 PDT	1620 PDT	0608 PST	1028 PST	0900 PDT	0830 PST	1230 PST	0800 PDT	0800 PDT	0930 PDT	0930 PDT	1000 PDT
NTS LOCATION	U12n.20	U12n.19	U12t.08	U12n.21	U12t.09	U12p.02	U12n.23	U12p.03	U12n.22	U12p.04	U12p.05	U12n.24
TYPE	Tunnel	Tunnel	Tunnel	Tunnel	Tunnel	Tunnel	Tunnel	Tunnel	Tunnel	Tunnel	Tunnel	Tunnel
PURPOSE	Weapons Effects	Weapons Effects	Weapons Effects	Weapons Effects	Weapons Effects	Weapons Effects	Weapons Effects	Weapons Effects	Weapons Effects	Weapons Effects	Weapons Effects	Weapons Effects
DEPTH (ft)	1,230	1,325	1,294	1,309	1,054	899	1,313	857	1,278	865	776	1,264
YIELD ¹¹	Low	Low	Low	Low	Low	Low	Low	Low	Low	Low	Low	Low

¹¹ Low indicates less than 20 kilotons.



Figure 2-1. A typical subsidence crater.

of device burial also reduced the chance of subsidence craters not forming in the alluvium. The depth of burial, for both shaft and tunnel tests, was scaled to the maximum credible yield, usually significantly larger than the expected yield. However, the minimum depth of burial was 600 feet.

Most vertical shaft underground tests conducted by DoD included a vertical line-of-sight (VLOS) pipe system to the surface and a mobile tower on the surface that contained the weapons-effects experiments (see Figure 2-2). The VLOS pipe system contained several mechanical closures designed to prevent the release of radioactivity into the atmosphere. These closures were open at the time of detonation but closed within milliseconds to stop the flow of material up the pipe. The open volume between the VLOS pipe and the wall of the drill hole was filled with sand and other materials. One or more non-porous material plugs were placed around the pipe. Electrical cables which went downhole were gas blocked to prevent gas seepage to the surface. Effects experiments were contained in a mobile tower on the surface that was moved away from the hole after device detonation but before surface collapse (formation of the subsidence crater). One problem was the possibility of seepage after surface collapse if some pathway to the surface developed. Some radioactive effluent was released into the atmosphere during several VLOS DoD tests.

2.2.2 Tunnel Emplacement.

Tunnel emplacement nuclear detonations were intended to be completely contained. The nuclear device was emplaced in a mined drift (tunnel) at a depth designed to contain the detonation. The native material at tunnel elevation was ash-fall tuff for tests covered in this volume. Chimneying of broken rock to the surface was rare because there was a layer of welded rhyolitic ash-flow tuff at and below the surface of Rainier Mesa. This tuff has a higher density than the ash-fall tuff and is more competent (has more strength) than the alluvium material in Frenchman and Yucca Flats. In addition, tunnel emplacements were buried deeper than

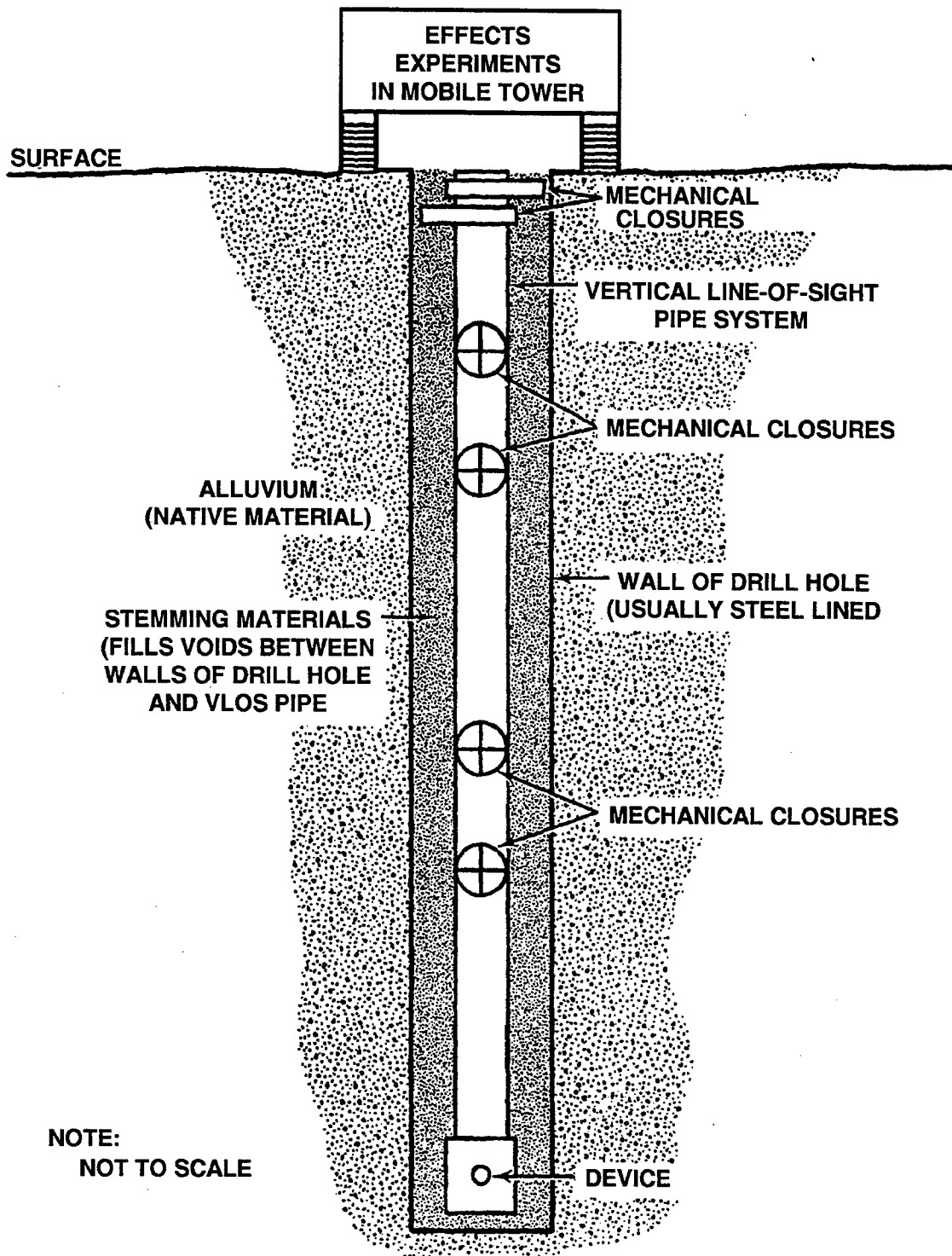

Figure 2-2. Vertical LOS pipe configuration.

required for containment, and the collapse chimney rarely extended to the surface. Tunnel emplacements were in one of several configurations: at the end of a single horizontal tunnel into a mountain or mesa; at the end of a drift (tunnel) within a tunnel complex; at the end of a horizontal tunnel driven from a vertical shaft; or in a cavity mined from a horizontal tunnel or vertical shaft.

Many of the tests described in this report included HLOS pipe systems placed in horizontal drifts in tunnel complexes, as seen in Figure 2-3. Each device was placed close to the end of a drift inside a tunnel complex. An HLOS pipe system (some over 1,000 feet long), including several mechanical closures and one or more test chambers (that contained effects experiments), were installed in the drift. The mined area surrounding the HLOS pipe was stemmed with various mixtures of grout to a distance of several hundred feet from the device location. This closure of the HLOS pipe in the stemmed area was the primary containment system. Ground shock produced by the expanding cavity exerted pressure on the tunnel walls and stemming materials, closing the HLOS pipe immediately after detonation and forming a stemming plug. All electrical cables and other penetrations within the stemmed area were gas blocked carefully to prevent or minimize seepage of radioactive gases through the stemming plug. The mechanical closures in the HLOS pipe were designed primarily to protect the effects experiments; however, they also had some effect on the formation of the stemming plug. The secondary (or backup) containment system included two or more concrete plugs, that were strategically keyed into the tunnel walls to prevent leakage of radioactive gases outside the tunnel should the primary system fail. These concrete plugs were designed to withstand the maximum expected pressure and temperature.

DNA has led the development of tunnel containment systems and has maintained continuing research and development programs to improve containment of tunnel tests.

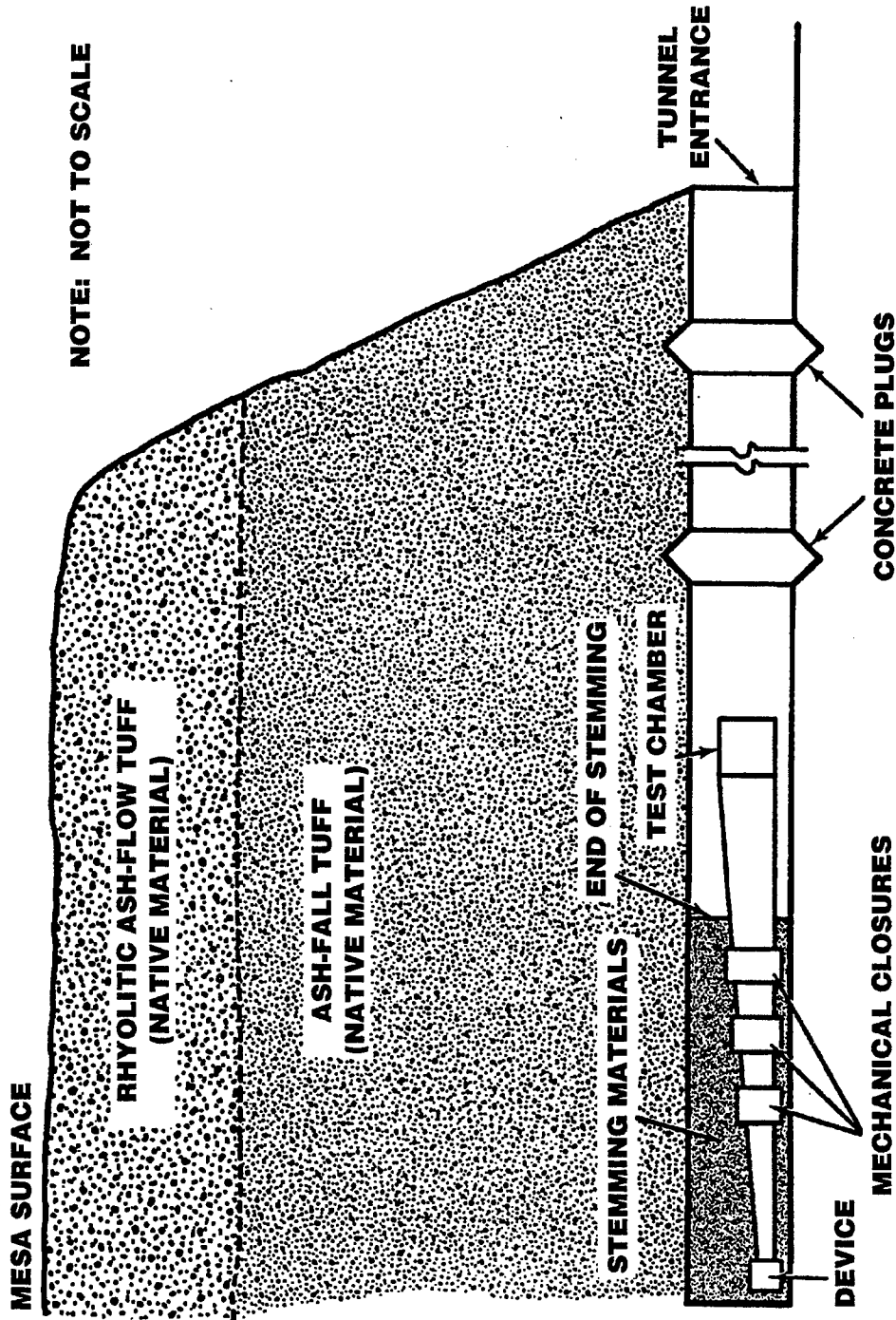

Figure 2-3. Horizontal LOS pipe configuration.

2.3 DIAGNOSTIC TECHNIQUES.

The transition from atmospheric to underground testing substantially reduced the release of radioactive materials to the atmosphere and required the development of new diagnostic techniques. During the atmospheric tests, high speed photography recorded fireball growth and aircraft collected samples from the radioactive cloud for diagnostic measurement analysis. Because such systems could not be used on underground tests, several new diagnostic techniques were developed. Some of these are discussed in the following subsections.

2.3.1 Radiation Measurements.

Measurements of radiation from an underground detonation were made possible by the development of a system of remote detectors and cabling that sent signals to recording facilities located at the surface. Detectors, using various physical characteristics of the radiations to be measured, were installed near the nuclear device. High-specification coaxial cable and connectors carried the measurement signals to the surface where electronic equipment, film, and magnetic tape recorded the signals or transmitted the signals by microwave to the CP.

Detector signals were on the way to recording equipment billionths of a second after a detonation, before the detectors were destroyed. These measurement systems required the most advanced electronic technology available. Considerable research and development were necessary to acquire and refine these capabilities.

2.3.2 Radiochemical Measurements.

Because clouds from atmospheric detonations no longer were available to sample for diagnostic purposes, techniques were developed to obtain samples of debris from underground detonations for radiochemical analyses and subsequent yield determinations. The first systems were radiochemical sampling pipes leading directly

from the device emplacements to filtering equipment at the surface. These pipes required closure systems to prevent overpressure from venting radioactive effluent into the atmosphere after samples were collected.

While these systems functioned as intended for most detonations, the systems did not function properly during all tests, and some radioactive effluent was released into the atmosphere. Subsequently, routine use of radiochemical sampling pipes to the surface was discontinued.

A major radiochemical sampling method that continued in use for shaft and tunnel detonations was posttest core drilling. The objective of this drilling was to obtain samples of solidified radioactive debris that had collected in a molten pool at the bottom of the cavity produced by the detonation. This method required and resulted in the development of precise directional drilling techniques and several advancements in the science of core drilling and radiochemical analysis.

2.4 EFFECTS EXPERIMENTS.

DoD/DNA tests were conducted primarily to obtain nuclear weapons-effects data. The effects of blast, shock, and thermal and nuclear radiations had been investigated earlier during atmospheric and underwater tests. Military equipment, structures, and materials had been exposed to various nuclear effects. The transition to underground testing required development of new test techniques. One important new technology was the simulation of high altitude (to exoatmospheric) conditions for radiation-effects experiments.

This simulation technique involved placing experiments inside test chambers and providing a low-pressure atmospheric condition from the nuclear device to the experiments. This was achieved by using large vacuum pumps to reduce pressure inside the steel LOS pipe to match the pressure of the desired altitude. Another technique was

the use of scatterers to direct radiation to experiments located outside the LOS pipe.

In addition to collecting radiation-effects data, other DNA NWET objectives were as follows: (1) to provide the desired nuclear effects environment; (2) to measure and document nuclear environments of interest; (3) to protect the experiments from damage, such as debris or ground shock; (4) to contain radioactive gases and debris underground; and (5) to manage the tests in a cost-effective manner. Scientific improvements were made in achieving these objectives. Cost effectiveness was accomplished primarily by designing facilities for maximum reuse.

Experiments were categorized as passive or active. Passive experiments involved placing experiment equipment in test chambers, exposing the equipment to the desired nuclear environment, removing the equipment, and analyzing it to obtain effects results. Active experiments utilized various sensors and high-speed electronic recording equipment to obtain data. Many active experiments also involved recovery and analysis to obtain effects results.

2.5 TUNNEL AND DRILLING AREA ACCESS REQUIREMENTS.

Access to underground work and drilling sites was controlled for a number of reasons. During construction, safety of both workers and visitors in these locations could have been jeopardized by carelessness or seemingly harmless activities of untrained and uncontrolled workers or visitors. When classified materials were in these locations, only personnel with appropriate security clearances were permitted access to the area. The presence, or anticipated presence, of radioactive material in a location required access control for radiological safety purposes. Access requirements established for the above purposes are discussed below.

2.5.1 Tunnel Access Control.

During construction and preparation for a DoD test in a tunnel or other underground work site, the Tunnel Superintendent was responsible to the REECo Project Manager for safety of personnel underground. From 1962 forward, Radsafe and tunnel logbooks usually were used to record names and radiation exposure information for only those persons entering a tunnel during posttest reentry and recovery operations. In the early 1970s, as a result of the Mine Safety and Health Act, tunnel logbooks were expanded to list all persons entering the tunnel (i.e., visitor, mining, drilling, Radsafe, etc.). Visitors and other personnel, who were not assigned to work in the tunnel, obtained permission for entry from the Superintendent or his representative. They were appraised of tunnel conditions and safety regulations and were listed in the logbooks. In the event of an accident or other emergency condition underground, the logbook provided information on numbers of personnel and their locations.

When classified material was in the tunnel prior to a test and during initial reentry after a test, the DoD Test Group Director, or his representative, was responsible for entry and safety of personnel underground. Security personnel checked for proper security and entrance clearances, maintained records of all personnel entering the tunnel, and safeguarded the device and other classified material. The check point was often well inside the portal thus allowing several activities at various work sites to be conducted simultaneously.

After detonation, aerial damage surveys to determine the accessibility of the various recovery stations were required before surface reentry operations were begun. When the reentry teams were given permission to depart Gate 300 (a check point set up in Area 3, just north of the turnoff to the CP, also known as Guard Station 300; see Figure 1-5) by the Test Controller, radiation and industrial hygiene surveys were conducted on the mesa and in the portal areas before any personnel were allowed in these areas.

Before underground recovery operations began, a listing was made of hazardous elements whose performance degradation; functional failure; or physical, chemical, or electrical properties constituted a posttest hazard within the test system complex. General requirements and standards governing safety were based on the DNA guidelines set forth in "Safety and Health Compliance Guide for Underground and Nuclear Effects Tests." Hazardous elements were defined to include active experiments and/or hardware containing radioactive, explosive, fire hazard, pressure vessel, evacuated container, electrical, toxic, and/or chemically hazardous components.

Instructions on the proper procedure, should a potential hazard have become a real hazard as a result of detonation, were made available to the underground reentry team and recovery personnel. Situations where permission was to be given before the tunnel reentry team would be allowed to proceed (including checking pressure and sampling gas on the WP side of the GSP and opening the OBP manway doors) were outlined in detail prior to reentry. Permission to proceed was given by a responsible party outside the tunnel complex on the basis of information transmitted by the reentry team. The required condition of the tunnel before experimenter personnel were allowed access to the test chambers was also outlined specifically.

Before experiments were released to the experimenters, each experiment was monitored for radioactivity and triple-bagged to reduce the spread of contamination inside the tunnel. Swipe samples were taken on experiments and equipment being removed from the tunnel area to verify that contamination standards were not exceeded. Experiments and equipment with higher-than-allowed removable contamination levels were taken to the Test Support Compound, that was equipped to disassemble radioactive/contaminated materials. Shipment from the Test Support Compound was restricted to organizations that were licensed to store and handle radioactive materials.

Control of tunnel access reverted to tunnel management personnel after reentry and recoveries. Entry procedures and use of the tunnel logbook were then implemented as discussed previously.

Additional access controls were instituted for radiological safety purposes after a test or during construction and test preparation when radioactivity from a previous test could be encountered. Part or all of a tunnel complex could be established as a radiation exclusion (radex) area.

All persons entering radex areas were logged on an "Area Access Register" form. Names and organizations represented were listed. Radiation exposures from reports for the year and quarter were listed upon entry. (The use of previous radiation exposure data was to ensure that personnel approaching current radiation exposure guide limits would not be allowed to enter radex areas when they could potentially accumulate exposures above those levels.) Self-reading pocket dosimeter measurements were added upon exit.

Before entering into a radex area, personnel were dressed in anticontamination clothing and respiratory protection as needed for the particular radiological conditions in the tunnel. Upon exit, the anticontamination clothing was removed, personnel were monitored for radioactive contamination, and decontamination was accomplished, if necessary.

2.5.2 Drilling Area Access Control.

Access to drilling areas was controlled by the drilling superintendent and the DoD TGD for the same reasons as access to underground workings was controlled. While drilling an emplacement shaft and during posttest drillback operations to recover radioactive core samples, personnel safety and compliance with safety regulations were emphasized continuously.

During pretest drilling activities, all visitors were required to contact the drilling superintendent before entry to the drilling site. Names of visitors and the purpose of each visit were

entered in the daily drilling report, and it was assured that visitors wore hard hats and understood safety regulations.

The laboratory that provided the device controlled access to the area, assisted by the security force personnel, when classified materials (including the nuclear device) were brought into the area for emplacement. After the test, when the drill site was a radex area, during classified material removal or posttest drilling, both security and radiological safety access controls were in effect as discussed under "Tunnel Access Control" (paragraph 2.5.1 above).

2.6 INDUSTRIAL SAFETY CONSIDERATIONS.

Implementation of an effective industrial safety program was an important part of any heavy construction operation. Mining and drilling operations had a particularly high accident potential. These operations at the NTS involved additional safety problems resulting from detonation-induced unstable ground conditions and the potential for encountering toxic gases, explosive mixtures, and radioactivity.

Miles of underground workings were constructed at several locations. More depth of vertical big holes (three-foot diameter or larger) was drilled than the known total drilled in the rest of the world. Directional and core drilling to recover radioactive debris samples after underground nuclear detonations advanced the science of these drilling techniques. These operations often were accomplished under unusual conditions with accompanying difficult safety problems.

The lost-time accident frequency, however, for the NTS support contractor employing most of the NTS personnel (REECO) was only a small fraction of the frequency for the heavy construction industry at large (as determined by annual surveys and reports of 300 heavy construction corporations). This excellent safety record was attained by continuing attention to indoctrinating and train-

ing NTS personnel, investigating and determining causes of accidents at the NTS, implementing and enforcing safety regulations, and, most important, maintaining the safety awareness of NTS personnel.

Safety was a joint effort by DOE, DNA, and their predecessors, and by the many other government agencies and contractors at NTS. Administered by REECo, the safety program enjoined all NTS personnel to conduct operations safely, and was exemplified by signs at the portal of a typical DoD tunnel complex as shown in Figure 2-4, one of which states, "Safety With Production is our Goal."

The safety procedures for all NTS operations are voluminous and cannot be included in this report. Appendix G, General Tunnel Reentry Procedures for Defense Nuclear Agency and Sandia Laboratories Nuclear Tests, May 1974, published by Sandia National Laboratories, is an example of a pertinent safety procedure. As this procedure indicates, several aspects of industrial safety are interrelated. Information on monitoring levels of radioactivity and personnel exposures to radiation is presented in Section 2.7, "Radiological Safety Procedures."

Monitoring of toxic, explosive gases was an important aspect of safety in underground workings, on drilling rigs, and in drilling hole cellars (the enlarged evacuated area under the drilling rig platform used for valving and other equipment). Toxic and explosive gases were created by both nuclear detonations and mining and drilling operations. The Draeger multi-gas detector and MSA explosimeter were able to detect such gases. The Fyrite or J&W oxygen indicator also was available to determine the oxygen content of the working atmosphere. Requirements were that the tunnel and drilling rig breathing atmosphere contain at least 19.5 percent oxygen. In addition, the breathing atmosphere had to contain less than the levels of toxic gases and percentage of the lower explosive limit (LEL) listed below. Explosimeter instruments were calibrated with 5.6 percent methane in air (adjusted for atmospheric temperature and pressure) as 100 percent of the



Figure 2-4. Portal of a typical DoD tunnel complex.

LEL for methane mixtures with air. Less than 100 percent of the LEL is not an explosive mixture of a gas or gases.

Gases	Maximum Concentration
Carbon monoxide, CO	50 ppm
Carbon dioxide, CO ₂	5,000 ppm
Nitric oxide plus nitrogen dioxide, NO + NO ₂	25 ppm
Nitrogen dioxide, NO ₂	5 ppm
Explosive mixtures	10% of the LEL

Procedures for controlling percentages of the LEL and toxic gases after each test are discussed in each of the test sections as appropriate.

2.7 RADIOLOGICAL SAFETY PROCEDURES.

Procedures were developed to evaluate radiological, toxic, and other hazards and to protect workers and the public from unnecessary exposures. Over the testing period discussed in this report, 1985-1992, several different procedures were in effect at different times as the DOE expanded its regulatory oversight to include environment, safety, and health. The following were the most recent procedures and implementation methods in place by the end of the testing period.

2.7.1 The U.S. Department of Energy, Nevada Test Site - Standard Operating Procedures (NTS SOP 5401 and 5402).

The NTS SOP 5401, "Environment, Safety, and Health Coordination Responsibility" (Appendix F), defined responsibilities and established criteria for coordination of radiological safety and clean-up; environmental restoration clean-up; and notification and record keeping associated with NTS programs under normal test conditions. The NTS SOP 5402, "Radiological Safety" (Appendix E), specifically defined radiological safety and radiation protection

responsibilities at the NTS. (The DOE Order 5480.11, "Radiation Protection for Occupational Workers," was a guideline for onsite radiological protection, defining criteria for occupational radiation exposure.) These criteria were implemented in DOE NV Order 54XG.1A, "NV Radiological Safety Manual."

2.7.2 The Standard Operating Procedures for the Health Protection Department, REECo.

These SOPs were reviewed and/or updated periodically to implement the environmental, safety, and health aspects of the DOE orders and SOPs discussed previously.

2.7.3 Implementation of Radiological Procedures.

The equipment, devices, capabilities and procedures for monitoring radiation levels in the environment and monitoring external and internal exposures of personnel are listed below:

A. Portable Radiation Detection.

- Eberline PAC-4G (alpha)
- Eberline PAC-4S (alpha)
- Eberline E-520 (beta and gamma)
- Ludlum Model 101 (beta and gamma)
- Ludlum 14C (beta and gamma)
- Ludlum Model 19 Micro-R-Meter (gamma)
- Technical Associates Cutie Pie (beta and gamma)
- Eberline Model RM-19 Radiation Detector (gamma)
- Eberline Model PIC-6A (beta and gamma)
- Eberline Model PNR-4 (fast and slow neutrons)
- Eberline E-140 (beta and gamma)
- Bendix T-290 Tritium Monitoring Detector
- Bendix T-446 Tritium Monitoring Detector
- TRITON Model 111 (tritium)
- EIC RO-3C Ion Chamber (beta and gamma)

B. Air Sampling.

Model 102 semi-portable sampler
Satellite sampler
Hurricane high-volume portable sampler (Gelman)
Vacuum pump low-volume portable sampler (Gelman)
Gast Model 2565 high-volume, high-flow sampler
Gast Model 1550 high-volume, low-flow sampler

C. Laboratory Analysis Capability.

The REECO Analytical Services Department Laboratory analyzed air, soil, water, surface swipes, nasal swabs, urine, and wound swab samples for some or all of the following determinations: gross alpha and beta, gross fission products, tritium, strontium-90, plutonium-239, and spectrographic analysis for specific gamma-emitting radionuclides. The laboratory also analyzed some of the above mentioned samples for nonradioactive materials, such as beryllium, through use of an emission spectrograph and by wet chemistry procedures. A spectrophotometer was used to analyze for other materials.

D. Monitoring of Personnel Exposures.

The NTS combination personnel dosimeter and security credential holder was placed in use in 1966 to provide the increased personnel dosimetry capability necessary to meet the radiation exposure problems associated with nuclear rocket testing and underground nuclear detonations. The holder was designed to accommodate a DuPont type 556 film packet, a fast neutron packet (containing Kodak Neutron Track, Type A [NTA] film), an identification plate, criticality accident components, the security credential, and a snap-type clip. The complete package had capabilities for determining beta, gamma, x-ray, thermal neutron, fast neutron, high-range gamma, and high-range neutron doses. Components for critical-

ity accidents (unintentional or accidental nuclear fissioning of device-critical materials) included materials which could detect and measure neutron and gamma radiation exposures above the ranges of the film packets. In March 1971, with the discontinuance of the DuPont film, NTS dosimetry operations converted to using the Kodak Type III film. This film packet contained two component films, one low range and one high range. Gamma exposure ranges of the two components were 30 mR to 10 R and 10 R to 800 R, respectively. The other components of the film badge, with the exception of the elimination of the Kodak NTA film from the film packet, remained essentially the same. In 1979 the Albedo neutron dosimeter, a thermoluminescent dosimeter (TLD) component system, was adopted at the NTS. This dosimeter was superior to the NTA film because it was a more sensitive dosimeter that responded to a much wider neutron energy range. The Albedo dosimeter was not part of the film dosimeter packet, but was only issued to those personnel who had a potential for exposure to a neutron source. The Albedo had its own holder that had to be worn flush with the body at all times. The NTS combination personnel dosimeter and security credential holder is shown in Figure 2-5. In 1984 the I.D. plate was eliminated and replaced by a bar-code issue system. This system was used from 1979 through 1986.

With the advent of the DOE requirements, established in the early 1980s, to restrict personnel exposures to as low as reasonably achievable (ALARA) and with emphasis on accurate dosimetry at low doses, DOE published a standard for performance testing of personnel dosimetry systems in December 1986. The standard describes minimum levels of acceptable performance and provides procedures for performance testing of these dosimetry systems.

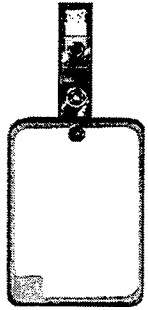

Clip

Security Credential



I.D. Plate
(eliminated in 1984)

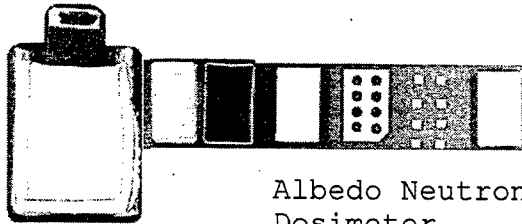

Albedo Neutron
Dosimeter



Kodak Type III Film Packet

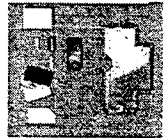

Criticality Components

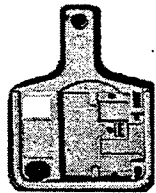

Film Packet and Credential Holder

Figure 2-5. NTS combination personnel dosimeter and security credential holder (1979-1986).

In the early 1980s, REECo Environmental Sciences Department personnel began evaluating TLD systems and other neutron dosimeters. This evaluation was initiated because the film badge and Albedo neutron TLD used at that time would not meet the new DOE requirements for greater sensitivity in measuring low exposures and for the level of reproducibility in evaluating doses.

After evaluating several dosimetry systems, the Panasonic TLD and the track etch neutron dosimeter were put into use in January 1987 replacing the Kodak Type III film and the Albedo neutron dosimeters, respectively. Figure 2-6 shows the Panasonic Model UD-802AS2 TLD dosimeter as it is inserted into the security credential holder. Figure 2-7 shows the four phosphor-element components that measure shallow dose equivalent, deep dose equivalent, and the low dose range. The high sensitivity of the last two components extend the dose range down to 0.1 mR. Figure 2-8 shows the track etch neutron dosimeter and its size relative to the security credential holder, while Figure 2-9 shows the components. The security credential holder was redesigned to accommodate both dosimeters. Again, the track etch dosimeter was only issued to those personnel who had the potential for exposure to a neutron source.

This dosimetry system, rather than defining limits based on the annual occupational whole-body penetrating radiation exposure guide, was designed under the specifics of the effective dose equivalent system. Ionizing radiation exposures were expressed as deep dose (mrem), shallow dose (mrem) and eye dose (mrem) equivalents. The TLDs were exchanged routinely each quarter for all individuals. The color code in the TLD window identified the quarter in which the TLD was worn.

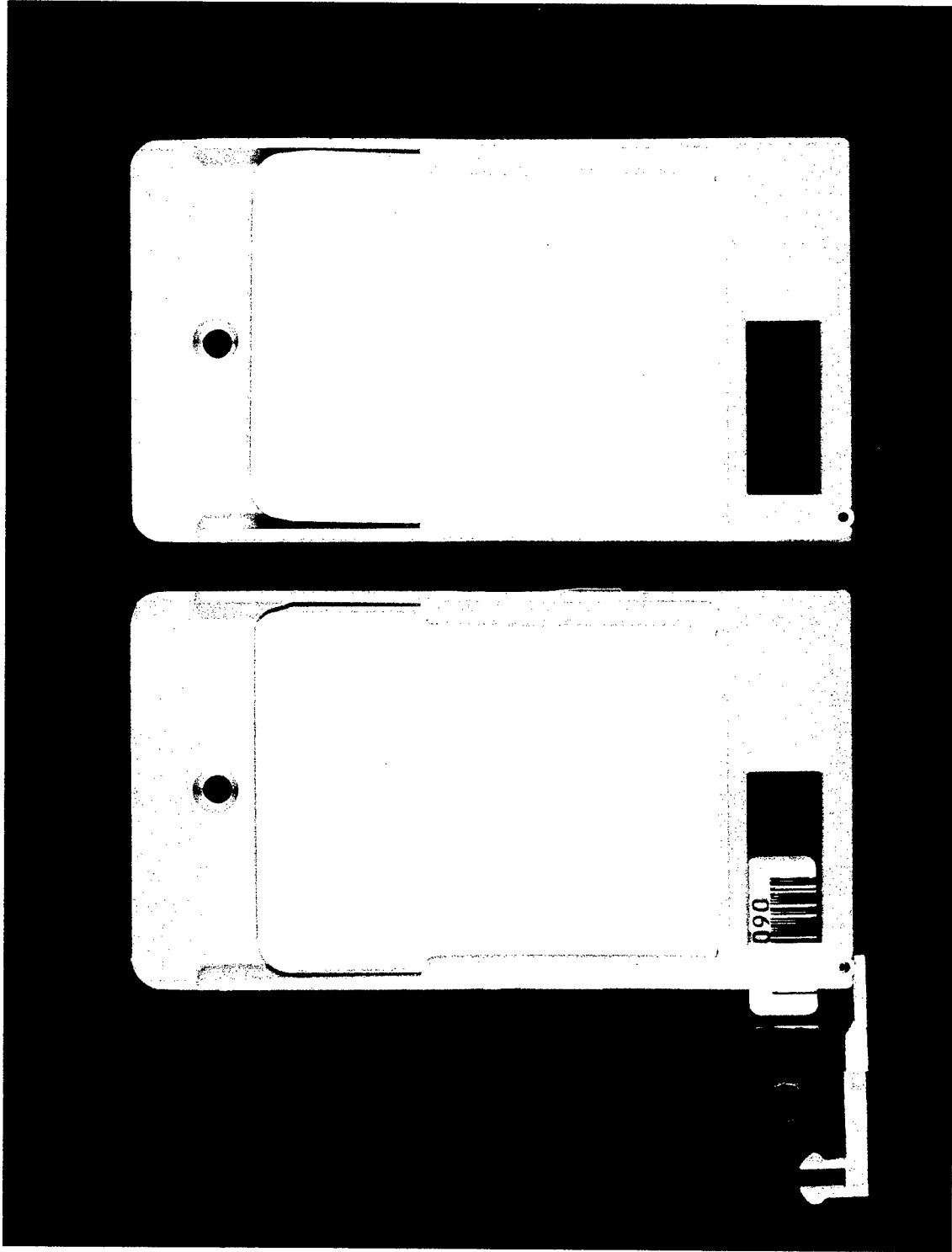

Figure 2-6. Panasonic personnel dosimeter and security credential holder.

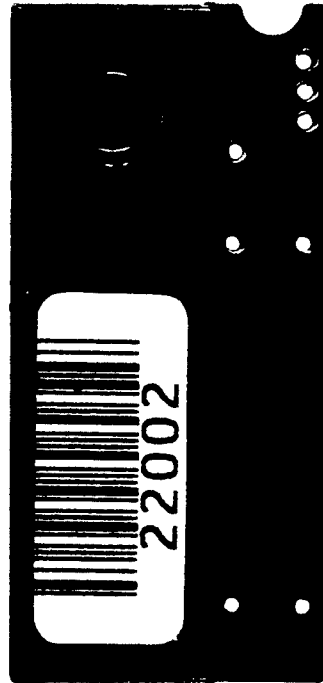
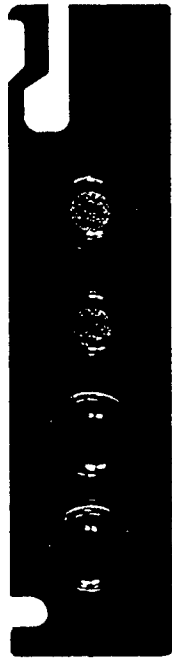
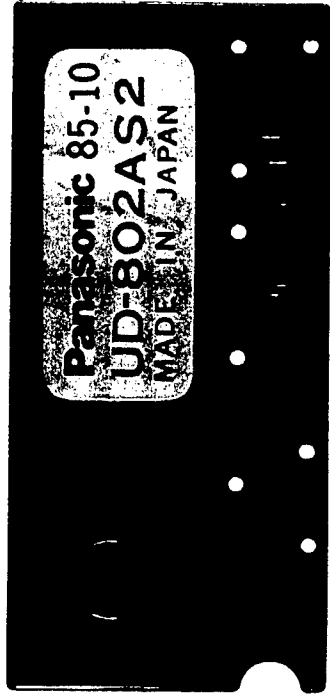

Figure 2-7. Panasonic TLD components.

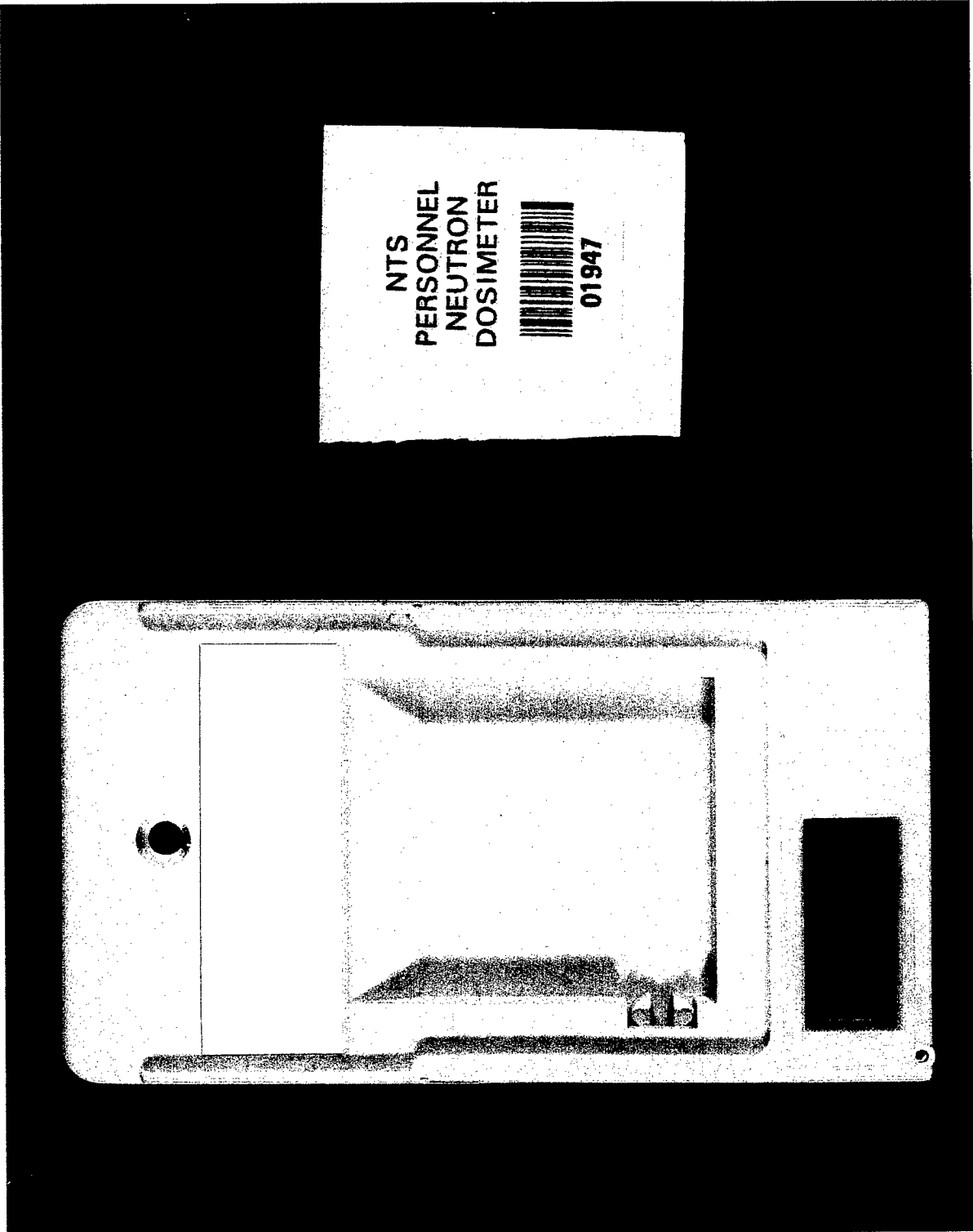

Figure 2-8. Track Etch neutron dosimeter packet.

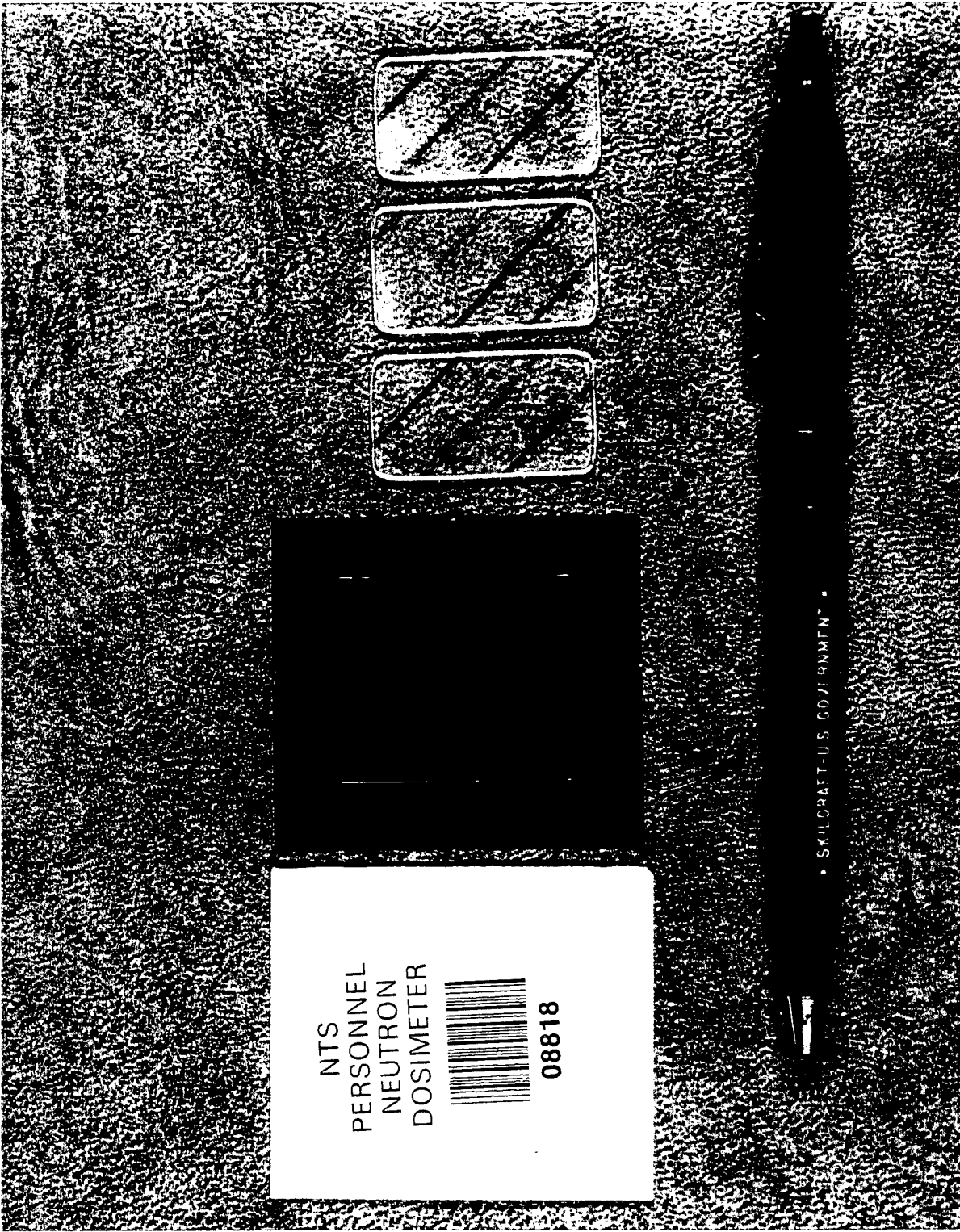

Figure 2-9. Track Etch neutron dosimeter components.

Personnel entering radex areas were also issued self-reading pocket dosimeters that indicated accumulated exposure. Upon exit, pocket dosimeter readings were entered on an Area Access Register and added to the yearly and quarterly accumulated exposures from the automated daily NTS radiation exposure report for use until TLD results were included. Pocket dosimeter readings were used as estimates because such readings were less accurate than the exposures recorded on TLDs.

This use of Area Access Registers helped to maintain personnel exposures below the radiation protection standard for the total effective whole-body dose equivalent of 5 rem per year and below the dose equivalent to the extremities of 50 rem per year. Personnel involved in the DoD tests described in this report had accumulated doses substantially below these exposure criteria.

2.7.4 Additional Methods Used to Control Radex Areas.

A daily log book was maintained by Radsafe monitors for each radex area. These logs were used to record the following information:

- A. Work accomplished - Which people worked where and what work was accomplished were briefly described. Any unusual conditions, such as equipment failure and operational difficulties, were listed.
- B. Visitors - First and last names of visitors were entered. Their destination and the reason for their visit were included. The time they entered and exited the area and results of personnel monitoring were recorded.
- C. Unusual occurrences - Any unusual events that occurred during the shift were recorded. Included in this type of entry were accidents, high-volume water seepage, or any other occurrences of an unusual nature.

- D. Surveys and samples - Routine surveys and samples were recorded as routine. However, the requester's name was required for special surveys and samples.
- E. Date and signature - The date and shift were entered at the beginning of the work period, and the logbook was signed before leaving the shift.

Personnel leaving radex areas removed anticontamination clothing and equipment and placed them in special containers for later laundering or disposal at the designated NTS burial site. Personnel then were monitored to ensure radiation levels were below the radiation exposure criteria defined in DOE Order 5480.11, "Radiation Protection for Occupational Workers." Personnel decontamination was accomplished if radiation levels were above specified limits. Decontamination usually was accomplished by vacuuming, removing radioactive particles with masking tape patches, washing hands or localized skin areas with soap and water, or showering with soap and water.

Vehicles and equipment removed from radex areas were monitored to ensure that they met criteria for unconditional release on or off the NTS (less than 0.4 mrad/h fixed beta plus gamma at contact and/or 1,000 disintegrations per minute [dpm] per 100 cm² of non-removable plutonium alpha; and less than 1,000 dpm/100 cm² of removable beta plus gamma and/or 100 dpm/100 cm² of swipeable plutonium alpha). Items exceeding these limits but below radex area levels could be conditionally released and moved onsite only.

2.8 TELEMETERED MEASUREMENTS OF RADIATION LEVELS.

Beginning in the early 1960s, various applications of radiation measurement telemetry were developed at the NTS to determine radiation levels at critical underground and surface areas following nuclear detonations. Multi-detector systems with range capabilities from 1 mR/h to 1,000 R/h and from 100 mR/h to 100,000 R/h continuously monitored locations of concern after

being calibrated and emplaced prior to each test. Ion chamber detectors were hard-wire linked by telephone trunk lines to exposure rate meters at a central console in CP-2. Detector locations were as far as 35 miles from this console. In 1974, these conditioned phone lines were supplemented by portable transmission stations. The detector was hard-wired into an area trailer and the signals were sent by microwave or hard-wire link to the Control Point.

These remote radiation monitoring systems provided data for reentry personnel participating in radiation surveys and recovery operations after each nuclear device detonation. The systems aided in substantially reducing exposure of personnel involved in reentry programs and were useful in detecting any venting or leakage of radioactive effluent to the atmosphere from an underground detonation.

2.8.1 Telemetry System in Use.

During the time frame of this report, the radiation telemetry system developed and used at NTS had specific applications depending upon distance, terrain, environment, and operational needs. The detection units and components in use for DoD tests in this report were part of the remote area monitoring system (RAMS). The principal piece of equipment used to form a RAM component was the RAMP-4. The RAMP-4 was a multichannel, hard-wire linked RAM component designed and modified by REECo Radsafe personnel and produced by the Victoreen Instrument Corporation. It consisted of a probe (Figure 2-10), that used a Neher-White gamma-sensitive ion chamber detector, linked by hard-wire and microwave communications to a readout console (Figure 2-11) in CP-1, CP-2 or the Control and Data Acquisition Center (CADAC). Readout from each detector displayed the data and time (in minutes after zero time).

The RAMS, using an eight-decade chamber, monitored and recorded actual pretest background readings that varied from 0.02 to 0.10 mR/h, depending on the chamber response and location. A check source was used in conjunction with the six logarithmic decades

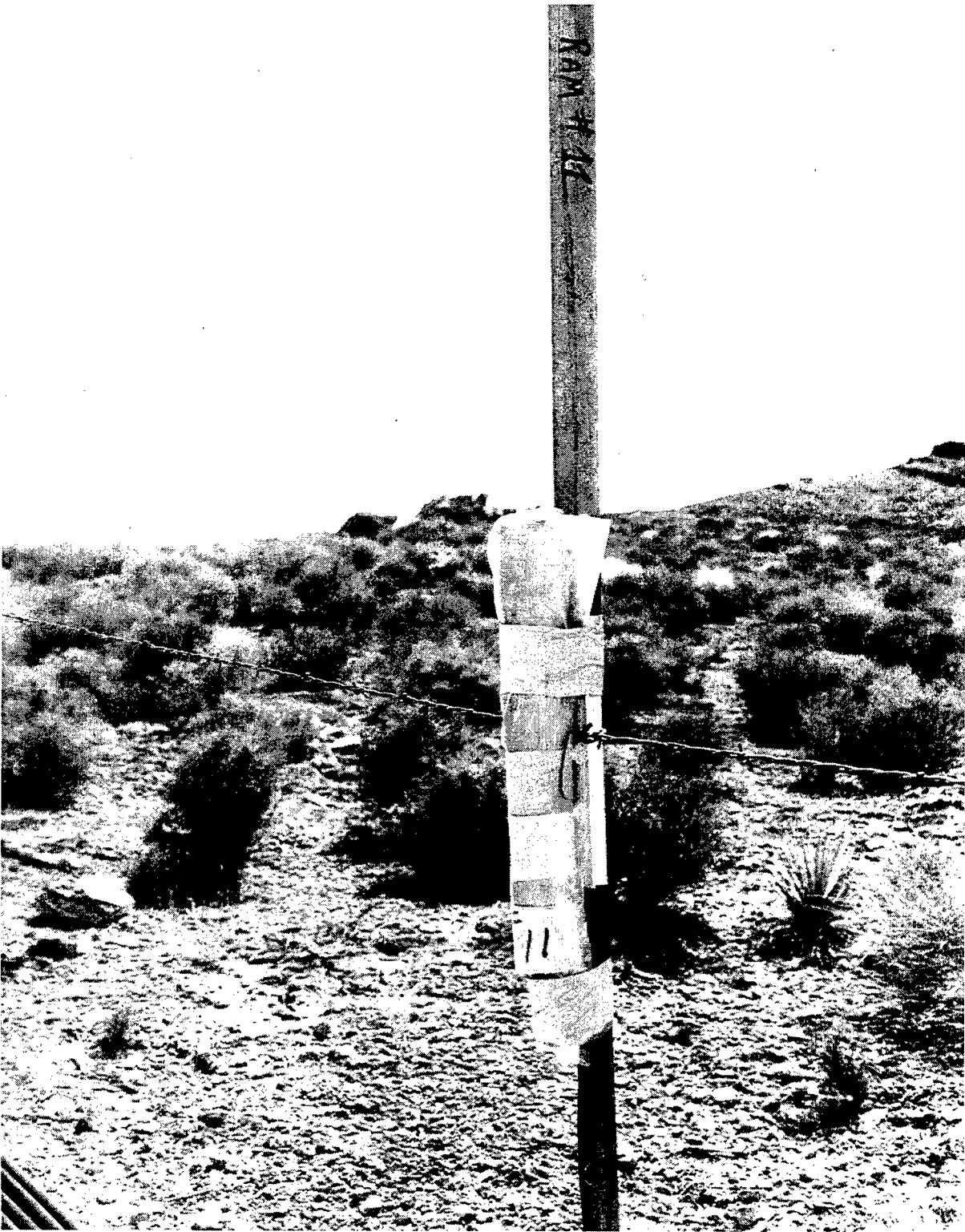

Figure 2-10. Neher-White RAM probe.

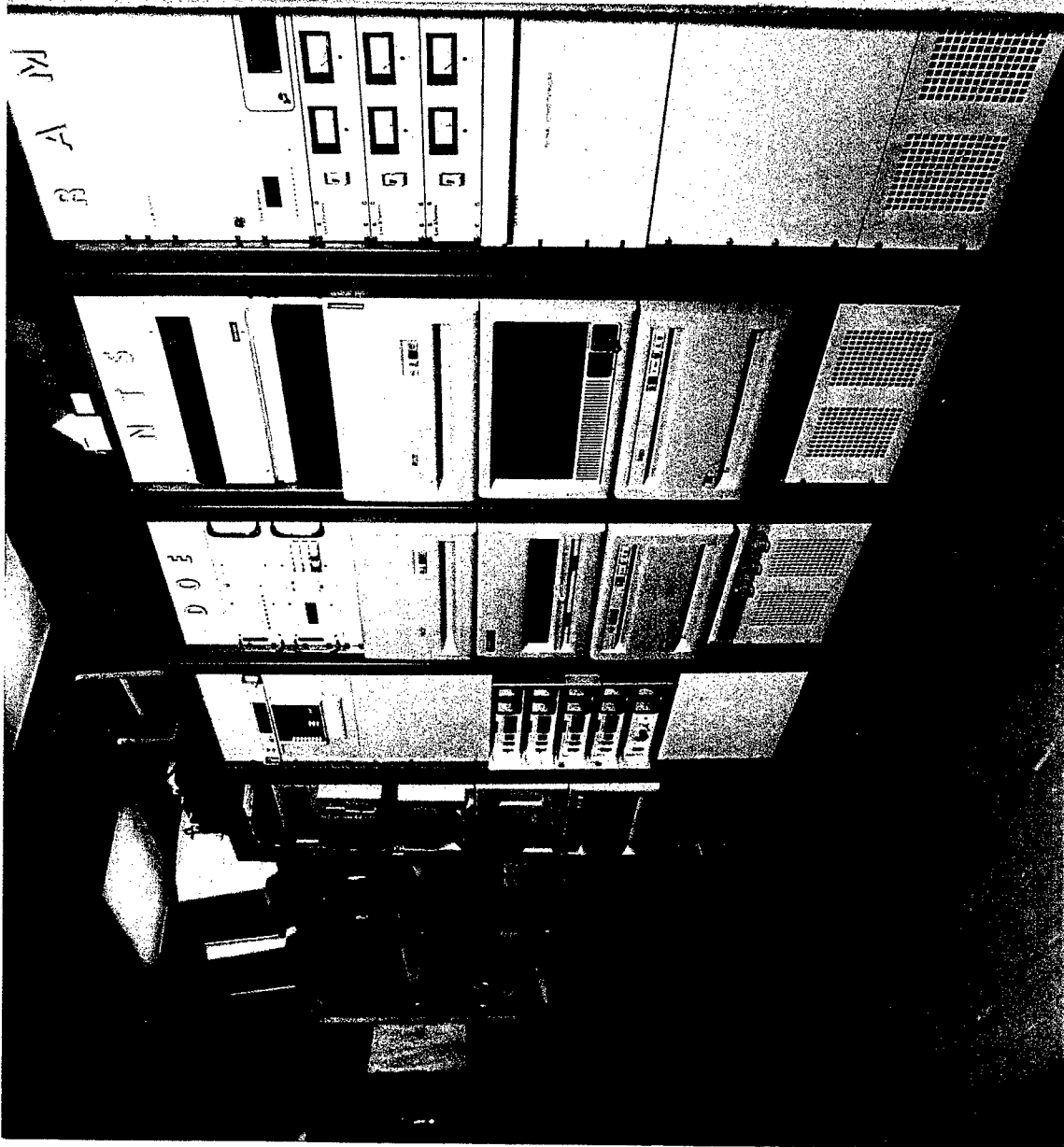

Figure 2-11. RAMS readout console.

(two three-decade scales) to provide a usual range of 1 mR/h to 1,000 R/h with a relative accuracy of 15 percent over the temperature range of 10° to 150°F up to 35 miles away. Extended range RAM units provided a range from 100 mR/h to 100,000 R/h.

2.8.2 Remote Area Radiation Detection Monitoring Support.

Approximately 20 detector units were positioned in the test area before a shaft test to continuously monitor radiological conditions and assess exposure rates before the test area was entered after detonation. Detectors were placed in circular arrays at appropriate distances from SGZ that varied with device yield and predicted wind direction (see Figure 2-12). RAM units for tunnel tests were placed somewhat differently based on each tunnel layout. Telemetry arrays for DoD tests varied between 15 and 50 stations depending upon the area or tunnel test location. Variable numbers of detectors were used aboveground and underground during tunnel tests and are discussed in each test section. The additional 50 permanently-established remote RAM and satellite stations operated continuously at living areas, work areas, and other locations throughout NTS (Figure 2-13). Tables 2-2 and 2-3 list these locations. Test-related temporary telemetry detectors operated from zero time until it was determined that release of radioactivity probably would not occur, or until any released radioactivity had decayed to near-background levels at the telemetry stations. For some of the earlier tests, readout locations were positioned near the Forward Control Point (FCP) or at locations where telephone lines were available, in addition to the readouts located at CP-2.

Radiation telemetry data were supplemented with information collected through a mobile air sampling program. Air sampling units were used to obtain samples of any radioactive effluent released at test time or during the posttest drilling operations. Prior to each nuclear detonation experiment, at least one sampler was placed at a specified location in the test area and remained in position until drillback operations were completed or the TGD authorized removal.

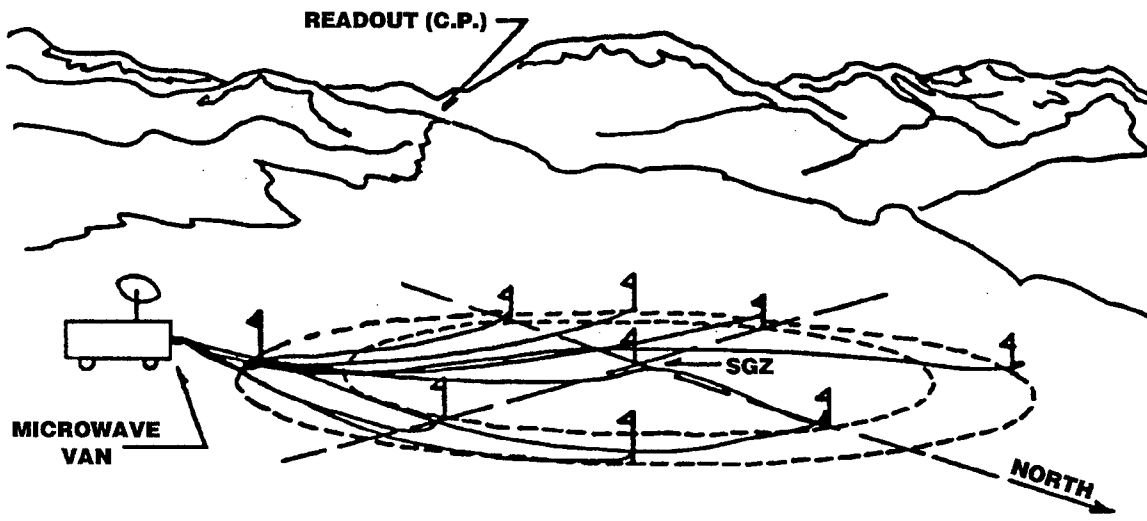

Figure 2-12. Typical remote radiation detection monitoring system for a shaft emplacement site.

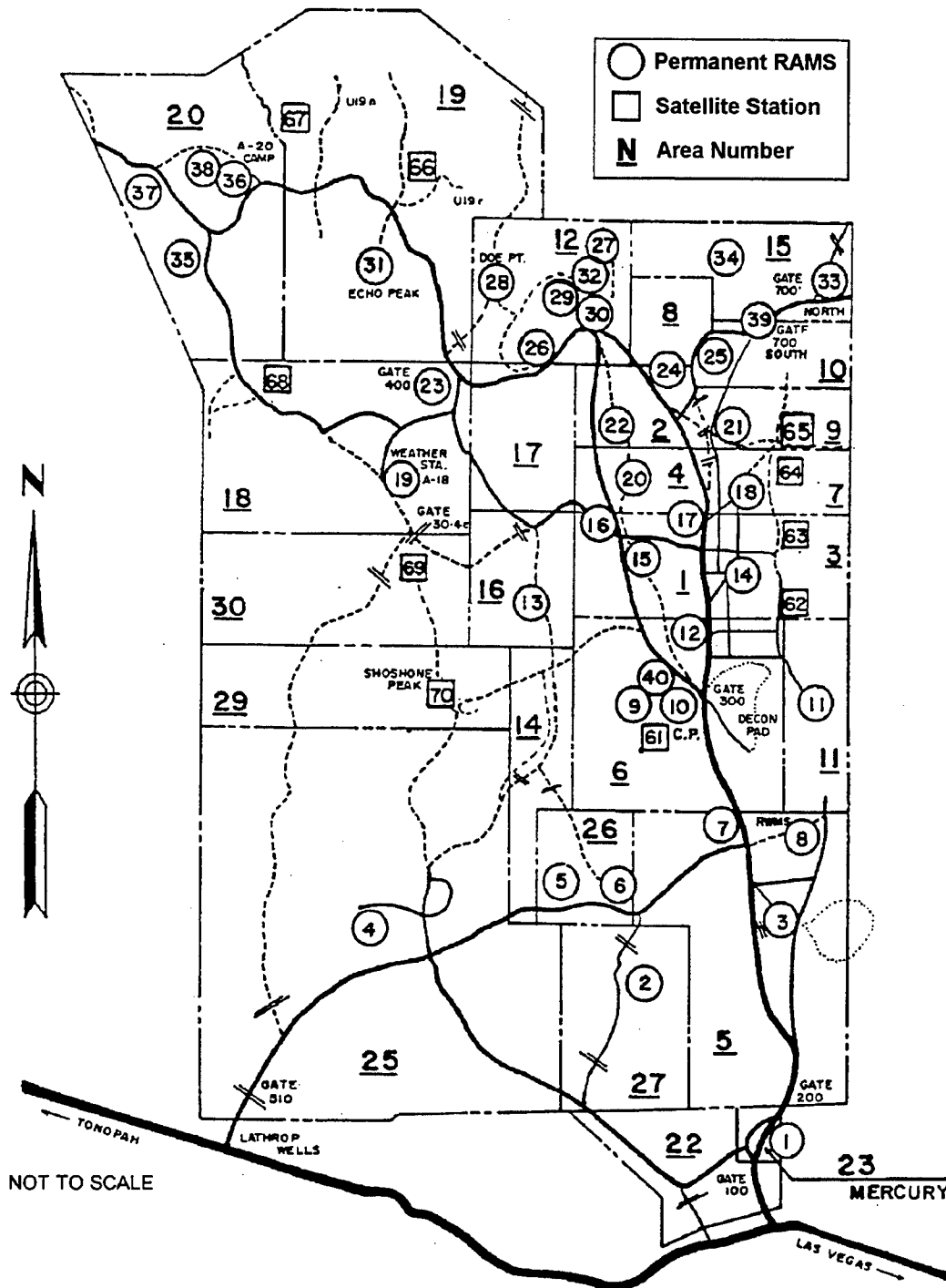

Figure 2-13. Permanently established remote radiation monitoring and satellite stations operated continuously throughout the NTS.

Table 2-2. NTS permanent RAMS.

Area	RAMS Number	Location	Area	RAMS Number	Location
1	15	Stake 1-H-1	12	28	DOE Point
1	16	Shaker Plant	12	27	P Tunnel
1	17	BJY	12	26	G Tunnel
2	22	2-300 Bunker	12	32	T Tunnel
2	24	Area 2 Camp	12	29	N Tunnel
3	14	Area 3 Camp	15	34	U15a Complex
4	20	4-300 Bunker	15	33	Gate 700 North
5	8	RWMS	16	13	U16a Tunnel
5	7	Stake M-57	18	19	Air Strip
5	3	Well 5-b	18	23	Area 17 Camp
6	9	3-11 Compound	19	31	Echo Peak
6	40	CP-1	20	38	U20aa
6	10	CP-2	20	37	U20i
6	12	Well 3-b	20	36	Area 20 Camp
7	18	7-300 Bunker	20	35	Pahute/A Rd. Jct.
9	21	9-300 Bunker	23	1	Mercury
10	25	10-300 Bunker	25	4	E-MAD
10	39	Gate 700 South	26	6	Gate 250
11	11	Tweezer Facility	26	5	Area 26
12	30	Area 12 Camp	27	2	Area 27

Table 2-3. NTS satellite stations.

Area	Satellite Number	Location
3	63	Stake CC-9
3	62	Stake OB-15
6	61	CP-1
7	64	Stake 7B-31
9	65	Stake 9B-39
18	68	Stake 18A-104
19	67	Silent VABM
19	66	U20t
29	70	Shoshone Peak
30	69	WSI Gate 30-4C

2.9 AIR SUPPORT REQUIREMENTS.

During the 1985 to 1987 time period, direct support for DoD underground nuclear tests was provided to NTO by the 4460th HS, of the 57th FWW, stationed at ISAFAP. They provided support for tests MILL YARD, DIAMOND BEECH, MIGHTY OAK, MIDDLE NOTE, MISSION GHOST, and MISSION CYBER. Through a Memorandum of Agreement between DOE/NV and DNA, EG&G/EM was tasked to provide air support for the following DoD-sponsored tests: MISTY ECHO, DISKO ELM, MINERAL QUARRY, DISTANT ZENITH, DIAMOND FORTUNE, and HUNTERS TROPHY. Less air support was required as the probability of venting radioactive effluent to the atmosphere decreased with development of more effective containment techniques.

2.9.1 Changes in Air Support Requirements.

After 1962, Air Force cloud-sampling and cloud-tracking aircraft generally were not required except for cratering tests conducted by the DOE where radioactive effluent clouds were anticipated.

Passage of the radioactive effluent through variable amounts and temperatures of rock and other media selectively retained some radionuclides underground, and changes occurred in the fission product ratios previously used during calculation and analysis of atmospheric detonation cloud samples. The value of analyzing particulate and gaseous cloud samples to determine characteristics of a detonation decreased accordingly.

The first change in cloud tracking and sampling support was to a lighter Air Force aircraft, the U-3A, with an Air Force pilot and EPA monitor. The EPA monitor also performed aerial monitoring of selected locations near SGZ and along the path of any effluent cloud. This air support later was performed by EPA and contractor personnel in their own aircraft.

Perimeter sweeps continued to be conducted daily by Air Force and Security personnel during reasonable flying weather to ensure that unauthorized vehicles were not entering the NTS over rough terrain or around security barricades on secondary roads. The L-20 aircraft, used prior to 1968, were replaced by helicopters and other aircraft. Air security sweeps of the immediate test area were conducted for a few hours before each detonation to assist in clearing the test area and to ensure that unauthorized vehicles were not approaching it from directions not controlled by manned security stations.

Air support for photography missions during tests, and initial radiation surveys after each test did not change. Helicopters with Air Force pilots generally were used with contractor and military photographers and Radsafe monitors.

2.9.2 Radsafe Support for Indian Springs Air Force Auxiliary Field Personnel.

Radsafe support facilities had been established about 20 miles southeast of Mercury at ISAFAF during earlier atmospheric testing. REECO provided all Radsafe support functions at the NTS. This included monitoring personnel stationed at the ISAFAF Radsafe

Quonset facility and maintaining a complete stock of film dosimeters (badges), radiation detection instruments, and anti-contamination clothing and equipment for use by air and ground crews. In 1974, after the responsibility for air support to NTS was transferred from AFSWC to the 57th FWW (see paragraph 1.3.2), helicopters continued to be supplied and manned by personnel stationed at ISAFAP. Radsafe personnel were not involved with these monitoring and photography support aircraft until they arrived at their NTS staging areas.

Radsafe monitors issued and exchanged film dosimeters, issued self-reading pocket dosimeters, provided anticontamination clothing and respiratory protection equipment, monitored aircraft and personnel after tests, decontaminated personnel, and assisted ground crew personnel with decontamination of aircraft at the NTS when necessary.

2.9.3 Radsafe Support for Helicopters.

Special helicopter Radsafe procedures were implemented for helicopters which staged from pads at the NTS, located east of Mercury highway near the CP area and near the Test Controller's FCP established for a particular underground test. Helicopter pilots usually landed at these locations and were briefed on their scheduled or other operational missions.

If the mission involved possible contamination of the helicopter, Radsafe monitors lined the floor with plastic (or kraft paper) secured with masking tape to facilitate decontamination. Film badges and pocket dosimeters were issued to pilots and crew members, and anticontamination clothing was available if needed.

Upon completion of missions, helicopters returned to the landing pads where they were checked for radiation and, if necessary, decontaminated by Radsafe monitors. Pilots and crew members were monitored and decontaminated as necessary at an adjacent forward Radsafe base station (or at CP-2) where pocket dosimeters were collected and read. Film badges were exchanged if exposures of

100 mR or more were indicated by pocket dosimeters. The same exchange procedure was used when TLDs were issued beginning in January 1987.

SECTION 3

MILL YARD AND DIAMOND BEECH TESTS¹²

3.1 TEST SUMMARY.

The jointly-sponsored MILL YARD (DoD/LANL) and DIAMOND BEECH (DoD/LLNL) were weapons-effects tests conducted at 1340 hours and 1620 hours PDT respectively, on 09 October 1985. Each test had a yield of less than 20 kilotons. The MILL YARD device was emplaced at a vertical depth of 1,230 feet and detonated in the U12n.20 drift, a 36-foot radius hemispherical cavity in the N tunnel complex. The DIAMOND BEECH device was detonated in the U12n.19 LOS drift at a vertical depth of 1,325 feet (see Figure 3-1). The purpose of the MILL YARD test was to study energy coupling, ground motion, air blast and cratering effects produced by a nuclear detonation over a free surface and to measure radiation-induced source region electromagnetic pulse (SREMP) signals in sensors. The DIAMOND BEECH test was designed to evaluate the radiation output of the device; to study containment-related data; and to investigate the performance of the LOS pipe and tunnel stemming plan.

After detonation, the MILL YARD test had some radioactive gas seepage on the working point side of the DPP where the gas was contained. When ventilation to the mesa was established, a controlled¹³ effluent release of the contained gases occurred. This effluent release, consisting primarily of xenons, occurred from approximately H+1.9 until H+2.5 days. A controlled release of the MILL YARD cavity occurred from approximately H+16 until H+18 days. The DIAMOND BEECH test also had two controlled ventilations. An

¹² These tests are discussed together because much of the construction, pretest, and posttest activities were conducted simultaneously.

¹³ The radioactive gas was passed through a filtering system where the particulates were removed before the gas was released through the tunnel ventilation system.

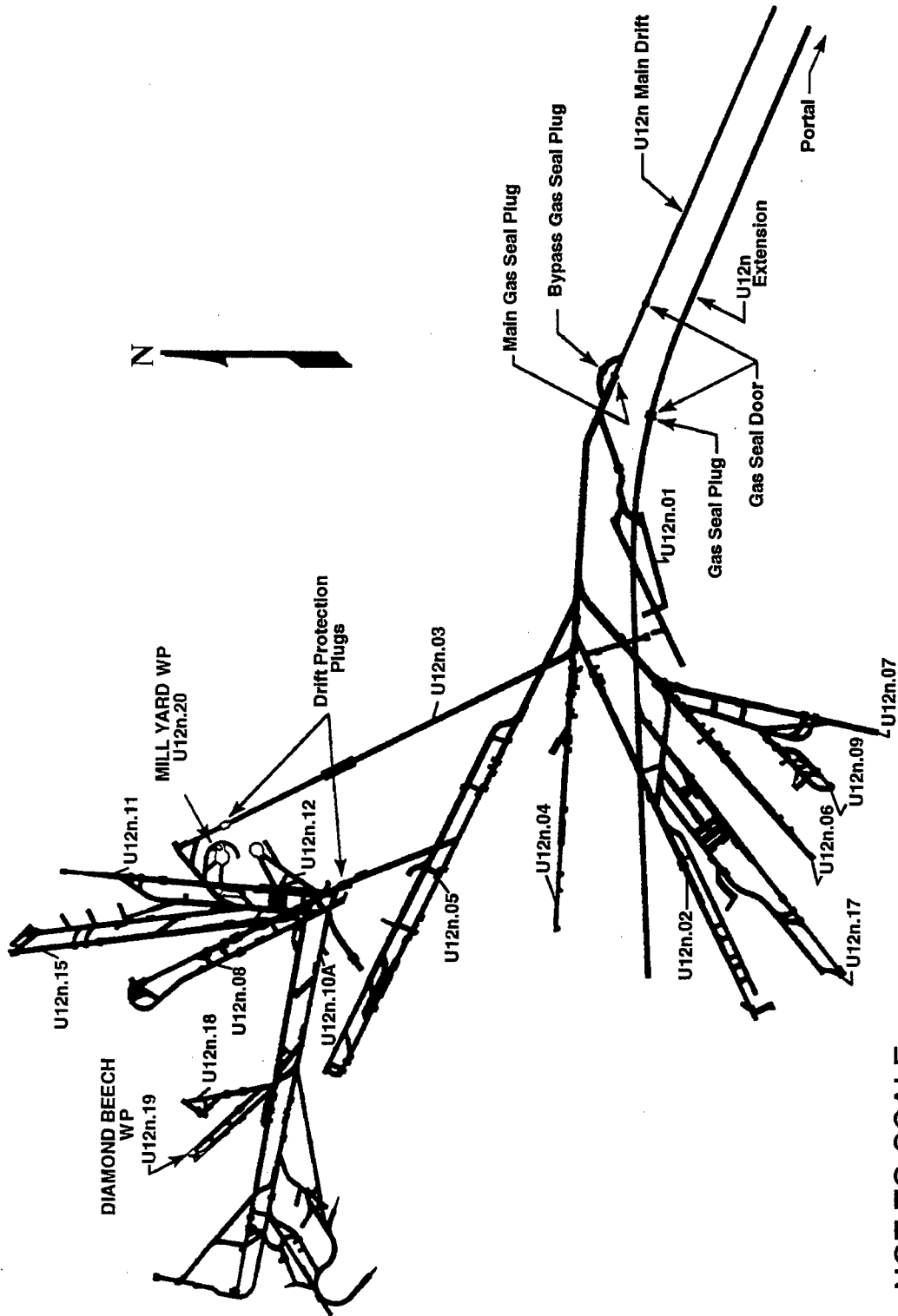

NOT TO SCALE

Figure 3-1. MILL YARD and DIAMOND BEECH tests - tunnel layout.

effluent release occurred when the tunnel was ventilated to the portal side of the U12n.19 FDPP from approximately H+1.8 until H+2.5 days. Additionally, an effluent release occurred upon ventilation of the U12n.19 main drift from approximately H+8 until H+9 days. From both tests only xenons were released, and all effluent was detected onsite only.

3.2 PRETEST ACTIVITIES.

3.2.1 Responsibilities.

Safe conduct of all MILL YARD and DIAMOND BEECH project activities in Area 12 was the responsibility of the DNA TGD, subject to controls and procedures established by the DOE Test Controller (TC). The DOE TC was responsible for safety of the public and onsite personnel during the test.

Project agencies were responsible for designing, preparing, and installing experiments, or delivering them to the installation contractor. After the test, these agencies were responsible for removing samples, analyzing instrument and sample data, and preparing project reports on experiment results.

Device safety and security procedures in the WP area and the timing and firing control room were in accordance with DOE Order 5610.3, "Program to Prevent Accidental or Unauthorized Nuclear Explosive Detonations." The LANL TGD had overall responsibilities for all operations involving the MILL YARD device as well as the timing control and the arming and firing of MILL YARD closures and experiments. Operations involving the DIAMOND BEECH device were the responsibility of the LLNL Test Director (TD). Both the LANL TGD and LLNL TD were responsible to the DOE TC for radiological safety within the designated area of the WP from device emplacement until detonation. After detonation, the DOE Test Controller relieved both the LANL TGD and the LLNL TD of their responsibilities. The DOE TC approved the controlled venting of the tunnel

complex and returned the responsibility for project activities back to the DNA TGD.

3.2.2 Planning and Preparations.

A. Tunnel Facilities Construction.

MILL YARD

The MILL YARD test was essentially like the MINI JADE test, having no line-of-sight pipe traditionally associated with tunnel tests. The U12n.20 complex consisted of a main access drift that provided access to the 36-foot radius hemispherical cavity; the lower drift; the middle drift; the upper drift; the cable drift; and instrument and support alcoves, some of which had been used for a previous test. (See Figure 3-2.)

The MILL YARD testbed cavity had an approximately 16.5-foot floor that was composed of a dry, porous desert alluvium (i.e., a desert sand). The cavity was mined in four segments beginning at the top of the cavity dome. Four access drifts were mined starting from the old U12n.11 LOS drift. Three of the access drifts connected the cavity to the U12n.20 main access drift.

Preliminary proposal meetings for MILL YARD began in March 1984 with an initial beginning-of-readiness period of 11 June 1985, and a proposed simultaneous execution with DIAMOND BEECH. Testbed configuration planning, soil sampling, and experiment proposals were discussed at meetings held from March through June 1984. Beginning in July, mining of the drifts was initiated along with activities to prepare for pre-MILL YARD high explosive (HE) tests scheduled for October. By the end of December, five of eight pre-MILL YARD HE tests were executed; all four drifts of the test complex as well as all alcoves were completed; and drilling and casing of the mesa camera drill hole was also

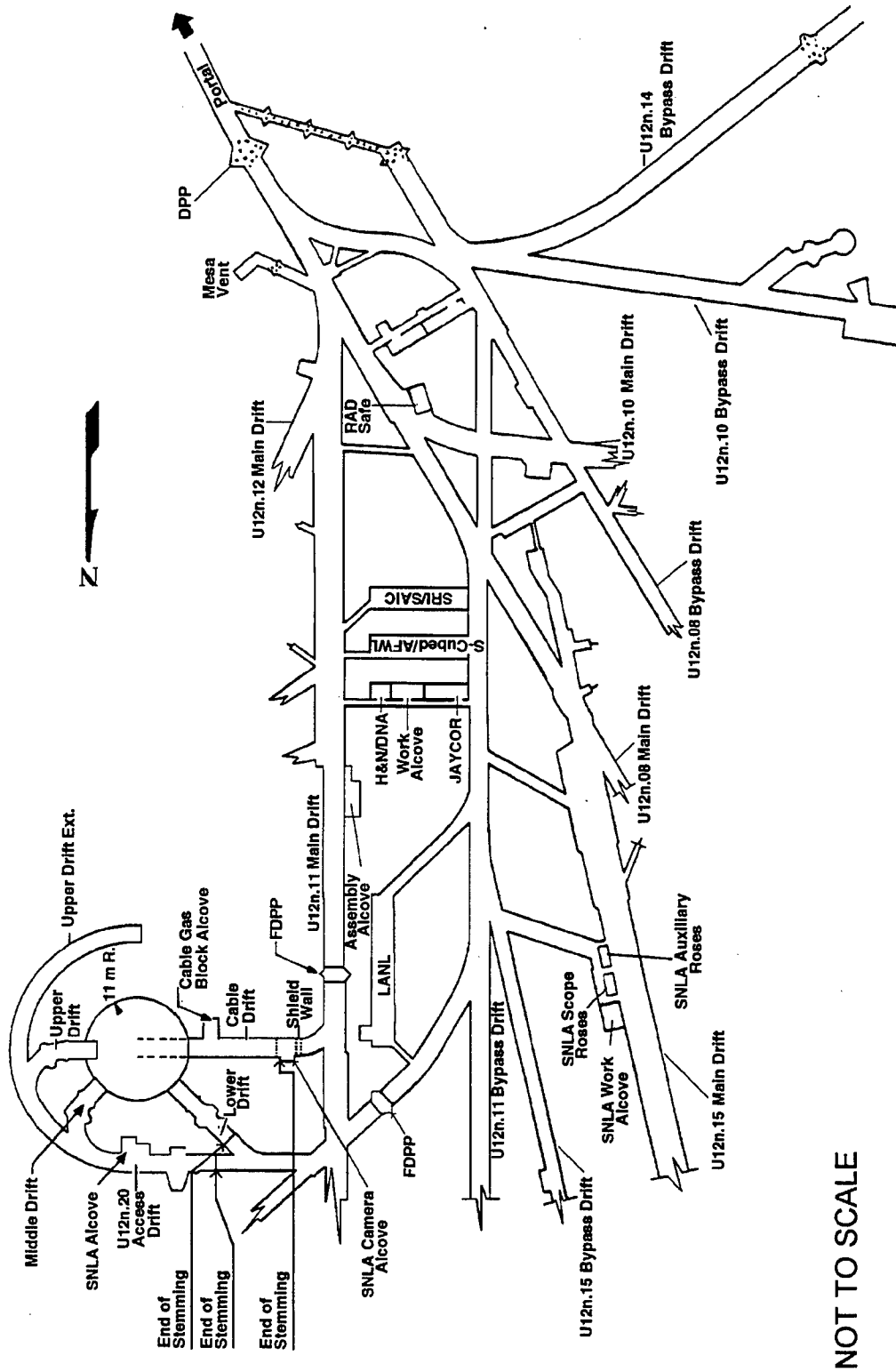

Figure 3-2. MILL YARD test - tunnel facilities layout.

completed. In addition, a new beginning-of-readiness period of 23 July 1985 was recommended.

During the early part of 1985, work on preparing the testbed and equipment installation in the cavity was ongoing. By the end of April, it was apparent that a July readiness date was not feasible, and in May, the beginning-of-readiness period was set at 1 October 1985. Work continued during the summer to complete construction of the testbed, decontaminate instrumentation used for previous tests, and install support equipment, as seen in Figures 3-3 and 3-4. In August, the readiness date was changed to 8-10 October. The first signal dry run (SDR) was performed on 28 August, and by 24 September, the mandatory full-power (MFP) signal dry run was conducted. Most of the experiments performed well, and the MFP was declared a success.

Remote gas sampling capabilities were incorporated during construction as well as capabilities for water, power, drain, and pressurization lines. Provisions were made to manually take gas samples from the WP side of the GSD, GSP, and main DPP during posttest reentry.

The following organizations were among those that fielded experiments for the MILL YARD test: Field Command, DNA conducted studies to evaluate the effectiveness of containment techniques; S-CUBED measured air blast and ground motion in the test cavity; Stanford Research Institute, International (SRII) conducted studies to measure the flow field produced by direct and air blast coupling of a nuclear detonation to a dry soil testbed; Sandia National Laboratories, Albuquerque (SNLA) studied energy coupling, air blast data, ground shock, and containment; Science Applications International Corporation (SAIC) studied particle velocity and displacement, shock velocity, and radiation diagnostics; LANL conducted Continuous Reflectometry for Radius versus Time Experiments (CORTEX) to measure shock propagation versus time; the New Mexico

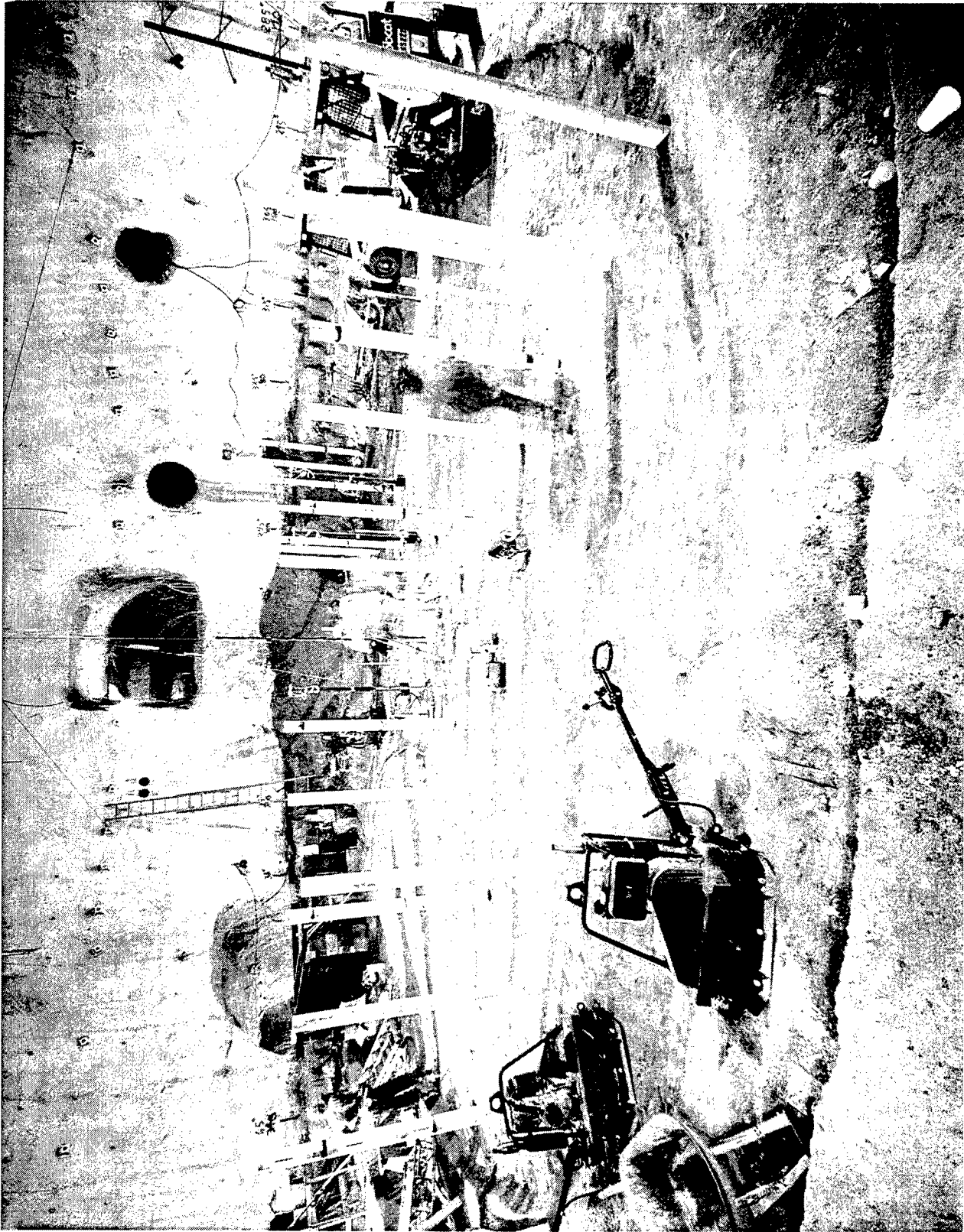

Figure 3-3. MILL YARD test - support equipment installation.

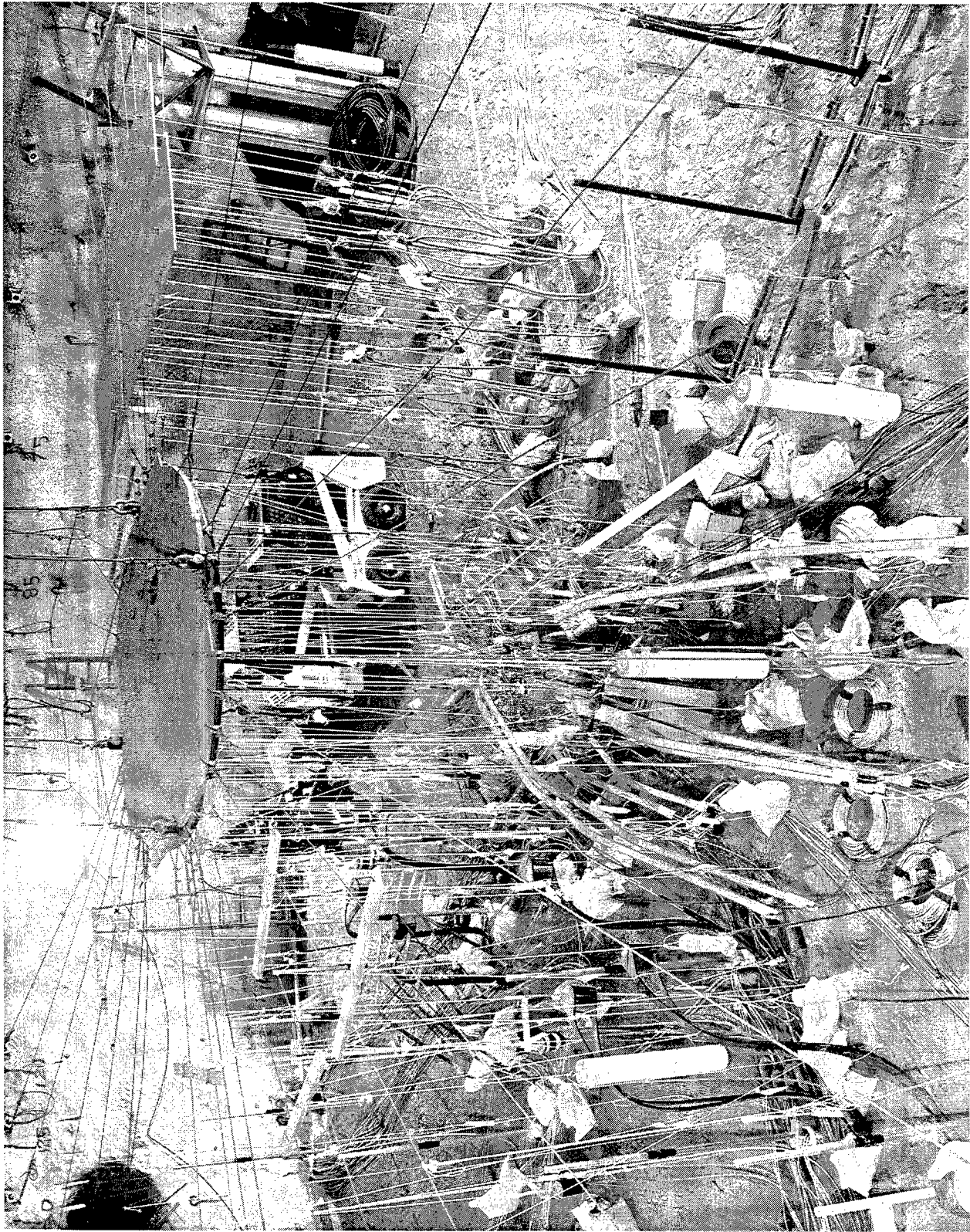

Figure 3-4. MILL YARD test - support equipment installation (Continued).

Engineering Research Institute (NMERI) whose experiments were sponsored by the Air Force Weapons Laboratory (AFWL) studied methods to measure displacement of soil surface and examined cratering and ejecta dynamics; and JAYCOR studied magnetic and electric fields, dose rates, cable current, and air chemistry.

The stemming plan for the U12n.20 complex is shown in Figure 3-5. The U12n.20 main access drift was stemmed with concrete to the steel bulkhead and then with HSG to just past the SNLA alcove. The remainder of the drift including the upper extension drift was stemmed with high-strength groutcrete. The lower, middle, and upper drifts, as well as the cable drift, were stemmed with concrete.

An MFP dry run for MILL YARD was conducted with the DIAMOND BEECH MFP and is discussed below.

DIAMOND BEECH

The DIAMOND BEECH test consisted of a main drift mined from the TOMME/MIDNIGHT ZEPHYR main drift and a bypass drift mined from the DIABLO HAWK main drift. In addition, some mechanical hardware and system components and spaces in existing drifts, including recording and instrument alcoves, were reused from previous tests. This reuse of resources and the decision to field both MILL YARD and DIAMOND BEECH concurrently, resulted in substantial savings for this program.

The U12n.19 complex consisted of a 250-foot long LOS pipe; a bypass drift; a zero room; two side drifts at angles from the main LOS drift for LLNL experiments; a side pipe at 230 feet from the WP for SNLA experiments; continuously diverging conical pipe sections (with helical inserts) out to a distance of 108 feet from the WP; a fast auxiliary closure (FAC) from 108 to 122 feet; and hardened pipe sections from 122 to 150 feet. As described for the MILL YARD test,

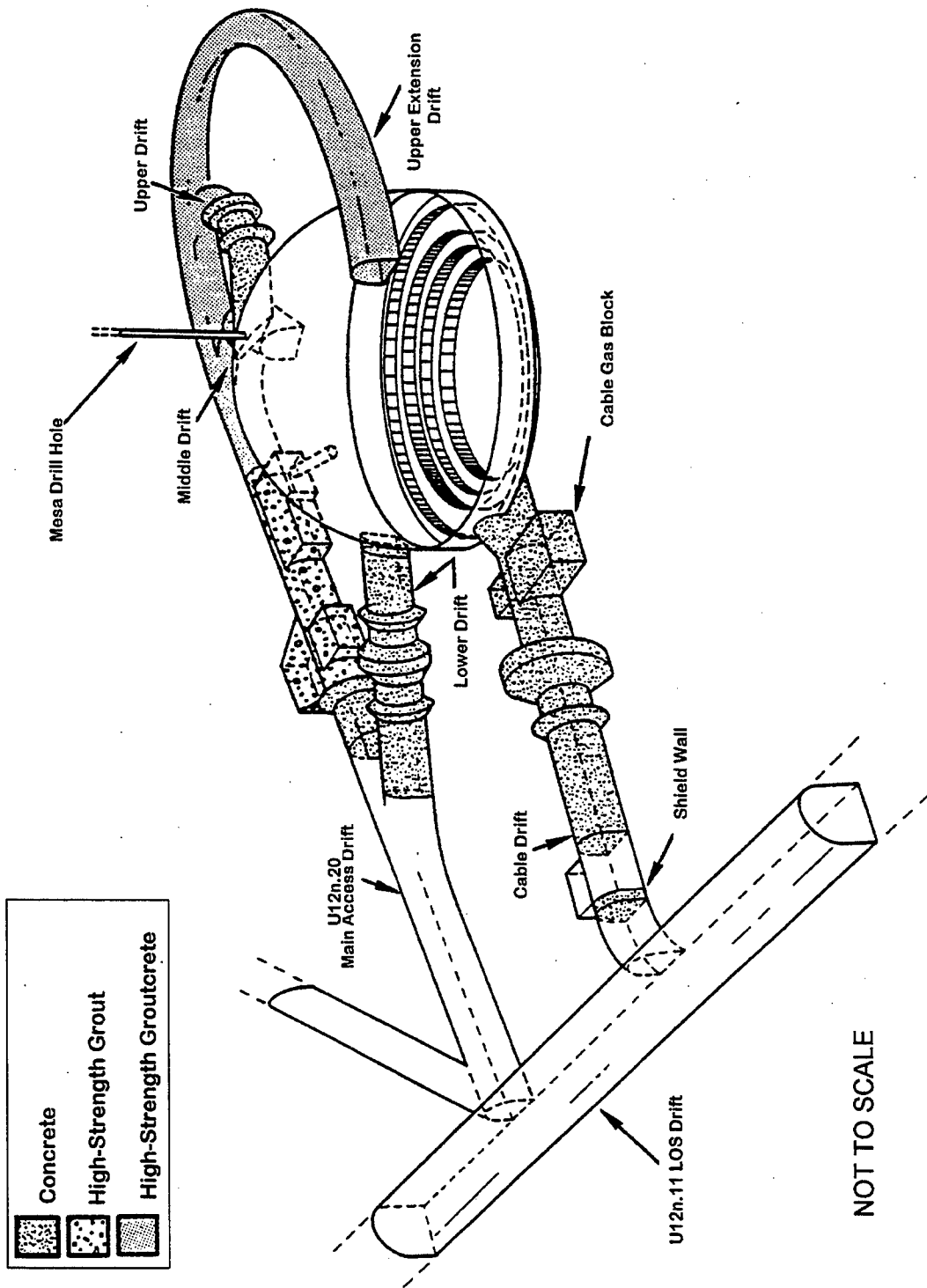

Figure 3-5. MILL YARD test - stemming plan.

remote gas sampling capabilities, and all utilities were incorporated during the construction phase of this test.

Preliminary proposal meetings began in March 1984 with construction design established and actual mining of the main and bypass drifts beginning in August and completed in October 1984. Crosscuts for experiments and diagnostics, FAC access, instrument drill holes, and alcove preparation were all completed by the end of 1984. The front end and LOS floor were poured, and all drilling was completed by the end of March 1985. From April through July, some instrumentation (decontaminated from the MISTY RAIN test) was installed, and prestemming of the main LOS drift was almost completed. In September, a cryogenic vacuum system was installed ahead of the FAC. This work was completed and operational by 22 September.

Experiments and related hardware were installed by the end of July. The following organizations were among those that fielded experiments for the DIAMOND BEECH test: LLNL conducted reaction history and multiple-gap photodiode measurements; LANL conducted CORTEX studies; SNLA studied device output and containment-related measurements; Lockheed Palo Alto Research Laboratory (LPARL) conducted diagnostic measurements; Science and Engineering Associates (SEA) conducted neutron time-of-flight studies; and JAYCOR measured radiation-induced signals in several types of sensors needed for a high-level SREMP test planned for performance at a future nuclear test.

The stemming plan for the U12n.19 complex is shown in Figure 3-6. The area around the DIAMOND BEECH WP (i.e., the zero room) was an air void, and the drift behind the zero room was filled with desert fines (sandbags). The main drift was stemmed RMG to 72 feet; followed by a short, strong RMG plug at 88 feet; then another short RMG plug at 102 feet; then SLG to 116 feet; followed by very high-strength concrete to 180 feet; then high-strength grout-

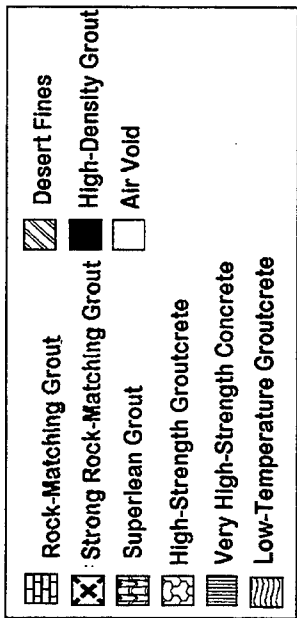

RS = Range Stations (distances in meters radially from the working point)

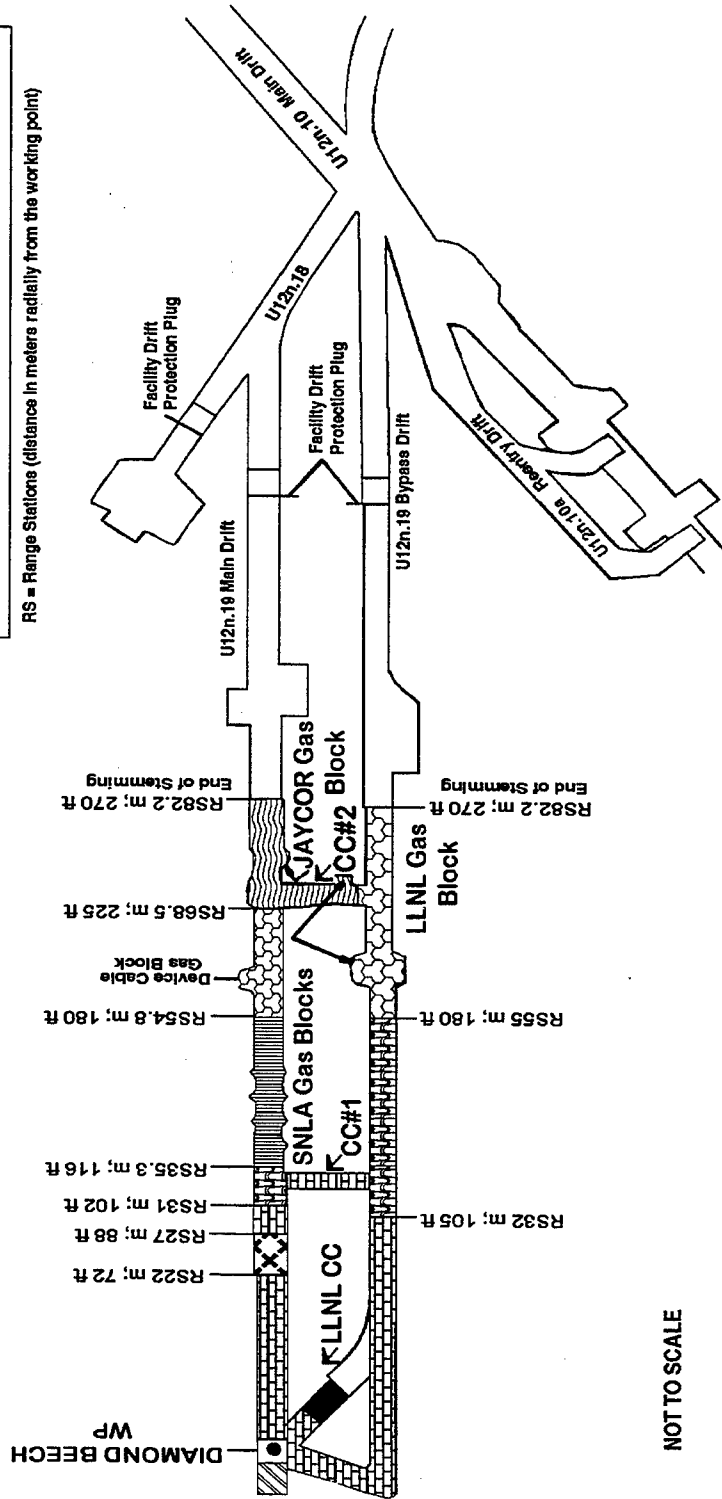

Figure 3-6. DIAMOND BEECH test - stemming plan.

crete to 225 feet; and then low-temperature groutcrete to 270 feet. The U12n.19 bypass drift was stemmed with RMG to 105 feet; then SLG to 180 feet; and then high-strength groutcrete to 270 feet. RMG was used to stem crosscut (CC) No. 1, while the LLNL CC also contained RMG and high-density grout, followed by an air void. Low-temperature groutcrete filled CC No. 2. The FDPPs, located in the main and bypass drifts, were three-meter long concrete plugs.

The MILL YARD and DIAMOND BEECH MFP dry runs were conducted on 24 September. MILL YARD's MFP was declared successful, but DIAMOND BEECH's MFP was rescheduled as neither the cryogenic or diffusion pumps were on. DIAMOND BEECH's MFP was rerun and declared successful on 25 September with device insertion for both tests occurring on 26 September. Some instrument modification was made for an experiment followed by final stemming and button-up operations.

B. Radiological Safety Support.

Procedures for radiation exposure and contamination control during these tests were in accordance with NTO SOP 0524 and requirements of responsible DoD representatives. Radsafe provided monitoring and equipment support.

Prior to the test, detailed radiological safety reentry plans were prepared and issued to participating agencies. Air sampling equipment was positioned in the test area. Radsafe monitors were briefed regarding surface reentry, manned stations, and security station requirements.

Radsafe monitoring teams and supervisory personnel were provided to perform initial radiation surveys, conduct aerial surveys by helicopter, and participate in reentry parties as needed. Radsafe personnel were also standing by at designated muster stations prior to detonation to perform surveys and provide emergency support as directed; to provide and issue anticontamination equipment and material,

portable instruments, and dosimeters; to operate area control check stations; and to perform personnel, equipment, and vehicle decontamination, as required.

Available anticontamination materials and equipment included head covers, coveralls, cloth shoe covers, totes, full-face masks, supplied-air breathing apparatus, plastic suits, plastic bags, gloves, and masking tape.

C. Telemetry and Air Sampling Support.

In addition to the permanent RAM units, 41 temporary units provided surface and underground coverage for MILL YARD and DIAMOND BEECH tests. There were also six underground diagnostic RAM units that provided monitoring data in the U12n.20 main access and cable drifts. Tables 3-1 and 3-2 list the locations of surface and underground RAMS, respectively. The locations of surface RAMS are shown in Figure 3-7 and those of underground RAM units are shown in Figure 3-8 and Figure 3-9. Diagnostic RAMS locations are shown in Figure 3-10. All RAM units were installed a minimum of five days prior to scheduled device detonation.

EPA operated continuous monitoring stations at 30 locations in the offsite area. All the stations had high-volume air samplers with collectors for particulates and reactive gases, 17 had tritium and noble gas samplers, and 23 had pressurized ion chamber gamma-rate detector/recorder systems in operation. Twenty-seven EPA personnel were fielded for offsite surveillance activities.

D. Security Coverage.

Device security procedures in the WP area and the timing and firing control room were in accordance with DOE Order 5610.3, "Program to Prevent Accidental or Unauthorized Nuclear Explosive Detonations." Beginning on D-1, all

Table 3-1. MILL YARD and DIAMOND BEECH tests RAMS unit locations
09 October 1985.

SURFACE

STATION NUMBER	LOCATION
1	On the tunnel drain line
2	On the tunnel vent line
3	On the mesa vent hole
4	On the U12n.20 peep hole
From U12n.20 SGZ:	
5	300 feet N 0° E azimuth
6	300 feet S 60° E azimuth
7	300 feet S 60° W azimuth
From U12n.19 SGZ:	
8	300 feet N 0° E azimuth
9	300 feet S 60° E azimuth
10	300 feet S 60° W azimuth

Table 3-2. MILL YARD and DIAMOND BEECH tests RAMS unit locations
09 October 1985.

UNDERGROUND

STATION NUMBER	LOCATION
11	In the U12n.20 access drift
12	In the U12n.20 lower drift
13	In the SNLA alcove 20-12
14	570 feet into the U12n.11 main drift
15	460 feet into the U12n.11 main drift
16	200 feet into the U12n.11 main drift
17	100 feet into the U12n.12 bypass drift
18	320 feet into the U12n.11 bypass drift
19	230 feet into the U12n.15 main drift
20	85 feet into the S-curve of U12n.08 bypass drift
21ER ¹⁴	85 feet into the S-curve of U12n.08 bypass drift
22	170 feet into the U12n.19 bypass drift
23	130 feet into the U12n.19 main drift
24	130 feet into the U12n.18 main drift
25	80 feet into the U12n.19 bypass drift
26	50 feet into the U12n.18 main drift
27	In the LLNL alcove 19-5

¹⁴ ER - Extended Range (instrument capable of reading 100 mR/h to 100,000 R/h).

Table 3-2. MILL YARD and DIAMOND BEECH tests RAMS unit locations
09 October 1985 (Continued).

UNDERGROUND

STATION NUMBER	LOCATION
28	500 feet into the U12n.10 bypass drift
29	250 feet into the U12n.10 bypass drift
30	400 feet into the U12n.10 main drift
31	185 feet into the U12n.10 main drift
32	435 feet into the U12n.08 main drift
33	600 feet into the U12n.05 main drift
34	2,600 feet into the U12n main drift
35	235 feet into the Gas Seal Plug bypass drift
36	2,300 feet into the U12n extension drift
37	1,700 feet into the U12n main drift
38	1,200 feet into the U12n main drift
39	200 feet into the U12n main drift
40	1,200 feet into the U12n extension drift
41	200 feet into the U12n extension drift

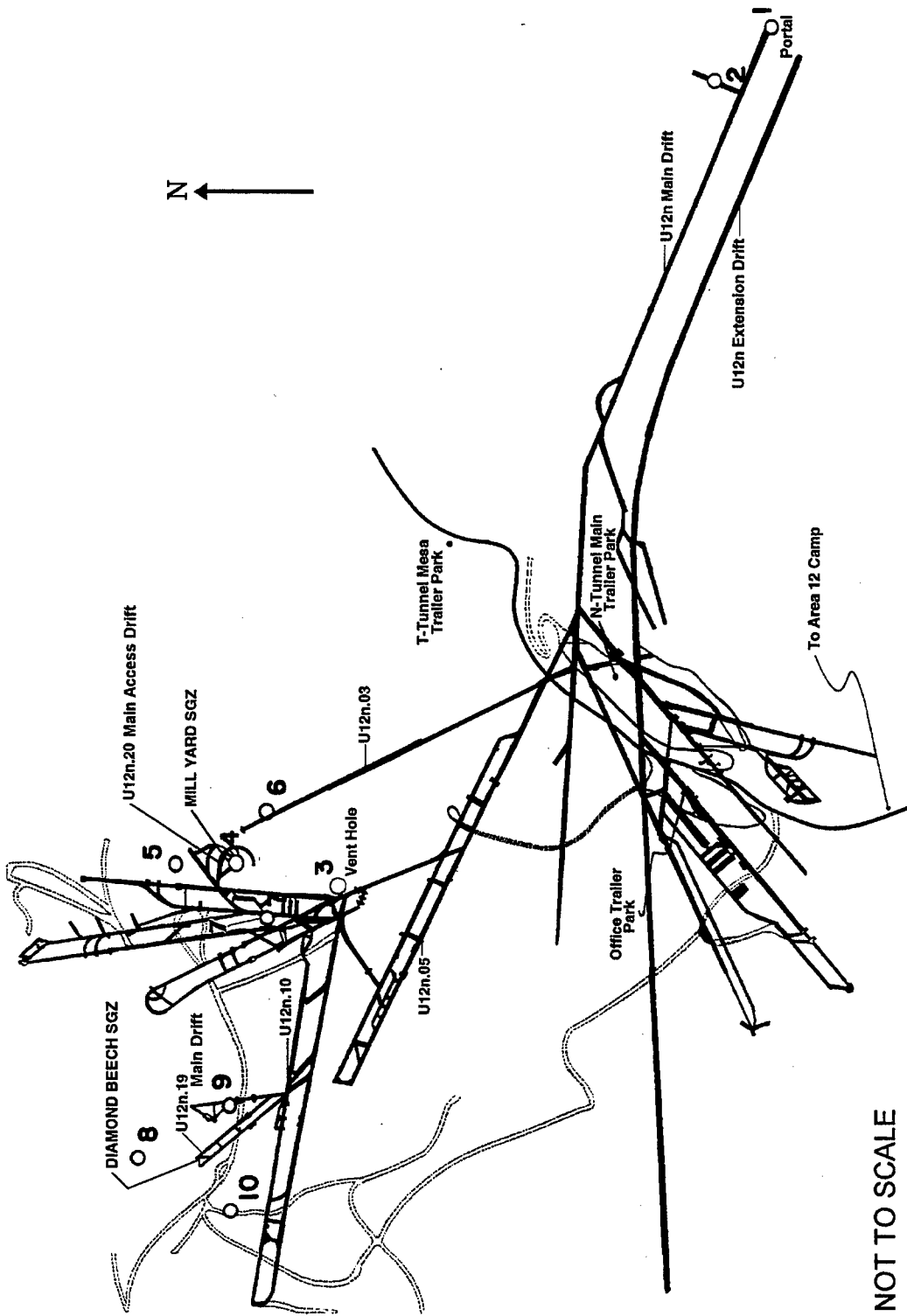

NOT TO SCALE

Figure 3-7. MILL YARD and DIAMOND BEECH tests - surface RAMS.

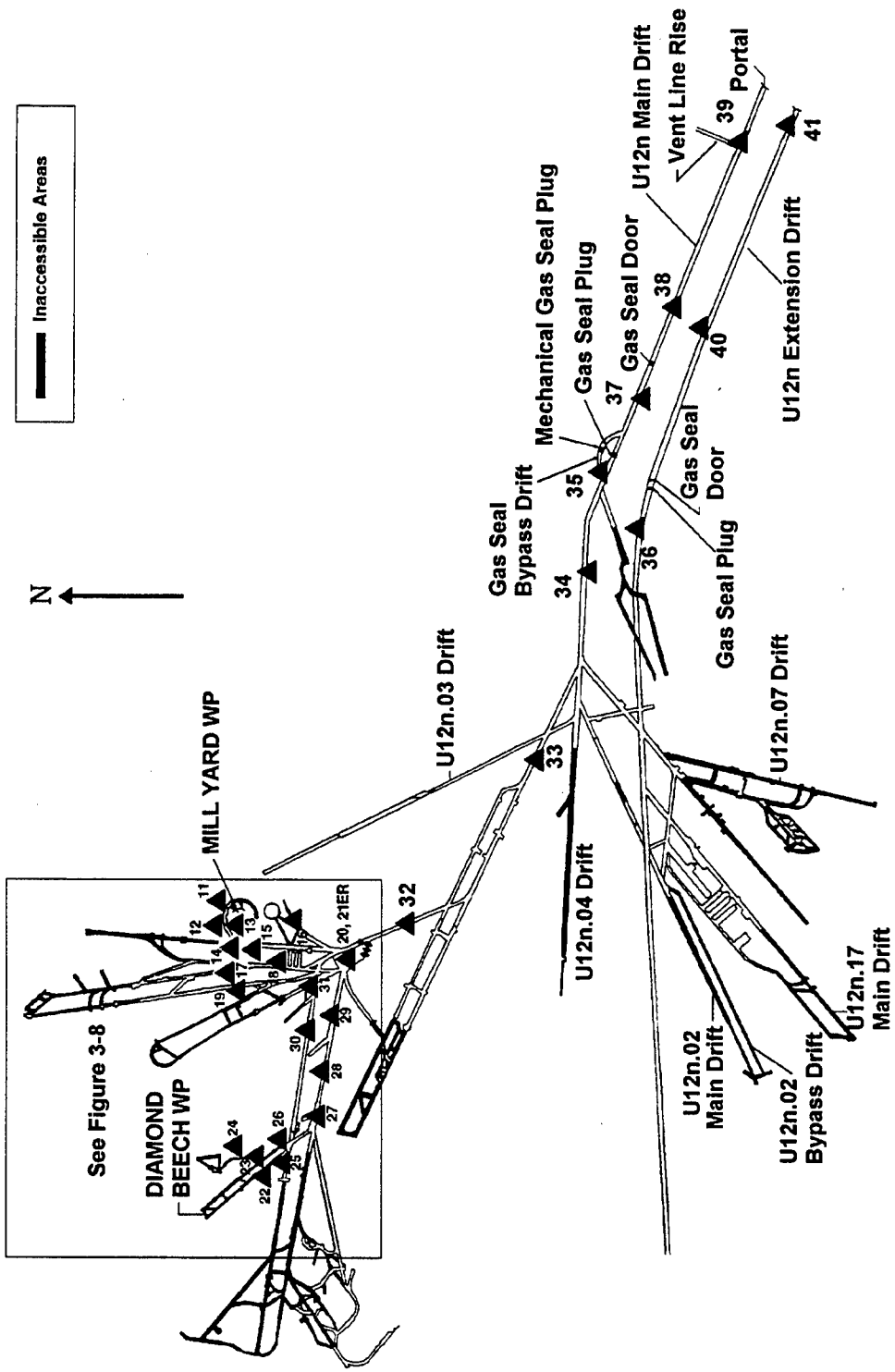

NOT TO SCALE

Figure 3-8. MILL YARD and DIAMOND BEECH tests - underground RAMS.

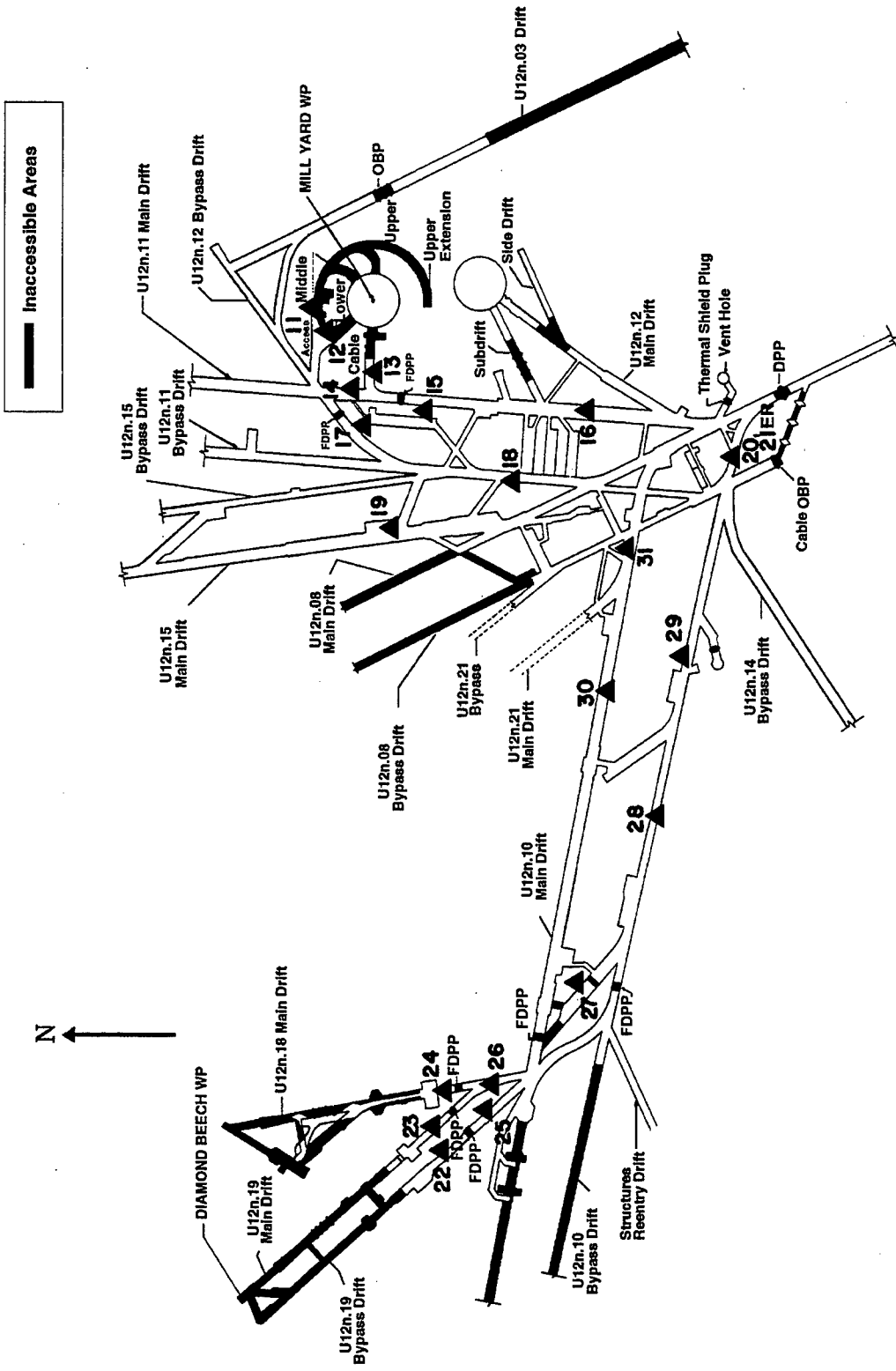

NOT TO SCALE

Figure 3-9. MILL YARD and DIAMOND BEECH tests - underground RAMS U12n.19/U12n.20 complex.

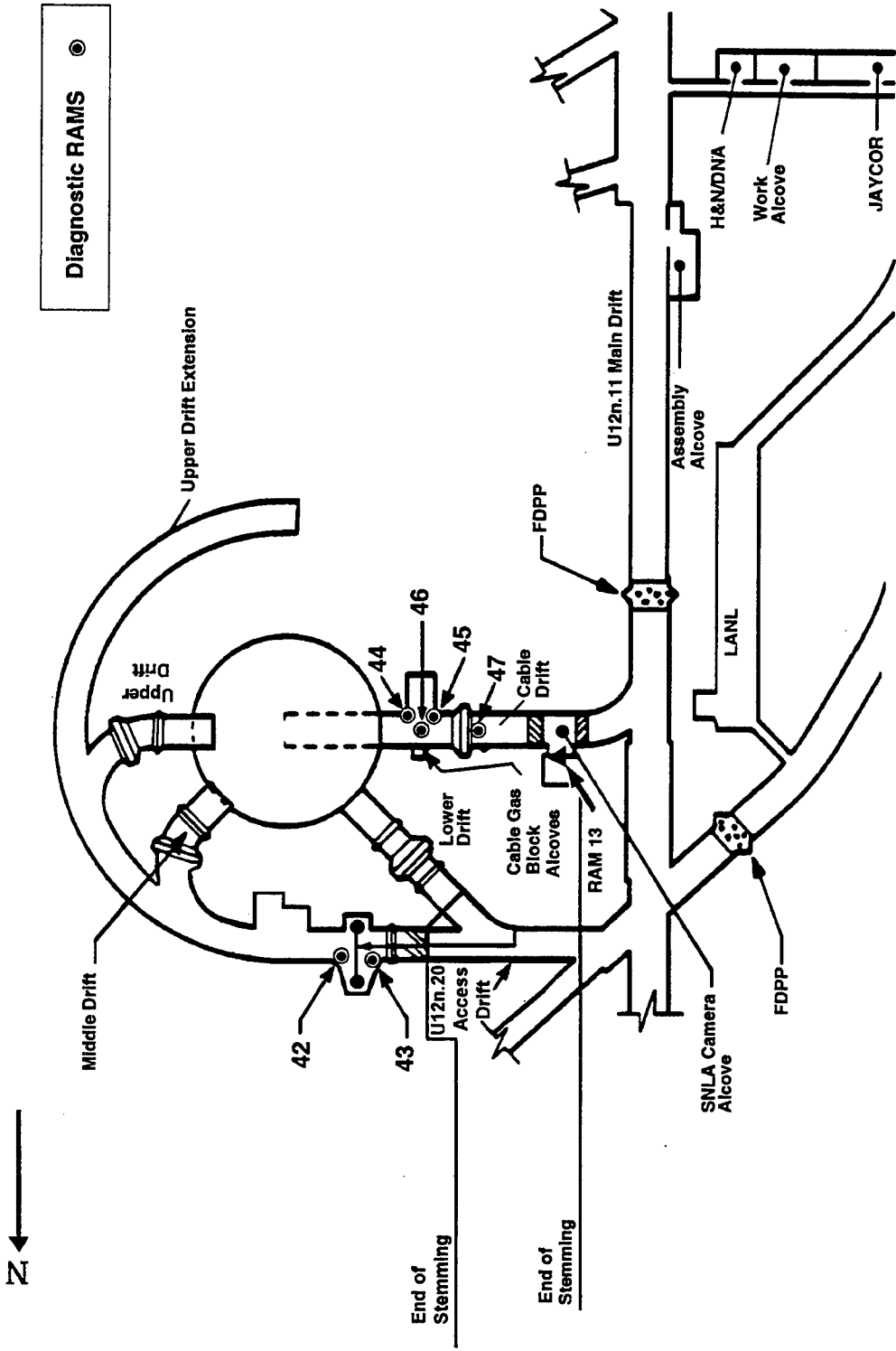

NOT TO SCALE

Figure 3-10. MILL YARD test - underground diagnostic RAMS.

personnel entering or exiting the controlled area were required to stop at muster or control stations for issue of stay-in badges. After control was established, all through traffic was diverted around the controlled area by use of screening stations. In accordance with the "Test Controller's Operations and Security Plan," contractors and agencies were to have all personnel not connected with this test out of the closed area before the final security sweep began.

E. Air Support.

Three UH1N helicopters and crews were provided by the USAF for cloud tracking and the TC's use, if needed. In addition, the USAF provided a WC-130 and/or a WC-135 aircraft and crew on standby status for cloud tracking. EG&G provided a Turbo Beech aircraft for cloud sampling and a Twin Bonanza for wind sound and cloud tracking duties, if necessary.

3.3 TEST-DAY ACTIVITIES.

3.3.1 Pretest Activities.

On 08 October 1985, at 2400 hours, all persons except the arming party, the tunnel button-up party, and the security guards were out of the tunnel and clear of the muster area. At approximately 0145 hours, permission was granted to arm the device. By 0615 hours button-up was completed and the party left the tunnel. The area was cleared of all personnel by 0652 hours.

A final readiness briefing was held at approximately 0700 hours on 09 October 1985, in anticipation of planned test executions at 0800 hours for MILL YARD and 1000 hours for DIAMOND BEECH. Weather conditions caused a delay of several hours. When test conditions were favorable, the countdown was started and proceeded through zero time. The MILL YARD device was detonated at 1340

hours PDT on 09 October 1985, and the DIAMOND BEECH device was detonated at 1620 hours PDT that same day.

3.3.2 Test Area Monitoring.

For the MILL YARD test, telemetry recording measurements began at 1340 hours on 09 October 1985. At 1341 hours, all RAM units (i.e., stations) were operational and remained so throughout the test period. All stations, except numbers 11 through 19, read background radiation levels (i.e., 0.05 mR/h) throughout the readout period. At H+1 minute, station numbers 11, 13, 14, 17, and 18 read 0.1 mR/h; station 12, located in the U12n.20 lower drift, had a reading of 74.5 mR/h. By H+57 minutes, station 13 had increased to its maximum reading of 10 mR/h, and station 12 was indicating 95 mR/h. Station 12 increased to its maximum reading of 1.58 R/h at H+2.67 hours, with the readings gradually decreasing to 0.4 mR/h at 1946 hours on 12 October. At that same time, station 13 had returned to reading background radiation levels. All RAM stations were secured at 1600 hours on 23 October 1985, and at that time, station 11 was reading 1.2 mR/h, and station 12 was reading 0.5 mR/h.

When recording telemetry measurements began at 1340 hours on 9 October for the MILL YARD test, station numbers 22 through 27 indicated background radiation levels until immediately after DIAMOND BEECH zero time at 1620 hours. At that time, station 23 became inoperative and remained that way throughout the test period. All other stations except numbers 24, 25, 26, 27, and 29 indicated background radiation levels throughout the entire readout period. Immediately at zero time, station 26 read 136 mR/h and station 29 read 7.4 mR/h. Station 26 registered its maximum reading of 2 R/h at H+13.8 minutes; however, the reading decreased to 10 mR/h at 2111 hours. Station 29 was reading 0.2 mR/h at 2111 hours, and stations 24, 25, and 27 were indicating near background radiation levels at that time. All stations were reading background radiation levels when stations were secured at 1600 hours on 23 October.

3.3.3 Initial Surface Radiation Surveys and Recovery Activities.

An initial seven-member surface reentry team departed the TC's barricade at Gate 300 at 1723 hours on 9 October 1985. A mobile base station was setup to provide for area control and equipment supply. All radiation readings were relayed as soon as they were obtained via Net 3 radio. By 1800 hours, initial survey teams had completed monitoring of the U12n tunnel portal yard and the ventilation pad above the portal. No radiation above normal background levels was detected. The survey team began gas sampling the tunnel air at 1919 hours, and team members stood by the portal area during data recovery. No toxic or explosive gases were detected on the WP side of the GSP. At 2032 hours, gas samples taken from the portal side of the U12n.19 DIAMOND BEECH FDPP indicated a exposure rate of 0.1 mR/h, a CO concentration of 10 ppm, 3 percent of the LEL, and 20 percent oxygen. Additional gas samples taken at 2048 hours from the WP side of the U12n.19 FDPP showed background radiation levels, no toxic or explosive gases, and the oxygen concentration was a normal 21 percent. Data recovery and gas sampling were completed by 2100 hours, and all personnel were checked out of the area by 2200 hours.

3.4 POSTTEST ACTIVITIES.

3.4.1 Tunnel Reentry Activities.

At 0815 hours on 10 October (D+1), a work party entered the tunnel proceeding as far as the GSP. Ventilation was established to the WP side of the GSP at 0925 hours by opening the 42-inch turntube. No toxic or explosive gases, and no radiation above background levels were detected. The oxygen level was a normal 21 percent. Anti-contamination clothing was worn by personnel during this initial reentry.

Reentry and rescue teams, wearing anticontamination clothing, left the portal for the GSP at 1045 hours on 10 October. At 1100 hours, reentry team No. 1 proceeded through the turntube to the WP

side of the GSP. Readings taken at the junction of the U12n.06 and U12n main drifts showed background radiation levels and no toxic or explosive gases. The reentry team then proceeded to the U12n.08 DPP. At 1206 hours, the team, wearing self-contained breathing apparatus (SCBA), opened the 36-inch turnout on the DPP and proceeded to the U12n.08 ventilation hole and thermal shield plug (TSP) where they then opened the downhole ventline closure and established controlled ventilation to the ventilation pad on the mesa. The teams returned to the portal side of the DPP at 1259 hours, and the ventilation fans on the mesa were turned on at 1305 hours.

At 1348 hours, reentry team No. 2, wearing anticontamination clothing and SCBA, departed the U12n.08 DPP and proceeded to the U12n.11 FDPP to start gas sampling on the WP side of the FDPP where readings taken from the gas sampling line were 0.2 mR/h, 20 ppm CO, no explosive gases, and 20.3 percent oxygen. The reentry team then checked the U12n.15 ROSES drift, drained freon from the MILL YARD Recorder and Oscilloscope Sealed Environmental System (ROSES) trailers, checked alcoves 20-1 through 20-3, and drained water from the U12n.10 main drift FDPP bladder. When the reentry team arrived at the U12n.11 FDPP at 1428 hours, readings taken from a gas sample showed 0.3 mR/h, 50 ppm CO, no explosive gases, and 20 percent oxygen. The team continued on to the U12n.10 bypass FDPP and the U12n.19 alcove where readings were 0.07 mR/h, 5 ppm CO, no explosive gases, and 19.5 percent oxygen. At 1534 hours, team No. 2 returned to the portal side of the U12n.08 DPP where reentry team No. 1 and the rescue team had also assembled. The teams departed the DPP at 1549 hours. By 1605 hours, all reentry personnel were surveyed and released from the portal.

On 11 October at 0942 hours, the reentry and rescue teams, wearing anticontamination clothing and SCBA, departed from the portal to the U12n.08 DPP. Reentry team No. 1 (now assigned to MILL YARD reentry) proceeded to walkout the U12n.11 bypass drift, the U12n.12 bypass drift, and arrived at the U12n.12 bypass FDPP at 1013 hours where the FDPP turnout was opened at 1019 hours and a flexible vent line was installed. This team continued on to the

U12n.11 main drift FDPP where gas samples taken from the WP side of the U12n.11 main drift FDPP indicated 0.15 mR/h, 35 ppm CO, no explosive gases, and 20.7 percent oxygen. The U12n.11 main drift turnout was opened at 1032 hours, and the team proceeded through the turnout to check the SNLA camera alcove. The shield wall door was opened. The team continued on to the U12n.20 lower drift bulkhead door that was opened at 1048 hours. Readings at the doorway were 100 mR/h and 7,000 ppm CO. Water and air samples, along with swipe samples, were taken and sent to the laboratory for analysis. The team returned to the fresh air station portal side where they were surveyed and released in the portal area at 1240 hours.

At 1630 hours that same day, both the scientific assessment and data and film recovery teams entered the U12n.20 alcoves and the SNLA camera alcove to assess conditions and recover data. All personnel were wearing two sets of anticontamination clothing and full-face respirators fitted with gas mask canisters containing charcoal impregnated with triethylenediamine (i.e., a canister approved for use for organic vapors and radionuclides). Readings in the camera alcove were 0.4 mR/h and only a trace of CO. By 15 October, most of the data and experiments had been recovered.

Reentry team No. 2 (now assigned to DIAMOND BEECH reentry) departed the U12n.08 DPP at 1143 hours on 11 October and proceeded toward the junction of the U12n.08 main drift and the U12n.10 bypass drift to the U12n.10 bypass FDPP. Readings taken from a gas sample from the WP side of the FDPP were 0.05 mR/h, 20 ppm CO, no explosive gases, and 20.6 percent oxygen. The turnout was opened on the FDPP at 1153 hours, and team No. 2 walked through crosscut No. 2 to the U12n.10 main drift FDPP where readings taken from the WP side of the FDPP were 0.05 mR/h, 30 ppm CO, no explosive gases, and 20 percent oxygen. At 1212 hours, the turnout was opened on the U12n.10 main drift FDPP to establish ventilation to the WP side of the FDPPs in both the U12n.10 main and bypass drifts. Water and air samples, along with smear samples, were taken and sent to the laboratory for analysis. Reentry team No. 2

then returned to the fresh air station on the portal side of the U12n.08 DPP at 1224 hours.

At 0900 hours on 22 October, a survey team entered the U12n.10 main drift FDPP wearing anticontamination clothing and full-face respirators fitted with GMRI canisters, to access conditions, recover experiments and take swipes. The maximum reading detected in the Red Shack area was a background radiation level of 0.05 mR/h.

3.4.2 Posttest Mining and Drilling.

Work began on mining out the GSP at 1830 hours on 10 October 1985, and was completed by 0220 hours on 11 October. From 11-15 October, miners removed the U12n.08 DPP; completed ventilation line hook-ups to prepare for the MILL YARD cavity ventilation; and began mining the U12n.12 bypass drift FDPP and the U12n.11 main drift FDPP. Miners had removed the turntubes from the FDPPs by 1800 hours on 15 October. By 17 October, miners, dressed in anticontamination clothing, were laying tracks through the U12n.11 FDPP and were working on the WP side of U12n.20 access drift shield wall, where readings were 0.4 mR/h and 120 ppm CO. Miners had removed the U12n.20 access drift bulkhead to extend the ventilation line to the shield wall, and LANL personnel began taking gas samples by 1405 hours on 17 October. Cavity ventilation began on 18 October, and gas sampling began at the cavity sampling port located in the U12n.20 access drift. Initial gas sample radiation readings indicated 1.7 mR/h. Cavity gas sampling and pressurization testing continued, and on 1 November underground cavity sampling ceased. Radiation surveys and reentry drift mining and cleanup continued until 12 November when operations shut down until after DIAMOND BEECH posttest work was completed.

On 22 October, drilling crews began setup operations on the mesa in preparation for drilling into the cavity so that a camera could be lowered to photograph the crater and the cavity. The turntube door on the predrilled U12n.20 peep hole No. 1 was opened on 22

October and the first two mechanical packers were removed from the hole. The third mechanical packer was removed on 23 October, and drillers completed preliminary preparations by welding a transition piece to the top of the casing. Drilling into the high-strength grout plug at 1,095 feet began on 28 October at 1115 hours. On 29 October the drill hole broke through to the cavity at 1197 feet. A camera run down the hole was started, but problems were encountered, and the camera was pulled out of the hole. On 31 October another camera run was attempted, but this was also not successful. The camera was pulled out of the hole, and a laser tool was lowered into the cavity to map the cavity and the crater size and shape. The laser survey was completed successfully at 1630 hours, and fitters began preparations to pressurize the cavity. The cavity was pressurized to 10 psi through peep hole No. 1, using compressed air and Freon. A gas sample taken from the cavity during the pressurization test showed 0.05 mR/h, 150 ppm CO, no explosive gases, and 20 percent oxygen. The mesa was secured at 1934 hours on 31 October. On 4 November, drillers removed the drilling rig and associated equipment from the mesa. Because of DIAMOND BEECH reentry operations, further cavity photography was delayed.

Work to set up downhole camera operations resumed in February 1986. After camera problems occurred, and a few downhole camera runs were made, work stopped on 6 February. Five camera runs were made on 27 February, and a laser distance measuring tool was lowered into the hole to re-map the crater size and shape. Surveys of the equipment showed low levels of contamination, and samples of the cavity gases showed 0.05 mR/h, no CO, and no explosive gases. Two additional camera runs were made on 29 July 1986.

Core sampling operations occurred from 3-5 December 1986, when crews, using a core extractor, pulled several samples (exact number not stated). Radiation readings on the samples were 0.05-0.1 mR/h. Operations were shut down on 9 December 1986. On 18 February 1987, crews set the cement plug at 1180 feet and capped the hole.

Mining in the U12n.10 bypass drift at the FDPP was started on 17 October and ventilation was established to the DIAMOND BEECH FDPP the next day. A ventilation line sample taken at 0500 hours on 18 October showed radiation readings at background levels, 30 ppm CO, no explosive gases, and 21 percent oxygen. Miners, in anticontamination clothing and full-face respirators, continued to work in the U12n.10 bypass drift and the U12n.19 LOS and bypass drifts. On 29 October at 0900 hours, miners began removing the turntube door in the U12n.19 bypass FDPP. The radiation reading at the FDPP was 0.05 mR/h. At 1700 hours when LPARL personnel, dressed in double anticontamination clothing and full-face respirators, entered the WP side of the U12n.19 FDPP to recover equipment, the exposure rate in the work area was 0.3 mR/h.

From November 1985 through July 1986, mining continued intermittently in the U12n.19 LOS and reentry drifts, test chamber, and FAC crosscuts. Probe hole drilling began in January 1986 and continued sporadically with core sampling beginning in April. Surveys of core samples taken showed background radiation levels. In July, crews removed portions of the LOS pipe that were sent to the decontamination pad.

3.4.3 Industrial Safety.

Checks for the presence of toxic gases and surveys to measure radiation and explosive gas levels were made on each shift. The results were then recorded in the monitors' logbook.

Appropriate safety measures were taken to protect mining personnel and prevent unsafe conditions. Industrial safety codes for mining, tunneling, and drilling were established by REECo and emphasized during all operations. A written standard operating procedure was required for each operation involving explosives, toxic materials, radioactive material, or any other operation with the potential for personal injury. Each individual involved in such an operation was required to know the contents of the applicable procedures.

The portal construction area and the tunnel were mandatory hard-hat and foot-protection areas (safety shoes, boots, DOE-issued miner's boots, or toe guards). All personnel on initial tunnel reentry teams were certified in the use of the Draeger self-contained breathing apparatus. Standard safety rules and regulations, as spelled out in the "U.S. Bureau of Mines Manual," were observed.

All explosives, electro-explosive components, solid propellants, toxic materials, and radioactive materials were handled, stored, and transported in accordance with applicable sections of the following documents:

1. Army Material Command Regulations (AMCR 385-100).
2. Appropriate DOE Orders in the 5400 and 5600 Series concerning Environmental Protection, Safety & Health Protection, and Defense Programs, respectively.
3. Individual safe operating procedures (by experimenter organization).
4. MILL YARD and DIAMOND BEECH Safety Regulations.

All personnel engaged in handling, storing, assembling, or installing explosives, propellants, or electro-explosive devices (or observers of those operations) were required to wear safety glasses or other eye protection which had been approved by the DoD safety coordinator.

3.5 RESULTS AND CONCLUSIONS.

Telemetry measurements began at 1340 hours on 9 October 1985, for the MILL YARD test, with the maximum reading of 1.58 R/h measured on RAM unit No. 12 at H+2.67 hours. All telemetry stations were secured at 1600 hours on 23 October with only stations 11 and 12 reading above background radiation levels at 1.2 mR/h and 0.5 mR/h, respectively. Telemetry measurements began at 1620 hours on 9 October for the DIAMOND BEECH test with station 26 recording a maximum reading of 2 R/h at H+13.8 minutes. All

stations read background radiation levels when they were secured at 1600 hours on 23 October.

The initial radiation surveys began at 1800 hours on 09 October and were completed at 2100 hours. No radiation above background levels was detected at the U12n tunnel portal yard area or at the ventilation pad above the portal. At 2032 hours, gas samples taken from the portal side of the U12n.19 DIAMOND BEECH FDPP indicated 0.1 mR/h, 10 ppm CO, 3 percent of the LEL, and 20 percent oxygen.

Reentry into the tunnel began at 0815 hours on 10 October. The maximum readings on this initial MILL YARD reentry at 1428 hours were taken from a gas sample obtained at the U12n.11 FDPP. Readings were 0.3 mR/h, 50 ppm CO, no explosive gases, and 20 percent oxygen. Subsequently, on 11 October, when reentry team No. 1 entered the U12n.20 lower drift, a survey at the bulkhead door showed readings of 100 mR/h and 7,000 ppm CO. The DIAMOND BEECH reentry team encountered background radiation levels in the U12n.10 main and bypass drifts.

Mining operations for the MILL YARD test began on 11 October. By 18 October cavity ventilation and gas sampling began. This work continued until 12 November when operations were shut down until after DIAMOND BEECH posttest work was completed. Drilling operations on the mesa commenced on 22 October when crews began preparations for drilling into the MILL YARD cavity. Successful photography to study the size and shape of the crater by lowering a camera into the cavity did not begin until 4 February 1986. Several camera runs were made between February and July 1986. Surveys of the equipment typically showed low levels of contamination, and analysis of gases from the cavity indicated readings of 0.05 mR/h, no CO, and no explosive gases. Core samples taken in December 1986 showed readings of 0.05-0.1 mR/h.

DIAMOND BEECH mining operations began on 17 October. By 29 October, miners began removing the turnout door at the U12n.19 bypass FDPP where the radiation reading was 0.05 mR/h. By the

time LPARL personnel, dressed in double anticontamination clothing, entered the WP side of the U12n.19 FDPP, a survey showed the radiation level was 0.3 mR/h in the stubs area. Underground probe hole drilling began in January 1986, with core sampling beginning in April. Surveys of core samples taken showed background radiation levels.

Personnel exposure data from self-reading pocket dosimeters were documented on Area Access Registers during individual entries (i.e., one individual may enter 50 times during a given time frame, and that is recorded as 50 entries) to MILL YARD and DIAMOND BEECH radex areas over a non-continuous time frame beginning 09 October 1985, and ending 08 December 1986. The self-reading pocket dosimeter was worn only for the time period that the individual was in the radex area, and it was read upon exit from the area. Therefore, during the time that an individual was in a radex area, that person wore both a film badge (a TLD after January 1987) and a pocket dosimeter. The pocket dosimeter was used as an indicator of potential radiation exposure to participants. It was not used as the dosimeter of record. The pocket dosimeter could electronically discharge when dropped or knocked, providing a false positive reading.

The film badge (later the TLD), as the dosimeter of record, was always worn by personnel upon entry onto the NTS and was not subject to these electronic problems incurred by pocket dosimeters. Film badges worn by these reentry personnel indicated that two individuals received some gamma exposure, most likely from the MILL YARD or DIAMOND BEECH tests. Since the film badge data provided a time frame when the exposure was obtained, but not the location where that exposure was obtained, it cannot be said with absolute certainty that these exposures were a result of the MILL YARD or DIAMOND BEECH tests. The minimum detectable gamma exposure with the NTS film badge dosimeter was 30 mR. The most common pocket dosimeter used read between 0 and 200 mR, however, high-range pocket dosimeters were used at certain times.

Area Access Register data summarized below show the number of entries during the time frame stated; the maximum exposure recorded on the pocket dosimeter for all participants and for DoD and DoD-contractor personnel; and the average exposure for the dosimeter data distribution for each of those groups. The average exposure is the sum total of all the exposures recorded from pocket dosimeter data for each group, divided by the total number of logged entries in that group.

Participants	Entries Logged	Maximum Exposure (mR)	Average Exposure (mR)
All	1,525	70	1.3
DoD	78	10	1.2

SECTION 4

MIGHTY OAK TEST

4.1 TEST SUMMARY.

MIGHTY OAK was a DoD/LLNL-sponsored weapons-effects test conducted at 0608 hours PST on 10 April 1986. The test had a yield of less than 20 kilotons and was emplaced at a vertical depth of 1,294 feet in the U12t.08 drift of the T tunnel complex (see Figure 4-1). The purpose of the MIGHTY OAK test was to study the blast-produced radiation effects on communications equipment and military hardware. Supporting experiments studied device performance, radiation diagnostics, and containment measurements.

Within minutes after detonation, it became apparent that there was radioactive material leaking beyond the U12t.08 complex DPPs, but not beyond the WP side of the GSP in the tunnel access drift. All radioactive material was contained within the tunnel, and no accidental release of radioactivity to the atmosphere occurred. Subsequently, with the approval of the DOE TC, eight controlled¹⁵ effluent releases of the contained gases occurred between 22 April and 19 May 1986. Xenon-133 and small amounts of iodine-131 and krypton-85, detected offsite by noble gas samplers, were attributed to this test. The air samples collected on May 6, 1986, in Colorado detecting iodine-131 were a result of the Chernobyl nuclear reactor disaster.

4.2 PRETEST ACTIVITIES.

4.2.1 Responsibilities.

Safe conduct of all MIGHTY OAK project activities in Area 12 was the responsibility of the DNA TGD, subject to controls and pro-

¹⁵ The radioactive gas was passed through a filtering system where the particulates were removed before the gas was released through the tunnel ventilation system.

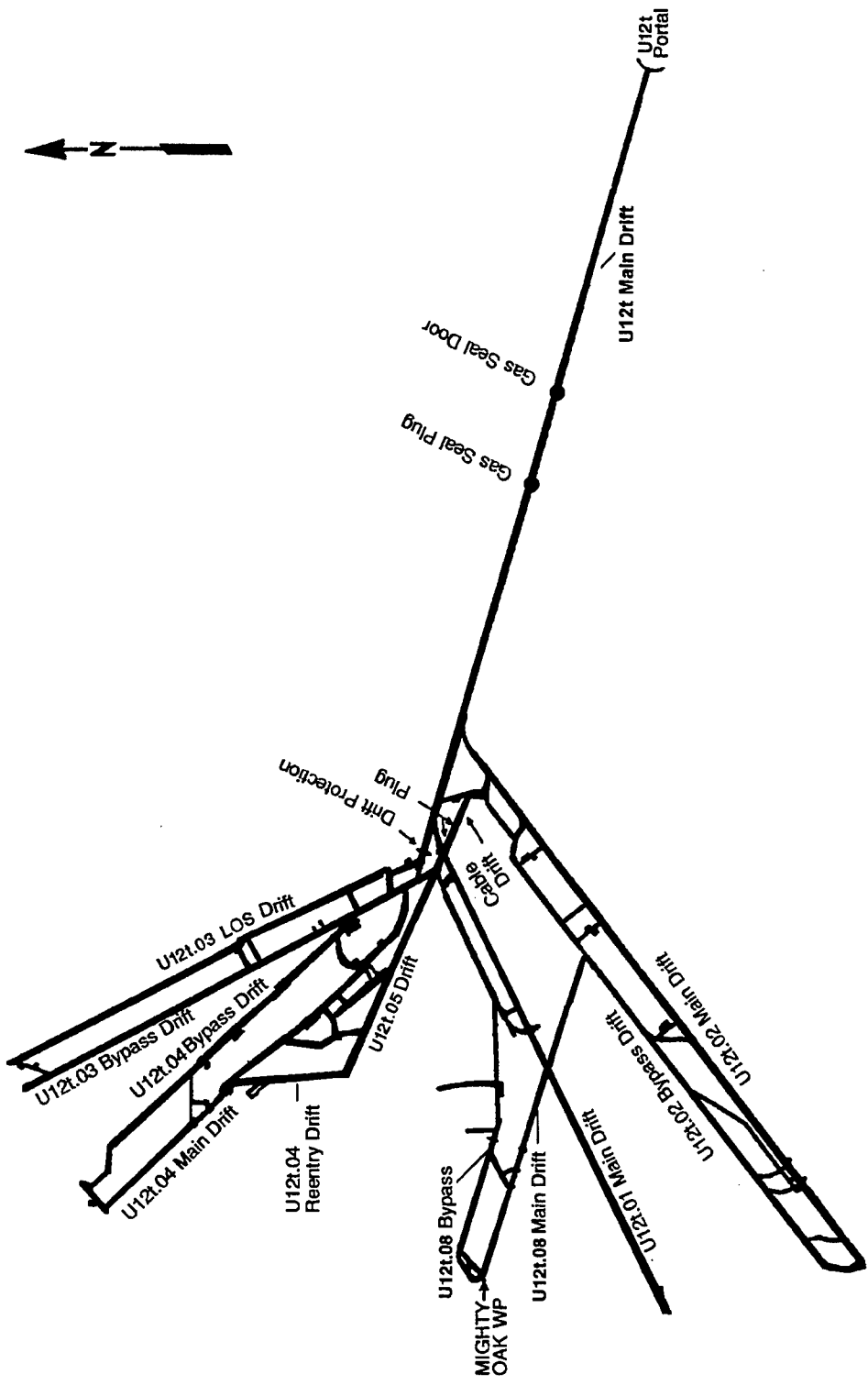

NOT TO SCALE

Figure 4-1. MIGHTY OAK test - tunnel layout.

cedures established by the DOE TC. The DOE TC was responsible for safety of the public and onsite personnel during the test.

Project agencies were responsible for designing, preparing, and installing experiments, or delivering them to the installation contractor. After the test, these agencies were responsible for removing samples, analyzing instrument and sample data, and preparing project reports on experiment results.

Device safety and security procedures in the WP area and the timing and firing control room were in accordance with DOE Order 5610.3, "Program to Prevent Accidental or Unauthorized Nuclear Explosive Detonations." The LLNL TD had overall responsibilities for all operations involving the MIGHTY OAK device as well as the timing control and the arming and firing of MIGHTY OAK closures and experiments. The LLNL TD was responsible to the DOE TC for radiological safety within the designated area of the WP from device emplacement until detonation. After detonation, the DOE TC relieved the LLNL TD of these responsibilities. The DOE TC approved the controlled venting of the tunnel complex and returned the responsibility for project activities back to the DNA TGD.

4.2.2 Planning and Preparations.

A. Tunnel Facilities Construction.

The MIGHTY OAK test site construction of the U12t.08 drift complex utilized the existing U12t.02 and U12t.01 drifts. The U12t.08 main drift was mined from the U12t.02 bypass drift, and the U12t.08 bypass drift was mined from the U12t.01 bypass drift. The main drift was 20 feet wide by 22 feet high at the portal end and 8.5 feet wide by 8.5 feet high from the mechanical auxiliary closure (MAC) to the zero room. The bypass drift was 12 feet high and 11 feet wide throughout its length except on the curves where it was enlarged to 14 feet wide to accommodate large experiments. The testbed consisted of a 911-foot long horizontal LOS pipe that was evacuated to simulate exoatmospheric

conditions. The U12t.08 complex consisted of one LOS drift, a bypass drift, a muffler, two auxiliary closures, the TAPS, one zero room, a test chamber, experiment and support alcoves, and a vacuum pumping and monitoring station (see Figure 4-2).

Construction activities began in late 1983 while MIDAS MYTH mining operations were still in progress. Originally, MIGHTY OAK was to be conducted in the U12t.07 drift, but because of ground shock problems experienced with MIDAS MYTH, it was felt that the U12t.07 drift would put the MIGHTY OAK WP too close to the MIDAS MYTH WP. Therefore, the location was changed to the U12t.08 drift.

Mining of the U12t.08 LOS and bypass drifts began early in 1984 and was completed in November. Mining of the Recorder and Oscilloscope Sealed Environmental System (ROSES) drift, the recording alcove, and the user and experimenter alcoves was conducted in parallel with the LOS drift. Installation of the LOS pipe began in January 1985 and was essentially completed by October. During this period, the installation of the cables, the MAC, the GSAC, and the TAPS was completed. By the end of October 1985, all of the instrument and experimenter alcoves, vacuum pump modules, and scatterer station installation were completed. Work on installing diagnostics hardware had begun. Between November 1985 and March 1986, all experiments, electronic and recording equipment, and cable connections were installed and checked out.

Remote gas sampling capabilities were incorporated during construction as well as capabilities for water, power, drain, and pressurization lines. Provisions were made to manually take gas samples from the WP side of the GSD, GSP, and main DPP during posttest reentry.

The stemming plan for the U12t.08 complex is shown in Figure 4-3. The stemming operations that began in 1985

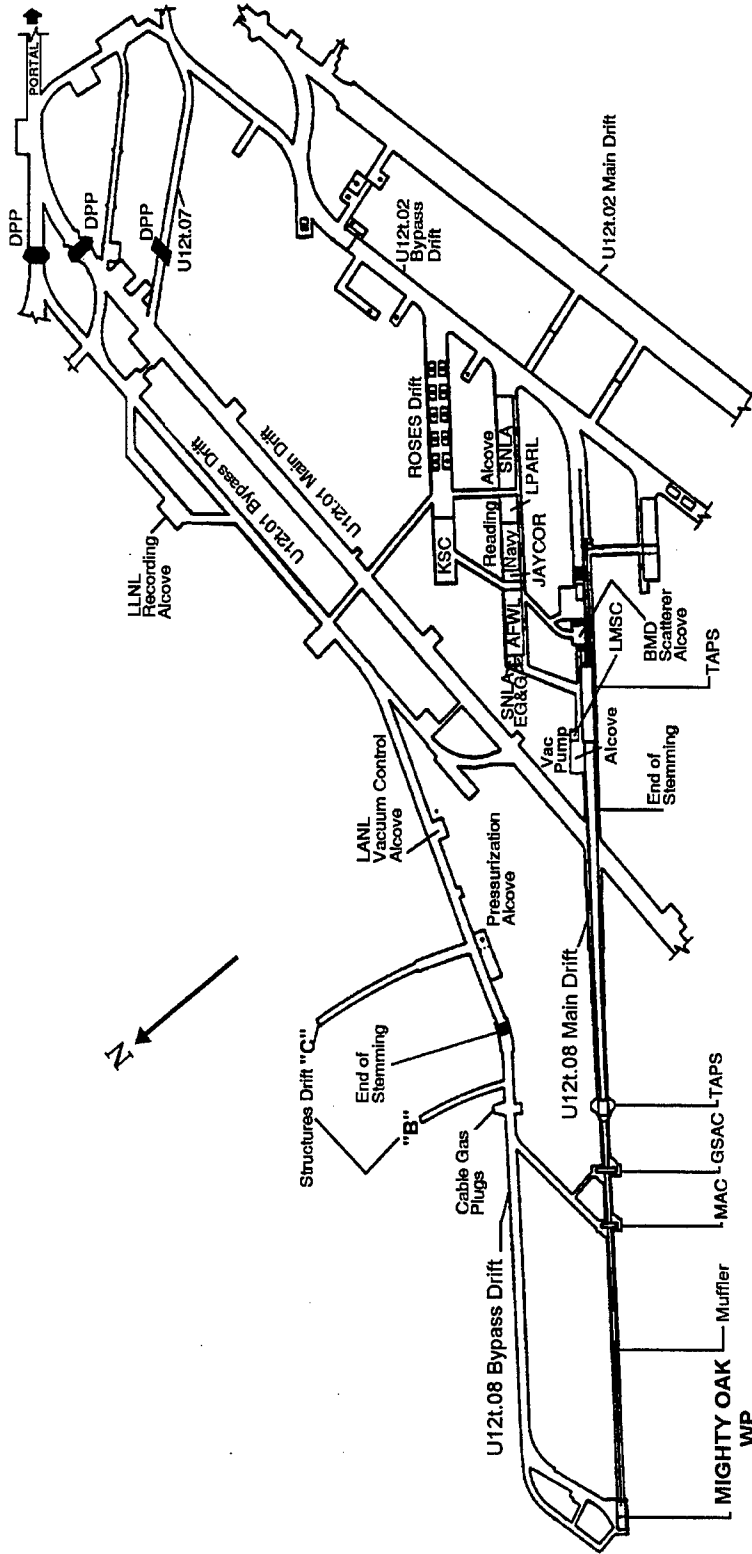

NOT TO SCALE

Figure 4-2. MIGHTY OAK test - tunnel facilities layout.

	Rockmatching Grout
	Superlean Grout
	Concrete
	High-Strength Groutcrete
	Very High-Strength Groutcrete
	High-Strength Grout
	High-Strength Concrete

RS = Range Station (distance in meters radially from Working Point)

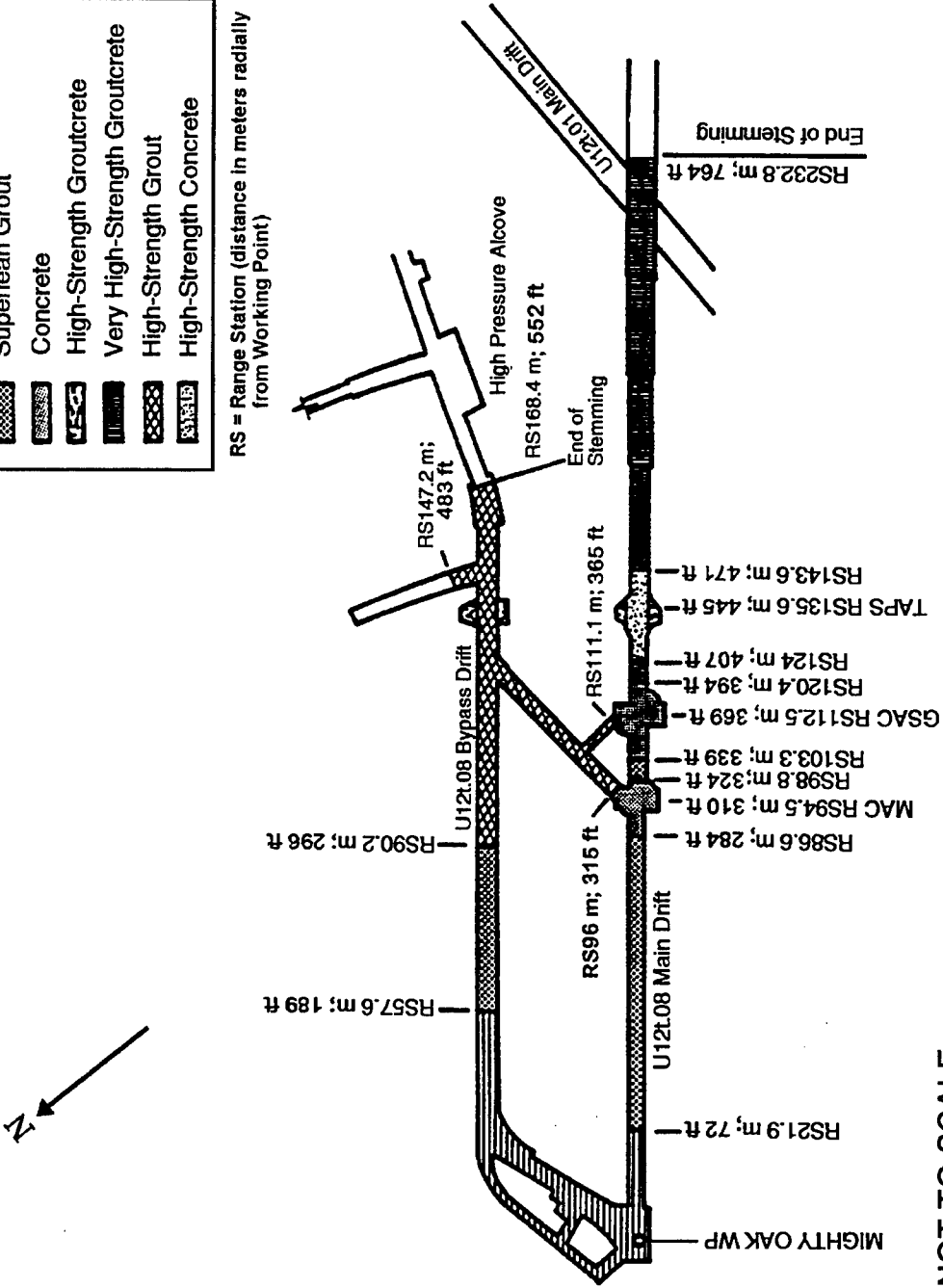

Figure 4-3. MIGHTY OAK test - stemming plan.

were completed in March 1986. Stemming materials (i.e., RMG, SLG, several types of high-strength groutcrete, and concrete) were pumped into all void areas from the MIGHTY OAK WP to a distance of 764 feet. The U12t.08 main drift was backfilled first with RMG to 72 feet; then with SLG to 284 feet; followed by concrete, high-strength concrete, and groutcrete surrounding the closures and TAPS; and finally with very high-strength groutcrete to 764 feet. The U12t.08 bypass drift was stemmed from the WP to a distance of 189 feet with RMG; then to 296 feet with SLG; and to 552 feet with HSG. All penetrations into the stemmed areas of the drifts (e.g., cables and water lines) were gas blocked to prevent the seepage of radioactive gases outside the stemmed region of the drifts.

Experiments and related hardware installations were completed by March 1986. The following organizations were among those that fielded experiments for the MIGHTY OAK test: Lockheed Missile and Space Company, Inc. (LMSC) conducted x-ray, neutron, and gamma spectrum and fluence studies; Kaman Sciences Corporation (KSC) conducted stress, acceleration, and particle velocity measurements; Boeing Technical Management Services, Inc. (BTMS) attempted to gain information on the trans-attack environment in underground cavities (the collapse of the area containing elements of the experiment resulted in lack of usable data); General Research Corporation (GRC) conducted satellite vulnerability studies; Science Applications International Corporation (SAIC) studied improving radiation environments to simulate specific conditions; S-CUBED measured and analyzed flow in the LOS pipe; APTEK, Inc. conducted impulse coupling experiments; the Air Force Weapons Laboratory (AFWL) and Aerospace conducted space components studies; Sandia National Laboratories, Albuquerque (SNLA) conducted advanced development and diagnostic experiments; and Lawrence Livermore National Laboratory (LLNL) conducted warhead impulse experiments.

The SDRs, that began in January and concluded on 2 March, were held to ensure that all systems were functioning properly in preparation for the MFP dry run. A successful MFP dry run was conducted for MIGHTY OAK on 25 March, and preparations for test execution began. On 10 April, the device was armed, and final button-up activities began.

B. Radiological Safety Support.

Procedures for radiation exposure and contamination control during this test were in accordance with NTO SOP 0501 and requirements of responsible DoD representatives. Radsafe provided monitoring and equipment support.

Prior to the test, detailed radiological safety reentry plans were prepared and issued to participating agencies. Air sampling equipment was positioned in the test area. Radsafe monitors were briefed regarding surface reentry, manned stations, and security station requirements.

Radsafe monitoring teams and supervisory personnel were provided to perform initial radiation surveys, conduct aerial surveys by helicopter, and participate in reentry parties as needed. Radsafe personnel were also standing by at designated muster stations prior to detonation to perform surveys and provide emergency support as directed; to provide and issue anticontamination equipment and material, portable instruments, and dosimeters; to operate area control check stations; and to perform personnel, equipment, and vehicle decontamination, as required.

Available anticontamination materials and equipment included head covers, coveralls, cloth shoe covers, totes, full-face masks, supplied-air breathing apparatus, plastic suits, plastic bags, gloves, and masking tape.

C. Telemetry and Air Sampling Support.

In addition to the permanent RAM units, 48 temporary units provided surface and underground coverage for the MIGHTY OAK test. Tables 4-1 and 4-2 list the locations of surface and underground RAMS, respectively. The locations of surface RAMS are shown in Figure 4-4, and those of underground RAM units are shown in Figures 4-5 and 4-6. All RAM units were installed a minimum of five days prior to scheduled device detonation. EPA operated continuous monitoring stations at 30 locations in the offsite area. All the stations had high-volume air samplers with collectors for particulates and reactive gases, 17 had tritium and noble gas samplers, and 23 had pressurized ion chamber gamma-rate detector/recorder systems in operation. Thirty EPA personnel were fielded for offsite surveillance activities.

D. Security Coverage.

Device security procedures in the WP area and the timing and firing control room were in accordance with DOE Order 5610.3, "Program to Prevent Accidental or Unauthorized Nuclear Explosive Detonations." Beginning on D-1, all personnel entering or exiting the controlled area were required to stop at muster or control stations for issue of stay-in badges. After control was established, all through traffic was diverted around the controlled area by use of screening stations. In accordance with the "Test Controller's Operations and Security Plan," contractors and agencies were to have all personnel not connected with this test out of the closed area before the final security sweep began.

E. Air Support.

Three UH1N helicopters and crews were provided by the USAF for cloud tracking and the Test Controller's use, if needed. In addition, the USAF provided a WC-130 and/or a

Table 4-1. MIGHTY OAK test RAMS unit locations 10 April 1986.

SURFACE

STATION NUMBER	LOCATION
From the U12t Portal:	
1	At the portal
2	On the vent line
3	On the vent line
4	333 feet N 09° W azimuth
5	344 feet N 68° E azimuth
6	289 feet S 76° E azimuth
7	389 feet S 09° E azimuth
8	323 feet S 43° W azimuth
9	564 feet N 74° W azimuth
10	653 feet S 81° E azimuth (on drain line)
11	2,005 feet S 88° E azimuth
From the U12t.08 SGZ:	
12	500 feet N 0° E azimuth
13	500 feet S 60° E azimuth
14	500 feet S 60° W azimuth

Table 4-2. MIGHTY OAK test RAMS unit locations 10 April 1986.

UNDERGROUND

STATION NUMBER	LOCATION
15	370 feet into the U12t.08 LOS drift
16	325 feet into the U12t.08 LOS drift
17	270 feet into the U12t.08 LOS drift
18	240 feet into the U12t.08 LOS drift
19	170 feet into the U12t.08 LOS drift
20	120 feet into the U12t.08 LOS drift
21	300 feet into the U12t.08 recording alcove
22	220 feet into the U12t.08 recording alcove
23	100 feet into the U12t.08 recording alcove
24	235 feet into the U12t.08 ROSES drift
25	145 feet into the U12t.08 ROSES drift
26	70 feet into the U12t.08 ROSES drift
27	70 feet at the LLNL alcove 8-10
28	640 feet into the U12t.02 bypass drift
29	430 feet into the U12t.02 bypass drift
30	310 feet into the U12t.02 bypass drift
31	615 feet into the U12t.02 LOS drift
32	100 feet into the U12t.02 bypass drift
33ER ¹⁶	100 feet into the U12t.02 bypass drift

¹⁶ ER - Extended Range (instrument capable of reading 100 mR/h to 100,000 R/h).

Table 4-2. MIGHTY OAK test RAMS unit locations 10 April 1986
(Continued).

UNDERGROUND

STATION NUMBER	LOCATION
34	At the crosscut to the LLNL alcove
35	900 feet into the U12t.08 bypass drift
36	720 feet into the U12t.08 bypass drift
37	575 feet into the U12t.01 work drift
38	290 feet into the U12t.01 work drift
39	3,850 feet into the U12t main drift
40	150 feet into the U12t.07 main drift
41	300 feet into the U12t.02 main drift
42	3,320 feet into the U12t main drift
43	2,800 feet into the U12t main drift
44	2,240 feet into the U12t main drift
45ER ¹⁷	2,240 feet into the U12t main drift
46	1,800 feet into the U12t main drift
47	900 feet into the U12t main drift
48	100 feet into the U12t main drift

¹⁷ ER - Extended Range (instrument capable of reading 100 mR/h to 100,000 R/h).

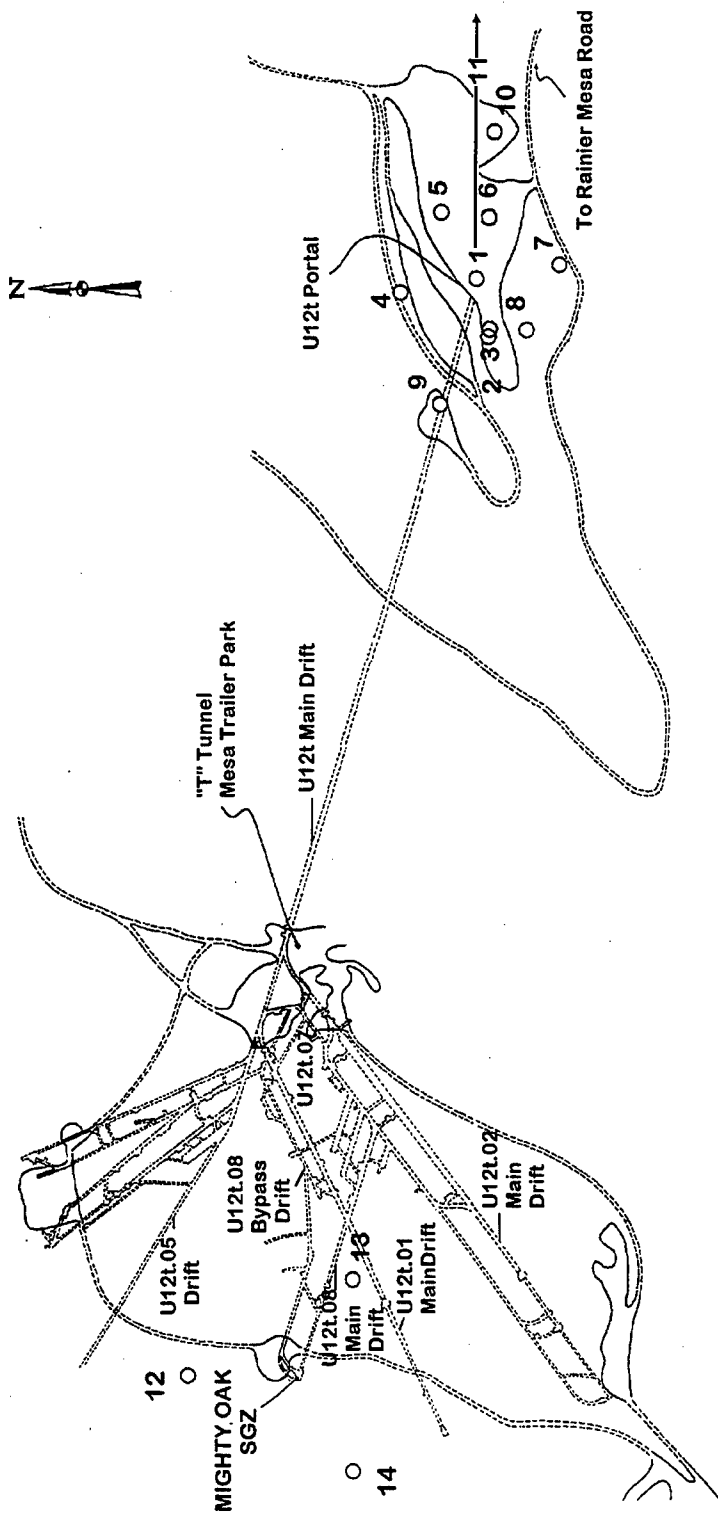

NOT TO SCALE

Figure 4-4. MIGHTY OAK test - surface RAMS.

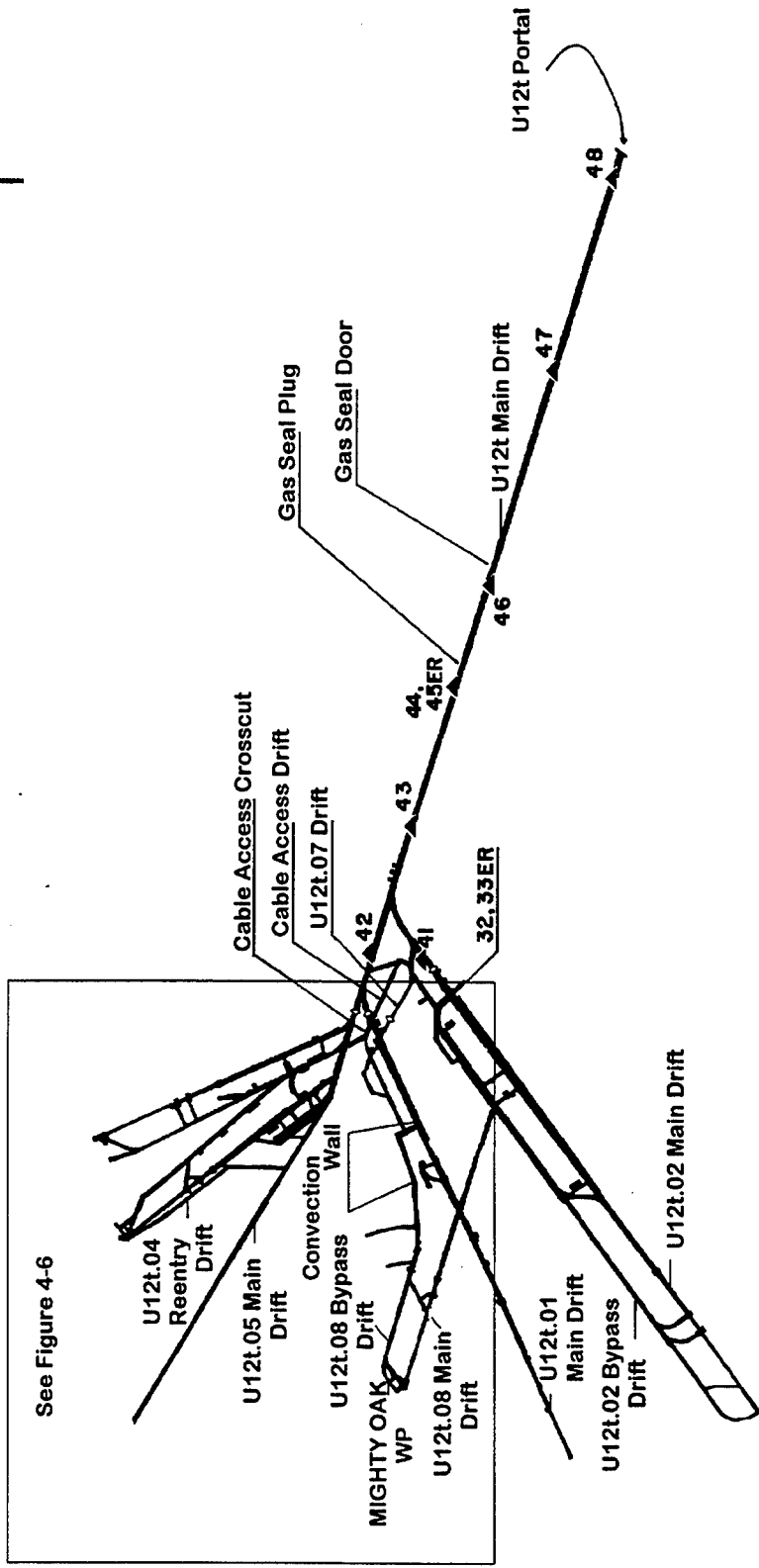

NOT TO SCALE

Figure 4-5. MIGHTY OAK test - underground RAMS.

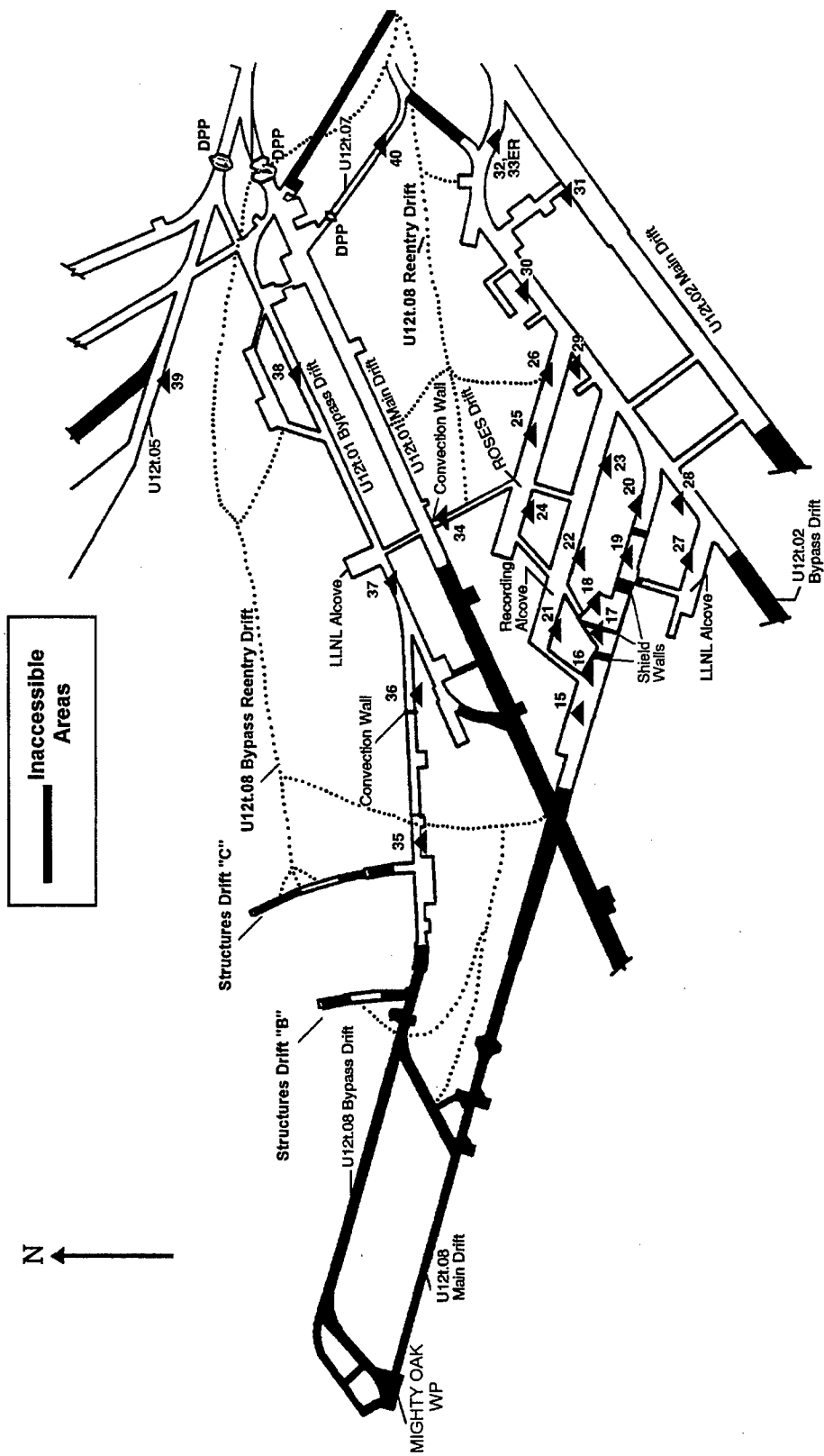

NOT TO SCALE

Figure 4-6. MIGHTY OAK test - underground RAMS and reentry drifts, U12t.08 complex.

WC-135 aircraft and crew on standby status for cloud tracking. EG&G provided a Turbo Beech aircraft for cloud sampling and a Twin Bonanza for taking wind soundings and for cloud tracking duties, if necessary.

4.3 TEST-DAY ACTIVITIES.

4.3.1 Pretest Activities.

After two days of postponements because of unfavorable weather, final preparations for detonation were initiated. On 09 April 1986, by approximately 2400 hours, all persons except the arming party, the tunnel button-up party, and the security guards were out of the tunnel and clear of the muster area. Soon after, permission was granted to arm the device. Following the departure of the arming party, button-up operations were completed, and the party left the tunnel. The area was cleared of all personnel in the early morning hours of 10 April.

A final readiness briefing was held at 0500 hours on 10 April 1986. The 15-minute countdown began at 0553 hours and proceeded uninterrupted until zero time. The MIGHTY OAK device was detonated at 0608 hours PST on 10 April 1986.

4.3.2 Test Area Monitoring.

Telemetry recording measurements began at 0608 hours on 10 April 1986, at which time all RAM units (i.e., stations) read background levels except those located in the U12t.08 main drift (numbers 15 through 20). Surface RAM units 12 and 13 were lost immediately after zero time also. At H+1 minute, station numbers 15 through 32 and 34 through 39 were reading off scale and remained there throughout the test period. At this point it became obvious that some radioactive material had leaked out of the LOS pipe (Vessel I), past the DPP (Vessel II) and into the U12t.08 main drift up to the GSP (Vessel III). Station 33 (an extended range RAM unit on the WP side of the DPP) and the RAM stations on the WP side of the

GSP (40-45) were all reading above background radiation levels. Station 33 read 3,690 R/h at approximately H+2.5 hours, and stations 40 and 41 were showing over 1,000 R/h. By H+27 hours RAM stations 40 and 41 were reading 11.6 R/h and 18.8 R/h, respectively and continued to decrease throughout the readout period. RAM station 2 was relocated and placed on the ventline filter box at the ventilation pad during tunnel ventilation; the maximum reading was 486 mR/h at 1405 hours on 25 April. All RAM stations were secured at 0940 hours on 27 May 1986, and at that time, station 42 was reading 0.3 mR/h.

4.3.3 Initial Surface Radiation Surveys.

An initial surface reentry team, along with the portal damage and data recovery crews, departed the TC's barricade at Gate 300 at 0915 hours on 10 April 1986. A mobile base station was setup to provide for area control and equipment supply. All radiation readings were relayed as soon as they were obtained via Net 3 radio. By 1000 hours, survey of the portal area and ventilation pad above the portal area was completed and damage assessment work was in progress. All radiation readings were at background levels (0.04 mR/h). By 1145 hours the data recovery and damage assessment teams had completed their work, and by 1200 hours the teams had departed the U12t portal for the security station. All radiation levels at the portal remained at background levels.

The gas sampling team began remote sampling at the portal on 14 April at 0755 hours. The first samples, taken at 0835 hours from the WP side of the GSP, indicate 0.4 mR/h radiation reading, 750 ppm CO, 20 percent of the LEL, and 20 percent oxygen. Additional samples taken from the portal side of the U12t.02 DPP at 0915 hours showed 0.15 mR/h radiation reading, 21 percent oxygen level, and no toxic or explosive gases.

4.4 POSTTEST ACTIVITIES.

4.4.1 Tunnel Reentry Activities.

The initial reentry team, wearing double anticontamination clothing and SCBA, entered the U12t tunnel portal at 1355 hours on 15 April. Gas samples taken from the WP side of the GSP prior to the team arrival showed maximum readings of 1.5 mR/h, 1,500 ppm CO, 25 percent of the LEL, and 20.5 percent oxygen. The reentry team proceeded to the GSD at 1410 hours where readings on the WP side of the GSD showed 0.04 mR/h and no toxic or explosive gases. The team opened the manway door on the GSD and proceeded to the GSP. Again, gas samples were taken from the WP side of the GSP. Data showed 1.2 mR/h, 2,600 ppm CO, 55 percent of the LEL, and 19 percent oxygen. The team then secured the manual valves on the sampling line and proceeded back through the manway door at the GSD and returned to the portal. All reentry personnel were surveyed and then released at 1523 hours.

On 16 April at 0919 hours, the reentry team, dressed in anti-contamination clothing and SCBA, again proceeded from the tunnel portal through the manway at the GSD to the GSP. A rescue team was standing by at the portal, if needed. Readings from gas samples taken from the WP side of the GSP were 1.5 mR/h, 3,000 ppm CO, 80 percent of the LEL, and 19 percent oxygen. The team prepared the tunnel for purging by connecting appropriate lines to the ventilation line. At 1044 hours the compressed air line valve was opened and a sample, taken from the attached flex line, indicated 4.5 mR/h. This team left for the portal at 1101 hours. These personnel were surveyed and then released.

A second reentry team, also dressed in anticontamination clothing and SCBA, left the portal at 1304 hours on 16 April and proceeded to the GSP. The air line valve was closed, and flex line removed from the ventilation line. The 36-inch turntube door on the GSP was opened and readings taken inside the turn tube were 0.7 mR/h, 10 percent of the LEL, and 20.5 percent oxygen. This team then exited the tunnel, closing the manway door at the GSD and returning to the portal. All personnel were surveyed and then released.

With the approval of the TC, a controlled ventilation of the tunnel between the GSP and the DPPs (Vessel III) began on 22 April at 0950 hours, and lasted until 0611 hours on 23 April. At 1235 hours that same day, the reentry and rescue teams, wearing anticontamination clothing and SCBA, departed for the GSD where the rescue team remained while the reentry team proceeded to the GSP and connected the compressed air and drain lines to the portal side of the GSP. The team then proceeded to the U12t.01 mechanical DPP (MDPP). Readings taken at the MDPP were 1.3 mR/h, 10 ppm CO, no explosive gases, and 17 percent oxygen. A gas sample taken from the WP side of the MDPP indicated 10.5 mR/h, 2,000 ppm CO, 100 percent of the LEL, and 3 percent oxygen. After connecting the drain line and opening the valve, the reentry team moved on to the U12t.02 DPP where the reading, at contact with the turntube door was 40 mR/h, and data from a gas sample taken from the WP side showed 10 mR/h, 100 percent of the LEL, and 2 percent oxygen. The team connected ventilation lines and then returned to the U12t.01 MDPP where they opened the turntube and took swipe samples for laboratory analysis. The reentry and rescue teams returned to the portal at 1550 hours where all personnel were surveyed before being released.

On 25 April at 1032 hours, intermittent tunnel ventilation from the WP to the DPPs began, with the TC's approval, and continued through 19 May. By 22 May, the tunnel environment allowed for normal tunnel ventilation to be reestablished.

4.4.2 Posttest Tunnel Rehabilitation, Mining, and Recoveries.

Beginning on 7 May, miners and Radsafe personnel, dressed in anticontamination clothing, opened the large GSD and started mining through the GSP. Simultaneously, workers began clean-up operations that included cleaning up debris; applying two coats of latex paint to the ribs and back (i.e., sides and ceiling) of the tunnel from the portal side of the U12t.02 DPP to the GSP; removing three to five inches of floor from the GSP to the U12t.02 DPP and replacing it with pea gravel; and cleaning the railroad tracks. All work on the WP side of the GSP required anticontam-

ination clothing and full-face respirators. Mining operations progressed as cleanup continued.

In an attempt to determine whether it was feasible to reenter the ROSES alcoves, two workers opened the crawlway through the U12t.02 DPP on 8 May. Radiation levels on the WP side of the DPP measured 28 R/h, and 5-10 R/h in the crawlway. This confirmed that reentry was not desirable at this time. The workers received iodine exposures of 70 and 200 mrem, respectively during this operation from a possible respirator leak or from skin absorption. However, these exposures are well within the guideline of 5,000 mrem/qtr, and no other incidences occurred.

Reentry mining began on 31 May 1986, when workers started mining the first reentry drift (i.e., the U12t.08 reentry drift) from the U12t.07 drift at a 5.5 percent upgrade. Figure 4-6 shows the reentry drifts that were mined after the MIGHTY OAK test. Workers mined a crosscut drift, on the WP side of the U12t.02 cable DPP (CDPP), to the U12t.02 bypass drift. A reentry attempt to reach the ROSES drift was staged with all personnel wearing anticontamination clothing and full-face respirators. However, when personnel encountered radiation readings of 8 R/h in the bypass drift, they quickly returned to the reentry drift, and a shotcreted bulkhead was installed in the crosscut drift. Mining continued toward the U12t.01 main drift, but work terminated on 17 June when this drift had to be abandoned and barricaded because weak rock and high radiation levels were encountered.

Miners extended the U12t.08 reentry drift to within 10 feet of the crosscut between the U12t.01 LOS drift and the ROSES alcove. From probe holes drilled into the crosscut, radiation readings of 1 R/h were obtained. From a probe hole into the ROSES alcove, a 2.5 R/h radiation level was obtained. A ROSES reentry drift was mined off the U12t.08 reentry drift at a downgrade to intersect the ROSES alcove. Initial inspection from probe holes showed that structurally the alcove was in good condition. When the damage assessment team entered the alcove on 25 September, they saw dry, powdery ash-type material on the floor, damaged cable insulation, and equipment damaged by exposure to high temperatures. The team

moved to the U12t.02 bypass drift that contained more ash-type material, and where radiation levels measured nearly 11 R/h. They quickly returned to the ROSES alcove. The workers then cut holes through the walls of several of the SNL ROSES because the hardware to be recovered could not be removed from the front of the instrument racks. They noted that the equipment inside had a burned appearance. On 14 October SNL personnel recovered the desired equipment from the ROSES.

In March 1987, the ROSES reentry drift was mined into the crosscut connecting the ROSES alcove and the U12t.01 main drift. Personnel measured a 40 mR/h radiation reading inside the crosscut where evidence of melted insulation was seen. Work continued in April when teams proceeded into the recording alcove where most of the instrumentation racks were in a massive pile and about two inches of dust was on the floor. The radiation level near the invert was 2 R/h. The team continued to the test chamber area where damage was apparent; however, the shield wall on the portal side of the test chamber was intact.

A second major reentry drift (designated as the bypass reentry drift) was started from the U12t.02 bypass drift and the T tunnel cable drift on 20 June 1986. The drift was mined on an upgrade crossing over the CDPD and MDPP and then the heading turned to parallel the LANL recording alcove. From there the drift was mined at a downgrade until the floor was at the same level as the U12t.01 bypass drift. A crosscut was mined to the LANL alcove where personnel, dressed in anticontamination clothing and full-face respirators, entered the alcove on 30 July and worked intermittently to recover data and equipment through 4 August. The alcove had evidence of exposure to high temperatures. Data films and equipment, including photographic and other recording equipment, that were recovered were both physically damaged and contaminated. Radiation level readings were 45 to 200 mR/h.

As this drift continued, it was mined to pass over the U12t.08 bypass drift and close to the U12t.08 LOS (main) drift. Radiation readings ranging from 2.5 to 8 R/h were recorded when a probe was

inserted into the LOS pipe between the TAPS and the end of stemming.

Mining of this portion of the new drift, termed the U12t.08 main reentry drift, continued parallel to the U12t.08 main drift in September. Holes were drilled into the main drift between the TAPS and the MAC and also to the WP side of the MAC. No pieces of LOS pipe were encountered in any of the drill holes. The highest radiation reading recorded in any probe hole was 140 mR/h. On 30 September, mining was stopped temporarily while several experiments were recovered.

In October 1986, mining of the U12t.08 bypass drift continued and work proceeded toward structures drift "B." Workers reached this area on 6 November and recovered some experiments. Radiation measurements showed background levels. Concurrently working nearby, miners reached structures drift "C" on 3 November where experiments were also recovered. The radiation reading was 30 mR/h.

Mining continued in the main reentry and bypass drifts through February 1987 as experimenters continued to recover data. In March a crosscut drift was mined from the U12t.08 main reentry drift to intersect the main (LOS) drift on the WP side of the TAPS. Observations from the mouth of the crosscut on 24 March revealed that parts of the LOS pipe were missing, and there was extensive damage in this section of the pipe. On 25 March a reentry team entered the LOS pipe to survey damage noting that a section of the LOS pipe at the end of stemming was missing. Doors of the GSAC and MAC were missing and there was considerable debris on the floor. On 27 March miners began another crosscut from the U12t.08 main reentry drift to intersect the main (LOS) drift on the WP side of the MAC. The crosscut drift was opened into the LOS drift on 9 April. A large amount of tuff had fallen onto the floor of the LOS drift making access difficult. Radiation readings in the LOS drift measured 40-50 mR/h. Further recovery work was limited and consisted of some mining and recovering of experiments.

4.4.3 Industrial Safety.

Checks for the presence of toxic gases and surveys to measure radiation and explosive gas levels were made on each shift. The results were then recorded in the monitors' logbook.

Appropriate safety measures were taken to protect mining personnel and prevent unsafe conditions. Industrial safety codes for mining, tunneling, and drilling were established by REECo and emphasized during all operations. A written standard operating procedure was required for each operation involving explosives, toxic materials, radioactive material, or any other operation with the potential for personal injury. Each individual involved in such an operation was required to know the contents of the applicable procedures.

The portal construction area and the tunnel were mandatory hard-hat and foot-protection areas (safety shoes, boots, DOE-issued miner's boots, or toe guards). All personnel on initial tunnel reentry teams were certified in the use of the Draeger self-contained breathing apparatus. Standard safety rules and regulations, as spelled out in the "U.S. Bureau of Mines Manual," were observed.

All explosives, electro-explosive components, solid propellants, toxic materials, and radioactive materials were handled, stored, and transported in accordance with applicable sections of the following documents:

1. Army Material Command Regulations (AMCR 385-100).
2. Appropriate DOE Orders in the 5400 and 5600 Series concerning Environmental Protection, Safety & Health Protection, and Defense Programs, respectively.
3. Individual safe operating procedures (by experimenter organization).
4. MIGHTY OAK Safety Regulations.

All personnel engaged in handling, storing, assembling, or installing explosives, propellants, or electro-explosive devices (or

observers of those operations) were required to wear safety glasses or other eye protection which had been approved by the DoD safety coordinator.

4.5 RESULTS AND CONCLUSIONS.

Telemetry recording measurements began at 0608 hours on 10 April 1986. Surface RAM units 12 and 13 were lost at zero time. By H+1 minute, station numbers 15 through 32 and 34 through 39 were reading off scale and remained there throughout the test period. A maximum reading of 3,690 R/h was recorded on RAM station 33 (an extended range RAM unit) at H+2.5 hours. The maximum surface RAM reading of 486 mR/h was recorded on station 2, that had been relocated to the ventline filter box on the ventilation pad at 1405 hours on 25 April. All readings continued to decrease, and all stations were secured at 0940 hours on 27 May.

The initial radiation surveys began at 0915 hours on 10 April and were completed at 1200 hours. No radiation above background levels was detected at the U12t tunnel portal yard area or at the ventilation pad above the portal. At 0835 hours on 14 April, the first gas samples taken from the WP side of the GSP indicated 0.4 mR/h, 750 ppm CO, 20 percent of the LEL, and 20 percent oxygen.

Reentry into the tunnel began at 1355 hours on 15 April. The reentry team proceeded to the GSP where a gas sample taken from the WP side of the GSP showed 1.2 mR/h, 2,600 ppm CO, 55 percent of the LEL, and 19 percent oxygen. Subsequently, on 23 April, when a controlled ventilation of the tunnel between the GSP and the DPPs was completed, reentry and rescue teams entered the tunnel and took gas samples from the WP side of both the U12t.02 and U12t.01 DPPs. The maximum radiation reading on a gas sample from the WP side of the U12t.02 DPP was 10 mR/h, and the maximum CO level of 2,000 ppm was recorded on the sample from the WP side of the U12t.01 DPP.

Rehabilitation, mining, and recovery operations for the MIGHTY OAK test began on 7 May 1986, with clean-up work completed by the end

of May. Because of unacceptably high radiation levels and damage and debris hampering reentry to the drifts, workers mined two new reentry drifts to facilitate experiment recoveries and inspect damage while implementing personnel safety by keeping exposures ALARA. The U12t.08 reentry drift and the extended portion (i.e., ROSES reentry drift) facilitated damage assessment work and equipment and experiment recovery in the ROSES, recorder, and experimenter alcoves. The maximum radiation level encountered by reentry personnel was 11 R/h. The bypass reentry drift that was extended and eventually mined parallel to the U12t.08 LOS (main) drift, facilitated recoveries from the LANL alcove, structures drifts, and with additional crosscuts to the LOS drift, provided access to the TAPS, GSAC, MAC, and the end of stemming. The maximum radiation level encountered by reentry personnel in these areas was 200 mR/h. Most of the recovery work was completed by April 1987.

Personnel exposure data from self-reading pocket dosimeters were documented on Area Access Registers during individual entries to MIGHTY OAK radex areas over a non-continuous time frame beginning 10 April 1986, and ending 15 June 1988 (see page 113 for a detailed explanation). Pocket dosimeters showed some indication of possible radiation exposure to DoD-affiliated personnel. Film badges worn by these reentry personnel indicated that possibly five DoD-affiliated individuals received some gamma exposure most likely from the MIGHTY OAK test. The minimum detectable gamma exposure with the NTS film badge dosimeter was 30 mR. Area Access Register data are summarized below.

Participants	Entries Logged	Maximum Exposure (mR)	Average Exposure (mR)
All	5,577	3,170	8.4
DoD	125	625	16

SECTION 5

MIDDLE NOTE TEST

5.1 TEST SUMMARY.

MIDDLE NOTE was a DoD/LLNL-sponsored weapons-effects test conducted at 1028 hours PST on 18 March 1987. The test had a yield of less than 20 kilotons, and the device was emplaced at a vertical depth of 1,309 feet in the U12n.21 drift of the N tunnel complex (see Figure 5-1). The purpose of the MIDDLE NOTE test was to test the survivability of military hardware in a nuclear detonation environment.

MIDDLE NOTE was satisfactorily contained, and no atmospheric release occurred. There was no contamination released beyond the stemming region (Vessel I) of the drift. All instrument alcoves were free of contamination, and there was no evidence of underground equipment damage.

5.2 PRETEST ACTIVITIES.

5.2.1 Responsibilities.

Safe conduct of all MIDDLE NOTE project activities in Area 12 was the responsibility of the DNA TGD, subject to controls and procedures established by the DOE TC. The DOE TC was responsible for safety of the public and onsite personnel during the test.

Project agencies were responsible for designing, preparing, and installing experiments, or delivering them to the installation contractor. After the test, these agencies were responsible for removing samples, analyzing instrument and sample data, and preparing project reports on experiment results.

Device safety and security procedures in the WP area and the timing and firing control room were in accordance with DOE Order

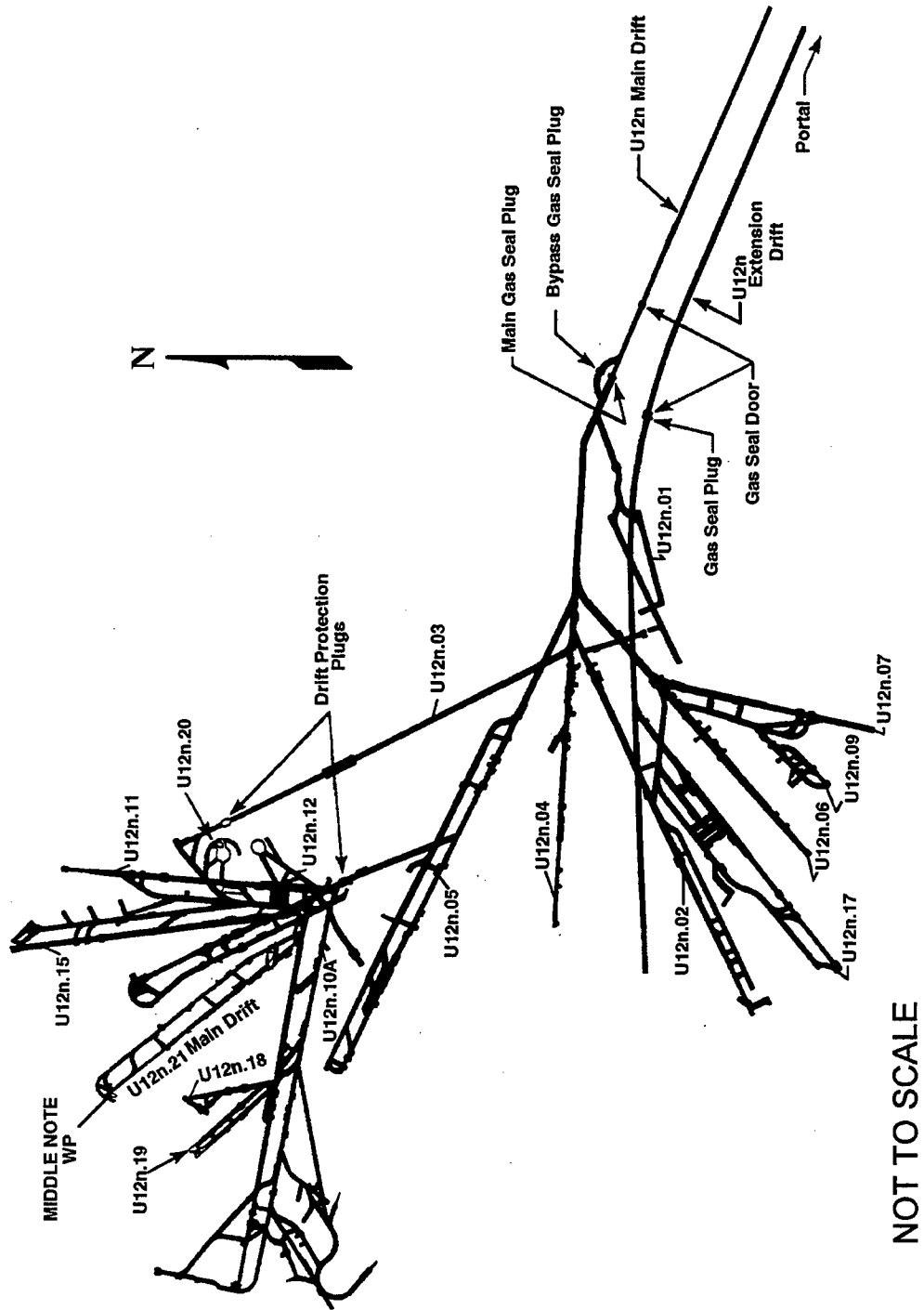

Figure 5-1. MIDDLE NOTE test - tunnel layout.

5610.3, "Program to Prevent Accidental or Unauthorized Nuclear Explosive Detonations." The LLNL TD had overall responsibilities for all operations involving the MIDDLE NOTE device as well as the timing control and the arming and firing of MIDDLE NOTE closures and experiments. The LLNL TD was responsible to the DOE TC for radiological safety within the designated area of the WP from device emplacement until detonation. After the detonation, the DOE TC relieved the LLNL TD of these responsibilities and returned the responsibility for project activities back to the DNA TGD.

5.2.2 Planning and Preparations.

A. Tunnel Facilities Construction.

The MIDDLE NOTE testbed was constructed in the U12n.21 drift, that was mined off the existing U12n.08 bypass and the U12n.10 main drifts. The main drift was 19 feet wide by 18 feet high at the portal end and was reduced in steps to 9 feet wide by 9 feet high to just forward of the keyway for the GSAC. The drift remained essentially the same from there to near the zero room. The bypass drift was 10 feet wide by 10 feet high throughout its length. The 810-foot long horizontal LOS pipe diverged from a small inside diameter in the zero room to over 10 feet at the back of test chamber (TC) No. 1. The U12n.21 complex consisted of an LOS drift, a bypass drift, two auxiliary closures, the TAPS, a debris barrier system (DBS), one zero room, three test chambers, scatterers, experiment and support alcoves, and a vacuum pumping alcove (see Figure 5-2).

Construction activities began after proposal review meetings in October 1984 and March 1985. By July 1985, initial mining of the main and bypass drifts was started. In September 1985, work was halted until after the MILL YARD and DIAMOND BEECH tests. Work resumed on 18 October, but by December 1985 mining had fallen behind schedule because of testbed design changes and elimination of some experiments. A new beginning of readiness of 2 December 1986

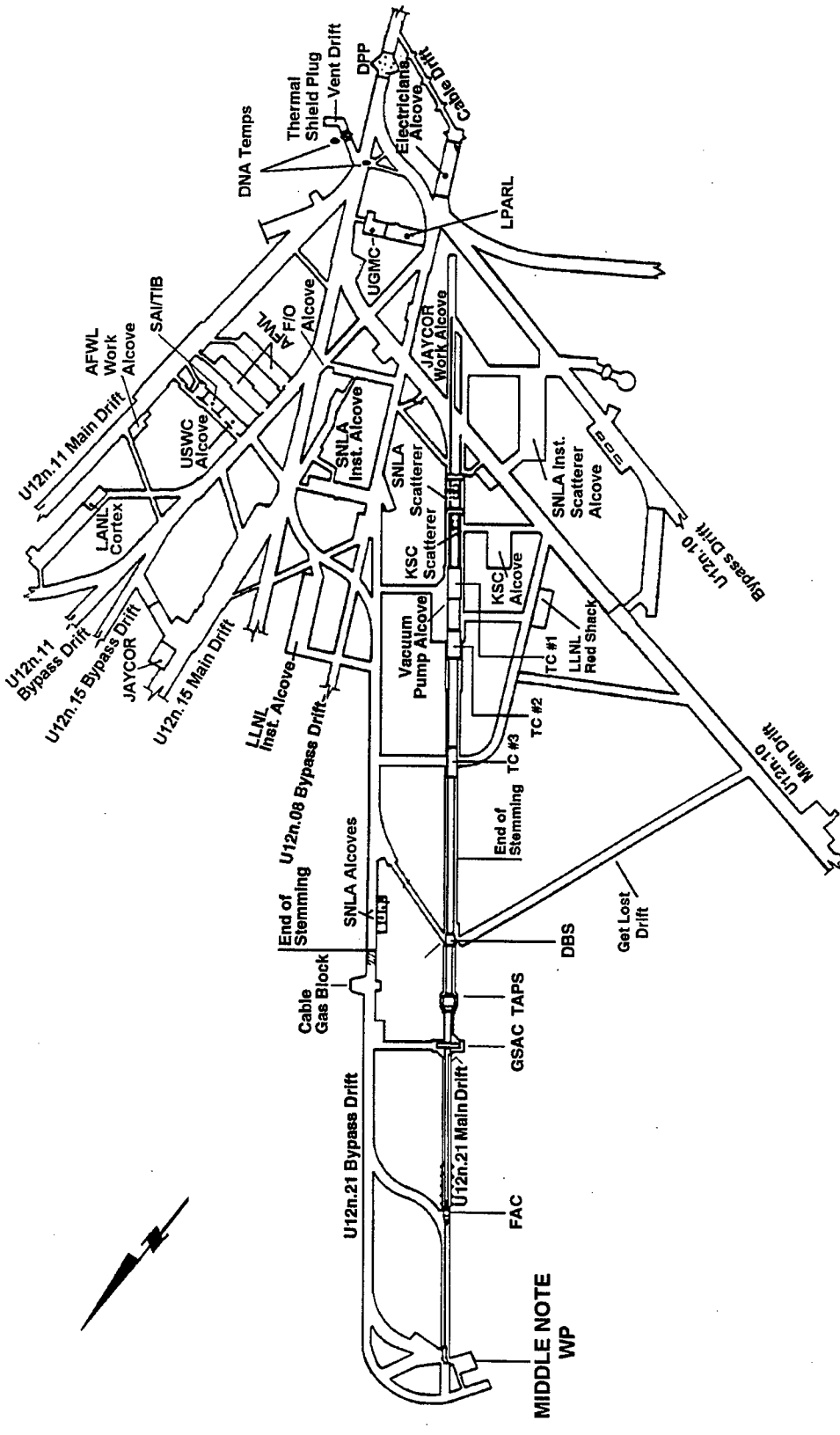

Figure 5-2. MIDDLE NOTE test - tunnel facilities layout.

was established. In January 1986, after additional experiment elimination because of budget cuts, work progressed and by the end of March, front-end assembly and equipment were being installed. In April, because of the effect of the MIGHTY OAK test and some other instrumentation problems, the beginning of the readiness period was moved to 17 March 1987. Changes in the pipe design were made in May 1986 with several sections of pipe being removed and replaced by hardened pipe with the capability to absorb longitudinal shock. A DBS, which had been in storage at NTS since 1972, was refurbished and modified and added to the LOS pipe string as an additional experiment protection device. In June the "get lost" drift from the DBS to the U12n.10 main drift was started. This drift allowed radioactive gases that escaped from the stemming column to be diverted by the DBS into unused tunnel space. In July, experiment changes were made; pipe design changes were made and reinstalled; and the FAC was repositioned.

Between September and December, most of the experiments were installed; a successful pressure/vacuum check was completed; a complete LOS pumpdown was completed; alcoves were pressurized and tested; test chamber bulkheads were mounted; instrument racks were installed; installation of cables between the FAC and WP was completed; and stemming in the LOS drift was started. In January and February 1987, experiment installation and cable hookups were completed, and by the end of February, SDRs were being conducted twice daily.

Remote gas sampling capabilities were incorporated during construction as well as capabilities for water, power, drain, and pressurization lines. Provisions were made to manually take gas samples from the WP side of the GSD, GSP, and main DPP during posttest reentry.

The stemming plan for the U12n.21 complex is shown in Figure 5-3. The front-end stemming operations began in

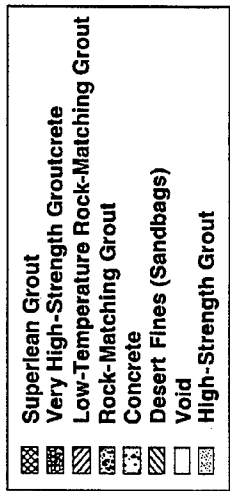

RS = Range Station (distance in meters radially from working point)

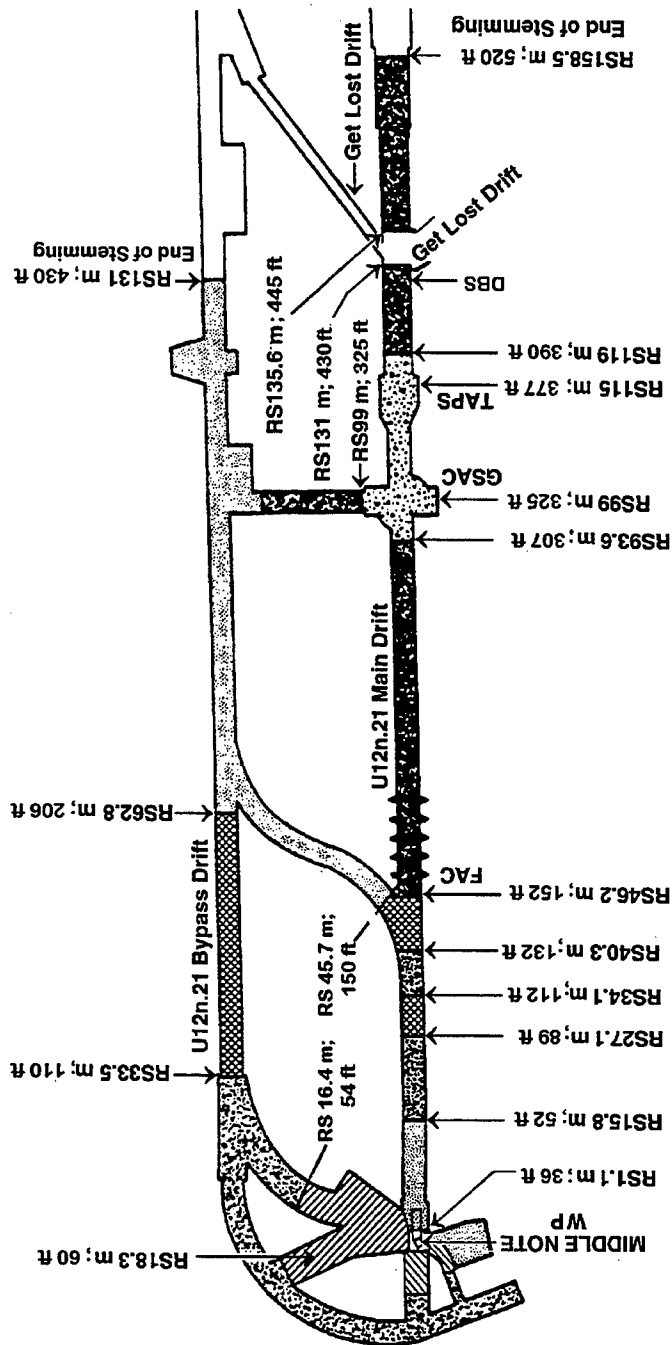

NOT TO SCALE

Figure 5-3. MIDDLE NOTE test - stemming plan.

December 1986 and were completed in March 1987. Stemming materials (i.e., HSG, RMG, SLG, several types of high-strength groutcrete and concrete) were pumped into all void areas from the MIDDLE NOTE WP to a distance of 520 feet. The area behind the WP was filled with desert fines (sandbags) and the area surrounding to 60 and 54 feet respectively, contained low-temperature RMG. The U12n.21 main drift was backfilled first with HSG to 52 feet; then with RMG to 89 feet; followed by SLG, RMG, SLG, and very high-strength groutcrete around the FAC; followed by hardened pipe sections to 307 feet; then concrete around the GSAC and TAPS to 390 feet; very high-strength groutcrete to 430 feet; an air void at the DBS; and very high-strength groutcrete to 520 feet. The U12n.21 bypass drift was stemmed to a distance of 110 feet with RMG; then to 206 feet with SLG; then to 430 feet with HSG. The crosscut drift from the bypass to the FAC was stemmed with HSG; and the crosscut drift to the GSAC and TAPS area was stemmed with very high-strength groutcrete. All penetrations into the stemmed areas of the drifts (e.g., cables and water lines) were gas blocked to prevent the seepage of radioactive gases outside the stemmed region of the drifts.

Experiment and related hardware installation was completed by March 1987. The following organizations were among those that fielded experiments for the MIDDLE NOTE test: the U.S. Air Force (USAF) conducted ballistic reentry vehicle passive decoy studies; Lockheed Palo Alto Research Laboratory (LPARL) conducted diagnostic measurements to characterize the x-ray, neutron, and gamma fluences and spectra in the LOS pipe; Science Applications International Corporation (SAIC), and S-CUBED studied the performance of test instrumentation development gauges subjected to a high radiation environment; JAYCOR conducted Internal Electro-magnetic Pulse (IEMP) instrumentation tests; U.S. Army Strategic Defense Command (USASDC) and JAYCOR conducted infrared window material optical properties experiments; Lawrence Livermore National Laboratory (LLNL) conducted

device performance studies; Sandia National Laboratory, Albuquerque (SNLA) conducted device radiation output studies and containment diagnostic experiments; and Los Alamos National Laboratory (LANL) conducted CORRTEX measurements.

The SDRs were conducted in February. The first MFP dry run was held on 27 February but was not completely successful. Additional MFP dry runs were conducted the first week in March, with the final one being successful. Preparations for test execution began. On 10 March, the device was emplaced and final stemming activities began. Because of a delay due to wind conditions, the DNA technical director asked for another dry run on 17 March. This was successful.

B. Radiological Safety Support.

Procedures for radiation exposure and contamination control during this test were in accordance with NTO SOP 0501 and requirements of responsible DoD representatives. Radsafe provided monitoring and equipment support.

Prior to the test, detailed radiological safety reentry plans were prepared and issued to participating agencies. Air sampling equipment was positioned in the test area. Radsafe monitors were briefed regarding surface reentry, manned stations, and security station requirements.

Radsafe monitoring teams and supervisory personnel were provided to perform initial radiation surveys, conduct aerial surveys by helicopter, and participate in reentry parties as needed. Radsafe personnel were also standing by at designated muster stations prior to detonation to perform surveys and provide emergency support as directed; to provide and issue anticontamination equipment and material, portable instruments, and dosimeters; to operate area control check stations; and to perform personnel, equipment, and vehicle decontamination, as required.

Available anticontamination materials and equipment included head covers, coveralls, cloth shoe covers, totes, full-face masks, supplied-air breathing apparatus, plastic suits, plastic bags, gloves, and masking tape.

C. Telemetry and Air Sampling Support.

In addition to the permanent RAM units, 51 temporary units provided surface and underground coverage for the MIDDLE NOTE test. Tables 5-1 and 5-2 list the locations of surface and underground RAMS, respectively. The locations of surface RAMS are shown in Figure 5-4, and those of underground RAM units are shown in Figures 5-5 and 5-6. All RAM units were installed a minimum of five days prior to scheduled device detonation.

EPA operated continuous monitoring stations at 30 locations in the offsite area. All the stations had high-volume air samplers with collectors for particulates and reactive gases, 17 had tritium samplers, 16 had noble gas samplers, and 23 had pressurized ion chamber gamma-rate detector/recorder systems in operation. Twenty-seven EPA personnel were fielded for offsite surveillance activities.

D. Security Coverage.

Device security procedures in the WP area and the timing and firing control room were in accordance with DOE Order 5610.3, "Program to Prevent Accidental or Unauthorized Nuclear Explosive Detonations." Beginning on D-1, all personnel entering or exiting the controlled area were required to stop at muster or control stations for issue of stay-in badges. After control was established, all through traffic was diverted around the controlled area by use of screening stations. In accordance with the "Test Controller's Operations and Security Plan," contractors and agencies were to have all personnel not connected with this

Table 5-1. MIDDLE NOTE test RAMS unit locations 18 March 1987.

SURFACE

STATION NUMBER	LOCATION
From the U12n Portal:	
1	On the tunnel drain line
2	On the tunnel vent line
3	400 feet N 16° E azimuth
4	275 feet N 89° E azimuth
5	365 feet S 16° E azimuth
6	480 feet S 12° W azimuth
7	560 feet S 48° W azimuth
8	420 feet N 69° W azimuth
On the Mesa:	
9	On the mesa ventline system
10	On the mesa ventline system
From the U12n.21 SGZ:	
11	400 feet N 00° E azimuth
12	400 feet S 60° E azimuth
13	400 feet S 60° W azimuth

Table 5-2. MIDDLE NOTE test RAMS unit locations 18 March 1987.

UNDERGROUND

STATION NUMBER	LOCATION
14	370 feet into the U12n.21 main drift
15	265 feet into the U12n.21 main drift
16	190 feet into the U12n.21 main drift
17	145 feet into the U12n.21 main drift
18	115 feet into the U12n.21 main drift
19	In LLNL gas system, in U12n.21 bypass drift
20	425 feet into the U12n.21 bypass drift on gas hose
21	On gas skid in the U12n.21 bypass drift
22	400 feet into the U12n.21 bypass drift
23	275 feet into the U12n.21 bypass drift
24	100 feet into the U12n.21 bypass drift
25	In the U12n.21 LLNL alcove 21-21
26	In the U12n.21 SNLA alcove 21-20
27	980 feet into the U12n.08 main drift
28	320 feet into the U12n.11 bypass drift
29	200 feet into the U12n.11 main drift
30	In the U12n.21 crosscut no. 2
31	In the U12n.21 KSC alcove 21-8 scatterer
32	150 feet into the U12n.21 crosscut no. 17 get lost drift
33	830 feet into the U12n.10 main drift

Table 5-2. MIDDLE NOTE test RAMS unit locations 18 March 1987
(Continued).

UNDERGROUND

STATION NUMBER	LOCATION
34	400 feet into the U12n.10 main drift
35	185 feet into the U12n.10 main drift
36	500 feet into the U12n.10 bypass drift
37	250 feet into the U12n.10 bypass drift
38	In the U12n.21 SNLA alcove 21-10 scatterer
39	120 feet into the U12n.14 bypass drift
40	710 feet into the U12n.08 main drift
41ER ¹⁸	710 feet into the U12n.08 main drift
42	435 feet into the U12n.08 main drift
43	600 feet into the U12n.05 main drift
44	2,600 feet into the U12n main drift
45	235 feet into the U12n gas seal bypass drift
46	2,300 feet into the U12n extension drift
47	1,700 feet into the U12n main drift
48	1,200 feet into the U12n main drift
49	200 feet into the U12n main drift
50	1,200 feet into the U12n extension drift
51	200 feet into the U12n extension drift

¹⁸ ER - Extended Range (instrument capable of reading 100 mR/h to 100,000 R/h).

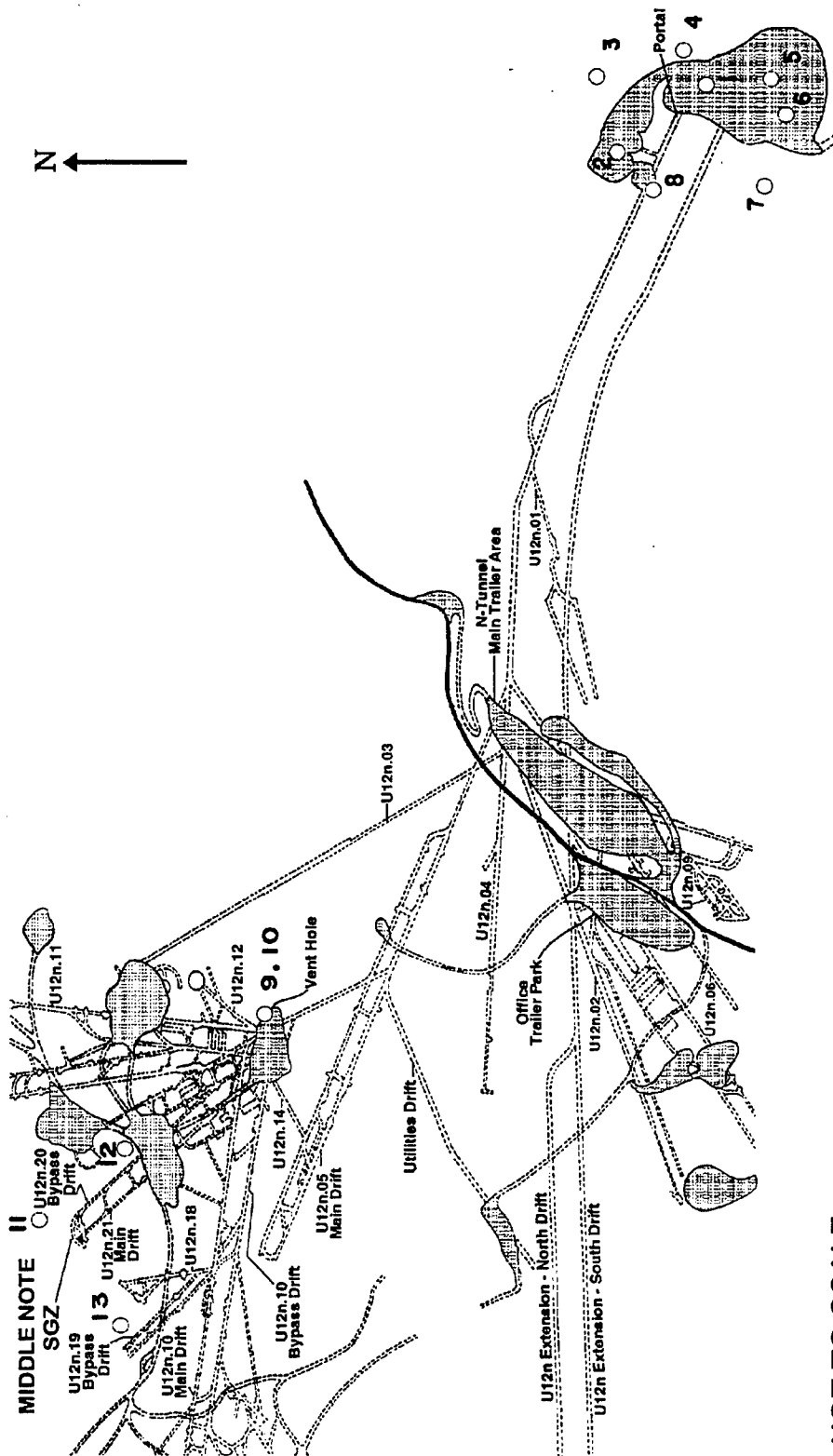

NOT TO SCALE

Figure 5-4. MIDDLE NOTE test - surface RAMS.

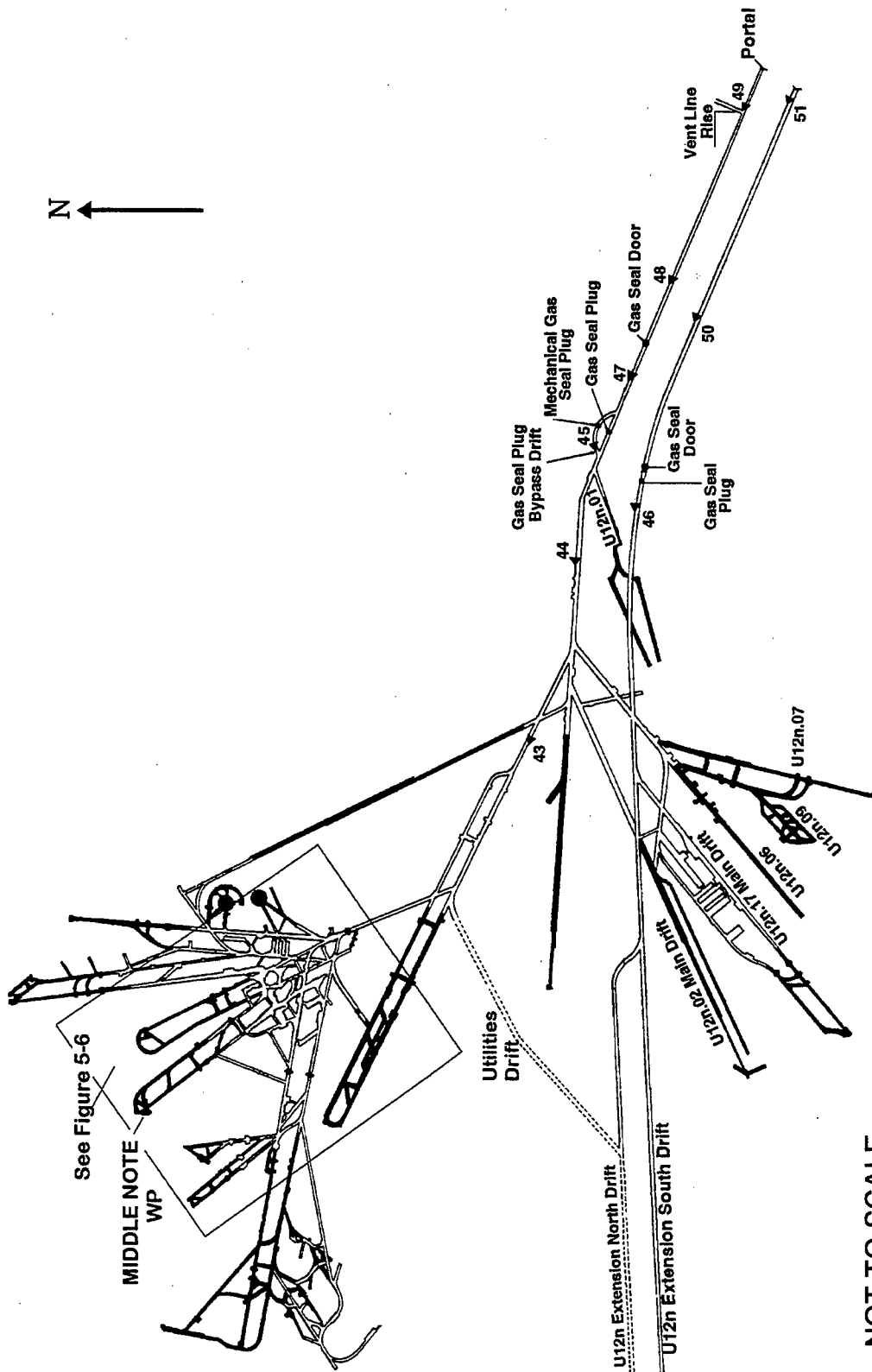

Figure 5-5. MIDDLE NOTE test - underground RAMS.

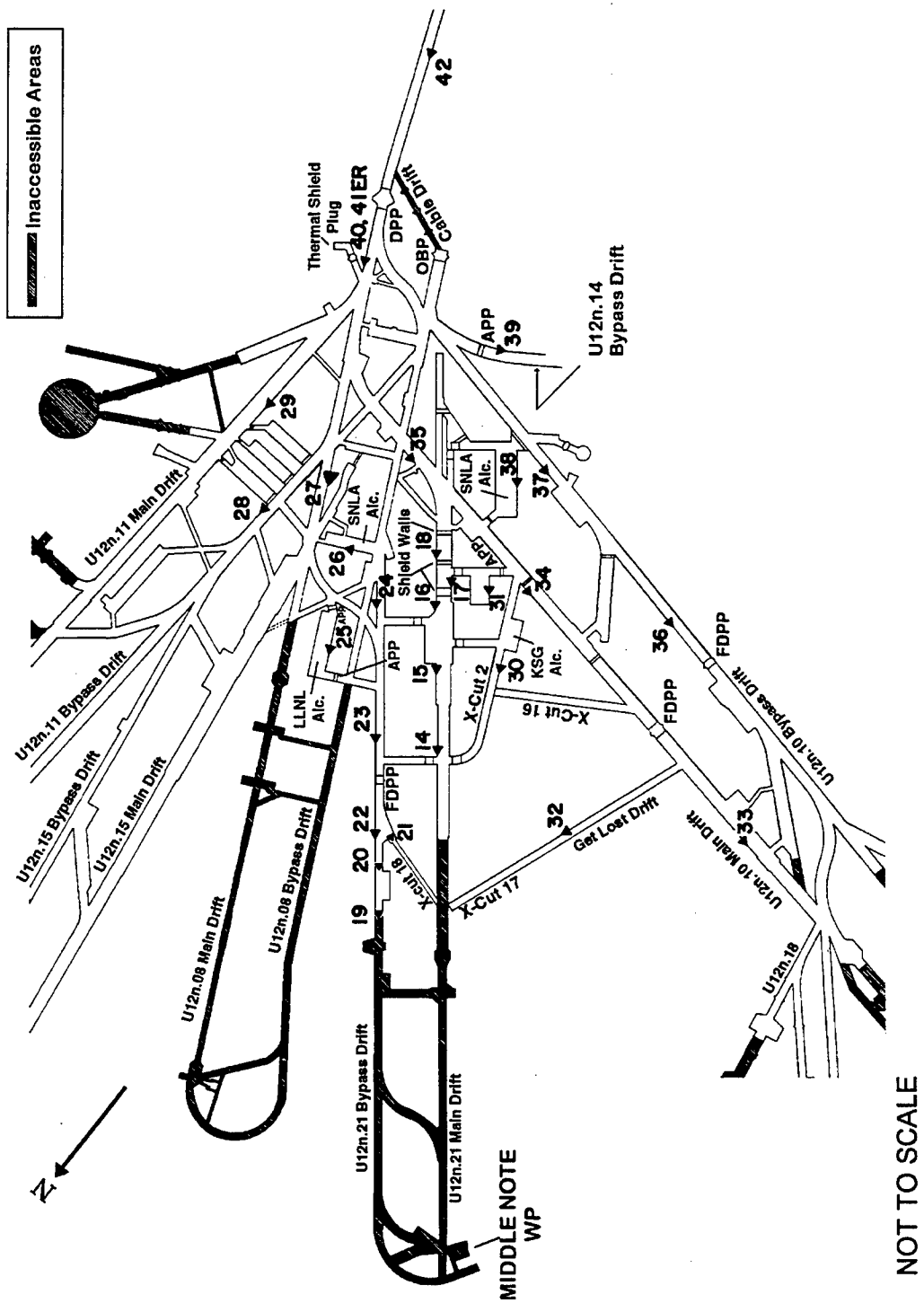

Figure 5-6. MIDDLE NOTE test - underground RAMS U12n.21 complex.

test out of the closed area before the final security sweep began.

E. Air Support.

Three UH1N helicopters and crews were provided by the USAF for cloud tracking and the Test Controller's use, if needed. In addition, the USAF provided a WC-130 and/or a WC-135 aircraft and crew on standby status for cloud tracking. EG&G provided a Turbo Beech aircraft for taking wind soundings and for cloud tracking duties and a King Air for cloud sampling, if necessary.

5.3 TEST-DAY ACTIVITIES.

5.3.1 Pretest Activities.

After almost two days of postponements because of unfavorable weather, final preparations for detonation were initiated. On 17 March 1987, by approximately 2400 hours, all persons except the arming party, the tunnel button-up party, and the security guards were out of the tunnel and clear of the muster area. Soon after, permission was granted to arm the device. Following the departure of the arming party, button-up operations were completed, and the party left the tunnel. The area was cleared of all personnel in the early morning hours of 18 March.

A final readiness briefing was held at 0500 hours on 18 March 1987 in anticipation of a 0700 hour test time. However, the replacement of a faulty valve caused a 3-hour and 28-minute delay. After the repair, the countdown resumed at T-30 minutes and proceeded uninterrupted until zero time. The MIDDLE NOTE device was detonated at 1028 hours PST on 18 March 1987.

5.3.2 Test Area Monitoring.

Telemetry recording measurements began at 1028 hours on 18 March 1987, at which time all RAM units (i.e., stations) were operational and remained so throughout the readout period. All stations except numbers 14 through 18, 21 through 24, 32, 34, and 35 read background levels throughout the readout period.

At H+2 seconds station 16 read 781 R/h, but this reading decreased to 603 mR/h at H+8 hours. Station 18 also showed an increased reading of 443 R/h at H+10 seconds. By H+3 hours, the reading was 1.7 R/h. RAM stations 21 through 24, 32, 34, and 35, located in the U12n.21 bypass drift, crosscut No. 17 (get lost drift), and the U12n.10 bypass drift, respectively, all indicated a brief rise at zero time, with station 24 indicating the maximum reading of 923 mR/h. By H+1 minute, the station 24 reading decreased to 5.5 mR/h. All RAM stations were secured at 1600 hours on 20 March, and at that time, station 14 was reading 15.5 mR/h; station 16 was reading 37.8 mR/h; and stations 17 and 18 were reading 25 mR/h. Stations 21 through 24, 32, 34, and 35 were all reading background levels.

5.3.3 Initial Surface Radiation Surveys.

An initial surface reentry team departed the TC's barricade at Gate 300 at 1143 hours on 18 March 1987. A mobile base station was setup to provide for area control and anticontamination clothing, and equipment supply. All radiation readings were relayed as soon as they were obtained via Net 3 radio. By 1215 hours, survey of the U12n portal area and ventilation pad above the portal area was completed. All radiation readings were at background levels (0.04 mR/h).

Survey teams stood by the U12n portal during data recovery and gas sampling of the tunnel atmosphere. No explosive or toxic gases were detected, and the oxygen level was 21 percent as measured on the WP side of the DPP. Gas sampling and data recovery were

completed by 1445 hours, and all personnel were checked out of the test location by 1530 hours on 18 March 1987.

5.4 POSTTEST ACTIVITIES.

5.4.1 Tunnel Reentry Activities.

The initial reentry work team entered the U12n tunnel portal at 0825 hours on 19 March. The work team proceeded to the GSP and established ventilation on the WP side of the GSP by opening the 42-inch turntube door at 1027 hours. No explosive or toxic gases were detected, and the oxygen level was 21 percent. All radiation readings were at background levels.

The initial reentry team No. 1 and the rescue team, dressed in anticontamination clothing, left the portal area at 1220 hours on 19 March and proceeded through the turntube at the GSP. At that point, team No.1 put on their SCBA. The team proceeded to the U12n.08 DPP where they opened the 36-inch turntube door at 1337 hours. The workers then proceeded to the U12n.08 vent hole and the thermal shield plug to install and hookup ventilation lines to the mesa. A survey at the vent hole showed no detectable explosive or toxic gases and no radiation above background levels. This reentry team then returned to the portal side of the DPP at 1417 hours, and the mesa ventilation system was turned on at 1420 hours.

At 1450 hours, this same team, wearing anticontamination clothing and SCBA, departed the U12n.08 DPP again and proceeded to shield wall No. 1 in the U12n.21 main drift. Gas samples taken from the WP side of shield wall No. 1 showed readings of 0.05 mR/h, 250 ppm CO, no explosive gases, and 21 percent oxygen. The reentry team opened the crawltube and drained the water bladder. Then the team crawled through shield wall No. 1 and proceeded to shield wall No. 2 where readings were 60 mR/h on contact, 100 ppm CO, no explosive gases, and 20.5 percent oxygen. The team then entered the U12n.21 main (LOS) drift through the shield wall crawltube in the crosscut

No. 2 drift. The maximum readings detected inside the LOS pipe at TC No. 3 were 200 mR/h, 2,000 ppm CO, 5 percent of the LEL, and 19 percent oxygen. Swipe samples were taken from inside the LOS pipe to be sent to the laboratory for analysis, and TC No. 3 door was closed. The team then returned to the portal side of the DPP at 1558 hours.

At 1625 hours that same day, reentry team No. 2, dressed in anticontamination clothing and SCBA, proceeded from the U12n.08 DPP to the U12n.21 bypass FDPP to begin gas sampling. Readings on samples taken from the gas sampling line on the WP side of the FDPP were 0.05 mR/h, 300 ppm CO, 7.5 percent of the LEL, and 20.5 percent oxygen. The team opened the turntube door on the FDPP; installed a flexline for ventilation; and proceeded to the door of TC No. 1 where readings of 100 mR/h on contact, 20 ppm CO, no explosive gases, and 20.5 percent oxygen were obtained. From there the team moved on to the LLNL APP and the U12n.21 bypass APP where they checked the pressure and took gas samples from the WP side of each Alcove Protection Plug (APP). In both locations radiation readings showed background levels, and flexlines were hooked up at both APPs for ventilation. Reentry team No. 2 returned to the U12n.08 DPP where the rescue team was standing by. Both teams departed for the portal at 1805 hours where they were surveyed and released at 1825 hours.

On 19 March at 1915 hours, data recovery teams entered the Sandia and LLNL alcoves to recover data. No anticontamination clothing was required during these recoveries, and the work was completed by 2015 hours.

The next day beginning at 0803 hours, reentry team No. 1 and the rescue team, dressed in anticontamination clothing and SCBA, checked out the U12n.21 alcoves and noted that there was very little structural damage. They then proceeded through the U12n.21 bypass FDPP to crosscut No. 18 where some damage was seen. There was debris on the LLNL gas bottle skid, and the floor was buckled and heaved up. Readings taken at the gas sample bottle skid showed background radiation levels, 150 ppm CO, 4 percent of the

LEL, and 21 percent oxygen. The team moved on to examine the scatterer alcoves and stub areas, taking readings and noting any damage. Ventilation to all alcoves and stub areas was established. The maximum radiation reading, taken at the SNLA stub area, was 2 mR/h. The reentry and rescue teams returned to the portal area where they were surveyed and released at 1105 hours. All air and water samples along with smears taken were sent to the laboratory for analysis.

Scientific assessment and data recovery teams, wearing anticontamination clothing and full-face respirators fitted with high-efficiency particulate aerosol (HEPA) filters, entered U12n.21 test chambers and alcoves for recovery work on 20 March. By 1500 hours, the teams had completed their work and returned to the U12n.08 DPP where they were surveyed and released. Over the next two months, experimenters worked on assessing equipment and experiments and packaging components to be sent to the respective laboratories.

5.4.2 Posttest Mining and Drilling.

Miners began mining out the GSP on 20 March and completed that task at 0655 hours that same day. Workers also mined out the U12n.08 DPP, completing that task by 2020 hours. On 24 March, mining began in the U12n.21 bypass drift, at the FDPP, and at the U12n.21 main drift shield and convection walls. Experiment and equipment recoveries continued, and the majority of the recoveries were completed by 31 March. However, equipment dismantling continued into May in some experiment alcoves while photography and survey work was ongoing.

Mining in the U12n.21 bypass drift and the crosscuts to the FAC, GSAC, and TAPS was ongoing from April through July 1987. Miners, wearing anticontamination clothing, drilled probe holes to determine conditions before mining progressed. By September, workers began removing sections of the LOS pipe, performing clean-up and maintenance in the alcoves and removing equipment. This work was done intermittently until April 1988.

On 23 November 1988, drillers set up a drilling rig in the U12n.21 bypass drift to begin core sampling. From November 1988 to early February 1989 when core sampling concluded, numerous core samples were taken between 200 and 480 feet of the WP. For the most part, anticontamination clothing was not required because readings indicated background radiation levels, no toxic or explosive gases, and 21 percent oxygen.

5.4.3 Industrial Safety.

Checks for the presence of toxic gases and surveys to measure radiation and explosive gas levels were made on each shift. The results were then recorded in the monitors' logbook.

Appropriate safety measures were taken to protect mining personnel and prevent unsafe conditions. Industrial safety codes for mining, tunneling, and drilling were established by REECO and emphasized during all operations. A written standard operating procedure was required for each operation involving explosives, toxic materials, radioactive material, or any other operation with the potential for personal injury. Each individual involved in such an operation was required to know the contents of the applicable procedures.

The portal construction area and the tunnel were mandatory hard-hat and foot-protection areas (safety shoes, boots, DOE-issued miner's boots, or toe guards). All personnel on initial tunnel reentry teams were certified in the use of the Draeger self-contained breathing apparatus. Standard safety rules and regulations, as spelled out in the "U.S. Bureau of Mines Manual," were observed.

All explosives, electro-explosive components, solid propellants, toxic materials, and radioactive materials were handled, stored, and transported in accordance with applicable sections of the following documents:

1. Army Material Command Regulations (AMCR 385-100).
2. Appropriate DOE Orders in the 5400 and 5600 Series concerning Environmental Protection, Safety & Health Protection, and Defense Programs, respectively.
3. Individual safe operating procedures (by experimenter organization).
4. MIDDLE NOTE Safety Regulations.

All personnel engaged in handling, storing, assembling, or installing explosives, propellants, or electro-explosive devices (or observers of those operations) were required to wear safety glasses or other eye protection which had been approved by the DoD safety coordinator.

5.5 RESULTS AND CONCLUSIONS.

Telemetry recording measurements began at 1028 hours on 18 March 1987, with a maximum reading on station 16 at H+2 seconds of 781 R/h from initial activation products. This reading decreased to 603 mR/h by H+8 hours. When all RAM stations were secured at 1600 hours on 20 March, station 14 was reading 15.5 mR/h; station 16 was reading 37.8 mR/h; and stations 17 and 18 were reading 25 mR/h. All other stations were reading background radiation levels.

The initial radiation surveys began at 1143 hours on 18 March and were completed at 1440 hours. No radiation above background levels was detected at the U12n tunnel portal yard area or at the ventilation pad above the portal. Gas samples taken from the WP side of the DPP indicated no toxic or explosive gases and 21 percent oxygen.

Reentry into the tunnel began at 0825 hours on 19 March, and reentry team No. 1 established ventilation to the mesa at 1420 hours. This team proceeded to the U12n.21 main drift where personnel surveyed the shield walls, crosscut No. 2 drift, and TC No. 3. Maximum readings, obtained at TC No. 3, were 200 mR/h,

2,000 ppm CO, 5 percent of the LEL, and 19 percent oxygen. That same day, reentry team No.2 proceeded to the U12n.21 bypass FDPP to take gas samples and survey and establish ventilation to the WP side of the LLNL APP. The maximum readings, obtained outside TC No. 1 door, were 100 mR/h on contact, 20 ppm CO, no explosive gases, and 20.5 percent oxygen. The next day, beginning at 0803 hours, reentry team No. 1 surveyed and checked the U12n.21 alcoves and stub areas for damage. Scientific assessment and data recovery teams also completed their work on 20 March.

Reentry mining began on 20 March when workers mined out the GSP and the U12n.08 DPP, completing that task by 2020 hours. On 24 March, mining began in the U12n.21 bypass drift, at the FDPP, and at the U12n.21 main drift shield and convection walls. Mineback and clean-up operations continued from April through September. In November core sampling began in the U12n.21 bypass drift. This work concluded in February 1989.

Personnel exposure data from self-reading pocket dosimeters were documented on Area Access Registers during individual entries to MIDDLE NOTE radex areas over a non-continuous time frame beginning 19 March 1987 and ending 11 August 1987 (see page 113 for a detailed explanation). Pocket dosimeters showed some indication of possible radiation exposure to DoD-affiliated personnel. TLDs worn by these reentry personnel indicated that possibly as many as 20 individuals received some gamma exposure most likely from the MIDDLE NOTE test. The minimum detectable gamma exposure with the NTS TLD is 15 mR. Area Access Register data are summarized below.

Participants	Entries Logged	Maximum Exposure (mR)	Average Exposure (mR)
All	1,256	117	1.9
DoD	172	117	4.9

SECTION 6

MISSION GHOST TEST

6.1 TEST SUMMARY.

MISSION GHOST was a DoD/LANL-sponsored weapons-effects test conducted at 0900 hours PDT on 20 June 1987. The test had a yield of less than 20 kilotons, and the device was emplaced in a 12.5-foot radius hemispherical cavity at a vertical depth of 1,054 feet in the U12t.09 drift of the T tunnel complex (see Figure 6-1). The major objective of the MISSION GHOST test was to obtain containment-related data for future cavity tests. In addition, test instrumentation development (TID) and SREMP experiments were conducted.

There was no accidental release of radioactivity from the MISSION GHOST test. All activity was satisfactorily contained within the cavity until ventilation to the mesa was established on 16 December 1987. At that time, a controlled¹⁹ intermittent release of krypton-85 occurred that lasted over a three-week period.

6.2 PRETEST ACTIVITIES.

6.2.1 Responsibilities.

Safe conduct of all MISSION GHOST project activities in Area 12 was the responsibility of the DNA TGD, subject to controls and procedures established by the DOE TC. The DOE TC was responsible for safety of the public and onsite personnel during the test.

Project agencies were responsible for designing, preparing, and installing experiments, or delivering them to the installation contractor. After the test, these agencies were responsible for

¹⁹ The radioactive gas was passed through a filtering system where the particulates were removed before the gas was released to the atmosphere.

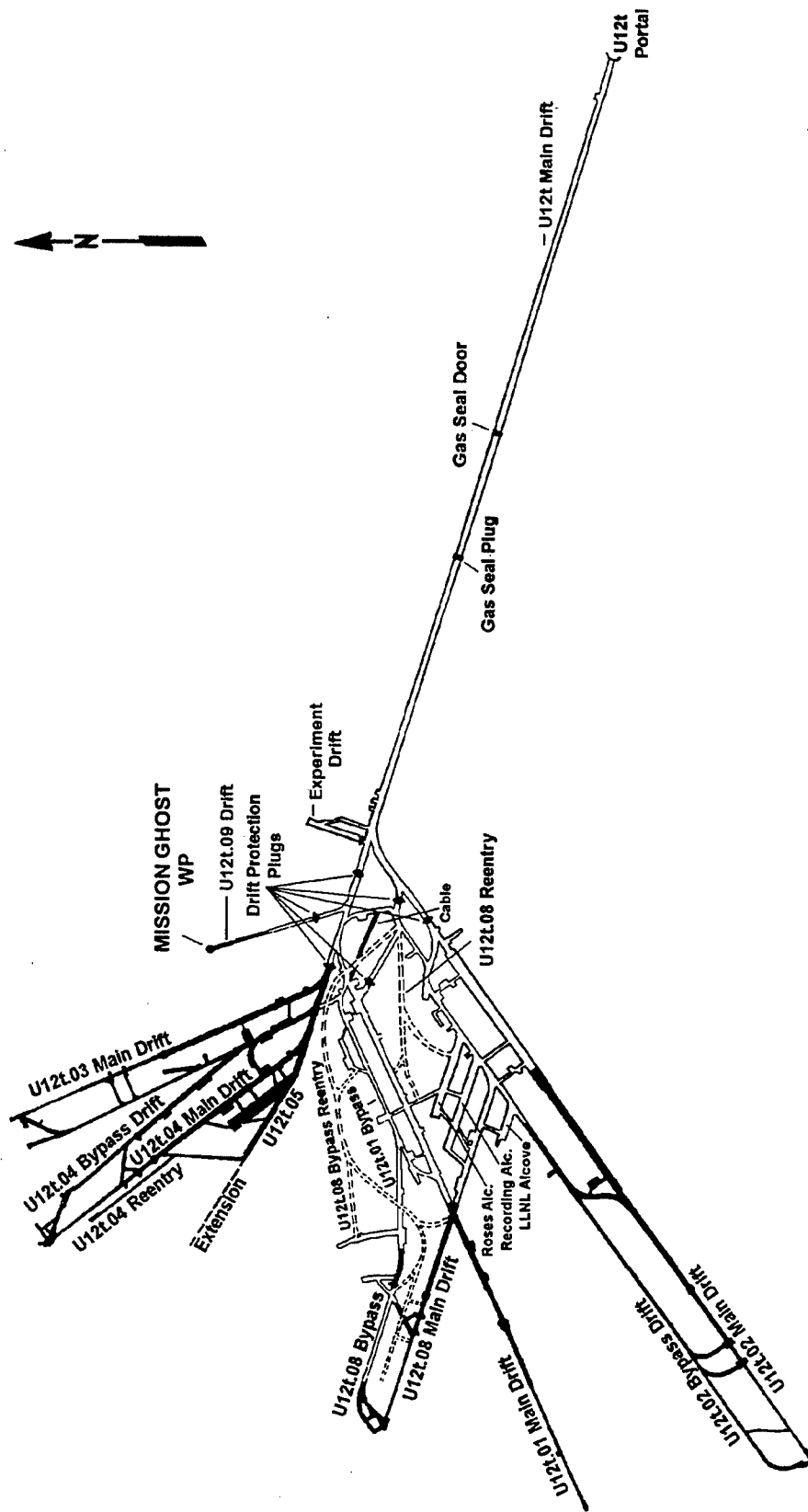

NOT TO SCALE

Figure 6-1. MISSION GHOST test - tunnel layout.

removing samples, analyzing instrument and sample data, and preparing project reports on experiment results.

Device safety and security procedures in the WP area and the timing and firing control room were in accordance with DOE Order 5610.3, "Program to Prevent Accidental or Unauthorized Nuclear Explosive Detonations." The LANL TD had overall responsibilities for all operations involving the MISSION GHOST device as well as the timing control and the arming and firing of MISSION GHOST closures and experiments. The LANL TD was responsible to the DOE TC for radiological safety within the designated area of the WP from device emplacement until detonation. After detonation, the DOE TC relieved the LANL TD of these responsibilities and returned the responsibility for project activities back to the DNA TGD.

6.2.2 Planning and Preparations.

A. Tunnel Facilities Construction.

The U12t.09 drift was mined to the north of the U12t main drift beginning on the opposite side of the U12t main drift from both the existing U12t.01 and U12t.02 drifts and between the existing entrances to both of those drifts. The drift was approximately 530 feet long (including the cavity at the WP end), and 10 feet wide by 10 feet high. The cavity was 25 feet in diameter and its floor was approximately 15 feet above the drift floor to accommodate the device mount and specific experiments. The test reused some of the tunnel support facilities and protection plugs in place from previous tests. The U12t.09 complex consisted of one access drift, a hemispherical cavity (zero room), and four alcoves (see Figure 6-2).

Plans for test construction activities began at a meeting held in April 1986 where the concept of a hemispherical-cavity containment test was discussed. By September approval and funding had been secured and testbed design and experiment planning began. Mining of the U12t.09 drift

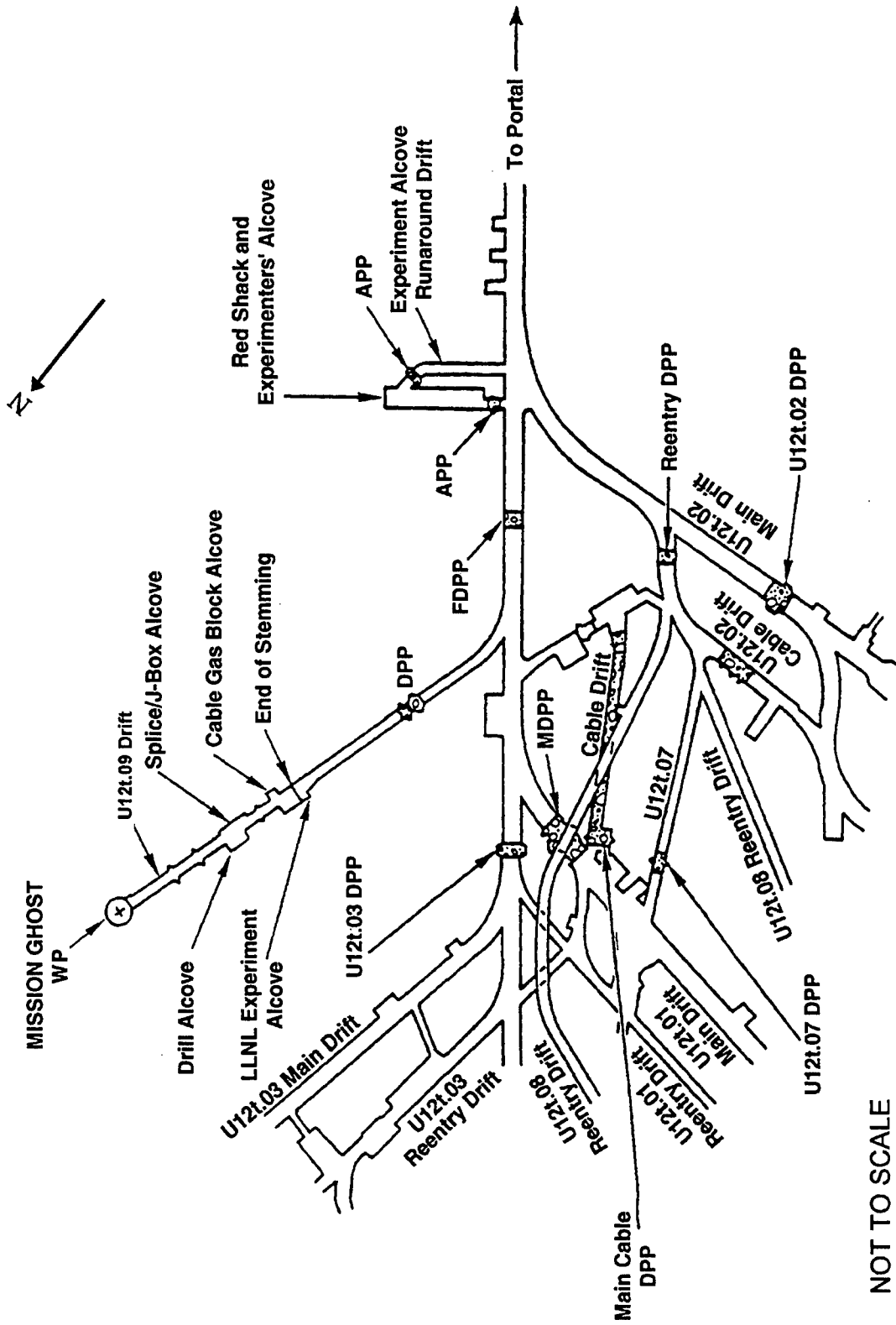

NOT TO SCALE

Figure 6-2. MISSION GHOST test - tunnel facilities layout.

began in December 1986. By the end of March 1987, the red shack and experimenters' alcove were completed. All cables and lines were installed and grouted; timing and firing and monitoring systems were prepared for installation; and experimenters had begun work at NTS. During the period April to June 1987, all experiments and electronic and recording equipment were installed and checked out. Cavity grout was poured; the trainway was installed in the GSP; protection plugs were poured; and instrumentation racks were installed in experimenter alcoves. Construction activities were conducted simultaneously with experimenter work, and SDRs were initiated in May.

Remote gas sampling capabilities were incorporated during construction as well as capabilities for water, power, drain, and pressurization lines. Provisions were made to manually take gas samples from the WP side of the GSD, GSP, and main DPP during posttest reentry.

The stemming plan for the U12t.09 complex is shown in Figure 6-3. High-strength RMG filled the cavity to a depth of 15.4 feet; the U12t.09 drift was also filled with high-strength RMG from the WP to a distance of 26 feet; then with RMG to 57 feet; followed by three sections of SLG, RMG, and SLG, respectively, to a distance of 87 feet; and the remaining stemmed portion to 213 feet with high-strength groutcrete. An air void existed from the end of stemming to the cable gas block alcove at 345 feet, and from that point, concrete surrounded the Vistanex bulkhead to 368 feet. All penetrations into the stemmed areas of the drifts (e.g., cables and water lines) were gas blocked to prevent the seepage of radioactive gases outside the stemmed region of the drifts.

Experiments and related hardware installations were completed by June 1987. The following organizations were among those that fielded experiments for the MISSION GHOST test: Science Applications International Corporation

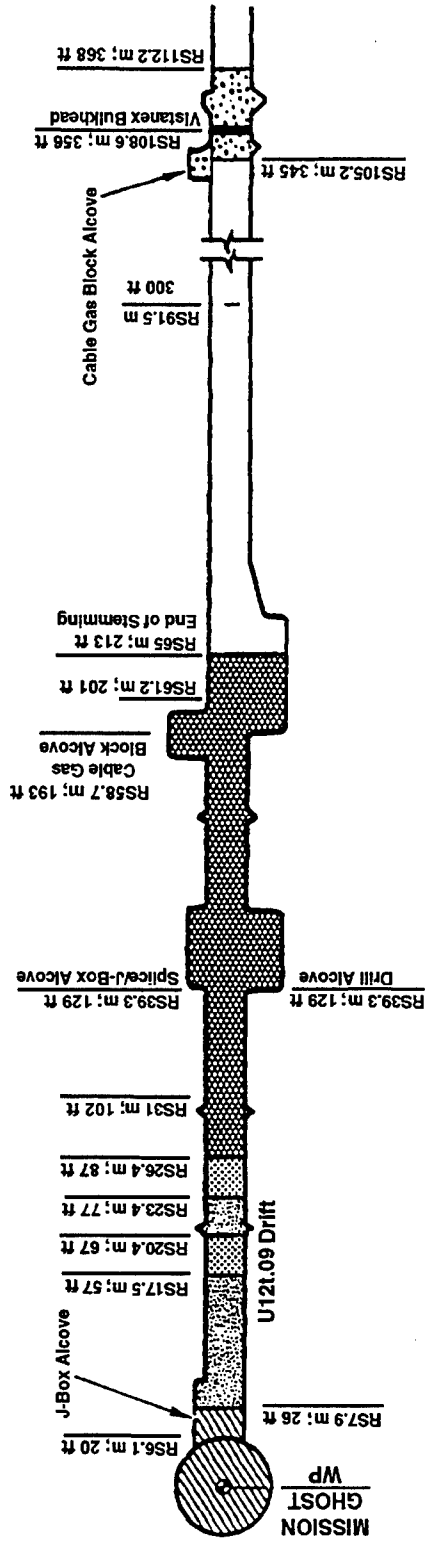
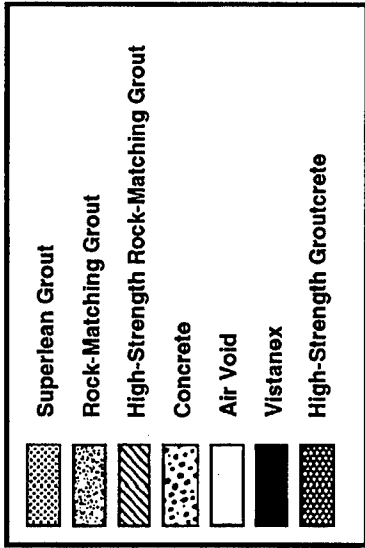

NOT TO SCALE

Figure 6-3. MISSION GHOST test - stemming plan.

(SAIC), Stanford Research Institute, International (SRII) and S-CUBED conducted TID experiments; JAYCOR conducted REMP experiments; SAIC, SRII, S-CUBED, and Science and Engineering Associates (SEA) conducted containment studies that involved taking stress measurements in specific environments; Test Construction Division, Test Directorate, FCDNA (FCTC) conducted containment experiments involving the propagation of fractures from the cavity to the tunnel complex or the surface; Sandia National Laboratories, Albuquerque (SNLA) conducted seismic ground-motion measurements; Los Alamos National Laboratory (LANL) conducted diagnostic measurements and a reaction history experiment; and Lawrence Livermore National Laboratory (LLNL) conducted cavity pressure and gas sampling experiments.

The SDRs continued into June. A MFP dry run was held on 10 June and after some faulty equipment was replaced, the run was declared valid. The device was emplaced and final stemming and button-up activities began. The final dry run was conducted on 19 June with the result being satisfactory, and preparations for test execution continued.

B. Radiological Safety Support.

Procedures for radiation exposure and contamination control during this test were in accordance with NTO SOP 0501 and requirements of responsible DoD representatives. Radsafe provided monitoring and equipment support.

Prior to the test, detailed radiological safety reentry plans were prepared and issued to participating agencies. Air sampling equipment was positioned in the test area. Radsafe monitors were briefed regarding surface reentry, manned stations, and security station requirements.

Radsafe monitoring teams and supervisory personnel were provided to perform initial radiation surveys, conduct aerial surveys by helicopter, and participate in reentry

parties as needed. Radsafe personnel were also standing by at designated muster stations prior to detonation to perform surveys and provide emergency support as directed; to provide and issue anticontamination equipment and material, portable instruments, and dosimeters; to operate area control check stations; and to perform personnel, equipment, and vehicle decontamination, as required.

Available anticontamination materials and equipment included head covers, coveralls, cloth shoe covers, totes, full-face masks, supplied-air breathing apparatus, plastic suits, plastic bags, gloves, and masking tape.

C. Telemetry and Air Sampling Support.

In addition to the permanent RAM units, 35 temporary units provided surface and underground coverage for the MISSION GHOST test. Tables 6-1 and 6-2 list the locations of surface and underground RAMS, respectively. The locations of surface RAMS are shown in Figure 6-4, and those of underground RAM units are shown in Figures 6-5 and 6-6. All RAM units were installed a minimum of five days prior to scheduled device detonation.

EPA operated continuous monitoring stations at 30 locations in the offsite area. All the stations had high-volume air samplers with collectors for particulates and reactive gases, 17 had tritium samplers, 16 had noble gas samplers, and 23 had pressurized ion chamber gamma-rate detector/recorder systems in operation. Twenty-eight EPA personnel were fielded for offsite surveillance activities.

D. Security Coverage.

Device security procedures in the WP area and the timing and firing control room were in accordance with DOE Order 5610.3, "Program to Prevent Accidental or Unauthorized Nuclear Explosive Detonations." Beginning on D-1, all

Table 6-1. MISSION GHOST test RAMS unit locations 20 June 1987.

SURFACE

STATION NUMBER	LOCATION
From the U12t Portal:	
1	At the portal
2	On the vent line
3	On the vent line
4	333 feet N 09° W azimuth
5	344 feet N 68° E azimuth
6	289 feet S 76° E azimuth
7	389 feet S 09° E azimuth
8	323 feet S 43° W azimuth
9	564 feet N 74° W azimuth
10	653 feet S 81° E azimuth (on the drain line)
11	2,005 feet S 88° E azimuth
From the U12t.09 SGZ:	
12	400 feet N 0° E azimuth
13	400 feet S 60° E azimuth
14	400 feet S 60° W azimuth

Table 6-2. MISSION GHOST test RAMS unit locations 20 June 1987.

UNDERGROUND

STATION NUMBER	LOCATION
15	In U12t.09 access drift, WP side of gas block
16	In U12t.09 access drift, portal side of gas block
17	In U12t.09 access drift, on gas sampling system
18	250 feet into the U12t.09 access drift
19ER ²⁰	250 feet into the U12t.09 access drift
20	100 feet into the U12t.09 access drift
21	3,530 feet into the U12t main drift
22	In the U12t main drift, gas sampling skid
23	3,280 feet into the U12t main drift
24	200 feet into the U12t.08 bypass reentry drift
25	200 feet into the U12t.08 reentry drift
26	300 feet into the U12t.02 main drift
27	3,150 feet into the U12t main drift
28	In the experimenter's alcove
29	2,800 feet into the U12t main drift
30	2,240 feet into the U12t main drift
31ER ²⁰	2,240 feet into the U12t main drift
32	1,800 feet into the U12t main drift
33	1,500 feet into the U12t main drift
34	900 feet into the U12t main drift
35	100 feet into the U12t main drift

²⁰ ER - Extended Range (instrument capable of reading 100 mR/h to 100,000 R/h).

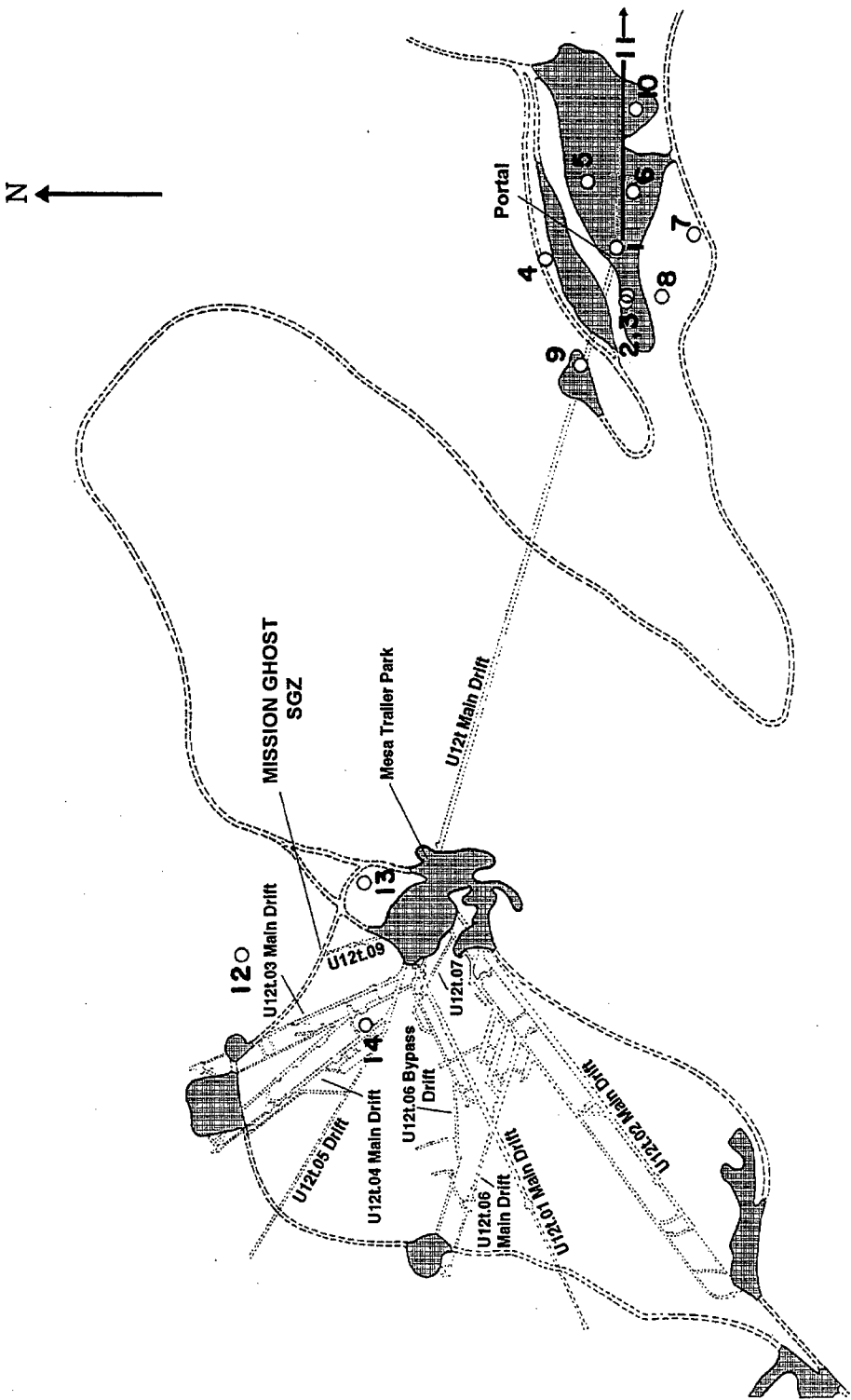

NOT TO SCALE

Figure 6-4. MISSION GHOST test - surface RAMS.

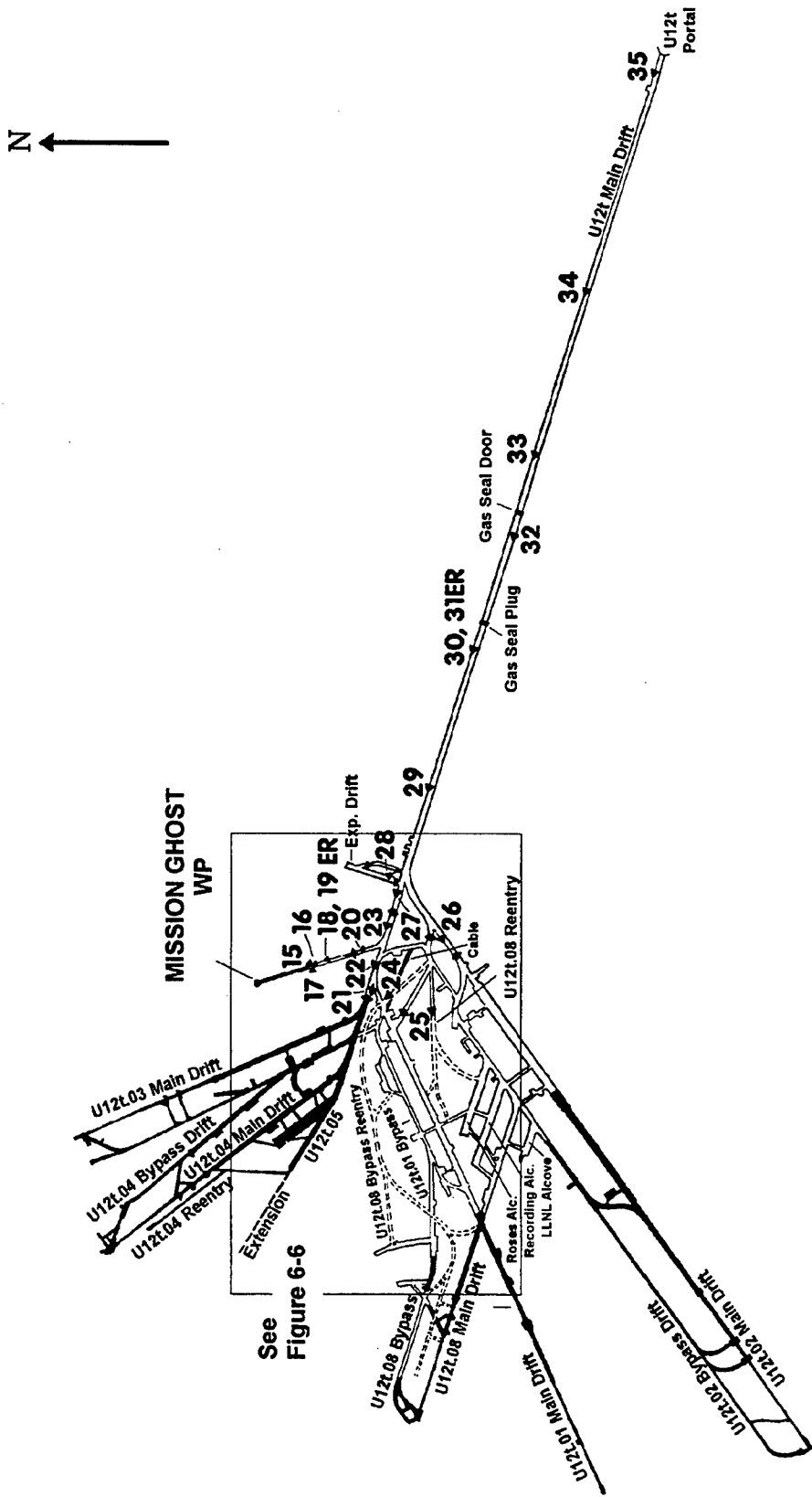

NOT TO SCALE

Figure 6-5. MISSION GHOST test - underground RAMS.

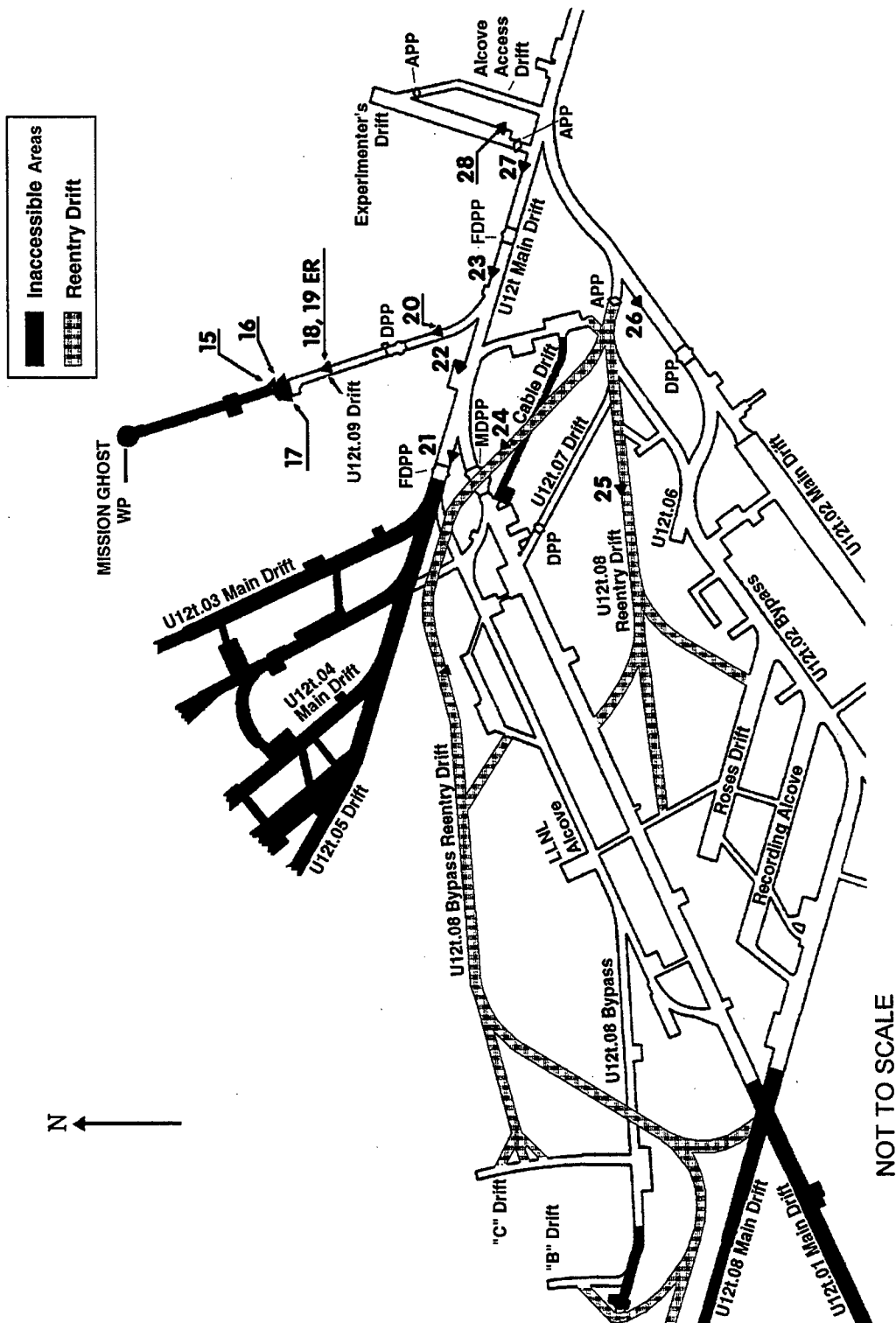

Figure 6-6. MISSION GHOST test - underground RAMS U12t.09 complex.

personnel entering or exiting the controlled area were required to stop at muster or control stations for issue of stay-in badges. After control was established, all through traffic was diverted around the controlled area by use of screening stations. In accordance with the "Test Controller's Operations and Security Plan," contractors and agencies were to have all personnel not connected with this test out of the closed area before the final security sweep began.

E. Air Support.

Three UH1N helicopters and crews were provided by the USAF for cloud tracking and the Test Controller's use, if needed. In addition, the USAF provided a WC-130 and/or a WC-135 aircraft and crew on standby status for cloud tracking. EG&G provided a Turbo Beech aircraft for taking wind soundings and for cloud tracking duties and a King Air for cloud sampling, if necessary.

6.3 TEST-DAY ACTIVITIES.

6.3.1 Pretest Activities.

On 19 June 1987, by approximately 2400 hours, all persons except the arming party, the tunnel button-up party, and the security guards were out of the tunnel and clear of the muster area. At 0430 hours, permission was granted to arm the device. Following the departure of the arming party, button-up operations were completed, and the party left the tunnel. The area was cleared of all personnel by 0830 hours on 20 June.

A final readiness briefing was held at 0700 hours on 20 June 1987 in anticipation of a 0900 hour test time. The five-minute count-down began at 0855 hours with indications that all systems were operating normally. The MISSION GHOST device was detonated at 0900 hours PDT on 20 June 1987.

6.3.2 Test Area Monitoring.

Telemetry recording measurements began at 0900 hours on 20 June 1987. At H+2 seconds all RAM units (i.e., stations) were indicating background radiation levels (0.04 mR/h). All stations, except station 17, were operational and remained so throughout the readout period. All RAM stations were secured at 1600 hours on 22 June.

6.3.3 Initial Surface Radiation Surveys.

An initial surface reentry team departed from the TC's barricade at Gate 300 at 0950 hours on 20 June 1987. A mobile base station was setup to provide for area control and anticontamination clothing and equipment supply. All radiation readings were relayed as soon as they were obtained via Net 3 radio. By 1023 hours, survey of the U12t portal area and ventilation pad above the portal area was completed. All radiation readings were at background levels.

Survey teams stood by the U12t portal during data recovery and gas sampling of the tunnel atmosphere. No explosive or toxic gases were detected and the oxygen level was 21 percent as measured on the WP side of the GSP; the WP side of the FDPP; and the portal side of the U12t.09 DPP. Gas sampling and data recovery were completed by 1215 hours, and all personnel were checked out of the test location by 1220 hours on 20 June 1987.

6.4 POSTTEST ACTIVITIES.

6.4.1 Tunnel Reentry Activities.

The initial reentry work team entered the U12t tunnel at 0748 hours on 21 June. The work team proceeded to open the GSD manway and then moved on to the GSP. Gas samples taken from the WP side of the GSP detected no explosive or toxic gases, and the oxygen level was 21 percent. All radiation readings were at background

levels. The work team installed railroad tracks through the GSD and then returned to the portal at 1038 hours.

The initial reentry team No. 1 and the rescue team, dressed in anticontamination clothing, left the portal area at 1030 hours on 22 June and proceeded to the GSP. At 1043 hours, team No. 1 put on their SCBA and proceeded through the GSP to the experimenters' APP. Readings from a gas sample taken from the WP side of the APP showed no explosive or toxic gases, and the oxygen level was 21 percent. Radiation readings were at background levels. After setting up a portable seismometer at the U12t.09 experimenters' alcove and the U12t main drift, team No. 1 continued on to the FDPP. Gas samples taken from the WP side of the FDPP showed background radiation levels, no explosive or toxic gases, and the oxygen level was 21 percent. Team No. 1 returned to the experimenters' alcove to evaluate conditions and take swipes. No damage to the alcove or instrument racks were noted.

Reentry team No. 1 returned to the portal side of the APP and removed their SCBA. Both the reentry and rescue teams then returned to the tunnel portal where they were surveyed and released at 1158 hours. All air and water samples along with swipes taken during reentry operations were sent to the laboratory for analysis.

Experimenters continued data and equipment recoveries and by 26 June the major portion of this work was completed. However, recoveries did continue while mining operations progressed.

6.4.2 Posttest Mining and Drilling.

Miners began mining out the GSP on 22 June and completed that task by 0050 hours on 23 June. By 0830 hours, experimenters began making recoveries from user alcoves. No anticontamination clothing was required during these activities, and all radiation readings were at background levels.

Workers also mined out the U12t.07 APP to continue MIGHTY OAK reentry work and to reestablish ventilation to the WP side of the the U12t.02 DPP. Work on the U12t.02 DPP required personnel to wear anticontamination clothing. By 28 June, rail lines had been put down through the U12t.07 APP, and workers were dismantling equipment in alcoves before removal.

Workers continued performing clean-up and preparing to set up the drilling rig. On 10 July, drillers set up a drilling rig in the instrument (experimenters') alcove and the began directional drilling toward the cavity. Workers began removing the FDPP in the main drift on 13 July, and this work progressed simultaneously with drilling activities in the experimenters' alcove. Typical survey data taken from the drill hole (designated RE#1) showed background radiation levels, no toxic or explosive gases, and 21 percent oxygen. Readings at the FDPP were similar.

When the depth of RE#1 drill hole reached 250 feet on 15 July, drillers were required to put on anticontamination clothing. Miners did likewise and also put on face masks when they began cutting the FDPP bulkhead. Drilling continued into August and by 06 August, RE#1 drill hole reached 494.4 feet, and work was halted at that point. As the core barrel was pulled from the RE#1 drill hole on 06 August, 100 ppm CO and 30 percent of the LEL were detected. No radiation readings above background levels were obtained.

Mining of the U12t.09 reentry drift was started on 07 August and by 14 August miners broke through to the U12t.09 main drift at the LLNL alcove. Miners shut down the drilling rig, rock bolted the reentry drift, and widened the access from the LLNL alcove to the main drift. A survey of the area showed no toxic or explosive gases and background radiation levels.

From September through December 1987, survey work continued and water was pumped from the cavity through the RE#1 drill hole. By early January 1988, workers were pressurizing the cavity by pumping air through the drill hole. On 7 January, drilling

resumed on RE#1 drill hole, and drillers broke into the cavity at 495.5 feet. Typical survey data from that drill hole showed no toxic or explosive gases and background radiation levels. Drilling ceased on RE#1 drill hole on 12 January at 585 feet.

Work continued into March on mining the reentry drift with several additional probe holes being drilled from the reentry drift. Holes were drilled at various locations, and numerous core samples were retrieved and surveyed. In early April 1988, workers at drill hole #4 (RE#4), wearing anticontamination clothing, totes, gloves, and slickers, were pumping large quantities of radioactive water from RE#4 drill hole. Surveys showed a maximum reading on a core sample of 150 mR/h, and 2.0 R/h at 51 feet into the drill hole. Work on other drill holes continued into July. From mid-April until July four crosscuts were mined from the right rib of the reentry drift. Three of the crosscuts were mined to intercept hydrofrac holes that were then surveyed and mapped. Crosscut No. 1 was mined to intercept the main drift to facilitate additional experiment recoveries. No anticontamination clothing was required for these activities. This work was completed by mid-July 1988.

Drilling from the mesa began on 23 July 1987. On 31 July at 0310 hours drillers broke into the cavity at 1134 feet. Surveys and swipes showed background radiation levels. By 1445 hours that same day, all activities were shut down and equipment was moved out of the area.

6.4.3 Industrial Safety.

Checks for the presence of toxic gases and surveys to measure radiation and explosive gas levels were made on each shift. The results were then recorded in the monitors' logbook.

Appropriate safety measures were taken to protect mining personnel and prevent unsafe conditions. Industrial safety codes for mining, tunneling, and drilling were established by REECo and emphasized during all operations. A written standard operating procedure was required for each operation involving explosives,

toxic materials, radioactive material, or any other operation with the potential for personal injury. Each individual involved in such an operation was required to know the contents of the applicable procedures.

The portal construction area and the tunnel were mandatory hard-hat and foot-protection areas (safety shoes, boots, DOE-issued miner's boots, or toe guards). All personnel on initial tunnel reentry teams were certified in the use of the Draeger self-contained breathing apparatus. Standard safety rules and regulations, as spelled out in the "U.S. Bureau of Mines Manual," were observed.

All explosives, electro-explosive components, solid propellants, toxic materials, and radioactive materials were handled, stored, and transported in accordance with applicable sections of the following documents:

1. Army Material Command Regulations (AMCR 385-100).
2. Appropriate DOE Orders in the 5400 and 5600 Series concerning Environmental Protection, Safety & Health Protection, and Defense Programs, respectively.
3. Individual safe operating procedures (by experimenter organization).
4. MISSION GHOST Safety Regulations.

All personnel engaged in handling, storing, assembling, or installing explosives, propellants, or electro-explosive devices (or observers of those operations) were required to wear safety glasses or other eye protection which had been approved by the DoD safety coordinator.

6.5 RESULTS AND CONCLUSIONS.

Telemetry recording measurements began at 0900 hours on 20 June 1987, and continued until 1600 hours on 22 June when all RAM stations were secured. All stations indicated background radia-

tion levels throughout the readout period except station 17 which was inoperative throughout this period.

The initial radiation surveys began at 0950 hours on 20 June and were completed at 1023 hours. No radiation above background levels was detected at the U12t tunnel portal yard area or at the ventilation pad above the portal. Gas samples taken from the WP side of the GSP indicated no toxic or explosive gases and 21 percent oxygen.

Reentry into the tunnel began at 0748 hours on 21 June, and reentry team No. 1 proceeded to the experimenters' alcove where workers noted that very little structural damage occurred. The team proceeded to the FDPP where gas samples were taken from the WP side of the FDPP. Sample readings showed no toxic or explosive gases, and the oxygen level was 21 percent. The reentry team No. 1 and the rescue team returned to the portal area where they were surveyed and released at 1158 hours. All samples collected during reentry operations were sent to the laboratory for analysis.

Reentry mining began on 22 June when workers mined out the GSP, completing that task by 0050 hours on 23 June. Miners drilled from the experimenters' alcove into the cavity taking numerous survey data. Typical survey data taken from the drill hole showed background radiation levels, no toxic or explosive gases, and 21 percent oxygen. A reentry drift was mined to the left of the U12t.09 main drift where miners broke through into the LLNL alcove. Several drill holes were drilled at various locations in the reentry drift, and numerous core samples were taken. The maximum reading on a core sample, taken from RE#4 drill hole, was 150 mR/h. A maximum reading of 2 R/h was recorded at 51 feet into the drill hole. Four crosscuts were mined from the reentry drift; three facilitated surveying and mapping hydrofrac holes; the fourth intercepted the main drift to facilitate further experiment recoveries. Tunnel mining work was completed in July 1988.

Mesa drilling operations were conducted from 23-31 July 1987. Workers drilled into the cavity taking surveys and swipes for analysis. All radiation readings were at background levels.

Personnel exposure data from self-reading pocket dosimeters were documented on Area Access Registers during individual entries to MISSION GHOST radex areas over a non-continuous time frame beginning 21 June 1987 and ending 22 April 1988 (see page 113 for a detailed explanation). Pocket dosimeters showed no indication of possible radiation exposure to DoD-affiliated personnel. TLDs worn by these reentry personnel indicated that no individuals received any reportable gamma exposure from the MISSION GHOST test. The minimum detectable gamma exposure with the NTS TLD is 15 mR. Area Access Register data are summarized below.

Participants	Entries Logged	Maximum Exposure (mR)	Average Exposure (mR)
All	642	3	0
DoD	6	0	0

SECTION 7

MISSION CYBER TEST

7.1 TEST SUMMARY.

MISSION CYBER was a DoD/LLNL-sponsored weapons-effects test conducted at 0830 hours PST on 02 December 1987. The test had a yield of less than 20 kilotons, and the device was emplaced at a vertical depth of 899 feet in the U12p.02 drift of the P tunnel complex (see Figure 7-1). The purpose of the MISSION CYBER test was to test the survivability of military hardware in a nuclear detonation environment.

The MISSION CYBER test was satisfactorily contained, and there were no unusual radiation effects observed.

7.2 PRETEST ACTIVITIES.

7.2.1 Responsibilities.

Safe conduct of all MISSION CYBER project activities in Area 12 was the responsibility of the DNA TGD, subject to controls and procedures established by the DOE TC. The DOE TC was responsible for safety of the public and onsite personnel during the test.

Project agencies were responsible for designing, preparing, and installing experiments, or delivering them to the installation contractor. After the test, these agencies were responsible for removing samples, analyzing instrument and sample data, and preparing project reports on experiment results.

Device safety and security procedures in the WP area and the timing and firing control room were in accordance with DOE Order 5610.3, "Program to Prevent Accidental or Unauthorized Nuclear Explosive Detonations." The LLNL TD had overall responsibilities for all operations involving the MISSION CYBER device as well as

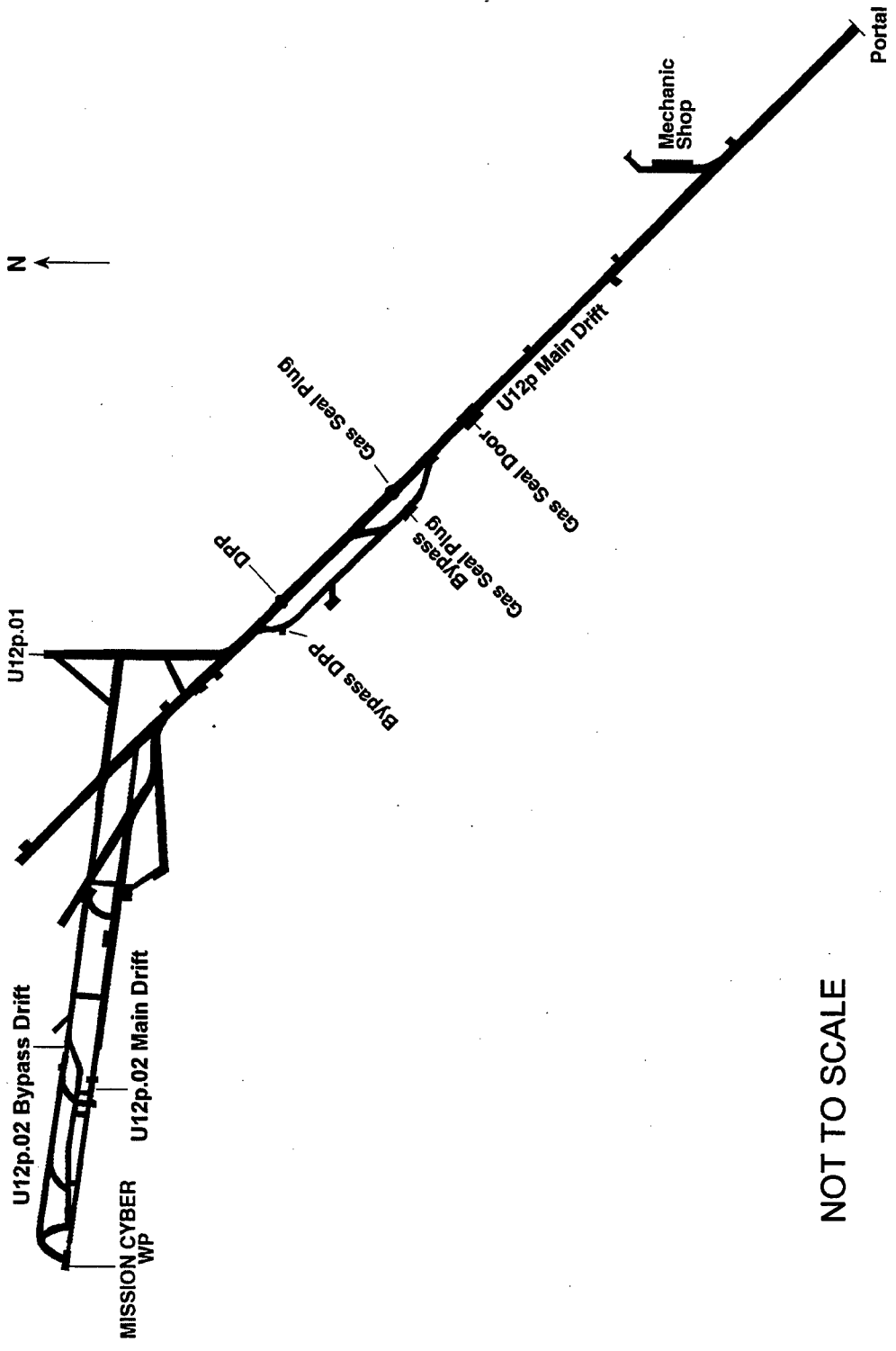

NOT TO SCALE

Figure 7-1. MISSION CYBER test - tunnel layout.

the timing control and the arming and firing of MISSION CYBER closures and experiments. The LLNL TD was responsible to the DOE TC for radiological safety within the designated area of the WP from device emplacement until detonation. After the detonation, the DOE TC relieved the LLNL TD of these responsibilities and returned the responsibility for project activities back to the DNA TGD.

7.2.2 Planning and Preparations.

A. Tunnel Facilities Construction.

The MISSION CYBER test was the first underground test conducted in P tunnel. The U12p.02 drift was mined to the west of the U12p main drift and off the U12p.01 drift that was used as an alcove for instrumentation. The testbed consisted of an 880 foot-long tapered steel LOS pipe with the source at one end and the bulk of experiments at the other end. The pipe diverged from a few inches in diameter to over 12 feet at the WP side of TC No. 1. Most of the experiments were located in one of three test chambers or in the area to the portal side of the test chamber. The U12p.02 complex consisted of a LOS drift, a bypass drift, a zero room, a FAC, a DBS, a GSAC, a TAPS, two bulkhead stations (designated TC Nos. 2 and 3), another TC, nine experiment and radiation diagnostic stubs, and a scatterer station (see Figure 7-2).

Plans for test construction activities began in January 1986 with a review by DNA of specific experiment proposals from DoD and DOE. Approvals and funding were secured and construction activities began in April 1986. Mining of the U12p.02 LOS and bypass drifts began in June and were essentially completed by December 1986. The LOS pipe installation began in January 1987; a prefit of experiments was conducted in May; and experiment installation began in late July to support a September readiness date. In August, SDRs began. In September, labor problems at the NTS de-

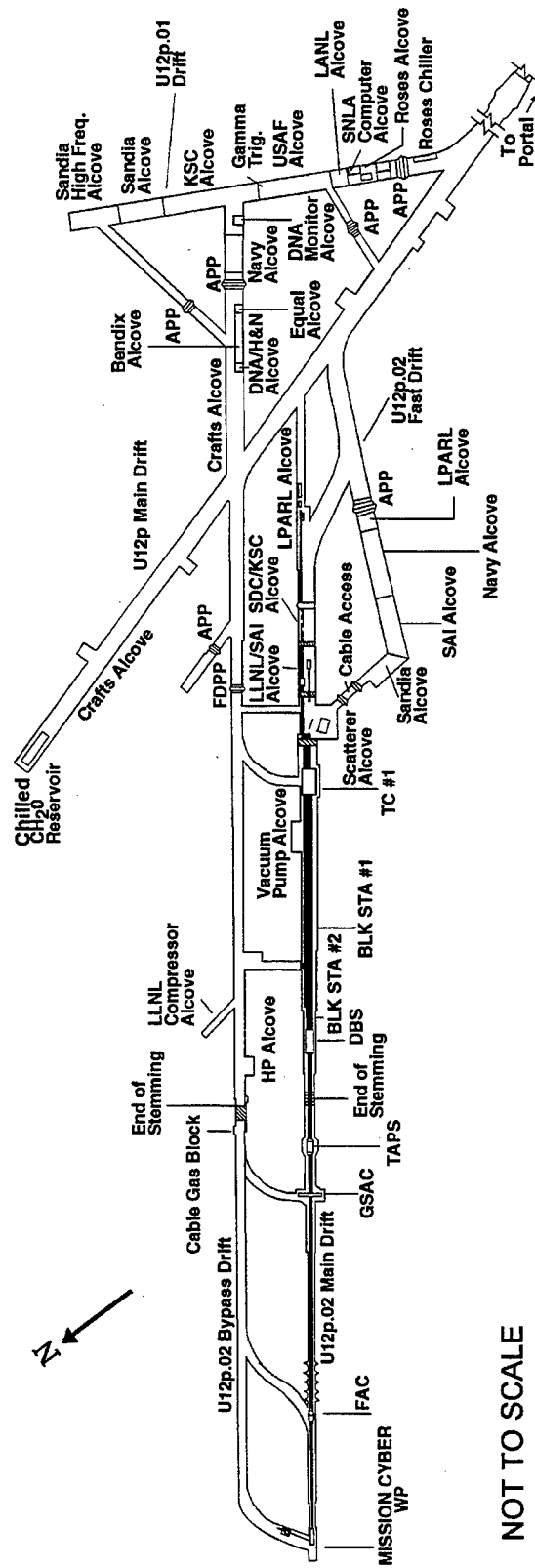

Figure 7-2. MISSION CYBER test - tunnel facilities layout.

layed some readiness activities, and final experiment-related installations were completed in November to support a rescheduled early December readiness date.

Remote gas sampling capabilities were incorporated during construction as well as capabilities for water, power, drain, and pressurization lines. Provisions were made to manually take gas samples from the WP side of the GSD, GSP, and the main and bypass DPPs during posttest reentry.

The stemming plan for the U12p.02 complex is shown in Figure 7-3. The area behind the WP was filled with desert fines. The main drift was stemmed with RMG to 52 feet; then to 89 feet with another type of RMG as well as from 112 to 132 feet; then with SLG from 89 to 112 feet as well as from 132 to 152 feet; and finally with high-strength concrete to 509 feet. The bypass drift was stemmed with one type of RMG to a distance of 52 feet and with another type of RMG to 110 feet; then with SLG to a distance of 201 feet; and the remaining stemmed portion to 509 feet with HSG. The FAC and the GSAC crosscuts were stemmed with HSG, and the gas block alcove, at 476 feet, was filled with concrete. All penetrations into the stemmed areas of the drifts (e.g., cables and water lines) were gas blocked to prevent the seepage of radioactive gases outside the stemmed region of the drifts.

Experiments and related hardware installations were completed by November 1987. The following organizations were among those that fielded experiments for the MISSION CYBER test: Harry Diamond Laboratories (HDL) and Kaman Sciences Corporation (KSC) conducted strategic defense initiative experiments; Massachusetts Institute of Technology/Lincoln Laboratory (MIT/LL), APTEC, Inc., and ACUREX conducted experiments using active impulse-coupling measurements; Sandia National Laboratories, Albuquerque (SNLA) conducted radiation output and containment diagnostics measurements; Lawrence Livermore National Laboratory (LLNL) conducted

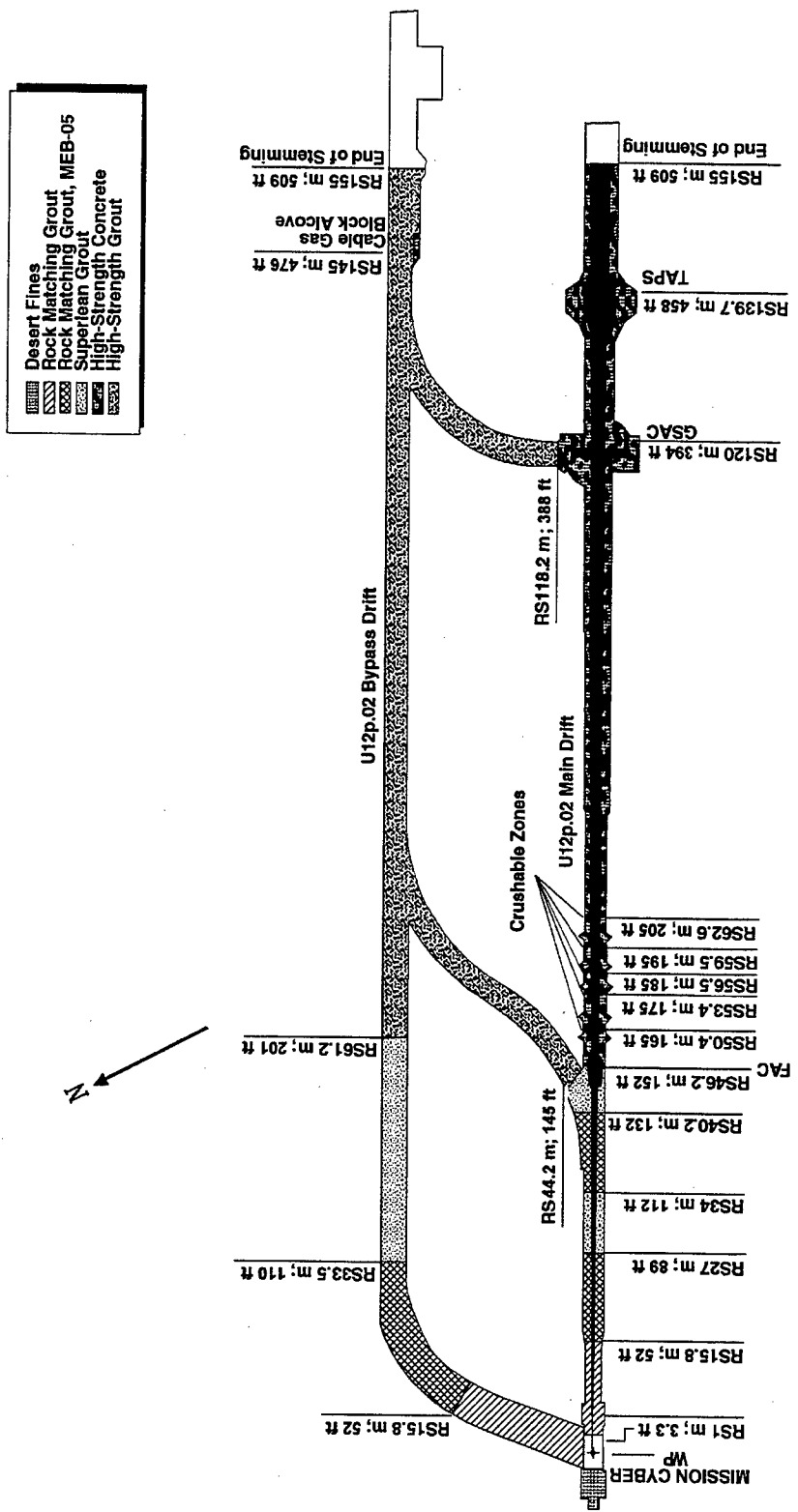

Figure 7-3. MISSION CYBER test - stemming plan.

device diagnostics measurements; Lockheed Palo Alto Research Laboratory (LPARL) and Science Applications International Corporation (SAIC) conducted radiation output measurements; Los Alamos National Laboratory (LANL), SNLA, and Mission Research Corporation (MRC) conducted advanced development tests; and General Research Corporation (GRC) conducted experiments to determine the lethality of the device against potential targets.

The first SDRs were conducted in August and continued into September, but as the readiness date slipped, some readiness activities were postponed. An MFP dry run, first scheduled for September, was rescheduled several times and finally completed successfully on 12 November at 0800 hours. The device was emplaced and final button-up and stemming activities were completed by late November. The final dry run was conducted on 30 November with the result being satisfactory, and preparations for test execution continued.

B. Radiological Safety Support.

Procedures for radiation exposure and contamination control during this test were in accordance with NTO SOP 0501 and requirements of responsible DoD representatives. Radsafe provided monitoring and equipment support.

Prior to the test, detailed radiological safety reentry plans were prepared and issued to participating agencies. Air sampling equipment was positioned in the test area. Radsafe monitors were briefed regarding surface reentry, manned stations, and security station requirements.

Radsafe monitoring teams and supervisory personnel were provided to perform initial radiation surveys, conduct aerial surveys by helicopter, and participate in reentry parties as needed. Radsafe personnel were also standing by at designated muster stations prior to detonation to per-

form surveys and provide emergency support as directed; to provide and issue anticontamination equipment and material, portable instruments, and dosimeters; to operate area control check stations; and to perform personnel, equipment, and vehicle decontamination, as required.

Available anticontamination materials and equipment included head covers, coveralls, cloth shoe covers, totes, full-face masks, supplied-air breathing apparatus, plastic suits, plastic bags, gloves, and masking tape.

C. Telemetry and Air Sampling Support.

In addition to the permanent RAM units, 41 temporary units provided surface and underground coverage for the MISSION CYBER test. Tables 7-1 and 7-2 list the locations of surface and underground RAMS, respectively. The locations of surface RAMS are shown in Figure 7-4, and those of underground RAM units are shown in Figures 7-5 and 7-6. All RAM units were installed a minimum of five days prior to scheduled device detonation.

EPA operated continuous monitoring stations at 30 locations in the offsite area. All the stations had high-volume air samplers with collectors for particulates and reactive gases, 17 had tritium samplers, 16 had noble gas samplers, and 23 had pressurized ion chamber gamma-rate detector/recorder systems in operation. Twenty-eight EPA personnel were fielded for offsite surveillance activities.

D. Security Coverage.

Device security procedures in the WP area and the timing and firing control room were in accordance with DOE Order 5610.3, "Program to Prevent Accidental or Unauthorized Nuclear Explosive Detonations." Beginning on D-1, all personnel entering or exiting the controlled area were required to stop at muster or control stations for issue of

Table 7-1. MISSION CYBER test RAMS unit locations 2 December 1987.

SURFACE

STATION NUMBER	LOCATION
From the U12p Portal:	
1	At the portal
2	46 feet N 38° W on the vent line
3	310 feet N 42° E azimuth
4	328 feet N 84° E azimuth
5	265 feet S 39° E azimuth
6	238 feet S 02° W azimuth
7	309 feet S 63° W azimuth
8	296 feet N 72° W azimuth
9	300 feet N 27° W azimuth
10	236 feet S 05° E on the tunnel drain line
11	1,017 feet N 74° E azimuth
12	1,950 feet S 50° E azimuth
From the U12p.02 SGZ:	
13	400 feet N 00° E azimuth
14	400 feet S 60° E azimuth
15	400 feet S 60° W azimuth

Table 7-2. MISSION CYBER test RAMS unit locations 2 December 1987.

UNDERGROUND

STATION NUMBER	LOCATION
16	710 feet into the U12p.02 LOS drift
17	580 feet into the U12p.02 LOS drift
18	410 feet into the U12p.02 LOS drift
19	At the U12p.02 LOS drift scatterer alcove 2-9
20	290 feet into the U12p.02 LOS drift
21	230 feet into the U12p.02 LOS drift
22	175 feet into the U12p.02 LOS drift
23	660 feet into the U12p.02 bypass drift
24ER ²¹	650 feet into the U12p.02 bypass drift
25	450 feet into the U12p.02 bypass drift
26	At the LLNL instrument alcove 2-5
27	At the U12p.02 Fast alcove, Sandia alcove 2-4
28	At the U12p.02 Fast alcove, Navy alcove 2-2
29	90 feet into the U12p.02 bypass drift
30	400 feet into the U12p.01 drift

²¹ ER - Extended Range (instrument capable of reading 100 mR/h to 100,000 R/h).

Table 7-2. MISSION CYBER test RAMS unit locations 2 December 1987
(Continued).

UNDERGROUND

STATION NUMBER	LOCATION
31	150 feet into the U12p.01 drift
32	2,880 feet into the U12p main drift
33	2,350 feet into the U12p main drift
34	2,180 feet into the U12p main drift
35ER ²²	2,180 feet into the U12p main drift
36	1,870 feet into the U12p main drift
37	400 feet into the U12p main drift bypass
38	1,450 feet into the U12p main drift
39	1,300 feet into the U12p main drift
40	800 feet into the U12p main drift
41	200 feet into the U12p main drift

²² ER - Extended Range (instrument capable of reading 100 mR/h to 100,000 R/h).

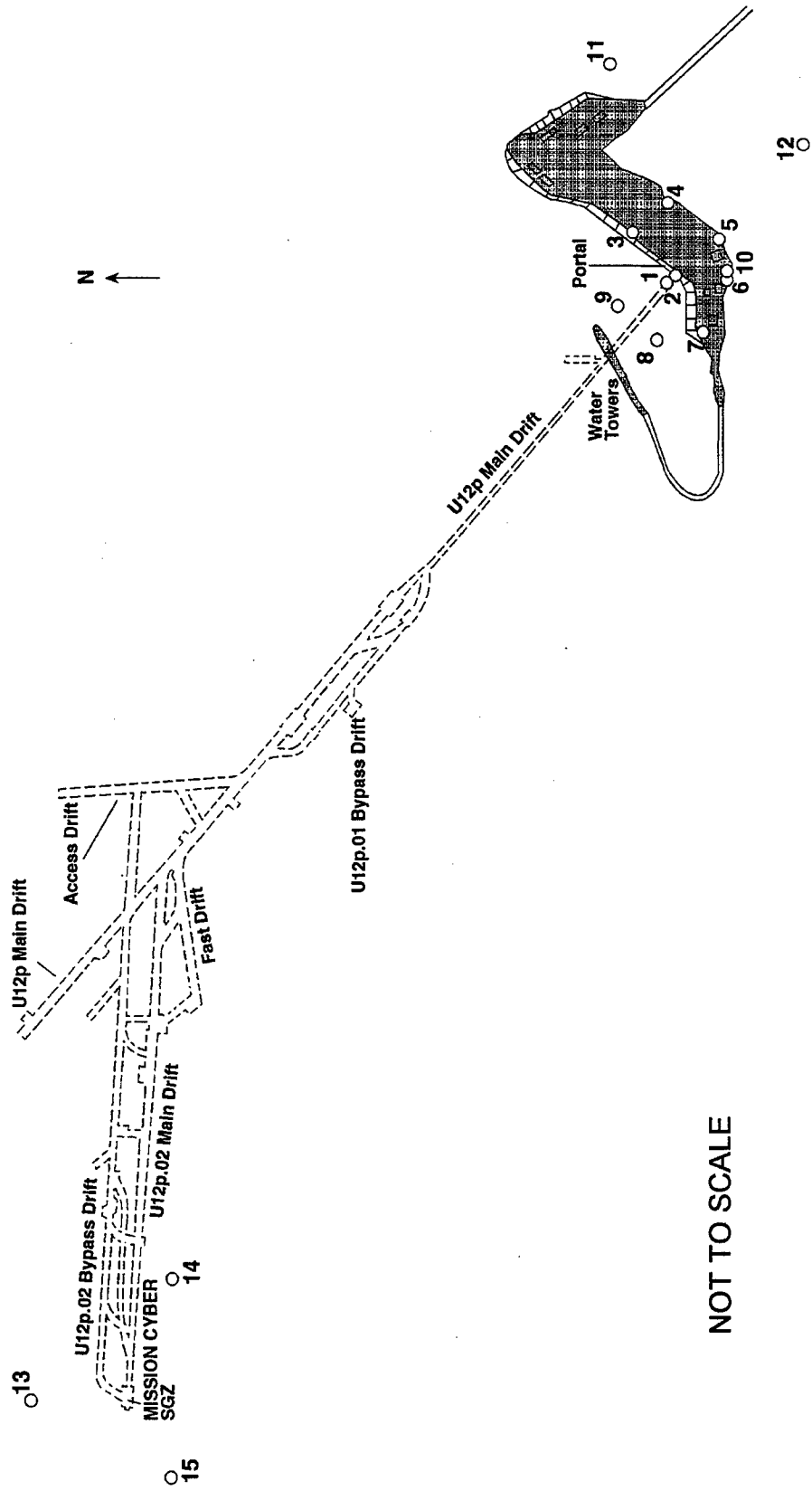

Figure 7-4. MISSION CYBER test - surface RAMS.

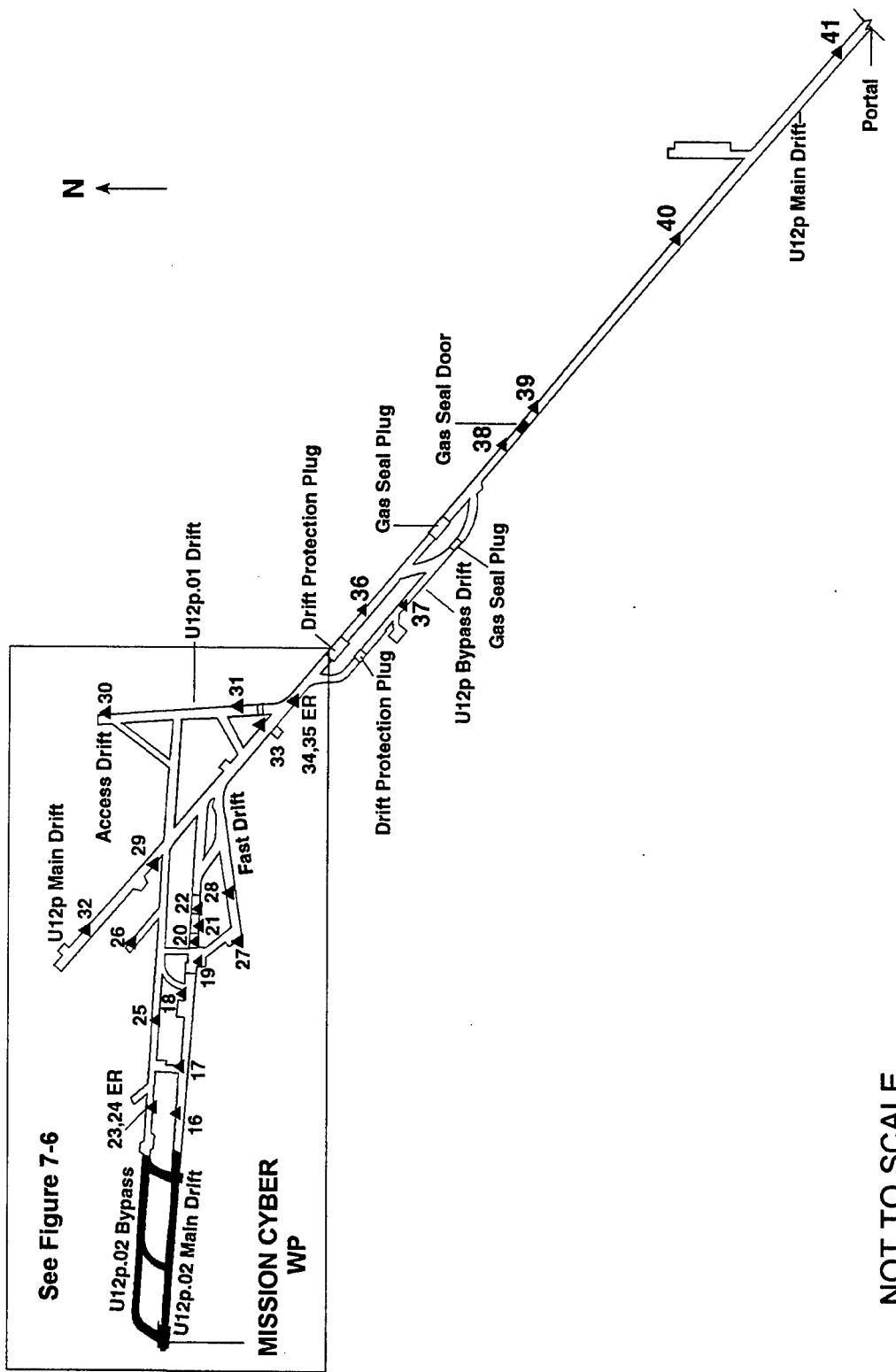
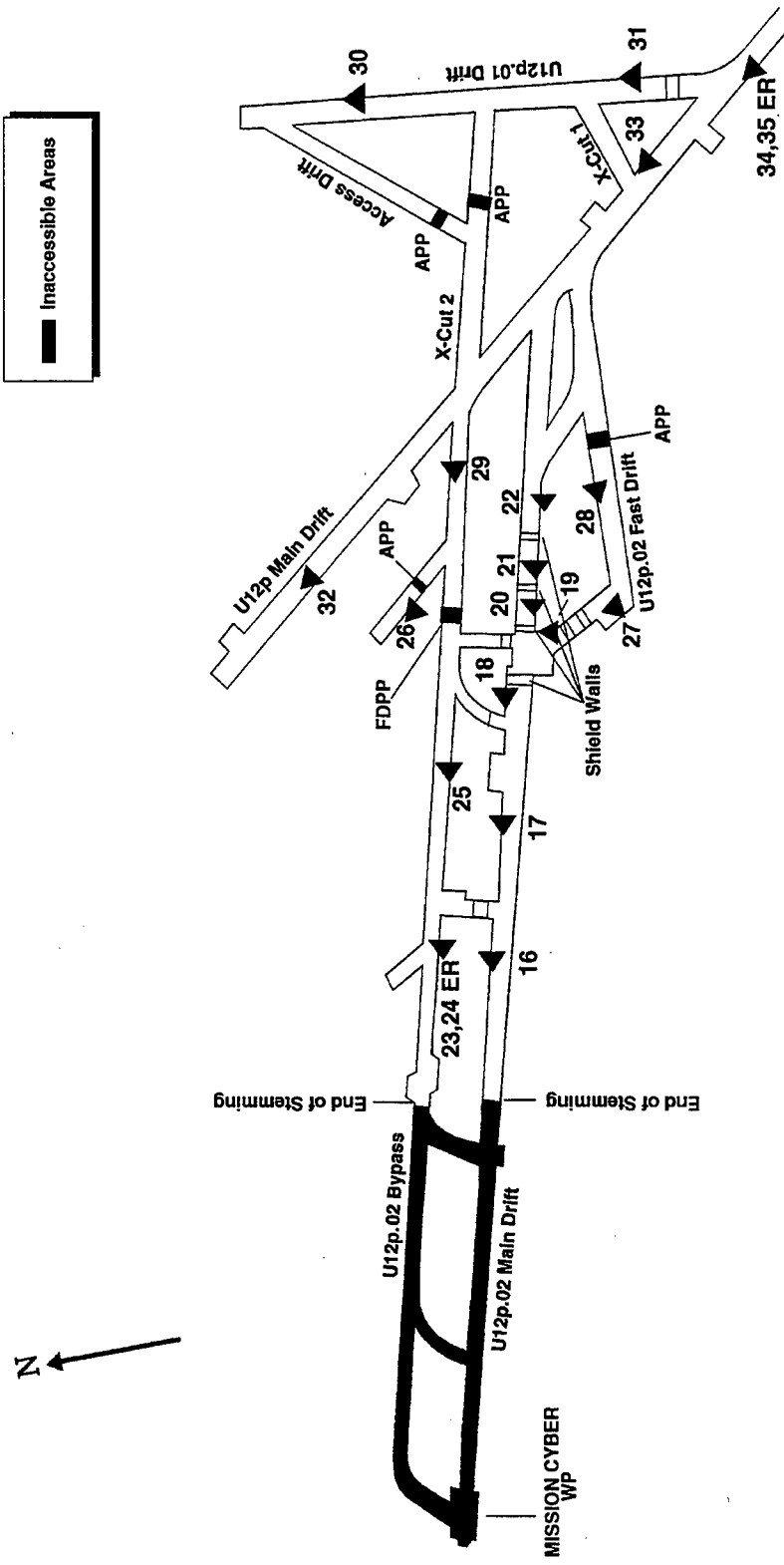

Figure 7-5. MISSION CYBER test - underground RAMS.



NOT TO SCALE

Figure 7-6. MISSION CYBER test - underground RAMS U12p.02 complex.

stay-in badges. After control was established, all through traffic was diverted around the controlled area by use of screening stations. In accordance with the "Test Controller's Operations and Security Plan," contractors and agencies were to have all personnel not connected with this test out of the closed area before the final security sweep began.

E. Air Support.

Three UH1N helicopters and crews were provided by the USAF for cloud tracking and the Test Controller's use, if needed. In addition, the USAF provided a WC-130 and/or a WC-135 aircraft and crew on standby status for cloud tracking. EG&G provided a Turbo Beech aircraft for taking wind soundings and for cloud tracking duties and a King Air for cloud sampling, if necessary.

7.3 TEST-DAY ACTIVITIES.

7.3.1 Pretest Activities.

On 01 December 1987, by approximately 2400 hours, all persons except the arming party, the tunnel button-up party, and the security guards were out of the tunnel and clear of the muster area. At approximately 0230 hours, permission was granted to arm the device. Following the departure of the arming party, button-up operations were completed, and the party left the tunnel. The area was cleared of all personnel by 0608 hours on 02 December.

A final readiness briefing was held at approximately 0700 hours on 02 December 1987 in anticipation of a 0830-hour test time. A countdown began at 0823 hours with indications that all systems were operating normally. The MISSION CYBER device was detonated at 0830 hours PST on 02 December 1987.

7.3.2 Test Area Monitoring.

Telemetry recording measurements began at 0829 hours on 02 December 1987. Immediately after zero time all RAM units (i.e., stations) were operational and indicating background radiation levels (0.04 mR/h) except stations 17 and 18. At H+10 seconds, the highest readings were recorded on station 17 indicating 833 R/h and station 18 indicating 685 R/h. By 1630 hours on 02 December, these readings had decreased to 106 mR/h and 254 mR/h, respectively. When all RAM stations were secured at 1000 hours on 08 December, all stations read background radiation levels except stations 18 which read 4.2 mR/h.

7.3.3 Initial Surface Radiation Surveys.

An initial surface reentry team departed from the TC's barricade at Gate 300 at 0943 hours on 02 December 1987. A mobile base station was setup to provide for area control and anticontamination clothing and equipment supply. All radiation readings were relayed as soon as they were obtained via Net 3 radio. By 1014 hours, the survey of the U12p portal area was completed. All radiation readings were at background levels.

Survey teams stood by the U12p portal during data recovery and gas sampling of the tunnel atmosphere. No explosive mixtures or toxic gases were detected and the oxygen level was 21 percent as measured on the WP side of the GSP; the WP side of the main drift DPP; the portal side of the FDPP; the end of stemming in the U12p.02 bypass drift; in the U12p.02 main (LOS) drift; and inside the U12p.02 LOS pipe. Low levels of radioactive gases were detected in the samples taken from the LOS drift and LOS pipes. Gas sampling and data recovery were completed by 1150 hours, and all personnel were checked out of the test location by 1425 hours on 02 December 1987.

7.4 POSTTEST ACTIVITIES.

7.4.1 Tunnel Reentry Activities.

Prior to entry of the work team, additional sampling of the tunnel atmosphere was completed. The initial reentry work team entered the tunnel at 0820 hours on 03 December. The work team proceeded to the GSD where a gas sample taken from the WP side of the GSD showed no explosive or toxic gases, 21 percent oxygen, and the radiation reading was at background levels. Miners then removed the GSD and the team proceeded to the GSP in the main drift bypass (i.e., the runaround). The team connected the ventilation line and took a gas sample from the WP side of this GSP. Again, all readings showed normal atmospheric conditions. The work team returned to the portal at 1237 hours.

The initial reentry team No. 1 and the rescue team, dressed in two suits of anticontamination clothing, left the portal at 1315 hours and proceeded to the bypass GSP. The rescue team stood by as team No.1 put on their SCBA and proceeded through the bypass GSP turn-tube and then through the bypass DPP crawltube to the U12p.02 LOS drift. All readings showed normal atmospheric conditions. The team proceeded to the U12p.02 FDPP and then to shield walls Nos. 1-4, each time taking a gas sample before proceeding through the respective crawltube. A gas sample from the WP side of shield wall No. 4 showed 5 ppm CO, no explosive gases, and 21 percent oxygen. The maximum exposure rate detected was 30 mR/h on the WP side of shield wall No. 3. This work was completed by 1500 hours.

Team No. 1 returned to the U12p.02 LOS FDPP and then proceeded to the U12p.02 bypass and through the U12p.02 bypass FDPP turntube to TC No. 2 and then to TC No.1, where a survey showed a maximum reading of 70 mR/h on the WP side of plug No. 2 at TC No. 1. No explosive or toxic gases were detected, and the oxygen level was 20 percent. Team No. 1 returned to the GSP at 1614 hours where they removed their SCBA and anticontamination clothing. All reentry personnel were surveyed and released at 1645 hours.

On 04 December at 0823 hours, reentry team No. 2, wearing anticontamination clothing and SCBAs, left the bypass GSP and proceeded to the Slow alcove, the Fast alcove, the LPARL stubs area and then to the LLNL alcove to establish ventilation, take gas samples and swipes and assess general conditions. Team No. 2 then proceeded to the U12p.02 bypass FDPP and TC No. 1 to take gas samples and swipes. Both the reentry team No. 2 and the rescue team then returned to the tunnel portal where they were surveyed and released by 1010 hours. All air and water samples along with swipes taken during reentry operations were sent to the laboratory for analysis.

Experiment recovery began on 09 December when personnel, dressed in anticontamination clothing, began removing experiments from TC No. 1. Experiments and equipment were taken to a packaging facility where they were surveyed, decontaminated, and packaged and shipped to the user's facility. This work continued into March 1988.

7.4.2 Posttest Mining and Drilling.

Miners began mining out the U12p main drift GSP on 04 December at 2100 hours and completed that task by 1800 hours on 05 December. Workers continued replacing ventlines and train tracks and removing the DPP. On 07 December, a miner, along with Radsafe and Industrial Hygiene personnel, all wearing anticontamination clothing and SCBAs, proceeded to walk through the LOS pipe to TC No. 1 and then to the DBS and bulkhead station No. 2 where a 17 mR/h exposure rate was detected. After this safety assessment, the scientific assessment team and photographers, dressed in anticontamination clothing and full-face respirators, arrived at TC No. 1 to check out equipment and take photographs.

Recoveries began on 09 December. The maximum reading of 70 mR/h was recorded on the recovered experiments taken from the scatterer alcove on 14 December. Workers, wearing anticontamination clothing, began removing shield walls Nos. 1 and 2 and establishing ventilation to the TAPS while others were drilling probe holes in

the reentry drift. On 17 December, Industrial Hygiene personnel measured 30,000 ppm CO and greater than 100 percent of the LEL from a probe hole in the reentry drift, but radiation readings were at background levels. Workers continued to blow air into the probe hole (designated probe hole No. 1), however, the levels of toxic and explosive gases fluctuated with changes in barometric pressure. A survey of the probe hole was made daily.

In January 1988 miners continued working in the LOS (main) drift and completed the removal of shield wall No. 3; began the removal of shield wall No. 4; established ventilation to the WP side of the TAPS; opened, surveyed, and entered through the TAPS to the GSAC inside the LOS pipe; and then raised and secured the TAPS. Mining the reentry drift resumed through the GSAC crosscut at 287 feet. Additional probe holes drilled were surveyed and again showed fluctuating levels of toxic and explosive gases, but radiation readings were at background levels.

During February hydrofracing experiments began in the reentry drift, and two additional probe holes were drilled from the reentry drift. Readings taken inside probe hole No. 2 on 03 February showed 1500 ppm CO, 100 percent of the LEL, and background radiation levels. Drillhole ball valves were closed on 05 February; however mining continued in the reentry drift.

Mining the reentry drift through the GSAC and FAC crosscuts and beginning the cavity runaround drift was accomplished in March. Numerous probe hole surveys were taken at various locations and headings from the reentry drift. The maximum radiation reading of 1.2 R/h was recorded from a survey of probe hole No. 11 on 11 April 1988. Mining and probe hole drilling continued in the cavity runaround drift, the reentry drift, and the LOS drift into June. Workers in the LOS drift were required to wear both anti-contamination clothing and full-face respirators at various times because radiation levels fluctuated greatly and sometimes exceeded 400 mR/h. Mapping and photography work was ongoing while mining progressed. TAPS recovery work continued into July.

7.4.3 Industrial Safety.

Checks for the presence of toxic gases and surveys to measure radiation and explosive gas levels were made on each shift. The results were then recorded in the monitors' logbook.

Appropriate safety measures were taken to protect mining personnel and prevent unsafe conditions. Industrial safety codes for mining, tunneling, and drilling were established by REECO and emphasized during all operations. A written standard operating procedure was required for each operation involving explosives, toxic materials, radioactive material, or any other operation with the potential for personal injury. Each individual involved in such an operation was required to know the contents of the applicable procedures.

The portal construction area and the tunnel were mandatory hard-hat and foot-protection areas (safety shoes, boots, DOE-issued miner's boots, or toe guards). All personnel on initial tunnel reentry teams were certified in the use of the Draeger self-contained breathing apparatus. Standard safety rules and regulations, as spelled out in the "U.S. Bureau of Mines Manual," were observed.

All explosives, electro-explosive components, solid propellants, toxic materials, and radioactive materials were handled, stored, and transported in accordance with applicable sections of the following documents:

1. Army Material Command Regulations (AMCR 385-100).
2. Appropriate DOE Orders in the 5400 and 5600 Series concerning Environmental Protection, Safety & Health Protection, and Defense Programs, respectively.
3. Individual safe operating procedures (by experimenter organization).
4. MISSION CYBER Safety Regulations.

All personnel engaged in handling, storing, assembling, or installing explosives, propellants, or electro-explosive devices (or observers of those operations) were required to wear safety glasses or other eye protection which had been approved by the DoD safety coordinator.

7.5 RESULTS AND CONCLUSIONS.

Telemetry recording measurements began at 0829 hours on 02 December 1987, and continued until 1000 hours on 08 December when all RAM stations were secured. At that time, all stations indicated background radiation levels except stations 18, 19, and 21 that indicated 4.2 mR/h, 11.8 mR/h, and 3.0 mR/h, respectively.

The initial radiation surveys began at 0943 hours on 02 December and were completed at 1425 hours. No radiation above background levels was detected at the U12p tunnel portal yard area or at the ventilation pad above the portal. Gas samples taken from the WP side of the GSP; the WP side of the main drift DPP; the portal side of the FDPP; the end of stemming in the U12p.02 bypass drift; in the U12p.02 main (LOS) drift; and inside the U12p.02 LOS pipe indicated no toxic or explosive gases and 21 percent oxygen. Analysis of samples from the LOS drift and LOS pipes showed low levels of radioactive gases.

Reentry into the tunnel began at 0820 hours on 03 December, when miners removed the GSD and proceeded to the bypass GSP where they established ventilation to the WP side of the GSP. Team No. 1, dressed in two suits of anticontamination clothing and SCBA proceeded to the U12p.02 FDPP and then to shield walls Nos. 1-4 where gas samples were taken before proceeding through the respective crawltube. The maximum exposure rate, 30 mR/h, was obtained from the WP side of shield wall No. 3, and a gas sample from the WP side of shield wall No. 4 showed 5 ppm CO, no explosive gases, and 21 percent oxygen. This work was completed by 1500 hours. Team No. 1 then surveyed the test chambers where a 70 mR/h reading

was obtained on the WP side of plug No. 2 at TC No. 1. Team No. 1 completed its work and was surveyed and released at 1645 hours.

On 04 December, reentry team No. 2, wearing anticontamination clothing and SCBAs, surveyed and swiped alcoves, the LPARL stubs area, and TC No. 1. Team No. 2 and the rescue team then returned to the portal area where they were surveyed and released at 1010 hours. All samples collected during reentry operations were sent to the laboratory for analysis.

Reentry mining began on 04 December when workers mined out the GSP, completing that task by 1800 hours on 05 December. Miners, assessment teams, and other support personnel wore anticontamination clothing and full-face respirators while working in the test chambers and alcoves. Probe hole drilling and reentry drift mining continued into June 1988. Probe hole surveys showed CO levels as high as 30,000 ppm; the level fluctuated with barometric pressure changes. The maximum radiation level detected from a probe hole survey was 1.2 R/h on 11 April 1988. Mining in the LOS drift, mapping and photography work, and TAPS recovery work was accomplished by July.

Personnel exposure data from self-reading pocket dosimeters were documented on Area Access Registers during individual entries to MISSION CYBER radex areas over a non-continuous time frame beginning 03 December 1987 and ending 13 July 1988 (see page 113 for a detailed explanation). Pocket dosimeters showed some indication of possible radiation exposure to DoD-affiliated personnel. TLDs worn by these reentry personnel indicated that possibly 12 individuals received some gamma exposure most likely from the MISSION CYBER test. The minimum detectable gamma exposure with the NTS TLD is 15 mR. Area Access Register data are summarized below.

Participants	Entries Logged	Maximum Exposure (mR)	Average Exposure (mR)
All	1272	682	3.6
DoD	113	100	2.2

SECTION 8

MISTY ECHO TEST

8.1 TEST SUMMARY.

MISTY ECHO was a DoD/LANL-sponsored weapons-effects test conducted at 1230 hours PST on 10 December 1988. The test had a yield of less than 150 kilotons, and the device was emplaced in a 36-foot radius hemispherical cavity at a vertical depth of 1,313 feet in the U12n.23 drift of the N tunnel complex (see Figure 8-1). The MISTY ECHO test was a phenomenology test to study ground shock and cratering. Measurements of SREMP-induced currents, radiation levels, magnetic and electric fields were made, and SREMP effects on antennae were also studied.

MISTY ECHO was satisfactorily contained, and no atmospheric release occurred from the test. However, there was a release of effluent during an experimental gas diagnostics program beginning on 26 January 1989, and continuing intermittently until 19 April 1989. The effluent was filtered before being released into the tunnel ventilation system.

8.2 PRETEST ACTIVITIES.

8.2.1 Responsibilities.

Safe conduct of all MISTY ECHO project activities in Area 12 was the responsibility of the DNA TGD, subject to controls and procedures established by the DOE TC. The DOE TC was responsible for safety of the public and onsite personnel during the test.

Project agencies were responsible for designing, preparing, and installing experiments, or delivering them to the installation contractor. After the test, these agencies were responsible for removing samples, analyzing instrument and sample data, and preparing project reports on experiment results.

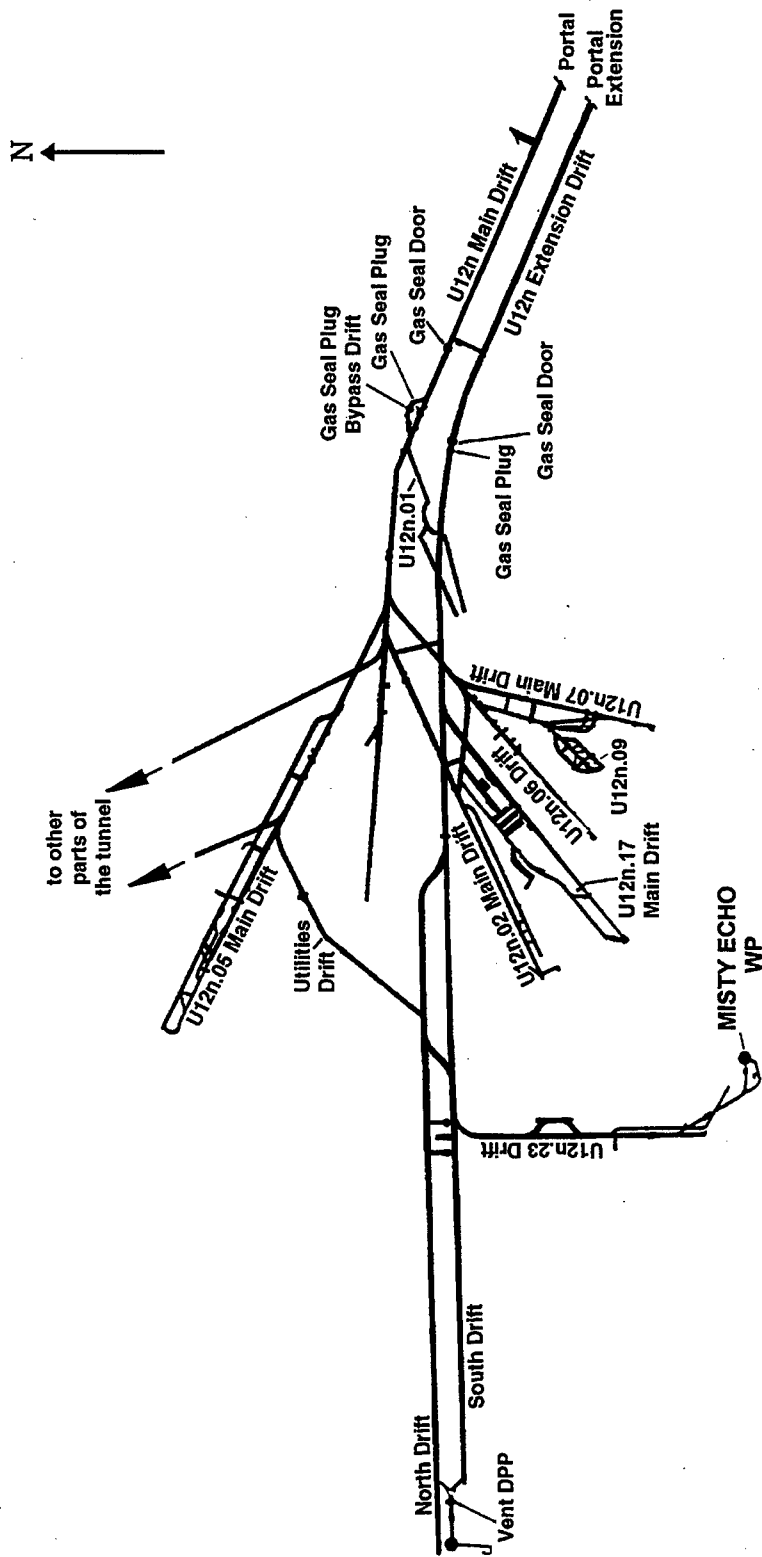

NOT TO SCALE

Figure 8-1. MISTY ECHO test - tunnel layout.

Device safety and security procedures in the WP area and the timing and firing control room were in accordance with DOE Order 5610.3, "Program to Prevent Accidental or Unauthorized Nuclear Explosive Detonations." The LANL TD had overall responsibilities for all operations involving the MISTY ECHO device as well as the timing control and the arming and firing of MISTY ECHO closures and experiments. The LANL TD was responsible to the DOE TC for radiological safety within the designated area of the WP from device emplacement until detonation. After detonation, the DOE TC relieved the LANL TD of these responsibilities and returned the responsibility for project activities back to the DNA TGD.

8.2.2 Planning and Preparations.

A. Tunnel Facilities Construction.

The U12n.23 drift was mined to the south of the extension drift and southwest of the U12n.02 and U12n.17 drifts. The drift was 14 feet wide by 14 feet high at the U12n south extension, decreasing to 14 feet by 10 feet and expanding to 14 feet by 12 feet as it entered the bottom of the test cavity. A 10 feet by 10 feet access drift, mined at a 17 percent upgrade, first headed southeast of the lower cavity drift and then east to intersect the cavity at the final floor level, (i.e., a total of 200 feet). The U12n.23 complex consisted of a lower access drift, a floor-level drift, a 59-foot high, 36-foot radius hemispherical cavity, and experiment and support alcoves (see Figure 8-2).

Construction activities began after planning meetings were held in May 1987. Initial mining of the 2,000-foot U12n.23 access drift was started in June and by mid-January 1988, mining had progressed to about 1,000 feet. The slower than anticipated progress was due to labor problems in autumn 1987, and then to selection of the exact location of the test cavity. Finally, problems with a fault were resolved, and a cavity location was selected in February. Cavity mining began in March and was completed in early July.

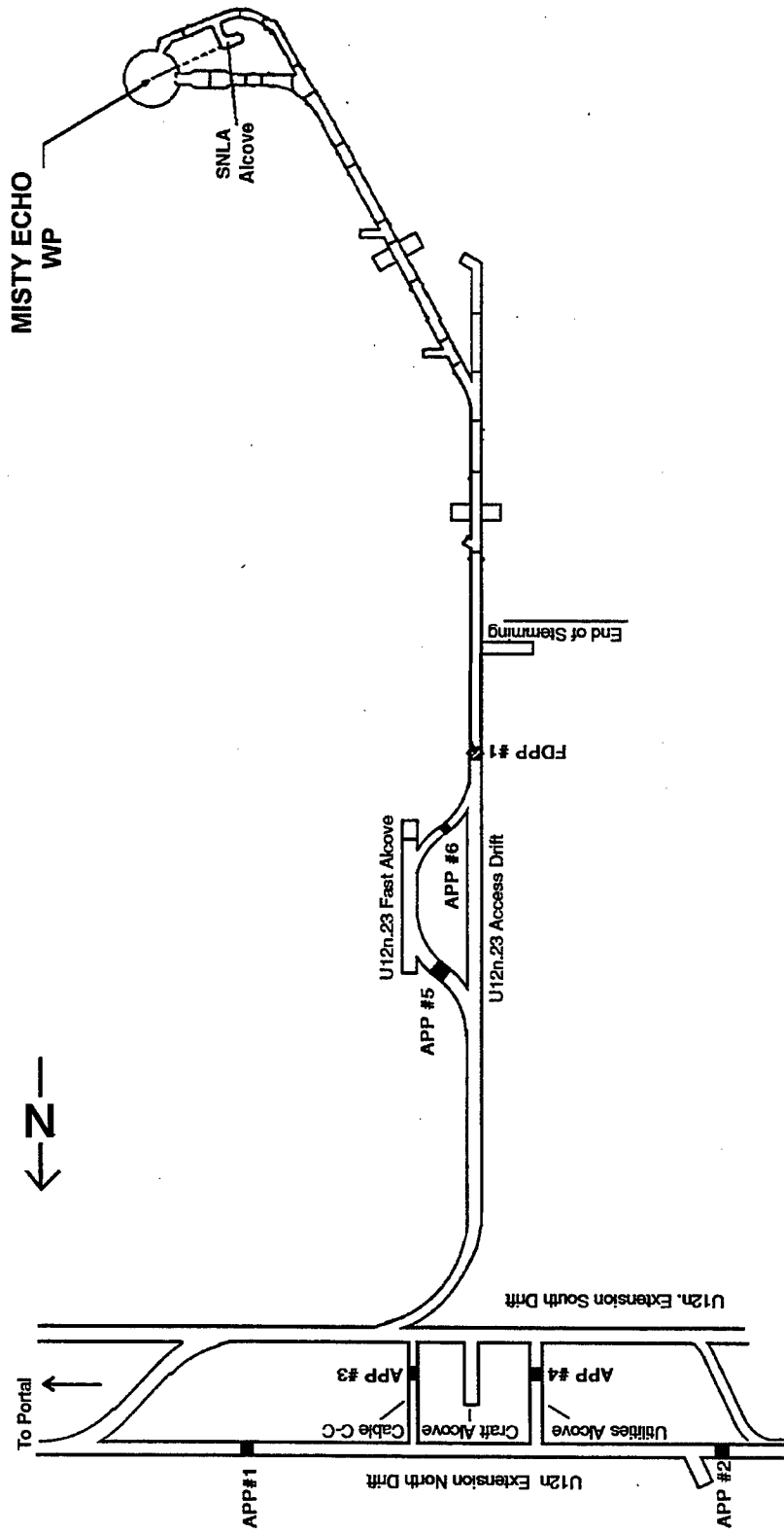

Figure 8-2. MISTY ECHO test - tunnel facilities layout.

Also in July cable installation in the U12n.23 drift was started, and support structures for experiments were installed. Figure 8-3 shows an overhead view of the cavity during construction. During the summer, construction continued as experiments and supporting equipment were installed. Cable installation was completed by late August. In early September the readiness period was moved from an earlier 23 November date to 15 December.

The SDRs began on 20 September, and the remainder of the experiments and support equipment were installed by mid-October. Work to fill the cavity floor with grout was completed in early November.

Remote gas sampling capabilities were incorporated during construction as well as capabilities for water, power, drain, and pressurization lines. Provisions were made to manually take gas samples from the WP side of the GSD, GSP, and main DPP during posttest reentry.

The stemming plan for the U12n.23 complex is shown in Figure 8-4. High-strength RMG was emplaced on the cavity floor and in the main access drift out to 75 feet; then RMG was placed out to 120 feet; followed by SLG to 140 feet; then alternating RMG and SLG out to 365 feet. From this point out to 490 feet HSG was emplaced; this was followed by SLG to 523 feet; and finally HSG was emplaced to the end of stemming at 801 feet. The upper access drift was stemmed with high-strength RMG out to 70 feet; then RMG to 140 feet; followed by SLG to 160 feet; and finally RMG to 180 feet. As a further safeguard against leaks, FDPPs and APPs were installed at various locations to protect equipment in the event of a containment failure. All penetrations into the stemmed areas of the drifts (e.g., cables and water lines) were gas blocked to prevent the seepage of radioactive gases outside the stemmed region of the drifts.



Figure 8-3. MISTY ECHO test - view of cavity.

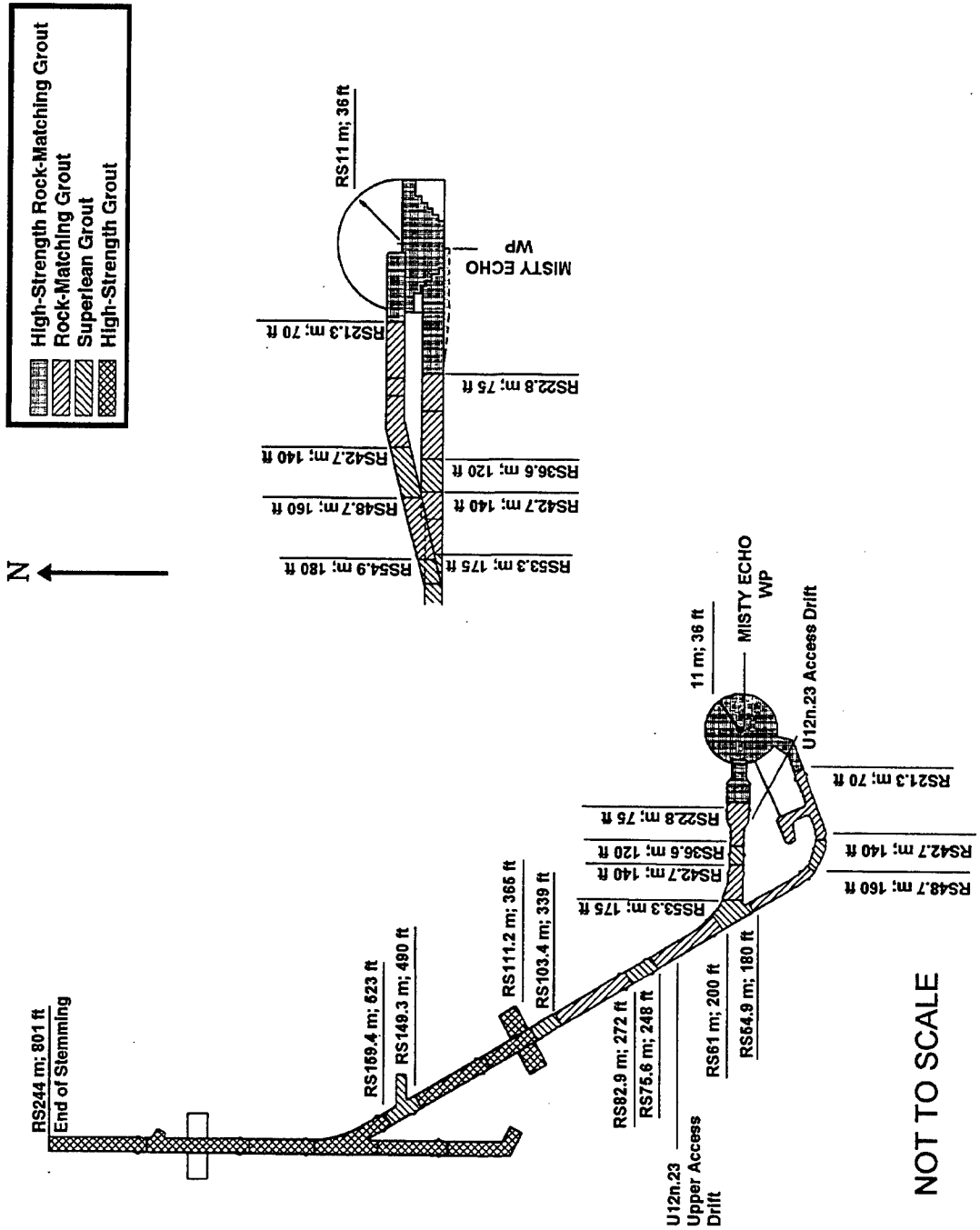

Figure 8-4. MISTY ECHO test - stemming plan.

Experiments and related hardware installations were completed by November 1988. The following organizations were among those that fielded experiments for the MISTY ECHO test: the Air Force Weapons Laboratory (AFWL) conducted particle displacement measurements in an environment associated with a nuclear test; Science Applications International Corporation (SAIC) conducted radiation and ground shock measurement experiments; S-CUBED conducted particle velocity waveform studies; JAYCOR conducted studies to obtain data on prompt SREMP environments; Stanford Research Institute, International (SRII) conducted field stress history and velocity history measurements; Science and Engineering Associates (SEA) conducted cavity pressure measurement experiments; Sandia National Laboratory, Albuquerque (SNLA) conducted experiments to study energy coupling, containment physics and containment diagnostics, tunnel and high frequency seismic measurements, and ground shock; Lawrence Livermore National Laboratory (LLNL) conducted gas chemistry and cavity wall blowoff experiments; and Los Alamos National Laboratory (LANL) conducted CORTEX measurements, device diagnostics, and tunnel, surface, and high frequency seismic experiments.

The SDRs began in September. An MFP dry run was held on 18 November that was declared successful, and preparations for test execution began. In early December, the device was emplaced, and final stemming activities were completed. A final dry run was conducted on 8 December.

B. Radiological Safety Support.

Procedures for radiation exposure and contamination control during this test were in accordance with NTS SOP 0501 and requirements of responsible DoD representatives. Radsafe provided monitoring and equipment support.

Prior to the test, detailed radiological safety reentry plans were prepared and issued to participating agencies.

Air sampling equipment was positioned in the test area. Radsafe monitors were briefed regarding surface reentry, manned stations, and security station requirements.

Radsafe monitoring teams and supervisory personnel were provided to perform initial radiation surveys, conduct aerial surveys by helicopter, and participate in reentry parties as needed. Radsafe personnel were also standing by at designated muster stations prior to detonation to perform surveys and provide emergency support as directed; to provide and issue anticontamination equipment and material, portable instruments, and dosimeters; to operate area control check stations; and to perform personnel, equipment, and vehicle decontamination, as required.

Available anticontamination materials and equipment included head covers, coveralls, cloth shoe covers, totes, full-face masks, supplied-air breathing apparatus, plastic suits, plastic bags, gloves, and masking tape.

C. Telemetry and Air Sampling Support.

In addition to the permanent RAM units, 41 temporary units provided surface and underground coverage for the MISTY ECHO test. Tables 8-1 and 8-2 list the locations of surface and underground RAMS, respectively. The locations of surface RAMS are shown in Figure 8-5, and those of underground RAM units are shown in Figure 8-6. All RAM units were installed a minimum of five days prior to scheduled device detonation.

EPA operated continuous monitoring stations at 34 locations in the offsite area. Thirty-one stations had high-volume air samplers with collectors for particulates and reactive gases, 18 had tritium samplers, 17 had noble gas samplers, and 27 had pressurized ion chamber gamma-rate detector/recorder systems in operation. Thirty EPA personnel were fielded for offsite surveillance activities.

Table 8-1. MISTY ECHO test RAMS unit locations 10 December 1988.

SURFACE

STATION NUMBER	LOCATION
From the U12n Portal:	
1	On the tunnel drain line
2	On the portal vent line
3	400 feet N 16° E azimuth
4	275 feet N 89° E azimuth
5	365 feet S 16° E azimuth
6	480 feet S 12° W azimuth
7	560 feet S 48° W azimuth
8	420 feet N 69° W azimuth
From the Mesa:	
9	On the mesa vent line
10	On the mesa vent line
11	On the mesa vent hole
From the U12n.23 SGZ:	
12	500 feet N 00° E azimuth
13	500 feet S 60° E azimuth
14	500 feet S 60° W azimuth
Geophones - from the U12n.23 SGZ:	
A	650 feet N 17° E azimuth
B	650 feet S 48° E azimuth
C	650 feet S 77° W azimuth

Table 8-2. MISTY ECHO test RAMS unit locations 10 December 1988.

UNDERGROUND

STATION NUMBER	LOCATION
15	950 feet into the U12n.23 main drift
12ER ²³	950 feet into the U12n.23 main drift
17	830 feet into the U12n.23 main drift
18	In the U12n.23 fast alcove
19	300 feet into the U12n.23 main drift
20	At the U12n.23 extension vent drift
21	7,000 feet into the U12n ext. south drift
22	5,500 feet into the U12n ext. south drift
23	7,000 feet into the U12n ext. north drift
24	6,000 feet into the U12n ext. north drift
25	5,600 feet into the U12n ext. north drift
26	4,800 feet into the U12n ext. north drift
27ER ²³	4,800 feet into the U12n ext. north drift
28	4,000 feet into the U12n extension drift
29	1,000 feet into the U12n ext. utilities drift
30ER ²³	1,000 feet into the U12n ext. utilities drift

²³ ER - Extended Range (instrument capable of reading 100 mR/h to 100,000 R/h).

Table 8-2. MISTY ECHO test RAMS unit locations 10 December 1988
(Continued).

UNDERGROUND

STATION NUMBER	LOCATION
31	200 feet into the U12n ext. utilities drift
32	600 feet into the U12n.05 main drift
33	2,900 feet into the U12n extension drift
34	2,300 feet into the U12n extension drift
35	1,200 feet into the U12n extension drift
36	200 feet into the U12n extension drift
37	2,600 feet into the U12n main drift
38	235 feet into the U12n gas seal bypass drift
39	1,700 feet into the U12n main drift
40	1,200 feet into the U12n main drift
41	200 feet into the U12n main drift

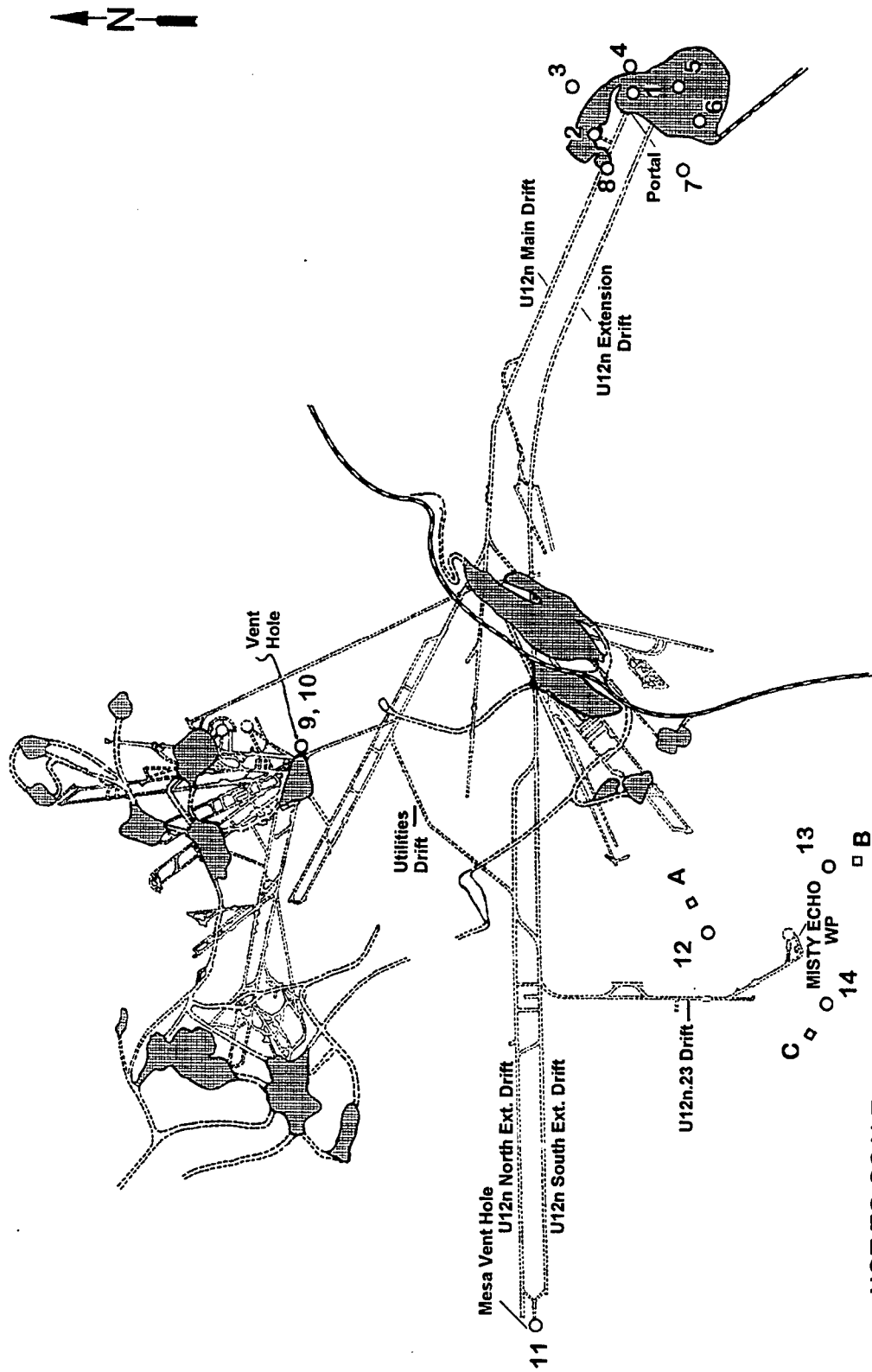
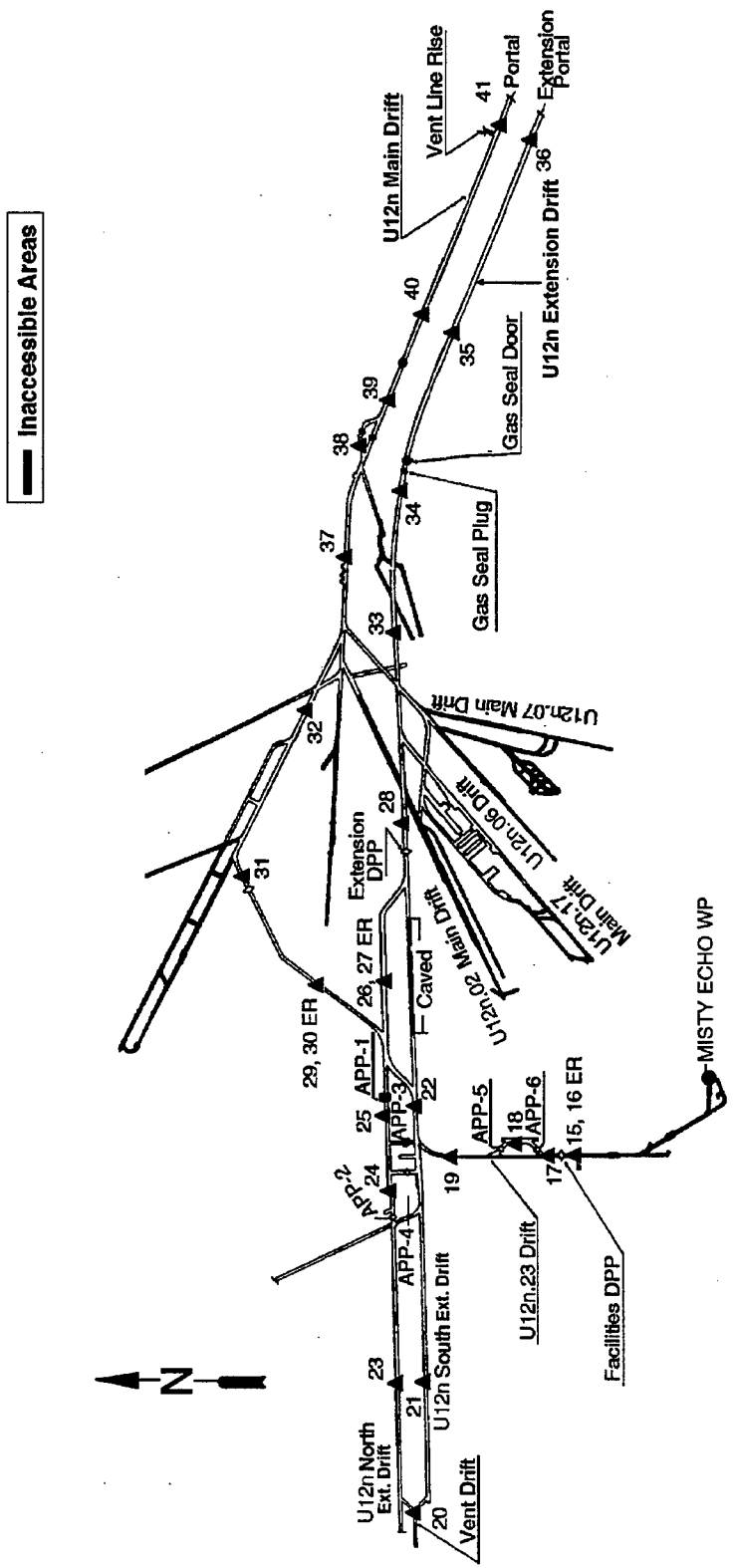

Figure 8-5. MISTY ECHO test - surface RAMS.



NOT TO SCALE

Figure 8-6. MISTY ECHO test - underground RAMS.

D. Security Coverage.

Device security procedures in the WP area and the timing and firing control room were in accordance with DOE Order 5610.3, "Program to Prevent Accidental or Unauthorized Nuclear Explosive Detonations." Beginning on D-1, all personnel entering or exiting the controlled area were required to stop at muster or control stations for issue of stay-in badges. After control was established, all through traffic was diverted around the controlled area by use of screening stations. In accordance with the "Test Controller's Operations and Security Plan," contractors and agencies were to have all personnel not connected with this test out of the closed area before the final security sweep began.

E. Air Support.

Three BO-105 helicopters and crews were provided by EG&G for cloud tracking and the Test Controller's use, if needed. In addition, the USAF provided a WC-130 and/or a WC-135 aircraft and crew on standby status for cloud tracking. EG&G also provided a Turbo Beech aircraft for taking wind soundings and for cloud tracking duties and a King Air for cloud sampling, if necessary.

8.3 TEST-DAY ACTIVITIES.

8.3.1 Pretest Activities.

As discussed at a weather briefing held on 8 December, weather predictions for the next day were not favorable. However, final preparations for detonation were initiated. On 8 December, by approximately 2400 hours, sweeps of the forward areas were completed and all persons except the arming party, the tunnel button-up party, and the security guards were out of the tunnel and clear of the muster area. Permission was granted to arm the device at

0430 hours. Final button-up operations were then completed, and the button-up party left the tunnel. Poor weather conditions placed the test on hold status.

A final readiness briefing was held on the morning of 10 December at 0700 hours, and because there appeared to be an opportunity for a favorable weather window about midday, preparations for test execution continued. The five-minute countdown was initiated at 1225 hours and proceeded uninterrupted until zero time. The MISTY ECHO device was detonated at 1230 hours PST on 10 December 1988.

8.3.2 Test Area Monitoring.

Telemetry recording measurements began at 1230 hours on 10 December 1988, at which time all RAM units (i.e., stations) were operational and remained so throughout the readout period. At H+2 seconds all RAMS read background levels and remained at background levels throughout the readout period. All RAM stations were secured at 1230 hours on 13 December.

8.3.3 Initial Surface Radiation Surveys.

An initial surface reentry team departed the TC's barricade at Gate 300 at 1324 hours on 10 December. A mobile base station was setup to provide for area control and anticontamination clothing and equipment supply. All radiation readings were relayed as soon as they were obtained via Net 3 radio. By 1401 hours, survey of the U12n portal yard area was completed. All radiation readings were at background levels (0.04 mR/h).

Survey teams stood by the U12n portal during gas sampling of the tunnel atmosphere. No toxic or explosive gases were detected, and the oxygen level was 21 percent as measured on the WP side of the GSP; the portal side of the utilities DPP (UDPP); the WP side of the UDPP; at the slow alcove; at the FDPP in the U12n.23 drift; and at the end of stemming. Gas sampling was completed by 1610 hours, and all personnel had departed from the portal area by 1615 hours.

8.4 POSTTEST ACTIVITIES.

8.4.1 Tunnel Reentry Activities.

The initial reentry team entered the U12n tunnel portal at 0825 hours on 11 December. Gas samples of the tunnel atmosphere taken just prior to work team reentry showed background radiation levels, no toxic or explosive gases, and 21 percent oxygen to the WP side of the GSD. The work team proceeded to open the GSD and install railroad tracks. No anticontamination clothing was required for this reentry. The work team returned to the portal at 1014 hours.

The initial reentry team No. 1 and the rescue team, dressed in anticontamination clothing, left the portal area at 1033 hours on 11 December and proceeded to the GSP. At that point, team No.1 put on their SCBA. The team proceeded into the U12n.08 drift to the main ventilation hole where they opened the hatch to establish ventilation to the mesa. At 1222 hours the ventilation fan was started as well as air samplers at the mesa ventilation pad. The samples showed no toxic or explosive gases, and 21 percent oxygen. No radiation above background levels was detected. This reentry team then returned to the utilities DPP where they reestablished ventilation at that point.

At 1326 hours, this same team, with the rescue team standing by at the utilities DPP (UDPP), proceeded to the U12n north extension drift and on to APP No. 1 where they took a gas sample from the WP side of APP No. 1. Again no toxic or explosive gases were detected, and the oxygen level was 21 percent. No radiation above background levels was detected.

At 1500 hours that same day, reentry team No. 2 and the rescue team proceeded to the UDPP where team No. 2 donned SCBAs. This team then moved on into the U12n south extension drift to the junction of the U12n.23 drift where some structural damage was noted. The team then went to the Fast Alcove, the FDPP and the slow alcove, taking gas samples at each location and opening

turntubes to ventilate the areas. Surveys showed that radiation readings were at background levels. Samples from the WP side of the FDPP indicated the oxygen level varied from 17-21 percent, 140 ppm CO, and 20 percent of the LEL. Very little structural damage was noted, and the instrument racks in the alcoves were in good condition.

Reentry team No. 2 returned to the UDPP where the rescue team was standing by. Both teams departed for the portal at 1717 hours where they were surveyed and released at 1740 hours. All air and water samples along with swipes taken were sent to the laboratory for analysis.

At 1825 hours, scientific data recovery teams accompanied by health protection monitors entered the tunnel to recover data. No anti-contamination clothing was required during these recoveries. Recovery personnel were surveyed and released at the portal by 2000 hours.

8.4.2 Posttest Mining and Drilling.

Miners began mining out the U12n extension drift GSP and the main drift GSP on 11 December at 2200 hours and completed that task by 0130 hours on 13 December. During December workers mined out the UDPP; installed railroad track; removed APP No. 1 in the north extension drift; removed APP No. 5 and the FDPP in the U12n.23 drift; performed general cleanup in the alcoves and drifts; removed materials and equipment from the tunnel; removed instrument racks from the fast alcove; established ventilation in the U12n.23 drift; and removed cables from the U12n.23 access drift at the end of stemming. No anticontamination clothing was required for this work. However, miners wore full-face masks when cutting the FDPP bulkhead. Radiation readings were at background levels, but at times, CO and NO₂ levels were 50 ppm, and oxygen levels were 19 to 21 percent.

By January 1989, miners began to mine a reentry drift (i.e., the U12n.23 reentry drift) from the left rib of the U12n.23 access

drift at 935 feet into the drift. A reentry drill hole, RE#1, was started from the fast alcove on 17 January. Drilling, core sampling, and gas sampling continued simultaneously with reentry drift mining. When the RE#1 drill hole reached 805 feet, workers put on raingear and totes because of water coming from the drill hole. By the end of January, RE#1 drill hole was drilled to 935.2 feet, and the hole was capped. Typical readings from drill hole sampling indicated background radiation levels, no toxic or explosive gases, and 21 percent oxygen.

By early February the reentry drift was mined to 375 feet, probe hole drilling from the face of the reentry drift was started, and crosscut No.1 was mined to 35 feet. Probe hole sampling from the reentry drift showed normal atmospheric conditions and background radiation levels. Reentry drift mining, probe hole sampling, and hydrofracing studies continued into September. Numerous probe holes were drilled, checking for "hot spots," as the U12n.23 reentry drift was extended. Readings varied from background radiation levels to 3.3 R/h from a probe hole drilled from 861 feet into the reentry drift. No toxic or explosive gases were detected, and the oxygen level was 21 percent. Miners wore raingear and anticontamination clothing during probe hole drilling operations. From September to December 1989 two crosscuts were mined from the right rib of the reentry drift. Mining activities, including photography and survey work continued until the end of April 1990.

8.4.3 Industrial Safety.

Checks for the presence of toxic gases and surveys to measure radiation and explosive gas levels were made on each shift. The results were then recorded in the monitors' logbook.

Appropriate safety measures were taken to protect mining personnel and prevent unsafe conditions. Industrial safety codes for mining, tunneling, and drilling were established by REECo and emphasized during all operations. A written standard operating procedure was required for each operation involving explosives,

toxic materials, radioactive material, or any other operation with the potential for personal injury. Each individual involved in such an operation was required to know the contents of the applicable procedures.

The portal construction area and the tunnel were mandatory hard-hat and foot-protection areas (safety shoes, boots, DOE-issued miner's boots, or toe guards). All personnel on initial tunnel reentry teams were certified in the use of the Draeger self-contained breathing apparatus. Standard safety rules and regulations, as spelled out in the "U.S. Bureau of Mines Manual," were observed.

All explosives, electro-explosive components, solid propellants, toxic materials, and radioactive materials were handled, stored, and transported in accordance with applicable sections of the following documents:

1. Army Material Command Regulations (AMCR 385-100).
2. Appropriate DOE Orders in the 5400 and 5600 Series concerning Environmental Protection, Safety & Health Protection, and Defense Programs, respectively.
3. Individual safe operating procedures (by experimenter organization).
4. MISTY ECHO Safety Regulations.

All personnel engaged in handling, storing, assembling, or installing explosives, propellants, or electro-explosive devices (or observers of those operations) were required to wear safety glasses or other eye protection which had been approved by the DoD safety coordinator.

8.5 RESULTS AND CONCLUSIONS.

Telemetry recording measurements began at 1230 hours on 10 December 1988, with all RAM stations operational and all reading

background radiation levels throughout the entire readout period. All RAM stations were secured at 1230 hours on 13 December.

The initial radiation surveys began at 1324 hours on 10 December and were completed at 1401 hours. No radiation above background levels was detected at the U12n tunnel portal yard area. Gas samples taken from the WP side of the GSP; the portal side of the utilities DPP; the WP side of the UDPP; at the slow alcove; at the FDPP in the U12n.23 drift; and at the end of stemming indicated no toxic or explosive gases and 21 percent oxygen.

Reentry into the tunnel began at 0825 hours on 11 December when reentry team No. 1 entered the tunnel and proceeded to the main ventilation hole where they established ventilation to the mesa at 1222 hours. This team proceeded to the U12n north extension drift where personnel took gas samples from the WP side of APP No. 1. Readings showed no toxic or explosive gases, and the oxygen level was 21 percent. No radiation above background levels was detected. That same day at 1500 hours, reentry team No. 2, wearing SCBAs, proceeded to the U12n.23 drift noting some structural damage and taking gas samples from the fast alcove, the FDPP, and the slow alcove. At each location they opened turn-tubes to ventilate the area. Sample data showed that on the WP side of the FDPP, readings were 17-21 percent oxygen, 140 ppm CO, and 20 percent of the LEL. Very little structural damage was noted, and the instrument racks in the alcoves were in good condition. By 1740 hours both the rescue and reentry No. 2 teams were surveyed and released from the portal area. Scientific assessment and data recovery teams also completed their work and were surveyed and released from the portal area by 2000 hours that same day.

Reentry mining began on 11 December when workers mined out the U12n extension GSP and the main drift GSP, completing that task by 0130 hours on 13 December. Miners mined a reentry drift from the left rib of the U12n.23 main access drift wearing full-face masks, raingear, and anticontamination clothing when conditions warranted it. Numerous probe holes were drilled as the reentry drift was

extended. Typical readings from probe hole sampling indicated background radiation levels, no toxic or explosive gases, and 21 percent oxygen. However, some "hot spots" showed increased radiation levels as high as 3.3 R/h with CO and NO₂ levels as high as 50 ppm. Equipment removal, drift rehabilitation, probe hole drilling, gas sampling, and mining, along with hydrofracing and photography work, were ongoing from December 1988 through the end of April 1990.

Personnel exposure data from self-reading pocket dosimeters were documented on Area Access Registers during individual entries to MISTY ECHO radex areas over a non-continuous time frame beginning 10 December 1988 and ending 30 April 1990 (see page 113 for a detailed explanation). Pocket dosimeters showed no indication of possible radiation exposure to DoD-affiliated personnel. TLDs worn by these reentry personnel indicated that no individuals received any reportable gamma exposure from the MISTY ECHO test. The minimum detectable gamma exposure with the NTS TLD is 15 mR. Area Access Register data are summarized below.

Participants	Entries Logged	Maximum Exposure (mR)	Average Exposure (mR)
All	670	18	0.5
DoD	15	0	0

SECTION 9

DISKO ELM TEST

9.1 TEST SUMMARY.

DISKO ELM was a DoD/LLNL-sponsored weapons-effects test conducted at 0800 hours PDT on 14 September 1989. The test had a yield of less than 20 kilotons, and the device was emplaced at a vertical depth of 857 feet in the U12p.03 drift of the P tunnel complex (see Figure 9-1). The purpose of the DISKO ELM test was to evaluate the survivability of military hardware in a nuclear-detonation environment, and provide an appropriate radiation environment for experiments relating to the Strategic Defense Initiative (SDI).

DISKO ELM was satisfactorily contained, and no atmospheric release occurred from the test. However, several controlled²⁴ effluent releases occurred when various sections of the LOS pipe were purged through the tunnel ventilation system. Several controlled releases also occurred as the result of an experimental gas diagnostics program.

9.2 PRETEST ACTIVITIES.

9.2.1 Responsibilities.

Safe conduct of all DISKO ELM project activities in Area 12 was the responsibility of the DNA TGD, subject to controls and procedures established by the DOE TC. The DOE TC was responsible for safety of the public and onsite personnel during the test.

²⁴ The radioactive gas was passed through a filtering system where the particulates were removed before the gas was released through the tunnel ventilation system. For this test, the term "controlled" also refers to the unfiltered releases that occurred during the experimental gas diagnostics program.

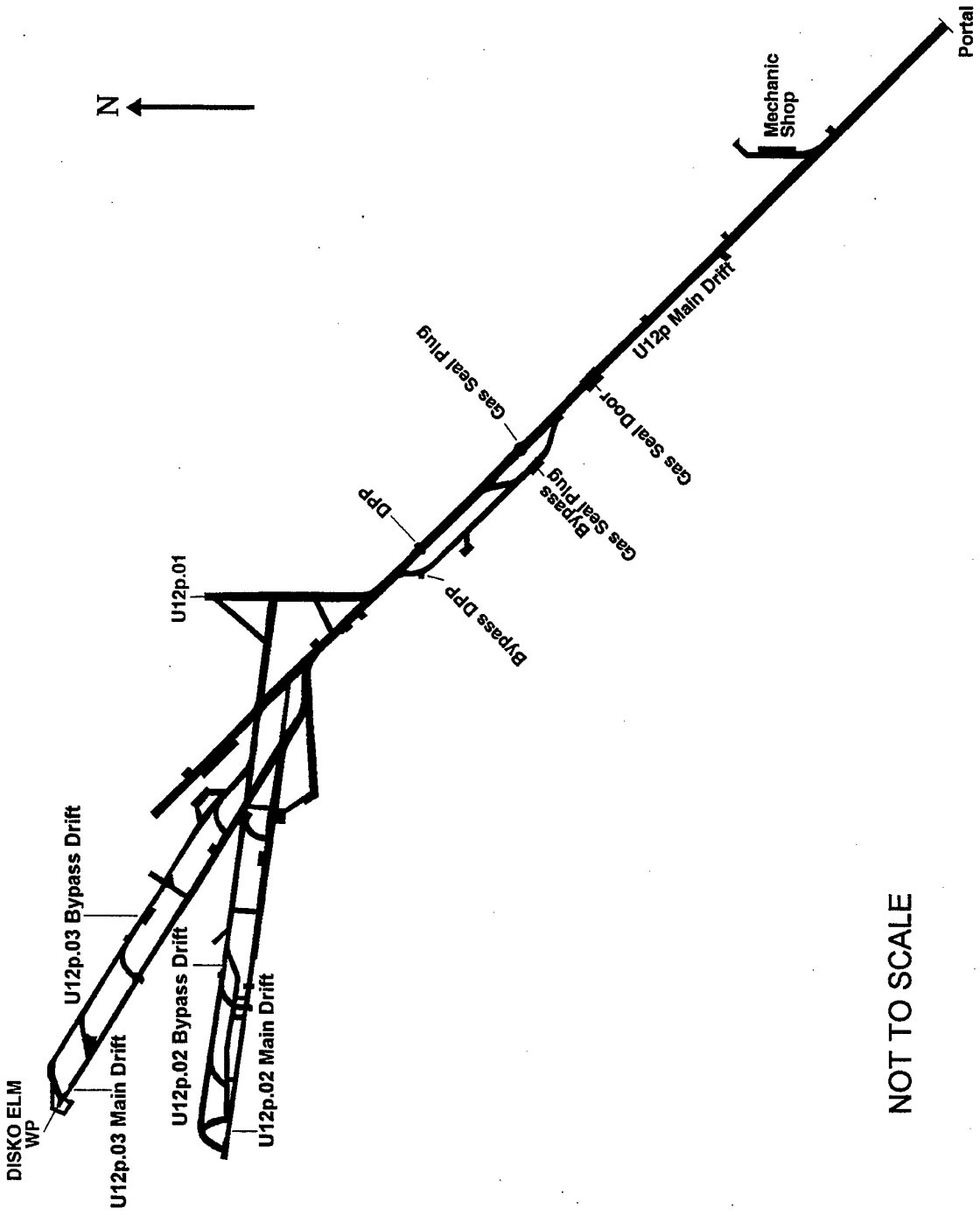

NOT TO SCALE

Figure 9-1. DISKO ELM test - tunnel layout.

Project agencies were responsible for designing, preparing, and installing experiments, or delivering them to the installation contractor. After the test, these agencies were responsible for removing samples, analyzing instrument and sample data, and preparing project reports on experiment results.

Device safety and security procedures in the WP area and the timing and firing control room were in accordance with DOE Order 5610.3, "Program to Prevent Accidental or Unauthorized Nuclear Explosive Detonations." The LLNL TD had overall responsibilities for all operations involving the DISKO ELM device as well as the timing control and the arming and firing of DISKO ELM closures and experiments. The LLNL TD was responsible to the DOE TC for radiological safety within the designated area of the WP from device emplacement until detonation. After detonation, the DOE TC relieved the LLNL TD of these responsibilities and returned the responsibility for project activities back to the DNA TGD.

9.2.2 Planning and Preparations.

A. Tunnel Facilities Construction.

The U12p.03 drift was mined south of the U12p main drift and between the main drift and the MISSION CYBER drifts. The testbed consisted of an 875-foot steel tapered LOS pipe diverging from an inside diameter (ID) at the WP of several inches to an ID of approximately 14 feet at the back of TC No. 1. The U12p.03 complex consisted of an LOS drift, a bypass drift, two auxiliary closures, the TAPS, a DBS, one zero room, two test chambers, scatterers, experiment and support alcoves, a vacuum pumping alcove, and a diagnostic/experiment stub system (see Figure 9-2). The MISSION CYBER recording alcoves were reused for this test.

Construction activities began after proposal review meetings were held in May and July 1987. Mining of the U12p.03 main and bypass drifts was started in January 1988 and was completed in June. By the end of August, components from

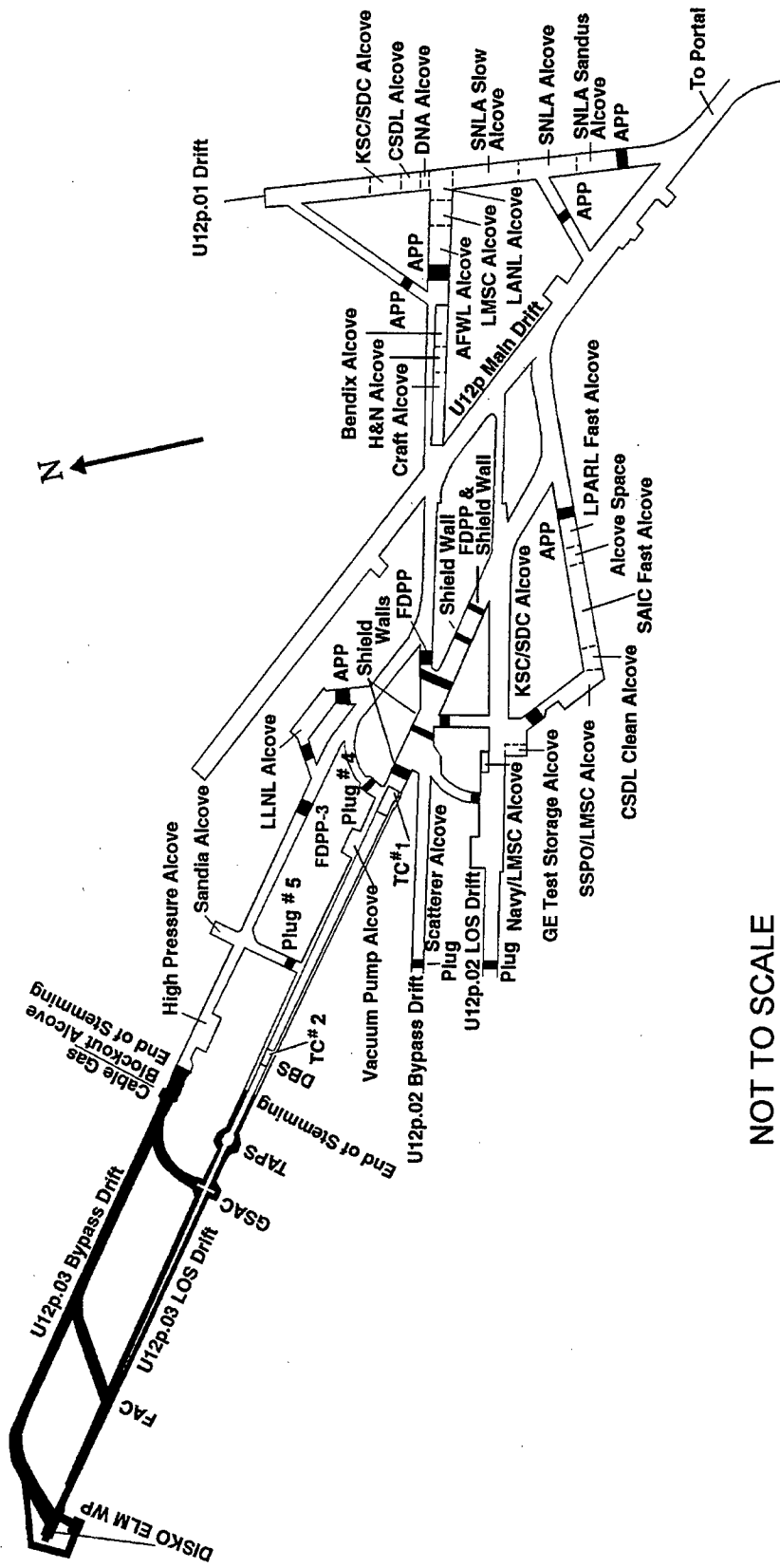

Figure 9-2. DISKO ELM test - tunnel facilities layout.

the MISSION CYBER LOS pipe were refurbished and installed for the DISKO ELM test. LOS pipe installation began in September and in October, changes in experiment proposals were reviewed that required increasing the size of the test chamber and the air scatterer. This redesign and refabrication of the bulkheads required the experiment prefit schedule to be moved from February 1989 to May. Cable installation progressed simultaneously with refabrication work. LOS pipe installation to the DNA/scatterer interfaces on the stub pipes was completed by mid-May, and experiment installation was completed by the end of June. The first SDR was conducted on 26 June, and the first mandatory SDR (MSDR) was conducted on 13 July.

Remote gas sampling capabilities were incorporated during construction as well as capabilities for water, power, drain, and pressurization lines. Provisions were made to manually take gas samples from the WP side of the GSD, GSP, and the main and bypass DPPs during posttest reentry.

The stemming plan for the U12p.03 complex is shown in Figure 9-3. The stemming operations were completed in early September 1989. Desert fines (sandbags) were emplaced behind the zero room. RMG was emplaced between the end of the zero room to 52 feet; followed by a different type of RMG to 89 feet; then SLG to 112 feet; followed by RMG to 131 feet; and then SLG to the FAC at 152 feet. The region beyond the FAC was stemmed with high-strength concrete to the end of stemming at 510 feet. The bypass drift had RMG emplaced to 116 feet; followed by SLG to 201 feet; and then HSG to the end of stemming at 510 feet. All penetrations into the stemmed areas of the drifts (e.g., cables and water lines) were gas blocked to prevent the seepage of radioactive gases outside the stemmed region of the drifts.

Experiments and related hardware installations began in June 1989 and were completed in early September. The

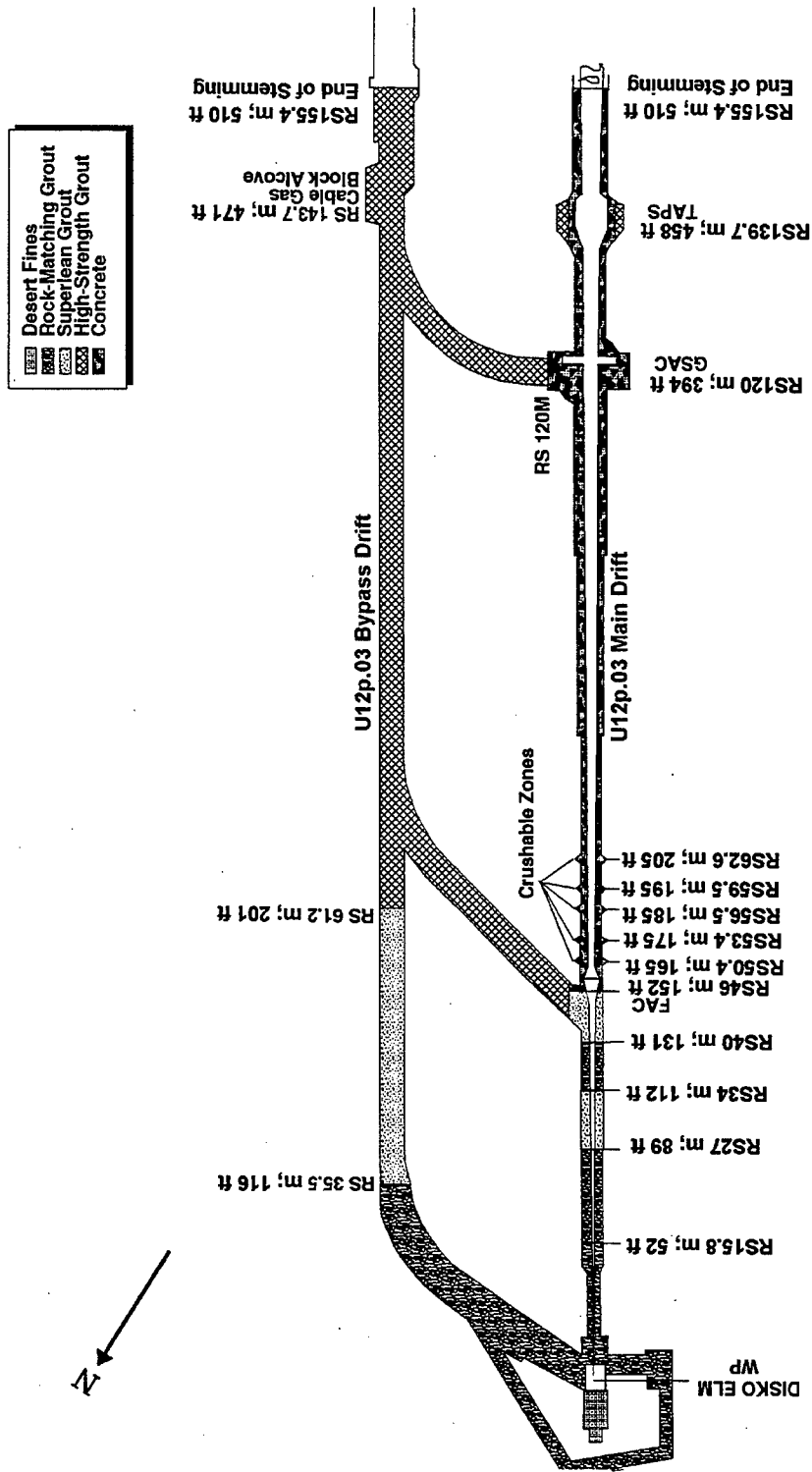

NOT TO SCALE

Figure 9-3. DISKO ELM test - stemming plan.

following organizations were among those that fielded experiments for the DISKO ELM test: the U.S. Air Force (USAF) conducted thin film magnetic memory studies as a replacement for plated wire memory; Science Applications International Corporation (SAIC) fielded a sensor seeker telescope experiment in support of the SDI ballistic missile defense system; JAYCOR conducted studies to investigate the operation of electronics and sensors through a nuclear exposure; Kaman Sciences Corporation (KSC) conducted tests on the thermostructural response of mirrors in support of the SDI program and radiation output measurements; Harry Diamond Laboratory (HDL) conducted studies to investigate damage to mirror and window materials upon exposure to radiation; Lockheed Missile and Space Corporation (LMSC) conducted missile body electronic experiments; Lockheed Palo Alto Research Laboratory (LPARL) conducted radiation output measurements; Lawrence Livermore National Laboratory (LLNL) conducted device diagnostic studies; and Sandia National Laboratory, Albuquerque (SNLA) conducted device radiation output studies and containment diagnostic experiments.

The SDRs began in June. An MFP dry run was held on 23 August and declared successful. The final stemming and grouting was completed on 7 September. The final dry run on 11 September was unsuccessful because of technical problems at the Portal Recording Station and a problem with an experiment. These problems were rectified, and the final dry run was rescheduled for 13 September. This was successfully completed, and plans continued for test execution.

B. Radiological Safety Support.

Procedures for radiation exposure and contamination control during this test were in accordance with NTS SOP 5402 and requirements of responsible DoD representatives. Radsafe provided monitoring and equipment support.

Prior to the test, detailed radiological safety reentry plans were prepared and issued to participating agencies. Air sampling equipment was positioned in the test area. Radsafe monitors were briefed regarding surface reentry, manned stations, and security station requirements.

Radsafe monitoring teams and supervisory personnel were provided to perform initial radiation surveys, conduct aerial surveys by helicopter, and participate in reentry parties as needed. Radsafe personnel were also standing by at designated muster stations prior to detonation to perform surveys and provide emergency support as directed; to provide and issue anticontamination equipment and material, portable instruments, and dosimeters; to operate area control check stations; and to perform personnel, equipment, and vehicle decontamination, as required.

Available anticontamination materials and equipment included head covers, coveralls, cloth shoe covers, totes, full-face masks, supplied-air breathing apparatus, plastic suits, plastic bags, gloves, and masking tape.

C. Telemetry and Air Sampling Support.

In addition to the permanent RAMS units, 46 temporary units provided surface and underground coverage for the DISKO ELM test. Tables 9-1 and 9-2 list the locations of surface and underground RAMS, respectively. The locations of the surface RAMS are shown in Figure 9-4, and those of underground RAM units are shown in Figures 9-5 and 9-6. All RAM units were installed a minimum of five days prior to scheduled device detonation.

EPA operated continuous monitoring stations at 34 locations in the offsite area. Thirty-one stations had high-volume air samplers with collectors for particulates and reactive gases, 19 had tritium samplers, 18 had noble gas samplers, and 28 had pressurized ion chamber gamma-rate detector/

Table 9-1. DISKO ELM test RAMS unit locations 14 September 1989.

SURFACE

STATION NUMBER	LOCATION
From the U12p Portal:	
1	At the portal
2	46 feet N 38° W on the vent line
3	310 feet N 42° E azimuth
4	328 feet N 84° E azimuth
5	265 feet S 39° E azimuth
6	238 feet S 02° W azimuth
7	309 feet S 63° W azimuth
8	296 feet N 72° W azimuth
9	300 feet N 27° W azimuth
10	236 feet S 05° E on the tunnel drain line
11	1,017 feet N 74° E azimuth
12	1,950 feet S 50° E azimuth
From U12p.03 SGZ:	
13	400 feet N 00° E azimuth
14	400 feet S 60° E azimuth
15	400 feet S 60° W azimuth
Geophones - from U12p.03 SGZ:	
A	650 feet N 37° E azimuth
B	650 feet S 157° E azimuth
C	650 feet N 277° W azimuth

Table 9-2. DISKO ELM test RAMS unit locations 14 September 1989.

UNDERGROUND

STATION NUMBER	LOCATION
16	600 feet into the U12p.03 LOS drift
17	450 feet into the U12p.03 LOS drift
18	275 feet into the U12p.03 LOS drift
19	230 feet into the U12p.03 LOS drift
20	160 feet into the U12p.03 LOS drift
21	120 feet into the U12p.03 LOS drift
22	85 feet into the U12p.03 LOS drift
23	60 feet into the U12p.03 LOS drift
24	500 feet into the U12p.03 bypass drift
25ER ²⁵	500 feet into the U12p.03 bypass drift
26	320 feet into the U12p.03 bypass drift
27	210 feet into the U12p.03 bypass drift
28	In the U12p.03 LLNL alcove
29	650 feet into the U12p.02 bypass drift
30	550 feet into the U12p.02 bypass drift
31	90 feet into the U12p.02 bypass drift
32	290 feet into the U12p.02 LOS drift

²⁵ ER - Extended Range (instrument capable of reading 100 mR/h to 100,000 R/h).

Table 9-2. DISKO ELM test RAMS unit locations 14 September 1989
(Continued).

UNDERGROUND

STATION NUMBER	LOCATION
33	In the U12p.02 alcove 2-11
34	In the U12p.02 fast alcove
35	400 feet into the U12p.01 drift
36	150 feet into the U12p.01 drift
37	2,880 feet into the U12p main drift
38	2,350 feet into the U12p main drift
39	2,180 feet into the U12p main drift
40ER ²⁶	2,180 feet into the U12p main drift
41	1,870 feet into the U12p main drift
42	400 feet into the U12p main drift bypass
43	1,450 feet into the U12p main drift
44	1,300 feet into the U12p main drift
45	800 feet into the U12p main drift
46	200 feet into the U12p main drift

²⁶ ER - Extended Range (instrument capable of reading 100 mR/h to 100,000 R/h).

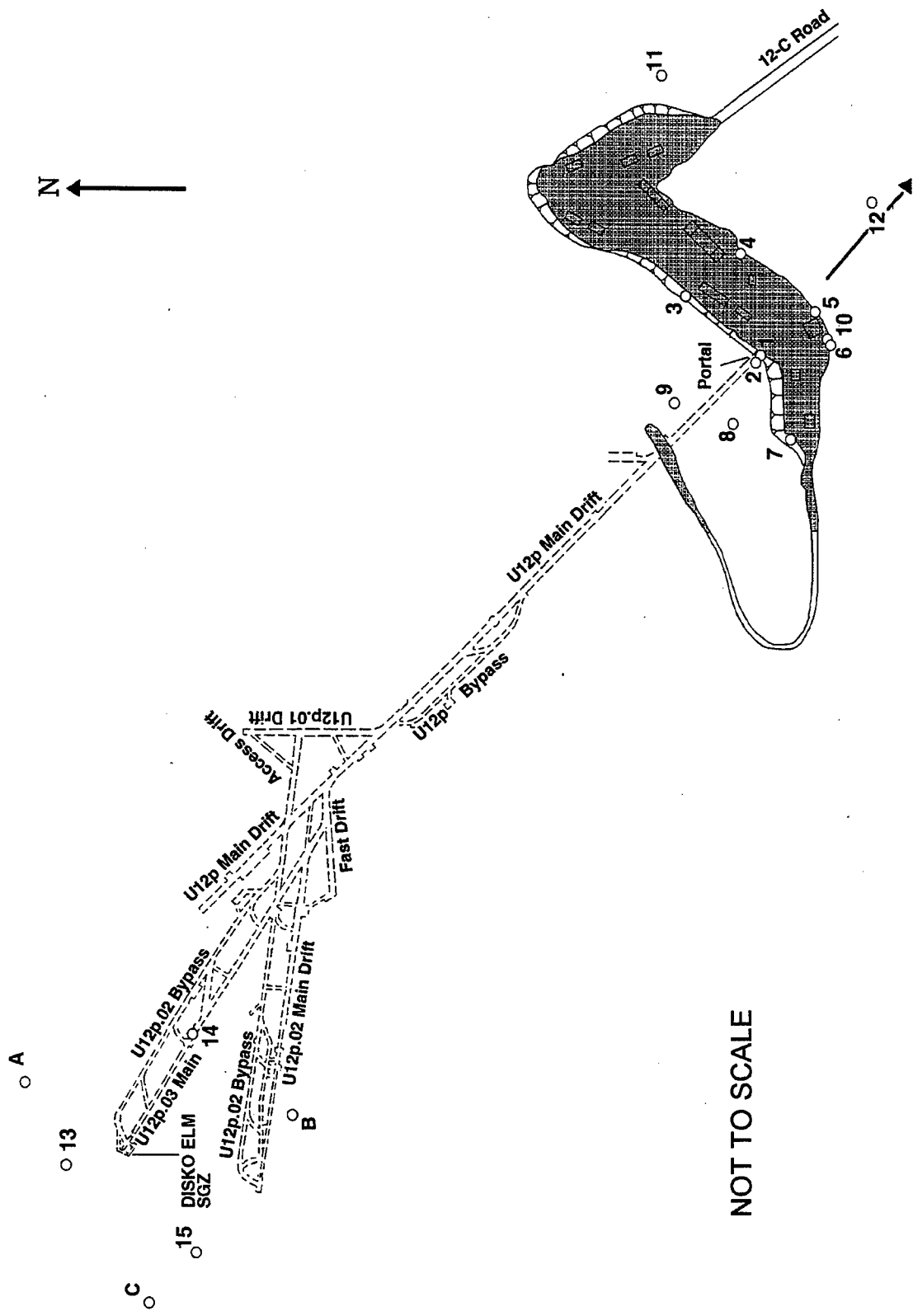
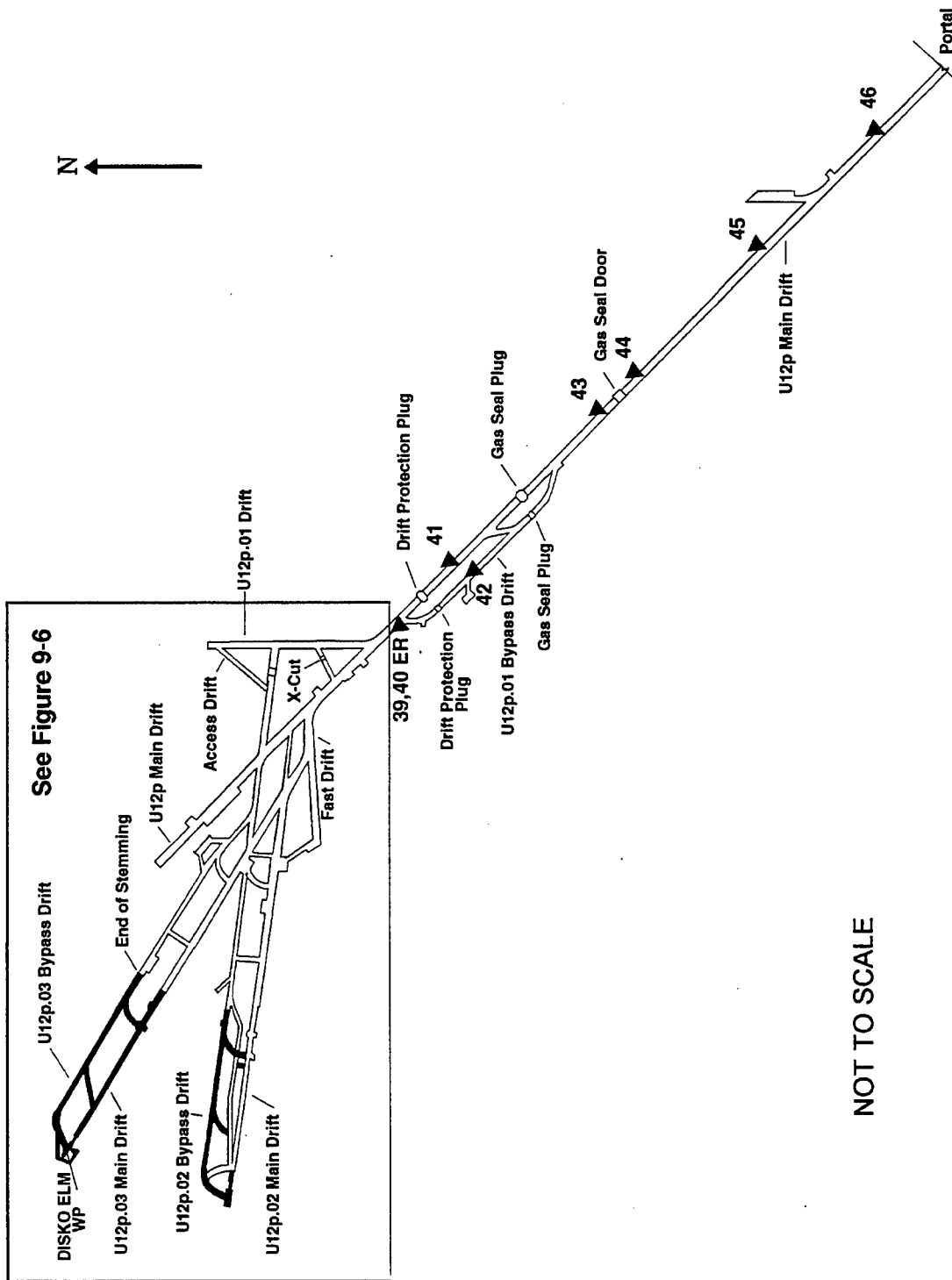
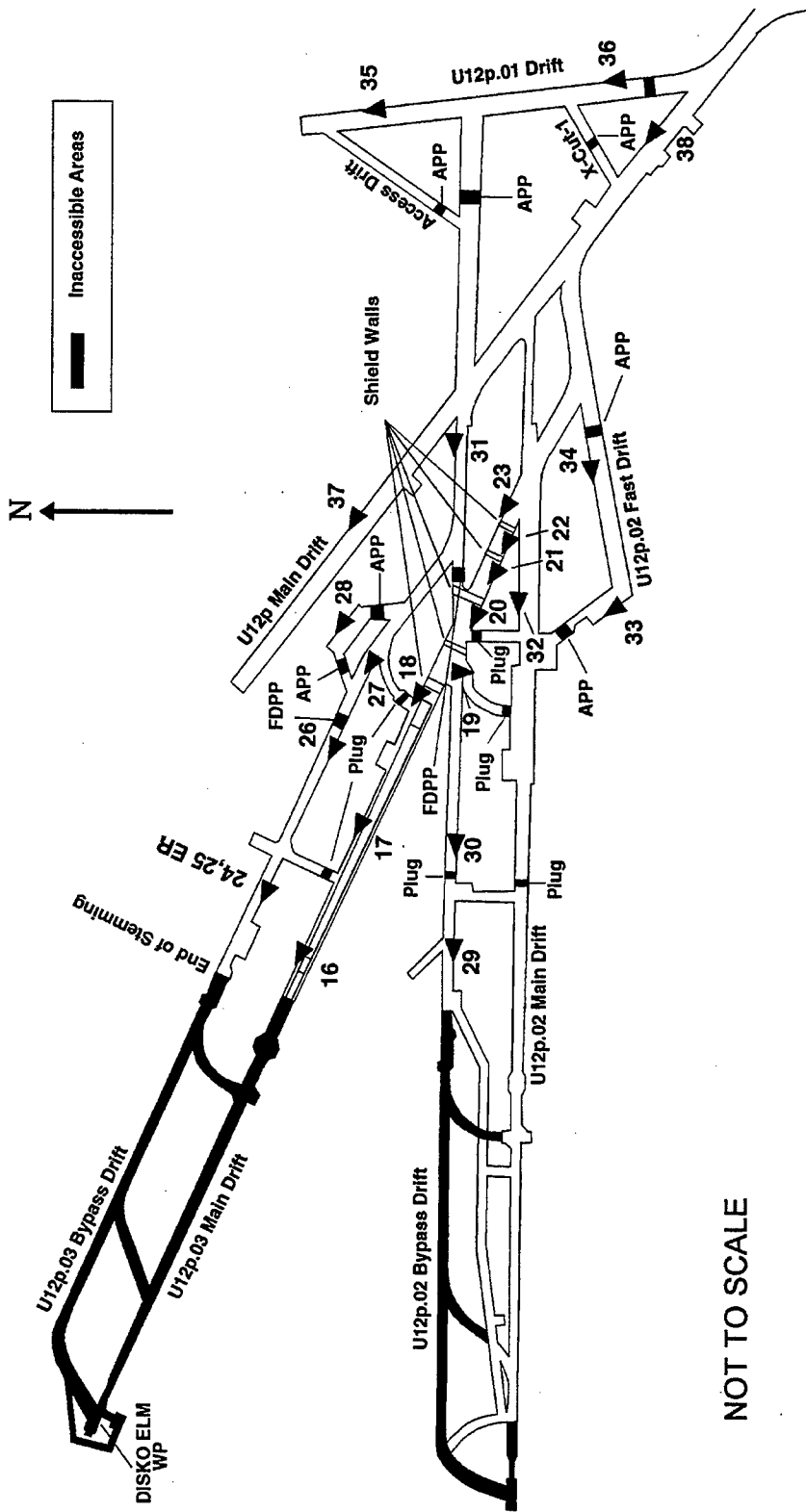

Figure 9-4. DISKO ELM test - surface RAMS.



NOT TO SCALE

Figure 9-5. DISKO ELM test - underground RAMS.



NOT TO SCALE

Figure 9-6. DISKO ELM test - underground RAMS U12p.03 complex.

recorder systems in operation. Twenty-nine EPA personnel were fielded for offsite surveillance activities.

D. Security Coverage.

Device security procedures in the WP area and the timing and firing control room were in accordance with DOE Order 5610.3, "Program to Prevent Accidental or Unauthorized Nuclear Explosive Detonations." Beginning on D-1, all personnel entering or exiting the controlled area were required to stop at muster or control stations for issue of stay-in badges. After control was established, all through traffic was diverted around the controlled area by use of screening stations. In accordance with the "Test Controller's Operations and Security Plan," contractors and agencies were to have all personnel not connected with this test out of the closed area before the final security sweep began.

E. Air Support.

Three BO-105 helicopters and crews were provided by EG&G for cloud tracking and the Test Controller's use, if needed. In addition, the USAF provided a WC-130 and/or a WC-135 aircraft and crew on standby status for cloud tracking. EG&G also provided two King Air aircraft to perform wind soundings, cloud sampling, and cloud tracking duties, if necessary.

9.3 TEST-DAY ACTIVITIES.

9.3.1 Pretest Activities.

After a two-day delay to correct technical problems, the test was rescheduled for 14 September. Final sweep of the forward areas was initiated at 0120 hours on 14 September. All persons except the arming party, the tunnel button-up party, and the security

guards were out of the tunnel and clear of the muster area. The arming party completed its work and departed. Final button-up operations were then completed, and the button-up party left the tunnel at 0722 hours.

A final readiness briefing was held early on 14 September. All technical problems were resolved, and the countdown proceeded uninterrupted through zero time. The DISKO ELM device was detonated at 0800 hours PDT on 14 September 1989.

9.3.2 Test Area Monitoring.

Telemetry recording measurements began at 0800 hours on 14 September 1989, at which time all RAM units (i.e., stations) except numbers 13, 14, and 15 were operational and remained so throughout the readout period. RAM stations 1-12, 27-29, and 33-46 all read background levels (0.04 mR/h) throughout the readout period.

At H+10 seconds, stations 16-23, located in the U12p.03 LOS (main) drift, indicated a sharp rise in radiation levels due to neutron activation. The maximum reading of 246.0 R/h was recorded at station 18; while all other stations between numbers 16-23 read between 2.5 and 189.0 R/h. Readings rapidly decreased, and by H+30 minutes, station 18 read 2.1 R/h and stations 16-23 read between 20 mR/h - 1.4 R/h. By H+5 hours, RAM stations 24-26 were showing increasing radiation readings indicating an internal leak of a small amount of noble gases from the end of stemming. A maximum reading of 4.2 mR/h was recorded on RAM station 24 at H+11 hours after which readings decreased rapidly. By H+24 hours, stations 16-23 were all reading less than 100 mR/h; station 24 was reading background levels; and station 26 was indicating 0.2 mR/h.

9.3.3 Initial Surface Radiation Surveys.

An initial surface reentry six-member team departed the TC's barricade at Gate 300 at 0946 hours on 14 September 1989. A mobile check van was setup to provide for area control and anti-contamination clothing and equipment supply. All radiation

readings were relayed as soon as they were obtained via Net 3 radio. By 1056 hours, survey of the U12p portal yard area was completed. All radiation readings were at background levels.

Survey teams stood by the U12p portal during gas sampling of the tunnel atmosphere. No toxic or explosive gases were detected and the oxygen level was 21 percent as measured on the WP side of the GSP, the WP side of the DPP, and the end of stemming. The initial gas sample taken from the LOS drift showed no explosive gases, 10 ppm CO, 20 percent oxygen, and a radiation reading of 1 mR/h. Gas sampling was completed by 1350 hours, and all personnel were checked out of the portal area by 1500 hours.

9.4 POSTTEST ACTIVITIES.

9.4.1 Tunnel Reentry Activities.

The initial reentry work team entered the U12p tunnel portal at 0905 hours on 15 September after additional gas samples were taken to ensure tunnel atmospheric conditions were acceptable. The work team proceeded to the GSP and established ventilation on the WP side of the GSP by opening the 48-inch turntube door at 0952 hours. No toxic or explosive gases were detected, and the oxygen level was 21 percent. All radiation readings were at background levels. No anticontamination clothing or respiratory protection was required during this part of the reentry.

The work team proceeded to the DPP at 1345 hours to inspect and take gas samples on the portal side of the DPP. Again, radiation readings were at background levels. No toxic or explosive gases were detected, and the oxygen level was 21 percent. The team exited the tunnel by 1408 hours.

As directed by DOE health and safety personnel, four M-102 air samplers and four noble gas samplers were positioned between 300 and 1,000 feet in each of four directions from the portal. The M-102s were operational by 1440 hours, and the noble gas samplers

were operational by 1733 hours. That same day, miners began dismantling the GSD.

The initial reentry team No. 1 and the rescue team, dressed in anticontamination clothing and SCBA, were allowed to make a limited reentry on 16 September so that LLNL personnel could make a minimum recovery of film and data from the LLNL alcove. At 0905 hours, the teams left the portal area and proceeded to the bypass DPP (BPDPP) where the rescue team remained while reentry team No. 1 proceeded to the U12p.02 main drift and the LPARL alcove where gas sample data showed no toxic or explosive gases, 21 percent oxygen, and a radiation reading of 0.06 mR/h. The team then proceeded to FDPP No. 2, the KSC alcove, and plug No. 2 where gas samples were taken on the WP side of plug No. 2. Sample readings showed no explosive gases, 10 ppm CO, and 20 percent oxygen. Radiation readings were at background levels. The team then proceeded to the LLNL alcove APP No. 7 where sample data showed no toxic or explosive gases, 20 percent oxygen, and background radiation levels.

The LLNL recovery team, wearing anticontamination clothing but no SCBA, departed the U12p portal at 1002 hours and arrived at the LLNL alcove at 1035 hours where they recovered film and data and departed the alcove at 1055 hours. The reentry team then returned to the BPDPP where they sealed the doors at 1125 hours. All personnel returned to the portal at 1140 hours.

At 0855 hours on 18 September, the reentry and rescue teams, dressed in anticontamination clothing and SCBA, proceeded to the portal side of the DPP where the rescue team stood by as the reentry team moved to the U12p.03 bypass drift; then through the crawlway door at plug No. 5 to the LOS drift; from there to TC No. 2 where they took a gas sample from the ventilation line. Readings on the sample were 0.4 mR/h, 1300 ppm CO, a trace of explosive gases, and 20 percent oxygen. The team then moved on to TC No. 1 where they again took a gas sample from the ventilation line. Readings were similar to those taken at TC No. 2. The team then returned to the U12p.03 bypass drift and proceeded through

the FDPP No. 1 crawltube and continued through the crawlway doors of shield walls taking readings as the team proceeded. The maximum reading in these areas, obtained on the WP side of shield wall No. 3, was 0.75 mR/h, 10 ppm CO, no explosive gases, and 20 percent oxygen. From there the team returned to the BPDPP at 1221 hours. The reentry and rescue teams returned to the portal and were surveyed and released by 1240 hours.

The reentry team completed all initial reentry work on 19 September when they reentered the tunnel at 0833 hours. No anticontamination clothing or SCBA was required for this work. The team proceeded through the slow alcove, several APPs, and then to the fast alcove taking gas samples throughout their walk through. Typical readings showed background radiation levels, no toxic or explosive gases, and 20 percent oxygen. The team returned to the DPP at 0927 hours and then exited the tunnel where they were surveyed and released at the portal area. All air and water samples along with smears taken were sent to the laboratory for analysis.

The next day, the scientific assessment team entered the tunnel at 0910 hours, wearing coveralls, totes, gloves and full-face respirators with HEPA filters. The team entered test chambers and alcoves to make a technical assessment of equipment and experiments. By 1300 hours, the team completed their work and returned to the portal area. Most experiment recovery work in the LOS pipe was completed by 29 September.

9.4.2 Posttest Mining and Drilling.

Miners began mining out the GSP on 16 September and completed that task later that same day. Workers also mined out the main drift DPP on 18 September. Mining began in the U12p.03 bypass drift, the alcoves, test chambers, and main drift continued as cleanup, experiment recoveries, and equipment dismantling and removal were ongoing. Drilling in the high pressure alcove in the U12p.03 bypass drift was started. Probe hole surveys showed a maximum

reading of 10 mR/h on contact from RE#2. No toxic or explosive gases were detected, and the oxygen level was 21 percent.

In mid-October, a U12p.03 reentry drift was started from the right rib of the U12p.03 bypass drift at 470 feet (i.e., at the junction of the U12p.03 bypass drift and the U12p.04 LOS drift concurrently being mined). Reentry mining continued in the U12p.03 LOS drift and into alcoves; in the U12p.03 bypass drift and U12p.03 reentry drift as numerous probe holes were drilled, cored, and surveyed to determine conditions before mining progressed. Anticontamination clothing and sometimes raingear were required depending on the work environment. Work in the high pressure alcove and the U12p.03 reentry drift usually required anticontamination clothing and full-face respirators. Surveys of probe holes, at times, indicated CO levels as high as 500 ppm; 20 percent of the LEL; and an 0.3 mR/h radiation reading. Mapping fractures and photography were ongoing as reentry work proceeded with probe hole drilling, removing the TAPS, and work in the GSAC crosscut through the end of December 1989.

When mining work resumed on 2 January 1990, the U12p.03 reentry drift had already been mined to 472 feet. This reentry drift was mined on a heading to intersect the U12p.03 bypass drift past the GSAC crosscut; then in a northwesterly direction; and finally the drift turned to intersect the LOS drift near the FAC crosscut. A 110-foot hot muck storage drift was mined off the right rib at 470 feet. During January the drift was being completed to 518 feet while probe hole drilling and surveying continued. Work stopped in the reentry drift on 17 January. Surveys and, in some instances, equipment removal work were also ongoing until the end of January in the muck storage area; in the LOS drift near the GSAC; in the high pressure alcove; in the fast alcove; and in other areas in the U12p.03 LOS and reentry drifts. Radiation readings ranged from background levels to 0.6 mR/h and CO levels were as high as 1,000 ppm. Mineback activities ceased in July 1990.

9.4.3 Industrial Safety.

Checks for the presence of toxic gases and surveys to measure radiation and explosive gas levels were made on each shift. The results were then recorded in the monitors' logbook.

Appropriate safety measures were taken to protect mining personnel and prevent unsafe conditions. Industrial safety codes for mining, tunneling, and drilling were established by REECo and emphasized during all operations. A written standard operating procedure was required for each operation involving explosives, toxic materials, radioactive material, or any other operation with the potential for personal injury. Each individual involved in such an operation was required to know the contents of the applicable procedures.

The portal construction area and the tunnel were mandatory hard-hat and foot-protection areas (safety shoes, boots, DOE-issued miner's boots, or toe guards). All personnel on initial tunnel reentry teams were certified in the use of the Draeger self-contained breathing apparatus. Standard safety rules and regulations, as spelled out in the "U.S. Bureau of Mines Manual," were observed.

All explosives, electro-explosive components, solid propellants, toxic materials, and radioactive materials were handled, stored, and transported in accordance with applicable sections of the following documents:

1. Army Material Command Regulations (AMCR 385-100).
2. Appropriate DOE Orders in the 5400 and 5600 Series concerning Environmental Protection, Safety & Health Protection, and Defense Programs, respectively.
3. Individual safe operating procedures (by experimenter organization).
4. DISKO ELM Safety Regulations.

All personnel engaged in handling, storing, assembling, or installing explosives, propellants, or electro-explosive devices (or observers of those operations) were required to wear safety glasses or other eye protection which had been approved by the DoD safety coordinator.

9.5 RESULTS AND CONCLUSIONS.

Telemetry recording measurements began at 0800 hours on 14 September 1989. At H+10 seconds stations 16-23 showed a rise in radiation levels as the result of neutron activation. At that time, station 18 read 246.0 R/h while the other stations read between 2.5 and 189.0 R/h. These readings decreased rapidly and by H+30 minutes, readings ranged from 20 mR/h to 2.1 R/h, with station 18 still reading the maximum. Internal leakage was detected at the end of stemming when, at H+5 hours, stations 24-26 showed a rise in radiation levels. Station 24 was reading 4.2 mR/h at H+11 hours. Readings decreased rapidly, and by H+24 hours, station 24 was reading background radiation levels; stations 16-23 were all reading less than 100 mR/h.

The surface initial radiation surveys began at 0946 hours on 14 September and were completed at 1500 hours. No radiation above background levels was detected at the U12p tunnel portal yard area. Gas samples taken from the WP side of the GSP, the WP side of the DPP, and the end of stemming indicated no toxic or explosive gases and 21 percent oxygen.

Reentry into the tunnel began at 0905 hours on 15 September, when the reentry work team established ventilation to the WP side of the GSP at 0952 hours. This team proceeded to the DPP where they took gas samples. Readings indicated no toxic or explosive gases, and the oxygen level was 21 percent. The team exited the tunnel by 1408 hours. As directed by DOE health and safety personnel, four M-102 air samplers and four noble gas samplers were positioned between 300 and 1,000 feet in each of four directions from the portal for monitoring the tunnel atmosphere.

On 16 September, reentry team No.1 and the rescue team, dressed in anticontamination clothing and SCBA, proceeded to the BPDPP where the rescue team remained as the reentry team checked out and took gas samples as they proceeded to the FDPP No. 2, the KSC alcove, APP No.2, and the LLNL alcove APP No. 7. Sample data showed no toxic or explosive gases, 20 percent oxygen, and background radiation levels. This was done so that LLNL personnel could make a limited reentry to recover film and data from the LLNL alcove. At 1005 that same day, the LLNL recovery team, dressed in anti-contamination clothing, entered the alcove, completed recoveries, and returned to the portal at 1140 hours.

On 18 September, the reentry team, dressed in anticontamination clothing and SCBA, surveyed and took gas samples as they proceeded through the U12p.03 complex. A ventilation line gas sample at TC No. 2 indicated 0.4 mR/h, 1300 ppm CO, a trace of explosive gases, and 20 percent oxygen. The next day, initial reentry survey work was completed when the team checked the alcoves and APPs. Typical readings showed background radiation levels, no toxic or explosive gases, and 20 percent oxygen.

The scientific assessment team, wearing coveralls, totes, gloves and full-face respirators with HEPA filters, entered alcoves and test chambers to make their technical assessment on 20 September. They completed their tasks by 1300 hours that day.

Reentry mining began on 16 September when workers mined out the GSP and then the U12p.03 DPP. While most experiment recovery work was completed by 29 September, equipment dismantling and removal continued during the next four months concurrently with reentry mining operations. The reentry bypass drift was started in mid-October, and as mining progressed, numerous probe holes were drilled, cored, and surveyed. Data was evaluated both to determine the tunnel environment for the proposed reentry drift heading and also to determine the environment in other areas (i.e., the GSAC and FAC areas) where reentry and assessment or recoveries would be made.

At times, anticontamination clothing and sometimes raingear were required depending on the work environment. Probe hole sampling revealed some "hot spots." However, for the most part, radiation readings ranged from background levels to 0.6 mR/h; CO levels ranged from 0-1,000 ppm. Very few samples showed evidence of explosive gases; and the oxygen level was usually 20 percent. Mineback operations for DISKO ELM test concluded in July 1990.

Personnel exposure data from self-reading pocket dosimeters were documented on Area Access Registers during individual entries to DISKO ELM radex areas over a non-continuous time frame beginning 15 September 1989 and ending in July 1990 (see page 113 for a detailed explanation). Pocket dosimeters showed some indication of possible radiation exposure to DoD-affiliated personnel. TLDs worn by these reentry personnel indicated that possibly one individual received some gamma exposure most likely from the DISKO ELM test. The minimum detectable gamma exposure with the NTS TLD is 15 mR. Area Access Register data are summarized below.

Participants	Entries Logged	Maximum Exposure (mR)	Average Exposure (mR)
All	621	14	0.3
DoD	184	10	0.4

SECTION 10

MINERAL QUARRY TEST

10.1 TEST SUMMARY.

MINERAL QUARRY was a DoD/LANL-sponsored weapons-effects test conducted at 0800 hours PDT on 25 July 1990. The test had a yield of less than 20 kilotons, and the device was emplaced at a vertical depth of 1,278 feet in the U12n.22 drift of the N tunnel complex (see Figure 10-1). The purpose of the MINERAL QUARRY test was to test the survivability of military hardware in a nuclear detonation environment. Supporting experiments provided an appropriate radiation environment for experiments relating to the SDI and the Special Program Offices (SPO).

MINERAL QUARRY was satisfactorily contained, and no atmospheric release occurred from the test. However, several controlled²⁷ effluent releases occurred when various sections of the LOS pipe were purged through the tunnel ventilation system. Several controlled releases also occurred as the result of an experimental gas diagnostics program.

10.2 PRETEST ACTIVITIES.

10.2.1 Responsibilities.

Safe conduct of all MINERAL QUARRY project activities in Area 12 was the responsibility of the DNA TGD, subject to controls and procedures established by the DOE TC. The DOE TC was responsible for safety of the public and onsite personnel during the test.

²⁷ The radioactive gas was passed through a filtering system where the particulates were removed before the gas was released through the tunnel ventilation system.

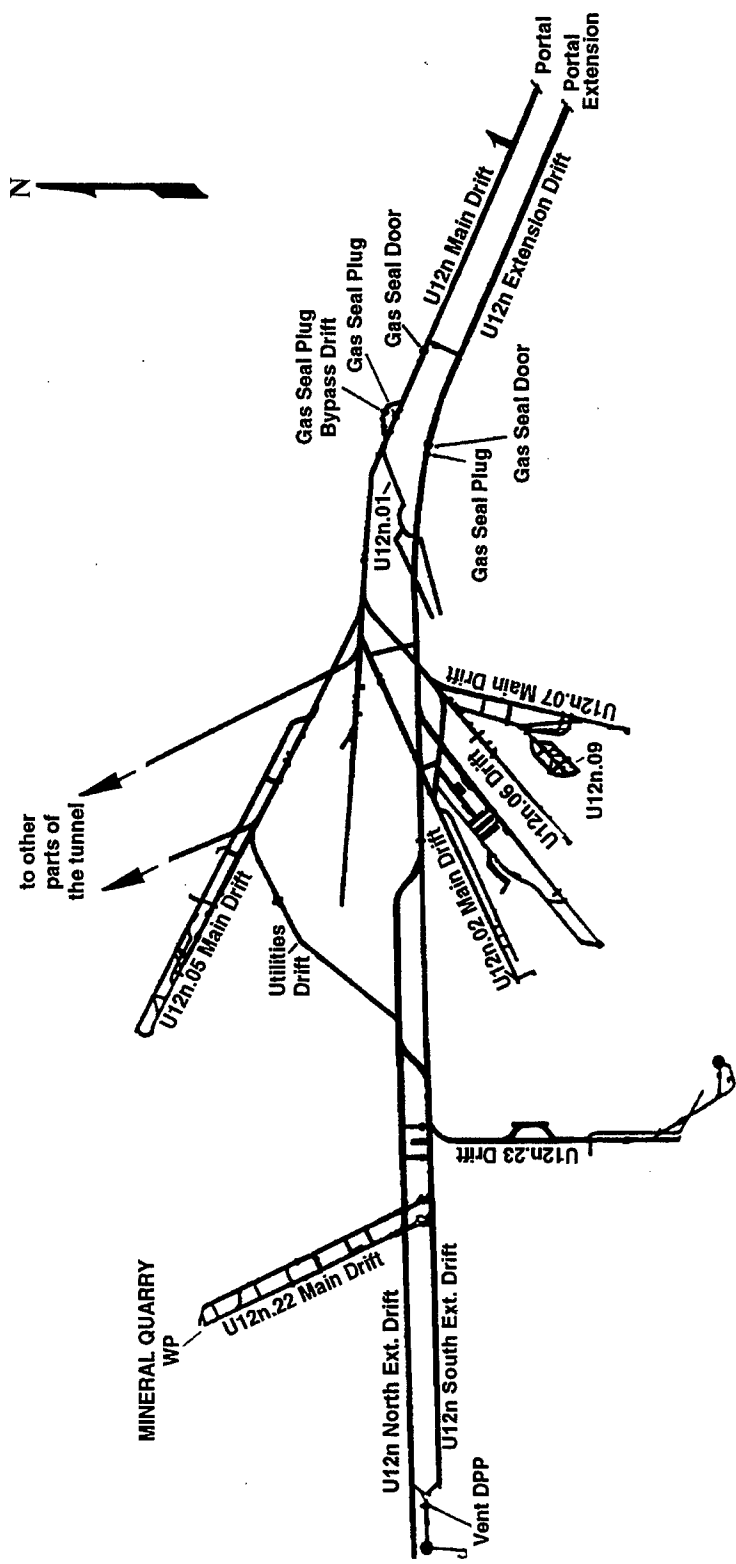

NOT TO SCALE

Figure 10-1. MINERAL QUARRY test - tunnel layout.

Project agencies were responsible for designing, preparing, and installing experiments, or delivering them to the installation contractor. After the test, these agencies were responsible for removing samples, analyzing instrument and sample data, and preparing project reports on experiment results.

Device safety and security procedures in the WP area and the timing and firing control room were in accordance with DOE Order 5610.3, "Program to Prevent Accidental or Unauthorized Nuclear Explosive Detonations." The LANL TGD had overall responsibilities for all operations involving the MINERAL QUARRY device as well as the timing control and the arming and firing of MINERAL QUARRY closures and experiments. The LANL TGD was responsible to the DOE TC for radiological safety within the designated area of the WP from device emplacement until detonation. After detonation, the DOE TC relieved the LANL TGD of these responsibilities and returned the responsibility for project activities back to the DNA TGD.

10.2.2 Planning and Preparations.

A. Tunnel Facilities Construction.

The MINERAL QUARRY drift complex, U12n.22, was mined in a northwesterly direction off the north side of the existing N tunnel north extension drift. The main drift was 17 feet wide by 16 feet high at the U12n extension drift end and diminished to 7 feet wide by 7 feet high at the WP end. The bypass drift was 12 feet wide by 12 feet high at the extension drift end and diminished to 10 feet wide by 12 feet high near the WP. The 1032-foot long horizontal LOS pipe diverged from a several-inch ID near the zero room to approximately 12 feet ID at the experiment bulkhead station end. The U12n.22 complex consisted of an LOS drift, a bypass drift, two auxiliary closures, the TAPS, hardened pipe section, one zero room, four experiment bulkhead stations, five radiation diagnostic pipe stubs, six experiment pipe stubs, a stub experiment station, experiment and

support alcoves, and a vacuum pumping alcove. The main instrumentation alcove was reused from the MISTY ECHO test, although it was enlarged to facilitate the requirements of the MINERAL QUARRY test. Figure 10-2 shows the tunnel layout. Construction activities began in January 1988 when mining of the LOS and bypass drifts was started. However, work on the drifts progressed intermittently as final construction on the preceding test, MISTY ECHO, was underway. Work was accelerated after the execution of MISTY ECHO, and the drifts were completed in March 1989. The installation of the LOS pipe began in June 1989 while the recording and main instrumentation alcoves were being refurbished from the MISTY ECHO test to meet the requirements of MINERAL QUARRY. Delays in construction were encountered because of non-availability of equipment.

In November 1989, a successful prefit of the LOS-mounted experiments was performed in the tunnel. However, delays in construction, hardware delivery, and cable installation, made it necessary for the Director for Test to delay the beginning of readiness for 30 days to 25 July 1990.

By April, the LOS pipe system was completed, and experiment installation was started. Again, because of delays in key deliveries, in addition to minor changes to experiment bulkheads, experiments were not completely installed until late May.

Remote gas sampling capabilities were incorporated during construction as well as capabilities for water, power, drain, and pressurization lines. Provisions were made to manually take gas samples from the WP side of the GSD, GSP, and main DPP during posttest reentry.

The stemming plan for the U12n.22 complex is shown in Figure 10-3. In the LOS drift, the area behind the zero room was filled with desert fines, then beyond the zero room void RMG was emplaced to 125 feet; followed by SLG to

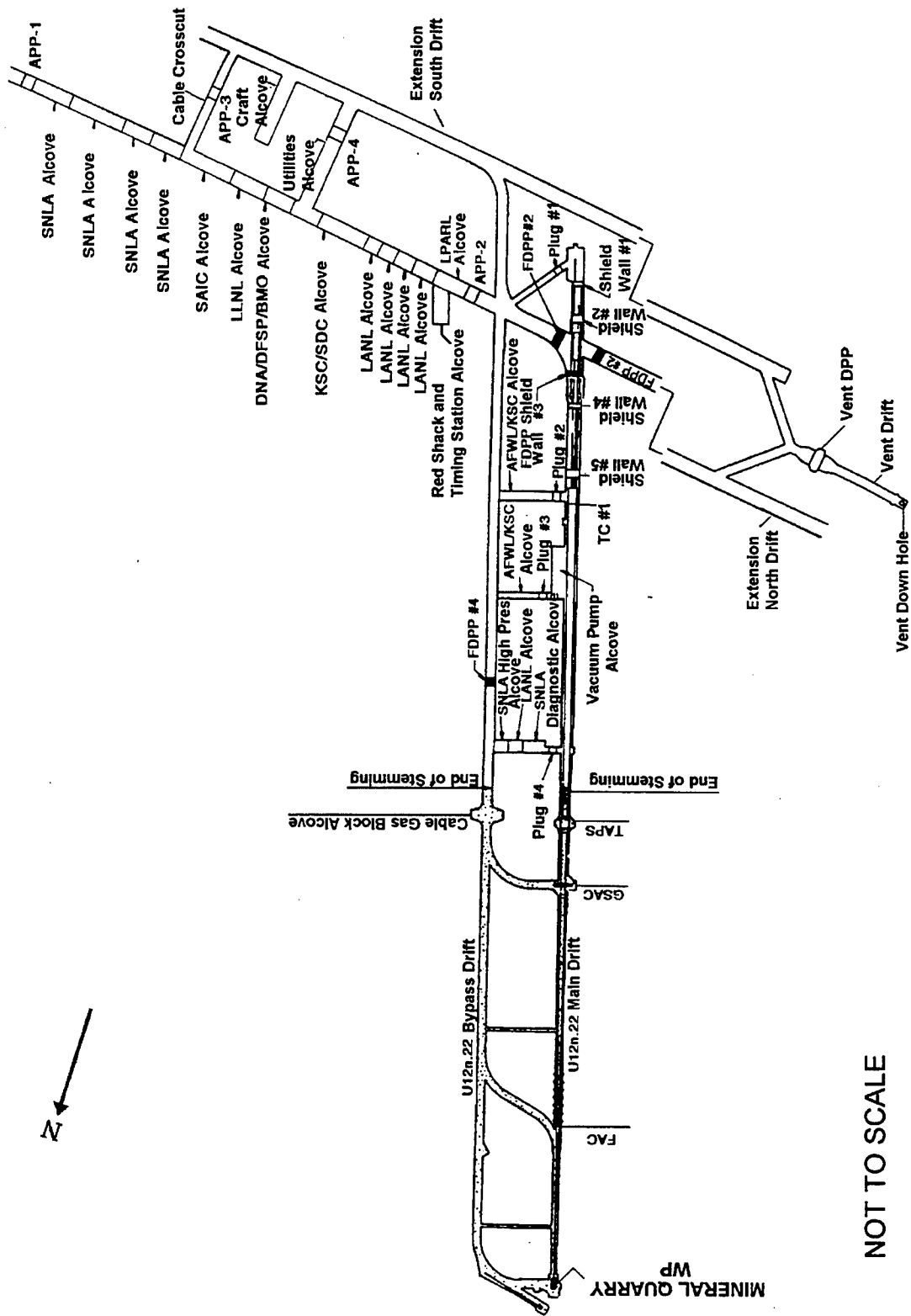

NOT TO SCALE

Figure 10-2. MINERAL QUARRY test - tunnel facilities layout.

	Desert Fines
	Rock-Matching Grout
	Superlean Grout
	High-Strength Grout
	Concrete
	Groutcrete

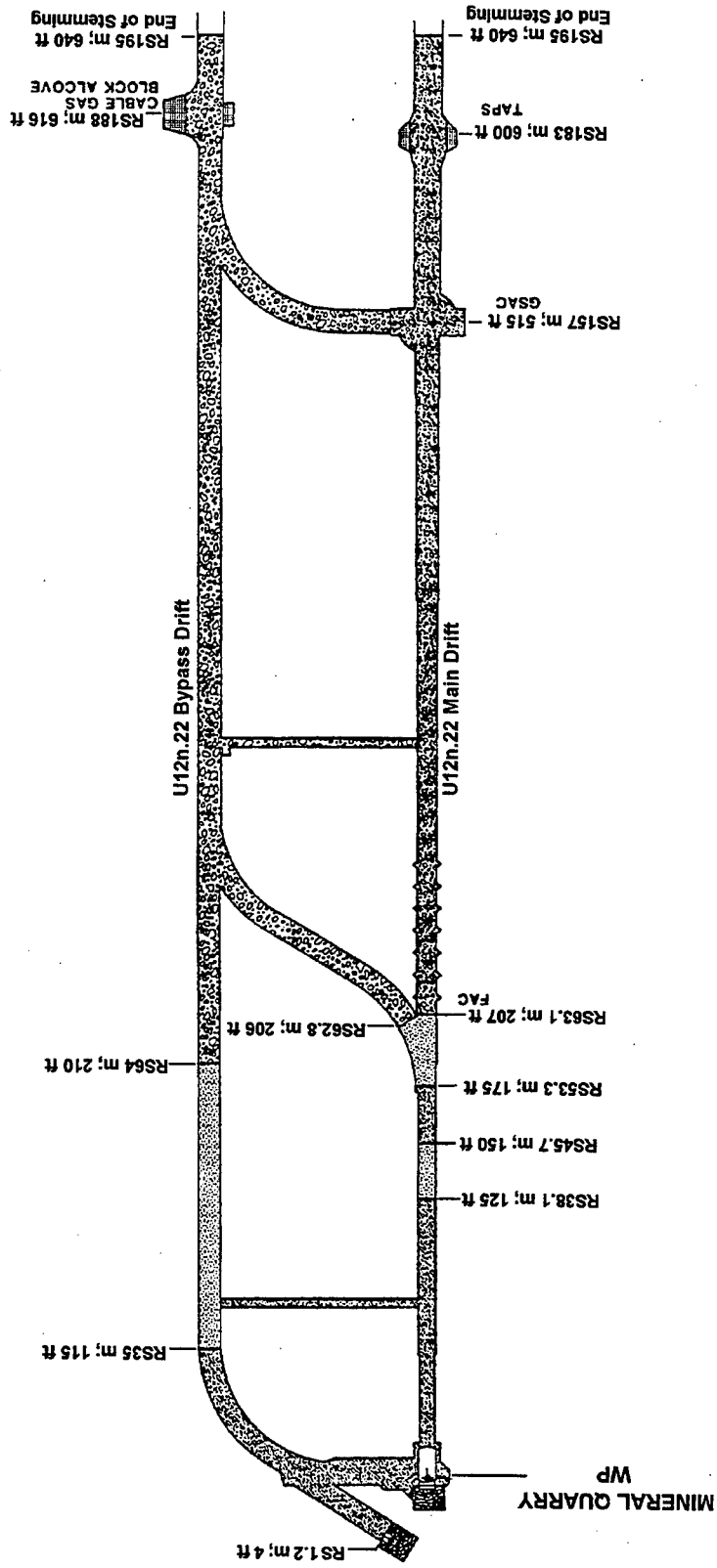

NOT TO SCALE

Figure 10-3. MINERAL QUARRY test - stemming plan.

150 feet; then RMG to 175 feet; followed SLG to 207 feet; and finally concrete and groutcrete to the end of stemming at 640 feet. The bypass drift was stemmed with desert fines for four feet and then to a distance of 115 feet with RMG; then to 210 feet with SLG; and then to 640 feet with HSG. The crosscut drift closest to the WP was stemmed with RMG while the other three crosscuts were stemmed with HSG. All penetrations into the stemmed areas of the drifts (e.g., cables and water lines) were gas blocked to prevent the seepage of radioactive gases outside the stemmed region of the drifts.

Experiments and related hardware installations were completed by July 1990. The following organizations were among those that fielded experiments for the MINERAL QUARRY test: the U.S. Army Strategic Defense Command (USASDC) conducted mirror and baffle experiments in support of SDI; Lockheed Palo Alto Research Laboratory (LPARL) conducted diagnostic measurements to characterize x-ray fluence and spectra and made sieve hole closure measurements for determining x-ray time-dependent flux at sieved stations; Science Applications International Corporation (SAIC) conducted sensor/seeker telescope experiments and radiation diagnostic studies; JAYCOR conducted space components LOS bulkhead experiments to support SDI and SPO milestones; General Research Corporation (GRC) conducted space components survivability experiments and advanced heat shield experiments; APTEK conducted reduced impulse material and related experiments; Sandia National Laboratory, Albuquerque (SNLA) conducted experiment protection and radiation and containment diagnostics experiments; and Los Alamos National Laboratory (LANL) conducted ground shock and ground motion measurements and device diagnostics studies.

The SDRs were started in April and continued into July. The MFP dry run was held on 11 July; however, the countdown was interrupted because of a pressure rise in the LOS pipe system. After adjustments were made, the problem was

corrected, and the countdown was restarted and completed uninterrupted. On 12 July, the device was emplaced and button-up stemming activities began. A final dry run was executed on 24 July.

B. Radiological Safety Support.

Procedures for radiation exposure and contamination control during this test were in accordance with NTS SOP 5402 and requirements of responsible DoD representatives. Radsafe provided monitoring and equipment support.

Prior to the test, detailed radiological safety reentry plans were prepared and issued to participating agencies. Air sampling equipment was positioned in the test area. Radsafe monitors were briefed regarding surface reentry, manned stations, and security station requirements.

Radsafe monitoring teams and supervisory personnel were provided to perform initial radiation surveys, conduct aerial surveys by helicopter, and participate in reentry parties as needed. Radsafe personnel were also standing by at designated muster stations prior to detonation to perform surveys and provide emergency support as directed; to provide and issue anticontamination equipment and material, portable instruments, and dosimeters; to operate area control check stations; and to perform personnel, equipment, and vehicle decontamination, as required.

Available anticontamination materials and equipment included head covers, coveralls, cloth shoe covers, totes, full-face masks, supplied-air breathing apparatus, plastic suits, plastic bags, gloves, and masking tape.

C. Telemetry and Air Sampling Support.

In addition to the permanent RAMS units, 50 temporary units provided surface and underground coverage for the MINERAL

QUARRY test. Tables 10-1 and 10-2 list the locations of surface and underground RAMS, respectively. The locations of surface RAMS are shown in Figure 10-4, and those of underground RAM units are shown in Figures 10-5, and 10-6. All RAM units were installed a minimum of five days prior to scheduled device detonation.

EPA operated continuous monitoring stations at 34 locations in the offsite area. Thirty-one stations had high-volume air samplers with collectors for particulates and reactive gases, 19 had tritium samplers, 17 had noble gas samplers, and 30 had pressurized ion chamber gamma-rate detector/recorder systems linked to CP-1 and the Las Vegas EPA office via satellite telemetry. Thirty-one EPA personnel were fielded for offsite surveillance activities.

D. Security Coverage.

Device security procedures in the WP area and the timing and firing control room were in accordance with DOE Order 5610.3, "Program to Prevent Accidental or Unauthorized Nuclear Explosive Detonations." Beginning on D-1, all personnel entering or exiting the controlled area were required to stop at muster or control stations for issue of stay-in badges. After control was established, all through traffic was diverted around the controlled area by use of screening stations. In accordance with the "Test Controller's Operations and Security Plan," contractors and agencies were to have all personnel not connected with this test out of the closed area before the final security sweep began.

E. Air Support.

Three BO-105 helicopters and crews were provided by EG&G for cloud tracking and the Test Controller's use, if needed. In addition, the USAF provided a WC-130 and/or a WC-135 aircraft and crew on standby status for cloud track-

Table 10-1. MINERAL QUARRY test RAMS unit locations 25 July 1990.

SURFACE

STATION NUMBER	LOCATION
From the U12n Portal:	
1	On the tunnel drain line
2	On the tunnel vent line
3	400 feet N 16° E azimuth
4	275 feet N 89° E azimuth
5	365 feet S 16° E azimuth
6	480 feet S 12° W azimuth
7	560 feet S 48° W azimuth
8	420 feet N 69° W azimuth
On the Mesa:	
9	On the mesa vent line
10	On the mesa vent line
11	On vent hole no. 2
From the U12n.22 SGZ:	
12	500 feet N 00° E azimuth
13	500 feet S 60° E azimuth
14	500 feet S 60° W azimuth
Geophones - from the U12n.22 SGZ:	
A	650 feet N 14° E azimuth
B	650 feet S 46° E azimuth
C	650 feet S 74° W azimuth

Table 10-2. MINERAL QUARRY test RAMS unit locations 25 July 1990.

UNDERGROUND

STATION NUMBER	LOCATION
15	540 feet into the U12n.22 main drift
16	420 feet into the U12n.22 main drift
17	325 feet into the U12n.22 main drift
18	180 feet into the U12n.22 main drift
19	120 feet into the U12n.22 main drift
20	50 feet into the U12n.22 main drift
21	15 feet into the U12n.22 stubs drift
22	55 into the U12n.22 stubs drift
23	100 feet into the U12n.22 stubs drift
24	450 feet into the U12n.22 bypass drift
25ER ²⁸	450 feet into the U12n.22 bypass drift
26	120 feet into the U12n.22 bypass drift
27	110 feet into the U12n.22 bypass drift
28	On the U12n extension vent drift
From the U12n portal unless otherwise indicated:	
29	7,000 feet into the U12n ext. north drift
30	7,000 feet into the U12n ext. south drift
31	300 feet into the U12n.23 main drift
32	6,000 feet into the U12n ext. north drift

²⁸ ER - Extended Range (instrument capable of reading 100 mR/h to 100,000 R/h).

Table 10-2. MINERAL QUARRY test RAMS unit locations 25 July 1990
(Continued).

UNDERGROUND

STATION NUMBER	LOCATION
33	5,600 feet into the U12n ext. north drift
34	5,550 feet into the U12n ext. south drift
35	4,800 feet into the U12n ext. north drift
36ER ²⁹	4,800 feet into the U12n ext. north drift
37	1,000 feet into the U12n utilities drift
38ER ²⁹	1,000 feet into the U12n utilities drift
39	200 feet into the U12n utilities drift
40	600 feet into the U12n.05 drift
41	4,000 feet into the U12n extension drift
42	2,900 feet into the U12n extension drift
43	2,300 feet into the U12n extension drift
44	2,600 feet into the U12n main drift
45	235 feet into the U12n gas seal bypass drift
46	1,700 feet into the U12n main drift
47	1,200 feet into the U12n main drift
48	200 feet into the U12n main drift
49	1,200 feet into the U12n extension drift
50	200 feet into the U12n extension drift

²⁹ ER - Extended Range (instrument capable of reading 100 mR/h to 100,000 R/h).

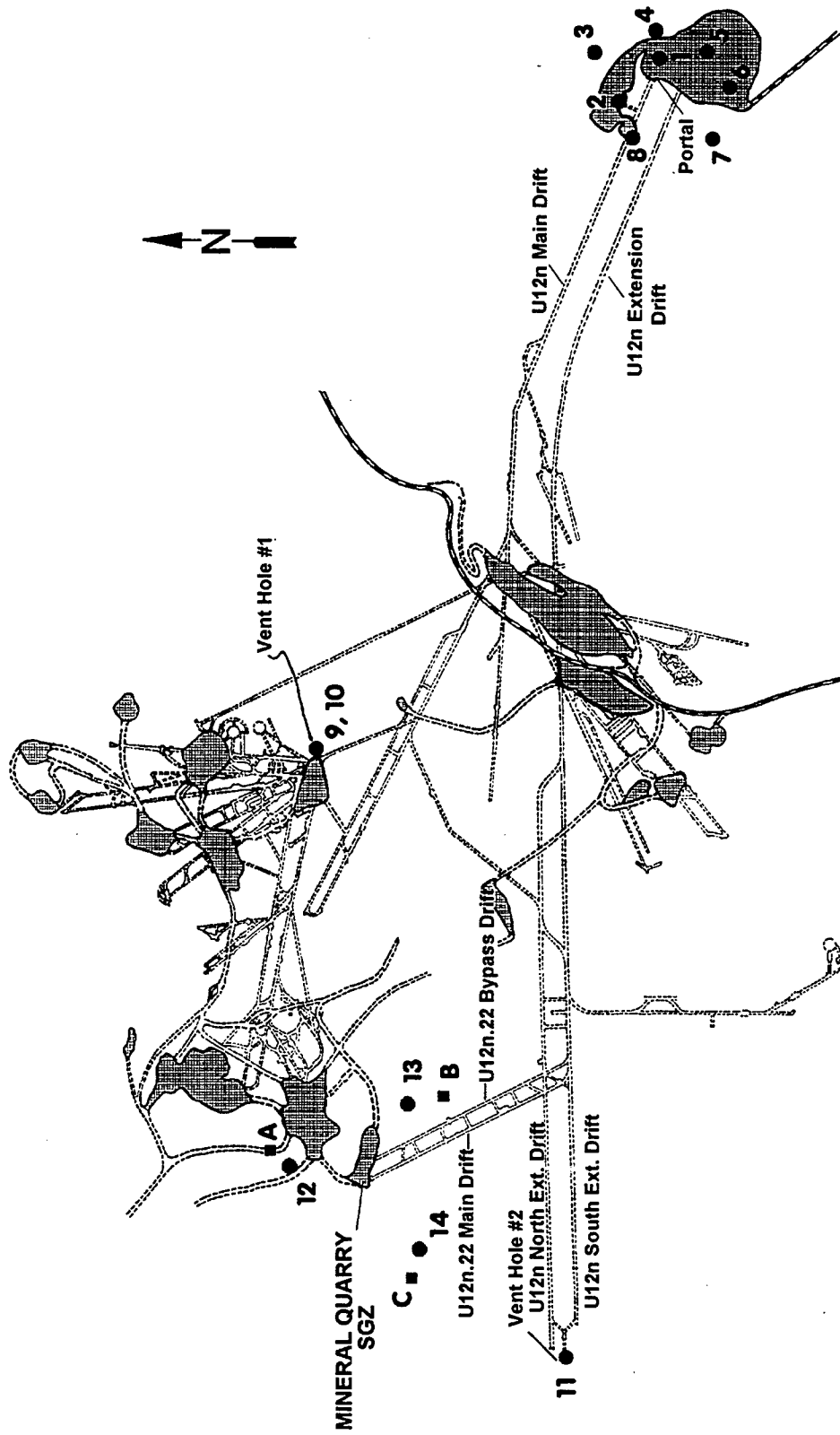

NOT TO SCALE

Figure 10-4. MINERAL QUARRY test - surface RAMS.

— Inaccessible Areas

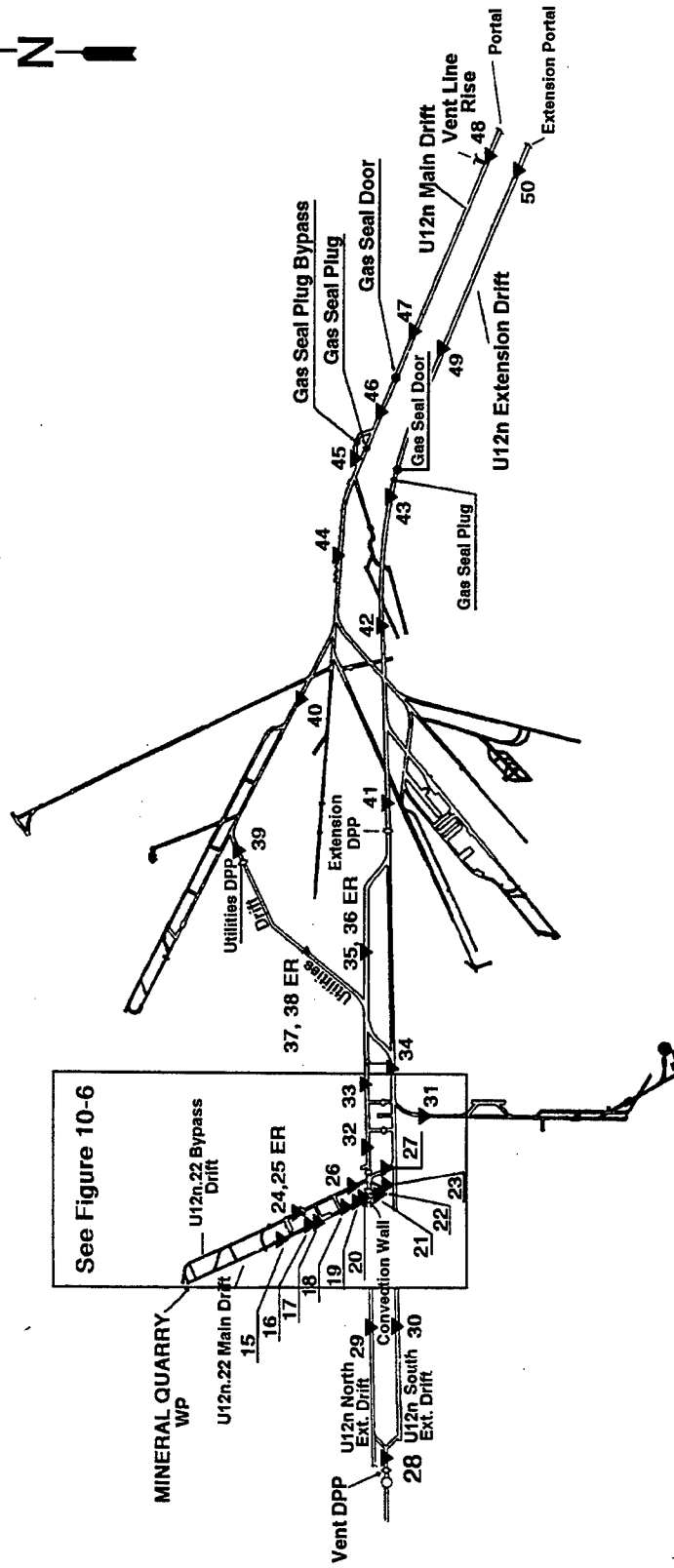

NOT TO SCALE

Figure 10-5. MINERAL QUARRY test - underground RAMS.

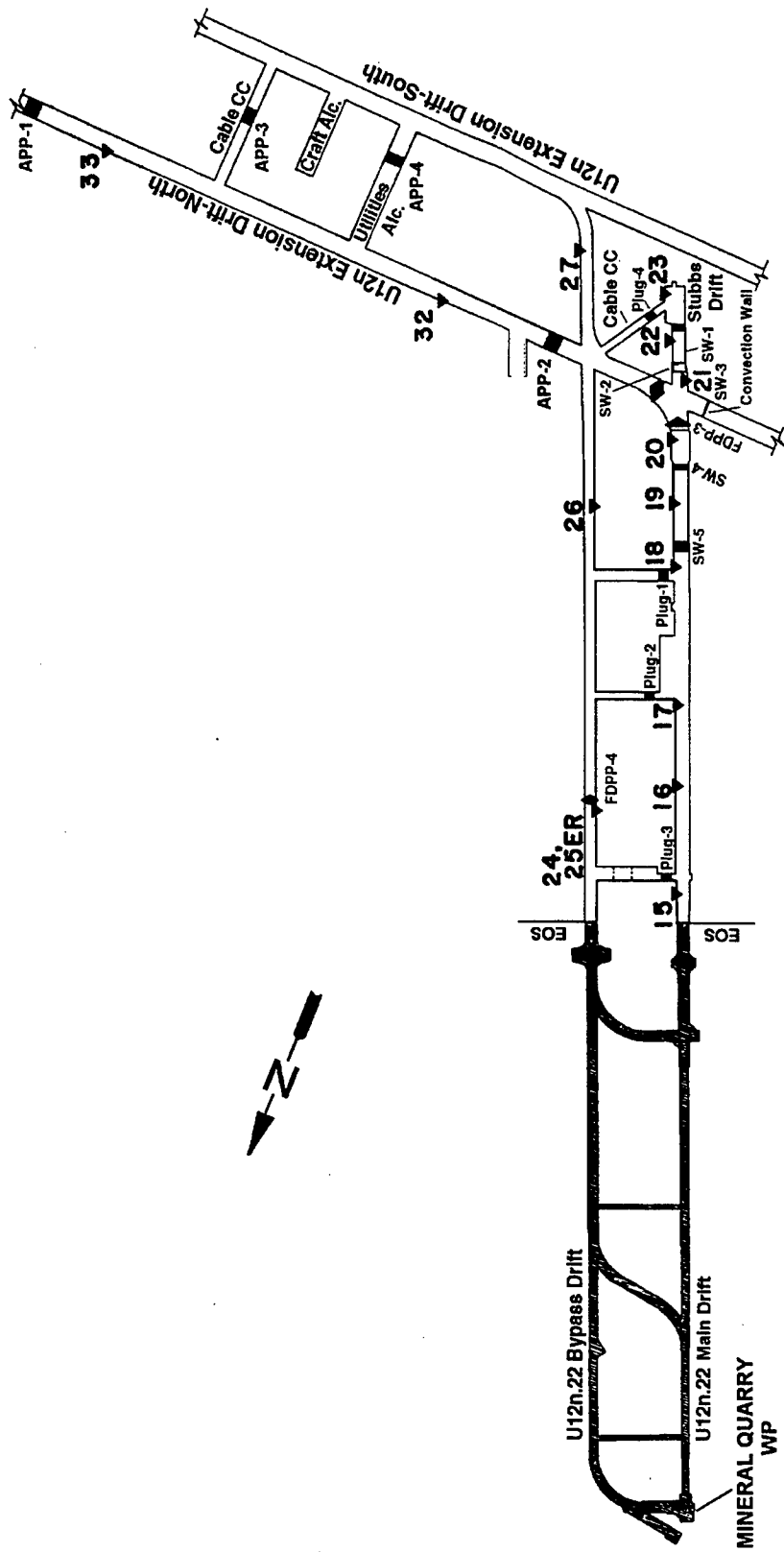

NOT TO SCALE

Figure 10-6. MINERAL QUARRY test - underground RAMS U12n.22 complex.

ing. EG&G also provided two King Air aircraft to perform wind soundings, cloud sampling, and cloud tracking duties, if necessary.

10.3 TEST-DAY ACTIVITIES.

10.3.1 Pretest Activities.

On 24 July 1990, by approximately 2400 hours, all persons except the arming party, the tunnel button-up party, and the security guards were out of the tunnel and clear of the muster area. Permission was granted to arm the device at 0145 on 25 July. Following the departure of the arming party, button-up operations were completed, and the party left the tunnel. The area was cleared of all personnel by 0700 hours of 25 July.

A final readiness briefing was held at 0600 hours on 25 July to confirm the technical readiness status and favorable weather conditions in anticipation of an 0800-hour test time. The count-down started at 0754 hours and proceeded uninterrupted until zero time. The MINERAL QUARRY device was detonated at 0800 hours PDT on 25 July 1990.

10.3.2 Test Area Monitoring.

Telemetry recording measurements began at 0800 hours on 25 July 1990, at which time all RAM units (i.e., stations) were operational and remained so throughout the readout period. Stations 1-14 and 24-50 read background levels (0.04 mR/h) at zero time and continued to indicate background radiation levels throughout the readout period.

At H+10 seconds, stations 15-23, located in the LOS drift, showed increased radiation levels due to neutron activation; however, levels decreased rapidly as decay occurred. Station 15 indicated the maximum reading of 537 R/h, but by H+30 minutes, the reading decreased to 4.5 R/h. By H+24 hours all RAM stations were reading

below 100 mR/h. All stations were secured at 1030 hours on 31 July.

10.3.3 Initial Surface Radiation Surveys.

An initial surface reentry team departed the TC's barricade at Gate 300 at 0941 hours on 25 July 1990. A mobile check van provided area control and anticontamination clothing and equipment supply. All radiation readings were relayed as soon as they were obtained via Net 3 radio. By 1015 hours, a survey of the U12n portal area was completed. All radiation readings were at background levels (0.04 mR/h).

Survey teams stood by the U12n portal during gas sampling of the tunnel atmosphere. No toxic or explosive gases were detected and the oxygen level was 21 percent as measured on the WP side of the GSP; the portal side and the WP side of the DPP; the end of stemming in the bypass and LOS drifts; and inside the LOS pipe. Gas sampling and data recovery were completed by 1344 hours, and all personnel were checked out of the test location by 1425 hours on 25 July.

10.4 POSTTEST ACTIVITIES.

10.4.1 Tunnel Reentry Activities.

The initial reentry work team entered the U12n tunnel portal at 0813 hours on 26 July. No anticontamination clothing was required for this part of the reentry work. A gas sample taken from the WP side of the GSD showed no toxic or explosive gases. The work team proceeded to the GSP where gas sample data again showed a normal tunnel environment. All radiation readings were at background levels. The team established ventilation on the WP side of the GSP, completed laying railroad track, and left the tunnel by 1022 hours.

The initial reentry team No. 1 and the rescue team, dressed in anticontamination clothing, left the portal area at 1055 hours that same day and proceeded through the turntube at the GSP. At that point, team No. 1 put on their SCBA, and the rescue team stood-by at the GSP. Team No. 1 proceeded to the U12n.08 DPP where they opened the 36-inch turntube door, and went through to open the thermal shield plug door and establish ventilation to the mesa at vent hole No. 1. The team then proceeded back through the U12n.08 drift and through the UDPP to APP No. 1 (in the slow alcove). At this time, the rescue team moved to the UDPP and remained there during reentry team activities. Team No. 1 opened the crawltube door on APP No. 1 and noted that tunnel atmospheric conditions were normal. This team proceeded back to the GSP where they met reentry team No. 2 (preparing to enter the tunnel). Team No. 1 exited the tunnel and were surveyed and released at 1425 hours.

At 1446 hours, team No. 2, wearing anticontamination clothing and SCBA, proceeded to the FDPP No. 2 in the U12n north extension drift. Gas samples taken from the WP side of FDPP No. 2 showed a normal tunnel environment. All radiation readings were at background levels. As the team proceeded through the FDPP crawltube and then through shield walls Nos. 3-5, they continued to take gas samples and also collected water samples from the floor. The water level on the floor between shield walls Nos. 4 and 5 was as high as the bottom of the crawltube. Gas sample data showed a maximum radiation reading of 5.0 mR/h (at shield wall No. 3), 8 ppm CO (at shield wall No. 4), no explosive gases, and 21 percent oxygen. The team moved to TC No. 1 where the radiation reading was 80 mR/h on contact with the door. It appeared that there was still a vacuum in the LOS pipe, so ventilation was not reestablished to the LOS pipe at this time. Team No. 2 returned to the UDPP at 1739 hours and exited the tunnel with the rescue team. Both teams were surveyed and released at the portal at 1805 hours.

At 1759 hours, data recovery teams entered the LPARL and slow alcoves to recover data. No anticontamination clothing was

required during these recoveries, and the work was completed by 1940 hours.

The next day, 27 July at 0830 hours, four reentry teams entered the tunnel to evaluate the tunnel environment. Team No. 1 proceeded to the end of the north extension drift to the vent DPP, opened the turntube, and established ventilation at vent hole No. 2. Team No. 2 proceeded to the vacuum alcove to open the vacuum valve through the HEPA filter to bring the LOS pipe back to atmospheric pressure. The other teams reestablished power to the tunnel. A team walk-through from the vent DPP end of north extension drift to the convection wall, at the U12n.22 LOS drift, was completed by 0950 hours. Tunnel atmospheric conditions in those areas were normal, and radiation readings were at background levels. However, between shield walls Nos. 1 and 2, a survey at 1105 hours showed a maximum reading of 4.0 mR/h. When TC No. 1 door was opened at 1445 hours and a gas sample taken, readings showed 400 mR/h, 46 ppm CO, no explosive gases, and 21 percent oxygen. At 1725 hours, an air sampler at the ventilation pad above vent hole No. 2 was started. Reentry teams left the tunnel by 1800 hours.

The scientific assessment team, wearing anticontamination clothing and full-face respirators, entered the alcoves and test chambers on 30 July at 0830 hours for evaluation and some recovery activities. The team proceeded through the shield walls, entered crosscut No. 2, and went as far as FDPP No. 4 in the U12n.22 bypass drift. At each location the team recovered TLDs. A survey in TC No. 2 showed a maximum reading of 60 mR/h on contact with the LOS pipe. By 1500 hours, the team had completed their work and exited the tunnel. They were surveyed and released.

From 1-13 August reentry personnel, wearing anticontamination clothing and full-face respirators, completed the major portion of LOS pipe experiment recovery. The maximum radiation reading inside the LOS pipe was 2.0 mR/h, and no toxic or explosive gases were detected. Recoveries in the stubs area continued until 6

September, but no anticontamination clothing was required. The maximum radiation reading was 0.3 mR/h.

10.4.2 Posttest Mining and Drilling.

Initially, miners began mining out the GSPs on the main and extension drifts and the UDPP on 27 July during reentry/recovery activities. However, there were no reentry mining operations for this test because of operational and budgetary constraints. There was one reentry probe hole (U12n.22 RE-1) drilled from the high pressure alcove, located at the bypass drift end of crosscut No. 3, to a point 150 feet above the WP. This work was done to obtain and analyze chimney gas samples and determine chimney radius. Drilling and core sampling were accomplished from October through December 1990.

10.4.3 Industrial Safety.

Checks for the presence of toxic gases and surveys to measure radiation and explosive gas levels were made on each shift. The results were then recorded in the monitors' logbook.

Appropriate safety measures were taken to protect mining personnel and prevent unsafe conditions. Industrial safety codes for mining, tunneling, and drilling were established by REECo and emphasized during all operations. A written standard operating procedure was required for each operation involving explosives, toxic materials, radioactive material, or any other operation with the potential for personal injury. Each individual involved in such an operation was required to know the contents of the applicable procedures.

The portal construction area and the tunnel were mandatory hard-hat and foot-protection areas (safety shoes, boots, DOE-issued miner's boots, or toe guards). All personnel on initial tunnel reentry teams were certified in the use of the Draeger self-contained breathing apparatus. Standard safety rules and regula-

tions, as spelled out in the "U.S. Bureau of Mines Manual," were observed.

All explosives, electro-explosive components, solid propellants, toxic materials, and radioactive materials were handled, stored, and transported in accordance with applicable sections of the following documents:

1. Army Material Command Regulations (AMCR 385-100).
2. Appropriate DOE Orders in the 5400 and 5600 Series concerning Environmental Protection, Safety & Health Protection, and Defense Programs, respectively.
3. Individual safe operating procedures (by experimenter organization).
4. MINERAL QUARRY Safety Regulations.

All personnel engaged in handling, storing, assembling, or installing explosives, propellants, or electro-explosive devices (or observers of those operations) were required to wear safety glasses or other eye protection which had been approved by the DoD safety coordinator.

10.5 RESULTS AND CONCLUSIONS.

Telemetry recording measurements began at 0800 hours on 25 July 1990, with a maximum reading on station 15 at H+10 seconds of 537 R/h from initial activation products. This reading decreased to 4.5 R/h by H+30 minutes. When all RAM stations were secured at 1030 hours on 31 July, RAM stations 15-23 were all reading below 100 mR/h. All other stations were reading background radiation levels.

The initial radiation surveys began at 0941 hours on 25 July and were completed at 1425 hours. No radiation above background levels was detected at the U12n tunnel portal yard area. Gas samples taken from the WP side of the GSP; the portal and WP side of the DPP; the end of stemming in the bypass and LOS drifts; and

inside the LOS pipe indicated no toxic or explosive gases and 21 percent oxygen.

Reentry into the tunnel began at 0813 hours on 26 July. Reentry team No. 1 established ventilation to the mesa at vent hole No.1 and then proceeded to inspect APP No. 1 (in the slow alcove). Surveys showed all tunnel atmospheric conditions were normal. That same day, at 1446 hours, reentry team No. 2 proceeded through shield walls Nos. 3-5, and then to TC No. 1 taking gas and water samples as they worked. The maximum radiation reading was 5.0 mR/h at shield wall No. 3, 8 ppm CO (at shield wall No. 4), no explosive gases, and 21 percent oxygen. The maximum reading obtained outside the TC No. 1 door was 80 mR/h on contact with the door. The next day, reentry team No. 2 opened the door at TC No. 1 at 1445 hours after the LOS pipe had been brought back to atmospheric pressure. Gas sample data showed 400 mR/h, 46 ppm CO, no explosive gases, and 21 percent oxygen. That day at 1725 hours, an air sampler at the ventilation pad above vent hole No. 2 was started.

Scientific assessment work and some recovery activities were conducted on 30 July. The team recovered TLDs at the shield walls, FDPP No. 4, and crosscut No. 2. The team completed their work by 1500 hours. The majority of experiment recovery work was completed during the first two weeks in August.

No reentry mining was done on this test. Only one reentry probe hole was drilled to analyze chimney gas samples and determine chimney radius. Posttest drilling and core sampling were accomplished from October through December 1990.

Personnel exposure data from self-reading pocket dosimeters were documented on Area Access Registers during individual entries to MINERAL QUARRY radex areas over a non-continuous time frame beginning 26 July 1990 and ending 10 July 1991 (see page 113 for a detailed explanation). Pocket dosimeters did not show any indication of possible radiation exposure to DoD-affiliated personnel. However, TLDs worn by these reentry personnel indicated that possibly one individual received some gamma exposure most likely

from the MINERAL QUARRY test. The minimum detectable gamma exposure with the NTS TLD is 15 mR. Area Access Register data are summarized below.

Participants	Entries Logged	Maximum Exposure (mR)	Average Exposure (mR)
All	596	0	0
DoD	205	0	0

SECTION 11

DISTANT ZENITH TEST

11.1 TEST SUMMARY.

DISTANT ZENITH was a DoD/LANL-sponsored weapons-effects test conducted at 0930 hours PDT on 19 September 1991. The test had a yield of less than 20 kilotons, and the device was emplaced at a vertical depth of 865 feet in the U12p.04 drift of the P tunnel complex (see Figure 11-1). The purpose of the DISTANT ZENITH test was to test the survivability of military hardware in a nuclear detonation environment. Supporting experiments included device and containment diagnostics studies and electromagnetic environmental measurements.

DISTANT ZENITH was satisfactorily contained, and no atmospheric release occurred from the test. However, several controlled³⁰ effluent releases occurred when various sections of the LOS pipe were purged through the tunnel ventilation system. Several controlled releases also occurred as the result of an experimental gas diagnostics program. When probe hole drilling occurred in May 1992, some noble gases were released.

11.2 PRETEST ACTIVITIES.

11.2.1 Responsibilities.

Safe conduct of all DISTANT ZENITH project activities in Area 12 was the responsibility of the DNA TGD, subject to controls and procedures established by the DOE TC. The DOE TC was responsible for safety of the public and onsite personnel during the test.

³⁰ The radioactive gas was passed through a filtering system where the particulates were removed before the gas was released through the tunnel ventilation system.

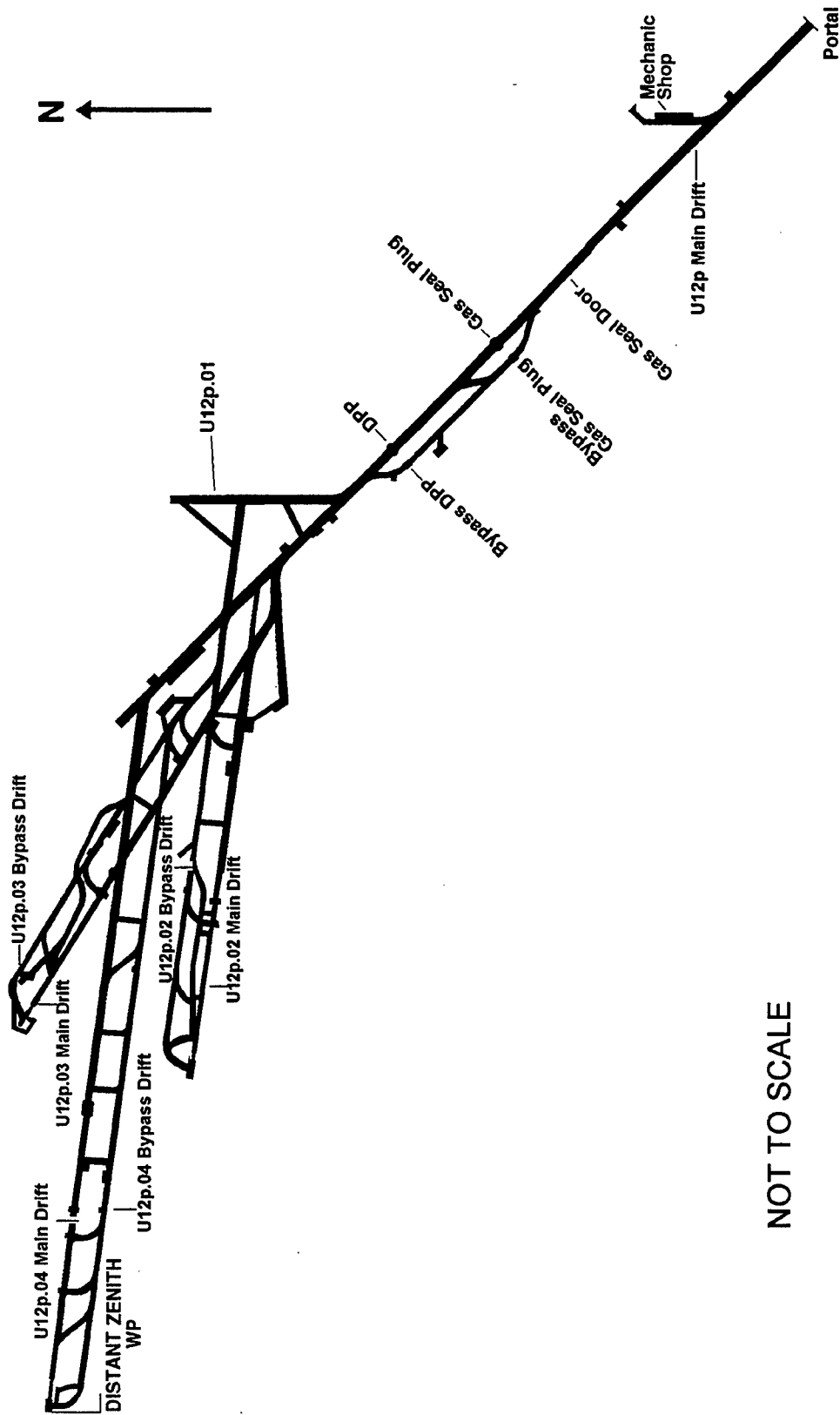

NOT TO SCALE

Figure 11-1. DISTANT ZENITH test - tunnel layout.

Project agencies were responsible for designing, preparing, and installing experiments, or delivering them to the installation contractor. After the test, these agencies were responsible for removing samples, analyzing instrument and sample data, and preparing project reports on experiment results.

Device safety and security procedures in the WP area and the timing and firing control room were in accordance with DOE Order 5610.10, "Nuclear Explosive and Weapon Safety Program." The LANL TGD had overall responsibilities for all operations involving the DISTANT ZENITH device as well as the timing control and the arming and firing of DISTANT ZENITH closures and experiments. The LANL TGD was responsible to the DOE TC for radiological safety within the designated area of the WP from device emplacement until detonation. After detonation, the DOE TC relieved the LANL TGD of these responsibilities and returned the responsibility for project activities back to the DNA TGD.

11.2.2 Planning and Preparations.

A. Tunnel Facilities Construction.

The DISTANT ZENITH drift complex, U12p.04, was mined in a westerly direction off the P tunnel main drift between the U12p.02 and U12p.03 drift complexes. The single taper 800-foot long horizontal LOS pipe diverged from a several-inch ID near the zero room to approximately 10 feet at the 800-foot end. The LOS pipe system was designed to provide exposure to all passive, active, and diagnostic experiments that were located in three experiment test cells between 1610 and 1770 feet. The tunnel region between the LOS pipe and the test cells, 850 to 1410 feet, contained several helium-filled mylar bags that were designed to improve the radiation transport between the evacuated LOS pipe and the primary exposure volume. Figure 11-2 shows an emplaced mylar bag. The U12p.04 drift complex components consisted of an LOS drift, a bypass drift, three closure mechanisms (i.e., the FAC, GSAC, stemming anchor closure [STAC]), the

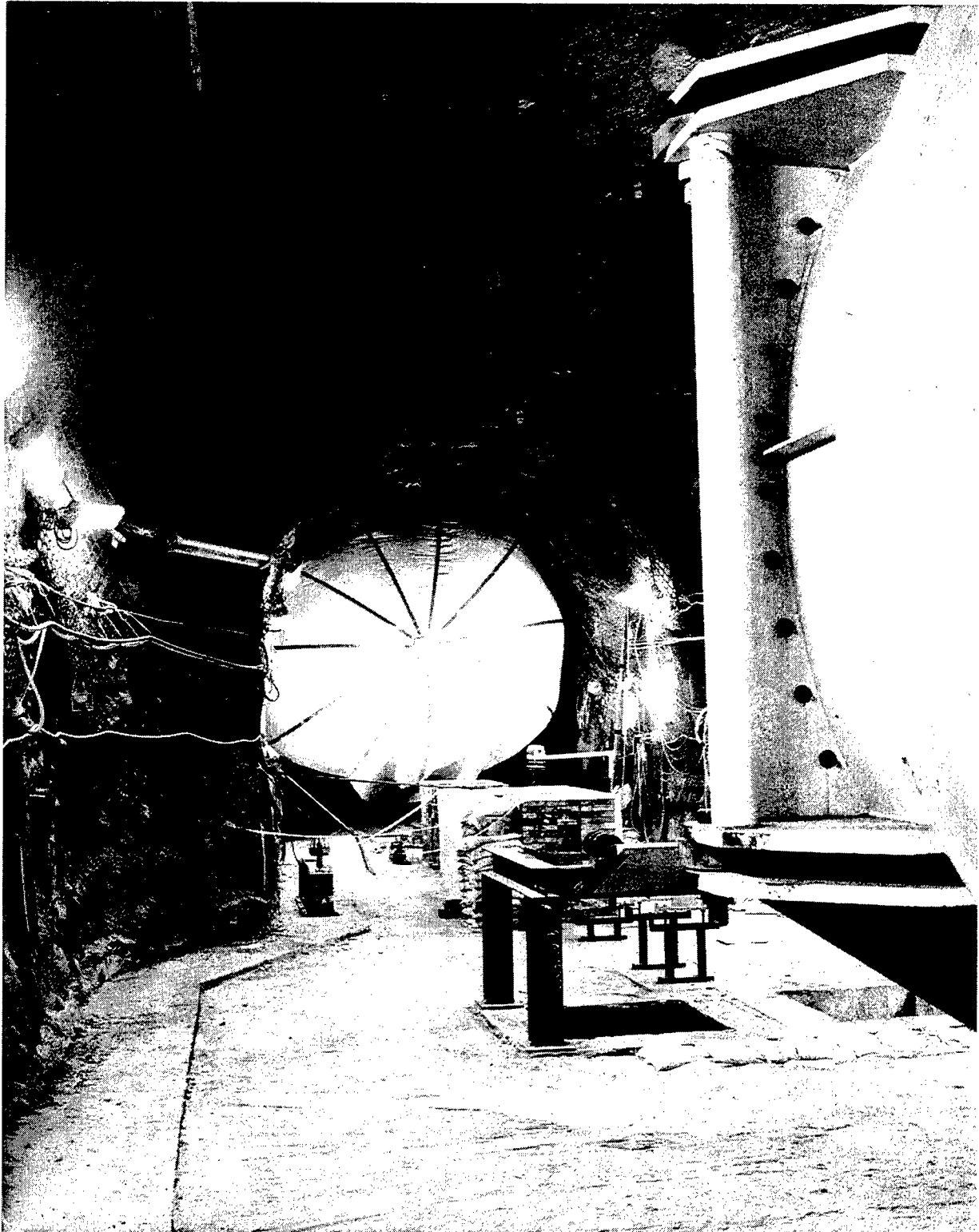

Figure 11-2. DISTANT ZENITH test - helium-filled mylar bag emplaced in drift.

TAPS, one zero room, a hardened pipe section, and a vacuum pumping system. No test chambers were located inside the LOS pipe. The facility drift and alcove protection locations are shown in Figure 11-3. The pumping system from the DISKO ELM test was reused after being modified to facilitate the requirements of the DISTANT ZENITH test.

Construction activities began in September 1989 when mining of the LOS and bypass drifts was started. This work was completed by June 1990. After a DISKO ELM one year review meeting was held on 10-11 October 1990, work on LOS pipe installation began in November; then the FAC, GSAC, and STAC were positioned on the LOS pipe in December; and the LOS pipe was completed to the end of stemming by February 1991. Work on constructing the first of three test cells began in January and all three cells were completed by March. Supply contractor problems and other shortages caused delays in cable and alcove turnover to experimenters. Finally in May, experiment installation began. Cable equalization began in June as did optical alignment of experiments in Test Cell 3.

The SDRs began on 9 July with varying amounts of participation because some experimenters' equipment was not operational. The first MSDR was held on 16 July as cable equalization work was still in progress. The SDRs continued through 27 August. An MFP dry run was completed on 29 August, and the next day LANL installed and checked out the device. Final stemming and button-up activities followed and continued through 14 September. The final dry run was completed on 17 September.

Remote gas sampling capabilities were incorporated during construction as well as capabilities for water, power, drain, and pressurization lines. Provisions were made to manually take gas samples from the WP side of the GSD, GSP, and the main and bypass DPPs during posttest reentry.

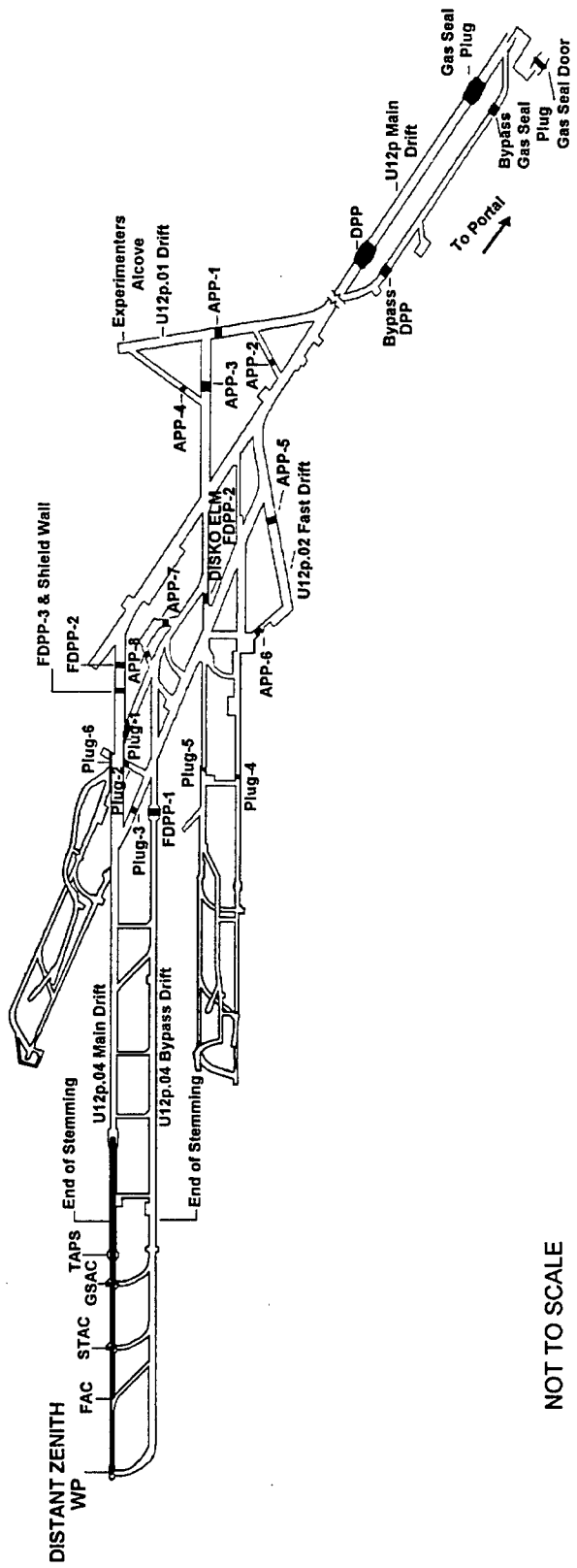
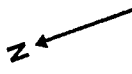

Figure 11-3. Distant Zenith test - facility drift and alcove protection plug locations.

The U12p.04 complex stemming plan, also indicating the previously described LOS pipe components within the stemmed area, is shown in Figure 11-4. The area behind the WP was filled with desert fines (sandbags). The main drift was stemmed with strong RMG to 59 feet; then with RMG to 101 feet; followed by SLG to 124 feet; then RMG to 148 feet; then SLG to 175 feet; and finally concrete surrounding the STAC, GSAC and TAPS out to 600 feet. The bypass drift was stemmed to a distance of 110 feet with RMG; then to 144 feet with gypsum cement groutcrete; followed by SLG to 190 feet; and then high-strength groutcrete to 605 feet. The crosscut drift from the bypass to the FAC was stemmed with SLG starting from 148 feet in the main drift to 175 feet in the crosscut drift and then high-strength groutcrete was used in the remainder of the crosscut. The crosscut drifts to the STAC and GSAC were also stemmed with high-strength groutcrete. All penetrations into the stemmed areas of the drifts (e.g., cables and water lines) were gas blocked to prevent the seepage of radioactive gases outside the stemmed region of the drifts.

Experiments and related hardware installations were completed by July 1991. The following organizations were among those that fielded experiments for the DISTANT ZENITH test: JAYCOR conducted radiation effects experiments; Harry Diamond Laboratories (HDL) conducted tactical electronics effects experiments; Science Applications International Corporation (SAIC) conducted gamma radiation diagnostics measurements; Science & Engineering Associates (SEA) conducted radiation output studies; Pacific Sierra Research (PSR) conducted electromagnetic environmental diagnostics experiments; Sandia National Laboratory, Albuquerque (SNLA) conducted device radiation output studies and containment diagnostic experiments; and Los Alamos National Laboratory (LANL) conducted device diagnostics studies and CORTEX measurements.

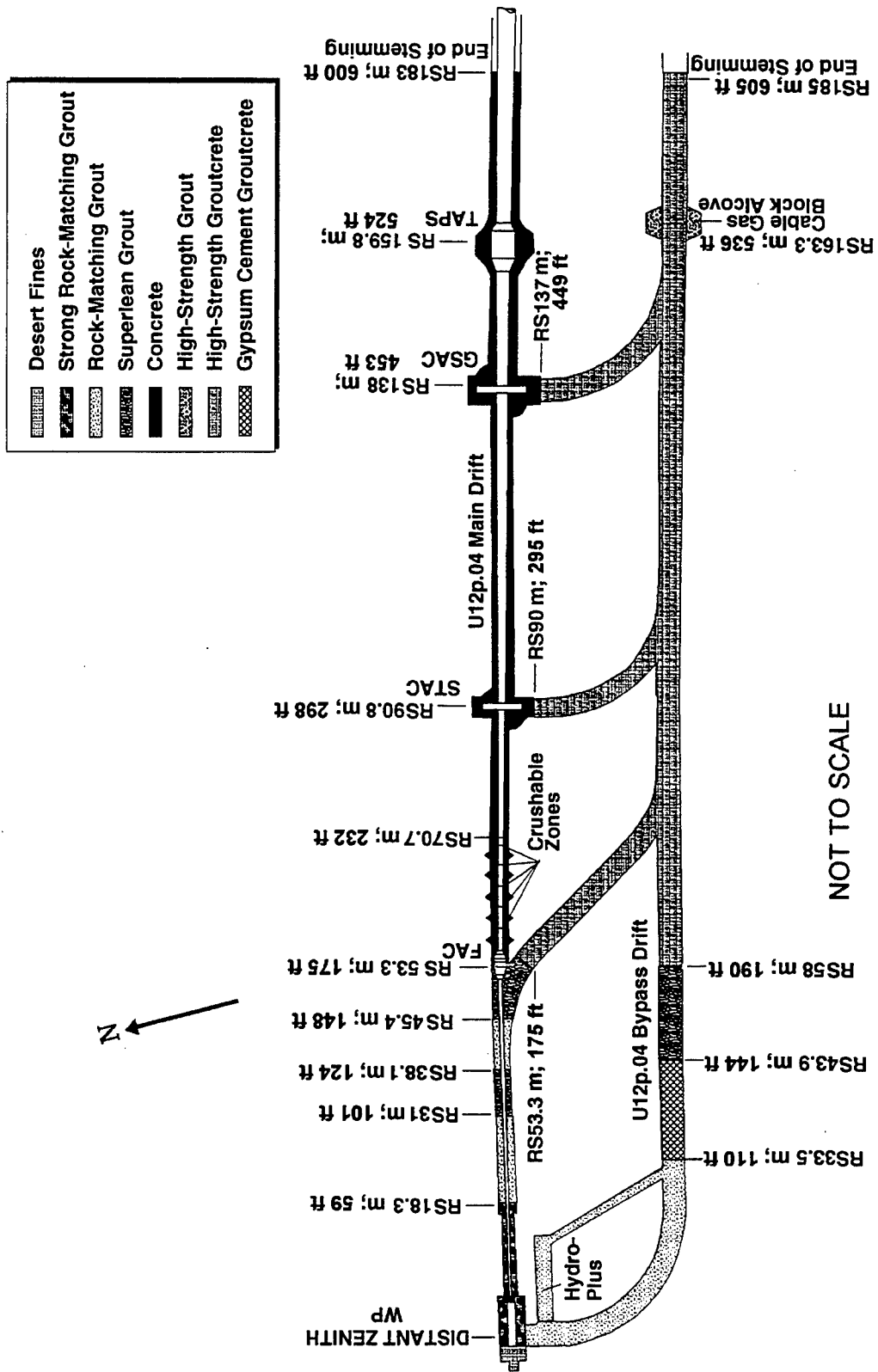

Figure 11-4. DISTANT ZENITH test - stemming plan.

Under the Threshold Test Ban Treaty (ratified by the U.S. in September 1990) protocol, the DNA/Radiation Sciences Directorate conducted the first Hydro-Plus experiment in a tunnel test. Instrumentation in the Hydro-Plus Drift provided data required for a treaty verification exercise.

The SDRs began in July. An MFP dry run was held on 29 August, and the next day, device insertion, final stemming, and button-up activities were accomplished.

B. Radiological Safety Support.

Procedures for radiation exposure and contamination control during this test were in accordance with NTS SOP 5401 and requirements of responsible DoD representatives. Radsafe provided monitoring and equipment support.

Prior to the test, detailed radiological safety reentry plans were prepared and issued to participating agencies. Air sampling equipment was positioned in the test area. Radsafe monitors were briefed regarding surface reentry, manned stations, and security station requirements.

Radsafe monitoring teams and supervisory personnel were provided to perform initial radiation surveys, conduct aerial surveys by helicopter, and participate in reentry parties as needed. Radsafe personnel were also standing by at designated muster stations prior to detonation to perform surveys and provide emergency support as directed; to provide and issue anticontamination equipment and material, portable instruments, and dosimeters; to operate area control check stations; and to perform personnel, equipment, and vehicle decontamination, as required.

Available anticontamination materials and equipment included head covers, coveralls, cloth shoe covers, totes, full-face masks, supplied-air breathing apparatus, plastic suits, plastic bags, gloves, and masking tape.

C. Telemetry and Air Sampling Support.

In addition to the permanent RAMS units, 45 temporary units provided surface and underground coverage for the DISTANT ZENITH test. Tables 11-1 and 11-2 list the locations of surface and underground RAMS, respectively. The locations of surface RAMS are shown in Figure 11-5, and those of underground RAM units are shown in Figures 11-6, and 11-7. All RAM units were installed a minimum of five days prior to scheduled device detonation.

EPA operated continuous monitoring stations at 44 locations in the offsite area. Thirty-three stations had high-volume air samplers with collectors for particulates and reactive gases, 20 had tritium samplers, 19 had noble gas samplers, and 40 had pressurized ion chamber gamma-rate detector/recorder systems linked to CP-1 and the Las Vegas EPA office via satellite telemetry. Twenty-eight EPA personnel were fielded for offsite surveillance activities.

D. Security Coverage.

Device security procedures in the WP area and the timing and firing control room were in accordance with DOE Order 5610.10, "Nuclear Explosive and Weapon Safety Program." Beginning on D-1, all personnel entering or exiting the controlled area were required to stop at muster or control stations for issue of stay-in badges. After control was established, all through traffic was diverted around the controlled area by use of screening stations. In accordance with the "Test Controller's Operations and Security Plan," contractors and agencies were to have all personnel not connected with this test out of the closed area before the final security sweep began.

Table 11-1. DISTANT ZENITH test RAMS unit locations 19 September 1991.

SURFACE

STATION NUMBER	LOCATION
From the U12p Portal:	
1	At the Portal
2	46 feet N 38° W on the vent line
3	310 feet N 42° E azimuth
4	328 feet N 84° E azimuth
5	265 feet S 39° E azimuth
6	238 feet S 02° W azimuth
7	309 feet S 63° W azimuth
8	296 feet N 72° W azimuth
9	300 feet N 27° W azimuth
10	236 feet S 05° E on the drain line
11	1,016 feet N 74° E azimuth
12	1,950 feet S 50° E azimuth
From the U12p.04 SGZ:	
13	400 feet N 00° E azimuth
14	400 feet S 60° E azimuth
15	400 feet S 60° W azimuth
Geophones - from the U12p.04:	
A	650 feet N 05° E
B	650 feet S 55° E
C	650 feet S 65° W

Table 11-2. DISTANT ZENITH test RAMS unit locations 19 September 1991.

UNDERGROUND

STATION NUMBER	LOCATION
16	1,145 feet into the U12p.04 LOS drift
17	900 feet into the U12p.04 LOS drift
18	650 feet into the U12p.04 LOS drift
19	400 feet into the U12p.04 LOS drift
20	310 feet into the U12p.04 LOS drift
21	270 feet into the U12p.04 LOS drift
22	190 feet into the U12p.04 LOS drift
23	130 feet into the U12p.04 LOS drift
24	1,150 feet into the U12p.04 bypass drift
25	800 feet into the U12p.04 bypass drift
26	400 feet into the U12p.04 bypass drift
27	275 feet into the U12p.04 bypass drift
28	300 feet into the U12p.03 bypass drift
29	325 feet into the U12p.03 LOS drift
30	At the 3-1 alcove
31	290 feet into the U12p.02 LOS drift
32	At the fast alcove
33	90 feet into the U12p.02 bypass drift

Table 11-2. DISTANT ZENITH test RAMS unit locations 19 September 1991 (Continued).

UNDERGROUND

STATION NUMBER	LOCATION
34	400 feet into the U12p.01 slow alcove
35	150 feet into the U12p.01 drift
36	2,880 feet into the U12p main drift
37	2,350 feet into the U12p main drift
38	2,180 feet into the U12p main drift
39ER ³¹	2,180 feet into the U12p main drift
40	1,870 feet into the U12p main drift
41	400 feet into the U12p main drift bypass
42	1,450 feet into the U12p main drift
43	1,300 feet into the U12p main drift
44	800 feet into the U12p main drift
45	200 feet into the U12p main drift

³¹ ER - Extended Range (instrument capable of reading 100 mR/h to 100,000 R/h).

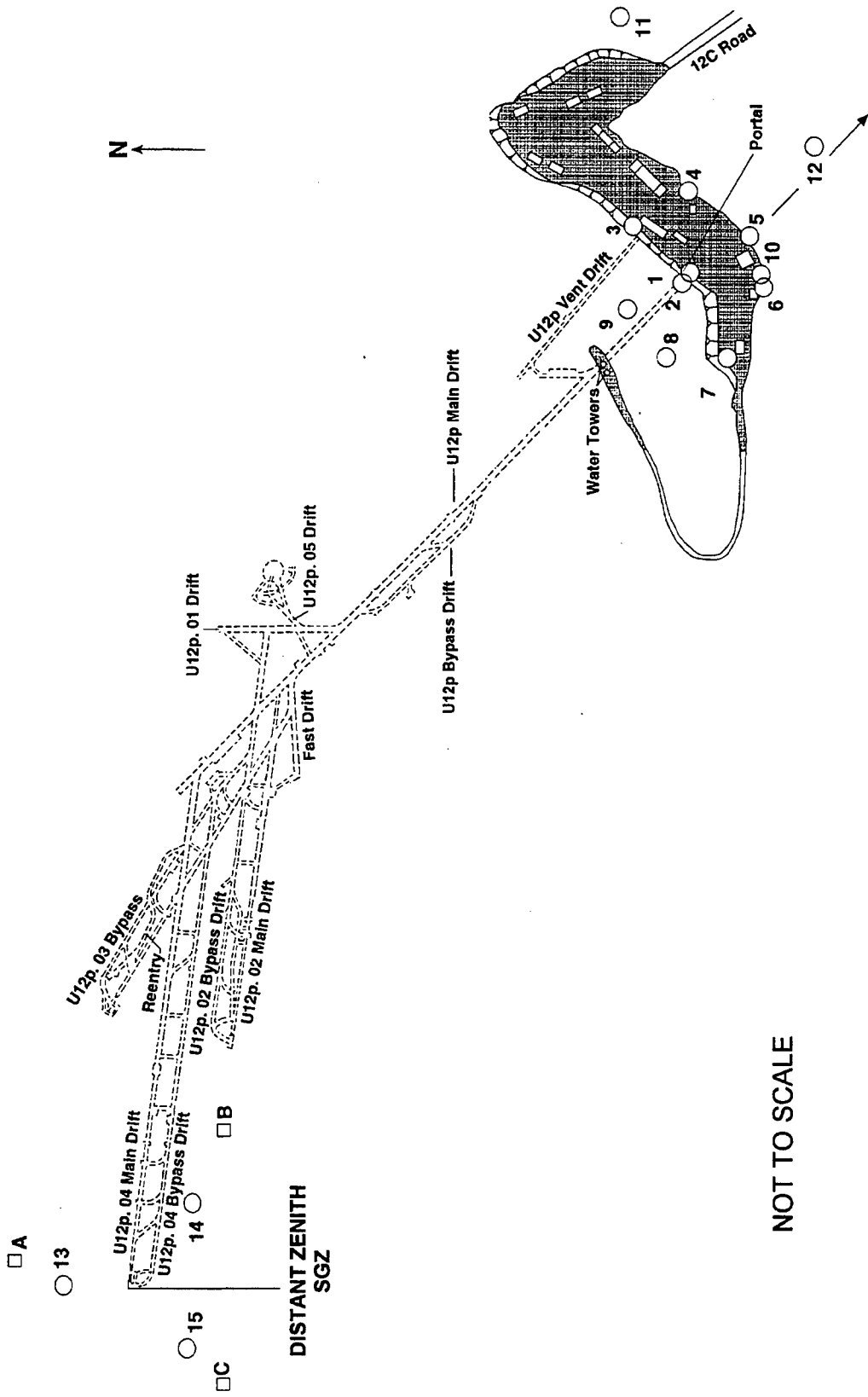
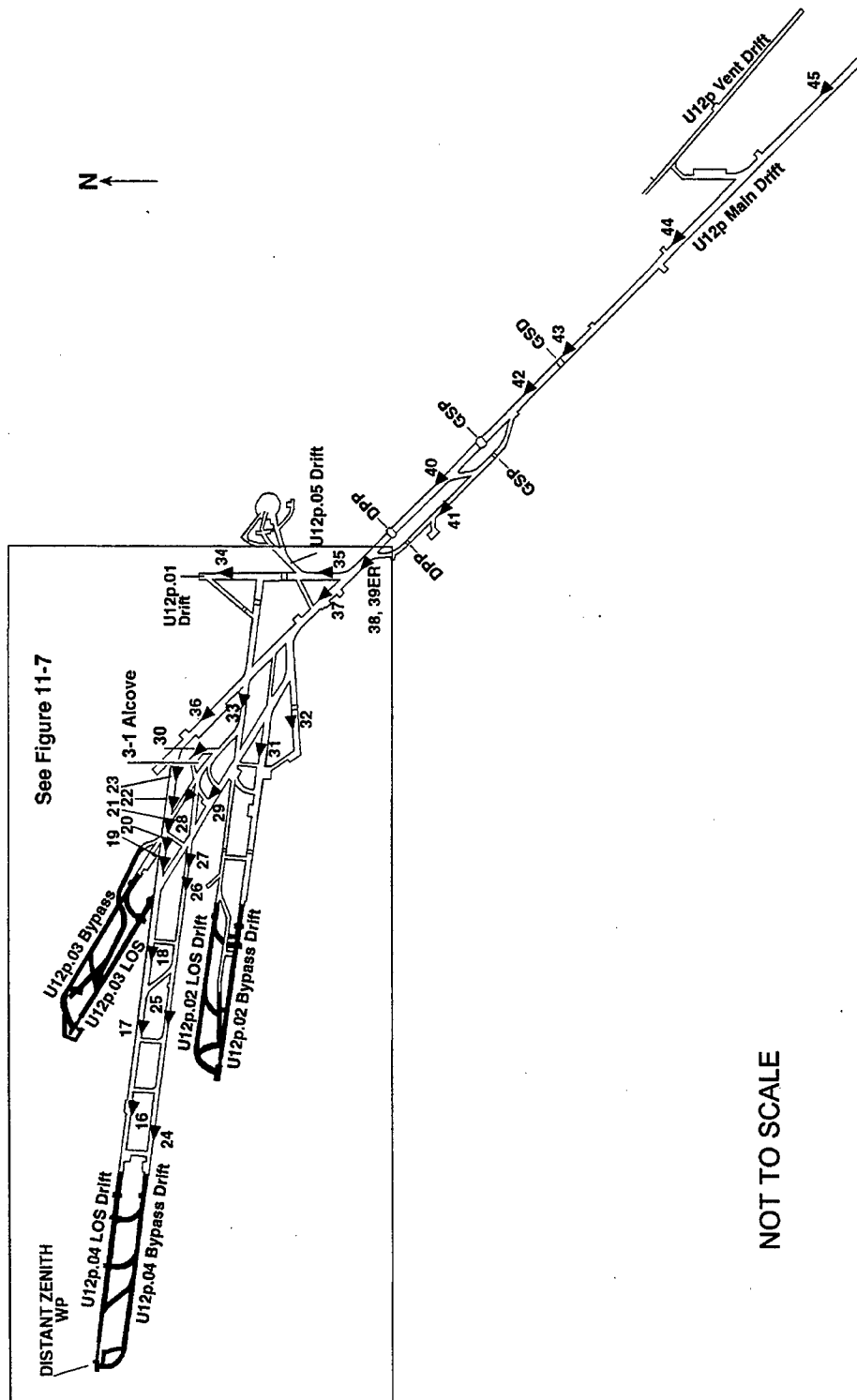
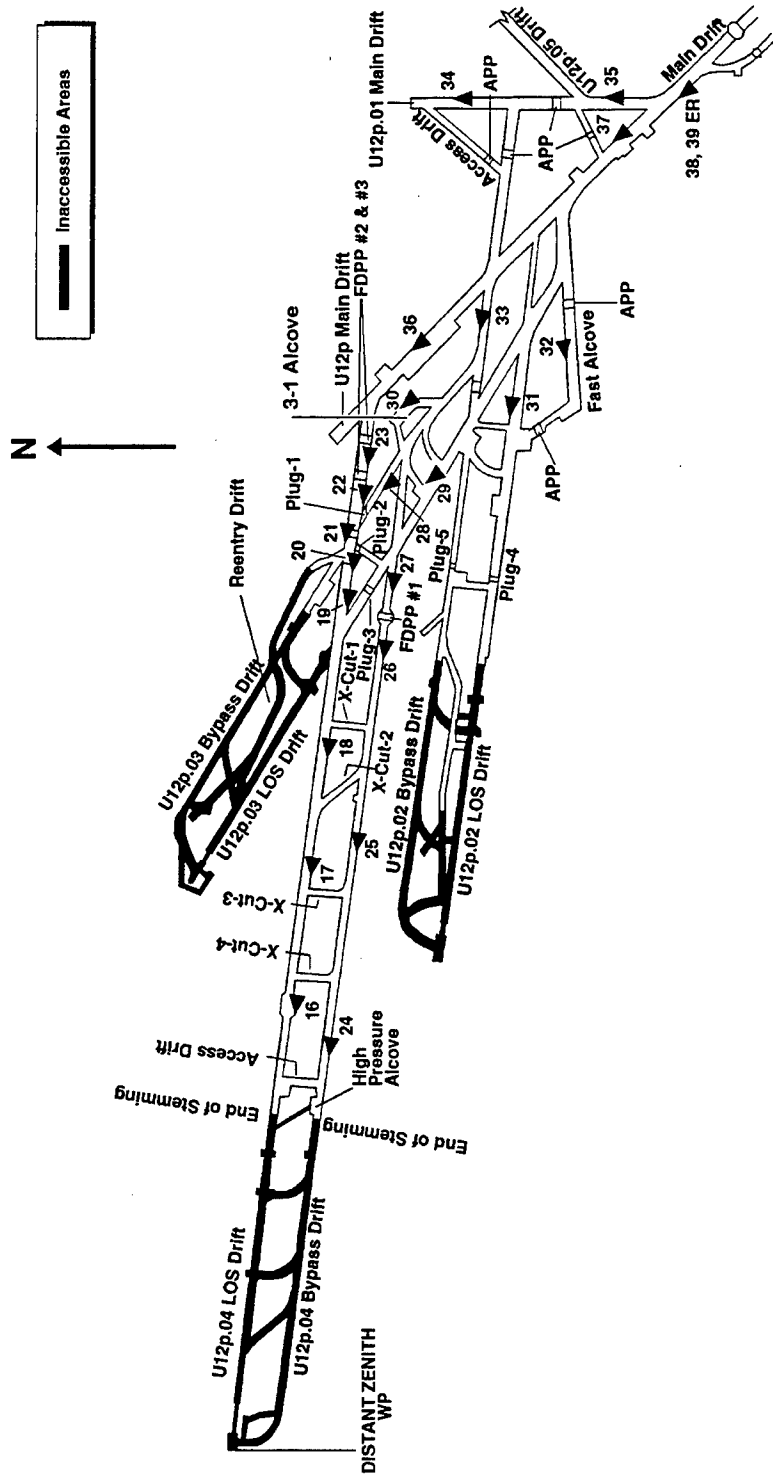

Figure 11-5. Distant Zenith test - surface RAMS.



NOT TO SCALE

Figure 11-6. DISTANT ZENITH test - underground RAMS.



NOT TO SCALE

Figure 11-7. DISTANT ZENITH test - underground RAMS U12p.04 complex.

E. Air Support.

Three helicopters and crews were provided by EG&G for cloud tracking and the Test Controller's use, if needed. In addition, the USAF provided a WC-135 aircraft and crew on standby status for cloud tracking. EG&G also provided two King Air aircraft to perform wind soundings, cloud sampling, and cloud tracking duties, if necessary.

11.3 TEST-DAY ACTIVITIES.

11.3.1 Pretest Activities.

On 18 September 1991, by approximately 2030 hours, all persons except the arming party, the tunnel button-up party, and the security guards were out of the tunnel and clear of the muster area. Soon after, permission was granted to arm the device. Following the departure of the arming party, button-up operations were completed, and the party left the tunnel. The area was cleared of all personnel by 0455 hours on 19 September.

A final readiness briefing was held in the early morning of 19 September. After a one-and-a-half-hour delay to assess a technical problem, the countdown proceeded uninterrupted until zero time. The DISTANT ZENITH device was detonated at 0930 hours PDT on 19 September 1991.

11.3.2 Test Area Monitoring.

Telemetry recording measurements began at 0930 hours on 19 September at which time all RAM units (i.e., stations) were operational and remained so throughout the readout period. Stations 1-15 and 27-45 read background levels at zero time and remained at background levels throughout the readout period. Immediately after zero time, stations 16-26 showed increased readings.

By H+10 seconds, stations 16-23, located in the LOS drift, recorded readings ranging from 24 mR/h (station 23) to greater than 1,000 R/h (station 16). These radiation levels were due to neutron activation; however the levels decreased rapidly as decay occurred. Stations 24-26 showed air activation only, however, no readings were given. The station 16 maximum reading of greater than 1,000 R/h decreased to 5.3 R/h by H+30 minutes. All stations were secured at 0930 hours on 23 September.

11.3.3 Initial Surface Radiation Surveys.

An initial seven-member surface reentry team departed the TC's barricade at Gate 300 at 1038 hours on 19 September 1991. A mobile check van was provided for area control and anticontamination clothing and equipment supply. All radiation readings were relayed as soon as they were obtained via Net 3 radio. By 1108 hours, a survey of the U12p portal yard area was completed. All radiation readings were at background levels (0.04 mR/h).

Survey teams stood by the U12p portal during initial gas sampling of the tunnel atmosphere. No toxic or explosive gases were detected and the oxygen level was 21 percent as measured on the WP side of the GSP; the WP side of the DPP; the portal side of the FDPP; the end of stemming in the bypass and LOS drifts; and outside the LOS pipe. Gas sampling was completed by 1356 hours, and all personnel were checked out of the test location by 1435 hours on 19 September.

11.4 POSTTEST ACTIVITIES.

11.4.1 Tunnel Reentry Activities.

The initial reentry work team entered the U12p tunnel portal at 0802 hours on 20 September. No anticontamination clothing was required for this part of the reentry work. Gas samples taken prior to reentry showed no toxic or explosive gases. The work team proceeded through the GSD manway door to the GSP where gas

sample data again showed a normal tunnel environment. All radiation readings were at background levels. The work team returned to the GSD at 0917 hours; dismantled the GSD; and began to install railroad tracks. They reestablished ventilation to the tunnel at 1120 hours and left the tunnel after completing their work.

The initial reentry team No. 1 and the rescue team, dressed in anticontamination clothing, left the portal area at 1129 hours on 20 September and proceeded to the portal side of the bypass GSP. At that point, team No. 1 put on their SCBA. The rescue team stood by as the team proceeded to the WP side of the main drift GSP, then moved on to the bypass DPP. A gas sample taken from the WP side of the bypass DPP indicated a normal tunnel atmosphere and background radiation levels. The team opened the crawltube door and reestablished ventilation to the WP side of the bypass DPP at 1240 hours. The rescue and communications teams moved forward to the portal side of the bypass DPP. Team No. 1 then proceeded to assess tunnel conditions and take gas samples as they walked through the U12p.04 drift complex. From the bypass DPP they moved to APP No. 1 (i.e., the slow alcove) where they opened the crawltube door and installed a security grate. From there the team moved to APP No. 5 where they repeated these actions. A gas sample taken from the WP side of APP No. 5 showed no toxic or explosive gases, and radiation readings were at background levels. By 1315 hours, the team reached FDPP No. 1 in the U12p.04 bypass drift. A gas sample taken from the WP side of FDPP No. 1 indicated 2 ppm CO, 1 percent of the LEL, 19.7 percent oxygen, and 0 percent helium. Again, radiation readings were at background levels. Upon opening the crawltube doors, a sample of the air on the WP side of FDPP No. 1 indicated 4.7 percent helium and 19.7 percent oxygen.

The team then proceeded to crosscuts Nos. 1 and 3 where at each helium fill station they vented the full or partially deflated helium bags. Radiation levels at crosscuts Nos. 1 and 3 were 8.0 and 15.0 mR/h, respectively. The team moved to the LOS drift where the team chief and a technician surveyed the end of the LOS pipe. A reading of 1.1 R/h on contact with the end of the LOS

pipe was recorded. The team moved on to check conditions at the plugs. Radiation readings were at background levels. By 1530 hours, the team had returned to the bypass DPP and removed their SCBA. Team No. 1 and the rescue team exited the tunnel and were surveyed and released at 1534 hours.

On 21 September at 0805 hours, the data recovery team removed data from the fast alcove. They completed their recoveries and exited the tunnel at 0914 hours, at which time all personnel and the equipment were surveyed and released.

The scientific assessment team, dressed in anticontamination clothing, entered the tunnel at 1023 hours and proceeded to check the APPs, and the test cells. Radiation readings were at background levels at the plugs; however, the maximum reading in the test cells was 50 mR/h in test cell No. 3. This team also checked conditions at the end of stemming in the LOS drift where a maximum reading of 200 mR/h was recorded. The team returned to the portal at 1410 hours where they were surveyed and then released.

On 23 September Sandia personnel recovered their experiments from the 3-1 alcove. Upon exit from the tunnel at 1040 hours, all personnel were surveyed and released. The next day at 1005 hours, LANL personnel began experiment recovery from the alcoves in the LOS drift at the end of stemming. In the LOS grout pit area, the maximum reading on contact with the experiments was 4.0 mR/h. Photographers entered the tunnel later that day to photograph areas inside the LOS pipe and in the test cells. This work was completed by 1430 hours, and recovery work was completed by 1450 hours. All personnel returned to the portal where they were surveyed and released. The majority of experiments had been recovered by 5 October; however, these activities continued until 25 October. The maximum reading recorded in the test cell area during experiment recovery was 30 mR/h.

11.4.2 Posttest Mining and Drilling.

Miners removed the GSD on 21 September and began work on the GSP later that day. By 23 September, the GSP work was completed and miners began removing the DPP. This work continued while scientific assessments and experiment recoveries were ongoing.

In late September, miners began removal of FDPP No. 1 as workers continued to disassemble and remove equipment from alcoves and test cells. Miners removed FDPP No. 2 and plug No. 3 early in October. On 14 October work began in the high pressure alcove, in the U12p.04 bypass drift, to set up the drilling rig in preparation for probe hole (RE#1 drill hole) drilling. The RE#1 drill hole was started on 17 October from the high pressure alcove and drilled approximately 654 feet into the chimney, above the test cavity. At a drill hole depth of 500 feet, radiation readings above background levels were detected, and personnel were required to dress in anticontamination clothing. The drill hole was completed on 24 October. Beginning on 28 October, LLNL began gas sampling activities as part of a two-month experimental gas diagnostics program.

In mid-November, miners began cutting the end of the stemming bulkhead and mining out a turnaround drift in the U12p.04 bypass drift in preparation for reentry drift mining. Beginning on 2 December, the reentry drift was mined through high-strength groutcrete along the bypass drift. As mining progressed, three original crosscuts were re-mined and redesignated as reentry crosscuts. The GSAC reentry crosscut mining started on 7 January 1992, from approximately 120 feet into the reentry drift and was mined through the stemming material to the LOS drift and around the GSAC. The STAC reentry crosscut was started on 31 January at approximately 285 feet in the reentry drift and mined through the stemming material to the LOS drift and around the closure so that it could be separated from the LOS pipe and removed for examination. The FAC reentry crosscut was started on 27 February at approximately 370 feet in the reentry drift and mined through the stemming material to the portal side of the FAC to gain entrance

into the LOS pipe for examining the portal end of the closure. Reentry mining was completed by late March, and related activities were completed in June.

For the most part, anticontamination clothing was not required during reentry mining because air sample readings indicated background radiation levels, no toxic or explosive gases, and 21 percent oxygen. When readings indicated toxic gases in reentry drifts, ventilation of the area was accomplished so that work could proceed.

11.4.3 Industrial Safety.

Checks for the presence of toxic gases and surveys to measure radiation and explosive gas levels were made on each shift. The results were then recorded in the monitors' logbook.

Appropriate safety measures were taken to protect mining personnel and prevent unsafe conditions. Industrial safety codes for mining, tunneling, and drilling were established by REECO and emphasized during all operations. A written standard operating procedure was required for each operation involving explosives, toxic materials, radioactive material, or any other operation with the potential for personal injury. Each individual involved in such an operation was required to know the contents of the applicable procedures.

The portal construction area and the tunnel were mandatory hard-hat and foot-protection areas (safety shoes, boots, DOE-issued miner's boots, or toe guards). All personnel on initial tunnel reentry teams were certified in the use of the Draeger self-contained breathing apparatus. Standard safety rules and regulations, as spelled out in the "U.S. Bureau of Mines Manual," were observed.

All explosives, electro-explosive components, solid propellants, toxic materials, and radioactive materials were handled, stored,

and transported in accordance with applicable sections of the following documents:

1. Army Material Command Regulations (AMCR 385-100).
2. Appropriate DOE Orders in the 5400 and 5600 Series concerning Environmental Protection, Safety & Health Protection, and Defense Programs, respectively.
3. Individual safe operating procedures (by experimenter organization).
4. DISTANT ZENITH Safety Regulations.

All personnel engaged in handling, storing, assembling, or installing explosives, propellants, or electro-explosive devices (or observers of those operations) were required to wear safety glasses or other eye protection which had been approved by the DoD safety coordinator.

11.5 RESULTS AND CONCLUSIONS.

Telemetry recording measurements began at 0930 hours on 19 September with a maximum reading on station 16 at H+10 seconds of greater than 1000 R/h as a result of initial activation products. This reading decreased to 5.3 R/h by H+30 minutes. When all RAM stations were secured at 0930 hours on 23 September, stations 1-15, and 23-45 were all reading background radiation levels.

The initial radiation surveys began at 1038 hours on 19 September and were completed at 1435 hours. No radiation above background levels was detected at the U12p tunnel portal yard area. Gas samples taken from the WP side of the GSP; the WP side of the DPP; the portal side of the FDPP; the end of stemming in the bypass and LOS drifts; and outside the LOS pipe indicated no toxic or explosive gases and 21 percent oxygen.

Reentry into the tunnel began at 0802 hours on 20 September. Reentry team No. 1, dressed in anticontamination clothing and SCBA, established ventilation to the WP side of the bypass DPP and

then proceeded to walk through the U12p.04 complex to assess tunnel conditions. They walked to crosscuts Nos. 1 and 3 where they inspected each helium fill station and vented the helium-filled bags. The maximum radiation readings at crosscut Nos. 1 and 3 were 8.0 and 15.0 mR/h, respectively. The team proceeded to the test cells where radiation readings were at background levels. Team No. 1 exited the tunnel with the rescue team at 1534 hours.

The next day, the data recovery and the scientific assessment teams completed their respective assignments so that both Sandia and LANL personnel could begin their experiment recovery activities on 23 September. The majority of experiments were recovered by 5 October.

A probe hole, drilled 654 feet from the high pressure alcove to the chimney above the cavity was completed on 24 October to facilitate a two-month gas sampling diagnostics program, conducted by LLNL. The program began on 28 October. A reentry drift was mined along the bypass drift through stemming material. Three crosscuts to the closures were also re-mined to gain access to the LOS pipe and to examine and remove closure components for examination. This work was conducted from November 1991 to March 1992, with related posttest activities being completed in June 1992. For most reentry work anticontamination clothing was not required. When surveys indicated the presence of toxic gases, ventilation was accomplished before work continued.

Personnel exposure data from self-reading pocket dosimeters were documented on Area Access Registers during individual entries to DISTANT ZENITH radex areas over a non-continuous time frame beginning 20 September 1991 and ending 23 June 1992 (see page 113 for a detailed explanation). Pocket dosimeters showed no indication of possible radiation exposure to DoD-affiliated personnel. TLDs worn by these reentry personnel indicated that no individual received any reportable gamma exposure from the DISTANT ZENITH test. The minimum detectable gamma exposure with the NTS TLD is 15 mR. Area Access Register data are summarized below.

Participants	Entries Logged	Maximum Exposure (mR)	Average Exposure (mR)
All	948	8.0	0
DoD	53	0	0

SECTION 12

DIAMOND FORTUNE TEST

12.1 TEST SUMMARY.

DIAMOND FORTUNE was a DoD/LANL-sponsored weapons-effects test conducted at 0930 hours PDT on 30 April 1992. The test had a yield of less than 20 kilotons, and the device was emplaced in a 36-foot radius near-hemispherical cavity at a vertical depth of 776 feet in the U12p.05 drift of the P tunnel complex (see Figure 12-1). The purpose of the DIAMOND FORTUNE test was to investigate the close-in airblast flow fields that would be produced by a modern nuclear device.

DIAMOND FORTUNE was satisfactorily contained, and no atmospheric release occurred from the test. However, several controlled effluent releases occurred intermittently through the tunnel ventilation system between 4 May and 2 July 1992.

12.2 PRETEST ACTIVITIES.

12.2.1 Responsibilities.

Safe conduct of all DIAMOND FORTUNE project activities in Area 12 was the responsibility of the DNA TGD, subject to controls and procedures established by the DOE TC. The DOE TC was responsible for safety of the public and onsite personnel during the test.

Project agencies were responsible for designing, preparing, and installing experiments, or delivering them to the installation contractor. After the test, these agencies were responsible for removing samples, analyzing instrument and sample data, and preparing project reports on experiment results.

Device safety and security procedures in the WP area and the timing and firing control room were in accordance with DOE Order

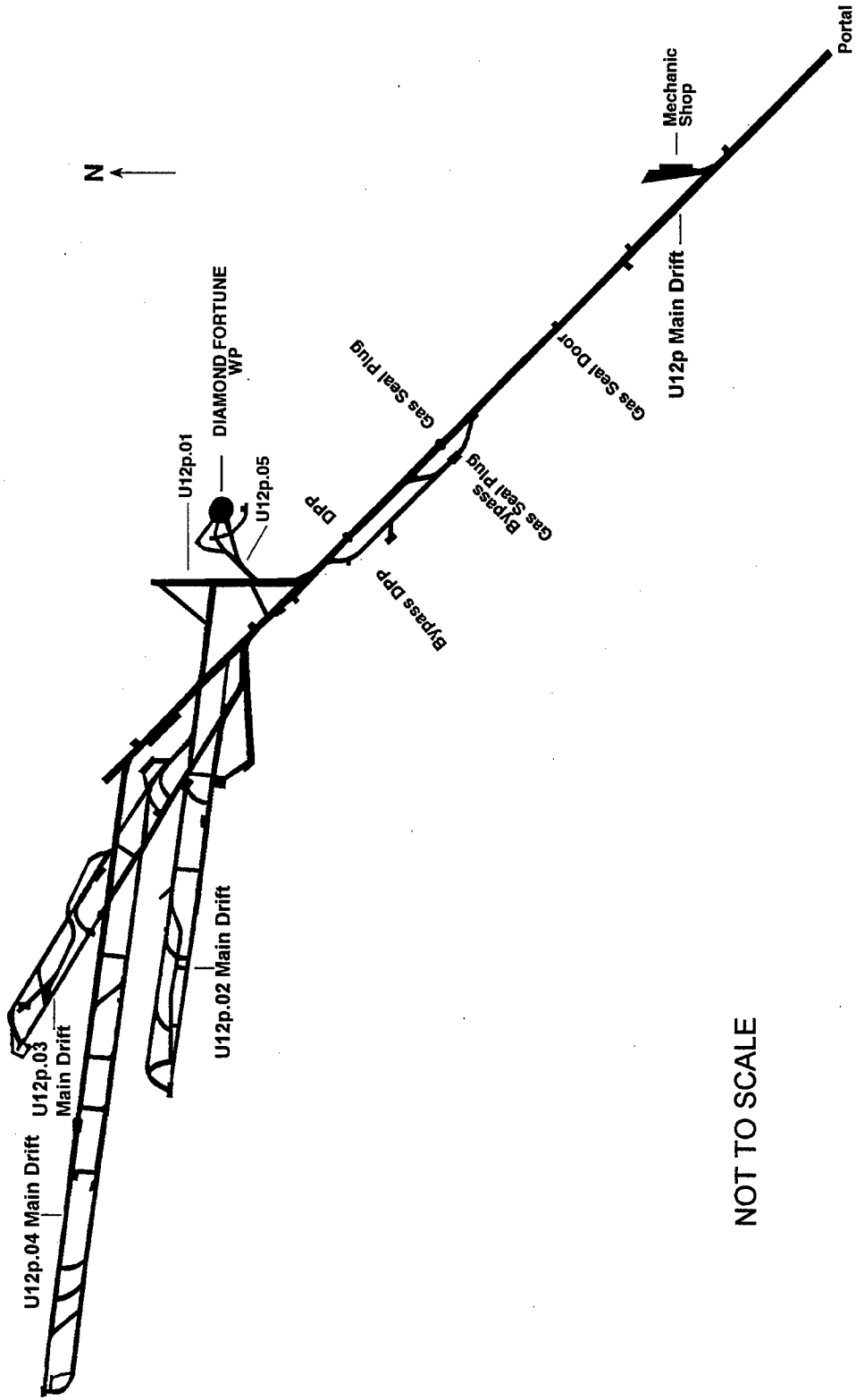

NOT TO SCALE

Figure 12-1. DIAMOND FORTUNE test - tunnel layout.

5610.10, "Nuclear Explosive and Weapon Safety Program." The LANL TGD had overall responsibilities for all operations involving the DIAMOND FORTUNE device as well as the timing control and the arming and firing of DIAMOND FORTUNE closures and experiments. The LANL TGD was responsible to the DOE TC for radiological safety within the designated area of the WP from device emplacement until detonation. After detonation, the DOE TC relieved the LANL TGD of these responsibilities and returned the responsibility for project activities back to the DNA TGD.

12.2.2 Planning and Preparations.

A. Tunnel Facilities Construction.

The DIAMOND FORTUNE drift complex, U12p.05, was mined off the U12p.01 drift. The cavity was mined 36 feet on one side and 42.6 feet on the other to allow an expanded field of view for the fireball photography experiment. The cavity floor was mined an additional 6.6 feet to allow for placement of experiments embedded in the cavity floor and then grouted to the final floor level. All experiments were located within the cavity, but all were not in the grout floor. Five gas-filled (Freon) mylar bags, emplaced on the floor between the 180 and 350 degree azimuths, were used to simulate the shock decursor effect (i.e., airblast pressure measurements). Figure 12-2 shows personnel emplacing one of the mylar bags in the cavity.

The U12p.05 drift complex consisted of a 10-foot wide by 11-foot high main access drift that entered the cavity at the floor level; a 10-foot wide by 10-foot high camera drift that entered the cavity at the 180 degree azimuth 13 feet below the final grout floor elevation; a 10-foot wide by 11-foot high cable drift that entered the cavity 13 feet below the final grout floor elevation; and the 10-foot wide by 10-foot high runaround drift that was approximately 110 feet long and approximately 29.5 feet from the cavity where experiments penetrated from the cavity wall to the run-

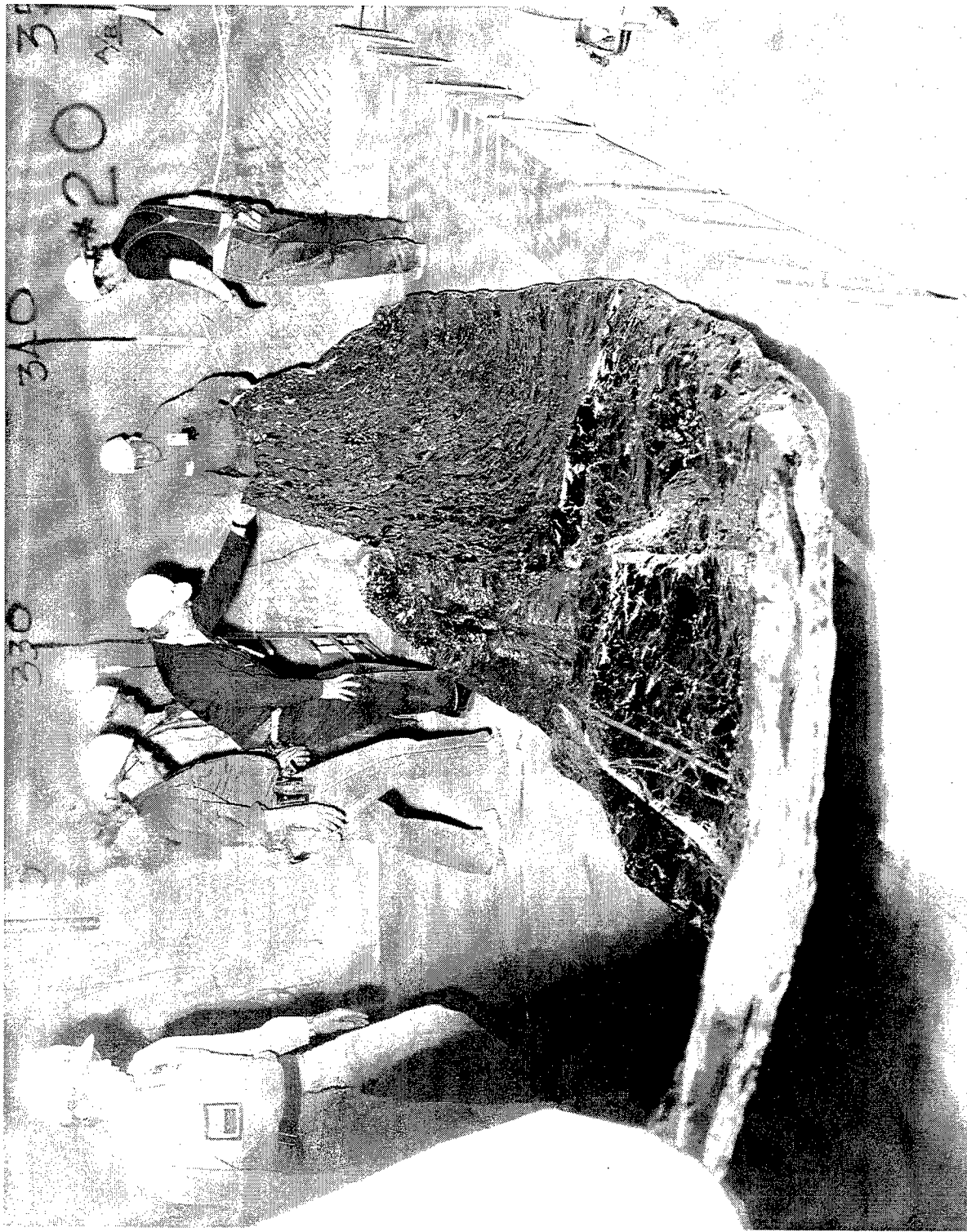

Figure 12-2. DIAMOND FORTUNE test - mylar bag emplacement in the cavity.

around drift. The drift complex layout is shown in Figure 12-3.

Construction activities began in December 1990, and by late June 1991 mining of the drifts and cavity were completed. However, with all resources needed to prepare DISTANT ZENITH for execution, work on DIAMOND FORTUNE was essentially stopped until after the 19 September detonation. This required the readiness date to be moved to early April 1992. In October, work on the LOS pipes in the camera drift, as well as bar gauge installation in the cavity was started. Further delays were encountered because of the cable pulling tasks, alcove turnover, changes as the result of an experiment review meeting, and regrouting in the cavity. These problems were rectified and work accelerated in January 1992. The cavity floor was poured in late January, and cable turnover to the experimenters was 95 percent complete at that time.

After changes in the Red Shack configuration were made in February, it was not likely that an early April readiness date could be met. Installation of pipes and experiments caused further delays, and the last cable turnover to experimenters did not occur until early March. The SDRs finally began on 26 February, and the first MSDR was held on 5 March. Some of the equipment did not function properly, and only about 50 percent of the gauges were online to their recording devices. Therefore, based on the dry run performance, a delay in readiness until 24 April was requested.

Because of leaks in the cable drift and the mirror and camera alcoves in late March, pressurization of the cavity was unsuccessful. Work to stop the leaks progressed into April; this delayed the MFP dry run and pushed the readiness date to 28 April. The camera experiment was brought back online when the leaks were stopped, and a successful MFP dry run was finally completed on 15 April. Minor

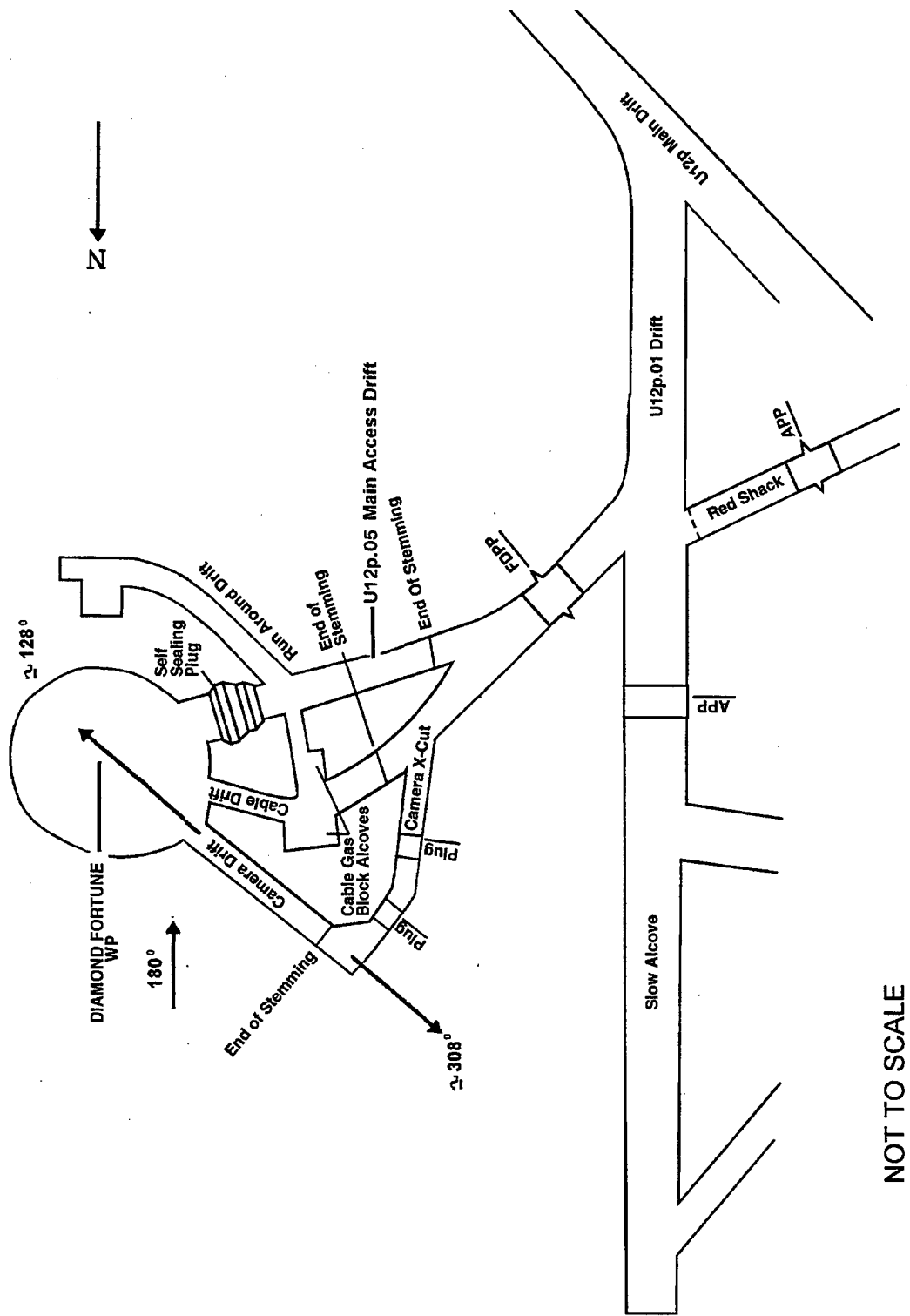

Figure 12-3. DIAMOND FORTUNE test - drift complex layout.

equipment replacements were made, and on 20 April, LANL emplaced and checked out the device. Final stemming and button-up activities followed. The final dry run was completed on 27 April.

Remote gas sampling capabilities were incorporated during construction as well as capabilities for water, power, drain, and pressurization lines. Provisions were made to manually take gas samples from the WP side of the GSD, GSP, and main DPP during posttest reentry.

The stemming plan for the U12p.05 complex is shown in Figure 12-4. Each of the drifts that entered the cavity was stemmed with HSG while the runaround drift was stemmed with RMG. The cable alcoves were stemmed with high-strength groutcrete. The cavity floor was filled in two pours. A modified MJ-2 mix containing Class A cement was used to fill the cavity floor to one foot of the final elevation. Then an MJ-2 mix containing a different cement was used to bring the floor to the required elevation. The self-sealing plug in the access drift was concrete, and the other plugs were either concrete or HSG. All penetrations into the stemmed areas of the drifts (e.g., cables and water lines) were gas blocked to prevent the seepage of radioactive gases outside the stemmed region of the drifts.

Experiments and related hardware installations were completed by March 1992. The following organizations were among those that fielded experiments for the DIAMOND FORTUNE test: S-CUBED conducted airblast pressure, radiation fireball, and thermal layer measurements; Science Applications International Corporation (SAIC) conducted shock time-of-arrival studies; Naval Research Laboratory/Information Services, Inc. (NRL/ISI) conducted fireball and shock photography experiments; Sandia National Laboratory, Albuquerque (SNLA) conducted airblast, containment, seismic verification technology, ground shock coupling, and radiation diagnostic experiments; Los Alamos National Laboratory

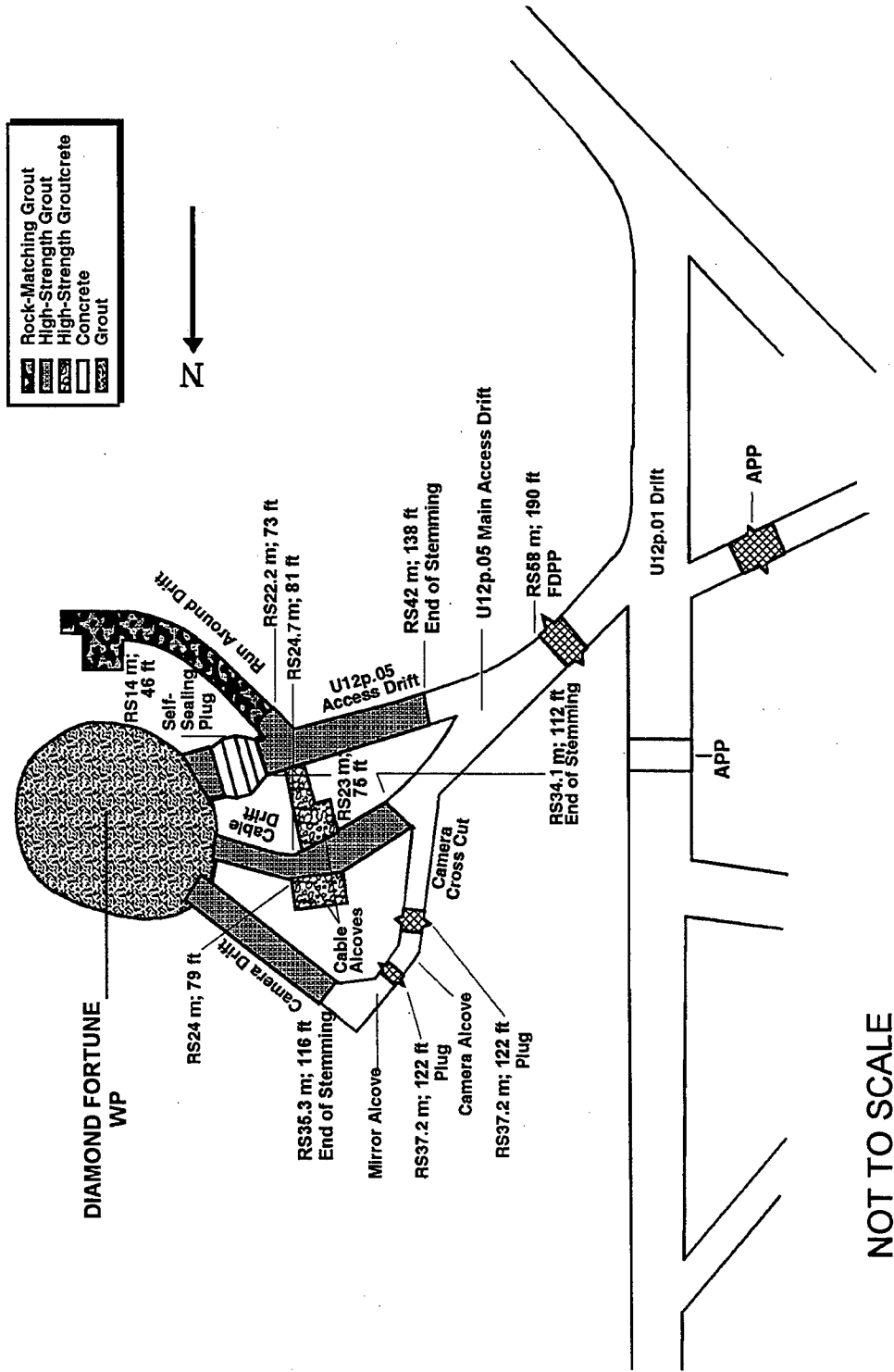

Figure 12-4. DIAMOND FORTUNE test - stemming plan.

(LANL) conducted gamma reaction history studies and a contained nuclear vessel experiment (CONVEX); and Lawrence Livermore National Laboratory (LLNL) conducted diagnostic and CONVEX studies.

An MFP dry run was held on 15 April. Device emplacement occurred on 20 April followed by final stemming and button-up activities. After the final dry run on 27 April, while the final testbed button-up operations were being completed, one of the mylar bags in the cavity ruptured. To prevent the Freon from jeopardizing primary test objectives, a 48-hour delay for test execution was imposed with the cavity being continually vented during that time. On 29 April the testbed was ready and button-up operations were repeated.

B. Radiological Safety Support.

Procedures for radiation exposure and contamination control during this test were in accordance with NTS SOP 5401 and requirements of responsible DoD representatives. Radsafe provided monitoring and equipment support.

Prior to the test, detailed radiological safety reentry plans were prepared and issued to participating agencies. Air sampling equipment was positioned in the test area. Radsafe monitors were briefed regarding surface reentry, manned stations, and security station requirements.

Radsafe monitoring teams and supervisory personnel were provided to perform initial radiation surveys, conduct aerial surveys by helicopter, and participate in reentry parties as needed. Radsafe personnel were also standing by at designated muster stations prior to detonation to perform surveys and provide emergency support as directed; to provide and issue anticontamination equipment and material, portable instruments, and dosimeters; to operate area

control check stations; and to perform personnel, equipment, and vehicle decontamination, as required.

Available anticontamination materials and equipment included head covers, coveralls, cloth shoe covers, totes, full-face masks, supplied-air breathing apparatus, plastic suits, plastic bags, gloves, and masking tape.

C. Telemetry and Air Sampling Support.

In addition to the permanent RAMS units, 40 temporary units provided surface and underground coverage for the DIAMOND FORTUNE test. Tables 12-1 and 12-2 list the locations of surface and underground RAMS, respectively. The locations of surface RAMS are shown in Figure 12-5, and those of underground RAM units are shown in Figures 12-6 and 12-7. All RAM units were installed a minimum of five days prior to scheduled device detonation.

EPA operated continuous monitoring stations at 34 locations in the offsite area. Thirty-one stations had high-volume air samplers with collectors for particulates and reactive gases, 15 had tritium samplers, 12 had noble gas samplers, and 30 had pressurized ion chamber gamma-rate detector/recorder systems linked to CP-1 and the Las Vegas EPA office via satellite telemetry. Twenty-four EPA personnel were fielded for offsite surveillance activities.

D. Security Coverage.

Device security procedures in the WP area and the timing and firing control room were in accordance with DOE Order 5610.10, "Nuclear Explosive and Weapon Safety Program." Beginning on D-1, all personnel entering or exiting the controlled area were required to stop at muster or control stations for issue of stay-in badges. After control was established, all through traffic was diverted around the controlled area by use of screening stations. In accor-

Table 12-1. DIAMOND FORTUNE test RAMS unit locations 30 April 1992.

SURFACE

STATION NUMBER	LOCATION
From the U12p Portal:	
1	At the Portal
2	46 feet N 38° W on vent line
3	310 feet N 42° E azimuth
4	328 feet N 84° E azimuth
5	265 feet S 39° E azimuth
6	238 feet S 02° W azimuth
7	309 feet S 63° W azimuth
8	296 feet N 72° W azimuth
9	300 feet N 27° W azimuth
10	236 feet S 05° E on drain line
11	1,016 feet N 74° E azimuth
12	1,950 feet S 50° E azimuth
From the U12p.05 SGZ:	
13	250 feet N 00° E azimuth
14	250 feet S 60° E azimuth
15	250 feet S 60° W azimuth
Geophone:	
A	At U12p.05 SGZ

Table 12-2. DIAMOND FORTUNE test RAMS unit locations 30 April 1992.

UNDERGROUND

STATION NUMBER	LOCATION
16	100 feet into the U12p.05 mirror alcove
17	73 feet into the U12p.05 camera alcove
18	50 feet into the U12p.05 camera crosscut
19	105 feet into the U12p.05 main drift
20	65 feet into the U12p.05 main drift
21	245 feet into the U12p.01 main drift
22	120 feet into the U12p.01 main drift
23	In the fast alcove
24	290 feet into the U12p.02 LOS drift
25	90 feet into the U12p.02 bypass drift
26	2,880 feet into the U12p main drift
27	2,350 feet into the U12p main drift
28	2,180 feet into the U12p main drift
29ER ³²	2,180 feet into the U12p main drift
30	1,870 feet into the U12p main drift
31	400 feet into the U12p bypass main drift

³² ER - Extended Range (instrument capable of reading 100 mR/h to 100,000 R/h).

Table 12-2. DIAMOND FORTUNE test RAMS unit locations 30 April 1992 (Continued).

UNDERGROUND

STATION NUMBER	LOCATION
32	1,450 feet into the U12p main drift
33	1,300 feet into the U12p main drift
34	800 feet into the U12p main drift
35	200 feet into the U12p main drift
36	1,150 feet into the U12p.04 bypass drift
37	800 feet into the U12p.04 bypass drift
38	400 feet into the U12p.04 bypass drift
39	275 feet into the U12p.04 bypass drift
40	325 feet into the U12p.03 LOS drift
Geophone:	
B	2,685 feet into the U12p main drift, left rib

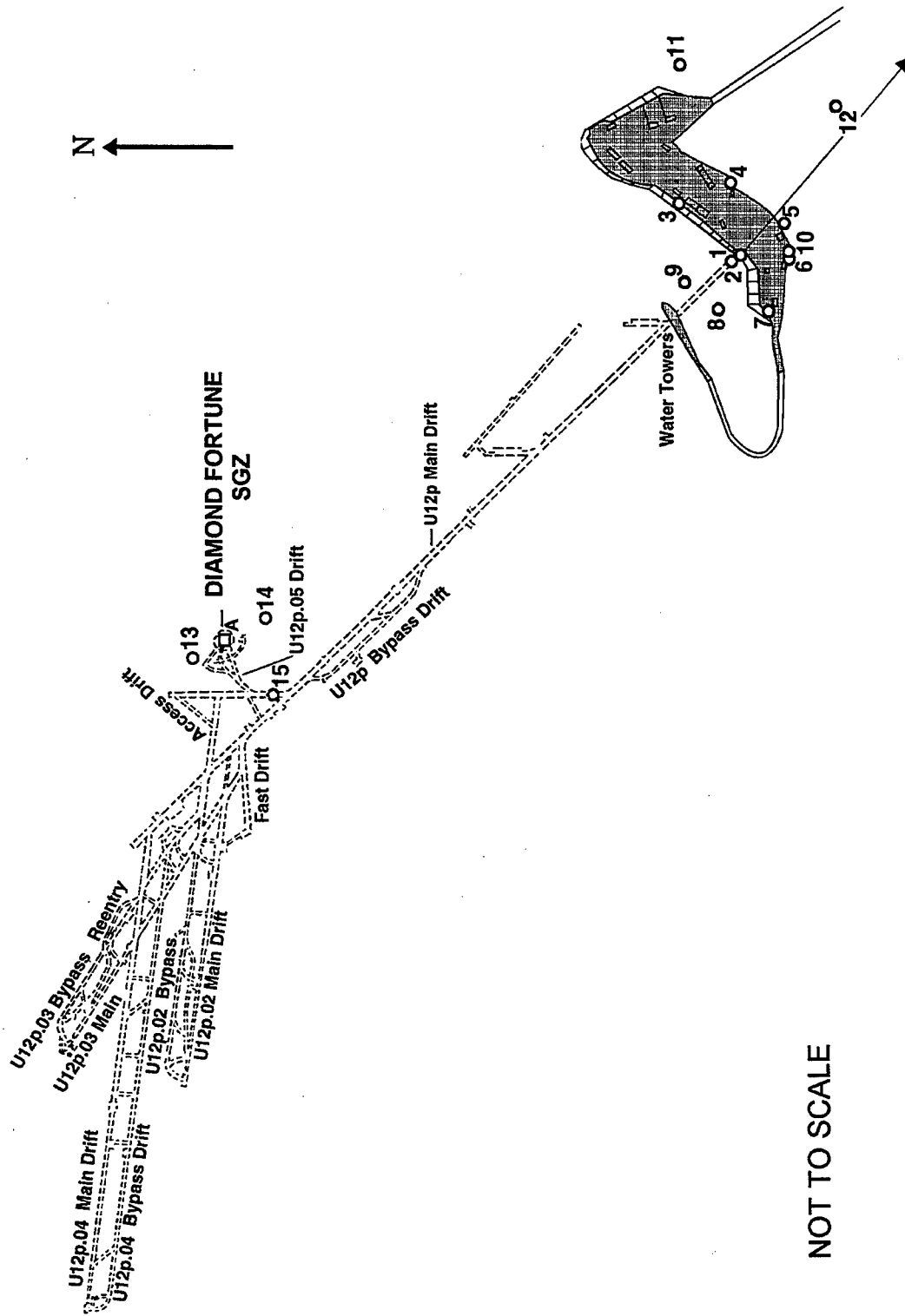

NOT TO SCALE

Figure 12-5. DIAMOND FORTUNE test - surface RAMS.

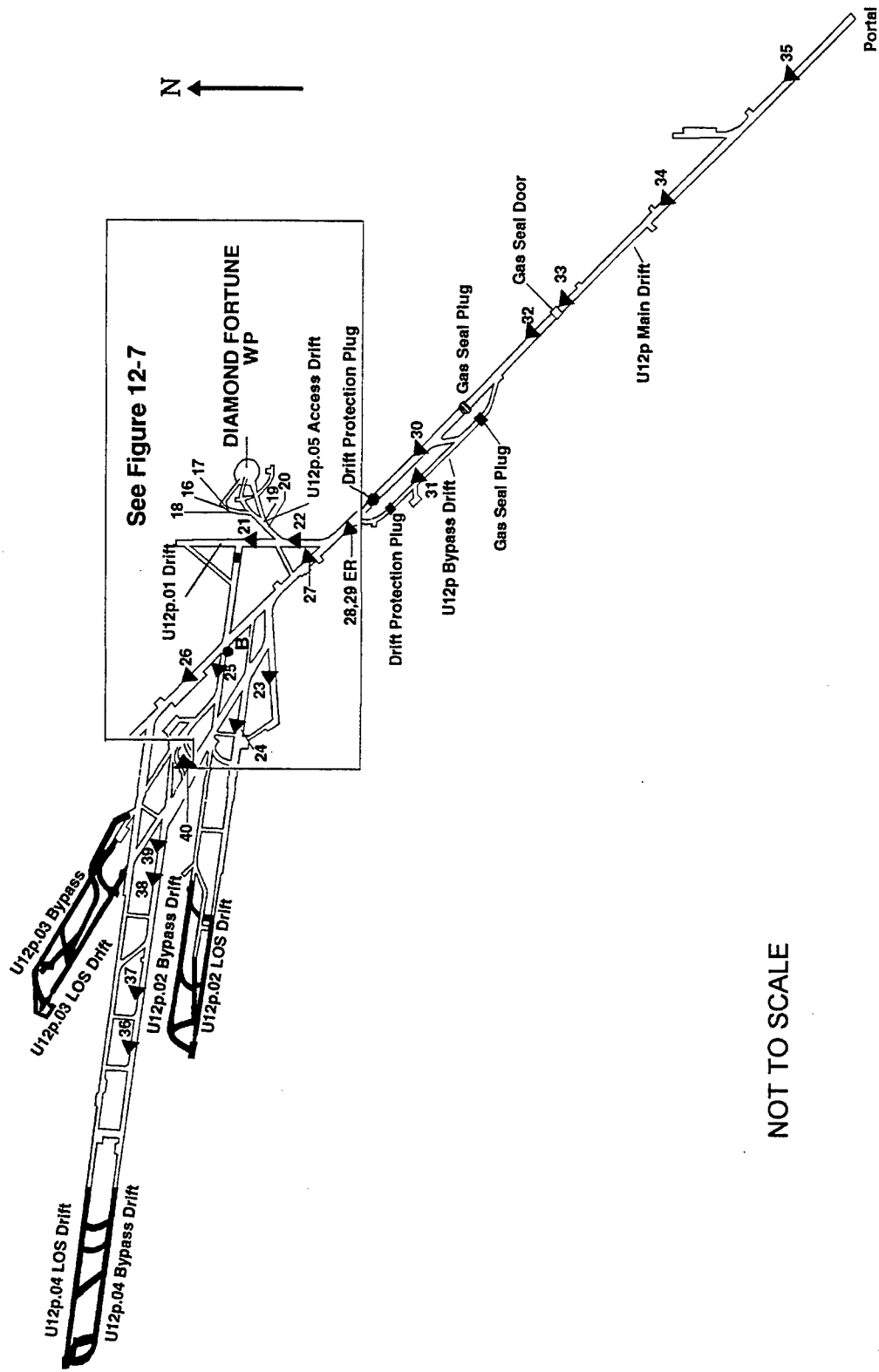

NOT TO SCALE

Figure 12-6. DIAMOND FORTUNE test - underground RAMS.

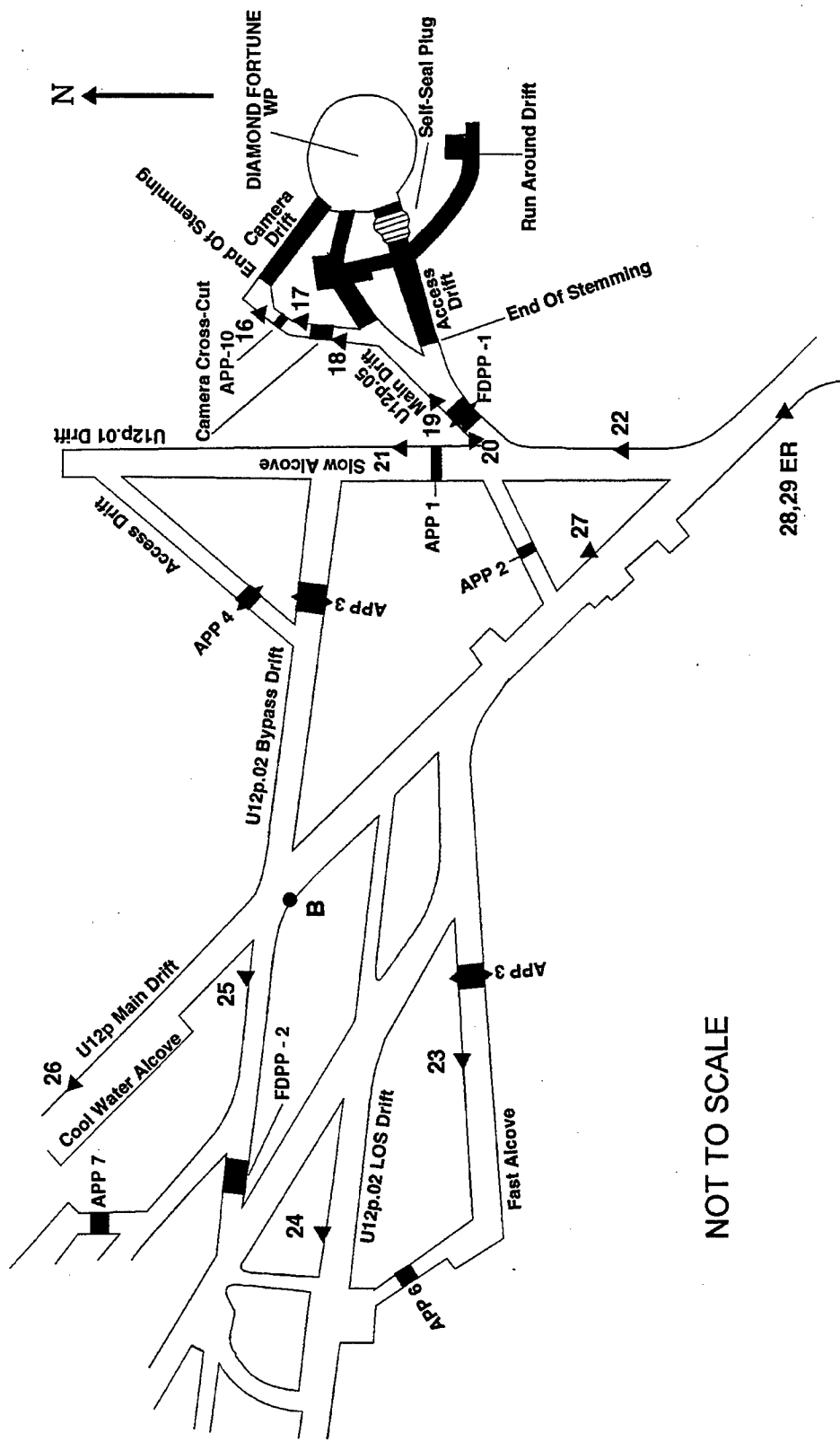

NOT TO SCALE

Figure 12-7. DIAMOND FORTUNE test - underground RAMS U12p.05 complex.

dance with the "Test Controller's Operations and Security Plan," contractors and agencies were to have all personnel not connected with this test out of the closed area before the final security sweep began.

E. Air Support.

Three BO-105 helicopters and crews were provided by EG&G for cloud tracking and the Test Controller's use, if needed. In addition, the USAF provided a WC-130 and/or a WC-135 aircraft and crew on standby status for cloud tracking. EG&G also provided two King Air aircraft to perform wind soundings, cloud sampling, and cloud tracking duties, if necessary.

12.3 TEST-DAY ACTIVITIES.

12.3.1 Pretest Activities.

On 30 April 1992, by approximately 0130 hours, all persons except the arming party, the tunnel button-up party, and the security guards were out of the tunnel and clear of the muster area. Soon after, permission was granted to arm the device. Following the departure of the arming party, button-up operations were completed, and the party left the tunnel. The area was cleared of all personnel by 0345 hours on 30 April.

A final readiness briefing was held in the early morning of 30 April. The countdown began at 0925 hours and proceeded uninterrupted until zero time. The DIAMOND FORTUNE device was detonated at 0930 hours PDT on 30 April 1992.

12.3.2 Test Area Monitoring.

Telemetry recording measurements began at 0930 hours on 30 April at which time all RAM units (i.e., stations) were operational and remained so throughout the readout period. Stations 1-15, 17, 23,

24, and 29(ER)-40 read background levels at zero time and remained at background levels throughout the readout period.

At H+70 seconds, station 16 read 11.6 mR/h, but this reading decreased to background levels by H+8.5 minutes. Station 18 read 4.0 mR/h at H+3.3 minutes, but was indicating background levels by H+1.4 hours. All stations were secured at 1400 hours on 11 May 1992.

12.3.3 Initial Surface Radiation Surveys.

An initial six-member surface reentry team departed the TC's barricade at Gate 300 at 1109 hours on 30 April 1992. A mobile check van was provided for area control and anticontamination clothing and equipment supply. All radiation readings were relayed as soon as they were obtained via Net 3 radio. By 1143 hours, a survey of the U12p portal yard area was completed. All radiation readings were at background levels (0.04 mR/h).

Survey teams stood by the U12p portal during initial gas sampling of the tunnel atmosphere. No toxic or explosive gases were detected, and the oxygen level was 21 percent as measured on the WP side of the U12p.05 DPP; the WP side of the bypass GSP; the portal side of the FDPP; and at the end of stemming. Radiation readings were at background levels. Gas sampling was completed by 1328 hours, and all personnel were checked out of the portal area by 1350 hours on 30 April and returned to the standby location at the P and T tunnel access roads.

By 1500 hours that day, it became apparent that radioactive gas was seeping into the tunnel complex. At 1615 hours, health and safety personnel entered the tunnel portal to take additional gas samples. The work was completed by 1720 hours and personnel departed from the area. Samples were sent to the laboratory for analysis.

12.4 POSTTEST ACTIVITIES.

12.4.1 Tunnel Reentry Activities.

The next day, 1 May, health and safety personnel returned to the portal to take additional gas samples as was done the previous day. Sampling data again showed no toxic or explosive gases, and radiation readings were at background levels. Gas sampling was completed by 0805 hours, and at 0835 hours, a work team and two communications technicians entered the U12p tunnel portal and proceeded to the GSD where they removed a portion of the door and moved on to the bypass GSP. They opened the turntube doors and reestablished ventilation on the WP side of the bypass GSP at 1106 hours. No toxic or explosive gases were detected, and the oxygen level was 21 percent. Low levels of radioactive noble gases were detected on the WP side of the GSP. The work team departed at 1315 hours.

From 1-4 May remote gas sampling of the tunnel from the portal continued. At 0835 hours on 4 May, after remote sampling was completed, the work team reentered the tunnel and turned on the ventilation fans.

At 1055 hours, the initial reentry team No. 1 and the rescue team, dressed in anticontamination clothing, left the portal area and proceeded to the GSD. The reentry team wore SCBA, but the rescue team, who stood by at the GSD, had theirs ready for use if necessary. Team No.1 proceeded first to the slow alcove, then to the APP No. 5 at the fast alcove, taking gas samples before proceeding through turntube doors. From there they moved to FDPP No. 1 in the U12p.05 main access drift; sampled the WP side and then proceeded to APP No. 10 in the camera crosscut drift. There they gas sampled the WP side before opening the turntube to establish ventilation. All gas samples taken during Team No. 1 reentry work indicated no toxic or explosive gases, and the oxygen level was 21 percent. All radiation readings were near background levels. Team No. 1 then returned to the portal where they were surveyed and released at 1315 hours.

Two data recovery teams entered the tunnel at approximately 1430 hours with one team proceeding to the fast alcove and the other team to the camera alcove (WP side of APP No. 10). Recovery activities were completed, and all personnel were surveyed and released at 1620 hours.

On 5 May miners began work on the GSP and the main and bypass DPPs. Health and safety personnel were constantly monitoring the P tunnel main drift, taking grab samples and swipes at numerous locations on the WP side of the main drift DPP. A gas sample taken at 1300 hours from the WP side of the main DPP showed 1000 ppm CO, 10 percent of the LEL, and 21 percent oxygen. Miners continued to work in the main drift, mining through the main DPP, and laying railroad track. This work was completed on 8 May.

Equipment recovery work from the slow alcove, the camera crosscut, the mirror alcove, and the T-1 alcove was started on 11 May. No anticontamination clothing was required during these recoveries, and the majority of the work was accomplished by 18 May.

12.4.2 Posttest Mining and Drilling.

After miners completed mining of the main GSP and DPP, reentry drift mining began on 25 May 1992. A reentry drift was started from the right rib of the main cavity access drift at about 100 feet into the drift (to the WP side of the removed FDPP No. 1) and was mined for approximately 50 feet. To prepare the cavity for possible later reentry, mining was stopped at that point, and the cavity was ventilated intermittently for approximately a two-month period to reduce the levels of toxic, explosive, and radioactive gases. Mining resumed on 7 July, and by the time the drift reached 112 feet, it became apparent that vertical fractures almost parallel to the reentry drift on the WP side of the curve of the drift were the source of increased radiation levels. As mining progressed, at least three probe holes were drilled in every mined face of the reentry drift to determine whether there were radioactive seams in the direction of reentry mining.

The reentry drift was advanced to the edge of stemming in the cavity runaround drift where probe hole drilling in the direction of the LANL CONVEX was accomplished to determine the level of contamination of the stemming material on the portal ends of the experiment. The reentry drift was then mined through the stemming grout on the cavity runaround drift until the portal ends of the six CONVEX pipes were uncovered. Radioactive water leaking from the CONVEX pipes hampered recovery of materials (i.e., coupons) contained in the pipes.

Mining resumed to the right of the LANL CONVEX to uncover the portal ends of the SNLA/LLNL CONVEX so that some measurements could be made. This work was completed successfully. Additional probe holes were drilled from the left rib of the reentry drift to obtain radiation levels on the portal side of the bulkhead where the SNLA/DNA windows experiment was located. Because radiation readings showed extensive contamination, investigation of this experiment was not accomplished. There was no further mining in the reentry drift nor was there any experiment recovery. Two bulkheads were constructed at 112 and 73.5 feet, respectively in the reentry drift. The drift between the bulkheads was filled with a stemming material to prevent access to the area.

12.4.3 Industrial Safety.

Checks for the presence of toxic gases and surveys to measure radiation and explosive gas levels were made on each shift. The results were then recorded in the monitors' logbook.

Appropriate safety measures were taken to protect mining personnel and prevent unsafe conditions. Industrial safety codes for mining, tunneling, and drilling were established by REECo and emphasized during all operations. A written standard operating procedure was required for each operation involving explosives, toxic materials, radioactive material, or any other operation with the potential for personal injury. Each individual involved in such an operation was required to know the contents of the applicable procedures.

The portal construction area and the tunnel were mandatory hard-hat and foot-protection areas (safety shoes, boots, DOE-issued miner's boots, or toe guards). All personnel on initial tunnel reentry teams were certified in the use of the Draeger self-contained breathing apparatus. Standard safety rules and regulations, as spelled out in the "U.S. Bureau of Mines Manual," were observed.

All explosives, electro-explosive components, solid propellants, toxic materials, and radioactive materials were handled, stored, and transported in accordance with applicable sections of the following documents:

1. Army Material Command Regulations (AMCR 385-100).
2. Appropriate DOE Orders in the 5400 and 5600 Series concerning Environmental Protection, Safety & Health Protection, and Defense Programs, respectively.
3. Individual safe operating procedures (by experimenter organization).
4. DIAMOND FORTUNE Safety Regulations.

All personnel engaged in handling, storing, assembling, or installing explosives, propellants, or electro-explosive devices (or observers of those operations) were required to wear safety glasses or other eye protection which had been approved by the DoD safety coordinator.

12.5 RESULTS AND CONCLUSIONS.

Telemetry recording measurements began at 0930 hours on 30 April 1992, with a maximum reading on station 16 at H+70 seconds of 11.6 mR/h. This reading decreased to background radiation levels by H+8.5 minutes. All RAM stations were secured at 1400 hours on 11 May.

The initial radiation surveys began at 1109 hours on 30 April and were completed at 1328 hours. No radiation above background

levels was detected at the U12p tunnel portal yard area. Gas samples taken from the WP side of the bypass GSP; the WP side of the U12p.05 DPP; the portal side of the FDPP; and the end of stemming indicated no toxic or explosive gases and 21 percent oxygen. That same day at 1615 hours, health and safety personnel entered the tunnel portal to take additional gas samples because it was apparent that radioactive gas was seeping into the tunnel complex.

From 1-4 May, remote gas sampling of the tunnel was accomplished, and on 4 May the work team turned on the tunnel ventilation fans. Reentry into the tunnel began at 1055 hours on 4 May when team No. 1 and the rescue team proceeded to the GSD (where the rescue team stood by). Reentry team No. 1, dressed in anticontamination clothing and SCBA, proceeded to the slow alcove, the fast alcove, FDPP No. 1, and APP No. 10. At each location the team took gas samples from the WP side before opening turntube doors and moving to the WP side of the barrier. Gas samples indicated no toxic or explosive gases and 21 percent oxygen. All radiation readings were at background levels. Team No. 1 exited the tunnel with the rescue team at 1315 hours. Two data recovery teams completed their work later that day.

From 5-8 May health and safety personnel continued to take swipes and grab samples from numerous locations on the WP side of the main DPP while miners began removal of the GSP and installation of railroad track. Equipment and experiment support recovery work was started on 11 May with the majority of the work completed by 18 May.

Reentry mining began on 25 May when a reentry drift was mined from the right rib of the main cavity access drift through the stemming grout of the cavity runaround drift to uncover the ends of the LANL CONVEX pipes and recover the experiments contained therein. Contaminated water in the pipes hampered this recovery. Mining to expose the pipes of the SNLA/LLNL CONVEX provided access to the experiment so that measurements on the strain gauges could be made. The SNLA/DNA windows experiment was not successfully

investigated because of the contaminated environment. Further mining and recovery work was suspended for the same reason.

Personnel exposure data from self-reading pocket dosimeters were documented on Area Access Registers during individual entries to DIAMOND FORTUNE radex areas over a non-continuous time frame beginning 1 May 1992 and ending 8 July 1992 (see page 113 for a detailed explanation). Pocket dosimeters showed no indication of possible radiation exposure to DoD-affiliated personnel. TLDs worn by these reentry personnel indicated that no individual received any reportable gamma exposure from the DIAMOND FORTUNE test. The minimum detectable gamma exposure with the NTS TLD is 15 mR. Area Access Register data are summarized below.

Participants	Entries Logged	Maximum Exposure (mR)	Average Exposure (mR)
All	118	2.0	0
DoD	5	0	0

SECTION 13

HUNTERS TROPHY TEST

13.1 TEST SUMMARY.

HUNTERS TROPHY was a DoD/LLNL-sponsored weapons-effects test conducted at 1000 hours PDT on 18 September 1992. The test had a yield of less than 20 kilotons, and the device was emplaced at a vertical depth of 1,264 feet in the U12n.24 drift of the N tunnel complex (see Figure 13-1). The purpose of the HUNTERS TROPHY test was to test the survivability of military hardware in a nuclear detonation environment.

HUNTERS TROPHY was satisfactorily contained, and no atmospheric release occurred from the test. However, several gas sampling filtered³³ releases occurred both during drilling operations and as the result of an experimental gas diagnostics program.

13.2 PRETEST ACTIVITIES.

13.2.1 Responsibilities.

Safe conduct of all HUNTERS TROPHY project activities in Area 12 was the responsibility of the DNA TGD, subject to controls and procedures established by the DOE TC. The DOE TC was responsible for safety of the public and onsite personnel during the test.

Project agencies were responsible for designing, preparing, and installing experiments, or delivering them to the installation contractor. After the test, these agencies were responsible for removing samples, analyzing instrument and sample data, and preparing project reports on experiment results.

³³ The radioactive gas was passed through a filtering system where the particulates were removed before the gas was re-released through the tunnel ventilation system.

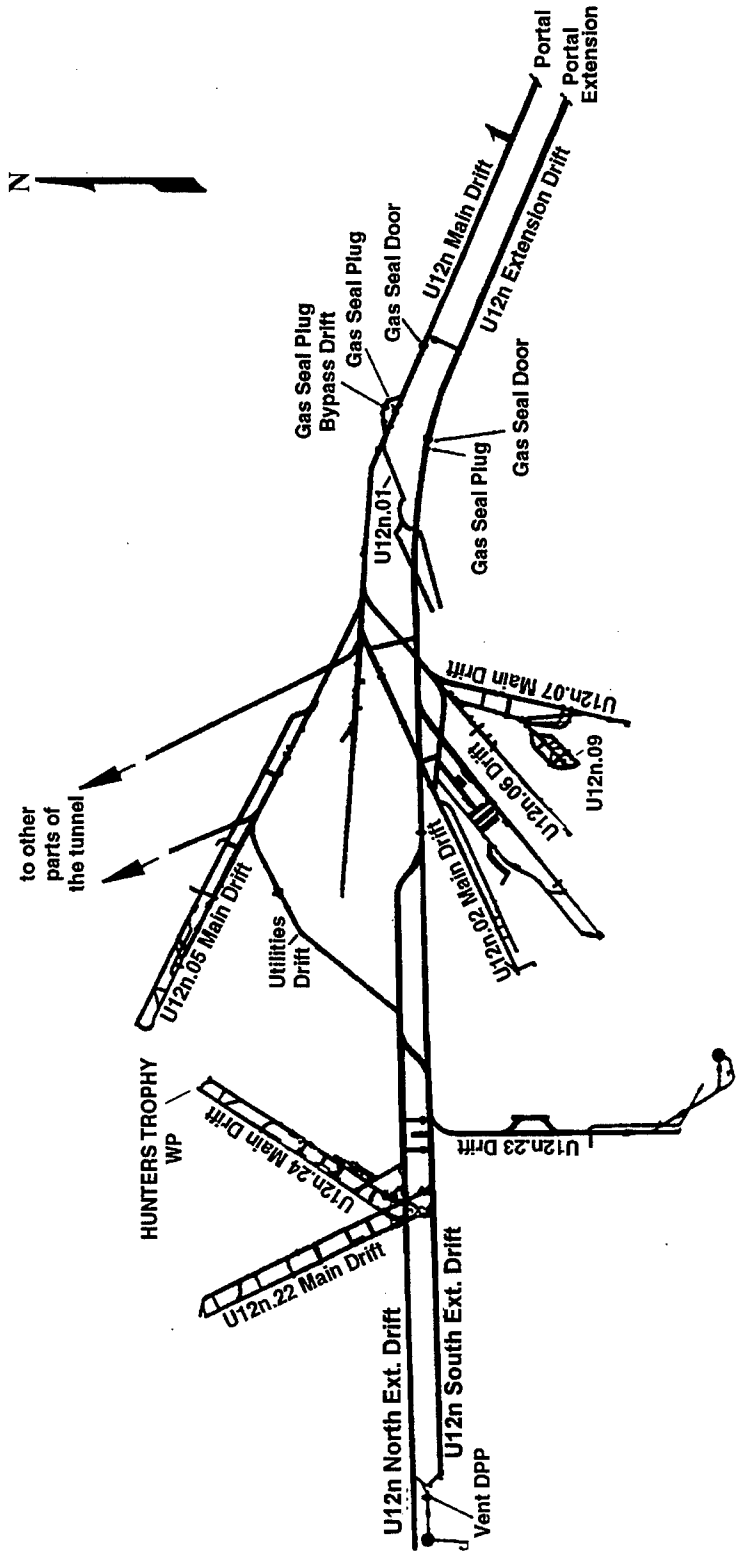

NOT TO SCALE

Figure 13-1. HUNTERS TROPHY test - tunnel layout.

Device safety and security procedures in the WP area and the timing and firing control room were in accordance with DOE Order 5610.10, "Nuclear Explosive and Weapon Safety Program." The LLNL TD had overall responsibilities for all operations involving the HUNTERS TROPHY device as well as the timing control and the arming and firing of HUNTERS TROPHY closures and experiments. The LLNL TD was responsible to the DOE TC for radiological safety within the designated area of the WP from device emplacement until detonation. After detonation, the DOE TC relieved the LLNL TD of these responsibilities and returned the responsibility for project activities back to the DNA TGD.

13.2.2 Planning and Preparations.

A. Tunnel Facilities Construction.

The HUNTERS TROPHY U12n.24 drift complex was mined off the U12n north extension drift. The LOS drift was 1,273 feet long and was connected by ten crosscuts to the 1,252-foot long bypass drift. The single taper steel 850-foot long horizontal LOS pipe was designed to contain experiments. The U12n.24 drift complex components consisted of an LOS drift, a bypass drift, three closure mechanisms (i.e., FAC, GSAC, and TAPS), one test chamber, the zero room, a hardened pipe section, seven pipe stubs, an air scatterer, and a vacuum-pumping system. The drift complex layout is shown in Figure 13-2.

Construction activities began in November 1990 when mining of the LOS and bypass drifts was started. From October 1990 until March 1991, technical review and experimenter design modification meetings were held to resolve technical and design changes as construction moved forward. By May 1991 the LOS and bypass drifts were completed, and mining of crosscuts and alcoves was started. Some design changes on the test chamber were made; however by September, the test chamber layout space allocation was completed as were the crosscuts and alcoves. The LOS pipe installation was

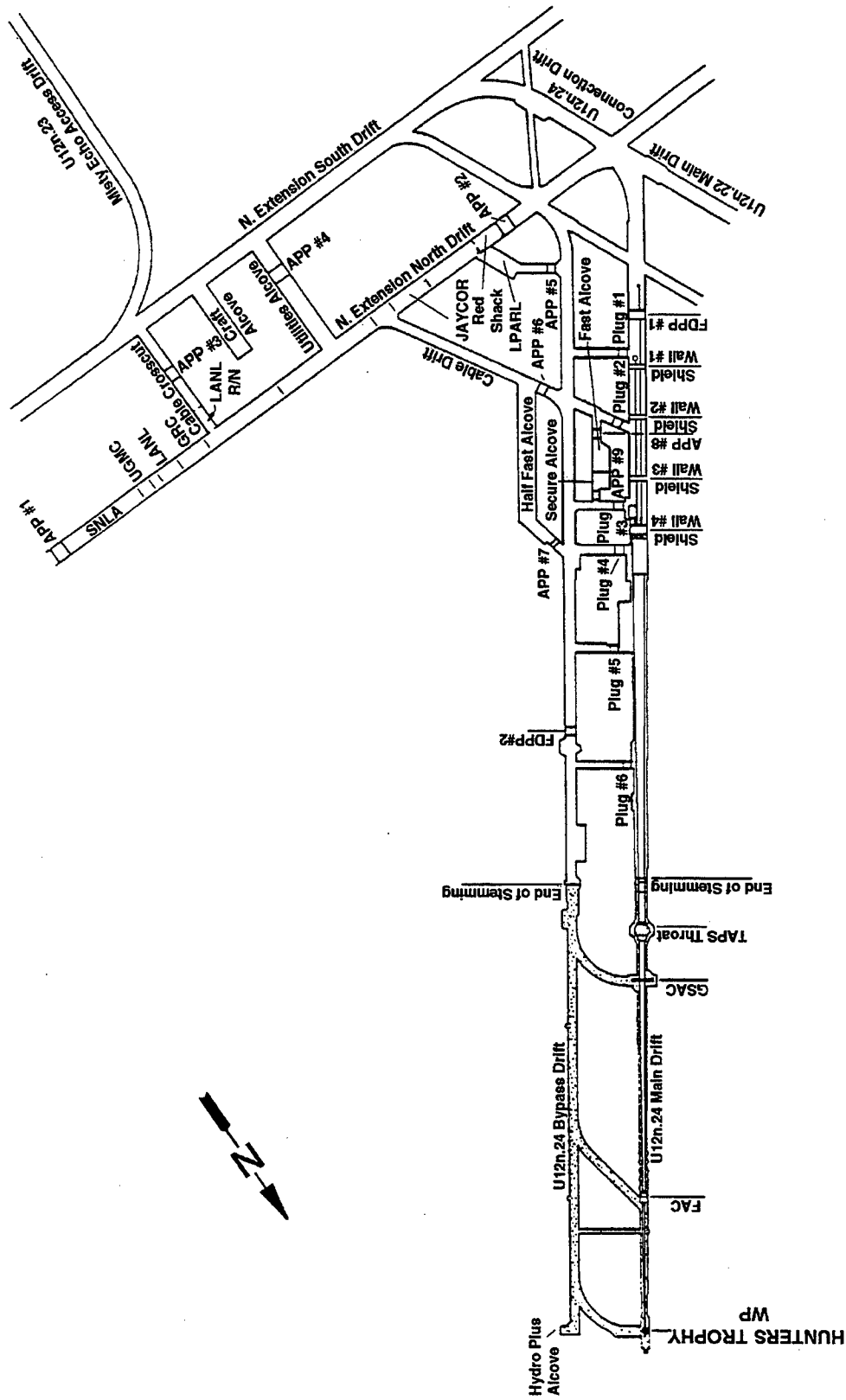

NOT TO SCALE

Figure 13-2. HUNTERS TROPHY test - drift complex layout.

started in September 1991 and was completed in March 1992. Test chamber and pipe stubs installation began in April, and by mid-June, about 20 percent of the experiments in test chamber had been installed. Changes in the construction schedule caused dry runs to be delayed to mid-July, and cable turnover to experimenters, which began in June, was not completed until August. Protection plugs were poured and pressure tested, and experiment installation was completed during August.

Because some experimenters' equipment was not operational, there was only limited participation for SDRs that began on 20 July. The first mandatory signal dry run was held on 28 July with 50 percent of the experimenters participating. An MFP dry run was completed on 2 September.

Remote gas sampling capabilities were incorporated during construction as well as capabilities for water, power, drain, and pressurization lines. Provisions were made to manually take gas samples from the WP side of the GSD, GSP, and main DPP during posttest reentry.

The stemming plan for the U12n.24 complex is shown in Figure 13-3. The area behind the WP was filled with desert fines (sandbags). The main drift was stemmed first with strong RMG to 53 feet; then with RMG to 89 feet; followed by SLG to 106 feet; then RMG to 131 feet; SLG to 151 feet; high-strength concrete (with crushable concrete sections) to 205 feet; and high-strength concrete to the end of stemming at 510 feet. The TAPS was surrounded by high-strength groutcrete. The bypass drift was stemmed to a distance of 110 feet with RMG; then to 200 feet with SLG; and then HSG to 512 feet. The crosscut drift closest to the WP was stemmed with RMG; the crosscuts from the bypass to the FAC and from the bypass to the GSAC were stemmed with HSG. All penetrations into the stemmed areas of the drifts (e.g., cables and water lines) were gas blocked to

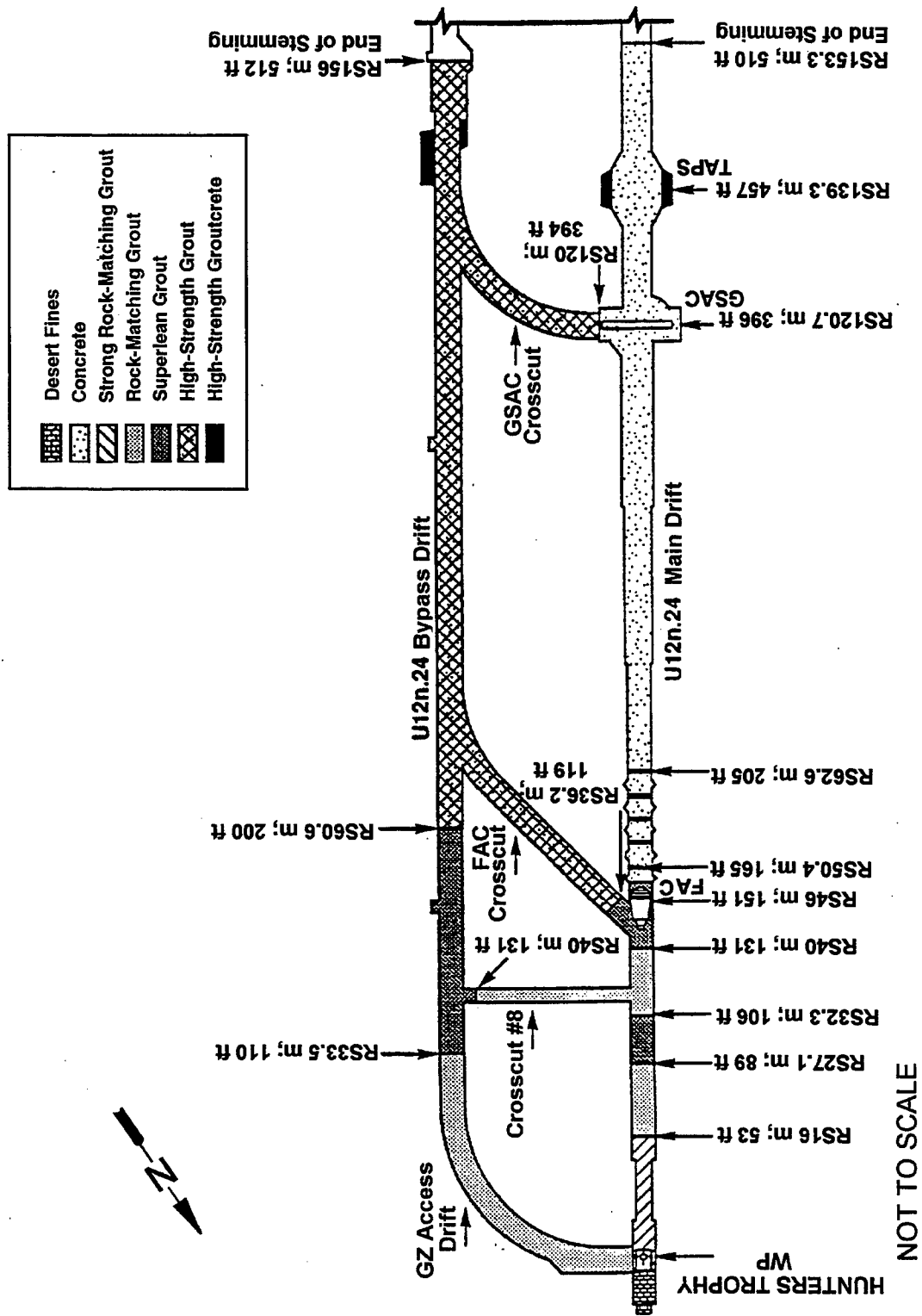

Figure 13-3. HUNTERS TROPHY test - stemming plan.

prevent the seepage of radioactive gases outside the stemmed region of the drifts.

Experiments and related hardware installations were completed by August 1992. The following organizations were among those that fielded experiments for the HUNTERS TROPHY test: Kaman Sciences Corporation (KSC) conducted optical baffle experiments; an advanced hardened avionics technology shield survivability experiment, and a magneto-resistive random access memory technology survivability experiment; Lawrence Livermore National Laboratory (LLNL) (in conjunction with Martin Marietta Corporation and TRW) conducted strategic defense systems studies; JAYCOR conducted satellite optics, laser/nuclear countermeasures, and coated mirror threshold experiments; Science Applications International Corporation (SAIC) conducted survivability studies in a hostile environment and LOS diagnostic measurements; Lockheed Palo Alto Research Laboratory (LPARL) conducted radiation diagnostic studies; Physitron, Incorporated conducted an x-ray pulse modulation system survivability experiment; APTEK Incorporated conducted thermal response x-ray and passive imaging x-ray diagnostic studies; Sandia National Laboratory, Albuquerque (SNLA) conducted radiation and containment diagnostics studies, and performed detonator and instrument development experiments; and Los Alamos National Laboratory (LANL) conducted ground motion studies and CORTEX measurements.

After an MFP dry run on 2 September, device insertion and final button-up stemming operations followed. This work was completed by 12 September. The DPP and GSP were constructed during the second week in September, and the final dry run was conducted on 17 September.

B. Radiological Safety Support.

Procedures for radiation exposure and contamination control during this test were in accordance with NTS SOP 5401 and

requirements of responsible DoD representatives. Radsafe provided monitoring and equipment support.

Prior to the test, detailed radiological safety reentry plans were prepared and issued to participating agencies. Air sampling equipment was positioned in the test area. Radsafe monitors were briefed regarding surface reentry, manned stations, and security station requirements.

Radsafe monitoring teams and supervisory personnel were provided to perform initial radiation surveys, conduct aerial surveys by helicopter, and participate in reentry parties as needed. Radsafe personnel were also standing by at designated muster stations prior to detonation to perform surveys and provide emergency support as directed; to provide and issue anticontamination equipment and material, portable instruments, and dosimeters; to operate area control check stations; and to perform personnel, equipment, and vehicle decontamination, as required.

Available anticontamination materials and equipment included head covers, coveralls, cloth shoe covers, totes, full-face masks, supplied-air breathing apparatus, plastic suits, plastic bags, gloves, and masking tape.

C. Telemetry and Air Sampling Support.

In addition to the permanent RAMS units, 53 temporary units provided surface and underground coverage for the HUNTERS TROPHY test. Tables 13-1 and 13-2 list the locations of surface and underground RAMS, respectively. The locations of surface RAMS are shown in Figure 13-4, and those of underground RAM units are shown in Figures 13-5 and 13-6. All RAMS units were installed a minimum of five days prior to scheduled device detonation.

EPA operated continuous monitoring stations at 34 locations in the offsite area. Thirty-three stations had high-volume

Table 13-1. HUNTERS TROPHY test RAMS unit locations 18 September 1992.

SURFACE

STATION NUMBER	LOCATION
From the U12n Portal:	
1	On the tunnel drain line
2	On the portal vent line
3	400 feet N 16° E azimuth
4	275 feet N 89° E azimuth
5	365 feet S 16° E azimuth
6	480 feet S 12° W azimuth
7	560 feet S 48° W azimuth
8	420 feet N 69° W azimuth
From the Mesa:	
9	On the mesa vent line No. 1
10	On the mesa vent line No. 1
11	On the mesa vent hole No. 2
From the U12n.24 SGZ:	
12	500 feet N 00° E azimuth
13	500 feet S 60° E azimuth
14	500 feet S 60° W azimuth
Geophones - from the U12n.24 SGZ:	
A	650 feet N 51° W azimuth
B	650 feet N 69° E azimuth
C	650 feet S 09° W azimuth

Table 13-2. HUNTERS TROPHY test RAMS unit locations 18 September 1992.

UNDERGROUND

STATION NUMBER	LOCATION
15	625 feet into the U12n.24 main drift
16	510 feet into the U12n.24 main drift
17	390 feet into the U12n.24 main drift
18	300 feet into the U12n.24 main drift
19	260 feet into the U12n.24 main drift
20	205 feet into the U12n.24 main drift
21	130 feet into the U12n.24 main drift
22	90 feet into the U12n.24 main drift
23	640 feet into the U12n.24 bypass drift
24	500 feet into the U12n.24 bypass drift
25	280 feet into the U12n.24 bypass drift
26	90 feet into the U12n.24 bypass drift
27	50 feet into the U12n.24 fast alcove
28	60 feet into the U12n.24 half-fast alcove
29	160 feet into the U12n.24 connecting drift
30	110 feet into the U12n.22 bypass drift
31	5 feet into the U12n. extension vent drift
32	7,000 feet into the U12n ext. south drift
33	300 feet into the U12n.23 main drift
34	5,500 feet into the U12n ext. south drift

Table 13-2. HUNTERS TROPHY test RAMS unit locations 19 September 1991 (Continued).

UNDERGROUND

STATION NUMBER	LOCATION
35	7,000 feet into the U12n ext. north drift
36	6,000 feet into the U12n ext. north drift
37	5,600 feet into the U12n ext. north drift
38	4,800 feet into the U12n ext. north drift
39ER ³⁴	4,800 feet into the U12n ext. north drift
40	1,000 feet into the U12n utilities drift
41ER ³⁴	1,000 feet into the U12n utilities drift
42	200 feet into the U12n utilities drift
43	600 feet into the U12n.05 main drift
44	4,000 feet into the U12n extension drift
45	2,900 feet into the U12n extension drift
46	2,300 feet into the U12n extension drift
47	1,200 feet into the U12n extension drift
48	200 feet into the U12n extension drift
49	2,600 feet into the U12n main drift
50	235 feet into the U12n gas seal bypass
51	1,700 feet into the U12n main drift
52	1,200 feet into the U12n main drift
53	200 feet into the U12n main drift

³⁴ ER - Extended Range (instrument capable of reading 100 mR/h to 100,000 R/h).

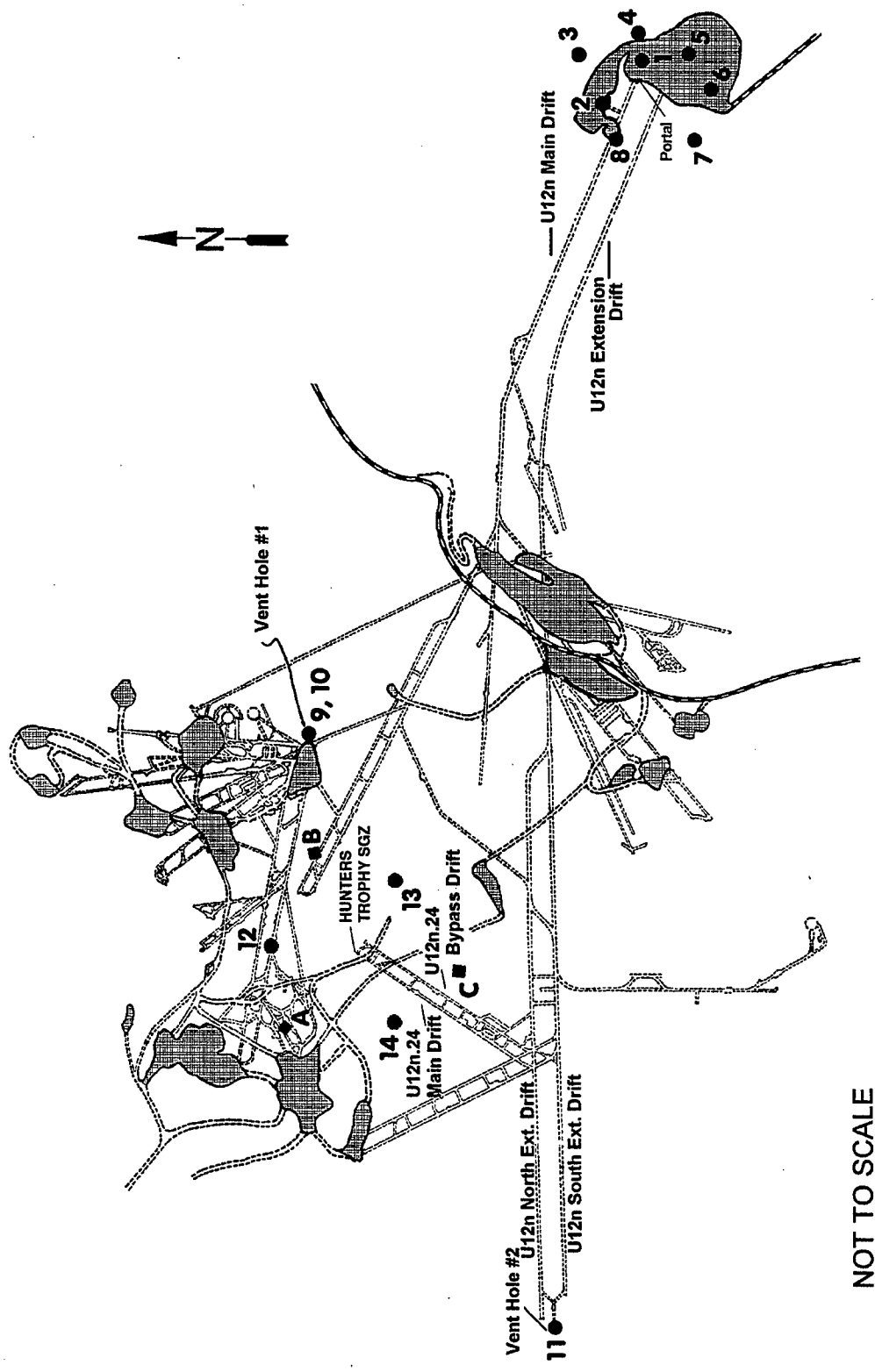

NOT TO SCALE

Figure 13-4. HUNTERS TROPHY test - surface RAMS.

— Inaccessible Areas

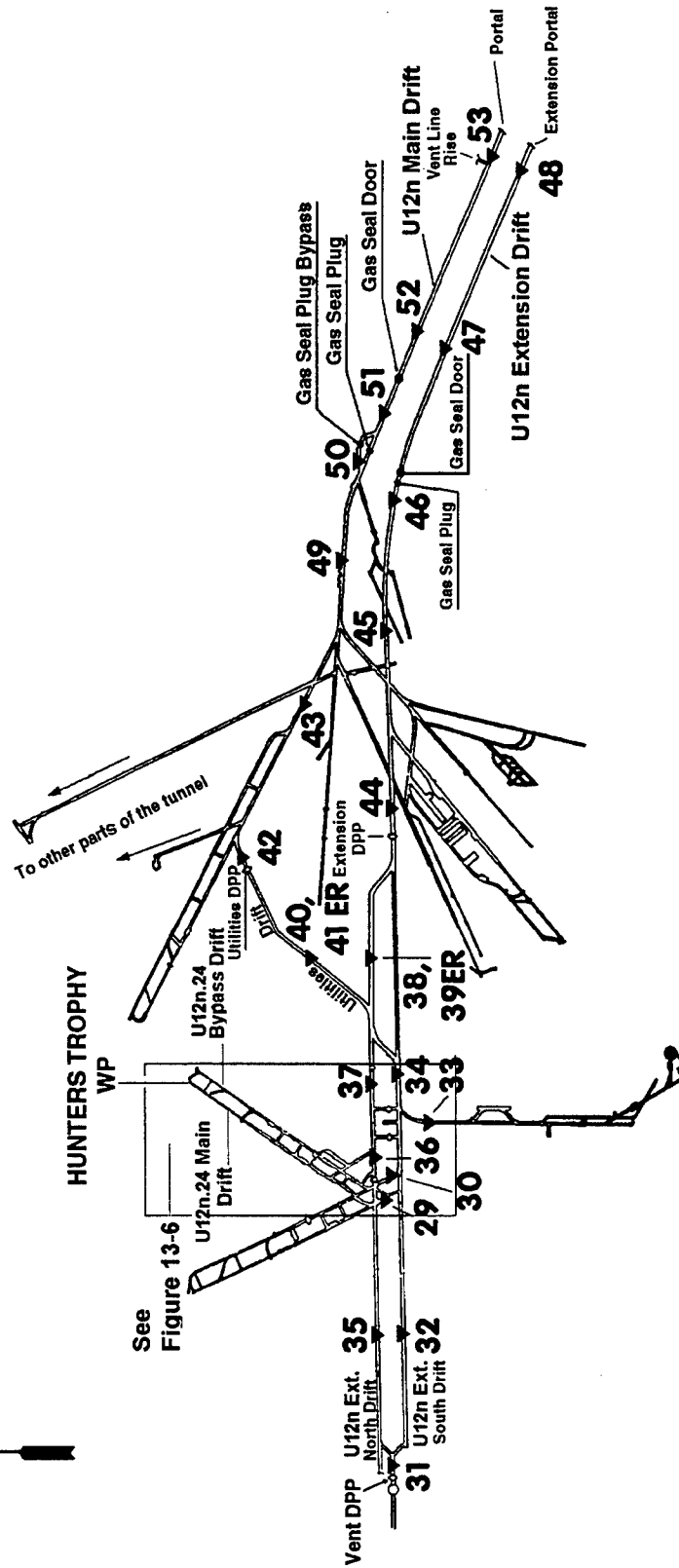

NOT TO SCALE

Figure 13-5. HUNTERS TROPHY test - underground RAMS.

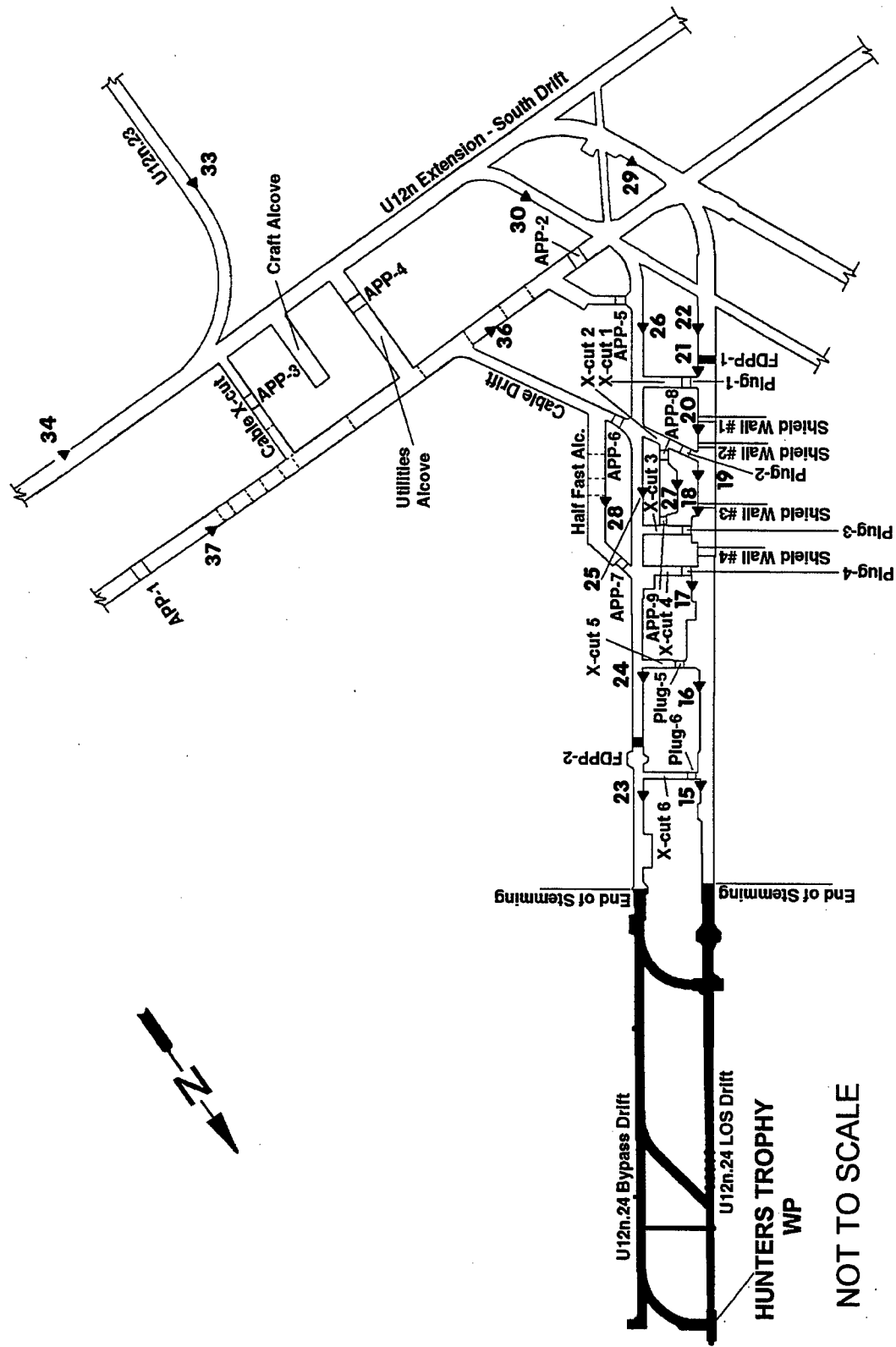

Figure 13-6. HUNTERS TROPHY test - underground RAMS U12n.24 complex.

air samplers with collectors for particulates and reactive gases, 19 had tritium samplers, 16 had noble gas samplers, and 30 had pressurized ion chamber gamma-rate detector/recorder systems linked to CP-1 and the Las Vegas EPA office via satellite telemetry. Twenty-nine EPA personnel were fielded for offsite surveillance activities.

D. Security Coverage.

Device security procedures in the WP area and the timing and firing control room were in accordance with DOE Order 5610.10, "Nuclear Explosive and Weapon Safety Program." Beginning on D-1, all personnel entering or exiting the controlled area were required to stop at muster or control stations for issue of stay-in badges. After control was established, all through traffic was diverted around the controlled area by use of screening stations. In accordance with the "Test Controller's Operations and Security Plan," contractors and agencies were to have all personnel not connected with this test out of the closed area before the final security sweep began.

E. Air Support.

Three BO-105 helicopters and crews were provided by EG&G for cloud tracking and the Test Controller's use, if needed. In addition, the USAF provided a WC-130 and/or a WC-135 aircraft and crew on standby status for cloud tracking. EG&G also provided two King Air aircraft to perform wind soundings, cloud sampling, and cloud tracking duties, if necessary.

13.3 TEST-DAY ACTIVITIES.

13.3.1 Pretest Activities.

On 17 September 1991, by approximately 2300 hours, all persons except the arming party, the tunnel button-up party, and the

security guards were out of the tunnel and clear of the muster area. Soon after, permission was granted to arm the device. Following the departure of the arming party, button-up operations were completed, and the party left the tunnel at approximately 0900 hours. The area was cleared of all personnel by 0930 hours on 18 September.

A final readiness briefing was held in the early morning of 18 September. The countdown proceeded uninterrupted until zero time. The HUNTERS TROPHY device was detonated at 1000 hours PDT on 18 September 1992.

13.3.2 Test Area Monitoring.

Telemetry recording measurements began at 1000 hours on 18 September at which time all RAM units (i.e., stations) were operational (except station 21) and remained so throughout the readout period. Stations 1-14 and 23-53 indicated background levels at zero time and remained at background levels throughout the readout period.

At just after zero time, stations 15-20 and 22 showed readings ranging from 1.7 to 353 R/h as the result of initial activation. These readings decreased rapidly, and by H+30 minutes, readings ranged from 36 mR/h to 1.7 R/h. Stations 17 and 19, respectively, recorded the maximum readings. All RAM stations were secured at 1300 hours on 22 September.

13.3.3 Initial Surface Radiation Surveys.

An initial surface reentry team departed the TC's barricade at Gate 300 at 1116 hours on 18 September 1992. A mobile base station was setup to provide for area control and anticontamination clothing and equipment supply. All radiation readings were relayed as soon as they were obtained via Net 3 radio. By 1151 hours, the survey of the U12n portal was completed. All radiation readings were at background levels (0.04 mR/h).

Survey teams stood by the U12n portal during initial gas sampling of the tunnel atmosphere. Gas samples were taken from the WP side of the bypass GSP; the portal side of the utilities DPP (UDPP); WP side of the UDPP; the end of stemming in the U12n.24 bypass drift; and both inside and outside of the LOS pipe in the LOS drift. No explosive gases were detected, and the oxygen level was 21 percent. A maximum concentration of 40 ppm CO was measured inside the LOS pipe. Radiation readings were at background levels. Gas sampling was completed by 1346 hours, and all personnel were checked out of the area by 1450 hours. All samples were sent to the laboratory for analysis.

13.4 POSTTEST ACTIVITIES.

13.4.1 Tunnel Reentry Activities.

The initial reentry work team entered the U12n tunnel portal at 0856 hours on 19 September after remote gas sampling showed little change in the results obtained on shot day. The work team proceeded to the GSP and established ventilation on the WP side of the GSP. The team laid down railroad track through the GSD before exiting the tunnel at 1027 hours. No anticontamination clothing was required for this work, and all radiation readings were at background levels.

The initial reentry team No. 1 and the rescue team, dressed in anticontamination clothing, (team No.1 also put on their SCBA) left the portal area at 1116 hours on 19 September and proceeded to the GSP runaround where a communications station and fresh air base was established. The rescue team stood by at that point. The team proceeded to the U12n.08 DPP where they opened the turn-tube door and then proceeded to the U12n.08 vent hole and the thermal shield plug to establish ventilation to the mesa. The mesa fan was turned on at 1230 hours.

Team No. 1 proceeded to the UDPP where a gas sample taken from the WP side showed no toxic or explosive gases, and no radiation above background levels. Team No. 1 then waited for the rescue and

communications personnel to arrive at the portal side of the UDPP where a fresh air base was established. Team No. 1 then moved from the utilities drift to APP No. 1 in the north extension drift where a gas sample taken from the WP side showed no toxic or explosive gases, and no radiation above background levels. Upon opening the turntube door, personnel noted approximately two inches of water on the floor. The team moved to the south extension drift, but a warning whistle on one team member's SCBA was activated, and the team returned to the UDPP. The team removed their SCBA and exited the tunnel at 1413 hours where they were surveyed and found to be free of contamination.

At 1425 hours that same day, team No. 2, wearing anticontamination clothing and SCBA, departed the portal and proceeded to examine the protection plugs in the U12n.24 LOS main and bypass drifts. The team took gas samples from the WP side of the protection plugs before opening turntube doors and proceeding through. There was water on the floor in crosscuts Nos. 2 and 3, and drain line valves were opened to alleviate this problem. The team moved to the U12n.24 bypass drift where they observed some tunnel damage on both the portal and WP sides of FDPP No. 2. Up to this point, all gas sample data showed normal tunnel conditions (i.e., no toxic or explosive gases, and no radiation above background levels).

When the team proceeded from the U12n.24 bypass drift to the WP side of plug No. 6 in crosscut No. 6, a reading of 0.6 mR/h on contact with the LOS pipe was obtained, and a 5.0 mR/h reading was recorded at 680 feet (i.e., near the WP side of RAM station No. 15) in the U12n.24 main drift. Readings were also taken on the WP side of crosscuts Nos. 4 and 5, and at each of the two doors of the test chamber that was located between those crosscuts. At 1649 hours the team, having proceeded through crosscut No. 5, opened test chamber No. 2 door and recorded a 15 mR/h reading just inside that door. The door was secured, and the team proceeded back through crosscut No. 5 to the U12n.24 bypass drift and to crosscut No. 4. Proceeding through that crosscut and through plug No. 4, the team arrived at test chamber No. 1 door and opened it at 1712 hours. The team recorded a 110 mR/h reading just inside

test chamber No. 1 door (the maximum reading obtained during these reentry activities). The team secured test chamber door No. 1 and proceeded to return to the UDPP, stopping at the slow alcove to assess conditions. Team No. 2 and the rescue and communications teams left the tunnel at 1815 hours. All personnel were surveyed and checked out clean.

At 1915 hours, three data recovery teams, wearing anticontamination clothing as required by the area of entry, proceeded to the scatterer pit area, the LPARL stubs area, and the slow alcove to retrieve data. This work was completed by 1955 hours, and all personnel were surveyed and released from the area.

The scientific assessment team, wearing anticontamination clothing and full-face respirators only when in the test chamber, entered the experiment areas and the test chamber on 24 September to complete their work. Then on 28 September, experiment recoveries began in the scatterer area, the alcoves, and in the test chamber. The majority of experiment recovery work was completed by 9 October.

13.4.2 Posttest Mining and Drilling.

Miners began mining out the U12n extension drift GSD and GSP on 19 September and began removal of the extension drift friction plug and FDPP on 21 September. No reentry mining operations were conducted as with previous DoD/DNA underground nuclear tests. One reentry drill hole (U12n.24 RE#1) was drilled for approximately 525 feet from the high pressure alcove in the bypass drift near the end of stemming to a point 120 feet above the WP to obtain chimney gas samples and determine the chimney radius. Gas sampling of the drill hole was conducted at three different times, and the drill hole was cemented about two weeks after sampling was completed.

13.4.3 Industrial Safety.

Checks for the presence of toxic gases and surveys to measure radiation and explosive gas levels were made on each shift. The results were then recorded in the monitors' logbook.

Appropriate safety measures were taken to protect mining personnel and prevent unsafe conditions. Industrial safety codes for mining, tunneling, and drilling were established by REECo and emphasized during all operations. A written standard operating procedure was required for each operation involving explosives, toxic materials, radioactive material, or any other operation with the potential for personal injury. Each individual involved in such an operation was required to know the contents of the applicable procedures.

The portal construction area and the tunnel were mandatory hard-hat and foot-protection areas (safety shoes, boots, DOE-issued miner's boots, or toe guards). All personnel on initial tunnel reentry teams were certified in the use of the Draeger self-contained breathing apparatus. Standard safety rules and regulations, as spelled out in the "U.S. Bureau of Mines Manual," were observed.

All explosives, electro-explosive components, solid propellants, toxic materials, and radioactive materials were handled, stored, and transported in accordance with applicable sections of the following documents:

1. Army Material Command Regulations (AMCR 385-100).
2. Appropriate DOE Orders in the 5400 and 5600 Series concerning Environmental Protection, Safety & Health Protection, and Defense Programs, respectively.
3. Individual safe operating procedures (by experimenter organization).
4. HUNTERS TROPHY Safety Regulations.

All personnel engaged in handling, storing, assembling, or installing explosives, propellants, or electro-explosive devices (or

observers of those operations) were required to wear safety glasses or other eye protection which had been approved by the DoD safety coordinator.

13.5 RESULTS AND CONCLUSIONS.

Telemetry recording measurements began at 1000 hours on 18 September with a maximum reading on station 17 at just after zero time of 353 R/h from initial activation products. By H+30 minutes, the maximum reading was 1.7 R/h as recorded on station 19. All RAM stations were secured at 1300 hours on 22 September.

The initial radiation surveys began at 1116 hours on 18 September and were completed at 1450 hours. No radiation above background levels was detected at the U12n tunnel portal yard area. Gas samples taken from the WP side of the bypass GSP; the portal side of the UDPP; the WP side of the UDPP; the end of stemming in the U12n.24 bypass drift; and both inside and outside of the LOS pipe indicated no explosive gases, background radiation levels, and 21 percent oxygen. A CO level of 40 ppm was detected inside the LOS pipe.

Reentry into the tunnel began at 0856 hours on 19 September, when the reentry work team established ventilation to the WP side of the GSP and laid railroad track through the GSD. Reentry team No. 1, wearing anticontamination clothing and SCBA, established ventilation to the mesa and proceeded to the UDPP where a gas sample taken from the WP side showed normal tunnel conditions. As the rescue and communications teams stood by at the UDPP, team No. 1 moved to the extension drifts where on the WP side of APP No. 1 they discovered water on the floor, and when a warning whistle sounded on one team member's SCBA, they returned to the UDPP and exited the tunnel.

Team No. 2, wearing anticontamination clothing and SCBA, entered the tunnel at 1425 hours and proceeded to the plugs, crosscuts, and the test chamber in the U12n.24 drift complex. Water was drained from the floor in crosscuts Nos. 2 and 3, and surveys on

contact with the LOS pipe and inside the test chamber showed readings of 0.6 to 110 mR/h. The maximum reading was recorded inside test chamber No. 1 door. Team No. 2, along with the rescue and communications personnel, exited the tunnel at 1815 hours. Three data recovery teams completed their work in the scatterer pit area, the LPARL stubs area, and the slow alcove by 1955 hours that same day.

The scientific assessment team, wearing anticontamination clothing and full-face respirators only when in the test chamber, completed their work on 24 September. Experiment recoveries began in the scatterer area, the alcoves, and in the test chamber on 28 September, and the majority of recovery work was completed by 9 October.

No reentry mining operations were conducted. Only one reentry drill hole was drilled from the high pressure alcove in the bypass drift to a point 120 feet above the WP to obtain chimney gas samples and measure the chimney radius.

Personnel exposure data from self-reading pocket dosimeters were documented on Area Access Registers during individual entries to HUNTERS TROPHY radex areas over a non-continuous time frame beginning 19 September 1992 and ending 1 December 1992 (see page 113 for a detailed explanation). Pocket dosimeters showed some indication of possible radiation exposure to DoD-affiliated personnel. TLDs worn by these reentry personnel indicated that no individual received any reportable gamma exposure from the HUNTERS TROPHY test. The minimum detectable gamma exposure with the NTS TLD is 15 mR. Area Access Register data are summarized below.

Participants	Entries Logged	Maximum Exposure (mR)	Average Exposure (mR)
All	922	20	0.3
DoD	86	10	1.1

SECTION 14

REFERENCES

1. Office of External Affairs, U.S. Department of Energy, Nevada Operations Office, Announced United States Nuclear Tests, NV0-209 (Rev. 14), December 1994.* (UNCLASSIFIED)
2. Devine, R. A., Blowing on the Wind: The Nuclear Test Ban Debate, Oxford University Press, NY, 1978. (UNCLASSIFIED)
3. Harris, P. S., et al., Defense Nuclear Agency, OPERATION PLUMBBOB, DNA 6005F, 15 September 1981.* (UNCLASSIFIED)
4. U.S. Senate Committee on Veterans Affairs, Veterans, Claims for Disabilities from Nuclear Weapons Testing, U.S. Government Printing Office, Washington DC, 1979. (UNCLASSIFIED)

DOE/NV, Announced Nuclear Tests, (n. 1).
Devine, Nuclear Test Ban Debate, (n. 2).
5. Weapons Effects Test Group, Field Command, Defense Atomic Support Agency, Orientation, Nevada Test Site, January 1962. (UNCLASSIFIED)
6. Weapons Test Division, Defense Atomic Support Agency, Orientation, Nevada Test Site, revised 15 August 1964. (UNCLASSIFIED)
7. Ponton, J., et al., Defense Nuclear Agency, Operation DOMINIC II, DNA 6027F, 31 January 1983.* (UNCLASSIFIED)
8. Liverman, J. L., Energy Research & Development Administration, Final Environmental Impact Statement, Nevada Test Site, Nye County, Nevada, ERDA-1551, September 1977.* (UNCLASSIFIED)

9. Butkovich, T. R., Lawrence Radiation Laboratory, University of California, Effects of Water Saturation on Underground Nuclear Detonations, UCRL-51110, 9 September 1971.* (UNCLASSIFIED)

U.S. Senate Committee on Veterans Affairs, Claims for Disabilities, (n. 4), on venting.
10. Health Protection Department, Reynolds Electrical & Engineering Co., Inc., "Standard Operating Procedures," January 1985-December 1992.** (UNCLASSIFIED)
11. Brady, W. J., et al., Reynolds Electrical & Engineering Co., Inc., Combination Personnel Dosimeter & Security Credential Holder, U.S. Department of Energy, NVO 162-27, October 1967.** (UNCLASSIFIED)
12. Friedrichs, R. E., et al., Reynolds Electrical & Engineering Company, Inc., A Proposal for Conversion from Film to Thermoluminescent Dosimeters at the Nevada Test Site, RRS-85-11, March 1983.** (UNCLASSIFIED)
13. Lantz, M. W., et al., Reynolds Electrical & Engineering Company, Inc. Technical Evaluation of a Fast Neutron Dosimeter, U.S. Department of Energy, NVO/0410-53, November 1979.** (UNCLASSIFIED)
14. McMullan, F. C., Kaman Sciences Corporation, DoD Nuclear Weapons Effects Tests Summary, Issue 18 for Calendar Years 1962-1987 (U), December 1990.*** (SECRET)
15. Office of Technology Assessment, Congress of the United States, The Containment of Underground Nuclear Explosions, released 1 November 1989.* (UNCLASSIFIED)
16. Department of Energy, Nevada Operations Office, NV Completion Report, Operation Charioteer (U), 1 October 1985 through 30 September 1986, NVO-310, September 1987.*** (SECRET)

17. Martin, C., Field Command, Defense Nuclear Agency, MILL YARD Event, Hussar Sword Series, Preliminary Results Report (U), POR 7182, 1 September 1986.*** (SECRET)
18. Stockton, J. R., Sciences & Engineering Associates, Inc., MILL YARD Event, Hussar Sword Series, Summary Report (U), DNA-TR-86-378, 1 November 1986.*** (SECRET)
19. Hoe, G., Field Command, Defense Nuclear Agency, MILL YARD Event, Hussar Sword Series (U), POR 7152, 1 February 1985.*** (SECRET)
20. Hendrickson, T. F., Field Command, Defense Nuclear Agency, MILL YARD Event, Hussar Sword Series, Test Execution Report (U), POR 7181, 1 February 1986.*** (SECRET)
21. Martin, C., Field Command, Defense Nuclear Agency, DIAMOND BEECH Event, Distant Arbor Series, Program Document (U), POR 7153, 1 May 1985.*** (SECRET)
22. Wainwright, S. D., Field Command, Defense Nuclear Agency, DIAMOND BEECH Event, Distant Arbor Series, Test Execution Report (U), POR 7183, 1 April 1986.*** (SECRET)
23. Department of Energy, Nevada Operations Office, Containment and Safety Assessment for the MIGHTY OAK Nuclear Weapons Effects Test, NVO-311, 1 May 1987.* (UNCLASSIFIED)
24. Hezlep, L. M., Field Command, Defense Nuclear Agency, MIGHTY OAK Event, Hussar Sword Series, Test Execution Report (U), POR 7176, 4 March 1987.*** (SECRET)
25. Cipperly, G. E., Field Command, Defense Nuclear Agency, MIGHTY OAK Event, Hussar Sword Series, Program Document (U), POR 7175, 30 January 1986.*** (SECRET)

26. Department of Energy, Nevada Operations Office, NV Completion Report, Operation Musketeer (U), 1 October 1986 through 30 September 1987, NVO-324, March 1989.*** (SECRET)
27. Fingerlos, J. P., Field Command, Defense Nuclear Agency, MIDDLE NOTE Event, Hussar Sword Series, Program Document (U), POR 7178, 1 January 1987.*** (SECRET)
28. Raglin, P. S., Field Command, Defense Nuclear Agency, MIDDLE NOTE Event, Hussar Sword Series, Test Execution Report (U), POR 7179, 27 July 1987.*** (SECRET)
29. Smythe, C., et al., Field Command, Defense Nuclear Agency, MISSION GHOST Event, Hussar Sword Series, Program Document (U), POR 7188, 8 April 1987.*** (SECRET)
30. Courson, L. A., Test Directorate, Defense Nuclear Agency, MISSION GHOST Event, Discus Wheel Series, Test Execution Report (U), POR 7189, 2 November 1987.*** (SECRET)
31. Department of Energy, Nevada Operations Office, NVO Completion Report, Operation Touchstone Part II (U), 1 October 1987 through 30 September 1988, NVO-327, August 1990.*** (SECRET)
32. Ashbaugh, J., et al, Test Directorate, Defense Nuclear Agency, MISSION CYBER Event, Hussar Sword Series, Program Document (U), POR 7210, 16 July 1987.*** (SECRET)
33. Raglin, P. S., Test Directorate, Defense Nuclear Agency, MISSION CYBER Event, Hussar Sword Series, Test Execution Report (U), POR 7211, May 1988.*** (SECRET)
34. Department of Energy, Nevada Operations Office, NVO Completion Report, Operation Cornerstone Part II (U), 1 October 1988 through 30 September 1989, NVO-338, February 1991.*** (SECRET)

35. Fingerlos, J. P., Test Directorate, Defense Nuclear Agency, MISTY ECHO Event, Discus Wheel Series, Program Document (U), POR 7268, 1 May 1988.*** (SECRET)
36. Lopez, W. J., Test Directorate, Defense Nuclear Agency, MISTY ECHO Event, Test Execution Report (U), POR 7269, 1 June 1989.*** (SECRET)
37. Exton, A., Test Directorate, Defense Nuclear Agency, DISKO ELM Event, Distant Arbor Series, Test Execution Report (U), POR 7231, 1 December 1990.*** (SECRET)
38. Smythe, C. et al, Test Directorate, Defense Nuclear Agency, DISKO ELM Event, Distant Arbor Series, Program Document (U), POR 7318, 1 February 1990.*** (SECRET)
39. Department of Energy, Nevada Operations Office, NVO Completion Report, Operation Aqueduct Part II (U), 1 October 1989 through 30 September 1990, DOE/NV-342, September 1991.*** (SECRET)
40. Fischer, D., et al, Test Directorate, Defense Nuclear Agency, MINERAL QUARRY Event, Hussar Sword Series, Program Document (U), POR 7353, 30 June 1989.*** (SECRET)
41. Fischer, D., et al, Test Directorate, Defense Nuclear Agency, MINERAL QUARRY Event, Program Document Addendum (U), POR 7353A, 1 June 1990.*** (SECRET)
42. Price, R. N., Field Command, Defense Nuclear Agency, MINERAL QUARRY Event, Test Execution Report (U), POR 7354, 1 November 1991.*** (SECRET)
43. Department of Energy, Nevada Operations Office, Nevada Operations Office Completion Report, Operation Sculpin Part II (U), 1 October 1990 through 30 September 1991, DOE/NV-347, June 1992.*** (SECRET)

44. Anderson, B. R., Field Command, Defense Nuclear Agency, DISTANT ZENITH Event, Preliminary Results Report (U), POR 7413, 1 September 1992.*** (SECRET)
45. Anderson, B. R., Test Directorate, Defense Nuclear Agency, DISTANT ZENITH Event, Program Document, (U), POR 7411, 1 May 1991.*** (SECRET)
46. Widby, R. B., Field Command, Defense Nuclear Agency, DISTANT ZENITH Event, Test Execution Report (U), POR 7412, 1 September 1992.*** (SECRET)
47. Department of Energy, Nevada Operations Office, Nevada Operations Office Completion Report, Operation Julin Part II (U), 1 October 1991 through 30 September 1982, DOE/NV-359, February 1991.*** (SECRET)
48. Roessler, F., Field Command, Defense Nuclear Agency, DIAMOND FORTUNE Event, Program Document, (U), POR 7414, 1 August 1991.*** (SECRET)
49. Price, R. N., Field Command, Defense Nuclear Agency, DIAMOND FORTUNE Event, Test Execution Report, (U), POR 7415, 1 November 1992.*** (SECRET)
50. Wohl, B., Field Command, Defense Nuclear Agency, HUNTERS TROPHY Event, Program Document (U), POR 7428, 1 March 1992.*** (SECRET)
51. Reynolds, G. A., Field Command, Defense Nuclear Agency, HUNTERS TROPHY Event, Test Execution Report (U), POR 7429, 1 October 1993.*** (SECRET)
52. Schoengold, C. R., et al., Bechtel Nevada, Radiological Effluents Released from Announced U.S. Continental Tests 1961 through 1992, U.S. Department of Energy, Nevada Operations Office, DOE/NV-317 (Rev. 1), August 1996.* (UNCLASSIFIED)

APPENDIX A
SOURCES OF INFORMATION

References are not indicated within the text of this report. However, key references are included in this list by section or part. Most unclassified references are available at the DOE/NV Public Reading Facility. Classified reference documents are available only to persons with an appropriate security clearance and a need-to-know justification for this information. These documents may be obtained through the Headquarters/Defense Special Weapons Agency (HQ/DSWA) Technical Resource Center in Alexandria, Virginia.

The Public Reading Facility is operated by Bechtel Nevada, the custodian of DoD and DOE nuclear testing personnel dosimetry records and other unclassified reference documents on DoD participation in atmospheric, oceanic, and underground nuclear weapons tests. Individuals may arrange to review available references for this report at the Public Reading Facility by contacting one of the following:

Safety and Health Division
U.S. Department of Energy
Nevada Operations Office
Post Office Box 98515
Las Vegas, NV 89193-8515
(702) 295-0961

or

DOE/NV Public Reading Facility
Bechtel Nevada
Post Office Box 98521 M/S NLV040
Las Vegas, NV 89193-8521
(702) 295-1628
e-mail: cic@nv.doe.gov

Major source documents can also be purchased through the National Technical Information Service (NTIS) listed below:

National Technical Information Service
5285 Port Royal Road
Springfield, VA 22161
(703) 487-4650

References available through public bookstores and libraries, through the U.S. Government Printing Office, and only at the Public Reading Facility are listed without asterisks. Asterisks after references or groups of references indicate availability as follows:

- * Available through the NTIS and the DOE/NV Public Reading Facility.
- ** Health Physics Department historical files, contact the DOE/NV Public Reading Facility; some information may be subject to Privacy Act restrictions.
- *** Available through the HQ/DSWA Technical Resource Center and subject to security clearance requirements.

Bechtel Nevada Health Physics Department Field Record Archives are maintained chronologically and by test and include the following:

- a. Procedures, Reentry Plans, Radsafe Plans, and Schedules of Tests.**
- b. Correspondence.**
- c. Reports, including onsite Radsafe and offsite USEPA test reports.**
- d. Exposure reports, Radsafe logbooks, Area Access Registers, radiation survey forms, telemetry forms, and other sampling and dosimetry forms.**

APPENDIX B

GLOSSARY OF TERMS

Access Drift	A passageway tunnel, usually parallel to the LOS drift, also known as the bypass, cable, reentry, or work drift, also in which cables from various experiments in the LOS pipe were laid on their way to being connected to the downhole cables in the cable alcove, and which was used for access to the main experiment (LOS) drift during construction and recovery phases of a test.
Activation Products	Nuclides made radioactive by neutrons from a nuclear detonation interacting with usually nonradioactive nuclides. Also called "induced activity."
Activity Radioactivity	Decay of radioactive material, usually expressed in disintegrations (of atoms) per minute (dpm).
Advisory Panel	A group of experts formed to advise the Test Manager (and later the Test Controller) concerning operational and safety factors affecting a test detonation.
AFSWC	The Air Force Special Weapons Center, located at Kirtland Air Force Base, Albuquerque, New Mexico. AFSWC provided air support to the AEC Test Manager for NTS testing activities.
AFSWP	The Armed Forces Special Weapons Project was activated on 1 January 1947, when the AEC was activated, to assume residual functions of the U.S. Army Manhattan Engineer District (see DASA).

Air Support	This included aircraft, facilities, and personnel required for various support functions during testing. Included were cloud sampling, and tracking, radiation monitoring, photography, and transport of personnel and equipment.
Alpha Particle	A particle emitted spontaneously from the nucleus of a radionuclide, primarily a heavy radionuclide. The particle is identical to the nucleus of a helium atom, having an atomic mass of four units and an electric charge of two positive units.
Alpine Miner	A continuous mining machine using a moveable boom with rotating cutting head.
Anticontamination Clothing	Outer clothing worn to prevent contamination of personal clothing, contamination of one's body, and the spread of contamination to uncontrolled areas.
Atmospheric Test Series	Series of U.S. nuclear tests conducted from 1945 through 1962, when most nuclear device detonations were conducted in the atmosphere.
Attenuation	The process by which photons or particles emitted by radionuclides are reduced in number or energy while passing through some medium.
Back	The top (ceiling) of a tunnel.
Background Radiation	There are three meanings for this term. The applicable meaning is determined by the context. The definitions are: <ol style="list-style-type: none"> 1) The radiations of man's natural environment, consisting of cosmic rays and those radiations which come from

the naturally radioactive nuclides of the earth, including those within one's body.

- 2) A level of radiation (above natural background radiation) that existed in a test area or location prior to a test.
- 3) Radiation levels extraneous to an experiment (the area exposure rate).

Ballroom

A large alcove in a tunnel used for placement of recording equipment (sometimes referred to as a Dance Hall).

Ball Valve

A rotating valve designed to close off and provide a gas seal in an LOS pipe in less than one second after detonation. It could be pneumatic, hydraulic, or spring driven.

Beta Particle

A negatively charged particle of very small mass emitted from the nucleus of a radionuclide, particularly from fission product radionuclides formed during nuclear detonations. Except for origin, the beta particle is identical to a high-speed electron. This may also be a positively charged particle of equal mass called a positron.

Bypass Drift

See Access Drift.

Bulkhead

Originally a navy term meaning a wall across a ship's hull or a passageway, usually containing a hatch or door. In this context, wall or embankment constructed in a mine or tunnel to protect against earth slides, fire, water, or gas.

Button-Up Activities	Procedures which consist primarily of completing the stemming; accomplishing the electrical checklist of tunnel portal and trailer park facilities; closing the OBP, gas seal plug, and gas seal door inside the tunnel; clearing the controlled area; and preparing command post and monitoring stations for the actual nuclear detonation.
Cable Drift	See Access Drift.
Cal-Seal	A high-density, high-strength, quick drying, and resilient commercial sealant (i.e., gypsum cement).
Cassette	A holder or container for a sample, an experiment, or a group of experiments.
Cavity Invert	See Invert.
Cellar	The excavated, large-diameter initial part of a drilled hole, over which the drill rig is placed and where valving and other equipment are located.
Chamber	A natural or man-made enclosed space or cavity.
Check Points or Check Stations	Geographic locations established and staffed to control entry into and exit from restricted areas.
Chimney	A roughly cylindrical volume of broken rock, formed by the collapse of the overburden. Occurs when decreasing gas pressure in the cavity formed by the nuclear detonation cannot support the weight of the rock.

Chromatograph A piece of equipment used to analyze mix-
tures of chemical substances by chromato-
graphic absorption.

Cloud Sampling The process of collecting particulate and
gaseous samples from an effluent cloud to
determine the amount of total airborne
radioactivity and specific radionuclides
in the cloud for subsequent analysis of
detonation characteristics. This type of
sampling usually was accomplished by spe-
cially equipped aircraft.

Cloud Tracking The process of monitoring and determining
the drift or movement of an effluent
cloud, usually performed by radiation mon-
itoring and visual sighting from aircraft.

Collar See "Shaft Collar."

Console A cabinet or panel containing instrumen-
tation for monitoring or controlling elec-
tronic or mechanical measurement devices.

Construction The distance in feet along the tunnel from
Station the portal or a particular junction, usu-
ally expressed in hundreds of feet plus
remaining whole feet. Construction sta-
tion 350 is expressed as CS 3+50, or sim-
ply station 3+50.

Containment The act of preventing release of any ra-
dioactive effluent into the atmosphere or
parts of a tunnel complex beyond the stem-
ming and other containment features. It
is used in reference to the stemming,
TAPS, OBP, or the gas seal plug. A test
is said to have been "contained" if no
effluent is released to the atmosphere or
if no radioactive material is released

underground beyond the stemmed portion of the tunnel.

Containment
Assessment Drift

Another name for an access or reentry drift.

Contamination

This is defined in two ways as follows:

- 1) May refer to the presence of fixed or removable radioactive material at a location. Contamination usually is caused by creation, distribution or contact with fission and activation products from a nuclear detonation or that material incorporated with particles from the test environment or device debris.
- 2) The term may also refer to the deposition on, or spreading of radioactive materials to undesirable locations, personnel, structures, equipment, or other surfaces outside a controlled area.

Controlled Release

Radioactive gas is passed through a filtering system to remove particulates before the gas is released into the atmosphere through the tunnel ventilation system.

Crater

The depression formed on the earth's surface by a near-surface, surface, or underground detonation. Crater formation can occur by the scouring effect of air blast, by throw-out of broken surface material, or by surface subsidence resulting from underground cavity formation and subsequent rock fall, or chimneying, to the surface.

Crater Experiment A test designed to breach and excavate the ground surface, thereby forming an ejecta crater (as opposed to a sink or subsidence crater).

D-1 The first day before a test. D-2 is the second day before detonation, D-3 is the third day before, etc.

D+1 The first day after a test. D+2 is the second day after detonation, D+3 is the third day after, etc.

DAC An experiment protection system no longer used. The DNA Auxiliary Closure (DAC) was a system for closing the LOS pipe milliseconds after device detonation.

Dance Hall A large alcove used for data recording equipment.

DASA AFSWP became the Defense Atomic Support Agency (DASA) in 1959. See AFSWP and DNA.

D-Day The term used to designate the day on which a test takes place.

Decontamination The reduction or removal of contaminating radioactive material from a structure, area, object, or person. Decontamination may be accomplished by (1) treating the surface to remove or decrease the contamination, (2) letting the material stand so that the radioactivity is decreased as a result of radioactive decay, or (3) fixing and covering the contamination to attenuate the radiation emitted.

Device Nuclear fission (or fission and fusion) materials together with arming, fusing, firing, high-explosive, canister, and di-

agnostic measurement equipment that have not been configured into an operational weapon.

DNA An acronym for the Defense Nuclear Agency, successor to DASA in 1971.

DoD An acronym for the U.S. Department of Defense, the federal executive agency responsible for the defense of the United States. Included in this group are the military services and special joint defense agencies.

Dose A quantity of ionizing radiation energy absorbed by a medium. For a person, dose units are in rem or rad.

Dose Rate An amount of ionizing radiation energy that an individual or material could absorb per unit of time. Dose rates are usually expressed as rad or rem per hour. Subdivisions of a rad or rem also are used, e.g., mrem/h means millirem per hour. (A millirem equals one thousandth of a rem.)

Dosimeter A device used to measure radiation doses. Devices worn or carried by individuals are called personnel dosimeters.

dpm Disintegrations per minute, which is a measure of radioactivity.

Draeger Breathing Apparatus See Scott-Draeger.

Draeger Multi-Gas Detector An instrument used to detect toxic gases. A sample of the ambient atmosphere is drawn through a selected chemical reagent

tube, which indicates the concentration of a particular toxic gas by changing color.

Dressed Out

Personnel dressed in anticontamination clothing and any associated equipment.

Drift

A horizontal or inclined passageway excavated underground. It is used interchangeably with the term "tunnel" at the NTS.

Drill Hole Designations

These are defined as follows:
From the surface -

PS-1V: Post-shot drill hole number 1-vertical

PS-1D: Post-shot drill hole number 1-directional

PS-1A: Post-shot drill hole number 1-angle

Each 'S' added after any of the above notations indicates a "sidetrack" or change of direction in the drill hole.

From underground locations sample recovery core holes are referred to as RE (Reentry) No. 1, RE No. 2, etc. ("DNRE" means the reentry hole was DNA requested.)

Dry Run

A rehearsal of the functions occurring in the minutes before and during a test. All timing and firing signals are sent in the proper sequence from the Control Room at CP-1. Each run begins with the first required timing and firing signal (normally minus 15 minutes) and ends with the firing signal. The audio countdown is transmitted over Net 1 (DNA) and on other nets as agreed upon with appropriate agencies. There are various types of dry runs de-

pending on the degree of participation required of the agencies involved.

Effects Experiments	Experiments with the purpose of studying the effects of a nuclear detonation environment on materials, structures, equipment, and systems. They include measurements of changes in the environment caused by the nuclear detonation, such as ground movement, air pressures (blast), thermal radiation, nuclear radiation, and cratering.
Event	See test.
Exoatmospheric	Term describing the area outside the gaseous mass which envelopes the earth.
Explosimeter	A battery-operated detector calibrated to indicate the concentration in the ambient atmosphere of explosive gases and vapors as a percent of the lower explosive limit (LEL) of hydrogen gas (four percent concentration in air) or methane gas (five percent in air).
Exposure	A measure, expressed in roentgens (R), of ionization produced by gamma or x rays in air. (This may also be represented by subdivisions of R; e.g., 1/1000 R = 1 milliroentgen [mR].)
Exposure Rate	Radiation exposure per unit of time, usually per hour, but it may be stated in smaller or larger units (e.g., R/sec, mR/h, R/day).
Face	The end of a tunnel or other excavation that is being worked to advance the tunnel.

FDR

A successful final dry run (FDR) is the last dry run before a test is detonated.

Film Badge

A dosimeter used for the indirect measurement of exposure to ionizing radiation. It generally contains two or three films of differing sensitivity. Films are wrapped in paper or other thin material that blocks light but is readily penetrated by radiations or secondary charged particles resulting from the radiations to be measured. Film packets generally have at least one metal filter or may be in holders with multiple filters. After being worn as a film badge or film dosimeter, films are developed and the degree of darkening (or optical density) measured indicates the radiation exposure. Film dosimeters commonly are used to indicate gamma and x ray exposures, but also can be designed to determine beta and neutron doses.

Fission

The process whereby the nucleus of a particular heavy element splits into (generally) two nuclei of lighter elements, with accompanying release of energy and neutrons. Fission is caused by the absorption of a neutron in the nucleus.

Fission Products

A general term used for the complex mixture of radioactive nuclides (see Radionuclides) produced as a result of nuclear fission.

Fissionable
Material

Material that can be fissioned by fast neutrons only. Used in reactor operations to mean reactor fuel.

Forward Control Point A geographic location in the forward test area, usually adjacent to the closed (or secured) test area.

Front-End Experiments Those experiments located in the immediate vicinity of the working point.

Full Power Full Frequency (FPPF) Dry Run Similar in intent to a mandatory full participation dry run. The FPPF is sometimes combined with the hot dry run (HDR). This run is optional with the device engineer. When this run is conducted, the LOS pipe is under vacuum, telephones and intercoms are disconnected, and tunnel utility and instrumentation power are operated in event-day configuration. All instrumentation is hooked up and operated in event-day configuration (simulators are not used).

Fusion The combination of two very light nuclei (of atoms) to form a relatively heavier nucleus, with an accompanying release of energy, is called fusion. (It is also known as thermonuclear fusion.)

Gamma Photons Electromagnetic radiations of high energy that are emitted from the nuclei of radio-nuclides. These photons are sometimes referred to as bundles of energy, and usually accompany other nuclear reactions, such as fission, neutron capture, and beta particle emission. Gamma photons, or rays, are identical with x rays of the same energy, except that x rays result from orbital electron reactions rather than being produced in the nucleus.

Gamma Shine The measurable gamma radiation intensity from an approaching or passing radioactive cloud, as opposed to measurements from or

in gamma-emitting fallout. This also includes gamma radiation scattered by air molecules, as opposed to direct radiation from a gamma source.

Gas Blocking

The application of approximately 10 psi of pressure between the Gas Seal Door and the Gas Seal Plug, during button-up procedures as an additional reassurance against low-pressure leaks. Embedding the inner components of cables in epoxy at appropriate locations, such as concrete or epoxy plugs.

Gas Seal Door

A steel door on the portal side of the Gas Seal Plug. It is closed during button up, with about a 10 psi gas pressure applied between the Gas Seal Plug and the Gas Seal Door as an additional reassurance against low-pressure leaks.

Gas Seal Plug

A containment feature within the tunnel complex; generally it is designed for 500°F and 500 psi. The Gas Seal Plug is sometimes referenced as the "hasty plug." This plug is similar to the Overburden Plug, but it is placed closer to the portal and seals off the entire tunnel complex from the portal.

Gate 300

Permanent security station in Area 6 near the Control Point facilities, at which reentry and recovery personnel wait during execution of a test. After reentry parties were released from this gate, they moved to the FCP and again awaited release.

Geiger-Müller Counter

An instrument consisting of a Geiger-Müller tube and associated electronic equip-

ment used to detect, display and sometimes record nuclear radiation levels.

Geophone

An instrument used to detect vibrations in rock or soil. At NTS, it is used remotely to detect rock falls, earth movement, and cavity collapse underground. It provides audible signal and visual display data.

Ground Zero

A term used during atmospheric testing to denote a point on the surface of the ground directly below or coinciding with an atmospheric detonation point (see surface ground zero and zero point).

Grout

A cementing or sealing mixture of cement and water to which sand, sawdust, or other fillers may be added. Some organic epoxy compounds are used where high strength or a controlled setting is desired.

H-hour

"Time zero" or the exact time of detonation to the minute, second, or fraction of a second; as opposed to H + 1 which implies one hour after detonation (unless otherwise noted in seconds or minutes), or H-1 which denotes one hour before detonation.

Hot Line

A location on the edge of a radex area where personnel exiting remove anticontamination clothing and equipment, are monitored for contamination, and are decontaminated as necessary before release. This term also was used to denote the centerline of a fallout pattern.

HYDROFRAC (Hydraulic Fracture)

Injection of a dye-containing fluid under pressure into rock which causes areas of the rock to open (i.e., crack) allowing the fluid to permeate the rock. The

	cracks can be traced upon mining into the area.
Invert	The bottom (floor) of a tunnel or other underground excavation (as in cavity invert).
Ion	An atomic particle or part of a molecule bearing an electric charge. Usually a positively charged ion and a negatively charged ion are formed as a pair (e.g., a negatively charged electron is displaced from its positively charged remaining atom).
Ionizing Radiation	Any particulate or electromagnetic radiation capable of producing ions, directly or indirectly, in its passage through air or matter. Alpha and beta particles produce ion pairs directly, while the electrons of initial ion pairs produced by gamma and x rays in turn produce secondary ionization in their paths. Neutrons may displace a positively charged part of a nucleus, such as a proton or alpha particle which produces secondary ionization.
Isotopes	Different types of atoms within the same element, all reacting approximately the same chemically, but differing in atomic weight and nuclear stability. For example, the element hydrogen has three isotopes; normal hydrogen (the most abundant) heavy hydrogen (deuterium), and radioactive hydrogen (tritium).
Keyed Concrete Plug	A concrete plug placed in an excavated area of greater diameter than the shaft or tunnel cross section such that the concrete is poured into the surrounding rock,

thus providing greater strength against over pressure from the nuclear detonation.

Leukemia Cluster	An apparent but unexpected or extraordinary group of leukemia cases within some number or group of persons.
Long Line	The longest gas sampling pipe into the tunnel which does not connect to the LOS pipe.
LOS Pipe	An evacuated pipe that extends from the device to the test chambers. It may be either horizontal or vertical, and in it are experiment protection devices and experiments.
Mandatory Full Participation (MFP) Dry Run	A dry run peculiar to DoD tests. Its purpose is threefold: first, to check all experiments with the event site electrical system in its shot configuration; second, to check for electrical crosstalk between experiments; and third, to operate all recording, timing, and monitoring equipment as closely to shot configuration as is possible. The pipe is under vacuum and the tunnel and portal instrumentation trailers are cleared of personnel. After a successful MFP dry run, all interconnections necessary to place experiments into shot configuration from the MFP configuration are made. Timing, firing, and monitoring system junction boxes are locked and no changes are made except with the express approval of device systems personnel and the Technical Director.
Manhattan Engineer District	The U.S. Army predecessor organization to the U.S. Atomic Energy Commission and the Armed Forces Special Weapons Project.

Manned Stations	Locations inside the closed and secured area which are occupied by authorized personnel during a test.
mR	Milliroentgens, a radiation exposure term meaning thousandth of a roentgen (R). (Also, see Exposure.)
mrad/h	A radiation intensity term traditionally used to show that gamma plus beta was being measured.
Mucking	Removal of broken rock from mining operations (also used loosely for drilling operations).
Muffler	An experiment protection component of the HLOS Vacuum System which is designed to break up high-energy flow within the HLOS system.
Noble Gases	Inert gases which do not react with other elements at normal temperature and pressure (i.e., helium, neon, argon, krypton, xenon, and, sometimes, radon).
Nuclear Device (vs. weapon or bomb)	A device in which most of the energy released in a detonation results from reactions of atomic nuclei, either fission, or fission and fusion. A device under development (see Device) is not considered a weapon or bomb. Both A- (or atomic) bombs and H- (or hydrogen) bombs could be called atomic weapons because both involve reactions of atomic nuclei. However, it has become customary to call weapons A-bombs if the energy comes from fission, and H-bombs if most of the energy comes from fusion (of the isotopes of hydrogen or other light nuclides - see definition). A developmental nuclear device is not a wea-

pon or weapon component until it can be mated to a delivery system.

Nuclear Device Tests	Tests carried out to supply information required for the design, improvement, or safety aspects of nuclear weapons, and to study the phenomena and effects associated with nuclear explosions.
Nuclear Weapon Tests	Tests that provide development and weapons effects information, and may or may not utilize a deliverable nuclear weapon.
Offsite	Radiation detected outside the Test Range Complex, an area that includes both the Nevada Test Site and the adjacent Nellis Air Force Range.
Onsite	Radiation from an unplanned release that was not detectable beyond the boundaries of the Test Range Complex.
Overburden	The consolidated and unconsolidated rock above a tunnel vertically to the surface; thus, it is the burden of rock over a tunnel.
Overburden Plug	A containment feature within the tunnel complex. It is now a high-strength concrete plug keyed into the tunnel rock near the test location and is generally designed to withstand 1000°F and 1000 psi. It originally was named because it was constructed to represent the same containment strength as the rock above the tunnel, or overburden.
Party Monitors	Radiation (Radsafe) monitors assigned to reentry and recovery parties or groups.

Portal Recording Station (PRS)	A building located outside of the tunnel where fiber optic cables are terminated and test data is recorded.
ppm (parts per million)	Term used when determining concentrations of toxic gases or other materials. It refers to either relative weight, such as micrograms of a material per gram of medium, or relative volume, such as cubic centimeters or milliliters per cubic meter.
Privacy Act	The Privacy Act of 1974 is part of Public Law 93-579. This is an Act to amend Title 5, U.S. Code, by adding Section 552a, which is to safeguard individual privacy from the misuse of federal agency records; to provide that individuals be granted access to records concerning them that are maintained by federal agencies; to establish a Privacy Protection Study Commission; and for other purposes.
rad	An acronym for "radiation absorbed dose," a unit of absorbed dose of ionizing radiation. A dose of one rad means the absorption of 100 ergs of energy from ionizing radiation per gram of absorbing material (e.g., body tissue).
Radex Area (Radiation Exclusion Area)	Any area which is controlled for the purpose of protecting individuals from exposure to radiation and/or radioactive materials.
Radiation Exposure	Exposure to radiation may be described by a number of terms. The type of radiation one is exposed to is important in establishing doses. External exposure can be from beta particles, neutrons, gamma and x rays; internal exposure is received from

	radionuclides deposited within the body which may emit alpha, beta, or gamma radiation and irradiate various body organs. (See Dose and Exposure.)
Radioactive Effluent	The radioactive material, steam, smoke, dust, and other particulate or gaseous debris released to the atmosphere from an underground nuclear detonation.
Radioactive or Fission Products	A general term for the complex mixture of radionuclides produced as a result of nuclear fission. (See Activation Products.)
Radionuclides	A collective term for all types of radioactive atoms of various elements, as opposed to stable nuclides. (See Isotopes).
Recovery Operations	Process of finding and removing experiments, by-products, or data from the test area after a test.
Red Shack	An underground (usually) intermediate point provided for the device laboratory's use in checking out and exercising the arming and firing system.
Reentry Drift	See Access Drift.
rem	An acronym for "roentgen equivalent man or mammal." A rad multiplied by the quality factor (QF) of a particular radiation equals the rem dose. Current QF values are one for x, gamma, and beta radiations, 10 for all neutrons, and 20 for alpha particles.
Rib	The side of the drift. The right or left rib is determined with one's back to the portal.

Rock Bolting	A construction technique to pin the rock to the rib or back and reinforce the tunnel walls. The bolts are driven into the wall perpendicular to the shaft. The ends project far enough for end plates to solidify the structure.
roentgen	A special unit of exposure. It is defined precisely as that quantity of gamma or x rays that, when completely stopped in air, will produce positive and negative ions with a total charge of 2.58×10^{-4} coulombs in one kilogram of dry air under standard conditions.
Safety Experiments	Device tests conducted to determine the safety of nuclear weapons during transportation and storage. During these tests, elements of the conventional high-explosive portions of the devices were detonated to simulate accidental damage and to determine the potential for this damage to result in significant nuclear yield. Data gained from the tests were used to develop devices that could withstand shock, blast, fire, and other accident conditions without producing a nuclear detonation.
Sandbag Plugs	Barriers used in tunnels and constructed of sandbags to help contain underground detonations and minimize damage to underground workings.
Scatterer Station	A point along an LOS pipe where the radiation flux is deflected into an area off the LOS pipe as required for the testing or exposure of scatterer area experiments.
Scientific Station	The distance in feet along the HLOS pipe measured from the zero point. These distances are generally expressed in whole

numbers or to the nearest complete hundredths of feet (if fractional). Scientific Station 650 is expressed as SS 6+50; Scientific Station 390.65 is expressed as SS 3+90.65.

Scott-Draeger
Self-Contained
Breathing Apparatus

A self-contained recirculating unit, complete with "full view" apparatus facepiece, compressed oxygen cylinder, breathing bag, carbon dioxide absorber, and pressure demand regulator. It is used when an extended exposure to an extremely hazardous or oxygen deficient atmosphere, or both, is required. This unit is capable of sustaining the wearer, under normal usage, for four to four and one-half hours; however, pertinent approved schedules limit NTS use to two hours.

Seismic Motion

Earth movement caused by an underground nuclear detonation, similar to that of a minor earthquake.

Shaft

A long narrow passage sunk into the earth, usually vertically, but inclined for some mining operations. Shafts for device emplacement, ventilation, or access to underground workings may be drilled or mined.

Shaft Collar

The area immediately around the shaft at ground level, usually cemented, which supports the head frame and other equipment.

Shielding Walls

Walls or barriers used to protect equipment or instrumentation from heat, blast, and radioactivity.

Slushing Operations

The process of moving broken rock with a scraper or scraper bucket. May be used on the surface or underground, where ore or

waste rock is slushed into hoppers or other locations for removal. (See Mucking.)

Spalling

Rock disintegration by evidenced flaking, chipping, peeling, or loosening of layers on the outside edges. It may be caused immediately after detonation by rock stressing near the detonation point. It also may result later, after continued stressing from temperature change expansion and contraction. Spalling also may result or begin when rock containing moisture is raised to a high temperature and expanding vapor creates fractures.

Stemming

The materials used to back-fill or plug the emplacement shaft, drift, or LOS drift to contain over pressure and radioactive material from a nuclear detonation.

Surface Ground Zero

The location on the ground surface directly above an underground zero point or directly below an air burst.

Survey

In the tunnels, a survey might include taking radiation readings with a portable instrument, checking for the presence of an explosive mixture with an MSA explosimeter or GPK, determining toxic gas levels with Draeger tubes, and/or checking for tunnel hazard and damage (also called a "walkthrough" or "walk-out"). Radsafe personnel made the radiation surveys. Radsafe or industrial hygiene personnel monitored LEL level and toxic gas levels, and tunnel mining and construction personnel performed walkthroughs usually accompanied by Radsafe and/or industrial hygiene support personnel. (See tunnel walk-out.)

TAPS (Tunnel and Pipe Seal)	An experiment protection feature along the LOS pipe which allows the experiments to be exposed to the desired levels of radiation while being protected from later arriving debris. It contains a massive steel door which closes after ground shock passes to form a 1000°F and 1000 psi seal. The TAPS also includes the high-strength concrete plug which surrounds the metallic shroud of the door.
Test	The preparations for, and actual testing of, a nuclear device. This includes arming and firing, detonation, concurrent measurements and effects, and later measurements and studies.
Test Chamber	A section of the LOS pipe in which experiments are placed. It may or may not be enlarged, depending upon the test design.
Test Controller	A DOE official designated by the Manager, Nevada Operations Office, to assume responsibility for the field operations involved in conducting a nuclear test at the Nevada Test Site.
Testing Organizations	Organizations conducting nuclear tests at the NTS (see DoD, DNA, LASL, LLL, and SL).
Thermal Shield Plug	A bulkhead built to close off a drift (usually the LOS pipe drift) that protects equipment and instruments on the portal side of the bulkhead. Construction and containment features of the bulkhead are determined by the nature of the test.
Tonopah Test Range	TTR is located in the northwest corner of Nellis Air Force Range near Tonopah, Nevada.

Trailer Park	Areas near a tunnel portal or on the Mesa where instrumentation or instrumentation support trailers are parked.
Tunnel	At NTS, a horizontal underground excavation driven on a predetermined line and grade to some specific target.
Tunnel Access	Entering a tunnel or tunnel complex upon approval of the Test Controller or Test Director during test operations, or upon approval of the Tunnel Superintendent during routine operations.
Tunnel and Pipe Seal	See TAPS.
Tunnel Complex	The complete set of underground workings and support equipment comprising one tunnel test area.
Tunnel Walk-Out	A visual, walking inspection of the tunnel or tunnel complex, usually performed as a part of the initial reentry after a detonation, to check for damage and hazards prior to allowing general access to the underground workings.
Turntube	In the tunnels at the NTS, a crawlway through a containment barrier (i.e., bulkhead, blast wall, or plug.) After a test, the crawlway is used for access through the barrier until the barrier or trainway can be mined out.
Type N Canisters	These canisters are used with face masks to absorb carbon monoxide.
Underground Structures Program	The fabrication and construction of test structures underground for the purpose of detonation effects evaluation.

User Any organization conducting nuclear tests at the NTS. (See Testing Organizations.)

VELA UNIFORM Department of Defense (DoD) program designed to improve the capability to detect, identify, and locate underground nuclear explosions.

Venting Release of radioactive material, gases, steam, smoke, dust and other particulate debris through a zone of weakness from the detonation-formed cavity into the atmosphere.

Weapons Effects Experiments Experiments with the purpose of studying the effects of a nuclear detonation environment on materials, structures, equipment, and systems. They include measurements of the changes in the environment caused by the nuclear detonation, such as ground movement, air pressures (blast), thermal radiation, nuclear radiation, and cratering.

Weather Briefings A part of the readiness briefings, which are meetings of test-associated administrators, advisors, and other technical personnel prior to each test for the purpose of evaluating weather conditions and forecasts on test day, and making decisions on any operational schedule changes necessary for safety reasons.

Work Drift See Access Drift.

Working Point The location in the emplacement hole centered in the nuclear device.

Workings An excavation or group of excavations made in mining, quarrying, or tunneling.

Chiefly plural, such as "the workings extended for miles underground."

x rays

Electromagnetic radiations produced by orbital electron reactions, as opposed to emission of gamma photons by nuclei of atoms. Otherwise, x rays are identical with gamma photons of the same energy.

Yield

The total effective energy released by a nuclear detonation. It is usually expressed in terms of equivalent tonnage of TNT required to produce the same energy release in an explosion. The total energy yield is manifested as nuclear radiation (including residual radiation), thermal radiation, and blast and shock energy. Actual distribution depends upon the medium in which the explosion occurs and upon the type of weapon or nuclear device.

Zero Point

The location of the center-of-burst of a nuclear device at the instant of detonation. The zero point in tests covered by this volume is always below ground.

APPENDIX C

ABBREVIATIONS AND ACRONYMS

The abbreviations and acronyms in the following list are used in this tenth volume of the DoD UNTPR reports. Additional information and definitions may be found in the text and in the Glossary of Terms.

ACUREX	Company name
AEC	Atomic Energy Commission
AEC/HQ	Atomic Energy Commission/Headquarters
AEC/NVOO	AEC Nevada Operations Office
AFSWC	Air Force Special Weapons Center
AFSWP	Armed Forces Special Weapons Project
AFWL	Air Force Weapons Laboratory
ALARA	As low as reasonably achievable
ALOO	Albuquerque Operations Office
APP	Alcove Protection Plug
APTEC	Company name
BPDPP	Bypass Drift Protection Plug
BTMS	Boeing Technical Management Services, Incorporated
CADAC	Control and Data Acquisition Center
CC	Crosscut
CDC	Centers for Disease Control (formerly the Center for Disease Control)
CDPP	Cable Drift Protection Plug
CEP	Containment Evaluation Panel
CIC	Coordination and Information Center
CO	Carbon monoxide
CO ₂	Carbon dioxide
CONVEX	Contained Nuclear Vessel Experiment
CORRTEX	Continuous Reflectometry for Radius versus Time Experiment
CP	Control Point
CP-1	Control Point, Building 1
CP-2	Control Point, Building 2

CP-9	Control Point, Building 9
CTO	Continental Test Organization
DASA	Defense Atomic Support Agency
DBS	Debris Barrier System
DMA	Division of Military Application
DNA	Defense Nuclear Agency
DoD	Department of Defense
DOE	Department of Energy
DOE/NV	Department of Energy, Nevada Operations Office
dpm	Disintegrations per minute
DPP	Drift Protection Plug
DSWA	Defense Special Weapons Agency (formerly DNA; name changed 1 July 1996)
EG&G	EG&G, Inc. (formerly Edgerton, Germeshausen, and Grier)
EPA	Environmental Protection Agency
ERDA	Energy Research and Development Administration
F&S	Fenix & Scisson, Inc.
FAC	Fast Auxiliary Closure
FC/DASA	Field Command, Defense Atomic Support Agency
FC/DNA	Field Command, Defense Nuclear Agency
FCNV	Field Command, Nevada Operations Office
FCP	Forward Control Point
FCT	Field Command Test
FCTC	Field Command, Test Construction (Division of Test Directorate)
FDPP	Facility Drift Protection Plug
FWW	Fighter Weapons Wing
GRC	General Research Corporation
GSAC	Gas Seal Auxiliary Closure
GSD	Gas Seal Door
GSP	Gas Seal Plug
GZ	Ground zero
H&N	Holmes & Narver, Incorporated
HDL	Harry Diamond Laboratory
HE	High explosives (conventional)

HEPA	High-efficiency particulate aerosol
HLOS	Horizontal line-of-sight
HQ/DASA	Headquarters, Defense Atomic Support Agency
HQ/DNA	Headquarters, Defense Nuclear Agency
HS	Helicopter Squadron
HSG	High-strength grout
IEMP	Internal Electromagnetic Pulse
ISA	Interservice Support Agreements
ISAFAP	Indian Springs Air Force Auxiliary Field (formerly Indian Springs Air Force Base)
JAYCOR	JAYCOR Corporation (derived from J. A. Young Corporation)
JCS	Joint Chiefs of Staff
KAFB	Kirtland Air Force Base
KSC	Kaman Sciences Corporation
kt	Kilotons
LANL	Los Alamos National Laboratory
LASL	Los Alamos Scientific Laboratory
LEL	Lower explosive limit
LLC	Limited-life components
LLL	Lawrence Livermore Laboratory
LLNL	Lawrence Livermore National Laboratory
LMSC	Lockheed Missile and Space Corporation
LOS	Line-of-sight
LPARL	Lockheed Palo Alto Research Laboratory
LRL	Lawrence Radiation Laboratory
LTBT	Limited Test Ban Treaty
LVFO	Las Vegas Field Office
MAC	Mechanical Auxiliary Closure
MDPP	Mechanical Drift Protection Plug
MED	Manhattan Engineer District
MFP	Mandatory full-power
MIT/LL	Massachusetts Institute of Technology/Lincoln Laboratory
mR	Milliroentgen
mR/h	Milliroentgens per hour

mrاد	Millirad
MRC	Mission Research Corporation
mrem	Millirem
mrem/qt	Millirem/per quarter
MSDR	Mandatory Signal Dry Run
NAFB	Nellis Air Force Base
NESS	Nuclear Explosive Safety Study
NMERI	New Mexico Engineering Research Institute
NO	Nitric oxide
NO ₂	Nitrogen dioxide
NO+NO ₂	Nitric oxide plus nitrogen dioxide
NOAA/ARL	National Oceanic & Atmospheric Administration/Air Resources Laboratory
NPG	Nevada Proving Ground
NRL/ISI	Naval Research Laboratory/Information Services, Incorporated
NSC	National Security Council
NTA	Neutron Track, Type A
NTIS	National Technical Information Service
NTO	Nuclear Test Organization
NTS	Nevada Test Site
NTSO	Nevada Test Site Organization
NV	DOE Nevada Operations Office
NVOO	Nevada Operations Office
NVCE	Nevada Operations Office, Construction Engineering Division
NVCG	Nevada Operations Office, Containment & Geotechnical Division
NVTC	Nevada Operations Office, Technical Compliance Division
NVTE	Nevada Operations Office, Technical Engineering Division
NVTO	Nevada Operations Office, Underground Test Operations Division
NVTS	Nevada Operations Office, Test Support Division
NVTV	Nevada Operations Office, Test Verification Operations Division
NWET	Nuclear weapons-effect test

OBP	Overburden Plug
OMA	Office of Military Application
PDT	Pacific Daylight Time
PI	Physics International
ppm	Parts per million
PSR	Pacific Sierra Research
psi	Pounds per square inch
PST	Pacific Standard Time
R&D	Research and development
rad	Radiation absorbed dose
rad/h	Radiation absorbed dose per hour
Radsafe	Health Protection Department (formerly Environmental Sciences Department), REECo
radsafe	Radiological safety, in general
RAMP-4	Multichannel, hard-wire linked, remote area gamma monitoring telemetry system
RAMS	Remote area monitoring system
REECo	Reynolds Electrical & Engineering Company, Inc.
rem	Roentgen equivalent man or mammal
R/h	Roentgens per hour
RMG	Rock-Matching Grout
ROSES	Recorder and Oscilloscope Sealed Environmental System
RSN	Raytheon Services Nevada
SAIC	Science Applications International Corporation
SC	Sandia Corporation
SCBA	Self-contained breathing apparatus
S-CUBED	Company name (formerly Systems, Science and Software)
SDR	Signal dry run
SDI	Strategic Defense Initiative
SEA	Science and Engineering Associates
SFOO	Santa Fe Operations Office
SGZ	Surface ground zero
SL	Sandia Laboratories
SLA	Sandia Laboratories, Albuquerque
SLG	Superlean Grout

SNL	Sandia National Laboratories
SNLA	Sandia National Laboratories, Albuquerque
SOP	Standard operating procedure
SPO	Special Program Offices
SRD	Secret Restricted Data
SREMP	Source Region Electromagnetic Pulse
SRI	Stanford Research Institute
SRII	Stanford Research Institute International
SSS	Systems, Science, and Software (S-CUBED)
STAC	Stemming Anchor Closure
TAC	Tactical Air Command
TAPS	Tunnel and Pipe Seal
TC	Test chamber
TC	Test Controller
TC/DASA	Test Command, Defense Atomic Support Agency
TC/DNA	Test Command, Defense Nuclear Agency
TD	Test Director
TDNM	Test Directorate, New Mexico Operations Office
TDNV	Test Directorate, Nevada Operations Office
TDTT	Test Directorate, Office of Test Science & Technology
TEP	Test Evaluation Panel
TGD	Test Group Director
TID	Test Instrumentation Development
TLD	Thermoluminescent dosimeter
TNT	Chemical high explosive, (2,4,6-trinitrotoluene)
TOAS	Underground Test Operations Division, Administration & Security Branch
TOST	Underground Test Operations Division, Supply & Transportation Branch
TOTO	Underground Test Operations Division, Test Operations Branch
TSP	Thermal Shield Plug
TTR	Tonopah Test Range
TTST	Office of Test Science & Technology, Simulation Technology Division
TTTT	Office of Test Science & Technology, Test Technology Division

TTUT	Office of Test Science & Technology, Underground Test Division
UCRL	University of California Radiation Laboratory
UDPP	Utilities Drift Protection Plug
UNTPR	Underground Nuclear Test Personnel Review
USAF	United States Air Force
USASDC	United States Army Strategic Defense Command
USGS	United States Geological Survey
VA	Veterans Administration
VLOS	Vertical line-of-sight
WETG	Weapons Effects Test Group
WP	Working point
WTD	Weapons Test Division

APPENDIX D

U.S. DEPARTMENT OF ENERGY
NEVADA TEST SITE
STANDARD OPERATING PROCEDURE

NTS-SOP 1102

CHAPTER 1102 THE NUCLEAR TEST ORGANIZATION

1. POLICY. Test execution shall conform to statutory, regulatory, and other responsibilities in accordance with delegations to the Manager, DOE Nevada Field Office (DOE/NV), by the Deputy Assistant Secretary for Military Application.
2. OBJECTIVE. The Nuclear Test Organization (NTO) is an organization formed for the purpose of conducting Nevada Test Site (NTS) nuclear tests, the composition of which may be readily adjusted or changed in response to the needs and technical objectives of the U.S. Department of Energy (DOE) nuclear test program.
3. GENERAL.
 - a. The NTO includes DOE, Department of Defense, laboratories, contractors, and associated federal agencies participating in, or providing support for, test operations at the NTS.
 - b. The test execution period begins on Day-1 (D-1) and ends when the Test Controller (TC) returns the NTS to normal operational control. Prior to D-1, the TC may activate elements of the NTO and conduct such activities as may be necessary for the preparation of the test.
 - c. Users are allowed maximum technical latitude in the conduct of their specific programs and are responsible for technical readiness. However, operations and facilities are required to be managed in a manner that protects the public and employee health and limits risks to the environment.
4. RESPONSIBILITIES AND AUTHORITIES.
 - a. Operational.
 - (1) Manager, DOE/NV. Administers programs for the conduct of nuclear tests that have been approved by DOE Headquarters (HQ) and delegates authority for test execution to a senior member of the DOE/NV staff designated as the TC.

INITIATED BY:
Test Operations Division

July 29, 1992

- (2) Test Controller. During the test execution period, the TC has the authority to proceed, delay, or postpone the execution of approved tests. The TC is assigned full responsibility for the safe conduct of each test. The DOE/NV master test schedule lists the individual scheduled to be the TC for each test.
- (3) Scientific Advisory Panel. Comprised of experts in the fields of underground testing phenomenology, meteorology, radiation medicine, health physics, off-site safety, and other disciplines pertaining to the safety of a specific activity. Members of the Panel are selected from candidates previously approved by the Manager, DOE/NV. The chairperson of the Panel is the scientific advisor nominated by the scientific sponsor of the test and approved by the Manager, DOE/NV. The Panel makes recommendations to the TC as to whether the test should proceed or be delayed.
- (4) Test Group Director (TGD)/Test Director (TD).
 - (a) Assigned by the scientific sponsor of the test to direct the fielding and technical aspects of experiments and tests. The TGD/TD for a specific test is selected from candidates previously approved by the Manager, DOE/NV.
 - (b) For each designated test, the assigned TGD/TD is responsible to ensure that all field operations are performed in compliance with the environmental protection policy of DOE/NV, which is to evaluate the potential environmental impacts of each test, and testing programs, to ensure that the impacts of testing are identified and minimized, and to ensure incorporation of national and international environmental protection goals in the formulation and implementation of testing programs.
- (5) Office of Assistant Manager for Environment, Safety, and Health.
 - (a) Provides a health physics advisor (HPA) providing advice to the TC on all significant matters relating to radiological safety.
 - (b) In the conduct of underground nuclear testing operations, verifies compliance with all environmental, safety, and health laws, regulations, standards, agreements, and DOE and DOE/NV Orders relative to environment and health protection.

July 29, 1992

- (6) Director, Test Operations Division. Provides a Radiological Operations Officer (ROO) to coordinate radiation safety operations for the TC during the test execution period. Also provides for operation of the Operations Control Center, Control Point 1, and appoints the test operations officer, test liaison officer, verification liaison officer, and air operations officer; and provides support in the area of communications. Serves as chairperson of the DOE/NV Verification Evaluation Panel.
- (7) Director, Nevada Test Site Office (NTSO). Provides a NTSO advisor to the TC to coordinate craft support, and a Mercury Control Center coordinator during nuclear test activities. Also provides an occupational safety advisor to the TC.
- (8) Director, Verification Management Division. Provides a DOE/NV verification representative to provide liaison and coordination between the On-Site Inspection Agency (OSIA) and DOE/NV for assigned nuclear tests. The verification representative will maintain close liaison with the TC and the testing party representative during the test operations period of the verification activities. Ensures that all DOE/NV Threshold Test Ban Treaty (TTBT) Protocol responsibilities are satisfied.
- (9) Director, Office of External Affairs. Provides a staff member to advise and assist the TC on the informational aspects of public safety and public affairs, and makes public announcements when so directed by the TC or the Manager, DOE/NV.
- (10) Director, Safeguards and Security Division. Assigns a security advisor to the TC to provide coordination on security matters.
- (11) Director, Safety and Health Division. Provides nuclear explosive safety advisors to the TC.
- (12) Director, Emergency Management Division. Assigns an emergency management advisor to the DOE/NV test controller to provide for preplanning and interface with the DOE Federal Radiological Monitoring and Assessment Center (FRMAC) in the event of an immediate, massive radioactive venting after a nuclear test.
- (13) Director, Environmental Protection Agency/Environmental Monitoring Systems Laboratory (EPA/EMSL). The EPA/EMSL provides a member to serve on the Scientific Advisory Panel, provides a comprehensive radiological surveillance and safety

July 29, 1992

program in off-site areas surrounding the NTS, and conducts a public contact and information program in the off-site area to ensure residents that safeguards are being employed to protect health and property from radiation or other test hazards off site.

- (14) Meteorologist-in-Charge, National Oceanic and Atmospheric Administration/Weather Service Nuclear Support Office (NOAA/WSNSO). Serves, or provides an alternate to serve, on the Scientific Advisory Panel, providing advice on expected meteorological conditions and potential radiological conditions relating to the safe conduct of each nuclear test.
- (15) Medical Doctor. A qualified doctor in radiation medicine will serve as a member of the Scientific Advisory Panel.
- (16) U.S. Air Force/DOE Liaison Office. Provides an advisor that is familiar with the Nellis Air Force Base range complex to the TC during nuclear test activities, who ensures that evacuation of Nellis Air Force Base range personnel can be accomplished in the event a radioactive venting occurs.

b. Review Panels. Review Panel members, either as a group or as individuals, may be called upon during nuclear test activities by the TC to provide expert advice necessary for the TC to make decisions to ensure the safe conduct of the nuclear test.

- (1) Threshold Treaty Review Panel. Evaluates and validates device designs of 125 kt or greater yields to determine if design yields are within the limits of the TTBT. Postmortem analyses are also evaluated if the post-shot prompt yield measurements data indicate that a threshold breach may have occurred. Reports on these evaluations are made to the Manager, DOE/NV.
- (2) Containment Evaluation Panel. Evaluates, as an independent agent, the containment design of each proposed nuclear test, ensuring that all relevant data is evaluated. The Manager, DOE/NV, is advised of the findings of the Panel in order to provide a basis for requesting detonation authority.
- (3) Nuclear Explosive Safety Study and Survey Group. Conducts safety analyses of all proposed operations involving nuclear explosives and prepares reports for appropriate approval and signature. An approved nuclear explosive safety study or survey is required before the detonation authority is granted.

July 29, 1992

- (4) Verification Evaluation Panel. Ensures that TTBT Protocol requirements are fulfilled to enable the weapons test community to carry out its treaty obligations in a manner that minimizes deleterious impacts on weapons testing and, at the same time, avoids possible treaty violations.
5. APPENDIX. Contains detailed description of assignment of responsibilities and authorities. Organization structure is included as Attachment 1 to this Appendix.
6. ATTACHMENT. A list of acronyms used throughout this NTS-SOP and the Appendix is in Attachment 1.

July 29, 1992

5 (and 6)

TABLE OF CONTENTS

	<u>PAGE</u>
<u>PART I--MANAGER, DOE NEVADA FIELD OFFICE</u>	I-1
<u>PART II--TEST CONTROLLER</u>	II-1
<u>PART III--TEST CONTROLLER'S SCIENTIFIC ADVISORY PANEL</u>	III-1
1. Scientific Advisory Panel	III-1
2. Scientific Advisor	III-1
3. Off-Site Radiological Safety Advisor	III-1
4. Meteorological Advisor	III-2
5. Medical Advisor	III-3
6. Health Physics Advisor	III-3
<u>PART IV--TEST GROUP DIRECTORS/TEST DIRECTORS</u>	IV-1
<u>PART V--DIRECTOR, NEVADA TEST SITE OFFICE</u>	V-1
<u>PART VI--DIRECTOR, TEST OPERATIONS DIVISION</u>	VI-1
<u>PART VII--DIRECTOR, VERIFICATION MANAGEMENT DIVISION</u>	VII-1
<u>PART VIII--DIRECTOR, OFFICE OF EXTERNAL AFFAIRS</u>	VIII-1
<u>PART IX--DIRECTOR, SAFEGUARDS AND SECURITY DIVISION</u>	IX-1
<u>PART X--DIRECTOR, SAFETY AND HEALTH DIVISION</u>	X-1
<u>PART XI--DIRECTOR, EMERGENCY MANAGEMENT DIVISION</u>	XI-1
<u>PART XII--USAF/DOE LIAISON</u>	XII-1
<u>PART XIII--THRESHOLD TREATY REVIEW PANEL</u>	XIII-1
1. Policy	XIII-1
2. Objective	XIII-1
3. Responsibilities and Authorities	XIII-1

July 29, 1992

TABLE OF CONTENTS
(Continued)

	<u>PAGE</u>
<u>PART XIV--CONTAINMENT EVALUATION PANEL</u>	XIV-1
1. Policy	XIV-1
2. Responsibilities and Authorities	XIV-1
3. D-1 Briefing	XIV-1
<u>PART XV--VERIFICATION EVALUATION PANEL</u>	XV-1
1. Purpose	XV-1
2. Policies	XV-1
3. Responsibilities	XV-1
4. Composition of the Panel	XV-2
5. Concept of Operations	XV-2
6. Term	XV-3

Attachment 1--DOE/NV Nuclear Test Organization

July 29, 1992

PART IMANAGER, DOE NEVADA FIELD OFFICE

1. Administers the preparation and execution of all programs and projects at the Nevada Test Site (NTS), and provides all construction and logistic support services and facilities required to support NTS users while ensuring compliance with all environmental, safety, and health laws, regulations, standards, agreements, and U.S. Department of Energy (DOE) and DOE Nevada Field Office (DOE/NV) Orders.
2. Provides support services to organizations participating in test, experimental, and other scientific activities; and performs the following, primarily by contracting with private firms and entering into interagency agreements for the management and operation of the NTS:
 - a. Furnishes project-related materials, equipment, and technical services required to support the technical effort of:
 - (1) Weapons laboratories; and
 - (2) Agencies sponsoring experiments or participating in the scientific aspects of experiments.
 - b. Carries out design and development of specialized equipment and technical processes to assist in attainment of technical objectives within the framework of the DOE requirements.
 - c. Provides for design, construction, operations, and maintenance of facilities associated with assigned functions. All capital asset structures and facilities will be budgeted or coordinated through DOE/NV.
 - d. Furnishes common services to NTS technical users in accordance with individual agreements with the test organizations, including work space; utilities; communications; transportation; housing, feeding, recreation, and other personal services; warehousing; common equipment and supplies; and other services, as appropriate.
 - e. Provides for technical safety studies and for scientific advisory information regarding meteorology, radiological safety, and other operational safety factors (including hydrological, seismic, geological, ecological, and biological studies, as required) to consider the feasibility, possible effects, timing, and safe execution of individual experiments.

July 29, 1992

- f. Provides guidance to NTS organizations on regulatory compliance requirements with federal and state laws, regulations, and DOE/NV Orders.
3. Appoints the Test Controller (TC) and announces the test execution period for each specific test; and heads the Nuclear Test Organization (NTO). Coordinates preparation and planning; and approves execution of authorized nuclear tests and biological, ecological, hydrological, radiological, and seismic studies; and performs other research and development activities approved by DOE Headquarters (HQ).
4. Provides legal, procurement, personnel, classification, security, communications, inspection, and budgetary services, as required.
5. Administers programs and performs functions other than those designated above, as may be directed or authorized.
6. In the event of a major radiological release, serves as the lead federal agency official (LFAO) to ensure that DOE/NV's emergency activities focus effectively on three aspects as follows:
 - a. Addressing on-site safety issues and operational activities to resolve the venting problem, and dealing with site restoration and recovery concerns. These on-site actions will be accomplished through the TC's NTO.
 - b. Ensuring that sufficient and appropriate off-site monitoring, evaluation, assessment, and data management control occur. These off-site actions will be managed by the TC's NTO for the first 24 hours after a radiological release. After 24 hours, this responsibility will be assumed by a Federal Radiological Monitoring and Assessment Center (FRMAC) director, reporting to the DOE/NV Manager as the LFAO.
 - c. Providing the direct interface with senior federal officials, elected officials, media representatives, and the public; both personally or through the FRMAC, as the situation requires.
7. In coordination with the DOE/HQ Operational Emergency Management Team, names a FRMAC director to assume the off-site responsibility for monitoring evaluation, assessment, and data management. The TC at D+1 will transfer appropriate NTO off-site assets and the off-site data flow to the FRMAC director. All reassigned assets will remain available to the TC based upon priority needs as determined by the LFAO.

July 29, 1992

PART IITEST CONTROLLER

1. Appointed by the Manager, DOE/NV; has full responsibility for the safe conduct of nuclear tests. The DOE/NV master test schedule lists the individual scheduled to be the TC.
2. Serves as the staff coordinator for the Manager, DOE/NV, during planning and test execution; becomes conversant with all significant actions pertaining to each assigned test.
3. On or about D-7, and on D-1, convenes a planning and safety review meeting where the TC and Scientific Advisory Panel are briefed by the sponsoring laboratories and support agencies on various test-related, technical, operational, verification, and safety interests.
4. Is familiar with the containment design and special features of the test. Prior to the D-1 readiness briefing, conducts a containment review, comparing the as-built configuration with the containment design, which was reviewed by the Containment Evaluation Panel (CEP); and determines whether the as-built configuration must be reevaluated by the CEP.
5. Provides policy guidance and direction pertaining to the execution of the assigned test during the test execution period. The TC will, however, during the preparation period, request information and furnish directions through established management channels.
6. Reviews and approves the Operations and Security Plan and other NTO plans affecting the execution of the assigned test.
7. In collaboration with the designated laboratory scientific advisor, ensures the availability of a Scientific Advisory Panel and qualified support staff to assist in the execution of the assigned test.
8. Assumes operational control of the NTS and the NTO during the test execution period when test-related activities have priority over all other NTS matters. (NOTE: Normally, this is the period of time following the completion of the D-1 readiness briefing through the time when initial reentry into the surface ground zero and trailer park is complete. It officially ends when the TC returns the NTS to normal operational control.) The TC has responsibility for the safe conduct of an assigned nuclear test and for compliance with DOE/NV Orders, instructions, and published policy. The TC is authorized to delay any

July 29, 1992

II-1

nuclear test or nuclear test-related activity when such delay is determined to be necessary to allow for further evaluation, a change in meteorological conditions, meeting Threshold Test Ban Treaty (TTBT) verification period of readiness requirements, or for other actions which will increase the likelihood of a safe test execution.

9. Communicates directly with the Emergency Operations Center (EOC), DOE/HQ, and DOE/NV, normally through the test liaison officer, during the test execution period; and immediately notifies the Manager, DOE/NV, and the EOC of significant operational matters.
10. Ensures that all underground nuclear events are reported immediately to the National Response Center (NRC) and the state of Nevada Emergency Management Division (EMD).
11. Serves as the DOE on-scene coordinating official who will converse with the NRC after initial notification has been made.
12. Responsible for ensuring compliance with the application of the technical provisions of the TTBT Protocol on each assigned nuclear test and the protection of classified information. Also serves as the senior NTS representative to the Coordinating Group, as defined in the TTBT Protocol.
13. In the event of a major radiological release, ensures that:
 - a. The Governors of Nevada, California, Utah, and Arizona are contacted and advised of the nature of the emergency and what actions are being taken; are informed that required remedial actions are being developed jointly with their radiological health and emergency services organizations; and are apprised of all significant developments.
 - b. State of Nevada and adjoining state radiological health and emergency services organizations are contacted to develop joint emergency response actions and also to ensure contact with DOE radiological assistance coordinators in affected areas.
14. In the event of a major radiological release, the TC at D+24 hours will transfer appropriate NTO off-site assets and the off-site data flow to the FRMAC director. All reassigned assets will remain available to the TC based upon priority needs as determined by the LFAO.

July 29, 1992

PART IIITEST CONTROLLER'S SCIENTIFIC ADVISORY PANEL

1. SCIENTIFIC ADVISORY PANEL. The Panel is comprised of individuals who have combined expertise in the fields of underground testing phenomenology, health physics, meteorology, radiation medicine, off-site radiological safety, and other subjects pertaining to the safety of a specific activity. The TC for a specific test, in collaboration with the scientific advisor, will ensure that the composition of the Panel is consistent with the needs for each particular event. Members of the Panel will be selected from candidates who have previously been approved by the Manager, DOE/NV. The chairperson of the Panel is the scientific advisor assigned by the scientific user. The Panel will convene at the request of the TC to evaluate containment, seismic shock, possible radiation releases, weather, and area control plans pertinent to a particular test involving potential hazards to off-site and on-site population and property. When requested, they will recommend to the TC the advisability of proceeding with, or delaying, the particular activity under consideration and advise the TC on specific programs associated with the execution of the test.
2. SCIENTIFIC ADVISOR. Previously nominated by the sponsoring user and approved by the Manager, DOE/NV; is assigned for each nuclear test conducted at the NTS. This individual must be familiar with the technical and scientific aspects of each assigned test, including device design, containment design, and construction, as well as test safety and control procedures. The advisor:
 - a. Serves as the chairperson of the TC's Scientific Advisory Panel and, in this capacity, reviews and approves minutes of the Panel meetings for each assigned test.
 - b. Advises the TC on all applicable scientific and technical matters related to the safe conduct of each assigned test.
 - c. Consults with individuals, laboratories, and participating agencies involved in the conduct of the test, furnishing advice and recommendations as appropriate.
3. OFF-SITE RADIOLOGICAL SAFETY ADVISOR. The off-site radiological safety advisor to the TC's Scientific Advisory Panel, previously nominated by the Director, Environmental Protection Agency/Environmental Monitoring Systems Laboratory (EPA/EMSL), and approved by the Manager, DOE/NV, is assigned for each nuclear test conducted at the NTS. This individual

July 29, 1992

must possess technical expertise in radiation protection procedures and criteria, be familiar with off-site areas, and be experienced in public relations aspects of a radiation safety program for the general public. The advisor participates fully in all deliberations concerned with conducting the test at hand or mitigating the consequences of any release of radioactivity. The advisor:

- a. Provides the TC with any necessary advice or recommendations which will help ensure the maximum protection of the public and the environment in the event of any radiological release and recommends protective actions to minimize radiation exposure of the public through all environmental pathways.
 - b. In the event of a release of radioactivity, assesses the observed radiation levels in comparison to the predictions and recommends modifications to the safety plan as necessary and appropriate.
 - c. When necessary, recommends that the off-site safety program be augmented by assistance from state or local authorities.
 - d. Ensures that all activities of the EPA are carried out as planned or directed and continuously evaluates the appropriateness of these actions.
 - e. With the data obtained from the EPA off-site monitors concerning downwind populations, agricultural areas, domestic animals, and milk-producing areas, advises the TC on the best course of action in a given situation.
4. METEOROLOGICAL ADVISOR. The meteorological advisor previously nominated by the Weather Service Nuclear Support Office (WSNSO) and approved by the Manager, DOE/NV, is assigned for each nuclear test conducted at the NTS. This individual is a meteorologist with expertise in nuclear meteorology and testing criteria and attends all NTS planning and readiness briefings. As a member of the Scientific Advisory Panel, participates fully in those deliberations conducted to formulate advice to the TC on test-related matters during nuclear field operations. The advisor:
- a. Develops a knowledge of meteorological conditions and related potential radiological effects for each test sufficient to understand the logic of weather predictions and the radiological estimates presented. From this knowledge he or she can provide advice on these matters to the Scientific Advisor and the TC.

July 29, 1992

- b. Directs all support efforts of the WSNSO contingent assigned to the test operation and any post-test support required, such as the Data Acquisition and Assessment Center.
 - c. Assesses the data received from the Meteorological Data Collection Center and advises the TC with regard to weather and radiological predictions for downwind areas of interest.
5. MEDICAL ADVISOR. The medical advisor, a physician (MD) with expertise in radiation medicine, is approved by the Manager, DOE/NV, as a member of the Scientific Advisory Panel and, as such, participates fully in all deliberations regarding the assigned test. The medical advisor:
- a. Provides any necessary medical advice (including radiation medicine) to the TC and other members of the Scientific Advisory Panel; recommends protective actions for the general public and personnel associated with the test activities.
 - b. In the event of an actual radiation exposure, provides medical advice to attending medical personnel.
6. HEALTH PHYSICS ADVISOR. The health physics advisor (HPA), with expertise in the area of radiological safety, is approved by the Manager, DOE/NV, and assigned by the Assistant Manager for Environment, Safety, and Health. The HPA, as a member of the Scientific Advisory Panel, participates fully in all deliberations regarding the assigned test. Specifically, the HPA will advise the DOE/NV TC on all significant matters relating to radiological safety.

July 29, 1992

III-3 (and III-4)

PART IV

TEST GROUP DIRECTORS/TEST DIRECTORS

Each laboratory/agency authorized to conduct experiments at the NTS will designate a test group director/test director (TGD/TD) who will be the official contact in all matters concerning a particular program of the laboratory/agency. The laboratory/agency:

1. Provides coordination of all activities, including occupational and radiological safety, within the operating area assigned to the laboratory/agency for a particular program.
2. Issues plans (e.g., RadSafe, classification summary/security plans, etc.) and schedules events with particular attention to those aspects which may affect the activities of other user programs or safety outside the assigned areas. Upon request by the Operations Coordination Center (OCC), submits detailed operations plans and schedules for review by the TC.
3. Prepares and submits operational reports, as requested by the TC.
4. Coordinates programs with other users and the OCC; makes every effort to work out problem areas with others before these problems are referred to the TC for resolution.
5. Ensures that all field operations are performed in compliance with DOE/NV environmental protection policy.

July 29, 1992

IV-1 (and IV-2)

PART V

DIRECTOR, NEVADA TEST SITE OFFICE

1. Provides direction and control of NTS construction and logistical support activities and coordinates planning. The Director, Nevada Test Site Office (NTSO), provides support to the TC during nuclear test activities and designates an NTSO advisor to:
 - a. Attend all briefings and represent the Director, NTSO, on the TC's staff.
 - b. Perform direct liaison between DOE and NTS organizations, as necessary, in support of the TC.
 - c. Coordinate evacuation of any area, as directed by the TC.
 - d. Maintain current information on the schedule of operations for each test and the activities of NTS organizations which might be affected by the test.
 - e. Report test information relative to secured areas, incidents, emergencies, etc., to the TC.
 - f. As required, provide a communications and/or electrical power advisor to the TC, who will attend briefings and provide technical advice and guidance on matters pertaining to the support of tests at the NTS.
2. Provides for the activation of the Mercury Control Center under the direction of a NTSO representative, at the time of D-Day readiness briefing, to coordinate actions and control of personnel in Mercury in connection with evacuation of one or more NTS areas.
 - a. The Director, NTSO, also provides an occupational safety advisor who reports to the TC at Control Point (CP)-1 during the test execution period and provides:
 - (1) Advice to the TC on all policies and procedures relative to normal safety matters.
 - (2) Expert safety advice to the TC during emergencies and coordinates necessary medical emergency response resources.

July 29, 1992

V-1 (and V-2)

PART VIDIRECTOR, TEST OPERATIONS DIVISION

Provides advice and assistance in the development of policies and procedures relating to operational control and safe conduct of experimental programs. The Director, Test Operations Division (TOD):

1. Ensures the most effective use of facilities involved in the conduct of nuclear tests at the NTS.
2. Ensures that consideration by the TC has been given to the status of programmatic and detonation authorities prior to the approval by the TC to move, emplace, stem, and detonate each device.
3. Ensures that predictions are provided for the TC on levels of ground motion expected at off-site locations and ensures instrumental monitoring and documentation of actual off-site ground motion resulting from tests.
4. Serves as chairperson of the DOE/NV Verification Evaluation Panel (VEP).
5. Provides direct support to the TC during the test execution period as follows:
 - a. Operations Coordination Center.
 - (1) Compiles data for, and publishes, the TC's operations and security plans for each test conducted at the NTS and for other programs where personnel movements and area closures are required.
 - (2) Assists the test operations officer in preparations for test execution and other forward area support.
 - (3) Compiles a complete and comprehensive list of personnel required to conduct a scheduled test, including normal reentry and recovery operations. This list will be alphabetized from forms submitted by participating agency personnel to the OCC.
 - (4) From D-1 to when the areas are released from test execution status, the OCC monitors field operations and coordinates activities between user agencies and support organizations in the forward area.

July 29, 1992

VI-1

- (5) Coordinates and sets up D-1 containment, classified, and readiness briefings.
- (6) Obtains assurance from each organization having personnel in the closed or controlled areas at shot time that those personnel are familiar with the emergency evacuation plan for their location.
- (7) Provides continuous manning of the OCC from 0800 hours on D-1 through the end of the test execution period.
- (8) As directed by the Chief, Operations Management Branch, TOD, provides an air operations officer for each nuclear test or operational event.
- (9) Arranges for an air traffic controller (ATC) (USAF ATC from Dreamland) to man the air operations center at the OCC CP-1.

b. Test Operations Officer.

- (1) Supervises, prepares, reviews, and executes the TC's Operations and Security Plan, which includes proposed area control, schedule of events, security interests, special instructions, air operations plan, and any other required plans. Prepares pre- and post-shot related reports as assigned.
- (2) Performs special assignments as directed by the TC.
- (3) Presents area control briefings for evaluation by the Scientific Advisory Panel and for use by laboratory and support participants.
- (4) Serves as the principal operations coordinator for the TC during the test execution period, directing activities of the operations support group to ensure that all required operational, security, and safety activities are properly implemented for each test.
- (5) Notifies the NRC of all underground nuclear events, along with the state of Nevada EMD.
- (6) Resides at CP-1 for at least 24 hours following event execution to coordinate emergency response functions should an unforeseen post-shot emergency problem occur.

July 29, 1992

VI-2

- c. Test Liaison Officer. Acts for the TC in the oral communication of test-related information between the Test Control Center at the NTS, the EOC, DOE/HQ, and DOE/NV during the operational period; and provides the EOCs with the following types of shot-related information:
- (1) Area control status and significant changes.
 - (2) Location of permanent, temporary, and special radiation area monitor system (RAMS) units.
 - (3) Weather and fallout (centerline, sector, and dose estimate) predictions.
 - (4) Scheduled times for briefings and any changes in detonation time.
 - (5) Names of the TC and Scientific Advisory Panel. The test liaison officer requests, from the EOCs, the names of those present in the EOC, DOE/HQ, and DOE/NV.
 - (6) Location of mines, buildings, etc. (if any), where people are stationed to make perceptibility readings.
 - (7) Shot-time activity (e.g., countdown, dust clouds, perceptible ground motion, release of radioactivity).
 - (8) RAMS, aircraft, and geophone readouts.
 - (9) TC's EOC standard operating procedure condition category.
 - (10) Other information as directed by the TC.
- d. Air Operations Officer.
- (1) Coordinates aircraft requirements to ensure timely support for test operations, to include DOE contractor and USAF Technical Applications Center (AFTAC) assets.
 - (2) After consultation with the TC, informs appropriate agencies (USAF and Federal Aviation Agency (FAA)) to close airspace as required.

July 29, 1992

- (3) Advises and makes recommendations to the TC relative to:
 - (a) Test-related problems as they may affect air operations.
 - (b) Special aircraft or operations incidents.
- (4) Provides the appropriate FAA office with factual information regarding incidents associated with the restricted flying area and with test activities.

e. Radiological Operations Officer.

- (1) Provides staff supervision of the implementation of the radiological safety policies of the TC.
- (2) Informs the TC of the status of the radiological conditions within the NTS.
- (3) Sponsors the preparation of both the on-site and off-site radiological safety plans for the NTS.
- (4) Reviews on-site and off-site radsafe procedures of DOE/NV and advises the TC of the completeness, adequacy, or necessity for revision.
- (5) Reviews testing laboratory's radsafe and reentry procedures and plans, and advises the TC of any inconsistencies with DOE/NV policy.
- (6) Prepares and presents the status of on-site radiological preparedness at the N-1 and N-Nav Panel readiness briefings.

all ongoing field activities, and ensure that all potential support resources (e.g., analytical laboratory, decontamination facilities, personnel, etc.) are available in a timely manner. Coordinates and documents radiological information with user and contractor groups, as time may allow, to ensure sound decisions can be rendered in establishing exclusion areas, evacuation of work forces, special monitoring requirements, etc. Ensures the prompt technical documentation of radioactive releases.

- (10) Performs investigations and makes reports on specific incidents, as may be specifically assigned by the TC.
 - (11) Assists in compiling and reviewing individual shot reports and/or other special reports, particularly with respect to radsafe conditions, as required.
 - (12) Reviews operations plans relative to radiation hazards and recommends appropriate action to the TC.
 - (13) Ensures that the proper protection equipment is available for all personnel north of Station 200 who are on the hard-core list.
 - (14) Coordinates with the on-site radiological contractor to ensure all necessary radsafe personnel and resources are available at event time.
 - (15) Coordinates with event laboratory and on-site radiological contractor when directing supplemental environmental sampling close in to the ground zero.
 - (16) Coordinates and proposes strategy for the use of the Blue Bird Team for concurrence of the TC.
 - (17) Coordinates the development of laboratory and contractor program documentation, including technical studies, reports, and operating procedures.
- f. Verification Liaison Officer. Assigned if test is verified under TTBT Protocol.
- (1) Serves as the liaison between the TC and the verification representative during the test operations period.

July 29, 1992

- (2) Ensures that notification, in writing, of planned time of test, delays or postponement, and termination or changes in the period of readiness are prepared for approval of the TC and submitted to the verification representative for distribution to the senior team leader at the NTS and/or designated seismic stations.
- (3) Ensures that all notifications are made within the time requirements specified in the Protocol.

July 29, 1992

VI-6

PART VII

DIRECTOR, VERIFICATION MANAGEMENT DIVISION

Provides a DOE/NV verification representative to provide liaison and coordination between the On-Site Inspection Agency (OSIA) and DOE/NV for each assigned nuclear test. The verification representative will maintain close liaison with the TC and the testing party representative during the test operations periods of the verification activities. Ensures that all DOE/NV TTBT Protocol responsibilities are satisfied.

July 29, 1992

VII-1 (and VII-2)

PART VIII

DIRECTOR, OFFICE OF EXTERNAL AFFAIRS

Serves as the field-level coordinator for all state and local public affairs, congressional relations, and public information actions dealing with DOE/NV, and is the official point of contact between news media and official participants in activities at the NTS. Assigns an Office of External Affairs (OEA) advisor to the TC during nuclear test activities to prepare, coordinate, and issue public announcements; and to review and approve public announcements, photographs, speeches, and other materials pertaining to nuclear test activities.

July 29, 1992

VIII-1 (and VIII-2)

PART IXDIRECTOR, SAFEGUARDS AND SECURITY DIVISION

Develops and executes policies and procedures relating to security and facilities protection programs at the NTS. Provides staff administration of the security policies and procedures of the TC during nuclear test activities by assigning a security advisor to the TC. The security advisor:

1. Assists the OCC in developing the area control plan of operation for presentation at the readiness briefing.
2. Advises the security contractor of proposed schedules of operations; authorizes the security contractor manpower, vehicle, and equipment requirements for the test; and ensures security contractor readiness.
3. Attends all briefings connected with the test and ensures that security contractor activities are scheduled to meet the approved schedule of operations.
4. Briefs the TC as to the location of all special nuclear material at the NTS, along with the amount and type of security coverage at each location.
5. Maintains liaison with the OCC to be currently informed of all changes in area control requirements.
6. Coordinates all changes in operational requirements with security contractor field operations to ensure prompt response to changing conditions; informs the TC when the operational area is clear of all personnel, other than approved manned stations.
7. Informs the TC of all immediate or potential security problems and makes recommendations pertaining thereto.
8. Following execution of a test, and upon authorization of the TC, directs reactivation of security safeguards as required within the operational area.
9. Prepares the Event Security Plan for inclusion in the TC's Event Operations and Security Plan.

July 29, 1992

IX-1 (and IX-2)

PART X

DIRECTOR, SAFETY AND HEALTH DIVISION

Evaluates programs for occupational safety and health, medical service, nuclear criticality safety, nuclear explosive safety, mining safety, aviation safety, motor vehicle safety, fire protection, and personnel assurance. Assigns a nuclear explosive safety advisor to the TC during nuclear test activities who is available during test activities to advise and assist the TC on matters pertaining to nuclear explosive safety. During D-Day readiness briefings, through test execution and until the TC returns the NTS to normal working conditions, the advisor is available on an "on-call" basis.

July 29, 1992

X-1 (and X-2)

PART XI

DIRECTOR, EMERGENCY MANAGEMENT DIVISION

Develops and administers emergency preparedness programs for DOE/NV. Provides for planning and conduct of DOE FRMAC field responses for major radiological emergencies. Assigns an emergency management advisor (EMA) to the TC during nuclear test activities. The EMA:

1. Attends all appropriate nuclear test briefings and represents the Director, EMD, on the TC's NTO staff.
2. Performs direct liaison between the NTO and the FRMAC, as necessary, in support of the TC in the event of an immediate, massive radioactive venting after a nuclear test.
3. Plans, coordinates, and assists in development of procedures for post-test emergency mitigation operations.

July 29, 1992

XI-1 (and XI-2)

PART XII

USAF/DOE LIAISON

Provides a liaison advisor who is familiar with the Nellis Air Force Base range complex to advise the TC during nuclear test activities. The advisor:

1. Coordinates all Nellis Air Force Base range activities that could be impacted by the test activities.
2. Provides the TC with any necessary advice or recommendations that will ensure the safety of all air and ground personnel on the range.

July 29, 1992

XII-1 (and XII-2)

PART XIIITHRESHOLD TREATY REVIEW PANEL

1. POLICY. The Threshold Treaty Review Panel (TTRP) was established to ensure that each nuclear test with a design yield of 125 kt or greater is conducted in conformance with U.S. policies for implementation of the TTBT, and to advise the Manager, DOE/NV.
2. OBJECTIVE.
 - a. No device will be tested which has a design yield in excess of 150 kt.
 - b. Any test with a design yield of 125 kt or greater will be reviewed by the TTRP for the purpose of reasonably ensuring that appropriate measures are taken to reduce the probability of the device yield exceeding 150 kt.
 - c. If two or more nuclear devices are to be detonated nearly simultaneously and in near proximity to one another so as to be individually indistinguishable by teleseismic means (NOTE: The proposed Peaceful Nuclear Explosion Treaty defines this as "two or more individual explosions for which the time interval between successive individual explosions does not exceed five seconds and for which the emplacement points of all explosives can be interconnected by straight line segments, each of which joins two emplacement points and each of which does not exceed 40 kilometers."), then these policies and procedures will be applied to the aggregate yield of the devices.
 - d. If prompt yield measurements data indicate a device yield exceeding 150 kt, then no other test with a design yield of 125 kt or greater will be placed in an irreversible position for 30 days from the time the National Security Council is notified, or for the period of the TTRP's reconsideration of that test, whichever is shorter.
3. RESPONSIBILITIES AND AUTHORITIES.
 - a. Evaluates and validates pre-shot design yield estimates.

July 29, 1992

XIII-1

- b. Evaluates the pre-shot estimate of underground yield to ensure that the design yield plus the estimated underground yield enhancement do not exceed the estimated underground yield in the range normally expected for a device with a design yield of 150 kt.
- c. Evaluates special measures, if necessary, for enhanced radiation devices to ensure that the design yield of such devices, plus their estimated underground yield enhancement, do not exceed the estimated underground yield for a nonenhanced radiation device with a design yield of 150 kt tested under the same conditions.
- d. Conducts a detailed postmortem analysis to evaluate the probability that a device yield exceeded the threshold, should post-shot prompt yield measurements data for that test indicate a breach may have occurred.
- e. Reviews available information and associated uncertainties and reports findings to the Manager, DOE/NV, should the design laboratory determine that a device yield greater than the threshold has occurred.
- f. Reports on evaluations to the Manager, DOE/NV.
- g. Submits statements in writing indicating each member's confidence in conformity to the TTBT.

July 29, 1992

XIII-2

PART XIVCONTAINMENT EVALUATION PANEL

1. POLICY. The CEP was established to evaluate each proposed test and to advise the Manager, DOE/NV, of its technical adequacy from the viewpoint of containment. The individual members are appointed by the Manager, DOE/NV, and report to him through the chairperson's summary of the deliberations of each test.
2. RESPONSIBILITIES AND AUTHORITIES.
 - a. Reviews pre-shot containment design and experimental features which affect the containment of each test.
 - b. Each member provides to the chairperson a categorization statement setting forth evaluations and rationales of the containment prospects for each test.
 - c. Provides to the Manager, DOE/NV, a written summary by the chairperson covering deliberations for each test and includes recommendations.
 - d. Reviews changes in containment design.
 - e. Reviews the effectiveness of containment of each test executed.
 - f. Revises requirements for information as new methods and performance data are acquired.
3. D-1 BRIEFING. On the day prior to scheduled detonation, the TGD/TD for the scheduled event (Defense Nuclear Agency (DNA), Lawrence Livermore National Laboratory (LLNL), or Los Alamos National Laboratory (LANL)) reviews the containment as-built details with the TC and the Scientific Advisory Panel. A representative from the other organizations is present and comments, as appropriate. Any containment features which, in the opinion of the TC, fall outside CEP expectations are referred back to the individual CEP members for resolution prior to execution of the test.

July 29, 1992

XIV-1 (and XIV-2)

PART XVVERIFICATION EVALUATION PANEL

1. PURPOSE. The VEP will conduct an independent review of the sponsoring laboratory's interpretation and application of the technical provisions set forth in the TTBT Protocol to ensure consistency and compliance with protocol requirements for all tests subject to verification. The Panel will not evaluate the application of the administrative and logistical requirements of the Protocol.
2. POLICIES.
 - a. The design, emplacement, and firing of each nuclear test will be conducted in a manner that conforms with U.S. obligations under the TTBT and which does not compromise the scientific objectives of the experiment or the ability to conduct the nuclear weapons test safely.
 - b. Consideration of costs and schedules shall not enter into the VEP review of the adequacy of the design and execution of the test from the standpoint of compliance with the TTBT. Such factors will be considered and applied, as appropriate, by DOE/NV management and the sponsoring laboratory.
3. RESPONSIBILITIES.
 - a. Assistant Manager for Operations (AMO).
 - (1) The AMO will appoint all members and alternates to serve on the VEP based upon nominations submitted by each individual's parent organization.
 - (2) Provides management direction and policy guidance to the Panel for the conduct of verification reviews. Reviews and approves the findings and recommendations of the Panel or requests further evaluation, as appropriate.
 - (3) The AMO has the authority to waive formal Panel reviews of design information provided with the initial notification of tests, as appropriate.
 - b. Sponsoring Laboratories. The laboratory responsible for the design and conduct of the test will prepare and submit to the Director, VMD, all technical information and data related to the verification

July 29, 1992

aspects of the test required to verify compliance with the provisions of the Protocol.

- c. Test Controller. Conducts a final verification review to ensure that the field application of the verification criteria is generally consistent with the designs reviewed by the VEP. Any significant deviations may be referred to the Panel for further consideration at the discretion of the TC.
- d. Director, VMD.
 - (1) Provides administrative support to the VEP, including the receipt and distribution of technical information and data prepared by the sponsoring laboratory members of the Panel.
 - (2) Provides scheduling requirements to the chairperson of the Panel to assist in the establishment of a timeline for the conduct of Panel activities.
 - (3) Serves as the DOE/NV office of record for all documents reviewed by the Panel, including their findings and recommendations.

4. COMPOSITION OF THE PANEL.

- a. The Panel will consist of a senior member of the DOE/NV staff, serving as chairperson, and a technical representative from each of the following: LANL, LLNL, Sandia National Laboratories, and the DNA. The chairperson and all members, including alternates, will be appointed by the AMO based upon nominations submitted by each individual's parent organization. The laboratory and DNA representatives should be individuals who do not have a direct responsibility for the conduct of the nuclear test being evaluated by the Panel.
- b. All members should be familiar with underground nuclear testing and the provisions of the TTBT Protocol.
- c. The Panel is authorized to utilize the services of technical subject matter specialists from DOE/NV, DOE/NV contractors, associated government agencies, or the laboratories, as required.

July 29, 1992

5. CONCEPT OF OPERATIONS.

- a. The VEP will function in an advisory capacity to the AMO. Actions, deliberations, evaluations, and recommendations of the Panel shall be fully documented for future reference or review.
- b. Copies of the interpretation and application of the verification design features developed by the sponsoring laboratory, along with conclusions and recommendations of the Panel, will be provided to each of the laboratories for reference documents in the design of future tests that may be subject to verification.
- c. The frequency and scheduling of Panel activities will depend upon the availability of design information from the sponsoring laboratory. As directed by the AMO, the chairperson of the Panel will coordinate directly with the Director, VMD, and the sponsoring laboratory to develop a mutually acceptable schedule for any required reviews. Although the deliberations of the Panel should be in sufficient depth to validate compliance with Protocol requirements, all meetings or reviews should be conducted promptly in order to avoid any undue delays in providing required notifications to the verifying party through prescribed channels or in the laboratory preparations for field construction.
- d. In the interest of conserving time, the chairperson has the option of polling the members by a conference call in lieu of convening a formal meeting of the Panel.
- e. The chairperson may request the sponsoring laboratory to attend meetings of the Panel, as required, to further explain their interpretation and application of Protocol requirements.
- f. The Panel will examine the feasibility of conducting a master study of the TTBT Protocol requirements, planned interpretation, and application by each of the laboratories to identify those features which the sponsoring laboratory may plan to uniformly apply to each test subject to verification. In such cases, the Panel may not need to reexamine those applications which have been determined to be in compliance for succeeding tests, unless there is a significant deviation. Any such master studies and subsequent updates or modifications will be submitted to the AMO for approval.

July 29, 1992

- g. The chairperson will submit a written summary of the Panel's deliberations, conclusions, and recommendations to the AMO.
6. TERM. This charter and the appointment of individual members of the VEP will expire December 31, 1992, unless specifically renewed by the AMO.

July 29, 1992

XV-4

D-35

ACRONYMS

AFTAC	Air Force Technical Applications Center
AMO	Assistant Manager for Operations
ATC	Air Traffic Controller
CEP	Containment Evaluation Panel
CP	Control Point
DNA	Defense Nuclear Agency
DOE	Department of Energy
DOE/NV	DOE Nevada Field Office
EMA	Emergency Management Advisor
EMD	Emergency Management Division
EOC	Emergency Operations Center
EPA/EMSL	Environmental Protection Agency/Environmental Monitoring Systems Laboratory
FAA	Federal Aviation Agency
FRMAC	Federal Radiological Monitoring and Assessment Center
HPA	Health Physics Advisor
HQ	Headquarters
LFAO	Lead Federal Agency Official
NRC	National Response Center
NTO	Nuclear Test Organization
NTS	Nevada Test Site
NTSO	Nevada Test Site Office
OCC	Operations Coordination Center
OEA	Office of External Affairs
OSIA	On-Site Inspection Agency
RAMS	Radiation Area Monitor System
ROO	Radiological Operations Officer
TC	Test Controller
TD	Test Director
TGD	Test Group Director

July 29, 1992

THE NUCLEAR TEST ORGANIZATION

UNITED STATES DEPARTMENT OF ENERGY
NUCLEAR TEST ORGANIZATION

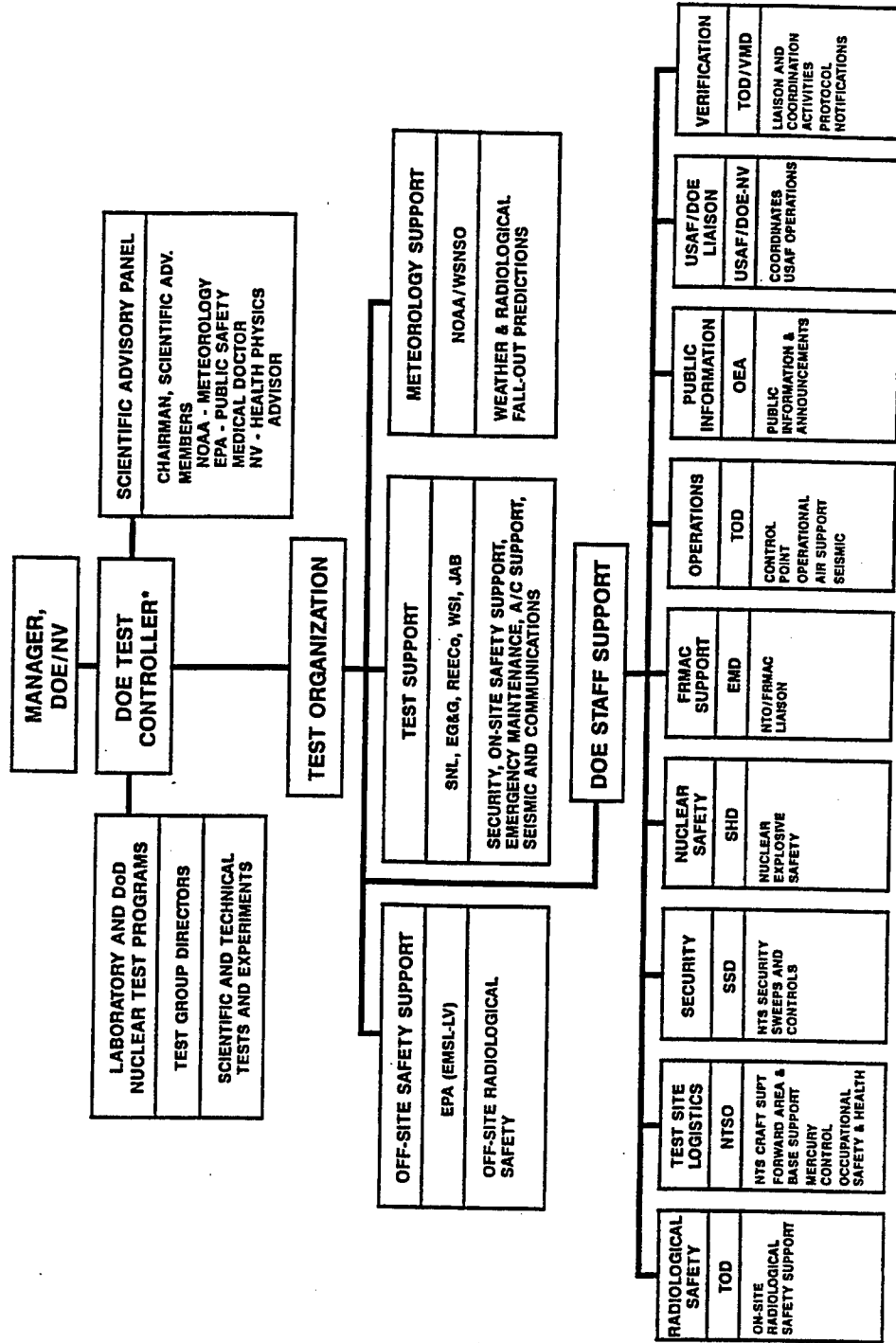

1 (and 2)

* DESIGNATED FOR EACH TEST.
(ASSUMES OPERATIONAL CONTROL OF NTS DURING TEST EXECUTION PERIODS)

APPENDIX E

U.S. DEPARTMENT OF ENERGY
NEVADA TEST SITE
STANDARD OPERATING PROCEDURE

NTS-SOP 5402

CHAPTER 5402 RADIOLOGICAL SAFETY

1. **POLICY.** All radiological operations conducted under the auspices of the DOE Nevada Field Office (DOE/NV) shall comply with the DOE and NV Orders 5480.11, RADIATION PROTECTION FOR OCCUPATIONAL WORKERS, of 12-21-88 and 5-7-91, respectively; and 54XG.1A, NV RADIOLOGICAL SAFETY MANUAL, of 10-21-91, for the protection of the work force and the general public. Exposures to radiation resulting from operations at the Nevada Test Site (NTS) shall be maintained as low within limiting values as reasonably achievable.
2. **OBJECTIVE.** To assign radiological safety responsibilities and delineate radiation protection responsibilities for all activities and operations at the NTS.
3. **RESPONSIBILITIES AND AUTHORITIES.**
 - a. **Manager, DOE/NV.**
 - (1) Ensures the radiological protection of all NTS program participants, including official visitors, temporary duty personnel, and property regardless of ownership or parent organization.
 - (2) Ensures that NTS activities are conducted in a manner which will protect the worker, general public, and/or private property.
 - b. **Test Controller (TC).** As the Manager's representative, is responsible for overall safety and health during nuclear test execution periods as defined in this NTS Standard Operating Procedure (NTS-SOP). (See NTS-SOP 1102, THE NUCLEAR TEST ORGANIZATION, of 6-15-89, for TC operational control.)
 - c. **Director, Test Operations Division (TOD).**
 - (1) Provides operational control and management of NTS radiological safety programs and activities through a radiological operations group (ROG).
 - (2) Ensures that all operations are conducted in accordance with applicable federal and state laws, and DOE-prescribed radiological safety Orders, standards, and guidelines.
 - (3) Coordinates the resolution of intra-organizational health physics issues originating from NTS activities.

INITIATED BY:
Test Operations Division

- (4) During test execution periods, provides a health physicist to perform the duties of the radiological operations officer.
- d. Director, Health Protection Division (HPD).
- (1) During Nontest Periods.
- (a) Establishes and promulgates ionizing radiation protection criteria and guidance for NTS organizations.
- (b) Conducts independent reviews, inspections, surveillance, and appraisals of DOE/NV radiological programs and activities to document compliance with applicable radiation protection standards.
- (2) During Test Execution Periods. Provides a health physicist to perform the duties of the radiological safety advisor to the TC's Scientific Advisory Panel.
- e. Director, Safety and Health Division. Ensures nuclear criticality safety.
- f. Director, Environmental Protection Division (EPD). Reviews all environmental protection activities for compliance with requirements.
- g. Test Group Directors. Coordinate all radiological safety and environmental protection activities within assigned areas or facilities.
- h. Reynolds Electrical & Engineering Co., Inc. Responsible to the Director, TOD, for the coordination of the radiological safety aspects of all NTS operations, except in areas that have been specifically transferred to another organization. Additionally, provides radiological safety services to NTS organizations, as requested.
- i. NTS Organizations.
- (1) Responsible to the Manager, DOE/NV, to the TC during nuclear test execution periods and to their parent organizations for radiological safety of their employees.
- (2) Ensures that their subcontractors are provided copies of, and comply with, applicable DOE and DOE/NV directives for radiological protection of their employees.
- j. Suspension and Work Resumption. In the event a procedure or practice of any organization is seriously jeopardizing the safety and health of personnel engaged in any operation and a decision to order work stopped is made, the decision must also be coordinated with other concerned organizations prior to resumption of work in accordance with

January 13, 1992

this NTS-SOP and with management agreements between the DOE San Francisco Field Office (SAN), DOE Albuquerque Field Office (AL), Defense Nuclear Agency (DNA), and DOE/NV.

4. PROCEDURES AND CONTROLS.

a. Procedures.

- (1) Radiological safety criteria for all activities at the NTS are addressed in NV Order 54XG.1A. Compliance with these procedures is required of all NTS users and contractors. The procedures are updated periodically with input from NTS users and contractors.
- (2) Each organization shall develop administrative controls to ensure DOE and DOE/NV radiological protection criteria are in effect. The organization currently delegated the radiological coordination responsibility for a location shall be responsible for the administrative control in effect. If the controls of a support organization are considered too restrictive, or in conflict with those of the organization responsible for the coordination of activities at the location, the Director, TOD, shall be consulted for long-term resolution of the disagreement.

b. Controls.

- (1) Regular field activity surveillance of contractor and laboratory operations by TOD, ROG.
- (2) Functional and management appraisals by HPD and EPD.
- (3) Surveillance and appraisals of laboratories and DNA under DOE/SAN, DOE/AL, and DNA management agreements with DOE/NV surveillance conducted by TOD, ROG, and appraisals and surveillance for compliance by HPD and EPD.

5. DEFINITIONS.

- a. Nuclear Test Execution Period. The period of time following the completion of the planning and safety briefing through the time when initial reentry into the surface Ground Zero or tunnel complex is complete, and the TC announces that all work forces may return to normal work areas, or as otherwise directed by the Manager, DOE/NV.
- b. Radiological Safety. As used herein, pertains to ionizing radiation (including X-rays).
- c. Ground Zero. That area in the vicinity of the nuclear device emplacement hole or tunnel drift, including the recording instrument trailer park and supporting equipment.

January 13, 1992

APPENDIX F

U.S. DEPARTMENT OF ENERGY
STANDARD OPERATING PROCEDURES
NEVADA TEST SITE

NTS-SOP-5401

5401 ENVIRONMENT, SAFETY, AND HEALTH
COORDINATION RESPONSIBILITY

1. POLICY

- a. Conduct Nevada Test Site (NTS) activities in a manner that protects the environment, safety, and health (ES&H) of all personnel and the public in accordance with federal and state laws and regulations and DOE policies, regulations, and standards.
- b. Reduce any potential safety and health risks to as low as reasonably achievable.
- c. Minimize the accidental damage or loss of government and privately owned equipment, materials, and property.
- d. Maintain occupational radiation exposure to as low as reasonably achievable.

2. OBJECTIVE

- a. Summarize ES&H responsibilities and authorities as set forth in other NTS Standard Operating Procedures (SOPs) for all operational and administrative activities at the NTS, including occupational safety, radiological safety, industrial hygiene, fire protection, environmental protection, nuclear criticality safety, nuclear explosive safety, aviation safety, medical services, firearms safety, explosive safety, or other programs affecting the well-being of persons or property.
- b. Define the process of assigning ES&H coordination functions and the responsibilities associated with such delegations.

3. RESPONSIBILITIES AND AUTHORITIES

- a. Manager, NV. Responsible for the environmental protection, safety, and health of all NTS operations, program participants and property regardless of ownership or parent organization, including official visitors and temporary duty personnel. Assures that NTS activities are conducted in a manner which will protect the safety and health of the NTS workers, general public, and private property.

October 10, 1990

- b. Test Controller. Responsible to the Manager, NV, for the overall NTS, including ES&H concerns, during test execution periods, relative to the field execution of nuclear tests (see NTS-SOP-1102). The test execution period begins upon completion of the readiness briefing on D-1 and ends when the Test Controller returns operational control back to the Director, Nevada Test Site Office (NTSO).

- c. Test Group Directors and Heads of Participating Test Site User Organizations, Contractor Operations Officials, and Other Groups
 - (1) Responsible to the Manager, NV, through the Assistant Manager for Operations (AMO); to the Test Controller during nuclear test execution periods; and to their parent organizations for environmental protection and the safety and health of their employees.
 - (2) Assure that adequate protection is being provided against accidental loss by fire or otherwise, of all government and private property under their cognizance.
 - (3) Responsible to the Director, NTSO, for coordination of ES&H requirements for all site, facilities, or operations which have been specifically assigned to them.
 - (4) Responsible to the Director, Test Operations Division (TOD), for coordination of radiological safety requirements for all sites, facilities, or operations which have been specifically assigned.

- d. Assistant Manager for Environment, Safety, and Health (AMESH). Responsible to the Manager, NV, for oversight and surveillance of NTS operations to assure compliance with applicable radiological, environment, safety, and health policies, regulations, and standards.

- e. Assistant Manager for Operations. Responsible to the Manager, NV, for assuring that all applicable ES&H policies, regulations, and standards are applied to NTS operations.

f. Director, Nevada Test Site Office

- (1) Provides operational control and management of NTS ES&H programs and activities.
- (2) Assures that all operations are conducted in accordance with applicable federal and state laws, and DOE prescribed ES&H orders, standards, and guidelines. Also assures that plans for NTS activities, including design plans, operating procedures, and equipment specifications, are coordinated with NV ES&H, as appropriate.
- (3) Approves and executes specific transfers for ES&H coordination responsibilities for a site, facility, or operation at the NTS to the appropriate NTS organization.
- (4) Notifies appropriate principal staff, contractors, and test site user organizations of each transfer and/or release of ES&H coordination responsibilities.
- (5) Responsible to the Test Controller for NTS activities during nuclear test execution periods.

g. Director, Test Operations Division

- (1) Provides operational control and management of NTS radiological safety programs and activities.
- (2) Assures that all operations are conducted in accordance with applicable federal and state laws, and DOE-prescribed radiological safety orders, standards, and guidelines.

h. Reynolds Electrical & Engineering Co., Inc. (REECO)

- (1) Responsible to the Director, NTSO, for the coordination of the ES&H aspects (excluding radiological safety) of all NTS operations except those areas or facilities that have been specifically transferred to another organization.
- (2) Responsible to the Director, TOD, for the coordination of the radiological safety aspects of all NTS operations unless those areas have been specifically transferred to another organization.

October 10, 1990

ENVIRONMENT, SAFETY, AND HEALTH
COORDINATION RESPONSIBILITY

NTS-SOP-5401

4. APPENDIX. Sets forth definitions, procedures, controls, notifications, and records for administering ES&H responsibilities at the NTS.

October 10, 1990

DEFINITIONS

1. Nuclear Test Execution Period. Normally, the period of time following completion of the D-1 Readiness Briefing through the time when initial reentry into the surface ground zero and trailer park is complete. It officially ends when the Test Controller permits all work forces to return to normal work areas and all operational coordination is returned to the Operations Coordination Center.
2. ES&H Coordination. This is an administrative assignment requiring managerial cognizance of those actions necessary to eliminate or reduce the possibility of injury, health hazard, or property loss.
3. ES&H Coordinator. The individual assigned by the responsible NTS organization to provide coordination of environmental protection, fire protection, radiological safety, occupational safety, and industrial hygiene activities with other participating organizations. A separate radiological coordinator may be assigned.
4. NTS Organizations. All organizations that are authorized to conduct activities at the NTS. These include User organizations, contractors, and other government agencies.
5. Radiological Coordinator. The individual assigned by the responsible NTS organization to provide coordination of radiological activities with other participating organizations, if assigned.
6. Responsible NTS Organization. Any organization authorized to perform activities at the NTS. Usually the organization that is assigned an area or facility.
7. Environment, Safety, and Health. Occupational safety, industrial hygiene, fire protection, medical services, aviation safety, motor vehicle safety, firearms safety, explosive safety, nuclear criticality safety, nuclear explosive safety, radiological safety, environmental protection, or other programs affecting the well being of persons or property.
8. Radiological Safety. As used herein, pertains to ionizing radiation (including x-rays) but excluding nuclear criticality.

October 10, 1990

9. Coordinating Organization. The NTS organization assigned ES&H coordination responsibility for a particular area or facility.

COORDINATION RESPONSIBILITIES

1. ES&H COORDINATION RESPONSIBILITY. Operational activities at the NTS are diverse involving the application of many different skills and occupational specialties and are often widely dispersed over a large geographical area. Several different organizations frequently perform work either as a closely integrated team or concurrently at any one location. In order to assure that the appropriate procedures and policies are uniformly considered and applied by all of the program participants, one responsible organization will be assigned overall ES&H coordination responsibilities by NV for that specific area or facility.
 - a. Assure all organizations performing operations within the designated area or facility are fully aware of the schedule of events and potential hazards or risks associated with each activity.
 - b. Analyze the cumulative effect of the combined operations of participating organizations to assure that individual operational activities will not jeopardize the safety and health aspects of other participants or other nearby operations.
 - c. DOE policies, regulations, and standards will be applied to all activities within the assigned area. It is recognized that the policies of some of the individual participating organizations may be even more stringent than those specified by the organization assigned ES&H coordination responsibility. To the extent possible organizational prerogatives shall be recognized. However, the ES&H coordinator should attempt to avoid the application of a double standard for personnel working in the same area. If such issues cannot be resolved to the mutual satisfaction of the parties they should be referred to the Director, NTSO, and/or TOD, for resolution as set forth in this SOP.
 - d. Identify potential ES&H hazards unique to the designated area, facility, site, or operation which are outside the normal hazards associated with the crafts involved. Initiate remedial actions as appropriate.
 - e. Mark, identify, or barricade potential hazards which cannot otherwise be corrected or removed. Notify the Operations Coordination Center (OCC), CP-1, of the purpose and location of road barricades and road closures.

October 10, 1990

- f. Coordinate questions or concerns regarding interpretation or applicability of ES&H orders and standards, through the Director, NTSO and/or TOD.
 - g. Control access to high-risk areas or exclusion zones by the use of road barricades or road closure and notify OCC of such activities. Assure precautionary procedures associated with such hazards or risks are known and understood by individuals entering the area.
 - h. Deny access to any individual or organizations that knowingly violate applicable ES&H regulations.
 - i. If there is no radiological coordinator assigned, the ES&H coordinator has radiological safety responsibility.
 - j. The transfer of ES&H coordination responsibility does not relieve any of the participating organizations of their responsibility for the safety and health of their individual employees.
2. RADIOLOGICAL COORDINATION RESPONSIBILITY. Certain activities at the NTS require simultaneous involvement by participating organization. To assure radiologically safe operations and compliance with applicable DOE orders throughout all NTS user organizations, it is necessary that one organization be responsible for the coordination of radiological concerns. Usually this responsibility is assigned concurrent with the ES&H coordination responsibility.
- a. Assure that all participating organizations perform activities and operations in accordance with acceptable required radiation protection standards.
 - b. Each NTS organization is responsible for performing operations in a radiologically safe manner. Each organization must conduct internal audits to assure adequate radiation health protection is provided throughout each organization.
 - c. Refer questions or issues concerning radiological safety to the Director, TOD, and coordinate with the Director, NTSO.
 - d. Post areas identified as containing some form of radioactive material or where activities involving radiation occur.

October 10, 1990

- e. Develop and maintain detailed operating procedures for all activities associated with the implementation of DOE and NV radiation protection requirements.
 - f. Control access to high-risk areas or exclusion zones. Assure precautionary procedures associated with such hazards or risks are known and understood by individuals entering these areas.
 - g. The transfer of radiological safety coordination responsibilities does not relieve any of the participating organizations of their responsibilities for providing safety and health protection to their individual employees.
3. ES&H/RADIOLOGICAL COORDINATION RESPONSIBILITY TRANSFER AND RELEASE
- a. The organization seeking or requiring the transfer or release of ES&H/radiological safety coordination responsibility for a particular NTS site, facility, or operation shall submit the appropriate request to NTSO. Pertinent information is to be provided on Appendix F and G of this SOP and submitted to NTSO.
 - b. For vertical tests the transfer of the site/operation from the Department of Energy (DOE) to the laboratory placing the device will occur when the diagnostic rack arrives at the ground-zero area (use Appendix F).
 - c. For DNA-sponsored Tunnel Tests
 - (1) The transfer from DOE to DNA will occur at the time of beneficial user occupancy in the tunnel complex (use Appendix F).
 - (2) Upon arrival of the device at the tunnel portal, the ES&H/radiological safety responsibilities will be transferred from DNA to the device laboratory. Upon completion of insertion, this responsibility will be transferred back to DNA except for the radiological safety coordination responsibility of the ground-zero test area until detonation takes place (use Appendix G).
 - (3) After detonation occurs, all radiological safety coordination responsibilities will be transferred back to DNA (use Appendix G).

October 10, 1990

- (4) Upon completion of reentry/recovery, ES&H/radiological safety coordination responsibilities for the tunnel test area will be transferred back to DOE from DNA (use Appendix F).
- d. The initiating organizations will submit the completed appendixes (F and G), as appropriate, to the Director, NTSO. NTSO will provide approval for ES&H responsibility transfer and release, forwarding the appendixes to the Director, TOD, for approval and coordination of radiological responsibility transfer and release. After the appropriate approval, the completed appendixes will be returned and assigned a control number by NTSO. NTSO will return all approved documents to the requesting organization.
 - e. Prior to release approval from ES&H/radiological safety coordination responsibility, the responsible organization shall provide, as an attachment to Appendix F, the following information:
 - (1) Area/facility status - potential for craters, crater size, are fences required, what diameter can fence be reduced to and when (provide diagrams).
 - (2) Environmental status - clean-up of surface debris, reseeded, what hazards/solid waste remains, i.e., cables, slabs, etc. (see Appendix E).
 - (3) Radiological status - identify contamination or radiation areas (provide a list and diagrams of areas) (see Appendix E).
 - (4) Monitoring status - is continued monitoring required? Provide list of elements to be monitored. What work is outstanding?

October 10, 1990

CONTROLS

1. Suspension of Activities

- a. If the assigned ES&H/radiological coordinator, or a designated representative determines that a procedure or practice of any organization presents an imminent threat to the safety or health of personnel engaged in any phase of an operation, they shall order work stopped immediately pending corrective action. These individuals also have the authority to deny access to the work location to any person who does not comply with established and/or posted safety regulations.
 - b. Likewise, any individual or organization working within the designated site or operation may suspend their own operations if the operation presents an imminent threat to the safety and health of themselves or their co-workers. Any such incidents shall be reported to the ES&H/radiological coordinator immediately.
 - c. When a stop-work order has been issued due to unacceptable safety and health conditions, the ES&H/radiological coordinator will advise the Director, NTSO, as soon as possible. Similarly, if the circumstances involve radiological safety, the Director, TOD, will be advised and coordinate with the Director, NTSO.
2. Work Resumption. After work has been suspended due to any inappropriate ES&H/radiological conditions or practices, only the ES&H/radiological coordinator may authorize resumption of work after the condition or practices have been satisfactorily resolved. The same notification channels will be observed as set forth in paragraph 1c above.
3. Disputes of Conflicts. Unresolved conflicts or disputes regarding the interpretation or application of NV ES&H and radiological policies or procedures will be referred to the Director, NTSO, or TOD, as appropriate.
4. Coordination by NTSO. The Director, NTSO, will ensure that corrective action has been completed before resumption of work is allowed regarding any work stoppage attributable to adverse conditions or practices.

October 10, 1990

NOTIFICATION AND RECORDS

1. NOTIFICATION

- a. Incidents (fires, accidents, health hazards, spills, etc.) which result in personal injury, radiation occurrences, or property loss, will be reported to the NV Emergency Duty Officer, 295-4015.
- b. Emergency Notification. Emergency notification, such as fire, personnel injury, etc., should be made to station 900, NTS extension 911, or by radio emergency MAY-DAY call.

2. RECORDS

- a. One signed copy of Appendixes E and/or F of this SOP, Transfer of ES&H Coordination Responsibility, will be maintained by the Director, NTSO.
- b. One signed copy of Appendixes E and/or F of this SOP, pertaining to the release of Radiological Safety Coordination Responsibility, will be maintained by the Chief, Operations Management Branch, CP-1.
- c. One signed copy of Appendixes E and/or F of this SOP, Transfer of ES&H and Radiological Safety Coordination Responsibility, will be retained by the requesting responsible organization.

October 10, 1990

RADIOLOGICAL/ENVIRONMENTAL RESTORATION RELEASE CRITERIA

Radiological Clean-up Criteria

1. The cleanup of active and inactive sites/facilities/operations, by responsible organizations, shall meet criteria specified in Radiological Safety Manual, NV Order 54XG.1, prior to releasing the assigned area.
2. TOD shall review and provide comments, if necessary, of the release request (Appendix F) from the responsible organization back to DOE.
3. Only when TOD has accepted the radiological clean-up actions, and upon the final approval of the Director of NTSO, can the organization with ES&H/radiological coordination release the assigned area.

Environmental Restoration Clean-up Criteria

1. The assigned organization shall provide certification of sampling for Resource Conservation & Recovery Act (RCRA) and mixed waste concerns. This documentation is required to indicate the presence of RCRA or mixed waste located at the site in question.
2. If it is determined necessary to ship hazardous wastes from the assigned area to an off-site storage facility, a hazardous waste shipping manifest must be provided as documentation.
3. A detailed list of waste streams from activities at the site must be submitted with Appendix F.

October 10, 1990

ENVIRONMENT, SAFETY, AND HEALTH/RADIOLOGICAL SAFETY
COORDINATION RESPONSIBILITY

PART I: Pursuant to the requirements established in NTS-SOP-5401, I request ES&H/Radiological Safety Coordination Responsibility for the following site/facility/operation at: _____

_____ be transferred to: _____
(Organization)

Effective date: _____

ES&H Coordinator: _____
(Responsible organization official)

Radiological Safety Coordinator: _____
(If assigned) (Responsible organization official)

Remarks/Exception: _____

ES&H Transfer approval: _____
(Director, Nevada Test Site Office) (date)

Transfer of Radiological
Safety approval: _____
(Director, Test Operation Division) (date)

PART II: I request that _____
(Organization)

be released from the ES&H/radiological safety coordination responsibility described in Part I. The condition of site/facility is (attach additional information sheet as specified in NTS-SOP-5401, if needed):

(Responsible organization official) (date)

Release approved, site/facility/operation accepted by DOE:

ES&H approval: _____
(Director, NTSO) (date)

Radiological approval: _____
(Director, TOD) (date)

October 10, 1990

SPECIAL COORDINATION RESPONSIBILITIES OF TUNNEL TEST AREAS

Pursuant to the requirements of NTS-SOP-5401, the following request is for the transfer and release of ES&H/radiological safety coordination responsibilities pertaining to the special identified condition for:

(event name and location)

1. Upon arrival of the device at the tunnel portal, the Defense Nuclear Agency (Nevada Operations) is released from all ES&H/radiological safety coordination responsibility. At this time all responsibilities will be transferred to:

(device laboratory)
until completion of insertion.

2. Upon completion of insertion of the device within the ground-zero area all coordination responsibilities, except radiological safety for:

(ground zero location)
will be transferred back to DNA until detonation occurs.

3. Upon detonation all radiological responsibility for:

(ground zero location)
will be transferred back to DNA.

Transfer approval: _____
(Director, NTSO) (date)

Transfer approval: _____
(Director, TOD) (date)

Acknowledged: _____
(DNA) (date)

Acknowledged: _____
(Device laboratory) (date)

October 10, 1990

APPENDIX G

SLA-74-0199

Printed May 1974

GENERAL TUNNEL REENTRY PROCEDURES FOR DEFENSE NUCLEAR AGENCY
AND SANDIA LABORATORIES NUCLEAR TESTS

J. H. Metcalf
Instrumentation, Dosimetry and NTS Projects Division, 3313
Sandia Laboratories, Albuquerque, New Mexico 87115

ABSTRACT

Underground weapons effects testing requires that personnel reenter the tunnel complex to recover data and scientific experiments for postshot evaluation. The preparation for and the handling of the hazards encountered during such reentry operations are described.

Issued by Sandia Laboratories, operated for the United
States Atomic Energy Commission by Sandia Corporation

NOTICE

This report was prepared as an account of work sponsored by the United States Government. Neither the United States nor the United States Atomic Energy Commission, nor any of their employees, nor any of their contractors, subcontractors, or their employees, makes any warranty, express or implied, or assumes any legal liability or responsibility for the accuracy, completeness or usefulness of any information, apparatus, product or process disclosed, or represents that its use would not infringe privately owned rights.

SF 1004-DF(2-74)

TABLE OF CONTENTS

	<u>Page</u>
Introduction	5
Responsibilities	5
Manager, NVOO	5
Test Controller	5
Test Group Director	5
SLA Environmental Health Department	6
NTS Support Contractor	6
Preshot Preparations for Reentry	6
Containment	6
Ventilation System	6
Environmental Instrumentation	6
Gas Sampling System	7
Reentry Communications System	7
Possible Hazards to Reentry Personnel	7
Radiation	7
Explosive and Toxic Gases	7
Tunnel Damage	8
Explosives	8
Toxic Materials	8
High-Pressure Gas Cylinders	8
Reentry Party Composition and Equipment	8
Guidelines for Initial Reentry Parties	10
Authorization	10
Activating & Monitoring Tunnel Ventilation System	10
Reentry Control Group	10
Team Limitations	10
Self-Contained Breathing Apparatus	11
Emergency Return to Portal	11
Rescue Team	11
Medical Support	11
Summary of Initial Tunnel Reentries	11
Preparation of Tunnel for Reentry	11
Evaluation of Tunnel Environment	12
Exploration of Tunnel	12

TABLE OF CONTENTS (cont.)

	<u>Page</u>
Scientific Assessment of the Experiments	13
Scientific Assessment Team	13
Photographic Documentation	13
Removal of Unexpended Explosives	13
Recovery of Experiments From the Test Chambers	13

GENERAL TUNNEL REENTRY PROCEDURES FOR DEFENSE NUCLEAR AGENCY
AND SANDIA LABORATORIES NUCLEAR TESTS

Introduction

Detonation of a nuclear device in an underground test facility adds many unique hazards to those existing in any underground construction. Instrumentation which can be remotely monitored can provide a general picture of conditions, but ultimately, personnel, properly protected from the hazards they might encounter, must reenter the tunnel to verify the condition of the facility.

Personnel from the Environmental Health Department of Sandia Laboratories have been participating in tunnel reentries since 1962. During this time experience, improvements in instrumentation, and changes in containment features have caused tunnel reentry procedures to be continually revised. This document describes preshot preparations and postshot procedures currently being used for safe and economical reentry and scientific recovery from a tunnel area.

Responsibilities

Manager, NVOO

The Manager, NVOO, is responsible for administering, preparing, and executing all programs and projects at NTS. He has the overall responsibility for the health and safety of both the general public and NTS personnel for all activities at the NTS. The Manager, NVOO, may delegate operational control of an approved program, project, or experiment to a Test Controller, who is responsible for field execution of that specific program.

Test Controller

The Test Controller has full responsibility during the test execution period for the safe conduct of the program to which he is assigned. By mutual agreement between the Test Controller and a scientific user, control of safety hazards within the area assigned for a particular activity may be delegated to the user's Test Group Director during times other than the test execution period.

Test Group Director

Whenever operational control is delegated to a Test Group Director, he is responsible to the Manager, NVOO, for the establishment and implementation of safety criteria within the assigned area. He will be responsible for submitting a plan for all operation to the Manager, NVOO for review and concurrence. Upon termination of need for the Test Group Director to retain control of the test complex, the Test Group Director will be relieved of safety responsibility.

SLA Environmental Health Department

During the time that the Test Group Director has operational safety responsibility, the Environmental Health Department will provide consultants who will advise the Test Group Director on tunnel reentry procedures (for Sandia and Defense Nuclear Agency sponsored events). These consultants will be familiar with the configuration of the test bed, and with possible postshot tunnel conditions and hazards. They will specify the necessary instrumentation to monitor the postshot conditions of the tunnel and will document any release of radioactive material to the environment. During postshot reentry and recovery operations, they will provide technical direction of radiation safety and industrial hygiene personnel provided by the NTS Support Contractor.

NTS Support Contractor

Reynolds Electrical & Engineering Company (REECO) is responsible for construction and mine safety for all personnel working underground. REECO will provide the personnel necessary for the support of the tunnel reentry and experiment recoveries. This includes mine-rescue-trained mining personnel, radiation safety monitors, and industrial hygiene and industrial safety personnel.

Preshot Preparations for Reentry

Containment

The stemming should contain the fireball and should thus minimize radioactivity and explosive and toxic gases in the experimental area. If the stemming fails, the overburden plug provides a secondary containment barrier. If the gases penetrate the overburden plug, the gas seal plug and/or the gas seal door should contain the gases within the tunnel complex.

Ventilation System

The tunnel ventilation system is set up so that all areas of the tunnel complex can be swept with fresh air from the portal. Valves which can be remotely operated from a manned location are installed in the ventilation and makeup lines in the gas seal door and/or gas seal plug and the overburden plug. The ventilation system utilizes a positive displacement Sutorbilt blower which is installed so that the air from the tunnel complex passes through a filter system before it is released to the atmosphere. Radiation detectors are placed on the ventilation lines to monitor the radioactive effluent released, and continuous samples are taken for isotope identification.

Environmental Instrumentation

Radiation detectors are installed in the tunnel complex to supply tunnel reentry personnel with information about radiation levels in the tunnel. Other types of instrumentation which are used to remotely monitor conditions in the tunnel include geophones and pressure and temperature gauges.

Gas Sampling System

Sampling lines for remotely taking gas samples from various points in the tunnel are installed during preparation of the facility for the test. Samples taken from these lines after test execution help to determine the concentration of explosive and toxic gases in the tunnel prior to reentry. Samples can usually be taken from inside the gas seal door and/or the gas seal plug, from both sides of the overburden plug, from the experiment drift near the stemming, and from the horizontal-line-of-sight (HLOS) pipe itself.

Reentry Communications System

The reentry communications system provides a communications link between the reentry control group in the trailer at the portal and the reentry party in the tunnel. This system consists of (1) a portable reel of WD-7 field wire and (2) a shielded cable, which is permanently installed in the tunnel. Access to this permanent cable is provided at designated locations along the reentry route. Preshot preparations for an event include installation and checkout of the shielded cable used for reentry communications.

Possible Hazards to Reentry Personnel

Radiation

Reentry teams may encounter radioactivity in the tunnel that results from any one or more of the following:

1. Gross failure of the stemming, in which case large quantities of fission products are deposited throughout the tunnel complex. When this condition exists, the team must be concerned with external radiation hazards and with control of contamination.
2. Seepage of radioactive gases or materials through fissures or fractures from ground zero. In this case, external radiation fields are not usually a significant hazard, but contamination control is of primary concern.
3. Activation of experiment samples and components of the HLOS pipe. If sample integrity is maintained after the event, contamination is only a minor problem and external radiation is the major consideration. If the sample contaminant is ruptured and the sample is dispersed throughout the test chamber, contamination control is of primary concern.

Explosive and Toxic Gases

Explosive and toxic gases may be produced as direct or secondary products of the detonation of the device. They may also be produced by the detonation of explosives used in some experimental samples or in HLOS pipe closure systems. These gases may be present in concentrations that are hazardous to personnel.

Tunnel Damage

The ground motion associated with the detonation of the device may cause structural damage to the tunnel. All reentry team members must be alert for unstable overhead conditions, such as hanging slabs and broken timber. They should also watch for broken ventilation lines and utility lines (water, compressed air, electrical cables). Physical damage to the tunnel may at times be such that rehabilitation of the drift must be accomplished before experiment recoveries can be initiated.

Explosives

Explosives are associated with pipe closure and sample protection systems, and may also be present as part of some of the experiments. These explosives, which may still be unexpended after the test, may have been sensitized by the exposure to the device radiation. If the unexpended explosives are contained in experiments in which the sample integrity has been maintained, they do not pose a significant hazard for initial reentry teams. However, team members should be aware of the possibility of unexpended high explosives lying on the bottom of the HLOS pipe.

Toxic Materials

Experiments to be exposed to radiations from the device may contain materials which have some degree of chemical toxicity. In particular, many experiments contain beryllium or have beryllium filters, a portion of which will be present in the postshot environment as finely divided dust. These materials are of concern primarily during postshot recovery of experiments when it is extremely probable that a portion of the dust will become airborne.

High-Pressure Gas Cylinders

Some experiments typically have pressurized gas as an integral part of the experimental system. The gas is usually supplied from high-pressure (2200 psi) gas cylinders which may have been damaged as a result of ground motion or high temperature. Reentry personnel must exercise caution around pressurized systems and will check them to see that the pressure has been bled off.

Reentry Party Composition and Equipment

A team for reentry into a tunnel following a nuclear test shall consist of a minimum of five personnel, one of whom shall be designated as a team chief. He will be responsible for the team during all work underground. All personnel participating as members of initial reentry parties must be certified in the use of USBM* -approved self-contained breathing apparatus. Composition of the reentry parties and their equipment is summarized in Table 1.

*U.S. Bureau of Mines

TABLE I

Summary of Reentry Parties and Equipment

Party Name	Equipment
<u>Initial Reentry Parties</u> 1. Team Chief 2. Radiation Safety Monitor 3. Industrial Hygiene Monitor 4. Two or More Miners	Full Radex clothing USBM-approved, 2-hour self-contained breathing apparatus Radiation detectors Explosimeter Toxic gas indicators Oxygen detector Hard-wire communications
<u>Work Party</u> 1. Team Chief 2. Radiation Safety Monitor 3. Industrial Hygiene Monitor 4. Miners and Support Personnel	Full Radex clothing Respiratory protection (as required) Radiation detectors Explosimeter Toxic gas indicators Oxygen detector
<u>Rescue Team</u> 1. Team Chief 2. Radiation Safety Monitor 3. Industrial Hygiene Monitor 4. Two or More Mine-Rescue Trained Personnel	Full Radex clothing USBM-approved, 2-hour self-contained breathing apparatus Radiation detectors Explosimeter Toxic gas indicators Oxygen detector Wire litters
<u>Scientific Assessment Team</u> 1. Team Chief 2. Radiation Safety Monitor 3. Industrial Hygiene Monitor 4. Scientific Advisors 5. Mine Support Personnel	Full Radex clothing Respiratory protection (as required) Radiation detectors Explosimeter Toxic gas indicators Oxygen detector

Guidelines for Initial Reentry Parties

Authorization

Initial reentry and each subsequent phase will be initiated upon authorization of the Test Group Director (TGD) with the concurrence of the Test Controller. Operational control will be retained by the TGD until all recovery and reentry mining operations are completed and tunnel access is returned to AEC control.

Activating and Monitoring Tunnel Ventilation System

Tunnel reentry will not start until after the tunnel ventilation system has been activated and samples of tunnel air have been taken and monitored at the portal. Evaluation of these samples must indicate that reentry can be made within the limitations of this procedure.

Reentry Control Group

The reentry control group will normally be composed of an SLA Environmental Health consultant, the TGD or his designated alternate, the tunnel construction engineer or some other person who has an intimate knowledge of tunnel construction details, a REECO Rad-Safe Superintendent, and a senior industrial hygienist. All activities of the reentry party in the tunnel are performed at the direction of this group, and any deviations from the guidelines presented in this procedure are by a consensus of its members. Communications between the reentry control group and the reentry party in the tunnel will be maintained whenever reentry teams are underground. All observations by team members during reentry will be communicated through the team chief to the reentry control group and will be recorded for future reference. Only one team will be in the tunnel at any one time unless otherwise directed by the reentry control group.

Team Limitations

Personnel radiation exposure limits for a reentry operation are 3 rem per calendar quarter (NTSO SOP Chapter 0524). If it is assumed that a person's exposure history would allow an accumulation of 3 rem during the operation, his exposure will be terminated when his pocket dosimeter indicates an accumulated exposure of 2 rem.

Except under extenuating circumstances and by mutual decision of the reentry control group and the team chief, reentry teams will not enter radiation fields greater than 10 R/h, nor will they enter areas in which the concentration of carbon monoxide is greater than 1000 ppm or the concentration of explosive gases is greater than 30 percent of the lower explosive limit (LEL).

Self-Contained Breathing Apparatus

Prior to entry into any potentially hazardous atmosphere, the self-contained breathing apparatus of each team member will be personally checked by the team chief and/or another certified person for proper fit and operation. Malfunctions of the breathing apparatus of any team member shall cause the reentry mission to be aborted.

Emergency Return to Portal

A reentry party will return to the portal as a result of any of the following conditions:

1. On decision of the team chief.
2. When any member of the reentry team has a McCaa oxygen supply less than 30 atmospheres or a Draeger pressure less than 450 psi.
3. On loss of communications with the reentry control group at the portal.

Rescue Team

A rescue team will be stationed near the portal or at the fresh air station underground at all times that reentry teams are in the tunnel. If located at the portal, the rescue team will have a train available for immediate departure. The rescue team will be dispatched only at the direction of the reentry control group and only after it has been determined that the rescue team can conduct its mission safely.

Medical Support

A medical technician with an ambulance and the necessary medical equipment will be available at the portal during initial reentry operations. This medical support will be released only at the direction of the reentry control group.

Summary of Initial Tunnel Reentries

This plan is written as though one team can complete the entire reentry operation. In actual practice, several teams will probably be necessary. As many teams as are needed will be used to complete the tunnel exploration.

Preparation of Tunnel for Reentry

As soon as possible after the event, and with the concurrence of the Test Controller, the tunnel ventilation system will be activated. The tunnel complex will be further prepared for reentry by securing all unnecessary power going into the tunnel. All downhole cables from the mesa trailer park will be disconnected in the cable splice shack and each cable termination will be taped. CABLES WILL NOT BE CUT WITHOUT SPECIAL AUTHORIZATION FROM THE TEST GROUP DIRECTOR. All electrical power to the mesa trailer park will be turned off. All instrumentation and utility power cables and telephone lines going into the tunnel from the portal will be disconnected or confirmed to be off. Cables for the tunnel ventilation system, the temperature and pressure monitors, the geophones, and the remote radiation monitoring system will be left connected.

Evaluation of Tunnel Environment

The reentry control group will review the data from the radiation system, the temperature and pressure monitors, the geophones, and the gas samples taken from the tunnel complex to assure that the reentry can be made within the limitations of this procedure. With this assurance, and when cleared by the TGD and the Test Controller, the reentry operation may begin. No changes will be made in the tunnel ventilation system or in any electrical system while reentry teams are underground.

Exploration of Tunnel

The reentry team will enter the tunnel by using a diesel locomotive for transportation and will proceed to the gas seal door. The team will monitor continuously for radioactivity and for toxic and explosive gases. These readings, as well as the progress of the team and the physical condition of the tunnel, will be reported to the reentry control group. Pressure gauges at the gas seal door will be checked, and a gas sample will be taken through the door to determine the environment on the working point side of the door. If conditions are satisfactory, the team will open the gas seal door and proceed to the gas seal plug.

The pressure gauges at the gas seal plug will be checked, and a gas sample will be taken from the working point side of the plug to determine the environment. If ventilation has not been reestablished remotely through this plug, the team will take the necessary steps to establish ventilation through the plug. If conditions permit, the team will then proceed to the overburden plug, where the same procedure will be followed.

After ventilation to the working point side of the overburden plug has been established and it has been determined that explosive and toxic gases are below the reentry guideline concentrations, the team will proceed through the overburden plug and check out the experiment drift complex. Team members will walk to the portal face of the stemming, if possible, monitoring continuously for radioactivity and for toxic and explosive gases. They will also observe the ventilation lines to assure themselves that the lines are intact, and will report this information, along with the general condition of the tunnel and the HLOS pipe, to the reentry control group. After the condition of the tunnel has been determined, the team will establish ventilation to the HLOS pipe. The doors to the test chambers will be opened and swipes will be taken from the floor of the test chambers. These swipes will be analyzed for beryllium and will also be used to identify the radionuclides present inside the HLOS pipe.

As soon as the reentry team has verified that the tunnel complex is within acceptable levels for radiation and for toxic and explosive gases and has determined the physical condition of the tunnel and HLOS pipe, the initial reentry operation is complete.

Scientific Assessment of the Experiments

Scientific Assessment Team

As soon as the initial reentry teams have verified that the tunnel and HLOS pipe are clear of hazardous amounts of radiation and of toxic and explosive gases and as soon as the physical hazards have been identified and repaired, as necessary, the scientific assessment team will enter the HLOS pipe and observe the condition of the experiments.

Photographic Documentation -- Photographic documentation of the condition of each experimental station may take place concurrently with or immediately after preliminary assessment of the experiments.

Removal of Unexpended Explosives -- Unexpended explosives which are found to be uncontained will be removed from the HLOS pipe before experiment recoveries are begun.

Recovery of Experiments From the Test Chambers

Before scientific recoveries may be begun, repair of the tunnel to the test chambers must be complete. This activity may include repairing broken lagging and removing hazardous conditions, as well as repairing railroad track and ventilation lines. Tunnel utility power will be restored before experiment recoveries (except for recovery of film) are begun.

After tunnel repairs have been completed, experiment agencies will be permitted to begin recovery of samples from the test chambers in order of priority. A radiation safety monitor will be present at the test chambers at all times to assist the experimenters and to help control contamination.

DISTRIBUTION LIST

DEPARTMENT OF DEFENSE

DIRECTOR
ARMED FORCES RADIOBIOLOGY RSCH INST
INFORMATION SERVICES DEPT
8901 WISCONSIN AVENUE
BETHESDA, MD 20889-5603
ATTN: TECHNICAL LIBRARY

ASSISTANT SECRETARY OF DEFENSE
(PUBLIC AFFAIRS)
WASHINGTON, DC 20301
ATTN: ASD(PA)

ASSISTANT TO THE SECRETARY OF DEFENSE
NUCLEAR CHEMICAL & BIOLOGICAL
DEFENSE PROGRAMS
THE PENTAGON
WASHINGTON, DC 20301-3050
ATTN: F CELEC, RM 3C125

DEFENSE TECHNICAL INFORMATION CENTER
8725 JOHN J KINGMAN RD., SUITE 0944
FORT BELVOIR, VA 22060-6218
ATTN: DTIC/OCF

HEADQUARTERS
DEFENSE THREAT REDUCTION AGENCY
45045 AVIATION DRIVE
DULLES, VA 20166-7517
ATTN: OST, LTC D PERRY

HEADQUARTERS
DEFENSE THREAT REDUCTION AGENCY
6801 TELEGRAPH ROAD
ALEXANDRIA, VA 22310-3398
ATTN: CP
ATTN: CPW
ATTN: CPWCT
ATTN: N SSA, W SUMMA
ATTN: N SSN/D M SCHAEFFER

DEFENSE THREAT REDUCTION AGENCY
ALBUQUERQUE OPERATIONS
1680 TEXAS ST. SE
KIRTLAND AFB, NM 87117-5669
ATTN: CPTO
ATTN: FCIN

DEFENSE THREAT REDUCTION AGENCY
NEVADA OPERATIONS
P O BOX 208
MERCURY, NV 89023-0208
ATTN: CPTPN L ASHBAUGH

DEP UNDER SEC OF DEFENSE
(ADV TECH)
PENTAGON RM 3E1044
WASHINGTON, DC 20301
ATTN: EXEC SECY

DEPARTMENT OF DEFENSE CONTRACTORS

ITT INDUSTRIES
ITT SYSTEMS CORP
ATTN: AODTRA/DASIAC
1680 TEXAS ST SE
KIRTLAND AFB, NM 87117-5669
ATTN: DASIAC
ATTN: DASIAC/DARE

ITT SYSTEMS CORP
2560 HUNTINGTON AVENUE
ALEXANDRIA, VA 22303
ATTN: D MOFFETT

JAYCOR
1410 SPRING HILL ROAD
SUITE 300
MCLEAN, VA 22102
ATTN: DR CYRUS P KNOWLES
ATTN: INFO SYSTEMS DIV (NTPR)
ATTN: STEVE POWELL

LOGICON ADVANCED TECHNOLOGY
6053 WEST CENTURY BOULEVARD
LOS ANGELES, CA 90045-6430
ATTN: BINKY LEE
ATTN: LIBRARY

LOGICON RDA
6940 S KINGS HWY
SUITE 202
ALEXANDRIA, VA 22310
ATTN: DAVID AUTON
ATTN: ROSEMARY HARRIS

LOGICON RDA
P O BOX 9377
ALBUQUERQUE, NM 87119-9377
ATTN: G GANONG

PACIFIC-SIERRA RESEARCH CORP.
2901 28TH STREET
SANTA MONICA, CA 90405-2938
ATTN: H BRODE

SCHAEFFER ASSOCIATES
4133 TAMWORTH RD
FORT WORTH, TX 76116-8121
ATTN: N SCHAEFFER

DISTRIBUTION LIST

DEPARTMENT OF DEFENSE CONTRACTORS

SCIENCE APPLICATIONS INTL CORP
P O BOX 1303
MCLEAN, VA 22102
ATTN: J KLEMM
ATTN: J MCGAHAN

TECHNICO SOUTHWEST INC
P O BOX 547
ESPANOLA, NM 87532-0547
ATTN: S LEVIN

THE RAND CORPORATION
P O BOX 2138
SANTA MONICA, CA 90407-2138
ATTN: TECH LIBRARY

DEPARTMENT OF ENERGY

BECHTEL NEVADA, INC
P O BOX 98521
LAS VEGAS, NV 89193-8521
ATTN: C SCHOENGOLD
ATTN: CIC

DEPARTMENT OF ENERGY
(NEVADA OPERATIONS OFFICE)
P O BOX 98518
LAS VEGAS, NV 89193-8518
ATTN: M MARELLI

DEPARTMENT OF ENERGY
HUMAN HEALTH & ASSESSMENTS DIV
WASHINGTON, DC 20545
ATTN: J S ROBERTSON, ER-73, GIN

DEPARTMENT OF ENERGY
OAK RIDGE NATIONAL LABORATORY
X-10 LABORATORY RECORDS DEPT.
P O BOX 2008
OAK RIDGE, TN 37831-6363
ATTN: C R RICHMOND, 4500N, MS 6253
ATTN: G KERR, BLDG 7509
ATTN: T JONES

UNIVERSITY OF CALIFORNIA
LAWRENCE LIVERMORE NATIONAL LAB
P O BOX 808
LIVERMORE, CA 94551-9900
ATTN: TECH LIBRARY

LOS ALAMOS NATIONAL LABORATORY
P O BOX 1663
LOS ALAMOS, NM 87545
ATTN: LAW LIBRARIAN
ATTN: MS P364 REPORT LIBRARY
ATTN: W FLOR (45-10)

NATIONAL ATOMIC MUSEUM
P O BOX 5400
ALBUQUERQUE, NM 87115-5400
ATTN: HISTORIAN

SANDIA NATIONAL LABORATORIES
ATTN: MAIL SERVICES
P O BOX 5800
ALBUQUERQUE, NM 87185-0459
ATTN: ORG 400
ATTN: TECH LIB

SANDIA NATIONAL LABORATORIES
P O BOX 238
MERCURY, NV 89023-0238
ATTN: M/S 944 J METCALF

DEPARTMENT OF THE AIR FORCE

AEROMEDICAL LIBRARY
DOCUMENT SERVICES SECTION
2511 KENNEDY CIRCLE
BROOKS AFB, TX 78235-5122
ATTN: DR A B COX/RZB
ATTN: LIBRARY

AIR FORCE CENTER FOR
RADIATION DOSIMETRY
IERA/SORD
2402 E DRIVE
BROOKS AFB TX 78235-5114
ATTN: NTPR

HEADQUARTERS
AIR FORCE MEDICAL OPERATIONS AGENCY
BUILDING 5681
BOLLING AFB, DC 20332-6188
ATTN: SGPA/LTCOL JORDAN

AIR UNIVERSITY LIBRARY
600 CHENNAULT CIRCLE
BLDG 1405 - ROOM 160
MAXWELL AFB, AL 36112-6424
ATTN: AUL-LSE

MILITARY AIRLIFT COMMAND
SCOTT AFB, IL 62225
ATTN: MACOS/XOND

US AIR FORCE ACADEMY
2354 FAIRCHILD DR SUITE 3A22
USAF ACADEMY, CO 80840-6214
ATTN: LIBRARY

DISTRIBUTION LIST

DEPARTMENT OF THE ARMY

PENTAGON LIBRARY AND
INFORMATION DIRECTORATE
ROOM 1A518
WASHINGTON, DC 20310-6080
ATTN: ARMY STUDIES

HEADQUARTERS
US ARMY CENTER OF MILITARY HISTORY
PULASKI BUILDING
20 MASSACHUSETTS AVE., NW
WASHINGTON, DC 20001-1432
ATTN: DAMH-HSR-L

COMMANDER
US ARMY MEDICAL DEPT CENTER & SCHOOL
FORT SAM HOUSTON, TX 78234-6100
ATTN: MCCS-FCS/COL DINIEGA

COMMANDER
US ARMY NUCLEAR & CHEMICAL AGENCY
7150 HELLER LOOP
SUITE 101
SPRINGFIELD, VA 22150-3198
ATTN: MONA-NU

DEPARTMENT OF THE NAVY

BUREAU OF MEDICINE & SURGERY
DEPARTMENT OF THE NAVY
2300 E STREET, NW
WASHINGTON, DC 20372-5300
ATTN: RADIATION AND UNDERSEA MEDICINE

CHIEF OF NAVAL OPERATIONS
2000 NAVY PENTAGON
DEPARTMENT OF THE NAVY
WASHINGTON, DC 20350-2000
ATTN: NOP 0455

MARINE CORPS HISTORY & MUSEUMS
WASHINGTON NAVY YARD, BLDG 58
WASHINGTON, DC 20374
ATTN: HISTORICAL DIVISION

DIRECTOR
NAVAL HISTORICAL CENTER
WASHINGTON NAVY YARD
901 M STREET SE
WASHINGTON, DC 02374-5060
ATTN: NAVY DEPARTMENT LIBRARY
ATTN: OPERATIONAL ARCHIVES BRANCH

NAVAL HOSPITAL CORPS SCHOOL
DEPARTMENT OF THE NAVY
GREAT LAKES, IL 60088
ATTN: LIBRARY

SUPERINTENDENT
NAVAL POSTGRADUATE SCHOOL
411 DYER ROAD
MONTEREY, CA 93943-50002
ATTN: CODE 52/LIBRARY

COMMANDER
NAVAL SEA SYSTEMS COMMAND
2531 JEFFERSON DAVIS HIGHWAY
ARLINGTON, VA 22242-5160
ATTN: CODE 04LR
ATTN: CODE 04N
ATTN: CODE 08R

COMMANDER
NAVAL SURFACE WARFARE CENTER
DAHLGREN DIVISION
17320 DAHLGREN ROAD
DAHLGREN, VA 22448-5000
ATTN: LIBRARY, CODE E231

OFFICE OF THE JUDGE ADV GEN
DEPT OF THE NAVY
200 STOVALL ST
ALEXANDRIA, VA 22332
ATTN: CODE 64.3

US MERCHANT MARINE ACADEMY
BLAND MEMORIAL LIBRARY
KINGS POINT, NY 11024
ATTN: XXXXX

OTHER GOVERNMENT

CENTRAL INTELLIGENCE AGENCY
WASHINGTON, DC 20505
ATTN: OFFICE OF MEDICAL SERVICES

ENVIRONMENTAL PROTECTION AGENCY
CARCINOGEN ASSESSMENT GROUP
OFC OF HEALTH & ENVIR ASSESSMENT
401 M STREET, SW
WASHINGTON, DC 20460-0999
ATTN: P MAGNO
ATTN: T THORSLUND (RD-689)

ENVIRONMENTAL PROTECTION AGENCY
OFFICE OF RADIATION PROGRAM
ANALYSIS AND SUPPORT DIVISION
WASHINGTON, DC 20460
ATTN: N NELSON (ANR-461)

FEDERAL EMERGENCY MANAGEMENT AGENCY
500 C. STREET, S.W.
SUITE 514
WASHINGTON, D.C. 20472
ATTN: OFC OF CIVIL DEFENSE

DISTRIBUTION LIST

OTHER GOVERNMENT

LIBRARY OF CONGRESS
JOHN ADAMS BUILDING
101 INDEPENDENCE AVE, S.E.
WASHINGTON, DC 20540

ATTN: LIBRARY SERVICE DIVISION
ATTN: SCIENCE & TECHNOLOGY DIV
ATTN: SERIAL & GOVT PUBLICATION

NATIONAL ACADEMY OF SCIENCES
2101 CONSTITUTION AVENUE
WASHINGTON, DC 20418
ATTN: IOM/MFUAS THAUL

NATIONAL CANCER INSTITUTE, NIH
ENVIRONMENTAL EPIDEMIOLOGY BRANCH
3C07 LANDOW BLDG
BETHESDA, MD 20205
ATTN: CLAND
ATTN: J FRAUMENI, EPN/543
ATTN: WBLOT

NATIONAL CANCER INSTITUTE, NIH
LABORATORY OF PATHOLOGY
BUILDING 10, RM 2A33
ATTN: ARABSON
ATTN: D PISTENMAA
ATTN: J WYNGAARDEN

NATIONAL CANCER INSTITUTE/CEB
EPN-400
BETHESDA, MD 20892
ATTN: DR B W WACHHOLZ
ATTN: DR G W BEEBE

NATIONAL INSTITUTE FOR OCCUPATIONAL
SAFETY & HEALTH
4676 COLUMBIA PARKWAY
CINCINNATI, OH 45226-1922
ATTN: WMURRAY, RM 308, C-27

NATIONAL LIBRARY OF MEDICINE, NIH
TECHNICAL SERVICES DIVISION-
SERIALS
8600 ROCKVILLE PIKE
BETHESDA, MD 20594
ATTN: LIBRARY

CHIEF
NUCLEAR MEDICINE SERVICE (115)
OLIN E TEAGUE VETERANS' CENTER
1901 SOUTH FIRST STREET
TEMPLE, TX 76501
ATTN: FC PETTY, MD

US DEPARTMENT OF COMMERCE
NATIONAL INSTITUTE OF STANDARDS &
TECHNOLOGY
CENTER FOR RADIATION RESEARCH
GAITHERSBURG, MD 20899
ATTN: LIBRARIAN

US DEPARTMENT OF HEALTH & HUMAN
SERVICES
BUREAU OF RADIOLOGICAL HEALTH
FOOD & DRUG ADMINISTRATION
5600 FISHERS LANE
ROCKVILLE, MD 20857-1706
ATTN: CSILVERMAN/HFX-101
ATTN: JVILLFORTH/HFX-1

US DEPARTMENT OF HEALTH & HUMAN
SERVICES
FOOD & DRUG ADMINISTRATION
5600 FISHER LANE
ROCKVILLE, MD 20850
ATTN: CDRH LIBRARY, HFZ-46
ATTN: GC JOHNSON, MD (OFFICE OF HEALTH AFF
ATTN: OFFICE OF HEALTH PHYSICS/HFZ-60

US DEPARTMENT OF HEALTH & HUMAN
SERVICES
HUBERT H. HUMPHREY BLDG., ROOM 706E
WASHINGTON, DC 20201
ATTN: OFC OF REGULATION REVIEW

US DEPARTMENT OF LABOR
200 CONSTITUTION AVE, NW
WASHINGTON, DC 20210-0999
ATTN: SWEINER, RM N3663

US DEPARTMENT OF LABOR
OCCUPATIONAL SAFETY & HEALTH ADMIN
200 CONSTITUTION AVENUE, SW
WASHINGTON, DC 20002-7308
ATTN: LIBRARY

US DEPARTMENT OF LABOR
WORKERS COMPENSATION PROGRAM
P O BOX 37117
WASHINGTON, DC 20013-7117
ATTN: LIBRARY

US DEPARTMENT OF VETERANS AFFAIRS
CENTRAL OFFICE
810 VERMONT AVE N.W.
SECTION 1, ROOM 855
WASHINGTON, DC 20421
ATTN: ED DAVENPORT(C&P)

DISTRIBUTION LIST

OTHER GOVERNMENT

US HOUSE OF REPRESENTATIVES
COMMITTEE ON COMMERCE
2125 RAYBURN HOUSE OFFICE BUILDING
WASHINGTON, DC 20515-6115
ATTN: SUBCOMMITTEE ON HEALTH & ENVIRONMENT

US HOUSE OF REPRESENTATIVES
COMMITTEE ON NATIONAL SECURITY
2120 RAYBURN
HOUSE OFFICE BUILDING
WASHINGTON, DC 20515-6035
ATTN: COMMITTEE ON ARMED SERVICES
ATTN: SUBCOMMITTEE ON MILITARY PERSONEL

US HOUSE OF REPRESENTATIVES
RAYBURN HOUSE OFFICE BUILDING
WASHINGTON, DC 20515
ATTN: MAJORITY COUNSEL

US SENATE
COMMITTEE ON ARMED SERVICES
WASHINGTON, DC 20510
ATTN: COMMITTEE ON ARMED SERVICES

US SENATE
COMMITTEE ON GOVERNMENTAL AFFAIRS
SUBCOMMITTEE ON ENERGY NUC
PROLIFERATION
& FEDERAL SERVICES
WASHINGTON, DC 20510
ATTN: SD 340 DIRKSEN

US SENATE
COMMITTEE ON VETERANS AFFAIRS
RUSSELL SENATE OFFICE BLDG
WASHINGTON, DC 20510
ATTN: DOCUMENT CONTROL
ATTN: MAJORITY COUNSEL

US SENATE
SUBCOMMITTEE OF NUCLEAR REGULATORY
COMMITTEE FOR ENVIRONMENT & PUBLIC
WORKS
ATTN: SUBCOMMITTEE ON ... & NUCLEAR SAFETY

WHITE HOUSE (THE)
218 OLD EXECUTIVE OFFICE BLDG
WASHINGTON, DC 20500
ATTN: DOMESTIC POLICY STAFF