

NATIONAL WIND TUNNEL COMPLEX



GOVERNMENT / INDUSTRY TEAM

Boeing
Department of Defense
GE Aircraft Engines
Lockheed Martin
McDonnell Douglas
NASA
Northrop Grumman
United Technologies Pratt & Whitney

NATIONAL WIND TUNNEL COMPLEX
Project Office
2000 Apollo Drive
Brook Park, Ohio 44142

NAS3-27330

Phase 2A Deliverable

Document No.: NWT-03-A-9000-01

NASA Document No.:

NASA CR-198491

Release: June 7, 1996

Title: NWTC Final Report

DISTRIBUTION STATEMENT A

Approved for public release
Distribution Unlimited

19960819 031

DISCLAIMER NOTICE

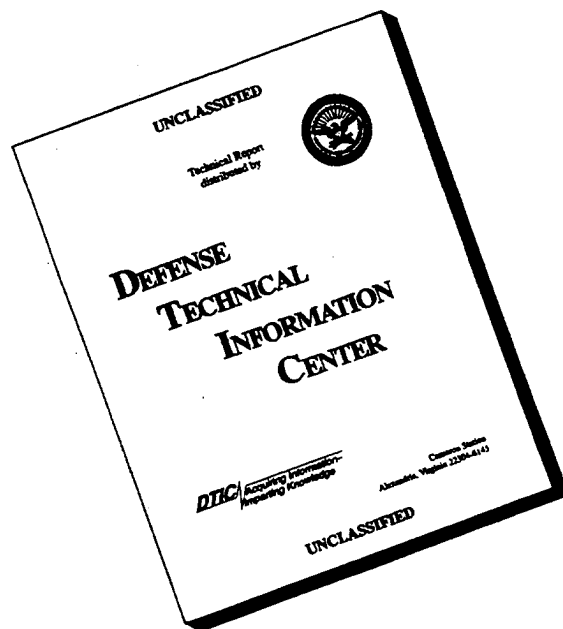

THIS DOCUMENT IS BEST QUALITY AVAILABLE. THE COPY FURNISHED TO DTIC CONTAINED A SIGNIFICANT NUMBER OF PAGES WHICH DO NOT REPRODUCE LEGIBLY.

NWTC Final Report

1. SUMMARY	1
2. INTRODUCTION	2
2.1 Background.....	2
2.2 Project Scope.....	2
2.3 Project Status	3
2.4 Document Organization.....	4
3. PROJECT OVERVIEW	4
3.1 Program/Project Structure.....	4
3.2 Project Organization	5
3.3 Acquisition Strategy	6
3.4 Design Overview	7
3.5 Program Risks.....	8
4. INDUSTRY BUSINESS ARRANGEMENTS AND FINANCIAL ALTERNATIVES	10
4.1 Business Management Plan	10
4.2 Contracts	10
4.3 Work Breakdown Structure	11
4.4 Cost Estimate	11
4.5 Schedule.....	13
4.6 Life Cycle Cost Model.....	13
5. CUSTOMER REQUIREMENTS AND OPERATIONS	15
5.1 Charter	15
5.2 Actions to Fulfill Charter	15
5.3 Individual Company/DoD/NASA Desires/Considerations	17
5.4 Results.....	17
5.5 Concerns/Open Issues.....	19
6. SITE EVALUATION	21
6.1 Background.....	21
6.2 Site Evaluation Committee (SEC) Charter	21
6.3 Process Development.....	21
6.4 Epilogue.....	22
7. WIND TUNNEL SYSTEM DEFINITION	23
7.1 Management Plan	23
7.2 Project Specification	24
7.3 Major Decisions.....	25
7.4 Performance Allocations to Segments	30
7.5 Risk Issues and Safety/Hazard Analyses	30
7.6 Performance Evaluation.....	32

NWTC Final Report

8. SYSTEM STUDIES41

8.1 Risk Reduction.....41

8.2 Concept Evaluation Studies.....42

8.3 Upgrade Studies.....42

8.4 Experiments and Studies.....44

8.5 Flow Quality Processes.....47

9. SEGMENT DEFINITION48

9.1 Carts, Balances, Test and Equipment System.....48

9.2 Flow Conditioning System58

9.3 Pressure System65

9.4 Compressor and Drive System74

9.5 Control and Information80

9.6 Auxiliary Plant Systems.....84

9.7 Infrastructure87

9.8 Site Contributions91

10. CONCLUDING REMARKS95

Appendix A: References A1

Appendix B: Archive ContentsB1

Appendix C: Report Distribution and Documentation Page.....C1

List of Figures

FIGURE 3-1: PROGRAM/PROJECT OFFICE RELATIONSHIP	5
FIGURE 3-2: PROJECT OFFICE ORGANIZATION	5
FIGURE 3-3: SE&I FUNCTIONS	6
FIGURE 3-4: SUBCONTRACT PLAN	7
FIGURE 3-5: TUNNEL CUT-AWAY VIEW	9
FIGURE 4-1: PROPOSED NWTC MANAGEMENT STRUCTURE	10
FIGURE 4-2: TIER 0 SCHEDULE	14
FIGURE 4-3: PRELIMINARY NWTC EXPENDITURE(OUTLAYS) PROFILE	14
FIGURE 5-1: OPERATING ENVELOPES	19
FIGURE 5-2: NWTC SINGLE TUNNEL USER DEMAND	20
FIGURE 6-1: SITE EVALUATION PROCESS	22
FIGURE 7-1: SE&I RESPONSIBILITIES.....	23
FIGURE 7-2: PDT RESPONSIBILITIES	23
FIGURE 7-3: PROGRESSIVE CONFIGURATION BASELINE	24
FIGURE 7-4: HAZARD ANALYSIS METHODOLOGY OF FLOW	33
FIGURE 7-5: WIND TUNNEL PERFORMANCE ENVELOPE. (CONTINUOUS POWER).....	36
FIGURE 7-6: AXIAL TURBULENCE DECAY FROM THE EXIT OF THE HEAT EXCHANGER TO THE TEST SECTION	37
FIGURE 7-7: PREDICTED PRESSURE FLUCTUATIONS FOR THE TEST SECTION WITHOUT MODEL STRUT CONTRIBUTION	38
FIGURE 9-1: TEST PDT ORGANIZATION	48
FIGURE 9-2: CLOSED JET TEST CART - VERTICAL STRUT CONFIGURATION.....	50
FIGURE 9-3: TEST CART - HIGH AOA CARRIAGE CONFIGURATION.....	51
FIGURE 9-4: OPEN JET TEST SECTION WITH EXTERNAL BALANCE AND MONOPOD MODEL SUPPORT SYSTEM.....	52
FIGURE 9-5: AIR CALIBRATION LABORATORY PROCESS DIAGRAM.....	57
FIGURE 9-6: AIR CALIBRATION LABORATORY SCHEMATIC.....	57
FIGURE 9-7: NWTC PRESSURE SYSTEMS SCHEMATIC.....	66
FIGURE 9-8: CONCEPTUAL SITE LAYOUT INFRASTRUCTURE.....	89
FIGURE 9-9: SEGMENT SUB-ELEMENTS	91
FIGURE 9-10: SITE CONTRIBUTED CONTROL AND INFORMATION SYSTEMS	94
FIGURE 9-11: NWTC INTERFACES WITH SITE CONTRIBUTED PLANT ELEMENTS.....	94

List of Tables

TABLE 3-1: MAJOR TUNNEL PERFORMANCE	7
TABLE 3-2: MPWT KEY PERFORMANCE AND FEATURES	8
TABLE 5-1: PERFORMANCE REQUIREMENTS	18
TABLE 7-1: FLOW QUALITY	26
TABLE 7-2: RISK IDENTIFICATION	31
TABLE 7-3: TECHNICAL RISK MITIGATION SUMMARY	32
TABLE 7-4: INFORMATION GENERATED BY THE AVAILABILITY ALLOCATION MODEL	38
TABLE 7-5: TYPICAL RESULTS FROM THE LIFE CYCLE COST MODEL.....	39
TABLE 7-6: PREDICTED VALUES OF SYSTEM LEVEL TPM'S.....	40
TABLE 8-1: CONCEPT EVALUATION STUDIES.....	42
TABLE 9-1: TEST PDT TRADES.....	50
TABLE 9-2: PRESSURE SYSTEM KEY REQUIREMENTS	67
TABLE 9-3: MITIGATION OF PRESSURE SHELL AND SUPPORT STRUCTURE RISKS	69

1. Summary

The National Wind Tunnel Complex (NWTC) Project was a strategic partnership between Industry and Government to design, build, and activate "world class" wind tunnel facilities for the development of future-generation commercial and military aircraft. The objective of the project was to provide transonic and low-speed test facilities capable of high-productivity testing with superior flow quality at Reynolds numbers that more accurately simulate actual flight conditions. This would allow Industry to design more efficient aircraft, in a shorter development time, at lower development costs, and thus enhance the competitive position of the US for world-wide commercial and military aircraft sales. This report summarizes the work of the NWTC Project office.

The NWTC Government/Industry partnership included: Boeing, Department of Defense, GE Aircraft Engines, Lockheed Martin, McDonnell Douglas, NASA, Northrop Grumman, and United Technologies Pratt & Whitney. Key to the partnership was the envisioned Government/Industry cost-sharing of the project. In order to execute the project, NASA established a Wind Tunnel Program Office (WTPO) and entered into a contract with The Boeing Company, as the representative of the Industry Team, to carry out the planning and preliminary design effort. This included technical/cost studies, conceptual design, preliminary engineering to define the program, optimization of the requirements, and estimation of the program cost.

The basis of these design activities was performance goals defined by the National Facilities Study Task Group on Aeronautical Research and Development Facilities. The group established two critically important measures of improved wind tunnel performance: higher Reynolds number capability and greater throughput productivity. The initial NWTC plan was for two high-performance wind tunnels (low speed and transonic) and their related process and test support facilities. The effort was later redirected to a single multi-purpose tunnel.

Phase 1, planning studies, was initiated in June 1994 and completed in December 1994. Phase 2A, preliminary design, was initiated in December 1994. A Systems Design Review (SDR) for the two-tunnel configuration was held in October 1995. The Project was contractually redirected in October 1995 to a single Multi-Purpose Wind Tunnel (MPWT). The design effort was terminated with the MPWT SDR in March 1996.

The Multi-Purpose Wind Tunnel presented at SDR provided a 13 x 16 ft Test Section, with a 7 atm shell, utilized a carting system, had a Mach range of 0.015 - 1.5, and provided a Reynolds number of 31 million at Mach 1. The configuration met the overall National Facility Study goals of being a World Class facility in terms of flow quality, high productivity, and low operation costs. It met the Reynolds number goal at transonic speeds; however, it did not meet the goal at low speeds. The configuration cost estimate was \$1.29B; recommendations were made of delayed/reduced capability which would reduce the costs to the \$1.2B project budget. Not included in the budget is necessary site supplied infrastructure with a value estimated at \$0.37B.

An important aspect of the project was the development of detailed performance requirements. An active Customer Requirements & Operations team, interacting with Government and Industry partnership members, translated the NFS national consensus requirements into detailed engineering requirements. This activity served to draw focus on the limit of existing technology in meeting the detailed engineering requirements.

NASA directed the NWTC to conduct an orderly phase out and closure following the MPWT SDR because of the "current fiscal situation". This report reflects the design maturity as of the SDR. The project was concluded by archiving all project information following the SDR. This project information archived includes: detailed customer requirements; site evaluation criteria; the functional baseline; concept evaluation studies; models (productivity, flow quality, and life cycle cost); the NWTC configuration represented by the definition of systems, subsystems, components, and their respective interfaces; definition of major procurement packages; definition of system, subsystem, and component acceptance testing; and NWTC activation and calibration tests. Additionally, a detailed cost estimate, schedule, and PDT specific supporting documentation, as well as general supporting data, are included in the archive. The archived data is available on CD ROM disks.

2. Introduction

2.1 Background

Research, development, and test facilities are critical to maintaining U.S. leadership in aerospace technologies. During the past ten years, several studies and reviews have been conducted to determine the National and Industry facility needs to ensure future U. S. leadership status. The most noteworthy of these are a Boeing corporate assessment in the late 1980s (Ref. 2-1), the joint NASA/DoD National Facilities Study (NFS) (Ref. 2-2) team including a Facilities Study Office (FSO) at Langley Research Center in 1993-94 (Ref. 2-3), a study by the ASEB of the National Research Council in 1993-94 (Ref. 2-4), and most recently, the NWTC Program/Project Office 1994-96 in Cleveland, Ohio which brought together a government and industry team chartered to develop detailed requirements and design concepts, and execute the acquisition process through a joint government-industry consortium. The results of these collective efforts have clearly been a consistent central theme and recommendation: **“The Nation needs to acquire modern, state-of-the-art, subsonic and transonic wind tunnels for industry (commercial and military) support”**.

Three areas of emphasis have consistently been evident throughout this process: 1) the need for improved information quality (higher Reynolds number, improved flow quality, and more accurate instrumentation), 2) a clear requirement for assured availability and high productivity to provide timely generation of wind tunnel information for airplane development projects, and 3) the need for competitive data production cost.

There has been a firm and consistent technical need throughout this ten year process of studies and reviews, and recommended technical solutions have changed very little. The technical requirements and basic design approach have matured and been refined, but essentially, the evolution from the requirement studies continued to confirm the same requirements. The NFS team was chartered “To formulate a coordinated national plan for world-class aeronautical and space facilities that meet the current and projected needs for commercial and government sponsored research and development, and national space operations.” The need today is clearly stated in a June 1994 AIAA paper (Ref. 2-5) summarizing the NFS results; “Subsonic and transonic wind tunnels were judged to be the most critical and of highest priority. It is the consensus of the U.S. industry and government that substantial gains in capability, productivity, and operating cost metrics are needed to provide the U.S. with world-class facilities for both commercial and military aircraft development. These gains cannot be achieved through improvements to existing national facilities. ... Facility concepts to meet the need have been defined.”

In order to accomplish the wind tunnel effort outlined by the NFS, NASA established a Wind Tunnel Program Office (WTPO) and entered into a contract with The Boeing Company, as the representative of the Industry Team, to carry out the planning and preliminary design effort as the first step in the acquisition process. The contract effort focused on the required planning studies (Phase 1) and preliminary design (Phase 2A) associated with the development of the NWTC, as the first step in the acquisition process.

It was the intent that the NWTC Program break new ground in government - industry relations and acquisition processes. “Re-engineering government” was envisioned to be a practical aspect of the Program. The NWTC government/industry partnership was based on using best commercial practices, which streamline acquisition processes and minimize oversight, and incorporated a systems engineering approach from project planning through project completion. The proposed joint funding of a major capital expenditure by government and industry was a major departure from traditional approaches. The establishment of a Project Team populated by the collective talents of all segments of the national aeronautical community carried this innovative theme forward. The NWTC Program was to acquire a **“best in the world, not to be surpassed”** development facility to support the U.S. airplane industry.

2.2 Project Scope

The Project scope included all aspects of the NWTC acquisition:

- establishing detailed requirements, based on NFS national consensus requirements and input from Government and Industry partners

NWTC Final Report

- preliminary planning
- conceptual design and studies
- preliminary and final design
- procurement, fabrication, and construction
- activation, calibration, and customer verification testing

Although not clearly stated in the documentation, the intent was to establish a commercially viable complex without long term government or industry financial subsidies.

The initial NWTC plan was for two high-performance wind tunnels (low speed and transonic) and their related process and test support facilities. The NWTC project was redirected from the two-tunnel configuration to a single Multi-Purpose Wind Tunnel (MPWT) located at an existing site. The project also assumed significant infrastructure contribution from the site. This change was made in October 1995, based on funding considerations, and provides a relatively high percentage of the total NWTC capability with approximately half of the required capital investment. Significant concern has been expressed in Industry related to the reduced low speed Reynolds number capability and the reduced capability to support two simultaneous major development programs. However, Industry did officially support the single tunnel concept as the best solution within the funding projections. If in the future current funding constraints are removed, Industry still supports the National Facility Study results, which were substantiated by the National Research Council, and recommends implementation of the full two-tunnel complex.

2.3 Project Status

A one day System Design Review (SDR) for the two tunnel concept was conducted in October 1995 (Ref. 2-6). Detailed customer requirements were presented. Conceptual designs and related design studies were also presented, and a NWTC design concept established. The two tunnel (transonic and subsonic) cost was estimated at \$2.5B with an initial operational capability (IOC) in late 2003.

In late 1995, the Project Office effort was redirected to the Multi-Purpose Wind Tunnel (MPWT) concept. The basic objective was to develop a \$1.2B design with a design-to-cost approach which met the most comprehensive set of NWTC requirements possible. An extensive two and one-half day SDR was conducted on 20-22 March 1996 (Ref. 2-7) for the MPWT concept.

The MPWT is a 13 x 16 foot transonic tunnel, approximately 20% larger than the two-tunnel transonic circuit. The controllable test section velocity covers the range of the original two tunnels. The MPWT represents over a 50% reduction in test section area as compared to the original subsonic tunnel design. The total pressure increase from five to seven atmospheres, which was added to provide higher Reynolds number capability for fighter models at high subsonic Mach numbers, compensates for a major portion of the low speed Reynolds number reduction due to size; however, there is an increased risk that wind tunnel models will not be able to use the full pressure capability of the tunnel for development purposes because of high aerodynamic loads.

The single tunnel concept presented at the March 1996 SDR had an estimated cost of \$1.29B versus a \$1.2B budget. Recommendations were made for delayed/reduced capability which would reduce the costs to the \$1.2B project budget. This closure on cost would have been addressed if the program had continued. There were several open issues related to the assumed site-provided equipment (value estimated at \$0.37B) and support capabilities. Some of the assumed capabilities exceed the capacity of any known sites and several integration issues related to reliability and automation appear to be formidable tasks which could not be adequately addressed until the site was selected by the government. The overall review conclusion was that the NWTC Project was ready to proceed with preliminary design, that the technology, risk, management, and economic issues, though challenging, were acceptable, and that the Project Team was established and ready to meet the challenge.

This report provides an overview of the NWTC Project results and accomplishments. It is anticipated that it will provide sufficient information to motivate the reader to explore the archived information base left as an NWTC legacy for future tunnel development projects.

2.4 Document Organization

The document is organized into ten sections as follows:

- Section 1 - Summary, provides a one page overview of this report.
- Section 2 - Introduction, defines the purpose and scope of the NWTC Project.
- Section 3 - Project Overview, gives a top level description of the project organization, business and management plan, single tunnel design, and project risks.
- Section 4 - Industry Business Arrangements and Financial Alternatives, describes the Government/Industry business arrangement, contracting plan, top level cost, and schedule of the project.
- Section 5 - Customer Requirements and Operations, describes the development of the customer/user requirements from Industry/DoD/NASA.
- Section 6 - Site Evaluation, provides a description of the process used for site evaluation and selection.
- Section 7 - Wind Tunnel System Definition, describes the NWTC system level processes, requirements, decisions including risk and performance evaluation.
- Section 8 - System Studies, is a description of the studies and experiments performed prior and during the project. It includes risk reduction, concept evaluation, and tunnel upgrade studies.
- Section 9 - Segment Definition, contains the detailed description and design of the defined segments of the NWTC.
- Section 10 - Concluding Remarks, final conclusion on the work accomplished.
- Appendix A - References, provides a list of references contained in this document.
- Appendix B - Archive List, a list of all documents being archived with the termination of the NWTC Project.

3. Project Overview

3.1 Program/Project Structure

The NWTC Government/Industry Team was composed of representatives from NASA, the Department of Defense, and major U. S. aerospace companies (Boeing, General Electric Aircraft Engines, Lockheed Martin, McDonnell Douglas, Northrop Grumman, and United Technologies Pratt and Whitney). NASA, as the Government agent responsible for the activity, established a Program Office to oversee the execution of the NWTC Program. NASA contracted with Boeing, as the representative of Industry Team, to establish a NWTC Project Office for project execution.

The Program Office was charged with Government oversight, development of incentives for superior Project Office performance, providing Government advocacy, ensuring access to Government expertise and assets, and investing in related technology to facilitate NWTC success. The relationship of the Program Office to the Project Office is shown in Figure 3-1.

The Project Office, as the representative agent of the Industry Team, was chartered with the responsibility of the design, construction, testing, and activation of the NWTC facilities and related systems. The Project Office was given the role of system integrator from development of detailed design specification through the activation and transition to fully productive customer support. A wide variety of major tasks such as site requirement analysis and evaluation, identification and validation of customer requirements, system engineering and integration, risk identification and management, subcontracting and construction management, and acceptance testing and calibration were given to the Project Office.

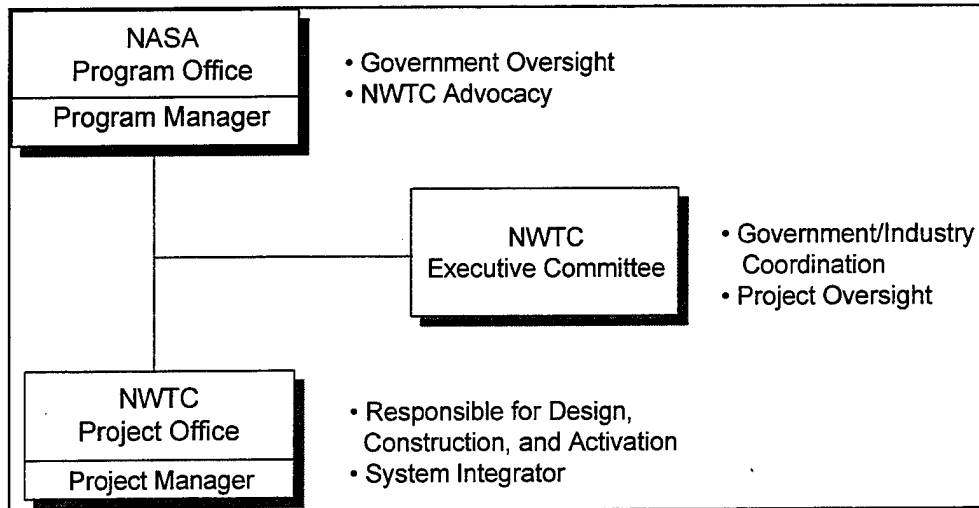

Figure 3-1: Program/Project Office Relationship

3.2 Project Organization

The NWTC Project Office was a product-focused matrix-organization, organized along functional lines with functional process owners reporting to the Project Manager, as shown in Figure 3-2. The four major activities were: Business Management and Planning, Customer Requirements and Operations, Site Evaluation, and Design/Build. These are described in the following paragraphs.

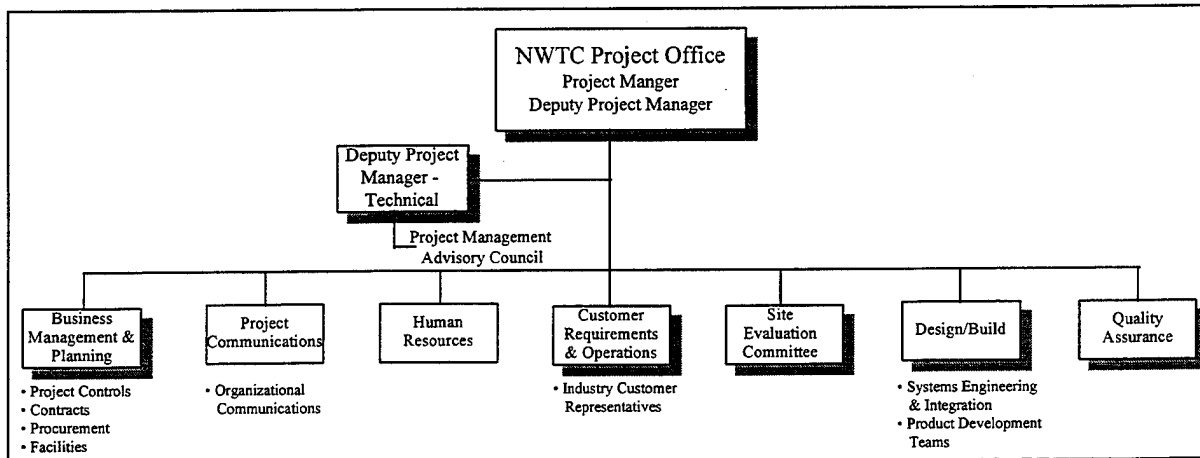

Figure 3-2: Project Office Organization

Business Management and Planning

The Business Management and Planning (BM&P) organization served as a traditional cost and schedule control monitor for the Project Manager. BM&P also served as the overall Project contract compliance monitor and provided materiel functions (e.g., purchasing and subcontracting) for the Project Office organizations. BM&P roles and responsibilities are described in Section 4.0.

Customer Requirements and Operations

The CR&O organization represented the NWTC Government and Industry aeronautical system development community. They defined and validated specifications and operational requirements used to optimize the design with respect to performance, cost and schedule. This group coordinated with their parent organizations

to ensure the test capabilities and operations meet expectations, and to define, interpret, and perform technical trades of test needs against predicted NWTC performance. The CR&O is further described in Section 5.0.

Site Evaluation Committee

The SEC worked with the CR&O, the Design/Build teams and Business Management and Planning under the direction of the Project Manager to identify site requirements and site related factors affecting the cost to design, construct and operate the facility in the various locations. The SEC would then solicit site proposals, and assess and rank the candidate list of potential sites. The SEC role in the Project is described in Section 6.0.

Design/Build

The Design/Build organization was responsible for the overall NWTC system technical development and integration. Design/Build was organized and functioned under a teaming concept. A Systems Engineering and Integration (SE&I) team was formed with Design/Build management, PDT leaders, and representatives from supporting organizations. Product Development Teams (PDTs) were chartered by segments consistent with the acquisitions plan. The number and make-up of the PDTs were selected based on experience and judgment of the senior members of the Design/Build team. The definitions of the PDT elements and the functional interfaces between them were established by the functional analysis process. The relationship of the SE&I team to the PDTs is shown in Figure 3-3.

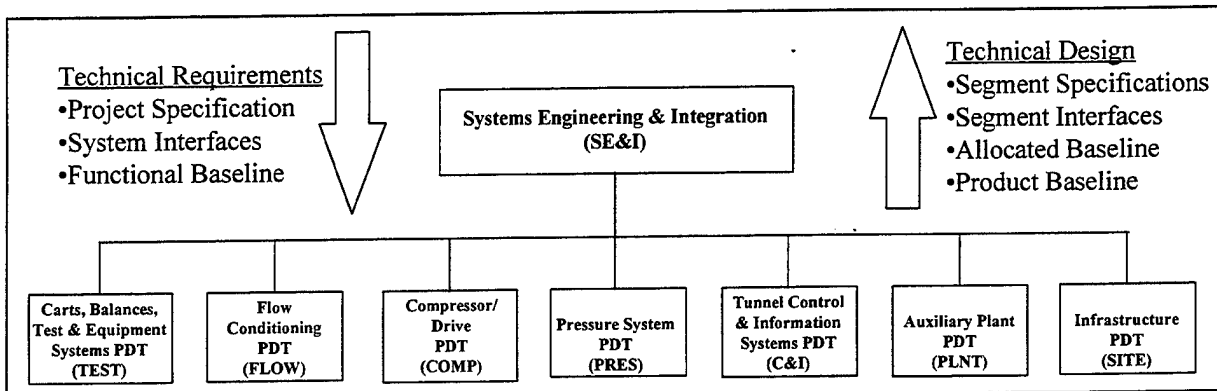

Figure 3-3: SE&I Functions

3.3 Acquisition Strategy

The overall acquisition strategy of the NWTC was to subcontract large work packages with suppliers who have demonstrated past superior performance. The Project Office and its design subcontractors would carry the design effort to the level necessary for procurement of these work packages. Where possible, these procurements would be on a competitive, fixed-price basis. The Project Office would be responsible for system integration. The six individual subcontractors would be responsible for fabrication, construction, segment activation and segment performance. The Project Office would be responsible for integrated system activation, integrated system performance, and tunnel calibration. Figure 3-4 depicts the acquisition plan as it relates to the seven PDTs derived from the major system elements and to the major subcontracts aligned with these system elements (Ref. 3-1).

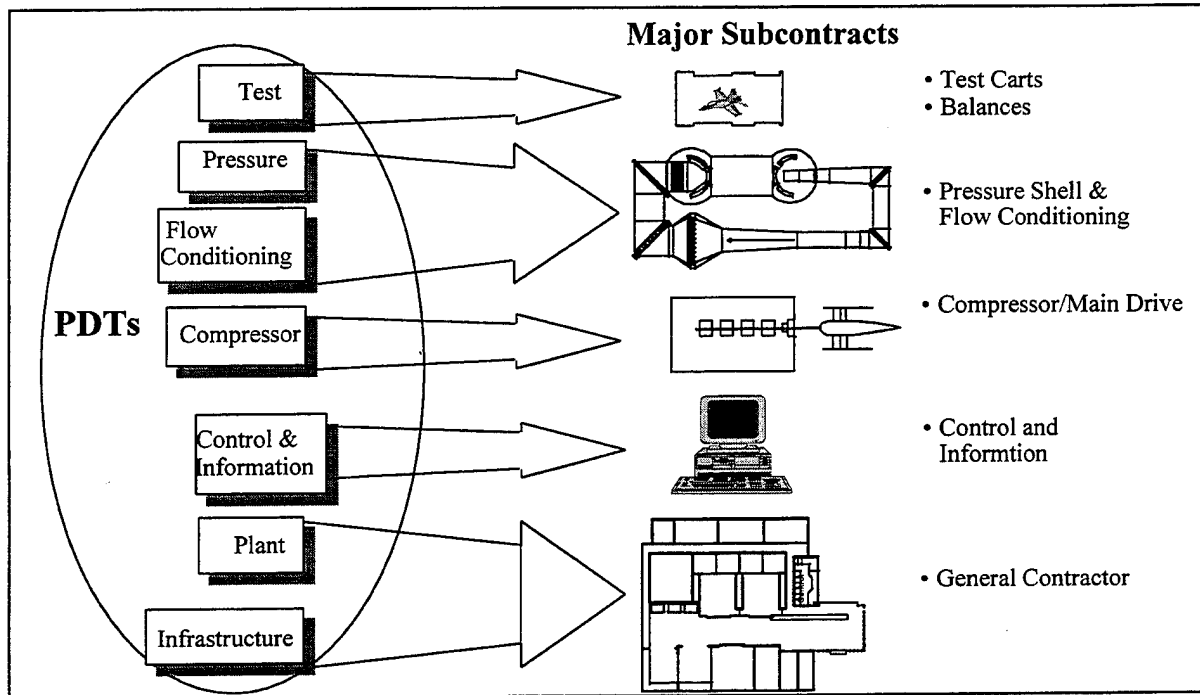

Figure 3-4: Subcontract Plan

3.4 Design Overview

The basis of the design was performance goals defined by the National Facilities Study Task Group on Aeronautical Research and Development Facilities. The CR&O team, interacting with Government and Industry partnership members, translated these NFS national consensus requirements into detailed engineering requirements. Through a detailed functional analysis approach, a two-tunnel configuration was developed, documented in the Project Specification (Ref. 3-2), and reviewed at SDR in October 1995. Major tunnel performance features are listed in Table 3-1. The program was based on a greenfield site, had an estimated cost of \$2.5 B, and an IOC of 2003.

<u>Low Speed Tunnel (LSWT)</u>	<u>Transonic Tunnel (TSWT)</u>
- Mach 0.015 - 0.6	- Mach 0.05 - 1.5
- 20 x 24 ft Test Section	- 11 x 15.5 ft Test Section
- Re 20 million @ M=0.3	- Re 28 million @ M=1
- Excellent Flow Quality	- Excellent Flow Quality
- High Productivity	- High Productivity
- Low Operating Cost	- Low Operating Cost

Table 3-1: Major Tunnel Performance

Both tunnels featured 5 ATM total pressure capability to attain the desired Reynolds number envelope, and isolation valves and a carting system to increase productivity. The transonic tunnel contained a flexible nozzle to attain the maximum Mach number of 1.5. The facility provided air capacity to support rapid model changes and propulsion testing, and multiple model preparation areas to support the build-up and check out of multiple customers' models.

At the direction of the NASA Program Office and the Project Executive Committee, the Project was redirected to a single Multi-Purpose Wind Tunnel (MPWT) in October 1995 (Ref. 3-3). The criteria and rationale for this single tunnel were:

- Single, multi-purpose tunnel
- Maintain full transonic capability

NWTC Final Report

- Incorporate low speed capabilities
 - maximize, within the constraints, low speed Reynolds number
 - provide open jet acoustic test capability
- Provide features which cannot be added later
- Compatibility with existing tunnels
- Assume a significant site contribution to infrastructure
- \$1.2 B program budget constraint

The conceptual design that was presented at the SDR in March 1996 provided an optimized design accommodating the requirements stated for information and flow quality, performance envelope and testing capabilities, throughput capacity and project cost goals. The baseline configuration included site layout, airline parameters, test, plant, infrastructure, controls and information, pressure, compressor, and flow conditioning and other performance features as reflected in Technical Performance Measurements (TPMS). The SDR configuration was predicated on locating the facility at an existing site, utilizing significant site supplied infrastructure, had a program cost of \$1.29B, and had an IOC of 2003. Key performance and features are listed in Table 2 and Figure 3-5 shows a cut-away rendition of the tunnel.

<u>Multi-Purpose Wind Tunnel (MPWT)</u>
- Mach 0.015 - 1.5
- 13 x 16 ft Test Section
- 7 Atmosphere Shell with Isolation Valves
- Reynolds Number 31 million @ M=1.0
- Multi-Function Split Carting System with Removable Pitch Strut
- Open Jet Test Cart System
- Plenum Evacuation System
- Flexible Nozzle
- Adjustable Slotted Test Section Walls
- High Accuracy Balances and Model Positioning System
- High Angle of Attack Model Support System
- Propulsion Simulation Testing Capability

Table 3-2: MPWT Key Features and Performance

3.5 Program Risks

The project engaged a formal risk process described in more detail in Section 7.5. Two Program level risks were identified.

The first was the risk associated with the Program accepting responsibility for Integrated System Performance, consistent with previous major facility programs. To mitigate this risk, the Project Office took lead responsibility for system integration. In executing this role, the Project Office worked with the major design contractor in an integrated organization to allow focus on the top level design issues and evaluate/make design risk decisions. This included chartering the appropriate teams to execute a system design, strengthening the System Design Group working in SE&I, and implementing disciplined system engineering methods throughout the project.

The second Program level risk involved the site supplied infrastructure capabilities and contributions. The project was to mitigate this risk by analyzing the current and probable future capabilities of existing sites and proceeding with a design, to the extent possible, within the selected site capability. Primary concern was size of the airplant, required to support the propulsion simulation system, which is larger than that at any known existing site.

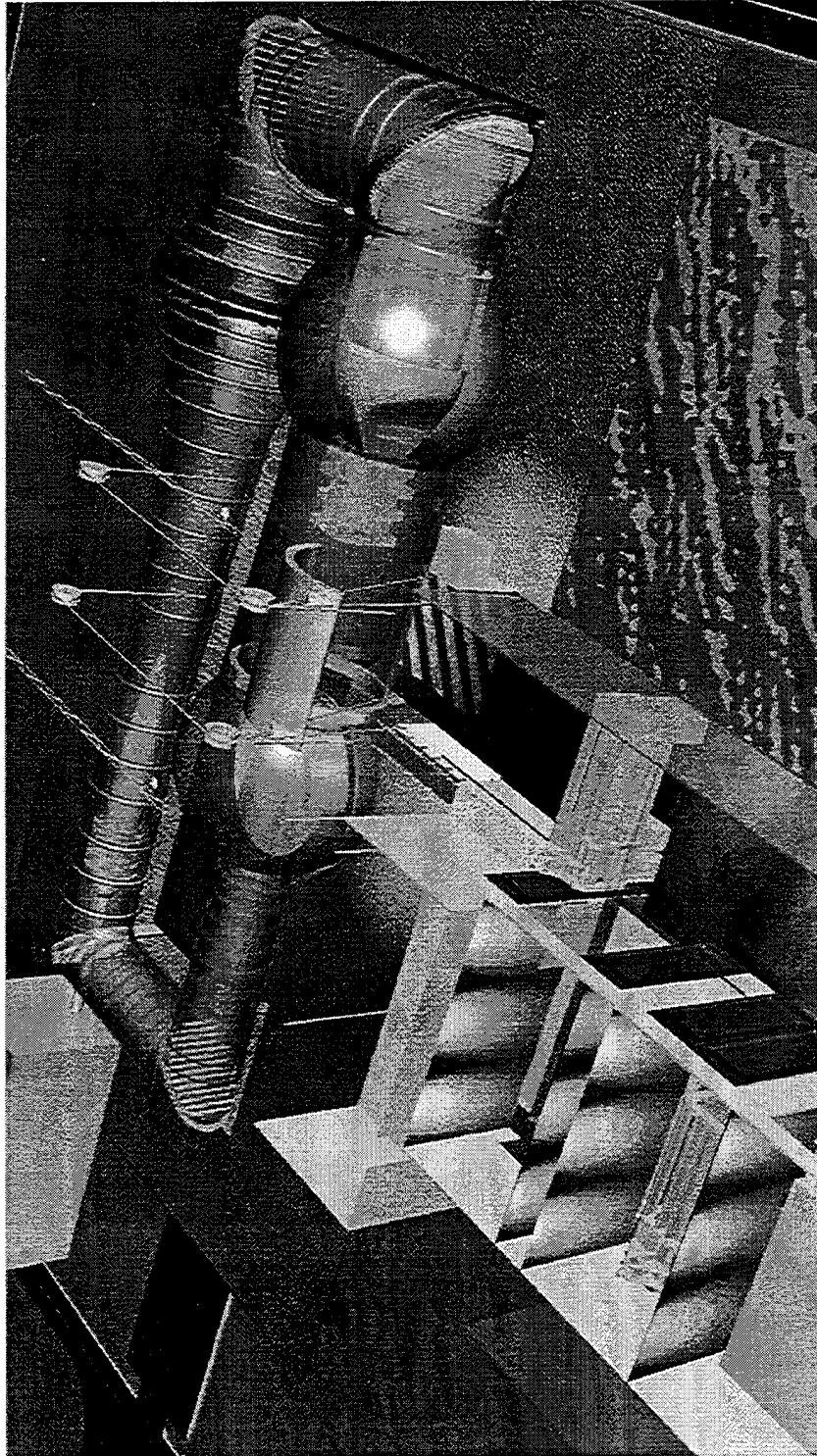

Figure 3-5: Tunnel Cut-Away View

4. Industry Business Arrangements and Financial Alternatives

4.1 Business Management Plan

During the life of the contract, many forms of business entities were explored that would bind the Industry Partners in a single business entity with the purpose of designing and building the NWTC, yet would provide each individual partner the desired protection from failure of the project, cost overruns, or individual partner business failures. The business structure chosen by the team was a Limited Liability Corporation (LLC). Under this form of business structure, the Industry Partners would be signatory to an LLC agreement formed to build the NWTC. Signatory partner corporations would invest in the LLC, but being an LLC, each corporation would have no financial or legal liability beyond the original investment.

The project team examined the possibility of financing the project in part by incurring project debt for construction and operation. Under this scenario, NASA, DoD, and the Industry Partners would invest in the project with the final approximate \$500 million to be financed and paid back by funds generated by the usage of the tunnels. However, current market price of wind tunnel testing would not support repayment of the incurred debt of the facility.

Congress directed NASA to seek the involvement of DoD as a full government partner along with NASA. The NWTC explored several tunnel configurations and capabilities and possible financial scenarios, and compared them with the possible sources of funds. The final proposed plan to provide funds to build the Multi-Purpose Wind Tunnel was a \$200M commitment from Industry and approximately \$1B from Government. It should be noted that a commitment had not been secured from the Government. It should also be emphasized that the plan was notional and was proposed prior to the completion of the March 1996 SDR cost estimate. The division of funds was to have been negotiated between the Industry Partners and the Governmental agencies involved, and would need to have closure with the final configuration and cost estimate.

In conjunction with the above financing plan, the management structure chosen as the plan to build the NWTC is shown in Figure 4-1.

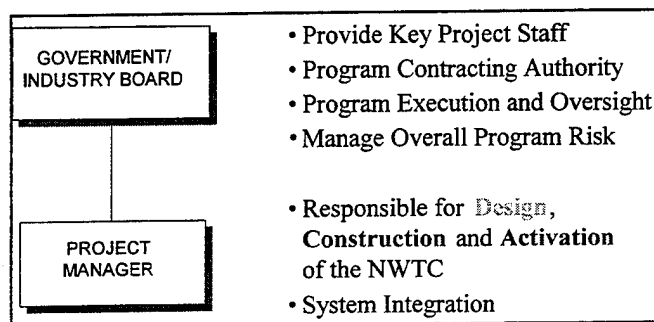

Figure 4-1: Proposed NWTC Management Structure

A joint Government / Industry Board would be established by a firm contractual relationship, and would manage and oversee the design, construction and activation of the NWTC. The responsibilities of this Board would be to provide program execution and program oversight. The Board would appoint a Project Manager, who would serve under the sole authority of the Board. The Project Manager's primary responsibility would be to design, build and activate the NWTC. The key project management and staff would be provided by the Board member companies and government organizations. The Project Manager would have the key project management and staff as direct reports.

4.2 Contracts

The contractual relationship between the Industry Partners and the Government would be limited to an agreement to allow for the Industry Partners to invest in the project and for the Industry Partners to provide key project

NWTC Final Report

management and staff. No other contractual relationship was envisioned to be necessary between the Industry Partners and the Government.

The Contract Plan to design and build the NWTC would be in concert with the Business Management Plan. The Government/Industry Board would approve major contracts, with contracting authority provided by a government agency, NASA or DoD. The contracts would allow technical administration of the contracts by the NWTC staff. All contract administration duties would be the responsibility of the project staff, under authority of the Contract Officer, including determination of completion status of each contract, cost and schedule tracking, and allowable progress payments. Since the contracting authority comes from a governmental agency, that agency would issue the project approved progress payments.

4.3 Work Breakdown Structure

The seven segments identified in the acquisition plan, and assigned to the separate PDTs, are:

1. Test Section
2. Flow Conditioning System
3. Compressor and Drive System
4. Pressure System
5. Control and Information Systems
6. Plant
7. Infrastructure

The Work Breakdown Structure (WBS) is broken down further within the PDT structure as follows:

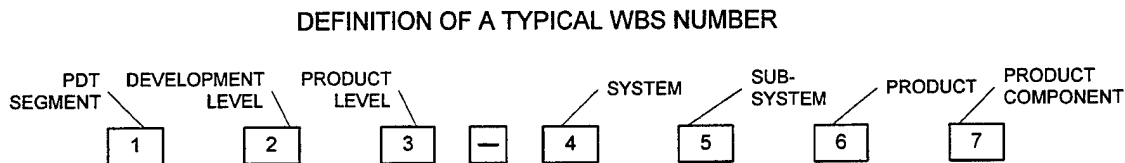

The last four numbers of the WBS are consistent with previous wind tunnel configurations including, The Boeing Wind Tunnel Complex, The National Facilities Study, The Risk Reduction Studies, and the first NWTC two tunnel configuration.

4.4 Cost Estimate

The primary source document for descriptions of the work to be estimated is the WBS dictionary (Ref. 4-1). This document consists of indexes which sort the titles of the items first, according to numerical order of the WBS number and second, according to the PDT number. Following the indexes are high level definitions of each item. The definitions were developed in conjunction with the Project Specifications (Ref 4-2) and Segment Specifications (Ref. 4-3). The Segment Specifications were developed by the PDT members having responsibility for the particular segment.

Construction cost estimates for each WBS element were based on the specifications and drawings, available at SDR, prepared by the specific PDT.

During preparation and pricing of the estimate, published reference data bases such as "RS Means, Cost Data" and "Richardson Process Plan Construction Estimating Standards" were used in order to establish recognized labor productivity standards. "Best commercial practices" were assumed, which lowers cost by streamlining acquisition

NWTC Final Report

processes and minimizing oversight. Risk factors were developed using the guidelines published in the NWTC Risk Management Plan (Ref. 4-4), and applied where appropriate, always at the lowest level of detail.

In all areas of the estimate in which "site conditions" had an impact on the estimated cost, assumed conditions established for a generic site were the basis for cost development.

The estimate for the project management costs are based on the staffing and facilities required to design, build and activate the NWTC using the project business plan and contracting plan.

Craft labor rates are composite crew rates which would be encountered in approximately 75% of the continental United States. The rates were compiled after research into Trade Labor Agreements in effect in several localities of the West, Central and Southeastern United States. The rates used are "fully burdened", including insurance, medical, vacation pay and tax factors normally applied to each particular craft. The assumption was made that sufficient labor forces would be available for employment on the NWTC workforce.

Potential major suppliers, such as builders of the pressure shells and drive systems, provided quotations for use in the estimate. Subcontractor and supplier quotations were included if they were available. Construction contractor and subcontractor markups within the body of the estimate are consistent with the Subcontract Plan (Ref. 4-5).

After total construction costs were compiled, sales taxes at a tax rate of 8% of material only costs were applied. A contingency of 20% of the total construction cost was also applied. Finally escalation at the rate of 3.5% per annum through the year 2003 was added to the total of all previous estimated costs. The final resultant of \$1.29 billion is the estimated cost of construction for the program contained inside the project boundaries, from SDR to final activation. Costs of approximately \$50M incurred prior to SDR are not included in the estimate. Many of those costs were incurred during the two-tunnel design studies and represent a sunk-cost to the MPWT project.

The project estimate is summarized below. The detailed cost estimate can be found in the NWTC archive.

	Product Development Team (PDT)	Construction Cost (\$1000)
100	Test	\$ 236,906
200	Flow	63,357
300	Compressor. Drive	123,106
400	Pressure	170,832
500	C & I	57,190
600	Plant	53,354
700	Site & Infrastructure	88,998
000	Project Management/General Contractor	<u>123,953</u>
	Total Construction Cost	\$ 917,606
	Contingency @ 20%	183,521
	Taxes @ 8% of total material, 1/2 subcontract costs	<u>39,888</u>
	Subtotal	\$ 1,141,015
	Escalation @ 3.5% / year	<u>155,863</u>
	Total MPWT Cost	\$ 1,296,878

Procedures, ground rules and assumptions to develop the cost of "Site Supplied Infrastructure" and backup information is the same as described above. The construction costs shown below are the estimated value of the infrastructure assumed to be supplied by the site. This estimate was done primarily for the site evaluation process so that a cost could be associated with infrastructure that a site may not have or plan to have. The estimated construction cost for the site supplied infrastructure was:

NWTC Final Report

Site Supplied Infrastructure		Construction Cost (\$1000)
1000	Site and Infrastructure	\$ 39,022
2000	Buildings	27,774
3000	Auxiliary Process Systems	102,112
4000	Low Speed Capabilities	(none)
5000	Transonic Wind Tunnel	(none)
7000	Model Support and Data Systems	<u>34,362</u>
		\$ 203,269
8000	Design Cost (estimated @ 10% of construction cost)	<u>20,327</u>
		\$ 233,596
9000	Program Management (estimated @ 15.6% of construction and design cost)	<u>34,881</u>
		\$ 258,477
	Contingency @ 20%	51,695
	Taxes @ 8% of total material, 1/2 subcontract costs	<u>12,060</u>
	Subtotal	\$ 322,233
	Escalation @ 3.5% / year	<u>43,824</u>
	Total Site Supplied Infrastructure Cost	\$ 366,057

This results in a total project estimated cost of \$1.663B if the project were to be built on a greenfield site.

4.5 Schedule

The Integrated Schedule (Ref. 4-6) covers four major areas "Customer Requirements and Operations" support, "Project Design," "Bid and Award", and "Construction and Activation." The CR&O covers the release of customer requirements to support Project Design. The "Project Design" portion covers the system integration efforts including conceptual, preliminary, and final design, as well as administrative support. Finally, the "Bid and Award" portion and "Construction and Activation" portion covers contract awards, construction, fabrication, installation and facility integration testing. To accurately reflect these time periods and the requirements of manpower and cost loading the activities it was necessary to use Primavera Project Planner as the scheduling program. The Tier 0 Integrated Schedule is shown in Figure 4-2.

Some fundamental underlying assumptions were made to produce the Tier 0 Schedule. They are: the NWTC would be built at an existing site, the design would commence with the configuration established at SDR, no additional requirements would be introduced after SDR, the pressure shell would be pneumatically tested, and the Bid and Award section is consistent with the subcontracting plan.

4.6 Life Cycle Cost Model

The NWTC Life Cycle Cost Model (Ref. 4-7) estimates the labor and material costs to plan, design, and construct and operate the NWTC. The labor and material costs are time phased using the project schedule. Total acquisition cost is determined by applying taxes, contingency and escalation to the time phased labor and material costs. The time phasing of the cost estimate is shown in Figure 4-3. No site supplied infrastructure costs were considered.

4.6.1 Acquisition Module

The Acquisition Module estimates the labor and material costs to plan, design, and construct the NWTC. The labor and material costs, known as the Conceptual Construction Cost Estimate (Ref. 4-8), are time phased using the project schedule. Total acquisition cost is determined by applying taxes, contingency, and escalation to the time phased labor and material costs.

NWTC Final Report

The figures that were used to reflect the monetary resources required to build the National Wind Tunnel Complex were obtained from the project estimating group. These numbers were then distributed over the construction schedule according to how the funds would be spent within each WBS. In most cases, the dollars associated with a certain WBS were allocated to the actual construction activity. A few activities, such as those with vendor proposed designs and/or extensive fabrications, had a portion of the dollars assigned to either the design or fabrication activities according to the extent that each subcontractor would require the funds.

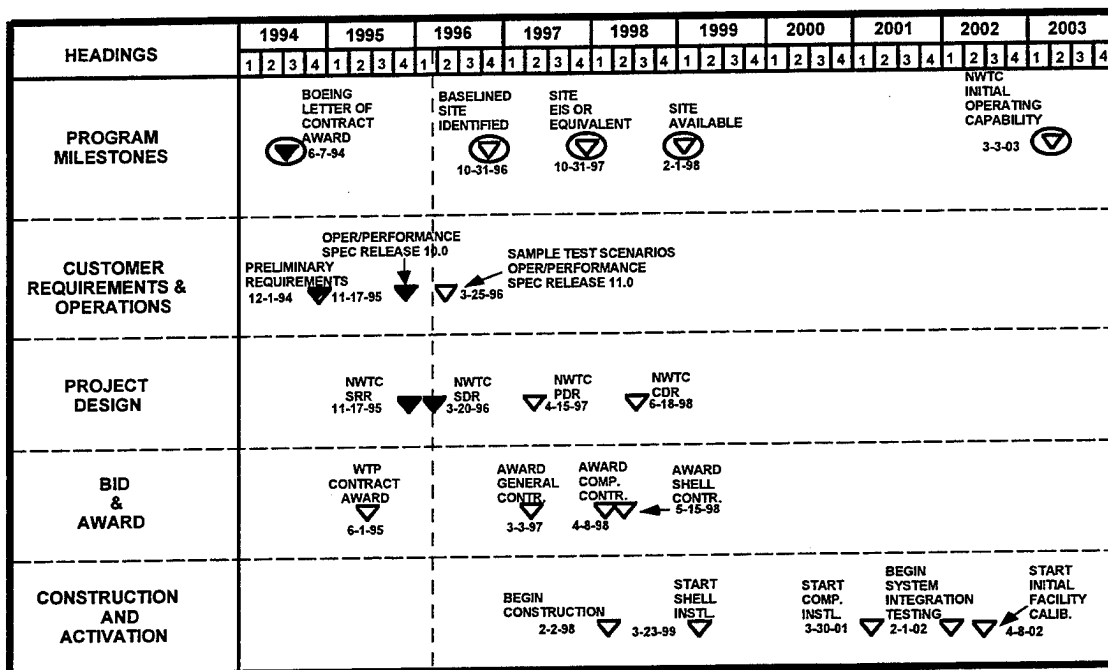

Figure 4-2: Tier 0 Schedule

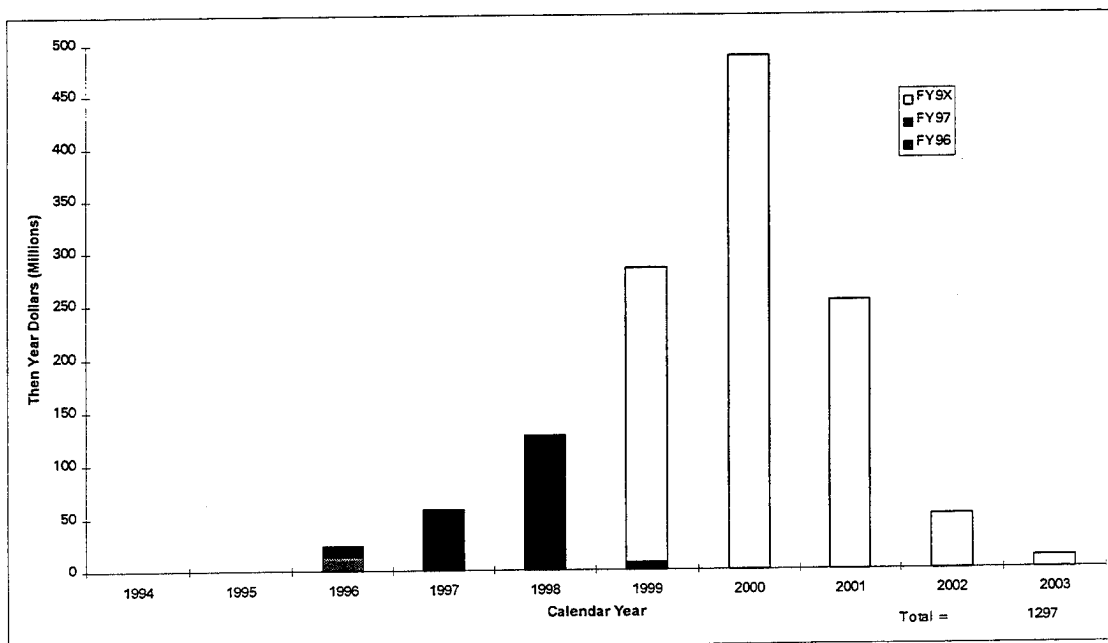

Figure 4-3: Preliminary NWTC Expenditure (Outlays) Profile

5. Customer Requirements and Operations

5.1 Charter

The primary objective of the Customer Requirements & Operations (CR&O) Team was to provide the Design/Build Team with a clear definition of Industry/Government consensus performance and operations requirements for the NWTC. The CR&O Team was comprised of representatives from NASA and DoD and from the companies participating in the program; Boeing, GE Aircraft Engines, Lockheed Martin, McDonnell Douglas, Northrop Grumman, and Pratt & Whitney.

5.2 Actions to Fulfill Charter

The overall performance requirements for the NWTC were those given by the Aeronautics R&D Facilities Task Group (AFTG) of the National Facilities Study (NFS), a study conducted jointly by NASA, DoD, DoC, DoT, NSF, and industry. The charter of the NFS was "To formulate a coordinated national plan for world-class aeronautical and space facilities that meet the current and projected needs for commercial and government sponsored research and development, and for national space operations." In May 1993, the Facilities Study Office (FSO) was formed to support the AFTG studies by providing timely development, reviews, and assessment of concepts and costs associated with configurations of the NWTC that the AFTG were considering.

The AFTG examined the status and requirements for aeronautics facilities against the competitive need. Emphasis was placed on ground-based facilities for subsonic, supersonic, and hypersonic aerodynamics and propulsion. Subsonic and transonic wind tunnels were judged to be the most critical and of highest priority. The AFTG concluded in the "National Facilities Study" report Volume 2 dated April 29, 1994 (Ref. 5-1) that:

"In order to alter the course of the competitive position of the U.S. aircraft industry, it is a consensus of industry and government that improvements to existing national facilities will not meet the requirements. The need exists for new tunnels with substantial increases in Reynolds number at subsonic and transonic speeds".

The consensus performance requirements for the subsonic and transonic tunnels were as follows:

"The low-speed tunnel goal should be the ability to test at full-scale Reynolds number (approximately 30 million) for some existing airplanes, productivity of 2 to 2 1/2 times existing wind tunnels which would yield 5 polars per occupancy hour, and operating costs equal to or less than current wind tunnels or approximately \$1000 per polar."

"The transonic goals were determined to be a Reynolds number of 30 million, productivity of 8 polars per occupancy hour, operating cost of \$2000 per polar, with good flow quality and accessibility"

The AFTG defined the preferred tunnel configurations to fulfill these requirements as follows:

Tunnel	Low-Speed	Transonic
Test Section Size	20 x 24 Feet	11 x 15.5 Feet
Mach No. Range	0.05 To 0.6	0.05 To 1.5
Total Pressure	5 Atmospheres	5 Atmospheres
Reynolds No.	20 Million @ M=0.3	28.2 Million @M=1.0

The NFS intent was to develop a **world class national wind tunnel complex, second to none**, that would enhance the U.S. competitive position well into the twenty-first century. These requirements were considered to be inviolable without consensus agreement of the participating companies, NASA, and DoD. The task of CR&O was to validate and further develop these requirements by tracing them to their source and ascertaining the reasoning that resulted in their selection. This was done, for the most part, by consulting members of the Aerodynamics/Aeroacoustics Working Group, a group appointed by the AFTG, and members of the FSO, because

NWTC Final Report

these groups had been instrumental in the process that led to the initial selection of the requirements. The requirements were then expanded, quantified, and translated into detailed engineering requirements.

Care was taken to avoid presenting a design solution as a requirement, except when necessary to clarify a preferred design approach. Each of the expanded requirements was the result of determining the requirement of each of the participating companies/NASA/DoD, defining the envelope that fulfilled the composite of the requirements, evaluating the practicality of the requirement, and then summarizing it in terms meaningful engineering terms to tunnel designers. The performance requirements were released in progressive stages as they became more refined. The final two-tunnel document was "Customer Performance Requirements, Release 4.3" dated October 31, 1995 (Ref. 5-2). The final single multi-purpose tunnel performance requirements was Release 11.0 dated May 3, 1996 (Ref. 5-3). Release 11.0 requirements are consistent with Release 10.0, which was the basis for SDR. Release 11.0 documents corrections, clarifications and improved data format that evolved during detailed coordination with the PDTs. Release 11.0 also lists the threshold values discussed in section 5.5 of this report. Volume I of these reports contains the requirements while Volume II contains all relevant rationale, traceability information and CR&O view of issues at project closure. The Table of Contents for Volume I of these reports is the same and is as follows:

- 1.0 Performance Requirements
- 2.0 Acoustics Test Requirements
- 3.0 Productivity and Throughput Requirements
- 4.0 Test Requirements
- 5.0 Model Load Requirements
- 6.0 Flow Quality Requirements
- 7.0 Measurement Requirements

A summary of the requirements is included in Section 5.4 of this report; the entire report has been archived.

The Customer Operations Requirements were defined to enhance the utility of the NWTC to the customer. These requirements were centered around the question, "What would a customer expect from the first contact with NWTC when he is planning a test until he is back in his office with reduced data?" The Customer Operations Requirements documents were also progressive releases with the final two-tunnel document Release 2.0 dated September 27, 1995 (Ref. 5-4) and the final multi-purpose tunnel document Release 11.0 dated May 3, 1996. These documents detail functional requirements in the following twelve areas:

- 1. Engineering Area
- 2. Model Preparation and Support Area
- 3. Final Build Up and Checkout Area
- 4. Model Shop Support
- 5. Balance Calibration Support Services
- 6. Instrumentation Calibration Support
- 7. Airflow Calibration Facility
- 8. Customer Test Support and Analysis Area
- 9. Customer Model Change
- 10. Equipment Storage
- 11. Data and Information Storage
- 12. Customer Amenities

In addition to the Performance and Operations Requirements documents, CR&O published Sample Test Scenarios representative of commercial and military aircraft development test programs, and propulsion simulation wind tunnel test programs. These scenarios were used to determine the impact of variations in model installation designs, cart requirements, and model support requirements on tunnel productivity. The final document on this subject was "NWTC Sample Test Scenarios, Release 11.0" dated March 19, 1996 (Ref. 5-5).

All three series of documents were prepared by CR&O Team members, reviewed by the whole Team, and then reviewed by the company or government agency the Team member represented. The entries that deviated from the

AFTG requirements and changes requested by the Design/Build Team after the documents were published were accepted only with consensus of the companies and agencies represented.

5.3 Individual Company/DoD/NASA Desires/Considerations

The expansion of the NFS requirements to detailed engineering requirements highlighted specific test needs of different elements of the aerospace industry. A few of the more significant needs are presented here to indicate the diversity of the test conditions and arrangements required.

High performance military aircraft, such as fighters and attack aircraft, must be tested at extremely high angles of attack, up to 90 degrees, and at Mach numbers up to 1.5 to provide a link between transonic and supersonic wind tunnel data. Rotorcraft require an even greater angle range, angles of attack from -20 to +110 degrees with yaw angles of ± 20 degrees.

Airport noise restrictions are becoming more severe; therefore, the aerospace companies have an urgent need for acoustics and open jet test capability, with mature phased-array technology. Higher engine by-pass ratios increase the need to carefully evaluate wing-pylon-nacelle interference effects with power simulation. The interference effects of the sting support strut on large semi-span transport models can be significant. In order to account for this possibility, the requirement that the strut be removable was included.

Additional information on other specific test needs can be found in Volumes I & II, Release 11.0 of the Customer Performance Requirements document, and in the Customer Operations Requirements document Release 11.0.

5.4 Results

CR&O expanded and quantified the NFS requirements and published Customer Performance Requirements and Customer Operations Requirements documents for both the two tunnel and for the single multi-purpose tunnel. Complete copies are available in the archive file; therefore, only a summary of the tunnel requirements will be presented here.

The requirements for the two tunnels defined by the NFS AFTG were used as the base-line until mid 1995. At that time, a study of tunnel size, operating pressure, low-speed capability, and cost was conducted by the Project Office. A single tunnel with a 13 x 16 foot test section appeared to be the best compromise within the projected budget limit of \$1.2 B and offered model size compatibility with some existing transonic and low-speed tunnels. The 13 x 16 foot tunnel is, however, considered by the rotorcraft manufacturers to be too small to accommodate their models.

As can be seen in Table 5-1, the two tunnel configuration fulfilled the NFS requirements. The transonic capabilities of the single multi-purpose tunnel exceeded the NFS Reynolds number requirements; however, the low-speed capabilities are only 66% of the NWTC LSWT desired Reynolds number of 20.4 million at 5 atmospheres.

Figure 5-1 presents the operating envelopes for all three tunnel configurations. This figure again illustrates that at the same total pressure (5 atm) the 20 x 24 foot low-speed tunnel provides capabilities that far exceed the single tunnel capability and more closely matches the NFS target Reynolds numbers. The total pressure in either tunnel could be increased; however, 5 atmospheres is near the current design limit for model loads. The 7 atmosphere total pressure was included to obtain higher Reynolds number for fighter aircraft and for constant Reynolds number testing below the model load-limiting Mach number.

NWTC Final Report

ITEM	Requirements Release 4.3		Requirements Release 11.0
	Low Speed Wind Tunnel	Transonic Wind Tunnel	Multi-Purpose Wind Tunnel
Mach No. Range - Closed Jet (1.)	0.015 to 0.6 (1.)	0.05 to 1.5 (1.)	0.015 to 1.50 (1.)
Mach No. Range - Open Jet (1.)	(2.)	N/A	0.015 to 0.6
Total Pressure Range (1.)	0.4 atm(min.) to 5 atm(max.)	0.2 atm(min.) to 5 atm(max.)	0.2 atm(min.) to 7 atm(max.)(9.)
Test Section Shape (3.)	Rectangular/[Slotted/Solid, (4.)]	Rectangular/[Slotted/Solid, (4.)]	Rectangular/[Slotted/Solid, (4.)]
Test Region Size	20x24 feet, 480 sq. ft.	11x15.5 feet., 170.5 sq. ft.	13x16 feet, 208 sq. ft.
Half Model Test Region Length (3.)	Figure 2 (6.)	21 feet, (6.)	26 feet, (6.)
Full Model Test Region Length (3.)	31 feet	18 feet	21 feet
Maximum Temperature	130 degrees F (5.)	130 degrees F (5.)	130 degrees F (5.)
Test Gas	Air	Air	Air
Drive Power Design Point	M = 0.3, T = 100 deg. F, P _t = 5 atm Model Drag = [(7.)] lbs.	M = 1.0, T = 100 deg. F, P _t = 5 atm Model Drag = [(7.)] lbs	M = 1.0, T _t = 100 deg. F, P _t = 5 atm Model Drag = [(7.)] lbs.
Reynolds No., (Re /Ft)@ Design Point, (8.)	20.4 x 10 ⁶ , (9.31 x 10 ⁶ /Ft.)	28.1 x 10 ⁶ , (21.45 x 10 ⁶ /Ft.)	30.9 x 10 ⁶ , (21.45 x 10 ⁶ /Ft.)
<p>Note: (1.) Operating envelope shall provide continuous operation over the full total pressure, Mach number range up to the maximum drive power limits, (2.) Max. achievable with closed-jet Design Point horsepower; but no lower than M = 0.35. Design shall not preclude addition of a test section insert necessary to achieve Mach no. 0.6 (3.) See Release 4.3 and 11.0 Volume II, Appendix B. (4.) Solid wall capability (sealed slots that do not affect the data significantly) is required for the test sections. (5.) Temperature controllability between maximum cooling capacity and 130 °F. (6.) The test section shall be reconfigurable to allow testing without the sting support system installed. (7.) Use model drag from Section 5.0, Model Loads Requirements, Release 4.3 or 11.0, Volume I. (as appropriate) (8.) Reynolds number reference length(cbar) = 0.1 $\sqrt{\text{height} * \text{width}(\text{test section})}$. cbar: LSWT = 2.19 ft.; TSWT = 1.31 ft.; Multi-Purpose = 1.44 ft. (9.) Tunnel will not be required to operate at test section dynamic pressures higher than that at the drive power design point.</p>			

Table 5-1: Performance Requirements

The estimated utilization of the NWTC was based on historic introductions and projections for commercial aircraft, and projected military aircraft derivatives and new programs. Projections for engine company and NASA use were based on historical information. Every effort was made to make the estimates as realistic as possible and, if there was any doubt, to lean toward conservatism (lower estimated test hours).

There was no significant change in the projected demand from the two tunnel complex to the single multi-purpose tunnel. These estimates indicated that the demand for either speed range was approximately equal at 1-1/2 shifts per day for a five-day week. There were some peak periods where the demand required that the single tunnel operate 3 shifts a day, five to six days a week. There was concern that the single tunnel would be scheduled near maximum throughput and peak period demands would exceed the capacity. Plots of the projected utilization are included here as Figure 5-2. Note: The "total unadjusted" curve represents the total user demand without the projected NWTC productivity/throughput improvements. The detailed write-up and back-up data are available in the NWTC data archive.

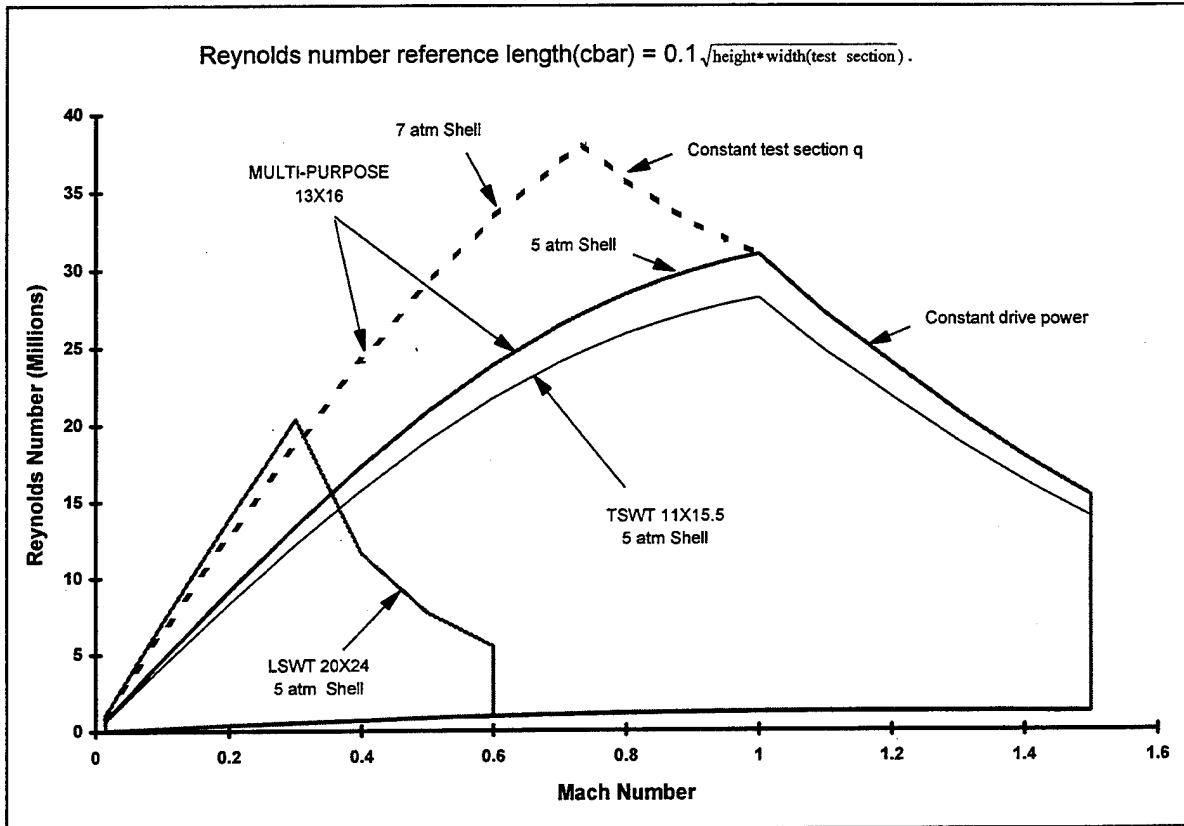

Figure 5-1: Operating Envelopes

5.5 Concerns/Open Issues

If the NWTC project had been completed, the MPWT would have been the “best in the world”. The conceptual design presented at the SDR had the combination of high productivity, high Reynolds number, and excellent flow quality envisioned by the National Facilities Study team and would have been an invaluable asset to the US aerospace industry.

The CR&O team, representing the customers, initially developed the detailed engineering requirements. Some of these requirements were considered by the Design/Build Team as far beyond the current state-of-the-art and hence not achievable. Therefore “threshold values”, considered aggressively achievable, were accepted by CR&O and Design/Build as the project design requirements. Requirements beyond these “threshold values” were recorded as “design goals.”

The flow qualities (see Table 7-1) illustrate this process. It should be noted that the flow quality levels defined as the threshold values were better than currently available anywhere and may truly represent the limit of what is physically attainable. The CR&O and Design/Build agreed that the project would continue to pursue design process improvements and/or research programs that would improve the possibility of moving from the “threshold values” to the “design goals”. Whatever the resolution, the process improvements and research programs needed to be brought to fruition within the NWTC schedule.

There are a number of open issues and concerns that the CR&O Team feels should be noted. In response to a Project management request to develop a list of candidate capabilities for cost reduction consideration, the CR&O Team conducted a detailed prioritization process of all NWTC requirements (see CR96--014 “CR&O Prioritization

NWTC Final Report

of Customer Requirements” in the NWTC Archive). The open jet cart was on this list because of its high cost and limited use; however, the aerospace companies need this capability to evaluate engine and airframe design configurations to determine compliance with the latest airport noise restrictions.

Other CR&O issues and concerns at SDR were:

- Flow quality including test section inflow noise, cross-stream velocity uniformity, temperature distribution, and flow stability, while significantly better than existing tunnels, were less than the desired design goals.
- Internal balances, compatible with model geometry, capable of providing a large load range with high accuracy, required a significant advance in technology.
- Angle of attack to 40 degrees for sting mounted low speed transport models could only be achieved by means of sting changes.
- Tunnel main drive power would limit the Reynolds number for large fighter models at high angles of attack at high subsonic speeds.

Many of these concerns would have been resolved naturally as the design matured. As each improvement or research program was completed, the requirements would have been reconsidered and revised as appropriate.

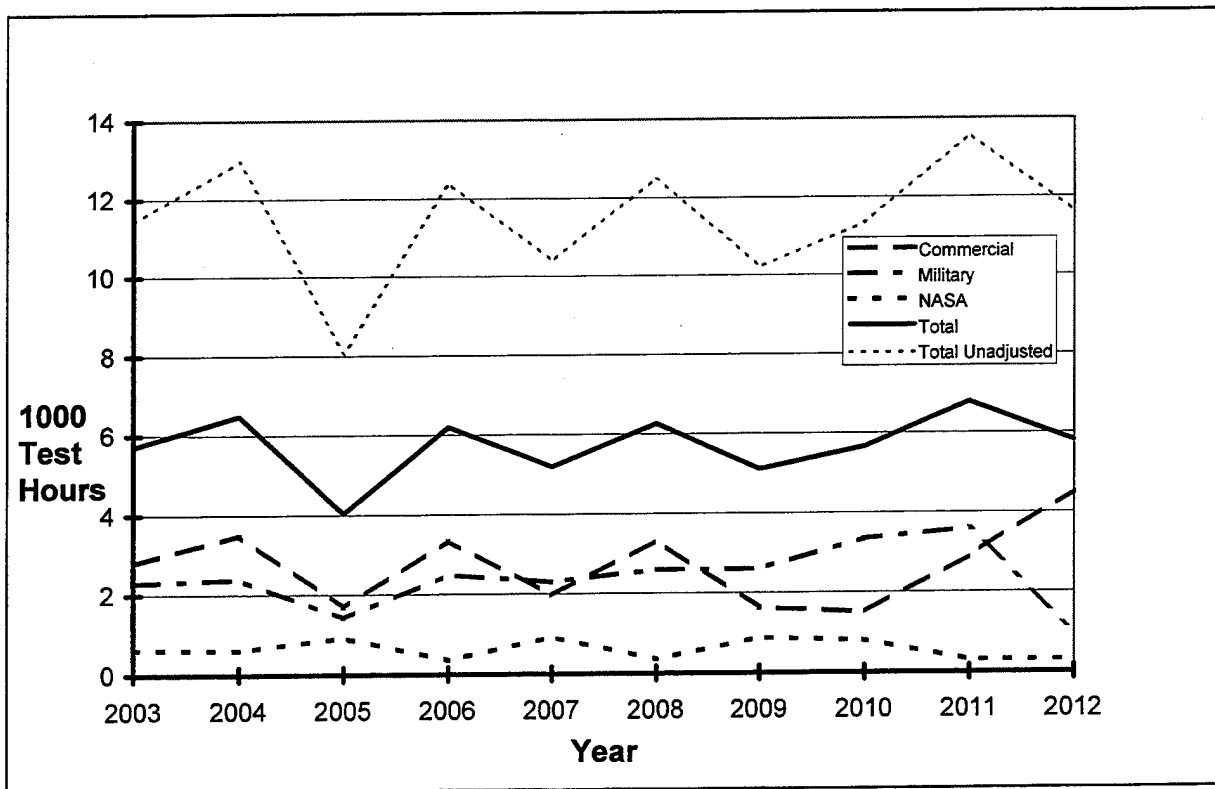

Figure 5-2: NWTC Single Tunnel User Demand

6. Site Evaluation

6.1 Background

The NWTC Program Plan (Ref. 6-1) directed that the site evaluation and selection process was to be conducted in a "fair and open" competition aimed at identifying the location within the U.S. that offered the most favorable combination of technical, economic and environmental strengths for development and operation of the NWTC. Candidate sites were to be solicited utilizing a "Request for Proposal (RFP)" process to the States with the Governors' offices being the point of contact. The Industry Team was tasked to form a Site Evaluation Committee (SEC) made up of representatives from each of the Industry partners for development and implementation of a site evaluation process. At the completion of their evaluation, the SEC was to deliver a final report to the Government which would identify:

- Those sites that met all minimum (threshold) requirements.
- Those "highly rated sites" that were chosen to receive site visits including the findings as a result of the visit.
- Those sites that were determined to be the "most competitive sites" acceptable to Industry in rank order including the technical and economic rationale for that conclusion.

Following the completion of the SEC process, the Government would prepare an Environmental Impact Statement (EIS) in compliance with the National Environmental Policy Act to provide further support for the final site selection decision.

6.2 Site Evaluation Committee (SEC) Charter

The charter of the Site Evaluation Committee (SEC) was established in response to Congressional legislation which directed the development of a competitive "site selection plan...based on best price and technical merit, including local cost sharing." Specifically the charter of the SEC was:

To develop and implement a site evaluation process which would identify and rank order the most competitive sites with the capability of achieving and maintaining state-of-the-art test facilities that enable the U.S. to maintain pre-eminence in the aerospace industry.

6.3 Process Development

Once formed in March 1994, the SEC selected Lockwood Greene as their siting consultant and primary strategy advisor. In an effort to identify the optimal process for the NWTC, the SEC reviewed Government and Industry activities which involved recent site competitions. Given the constrain of a "fair and open" competition, the SEC was considered a sensitive process and access to information was restricted to SEC members and support staff only.

Solicitation and Evaluation Process

Primary features of the NWTC site solicitation and evaluation process include, but are not limited to:

- Participation open to each of the fifty States
- No limit on the number of proposals from any State.
- Communications through the Governors' or his/her single point designee.
- An invitation to participate and a solicitation notice would be issued to each State.
- A solicitation conference would be conducted to assure adequate communication of the process.
- A Request for Proposal (RFP) would be issued to each State Governors' Office.
- A pre-proposal conference would be held to answer questions or clarify content of the RFP
- Proposals would be received, cataloged, numbered and secured for access by the evaluating team only.

NWTC Final Report

- Proposals would be evaluated for conformance with threshold requirements and overall completeness (Initial Review).
- Proposals satisfying the initial review would be further assessed (Detailed Review) to judge on a comparative basis how well the proposals meet more detailed evaluation criteria.
- As a result of the detailed review, a list of "highly rated sites" would be generated.
- The SEC would arrange and conduct site visits to the "highly rated sites".
- A final evaluation after the site visits would identify and rank order the "most competitive sites" acceptable to industry.
- The SEC would develop and issue a final report to the Government.

A graphical depiction of this process is included as Figure 6-1.

Site Evaluation Schedule

The SEC process was expected to require approximately 8-1/2 months to complete. The site selection was required to be completed prior to initiation of the final design. The environmental impact statement for the selected site was planned to be completed before start of construction.

6.4 Epilogue

Due to program uncertainties and political sensitivities, the site evaluation process was never authorized for implementation. However, the solicitation documents have been completed, delivered to NASA, and archived by the Government for possible future use.

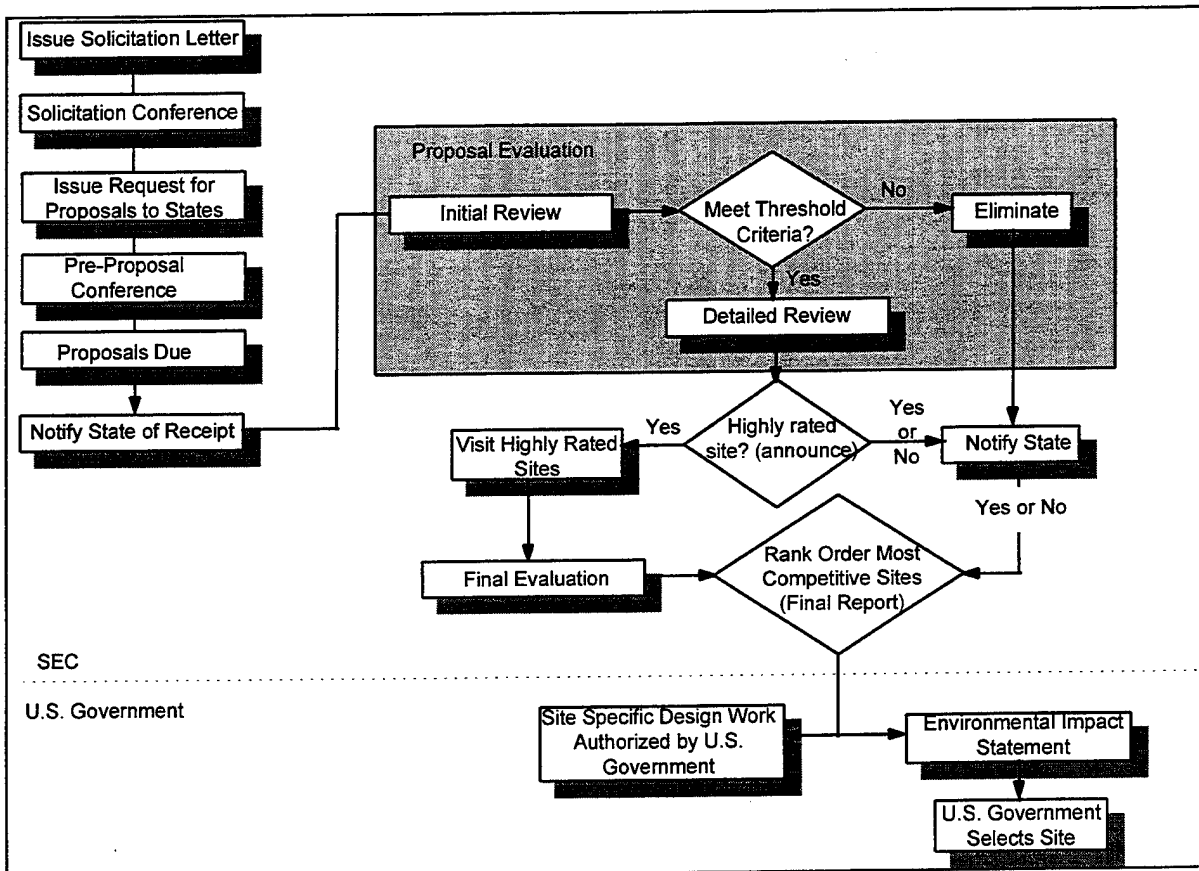

Figure 6-1: Site Evaluation Process

7. Wind Tunnel System Definition

7.1 Management Plan

The NWTC Management Organization, Team Chartering and Design Process addresses the relationships and interactions between the Systems Engineering and Integration (SE&I) team and the Product Development Teams (PDTs). The SE&I team has primary overall design process responsibility. The high degree of authority and responsibility assigned to the PDTs reflects the team-based operations that are a key aspect of the NWTC Project Office (Ref 7-1).

7.1.1 SE&I Charter

The top level SE&I roles and responsibilities are shown in Figure 7-1. The Systems Engineering and Integration team is the “system architect” of the NWTC System. The SE&I team represents the Design/Build Manager and participates with the PDTs to ensure the detailed design satisfies the system-level requirements. SE&I responsibility includes system-level integration and interface issue resolution, as well as serving as the focal point for implementation of the key design processes discussed in section 7.1.2. (Ref 7-2)

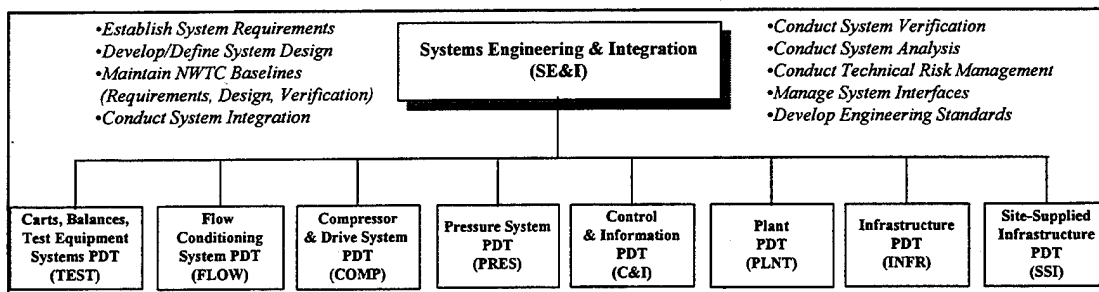

Figure 7-1: SE&I Responsibilities

The NWTC Product Development Teams are the “designers and builders” of the NWTC System. The PDTs are responsible for meeting the established requirements with a detailed design and providing verified equipment for final integration into the NWTC System. The roles of the PDTs are shown in Figure 7-2. The PDTs continue the design synthesis and system analysis process to produce the allocated segment baseline and produce segment baselines.

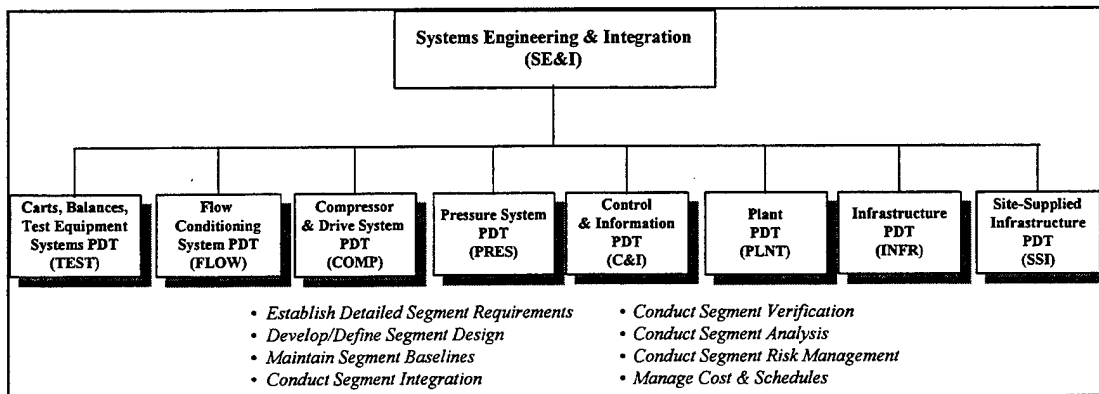

Figure 7-2: PDT Responsibilities

7.1.2 Configuration Management

The configuration management (CM) function for the NWTC was established to maintain positive control of the identified project configuration baseline and all changes to baseline documentation. (Ref 7-3) Figure 7-3 illustrates the progressive nature of this process and how the detail becomes refined as the design evolves. The NWTC configuration management function is implemented with several baseline control levels that provide for the review and disposition of evolving requirements and design solutions. The level of control imposed is dependent on the nature and breadth of the proposed change, and the impact it has on the project and PDT requirements and documentation. These levels of control use decision management boards consisting of the Configuration Control Board, for those proposed changes that impact contractual or project (system) level requirements, and the Design Decision Board (DDB) for those decisions that do not require CCB control, but impact more than one PDT. Design decisions that impact only a single PDT are made within the affected PDT.

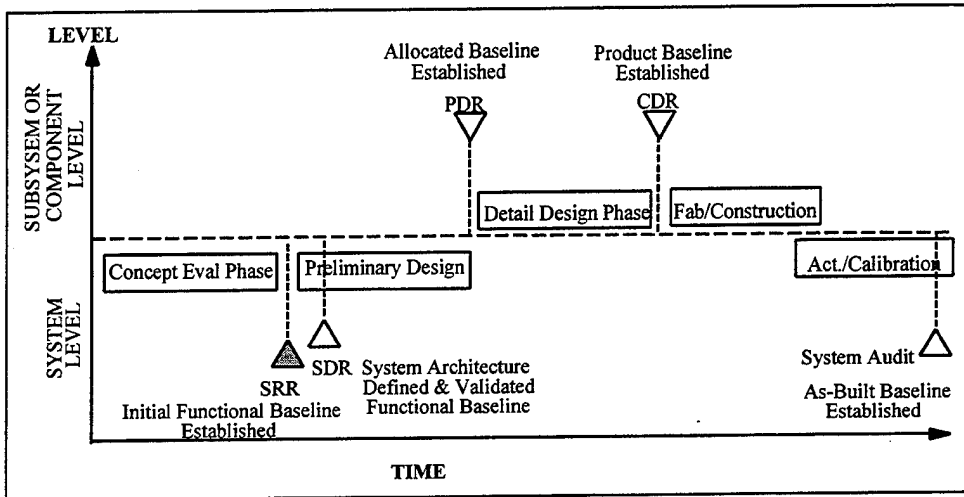

Figure 7-3: Progressive Configuration Baseline

NWTC functional and physical interfaces are outlined in the Project Specification and detailed in Interface Control Documents. All System level interfaces that will be controlled are documented in the Baseline Interface Index. The Project Specification establishes the major boundaries and top-level interfaces that are housed in the Baseline Interface Index. ICDs document the design constraints of the interfaces. Similarly, management of the interfaces is outlined in the Technical Management Plan, and the specific interface control procedures are described in the Configuration Management Plan.

The concept for managing NWTC interfaces was to establish an Interface Control Working Group. (ICWG) The ICWG was established as the formal communication link accomplishing, planning, coordinating, tracking, negotiating and controlling interface activities among the NWTC Project Office and the PDTs. The ICWG was to control the inter-segment interfaces, while the PDTs controlled their own intra-segment interfaces. [Configuration Management Plan]

7.2 Project Specification

The Project Specification describes the National Wind Tunnel Complex (NWTC) by establishing its performance, design, qualification, and delivery preparation requirements. This document is intended to establish the performance and constraint requirements of the NWTC at a functional level and translates customer-defined requirements into engineering specifications by establishing top-level requirements for the subordinate elements of the System (e.g., hardware and software subsystems) that are a result of the chosen NWTC System architecture. The Project Specification is the foundation document used to define the Functional Baseline for initiation of preliminary design by the PDTs (Ref 7-4). This document was based on Release 10.0 of the Requirements from Customer Requirements and Operations Team (Ref 7-5).

The Functional Analysis (FA) approach used on the NWTC program captures functional sequencing, data, material and resource flows, control flows, and most of the important information necessary to describe System behavior in a graphical format known as Behavior Diagrams (BDs). An explanation of the FA Behavior Diagrams process and notations is covered in Appendix D of the Project Specification, Reading NWTC Behavior Diagrams. The Functional Analysis Report contains all of these functional relationships (Ref 7-6). Designers were provided with the basic requirements necessary to accomplish the task of Building the NWTC. The Performance criteria were generated with the CR&O, and were inserted into their appropriate specification section. The Functional Analysis functions were then defined for each System segment and the associated reference behavior diagrams, which present the detailed functions, flows and their decomposition.

The NWTC had established Functional Interfaces, both with the external environment and between its major elements. The top-level functional and physical interface requirements were established in this specification and detailed in Interface Control Documents (ICDs). The system level interfaces are contained in the Baseline Interface Index (Ref 7-7). The Segment Characteristics of the seven segments comprising the NWTC System, as well as the Site Contributions (SC) are contained in terms of their physical characteristics/interfaces and a concept overview of each segment. The purpose was to initiate the translation of the functional requirements into a physical design and architecture, and to provide requirements traceability for the Interface Control Documents. The characteristics concentrated on the physical, electronic, environmental, and similar interfaces as well as their Work Breakdown Structure (WBS) elements assigned to the development and/or product specifications defining the component.

7.3 Major Decisions

The development of the performance and functional requirements for the NWTC highlighted numerous concept level decisions that had to be made. These were required to simultaneously define aggressively achievable performance levels and physical descriptions of the hardware necessary to achieve those levels. The following sections outline those decisions.

7.3.1 Flow Quality

During late 1995, a significant amount of analysis was conducted concerning the flow quality requirements for the single tunnel NWTC. These requirements, set forth in CR&O 10.0, were established by examining the types and quality of testing they desired in the facility. Turbulence requirements were established through an analysis of criteria required to accomplish natural laminar flow testing. These criteria generated requirements for noise, as did considerations of acoustic measurements in the closed or open jet. Some flow uniformity requirements were set by establishing acceptable data correction levels as seen in Table 7-1 below.

The System Design Team indicated that many of the requirements were unachievable, either physically or under the project constraints. A benchmarking exercise to define the state-of-the-art clearly indicated that many of the requirements were significantly more stringent than any comparable facility.

It was agreed in a series of meetings between CR&O and the System Design Team to cast the requirements as a set of threshold values and goal values as shown in Figure 7-4. The threshold values would be considered as minimum acceptable flow quality requirements. If the original CR&O requirement was considered achievable by System Design, the threshold and goal values were the same. If a particular value was considered unachievable, a threshold value was established, and the CR&O requirement was recorded as a goal. It should be noted that all of the threshold values handled in this manner were beyond the current state-of-the-art. This approach was adopted by the Project and the values were included in this format in the Project Specification.

As a condition of this approach, it was agreed to develop improved processes designed to increase the possibility of pushing the performance past the threshold values, and approach the goal values. These plans would also serve to abate the inherent risk in the threshold values, as well. These plans are discussed in Section, 8.5, Flow Quality Processes.

FLOW QUALITY PARAMETER	REQUIREMENTS		STATE-OF-THE-ART	
	DESIGN GOALS	THRESHOLD VALUES	VALUE	LOCATION
Test Volume Area Ratio Length Ratio	~65% ~1.62	~65% ~1.6	~25% <1.0	AEDC 16T/DNW 16T/8 Ft TPT/MSWT/ETW
Total Temperature Reference Value Distribution	±1°F ±1°F	1°F (2σ) 1°F (2σ)	1.6°F (2σ) 2°F (2σ)	DNW
Turbulence; Axial Component u'/U (%)	0.05	0.05	0.05 up to M=0.4 / 0.06 up to M=0.6 / ~0.2%	8ft TPT / Ames 12 Ft / AEDC 16T
Turbulence; Cross Components v'/U, w'/U(%)	0.05	0.1	0.1 / 0.3 / 0.2 (twice axial) Cross comp's lower than axial	DNW/DRA/ARA 9x8 Ft, Tohoku (Japan)
Static Pressure Fluctuations, ΔCp _(rms) Closed Jet Test Section	0.3	0.3 @ M=0.3; 0.6 @ M=0.8	0.75 / 1.1 / ~1.1 2.4% / 1.75%	NLR HST / ETW / MSWT 16T/Ames 11 Ft
Background Noise; Open Jet Test Section 1/3 Oct. Band SPL, dB	85dB @ 100Hz, 72 dB @ 1kHz, 55dB @ 10kHz @ M=0.3	85dB @ 100Hz, 72 dB @ 1kHz, 55dB @ 10kHz @ M=0.3	72 dB @ 1kHz, 62 dB @ 10 kHz (scaled to M=0.3)	DNW (Open Jet) No data available @ 100 Hz
Stream Angle	<±0.1° @ M=0.3, Pt=5atm	0.13 [2σ] @ M = 0.3	≥0.1° / ± 0.12° upwash; ± 0.06 sidewash	ARA 9x8 Ft AEDC 16T
Stream Angle Gradient	0.016 to 0.23°/ft for half and full models (resp.)	0.015 deg/ft, ± 6 ft from external balance center	0.01°/ft	AEDC 16T
Mach Number Reference Value	0.0004 @ M=0.3; 0.0005 @ M=0.8; 0.0008 @ M=1.5	0.001 @ M=0.3 to 0.8; 0.0025 @ M=1.5	0.003 @ M=0.3; 0.002 @ M=0.8; 0.005 @ M=1.5	
Mach Number - Variance	±0.0003 @ M=0.3; ±0.002 @ M=0.8; ±0.004 @ M=1.5	0.001 @ M=0.3; 0.002 @ M=0.8; 0.006 @ M=1.5 (2σ)	0.001 to 0.003 @ M<1 (2σ); 0.005 to 0.008 @ M>1 (2σ)	ETW / 16T / NLR HST / S3MA
Mach Number Gradient [per ft] Half Span Models Full Span Models	±5x10 ⁻⁹ /ft @ M=0.3; ±2x10 ⁻⁶ /ft @ M=0.8 ±1x10 ⁻⁷ /ft @ M=0.3; ±3x10 ⁻⁵ /ft @ M=0.8	±0.0001/ft for half and full span models	±0.005/ft for half and full span models	16T
Tunnel Stability (10 sec period) Pt Pst	±3 psf over 10sec @ M=0.3, Pt=5atm ±5.5 psf over 10sec @ M=0.8, Pt=5atm	±3psf @ M=0.3; ±5.5psf @ M=0.8	3 psf @ M=0.8, Pt=2.5 atm (2σ)	
Tt Mach No,	±0.5°F over 10 sec. ≤0.0005	± 0.5°F	1°F or greater (2σ) 0.0005 @ low Re to 0.001 @ high Re (M=0.78)	ETW

Table 7-1: Flow Quality

NWTC Final Report

7.3.2 Design Decisions

A number of major design decisions were reviewed and approved by the Design Board. The following table is a summary of those decisions. Shown in the table are the Design Decision Notice (DDN) number, the DDN title and PDT that performed the trades, and a description of the decision. DDN # 1-10 were performed during the two tunnel phase of the program. The outcome of these decisions were maintained unless changed by a subsequent DDN (e.g. single tunnel airline DDN #13 was a change to DDN #3). Further details of the decisions can be found in the archive index section on Configuration and Change Management which contains the DDNs, logs, and minutes.

Three design decisions were considered as being owned specifically by SE&I, setting the configuration for the open jet, the definition of the basic tunnel airlines, and the definition of 7 ATM capability.

Involved in the decision regarding the open jet, DDNs 11 and 18 (Ref 7-8, 7-9) were questions of space, power, and the associated noise levels. This decision demonstrated an open jet layout could be accommodated that supplied all of the measurement distances and directivity angles required and estimated that the compressor, sized for other operations, could supply sufficient pressure ratio for the open jet. The circuit was predicted to have noise levels higher than those required. Acoustically treated turning vanes for corner 1 were adopted, which brought the noise levels closer to the requirement with minimal cost impact. This decision also underscored the necessity to examine the design of acoustic turning vanes in a transonic tunnel environment.

DDN #	Title/Responsibility	Description
1	Plenums/Carting Test PDT Boarded 7/11/95	Five configuration options for plenum/carting options were traded: 1) fixed cart and plenum, 2) rotatable cart/fixed plenum, 3) extractable cart/fixed plenum, 4) extractable cart and plenum, 5) dual test legs. Option 3 included three sub-options for spherical plenum, cylindrical plenum/clam shell door, and cylindrical plenum/elliptical head door. Comparisons and evaluations of adaptability, productivity, operating cost, risk and capital cost for each option were presented. The decision was made to use an extractable carting system and fixed cylindrical plenum with clam shell based on the data, including satisfactory adaptability ratings, and capital cost savings.
2	Site Layout Plant PDT Boarded 8/22/95	Four layout configurations were under consideration (H, I(1), I(2), and I(2a)). Recommendation was made to accept I(2a), which includes separated (rather than adjacent) compressor drives for the tunnels, and reserves areas for future expansion to accommodate a third wind tunnel.
3	TSWT/LSWT Airlines SE&I Boarded 7/18/95	Original two tunnel airline decision. Updated by DDN #13 for the single tunnel. Discussion for TSWT focused on slotted wall configuration, circuit airlines and performance; for LSWT on circuit airlines, performance and test section length. Conclusion reached was to adopt the Concept Evaluation (CES) Airlines as defined in the CES Airlines report dated June 1995.
6	Cyclic Fatigue Pressure PDT Boarded 7/11/95	Decision on requirements and factors impacting the cyclic fatigue design criteria, including internal and external pressure requirements, service life, cyclic pressure rates, stress concentration factors and occupancy hours per year. Recommendation to set cyclic life span to be used for NWTC design criteria at 40,000 cycles for the tunnel ducting, and 160,000 cycles for the plenum
7	Pressure Testing Pressure PDT Boarded 1/15/96	Rationale for pneumatically proof testing the NWTC pressure shell with some additional measures beyond ASME code requirements.

NWTC Final Report

DDN #	Title/Responsibility	Description
8	Plant Configuration/ Capacity Plant PDT Boarded 7/19/95	Review of air plant functions and requirements and the concept addressed in the risk reduction study. Options were addressed that included a configuration using compressors only, and using a combination of compressors and storage capability. The combination of compressors and storage tanks was recommended to obtain the required flow rates. Recommended compressor capacity of 240 lbm/sec, and storage capacity of 700,000 cubic ft, nominal 300 psig system.
9	Isolation Valves Pressure PDT Boarded 7/19/95	Addresses the risk reduction study air plant criteria and capabilities, and evaluated the hardware and structural implications of isolation valves. The evaluation revealed that the removal of isolation would increase capital cost by approximately \$6M. Operating costs were also significantly higher for a "no-valve" configuration, and flexibility/versatility and productivity was reduced. Recommendation was to retain the isolation valve.
10	Slotted Wall Configuration Test PDT Boarded 8/22/95	Slotted wall configuration design requirements that revised the requirements defined in the DDN 3 CES Airlines report. For TSWT, the revised requirements increase the number of floor/ceiling slots from 10 to 14, with a constant 1.5" slot width, reduce control segment length from 48 to 30 inches, and added acoustic fillers. For LSWT, the revised requirements increase the number of floor/ceiling slots from 11 to 12, decreased the number of sidewall slots from 9 to 8, with a constant 3" slot width, added a control segment length of 46 to 48 inches, and added acoustic fillers and slot covers.
11	Open Jet Test PDT Boarded 12/15/9	Provide Open Jet capability in Single Tunnel within Closed Jet cart length and plenum diameter and Closed Jet compressor capability.
12	Air Plant Definitions Plant PDT Boarded 1/30/96	Specific Pressure, Pumping Capacity and Storage Volume requirements were proposed for the Tunnel Pressurization, Vacuum and Propulsion Model Air. It was agreed that the PES would not be used to pump up the system
13	Single Tunnel Airlines SE&I Boarded 12/19/9	Reflects airlines appropriate to a 13-foot by 16-foot test section. Other parameters include the current compressor map baseline, 360K continuous and 414K intermittent Main Drive horsepower, and 3% Plenum Evacuation System at Mach 1.0. The principal change is an increase in plenum shell diameter to 76 feet, as showing preliminary drawing number NWTCS100, dated 12-5-95. This configuration is based on retaining a "reasonable"-sized tunnel, and compressor efficiency above 75% in the Mach 0.8 range.
14	Seven Atmosphere Definition SE&I Boarded 1/15/96	Defines 7 atmosphere capability to be: 1.) Isolation valves for 5 Atm operation only; 2.) Design "Internals" for operation to 7 Atm within required performance envelope; 3.) PES ducts and valves designed for 7 Atm pressure. PES airflow and horsepower remain sized for 5 Atm and supersonic requirements.; 4.) 25% of the full pressure cycles will be to 7 atmospheres.
15	Site Considerations Site PDT Boarded 1/30/96	Provided a drawing of the proposed Site Layout and provided data regarding what was expected to be provided by an existing site and what was expected to be provided by the NWTC.

NWTC Final Report

DDN #	Title/Responsibility	Description
16	Rear Strut Model Support & Test Carts Test PDT Boarded 1/29/96	Rationale for various test cart options. The carts were determined to be separable into two sections - a test section cart and a model support section cart. There will be two high AOA and external balance test section carts and three support section carts: two vertical strut support section carts and one dummy support section cart. A further recommendation was made to provide wings level yaw with a reduced load set using a turntable mounted in the model attached to an upswept sting. The configuration does not meet the CR&O 50 ^o Dynamic range requirements for transports and 100 ^o Dynamic range requirements for fighters..
17	Plenum Design Pressure PDT Boarded 1/29/96	The decision to use a fixed plenum versus a movable plenum was re-examined relative to a single tunnel facility (see DDN #1). The conclusion was made that the single tunnel requirements do not alter the basis for selecting the fixed plenum configuration with extractable carts.
18	Open Jet Noise Test PDT Boarded 1/29/96	Four configuration options for noise abatement were traded. The option chosen added treatment to corner #1 with the number of turning vanes reduce from 14 to 7 atm and chord increased from 6 ft. to 12 ft.
19	Tunnel Anchor Point Pressure PDT Boarded 2/16/96	Six anchor points were studied and traded. Recommendation was accepted to locate a single anchor point upstream of the Heat Exchanger directly across from the test section. Each end of the Compressor would be supported and allow for axial movements (guided support).

Three design decisions were considered as being owned specifically by SE&I, setting the configuration for the open jet, the definition of the basic tunnel airlines, and the definition of 7 ATM capability.

Involved in the decision regarding the open jet, DDNs 11 and 18 (Ref 7-8, 7-9) were questions of space, power, and the associated noise levels. This decision demonstrated an open jet layout could be accommodated that supplied all of the measurement distances and directivity angles required and estimated that the compressor, sized for other operations, could supply sufficient pressure ratio for the open jet. The circuit was predicted to have noise levels higher than those required. Acoustically treated turning vanes for corner 1 were adopted, which brought the noise levels closer to the requirement with minimal cost impact. This decision also underscored the necessity to examine the design of acoustic turning vanes in a transonic tunnel environment.

Airlines and the associated sizing were adopted in DDN 13 (Ref 7-10). Two main issues were discussed: The prediction and values for the required tunnel power, and the required tunnel pressure ratio. The SE&I recommended a baseline configuration including 360K continuous, 414K overload main drive hp, with a 3% PES at Mach 1.0. This baseline was adopted. The CR&O requirements for the fighter cases requires significantly higher power and pressure ratio than any of the transport cases, and according to the SE&I calculations, the baseline compromises the fighter requirements. This would cause ~ 33% decrease in maximum Reynolds number for some of those cases. Additionally, the initial compressor design showed the high pressure ratio, Mach 1.5 fighter cases seemed to have an uncomfortably small stall margin. A major area of uncertainty was identified in these predictions, regarding the added power required on account of the influence of a large model wake on the performance of the test section, reentry region and high speed diffuser. Further analysis closed the degree of uncertainty in this area. It was expected that data from the High Speed Leg Experiment (Ref 7-11) would have

helped clarify the situation. A study was later completed to look at alternatives to the selected baseline (Ref 7-12). This would have been used in discussions subsequent to SDR.

DDN 14 (Ref 7-13) defined the definition of 7 ATM capability. The conceptual cost estimate includes a 7 ATM capability, but had no further definition of what that capability encompassed. The baseline configuration was established the performance envelope as having a constant power line between 5 ATM total pressure at $M=1.0$ and 7 ATM at $M<1.0$. The tunnel "internals" were to be designed for operation within this performance envelope. The isolation valves were designed for 5 ATM operation only. Additionally, the PES ducts, valves and compressor cases designed for 7 atm, while the PES airflow and horsepower sized for 5 ATM and supersonic requirements.

7.4 Performance Allocations to Segments

At the closure of the project, specifications consisted of two levels: The Project Specification, which contained the performance levels for the overall system as developed with the CR&O team, and the draft Segment Specifications, (Ref 7-14) which correspond to the project development team (PDT's) packages. The performance requirements for the wind tunnel segments are contained in the appropriate sections of those Segment Specifications.

Segment performance levels were derived by the System Design Team, and the greater SE&I team. A wind tunnel system was defined based on early design and analysis using theoretical and empirical tools, supported by existing data bases and specialized consultants. A first cut at the appropriate specifications for the tunnel components was derived from this analysis and allocated to the segment level. The allocations were iterated with the project development teams and would have been verified and/or upgraded during the preliminary design phase of the project, based on more detailed analysis and a risk mitigation program.

Prior to SDR, design analysis at the Systems level and at the PDT level was proceeding in parallel. A matrix of required performance parameters required by the PDTs to proceed into preliminary design was developed and designated the "TBD Matrix" (Ref 7-15). The list was to have served merely as a tracking tool while the parameters were determined. Once derived, the data would have been allocated to the appropriate Segment Specifications or Interface Control Documents. Given that the project was notified prior to SDR to shut down, this matrix represents the most complete list of component performance allocations at the stop work point.

Subsequent to SDR, the System Design team would have maintained the responsibility for System level performance. As such, they would have maintained the balance between the requirements at the Segment level. That team would have carried approval authority for any changes to the requirements to the Segment Specifications. Systems Engineering would have maintained the traceability of the requirements through the specifications.

7.5 Risk Issues and Safety/Hazard Analyses

Two studies were performed to assess the system level risks and the hazards associated with NWTC. Both studies were conducted utilizing the hazard inventory technique of MIL-STD-882C (Ref 7-16) and produced subjective lists of risks and hazards. The risk assessment emphasized the performance, cost, and schedule issues, and were ranked from Zone 1 to Zone 3 following the MIL-STD techniques. Risks identified at the PDT and SE&I levels were rolled up into risks impacting the program level. The safety/hazard analysis focused on hazards associated with personnel, equipment, downtime, and data integrity. The two studies, while emphasizing different aspects of the overall risk assessment, were complementary. System safety issues identified in the risk assessments contributed directly to the safety and hazard analyses.

From the risk identification process, 7 Zone 1 risks and 28 Zone 2 risks were identified in total. There were two (2) Zone 1 risks and eleven (11) Zone 2 risks which were categorized as SE&I risks. (Risks identified specifically with the segments are discussed in Section 9.) Of the SE&I risks, two of the Zone 2 risks impact the project at the senior management level and were not classified as technical risks. The risks identified here are summarized in Table 7-2:

It is a policy requirement that the Zone 1 risks be mitigated, while Zone 2 risks require written time-limited waivers, which must be endorsed by management.

The mitigation plans for the technical risks were identified. All of these plans involved some aspect of the Experiments and Computational Studies, which either have been initiated by the Studies Approval Board (SAB), or were planned for presentation for approval to the SAB. Information concerning these items is contained in Sections 8.4 and 8.5. The roles of these Experiments and Studies in mitigating the system level technical risks are summarized in Table 7-3.

The two Zone 1 risks consist of: (1) the Open Jet Static Pressure Stability and Unsteadiness and (2) the Tunnel Internal Noise. The Open Jet risk is summarized in [Risk Management Plan]. The hierarchy of risks associated with the Open Jet are : (1) the configuration may lead to excessive jet instability and large pressure fluctuations, (2)

<u>RISK</u>	<u>ZONE</u>	<u>TYPE</u>
• Open Jet Capability	1	Technical
• Tunnel Internal Noise	1	Technical
• Back Leg Flow Uniformity and Unsteadiness	2	Technical
• High Speed Leg Flow Uniformity and Unsteadiness	2	Technical
• Slotted Wall design Impact on Acoustics and Flow Uniformity	2	Technical
• Acoustic Treatment	2	Technical
• Sub-scale Experiment Validation (CFD)	2	Technical
• Laminar Flow Test Capability	2	Technical
• Contraction Design Effect on Flow Quality	2	Technical
• Turbulence Reduction System	2	Technical
• Flexible Nozzle Performance	2	Technical
• Lack of Site-specific Constraints for Preliminary Design	2	Programmatic
• Inability to Design to Costs	2	Programmatic

Table 7-2: Risk Identification

the compressor power and pressure ratio required to operate the open jet may be excessive, and (3) the open jet background noise may not meet the CR&O requirements for overall noise level or spectral content. Because the current state-of-the-art is such that the design can only be accomplished empirically, the primary risk mitigation technique involves a number of experimental studies in axisymmetric configurations to investigate jet collector geometry, tests in sub-scale and associated full-scale open jet facilities to establish scaling relationships, tests in a sub-scale rectangular open jet configuration to validate stable operation and to determine pressure drop across the open jet, and tests in a complete circuit configuration to investigate jet instability coupling with complete tunnel resonance. These studies will mitigate the Zone 1 risk and reduce the risks to Zone 2.

The Tunnel Internal Noise risk is also summarized in the Risk Management Plan (Ref 7-17). The primary risk is that the noise generated by the wind tunnel internal components will exceed the CR&O requirements for the test section region. The various noise sources consist of flow separation on surfaces in adverse pressure gradient regions, wakes from internal components, noise generated from bumps and gaps, and compressor noise propagated through the tunnel circuit. The mitigation consists of employing scale experimental studies to isolate and characterize the noise sources, and during validation tests, measure noise spectra, identifying noise sources and applying appropriate acoustic treatment.

Concurrent with the technical risk analyses discussed above, a preliminary hazard analysis (Ref 7-18) was conducted. Checklists, operational "walkthrough" simulations, intuitive engineering skills, and reliance on past experience with similar systems were employed. The goals of the study were to (1) identify all non-trivial system hazards, (2) assess the risks of these hazards, (3) reduce untenably high risks to acceptable levels, and (4) document the results. The methodology employed is summarized in Figure 7-4.

NWTC RISK DESCRIPTOR	RISK MITIGATION EXPERIMENTS/STUDIES					
	HS LEG	BACK LEG	SLOTS	OPEN JET	* CONTR & TRS *	NOISE PROCS
OPEN JET CAPABILITY				X		
NOISE (TUNNEL INTERNAL)	W		X			X
BACK LEG FLOW UNIFORMITY & UNSTEADINESS		X				
HIGH SPEED LEG FLOW UNIFORMITY & UNSTEADY SLOTTED WALL DESIGN IMPACT ON NOISE & FLOW ACOUSTIC TREATMENT	X	X			W	
SUBSCALE EXPERIMENT VALIDATION (CFD)			W			X
LAMINAR FLOW TEST CAPABILITY	X	W		X		
CONTRACTION DESIGN EFFECT ON FLOW QUALITY	W	W			X	X
TURBULENCE REDUCTION SYSTEM					X	
FLEXIBLE NOZZLE PERFORMANCE	W				X	
X = RISK STRONGLY ADDRESSED W= RISK WEAKLY ADDRESSED * = IN PLANNING						

Table 7-3: Technical Risk Mitigation Summary

The analysis produced 106 hazards for the seven PDTs. The Hazard Worksheets for all of these hazards are given in "Progress and Status, System Safety Program (Ref 7-19).

This number of hazards is judged to be low when compared to other programs of like magnitude and complexity at a similar level of maturity. This is due, in part, to the relatively late start of the hazard analysis, some variations in the criteria used to evaluate hazards, and the assurance of code worthiness in the design procedures. Feasible countermeasures are foreseen for significant risks such that post-countermeasure residual risks are at the lowest recordable level (Code 3) for most identified hazards. More sophisticated analyses will be needed during later design phases for certain critical hazards such as: (1) double-seal failure at a single isolation valve and (2) nozzle jack position error. The current studies provide a good foundation for continued hazard analysis.

7.6 Performance Evaluation

As a key element of any project, performance and its evaluation received considerable project attention. Emphasis was placed on quantifiable predictions of tunnel performance. This was approached by developing the models and approaches for making such predictions. These tools also were considered invaluable aids in requirements allocation, trade studies and design. The project instituted Technical Performance Measurements (TPMs) to track performance. Both system and segment level TPMs were being developed. Both the system modeling and TPMs are presented in this section.

7.6.1 Modeling Description

7.6.1.1 Productivity

The purpose of NWTC Productivity Model (Ref 7-20) was to predict system performance in terms of polars per year, to aid in trade studies, and to predict energy and air usage. Thus, the model had evolved to more of an overall system simulation tool than just a method of predicting throughput. The model had been used to calculate the productivity Technical Performance Measurement (TPM) as well as support trade studies on isolation valves, air plant capacity, and the number of test section carts required. The results from the model were also a key input to the cost model and as such directly affected the estimate for the overall program cost.

The sample scenarios developed by CR&O (Ref 7-21) were used as inputs to the model. These scenarios are event sequences that describe the actions that take place for a hypothetical test of a certain type (e.g. Configuration Development or Loads). Another input into the program were estimates of scheduled and unscheduled maintenance provided by the reliability model. (See Section 7.6.1.7.) The model functioned by summing times, energy, and air

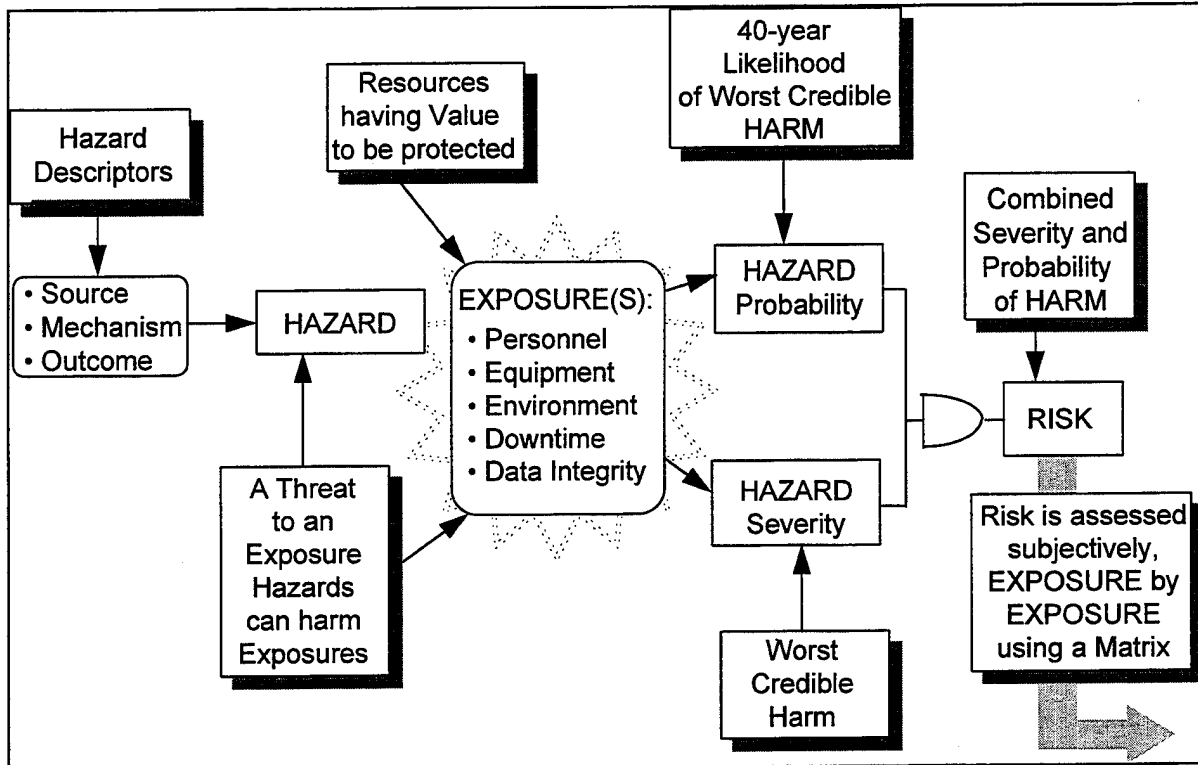

Figure 7-4: Hazard Analysis Methodology of Flow

usage associated with the events described in the sample scenario, the magnitudes of which were calculated using information from PDTs on the various system components.

The requirement for the productivity of NWTC was that it should be twice as productive as existing facilities. The facilities chosen for this comparison were AEDC 16T for transonic testing and the DRA 5 meter tunnel for low speed testing. To compute the productivity of these facilities, the model was modified to accommodate the individual features of these tunnels for four sample commercial test scenarios and the results were compared against actual run logs. The resulting requirements can be found in Section 7.6.

At the closure of the project, the model had attained a high level of maturity and had become an important tool for making design decisions. It was generally felt that the productivity estimates as reflected in the TPMs for NWTC were optimistic, but that corrections could be made by investigating the inefficiencies, for example, associated with the interaction between the facility and its human operators.

7.6.1.2 Dynamic Model

Wind Tunnel Dynamic Modeling (Ref 7-22) addresses prediction of dynamic behavior of the wind tunnel Mach number, temperature, and pressure processes. The wind tunnel dynamic behavior has significant impact on wind tunnel productivity, flow quality and power demand.

An early effort was conducted using an existing simulation program (DYFA) to generate interim estimates of the Mach number, pressure and temperature control response. This program was also used to simulate tunnel

NWTC Final Report

pressurization, the evacuation of the isolated test section plenum and the equalization of plenum pressure with the rest of the tunnel using bleed valves.

In response to concerns about the frequency response capability of the existing tool, development of a different approach was undertaken in the Project Office. This SI Performance Dynamic Model was based on a finite-difference solution to the friction-less flow (Euler) equations in one dimension. Versions of the model were programmed in Visual Basic and FORTRAN and run on either a PC or work station, respectively. The Visual Basic model was much further developed than the FORTRAN version and was the version discussed [dynamic model document]. Development of a special FORTRAN version for use with the dynamic analysis software package, Easy5, was begun, but was incomplete. Since development of the NWTC Dynamic model was still in the beginning stages, a thorough development of the actual tunnel geometry, losses and subsystems was not implemented. A model of the Ames 11' wind tunnel (to be used for validation) was the most complete version.

The Wind Tunnel Dynamic Model was a specialized tool for the evaluation of tunnel dynamics. It would not necessarily provide an accurate steady-state simulation. Rather, results from separate steady state analysis and modeling tools were required to tune the dynamic model to provide reasonable steady state results. The dynamic model was an engineering code and as such, results from the model must be applied within the framework of assumptions made in the model.

7.6.1.3 Information Quality

A basic requirement of the NWTC was the production of quality information. To support this requirement, an analytical capability was required to: 1) Evaluate design specifications relative to meeting CR&O requirements, (2) allocate elemental uncertainty requirements to PDTs, (3) define test data uncertainty, and validity during actual wind tunnel operation.

An Information Quality Model (IQM) (Ref 7-23) was developed that meets the requirements stated above with respect to calculating the tunnel test conditions and model load coefficients, and propagating the estimated errors in the basic measurements to determine the uncertainty of the calculated output parameters. The model was based on the anticipated NWTC instrumentation systems and data reduction equations. However, only static stability force testing was modeled. Sub models were developed for analysis of force/moment and pressure measurement devices to simulate the environmental and operational effects that would be experienced in the wind tunnel as opposed to the instrument calibration facilities.

Methodology described in AGARD-AR-304 and AIAA Standard 701-1995 was used for measurement uncertainty analysis and error propagation. The NWTC IQM was a modified version of the AEDC IQM and data reduction equations were the same as those used for Tunnel 16T except for changes to accommodate (1) optical measurement of model attitude, (2) delta pressure measurement for tunnel calibration at low Mach numbers, (3) calculation of ML/D, and (4) processing of data acquired using an external balance.

Verification and validation was accomplished by (1) reverse calculation through the data reduction equations, processing of known test cases, (2) visual examination of the code, and finally, (3) a Monte Carlo simulation developed by Dr. Hugh Coleman of the University of Alabama at Huntsville to provide validation of the error propagation process.

The IQM has been used to study the effect of measurement uncertainty on the uncertainty in the calculation of tunnel conditions--Mach number, dynamic pressure, and Reynolds number. The IQM proved to be a valuable tool for determining the crossover points for using delta pressure or absolute pressure measurement, and for determining the number of pressure transducer ranges needed to achieve the required uncertainty level.

The IQM was used to investigate CR&O's "Fighter" and "Transport" test scenarios based on approximate performance data for F-22 type and C-5 type aircraft. Cruise drag, climb drag, and maximum lift were selected as the conditions to be studied and also used as Technical Performance Measures (TPMs). The process used for this study was as follows:

NWTC Final Report

1. Sensitivities were determined for the parameters listed above by setting all errors, except one, to zero and determining cruise drag. This process was repeated until all sensitivities were determined.
2. Error limits were input into the IQM based on Section 7.0 (Measurement Requirements). Parameters included tunnel-condition pressures, base/cavity pressures, forces/moments, model attitude, total temperature, and centerline pipe pressures (tunnel calibration).
3. The model was run, with the fighter and transport scenarios, to determine cruise drag, climb drag and maximum lift based on CR&O's uncertainty limits. The resulting values established the CR&O requirements.
4. Since the CR&O error limits were based on a percent of reading (unachievable at low values because the error approaches zero as the reading approaches zero), new error limits were input to the IQM which included a "percent of range" as well as a "percent of reading" term. The resulting error limits were established considering CR&O error limits at the high end of the selected range.
5. The model was again run with the fighter and transport scenarios to determine cruise drag, climb drag, and maximum lift using the modified CR&O error limits. The results were presented at SDR as the current values of the TPMs.
6. After SDR, the error limits were adjusted to reflect predicted state-of-the-art capability at the time of final instrumentation design. The IQM was run using these error limits. In this case the TPM values were in line with the CR&O requirement and the input uncertainties used were established as the baseline uncertainty allocations.

A plan was developed to expand the IQM capabilities to include calculation of corrections to the model load coefficients for the effects of flow quality deficiencies and wall and model-support-system interference, as well as estimation of remaining uncertainty. [x] The IQM currently contains a worksheet that provides inclusion of these corrections and uncertainty estimates, however, they must be subjectively determined.

The tasks listed below describe the work that would have been accomplished if the project had been continued. If the project is reactivated, these items are recommended for completion to achieve the intended objectives for the IQM.

1. Implementation of the Flow Quality and Wall Interference Plan
2. Derivation using the expanded model, with CR&O, of requirements for corrected data
3. Interaction with the IPTs to re-establish the baseline uncertainty allocation
4. Analysis of detailed design of instrumentation components using the pressure and force/moment sub-models. A sub-model for model attitude should be developed following preliminary design and all sub-models should be refined as the designs mature.
5. Continuing analysis of technical performance as designs and products are developed
6. Expand IQM to support test types other than static stability force testing; such as, model surface pressure distribution, cold flow engine/inlet, and ground plane testing.
7. Delivery of a production IQM for use during NWTC operation to verify information quality

7.6.1.4 Performance Envelope - Reynolds Number vs Mach Number

The wind tunnel performance envelope is calculated output from the *Wind Tunnel Loss Code Model* (Ref 7-24). The Wind Tunnel Loss Code was an analytical tool used to predict the overall wind tunnel operating envelope. This was accomplished by computing the loss and pressure drop for each component in the wind tunnel. The component losses were then added around the circuit to obtain an overall loss. A calculation of Reynolds number per foot was made at certain wind tunnel conditions and geometry over the given wind tunnel Mach number range. This was then plotted, yielding in the performance envelope. The Wind Tunnel Loss Code is written in EXCEL Version 5.0 and Visual Basic Version 3.0.

The performance envelope calculated from the loss code has the following limitations:

- The model and therefore the model wake is not included with in the current analysis and has to be incorporated as a delta power effect to predict maximum power requirement

- Data spread for NASA Langley 16 ft, NTF, and ETW (optimized test legs) is six per cent for the testleg in the loss model, translating into uncertainty in achievable Re number at the maximum power of approximately eight per cent without the model in the tunnel

The code was then run for constant total pressure lines of 5 and 7 atmospheres. All data and plots are within the program description in the code. Figure 7-5 represents a typical output plot for the wind tunnel performance envelope.

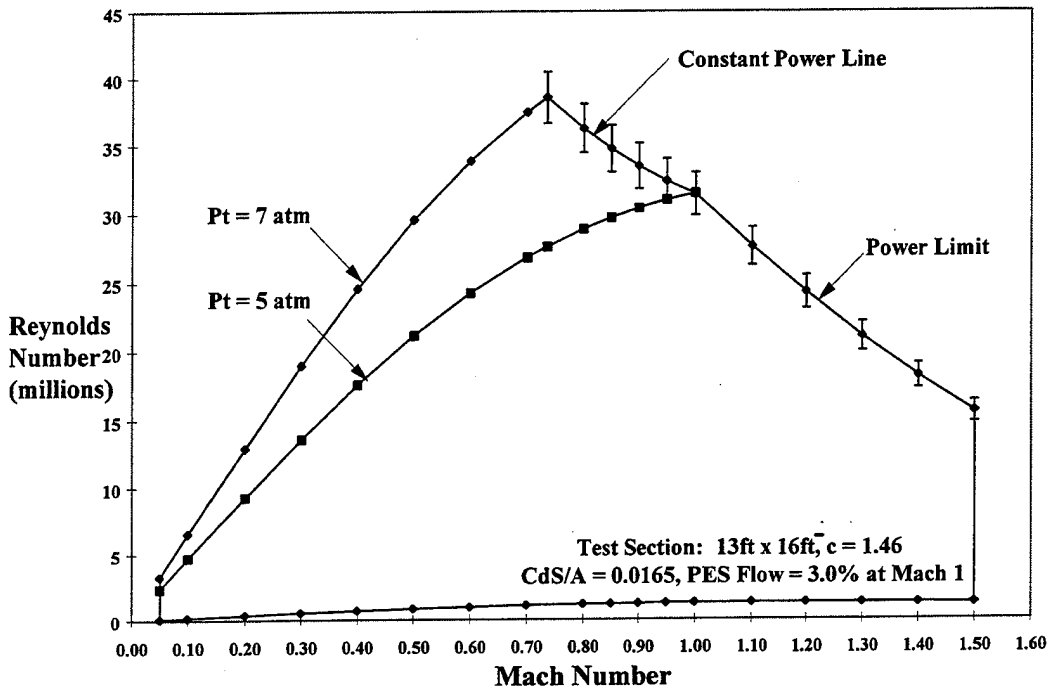

Figure 7-5: Wind Tunnel Performance Envelope. (Continuous Power)

7.6.1.5 Turbulence Model - (u'_{rms}/U)

The wind tunnel turbulence is predicted output from the *TURBULENCE CODE FOR THE TURBULENCE REDUCTION SYSTEM (TRS)*. This program was intended to be used and modified to reflect the desired TRS, as well as the overall wind tunnel geometry. This model methodology was a one-dimensional analysis along the centerline of the tunnel. Code elements have been validated with data from the BLASTANE experiments conducted at the NASA Ames Research Center. Also, the code was validated and determined to be conservative in the calculation of the axial turbulence in test sections from existing facilities. Shown below in Figure 7-6 is the representative output for the code with the given geometry for the at SDR.

The turbulence model was formulated and written with the following assumptions and limitations:

- The turbulence signal is separated from the noise contamination
- Isotropic turbulence in the crossflow plane
- Classical semi-empirical approach
- Axial component of the turbulence drives the cross component
- Very little turbulence data is available for wind tunnel components at high Reynolds number
- Effect of the turning vanes only arise as a scaling effect on the honeycomb
- Assumes no potential areas of separation
- Value of turbulence at the compressor flow exit is not known

The natural extension of this methodology would be to include the lateral components of the turbulence throughout the wind tunnel circuit, validate the code with data taken from the experiments and incorporating empirical terms from data taken regarding individual elements and/or CFD analysis. This would produce a higher confidence, higher capability model.

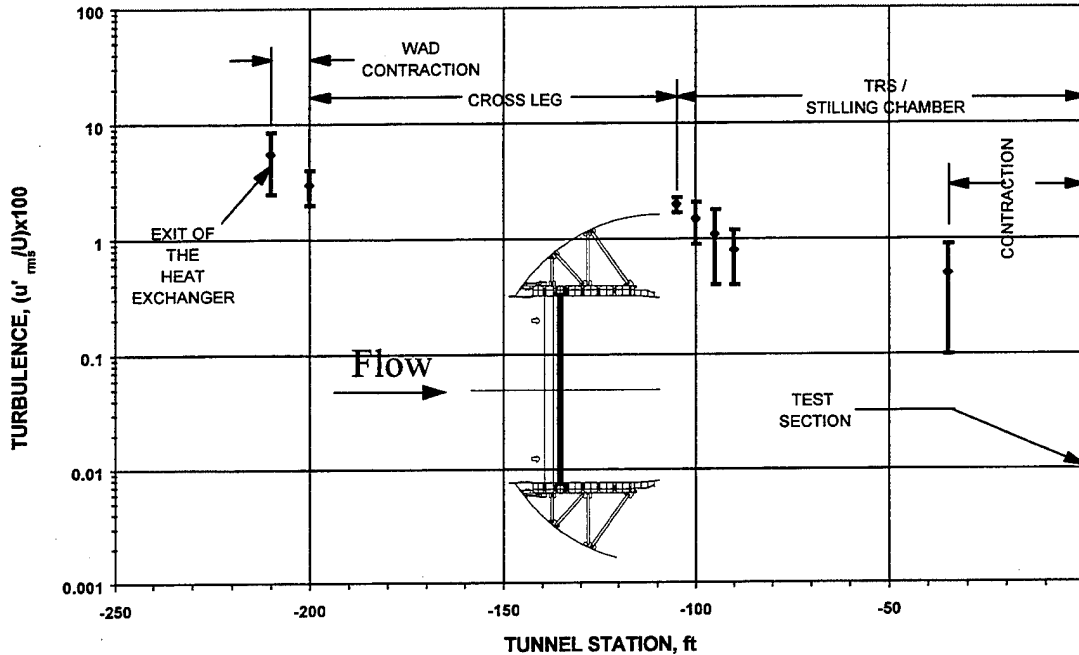

Figure 7-6: Axial Turbulence Decay from the Exit of the Heat Exchanger to the Test Section

7.6.1.6 Noise (Static Pressure Fluctuations) Model - (p'_{rms}/q)

The wind tunnel noise was calculated output from the methodology for predicting the static pressure fluctuations from the integration of the overall static pressure fluctuation spectrum curve. This curve was summed from individual curves from propagation of the compressor (both upstream and downstream), heat exchanger, turning vanes, high speed diffuser and Wide Angle Diffuser. (WAD) Contributing spectra curves from the Slotted Walls, Plenum Chamber, Model Strut, and possible noise source coupling were not used in the prediction of Figure 3. A value of 0.007 for (p'_{rms}/q) at a Mach number of 0.8 was computed without the strut noise contribution, and a value of 0.009 with the strut noise contribution.

This then determined the typical transonic peak at Mach 0.8. A typical transonic wind tunnel (p'_{rms}/q) vs Mach number was matched to the peak value to yield the predicted levels in Figure 7-7.

The static pressure fluctuations method/model was not a formal model and is only a method to arrive at the test section value of the noise. The following are assumptions and limitations of the method:

- The major noise source is in the test section area
- Noise mechanisms in the test section area are relatively unknown
- Major noise sources are assumed to be discrete tones
- Individual noise sources in the wind tunnel circuit are not coupled
- Compressor exit flow field is unknown
- Low frequency noise is not accounted for
- Gaps and steps and screen liner interfaces are not taken into account

Since no known analysis existed for the prediction of the noise levels in the wind tunnel, the natural extension of this methodology would be to include data taken from experiments and incorporate empirical terms from data taken of individual elements and/or analysis.

PREDICTED PRESSURE FLUCTUATIONS

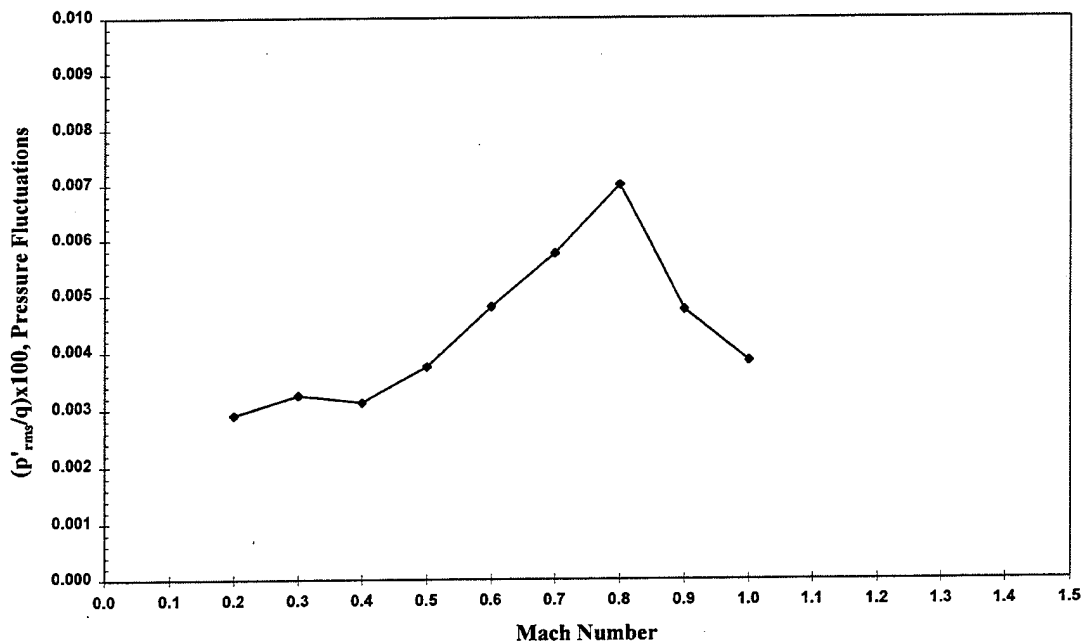

Figure 7-7: Predicted Pressure Fluctuations for the Test Section without model strut contribution

7.6.1.7 Availability Allocation Model (Ref 7-25)

A tunnel availability/maintenance cost computer model, commonly referred to as the reliability model, was developed to run on Windows EXCEL for estimating the tunnel availability TPM metric along with a range of uncertainty, allocating Segment Level Downtimes Specs to the Product Design Teams, providing unproductive downtime values into the Productivity Model, and providing a Yearly Maintenance Budget to the Cost Model at the NWTC. The availability model utilizes pertinent data provided by each Product Design Team. The model was used to study the sensitivity of the inputted data and find optimum preventative maintenance intervals which minimize tunnel downtimes and costs. For all components and systems, reliability was based on an exponential distribution function, assuming a constant failure rate. The results were based on a tunnel operating scenario of 3 shifts, 5 days a week and 50 weeks a year. Results were supplied to (a) TPM metric, (b) Segment Level Specs, (c) Productivity Model and (d) Cost Model. These allocations are listed in Table 7-4.

(a) TECHNICAL PERFORMANCE MEASUREMENT		(b) SEGMENT LEVEL ALLOCATIONS		(c) PRODUCTIVITY DOWNTIME
Tunnel	Budgeted	PDT	Downtime	Scheduled Downtime = 7%
Availability	Maintenance Cost	Compressor	7.0%	Unscheduled Downtime = 7%
5700 hrs	\$ 930K	Pressure	4.1%	
5200 hrs	\$ 2100K	Plant	7.8%	
4700 hrs	\$ 3400K	C & I	4.8%	(d) YEARLY BUDGETED
		Test	9.2%	MAINTENANCE COST
		Flow Conditioning	2.6%	\$2,100,000

Table 7-4: Information Generated by the Availability Allocation Model

Discussions with SI personnel and PDT representatives took place to discuss where and how the availability modeling effort should proceed through the Preliminary and Final design process. It was agreed that a central team of expertise in reliability analysis should be formed to handle this modeling effort, and provide feed-back risk assessments to the PDT designs for meeting the tunnel reliability/availability goals and objectives, in a proactive

NWTC Final Report

environment. Based on these meetings and personnel observations in developing the allocation model, the following recommendations are proposed:

- Form a focal team of expertise in reliability/availability modeling who will pro-actively analyze and provide input to the Product Design Teams.
- FMEA and Fault Tree Analysis need to be performed to evaluate:
 - Failure modes and effects to components and/or system
 - Appropriate preventative maintenance procedures and repair time intervals
 - Downtime hours incurred for preventative maintenance and repairs of predicted catastrophic failures.
 - Dollar costs incurred for doing preventative maintenance and repairing the predicted catastrophic failures
- Through analysis, better definition of Reliability distribution vs time which best fits each component or system as opposed to simplified use of the exponential distribution with constant failure rate.
- The maintenance budget appears too low, based on percent of capital investment, and needs to be revisited.
- Facility operations engineering personnel should be involved in supplying downtimes and dollar estimates into the facility maintenance and repairs.
- Mechanical and electrical designs needs to be matured to where system components can be defined so the allocation processes can be revisited.

7.6.1.8 Life Cycle Cost (Ref 7-26)

The Life Cycle Model provided estimates of the cost of acquisition, operation, and maintenance of the National Wind Tunnel Complex (NWTC). The Model is in a Microsoft Excel Workbook file, Version 5.0C. The Life Cycle Model was comprised of the Acquisition Module, the Operating and Maintenance (O&M) Module and the Life Cycle Cost Module. Typical results are shown in Table 7-5.

The Acquisition Module estimates the labor and material costs to plan, design, and construct the NWTC. The labor and material costs, known as the Conceptual Construction Cost Estimate, are time phased using the project schedule. Total acquisition cost is determined by applying taxes, contingency, and escalation to the time phased labor and material costs.

The O&M Module calculates the annual operating staff, maintenance labor, non-labor, equipment replacement, and utility costs of NWTC operations. Some of the inputs to this module are based on throughput figures from the Productivity Model.

The Life Cycle Cost Module determines the present value of the cost to build and operate the NWTC over 30, 40, and 50 years.

DOLLARS ARE IN MILLIONS

Category	O&M Costs-1 Shift			O&M Costs-2 Shifts			O&M Costs-3 Shifts		
	Facility Life In Years			Facility Life In Years			Facility Life In Years		
	30	40	50	30	40	50	30	40	50
Cost of Construction	918	918	918	918	918	918	918	918	918
Contingency	184	184	184	184	184	184	184	184	184
Taxes	43	43	43	43	43	43	43	43	43
Total Acquisition Cost	\$1,144	\$1,144	\$1,144	\$1,144	\$1,144	\$1,144	\$1,144	\$1,144	\$1,144
Operating Staff	282	376	471	339	452	565	403	538	672
Maintenance Labor	23	31	39	28	37	47	33	44	54
Nonlabor	55	74	92	62	82	103	69	91	114
Equip Replacement	138	184	229	275	367	459	413	551	688
Utilities	169	225	281	337	450	562	506	674	843
Total O&M Cost	\$667	\$889	\$1,112	\$1,041	\$1,388	\$1,735	\$1,423	\$1,897	\$2,372
Present Value	\$1,811	\$2,034	\$2,256	\$2,185	\$2,532	\$2,879	\$2,567	\$3,042	\$3,516

Table 7-5: Typical Results From the Life Cycle Cost Model

The Life Cycle Cost Model was only concerned with cost issues, thus Pricing and Management of the NWTC are not addressed by the Life Cycle Cost Model. Insurance, Depreciation, and Operating Taxes were also not Considered. No Site Supplied Costs were considered. Future revisions of the Model would have included more

NWTC Final Report

sophisticated forecasting of Capital Replacement requirements. The Cost Model would have eventually merged with the Productivity Model.

7.6.2 Technical Performance Measurements (TPMs)

The Technical Performance Measurements are described in detail in the Systems Performance Evaluation Report (Ref 7-27). TPMs are chosen measurable parameters that can be tracked throughout all phases of the wind tunnel design, construction, and life. They are a management tool for assessment of predicted performance for certain key requirements. The System Level TPMs chosen for this project were: Performance Envelope (Metric: Re vs. Mach capability), Productivity (Metric: Polars/Year), Information Quality (Metric: Measurement Uncertainty), Flow Quality Turbulence and Noise (Metric: (u' rms/U) and (p' rms/q)), Predicted Facility Availability (Metric: Hours/Year), and Cost/Polar (Metric: Dollars/ Polar). These TPMs were not meant to be all inclusive, but rather indicators of performance areas needing heightened visibility. The TPMs could have been modified to include other parameters if their high risk required their measurement and tracking. Values of the chosen TPMs are presented in Table 7-6.

TPM	Condition/Units	Requirements	Prediction	Uncertainty	
		Threshold/Goal		Upper Bound	Lower Bound
Performance Envelop*	Re vs. Mach		max power lines	+5%	-5%
Productivity:	Transonic, Polars/Year	22600	31300	35000	24000
	Lowspeed, Polars/Year	10600	11500	12500	8000
Information Quality - Uncertainty in:	Transport Cruise Drag Coefficient	0.00012**	0.00010	0.00015	0.000078
	Fighter Cruise Drag Coefficient	0.00008**	0.00007	0.00012	0.000048
	Transport Climb Drag Coefficient	0.00128**	0.00165	0.00215	0.00140
	Transport Max Lift Coefficient	0.016**	0.038	0.043	0.032
Flow Quality:	Axial Turbulence, (u'rms/U) x 100	0.050	0.048	0.066	0.030
	Static Press. Fluctuations, (p'rms/q) x 100	0.60/0.3	0.70	0.09	0.05
Predicted Facility Availability	Hours/Year	5580	5200	5700	4600
Cost/Polar:	Transonic, \$/polar	1244	821	1150	600
	Lowspeed, \$/polar	1721	1137	1400	850

* See Re vs. Mach Figure

** Derived From CR&O Requirements

Table 7-6: Predicted Values of System Level TPM's

The major concerns at the time of SDR were as follows:

- Performance Envelope** - resolve circuit losses, including wind tunnel model interference effects
- Productivity** - investigate "human factors" and reliability in models and perform closer examination of dynamic effects
- Information Quality** - develop requirements and predictions for corrected data

Flow Quality - add study results, including characterization of sources
Facility Availability - allow design to mature
Cost/Polar - develop NWTC pricing structure

The implementation of these concerns would not only insure a more accurate measurement of the TPM, but could also lower the risk of the parameter being tracked.

8. System Studies

8.1 Risk Reduction

The Risk Reduction Studies were initiated prior to the formal start of the NWTC Project and provided critical information. The studies were a group of activities to examine critical elements to reduce the functional, cost and schedule risks of achieving the national requirements. Additionally, they were to provide a functional baseline concept using current best design practices. As such, the initial risk/cost trade studies necessary to develop the concepts were carried out. Performed between mid-April and the end of September, 1994, the studies were directed in three categories: Tunnel Aerodynamics, Productivity Issues, and Technology Issues. The actual areas of concern are shown below:

- Tunnel Aerodynamics: Integrated Aerolines and Auxiliary Systems; Choke and Re-Entry
- Productivity Issues: Carts, Test Sections, Model Supports; External Balance; Isolation Valves
- Technology Issues: Open Jet Test Section; Wall Interference

Work was accomplished by Sverdrup, ASE, Georgia Tech and AEDC. Oversight was performed by NASA ARC and AEDC. The following is a discussion of some of the major conclusions.

In the examination of the tunnel aerolines, the carts were laid out considering steady state disturbance fields created by the pitch strut and the required flow forming regions. The contraction ratio was examined, and the choke was removed, citing only minimal gains in terms of test section noise.

The anchor point for the tunnel was considered at either the test section, the compressor, or both. The recommendation was made to anchor in both places, and consider expansion joints as a technology development area. (Further work in the Concept Evaluation Studies, Section 8.2 and later design decisions, Section 7.3.2 revisited this issue.)

The carting studies included examining the mechanical aspects for model installation, examining a hatch, rolling plenum, turntable arrangement or a door. The study recommended the rolling plenum over the hatch, citing lower risk in design, fabrication, construction and cost. Additionally, the arrangement of the test carts themselves was examined, looking at one or two part carts, with either a fully removable cart or just a removable floor piece. The study concluded that the test carts should be one piece, fully removable universal carts, combining the external balance and pitch strut capabilities on the same cart. (It should be noted that this study was conducted before requirements, such as the removable pitch strut, were developed. See Section 7.3.2.) This combination of rolling plenum and test carts also drove a recommendation of a dedicated plenum for each cart, explaining advantages in productivity, reliability and lower risk, for a relatively small capital cost increase. Studies examining the pitch strut looked at options of either an arc sector, or a one or two piece vertical pitch strut. A single piece vertical pitch strut was recommended.

The methods for anchoring the external balance were studied, looking at anchoring directly to ground, anchoring to the plenum or anchoring to the test cart. Considerations were given to the necessary space and stiffness requirements for the balance. The recommendation was made to anchor the balance to the test cart.

During the studies, the isolation valves were also an area of particular focus. Ten different concepts, including plug valves, cylindrical gate valves and split gate valves were considered. The plug valve was unanimously recommended. Further details of the work may be found in (Ref 8-1).

8.2 Concept Evaluation Studies

During the course of the project, a suite of studies, the Concept Evaluation Studies (CES) (Ref 8-2) were commissioned and executed. The objective of these investigations was to develop more detailed design data for specific concepts, and thereby identifying any inherent limitations of that concept. CES were selected from a prioritized list of candidate topics. Criteria for selection included estimated level of risk and estimated level of applicability of study results and conclusions to various tunnel configurations. This work was done in parallel with the requirements and system development of the overall NWTC.

These studies, covering a wide range of topics, are identified in Table 8-1. When completed, the studies were evaluated for applicability of the generated data to the actual design of the NWTC. These forms can be found in the Study section of the NWTC archive.

CES No.	Document Title	CES No.	Document Title
1-01	Anchor Point Study (Archive single tunnel)	3-04	Variable Stiffness Balance/Support
1-02	Single/Double/Compressor Assessment	3-06	Data Acquisition System Uncertainty Analysis
1-03 & 1-04	Productivity (LSWT & TSWT)	3-07	Plant-Wide Automation System
	Hybrid PES/Rentry System	3-08	Transducer Accuracy and Specification Requirements
1-06 & 1-07	Aerolines Study	3-09	Tunnel Parameter Uncertainty Analysis
1-08	Cart Systems	3-10	Balance Calibrations
1-09	Cart Lengths	3-11 & 3-12	LSWT Pitch Strut Effects
1-10	Plenum-Shell Anchor (Seismic)	3-12 & 3-14	TSWT Pitch Strut Effects
1-11	Pressure Shell/Test Leg Integration	3-13	LSWT Corner Fillets Effects
1-12	TSWT /Structural Analysis	3-15	Data Acquisition System Location
2-01	Plant-Wide Control System Architecture	3-16	Laminar Flow Quality Requirements
2-03	Pressure/Vacuum Air Storage vs Compressor Capacity	3-17	Finite Element Analysis for Balances and Models
2-04	Shared Use of Compressors for Pressurization & PES	3-18	Full Model External Balance Mounting Req's
2-05	Physical, Computing, and TEMPEST Security	3-19	LIDAR Enhanced Laser Doppler Velocimetry
2-06	Main Drive Motor Control and Transient Response	3-20	Optical Access to Test Section
3-01	Model Design for High Total Pressures (Boeing) (5-8 Atm)	3-21	Removal of LDV Particles from the Airstream
3-01	Model Design for High Total Pressures (McDonnell Douglas)	3-22	Data Acquisition and Processing System Architecture
3-03	Internal/External Balances	4-01	CES Slot Aerodynamic Study

Table 8-1: Concept Evaluation Studies

8.3 Upgrade Studies

During the performance of the NWTC project, several opportunities occurred to examine other possible approaches to meet the National Consensus Requirements. These studies investigated various levels of upgrades to existing facilities, and attempted to quantify the associated predicted performance, cost and schedule.

8.3.1 Ames Upgrade

The Unitary High Reynolds Number Circuit (UHRC) study (Ref 8-3) was performed to validate, further develop, and refine the UHRC concept. This concept was essentially to add a second test leg to the existing Unitary 11 ft tunnel, resulting in a configuration with two test legs sharing a common drive leg. This is similar to the existing arrangement of the 9 X 7 and 8 X 7 foot supersonic legs in the same facility.

The overall conclusion of the study was that the UHRC concept, with the changes incorporated throughout the study, was valid in that the performance originally projected by ARC could be achieved. Specifically:

NWTC Final Report

1. Two concepts for the UHRC were considered, a 11x12-ft test section without PES, and a 11x15.5-ft test section with PES. Both configurations appeared feasible, including corner isolation valves, test section access, and tunnel anchoring concept.
2. The prediction of flow quality for the UHRC was evaluated using the assumptions and technology database developed for the NWTC TSWT. Within the scope of the technology database and the ability to measure flow quality, the UHRC was found to meet the "Consensus Requirements" being considered for the NWTC at that point in time. Owing to the scope limitations of this study, no attempt was made to evaluate the flow quality using techniques further developed by the NWTC project, or comparisons made to further refined NWTC requirements.
3. The prediction of productivity was developed using the productivity model developed for the NWTC TSWT with modifications to account for differences in the tunnel hardware and the operating scenarios. For the single-point test model, the required 8 polars per occupancy hour was achieved. Incorporating model change out into the system, and assuming a schedule of tests, the throughput was predicted to be roughly equivalent to that of the NWTC TSWT.
4. A 5 ATM total pressure was selected for the UHRC. The performance of the facility based on chord Reynolds number and Mach number range was as follows:
 - a) The UHRC 11x15.5-ft configuration will meet the National Facility Study (NFS) consensus Reynolds number requirements in the Mach number range from 0.2 to 1.2. Additional studies of the test section flow forming in the Mach 1.2 range were suggested.
 - b) The UHRC 11x12-ft configuration will meet approximately 77% of the NFS consensus Reynolds number requirements in the Mach number range from 0.2 to 0.9.
5. The performance of the existing 11-ft test leg will be enhanced by the addition of the UHRC. The increased power for the UHRC will allow operation of the 11-ft test leg at significantly increased Reynolds numbers in the Mach number 1.1 to 1.5 range.
6. The cost estimates for the two configurations were developed as follows (August 10, 1996):
 - a) UHRC 11x12-ft configuration: \$411.8 million
 - b) UHRC 11x15.5-ft configuration: \$501.5 millionThe schedule would require about 1-year of 11-ft tunnel additional downtime for construction of the UHRC leg, and provided UHRC test leg IOC in the year 2001.

8.3.2 AEDC Tunnel 16T Upgrade Study

This study evaluated two concepts for upgrading AEDC Tunnel 16T for high Reynolds number operation (Ref 8-4). Option 1 involves upgrading the existing 16T circuit for operation at 4.1 ATM total pressure, and Option 2 is a new 4.1 ATM circuit obtained by adding three new legs to the existing 16T compressor leg. The objectives of the study were:

1. determine feasibility and estimate performance
2. estimate tunnel productivity
3. estimate acquisition and operations costs
4. develop an acquisition schedule

In the paragraphs below, summaries are provided for each of these objectives

Feasibility and Performance – Both options are technically feasible and will produce Reynolds number performance that meets the NWTC requirements for the 11x15.5-ft TSWT. At the design point of Mach 1.0, 4.1 ATM, 100°F, Option 1 requires main drive power of 713,000 hp (based on 15% motor overload), with drive motors M1/M4 rated at 250,000 hp. Option 2, with a more efficient circuit scaled from TSWT, requires 364,000 hp (continuous), with drive motors M1/M4 rated at 122,000 hp.

With regard to flow quality, Option 1 design concepts may achieve the flow quality levels currently observed in 16T, but TSWT flow quality levels could not be achieved. For Option 2, which is based on the TSWT concepts, the TSWT flow quality levels would not be achieved because constant speed motors are used in Option 2 to drive the compressor. This constant-speed drive concept produces lower compressor efficiency for some conditions, which yields lower flow quality levels.

The effect of compressor noise spectra on tunnel interior noise levels can be reduced to acceptable levels in both Options 1 and 2 by applying acoustic treatments. Exterior sound levels resulting from radiated compressor noise in Options 1 and 2 will increase over current 16T exterior sound levels because of increased power levels and the elimination of an acoustic enclosure building from the design concepts.

Productivity – The testing productivity of 16T Options 1 and 2 - in terms of tests per year or polars per year - is nominally the same as TSWT, based on the test scenarios evaluated during the study.

Acquisition and Operating Costs – Acquisition costs are \$470M and \$970M for Options 1 and 2, respectively. Operating costs for both 16T options are higher than TSWT, with Option 1 being 89% higher and Option 2 being 36% higher. Option 1 operating cost is substantially higher because of the high main drive power required in this circuit. While the Option 2 circuit is scaled from TSWT, Option 2 operating costs are higher because of the combination of test section size and operating pressure.

Schedule – Option 1 requires 4.5 years for design, construction, and activation, while Option 2 requires approximately 7 years. Tunnel 16T downtime during implementation of the upgrades would be 12 months for Option 1 and 24 months for Option 2.

8.4 Experiments and Studies

A key element of the NWTC risk reduction strategy was the program of experiments and studies that were initiated to address specific areas of technical risk. These activities were in addition to normal design activities and trade studies necessary for the specification of a large pressure wind tunnel. Experiments and studies were chartered in four areas:

1. High Speed Leg
2. Back Leg
3. Slotted Walls
4. Open Jet

The process for study initiation evolved over the lifetime of the Project Office, but basically involved management review and approval of a study program developed with the participation of SE&I Performance, WTP aerodynamicists, experiment site managers, and selected technical experts. The resulting joint ownership and agreement on a test program, including schedule, were key features of this process (Ref 8-5).

The first studies to get underway involved slotted wall configuration development activities (March 1995). The high speed and back leg activities started in August 1995. Open jet discussions took place in the Fall, 1995, with a test program in place in January 1996. In October 1995, with the change of NWTC project direction from two tunnels to one tunnel, adjustments were made to experiment planning and design.

Activities in each of these areas are described below. Objectives, approach, and status are discussed for each activity. Since the decision to close-down NWTC Project activities by early June 1996, certain activities were curtailed or canceled, while others continued to a logical conclusion, albeit on an accelerated schedule.

8.4.1 High Speed Leg (Ref 8-6)

Objectives:

1. Determine test leg pressure loss as a function of test article and plenum evacuation system (PES) massflow for the operating Mach number range.

2. Develop re-entry, model support, and PES configuration for minimum pressure fluctuations in the test section, while maintaining acceptable longitudinal static pressure distribution.

Approach:

A 1/13 scale, ejector-driven, indraft tunnel was designed and fabricated at the ASE-FluidDyne Aerotest Laboratories in St. Paul. It simulated the NWTC MPWT from just downstream of the turbulence reduction system (TRS), through the contraction, flow-forming region, test section, model support section, high speed diffuser, and corner #1 vane set. Various re-entry and model support configurations were to be tested to maximize flow quality in the test section (with regard to pressure fluctuations and longitudinal pressure gradient). Test articles representing transport and fighter wind tunnel models were to be used to establish separated wake effects on high speed diffuser performance. Fixed contour nozzle blocks were to be used to achieve supersonic Mach numbers.

A second test activity involved static pressure and noise measurements in the Medium Speed Wind Tunnel (MSWT) in South Africa, and correlating these measurements with measurements in the high speed leg test rig described above, but modified to more closely resemble the MSWT re-entry and model support configuration. In addition, turbulence and turbulence decay data was to be gathered to support the Back Leg Study. This data correlation was to aid in the extrapolation of model tunnel results to full scale, especially with regard to test leg loss.

Cost and schedule: The design and fabrication of the high speed test leg, performance of the model tunnel test program, and planning and performance of the MSWT test were budgeted for \$1,648K. The MSWT test was scheduled for April, 1996. All model testing was to have started in April, 1996, and to have been completed by September, 1996.

Outputs: The primary output of this test was to be a validated re-entry/model support configuration for best flow quality in the test section, and a prediction of power required to drive the test leg over the full range of Mach number and for various PES/re-entry operating scenarios.

Status: With the project shut-down decision, all testing activities in the high speed leg study were canceled. Fabrication of the high speed leg model tunnel was completed, with the components to be checked for assembly fit, and then shipped to the Fluid Mechanics Laboratory (FML) of the NASA Ames Research Center for eventual assembly and testing.

8.4.2 Back Leg (Ref 8-7)

Objectives:

1. Validate performance of proposed diffuser designs, including determination of back leg pressure loss and the required flow conditioning to insure steady flow over a range of compressor exit profiles.
2. Measure flow profiles (static and total pressures, dynamic pressures, turbulence) at the exit of the heat exchanger.

Approach:

A 1/23 scale, ejector-driven, indraft tunnel was designed and fabricated at the Fluid Mechanics Laboratory (FML) at the NASA Ames Research Center. This model tunnel simulated the Back Leg of the MPWT, from the compressor nacelle to the entrance of the third corner. The compressor was not modeled explicitly.

CFD analysis of the diffusers was done by the CFD Development group at Northrop-Grumman using a Navier-Stokes code modified to include screen flow characteristics (pressure drop and change in flow angle).

Cost and schedule: The estimated cost of this work package was about \$1,036K, most of which was devoted to the experimental tasks. The initial experimental test plan was to extend for about a year (September 1995 to September 1996). CFD analysis efforts paralleled the acquisition of experimental data.

Outputs: The output of this study activity was to be a back leg diffuser configuration that did not have unacceptable unsteady separation characteristics, along with a characterization of the velocity and turbulence

profiles exiting the heat exchanger. The CFD component of the work was to result in a validated CFD diffuser analysis methodology, and predictions of diffuser performance at high Reynolds number and for a variety of compressor exit flow profiles.

Status: The FML will continue this test activity beyond June 1996. By June, testing will have been completed on the baseline NWTC back leg configuration with a variety of flow resistance screens. Pressure and turbulence profiles downstream of the heat exchanger will be measured for the baseline NWTC heat exchanger configuration.

8.4.3 Slotted Walls (Ref 8-8)

Objectives:

1. Establish ventilated wall configuration (number of slots, maximum slot width, number of control segments).
2. Establish wall interference reduction and correction methodology using variable-resistance slotted walls.
3. Optimize and validate slot acoustic and aerodynamic performance over a representative range of wall boundary layer thickness, inflow, and outflow.

Approach:

A combined experimental and computational approach was implemented to address the development of a variable-resistance slotted wall. The type of wall investigated consists of longitudinal slots with inclined baffles. The number of slots necessary was postulated by CR&O technical support and validated by a CES performed by Boeing. [x] Calculation of the interference of ideal porous wind tunnel walls (simulating the far-field behavior of the baffled slots), including calculations with variable resistance, was done at AEDC.

The experiments originally envisioned for this work were twofold: an acoustic test of a multitude of baffle configurations aimed at finding the quietest one(s); and a measurement of pressure-crossflow characteristics for the quietest baffle configurations. Only the first experiment was commissioned and completed. Three floor slats in the 14-ft Transonic Wind Tunnel were removed to provide space for a single test slot for mounting up to 24 one-ft long slot baffle segments. Acoustic characteristics of each segment were measured using two dynamic pressure transducers within the slot. Floor boundary layer thickness was varied using a series of pins upstream of the test slot. Slot acoustics were measured over a range of Mach number (0.3 to 0.92) and with outflow to the plenum through the test section walls due to an imposed pressure distribution from a large sting-mounted wing-body model. A candidate configuration that did not produce strong resonances over the full range of conditions was identified.

Cost and schedule: The total estimated cost of study activities related to slotted wall development and specification was \$760K. The period of performance covered about 15 months (March 1995 through May 1996).

Outputs: This work resulted in a proposed ventilated wall configuration of the NWTC consisting of 44 longitudinal slots, with angled baffle inserts specially configured for low noise generation. A wall interference reduction and evaluation methodology has been proposed and evaluated computationally for two models at several flight conditions.

Status: Continuing development of wall interference technology will be the responsibility NASA Aero Facilities.

8.4.4 Open Jet (Ref 8-9)

Objectives:

1. Establish nozzle/collector geometry for stable jet operation, including effects of tunnel duct resonances.
2. Establish maximum open jet Mach number, and test leg pressure drop.

Approach:

An experimental program with four activities was synthesized to address open jet stability in a logical and phased manner. The first activity (Phase I) focused on the direct nozzle-collector feedback interaction by duplicating the NWTC nozzle-collector area ratio and length ratios. This experiment utilized the Georgia Tech Research Institute's 28-in open jet facility to investigate several basic collector geometries and collector breather gaps.

The second activity (Phase II) took advantage of a pair of McDonnell-Douglas open jet facilities: the 15-ft by 20-ft Mini-Speed Wind Tunnel (MSWT) and a 0.06 scale model of this facility, the Multi-Adjustable Research Tunnel (MART). It is known that open jet dynamics depend on boundary layer characteristics at the nozzle exit. Various means of modifying this boundary layer at model scale were investigated in order to find the best match to full-scale jet dynamics. Results of this study were to have supported the next two model tunnel investigations.

The third open jet experiment (Phase III) was designed as an adjunct to the high speed leg experiment at ASE-Fluidyne. It involved the fabrication of an open jet test section cart, using lessons learned from Phases I and II, for the high speed leg setup, in order to determine jet stability in the presence of the correct plenum and test leg volumes and possible resulting resonances. Since this tunnel is ejector-driven, test Mach numbers up to 0.6 were anticipated.

The final open jet experiment (Phase IV) involved building up the rest of the tunnel circuit around the high speed test leg. The ejector drive would be replaced by an off-the-shelf blower which would be able to produce open jet Mach numbers up to about 0.35. This test setup would be used to investigate jet stability in the presence of all possible tunnel duct resonances.

Cost and schedule: The estimated total cost for completion of all four activities was \$1,035K. All activities were to have been completed within about 9 months of initiation (January to September 1996).

Outputs: The output of these study activities was to be an open jet nozzle/collector configuration which results in stable jet operation for a Mach number of at least 0.35. The maximum open jet Mach number for this configuration would likewise be determined.

Status: Only the first two open jet experiments were completed. On account of cancellation of the NWTC, Phases III and IV were canceled.

8.5 Flow Quality Processes

Flow quality processes represent suggested wind tunnel design and analysis procedures to both ensure the attainment of the threshold values and to provide the best opportunity for achieving the design goals. Emphasis was given to studies addressing two critical flow quality parameters; turbulence intensity and static pressure fluctuations. These processes were being developed as the project was terminated. The descriptions below were the current descriptions of the processes.

8.5.1 Contraction/Turbulence Reduction System (Ref 8-10)

This process involved an approach to both the steady state (uniformity) and the fluctuating (turbulence) concerns surrounding the contraction and turbulence reduction system. Uniformity was to be explored by performing analysis/design cycles for contraction contours, where design solutions were to be evaluated using a Navier-Stokes code, and new contours developed with a constrained optimization code. These cycles would also be used to evaluate effects on uniformity of screen turning properties and manufacturing constraints. Experimental study of turning and the turbulence generation and attenuation characteristics of various turbulence reduction system components would have been conducted in a facility such as the Boeing Supersonic Wind Tunnel, configured to deliver low speed and NWTC full scale Reynolds numbers. Complete turbulence reduction system performance would also have been validated. Other experiments would be performed to validate turbulence growth/decay laws at high Reynolds numbers. This work was considered for the Ames 12 ft pressure wind tunnel. The final configurations for the contraction/turbulence reduction system would be verified as a supplement to the High Speed Leg Experiment.

8.5.2 Static Pressure Fluctuations (Ref 8-11)

This effort was a focused combination of experimental and analytical efforts. A significant component required optimizing the flow in the annular and wide angle diffusers as part of the Back Leg study, conducted at NASA Ames. An initial study of test section noise would be performed as part of the high speed leg study. If the static pressure fluctuation levels were higher than anticipated, additional work would be added to locate and attenuate the

noise sources. Additionally, a study of slot noise properties was conducted in the Ames 14 Ft. (See Section 8.4.3.) The objective was to identify candidate slot fillers that greatly reduced slot noise. Noise sources such as the compressor, the heat exchanger and the turning vanes would be initially approached analytically. During design, details such as steps, gaps, screen/liner interfaces etc. would be examined as possible disturbance sources. Finally, this process would have defined and recommended resources necessary for rapid identification/suppression of noise sources during activation of the NWTC.

9. Segment Definition

9.1 Carts, Balances, Test and Equipment System

9.1.1 Management Plan

9.1.1.1 Statement of Work

The Carts, Balances, Test and Equipment Systems (TEST) Product Development Team (PDT) was responsible for assembly, disassembly, handling and positioning of the model and other hardware that make up the test article. This included providing a test section cart system that allowed models to be setup, checked, transported into the wind tunnel circuit, and tested. The carts contain model support systems, balances and all local controls associated with positioning the model and acquiring force data. The test section area of the carts enclose the high quality flow region where the model is positioned and data are taken. Calibration equipment is provided to calibrate the balances and propulsion simulators, and verify test section flow qualities.

9.1.1.2 Organization

The TEST PDT was organized around the core sub-PDTs, as shown in Figure 9-1. The core elements were the Closed Jet Carts and the Open Jet Cart with the Associated Anechoic Chamber. The Closed Jet Carts included the test section, the strut and sting model support, the high angle of attack (AOA) model support, the elevated ground plane, the data acquisition system (DAS) pressure chamber and the cart transport system.

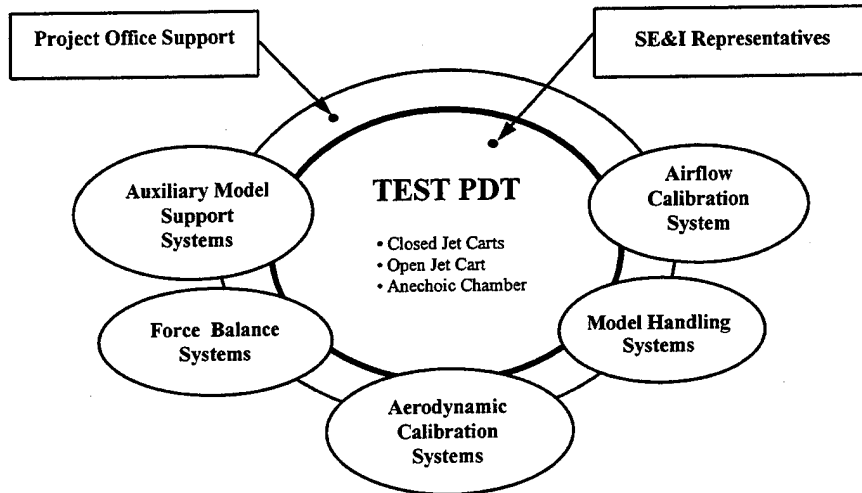

Figure 9-1: TEST PDT Organization

There were five other sub-PDTs that had strong functional interactions with the core sub-PDTs. Auxiliary Model Support Systems included half-model floor mount, plate mount, and various floor-mounted pedestal systems. Aiolos had responsibility for leading this sub-PDT. The Model Handling Systems would provide capability to handle the model from the time it arrives at the facility until it leaves the facility. The Force Balance Systems include internal and external balances, an Automatic Balance Calibration System (ABCS), and hinge moment

balance calibration fixtures. The Aerodynamic Calibration Systems included the calibration equipment such as calibration models, boundary layer rakes, probes and a test section static pipe. This sub-PDT had responsibility for conducting aerodynamic calibration of the test section when facility calibration was completed. The Airflow Calibration Laboratory provided capability for measuring airflow for large flow-through, blowing, and powered nacelles at total pressures up to five (5) atmospheres. Additional details are provided in the draft of the TEST Segment Specification draft.

9.1.2 Segment Specifications

A draft release of the TEST PDT Segment Specification was available at SDR. As the Project Specification (Ref 9-1) allocated function, performance, design constraints, and interfaces to each PDT, so did the TEST Segment Specification allocate these to the individual elements assigned to the TEST PDT. The Segment Specification (Ref 9-2) was on schedule to be formally released by PDR, concurrent with the development and release of interface control documentation. For more information, refer to the project documentation regarding specification development and the project specification tree.

9.1.3 Design Concepts

9.1.3.1 Trade Studies

The TEST configuration is driven by top level system requirements of high Reynolds number, flow quality, productivity/throughput, model load measurement, optical measurement, and accommodation for various model mountings. The physical architecture defined at SDR is a result of desirable and practical tradeoffs among defined user requirements, life cycle cost, technology risk, and capital cost and schedule constraints. One major result of these trades is the use of a two-part closed jet cart which provides broad, yet economical, flexibility both for current model mounting needs and growth potential for unanticipated future needs. The carting concept includes a high load vertical strut-sting with a dynamic pitch range of 30 degrees, high angle of attack strut-sting with a dynamic pitch range of 90 degrees, and external balance floor mount model support systems. Both strut-sting model support systems can be removed from the test section flow region to accomplish undisturbed floor mount testing.

At the time of SDR, two system level requirements could not be met. 1) The optical access requirements necessary for full coverage using current LDV technology equipment is inconsistent with the wall slot spacing requirement. All other optical access requirements were achieved. Current technology LDV equipment will not fit between the established wall slots. If the slot spacing is increased, system flow quality requirements may not be achievable. 2) The technology does not currently exist to meet the requirements for internal force balance measurement range and accuracy. A technology development program is recommended. All other elements of the TEST PDT are configured to meet all of the other functional and performance requirements.

As part of the systems engineering approach, trade studies were conducted to support configuration development. The most significant trades are identified in Table 9-1.

9.1.3.2 Closed Jet Carts

The primary functions of the closed jet test cart are to support the model during testing and confine the test region flow (Ref. WBS numbers 1214650 and 1215570). Early in the NWTC program, multiple, removable test section carts were selected as the design solution which would provide optimum tunnel utilization (Ref 9-3). A system with multiple, interchangeable test carts increases availability of the tunnel for testing. In turn, increased availability reduces operating costs and increases annual throughput. Removable test carts also achieve the requirement for adaptability for future modifications. The decision to employ removable carts was reviewed and affirmed in Design Decision Notice (DDN) # 1 on July 10, 1995 (Ref 9-4). See Figures 9-2 and 9-3 for further details.

TRADE	RESULTS	REFERENCE
Wings level yaw configuration	Yaw head on upswept sting (transonic) Floor mount bipod (low speed)	DDN 16
Sting mount configuration	30 deg. range vertical strut 90 deg. carriage strut	DDN 16
Floor mount test without rear strut	Two-part cart	DDN 16
Number and type of carts	2 vertical strut aft carts 1 blank aft cart 2 fore carts - external balance and carriage	DDN 16
Cart transport system (Risk Reduction Study re-evaluated)	Air bearings	Calculations
Optical access	432 windows with 7" and 10" widths	Calculations
DAS room location	Attach to cart inside tunnel plenum	Calculations
Model position measurement	Optical measurement	Calculations
External balance	Laser inferometer deflection measurement	
Test cart position alignment accuracy (CES study results reevaluated)	0.027" along cart centerline	CES - Pressure Shell/ Test Leg Interaction Study
Test section slotted wall design	14 floor/ceiling slots, 8 sidewall slots 1.5" slot width 30" long slot control segments 10% porosity, acoustic fillers, solid covers	DDN 10
Vertical strut - 2 vs 4 sets of side bearings	4 required due to pitch range and large overhang of strut from bearing	Calculations
Vertical strut and arc sector - reaction of side load to fixed strut	Due to load magnitude, load must be shared by fixed and movable strut bearings	Calculations
Propulsion simulation air supply to model	Air supply to model will be routed partially through the strut and partially outside the strut	Segment Spec./ Calculations

Table 9-1: TEST PDT Trades

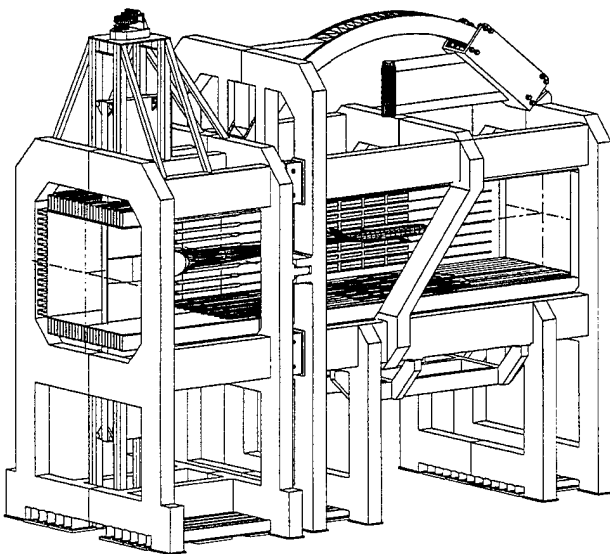

The test cart system that evolved during the preliminary design process includes the test section walls, several model support and manipulation systems, data interface features, an environmentally controlled data acquisition system enclosure, and a cart transport system. The cart system provides three independent model support systems: a -10° to +20° (angle of attack range) vertical strut and sting, a 0° to +90° carriage supported sting system for fighter models, and an external balance with floor turntable

Figure 9-2: Closed Jet Test Cart - Vertical Strut Configuration

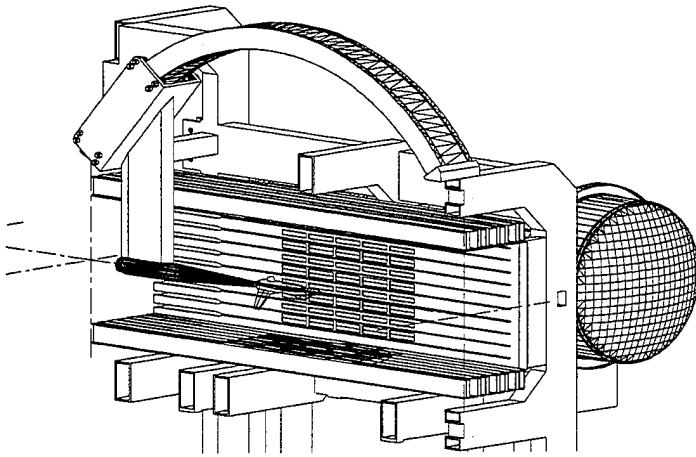

To eliminate aerodynamic disturbances from the vertical strut during floor mounted tests, the cart separates into two individual segments, a forward cart segment and aft cart segment. The cart separation plane is located at the end of the high quality test flow region, at the upstream edge of the model support region re-entry flaps. The aft cart segment containing the vertical strut can be removed and replaced with an aft cart segment containing a duct only. This allows floor mounted testing free of vertical strut induced interferences.

Figure 9-3: Test Cart - High AOA Carriage Configuration

The test carts are transported from the tunnel test position to the model installation bays on an air bearing suspension system. Inflatable air bearings lift the test cart which is moved by air powered tractors. There are two tractors on the forward cart section and two on the aft cart section. Each section of the cart may be independently transported during cart re-configurations operations. An automated alignment and latching system provides for quick connection of the forward and aft cart segments to each other. Another automated system aligns and latches the full cart assembly to its hard points in the tunnel circuit.

All four test section walls on the forward cart segment are slotted to accommodate transonic testing (Ref 9-5). Flow through the slots is controlled by sliding segmented cut-off plates on the back side of the slot. An actuator provided at each segment break point enables piecewise, continuous variation in slot width along the length of the test section. Slot fillers are provided to allow for solid wall testing.

The test section walls are equipped with a number of adjustment features to allow control of air flow and to align the flow surfaces. At the upstream end of the forward cart segment, tapered alignment pins engage the flexibly supported wall panels to create a precise, step-free mating with the contraction. To deblock and control flow around the model and vertical strut, the side walls in both the forward and aft cart segments have a powered motion which allows variation of the wall angle with respect to the tunnel longitudinal axis. Aft of the model, flow deblocker channels and powered flow re-entry flaps return flow from the plenum back to the airstream.

Numerous windows, having widths of 7 and 10 inches in alternate rows, are provided in the test section walls to allow optical access to the test region. As discussed in Section 9.1.3.1, the LDV optical access requirements have not been fully met.

Two aft cart segments containing vertical strut model supports and one blank aft cart segment are provided. Two forward carts with high angle of attack (AOA) model support systems are also provided. (Ref 9-6). The closed jet cart configurations are shown in drawings 4189-5, 4196-1, 4202, 4202-1, 4204, 4204-1, 4204-2, 4204-3, 4204-4, 4204-5, 4204-6, 4204-7, 4204-8 and 4204-9.

9.1.3.3 Open Jet Cart

The NWTC facility includes an open jet test section which would be used for a wide variety of aeroacoustic tests (Ref 9-7). The open jet test section is configured on a transfer cart which replaces the closed jet cart when the wind

tunnel is re-configured for open jet testing. The key elements and dimensions for the open jet are shown in Figure 9-4.

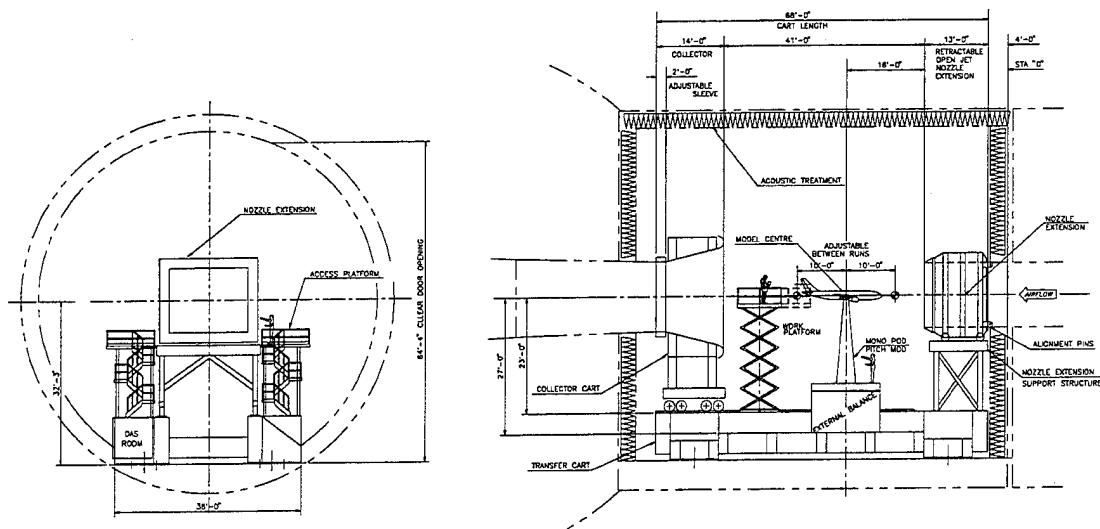

Figure 9-4: Open Jet Test Section with External Balance and Monopod Model Support System

The geometry of the open jet test section has been established to meet out-of-flow sound measurement requirements, constraints imposed by the closed jet geometry, jet stability requirements and aerodynamic simulation requirements. The final geometry is documented in (Ref 9-8).

The jet is defined by a nozzle extension, which is permanently fixed to the transfer cart, and a collector, which is supported by the transfer cart but may be interchanged with a second collector. The overriding technical concern with this test section configuration is the possibility of jet instability coupling with wind tunnel circuit resonances. This can result in large static pressure and jet velocity fluctuations which could ultimately limit the maximum speed in the open jet test section (Ref 9-9). Jet unsteadiness was identified as a Zone 1 risk (Ref 9-10) and an open jet experimental test program was defined to address this risk. The baseline collector geometry has a modest inlet flair of 14° with a breather at the collector throat. The throat area is set by the test section diffuser inlet geometry required by the closed jet test section. The experimental program will be used as design tool to verify and/or refine the geometric details for the open jet test section. Parameters such as the ratio of nozzle area to collector throat area, the collector breather area, the collector shape and flair angle would be systematically varied in the experiments.

The open jet test section is operated in an anechoic environment that is achieved by means of sound absorbing wedges attached to the inside of the plenum shell. This treatment will also be mounted on the upstream and downstream plenum bulkheads and the plenum hatch. Most other reflective surfaces will be acoustically treated (transfer cart structure, etc.) and the extent of this secondary treatment would be established during preliminary design.

The open jet test section is operated at 1 atmosphere static pressure and this pressure would be passively controlled by allowing the plenum to breath. The configuration of the breather has not been established at this time.

The open jet test cart is of a modular design to permit easy re-configuration for different test scenarios. Hardware elements are interchanged in the preparation bay where the various components are stored on elevated rails. This test section must support testing of fixed wing and rotorcraft complete models, fixed wing half models, and engine models. The resultant model support systems are a floor mounted strut (monopod) with and without an external balance, a rear strut (with and without internal balance) and a ground plane (with and without half model support system). Two collector assemblies have been included, one clean collector to be used in conjunction with the monopod model support system and a second collector with a pitch strut.

The open jet external balance is installed on a sub-frame which is floating during cart transfer and is attached directly to the plenum shell when the open cart is installed in the wind tunnel circuit. The balance is thus grounded directly through the plenum shell which provides a stiff balance foundation. The external balance can be interchanged with an adjustable monopod support base which provides axial positioning capability, while under test, for monopod supported models. This capability is required in order to increase the microphone angular viewing range.

The open jet can also be configured as a $\frac{3}{4}$ open jet test section with a removable floor section that extends from the nozzle exit through to the collector inlet. This floor includes a boundary layer removal system and a half model turntable. It is used for half model tests and to provide ground simulation for Rotorcraft tests.

A large DAS room, with uninterruptable power, is included on the transfer cart (see Figure 9-4 above). This space is conditioned but the DAS room is not a pressure vessel (as for the closed jet) because the open jet is always operated at one atmosphere.

The various open jet configurations are shown on drawings 4025-102, 4025-105, 4025-108, 4025-110, 4025-111, 4025-112, 4025-113, and 4025-114 (Ref 9-11).

9.1.3.4 Force Balances

The Force Balance sub-PDT has proposed and provided cost, schedule and equipment performance estimates for: three (3) external balances - one (1) for the open jet cart, and one (1) for each of the two (2) closed jet carts; three (3) internal balance designs - low range, high range and blowing with two (2) copies of each to be provided; an automated balance calibration system for the calibration of both the external and the internal balances of the NWTC; and three (3) calibration fixtures for control surface calibrations - hinge moment calibration fixture, wing bending moment calibration fixture, and a fin bending moment calibration fixture. For an elaboration of the cost and schedule estimates, please refer to the integrated cost and schedule estimates compiled by the NWTC Project Office, WBS numbers 1317130, 1317321, 1317322, 8700 and 9000.

The risk assessment of the equipment to be supplied by this sub-PDT has identified both the external balances and the automated balance calibration system to be Zone 2 risks owing to technology maturity. The calibration fixtures were identified as Zone 3 risks with no complications foreseen. The internal balances were assessed to be Zone 1 risk as no technology exists which is capable of meeting NWTC requirements. For example, static load resultants are on the order of 7 and 12 times as large as the respective resultant forces and moments experienced by some of the largest internal balances available today. These loads, in combination with a requirement of 100% dynamic load capability and a required increase in accuracy of an order of magnitude, precludes current state of the art approaches.

To satisfy NWTC requirements for the internal balance accuracy, repeatability, and resolution experienced at the load magnitudes described in the Project Specification which originate from CR&O version 10.0 Master Requirements Document, the Force Balance sub-PDT has recommended a technology research and development effort. The proposed plan suggests three (3) persons be assigned for a period of two and a half (2.5) years to research available technologies for application to internal balances and to develop and test these technology options. Strain gauge technology offers only a small incremental improvement. The use of strain gauges will not alleviate the large hysteresis owing to anelasticity, as this requires operating in a low stress environment which is contradictory to the use of strain gauges. Thus, investigation must focus on non-conventional methods such as laser interferometer deflection measurement techniques. This enabling technology development is considered essential in achieving the full potential of a high Reynolds number facility.

9.1.3.5 Model Handling Systems

The Model Handling Systems cover all equipment required for the movement and handling of test models within the NWTC facility (Ref. WBS numbers 1615640 and 1617440). The status as of the System Design Review (SDR) was only conceptual. The basic functional requirements had been identified, but little preliminary design work has been completed. The basic requirements can be grouped into the following categories:

NWTC Final Report

- Transfer of models within facility: covers the transfer of partial and complete models from the shipping/receiving area to the model preparation areas, as well as the transfer to any other areas of the facility, such as the machine shop.
- Assembly of models: includes all standard and special tools needed to assemble, disassemble and check out models in both the model preparation rooms and in the test carts.
- Installation of models into test carts: includes all necessary transfer carts and elevator devices to position and install or remove a model in the test cart, both in the cart build up bays and in the circuit.
- Model changes with test cart in circuit: includes both minor model changes with model installed on model support system and major model changes such as replacement of a wing section (definition of major model change requirements can be found in the Customer Operations Requirements document, Release 10.0). Also included in this category are model access platforms in the test carts.

9.1.3.6 Local Controls

The TEST PDT is responsible for the test cart local control systems and utility distribution required to meet the productivity, flow quality and functional requirements. The control systems can be divided between closed jet carts, open jet cart, and the airflow calibration laboratory. The individual systems include cart guidance and movement; cart alignment and installation; model support systems (rear mounted sting, high angle of attack, and external balance mounts); model position measurement; propulsion simulation air; variable slot geometry; wall angle position; re-entry flaps; ceiling and floor doors; elevated ground plane; open jet nozzle and collector position and airflow calibration lab chamber pressure, propulsion simulation air, and data acquisition. These local control systems receive setpoint commands from the C&I PDT tunnel supervisory system and send status and sensor data in return. A detailed decomposition of the data flows between these systems can be found in the "C&I PDT Functional Decomposition" document.

The control system trade studies conducted prior to SDR concentrated on the two highest risk areas impacting the control designs. First, the model attitude measurement accuracy requirement of +/- 0.005 degrees for pitch angles between -10 and +40 degrees requires that a direct measurement of the attitude is available. A trade study (see "Attitude Measurement Trade Study" calculation package) investigated optical and model mounted measurement sensors. This study identified the OPTOTRAK system as the primary measurement device with model mounted accelerometers as a backup sensor. The OPTOTRAK system employs test article flush mounted diodes and multiple wall mounted charged coupled device sensor heads. The diodes in the test article are strobed in sequence while the sensor heads triangulate the position of each diode. The system appears to provide the required attitude accuracy over the entire test article range of motion.

Model support flexibility is the second high risk area. Sting model support systems are exhibiting first fundamental bending modes at 2-3 Hz. Analysis was conducted (see model support dynamics calculation packages) which demonstrated that a 1-1.5 Hz bandwidth controller could avoid model support excitation and still meet the transient response productivity requirements. Further risk reduction plans have been identified and include a more detailed system analysis employing higher fidelity models to refine the expected attitude measurement accuracy and confirm the performance of the model support controller.

9.1.3.7 Auxiliary Model Support Systems

The Auxiliary Model Supports serve primarily to mount full, half and propulsion models to the sting mounted model supports and to the external balances (Ref. WBS number 7430). A wide range of test configurations and model loads are outlined in the Customer Performance Requirements document, Release 10.0 and both the Primary and Auxiliary Model Supports were developed to meet these requirements.

The main categories for the auxiliary supports are:

- Rear sting supports for closed and open jet carts

- External balance supports for closed and open jet carts
- Other supports

Further details on the Auxiliary Model Supports can be found in document NWT-01-B-1774-01.

9.1.3.8 Aerodynamic Calibration Equipment

This sub-PDT has responsibility for the Aerodynamic Calibration of the Test Section (WBS 151-5920), the Calibration of Hardware (WBS 151-7170), and the Calibration Models (WBS 151-7180).

The requirement for this sub-PDT is to "Provide Calibrated Test Sections". The Aerodynamic Calibration task will interface closely with the Test and Validation task, which was planned by the Systems Design and Engineering group, to determine the optimum Test Section flow control settings and to perform the aerodynamic calibration.

The requirements for Calibration Hardware and Calibration Models are to provide hardware and models needed to support the "Test and Validation" and the "Aerodynamic Calibration" tasks for the life of the tunnel. The hardware equipment concepts needed to support these requirements include three (3) twelve-inch Boundary Layer Rakes, a seventy-foot Long Static Probe and a Flow Field Survey rig. The Long Static Probe consists of seven (7) ten-foot sections of which five sections are instrumented with static pressures. This probe will be held in place with cables. The aft end will be mounted under tension to decrease probe sag. The Flow Field Survey rig is a device which will traverse a variety of flow probes throughout the entire test volume. This system will mount independent of the model mounting system.

A Model Wake Survey system, which will satisfy the requirements for model wake surveys, was added to this sub-PDT by virtue of its similarities to the Flow Field Survey rig. This system will mount independent of the model mounting system and survey the wakes behind the models.

The calibration models needed to support the requirements include a full-span model, a semi-span model and a supersonic model. The full-span model will be a transonic transport configuration. This model will have a cruise wing and a high lift wing. Removable horizontal and vertical tails will be provided. The models will be usable with all the full-span model mounting systems. The semi-span model will be of the same configuration as the full-span model and will be furnished with three (3) wings: a cruise wing, a high lift wing and a symmetrical wing. The symmetrical wing is needed because the model cannot be mounted inverted to measure the Test Section integrated flow angularity. A removable horizontal tail will also be provided. The semi-span model will be floor mounted with a non-metric stand off plate. A Supersonic Calibration model of a fighter configuration will be provided for calibration up to the tunnel maximum Mach of 1.5. All models will have static pressure taps installed.

Preliminary concepts satisfy the requirements that have been identified. Budget and schedule estimates have been made to support the Systems Design Review. Aerodynamic calibration equipment design was conceptual at the SDR. Additional requirements for the equipment and calibration processes might be identified during preliminary and final design. The cost of such additions is captured to some degree by the risk factor.

9.1.3.9 Air Flow Calibration System

The primary function of the Air Calibration Laboratory (ACL) is to independently measure the effects of wind tunnel model internal flow in order to correct wind tunnel external flow measurements (Ref. WBS number 7120). A secondary function is to calibrate measuring devices such as flow meters and instrumented rakes. The ACL utilizes a pressure vessel functioning as the test cell. This test cell is equipped with a 3-component force balance and an extensive array of model air supplies and associated flow measuring/flow control elements.

The governing design criteria originate in the "Customer Performance Requirements Document". In general, those criteria relating to propulsion type test articles are directly applicable to the ACL. The wind tunnel propulsion test articles include those with: flow-through nacelles, blown nacelles, turbine powered simulators, ejector pumping and inlet performance measurement features. The ACL test articles may be either removable engine models, typical of commercial aircraft testing, or integrated airframe models, typical of military aircraft testing.

The current design status is in the conceptual stage. The next logical step in the design process is to continue to define and/or clarify design criteria that are unique to the ACL and are not within any current customer requirements documentation. Three important examples of undeveloped criteria follow.

First, the ACL must have exhaust gas treatment flow elements to substitute for functionality of the circulating air within the wind tunnel. When operating the ACL in a sub-atmospheric mode, the exhaust gas treatment must include test cell evacuation flow elements. The exhaust could be pumped by ejectors, discharged through the facility vacuum systems or pumped by the Plenum Evacuation System (PES) system. The required capacity of the exhaust subsystem and the size of piping is determined from the maximum expected volumetric flow in the sub-atmospheric mode. This flow criterion has not been defined because it was not necessary for wind tunnel design work.

Secondly, inlet air is directly supplied by the circulating airstream within the wind tunnel. This air must be supplied by an external source within the ACL. Criteria must also be established to have a basis for designing ACL inlet air supply flow elements.

Third and lastly, Release 10.0 of the Customer Performance Requirements document provides information with respect to the maximum model size and model support loads for the wind tunnel. Since the largest wind tunnel models are commercial aircraft based test articles, only removable engine models must be tested within the ACL on a one-at-a-time basis. Furthermore, the definitive loads for wind tunnel models are caused by the external flow, and the internal flow loads of the ACL are much lower. Therefore, the design constraining model size, model loads, and maximum model air supply requirements must be defined uniquely for the ACL.

Given the need for definition of basic ACL design criteria, Figures 9-5 and 9-6 are only conceptual. These figures demonstrate a process diagram of the principal ACL supply and exhaust streams, as well as a schematic representation of the ACL identifying key required design features. The process diagram provides process fluid interfaces and a conceptual allocation of flow elements. The essential feature is to provide good measurement and process control over a very wide range of test parameters. Note that all of the model air supplies flow elements to the ACL have an equivalent within one of the test carts. It is prudent that they are identically matched, and, therefore, the derivation of ACL model air valve specifications will be done during wind tunnel cart design activity.

There are no existing facilities that can provide the capability required of the NWTC ACL. Typical existing facilities utilize either atmospheric inlet or exhaust, and have a test cell flow rating an order of magnitude lower than that required for the NWTC ACL.

9.1.4 Risk And Mitigation

Technical risks, safety hazards and reliability associated with the TEST PDT were identified and evaluated. The results are contained in the project level documentation regarding these subjects. To date, four Zone 1 hazards have been identified; personnel trapped in tunnel during operation, internal balance overload, noise from propulsion simulation testing, test section integrity during the access phase. Each of these was identified in a preliminary assessment. Identification of hazards and development of mitigation plans would continue over the course of the design phase. Six zone 1 risks have been identified; model position measurement accuracy, model support dynamics, model supports, internal balances, test section windows, and open jet unsteadiness. Mitigation plans for each of these risks have been explored and are documented with the project level risk management plans (Ref 9-12).

9.1.5 Recommendation

The TEST PDT is responsible for many of the most demanding functions and high risk elements of the National Wind Tunnel Complex. To meet these challenges, several enabling technologies need to be developed. The zone 1 risks identified by the TEST PDT represent the core functions of the facility and advancement of these technologies must be continued. These risks are documented and mitigation options explored in the project risk management program. Implementation of the risk mitigation plans is strongly recommended prior to or concurrent with the continuation of the NWTC project. Summaries of the risks and mitigation options are presented below.

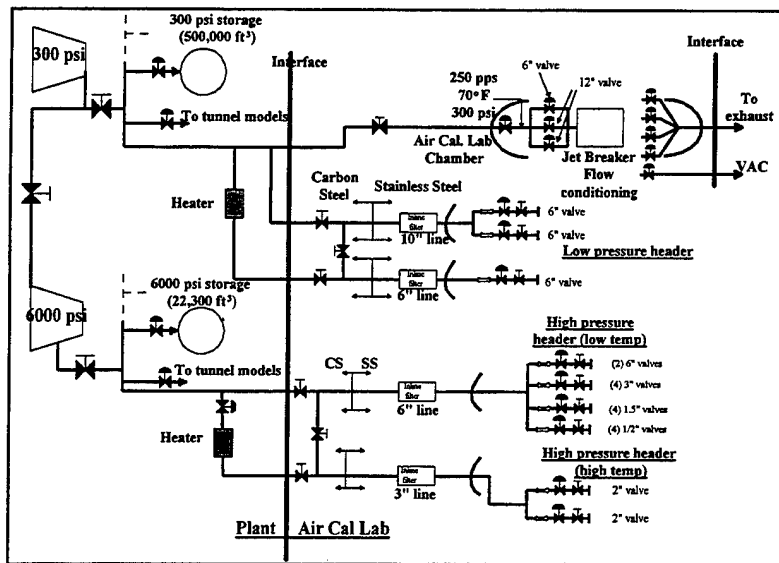

Figure 9-5: Air Calibration Laboratory Process Diagram

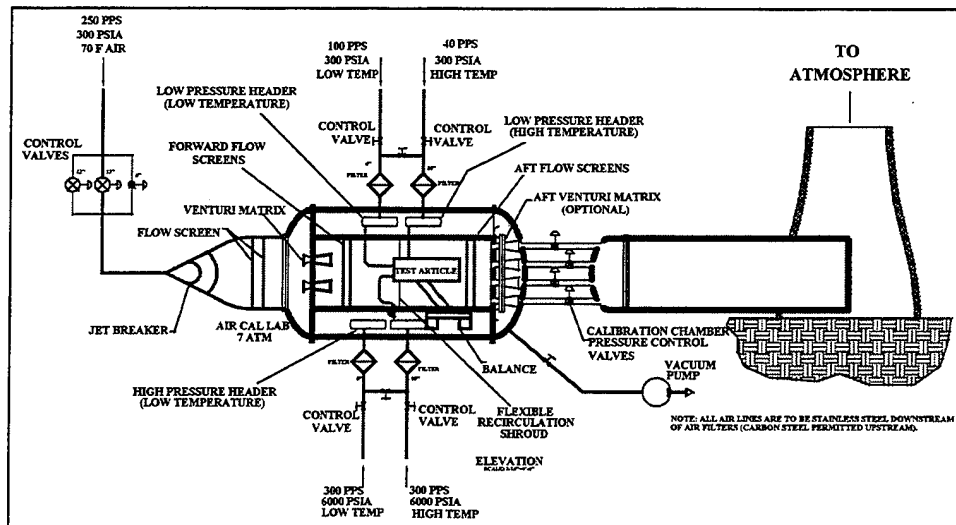

Figure 9-6: Air Calibration Laboratory Schematic

Model and model support dynamics plague existing high dynamic pressure facilities and cause reduced testing capabilities. Dynamic problems are increased due to stringent flow quality requirements and a wide range of model orientations resulting in very flexible structural systems. It is necessary to fully explore the existing knowledge of model support dynamics and analytically evaluate options that allow testing at the full capability of the tunnel. Mitigation options include: researching dynamic model loads through previous experience, analytical methods and experimental methods; developing a model that correlates with existing high dynamic pressure facilities; using a load monitoring system to identify and prevent potentially dangerous situations; and designing tunnel hardware to

be adaptable so dynamic response is reduced (for example a sting tether, variable stiffness devices and active control systems).

Very high data quality requirements were specified for NWTC. Examples include a 0.005° model pitch angle measurement accuracy and a 0.01%/0.03% full scale accuracy of model forces/moments. Extrapolation of current demonstrated technologies could meet the requirements of model position measurement accuracy and external balance accuracy. However, these are still classified as risk items. Mitigation options include: development of new technology laser interferometric force transducers and a non-orthogonal space frame for application in external balances; and performance characterization tests of the OPTOTRAK model position measurement system in the presence of vibration and window optics to determine wall mounting stiffness requirements, vibration isolation requirements, and optical window calibration requirements. Internal balance requirements represent a three-to-seven times increase in resultant load ranges, a two-to-twenty times increase in resultant moment ranges and a nine-to-twenty times increase in accuracy. No technology exists to satisfy these requirements. There is an urgent need to start a technology research and development effort as soon as possible. Although it is difficult to conceive of internal balances meeting the requisite performance, any gains that can be made are highly beneficial since balance uncertainty is one of the top two sources of uncertainty.

Experimental tests with a 1/13th scale model were scheduled to occur in the spring of 1996 at the ASE-Fluidyne laboratory. The test hardware has been designed and manufactured prior to project cancellation. The high speed leg experiments would have confirmed the closed jet test section design, addressed power requirements and determined the contribution of the flow re-entry system and the model support region to test section flow quality. The open jet test section experiments would have addressed open jet stability coupling with test leg resonances, the maximum Mach number achievable with the open jet and the open jet stability coupling with the full circuit resonances. The model hardware is adapted to the ASE-Fluidyne laboratory and testing could begin almost immediately. It is strongly recommended that these tests be conducted as they would answer basic questions regarding the feasibility of the NWTC open jet test section and closed jet test section flow quality requirements.

9.2 Flow Conditioning System

The Flow Conditioning Systems (FLOW) consists of various mechanisms and structures contained within the wind tunnel pressure shell which provide the means to manipulate the air flow. The major sub-systems of FLOW are: Stilling Chamber (screens, honeycomb, liners), Heat Exchanger, Flexible Nozzle, Turning Vanes, and Transition Diffuser.

9.2.1 Management Plan

The NWTC FLOW effort was executed using a Product Development Team (PDT) approach. A Team Execution Plan (TEP) was developed and documented in (Ref 9-13). This document contains the team goals and strategy, team organization, roles and responsibility, statement of work, task descriptions, interface requirements, activity networks and schedule, risk management, and deliverables.

The Technical Assistance Contractors (TAC) provided technical responses to the PDT developed tasks per NWTC approved task orders.

9.2.1.1 Team Goal and Statement of Work

The team goal was to deliver an integrated system to meet the contract cost, schedule, quality, and performance requirements. The team goal was achieved by implementing the Technical Management Plan, Configuration Management Plan, Risk Management Plan, and Project Integration and Control Plan.

The statement of work was to develop conceptual designs into integrated solutions, with the designs to reflect details of major system components.

9.2.1.2 PDT Organization

The PDT was organized based on 6 Work Breakdown Structures (WBS): FLOW Aerodynamics, Stilling Chamber, Heat Exchanger, Flexible Nozzle, Turning Vanes, and Transition Diffuser. Support was provided by NWTC Project Office and TAC.

9.2.1.3 Deliverables

The key deliverables for the FLOW PDT are: Segment Specification, Development Specification, Safety and Hazard Analysis, Reliability and Maintainability, Producibility and Constructability Report, Risk Reduction and Value Engineering, Preliminary Design Drawings, Design Calculation Packages, and Commissioning and Activation Test.

9.2.2 Segment Specification

The segment level requirements for the FLOW PDT design are based upon the functional and performance requirements from the Project Specification, Document No. NWT-SS-A-9300-01 Rev B, and the derived requirements from the aerodynamic design. The FLOW PDT Segment Specification (Ref 9-14), describes the performance characteristics, reliability, maintainability, availability, and verification. The relationship between the FLOW PDT Technical Performance Measures (TPM) and the System Level TPM's are documented in the SDR presentation document.

9.2.3 Design Concepts

The effort of the PDT during preliminary design is primarily focused on the concept development of the FLOW subsystems, and the preparation of the Segment Specification, Development Specification, and interface requirements. Reference design concepts are documented in the SDR presentation.

9.2.3.1 FLOW Aerodynamics

The FLOW Aerodynamics cover the preliminary aerodynamic work for each subsystem, mainly establishing the criteria and general configuration.

The Stilling Chamber Liner major criteria are:

- Provide a porous section for pressure equalization to isolation valve sphere
- Minimize leakage across flow conditioning elements
- Ensure the dimensional accuracy
- Minimize the size of steps and gaps

The Screens and Honeycomb criteria are:

- Provide turbulence attenuation to meet flow quality goals
- Minimize pressure loss sufficiently to meet flow quality goals
- Ensure honeycomb alignment and uniformity to meet flow quality requirements
- Provide sufficient honeycomb depth for fully developed flow over operating range

The Fixed Contraction Criteria are:

- Provide smooth transition from circular to rectangular cross-section
- Minimize cross flow components into the flow
- Provide adequate flow uniformity at nozzle interface

The Flexible Nozzle Criteria are:

- Provide Mach number uniformity that meets flow quality goals
- Minimize Flexible Nozzle length
- Provide continuous flow surface interface with the test section

The Transition Diffuser criteria are:

- Provide smooth transition from rectangular to circular cross-section
- Provide porous section for pressure equalization with downstream isolation valve sphere

The Turning Vanes criteria are:

- Provide uniform flow turning with minimum flow angle at exit
- Ensure low pressure loss
- Provide acoustic treatment for all vanes

The Heat Exchanger criteria are:

- Provide capacity to extract the power point heat load
- Provide wide angle diffuser to decelerate the flow to the heat exchanger without recirculation zones
- Minimize flow induced vibration

9.2.3.2 Stilling Chamber

The design features translatable and removable canisters - the inside of which form the liner surfaces. The movement feature provides for separation of 2 adjacent canisters thereby giving access to screen and honeycomb attachment hardware which is otherwise hidden by the liners. The canisters are centerline-guided on 4 support rails spaced 90 deg. apart (i.e., at top, bottom, and sides). The centerline-guide approach allows for thermal growth and contraction of the canisters while maintaining tunnel alignment. The side rails support the dead weight.

The sizing of the side rails (that carry the weight) should consider minimal deflection due to dead weight, yet have enough lateral compliance so that the structural support members to the sphere have reduced coupling. The overall method of support to the sphere needs a thorough study. The canister axial loading could be carried by the structure that supports the fixed contraction section. Thermal growth of canisters in the axial direction could then be accommodated by allowing movement in the upstream direction.

The liner internal diameter is 56.5' whereas the diameter of the sphere containing it is 106'. The movable hardware weighs about 600,000 pounds. ASTM-516-gr.70 is a candidate material for the plates that make up the canisters. It has a minimum ultimate strength of 70 ksi and yield strength of 38 ksi.

Canister translation capability will be provided by a screw jack at each of the 2 side rail locations. The side rails are the best locations for the actuators because they are at the horizontal location of the canisters' center of gravity. The sliding joint uses a commercially available inflatable seal (Prespray Pneuma-Seal).

Although the current configuration calls for 2 screens followed by the honeycomb, provisions have been made to allow for easy installation of up to 2 more screens downstream of the honeycomb, if required.

Plenum backflow will be minimized by incorporating silicone rubber seals in-between canisters (Rubbercraft dam gate silicone rubber "P" seals - which are also used in the Ames 12 Foot tunnel).

The NWTC configuration for stilling is 2 screens followed by honeycomb, as mentioned earlier. The screen diameter is about 57.5 feet and both are 0.041" dia. 304 stainless steel wire with a mesh spacing of 6 wires per inch. One hundred and twenty equally spaced springs are used (spaced about 18" apart). Splices are a minimum of 11.5 feet apart.

Each screen is held at the edge with a segmented retaining bar. The retaining bars in conjunction with their splice bars can grow radially as the springs are tensioned. Every 3 degrees, a spring-loaded rod is attached with a bracket assembly. Bushings would be inserted into the support ring holes to promote smooth operation of the tension rods.

The proposed screens were analyzed using the Cooksey equations at the worst case condition: $p=7$ atm and $M=.735$ in the test section. This operating condition generates a pressure drop of 0.146 psi across the clean screen and an axial load of nearly 53,000 pounds. The center deflection is 17.5 inches. The safety factor, based on the ratio of the load to produce yielding to the load itself was 6 for the case analyzed. The flow angularity at the $2/3$ radius point leaving the screen is 3 degrees. Spring stiffness effects and temperature were not included in this case.

NWTC Final Report

To meet the stringent flow quality requirements of the NWTC, the honeycomb design is of a homogeneous construction, with no perimeter bands or vertical support ribbons.

The modules, each about 4 feet tall, will span the entire width if possible - as long as 58 feet. If it determined that shipping and handling problems would dictate a shorter module length, then butterfly strip joints will be used. Horizontal joints between modules will be accomplished by spot welding of the honeycomb cells at the construction site under controlled conditions.

The whole structure, including connections to its support canister, should be built-up at the construction site in a building prior to installation in the tunnel, and prior to completion of the upper portion of the sphere. The total weight of the honeycomb is about 50 tons. It will see a maximum axial loading of about 63,000 pounds.

At the upstream end, the contraction section is the same diameter as the flow conditioning section: 56.5 feet. It gradually changes from circular to rectangular. The overall contraction area ratio from the flow conditioning section to the test section is 12. The contraction area ratio for the portion covered here (upstream of the isolation valve) is about 5.

Making the homogeneous honeycomb design a reality will be a challenge. Important issues are: 1) sag of cell structure and induced stresses and possible buckling of foil due to its own weight, 2) additional weight of trapped water from cleaning and removal of the water afterward, 3) possibility of buckling of upstream face under maximum air loading, 4) number of and placement of welds at each node, 5) fixed edge boundary condition effect on the honeycomb's ability to accommodate thermal growth and contraction of cell structure, 6) manufacture and shipment to job site of 58' long modules, and 7) meeting cell parallelism requirements - which are very tight.

Maintaining alignment of the stilling chamber with the test leg will be a challenge because of the enormous sizes involved. Also, at the SDR, concern was expressed that the contraction contour be verified prior to cutting metal (CFD). In addition, maintaining tight tolerances during the manufacture of the contraction will be difficult and costly.

9.2.3.3 Heat Exchanger

The concept selected for design development is based on the continuous plate-fin surface. This surface has 5/8" diameter staggered tubes.

The baseline concept was modified from the CES design (Ref 9-15) to account for changes in the requirements when the project was down-scoped to a single tunnel enhanced TSWT. The "new baseline" concept provides good flow quality and rugged construction for high dynamic pressure environment. The change to the single tunnel resulted in an increase in the heat exchanger diameter from 75' to 88'-4" and an increase in drive horsepower from 280,000 hp to 360,000 hp. The resulting power density is approximately 200,000 Btu/hr/ft². The cooling water piping requirements increase proportionally.

The concept developed during the preliminary design for the single tunnel TSWT consisted of planar, cross-counterflow, tube-fin type heat exchanger, located in the back leg downstream of the compressor in a pressure shell bulge region. It is of modular construction with 74 full size module and 8 half size. The support structure is covered with aerodynamic fairings. It has contoured wide angle diffuser and contraction.

The heat exchanger surface is a plain, continuous plate, tube fin heat exchanger configured in a 16 row, 4 pass, cross-counterflow arrangement. The heat exchanger tubes are 5/8" OD, 0.049" wall copper tubes on a horizontal pitch of 1.75" and a vertical pitch of 1.5". The plate fins are 26 gauge aluminum spaced 7.75 fins per inch.

The horizontal tubes allow the heat exchanger modules to be filled and drained much easier than with vertical tubes. The continuous plate-fins provide support for tubes over the entire finned length.

NWTC Final Report

The individual modules have a face area of 63 square feet (full size modules). The total heat exchanger face area is 4686 square feet. The full size modules are nominally 6' x 12' x 2' deep. The half size modules are nominally 6' x 6' x 2'. The total blockage on account of the vertical and horizontal struts is approximately 24%.

The cooling water connections are located on the upstream side of the heat exchanger. Both the supply and return connections are on the same end of the module. This cooling water connection arrangement allows all of the internal piping to be located on the upstream side of the modules. This in turn allows the modules to be installed and removed (if necessary) from the downstream side of the heat exchanger structure.

The estimated module weight is 8,000 lbs dry and 10,000 lbs wet.

The strut/module structural system consists of eight vertical struts and fifteen horizontal struts. The supply and return piping for each module is routed through the horizontal struts to a point outside the pressure shell.

The total weight of the system is between 1.5 and 2 million pounds, and is carried exclusively by the vertical struts which are hung from the top and guided at the bottom so that the entire cross-section of the strut is in tension. By avoiding compression zones all together, the possibility of buckling is eliminated. The horizontal stability of the heat exchanger assembly is accomplished through the use of seismic links that allow for the thermal expansion while providing structural stability.

The cooling water system consists of two primary cooling circuits feeding 48 modules on one side of the heat exchanger and 34 modules on the other side. Individual control valves in the return lines from each module will be used to balance the cooling water flow through the modules. In addition, coarse and fine control valves in a bypass line between the main supply and return lines will be used to maintain a constant supply pressure to the heat exchanger. These valves will allow the cooling water pumps to operate at a constant load condition. Coarse and fine control valves in the main cooling water return line will be used to control global flow through the heat exchanger. These valves will serve as temperature control valves.

The heat exchanger modules are supplied from both sides of the tunnel at each module row elevation. The piping is routed to the modules through the horizontal struts. The connections to the modules are made inside the vertical strut space.

The cooling water supply and return lines are routed to/from vertical risers located on each side of the tunnel. A 72" diameter supply and return riser is provided for 48 modules on one side and a 60" supply and return riser is provided for the remaining 34 modules. The riser diameters are sized for a 7 fps water velocity. The risers will be supported by a structural steel support structure. The support structure will also provide access to the 8" supply and return lines for maintenance.

The primary personnel hazards that have been identified so far include exposure to fall hazards (working at heights), and exposure to crushing hazards (lifting of heavy objects).

The primary equipment hazards that have been identified so far include potential freezing of coils due to weather conditions, and potential freezing of coils due to blow-down of tunnel from operating pressure.

The primary operational hazards that have been identified so far include cooling water leaks into tunnel, and air leaks into cooling water piping.

9.2.3.4 Flexible Nozzle

The Flexible Nozzle consists of Flexible nozzle Structure, Flexible Walls Assembly, Sidewalls Assembly, Nozzle Exit Adjustment Assembly, and Nozzle Slip Joint Arrangement.

The Flexible Nozzle Structure consists of four vertical octagonal box frames, tied together by horizontal side box beams. The octagonal shaped frames fit the cylindrical plenum efficiently and are easier to fabricate than circular

frames. The Flexible Nozzle Structure provides attachment points for the Sidewalls Assembly, Flexible Walls Assembly, and Nozzle Exit Adjustment Assembly.

The Flexible Nozzle Structure is attached to the tunnel pressure shell through interface points defined for the upstream and downstream octagonal frames.

The Flexible Walls Assembly consists of top and bottom Flexible Walls. The Flexible Plates are attached to the actuators by using hinge assemblies. These hinge assemblies provide for the required movement of the plates, relieve stresses, and reduce distortions produced by temperature differentials between the Flexible Plates and the Flexible Nozzle Structure.

The Flexible Plates are integral pieces of heat treated steel plates finish machined on both flow and non-flow sides. They have provisions for attaching hinge assemblies, on the non-flow side at 18 axial locations, with 19 hinges per location, and for attaching at the downstream end to the support structure. Seal grooves are provided on each edge for sealing between the Flexible Plates and the Sidewalls Assembly. A seal groove is provided on the non-flow side near the downstream end for sealing between the Flexible Plates and the Flexible Nozzle Structure.

The nozzle actuator assemblies are used to control the position of flexible plate with respect to the Flexible Nozzle Structure and provide adjustment for the Flexible Walls. Each nozzle actuator assembly is an electromechanical drive system. It consists of two screw-jack mechanical actuators which are coupled together through the output shaft of a gear reducer and driven by an electric servomotor.

The Sidewall Assembly consists of Sidewall Plates and Sidewall Structures. The Sidewall Plates are solid steel, constant thickness, finish machined plates which form the sides of the adjustable nozzle. The plates provide the surface on which the flexible wall edge seals move as the nozzle contour is adjusted. The Sidewall Plates "float" on teflon pads and are attached to the Sidewall Structure with flanged clamps. The Sidewall Plates withstand the pressure loads imposed during tunnel operation and transfer these loads to the Sidewall Structure.

The Nozzle Exit Adjustment Assembly consists of a doubler plate attached to the flex plate with a tapered shim plate sandwiched between the doubler plate and the nozzle support structure.

The Flexible Nozzle slip joint arrangement consists of a fairing plate, a bearing bar, and spring loaded roller assemblies. As the plate translates from the Mach 1.0 contour to the Mach 1.5 contour, it must have provision for axial movement and a small angle-of-rotation.

Further investigation and development of contacts with potential fabricators/suppliers need to be accomplished to determine the availability of flex plates which can be fabricated and furnished in one piece.

The plate protection devices design has not been started at this time and also the plate position indication devices have not been selected. This work should be continued shortly after the project is restarted.

The nozzle support frame finite element stress and deflection analysis should be developed.

All the interfaces which have been started should be continued and those not defined at this time should be completed.

Constructability and installation scenarios should be further developed utilizing the inputs from potential constructors, fabricators, and installers of equipment of this physical size and complexity.

9.2.3.5 Turning Vanes

The acoustically treated Turning Vanes were designed based on a built-up cross section supporting the exterior perforated plate. The built up sections are formed by a main center support rib with light gage I-sections providing the support to the external skin. The leading edge is a circular tube to provide capability to resist impact from high

energy debris. The circular tube also provides support for thermal probes to be mounted along the leading edge of the Turning Vanes and for electrical wire to run down the interior of the tube.

Channels are welded along the vertical edges of the perforated plate panels to provide a "pocket" for the connections to the I-section flanges. Access holes would be provided through the perforated plate to attach or remove the nuts. The bolts or threaded studs are welded to the flanges of the I-sections. The "pocket" connection provides for a Turning Vane exterior surface that is not interrupted by protruding connectors.

It is anticipated the acoustic treatment would be a "pillow" type construction with glass wool fibers wrapped by fiberglass cloth and protected from the perforated plate by a wire mesh. The pillows would conform to the open cells of the Turning Vane built up framing.

The Turning Vanes hang from their respective top connections with the thermal expansion/contraction connections at the base. This results in axial tension rather than compression due to the weight of the vanes.

The preliminary design of the Turning Vanes progressed to a point that all structural requirements can be met. All Turning Vanes have a rotational capability of $\pm 4^\circ$ to increase flow quality at each of the corners. Each vane can be adjusted independently of others within a set.

Details of the FOD screen and corner 2 interfaces with the compressor drive shaft fairing remain to be developed.

The thermal conditions should be revisited due to the removal of the enclosure of the complete tunnel in a building. The 55° F temperature differential may not be applicable.

The acoustic treatment should be studied prior to the completion of the design. The sizing of the cavities and the type of material should be determined during these studies.

9.2.3.6 Transition Diffuser

The main criteria for the design of the Transition Diffuser was the "ASME Boiler and Pressure Vessel Code VIII" (Ref 9-16). Additionally, the "AISC Steel Construction Manual" (Ref 9-17) was used. Maximum total stress of each composite stiffener section was calculated using membrane stress plus bending stress. The total maximum allowable was 23,100 psi.

The composite stiffeners were spaced at a maximum of 22.5 in at the circular end to 33 in at the rectangular end. The 1 in thick shell was used only on the outside portion of the diffuser. The remaining inside portion of the diffuser used 3/4 in thick shell.

The flanges of the stiffener ranges from 2 in x 9 in to 3/4 in x 6 in. The webs range from 3/4 in x 34 in to 1/2 in x 10 in.

The total area for the surface liner is approximately 8,170 sq ft. The total weight for the Transition diffuser is 727,000 lbs.

All design requirements for the Transition Diffuser can be met, and there are no problems expected during the final design.

9.2.4 Risk and Mitigation

A risk assessment of the FLOW was conducted as part of the system engineering effort that resulted in no Zone 1 risks and two Zone 2 risks. The Zone 2 risks, with mitigation options, identified in the FLOW PDT are:

- Heat Exchanger performance
 - Cooling modules designed, fabricated, and tested by reputable manufacturer
- Flexible Nozzle performance
 - Use high accuracy actuators operated by closed loop DC servomotors

- Incorporate safety features to protect flex plates

Following the System Safety Plan methodology, a number of hazards have been identified, risks assessed, and countermeasures developed for the FLOW PDT. Additional information on risk assessment and system safety analysis is available in the SDR presentation for the System Design & System Engineering.

9.2.5 Recommendation

The FLOW PDT received a favorable report following the SDR held on March 20, 21, and 22, 1996. Although there are a few open issues, as it might be expected at this stage of the project, the conclusion of the reviewing committee was that this segment of the NWTC is on the right track. Our recommendation is to continue work on this segment as outlined in our "Plan to PDR".

These plans are to continue to develop integrated design solutions for every subsystem, complete the Segment Specification, develop Development Specifications, complete design analysis, complete Interface Control Documents, complete Safety and Hazard analysis, develop Reliability and Maintainability Assessments, develop Producibility and Constructability reviews, and produce Commissioning and Activation Test plans. Continued design of the FLOW PDT components will be closely tied to the site selection process, most specifically the heat exchanger and pipe sizing.

9.3 Pressure System

9.3.1 Management Plan

The NWTC Pressure System provides a means of effective containment of pressure and channeling of airflow, and includes the pressure shell, support structure, test section plenum and internals, isolation valve assemblies, and tunnel distribution piping. A schematic of the Pressure System is shown in Figure 9-7. The NWTC Pressure System effort was executed using a Product Development Team (PDT) approach. A charter was developed for the Pressure System PDT which contained the team scope, roles and responsibilities, deliverables, and processes. A Team Execution Plan (TEP) was also developed (Ref 9-18). This document contained the team organization, statement of work, technical description summary, interface requirements, logic networks and schedules, team responsibilities, risk management and metrics.

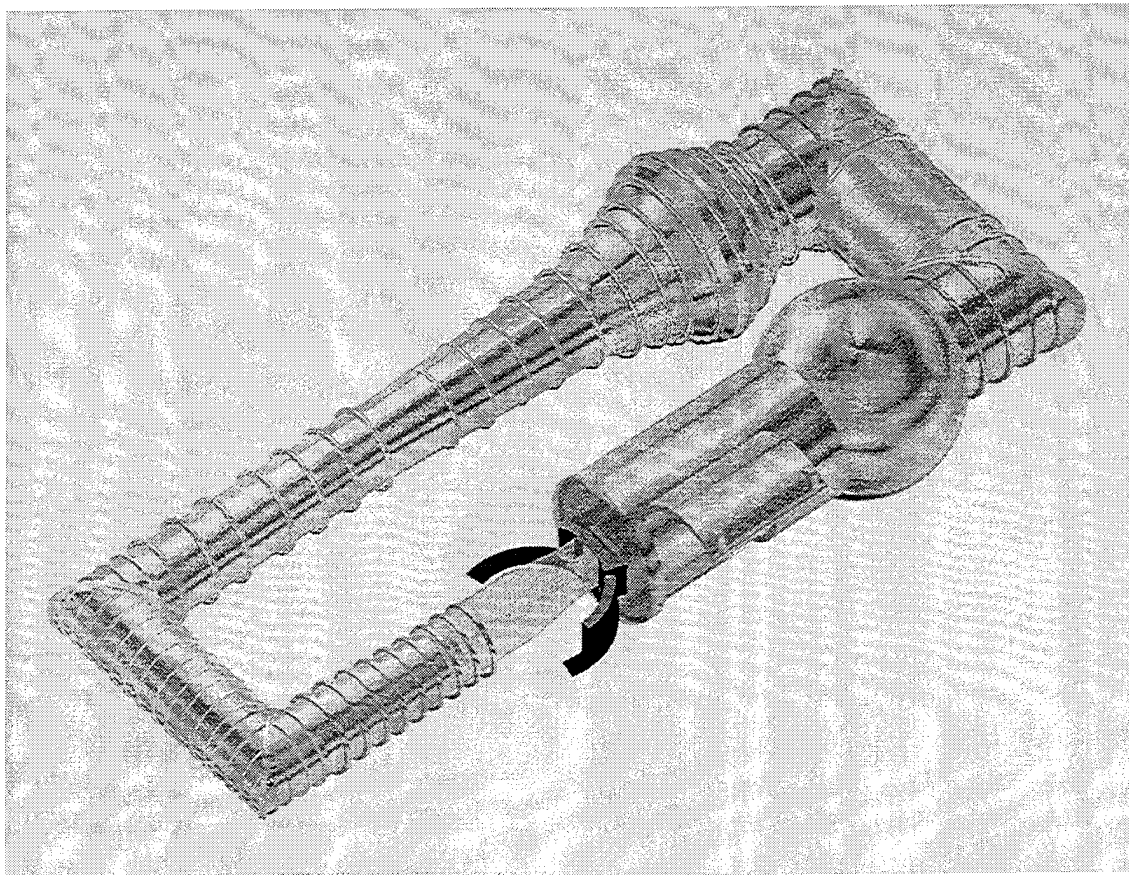

Figure 9-7: NWTC Pressure Systems Schematic

9.3.2 Segment Specification

9.3.2.1 Requirements

Pressure System segment requirements were derived from the NWTC Project Specification (NWT-SS-A-9300-01) and documented in the Pressure System Segment Specification (Ref 9-19). The primary functional requirement of the Pressure System is to provide a pressure working environment for testing, which includes containment of pressure and channeling of air flow. Subfunctions of the Pressure System are to contain flow at pressure, pressurize/depressurize the tunnel, and accommodate test article change access. Major Pressure System performance requirements are shown in Table 9-2.

9.3.2.2 Key Interfaces

Key interfaces between the Pressure System and other segments are the following:

- Test - Test Carts
- Flow Conditioning - Heat Exchanger, Flex Nozzle, Turning Vanes, Stilling Chamber
- Site - Foundations
- Compressor & Drive - Compressor Shell, Drive Shaft
- Plant - Plenum Evacuation System, Low Pressure Air & Vacuum, High Pressure Air

9.3.3 Design Concepts

9.3.3.1 Pressure Shell & Support Structure Configuration

The Pressure Shell and Support Structure Subsystem includes the pressure containment boundary plate and external

PARAMETER	REQUIREMENT
Airline Geometry	Drawing Number NWTC S100
Operating Pressure Range	0.2 atm abs to 7.0 atm abs
Ambient Temperature Range	-20°F to +110°F
Maximum Operating Temperature	215°F between compressor exit and heat exchanger 130°F remainder of tunnel circuit
Operating Life	40 years
Fatigue Life - Tunnel Ducting - Plenum & Isolation Valves	40,000 cycles 160,000 cycles
Reliability	MTTF > 40 air on hours
Maintainability	MTTR > 2 clock hours
Acoustic Testing Measurement Radius (minimum)	33.5 feet
Airline Tolerances	Steps, gaps, alignment tolerances, and flow surface waviness sufficient to meet flow quality requirements

Table 9-2: Pressure System Key Requirements

stiffeners that are required for the internal and external operating pressures. All penetrations, including but not limited to, electrical, controls and instrumentation, process, personnel and equipment manways and hatches, and miscellaneous mechanical penetrations are included, along with all access doors with required ladders and platforms. The scope of supply for this subsystem also includes the two isolation valve bulkheads and the structural bulkhead required to provide a load path for loads from the flex nozzle and the test cart. Structure for attaching the internal components to the interior of the pressure shell is included. The scope of supply also encompasses the support structure which includes the fixed anchor components, hinged supports, guide supports, and attachments required for the interfaces between the support structure and both the pressure shell and the foundations (top of concrete).

In addition to complying with the major performance requirements described in the NWTC Project Specification (NWT-SS-A-9300-01), the pressure shell and support structure must be designed to satisfy the following performance/design requirements:

- Provide a closed loop air path for containment of both the maximum internal pressure of 7 atm abs (88.2 psig) and the minimum internal pressure of 0.2 atm abs (-11.8 psig)
- React to both steady state and transient tunnel loadings

Requirements which were considered to have the greatest impact on the design of this subsystem were:

- Operating pressure range of 0.2 atm abs (min) to 7 atm abs (max) resulting in a design pressure range of 13 psig external to 100 psig internal
- Axial thermal gradient resulting from the heat of compression in the tunnel circuit
- Physical characteristics of pressure shell necessary to conform to the airline characteristics specified by the airline definition
- Facility Life > 40 Years: 40,000 pressurization cycles for full tunnel circuit
 - ◊ 30,000 cycles of 5 atm abs operation
 - ◊ 10,000 cycles of 7 atm abs operation
- 160,000 pressurization cycles for the test section plenum
 - ◊ additional 130,000 cycles of 5 atm operation for plenum shell
 - ◊ 160,000 cycles of 5 atm abs operation for isolation valves / bulkheads

Major technical risk areas identified prior to or very early in the preliminary design phase included:

- Material Selection
- Pressure Shell Proof Test
- Anchor & Support Configuration
- Fabrication & Constructability

- Test Leg Alignment

Development of the pressure shell was based on the requirements of the 1995 ASME Boiler & Pressure Vessel (B&PV) Code, Section VIII, Division 2, the design and construction code. All pressure shell elements in the tunnel circuit are bodies of cylindrical or spherical revolution. The support structure development was based on the requirements of the Ninth Edition of the AISC Manual of Steel Construction, Allowable Stress Design. The material selected for the pressure shell was SA516 Gr 70, while the material for the support structure was chosen to be ASTM A572 Gr 50. The general arrangement of the tunnel shell is shown on drawing number NWTC S001 and S002 (Ref 9-20). Details of the pressure shell are shown on drawing numbers NWTC S003 through S007 (Ref 9-21).

Recommended actions for the pressure proof testing of the tunnel pressure shell were developed and are described and contained in "NWTC Pressure Proof Test Assessment" (Ref 9-22). A pneumatic proof test incorporating additional measures beyond the ASME B&PV Code requirements was recommended and approved by the Design Board as DDN #7 (Ref 9-23).

Tunnel anchor point studies were conducted to assess the impact of various anchor/support configurations on key tunnel components. The results of the analyses were evaluated relative to the compressor case interface loads, displacements at key tunnel components (test section, heat exchanger, compressor, corner no. 2, and cross leg no. 1), foundation loads, and the elliptical girders at the four mitered corners. A recommended tunnel anchor location and remaining tunnel supports was developed using the results of the analyses and input recommendations from the compressor technical assist contractors. Those recommendations, described in "Wind Tunnel Anchorage Study" were approved by the Design Board as DDN # 19 (Ref 9-24).

Fabrication and constructability issues of the pressure shell and certain internal components were addressed through Task Order Work Authorization(TOWA) #4. This effort involved four technical assist contractors having capabilities for fabrication, construction, and erection of the tunnel. Each contractor was requested to review the preliminary pressure shell design for details that might present problems with the selected design and construction code, and to independently present and report their findings.. The consensus from the contractors was that the pressure shell concept as currently defined is generally constructable. Each contractor provided specific recommendations that should be addressed if the design of the tunnel continues. These recommendations are contained in the reports submitted in response to TOWA #4.

Initial alignment of the airline between the entrance to the contraction section and the exit of the test section to satisfy the tolerances for the shell flow surfaces and maintaining the alignment was addressed, and a support and alignment concept was developed. An analytical approach to predict the thermal interactions in the test leg was outlined. The analysis will account for transverse and axial thermal gradients between the critical points, and will superimpose other thermal misalignment deflections to this analysis. The concept utilizes the two isolation valve pressure bulkheads and a stiff structural bulkhead located at the intersection of the exit of the flexible nozzle and the entrance to the test section. Components of the flowline are attached to, or supported by, these three very stiff internal structures in a manner to provide a load path for the gravity and thrust loads while accommodating the thermal displacements. The upstream isolation valve and contraction are mounted to a common space frame structure which is attached to the upstream isolation valve bulkhead. These schemes require detailed analyses and development prior to a 30% design phase.

Intra-segment and inter-segment interfaces were identified for the pressure shell and support structure. The intra-segment interfaces or interfaces within the Pressure Shell PDT are:

- Test Section Plenum & Internals
 - Test Section Plenum Shell Attachment
- Isolation Valves
 - Bulkhead Adapters Attachment
 - Valve/Insert Track & Guide System Attachment
 - Service Air Piping Penetration

NWTC Final Report

- Tunnel Piping Distribution
 - LP Air & Vacuum Duct Penetration
 - HP Air Duct Penetration
 - Tunnel Drain Penetration
 - Tunnel Cleaning Connection Penetration
 - Exhaust Air Duct Penetrations
 - Hydraulics Piping Penetrations
 - Service Air Piping Penetrations
 - Cooling Water Piping Penetrations

Inter-segment interfaces or interfaces of other PDTs' with the Pressure Shell & Support Structure PDT are:

- Test
 - Test Cart Alignment & Latching
- Compressor / Drive
 - Compressor Casing/Tailcone/Shaft Seal Attachment
- C & I
 - Access Logic System
 - Electrical Power Penetration
 - Controls & Instrumentation Penetrations
- Plant
 - PES Piping Manifold Attachment
- Site
 - Tunnel Foundations Attachment
 - Tunnel Sunshade Attachment
- Flow
 - Heat Exchanger Attachment/Piping Penetration/Geometry
 - Turning Vanes Attachment
 - Settling Chamber Attachment/Geometry
 - Flex Nozzle Attachment/Sealing
 - Test Section Entry Liner Attachment/Geometry
 - Transition Diffuser Liner Attachment/Geometry

Risk mitigation of the five major technical risk areas identified in the pressure shell and support structure is summarized in Table 9-3.

RISK	MITIGATION MEASURES
Material Selection	Material selected (SA516 Gr 70) which exhibits ductile behavior at test and operating conditions
Proof Test	Measures taken to ensure test safety and ductile behavior of shell material during test including toughness requirements exceeding ASME Code and test temperature above ASME Code minimum allowable temperature
Anchor & Support Configuration	Conducted assessment of anchor configurations and selected configuration most compatible with individual circuit component operation
Fabrication & Constructability	Constructability review performed by major pressure vessel fabricators
Test Leg Alignment	Initiated development of analytical models to assess test leg deflections and alignment requirements during thermal excursions

Table 9-3: Mitigation of Pressure Shell and Support Structure Risks

Critical issues which must be addressed prior to PDR are:

- Heat exchanger pressure shell configuration (spherical vs conical/cylindrical combination)

NWTC Final Report

- Isolation valve bulkheads
- Structural support at flex nozzle/test section/test cart interface region
- Test leg alignment
- Pressure shell penetrations
- Seismic effects
- Internal and external attachments to pressure shell

9.3.3.2 Isolation Valve Assembly Configuration

The isolation valve subassemblies include; the isolation valve structure, flow liner insert structure, bulkhead adapter and seals, drive system, guide and roller system, valve translation system, and the alignment and latching system.

Isolation valves are provided at the upstream end of the flexible nozzle and at the downstream end of the test section, so the test section area can be isolated from the rest of the tunnel to permit personnel access to models in the test section. It is the function of the isolation valve to move from a "parked" position to the tunnel centerline where it must provide a sealed enclosure at the bulkhead opening. Additionally, the isolation valve must permit the insertion of the flow liner insert into the tunnel circuit to form a stepless transition between the contraction and bulkhead adapter during testing operations. Both units have individual "parked" positions, travel on a common rail system, and share the same horizontal roller support system.

The performance requirements for the isolation valve include: 1) operating pressure range: 1 to 5 atm abs (no vacuum operating condition), 2) number of pressure cycles: 160,000, 3) maximum valve stroke time: 230 seconds, 4) survivability temperature range: -20 to 130 degrees F, 5) flow liner insert operating temperature range: 50 to 130 degrees F, 6) upstream and downstream bulkhead opening: varies from 342 inches wide by 461 inches high to 316 inches wide by 279 inches high, 7) upstream and downstream flow liner insert dimensions: varies from 198.16 inches wide by 398.07 inches high to 192.16 inches wide by 326.39 inches high, 8) flow liner insert allowable steps and gaps: 3/4 inch maximum gap with 1/4 inch maximum aft facing step, 9) flow liner insert pressure loading: varies from 4.74 to 7.36 psig over the length of the insert, and 10) maximum allowable deflection for flow liner insert: 1/8 inch deviation from the required air line profile.

The isolation valve, which is a segment of a cylindrical shaped structure, and its subassembly structures are to be fabricated from A516 grade 70 steel. The overall valve body depth required for the pressure loading is 56.0 inches, measured from the outside face of pressure plate to outer face of the flanges. The valve body is a heavy structural tee reinforced pressure plate. To minimize safety risks, all welds in the isolation valve will be full penetration welds where possible. This will minimize concerns associated with stress risers which occurs when fillet welds are used. The maximum stress intensities predicted in the valve, as determined by finite element analysis, was 14,300 psi in the flanges of the tee's and 7500 psi in the pressure plate. These stresses are acceptable if full penetration welds are used. The maximum deflection predicted at the center of the valve was 0.26 inches.

The sides of the flow liner insert are designed as a two cell box which is 24 inches in depth. The flow liner is compliantly suspended in a support structure which uses the same transport rail and lateral support system as the isolation valve. The maximum stress intensities predicted by finite element analysis for the insert pressure loading were low due to the 1/8 inch deviation limitation on deflection. The maximum deflection was therefore predicted as a 1/8 inch deviation from the air line. The support structure is designed to carry the insert and is of sufficient stiffness to minimize deflections while the insert is transported from one position to the next.

The bulkhead adapter is a structure located between the bulkhead and isolation valve, and provides the bearing surface for the valve inflatable seals. The isolation valve inflatable seals are attached in slots on the bearing surface of the bulkhead adapter. Two inflatable seals are provided for seal redundancy to reduce the risk of a seal failure. The pressure loading from the isolation valve is transferred through the bulkhead adapter to the bulkhead. Finite element stress analysis predicts the stress intensities and deflections are significantly below allowable values.

The drive system for the isolation valve and flow liner insert is designed as an independent assembly in each structure. Since each unit can be operated individually, they are controlled to operate simultaneously while maintaining a fixed separation between the two structures. The isolation valve is designed for 4 drive units and the flow liner insert is designed for 3 drive units and both include a safety factor of 3 on horsepower. The drive system is a positive drive system which runs on a drive chain which is fixed to and continuously supported by a chain support structure.

The guide and roller system for the isolation valve and flow liner insert consists of a single crane rail and multiple lateral rollers fixed to the top and bottom isolation valve support frames for the valve track. There are 4 retractable rollers located at the top and bottom of the valve. When the rollers are retracted, the valve clamps can be attached to the valve and then used to pull the valve body against the bulkhead adapter seals. Axial translation of the valve body is accomplished by a series of rollers located in the valve body just above the drive system.

Three critical design issues were identified for the isolation valve system and steps were taken to minimize the risk. The first major design issue is the extraction and insertion of the isolation valve and flow liner insert as required for operation of the tunnel. The drive systems for the isolation valve and flow liner insert were designed with a margin on drive power to minimize failure due to insufficient drive power. The components used in the drive system were chosen so that synchronized operation of the drives on the valve and insert could be achieved while maintaining a fixed separation between the units. A positive drive system was chosen over a traction drive system to minimize risk associated with the translation of the valve and insert. To maintain the alignment of the isolation valve and flow liner insert guide system, a common structure is used for the system. The second major design issue is associated with the operation of the flow liner insert in maintaining its alignment with the flow path. To minimize the risk of misalignment, the flow liner insert is mounted on a compliant structure. The insert will be clamped to both the liner in the bulkhead adapter and the contraction section to help control the misalignment between the two segments. The third major design issue identified for the isolation valve is the relative deflections between the valve structure and bulkhead adapter. The relative deflections are minimized by providing a mechanical locking system between the two structures which will not permit significant translations between the two structures. Inflatable seals were chosen so that a small amount relative movement could occur without the relief of pressure across the isolation valve. The design by finite element analysis was a deflection controlled design.

9.3.3.3 Test Section Plenum & Internals Configuration

The test section plenum & internals subsystem encompasses:

- The plenum
- Provisions for transferring the test cart between the support building and the plenum
- All test cart support and alignment provisions inside the plenum
- All personnel access provisions into the plenum and interior to the plenum

The engineering effort to incorporate the plenum shell into the performance of the tunnel circuit has been transferred to the pressure shell subsystem for ease of integration.

Two studies have been completed as part of this subsystem. The first study (DDN # 1) evaluated alternative schemes for exchanging the models. Seven different schemes were configured and evaluated. Characteristics of these schemes ranged from a fixed plenum with fixed test section through a variety of fixed plenums with extractable test sections, a dual test leg tunnel, and a movable plenum with extractable test section. These concepts were evaluated using the criteria of capital cost, operating cost, productivity, risk, versatility, and flexibility. Initial effort in this study eliminated all options but the movable plenum with extractable test cart and the fixed plenum with side access door (clam shell) and extractable test cart. These two alternatives were compared directly in a "head-to-head" competition using the same evaluation criteria. From this effort, DDN # 1 decided that a system of extractable test carts will be used, and the tunnel will be configured using a fixed plenum with side access door.

The DDN # 1 work was completed for the two tunnel configuration of the NWTC. After the decision was made to change to a single tunnel configuration, and the requirements for the single tunnel were established with a high degree of confidence, the second study (DDN # 17) was conducted to determine if the adjusted requirements altered

any of the DDN # 1 decisions. DDN # 17 concluded that the DDN # 1 decisions are still valid. Subsystem concept development has proceeded on this basis (Ref 9-26).

The proportions of the closed test section cart controls the space and weight provisions that need to be made in the plenum. This information is developed in the TEST PDT and includes:

- Cart clear height = 64 feet
- Cart clear length = 68 feet
- Cart estimated weight = 1,800,000 pounds
- DAS container will be mounted on the test cart, centered on the air path horizontal centerline, on the side of the cart opposite the plenum access door
- Cart will be supported by air bearings during transport

The size of the cart access opening was driven by the size of the test section carting systems designed by the TEST PDT. The plenum diameter has been chosen at 76 feet as a compromise between the desire to minimize the plenum volume and the need to have a ducting structure that has minimal distortions in the region of the cart access door opening. This plenum size is sufficient to accommodate the open jet requirements that are currently formulated, but open jet testing was not a sizing criteria. Further development of this design needs to evaluate the gross ducting behavior and the stiffening in the region of the access door opening. When this work is done, it is possible that there will be an advantage to increasing the diameter of the plenum further.

The cart access door opening has been sized to provide 3 inches nominal clearance to the test cart at the door head and 9 inches on each side. The door is configured to participate in the "hoop" load applied to the pressure shell, but not the longitudinal ducting loads. This is considered the best compromise for pressure boundary integrity and economy of construction. Latch and hinge pins for the access door are located at the bending neutral axis for the pressure stiffening, so that the large magnitude pressure induced loads transmitted through these features will not induce internal bending stresses on either side of the connections.

The access door is actuated using an external independent structure and a counterweighted wire rope drive system. The wire ropes tentatively selected have a factor of safety above 6, and the characteristics of this part of the subsystem is comparable to those of large vertical lift railroad bridges.

A concept is developed for a test cart access bridge. This feature is moved into place after the access door is opened and supplies an air tight surface over which the test cart can be flown between the support building and the plenum. It is lowered to a stored position to provide clearance for actuation of the access door. The access bridge is connected to the plenum so that its alignment to the plenum is preserved for all conditions of thermal strain in the tunnel ducting. A ledge and a solid lubricant slide bearing are provided at the building end of the bridge to facilitate motion. When the bridge is raised, it is pinned to the plenum at the locations where the access door is latched. When it is lowered, it is pinned at two other locations.

The plenum floor is a stiffened plate supported on diaphragms located in the same plane as the pressure shell stiffening rings. In addition to providing support for the test cart during its movement, this system will augment the local stiffness of the plenum. Further analysis will determine the extent of benefit of this additional stiffening.

A system of retractable linkages is conceived by the TEST PDT for aligning and supporting the test cart in its installed position. This arrangement counts on using the air bearings to "jack" the test cart off the dead weight supports. When a cart is brought into the plenum, the air bearings will be inflated until the cart has been positioned, the alignment devices have been engaged, and the dead weight transfer supports have been deployed. The air bearings will then be deflated, and the cart will settle onto its supports. A system of flaps are built into the flow liner downstream from the cart to provide maneuvering room for the cart.

Access to the DAS container mounted on the closed test section cart is provided by a "telescoping" eight foot diameter tube. This tube will be clamped to a mating flange on the DAS container. Inflatable seals are used at the tube/container and tube/pressure shell interfaces. The pressure loading applied to the telescoping tube will be supported by the actuators used to position the tube.

9.3.3.4 Tunnel Distribution Piping Configuration

The Tunnel Piping/Valving Distribution Subsystem includes distribution piping from flanged interface points with the plant systems near the tunnel to the use points on the tunnel circuit. Also, the valving associated with the operation and control of the wind tunnel is included in the distribution system. The Main Distribution Subsystems include a) the low pressure air, b) vacuum, c) exhaust, and d) high pressure air.

The Low Pressure Air Subsystem will utilize the 500,000 ft³ and 300 psig conditioned air from the Plant System to pressurize the tunnel. The tunnel will be pressurized from 1 atm to 5 atm in 40 minutes. The maximum tunnel pressure is 7 atm (absolute) with the isolation valves open. The subsystem downstream of the plant interface flange will have double isolation valves and two control valves to reduce the storage pressure to tunnel requirements. The air will be injected radially through a manifold and multiple penetrations into the tunnel, downstream of the main compressor. Tunnel pressure will be controlled through the air control valves and multiple pressure sensors in the tunnel. Besides the tunnel pressurization, an independent plenum pressurization requirement to pressurize the plenum from 1 to 5 atm in 1 minute will be accomplished by plenum pressure equalization valves that will equalize the pressure on both sides of the isolation valves, and will be augmented by additional air injection.

The Vacuum Subsystem will utilize the 67,000 ft³ vacuum storage spheres and additional vacuum pumps to evacuate the complete tunnel from 1 atm. to 0.2 atm. in 40 minutes. The subsystem, downstream of the plant interface flange, will have double isolation valves and two control valves to provide coarse and fine control of the tunnel vacuum pressure. The tunnel will be evacuated through a manifold located between corners number 3 and 4.

The Exhaust Subsystem will utilize tunnel ducting and valving a) to vent the complete tunnel from 5 atm to 1 atm in 40 minutes and b) to vent the isolated plenum from 5 atm. to 1 atm in 1 minute. There are two exhaust duct penetrations; one penetration is located in the vacuum manifold and the other penetration is located in the PES (Plenum Evacuation System) suction line. The air is exhausted through a control valve to a common exhaust stack, complete with a silencer.

The High Pressure Air Subsystem utilizes 6000 psig high pressure air from 22,300 ft³ air bottles that is heated to meet the model high pressure air requirements. Maximum requirement is 420 Lbs/Sec at 3600 psig pressure and 1500 ° F. temperature. The subsystem, downstream of the plant interface flange, will have double isolation valves, a pressure control valve, and a subsystem relief valve. The subsystem will also include a high pressure vent, complete with a silencer, and relief valves.

Secondary Distribution Subsystems include a) tunnel and bulkhead relief, b) cooling water, c) service and instrument air, d) hydraulic, e) tunnel cleaning, and f) tunnel drain subsystems. These subsystem are also recognized as part of this PDT. Design requirements and one line schematics were developed for each subsystem to determine a preliminary cost estimate.

9.3.3.5 Critical Configuration & Design Issues

Post-SDR critical configuration and design issues have been identified for the Pressure System. Configurational issues related to the Pressure System which should be evaluated are:

- The use of isolation valves in the tunnel circuit
- The use of a spherical pressure shell to enclose the heat exchanger region
- The use of a flow liner inside a conical pressure shell to form the transition diffuser
- Incorporation of constructability features, increased wide-angle diffuser length, and space for Corner #1 acoustic turning vanes into the tunnel airlines

Critical Pressure System design issues which should be addressed during the remainder of preliminary design are:

- Seismic effects
- Component/Subsystem constructability
- Quantification (location, geometry, loads)
- Test leg alignment

- Penetration identification and definition
- Pressure shell attachment structure details
- Final definition of required tolerances
- Test section plenum data acquisition system connector design details
- Detailed structural analysis of isolation valve and plenum cart access hatch
- Tunnel piping routing and space envelope
- Development of heat exchanger pressure shell

9.3.4 Risk and Mitigation

A risk assessment of the Pressure System was conducted as a part of the systems engineering effort and Zone 2 risks were identified. Zone 2 risks require written time-limited waiver, endorsed by management. Three Zone 2 risks were identified in the Pressure System:

- Test Leg Alignment: Angular alignment of the test leg from the inlet to the contraction to the test section exit
- Isolation Valve Design: Extraction/Insertion, alignment and sealing of isolation valve and flow liner insert
- Plenum Clam Shell Door Latch, Hinge, and Seal: Ability of clam shell door to resist pressure loads and seal

Mitigation of these risks were addressed in the configuration descriptions of each subsystem.

The following safety hazards have been identified for the Pressure System as a part of the safety & hazards analysis:

- Uncommanded/Inadvertent Isolation Valve Drive
- Isolation Valve Seal Over pressure Burst
- Isolation Valve/Flow Liner Insert "Collision"
- Bulkhead Adapter-Isolation Valve Interface Rotation
- Double Seal Failure at Single Valve
- Foreign Object on Isolation Valve Transversement Rail
- Isolation Valve Misalignment/Seal Makeup Failure
- Foreign Objects Left Inside Tunnel Prior to Tunnel Start
- Over pressure Rupture of Pressure Shell
- Physical Injury/Death as a Result of Person Being Trapped in Tunnel
- Inadvertent Opening of Hatch With Tunnel in Operation
- Circumvention of the Kirk Key Interlock System
- Inadvertent Evacuation/Pressurization by Operator
- Personnel Exposure to Excessive Noise
- Over temperature of Tunnel Circuit Due to Heat of Compression

Countermeasures were developed to mitigate the risk of the above hazards and documented.

9.3.5 Recommendations

It is recommended that some of the more critical issues raised at the Pressure System SDR be addressed in an expeditious manner. Major issues to be addressed are:

- Re-evaluation of fatigue cycles
- Detailed finite element analysis of test section plenum clam shell door opening
- Test leg airstream alignment
- Code impact of difference in pressure rating of the pressure shell and isolation valves
- Pressure shell attachments and penetrations

9.4 Compressor and Drive System

The Compressor/Drive System is comprised of the compressor, motors and motor controls, lubrication and cooling system, and the fan blade handling system. The compressor provides the air flow through the tunnel circuit ducting for establishing test conditions. The compressor section will be installed within the circuit ducting to form a part of

the pressure vessel. To drive the compressor, multiple in-line electric motors receive variable frequency power from the motor drive control system. The lubrication system provides drive train and compressor lubrication and high pressure lifting oil for start-up and low speed operation. The cooling system distributes cooling water to heat exchangers supplied with drive motors, static converters, and the lubrication system. The blade handling system is an apparatus for safely handling compressor blades during replacement or repair operations.

9.4.1 Management Plan

The NWTC Compressor & Drive System effort was executed using a Product Development Team (PDT) approach. A Team Execution Plan (TEP) was developed (Ref 9-27). This document contains the team goals and strategy, team organization, roles and responsibilities, statement of work, task descriptions, interface requirements, activity networks and schedule, risk management, and deliverables.

Technical assistance was provided the PDT by Mitsubishi, TLT, and Westinghouse who were under contract to the NWTC. The Technical Assistance Contractors (TAC) provided technical responses to the PDT developed tasks per NWTC approved task orders. Responses were received on five tasks and are available for review in the NWTC SE&I files.

9.4.2 Segment Specifications

The segment level requirements for the Compressor & Drive System design are based upon the functional and performance requirements from the Project Specification, and the derived requirements from the aerodynamic design. The Compressor & Drive System Segment Specifications (Ref 9-28), describes the performance characteristics, system capability, interfaces (internal and external), physical characteristics, reliability, maintainability, availability, and verification. The relationship between the Compressor/Drive Technical Performance Measures (TPM) and the System Level TPM's are documented in the SDR presentation document.

9.4.3 Design Concepts

The effort of the PDT during preliminary design is primarily focused on the preparation of the Development Specification and interface requirements to establish the basis for product-level subteam PDT's to perform final design and produce Compressor/Drive system components. To assist in this task, a reference design for the Compressor/Drive System will be developed. The reference design will not be contractually binding for the suppliers but will be a guide for better understanding and communication. The design will also ensure that the Wind Tunnel Partner's (WTP) Standard of Care requirements are satisfied by demonstrating feasibility of concept for critical components and providing constructability review of preliminary design concepts. The design will enhance the quality of the Development Specification and provide a basis for technical evaluation of suppliers proposals. Reference design concepts are documented in the SDR presentation.

9.4.3.1 Compressor Aerodynamic Design

In order to develop a compressor aerodynamic design which matches the tunnel operating map, the following steps were taken. First, a design point, flow annulus, rotational speed, and inlet flow angle were selected. The design point was selected at a total pressure ratio of 1.3 at a corrected mass flow of 12200 lbm/sec by examination of the facility operating map and using previous experience. A rotor tip diameter of 29 ft 10 in and a hub diameter of 19 ft 5 in was selected based on scaling previous successful designs such as the AEDC 16T, Ames 11 ft, and MSWT (Ref. 9.4.3.1-1) compressors. A design point rotational speed of 540 rpm was set based on scaling of previous designs. An inlet flow angle of 15 deg was selected. Three compressor stages were selected so that the Mach 1.5 operating pressure ratio requirements could be met.

Compressor geometry was generated by a Sverdrup developed compressor design code. The design code uses an equal total enthalpy rise per stage based on radial equilibrium. The flow passage has a constant annulus. Repeating stages are specified so that all rotor blades are the same and likewise, all stator blades are the same. Inlet guide and outlet guide vanes having the same blade type and chord as the stators are included in the design.

NACA 65 series blades at zero incidence were assumed. Rotor blade thickness-to-chord ratio varies from 14% at the blade root to 6% at the tip, and stator blade thickness-to-chord is consistent at 12%. Chord-to-gap ratio for the rotor blades was 1.05 at the mid line and 1.33 for the stator blades at the mid line. The rotor blade root chord was

3.0 ft and the tip chord was 2.25 ft. A total of 31 blades per stage are used. The stator blades had a chord of 1.91 ft and there are 54 blades per stage. The difference between the rotor and stator blade numbers was selected so that the fundamental tone at the blade passing frequency would be reduced over much of the compressor operating range.

Constant mean swirl tangential velocity distribution was specified. This means that the distribution of absolute tangential velocity is specified to have the following forms at the design point upstream and downstream of the rotor blades:

$$\begin{aligned} V_{\theta} &= C_1 - C_2/r && \text{(upstream)} \\ V_{\theta} &= C_2 + C_2/r && \text{(downstream)} \end{aligned}$$

The constants C_1 and C_2 are determined from the desired stage pressure rise. The AEDC 16T compressor blades were designed with this velocity distribution.

The Dynatech HT0300 compressor performance code was used to estimate the aerodynamic performance of the compressor geometry developed with the procedure described above. The version of the code used had a slightly modified cascade correlation which resulted in a better match to data at higher flow rates. This code has been shown to compare well with data and other compressor codes and with more recent versions as was done during the Ames Unitary Upgrade Study (Section 8.3.1). It should be pointed out that performance estimates can deteriorate in the upper left corner of the operating envelope.

Compressor performance estimates from the Dynatech code were compared to the tunnel operating map. Transonic operation was optimized by using a variable stagger stator blade setting which was derived using the code input feature which allows rapid change of the stator blade stagger. An efficiency of 78% at the Mach 1.0, 5 atm power point condition was obtained. Substantial stall margin for open jet operation is obtained for this configuration. Good stall margin for Mach 1.5 cases at CdS/A up to 0.05. The stall margin is reduced for Mach 1.5 at CdS/A of 0.086 (fighter at 60° angle of attack). This reduced stall margin, along with the limitations of the code estimates in this region and probable flow distortion due to a large model wake, indicates that compressor configuration optimization which results in a larger stall margin is desirable.

9.4.3.2 Compressor Mechanical Design

The approach for the reference design was to begin with proven concepts. Critical components were identified which included the major sub-elements such as the rotor blades, rotor assembly (disk, stub shafts and spacers), drive shaft, seals, bearings, non-rotating vanes, casing, tail cone/nose cone, and the health level monitoring system. The AEDC 16T was the basis for the rotor, casing, bearings, blades and blade attachment. The Ames 11X11 Foot Unitary was the basis for carbon composite blades and blade attachment, and the Boeing Transonic Wind Tunnel provided an example for the rotor blade attachment. A comparison of the AEDC 16T and the NWTC compressors shows the machines are essentially the same size. The major differences are horsepower, pressure at the power point, and the maximum air loads.

Computer codes, developed by NASA LRC, were obtained for the analysis of oscillatory airloads on the blades, to perform the composite blade structural analysis and for an integrated composite analysis with damping capabilities. In conjunction with the above codes, a FEA of the blades, casing, supports and ducting attachment would be performed. The rotor assembly and drive train would have a dynamic analysis to investigate lateral and torsional properties.

Design drivers for the rotor blades were identified with the most critical being weight, centrifugal loads, fatigue life, and ease of installation. In an effort to minimize the weight and resulting centrifugal force, steel, aluminum, and carbon reinforced plastic were examined for use as a blade material. Blade stress was calculated based upon the airloads, offset bending loads, and the centrifugal force for each of the materials. Blade rake and twist was calculated and included in the analysis to reduce the gas bending stress. To evaluate the three materials, a decision

matrix was developed that included six attributes with weighting factors assigned to each. Based upon this evaluation, the carbon fiber reinforced plastic would be the best material for the rotor blades.

In an effort to satisfy the requirement for ease of installation, three methods of attaching the rotor blade to the disk were investigated. Option one used a root block and dove-tail arrangement similar to the design for the Ames tunnel. This method requires the blade to be moved axially to disengage the root block from the dove-tail and for this reason is more difficult to remove. Option two was based upon the Boeing tunnel concept in which a blade support block is attached to the disk and the blade is then attached to this block. This allows the blade to be removed in a radial direction. The third option is the design developed for the composite blades in the AEDC 16T. A support block is pinned to the disk and the blade is pinned to this support block. The blade can be removed by removing the pin and withdrawing the blade radially. The three options were evaluated using a decision matrix that included five attributes with weighting factors assigned to each. Each attribute was rated for each option and the weighting factor applied. Based upon this evaluation, option 3 was judged to be the most desirable for the method of rotor blade attachment.

The rotor assembly consist of the stub shafts (upstream and downstream), rotor disks, rotor blades, inner spacer, outer spacer, and connecting rods securing the stub shafts to the rotor disks. A weight analysis was made in addition to static deflections and rotor stress calculations (i.e. centrifugal loads, radial and tangential stresses). The stub shafts were sized using a solid shaft calculation from the ASME "Guide to Transmission Design" (Ref 9-29). A lateral critical speed calculation was made based upon the ASME guide. The results indicated good margins of safety for the reference design.

The drive shaft calculations included static deflection and first lateral critical speed analysis. The length of the drive shaft was approximately 50 feet with an outer diameter of 38 inches. Specific decisions concerning drive shaft seals are considered a part of a trade study to be conducted in the future. The bearings selected were based upon a preliminary recommendation by Kingsbury and are the tilting pad hydrodynamic type design.

The non-rotating vanes consists of the Inlet Guide Vanes (IGV), Stator Vanes, and the Outlet Guide Vanes (OGV). The IGVs and each row of the Stator Vanes must be independently and remotely adjustable. Key design issues to be resolved include the mechanism for vane articulation and synchronous movement. Additionally, several IGVs, Stators and OGVs will need to be removed to provide access to the rotor blades for inspection and removal.

9.4.3.3 Motor & Motor Controls Electrical Design

The motor & motor control components were selected to provide sufficient power to drive the compressor throughout the operating speed and pressure range, while limiting unnecessary demands on the electrical utility and the NWTC electrical power system. Design requirements dictate a maximum electrical rate change of 2 MW/sec, maximum electrical power step of 309 MW, a power factor of 98 percent or less, and a total harmonic distortion of 2.5 percent or less.

The approach for the reference design was selected from proven concepts and inputs from the Technical Assistance Contractors. Critical components were identified as (1) static converters providing variable speed control for the compressor drive motors, (2) motors driving the compressor, and (3) health and safety monitoring systems to protect personnel and equipment.

The number, type, and rating of the static converters and motors used in the reference design are as follows:

Static Converters

- Number - 4
- Type - Load Commutated Inverter (LCI)
- Rating - 110,000 Hp
- Input voltage - 13.8 KV @ 60 Hz
- Output voltage - 0 to 13.8 KV @ 0 to 60 Hz
- Rectifier pulse input - 12

NWTC Final Report

- Inverter pulse output - 12
- Reactor rating - 20 millihenry, 13.8 KV, 8500 amperes
- Deionized water cooled semiconductors
- Air cooled reactor
- Faraday shielded input transformers

Motors

- Number - 4
- Type - Synchronous
- Poles - 12
- Rating - 90,000 Hp (continuous) /103,000 Hp (30 minutes) at 13.2 KV
- Synchronous speed - 600 RPM
- Speed range - 0 to 600 RPM
- Totally enclosed water to air cooling
- Static exciter excitation
- Four stator windings per phase offset by 30 electrical degrees
- Maximum torque - 5.50×10^6 foot pounds

The LCIs must accelerate the compressor/drive motors to any desired speed from 60 RPM to 600 RPM and maintain that speed within ± 1 RPM indefinitely. The LCIs must be coordinated to insure equal motor load sharing. The LCIs must use regenerative braking to decelerate the compressor/motor drive from full speed down to 60 RPM. The 11th, 13th, 23rd, and 25th harmonics generated by the LCIs must be filtered on the output side of each LCI input transformer. The filters must be selected to provide a power factor of 98 percent at the utility providing electrical power to the NWTC.

Primary power for the compressor/motor drive system will be distributed at 138 KV. The LCI input transformers will be located in a electrical substation sited as near as possible to the motor drive building to limit motor feeder losses as well as harmonics and voltage drop.

9.4.3.4 Motor & Motor Controls Mechanical Design

The critical components for the mechanical design of the Motors and Motor Controls task were identified as the turning gear, couplings, brake, bearings, and the drive train torsional oscillation analysis.

The turning gear must rotate the compressor rotor assemble, drive shaft, and motor drive train at approximately 1 rpm and provide a jog capability for use during blade inspection and maintenance. The drive must be easily disengaged from the drive train during normal operation. To meet the tunnel operating requirement of 0.015 Mach number, the compressor must operate at approximately 5 rpm. There is some question concerning the ability of the LCI motor controls to provide the accuracy required in this range. Because of this, there is potentially a need to incorporate an auxiliary drive into the turning gear design that would provide the necessary power to operate the tunnel in the speed range of 5 to 60 rpm. This would require a motor of approximately 2500 hp and a motor control system to vary the speed between 1 and 60 rpm.

The main requirements for the coupling are to transmit 5.5 million foot pounds of torque at 400 rpm, provide for an axial movement of 4.75 inches and provide the required torsional stiffness that is yet to be determined. The main design drivers are the axial displacement and the high torque required to be transmitted. A concept for the coupling has not been identified. This was one of the tasks that was anticipated for the Tech Assist Contractors had the project continued. Configuration issues identified included the drive shaft/ component arrangement and coupling design.

Regenerative braking will be used to decelerate the compressor and motor drive train to approximately 60 rpm, at which point, the mechanical brake will be applied to complete the deceleration within the specified time. The brake must hold the rotating components stationary with the maximum static unbalanced load. The brake system must be

remotely operated. The main design drivers are the inertia loads and the possibility of over heating. A caliper/disc brake system that is hydraulically actuated and air cooled is envisioned for the reference design.

Journal bearings are required for each motor with thrust capability included in one journal bearing. The bearings must provide for high pressure lift capability and have the necessary stiffness to maintain a 10% margin from the first lateral critical speed. For multiple motors, commonality for the bearings should be maintained. For the reference design, the same type bearing used on the compressor would be used for the motors.

A critical element is the drive train torsional oscillation analysis. This system analysis of the drive train is required for selecting/designing components such as shafts, bearings, couplings and identifying torsional resonance. The analysis includes inertia, dampening, and stiffness associated with all rotating components and bearings, the input torque pulsation from the variable frequency drive system, and the unsteady aerodynamic force on the compressor blades.

9.4.3.5 Lubrication and Cooling System

The lubrication system provides lubrication and high pressure lifting oil as required for the compressor and drive motor bearings, drive shaft bearings, and turning gear drive system. The reference design concept is a distributive system with dedicated subsystems for each of the major components as shown in the drawings "Pressure System Main Compressor Oil Sys Schem" numbers M0010 -M0050 (Ref 9-30). Health monitoring of the lubrication system includes flow switches, temperature and pressure measurements at each bearing.

The cooling system provides for the distribution of cooling water to the heat exchangers that are supplied with the drive motors, static converters, and the lubrication system. Each independent system includes control valves and all other components necessary to supply the required flow of cooling water, at the required temperature and pressure, through each heat exchanger and discharging to the return line.

9.4.4 Risk and Mitigation

A risk assessment of the Compressor & Drive System was conducted as a part of the system engineering effort that resulted in no Zone 1 risks and two Zone 2 risks. Zone 2 risks require a written time-limited waiver, endorsed by management. The Zone 2 risks, with mitigation options, identified in the Compressor & Drive system are:

- Compressor performance below specifications due to uncertainties in aerodynamic design analysis and off-design performance predictions—impact Re/Mach performance
 - Calibrate/compare design codes, including comparison to TAC data
 - Build and test scale model compressor rig to verify design
- Capability to control motor drive shaft speed at low RPM (low Mach no.) with LCI drive—impacts Re/Mach & flow quality
 - Obtain support from TAC on alternate technical solutions

Following the System Safety Plan methodology 18 hazards have been identified, risks assessed, and countermeasures developed for the Compressor & Drive System. A partial list of the hazards are:

- Compressor blade loss
- Disk rupture or failure
- Compressor stall/surge
- Electrical equipment lightning exposure
- Short circuit in high & medium voltage equipment

Additional information on risk assessment and system safety analysis is available in the SDR presentation for the System Design & System Engineering.

9.4.5 Recommendation

9.4.5.1 Future Plans

The PDT's future work plans are to continue to develop the reference design and segment specifications, define and develop the interface documents and complete the identification of all design requirements. The TAC responses have to be reviewed and integrated into the design concepts. Also, tasks have to be defined for constructability reviews, development specification reviews, and drive train analysis review by the TAC's.

9.4.5.2 Concerns

Concerns that have been identified as SCOM issues are:

- Compressor aerodynamics: power point efficiency & stall margin
- Compressor supports for axial tunnel movement
- Number/capacity of static converters and drive motors
- Drive train dynamic analysis
- Drive shaft/component arrangement and axial displacement coupling
- Selecting and locating equipment to reduce cost and optimize performance and reliability.
- Selecting technique for low speed drive motor/compressor control (below 60 RPM)
- Selection of equipment and integration of power factor correction capacitors, harmonic filters, and static VAR control to optimize harmonic filtering and limit power system resonance.
- Integration of electrical and mechanical design to limit transient and steady state torsional excitations and to ensure rapid passing through torsional resonance.

The health and safety monitoring systems were not developed but must follow codes and standards to ensure personnel safety, limit equipment damage and minimize downtime.

9.5 Control and Information

9.5.1 Management Plan

The Control and Information (C&I) Team Execution Plan (Ref 9-32), defines in detail the approach and processes used by the C&I Product Development Team (PDT) to design, build, and activate the C&I segment and to successfully meet NWTC performance, quality, schedule, and cost requirements.

9.5.2 Segment Specification

NWTC requirements allocated to the C&I PDT are defined in the Control and Information Segment Specification (Ref 9-33). Additional requirements were obtained by surveying existing wind tunnel facilities to capture "lessons learned" and "desired features." These requirements are described in the Control and Information Requirements Survey White Paper (Ref 9-34).

9.5.3 Design Concepts

The C&I PDT performed a functional analysis to aid in the definition of functional and physical baseline. The results of this analysis are documented in the Control and Information Functional Decomposition (Ref 9-35). There are three major design concepts associated with the C&I segment: Control System, Data Acquisition and Processing System, and Facility Support and Communication System. These design concepts are described in detail in the NWTC System Design Review, Control and Information Vugraph Package, and are briefly summarized in the following sections.

9.5.3.1 Control System

The following control system description summarizes the key elements presented at the NWTC System Design Review, Control and Information session. The goals of customer focus, security, and productivity have served to set design priorities in establishing the following control system concept.

9.5.3.1.1 Control System Concept

Control processes are highly distributed. This allows for stand-alone development, startup, and checkout of various subsystems. Maintenance and upgrades can be performed on an isolated basis by subsystem. Identification and repair of faults are enhanced with subsystem fault diagnostics and self test capabilities, thus yielding a reduced Mean Time To Repair and an improved system availability.

The conceptual network interconnection of high-level control system functions provides for secured physical patching of dedicated network segments for each allocated customer. Productivity is addressed by providing necessary dedicated control functions in each allocated area (Preparation Area, Customer Suite, Build Bay area and Active Test). In general, control system functionality is allocated in a three layer hierarchy:

1. Tunnel Automation Executive functions.
2. Integrated Tunnel Controller functions.
3. Process Control Subsystem functions.

The following sections provide brief descriptions of each layer's functions and features.

9.5.3.1.2 Tunnel Automation Executive

This Tunnel Automation Executive layer functions and features are:

1. The primary customer interface must be easy to use and perhaps be compatible with a variety of computing platforms.
2. Development of test matrices and plans is supported by this layer. Provisions to modify the matrices "on - the - fly" during an active test must also be accommodated.
3. On-line execution of the matrix for the active test is a primary function provided by this layer. In a Automatic or Semi-automatic mode, this process forwards test condition setpoints to the integrated tunnel process control layer to be dispatched.
4. Additionally, this layer provides tools to provide the customer with projections of power utilization and projected tunnel occupancy times.

9.5.3.1.3 Integrated Tunnel Controller

The Integrated Tunnel Controller layer provides:

1. Integrated, safe sequencing of tunnel start-up and shutdown operations.
2. Operator Interface to Integrated Tunnel Controller functions including the selection and bumpless transition of operating modes (Automatic, Semi-automatic and Manual).
3. Status and mode selection capabilities for lower layer process control subsystem functions.
4. Staging of test conditions through orderly pre-defined dispatching of setpoints to tunnel process control subsystems, as well as test article position and data acquisition functions.

9.5.3.1.4 Process Control Subsystem

The Process Control Subsystem layer includes subsystem to control tunnel environment and access functions, including Tunnel Temperature Control, Mach Number Control, Pressure and Humidity Control as well as Tunnel Access Control. Detailed descriptions of these subsystems developed to the SDR level are included in following section. The design focus for these subsystems is support of productivity. To ensure that the productivity goals are met, each control subsystem must achieve the desired condition with a minimum of interaction between systems. Each subsystem must maintain the established condition through process disturbances including blockage changes due to model position commands. Control strategies to be validated using mathematical models include:

1. Application of a model based predictor corrector strategy for tunnel temperature control. This strategy applies feed forward of compressor horsepower, inlet water temperature and air velocity to predict appropriate return water valve position.

2. Control of Mach number will implement a neural network to learn and react to the interactions between model position changes and Mach Number. Control effectors will include systems with effective dynamic response such as P.E.S. mass flow or Flap position. Fuzzy logic will also be implemented to minimize interaction of the pressure control subsystem and the Mach number control subsystem, both of which use stilling chamber total pressure as a primary feedback element.
3. The pressure control subsystem will implement fuzzy logic to minimize subsystem interaction with the Mach number control subsystem as well as interactions with the model position subsystem.

9.5.3.2 Data Acquisition and Processing System

The NWTC test data system is intended to support three main functions – data acquisition, data storage, and data processing/analysis – in an environment that meets the security requirements of the NWTC. Multiple mobile data systems are required to support productivity goals. One data system will be supplied with each test section cart and shall allow for concurrent model build-up activities in the cart build bays.

Each system may be described as having a dedicated, distributed, object oriented architecture. It is distributed across a high speed network back plane with the major functions being performed by compute resource nodes on this back plane. Use of smart "front-end" sub-systems will allow for individual acquisition configuration and specialized data handling while maintaining an integrated acquisition system as a whole. The object oriented design methodology will allow for unrestricted incorporation of existing "legacy", as well as user designed, software into this cohesive, integrated system.

The test data system design allows a high degree of flexibility in configuring the system to meet the requirements of a particular test. The use of standard software and hardware interfaces will allow for system expansion to include new measurement systems using state-of-the-art measurement techniques. An additional benefit is that user-supplied equipment may be integrated into the system if the equipment conforms to these interface standards.

Security requirements are satisfied through the use of customer dedicated systems combined with secure network servers. The secure network servers are required to connect the dedicated test data systems to required common computer resource nodes (the calibration lab, for example). Through this combined use of network switching/disconnection and physical isolation methods, most customer required levels of security should be attainable.

9.5.3.3 Facility Support and Communication Systems

The following description of the Facility Support and Communication Systems summarizes the key elements presented at the NWTC Control and Information Systems SDR. The goal of a secure and reconfigurable communication system designed to meet both the needs of the customers and NWTC operations serve as the basis for the following concepts. The presentation also provide a review of the Control and Information System functions which are required of the Site Supplied Infrastructure to support the NWTC.

9.5.3.3.1 Communication System Concept

The Communication Systems Concept is based upon provision of an NWTC network using Asynchronous Transfer Mode (ATM) technology which interfaces with the communication system provided by an existing Site Supplied Infrastructure (SSI). The NWTC Network concept supports the C&I Vision Concept of Operations where the customer is provided access to information throughout the facility as required, depending upon the stage of testing. Customer systems are isolatable and configuration controlled in a Network Control Center. Security is assured through the use of network firewalls between priority data and general systems information.

9.5.3.3.2 Facility Support Systems

The Facility Support Systems include those information systems which are required to support the customer in the conduct of testing and the facility personnel in the operation of the facility. They include the following systems:

1. Voice systems including telephones and paging
2. Customer video teleconferencing from the customer suites

3. Work stations and printers within the customer suites
4. Video Monitoring Systems of the test article in the build bay, transfer corridor, and test section area
5. Voice and video systems between the customer suite and control room during testing
6. Lab Support Systems to provide integrated data management for the Balance Calibration Lab, the Airflow Calibration Lab, and the NWTC Development Labs

9.5.3.3.3 Site Supplied Infrastructure

The following Control and Information system functions are required of an existing site to support the NWTC functionality, ensure tunnel productivity and performance, and to support the customer in accordance with the established operational philosophy for the NWTC. These functional systems include:

1. Lab Calibration Systems to provide general instrumentation calibration labs, standards, procedures, data base functions, and equipment maintenance.
2. Business Management Systems to provide facility scheduling and allocation, financial management, inventory control, and the customer support functions of data archiving and pre-test/post-test coordination.
3. NWTC Operations Management Systems which provide for operation and maintenance of the NWTC facility, facility configuration management, auxiliary data acquisition, physical security, and electronic security of SSI data.
4. Plant Site Controller which performs control and monitoring of plant systems which support the NWTC. Display of plant information and analysis for trends and unscheduled maintenance is also required of the Site Supplied Infrastructure.

9.5.4 Risk and Mitigation

Using the Risk Management Plan techniques developed by System Engineering, the C&I PDT evaluated team risks and identified four Level 2 risks that required mitigation to support the NWTC Systems Design Review. These risks included:

1. Implementation of obsolete electronic product technology due to the length of the NWTC schedule.
2. Unsuccessful integration of NWTC electronic products due to lack of compatibility. Several PDTs were supplying electronic products that would require integration into the final NWTC global network, and the C&I PDT had the responsibility to coordinate this integration.
3. Failure of site supplied infrastructure to supply the functionality required to satisfy NWTC requirements.
4. System/software design in an environment of ill-defined or constantly changing requirements.

The NWTC System Design Review, Control and Information Vugraph Package contains a detailed discussion of the major mitigation points for each risk listed in Vugraphs 158 through 168. The most critical risk, as determined by the C&I PDT, was the fourth risk which was concerned with the evolution of product requirements.

This risk was of major concern because of its negative effect upon the early stages of product design. Because the NWTC had an eight year development schedule, an erroneous perception existed in some areas that the development of specific operational philosophies and data measurement requirements could be delayed to later stages of tunnel development. Team experience indicated that if this perception prevailed, the C&I team would be immersed in a set of fluid and perhaps contradictory requirements late in the product development stage which would disrupt the progress achieved to that point in time.

The mitigation plan for this risk included close coordination with the Operations Group early in Preliminary Design to specifically define tunnel operational modes and measurement requirements. Once stable requirements were established, emphasis would shift to the design of custom tunnel operational tools with a focus on the customer. It was deemed critical to actively involve customers and operators in the design of their interfaces to C&I PDT products. This would be accomplished by using a rapid prototype approach where customers and operators could evaluate designs and simulated operations; then based on feedback, designs would be modified to achieve an acceptable interface. Once this was achieved, modifications to interface requirements would become formal and put

under control of an overview board. This approach provided the C&I PDT with the best formula for developing the team's products with stable requirements.

9.5.5 Recommendations

During the NWTC System Design Review, Control and Information session, an independent team of reviewers made recommendations which have been documented and are presented in the following sections. The Control & Information team concurs with the reviewers recommendations listed below.

9.5.5.1 General Recommendations

1. Inadequate time provided to review detailed schedule and cost data
2. Don't recommend using traditional design/construction approach for C&I products; endorse integrated Design Build process
3. Breakout and track software design cost as separate item
4. Apply Software Engineering Institute (SEI) level 2 & 3 to address configuration/change control & software management issues
5. Reinforce the need for open architecture wherever possible
6. Reinforce the need for fault detection to prevent catastrophic failures, but permit degraded system operation when appropriate
7. Provide test matrix tool set to analyze/execute the test plan
8. Review "virtual" customer suite concept from safety and operations perspective
9. Incorporate the means for fault isolation, diagnostics, and predictive maintenance

9.5.5.2 Control System Recommendations

1. Attempt to perform experiments in an existing facility to evaluate control system algorithms or incorporate existing algorithms into NWTC
2. Utilize real-time simulation in development lab subsequent to construction
3. Need to define requirements for Mach number settling times resulting from model motion and changing tunnel condition
4. Adaptive control methodology (i.e., neural networks, fuzzy logic) has potential to improve productivity

9.5.5.3 Information System Recommendations

1. User interface for test engineering should be user friendly and result in minimal impact on real-time performance due to user supplied software
2. Given extreme ranges, define how instrumentation (both information and control) will be switched/protected and still provide accuracy (multiple transducers and limit checking)
3. Provide DAS power and HVAC during test section movement
4. Review requirement for archiving data for 20 years in a secure environment
5. Provide customer with real-time measurement uncertainty and validation data for all facility and model measurements; SPC methods

9.6 Auxiliary Plant Systems

9.6.1 Management Plan

9.6.1.1 Auxiliary Plant Systems Team Charter

Scope: The Auxiliary Plant Systems Product Development Team (PDT) is responsible for all aspects of the Auxiliary Plant System Segment of the NWTC including segment design, procurement, manufacturing, construction, installation, commissioning and segment acceptance. The team is responsible for delivering an integrated segment that meets or exceeds the expectations in segment performance, cost, and schedule constraints, and interfaces with other segments in a manner that maximizes the NWTC performance. The PDT will develop the specifications for the components and products that comprise this segment.

The Auxiliary Plant Systems Team Charter further identifies the Statement of Work, Deliverables, Roles and Responsibilities, Processes, and the Team Members for the Auxiliary Plant Systems Product Development Team.

9.6.1.2 Team Execution Plan,

The Auxiliary Plant Systems Team Execution Plan (Ref 9-36), defines the processes which will be used by the Auxiliary Plant Systems PDT to design, procure, manufacture, construct, install, commission and accept the Auxiliary Plant Systems segment, and to successfully meet NWTC performance, schedule, and cost requirements.

9.6.2 Segment Specification

9.6.2.1 Introduction/Background

The Auxiliary Plant Systems Segment Specification (Ref 9-37) provides the requirements for design, fabrication and test of this segments products to support the NWTC.

- **PLANT AIR DISTRIBUTION PIPING & STORAGE**

Provides low pressure air distribution piping and storage tank and controls, vacuum system distribution piping and controls and the high pressure air distribution piping, heaters and controls.

- **COOLING WATER DISTRIBUTION**

Provides coolant water (serving the tunnel heat exchanger and various equipment loads) distribution piping and controls.

- **TUNNEL CLEANING SYSTEM & DISTRIBUTION PIPING**

The system is responsible to restore full capability to the tunnel internals when operating performance deteriorates due to accumulation of foreign matter.

- **PLENUM EVACUATION SYSTEM (PES)**

Maintains flow quality by removing air from the test section and re-injecting the air back into the tunnel upstream of the compressor. The PES includes compressors, air coolers, ducting and controls for a complete system.

- **HYDRAULIC POWER SYSTEM**

Provides hydraulic power to support test article positioning in each build-up bay and in the test section, tunnel isolation valves and the flex nozzle. The system includes hydraulic compressors, piping, lube cooling, connections and controls.

The segment specifies Performance Characteristics, Capability Relationships, Interface Descriptions, Physical Characteristics, Quality Factors, and Environmental Conditions for the five major system types listed above. It also addresses the Specialty Engineering Characteristics, Expansion potential, Materials and Construction processes, Security, Operations and Logistics, Procurement issues and Personnel. Specific products included in this segment are identified in the Auxiliary Plant Systems Segment Specification .

Procedures and standards that constrain the design of Auxiliary Plant Systems Segment products are identified in the Infrastructure Segment Design Criteria (Ref 9-38). Additional constraints relative to security issues are identified in the Preliminary Security Criteria (Ref 9-39).

9.6.2.2 Performance Evaluation

The System Performance Evaluation Report (Ref 9-40) established a Facility Availability TPM requirement/metric of 5580 hours per year.

An operating plan constraint requiring three, 8-hour shifts/day, 5 to 6 days/week (275 days/year) is established by the Customer Performance Requirements. Further advice is provided to "not preclude efficient 3 shift/day, 7 days/week surge operation for an extended period of several months at a time".

Customer Operations Requirements supplement the Customer Performance Requirements to provide a "complete definition of the NWTC facility requirements from a customer perspective". The Customer Operations Requirements provide a summary and detailed breakdown for thirteen functional areas:

NWTC Final Report

9.6.2.3 Functional Analysis

The Functional Analysis process was utilized within the NWTC project to help define the functional definitions and functional interfaces for each segment. The eight basic functions for the Auxiliary Plant Systems Segment are as follows:

Provide Tunnel Pressurization Air, Distribution & Storage	Provide Vacuum Distribution
Provide Propulsion Simulation Air Distribution	Remove Test Section Air
Provide Process Coolant Distribution	Provide Hydraulic Power
Provide NWTC Plant Controls	Provide Tunnel Cleaning System

A complete set of behavior diagrams, functional descriptions, and functional flows is contained in the Functional Analysis Review Report (Ref 9-41).

9.6.2.4 Physical Description

Basic product descriptions are provided in the NWTC Project Work Breakdown Structure (WBS) Dictionary (Ref 9-42). Expanded descriptions, including baseline assumptions for cost estimating purposes, are included in the Auxiliary Plant Systems Segment Specification. See Figure 9-8, for a Conceptual Plant Layout.

9.6.2.5 Interface Definition

Segment-to-segment, and segment-to-external community interfaces are identified in the Baseline Interface Index (Ref 9-43). Expanded interface descriptions, and identification of intra-segment interfaces, are provide in the Auxiliary Plant Systems Segment Specification.

9.6.3 Design Concepts

9.6.3.1 Design Decision Notices

The NWTC Air Plant Configuration/Capacity was initial established by DDN #8 (Ref 9-44). The configuration was revisited in DDN #12 (Ref 9-45) at the conversion from two tunnels to one. The description of all the major configuration items is contained in the Configuration Description Document (Ref 9-46).

The SDR baseline configuration for the Auxiliary Plant Air Systems Segment was established by DDN#12. This baseline configuration was utilized in the development of the Auxiliary Plant Systems Segment Specification, segment schedule, and segment cost estimate. DDN #12 accomplished the following:

- Established the NWTC Auxiliary Plant Air Systems Baseline consisting of the following capabilities:
 - Deliver at the tunnel interface 330 pounds per second average (420 PSI maximum) at 4000 PSI and 200 to 600 ° F for a 15 minute duration with a 20 minute recharge period.
 - Provide low pressure air: 300 psi @ 200 pounds per second with 500,000 cu. ft. of storage.
 - Provide high pressure air: 6,000 psi @ 200 pounds per second with 22,300 cu. ft. of storage.
 - Provide vacuum: .07 atm @ 30,000 acfm with 50,000 cu. ft. of storage.

9.6.3.2 Site Evaluation Committee

The Auxiliary Plant Systems PDT worked with the Site Evaluation Committee in developing the initial Auxiliary Plant Systems segment definition. A draft "Good Site" document was jointly created which identified certain "threshold" requirements that every potential site must meet in order to be consider as a viable site. A matrix of additional desirable contributions which a "good site" might bring to the NWTC was also included in the document. This "good site" document established the basic interface parameters with utility providers and with the external community on which the Interface Segment was developed.

On redirection to the single tunnel concept, the Auxiliary Plant Systems PDT worked closely with the NWTC Site Evaluation Committee to develop a new site requirements document. This document is the Design Integration SEC Support Summary (Ref 9-47). This document has been updated to reflect increased electrical loads imposed by DDN#13.

9.6.3.3 Segment Configuration Options

PES NOISE IMPACT ON INTERNAL ACOUSTIC NOISE:

Determine if the PES operation adversely impacts test section acoustic noise. Requires a trade study in cooperation with the Test PDT, the Flow Conditioning PDT and C R& O to determine acceptable noise generation of each contributing component and the accumulated impact on the overall noise level in the test section.

SITE PARAMETERS ISSUE:

Identify differences between actual site-specific and baseline design assumptions: e.g., physical locations of existing Auxiliary Plant Systems; capacities and Specialty Engineering characteristics of existing equipment and systems and existing environmental conditions. Requires field surveys after a construction site is selected.

9.6.4 Risks and Mitigation

9.6.4.1 System Risk Management Decision Outlines

The Auxiliary Plant Systems Segment identified one, zone 1, and one zone 2 cost risks related to segment products.

- Zone 1: Assumptions About Site Contributed Auxiliary Plant Systems Capacities
- Zone 2: Existing "...ilities" of Site Contributed Auxiliary Plant Systems

Risk Management Decision Outline sheets fully describing these risks, the risk classification/analysis, alternative means of mitigation, recommended mitigation plan, and post-mitigation risk analysis are provided in the System Risk Management Decision Outlines.

9.6.4.2 Segment Safety Analysis

The Auxiliary Plant Systems Segment did not identify any risks associated with the segment prior to SDR. However, the issue was raised by the SDR review team and is discussed in the SDR Package.

9.6.5 Recommendations

9.6.5.1 Site Contributions Issues

A site should be selected and the field surveys and evaluation studies should be conducted as an integral part of this issue resolution process.

9.7 Infrastructure

9.7.1 Management Plan

9.7.1.1 Infrastructure Team Charter

Scope: The Infrastructure Product Development Team (PDT) is responsible for all aspects of the Infrastructure Segment of the NWTC including segment design, procurement, manufacturing, construction, installation, and segment acceptance. The team is responsible for delivering an integrated segment that meets or exceeds the expectations in segment performance, cost, and schedule constraints, and interfaces with other segments in a manner that maximizes the NWTC performance. The PDT will develop the specifications for the components and products that comprise this segment.

The Infrastructure Team Charter further identifies the Statement of Work, Deliverables, Roles and Responsibilities, and Management Processes for the Infrastructure Product Development Team.

9.7.1.2 Team Execution Plan

The Infrastructure Team Execution Plan (Ref 9-48) defines the processes which will be used by the Infrastructure Product Development Team (PDT) to manage, design, procure, manufacture, construct, install, and accept the Infrastructure segment, and to successfully meet NWTC performance, schedule, and cost requirements.

9.7.2 Segment Specification

9.7.2.1 Introduction/Background

The Infrastructure Segment (Ref 9-49) provides the general and global systems required to support the NWTC.

- **PHYSICAL SITE**
Includes earthwork; drainage systems; roads and paving; and landscaping
- **DISTRIBUTED SERVICES**
Includes sanitary sewers; potable water, fuel, steam, shop air, and electrical power distribution systems; and utilidors
- **SAFETY AND PHYSICAL SECURITY**
Includes fire protection, detection and alarm systems; access control systems; secure storage; lightning protection; and outdoor lighting.
- **BUILDINGS**
Includes the Model, Test Prep, and Control building; the Main Drive System building; and the PES building.

The segment is divided into three components that reflect typical construction sequences which occur during a major project; Site Development, Infrastructure, and Buildings. Specific products included in this segment are identified in the Infrastructure Segment Specification.

Procedures and standards that constrain the design of Infrastructure Segment products are identified in the Segment Design Criteria. Additional constraints relative to security issues are identified in the Preliminary Security Criteria.

9.7.2.2 Performance Evaluation

The System Performance Evaluation Report, established a Facility Availability TPM requirement/metric of 5580 hours per year.

An operating plan constraint requiring three, 8-hour shifts/day, 5 to 6 days/week (275 days/year) is established by the Customer Performance Requirements. Further advice is provided to "not preclude efficient 3 shift/day, 7 days/week surge operation for an extended period of several months at a time".

Customer Operations Requirements, supplement the Customer Performance Requirements to provide a "complete definition of the NWTC facility requirements from a customer perspective". The Customer Operations Requirements provide a summary and detailed breakdown for thirteen functional areas:

9.7.2.3 Functional Analysis

The Functional Analysis process was utilized within the NWTC project to help define the functional definitions and functional interfaces for each segment. The four basic functions for the Infrastructure Segment are as follows:

- Provide Utilities & Distribute Within the NWTC
- Manage Interactions With the Environment
- Provide Transportation Systems
- Support Human Activities

A complete set of behavior diagrams, functional descriptions, and functional flows are contained in the Functional Review Report.

9.7.2.4 Physical Description

Basic product descriptions are provided in the NWTC Project Work Breakdown Structure (WBS) Dictionary. Expanded descriptions, including baseline assumptions for cost estimating purposes, are included in the Infrastructure Segment Specification. See Figure 9-8, for a Conceptual Plant Layout.

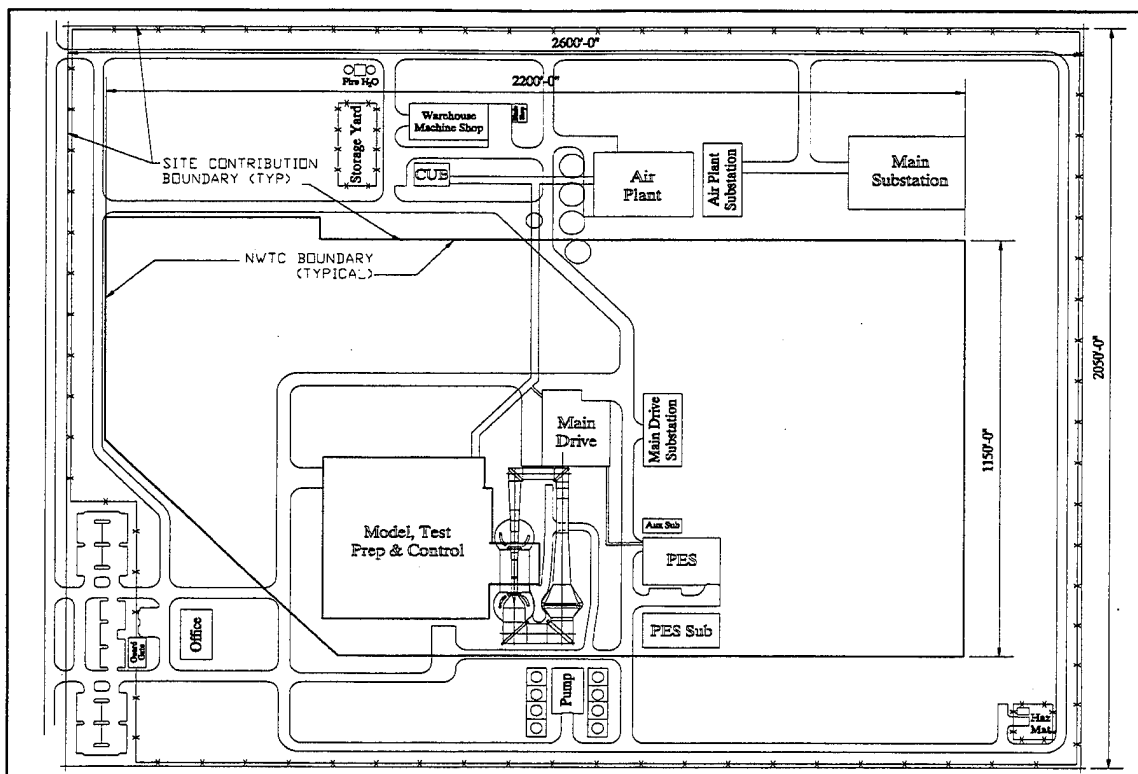

Figure 9-8: Conceptual Site Layout Infrastructure

9.7.2.5 Interface Definition

Segment-to-segment, and segment-to-external community interfaces are identified in the Baseline Interface Index. Expanded interface descriptions, and identification of intra-segment interfaces, are provide in the Infrastructure Segment Specification.

9.7.3 Design Concepts

9.7.3.1 Design Decision Notices

A process for reaching closure on the NWTC site configuration was established by DDN #2 (Ref 9-50) The SDR baseline configuration for the Infrastructure Segment was established by DDN#15 (Ref 9-51). This baseline-configuration was utilized in the development of the Infrastructure Segment Specification, segment schedule, and segment cost estimate. DDN #15 accomplished the following:

- Established a Conceptual Site Layout
- Established a Site Contributions Baseline
- Established the NWTC Infrastructure Baseline
- Quantified the Boundary Conditions between the Infrastructure Segment and Site Contributions. (i.e., identified what specific site contributions are received by the NWTC)

9.7.3.2 Site Evaluation Committee

The Infrastructure PDT worked closely with the Site Evaluation Committee in developing the initial Infrastructure segment definition. A draft "Good Site" document was jointly created which identified certain "threshold" requirements that every potential site must meet in order to be consider as a viable site. A matrix of additional desirable contributions which a "good site" might bring to the NWTC was also included in the document. This "good site" document established the basic interface parameters with utility providers and with the external community on which the Interface Segment was developed.

NWTC Final Report

In response to budget constraints, late in 1995 the project office site selection approach was revised to define specific contributions which a site would provide from existing infrastructure, or which an undeveloped site would provide in new infrastructure. Again, the Infrastructure PDT worked closely with the NWTC Site Evaluation Committee to develop a new site requirements document. This document is the Design Integration SEC Support Summary. During the NWTC archiving process, this document has been updated to reflect increased electrical loads imposed by DDN#13 (Ref 9-52).

9.7.3.3 Segment Configuration Options

TUNNEL SUN-SHADE ISSUE:

Determine if a full acoustical enclosure is required to meet NASA and OSHA regulations, and to mitigate environmental noise impacts on the external community. Requires a trade study after a construction site is selected.

SITE PARAMETERS ISSUE:

Identify differences between actual site-specific and baseline design assumptions. e.g., physical locations of existing infrastructure, capacities, and Specialty Engineering characteristics of existing equipment and systems; soil conditions; and environmental conditions. Requires field surveys after a construction site is selected.

9.7.4 Risk and Mitigation

9.7.4.1 System Risk Management Decision Outlines

The Infrastructure Segment identified two zone 2 cost risks related to segment products.

- Assumptions About Site Contributed Infrastructure Capacities
- Existing "...ilities" of Site Contributed Infrastructure

It is recommended that these risks be mitigated to a zone 3 level by conducting field surveys, after site selection, of actual site conditions and evaluating proposed site infrastructure contributions. Risk Management Decision Outline sheets fully describing these risks, the risk classification/analysis, alternative means of mitigation, recommended mitigation plan, and post-mitigation risk analysis are provided in the Risk Management Plan (Ref 9-53).

9.7.4.2 Segment Safety Analysis

The Infrastructure Segment identified four, code 2, safety hazards related to segment products.

- Inadvertent Fall Into Open Pits (SITE-0001)
- Inadvertent Natural Gas Discharge (SITE-0002)
- Inadvertent Electrical Contact (SITE-0003)
- Inadvertent Diesel Fuel Leakage (SITE-0004)

These risks can be mitigated to the code 3, permissible operation, level by complying with standard design codes, rules, and regulations; and by the implementation of appropriate personnel training and operations procedures. Safety Hazard Analysis sheets fully describing these hazards, the initial risk assessment, countermeasures, and post-countermeasure risk assessment are provided in the System Safety Program Report (Ref 9-54).

9.7.5 Recommendations

9.7.5.1 Site Contributions Issues

A site should be selected and the field surveys and evaluation studies (recommended by the PDT Risk Management as mitigation activities) should be conducted as an integral part of this issue resolution process.

9.7.5.2 Trade Study

The "environmental enclosure" trade study identified as an Infrastructure PDT SCOM item should be conducted:

- To resolve the environmental noise issue.

9.8 Site Contributions

9.8.1 Management Plan

9.8.1.1 Assigned Responsibilities

The Site Contributions Segment is represented by a functional manager within the NWTC Project Office. It is not represented by a single chartered PDT as are Segments 1 through 7 of the NWTC Design Build Organization. The functional manager is a member of the SE&I team.

The products outlined in Segment 8 interface directly with the Control & Information (PDT 5), Plant (PDT 6) and Infrastructure (PDT 7) product development teams. As shown in Figure 9-9, the Segment is divided into three sub-segment elements that correspond to the interfacing PDTs. PDTs 5, 6 and 7 have the responsibility of managing their respective interfaces with Segment 8, establishing a baseline for the Site Contributions, and quantifying the boundary conditions between NWTC and the assumed Site Contributions. Segment 8 establishes the operational & functional requirements for these site supplied elements.

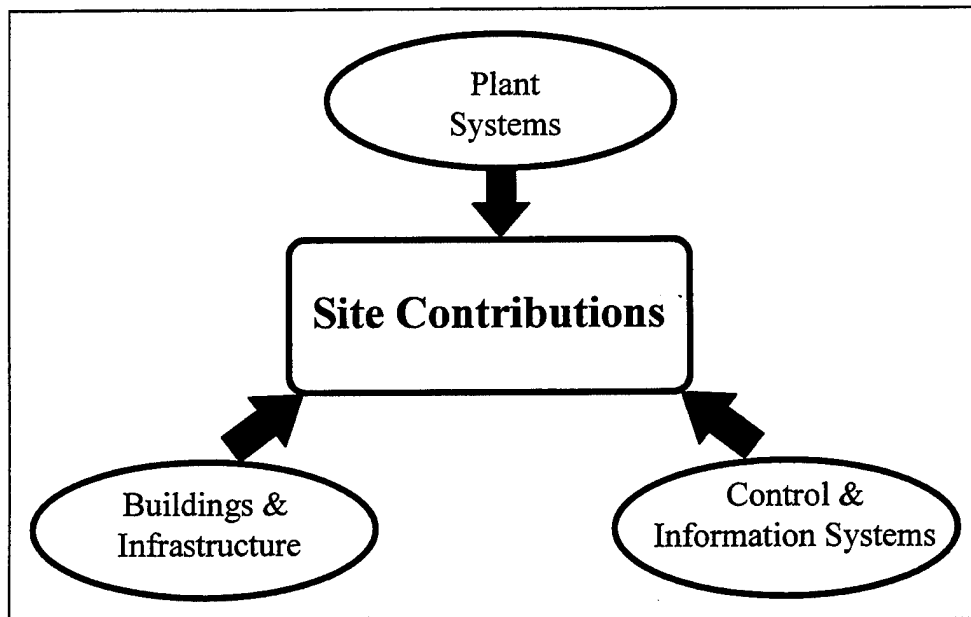

Figure 9-9: Segment Sub-Elements

Since no PDT was formed to represent Segment 8, neither a Team Charter nor a Team Execution Plan exists for this segment.

9.8.2 Segment Specification

9.8.2.1 Introduction / Background

The Site Contributions Segment provides for the Auxiliary Plant Systems, the Infrastructure, and the Control and Information Systems required to support the NWTC .

PLANT CONTRIBUTIONS

Includes High Pressure Air, Low Pressure Air, Vacuum Air, and Process Cooling Water to support NWTC requirements. These systems interface with products in Segment 6 (Plant PDT) which provide for the distribution of these elements. Segment 8 provides the requirements for quantity, quality, availability and reliability of these process systems to support NWTC requirements.

INFRASTRUCTURE CONTRIBUTIONS

Includes engineering office space, warehouse space, compressor blade shop, major machine shops, roads, site clearing, security fencing and utilities (electricity, domestic water, sanitary sewer, and natural gas etc.).

CONTROL AND INFORMATION SYSTEMS

Includes Facility Monitoring Systems, Business Systems and Data analysis systems to support NWTC requirements. See Figure 9-10.

The components described above comprise the Site Contributions Segment. Specific descriptions of the products within these components are contained in the Site Contributions Descriptions Document (Ref 9-55). The descriptions establish the baseline assumptions which support the NWTC cost estimate for Segment 8. Additionally, the requirements and assumptions for Segment 8 support the baseline assumptions for products in Segment 5, 6 and 7.

When an actual site is chosen, the assumptions contained in the Site Contributions Description Document would form the baseline for comparison and determination of the suitability and adequacy of existing process systems, infrastructure, control and information systems.

9.8.2.2 Performance Evaluation

The System Performance Evaluation Report, established a Facility Availability TPM requirement/metric of 5580 hours per year. An operating plan constraint requiring three, 8-hour shifts/day, 5 to 6 days/week (275 days/year) is established by the Customer Performance Requirements. Further advice is provided to "not preclude efficient 3 shift/day, 7 days/week surge operation for an extended period of several months at a time".

Customer Operations Requirements, supplement the Customer Performance Requirements to provide a "complete definition of the NWTC facility requirements from a customer perspective". The Customer Operations Requirements provide a summary and detailed breakdown for thirteen functional areas.

Controls and Information (PDT 5), Auxiliary Plant (PDT 6), and Infrastructure (PDT 7) Segment Products are dependent on the performance of the Site Contributions products.

9.8.2.3 Functional Analysis

The Functional Analysis process was used by the project to assist in the definition of functional definitions and functional interfaces for each segment. The four basic functions for the Site Contributions Segment are as follows:

- Provide Utilities & Distribute within the NWTC
- Manage Interactions with the Environment
- Provide Transportation Systems
- Support Human Activities

An important note here is that the functional analysis was originally done with all the above functions provided by PDTs 6 and 7. Refer to the Control and Information Systems (PDT 5) Final Report for discussion of functional analysis as it relates to that component. The behavior diagrams, functional descriptions, and functional flow diagrams are contained in the Functional Review Report.

9.8.2.4 Physical Descriptions

Basic product descriptions are provided in the NWTC Project Work Breakdown Structure Dictionary. Expanded descriptions, including baseline assumptions for cost estimating purposes, are included in the Site Contributions Descriptions Document. See Figure 9-8, for a Conceptual Plant Layout.

9.8.2.5 Interface Descriptions

Descriptions of inter-segment interfaces are contained in the Site Contributions Descriptions Document and an in depth discussion of interfaces for Plant, Infrastructure and Site Interfaces is contained in the NWTC Integration Study (Ref 9-56).

9.8.3 Design Concepts

9.8.3.1 Design Decision Notices

Design Decision Notice #12 established the Site Contributed Auxiliary Plant baseline requirements. See Figure 9-11. The following items summarize DDN #12:

- CUSTOMER HIGH PRESSURE AIR REQUIREMENTS
330 pps (420 pps max) @ 3600 psi for 15 min - 20 min recharge
- RECOMMENDED AIR PLANT SIZE (meets requirements)
L.P. Air: 300 psi, 200 pps, 500,000 cu.ft. storage
Vac. Plt: 0.07 atm, 30,000 acfm, 50,000 cu.ft. storage
H.P. Air: 6,000 psi, 200 pps, 22,300 cu.ft. storage

Design Decision Notice #15 established the baseline configuration for the Infrastructure Segment (Segment 7) and hence established what the Site Contributions requirements would need to be to support the NWTC. DDN #15 accomplished the following:

- Established a Conceptual Site Layout
- Established a Site Contributions Baseline
- Established the Infrastructure Baseline

9.8.3.2 Site Evaluation Committee

The original two-tunnel concept assumed site contributions at a level consistent with a "greenfield site". This approach established requirements for basic utilities and site conditions such as electric service, domestic water availability and service, certain environmental parameters and site conditions. As the transition to a single tunnel concept took place, the document which described the "greenfield site" conditions (called the Good Site Document) was amended to incorporate the assumptions made for additional products which would be supplied by an existing site. This approach was taken in order to address NWTC budget constraints.

The assumptions which define the elements that would be Site Contributed were developed in close coordination with the NWTC Site Evaluation Committee. The Design Integration SEC Support Summary captures the cooperative effort in developing the Site Contributions assumptions.

9.8.4 Risk and Mitigation

9.8.4.1 System Risk Management Decisions

During the risk analysis process, risks were identified by the Plant and Infrastructure PDTs which relate to Site Contributions Assumptions. These zone 2 cost risks are as follows:

- Assumptions about Site Contributed Plant and Infrastructure Capacities
- Existing "ilities" of Site Contributed Plant and Infrastructure

Consideration of these risks is very important in the validation of the NWTC Cost /Estimate since the assumptions made about site contributions suggest that the products exist in the capacity, quantity, availability, and reliability required to operate the NWTC. However, all elements assumed to be existing do not currently exist at any known site.

The mitigation of these system level risks requires making an assessment of the elements included in the Site Contributions Segment after a site is chosen. At that time the program would be able to assess the true impact of the assumptions that were made regarding capacities and the "ilities" associated with Site Contributed Auxiliary Plant, Infrastructure, Control, and Information Systems.

9.8.4.2 Segment Safety Analysis

A Safety Analysis was not prepared for this segment since actual site conditions are unknown.

9.8.5 Recommendations

9.8.5.1 Site Contributions Issues

A site should be selected and the field surveys and evaluation studies should be conducted as an integral part of this issue resolution process.

9.8.5.2 PDT Organization

Site Contribution requirements, interfaces, and management should be assigned to effected PDTs and be closely tracked by the Systems Engineering and Integration (SE&I) team.

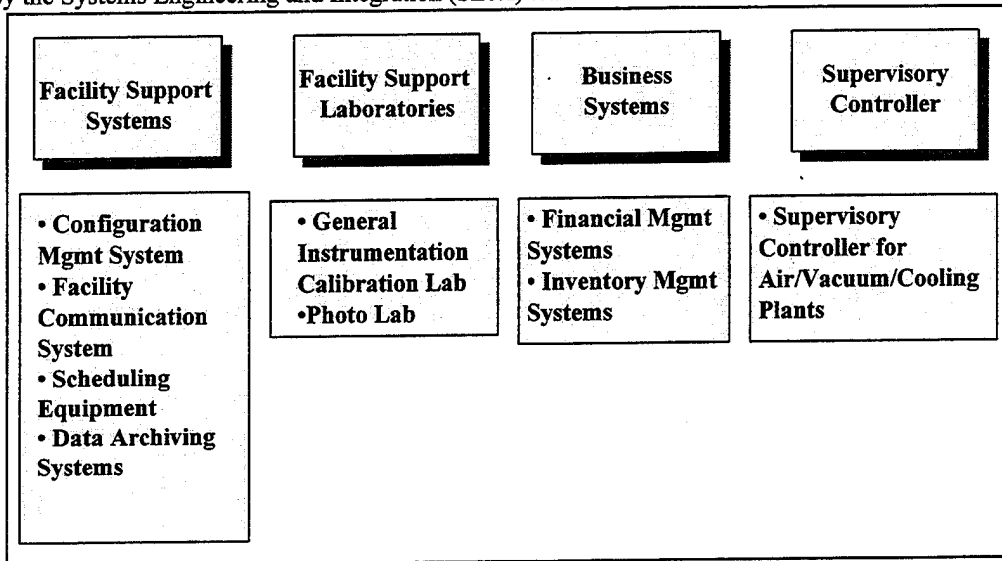

Figure 9-10: Site Contributed Control and Information Systems

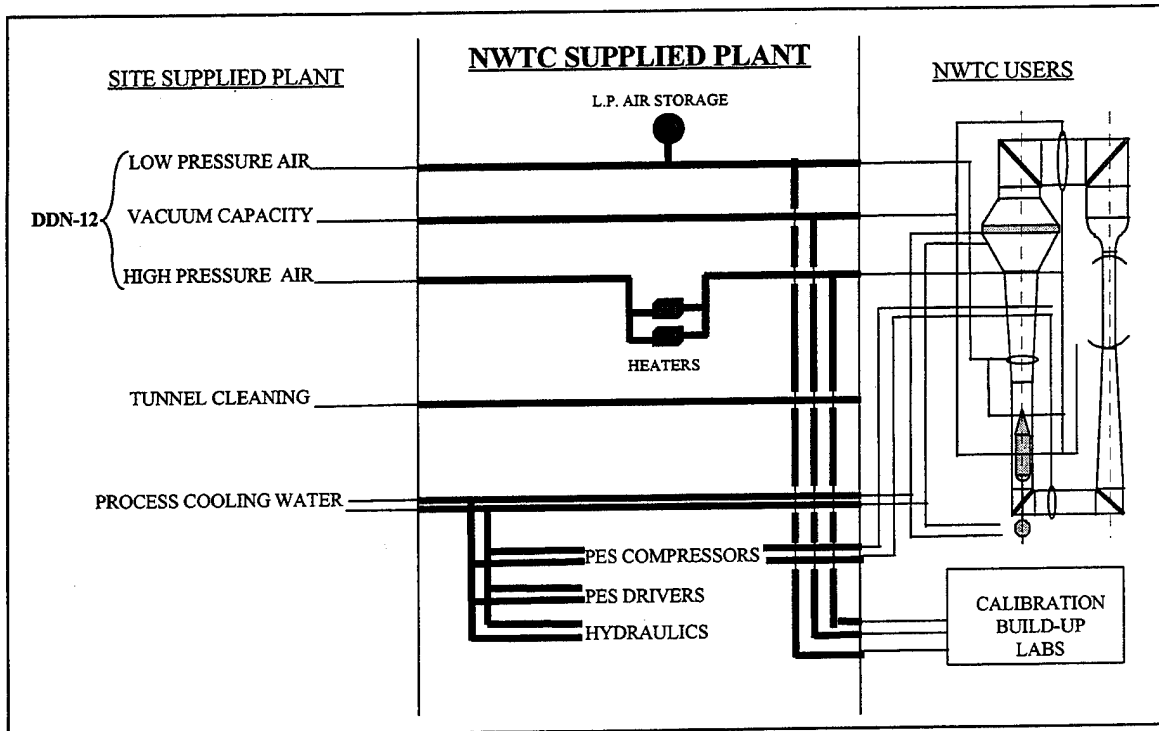

Figure 9-11: NWTC Interfaces with Site Contributed Plant Elements

10. Concluding Remarks

The National Facilities Study (NFS) set forth challenging goals for the NWTC in terms of: Reynolds number, flow quality, productivity, and operating costs.

The NFS envisioned two tunnels to meet these goals, and this was the initial approach of the NWTC Project. Because of budget constraints, the effort was redirected to a single Multi-Purpose Wind Tunnel (MPWT). The MPWT concept presented in this final report is a viable design that meets most of the goals of the NWTC as outlined by the NFS, with the notable exception of Reynolds number at low speeds.

This MPWT concept as detailed in the Project Specification, and reviewed at the SDR, closes on configuration, performance, and schedule. The configuration cost estimate was \$1.29B; recommendations were made of delayed/reduced capability which would reduce the costs to the \$1.2B project budget. Not included in the budget is necessary site supplied infrastructure with a value estimated at \$0.37B.

The key conclusions to be drawn from NWTC Project effort are:

- The facility can be designed to meet the high productivity requirements.
- Flow quality "thresholds", acceptable to Industry, can be met. Risk mitigation was to be put in place to achieve even higher customer "goals".
- The facility can achieve the operating cost goals, even considering the inherently higher costs of high Reynolds number operation..
- All of the NFS transonic capability can be achieved in the single multi-purpose wind tunnel.
- All of the NFS low speed capability can be achieved in the single multi-purpose wind tunnel, with the exception of Reynolds number which would be 66% of the NFS goal.
- The facility can be built within the \$1.2 billion design to cost budget
 - This would require some reduction of capability compared to the SDR configuration.
 - This assumes the utilization of significant site supplied infrastructure, with major cost risk associated with the availability of a high pressure airplant.
- The facility can be designed, constructed, and activated in a seven year schedule from SDR to fully-ready user testing assuming a timely siting decision following SDR.

The NWTC project was ready to proceed to Preliminary Design, where more detailed analysis would have focused on the key issues and risk areas noted above. Although there were still many challenges ahead, no show stoppers have been identified that would have caused any major deviation from the configuration, performance, schedule, and cost as presented in the SDR and described in the archived data.

Appendix A - Reference List

Note: The following titles and all relevant information can be found in the NWTC archive.

Section 1.0

(NONE)

Section 2.0

- 2-1 Fiscal Year 1995, NASA Aeronautical Research & Technology Budget Authorization Hearing (Boeing Wind Tunnel Corporate Assessment, 1984, referenced within) (d187.htm)
- 2-2 National Facilities Study Summary Report (d255.htm)
- 2-3 Facilities Study Office Final Report - NWTC (d183.htm)
- 2-4 Assessing the National Plan for Aeronautical Ground Test Facilities (copyright.htm)
- 2-5 National Planning for Aeronautical Test Facilities (copyright.htm)
- 2-6 System Design Review (SDR) Meeting Minutes (d350.htm)
- 2-7 Single Tunnel System Design Review (SDR) Data (d587.htm)

Section 3.0

- 3-1 Subcontract Management Plan (subplan 3.doc), (d345.htm)
- 3-2 Project Specification Release Revision B: 3/3/96 (One Tunnel SDR) (specbdoc.htm)
- 3-3 Change Request - CR#6, Redefinition of NWTC from a Two Tunnel to a Single Multipurpose Tunnel Complex (cr-6.doc)

Section 4.0

- 4-1 Project Work Break Down Structure (WBS) Dictionary (d294.htm)
- 4-2 Project Specification Release Revision B: 3/3/96 (One Tunnel SDR) (specbdoc.htm)
- 4-3 Segment Specifications (d513.htm, d528.htm, d529.htm, d548.htm, d508.htm, d473.htm, d462.htm) (segment.htm)
- 4-4 Risk Management Plan (riskrevb.doc)
- 4-5 Subcontract Management Plan (subplan 3.doc), (d345.htm) (subcontr.htm)
- 4-6 NWTC Integrated Schedules Volumes 1 and 2 (intsched.htm)
- 4-7 Life Cycle Cost Model (Two Tunnels: d551.htm), (One Tunnel: d616.htm)
- 4-8 Construction Cost Estimate (2revest.htm), (Original Two Tunnel: 1tcstest.htm, Original Two Tunnel: 2torgest.htm) (estimate.htm)

Section 5.0

- 5-1 Task Group on Aeronautical Research and Development Facilities Report - Vol. 2 (d254.htm)
- 5-2 Customer Requirements, Release 4.3, Vol. 1 of 2, Vol. 2 of 2 (d145.htm)
- 5-3 Customer Operations Requirements, Single, Multi-Purpose Transonic Tunnel, Release 11.0 (d618.htm)
- 5-4 Customer Operations Requirements, Release 2.0 (cr95_053.doc)
- 5-5 NWTC Sample Test Scenarios, Release 11.0 (cro11.doc.htm)

NWTC Final Report

Section 6.0

6-1 Program Plan (d759.htm)

Section 7.0

- 7-1 NWTC Tech Mgt Plan (tmp50907.doc) New, (tmp 60212.doc) Rev A (techmgmt.htm)
- 7-2 Systems Engineering & Integration Team Execution Plan (ben_chtr.doc)
- 7-3 Configuration Management Plan - Revision A (cmprev_a.doc)
- 7-4 Project Specification Release Revision B: 3/3/96 (One Tunnel SDR) (specbdoc.htm)
- 7-5 CR&O, Release 10.0 (cr95_058.doc)
- 7-6 Functional Analysis Review Report (d774.htm) (funreview.htm)
- 7-7 Baseline Interface Index (d562.htm)
- 7-8 DDN 11 (d480.htm)
- 7-9 DDN 18 (d487.htm)
- 7-10 DDN 13 (d482.htm)
- 7-11 High Speed Leg Model Design Criteria (d639.htm)
- 7-12 Tunnel Upgrade Options for Achieving Full Span Fighter Model Test Conditions (Trade Study) (d550.htm)
- 7-13 DDN 14 (d483.htm)
- 7-14 Segment Specifications (Archive Index BB) (segment.htm) (segment.htm)
- 7-15 Project Specification (TBD) Matrix (tbd_sdr.xls)
- 7-16 MIL-STD-882C (standard.htm)
- 7-17 Risk Management Plan (riskrevb.doc)
- 7-18 Progress and Status, System Safety Program, NWTC Preliminary Design (d837.htm)
- 7-19 NWTC Productivity Model Document (sdd.doc)
- 7-20 NWTC Sample Test Scenarios (cro11doc.htm)
- 7-21 NWTC Dynamic Model Document (dynamic1.doc)
- 7-22 NWTC Information Quality Model Document (d829.htm)
- 7-23 Performance Envelop, Turbulence Fluctuations, and Static Pressure Fluctuations Model Code Manual (d830.htm)
- 7-24 NWTC Availability Allocation Model Document (relreprt.doc)
- 7-25 NWTC Life Cycle Cost Model (Two Tunnels: d551.htm), (One Tunnel: d616.htm) (lifecost.htm)
- 7-26 Systems Performance Evaluation Report (d544.doc)

Section 8.0

- 8-1 NWTC Risk Reduction Studies (Archive Index AB) (riskred.htm)
- 8-2 NWTC Concept Evaluation Studies (Archive Index AA) (concept.htm)
- 8-3 Unitary High Reynolds Number Circuit (UHRC) Study (d725.htm)
- 8-4 AEDC 16 T Upgrade Study (d442.htm)
- 8-5 Study Approval Board Documentation (d638.htm)
- 8-6 High Speed Leg Study (639-643) (d639.htm) (hispdleg.htm)
- 8-7 Back Leg Study (644-647) (d644.htm, d645.htm, d646.htm, d647.htm) (backleg.htm)
- 8-8 Slotted Walls Study (648,650) (d648.htm, d650.htm) (slotwall.htm)
- 8-9 Open Jet Study (651,652) (d651.htm, d652.htm) (openjet.htm)
- 8-10 Flow Quality Requirements, Decisions, and Recommendations (d586.htm)
- 8-11 Slot Baffle Acoustics Test Report (d650.htm)

NWTC Final Report

Section 9.0

- 9-1 Project Specification Release Revision B: 3/3/96 (One Tunnel SDR) (specbdoc.htm)
- 9-2 Test Segment Specification (testspc.doc)
- 9-3 Risk Reduction Studies (d424.htm) (riskred.htm)
- 9-4 DDN 1 (d478.htm)
- 9-5 DDN 10 (d479.htm)
- 9-6 DDN 16 (d485.htm)
- 9-7 CR&O Release 10.0 (cr95_058.doc)
- 9-8 DDN 11 (d480.htm)
- 9-9 Aeroacoustic Performance of Open Jet Wind Tunnels (d010.htm)
- 9-10 NWTC Risk Management Plan (riskrevb.doc)
- 9-11 Risk Reduction Drawings - LSWT & TSWT (d394.htm)
- 9-12 Project Level Risk Management Plans (riskrevb.doc)
- 9-13 Flow Segment Team Execution Plan (flowtep.htm)
- 9-14 Flow Segment Specification (flowspec.doc)
- 9-15 Concept Evaluation Studies (Archive Index AA) (concept.htm)
- 9-16 ASME Boiler and Pressure Vessel Code (standard.htm)
- 9-17 AISC Steel Construction Manual (standard.htm)
- 9-18 Pressure Segment Team Execution Plan (d530.htm)
- 9-19 Pressure Segment Specification (presseg.doc)
- 9-20 NWTC Drawing S001, and S002 (d394.htm)
- 9-21 NWTC Drawings S003 - S007 (d394.htm)
- 9-22 NWTC Pressure Proof Test Assessment (d673.htm)
- 9-23 DDN 7 (d494.htm)
- 9-24 Wind Tunnel Anchorage Point, DDN 19 (d381.htm, d488.htm, d277.htm) (anchorpt.htm)
- 9-25 DDN 17 (d486.htm)
- 9-26 Compressor and Drive Segment Team Execution Plan (d463.htm)
- 9-27 Compressor and Drive Segment Specification (cmpdrsp1.doc)
- 9-28 ASME "Guide to Transmission Design" (standard.htm)
- 9-29 Pressure System Main Compressor Oil System Schematic numbers M0010-M0050 (d394.htm)
- 9-30 NWTC System Safety Plan (d353.htm)
- 9-31 Controls and Information (C&I) Segment Team Execution Plan (tep.doc)
- 9-32 C&I Segment Specification (ci_seg.doc)
- 9-33 C&I Requirements Survey White Paper (reqwhite.doc)
- 9-34 Controls and Information Functional Decomposition (ci_decom.doc)
- 9-35 Auxiliary Plant Segment Team Execution Plan (executn.doc)
- 9-36 Auxiliary Plant Segment Specification (plntseg.htm)
- 9-37 Infrastructure Segment Design Criteria (criteseg.doc)
- 9-38 Preliminary Security Criteria (presecur.doc)
- 9-39 Systems Performance Evaluation Report (d544.doc)

NWTC Final Report

Section 9.0 (Cont'd)

- 9-40 Functional Analysis Review Report (d774.htm)
- 9-41 NWTC Project Work Breakdown Structure (d294.doc)
- 9-42 Baseline Interface Index (d562.htm)
- 9-43 DDN 8 (d495.htm)
- 9-44 DDN 12 (d481.htm)
- 9-45 Configuration Description Document (cdd_pics.doc)
- 9-46 Design Integration SED Support Summary (sec1_a.doc)
- 9-47 Infrastructure Segment Team Execution Plan (infra_pln.doc)
- 9-48 Infrastructure PDT Segment Specification (d513.htm)
- 9-49 DDN 2 (d489.htm)
- 9-50 DDN 15 (d484.htm)
- 9-51 DDN 13 (d482.htm)
- 9-52 System Risk Management Decision Outlines (riskrevb.doc)
- 9-53 Site Contributions Descriptions Document (d536.htm)
- 9-54 NWTC Integration Study (intgstud.htm)

Appendix B

Archive Contents

The NWTC archive is a digital set of data that was produced as a deliverable for the NASA - Boeing contract NAS3-27330. It includes technical and administrative documentation developed in support of the NWTC contract, as well as general research data used by the NWTC project.

The data in the archive consists of over 700 separate data files covering NWTC related studies, reports, specifications, requirements, software models, configuration management documents, Technical Review meeting documents, design calculations, research notes, drawings, cost estimates, select business management documents and miscellaneous other presentations, memos and minutes. The attached archive tree depicts the general structure and content of the archive and its main menus.

The archive is contained on a set of six ROM compact disks (CD-ROM), and is presented with an included Web page format interface. Where possible, the data files are stored in native format. The majority of native formats found in the archived documents are Word 6.0, Excel 5.0, Powerpoint, and AutoCAD 13, although any native format documents were accepted. Documents that were not available in native format (i.e., available in paper only) were electronically scanned to produce digital images for archiving.

Detailed user instructions for the archive are contained in a booklet included with each CD-ROM set. Please note that disks one through six contain over 98% of the data files and have been included in all distributed sets. The seventh disk, however, contains Site Evaluation documentation that has been deemed sensitive in nature, and therefore has limited distribution. If you require any of the documentation on the seventh disk, you must contact Mr. William Stamper, Aeronautics Facilities Manager, NASA Headquarters, Washington DC, 20546-0001, phone (202)-358-1133, to request the data.

NWTC ARCHIVE

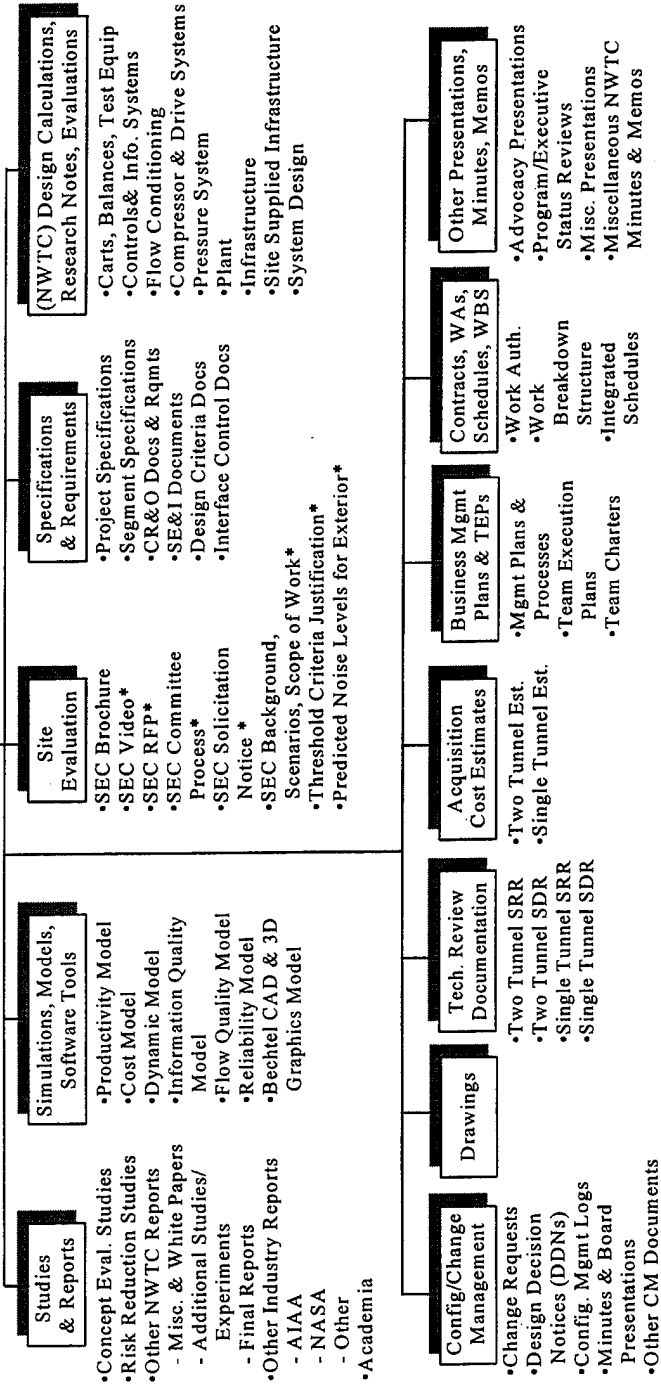

* These Site Evaluation Committee (SEC) items are deemed sensitive in nature, and are contained on the separate Limited-Distribution CD.

NWTC Final Report Distribution

AEDC-CEC (12)

100 Kindel Drive #B-322

Arnold Air Station, Tennessee 37389-2322

Attention: Jim Parker (4)
Defense Technical Information Center - 2 each
AEDC Historian
AEDC Technical Library
AEDC/DOF
AEDC/XP
Sverdrup/16T
AF/TER

AIAA

370 L'Enfant Promenade, S.W.

Washington, D.C. 20024-2518

Attention: Kristen Burch

ASC/ENF, (2)

Building 125

2335 Seventh Street #6

Wright Patterson AFB, Ohio 45433-7809

Attention: Kent Copeland
Norm Scaggs

Aero Systems Engineering, Inc. (2)

358 East Filmore Avenue

Saint Paul, Minnesota 55107-1289

Attention: Don Kamis

Babcock & Wilcox

91 Stirling Avenue

Barberton, Ohio 44203

Attention: Laurie Wessel

Bechtel National, Incorporated

45/29/C-71

45 Fremont Street

San Francisco, California 94119-3965

Attention: Ron Naventi

Bodi & Associates

2215 Chesterland Avenue
Lakewood, Ohio 44107-6111
Attention: Bob Bodi

The Boeing Company (6)

P.O. Box 3707
Seattle, Washington 98124-2207
Attention: Jerry Lundry M/S 19-MR
Kent Peterson M/S 2R-71
Roger Seeman M/S 19-MF
Kevin Watson M/S 1W-82
ISS Technical Library M/S 62-LC
Renton Technical Library M/S 74-60

CB&I

1502 North Division Street
Plainfield, Illinois 60554-8929
Attention: Dale Swanson

DiversiTech, Inc.(2)

2390 Struble Road
Cincinnati, Ohio 45231
Attention Don Dusa
Bernie Niehaus

General Dynamics

Electric Boat Corporation
Department 951
Quonset Point Facility
North Kingston, Rhode Island 02852-1009
Attention: David Rothfuss

GE Aircraft Engines (2)

One Newmann Way
M/S A-410
Cincinnati, Ohio 45215
Attention: Don Dietrick
Bob Delaney

Lockheed Martin (7)

Low Speed Wind Tunnel
1055 Richardson Road
Smyrna, Georgia 30080

Attention: Brooks Maddox
Chet Ciancarelli
Mike Pohlig
Richard Williams
Bob Dinal
Tom Winn
Mark Carlson

McDonnell Douglas (4)

2401 E. Wardlow Road
Long Beach, California 90807-4418

Attention: Perry Goldberg M/C 71-35
John Braun M/C 35-04
Rob Gregg M/C 800-12
Andy Magata M/C 1-22272

Micro Craft Inc.

P.O. Box 370
207 Big Springs Avenue
Tullahoma, Tennessee 37388-0370
Attention: Lowell Keel

NASA Headquarters (2)

Washington, D.C. 20546-001
Attention: Bill Stamper / Code R (2)

NASA Lewis Research Center (78)

21000 Brookpark Road
Cleveland, Ohio 44135

Attention: Marty Kress M/S 3-2
John Schaefer M/S 6-9
Gene Stygles M/S 6-9
Ron Sepesi (64) M/S 500-313
Daniel Larson M/S 501-8
Daniel Gaunter M/S 86-15
Coordination Center (9) M/S 60-1

NASA Ames Research Center (7)

Moffett Field, California 94035

Attention: Joseph Hurlbut M/S 213-1
Frank Kmak M/S 227-6
Lado Muhlstein M/S 227-4
Cliff Imprescia M/S 213-1
Ames Main Library,
Research Info. Services M/S 202-3
Code J Engineering
Document Center M/S 213-11
Sandy Davis M/S 260-1

NASA Langley Research Center (5)

Hampton, Virginia 23681-0001

Attention: Earl Booth
Roy Harris
Sammie Joplin
Henry Wright
Blair Gloss

Center for Aerospace Information (CASI) (50)

800 Elkridge Landing Road
Lithicum Heights, Maryland 21090-2934
Attention: Cynthia Barnes

Georgia Institute of Technology

Acoustics and Aerodynamics Branch, GTRI/AERO
Atlanta, Georgia 30332-0800
Attention: Krish Ahuja

Northrop Grumman Corporation (3)

Military Aircraft Systems
8900 E. Washington Blvd.
Pico Rivera, California 90660-3783
Attention: P.T. Wooler M/C T200/GK
D.E. Wood M/C T600/GB
J.A. Dahlin M/C W992/UB

OUSD (A&T)

Room 3D 1067
3110 Defense, The Pentagon
Washington, DC 20301-3110
Attention: Irv Boyles

Pitt-Des Moines

34000 Grand Avenue
Pittsburgh, Pennsylvania 15225
Attention: Robert Watson

Pratt & Whitney (3)

17900 Beeline Highway
Jupiter, Florida 33478
Attention: Karen Barker (3)

Raytheon Engineering & Construction

10900 N.E. 8th Street
Bellevue, Washington 98004
Attention: Dave Lotta

Ring Technical Services, Inc.

1923 Waters Edge Drive
Westlake, Ohio 44145
Attention: Dr. Leon Ring

Scitor

Seattle Operations
14205 S.E. 36th Street #200
Bellevue, Washington 98006
Attention: Ben Bicknell

Sverdrup Technology, Inc.

600 William Northern Blvd.
Tullahoma, Tennessee 37388
Attention: Rogers Starr

Westinghouse Marine Division

401E. Hendy Avenue
Sunnyvale, California 94088-399
Attention: Jack Tavaris

NWTC Final Report

Report Documentation Page			Form Approved OMB No. 0704-0188	
Public reporting burden for this collection of information is estimated to average 1 hour per response, including the time for reviewing instructions, searching existing data sources, gathering and maintaining the data needed, and completing and reviewing the collection of information. Send comments regarding the burden estimates or any other aspect of this collection of information, including suggestions for reducing this burden, to Washington Headquarters Services, Directorate for Information, Operations and Reports, 1215 Jefferson Davis Highway, Suite 1204, Arlington, Va. 22202-4302, and to the Office of Management and Budget, Paperwork reduction Project (0704-0199), Washington, DC 20503				
1. AGENCY USE ONLY (Leave Blank)	2. REPORT DATE June 7, 1996	3. REPORT TYPE AND DATES COVERED Final Contractor Report		
4. TITLE AND SUBTITLE National Wind Tunnel Complex (NWTC) Final Report			5. FUNDING NUMBERS C-NAS3-27330	
6. AUTHOR(S) The Boeing Company				
7. PERFORMING ORGANIZATION NAME(S) AND ADDRESS(ES) The Boeing Company P.O. Box 3707 Seattle, Washington 98124-207			8. PERFORMING ORGANIZATION REPORT NUMBER E-10279	
9. SPONSORING / MONITORING AGENCY NAME(S) AND ADDRESS(ES) National Aeronautics and Space Administration Lewis Research Center Cleveland, Ohio 44135-3191			10. SPONSORING / MONITORING AGENCY REPORT NUMBER NASA CR-198491	
11. SUPPLEMENTARY NOTES Leon Ring, Ring Technical Services, 1923 Waters Edge Drive, Westlake, Ohio 44145; William Dodge, Steve Sawyer, Alex Krynytzky, Bob Borst, Wyman Heckel, Mike Grady, and John Bittinger, The Boeing Company, P.O. Box 3707, Seattle, Washington 98124-2207; Dave Lalor, McDonnell Douglas Company, 2401 East Wardlow Road, Long Beach, California 90807-4418; Tom Moll, Aero Systems Engineering, Inc., 358 East Filmore Avenue, St. Paul, Minnesota 55107-1289; Paul Townsen, Ron Hamilton, Mike Chaney, and Don Gregory, Sverdrup Technology, Inc., 600 William Northern Blvd., P.O. Box 884, Tullahoma, Tennessee 37388; Lowell Keel, Microcraft, 207 Big Springs Avenue, P.O. Box 370, Tullahoma, Tennessee, 37388-0370; Ben Bicknell, Scitor Corporation, 14205 SE 36th Street, Suite 200, Bellevue, Washington 98006-1598. Responsible Person, Ronald W. Sepesi, Wind Tunnel Program Office, organization code 0110, (216) 433-2792.				
12a. DISTRIBUTION/AVAILABILITY STATEMENT Unclassified - Unlimited Subject Category 09 This Publication is available from the NASA Center for AeroSpace Information, (301) 621-0390			12b. DISTRIBUTION CODE	
13. ABSTRACT (Maximum 200 Words) The National Wind Tunnel Complex (NWTC) Final Report summarizes the work carried out by a unique Government / Industry partnership during the period of June 1994 through May 1996. The objective of this partnership was to plan, design, build and activate "world class" wind tunnel facilities for the development of future-generation commercial and military aircraft. The basis of this effort was a set of performance goals defined by the National Facilities Study (NFS) Task Group on Aeronautical Research and Development Facilities which established two critical measures of improved wind tunnel performance; namely, higher Reynolds number capability and greater productivity. Initial activities focused upon two high-performance tunnels (low-speed and transonic). This effort was later descope to a single multipurpose tunnel. Beginning in June 1994, the NWTC Project Office defined specific performance requirements, planned site evaluation activities, performed a series of technical / cost trade studies, and completed preliminary engineering to support a proposed conceptual design. Due to budget uncertainties within the Federal government, the NWTC project office was directed to conduct an orderly closure following the Systems Design Review in March 1996. This report provides a top-level status of the project at that time. Additional details of all work performed have been archived and are available for future reference.				
14. SUBJECT TERMS Wind tunnels; Subsonic wind tunnels; Transonic wind tunnels; Test facilities			15. NUMBER OF PAGES 116	
			16. PRICE CODE A06	
17. SECURITY CLASSIFICATION OF REPORT Unclassified	18. SECURITY CLASSIFICATION OF THIS PAGE Unclassified	19. SECURITY CLASSIFICATION OF ABSTRACT Unclassified	20. LIMITATION OF ABSTRACT	

Standard Form 298 (Rev. 2-89)
Prescribed by ANSI Std. Z39-18
298-102