

AD-A239 420



3

1991 JOINT DOD
STANDARDIZATION AND
DATA/CONFIGURATION MANAGEMENT CONFERENCE

**CONDUCTING BUSINESS
UNDER THE DMR**

DTIC
S D
AUG 13 1991
D



MAY 13 - 17, 1991

THE HOLIDAY INN CROWNE PLAZA HOTEL
ARLINGTON, VIRGINIA

SPONSORED BY:
OFFICE OF THE ASSISTANT
SECRETARY OF DEFENSE
(PRODUCTION AND LOGISTICS)

91-07648



91 8 13 001

**Best
Available
Copy**

FOREWORD

1991 JOINT DOD STANDARDIZATION AND DATA/CONFIGURATION MANAGEMENT CONFERENCE

MAY 13-17, 1991

THE HOLIDAY INN CROWNE PLAZA HOTEL, ARLINGTON, VIRGINIA

This publication contains papers and presentations from the 1991 Joint DoD Standardization and Data/Configuration Management Conference. Workshop summaries have been provided and recommendations will be evaluated and appropriate action taken to implement or make other disposition.

These proceedings contain presentations made by numerous leaders and experts in the fields of standardization, data and configuration management, acquisition, as well as many other related areas. The conference focused on current problems, provided a forum for managers and action officers to exchange information and relate "success stories," and examined our future under defense management review. A number of recommendations and policy changes were made by panels and workshops and the Director, Manufacturing Modernization Directorate will ensure that the appropriate DoD offices address these recommendations.

Credit for this conference's success goes to the tutorial leaders, panel chairmen and their panelists, and workshop leaders, who gave generously of their time, effort, and talent, and to the participants who kept the discussions lively and meaningful.

Questions or comments on the conference or these proceedings should be directed to Mr. Stephen Lowell or Mrs. Sharon Strickland, of the Defense Standardization Program Division, on 703-756-2340 or DSN 289-2340.



Approved For	
NIS - Chief	
DIC - Chief	
Undersecretary	
for	
By	
Date	
Availability	
Dist	
A-1	

1991 JOINT DOD STANDARDIZATION AND DATA/CONFIGURATION MANAGEMENT CONFERENCE

CONDUCTING BUSINESS UNDER THE DMR

MAY 13-17, 1991

THE HOLIDAY INN CROWNE PLAZA HOTEL, ARLINGTON, VIRGINIA

The 1991 Joint DoD Standardization and Data/Configuration Management Conference was the first Manufacturing Modernization Directorate conference convened by the Director to address the dramatic effect Secretary Cheney's Defense Management Review has had and will continue to have on our programs. Under the DMR, DoD is being asked to continue to do more with less; to identify measurable goals; to improve efficiency and effectiveness; and to better define lines of responsibility, authority, and accountability. We have been asked to change our business practices and the conference provided a forum to discuss with the Standardization and Data/Configuration Management communities the future of our programs. The conference theme, "Conducting Business Under the DMR," recognizes the roles Standardization, Data and Configuration Management have in improving the quality and reliability of our defense materiel and weapon systems.

Conference participants were from defense contractors, non-Government standards bodies, industry associations, and DoD weapons systems program managers and their staffs, as well as from DoD's Standardization and Data/Configuration Management communities.

TABLE OF CONTENTS

	PAGE
Foreword	i
Summary	iii
Content	v

TUTORIALS

Tutorial S-1	How to Write A Commercial Item Description, <i>Chris Metz</i> , OASD(P&L)MMD	1-1
Tutorial S-2	Types of Documents, <i>Rae Walker</i> , Army Logistics Mgmt. College	2-1
Tutorial S-3	Data in Specifications and Standards, <i>Donald Langkamp</i> , OASD(P&L)MMD	3-1
Tutorial S-4	Repeat of Tutorial S-1 (See section 1-1)	4-1
Tutorial S-5	Roles of Standardization Management Activities, <i>Rae Walker</i> , ALMC	5-1
Tutorial S-6	Tailoring of Specifications and Standards, <i>Steve Lowell</i> , OASD(P&L)MMD	6-1
Tutorial D-1	How to Write a Data Item Description, <i>Brenda Stanley</i> , Hqtrs, AFLC	7-1
Tutorial D-2	MIL-T-31000, <i>Roland Henderson</i> , OASD(P&L)MMD	8-1
Tutorial D-3	How to Prepare the New DD Form 1423, <i>Regina Long</i> , USAF	9-1

GENERAL SESSION

Keynote Address -- <i>Paul A. Strassmann</i> , Director, Defense Information, Office of the Assistant Secretary of Defense for Command, Control, Communications, and Intelligence	10-1
Panel On Impact of Defense Management Review (DMR) on Standardization, Data Management, and Configuration Management Programs:	
Presentations by:	
<i>Nicholas M. Torelli, Jr.</i> , Deputy Assistant Secretary of Defense for Production Resources	11-1
<i>Darold L. Griffin</i> , Principal Assistant Deputy for Research, Development and Acquisition, Headquarters, Army Materiel Command	12-1
<i>CAPT. Gary L. Averett</i> , USN, Acting Director, Acquisition Process Office, Office of the Assistant Secretary of the Navy (Research, Development and Acquisition)	13-1
<i>BGEN William E. Collins</i> , Assistant for Reliability, Maintainability and Quality to the Deputy Assistant Secretary of the Air Force for Management Policy and Program Integration	14-1
<i>Henry A. Filippi</i> , Executive Director, Technical and Logistics Service,	15-1

PANELS AND WORKSHOPS

	PAGE
Nondevelopmental Item Program, <i>Gregory E. Saunders</i> , Chair, OASD(P&L)MMD	16-1
PANEL A - JUSTIS, <i>Col. Gilbert E. Mayeux II</i> , Chair, Air Force Logistics Command	17-1
PANEL B - DoDD 5000.1 and DoDI 5000.2, <i>Carl Berry</i> , Chair, OASD(P&L)MMD	18-1
PANEL D - Technical Data Infrastructure, <i>Richard Donnelly</i> , Chair, OASD(P&L)MMD	19-1
Changes to DoD 4120.3-M, <i>Steve Lowell</i> , Chair, OASD(P&L)MMD	20-1
Metric Program, <i>John Tascher</i> , Chair, OASD(P&L)MMD	21-1
Standardization Automation Panel, <i>Tom Ballantine</i> , Chair	22-1
Workshop I - Configuration Management, <i>Fred C. Lewis</i> , Chair	23-1
Workshop II - MIL-HDBK-TDP, <i>Roland Henderson</i> , Chair	24-1
Workshop III - CM/DM Contractor Certification, <i>Jim Whisenant</i> , Chair	25-1
Workshop IV - Technical Data Management, <i>Donald Langkamp</i> , Chair	26-1
Qualified Manufacturers List, <i>Darrell Hill</i> , Chair	27-1
Eliminating Hazardous Material Requirements in Specifications and Standards, <i>Frank Traceski</i> , Chair	28-1
Workshop S-1 - DoD Single Stock Point, <i>Marilyn-Stewart Fridley</i> , Chair	29-1
Workshop S-2 - Coordination of Documents, <i>Paul Tremblay</i> , Chair	30-1
Workshop S-3 - Program Plans, <i>Frank Traceski</i> , Chair	31-1
Workshop S-4 - Standardization Directory, SD-1, <i>Lee Nilo</i> , Chair	32-1
Workshop S-5 - Overage Document Review Process, <i>Scott Kuhnen</i> , Chair	33-1
Workshop S-6 - Item Reduction, <i>Willis Drake</i> , Chair	34-1
Conference Summary Recommendations	35-1
Conference Attendees	36-1

TUTORIAL S-1

HOW TO WRITE A COMMERCIAL ITEM DESCRIPTION

**CHRIS METZ, OFFICE OF THE ASSISTANT SECRETARY OF
DEFENSE (PRODUCTION AND LOGISTICS), MANUFACTURING
MODERNIZATION DIRECTORATE**



DoD NDI ACQUISITION TRAINING

**COMMERCIAL ITEM
DESCRIPTIONS**

COMMERCIAL ITEM DESCRIPTIONS

DEFINED

- **SIMPLIFIED PRODUCT DESCRIPTION**
- **FUNCTIONAL OR PERFORMANCE ORIENTED**
- **USED FOR INHERENTLY COMMERCIAL ITEMS**
- **MANAGED BY GSA**
- **FOR USE THROUGHOUT FEDERAL GOVERNMENT**

DODD 5000.1

PART 1C. ACQUIRING QUALITY PRODUCTS

"MAXIMUM PRACTICABLE USE SHALL BE MADE OF COMMERCIAL AND OTHER NONDEVELOPMENTAL ITEMS. IN DESCRIBING THESE ITEMS, MAXIMUM PRACTICABLE USE SHALL BE MADE OF NONGOVERNMENT STANDARDS AND COMMERCIAL ITEM DESCRIPTIONS."

DODI 5000.2

PART 6 SECTION L - NONDEVELOPMENTAL ITEMS

- DEFINES NDI AND COMMERCIAL PRODUCT
- REQUIREMENTS DEFINITION
- SUITABILITY
- LOGISTICS SUPPORT
- ACQUISITION STRATEGY

COMMERCIAL PRODUCT

AN ITEM PRODUCED FOR SALE IN THE COMMERCIAL
MARKETPLACE

.. CONSUMER OR INDUSTRIAL MARKET

.. ESTABLISHED PRICE

.. UPGRADES

.. MODIFICATIONS (COMMERCIAL-TYPE)

CID POLICY/GUIDANCE

- **FPMR 101-29 (DECEMBER 1981)**
- **JANUARY 1988 LETTER - DRAFT FPMR 101-29
CHAPTERS 3 PART 1 AND CHAPTER 7**
- **NOVEMBER 1988 - USE DRAFT**
- **AUGUST 1990 - GUIDANCE ON CIDS**
- **OCTOBER 1990 - GUIDANCE ON MARKET
ACCEPTABILITY**

NICHES

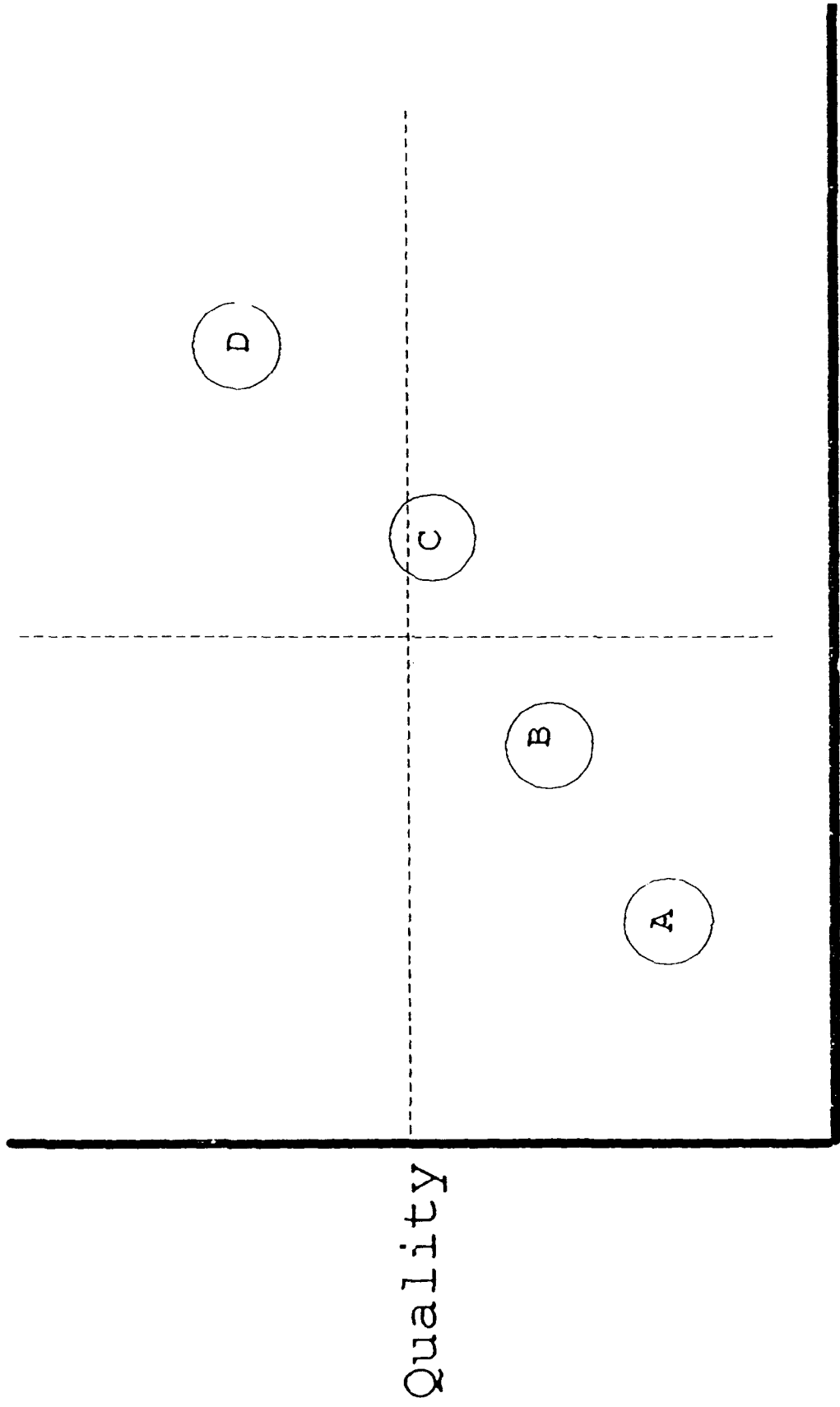

COMMERCIAL ITEM DESCRIPTIONS

KEY ELEMENTS OF CID USAGE

- **COMMERCIAL ITEMS AND MARKETS**
- **COMMERCIAL METHODS AND MATERIALS**
- **COMMERCIAL QUALITY ASSURANCE PROCEDURES**
- **PERFORMANCE REQUIREMENTS**

MARKET RESEARCH

- **TRADE SHOWS**
- **MAIL SURVEYS**
- **SAMPLES/TEST & EVALUATION**
- **INDUSTRY PUBLICATIONS**
- **AUTOMATED CATALOGS**

COMMERCIAL ITEM DESCRIPTIONS

KEY ELEMENTS OF CID USAGE

- **COMMERCIAL ITEMS AND MARKETS**
- **COMMERCIAL METHODS AND MATERIALS**
- **COMMERCIAL QUALITY ASSURANCE PROCEDURES**
- **PERFORMANCE REQUIREMENTS**

COMMERCIAL ITEM DESCRIPTIONS

CID CHARACTERISTICS

- **GENERAL STATEMENT OF REQUIREMENTS**
 - **LIMITED DESIGN REQUIREMENTS**
 - **STATED IN PERFORMANCE TERMS**
 - **RANGE OF ALTERNATIVES**
- **QUALITY ASSURANCE**
 - **COMMERCIAL PRACTICES**
 - **MARKET ACCEPTABILITY**

COMMERCIAL ITEM DESCRIPTIONS

CID ORGANIZATION

- ABSTRACT
- SALIENT CHARACTERISTICS
- REGULATORY REQUIREMENTS
- QUALITY ASSURANCE PROVISIONS
- PACKAGING
- NOTES

COMMERCIAL ITEM DESCRIPTIONS

ABSTRACT-PURPOSES

- AID USERS IN SELECTING CID
- AID SUPPLIERS IN IDENTIFYING ITEMS
- COMMERCE BUSINESS DAILY SYNOPSIS

COMMERCIAL ITEM DESCRIPTIONS

ABSTRACT - CONTENTS

- RANGE OF ITEMS AND CLASSIFICATIONS
- INTENDED USE
- WRITTEN AND GRAPHIC DESCRIPTIONS

COMMERCIAL ITEM DESCRIPTIONS

SAMPLE CID ABSTRACT

"... COVERS TREE SHAPE, RADIUS NOSE, HIGH SPEED STEEL OR TUNGSTEN CARBIDE ROTARY FILES OF THE STANDARD, HEAVY DUTY, AND COMMERCIAL TYPE USED IN THE PRODUCTION ENVIRONMENT. FIGURE 1 DEPICTS THE SHAPE OF THESE FILES."

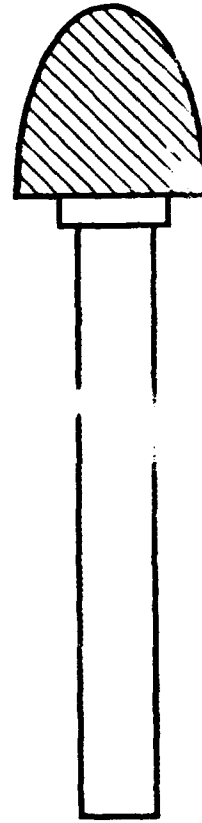

FIGURE 1

COMMERCIAL ITEM DESCRIPTIONS

SALIENT CHARACTERISTICS – PURPOSE

- **TECHNICAL REQUIREMENTS FOR ITEMS**
- **SIMILAR TO REQUIREMENTS SECTION OF MILITARY SPECIFICATIONS**

COMMERCIAL ITEM DESCRIPTIONS

SALIENT CHARACTERISTICS -- RESOURCES

- SAMPLE PRODUCTS
- INDUSTRY PUBLICATIONS
- TECHNICAL JOURNALS
- PREVIOUS CONTRACTS
- SUPPLIERS AND USERS
- TRADE REFERENCES
- SD-5, LOCATING OFF-THE-SHELF ITEMS
- TRADE SHOWS
- DATA EXCHANGE PROGRAMS
- STANDARDIZATION ORGANIZATIONS

CID SUCCESS

- **OVERCOMING "BUSINESS AS USUAL"**
- **COMMUNICATION WITH USERS, SUPPLIERS, BUYERS**
- **WELL-WRITTEN COMMERCIAL ITEM DESCRIPTION**

COMMERCIAL ITEM DESCRIPTIONS

SALIENT CHARACTERISTICS - EXTRACTS

"THE MANDREL SHALL HAVE A HARDNESS OF NOT LESS THAN 60 AND NOT MORE THAN 65 ON THE ROCKWELL 'C' SCALE."

"THE TENSILE STRENGTH SHALL BE 1,100 PSI MINIMUM WHEN TESTED IN ACCORDANCE WITH ASTM D412."

COMMERCIAL ITEM DESCRIPTIONS

SALIENT CHARACTERISTICS -- TOOLS AND TECHNIQUES

- **PERFORMANCED-ORIENTED REQUIREMENTS**
- **INDUSTRY INFORMATION AND PARTICIPATION**
- **APPLICATION OF REFERENCED REQUIREMENTS
DOCUMENTS**
- **TAILORING OF REFERENCED REQUIREMENTS
DOCUMENTS**

COMMERCIAL ITEM DESCRIPTIONS

QUALITY ASSURANCE PROVISIONS - APPROACHES

- **CONTRACTOR CERTIFICATION STATEMENT**
- **BID SAMPLES**
- **MARKET ACCEPTABILITY**
- **TESTING AND INSPECTION**

COMMERCIAL ITEM DESCRIPTIONS

TESTING AND INSPECTION REQUIREMENTS

- **AVOID "HOW TO" TEST PROCEDURES**
- **DO NOT REFER TO MILITARY STANDARDS**
- **CONSIDER ALTERNATIVE QA PROVISIONS**

COMMERCIAL ITEM DESCRIPTIONS

MARKET ACCEPTABILITY CRITERIA BACKGROUND

- ESTABLISHED FOR USE IN CIDS
- CRITICIZED FOR HURTING GOVERNMENT SUPPLIERS
- PROHIBITED IN FY 84 DoD APPROPRIATION ACT
- PROHIBITED LIFTED IN FY 86 DoD APPROPRIATION ACT
- DoD MARKET ACCEPTABILITY GUIDANCE ISSUED
(APP. F, SD-2)

COMMERCIAL ITEM DESCRIPTIONS

MARKET ACCEPTABILITY CRITERIA EXAMPLES

CONTRACTOR CERTIFICATION STATEMENT AND...

" ...HAVE PRODUCED SIMILAR EQUIPMENT AND MATERIAL FOR A PERIOD OF AT LEAST TWO YEARS TO THE GOVERNMENT OR COMMERCIAL USERS."

" ...PROPOSED COMPRESSORS SHALL HAVE BEEN IN SATISFACTORY COMMERCIAL OR GOVERNMENT USE FOR TWO YEARS PRIOR TO BID OPENING."

" ...SUCCESSFULLY OPERATED IN A PRODUCTION ENVIRONMENT AT COMMERCIAL OR GOVERNMENT SITES FOR AT LEAST A SIX MONTH PERIOD..."

COMMERCIAL ITEM DESCRIPTIONS

MARKET ACCEPTABILITY CRITERIA - CATAGORIES

- **UNITS SOLD**
- **MARKET SHARE**
- **SALES VOLUME**

COMMERCIAL ITEM DESCRIPTIONS

MARKET ACCEPTABILITY CRITERIA - CHARACTERISTICS

- **BASE MA ON MINIMUM NEEDS**
- **TAILOR CRITERIA TO PRODUCT OR MARKET**
- **DO NOT PRECLUDE GOVERNMENT SUPPLIERS**
- **USE IN CONJUNCTION WITH CERTIFICATION STATEMENT**
- **DOCUMENT AND MAINTAIN JUSTIFICATION FOR USE**

COMMERCIAL ITEM DESCRIPTIONS

TESTING AND INSPECTION EXAMPLES

"EACH GROOVING MACHINE SHALL BE VISUALLY EXAMINED TO DETERMINE CONFORMANCE WITH ALL REQUIREMENTS OF THIS DESCRIPTION."

"EACH GROOVING MACHINE SHALL BE OPERATED WITHOUT PERFORMING GROOVING OPERATIONS TO ENSURE OPERATION OF ALL MOVING PARTS AND ADJUSTING MECHANISMS."

COMMERCIAL ITEM DESCRIPTIONS

CONTRACTOR CERTIFICATION STATEMENT

- **STATEMENT IN APP. C, NDI HANDBOOK**
- **COMPLIANCE WITH CID AND RELEVANT SPECIFICATIONS**
- **STATEMENT MAY BE MODIFIED**
- **USED IN CONJUNCTION WITH BID SAMPLES**

COMMERCIAL ITEM DESCRIPTIONS

REGULATORY REQUIREMENTS

- **APPLICABLE FEDERAL REQUIREMENTS**
- **SHOULD NOT BE INCLUDED IN SALIENT CHARACTERISTICS**
- **EXAMPLES**
 - **DEPARTMENT OF AGRICULTURE STANDARDS**
 - **FOOD, DRUG, AND COSMETIC ACT REQUIREMENTS**

COMMERCIAL ITEM DESCRIPTIONS

PACKAGING

- **COMMERCIAL PRACTICES PREFERRED**
- **SPECIAL REQUIREMENTS ALLOWED BUT DISCOURAGED**
- **WITH NO SPECIAL REQUIREMENTS, CID SHALL CONTAIN THIS STATEMENT:**

"PRESERVATION, PACKING, LABELING, AND MARKING SHALL BE AS SPECIFIED IN THE CONTRACT OR ORDER."

COMMERCIAL ITEM DESCRIPTIONS

NOTES

- **ADDITIONAL INFORMATION FOR USERS AND SUPPLIERS**
- **SOURCES FOR REFERENCED DOCUMENT**
- **ORDERING DATA**
- **SOURCES OF SUPPLY**

COMMERCIAL ITEM DESCRIPTIONS

SUMMARY

- COMMERCIAL AND COMMERCIAL TYPE ITEMS
- PERFORMANCE OR FUNCTIONAL REQUIREMENTS
- LIMIT "HOW TO" AND GOVERNMENT DOCUMENT REFERENCES
- QA THROUGH MARKET ACCEPTABILITY PREFERRED



TUTORIAL S-2

TYPES OF DOCUMENTS

RAE WALKER, ARMY LOGISTICS MANAGEMENT COLLEGE



TUTORIAL S-2

TYPES OF DOCUMENTS

DEFINITION of A SPECIFICATION

A Document prepared specifically to support contracting which clearly and accurately describes the essential technical requirements for purchased material. Procedures necessary to determine that the requirements for the purchased material covered by the specification have been met shall also be included.

REFERENCE OOD MANUAL 4170 3 M

DEFINITION OF A SPECIFICATION

A specification is a voluminous and painstakingly dry document, designed to hamper, harass, and confuse contractors, disturb the digestion and emotional stability of Congressmen, and to discriminate equally against both large and small business.

BASIC FEDERAL SPEC IDENTIFICATION

W - P - 506

PROCUREMENT GROUP FIRST LETTER OF NAME OF ITEM NUMBER ASSIGNED BY GSA

FEDERAL SPECIFICATION PROCUREMENT GROUPS

A AIRCRAFT, BOATS, SHIPS
 B ANIMALS
 C ANIMAL PRODUCTS
 D ARMS (SMALL)
 F BOILERS, ENGINES & TANKS
 E ARTILLERY
 G BOOKS & PRINTED MATTER
 H BROOMS & BRUSHES
 J CABLE & WIRE (INSULATED)
 K CANVAS ARTICLES
 L CELLULOSE & PRODUCTS
 M CERAMICS
 N CEREALS & PRODUCTS
 O CHEMICALS
 P CLEANING, & POLISHING MATERIALS
 Q COAL & PRODUCTS
 R COAL TAR & PRODUCTS
 S COOKING & HEATING APPARATUS
 FURNANCES, & OVENS (NONELECTRIC)
 T CORDAGE, TWINE & PRODUCTS
 U DRUGS & MEDICINES
 V DRY GOODS & NOTIONS
 W ELECTRICAL APPARATUS
 X EXPLOSIVES
 Y FRUITS
 Z FRUIT PRODUCTS

FEDERAL SPECIFICATION PROCUREMENT GROUPS

AA FURNITURE
 BB GASES
 CC GENERATORS & MOTORS
 DD GLASS & GLASSWARE
 EE GROCERIES
 FF HARDWARE
 GG INSTRUMENTS
 HH INSTRUMENTS MATERIALS
 JJ KNIT GOODS, NETTING & WEBBING
 KK LEATHER & LEATHER GOODS
 LL LIVESTOCK, POULTRY & MARINE PRODUCTS
 MM LUMBER & TIMBER
 NN LUMBER PRODUCTS
 OO MACHINERY
 PP MEATS & SEA FOOD
 OO METALS
 RR METAL PRODUCTS
 SS MINERALS & PRODUCTS (NONMETALIC)
 TT PAINTS, PIGMENTS, VARNISHES & PRODUCTS
 UU PAPER AND PRODUCTS
 VV PETROLEUM AND PRODUCTS
 WW PIPE, PIPE FITTINGS, PLUMBING, FIXTURES, TUBES & TUBING (METALIC)
 XX PUMPS
 ZZ RUBBER & RUBBER GOODS

Federal Specification Procurement Groups

AAA Scales
 BBB Suits & Uniforms
 CCC Textiles (Yardage)
 DDD Textile Products
 EEE Tobacco & Products
 FFF Toilet Articles
 GGG Tools
 HHH Vegetables
 JJJ Vegetable Products
 KKK Vehicles
 LLL Wood Products
 MMM Adhesives
 NNN Reserves for future use
 PPP Packaging & Packing

COORDINATED FEDERAL SPECIFICATIONS

REVISION INDICATOR

W-P-506 A

JUNE 18, 1990 DATE OF APPROVAL

SUPERSEDING

INTERIM FEDERAL SPEC W-P-00506 (GSA-FSS)

MAY 10, 1984

SUPERSEDING DATA

INTERIM FEDERAL SPECIFICATION

INTERIM FED SPEC DESIGNATOR

W-P-00506 (GSA-FSS)
MAY 2, 1990

DATE OF
APPROVAL

PREPARING ACTIVITY
SYMBOL

BASIC MILITARY SPEC IDENTIFICATION

FIRST LETTER OF
TITLE OF SPEC

REVISION INDICATOR

MIL-S-83490A

MIL SPEC SYMBOL

NUMBER ASSIGNED BY DEPT

COORDINATED MILITARY SPECIFICATION

MIL-P-289
31 JANUARY 1991

LIMITED COORDINATION MILITARY SPEC

MIL-W-16878E (NAVY)
10 MAY 1986

LIMITED COORDINATION MILITARY SPEC

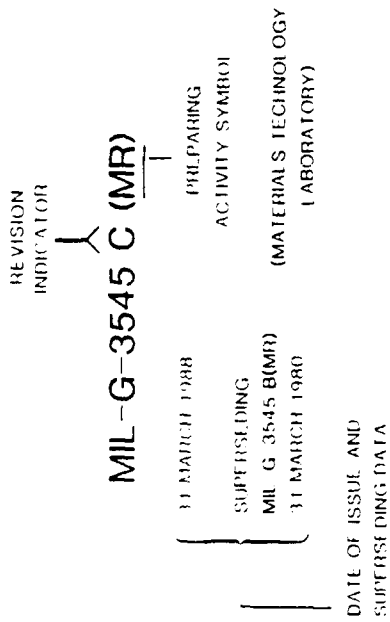

"USED IN LIEU OF" LIMITED COORDINATION MILITARY SPEC

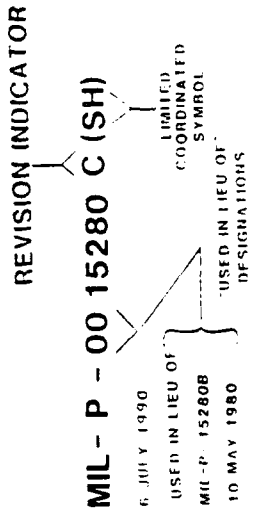

MEASUREMENT SYSTEM IDENTIFICATION

EXAMPLES

METRIC

MIL-A-100 27 APR 1960

INCH-POUND

MIL-A-100 27 APR 1960

NOT-MEASUREMENT SENSITIVE

MIL-A-100 27 APR 1960

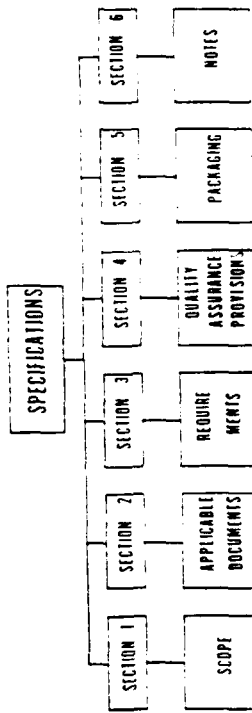

ALL MATERIAL PRODUCT AND EQUIPMENT SPECIFICATION SHALL CONTAIN 6 NUMBERED SECTIONS
 THESE SECTIONS SHALL REMAIN THE SAME REGARDLESS OF THE CONTENT OF THE SPECIFICATION

**ASSOCIATED SPECIFICATION DOCUMENTS
AMENDMENTS**

USED TO MAKE BRIEF OR MINOR CHANGES AND TO CORRECT ERRORS.

EXAMPLE

MIL C-35031C
SUPPLEMENT 1
26 JANUARY 1982

MILITARY SPECIFICATION
CAPACITORS, FIXED, ELECTROLYTIC, TANTALUM

PAGE 6

3 26. Third example, under "12345 Source Code" Add "M Optional trademark"

PAGE 19

6.1, line 3 Delete "Unless otherwise specified" and substitute "Except for style CSRS1" [see 3.1]

NOTICES

USED TO HANDLE ADMINISTRATIVE DETAILS, SUCH AS CANCELLATION OR REINSTATEMENT OF STANDARDIZATION DOCUMENTS

EXAMPLE

NOTICE
OF CANCELLATION

MIL C 11701B(1)
NOTICE 1
24 AUGUST 1979

MILITARY SPECIFICATION
COMPRESSORS, RECIPROCATING, POWER DRIVEN
(FOR DIESEL ENGINE STARTING)

SPECIFICATION MIL C 13701B(1), DATED 31 AUGUST 1971 IS HEREBY CANCELLED
WITHOUT REPLACEMENT

PREPARING ACTIVITY
ARMY ME

DEFINITION of A STANDARD

A Document that establishes engineering and technical requirements for processes, procedures, practices and methods that have been adopted as standard standards may also establish requirements for selection, application and design criteria for material

REFERENCE DOD MANUAL 4120.3 M

MILITARY STANDARDS ARE

USED FOR COMPREHENSIVE PRESENTATION OF:

Engineering practices
Test methods
Procedures
Processes
Codes
Safety requirements
Abbreviations
Standard item characteristics
Standard equipment characteristics
Family of end-items characteristics

COORDINATED MILITARY STANDARD

MIL-STD-1459A
6 MAY 1990

**COORDINATED MILITARY STANDARD
SUPERSEDED ANOTHER**

MIL-STD-3B
18 MAY 1990
SUPERSEDING
MIL-STD-3A
12 APRIL 1985

SECTIONALIZED MILITARY STANDARD

MIL-STD-176-1
MIL-STD-176-2
MIL-STD-176-3

**LIMITED COORDINATION MILITARY
STANDARD**

MIL-STD-653(ARMY)
20 APRIL 1990

**"USED IN LIEU OF" LIMITED COORDINATION
MILITARY STANDARD**

MIL-STD-001425C(ME)
30 MAY 1990
USED IN LIEU OF
MIL-STD-1425B
6 APRIL 1984

**LIMITED COORDINATION MILITARY
STANDARD**

MIL-STD-1234(AR)
2 JANUARY 1990

COORDINATED MILITARY HANDBOOK

MIL-HDBK-245
6 JUNE 1990

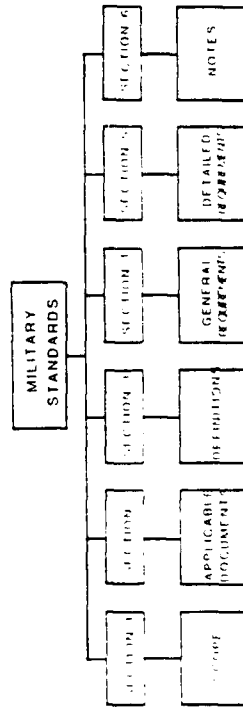

THE ABOVE FORMAT IS ALSO RECOMMENDED FOR MILITARY HANDBOOKS
IF THERE IS NO INFORMATION PERTINENT TO ANY OF THE SIX SECTIONS,
THE FOLLOWING SHALL APPEAR BELOW THE SECTION HEADING

"THIS SECTION IS NOT APPLICABLE TO THIS (STANDARD) (HANDBOOK)"

MEASUREMENT SYSTEM IDENTIFICATION

METRIC

MIL-STD-1234

NOT MEASUREMENT SENSITIVE

MIL-HDBK-1234

INCH-POUND

MIL-BUL-1234

COORDINATED MILITARY BULLETIN

MIL-BUL-34
21 FEBRUARY 1990

COORDINATED FEDERAL STANDARD

FED-STD-880
MARCH 3, 1990

NOTICE OF
ADOPTION

ADOPTION NOTICE 1
20 APRIL 1990 FOR
ASTM B504
27 MAY 1984

COMMERCIAL ITEM DESCRIPTION

A-A-123
MAY 18, 1990

CID FORMAT

ABSTRACT: COMBINATION SCOPE AND INTENDED USE OF THE ITEM PROVIDES POTENTIAL SUPPLIERS AND USERS A BRIEF DESCRIPTION OF THE ITEM.

SALIENT CHARACTERISTICS: TECHNICAL ASPECTS OF AN ITEM BASED ON USER REQUIREMENTS AND MARKET RESEARCH AND ANALYSIS.

QUALITY ASSURANCE PROVISIONS: INCLUDES CONTRACTOR CERTIFICATION STATEMENT (MANDATORY) AND EXAMINATION AND TESTING PROVISIONS, AS APPROPRIATE.

REGULATORY REQUIREMENTS: FEDERAL REGULATORY REQUIREMENTS, SUCH AS DEPT OF AGRICULTURE STANDARDS AND THE DRUG AND COSMETIC ACT.

PACKAGING - INCLUDES GENERAL COMMERCIAL PACKAGING STANDARDS, SUCH AS ASTM-D-3951-88, OR SPECIAL PACKAGING REQUIREMENTS, AS APPROPRIATE.

NOTES - CONTAINS RELEVANT INFORMATION USEFUL TO BUYERS, USERS, AND SUPPLIERS, SUCH AS ORDERING DATA.

PURCHASE DESCRIPTIONS

- SHOULD SET FORTH THE ESSENTIAL PHYSICAL AND FUNCTIONAL CHARACTERISTICS OF MATERIALS OR SERVICES
- SHOULD INCLUDE, AS NECESSARY, THE FOLLOWING:
 - COMMON NOMENCLATURE
 - KIND OF MATERIAL
 - ELECTRICAL DATA
 - DIMENSIONS, SIZE OR CAPACITY
 - PRINCIPLES OF OPERATION
 - RESTRICTIVE ENVIRONMENTAL CONDITIONS
 - INTENDED USE
 - OTHER PERTINENT INFORMATION

ORDER OF PREFERENCE (MIL-STD-970)

1. MULTI-NATIONAL TREATY ORGANIZATION STANDARDIZATION AGREEMENTS AND FEDERALLY MANDATED RULES AND REGULATIONS
2. NON-GOVERNMENT STANDARDS
 - ADOPTED INTERNATIONAL STANDARDS
 - ADOPTED U.S. NON-GOVERNMENT STANDARDS
 - OTHER INTERNATIONAL/U.S. NON-GOVERNMENT STANDARDS
3. COMMERCIAL ITEM DESCRIPTIONS
4. FEDERAL SPECIFICATIONS/STANDARDS
5. FULLY COORDINATED MIL/DOD SPECIFICATIONS/STANDARDS
6. LIMITED COORDINATED MIL/DOD SPECIFICATIONS/STANDARDS
7. LOCALLY PREPARED ONE TIME USE PURCHASE DESCRIPTIONS

TYPES OF SPECIFICATIONS

TYPE A - SYSTEM SPECIFICATION - States technical and mission requirements for a system as an entity, allocates requirements to functional area and defines the interfaces between or among the functional areas.

TYPE B - DEVELOPMENT SPECIFICATION - States the requirements for the design or engineering development of a product during the development period. Contains requirements allocated to the item from the system specification.

TYPE C - PRODUCT SPECIFICATION - Applicable to any item below the system level, and may be oriented toward procurement of a product through specification of primarily function (performance) requirements or primarily fabrication (detail design).

TYPES OF SPECIFICATIONS (cont'd)

TYPE D - PROCESS SPECIFICATION - Applicable to a service which is performed on a product or material. Examples are: heat treatment, welding, plating, packing, microfilming, marking, etc.

TYPE E - MATERIAL SPECIFICATION - Applicable to a raw material (chemical compound), mixture (cleaning agent, paint) or semi-fabricated material (electrical cable, copper tubing) which are used in the fabrication of a product.

ACQUISITION MILESTONES & PHASES

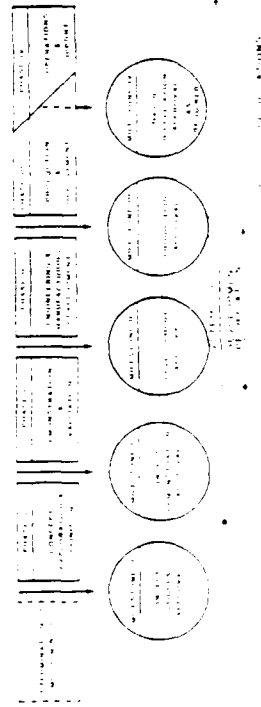

Mr. Raenord B. Walker
U.S. Army Logistics Management College
ATTN: AMXMC-ACM-MA
Fort Lee, VA 23801-6048

AUTOVON 687-4592
COMMERCIAL (804) 734-4592

ACQUISITION MILESTONES & PHASES

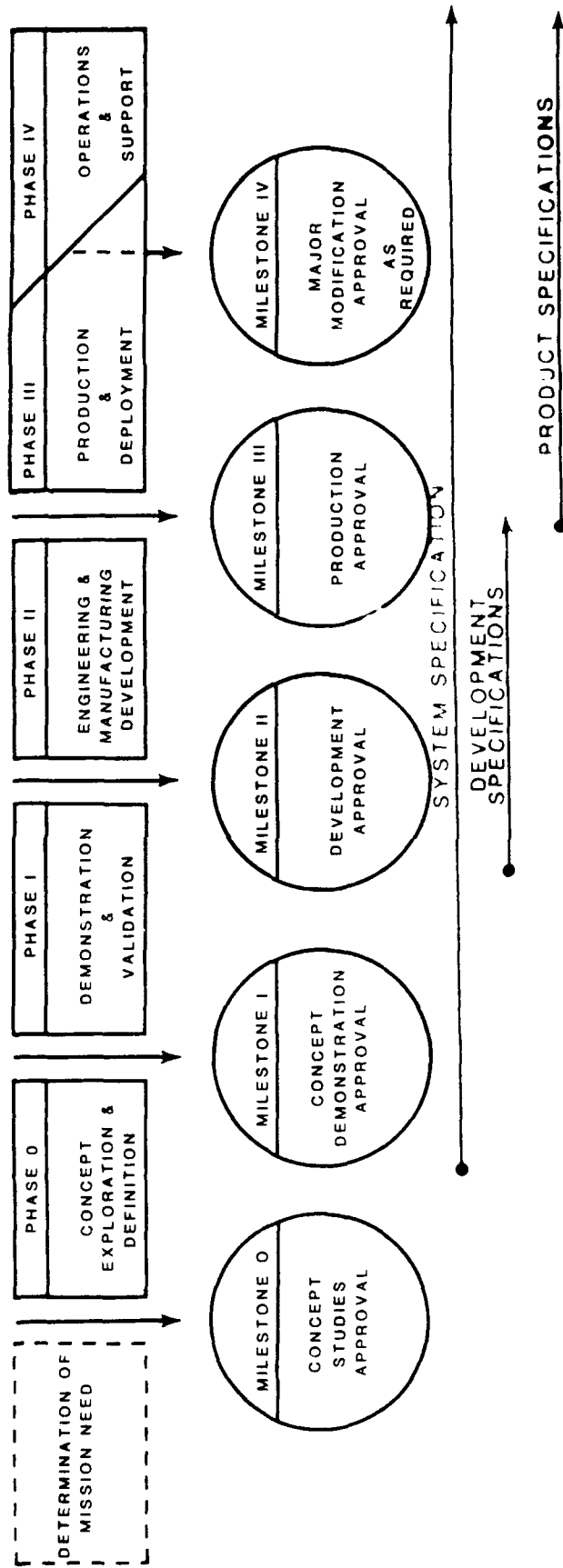



TUTORIAL S-3

DATA IN SPECIFICATIONS AND STANDARDS

**DONALD LANGKAMP, OFFICE OF THE ASSISTANT SECRETARY
OF DEFENSE (PRODUCTION AND LOGISTICS), TECHNICAL DATA
AND MANUFACTURING DIVISION**



TUTORIAL S-3

**DATA REQUIREMENTS IN MILITARY
SPECIFICATIONS AND STANDARDS**

by

**DONALD LANGKAMP
DASD (PR) MMD/TD&MD
5203 Leesburg Pike
Falls Church, VA 22041**

OVERVIEW

DEFINITIONS OF TERMS/ACRONYMS

BACKGROUND

MIL-STD-961C REQUIREMENTS

MIL-STD-962B REQUIREMENTS

OVERVIEW OF THE AMSDL

IDENTIFICATION OF DID'S USING THE AMSDL

PREPARATION OF DID'S LAW DOD-STD-963A

SUBMITTAL OF SPECIFICATIONS, STANDARDS, AND DID'S
TO TD&MD FOR OMB CLEARANCE

DEFINITIONS OF TERMS/ACRONYMS

AMSC NUMBER **ACQUISITION MANAGEMENT SYSTEMS CONTROL NUMBER**
ASSIGNED BY DASD(PR)-TD&MD TO SPECIFICATIONS, STANDARDS, AND DID'S TO SIGNIFY OMB CLEARANCE OF DATA REQUIREMENTS.

AMSDL **ACQUISITION MANAGEMENT SYSTEMS AND DATA REQUIREMENTS CONTROL LIST**
IDENTIFIED AS DOD 5010.12-L. DOD INDEX OF ALL OMB-CLEARED DATA REQUIREMENTS DOCUMENTS.

CDRL **CONTRACT DATA REQUIREMENTS LIST**
DD FORM 1423. LISTS DATA REQUIREMENTS AUTHORIZED TO BE ACQUIRED FOR A SPECIFIC CONTRACT.

DASD(PR)-TD&MD = **DEPUTY ASSISTANT SECRETARY OF DEFENSE (PRODUCTION RESOURCES) - TECHNICAL DATA AND MANUFACTURING DIVISION**

DEFINITIONS OF TERMS/ACRONYMS

DFARS

**DEFENSE FEDERAL ACQUISITION
REGULATION SUPPLEMENT**

**DOD SUPPLEMENT TO FEDERAL ACQUISITION
REGULATION USED IN ACQUISITION OF SUPPLIES
AND SERVICES WITH APPROPRIATED FUNDS.**

DID

DATA ITEM DESCRIPTION

**DD FORM 1664. DEFINES DATA CONTENT AND
FORMAT PREPARATION INSTRUCTIONS AND
INTENDED USE, FOR DATA REQUIRED TO BE
DELIVERED TO THE GOVERNMENT BY A
CONTRACTOR.**

OMB

OFFICE OF MANAGEMENT AND BUDGET

**FEDERAL OFFICE ASSIGNED OVERALL
RESPONSIBILITY FOR PUBLIC LAW 96-511,
PAPERWORK REDUCTION ACT OF 1980.**

BACKGROUND

- PUBLIC LAW 96-511, PAPERWORK REDUCTION ACT OF 1980
- ESTABLISHED LAWS AND RULES FOR ELIMINATING UNNECESSARY PAPERWORK BURDENS IMPOSED BY FEDERAL AGENCIES (E.G., DOD) ON THE PUBLIC (E.G., CONTRACTORS)
- REQUIRES ALL FEDERAL AGENCIES TO OBTAIN PRIOR APPROVAL FROM OMB ON ANY REQUEST FOR INFORMATION FROM THE PUBLIC
- REQUIRES EACH REQUEST FOR INFORMATION TO DISPLAY AN OMB CONTROL NUMBER AND EXPIRATION DATE

BACKGROUND

- PUBLIC LAW 96-511 (CONT'D)
- DOD ARGUED UNSUCCESSFULLY THAT CONTRACTORS ARE REIMBURSED UNDER CONTRACTS FOR DATA (NOT A BURDEN) AND PUBLIC LAW SHOULD NOT APPLY
- OMB CONCURRED WITH DOD THAT DISPLAY OF OMB CONTROL NUMBER AND CLEARANCE EXPIRATION DATE WAS NOT REQUIRED ON EACH DATA ITEM
- OMB CONTROL NO. 0704-0188 ASSIGNED TO AMSDL, PROVIDING BLANKET CLEARANCE FOR ALL DATA REQUIREMENTS LISTED
- OMB CLEARANCE FUNCTION FOR DATA ITEMS TO BE LISTED IN AMSDL DELEGATED TO OSD (DASD(PR)-TD&MD)
- AMSC NUMBERS USED BY DASD(PR)-TD&MD TO SIGNIFY OMB CLEARANCE HAS BEEN GRANTED

BACKGROUND

- **DFARS SUBPART 227.475-1**
- **REQUIRES CLAUSE 252.227-7031 BE INCLUDED IN ALL SOLICITATIONS AND CONTRACTS:**
 - DATA REQUIREMENTS**
 - (A) DATA MEANS RECORDED INFORMATION, REGARDLESS OF FORM OR CHARACTERISTICS.**
 - (B) THE CONTRACTOR IS REQUIRED TO DELIVER ONLY THE DATA ITEMS LISTED ON THE DD FORM 1423 (CONTRACT DATA REQUIREMENTS LIST) AND DATA ITEMS IDENTIFIED IN AND DELIVERABLE UNDER ANY CONTRACT CLAUSE OF FAR SUBPART 52.2 AND DOD FAR SUPPLEMENT SUBPART 252.2 MADE A PART OF THE CONTRACT.**

BACKGROUND

- DFARS SUBPART 227.475-1 (CONT'D)
- EXCEPTIONS TO INCLUSION OF CLAUSE
- ANY CONTRACT NOT EXCEEDING \$25,000
- ANY CONTRACT AWARDED TO A CONTRACTOR OUTSIDE U.S.
- ANY R&D CONTRACT WHEN REPORTS ARE ONLY DELIVERABLE ITEM(S)
- ANY SERVICE TYPE CONTRACT WHERE PCO DETERMINES USE OF DD 1423 IS IMPRACTICAL WITH RESPECT TO RECORDS PREPARED IN PERFORMING O&M

BACKGROUND

- **DFARS SUBPART 227.475-1 (CONT'D)**
- **EXCEPTIONS TO INCLUSION OF CLAUSE (CONT'D)**
 - **ANY CONTRACT WHERE CONSTRUCTION & ARCHITECTURAL DRAWINGS AND SPECIFICATIONS ARE ONLY DELIVERABLE ITEMS**
 - **ANY CONTRACT FOR COMMERCIAL ITEMS WHEN ONLY DELIVERABLE DATA IS SUCH AN ITEM OR WOULD BE FURNISHED WITH SUCH ITEMS AS CUSTOMARY PRACTICE**
 - **ANY CONTRACT FOR ITEMS CONTAINING MATERIAL REQUIRING CONTROLS TO ASSURE ADEQUATE SAFETY TO LIFE AND PROPERTY WHEN ONLY DELIVERABLE DATA IS MATERIAL SAFETY DATA SHEETS**

MIL-STD-961C REQUIREMENTS

- PHYSICAL COMMODITIES SPECIFICATIONS
- REQUIREMENTS PARAGRAPHS SHOULD NOT CONTAIN TASKING PARAGRAPHS THAT MAY RESULT IN GENERATION OF DATA
- DATA REQUIREMENTS MUST BE SPECIFIED ON DD FORM 1423; OR, WHEN DD FORM 1423 IS NOT REQUIRED PER DFARS, SPECIFIED IN THE CONTRACT
- A PARAGRAPH MAY BE INCLUDED IN SECTION 6 OF THE SPECIFICATION TO INDICATE DATA WHICH MAY BE REQUIRED AND SHOULD BE CONSIDERED

MIL-STD-961C REQUIREMENTS

- PHYSICAL COMMODITIES SPECIFICATIONS (CONT'D)
- EXAMPLE TASKING PARAGRAPH:

***4.7 TESTS.**

4.7.1 FUNCTIONAL TEST. THE PUMP SHALL BE OPERATED 1 HOUR AT RATED CAPACITY AND SHALL BE OPERATED AS REQUIRED TO VERIFY THE FUNCTIONAL OPERATION OF THE CONTROLS.*

MIL-STD-961C REQUIREMENTS

- PHYSICAL COMMODITIES SPECIFICATIONS (CONT'D)
- EXAMPLE SECTION 6 PARAGRAPH:

"6.3 CONSIDERATION OF DATA REQUIREMENTS. THE FOLLOWING DATA REQUIREMENTS SHOULD BE CONSIDERED WHEN THIS SPECIFICATION IS APPLIED ON A CONTRACT. THE APPLICABLE DATA ITEM DESCRIPTIONS SHOULD BE REVIEWED IN CONJUNCTION WITH THE SPECIFIC ACQUISITION TO ENSURE THAT ONLY ESSENTIAL DATA ARE REQUESTED/PROVIDED AND THAT DID'S ARE TAILORED TO REFLECT THE REQUIREMENTS OF THE SPECIFIC ACQUISITION. TO ENSURE CORRECT CONTRACTUAL APPLICATION OF THE DATA REQUIREMENTS, CONTRACT DATA REQUIREMENTS LISTS (DD 1423) MUST BE PREPARED TO OBTAIN THE DATA, EXCEPT WHERE DFARS 27.475-1 EXEMPTS THE REQUIREMENT FOR A DD 1423.

<u>REFERENCE PARA</u>	<u>DID NUMBER</u>	<u>DID TITLE</u>	<u>SUGGESTED TAILORING</u>
4.7	DI-NDTI-80909	TEST REPORTS	DELETE 10.1.A

THE ABOVE DID'S WERE THOSE CLEARED AS OF THE DATE OF THIS SPECIFICATION. THE CURRENT ISSUE OF DOD 5010.12-L, AMSDL, MUST BE RESEARCHED TO ENSURE THAT ONLY CURRENT, CLEARED DID'S ARE CITED ON THE DD 1423."

MIL-STD-961C REQUIREMENTS

- PHYSICAL COMMODITIES SPECIFICATIONS (CONT'D)
- SPECIFICATIONS REQUIRING THAT RECORDS BE MAINTAINED (NO DELIVERABLE DATA)
 - "RECORD KEEPING" DATA
 - MUST BE SUBMITTED TO TD&MD FOR OMB CLEARANCE AND ASSIGNMENT OF AMSC NUMBER

MIL-STD-961C REQUIREMENTS

- DATA PRODUCT REQUIREMENTS
- EXAMPLES: DOD-STD-100, ENGINEERING DRAWING PRACTICES
MIL-T-31000, TECHNICAL DATA PACKAGES
- REQUIRE CONCURRENT PREPARATION OF DID'S IAW
MIL-STD-963A
- A PARAGRAPH MUST BE INCLUDED IN SECTION 6 TO
CITE ASSOCIATED DID'S
- SPECIFICATIONS AND DID'S COORDINATED
CONCURRENTLY
- SPECIFICATIONS AND DID'S SUBMITTED TO DASD(PR)-TD&MD,
VIA DOD COMPONENT DATA MANAGEMENT
REPRESENTATIVE, FOR OMB CLEARANCE AND
ASSIGNMENT OF AMSC NUMBERS

MIL-STD-961C REQUIREMENTS

- DATA PRODUCT SPECIFICATIONS (CONT'D)
- EXAMPLE SECTION 6 PARAGRAPH:

"6.3 DATA REQUIREMENTS. THE FOLLOWING DATA ITEM DESCRIPTIONS (DID'S) MUST BE LISTED, AS APPLICABLE, ON THE CONTRACT DATA REQUIREMENTS LIST (DD 1423) WHEN THIS SPECIFICATION IS APPLIED ON A CONTRACT, IN ORDER TO OBTAIN THE DATA, EXCEPT WHERE DFARS 27.475-1 EXEMPTS THE REQUIREMENT FOR A DD 1423.

<u>REFERENCE PARA</u>	<u>DID NUMBER</u>	<u>DID TITLE</u>
3.1	DI-DRPR-81000	PRODUCT DRAWINGS & ASSOCIATED LISTS

THE ABOVE DID'S WERE THOSE CLEARED AS OF THE DATE OF THIS SPECIFICATION. THE CURRENT ISSUE OF DOD 5010.12-L, AMSDL, MUST BE RESEARCHED TO ENSURE THAT ONLY CURRENT, CLEARED DID'S ARE CITED ON THE DD 1423."

MIL-STD-961C REQUIREMENTS

- SPECIFICATIONS FOR TECHNICAL MANUALS FOR INSTALLATION, OPERATION, MAINTENANCE, TRAINING, AND SUPPORT OF WEAPON SYSTEMS, WEAPON SYSTEM COMPONENTS, AND SUPPORT EQUIPMENT
- DO NOT REQUIRE DID'S
- MUST BE SUBMITTED TO DASD(PR)-TD&MD FOR OMB CLEARANCE AND ASSIGNMENT OF AMSC NUMBER
- A PARAGRAPH MUST BE INCLUDED IN SECTION 6 TO INDICATE PROPER CONTRACTUAL METHOD OF ACQUIRING TECHNICAL MANUALS

6.3 TECHNICAL MANUAL ACQUISITION. THIS SPECIFICATION MUST BE LISTED ON THE CONTRACT DATA REQUIREMENTS LIST (DD 1423) IN ORDER TO ACQUIRE THE TECHNICAL MANUALS DESCRIBED BY THIS SPECIFICATION, EXCEPT WHERE DFARS 227.475-1 EXEMPTS THE REQUIREMENT FOR A DD 1423.

MIL-STD-961C REQUIREMENTS

- **DATA NECESSARY FOR QUALIFICATION AND QUALIFICATION RETENTION**
- **DO NOT REQUIRE DID'S**
- **WILL NOT BE LISTED ON DD 1423**

MIL-STD-961C REQUIREMENTS

- **AMSC NUMBER**
- **AMENDMENTS AND SUPPLEMENTS CARRY SAME NUMBER AS BASIC OR "AMSC N/A" AS APPLICABLE**
- **NEW AMSC NUMBER ASSIGNED WHEN SPECIFICATION IS REVISED, AS APPLICABLE**
- **NOTICES (VALIDATION, INACTIVE FOR NEW DESIGN, CANCELLATION, REINSTATEMENT) CARRY NOTATION "AMSC N/A"**
- **SPECIFICATION SHEETS CARRY NOTATION "AMSC N/A"**
- **NPFC WILL NOT PRINT DOCUMENT WITHOUT AMSC NUMBER OR "AMSC N/A"**

MIL-STD-961C REQUIREMENTS

- RIGHTS IN DATA
- ACQUISITION OF RIGHTS IN DATA SHALL NOT BE MADE THROUGH THE MEDIUM OF A SPECIFICATION (REF. DFARS 227.4 FOR APPROPRIATE CLAUSES)

MIL-STD-962B REQUIREMENTS

- **COMMODITY DOCUMENTS**
- **SHALL NOT CONTAIN REQUIREMENTS FOR DATA**
- **DATA REQUIREMENTS MUST BE SPECIFIED ON DD FORM 1423; OR, WHEN DD FORM 1423 IS NOT REQUIRED PER DFARS, SPECIFIED IN THE CONTRACT**
- **A PARAGRAPH MAY BE INCLUDED IN SECTION 6 OF THE STANDARD TO INDICATE DATA WHICH MAY BE REQUIRED AND SHOULD BE CONSIDERED**

MIL-STD-962B REQUIREMENTS

- PROCESS DOCUMENTS
- STANDARDS RESULTING IN REQUIREMENT FOR DATA
 - REQUIRE CONCURRENT PREPARATION OF DID'S IAW DOD-STD-963A OR CAN CITE EXISTING, CLEARED DID'S IF APPLICABLE AND APPROPRIATE
 - AT END OF TASKING PARAGRAPHS THAT GENERATE DATA, REFERENCE MADE TO SECTION 6 OF THE STANDARD
 - A PARAGRAPH MUST BE INCLUDED IN SECTION 6 TO CITE ASSOCIATED DID'S
 - STANDARDS AND DID'S COORDINATED CONCURRENTLY
 - STANDARDS AND DID'S SUBMITTED TO DASD(PR)-TD&MD, VIA DOD COMPONENT DATA MANAGEMENT REPRESENTATIVE, FOR OMB CLEARANCE AND ASSIGNMENT OF AMSC NUMBERS

MIL-STD-962B REQUIREMENTS

- PROCESS DOCUMENTS (CONT'D)
- STANDARDS RESULTING IN REQUIREMENT FOR DATA (CONT'D)
 - EXAMPLE TASKING PARAGRAPH:

"5.4 PROBLEM AND FAILURE REPORTING. A FAILURE REPORT SHALL BE INITIATED AT THE OCCURRENCE OF EACH PROBLEM OR FAILURE OF CONTRACTOR HARDWARE AND SOFTWARE AND GOVERNMENT FURNISHED EQUIPMENT (SEE 6.3)."
 - EXAMPLE SECTION 6 PARAGRAPH:

"6.3 DATA REQUIREMENTS. THE FOLLOWING DATA ITEM DESCRIPTIONS (DID'S) MUST BE LISTED, AS APPLICABLE, ON THE CONTRACT DATA REQUIREMENTS LIST (DD 1423) WHEN THIS STANDARD IS APPLIED ON A CONTRACT, IN ORDER TO OBTAIN THE DATA EXCEPT WHERE DFARS 227.475-1 EXEMPTS THE REQUIREMENT FOR A DD 1423.

<u>REFERENCE PARA</u>	<u>DID NUMBER</u>	<u>DID TITLE</u>
5.4	DI-RELI-80253	FAILED ITEM ANALYSIS REPORT

THE ABOVE DID'S WERE THOSE CLEARED AS OF THE DATE OF THIS STANDARD. THE CURRENT ISSUE OF DOD 5010.12-L, AMSDL, MUST BE RESEARCHED TO ENSURE THAT ONLY CURRENT, CLEARED DID'S ARE CITED ON THE DD 1423."

MIL-STD-962B REQUIREMENTS

- PROCESS DOCUMENTS (CONT'D)
- STANDARDS PREPARED TO ADDRESS DATA PRODUCTS
- REQUIRE CONCURRENT PREPARATION OF DID'S IAW DOD-STD-963A
- A PARAGRAPH MUST BE INCLUDED IN SECTION 6 TO CITE ASSOCIATED DID'S
- STANDARDS AND DID'S COORDINATED CONCURRENTLY
- STANDARDS AND DID'S SUBMITTED TO DASD(PR)-TD&MD VIA DOD COMPONENT DATA MANAGEMENT REPRESENTATIVE, FOR OMB CLEARANCE AND ASSIGNMENT OF AMSC NUMBERS

MIL-STD-962B REQUIREMENTS

- PROCESS DOCUMENTS (CONT'D)
- STANDARDS PREPARED TO ADDRESS DATA PRODUCTS (CONT'D)
- EXAMPLE SECTION 6 PARAGRAPH:

"6.3 DATA REQUIREMENTS. THE FOLLOWING DATA ITEM DESCRIPTIONS (DID'S) MUST BE LISTED, AS APPLICABLE, ON THE CONTRACT DATA REQUIREMENTS LIST (DD 1423) WHEN THIS STANDARD IS APPLIED ON A CONTRACT, IN ORDER TO OBTAIN THE DATA, EXCEPT WHERE DFARS 27.475-1 EXEMPTS THE REQUIREMENT FOR A DD 1423.

<u>REFERENCE PARA</u>	<u>DID NUMBER</u>	<u>DID TITLE</u>
4.1	DI-MISC-80001A	MILITARY SPECIFICATION

THE ABOVE DID'S WERE THOSE CLEARED AS OF THE DATA OF THIS STANDARD. THE CURRENT ISSUE OF DOD 5010.12-L, AMSDL, MUST BE RESEARCHED TO ENSURE THAT ONLY CURRENT, CLEARED DID'S ARE CITED ON THE DD 1423."

MIL-STD-962B REQUIREMENTS

- PROCESS DOCUMENTS (CONT'D)
 - STANDARDS FOR TECHNICAL MANUALS FOR INSTALLATION, OPERATION, MAINTENANCE, TRAINING, AND SUPPORT OF WEAPON SYSTEMS, WEAPON SYSTEM COMPONENTS, AND SUPPORT EQUIPMENT
 - DO NOT REQUIRE DID'S
 - MUST BE SUBMITTED TO DASD(PR)-TD&MD FOR OMB CLEARANCE AND ASSIGNMENT OF AMSC NUMBER
 - A PARAGRAPH MUST BE INCLUDED IN SECTION 6 TO INDICATE PROPER CONTRACTUAL METHOD OF ACQUIRING TECHNICAL MANUALS

6.3 TECHNICAL MANUAL ACQUISITION. THIS STANDARD MUST BE LISTED ON THE CONTRACT DATA REQUIREMENTS LIST (DD 1423) IN ORDER TO ACQUIRE THE TECHNICAL MANUALS DESCRIBED BY THIS STANDARD, EXCEPT WHERE DFARS 227.475-1 EXEMPTS THE REQUIREMENT FOR A DD 1423.

MIL-STD-962B REQUIREMENTS

- PROCESS DOCUMENTS (CONT'D)
- STANDARDS REQUIRING ONLY THAT RECORDS BE MAINTAINED (NO DELIVERABLE DATA)
- "RECORD KEEPING" DATA
- DID'S NOT REQUIRED
- MUST BE SUBMITTED TO DASD(PR)-TD&MD FOR OMB CLEARANCE AND ASSIGNMENT OF AMSC NUMBER

MIL-STD-962B REQUIREMENTS

- **MILITARY HANDBOOKS AND BULLETINS**
- **SHALL NOT CONTAIN DATA REQUIREMENTS**
- **SHALL CARRY NOTATION "AMSC N/A"**

MIL-STD-962B REQUIREMENTS

- **AMSC NUMBER**
- **CHANGE NOTICES CARRY SAME NUMBER AS BASIC OR "AMSC N/A" AS APPLICABLE**
- **NEW AMSC NUMBER ASSIGNED WHEN STANDARD IS REVISED, AS APPLICABLE**
- **OTHER NOTICES (VALIDATION, INACTIVE FOR NEW DESIGN, CANCELLATION, REINSTATEMENT) CARRY NOTATION "AMSC N/A"**

MIL-STD-962B REQUIREMENTS

- RIGHTS IN DATA
- ACQUISITION OF RIGHTS IN DATA SHALL NOT BE MADE THROUGH THE MEDIUM OF A STANDARD (REF. DFARS 227.4 FOR APPROPRIATE CLAUSES)

ACQUISITION MANAGEMENT SYSTEMS AND DATA REQUIREMENTS CONTROL LIST (AMSDL)

- OVERVIEW OF THE AMSDL AND AMSDL NOTICES
- IDENTIFIED AS DOD 5010.12-L
- IDENTIFIES ALL "INFORMATION COLLECTION REQUEST"
GRANTED OMB CLEARANCE IN ACCORDANCE WITH PUBLIC
LAW 96-511, "PAPERWORK REDUCTION ACT," FOR USE IN
DEFENSE CONTRACTS
- REFLECTS OMB CLEARANCE NUMBER 0704-0188
- REFLECTS OMB CLEARANCE EXPIRATION DATE
OF 30 JUNE 1992

ACQUISITION MANAGEMENT SYSTEMS AND DATA REQUIREMENTS CONTROL LIST (AMSDL)

- OVERVIEW OF THE AMSDL AND AMSDL NOTICES (CONT'D)
- ONLY APPROVED LIST OF APPROVED SOURCE DOCUMENTS AND DATA ITEM DESCRIPTIONS
- CENTRALLY MANAGED BY OFFICE OF ASSISTANT SECRETARY OF DEFENSE (ACQUISITION AND LOGISTICS) - TD&MD
- PUBLISHED BI-ANNUALLY - APRIL AND OCTOBER
- PRINTED, STOCKED, DISTRIBUTED BY NAVAL PUBLICATIONS AND FORMS CENTER (NPFC)

ACQUISITION MANAGEMENT SYSTEMS AND DATA REQUIREMENTS CONTROL LIST (AMSDL)

- OVERVIEW OF THE AMSDL AND AMSDL NOTICES (CONTD)
- AMSDL NOTICES
 - COMMUNICATE CHANGES MADE TO THE AMSDL BETWEEN SEMI-ANNUAL PUBLICATION
 - CONTAIN UP TO FIVE SECTIONS
 - TRANSMITTAL SHEET - PEN-AND-INK CHANGES AND SPECIAL NOTICES
 - CHANGES TO AMSDL PART I
 - CHANGES TO AMSDL PART II
 - CHANGES TO AMSDL PART IV-A
 - CHANGES TO AMSDL PART IV-B

ACQUISITION MANAGEMENT SYSTEMS AND DATA REQUIREMENTS CONTROL LIST (AMSDL)

- COMPOSITION OF THE AMSDL
 - PART I - LISTING OF SOURCE DOCUMENTS
 - PRECEDED BY PART I INDEX OF SOURCE DOCUMENTS
 - ARRANGED BY DATA FUNCTIONAL AREA ASSIGNMENTS IN ALPHABETICAL ORDER (I.E., ADMIN, ATTS, CMAN, ETC.)
 - IDENTIFIES DOCUMENT NUMBER, TITLE, OPR, AMSC NUMBER, AND DATE, AND LISTS ASSOCIATED DIDs WITH THEIR TITLE, OPR, AMSC NUMBER, AND DATE
 - ALSO LISTS, AT THE END OF EACH FUNCTIONAL AREA, TYPE II DIDs ASSIGNED TO EACH AREA

DEPARTMENT OF DEFENSE
ACQUISITION INFORMATION ANALYSIS AREAS
(UPDATED AS OF 91 JAN 09)
(# = SOURCE DOCUMENT CANCELLED/SUPERSEDED)

PROGRAM AREA: ILSS SYSTEM DOCUMENTS
INTEGRATED LOGISTICS SUPPORT STANDARDS

DOCUMENT NR	TITLE	DPR	APPROVAL	DOC DATE
-----	-----	---	AMSC	-----
MIL-P-15137C(2)	PROVISIONING TECHNICAL DOCUMENTATION FOR REPAIR PARTS FOR ELECTRICAL AND MECHANICAL EQUIPMENT (NAVAL SHIPBOARD USE)	N/BUSHIPS	N0422	06NOV54
MIL-P-24310(1)	PROVISIONING MONITORING SYSTEM PROCEDURES FOR NAVAL SHIPBOARD ELECTRICAL AND MECHANICAL EQUIPMENT AND COMPONENTS	N/SEA-311	N1559	06NOV57
MIL-D-26239A	DATA, QUALITATIVE AND QUANTITATIVE PERSONNEL REQUIREMENTS INFORMATION (QPRI)	F/SEPS	F1726	14APR61
DI-H-3253	QUALITATIVE AND QUANTITATIVE PERSONNEL REQUIREMENTS INFORMATION (QPRI), PART I: FIELD AND ORGANIZATION MAINTENANCE	F/AFSC		24JUG70
DI-H-3254	QUALITATIVE AND QUANTITATIVE PERSONNEL REQUIREMENTS INFORMATION (QPRI), PART II: DEPOT-LEVEL SUPPORT	F/AFSC		24JUG70
MIL-T-29053A	TRAINING REQUIREMENTS FOR AVIATION WEAPON SYSTEMS	N/NTEC	N3137	14DEC79
MIL-T-8121(3)	TRAINERS, MAINTENANCE EQUIPMENT AND SERVICES, GENERAL SPECIFICATION FOR	N/A	N1522	25MAR53
DI-A-6103A	REPORT, MATERIAL REQUIREMENTS/RECEIPT, MAINTENANCE TRAINING EQUIPMENT	N/AIR-413		08FEB74
DI-E-6118A	REPORTS, ENGINEERING CHANGES STATUS-MAINTENANCE TRAINING EQUIPMENT	N/AIR-413		08FEB74
DI-E-6119A	REPORT, EQUIPMENT CONFIGURATION ACCOUNTABILITY-MAINTENANCE TRAINING EQUIPMENT	N/AIR-413		08FEB74
DI-E-6122A	SPECIFICATIONS-TRAINERS, MAINTENANCE, EQUIPMENT AND SERVICES	N/AIR-413		08FEB74
DI-F-6125A	REPORT, COST, MAINTENANCE TRAINING EQUIPMENT	N/AIR-413		08FEB74
DI-H-6129A	OUTLINES, ACCEPTANCE AND TEST, MAINTENANCE TRAINING EQUIPMENT	N/AIR-413		08FEB74
DI-H-6132A	RECORDS, EQUIPMENT SERVICE, MAINTENANCE TRAINING EQUIPMENT	N/AIR-413		08FEB74
DI-H-6133A	MANUALS, PHOTOGRAPHIC, MAINTENANCE TRAINING EQUIPMENT	N/AIR-413		08FEB74
DI-H-6134A	REPORTS, ENGINEERING AND PRODUCTION PROGRESS-MAINTENANCE TRAINING EQUIPMENT	N/AIR-413		08FEB74
DI-H-6135A	REPORTS, FACILITIES - MAINTENANCE TRAINING EQUIPMENT	N/AIR-413		08FEB74
DI-H-6136A	REPORTS, ACCEPTANCE - MAINTENANCE TRAINING EQUIPMENT	N/AIR-413		08FEB74
DI-L-6139A	REPORTS, REJECTED/NON-OPERABLE PARTS UTILIZATION, MAINTENANCE TRAINING EQUIPMENT	N/AIR-413		08FEB74
DI-M-6152A	MANUALS, OPERATION AND MAINTENANCE INSTRUCTION, MAINTENANCE TRAINING EQUIPMENT	N/AIR-413		08FEB74
DI-P-6164A	REPORT, MATERIAL SHORTAGE-MAINTENANCE TRAINING EQUIPMENT	N/AIR-413		08FEB74
DI-F-6203	REPORT, FUNDING STATUS, BASIC ORDERING AGREEMENT - MAINTENANCE TRAINING EQUIPMENT	N/AIR-413		08FEB74

DOCUMENT NR	TITLE	DPR	APPROVAL AMSC	DDCDATE
DI-E-6204	EXHIBITS, ENGINEERING CHANGE PROPOSALS-TRAINING COURSES, MAINTENANCE TRAINING EQUIPMENT RELATED ITEMS AND SERVICE CHARTS, MILESTONES - MAINTENANCE TRAINING EQUIPMENT	N/AIR-413		08FEB74
DI-H-6205	REPAIR AND REHABILITATION OF RADAR SETS: GENERAL SPECIFICATION FOR	N/AIR-413	N1745	08FEB74
MIL-R-821730	COMMERCIAL REPAIR PARTS SUPPORT, GENERAL SPECIFICATION FOR	M/LMC2		12FEB76
MIL-C-82177A	CONTRACTOR TECHNICAL INFORMATION CODING OF REPLENISHMENT PARTS	M/CSY10	N1722	16JUN72
MIL-STD-789C	CONTRACTOR TECHNICAL INFORMATION CODING OF REPLENISHMENT PARTS	M/ESSD-93	N2675	14OCT93
DI-P-7128	TECHNICAL DATA IDENTIFICATION CHECK LIST	N/NAVY(AS)		14OCT93
DI-P-7129	FITTING OUT PROCEDURES	N/NAVY(AS)		14OCT93
MIL-STD-1339	OUTFITTING OPERATIONS PLAN	N/N/SEA	N4896	27FEB90
DI-ILSS-80947	OUTFITTING MATERIAL STATUS REPORT	N/SH/CEL	N4897	27FEB90
DI-ILSS-80948	BINNED MATERIAL LIST	N/SH/CEL	N4898	27FEB90
DI-ILSS-80949	SHIPBOARD OPERATING SPACE ITEMS (OSI) STORAGE LOCATION	N/SH/CEL	N4899	27FEB90
DI-ILSS-80950	RESIDUAL ASSET FILE (RAF) REPORT	N/SH/CEL	N4900	27FEB90
DI-ILSS-80951	INCREMENTAL ASSET REPORT	N/SH/CEL	N4901	27FEB90
DI-ILSS-80952	STOCK RECORDS	N/SH/CEL	N4902	27FEB90
DI-ILSS-80953	CONTRACTOR FURNISHED (CF) OPERATING SPACE ITEM (OSI) REQUIREMENTS REPORT	N/SH/CEL	N4903	27FEB90
DI-ILSS-80954	GOVERNMENT FURNISHED (GF) RESIDUAL ASSET FILE (RAF) OUTSTANDING REQUISITION DATA	N/SH/CEL	N4904	27FEB90
DI-ILSS-80955	NON-READY FOR ISSUE (N/N-RFI) MATERIAL REPORT	N/SH/CEL	N4905	27FEB90
DI-ILSS-80956	INTEGRATED ALLIANCE DOCUMENT (IAD)	N/SH/CEL	N4906	27FEB90
DI-ILSS-80957	INTEGRATED COSAL (ICOSAL) DATA	N/SH/CEL	N4907	27FEB90
DI-ILSS-80958	COORDINATED SHIPBOARD ALLOWANCE LIST (COSAL) BASELINE	N/SH/CEL	N4908	27FEB90
DI-ILSS-80959	ASSET FILE-STORAGE (BAF_SFI) RECONCILIATION REPORT	N/SH/CEL	N4909	27FEB90
DI-ILSS-80960	ALLOWANCE SHORTAGE LIST	N/SH/CEL	N4910	27FEB90
MIL-STD-1375 + NOTICE 1	PROVISIONING, INITIAL SUPPORT, GENERAL REQUIREMENTS FOR	N/SUP-0341	N1549	29NOV74
MIL-STD-1379	MILITARY TRAINING PROGRAM	N/SH	N5039	05DEC90
DI-ILSS-81069	TRAINING SITUATION REPORT	N/SH	N5040	05DEC90
DI-ILSS-81070	TRAINING PROGRAM DEVELOPMENT AND MANAGEMENT PLAN	N/SH	N5041	05DEC90
DI-ILSS-81071	INDIVIDUAL TRAINING PLAN	N/SH	N5042	05DEC90
DI-ILSS-81072	MEDIA SELECTION MODEL REPORT	N/SH	N5043	05DEC90
DI-ILSS-81073	TRAINING EQUIPMENT REQUIREMENTS DOCUMENT	N/SH	N5044	05DEC90
DI-ILSS-81074	TRAINING SYSTEM IMPLEMENTATION PLAN	N/SH	N5045	05DEC90
DI-ILSS-81075	TRAINING COURSE CONTROL DOCUMENT	N/SH	N5046	05DEC90
DI-ILSS-81076	TRAINING EVALUATION PLAN	N/SH	N5047	05DEC90
DI-ILSS-81077	MISSION PERFORMANCE STANDARDS	N/SH	N5048	05DEC90
DI-ILSS-81078	MISSION, COLLECTIVE, INDIVIDUAL, AND OCCUPATIONAL TRAINING TASK ANALYSIS REPORT	N/SH	N5049	05DEC90
DI-ILSS-81079	PERSONNEL PERFORMANCE PROFILE TABLES	N/SH	N5050	05DEC90
DI-ILSS-81080	TRAINING PATH SYSTEM REPORT	N/SH	N5051	05DEC90
DI-ILSS-81081	INDIVIDUAL TRAINING STANDARDS	N/SH	N5052	05DEC90

! * CHANGED SINCE LAST ISSUE OF AMSDL

1-48

ACQUISITION MANAGEMENT SYSTEMS AND DATA REQUIREMENTS CONTROL LIST (AMSDL)

- COMPOSITION OF THE AMSDL (CONT'D)
 - PART II - LISTING OF DATA ITEM DESCRIPTIONS (DIDs)
 - LISTS ALL CLEARED TYPE I AND II DIDs IN NUMERICAL ORDER
 - PROVIDES DID NUMBER, TITLE, OPR, AMSC NUMBER, APPROVAL DATE, AND SOURCE DOCUMENT NUMBER
 - PART III - KEYWORD INDEX OF DIDs
 - LISTS THE TITLE OF EACH DID BY KEYWORDS WITHIN THE TITLE
 - KEYWORD CENTERED IN TITLE COLUMN, WITH REMAINDER OF TITLE IN NORMAL POSITION TO THE LEFT OR RIGHT
 - SHOWS DID TITLE, NUMBER, AND SOURCE DOCUMENT NUMBER

DEPARTMENT OF DEFENSE
ACQUISITION MANAGEMENT SYSTEMS AND DATA REQUIREMENTS CONTROL LISTING (AMSDL)

DDO 5010.12-L

PART II

NUMERICAL LISTING OF OIDS

09 JAN 91

OID NUMBER	TITLE	DPR	APVL AMSC	APVL DATE	SOURCE DOCUMENT NUMBER
DI-A-1004	WORK BREAKDOWN STRUCTURE	A/DRCRD		15DEC69	MIL-STD-881A
DI-A-1005A	PROGRESS/STATUS MEETING REPORT	F/AFSC-SD	F3430	15JAN85	STATEMENT OF WORK
DI-A-1012	DOCUMENTS REQUIRED BY NATIONAL RANGES	A/DRSTE		15DEC69	TO BE DETERMINED
DI-A-1013	DATA PROCESSING UTILIZATION	A/CSA		15DEC69	TO BE DETERMINED
DI-A-1035	CONTRACTOR'S STANDARD OPERATING PROCEDURE	A/DELHD-R4	A3551	06MAY85	STATEMENT OF WORK
DI-E-1101C	CONFIGURATION STATUS ACCOUNTING AND ENGINEERING RECORDS	A/DRSMI		14APR77	MIL-STD-482A
DI-E-1104A	SPECIFICATIONS	A/DRCRD		01MAY72	MIL-STD-490 + NOTICE 2
DI-E-1124C	WEIGHT AND BALANCE DATA - ARMY AIRCRAFT	A/DRDVA-EQA		20NOV78	MIL-W-25140R
DI-E-1135	SITE FACILITIES DESIGN DATA	A/USACC		02MAY77	MIL-STD-1521A + NOTICE 1
DI-E-1139	RADIO ANTENNA TOWER DESIGN DATA	A/USACC		02MAY77	MIL-T-25433(1)
DI-F-1203	BUDGETARY COST ESTIMATE FOR PRODUCTION PROGRAM	A/DRCDF		15DEC69	MIL-STD-881A
DI-F-1211	CONTRACTOR'S PLANT COST STATEMENT BY APPROPRIATION	A/DRCDF		07FEB80	MIL-STD-1260
DI-F-1212	CONTRACTOR'S ITEM PRODUCTION COST STATEMENT (UNIT COST)	A/DRCDF		07FEB80	MIL-STD-1260
DI-F-1213	PERSONNEL UTILIZATION REPORT	A/DRCDF		07FEB80	MIL-STD-1260
DI-F-1215	LIFE CYCLE COST ESTIMATE DOCUMENT	A/DELNV	A3541	08JUL85	STATEMENT OF WORK
DI-F-1216	SESAME BUDGET DATA	A/AMSMI	A3579	06JUN85	STATEMENT OF WORK
DI-H-1323A	ACCIDENT REPORT	A/DRCSF		04JUN71	TO BE DETERMINED
DI-H-1324A	ACCIDENT EXPOSURE SUMMARY	A/DRCSF		04JUN71	TO BE DETERMINED
DI-H-1325A	NUCLEAR SAFETY STUDIES AND REVIEW DATA	A/DRCSF		04JUN71	TO BE DETERMINED
DI-H-1327A	SURFACE DANGER AREA DATA	A/DRCSF		04JUN71	TO BE DETERMINED
DI-H-1328A	ACCIDENT PREVENTION SAFETY PROGRAM	A/DRCSF		04JUN71	TO BE DETERMINED
DI-H-1329A	ACCIDENT/INCIDENT REPORT	A/DRCSF		04JUN71	TO BE DETERMINED
DI-H-1332A	RADIOACTIVE MATERIAL DATA	A/DRCSF		04JUN71	TO BE DETERMINED
DI-L-1414	TRANSPORTABILITY CLEARANCE DIAGRAM	A/DRCSF		15DEC69	MIL-D-1000A(1)
DI-L-1415B	GOCO PLANT RCS REPORT	A/DRSAR		10DEC79	TO BE DETERMINED
DI-L-1423	STORAGE SERVICEABILITY STANDARDS	A/DRDEL		29DEC83	TO BE DETERMINED
DI-P-1600	VALUE ENGINEERING DATA REPORT	A/DRCRD		15DEC69	MIL-V-39352(1)
DI-P-1602	VALUE ENGINEERING PLAN	A/DRCRD		15DEC69	MIL-V-39352(1)
DI-P-1606	PROGRAM STATUS REPORT (COST DATA)	A/DRCM4		15DEC69	TO BE DETERMINED
DI-P-1628A	OVERHAUL AND SPARE PARTS REPORTING	A/DRDVA		01MAY72	TO BE DETERMINED
DI-P-1632	REPAIR/MODIFICATION/OVERHAUL STATUS REPORT	A/DRDVA		23OCT79	TO BE DETERMINED
DI-P-1633	PRODUCTION CONTRACT SUMMARY REPORT	A/DRDVE		07OCT80	TO BE DETERMINED
DI-P-1637	REQUEST FOR REPAIR WELDING APPROVAL FOR FORGINGS OR CASTINGS	A/DRDEL	A3395	05SEP84	MIL-S-45172A(MR)
DI-F-1639	CHEMICAL AND PHYSICAL PROPERTIES FOR FORGINGS OR CASTING ANALYSIS REPORT	A/AMXNR-SMS	A3386	05SEP84	MIL-S-45172A(MR)
DI-P-1641	MANUFACTURING METHODS REPORT (INTERIM)	A/AMSMI	A3615	12JUN85	STATEMENT OF WORK
DI-P-1645	MANUFACTURING METHODS (FINAL REPORT)	A/AMC-YI	A3619	12JUN85	STATEMENT OF WORK
DI-P-1652	SURGE INVENTORY CONTROL/UTILIZATION DATA REPORT	A/AMSMI	A3546	03MAY85	STATEMENT OF WORK
DI-R-1773	FACILITY SECURITY PLAN	A/SMCCR-PMP	A3567	25MAY85	STATEMENT OF WORK
DI-R-1779	NUCLEAR, BIOLOGICAL AND CHEMICAL (NBC) CONTAMINATION SURVIVABILITY PROGRAM PLAN	A/DELNV	A3643	15JUL85	STATEMENT OF WORK

SOURCE
DOCUMENT NR.

TITLE	DID NR.	SOURCE DOCUMENT NR.
ALYSIS AND CORRECTIVE ACTION SYSTEM (FRACAS) PLAN	DI-R-21597	MIL-STD-2155(AS)
TASK ASSIGNMENT PLAN	DI-MGMT-80057	STATEMENT OF WORK
MANUFACTURING PLAN	DI-MISC-80074	MULTIPLE
INTEGRATED LOGISTICS SUPPORT PLAN	DI-ILSS-80095	DDD-STD-1702(NS)
TECHNICAL MANUAL PUBLICATION PLAN	DI-TMSS-80063	MULTIPLE
TECHNICAL MANUAL VALIDATION PLAN	DI-TMSS-80069	MULTIPLE
SYSTEM SAFETY PROGRAM PLAN	DI-SAFT-80100	MULTIPLE
MANAGEMENT PLAN	DI-MGMT-80096	STATEMENT OF WORK
TECHNICAL PLAN	DI-OCIC-80097	STATEMENT OF WORK
MEDICAL AND HEALTH PLAN	DI-MISC-80123	STATEMENT OF WORK
TRAINING PLAN	DI-ILSS-80143	STATEMENT OF WORK
MAINTAINABILITY DEMONSTRATION PLAN	DI-MNTY-80145	STATEMENT OF WORK
QUALITY CONTROL PLAN	DI-OCIC-80147	STATEMENT OF WORK
TELECOMMUNICATIONS SYSTEM INSTALLATION PLAN	DI-CORR-80150	STATEMENT OF WORK
FACTORY TEST PLAN	DI-OCIC-80153	STATEMENT OF WORK
ACCEPTANCE TEST PLAN	DI-OCIC-80154	STATEMENT OF WORK
INSTALLATION TEST PLAN	DI-OCIC-80155	STATEMENT OF WORK
DESIGN PRODUCEILITY PROGRAM PLAN	DI-MISC-80163	STATEMENT OF WORK
MATERIEL DETERIORATION PREVENTION PLAN	DI-MISC-80171	STATEMENT OF WORK
DATA MANAGEMENT PLAN	DI-MISC-80168	MULTIPLE
PRODUCTION TEST PLAN	DI-MNTY-80173	STATEMENT OF WORK
TECHNICAL MANUAL PUBLICATION PLAN	DI-TMSS-80195	DDD-4-85001(NS)
ELECTROMAGNETIC INTERFERENCE CONTROL PLAN	DI-EMCS-80199	MULTIPLE
ELECTROMAGNETIC INTERFERENCE TEST PLAN	DI-EMCS-80201	MULTIPLE
HUMAN FACTORS DEVELOPMENT PLAN	DI-HFAC-80210	MIL-STD-1794(USAF)
RELIABILITY TEST PLAN	DI-RELI-80250	MULTIPLE
CORRECTIVE ACTION PLAN	DI-RELI-80254	MIL-STD-781D
NUCLEAR HARDNESS AND SURVIVABILITY PROGRAM PLAN	DI-ENVR-80262	DDD-STD-1766A(USAF)
HARDNESS ASSURANCE PLAN	DI-ENVR-80263	DDD-STD-1766A(USAF)
HARDNESS MAINTENANCE PLAN	DI-ENVR-80264	DDD-STD-1766A(USAF)
HARDNESS SURVEILLANCE PLAN	DI-ENVR-80265	DDD-STD-1766A(USAF)
TUREBORNE VIBKATORY ACCELERATION MEASUREMENT PLAN	DI-HFAC-80273	MIL-STD-740-2(5H)
EQUIPMENT AIRBORNE SOUND MEASUREMENT PLAN	DI-HFAC-80270	MIL-STD-740-1(5H)
SOFTWARE DEVELOPMENT PLAN	DI-MCCR-80297	DDD-STD-1703(NS)
SOFTWARE QUALITY ASSURANCE PLAN	DI-MCCR-80299	DDD-STD-1703(NS)
SOFTWARE CONFIGURATION MANAGEMENT PLAN	DI-MCCR-80300	DDD-STD-1703(NS)
SOFTWARE GENERAL UNIT TEST PLAN	DI-MCCR-80307	DDD-STD-1703(NS)
SOFTWARE SYSTEM INTEGRATION AND TEST PLAN	DI-MCCR-80308	DDD-STD-1703(NS)
SOFTWARE DEVELOPMENT TEST AND EVALUATION PLAN	DI-MCCR-80309	DDD-STD-1703(NS)
SOFTWARE END-PRODUCT ACCEPTANCE PLAN	DI-MCCR-80319	DDD-STD-1703(NS)
FOLLOWER SOURCE SELECTION PLAN	DI-MISC-80324	STATEMENT OF WORK
FOLLOWER CERTIFICATION PLAN	DI-MISC-80328	STATEMENT OF WORK
TECHNOLOGY TRANSFER PLAN	DI-MISC-80330	STATEMENT OF WORK
TASK ORDER MANAGEMENT PLAN	DI-MGMT-80347	DDD-STD-2186(54)
OUTSIDE PLANT EQUIPMENT INSTALLATION PLAN	DI-MGMT-80354	STATEMENT OF WORK
CUTOVER PLAN	DI-MGMT-80355	STATEMENT OF WORK
CONNECTION APPROVAL (CA) PLAN	DI-MGMT-80356	STATEMENT OF WORK
RING AND CONTROL SYSTEMS (EMCS) FACTORY TEST PLAN	DI-ATTS-80360	MIL-STD-2202
PERFORMANCE VERIFICATION AND ENDURANCE TEST PLAN	DI-ATTS-80363	MIL-STD-2203
IMPLEMENTATION MANAGEMENT PLAN	DI-MISC-80367	STATEMENT OF WORK
PHASED SUPPORT PLAN	DI-ILSS-80037A	STATEMENT OF WORK

FAILURE REPORTING, AN

EQUIPMENT STRUC

SOF

REAL TIME OUTFITTING MANA

ENERGY MONITO

ENERGY MONITORING AND CONTROL SYSTEMS (EMCS)

111-98

! = CHANGED SINCE LAST ISSUE OF AMSDL

ACQUISITION MANAGEMENT SYSTEMS AND DATA REQUIREMENTS CONTROL LIST (AMSDL)

- COMPOSITION OF THE AMSDL (CONT'D)
- PART IV-A - CANCELLED/SUPERSEDED SOURCE DOCUMENTS
 - LISTS SOURCE DOCUMENT NUMBER, OPR, AMSC NUMBER, AND STATUS (I.E., CANCELLED OR THE DOCUMENT WHICH SUPERSEDED IT)
- PART IV-B - CANCELLED/SUPERSEDED DIDS
 - LISTS DID NUMBER, OPR, AND STATUS (I.E., CANCELLED OR THE DID WHICH SUPERSEDED IT)

DEPARTMENT OF DEFENSE
ACQUISITION MANAGEMENT SYSTEMS AND DATA REQUIREMENTS CONTROL LISTING (AMSDL)
DOD 5010.12-L

PART IV
CANCELLED/SUPERSEDED LIST
09 JAN 91

CANCELLED SOURCE DOCUMENTS
SECTION A

SOURCE DOCUMENT NR	DPR	AMSC NR	STATUS
MIL-P-1166(2)	N/ESSD-93	M1688	MIL-P-1166H
MIL-D-1000	A/SHUFA-550	A1723	DJD-D-1000B(1)
MIL-D-1000/1A	N/NAVAIR	N2306	CANCELLED
MIL-D-1000/2A	N/NAVSEC	N2331	DJD-D-1000B(1)
MIL-D-1000/3(1)	N/NAVELEX	N2308	CANCELLED
MIL-D-1000/4	N/NAVWEPSSS	N2318	CANCELLED
MIL-D-1000/5(1)	A/AMSEL-RD	A2295	CANCELLED
MIL-D-1000/6	A/AMSEL-RD	A2296	CANCELLED
MIL-D-1000/7	A/AMSEL-RD	A2294	CANCELLED
MIL-D-1000/8	A/AMSEL-RD	A2298	CANCELLED
MIL-D-1000/9(1)	A/AMSEL-RU	A2299	CANCELLED
MIL-D-1000/10(1)	A/AMSEL-RD	A2311	CANCELLED
MIL-D-1000/11	A/AMSEL-RD	A2313	CANCELLED
MIL-D-1000A(1)	A/SARFA-HDM	A1873	DJD-D-1000B(1)
DOD-D-1000B(3)	A/AR	A3007	DJD-D-1000B(4)
MIL-M-51660	F/AFLC/LOLM	F3219	MIL-M-5166D + AMEND 1
MIL-E-5272C + AMEND 2	F/SEPS	F1657	MIL-STD-810C
MIL-H-5288	F/AFLC		MIL-M-5288F
MIL-H-5288A	F/AFLC		MIL-M-5288F
MIL-H-5288B	F/AFLC		MIL-M-5288F
MIL-H-005288C	F/AFLC		MIL-M-5288F
MIL-M-005288D	F/AFLC		MIL-M-5288F
MIL-M-5288E	F/AFLC/MMDM		MIL-M-5288F
MIL-E-5400R	N/ESSD-93	N2037	MIL-E-5400T
MIL-I-6870D	F/ASD/ENESS	F2637	MIL-I-6870E
MIL-F-7179E(1)	N/ESSD-93	N1971	MIL-F-7179F
MIL-T-7578K	F/AFLC	F2276	MIL-T-39804(1)
MIL-H-8031	F/AFLC		MIL-L-8031D
MIL-H-8031A	F/AFLC		MIL-L-8031D
MIL-L-8031B	F/AFLC		MIL-L-8031D
MIL-L-8031C	F/AFLC		MIL-L-8031D
MIL-E-8189H	N/ESSD-93	N2672	MIL-E-5400T
MIL-I-8500C(1)	G/MSSA	F2332	MIL-T-8500D
MIL-M-8555B	N/NAVAIR	N1868	MIL-M-8555C
MIL-A-8591E	N/ESSD-93	N2005	MIL-A-8591F(1)
MIL-A-8591F(1)	N/ESSD-93	N3062	MIL-A-8591G
MIL-M-8604(1)	N/AIR-52021	N2653	MIL-M-8604A
MIL-D-8683A	N/NAVAIR-X	N2127	MIL-D-8683B(1)
MIL-F-8785B(2)	F/ASMP	F1833	MIL-F-8785C

DI0 NUMBER	OPR	STATUS	DI0 NUMBER	OPR	STATUS
UDI-H-1013	N/USN-61756	CANCELLED	UDI-R-1071	N/USN-61756	CANCELLED
DI-A-1014	A/DRCPA	CANCELLED	UDI-T-1073	N/USN-61756	CANCELLED
UDI-H-1014	N/USN-61756	CANCELLED	UDI-M-1079	N/USN-61756	CANCELLED
DI-A-1015A	A/USAMC	CANCELLED	UDI-R-1085	N/USN-61756	CANCELLED
UDI-T-1015	N/USN-61756	DI-F-6000C	UDI-R-1085	N/USN-61756	CANCELLED
DI-A-1016	A/DRCRP	CANCELLED	UDI-R-1087	N/USN-61756	CANCELLED
UDI-T-1016	N/USN-61756	CANCELLED	UDI-R-1089	N/USN-61756	CANCELLED
DI-A-1017	A/USAMC-RD	DI-SAFT-80974	UDI-M-1089	N/USN-61756	CANCELLED
DI-A-1018	A/DRSMI	DI-MISC-80857	DI-E-1100A	A/ORDAR	DI-CMAN-90858
UDI-T-1018	N/USN-61756	CANCELLED	DI-E-1101B	A/USAMC-RD	DI-E-1101C
UDI-T-1019A	N/USN-61756	CANCELLED	DI-E-1102A	A/ORDAR	DI-CMAN-90644
DI-A-1020	A/BMDATC	CANCELLED	DI-E-1103B	A/ORDAR	DI-CMAN-80453
DI-A-1021	A/BMDATC	DI-MGMT-80909	DI-E-1105	A/USAMC	CANCELLED
DI-A-1022	A/BMDS-C-AV	DI-MGMT-80934	DI-E-1106A	A/DRCRD	DI-E-1105B
UDI-R-1022	N/USN-61756	DI-MGMT-80934	DI-E-1106B	A/AMC-MI	DI-MISC-80749
UDI-T-1023	N/USN-61756	CANCELLED	DI-E-1107A	A/AMCRD	DI-E-7031
DI-A-1024	A/STEMS	CANCELLED	DI-E-1109	A/DRCRD	DI-E-7194
DI-A-1025	A/AMCQA	DI-MISC-80733	DI-E-1109	A/DRCRD	CANCELLED
DI-A-1026	A/AHSMI	DI-MISC-80734	DI-E-1110	A/AMCRD	DI-E-7031
UDI-T-1026	N/USN-61756	CANCELLED	DI-E-1111	A/DRCRD	CANCELLED
DI-A-1027	A/BMDS-C-HP	DI-MGMT-80057	DI-E-1112	A/DRCRD	DI-EDRS-90907
UDI-T-1027B	N/USN-61756	CANCELLED	DI-E-1113	A/DRCRD	CANCELLED
DI-A-1028	A/BMDS-C-HP	DI-MGMT-80057	DI-E-1114	A/DRCRD	DI-EDRS-90940
UDI-R-1029A	N/USN-61756	CANCELLED	DI-E-1115B	A/DRCRD	DI-CMAN-90776
UDI-H-1033	N/USN-61756	CANCELLED	DI-E-1116A	A/AMCRD	DI-E-7028A
DI-A-1036	A/DELNV	CANCELLED	DI-E-1117A	A/DRCRD	DI-E-7099
DI-A-1037	A/AMSMC	CANCELLED	DI-E-1118	A/USAMC	DI-E-7031
DI-A-1038	A/AHSMI	CANCELLED	DI-E-1119	A/DRCRD	DI-ENVR-90905
DI-A-1039	A/AMSMI	DI-MISC-80749	DI-E-1120	A/USAMC(MI)	CANCELLED
UDI-P-1039	N/USN-61756	CANCELLED	DI-E-1121	A/USAMC	DI-E-1127
UDI-P-1040	N/USN-61756	CANCELLED	DI-E-1122	A/ORDAV	CANCELLED
UDI-R-1041	N/USN-61756	CANCELLED	DI-E-1123	A/DRCRD	DI-MGMT-90797
UDI-P-1043	N/USN-61756	CANCELLED	DI-E-1124A	A/USAMC(AV)	DI-E-1124C
UDI-R-1044A	N/USN-61756	CANCELLED	DI-E-1124B	A/ORDAV-EQA	DI-E-1124C
UDI-R-1045A	N/USN-61756	CANCELLED	DI-E-1125	A/DRCM	DI-MCCR-90700
UDI-R-1046A	N/USN-61756	CANCELLED	DI-E-1126A	A/DRCRD	DI-CMAN-90642
UDI-R-1047A	N/USN-61756	CANCELLED	DI-E-1127	A/DRCRD	DI-MISC-80750
UDI-H-1052A	N/USN-61756	CANCELLED	DI-E-1128	A/ECOM	DI-R-7051
UDI-M-1053A	N/USN-61756	CANCELLED	DI-E-1129	A/DRCOE	CANCELLED
UDI-M-1055	N/USN-61756	CANCELLED	DI-E-1130	A/DRCOE	DI-MISC-80751
UDI-M-1056A	N/USN-61756	CANCELLED	DI-E-1131	A/DRCRD	DI-ENVR-90490
UDI-M-1057	N/USN-61756	CANCELLED	DI-E-1132	A/DRCOE	CANCELLED
UDI-A-1062	N/USN-61756	CANCELLED	DI-E-1133	A/DRCRD	DI-MISC-80752
UDI-M-1063	N/USN-61756	CANCELLED	DI-E-1134	A/ORDAV	CANCELLED
UDI-R-1065A	N/USN-61756	CANCELLED	DI-E-1135	A/USACC	DI-TCPS-91120
UDI-R-1066A	N/USN-61756	CANCELLED	DI-E-1137	A/USACC	DI-MGMT-81118
UDI-R-1067A	N/USN-61756	CANCELLED	DI-E-1139	A/USACC	CANCELLED
UDI-R-1068	N/USN-61756	CANCELLED	DI-E-1140	A/USACC	CANCELLED
UDI-T-1069A	N/USN-61756	CANCELLED	DI-E-1141	A/USACC	CANCELLED
UDI-A-1070A	N/USN-61756	CANCELLED	DI-E-1142	A/USACC	DI-MISC-81119

IDENTIFICATION OF DID'S USING THE AMSDL

- **FIRST ENSURE AMSDL IS LATEST VERSION**
- **CHECK KEYWORD INDEX OF DID'S (PART III OF THE AMSDL)**
- **REVIEW DID'S FOR POSSIBLE USE**
- **TAILORING**
 - **CAN ONLY CONSIST OF DELETION OF REQUIREMENTS CONTAINED IN THE DID WHICH ARE NOT APPLICABLE OR REQUIRED FOR THE SPECIFIC ACQUISITION**
 - **CAN ONLY BE DONE IN BLOCK 16 OF THE DD 1423**
 - **ADDITIONAL OR CLARIFYING REQUIREMENTS CANNOT BE ADDED BY INDICATING IN A SPECIFICATION OR STANDARD**

PREPARATION OF DATA ITEM DESCRIPTIONS (DID'S)

- PREPARED IAW DOD-STD-963A
- THREE TYPES
 - TYPE I - APPROVED FOR REPETITIVE USE. HAS A SOURCE DOCUMENT (I.E., MILITARY SPECIFICATION OR STANDARD) WHICH GENERATES THE DATA REQUIREMENT.
 - TYPE II - APPROVED FOR REPETITIVE USE. HAS NO SOURCE DOCUMENT. HAS SOW TASK WHICH GENERATES THE DATA REQUIREMENT
 - TYPE III - APPROVED FOR ONE-TIME ACQUISITION. UNIQUE DATA REQUIREMENT APPLICABLE TO A SINGLE CONTRACT

DATA ITEM DESCRIPTION

Form Approved
OMB No. 0704-0188

Public reporting burden for this collection of information is estimated to average 110 hours per response, including the time for reviewing instructions, searching existing data sources, gathering and maintaining the data needed, and completing and reviewing the collection of information. Send comments regarding this burden estimate or any other aspect of this collection of information, including suggestions for reducing this burden, to Washington Headquarters Services, Directorate for Information Operations and Reports, 1215 Jefferson Davis Highway, Suite 1204, Arlington, VA 22202-4302, and to the Office of Management and Budget, Paperwork Reduction Project (0704-0188), Washington, DC 20503.

1. TITLE Product Drawings and Associated Lists	2. IDENTIFICATION NUMBER DI-DRPR-81000
---	---

3. DESCRIPTION/PURPOSE

3.1 Product Drawings and associated lists provide engineering data to support competitive procurement and maintenance for items substantially identical to original items. These drawings represent the highest level of design disclosure.

4. APPROVAL DATE (YYMMDD) 890911	5. OFFICE OF PRIMARY RESPONSIBILITY (OPR) DO	6a. DTIC APPLICABLE	6b. GIDEP APPLICABLE
--	---	---------------------	----------------------

7. APPLICATION/INTERRELATIONSHIP

7.1 This Data Item Description (DID) contains the format and content preparation instructions for Product Drawings and associated lists resulting from the work task described by 3.6.3 of MIL-T-31000.

7.2 This DID is applicable to the acquisition of military systems, equipments and components. It is intended for acquiring drawings and associated lists

(Continued on Page 2)

8. APPROVAL LIMITATION	9a. APPLICABLE FORMS	9b. AMSC NUMBER D4816
------------------------	----------------------	------------------------------

10. PREPARATION INSTRUCTIONS

10.1 Reference documents. The applicable issue of the documents cited herein, including their approval dates and the dates of applicable amendments and revisions, shall be as cited in the contract or purchase order.

10.2 General. Product drawings and associated lists shall meet the requirements of MIL-T-31000 and the DD Form 2554-1 incorporated into the contract or purchase order. Product drawings and associated lists shall provide the design disclosure information necessary to enable a manufacturer of similar products at the same of similar state of the art to produce and maintain quality control of item(s) so that the resulting physical and performance characteristics duplicate those of the original design. These drawings shall:

- a. Reflect the end-product at its current level of design maturity.
- b. Provide the engineering data for Logistics Support products.
- c. Provide the necessary data to permit competitive acquisition of items identical to the original items(s).

(Continued on Page 2)

11. DISTRIBUTION STATEMENT

DISTRIBUTION STATEMENT A: Approved for public release; distribution is unlimited.

PREPARATION OF DATA ITEM DESCRIPTIONS (DIDs)

- INSTRUCTIONS FOR PREPARATION OF DIDs
 - GENERAL INSTRUCTIONS
 - SINGLE DATA PRODUCT
 - DID STRUCTURE (BLOCK 10)
 - SELF-CONTAINED
 - ABSTRACT-REFERENCE
 - OMISSION OF WORK TASKS
 - CLASSIFIED DIDs
 - OMISSION OF PACKAGING INSTRUCTIONS
 - TAILORING

PREPARATION OF DATA ITEM DESCRIPTIONS (DIDs)

- INSTRUCTIONS FOR PREPARATION OF DIDs (CONT'D)
 - GENERAL INSTRUCTIONS (CONT'D)
 - LANGUAGE STYLE
 - GPO STYLE MANUAL
 - ABBREVIATIONS AND ACRONYMS
 - SIGNS AND SYMBOLS
 - SHALL, WILL, SHOULD, MAY
 - AND/OR
 - COMMONLY USED WORDS AND PHRASES
 - PROHIBITED TERMS

PREPARATION OF DATA ITEM DESCRIPTIONS (DIDs)

- INSTRUCTIONS FOR PREPARATION OF DIDs (CONTD)
 - GENERAL INSTRUCTIONS (CONTD)
 - PARAGRAPH NUMBERING, IDENTIFICATION,
AND STRUCTURE
 - UNDERLINING
 - TABLES
 - FIGURES
 - FOOTNOTES
 - FOLDOUTS
 - FORMS

PREPARATION OF DATA ITEM DESCRIPTIONS (DIDs)

- INSTRUCTIONS FOR PREPARATION OF DIDs (CONT'D)
 - GENERAL INSTRUCTIONS (CONT'D)
 - EXTERNAL DOCUMENTATION
 - REFERENCES
 - DEFINITIONS
 - PAGE NUMBERING
 - DID MANUSCRIPT

PREPARATION OF DATA ITEM DESCRIPTIONS (DIDs)

- INSTRUCTIONS FOR PREPARATION OF DIDs (CONT'D)
- DETAILED INSTRUCTIONS
 - BLOCK 1 - TITLE
 - MEANINGFUL NAME FOR DATA PRODUCT
 - KEYWORD IDENTIFICATION
 - LIMITED TO 130 SPACES
 - ABBREVIATIONS AND ACRONYMS
 - DIRECT READING METHOD

PREPARATION OF DATA ITEM DESCRIPTIONS (DIDs)

- INSTRUCTIONS FOR PREPARATION OF DIDs (CONTD)
- DETAILED INSTRUCTIONS (CONTD)
 - BLOCK 2 - IDENTIFICATION NUMBER
 - LEAVE BLANK
 - TYPES I AND II ASSIGNED BY TD&MD
 - DI-MISC-80000
 - TYPE III ASSIGNED BY SERVICE/AGENCY
DATA MANAGEMENT FOCAL POINT

PREPARATION OF DATA ITEM DESCRIPTIONS (DIDs)

- INSTRUCTIONS FOR PREPARATION OF DIDs (CONT'D)
- DETAILED INSTRUCTIONS (CONT'D)
 - BLOCK 3 - DESCRIPTION/PURPOSE
 - ABSTRACT OF DATA CONTENT REQUIREMENTS
 - PURPOSE FOR WHICH DATA IS ACQUIRED
- BLOCK 4 - APPROVAL DATE
 - LEAVE BLANK
 - TYPE I AND II ASSIGNED BY DDMO
 - TYPE III ASSIGNED BY SERVICE/AGENCY DATA MANAGEMENT FOCAL POINT

PREPARATION OF DATA ITEM DESCRIPTIONS (DIDs)

- INSTRUCTIONS FOR PREPARATION OF DIDs (CONT'D)
- DETAILED INSTRUCTIONS (CONT'D)
 - BLOCK 5 - OFFICE OF PRIMARY RESPONSIBILITY
 - WHEN DID PREPARER IS PREPARING ACTIVITY OF SOURCE DOCUMENT
 - USE PREPARING ACTIVITY CODE (E.G., SH, MI, AF10)
 - WHEN DID PREPARER IS NOT PREPARING ACTIVITY OF SOURCE DOCUMENT OR DID HAS NO SOURCE DOCUMENT
 - USE COMPONENT AND ORGANIZATIONAL CODE (E.G., F/AFSC-PLX, D/DDMO)

PREPARATION OF DATA ITEM DESCRIPTIONS (DIDs)

- INSTRUCTIONS FOR PREPARATION OF DIDs (CONT'D)
- DETAILED INSTRUCTIONS (CONT'D)
 - BLOCK 6a - DTIC APPLICABLE
 - ENTER "X" WHEN COPIES OF DATA ARE TO BE SUBMITTED TO DEFENSE TECHNICAL INFORMATION CENTER
 - OTHERWISE, LEAVE BLANK
 - IF DTIC APPLICABLE, ENTER DTIC ADDRESS IN BLOCK 7 OF DID
 - BLOCK 6b - GIDEP APPLICABLE
 - ENTER "X" IF COPIES OF DATA ARE TO BE SUBMITTED TO GOVERNMENT-INDUSTRY DATA EXCHANGE PROGRAM
 - OTHERWISE, LEAVE BLANK
 - IF GIDEP APPLICABLE, ENTER GIDEP OPERATIONS CENTER ADDRESS IN BLOCK 7 OF DID

PREPARATION OF DATA ITEM DESCRIPTIONS (DIDs)

- INSTRUCTIONS FOR PREPARATION OF DIDs (CONT'D)
 - BLOCK 7 - APPLICATION/INTERRELATIONSHIP
 - FOR TYPE I DIDs, IDENTIFY SOURCE DOCUMENT AND PARAGRAPH(S) THEREIN THAT CONTAIN TASK(S) THAT GENERATE DATA PRODUCT
 - FOR TYPE II DIDs, INCLUDE STATEMENT THAT DATA PRODUCT IS GENERATED BY TASK REQUIREMENT OF CONTRACT
 - LIST OTHER DATA ITEMS, BY DID NUMBER, WITH SIGNIFICANT RELATIONSHIP TO THE DID, SHOWING MANDATORY, TYPICAL, RESTRICTED USE
 - LIST DIDs BEING CANCELLED OR SUPERSEDED BY THE NEW OR REVISED DID
 - FOR TYPE III DIDs, INCLUDE STATEMENT THAT DID IS FOR ONE-TIME USE AND IDENTIFY SOLICITATION OR CONTRACT NUMBER

PREPARATION OF DATA ITEM DESCRIPTIONS (DIDs)

- INSTRUCTIONS FOR PREPARATION OF DIDs (CONT'D)
- DETAILED INSTRUCTIONS (CONT'D)
 - BLOCK 8 - APPROVAL LIMITATIONS
 - TYPE I - AND II - LEAVE BLANK; TO BE USED BY TD&MD
 - TYPE III - IDENTIFY SOLICITATION OR CONTRACT NUMBER

PREPARATION OF DATA ITEM DESCRIPTIONS (DIDs)

- INSTRUCTIONS FOR PREPARATION OF DIDs (CONT'D)
- DETAILED INSTRUCTIONS (CONT'D)
 - BLOCK 9a - APPLICABLE FORMS
 - IDENTIFY, BY FORM NUMBER, FORMS TO BE COMPLETED BY CONTRACTOR IN PREPARATION OF DATA PRODUCT
 - BLOCK 9b - AMSC NUMBER
 - TYPE I AND II - LEAVE BLANK; TO BE ASSIGNED BY TD&MD
 - TYPE III - LEAVE BLANK; AMSC NUMBER WILL NOT BE ASSIGNED

PREPARATION OF DATA ITEM DESCRIPTIONS (DIDs)

- INSTRUCTIONS FOR PREPARATION OF DIDs (CONT'D)
- DETAILED INSTRUCTIONS (CONT'D)
- BLOCK 10 - PREPARATION INSTRUCTIONS
 - ONLY CONTRACTUALLY BINDING PORTION
 - CLEAR, COMPLETE, MAXIMIZED DELINEATION OF DATA CONTENT AND FORMAT REQUIREMENTS
 - WHEN BLOCK 10 OF DID IDENTIFIES REFERENCE DOCUMENT FOR FURTHER PREPARATION INSTRUCTIONS, 10.1 SHALL BE STANDARD PARAGRAPH
 - PHRASES NECESSARY TO IDENTIFY SPECIFIC REQUIREMENTS OF PARTICULAR DOD COMPONENT ALLOWED
 - REFERENCES TO OTHER DIDs ALLOWED FOR INFORMATION GUIDANCE ONLY
 - CONTRACTOR TASKING NOT ALLOWED

PREPARATION OF DATA ITEM DESCRIPTIONS (DIDs)

- INSTRUCTIONS FOR PREPARATIONS OF DIDs (CONT'D)
- DETAILED INSTRUCTIONS (CONT'D)
 - BLOCK 11 - DISTRIBUTION STATEMENT
 - ENTER APPROPRIATE DISTRIBUTION STATEMENT FOR DID, NOT FOR THE DATA PRODUCT DESCRIBED BY THE DID
 - EXCEPT WHEN CLASSIFIED OR UNDER SPECIAL CIRCUMSTANCES, DISTRIBUTION STATEMENT "A" IS TO BE ENTERED

DATA REQUIREMENTS IN MILITARY SPECIFICATIONS AND STANDARDS

SUBMITTAL OF SPECIFICATIONS, STANDARDS, AND DID'S TO DASD(PR)-TD&MD

- SPECIFICATIONS AND STANDARDS REQUIRING PREPARATION OF DATA AND WHICH CITE NEW DID(S) PREPARED BY THE PA CONCURRENTLY WITH THE SPECIFICATION OR STANDARD
- AFTER COORDINATION WITH REQUIRED ACTIVITIES, IN ACCORDANCE WITH DOD 4120.3-M, PA SUBMITS COPY OF SPECIFICATION OR STANDARD, ORIGINAL (CAMERA READY COPY) OF DID(S), AND ONE COPY OF DID(S) REPRESENTING FINAL VERSION, THROUGH THE SERVICE/AGENCY DATA MANAGEMENT FOCAL POINT, TO DASD(PR)-TD&MD FOR CLEARANCE AND ASSIGNMENT OF AMSC AND DID NUMBERS
- IF DOCUMENT(S) IS(ARE) NOT ACCEPTABLE, DASD(PR)-TD&MD FORWARDS LETTER TO PA, THROUGH DATA MANAGEMENT FOCAL POINT AS APPROPRIATE, INDICATING REQUIRED CORRECTIONS
- 30-DAY TURAROUND GOAL FOR FIRST SUBMITTALS AND 2-WEEK TURNAROUND GOAL FOR RESUBMITTALS

DATA REQUIREMENTS IN MILITARY SPECIFICATIONS AND STANDARDS

SUBMITTAL OF SPECIFICATIONS, STANDARDS, AND DID'S TO DASD(PR)-TD&MD

- SPECIFICATIONS AND STANDARDS WITH NO DATA PREPARATION OR RECORD KEEPING REQUIREMENTS
- ANNOTATE "AMSC N/A" IN BOTTOM LEFT CORNER OF FIRST PAGE OF MANUSCRIPT SUBMITTED FOR PRINTING--DO NOT SUBMIT TO DASD(PR)-TD&MD
- SPECIFICATIONS AND STANDARDS REQUIRING PREPARATION OF DATA AND WHICH CITE EXISTING CLEARED DIL'S ONLY IN SECTION 6; AND SPECIFICATIONS AND STANDARDS WITH RECORD KEEPING REQUIREMENTS
- AFTER COORDINATION WITH REQUIRED ACTIVITIES, IN ACCORDANCE WITH DOD 4120.3-M, PREPARING ACTIVITY (PA) SUBMITS COPY OF DOCUMENT REPRESENTING FINAL VERSION TO DASD(PR)-TD&MD FOR CLEARANCE AND ASSIGNMENT OF AMSC NUMBER

TDMD POINTS OF CONTACT :

**MR. DONALD LANGKAMP (POLICY)
MRS. DOROTHY WRIGHT (AMSDL & DIDS)**

**DASD (PR) TDMD
5203 LEESBURG PIKE
SUITE 1401
FALLS CHURCH, VA 22041-3466
(703) 756-2554 OR AV 289-2554**

Recommended Training

Course Title : Defense Specification Management

Course Number : 8D-F1 (Source : DoD 5010.16-C)

Location : U.S. Army Logistics Management College
Fort Lee, VA

Course Instructor : Mr. Rae Walker

Telephone : Commercial 804 / 734-1047
AUTVON 687-1047

Course Dates : 03 Jun 1991 - Philadelphia VA
21 Oct 1991 - Springfield, VA
16 Sep 1991 - Ft. Lee, VA
06 Jan 1992 - Ft. Lee, VA
09 Mar 1992 - Ft. Lee, Va

TUTORIAL S-4

HOW TO WRITE A COMMERCIAL ITEM DESCRIPTION

REFEAT SESSION OF TUTORIAL S-1. REFER TO S-1.

TUTORIAL S-5

ROLES OF STANDARDIZATION MANAGEMENT ACTIVITIES

RAE WALKER, ARMY LOGISTICS MANAGEMENT COLLEGE



TUTORIAL S-5

DIFFERENT ROLES OF STANDARDIZATION MANAGEMENT ACTIVITIES

STANDARDIZATION MANAGEMENT ACTIVITY (SMA)

- LEAD STANDARDIZATION ACTIVITY
(ASSIGNEE/LEAD SERVICE ACTIVITY)
- PREPARING ACTIVITY
- MILITARY COORDINATING ACTIVITY
- PARTICIPATING ACTIVITY
- CUSTODIAN
- REVIEW
- USER
- AGENT
- ITEM REDUCTION STUDY PREPARING ACTIVITY
AND CONSULTANT TO THE COMMANDER
ON PRODUCT STANDARDIZATION

THE ROLE OF THE LSA

- LSA RESPONSIBILITIES
- PURPOSE OF PROGRAM PLAN
- PRIORITIES/FREQUENCY CODES
- APPROVAL OF PROGRAM PLANS
- FORMAT/STRUCTURE OF PROGRAM PLANS

LEAD STANDARDIZATION ACTIVITY (LSA)

THE ACTIVITY RESPONSIBLE FOR THE DEVELOPMENT,
PREPARATION, AND IMPLEMENTATION OF A PROGRAM PLAN
AND FOR STANDARDIZATION IN AN AREA OR FEDERAL
SUPPLY CLASS, AS DELEGATED BY THE COGNIZANT
DEPARTMENTAL STANDARDIZATION OFFICE

LEAD STANDARDIZATION ACTIVITY RESPONSIBILITIES

- DOCUMENT ENTRY CONTROL THROUGH ASSIGNMENT OF PROJECT NUMBERS
CHALLENGE FILED FOR STANDARDIZATION DOCUMENT IF ITEM APPEARS COMMERICAL. WHAT IS THE POTENTIAL FOR A NGS OR CID
COULD EXISTING MIL OILED DOCUMENT BE MODIFIED TO MEET NEED OF MILITARY STYLE OR STD SHOULD BE LAST OPTION
- PREPARE S PROGRAMS PLANS
IDENTIFY STANDARDIZATION PROBLEMS & OPPORTUNITIES
PLAN FOR FUTURE EFFORTS IN NGS, CIDS, METRIC, ELIMINATION OF HAZARDOUS MATERIALS, ETC
- SERVE AS MEDIATOR IN STANDARDIZATION DISPUTES

PURPOSE OF PROGRAM PLAN

- MANAGEMENT TOOL FOR DECISION MAKING AT ALL LEVELS WITHIN DOD
- OUTLINES ACTIVITIES NECESSARY TO ACHIEVE STANDARDIZATION IN ASSIGNED AREAS, FSCs OR FSGs
- IDENTIFY STANDARDIZATION PROBLEMS
- BLUEPRINT FOR THE FUTURE

PRIORITIES FREQUENCY CODES

HIGH (PRIORITY 1) FREQUENCY CODE 2
MEDIUM (PRIORITY 2) FREQUENCY CODE 5
LOW (PRIORITY 3) FREQUENCY CODE 0

APPROVAL / SIGNATURE LEVEL OF PROGRAM PLANS

PRIORITY 1 - SPD, MMD
PRIORITY 2 - DEPSO
PRIORITY 3 - DEPSO

DEPARTMENT OF DEFENSE
STANDARDIZATION
PROGRAM PLAN

SOLDERING

REVISION 3



FISCAL YEARS: FY 90 - FY 94
APPROVED: MAY 19, 1989
LEAD STANDARDIZATION ACTIVITY: DEFENSE QUALITY AND STANDARDIZATION
OFFICE (DQSO)

DISTRIBUTION STATEMENT A. Approved for public release; distribution unlimited.

AMSC N/A

AREA-SOLD

Soldering Standardization Area (SOLD) Program Plan
Revision 3

The Soldering Standardization Area (SOLD) Program Plan is approved for implementation and execution within the Department of Defense (DoD). A primary goal of this plan is to establish DoD objectives in the SOLD area and provide a management tool for decision making at all levels within DoD.

Responsibility and authority for the development and coordination of this plan is assigned to the Office of Secretary of Defense, Defense Quality and Standardization Office. This activity is responsible for implementation and continued management of the SOLD area. It is the responsibility of each identified DoD activity to support the implementation of this plan and provide the resources necessary to complete the identified tasks within the software schedule of the plan, or under the auspices of the Defense Standardization Program (DSP).

Approved:

19 MAY 1989

Date

[Signature]
Greg Brinkley
Acting Director
Standardization and Quality
Management

Point of Contact:

Point of Contact:

1001 Hqs. 2250 or Autovon 225 2250

Telephone

SOLD Program Plan
Revision 3

DoD Standardization Activity

DQSO (SO)

Director:
Defense Quality and Standardization Office
ATTN: Standardization Division
1203 Llewellyn Place, Suite 1403
Falls Church, VA 22041-3400

Point of Contact: Mr. Eula L. Speed
Program Plan Manager
Telephone: (703) 756-2345 or AV 239-2345

Performance Activities

Army (AC)

Commander:
U.S. Army Missile Command
ATTN: AMSM/RD SE TO ST
Redstone Arsenal, AL 35898-5270

Telephone: (205) 974-1335 or Autovon 746-1335

Naval (AS)

Commanding Officer:
Naval Air Engineering Center
Systems Engineering and Standardization
Department (SESD) Code 21
Langston, VA 22073-5100

Point of Contact: Mr. C. Mead
Telephone: (703) 325-2328 or Autovon 624-2328

Air Force (AF)

Aeronautical Systems Division, AFSC
Standardization Division
ASD/ENCS
Wright-Patterson AFB, OH 45433-6111

Telephone: (513) 235-6295 or Autovon 785-6295

SOLD Program Plan
Revision 3

Non-government Standards Bodies

American Welding Society (AWS)
550 N.W. LeJeune Rd.
Miami, FL 33132

Point of Contact: Dr. Gus Ziegenfuss
Telephone: (800) 443-9333

Electronic Industries Association (EIA)
Liaison Guidance and Control Systems Division
5500 Canoga Avenue, M.S. 77
Woodland Hills, CA 91367

Point of Contact: Dr. Robert Hoover
Telephone: (818) 615-2867

Association for Interconnection and Packaging Electronic Circuits (AIPC)
7380 North Lincoln Avenue
Lincolnwood, IL 60466

Point of Contact: Mr. Dieter W. Bertram
Telephone: (312) 677-2810

CONTENTS

EXECUTIVE SUMMARY AND SCOPE.....	APPENDICES
I. Purpose.....	
II. Scope.....	
III. Standardization Documents in SOLD.....	
OBJECTIVES PLANS.....	
I. DoD Activities.....	
II. Non-government Activities.....	
PROBLEMS OF THE AREA.....	
I. Total Quality Management.....	
II. Automated Inspection.....	
III. Certification.....	
IV. Airframe Aging Technologies.....	
V. Surface Mount Devices.....	
PROPOSED ACTIONS.....	
I. Total Quality Management Demonstration.....	
II. Evaluation of Automated Inspection.....	
III. DOD STD 2000 Certification Board.....	
IV. EIA Soldering Technology Committee.....	
V. Surface Mount Technology (SMT) Requirements.....	
ONGOING PROJECTS.....	
PLANNED PROJECTS.....	
SPECIAL CONSIDERATIONS.....	
I. Non-government Standard Activities.....	
II. Overage Documents.....	
III. Metrics.....	
IV. International Standardization.....	
V. Engineering Support.....	

CONTENTS (Continued)

APPENDICES

Appendix A	History Government Standardization Activities.....	
Appendix B	Standardization Documents.....	
Appendix C	Introduction.....	

PREPARING ACTIVITY

THE MILITARY ACTIVITY OR THE FEDERAL CIVIL AGENCY
(FOR FEDERAL DOCUMENT ONLY) RESPONSIBLE FOR
PREPARATION AND MAINTENANCE OF STANDARDIZATION
DOCUMENTS OR THE CONDUCT OF STUDY PROJECTS

MILITARY COORDINATING ACTIVITY

THE MILITARY ACTIVITY RESPONSIBLE FOR COORDINATING,
RECONCILING AND COLLATING THE MILITARY COMMENTS FOR
THE DOD ON A FEDERAL STANDARDIZATION DOCUMENT PREPARED
BY A FEDERAL CIVIL AGENCY UNDER AN ESTABLISHED PROJECT
MILITARY COORDINATING ACTIVITY ALSO IDENTIFIES THE MILITARY
ACTIVITY RESPONSIBLE FOR COORDINATION OF A NON-GOVERNMENT
STANDARDIZATION DOCUMENT IN THE DOD

PARTICIPATING ACTIVITY

THE ACTIVITY DESIGNATED BY ITS DEPSO TO REPRESENT THE DEPARTMENT/AGENCY IN A COLLABORATIVE STANDARDIZATION EFFORT USUALLY FOR THE PURPOSE OF PLANNING WITHIN A FSC OR AN AREA

CUSTODIAN

THE ACTIVITY RESPONSIBLE FOR COORDINATION AND THE SUBSEQUENT DEVELOPMENT OF A CONSOLIDATED POSITION OF STANDARDIZATION PROJECTS WITHIN ITS OWN DEPARTMENT/ AGENCY.

REVIEW ACTIVITY

AN ACTIVITY HAVING AN ESSENTIAL TECHNICAL INTEREST IN THE STANDARDIZATION DOCUMENT, THUS REQUIRING A REVIEW OF ALL PROPOSED ACTIONS AFFECTING IT

USER ACTIVITY

AN ACTIVITY USING A STANDARDIZATION DOCUMENT BUT WHOSE INTEREST IS NOT SUFFICIENT TO REQUIRE ACTIVE PARTICIPATION IN THE COORDINATION OF THE DOCUMENT

AGENT

AN ACTIVITY CONDUCTED AND BY AUTHORITY OF THE PREPARING ACTIVITY IN THE PREPARATION OF STANDARDIZATION DOCUMENTS, PERFORMANCE OF STUDY PROJECTS, AND ADMINISTRATION OF ONE OF THE PREPARING ACTIVITY HOWEVER, RELATIVE RESPONSIBILITY AND APPROVAL AUTHORITY FOR THE WORK ACCOMPLISHED

ITEM REDUCTION STUDY

THE DETERMINATION OF UNNEEDED ITEMS CURRENTLY IN THE SUPPLY SYSTEM. THIS INVOLVES A SUPPLY TECHNICAL REVIEW OF DUPLICATING, OVERLAPPING ITEMS. IT LEADS TO REDUCTION IN A NUMBER OF SIMILAR ITEMS

WORKFLOW COORDINATED STANDARDIZATION PROJECTS

- 1 USA FOR PROJECT
- 2 PROJECT # ASSIGNED
- 3 PA INITIATES PROJECT OR SCHEDULES PROJECT
- 4 PROJECT IN COORDINATION
- 5 COMMENTS SUBMITTED
- 6 RESOLVES COMMENTS, COMPLETES PROJECT, SUBMITS STDZN ACCOM

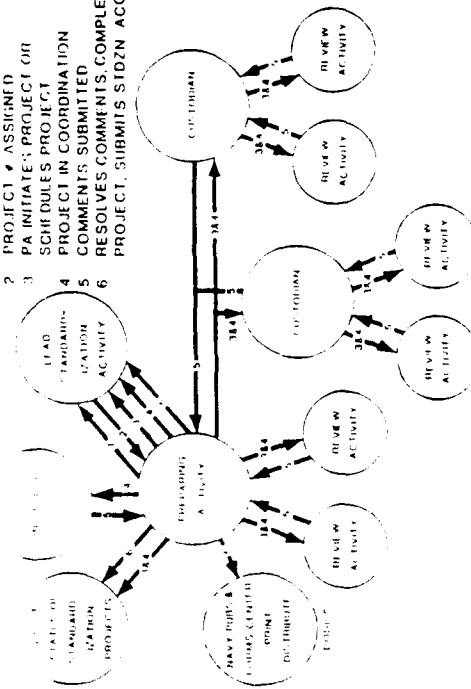

Mr. Raenord B. Walker
U.S. Army Logistics Management College
ATTN: AMXMC-ACM-MA
Fort Lee, VA 23801-6048

AUTOVON 687-4592
COMMERCIAL (804) 734-4592

TUTORIAL S-6

TAILORING OF SPECIFICATIONS AND STANDARDS

**STEVE LOWELL, OFFICE OF THE ASSISTANT SECRETARY OF
DEFENSE (PRODUCTION AND LOGISTICS), STANDARDIZATION
PROGRAM DIVISION**

TAILORING OF SPECIFICATIONS AND STANDARDS



TUTORIAL PURPOSE

- o TO PROVIDE TAILORING INSTRUCTION USEFUL TO SPEC WRITERS/EDITORS WHEN DRAFTING A MILITARY SPECIFICATION OR STANDARD**
- o THE TUTORIAL DOES NOT COVER THE BROADER PRINCIPLES OF ACQUISITION STREAMLINING, OR TAILORING OF DATA ITEM DESCRIPTIONS, STATEMENTS OF WORK, OR CONTRACT LANGUAGE.**

TAILORING DEFINED

**EVALUATION OF SELECTED REQUIREMENTS AND
MODIFICATION OF THESE REQUIREMENTS TO ENSURE THAT
EACH CONTRIBUTES TO AN EFFECTIVE BALANCE BETWEEN
NEED AND COST**

TAILORING TECHNIQUES

- EXTRACTING REQUIREMENTS**
- LIMITING REQUIREMENTS**
- REWRITING REQUIREMENTS**
- ELIMINATING REQUIREMENTS**
- SECTIONALIZING STANDARDS**

EXTRACTING REQUIREMENTS

- **IF A REQUIREMENT IS NOT TOO LONG OR COMPLICATED, IT IS USUALLY BETTER TO EXTRACT IT RATHER THAN REFERENCE ANOTHER DOCUMENT OR PORTION OF ANOTHER DOCUMENT.**

EXTRACTING REQUIREMENTS

- o EXAMPLE: A SPECIFICATION CONTAINS THE FOLLOWING REQUIREMENT:

"MIXING WATER. THE MIXING WATER SHALL CONFORM TO THE REQUIREMENTS OF ASTM C 94."

ASTM C 94 REQUIREMENT READS: "THE MIXING WATER SHALL BE CLEAR AND APPARENTLY CLEAN. IF IT CONTAINS QUANTITIES OF SUBSTANCES WHICH DISCOLOR IT OR MAKE IT SMELL OR TASTE UNUSUAL OR OBJECTIONABLE OR CAUSE SUSPICION, IT SHALL NOT BE USED UNLESS SERVICE RECORDS OF CONCRETE MADE WITH IT OR OTHER INFORMATION INDICATES THAT IT IS NOT INJURIOUS TO THE QUALITY OF THE CONCRETE."

LIMITING APPLICABILITY OF REFERENCED DOCUMENTS

- ONLY RARELY SHOULD A DOCUMENT BE REFERENCED IN TOTAL WITHOUT ANY LIMITATIONS ON THE APPLICABLE REQUIREMENTS.**
- EXAMPLE: "THE UNIT SHALL BE TESTED IN ACCORDANCE WITH MIL-STD-810." (MIL-STD-810 HAS MANY TESTS. IT IS INCONCEIVABLE THAT THEY WOULD ALL BE APPLICABLE.)**
- EXAMPLE: "THE REQUIREMENTS SPECIFIED IN MIL-E-5400 ARE APPLICABLE AS REQUIREMENTS OF THIS SPECIFICATION." (MIL-E-5400 IS A 71 PAGE GENERAL REQUIREMENTS DOCUMENT)**

LIMITING APPLICABILITY OF REFERENCED DOCUMENTS

- o THE FOLLOWING EXAMPLE CAME FROM ONE SPEC:

"ZINC PART AND ZINC-PLATED PARTS SHALL BE TREATED IN ACCORDANCE WITH QQ-Z-325." (QQ-Z-325 HAS MANY DIFFERENT TYPES & CLASSES)

"EXTERNAL VOLTMETER RESISTORS SHALL BE IN ACCORDANCE WITH MIL-R-39005." (MIL-R-39005 HAS MANY DIFFERENT TYPES WITH DIFFERENT RESISTANCE VALUES, FAILURE RATES, ETC.)

"ALUMINUM ALLOYS SHALL BE ANODIZED IN ACCORDANCE WITH MIL-A-8625 OR BE GIVEN A CHEMICAL TREATMENT IN ACCORDANCE WITH MIL-C-5541." (MIL-A-8625 HAS DIFFERENT TYPES AND CLASSES AND MIL-C-5541 HAS DIFFERENT CLASSES.)

REWRITING REQUIREMENTS

- **WHAT IS THE REAL REQUIREMENT?**
- **CHALLENGE REQUIREMENTS**
- **STATE WHAT THE REQUIREMENT IS, NOT HOW TO ACHIEVE THE REQUIREMENT**

EXAMPLES OF REQUIREMENTS THAT NEED TO BE REWRITTEN

- "EACH EXTINGUISHER SHALL BE PROVIDED WITH A METAL CLIP OR BRACKET TO HOLD THE DISCHARGE HORN WHEN NOT IN USE."

REWRITE: "THE NAMEPLATE BAND SHALL INCLUDE A CLIP TO HOLD THE DISCHARGE HORN WHEN NOT IN USE."

- "THE DISCHARGE HORN SHALL BE CONICAL IN SHAPE."

REWRITE: "DISCHARGE HORN SHALL BE CONICAL, CYLINDRICAL, OR ANY OTHER COMMERCIALY ACCEPTABLE SHAPE."

EXAMPLES OF REQUIREMENTS THAT NEED TO BE REWRITTEN

- "THE MISSILE TRANSPORT SHALL BE CAPABLE OF ACHIEVING A HIGHWAY SPEED OF 55 MPH FULLY LOADED IN 11 MPH HEAD WIND."

REWRITE: "THE MISSILE TRANSPORT SHALL BE CAPABLE OF ACHIEVING A HIGHWAY SPEED OF 50 MPH."

EXAMPLES OF REQUIREMENTS THAT NEED TO BE REWRITTEN

- "THE ANTENNA SHALL BE PROVIDED WITH A LIGHTNING ARRESTER, DESIGNED IN ACCORDANCE WITH MIL-A-9094."

REWRITE: "IF REQUIRED BY THE DETAIL SPECIFICATION, LIGHTNING PROTECTION SHALL BE INCORPORATED IN THE ANTENNA OR ANTENNA COUPLER."

EXAMPLES OF REQUIREMENTS THAT NEED TO BE REWRITTEN

- o "PLASTIC MATERIALS USED IN THE FABRICATION OF ANY PART OF THE ANTENNA SHALL MEET THE RESISTANCE TO RAIN EROSION REQUIREMENTS OF MIL-R-7094 OR ALL EXTERIOR PLASTIC PARTS SHALL BE PROTECTED WITH AN EROSION RESISTANT MATERIAL SO THAT THE COMBINATION SHALL MEET THE REQUIREMENTS OF MIL-P-7094 AND MIL-P-8013."

REWRITE: "THE RAIN TEST SHALL BE IN ACCORDANCE WITH MIL-STD-810, METHOD 506."

EXAMPLES OF REQUIREMENTS THAT NEED TO BE REWRITTEN

- "CEMENT SHALL CONFORM TO THE REQUIREMENT IN
ASTM C 94."

REWRITE: "CEMENT SHALL CONFORM TO ASTM C 150 OR ASTM
C 595, AS SPECIFIED IN THE CONTRACT OR ORDER (SEE
6.2)."

ALTERNATIVE REWRITE: "CEMENT SHALL CONFORM TO ASTM C
150."

ELIMINATING REQUIREMENTS

- IF A REQUIREMENT IS SO OPEN ENDED, AMBIGUOUS, GENERAL, OR CONFUSING, IT MAY BE BETTER TO ELIMINATE RATHER THAN REWRITE. THE FOLLOWING ARE SOME EXAMPLES:

"THE WORKMANSHIP SHALL BE FIRST CLASS IN EVERY RESPECT."

"THE REQUIREMENTS SPECIFIED IN MIL-E-5400 ARE APPLICABLE AS REQUIREMENTS OF THIS SPECIFICATION."

"WHEREVER PERIODIC MAINTENANCE, INSPECTION OR CLEANING IS TO BE CARRIED OUT, THE DETAILED REQUIREMENTS OF THIS SPECIFICATION SHALL BE CONTINGENT UPON FAITHFUL ACCOMPLISHMENT OF SUCH TASKS AND THE NATURE AND INTERVALS FOR SUCH MAINTENANCE SHALL BE STATED AS PART OF THE SECTION WHICH DESCRIBES EACH SUCH DEVICE REQUIRING THIS SERVICE."

SECTIONALIZING STANDARDS

- TRY TO ARRANGE REQUIREMENTS INTO INDEPENDENT SECTIONS OR COHERENT GROUPS TO MAKE CITING OF EXACT REQUIREMENT EASY
- GOOD EXAMPLES OF SECTIONALIZED STANDARDS INCLUDE:
 - MIL-STD-454 (DIVIDED INTO 75 REQUIREMENTS)
 - MIL-STD-810 (DIVIDED INTO METHODS)
 - MIL-STD-1388-1 (DIVIDED INTO TASKS)

PROVIDE INFORMATION TO USER ON HOW TO TAILOR STANDARD

- **MIL-STD-1388-1 AND MIL-STD-1388-2 INSTRUCT THE USER TO TAILOR REQUIREMENTS AND PROVIDE GREAT DETAIL ON HOW TO TAILOR**
- **MIL-STD-810 REQUIRES TAILORING AND GIVES SIMPLE INSTRUCTIONS**

USEFUL TAILORING GUIDES

- MIL-HDBK-248, "ACQUISITION STREAMLINING" (PRIMARYLY SEE APPENDIX A)
- MIL-HDBK-800, "DOCUMENTATION STREAMLINING"

RESULTS OF NOT TAILORING REQUIREMENTS

- UNNECESSARY COSTS**
- REDUCED QUALITY**
- COMPLIANCE IS DIFFICULT OR IMPOSSIBLE**
- GOVERNMENT CITES REQUIREMENTS IT HAS NEVER READ**
- DISRESPECT FOR ALL REQUIREMENTS**
- IMPORTANT REQUIREMENTS BECOME LOST**

TUTORIAL D-1

HOW TO WRITE A DATA ITEM DESCRIPTION

**BRENDA STANLEY, HEADQUARTERS, AIR FORCE LOGISTICS
COMMAND**

DATA ITEM DESCRIPTION		FORM APPROVED OSM NO. 0707-0108	
1. NAME		2. RESPONSIBLE NUMBER	
3. DESCRIPTION/PURPOSE			
4. APPROVAL DATE FPO/MS	5. CASE OFFICER/ASSIGNMENT OFFICER	6. FPO/MS/AFSC/AFSC/AFSC	7. DESIG/AFSC/AFSC
PREPARING DATA ITEM DESCRIPTIONS			
8. APPROVAL LOCATION	9. APPLICABLE FORMS	10. ASST NUMBER	
11. FEEDBACK INSTRUCTIONS			
12. DISTRIBUTION PLAN/STAMP			
13. FORM NO. AND DATE		14. FORM NO. AND DATE	

TUTORIAL PRESENTED BY: BRENDA STANLEY, HQ AFLC/ENCP

PROBLEM-SOLVING TECHNIQUE

- IDENTIFY CUSTOMER REQUIREMENTS
- ANALYZE THE PROBLEMS
- ANALYZE POSSIBLE SOLUTIONS
- SELECT THE BEST
- IMPLEMENT THE SOLUTIONS
- EVALUATE THE SOLUTIONS

DID ADMINISTRATIVE PROCESS FLOWCHART

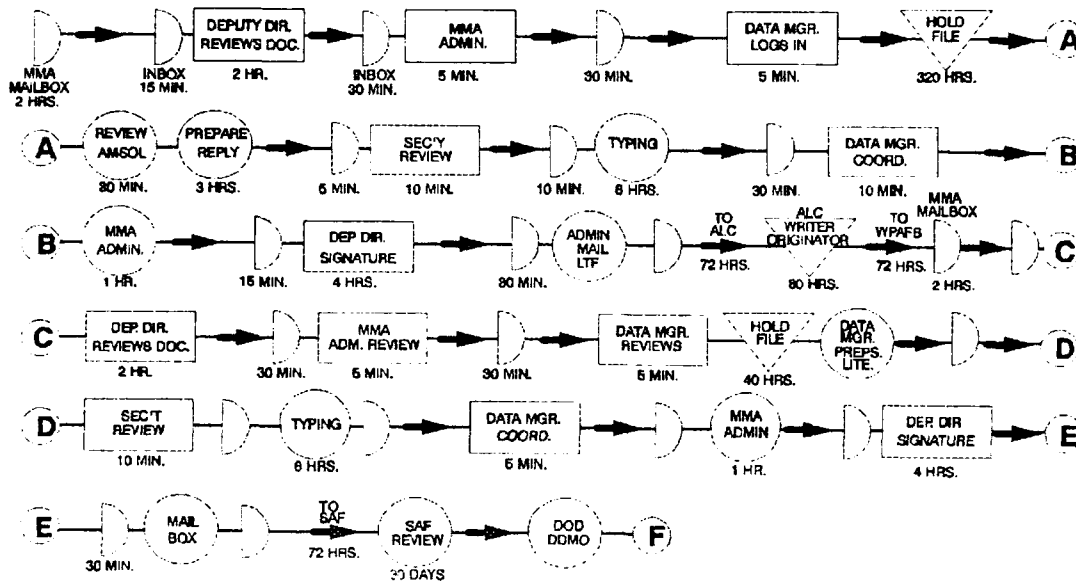

DID ADMINISTRATIVE PROCESS FLOWCHART

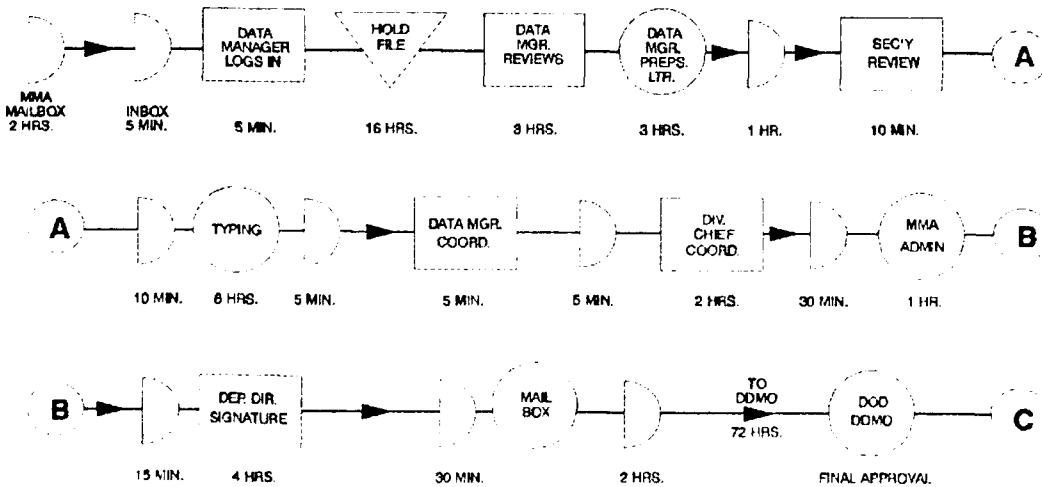

DID REVIEW AND APPROVAL PROCESS FLOW CHART

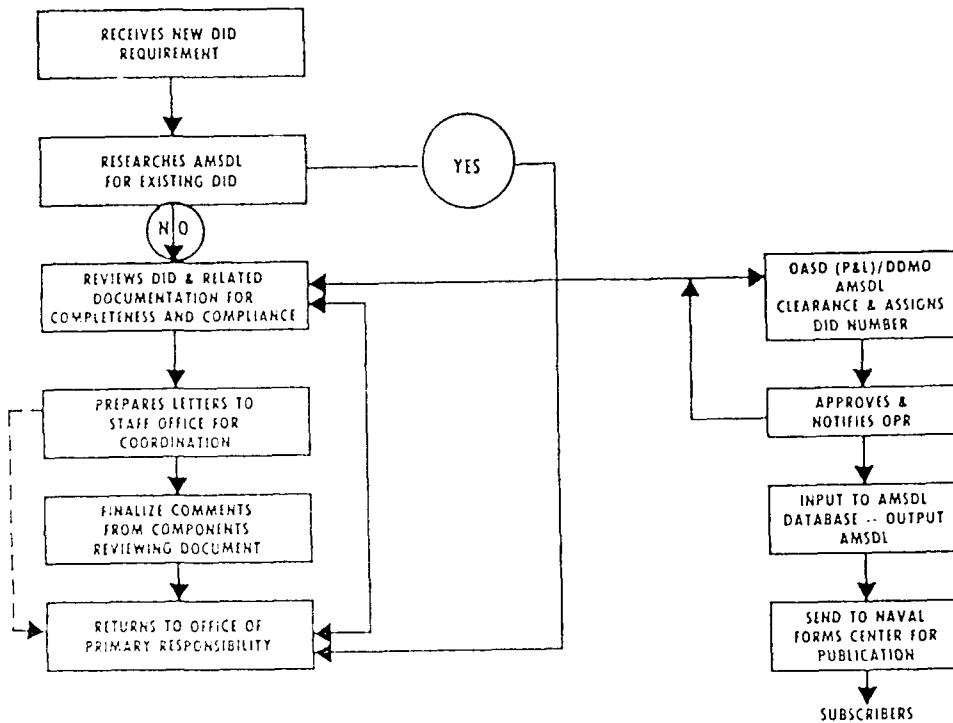

DID PROCESS IMPROVEMENTS

DID OPR RESPONSIBLE FOR QUALITY

DID OPR CERTIFIES QUALITY

DID OPR RESPONSIBLE FOR COORDINATION
WITH USERS AND SOURCE DOCUMENT OPRS

**INSTRUCTIONS FOR PREPARATION
OF DIDS**

Keyword

Acronyms Spelled Out

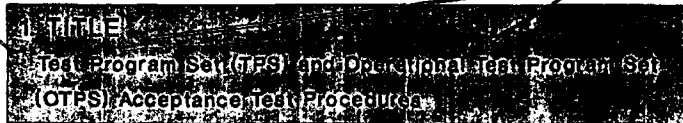

Direct Reading Method

- CLEARLY DEFINED, MEANINGFUL DATA PRODUCT
- LIMITED TO 130 SPACES

**INSTRUCTIONS FOR PREPARATION
OF DIDS (CONT'D)**

Number Assigned by DQSO

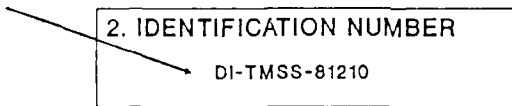

- TYPE I & II STANDARD DIDS

Block of #s Assigned by

*Command Data
Mgmt Officer*

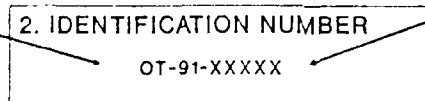

Actual Number Assigned by

*Subcommand Data
Mgmt Officer*

- TYPE III ONE-TIME DIDS
- ONE-TIME USE ONLY

**ONE-TIME DID NUMBER
ASSIGNMENT**

10000 - ARMY
20000 - NAVY
30000 - AIR FORCE
40000 - DEFENSE INTELLIGENCE AGENCY
45000 - MARINE CORP
50000 - DEFENSE COMMUNICATIONS AGENCY
55000 - DEFENSE MAPPING AGENCY
60000 - DEFENSE NUCLEAR AGENCY
65000 - DEFENSE LOGISTICS AGENCY
70000 - NATIONAL SECURITY AGENCY
75000 - NOT ASSIGNED

**INSTRUCTIONS FOR PREPARATION
OF DIDS (CONT'D)**

A Short Description - What Is the Data?

3. DESCRIPTION/PURPOSE

3.1 This plan describes the contractor's maintainability program, how it will be conducted, and the controls and monitoring provisions levied on subcontractors and vendors. The principal use is to provide the contracting activity a basis for review and evaluation of the maintainability program and its proposed components.

Who and What Is the Data For?

- A CLEAR, CONCISE DESCRIPTION OF THE DATA
- WHAT THE DATA IS USED FOR
- WHO USES THE DATA
- AIDS THE GOVERNMENT IN SELECTING DIDS

**INSTRUCTIONS FOR PREPARATION
OF DIDS (CONT'D)**

Assigned by DQSO

4. APPROVAL DATE YYMMDD	6. OFFICE OF PRIMARY RESPONSIBILITY (OPR) 16 or F/AFLC-ENCP
-----------------------------------	---

Use SD-1 Code if Preparer of Source Document
 Use Component & Organization Codes if NOT Preparer of Source Document or DID is a Type II (SOW Is Source)

- AIDS IN REVIEW AND UPDATE OF DIDS
- DIDS SHOULD BE UPDATED AT LEAST EVERY 10 YEARS

**INSTRUCTIONS FOR PREPARATION
OF DIDS (CONT'D)**

6a. DTIC APPLICABLE <input checked="" type="checkbox"/>	6b. GIDEP APPLICABLE <input type="checkbox"/>
---	---

Copies Required by DTIC

- DTIC REQUIRES COPIES OF R&D REPORTS
- GIDEP COPIES, WHEN CONTRACT SPECIFIES
- IF DTIC/GIDEP COPIES REQUIRED, INCLUDE ADDRESSES IN BLOCK 7
- AIDS GOVERNMENT IN PREPARING CDRL

INSTRUCTIONS FOR PREPARATION OF DIDS (CONT'D)

Source Document

Bollorplate Paragraph for Type I DID

7. APPLICATION/INTERRELATIONSHIP
 7.1 This Data Item Description (DID) contains the format and content preparation instructions for data resulting from the work task described by 4.5.1 of MIL-STD-810D
 7.2 This DID is applicable to equipment environmental tests which include design evaluation tests, operational worthiness tests, and qualification tests.
 7.3 This DID supersedes DI-T-5143A and UDI-T-20486.

Interrelationship Paragraph

Application Paragraph

- BLOCK 7 FOR A TYPICAL TYPE I DID
- CITES PARAGRAPH AND NUMBER OF SOURCE DOCUMENT
- COORDINATE WITH SOURCE DOCUMENT OPR

INSTRUCTIONS FOR PREPARATION OF DIDS (CONT'D)

8. APPROVAL LIMITATION	9a. APPLICABLE FORMS AF 858	9b. AMSC NUMBER
------------------------	--------------------------------	-----------------

Mandatory Forms

Assigned by DQCO

- TYPE I & II DIDS
- FORMS CITED IN DID MUST:
 - ● BE NUMBERED
 - ● INCLUDE ADN
 - ● INCLUDE OMB CLEARANCE NUMBER
 - ● BE COORDINATED WITH FORM'S OPR

INSTRUCTIONS FOR PREPARATION OF DIDS (CONT'D)

Boilerplate Paragraph for a Type II DID

7. APPLICATION/INTERRELATIONSHIP

7.1 This Data Item Description (DID) contains the format and content preparation instructions for the data product generated by the specific and discrete task requirement as delineated in the contract.

7.2 This DID is applicable in any contracts where vehicle maintenance and repairs are required.

7.3 This DID supersedes DI-A-1022C.

Interrelationship Paragraph

Application Paragraph

- BLOCK 7 FOR A TYPICAL TYPE II DID
- CITES CONTRACT (SOW) AS A SOURCE DOCUMENT
- REFERENCE IN SOW TASKING PARAGRAPH

INSTRUCTIONS FOR PREPARATION OF DIDS (CONT'D)

Boilerplate Paragraph for a Type III DID

7. APPLICATION/INTERRELATIONSHIP

7.1 This Data Item Description (DID) contains the format and content preparation instructions for the data product generated by the specific and discrete task requirement as delineated in the contract.

7.2 This DID is for one-time use for solicitation N0012-90-1-3456.

Boilerplate Application Paragraph

- BLOCK 7 FOR A TYPICAL TYPE III DID
- CITES CONTRACT (SOW) AS A SOURCE DOCUMENT
- APPLIED TO SINGLE CONTRACT WHEN EXISTING DID WON'T WORK - LAST RESORT

**INSTRUCTIONS FOR PREPARATION
OF DIDS (CONT'D)**

8. APPROVAL LIMITATION N00012-90-1-3456 <i>Solicitation Number</i>	9a. APPLICABLE FORMS <i>Normally Blank</i>	9b. AMSC NUMBER <i>Left Blank</i>
---	--	---

- TYPE III DIDS
- FORMS SHOULDN'T BE USED IN TYPE III DIDS

**INSTRUCTIONS FOR PREPARATION
OF DIDS (CONT'D)**

Underlined Headers *Mandatory Paragraph for Type I DID*

10. PREPARATION INSTRUCTIONS

10.1 Reference documents. The applicable issue of the documents cited herein, including their approval dates and dates of any applicable amendments, notices, and revisions, shall be as specified in the contract.

10.2 Format. Contractor format is acceptable. *Source Paragraph*

10.3 Content. The report shall include all the information required by paragraph 103.2 of MIL-STD-470 which consists of: *Source Document*

10.3.1 Work accomplished. The work accomplished and results obtained on each task defined by the contractor's approved program plan.

10.3.2 Problems. A list of current problems containing:

a. A serial number assigned to identify the problem.

(Continued on Page 2)

Left Justified *Continuation Page Note*

- BLOCK 10 FOR A TYPICAL TYPE I DID
- CONTRACTUALLY BINDING CONTRACTOR INSTRUCTIONS

INSTRUCTIONS FOR PREPARATION OF DIDS (CONT'D)

Self-contained Instructions

10. PREPARATION INSTRUCTIONS

10.1 Format. Contractor format is acceptable.

10.2 Content. The report shall include the following information:

10.2.1 Work accomplished. The work accomplished and results obtained on each task defined by the contractor's approved program plan.

10.2.2 Problems. A list of current problems containing:

- a. A serial number assigned to identify the problem.
- b. The date on which the problem was first detected.
- c. A short statement of accomplishment to date or a cross-reference to other reports.

(Continued on Page 2)

Left Justified

Continuation Page Note

- BLOCK 10 FOR A TYPICAL TYPE II DID
- CONTRACTUALLY BINDING CONTRACTOR INSTRUCTIONS

INSTRUCTIONS FOR PREPARATION OF DIDS (CONT'D)

Normal Distribution Statement

11. DISTRIBUTION STATEMENT

DISTRIBUTION STATEMENT A. Approved for public release; distribution is unlimited.

DD Form 1664, APR 89

Previous editions are obsolete.

Page ___ of ___ Pages

Only Approved Edition

Current Page Total Pages

- MANDATORY DISTRIBUTION STATEMENT FOR UNCLASSIFIED DIDS WITHOUT PRIOR COORDINATION WITH DQSO
- SUBMITTED DIDS MUST USE PRINTED FORM (OR APPROVED COMPUTER-GENERATED FORM) FOR THE FIRST PAGE

**INSTRUCTIONS FOR PREPARATION
OF DIDS (CONT'D)**

Block 10, Preparation Instructions (Continued)

10.2.2 Monthly report. The format and content of the report shall be similar to the sample format of Figure 1. *Reference*

MONTHLY REPORT OF WATER USE

1. WATER PERMIT NUMBER:
2. NAME OF PERMIT HOLDER:
3. GALLONS USED:
SIGNATURE: _____ DATE: _____

FIGURE 1. Sample monthly report of water use
Roman Numerals

- PLACE BELOW REFERENCE, ON NEXT PAGE, OR AT END OF DID
- PLACE NOTES BELOW FIGURE, ABOVE TITLE

**INSTRUCTIONS FOR PREPARATION
OF DIDS (CONT'D)**

Table Reference

10.2.11 KLLA. Kit 'A' shall primarily contain high mortality repair parts that can be identified in the 'A' column of the test equipment and tool kit listing in TABLE I. *Roman Numerals*

TABLE I. Test equipment and tool kit list

Nomenclature	KIT	A	B1	B2	C
Calibrator-Analyzer, Pneumatic		X	X	X	X
Defibrillator Tester		X			
IV Infusion Pump Analyzer		X	X		
Oscilloscope, Dual Trace, Storage, 50 MHz Limit			X		
Light Meter, Dual Area and Spot Reading w/Attachments		1/	X		X

1/Partially applies *Footnote*

Table Boxed

- IF POSSIBLE, TABLE FOLLOWS FIRST REFERENCE
- IF NOT, PLACE AT END OF TEXT

INSTRUCTIONS FOR PREPARATION OF DIDS (CONT'D)

Same Side, Bottom Margins as First Page

Block 3, Description/Purpose (Continued)

and pertinent vehicle information, describe the deficiency, and assist in determining the proper corrective action for maintenance personnel.

Minimum 1" Margin at Top

Block 10, Preparation Instructions (Continued)

d. The activity assigned to work on the problem.

10.2.4 Action accounting. A specific accounting of each design review action remaining open, and a description of actions taken.

Solid Line Between Blocks

Page 2 of 2 Pages

Even Page Numbering - Bottom Left, Odd - Bottom Right

- CONTINUATION PAGE FORMAT
- USE 8 1/2" X 11" WHITE BOND PAPER

DID PROHIBITIONS

TASKING LANGUAGE
PACKAGING OR DELIVERY INSTRUCTIONS
PERMITS TAILORING UP
ACRONYMNS, ABBREVIATIONS NOT SPELLED OUT
USES CLASSIFIED TITLE
USES NON-VALID SOURCE DOCUMENT
USES FOLDOUTS
USES EXTERNAL DOCUMENTATION
MULTIPLE DATA PRODUCTS

TUTORIAL D-2

MIL-T-31000

**ROLAND HENDERSON, OFFICE OF THE ASSISTANT SECRETARY
OF DEFENSE (PRODUCTION AND LOGISTICS), TECHNICAL DATA
AND MANUFACTURING DIVISION**

MIL-T-31000
General Specification for Technical Data Packages

Good afternoon, ladies and gentlemen. I am Roland Henderson, a technical data management specialist with the Technical Data and Manufacturing Division of the Manufacturing Modernization Directorate within the Office of the Assistant Secretary of Defense for Production and Logistics. Before I start on MIL-T-31000, I would like to give you some idea of what this office is and what it does.

From December 1988 to December 1990 we were known as the Defense Quality and Standardization Office (DQSO). Prior to that we were called the Defense Data Management Office (DDMO), and the Defense Materials Specifications and Standards Office, or DMSSO. Within OSD, this office has the responsibility for the oversight and management of the Defense Standardization Program. The Division, in which I work, has the oversight and management responsibilities for the Configuration Management, Drawing Practices, Engineering Data Reproduction Systems and Technical Manual standardization areas. In addition, we are responsible for management and oversight of DoD's Technical Data Management Program and serve as the AMSDL Clearance Office which approves Data Item Descriptions and source documents for use in acquiring technical data.

Now lets take a look at materiel acquisition strategies and data acquisition tools. On the left we have strategies, such as sole source, competition, break out, leader-follower and teaming to name a few. To support strategies we need varying degrees of technical data. On the right we have some of the tools that we can use to acquire technical data (as well as materiel) such as specifications, data item descriptions, statements of work, contract clauses, standards, etc. Each of these tools has certain functions or roles to play in the acquisition of data and materiel. Since MIL-T-31000 is a specification and has associated data item descriptions, or DIDs, I am going to focus for a moment on these two tools.

Military specifications such as MIL-T-31000 must conform to the requirements of MIL-STD-961, the military standard for preparing specifications. By definition, they are documents that "describe the essential requirements for purchasing materiel." That is they are intended specifically for use in acquisition. One of the key provisions of MIL-STD-961 is that rights in data or the ownership of intellectual property cannot be acquired through the medium of a specification. When a specification defines a data product, it must be accompanied by a DID to define, either directly or by reference, the content and format requirements of that data product. DIDs must

conform to the requirements of MIL-STD-963 the preparation standard for data item descriptions. Like specifications, DIDs cannot be used as the medium for acquiring data rights or ownership of intellectual property. These documents merely what the data is to be like, not who has the right to use it. That has to be defined in the contract in accordance with the Defense Federal Acquisition Regulations.

The first objective in generating this document was to bring together the various of elements of technical data that comprise TDPs into one specification. The second objective of this effort was to begin standardizing the ordering techniques used by the Services and Commands to order data, especially engineering drawings.

For many years now, DoD personnel involved in acquiring technical data have tended to work in "walled cities" so to speak. As a result of the old attitude we often acquired TDPs that contained both gaps and overlaps as shown on the left. This has been particularly true in the drawing world. If you asked drawing people about specifications or software documentation they would with "I don't know! I do drawings." In today's world of increasingly complex technologies and weapons systems, the DoD data manager must look at the various types of technical data with more panoramic perspective. They must learn to select various data products and to cut and fit these products to build a complete TDP without the gaps and overlaps that have traditionally occurred.

To help meet our second objective, we developed standardized ordering forms to be use DoD-wide in ordering drawings and specifications. Until now there have been numerous forms and attachments used to identify engineering drawing requirements in a contract or purchase order. For example, three major Navy systems commands, each have a form for tailoring drawing requirements, yet none of them are the same. Now think about compounding this condition across all the services, agencies, commands, centers and activities and you can readily see that any one service or command would have difficulty in determining what data requirements were imposed by another. If a Government activity has difficulty understanding another activity's data requirements are, imagine the plight of a contractor that has to deal with several Government customers.

At this point lets look at of the background of MIL-T-31000. The push for this document got started about six years ago when the stories about the high costs of spares and repair parts started hitting the headlines across the country. Lack of competition in spares procurement was cited as a major factor in these costs. In turn, a lack of available, adequate technical data was cited as the major obstacle to increased competition. As a result, the Under Secretary of Defense for Research and Engineering chartered an

Executive Steering Group and a supporting working group to review the Defense data management program and to develop improvements for that program. One of the recommendations developed by these groups was that DoD develop a new specification for acquiring technical data. That recommendation was approved by the senior levels of OSD and a commitment to that end was made to Congress as part of DoD's Data Management Improvement Plan. (This plan had been required by the PL 98-525, the Defense Procurement Reform Act of 1984.

About that same time the Army was in the process of revising their limited coordination specification for TDPs, MIL-T-60350A. Since the commitment had been made for a DOD-wide document, the Army effort was expanded to include the other Services and Agencies. This was the origin of the now infamous MIL-T-XXX. After coordination by the Army, MIL-T-XXX was introduced at the Third Data Management Conference sponsored by our office and held in Springfield, Virginia in 1985.

The reaction from the attendees, especially those from the Navy and Air Force, clearly indicated that draft would not be accepted DoD-wide. Following the conference, OSD established an Executive Steering Group for MIL-T-XXX, chaired by OSD and populated by representatives from each of the Services and DLA. After re-coordinating the document throughout DoD and Industry, the Steering Group chartered an Ad Hoc Working Group, also known as the Tiger Team. The tiger team was composed of individuals selected from each of the Services and DLA, and chaired by the Air Force. At that time, I worked for a field activity of the Naval Air Systems Command and was one of the Navy representatives on the tiger team.

In April 1987, they locked us up in San Antonio to resolve the service positions, respond to Industry's comments, and to hammer out a draft acceptable to all of DoD. One of the ground rules was that if a service insisted that they had to have a certain data product, it had to be included. After two weeks, we thought we had a document that everyone could live with. The Preparing Activity finalized the draft and re-circulated it for comment within DoD. When we got the comments back, we found that there still was no consensus on the document. Basically we were right back where we had started.

In the early part of 1988, the Army came to OSD and stated that they had Army-wide concurrence on a TDP specification and requested permission to publish a limited coordination version. This Army version was identified as MIL-T-47500(MI) and its associated slash sheets. OSD allowed the document to be published on the condition that we would still work towards a DoD-wide document and that the Army version would be withdrawn when the DoD version was published. Subsequent to our approval of MIL-T-47500 the Army informed OSD that

they could not continue to support the DoD effort as preparing activity due reductions in budget and personnel. In the mean time, the Navy submitted a hastily prepared draft that was circulated to the Executive Steering Group and members of the tiger team. Again there was no consensus.

Here we were in late 1988 and no closer to a consensus than we were in 1986. At this time that we decided to exercise OSD's authority under the Defense Standardization Program and take the preparing activity responsibilities into OSD. We also decided at this time that there would be no further formal coordinations of the document,

MIL-T-31000 became mandatory for use on new programs - those passing Milestone 1 - on or after 1 July 1990. It replaces DOD-D-1000B and the Army's MIL-T-47500 series of documents. Follow-on procurements under existing programs may continue to use the older documents or convert to MIL-T-31000, whichever makes the most sense. What we are looking for is that acquisition managers used good judgement and common sense. If you have a follow-on procurement you should consider the life cycle phase of the program. If you are near the end of production, don't change just for the sake of changing. However, if you're early in the production phase then it would make sense to develop an efficient and cost effective transition to 31000 because in a few years the older specifications such as 1000 and 47500 will be the aberration instead of the norm. Furthermore, the contractor should be a part of the decision making process in determining whether or not to transition an existing to MIL-T-31000.

Now lets consider the structure and philosophy behind MIL-T-31000. The structure that we decided on is that of a single specification in lieu of a basic specification and several "slash sheets" as had been proposed under MIL-T-XXX. We divided the data products into two broad subject areas, TDP elements and TDP management data products. TDP elements are those data products that actually pertain to the item being documented. They consist of such things and drawings and specification that actually describe the materiel. TDP management data products are those data products that pertain to the development and management of the TDP itself, rather than to the materiel which the TDP represents.

One of the most important things for both Government and Industry personnel to remember about MIL-T-31000 is that it works on a zero based philosophy. By that I mean that no TDP element or TDP management data product is automatically required. There is no automatic tiering of data products. Each and every data product that the Government intends to receive must be actively selected and listed on the DD1423 as a separate CDRL entry. Just because the Government orders a Product drawing package which includes source control

drawings or critical manufacturing processes, it does not mean that the contractor automatically has to prepare source control drawing approval requests or critical manufacturing process descriptions. If the Government wants these items they must be specifically identified on the CDRL.

The TDP elements consist of six types of engineering drawings and associated lists; military and program peculiar specifications; preservation, packaging, packing and marking data; software and software documentation; special inspection equipment support data; and test requirements documents. I'll be going over each of these separately.

This is the first time that I've mentioned special inspection equipment or special tooling. Let me caution you now that for the purposes of MIL-T-31000, the terms SIE and ST have very narrow meanings as compared to their use in DFARS with regards to facilities or Government Furnished Equipment. As used here, the terms refer to that inspection equipment or tooling that is critical, or mandatory, to the successful manufacture of the item. Also, the term Quality Assurance Provisions or QAPs as used here refers to a specific method of documenting certain quality assurance requirements.

These are the six types of engineering drawings and associated lists available under MIL-T-31000. I'll go over each of them separately.

First, there are two types of design drawings, conceptual design and developmental design. These drawings correspond to the level 1 drawings under DOD-D-1000. We all recognize the difference between the two, we order them at different stages of the program, and use them for different purposes. However, if you go back and look at 1000 you will find that it never separates the requirements for each type. In every instance in 1000, the term is "conceptual and developmental design". In MIL-T-31000 we have separated the requirements through separate DID's and worksheets or DD Forms.

The core of most TDPs are what we now call product drawings and associated lists. Product drawings replace both the level 2 and level 3 drawings under 1000. Again, if you look back at 1000 you will find that it goes to great lengths spelling out requirements for level 2 and level 3 drawing packages. Then at the end it says that "unless tailored" they are essentially the same. Under MIL-T-31000, we have combined the two and tied the requirements for design definition to the level of design maturity of the item being documented. After all, that's what the drawings should follow anyway. You can't get ahead of the level of design maturity and you had better not get very far behind it or you're going to have some real problems.

Two new options for product drawings are the Army's QAPs and vendor substantiation data for aerospace propulsion system products. These go back to the basic ground rule at San Antonio that said that if a Service insisted that they needed a data product or type of data, it had to be included. The QAPs are a very restrictive method of specifying inspection techniques for certain types of materiel. The vendor substantiation data relates to qualifying sources of supply for certain components of items such as jet engines.

Commercial drawings are a new type that has been added to enable the Government to obtain engineering drawings to support commercial off-the-shelf items acquired under the Non-developmental item initiatives. The term "commercial item" is defined as it is under the NDI initiatives. No Government requirements are to be imposed on these drawings. They represent whatever the contractor developed to support the item as it was manufactured and marketed. Since the Government cannot impose requirements on these drawings, we caution Government personnel to review the drawings to insure that they will meet the Government's needs prior to contracting for them. The appropriate place for this review to take place is during the decision making process that results in the decision to buy the commercial item. The availability of adequate data to fulfill life cycle support plans should be a key factor in that decision. Finally, commercial drawings are not to be used to document items developed at Government expense nor are they to be used in lieu of specification or source control drawings in systems for which product drawings have been ordered.

Special inspection equipment and special tooling drawings and associated lists are not really new requirements. Remember that these terms are limited to equipment and tooling mandatory to manufacturing the product. These requirements were previously hidden in Level 3 as details of unique or critical manufacturing and inspection requirements. Under Level 3 of 1000, the same design disclosure requirements applied to these drawings as applied to the drawings for the item being documented. What is new is that we have reduced the requirements for SIE and ST drawings as defined in MIL-T-31000. Under 31000, only the essential characteristics of the equipment or tooling as it impacts the product are required. The reason for this is that the equipment or tooling would only be duplicated in an alternate manufacturing environment. In that instance, factors such as production quantities and manufacturing environment differences would have a significant impact.

Most of all, SIE and ST drawings are not intended to document logistics support equipment that is to be deployed to the fleet, field or air wing for maintenance of the weapon system. The Government should be ordering the same of drawings for that type of support equipment as for the item which is being supported.

There are three data products that may be required to support the SIE. They are listed here as SIE operating instructions, descriptive documentation, and calibration procedures. As you will notice there is a lot of duplication between the content requirements in the three DIDs. Therefore it is imperative that the Government data manager tailor these DIDs whenever they are used to eliminate duplicative requirements.

For specifications, MIL-T-31000 refers to the existing standards and DIDs. We did not try to re-invent the wheel. Both military and program peculiar specifications can be ordered, as well as their respective associated documents. (For example: Specification Change Notices). You should not be seeing many requirements for military specifications on weapons systems contracts. However, DoD activities frequently use support contractors to do the actual writing and preparation of military specifications. Under weapons systems contracts, you would see primarily program peculiar specs. The ordering forms really only serve to call the Government data manager's attention to the fact that additional Contract Data Requirements List entries for associated documents may be necessary whenever specifications are ordered.

As with specifications, we relied on existing standards and DIDs for most of the remaining TDP elements. Preservation, packaging, and marking data under MIL-STD-2073-1; software and software documentation under MIL-STD-2167; and test requirements documents under MIL-STDs 1345 and 1519. Under revision A to MIL-T-31000 we will be deleting software from the specification but retaining software documentation. Software is actually materiel the same as the item being documented rather than "data". However, software documentation is in fact data.

Again I want to emphasize that one thing to remember about all of these TDP elements, as well as the TDP data management products is that none of them are automatically imposed in a contract by a requirement for another data product. Each data product must be specifically called out as a CDRL entry item.

The other broad category of subject matter is the TDP management data products. These data products enable the Government to monitor the development and generation of the TDP in varying degrees. Whether or not these items should be imposed in a contract is a matter of judgement. Hopefully, the Government data manager will take a contractor's past performance into consideration when making these decisions.

The drawing number assignment report should only be used when drawings are being identified with Government drawing numbers. It

provides the Government agent responsible for maintaining that activities drawing number records with the information necessary to complete the files.

Quality engineering planning lists are used to support the Army's QAPs. In the basic issue of MIL-T-31000 QEPLs were listed as a TDP element. In Interim Amendment 1, they were reclassified as a TDP management data product rather than a TDP element. QEPLs provide a Government quality manager with a tool to monitor the development of the quality assurance provisions for the product being developed. They provide a cross reference between the engineering documentation and the quality documentation.

One of the most controversial items from Industry's point of view is the source control drawing approval request. This item allows the Government program manager to influence the use of the designation "source control" for items used in the product. The reason for maintaining this type of control over the TDP is the recent interpretations of the Competition in Contracting Act. Under this law, the Government must maintain two or more active sources for any item for which there is a qualification requirement. It has been determined that source control drawings fall into this category just as do Qualified Products Lists. Also, if there are not two active sources, the Government must actively solicit additional sources and permit small business to attempt to qualify. If the small business does qualify, then the Government can be held liable for the qualification costs.

Similarly, the proposed critical manufacturing process description gives the Government an opportunity to approve or disapprove the designation of a process as critical or mandatory to the manufacture of the product. The intent here is to prevent the designation of proprietary processes as critical when they are not in fact mandatory to the successful manufacture of the product.

The TDP quality control program plan gives the Government insight into how the contractor is managing the development and generation of the TDP. We have cautioned against requiring this item, if the data is available under a higher lever program plan, such as a MIL-Q-9858 program plan. This data item might be imposed on contracts for data only, such as when the Government goes to fill holes in a TDP for a larger item.

The TDP validation report requires the contractor to explain what measures he has taken to insure that the TDP is current, complete, accurate, and meets the contract requirements. It is not a certification as defined by the DFARS clauses for certification of data.

As I mentioned before, there are two appendices. Appendix A provided basic selection and ordering guidance for the Government data manager. We do not attempt to teach the data manager how acquire and manage data. We must assume that they know how to do their job. However, we do try to provide basic guidance in how to use this specification. Section 30 identifies each of the data products and provides guidance on its intended use; identifies the appropriate DID; and if applicable, DD Form or selection worksheet. Section 40 contains guidance on completing the ordering forms.

Appendix B contains detailed instructions on using the QAP symbols and notes as an option under product drawings. This appendix doesn't really belong here as part of the specification; however, there was not another vehicle available. This appendix should only be imposed by selected Army commands and only on certain types of products. DOD-STD-100E is currently in the revision process and an appendix to 100E may take the place of Appendix B in the future.

The use of a DoD-wide form for ordering drawings and specifications lays the groundwork for increased standardization of data requirements across commands, services, and eventually DoD. These forms are intended to be used as an extension of Block 16 of the CDRL. They provide for the selection of the options applicable to each data product. We established separate forms for each of the drawing types and specifications to avoid the application of excessive requirements. Each form ends with a block titled "Other tailoring". This block may be used to tailor any requirement of MIL-T-31000, an applicable standard such as MIL-STD-100, the DID, or any other document affecting the content, format of media of the data product.

In August of 1990, we issued an Interim Amendment 1 to emphasize the selective application and tailoring aspects of MIL-T-31000. We also used that opportunity to clarify the flow down requirements. In the basic document the text requiring the flow down of data requirements had two problems. One, it was "how-to-manage" language and two, it was un-doable. The current language simply states that the contractor is responsible for providing data meeting the contract data requirements for items procured from subcontractors or suppliers. The old text actually told the contractor how to write his subcontracts. The reason I say that the old text represented an un-doable requirement is that many times subs or suppliers simply refuse to give the Government or the contractor data. However, we are still going to use their product because they make the best around or the only one that will meet the engineering requirements of the end item.

Whenever I get into a discussion on TDPs, three data management issues repeatedly come up. So at this time I am going to briefly

discuss data rights, digital data requirements and technology transfer.

In the area of data rights, we have relied on the FAR/DFARS clauses. In all honesty, I feel that the issue of data rights is a contract matter that must be addressed in each contract, not in specification for acquiring data. Even if we did try to address the subject, I don't believe that we could keep up with the changes taking place today.

In the area of digital data, we refer users to MIL-HDBK-59, the CALS Implementation Guide, for guidance in selecting and specifying digital requirements for data products. It would be foolish and counterproductive to try to duplicate all of the guidance in that document in 31000 and inevitably discrepancies would arise.

Now lets talk briefly about technology transfer, although it is not limited to a discussion of MIL-T-31000. There have been accusations that MIL-T-31000 attempts to transfer technology through technical data. This is not the intent of MIL-T-31000. We do have people in the Government that think they can transfer technology with technical data alone. It simply can't be done. Potential alternate sources for items documented under 31000 must have the technological skill, the capacity and the experience to produce the item. The TDP elements of 31000 are intended to merely define what the item is that is to be produced, not to teach someone how to produce items in that line of technology.

That essentially concludes my presentation on MIL-T-31000 as it exists today. But what's next? We are currently working on a revision. We hope to have it released by the end of January 1991 for formal coordination. We are trying to incorporate lessons learned and are considering the addition of some specialized data products such as Ship Alteration drawings, Site Installation drawings and perhaps something for the cataloging and provisioning functions. The initial distribution of the draft was mailed out to the SD-1 coordination list on May 10, 1991. Comments are due back to my office on September 15th. This represents an extended comment period of four months so we will not be granting extensions of the comment deadline.

The most ambitious project we are undertaking is to develop a handbook on the acquisition, management and use of TDPs. In this handbook we will attempt to provide guidance on a broad spectrum issues. Among them are:

- DOD, Service and Command policies & procedures
- TDPs and their relationship to other disciplines such as configuration management, data-like products such as master patterns, etc.

- CALS and digital data requirements and capabilities
- Points of contact, repositories, etc.

The handbook may be accompanied by some other document such as a Military Bulletin or directory to permit us to keep the document up to date with a minimum of "coordination" and red tape. The handbook will be the subject of a workshop that I will be conducting later in this conference. I invite you to join with us in its development over the next several months.

In closing, I invite you to contact me whenever you have a question regarding MIL-T-31000 or any other issue related to technical data management. In case you did not get my phone number, its (703) 756-2554 or autovon 289-2554. If I can't answer your questions, I'll certainly try to find someone who can.

MIL-T-31000

GENERAL SPECIFICATION FOR TECHNICAL DATA PACKAGES

MR. ROLAND G. HENDERSON
OASD(P&L) / MFG. MODERNIZATION DIR.
TECHNICAL DATA & MFG. DIVISION
5203 LEESBURG PIKE, SUITE 1403
FALLS CHURCH, VA 22041-3466

(703) 756-2554 AV 289-2554

MIL-T-31000

ACQUISITION ISSUES

STRATEGIES

SOLE SOURCE

COMPETITION

BREAKOUT

LEADER - FOLLOWER

TEAMING

VS.

TOOLS

SPECIFICATIONS

DATA ITEM DESCRIPTIONS

STATEMENTS OF WORK

CONTRACT CLAUSES

STANDARDS

MIL-T-31000

SPECIFICATIONS & DATA ITEM DESCRIPTIONS

- o **SPECIFICATION COVERAGE**
 - DESCRIBE ESSENTIAL TECHNICAL REQUIREMENTS FOR PURCHASING MATERIEL
(MIL-STD-961C, para 4.2)

- o **SPECIFICATION LIMITATION ON DATA RIGHTS**
 - ACQUISITION OF RIGHTS OR OTHER DATA SHALL NOT BE MADE THROUGH A SPECIFICATION
(MIL-STD-961C, para 4.3.5)

- o **DATA ITEM DESCRIPTION COVERAGE**
 - DELINEATES THE CONTENT AND FORMAT REQUIREMENTS OF A DATA PRODUCT
(MIL-STD-963a, para 4.5)

MIL-T-31000

OBJECTIVES

- o BRING TOGETHER THE ELEMENTS OF TECHNICAL DATA PACKAGES INTO ONE SPECIFICATION.

- o STANDARDIZE ORDERING TECHNIQUES

MIL-T-31000

BACKGROUND

- o LACK OF DATA & SPARES COMPETITION
- o DEF. PROCUREMENT REFORM ACT OF 1984
- o DATA MANAGEMENT IMPROVEMENT PLAN
- o NEW SPECIFICATION FOR TDPs

MIL-T-31000

BACKGROUND (CONT'D)

- o MIL - T - XXX (Services & Industry)
- o AD HOC WORKING GROUP (TIGER TEAM)
- o MIL - T - 47500 (MI) & SLASH SHEETS
 - ARMY ONLY
 - CONDITIONAL RELEASE
- o OSD = PREPARING ACTIVITY

MIL-T-31000

EFFECTIVITY

- o **REPLACES**
 - DOD-D-1000 B
 - MIL-T-47500 (MI) & SLASH SHEETS

- o **MANDATORY FOR NEW PROGRAMS**
 - 1 JULY 1990

- o **EXISTING PROGRAMS MAY:**
 - USE EXISTING DOCUMENTS
 - CONVERT TO MIL-T-31000

- o **COMMON SENSE & GOOD JUDGEMENT**
 - GOVT & CONTRACTOR DECISION
 - LIFE CYCLE PHASE

MIL-T-31000

STRUCTURE

- o **TDP ELEMENTS**
 - DEFINE OR PERTAIN TO THE ITEM OR MATERIEL DOCUMENTED BY THE TDP

- o **TDP MANAGEMENT DATA**
 - PERTAIN TO THE DEVELOPMENT OR MANAGEMENT OF THE TDP ITSELF, NOT THE ITEM OR MATERIEL

- o **ZERO BASED PHILOSOPHY**
 - NO AUTOMATIC TIERING
 - EACH DATA PRODUCT MUST BE SELECTED AND LISTED ON THE DD1423 AS A SEPARATE CDRL ENTRY

MIL-T-31000

TDP ELEMENTS

- o DRAWINGS - 6 TYPES
- o SPECIFICATIONS
- o PRESERVATION, PACKAGING, PACKING & MARKING DATA
- o SOFTWARE & SOFTWARE DOCUMENTATION
- o OTHER
 - SIE SUPPORT DATA
 - TEST REQUIREMENTS DOCUMENTS

MIL-T-31000

DRAWINGS & ASSOCIATED LISTS

- o DESIGN
 - CONCEPTUAL
 - DEVELOPMENTAL
- o PRODUCT
- o COMMERCIAL
- o SPECIAL INSPECTION EQUIPMENT
- o SPECIAL TOOLING

MIL-T-31000

DESIGN DRAWINGS & ASSOCIATED LISTS

- o **CONCEPTUAL**
 - CONCEPT EVALUATION OF PRELIMINARY DESIGN

- o **DEVELOPMENTAL**
 - DESIGN APPROACH & PROTOTYPES FOR TEST

- o **SEPARATE REQUIREMENTS**

- o **SEPARATE DIDs & WORKSHEETS**

MIL-T-31000

PRODUCT DRAWINGS & ASSOCIATED LISTS

- o **NO LEVEL 2**

- o **DESIGN MATURITY**

- o **OPTIONS FOR:**
 - QUALITY ASSURANCE PROVISIONS
 - VENDOR SUBSTANTIATION DATA

MIL-I-31000

COMMERCIAL DRAWINGS & ASSOCIATED LISTS

- o **COMMERCIAL ITEMS**
 - PRODUCTS, MATERIALS, COMPONENTS, SUBSYSTEMS OR SYSTEMS SOLD OR TRADED TO THE GENERAL PUBLIC IN THE COURSE OF NORMAL BUSINESS OPERATIONS AT PRICES BASED ON ESTABLISHED OR MARKET PRICES.
- o **NO GOVERNMENT REQUIREMENTS**
- o **REVIEW BEFORE PURCHASING RECOMMENDED**
- o **NOT FOR ITEMS DEVELOPED AT GOVT. EXPENSE**

MIL-T-31000

SIE & SPECIAL TOOLING DRAWINGS AND ASSOCIATED LISTS

- o **PREVIOUSLY INCLUDED IN LEVEL 3**
- o **LIMITED TO MANUFACTURING SUPPORT ITEMS**
- o **NOT FOR DOCUMENTING SUPPORT EQUIPMENT**
- o **REDUCED REQUIREMENTS**
 - VENDOR PART NUMBERS
 - ESSENTIAL CHARACTERISTICS TO DUPLICATE FUNCTION

MIL-T-31000

SPECIAL INSPECTION EQUIPMENT SUPPORT DATA

- o **SIE OPERATING INSTRUCTIONS**
- o **SIE DESCRIPTIVE DOCUMENTATION**
- o **SIE CALIBRATION PROCEDURES**

MIL-T-31000

SPECIFICATIONS

- o **MIL - STD - 961**
- o **MIL - STD - 490**
- o **EXISTING DIDs & STANDARDS**
- o **ASSOCIATED DOCUMENTS**
- o **ORDERING FORMS**

MIL-T-31000

OTHER TDP ELEMENTS

- o PRESERVATION, PACKAGING, PACKING AND MARKING DATA -- (MIL- STD - 2073 - 1)

- o SOFTWARE & SOFTWARE DOCUMENTATION -- (MIL-STD-2167)

- o TEST REQUIREMENTS DOCUMENTS -- (MIL-STD-1345 OR MIL-STD-1519)

MIL-T-31000

TDP MANAGEMENT DATA PRODUCTS

- o DWG. NUMBER ASSIGNMENT REPORT

- o QUALITY ENGINEERING PLANNING LISTS

- o SOURCE CONTROL DWG. APPROVAL REQUEST

- o PROPOSED CRITICAL MFG. PROCESS DESCRIPTION

- o TDP QUALITY CONTROL PROGRAM PLAN

- o TDP VALIDATION REPORT

MIL-T-31000

APPENDICES

- o **A --- SELECTION & ORDERING GUIDANCE**

- o **B --- QUALITY ASSURANCE PROVISIONS**
 - ARMY UNIQUE
 - DESCRIPTION OF INSPECTION REQUIREMENTS

MIL-T-31000

STANDARD ORDERING FORMS

- o **DRAWINGS & SPECIFICATIONS**

- o **EXTENSION OF BLOCK 16 OF CDRL**

- o **PROVIDE FOR OPTION SELECTION**

- o **AVOID EXCESSIVE REQUIREMENTS**

- o **FACILITATES TAILORING**

MIL-T-31000
FORMS - OTHER TAILORING BLOCK

8. VENDOR (Name)
a. NOT REQUIRED
9. OTHER TAILORING (Attach additional sheets as necessary)

DD Form 2554-1, DEC 89

— TAILOR MIL-T-31000, DOD-STD-100, A DID OR ANY OTHER DOCUMENT AFFECTING THE CONTENT, FORMAT OR MEDIA OF THE DATA PRODUCT. (App. A, 40.2.10)

MIL-T-31000

INTERIM AMENDMENT 1

- o **EMPHASIZES:**
 - SELECTIVE APPLICATION
 - TAILORING

- o **CLARIFIES:**
 - FLOWDOWN REQUIREMENT INTENT
 - APPLICABILITY OF QAPs

- o **CORRECTS TYPOGRAPHICAL ERRORS**

MIL-I-31000
DATA MANAGEMENT ISSUES

- o **DATA RIGHTS**
 - CONTRACT OR PURCHASE ORDER DEFINES
 - FAR/DFARS CONTOLS

- o **DIGITAL DATA**
 - MIL-HDBK-59A

- o **TECHNOLOGY TRANSFER**
 - SKILL, CAPACITY, AND EXPERIENCE
 - TDP DEFINES WHAT TO PRODUCE

MIL-T-31000
FUTURE ACTIONS

- o **REVISION EFFORT UNDERWAY**
 - LESSONS LEARNED
 - CONSIDER ADDITIONAL ITEMS (AS PROPOSED)

- o **MIL - HDBK - TDP**
 - ACQUISITION, MANAGEMENT & FUNCTIONAL USAGE
 - DOD, SERVICE, COMMAND POLICIES & PROCEDURES
 - ASSOCIATED DISCIPLINES (CM, MASTER PATTERNS , ETC.)
 - CALS & DIGITAL DATA REQUIREMENTS
 - POINTS OF CONTACT,REPOSITORIES, ETC. (MIL-BUL-TDP?)



TUTORIAL D-3

HOW TO PREPARE THE NEW DD FORM 1423

**REGINA LONG, AIR FORCE DIRECTORATE OF BOMBERS AND
TANKERS, SYSTEMS PROGRAM OFFICE**

TUTORIAL D-3

HOW TO PREPARE THE NEW DD FORM 1423

by

REGINA LONG

Aeronautical Systems Division

Air Force Systems Command

United States Air Force

Wright-Patterson Air Force Base, Ohio

DISTRIBUTION STATEMENT C: Distribution authorized to US Government agencies and their contractors for Administrative reasons, 10 April 1991. Other requests for this document shall be referred to ASD/SDBC, Wright-Patterson AFB Ohio 45433-6503.

CONTRACT DATA REQUIREMENTS LIST

(CDRL)

DD FORM 1423 (JUN 90)

- o DD FORM 1423 (4 Data Items)
- o DD FORM 1423-1 (1 Data Item)
- o DD FORM 1423-2 (2 Data Items)

CONTRACT DATA REQUIREMENTS LIST

Form Approved
OMB No. 0704-0188

Public reporting burden for this collection of information is estimated to average 440 hours per response, including the time for reviewing instructions, searching existing data sources, gathering and maintaining the data needed, and completing and reviewing the collection of information. Send comments regarding this burden estimate or any other aspect of this collection of information, including suggestions for reducing this burden, to Department of Defense, Washington Headquarters Services, Directorate for Information Operations and Reports, 1215 Jefferson Davis Highway, Suite 1204, Arlington, VA 22202-4302, and to the Office of Management and Budget, Paperwork Reduction Project (0704-0188), Washington, DC 20503. Please DO NOT RETURN your form to either of these addresses. Send completed form to the Government Issuing Contracting Officer for the Contract/PR No. listed in Block E.

A. CONTRACT LINE ITEM NO.		B. EXHIBIT		C. CATEGORY:							
				TDP		TM		OTHER			
D. SYSTEM/ITEM				E. CONTRACT/PR NO.		F. CONTRACTOR					
1. DATA ITEM NO.	2. TITLE OF DATA ITEM			3. SUBTITLE							
4. AUTHORITY (Data Acquisition Document No.)			5. CONTRACT REFERENCE			6. REQUIRING OFFICE					
7. DD 250 REQ	9. DIST STATEMENT REQUIRED	10. FREQUENCY		12. DATE OF FIRST SUBMISSION		14. DISTRIBUTION					
8. APP CODE		11. AS OF DATE		13. DATE OF SUBSEQUENT SUBMISSION		a. ADDRESSEE		b. COPIES			
16. REMARKS						Draft		Final			
								Reg	Repro		
						15. TOTAL		→			
1. DATA ITEM NO.	2. TITLE OF DATA ITEM			3. SUBTITLE							
4. AUTHORITY (Data Acquisition Document No.)			5. CONTRACT REFERENCE			6. REQUIRING OFFICE					
7. DD 250 REQ	9. DIST STATEMENT REQUIRED	10. FREQUENCY		12. DATE OF FIRST SUBMISSION		14. DISTRIBUTION					
8. APP CODE		11. AS OF DATE		13. DATE OF SUBSEQUENT SUBMISSION		a. ADDRESSEE		b. COPIES			
16. REMARKS						Draft		Final			
								Reg	Repro		
						15. TOTAL		→			
1. DATA ITEM NO.	2. TITLE OF DATA ITEM			3. SUBTITLE							
4. AUTHORITY (Data Acquisition Document No.)			5. CONTRACT REFERENCE			6. REQUIRING OFFICE					
7. DD 250 REQ	9. DIST STATEMENT REQUIRED	10. FREQUENCY		12. DATE OF FIRST SUBMISSION		14. DISTRIBUTION					
8. APP CODE		11. AS OF DATE		13. DATE OF SUBSEQUENT SUBMISSION		a. ADDRESSEE		b. COPIES			
16. REMARKS						Draft		Final			
								Reg	Repro		
						15. TOTAL		→			
1. DATA ITEM NO.	2. TITLE OF DATA ITEM			3. SUBTITLE							
4. AUTHORITY (Data Acquisition Document No.)			5. CONTRACT REFERENCE			6. REQUIRING OFFICE					
7. DD 250 REQ	9. DIST STATEMENT REQUIRED	10. FREQUENCY		12. DATE OF FIRST SUBMISSION		14. DISTRIBUTION					
8. APP CODE		11. AS OF DATE		13. DATE OF SUBSEQUENT SUBMISSION		a. ADDRESSEE		b. COPIES			
16. REMARKS						Draft		Final			
								Reg	Repro		
						15. TOTAL		→			
1. DATA ITEM NO.	2. TITLE OF DATA ITEM			3. SUBTITLE							
4. AUTHORITY (Data Acquisition Document No.)			5. CONTRACT REFERENCE			6. REQUIRING OFFICE					
7. DD 250 REQ	9. DIST STATEMENT REQUIRED	10. FREQUENCY		12. DATE OF FIRST SUBMISSION		14. DISTRIBUTION					
8. APP CODE		11. AS OF DATE		13. DATE OF SUBSEQUENT SUBMISSION		a. ADDRESSEE		b. COPIES			
16. REMARKS						Draft		Final			
								Reg	Repro		
						15. TOTAL		→			
G. PREPARED BY				H. DATE		I. APPROVED BY				J. DATE	

17. PRICE GROUP
18. ESTIMATED TOTAL PRICE

17. PRICE GROUP
18. ESTIMATED TOTAL PRICE

17. PRICE GROUP
18. ESTIMATED TOTAL PRICE

17. PRICE GROUP
18. ESTIMATED TOTAL PRICE

CONTRACT DATA REQUIREMENTS LIST

(1 Data Item)

Form Approved
OMB No. 0704-0188

Public reporting burden for this collection of information is estimated to average 110 hours per response, including the time for reviewing instructions, searching existing data sources, gathering and maintaining the data needed, and completing and reviewing the collection of information. Send comments regarding this burden estimate or any other aspect of this collection of information, including suggestions for reducing this burden, to Department of Defense, Washington Headquarters Services, Directorate for Information Operations and Reports, 1215 Jefferson Davis Highway, Suite 1204, Arlington, VA 22202-4302, and to the Office of Management and Budget, Paperwork Reduction Project (0704-0188), Washington, DC 20503. Please DO NOT RETURN your form to either of these addresses. Send completed form to the Government Issuing Contracting Officer for the Contract/PR No. listed in Block E.

A. CONTRACT LINE ITEM NO.		B. EXHIBIT		C. CATEGORY: TDP _____ TM _____ OTHER _____				
D. SYSTEM/ITEM			E. CONTRACT/PR NO.		F. CONTRACTOR			
1. DATA ITEM NO.	2. TITLE OF DATA ITEM			3. SUBTITLE				
4. AUTHORITY (Data Acquisition Document No.)			5. CONTRACT REFERENCE		6. REQUIRING OFFICE			
7. DD 250 REQ	9. DIST STATEMENT REQUIRED	10. FREQUENCY		12. DATE OF FIRST SUBMISSION				
8. APP CODE		11. AS OF DATE		13. DATE OF SUBSEQUENT SUBMISSION				
14. DISTRIBUTION						b. COPIES		
						a. ADDRESSEE		
16. REMARKS						Reg	Repro	
						15. TOTAL →		
G. PREPARED BY			H. DATE	I. APPROVED BY		J. DATE		

17. PRICE GROUP

18. ESTIMATED TOTAL PRICE

PART I

**INSTRUCTIONS FOR COMPLETING
ITEMS A THROUGH J
ON THE NEW DD FORM 1423**

NEW DD FORM 1423 (JUN 98)

ITEM A: CONTRACT LINE ITEM NUMBER

- o ENTER THE CONTRACT LINE ITEM NUMBER
<CLIN> THAT IS ASSOCIATED WITH THE CDRL

NEU DD FORM 1423 (JUN 90)

ITEM B: EXHIBIT

- o ENTER THE EXHIBIT FOR THE CDRL
- o THIS ENTRY IS AN ALPHA 'A' THROUGH 'Z'
BUT NEVER 'I' OR 'O'

NEW DD FORM 1423 (JUN 90)

ITEM C: CATEGORY

- o CHECK THE APPROPRIATE CATEGORY FOR:
 - TECHNICAL DATA PACKAGE (TDP)
 - TECHNICAL MANUAL (TM)
 - OTHER (I.E., PROVISIONING,
CONFIGURATION MANAGEMENT, ETC.)

NEW DD FORM 1423 (JUN 90)

ITEM D: SYSTEM/ITEM

o IDENTIFY THE SYSTEM, ITEM OR PROJECT
BY DESIGNATOR OR NAME

- EXAMPLE: B-1B, ATF, F-16

**ITEM E: CONTRACT/PURCHASE REQUEST
NUMBER**

- o SOME ACQUISITION AGENCIES ASSIGN A CONTRACT NUMBER FROM START OF THE ACQUISITION. THE ASSIGNED NUMBER DIFFERENTIATES THE SUBJECT ACQUISITION FROM ALL OTHERS, AND DOES NOT CHANGE
- o SOME PROCURING AGENCIES ASSIGN A PURCHASE REQUEST NUMBER THAT STAYS AFFIXED UNTIL THE NEGOTIATED CONTRACT AT WHICH TIME THE PR NUMBER IS REMOVED AND THE CONTRACT NUMBER IS AFFIXED

NEW DD FORM 1423 (JUN 90)

ITEM F: CONTRACTOR

o ENTER THE CONTRACTOR'S NAME OR
ACRONYM

o TO BE COMPLETED AFTER CONTRACT AWARD

NEW DD FORM 1423 (JUN 90)

ITEMS G & H: PREPARED BY & DATE

- o ENTER THE NAME, TITLE AND OFFICE SYMBOL
OF THE DATA MANAGER RESPONSIBLE FOR
PREPARATION OF THE CDRL
- o DATE OF PREPARER'S SIGNATURE
- o ITEMS G & H MUST BE COMPLETED EACH TIME A
CDRL IS PREPARED OR WHEN A CDRL IS REVISED

NEW DD FORM 1423 (JUN 90)

ITEMS I & J: APPROVED BY & DATE

- o ENTER THE NAME, TITLE AND OFFICE SYMBOL
OF THE PROGRAM MANAGER OR THE DESIGNEE
RESPONSIBLE FOR APPROVING THE CDRL
- o DATE OF APPROVAL AUTHORITY'S SIGNATURE
- o ITEMS I & J MUST BE COMPLETED WHEN A CDRL
IS PREPARED AND WHEN A CDRL IS REVISED

PART II

**INSTRUCTIONS FOR COMPLETING
ITEMS 1 THROUGH 16*
OF THE NEW DD FORM 1423**

***COMMONLY REFERRED TO AS BLOCKS 1 THROUGH 16, AS IN THIS BRIEFING**

NEW DD FORM 1423 (JUN 90)

BLOCK 1: DATA ITEM NUMBER

- o ENTER CDRL SEQUENCE NUMBER
- o THIS NUMBER WILL BE USED FOR TRACKING PURPOSES
- o REFER TO DOD FAR SUPPLEMENT SUPART 4.71 (SPECIFICALLY, DFARS 4.7106) FOR NUMBER SEQUENCING AND STRUCTURE
- o NOTE: WHEN THE CDRL CONTAINS LESS THAN 1,000 DATA LINE ITEMS, THE LAST THREE DIGITS OF THE EXHIBIT LINE MAY BE NUMBERED NUMERICALLY

NEW DD FORM 1423 (JUN 90)

BLOCK 2: TITLE OF DATA ITEM

- o ENTER THE TITLE AS IT APPEARS ON DATA ACQUISITION DOCUMENT CITED IN BLOCK 4
 - A. ENTER THE EXACT TITLE AS IT APPEARS IN BLOCK 1 OF THE DATA ITEM DESCRIPTION (DID) (DD FORM 1664)
 - B. SELECT AN APPROPRIATE TITLE WHEN DATA FORMAT IS IN ACCORDANCE WITH A MILITARY SPECIFICATION OR STANDARD. FOR TECHNICAL MANUALS, INCLUDE THE SPECIFIC TYPE OF TECHNICAL MANUAL BEING ACQUIRED.
 - C. IF A 'ONE-TIME' DID IS USED, ENTER THE EXACT TITLE AS IT APPEARS IN BLOCK 1 OF THE DD FORM 1664
- o NOTE: DO NOT PARAPHRASE TITLES

NEW DD FORM 1423 (JUN 90)

BLOCK 3: SUBTITLE

- o ENTER SUBTITLE OF DATA ITEM FOR FURTHER
DEFINITION OF DATA ITEM
- o THIS BLOCK IS OPTIONAL
- o WHEN USING THIS BLOCK, IF NECESSARY,
USE BLOCK 16 FOR FURTHER IDENTIFICATION
OF THE DATA ITEM

**BLOCK 4: AUTHORITY (DATA ACQUISITION
DOCUMENT NUMBER)**

- o ENTER THE NUMBER OF THE DOCUMENT THAT APPROPRIATELY DEFINES DATA CONTENT AND FORMAT REQUIREMENTS
 - A. DATA ITEM DESCRIPTION (DID) NUMBER (AS IT APPEARS IN BLOCK 2 OF THE DD FORM 1664 ADD '/T' IF THE DID HAS BEEN TAILORED.)
 - B. MILITARY SPECIFICATION NUMBER
 - C. MILITARY STANDARD
 - D. ONE-TIME DID NUMBER

- o ITEMS A THROUGH C ABOVE ARE CONTAINED IN DOD S010.12-L, ACQUISITION MANAGEMENT SYSTEM AND DATA REQUIREMENTS CONTROL LIST (AMSDL)

- o ITEM D ASSIGNED BY APPLICABLE DOD COMPONENT

HEU DD FORM 1423 (JUN 90)

BLOCK 5: CONTRACT REFERENCE

- o ENTER THE SPECIFIC PARAGRAPH NUMBER OF THE STATEMENT OF WORK, SPECIFICATION, STANDARD, OR OTHER APPLICABLE DOCUMENT WHICH CONTAINS THE TASKING WHICH GENERATES A REQUIREMENT FOR THE DATA ITEM

NEW DD FORM 1423 (JUN 90)

BLOCK 6: REQUIRING OFFICE

- o ENTER TECHNICAL OFFICE RESPONSIBLE FOR ENSURING ADEQUACY OF THE DATA ITEM
- o WHEN DATA REQUIRE APPROVAL, THIS OFFICE IS RESPONSIBLE FOR DETERMINING IF THE DATA SUBMITTED SHOULD BE APPROVED AS SUBMITTED OR REVISED TO MEET CONTRACT REQUIREMENTS

NEW DD FORM 1423 (JUN 90)

BLOCK 7: DD 250 REQUIRED

- o SPECIFY REQUIREMENT FOR INSPECTION/
ACCEPTANCE OF THE DATA ITEM BY THE
GOVERNMENT
- o DESIGNATE THE LOCATION (CONTRACTOR'S
FACILITY OR DESTINATION) FOR PERFORMANCE,
OF GOVERNMENT INSPECTION AND ACCEPTANCE,
BY ENTERING THE APPLICABLE CODE:
 - SEE NEXT CHART FOR APPLICABLE CODES
- o WHEN DD FORM 250 IS NOT REQUIRED, 'LT'
(LETTER TRANSMITTAL SHOULD BE INDICATED
IN BLOCK 7

NEW DD FORM 1423 (JUN 90)

BLOCK 7: (continued)

<u>CODE</u>	<u>INSPECTION</u>	<u>ACCEPTANCE</u>
SS	SOURCE	SOURCE
DD	DESTINATION	DESTINATION
SD	SOURCE	DESTINATION
DS	DESTINATION	SOURCE
LT	LETTER OF TRANSMITTAL ONLY	
NO	INSPECTION/ACCEPTANCE NOT REQUIRED	
XX	INSPECTION/ACCEPTANCE REQUIREMENT SPECIFIED ELSEWHERE IN CONTRACT	

S (SOURCE) = INDICATES THE CONTRACTOR'S FACILITY
D (DESTINATION) = NORMALLY INDICATES THE PRIMARY
DISTRIBUTION POINT

NEW DD FORM 1423 (JUN 90)

BLOCK 8: APPROVAL CODE

- o SPECIFY REQUIREMENT FOR APPROVAL OF A DRAFT BEFORE PREPARATION OF THE FINAL DATA ITEM. FOR EXAMPLE, ENTER 'A' IF APPROVAL IS REQUIRED OR 'NO' IF NO APPROVAL IS REQUIRED.
- o APPROVAL REQUIRES A NOTE IN BLOCK 16 SPECIFYING THE TIME PERIOD REQUIRED BY THE GOVERNMENT TO REVIEW AND APPROVE/ DISAPPROVE AS WELL AS THE LENGTH OF TIME ALLOWED FOR THE CONTRACTOR TO RESUBMIT.
- o DO NOT ENTER 'A' IN THIS BLOCK WHEN BLOCK 7 IS REQUIRING A DD FORM 250

BLOCK 9: DISTRIBUTION STATEMENT

- o FOR TECHNICAL DATA, SPECIFY REQUIREMENT FOR CONTRACTOR TO MARK THE APPROPRIATE DISTRIBUTION STATEMENT ON THE DATA
- o ENTER ONE OF THE FOLLOWING CODES:
 - IF A DISTRIBUTION STATEMENT IS REQUIRED, ENTER THE APPROPRIATE DISTRIBUTION STATEMENT LETTER A, B, C, D, E, F OR X.
 - IF THE APPROPRIATE DISTRIBUTION STATEMENT IS UNKNOWN AT THE TIME OF CONTRACT AWARD, ENTER 'TBD'. THE DISTRIBUTION STATEMENT IS TO BE DETERMINED AT A LATER DATE.
 - IF A DISTRIBUTION STATEMENT IS NOT REQUIRED (NON-TECHNICAL DATA), ENTER 'N/A'.

NEW DD FORM 1423 (JUN 90)

BLOCK 9: (continued)

- o IF DISTRIBUTION STATEMENT A (APPROVED FOR PUBLIC RELEASE) IS USED, THE GOVERNMENT TECHNICAL OFFICE MUST REQUEST PERMISSION FROM THE OFFICE OF PUBLIC AFFAIRS PRIOR TO APPROVAL/ACCEPTANCE OF THE DATA FOR DISTRIBUTION

- o REFERENCE DODD 5230.24 AND MIL-STD-1806

NEW DC FORM 1423 (JUN 90)

BLOCK 10: FREQUENCY

o SPECIFY NUMBER OF TIMES THE DATA ITEM
IS TO BE SUBMITTED

o ENTER IN BLOCK 10:

- SEE NEXT CHART FOR CODES/ABBREVIATIONS
APPLICABLE TO BLOCK 10

NEW DD FORM 1423 (JUN 90)

BLOCK 10: (continued)

o FREQUENCY CODES/ABBREVIATIONS:

<u>CODE</u>	<u>MEANING</u>
DAILY	DAILY
WEEKLY	WEEKLY
BI-WEEKLY	EACH TWO WEEKS
MONTHLY	MONTHLY
BI-MONTHLY	EACH TWO MONTHS
QUARTLY	QUARTERLY
ANNUALLY	ANNUALLY
SEMIANNUALLY	EACH SIX MONTHS
ONETIME	ONE TIME
ONE/REVISIONS	ONE TIME & REVISIONS
R/AS REQUIRED	REVISIONS AS REQUIRED
AS REQUIRED	AS REQUIRED
DEFERRED DELIVERY	DEFERRED DELIVERY
ONE/TIME PRELIMINARY DRAFT	ONE TIME PRELIMINARY DRAFT
TWO SEPARATE SUBMITTALS	TWO SEPARATE SUBMITTALS

BLOCK 10: (continued)

- o WHEN 'ASREQ' IS USED IN BLOCK 10, AN EXPLANATION OF THE REQUIREMENT MUST BE ENTERED IN BLOCK 16
- o IN ADDITION TO THE FREQUENCY CODES/ ABBREVIATIONS PREVIOUSLY LISTED, THE FOLLOWING CODES/ABBREVIATIONS ARE COMMONLY USED:

<u>CODE</u>	<u>MEANING</u>
ASGEN	AS GENERATED*
XTIME	NUMBER OF TIMES TO BE SUBMITTED (I.E., 3TIME)

*SAME AS FOR 'ASREQ', BLOCK 16 MUST CONTAIN AN EXPLANATION OF THE REQUIREMENT.

BLOCK 11: AS OF DATE

- o SPECIFY AS OF DATE OF DATA ITEM:
 - IF THE DATA IS TO BE SUBMITTED ONLY ONCE, ENTER THE 'AS OF' DATE AS FOLLOWS:
YEAR/MONTH/DAY (E.G., '90MAR10')
 - IF THE DATA IS SUBMITTED MULTIPLE TIMES, ENTER THE NUMBER OF CALENDAR DAYS AFTER THE END OF THE REPORTING PERIOD THE REQUIRING OFFICE IS TO RECEIVE THE DATA
 - IF DATA IS REQUIRED PRIOR TO END OF REPORTING PERIOD, EXPLAIN IN BLOCK 16
 - IF AN 'AS OF' DATE IS NOT APPLICABLE, ENTER 'N/A' (NOT APPLICABLE)

BLOCK 12: DATE OF FIRST SUBMISSION

- o SPECIFY WHEN FIRST SUBMITTAL IS REQUIRED
- o ENTER THE DATE OF SUBMISSION AS APPROPRIATE
 - YEAR/MONTH/DAY
 - MILESTONE OR EVENT
 - IF DATE IS NOT KNOWN OR NEEDS MORE CLARIFICATION, INDICATE IN BLOCK 12, 'SEE BLOCK 16' AND INCLUDE IN BLOCK 16 AN EXPLANATION OF THE REQUIREMENT
 - IF DATA IS SUBJECT TO DEFERRAL DELIVERY, ENTER 'DFDEL'
- o DO NOT INSERT CLASSIFIED DATES

NEW DD FORM 1423 (JUN 90)

BLOCK 13: DATE OF SUBSEQUENT SUBMISSIONS

- o IF DATA ITEM WILL BE SUBMITTED MORE THAN
ONCE, ENTER THE DATE(S) OF SUBSEQUENT
SUBMISSIONS
- o IF SUBMITTAL IS CONSTRAINED BY A SPECIFIC
EVENT OR MILESTONE, EXPLAIN IN BLOCK 16
- o DO NOT INSERT CLASSIFIED DATES

NEW DD FORM 1423 (JUN 98)

BLOCK 14: DISTRIBUTION

- o ENTER THE ADDRESSEE IN BLOCK 14.A AND THE NUMBER OF DRAFT COPIES AND THE NUMBER OF FINAL COPIES (REGULAR AND REPRODUCIBLE) IN BLOCK 14.B TO BE PROVIDED TO EACH

NEW DD FORM 1423 (JUN 90)

BLOCK 14.A: ADDRESSEE

- o USE OFFICE SYMBOLS/CODES, CONTRACTOR INITIALS, ETC.
- o ATTACH A LIST EXPLAINING THESE CODES TO THE CONTRACTOR
- o THE FIRST ADDRESSEE SHOULD BE THE ACCEPTANCE ACTIVITY FOR THE DATA AS NOTED IN BLOCK 6 OR OTHERWISE STATED IN BLOCK 16
- o IF DATA IS NOT ACTUALLY TO BE DELIVERED TO THE GOVERNMENT OR TO ASSOCIATED CONTRACTORS OR IF DEFERRED DELIVERY IS REQUIRED, ENTER THE APPROPRIATE INSTRUCTIONS IN BLOCK 16
- o DO NOT INSERT CLASSIFIED LOCATIONS

BLOCK 14.B: (continued)

- o FINAL COPIES (REGULAR OR REPRODUCIBLE)
 - SPECIFY NUMBER OF REGULAR COPIES FOR EACH ADDRESSEE
 - SPECIFY NUMBER OF REPRODUCIBLE COPIES, IF ANY, FOR EACH ADDRESSEE
 - IF A REPRODUCIBLE COPY (E.G., VELLUM, NEGATIVE, FLOPPY DISK, ETC.) ARE REQUIRED, IDENTIFY IN BLOCK 16 THE SPECIFIC TYPE, KIND, QUANTITY, ETC., OF REPRODUCIBLE COPIES TO BE DELIVERED

NEW DD FORM 1423 (JUN 90)

BLOCK 15: TOTAL

- o ENTER THE TOTAL NUMBER OF DRAFT AND
FINAL COPIES (REGULAR AND REPRODUCIBLE)
REQUIRED BY BLOCK 14

- o IF DISTRIBUTION FLUCTUATES, USE A
NOT-TO-EXCEED (NTE) NUMBER

NEW DD FORM 1423 (JUN 90)

BLOCK 16: REMARKS

- o USE THIS BLOCK TO EXPLAIN THE FOLLOWING,
IF REQUIRED:
 - A. TAILORING REQUIREMENTS OF THE DOCUMENT
LISTED IN BLOCK 4
 - TAILORING IS THE DELETION OF
REQUIREMENTS FROM THE DOCUMENTS
 - TAILORING OF A DID (DD FORM 1664)
APPLIES ONLY TO BLOCK 10 OF THE DID

BLOCK 16: (continued)

- B. CLARIFYING OF ANY REQUIREMENTS
CONTAINED IN THE PREVIOUS BLOCKS
(BLOCKS 1 THROUGH 15)**

**NOTE: ENTER THE NUMBER OF THE CLARIFIED
BLOCK OVER THE CLARIFICATION MESSAGE
(E.G., BLOCK 14: THE REPRODUCIBLE SHALL
BE...)**

- C. ANY RESUBMITTAL SCHEDULE OR SPECIAL
CONDITIONS INVOLVED IN UPDATING DATA
SUBMITTED FOR GOVERNMENT APPROVAL**

NEW DD FORM 1423 (JUN 90)

BLOCK 17: PRICE GROUP

- o THE CONTRACTOR (IN RESPONSE TO A REQUEST FOR PROPOSAL) IS REQUIRED TO ENTER THE APPROPRIATE PRICE GROUP AS LISTED ON THE REVERSE SIDE OF THE NEW DD FORM 1423 (JUN 90)

INSTRUCTIONS FOR COMPLETING DD FORM 1423

(See DoD 5010.12-M for detailed instructions.)

FOR GOVERNMENT PERSONNEL

- Item A.** Self-explanatory.
- Item B.** Self-explanatory.
- Item C.** Mark (X) appropriate category: TDP - Technical Data Package; TM - Technical Manual; Other - other category of data, such as "Provisioning," "Configuration Management", etc.
- Item D.** Enter name of system/item being acquired that data will support.
- Item E.** Self-explanatory (to be filled in after contract award).
- Item F.** Self-explanatory (to be filled in after contract award).
- Item G.** Signature of preparer of CDRL.
- Item H.** Date CDRL was prepared.
- Item I.** Signature of CDRL approval authority.
- Item J.** Date CDRL was approved.
- Item 1.** See DoD FAR Supplement Subpart 4.71 for proper numbering.
- Item 2.** Enter title as it appears on data acquisition document cited in Item 4.
- Item 3.** Enter subtitle of data item for further definition of data item (optional entry).
- Item 4.** Enter Data Item Description (DID) number, military specification number, or military standard number listed in DoD 5010.12-L (AMSOL), or one-time DID number, that defines data content and format requirements.
- Item 5.** Enter reference to tasking in contract that generates requirement for the data item (e.g., Statement of Work paragraph number).
- Item 6.** Enter technical office responsible for ensuring adequacy of the data item.
- Item 7.** Specify requirement for inspection/acceptance of the data item by the Government.
- Item 8.** Specify requirement for approval of a draft before preparation of the final data item.
- Item 9.** For technical data, specify requirement for contractor to mark the appropriate distribution statement on the data (ref. DoDD 5230 24).
- Item 10.** Specify number of times data items are to be delivered.
- Item 11.** Specify as-of date of data item, when applicable.
- Item 12.** Specify when first submittal is required.
- Item 13.** Specify when subsequent submittals are required, when applicable.
- Item 14.** Enter addressees and number of draft/final copies to be delivered to each addressee. Explain reproducible copies in Item 16.
- Item 15.** Enter total number of draft/final copies to be delivered.
- Item 16.** Use for additional/clarifying information for Items 1 through 15. Examples are: Tailoring of documents cited in Item 4; Clarification of submittal dates in Items 12 and 13; Explanation of reproducible copies in Item 14; Desired medium for delivery of the data item.

FOR THE CONTRACTOR

Item 17. Specify appropriate price group from one of the following groups of effort in developing estimated prices for each data item listed on the DD Form 1423.

a. **Group I. Definition -** Data which is not otherwise essential to the contractor's performance of the primary contracted effort (production, development, testing, and administration) but which is required by DD Form 1423.

Estimated Price - Costs to be included under Group I are those applicable to preparing and assembling the data item in conformance with Government requirements, and the administration and other expenses related to reproducing and delivering such data items to the Government.

b. **Group II. Definition -** Data which is essential to the performance of the primary contracted effort but the contractor is required to perform additional work to conform to Government requirements with regard to depth of content, format, frequency of submittal, preparation, control, or quality of the data item.

Estimated Price - Costs to be included under Group II are those incurred over and above the cost of the essential data item without conforming to Government requirements, and the administrative and other expenses related to reproducing and delivering such data item to the Government.

c. **Group III. Definition -** Data which the contractor must develop for his internal use in performance of the primary contracted effort and does not require any substantial change to conform to Government requirements with regard to depth of content, format, frequency of submittal, preparation, control, and quality of the data item.

Estimated Price - Costs to be included under Group III are the administrative and other expenses related to reproducing and delivering such data item to the Government.

d. **Group IV. Definition -** Data which is developed by the contractor as part of his normal operating procedures and his effort in supplying these data to the Government is minimal.

Estimated Price - Group IV items should normally be shown on the DD Form 1423 at no cost.

Item 18. For each data item, enter an amount equal to that portion of the total price which is estimated to be attributable to the production or development for the Government of that item of data. These estimated data prices shall be developed only from those costs which will be incurred as a direct result of the requirement to supply the data, over and above those costs which would otherwise be incurred in performance of the contract if no data were required. The estimated data prices shall not include any amount for rights in data. The Government's right to use the data shall be governed by the pertinent provisions of the contract.

BLOCK 18: ESTIMATED TOTAL PRICE

o THE CONTRACTOR IS REQUIRED TO ENTER THE
ESTIMATED TOTAL PRICE

o NOTE: THE PRICE YOU PAY FOR A DATA ITEM WILL
BE BASED ON WHAT IT COSTS THE SELLER TO
FURNISH THE ITEM OVER AND ABOVE THE COSTS
IT WOULD INCUR IF YOU DID NOT REQUIRE IT AT
ALL. THIS IS CALLED 'OVER AND ABOVE
CONCEPT OF PRICING'.

THIS CONCLUDES TUTORIAL D-3.

THANK YOU FOR ATTENDING THIS TUTORIAL.

IF THERE ARE ANY QUESTIONS, I WILL BE GLAD TO
ATTEMPT TO ANSWER THEM AT THIS TIME. IF NOT,

THIS CONCLUDES THE TUTORIAL ON 'HOW TO PREPARE
THE NEW DD FORM 1423'.

GENERAL SESSION

KEYNOTE ADDRESS

PAUL A. STRASSMANN

**DIRECTOR, DEFENSE INFORMATION, OFFICE OF THE
ASSISTANT SECRETARY OF DEFENSE FOR COMMAND,
CONTROL, COMMUNICATIONS, AND INTELLIGENCE**



KEYNOTE ADDRESS

BY

MR. PAUL A. STRASSMANN

DIRECTOR, DEFENSE INFORMATION

OFFICE OF THE ASSISTANT SECRETARY OF DEFENSE

(COMMAND, CONTROL, COMMUNICATIONS, AND INTELLIGENCE)

This is the story of the Irish tailor who was asked on Columbus Day to substitute for Pavaroti at an Italian fraternity meeting in Brooklyn. He had two choices. He either could do "O Sole Mio," or pretend it's St. Patrick's day. I will pretend today that I can talk about software instead of whatever Mr. Quayle* was going to talk about. I'm going to just shift the agenda to suit my particular holiday today.

Now how do I get you to talk about software if the title of your conference is "Conducting Business Under the DMR"? The way I'm going to do it is to tell you first what is DMR; how Corporate Information Management (CIM) fits into DMR; and then get to the topic that I shall talk about.

*Originally, the opening address for this event was scheduled for the Honorable J. Danforth Quayle, Vice President of the United States.

DMR is a \$70.8 billion task which is part of the \$410 billion down-sizing of the DoD. One of the unique attributes of DMR is not only is the mortgage payable five years from now, but the mortgage is to be paid every year. It has to be amortized, so this is not a balloon payment. Consequently, if we don't make the DMR savings of \$70.8 billion, our defense forces will be reduced and our military power will be diminished. Therefore, the DMR targets must be met.

As you know, DMR is the plan to achieve savings through doing business differently, changing management practices. When I looked at the \$70.8 billion target task for changing management practices, I found about \$36 billion out of that total attributable to information technology. Corporate Information Management (CIM) is an information technology and information management activity which is trying to deliver about half of the DMR savings through changes in management practices first. Using information technology software and hardware to facilitate that change is then only a second priority.

I want to emphasize here that software and hardware is the rail on which the train of DMR savings will move. The information technology is therefore not the primary focus. It is an essential means for achieving the expected savings. The bulk of the savings is in changing business methods.

Let me illustrate what I mean by changes in business methods. It involves ordering the same item for DoD as for other organizations. One item was purchased by the Navy, the other was purchased by a public service agency of Maricopa County, Arizona. The Navy acquisition document for this \$50 item had five agencies involved; three of them in the Pentagon on different floors, one in Crystal City, Virginia, and one of them, the paying agent, in St. Louis. I counted the number of identifying digits on the Navy document. This is an indication of the data complexity for any transaction. As a rule of thumb, it costs about a dollar per document to identify the digit on the document and process it accurately. This particular document for a \$50 item had 150 identifying digits. Those of you who are mathematicians should realize that 10 to the 150th power is a number which is larger than the number of molecules in the universe. I just wonder what the Navy is going to identify when they buy a \$50 item.

Maricopa County, Arizona, had the same kind of fiduciary responsibility as the Navy. They were able to buy that identical \$50 item with only 12 codes for not more than \$8 total.

So, the essence of CIM is to find ways of simplifying business processes which would reduce the overhead costs. Even a Navy \$800

toilet seat costs only about \$1.80 in manufacturing costs, with only 80 cents worth of materials. So we certainly have a target of opportunity in the simplification of business processes.

I want to emphasize that there is no point in using information technology to do something faster and more efficiently that should not be done at all. Therefore, let's not computerize things which we should not computerize.

With this preface, I'll get straight to the subject I want to talk about. Once you decide to computerize, and you do not have much time to reshuffle your existing organizations and your business processes, how do you do that? And, considering the very short implementation schedule that you have, namely another five years, how do you transform the existing information technology assets when you have about 1.5 billion lines of software code already in inventory in DoD?

Depending on your estimate of acquisition costs per line of code, debugged and error free, and depending on your estimate of the number of dollars it takes to buy and maintain a line of code, the software inventory inside of DoD is truly awesome. Our ability to change, modify, or upgrade is very difficult. The sole reason for this difficulty is the fact that this code has been manufactured by

artists operating in a mode similar to medieval kinds of workshops. Even a cottage industry would be an advance over the current mode of protection of software because our programmers are largely used to unlimited latitude in practicing their art of writing software.

Within CIM, the underpinning, the vehicle for bringing in major changes in the delivery of software to DoD will be accomplished in the next two years by converting the current, craft-like software workshops into a highly disciplined manufacturing process. In fact, we will be the first major organization in the world totally committed to this goal.

Each of you needs to know what this precisely means. We have adopted the Army's data definition approach and data modeling approach as the standard for DoD. We are going to build on the Army's data management program and data definition program by publishing a DoD thesaurus and library system for defining data. In fact, the Army has done a number of analyses of business processes, and has found that if you do data modeling of a big system, you discover an enormous amount of redundancy. The kind of compression that you get is any where from 10 to 1 to 20 to 1. For instance, the Navy purchase order of 150 codes basically has only about 10 or 15 essential codes. The rest of it is redundant. Therefore, the new objective of DoD data management is to capture unique data at point

of entry into DoD, achieve zero defects, and then never re-enter that piece of data anywhere. This sort of simplification is now common place in the quality manufacturing processes.

When I look at the amount of money being spent in data center operations, which is about \$5 billion a year, most of the tape spinning that takes place is just coordinating application A with application B with application C. It is basically trying to match data or incompatible sets of data definitions. In the future, we expect to bring all applications under central data management, using only standard data elements as the material from which to control application. Ultimately, we shall standardize all data definitions and put a DoD standard stamp on each data element.

To establish a data element as an interchangeable part is a complex task. It's not just a data dictionary. This is not a Webster's Dictionary where data means this and that. You need an elaborate certification, definition coding dissemination process so that everyone throughout DoD can be issued data elements as a standard reusable component rather than an opportunity to exercise programmers' imaginations.

Data are the ties on which you put the rails, but the real rails are not the data. The real rail is code. The Army has in place a

system called "Rapid" at Fort Belvoir, in which they had started looking at collections of code as pre-fabricated sub-assemblies. They started using pieces of code as reusable components.

For instance, the date that appears on your check or statement or your purchase order or shipping document is really generated by a fairly sophisticated routine that can distinguish leap years, holidays, time of the day, day of the week, and the fairly tricky transition into the year 2000. Software codes that generate dates have been written and rewritten over and over again not only by our own programmers, but also by contractors. In maybe 1.5 billion coding statements currently in DoD inventory, we may have thousands of procedural definitions of a date, each of which may have anywhere from 400 to 1000 lines of code. So, here you are talking about an item that could possibly cost \$50,000, when it's a fully reusable component. It is our commitment to such elements as reusable generic definitions, such as a check writer or report writer, a date naming convention, and a serial number convention, to put a standardization stamp on it and start treating software as reusable components.

The Army has just fielded two new applications in less than four months. Each application has more than 100,000 lines of code. Over 55% of those applications were made out of reusable components acquired basically at zero cost. We are going to industrialize the

production of software as a reusable set of components. This is the big news. If you take any big news away from this morning's discussion, it is that we are going to industrialize the process of software production. We are going to look at software as a manufacturing process for putting together, out of reusable components, new applications so that they can be fielded by assembly and not as a totally new and unique creation. We intend to also issue these components to our contractors so they don't charge us for things that we already own a thousand times over. The availability of pieces of software ranging anywhere from 50 lines to 5000 lines of code will become the asset of DoD and will become the base for rapid fielding of new applications so that we can introduce new innovation and not be forced to perpetuate the old procedures, which are costly and obsolete.

That, however, is not sufficient and not enough. It's the tooling used in the manufacturing of software that assures that the rapid manufacturing of new software is materialized. The Information Process Technology Board has just asked the Air Force to accelerate their planned deployment of standard software tooling and make it a DoD product that shall be available as the sole DoD software tooling method. We cannot have software anymore that looks like a Philips-head screw that has five grooves. We have to standardize our tooling so that we can maintain and combine applications out of our inventory

of existing software, using the same tooling set for all software and sub-assemblies.

The tooling system is going to be a very ambitious, large effort. It will have an extremely short pay back. We expect to start fielding pieces of this tooling sometime this fall, with full scale implementation early next year. This software tooling will ultimately be reissuable to our contractors because that's how we will assure ourselves that we have a rational production process that will yield to DoD software that is a valuable, reusable, and maintainable asset.

In conclusion, let me reiterate that reducing and streamlining information handling costs are perhaps one of the principal tasks for the DoD in the years to come.

More effective information handling is the target of opportunity for DoD. Since the software residing in our computers continues to shape how we manage, I hope that you will find this a challenge. The success of taking software as a manufacturing item rests largely on the superb enthusiasm and commitment of this audience and you should be able to influence when we begin full implementation of this new technology.

Thank you very much for listening to this message. At this point, I wonder if you have any questions concerning my comment about the future of the software to support the CIM program. Questions, please????

GENERAL SESSION

PANEL ON IMPACT OF DEFENSE MANAGEMENT REVIEW (DMR) ON STANDARDIZATION, DATA MANAGEMENT, AND CONFIGURATION MANAGEMENT PROGRAMS

Moderator, Richard Donnelly, Director, Manufacturing Modernization Directorate, Office of the Assistant Secretary of Defense (Production and Logistics)

Panel Members:

Nicholas M. Torelli, Deputy Assistant Secretary of Defense (Production Resources)

Darold L. Griffin, Principal Assistant Deputy for Research, Development and Acquisition, Headquarters, Army Materiel Command

Captain Gary L. Averett, USN, Acting Director, Acquisition Process Office, Office of the Assistant Secretary of the Navy (Research, Development and Acquisition)

BGEN William E. Collins, Assistant for Reliability, Maintainability and Quality to the Deputy Assistant Secretary of the Air Force for Management Policy and Program Integration.

Henry A. Filippi, Executive Director, Technical and Logistics Services, Defense Logistics Agency

REMARKS BY

MR. NICHOLAS M. TORELLI, JR.
DEPUTY ASSISTANT SECRETARY OF DEFENSE (PRODUCTION RESOURCES)

GOOD MORNING. AS MANY OF YOU ALREADY KNOW, I AM SOMEWHAT THE NEW KID ON THE BLOCK HAVING ASSUMED THE DUTIES AS THE DEPUTY ASSISTANT SECRETARY FOR PRODUCTION RESOURCES JUST SIX MONTHS AGO. BUT IN THESE FEW MONTHS, I HAVE COME TO APPRECIATE MANY OF THE CHALLENGES FACING THE STANDARDIZATION, DATA MANAGEMENT, AND CONFIGURATION MANAGEMENT COMMUNITIES. ONE OF GREATEST OF THESE CHALLENGES --- AND INDEED, IT IS THE FOCUS OF THIS CONFERENCE --- WILL BE TO DEVISE NEW, MORE EFFICIENT AND EFFECTIVE WAYS FOR THE DOD AND ITS CONTRACTORS TO CONDUCT BUSINESS AND ACHIEVE THE OBJECTIVES ESTABLISHED BY SECRETARY CHENEY IN HIS DEFENSE MANAGEMENT REPORT TO THE PRESIDENT.

IN ITS BROADEST CONTEXT, THE DEFENSE MANAGEMENT REPORT, OR DMR, SETS FORTH A PLAN TO ACHIEVE THREE OBJECTIVES: (1) TO IMPLEMENT FULLY THE RECOMMENDATIONS OF THE PACKARD COMMISSION; (2) TO IMPROVE SUBSTANTIALLY THE PERFORMANCE OF THE DEFENSE ACQUISITION SYSTEM; AND (3) TO MANAGE MORE EFFECTIVELY THE DEPARTMENT OF DEFENSE AND DEFENSE RESOURCES.

IN LIGHT OF THE INCREDIBLE SUCCESS OF SUCH RECENTLY FIELDDED WEAPON SYSTEMS AS THE PATRIOT, THE TOMAHAWK, THE STEALTH FIGHTER, AND THE ABRHAMS TANK IN OPERATION DESERT STORM, SOME PEOPLE MAY QUESTION THE NEED TO OVERHAUL AN ACQUISITION SYSTEM CAPABLE OF PRODUCING THIS WEAPONRY. SUCH THINKING, HOWEVER, WOULD BE VERY SHORT SIGHTED. THE 1990'S WILL PRESENT MAJOR CHALLENGES TO THE MILITARY STRENGTH OF THE UNITED STATES, AND TO ITS ECONOMY. OPERATION DESERT STORM ONLY TEMPORARILY HALTED THE BILLION DOLLAR CUTS THAT ARE SCHEDULED FOR DOD.

IF PROJECTIONS ARE CORRECT, IN THE 1995-1996 TIME FRAME, ONLY 18% OF THE FEDERAL BUDGET AND LESS THAN 4% OF THE GROSS NATIONAL PRODUCT WILL BE SPENT ON DEFENSE. COMPARE THIS TO THE VIETNAM YEARS WHEN 43% OF THE FEDERAL BUDGET AND OVER 9% OF THE GROSS NATIONAL PRODUCT WENT TO DEFENSE, OR THE PEAK YEAR OF THE REAGAN ADMINISTRATION WHEN 27% OF THE FEDERAL BUDGET AND OVER 6% OF THE GROSS NATIONAL PRODUCT WENT TO DEFENSE, AND YOU CAN BEGIN TO APPRECIATE THE SIGNIFICANCE OF THESE CUTS.

WHILE THE DEFENSE BUDGET IS DECREASING, ACQUISITION COSTS ARE SKYROCKETING. A PATRIOT MISSILE COSTS \$1.5 MILLION. A B-1B BOMBER IS OVER \$200 MILLION. A SINGLE AIRCRAFT CARRIER IS ABOUT \$3.5 BILLION. IF COSTS

CONTINUE TO RISE AT THE CURRENT RATE OF ABOUT 7% PER YEAR IN CONSTANT DOLLARS, THE NEXT GENERATION OF WEAPON SYSTEMS COULD COST TWICE AS MUCH. THE RESULT WILL BE A NATION THAT IS UNABLE TO BUY THE NUMBER OF SHIPS, PLANES, AND TANKS THAT IT NEEDS. TODAY, WE WERE ABLE TO SEND A VERY FORMIDABLE FORCE TO THE MIDDLE EAST, BUT WE MAY NOT HAVE SUCH CAPABILITIES IN THE FUTURE UNLESS WE CAN IMPROVE THE EFFICIENCY OF OUR ACQUISITION PRACTICES AND BRING COSTS UNDER CONTROL. THIS IS WHAT THE DMR IS ALL ABOUT.

THE STANDARDIZATION, DATA MANAGEMENT, AND CONFIGURATION MANAGEMENT COMMUNITIES PLAY AN IMPORTANT ROLE IN HELPING PROGRAM OFFICES CONTROL COSTS AND ESTABLISH PERFORMANCE CAPABILITIES FOR WEAPON SYSTEMS. THAT IS THE REASON THE DMR FOCUSED SO STRONGLY ON YOUR AREAS. YOU ARE THE ONES THAT DOCUMENT TECHNICAL REQUIREMENTS AND CAN HELP STREAMLINE THOSE REQUIREMENTS. YOU ARE THE ONES INVOLVED IN PARTS CONTROL RECOMMENDATIONS. YOU ARE THE ONES INVOLVED IN COMMERCIAL VERSUS MILITARY UNIQUE TRADE-OFF DECISIONS.

ESSENTIALLY, THE IMPACT THE DMR WILL HAVE ON YOUR PROGRAMS, AND THE CONTRIBUTION YOUR PROGRAMS CAN MAKE TO REALIZING SECRETARY CHENEY'S DMR OBJECTIVES CAN BE COLLECTIVELY DISCUSSED UNDER FOUR BROAD CATEGORIES: (1) EXPANDED COMMERCIAL ACQUISITION; (2) IMPROVED TRAINING ; (3) IMPROVED PROGRAM MANAGEMENT; AND (4) STREAMLINED REQUIREMENTS.

THE NUMBER ONE OBJECTIVE OF THE DMR, AND WHAT WAS REALLY ITS GENESIS, WAS TO IMPLEMENT FULLY THE RECOMMENDATIONS OF THE PACKARD COMMISSION. IN 1986, THE PACKARD COMMISSION MADE A STRONG CASE FOR MILITARY USE OF COMMERCIAL COMPONENTS AND PRACTICES BY DEMONSTRATING THAT DRAMATIC QUALITY IMPROVEMENTS AND COST REDUCTIONS COULD BE REALIZED THROUGH THE USE OF TECHNOLOGY THAT IS NOW PREVALENT THROUGHOUT THE COMMERCIAL SECTOR. SINCE THE PACKARD COMMISSION REPORT, THERE HAS BEEN SOME PROGRESS IN COMMERCIAL ACQUISITION. FOR EXAMPLE, SINCE 1986, WE REDUCED THE NUMBER OF MILITARY SPECIFICATIONS FROM OVER 27,000 TO ABOUT 26,000 WHILE INCREASING THE NUMBER OF DOD ADOPTIONS OF NON-GOVERNMENT STANDARDS FROM ABOUT 4,000 TO OVER 5,000 DOCUMENTS. WE HAVE ALSO NEARLY DOUBLED THE NUMBER OF COMMERCIAL ITEM DESCRIPTIONS FROM 2,100 TO 4,100.

HOWEVER, MUCH REMAINS TO BE DONE. THE DEFENSE SCIENCE BOARD ISSUED TWO FOLLOW-ON REPORTS TO THE PACKARD COMMISSION'S RECOMMENDATION TO INCREASE THE USE OF COMMERCIAL ACQUISITION. ESSENTIALLY, WHILE BOTH REPORTS ACKNOWLEDGED SOME PROGRESS, THEY NOTED A NUMBER OF REGULATORY AND STATUTORY BARRIERS, PARTICULARLY IN

THE AREA OF COMMERCIAL PROCUREMENT PRACTICES. THE DEFENSE SCIENCE BOARD ALSO NOTED THAT A MILITARY-UNIQUE MIND SET HAS EVOLVED IN THE DOD THAT MAKES IT DIFFICULT TO ACCEPT COMMERCIAL PRODUCTS AND PROCESSES. QUITE FRANKLY, SOME DOD ACQUISITION PERSONNEL ARE DISTRUSTFUL OF THE QUALITY OF COMMERCIAL PRODUCTS, DESPITE EVIDENCE THAT IN MANY CASES, COMMERCIAL PRODUCTS AND PROCESSES ARE OF A HIGHER QUALITY THAN THAT BUILT TO MILITARY-UNIQUE SPECIFICATIONS. FOR EXAMPLE, A DEFENSE SCIENCE BOARD STUDY OF COMPARABLE ELECTRONIC SYSTEMS, SUCH AS COMPUTERS, RADIOS, SENSORS, AND DISPLAYS FOUND THE COMMERCIAL EQUIVALENTS TO BE BETWEEN TWO AND TEN TIMES LESS EXPENSIVE, UP TO FIVE TIMES FASTER TO ACQUIRE, OFTEN MORE RELIABLE, ONE TO THREE YEARS MORE ADVANCED IN TECHNOLOGY, AND CAPABLE OF WITHSTANDING HARSH ENVIRONMENTS.

AS I MENTIONED EARLIER, A MAJOR OBSTACLE TO INCREASING OUR RELIANCE ON COMMERCIAL PRODUCTS AND PROCESSES HAS ALWAYS BEEN CHANGING THE DOD MINDSET TOWARDS COMMERCIALITY. WHEN SOMEONE HAS BEEN USING A MILITARY SPECIFICATION OR STANDARD SUCCESSFULLY FOR 20 YEARS, IT IS VERY DIFFICULT TO SUGGEST THERE MAY BE A BETTER WAY. THERE ARE ALSO A NUMBER OF LEGITIMATE CONCERNS ABOUT PROBLEMS ASSOCIATED WITH LOGISTICS SUPPORT, DATA RIGHTS, WARRANTIES, CONFIGURATION MANAGEMENT AND CONTROL, AND FOREIGN SOURCES. WE ARE TRYING TO CHANGE PEOPLE'S MINDSETS AND PROVIDE ANSWERS OR APPROACHES TO LEGITIMATE CONCERNS IN TWO WAYS. FIRST, THROUGH TRAINING, AND I WILL SPEAK MORE ON THIS LATER. SECONDLY, WE HAVE RECENTLY PUBLISHED A NONDEVELOPMENTAL ITEM PROGRAM HANDBOOK ENTITLED "BUYING NDI" THAT PROVIDES GUIDANCE ON USING COMMERCIAL AND OTHER TYPES OF NONDEVELOPMENTAL ITEMS TO MEET DOD NEEDS. NOW I MUST OFFER A WORD OF CAUTION. THIS HANDBOOK IS NOT A COOK BOOK THAT GIVES A RECIPE FOR TROUBLE FREE COMMERCIAL ACQUISITION. THE PURPOSE OF THIS GUIDANCE HANDBOOK IS TO STIMULATE YOUR THINKING TO ALLOW YOU TO DEVELOP NEW CREATIVE APPROACHES TO OVERCOMING PERCEIVED AND REAL IMPEDIMENTS TO COMMERCIAL ACQUISITION.

A NUMBER OF RECENT ACTIONS HAVE BEEN TAKEN TO PROMOTE THE USE OF COMMERCIAL COMPONENTS IN MILITARY SYSTEMS. ONE PROACTIVE STEP TAKEN BY WORKING GROUP 9 ON SPECIFICATIONS AND STANDARDS UNDER THE DMR REGULATORY RELIEF TASK FORCE WAS TO CONDUCT A ZERO-BASED REVIEW OF OVER 35,000 MILITARY AND FEDERAL SPECIFICATIONS AND STANDARDS. A MAJOR PART OF THAT REVIEW WAS DIRECTED TOWARDS CONSIDERATION OF COMMERCIAL ALTERNATIVES TO MILITARY-UNIQUE REQUIREMENTS DOCUMENTS. AS A RESULT OF THIS HERCULEAN EFFORT, NEARLY 5,000 MILITARY AND FEDERAL SPECIFICATIONS AND STANDARDS WILL BE CANCELLED, AND MANY OF THESE WILL BE REPLACED BY NON-GOVERNMENT STANDARDS AND COMMERCIAL ITEM DESCRIPTIONS.

IN THE AREA OF NEW POLICIES AND PROCEDURES, THERE IS A PROPOSED CHANGE TO PART 10 OF THE FEDERAL ACQUISITION REGULATION THAT WILL REQUIRE THE USE OF A NON-GOVERNMENT STANDARD OR COMMERCIAL ITEM DESCRIPTION IN LIEU OF A MILITARY SPECIFICATION OR PURCHASE DESCRIPTION. THE ONLY EXCEPTIONS TO THIS ORDER OF PREFERENCE WILL BE IF A REQUIREMENTS DOCUMENT IS MANDATED BY LAW OR IF THE NON-GOVERNMENT STANDARD OR COMMERCIAL ITEM DESCRIPTION DOES NOT MEET THE GOVERNMENT'S NEEDS. WHILE THIS HAS BEEN A DOD POLICY FOR A NUMBER OF YEARS, THIS IS THE FIRST TIME IT HAS FOUND ITS WAY INTO THE FEDERAL ACQUISITION REGULATION.

A NEW PROCEDURE BEING PURSUED UNDER A RECOMMENDATION FROM THE DMR'S WORKING GROUP 9 IS TO SIMPLIFY THE PROCESS THE DOD USES TO ADOPT NON-GOVERNMENT STANDARDS. BY MAKING IT EASIER TO ADOPT NON-GOVERNMENT STANDARDS, WE BELIEVE THE NUMBER OF ADOPTED COMMERCIAL STANDARDS COULD BE INCREASED FROM 5,000 TO 10,000 IN LESS THAN TWO YEARS. THIS SIMPLIFIED ADOPTION PROCESS WILL BE JUST ONE OF MANY DMR-RELATED CHANGES THAT WILL BE INCLUDED IN A MAJOR REVISION TO THE DEFENSE STANDARDIZATION MANUAL THAT WILL BE OUT FOR COMMENT WITHIN THE NEXT FEW MONTHS.

WHILE NEW POLICIES, PROCEDURES, AND INITIATIVES ARE ALL GOOD AND NECESSARY TO PROVIDE DIRECTION, THEY DO NOT REALLY ACCOMPLISH ANY GOAL OR TASK.... PEOPLE DO. ONE VERY IMPORTANT POINT MADE BY THE DEFENSE MANAGEMENT REPORT IS THAT A HIGHLY TRAINED AND MOTIVATED WORK FORCE WILL BE NEEDED IF WE ARE TO MEET THE CHALLENGE OF PROVIDING A CAPABLE MILITARY FORCE WITH LESS RESOURCES. I COULD NOT AGREE MORE. UNFORTUNATELY, TRAINING IN ACQUISITION IS AN AREA WHERE THE DOD HAS NOT DONE A PARTICULARLY GOOD JOB. THERE NEVER SEEMS TO BE ENOUGH OF THE RIGHT COURSES, AND TRAINING DOLLARS ARE ALWAYS THE FIRST TO BE CUT.

WHILE WE STILL HAVE A LONG WAY TO GO IN TRAINING, WE HAVE TAKEN SOME SIGNIFICANT FIRST STEPS THAT WE HOPE WILL PAY BIG DIVIDENDS. IN OCTOBER 1990, WE BEGAN TEACHING THE FIRST OF 70 FULLY FUNDED CLASSES ON NONDEVELOPMENTAL ITEMS AND COMMERCIAL ACQUISITION. IF ANYONE EVER HAD A DOUBT ABOUT THE CRYING NEED FOR MORE TRAINING, LET ME SHARE A STATISTIC WITH YOU. THERE HAVE BEEN ABOUT 10,000 SLOTS REQUESTED FROM THE MILITARY DEPARTMENTS AND AGENCIES FOR THIS COURSE. OBVIOUSLY, SUCH A DEMAND CANNOT BE MET BY 70 CLASSES.

WE ARE PLANNING LONG-TERM STEPS TO HAVE THIS NONDEVELOPMENTAL ITEM AND COMMERCIAL ACQUISITION COURSE, AS WELL AS OUR TWO SPECIFICATION MANAGEMENT COURSES THAT ARE ALSO UNABLE TO MEET THE CURRENT DEMAND, INCLUDED UNDER THE ACQUISITION CAREER ENHANCEMENT

PROGRAM. WE HOPE THAT UNDER THIS PROGRAM, ADDITIONAL FUNDING AND COURSE INSTRUCTORS WILL BE PROVIDED TO SERVE THE TRAINING NEEDS OF THE ACQUISITION COMMUNITY.

ONE OF DMR'S THREE OBJECTIVES IS TO IMPROVE THE MANAGEMENT OF DOD RESOURCES. A MAJOR CRITICISM OF THE CURRENT ACQUISITION PROCESS IS THAT WE MAKE DECISIONS ON A SHORT-TERM, ISSUE-BY-ISSUE BASIS. AS A RESULT, WE TEND TO BE FIRE FIGHTERS RATHER THAN MANAGERS OF OUR PROGRAMS. WE SEEM TO BE LACKING IN TWO CRITICAL AREAS --- ADEQUATE MEASURING TOOLS AND LONG-RANGE STRATEGIC PLANNING.

WORKING GROUP 9 OF THE DMR ESTABLISHED A NUMBER OF AMBITIOUS GOALS THAT INCLUDED ELIMINATING UNNECESSARY MILITARY-UNIQUE REQUIREMENTS; INCREASING RELIANCE ON COMMERCIAL PRODUCTS AND PROCESSES; RESPONDING TO NEW REQUIREMENTS IN THE FUTURE WITH METRIC DOCUMENTS; AND IDENTIFYING AND ELIMINATING HAZARDOUS MATERIALS. WHILE THIS IS ALL WELL AND GOOD, I WOULD HAVE TO ASK THESE QUESTIONS: "HOW WILL WE KNOW WHEN WE ARE DONE?" "WHEN CAN WE PROCLAIM VICTORY IN ACCOMPLISHING ONE GOAL AND MOVE ON TO ANOTHER?" "WHAT MEASUREMENTS ARE WE USING TO EVALUATE OUR SUCCESS?"

QUANTIFYING SUCCESS WILL NOT BE EASY, BUT IT IS NECESSARY. UNDER WORKING GROUP 9 OF THE DMR, A SUBSTANTIVE DATA BASE OF INFORMATION WAS COLLECTED TO ALLOW US TO TRACK PROGRESS IN A NUMBER OF KEY AREAS. BUT THIS BEAN COUNTING ANALYSIS SERVES ONLY AS AN INDICATOR AND CANNOT SUBSTITUTE FOR TRUE PLANNING.

WE HAVE A NUMBER OF PLANNING INITIATIVES UNDER CONSIDERATION AT PRESENT, INCLUDING A SENIOR LEVEL STRATEGIC PLANNING OFF-SITE, AND SELECTIVE WEAPON SYSTEM REVIEWS TO EVALUATE THE APPLICATION OF OUR POLICIES AND DOCUMENTS AT DIFFERENT MILESTONES. THE ONE AREA OF PLANNING, HOWEVER, WHERE YOU CAN MAKE AN IMMEDIATE DIFFERENCE IS IN IMPROVING THE QUALITY AND IMPLEMENTATION OF YOUR STANDARDIZATION PROGRAM PLANS. BY AND LARGE, EXISTING PROGRAM PLANS PROVIDE DATA, BUT LITTLE OR NO PLANNING. WORKING GROUP 9 FOUND THAT VERY FEW PROGRAM PLANS ARE DEVELOPED WITH INPUT FROM PROGRAM OFFICES, MAINTENANCE OFFICES, VALUE ENGINEERING, OR ANY OTHER DISCIPLINE THAT IS OUTSIDE THE STANDARDIZATION STOVEPIPE. IF YOU DO NOT INVOLVE THE USERS OF THE TECHNICAL DOCUMENTS, PROCESSES, OR EQUIPMENT, IT IS IMPOSSIBLE TO DEVELOP A TRULY MEANINGFUL PLAN, OR ONE THAT PEOPLE CARE ABOUT BEING IMPLEMENTED.

ONE AREA WHERE WE ARE SEEING THE FRUITS OF A GOOD PROGRAM PLAN COUPLED WITH ACTION IS IN CONFIGURATION MANAGEMENT. IN RESPONSE TO A

DMR GOAL TO IMPROVE THE QUALITY OF OUR REQUIREMENTS DOCUMENTS BY ELIMINATING REDUNDANT, UNNECESSARY, AND CONFLICTING REQUIREMENTS, A CONFIGURATION MANAGEMENT PROGRAM PLAN WAS PUBLISHED LAST YEAR THAT PLANNED FOR THE DEVELOPMENT OF A SINGLE TOP LEVEL STANDARD AND ASSOCIATED GUIDANCE HANDBOOK TO CONSOLIDATE AND STREAMLINE ALL ASPECTS OF CONFIGURATION MANAGEMENT, CANCEL SEVEN EXISTING STANDARDS, AND PROVIDE EXTENSIVE TAILORING GUIDELINES TO PRECLUDE OVERAPPLICATION OF REQUIREMENTS. WHAT IS MOST SIGNIFICANT, HOWEVER, IS NOT THE PLAN, BUT THE ACTION THAT FOLLOWED THE PLAN. FOR THE LAST SEVERAL MONTHS, THERE HAS BEEN AN INTENSIVE, COORDINATED EFFORT INVOLVING THE MILITARY DEPARTMENTS, DEFENSE AGENCIES, AND INDUSTRY ASSOCIATIONS TO DRAFT THE NECESSARY STANDARD AND HANDBOOK, AND I UNDERSTAND THAT BEGINNING TOMORROW, MILITARY AND INDUSTRY USERS OF THESE DOCUMENTS WILL BE LOCKED AWAY IN A TWO DAY WORKSHOP TO RESOLVE ANY DIFFERENCES AND WORK TOWARDS SIGNIFICANTLY IMPROVING THE CONFIGURATION MANAGEMENT PROCESS. THIS IS HOW THE PROGRAM PLANNING PROCESS IS SUPPOSED TO WORK.

WHAT IS OCCURRING IN THE CONFIGURATION MANAGEMENT PROGRAM ILLUSTRATES THE THIRD MAJOR IMPACT THE DMR WILL HAVE ON YOUR PROGRAMS, AND THAT IS THE STREAMLINING OF ALL REQUIREMENTS, POLICIES, AND PROCESSES. FOR EXAMPLE, THE RECENT REVISION TO DOD DIRECTIVE 5000.1 ON "DEFENSE ACQUISITION" CANCELLED 58 DOD DIRECTIVES AND INSTRUCTIONS, INCLUDING NINE POLICY DOCUMENTS GOVERNING STANDARDIZATION, DATA MANAGEMENT, AND CONFIGURATION MANAGEMENT. THE CORE OF THESE CANCELLED POLICY DOCUMENTS CAN NOW BE FOUND IN DOD INSTRUCTION 5000.2 ON "DEFENSE ACQUISITION MANAGEMENT POLICIES AND PROCEDURES," BUT THE MORE DETAILED OR "HOW-TO" REQUIREMENTS WERE INTENTIONALLY OMITTED IN AN EFFORT TO PROMOTE MORE CREATIVE THINKING AND INDIVIDUAL JUDGMENT. THE CURRENT TREND IS TO RELY MORE ON GUIDANCE HANDBOOKS THAT SUGGEST ALTERNATIVES OR PROBLEM SOLVING TECHNIQUES TO MEET BROAD POLICY GOALS. THE RECENT NONDEVELOPMENTAL ITEM HANDBOOK IS A GOOD EXAMPLE OF THIS NEW PHILOSOPHY. THE MANDATORY NDI POLICIES AND PROCEDURES IN DOD INSTRUCTION 5000.2 COVER LESS THAN 2 PAGES, BUT THE GUIDANCE ON WHAT TECHNIQUES CAN BE USED TO MEET THESE POLICIES IS COVERED IN A 140 PAGE HANDBOOK.

IN ADDITION TO CONSOLIDATING AND STREAMLINING A NUMBER OF DOD POLICIES, DOD INSTRUCTION 5000.2 ALSO ESTABLISHES A NUMBER OF NEW BUSINESS STRATEGIES FOR THE FUTURE. FOR INSTANCE, IN THE AREA OF DATA MANAGEMENT, DOD INSTRUCTION 5000.2 REQUIRES THE ACQUISITION OF TECHNICAL DATA IN DIGITAL FORM UNLESS IT IS NOT COST-EFFECTIVE FOR THE GOVERNMENT. IT ALSO STRESSES THAT MAXIMUM USE SHOULD BE MADE OF AVAILABLE CONTRACTOR AUTOMATED DATA BASES. BY ACQUIRING DIGITIZED DATA, WE CAN PROVIDE DATA MANAGERS AND THEIR CUSTOMERS WITH AN ADDED

FLEXIBILITY CURRENTLY NOT AVAILABLE. WITH DIGITAL DATA STORED IN AN INTEGRATED WEAPON SYSTEMS DATA BASE, THE ENGINEERING, MANUFACTURING, AND LOGISTICAL INFORMATION CAN BE ACCESSED AND MANIPULATED WITH GREAT EFFICIENCY TO SATISFY A MULTITUDE OF FUNCTIONS.

IN THE FINAL ANALYSIS, IT IS TOO EARLY TO ASSESS THE EXACT IMPACT THE DMR WILL HAVE ON THE STANDARDIZATION, DATA MANAGEMENT, AND CONFIGURATION MANAGEMENT PROGRAMS. HOWEVER, IT IS A CERTAINTY THAT SIGNIFICANT CHANGES IN THE ACQUISITION PROCESS MUST TAKE PLACE OR WE WILL BE HARD PRESSED TO MEET THE DEFENSE NEEDS OF THIS COUNTRY IN THE FUTURE. WHAT THE DMR HAS PROVIDED IS AN OPPORTUNITY TO MAKE THE KIND OF PROCESS CHANGES THAT WERE ALWAYS CONSIDERED IMPOSSIBLE. IN THE PAST, IT WAS CONVENIENT, AND ALSO PROBABLY TRUE, TO CLAIM THAT SMART WAYS OF CONDUCTING BUSINESS COULD NOT BE PURSUED BECAUSE OF SOME LAW, THE FEDERAL ACQUISITION REGULATION, OR DOD POLICY. THE DMR HAS OPENED UP ALL THESE AREAS TO CHANGE. HUNDREDS OF DOD POLICY DOCUMENTS HAVE BEEN CANCELLED, CONSOLIDATED, OR REWRITTEN. THE SAME THING IS HAPPENING WITH THOUSANDS OF CLAUSES IN THE FEDERAL ACQUISITION REGULATION AND THE DOD SUPPLEMENT. CONGRESS HAS ALSO EXPRESSED A WILLINGNESS TO CONSIDER ANY LEGISLATIVE CHANGES NEEDED TO IMPROVE DEFENSE ACQUISITION.

DURING THIS WEEK, EVERYONE HERE WILL HAVE AN OPPORTUNITY TO SHAPE THE WAY WE DO BUSINESS IN THE FUTURE DURING THE VARIOUS PANEL AND WORKSHOP SESSIONS. I CAN ASSURE YOU OF MY PERSONAL INTEREST IN THE RECOMMENDATIONS COMING FROM THIS CONFERENCE, AND I PLAN TO WORK WITH MY STAFF AND THE SERVICE AND AGENCY EXECUTIVES ON THIS PANEL TODAY TO IMPLEMENT AS MANY OF THESE RECOMMENDATIONS AS POSSIBLE IN THE SHORTEST AMOUNT OF TIME.

THE FINAL POINT I WANT TO MAKE ABOUT THE DMR CAN BEST BE SUMMED UP BY SECRETARY CHENEY'S CONCLUDING SENTENCE IN HIS LETTER TO PRESIDENT BUSH WHICH STATED THAT IMPLEMENTING THE DMR RECOMMENDATIONS "WILL DEMAND THE DEPARTMENT'S SUSTAINED ATTENTION AND DILIGENT EFFORT IN THE YEARS AHEAD." I THINK EVERYONE APPRECIATES THAT REFORMING THE ACQUISITION SYSTEM WILL BE A LONG, ARDUOUS PROCESS AND THERE WILL BE MISTAKES AND RISKS. BUT I WOULD SUBMIT TO YOU THAT THE RISK OF NOT CHANGING IS FAR GREATER THAN THE RISK OF CHANGE. THE ENTIRE DEFENSE ACQUISITION COMMUNITY NEEDS TO WORK TOGETHER AS A TEAM TO MAKE THE REAL PROGRESS NECESSARY IN PROVIDING THE HIGHEST QUALITY PRODUCTS AND SERVICES TO THE MEN AND WOMEN IN THE FIELD ON TIME AND WITHIN BUDGET. THANK YOU.



Mr. Nicholas M. Torelli, Jr., Deputy Assistant Secretary of Defense for Production Resources, Office of the Assistant Secretary of Defense for Production and Logistics, addressing the May 14, 1991, General Session of the DoD Standardization and Data/Configuration Management Conference.



Mr. Richard Donnelly, Director, Manufacturing Modernization Directorate, Office of the Assistant Secretary of Defense for Production and Logistics, introducing Mr. Paul Strassmann, Director, Defense Information, Office of the Assistant Secretary of Defense for Command, Control, Communications, and Intelligence, as the keynote speaker for the May 14 General Session of the conference.

DEFENSE
MANAGEMENT
REVIEW
IMPACTS FOR THE
ARMY

PRESENTED TO
1991 JOINT DOD
STANDARDIZATION AND
DATA/CONFIGURATION MANAGEMENT
CONFERENCE

BY
D. L. GRIFFIN
PRINCIPAL ASSISTANT DEPUTY
FOR
RESEARCH, DEVELOPMENT AND ACQUISITION

14 MAY 1991

OFFICE OF
DEPUTY COMMANDING GENERAL
FOR
RESEARCH, DEVELOPMENT
AND ACQUISITION

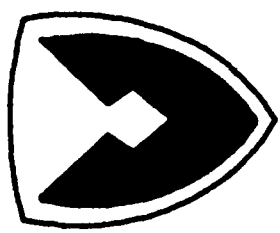

US ARMY MATERIEL COMMAND
ALEXANDRIA, VIRGINIA



OUTLINE

- CONTRACTOR CERTIFICATION
- SPECIFICATIONS AND STANDARDS
- DATA ITEM MANAGEMENT
- TECHNICAL DATA PACKAGES
- CONFIGURATION MANAGEMENT
- SUMMARY

AMC



ACQUISITION STRATEGY

- DEVELOP PROCESSES DURING FSD
 - DEVELOPMENT SCOPE OF WORK
 - CONCURRENT ENGINEERING DESIGN TEAM
 - EQUAL EMPHASIS ON PROCESS AND PRODUCT
 - INITIAL PRODUCTION BY DEVELOPER
- PROOF OF PRODUCTION DURING FULL SCALE DEVELOPMENT
- PERFORMANCE SPECIFICATIONS
- GREATER EMPHASIS ON DUAL-USE TECHNOLOGIES
- PRODUCIBILITY, QUALITY AND PRODUCTION ARE DEVELOPMENT SOURCE SELECTION FACTORS

AMC



CONTRACTOR CERTIFICATION PROGRAM

- ORIENTED TO PROCESS CONTROL
- PERFORMANCE METRICS
 - FIRST PASS ACCEPTANCE
 - CYCLE TIME
 - COST
- CERTIFICATION OF GOVERNMENT PLAYERS
- BEST VALUE SOURCE SELECTION/CONTRACT AWARD

AMC



CONTRACTOR SELF GOVERNANCE AND CERTIFICATION

REQUIRE:

- **LONG TERM GOVERNMENT AND CONTRACTOR RELATIONSHIPS**
- **LONG TERM CONTRACTOR AND SUB-CONTRACTOR RELATIONSHIPS**
- **ELIMINATION OF BARRIERS BETWEEN DEFENSE
AND COMMERCIAL BUSINESS PRACTICES**
- **CERTIFIED SUPPLIERS AS WELL AS PRIME CONTRACTORS**

AMC



**ARMY MATERIEL SYSTEMS ANALYSIS ACTIVITY
SPECIFICATIONS AND STANDARDS REVIEW RESULTS**

- **FEW SPECIFICATIONS AND STANDARDS ARE TRULY MULTIPLE USE DOCUMENTS**
- **MOST FREQUENTLY REFERENCED ARE THE MOST FREQUENTLY USED**
- **LEAST FREQUENTLY REFERENCED ARE AMONG THE LEAST FREQUENTLY USED**
- **CLASSES OF HIGH USAGE SPECIFICATIONS AND STANDARDS**
 - **FUNCTIONAL (DRAWING PRACTICES, QUALITY, SOLDERING)**
 - **ELECTRONICS (PRINTED WIRING BOARDS)**
 - **PACKAGING AND MARKING**

AMC



APPLICATION OF
SPECIFICATIONS AND STANDARDS
POLICY

- FULL SCALE DEVELOPMENT
- SPECIFICALLY CITED IN THE CONTRACT SOW
OR PERFORMANCE SPECIFICATION
- SPECIFICALLY TAILORED
- PRODUCTION - DIRECTLY CITED IN THE TECHNICAL DATA PACKAGE
- NON-DEVELOPMENTAL - DIRECTLY CITED IN TECHNICAL DOCUMENTATION

AMC



DATA ITEM DESCRIPTION FUNCTIONAL POLICY

- THE HEAD OF THE CONTRACTING ACTIVITY (HCA) SHALL ENSURE MANAGEMENT REQUIREMENTS, FUNCTIONAL REQUIREMENTS, AND DATA REQUIREMENTS ARE FULLY JUSTIFIED AS ESSENTIAL AND COST EFFECTIVE PRIOR TO THEIR USE IN A SOLICITATION OR CONTRACT.
- THE HEAD OF THE CONTRACTING ACTIVITY (HCA) OR A MEMBER OF THE SENIOR EXECUTIVE SERVICE (SES) DESIGNATED BY THE HCA SHALL HAVE AUTHORITY FOR APPROVING THE JUSTIFICATIONS.

AMC



TECHNICAL DATA PACKAGES

- GOAL IS TO BUY THE MINIMUM ESSENTIAL DATA IN THE FORM OF TOPS FOR REPROCUREMENT AND LOGISTICS SUPPORT
- EMPHASIS IS ON "WHAT, NOT HOW TO"
- REQUIRES MORE COMPREHENSIVE ACQUISITION AND SUPPORT PLANNING
 - LIFE CYCLE SUPPORT
 - OPTIONS INCLUDED IN DEVELOPMENT CONTRACT
- DON'T BUY WHAT WE DON'T NEED

AMC



CONFIGURATION MANAGEMENT

- AUDITS TO ASSURE PROCESSES ARE IN CONTROL
- ASSURE PROCESSES REMAIN IN CONTROL
- ECPS, DEVIATIONS, AND/OR WAIVERS WILL NOT BE CARRIED FORWARD
- ECPS, DEVIATIONS, AND/OR WAIVERS MUST BE CLOSED LOOP

AMC



SUMMARY

- DEVELOPMENT CONTRACTOR WILL BE INITIAL PRODUCTION CONTRACTOR
- PRODUCTION PROVE-OUT DURING DEVELOPMENT
USING PRODUCTION TYPE TOOLING AND PROCESSES
- CONTRACTOR CERTIFICATION

PROCESSES + PRODUCIBILITY = SYSTEMS PERFORMANCE

AMC

DEFENSE MANAGEMENT REPORT



DEPARTMENT OF THE NAVY

KEY ELEMENTS OF DON IMPLEMENTATION

- **ACQUISITION SECRETARIAT STREAMLINED**
- **ACQUISITION MANAGEMENT STRUCTURE CLARIFIED**

DON DMR IMPLEMENTATION GOALS

- **FULLY IMPLEMENT BOTH THE INTENT AND SPECIFIC DIRECTIONS OF THE DMR IN A MANNER THAT ENHANCES OUR ABILITY TO MEET THE WARFIGHTING NEEDS OF THE CINCs**
- **ENSURE COMPLIANCE WITH ALL PROVISIONS OF THE GOLDWATER-NICHOLS REORGANIZATION ACT AND OTHER STATUTORY REQUIREMENTS**
- **RESOLVE OTHER ORGANIZATIONAL AND MANAGEMENT ISSUES DURING THE IMPLEMENTATION PLANNING PROCESS**
- **REDUCE MANAGEMENT COSTS TO AVOID LARGER CUTS TO OPERATING FORCES**

SECRETARIAT REORGANIZATION

BEFORE DMR

- THE SECRETARY OF THE NAVY OR UNDER SECRETARY OF THE NAVY SERVES AS THE NAVY'S ACQUISITION EXECUTIVE--NOT FULL TIME
- ACQUISITION STAFF SUPPORT RESPONSIBILITIES SPLIT BETWEEN THE ASSISTANT SECRETARIES FOR RESEARCH, ENGINEERING AND SYSTEMS AND SHIPBUILDING AND LOGISTICS
- MANY ACQUISITION PROGRAM MANAGEMENT DECISIONS MUST BE REVIEWED AND CLEARED BY SECRETARIAT STAFF

AFTER DMR

- ASSISTANT SECRETARY OF THE NAVY FOR RESEARCH, DEVELOPMENT AND ACQUISITION SERVES AS THE NAVY'S FULL-TIME ACQUISITION EXECUTIVE
- ALL SECRETARIAT ACQUISITION STAFF RESPONSIBILITIES EXERCISED IN THE OFFICE OF THE ASSISTANT SECRETARY FOR RESEARCH, DEVELOPMENT AND ACQUISITION
- AUTHORITY AND ACCOUNTABILITY REFOCUSSED IN LINE MANAGERS, AND PUSHED DOWN TO PROGRAM MANAGERS AND THEIR DIRECT SUPERVISORS
- ASSISTANT SECRETARY FOR INSTALLATIONS AND ENVIRONMENT PROVIDES FULL-TIME, TOP-LEVEL FOCUS CONCERNS

SECRETARIAT REORGANIZATION (CONTINUED)

BEFORE DMR

- NO SINGLE FOCAL POINT FOR COORDINATION OF DON POSITION ON INTERNATIONAL PROGRAMS
- RESPONSIBILITY FOR ASW TECHNOLOGY AND PROGRAM DEVELOPMENT FRAGMENTED
- ADP ACQUISITION NOT CONDUCTED UNDER REGULAR ACQUISITION OVERSIGHT STRUCTURE

AFTER DMR

- THE OFFICE OF THE ASSISTANT SECRETARY FOR RESEARCH, DEVELOPMENT AND ACQUISITION IS FOCAL POINT FOR COORDINATION OF ALL INTERNATIONAL PROGRAMS
- THE OFFICE OF THE ASSISTANT SECRETARY FOR RESEARCH, DEVELOPMENT AND ACQUISITION PROVIDES A CENTRAL FOCUS FOR ASW TECHNOLOGY AND DEVELOPMENT
- ASSISTANT SECRETARY OF THE NAVY FOR RESEARCH, DEVELOPMENT AND ACQUISITION SERVES AS THE SENIOR INFORMATION RESOURCES MANAGEMENT OFFICIAL

SECRETARIAT ORGANIZATION NEW

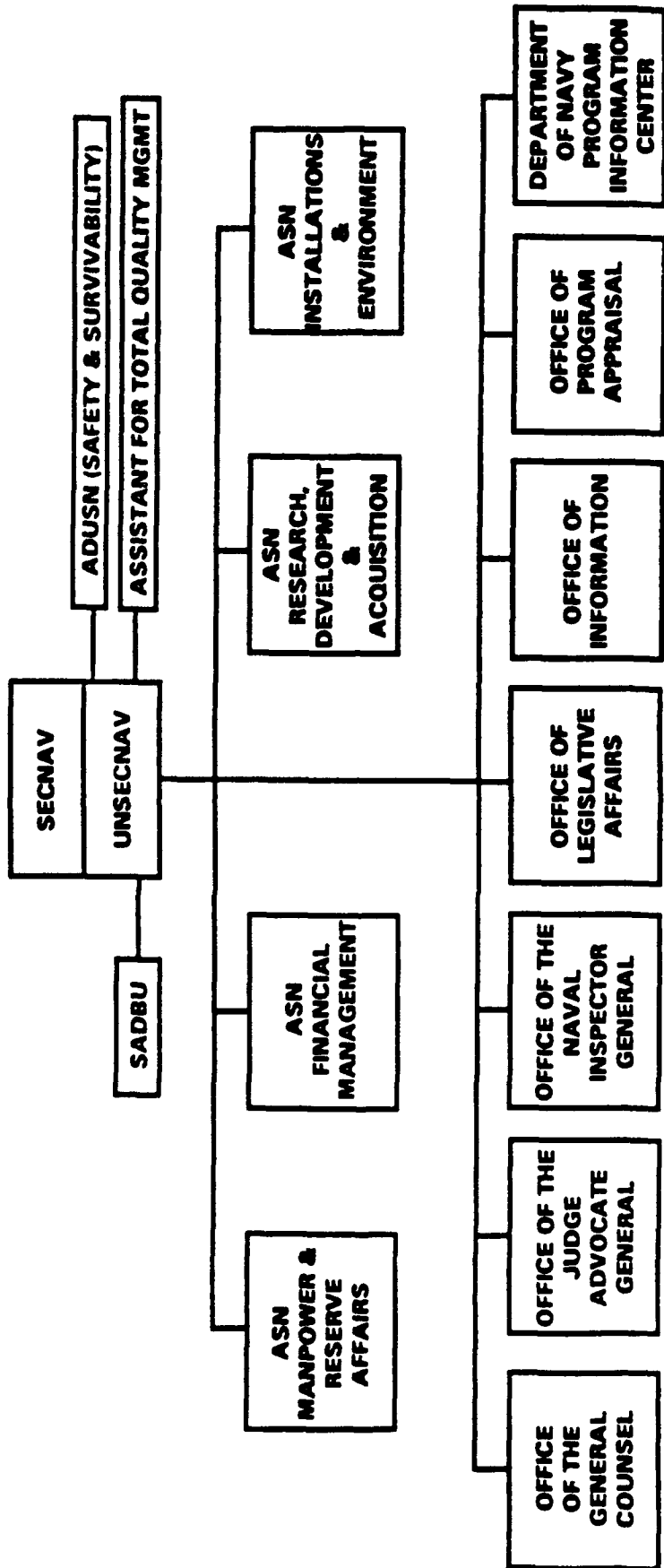

SECRETARIAT ACQUISITION ORGANIZATION POST DMR

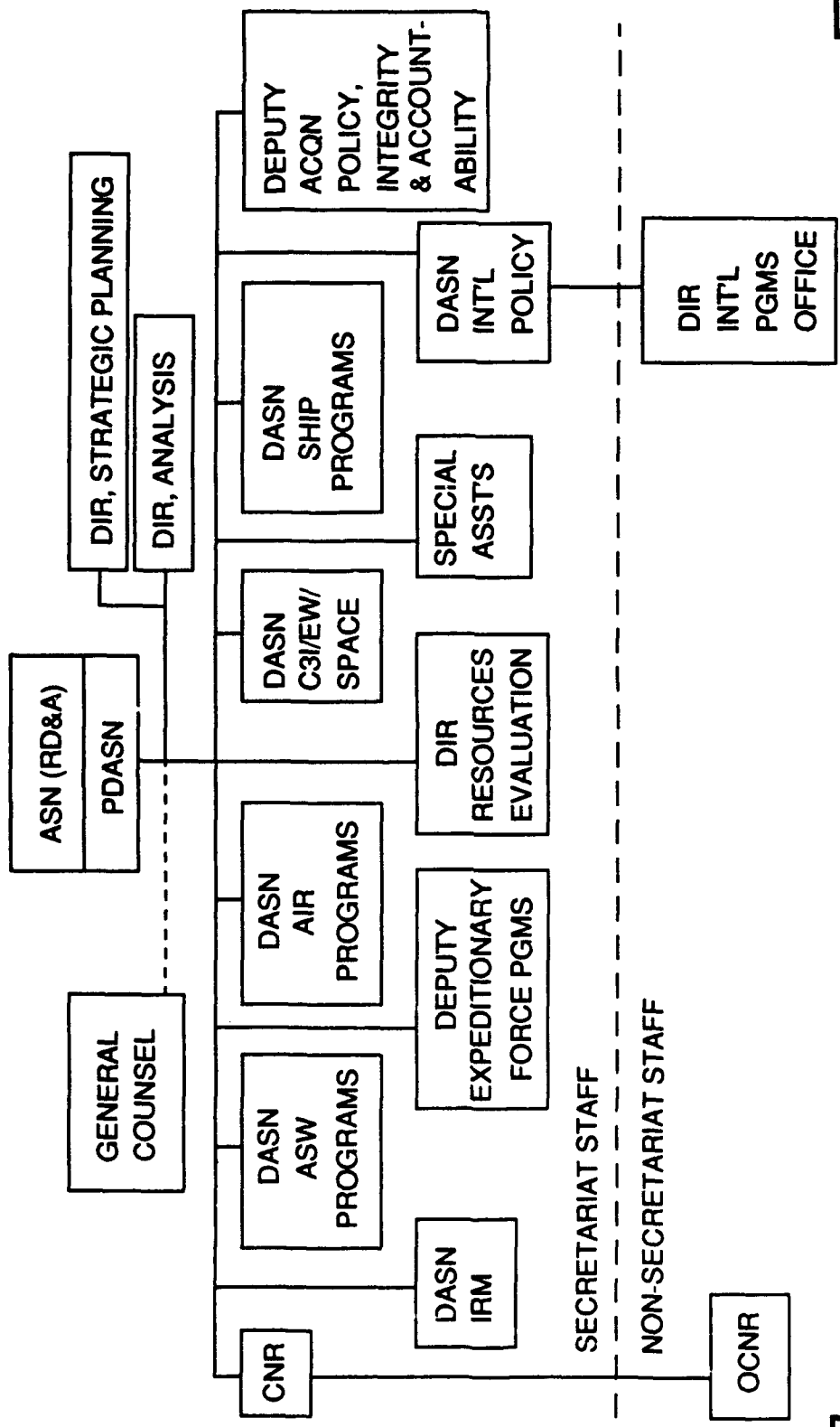

ACQUISITION MANAGEMENT STRUCTURE

BEFORE DMR

- FOUR NAVY AND ONE MARINE CORPS COMMANDS (SYSTEM COMMANDS) MANAGE ALL WEAPON SYSTEM ACQUISITION PROGRAMS
- SUBSTANTIAL ACQUISITION DECISION AUTHORITY RESERVED TO THE SECRETARIAT AND/OR SYSTEM COMMANDERS
- SYSTEM COMMANDERS EXERCISE CRADLE-TO-GRAVE LIFE CYCLE ACQUISITION AND MANAGEMENT RESPONSIBILITY FOR ALL ASSIGNED WEAPON SYSTEMS

AFTER DMR

- SIX NEW PROGRAM EXECUTIVE OFFICERS (PEOs) AND FOUR DIRECT REPORTING PROGRAM MANAGERS (PMs) DEVOTE FULL-TIME TO ASSIGNED PROGRAMS
- PEOs AND DIRECT REPORTING PMs EMPOWERED WITH DECISION AUTHORITY PREVIOUSLY RESERVED TO THE SECRETARIAT AND/OR SYSTEM COMMANDERS
- SYSTEM COMMANDS MISSION REFOCUS TO MANAGE ACQUISITION PROGRAMS NOT ASSIGNED TO PEOs; PROVIDE MATRIX SUPPORT TO THE PEOs; AND PROVIDE LOGISTICS SUPPORT
- MANAGEMENT OF CERTAIN MATURE, STABLE ACQUISITION PROGRAMS RETAINED BY THE SYSTEM COMMANDS, WITH USD(A) APPROVAL

MAJOR PROGRAM ASSIGNMENTS

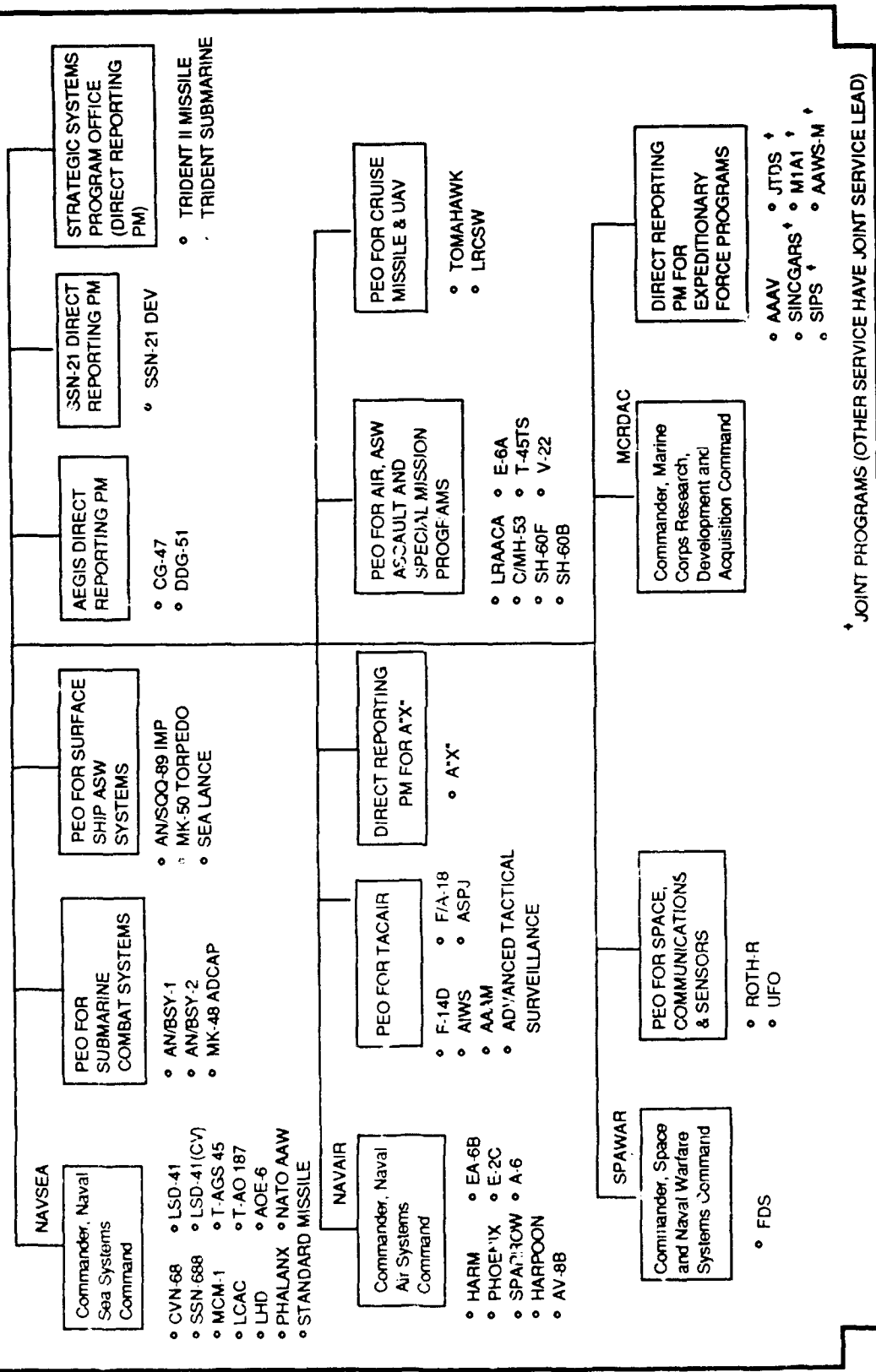

† JOINT PROGRAMS (OTHER SERVICE HAVE JOINT SERVICE LEAD)

THE ADMINISTRATIVE BURDEN IN PERSPECTIVE

DoD Directives & Instructions

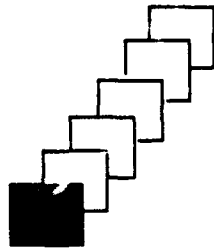

- 500 + Documents
- Includes 146 "Advocacy" Documents

Procurement & Contracting Guidance

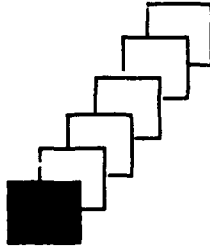

- 400 + DFARS Clauses and 66,000 + Lines of Text
- 80 Dept/Agency Contract Clauses and 44,000 Agency Supplement Lines of Text
- 12,000 Component-level Contract Clauses and 1,700,000 Component-level Lines of Text

Specifications & Standards

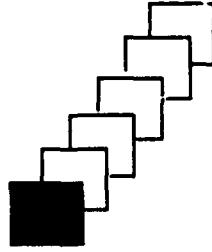

- 27,000 Mil Specs
- 7,000 Mil Stds
- 16,000 Related Documents



- STIFLING BURDEN
- ADMINISTRATIVE MAZE
- MAJOR RESTRUCTURING/REVISIONS REQUIRED

REDUCING THE SELF-IMPOSED BURDEN

● **ACTION PLAN PROVIDES FOR THE CANCELLATION, CANCELLATION AND COMBINATION, OR REVISION AND REISSUANCE OF:**

- 300 (78%) OF 383 DoD DIRECTIVES/INSTRUCTIONS REVIEWED

- 274 (64%) OF 431 DFARS CLAUSES

- 52,450 (79%) OF 66,665 LINES OF DFARS TEXT

- 61 (76%) OF 80 DEPARTMENT/AGENCY CONTRACT CLAUSES

- 23,065 (52%) OF 44,060 LINES OF DEPARTMENT/AGENCY TEXT

REDUCING THE SELF-IMPOSED BURDEN

- **ISSUE BY 1 JULY 1990, A NEW SET OF STREAMLINED DoD-LEVEL DIRECTIVES AND INSTRUCTIONS (NOW DUE FEBRUARY 1991)**
- **PUBLISH FOR PUBLIC COMMENT BY AUGUST 1990, A REVISED DFARS; AND A FINAL DFARS BY FEBRUARY 1991**
- **IMPLEMENT RECOMMENDATIONS ON 1,537 STANDARDS BY JUNE 1991; IMPLEMENT RECOMMENDATIONS ON 48,500 SPECIFICATIONS AND OTHER DOCUMENTS BY JUNE 1992**

NAVY TRAINING IN STANDARDIZATION

- Acquisition Streamlining (Sponsor: ASN(RDA))
 - 1,000 DON and contractor personnel per year (approx.)
- Writing Specifications (Sponsor: NAVSEA 55Z)
 - 120 NAVSEA and contractor personnel per year (approx.)
- Defense Specification Management Course (ALMC for OSD)
 - 100 DON personnel per year (approx.)
- Data Management (Sponsor: CCPO)
 - 50 DON personnel per year (approx.)
- Configuration Management (Sponsor: CCPO)
 - 175 DON personnel per year (approx.)

NAVY COMMERCIALIZATION OF STANDARDIZATION DOCUMENTS

- 12,596 NAVY MIL/FED SPECS/STDS LISTED IN DODISS
 - 2,116 "NAVY" NON-GOVERNMENT STANDARDS (NGS) LISTED
 - 160 NAVY COMMERCIAL ITEM DESCRIPTIONS (CIDS) LISTED
- DMR REVIEW IDENTIFIED 300-400 ADDITIONAL NAVY DOCUMENTS FOR CONVERSION TO NGS/CID
- NAVY INITIATIVES:
 - NAVFAC: GUIDE SPECIFICATION CONVERSION PROGRAM
 - GOAL: ADOPT 130 NGS PER YEAR
 - NGS ADOPTED TO DATE - 1299
 - NGS TO BE ADOPTED - 1701
 - NAVSEA: ASTM COMMITTEE F-25 ON SHIPBUILDING
 - TOTAL NAVSEA NGS/CID TO DATE - 104
 - NAVSEA NGS/CID IN PROCESS - 60
- DRMD 901 = "THE 10% SOLUTION"
 - DOD GOAL: CONVERT 10% OF MILITARY SPECIFICATIONS TO COMMERCIAL-TYPE DOCUMENTS PER YEAR
 - THE NAVY IS ATTEMPTING TO DO ITS PART

SLIDE 1

GOOD MORNING. I AM CAPTAIN GARY AVERETT FROM THE OFFICE OF THE ASSISTANT SECRETARY OF THE NAVY FOR RESEARCH, DEVELOPMENT AND ACQUISITION. MY BOSS, REAR ADMIRAL BILL HAUENSTEIN, THE NAVY STANDARDIZATION EXECUTIVE WAS UNABLE TO JOIN YOU TODAY.

THIS MORNING I WOULD LIKE TO BRIEFLY ADDRESS SOME OF THE MORE SIGNIFICANT CHANGES THE DMR HAS MADE WITHIN THE NAVY ACQUISITION STRUCTURE AND OUR ACQUISITION POLICY AND TO BRIEFLY DISCUSS SOME OF THE IMPACTS IN THE AREA OF STANDARDIZATION.

SLIDE 2

THE NAVY'S IMPLEMENTATION OF THE DMR FOCUSED ON THREE KEY ELEMENTS:
REORGANIZATION OF THE NAVY SECRETARIAT
RESTRUCTURING OF THE NAVY ACQUISITION MANAGEMENT ORGANIZATION
ENHANCING THE ACQUISITION WORKFORCE

SLIDE 3

SECRETARY GARRETT'S OBJECTIVES IN GUIDANCE TO THE TASK FORCE WERE TO ENSURE WE MAINTAINED OUR ABILITY TO MEET WARFIGHTING NEEDS OF THE ACTIVE FORCES; TO COMPLY WITH THE INTENT AND SPECIFIC REQUIREMENTS OF THE GOLDWATER-NICHOLS REORGANIZATION ACT AND OTHER ACQUISITION STATUTORY REQUIREMENTS; AND TO MAKE SOME KEY CHANGES TO REFLECT A NEW THRUST IN ACQUISITION; THAT IS A SMALLER, MORE EFFICIENT ACQUISITION ORGANIZATION, TO PLACE AUTHORITY AND RESPONSIBILITY AT THE LOWEST PRACTICAL LEVEL AND TO REDUCE THE NUMBER AND POWER OF THE MANY FUNCTIONAL/SPECIALTY "ADVOCATES" THAT HAD PREVIOUSLY SLOWED OR TIED UP THE ACQUISITION PROCESS.

SLIDE 4

THIS AND THE NEXT SLIDE SHOW SOME OF THE SPECIFIC SECRETARIAL ORGANIZATION CHANGES THAT WERE MADE:

- 1) FULL TIME SAE; FORMERLY ASN (RESEARCH, ENGINEERING AND SYSTEMS) AND ASN (SHIPBUILDING AND LOGISTICS) PERFORMED KEY MANAGERIAL AND APPROVAL ROLES IN THE NAVY ACQUISITION CHAIN WHICH VIOLATED GOLDWATER-NICHOLS REQUIREMENT FOR A SINGLE ACQUISITION EXECUTIVE IN THE CHAIN FROM PM THROUGH PEO THROUGH SAE TO DAE.
- 2) CONSOLIDATION OF ALL ACQUISITION FUNCTIONS ON ONE STAFF WITH THE EXCEPTION OF OPERATIONAL REQUIREMENTS DETERMINATION AND INDEPENDENT TEST AND EVALUATION WHICH REMAIN WITH THE CHIEF OF NAVAL OPERATIONS.
- 3) APPROVAL AUTHORITY FOR ACQUISITION PLANS, BUSINESS CLEARANCES AND A SIGNIFICANT PORTION OF THE JUSTIFICATION AND APPROVAL DOCUMENTS FOR OTHER THAN FULL AND OPEN COMPETITION HAVE BEEN PUSHED DOWN BELOW THE SECRETARIAT

SLIDE 5

4) SPECIFIC FOCAL POINTS FOR KEY MANAGERIAL AREAS SUCH AS OVERSEEING NAVY INSTALLATIONS AND THE MANAGEMENT OF THE ENVIRONMENTAL CONCERNS BY A NEWLY ESTABLISHED ASSISTANT SECRETARY OF THE NAVY FOR INSTALLATIONS AND ENVIRONMENT; A FOCAL POINT FOR NAVY COORDINATION ON ALL INTERNATIONAL PROGRAMS; A FOCAL POINT FOR ASW TECHNOLOGY AND DEVELOPMENT AND A FOCUS ON ADP ACQUISITION.

SLIDE 6

THIS SLIDE SHOWS THE NEW SECRETARIES FOR RESEARCH, DEVELOPMENT AND ACQUISITION AND INSTALLATIONS AND ENVIRONMENT. THE NEW ACQUISITION SECRETARIAT REPRESENTS A REDUCTION IN STAFFING FROM APPROXIMATELY 280 ON THE FORMER ASSISTANT SECRETARIES FOR RESEARCH, ENGINEERING AND SYSTEMS AND SHIPBUILDING AND LOGISTICS TO A CURRENT LEVEL OF 180; SOON TO BE REDUCED TO 150; NEARLY A 50% REDUCTION IN THE STAFF LEVEL. MR. JERRY CANN (ASN RD&A) IS THE NAVY ACQUISITION EXECUTIVE.

SLIDE 7

THE NEW ORGANIZATION OF ASN RD&A INCLUDES SEVERAL KEY DEPUTIES AS I MENTIONED EARLIER. THE SECRETARIAT REORGANIZATION ALSO RESULTED IN SOME ADVOCACY CHANGES. FOR EXAMPLE, THE INDIVIDUAL POSITIONS OF THE SPECIFICATION CONTROL ADVOCATE GENERAL AND THE COMPETITION ADVOCATE GENERALS WERE DISESTABLISHED; THESE FUNCTIONAL AREAS WERE INCORPORATED WITHIN THE STAFF OF THE DEPUTY FOR ACQUISITION POLICY, INTEGRITY AND ACCOUNTABILITY -- REAR ADMIRAL HAUENSTEIN. SPECIFICALLY, POLICY FOR ACQUISITION STREAMLINING, SPECIFICATIONS AND STANDARDS, NON-DEVELOPMENTAL ITEMS, AS WELL AS THE FUNCTIONS OF THE COMPETITION ADVOCATE OMBUDSMEN AND THE COST/SCHEDULE CONTROL SYSTEM CRITERIA AND GENERAL IMPLEMENTATION OVERSIGHT FOR WEAPON SYSTEM ACQUISITION POLICY ARE ALL WITHIN MY ORGANIZATION, THE ACQUISITION PROCESS DIRECTORATE.

SLIDE 8

BELOW THE SECRETARIAT, SEVERAL STRUCTURAL CHANGES HAVE BEEN IMPLEMENTED. WE HAVE ESTABLISHED SIX PROGRAM EXECUTIVE OFFICERS AND NOW FIVE DIRECT REPORTING PROGRAM MANAGERS TO DEVOTE FULL TIME TO THE MANAGEMENT OF ASSIGNED PROGRAMS. WE HAVE ALSO DELEGATED SOME OF THE DECISION MAKING AUTHORITY PREVIOUSLY HELD AT THE SECRETARIAT. AND THE HARDWARE SYSTEMS COMMANDERS NOW OVERSEE MATURE MAJOR DEFENSE ACQUISITION PROGRAMS NOT ASSIGNED TO PEOS/DRPMS AND PROVIDE MATRIX SUPPORT TO PEOS/DRPMS FOR SUCH THINGS AS FINANCIAL MANAGEMENT, ENGINEERING SUPPORT, LOGISTICS SUPPORT AND CONTRACTING.

SLIDE 9

OF THE APPROXIMATELY 60 MAJOR DEFENSE ACQUISITION PROGRAMS WITHIN THE NAVY, 23 ARE UNDER PEOS, 8 ARE UNDER DIRECT REPORTING PROGRAM MANAGERS AND THE BALANCE OF MATURE PROGRAMS ARE STILL UNDER THE OVERSIGHT OF THE HARDWARE SYSTEMS COMMANDERS ACTING AS PEOS. OF NOTE, A RECENT DECISION ESTABLISHED THE NEW A"X" PROGRAM, THE SUCCESSOR TO THE A-12 PROGRAM, AS A DIRECT REPORTING PROGRAM.

SLIDE 10

IN ADDITION TO THESE ORGANIZATIONAL CHANGES, WE HAD TO EXAMINE THE TREMENDOUS ADMINISTRATIVE BURDEN WE HAVE BUILT OVER TIME AND LAID AT THE FEET OF THE PROGRAM MANAGER. OVER 500 POLICY DIRECTIVES, THOUSANDS OF CONTRACTING CLAUSES AND LINES OF CONTRACTING POLICY GUIDANCE, AND THOUSANDS OF MILITARY SPECS AND STANDARDS -- THIS IS TOO MUCH.

SLIDE 11

AS MANY OF YOU ARE AWARE, WE HAVE REVIEWED A LARGE MAJORITY OF THESE ADMINISTRATIVE DOCUMENTS AND WE ARE CONTINUING TO ELIMINATE, CONSOLIDATE AND/OR OTHERWISE STREAMLINE THEM.

SLIDE 12

SPECIFICALLY, DOD SET OUT TO REVISE AND ISSUE A NEW SET OF OVERALL ACQUISITION POLICY/PROCEDURE GUIDANCE DIRECTIVES. THESE WERE SIGNED OUT 23 FEB 91

A COMPLETE RE-DO OF THE DFARS HAS ALSO BEEN UNDERTAKEN AND I BELIEVE A NEW REVISED, PLAIN-ENGLISH VERSION IS DUE OUT THIS SUMMER.

AN ON-GOING EFFORT IS IN PROCESS AMONG THE THREE SERVICES TO IMPLEMENT THE RECOMMENDATIONS OF THE SPECIAL DMR TASK FORCE REVIEW OF SPECS AND STANDARDS. THIS IS, HOWEVER, A FORMIDABLE TASK, ESPECIALLY WITH THE DRAWDOWN OF STAFF AND OTHER RESOURCES AND THE RECENT EMPHASIS TO SIGNIFICANTLY DOWNSIZE THE DOD BUDGET. AS A RESULT, THE NAVY IS HAVING TO PRIORITIZE THOSE IMPLEMENTATION EFFORTS TO THE MOST IMPORTANT AND CRITICAL DOCUMENTS.

SLIDE 13

SHIFTING TO THE ACQUISITION PERSONNEL SIDE, THIS IS A BUSY CHART ON IMPROVEMENTS TO THE NAVY ACQUISITION WORKFORCE WHICH I WILL NOT TRY TO ADDRESS IN DETAIL OTHER THAN TO SAY THAT OUR INITIAL PLANNING DONE UNDER THE DMR HAS HAD TO BE REVISITED TO ACCOMMODATE THE RECENTLY PASSED MAVROULES LEGISLATION, OFFICIALLY KNOWN AS THE DEFENSE ACQUISITION WORKFORCE IMPROVEMENT ACT OF 1991. SUFFICE IT TO SAY THAT OVER THE NEXT FEW YEARS, SIGNIFICANT CHANGES WILL BE MADE IN THE TRAINING AND EXPERIENCE DEVELOPMENT OF NAVY PERSONNEL INVOLVED IN

THE ACQUISITION PROCESS. BOTTOM LINE IS THAT WE ARE ANTICIPATING A MORE KNOWLEDGEABLE, SKILLED AND EXPERIENCED WORKFORCE TO FILL INCREASINGLY CRITICAL ACQUISITION BILLETS AS THESE FOLKS PROGRESS UP A MORE RIGOROUS AND MORE CLEARLY DEFINED CAREER PATH TO MANAGEMENT OF OUR MOST COMPLEX AND MOST EXPENSIVE ACQUISITION PROGRAMS.

SLIDE 14

AS PART OF ASSISTANT SECRETARY TORELLI'S FOCUS ON TRAINING AND IN SUPPORT OF THE NEED TO IMPROVE OUR ACQUISITION WORKFORCE IN THE AREAS OF STANDARDIZATION AND DATA/CONFIGURATION MANAGEMENT, THE NAVY HAS BEEN ACTIVE IN PROVIDING A VARIETY OF TRAINING CLASSES/COURSES AS INDICATED HERE. IT IS OUR INTENT TO INTEGRATE THESE INTO OUR FINAL TRAINING PLAN AND REQUIREMENTS FOR KEY ACQUISITION PROFESSIONALS AS WE IMPLEMENT THE DAWIA.

SLIDE 15

SECRETARY TORELLI ALSO ADDRESSED A NEED TO FOCUS ON COMMERCIAL ACQUISITION AND THE TRANSITION TO MORE COMMERCIAL STANDARDIZATION DOCUMENTS. THE NAVY HAS A LARGE NUMBER OF MIL/SPECS AND STANDARDS IN THE DODISS AND MUCH SMALLER NUMBER OF NON-GOVERNMENT STANDARDS AND COMMERCIAL ITEM DESCRIPTIONS. A SIGNIFICANT NUMBER HAVE BEEN EARMARKED FOR CONVERSION.

WITHIN THE GENERAL GUIDELINES FROM OSD, THE NAVY HAS UNDERTAKEN A COUPLE OF NOTEWORTHY INITIATIVES. THE NAVAL FACILITIES ENGINEERING COMMAND (NAVFAC) USES GUIDE SPECIFICATIONS AS THEIR PRIMARY SOURCE DOCUMENTS WHICH ARE EDITED AND TAILORED BY NAVFAC DESIGNERS IN PREPARING THE TECHNICAL REQUIREMENTS FOR CONSTRUCTION PROJECTS. THESE GUIDE SPECIFICATIONS REFERENCE ABOUT 2400 NGSS, MANY OF WHICH HAVE NOT YET BEEN ADOPTED BY DoD. THEY ALSO REFERENCE ABOUT 600 MILITARY AND FEDERAL SPECIFICATIONS AND STANDARDS. FOR ABOUT TEN YEARS, NAVFAC HAS BEEN PROACTIVELY PURSUING A DUAL PROGRAM OF ADOPTING ABOUT 130 OF THE UNADOPTED REFERENCED ASTM, ANSI, AND ASME STANDARDS PER YEAR AND HAS ALSO BEEN WORKING WITH THOSE NON-GOVERNMENT STANDARDS BODIES TO DEVELOP NGSS TO REPLACE THE REFERENCED MILITARY AND FEDERAL DOCUMENTS. TO DATE, NAVFAC HAS ADOPTED ABOUT 1300 NGSS WHILE CANCELING ABOUT 1100 GOVERNMENT STANDARDS. THEY HAVE IDENTIFIED ABOUT 1700 MORE NGSS TO BE ADOPTED. WHEN COMPLETE, THE NAVFAC EFFORT ALONE WILL HAVE ALMOST DOUBLED THE NUMBER OF NGSS ADOPTED BY THE DON.

THE NAVAL SEA SYSTEMS COMMAND (NAVSEA) ALSO HAS ACTIVE COMMERCIALIZATION EFFORTS INVOLVING SEVERAL NON-GOVERNMENT STANDARDIZATION BODIES. NAVSEA WAS THE PRIME MOVER IN ESTABLISHING THE ASTM COMMITTEE F-F-25 ON SHIPBUILDING. THIS COMMITTEE HAS AS ITS PURPOSE THE ADOPTION OR CREATION OF ASTM STANDARDS FOR HULL, MECHANICAL, AND ELECTRICAL (HM&E) EQUIPMENTS AND SYSTEMS USED IN U.S. NAVY SHIPS. OTHER NON-GOVERNMENT STANDARDIZATION BODIES WITH WHICH NAVSEA IS WORKING INCLUDE SAE, AWS, AND EIA. WHILE THE TOTAL NUMBER OF ALL NGSS ADOPTED BY

NAVSEA IS NOT YET LARGE, IT IS A DEDICATED EFFORT WHICH HAS THE FULL SUPPORT OF NAVSEA UPPER MANAGEMENT.

IN ANOTHER VEIN, THE DEFENSE MANAGEMENT REVIEW DECISION 901 REQUIRES DOD TO CONVERT MILITARY SPECS TO COMMERCIAL-TYPE DOCUMENTS AT A RATE OF 10% PER YEAR IN ORDER TO REDUCE SUPPLY SYSTEMS COSTS. THIS OBJECTIVE WILL CONTINUE TO CHALLENGE THE SERVICES FOR MANY YEARS TO COME AND IN THE ERA OF REDUCED STAFFING AND LIMITED FINANCIAL RESOURCES TO EXECUTE THIS TASK, IT IS UNCERTAIN IF THE GOALS CAN REALISTICALLY BE ACHIEVED; HOWEVER, THE NAVY WILL CONTINUE TO PURSUE EFFORTS TO ADOPT NGSS AND TO WRITE CIDS ON A PRIORITIZED BASIS.

IN SUMMARY, THE DMR HAS RESULTED IN A NUMBER OF ORGANIZATIONAL, STRUCTURAL AND PROCEDURAL CHANGES IN THE WAY THE NAVY CONDUCTS ITS ACQUISITION BUSINESS. THE CHALLENGES TO EACH OF THE SERVICES TO ADJUST TO THESE NEW REQUIREMENTS AND TO THE DOWNSIZING OF THE DOD IN GENERAL WILL CREATE MANY OPPORTUNITIES AND PROBLEMS. IN MANY CASES, THESE CHALLENGES WILL LIKELY FURTHER THOSE EXISTING, AS WELL AS FUTURE, NAVY AND INDUSTRY WORKING GROUP RELATIONSHIPS TO MANAGE THE COMPLEX WORLD OF BOTH MILITARY AND COMMERCIAL STANDARDIZATION DOCUMENTS.
THANK YOU.

**COMMENTS FROM BGEN WILLIAM E. COLLINS
AIR FORCE STANDARDIZATION EXECUTIVE
ORAL PRESENTATION GIVEN ON MAY 14, 1991**

Written comments are not available -- refer to Panel A - JUSTIS portion of the proceedings for similar topic review.

IMPACT OF DEFENSE MANAGEMENT REVIEW
ON
STANDARDIZATION, DATA MANAGEMENT,
AND
CONFIGURATION PROGRAMS

'GOING COMMERCIAL'

PRESENTED BY
MR. H. FILIPPI
14 MAY 1991

1991 STANDARDIZATION & DATA/CONFIGURATION MANAGEMENT CONFERENCE

WE AS A COMMUNITY NEED TO GET OUR HEADS TOGETHER TO INSURE SUCCESS OF THE DMR, AND CREDIBILITY FOR OURSELVES AND OUR DISCIPLINE IN DOING THINGS SMART. NOTIONS SUCH AS THE NEW DEFENSE BUSINESS OPERATING FUND (DBOF) WILL REQUIRE THAT WE DO THINGS MORE IN TUNE WITH PRIVATE-SECTOR CORPORATE STRATEGY AND PLANNING. WE'VE GOT TO ACT LIKE A BUSINESS AND PAY OUR WAY. ONE OF THE OPPORTUNITIES, AND DEFINITELY A CHALLENGE, IS THE DMR NOTION OF 'GOING COMMERCIAL' AND FOR THIS REASON I'D LIKE TO FOCUS ON THIS ASPECT TODAY.

AT DLA, WE HAVE DEVELOPED A STRATEGIC PLAN FOR THE FUTURE. WE HAVE ESTABLISHED QUALITY MANAGEMENT BOARDS TO ADDRESS OUR BREAKTHROUGH STRATEGIES. ONE OF THE QUALITY MANAGEMENT BOARDS FOCUSES ON DIALOGUE WITH INDUSTRY AND ONE OF THE BREAKTHROUGH STRATEGIES IS THE ADOPTION OF COMMERCIAL PRACTICES.

'GOING COMMERCIAL' - DLA PERSPECTIVE

THE GOAL OF 'GOING COMMERCIAL' AIN'T NEW. OVER THE YEARS THERE HAS BEEN LONG AND, IN MY OPINION, SOMEWHAT TEDIOUS ONGOING ACTIVITY IN THE AREA OF DEVELOPING 'COMMERCIAL' POLICY AND PROCEDURES AT HIGH LEVELS.

IN 1972, THE COMMISSION ON GOVERNMENT PROCUREMENT RECOMMENDED THAT THE GOVERNMENT SHIFT TO BUYING COMMERCIAL PRODUCTS IN LIEU OF PROCURING GOVERNMENT-UNIQUE ITEMS; THEY ALSO RECOMMENDED UTILIZING EXISTING COMMERCIAL DISTRIBUTION CHANNELS RATHER THAN DUPLICATING THEM FOR GOVERNMENT PURPOSES.

IN 1976, THE OFFICE OF FEDERAL PROCUREMENT POLICY FORMULATED THE COMMISSION'S RECOMMENDATIONS INTO GOVERNMENT POLICY.

IN 1986, THE PRESIDENT'S BLUE RIBBON COMMISSION ON DEFENSE MANAGEMENT
('PACKARD COMMISSION') ISSUED A FINAL REPORT STATING THAT THE GOVERNMENT
SHOULD MAKE GREATER USE OF OFF-THE-SHELF PRODUCTS.

THE 1986 DEFENSE SCIENCE BOARD REPORT 'USE OF COMMERCIAL COMPONENTS IN
MILITARY EQUIPMENT' RECOGNIZED THE DIFFERENCE BETWEEN COMMERCIAL PRODUCTS AND
COMMERCIAL PRACTICES.

THE NDI PREFERENCE ACT OF 1987 REQUIRED THAT DOD STATE REQUIREMENTS FOR
SUPPLIES IN TERMS OF FUNCTIONS TO BE PERFORMED, PERFORMANCE REQUIRED, AND
ESSENTIAL PHYSICAL CHARACTERISTICS TO ENCOURAGE THE USE OF NDI. THE ACT ALSO
REQUIRED THAT A PREFERENCE FOR NDI GOVERN DOD ACQUISITIONS.

IN 1988, THE ENHANCING DEFENSE STANDARDIZATION REPORT STATED THAT MILITARY
SPECIFICATIONS MAY NO LONGER BE ISSUED OR REVISED FOR NEARLY 400 FEDERAL
SUPPLY CLASSES WHERE THERE IS A HIGH POTENTIAL FOR COMMERCIAL ACQUISITION.
(THE EMPHASIS HERE WAS TO FORCE CHANGE BY MANDATE)

IN 1989, THE DEFENSE MANAGEMENT REVIEW ACKNOWLEDGED THE CONCLUSIONS OF
PREVIOUS STUDIES AND RECOMMENDED THAT THE CONTRACTING PROCESS BE SIMPLIFIED
AND PRACTICES INHIBITING THE ACQUISITION OF NDI BE ELIMINATED.

ALSO IN 1989, OSD ISSUED A LETTER ON THE NONDEVELOPMENTAL ITEM PROGRAM WITH 31
ACTION ITEMS PRIMARILY ADDRESSING POLICY AND GUIDANCE.

AND FINALLY, A DODWIDE PROCUREMENT CONFERENCE WAS RECENTLY HELD.

IN THE PAST, THE SENATE HAS HELD HEARINGS ON DOD'S INADEQUATE USE OF OFF-THE-SHELF ITEMS. CRITICISM WAS DIRECTED TOWARD THE LACK OF OSD LEADERSHIP AND OVER-SPECIFICATION BY THE MILITARY DEPARTMENTS. 'SPECS ARE EVIL' IS STILL THE RALLYING CRY OF CONGRESSIONAL CRITICS.

OVER THE YEARS MUCH HAS BEEN DONE TO DEVELOP POLICY AND GUIDANCE. WE NEED TO GO THE NEXT STEP AND BEGIN TO IMPLEMENT COMMERCIAL INITIATIVES. IF OUR EXTERNAL CRITICS ARE TO BELIEVE DOD IS SERIOUS ABOUT GOING COMMERCIAL, WE SIMPLY HAVE TO GET BEYOND PLATITUDES AND GET BEHIND THE DMR! ALL OF US NEED TO GET ON WITH THE ARDUOUS PROCESS OF LOGGING IN MORE & MORE SUCCESS STORIES AND DOCUMENTING THE INHIBITORS, WHEN WE HAVE FAILURES, WHICH MUST BE OVERCOME IF WE ARE GOING TO ESTABLISH CREDIBILITY. IN MY OPINION, ONE OF THE BIGGEST IMPEDIMENTS TO GOING COMMERCIAL IS THAT WE DON'T KNOW WHO THE ENEMY IS, AND WHAT CONSTITUTES A VICTORY. FOR EXAMPLE IS NDI A SUCCESS? WE HAVEN'T INVENTED A NEW PRODUCT IN DLA SINCE I'VE BEEN THERE - AND THAT'S AWHILE. FUNDAMENTALLY, WE ARE 100% NDI. SHALL I DECLARE A SUCCESS IN DLA AND GO HOME? I DON'T THINK MR. TORELLI WOULD LET ME. LESS THAN 20% OF OUR ITEMS ARE COVERED BY SPECS. IF 'SPECS ARE EVIL,' WE IN DLA ARE ANGELIC. SHALL I DECLARE SUCCESS BASED ON THAT THEME? I THINK NOT. ABOUT 50% OF OUR ITEMS ARE BOUGHT BY PART NUMBERS! THAT IS WITH NO DATA AT ALL. THIS SCENARIO GETS YOU VERY NERVOUS IN A SPARE PARTS HORROR STORY ENVIRONMENT. LOVE TO HAVE HAD A SPEC ON THESE ITEMS DURING THE EARLY TO MID 80'S. IS THIS A COMMERCIAL SUCCESS? I DON'T THINK SO.

DMR ACTIVITIES

I BELIEVE IT IS THE INTENT OF THE DMR PROCESS TO EFFECT CHANGES WHICH OTHERWISE WOULD NOT BE POSSIBLE BECAUSE OF INSTITUTIONAL INERTIA. NOW, LET'S TALK ABOUT SOME OF THE SPECIFIC DMR INITIATIVES.

DMR-WG9

SINCE AUGUST 1989, THE DEFENSE MANAGEMENT REVIEW, SPECIFICATIONS AND STANDARDS WORKING GROUP (DMR-WG 9) HAS BEEN MEETING UNDER A CHARTER TO CONDUCT A ZERO-BASED REVIEW OF SPECIFICATIONS AND STANDARDS USED BY THE DOD. A REVIEW OF 35,363 SPECIFICATIONS, STANDARDS, AND HANDBOOKS WAS CONDUCTED FROM SEPTEMBER 1989 THROUGH SEPTEMBER 1990. 5,708 DOCUMENTS WERE IDENTIFIED AS COVERING COMMERCIAL PRODUCTS. 5,624 WERE IDENTIFIED AS COVERING MODIFIED, COMMERCIAL-TYPE DOCUMENTS. THIS INDICATES THAT A TOTAL OF 11,332 SPECIFICATIONS/STANDARDS HAVE COMMERCIAL POTENTIAL. THE DMR REVIEW SPECIFICALLY IDENTIFIED 2,363 SPECIFICATIONS AND STANDARDS WHICH NEED TO BE CONVERTED TO COMMERCIAL ITEM DESCRIPTIONS (CID), AND 1,131 SPECIFICATIONS/STANDARDS WHICH NEED TO BE CONVERTED TO NON-GOVERNMENT STANDARDS (NGS). WITHIN DLA, OUR DEFENSE SUPPLY CENTERS HAVE IDENTIFIED 1,371 MILITARY AND FEDERAL SPECIFICATIONS FOR CONVERSION TO CIDs. THE DEFENSE PERSONNEL SUPPORT CENTER'S MEDICAL DIRECTORATE, SERVING AS AGENT FOR THE DEFENSE MEDICAL STANDARDIZATION BOARD, HAS 1,366 OF THESE ACTIONS. THIS REPRESENTS 57% OF THE ENTIRE CID ACTIVITY UNDER THE DMR-WG 9 EFFORT. WHILE I WOULD LIKE TO NOTE HERE THAT DPSC IS DOING A YEOMAN'S JOB, I'M VERY CONCERNED WITH A NUMBER THAT SAYS OUT OF 35,000 + DOCUMENTS ONLY 3494 WILL BE CONVERTED TO CIDS OR NGS.

IF ONE WERE TO LOOK AT (A) THE DMR BASELINE OF 35,363 SPECS, STANDARDS, AND HANDBOOKS, (B) THE COMMERCIAL POTENTIAL OF 11,332 DOCUMENTS (POTENTIAL CIDs OR NGSs), AND (C) THE ACTUAL NUMBER OF DOCUMENTS BEING CONVERTED TO CIDs OR NGSs, I.E., 3,494., THE FOLLOWING CONCLUSIONS CAN BE MADE:

A. SIXTY-SEVEN PERCENT (67%) OF THE SPECIFICATIONS AND STANDARDS REVIEWED HAVE MILITARY UNIQUE REQUIREMENTS.

B. CONVERSELY, THERE IS A COMMERCIAL POTENTIAL FOR ONE-THIRD OF THE DOCUMENTS REVIEWED.

BASED ON 1990 DOD INDEX OF SPECIFICATIONS AND STANDARDS (DODISS) STATISTICS AND PLANNED DMR PROJECTS, ONE-FOURTH WILL BE CIDs OR NGSs. AT BEST, THE NUMBER OF DODISS DOCUMENTS DESCRIBING A COMMERCIAL ITEM IS SOMEWHERE BETWEEN 25% AND 33%. THEREFORE, IS THE CONVERSION OF MILITARY SPECIFICATIONS TO COMMERCIAL ITEM DESCRIPTIONS THE APPROPRIATE YARDSTICK TO MEASURE PROGRESS TOWARDS THE USE OF COMMERCIAL PRODUCTS? ANOTHER DMRD WHICH IS PURSUING A SIMILAR APPROACH IS DMRD 901.

DMRD 901 - DEFENSE MANAGEMENT REPORT DECISION 901, 'REDUCING SUPPLY SYSTEM COSTS'

THIS INITIATIVE IS INTENDED TO GIVE MANAGERS THE VISIBILITY AND FLEXIBILITY TO MANAGE SUPPLY COSTS BETTER. ONE OF THE GOALS IS TO INCREASE THE USE OF COMMERCIAL ITEMS BY 10% ANNUALLY AND, THEREBY, REDUCE THE NUMBER OF ITEMS MADE TO MORE EXPENSIVE MILITARY SERVICE SPECIFICATIONS.

EXAMPLES OF ITEMS, CITED IN THE DOD JUSTIFICATION OF ESTIMATES FOR DEFENSE MANAGEMENT REPORT INITIATIVES, THAT WILL NO LONGER BE PROCURED TO MILITARY SPECIFICATIONS INCLUDE COMMON ITEMS SUCH AS TOOTHPICKS AND UNDERGARMENTS. (DOD DOES NOT PROCURE TOOTHPICKS; GSA DOES TO A FEDERAL SPECIFICATION).

THE PREMISE THAT INCREASING THE USE OF COMMERCIAL ITEMS WILL REDUCE THE NUMBER

OF MILITARY SPECIFICATIONS IS INVALID. LESS THAN 20% OF THE PROCUREMENT DOCUMENTS USED BY THE DEFENSE LOGISTICS AGENCY'S SUPPLY CENTERS ARE MILITARY SPECIFICATIONS. WE PROCURE COMMERCIAL PRODUCTS THROUGH MANY TECHNICAL DOCUMENTS OTHER THAN SPECS, FOR EXAMPLE, ORIGINAL EQUIPMENT MANUFACTURER'S DRAWINGS, VENDOR'S PART NUMBERS, ETC. THE PREMISE THAT REDUCING THE NUMBER OF MILITARY SPECIFICATIONS WILL INCREASE THE USE OF COMMERCIAL ITEMS IS ALSO NOT TOTALLY VALID. IN MANY CASES, DOD WILL END UP BUYING THE COMMERCIAL ITEM WHETHER IT IS DESCRIBED BY A MILITARY SPECIFICATION OR A COMMERCIAL ITEM DESCRIPTION.

INCREASING THE USE OF COMMERCIAL ITEMS, WHERE APPROPRIATE, IS AN ADMIRABLE GOAL AND CONSIDERING IT IN PERFORMANCE EVALUATIONS (AS MANDATED BY DMRD 901) MAY BE OF SOME BENEFIT. HOWEVER, A STRAIGHT 10 PERCENT PER YEAR MAY NOT BE THE CORRECT GOAL IN EVERY CASE. ALSO, THE DMRD 901 INAPPROPRIATELY ASSIGNS THE GOALS TO THE SENIOR MANAGERS OF SUPPLY ACTIVITIES. SPECIFIC GOALS SHOULD BE SET BY THE SENIOR MANAGER OF THE SPECIFICATION PREPARING ACTIVITY WHICH HAS RESPONSIBILITY AND CONTROL OVER THEIR REQUIREMENTS. IN ORDER TO DETERMINE A 10 PERCENT IMPROVEMENT, A BASELINE NEEDS TO BE ESTABLISHED. ONE BASELINE COULD BE A 10 PERCENT INCREASE OF THE NUMBER OF COMMERCIAL ITEM DESCRIPTIONS ALREADY IDENTIFIED IN THE DODISS (CURRENTLY 8 PERCENT - 1990 DATA). ANOTHER OPTION IS THAT THE BASELINE CONSIST OF MILITARY SPECIFICATIONS SUITABLE FOR CONVERSION TO CIDs OR NGSs (AS PREVIOUSLY STATED THE DMR-WG 9 REVIEW IDENTIFIED 11,332 DOCUMENTS HAVING COMMERCIAL POTENTIAL). TRACKING THE CONVERSION OF THESE DOCUMENTS WOULD BE A NATURAL EXTENSION TO THE ONGOING EFFORTS OF THE DEFENSE MANAGEMENT REVIEW WORKING GROUP ON SPECIFICATIONS AND STANDARDS. ESTABLISHING A BASELINE IS ONLY A PARTIAL SOLUTION TO INCREASING THE USE OF COMMERCIAL PRODUCTS. WE MUST ALSO CONSIDER COMMERCIAL PRACTICES. WE NEED TO EXAMINE HOW WE CAN ENCOURAGE MORE PARTICIPATION IN OUR PROCUREMENT

PROCESS BY THOSE FIRMS ALREADY DOING BUSINESS IN THE COMMERCIAL MARKETPLACE. THIS BRINGS US TO DMRD 903, CHANGE CLOTHING AND TEXTILE POLICIES, AND IN PARTICULAR, THE USE OF COMMERCIAL SPECIFICATIONS.

DMRD 903 - DEFENSE MANAGEMENT REPORT DECISION 903, CHANGE CLOTHING AND TEXTILE POLICIES

THIS DMRD INDICATES THAT MOST OF THE CLOTHING ITEMS PROCURED BY DLA ARE BASED ON MILITARY SPECIFICATIONS. THE USE OF THESE SPECIFICATIONS RESULTS IN HIGHER COSTS TO THE DEPARTMENT OF DEFENSE AND, IN SOME CASES, IN THE LARGE COMMERCIAL MANUFACTURERS REFUSING TO BID ON DOD WORK. OF THE 8,900 CLOTHING ITEMS MANAGED BY DLA, ONLY 363 HAVE BEEN IDENTIFIED AS CANDIDATES FOR COMMERCIAL ITEM DESCRIPTIONS, AND OF THOSE, ONLY 78 HAVE BEEN DEVELOPED AND APPROVED BY THE MILITARY SERVICES. IN ORDER TO ADDRESS THE USE OF COMMERCIAL SPECIFICATIONS, STANDARDIZATION, SIZE REDUCTION, AND SPECIFICATION PREPARATION, MR. BERTEAU, THE PRINCIPAL DEPUTY TO THE ASSISTANT SECRETARY OF DEFENSE FOR PRODUCTION AND LOGISTICS, ESTABLISHED A CLOTHING AND TEXTILE (C&T) FLAG OFFICERS STEERING GROUP AND FOUR WORKING GROUPS. ONE OF THE WORKING GROUPS IS THE COMMERCIAL SPECIFICATION WORKING GROUP. PART OF THE WORKING GROUP'S EFFORTS IS TO MONITOR TWO COMMERCIAL PROCUREMENT DEMONSTRATION PROGRAMS WHICH ARE ALREADY UNDERWAY.

THE CLOTHING DEMONSTRATION PROGRAM

THE DPSC HAS PREPARED COMMERCIAL PRODUCT DESCRIPTIONS FOR 20 CLOTHING AND TEXTILE ITEMS. TO DATE, 17 SOLICITATIONS HAVE BEEN ISSUED AND 14 CONTRACTS AWARDED. ITEMS BEING PROCURED RANGE FROM BRIEFS AND GLOVES, TO SOCKS AND UNDERSHIRTS.

THE COMMERCIAL ACQUISITION DEMONSTRATION PROGRAM

OSD ESTABLISHED THIS PROGRAM TO TEST OUR ABILITY TO PROCURE A WIDE VARIETY OF ITEMS ON A COMMERCIAL BASIS, AND TO IDENTIFY ANY INHIBITORS TO PROCUREMENT WHICH ARE BEYOND DOD CONTROL AND REQUIRE HELP FROM CONGRESS. THE DEFENSE SUPPLY CENTERS ARE RESPONSIBLE FOR PROCURING 11 OF THE 25 ITEMS INCLUDED IN THE PROGRAM. THE OSD HAS APPROVED THE CIDs FOR THE FOLLOWING ITEMS WITH PROCUREMENT ACTIONS UNDERWAY IN THE CENTERS: FLUORESCENT LAMPS (DEFENSE GENERAL SUPPLY CENTER (DGSC)), GASOLINE LANTERNS (DGSC), MILITARY POLICE BELT (DPSC), WOMAN'S ACRYLIC SWEATER (DPSC), MEN'S UNDERSHIRT (DPSC), CANDY CONFECTIONS (DPSC), AND EXAMINING TABLE (DPSC). DPSC ALSO SERVES AS THE PREPARING ACTIVITY FOR THE EXAMINING TABLE CID.

THE DEMONSTRATION PROGRAMS PROVIDE THE FOLLOWING OPPORTUNITIES:

- A. ALLOW OUR PROCURING ACTIVITIES LATITUDE TO DEVELOP ACQUISITION STRATEGIES WHICH ENCOMPASS GOOD BUSINESS PRACTICES, I.E, ECONOMIES OF SCALE, COMMERCIAL PACKAGING AND MARKING, AND COMMERCIAL DISTRIBUTION SYSTEMS.
- B. DEVELOP COMMERCIAL SOURCES AND ENCOURAGE INDUSTRY INVOLVEMENT.
- C. IDENTIFY INHIBITORS TO OUR ABILITY TO PROCURE COMMERCIAL PRODUCTS.

PROGRESS TO DATE

THE DMR EFFORTS ADDRESSING COMMERCIAL PRODUCTS UNDER DMR-WG9, DMRD 901 AND 903 ALL HAVE A COMMON MESSAGE...DEVELOP MORE CIDS. THE NUMBER OF CIDS (4100) LISTED IN THE DODISS HAS DOUBLED IN THE LAST 5 YEARS. THE PERCEPTION IS IF WE DEVELOP CIDS WE CAN BUY COMMERCIAL PRODUCTS. THE FACT IS WE, AT DLA, BUY 100% NONDEVELOPMENTAL ITEMS, AND LESS THAN 20% OF OUR ITEMS ARE PROCURED TO MILITARY SPECIFICATIONS. WE PROCURE OUR ITEMS OF SUPPLY BY USING COMMERCIAL PART NUMBERS, VENDOR CATALOG DESCRIPTIONS AND OTHER METHODS COMMONLY USED BY THE PRIVATE SECTOR TO DESCRIBE THEIR PRODUCTS.

REGARDING COMMERCIAL PRACTICES, RECENT DEVELOPMENTS ON COMMERCIAL PRODUCTS CONTRACTING INCLUDE:

A. PROPOSED LEGISLATION - NONDEVELOPMENTAL ITEM ACQUISITION ACT OF 1991 WHICH (1) GIVES PREFERENCE TO ACQUISITION OF NONDEVELOPMENTAL ITEMS, (2) ALLOWS US TO CONSIDER PAST PERFORMANCE, AND (3) REQUIRES AGENCIES TO USE MARKET ACCEPTANCE CRITERIA WHERE APPROPRIATE.

B. BEST VALUE CONTRACTING (E.G., SOURCE SELECTION, COMPETITION FOR PERFORMANCE) - FOR THE MOST PART, DLA IS NOT LOOKING FOR HIGHER QUALITY ITEMS OR SERVICES THAN THOSE DESCRIBED IN THE SPECIFICATIONS, WE ARE LOOKING FOR THE CONTRACTOR WHO CAN MEET THOSE SPECIFICATIONS. IN ORDER TO DO THIS, WE LOOK PRIMARILY AT PAST PERFORMANCE AND OTHER INDICATORS OF PERFORMANCE RISK.

C. LONG TERM CONTRACTING - THE AGENCY IS NOW PLACING MAJOR NEW EMPHASIS UPON MORE LONG-TERM CONTRACTING. RATHER THAN MAKING ONE-TIME, FIXED QUANTITY PROCUREMENTS OF A SINGLE ITEM, EITHER FOR STOCK OR DIRECT DELIVERY, WE ARE

EMPHASIZING INDEFINITE DELIVERY CONTRACTS OF AT LEAST ONE-YEAR'S DURATION. WHERE TECHNOLOGY, ECONOMIC CONDITIONS AND DEMAND PATTERNS ARE STABLE ENOUGH, WE USE TWO OR THREE YEAR OPTIONS OR MULTIYEAR CONTRACTS. WE ALSO WANT TO COUPLE THIS EFFORT WITH A TECHNIQUE KNOWN AS 'FAMILY BUYS'. ITEMS THAT ARE MERELY DIFFERENT SIZES OR COLORS OR DIFFERENT COMPONENTS OF AN END ITEM ARE GROUPED TOGETHER ON A SINGLE SOLICITATION. THIS METHODOLOGY HAS BEEN IN USE IN SOME OF OUR ASSIGNED COMMODITIES FOR A LONG TIME, E.G., PETROLEUM AND PERISHABLE SUBSISTENCE. OUR HARDWARE CENTERS ARE NOW PURSUING THIS TECHNIQUE.

SUCCESS IS HARD TO DEFINE WHEN THE GOAL IS NOT CLEAR. IF OUR GOAL IS TO CONVERT MILITARY SPECIFICATIONS TO COMMERCIAL ITEM DESCRIPTIONS IN ORDER TO SAVE MONEY, THAN THE RESULTS ARE DEBATABLE. FOR EXAMPLE, KNIT WATCH CAPS BOUGHT TO A CID COST \$1.73 (EA) - PREVIOUSLY \$1.80 WHEN BOUGHT TO A MIL SPEC. HOWEVER, FIREMAN'S BOOTS COST \$30.04 (EA) TO A CID VS \$26.11 TO A SPEC. IT SHOULD BE NOTED THAT WE PROCURED BOTH ITEMS FROM ENDICOTT JOHNSON, A MAJOR MANUFACTURER (ANNUAL SALES OF 210 MILLION; 5,000 EMPLOYEES). IN CONFORMING TO THE REQUIREMENTS OF THE SPECIFICATION, EXTRAS, 'BELLS AND WHISTLES, ARE NOT INCLUDED IN THE MANUFACTURE OF THE BOOT. THE INCLUSION OF THESE NONESSENTIALS RAISES THE PRICE OF THE OFF-THE-SHELF PRODUCT. ALSO, THERE WAS NO PRICE DIFFERENCE WHEN WE BOUGHT WHITE HANDKERCHIEFS USING EITHER A SPEC OR A CID. THE SUPPLIER IN THIS CASE WAS A NATIONAL INDUSTRIES FOR THE BLIND/NATIONAL INDUSTRIES FOR THE SEVERELY HANDICAPPED (NIB/NISH) SOURCE.

CONCLUSION/RECOMMENDATIONS

TO SUMMARIZE LET ME MAKE THE FOLLOWING POINTS:

A. MUCH HAS BEEN DONE, BUT THERE IS STILL A LOT TO DO.

B. WHAT IS NEEDED IS SPECIFICATION ADVOCATES WITHIN OUR OWN STANDARDIZATION COMMUNITIES WHO ESPOUSE THE VIRTUES OF MILITARY SPECIFICATIONS AND STANDARDS IN ORDER TO QUIET OUR CONGRESSIONAL CRITICS. MILITARY SPECIFICATIONS REPRESENT ONE OF SEVERAL METHODS AVAILABLE TO OUR PROCURING ACTIVITIES FOR BUYING ITEMS WHICH MEET THE NEEDS OF THE MILITARY SERVICES. MILITARY SPECIFICATIONS ARE DOD CORPORATE DOCUMENTS USED TO ADVANCE STANDARDIZATION; AVOID DUPLICATION; ELIMINATE PROLIFERATION; AND INCREASE COMPETITION. HISTORICALLY MILITARY SPECIFICATIONS WERE, AND ARE, USED BECAUSE OF THE LACK OF ALTERNATIVE METHODS, I.E., NON-GOVERNMENT DOCUMENTATION SUITABLE FOR PROCUREMENT PURPOSES.

C. THERE IS A NEED FOR A CLEARLY DEFINED FOCAL POINT FOR ALL OF THE OSD/DOD COMMERCIAL INITIATIVES. UNDER OSD LEADERSHIP, A SENIOR LEVEL GROUP FROM THE MILITARY DEPARTMENTS AND DLA COULD BE ESTABLISHED TO TRANSITION FROM POLICY AND GUIDANCE ISSUES TO THE PLANNING AND IMPLEMENTATION PHASE.

D. THE MOST IMPORTANT ACTION THAT NEEDS TO BE ACCOMPLISHED IS THE SETTING OF THE GOAL FOR 'GOING COMMERCIAL'. IT COULD BE REDUCING THE NUMBER OF MILITARY SPECIFICATIONS WHICH ARE USED TO PROCURE COMMERCIAL ITEMS, INCREASING THE USE OF COMMERCIAL BUYING PRACTICES, OR JUST IDENTIFYING HOW MANY COMMERCIAL ITEMS ARE IN THE DOD SUPPLY SYSTEM AND DECLARING VICTORY.

E. THE SECOND MOST IMPORTANT ACTION THAT NEEDS TO BE DONE IS TO DETERMINE AN APPROPRIATE YARDSTICK FOR MEASURING PROGRESS.

F. OTHER ACTIONS FOR CONSIDERATION INCLUDE ADDRESSING THE INTERACTION OF THE DEFENSE INDUSTRIAL BASE WITH THE COMMERCIAL MARKETPLACE; IDENTIFYING INHIBITORS WHICH PRECLUDE COMMERCIAL MANUFACTURERS FROM DOING BUSINESS DIRECTLY WITH DOD; AND THE IMPACT, IF ANY, ON THE DOD SUPPLY SYSTEM, I.E., CONFIGURATION CONTROL AND INTERCHANGEABILITY.

FINALLY, IF WE ARE TRULY GOING TO INCORPORATE COMMERCIAL PRACTICES, WE MUST BE PERMITTED TO ESTABLISH SOURCES OF SUPPLY BASED ON SUPPLIER PREFERENCE RATHER THAN PRODUCT-ORIENTED PROCUREMENTS.

NONDEVELOPMENTAL ITEM PROGRAM PANEL

Chair - Gregory E. Saunders, Office of the Assistant Secretary of Defense (Production and Logistics),
Manufacturing Modernization Directorate

Panel Members:

Rich Blaue, Air Force Systems Command, Electronics Systems Division

Steve Gershman, Office of the Assistant Deputy Under Secretary of the Navy (Safety and Survivability)

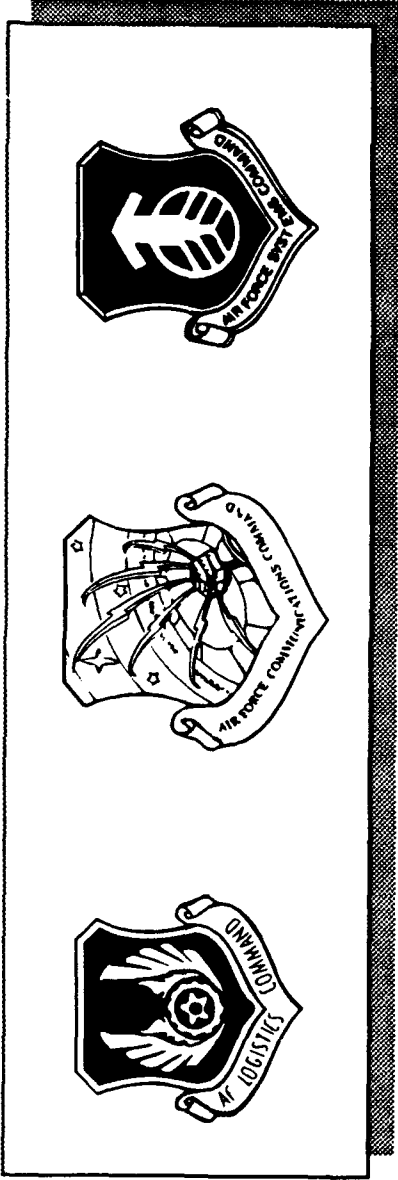

JOINT COMMAND

COMMERCIAL OFF-THE-SHELF (COTS) SUPPORTABILITY WORKING GROUP (CSWG)

FINAL RECOMMENDATIONS

PRESENTED BY:

RICH BLEAU
ALD/OE (ESD/AL)
CHAIRMAN, CSWG

OUTLINE

- **BACKGROUND**
- **CHARTER**
- **MAGNITUDE OF EFFORT**
- **KEY ISSUES/RECOMMENDATIONS**
- **CONCLUSION**

BACKGROUND

- COMMERCIAL ITEM EMPHASIS AND USE INCREASING

- GROWING RECOGNITION OF SUPPORT ISSUES



- MULTI - COMMAND MEMBERSHIP

— AFSC	CSD	OO-ALC	SSD
— AFLC	BMO	TAC	SM-ALC
— AFCC	ATC	HSD	SAC
— ALD	ASD	ESD	WR-ALC
— MAC	EID	SA-ALC	AFSPACECOM

PROBLEM

- **STANDARD SUPPORT APPROACHES NOT SUITED TO COTS ITEMS**
- **SUPPORT APPROACHES FOR COTS ITEMS NOT DEVELOPED OR STANDARDIZED**
 - **ACQUISITION POLICIES AND PROCEDURES**
 - **LONG TERM SUPPORT POLICIES AND PROCEDURES**
- **INHERENT SUPPORT CAPABILITY NOT BEING UTILIZED FULLY**

CHARTER

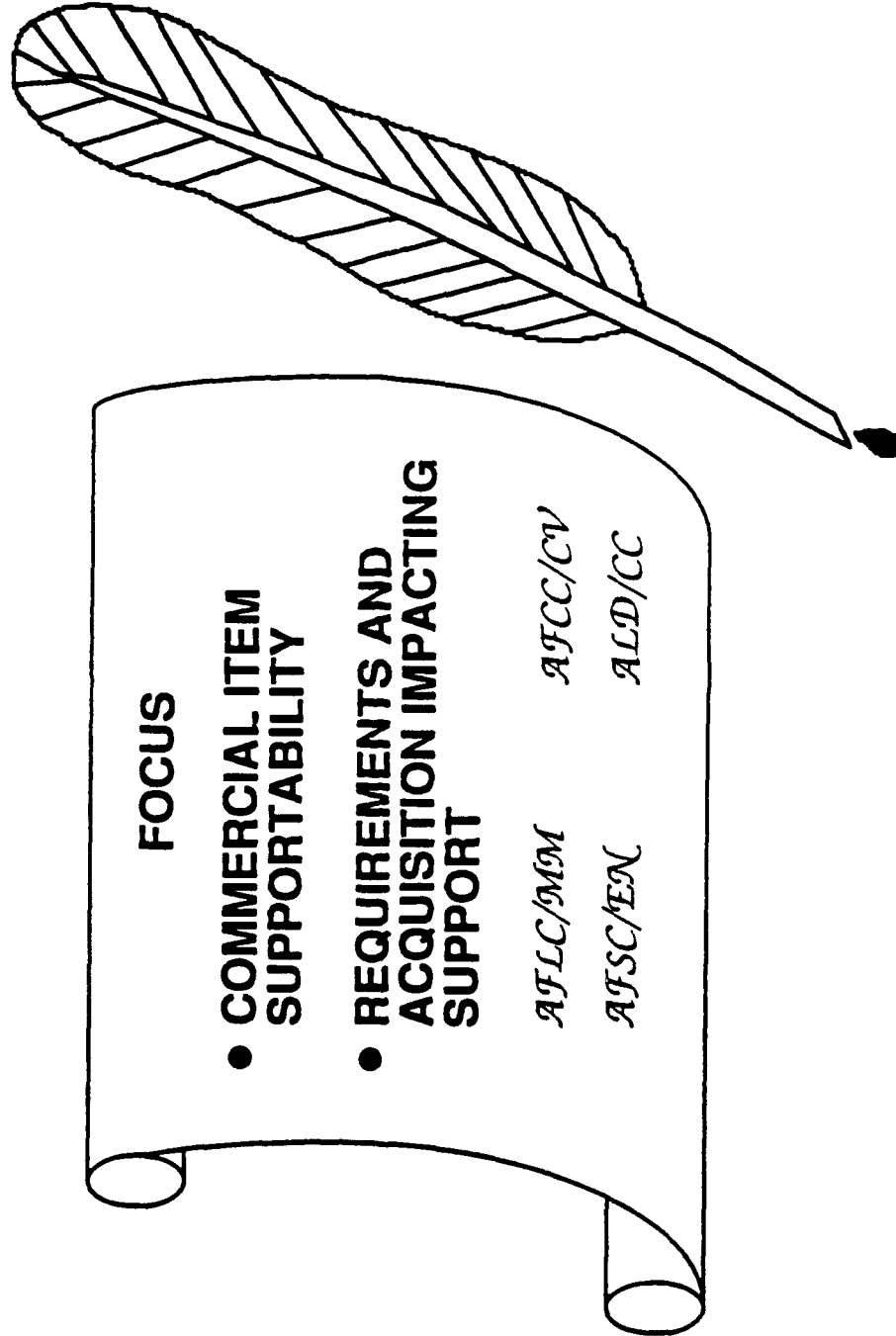

METHODOLOGY

SUBTEAMS

ACQUISITION USER/SUPPORT INDUSTRY

SUPPORTABILITY
REQUIREMENTS
ACQUISITION

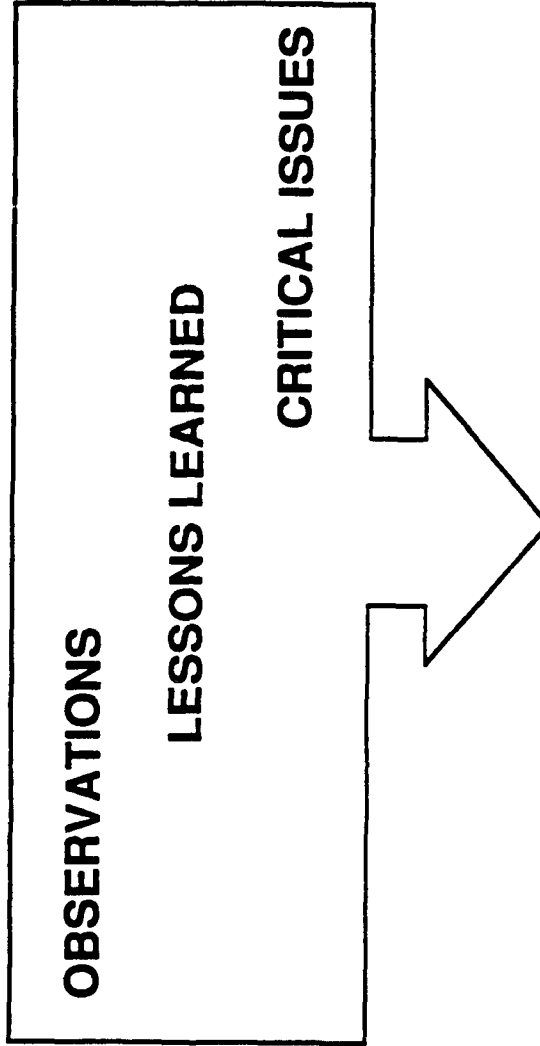

RECOMMENDATIONS

OBJECTIVE

**RECOMMEND POLICY AND PROCEDURES
FOR THE SUPPORT OF COMMERCIAL ITEMS
IN THE AIR FORCE**

MAGNITUDE OF EFFORT

- **25 ACTIVE TEAM MEMBERS**
- **21 LOCATIONS VISITED**
- **127 ORGANIZATIONS CONTACTED**
- **201 PEOPLE INTERVIEWED**
- **OVER 500 TDY MAN/DAYS IN 1990**
- **59 SIGNIFICANT OBSERVATIONS**
- **16 KEY ISSUES**
- **16 LESSONS LEARNED**
- **23 SPECIFIC RECOMMENDATIONS**
- **11 MAJOR RECOMMENDATIONS**

RECOMMENDATIONS

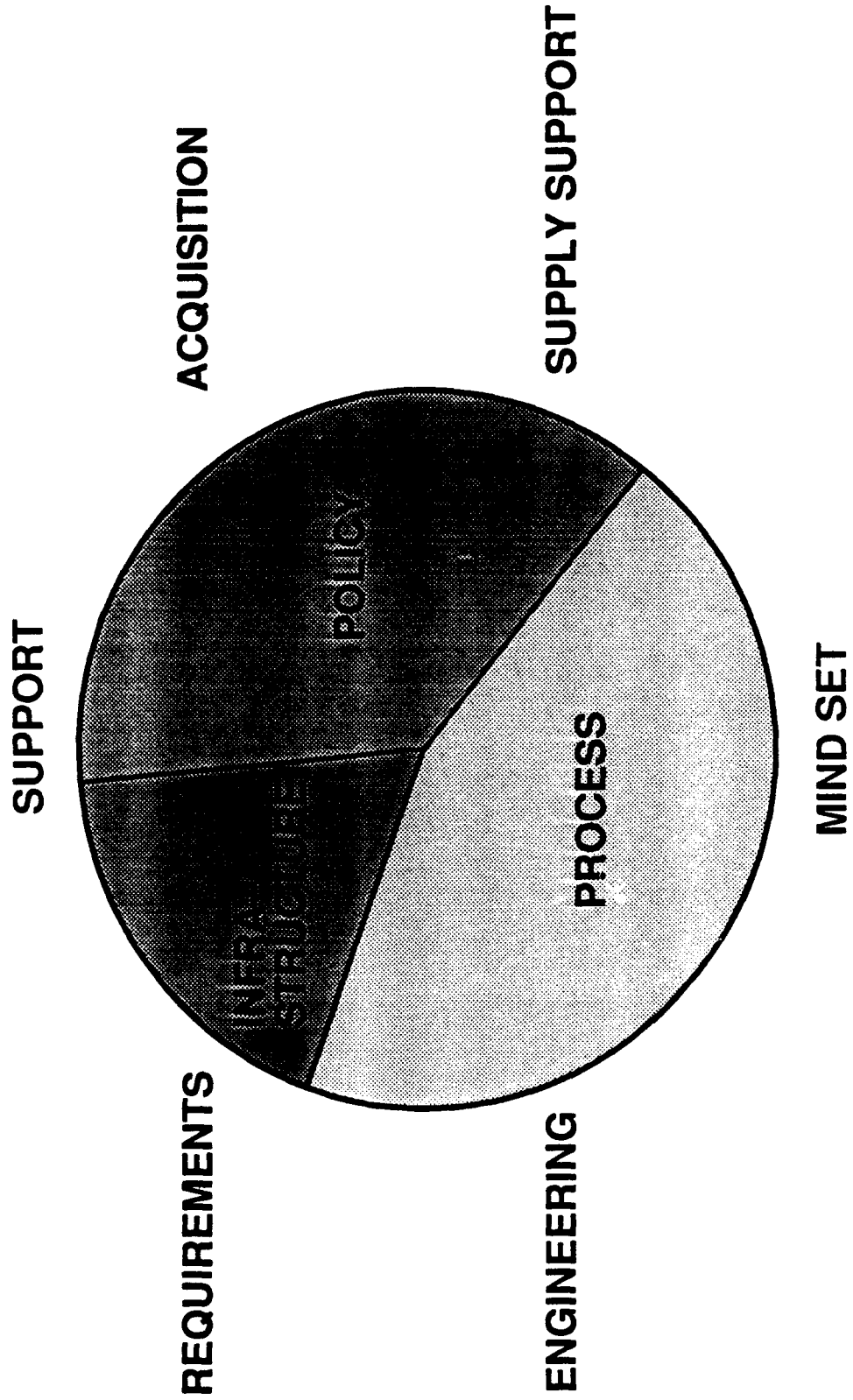

SUPPORT APPROACHES

KEY ISSUES

- **COMMERCIAL ITEMS CHANGE WITH MARKET**
- **ACQUISITION/DEPLOYMENT FAST PACED**
- **REGULATIONS, PROCESSES AND MIND SET
GEARED TO DEVELOPMENTAL ITEMS**

SUPPORT APPROACHES

- **POLICY RECOMMENDATION #1**
 - **CONTRACTOR SUPPORT PREFERRED**
UNLESS MISSION NEEDS ARE NOT MET

- **POLICY RECOMMENDATION #2**
 - **APPLY VENDOR SUPPORT CONCEPTS WHETHER**
SUPPORT IS ORGANIC OR CONTRACT

ACQUISITION STRATEGY

KEY ISSUES

- UP-FRONT SUPPORT PLANNING INADEQUATE
- ACQUISITION/DEPLOYMENT FAST PACED
- PLANNED REPLACEMENT VITAL TO SUPPORT STRATEGY

ACQUISITION STRATEGY

- POLICY RECOMMENDATION #3
 - UP FRONT SUPPORT REQUIREMENTS, STRATEGY, AND CONTRACTING FOR COMMERCIAL ITEMS

- PROCESS CHANGE #1
 - ACQUISITION AGENCY FUND INITIAL SUPPORT OF ORGANICALLY SUPPORTED ITEMS

ENGINEERING APPROACHES

KEY ISSUES

- MODIFICATION = DIFFERENTIATION
- MODS OCCURRING ON MANY COMMERCIAL ITEMS
- MORE SYSTEM INTEGRATION EMPHASIS NEEDED

ENGINEERING APPROACHES

- POLICY RECOMMENDATION #4
 - DON'T MODIFY COMMERCIAL ITEMS
- PROCESS CHANGE #2
 - EMPHASIZE SYSTEM INTEGRATION TOOLS TO MEET THE ENGINEERING CHALLENGE FOR COMMERCIAL ITEMS

ENGINEERING APPROACHES

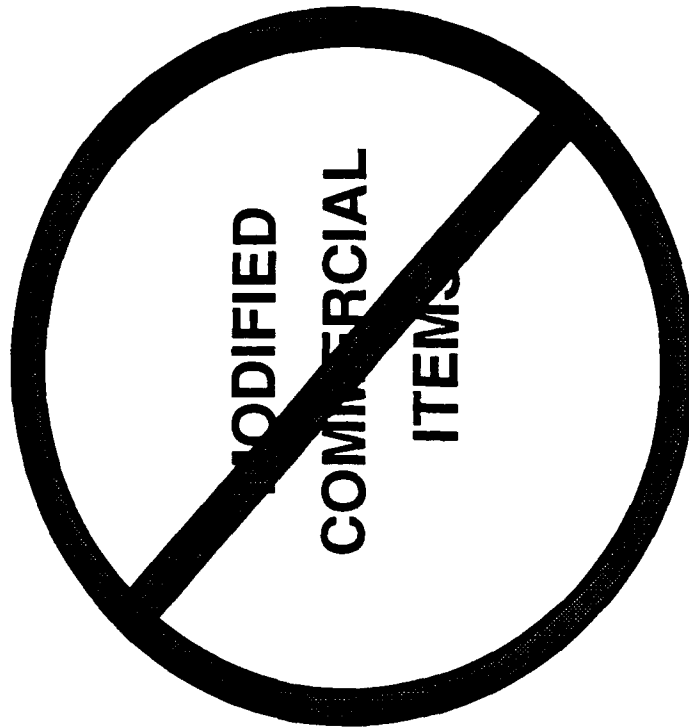

ENGINEERING APPROACHES

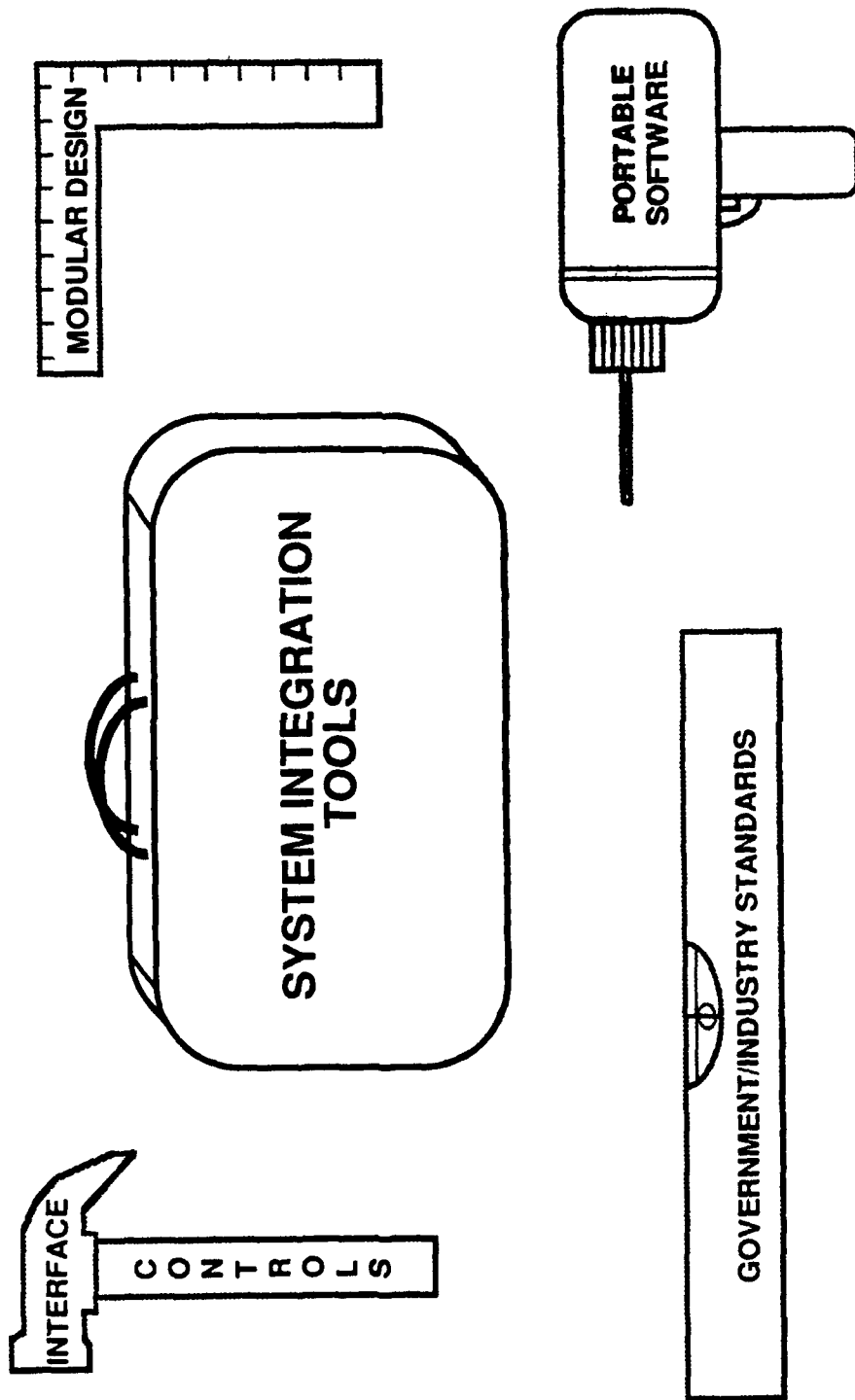

REQUIREMENTS PROCESS

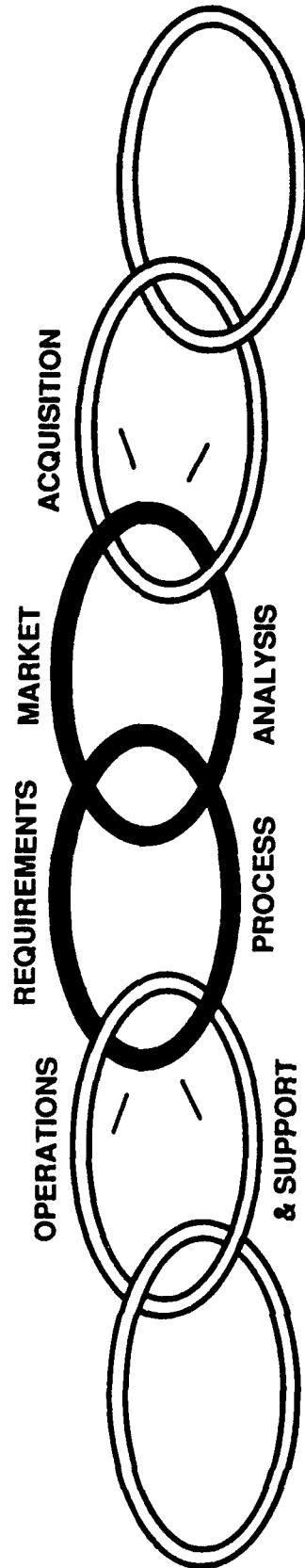

COMPETITIVE MATRIX

REQUIREMENTS	VENDORS									
	A	B	C	D	E	F	G	H	I	J
MAXIMUM DIMENSIONS	X	X	X	X	X	X	X	X	X	X
MAXIMUM WEIGHT	X	X	X	X	X	X	X	X	X	X
RELIABILITY	X	X	X	X	X	X	X	X	X	
MAINTAINABILITY	X	X	X	X	X	X	X	X		
FUNCTIONAL CAPACITY 1	X	X	X	X	X	X	X	X		
2	X	X	X	X	X	X	X			
3	X	X	X	X	X					
4	X	X	X	X						
5	X	X								
6										

X - REQUIREMENT MET

REQUIREMENTS PROCESS

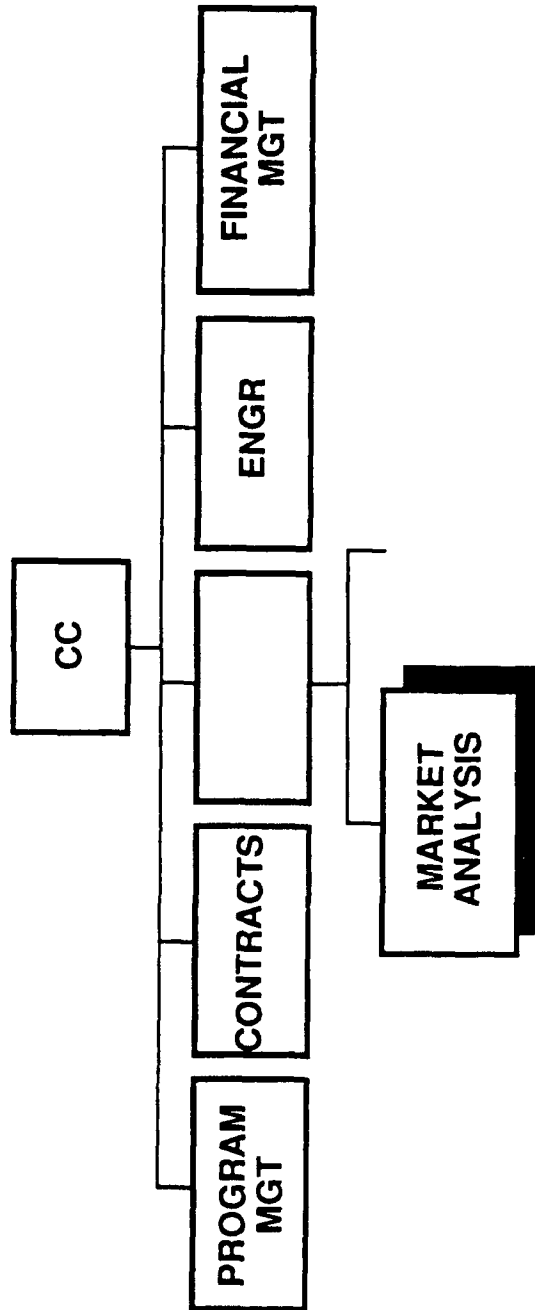

SUPPLY SUPPORT

KEY ISSUES

- **MANY COMMERCIAL ITEM SPARES ARE AIR FORCE OWNED**
- **MANY AF-OWNED ITEMS LEFT OUT OF SUPPLY SYSTEM**
- **CURRENT SUPPLY SYSTEM ORIENTED TOWARD DEVELOPMENTAL ITEMS**

SUPPLY SUPPORT

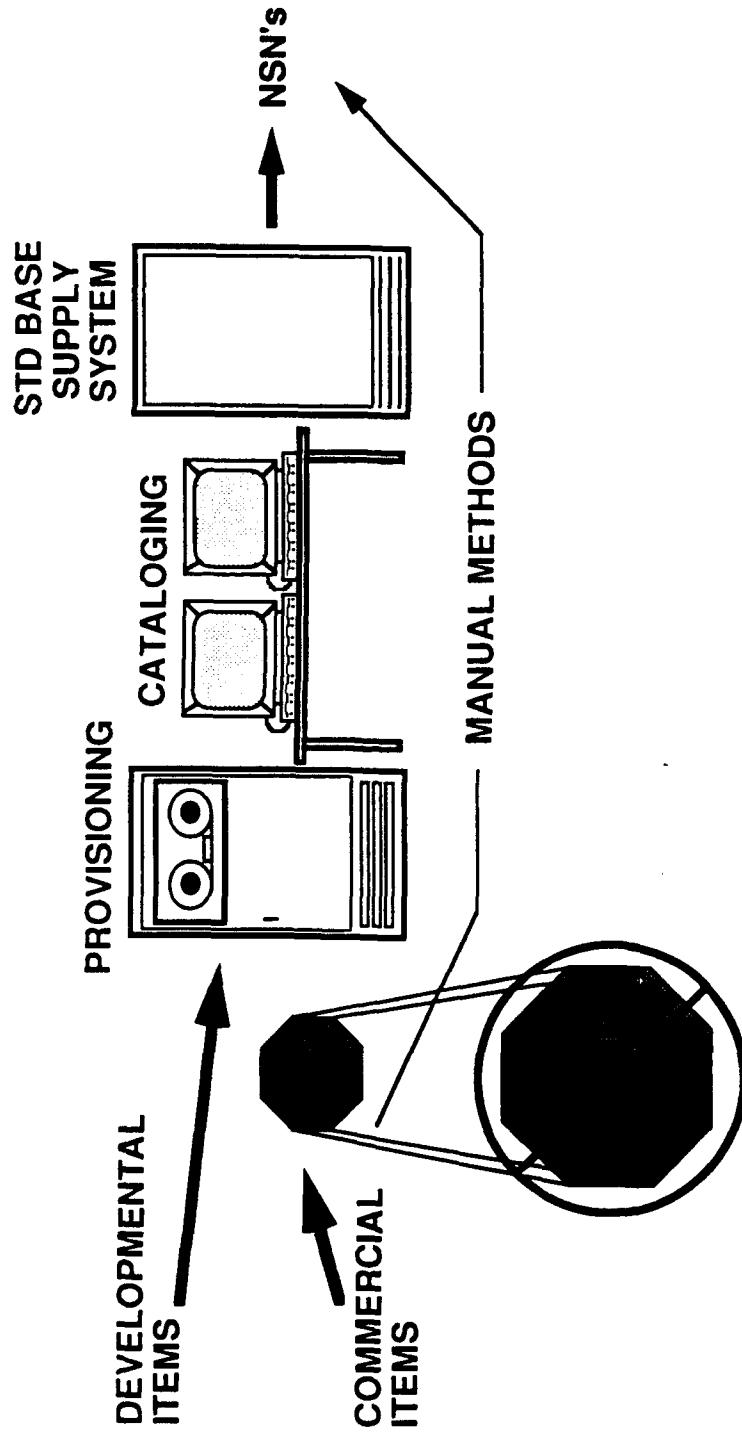

SUPPLY SUPPORT

- PROCESS CHANGE #4
 - MODIFY CATALOGING PROCESS AND STANDARD BASE SUPPLY SYSTEM (SBSS) FOR COMMERCIAL ITEMS

MIND SET

KEY ISSUES

- **COMMERCIAL ITEMS ~~✓~~ DEVELOPMENTAL ITEMS**
- **MIND SET CONTRIBUTES TO SUPPORTABILITY PROBLEMS**
- **CORPORATE KNOWLEDGE/LESSONS LEARNED NOT CAPTURED**
- **FULL POLICY, PROCESS, TRAINING IMPLEMENTATION 3-4 YEARS AWAY**
- **CENTER OF EXCELLENCE NEEDED**

MIND SET

- PROCESS CHANGE #5
 - TRAINING TO CHANGE DEVELOPMENTAL MIND SET AND IMPROVE SKILLS

- INFRASTRUCTURE CHANGE #2
 - NEED COMMERCIAL ITEM SUPPORT CENTER OF EXCELLENCE UNTIL NEW POLICY AND PROCESSES IN PLACE

CONCLUSION

- SUPPORTABILITY WILL BE IMPROVED BY:
- RECOGNITION OF COMMERCIAL ITEM UNIQUENESS
- NEW WAYS OF DOING BUSINESS
 - UP-FRONT STRATEGY AND CONTRACTING
 - NO MODIFICATIONS
 - MARKET ANALYSIS
- CHANGES IN MIND SET

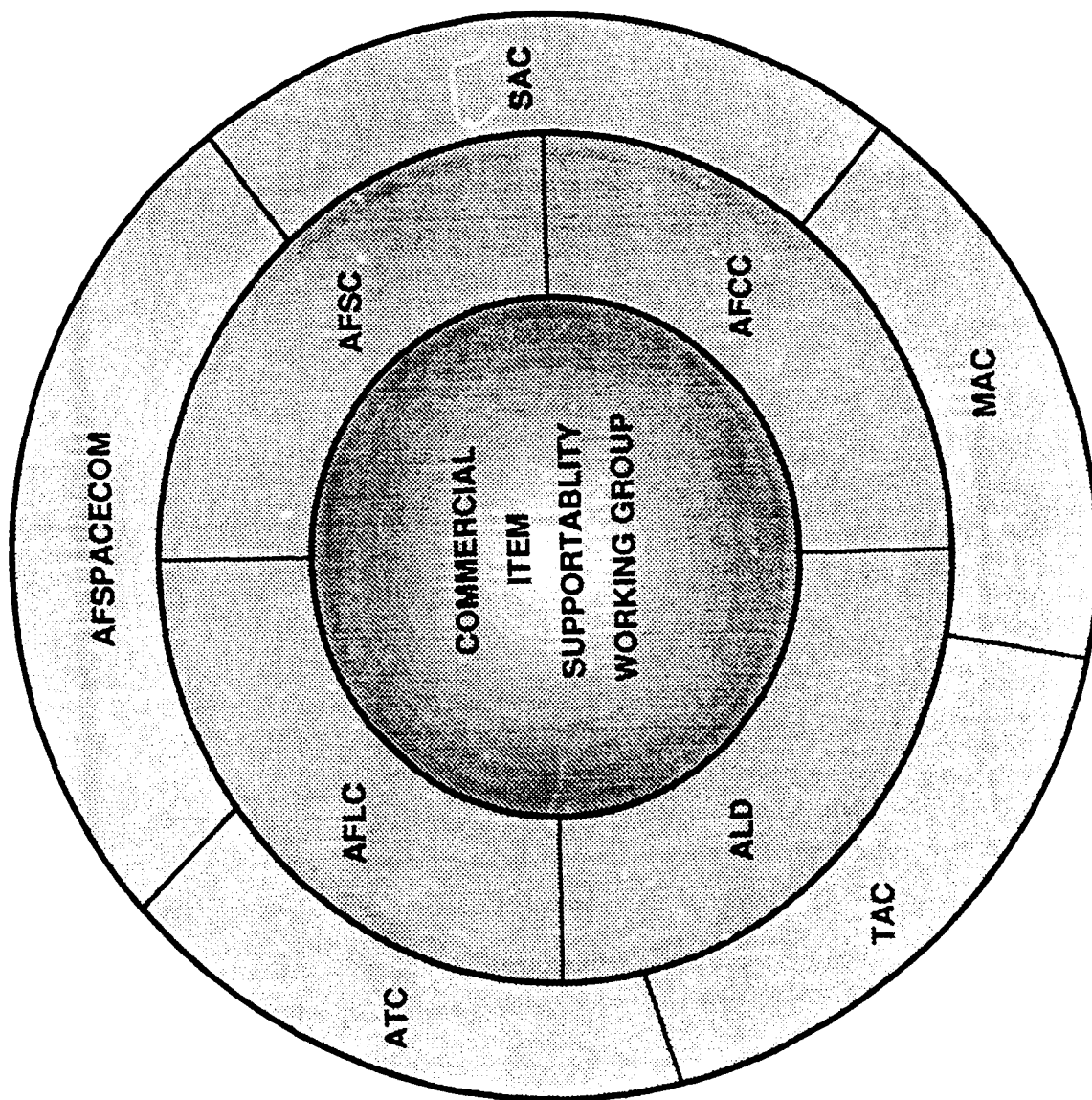

Procurement of Non-Developmental Items (NDIs)



Presented By:
Steve Gershman
NAVSEA 91L
15 May 1991

AGENDA

- Introduction
 - Overview of Navy NDI Program (Film)
 - Presentation
 - Definition of NDIs
 - NDI Path
 - Guidance for procuring NDIs
 - Commercial Item Description for Ceramic Composite Ballistic Armor
-

● ● Overview of the Navy's NDI Program

- **Film**
 - **Location of CINCLANTFLT NDI Facility**
 - Naval Operating Base Norfolk, Shore Intermediate Maintenance Activity (SIMA) Code N-432F
 - **Points of Contact**
 - Master Chief John Taggart
 - Master Chief Ruben Davis (804) 444-9857,
(804) 445-1012
 - **Please call in advance for an appointment.**
-

Presentation

3 Main Ingredients Required to Procure NDIs:

- **Ambition**
- **Determination**
- **Perseverance**
 - **Don't be afraid of hard work**
 - **Expect resistance to your efforts**
 - **Be prepared to hurdle barriers**

Non-Developmental Items Defined

• Section 2325, Chapter 138 of Title 10 United States Code defines NDIs as:

- " (1) Any item of supply that is available in the commercial marketplace;
(2) any previously-developed item of supply that is in use by a department or agency of the United States, a State or local government, or a foreign government with which the United States has a mutual defense cooperation agreement;
(3) any item of supply described in paragraph (1) or (2) that requires only minor modification in order to meet the requirements of the procuring agency; or
(4) any item of supply that is currently being produced that does not meet the requirements of paragraph (1), (2) or (3) solely because the item - -
(A) is not yet in use, or
(B) is not yet available in the commercial marketplace."
-

NDI Path

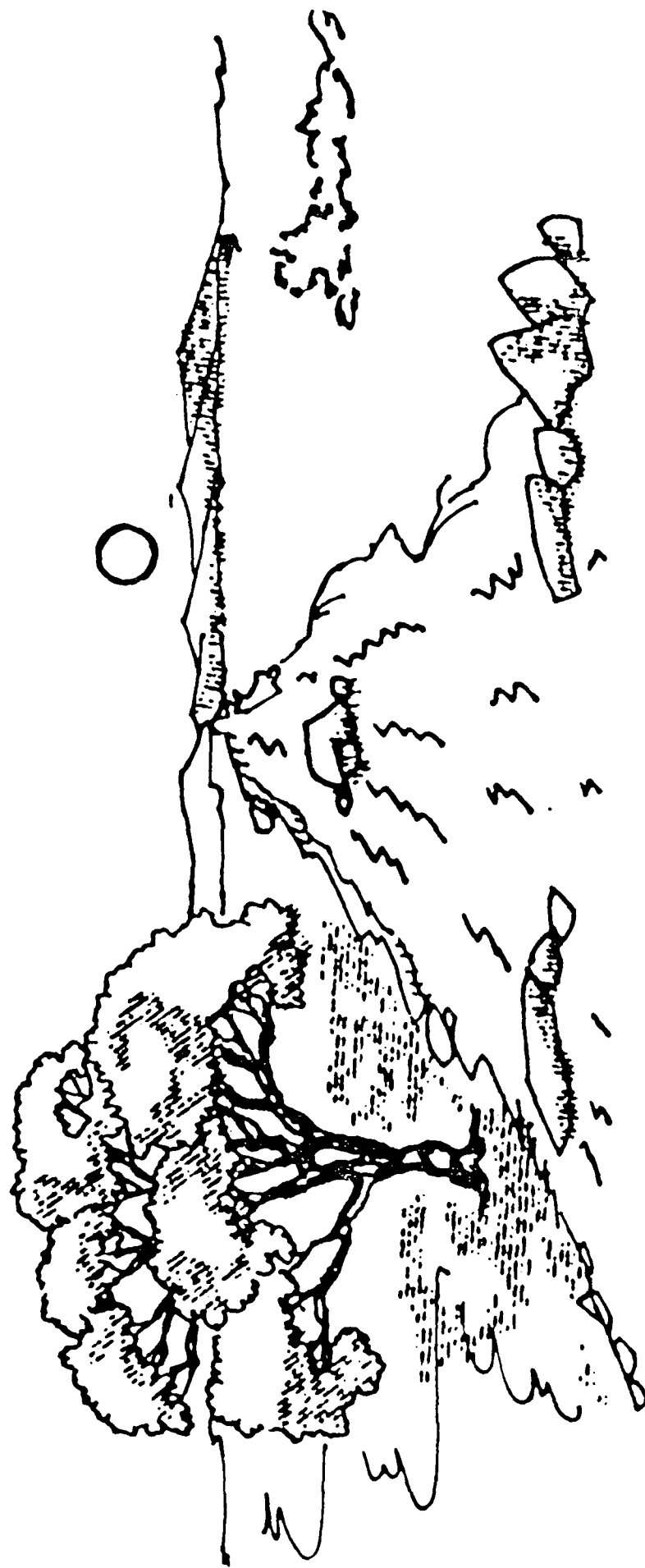

● ● Guidance for Procuring NDIs

- Determine what specific system, equipment, or service is needed to fulfill your application.
- Decide if NDI will satisfy most or all of your requirements, if not, consider a Commercial or Industrial Specification (ASTM/ANSI).
Use a Military Specification as a last resort.

- (1) Commercial-Off-The-Shelf (COTS)
 - (2) Commercial or Industrial Specification
(ANSI/ASTM)
 - (3) MIL-SPEC
-

Guidance for Procuring NDIs (cont.)

- **Perform a market survey.**
 - **Some available sources:**
 - **Thomas Register, Commerce Business Daily (CBD) responses, Yellow Pages, Bidders Lists for that commodity, etc.**
 - **DLSC, TLRN, Haystack, Partsmaster, Specmaster data bases, etc.**
 - **Attend Trade Shows, Exhibits, Conventions, etc.**
-

● ● Guidance for Procuring NDIs (cont.)

- Identify sources that have a readily deployable system, equipment or service, or one that can be modified to meet the user's needs.
 - Obtain sample, if possible.
-

Guidance for Procuring NDIs (cont.)

- **If Commercial-Off-The-Shelf (COTS) will suffice, and has proven market acceptability, write a Commercial Item Description (CID) that identifies salient characteristics and minimum essential requirements, such as:**
 - **Performance Criteria**
 - **Environmental Material Requirements**
 - **Special Testing or Independent Lab Testing if necessary**
 - **Special packaging, marking and labeling if other than commercial acceptable standard practice. (MFG./mfg date/production lot no./sequential serial no.).**
 - **Warranty/liability of manufacturer**
 - **Deliverables identified/timeframe**
-

Guidance for Procuring NDIs (cont.)

- **Identify both interim and long-term Integrated Logistics Support, Training and Life Cycle Support methodology.**
 - **Include such data in CID**
 - **Identify a specific method for support, such as:**
 - **Provisioning Line Item for Spare/Repair Parts**
 - **Negotiate a Technical Services Support Contract**
 - **Repair Basic Ordering Agreement (BOA)**
 - **Beyond Economic Repair - Disposal?**
-

Guidance for Procuring NDIs (cont.)

- **Prepare a Request for Contractual Procurement (RCP).**
 - **Submit RCP to Contracting Officer.**
 - **Obtain a pre-bid sample when necessary for technical assessment. If no sample is submitted, vendor could be considered non-responsive to the solicitation (RFP, RFQ, IFB).**
-

Guidance for Procuring NDIs (cont.)

- **Keep Contracting Officer informed of status and progress at all times.**
 - **Document all telephone conversations with the manufacturer.**
 - **Be careful not to unknowingly give guidance which may be construed as "Constructive Changes" to the actual contractual requirements, negotiate pricing or discuss funding levels of contract.**
 - **Deal directly with the Contracting Officer - let the Contracting Officer make the call and follow up with a letter of direction.**
-

NDI Visionaries

Consider NDIs in the Acquisition Process

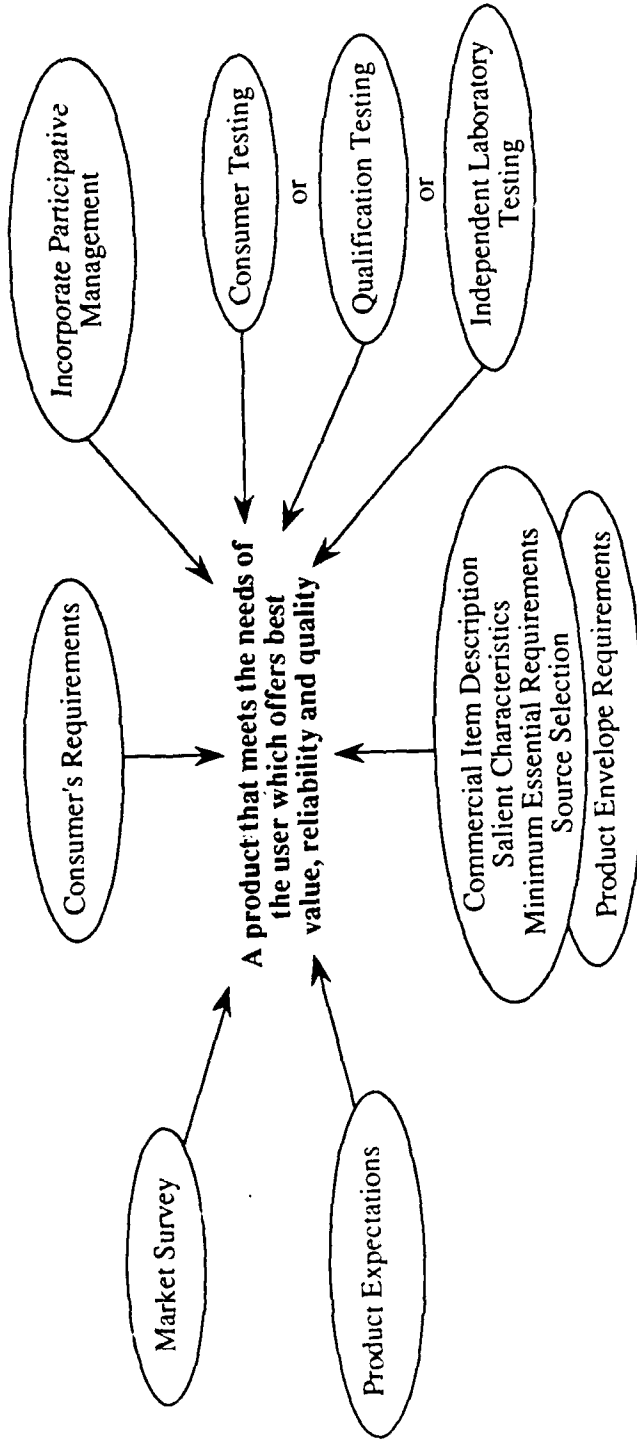

The critical issue is to successfully plan and identify specific wants/needs up front:

- Quality
- Reliability
- Logistics Support
- Technical Data (manuals, diagrams, parts lists)
- Special Tools/Test equipment
- Notice of change in product

"Support from the Top"

- **DMR initiatives provide the Program Office or the procuring activity the flexibility to use common sense and good judgement.**
 - **SECNAVINST 4210.7A states that NDI procurement is of such importance, that existing DoN acquisition requirements and regulations will be waived where significant cost or schedule benefits can be achieved by procurement of NDI.**
 - **Exceptions to these NDI policies shall be granted only by SECNAV.**
-

BALLISTIC ARMOR PANEL

Purchase Description

This purchase description describes ballistic armor panels constructed of composite materials for mounting around exposed, small-caliber gun positions on naval ships. These panels provide protection against small-caliber, armor piercing projectiles fired from close ranges.

An armor panel consists of ballistic grade ceramic tiles bonded to a non-metallic laminate component. The entire surface of the each panel is covered by a spall cover. Each armor panel measures 42 to 43 inches in length by 24 to 24-3/4 inches in width with a maximum thickness of 2 inches. The areal density of a production ballistic armor panel, including the spall cover, is not in excess of 19 pounds per square foot. The nominal weight of a single panel is 128 pounds. A durable, permanent weather covering protects the armor panel from absorbing moisture which produces corrosion in an at-sea environment and provides abrasion protection during handling. The spall cover can be the weather cover. Complete panels are painted haze grey #27 as described in Federal Specification TT-E-490. All panels are identical in construction and configuration.

The armor panels meet or exceed the ballistic performance requirements of the commercial panel manufactured by _____, Part No. Grade 180-24X42 as defined by attached independent laboratory test data record. The lowest acceptable protective ballistic limit velocity (V_{50}), to be fired on joints, is _____ feet per second. The armor panels must also withstand multiple projectile hits not closer than eight inches from a previous hit and not closer than four inches from any edge when subjected to the ballistic threat described by the attached test data record. The spall cover is included as part of this test to demonstrate the containment of spall from the projectile impact. The armor panels are designed and constructed to meet the ballistic requirements over a temperature range of -20 degrees F to 130 degrees F and up to 95% relative humidity.

Each armor panel is marked in the following manner: The ceramic side (front side) of each panel is clearly lettered in 2-inch high, black lettering to read "FACE THIS SIDE TO ENEMY". The non-metallic laminate side (back side) is lettered in the same manner to read "FACE THIS SIDE TO MACHINE GUN OPERATOR". A permanent metal identification tag is attached with epoxy to the armor panel (mechanical fasteners such as nails or screws are NOT to be used) and contains the following information: contract number, lot number, sequential serial production number, manufacturer's name and address, manufacturer's part number, and date of manufacturer.

For this procurement, lot acceptance testing at a government-authorized facility will be performed in the presence of a government representative in accordance with MIL-STD-662. Three panels will be randomly selected by the government from each production lot of 150 panels, or partial lot. The manufacturer is required to obtain a Certificate of Conformance (C of C) from their distributors of raw materials. The manufacturer is required to maintain records of raw materials used in each production lot, a record of production procedures and the manufacturer's record of production lots in case of a failure during acceptance testing. Shipment of a production lot will not be allowed until acceptance testing is successfully completed.

Since these panels are commercial construction, the manufacturer warrants the armor panels for full ballistic integrity for 2 years from date of manufacture.

Suggested Reading

- **SECNAVINST 4210.7A, *Effective Acquisition of Navy Material* of 16 Jan 87**
 - **OASD Publication SD-2, *Buying NDIs* of Oct 90**
 - **DoD Directives 5000.1 (Part 1)/5000.2 (Parts 6, Section L, 7 and 10, Section C) of 28 Feb 91**
 - **Federal Acquisition Regulation (FAR) 15.804, *Cost and Pricing Data***
-

Suggested Reading (cont.)

- *Integrating Commercial and Military Technologies for National Strength - An Agenda for Change* published by Center for Strategic and International Studies, Mar 91, ISBN 0-89206-167-7

\$19.95 plus \$2.95 postage

20-30 copies - 20% discount

30-over - 30% discount

ATTN: Ms. Heidi Shinn (202) 775-3119.

PANEL A - JUSTIS

Chair - Colonel Gilbert E. Mayeux II, Air Force Logistics Command, Logistics Management System Center

Panel Members:

Ivan Galysh, Army Materiel Command

CDR. Tom Ballew, Office of the Deputy Chief of Naval Operations (Logistics)

Julia Lawson, Headquarters, United States Air Force (Logistics)



**JOINT UNIFORM SERVICE
TECHNICAL INFORMATION SYSTEM**



BRIEFER

**COLONEL G.E. MAYEUX II
AFLC LMSC/SB
WRIGHT-PATTERSON AFB, OH 45433**

**DSN 787-8300
COMMERCIAL (513) 257-8300
FAX DSN 787-3040**



TECHNICAL ORDER DEVELOPMENT



THE
PAPER MONSTER



DEFICIENCIES

- MANY SYSTEMS 1960's VINTAGE
- COMPLEX ACQUISITION PROCESS
- EXCESSIVE TIME TO PROCESS T.M. CHANGES
- CONFLICTING POLICY REGULATIONS
- LARGE/COSTLY PAPER STORAGE
- CANNOT PROCESS DIGITAL DATA



WHAT IS JUSTIS ?

- PROGRAM TO MODERNIZE THE OVERALL MANAGEMENT OF DOD TECHNICAL ORDERS / MANUALS
- INFRASTRUCTURE TO AUTOMATE THE DEVELOPMENT, ACCEPTANCE, STORAGE, MANAGEMENT AND DISTRIBUTION OF TECHNICAL DOCUMENTS WORLDWIDE

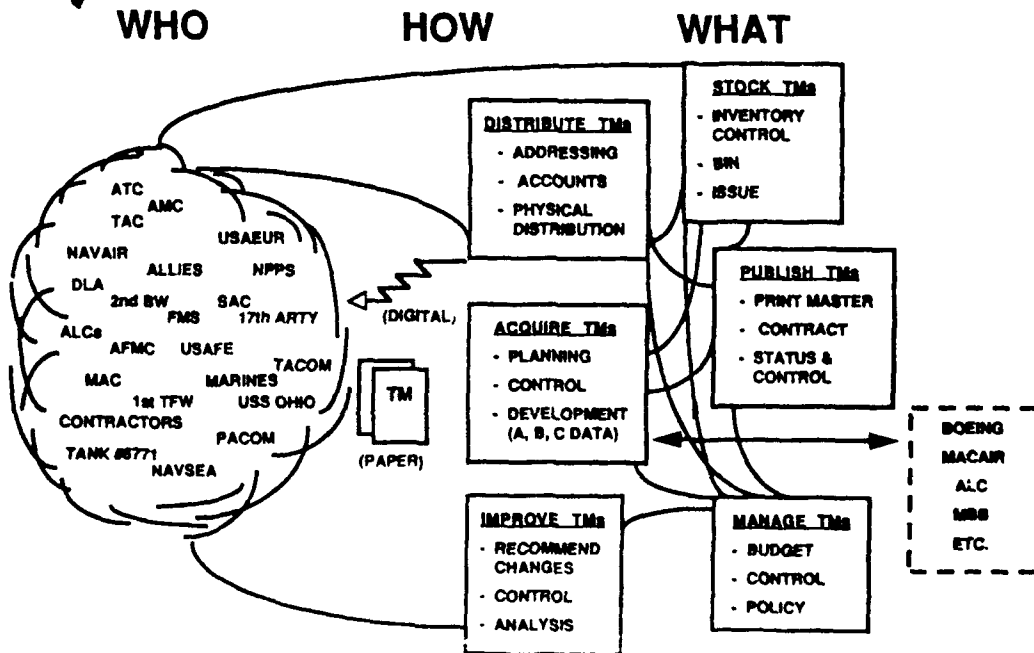

INFORMATION EVO\REVOLUTION

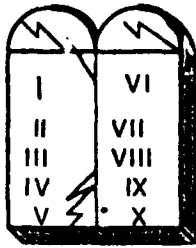

ONE COPY READABLE
ONLY AT THE ARC OF
THE COVENANT



COPIED BY
HAND OR PRESS

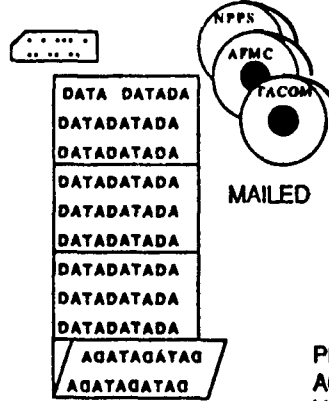

BATCHED

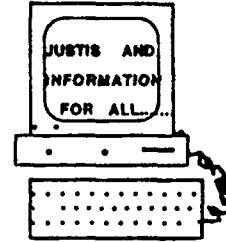

PERSONAL INFORMATION
ACCESS CONCEPT OF
VANEVAR BUSH

ACCESS BY ONE ACCESS BY A FEW ACCESS BY MANY ACCESS BY ALL



PROGRAM BACKGROUND

AF CALS/MIO T.O. MODERNIZATION STUDY	OCT 87
AFTOMS PMD	JUN 88
AFTOMS MAISRC 0	MAY 89
DMRD 925	NOV 89
AFTOMS RENAMED JUSTIS	FEB 90

TEAM OBJECTIVES

- IDENTIFY ARMY, NAVY AND AIR FORCE TECHNICAL MANUAL SYSTEM FUNCTIONALITY
 - CURRENT METHODS/PROCEDURES
 - PROPOSE METHODS/PROCEDURES
 - SPECIFIC/UNIQUE FUNCTIONAL AND SYSTEM REQUIREMENTS
 - DOCUMENT THE FUNCTIONAL/SYSTEM REQUIREMENTS IN THE MULTI-SERVICE FUNCTIONAL DESCRIPTION (FD)
-

ACCOMPLISHMENTS

- VOLUNTARY, BOTTOM-UP COOPERATION; NOT TOP-DOWN DIRECTED
- JUSTIS TDY TO ARMY & NAVY TO COLLECT REQUIREMENTS IN PREPARATION FOR MULTI-SERVICE SYSTEMS REQUIREMENTS DEFINITION
- FUNCTIONAL DESCRIPTION (FD) DEVELOPMENT
 - MULTI-SERVICE SRR's NOV '90 / MAR '91
- SERVICE DEPUTY ASSIGNMENTS



• DMRD 925, 10 NOVEMBER 1989

SUBJECT: DEVELOP STANDARD ADP SYSTEMS

COMPONENTS: AIR FORCE, ARMY, NAVY, DEFENSE AGENCIES

**ISSUES: INDIVIDUAL SERVICES MUST NOT EXPEND
RESOURCES TO DEVELOP SYSTEMS OR SOFTWARE
TO MEET THE SAME FUNCTIONAL REQUIREMENTS**

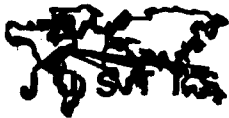

JUSTIS Supports CALS Goals

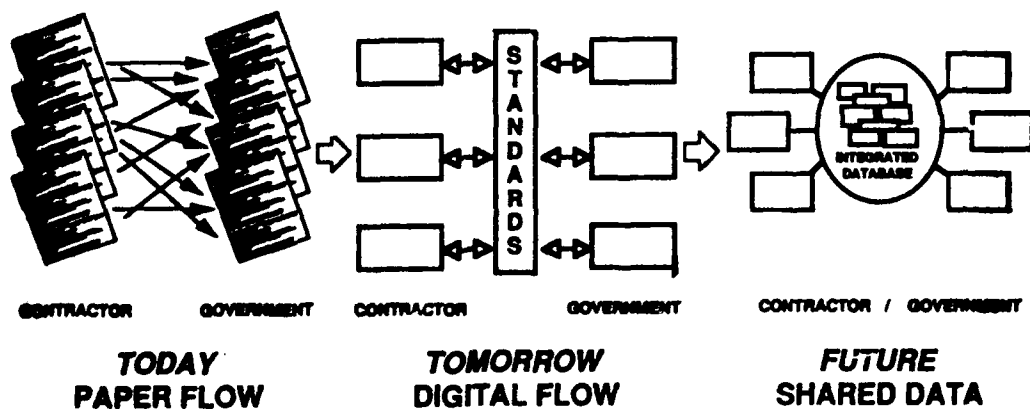

JUSTIS JOINT-SERVICE ACTIVITIES

- JOINT-SERVICE TM INFRASTRUCTURE WORKING GROUP
 - AUGUST 1989 MEETING
 - INTITIAL KICKOFF WITH ARMY, NAVY, DLA
 - EDUCATIONAL
 - DEFINED AFTOMS CONCEPTS, GOALS, TARGETS
 - AUGUST 1989 ARMY/NAVY REVIEW OF AIR FORCE
 - REQUIREMENTS IDENTIFICATION PROCESS PRESENTED
 - REQUESTED
 - REVIEW FD FOR PERCENT FIT
 - IDENTIFY ADDITIONAL NEEDS
 - APRIL 1990
 - ARMY TEAM FORMED
 - NAVY TEAM FORMED

NAVY TECHNICAL MANUALS

AUTOMATION TRANSITION CONCEPT

JUSTIS PROVIDES OPPORTUNITY TO:

- LOOK AT TECHNICAL MANUAL PROCESSES...
 - DETERMINE WHERE BEST PERFORMED
 - AUTOMATE

- LOOK AT NAVY SYSTEMS...
 - INTERFACE, OR
 - ENHANCE/UPGRADE

JUSTIS Concept of Engineering

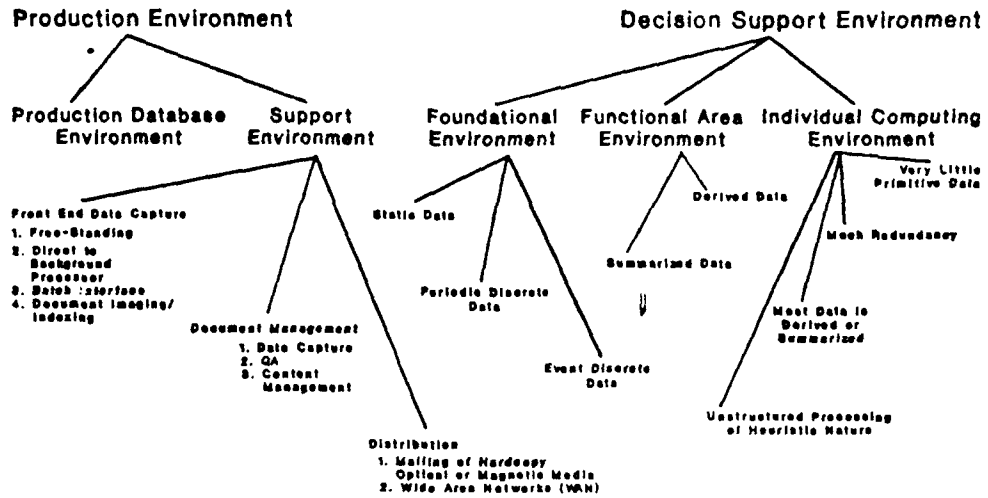

TECHNICAL MANUAL AUTOMATION

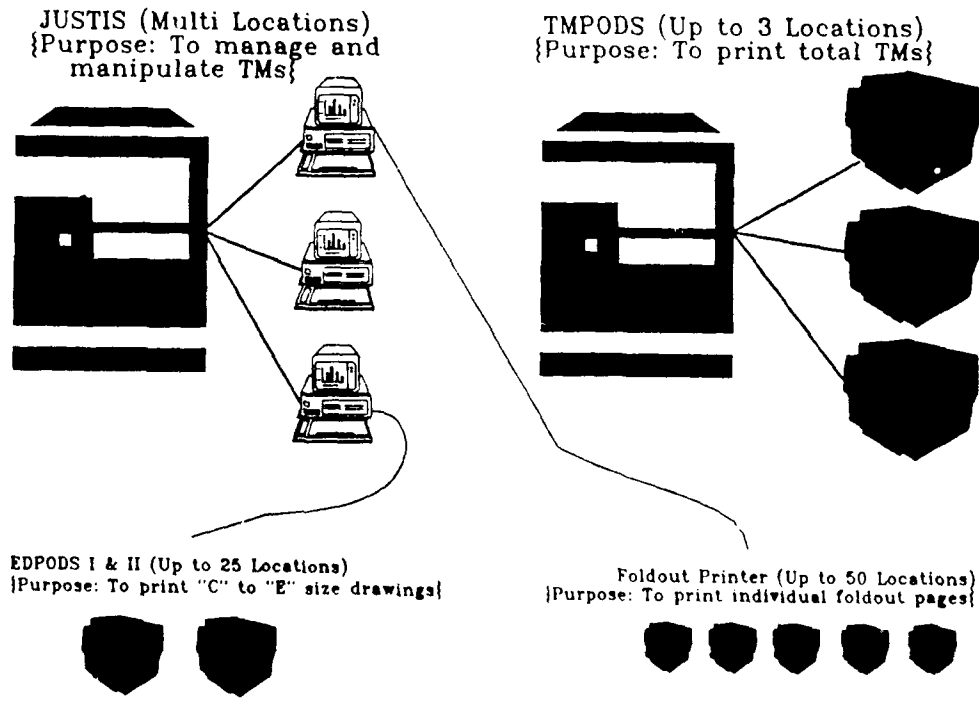

EXISTING AUTOMATED DATA SYSTEMS

SERVICE	TYPE OF AUTOMATED DATA SYSTEM	
	MIS	ELECTRONIC PUBLISHING
ARMY	3	1
NAVY	4	3
AIR FORCE		1
USMC		1

EXISTING AUTOMATED DATA SYSTEMS

WHAT SYSTEMS SUPPORT TECHNICAL MANUAL
FUNCTIONS TODAY?

- CAN EXISTING SYSTEMS BE EXPANDED TO
INCLUDE OTHER SERVICES' REQUIREMENTS?

- MODULARITY
- PORTABILITY
- REUSABILITY

PRESENTATION DEVICES

WHY AREN'T USER (TECHNICIAN) DEVICES
PART OF JUSTIS?

ENVIRONMENT	PROGRAM
WORK CENTER	REQ'TS CONTRACTS
WORK SITE	IETMS (IMIS, etc.)

PARTICIPATION IN JCMO/OSD CALS ARCHITECTURE

- MEMBERSHIP ON EACH TIGER TEAM
- EXPERIENCE WITH MODELING

PRESENTATION DEVICES

- WHERE SHOULD STANDARDIZATION BE?

- * DIGITAL FORMAT
- * INTERFACES
- * RETRIEVAL SOFTWARE
- * OPERATING SYSTEM
- * HARDWARE

PANEL B

DODD 5000.1 & DODI 5000.2

Chair - Carl Berry, Office of the Assistant Secretary of Defense (Production and Logistics), Technical Data and Manufacturing Division

Panel Members:

Ann Reese, Defense Management Report Implementation Coordination Office

Alfredo Campo, Office of the Deputy Assistant Secretary of the Army (Logistics)

Oscar Goldfarb, Office of the Deputy Assistant Secretary of the Air Force for Communication, Computers and Logistics

William Campbell, Naval Supply Systems Command

Panel B, DoD 5000.1 and .2

The scope of Panel B was enlarged by the Chairman to include other aspects of the Defense Management Review (DMR). This was done to provide ample insight into the synergism of changes occurring throughout DoD as a result of the review. There were four panelists who gave presentations. The first, Mrs. Ann Reese, the Deputy Director, Defense Management Report for Implementation and Coordination, gave an overview of the DMR and its current status. Initiatives to date include:

O The Corporate Information Management initiative establishes an improved business framework to provide accurate and timely information to senior managers. A Defense-wide communications and computing system eliminates expensive and redundant development costs associated with the many computer and information systems of the Department. Many current systems do not communicate with each other, creating such inefficiencies as 27 different civilian payroll systems. They can now be combined into one.

O Establishment of the Defense Finance and Accounting Service, under which 250 accounting systems will be streamlined into a handful of carefully tailored business and finance accounting systems. Accounting policy guidance will be reduced from 50,000 pages of regulation to 20,000. The number of personnel devoted to writing policy direction will be cut by half.

O Establishment of Defense Contract Management Command to consolidate all contract administration services, including the military service plant representative offices as well as other contract administration functions, such as evaluating and negotiating contract bids and processing payments. Establishing of the command permitted streamlining from nine locations to five.

O In the specific area of defense acquisition policy, 76 percent of DoD directives and instructions will be eliminated, combined, or significantly changed. The revised cornerstone acquisition directive alone cancelled 50 separate directives, instructions, and manuals as well as 15 policy memoranda. Half of the Defense Federal Acquisition Regulatory Supplement (DFARS) will be cancelled, and 14 percent of the military specifications and standards will be eliminated. For the first time, all of the basic acquisition policies and procedures are contained in one series of three documents that require no supplementary guidance to be provided by the individual military departments. The revised Defense Acquisition Directives create a single, uniform acquisition system throughout the department, covering clear acquisition strategies thorough program planning, sound risk management techniques, and systematic program tracking against plan. Streamlined management with direct, abbreviated lines of authority and clear accountability, strengthens defense acquisition.

O Several initiatives will reduce costs throughout DoD's supply system while maintaining and improving support to the armed forces. All 30 general supply depots will be consolidated. These depots include 3400 warehouses, in which over \$100 billion of inventory is stored. Consolidation will improve the utilization of DoD's existing supply capacity.

O DoD is coordinating all research and advanced engineering activities, and the military departments are streamlining their R&D facilities to encourage technical competition among the laboratories. The objective of this effort is to strengthen military capabilities and to reduce costs by exploiting innovative and commercially developed technologies.

Following her overview, each of the Services Representatives presented their views on how they were planning to implement DMR initiatives within their organizations. The Services were represented by Mr. Fred Campo, the Assistant Deputy Assistant Secretary of the Army for Logistics, Mr. Oscar Goldfarb, the Assistant Deputy Secretary of the Air Force for Logistics, and Mr. William Campbell, the Deputy Commander, Engineering and Quality for NAVSUP. Each of the representatives acknowledge that DoD's business rules were changing. An example of this is the fact that a user of items such as engineering drawings, will be expected to pay for the data needed to perform its mission. This would apply to the Defense Logistics Agency who requires technical data to replenish spare parts. Each individual acknowledged that the changes brought about by DMR are real and that the conduct of operation for the future is different and irreversible.

All of the Service speakers discussed at length the importance of automation in the new business environment. Each has either fielded or is fielding automated systems to capture electronically engineering drawings and associated data. The Army and the Air Force have developed jointly the Digital Storage and Retrieval Engineering Data System and the Engineering Data Computer Assisted Retrieval System (DSREDS/EDCARS) and have installed these systems at their primary repository sites. The Navy is developing its Engineering Data Management Information and Control System which is scheduled for deployment later this year. Each of these efforts will improve the Services ability to cope with increasing quantities of engineering drawings, reduce delays in turnaround time and backlogs, and provide more complete drawing packages and better baseline control through improved file management.

Lastly, all of the representatives agreed that the DoD Components must adopt to the forthcoming changes. Each emphasized the need for the present culture and mind set to revise its way of thinking and of doing business in order to successfully adopt to the new environment created by the DMR.

NAVY TECHNICAL DATA MANAGEMENT

W. H. CAMPBELL
DEPUTY COMMANDER,
ENGINEERING & QUALITY
NAVAL SUPPLY SYSTEMS COMMAND

CS91-10

OUTLINE

- CHANGING ENVIRONMENT
- DMRD'S
 - IMPACTS
 - DMRD 901/939
- TD CHALLENGES
- FUTURE

CHANGING ENVIRONMENT

- DOD
 - RENEWED EMPHASIS ON EFFICIENCY/
COST EFFECTIVENESS
 - CHANGING SECURITY THREAT
- INDUSTRY
 - SHRINKING BUSINESS BASE
 - INCREASED COMPETITION
- NAVY
 - SHRINKING BUDGET
 - SECURITY THREATS UNCLEAR

DMRD IMPACTS ON TECHNICAL DATA (TD)

- CIT/EDMICS
 - TRANSFER TD TO DLA
 - ACCELERATE EDMICS DEPLOYMENT
- CALS COMPLIANT TD
- DMRD 901/939 FUNDING TO BUY TD

DMRD 901/989

- 901
 - NSF PROCUREMENT OF TD
 - BETTER ID OF TD TO BUY
 - BUYING APPROPRIATE LEVEL OF TD
 - ADVANCED PLANNING OF TD BUYS

- 939
 - ONE TIME FUNDING
 - BUY IN CALS COMPLIANT (DIGITAL) FORM

DMRD-12

TD CHALLENGES

- PRODUCT DATA EXCHANGE SPECIFICATION (PDES)
- FLEXIBLE COMPUTER INTEGRATED MANUFACTURING (FCIM)
- CALS TD STANDARDS
- ROLE OF TD REPOSITORIES

DMRD-12

FUTURE

- IMPORTANCE OF TD WILL INCREASE
- EFFECTS OF CHANGING ENVIRONMENT PROBABLY IRREVERSABLE
- OPPORTUNITIES TO IMPROVE TD MANAGEMENT

DMR-114

PANEL D
TECHNICAL DATA INFRASTRUCTURE

Chair - Richard Donnelly, Director, Manufacturing Modernization Directorate, Office of the Assistant Secretary of Defense, Production and Logistics

Panel Members:

Thomas Bozek, Director, Policies and Standards, Office of the Assistant Secretary of Defense for Command, Control, Communications, and Intelligence (Information Systems)

Marianne Pietras, Office of the Assistant Secretary of Defense for Production and Logistics, CALS/Electronic Data Interchange Office

Captain William Hicks, USN, Director, Joint CALS Management Office

Jack Bartley, OSD Focal Point, Electronic Commerce/Electronic Data Interchange (EDI), Office of the Assistant Secretary of Defense for Production and Logistics

Michael Craner, Director for ADP Systems and Technology, Office of the Assistant Secretary of Defense for Production and Logistics

PRESENTATION ON
DOD CORPORATE INFORMATION MANAGEMENT (CIM)
BY MR. TOM BOZEK
TO THE
1991 JOINT DOD STANDARDIZATION AND
DATA/CONFIGURATION MANAGEMENT CONFERENCE
MAY 15, 1991

- CIM established to reduce non-value added work and costs
- Primary objective is business process improvement; role of IT is supportive
- CIM Initiative has had two thrusts
 - Functional Groups (Civilian Payroll, Distribution Centers, Financial Operations, Government Furnished Material, Civilian Personnel, Medical, Material Management, and Contract Payment)
 - Groups have continued functional analysis and decomposition, process modeling and data modeling
 - "Interim" or "migration" systems are being evaluated by assigned Executive Agents in MILDEPS & Agencies
 - ELG CIM Plan submitted to DepSecDef in Sept. 1990
 - Plan organization: mission, principles, visions, situation analysis, goals and strategies
 - Examples of Guiding Principles
- SecDef Nov. 16, 1990
 - Approved CIM principles for implementation
 - Assigned ASD(C3I) as senior IRM and
 - Required Plan for implementing CIM principles
- ASD(C3I) plan approved Jan. 14, 1991 by DepSecDef: Summary of Implementation policies & programs
 - Establish & centrally manage data & information system programs DoD-wide
 - Establish Information Policy Council to exchange information management concepts and plans
 - Formulate plans to implement strategies recommended in ELG plan
 - Develop plan for transition of ADPE operations to fee-for-service basis
- Current Actions
 - Main Thrusts in the Functional/Technical Relationship
 - Restructure functional business practices

- Develop/acquire enabling Technology
- Information Technology Policy Board (ITPB) established
- Enabling Technology Thrusts
 - Data management focus on data administration for data elements, data modeling and repository selection
 - DoDD 5000.11 (policy update) & 5000.11-M (implementation procedures)
 - Needed by Services & Agencies, CIM Functional Groups, CALS, EDI, and others
 - Army is Data Management EA: preparing implementation plan for ITPB approval
 - Open Systems Environment Commitment
 - NIST APP (GOSIP, POSIX, and other standard specs stated in FIPS)
 - DMR Group "Strategies for Open Systems" for architecture framework and management process
 - Federal Open Systems Users Council, X/Open and other consortia
 - System/Software Engineering and Reengineering
 - Software productivity improvements, reusability
 - Ada Business Case
 - Air Force EA for tooling using the AF I-CASE initiative as the departure point
- Summary
 - CIM initiative established to reduce non-value added work and costs
 - Calls for major reengineering and restructuring of business practices and administrative processes in DoD
 - Technology component of CIM is supportive of improved business practices and includes program components for heavy emphasis on data management, open systems architecture, and software tools for engineering and reengineering

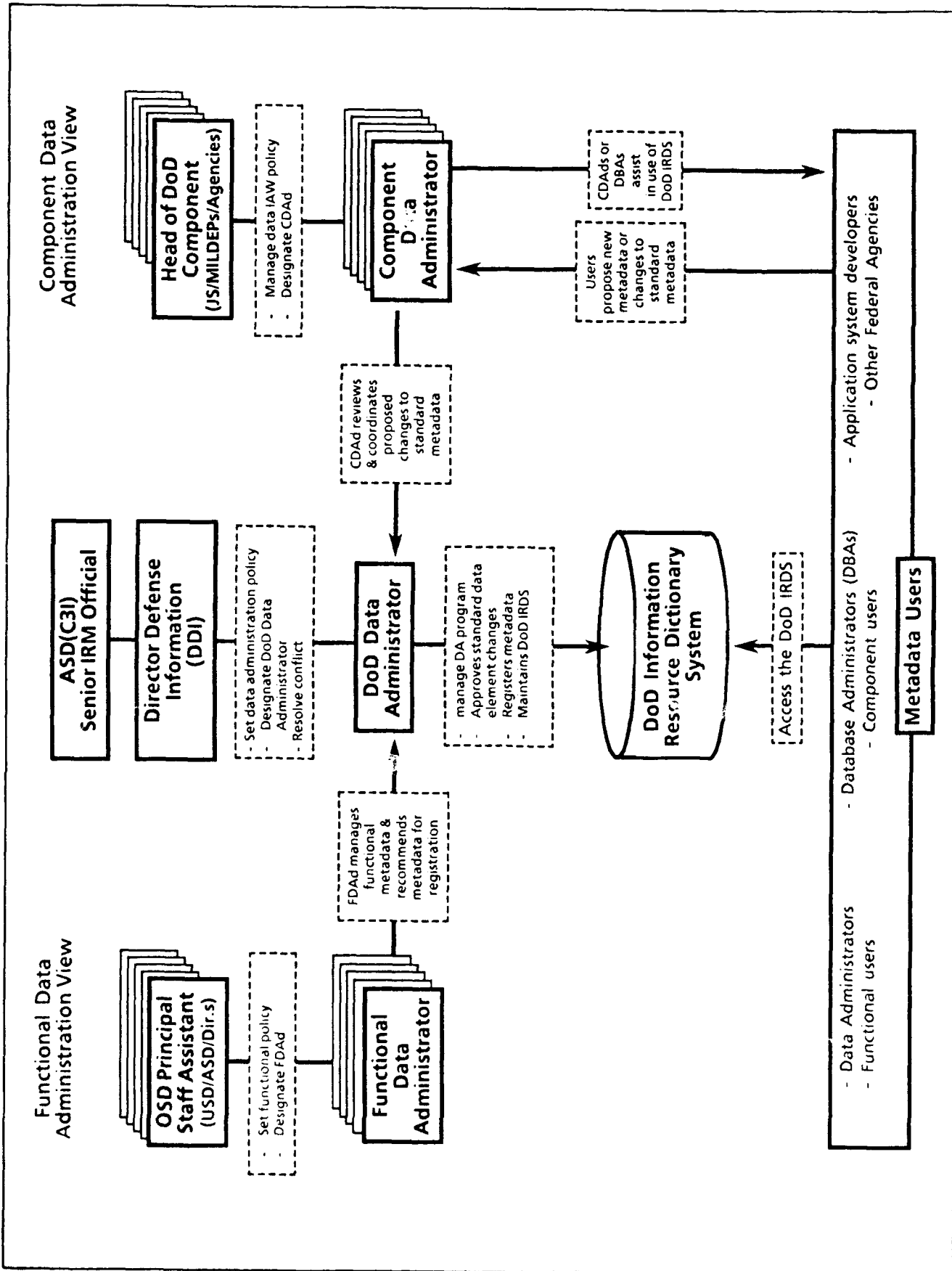

DoD Data Administration Organization and Responsibilities



Computer-aided Acquisition and Logistic Support

CALS

Enabling Process Improvements

Marianne Pietras
Office of the Secretary of Defense

WHAT IS CALS?

CALS is DoD's strategy for the transition to improved processes using automation and integration of technical information for weapon system acquisition, design, manufacturing and support

Demonstrated Benefits: Better quality, lower costs, shorter leadtimes

Observations

1. This transition is inevitable. Has already begun in industry.
2. CALS brings coherence, avoids inefficient patchwork of local solutions.
3. The faster we implement CALS, the more we benefit.

THE TREND TOWARD CALS

Industry Motivating Factors

- o Global competition
 - Better quality, shorter leadtimes, lower costs
- o Exploit integrated information technologies
 - Enterprise Integration
 - Industrial Networking (EDI, CALS)

DoD Motivating Factors

- o Shrinking defense budgets
 - Better quality, shorter leadtimes, lower costs
- o Alignment with industry trends and standards
 - Payoffs in both economic and military strength

ENVIRONMENTAL TRENDS

Past

- o Paper-based technical data
- o Islands of automation
- o Redundant data
- o Disconnected functions
- o Hierarchical organizations

Future

- o Digital data products
- o Integrated infrastructure systems
- o Create data once, use many times
- o Functional integration
- o Networked organizations

CALS STRATEGY

- o Build on industry trends. Focus and accelerate.
- o Manage key areas to enable implementation
 - Standards and Technology
 - Acquisition Guidance and Incentives
 - DoD Infrastructure Modernization and Integration
 - Cultural Change

DoD CALS COORDINATION

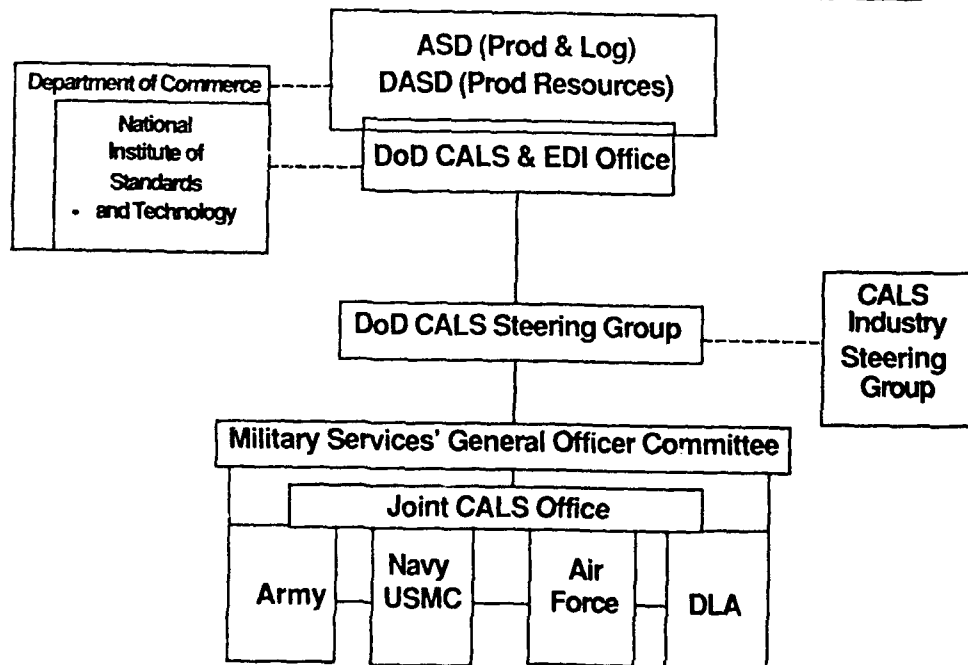

CALS / CE INDUSTRY STEERING GROUP

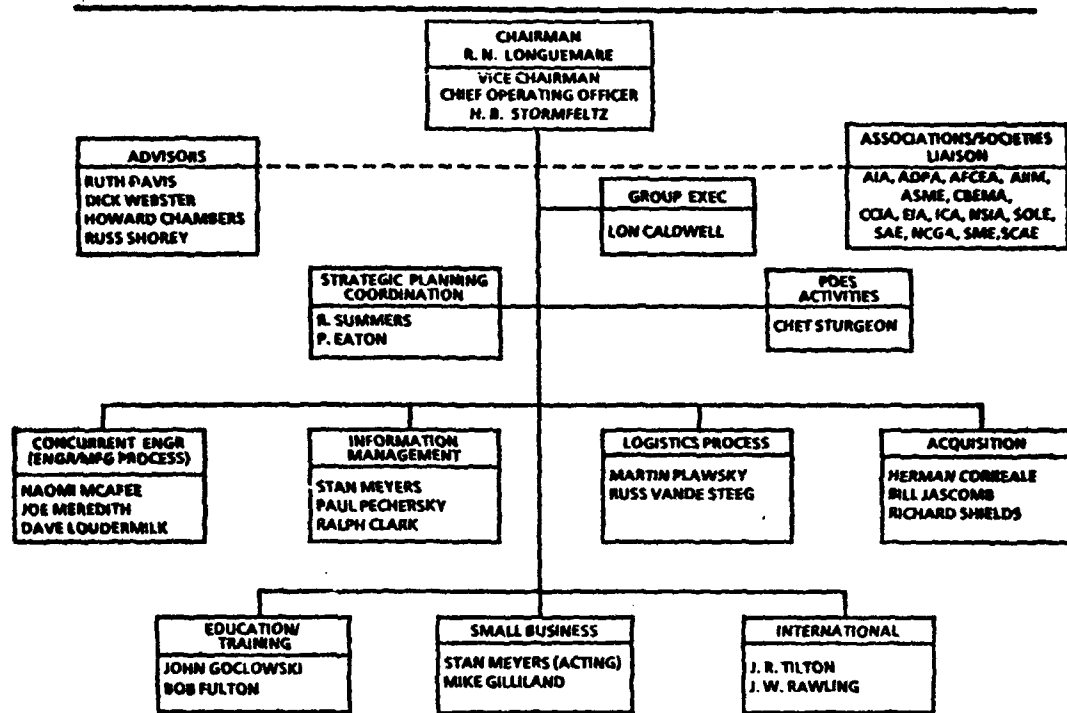

CALS POLICY IMPLEMENTATION

DoDI 5000.2, 23 Feb 91

ADMINISTRATIVE

- o DoDD 5000.1 - Defense Acquisition
- o DoDI 5000.2 - Defense Acquisition Management:
Policies and Procedures
- o Cancels 5 Aug 88 DepSecDef CALS Policy Memorandum

DEFENSE ACQUISITION POLICY

"In general, preference shall be given to contractor information services and online access instead of data deliverables. Where data delivery is required, preference shall be given to delivery in machine-readable digital form rather than paper wherever feasible."

CORPORATE PRIORITIES

Near-term

- o Develop DoD CALS action plan which delineates near-term and strategic goals and the concept of operations. Manage and direct DoD CALS efforts in accordance with action plan. Review and assess progress on a quarterly basis and modify plan, as required.
- o Build, demonstrate and maintain business case for CALS/EDI.
- o Establish, demonstrate and maintain joint service architecture that provides the foundation for the integrated development and implementation of CALS infrastructure programs.
- o Develop and demonstrate product data standards for DoD applications and participate jointly with the Department of Commerce in the development of a national PDES initiative.

(S&I)

CORPORATE PRIORITIES

Long-term

- o Enhance the DoD CALS infrastructure to maintain responsiveness to user requirements through the application of new, mature technologies and standards.
- o Initiate a transition strategy based upon the business case to incorporate product data standards and technology to improve DoD acquisition and logistic support processes.
- o Develop and demonstrate DoD business practices using CALS/EDI that will support the concept of a defense technology reserve.

(S&I)

JOINT CALS MANAGEMENT ORGANIZATION

CAPTAIN W. L. HICKS, USN DIRECTOR,
JOINT CALS MANAGEMENT OFFICE

WHAT IS CALS?

CALS IS DOD'S STRATEGY FOR THE TRANSITION TO IMPROVED PROCESSES USING AUTOMATION AND INTEGRATION OF TECHNICAL INFORMATION FOR WEAPON SYSTEM ACQUISITION, DESIGN, MANUFACTURING AND SUPPORT.

DEMONSTRATED BENEFIT :

- BETTER QUALITY, LOWER COSTS, SHORTER LEADTIMES

OBSERVATIONS:

- THIS TRANSITION IS INEVITABLE. HAS ALREADY BEGUN IN INDUSTRY.
- CALS BRINGS COHERENCE, AVOIDS INEFFICIENT PATCHWORK OF LOCAL SOLUTIONS
- THE FASTER WE IMPLEMENT CALS, THE MORE WE BENEFIT

COMPUTER-AIDED ACQUISITION AND LOGISTICS SUPPORT

- INTEGRATION OF THE COMPUTER-AIDED PROCESS IN USE THROUGHOUT THE WEAPON SYSTEM LIFE CYCLE
- MAKING THE WEAPON SYSTEM LIFE CYCLE INFORMATION A VALUABLE RESOURCE
- TRANSFORMATION OF ACQUISITION AND LOGISTICS INFRASTRUCTURE
- CUTTING COSTS WHILE IMPROVING QUALITY

THE IMPORTANCE OF CALS

TO INDUSTRY:

- AUTOMATION AND INTEGRATION ARE NECESSARY TO STAY COMPETITIVE
- DOD LEADERSHIP IN CALS OFFERS A WELCOME RALLYING POINT

TO DOD:

- MORE THAN 1/3 OF DOD BUDGET IS INVOLVED IN ACQUISITION AND LOGISTICS SUPPORT
 - CALS OFFERS 20-30% SAVINGS IN INFORMATION INTENSIVE PROCESSES (ENGINEERING, MANUFACTURING, SUPPORT)
- USERS IN THE FIELD ARE FACED WITH TOO MUCH PAPER
 - EXPENSIVE, VOLUMINOUS, OUT OF DATE, HARD TO USE

THIS IS A BIG DEAL

THIS IS A BIG DEAL. . .

PRESENTLY WITHIN THE NAVY/MARINE CORPS:

- **237 million drawings in storage ashore.**
- **15 million Technical Manuals in Storage**
- **Annual Cost \$4,000,000,000**

Army and Air Force statistics are of a similar magnitude

THIS IS A BIG DEAL. . .

**In USS Vincennes there are
23.5 tons of paper above
the main deck.**

THIS IS A BIG DEAL. . .

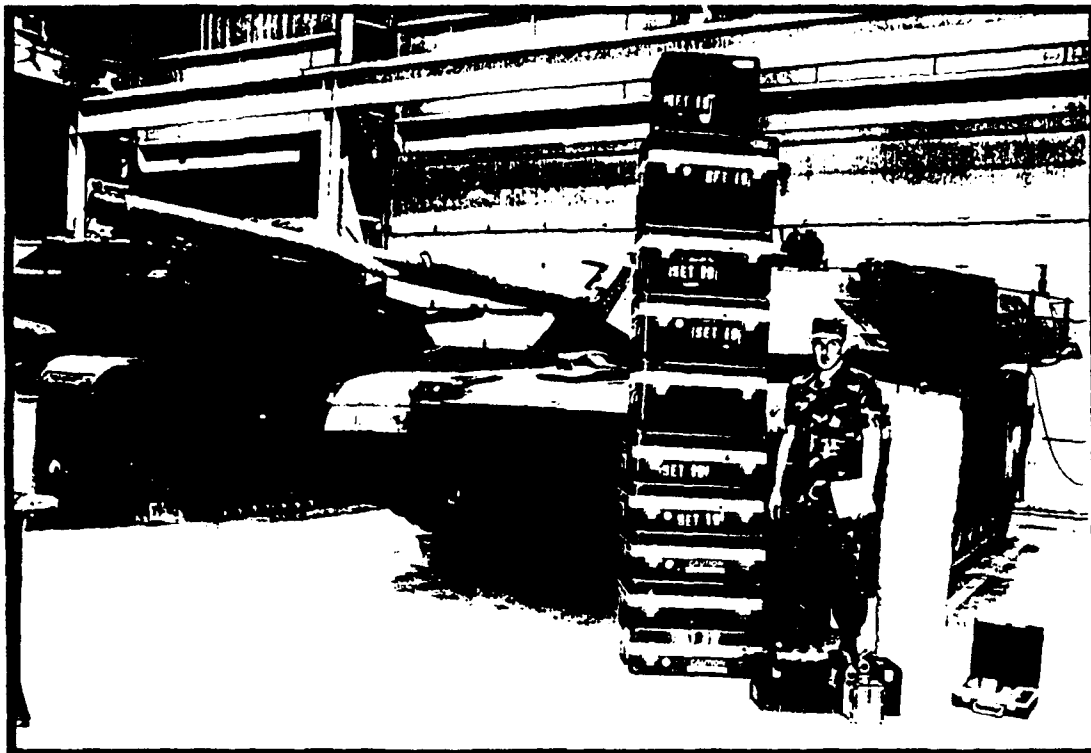

3 490 165

THIS IS A BIG DEAL. . .

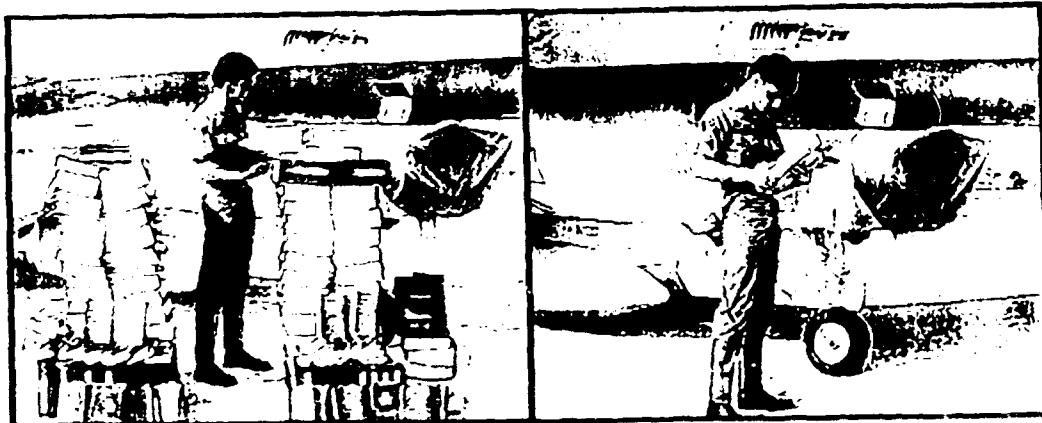

LONG RANGE VISION CALS ARCHITECTURE

INTERRELATIONSHIP AND INTERACTION OF:

- DATA (IWSDB) LIFE CYCLE VIEW
 - CREATE
 - MANAGE
 - USE
- ALL FUNCTIONS SUPPORTED BY THE DATA
 - DESIGN
 - MANUFACTURE
 - SUPPORT
 - ETC
- NETWORK TO LINK USERS TO FUNCTIONS AND FUNCTIONS TO DATA
- HARDWARE & SOFTWARE (SYSTEMS)
 - TOOLS NEEDED TO IMPLEMENT THE VISION
 - THE ONLY VISIBLE MANIFESTATION OF THE VISION

ENVIRONMENT CREATED BY THE ARCHITECTURE

- INFORMATION INTEGRATED WITH PROCESSES THAT REQUIRE THE INFORMATION, SUPPORTED BY A NETWORK THAT CAN DELIVER THE INFORMATION
- COMMON DATABASE SUPPORTS ALL LEVELS OF ENTERPRISE (ORGANIZATION) REQUIREMENTS
 - POLICY
 - IMPLEMENTATION
- NETWORKS-
 - PHYSICAL & LOGICAL
 - USERS ACCESS ANY INFORMATION AT ANY LOCATION AT ANY TIME
- CONTROL- MANAGED DATA & CONTROLLED PROCESSES ALLOW EFFECTIVE CHANGE MANAGEMENT
 - SECURITY OF INFORMATION AND "NEED TO KNOW" CONTROLLED AMONG CREATORS, USERS AND OWNERS OF INFORMATION

WHAT THE NEW ENVIRONMENT OFFERS

- DISCIPLINED CONFIGURATION MANAGEMENT OF DATA AND PROCESSES
- ELIMINATION OF DUPLICATE PROCESSES AND DATA
- PROVIDES SIMPLER AND QUICKER ACCESS TO INFORMATION
- IMPROVED FORCE READINESS

CALS ARCHITECTURE CURRENT VIEW

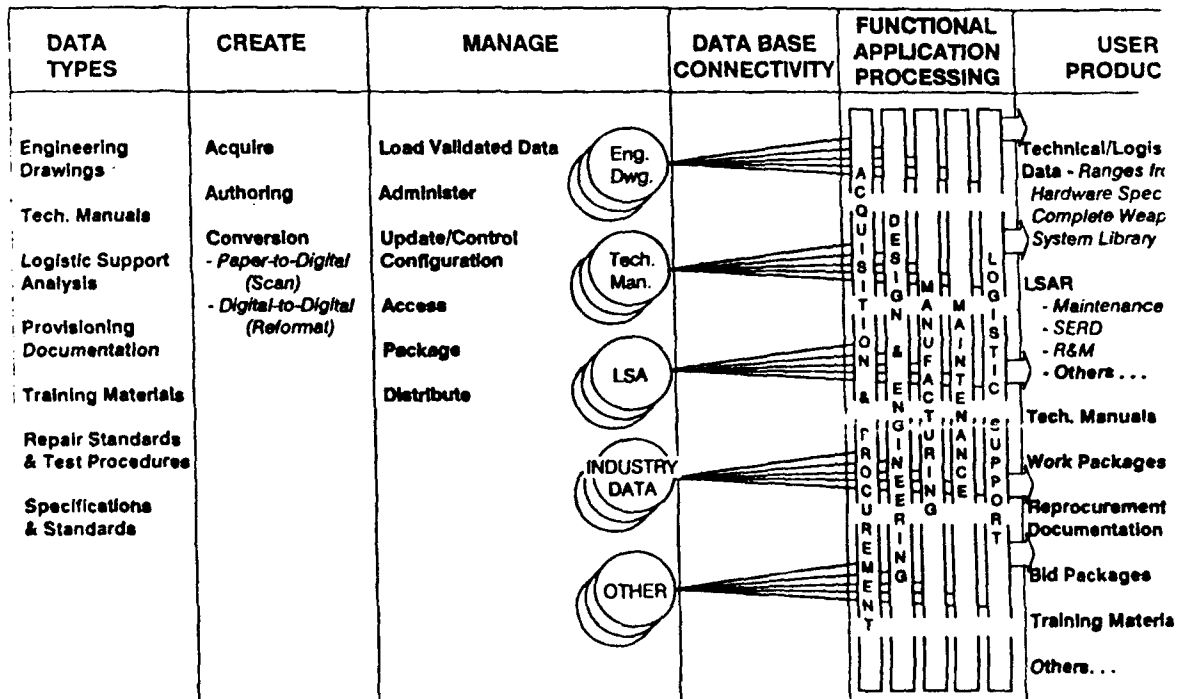

CALs ARCHITECTURE INTERIM VIEW

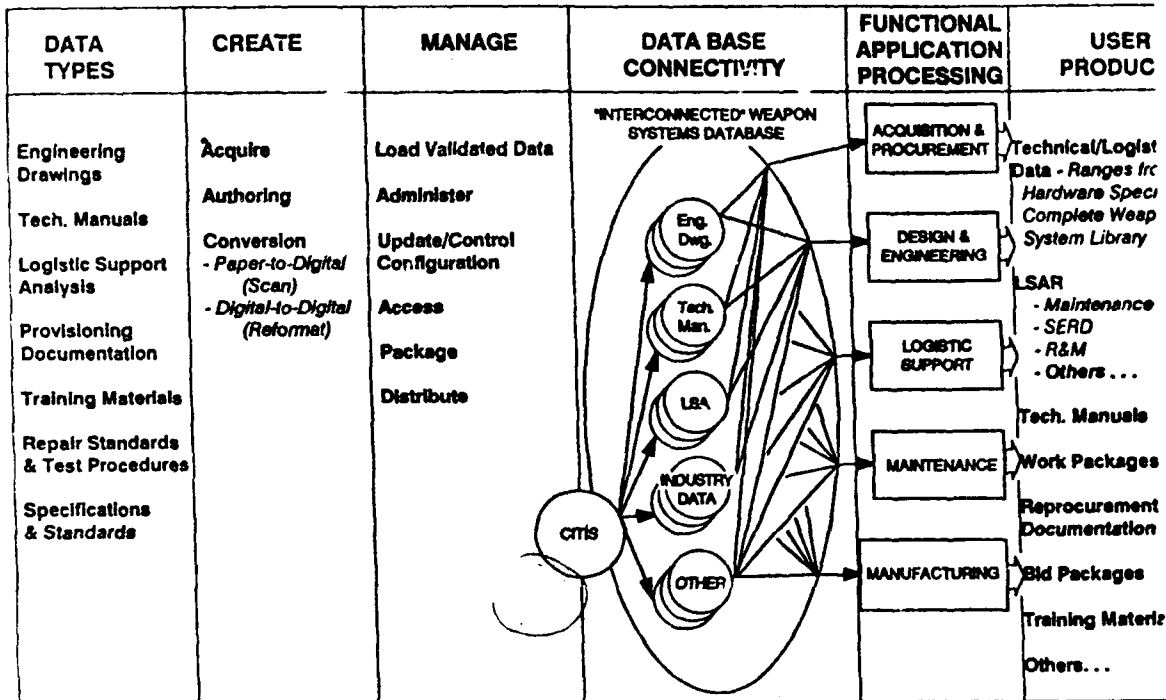

CALs ARCHITECTURE FUTURE GOAL

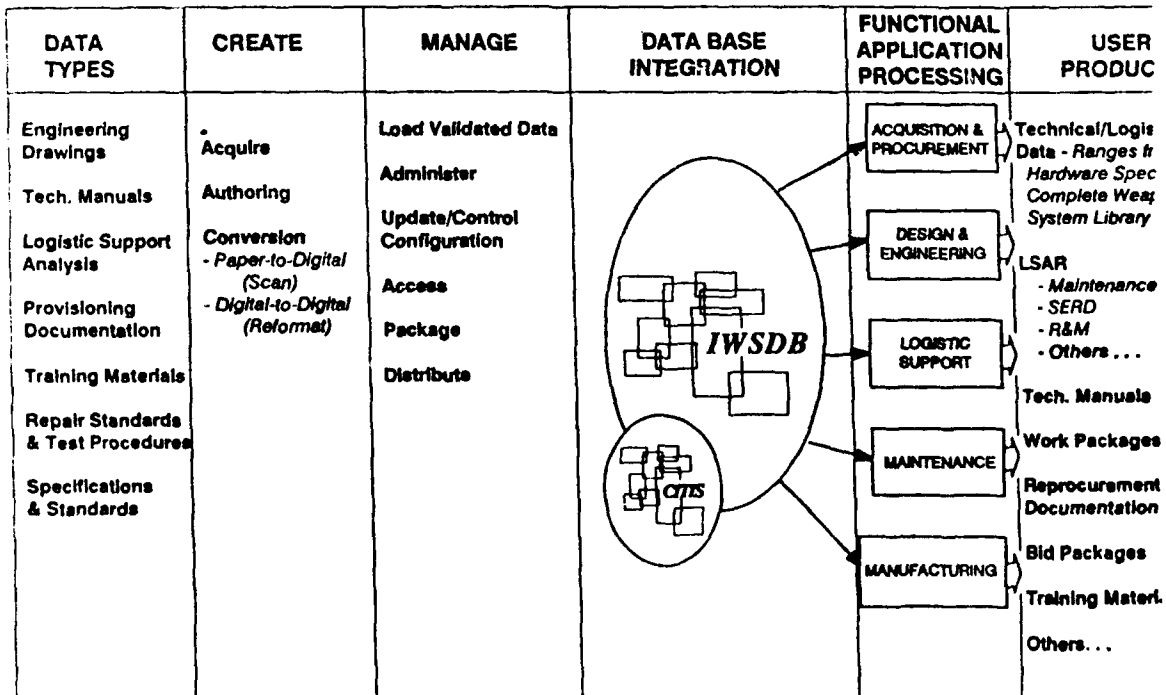



MISSION

"Develop the framework or Architecture to guide DoD Technical Information Infrastructure Modernization."

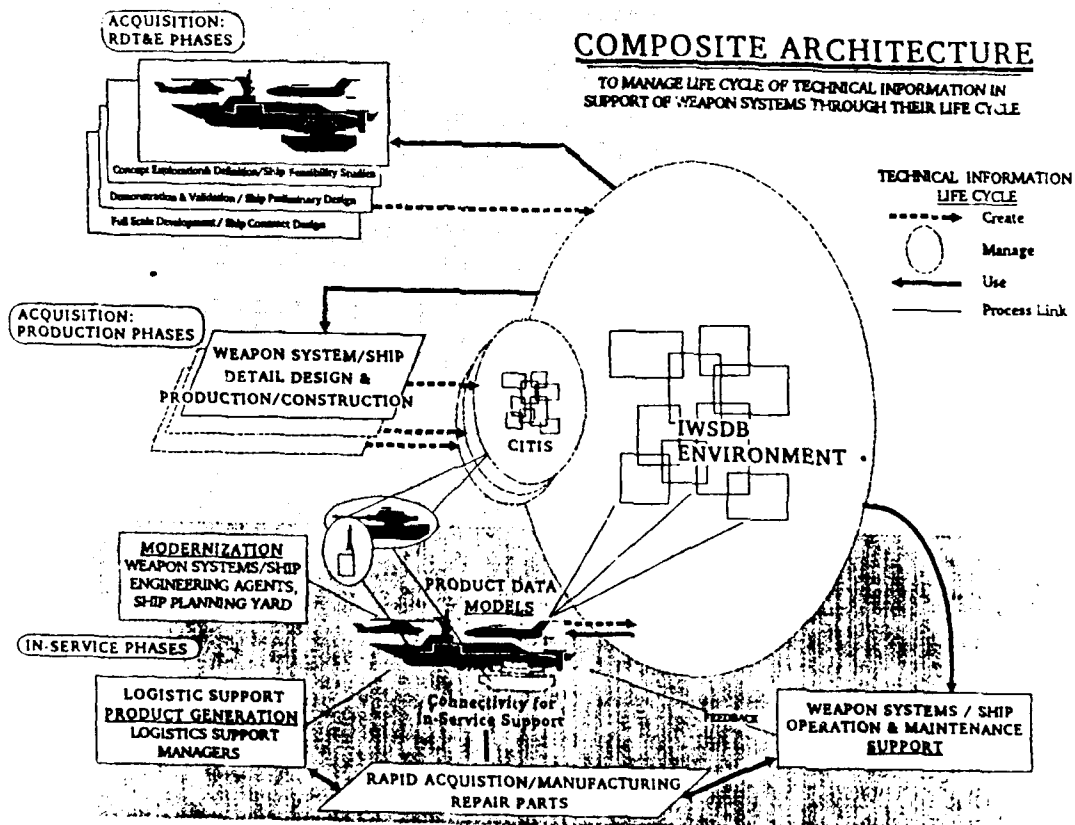

Industry view



CALS Architecture Study

CALS INFRASTRUCTURE MODERNIZATION PROCESS MODEL

0. Given a Functional Vision
1. Define CALS Business Models / Processes (Services and DLA)
(Generic Architecture)
 - Include CALS Performance Measures
 - Cost / Savings
 - Quality
 - Responsiveness
2. Map CALS Process and Data Model Architectures with existing and planned programs.
(Map to Generic Architecture)
3. Determine Overlap & Deficiencies in Business and Data Models/Systems.
(Determine System Overlaps and Gaps)
4. Define CALS Composite Business & Data Model to support requirements for future CALS Strategy.
(Eliminate Overlaps, Fill Gaps)

CALS INFORMATION MANAGEMENT TIME LINE

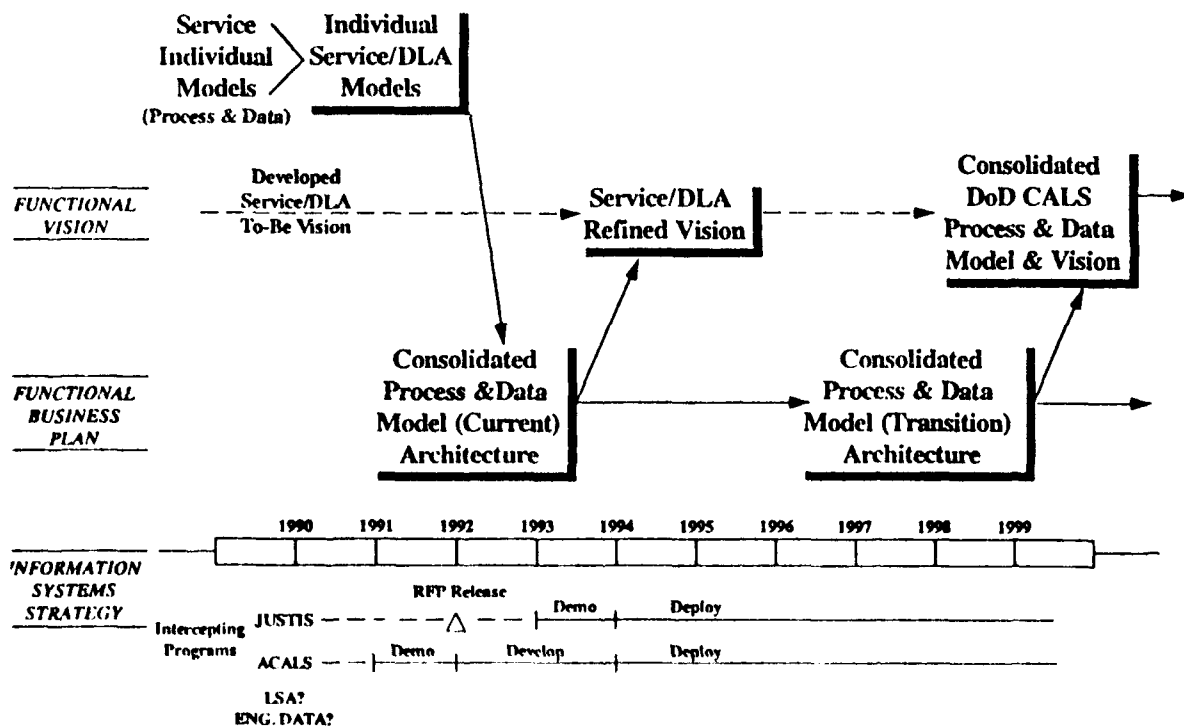

JOINT MANAGEMENT OBJECTIVES

- **SUPPORT CONSISTENT IMPLEMENTATION OF CALS THROUGHOUT DoD**
 - **FORMULATE STRATEGIES FOR DEVELOPMENT OF COMMON SYSTEMS**
 - **CONSISTENT WITH CIM/MAISRC**
 - **SUPPORT COMMON DoD CALS ARCHITECTURE**
 - **PROVIDE MANAGEMENT COORDINATION**
 - **STANDARDS**
 - **TRAINING REQUIREMENTS**
 - **ACQUISITION LANGUAGE**
-

JCMO ACTIVITY

- **ESTABLISH JOINT OFFICE - SKYLINE -**
- **PREPARE / SUPPORT REPORT TO CONGRESS - CALS MASTER PLAN**
- **JOINT REQUIREMENTS FOR A-CALS**
- **DESIGNATE CALS STANDARD SYSTEM AND EXECUTIVE AGENTS**
 - **BOUNDARIES WITH M.M. LOGISTIC INTERIM STANDARD SYSTEM PLAN**
 - **PROCEDURES FOR EXECUTIVE AGENTS**
 - **SYSTEM VS AREA DECISIONS**
- **DEVELOP DoD INFRASTRUCTURE ARCHITECTURE AS OVERLAY TO INDIVIDUAL SERVICE ARCHITECTURE**
 - **DATA DICTIONARY**
 - **INDIVIDUAL SERVICE ARCHITECTURE**
 - **DEFINE METHODOLOGY**
- **DEVELOP CALS CORPORATE STRATEGY**
- **EXPO PLANNING AND SUPPORT**
- **STANDARD DEVELOPMENT AND MATURATION**
- **ACQUISITION GUIDANCE**



ELECTRONIC DATA INTERCHANGE/ ELECTRONIC COMMERCE PROJECT

Information Briefing

Jack Bartley



Definitions



Electronic Commerce (EC)
The end-to-end digital exchange of all information needed to conduct business.

Electronic Data Interchange (EDI)
The exchange of formatted business transactions from one computer to another.

American National Standards Institute (ANSI) X12
The national, voluntary standard for EDI which provides dictionary, syntax, formats and enveloping procedures for the movement of business transactions from one computer to another.

Electronic Data Interchange (EDI)

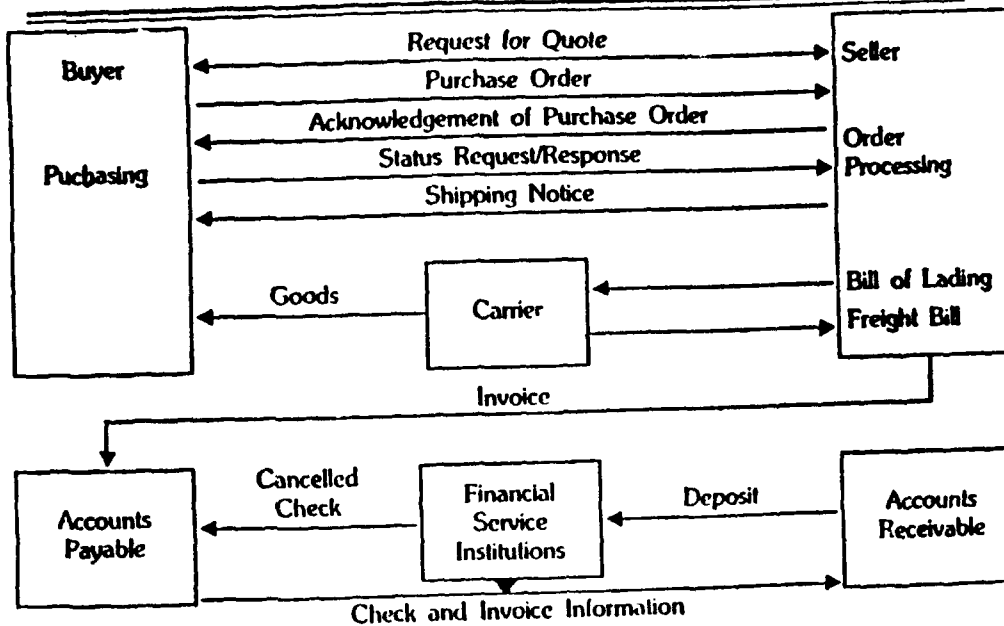

ELECTRONIC COMMERCE

CREATE DIGITAL ENVIRONMENT FOR ALL BUSINESS COMMUNICATIONS

UTILIZE AVAILABLE TECHNOLOGY TO MEET DIVERSE NEEDS AND CAPABILITIES

- TRANSACTION PROCESSING
- E-MAIL
- BULLETIN BOARDS
- FAX
- DATA SHARING
- DATA PROTECTION

COMMON INTEGRATED APPROACH TO IMPLEMENTATION

DoD CONTRACTS - FY88

DOLLARS AND ACTIONS

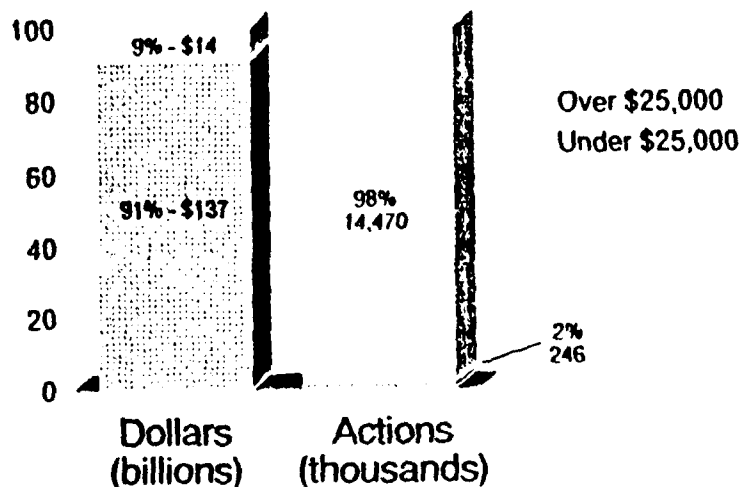

WHY EC FOR DoD



- Standard approach to EC
 - Improves responsiveness
 - Shortens lead times
 - Reduces workload
 - Eliminates errors
- Enables DoD to take advantage of innovations in the way we do business
 - J.I.T.
 - Flexible manufacture
 - Rapid distribution
 - More effective use of industrial base
 - Central pay



EC GOALS



- Maximum use of EC for all business
- Common approach to implementation consistent with related DoD initiatives
- Single, coordinated DoD position to industry
- Phased implementation in partnership with other Public and Private Sectors
- Adopt X12 as EDI standard and support convergence of X12 with EDIFACT
- EDI to be normal way of doing business by mid 1990s



DoD EC OBJECTIVES BY Q4/FY-94



- Develop capability to process 80% of basic EDI transactions
- Involve 25,000 vendors in EDI/Electronic bulletin boards
- Involve 50% of DoD in EDI/Electronic bulletin board activities
- Establish capability for processing a full range of standard transactions



- Initial EDI policy issued
- Many pilots underway
- Executive Agent established
- Final draft of implementation guidelines near completion
- Lead engineering/development organization established
- Standard systems approach being pursued
- Baseline functional projects initiated
- Protection of data in testing/application to EDI being analyzed
- Small businesses/Banks strategy being developed
- Initial economic analysis underway

STANDARD APPROACH TO SYSTEMS
SUPPORT

PHASE I DEVELOP NEAR TERM SOLUTIONS

- FLEXIBLE, EXPANDABLE AND SECURE
- BE CAPABLE OF INTERCHANGING DATA OVER AMONG DIVERSE ADP SYSTEMS AND INDEPENDENT OF SPECIFIC NETWORK SOLUTIONS
- MINIMIZE DISRUPTION TO CURRENT OPERATIONS - TRANSPARENT TO USERS
- EASY ACCESS AND LOW COST - MAKING MAXIMUM OF EXISTING DOD/FEDERAL CONTRACTS (OFF-THE-SHELF) AND LIVERMORE GATEWAY SOFTWARE
- MAKE TECHNOLOGY AVAILABLE TO OTHER P&L INITIATIVES (E.G., CALS AND MODELS)

PHASE II - PROPOSE LONG TERM SOLUTIONS ORIENTED TO LONG TERM NEEDS ARE NOT CONSTRAINED BY CURRENT CONTRACTS OR TECHNOLOGY

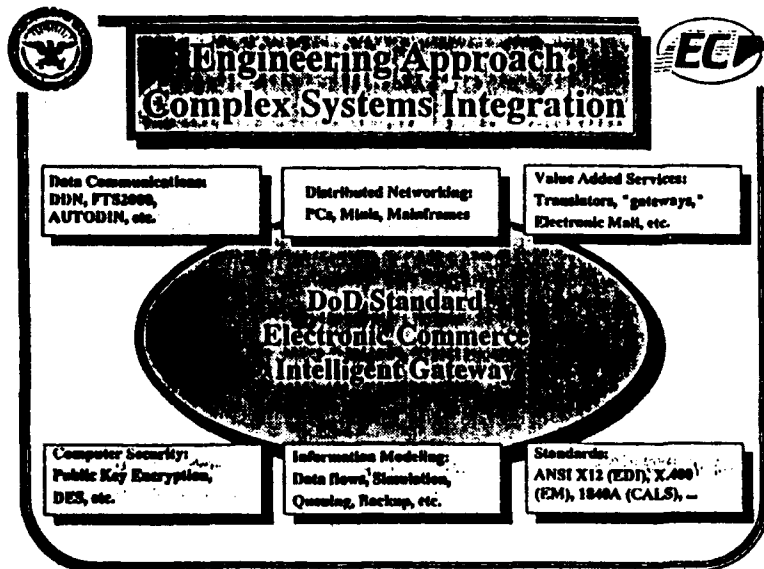

DOD PROTECTION

REQUIREMENTS NO GREATER THAN FOR PAPER

USE MINIMUM FORM OF PROTECTION

DISCRIMINATE IN APPLICATION

- o TRANSACTION SET
- o DOLLAR VALUE
- o DATA ELEMENT

ASSIGN RESPONSIBILITY AND LIABILITY

- o ORIGINATOR
END-TO-END
TO POINT OF INITIAL RECEIPT
- o THIRD PARTIES
- o RECIPIENT
AT POINT OF ENTRY
AT POINT OF STORAGE

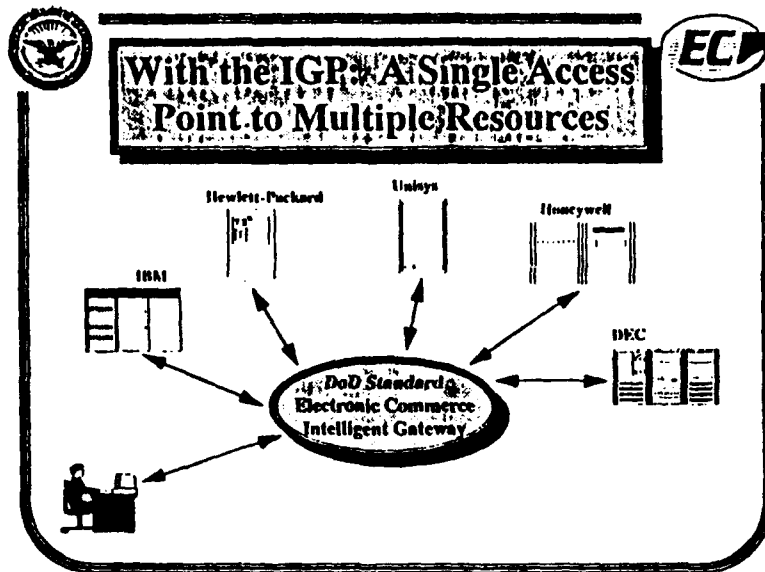

INTELLIGENT GATEWAY PROCESSOR

- UNIX BASED SOFTWARE
- DESIGNED FOR "INTELLIGENT" CONNECTIVITY TO HETEROGENEOUS COMPUTERS

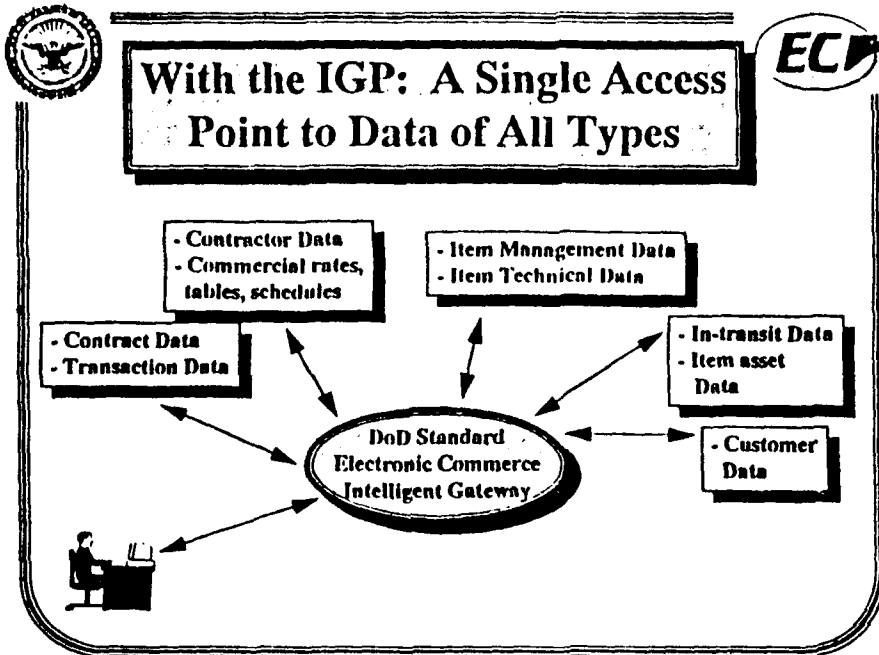

DOD PROTECTION

REQUIREMENTS NO GREATER THAN FOR PAPER

USE MINIMUM FORM OF PROTECTION

DISCRIMINATE IN APPLICATION

- o TRANSACTION SET
- o DOLLAR VALUE
- o DATA ELEMENT

ASSIGN RESPONSIBILITY AND LIABILITY

- o ORIGINATOR
END-TO-END
TO POINT OF INITIAL RECEIPT
- o THIRD PARTIES
- o RECIPIENT
AT POINT OF ENTRY
AT POINT OF STORAGE

CALS and EC

- o 2 Complementary Initiatives
 - o Pursuing Common Technical Solutions For Interchanging CALS and EC information
 - o Support including CALS Data within EDI transactions
 - o Committed to use of EDI transactions in CALS whenever appropriate
-

EC/CALS COMING TOGETHER IN DOD

COMMITTED TO WORK WITH INDUSTRY TO CREATE DIGITAL ENVIRONMENT

- FUNDAMENTAL CHANGE
- BETTER QUALITY
- IMPROVED RESPONSIVENESS
- LOWER COSTS
- STRONGER MILITARILY AND
ECONOMICALLY

SHARE COMMON APPROACH/SINGLE FACE TO INDUSTRY

- ORGANIZATIONAL ALIGNMENT
- PURSUING COMMON TECHNICAL SOLUTIONS
- PILOT PROJECTS
- USE EDI TRANSACTIONS IN CALS

FUTURE

ELECTRONIC COMMERCE

INTEROPERABILITY
DATA SHARING
AUTOMATED WORKPLACE

IMPROVED PERFORMANCE

READINESS AND RESPONSIVENESS
WEAPONS SYSTEM MANAGEMENT
TOTAL QUALITY MANAGEMENT
PROCESS TRACKING AND RESOURCE
CONTROL

MODERNIZED OPERATIONS

IMPROVED COMMUNICATIONS,
ADVANCED TECHNOLOGY AND MUTUAL
DEPENDENCE

CHANGES TO DOD 4120.3-M

Steve Lowell, Office of the Assistant Secretary of Defense for Production and Logistics, Standardization Program Division

CHANGES TO

DOD 4120.3-M

TYPES OF CHANGES

- PHILOSOPHICAL
- ADMINISTRATIVE
- DELETED SECTIONS
- CHANGES TO EXISTING SECTIONS
- CONFERENCE GENERATED CHANGES
- NEW POLICIES/PROCEDURES

PHILOSOPHICAL

- **CONSISTENT WITH DMR PHILOSOPHY**
- **FEW, SIMPLE REQUIREMENTS**
- **MAXIMIZE PROGRAM FLEXIBILITY**
- **CLEAR LINES OF RESPONSIBILITY/AUTHORITY**
- **PROMOTE SYNERGISM BETWEEN PROGRAMS**

ADMINISTRATIVE

- **REFLECT NEW ORGANIZATIONS AND ASSIGNMENTS**
- **INCORPORATE EXISTING CHANGE NOTICES AND POLICY MEMORANDA**
- **DELETE REFERENCES TO DIRECTIVES AND INSTRUCTIONS CANCELLED BY DODD 5000.1**

DELETED SECTIONS

- STANDARDIZATION PROGRAM GUIDANCE**
- STANDARDIZATION ACCOMPLISHMENT REPORT**
- WORKING GROUPS**

CHANGES TO EXISTING SECTIONS

- IMPROVE AND EXPAND DEFINITIONS
- REPLACE THE DEFENSE MATERIEL SPECIFICATIONS & STANDARDS BOARD WITH COUNCIL THAT OVERSEES STANDARDIZATION, COMMERCIAL ACQUISITION, STREAMLINING, ETC.
- BETTER DEFINE ROLES AND RESPONSIBILITIES FOR DEPARTMENT AND AGENCY STANDARDIZATION OFFICES, LEAD STANDARDIZATION ACTIVITIES, CUSTODIANS, AND REVIEW AND USER ACTIVITIES
- BETTER DEFINE DOD AND GSA ROLES AND RESPONSIBILITIES IN DOD PROCESSING OF FEDERAL DOCUMENTS

CHANGES TO EXISTING SECTIONS (CONT'D)

- SIMPLIFY NON-GOVERNMENT STANDARD ADOPTION
PROCESS**
- ADDRESS APPLICATION & TAILORING OF SPECS AND
STANDARDS**

CONFERENCE GENERATED CHANGES?

- SUBMITTAL, REPRODUCTION, AND DISTRIBUTION OF STANDARDIZATION DOCUMENTS
- COORDINATION
- PROGRAM PLANS
- STANDARDIZATION DIRECTORY
- OVERAGE DOCUMENT REVIEW PROCESS
- VALIDATIONS
- ITEM REDUCTION

NEW POLICIES/PROCEDURES

- **COMMERCIAL ITEM DESCRIPTIONS**
- **PURCHASE DESCRIPTIONS**
- **PROGRAM PECULIAR DOCUMENTS VS. STANDARDIZATION DOCUMENTS (I.E., MIL-STD-490 VS MIL-STD-961)**
- **PARTS CONTROL**
- **QUALIFIED MANUFACTURERS LIST**

METRIC PROGRAM

John Tascher, Office of the Assistant Secretary of Defense for Production and Logistics, Standardization Program Division

DOD METRICATION PROGRAM

PURPOSE OF PRESENTATION

- TO EXPLAIN THE DOD APPROACH TO DEVELOPMENT OF METRIC STANDARDS AND SPECIFICATIONS
- TO DESCRIBE THE PLAN FOR DEVELOPING NEEDED METRIC STANDARDS IDENTIFIED BY THE PREPARING ACTIVITIES DURING THE DMR SURVEY

DOD METRICATION PROGRAM

SECTION 5164, METRIC USAGE, IN OMNIBUS TRADE AND COMPETITIVENESS ACT

- O AMENDS THE METRIC CONVERSION ACT OF 1975 BY ADDING SEVERAL PARAGRAPHS INCLUDING:
 - O METRIC IS PREFERRED BY U.S. TRADE AND COMMERCE
 - O FEDERAL AGENCIES USE METRIC SYSTEM IN PROCUREMENTS, GRANTS, AND OTHER BUSINESS-RELATED ACTIVITIES BY END OF FY 1992
 - O FEDERAL AGENCIES ESTABLISH GUIDELINES
 - O FEDERAL AGENCIES SUBMIT ANNUAL METRIC REPORT TO CONGRESS
 - O REVIEW OF FEDERAL AGENCIES ACTIONS BY COMPTROLLER GENERAL AT THE END OF FY 1992

DOD METRICATION PROGRAM

DODI 5000.2, PART 6, SECTION M, USE OF THE
METRIC SYSTEM

- "METRIC SYSTEM SHALL BE USED IN ALL DOD ACTIVITIES INCLUDING THOSE ELEMENTS OF DEFENSE SYSTEMS REQUIRING NEW DESIGN"
- "MILESTONE DECISION AUTHORITIES MAY GRANT WAIVERS ON A CASE-BY-CASE BASIS IF THE USE OF THE METRIC SYSTEM IS NOT IN THE BEST INTEREST OF THE DOD"

DOD METRICATION PROGRAM

DODI 5000.2, PART 6, SECTION M, USE OF THE
METRIC SYSTEM (CON'T)

- "THE MEASUREMENT UNITS IN WHICH A SYSTEM WAS ORIGINALLY DESIGNED WILL BE RETAINED FOR THE LIFE OF THE SYSTEM, UNLESS THE PROCURING ACTIVITY DETERMINES IT IS MORE ADVANTAGEOUS TO CONVERT TO THE METRIC SYSTEM."

- "ITEMS OF COMMERCIAL DESIGN WILL BE SPECIFIED IN METRIC UNITS WHEN ECONOMICALLY AVAILABLE AND TECHNICALLY ADEQUATE, OR WHEN OTHERWISE DETERMINED BY THE PROCURING ACTIVITY TO BE IN THE BEST INTEREST OF THE DEPARTMENT OF DEFENSE."

DOD METRIC TRANSITION PLAN

GENERAL APPROACH

- BUY COMMERCIAL
- INDUSTRY HAS CONVERSION PLANS - DOD FACILITATES
- INDUSTRY HAS NO CONVERSION PLANS - DOD DOES NOT INITIATE
- DOD SETS REQUIREMENTS
- TRANSITION IS PRACTICAL - DOD INITIATES METRIC TRANSITION
- TRANSITION IS NOT PRACTICAL - DOD DOES NOT INITIATE TRANSITION

DOD METRICATION PROGRAM

DOD "SETS REQUIREMENTS" ACQUISITIONS

- DOD PROGRAMS DEFINE REQUIREMENTS IN METRIC IN ACCORDANCE WITH DODI 5000.2. ADDRESS METRIC DURING PROGRAM REVIEWS.
- PREPARING ACTIVITIES DOCUMENT THE REQUIREMENTS OF PROGRAMS; THE PAS DO NOT "DRIVE THE METRIC TRAIN"
- BUT, PAS NEED TO EMPHASIZE METRIC WITHIN THEIR DEVELOPMENT EFFORTS.
- DOD METRIC DOCUMENT DEVELOPMENT EFFORTS CONCENTRATED IN "DOD SETS REQUIREMENTS" AREAS.

DOD METRICATION PROGRAM

DEFINITION OF METRIC SPECIFICATION IN MIL-STD-961C

**REQUIREMENTS ARE GIVEN IN ROUNDED,
RATIONAL, METRIC UNITS, USUALLY AS A RESULT
OF BEING ORIGINALLY DEVELOPED IN METRIC.
THE MAGNITUDES EXPRESSED ARE MEANINGFUL
AND PRACTICAL... METRIC SPECIFICATIONS ARE
DEVELOPED FOR ITEMS TO INTERFACE OR
OPERATE WITH OTHER METRIC ITEMS.**



DOD METRICATION PROGRAM

SOFT AND HARD CONVERSION

- **SOFT CONVERSION - MULTIPLY NON-METRIC MAGNITUDE BY RELEVANT CONVERSION FACTOR, THEN ROUND TO NUMBER OF SIGNIFICANT DIGITS TO APPROXIMATE ORIGINAL PRECISION**

(E.G. 1-lb, 5-lb, AND 10-lb PACKAGES TO 0.453 kg, 2.27 kg, AND 4.53 kg)

- **HARD CONVERSION - CHANGE FROM MAGNITUDE IN NON-METRIC TO SOMEWHAT DIFFERENT MAGNITUDE EXPRESSED IN CONVENIENT METRIC UNITS**

(E.G. 1-lb, 5-lb, AND 10-lb PACKAGES TO 0.5 kg, 2.5 kg and 5 kg)

DOD METRICATION PROGRAM

SOFT CONVERSIONS APPROPRIATE:

- TECHNOLOGIES BASED ON INCH-POUND INTERNATIONALLY
- ITEMS WHERE INTEROPERABILITY OR INTERFACING NOT NEEDED, AND NO NEED FOR INTERNATIONAL STANDARDIZATION
- ITEMS OR PROCESSES WHERE ROUNDED, RATIONAL NUMBERS ARE NOT USUAL IN EITHER SYSTEM
- MANY TEST METHODS AND PROCESS STANDARDS

DOD METRICATION PROGRAM

HARD CONVERSIONS APPROPRIATE:

- NEED FOR INTERNATIONAL HARMONIZATION
- INTERFACE WITH METRIC HARDWARE
- BUILDING BLOCK ITEMS SUCH AS WIRE SIZES, SCREW THREAD FORMS, FASTENERS, TUBING SIZES, AND DIMENSION STOCK MATERIAL TO PROVIDE METRIC COMPONENTS
- SITUATIONS TO PERMIT THE USE OF METRIC SYSTEM STANDARDS, PRODUCTION MACHINERY, SPARE PARTS, AND MAINTENANCE TOOLS

DOD METRICATION PROGRAM

HARD CONVERSIONS APPROPRIATE (CON'T) :

- REDUCTION OF TYPES, STYLES OR CLASSES OR PRODUCTS WOULD BE FACILITATED BY ADOPTION OF FAMILY OF METRIC ITEMS
- ITEMS PECULIAR TO DOD AND REPRESENT TECHNOLOGICAL ADVANCES

DOD METRICATION PROGRAM

- NO CONVERSIONS ARE NEEDED FOR:
 - ITEMS BECOMING OBSOLETE
 - ITEMS CONTINUING IN USE WITHOUT MODIFICATIONS, SUCH AS SPARE PARTS, AND MAINTENANCE TOOLS
 - ITEMS OF VERY LIMITED APPLICATIONS WHERE COSTS OF METRIC OUTWEIGH BENEFITS
- NOT MEASUREMENT SENSITIVE DOCUMENTS

DOD METRICATION PROGRAM

INCREASING USE OF METRIC VERSIONS OF SPECS AND STANDARDS

- NEW METRIC DOCUMENTS OFTEN WILL SUPPLEMENT INCH-POUND DOCUMENTS, AND NOT NECESSARILY REPLACE THEM
- OVER TIME, USE OF METRIC DOCUMENTS WILL INCREASE, WHILE USE OF INCH-POUND DOCUMENTS WILL DECREASE
- EVENTUALLY, CAN CANCEL, OR PUT IN "DO NOT USE FOR NEW DESIGN" CATEGORY, INCH-POUND

DOD METRICATION PROGRAM

APPROACHES IN DEVELOPING METRIC DOCUMENT:

- NEW PARALLEL DOCUMENT: FOR COMPLEX DOCUMENTS WITH MANY CONVERSION-SUSCEPTIBLE MEASUREMENTS
- METRIC APPENDIX: FOR LESS COMPLEX DOCUMENTS AND CASES WHERE ORIGINAL DOCUMENT NUMBER IS IMPORTANT. THE APPENDIX WOULD REFER TO THE BASIC DOCUMENT FOR TECHNICAL FEATURES AND CITE ONLY THE METRIC REQUIREMENTS.
- METRIC NOTES: FOR RELATIVELY SIMPLE DOCUMENTS WITH FEW MEASUREMENT UNITS.

DOD METRICATION PROGRAM

APPROACHES IN DEVELOPING METRIC DOCUMENT (CON'T)

- CONTRACT WORDING: METRIC REQUIREMENTS CAN BE INSERTED IN CONTRACTS IN LIEU OF DEVELOPMENT OF METRIC SPECS AND STANDARDS

DOD METRICATION PROGRAM

- DUAL DIMENSIONING IN STANDARDS AND SPECS
- AVOID USE OF BOTH METRIC AND INCH-POUND ON DRAWINGS OR OTHER PICTORIAL ILLUSTRATIONS
- CAN USE TABLES TO TRANSLATE SPECIFIC INCH-POUND UNITS TO METRIC UNITS
- IN TEXT, METRIC UNITS CAN BE USED IN PARENTHESIS WHEN INCH-POUND IS PREFERRED
- IN TEXT, INCH-POUND MAY BE OMITTED OR USED IN PARENTHESIS WHEN METRIC IS PREFERRED

DOD METRICATION PROGRAM

DMR MEASUREMENT BASIS LISTING

OUT OF APPROXIMATELY 37,000 LISTED*:

- METRIC DOCUMENTS 1692
- NOT MEASUREMENT SENSITIVE DOCUMENTS 3143
- METRIC VERSION REQUIRED DOCUMENTS 2607

*MIL-SPECS, MIL-STDS, FED-SPECS, FED-STDS, AND MIL-HDBKS ONLY

DOD METRICATION PROGRAM

REVIEWS BY NON GOVERNMENT STANDARDS COMMITTEES

- NINE CONTRACTORS IDENTIFIED 7202 NEEDED METRIC DOCUMENTS
- OF THESE, 1830 WERE ISSUED BY NGS COMMITTEES
- ASTM, SAE, EIA, ASME, AND NASC WERE PRINCIPAL BODIES
- LETTERS TO EACH ASKING FOR COMMENTS
- ADDRESS FINDINGS AND RECOMMENDATIONS AT NOVEMBER 1991 EQUAL PARTNER CONFERENCE

DOD METRICATION PROGRAM

PREPARING ACTIVITIES' LISTS OF NEEDED METRIC DOCUMENTS - DMR REVIEW

- EVEN THOUGH PREPARING ACTIVITIES DO NOT DRIVE THE METRIC TRAIN, THEY ARE MORE THAN JUST PASSENGERS
- SENT LISTS OF NEEDED METRIC DOCUMENTS IDENTIFIED BY THE INDIVIDUAL PAS TO THE PAS WITH REQUEST THAT THEY PLAN FOR DEVELOPMENT
- COMMENTS FROM NGS COMMITTEES WILL BE FORWARDED TO APPROPRIATE PAS
- WELCOME COMMENTS FROM THE PAS

DOD METRICATION PROGRAM

METRIC PLANS IN STANDARDIZATION PROGRAM PLANS

- FSC/AREA LISTS OF NEEDED METRIC DOCUMENTS SENT TO LSAS
- LSAS CAN LIST NEEDED DOCUMENTS, AND DESCRIBE THE PLANS AND SCHEDULES FOR DEVELOPMENT, IN STANDARDIZATION PROGRAM PLANS
- GOOD EXAMPLE OF A PROGRAM PLAN IS THE REVISION 7 OF HUMAN FACTORS
- UNDERSTAND THAT AS PROGRAMS AND REQUIREMENTS CHANGE, THE PLANS AND SCHEDULES CAN BE MODIFIED

DOD METRICATION PROGRAM

RESULTS NEEDED FROM THIS EFFORT

- PLANS AND SCHEDULES FOR DEVELOPMENT OF NEEDED SPECS AND STANDARDS
- INCORPORATION OF PLANS AND SCHEDULES INTO STANDARDIZATION PROGRAM PLANS
- REPORT TO CONGRESS ON FINDINGS, PLANS, AND RECOMMENDATIONS ON DOD'S PROGRAM FOR DEVELOPING NEEDED METRIC SPECS AND STANDARDS

STANDARDIZATION AUTOMATION PANEL

Chair, Tom Ballantine, Office of the Assistant Secretary of Defense for Production and Logistics,
Standardization Program Division

Panel Members:

Jeff Williams, Navy Publishing and Printing Service

Lynn S. Mohler, Army Materiel Command

Dr. Lane B. Scheiber, Institute for Defense Analysis

SYNOPSIS OF THE PANEL ON STANDARDIZATION AUTOMATION

The Panel on Standardization Automation provided an insight into automation in the Defense Standardization Program (DSP) over the past twenty years and how because of the limited number of automation tools available, the DSP community was forced to practice standardization automation. As more automation tools became available, less standardization automation was being practiced.

There are many things occurring to help bring about standardization automation. The first presentation provided insight on the efforts of the Navy Publishing and Printing Service to enhance the Navy Publishing On Demand System (NPODS Enhanced). It addressed NPPS's efforts to provide a intelligent DoDISS database fully CALS compliant with SGML tagged ASCII and the benefits to be derived, and their effort to provide an Authoring System to facilitate document creation and manipulation in SGML format.

The next presentation provided an overview of the Automation Capabilities for Army Standardization Communication. It described the Army's efforts to provide information on the DSP to the Army Acquisition Community. The first phase of the effort was to provide on-line access to an existing data base called the Acquisition Streamlining and Standardization Information System (ASSIST). ASSIST will give Army acquisition managers visibility over all standardization documents and data requirements referenced in contract documents and identify voids in contract documents, thus providing them a tool to perform streamlining reviews.

The final presentation provided an overview of the Interoperability Decision Support System (IDSS). The IDSS was initially developed to support interoperability, standardization and cooperative efforts with our allies, and could provide the DSP with a means to electronically provide bulletin board information, coordination and approval of DoDISS documents, distribute information on standardization, locate points of contact in Government and industry, and many other areas of interest to the DSP.

The final comments provided a message that rather than being little standardization automation stars, we must pull together and become one big standardization automation star.

Navy Publishing On Demand System Enhanced

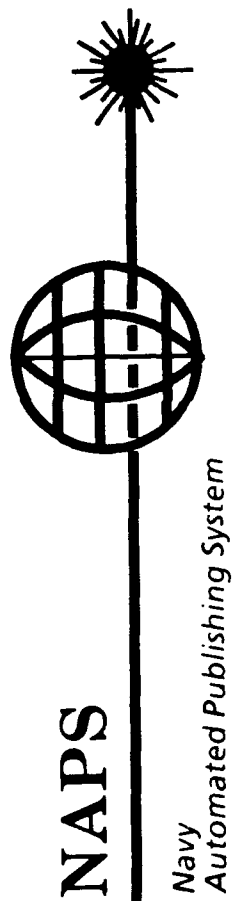

Navy Publishing
and
Printing Service

15 May 1991

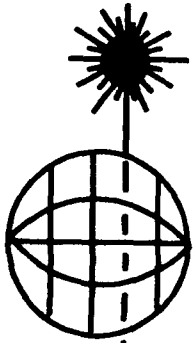

Topics of Discussion

- Background of current database and limitations
- Reasons for and benefits of an intelligent database
- Impact on Standardization Program
- Methodology for making transition
 - Pilot Test
 - Who, What, When, and How?
- Authoring System
- Other NPODS *Enhanced* capabilities

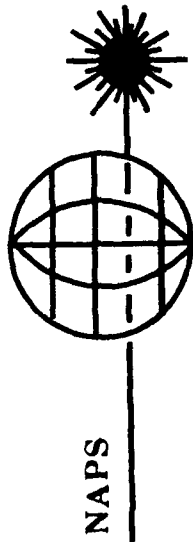

NAVY PUBLISHING ON DEMAND SYSTEM
Enhanced

Background of Current Database and Limitations

- NPODS document database over 600K pages
- Documents in image form
 - Due to lack of confidence in character recognition in early 80's
 - Large files (125K bytes/pg. compressed)
 - Data has no informational value but accurately reflects page
 - Unwieldy for distribution and manipulation-good for printing on specially designed system and records management purposes

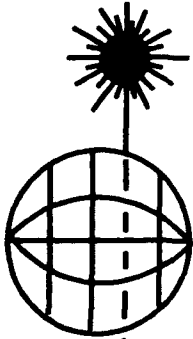

Reasons for and Benefits of an Intelligent Database

(CALS Compliant SGML tagged ASCII)

- Unlocks information and makes it accessible
 - Allows electronic interchange (2.5K bytes/pg.)
Coordination, input to DODSSP, interchange and data reuse
 - Full text search and query capabilities
Further enhanced by tags
Research any reference in seconds
 - Automatic generation of documents indices
- Makes creation, revision, coordination and management easier, less costly and quicker
- Enhancement designed to satisfy needs of Standardization program

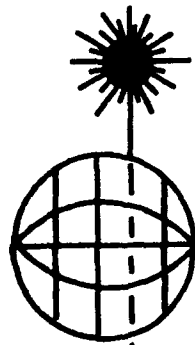

NAPS

NAVY PUBLISHING ON DEMAND SYSTEM

Enhanced

Impact on Standardization Program

- Though conversion process is nearly 100% accurate, need validity approval by PAs as official document
- Recommended change in document update concept
 - Whole document vice loose leaf pages
- Changes in Standardization Program's "way of doing business"

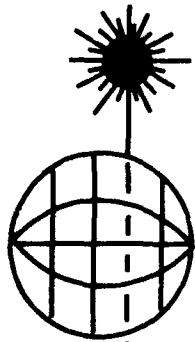

Methodology for Making Transition

Pilot Test

- 8 PA sites identified
- Sites will be provided various COTS authoring software to test and evaluate for program buy
- Current and near-term documents up for review will be utilized
- Test could start within next 30 days

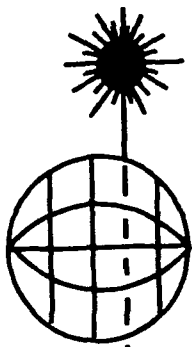

NAPS

NAVY PUBLISHING ON DEMAND SYSTEM
Enhanced

Methodology for Making Transition (cont'd)

- Conversion designed to have least impact on program but with greatest results and highest accuracy
 - Paper documents w/ changes incorporated prepared by NPPS-conversion by document type according to decision matrix
- Documents for internal use by PA could be available after pilot test and within 1 year completely converted
- At document revision cycle and as time permits, PAs to validate documents

NAPS

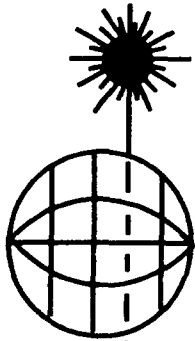

NAVY PUBLISHING ON DEMAND SYSTEM
Enhanced

Authoring System

- Provided by NPPS to facilitate document creation and manipulation in SGML format
 - Helps assure presence of mandatory information and maintain format
- Other capabilities can be added such as:
 - automatic boilerplate insertion
 - content guidance
 - terminology check
 - on-line help

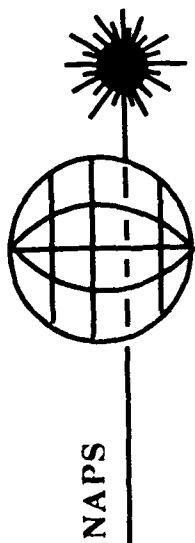

**NAVY PUBLISHING ON DEMAND SYSTEM
Enhanced**

Other Capabilities of NPODS Enhanced

- Bulletin board for coordination, PA/DODSSP document interchange, Standardization management info, E-mail etc.
- Automatically capture most ASSIST information

**AUTOMATION CAPABILITY
FOR
ARMY STANDARDIZATION COMMUNITY**

OUTLINE

- PURPOSE
- REQUIREMENTS FOR INFORMATION
- DEFINITION OF ASSIST
- TODAY - WHAT ASSIST IS
- WHAT ASSIST IS NOT
- BACKGROUND OF ARMY'S EFFORTS
WITH ASSIST
- WHERE WE ARE TODAY
- WHERE WE NEED TO GO
- SUMMARY

PURPOSE OF BRIEFING

DESCRIBE THE ARMY'S EFFORTS TO PROVIDE INFORMATION ON THE DEFENSE STANDARDIZATION PROGRAM TO THE ARMY ACQUISITION COMMUNITY.

THE FIRST PHASE OF THE EFFORT IS TO PROVIDE ON-LINE ACCESS TO AN EXISTING DATA BASE CALLED AUTOMATED SPECIFICATIONS AND STANDARDS INFORMATION SYSTEM (ASSIST).

DEFENSE STANDARDIZATION PROGRAM

- IS STANDARDIZATION AND LIMITATION
OF ENGINEERING CRITERIA - BY
CONSENSUS - THROUGH
SPECIFICATIONS AND STANDARDS.**
- USED IN THE PROCUREMENT PROCESS
TO DESCRIBE PRODUCTS AND
PROCESSES IN ORDER TO PROVIDE
COST/EFFECTIVE LOGISTICAL SUPPORT.**

REQUIREMENTS FOR INFORMATION

**ARMY ACQUISITION
COMMUNITY e.g.**

- **ARMY DEPARTMENTAL STANDARDIZATION
OFFICE**
- **29 STANDARDIZATION MANAGEMENT
ACTIVITIES**
- **R&D ENGINEERS**

**NEEDS ACCESS TO INFORMATION RELATING TO THE
APPROXIMATELY 66,000 STANDARDIZATION DOCUMENTS
AND THE ABILITY TO MANIPULATE THAT INFORMATION**

**CURRENTLY, NO DOD OR ARMY SYSTEM EXISTS TO MEET
THIS NEED**

REQUIREMENTS FOR INFORMATION (Cont'd)

RECENT STUDIES ON STANDARDIZATION HAVE RECOMMENDED AUTOMATION:

- **REPORT BY R.B. TOTH ASSOCIATES ON ASSESSMENT OF
THE DEFENSE STANDARDIZATION AND SPECIFICATION
PROGRAM - 1984**
- **DEFENSE SCIENCE BOARD REPORT ON THE USE OF
COMMERCIAL COMPONENTS IN MILITARY EQUIPMENT - 1987**
- **USD(A) REPORT ON ENHANCING DEFENSE
STANDARDIZATION - 1988**
- **JOINT LOGISTICS COMMANDER'S PANEL ON
STANDARDIZATION - 1988**
- **DEFENSE STANDARDIZATION AUTOMATION TEAM
STUDY - 1988**
- **PROCEDURES PROCESS ACTION TEAM REPORT TO WORKING
GROUP 9 OF THE DEFENSE MANAGEMENT REVIEW - 1990**
- **WORKING GROUP 9 (SPECIFICATIONS AND STANDARDS) OF
THE DEFENSE MANAGEMENT REVIEW (DRAFT) - 1990**

POTENTIAL USERS AND USAGES

ARMY DEPARTMENTAL STANDARDIZATION OFFICE (DEPSO):

- MANAGEMENT INFORMATION
- ARMY-WIDE PROGRAM OVERSIGHT
- POLICY OVERSIGHT REVIEW
- WHAT-IF ANALYSES FOR POLICY CONSIDERATIONS/ IMPACTS
- ANALYSES FOR PROCESS IMPROVEMENT

RESEARCH AND DEVELOPMENT SCIENTISTS AND ENGINEERS

- REVIEW CURRENT STANDARDIZATION DOCUMENT TITLES BY AREA OF INTEREST
- VISIBILITY OF TECHNOLOGY CHANGES (PROJECT STATUS)

STANDARDIZATION PROGRAM MANAGERS (SMA's AND LSA's)

- IDENTIFY AND MANAGE DOCUMENTS IN ASSIGNED FSCs AS WELL AS OTHER INTERESTS
- PROGRAM OVERSIGHT OF ASSIGNED AREAS

POTENTIAL USERS AND USAGES (Cont'd)

STANDARDIZATION DOCUMENT PREPARATION ENGINEERS:

- IDENTIFY OVERAGE DOCUMENTS
- MANAGE DEFENSE MANAGEMENT REVIEW (DMR) RECOMMENDED IMPROVEMENT ACTIONS
- ASSIST IN PREPARATION OF NEW/REVISED DOCUMENTS
- VALIDATE CURRENCY OF REFERENCES IN NEW/REVISED DOCUMENTS
- IDENTIFY OTHER DOCUMENTS EFFECTED BY CANCELLATION OF A DOCUMENT
- IDENTIFY DOCUMENTS REQUIRING QUALIFICATION
- IDENTIFY DOCUMENTS THAT REQUIRE USE OF A PARTICULAR MATERIAL

SYSTEMS APPLICATION ENGINEERS:

- ASSIST STREAMLINING
- ASSURE ACCURACY AND CURRENCY OF DOCUMENTS REFERENCED BY A DOCUMENT

POTENTIAL USERS AND USAGES (Cont'd)

ACQUISITION MANAGERS:

- **VISIBILITY OVER ALL DOCUMENTS REFERENCED**
- **VISIBILITY OVER DATA REQUIREMENTS**
- **IDENTIFY VOIDS IN CONTRACT DOCUMENTS
(CANCELLED DOCUMENTS)**
- **TOOL TO PERFORM/REVIEW STREAMLINING**

OTHERS:

- **NATO AND ABCA COMMUNITIES**
- **ENVIRONMENTAL PROGRAM MANAGERS**
- **METRICATION MANAGERS**
- **RFP REVIEW TEAMS**
- **SPECIAL ISSUES e.g. FASTENERS**

DEFINITION OF ASSIST

**AUTOMATED SPECIFICATIONS AND STANDARDS
INFORMATION SYSTEM (ASSIST) IS**

**AN AUTOMATED DATA BASE THAT CONTAINS THE
INDEX AND SOME ASSOCIATED DATA ON THE
APPROXIMATELY 66,000 STANDARDIZATION
DOCUMENTS IN THE DOD SYSTEM**

TODAY - WHAT ASSIST IS

A DATA BASE

- MAINTENANCE FUNDED BY OSD
- MAINTENANCE BY CONTRACTOR, USI, THROUGH THE NAVAL AIR ENGINEERING CENTER, LAKEHURST, NJ
- AVAILABLE FROM NAVAL PUBLICATIONS CENTER, PHILADELPHIA, PA
- RESIDES IN AN ORACLE DBMS
- CONTAINS INDEX INFORMATION ON ALL DOD DOCUMENTS (NOT ARMY UNIQUE)

INFORMATION FROM THE DATA BASE:

- AVAILABLE TO OASD (P&L) ONLY
- BY TELEPHONE REQUEST
- SPECIAL COMPUTER RUN
- OUTPUT MAILED TO OASD (P&L)

INFORMATION FLOW PROCESS

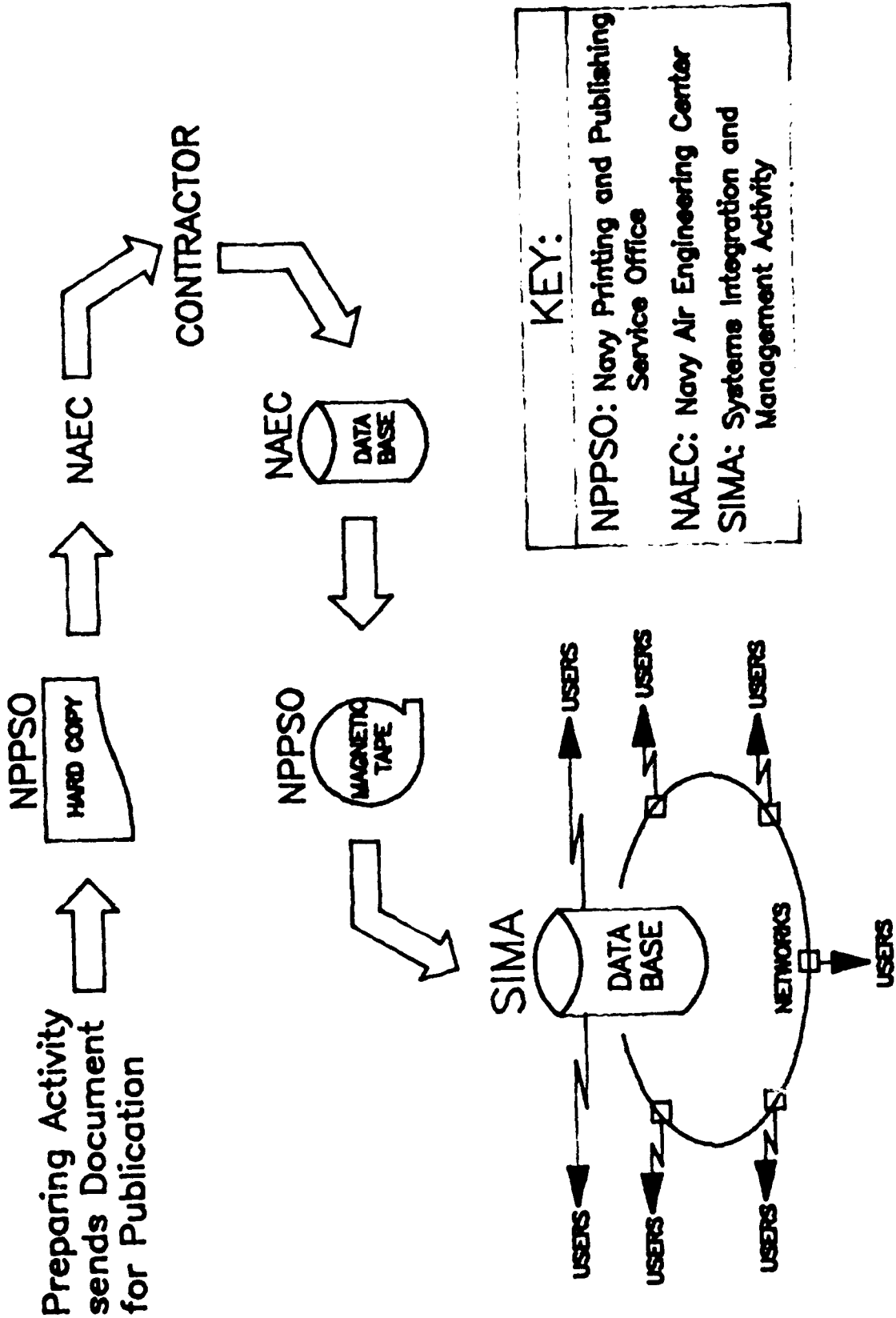

TODAY - WHAT ASSIST IS (Cont'd)

DATA BASE CONTAINS INDEX INFORMATION ON STANDARDIZATION DOCUMENTS

- **MILITARY**
 - SPECIFICATIONS
 - STANDARDS
 - HANDBOOKS
 - BULLETINS
 - AERONAUTICAL STANDARDS

- **FEDERAL**
 - SPECIFICATIONS
 - STANDARDS
 - FEDERAL INFORMATION PROCESSING STANDARDS
 - COMMERCIAL ITEM DESCRIPTIONS

- **OTHER**
 - INDUSTRY STANDARDS
E.G. ANSI, ASTM, IEEE, SAE, AIA, ASME

TODAY - WHAT ASSIST IS (Cont'd)

TYPES OF DATA ELEMENTS

- **DOCUMENT NUMBER**
- **APPROVAL DATE**
- **TYPE OF DOCUMENT AND SERIES**
- **TITLE**
- **REFERENCES**
- **FSC**
- **VALIDATION DATE**

DATA BASE STATISTICS:

- **62 MEGABYTES OF DATA**
- **APPROX 43,000 ACTIVE MIL DOCUMENTS**
 12,000 INACTIVE/CANCELLED DOCUMENTS
 11,000 OTHER DOCUMENTS
 66,000 TOTAL DOCUMENTS
- **APPROX 400,000 REFERENCES ARE MADE BY**
 ACTIVE DOCUMENTS

POTENTIAL INFORMATION

TYPES OF INFORMATION (REPORTS) THAT CAN BE GENERATED:

- SPECIFICATION TREES
- REFERENCED BY OTHER DOCUMENTS
- KEYWORD SEARCH (IN TITLE)
- QPL REQUIREMENTS
- OVERAGE DOCUMENTS
- LIST OF DOCUMENTS - ALPHABETICAL, NUMERICAL, FSC, PA
- INTEREST OTHER THAN PA
- NON-GOVERNMENT STANDARDS
- CANCELLED/INACTIVE DOCUMENTS

PLANNED ADDITIONS TO DATA BASE:

- ALL DODISS DATA AND DMR SURVEY DATA
- PROJECT DATA (SD-4)
- NPODS INDEX
- STANDARDIZATION DIRECTORY (SD-1)
- QUALIFIED PRODUCTS LIST
- INTERNATIONAL STANDARDIZATION DOCUMENTS

WHAT ASSIST IS NOT

NOT A SIMPLE DATA BASE

NOT DESIGNED FOR EASY RETRIEVAL

- **FIVE FILES LINKED ONLY BY UNIQUE ASSIST ASSIGNED ID NUMBER**
- **SEVEN EXISTING CONTRACTOR-DEVELOPED RETRIEVAL PROGRAMS REQUIRED 30,000 LINES OF CODE**

BEFORE ARMY EFFORT

- **NOT AVAILABLE FOR ON-LINE ACCESS**
- **NOT INTERACTIVE**

BACKGROUND OF ARMY'S EFFORTS WITH ASSIST

- **AMSAA ACQUIRED AND LOADED ASSIST ON ITS
CRAY COMPUTER - NOV 1989**
 - **FOR SPECIAL ANALYTICAL STUDY**
 - **IS NOT EQUIPPED TO PROVIDE ON-LINE
SERVICE**
 - **IS NOT MISSIONED TO PROVIDE ON-GOING
SPECIAL REPORTS**
- **SIMA WAS REQUESTED IN JULY 1990 TO OBTAIN
ASSIST AND MAKE IT AVAILABLE TO ALL ARMY
USERS**

WHERE WE ARE TODAY

SIMA HAS:

- **ACQUIRED ASSIST DATA BASE**
- **CONVERTED TO DATACOM DATA BASE**
- **LOADED ON AMDAHL COMPUTER**
- **ARRANGED WITH NAVY TO RECEIVE NEW RELEASES OF ASSIST**
- **DATA BASE AVAILABLE FOR ACCESS**

WHERE WE ARE TODAY (Cont'd)

SIMA CURRENTLY:

- CONVERTING EXISTING CONTRACTOR - WRITTEN PROGRAMS TO DATACOM
 - PYRAMID - GENERATES SPECIFICATION TREE TO ANY TIER
 - OUTPUT TO SIMA PRINTER ONLY
 - REF LIST - LISTS FIRST TIER REFERENCES
 - OUTPUT TO TERMINAL i.e. INTERACTIVE
 - REF PRINT - SAME AS REF LIST EXCEPT OUTPUT TO SIMA PRINTER ONLY
 - KEY WORD - IDENTIFIES DOCUMENTS BY KEY WORDS IN TITLE
 - OUTPUT TO SIMA PRINTER ONLY
 - REF BY COUNT - GIVES NUMBER OF DOCUMENTS THAT REFERENCE A DOCUMENT
 - OUTPUT TO THE TERMINAL
 - BCH REF BY - LISTS ALL DOCUMENTS THAT REFERENCE A GIVEN DOCUMENT
 - OUTPUT TO SIMA PRINTER ONLY
 - INT REF BY - LISTS ALL DOCUMENTS THAT REFERENCE A GIVEN DOCUMENT
 - OUTPUT TO THE TERMINAL
- PREPARING INITIAL IMPLEMENTATION PACKAGE
 - BASIC SET OF RETRIEVAL PROGRAMS
 - DOCUMENTATION OF SYSTEM

MILESTONES

INITIAL REQUEST (SCR)	27 JUL 90
DATA BASE CREATED AND POPULATED	30 AUG 90
CONVERSION-REF BY COUNT	30 SEP 90
CONVERSION-BCH REF BY	5 OCT 90
CONVERSION-PYRAMID	9 NOV 90
CONVERSION-INT REF BY	30 NOV 90
CONVERSION-REF LIST	30 NOV 90
CONVERSION-REF PRINT	30 NOV 90
SIWG CONFERENCE-ANNOUNCE CAPABILITY	16 JAN 91
DEVELOP BASIC SET OF QUERIES	1 FEB 91
MEMO TO SMA'S-INFO & FCG FORMATION	1 FEB 91
FORM FCG	3 MAR 91
FCG VENUS CONFERENCE	4 MAR 91
PREPARE USER DOCUMENTATION	1 APR 91
START CUSTOMER SERVICE AND TRAINING	1 APR 91
FCG MEETING & INITIAL TRAINING AT SIMA	2-3 APR 91
NEXT FCG MEETING	25 JUN 91

WHERE WE NEED TO GO

INITIATE PHASED APPROACH TO PROVIDE ACCESS AND TRAINING

REDESIGN/CONVERT PRE-WRITTEN PROGRAMS FROM CENTRAL SITE PRINTER OUTPUT TO INTERACTIVE SCREEN OUTPUT

DESIGN ADDITIONAL RETRIEVAL PROGRAMS FOR THE NEW DATA ELEMENTS BEING ADDED TO ASSIST AND FOR NEW USER REQUIREMENTS

STAFF AND TRAIN SIMA PERSONNEL TO PROVIDE FULL RANGE OF CUSTOMER SERVICES

DEVELOP CAPABILITY TO SEND OUTPUT TO USER'S PRINTERS

NEGOTIATE WITH OSD TO FUND EFFORT TO EXPAND SERVICE TO:

- OASD (P&L)
- NAVY
- AIR FORCE
- DLA
- OTHER GOVERNMENT AGENCIES

ADD NEW DATA ELEMENTS FOR PA USE

LINKAGE TO OTHER SYSTEMS - INTERNATIONAL, DATA MANAGEMENT

SUMMARY

- **PROCEED WITH EFFORT TO PROVIDE ON-LINE ACCESS TO ASSIST FOR THE ARMY COMMUNITY**
- **MAINTAIN AN ACTIVE FCG**
- **NEED ARMY FUNDING**
- **SEEK OSD FUNDING FOR SIMA AND EXPAND SERVICE TO ALL DOD**

UNCLASSIFIED

**INTEROPERABILITY DECISION SUPPORT SYSTEM
(IDSS)**

**PRESENTED TO THE 1991 JOINT DOD STANDARDIZATION AND
DATA/CONFIGURATION MANAGEMENT CONFERENCE**

MAY 15 1991

UNCLASSIFIED

WHAT IS IDSS?

IDSS IS:

- AN INFORMATION SYSTEM TO SUPPORT THOSE WORKING ON INTEROPERABILITY, STANDARDS AND COOPERATIVE EFFORTS WITH OUR ALLIES
- A DIAL-IN, USER FRIENDLY, 24 HOUR-A-DAY COMPUTER NETWORK WITH WORLDWIDE ACCESS
- ADVANCED TECHNOLOGY TO MEET DoD's NEED FOR COMPUTER NETWORKS AT REDUCED COST, BOTH IN ACQUISITION AND O&M

SOME ORGANIZATIONS USING IDSS

- OSD**
- Command, Control, Communications and Intelligence (C³I)
 - Industrial and International Programs (I&IP)
 - Production and Logistics (P&L)
 - Tactical Warfare Programs (TWP/CFE)
- OJCS**
- J6 - Command, Control and Communications
 - Military Communications and Electronics Board
- Agencies**
- Defense Communications Agency (DCA)
 - Defense Nuclear Agency (DNA)
 - Defense Intelligence Agency (DIA)
 - Joint Tactical Command, Control and Communications Agency (JTC³A)
 - National Security Agency (NSA)
 - Defense Security Assistance Agency (DSAA)
- Army**
- Headquarters, Department of the Army
 - Army Materiel Command (AMC)
 - U.S. Army Europe (USAREUR)
- Air Force**
- Headquarters, Department of the Air Force
- NATO**
- U.S. Mission to NATO
 - U.S. Military Delegation to NATO

UNCLASSIFIED

EXAMPLES OF WHAT THEY USE IDSS FOR

- CONDUCT PRE-MEETING PLANNING AND COORDINATION
- COORDINATE OFFICIAL U.S. POSITIONS
- DISTRIBUTE RESULTS OF MEETINGS
- DISTRIBUTE INFORMATION ON STANDARDS
- COLLECT AND DISTRIBUTE DATA
- PROVIDE BULLETIN BOARD TYPE INFORMATION
- GATHER, COORDINATE, AND APPROVE CFE TREATY DATA
- DISTRIBUTE TEST PLANS AND RESULTS
- LOCATE POINTS OF CONTACT
- FIND ORGANIZATIONS IN SPECIFIC AREAS OF INTEREST

22-37

UNCLASSIFIED

LS/kw/10/25/90-4

UNCLASSIFIED

EXAMPLES OF NON-U.S. LOCATIONS FROM WHICH USERS CALL IDSS

ANKARA, TURKEY	OSLO, NORWAY
ATHENS, GREECE	OTTAWA, CANADA
BONN, GERMANY	PARIS, FRANCE
BRUSSELS, BELGIUM	RAMSTEIN, GERMANY
CAIRO, EGYPT	ROME, ITALY
CANBERRA, AUSTRALIA	SEOUL, KOREA
COPENHAGEN, DENMARK	SINGAPORE, SINGAPORE
LISBON, PORTUGAL	TEL AVIV, ISRAEL
LONDON, ENGLAND	THE HAGUE, NETHERLANDS
MANILA, PHILIPPINES	TOKYO, JAPAN
MADRID, SPAIN	VAIHINGEN, GERMANY

UNCLASSIFIED

LS/06/07/90/cph01

BASIC GENERALIZED HOST CONCEPT

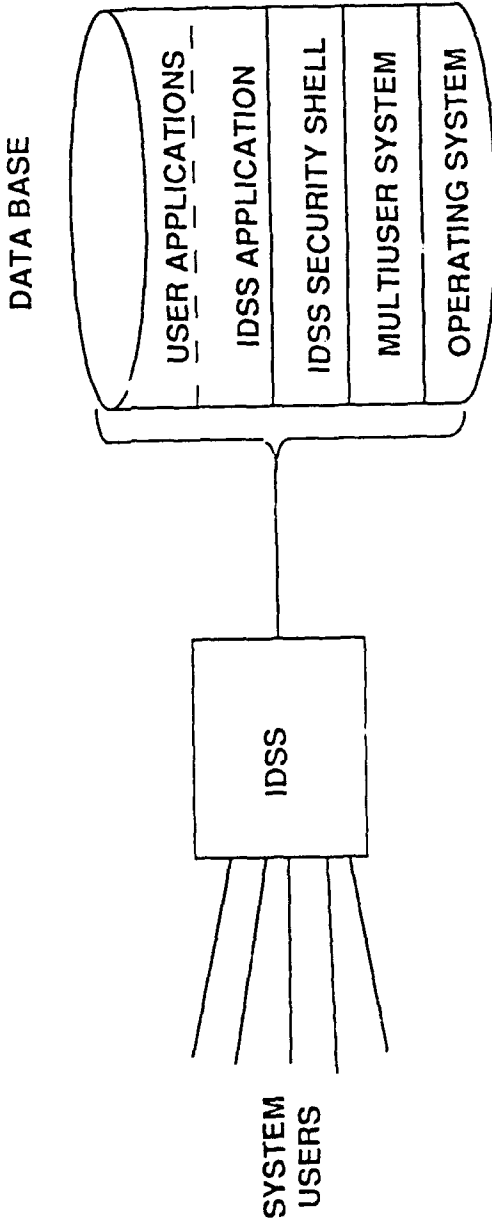

IDSS APPLICATION

- BASIC DATA BASE
 - Organizations
 - Points of Contact
 - Meetings
 - Documents
 - Positions and Policies
 - Glossary/Dictionary
- ELECTRONIC MAIL/DDN MAIL
- WORLDWIDE COMMUNICATIONS
- UNCLASSIFIED AND CLASSIFIED CAPABILITY
- PROTECTION OF ALL INFORMATION

EXAMPLES OF USER APPLICATION

- Required Operational Capabilities
- Five Year Interoperability Assurance Program
- International Message Catalog
- Office of Defense Cooperation
- Foreign Market Analysis System
- International Standards Database
- Conventional Arms Asset Tracking System
- Management Information System, International Logistics

UNCLASSIFIED

SEAMLESS/MODULAR/OPEN SYSTEMS CONCEPT

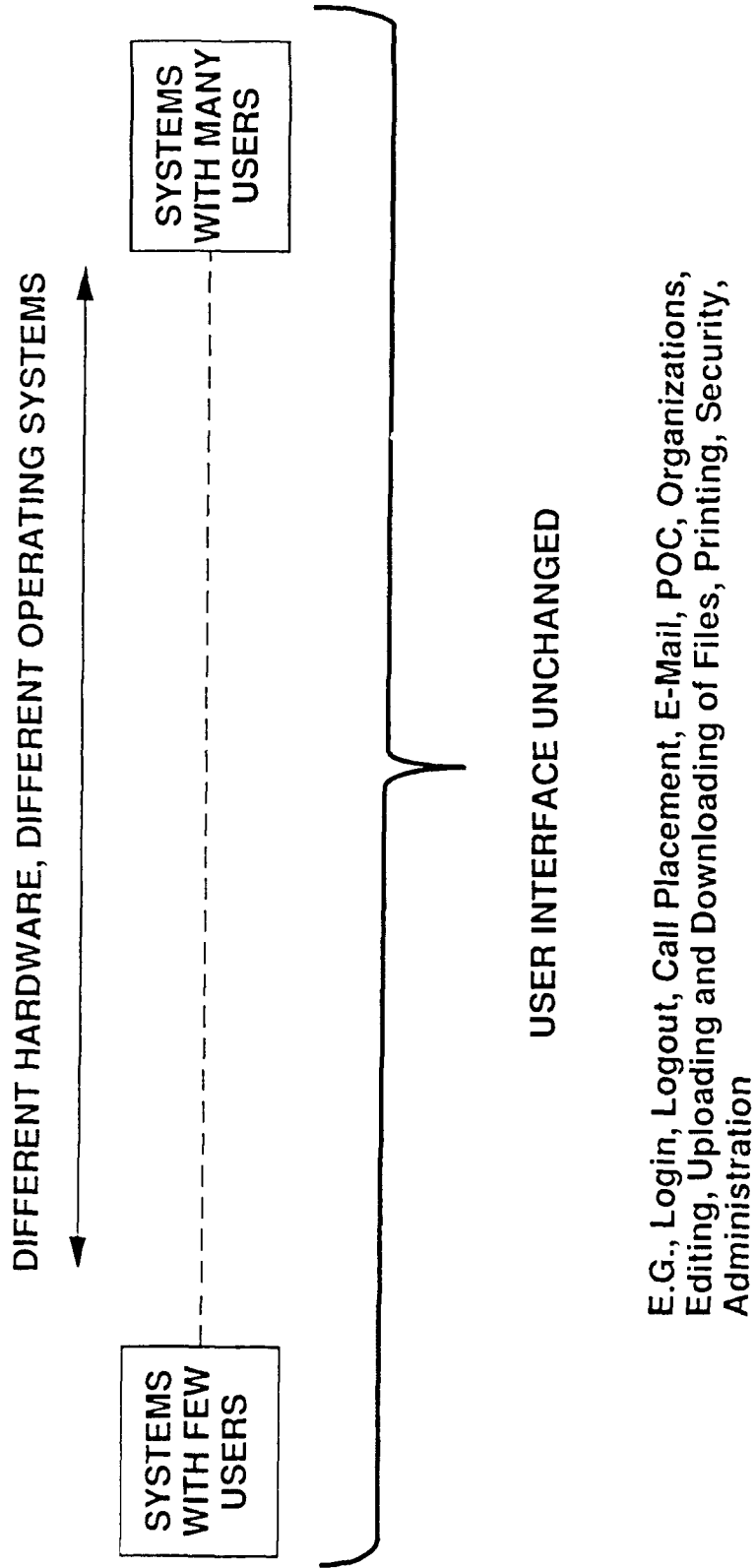

UNCLASSIFIED

CURRENT STATUS

FOUR SYSTEMS OPERATING, THREE IN CONCEPT/DEVELOPMENT

SYSTEM

NETWORK TYPE

1 UNCLASSIFIED

Basic with Dial-Out

- Operating for 4 Years
- 800 + User Accounts/35 User Groups
- DDN, Telnet, Data America & AT&T
- Operate in U.S. + 22 Other Nations

2 CLASSIFIED

Basic

- Operating for 1.5 Years
- Uses STU Ills for Crypto
- Initial CFE Treaty Host

3 ABCA

Basic

- First Clone
- Turn-Key Operation
- Operated by ABCA

4 JTC3A

Basic

- In Development

5 NATO CONNECTION

Network of Networks

- In Development

6 CFE TREATY - USAREUR

Basic

- In Development

7 CFE - TEST

Network of Networks

- Operational

Basic

UNCLASSIFIED

SOME SYSTEM SECURITY MEASURES

- **SYSTEM ACCESS CONTROLS**
 - Unique Usernames
 - 7 or 8 character passwords
 - Unique protocol
 - Time limited log-on
 - Aborted attempts recorded
 - Crypto on classified system
 - Designed to C2 level trusted system

- **DATA ACCESS CONTROLS**
 - User authorization code
 - User kept in application program
 - Application programs can have additional controls
 - Error conditions terminate user access

- **VIRUS PROTECTION**
 - User can not upload and run a program
 - Users can not modify programs on-line
 - IDA reviews programs before putting on host

UNCLASSIFIED

AN OVERVIEW OF THE NATO CONNECTION CONCEPT

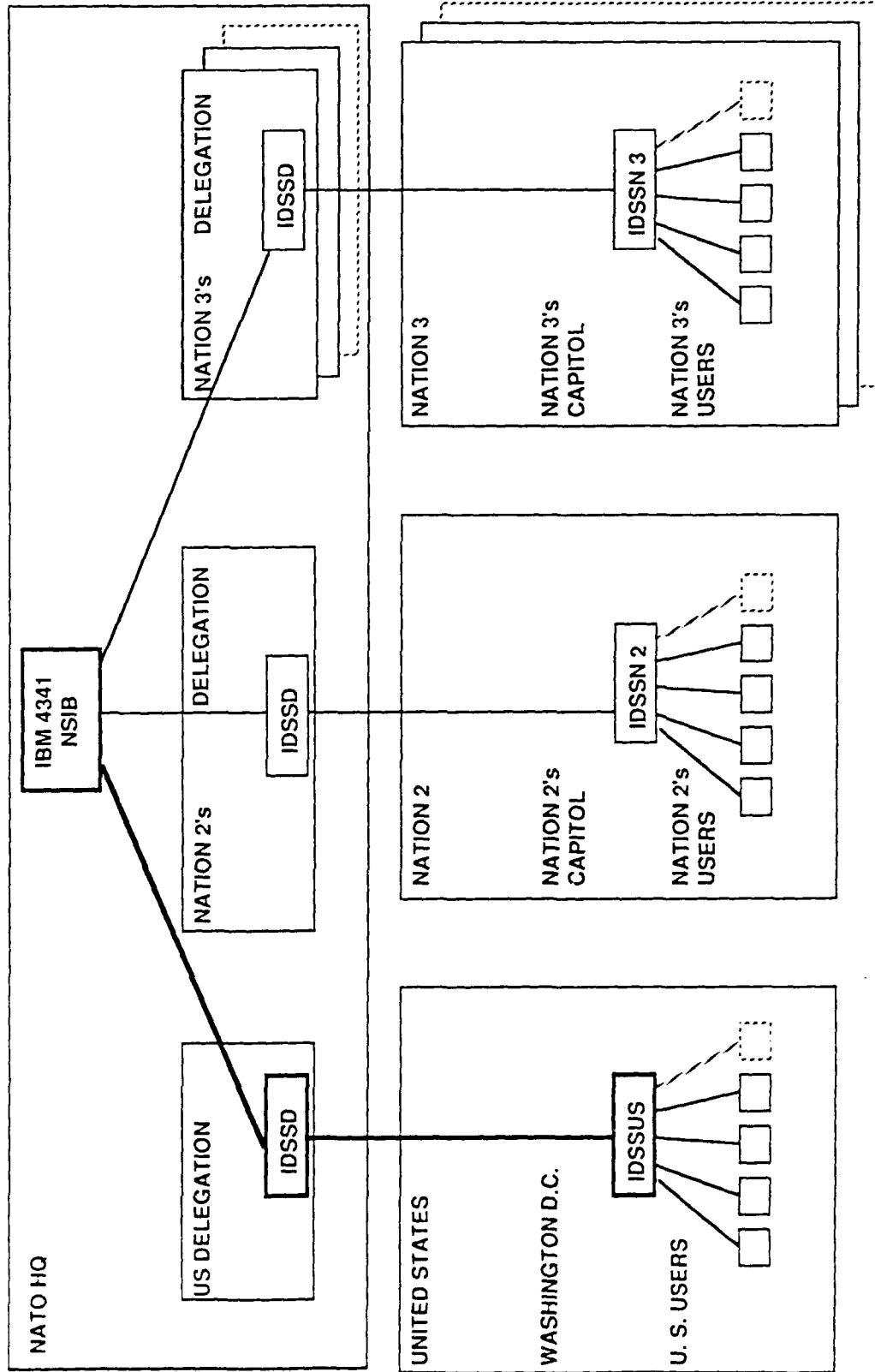

UNCLASSIFIED

UNCLASSIFIED

CONCEPT FOR PROVIDING AROUND-THE-WORLD ACCESS TO SECURITY ASSISTANCE DATA

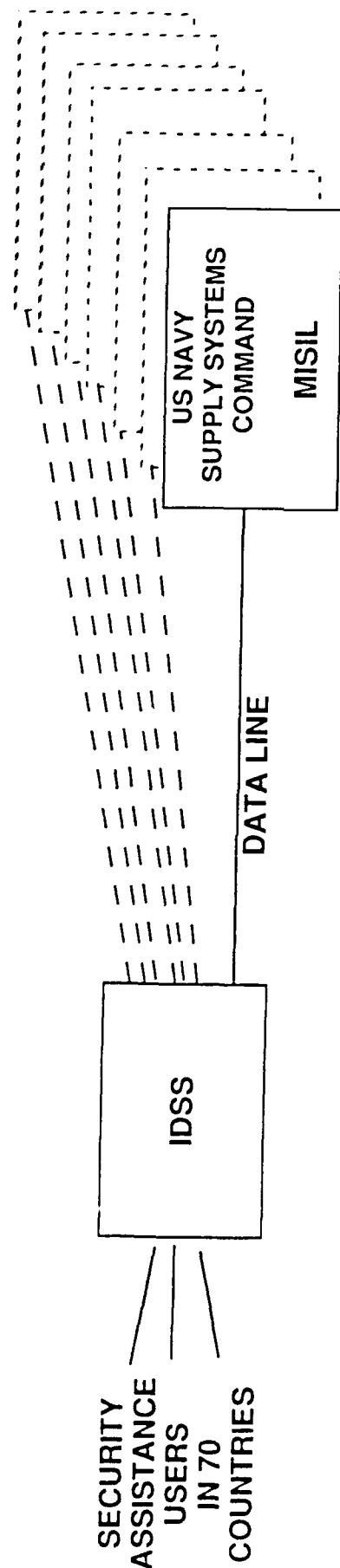

22-44

ISVG 03/11/91-01

UNCLASSIFIED

UNCLASSIFIED

SUMMARY OF WHAT HAS BEEN DEVELOPED

- Generalized, Low Cost, User Friendly, Dial-In Multiuser Systems
 - PC Based Modular Architecture
 - IDSS Software, Which DoD Owns, Provides
 - Security
 - Basic Functions
 - Basic Databases

- Generalized for Wide Application, Easy to Clone
 - Turn-Key Systems
 - Select Hardware/Operating System
 - Add IDSS Software
 - User Customization
 - User Adds Specific Applications

WORKSHOP I - CONFIGURATION MANAGEMENT

Chair, Fred C. Lewis, Naval Air Systems Command

Co-Chair: Linda J. Berry, Space and Naval Warfare Systems Command

WORKSHOP I, CONFIGURATION MANAGEMENT

CHAIR: MR. FRED LEWIS, NAVAIR
CO-CHAIR: MS. LINDA BERRY, SPAWAR

ABSTRACT

In November, 1988 a task was initiated to develop a new top level configuration management standard, MIL-STD-973 and companion handbook, MIL-HDBK-61. This is a DMR initiative to update and consolidate several existing configuration management standards, including MIL-STDs-480, 481, 482, 483, 1456 and 1521. MIL-STD-973 is in formal coordination and the handbook is in draft format. The tasks of the Configuration Management Workshop at the May 1991 conference were to review and input to draft MIL-HDBK-61 and MIL-STD-973.

INTRODUCTION

The workshop consisted of 88 participants from government and industry. The workshop opened with remarks from Ms. Linda Burgher on workshop objectives, background information, and program status. The following provides a listing of the various tasks assigned to individual groups during the two day workshop:

- o Development of Statement of Work to implement MIL-STD-973
- o ECP Short Form Procedure using MIL-STD-973 vs MIL-STD-481
- o Identification of CM Software Data Elements using DOD-STD-2167A
- o Comparison of Configuration Status Accounting Data Elements in MIL-STD-973 vs MIL-STD-1388-2B
- o Comparison of Data Elements of TD/CMS, SCLISIS and CLIP
- o Development of System Life Cycle and Hierarchy of System Component Diagrams
- o Development of Draft Diagrams for MIL-HDBK-61
- o Development of Checklist for CM elements and RFPs
- o Identification of mutual CM and provisioning process improvements
- o Verification of MIL-STD-973 sufficiently covers software requirements using DOD-STD-2167A

RECOMMENDATIONS

The following workshop recommendations address the major areas of concern resulting from work tasks above. The recommendations are not listed in any order of importance or priority.

- o Add a section of ECP Short Form into MIL-HDBK-61
- o Rework Configuration Status Accounting (CSA) section in MIL-STD-973
- o Develop figures to illustrate CSA
- o Definition of Non Developmental Item (NDI) consistent with DODD 5000.1 and 5000.2
- o Continue work efforts with the DoD Provisioning Policy Group

CONCLUSION

The products developed as a result of the above tasks will be reviewed by the Configuration Management Advisory Group (CMAG). The final results of this review will be incorporated into MIL-STD-973 and MIL-HDBK-61. The work efforts of the attendees will enhance the top level CM standard and companion handbook.

WORKSHOP II - MIL-HDBK-TDP

Chair, Roland Henderson, Office of the Assistant Secretary of Defense for Production and Logistics,
Technical Data and Manufacturing Division

SUMMARY OF WORKSHOP 2

MIL-HDBK-TDP

Chaired by:
Roland G. Henderson
Office of Assistant Secretary of Defense
for Production & Logistics

SUMMARY:

The objective of this workshop was to identify topics and sub-topics to be addressed in a comprehensive guide for use by all personnel involved in the acquisition, generation, management and use of technical data packages. The proposed handbook is not intended to supersede the existing guidance but rather to place road signs to that guidance where it exists. Where no guidance exists, the handbook will identify the sources of requirements and provide information on their implementation. The following major sections were proposed for the handbook as well as numerous subheadings:

- | | |
|---|---|
| 1. PUBLIC LAWS, REGULATIONS, AND DOD POLICIES | 7. OPTION SELECTION & TAILORING |
| 2. RELATED DISCIPLINES | 8. MEDIA FOR DATA PRODUCTS. |
| 3. COMPOSITION AND USES OF TDPs | 9. VERIFICATION AND VALIDATION |
| 4. DETERMINING TDP NEEDS | 10. DATA RIGHTS AND INTELLECTUAL PROPERTY |
| 5. ACQUISITION DOCUMENTS | 11. COST OF DATA |
| 6. DATA REQUIREMENTS VS. TASKS | 12. CONTRACTUAL ASPECTS OF TDP MANAGEMENT |

RECOMMENDATION:

The Workshop gave special consideration to the possibility of including guidance for the application and tailoring of MIL-STD-100, Engineering Drawing Practices, in the handbook. The consensus was that a separate handbook should be developed for that guidance.

ACTION REQUIRED:

1. The workshop chair will forward the above recommendation to the Preparing Activity for MIL-STD-100 and the Drawing Practices Advisory Group for action.

2. The handbook will be distributed through SD-1 coordination channels for identification of additional topics, subheadings, and recommended text before formal coordination of a draft.

WORKSHOP III - CM/DM CONTRACTOR CERTIFICATION

Chair: Jim Whisenant, International Business Machines (IBM)

Co-Chair: Carol A. Sitroon, Army Armament Research, Development and Engineering Center, Battlefield Automation Technical Data Directorate

WORKSHOP III, CM/DM CONTRACTOR CERTIFICATION

CO-CHAIRS: MR. JIM WHISENANT, IEM/FSD
MS. CAROL SITROON, ARDEC

ABSTRACT

In December 1989, a task was initiated to establish a program for certifying the configuration management (CM)/data management (DM) processes within Industry to reduce acquisition costs, require less DoD surveillance and embrace the total quality concept. The specific task of the Certification Workshop at the May 1991 conference was to review and input to a strawman military standard which will contain certification criteria and procedures for the conduct of the program.

INTRODUCTION

The workshop consisted of 42 participants from both DM and CM backgrounds with government and industry evenly represented. The workshop opened with remarks from the co-chairs on workshop objectives, background information, and program status, including a general discussion and question period on the subject of CM/DM certification. The following, while not all inclusive, provides a representation of the issues and concerns expressed by the group:

- o Value added by certification
- o Role of Industry in certification teams
- o Role of Industry in the establishment of certification criteria
- o Length of certification period and renewal criteria
- o Appeal process
- o Certification by individual contract or all inclusive
- o Certified industries to receive special considerations
- o Levels of certification required, i.e., "build to print" vs. "design, build, test" of a major complex weapons system
- o What will be certified -- people, areas or processes?
- o Applicability of a "Grandfather Clause"

Discussion related to the above issues and concerns and subsequent group consensus established a common ground for the draft document review and recommendations. Due to the extensive review comments to the document, they will not be repeated herein but will be incorporated into the next version prior to DoD and Industry review.

RECOMMENDATIONS

The following workshop recommendations address the major areas of concern resulting from the document review. The recommendations are not listed in any order of importance or priority.

- o Certification should be administered at the DoD level and not by individual services or agencies
- o Certification can be for both disciplines (CM/DM) together or separately
- o Certification teams must not include industry representatives
- o Development of the certification review teams, contents of data required and evaluation/negotiating must be a consolidated effort between DoD and Industry
- o Length of certification period should be a minimum of 5 years and a maximum of 10 years
- o Industry must include methods or techniques to measure and indicate continuous level of quality
- o Establish an appeal process and criteria comprised of government and industry members
- o Weighting, pass/fail grading criteria should be in a stand-alone document, e.g., handbook, versus in the standard
- o Certification renewal should be based on performance and quality indications
- o Determine need for different levels of certification with Industry
- o Utilize the CM check list in MIL-STD-973 as basis for certification criteria
- o Participation in the certification program should be voluntary with no special considerations given for being certified. Should not be used for or included as a requirement
- o Certification should be of the CM/DM processes as a discipline, not people oriented or contract driven

CONCLUSION

The consensus of the group was for DoD and Industry to actively pursue implementation of the CM/DM Contractor Certification Program. This program embraces the concepts of acquisition streamlining, total quality management, the Defense Management Review, MIL-STD-973, DOD-STD-1700 and produces cost savings in terms of data which can be re-allocated for additional hardware/software products.

WORKSHOP IV - TECHNICAL DATA MANAGEMENT

Chair: Donald Langkamp, Office of the Assistant Secretary of Defense for Production and Logistics,
Technical Data and Manufacturing Division

WORKSHOP IV - TECHNICAL DATA MANAGEMENT

CHAIRPERSON : MR. DONALD LANGKAMP, DASD (PR) TDMD

ABSTRACT

The objective of Workshop IV was to become aware of the direction that Technical Data Management is taking during the 1990's based on the impact of the Defense Management Review and the strong preference for access to contractor digital information through implementation of a CALS Program. Phase II of the CALS Program requires direct access to the contractors data base which will be provided as a service by the prime contractor in accordance with the requirements of MIL-C-CITIS (draft). Workshop IV consisted of eight task groups which reviewed MIL-C-CITIS from five aspects, looked at the requirements for a Technical Data Management - Data Elements Dictionary, and also reviewed the draft versions of DoD 5010.12-M and MIL-STD-963B for compliance with CALS Program requirements. The workshop was fortunate to have as a guest speaker Mr. William Howard who provided a briefing that outlined the CALS Program vision and where MIL-C-CITIS fits in this vision. Mr. Howard is under contract to the OSD CALS Office as a consultant and has had a major role in developing CALS Program policy and the MIL-C-CITIS (draft) specification.

INTRODUCTION

The workshop consisted of 82 participants from Government and Private Industry. The workshop opened with remarks from Mr. Donald Langkamp regarding workshop purposes and objectives, the agenda to be followed and introduction of the guest speaker Mr. William Howard. The following provides a listing of the titles and objectives of tasks assigned to the eight task groups during the two day workshop.

Task Group 1 : MIL-C-CITIS ; Review of latest draft version.

Objectives : The main objectives of the group were to review the draft CITIS specification for compliance with format and content requirements of MIL-STD-961, to identify CITIS implementation issues and to recommend specification improvements. Consideration was also to be given to the feasibility of developing a separate Military Standard for the four Levels of Service contained in CITIS specification, paragraph 3.7 since the precise definition of these Levels are of paramount importance to the success of the CALS / CITIS effort.

Task Group 2 : MIL-C-CITIS; Data Requirements Definition.

Objectives : The main objectives of the group were to review the draft CITIS specification for compliance with format and content requirements of MIL-STD-961, to identify CITIS implementation issues and to recommend specification improvements. Consideration was also to be given to the feasibility of developing a separate Military Standard for the four Levels of Service contained in CITIS specification, paragraph 3.7 since the precise definition of these Levels are of paramount importance to the success of the CALS / CITIS effort.

Task Group 3 : MIL-C-CITIS; CLINs, CDRLs, and DIDs.

Objectives : The main objectives of the group were to provide comments and recommendations for a new CLIN, new information on CDRLs, and highly tailored DIDs to implement MIL-C-CITIS in weapon system acquisitions. The group should use Section 60 of the specification as a starting point and consider various scenarios for the four different levels of service and types of data to be included in the CITIS.

Task Group 4 : MIL-C-CITIS ; Implementation Guidance

Objectives : The primary objectives of the group were to review the draft MIL-C-CITIS specification for implementation problems and the adequacy of the implementation guidance.

Task Group 5 : DI-ILSS-CALSIP; Review of proposed draft Data Item Description (DID)

Objectives : The main objectives of the group were to review the proposed draft DID for compliance with format and content requirements of DOD-STD-963, to identify DID implementation issues and to recommend necessary changes or improvements. Consideration was also be given as to whether MIL-C-CITIS is the most logical document to require preparation of this DID or would MIL-STD-1840 be more appropriate.

Task Group 6 : Technical Data Management (TDM) Data Element Dictionary; Feasibility of

Objectives : The main objectives of the group were to understand the need for data elements in the CALS environment and to review existing reports on efforts to develop Data Element Dictionaries for other disciplines in order to establish the feasibility of developing a separate TDM Data Element Dictionary (TDM-DED). If the group determined that a separate TDM-DED is feasible, then they were to develop a general statement providing the rationale for this determination and, if possible, also provide an approach indicating how this task could be accomplished. If the group determined that a separate TDM-DED is not feasible, then they were to develop a detailed statement providing the rationale for this determination.

Task Group 7 : 5010.12-M ; Review of final version

Objectives : The main objectives of the group were to review the final version of DoD 5010.12-M for clarity and content, the incorporation of CALS considerations regarding digital data, and to recommend specific improvements in the manual. This Task Group's function was to provide the last formal review and update before the manual is forwarded for signature.

Task Group 8 : MIL-STD-963B; Review of latest draft version

Objectives : The main objectives of the group were to review the draft MIL-STD-963B for compliance with the format and content requirements of MIL-STD-962, to review the coordination and approval issues of Chapter 8 of DoD 5010.12-M for compatibility with MIL-STD-963B, and to review the DI-ILSS-CALSIP DID for compliance with MIL-STD-963B requirements.

RECOMMENDATIONS

The following are a summary of the recommendations made by each task group based on their efforts during the two day workshop period:

O Task Groups 1 through 4 reviewed various aspects of MIL-F-CITIS (draft) and developed a total of 38 comments, questions and recommendations that reflected the need for expanded definition of the four levels of service referenced in the CITIS specification, cited confusion over the overlapping functions of two similar Data Item Descriptions (DIDs) , ie. DI-ILSS-CALSIP and DI-ILSS-CITISP, recommended deletion of Figure 1 and numerous changes to Figures 5 through 8 and the need for a comprehensive editorial review.

O Task Group 5 reviewed Data Item Description (DID) DI-ILSS-CITIS and developed a total of 10 comments that recommended various changes to Blocks 1 and 7, major rewrite recommendations for Block 10 and the observation that the form number used should be DD Form 1664 vice DD Form 1644.

O Task Group 6 examined the need for and an approach to developing a Technical Data Management - Data Element Dictionary (TDM-DED) and determined that given the current CALS/CIM environment, the need for a TDM-DED is mandatory and should be an integral component of the CALS Program Data Element Dictionary. The basic characteristics of the TDM-DED should be that it include only data elements unique to TDM such as DD Forms 1423 and 1664 (CDRLs and DIDs), identify any shared data elements with other disciplines such as configuration management and ILS and be compatible with the CALS Program Data Element Dictionary.

O Task Group 7 reviewed DoD 5010.12-M (draft) for clarity and content, incorporation of CALS Program considerations and to recommend specific improvements in the manual. A total of 63 comments were developed, a majority of which recommended specific improvements in Section 2 (Identification and Establishment of Data Requirements) and Section 3 (Acquisition of Data) of the manual.

O Task Group 8 reviewed MIL-STD-963B (draft) for compliance with MIL-STD-962 which establishes the requirements for the preparation of military standards and developed a total of 13 comments that fall into the following categories: 1. Conflicts with MIL-STD-962 (6 comments) 2. Missing requirements (4 comments) 3. Paragraphs considered unnecessary (3 comments)

CONCLUSIONS

One of the most important benefits of Workshop IV was the realization by attendees that times are changing rapidly toward a paperless office and personnel in the field of Technical Data Management must be aware of how these changes impact the way we do business. Also, attendees came to realize that in order to function successfully the time is upon us when Technical Data Managers will be required to be highly "Automation Literate". All comments developed by Task Groups 1 through 5 will be forwarded to the OSD - CALS Office for consideration and action as appropriate. The comments developed by Task Groups 6 through 8 will be considered and acted upon as appropriate by the DASD (Production Resources) - Technical Data and Manufacturing Division.

QUALIFIED MANUFACTURERS LIST

Chair - Darrell Hill, Defense Electronics Supply Center

**QUALIFIED MANUFACTURER LIST
(QML)**

PREPARE A "LIVING" SPECIFICATION

DEFINITION: A DOCUMENT WRITTEN IN A
FORMAT THAT WILL ALLOW THE
"RAPID" INSERTION OF NEW
TECHNOLOGY ITEMS AND PROVIDE
FOR **"CONTINUOUS"** QUALITY
IMPROVEMENTS WITHOUT
BENEFIT OF A MAJOR REVISION
OR UPDATE

**INITIAL AREA
OF CONSIDERATION**

MICROCIRCUITS

HYBRID MICROCIRCUITS

GOALS

- MAINTAIN WORLD CLASS U.S. MANUFACTURING BASE
- ONE SYSTEM FOR PRODUCING PRODUCT FOR BOTH COMMERCIAL AND MILITARY ; ADOPT BEST COMMERCIAL PRACTICES
- MORE PRODUCT OFFERED AS "QUALIFIED" WITH EARLIER AVAILABILITY TO MILITARY
- REDUCTION OF END-OF-LINE TESTING
- PROVIDE CUSTOM AND STATE-OF-ART PRODUCTS

QML PROGRAM

- o ONE SYSTEM:
 - oo QUALITY SYSTEM WITH MANAGEMENT COMMITMENT AND SUPPORT
 - oo VALIDATE (AUDIT) THE MANUFACTURERS OVERALL SYSTEM FOR PRODUCING PRODUCT
 - oo VALIDATE PROCESSES, MATERIAL AND TECHNOLOGY
- o RAPID INSERTION:
 - oo QUALIFICATION BY TEST VEHICLE (e.g., SEC,TCV)
 - oo INTERNAL QUALIFICATION (NEW DESIGN/REDESIGNS)
 - oo TECHNICAL REVIEW BOARD OVERSIGHT
 - oo CONVERSION OF CUSTOMER REQUIREMENTS

QML PROGRAM - CONTINUED

- 0 REDUCED TESTING:
 - 00 SELF AUDITS
 - 00 PROCESS MONITORS IN LINE
 - 00 STATISTICAL PROCESS CONTROL (SPC)
- 0 VERIFY CONTINUOUS IMPROVEMENTS
 - 00 PARTS PER MILLION (PPM) DATA
 - 00 YIELD DATA
 - 00 FIELD FAILURE RETURNS

TECHNOLOGY REVIEW BOARD (TRB)

THE TRB IS A DESIGNATE GROUP WHICH IS EMPOWERED TO OVERSEE ALL TECHNICAL, QUALITY, AND RELIABILITY ISSUES INVOLVING QML PRODUCTS. IT IS ACTIVELY INVOLVED IN ALL ASPECTS OF CERTIFICATION, QUALIFICATION, MANUFACTURING, AND PRODUCT CHANGES. TRB PROVIDES MINUTES TO THE GOVERNMENT DESCRIBING THEIR DECISIONS.

CONVERSION OF CUSTOMER REQUIREMENTS

A SYSTEM WHERE THE MANUFACTURER COMPARES THE CUSTOMER'S REQUIREMENTS TO THE APPROVED QML ENVELOPE AND INITIATES ACTIONS IF NEEDED (I.E., GAIN ADDITIONAL CERTIFICATION/ QUALIFICATION, GENERATE PART SOFTWARE) TO BUILD AND DELIVER A PRODUCT WHICH MEETS THE CUSTOMER'S NEEDS AND STILL CONFORMS TO HIS CERTIFIED/QUALIFIED IN-HOUSE CAPABILITIES.

COMPARISON

MIL-M-38510	o	MIL-I-38535
STANDARD MICROCIRCUITS (e.g., SSI, MSI)	o	ADVANCED MICROCIRCUITS (e.g., ASIC, VHSIC)
INDIVIDUAL PRODUCTS BASELINED & QUALIFIED	o	PROCESSES/MATERIALS BASELINED & QUALIFIED USING SEC/TCV/PMS & TWO PRODUCTION DEVICES
QPL	o	QML
NO TRB - JAN PROGRAM MANAGER	o	TRB CONTROLS PROGRAM
DESC NOTIFIED & APPROVES ALL MAJOR CHANGES PRIOR TO SHIP	o	TRB HANDLES MAJOR CHANGES DESC NOTIFIED FIRST YEAR TRB MINUTES THEREAFTER
DESIGN NOT REVIEWED BUT SPECIFIC DESIGN RULES APPLY	o	DESIGN CENTER CERTIFIED THIRD PARTY DESIGNS PERMITTED.
ALL PROCESSING (F.A.T) WITHIN COMPANY	o	THIRD PARTY ASSEMBLY & TEST BEING CONSIDERED
'J OR JAN' BRANDED	o	'Q OR QML' BRANDED
ONSHORE	o	INITIALLY ONSHORE
TYPICALLY SEPARATE MILITARY FLOW	o	COMMERCIAL/MILITARY ONE FLOW

VALIDATION TEAMS

- DESC (CHAIRMAN)
- OEMs REPRESENTATIVES (i.e., MAJOR CUSTOMERS)
- CLASS S REPRESENTATIVES
- RAD HARD REPRESENTATIVES
- SELECTED INDUSTRY EXPERTS

ONE PART - ONE PART NUMBER

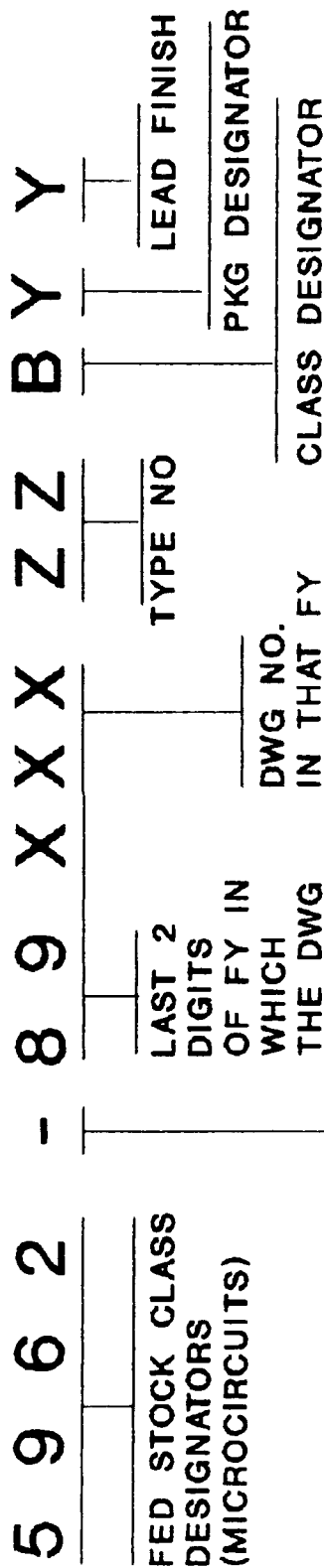

WHICH ALSO IDENTIFIES
 GEN. SPEC OR DWG FOR:
 1,2,1,MIL-STD-883----M
 MIL-M-38510-----B OR S
 MIL-M-38534-----H OR K
 MIL-I-38535-----Q OR V

RAD HARD IDENTIFIER
 M,D FOR DEVICE CLASS M
 M,D,R,H FOR DEVICE CLASSES
 B,S,H OR K
 * PER DEVICE PROCUREMENT
 DOCUMENT FOR DEVICE
 CLASSES Q OR V.

FOR EXISTING MIL-M-38510 ASSOCIATED DETAIL, SPECIFICATION SHEET, THE "LAST 2 DIGITS OF FY" AND DWG NUMBER WILL CONSIST OF FIRST TWO DIGITS OF MIL-M-38510 (i.e., 38) FOLLOWED BY THE THREE DIGIT IDENTIFIER ASSIGNED TO THE DETAIL SHEET (e.g.,/339)

MANUFACTURER 1/ AT&T MICROELECTRONICS 555 UNION BLVD AL. PA 18103		CAGE CODE 98379	SYMBOL CODE CER11
TEST REPORT QM1001 1289	PRODUCT CLASS DESIGNATOR Q	RADIATION HARDNESS LEVEL NON-RADHARD	TECHNOLOGY 1.25µm CMOS SLM & DLM
PRODUCT TYPES ASICS FULL CUSTOM/STANDARD CELL		DESIGN CENTER LOCATION: ALLENTOWN PA LINE: LAB 5227\5223 FLOW: A89ALI528	
MASK DEVELOPMENT LOCATION: ALLENTOWN PA LINE: MOS V FLOW: SIF-MK29-MFG.METH			
WAFER FABRICATION OPERATION(S)			
LOCATION: ALLENTOWN PA LINE: MOS V FLOW: PFC-074-LOG84 & PFC-074-LOG185		LOCATION: LINE: FLOW:	
ASSEMBLY OPERATION(S)			
LOCATION: ALLENTOWN PA LINE: JIT MOS CERAMIC ASSY FLOW: SIF-QMP3-FLOW		LOCATION: ALLENTOWN PA LINE: JIT MOS CERAMIC FLOW FLOW: SIF-QMP3-FLOW	
TEST OPERATION(S)			
ENVIRONMENTAL LOCATION: ALLENTOWN PA LINE: RELIABILITY LAB FLOW: QMP3-BIC/SIF-IL5349FLOW2			
PACKAGE INFORMATION 2/			
TYPE: CASE OUTLINE: LEAD COUNT: MATRIX SIZE: LEAD FINISH:	PIN GRID ARRAY P-AE 133 13 X 13 GOLD	DUAL-IN-LINE D-10 28 --- GOLD	CHIP CARRIER FLAT PACKS MISC PACKAGES
SPECIFIC PRODUCT TYPES 3/			
MISCELLANEOUS DATA			
STANDARD MILITARY DRAWING 5962-9070401QXX		ESD CLASS 1(1.4)	MANUFACTURER SIMILAR PART NUMBER 4/ WE-DSP-16
PRODUCT TYPE / DESCRIPTION 5/ DIGITAL SIGNAL PROCESSOR, 16 BIT		SHIPPED NO	

QML PROGRAM STATUS

<u>CO.</u>	<u>CERTIFIED</u>	<u>QUALIFIED</u>	<u>Q</u>	<u>Y</u>	<u>RHA</u>	<u>COMMENTS</u>
INTEL	8 MAR 90	10 OCT 90	X			1.0 MICRON STANDARD PRODUC UP, PERIPHERALS
AT&T	19 DEC 89	30 MAR 90	X	X	X	1.25 MICRON CUSTOM & STANDARD PRODUC
IBM	14 DEC 90		X	X	X	1.25 MICRON CUSTOM SEMI CUSTOM LOGIC & MEMORY
HONEY - WELL	30 NOV 90		X	X	X	1.25 MICRON CUSTOM SEMI CUSTOM LOGIC & MEMORY
T.I.	PENDING		X			1.0 MICRON STANDARD PRODUC LOGIC & MEMORY

QML FUTURE GROWTH

AMI/GOULD: PRE-REVIEW JUNE 91

INFORMATION REQUESTED BY:

NATIONAL*
MOTOROLA MPO
HUGHES SYSTEMS
RAYTHEON
VLSI TECHNOLOGIES
HEWLETT PACKARD

* VISITED DESC

POTENTIAL APPLICATIONS

- CUSTOM PRODUCTS
- PRODUCTS WITH SHORT LIFE CYCLES
- COMPLEX PRODUCTS WITH EXTENSIVE TESTING REQUIREMENTS
- PRODUCTS WITH MANY VARIATIONS IN DESIGN

EXPAND SCOPE

- **65 OTHER MILITARY SPECIFICATIONS IDENTIFIED FOR ENHANCEMENTS**

SUMMARY

- MIL-1-38535 PROMOTES GOOD BUSINESS PRACTICES, RELIABILITY AND QUALITY IMPROVEMENTS
- UTILIZING QML, QUALITY IS BUILT INTO THE PRODUCT RATHER THAN INSPECTING QUALITY IN
- A NEW WAY OF DOING BUSINESS

ELIMINATING HAZARDOUS MATERIAL REQUIREMENTS IN SPECIFICATIONS AND STANDARDS PANEL

Chair - Frank T. Traceski, Office of the Assistant Secretary of Defense for Production and Logistics,
Industrial Engineering and Quality Directorate

Panel Members:

Stephen O. Anderson, Ph.D., Environmental Protection Agency

George E. Husman, BASF Structural Materials, Inc.

1991 STANDARDIZATION & DATA/CONFIGURATION MANAGEMENT CONFERENCE

**"Conducting Business Under the DMR"
May 14-17, 1991
Arlington, VA**

**ELIMINATING HAZARDOUS MATERIAL REQUIREMENTS IN
SPECIFICATIONS AND STANDARDS**

**Frank T. Traceski
Office of the Deputy Assistant Secretary of Defense
(Production Resources)
Industrial Engineering and Quality Directorate
5203 Leesburg Pike (Suite 1403)
Falls Church, VA 22041**

DEFINITION
OF
HAZARDOUS MATERIAL

DoD Defines "Hazardous Material" As Anything that Due to its Chemical, Physical, or Biological Nature Causes Safety, Public Health or Environmental Concerns that Result in an Elevated Level of Effort to Manage It.

(Source: DoD Hazardous Materials Pollution Prevention Committee Meeting, 27 July 1990)

To Identify Hazardous Materials Refer to EPA Title III List of Lists, Consolidated List of Chemicals Subject to Reporting Under Title III of the Superfund Amendments and Reauthorization Act (SARA) of 1986.
(Source: EPA Office of Toxic Substances)

HAZARDOUS MATERIALS

General Classification:

Inorganic Compounds and Elements
Organic Compounds

Examples:

- **Heavy Metals (Pb, Hg, Cd, Be, etc.)**
- **Radioactive Substances**
- **Explosives**
- **Propellants**
- **Pesticides/Herbicides**
- **Various Industrial Chemicals**

DOD DIRECTIVE 4210.15
"Hazardous Materials Pollution Prevention"

(July 27, 1989)

It is DoD Policy that Hazardous Material Shall Be Selected, Used, and Managed Over its Life Cycle so that the DoD Incurs the Lowest Cost Required to Protect Human Health and the Environment.

Emphasis Must be on Less Use of Hazardous Materials in Processes and Products, as Distinguished from End-of-Pipe Management of Hazardous Waste.

ASD(P&L) Shall Promote Hazardous Materials Pollution Prevention within the DoD.

SMA Action:

Where a Document Allows for the Use of Hazardous Material or a Process Is Using Hazardous Material and a Less Hazardous Substitute Is, or Could Be Available, Revise the Document, Process or Operating Procedure, to Facilitate the Use of the Substitute.

**CURRENT DOD POLICY ON HAZARDOUS MATERIALS IN
MILITARY SPECIFICATIONS**

**ASD(P&L) Requires that Acquisition DoD Components Revise by
31 December 1993 All Appropriate Military Specifications with the
Objective of Reducing Use of Hazardous Materials to the Fullest
Extent Practicable.**

**MIL-STD-961C: General Requirement for Hazardous Material
Specifications**

**Paragraph 4.2.2 - Material Safety Data Sheets
(See FED-STD-313)**

**MIL-STD-961C: Detail Requirement for Hazardous Material
Paragraph 5.3.3.6 - Marking and Labeling**

DEFENSE ENVIRONMENTAL MANAGEMENT STUDY

- **Under Defense Management Review (DMR), the Under Secretary of Defense for Acquisition (USDA) Initiated a Defense Environmental Management Study**
- **Goal is to Establish the DoD Leadership Role in Environmental Compliance without Degrading Military Capability**
- **DoD Is Identifying Existing Problems and Opportunities for Environmental Improvements**
 - Degradable Materials**
 - Recycling**
 - Revision of Military Specifications**
 - Research on New Materials & Processes**

HAZARDOUS MATERIALS - ROLE OF LSAs & PAs

LEAD STANDARDIZATION ACTIVITIES (LSAs) MUST ENSURE THAT THEIR STANDARDIZATION PROGRAM PLANS ADDRESS HAZARDOUS MATERIALS. THE GOAL SHOULD BE TO REDUCE OR ELIMINATE (IF POSSIBLE) THE REQUIREMENTS FOR HAZARDOUS MATERIALS IN DOD SPECIFICATIONS.

PREPARING ACTIVITIES (PAs) NEED TO REVISE MILITARY AND FEDERAL SPECIFICATIONS AND STANDARDS TO THE FULLEST EXTENT PRACTICABLE TO ACHIEVE THIS GOAL.

PRINT ORDER (MIL SPECS & STANDARDS) (INITIAL)

NPPSO-5604/4 (REV. 11-90)

DO NOT WRITE IN THIS SPACE - NPPSO USE ONLY

- 1 No carbon required to complete this form. Submit original and three (3) copies for each item.
- 2 Originator complete Section I. Mail with copy for printing to:
 NAVY PUBLISHING AND PRINTING SERVICE OFFICE
 BLDG 4D NPM DODSSP
 700 ROBBINS AVENUE
 PHILADELPHIA, PA 19111 5094

SECTION I

DOCUMENT NUMBER		DOCUMENT DATE	
ORIGINATING OFFICE	ORDER NO. (local use)	DATE OF ORDER	TOTAL PAGES (including blanks)

TYPE OF ACTION (X THE APPROPRIATE BOX) (IF THE CANCELLATION BOX IS MARKED, DO NOT MARK ANY OTHER BOX)

NEW
 REVISION
 AMEND/CHANGE
 VALIDATION
 ADOPTION
 INACTIVATION FOR NEW DESIGN
 REINSTATEMENT
 CANCELLATION

COORDINATION <input type="checkbox"/> FULL <input type="checkbox"/> LIMITED	IS QUALIFICATION REQUIRED? <input type="checkbox"/> YES <input type="checkbox"/> NO	ARE DIDS CITED IN SECTION 6? <input type="checkbox"/> YES <input type="checkbox"/> NO
--	--	--

COMMERCIAL PRODUCT, PROCESS, PRACTICE, ETC. <input type="checkbox"/> YES <input type="checkbox"/> NO <input type="checkbox"/> MODIFIED COMMERCIAL <input type="checkbox"/> IS A NON-GOVERNMENT STANDARD (NGS) UNDER DEVELOPMENT THAT COULD REPLACE THIS DOCUMENT? <input type="checkbox"/> YES <input type="checkbox"/> NO IF SO, WHAT NGS BODY IS INVOLVED? _____	MEASUREMENT SYSTEM. <input type="checkbox"/> METRIC <input type="checkbox"/> INCH-POUND <input type="checkbox"/> NON-MEASUREMENT SENSITIVE <input type="checkbox"/> METRIC VERSION OF DOCUMENT REQUIRED DOES DOCUMENT CONTAIN FIXED ALLOWABLE LEVELS OF DEFECTS (E.G. AQL OR LTPD)? <input type="checkbox"/> YES <input type="checkbox"/> NO
--	---

MULTI-NATIONAL STANDARDIZATION AGREEMENT IMPLEMENTED: YES NO
 STANDARDIZATION AGREEMENT NO(S): _____

DOES THE DOCUMENT SPECIFY HAZARDOUS MATERIALS CONTAINED ON THE ENVIRONMENTAL PROTECTION AGENCY, OFFICE OF TOXIC SUBSTANCES, TITLE III LIST OF LIST (EPA 560/4-90-011, dated JANUARY 1990); OR DOES THE DOCUMENT SPECIFY CHLOROFLUOROCARBONS (CFCs), HALONS, OR CHLORINATED SOLVENTS?
 YES NO (THE CHEMICAL NAME OF THE SUBSTANCE(S) SHALL BE INCLUDED AS A KEYWORD)

RETURN ORIGINAL COPY (with original to NPPSO)	REMARKS
---	---------

SECTION II (FOR OFFICIAL USE ONLY)

QUANTITIES FOR INITIAL PRINTING

ARMY	NAVY	AIR FORCE	DIA	SUBSCRIPTIONS		TOTAL

PRORATION OF PRINTING CHARGES

\$	\$	\$	\$	\$	\$	\$
----	----	----	----	----	----	----

REMARKS

**OCCUPATIONAL HEALTH, SAFETY, & ENVIRONMENTAL
CONCERNS**

WORKER SAFETY

INDUSTRIAL AND ENVIRONMENTAL TOXICITY

AIR, WATER, AND LAND POLLUTION

Ecology

Disposal of Hazardous Wastes

DOD HAZARDOUS WASTE

DoD Generates Over 400,000 Tons of Hazardous Waste Each Year from its Industrial Processes Used Primarily to Repair and Maintain Weapon Systems.

To Avoid Disposal Costs, DoD Has Adopted Programs to Reduce Hazardous Waste Generation and Limit the Amount of Hazardous Materials and Waste That Must Be Disposed Of.

Source: Department of Defense Management of Hazardous Materials, GAO/T-NSIAD-90-51, June 28, 1990

One Way to Reduce Generation of Hazardous Waste Is To Minimize Requirements for Hazardous Materials in Military and Federal Specifications and Standards.

DOD HAZARDOUS WASTE

Some 17,000 Waste Sites Have So Far Been Found at 1,800 Military Installations.

This Year the Pentagon Is Spending \$1.1 Billion To Clean Up Its Hazardous Waste.

DoD Estimates that It Will Cost \$20 Billion for Total Clean-Up.

Source: Government Executive, "The Greening of Government," March 1991, p. 23.

CURRENT PROBLEMS

OZONE-DEPLETING COMPOUNDS (ODCs)

Chlorofluorocarbons (CFCs)

Halons

Methyl Chloroform

Carbon Tetrachloride

ASBESTOS (EPA Ban)

CADMIUM (Occupational Safety and Industrial Base)

Proposed OSHA Standard

PLASTICS (Hazardous to Marine Life)

Recycled Plastics

Degradable Plastics

MONTREAL PROTOCOL

Substances that Deplete the Ozone Layer

CFC - 11

CFC - 12

CFC - 113

CFC - 114

CFC - 115

Halon - 1211

Halon - 1301

Halon - 2402

Carbon Tetrachloride

Methyl Chloroform

**There are 500 Military/Federal Specifications and Standards
which Require these Ozone-Depleting Compounds.**

CFC ALTERNATIVES THAT CONTAIN HYDROGEN

Chlorofluorocarbons

CFC-11 (CCl_3F)

CFC-12 (CCl_2F_2)

CFC-113 ($\text{CCl}_2\text{FCClF}_2$)

CFC-114 ($\text{CClF}_2\text{CClF}_2$)

CFC-115 (CClF_2CF_3)

Alternatives

HCFC-123 (CHCl_2CF_3)

HCFC-141b ($\text{CH}_3\text{CCl}_2\text{F}$)

HCFC-134a (CH_2FCH_3)

HCFC-225ca ($\text{CF}_3\text{CF}_2\text{CHCl}_2$)

HCFC-225cb ($\text{CHClFCH}_2\text{CClF}_2$)

HCFC-124 (CHClFCH_3)

HFC-125 (CHF_2CF_3)

Source: SAMPE Journal, Vol. 27, No. 1, January/February 1991, p. 76

basis of U.S. standards, it said. "The United States experience with pesticide use has not been such that Canadians should try to emulate it," the report said.

Ozone Depletion

HALON ALTERNATIVES TOP DOD'S CONCERNS; 500 PROCUREMENT SPECIFICATIONS MUST BE REVISED

The Department of Defense official that oversees all U.S. military purchases and standards told a congressionally mandated advisory committee Jan. 10 that DOD should become a leader in the development of substitutes for halons.

The United States agreed to phaseout the use of certain halons, chlorofluorocarbons, and other compounds when it signed the Montreal Protocol on Substances that Deplete the Ozone Layer in 1987 (11 CRR 991).

David Berteau, deputy assistant secretary of defense for production and logistics, said the U.S. military has an opportunity to be a leader in development of alternatives to halons because DOD purchases of them constitute 35 percent of the halon market.

He also said there has been "a major change in DOD's approach to environmental issues. There is increased awareness of the interrelatedness of DOD's activities and its impacts on the planet and people."

Today, DOD's definition of "mission accomplished" includes environmental compliance concerns, he added.

Berteau told DOD's CFC advisory committee that it had the "double joy" of developing specific solutions as well as a process to enable the U.S. military to make the shift away from ozone depleting chemicals.

"Make sure your solutions are not the genesis of the next round of problems," Berteau cautioned the committee.

The committee must send its second report to Congress, an assessment of the costs and feasibility of complying with the Montreal Protocol, by June 30. By law, the committee has equal representation from military, industry, and Environmental Protection Agency officials (14 CRR 1105).

Daunting Task

Since the Montreal Protocol was revised in June 1990, adding two more chemicals to the list of substances to be phased-out, the number of military specifications that must be revised increased from about 300 to 500, a DOD official told BNA.

About 500 primary specifications require the use of chemicals included in the international agreement and must be revised. Frank Traceski, a DOD official, explained. In addition, there are about 9,000 secondary specifications that reference the primary specifications that use CFCs and halons, he said.

Previously, Traceski estimated it would cost \$500 million to revise these specifications.

The committee's recommendations for revision of military specifications must be "complimentary" to the department's on-going efforts to review its standards, Berteau said.

"I'm trying to solve the overall problem of the development and revision of military specifications and standards. It is not just a sense of coordination that is needed," Berteau explained. DOD must change fundamentally the way specifications and standards are written, used, and revised, he added.

Stephen Andersen of EPA's Office of Air and Radiation suggested that DOD designate two people to answer ques-

tions about CFC alternatives for military services. This could promote the use of "conspicuous alternatives," he explained.

Pesticides

FOOD PROCESSORS CALL FOR NATIONAL UNIFORMITY OF TOLERANCES, PRE-EMPTION OF STATE AUTHORITY

Federal laws regulating pesticides should be changed in the 102nd Congress to make tolerance levels for pesticide residues in food uniform across the country, John Cady, president of the National Food Processors Association, told a press conference Jan. 10.

"We don't need 50 [Environmental Protection Agencies] and 50 sets of pesticide rules that are bound to shut some foods out of some states," Cady maintained. "Dramatically different pesticide standards don't produce dramatically different levels of safety. We need one set of good rules and we need to make them stick."

Contending that consumers of different states "should not be subjected to differing tolerances and warnings," Cady called on Congress to amend the Federal Food, Drug, and Cosmetic Act and the Federal Insecticide, Fungicide, and Rodenticide Act to provide a uniform "negligible risk" standard for pesticide residues in food. NFPA is developing bill language.

In a written statement to reporters, the National Agricultural Chemicals Association commended the food processing industry's proposal. Among other benefits, NACA President Jay Vroom said, the proposal would "assure that the so-called 'minor' crops that are so essential to the diet and good health remain abundant on America's tables."

While the NFPA proposal is similar to the administration's 1989 food safety proposal, NFPA would define negligible risk differently.

"The risk level needs to be a flexible level that adjusts itself to technology and science," Cady told BNA.

Key to the administration's proposal is the replacement of the Delaney Clause, Section 409 of FFDCA, which sets a zero-risk standard prohibiting residues of carcinogenic pesticides that concentrate in processed foods. Instead, EPA would use a negligible risk standard for pesticide residues in raw and processed foods defined as a level ranging between 1 in 100,000 and 1 in 1 million chance of dying from cancer from exposure to pesticides over 70 years. EPA currently maintains a policy that a de minimis exception exists to the Delaney Clause allowing for a 1 in 1 million standard for pesticide residues on processed foods (12 CRR 1959, 13 CRR 939).

Focus Should Be On Actual Residue Levels

But Cady promoted a definition of negligible risk that would focus on actual, rather than theoretical residue levels. He said this would develop more realistic risk projections. The definition, however, would not "identify a specific level of risk that would be considered negligible or a numerical expression of that level."

"EPA should be required to calculate dietary exposure on the basis of the percent of raw agricultural commodities or processed food actually treated with a pesticide, and on the basis of the actual residue levels detected in the treated commodities and the processed food produced from those commodities," Cady suggested.

Such a standard would allow EPA to decide case by case which chemicals compromise health, Cady maintained. It also would steer the agency away from use of computer

ASBESTOS

- EPA Rule (1989) Prohibits Manufacture of Asbestos
- DoD/EPA Memorandum of Understanding (MOU) Provides Exemption for Military-Unique Uses
- About 100 Military/Federal Specifications Require Asbestos
- DoD Components Need to Review Specifications

ASBESTOS REPLACEMENT
(C-5 AIRCRAFT)

**C-5B Aircraft Uses Gasket Material
Composed of Aramid/Fiberglass Materials
with a Silicone Coating as a Replacement for
Asbestos-Containing Gasket Material Used on
C-5A.**

Source: SAMPE, Vol. 33, March 1988, p.1065

DOD DEGRADABLE PLASTICS STUDY

- National Defense Authorization Act for 1989 Required DoD to Conduct a Study of its Use of Disposable Plastic Items
- 3,559 Disposable Plastic Items in Supply System, Including Plastic Bags, Utensils, Medical Supplies, Packaging Materials, Etc.
- 771 Items Are Potential Candidates for Degradable Plastics Substitution
- DoD Study Identified Need for Standards

BIODEGRADABLE BAG PURCHASE REQUIREMENT

- **National Defense Authorization Act for 1990-1991 Requires DoD to Purchase Biodegradable Plastic Bags**
- **DoD Reply to Congress States that Standards Are Needed for Testing Degradable Plastics**
- **DoD Participates with ASTM D20.96**
- **Need for DoD and Industry Research on Degradable Plastics**

U.S. ARMY RESEARCH ON BIODEGRADABLE POLYMERS

- **Biological Sciences Division of the U.S. Army Natick Research, Development and Engineering Center (Natick, Mass.)**
- **Food Packaging Applications**
- **Bacterial and Fungal Polysaccharides (Chitosan and Pullulan)**
- **International Treaty for the Prevention of Pollution from Ships (Mandates Navy to Stop Dumping Plastics Waste into the Ocean by 1993)**
- **Research on Test Methods and Materials**
- **\$2.9 Million to Natick RDE in 1991 for Development of Biodegradable Plastics Using Starch-Based Polymer Technology**

EPA INITIATIVE TO PREVENT TOXIC CHEMICAL POLLUTION

Industrial Toxics Project Identifies 17 High Priority Toxic Chemicals

**Benzene, Cadmium, Carbon Tetrachloride, Chloroform,
Chromium, Cyanides, Dichloromethane, Lead, Mercury,
Methyl Ethyl Ketone, Methyl Isobutyl Ketone, Nickel,
Tetrachloroethylene, Toluene, Trichloromethane,
Trichloroethylene, and Xylene(s)**

**STRATEGIC ENVIRONMENTAL RESEARCH
AND DEVELOPMENT PROGRAM**

Public Law 101-510, Nov. 5, 1990

Basic and Applied R & D of Environmental Technologies

Environmental Restoration

Waste Minimization

Hazardous Waste Substitution

Global Change Research

Council

Scientific Advisory Board

\$60 Million for FY91

**OFFICE OF THE DEPUTY ASSISTANT
SECRETARY OF DEFENSE
(ENVIRONMENT)**

**DASD(E) - Mr. Thomas Baca, Pentagon Rm 3D833
(703) 695-7820**

Assistant DASD(E)

**Mr. Russel Milnes
(703) 695-7820**

Director, Environmental Technology Division

**Mr. Richard Kibler
(703) 325-2211**

Director, Environmental Policy Division

**Colonel Ken Cornelius
(703) 325-2211**

SUMMARY

- **DoD Intends to Be the Federal Leader in Environmental Compliance**
- **Environmental Considerations Are Being Integrated into the DoD Acquisition Process**
- **Efforts Are Underway to Revise or Cancel Specifications to Reduce or Eliminate Hazardous Materials and Environmentally Undesirable Materials**



**ADVANCED POLYMER MATRIX COMPOSITE MATERIALS
ENVIRONMENT, HEALTH & SAFETY**

GEORGE HUSMAN

**ENVIRONMENTAL, HEALTH & SAFETY
STEERING COMMITTEE CHAIR**

**SUPPLIERS OF ADVANCED COMPOSITE
MATERIALS ASSOCIATION**

SACMA

DODOT-91

SACMA

INTERNATIONAL MEMBERSHIP *

USA

3M Company
Allied Signal
American Cyanamid
Amoco
Dow Chemical
DuPont
Ethyl
Ferro
Hercules
Hexcel
Owens-Corning
Phillips 66

EUROPE

AKZO
BASF
Bayer
BP
Celanese
Dow
DuPont
Ethyl
Ferro
Hercules
Hexcel
Owens-Corning
Phillips 66

JAPAN

Asahi Kasei
Mitsubishi Rayon
Toyo Rayon
Toyo Industries



* MEMBER PARENT COMPANY HEADQUARTERS COUNTRY

SACMA

DOD02-91

SACMA

SACMA MISSION STATEMENT

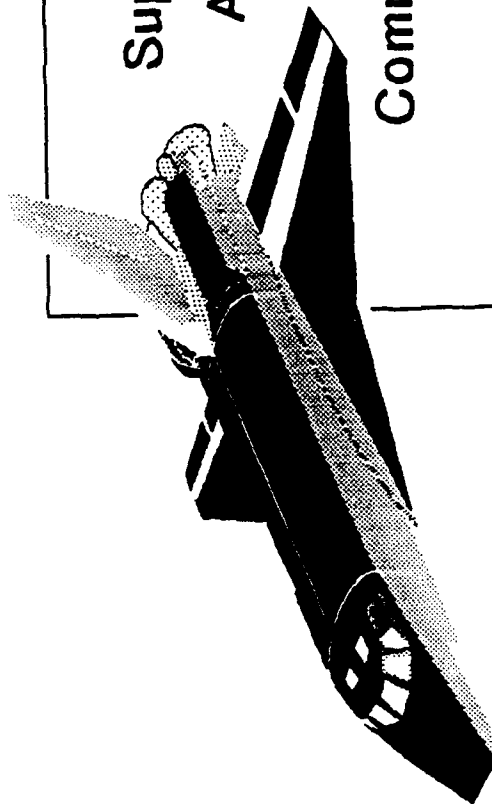

Support Growth of U.S.
Advanced Composites
Industry Based on
Common, Not Competitive,
Interests.

SACMA

SACMA PURPOSES & OBJECTIVES

- Represent industry before government.
- Collect and publish industry statistics.
- Promote use of advanced composite materials.
- Solve common environmental/health/safety problems.
- Develop recommended industry methods & practices.
- Increase public awareness of advanced composites.
- Build industry skill base.

SACMA WORLD GROWTH - ADVANCED COMPOSITES

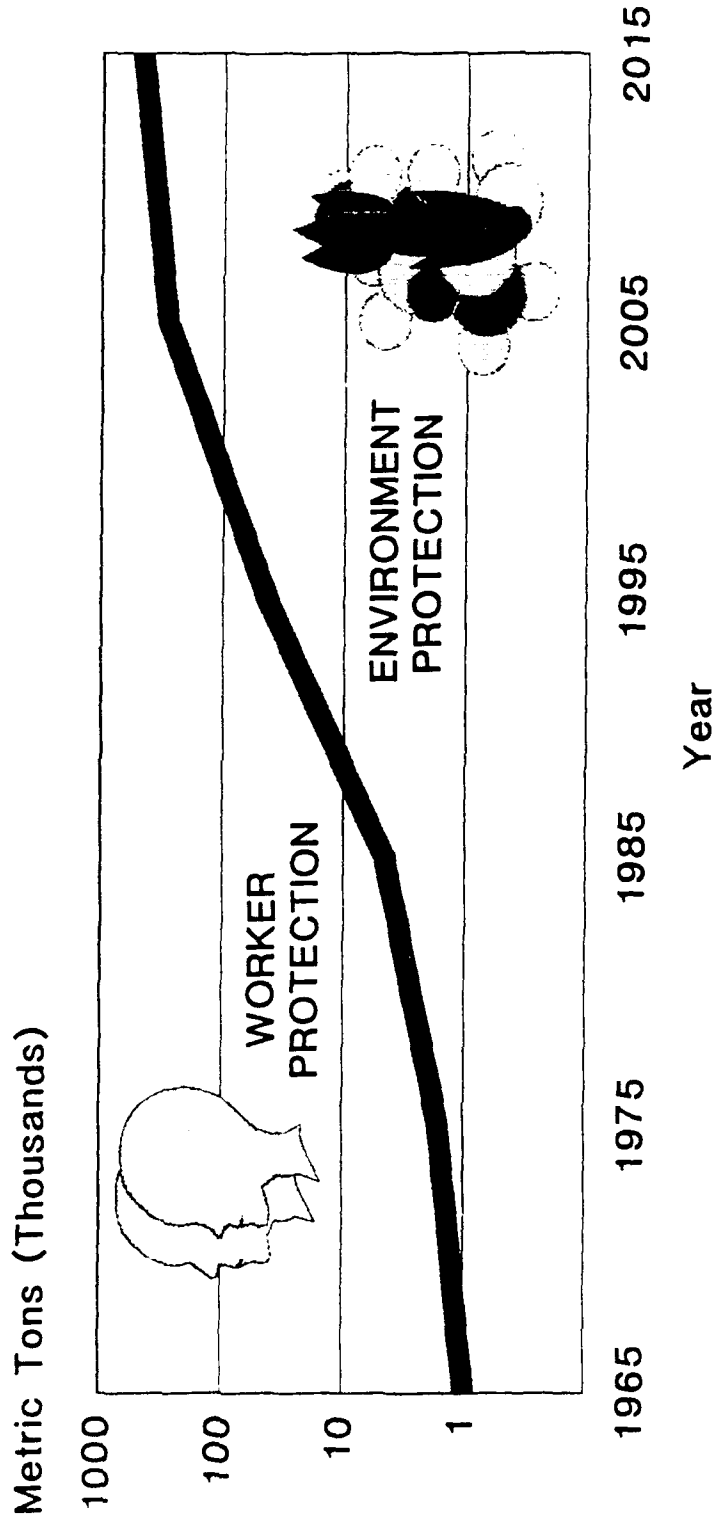

SACMA

COMPOSITES POSE SERIOUS HAZARDS

QUERIES ON COMPOSITES' TOXICITY

SENATE TO PROBE HEALTH RISKS...

Senate Committee on Environment
and Public Works

Subcommittee on Toxic Substances,
Environmental Oversight,
Research and Development

WE CAN NOT TOLERATE STONE-AGE
PROTECTIONS FOR SPACE-AGE DANGERS.

Honorable Harry Reid
United States Senate

Industry ne
disposal of
Problems h
Burbank, C
alleging th
materials b
However, c
claims Zoy
San Leand
One of the
has yet fo
they don't
This may
With the a
thousands
Mr. Luce t
in the me
"First, org
cross-trai
working se
Management
should reve
matrix of t
A company
pleted pro

Industry ne
disposal of
Problems h
Burbank, C
alleging th
materials b
However, c
claims Zoy
San Leand
One of the
has yet fo
they don't
This may
With the a
thousands
Mr. Luce t
in the me
"First, org
cross-trai
working se
Management
should reve
matrix of h
A company
pleted pro

Industry ne
disposal of
Problems h
Burbank, C
alleging th
materials b
However, c
claims Zoy
San Leand
One of the
has yet fo
they don't
This may
With the a
thousands
Mr. Luce t
in the me
"First, org
cross-trai
working se
Management
should reve
matrix of h
A company
pleted pro

SACMA

ADVOCACY

GOVERNMENT

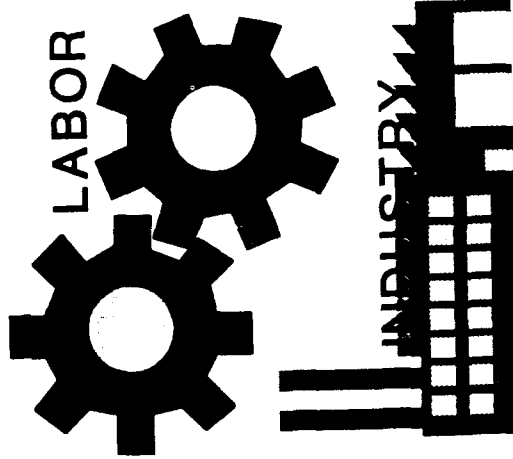

**RESPONSIBLE USE
SAFE HANDLING
ENVIRONMENTAL PROTECTION**

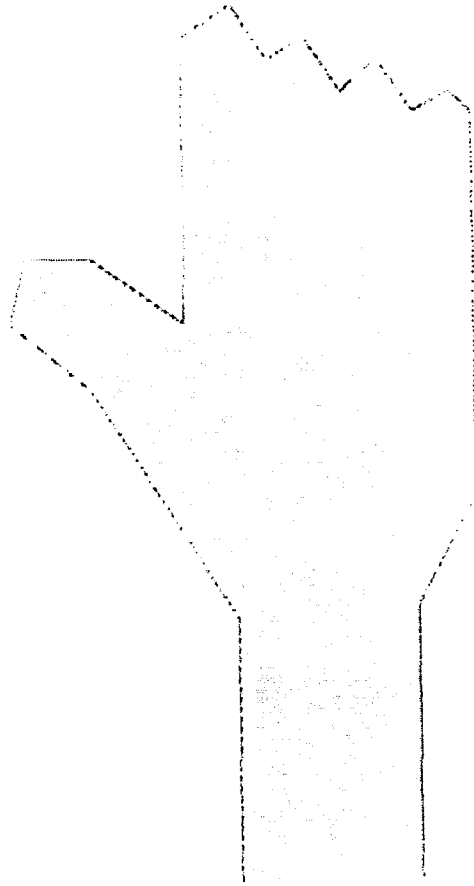

SACMA

SAMPE07-91

SACMA

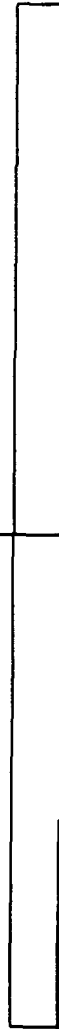

- REGULATORY AFFAIRS
- WASTE MANAGEMENT



- SAFE HANDLING BOOKLET
- WORKER TRAINING
- OSHA MANUAL



- INFORMATION EXCHANGE
- OFF-GASSING/ COMBUSTION PRODUCTS
- COMPOSITE DUST
- NEUROTOXICITY
- CARBON FIBER

SACMA

DOD03-91

SACMA

REGULATORY AFFAIRS TASK FORCE

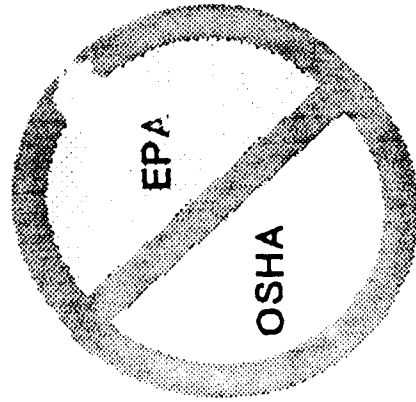

Regulations

REVIEW RULES PROPOSED
BY EPA AND OSHA
TO ASSESS IMPACT ON
ADVANCED COMPOSITE
INDUSTRY AND, WHEN
WARRANTED, PREPARE
COMMENTS ON BEHALF
OF SACMA

SACMA

DOD04-91

SACMA

WASTE MANAGEMENT TASK FORCE

**DEVELOP RECOMMENDED PRACTICE
FOR DISPOSAL OF PREPREG WASTE**

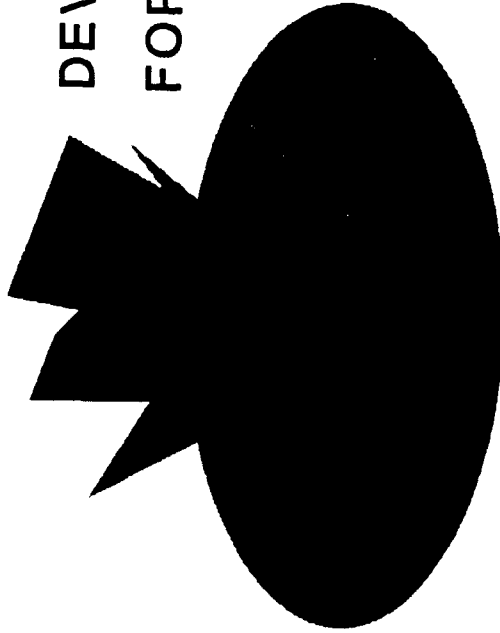

SACMA

4-WM-90



SACMA
SAFE HANDLING OF
ADVANCED COMPOSITE MATERIALS

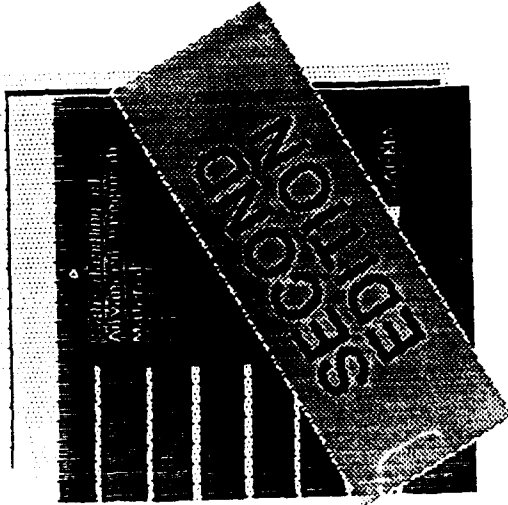

- Introduction
 - Health Information Terminology
 - Industrial Hygiene
 - Health & Safety Hazards Of Processes
- Toxicologic Properties Of Components
 - Bibliography

SACMA

SAVE YOUR SKIN !

VIDEO

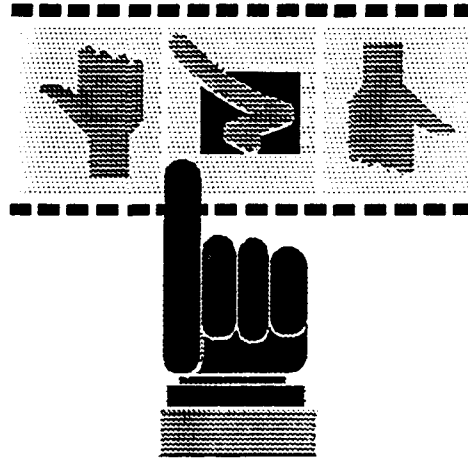

BOOKLET

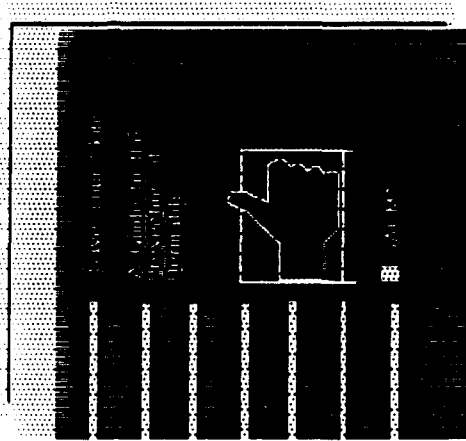

SACMA

SB534-81

SACMA

SACMA - OSHA INTERFACE

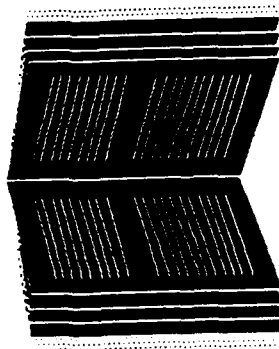

MISSION

To maximize information exchange
between SACMA and OSHA
to identify and minimize
potential risk to worker health
from use of
advanced composite materials.

SACMA

CARBON FIBER TASK FORCE

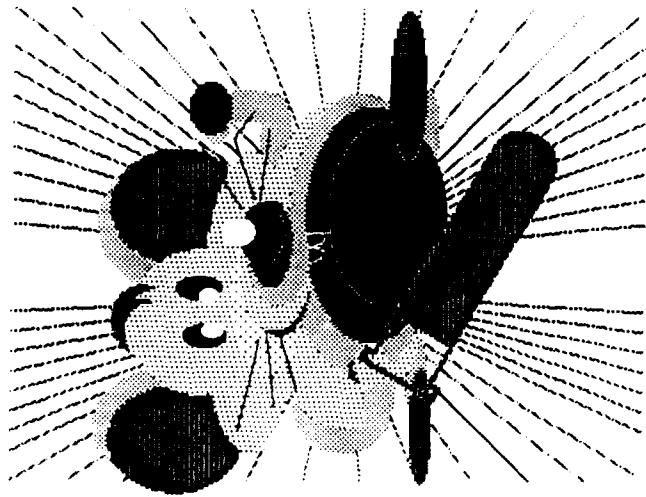

DEVELOP AND ASSESS HEALTH
EFFECTS DATA PERTINENT TO
CARBON FIBER

SACMA

SACMA

SACMA - AIA JOINT WORKING GROUP

- INDUSTRY NETWORKING
- JOINT RESEARCH
- LITERATURE SEARCH
- RESPONSIBLE USE
- TRAINING AIDES

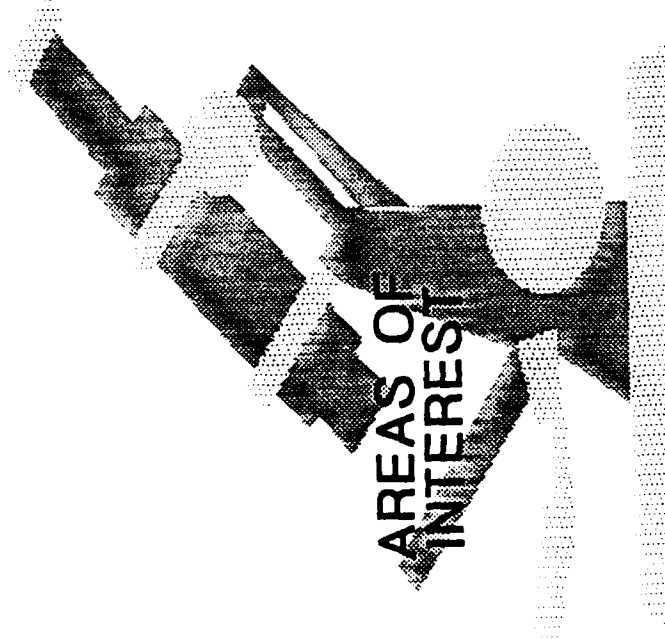

SACMA

INFORMATION EXCHANGE TASK FORCE

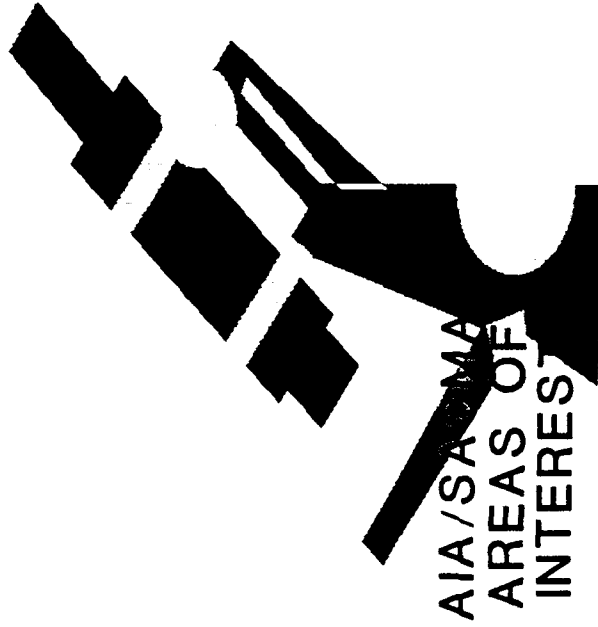

8112

SACMA

DOD06-91



SACMA

JOINT RESEARCH

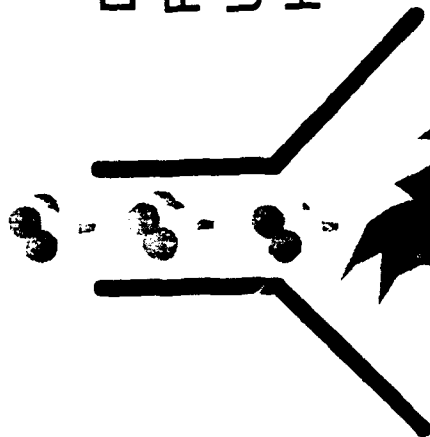

OFF-GAS/SING/
COMBUSTION
PRODUCTS

DEFINE EXPERIMENTAL TEST
PROCEDURES TO PROVIDE
USEFUL DATA TO ASSESS
HEALTH RISKS

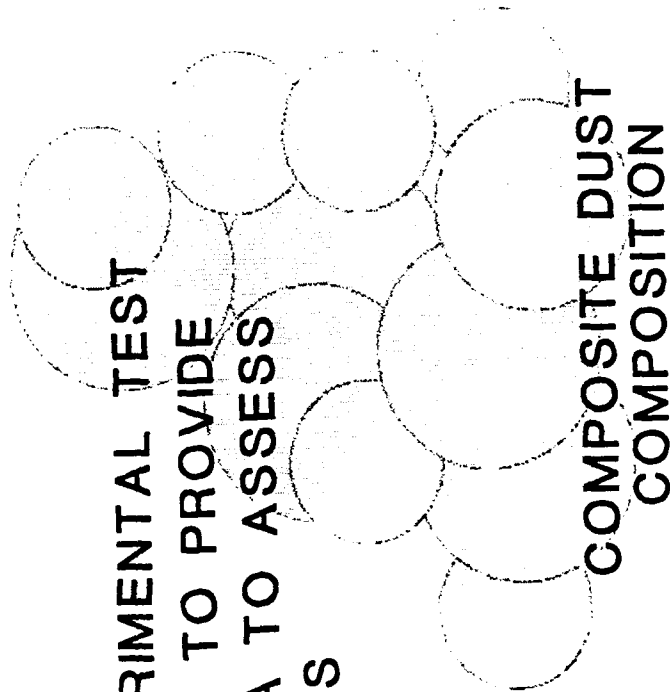

COMPOSITE DUST
COMPOSITION

SACMA

LITERATURE SEARCH



- Neurotoxicological Effects
- Worker Sensitization
- Multiple Chemical Exposures

**REACTIVE
CHEMICALS**

SACMA

SIB527-91

SACMA

RECOMMENDATIONS

- Increase Funding For EPA & Health Research Agencies For Testing In The Following Areas:
 - Neurotoxicological Effects Of Chemical Exposure
 - Worker Sensitization To Low Levels Of Chemical Exposure
 - Combined Hazard Of Multiple Chemicals

SACMA

POLICY AND OBJECTIVES

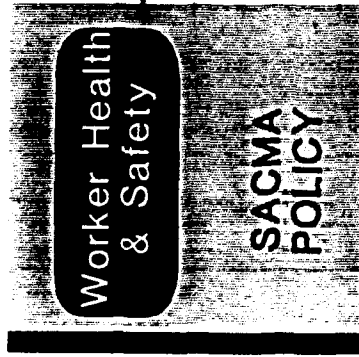

↑

SACMA Is Dedicated To Minimizing Any Risk In Handling Advanced Composite Materials By A Concerted Program Of Research, Education And Communication.

↑

SACMA Is Dedicated To Putting In Place Recommended Guidelines For Proper Management Of Polymer Matrix Composite Waste

SACMA

NATIONAL STRATEGIC PLAN

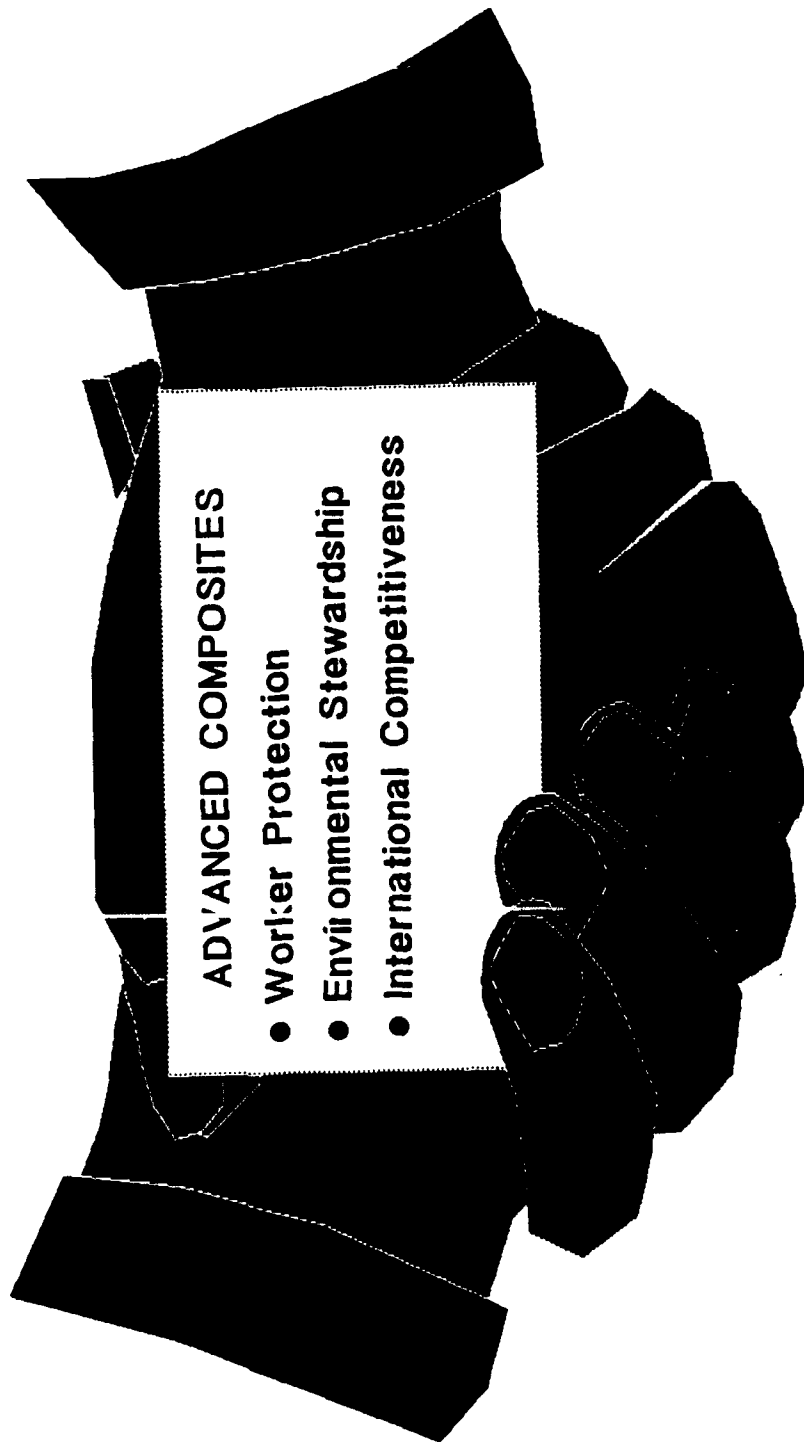

WORKSHOP S-1 - DOD SINGLE STOCK POINT

Chair - Marilyn Stewart-Fridey, Navy Publishing and Printing Service Office, Philadelphia

RECOMMENDATIONS FOR THE DODSSP

- o ADD DISTRIBUTION STATEMENT FIELD TO DODISS.
- o HAVE DODISS, ASSIST, AND SD-4 AVAILABLE ON MAG-TAPE THROUGH A SUBSCRIPTION.
- o UPDATE THE DOD-4120.3-M, SEC-3-903 TO BETTER EXPLAIN HOW TO PREPARE CAMERA READY COPY FOR SCANNING.
- o EXPLORE THE POSSIBILITY OF E-MAIL AS PART OF NPODS ENHANCED.
- o ON-LINE - LOOK-UP TO DLSC DATABASE TO RELEASE DISTRIBUTION STATEMENTS "C" AND "D" DOCUMENTS TO APPROVED CONTRACTORS
- o REVISE DODISS SO ALL PARTS CONTAIN THE SAME INFORMATION.

NAVY PUBLISHING AND PRINTING

SERVICE OFFICE

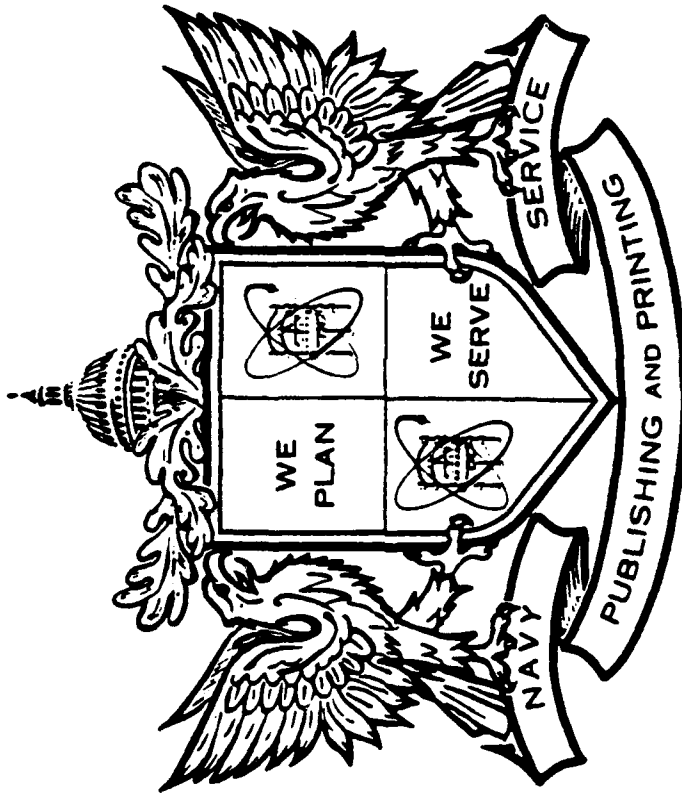

PHILADELPHIA

— NPPS —



WORLDWIDE NPPS FACILITIES

WORKSHOP S-1 DOD SINGLE STOCK POINT (DODSSP)

This workshop will try to develop recommendations on how to improve the process of transmitting and receiving standardization documents from the DOD Single Stock Point (DODSSP) and how to improve the DOD Index of Specifications and Standards.

NPODS

THE NAVY PUBLISHING ON DEMAND SYSTEM

NPODS

- **AUTOMATED COMPUTER AND PRINT SYSTEM**
 - **DATABASE MANAGEMENT**
 - **STORAGE**
 - **OUTPUT**
- **USES OPTICAL DISK BASED TECHNOLOGY**
- **HIGH SPEED LASER PRINTER OUTPUT**

BACKGROUND

NEED

- **SHELF STORAGE**
 - **MANUAL PROCESS**
 - **LABOR INTENSIVE AND TIME CONSUMING**
 - **OUT OF STOCK SITUATIONS**
- **REDUCED COMPETITION**
- **COSTLY**

BACKGROUND

SOLUTION

- 1979 BASELINE STUDY
- 1982-3 CONGRESSIONAL AND OSD APPROVAL
- 1984 FUNDING APPROVED THROUGH NPPS
- 1986 CONTRACT AWARD
- 1987 SYSTEM OPERATIONAL
- 1989 DATABASE COMPLETE

BENEFITS

- **QUICKER TURNAROUND**
- **COST SAVINGS**
- **INCREASED COMPETITION**
- **SYSTEM INTEGRITY**
- **SPACE SAVINGS**

STATUS

- STEADY STATE ENVIRONMENT
- OVER 600,000 PAGES IN DATABASE
- OVER 43,000 FAMILIES
- ORDERS ENTERED ONE DAY, PRINTED AND MAILED THE NEXT DAY

FUTURE

NPODS ENHANCED

- **MAKE SYSTEM CALS COMPLIANT**
 - **SGML TAGGED ASCII**
- **BULLETIN BOARD**
- **AUTOMATICALLY CAPTURES MOST ASSIST INFORMATION**
- **AUTOMATED AUXILIARY SYSTEM**

**DEPARTMENT OF DEFENSE
SINGLE STOCK POINT
(DODSSP)
FOR
STANDARDIZATION DOCUMENTS**

NAVY PUBLISHING AND PRINTING SERVICE OFFICE,

PHILADELPHIA

DoD SINGLE STOCK POINT FOR SPECIFICATIONS AND STANDARDS

- Based on Supply Corps 2010 study Naval Supply Systems Command initiated consolidation study of the Naval Publications and Forms Center (NPFC).
- Purpose - to merge similar functions.
- Decision to transfer functions associated with fully functional Print-On-Demand applications to the Navy Publishing and Printing Service.
- Transfer of the DODSSP effected 23 September 1990.

ACCOMPLISHMENTS

- Revised and published: *A Guide for Private Industry, How to Obtain Specifications and Standards from the DOD Single Stock Point.*
- Established a Contract with ASTM to print on demand ASTM documents that are adopted by DoD.
- Established an agreement with AIA to print on demand AIA documents that are adopted by DoD.
- Customer address data base purged of duplicate addresses. Approximately 20,000 addresses deleted.
- System modified to generate a letter informing Non-DoD customers where to obtain Non-Government Standards. The association's name and address is furnished.
- Automatic release of Distribution Statement "A" Documents to foreign requestors.
- Reestablished the "DID Set" as a product.

DoD Single Stock Point

TOPICS OF DISCUSSION

- 1. Distribution Statements**
- 2. Subscriptions**
- 3. Copy Quality**
- 4. Proposed restructuring of Department of Defense Index of Specifications and Standards (DODISS)**
- 5. Print Order Form 5604/4**
- 6. Non-Government Standards**

MIL-X-XXXXX Requires "release approval".
Submit your request via the preparing activity of the
document:

STANDARDS DIVISION

ASD/ENES

WRIGHT-PATTERSON AFB, OH 45433-6503

PROPOSAL:

Release all documents that have
distribution statements of "C" or "D" to all
contractors that appear on the Defense
Electronic Supply Center (DESC) listing of
approved contractors.

**NO RELEASE APPROVAL REQUIRED FROM THE
PREPARING ACTIVITY**

CONCERNS:

**Are documents marked with the proper
distribution statement?**

Do all preparing activities want this?

DODISS MASTER FILE TAPE:

Cost \$2,000.00, per year or \$500.00 per tape

ASSIST TAPE:

Cost \$3,000.00 per year or \$700.00 per tape

(DID) SETS:

Cost \$400.00 per set

Complete DID sets will be issued 4 times a year. Orders will be accepted up to 15 days prior to the distribution date.

Cut-off Date

1 July
1 October
1 January
1 April

Distribution Date

15 July
15 October
15 January
15 April

**AREA "SDMP" - STANDARDIZATION AND DATA
MANAGEMENT PROGRAMS**

Includes:

DOD4120.3-M

SD-1- STANDARDIZATION DIRECTORY

SD-2- NONDEVELOPMENTAL ITEM PROGRAM

SD-3- Personnel Participating in NATO Standardization , A Guide for DOD

SD-4- Status of Standardization Projects

SD-5- Locating of the shelf items

SD-6- Provisions Governing Qualification (Qualified Products List)

SD-7- An overview of the DOD Parts Control Program

**SD-8- An overview of the Defense Standardization and Specification
Program (DSSP)**

SD-9- DOD interaction with non-government Standards Bodies

SD-10- Guide for Identification and Development of Metric Standards

Address your request in letter form to:

**DODSSP
SUBSCRIPTION SERVICES DESK
700 ROBBINS AVE.
BLDG. 4-D
PHILADELPHIA, PA 19111-5094**

**List your desired FSC or AREA
Call (215) 697-2569 for current price.**

**Enclose \$16.00 per FSC or AREA
(current price MAY '91)**

PROPOSAL:

**Review DOD Requirements every year
Develop an Abridged Version of DODISS**

CONCERNS:

What data fields are needed?

SCANNING PROCESS

Acceptable copy is forwarded for Scanning, pagination, and enhancement (darkening)

1. Page counts and distribution codes are reviewed.
2. Documents are scanned- 300 dot matrix.
3. Scanned images are transmitted to Mag disk storage and compressed.
4. Images are then written to a 12" optical platter.
5. A "QA" copy is retrieved from the NPODS and reviewed
6. Documents that pass this QA have their status changed to optical.
7. Once on optical, orders can be filled electronically.
8. Superseded revisions, amendments, notices, etc. become historical documents.

Quality of Initial Documents

Majority of documents received are of sufficiently good quality to scan.

But, some problems do persist:

- The print is gray in color (didn't use new ribbon)
- Dot Matrix printer used (individual characters break up)
- Contrasting type-faces on same page- Bold, Demi faces used with light and Italic faces.
- Quality of print changes within a document (good pages- bad pages) Scanners need consistency.
- Xeroxed copies of DD 1426's are being sent in, instead of sending original copy.
- Some P.A.'s send in xeroxed copies instead of originals.
- Original copies are stapled and/or folded.
- Original copies may be damaged in mail- not packaged correctly.

Recommendations to improve quality and processing time:

- Check your copy for quality before sending it to DODSSP (The NPODS scanner can only distinguish black and white and not shades of gray).
- If possible use a laser printer, they produce a better quality print.
- Use protective materials and proper containers when shipping initial documents to the DODSSP.
- Do not staple and/or fold documents.
- Use a fresh mylar ribbon when preparing an original document.
- Use 8-1/2" x 11" plain white bond paper.
- Use proper margins (heads trim edges uniform).
- Use original copy of DD 1426's.

Re-Structured DODISS

1. Revise DODISS so that all parts contain the same information
 - a. Add validation, user, reviewer information to Part 1 Alpha and Part 2 Numeric listings
 - b. Add new or change indicators to the Alpha and FSC listings
 - c. Number the FSC listing as Part 3 and the Numeric Appendix of Cancelled Documents as Part 4
 - d. Revise the introductions so they address that Index only

Print Order Form NPPSO 5604/4 (Rev 11-90)
(Do not xerox this form - order from NPPSO Phila. 4-part NCR)

The following must be completed
SECTION 1

- Document Number (Include revision letter or number)
- Document Date
- Originating Office
- Date of Order
- Total Pages (Include blank pages)
- Type of Action- "X" the appropriate box
- If cancellation block is marked "DO NOT COMPLETE THE REST OF THE FORM."

- **Coordination**
 - **Is qualification required?**
 - **Are DID's cited in section 6?**
 - **Commercial product, Process practice, etc.**
 - **Measurement system**
 - **Does document contain fixed allowable levels of defects**
 - **Multi-National Standardization Agreement**
 - **Does document specify hazardous materials etc.?**
- (the chemical name of the substance(s) shall be included as the keyword)**

Optional (Section 1 cont'd)

- **Order No. (local use)- Some preparing activities will put in the project No.**
- **Return Original Copy (complete address) if you want your copy back**
- **Remarks - Can be used for special distribution or POC of the document (include phone #)**

Section 2

- **Will be completed by the DODSSP**

Commercial customers ordering non-government documents are now being informed by letter of the address where they may obtain the document.

Explain DODISS indexing of documents

Explain NPODS indexing of documents

Explain NPODS conversion going on

WORKSHOP S-2 - COORDINATION OF DOCUMENTS

Chair - Paul Tremblay, Army Armament Research, Development and Engineering Center

1991 STANDARDIZATION & DATA / CONFIGURATION MANAGEMENT CONFERENCE

WORKSHOP S-2 COORDINATION OF DOCUMENTS PAUL TREMBLAY

The following is provided in summary of conclusions and recommendations derived from Workshop S-2:

A. Utilization should be made of advance notification of intent to initiate a revision project.
Rationale: A letter to DoD and Industry interested parties could provide insight as to problem areas or needed changes therefore saving time in comment resolution.

B. Provide for an automated coordination and comment submission process.
Rationale: In this manner drafts could be available "on-line" on a bulletin board type basis, and comments would be accessible as an electronic file manageable by various software.

C. Utilize form letter or postcard notification of existence of a draft available for comment.
Rationale: This would help in avoiding coordination with activities having "no interest".

D. Announce draft availability through DODISS NOTICE or CBD.
Rationale: Same as benefit derived from "C" above.

E. Regarding amendment or revision projects, make margin annotations or summary of changes sheet mandatory.
Rationale. The option of providing no margin annotations because of extensiveness of changes is being abused and reviewer needs a ready summary of changes to facilitate review and composition of a timely reply.

F. Consideration should be given to forming a Process Action Team for reviewing coordination process and realizing needed changes.
Rationale: Much of the coordination process is nearly regarded as an institution, and making changes will be difficult.

) G. Make mandatory the providing to the LSA project conclusion detail, e.g., date of new revision and supersession data. Do so through use of DD Form 1585, Project Conclusion.
Rationale: This would facilitate task of LSA in keeping current with condition of documents within his assigned FSC.

WORKSHOP S-3 PROGRAM PLANS

Chair - Frank T. Traceski, Office of the Assistant Secretary of Defense for Production and Logistics,
Industrial Engineering and Quality Directorate

SUMMARY OF WORKSHOP S-3 - PROGRAM PLANS

SUMMARY.

The S-3 Workshop on Standardization Program Plans addressed the DoD policy delineated in DoD 4120.3-M, Defense Standardization Manual, Change 6, dated 13 September 1988. The following topics were discussed:

- (1) Purpose
- (2) Responsibilities
- (3) Scheduling
- (4) Coordination
- (5) Authorization/Authentication
- (6) Content
- (7) Other Considerations
- (8) Format
- (9) Elements (such as nondevelopmental items, hazardous materials, international standardization, nongovernment standards, commercial item descriptions, etc.)

No major OSD policy changes were recommended. The workshop participants concluded that there was enough flexibility in the policy to allow for timely execution by the Lead Standardization Activities (LSAs).

RECOMMENDATIONS.

The following problem areas were identified for improvement:

(1) Resources - It was recommended that authorities controlling resources make a commitment to implementing standardization program plans. In some cases, this requires support from the technical directors.

(2) Authorization - A higher level of priority is needed for some plans to effect implementation.

(3) Content - There is a need to improve feedback to program planners through more effective coordination and communication with program offices and users.

(4) Other Considerations - DMR survey data should be made available to LSAs and preparing activities for program planning purposes.

LSAs are responsible for (1) through (3).
Item (4) is a DASD(PR) action item.

WORKSHOP S-4 - STANDARDIZATION DIRECTORY, SD-1

Chair - Lee Nilo, Naval Sea Systems Command

SUMMARY

WORKSHOP S-4 - STANDARDIZATION DIRECTORY, SD-1

THE WORKSHOP ATTENDEES WERE FAVORABLY DISPOSED TO THE CURRENT HARDCOPY DOCUMENT, FINDING IT USER-FRIENDLY, BUT SLOW-GOING. DURING THE GENERAL DISCUSSION OF THE SD-1 AND ITS CONTENTS, A NUMBER OF POSITIVE SUGGESTIONS FOR READABILITY IMPROVEMENT AND RELEVANCY WERE MADE. FROM AMONG THESE, KEY ISSUES CHOSEN FOR FOLLOW-UP INCLUDE: (1) STANDARDIZE THE ADDRESSEE FORMAT SO THAT INTERESTS ARE IMMEDIATELY CLEAR, FOREGOING PARENTHETICAL INFORMATION. PROVIDE FULL ADDRESSES/PHONE NUMBERS FOR EACH CONTACT WITHIN AN ORGANIZATION. (2) DELETE THE DOCUMENT REQUIREMENTS TABLE/"DOCUMENT CODES" FROM PART 2. CAP AT ONE HARDCOPY AND ONE ELECTRONIC VERSION OF DRAFT DOCUMENTS WITHIN FSGs/FSCs/AREAs LISTED WITH EACH ADDRESS. (3) ADD FSGs/FSCs/AREAs OF INTEREST TO LISTED NONGOVERNMENT STANDARDS BODIES. (4) COMPARE DISTRIBUTION LISTS FOR "SD-1" AND "SDMP" FOR DUPLICATION. (5) IDENTIFY, VERIFY AND LIST LSA AND PARTICIPATING ACTIVITIES FOR THOSE FSG's THAT CONTAIN DOCUMENTS. (6) REQUEST THAT "USER" ACTIVITIES BE DELETED FROM THE FSC DODISS AND "REVIEWER" SPACE EXPANDED. (7) REDUCE FRONTMATTER TO ESSENTIALS, SUCH AS THE PURPOSE AND SCOPE.

ATTENDEES OVERWHELMINGLY RECOMMENDED AUTOMATION IN THE NEAR TERM TO GREATLY IMPROVE THE USEABILITY OF THE STANDARDIZATION DIRECTORY. INCORPORATION INTO THE "ASSIST" DATABASE WILL ENABLE THE READER TO MANIPULATE THE DATA TO PRODUCE DISTRIBUTION LISTS FOR REVIEW COORDINATION OF DRAFT DOCUMENTS, SORTS BY STANDARDIZATION ASSIGNMENTS, FSG/FSC/AREA, ORGANIZATIONS, ETC. AND READILY LOCATE APPROPRIATE POINTS OF CONTACT. THE SD-1 SHOULD BE MADE AVAILABLE FOR DISTRIBUTION IN ASCII, AS WELL AS HARDCOPY, UNTIL INCORPORATED INTO ASSIST.

WORKSHOP S-5 - OVERAGE DOCUMENT REVIEW PROCESS

Chair - Scott Kuhnen, Air Force Systems Command, Aeronautical Systems Division

Standardization Workshop S-5 Overage Document Review Process

This workshop was well attended and the attendees were largely "participants" rather than just witnesses. After an examination of various opinions/problems within this part of the standardization program, the participants began to brainstorm new ideas. This was a healthy give-and-take process which often found itself broadening the scope of the workshop agenda from "overage document review" into the philosophy/strategy of document maintenance as a whole. Workshop participants quickly acknowledged that looking at only one piece of the document maintenance process in isolation does not necessarily lead to solutions that truly add value and quality to the whole program. Because of this, many ideas surfaced which were not accompanied by recommendations. Nonetheless, the following ideas and recommendations are offered:

IDEA #1: Maintenance of standardization documents *is* necessary. However, flexibility in respect to both "time" and "action required" would be beneficial. That is, preparing activities should have latitude to use a variety of mechanisms (revision, amendment, inactive for new design, validation, etc.) on a timetable "tailored" specifically for that document/FSC/technology area, not just every five years. Participants recognize that some documents should be on a fast track — while some others could be on a slow track.

RECOMMENDATION #1: Build flexible timetables into the clock which controls/triggers the overage document review process. Rather than "fixed" time to take action, *i.e.*, five years, develop policy which allows documents to be fitted into "windows of time." For example, fast track documents would get from two to five years to be updated before LSAs would need to take action, while slower track documents might get five to ten years before action is required. This judgement call to be made by the document's preparing activity.

IDEA #2: The extent of the overage document problem is unknown. Put another way, many participants are unsure about the percentage or number of documents which are actually overage. This uncertainty is compounded by the widespread impression that less-than-honest validations are taking place merely to get off the overage document list distributed by the DoD Single Stock Point (DoDSSP).

RECOMMENDATION #2: If the numbers exist, provide them to the entire standardization community. If the statistics do not exist, survey the community to gather them.

IDEA #3: Use "Sunset Clauses." Rather than putting documents into the system, thus giving them life and assuming responsibility for their maintenance practically *ad infinitum*, preparing activities could issue documents which are given specific dates when they will reach the end of existence. Then, if no action to revise or validate that document is taken, it could

automatically and painlessly pass out of the system. This "automatic" passing out of the system could be handled without coordination or involvement by LSAs, but rather by the DoDSSP.

RECOMMENDATION #3: In the area concerning *Identification of military specifications/standards* (see paragraph 5.2.3 of MIL-STD-961 and paragraph 5.3.2 of MIL-STD-962), a recommendation was made to include the date of the next review/revision to that document. The suggester envisions something like this:

MIL-HDBK-1553A
1 November 1988
SUPERSEDING
MIL-HDBK-1553
9 November 1984
Next Review / Revision
November 1992

This idea is appealing because it alerts all users of this document when changes are needed in order to impact the next change action. Section 6 of a specification could explain when the review cycle was intended to start and finish, thus acting to solicit comments/suggestions in time to make the next review/revision. This practice also instills "commitment" on the part of the preparing activity and advertises that commitment to users. It is a pro-active statement that, rather than having a document "floating free" in the system, we have control of a process which assures and demonstrates our commitment to quality documents through a quality process.

IDEA #4: Don't forget GSA! More than one workshop participant pointed out that the General Services Administration (GSA) administers a large body of documents, also. In some cases, there are relationships between DoD documents, especially within DLA, and GSA documents. Similar procedures and policies should be used in terms of document maintenance.

RECOMMENDATION #4: Increased communication and coordination of documentation policy between DoD and GSA is recommended. This should include GSA's involvement in future strategic planning, including the creation of automated tools.

IDEA #5: Eliminate validation notices completely. The mere existence of a mechanism which allows preparing activities to almost effortlessly keep documents from appearing on the only quality checklist which is institutionalized into our process biases the system to validate rather than go through more arduous processes to assure currency. There is a line of thought which says that documents should either be technically updated or pass out of the system entirely.

RECOMMENDATION #5: Although this idea is appealing to owners of "development" documents, documents which must stay up-to-date in order to be effective, it is not especially relevant to owners of long-term reprourement documents. However, by combining several of the ideas here presented, a combination strategy falls out which might well serve our needs. That is, allow validation notices, but only one. After one occurrence of a validation notice, require the next action to be a technical revision, including amendment, notice, inactive for new design, etc. The preparing activity could place a sunset clause on the document which allows for one validation notice. Then, if no technical update takes place within a certain time frame after that validation notice is issued, the document would automatically pass out of the system.

IDEA #6: Regardless what changes are made, they should not add to the amount of paperwork, administrative burden, and bureaucracy we already face. Automated tools should enhance the process, not just make a faulty process faster. If validation is determined necessary, standard forms should be used. Also, the validation process itself should involve actions which truly add value. An example given was accomplishment of an ASSIST search to determine what documents reference that particular document or are referenced by that document. Such information should lead to examination of whole families of documents concurrently to determine if changes are necessary, rather than treating all documents sequentially: this document this year, that document next year, and another document in a couple of years.

RECOMMENDATION #6: All these ideas should be preserved and explored further. Given the global failure of other mechanisms to effectively reduce the shear size and magnitude of the documents in the DoDISS, this might be a helpful strategy in the standardization program of the future.

FINAL IDEA: We are confronted with a very large problem. Too large for an afternoon workshop; and much more than just a problem with overage documents.

FINAL RECOMMENDATION: Charter a Process Action Team (PAT) to examine the existing processes, make recommendations, and develop tools which improve the entire process. Let the participants in this conference, including the many persons who were interested in attending but could not get in because of the limited availability, be the resource upon which we draw the talent to form the team. Involve the Data Community, Configuration Community, Standardization Community, and an automation group well-versed in standardization documentation/coordination processes to develop recommendations which serve the total acquisition-documentation system, cradle-to-grave.

Interested in being involved? Contact Mr Stephen Lowell, OASD(P&L)MMD, 5203 Leesburg Pike, Suite 1403, Falls Church, VA 22041-3466, (703)756-2340 or AV289-2340.

**1991 JOINT DOD STANDARDIZATION AND DATA
CONFIGURATION MANAGEMENT CONFERENCE**

WORKSHOP S-5

“OVERAGE DOCUMENT REVIEW PROCESS”

**Referee: Scott Kuhnen
ASD/ENES**

OVERAGE DOCUMENT REVIEW

“The Overage Document Review is a systematic evaluation of all standardization documents to ensure their currency and necessity. Active documents listed in the DODISS are classified as overage if they have become 5 years old, or older, during the last FY and if they have not been amended, revised, or validated during the last 5 years preceding 1 October. Each review performed on a standardization document should result in one of the following actions:

- a. Validation of the document
- b. Establishment of a revision or amendment project to update the document
- c. Issuance of a notice to inactivate the document for new design
- d. Cancellation of the document.”

WHAT IS THE PROBLEM?

Is it over age or overage or over-age?

Dictionary shows it as: over·age

WHAT IS THE SOLUTION?

Is it work shop or workshop or work-shop?

Dictionary shows it as: work·shop

“3: a usu. brief intensive educational program for a relatively small group in a given field that emphasizes participation in problem-solving efforts

WHO CONTROLS THE OVERAGE DOCUMENT REVIEW PROCESS?

“3-1106 OVERAGE DOCUMENT NOTIFICATION

The DoDSSP shall mail a machine listing (in triplicate) of overage documents and one copy of each document to appropriate preparing activities as recorded in Part 2 of the SD-1 so as to be received by 15 December of each year.”

3-1107 ACTION REQUIRED OF PREPARING ACTIVITIES

blah blah blah

3-1108 ACTION REQUIRED OF ASSIGNEE/LEAD SERVICE ACTIVITIES

blah blah blah

Preparing Activity (PA)

3-1107 ACTION REQUIRED OF PREPARING ACTIVITIES

“Upon receipt each year of the listing from the DoDSSP (see 3-1106), the preparing activities will review their documents in accordance with the following:

- a. Limited coordination documents blah blah blah
- b. Coordinated documents blah blah blah
- c. Reporting:

By 15 June each year, preparing activities will send one copy of the machine listing of coverage documents to the appropriate DepSO annotated to reflect cancellation, validation, or requirements for amendment or revision(see 2-502). In addition, the preparing activity will furnish an annotated listing to the appropriate Assignee Activities to assist them in updating annual Program Analyses and the overall FYDSSP.”

Lead Standardization Activity (LSA)

3-1108 ACTION REQUIRED OF THE ASSIGNEE/LEAD SERVICE ACTIVITIES

“..shall unilaterally initiate a project, and prepare and coordinate a cancellation notice for each standardization document which has become six years old or older, if it has not been amended, revised, or validated during the last six years and for which an active project to revise, amend, or cancel has not been initiated. As a result of coordination, the LSA shall approve and publish the cancellation notice if no objection has been received; assign the project to revise the document to any activity indicating that it has the need for the document as well as the resources to complete the project in a timely manner; or issue a notice masking the document inactive for new design of the results of the coordination so indicate.”

Lead Standardization Activity (LSA)

3-1108 FINAL DISPOSITION BY LSA

“The LSA shall not permit any standardization document to remain active if it has not been revised, amended, or validated during the preceding nine years.”

WHAT IS THE PROBLEM?

“The Overage Document Review Process:

- is not working
- appears not to be working
- never will work
- all of the above

NO, REALLY. WHAT IS THE PROBLEM?

“Current policy allows the preparing activity to unilaterally validate an overage document without requiring a project number or coordination. Some activities believe that this leaves the custodians and the review and user activities out of the process, and allows the validation of technically incorrect and inadequate documents. It becomes a question of whether to require outside review of validations or trust the preparing activity to do what is technically correct.”

OASD (P&L) SPD, Ltr dated 5 Mar 91

NO, REALLY. WHAT IS THE PROBLEM?

“There is also some displeasure with the Lead Standardization Activity (LSA) having the authority to cancel an overage document for which the preparing activity has not taken appropriate action to update, cancel, or validate after 6 years. However, some LSAs believe such authority is needed to force preparing activities to conduct an overage document review.”

OASD (P&L) SPD, Ltr dated 5 Mar 91

NO, REALLY. WHAT IS THE PROBLEM?

“Another issue is whether the 5 year time frame is correct. While nearly every private sector standards organization has a 5 year validation cycle, some people believe it should be longer, others shorter, and others think it should vary according to the Federal Supply Class.”

OASD (P&L) SPD, Ltr dated 5 Mar 91

OVERAGE DOCUMENT REVIEW

“The Overage Document Review is a systematic evaluation of all standardization documents to ensure their currency and necessity. Active documents listed in the DODISS are classified as overage if they have become 5 years old, or older, during the last FY and if they have not been amended, revised, or validated during the last 5 years preceding 1 October. Each review performed on a standardization document should result in one of the following actions:

- a. Validation of the document
- b. Establishment of a revision or amendment project to update the document
- c. Issuance of a notice to inactivate the document for new design
- d. Cancellation of the document.”

WHAT DO SOME OTHERS THINK?

“Specifications should be considered for cancellation or inactivation if no purchases have been made during the last five years;

“A standardized ODR form should be adopted;

“Documents to be reviewed should be accompanied by an ASSIST ‘Ref-list’ report citing the status of first tier references;

“We also recommend using ‘Ref-by’ reports showing where the documents are used during the review.”

NAVAIR, FAX dated 10 Apr 91

WHAT DO SOME OTHERS THINK?

“Recommended comments on Change 3 of Section II:

Para 3-1106: Rewrite para in its entirety

Reason: Change in policy; DoDSSP was requested by OASD (P&L) to furnish preparing activities a listing of their overaged documents bi-monthly in lieu of an annual distribution;

Para 3-1108: Rewrite para to reflect authority for cancelling documents

Reason: Lead Standardization Activities (LSAs) should not be tasked with the authority and responsibility for coordinating...Resources are not available to LSAs for conducting this added workload. Example: Natick (GL) is LSA for 78 FSCs covering thousands of other PA's documents”

“Service and Agency DepSOs should be the only authority to have unilateral document cancellation responsibility.

STRNC-AED, Ltr dated 5 Apr 91

WHAT DO SOME OTHERS THINK?

“Please discuss:

Maintenance of overaged documents that have either an interim amendment or revision in effect;

Setting a maximum time limit on the cancellation of standardization documents that are replaced by another document. Suggest that replaced documents be cancelled within one year from the date of the approved or adopted replacement document;

Please contact GSA! Federal documents prepared by GSA should be maintained the same as DoD--prepared standardization documents.”

STRNC-AED, Ltr dated 5 Apr 91

Date

Desktop / doc. name

hit escape, hold shift & press #3 on first page

WHAT DO SOME OTHERS THINK?

“The Defense Construction Supply Center Activity (CS) would like to see the Overage Document Notification listing, DoD 4120.3-M, paragraph 3-1106, mailed as required regularly.”

“Does DoD 4120.3-M, paragraph 3-1109, apply to General Services Administration (GSA) documents? A large number of GSA controlled documents are overage.”

DCSC-SSM, Ltr dated 29 Mar 91

WHAT DO SOME OTHERS THINK?

“..mention the importance of notifying GSA when a Federal Product Description (FPD) has been validated by a DoD activity... We have seen instances where DoD activities have validated FPDs and not notified GSA, and we feel that this is a deficiency in the system.”

“We might also discuss revising procedures in the DoD 4120.3-M to require coordination, or in the least notification to GSA, when an FPD is validated.”

GSA/FSS, FAX dated 30 Apr 91

WHAT DO SOME OTHERS THINK?

“Observation: In many cases, the review is incomplete and the document validated in order to remove it from the overage listing. This is understandable with reduced personnel and increased workload experienced by many preparing activities. However, it does not assure the DoD a battery of viable documents...

Recommendation: Policy change be made to require assignment of project numbers for validation notices. As a minimum, the Lead Standardization Activity (LSA) and procuring activity should have coordination interest in the proposed action. Also recommend that no documents be continually validated if the last action date (basic, revision, or amendment) is more than twenty years old.”

DGSC-SSM, Ltr dated 02 Apr 91

WHAT DO SOME OTHERS THINK?

“Para 3-1107a.3 of DoD 4120.3-M currently states that a limited coordinated document may be cancelled (without coordination) and that the LSA be notified by DD Form 1865 when the action is forwarded to the DoDSSP. This represents a potential problem to the procuring activity who might be in the acquisition process of replacing depleted stock. There could possibly be other services using the item who have registered themselves in the DoDISS.

Recommendation: Policy be changed to require coordination with the LSA and procuring activity as is mentioned in paragraph 3-1107b.3 for cancellation of coordinated documents.”

DGSC-SSM, Ltr dated 02 Apr 91

WHAT DO SOME OTHERS THINK?

“The ‘Overage Document Review Process’ has been reviewed by this activity (MI). Since no problems have been encountered with the present process, we feel it is adequate for our needs and no changes are required.”

AMSMI-RD-SE-TD-ST, Ltr dated 1 Apr 91

WHO CONTROLS THE OVERAGE DOCUMENT REVIEW PROCESS?



DoDSSP
“notify”



Preparing Activity
“take action”



Lead Standardization Activity (LSA)

“If action taken, do nothing”
If no action taken, kill the document!”

I Say Again...

**WHO CONTROLS THE OVERAGE
DOCUMENT REVIEW PROCESS?**

DoDSSP

“automated, mechanical, no brainer”

Preparing Activity

“running out of people, barely keeping up,
need to be responsive to local management,
not some automated, date-driven
administrative function”

Lead Standardization Activity (LSA)

“see above notation concerning Preparing Activity”

WHAT CAN WE DO?

“Essentially, we are open to any suggestion that does not eliminate the overage document review process. Recommendations should also ensure that any validation process does the intended job of ensuring a technically current document and giving users some visible sign that the document has been validated.”

WHAT CAN WE DO?

MAKE RECOMMENDATIONS!

RECOMMENDATIONS

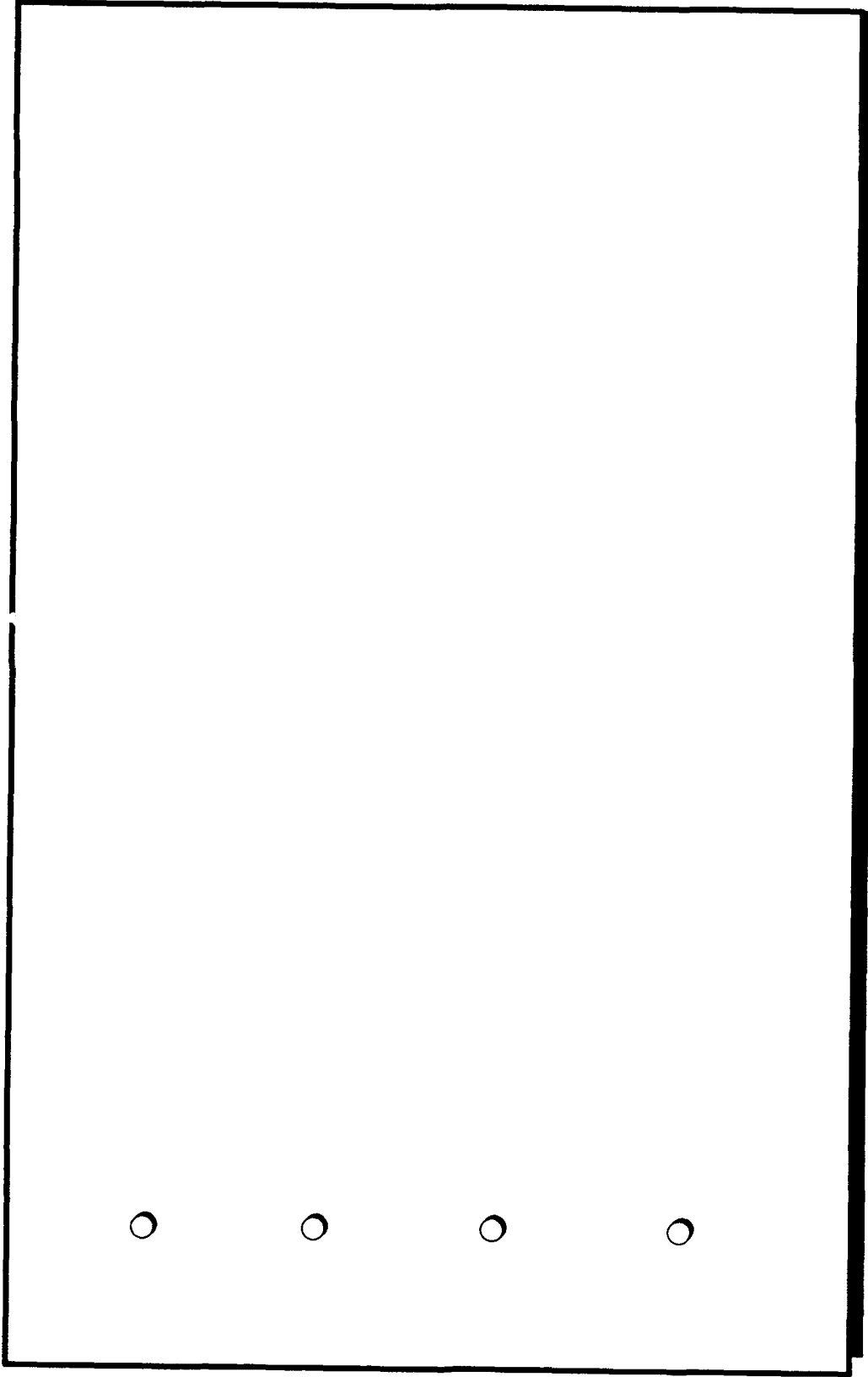

WORKSHOP S-6 ITEM REDUCTION

Chair - Willis Drake, Defense Logistics Agency

ITEM REDUCTION (S-6) WORKSHOP SUMMARY

1. There were 42 attendees that participated in the Item Reduction Workshop. The attendees represented the Army, Navy, Air Force, GSA, HQ DLA, DLA Defense Supply Centers, and DLA Systems Automation Center (DSAC). Attached is a list of the workshop attendees.

2. The workshop agenda focused discussion on the following four topics:

- a. Management of Standardization Relationship Families.
- b. Continuity of DoD I&S and Standardization Policy.
- c. Overview of the Cancellation and Reduction Team (CART) Efforts.
- d. Future Actions Concerning Item Reduction Studies.

3. The major problem or concern expressed by the attendees was the length of time it takes the Military Services to complete the coordination of an Item Reduction Study (IRS). The time the Services are taking to complete the IRS coordination process exceeds by far the timeframes stated in the Defense Standardization Manual (DoD 4120.3-M).

4. The following four issues and the proposed recommendations also generated a considerable amount of discussion. These recommendations will be acted on accordingly.

a. ISSUE: The IRSs are not being coordinated within the timeframes identified in DoD 4120.3-M.

RECOMMENDATION: Coordinate up-front (prior to conducting an IRS) the criteria for conducting an IRS, i.e., material, size, reliability, etc.

b. ISSUE: The establishment of a standardization relationship will not automatically result in that relationship being established as a DoD I&S Family Group.

RECOMMENDATION: Enforce the I&S policy, through procedures or systemic process, which will require that standardization relationships (coordinated during an IRS) will result in the establishment of DoD I&S Family Groups in the Defense Logistics Information System (DLIS).

c. ISSUE: IRSs are not being conducted in some Federal Supply Classes (lack of resources).

RECOMMENDATION: The Defense Supply Centers (DLA) should negotiate with the Military Services and the Standardization Program Division of the Manufacturing Modernization Directorate (OASD(P&L)MMD/SD) to obtain standardization responsibility for those FSCs. DLA will now manage a greater percentage of the items after the Consumable Item Transfer, where the potential for item reduction exists.

d. ISSUE: Currently, the system will allow NSNs in a standardization relationship to have different item managers.

RECOMMENDATION: Establish, coordinate and publish standardization policy that will prevent NSNs in an Item Standardization Relationship (ISC 1/3 or B/E) from having a different item manager.

1 Atch

ITEM REDUCTION

(S-6)

WORKSHOP

WILLIS L. DRAKE
DLA-S
16 MAY 1991

ITEM REDUCTION (S-6) WORKSHOP OVERVIEW

- WELCOME REMARKS AND INTRODUCTIONS
- MANAGEMENT OF STANDARDIZATION RELATIONSHIP FAMILIES
- CONTINUITY OF DOD I&S AND STANDARDIZATION POLICY
- OVERVIEW OF CANCELLATION AND REDUCTION TEAM (CART) EFFORTS
- FUTURE ACTIONS CONCERNING ITEM REDUCTION STUDIES

ITEM REDUCTION (S-6) WORKSHOP

WELCOME AND INTRODUCTIONS

- WELCOME AND OPENING REMARKS
 - FORMAT FOR CONDUCTING THE WORKSHOP
 - RECORDING OF DISCUSSION TOPICS
 - METHOD FOR PROVIDING FEEDBACK

- INTRODUCTIONS
 - NAME
 - ORGANIZATION (SERVICE/AGENCY/CENTER)
 - FUNCTIONAL AREA

ITEM REDUCTION (S-6) WORKSHOP

MGT OF STDZN RELATIONSHIP FAMILIES

- CURRENT POLICY WILL ALLOW MIXED MANAGEMENT FOR STANDARDIZATION RELATIONSHIPS
 - DISADVANTAGES
 - STOCK MANAGED DIFFERENTLY
 - LACK OF FAMILY VISIBILITY BY ITEM MANAGERS
 - IT TAKES LONGER AND IS MORE COMPLEX TO ESTABLISH A DOD I&S FAMILY
 - CONSIDERATIONS
 - APPLY DOD POLICIES/PROCEDURES DURING IRS COORDINATION (SAME MANAGERS, FSCs, U/I)
 - IDENTIFY/RECORD ORDER OF USE DURING IRS COORDINATION PROCESS

ITEM REDUCTION (S-6) WORKSHOP

CONTINUITY OF DOD I&S AND STDZN POLICIES

- CONCURRENTLY ESTABLISH AN I&S FAMILY WHEN A STANDARDIZATION RELATIONSHIP IS ESTABLISHED
- EDIT/VALIDATION CRITERIA - ?
 - POLICY
 - PROCEDURAL
 - SYSTEMIC

ITEM REDUCTION (S-6) WORKSHOP

STDZN DECISIONS CONVERTED TO I&S FAMILIES

- DISCUSSION:
 - MILITARY SERVICES MAY NOT BE AUTOMATICALLY CREATING DOD I&S FAMILIES RESULTING FROM STANDARDIZATION RELATIONSHIPS COORDINATED DURING ITEM REDUCTION STUDIES

- ISSUE:
 - DLAR 4140.66, ELIMINATION OF DUPLICATION IN THE MGT & LOGISTICS SUPPORT OF I&S ITEMS
 - PARAGRAPH 4-3 (COLLABORATION)
 - PARAGRAPH 4-10 (ITEM STANDARDIZATION)

ITEM REDUCTION (S-6) WORKSHOP OVERVIEW OF CART EFFORTS

- ESTABLISHMENT - SEP 90
- PARTICIPANTS - MILITARY SERVICES
(ARMY, NAVY, AIR FORCE,
MARINE CORPS)
- DLA HQ, SUPPLY CENTERS
(DCSC, DESC, DGSC, DISC),
DLSC AND DSAC
- GOALS
- OPPORTUNITIES
- SPECIAL ISC 3/E PROJECT
- RECOMMENDATIONS

ITEM REDUCTION (S-6) WORKSHOP DISCUSSION

- CART GOALS:
 - REDUCE TIMEFRAME ISC 3/E ITEMS REMAIN IN THE SUPPLY SYSTEM
 - PREVENT PROCUREMENT OF VALID ISC 3/E ITEMS
 - EFFECT TIMELY CANCELLATION OF ISC 3/E ITEMS WITHOUT STOCK ON HAND

ITEM REDUCTION (S-6) WORKSHOP DISCUSSION

- THE CART LOOKED AT OPPORTUNITIES TO:
 - REDUCE THE DOD INVENTORY
 - ATTRITE STOCK ON NONSTANDARD ITEMS
 - ELIMINATE UNNEEDED NSNs FROM THE FEDERAL CATALOG SYSTEM
 - CANCEL NONSTANDARD NSNs WITHOUT STOCK ON HAND

ITEM REDUCTION (S-6) WORKSHOP DISCUSSION

- THE CART CONDUCTED A SPECIAL PROJECT TO:
 - IDENTIFY NONSTANDARD NSNs WITH NO STOCK ON HAND
 - APPROXIMATELY 95,000 NSNs ARE IN THIS CATEGORY
 - GENERATE THE APPROPRIATE CANCEL-USE TRANSACTIONS FOR NSNs WITH ONLY U.S. RECORDED USERS

ITEM REDUCTION (S-6) WORKSHOP DISCUSSION

- COLLABORATE WITH NATO COUNTRIES FOR CANCEL-USE ACTIONS
- APPROXIMATELY HALF OF THE 95,000 NSNS ARE IN THIS CATEGORY
- CHANGE NIIN STATUS CODE TO '1' FOR NSNS WITH "NATO INTEREST ONLY"

**ITEM REDUCTION (S-6) WORKSHOP
ISC 3/E POPULATION**

	<u>STOCK ON HAND</u>	<u>NO STOCK ON HAND</u>
ARMY	1,501	1,685
NAVY	5,176	6,202
AIR FORCE	10,460	18,071
MARINE CORPS	12	27
DLA	81,955	68,187
TOTAL	99,104	94,172

ITEM REDUCTION (S-6) WORKSHOP CONCLUSION

- CART RECOMMENDATIONS:
 - AUTOMATE THE CANCEL-USE PROCESS FOR NONSTANDARD (ISC 3/E) NSNs WITH NO STOCK ON HAND
 - AUTOMATE THE PROCESS TO CHANGE THE NIIN STATUS CODE TO "1" FOR NATO-INTEREST-ONLY NSNs
- CONDUCT AN ANNUAL REVIEW OF NONSTANDARD (ISC 3/E) NSNs TO:
 - PREVENT PROCUREMENT OF VALID ISC 3/E NSNs
 - PREVENT NONSTANDARD NSNs FROM REMAINING IN THE SYSTEM SO LONG (10-20 YEARS)

1991 JOINT DOD STANDARDIZATION AND DATA/CONFIGURATION MANAGEMENT CONFERENCE

SUMMARY OF RECOMMENDATIONS

Workshop I - Configuration Management

Chair - Fred C. Lewis

Co-Chair - Linda J. Berry

1. Add a section of Engineering Change Proposal (ECP) Short Form into MIL-HDBK-61
2. Rework Configuration Status Accounting (CSA) section in MIL-STD-973
3. Develop figures to illustrate CSA
4. Definition of Nondevelopmental Item (NDI) consistent with DODD 5000.1 and 5000.2
5. Continue work efforts with the DoD Provisioning Policy Group

The products developed as a result of the above tasks will be reviewed by the Configuration Management Advisory Group (CMAG). The final results of this review will be incorporated into MIL-STD-973 and MIL-HDBK-61. The work efforts of the attendees will enhance the top level CM standard and companion handbook.

Workshop II - MIL-HDBK-TDP

Chair - Roland Henderson

The workshop gave special consideration to the possibility of including guidance for the application and tailoring of MIL-STD-100, **Engineering Drawing Practices**, in the handbook. The consensus was that a separate handbook should be developed for that guidance.

Actions Required:

1. The workshop chair, Roland Henderson, will forward the above recommendations to the preparing activity for MIL-STD-100 and the Drawing Practices Advisory Group for action.
2. The handbook will be distributed through SD-1 coordination channels for identification of additional topics, subheadings, and recommended text before formal coordination of a draft.

Workshop III - CM/DM Contractor Certification

Chair - Jim Whisenant

Co-Chair - Carol A. Sitroon

1. Certification should be administered at the DoD level and not by individual services or agencies.
2. Certification can be for both disciplines (CM/DM) together or separately.
3. Certification teams must not include industry representatives.
4. Development of the certification review teams, contents of data required and evaluation/negotiating must be a consolidated effort between DoD and industry.
5. Length of certification period should be a minimum of 5 years and a maximum of 10 years.
6. Industry must include methods or techniques to measure and indicate continuous level of quality.
7. Establish an appeal process and criteria comprised of government and industry members.
8. Weighting, pass/fail grading criteria should be in a stand-alone document, e.g., handbook, versus in the standard.
9. Certification renewal should be based on performance and quality indications.
10. Determine need for different levels of certification with industry.
11. Utilize the CM check list in MIL-STD-973 as basis for certification criteria.
12. Participation in the certification program should be voluntary with no special considerations given for being certified. Should not be used for or included as a requirement.
13. Certification should be of the CM/DM processes as a discipline, not people oriented or contract driven.

The consensus of the group was for DoD and industry to actively pursue implementation of the CM/DM Contractor Certification Program. This program embraces the concept of acquisition, streamlining, total quality management, the Defense Management Review, MIL-STD-973, DOD-STD-1700 and produces cost savings in terms of data which can be re-allocated for additional hardware/software products.

Workshop S-1 - DoD Single Stock Point

Chair - Marilyn Stewart-Fridey

1. Add distribution statement field to the DODISS.
2. Have DODISS, ASSIST, and SD-4 available on magnetic tape through a subscription.
3. Update DoD 4120.3M to better explain how to prepare camera ready copy for scanning.
4. Explore the possibility of E-Mail as part of NPODS enhanced.
5. On-line look-up to DLSC database to release distribution statements "C" and "D" documents to approved contractors.
6. Revise DODISS so all parts contain the same information.

Workshop S-2 - Coordination of Documents

Chair - Paul Tremblay

1. Utilization should be made of advance notification of intent to initiate a revision project.
2. Provide for an automated coordination and comment submission process.
3. Utilize form letter or postcard notification of existence of a draft available for comment.
4. Announce draft availability through DODISS NOTICE or CBD.
5. Regarding amendment or revision projects, make margin annotations or summary of changes sheets mandatory.
6. Consideration should be given to forming a Process Action Team for reviewing coordination process and realizing needed changes.
7. Make mandatory the providing to the LSA project conclusion detail, e.g., date of new revision and supersession data. Do so through the use of DD Form 1585, Project Conclusion. This would facilitate task of LSA in keeping current with condition of documents within his assigned FSC.

Workshop S-3 - Program Plans

Chair: Frank Traceski

1. Make a commitment to implementing standardization program plans. In some cases, this requires support from the technical directors.
2. Consider a higher level of priority for some plans to effect implementation.
3. To improve feedback to program planners through more effective coordination and communication with program offices and users.
4. Make DMR survey data available to LSAs and preparing activities for program planning purposes.

Workshop S-4 - Standardization Directory, SD-1

Chair: Lee Nilo

1. Standardize the addressee format so that interests are immediately clear, foregoing parenthetical information. Provide full addresses/phone numbers for each contact within an organization.
2. Delete the document requirements table/"document codes" from Part 2. Cap at one hardcopy and one electronic version of draft documents within FSGs/FSCs/AREAS listed with each address.
3. Add FSGs/FSCs/AREASs of interest to listed nongovernment standards bodies.
4. Compare distribution lists for "SD-1" and "SDMP" for duplication.
5. Identify, verify and list LSA and participating activities for those FSG's that contain documents.
6. Request that "user" activities be deleted from the FSC DODISS and "Reviewer" space expanded.
7. Reduce front matter to essentials, such as the purpose and scope.

Workshop S-5 - Overage Document Review Process

Chair: Scott Kuhnen

Idea 1 - Maintenance of standardization documents is necessary. However, flexibility in respect to both "time" and "action required" would be beneficial. That is, preparing activities should have latitude to use a variety of mechanisms (revision, amendment, inactive for new design, validation, etc.) on a timetable "tailored" specifically for that document/FSC/technology area, not just every five years. Participants recognize that some documents should be on a fast track -- while others could be on a slow track.

Recommendation 1 - Build flexible timetables into the clock which controls/triggers the overage document review process. Rather than "fixed" time to take action, i.e., five years, develop policy which allows documents to be fitted into "windows of time." For example, fast track documents would get from two to five years to be updated before LSAs would need to take action, while slower track documents might get five to ten years before action is required. This judgement call to be made by the document's preparing activity.

Idea 2 - The extent of the overage document problem is unknown. Put another way, many participants are unsure about the percentage or number of documents which are actually overage. This uncertainty is compounded by the widespread impression that less-than-honest validations are taking place merely to get off the overage document list distributed by the DoD Single Stock point (DoDSSP).

Recommendation 2 - If the numbers exist, provide them to the entire standardization community. If the statistics do not exist, survey the community to gather them.

Idea 3 - Use "Sunset Clauses." Rather than putting documents into the system, thus giving them life and assuming responsibility for their maintenance practically ad infinitum, preparing activities could issue documents which are given specific dates when they will go out of existence. Then, if no action to revise or validate that document is taken, it could automatically and painlessly pass out of the system. This "automatic" passing out of the system could be handled without coordination or involvement by LSAs, but rather by the DoDSSP.

Recommendation - 3 In the area concerning identification of military specifications/standards (see paragraph 5.2.3 of MIL-STD-961 and paragraph 5.3.2 of MIL-STD-962), a recommendation was made to include the date of the next review/revision to that document. The suggestor envisions something like this:

MIL-HDBK-1552A
1 November 1988
SUPERCEDING
MIL-HDBK-1553
9 November 1984
Next Review/Revision
November 1992

This idea is appealing because it alerts all users of this document when changes are needed in order to impact the next change action. Section 6 of a specification could explain when the review cycle was intended to start and finish, thus acting to solicit comments/suggestions in time to make the next review/revision. This practice also instills "commitment" on the part of the preparing activity and advertises that commitment to users. It is a pro-active statement that, rather than having a document "floating free" in the system, we have control of a process which assures and demonstrates our commitment to quality documents through a quality process.

Idea - 4 Don't forget GSA! More than one workshop participant pointed out that the General Services Administration (GSA) also administers a large body of documents. In some cases, there are relationships between DoD documents, especially within DLA, and GSA documents. Similar procedures and policies should be used in terms of document maintenance.

Recommendation - 4 Increased communication and coordination of documentation policy between DoD and GSA is recommended. This should include GSA's involvement in future strategic planning, including the creating of automated tools.

Idea - 5 Eliminate validation notices completely. The mere existence of a mechanism which allows preparing activities to almost effortlessly keep documents from appearing on the only quality checklist which is institutionalized into our process biases the system to validate rather than go through more arduous processes to assure currency. There is a line of thought which says that documents should either be technically updated or pass out of the system entirely.

Recommendation - 5 Although this idea is appealing to owners of "development" documents, documents which must stay up-to-date in order to be effective, it is not especially relevant to owners of long-term procurement documents. However, by combining several of the ideas presented, a combination strategy falls out which might well serve our needs. That is, allow validation notices, but only one. After one occurrence of a validation notice, require the next action to be a technical revision, including amendment, notice, inactive for new design, etc. The preparing activity could place a sunset clause on the document which allows for one validation notice. Then, if no technical update takes place within a certain time frame after that validation notice is issued, the document would automatically pass out of the system.

Idea - 6 Regardless what changes are made, they should not add to the amount of paperwork, administrative burden, and bureaucracy we already face. Automated tools should enhance the process, not just make a faulty process faster. If validation is determined necessary, standard forms should be used. Also, the validation process itself should involve actions which truly add value. An example given was accomplishment of an ASSIST search to determine what documents reference that particular document or are referenced by that document. Such information should lead to examination of whole families of documents concurrently to determine if changes are necessary, rather than treating all documents sequentially: this document this year, that document next year, and another document in a couple of years.

Recommendation - 6 All these ideas should be preserved and explored further. Given the global failure of other mechanisms to effectively reduce the shear size and magnitude of the documents in the DODISS, this might be a helpful strategy in the standardization program of the future.

Final Idea - We are confronted with a very large problem. Too large for an afternoon workshop, and much more than just a problem with overage documents.

Final Recommendation - Charter a Process Action Team (PAT) to examine the existing processes, make recommendations, and develop tools which improve the entire process. Let the participants in this conference, including the many persons who were interested in attending but could not get in because of the limited availability, be the resource upon which we draw the talent to form the team. Involve the Data Community, Configuration Community, Standardization Community, and an automation group well-versed in standardization documentation/coordination processes to develop recommendations which serve the total acquisition-documentation system, cradle-to-grave.

Workshop S-6 Item Reduction

Chair: Willis Drake

Issue: Item Reduction Studies (IRS) are not being coordinated within the time frames identified in DoD 4120.3-M.

Recommendation: Coordinate up-front (prior to conducting an IRS) the criteria for conducting an IRS, i.e., material, size, reliability, etc.

Issue: The establishment of a standardization relationship will not automatically result in that relationship being established as a DOD Interchangeability and Substitutability (I&S) Family Group.

Recommendation: Enforce the I&S policy, through procedures or systematic process, which will require that standardization relationships (coordinated during an IRS) will result in the establishment of DoD I&S Family Groups in the Defense Logistics Information System (DLIS).

Issue: IRS are not being conducted in some Federal Supply Classes (lack of resources).

Recommendation: The Defense Supply Centers (DLA) should negotiate with the Military Services and the Standardization Program Division, Manufacturing Modernization Directorate, to obtain standardization responsibility for those FSCs. DLA will now manage a greater percentage of the items after the Consumable Item Transfer, where the potential for item reduction exists.

Issue: Currently, the system will allow NSNs in a standardization relationship to have different item managers.

Recommendation: Establish, coordinate, and publish standardization policy that will prevent NSNs in an Item Standardization Relationship (ISC 1/3 or B/E) from having a different item manager.

CEREMONY - PRESENTATION OF THE AMERICAN DEFENSE PREPAREDNESS ASSOCIATION (ADPA) AWARDS

On May 15, 1991, Mr. John Hart, Chairman, Technical Documentation Division, ADPA, presented the Robert H. Stearns Awards for outstanding achievement to two conference attendees-- Mr. Roland G. Henderson, Office of the Assistant Secretary of Defense for Production and Logistics, Technical Data and Manufacturing Division; and Mr. Richard A. Barta, Federal Service Division Manager of Standards, IBM. The Stearns Award has been awarded since 1963 to honor Mr. Stearns (deceased) and as a vehicle to recognize those who have demonstrated outstanding qualities in the following attributes:

- o Devotion to the field of documentation and meaningful achievement therein
- o Vigorous and articulate in establishing and logically supporting a position
- o Energetic with singleness of purpose
- o Patriotic, honorable, pleasant, humble, sincere



Mr. Roland G. Henderson is pictured receiving the Stearns award from Mr. John Hart, Chairman, Technical Documentation Division, ADPA, for his outstanding career work in the field of Engineering Documentation.



Mr. Richard "Dick" Barta is pictured receiving the Stearns award from Mr. John Hart, Chairman, Technical Documentation Division, ADPA, for his outstanding career work in the field of Engineering Documentation. Both Mr. Barta and Mr. Henderson (pictured in top photo) collectively have 53 years of involvement in the fields of standardization and technical documentation work.

CONFERENCE ATTENDEES

MICHAEL P ABEL
OCEAN & RADAR SYSTEMS DIVISION
GENERAL ELECTRIC
P.O. BOX 4640
ELECTRONIC PARK BLDG. 5, ROOM F-5
SYRACUSE, NY 13221

DANIE ABSHER
ASD/ENC
WPAFB, OH 45433

DAVID Y ALLEN
VME LABORATORIES INC.
1418 UPFIELD DRIVE
CARROLLTON, TX 75006

ROBERT L ALLISON
OFFICE OF ACQUISITION
ASON-GA-PD
BLDG. 133
FORT RITCHIE, MD 21719-5010

THOMAS J ALTOBELLI
US ARMY TANK-AUTOMOTIVE COMMAND
AMSTA-6000
WARREN, MI 48397-5000

MICKEY ANDER
NAVSEA SYSTEMS COMMAND
SEA 441031
NIO RM. 10E42
WASHINGTON, DC 20362-5101

HATTIE T ANDERSON
JOHNS HOPKINS UNIV. APPLIED PHYSICS LABORATORY
MACIS (MGT. & CONTRACTS INFO. SERVICE)
JOHNS HOPKINS RD, BLDG. 14, RM. 814M
LAUREL, MD 20723-6099

JAMES L ANDERSON
US POSTAL SERVICE
PROGRAM MANAGER CONFIGURATION MANAGER
475 L'ENFANT PLAZA, SW
RM 6631
WASHINGTON, DC 20260-7312

GENNIS L ANDERSON
AFIC-CASC
SPECIFICATION & STANDARDS PROGRAM OFFICE
74 N. WASHINGTON AVE
BATTLE CREEK, MI 49017-3094

MARIANNE M ANDRES
GENERAL DYNAMICS
DATA MANAGEMENT
C2-8720
P.O. BOX 85990
SAN DIEGO, CA 92186-5990

JAMES ARCHIBALD
US ARMY AVIATION SYSTEMS COMMAND
AMSAV-MEC
4300 GOODFELLOW BLVD,
BLDG. 3
ST. LOUIS, MO 63120-1798

DARRELL F ARD
E-SYSTEM INC.
GARLAND DIVISION
4-56000
P.O. BOX 660023
DALLAS, TX 75266-0023

CONFERENCE ATTENDEES

IRIS C ARECCHI
US AIR FORCE, 18540CISS/END
1854 COMMAND
CONTROL & INTELLIGENCE SUPPORT SQUADRON
HICKAM AFB, HI 96853

VERNON C BALL
SPACE SYSTEMS DIVISION (SSD)
SSD/SDMS
LOS ANGELES AFB, CA 90009-2960

BORIS A ARRATIA
NOMURA ENTERPRISE INC.
2632 5TH STREET
FOCI ISLAND, IL 61201

THOMAS BALLENTINE
OASD (P&L) MMD
5203 LEESBURG PIKE
SUITE 1403
FALLS CHURCH, VA 22041-3466

HERBERT L ATRINS
ADPA
19253 DUNBRIDGE WAY
GAITHERSBURG, MD 20879-2909

MICHAEL A BANCALE
THE ANALYTIC SCIENCES CORP.
2555 UNIVERSITY BLVD.
FAIRBORN, OH 4524

GARY L AVERETT
ASST. SEC. OF THE NAVY (RD&L)
AF1A74F
WASHINGTON, DC 20350-1000

MICHAEL D BANCROFT
JOHN J. McMULLEN ASSOCIATES
2341 JEFFERSON DAVIS HWY.
SUITE 715
ARLINGTON, VA 22202

KATHLEEN S BADEN
GSA - FEDERAL SUPPLY SERVICE
ISS-FOFE
1941 JEFFERSON DAVIS HWY
DM-4, RM. 522
WASHINGTON, DC 20406

RUTH D BARR
NAVAL WEAPONS CENTER
CODE 3652
BLDG 02466, ROOM 1601
CHINA LAKE, CA 93555

JAY C BADEY
NAVAL AIR SYSTEMS COMMAND
1411 JEFFERSON DAVIS HWY
ARLINGTON, VA 20261

RICHARD R BARTA
IBM, FEDERAL SECTOR DIVISION
MD 0006
RT 17C
1024
OWEGO, NY 13827

CONFERENCE ATTENDEES

KLAUS J BARTHEL
NAVAL SEA LOGISTICS CENTER
5450 CARLISLE PIKE
BLDG. 307
MECHANICSBURG, PA 17055-0795

PAULINE M BAUMGARTNER
HARRY DIAMOND LABORATORIES
SLEMD-TS-6
2800 FOWDER MILL ROAD
ADELPHI, MD 20783-1197

ELONA BEANS
ARMSTRONG LABORATORY (AL), DET 1/TIP
BLDG. 29, ROOM 302
WPAFB, OH 45433-6573

RAYMOND J BECKINGHAM
MCDONNELL DOUGLASS CORP.
BLDG. 530, MAIL STOP B325
5000 E. MCDOWELL
MESA, AZ 85205

RICHARD L BEECHEY
DEFENSE LOGISTIC AGENCY
DESC-EPE
1507 WILMINGTON PIKE
DAYTON, OH 45444

ROBERT V BEERMANN
US ARMY ARDEC
SMCAF-BAC-5
BUILDING 6
PICATINNY ARSENAL, NJ 07806-5000

PAUL BEHRENS
US ARMY AVIATION SYSTEMS COMMAD
4300 GOODFELLOW BLVD.
BLDG. 3
ST. LOUIS, MO 63120-1798

SUSAN P BELFLOWER
WR-ALC/FMRCC
WARNER ROBBINS AFB, GA 31098-5609

RONALD H BERLACK
LOCKEED SANDERS
NHQ4-0180
P.O. BOX 865
NASHUA, NH 03061-0868

CARL L BERRY
TECHNICAL DATA AND MANUFACTURING DIVISION
5203 LEESBURG PIKE
SUITE 1403
FALLS CHURCH, VA 22041-3466

LINDA J BERRY
SPAWAR
003-221
NATIONAL CENTER ONE
ROOM 12W12
WASHINGTON, DC 20363

GEO D BIACH
DoD-ENGINEERING DATA REPRODUCTION SYSTEMS
SMA CODE 16
HQ AFLE/MDDB
BLDG. 262, POST 119R
WPAFB, OH 45433-5001

CONFERENCE ATTENDEES

STEVEN D BIGELOW
HQ SPACE SYSTEMS DIVISION (SSD)/CWIC
P.O. BOX 92960
LOS ANGELES AIR FORCE BASE
LOS ANGELES, CA 90009-2960

LULLIE B BOWERS
SRA CORPORATION
550 N. CONTINENTAL BLVD.
SUITE 190
EL SEGLUNDO, CA 90245

ELIZABETH A BLANTON
ASD/RWCC
WPAFB, OH 45433-6503

MARCIA A BOYNTON
FORT BELVOIR RD&E CENTER
STRBE-TSQ
BLDG. 1445, RM. 94
FORT BELVOIR, VA 22060-5606

RICHARD D BLEAU
HQ ESD/AL
HANSCOM AFB
HANSCOM AFB, MA 01731

RICHARD L BRAWLEY
DEFENSE FUEL SUPPLY CENTER
DFSC-WSS
CAMERON STATION RM 8C214
ALEXANDRIA, VA 22305-6160

FRANK L BOALS
NAVAL MEDICAL LOGISTICS COMMAND
CODE 3
BLDG. 830, FORT DETRICK
FEDERICK, MD 21702-5015

MARY E BRICKERD
HARRY DIAMOND LABORATORIES
SLCHD-TS-SC
2800 POWDER MILL ROAD
BLDG. 202, ROOM 46061
ADELPHI, MD 20783-1197

HELEN C BOGGS
U.S. ARMY MISSILE COMMAND
AMEMI-RD-SE-TD-ST
REDSTONE ARSENAL, AL 35898-5270

DOROTHY M BROOKS
WR-ALC-LFC
ROBBINS AFB
WARNER ROBBINS, GA 31098-5315

MARIE C BOTTOMS
FRD INC.
2101 CRYSTAL DR.
CP-2, RM. 400
ARLINGTON, VA 22202

CALVIN BROWN
DEFENSE SYSTEMS MANAGEMENT COLLEGE
DSMC-DRJ-R
FORT BELVOIR, VA 22060

CONFERENCE ATTENDEES

DOROTHY H BROWN
CONFIGURATION/DATA MANAGEMENT
P.O. BOX 92960
BLDG. 100, RM 1548
LOS ANGELES, CA 90009-2960

WILLIAM A BURK
USAF-SSD/CWCAI (CIVILIAN CONTRACTOR) BWI
P.O. BOX 92960
BUILDING 110 RM 2262D
LOS ANGELES AFB, CA 90009-2960

KAREL A BROWN
NAVAL WEAPONS SUPPORT CENTER
ELECTRONIC WARFARE DEPT.
CODE 801
BLDG. 3168
CRANE, IN 47522-5080

JACQUELINE A BURKE
AMCCOM, CHEMICAL RD&E CENTER
SMCCR-PMP-C
ABERDEEN PROVING GRD, MD 21010-5423

RALPH F BROWNE
ESD/T&O
CONFIG. & DATA MAMGT. DIVISION
HANSCOM AFB
BLDG. 1630
BEDFORD, MA 01731

JANICE L BURNS
HALLIBURTON LOGGING SERVICES
3036 YUCCA RD.
WILLOW PARK, TX 76087

HEIDI C BUCK-HULL
554 RANGE GROUP/RDX
NELLIS AFB
BLDG. 200, RM.215
LAS VEGAS, NV 89191-5000

DAN BURRS
FMC CORP
NAVAL SYSTEMS DIVISION
M228
4800 EAST RIVER RD
MPLS, MN 55421

MAX C BUNNER
ANALYSIS & TECHNOLOGY INC.
2121 CRYSTAL DR. #800
ARLINGTON, VA 22202

CASSANDRA F BUTLER
GE AEROSPACE, GESD
4EGIS TECHREP
PMS400NAF MAIL STOP 127-233
MOORESTOWN, NJ 08057

LINDA S BURGER
TECHNICAL DATA & MANUFACTURING DIVISION
5203 LEESBURG PIKE
SUITE 1402
FALLS CHURCH, VA 22041-3466

JAMES D BUTTS
NAVAL SEA LOGISTICS CENTER
CODE 2213, BLDG. 307
5450 CARLISLE PIKE P.O. BOX 2060
MECHANICSBURG, PA 17055-0795

CONFERENCE ATTENDEES

STEVEN J BUZINSKI
485 ENGINEERING INSTALLATION GROUP
STANDARDS/REVIEW BRANCH EIR
BRIDGES ROAD
DEPOT ONE, DATA MANAGEMENT OFFICE
GRIFFISS AFB, NY 13441-6348

STANLEY D CAINE
NAVAL WEAPONS CENTER
CODE 16522
ENGINEERING LAB
Bldg. 02486, RM. 1550
CHINA LAKE, CA 93555-6001

DAVID A CALEF
ROCKWELL INTERNATIONAL
D.A. CALEF D/175 03-FC95
3270 MIRALOMA AVE
P.O. BOX 3105
ANGELES, CA 92803-3105

THERESA M CALVIN
SANTA BARBARA RESEARCH CENTER
BUILDING 630, MAIL STOP 59
75 GORDMAN DRIVE
GOLETA, CA 93117

ALBERT CAMPBELL
TEANS INSTRUMENTS INC.
ELECTRIC WARFARE DIVISION
N 5 2210
5805 MARK BARLING BLVD.
COLORADO SPRINGS, CA 80919

DENNIS D CARLSON
CONTROL DATA CORPORATION/ADPA
H06527
3101 EAST 80TH STREET BOX 609
MINNEAPOLIS, MN 55440

AL CARR
HQ AMC
AMCCE-PSE
5001 EISENHOWER AVE.
ALEXANDRIA, VA 22333-0001

MARY J CARRICO
NAVAL WEAPONS SUPPORT CENTER CRANE
CODE 5024
BLDG. 3031
CRANE, IN 47522-5050

JAY B CARSON
DEFENSE LOGISTICS AGENCY
CAM. STA.
4C587
ALEXANDRIA, VA 22304-6100

CHARLES A CARTER
SAF/AGXE (AIR FORCE DEPARTMENTAL STDZ. OFFICE
PENTAGON
WASHINGTON, DC 20330-1000

CONFERENCE ATTENDEES

CLAUDE F CASSADY
NAVAL SEA SYSTEMS COMMAND
SEA-5523B
WASHINGTON, DC 20362-5101

ALAN CHVOTKIN
SUNDSTAND
2101 WILSON BLVD., SUITE 1002
ARLINGTON, VA 22209

LOUISE A CAULFIELD
NAVY CLOTHING & TEXTILE RESEARCH FACILITY
KANSAS STREET
P.O. BOX 59
BLDG. 66
NATICK, MA 01760-0001

PHILIP W CLARK
LOGISTICS MANAGEMENT INSTITUTE
6400 GOLDSBORO ROAD
BETHESDA, MD 20817-5886

BARBARA M CELESTINE
CONFIGURATION/DATA MANAGEMENT DIVISION
SSD/MZEED, BLDG# 120 ROOM 235F
P.O. BOX 92060
LOS ANGELES AFB, CA 90009-2960

JOSEPH COHEN
NAVAL OCEAN SYSTEMS CENTER
CODE 921
SAN DIEGO, CA 92152

ANDREW D C. PTO
STANDARDIZATION PROGRAM DIVISION
5203 LEESBURG PIKE
SUITE 1407
FALLS CHURCH, VA 22041-3466

WILLIAM E COLLINS
SAF/ADX
PENTAGON
WASHINGTON, DC 20330-1000

FORD E CH' WORTH
NAVAL FACILITIES ENGR. COMMAND
CODE DS02R
200 STONAL STREET
ALEXANDRIA VA 22332

GLEN W COLMAN
NAVAL SEA SYSTEMS COMMAND
2521 S. JEFFERSON DAVIS HIGHWAY
NATIONAL CENTER 2, RM 12W17
ARLINGTON, VA 22202-5101

THOMAS CHLEBOSKI
US ARMY AMCCOM, ARDEC
SMC/AR-BAC-5
BLDG. 6
PITCHINNY ARSENAL, NJ 07806-5000

MARY A COOPER
ASD/YPCA-2
B-12, AREA B
ROOM 217
WPAFB, OH 45433-6503

CONFERENCE ATTENDEES

GERALD S COX
NATO/NADISA
SSB/CMB
AFD, NY 09667-5381

SHARON J DAVIS
E-SYSTEM INC.
GARLAND DIVISION
P.O. BOX 660023
DALLAS, TX 75266-0023

MICHAEL D CRANER
LOGISTIC INFORMATION MANAGEMENT
RM. 2B788
THE PENTAGON
WASHINGTON, DC

KENNETH D DAWSON
HQ AFLC/LGTFM
WPAFB, OH 45433-5999

SUSAN N CROSSWAIT
USMC-MITESA
STATION HQ-10B
MITESA
BLDG. 31
CAMP PENDLETON, CA 92055-5080

WILLIAM A DEAN
AIR FORCE INSTITUTE OF TECHNOLOGY
AFIT/LSY
WPAFB, OH 45433-6583

BARBARA A CROWE
NAVAL SEA SYSTEMS COMMAND
552314
MC-4, RM. 43E
ARLINGTON, VA 22202

LYDIA DECKER
MODERN TECHNOLOGIES CORP.
1313 S.E. MILITARY DRIVE
SUITE 110
SAN ANTONIO, TX 78214

ROBERT A DAMICO
HQ. BALLISTICS SYSTEMS ORG.
BLDG. 5067 RM. 601
HORTON AFB, CA 92409-6468

JOSEPH DEL GROSSO
US ARMY, PROJECT MANAGER-SATELLITE COMMUNICAT
DFAC-CM-SC-DT
BLDG. 209
FORT MONMOUTH, NJ 07703

MICHAEL A DANIELS
VSE CORPORATION
275 EISENHOWER AVENUE
HERFORDIA, VA 22014

KAREN A DIACO
HQ ESD/EN-4
BLDG. 6, 1302FA
HANSCOM AFB, MA 01731

CONFERENCE ATTENDEES

CHARLES H DICKSON
NAVAL COASTAL SYSTEMS CENTER
CODE 7510
BLDG. 435
PANAMA CITY, FL 32407-5000

JAMES G DORR
NATSF PRODUCTION ENGINEERING DEPT.
NATSF-60
9 & M STREET, SE.
BUILDING 220, RM. 300
WASHINGTON, DC 20374

MARTIN A DIGGS
NATSF PRODUCTION ENGINEERING DEPT.
NATSF-60
9 & M STREET, SE.
BLDG. 220, RM. 300
WASHINGTON, DC 20374

WILLIS L DRAKE
ENGINEERING PROGRAM DIVISION
DIR. OF TECHNICAL & LOGISTICS SERVICES
DLA-SE
4C572
ALEXANDRIA, VA 22304-6100

GARY R DILLARD
DEFENSE INDUSTRIAL PLANT EQUIPMENT CENTER
DIPEC-SS
2163 AIRWAYS BLVD.
MEMPHIS, TN 38114-5297

BARRY M DUBE
NATSF PRODUCTION ENGR. DEPT.
NATSF-60
9 & M STREET, SE.
BLDG. 220, RM. 300
WASHINGTON, DC 20374

SHARON K DILTZ
ASD/RWCC
WP4FB, OH 45433-6503

DUANE M DUVALL
ALLIANT TECHSYSTEMS INC.
6500 HARBOUR HEIGHTS PARKWAY
EVERETT, WA 98204-8899

BARBARA A DINARDO
BATTLE AUTOMATION & TECH. DATA DIR.
SMCAF-DAT-0, BLDG. 12
BLDG. 37
PICATINNY ARSENAL, NJ 07806-5000

JACK H EASLEY
DEFENSE INDUSTRIAL PLANT EQUIPMENT CENTER
DIPEC-SF
2163 AIRWAYS BLVD.
BLDG. 210
MEMPHIS, TN 38114-5051

JAMES V DIPAOLO
SPACE & NAVAL WARFARE SYSTEMS COMMAND
DEPT. OF NAVY
WASHINGTON, DC 20363-5100

STEVEN EASTERBROOK
BARCOCK & WILCOCK
SHOP 78
MT. ATHOS ROAD
LYNCHBURG, VA 24551

CONFERENCE ATTENDEES

WILLIAM V EDMONDS
4900 OSS/LB3F
LANGLEY AFB, VA 23665-7399

BARBARA J ELLISON
GSA-FSS
FCRE
CRYSTAL MALL 4, RM 522
WASHINGTON, DC 20406

JAMES F EDWARDS
JOHN J. MCMULLEN ASSOCIATES
2341 JEFFERSON DAVIS HWY.
CENTURY BLDG., SUITE 715
ARLINGTON, VA 22202

WARREN B ESTEP
NAVY SHIPS PARTS CONTROL CENTER
DLA INTERFACE DIVISION
0542, BLDG. 312
5450 CARLISLE PIKE, P.O. BOX 2020
MECHANICSBURG, PA 17055

PATRICIA D EDWARDS
AMCOM, CHEMICAL RD&E CENTER
SMCR-FMP-C
BLDG. E3331, RM.107
ABERDEEN, MD 21010-5423

SHARON E EUBANK
BALLISTIC MISSILE ORGANIZATION
MCI/ARM
NORTON AFB, CA 92409-6468

MARLENE V EDWARDS
OKLAHOMA CITY AIR LOGISTICS CEN.
OE-ALC/TIMLA
BLDG 30001
TINKER AFB, OK 73145-5990

LORI A EVA
TECHNICAL AND MANAGEMENT SERVICES CORP.
187 ROUTE 36
WEST LONG BEACH, NJ 07764

DARLENE S ENWALL
NAVAL WEAPONS SUPPORT CENTER
CODE 602A
BLDG. 2940W
CRANE, IN 47522-5060

GERALD A FACON
NORTHRCP CORPORATION
612/XD
8900 EAST WASHINGTON BLVD.
PICO RIVERA, CA 90660-3737

SHARON M ELLIS
NAVAL SEA SYSTEMS COMMAND
59332
MC-4, RM. 418
WASHINGTON, DC 20362

ROBYN B FAIT
US MARINE CORPS - MCRDAC
ATTN: PSD-D
CLARENDON BLDG.
ROOM 315
WASHINGTON, DC 20380-0001

CONFERENCE ATTENDEES

ANTHONY J FATZ
DPRO, WESTINGHOUSE-BALTIMORE
1285
P.O. BOX 1693
BALTIMORE, MD 21203-1693

STANLEY M FJOSER
GSA
6FEMR-T
1500 E. BANNISTER RD.
KANSAS CITY, MO 64131

CHARLES H FEATHER
S. SYSTEM CORP.
9800 LA CIENEGA BLVD.
SUITE 201
INGLEWOOD, CA 90301

MICHAEL R FLEISCHER
SANTA BARBARA RESEARCH CENTER
75 CROMAR DRIVE
BLDG. B31, MAIL STATION 67
GOLETA, CA 93117

JANET R FEE
ESD/TNC
SMEF IV
HAFF, MA 01731

LORETTA FLOURNOY
S. SYSTEMS CORPORATION
9800 LA CIENEGA BLVD.
SUITE 201
INGLEWOOD, CA 90301

MARY M FIERRO
S. SYSTEMS CORPORATION
9800 LA CIENEGA BLVD.
SUITE 201
INGLEWOOD, CA 90301

MARJORIE FLOYD
MODERN TECHNOLOGIES CORP.
4032 LINDEN AVE.
DAYTON, OH 45432

WILLIAM S FINKEL
ENGR. PROGRAM DIV., TECH & LOG. SER.
DLA-SE
5010 DUKE STREET
RM. 4C572, CAMERON STATION
ALEXANDRIA, VA 22304-6100

KATHLEEN M FONG
ALLIANT TECHSYSTEMS INC.
MN48-2100
7228 NORTHLAND DR.
BROOKLYN PARK, MN 55428

ALFRED FISHER
SPACE SYSTEMS DIVISION
P.O. BOX 92960
LOS ANGELES AFB, CA 90009-2960

TOM H FORD
00-ALC/PMDE
HILL AIR FORCE BASE
BLDG. 1205
HILL AFB, UT 94056

CONFERENCE ATTENDEES

VVONNE V FOWLKES
NAVAL SEA SYSTEMS COMMAND
04TD22
2531 CYRYSTAL DRIVE
NC#3, RM. 10E42
APLINGTON, VA 22202

JAY B FREE
ASD/ENES
ENGINEERING DOCUMENTS DIVISION
BLDG. 126
WPAFB, OH 45433-6503

BARBARA A FOX
DLA SYSTEMS AUTOMATION CENTER
DSAC-DPL
P.O. BOX 1505
BLDG. 27, SECTION 6
COLUMBUS, OH 43216-5002

JAMES T FREEMAN
NAVAL AIR ENGINEERING CENTER
SESD-5312
BLDG. 120
LAKE HURST, NJ 08733

BARBARA B FOX
ASD/SOFC
WPAFB, OH 45433-6503

KRISTIE L FREI
NATIONAL SECURITY AGENCY
T-2136
9800 SAVAGE RD.
FT. MEADE, MD 20755-6000

ELEANOR J FOX
HUGHES AIRCRAFT CO.
BLDG. 736, MS 221
6155 EL CAMINO REAL
CARLSBAD, CA 92009

MICHAEL E FREIRIA
ESL INC.
J5-3
495 JAVA DRIVE
SUNNYVALE, CA 94088-3510

JAMES J FRAIN
NAVAL SEA SYSTEMS COMMAND
5E4-04T042
WASHINGTON, DC 20362-5101

ALMA-MARIE FRYE
DEFENSE INTELLIGENCE AGENCY
RSC-1
SCOLLING AFB
BLDG. 6000
WASHINGTON, DC 20340-3212

TOLY E FREDERICK
NAVAL WEAPONS SUPPORT CENTER
CODE 0122
BLDG. 07
DARNE, IN 47522-5070

HERMAN G GAINES
NAVAL AVIATION SUPPLY OFFICE
ASO, CODE 0513.12
700 ROBBINS AVE.
PHILADELPHIA, PA 19111

CONFERENCE ATTENDEES

MICHAEL A GALLOGLY
HQ BMO/M6SM
BLDG. 951, RM 222
NORTON AFB
SAN BERNARDINO, CA 92409

CYNTHIA M GENTRY
BELVOIR RD&E CENTER
STRBE-TSO
BLDG. 1445, RM.81
FORT BELVOIR, VA 22060-5606

MARY A GAMBLE
ASD/Y6DT
EGLIN AFB, FL 32542-5000

PETER GEORANTZIS
ARDEC
SMACAR-BAC-5
BLDG. 6
PICATINNY ARSENAL, NJ 07806-5000

JOSEPH R GARAFOLA
COMPREHENSIVE TECHNOLOGIES INTERNATIONAL INC.
1725 JEFFERSON DAVIS HWY.
SUITE 301
ARLINGTON, VA 22202

STEVEN B GERSHMAN
NAVAL SEA SYSTEMS COMMAND
SEA-91L
2531 JEFFERSON DAVIS HWY.
NATIONAL CENTER 3
ARLINGTON, VA 22202

FREDERICK C GARBER
BOEING DEFENSE & SPACE GROUP
MS 8Y-25
P.O. BOX 3999
SEATTLE, WA 98124

GEORGE GIANIOS
NAVY PUBLISHING AND PRINTING
DEPUTY DIRECTOR
700 ROBBINS AVE.
ROOM 4D
PHILADELPHIA, PA 19111

ANTHONY M GENTILCORE
SPACE & NAVAL WARFARE SYSTEMS COMMAND
ACQUISITION & PROGRAM APPRAISAL DIVISION
SPAWAR 003-123
2511 JEFFERSON DAVIS HWY., NC-1, RM 12E2B
ARLINGTON, VA 22202

GREGG S GILDEA
US ARMY NATICK R&D AND ENGR. CENTER
FOOD ENGINEERING DIRECTORATE
STRNC-WEE
KANSAS STREET
NATICK, MA 01760-5018

RICHARD E GENTILD
NATSF PRODUCTION ENGR. DEPT.
NATSF-611
9 & M STREET, SE.
BLDG. 220, RM.300
WASHINGTON, DC 20374

JAMES E GILES
LOGISTICS MANAGEMENT INSTITUTE
6400 GOLDSBORO ROAD
BETHESDA, MD 20817-5886

CONFERENCE ATTENDEES

JAMES GILL
NAVSEA
G41D35
NATIONAL CENTER #3, RM. 10W26
WASHINGTON, DC 20362-5101

ROBERT S GOURLAY
US ARMY DECOM INTELLIGENCE MATERIEL MGMT. CEN
SELIM-CTM, STOP 77
VINT HILL FARMS STATION
WARRENTON, VA 22186-5277

ROBERT GILLESPIE
DEFENSE INDUSTRIAL SUPPLY CENTER
D13C-53AA
700 ROBBINS AVE.
BLDG. 3
PHILADELPHIA, PA 19111

CATHY GRAHAM
NAVAL AIR SYSTEMS COMMAND
DATA MANAGEMENT
AIR-51123
JF-2, RM. 1290
ARLINGTON, VA 22111

GLORIA D WILLIAM
UNITEYS DEFENSE SYSTEMS INC.
500 MACARA AVE
SUNNYVALE, CA 94086

CHERYL L GRAVER
AIR FORCE ASD/VLMC
4032 LINDEN AVE.
DAYTON, OH 45432

BEVERLY A GOODSHALL
SPACE SYSTEMS DIVISION
P.O. BOX 92560
WORLDWAY POSTAL CENTER
LOS ANGELES AFB, CA 90009

REGINA L GRAY
DEFENSE FUEL SUPPLY CENTER
TECHNICAL SERVICE DIVISION
DFSC-GSA
CAMERON STATION, BLDG. 8
ALEXANDRIA, VA 22304-6160

LEANN GONZALES
HUGHES AIRCRAFT
EDGE CONFIGURATION/DATA MANAGEMENT
4109
2000 E. EL SEGUNDO
EL SEGUNDO, CA 90245

STEVEN GUNTHER
LABCOM/ETDL
SLCET-RS
PORT MONMOUTH, NJ 07703

ANNETTE F GORANSON
NAVAL SEA SYSTEMS COMMAND
CODE 552034
2341 S. JEFFERSON DAVIS HWY.
NO-4, RM. 438
ARLINGTON, VA 22202

JOY T GUYER
NAVAL SEA SYSTEMS COMMAND
CODE 552034
2341 S. JEFFERSON DAVIS HWY.
NO-4, RM. 438
ARLINGTON, VA 22202

CONFERENCE ATTENDEES

ROBERT HAMMOND
US ARMY AVIATION SYSTEMS COMMAND
AMSAV-MEC
4300 GOODFELLOW BOULEVARD
BLDG. 3
ST. LOUIS, MO 63120-1798

JOHN R HART
ADPA (BOEING)
6U-EL
BOX 3707
SEATTLE, WA 98124

JOHN D HANNIGAN
MAGNAVOX, NVSG
120 ASHBURN ROAD
ASHBURN, VA 22011

JOHN D HARTSELL
AMCPSCC
SDSTO-TE-S
TOBYHANNA, PA 18466-5097

JAMES H HANSEN
E.E. NIENHOFF & CO. INC.
2021 LEE STREET
EVANSTON, IL 60202

KENNETH G HAUG
MARTIN MARIETTA CORPORATION
307
6801 ROCKLEDGE DRIVE
BETHESDA, MD 20817

ALBERT H HARACZ
NAVAL AIR SYSTEMS COMMAND
AIR-411
JP-2, RM. 170
WASHINGTON, DC 20361-4110

JANET A HEALY
PACIFIC MISSILE TEST CENTER
F-14 AIRCREW TRAINER BRANCH
CODE 9044
POINT MUGU, CA 93042-5000

CORAL K HARRIS
OPERATIONAL TEST AND EVALUATION COMMAND (OPTE)
OSTE-OPC
PARK CENTER IV, 4501 FORD AVE. #1050
ALEXANDRIA, VA 22302-1458

LINDA D HEAL
MMD/TD&MD
5203 LEESBURG PIKE
SUITE 1401
FALLS CHURCH, VA 22041-3466

HARLAN H HARRISON
FMC CORP. NAVAL SYSTEM DIVISION
T-510
4300 EAST RIVER ROAD
MINNEAPOLIS, MN 55421-1498

ROLAND G ANDERSON
MMD/TD&MD
5203 LEESBURG PIKE
SUITE 1401
FALLS CHURCH, VA 22041-3466

CONFERENCE ATTENDEES

BRENDA M HENDERSON-EL
NAVSEA 55Z
SEA-55Z3
2341 S. JEFFERSON DAVIS HWY.
NC-4, RM. 438
ARLINGTON, VA 22202

ROBERT W HIEBERT
HQ. AMC
AMCCE-PSE
5001 EISENHOWER AVE
ALEXANDRIA, VA 22311

CONNIE J HENRY
ASD/ENES
BLDG. 126/BAY 125
WPAFB, OH 45433-6503

ELAINE B HILD
DEFENSE PERSONNEL SUPPORT CENTER
DPSC-MSTE-19
2800 SOUTH 20TH STREET
PHILADELPHIA, PA 19101

MARIA J HERMANSON
NAVAL OCEAN SYSTEMS CENTER
CODE 9211
271 CATALINA BLVD BLDG. 33, ROOM 2064
SAN DIEGO, CA 92152-5000

DARRELL L HILL
DESC
EQ
1507 WILMINGTON PIKE
DAYTON, OH 45444

TERRY J HIBBARD
NAVAL SEA LOGISTICS CENTER
P.O. BOX 2060
5450 CARLISLE PIKE
BLDG. 307
MECHANICSBURG, PA 17055-0795

STEVEN R HOFINGER
KILKEARY, SCOTT & ASSOC., INC.
(SUBSIDIARY OF UNIVERSAL SYSTEMS, INC.)
4350 FAIR LANES COURT
SUITE 300
FAIRFAX, VA 22003

JOHN T HIGHMAN
NAVAL WEAPONS SUPPORT CENTER CRANE
3001
CRANE, IN 47522

YOLANDA C HOHMANN
BALLISTIC MISSILE ORGANIZATION (BMO)/M65M
NORTON AFB
BLDG. 951, RM 222
SAN BERNARDINO, CA 92409

LINDSEY M HICKS
DEFENSE FUEL SUPPLY CENTER
DFSC-PSE
CAMERON STATION
BLD 14
ALEXANDRIA, VA 22304-6160

MICHAEL HOLLOWAY
ASD/RWCE
WPAFB, OH 45433-6503

CONFERENCE ATTENDEES

ROBERT E HOFF
21-10/SATELLITE SUPPORT ENGINEERING
LOCKHEED TECHNICAL OPERATION CO.
1309 MOFFETT PARK DRIVE, BLDG. 100, RM. 540
SUNNYVALE, CA 94088-1687

GILLIAN J HORNA
PRC INC.
2121 CRYSTAL DRIVE
SUITE 400
ARLINGTON, VA 22202

ROSIE M HOSKIN
BELVIER RD&E CENTER
STRBE-TSD
BLDG. 1445, RM. B1
FORT BELVIER, VA 22060-5606

RON C HOUSTON
E-SYSTEMS
GREENVILLE DIVISION
P.O. BOX 6056
GREENVILLE, TX 75401-6056

PAULA J HOWARD
NAVAL AIR SYSTEMS COMMAND
A1F-5112
JF-2, RM. 1290
WASHINGTON, DC 20341-5110

CHRISTINE C HOWARD
PRC INC
20P4.07
2121 CRYSTAL DRIVE
ELITE 400
ARLINGTON, VA 22202

GEORGE J HROMNAK
HD. ARDEC
SMAR-BA
BLDG. 12
PICATINNY ARSENAL, NJ 07806-5000

CLIFFORD W HUBBARD
US ARMY MATERIALS TECHNOLOGY LAB.
SLCMT-MEE
ARSENAL STREET
WATERTOWN, MA 02172

OLIVER R HUDN
SPACE SYSTEMS DIVISION/CNT
P.O. BOX 92960
LOS ANGELES, CA 90009

JANICE C HUTCHENS
ENGINEERING PROGRAMS DIVISION
DLA-SEE
CAMERON STATION
40587
ALEXANDRIA, VA 22304

JUDYTH J INGRAM
NAVAL SEA SYSTEMS COMMAND
SEA-55233
DEPT. OF NAVY
WASHINGTON, DC 20362-5000

JUDITH S IRELAND
DAFD(P&L) MMD
5203 LEESBURG PIKE
SUITE 1403
FALLS CHURCH, VA 22041-3466

CONFERENCE ATTENDEES

BOB IRVING
NAVY PUBLISHING AND PRINTING
DIRECTOR PROCUREMENT
700 ROBBINS AVE.
A/B
PHILADELPHIA, PA 19111

WRAY JACQUES
DEPARTMENT OF NATIONAL DEFENSE
DIR. OF ENGR. MF&S
DEMPS 4-2-2
MSGN GEORGE R. PEARKES BLDG.
OTTAWA CANADA, KIA 0K2

BARBARA A IRWIN
ARMY R&E CENTER
SPECIFICATION & STANDARDIZATION OFFICE
SMCAR-BAC-S
BLDG. 5
PICATINNY ARSENAL, NJ 07806

DONNA S JAMES
NAVSEA OATD
SEA-04TD45
2531 CRYSTAL DRIVE
NC-3, RM 10E50
ARLINGTON, VA 22202

MADELEINE M ISTVAN
ASDYENES
WPAFB, OH 45433-6503

CARLA E JENKINS
OASD(P&L) MMD
STANDARDIZATION PROGRAM DIVISION
5203 LEESBURG PIKE, SUITE 1403
FALLS CHURCH, VA 22041-3466

NORMA F JACKSON
HQ. USAF/ SPACE SYSTEMS DIVISION
CONFIGURATION/DATA MANAGEMENT DIVISION
350/MSPEC, BLDG. 120, RM. 130
P.O. BOX 92960
LOS ANGELES AFB, CA 90009-2960

BOB JOHNSON
ASD/VB
CHIEF CONFIGURATION/DATA MGMT. DIVISION
BLDG. 52, RM. 215
WPAFB, OH 45433-6503

FRID R JOADSON
MILITARY TRAFFIC MGMT. COM.
TRANSPORTATION ENGR. AGENCY
P.O. BOX 6276
12088 HARWIDY BLVD.
NEWPORT NEWS, VA 23616-0276

GEORGANN A JOHNSON
MODERN TECHNOLOGIES CORP.
4032 LINDEN AVE.
DAYTON, OH 45432

ROBERT JACOBSE
VA SF PRODUCTION ENGR. DEPT.
3 & M STREET, SE.
BLDG. 124, ROOM 300
WATERBURY
WASHINGTON, DC 20374

JUDITH L JOINER
HQ AIR TRAINING COMMAND
HQ ATC/TTR
RANDOLPH AFB, TX 78150-5001

CONFERENCE ATTENDEES

JOHN J JONES
DEFENSE CONSTRUCTION SUPPLY CENTER
DCSC-SSM, BLDG. 12 6, RM 608
P.O. BOX 3990 E. BROAD STREET
COLUMBUS, OH 43216-5000

RIAD S KATIB
TACOM-AMSTA-GDS
ATTN:AMSTA-GDS
WARREN, MI 48397-5000

STEPHEN JONES
DEFENSE INDUSTRIAL SUPPLY CENTER
700 ROBBINS AVE
PHILADELPHIA, PA 19111

ROBERT H KEELER
NAVAL SEA LOGISTICS COMMAND
CODE 221
5450 CARLISLE PIKE
P.O. BOX 2060
MECHANICSBURG, PA 17055-0795

HUBERT L JONES
DYNAMIC SYSTEMS
2361 JEFFERSON DAVIS HWY
SUITE 912
ARLINGTON, VA 22202

ESTHER K KELLER
SPACE SYSTEMS DIVISION
AAD/SOMS
P.O. BOX 92960
LOS ANGELES AFB, CA 90009-2960

RICHARD J JONES
NAVAL SEA LOGISTICS CENTER
CODE 225
P.O. BOX 2060, 5450 CARLISLE PIKE
BLDG. 307
MECHANICSBURG, PA 17055-0795

TERRY R KELLEY
NAVSEA 5522
SEA-55221
2341 S. JEFFERSON DAVIS HWY
NC4, RM 400
ARLINGTON, VA 22202

ROBERT A JORDAN
DEFENSE ELECTRONICS SUPPLY CENTER
15 WILMINGTON AVE
DAYTON, OH 45444-6275

ARLENE D KEMNITZ
NORTHROP CORPORATION
ELECTRONIC SYSTEMS DIVISION
MANAGER, TECH. DATA MGMT.
600 HIGGS ROAD, ROOM 25107
ROLLING MEADOWS, IL 60008

FREDERICK A KAELEN
DEFENSE INDUSTRIAL SUPPLY CENTER
700 ROBBINS AVE
BLDG. D SECTION B
PHILADELPHIA, PA 19111

SEN TIM
TRACOM, AMCOM, AND
ENTRA-RETEB
FA 107
HERBERT FROVING, MD 21010-5423

CONFERENCE ATTENDEES

ROBERT D KIMBLE
NAVAL AIR SYSTEMS COMMAND
AIR-51122F
3F-2, RM. 1290
WASHINGTON, DC 20361-5110

SIEGFRIED H KRAHNER
THE BOEING COMPANY
P.O. BOX 3999
M.S. 9F-17
SEATTLE, WA 98124-2499

MARITA ANN KING
CACI-FEDERAL, INC.
3040 WILLIAMS DRIVE
SUITE 600
FAIRFAX, VA 22031

JAY L KRATZ
DEFENSE INDUSTRIAL SUPPLY CENTER
700 ROBBINS AVE.
PHILADELPHIA, PA 19111-5096

BARBARA J KNAPP
US ARMY CHEMICAL RD&E CENTER
SMOOR-FEV
EGGSD, RM 147
ABERTREEN, MD 21010-5423

LESLIE R KRUEGER
NAVCOASTSYSCEN-NAVAL COASTAL SYSTEM CENTER
CODE 7510
BLDG. 425
PANAMA CITY, FL 32407-5000

HELEN M KNELL
DEFENSE INDUSTRIAL SUPPLY CENTER
700 ROBBINS AVE
PHILADELPHIA, PA 19111

MICHAEL D KRUPA
US AIR FORCE
WPAFB, OH 45433

JAMES J KNOWLES
HQ -MC
AMOLE-PSE
501 EISENHOWER AVE.
ALEXANDRIA, VA 22304-0001

DAWN J KUCERA
HQ PACAF/SCW
HICKMAN AFB, HI 96797

JOHN M KOEHLER
NAVAL AIR SYSTEMS COMMAND
STANDARDIZATION OFFICE
AIR-51122
1401 JEFFERSON DAVIS HWY.
WASHINGTON, DC 20361-5110

ROBERT B KUHNEN
ASST/ENEE
WPAFB, OH 45433-6503

CONFERENCE ATTENDEES

MICHAEL G KURSAWE
NAVAL SHIP WEAPON SYSTEMS ENGINEERING STATION
CODE 5822
BLDG. 444
PORT HUENEME, CA 93043-5007

CINDY LATIMER
DYNAMIC SYSTEMS
635 SLATERS LANE
SUITE 100
ALEXANDRIA, VA 22202

DALE L LA FORREST
US ARMY TANK-AUTOMOTIVE COMMAND
AMSTA-3DD
WARREN, MI 48397-5000

STEPHEN M LAUTMAN
DEFENSE PERSONNEL SUPPORT CENTER
TECH. OPER., DIR. OF MED. MAT.
DPSC/MSD
2800 S. 20TH STREET, 9-3-F
PHILADELPHIA, PA 19101

GERALD W LA WALL
HQ NATIONAL SECURITY AGENCY
T-244
9800 SAVAGE ROAD
FT. MEADE, MD 20755

FRED R LAWSON
DLA-SE, ENGINEERING PROGRAMS DIVISION
CAMERON STATION
ALEXANDRIA, VA 22151

FRANK J LAFORGIA
DEFENSE INDUSTRIAL SUPPLY CENTER
DISC-ECB
700 ROBBINS AVE.
BLDG. 38
PHILADELPHIA, PA 19111-5096

CLIFFORD R LEDERER
CIVIL ENGINEER SUPPORT OFFICE
CODE 1564
NAVAL CONSTRUCTION BATTALION CENTER
PORT HUENEME, CA 93042-5000

DONALD E LANGRAMP
DASD/PRY MM/TMD
5200 LEESEBURG FIVE
SUITE 1403
FALES CHURCH, VA 22041-3466

NORMAN E LEXANG
HARRY DIAMONDS LABORATORIES
2800 POWDER MILL ROAD
BLDG. 202, RM 4F020
ADELPHI, MD 20783-1197

JUDY M LAFSON
BOEING AEROSPACE & ELECTRONICS
M/S CW-73
P.O. BOX 3799
SEATTLE, WA 98124

RANDALL W LEMOND
INFORMATION HANDLING SERVICES
15 INVERNESS WAT EAST
BLDG. 6
ENGLEWOOD, CO 80150

CONFERENCE ATTENDEES

JAMES D LEONARD
IBM
CONFIGURATION MANAGEMENT
DEPT. TJS, BLDG. 003C
6300 DIAGONAL HWY.
BOULDER, CO 80301

REGINA LONG
ASD/SDBC
WPAFB, OH 45433

EDWARD J LEWANDOWSKI
US ARMY MATERIEL COMMAND
AMCICP-1ST-L
5001 EISENHOWER AVE
ALEXANDRIA, VA 22333

STEPHEN C LOWELL
OASD (P&L) MM/SPD
5203 LEESBURG PIKE
SUITE 1403
FALLS CHURCH, VA 22041-3466

GLORIA L LEWIS
MODERN TECHNOLOGIES CORP.
4022 LINDEN AVE
DAYTON, OH 45432

MARIA LUCCI
NAVAL AIR ENGINEERING CENTER
CODE 5312
LAKE HURST, NJ 08733

FRED C LEWIS
NAVAL AIR SYSTEMS COMMAND
AIR-1006
14111 JEFFERSON DAVIS HWY.
JP-1, RM. 580
ARLINGTON, VA 22202

EMERY A LUCIER
ARMY NATICK RD&E CENTER
ADVANCE SYSTEM CONCEPTS & INTERGRATION DIR.
STRNC-AED
KANSAS STREET, DEVELOPEMENT 107
NATICK, MA 01760-5015

MARY F LISTMAN
NATIONAL SECURITY AGENCY
T-3136
9800 SAVAGE ROAD
FT. MEADE, MD 20755-6000

CORNELIUS E LYON
CRUISE MISSILE PROJECT
PMA-280116, MAIL STOP 04
1213 JEFFERSON DAVIS HWY
CRYSTAL GATEWAY 4, RM. 521
WASHINGTON, DC 20361-1014

AGLEDA H LONG
SPACE SYSTEMS DIVISION/MZEE
P.O. BOX 92960
LOS ANGELES AFB, CA 90009-2960

JOSE R MABESA
US ARMY TANK-AUTOMOTIVE COMMAND
AMSTA-GDS
WARREN, MI 48397-5000

CONFERENCE ATTENDEES

ROY E MABRY
ITAL
CODE 071
BLDG. 166
WNY
WASHINGTON, DC 20374-1662

JAMES W MACK
US ARMY TANK-AUTOMOTIVE COMMAND
AMSTA-GDD
WARREN, MI 48397-5000

PAUL M MAHAR
GENERAL DYNAMICS, FORTH WORTH DIVISION
MAIL ZONE 6482
F.O. BOX 748
FORTH WORTH, TX 76101

YULETHA H MAHONEY
MMD/TD&MD
5200 LEESBURG PIKE
SUITE 1403
FALLS CHURCH, VA 22041-3466

EUGENE MAISANO
DEFENSE INDUSTRIAL SUPPLY CENTER
DISC-EC
700 ROBBINS AVE.
BLDG. 3B
PHILADELPHIA, PA 19111-5096

TONIA MALAMISORA
MODERN TECHNOLOGIES
1310 S.E. MILITARY DRIVE
SUITE 110
SAN ANTONIO, TX 78214

ANITA K MANNING
NCBC
CESD 1543F
PORT HUENEME, CA 94043-5000

MICHAEL E MANNING
HUGHES AIRCRAFT CO.-EDSG
BLDG. E1, M/S D149
2000 E. EL SEGUNDO BLVD.
EL SEGUNDO, CA 90245

MARTIN P MANNION
TECHNICAL SERVICES-MEDICINE MATERIEL
DPSG-MST
2800 S.20TH STREET
9-3-F
PHILADELPHIA, PA 19101

RICHARD V MARBAIS
DEFENSE ELECTRONICS SUPPLY CENTER
DESC-ES
1507 WILMINGTON PIKE
DAYTON, OH 45444-5274

ANN M MARBURGER
AFNRL/RS
AIR FORCE HUMAN RESOURCES LAB.
BLDG. 190, AREA B
WPAFB, OH 45433-6503

GLENDA K MARCUS
ASD/YHC
EGLIN AFB, FL 32542-5000

CONFERENCE ATTENDEES

SANDRA L MARKMAN
OLIN CORP.-ORDNANCE DIV.
S.L.MARKMAN M/S 26
10101 9TH ST. N
ST. PETERSBURG, FL 33742

THOMAS N MAZZA
PM TRADE
AMCPM-TND-SP
12350 RESEARCH PARKWAY
ORLANDO, FL 32826-3276

SUSANO MASCORRO
SPACE SYSTEMS DIVISION
PROPULSION SYSTEMS PROGRAM OFFICE
ASD/YZW
WPAFB, OH 45433-6503

DAVID G MEIER
DIPEC-SSA
SSA/MEIER
2163 AIRWAYS BLVD.
210-1
MEMPHIS, TN 38114

CARLOS H MASSIATTE
DIRECTORATE OF SUPPLY AND TRANSPORTATION
LESW
BLDG. 2000
SAN ANTONIO, TX 78243-5000

SUSIE MENDIOLA
KELLY AFB
SA-ALC/FMRP
KELLY AFB, TX 78241

VICTOR MATSUG
PRC INC.
ZCP-4.07
2121 CRYSTAL DRIVE
SUITE 400
ARLINGTON, VA 22202

JACKIE MERCER
NAVAL AIR SYSTEMS COMMAND
DATA MANAGEMENT
AIR-51123B
JP-2, RM. 1290
ARLINGTON, VA 22111

KATIE G MATTHEWS
SPACE AND NAVAL WARFARE SYSTEMS COMMAND
PD50P2F
2511 JEFFERSON DAVIS HWY.
NC#1, 12E40
ARLINGTON, VA 20363

JOHN G MEREDITH
US ARMY TACOM
ASMTA-GDCD
WARREN, MI 48397-5000

PEGGY A MAYHEW
SPACE SYSTEMS DIVISION
MHP, BLDG. 120, RM 2013
2500 E. EL SEGUNDO BLVD.
EL SEGUNDO, CA 90260

SAMUEL E MERRITT
DEFENSE CONSTRUCTION SUPPLY CENTER
DCSC-SSM, BLDG. 12-6, RM 608
P.O. BOX 3990 E. BOARD ST.
COLUMBUS, OH 43216-5000

CONFERENCE ATTENDEES

BARBARA J MERRITT
IBM, FEDERAL SECTOR DIVISION
MDG306
RT. 17C
102A
OWEGO, NY 13827

ROBERT A MIRCHEFF
DEFENSE LOGISTICS AGENCY
QUALITY DIRECTORATE
DLA-BEL
CAMERON STATION
ALEXANDRIA, VA 22304-6100

MICHAEL J MERTLE
NAVY SHIP PARTS CONTROL CENTER
5450 CARLISLE PIKE BOX 2020
BLDG. 309
MECHANICSBURG, PA 17055

WILLIAM S MITCHELL
KILEARY, SCOTT & ASSOC, INC.
(SUBSIDIARY OF UNIVERSAL SYSTEMS INC.)
4350 FAIR LANES COURT
SUITE 300
FAIRFAX, VA 22033

CHRISTINE METZ
DASD(P&L)MM
THE PENTAGON
ROOM 2A318
WASHINGTON, DC 20301-8000

LYNN S MOHLER
HQ AMC
AMCDE-PSE
5001 EISENHOWER AVE
ALEXANDRIA, VA 22333

EDWARD R MIDDLETON
AT&T FEDERAL SYSTEM ADVANCED TECHNOLOGIES
P.O. BOX 20046
GUILFORD CENTER, RM W1H63
GREENSBORO, NC 27420

EVELYN M MOHN
ASD/VSCD
WPAFB, OH 45433

JOHN T MILLER
GSA-F3E
FORE
CRYSTAL MALL, BLDG. 4
WASHINGTON, DC 20406

DONALD B MOOR
US ARMY MISSILE COMMAND
AMSMI-RD-5E-TD-DM
BUILDING 3749
REDSTONE ARSENAL, AL 35898-5270

LINDA MILLER
ALD/L56
WPAFB, OH 45433

JACK Z MOORE
VSE CORPORATION
2550 HUNTINGTON AVE.
ALEXANDRIA, VA 22303

CONFERENCE ATTENDEES

DAVID E MOORE
DEFENSE ELECTRONICS SUPPLY CENTER (DESC)
ECT
1507 WILMINGTON PIKE
BLDG. 45
DAYTON, OH 45444

DONALD G McDOUGALL
TRW BALLISTIC MISSILE DIVISION
P.O. BOX 1310
M/S 526/633
SAN BERNARDINO, CA 92402-1310

NANCY T MORRIS
SPACE AND MISSILE SYSTEMS DIVISION
MSGC
P.O. BOX 92960, WORLDWAY POSTAL CENTER
LOS ANGELES, CA 90009-2960

FRANK A McELFISH JR.
TECHNOLOGY APPLICATION, INC.
555 AIRPORT WAY
SUITE E
CAMARILLO, CA 93010-5837

WILLIAM F MULLINS
NAVAL EOD TECHNOLOGY CENTER
CODE 05 (RESOURCES DEPT)
INDIAN HEAD, MD 20640-5070

JAMES M MCGINN
NAVAL AIR SYSTEMS COMMAND
SYSTEM SPEC., STDZ & DATA MGMT. BRANCH
AIR-5112
JP-2, RM.1290
WASHINGTON, DC 20361

BARBARA A MURPHY
ASD/YPDA
BLDG. 12, AREA B
ROOM 215
WPafb, OH 45433-6503

JEROME S McKAY
SPAWAR
PD 50P26
2511 JEFFERSON DAVIS HWY
NC-1, RM 12E40
WASHINGTON, DC 20363-5100

THOMAS H MURPHY
CRDEC
SMCCR-FE,
E3300, ROOM 147
EDGEWOOD, MD 21010

MARY F McNEAL
NAVAL SEA SYSTEMS COMMAND
04TD36
2531 JEFFERSON DAVIS HWY
NATIONAL CENTER #3, RM 10W26
ARLINGTON, VA 22202

BILLY J McCOY
US ARMY CECOM
AMSEL-ED-TM
CECOM OFFICE BUILDING
FORT MONMOUTH, NJ 07703-5000

MARVIN E McPHERSON
552331
2341 S. JEFFERSON DAVIS HWY.
MC-1, RM. 408
ARLINGTON, VA 20362-5101

CONFERENCE ATTENDEES

STEVEN J McQUEEN
DEFENSE INDUSTRIAL SUPPLY CENTER
DISC-EDF
700 ROBBINS AVE.
BLDG. 3B
PHILADELPHIA, PA 19111-5096

VINCE A NESS
LTV AEROSPACE AND DEFENSE
49R-17
P.O. BOX 655907
DALLAS, TX 75265-5907

ROSINA McWHIRTER
CRUISE MISSILE PROJECT
PMA 280117, MAIL STOP 04
1213 JEFFERSON DAVIS HWY
CRYSTAL GATEWAY 4, RM 521
WASHINGTON, DC 20361-1014

HY T NGUYEN
NAVAL SEA COMBAT SYSTEMS ENGR. STATION
CODE 411
835 PHILPOTTS ROAD
NORFOLK, VA 23513

YVONNE NASSIF
NORC
CESO, CODE 1543.H
C.B.C. BASE, BLDG. 1443
PORT HUENEME, CA 9330433

JUANITA R NICKELBERRY
DEFENSE INDUSTRIAL PLANT EQUIPMENT CENTER
TECHNICAL OPERATIONS DIVISION
DIPEC-SP
2163 AIRWAYS BLVD BLDG. 210/1
MEMPHIS, TN 38114

LORRAINE L NEAGLE
SSD-TITAN SYSTEM PROGRAM OFFICE
SSD/MEDC
2400 E. EL SEGUNDO BLVD.
BLDG. 125, RM 1013
EL SEGUNDO, CA 90245

ARLEEN P NILO
NAVSEA-DEPSO
SEA 5523-NM
NC-4, RM. 438
WASHINGTON, DC 20362-5101

DAVID W NELSON
NAVAL SEA SYSTEMS COMMAND
SEA 5513-NM (NAVY DEPSO)
WASHINGTON, DC 20362

RICHARD W NOWINSKI
DLA-SEP
2303 GALLEY COURT
WOODBIDGE, VA 22192

REBECCA A NELSON
NAVAL SEA SYSTEMS COMMAND
NAVSEA 91 9508
2531 JEFFERSON DAVIS HWY
NC #3, 9508
WASHINGTON, DC 20362-5101

GEORGE A NOYES
HQ. AFSC/ENMG
ANDREWS AFB, DC 20334

CONFERENCE ATTENDEES

PETER J O'DAY
US ARMY
ETDL SLCET-RS
FORT MONMOUTH, NJ 07703-5000

CAROL A OTTERSON
PACIFIC MISSILE TEST CENTER
CODE 2063
BLDG. 244
POINT MUGU, CA 93042

ERNIE S O'DELL
DEPARTMENT OF NATIONAL DEFENSE
DIR. OF ENGR. MP&S
DEMP5 2-4-3
MGEN GEORGE R. PEARKES BLDG.
OTTAWA CANADA, K1A 0K2

DALE L PADGETT
NAVAL WEAPONS SUPPORT CENTER
CODE 7025
BLDG. 37
CRANE, IN 47522-5070

JANE A O'MELIA
MANUFACTURING MODERNIZATION DIRECTORATE
TECHNICAL DATA & MANUFACTURING DIVISION
5203 LEESBURG PIKE
SUITE 1403
FALLS CHURCH, VA 22041-3466

DAVID R PALUMBO
DEFENSE INDUSTRIAL SUPPLY CENTER
SDAB
700 ROBBINS AVE
BLDG. 3
PHILADELPHIA, PA 19111

PATRICIA R O'NEIL
PACIFIC MISSILE TEST CENTER
CODE 1057
BLDG. 7020
POINT MUGU, CA 93042-5000

JUDY L PEDIGO
SPACE SYSTEMS DIVISION
P.O. BOX 92960
LOS ANGELES AFB, CA 90009

RICHARD W OGBERS-HOK
ASD/XAC
BLDG. 809
BROOKS AFB
SAN ANTONIO, TX 78235-5000

DAVID D PERI INS
SPACE & NAVAL WARFARE SYSTEMS COMMAND
SPAWAR 003-114
WASHINGTON, DC 20363-5100

RANDALL M OMLIE
ALLIANT TECH SYSTEMS
MN48-1100
7128 NORTHLAND DRIVE
BROOKLYN PARK, MN 55428

ANN PETERSON
LTV AEROSPACE AND DEFENSE
291-7A
P.O. BOX 655907
DALLAS, TX 75265-5907

CONFERENCE ATTENDEES

JOYCE L PEZICK
DEFENSE INDUSTRIAL SUPPLY CENTER
700 ROBBINS AVE.
BLDG. 3B
PHILADELPHIA, PA 19111-5096

ANTHONY F PREENZA
NAVY PUBLICATION & PRINTING
NPO-1
700 ROBBINS AVE
BLDG. 4/D
PHILADELPHIA, PA 19111

ANTHONY V PICARDI
DEFENSE PERSONNEL SUPPORT CENTER, MEDICAL MAT
DPSC-MSTE, BLDG. 9, ROOM 9F
2800 S. 20TH STREET
PHILADELPHIA, PA 19101

SANDRA PRIOR
JOHN J. McMULLEN ASSOC.
2341 JEFFERSON DAVIS HWY.
CENTURY BLDG., SUITE 715
ARLINGTON, VA 22202

ANTHONY J PIZZO
NAVAL AIR ENGINEERING CENTER
CODE 5312
LAKEHURST, NJ 08733-5100

RON E PRUIETT
COMFTEK RESEARCH INC.
4849 VIEWRIDGE AVE
SAN DIEGO, CA 92123

DAVID L POLLOM
NAVAL OCEAN SYSTEMS CENTER
CODE 9211, BLDG. 33, ROOM 2064
271 CATALINA BLVD.
SAN DIEGO, CA 92152-5000

CHERYL I QUINN
S. SYSTEMS CORP
9800 LA CIENEGA CORP.
SUITE 201
INGLEWOOD, CA 90301

ROBERT E POOVEY
US ARMY MISSILE COMMAND
AMSMI-RD-SE-TD-DM
BLDG. 3749
REDSTONE ARSENAL, AL 35898-5270

NORMAN RADITZ
NAVAL AIR ENGINEERING CENTER
CODE 531
BLDG. 120
LAKEHURST, NJ 08733

DENNIS POPVICH
MODERN TECHNOLOGIES CORP.
4134 LINDEN AVENUE
DAYTON, OH 45432

LUCILLE J RALLES
SYSTEMS RESEARCH & APPLICATIONS CORP (SRA COR)
550 NORTH CONTINENTAL BLVD.
SUITE 190
EL SEGUNDO, CA 90245

CONFERENCE ATTENDEES

RATNAWATI S RAMIREZ
SSG/CLZE
BLDG. 100, RM. 2764C
AREA 'A'
LOS ANGELES AFB, CA 90009-2960

SCOTT REYNOLDS
HQ. USAF/BGSSATERIEL COMMAND
PENTAGON
ROOM 5B269
WASHINGTON, DC 20232-2367

DAVID RATTNER
DECOM
AMSEL-ED-TM
FORT MONMOUTH, NJ 07703

JANET L RHOADES
ASD/YCC
BLDG. 17
WPAFB, OH 45433-6503

WILLIAM G REEDER
DEFENSE CONSTRUCTION SUPPLY CENTER
3990 E. BROAD STREET
COLUMBUS, OH 43216-5000

LARRY R RICHARDS
JOHN J. McMULLEN ASSOCIATE
2341 JEFFERSON DAVIS HWY.
CENTURY BLDG, SUITE 715
ARLINGTON, VA 22203

LESLIE A REND
BOEING AEROSPACE & ELECTRONICS
M/S 8M-21
O.G. BOX 3707
SEATTLE, WA 98124

ROSEMARY RICHARDSON
NAVAL AIR SYSTEMS COMMAND
AIR-51123C
JP-2, RM. 1290
WASHINGTON, DC 20361-5110

JOHN M REUTER
US ARMY DECOM
AMSEL-ED-TP
FORT MONMOUTH, NJ 07703

SANDRA J RICHARDSON
ASD/YSCD
BLDG. 16
DAYTON, OH 45433-6503

JULIA M REYNOLDS
NAVAL WEAPONS SUPPORT CENTER
ORDNANCE ENGINEERING DEPT.
CODE 501
BLDG. 2540
CRANE, IN 47522

RONALD D RICHTER
SYSCON CORP.
2341 JEFFERSON DAVIS HWY.
NC-4 #1138
ARLINGTON, VA 22202

CONFERENCE ATTENDEES

JAMES W RICKENBAUGH
US ARMY, TROOP SUPPORT COMMAND
AMSTR-HEAD
4300 GOODFELLOW BLVD.
ST. LOUIS, MO 63120-1798

DEBORAH A RIVERS
NAVAL SEA SYSTEMS COMMAND
2341 JEFFERSON DIVIS HWY.
RM. 438
ARLINGTON, VA 22202

THOMAS J RIDGWAY
TECHNICAL AND LOGISTICS SERVICES DIRECTORATE
DLA-SEE
CAMERON STATION
4C572
ALEXANDRIA, VA 22304-6100

NANCY J ROBERTS
ASD/RWCC
WPAFB, OH 45433-6503

BARBARA A RILEY
HQ AMC (ARMY MATERIEL COMMAND)
AMCFF-P
5001 EISENHOWER AVE.
RM. 9554
ALEXANDRIA, VA 22333-0001

RICHARD J RODEMER
NAVY PUBLICATIONS AND PRINTING SERVICE
NPM-DODSSP
700 ROBBINS AVE.
BLDG. 4D
PHILADELPHIA, PA 19111-5094

GERALD M RING
JTC3A
ATTN: CSA-STC
BLDG. 286
FORT MONMOUTH, NJ 07703-5513

ROBERT R RODGERS
NAVAL AVIONICS CENTER
CODE 814
6000 E. 21ST STREET
INDIANAPOLIS, IN 46219-2189

HECTOR J RIOS
US ARMY CECOM
AMSEL-RD-C3-LA-F
FORT MONMOUTH, NJ 07703

PETER E ROJAS
SPACE SYSTEMS DIVISION/MZEE
SSD/MZEE
P.O. BOX 92960
BLDG. 120, RM. 235B
LOS ANGELES AFB, CA 90009-2960

PHIL RIVERA
HUGHES AIRCRAFT COMPANY
2000 EAST IMPERIAL HIGHWAY
BLDG. R1, MAIL STOP 5A27
EL SEGUNDO, CA 90009

KIM K ROLLINS
NAVAL SEA SYSTEMS COMMAND
SEA-55232
2341 S. JEFFERSON DAVIS HWY
MC-4, RM. 43E
ARLINGTON, VA 22202

CONFERENCE ATTENDEES

NATHAN ROSENBAUM
DEFENSE TECHNICAL INFORMATION CENTER
DTIC-HDB
CAMERON STATION, BUILDING 5
ALEXANDRIA, VA 22304-3145

MICHAEL W RUSSELL
HQ, US ARMY MATERIEL COMMAND
AMCSM-MMS
5601 EISENHOWER AVE.
ALEXANDRIA, VA 22333-0001

TERRAIN L ROSS
PACIFIC MISSILE TEST CENTER
CODE 1057
BLDG. 7020, FM.158
POINT MUGU, CA 93042-5000

BARBARA D SALAZAR
AF CRYPTOLOGIC SUPPORT CENTER
ELECTRONIC SECURITY COMMAND
MMOWD
SAN ANTONIO, TX 78243-5000

RICHARD P ROUSSIN
NAVAL AIR SYSTEMS COMMAND
AIR-4112C1
WASHINGTON, DC 20361-4110

ROSEMARY C SALEM
NAVY CLOTHING & TEXTILE RESEARCH FACILITY
CODE 50
P.O. BOX 59
NATICK, MA 01760-0001

ROGER D RUBIO
SA-ALC
SFRT-1
FELLY AFB, TX 78241-5000

MYRTLE L SAMS
NAVAL AIR SYSTEMS COMMAND
AIR-51122E
WASHINGTON, DC 20361-5110

SHIRLEY A RUDDUCK
ASD/ASST (SRAM II SPD)
WRIGHT-PATTERSON AFB, OH 45433-6503

EVELYN E SARANITA
DCMDC-DPRO/McDONNELL DOUGLASS CORP
P.O. BOX 516
ST. LOUIS, MO 63166

DEARL D RUNYAN
NAVAL WEAPONS SUPPORT CENTER
CODE OSD
CTR-1
OFANE, IN 47522

ROGER C SATTLER
FRC INC.
2121 CRYSTAL DRIVE
CP-2, SUITE 400
ARLINGTON, VA 22202

CONFERENCE ATTENDEES

JOHN G SEUBERT
NAVAL WEAPONS SUPPORT CENTER CRANE
CODE 50223
CRANE, IN 47522-5050

WAYNE L SMITH
HQ ATC/TTOR
RANDOLPH AFB, TX 78150-5001

MICHAEL SHEA
NATSF PRODUCTION ENGINEERING DEPT.
NATSF-60
9 & M STREET, SE.
BLDG. 220, ROOM 300
WASHINGTON, DC 20374

WILLIAM M SMITH
DEFENSE GENERAL SUPPLY CENTER
DGSC-SSC
RICHMOND, VA 23297-5000

BETTY J SHONEBARGER
DLA SYSTEMS AUTOMATION CENTER
DSAC-DLC
P.O. BOX 1605
BLDG. 27, SECTION 6
COLUMBUS, OH 43216-5002

JOSEPH J SMITH
ARMY NATICK RD&E CENTER
ADVANCE SYSTEMS CONCEPTS ANFD INTEGRATION DIR
STRNC-AED
KANSAS STREET, RESEARCH 242
NATICK, MA 01760-5015

CAROL A SITROON
BATTLEFIELD AUTOMATION AND TECHNICAL
DATA DIRECTORATE
SMCAR-BAT-0, BLDG.12
ROOM 37
PICATINNY ARSENAL, NJ 07806-5000

RODNEY W SMITH
US ARMY MATERIEL COMMAND
AMCICP-151-5
5001 EISENHOWER AVE.
ALEXANDRIA, VA 22333

FRANCINE L SKAGGS
PROPULSION SYSTEMS PROGRAM OFFICE
WPAFB, OH 45433-6503

TED G SMITH
USA LABCOM (ETDL)
ELEC. TECHN & DEVICES LAB
SLCET-RE
FT. MONMOUTH, NJ 07703-5302

SANDRA L SLICK
SUNSTRAND DATA CONTROL
MS-25
15001 NE. 36TH STREET
REDMOND, WA 98073

CHARLES V SNYDER
AFLC-CASC
SPECIFICATION & STANDARDIZATION PROGRAM OFFC.
74 N. WASHINGTON AVE
BATTLE CREEK, MI 49017-3094

CONFERENCE ATTENDEES

GREGORY E SAUNDERS
DASD(PR)/MM
ROOM 2A318
PENTAGON
WASHINGTON, DC 20301-8000

RICHARD SCHOENIGER
DEFENSE INDUSTRIAL SUPPLY CENTER
700 ROBBINS AVE.
PHILADELPHIA, PA 19111

BRIAN A SAVAGE
SUNSTRAND DATA CONTROL
M/S 25
15001 NE 36TH STREET
REDMOND, WA 98073

BERNARD SCHULDINER
US ARMY CECOM
AMSEL-ED-TM
CECOM OFFICE BUILDING
FORT MONMOUTH, NJ 07703

DEBORAH A SCANNELL
S. SYSTEMS CORP.
9800 LA CIENEGA BLVD.
SUITE 201
INGLEWOOD, CA 90301

HERSHALL E SCOTT
ASD/YBC
AREA B, BLDG. 52, RM215
WPAFB, OH 45433

RICHARD SCARINZI
US ARMY CECOM
AMSEL-ED-TP
FORT MONMOUTH, NJ 07703-5000

JACQUELYN D SCOTT
ASD/VFCE
BLDG. 56/ BAY 4
WPAFB, OH 45433-6503

STEPHEN H SCHLECHTY
AERONAUTICAL
SYSTEMS DIVISION
ASD/AECM
BLDG. 57, BAY 1
WPAFB, OH 45433

JANICE M SCOTT
COMMANDER, NAVAL SEA SYSTEMS COMMAND
2341 S. JEFFERSON DAVIS HWY.
NC-4, RM. 430
CRYSTAL CITY, VA 20362-5101

THOMAS E SCHNEIDER
US ARMY INDUSTRIAL ENGINEERING ACTIVITY
AMILB-FA
ROCK ISLAND, IL 61299-7260

PAMELA SCOTT
AIR FORCE SYSTEMS COMMAND
ASD/ENES
WPAFB, OH 45433

CONFERENCE ATTENDEES

MARY A STAFFORD
SPACE AND NAVAL WARFARE SYSTEMS COMMAND
SPANAR 003-124D
NATIONAL CENTER #1, RM 12E18
WASHINGTON, DC 20363-5100

RONALD W STEVENS
NAVAL SUPPLY SYSTEMS COMMAND
SUP-521A
1755 JEFFERSON DAVIS HWY.
CRYSTAL SQUARE 5, RM 511
ARLINGTON, VA 22202

BRENDA L STANLEY
AIR FORCE LOGISTICS COMMAND
HQ AFLC/MMDB
WPAFB, OH 45433-5001

JAMES W STEWART
SPACE SYSTEMS DIVISION/CNT
P.O. BOX 92960
LOS ANGELES, CA 90009

SID STASTNY
LTV AEROSPACE AND DEFENSE
7-04
F.O. BOX 655907
DALLAS, TX 75265-5907

MARILYN STEWART-FRIDEY
NAVY PUBLISHING & PRINTING
DIRECTOR
700 ROBBINS AVE.
BLDG. 4D
PHILADELPHIA, PA 19111

LESLIE J STEADMAN
ASD/WL/XG
DATA MANAGEMENT OFFICE
WPAFB, OH 45433-6523

RICHARD STRANG
DEFENSE INDUSTRIAL SUPPLY CENTER
700 ROBBINS AVE.
PHILADELPHIA, PA 19111

CAROL A STEELE
PECOMFANDUAV
CRYSTAL GATEWAY 4, RM 306
WASHINGTON, DC 20361-1014

SHARON STRICKLAND
OASD, STANDARDIZATION PROGRAM DIVISION
5203 LEESBURG PIKE
SUITE 1403
FALLS CHURCH, VA 22041-3466

STANLEY L STEIGER
SA-ALC
SFR-
115 W. CASTANO
SAN ANTONIO, TX 78209

JANICE E STRICKLAND
SSD-TITAN SYSTEMS PROGRAM OFFICE
SSD/MEOC
2400 E. EL SEGUNDO BLVD
BLDG. 125, RM 1013A
LOS ANGELES, CA 90009-2960

CONFERENCE ATTENDEES

STARLENE Z STRICKLAND
BOEING SUPPORT SERVICES
MAIL STOP 8X-55
P.O. BOX 3707
SEATTLE, WA 98124-2207

FRANCES M TAYLOR
SSD-ADVANCE LAUNCH DEV. PROGRAM OFFICE
SSD/XRHM
3400 E. EL SEGUNDO BLVD
BLDG. D-9, RM 3662K
LOS ANGELES, CA 90009-2960

JAMES H SULLIVAN
HQ ARMY MATERIEL COMMAND
AMCE-PS
5001 EISENHOWER AVE.
ALEXANDRIA, VA 22333-0001

EILEEN M TEDROW
NAVSEA
SEA-552AA
NC#4, RM. 430
WASHINGTON, DC 20362-5101

ROBERT J SWANSON
AMCE-PPA
5001 EISENHOWER AVE.
ALEXANDRIA, VA 22333-0001

OTAWAY M THOMAS
CUBIC DEFENSE SYSTEMS
P.O. BOX 85587
SAN DIEGO, CA 92186-5587

JOHN M TASCHER
MMD/SPD
5203 LEESBURG PIKE
SUITE 1403
FALLS CHURCH, VA 22041-3466

RICHARD C THOMAS
FMC GROUND SYSTEMS DIV.
P-82
2890 DE LA CRUZ
BOX 58123
SANTA CLARA, CA 95052

DAVID A TAYLOR
DEFENSE LOGISTICS AGENCY
DLA-SEE
HQ, CAMERON STATION
45587
ALEXANDRIA, VA 22304

TERRY L THOMPSON
HQ, AMC
AMCICP-AA
5001 EISENHOWER AVE.
ALEXANDRIA, VA 22333-0001

HARRIET E TAYLOR
US ARMY BELVILIOR RD&E CENTER
STRBE-TSE
MAIL STOP 606
FORT BELVOIR, VA 22026-5606

LESLIE A THOMPSON
BOEING AEROSPACE AND ELECTRONICS
JR-02
499 BOEING BLVD.
BLDG. 48-21
HUNTSVILLE, AL 35824-6402

CONFERENCE ATTENDEES

SUE A THOMSON
ASD/SDFC
WPAFB, OH 45433-6503

BASSETT W ULLOM
FIELD COMMAND, DEFENSE NUCLEAR AGENCY
FCLMCS
KIRKLAND AFB, NM 78115-5000

FRANK T TRACESKI
DASD (PR)
5203 LEESEBURG PIKE
SUITE 1403
FALLS CHURCH, VA 22041-3466

ROLAND K USHER
ESD/EN-4
HANSCOM AFB
BEDFORD, MA 01731-5000

RAYMOND P TREMELAY
US ARMY ARMAMENT R,D&E CENTER (ARDEC)
CMCAR-BAC-S
BLDG. 6
PICATINNY ARSENAL, NJ 07806-5000

ROBERT E VAN DERMAV
NAVAL SHIP WEAPON SYSTEMS ENGINEERING STATION
CODE 5822
BLDG. 444
FORT HUENEME, CA 93042-5007

RICHARD L TUCK
WESTINGHOUSE (NAVAL SYSTEMS DIVISION)
1901 EUCLID AVE.
PLANT 1
CLEVELAND, OH 44117

SUSAN J VANDERMEYS
RTG (COMPASS)
1040 BROAD STREET
SHREWSBURY, NJ 07702

VALERY TURKOV
DISC
700 ROBBINS AVE
PHILADELPHIA, PA 19111

GENE VANDERPOOL
WR-ALC/LZMC
ROBBINS AFB, GA 31098-5365

JEFFREY L TYRRELL
ASD/YMC
EGLIN AFB, FL 32542-5000

JOSEPH A VERAS
McDONNELL DOUGLAS ELECTRONIC SYSTEMS CO.
43 RD, 5004264
P.O. BOX 426
ST. CHARLES, MO 63302

CONFERENCE ATTENDEES

MINH VUONG
TECHNICAL DATA & MANUFACTURING DIVISION
5203 LEESBURG PIKE
SUITE 1403
FALLS CHURCH, VA 22041-3466

SHERRIE L WARD
PRC INC.
2121 CRYSTAL DRIVE
SUITE 400
CP-2
ARLINGTON, VA 22202

ROBERT V WALKER
AEDC/DEEM
ARNOLD AFB, TN 37389

BEVERLY A WARREN
ASD/YGEC (SRAM II SPO)
WRIGHT-PATTERSON AFB, OH 45433-6503

CLARA WALKER
SAF/AQ4E (AIR FORCE DEPT. STDN. OFFICE)
PENTAGON
WASHINGTON, DC 20330-1000

ANGELA R WASHINGTON
SPACE SYSTEMS DIVISION
2400 E. EL SEGUNDO BLVD.
ATTN: CNSM BLDG. 105, ROOM 1440C
EL SEGUNDO, CA 90009

DAVID W WALKER
WESTINGHOUSE
DEPT. 625
1901 EUCLID AVE.
BLDG. 1
CLEVELAND, OH 44124

REUBEN W WASSERMAN
AERONAUTICAL SYSTEMS DIVISION
ASD/ENFZ
WPAFB, OH 45433-6503

RAENORD B WALKER
ALMC
AMCMC-ACM-MA
BLDG. F-12500
FORT LEE, VA 23801-6048

ESTELLE C WAYMIRE
2750 LOGISTICS & OPERATION GROUP (AFLC)
ELECTRONIC SUPPORT DIVIISON
1507 WILMINGTON PIKE - GENTILE AFS OH
BLDG. 2
DAYTON, OH 45444-5400

FANGMING A WANG
SPACE SYSTEMS DIVISION
SSD/SDMS
P.O. BOX 92960
LOS ANGELES, CA 90009-2960

HAL E WEIDNER
INDUSTRIAL ENGINEERING ACTIVITY
AMXIB-F5
ROCK ISLAND, IL 61299-7260

CONFERENCE ATTENDEES

EVA M WHALEY
ARNOLD ENGINEERING DEVELOPMENT CENTER
AEDC/XRD
ARNOLD AFB, TN 37389

JEFFREY W WILLIAMS
NAVY PUBLISHING & PRINTING SERVICE
CODE 42
BLDG 178-2, WNY
WASHINGTON, DC 20374-5087

JIM T WHISENANT
IBM
MS 259/033
9500 GODWIN DIRVE
MANASSAS, VA 22110

MARGARET D WILSON
SANTA BARBARA RESEARCH CENTER
BLDG B30, MAIL STATION 59
GOLETA, CA 93117

CARLOTTA T WHITE
NAVAL SEA SYSTEM COMMAND
2341 JEFFERSON DAVIS HWY.
NC-4, RM. 438
ARLINGTON, VA 20362-5101

JOANNE R WILSON
THE BOEING COMPANY
20403 68TH AVE. SO.
M/S 8A-06
KENT, WA 98032

HOWARD I WILDMAN
NAVSEA
SEA-55Z
2341 JEFFERSON DAVIS HWY.
RM. 430
ARLINGTON, VA 22202

CHARLOTTE J WINFREY
PACIFIC MISSILE TEST CENTER
CODE 2063
BLDG. 244
POINT MUGU, CA 93303-5000

JEAN C WILEY
DLA-SE
CAMERON STATION
ALEXANDRIA, VA 22304-6100

SHERYL A WINGARD
NAVAL ELECTRONIC SYSTEMS ENGINEERING CENTER
CODE 200L
MARE ISLAND NAVAL SHIPYARD
BLDG. H83
VALLEJO, CA 94592-5017

JOYCE C WILLIAMS
GSA/FEDERAL SUPPLY SERVICE
FCRE
1941 JEFFERSON DAVIS HWY.
CM-4, RM. 522
WASHINGTON, DC 20406

JOHN T WINTERS
TECHNICAL DATA & MANUFACTURING DIVISION
5203 LEESBURG PIKE
SUITE 1403
FALLS CHURCH, VA 22041-3466

CONFERENCE ATTENDEES

WILLIAM G WISE
US NAVY, SHIP PARTS CONTROL CENTER
CODE 05123
BOX 2020
MECHANICSBURG, PA 17025

LORRAINE E WRIGHT
ASD/ENES
AREA B
BLDG. 126, BAY 125
WPAFB, OH 45433-6503

JANICE D WOLLABER
DEFENSE MAPPING AGENCY
ADLVA-3
8613 LEE HIGHWAY
FAIRFAX, VA 22031-2137

ARTHUR G YATES
DPRO, WESTINGHOUSE-BALTIMORE
1285
P.O. BOX 1693
BALTIMORE, MD 21203-1693

JOHN L WOLOSZYN
DEFENSE PERSONNEL SUPPORT CENTER
DPSC-HSL 4435
2800 S. 26TH STREET
PHILADELPHIA, PA 19101-8419

SHARON R ZACK
BALLISTIC MISSILE OFFICE
MCIP
NORTON AFB
BLDG. 953, RM 1135
SAN BERNARDINO, CA 92409

COLLEEN R WOMACK
ASD/AFSA
WPAFB, OH 45433-6503

PETER ZIMBRAN
DEFENSE ELECTRONIC SUPPLY CENTER
DESC-EM
1507 WILMINGTON PIKE
DAYTON, OH 45444

EVERETT A WOODWARD
ALLIANT TECHSYSTEMS INC.
6500 HARBOUR HEIGHTS PARKWAY
EVERETT, WA 98204-8899

EUGENE ZYBLIKIEWYCZ
DEFENSE INDUSTRIAL SUPPLY CENTER
DISC-ESA
700 ROBBINS AVE
PHILADELPHIA, PA 19111

DOROTHY J WRIGHT
DASS (ARL) MPO/TOMO
5010 LEESBURG PIKE
SUITE 1400
FAULS CHURCH, VA 22041-3466