

AD-A125 167

AERODYNAMICALLY EFFICIENT GRADIENT REFRACTIVE INDEX
MISSILE SEEKER LENS(U) NAVAL POSTGRADUATE SCHOOL
MONTEREY CA H M CARR OCT 82 NPS67-82-012

1/6

UNCLASSIFIED

. F/G 16/4

NL

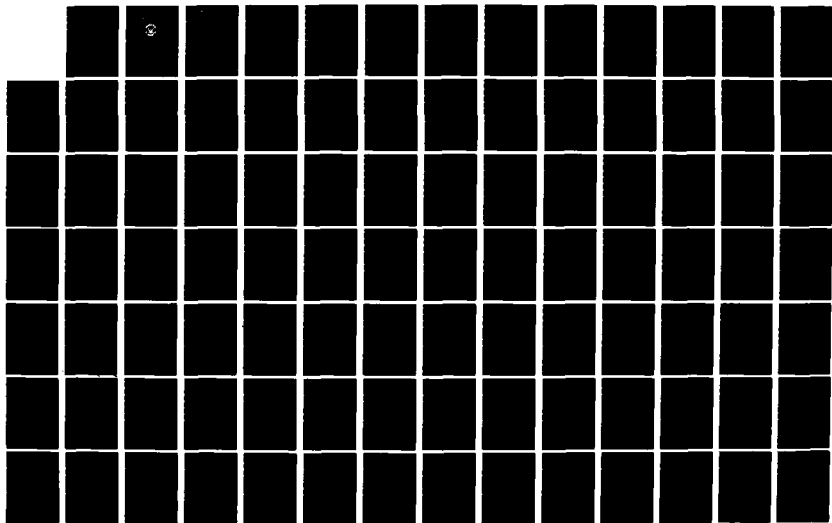

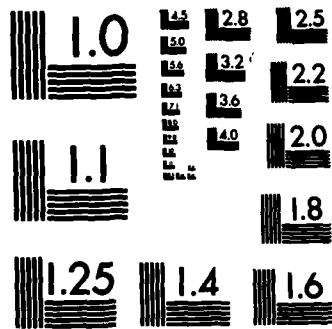

MICROCOPY RESOLUTION TEST CHART
NATIONAL BUREAU OF STANDARDS-1963-A

2

NAVAL POSTGRADUATE SCHOOL Monterey, California

AD A1 25167



DTIC
SELECTED
MAR 3 1983
A

THESIS

AERODYNAMICALLY EFFICIENT
GRADIENT REFRACTIVE INDEX
MISSILE SEEKER LENS

by

Herbert M. Carr III

October 1982

Thesis Advisor:

A. E. Fuhs

Approved for public release; distribution unlimited.

Prepared for: Defense Advanced Research Projects Agency
1400 Wilson Boulevard
Arlington, VA 22209

DTIC FILE COPY

88 02 020 059

UNCLASSIFIED

SECURITY CLASSIFICATION OF THIS PAGE (When Data Entered)

REPORT DOCUMENTATION PAGE		READ INSTRUCTIONS BEFORE COMPLETING FORM
1. REPORT NUMBER NPS67-82-012	2. GOVT ACCESSION NO. AD-A2285467	3. RECIPIENT'S CATALOG NUMBER
4. TITLE (and Subtitle) Aerodynamically Efficient Gradient Refractive Index Missile Seeker Lens		5. TYPE OF REPORT & PERIOD COVERED Master's Thesis; October, 1982
7. AUTHOR(s) Herbert M. Carr III		6. PERFORMING ORG. REPORT NUMBER
9. PERFORMING ORGANIZATION NAME AND ADDRESS Naval Postgraduate School Monterey, California 93940		8. CONTRACT OR GRANT NUMBER(s) DARPA ORDER 4035
11. CONTROLLING OFFICE NAME AND ADDRESS Naval Postgraduate School Monterey, California 93940		10. PROGRAM ELEMENT, PROJECT, TASK AREA & WORK UNIT NUMBERS
14. MONITORING AGENCY NAME & ADDRESS (if different from Controlling Office) LTC. Rene Larriva Defense Advanced Research Projects Agency 1400 Wilson Blvd. Arlington, VA 22209		12. REPORT DATE October, 1982
16. DISTRIBUTION STATEMENT (of this Report) Approved for public release; distribution unlimited.		13. NUMBER OF PAGES 483
17. DISTRIBUTION STATEMENT (of the abstract entered in Block 20, if different from Report)		15. SECURITY CLASS. (of this report) Unclassified
18. SUPPLEMENTARY NOTES		15a. DECLASSIFICATION/DOWNGRADING SCHEDULE
19. KEY WORDS (Continue on reverse side if necessary and identify by block number) Missile Sensors Conical Optics Missile Aerodynamics Conical Lens Projectile Aerodynamics Guided Projectile Gradient Refractive Index Lens Design		
20. ABSTRACT (Continue on reverse side if necessary and identify by block number) * This thesis explores the use of a pointed seeker lens designed using a spherically symmetric gradient refractive index (GRIN). The design helps to solve the current design conflict between optical quality and aerodynamic drag inherent in hemispherical seeker lenses. Equations for lens design and the evaluation of off-axis lens performance have been developed for both a homogeneous version and a GRIN version of the pointed		

SECURITY CLASSIFICATION OF THIS PAGE/When Data Entered

#20 - ABSTRACT - (CONTINUED)

seeker lens. The homogeneous lens is used as a comparison and a check for the GRIN lens. A FORTRAN program (GISL) has been written and employed to evaluate and compare both the homogeneous lens and many different configurations of possible GRIN lens designs. Results indicate that the GRIN lens has highly superior off-axis imaging performance as compared to the homogeneous lens. The best results were obtained for the GRIN lens with a fifty percent, positive, spherically symmetric gradient index with center of symmetry interior to the lens. Only very slightly inferior performance was observed with a five percent version of the same lens; such a lens possible can be manufactured today. GRIN lens performance also indicates that for objects off-axis by more than 17.2 degrees a large scale, multiple element sensor array may be required; with such a sensor array, objects off-axis by more than 37.2 degrees may require mirror elements to compensate for image movement.

Available	
NTIS	
DIC	
Availability	
Dist	
A	



Approved for public release; distribution unlimited.

Aerodynamically Efficient
Gradient Refractive Index
Missile Seeker Lens

by

Herbert M. Carr III
Captain, United States Army
B.S., University of Texas, 1971

Submitted in partial fulfillment of the
requirements for the degree of

MASTER OF SCIENCE IN ENGINEERING SCIENCE

from the
NAVAL POSTGRADUATE SCHOOL
October 1982

Author:

H. M. Carr III

Approved by:

Allen E. Fube

Thesis Advisor

Max F. Pluta

Chairman, Department of Aeronautics

William M. Tolles

Dean of Science and Engineering

ABSTRACT

This thesis explores the use of a pointed seeker lens designed using a spherically symmetric gradient refractive index (GRIN). The design helps to solve the current design conflict between optical quality and aerodynamic drag inherent in hemispherical seeker lenses. Equations for lens design and the evaluation of off-axis lens performance have been developed for both a homogeneous version and a GRIN version of the pointed seeker lens. The homogeneous lens is used as a comparison and a check for the GRIN lens. A FORTRAN program (GISL) has been written and employed to evaluate and compare both the homogeneous lens and many different configurations of possible GRIN lens designs. Results indicate that the GRIN lens has highly superior off-axis imaging performance as compared to the homogeneous lens. The best results were obtained for the GRIN lens with a fifty percent, positive, spherically symmetric gradient index with center of symmetry interior to the lens. Only very slightly inferior performance was observed with a five percent version of the same lens; such a lens possibly can be manufactured today. GRIN lens performance also indicates that for objects off-axis by more than 17.2 degrees a large scale, multiple element sensor array may be required; with such a sensor array, objects off-axis by more than 37.2 degrees may require mirror elements to compensate for image movement.

TABLE OF CONTENTS

I.	INTRODUCTION -----	36
II.	THE HOMOGENEOUS LENS -----	40
	A. THEORY -----	40
	B. ASSUMPTIONS AND SIGN CONVENTION -----	40
	C. HIN LENS DESIGN -----	41
	D. SKEW RAYS -----	49
	E. RADIANT ENERGY LOSS -----	68
	F. OPTICAL PATH LENGTH (OPL) -----	70
III.	THE GRIN LENS -----	71
	A. THEORY -----	71
	B. ASSUMPTIONS -----	78
	C. GRIN LENS DESIGN PARAMETERS -----	78
	D. GRIN LENS DESIGN -----	78
	E. SKEW RAYS IN GRIN -----	86
IV.	LENS PERFORMANCE PARAMETERS -----	96
V.	RESULTS FOR THE HOMOGENEOUS LENS -----	100
VI.	GRIN LENS RESULTS -----	117
VII.	CONCLUSION -----	134
VIII.	RECOMMENDATIONS FOR FUTURE WORK -----	135
APPENDIX A:	COMPUTER LOGIC FLOW DIAGRAMS FOR PROGRAM GISL -----	136
APPENDIX B:	LISTING OF FORTRAN PROGRAM GISL -----	145
APPENDIX C:	SAMPLE TABULAR OUTPUT FROM PROGRAM GISL --	169
APPENDIX D:	HIN LENS PERFORMANCE PLOTS -----	182
APPENDIX E:	GRIN LENS PERFORMANCE PLOTS IN THE LOW RANGE OF INDICES OF REFRACTION ($a = 2.25$) -----	209

APPENDIX F: GRIN LENS PERFORMANCE PLOTS IN THE HIGH RANGE OF INDICES OF REFRACTION ($a = 9.00$) -----	301
APPENDIX G: "BEST" GRIN LENS PERFORMANCE PLOTS IN THE F/2 CONFIGURATION -----	429
APPENDIX H: "BEST" GRIN LENS PERFORMANCE PLOTS IN THE F/1 CONFIGURATION -----	453
LIST OF REFERENCES -----	480
INITIAL DISTRIBUTION LIST -----	482

LIST OF TABLES

1.	Explanation of Lens Shape Plot Legend -----	102
2.	Explanation of Object Plane Plot Legend -----	105
3.	Explanation of Spot Diagram Legend -----	108
4.	Skew Ray Intensities of HIN Lens -----	110
5.	Comparison of HIN and GRIN Lens Designs -----	131

LIST OF FIGURES

1. Lens Shapes -----	39
2. Conceptual Drawing and Coordinate System of Outer Surface Solution -----	42
3. Ray Trace Geometry -----	45
4. Coordinate Transformation -----	51
5. Geometry of Skew Ray Intercept with Outside Surface -----	53
6. Kingslake's Skew Ray Diffraction Diagram -----	60
7. GRIN Lens Geometry -----	72
8. Excluded Regions for Center of Symmetry Due to Singularities -----	77
9. GRIN Ray Intercept Geometry -----	80
10. Expanded View, Intercept Geometry -----	81
11. Homogeneous Lens Shape for $N_2 = 1.5$ -----	101
12. Example Object Plane -----	106
13. Spot Diagram for HIN Lens Design Shown in Figure 11 -----	107
14. Nondimensional Encircled Energy Plot for HIN Lens Design of Figure 11 -----	111
15. HIN Lens Spot Size versus α_p for $N_2 = 1.5$ -----	113
16. HIN Lens Centroid Movement versus α_p at $N_2 = 1.5$ --	114
17. HIN Lens Spot Size versus Edge Thickness at $\alpha_p = 0.3$ Radians and $N_2 = 1.5$ -----	115
18. Example GRIN Lens Design with 10% Negative Gradient at $OB = 1.0$ -----	118
19. Example GRIN Lens Object Plane -----	119
20. Intensity Contours of the Example GRIN Lens Shown in Figure 18 -----	121

21.	Example GRIN Spot Diagram at $\alpha_p = 0.4$ Radians for GRIN Lens Design Shown in Figure 18 -----	122
22.	Example GRIN Encircled Energy Plot Corres- ponding to Figure 21 -----	123
23.	Contour Plot Summary of GRIN Lens Spot Size Performance for $\alpha_p = 0.3$, $a = 2.25$ -----	126
24.	Contour Plot Summary of GRIN Lens Spot Size Performance for $\alpha_p = 0.3$, $a = 9.00$ -----	127
25.	"Best" GRIN Lens Centroid Movement for F/Numbers of F/1 and F/2 -----	129
26.	"Best" GRIN Lens Spot Size Performance for F/Numbers of F/1 and F/2 -----	130
D-1.	Object Plane at $\alpha_p = 0.0$ Radians for HIN Lens Design Shown in Figure 11 -----	182
D-2.	Spot Diagram Corresponding to Object Plane of Figure D-1 -----	183
D-3.	Object Plane at $\alpha_p = 0.1$ Radians for HIN Lens Shown in Figure 11 -----	184
D-4.	Spot Diagram Corresponding to Figure D-3 -----	185
D-5.	Encircled Energy Plot for the Spot Diagram of Figure D-4 -----	186
D-6.	HIN Object Plane at $\alpha_p = 0.2$ Radians, $N_2 = 1.5$ ----	187
D-7.	Spot Diagram of HIN Lens at $\alpha_p = 0.2$ Radians, $N_2 = 1.5$ -----	188
D-8.	Encircled Energy Plot of HIN Lens at $\alpha_p = 0.2$ Radians, $N_2 = 1.5$ -----	189
D-9.	HIN Object Plane at $\alpha_p = 0.3$ Radians, $N_2 = 1.5$ ----	190
D-10.	Spot Diagram of HIN Lens at $\alpha_p = 0.3$ Radians, $N_2 = 1.5$ -----	191
D-11.	HIN Lens Encircled Energy at $\alpha_p = 0.3$ Radians, $N_2 = 1.5$ -----	192
D-12.	HIN Object Plane at $\alpha_p = 0.4$ Radians, $N_2 = 1.5$ ----	193
D-13.	Spot Diagram of HIN Lens at $\alpha_p = 0.4$ Radians, $N_2 = 1.5$ -----	194

D-14.	Encircled Energy Plot at $\alpha_p = 0.4$ Radians, $N_2 = 1.5$ ----- α_p -----	195
D-15.	HIN Lens Object Plane at $\alpha_p = 0.5$ Radians, $N_2 = 1.5$ ----- α_p -----	196
D-16.	Spot Diagram of HIN Lens at $\alpha_p = 0.5$ Radians, $N_2 = 1.5$ ----- α_p -----	197
D-17.	Encircled Energy Plot at $\alpha_p = 0.5$ Radians, $N_2 = 1.5$ ----- α_p -----	198
D-18.	HIN Object Plane at $\alpha_p = 0.6$ Radians, $N_2 = 1.5$ -	199
D-19.	Spot Diagram of HIN Lens at $\alpha_p = 0.6$ Radians, $N_2 = 1.5$ ----- α_p -----	200
D-20.	Encircled Energy Plot at $\alpha_p = 0.6$ Radians, $N_2 = 1.5$ ----- α_p -----	201
D-21.	HIN Object Plane at $\alpha_p = 0.7$ Radians, $N_2 = 1.5$ -	202
D-22.	Spot Diagram of HIN Lens at $\alpha_p = 0.7$ Radians, $N_2 = 1.5$ ----- α_p -----	203
D-23.	Encircled Energy Plot at $\alpha_p = 0.7$ Radians, $N_2 = 1.5$ ----- α_p -----	204
D-24.	HIN Lens Design for $N_2 = 3.0$ -----	205
D-25.	Object Plane of HIN Lens in Figure D-24 at $\alpha_p = 0.3$ Radians -----	206
D-26.	Spot Diagram Corresponding to Figure D-25 -----	207
D-27.	Encircled Energy Plot for Spot Diagram of Figure D-26 -----	208
E-1.	GRIN Lens Shape at +50%, OB = 0.05, a = 2.25 ---	209
E-2.	Grid Plane at $\alpha_p = 0.3$ for Lens of Figure E-1 --	210
E-3.	Spot Diagram for Grid of Figure E-2 -----	211
E-4.	Encircled Energy of Figure E-3 -----	212
E-5.	GRIN Lens Shape at +50%, OB = 0.15, a = 2.25 ----	213
E-6.	Grid Plane at $\alpha_p = 0.3$ for Lens of Figure E-5 --	214
E-7.	Spot Diagram for Grid of Figure E-6 -----	215

E-8.	Encircled Energy of Figure E-7 -----	216
E-9.	GRIN Lens Shape at -2%, OB = 0.20, a = 2.25 ----	217
E-10.	Grid Plane at $\alpha_p = 0.3$ for Lens of Figure E-9 --	218
E-11.	Spot Diagram for Grid of Figure E-10 -----	219
E-12.	Encircled Energy of Figure E-11 -----	220
E-13.	GRIN Lens Shape at -5%, OB = 0.20, a = 2.25 ----	221
E-14.	Grid Plane at $\alpha_p = 0.3$ for Lens of Figure E-13 -	222
E-15.	Spot Diagram for Grid of Figure E-14 -----	223
E-16.	Encircled Energy of Figure E-15 -----	224
E-17.	GRIN Lens Shape at +5%, OB = 0.20, a = 2.25 ----	225
E-18.	Grid Plane at $\alpha_p = 0.3$ for Lens of Figure E-17 -	226
E-19.	Spot Diagram for Grid of Figure E-18 -----	227
E-20.	Encircled Energy of Figure E-19 -----	228
E-21.	GRIN Lens Shape at +10%, OB = 0.20, a = 2.25 ---	229
E-22.	Grid Plane at $\alpha_p = 0.3$ for Lens of Figure E-21 -	230
E-23.	Spot Diagram for Grid of Figure E-22 -----	231
E-24.	Encircled Energy of Figure E-23 -----	232
E-25.	GRIN Lens Shape at +25%, OB = 0.20, a = 2.25 ---	233
E-26.	Grid Plane at $\alpha_p = 0.3$ for Lens of Figure E-25 -	234
E-27.	Spot Diagram for Grid of Figure E-26 -----	235
E-28.	Encircled Energy of Figure E-27 -----	236
E-29.	GRIN Lens Shape at +50%, OB = 0.20, a = 2.25 ---	237
E-30.	Grid Plane at $\alpha_p = 0.3$ for Lens of Figure E-29 -	238
E-31.	Spot Diagram for Grid of Figure E-30 -----	239
E-32.	Encircled Energy of Figure E-31 -----	240
E-33.	GRIN Lens Shape at -10%, OB = 0.30, a = 2.25 ---	241

E-34.	Grid Plane at $\alpha_p = 0.3$ for Lens of Figure E-33 -	242
E-35.	Spot Diagram for Grid of Figure E-34 -----	243
E-36.	Encircled Energy of Figure E-35 -----	244
E-37.	GRIN Lens Shape at -25%, OB = 0.35, a = 2.25 ---	245
E-38.	Grid Plane at $\alpha_p = 0.3$ for Lens of Figure E-37 -	246
E-39.	Spot Diagram for Grid of Figure E-38 -----	247
E-40.	Encircled Energy of Figure E-39 -----	248
E-41.	GRIN Lens Shape at -5%, OB = 1.00, a = 2.25 ----	249
E-42.	Grid Plane at $\alpha_p = 0.3$ for Lens of Figure E-41 -	250
E-43.	Spot Diagram for Grid of Figure E-42 -----	251
E-44.	Encircled Energy of Figure E-43 -----	252
E-45.	GRIN Lens Shape at -10%, OB = 1.00, a = 2.25 ---	253
E-46.	Grid Plane at $\alpha_p = 0.3$ for Lens of Figure E-45 -	254
E-47.	Spot Diagram for Grid of Figure E-46 -----	255
E-48.	Encircled Energy of Figure E-47 -----	256
E-49.	GRIN Lens Shape at -25%, OB = 1.00, a = 2.25 ---	257
E-50.	Grid Plane at $\alpha_p = 0.3$ for Lens of Figure E-49 -	258
E-51.	Spot Diagram for Grid of Figure E-50 -----	259
E-52.	Encircled Energy of Figure E-51 -----	260
E-53.	GRIN Lens Shape at +5%, OB = 1.00, a = 2.25 ----	261
E-54.	Grid Plane at $\alpha_p = 0.3$ for Lens of Figure E-53 -	262
E-55.	Spot Diagram for Grid of Figure E-54 -----	263
E-56.	Encircled Energy of Figure E-55 -----	264
E-57.	GRIN Lens Shape at +10%, OB = 1.00, a = 2.25 ---	265
E-58.	Grid Plane at $\alpha_p = 0.3$ for Lens of Figure E-57 -	266
E-59.	Spot Diagram for Grid of Figure E-58 -----	267

E-60.	Encircled Energy of Figure E-59 -----	268
E-61.	GRIN Lens Shape at +25%, OB = 1.00, a = 2.25 ---	269
E-62.	Grid Plane at $\alpha_p = 0.3$ for Lens of Figure E-61 -	270
E-63.	Spot Diagram for Grid of Figure E-62 -----	271
E-64.	Encircled Energy of Figure E-63 -----	272
E-65.	GRIN Lens Shape at +50%, OB = 1.00, a = 2.25 ---	273
E-66.	Grid Plane at $\alpha_p = 0.3$ for Lens of Figure E-65 -	274
E-67.	Spot Diagram for Grid of Figure E-66 -----	275
E-68.	Encircled Energy of Figure E-67 -----	276
E-69.	GRIN Lens Shape at -5%, OB = 3.50, a = 2.25 ----	277
E-70.	Grid Plane at $\alpha_p = 0.3$ for Lens of Figure E-69 -	278
E-71.	Spot Diagram for Grid of Figure E-70 -----	279
E-72.	Encircled Energy of Figure E-71 -----	280
E-73.	GRIN Lens Shape at -10%, OB = 3.50, a = 2.25 ---	281
E-74.	Grid Plane at $\alpha_p = 0.3$ for Lens of Figure E-73 -	282
E-75.	Spot Diagram for Grid of Figure E-74 -----	283
E-76.	Encircled Energy of Figure E-75 -----	284
E-77.	GRIN Lens Shape at +5%, OB = 4.00, a = 2.25 ----	285
E-78.	Grid Plane at $\alpha_p = 0.3$ for Lens of Figure E-77 -	286
E-79.	Spot Diagram for Grid of Figure E-78 -----	287
E-80.	Encircled Energy of Figure E-79 -----	288
E-81.	GRIN Lens Shape at +10%, OB = 4.00, a = 2.25 ---	289
E-82.	Grid Plane at $\alpha_p = 0.3$ for Lens of Figure E-81 -	290
E-83.	Spot Diagram for Grid of Figure E-82 -----	291
E-84.	Encircled Energy of Figure E-83 -----	292
E-85.	GRIN Lens Shape at +25%, OB = 4.00, a = 2.25 ---	293

E-86.	Grid Plane at $\alpha_p = 0.3$ for Lens of Figure E-85 -	294
E-87.	Spot Diagram for Grid of Figure E-86 -----	295
E-88.	Encircled Energy of Figure E-87 -----	296
E-89.	GRIN Lens Shape at +50%, OB = 4.00, a = 2.25 ---	297
E-90.	Grid Plane at $\alpha_p = 0.3$ for Lens of Figure E-89 -	298
E-91.	Spot Diagram for Grid of Figure E-90 -----	299
E-92.	Encircled Energy of Figure E-91 -----	300
F-1.	GRIN Lens Shape at -5%, OB = 0.05, a = 9.00 ----	301
F-2.	Grid Plane at $\alpha_p = 0.3$ for Lens of Figure F-1 --	302
F-3.	Spot Diagram for Grid of Figure F-2 -----	303
F-4.	Encircled Energy of Figure F-3 -----	304
F-5.	GRIN Lens Shape at -10%, OB = 0.05, a = 9.00 ---	305
F-6.	Grid Plane at $\alpha_p = 0.3$ for Lens of Figure F-5 --	306
F-7.	Spot Diagram for Grid of Figure F-6 -----	307
F-8.	Encircled Energy of Figure F-7 -----	308
F-9.	GRIN Lens Shape at -25%, OB = 0.05, a = 9.00 ---	309
F-10.	Grid Plane at $\alpha_p = 0.3$ for Lens of Figure F-9 --	310
F-11.	Spot Diagram for Grid of Figure F-10 -----	311
F-12.	Encircled Energy of Figure F-11 -----	312
F-13.	GRIN Lens Shape at -50%, OB = 0.05, a = 9.00 ---	313
F-14.	Grid Plane at $\alpha_p = 0.3$ for Lens of Figure F-13 -	314
F-15.	Spot Diagram for Grid of Figure F-14 -----	315
F-16.	Encircled Energy of Figure F-15 -----	316
F-17.	GRIN Lens Shape at +5%, OB = 0.05, a = 9.00 ----	317
F-18.	Grid Plane at $\alpha_p = 0.3$ for Lens of Figure F-17 -	318
F-19.	Spot Diagram for Grid of Figure F-18 -----	319

F-20.	Encircled Energy of Figure F-19 -----	320
F-21.	GRIN Lens Shape for +10%, OB = 0.05, a = 9.00 --	321
F-22.	Grid Plane at $\alpha_p = 0.3$ Radians for Lens of Figure F-21 -----	322
F-23.	Spot Diagram for Grid of Figure F-22 -----	323
F-24.	Encircled Energy of Figure F-23 -----	324
F-25.	GRIN Lens Shape for +25%, OB = 0.05, a = 9.00 --	325
F-26.	Grid Plane at $\alpha_p = 0.3$ for Lens of Figure F-25 -	326
F-27.	Spot Diagram for Grid of Figure F-26 -----	327
F-28.	Encircled Energy of Figure F-27 -----	328
F-29.	GRIN Lens Shape at +50%, OB = 0.05, a = 9.00 ---	329
F-30.	Grid Plane at $\alpha_p = 0.3$ for Lens of Figure F-29 -	330
F-31.	Spot Diagram for Grid of Figure F-30 -----	331
F-32.	Encircled Energy of Figure F-31 -----	332
F-33.	GRIN Lens Shape at -5%, OB = 0.20, a = 9.00 ----	333
F-34.	Grid Plane at $\alpha_p = 0.3$ for Lens of Figure F-33 -	334
F-35.	Spot Diagram for Grid of Figure F-34 -----	335
F-36.	Encircled Energy of Figure F-35 -----	336
F-37.	GRIN Lens Shape at -10%, OB = 0.20, a = 9.00 ---	337
F-38.	Grid Plane at $\alpha_p = 0.3$ for Lens of Figure F-37 -	338
F-39.	Spot Diagram for Grid of Figure F-38 -----	339
F-40.	Encircled Energy of Figure F-39 -----	340
F-41.	GRIN Lens Shape at -25%, OB = 0.20, a = 9.00 ---	341
F-42.	Grid Plane at $\alpha_p = 0.3$ for Lens of Figure F-41 -	342
F-43.	Spot Diagram for Grid of Figure F-42 -----	343
F-44.	Encircled Energy of Figure F-43 -----	344
F-45.	GRIN Lens Shape for -50%, OB = 0.20, a = 9.00 --	345

F-46.	Grid Plane at $\alpha_p = 0.3$ for Lens of Figure F-45 -	346
F-47.	Spot Diagram for Grid of Figure F-46 -----	347
F-48.	Encircled Energy of Figure F-47 -----	348
F-49.	GRIN Lens Shape for +5%, OB = 0.20, a = 9.00 ---	349
F-50.	Grid Plane at $\alpha_p = 0.3$ for Lens of Figure F-49 -	350
F-51.	Spot Diagram for Grid of Figure F-50 -----	351
F-52.	Encircled Energy of Figure F-51 -----	352
F-53.	GRIN Lens Shape at +10%, OB = 0.20, a = 9.00 ---	353
F-54.	Grid Plane at $\alpha_p = 0.3$ for Lens of Figure F-53 -	354
F-55.	Spot Diagram for Grid of Figure F-54 -----	355
F-56.	Encircled Energy of Figure F-55 -----	356
F-57.	GRIN Lens Shape at +25%, OB = 0.20, a = 9.00 ---	357
F-58.	Grid Plane at $\alpha_p = 0.3$ for Lens of Figure F-57 -	358
F-59.	Spot Diagram for Grid of Figure F-58 -----	359
F-60.	Encircled Energy of Figure F-59 -----	360
F-61.	GRIN Lens Shape at +50%, OB = 0.20, a = 9.00 ---	361
F-62.	Grid Plane at $\alpha_p = 0.3$ for Lens of Figure F-61 -	362
F-63.	Spot Diagram for Grid of Figure F-62 -----	363
F-64.	Encircled Energy of Figure F-63 -----	364
F-65.	GRIN Lens Shape at -5%, OB = 1.00, a = 9.00 ----	365
F-66.	Grid Plane at $\alpha_p = 0.3$ for Lens of Figure F-65 -	366
F-67.	Spot Diagram for Grid of Figure F-66 -----	367
F-68.	Encircled Energy of Figure F-67 -----	368
F-69.	GRIN Lens Shape at -10%, OB = 1.00, a = 9.00 ---	369
F-70.	Grid Plane at $\alpha_p = 0.3$ for Lens of Figure F-69 -	370
F-71.	Spot Diagram for Grid of Figure F-70 -----	371

F-72.	Encircled Energy of Figure F-71 -----	372
F-73.	GRIN Lens Shape at -25%, OB = 1.00, a = 9.00 ---	373
F-74.	Grid Plane at $\alpha_p = 0.3$ for Lens of Figure F-73 -	374
F-75.	Spot Diagram for Grid of Figure F-74 -----	375
F-76.	Encircled Energy of Figure F-75 -----	376
F-77.	GRIN Lens Shape at -50%, OB = 1.00, a = 9.00 ---	377
F-78.	Grid Plane at $\alpha_p = 0.3$ for Lens of Figure F-77 -	378
F-79.	Spot Diagram for Grid of Figure F-78 -----	379
F-80.	Encircled Energy of Figure F-79 -----	380
F-81.	GRIN Lens Shape at +5%, OB = 1.00, a = 9.00 ----	381
F-82.	Grid Plane at $\alpha_p = 0.3$ for Lens of Figure F-81 -	382
F-83.	Spot Diagram for Grid of Figure F-82 -----	383
F-84.	Encircled Energy of Figure F-83 -----	384
F-85.	GRIN Lens Shape at +10%, OB = 1.00, a = 9.00 ---	385
F-86.	Grid Plane at $\alpha_p = 0.3$ for Lens of Figure F-85 -	386
F-87.	Spot Diagram for Grid of Figure F-86 -----	387
F-88.	Encircled Energy of Figure F-87 -----	388
F-89.	GRIN Lens Shape at +25%, OB = 1.00, a = 9.00 ---	389
F-90.	Grid Plane at $\alpha_p = 0.3$ for Lens of Figure F-89 -	390
F-91.	Spot Diagram for Grid of Figure F-90 -----	391
F-92.	Encircled Energy of Figure F-91 -----	392
F-93.	GRIN Lens Shape at +50%, OB = 1.00, a = 9.00 ---	393
F-94.	Grid Plane at $\alpha_p = 0.3$ for Lens of Figure F-93 -	394
F-95.	Spot Diagram for Grid of Figure F-94 -----	395
F-96.	Encircled Energy of Figure F-95 -----	396
F-97.	GRIN Lens Shape at -5%, OB = 2.00, a = 9.00 ----	397

F-98.	Grid Plane at $\alpha_p = 0.3$ for Lens of Figure F-97 --	398
F-99.	Spot Diagram for Grid of Figure F-98 -----	399
F-100.	Encircled Energy of Figure F-99 -----	400
F-101.	GRIN Lens Shape at -10%, OB = 2.00, a = 9.00 ----	401
F-102.	Grid Plane at $\alpha_p = 0.3$ for Lens of Figure F-101 -	402
F-103.	Spot Diagram for Grid of Figure F-102 -----	403
F-104.	Encircled Energy of Figure F-103 -----	404
F-105.	GRIN Lens Shape at -25%, OB = 2.00, a = 9.00 ----	405
F-106.	Grid Plane at $\alpha_p = 0.3$ for Lens of Figure F-105 -	406
F-107.	Spot Diagram for Grid of Figure F-106 -----	407
F-108.	Encircled Energy of Figure F-107 -----	408
F-109.	GRIN Lens Shape at -50%, OB = 2.00, a = 9.00 ----	409
F-110.	Grid Plane at $\alpha_p = 0.3$ for Grid of Figure F-109 -	410
F-111.	Spot Diagram for Grid of Figure F-110 -----	411
F-112.	Encircled Energy of Figure F-111 -----	412
F-113.	GRIN Lens Shape at +5%, OB = 4.00, a = 9.00 -----	413
F-114.	Grid Plane at $\alpha_p = 0.3$ for Lens of Figure F-113 -	414
F-115.	Spot Diagram for Grid of Figure F-114 -----	415
F-116.	Encircled Energy of Figure F-115 -----	416
F-117.	GRIN Lens Shape at +10%, OB = 4.00, a = 9.00 ----	417
F-118.	Grid Plane at $\alpha_p = 0.3$ for Lens of Figure F-117 -	418
F-119.	Spot Diagram for Grid of Figure F-118 -----	419
F-120.	Encircled Energy of Figure F-119 -----	420
F-121.	GRIN Lens Shape at +25%, OB = 4.00, a = 9.00 ----	421
F-122.	Grid Plane at $\alpha_p = 0.3$ for Lens of Figure F-121 -	422
F-123.	Spot Diagram for Grid of Figure F-122 -----	423

F-124.	Encircled Energy of Figure F-123 -----	424
F-125.	GRIN Lens Shape at +50%, OB = 4.00, a = 9.00 ----	425
F-126.	Grid Plane at $\alpha_p = 0.3$ for Lens of Figure F-125 -	426
F-127.	Spot Diagram for Grid of Figure F-126 -----	427
F-128.	Encircled Energy of Figure F-127 -----	428
G-1.	"Best" GRIN Lens Shape with 50% Gradient, OB = 0.05 and a = 9.00 in the F/2 Configuration -	429
G-2.	Grid Plane at $\alpha_p = 0.0$ for Lens of Figure G-1 ---	430
G-3.	Spot Diagram for Grid of Figure G-2 -----	431
G-4.	Grid Plane at $\alpha_p = 0.1$ for Lens of Figure G-1 ---	432
G-5.	Spot Diagram for Grid of Figure G-4 -----	433
G-6.	Encircled Energy of Figure G-5 -----	434
G-7.	Grid Plane at $\alpha_p = 0.2$ for Lens of Figure G-1 ---	435
G-8.	Spot Diagram for Grid of Figure G-7 -----	436
G-9.	Encircled Energy of Figure G-8 -----	437
G-10.	Grid Plane at $\alpha_p = 0.4$ for Lens of Figure G-1 ---	438
G-11.	Spot Diagram for Grid of Figure G-10 -----	439
G-12.	Encircled Energy of Figure G-11 -----	440
G-13.	Grid Plane at $\alpha_p = 0.5$ for Lens of Figure G-1 ---	441
G-14.	Spot Diagram for Grid of Figure G-13 -----	442
G-15.	Encircled Energy of Figure G-14 -----	443
G-16.	Grid Plane at $\alpha_p = 0.6$ for Lens of Figure G-1 ---	444
G-17.	Spot Diagram for Grid of Figure G-16 -----	445
G-18.	Encircled Energy of Figure G-17 -----	446
G-19.	Grid Plane at $\alpha_p = 0.7$ for Lens of Figure G-1 ---	447
G-20.	Spot Diagram for Grid of Figure G-19 -----	448
G-21.	Encircled Energy of Figure G-20 -----	449

G-22.	Grid Plane at $\alpha_p = 0.8$ for Lens of Figure G-1 ---	450
G-23.	Spot Diagram for Grid of Figure G-22 -----	451
G-24.	Encircled Energy of Figure G-23 -----	452
H-1.	"Best" GRIN Lens Shape with 50% Gradient, OB = 0.05, and a = 9.00 in the F/1 Configuration -	453
H-2.	Grid Plane at $\alpha_p = 0.0$ for Lens of Figure H-1 ----	454
H-3.	Spot Diagram for Grid of Figure H-2 -----	455
H-4.	Grid Plane at $\alpha_p = 0.1$ for Lens of Figure H-1 ----	456
H-5.	Spot Diagram for Grid of Figure H-4 -----	457
H-6.	Encircled Energy of Figure H-5 -----	458
H-7.	Grid Plane at $\alpha_p = 0.2$ for Lens of Figure H-1 ----	459
H-8.	Spot Diagram for Grid of Figure H-7 -----	460
H-9.	Encircled Energy of Figure H-8 -----	461
H-10.	Grid Plane at $\alpha_p = 0.3$ for Lens of Figure H-1 ----	462
H-11.	Spot Diagram for Grid of Figure H-10 -----	463
H-12.	Encircled Energy of Figure H-11 -----	464
H-13.	Grid Plane at $\alpha_p = 0.4$ for Lens of Figure H-1 ----	465
H-14.	Spot Diagram for Grid of Figure H-13 -----	466
H-15.	Encircled Energy of Figure H-14 -----	467
H-16.	Grid Plane at $\alpha_p = 0.5$ for Lens of Figure H-1 ----	468
H-17.	Spot Diagram for Grid of Figure H-16 -----	469
H-18.	Encircled Energy of Figure H-17 -----	470
H-19.	Grid Plane at $\alpha_p = 0.6$ for Lens of Figure H-1 ----	471
H-20.	Spot Diagram for Grid of Figure H-19 -----	472
H-21.	Encircled Energy of Figure H-20 -----	473
H-22.	Grid Plane at $\alpha_p = 0.7$ for Lens of Figure H-1 ----	474
H-23.	Spot Diagram for Grid of Figure H-22 -----	475

H-24.	Encircled Energy of Figure H-23 -----	476
H-25.	Grid Plane at $\alpha_p = 0.8$ for Lens of Figure H-1 ---	477
H-26.	Spot Diagram for Grid of Figure H-25 -----	478
H-27.	Encircled Energy of Figure H-26 -----	479

LIST OF SYMBOLS

Symbol in Equations	FORTRAN Symbol	Equation Number Where First Introduced	Definition	Units
a	A	113	Parameter of gradient index function	Nondimensional
a		41	Defined by Equation 44	
A		24	Defined by Equation 25	
A		137	Defined by Equation 138	
A ₁		161	Defined by Equation 164	
A ₂		160	Defined by Equation 161	
A ₃		169	Defined by Equation 170	
A ₅		179	Defined by Equation 184	
A ₆		178	Defined by Equation 181	
AB	AB	30	Line segment from A to B, from nose to apex of cone	Nondimensional
b	B	113	Parameter of gradient index function	Nondimensional
b		41	Defined by Equation 45	
B		24,137	Defined by Equation 26	
B ₁		161	Defined by Equation 165	
B ₂		160	Defined by Equation 162	
B ₅		179	Defined by Equation 185	
B ₆		178	Defined by Equation 182	
BF	BF	2	Line segment from B to F, focal length	Nondimensional
c		41	Defined by Equation 46	

c		24	Defined by Equation 27	
c		137	Defined by Equation 139	
c_1		161	Defined by Equation 166	
c_2		160	Defined by Equation 163	
c_6		178	Defined by Equation 183	
d		41	Defined by Equation 47	
d	ERROR	142	Error parameter in meridian plane ray intercept with outside surface	Nondimensional
D	D2	72	Geometrical length of skew ray in homogeneous lens	Nondimensional
D'	D3	95	Geometrical length of skew ray from cone to image plane	Nondimensional
DYDXN(J)	DYDXN(J)	20	Slope of normal to outside surface in the meridian plane at the Jth point	Nondimensional
DYDXT(J)	DYDXT(J)	21	Slope of outside surface tangent in the meridian plane at the Jth point	Nondimensional
$DYDXN_{PIM}$		51	Slope of normal to outside surface in the meridian plane. Interpolated value	Nondimensional
e	E	108	Spherical GRIN scalar invariant	Nondimensional
e		41	Defined by Equation 48	
$f(x,y,z)$			General function of x, y, and z	
f_x		82	Partial derivative of function f with respect to x	

f_y		82	Partial derivative of function f with respect to y	
f_z		82	Partial derivative of function f with respect to z	
i		186	Summation index	
\hat{i}		53	Unit vector in the x direction	
I	I	3	Number of angular increments in lens design algorithm	
I_A			Fraction of absorbed radiant energy during transmission through the lens	Nondimensional
I_1	$I1$	17	Angle of incidence with respect to local normal at outside surface	Radians
I_1'	$I1P$	16	Angle of refraction with respect to the local normal at the outside surface	Radians
I_2	$I2$	12	Angle of incidence with respect to the local normal at the inside surface	Radians
I_2'	$I2P$	10	Angle of refraction with respect to the local normal at the inside surface	Radians
I_R		102	Fraction of reflected radiant energy at the surface interface	Nondimensional
I_T	$NINCTY$	102	Fraction of transmitted radiant energy at the interface	Nondimensional
I_i	$NINCTY(G)$	190	Intensity element of intensity summation	Nondimensional

I_{av}	XMAVE	190	Average value of ray intensity	Nondimensional
\hat{j}		53	Unit vector in the x-direction	
J	J	4	Ray Number index	
k	LK	63	Direction cosine, x-direction, of outside surface normal	
k'	LKP	83	Direction cosine, z-direction, of inside surface normal	
\hat{k}		55	Unit vector in y-direction	
K	CK	58	x-direction cosine of ray exterior to lens surface	
K'	CKP	63	x-direction cosine of ray inside the lens	
K''	CKPP	92	x-direction cosine of the ray after refraction by the lens	
l	LL	64	y-direction cosine of outside surface normal	
l'	LLP	84	y-direction cosine of inside surface normal	
L	CL	58	y-direction cosine of the ray external to the lens	
L'	CLP	64	y-direction cosine of the ray internal to the lens	
L''	CLPP	93	y-direction cosine of the ray after diffraction by the lens	

l_0		122	Generalized z-direction cosine of the initial ray direction in GRIN	
m	LM	65	z-direction cosine of outside surface normal	
m		38	Generalized slope of a line segment	
m'	LMP	85	z-direction cosine of inside surface normal	
M	QM	58	z-direction cosine of ray external to the lens	
M'	QMP	65	z-direction cosine of ray internal to the lens	
M''	QMPP	94	z-direction cosine of ray after refraction by the lens	
n		108	Generalized local value of the gradient refractive index	Nondimensional
n_0		109	Generalized value of the gradient index at the initial intercept point	Nondimensional
n_2	N2	125	Local lens interior value of the GRIN	Nondimensional
N		186	Generalized nth value of summation index	
N_1	N1	1	Homogeneous index of refraction of medium 1, exterior to lens	Nondimensional
N_2	N2	1	Homogeneous index of refraction of medium 2, interior to lens	Nondimensional
N_3	N3	12	Homogeneous index of refraction of medium 3, behind the lens	Nondimensional
\bar{N}'		55	Normal vector at the point of intersection at the outside surface	

\bar{N}_m		53	Normal vector in the meridian plane corresponding to \bar{N}'	
\hat{N}_i		80	Generalized surface normal unit vector	
N_{ti}		104	Ratio of indices of refraction at an interface	Nondimensional
\hat{N}_{po}		148	Unit normal vector to plane of skew ray	
N_{pox}	NPOX	149	Defined by Equation 150	
N_{poy}	NPOY	149	Defined by equation 151	
N_{poz}	NPOZ	149	Defined by Equation 152	
OB	OSYMB	126	Line segment from the center of symmetry of the GRIN function, O_s , to B, the origin	Nondimensional
O_s		112	Location of the GRIN center of symmetry on the lens axis	Nondimensional
P_0		120	Generalized initial x-direction cosine of the GRIN ray	
P_1		76	Defined by Equation 77	
P_2		76	Defined by Equation 78	
P_3		76	Defined by Equation 79	
PAR1	PAR1	40	Defined by Equation 41	
PAR2	PAR2	40	Defined by Equation 42	
PAR3	PAR3	40	Defined by Equation 43	
q_0		121	Generalized y-direction cosine of initial GRIN ray direction	
Q		5	Perpendicular distance between ray and line parallel to ray through the origin at B in Figure 3	Nondimensional

QP		37	Line segment defined by Figure 5	Nondimensional
QP'		37	Line segment defined by Figure 5	Nondimensional
r	RAD	108	Radial coordinate in GRIN from O_s	Nondimensional
r_0	RO	108	Initial value of r at ray intercept point	Nondimensional
\hat{r}_0		146	Unit vector in direction from O_s to intercept point on outside surface	
r_{ox}	ROX	151	x-direction cosine of \hat{r}_0	
r_{oy}	ROY	150	y-direction cosine of \hat{r}_0	
r_{oz}	ROZ	150	z-direction cosine of \hat{r}_0	
\hat{r}_{iH}		156	Unit vector from O_s to point of homogeneous intercept on inside surface	
r_g	RADH	160	Geometrical radius from O_s to cone during iteration for the inside surface intercept	Nondimensional
r_{PI}	RAD	174	Radius to inside surface intercept as found by iteration	Nondimensional
r_{11}		103	Reflection coefficient for parallel E vector	Nondimensional
r		104	Reflection coefficient for perpendicular E vector	Nondimensional
R	R	2	Maximum inside radius of cone measured from the lens axis	Meters
R	RAD	33	Radius of circle in the y-z plane	Nondimensional
\hat{R}		57	Unit vector in the ray direction	

\bar{R}'		62	Vector in the direction of refracted ray	
R_2	RZERO	113	Maximum possible radius in GRIN	Nondimensional
S	S	51	Line segment in the meridian plane; see Figure 5	Nondimensional
ST	ST	51	Inclusive line segment in the meridian plane; see Figure 5	Nondimensional
T	T	14	Edge thickness of the lens	Nondimensional
U	U	17	Direction of the ray with respect to the lens axis in the meridian plane	Radians
U'	UP	13	Direction of the ray inside the lens with respect to the lens axis in the meridian plane	Radians
U''	UDP	4	Angle between ray and lens axis at the focal point in the meridian plane	Radians
v		115	Integration variable	Nondimensional
x		22	General x-coordinate along lens axis	Nondimensional
x'		30	General x-coordinate in the grid plane (tilted)	Nondimensional
x		2	Absolute value of any quantity x	
x_0	XO	40	x-coordinate of outside surface skew ray intercept	Nondimensional
x_i	XI	69	x-coordinate of inside surface intercept	Nondimensional

x_{im}	XIM	95	x-coordinate in the image plane (Spot Diagram)	Nondimensional
x_{1H}	X1H	130	First x-coordinate of imaginary homogeneous intercept in GRIN design	Nondimensional
x_p	XP	135	x-coordinate of the first intermediate point on the GRIN ray during iteration in the design algorithm	Nondimensional
x'_{1H}	X1HP	141	Second x-coordinate of imaginary homogeneous intercept in GRIN design	Nondimensional
$x_p^{m \dots}$	XP	143	Successive values of x_p during iteration	Nondimensional
x_{PIM}		52	x-coordinate of ray intercept in meridian plane	Nondimensional
$x_1(J)$	X1(J)	14	x-coordinate of the Jth ray on the outside surface in the meridian plane	Nondimensional
$x_2(J)$	X2(J)	5	x-coordinate of the Jth ray on the inside surface in the meridian plane	Nondimensional
y		22	General y-coordinate (vertical)	Nondimensional
y'		31	y-coordinate in the tilted grid plane	Nondimensional
y_0	Y0	49	y-coordinate of outside surface skew ray intercept	Nondimensional
y_i	YI	170	y-coordinate of inside surface skew ray intercept	Nondimensional

y_{im}	YIM	96	y-coordinate of the skew ray in the image plane (Spot Diagram)	Nondimensional
y_{1H}	Y1H	131	First y-coordinate of imaginary HIN intercept in GRIN design (iteration)	Nondimensional
y'_{1H}	Y1HP	137	Second y-coordinate of imaginary HIN intercept in GRIN design (iteration)	Nondimensional
y_p	YP	136	x-coordinate of the first intermediate point on the GRIN ray during iteration in the design algorithm	Nondimensional
$y_p^{...}$	YP	144	Successive values of y_p during iteration	Nondimensional
y_c	YCENTR	186	y-coordinate of the image centroid in the Spot Diagram	Nondimensional
y_i	YIM(G)	186	Individual y-coordinates of image plane ray intercept	Nondimensional
$y_1(J)$	Y1(J)	15	y-coordinate of the Jth ray on the outside surface in the meridian plane	Nondimensional
$y_2(J)$	J2(J)	5	y-coordinate of the ray on the inside surface in the meridian plane	Nondimensional
z		32	General z-coordinate (horizontal)	Nondimensional
z'		32	z-coordinate in the grid plane (tilted)	Nondimensional
z_0	ZO	50	z-coordinate of the skew ray on the outside surface	Nondimensional
z_i	ZI	71	z-coordinate of the skew ray on the inside surface (cone)	Nondimensional

z_{im}	ZIM	97	z-coordinate of the skew ray in the image plane (Spot Diagram)	Nondimensional
α	ALPHA	2	Cone half-angle	Radians
α_p	ALFAP	30	Grid plane tilt angle with respect to the lens axis	Radians/Degrees
β	BETA	2	Total angle between lens axis and the point of maximum radius of the cone; measured at the focal point	Radians
γ	GAMMA	29	Nose half-angle (opaque region)	Radians
δ		120	Defined by Equation 124	
$\Delta U''$	DLUDP	3	Angle between successive rays at the focal point	Radians
Δx		52	Incremental change in x; see Figure 5	
Δy		52	Incremental change in y; see Figure 5	
ϵ	EPSILON	109	Sign function (± 1)	
ζ	ZETA	134	Angle between instantaneous GRIN ray direction and the lens axis in the meridian plane	Radians
η		120	Defined by Equation 123	
θ		108	Generalized angular coordinate of GRIN ray in the plane of the ray	Radians
θ_1		1	Generalized angle of incidence with respect to the local normal	Radians
θ_2		1	Generalized angle of refraction with respect to the local normal	Radians
θ_0	THETA0	108	Reference (at surface intercept) in GRIN	Radians

θ_H	THETAH	125	Iteration trial value of θ	Radians
θ_T		125	Total angular GRIN coordinate	Radians
θ_p	THETAP	173	Trial values of θ during iteration	Radians
θ'_p	XNEW	173	Revised trial value of θ during iteration	Radians
μ		54	Angle between meridian plane and the point of intersection on the outside surface	Radians
π	PI	13	Proportionality factor between the circumference and the diameter of a circle; 3.14159...	Radians
σ_r	RMSRAD	189	Spot size; RMS radius of image	Nondimensional
σ_y	SIGMA Y	188	Standard deviation of y-coordinates of rays in the Spot Diagram	Nondimensional
σ_z	SIGMA Z	187	z-standard deviation of rays in the Spot Diagram	Nondimensional
ϕ	PHI	57	Angle between skew ray and the outside surface with respect to the surface normal	Radians
ϕ'	PHIP	61	Refraction angle between skew ray and the outside surface normal	Radians
ϕ_i	PHII	90	Angle of skew ray intercept with respect to the inside surface normal	Radians
ϕ'_i	PHIIP	91	Refraction angle of skew ray with respect to the inside surface normal	Radians

ψ	PSI	118	Angle between skew ray direction and radial direction from O_s	Radians
ψ_0	PSI0	109	Initial value of angle ψ at point of intercept at outside surface	Radians

ACKNOWLEDGEMENTS

The author would like to express his sincere appreciation to Distinguished Professor Allen E. Fuhs for his invaluable guidance, friendship, and time away from sabbatical. Without him this thesis would not have been possible.

The author would also like to thank Dr. Oded Amichai for his friendship and his assistance in many areas most notably in the intricacies of the IBM 3033.

I. INTRODUCTION

Historically, the design of tactical missiles employing passive or semiactive infrared (IR) seekers has involved a difficult compromise between aerodynamic requirements and optical or seeker requirements. Whereas aerodynamically the missile nose region should be sharp in order to reduce drag, optically it should be hemispherically shaped for image quality and as large as possible to increase aperture and therefore acquisition or tracking range. Some IR homing missiles designed for very short range anti-armor missions have totally ignored nose drag in order to optimize seeker performance while other designs for longer range missiles requiring high cruise velocities and greater aerodynamic efficiency have used the blunted ogive as a compromise. There have not been any IR designs which have ignored optics in favor of aerodynamics; nor has there been employed a pointed seeker lens with the desired optical qualities.

In order to increase the performance of optically guided missiles beyond the current state of development, the conflict between aerodynamic requirements and optical restrictions must be resolved. Significant improvement in missile performance by increasing thrust is not likely due to the highly advanced state of propulsion today. One way to resolve the aerodynamics-optics problem is to design a pointed lens which has, if not

imaging quality, enough optical performance to allow the reduction of tracking data.

The lens must be in the general shape of a cone or ogive with half angle compatible with the design free stream Mach number in order to maintain an attached shock wave. Such a spike-shaped lens might also be used in the diffuser portion of an optically guided ramjet with nose inlet to conserve stagnation pressure. A diffuser-lens may benefit by a semi-isentropic spike shaped lens.

Poor optical performance due to the pointed shape of sharp lenses has precluded their use. Gradient Refractive Index (GRIN) materials, however, permit the lens designer the freedom to spatially vary the lens index of refraction to compensate for a traditionally poor optical shape. Although the use of GRIN has seen widespread use in fiber optics technology, it has been used infrequently in lens applications until recently. Lens designers are discovering that multiple-element photographic objectives may be redesigned using a two-element gradient lens [1]. It should be noted, however, that such GRIN lens have not yet been successfully fabricated even though large index changes in glass have been accomplished by the diffusion of doped electropolarizable ions [2]. Extensive research is being conducted in the creation of ever larger and more precise gradients. A total change in refractive index of approximately five percent is currently attainable.

At the Naval Postgraduate School, Frazier [3], Terrell [4], and Amichai [5] have studied GRIN as applied to the sharp lens problem. The brief introduction by Frazier was followed by Terrell who designed a sharp lens having a conical outside surface and a variable inner surface using a homogeneous index (HIN) and then also briefly touched on the GRIN application. Amichai extended Terrell's lens to the GRIN case and included preliminary results from this thesis in a computer routine intended as a framework for lens optimization by following researchers.

This thesis investigates the design and off-axis performance (skew rays) of a GRIN seeker lens having a variable outer surface and a fixed right circular cone as an inside surface. The variable outside surface is determined by the character of the spherical gradient employed and varies from a pseudo ogive to an approximate isentropic spike as shown in Figure 1. First, the theory of the HIN lens is developed, followed by the design of a homogeneous lens intended both as a comparison and a check for the GRIN lens theory and the design which follows. Lens performance parameters are discussed and results presented for both the HIN and GRIN lenses.

OUTSIDE CONE

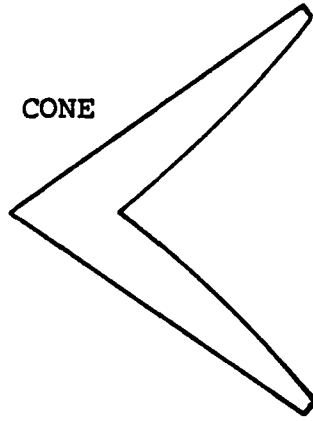

(a) Terrell's Lens With Conical Outer Surface

INSIDE CONE

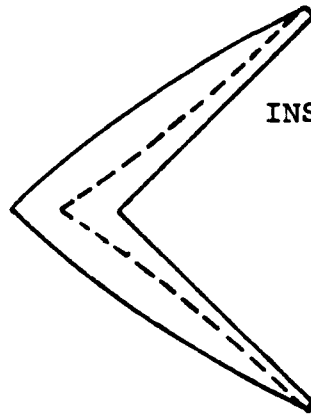

(b) Lens Shapes In This Thesis With Conical Inner Surface.

Figure 1. Lens Shapes

II. THE HOMOGENEOUS LENS

A. THEORY

Snell's law is the cornerstone of contemporary lens design in homogeneous optical materials. In the HIN case Snell's law is used in the familiar form

$$N_1 \sin \theta_1 = N_2 \sin \theta_2 \quad (1)$$

where N_i is the index of refraction of the material corresponding to surface intercept angle θ_i , with respect to the surface normal, at the interface between surfaces. Lens geometry and the relative values of N_i determine the resultant optical behavior.

B. ASSUMPTIONS AND SIGN CONVENTION

In order to simplify the design and analysis of the seeker lens problem, certain assumptions have been introduced. Although energy loss upon transmission through the lens at each surface is calculated, it is assumed that the light is monochromatic radiation, time dependent electric and magnetic fields. Light impinging upon the lens is assumed to have a planar wave front as if propagating from an object at infinity. The presence of a shock wave attached to the lens is ignored as are any other regions of expansion or compression in the flow field about the lens [6]. Furthermore, the index of refraction of the free stream is assumed

to be equal to that of the interior space behind the lens even though computer routines were written with the flexibility to process unequal values.

The sign convention used is a right handed system with spatial coordinates positive to the right, up, and out of the page as seen by the reader. All angles are assumed positive counterclockwise from point of reference unless otherwise noted. All linear dimensions are implicitly non-dimensionalized with respect to the maximum radius of the right circular cone forming the inside surface of the lens.

C. HIN LENS DESIGN

The lens design procedure consists of calculating both the loci of points forming the outside surface and the slope of the surface at each point in the meridian plane. It is convenient to approach the problem by placing a point source of light at the design focal point F and calculating successive refracted ray paths U' using Snell's law at points D_i on the inside surface in Figure 2. Points E_i are formed by the intercept of the refracted ray and the slope of the outside surface as extended from the previous point E_{i-1} . The tangent to the surface which will refract the ray in the desired direction, U , may again be found from Snell's law. The accuracy of the calculated surface increases as the spacing between points decreases or as angle $\Delta U''$ becomes very small. The final ray is parallel to the lens axis and point D_n corresponds to point B , which is the origin. The area

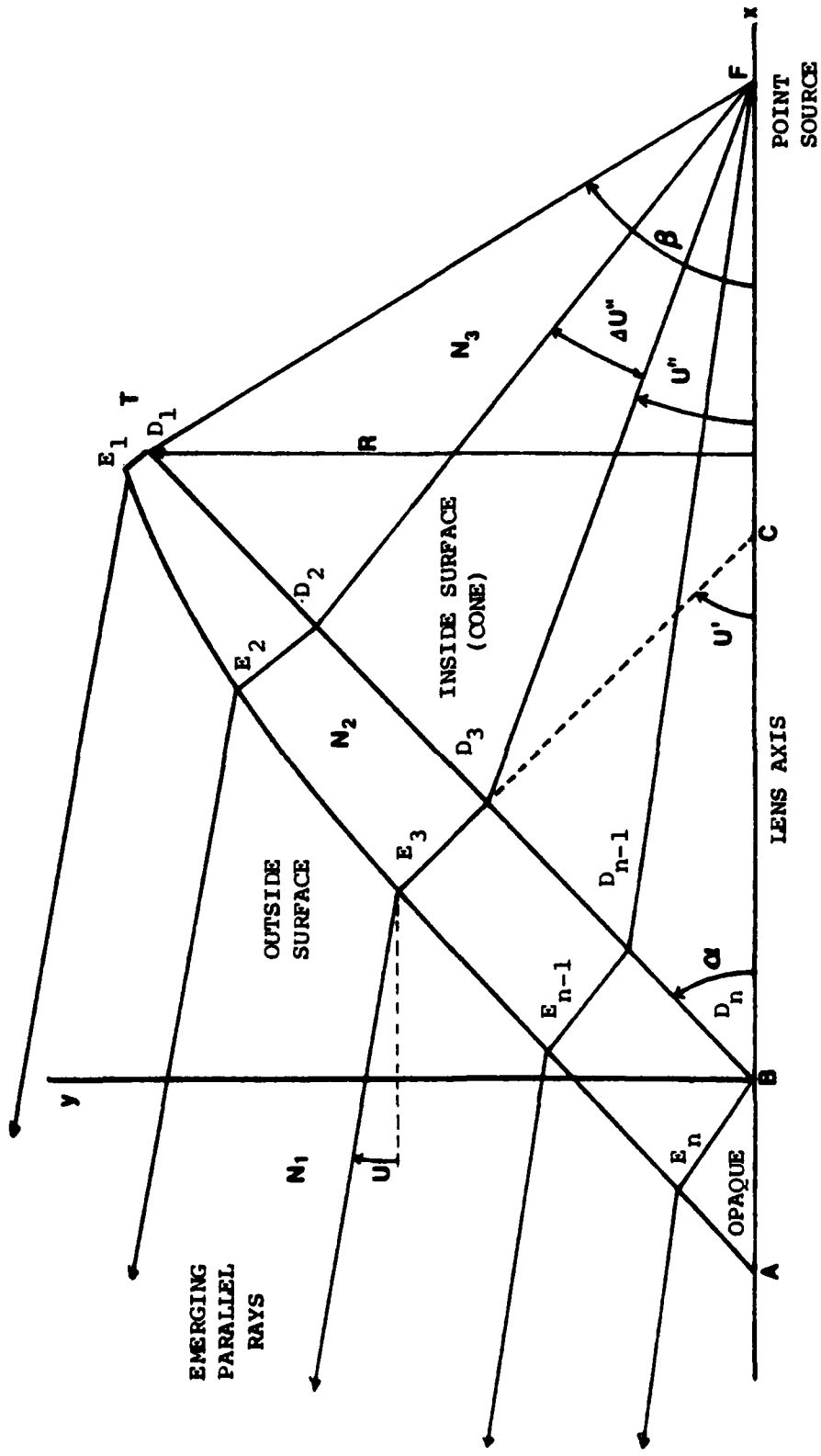

Figure 2. Conceptual Drawing and Coordinate System of Outer Surface Solution

formed by the triangle ABE_n is opaque to prevent rays from scattering through the opposite side of the lens.

A particular lens is begun by specifying the focal length BF , the cone half-angle α , the indices of refraction N_1 , N_2 , and N_3 , the cone radius at the edge R , the ray direction angle U , and the total number of rays to be traced. The thickness, T , of the lens at the edge (E_1D_1) must also be specified in order to define which of the family of possible outer surfaces will be calculated. In general, angle U will be taken to be zero in order to investigate objects on-axis at infinity. R will always be set equal to one and to nondimensionalize all linear dimensions every length is implicitly expressed as a ratio with respect to R . The angle β at the focal point is measured from the lens axis to D_1 and is expressed as

$$\tan |\beta| = \frac{R}{(BF - R \cdot \cotan \alpha)} \quad (2)$$

Thus, if $I+1$ is the total number of rays to be traced, then

$$\Delta U'' = \beta/I \quad (3)$$

and

$$U'' = \beta - J \cdot \Delta U'' \quad (4)$$

where J is the ray number. To begin the lens design the

coordinates $x_2(J), y_2(J)$ of point D_J must be found. Here the subscript 2 refers to the inside surface where $x_1(J), y_1(J)$ are the coordinates of E_J on the outside surface.

Following Kingslake [7], Q in Figure 3 may be expressed as

$$Q = BF \sin U'' = x_2(J) \sin U'' + y_2(J) \cos U'' \quad (5)$$

But,

$$y_2(J) = x_2(J) \tan \alpha \quad (6)$$

so that

$$BF \sin U'' = x_2(J) [\sin U'' + \tan \alpha \cos U''] \quad (7)$$

Now, $x_2(J)$ and $y_2(J)$ are

$$x_2(J) = \frac{BF \sin U''}{[\sin U'' + \tan \alpha \cos U'']} \quad (8)$$

$$y_2(J) = \frac{BF \sin U'' \tan \alpha}{[\sin U'' + \tan \alpha \cos U'']} \quad (9)$$

Looking now to find the incident angle I_2' which the ray forms with the inside surface at D_J it can be seen that

$$\tan (\alpha + I_2') = \frac{BF - x_2(J)}{y_2(J)} \quad (10)$$

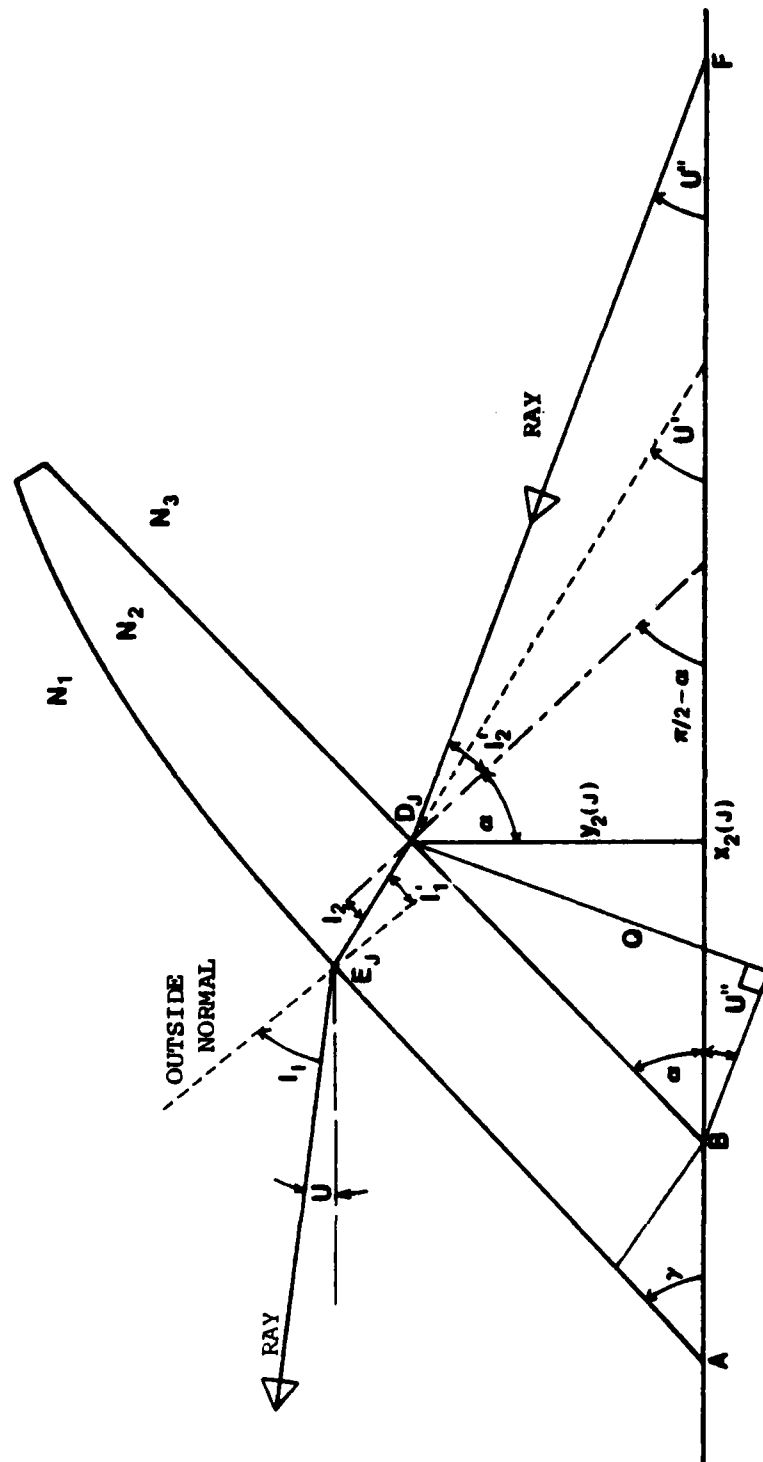

Figure 3. Ray Trace Geometry

Substituting into Equation (1), Snell's law, the refraction angle I_2 can now be written as

$$I_2 = \sin^{-1} \left[\left(\frac{N_3}{N_2} \right) \sin I_2' \right] \quad (12)$$

The path of the ray inside the lens may now be expressed in the form of the angle U' where

$$U' = \left(\frac{\pi}{2} - \alpha \right) - I_2 \quad (13)$$

To this stage all rays are treated the same. Now, however, a differentiation must be made between the outermost ray which defines the edge of the lens and all other subsequent rays.

For the outermost ray the thickness, T , of the lens at the edge can be specified which yields $x_1(l)$ and $y_1(l)$ immediately:

$$x_1(l) = x_2(l) - T \cos U' \quad (14)$$

$$y_1(l) = y_2(l) + T \cos U' \quad (15)$$

At point E_1 we may write Equation (1) again to obtain

$$I_1' = \sin^{-1} \left[\left(\frac{N_1}{N_2} \right) \sin I_1 \right] \quad (16)$$

where angles I_1 and I_1' are the incident and refracted angles at the outside surface and are not yet known. Angles I_1 and I_1' may be found by first noting that

$$U + I_1 = U' + I_1' \quad (17)$$

then substituting Equation (16) into (17) and rearranging terms to obtain

$$I_1 = U' - U + \sin^{-1} \left[\left(\frac{N_1}{N_2} \right) \sin I_1' \right] \quad (18)$$

It can be shown after some algebraic manipulation that Equation (18) may be solved for the angle I_1 in the form

$$I_1 = \sin^{-1} \left\{ \frac{\sin^2(U' - U)}{[\cos(U' - U) - N_1/N_2]^2 + \sin^2(U' - U)} \right\}^{1/2} \quad (19)$$

Angle I_1' may be found, if desired, by substitution of Equation (19) into Equation (16). Of more importance, however, is the determination of the slope of the outer surface and the surface normal. Now that angle I_1 is known these slopes may be written as

$$DYDXN(J) = \frac{dy}{dx} \Big|_{\text{normal}} = -\tan(U + I_1) \quad (20)$$

and

$$DYDXT'(J) = \frac{dy}{dx} \Big|_{\substack{\text{surface} \\ \text{tangent}}} = \cotan(U + L_1) \quad (21)$$

Equations (20) and (21) may be evaluated by using Equation (19) for I_1 .

Now that all the parameters are known for the first ray, the remainder of the points E_J and the respective slopes may be found. Each successive ray is traced as before by Equations (4) through (13). Equations (14) and (15), however, may not now be used since the lens thickness along the ray can not be specified. Instead, the intersection of the ray and the surface slope from the previous ray is used to define the new point E_{J+1} . The intersection is found by first writing the equations of lines representing the ray and the surface tangent. For the ray:

$$y = -x \tan U' + y_2(J) + x_2(J) \tan(U') \quad (22)$$

For the surface tangent:

$$y = x \cot(I_1 + U) + y_1(J-1) - x_1(J-1) \cot(I_1 + U) \quad (23)$$

Equations (22) and (23) are solved simultaneously to yield the coordinates of E_J which are

$$y_1(J) = \left\{ \frac{A + B}{C} \right\} \quad (24)$$

where:

$$A = \cot(I_1 + U) \cot(U') [y_2(J) + x_2(J) \tan(U')] \quad (25)$$

$$B = y_1(J-1) - x_1(J-1) \cot(I_1 + U) \quad (26)$$

$$C = 1 + \cot(I_1 + U) \cot(U') \quad (27)$$

and

$$x_1(J) = \cot(U') [-y_1(J) + y_2(J) + x_2(J) \tan(U')] \quad (28)$$

Now Equations (19), (20), and (21) are used to calculate I_1 and the slopes at E_J . Therefore, the remainder of the lens surface may be generated. The opaque region at the surface is formed by extending the slope of the surface at E_K to intersect the lens axis. Here, K refers to the last ray. The nose half-angle, γ , thus formed is given by

$$\tan \gamma = \left. \frac{dy}{dx} \right|_{\text{surface}, E_K} \quad (29)$$

D. SKEW RAYS

A skew ray is one that begins from an off-axis object point and enters the lens either in front of or behind the meridian plane ($z = 0$). For every skew ray, there is a corresponding mirror image skew ray on the opposite side of the meridian plane so that two skew rays are traced at the

expense of only one calculation. These two skew rays intersect at the same diaphragm.

Large numbers of skew rays are traced through a lens in order to study lens performance at different obliquities. The procedure is to superimpose a grid over the lens aperture and to trace rays through the intersections of the grid, through the lens and onto the image plane. An image plane spot diagram and an energy density plot are then constructed for study.

To accomplish this, the aperture grid has been attached to the nose (opaque region) of the seeker lens at station A; see Figure 3. The plane of the aperture grid is tilted relative to the lens by a variable angle. A transformation between the grid coordinates and the lens coordinates has been derived to connect skew rays from grid to intercept with the outside surface of the lens. Referring to Figure 4, it can easily be seen that

$$x' = [x + AB] \cos \alpha_p - y \sin \alpha_p \quad (30)$$

$$y' = [x + AB] \sin \alpha_p + y \cos \alpha_p \quad (31)$$

$$z' = z \quad (32)$$

where α_p is the tilt of the grid plane, AB is the length of the opaque nose portion on the x-axis. Both z and z' are positive out of the page.

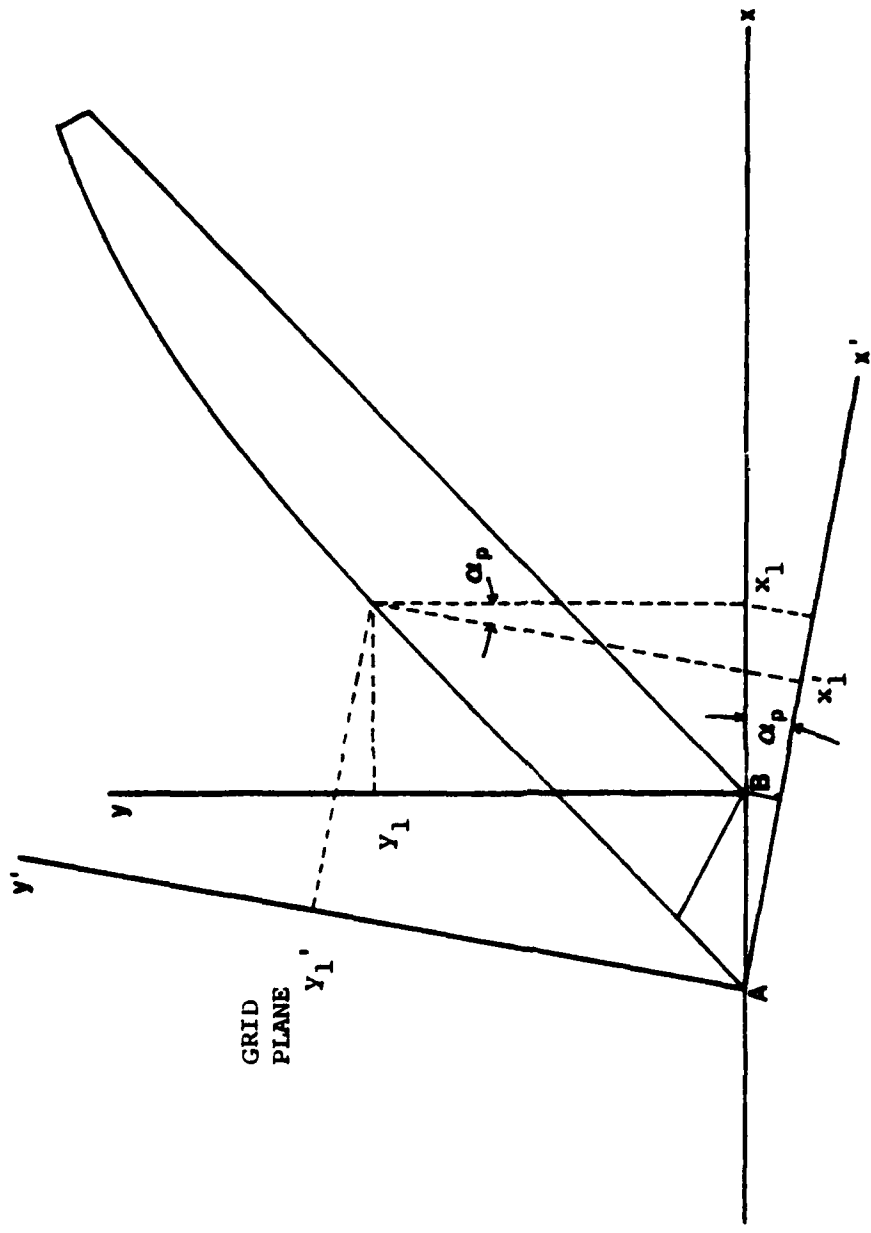

Figure 4. Coordinate Transformation (z and z' are out of the page)

The three dimensional lens outer surface is generated by rotating the array of outer surface coordinates in the merid-
ian plane through 2π about the lens axis. Each pair of
coordinates $x_1(J), y_1(J)$ thus describe a circle in the $y-z$
plane of the lens. This circle transforms, however, to an
ellipse in the grid plane given by the equation

$$y' = [x + AB] \sin \alpha_p \pm \sqrt{R^2 - z'^2} \cos \alpha_p \quad (33)$$

where R is the radius of the circle in the $x-y$ plane. R
may be expressed by the familiar equation of a circle

$$R^2 = y^2 + z^2 \quad (34)$$

in the $y-z$ plane of the lens, or by solving Equation (33)
for R in the grid plane

$$R^2 = z'^2 + \left(\frac{y'}{\cos \alpha_p} - (x + AB) \tan \alpha_p \right)^2 \quad (35)$$

With the aid of the foregoing groundwork, the x, y, z coor-
dinates of the ray intercept with the outer surface may be
found. To see how this is accomplished, first refer to Figure
5. The skew ray will pass outside the circle formed by rotat-
ing some point $x_1(J), y_1(J)$ and inside the next circle formed
by rotating $x_1(J-1), y_1(J-1)$. In so doing the skew ray will

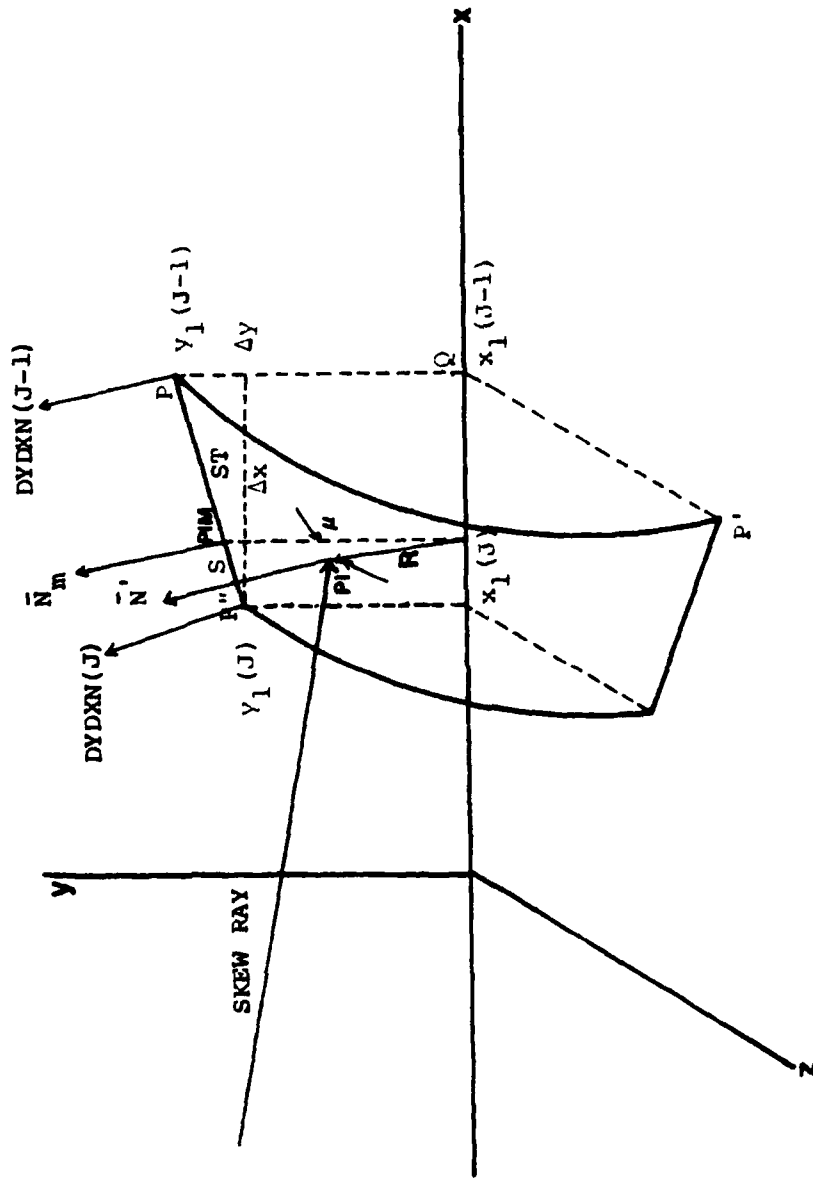

Figure 5. Geometry of Skew Ray Intercept With Outside Surface. X, Y Plane is the Meridian Plane. \bar{N}_m is the Surface Normal in the Meridian Plane; \bar{N} the Surface Normal at the Point of Intercept, PI.

intercept an imaginary cone formed by the two circles.¹ Now, the y', z' of the skew ray in the grid plane and a trial value $x_1(J)$ from the array of surface points are substituted into Equation (35) and a value for R is calculated. If R is greater than $y_1(J)$ but less than $y_1(J-1)$ than the appropriate circles have been found. If not, another trial value of $x_1(J)$ is picked. In practice the $x_1(J)$ corresponding to

$$y_1(J) = z' \quad (36)$$

is chosen as the first trial value and subsequent trial values are $x_1(J-1)$, $x_1(J-2)$ and so forth.

The equation of the cone passing through the two circles may be derived by again referring to Figure 5 and noting that

$$QP = QP' = \sqrt{y^2 + z^2} = R \quad (37a)$$

$$QP = y = m[x - x_1(J)] + y_1(J) \quad (37b)$$

where the slope m is given by

¹Recall that a straight line between points E_J was used to form the outer surface in the meridian plane. These approximations are valid only if the spacing between points or circles is very small.

$$m = \frac{y_1^{(J-1)} - y_1^{(J)}}{x_1^{(J-1)} - x_1^{(J)}} \quad (38)$$

and therefore

$$R^2 = \left\{ \left[\frac{y_1^{(J-1)} - y_1^{(J)}}{x_1^{(J-1)} - x_1^{(J)}} \right] [X - X(j)] + y_1^{(J)} \right\}^2 \quad (39)$$

By equating Equation (39) to Equation (35) and solving for x , the expression for the x -coordinate, x_0 , of the outside surface ray intercept may be found. After some algebra, this reduces to the complicated relationship

$$x_0 = \frac{\text{PAR1}}{\text{PAR2}} \pm \sqrt{\frac{\text{PAR1}}{\text{PAR2}} - \frac{\text{PAR3}}{\text{PAR2}}} \quad (40)$$

where:

$$\text{PAR1} = ab + ce - b^2 AB - c^2 d \quad (41)$$

$$\text{PAR2} = b^2 - c^2 \quad (42)$$

$$\text{PAR3} = a^2 + b^2 (AB)^2 - 2abAB + z' - (e - cd)^2 \quad (43)$$

and where

$$a = y' / \cos \alpha_p \quad (44)$$

$$b = \tan \alpha_p \quad (45)$$

$$c = \frac{y_1(J-1) - y_1(J)}{[x_1(J-1) - x_1(J)]} \quad (46)$$

$$d = x_1(J) \quad (47)$$

$$e = y_1(J) \quad (48)$$

It has been found that the plus sign in Equation (40) gives the correct values until PAR1/PAR2 becomes greater than $x_1(1)$ at which time the negative sign must be used. It now follows from Equations (31), (32) and (40) that the y_0 and z_0 coordinates of the intercept are

$$y_0 = \frac{y'}{\cos \alpha_p} - (x_0 + AB) \tan \alpha_p \quad (49)$$

and

$$z_0 = z' \quad (50)$$

The next step in tracing the skew ray is to ascertain the direction cosines of the ray inside the lens after refraction at the outside surface. This is accomplished in a series of steps beginning with the determination of the angle ϕ which the skew ray makes with the normal to the surface at the point of intercept. Angle ϕ may be found by taking the scalar product of the direction cosines of the

skew ray and the surface normal. Thus to find ϕ , the surface normal must first be obtained.

As might be surmised by the reader, the direction cosines of the surface normal can be found by taking the gradient of Equation (39) with Equation (37) substituted for R. Several orders of magnitude may be gained in accuracy, however, if the normal \bar{N}_m is found by interpolation in the meridian plane and then rotated to the point of intercept by angle μ as in Figure 5. This interpolation procedure involves multiplying the ratio S/ST with the difference between $DYDXN(J)$ and $DYDXN(J-1)$ and adding the product to $DYDXN(J)$.

$$DYDXN_{PIM} = \frac{S}{ST}(DYDXN(J-1) - DYDXN(J)) + DYDXN(J) \quad (51)$$

where subscript PIM refers to point of intersection, meridian. Values of the slopes of the normals in the meridian plane, $DYDXN(J)$, are given by Equation (20) and S and ST are the linear separation of points P", PIM and P", P respectively. S/ST is given by

$$\frac{S}{ST} = \frac{[(R - y_1(J))^2 + (x_{PIM} - x_1(J))^2]^{1/2}}{(\Delta x^2 + \Delta y^2)^{1/2}} \quad (52)$$

Therefore, the normal vector, \bar{N}_m , in the meridian plane is

$$\bar{N}_m = \left(\frac{1}{DYDXN_{PIM}} \right) \hat{i} + \hat{j} \quad (53)$$

and since

$$\tan \mu = \frac{z'}{y_0} = \frac{z_0}{y_0} \quad (54)$$

the normal vector at the point of intersection on the outside surface becomes

$$\bar{N}' = \left(\frac{1}{DYDXN_{PIM}} \right) \hat{i} + \cos(\tan^{-1} \frac{z_0}{y_0}) \hat{j} + \sin(\tan^{-1} \frac{z_0}{y_0}) \hat{k} \quad (55)$$

and

$$|\bar{N}'| = [DYDXN_{PIM}^{-2} + 1]^{1/2} \quad (56)$$

Now the scalar product of the skew ray vector, \hat{R} , and surface normal, \bar{N}' , may be performed to find ϕ . Since the acute angle between these vectors is required, the dot product must be written

$$\hat{R} \cdot \bar{N}' = |\bar{N}'| \cos(\pi - \phi) \quad (57)$$

Substituting Equation (55) for \bar{N}' and noting that

$$\hat{R} = K\hat{i} + L\hat{j} + M\hat{k} = \cos \alpha_p \hat{i} - \sin \alpha_p \hat{j} \quad (58)$$

the left side of Equation (56) may be expanded to

$$\hat{R} \cdot \bar{N}' = \frac{\cos \alpha_p}{DYDXN_{PIM}} - \sin \alpha_p \cos(\tan^{-1} \frac{z_0}{y_0}) \quad (59)$$

Solving Equation (56) for the angle ϕ and introducing Equation (58), the expression for angle ϕ becomes

$$\phi = \pi - \cos^{-1} \left\{ \frac{\frac{\cos \alpha_p}{DYDXN_{PIM}} - \sin \alpha_p \cos(\tan^{-1} \frac{z_0}{y_0})}{[DYDXN_{PIM}^{-2} + \cos^2(\tan^{-1} \frac{z_0}{y_0}) + \sin^2(\tan^{-1} \frac{z_0}{y_0})]^{1/2}} \right\} \quad (60)$$

Now that the acute angle, ϕ , between the ray and the outside surface normal is known, ϕ' , the angle between the refracted ray inside the lens and the surface normal may be found using Snell's law.

$$\phi' = \sin^{-1} \left(\frac{N_1}{N_2} \sin \phi \right) \quad (61)$$

The next step is to ascertain the direction cosines K' , L' , M' of the refracted ray inside the lens. Following Kingslake [7], Figure 6 shows the optical vector relationship between \bar{R} , the skew ray, \bar{R}' , the refracted skew ray, \bar{N}' , the surface normal, and the indices of refraction of the two media. Algebraically this relationship is written as

$$N_2 \bar{R}' = N_1 \bar{R} + (N_2 \cos \phi' - N_1 \cos \phi) \bar{N}' \quad (62)$$

By resolving Equation (61) into component form, the direction cosines of \bar{R}' may be found. After rearranging, K' , L' , and M' become

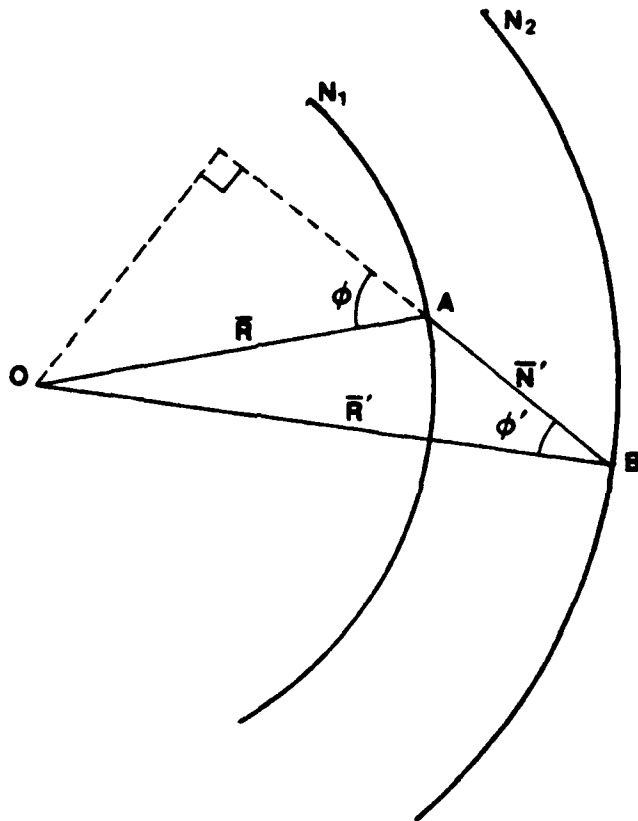

Figure 6. Kingslake's Skew Ray Diffraction Diagram

$$K' = \frac{N_1}{N_2} K + (\cos \phi' - \frac{N_1}{N_2} \cos \phi) k \quad (63)$$

$$L' = \frac{N_1}{N_2} L + (\cos \phi' - \frac{N_1}{N_2} \cos \phi) \ell \quad (64)$$

$$M' = \frac{N_1}{N_2} M + (\cos \phi' - \frac{N_1}{N_2} \cos \phi) m \quad (65)$$

where K, L, and M are given by Equation (57) and k, ℓ , m are

$$k = \frac{DYDXN_{PIM}^{-1}}{|\bar{N}'|} \quad (66)$$

$$\ell = \frac{\cos(\tan^{-1} \frac{z_0}{y_0})}{|\bar{N}'|} \quad (67)$$

$$m = \frac{\sin(\tan^{-1} \frac{z_0}{y_0})}{|\bar{N}'|} \quad (68)$$

Again, $|\bar{N}'|$ in Equations (66) through (68) is expressed by Equation (56).

At this stage in the process of tracing the skew ray, the coordinates of the external ray intercept x_0, y_0, z_0 are known as are the direction cosines K', L', M' of the skew ray inside the lens. The next step is, of course, to find the ray intercept with the inside surface (cone) and the direction of the ray subsequent to refraction. The intermediate steps are similar to, if not identical with,

the foregoing. One major difference, however, is that the inside conical surface may be expressed analytically and the intercept coordinates x_i , y_i , z_i may be found exactly without approximation. Proceeding, it can be seen that if x_i , y_i , z_i were already known, Equations (63), (64), and (65) could be rewritten as

$$K' = \frac{x_i - x_0}{D} \quad (69)$$

$$L' = \frac{y_i - y_0}{D} \quad (70)$$

$$M' = \frac{z_i - z_0}{D} \quad (71)$$

where D is the distance between surface intercept points.

Upon rearranging:

$$x_i = DK' + x_0 \quad (72)$$

$$y_i = DL' + y_0 \quad (73)$$

$$z_i = DM' + z_0 \quad (74)$$

Furthermore, there exists a relationship between x_i , y_i , and z_i which is given by the expression for the inside conical surface:

$$y_i^2 + z_i^2 - x_i^2 \tan^2 \alpha = 0 \quad (75)$$

where α is the half-angle of the cone. Substituting Equations (72), (73), and (74) into Equation (75) and solving for D, it is seen that

$$D = \frac{-P_1}{P_2} \pm \frac{\sqrt{P_1^2 - P_2 P_3}}{P_2} \quad (76)$$

where

$$P_1 = L'y_0 + M'z_0 - K'x_0 \tan^2 \alpha \quad (77)$$

$$P_2 = L'^2 + M'^2 - K'^2 \tan^2 \alpha \quad (78)$$

and

$$P_3 = y_0^2 + z_0^2 - x_0^2 \tan^2 \alpha \quad (79)$$

Correct values for D are obtained by using the minus sign in Equation (76). Now that D is known, values for K' , L' , M' , x_0 , y_0 , and z_0 are substituted into Equations (72), (73), and (74) to yield the coordinates of the inside surface intercept point.

In the case of the inside surface, the gradient may be used to obtain the surface normal at the point of intercept since this surface has been expressed analytically. If Equation (75) is denoted by $f(x,y,z)$ then

$$\hat{N}_i = \frac{\nabla f}{|\nabla f|} \Big|_{x_i, y_i, z_i} \quad (80)$$

where \hat{N}_i is the unit vector in the direction of the surface normal at the point of intercept. Here,

$$\bar{\nabla}f = \frac{\partial f}{\partial x} \hat{i} + \frac{\partial f}{\partial y} \hat{j} + \frac{\partial f}{\partial z} \hat{k} \quad (81)$$

or alternately,

$$\bar{\nabla}f = f_x \hat{i} + f_y \hat{j} + f_z \hat{k} \quad (82)$$

Thus, the direction cosines of the normal k' , l' , m' may be expressed as

$$k' = \frac{f_x}{|\bar{\nabla}f|} \quad (83)$$

$$l' = \frac{f_y}{|\bar{\nabla}f|} \quad (84)$$

$$m' = \frac{f_z}{|\bar{\nabla}f|} \quad (85)$$

where:

$$f_x = -2x_i \tan^2 \alpha \quad (86)$$

$$f_y = 2y_i \quad (87)$$

$$f_z = 2z_i \quad (88)$$

and

$$|\bar{\nabla}f| = 2[x_i^2 \tan^4 \alpha + y_i^2 + z_i^2]^{1/2} \quad (89)$$

Now that the two unit vectors \hat{R}' and \hat{N}' are known the incident acute angle of the skew ray with the inside surface, ϕ_i , may be ascertained by again taking the scalar product as in Equation (57). Thus,

$$\phi_i = \pi - \cos^{-1}[K'k' + L'\ell' + M'm'] \quad (90)$$

and using Equation (1) again

$$\phi_i' = \sin^{-1}\left[\frac{N_2}{N_3} \sin \phi_i\right] \quad (91)$$

where ϕ_i' is the acute angle between the skew ray and the surface normal after refraction at the inside surface.

Direction cosines K'' , L'' , M'' of the skew ray after refraction are found analogously to K' , L' , and M' in Equations (63), (64) and (65). Here, however, N_2 , N_3 , K' , L' , M' , ϕ_i , ϕ_i' , and k' , ℓ' , m' are substituted for N_1 , N_2 , K , L , M , ϕ , ϕ' , and k , ℓ , m respectively. Thus

$$K'' = \frac{N_2}{N_3} K' + \left(\cos \phi_i' - \frac{N_2}{N_3} \cos \phi_i\right) k' \quad (92)$$

$$L'' = \frac{N_2}{N_3} L' + \left(\cos \phi_i' - \frac{N_2}{N_3} \cos \phi_i\right) \ell' \quad (93)$$

and

$$M'' = \frac{N_2}{N_3} M' + (\cos \phi_i' - \frac{N_2}{N_3} \cos \phi_i) m' \quad (94)$$

Finally, the skew ray intercept with the image plane may be found. The image plane is treated as another surface along the path of the skew ray, and the intercept coordinates x_{im} , y_{im} , z_{im} are easy to find. Equations (72), (73) and (74) may be used again in the form

$$x_{im} = D'K'' + x_i \quad (95)$$

$$y_{im} = D'L'' + y_i \quad (96)$$

$$z_{im} = D'M'' + z_i \quad (97)$$

where D' , in this instance, is the linear separation between coordinates x_i , y_i , z_i at the inside surface and x_{im} , y_{im} , z_{im} of the image plane. Furthermore,

$$x_{im} = BF \quad (98)$$

is the equation of the image plane. It follows that

$$D' = \frac{(BF - x_i)}{K''} \quad (99)$$

after substitution of Equation (98) into Equation (95).

Therefore,

$$y_{im} = \left[\frac{BF - x_i}{K''} \right] L'' + y_i \quad (100)$$

and

$$z_{im} = \left[\frac{BF - x_i}{K''} \right] M'' + z_i \quad (101)$$

Hence, the skew ray has been traced onto the image plane at the focal point of the lens. The y_{im} coordinate of the corresponding mirror image skew ray is the same as Equation (100). The z_{im} coordinate, however, is the negative of Equation (101) since the mirror image ray is behind (when viewed along the z-axis) the meridian plane. After tracing a complete set of skew rays through the lens a spot diagram may be plotted. Clearly, the number of rays to be traced depends entirely upon the incremental size of the aperture grid chosen. According to Kingslake [7], at least 100 rays must be traced to give a fair approximation of the actual image. In addition to the spot diagram, an energy density plot may now be constructed by counting the number of rays within progressively larger radii from the image centroid and then plotting the number of rays as a function of radius. Here, each ray is assumed to contain a unit, nondimensional, amount of radiant energy for convenience.

E. RADIANT ENERGY LOSS

In reality, each ray loses intensity upon transmission at each interface. Of the total amount of energy contained in each ray, a fraction I_T will be transmitted, a fraction I_R will be reflected, and a fraction I_A will be absorbed by the medium into which the ray is propagating. Since it has been assumed that absorption is negligible, it must be true that

$$I_T + I_R = 1 \quad (102)$$

Furthermore, the relative amounts of transmitted and reflected electromagnetic energy may be calculated by the well-known Fresnel Equations which state the dependency of I_T and I_R upon the angle of incidence and the indices of refraction at the interface. That I_T and I_R are further dependent upon the orientation of the electric vector with respect to the geometry of ray incidence is fundamental to the boundary conditions which govern the form of the Fresnel relations as derived in Hecht-Zajac [8]. Since this thesis examines lens response to monochromatic radiation, the indices of refraction are not considered as a function of wavelength; further, the electric vector orientation is assumed to be rapidly and randomly changing with time. By time averaging field components, it may be seen that the reflectance is

$$I_R = \frac{1}{2}(r_{\perp}^2 + r_{\parallel}^2) \quad (103)$$

where

$$r_{\perp} = \frac{\cos \phi - (N_{ti}^2 - \sin^2 \phi)^{1/2}}{\cos \phi + (N_{ti}^2 - \sin^2 \phi)^{1/2}} \quad (104)$$

and

$$r_{\parallel} = \frac{N_{ti}^2 \cos \phi - (N_{ti}^2 - \sin^2 \phi_i)^{1/2}}{N_{ti}^2 \cos \phi + (N_{ti}^2 - \sin^2 \phi)^{1/2}} \quad (105)$$

Here, N_{ti} is the ratio of the index of refraction of the transmission side of the interface to the index of refraction of the incident side. From Equation (102) it now follows that the transmittance through the interface is

$$I_t = 1 - I_R \quad (106)$$

The total transmittance through the lens is simply the product of I_t at the outside surface with that of the inside surface where ϕ_i is substituted for ϕ in Equations (104) and (105).

Total internal reflection of the ray may occur at the inside surface if the incident angle becomes too large. Following Reference (7), this occurs when angle ϕ_i is equal to or greater than $\pi/2$. Thus, Snell's law becomes

$$\sin \phi_i = \frac{N_3}{N_2} \quad (107)$$

and any ray with ϕ_i equal to or greater than this will be

totally internally reflected. In this thesis such rays are labeled "failed rays" since they fail to intersect the image plane. If N_2 is 1.5 and N_3 is 1.0, the incident angle for total internal reflection is 41.81° , or greater.

F. OPTICAL PATH LENGTH (OPL)

The optical path length of a skew ray is an analytical tool with which the researcher may ascertain the phase of a ray at the end of the path. By so doing, the image diffraction pattern may be constructed which shows the addition or subtraction of amplitude depending upon relative phase. Since each ray must begin with the same phase, monochromatic radiation is used for diffraction experiments. OPL is included here only as a matter of interest. The calculation of optical path length is simply the sum of the geometrical path segments of a ray multiplied by the corresponding index of refraction of the medium for that segment.

III. THE GRIN LENS

A. THEORY

This thesis assumes a spherically symmetric, inhomogeneous, isentropic medium in which the refractive index varies from point to point but is independent of direction at each point. The refractive index is a function of the coordinates of the points of the region being considered. The problem of describing the resulting curved paths of rays in such GRIN materials has been solved long ago in the form of a single second order vectorial differential equation. Marchand [9] has shown that the solution to the differential equation in the case of spherical gradients can be written in polar coordinates in the plane of the ray as

$$\theta = \theta_0 + e \int_{r_0}^r \frac{dr}{r [n^2 r^2 - e^2]^{1/2}} \quad (108)$$

Here r_0 and θ_0 are values of r and θ at a convenient reference point on the ray and $|e|$ is a scalar constant along the ray given by

$$e = \epsilon n_0 r_0 \sin \psi_0 \quad (109)$$

Referring to Figure 7, r is measured from the center of symmetry of the index function; angles θ and θ_0 are measured

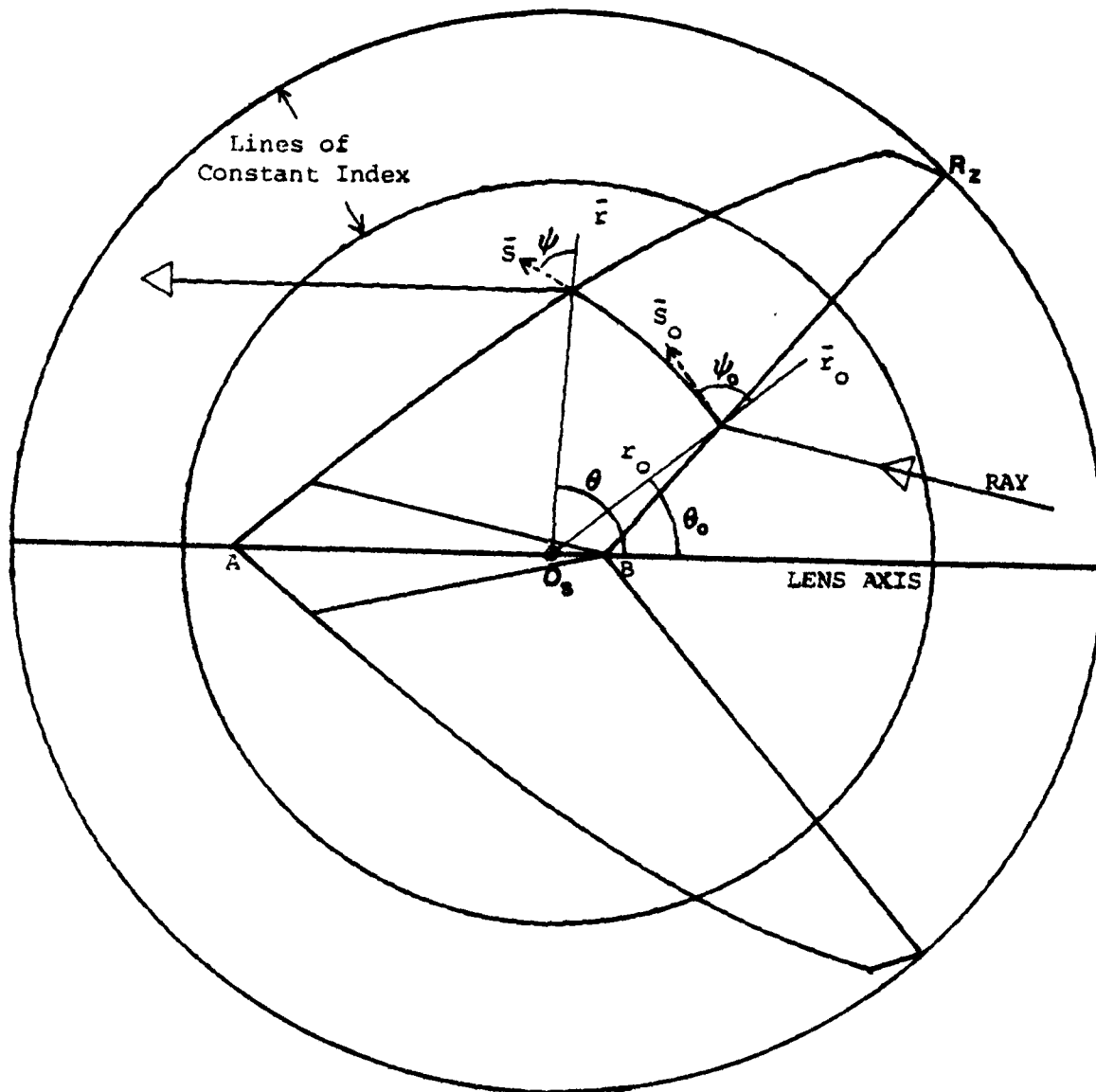

Figure 7. Grin Lens Geometry

counterclockwise from the lens axis; angles ψ and ψ_0 are measured counterclockwise from the radius vector to the instantaneous ray direction vector. ϵ is the sign function expressed as

$$\epsilon = \text{sgn } |\psi_0| = \pm 1 \quad (110)$$

where

$$|\psi_0| > \pi/2 \quad (111)$$

In Equation (109), n_0 refers to the index function n evaluated at r_0 . The form of n has been chosen as

$$n = n(O_s, r) \quad (112)$$

where O_s denotes the position of the center of symmetry on the lens axis (shown in Figure 7) and r is the radial coordinate from O_s to the point in question. This form allows the study of the effects on lens performance as O_s is changed.

More specifically, in order to allow the analytical integration of Equation (108), the expression used for $n(O_s, r)$ is a generalized version of that employed by Luneburg as described by Marchand [9]. Here

$$n = \left[a + b \left(\frac{r}{R_z} \right)^2 \right]^{1/2} \quad (113)$$

whereas Luneburg used specific values for a and b. Generalizing the index function enables the strength, or percent change of the gradient to be varied as well as the algebraic sign of the gradient. If the parameter b is negative, a decreasing parabolic gradient results; conversely a positive b yields an increasing parabolic gradient. By visualizing a plane wave front passing through a spherical gradient, it may be seen that the negative gradient results in light rays bending forward at the center, as shown in Figure 7, whereas a positive gradient has the opposite effect. This principle was used by Wood, as related by Marchand [9], in constructing simple lenses having plane faces and a radial index. The Wood lens acted as a converging or diverging lens depending upon the sign of the gradient used.

Additionally, it must be noted that if the parameter b is equal to zero, Equation (113) reduces to

$$n = \sqrt{a} \quad (114)$$

which is a HIN lens having constant index of refraction. This fact has facilitated the correlation of GRIN and HIN computer trace algorithms.

Equation (108) may be integrated by a change of variable using the relation

$$v = \left(\frac{r_0}{r}\right)^2 \quad (115)$$

which leads to the solution

$$\theta = \theta_0 - \frac{\epsilon}{2} \left\{ \sin^{-1} \left[\frac{2e^2/r^2 - a}{\sqrt{a^2 + 4be^2/R_z^2}} \right] - \sin^{-1} \left[\frac{2e^2/r_0^2 - a}{\sqrt{a^2 + 4be^2/R_z^2}} \right] \right\} \quad (116)$$

Equation (116) gives θ as a function of r . This equation can be easily solved for r as a function of θ in the form

$$r = \frac{\sqrt{2} |e|}{\left\{ a + \sqrt{a^2 + \frac{4be^2}{R_z^2}} \sin \left[-2\epsilon(\theta - \theta_0) + \sin^{-1} \left[\frac{2e^2/r_0^2 - a}{\sqrt{a^2 + 4be^2/R_z^2}} \right] \right] \right\}^{1/2}} \quad (117)$$

The instantaneous direction of the ray at any point r, θ may be ascertained by using the invariance of e . Hence,

$$e = \epsilon n r \sin \psi = \epsilon n_0 r_0 \sin \psi_0 \quad (118)$$

and

$$\psi = \sin^{-1} \left[\frac{n_0 r_0 \sin \psi_0}{nr} \right] \quad (119)$$

Furthermore, the orientation of the plane of the ray may be easily deduced since every ray in a spherical medium is a plane curve lying in a plane through the center of symmetry.

Using this fact, Marchand [9] has shown that a suitable conversion from coordinates r and θ in the plane of the ray to global Cartesian coordinates may be written in the form

$$x = r \left(\delta \frac{x_0}{r_0} + \eta p_0 \right) \quad (120)$$

$$y = r \left(\delta \frac{y_0}{r_0} + \eta q_0 \right) \quad (121)$$

$$z = r \left(\delta \frac{z_0}{r_0} + \eta l_0 \right) \quad (122)$$

Here p_0, q_0, l_0 are the initial direction cosines of the ray at r_0, θ_0 ; $x_0, y_0,$ and z_0 are the Cartesian coordinates corresponding to r_0, θ_0 . The parameters δ and η are given by Marchand as

$$\eta = \sin \theta / \sin \psi_0 \quad (123)$$

$$\delta = \cos \theta - \eta \cos \psi_0 \quad (124)$$

It should be noted that Equation (117) may become singular for certain rays where ψ or ψ_0 become very close to zero or π . This singularity may be more easily seen in Equation (123) where η becomes indeterminate as both θ and ψ_0 approach zero and/or π . In practice these conditions occur when O_s is located either far out in object space, coincident with B, or on the image side of the lens; see Figure 8. Positioning

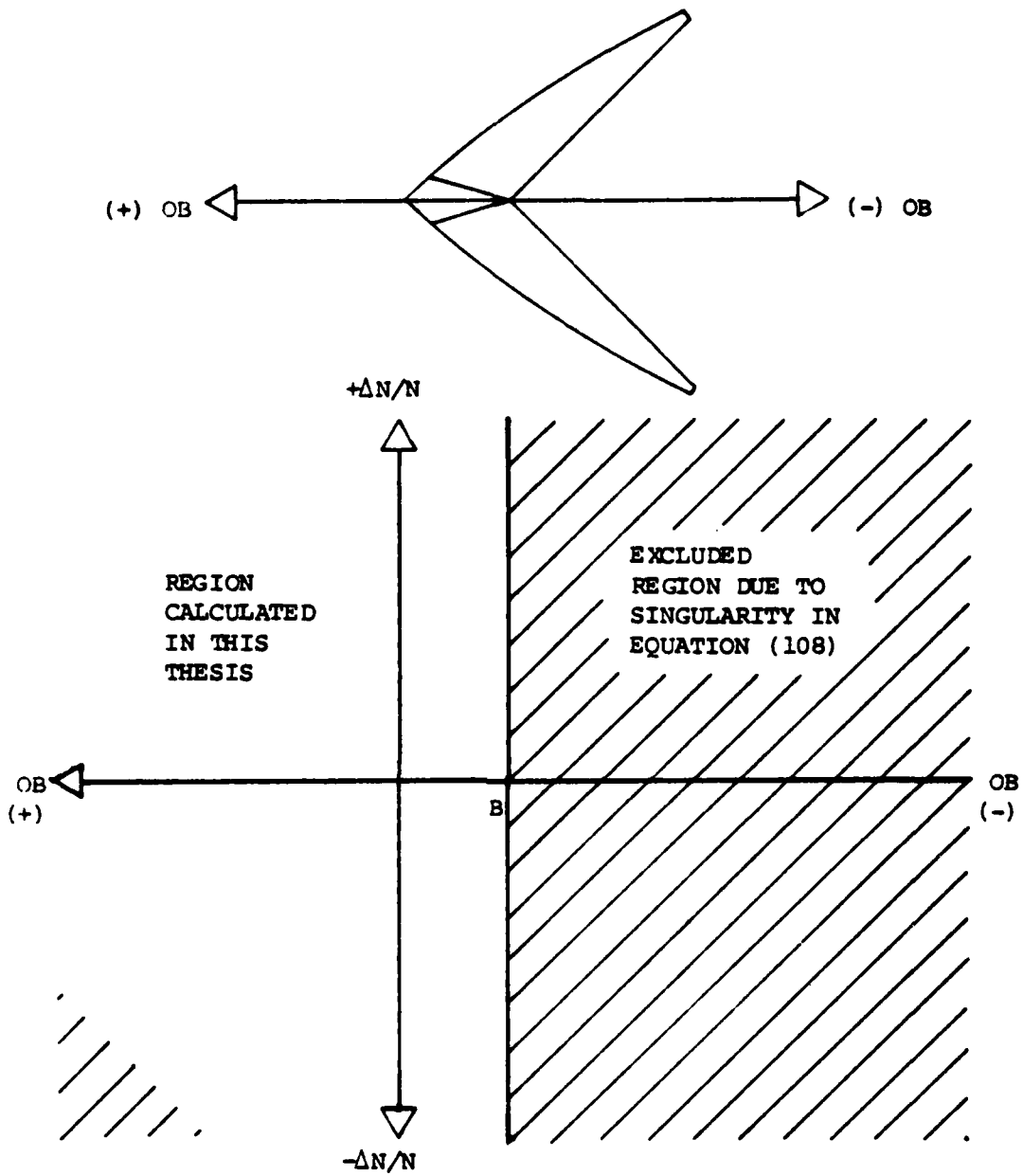

Figure 8. Excluded Regions for Center of Symmetry Due to Singularities

the center of symmetry at these locations has therefore been avoided.

B. ASSUMPTIONS

The aforementioned assumptions for the HIN case also apply here. Additionally, it must be assumed, as depicted in Figure 7, that the GRIN lens could or soon may be fabricated from a sphere of dielectric material with the required spherically symmetric parabolic gradient.

C. GRIN LENS DESIGN PARAMETERS

In the HIN lens, the available design parameters are basic. These include: F , R , T , α , U , and N_2 . Parameters available for varying the design of the GRIN lens, however, include those of the HIN case but expand the index of refraction variable N_2 into O_s , a , $+b$, and $-b$. These additional lens design parameters greatly expand the lens designer's power to bend radiant energy to his will.

D. GRIN LENS DESIGN

The GRIN lens design procedure, although paralleling that of the HIN case, is somewhat more complicated in that the rays are now curved and the index of refraction varies. Accordingly, the same design process is used but with more intermediate calculations required.

The additional calculations arise since the intercept of the GRIN ray with the surface tangent cannot be solved in closed form, and an iterative solution must be used.

The reader will note that Equation (117) will yield r if $(\theta - \theta_0)$ is known. Hence the iterative procedure is to "guess" $(\theta - \theta_0)$ based on the HIN coordinates x_{1H}, y_{1H} which are calculated as in the homogeneous lens. Thus

$$\theta_H = \theta_T - \theta_0 \quad (125)$$

in Figure 9 is used in Equation (117) to find point p . The tangent to the ray path at point p is now extended to intercept the surface tangent again using the homogeneous intercept relations to find x'_{1H}, y'_{1H} . The prime superscripts indicate successive iteration values. The distance d is employed as a measure of the error of point p . If d is not within an acceptable margin then θ'_H is calculated based on x'_{1H}, y'_{1H} and the procedure repeated to find p' in Figure 9. If d' is not within allowable error then the iteration continues until it is acceptable. In practice, this iteration procedure has proved to be extremely rapid, rarely requiring more than three iterative steps before converging. Slight modifications, however, must be introduced to handle a positive gradient. Furthermore, if O_s is located outside the lens proper, a decreasing angular increment must be subtracted from θ_H to ensure that each radial vector r_H, r'_H, \dots intersects the ray during iteration. These modifications to the intercept iteration procedure are recorded in the program listing for program GISL (for Gradient Index Seeker Lens). Refer to Appendices A, B, and C for a full description of GISL.

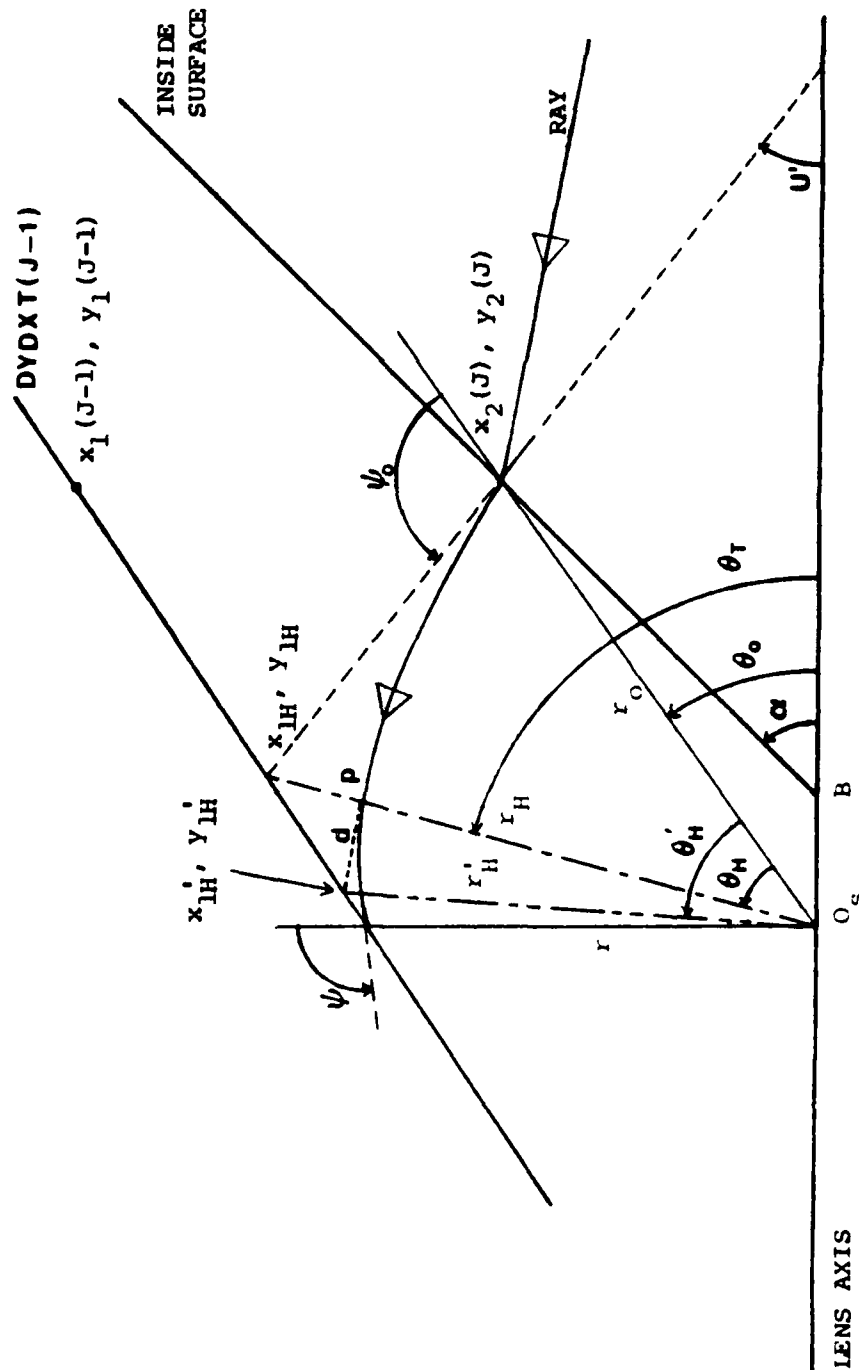

Figure 9. Grin Ray Intercept Geometry

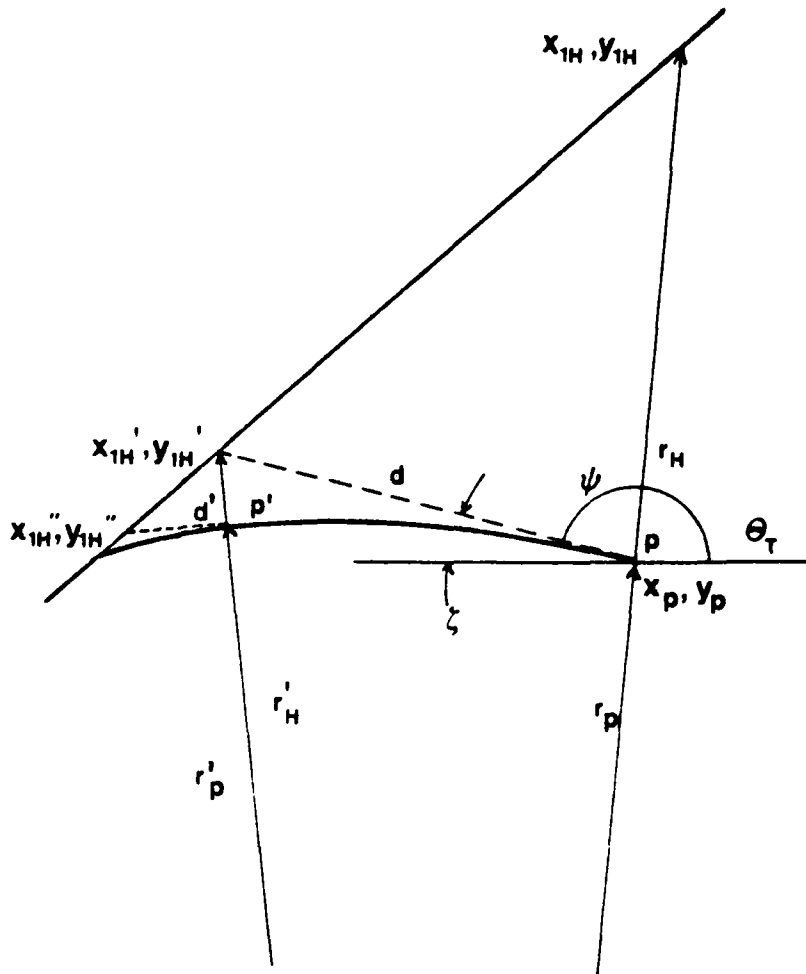

Figure 10. Expanded View, Intercept Geometry

With the overall iterative intercept procedure now being clear, the mathematical details of the GRIN lens design follow. Referring again to Figure 9, the GRIN ray is traced as in the HIN design procedure to obtain the coordinates $x_2(J), y_2(J)$ on the inside surface in the meridian plane. Now, before Snell's law can be used, the index of refraction must be found at these coordinates. Using Equation (113)

$$n_2 = \left[a + b \left(\frac{r_0}{R_2} \right)^2 \right]^{1/2} \quad (125)$$

where

$$r_0 = \sqrt{(x_2(J) + OB)^2 + y_2(J)^2} \quad (126)$$

and where

$$R_2 = \sqrt{(x_2(1) + OB)^2 + y_2(1)^2} \quad (127)$$

Furthermore, by inspection it can be easily seen that

$$\psi_0 = \pi - U' - \theta_0 \quad (128)$$

U' is identical to the HIN case¹ and

¹Here Equation (125) must be substituted for N_2 in Equation (12).

$$\theta_0 = \tan^{-1} \left[\frac{y_2(J)}{y_2(J) + OB} \right] \quad (129)$$

In Equations (126) through (129) OB is the line segment from O_s to B and is defined as a positive quantity to the left of B for algebraic ease of manipulation. By substitution into Equation (109) the scalar constant, e, of the ray can now be found. Furthermore, since angle U' is now known coordinates x_{1H}, y_{1H} may be calculated using Equations (14) and (15) or Equations (24) through (28).

For the first ray defining the edge of the lens, Equations (14) and (15) are employed, and, since no iteration is required, angle $(\theta_T - \theta_0)$ is used in Equation (117) to find r immediately. Here

$$\cos \theta_T = \frac{x_{1H} + OB}{r_H} \quad (130)$$

and

$$r_H = \sqrt{(x_{1H} + OB)^2 + y_{1H}^2} \quad (131)$$

Thus

$$x_1(1) = r \cos \theta_T - OB \quad (132)$$

and

$$y_1(1) = r \sin \theta_T \quad (133)$$

are the coordinates of the first point on the outside surface. Since e is known, Equation (119) is employed to find the angle ψ . Angle ζ in Figure 10 is employed to translate ψ into the ray direction with respect to the lens axis by the relation

$$\zeta = \pi - (\psi + \theta_T) \quad (134)$$

Therefore, by substituting ζ for U' in Equations (19), (20), and (21), $DYDXN(1)$ and $DYDXT(1)$ may be found. Here again, N_2 in Equation (19) must be replaced by n_2 as given by Equation (113) evaluated at $x_1(1), y_1(1)$.

Now that the first point on the outside surface is known, along with the surface tangent, the remainder of the K number of rays may be processed to yield the balance of the outside surface. Each subsequent intercept between ray and tangent must be iterated. Thus, unlike the first ray, once x_{1H}', y_{1H}' , r_H' , r_p , ψ , and ζ are known, x_{1H}' and y_{1H}' are ascertained by the substitution of the coordinates of point p for $x_2(J), y_2(J)$ in Equations (24) through (28) with U' replaced by ζ . The coordinates of point p are

$$x_p = r_p \cos \theta_T - OB \quad (135)$$

$$y_p = r_p \sin \theta_T \quad (136)$$

Therefore

$$y_{1H}' = \left\{ \frac{A + B}{C} \right\} \quad (137)$$

where

$$A = \cot(I_1 + U) \cot \zeta [y_p + x_p \tan \zeta] \quad (138)$$

$$B = y_1(J-1) - x_1(J-1) \cot[I_1 + U] \quad (26)$$

$$C = 1 + \cot(I_1 + U) \cot \zeta \quad (139)$$

and

$$I_1 = \sin^{-1} \left\{ \frac{\sin^2(\zeta - U)}{[\cos(\zeta - U) - N_1/n_2]^2 + \sin^2(\zeta - U)} \right\} \quad (140)$$

Note that n_2 in Equation (140) is found from Equation (113) evaluated at r_p .

Additionally,

$$x_{1H}' = \cot \zeta [-y_{1H}' + y_p + x_p \tan \zeta] \quad (141)$$

Now the error, d , may be evaluated as

$$d = \sqrt{(x_p - x_{1H}')^2 + (y_{1H}' - y_p)^2} \quad (142)$$

Here d is compared to 1×10^{-5} . If d is larger than this value then the entire procedure is repeated by substituting x_{1H}', y_{1H}' for x_{1H}, y_{1H} and so forth. Once the error criteria are satisfied

$$x_1(J) = x_p^{\dots} \quad (143)$$

$$y_1(J) = y_p^{\dots} \quad (144)$$

and the next ray is processed. Correlation between GRIN (with b set equal to zero) and HIN design procedures run with identical parameters has shown agreement to the fifth and sixth decimal places.

E. SKEW RAYS IN GRIN

GRIN skew rays are handled analogously to the homogeneous case with the same coordinate transformation from grid plane to global coordinates being required. It is only after the initial directions cosines of the GRIN skew ray K' , L' , M' are found that the differences between GRIN and HIN appear. The only exception to this being the use of Equation (113) in Snell's law for refraction at the interface. Since the GRIN skew rays display curvature in a plane through O_s , K' , L' , and M' are constantly changing until intercept with the inside conical surface. Therefore, not only must the plane of the skew ray be analytically described, but the final values of K' , L' , M' must be found. Due to the nature of

GRIN rays, the procedure for finding the ray intercept with the conical inside surface is different from both the HIN case and the iteration procedure employed in the meridian plane due to the multiplicity of the geometry encountered. The Newton-Raphson iteration routine has been found to be ideal for this purpose.

To begin, the magnitude and direction of the initial radius vector \bar{r}_0 from O_s for x_0, y_0, z_0 must be ascertained. The magnitude is given by

$$r_0 = [(x_0 + OB)^2 + y_0^2 + z_0^2]^{1/2} \quad (145)$$

Therefore the unit vector in the direction of the intercept is

$$\hat{r}_0 = \frac{x_0 + OB}{r_0} \hat{i} + \frac{y_0}{r_0} \hat{j} + \frac{z_0}{r_0} \hat{k} \quad (146)$$

The plane of the ray may be fully described by the vector normal to the plane. Two vectors, \hat{r}_0 and \hat{R} lie in the plane of the ray. \hat{R} is the unit vector in the initial direction of the ray after refraction and described using direction cosines as

$$\hat{R} = K'\hat{i} + L'\hat{j} + M'\hat{k} \quad (147)$$

Thus, the plane of the ray may be described by the cross product

$$\hat{N}_{P_0} = \hat{r}_0 \times \hat{R} \quad (148)$$

or

$$\hat{N}_{P_0} = N_{P_{0x}} \hat{i} + N_{P_{0y}} \hat{j} + N_{P_{0z}} \hat{k} \quad (149)$$

where

$$N_{P_{0x}} = r_{0y}M' - r_{0z}L' \quad (150)$$

$$N_{P_{0y}} = r_{0z}K' - r_{0x}M' \quad (151)$$

and

$$N_{P_{0z}} = r_{0x}L' - r_{0y}K' \quad (152)$$

In Equations (150), (151), and (152) r_{0x} , r_{0y} , and r_{0z} refer to the x, y, and z components of \hat{r}_0 in Equation (146). Furthermore, the angle ψ_0 between \hat{r}_0 and \hat{R} may be found from the dot product as

$$\psi_0 = \cos^{-1}[r_{0x}K' + r_{0y}L' + r_{0z}M'] \quad (153)$$

Now the scalar invariant e may be found. Substituting known values into Equation (109):

$$e = \epsilon \left[a + b \left(\frac{r_0}{R_z} \right)^2 \right]^{1/2} r_0 \sin \psi_0 \quad (154)$$

where R_z is unchanged from that found during previous calculations for the lens shape by Equation (127).

With the foregoing groundwork established, the intercept of the ray with the inside surface may be calculated. The Newton-Raphson iteration scheme requires the calculation of the radius vector from O_s to the cone by geometrical methods and the radius to the ray by GRIN theory. The difference between the two radii is then divided by the difference between the derivatives of the two functions. The resulting quantity is subtracted from the trial angle, θ_p , in the plane of the ray, to give a new trial angle θ'_p . The process is continued until the difference between radii is less than 1×10^{-5} . The first trial angle is measured to a reference HIN intercept as if the material were homogeneous since the actual GRIN ray curves only slightly. The coordinates of this HIN intercept point are designated x_{iH} , y_{iH} , z_{iH} and are derived using the HIN equations as before. To obtain the first trial angle, the scalar product between \hat{r}_0 and \hat{r}_{iH} is used. Here

$$r_{iH} = \left[(x_{iH} + OB)^2 + y_{iH}^2 + z_{iH}^2 \right]^{1/2} \quad (155)$$

and

$$\hat{r}_{iH} = \frac{x_{iH} + OB}{r_{iH}} \hat{i} + \frac{y_{iH}}{r_{iH}} \hat{j} + \frac{z_{iH}}{r_{iH}} \hat{k} \quad (156)$$

Thus,

$$\theta_p = \cos^{-1}[r_{0x}r_{iHx} + r_{0y}r_{iHy} + r_{0z}r_{iHz}] \quad (157)$$

where r_{iHx} , r_{iHy} , and r_{iHz} are the x, y, and z components of r_{iH} , respectively.

In Equation (117) θ_p is substituted for $(\theta - \theta_0)$ to yield r as required by the iteration procedure. The geometrical radius, r_g , is not so easily acquired. First, note that the equation of the plane of the ray inside the lens is given by

$$N_{p0x}(x-x_0) + N_{p0y}(y-y_0) + N_{p0z}(z-z_0) = 0 \quad (158)$$

Secondly, the equation of the conical surface is given by Equation (75). The combination of the plane of the ray and the cone yield the loci of possible intercept points on the inside surface. In Cartesian coordinates, the sum of Equations (75) and (158) is

$$\begin{aligned} x(N_{p0x} - x \tan^2) + y[N_{p0y} + y] + z[N_{p0z} + z] - N_{p0x}x_0 \\ - N_{p0y}y_0 - N_{p0z}z_0 = 0 \end{aligned} \quad (159)$$

Equation (159) must be transformed into coordinates r and θ_p

in the plane of the ray. The transformation is made possible using Equations (120) through (124). Upon substitution, and after solving for r_g , Equation (159) becomes

$$r_g = \frac{-B_2}{2A_2} \pm \sqrt{\frac{B_2^2}{4A_2^2} + \frac{C_2}{A_2}} \quad (160)$$

where

$$A_2 = B_1^2 + C_1^2 - A_1^2 \tan^2 \alpha \quad (161)$$

$$B_2 = B_1 N_{poy} + C_1 N_{poz} + A_1 N_{pox} + 2A_1 OB \tan^2 \alpha \quad (162)$$

$$C_2 = OBN_{pox} + OB^2 \tan^2 \alpha + N_{pox} x_0 + N_{poy} y_0 + N_{poz} z_0 \quad (163)$$

and

$$A_1 = \frac{\delta}{r_0} (x_0 + OB) + \eta K' \quad (164)$$

$$B_1 = \frac{\delta y_0}{r_0} + \eta L' \quad (165)$$

$$C_1 = \frac{\delta z_0}{r_0} + \eta M' \quad (166)$$

Here, δ and η are found from

$$\eta = \sin \theta_p / \sin \psi_0 \quad (167)$$

and

$$\delta = \cos \theta_p - \cos \psi_0 \quad (168)$$

which follow from Equations (123) and (124). The plus sign in Equation (160) yields the correct values. Now that r of the ray and r_g of the surface are known, the derivatives of r and r_g with respect to θ at θ_p must be found. It can be shown that for the ray

$$\left. \frac{dr}{d\theta} \right|_{\theta_p} = \frac{\epsilon r^3}{2e^2} \cos[-2\epsilon \theta_p + \sin^{-1}(A_3)] \quad (169)$$

where

$$A_3 = \frac{2e^2/r_0^2 - a}{\sqrt{a^2 + 4be^2/R_z^2}} \quad (170)$$

The derivative of r_g is somewhat more complicated. With persistence, however, it can be shown that

$$\frac{dr_g}{d\theta} = -\frac{1}{2A_2^2} \left[A_2 \frac{dB_2}{d\theta} - B_2 \frac{dA_2}{d\theta} \right] + \frac{1}{2} \left[\frac{B_2^2}{4A_2^2} + \frac{C_2}{A_2} \right]^{-1/2} [C_3] \quad (171)$$

where A_2 , B_2 , and C_2 are given by Equations (161) through (168) and

$$C_3 = \left[\frac{1}{2A_2^4} (A_2^2 B_2 \frac{dB_2}{d\theta} - B_2^2 A_2 \frac{dA_2}{d\theta}) - \frac{C_2}{A_2^2} \frac{dA_2}{d\theta} \right] \quad (172)$$

Therefore, the r and θ_p to the intercept are found by iteration of revised trial values

$$\theta'_p = \theta_p - \frac{(r - r_g)}{\left(\frac{dr}{d\theta} - \frac{dr_g}{d\theta}\right)} \quad (173)$$

In practice the quotient of differences in Equation (173) is reduced by a factor of 1.3 to slow convergence and provide stability. The number of iterations, however, rarely exceeds five.

Values for r and θ_p are now transformed into Cartesian coordinates x_i, y_i, z_i by substitution into Equations (120) through (124). Next, the values of the direction cosines $K', L',$ and M' at the intercept are needed. The angle ψ between the radius vector and the tangent to the ray at intercept may first be deduced from the scalar invariant, e . Hence

$$\psi = \sin^{-1}\left(\frac{e}{n_2 r_{pI}}\right) \quad (174)$$

Where e is known, n_2 is evaluated at r_{pI} ; r_{pI} is the radius to the intercept as found by the iteration above. Three constraints on the direction cosines may be written. These are:

- 1) The scalar product of the radius vector, \hat{r}_{pI} , and the instantaneous ray direction vector, \hat{R} , at intercept.
- 2) The scalar product of the normal to the plane of the ray \hat{N}_{p0} and \hat{R} .

3) The sum of the squares of the direction cosines must sum to unity.

Mathematically, the above constraints are written as

$$\frac{(x_i + OB)}{r_{PI}} K' + \frac{y_i}{r_{PI}} L' + \frac{z_i}{r_{PI}} M' = \cos \psi \quad (175)$$

$$N_{p0x} K' + N_{p0y} L' + N_{p0z} M' = 0 \quad (176)$$

$$K'^2 + L'^2 + M'^2 = 1 \quad (177)$$

To find K' , L' , and M' , Equations (175), (176) and (177) are solved simultaneously. It can be shown that the solution leads to

$$M' = \frac{-B_6}{2A_6} \pm \sqrt{\frac{B_6^2}{4A_6^2} - \frac{C_6}{A_6}} \quad (178)$$

$$L' = A_5 - B_5 M' \quad (179)$$

$$K' = (1 - L'^2 - M'^2)^{1/2} \quad (180)$$

where

$$A_6 = [1 + \left(\frac{N_{p0z}}{N_{p0x}}\right)^2] B_5^2 - \frac{2 N_{p0y} N_{p0z}}{N_{p0x}^2} B_5 + \left(\frac{N_{p0z}}{N_{p0x}}\right)^2 + 1 \quad (181)$$

$$B_6 = \frac{2 N_{p0y} N_{p0z}}{N_{p0x}} A_5 - \left[1 + \left(\frac{N_{p0z}}{N_{p0x}} \right)^2 \right] A_5 B_5 \quad (182)$$

$$C_6 = \left[1 + \left(\frac{N_{p0z}}{N_{p0x}} \right)^2 \right] A_5^2 - 1 \quad (183)$$

and

$$A_5 = \frac{N_{p0x} \cos \psi}{N_{p0x} B_4 - N_{p0y} A_4} \quad (184)$$

$$B_5 = \frac{N_{p0x} C_4 - N_{p0z} A_4}{N_{p0x} B_4 - N_{p0y} A_4} \quad (185)$$

Furthermore, in Equations (184) and (185), A_4 , B_4 , and C_4 are the coefficients of K' , L' and M' in Equation (175).

Now that the direction cosines of the ray are known at the point of intersection with the inside surface, the index of refraction, n_2 , is computed by substituting r_{pI} into Equation (113). The remainder of the skew ray trace to the image plane is identical to the homogeneous procedure.

AD-A125 167

AERODYNAMICALLY EFFICIENT GRADIENT REFRACTIVE INDEX
MISSILE SEEKER LENS(U) NAVAL POSTGRADUATE SCHOOL
MONTEREY CA H M CARR OCT 82 NPS67-82-012

2/6

UNCLASSIFIED

F/G 16/4

NL

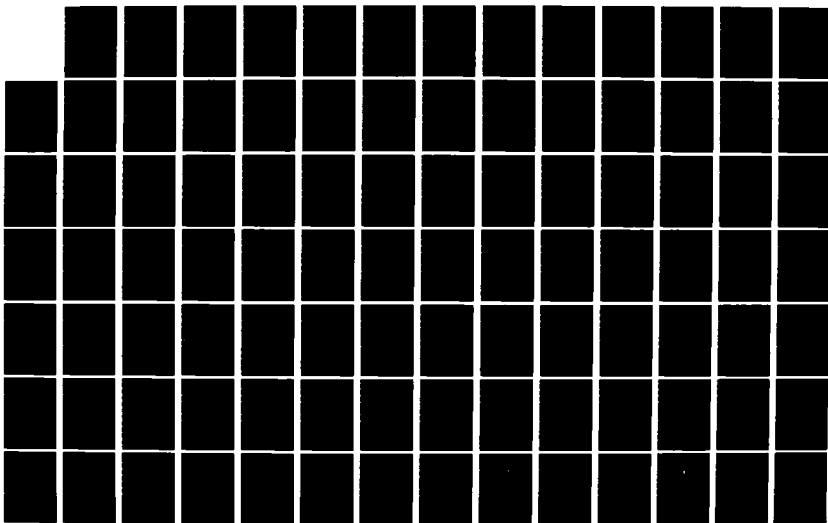

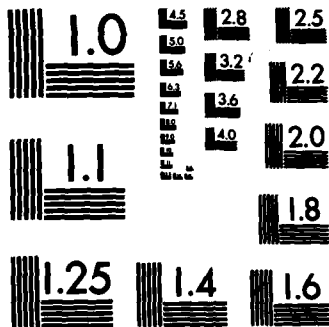

MICROCOPY RESOLUTION TEST CHART
NATIONAL BUREAU OF STANDARDS-1963-A

$$B_6 = \frac{2 N_{p0y} N_{p0z}}{N_{p0x}} A_5 - \left[1 + \left(\frac{N_{p0z}}{N_{p0x}} \right)^2 \right] A_5 B_5 \quad (182)$$

$$C_6 = \left[1 + \left(\frac{N_{p0z}}{N_{p0x}} \right)^2 \right] A_5^2 - 1 \quad (183)$$

and

$$A_5 = \frac{N_{p0x} \cos \psi}{N_{p0x} B_4 - N_{p0y} A_4} \quad (184)$$

$$B_5 = \frac{N_{p0x} C_4 - N_{p0z} A_4}{N_{p0x} B_4 - N_{p0y} A_4} \quad (185)$$

Furthermore, in Equations (184) and (185), A_4 , B_4 , and C_4 are the coefficients of K' , L' and M' in Equation (175).

Now that the direction cosines of the ray are known at the point of intersection with the inside surface, the index of refraction, n_2 , is computed by substituting r_{pI} into Equation (113). The remainder of the skew ray trace to the image plane is identical to the homogeneous procedure.

IV. LENS PERFORMANCE PARAMETERS

The function of the seeker lens is to focus electromagnetic energy either reflected from or emitted by the target onto a detector. Angular displacement of the target with respect to the missile body axes as well as target angular rate information are both desired outputs from the seeker. Hence, it is not only important just to be able to detect the target by focusing energy into a spot on the detector, it is equally important that this spot be as small as possible to enable the precise position of the spot on the detector to be discerned.

The ability of a lens to focus an object to a small spot does not guarantee the quality of the image. For a FLIR optical system extensive effort is expended to obtain an image with minimum aberration [10]. Seeker optics, however, are generally non-imaging devices where the presence of the different aberrations does not detract from the function of the seeker as long as a tight image is maintained [11].

Accordingly, the most important parameter by which seeker lens performance is judged is that of spot size at different obliquities. Since the image found at the focal point is not necessarily circular nor equally dense, the standard deviation in the y and z directions with respect to image centroid is used to define spot size.

Therefore, once the coordinate pairs of all the skew rays have been calculated in the image plane, the first step in

the analysis of lens performance is to calculate the image centroid [12]. If the spot diagram is composed of N rays, the centroid location, y_c is

$$y_c = \frac{1}{N} \sum_{i=1}^N Y_i \quad (186)$$

Since there is symmetry about the x - y plane, the z coordinate of the centroid will always be zero.

The next step in finding the spot size is to find the standard deviations of the spot diagram in the y and z directions. This is accomplished by summing the squares of the differences of the intercept coordinates with respect to the centroid and then dividing by the number of rays. The standard deviations then, are given by

$$\sigma_z^2 = \frac{1}{N} \sum_{i=1}^N z_i^2 \quad (187)$$

and

$$\sigma_y^2 = \frac{1}{N} \sum_{i=1}^N (Y_i - y_c)^2 \quad (188)$$

The spot size, σ_r , is now defined by

$$\sigma_r = \sqrt{\sigma_z^2 + \sigma_y^2} \quad (189)$$

Of further interest in appraising lens performance is the energy density of the image as a function of radius from the centroid. In nondimensional form, this is simply the number of rays in the spot diagram within a succession of circles of increasing size overlaid about the centroid. Here, each ray is assumed to carry a unit amount of radiant energy. This type of plot facilitates the comparison of different lens designs by detailing the distribution of energy within each image. Clearly, it is desirable to have as much energy as possible concentrated very close to the image centroid. Between two lenses with equal spot sizes, the preferred lens has more energy concentrated within a smaller radius.

Every ray, however, does not deliver an equal amount of energy to the focal plane. It is prudent, therefore, to include as a performance parameter the average ray intensity. Again, for N rays, the intensity I of each ray is summed and normalized by N to yield

$$I_{av} = \frac{1}{N} \sum_{i=1}^N I_i \quad (190)$$

Finally, each lens design is checked for "failed rays". The reader will recall that these rays fail to intercept the image plane due to total internal reflection, total external reflection, or failure to intercept the inside surface within the bounds of the lens. Hence, a lens design with fewer "failed rays" or no "failed rays" at all is a preferred lens.

Although there are many other performance criteria by which lenses are compared, the foregoing parameters are more than sufficient to judge the merit of preliminary seeker lens designs. It should be noted, however, that notwithstanding the fact that the image centroid and standard deviations were used as stepping stones to obtain image spot size, they have significant meaning of their own. The standard deviations σ_y and σ_z inform the lens designer as to the horizontal and vertical spread of the image. Image centroid location, y_c , at increasing obliquities is of obvious importance since excessive displacement will cause the image to miss the detector entirely and would dictate the necessity for a second lens element to dampen the movement. Furthermore, since Line of Sight (LOS) measurement accuracy to the target is highly dependent upon the linearity of y_c as a function of the lens tilt angle, lens designs which exhibit a greater degree of such linear behavior are the preferred designs.

To summarize, it is sufficient to note that although spot size is the most important of the performance parameters, every other parameter has a significant impact on the performance of a particular lens.

V. RESULTS FOR THE HOMOGENEOUS LENS

The performance of the homogeneous lens is presented primarily as a comparison with which to compare the performance of the GRIN lens. Here, the relationship of spot size to increasing lens obliquity and lens thickness are presented as well as the image centroid movement as a function of obliquity. Additionally, the reader is introduced to the four basic computer plots used to display the results: lens shape, object plane with superimposed skew ray grid, image plane or spot diagram, and energy density. These plots were generated on the VERSATEC Plotter using arrays of data points produced by program GISL on the IBM 3033 mainframe computer.

To begin, Figure 11 shows the homogeneous lens shape. The first of the four basic plots, the lens shape plot, presents the lens side view in the meridian plane. The outer surface (curved) and the inner surface (cone) are constructed by connecting the points $x_1(J)$, $y_1(H)$ and $x_2(J)$, $y_2(J)$, respectively, by straight lines. At the apex of the lens about the lens axis is a trapezoidal region which represents the opaque nose area. In the legend are listed the lens design parameters and the significant calculated dimensions of the lens. Since all linear dimensions are implicitly normalized with respect to the maximum inside radius, R , the lens may be scaled up or down by multiplying each dimension by a factor of R_{new}/R . Beginning at the top, the parameters listed in the legend are explained in Table 1.

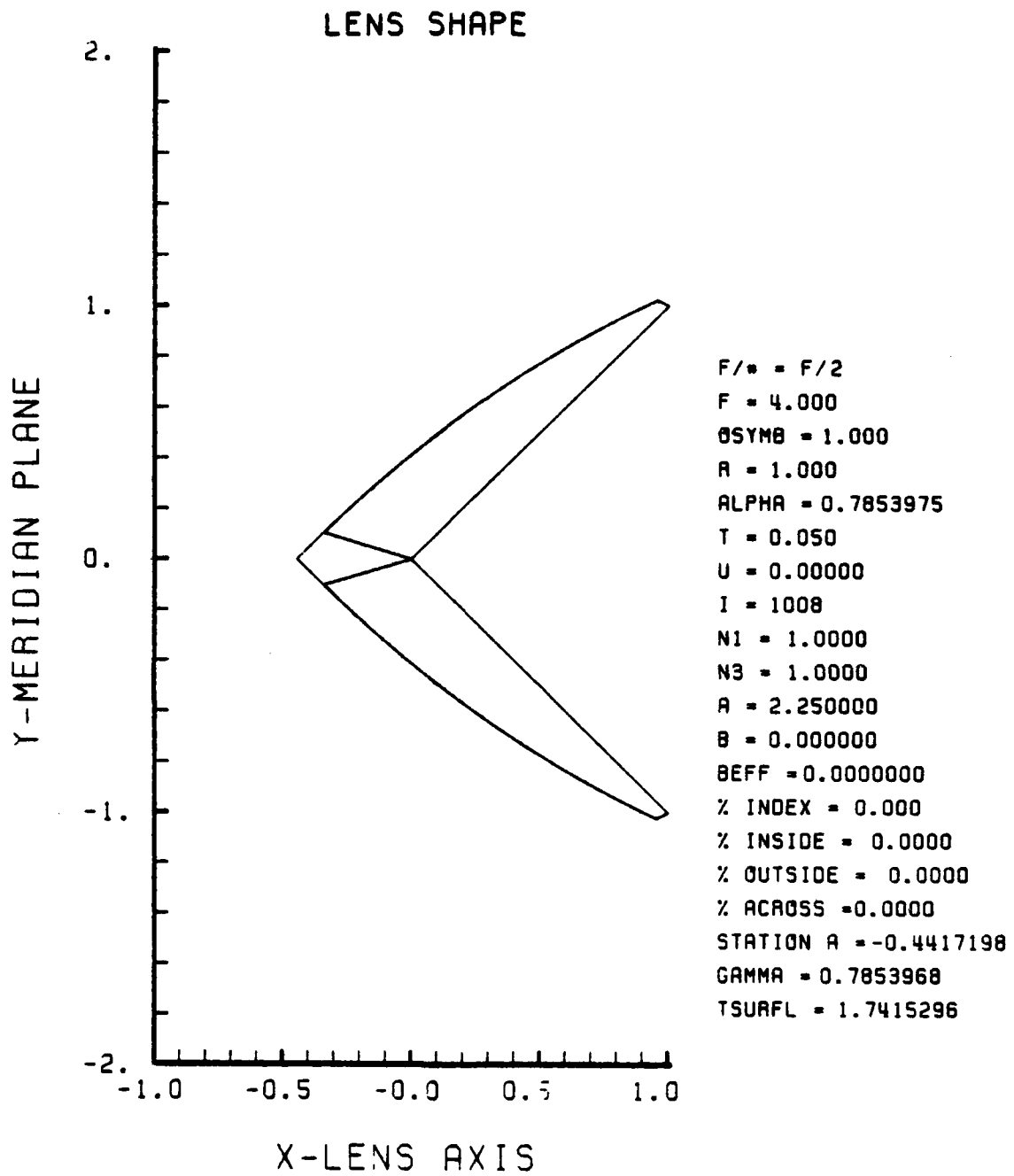

Figure 11. Homogeneous Lens Shape for $N_2 = 1.5$

TABLE 1

Explanation of Lens Shape Plot Legend

<u>PARAMETER</u>	<u>TYPE OF PARAMETER</u>	<u>MEANING</u>
F/#	DESIGN	F number. $F/\# = F/2R$
F	DESIGN	Focal length from B.*
OSYMB	DESIGN	OB. Line segment O_g to B (positive to left). Immaterial in HIN
R	DESIGN	Maximum radius of cone*
ALPHA	DESIGN	α --cone half-angle,* radians
T	DESIGN	Edge thickness*
U	DESIGN	Incident ray offset angle (design)*, radians
I	DESIGN	Number of iterations. I+1 = number of rays
N_1	DESIGN	Free stream index of refraction
N_3	DESIGN	Index of refraction of interior lens cavity
A	DESIGN	a in $n_2(r) = \sqrt{a + b(r^2/R_z^2)}$, gradient refractive index function. $N_2 = \sqrt{a}$ in HIN.
B	DESIGN	b in $n_2(r)$. Zero in HIN
B_{EFF}	CALCULATED	b effective = b/R_z^2
% Index	DESIGN	Percent change in $n_2(r)$ from $r = 0$ to $r = R_z$
% Inside	CALCULATED	Percent change in $n_2(r)$ along inside surface from lens axis to edge
% Outside	CALCULATED	Percent change in $n_2(r)$ along outside surface from opaque region to edge

Table 1 (Continued)

<u>PARAMETER</u>	<u>TYPE OF PARAMETER</u>	<u>MEANING*</u>
% Across	CALCULATED	Percent change in $n_2(r)$ across lens from left axis to outside surface at the thickest point
STATION A	CALCULATED	x-coordinate at nose of lens*
GAMMA	CALCULATED	γ --nose half-angle of opaque nose region, radians
TSURFL	CALCULATED	Total outside surface length from Station A to the edge

* Refer to Figure 2 for clarification

The HIN lens shape has a convex outer surface with maximum thickness on axis of almost ten times the edge thickness. Although the lens has a good aerodynamic shape resembling an ogive, the outer surface is not a circular arc nor can a single analytical function be fitted to the array of points describing the surface. Note that the nose half-angle, γ , is almost identical to the cone half-angle, α .

All lenses have been designed with a cone half-angle of 45° which is approximately the maximum angle for which aerodynamically efficient lens shapes may be designed, considering a free stream Mach Number not to exceed three. Without exception, overall lens performance is more severely degraded as angle α is reduced.

Table 2 explains the legend of Figure 12, which is the second basic plot. Here the lens is depicted as seen from the skew ray grid plane. The lens tilt angle, α_p , causes the equally spaced (in J) circles describing the surface of the lens to appear as ellipses. In Figure 12, the grid spacing has been reduced from 0.1, which is normally used, to 0.3 to allow identification of individual rays for correlation with the image plane spot diagram. Although the small number of rays used is not sufficient to give an accurate definition of spot size, the number is sufficient to describe where rays in the object plane are being focused in the image plane by the HIN lens. The skew rays in Figure 12 have been numbered in the order in which they were processed. Actually, only rays 1 through 19 were actually traced; 20 through 33 are

TABLE 2

Explanation of OBJECT PLANE Plot Legend

<u>PARAMETER</u>	<u>TYPE OF PARAMETER</u>	<u>MEANING</u>
ALFAP	Analysis	α_p . Lens tilt angle, radians
Rays	Analysis	Total number of rays processed
Failed Rays	Analysis	Total number of rays failing to pass through the lens*

* Failed Rays are indicated on the plot by a diamond superimposed on the grid location of the ray.

mirror image skew rays. Ray 30 corresponds to ray 14, for example, Here, the lens has been tilted by 0.4 radians, or 22.9 degrees, and 33 rays have been processed of which none have failed to intercept the image plane. The staircase pattern has been added in this case in order to show the resulting distortion present in the image plane (Figure 13).

The Spot Diagram in Figure 13 is an example of the third basic computer plot; see Table 3. Unlike most Spot Diagrams, this example has the individual rays numbered for comparison with Figure 12; also the resulting distorted staircase pattern is sketched. By cross-referencing individual rays between Figures 12 and 13, it is possible to recognize where certain areas of the lens are focusing rays in the image plane. Rays 1, 4, 20, and 22 about the opaque nose region form a coma tail which contributes most of the image spread. Rays 33,

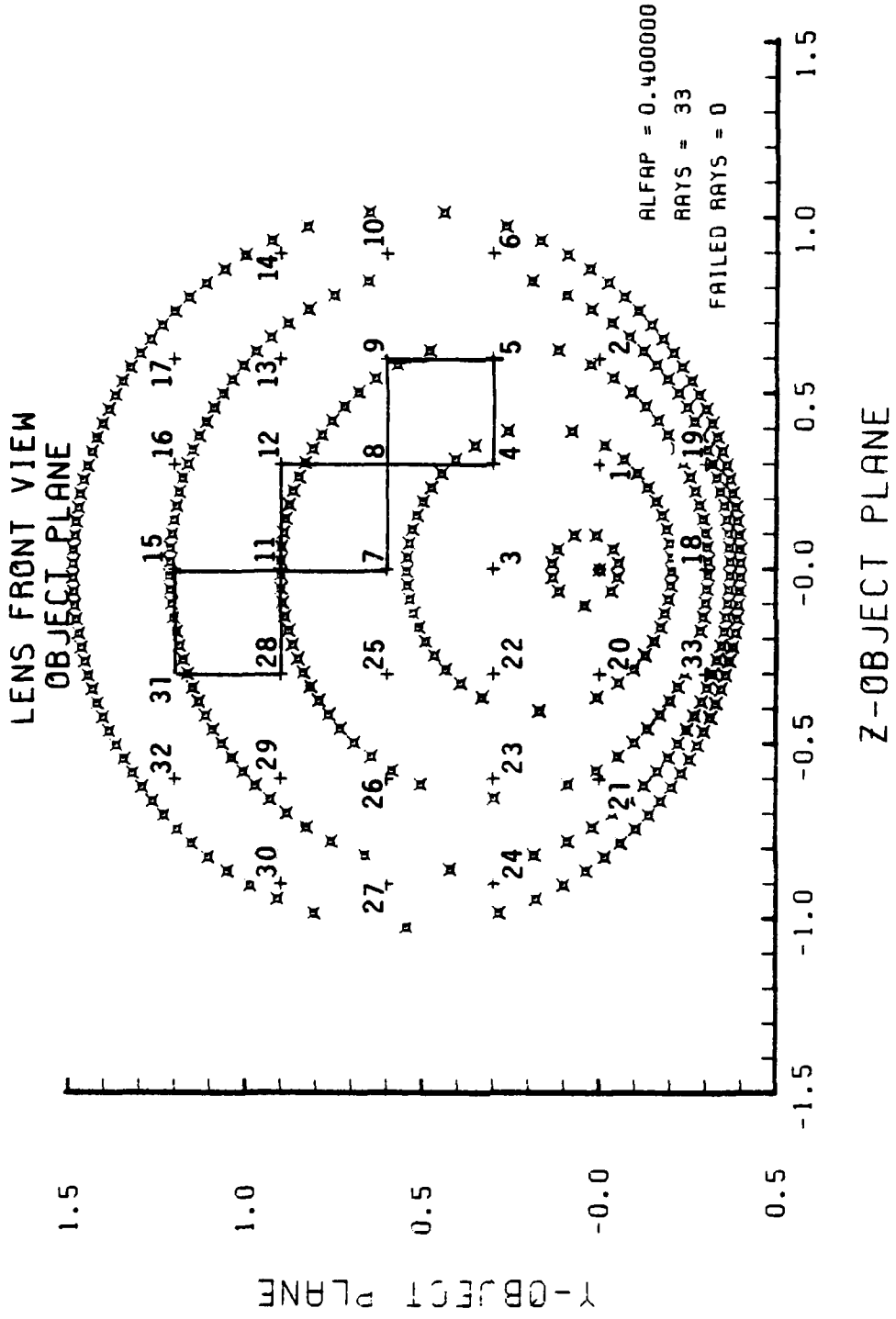

Figure 12. Example Object Plane

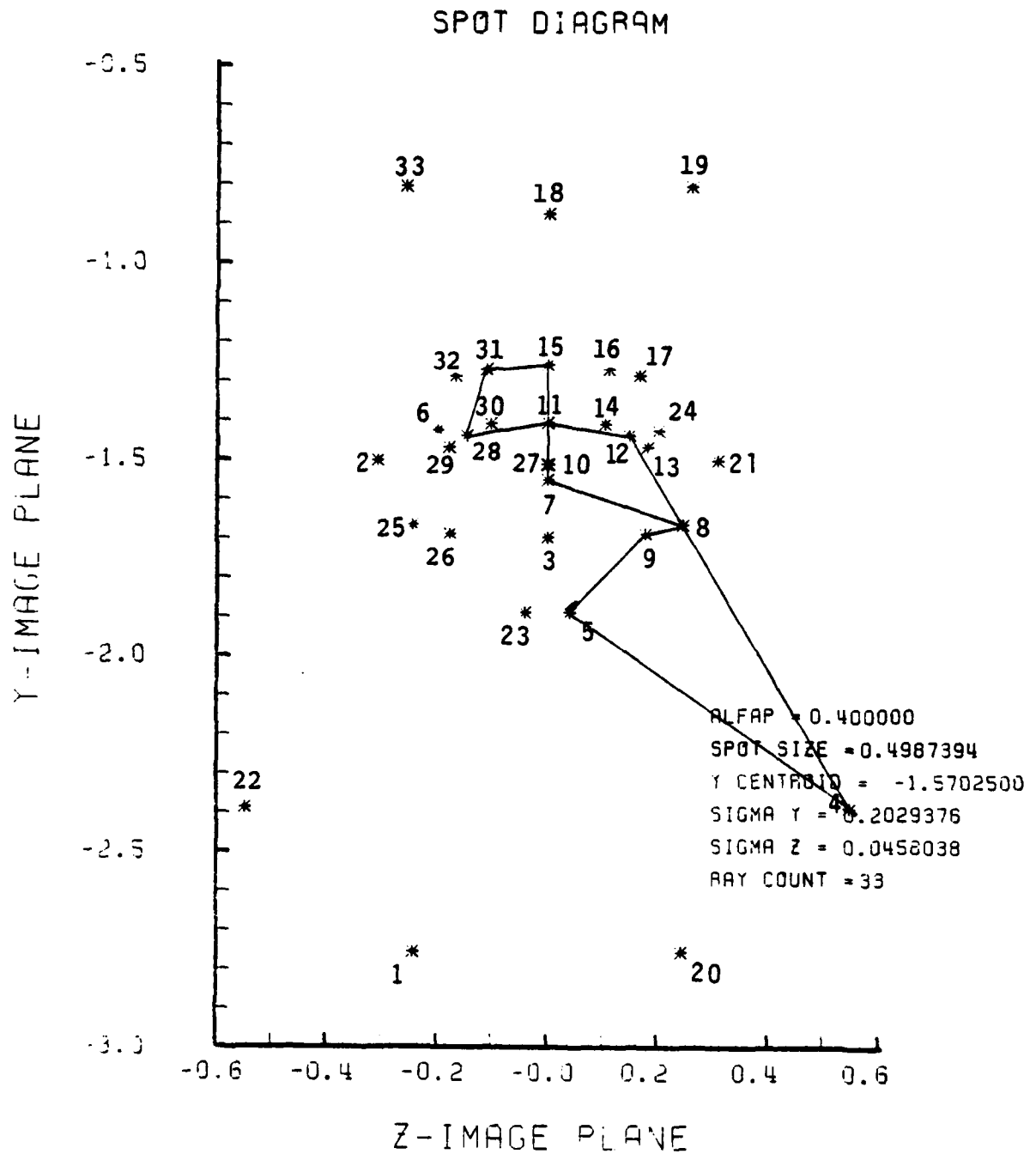

Figure 13. Spot Diagram for HIN Lens Design Shown in Figure 11

TABLE 3

Explanation of Spot Diagram Legend

<u>PARAMETER</u>	<u>TYPE OF PARAMETER</u>	<u>MEANING</u>
ALFAP	Analysis	α_p , lens tilt angle, radians
SPOT SIZE	Performance	σ_r , see Equation (189)
Y-CENTROID	Performance	Y_C , y-coordinate of image centroid; see Equation (186)
SIGMA Y	Performance	σ_y , y-standard deviation; see Equation (188)
SIGMA Z	Performance	σ_z , z-standard deviation; see Equation (187)
RAY COUNT	Performance	Number of rays striking the image plane

18, and 19 from the bottom portion of the homogeneous lens are imaged at the top and are widely separated from the core of the image. In general, the regions of the lens which have been found to contribute the bulk of the widely spaced rays are the immediate nose region and the lower portion of the lens.

Furthermore, the distortion present in the image of the staircase pattern clearly shows that regions closest to the nose yield the greatest distortion. Horizontal lines are switched end for end and tilted approximately 45 degrees.

The upper portion of the lens performs the best. Rays 3, 7, 11, and 15 in the meridian plane are focused on the Y_{IM} axis in a fairly tight region; rays 10, 14, 17, 27, 30,

and 32 about the upper periphery in the object plane are all focused within the image core.

Table 3 explains the legend of the spot diagram. It is seen that the standard deviation in the y-direction is approximately five times that of the z-direction. This elongation of the image is not readily evident in the spot diagram since the ordinate and abscissa have not been plotted with equal increments. This results from the great disparity between Spot Diagrams of the various lens designs studied. It is important, therefore, for the reader to take careful note of the relative sizes of the y_{IM} and z_{IM} axes.

Of primary importance is the spot size in Figure 13. The value for spot size is adversely affected by the poorest performing regions of the lens. Were it not for these errant rays, the spot size would be considerably smaller. The image intensity pattern is benefitted, however, by the fact that the rays spread the farthest from the centroid contribute significantly less energy per ray than those being focused in the core of the image. Table 4 lists the relative intensities of the primary skew rays plotted in Figure 13. It is seen that the high intercept angles experienced by the rays closest to the bottom of the lens and, to a lesser extent, those near the nose, result in higher reflectivity and lower transmission through the lens.

In the legend of Figure 14, the average of ray intensity is given. The Spot Diagram Energy Density distribution may be seen at a glance. The fraction of energy (number of rays)

TABLE 4

Skew Ray Intensities of HIN Lens

a) Numerical Order

<u>Ray</u>	<u>Intensity</u>	<u>Ray</u>	<u>Intensity</u>
1	0.746	11	0.919
2	0.789	12	0.918
3	0.921	13	0.910
4	0.892	14	0.887
5	0.877	15	0.918
6	0.811	16	0.916
7	0.920	17	0.910
8	0.917	18	0.640
9	0.904	19	0.576
10	0.870		

b) In order of Descending Intensity

<u>Intensity</u>	<u>Ray(s)</u>	<u>Intensity</u>	<u>Ray(s)</u>
0.921	3	0.887	14
0.920	7	0.877	5
0.919	11	0.870	10
0.918	12,15	0.811	6
0.917	8	0.789	2
0.916	16	0.746	1
0.910	13,17	0.640	18
0.904	9	0.576	19
0.892	4		

SPOT DIAGRAM ENERGY DENSITY

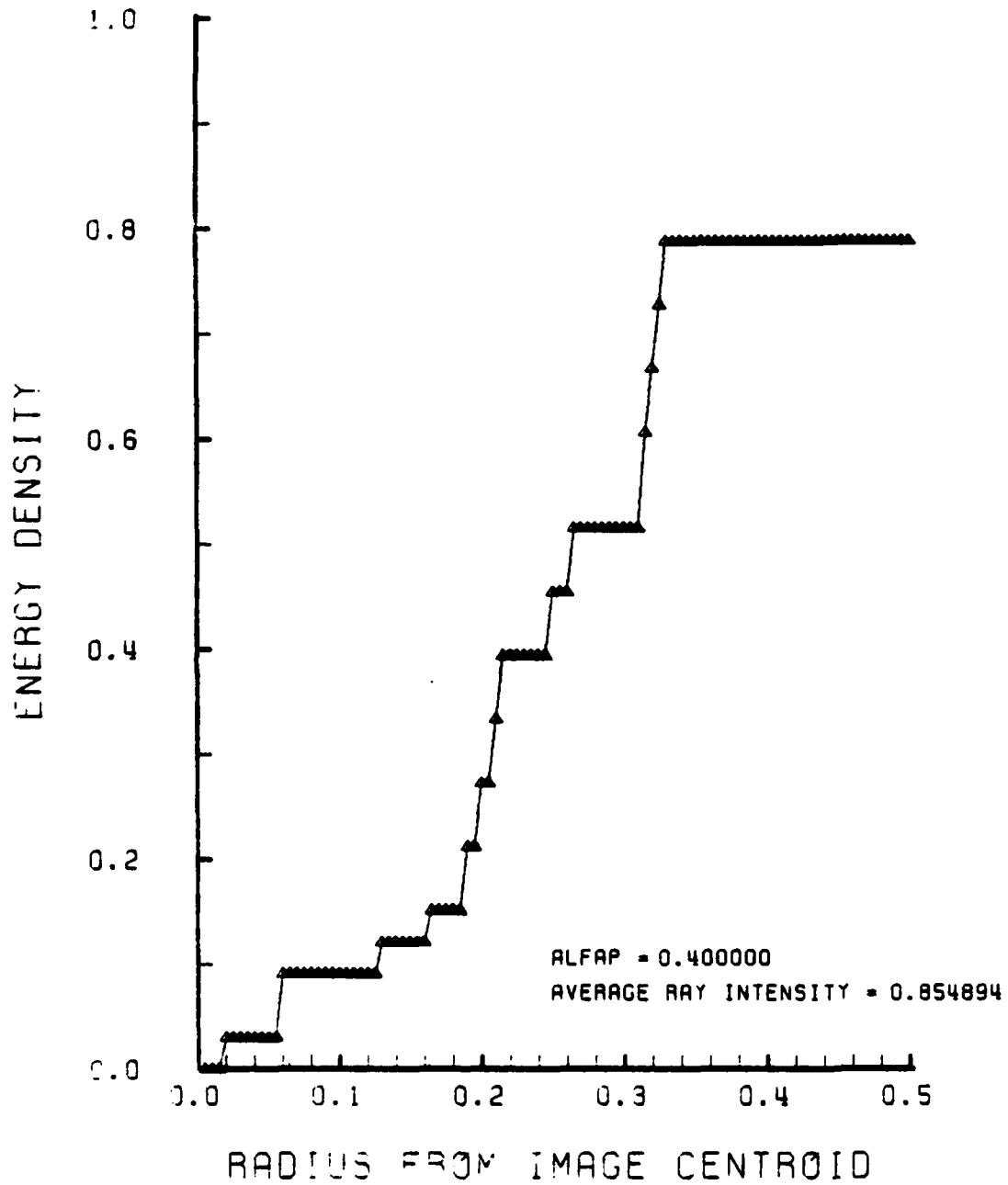

Figure 14. Nondimensional Encircled Energy Plot for HIN Lens Design of Figure 11

shown as a function of radius from the Spot Diagram centroid is normalized with respect to the total number of rays traces (Rays, in Figure 12) regardless of whether all of the rays successfully intercepted the image plane. Thus the fourth basic plot may be used in conjunction with the Spot Diagram to further define the image concentration with respect to the centroid.

The response of the HIN lens to increasing tilt angles is given in Figures D-1 through D-23 where the index of refraction of the lens has been set at 1.5. Whereas the spot size at $\alpha_p = 0.0$ is very small, that at $\alpha_p = 0.7$ radians is quite large at 67% of the lens radius. Figures 15 and 16 summarize spot size and centroid locations for the lens. Spot size growth, although somewhat irregular at the higher angles, is pronounced. Furthermore, the centroid movement is seen to be an approximately linear function of α_p until $\alpha_p \approx 0.3$ and easily exceeds the radial dimension of the lens at higher tilt angles.

Figure 17 shows that the HIN lens may be slightly improved by increasing the edge thickness, T , by a small amount. The lens may be otherwise tuned to improve performance at certain tilt angles by designing the lens with U slightly greater than zero. These performance improvements are practically insignificant, however, and neither lens tuning by the parameter U nor T produce improvement across the spectrum of tilt angles. Instead, an improvement at one α_p usually has resulted in a degradation at others.

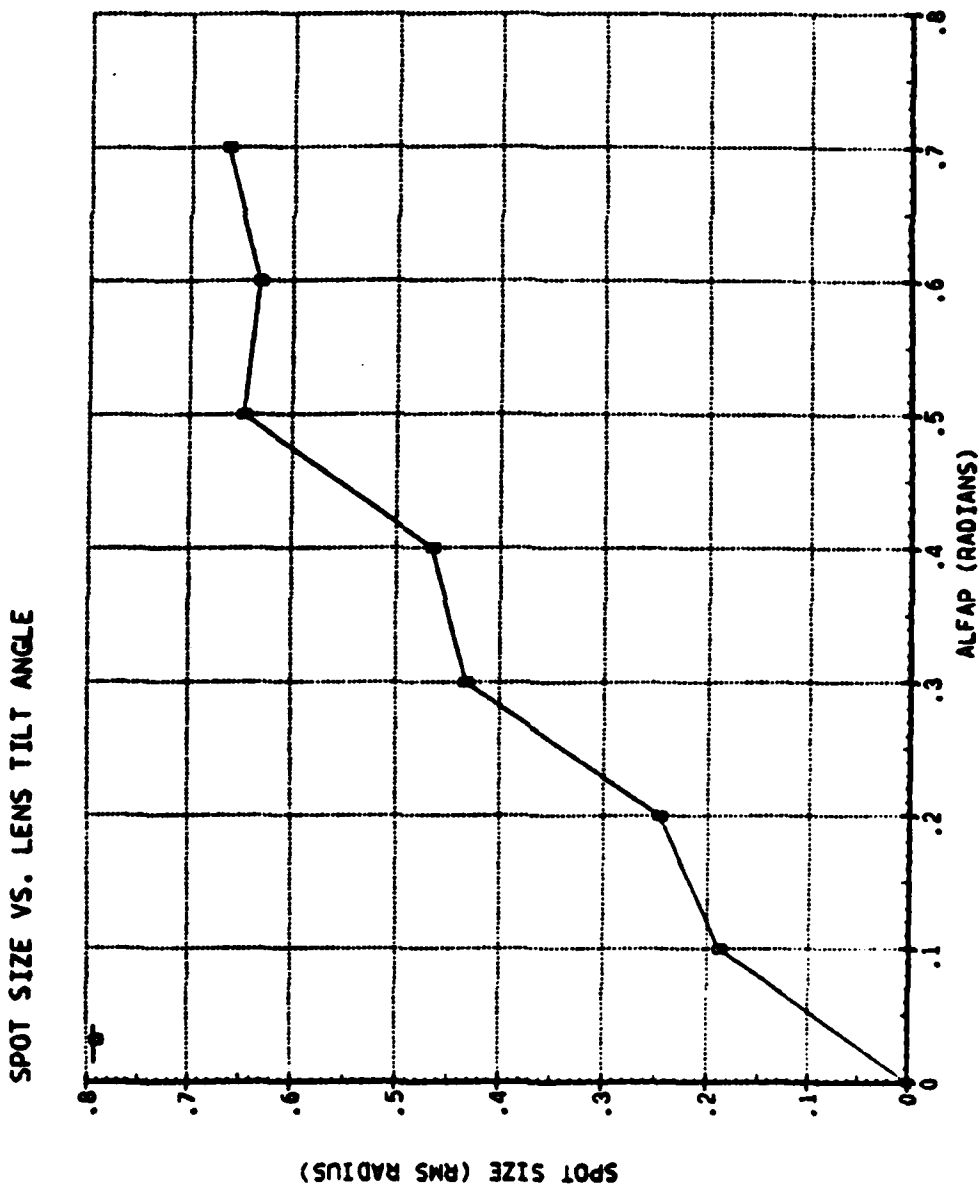

Figure 15. HIN Lens Spot Size versus α_p for $N_2 = 1.5$

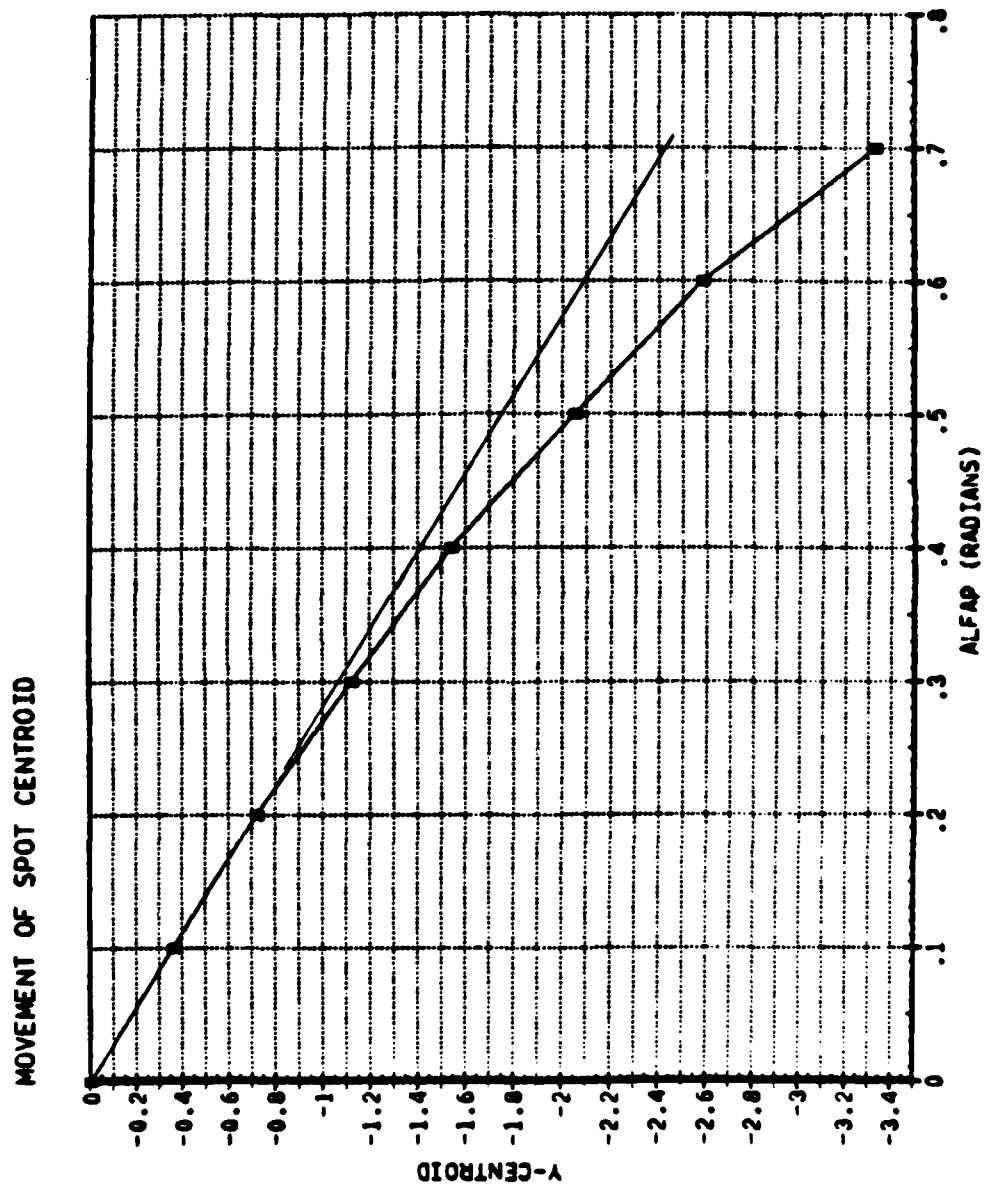

Figure 16. HIN Lens Centroid Movement versus α_p at $N_2 = 1.5$

SPOT SIZE VS. EDGE THICKNESS

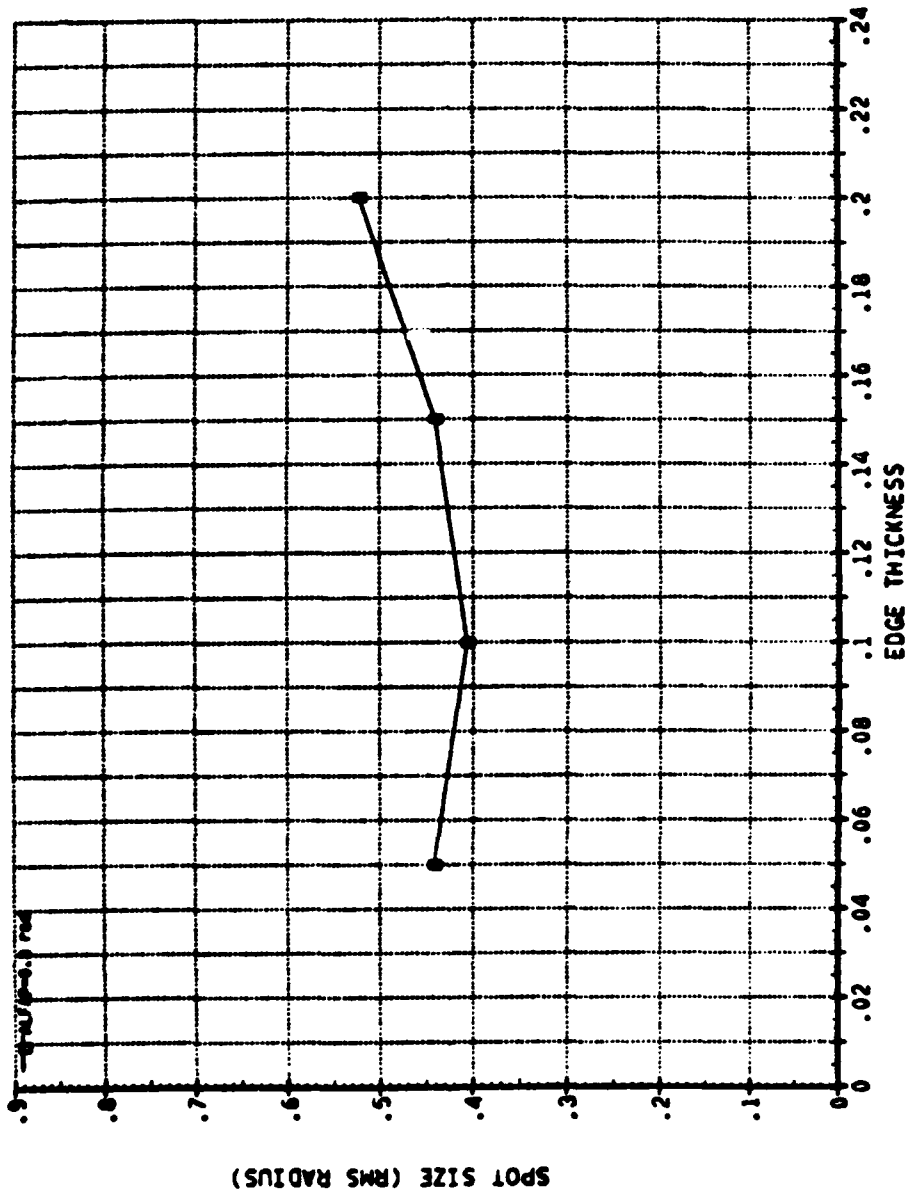

Figure 17. HIN Lens Spot Size versus Edge Thickness at $\alpha_p = 0.3$ Radians and $N_2 = 1.5$

Finally, the homogeneous lens is shown with index of refraction of three at the intermediate tilt angle of 0.3 radians in Figures D-24 through D-27. The lens shape required to accommodate the higher index of refraction is seen to be thinner and displays less outside surface curvature than the HIN lens with $N_2 = 1.5$. Spot size is significantly reduced. Since infrared lenses such as germanium generally have fairly high refractive indices, improved lens performance at these higher values is encouraging.

VI. GRIN LENS RESULTS

The performance of the GRIN lens is similar in many respects to the homogeneous lens. The relationship between characteristic regions of the GRIN lens, such as the lower lens portion, and where these regions image bundles of rays is identical to the HIN lens as depicted in Figures 11 and 12. The growth of spot size with increasing α_p and the respective movement of image centroid typical of the homogeneous lens is clearly displayed by the GRIN lens as well.

The measure of the superiority of the GRIN lens, therefore, lies in the successful correction or improvement of the deficiencies seen in the HIN lens. Here, the reduction of spot size is of primary concern.

As a modest example of the ability of the gradient refractive index to reduce spot size, the GRIN lens design shown in Figure 18 is examined. This lens is very similar in shape to the homogeneous lens with $N_2 = 1.5$. Note, however, that unlike the HIN lens, the nose half-angle, γ , is slightly larger than that of the cone, indicating more outside surface curvature. The object plane for this lens, at $\alpha_p = 0.4$, is shown in Figure 19. Here, the error in focusing rays present in the image plane has been superimposed over the grid plane. y_{IM} coordinate error contours (with respect to the centroid) are shown in the left half of the plane and z_{IM} contours in the right. These contours vividly show that the largest

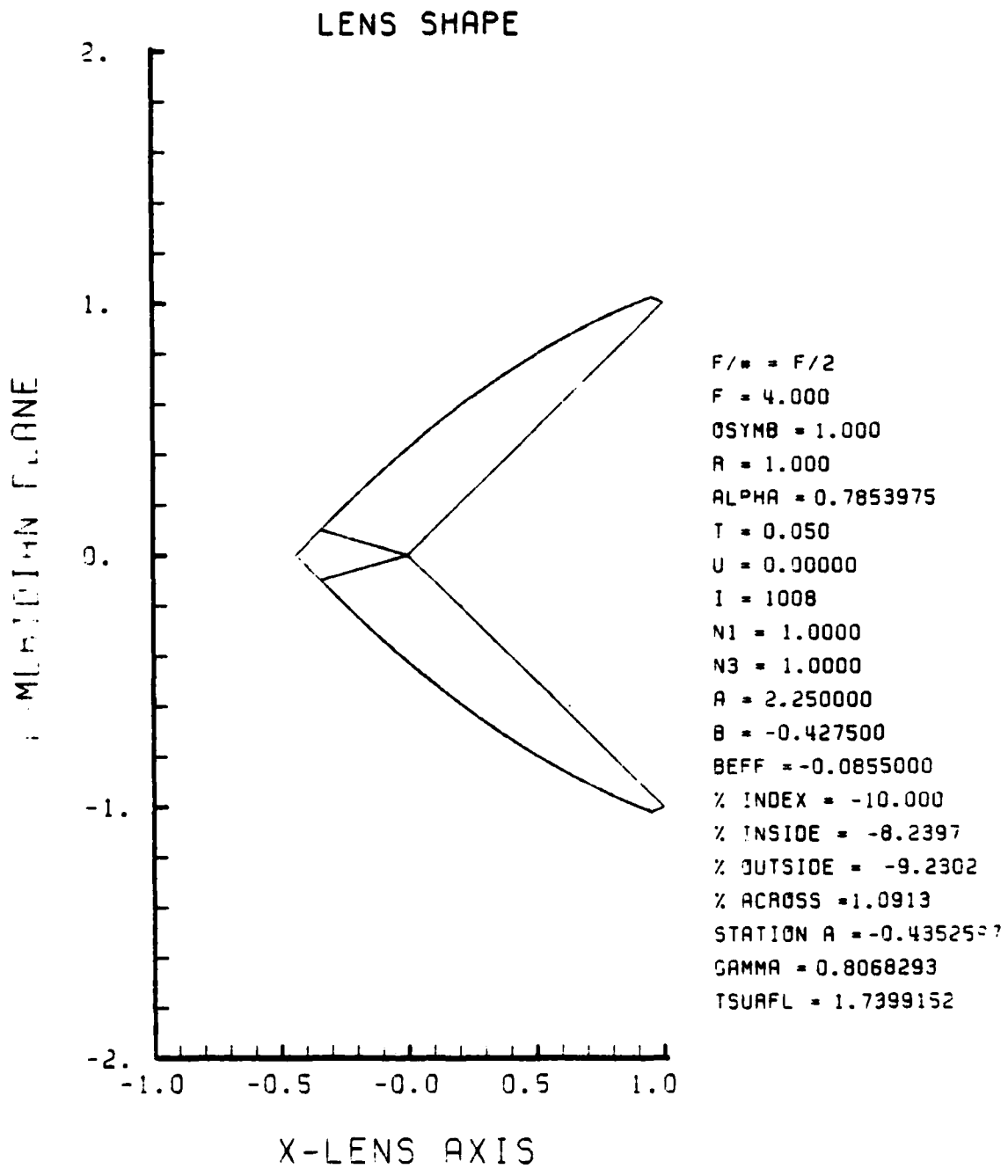

Figure 18. Example GRIN Lens Design with 10% Negative Gradient at OB = 1.0

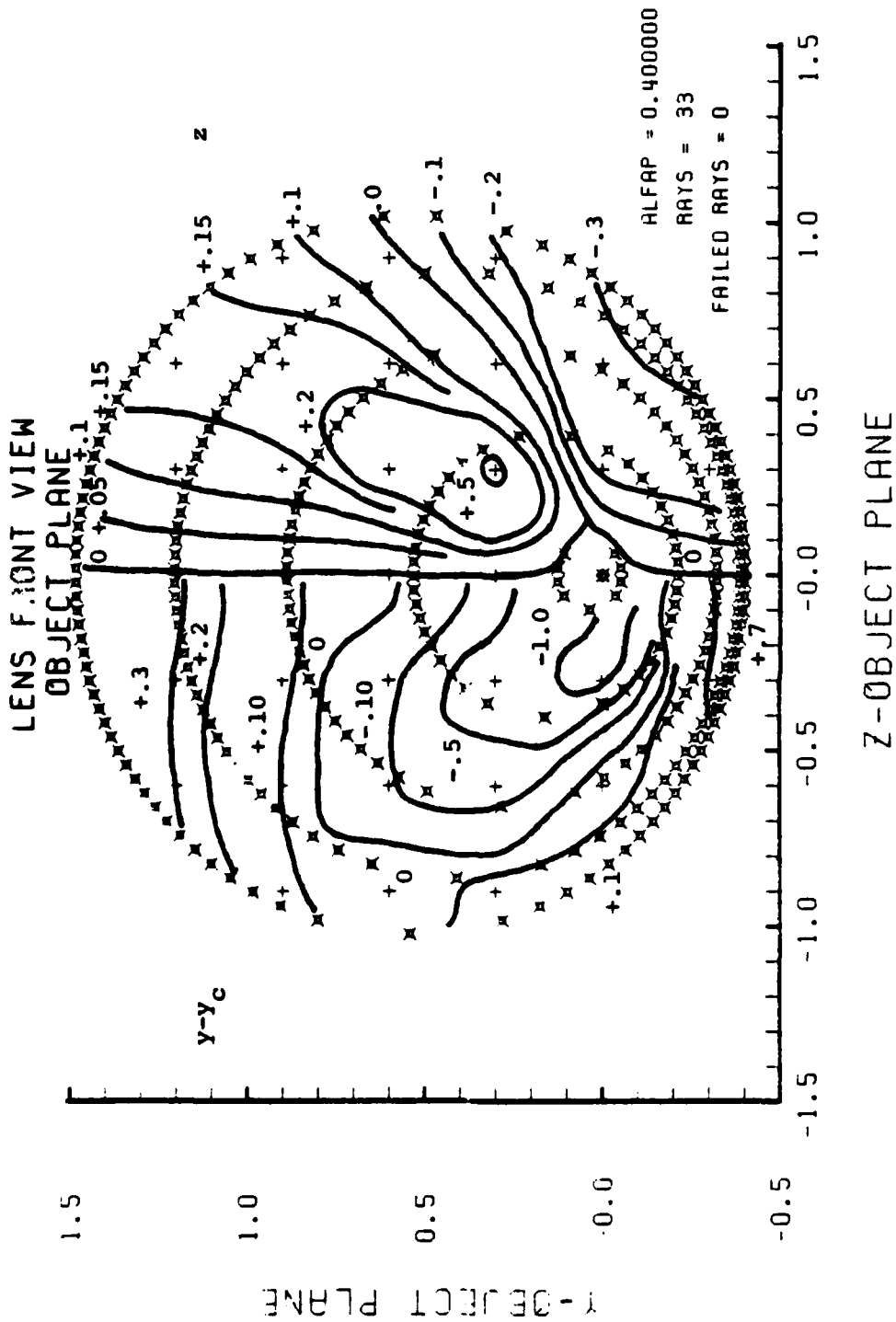

Figure 19. Example GRIN Lens Object Plane. Contours in the Left Half Depict the Difference Between the y Coordinate in the Image Plane and Image Centroid. The Right Hand Contour Shows the Corresponding z Displacement in the Image Plane.

errors in both y and z stem from the nose and bottom of the lens. The best performance is contributed by the upper central region. The reader will note that negative errors in z occur below the $y_0 = 0$ plane of the lens and that negative errors in y straddle the $y_0 = 0$ plane.

The corresponding intensity contours are displayed in Figure 20. Of significance here is that regions which perform relatively well in y and z error also perform well in transmitting energy. Regions of the lens which are characterized by relatively high angles of incidence, therefore, perform the poorest and have the most to gain from better combinations of gradient index and O_s .

The Spot Diagram, Figure 21, displays an image pattern virtually identical with the HIN lens in Figure 11. The GRIN spot size, σ_x , however, is slightly smaller by approximately 2% and both σ_y and σ_z are correspondingly smaller which indicates superior performance by the GRIN version. Image centroid for the GRIN is displaced further than that for HIN. The average intensity transmitted by the GRIN lens compares favorably at 0.88 as opposed to the average intensity of the HIN at 0.85. Further evidence of superiority of the GRIN lens is seen in the form of a steeper slope to the Encircled Energy Plot (Figure 22) than that of the HIN lens in Figure 13.

Although the example GRIN design displays marginal superiority, some GRIN designs do not. In particular, it

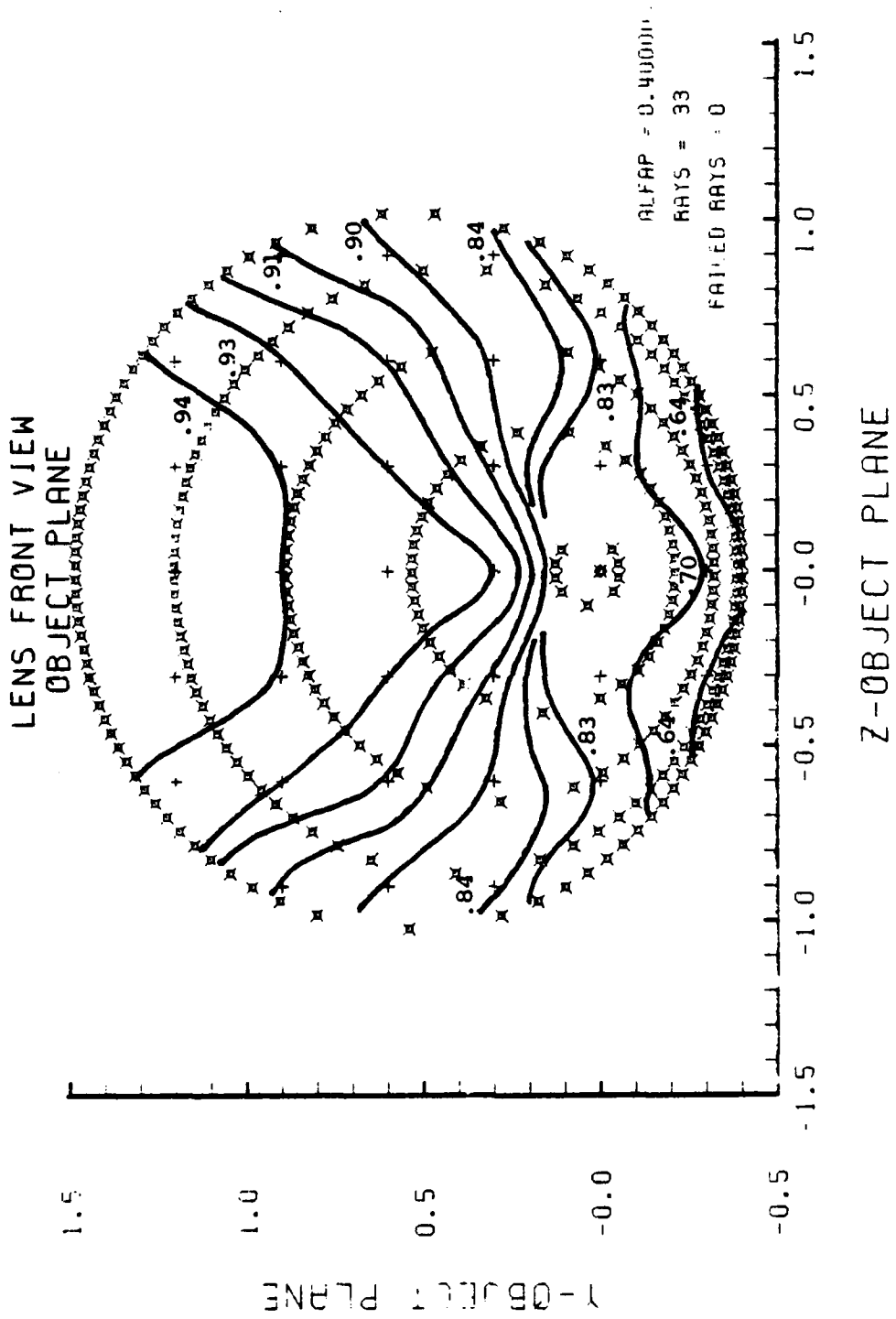

Figure 20 . Intensity Contours of the Example GRIN Lens Shown in Figure 45

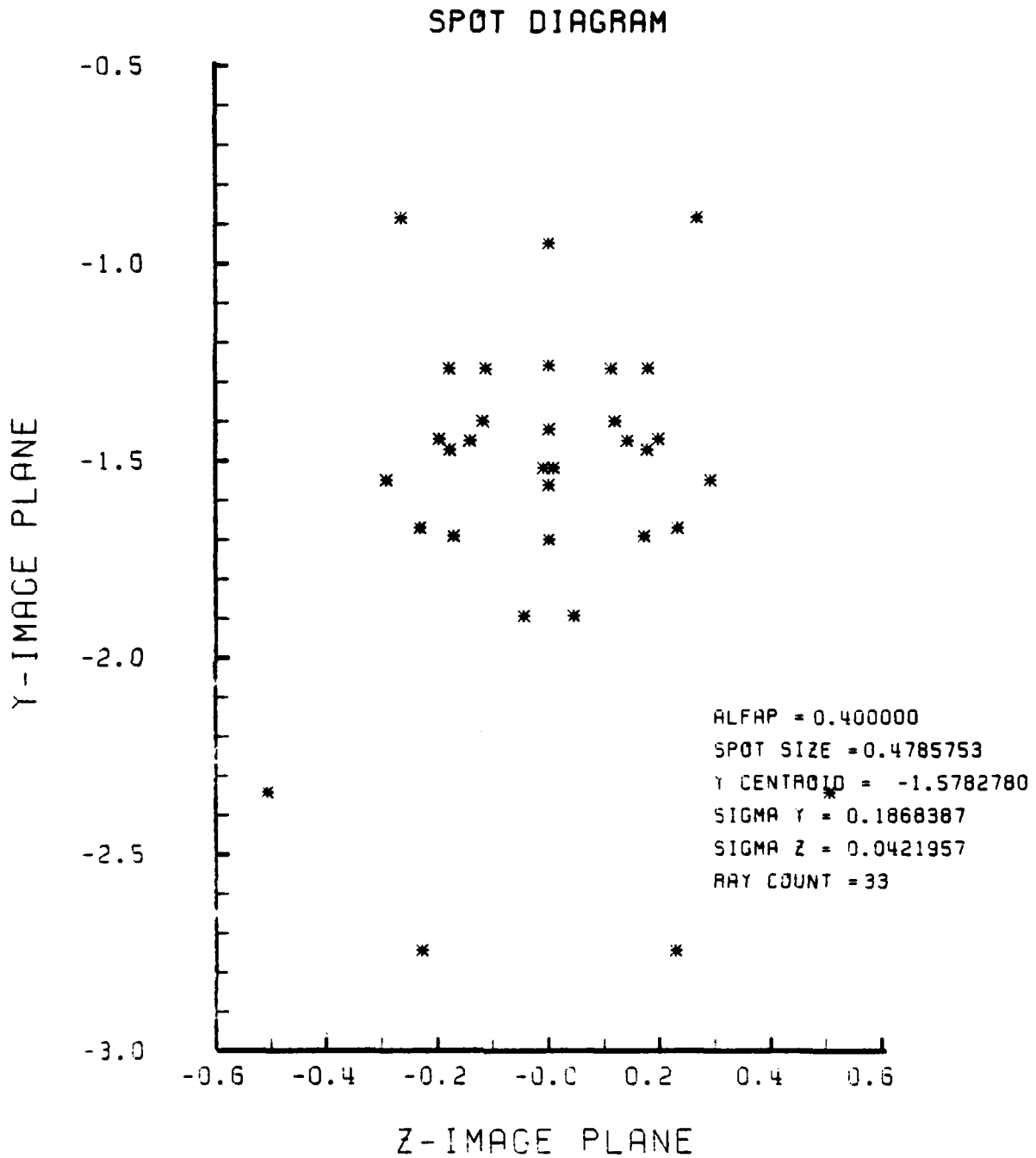

Figure 21. Example GRIN Spot Diagram at $\alpha_p = 0.4$ Radians for GRIN Lens Design Shown in Figure 18

SPOT DIAGRAM ENERGY DENSITY

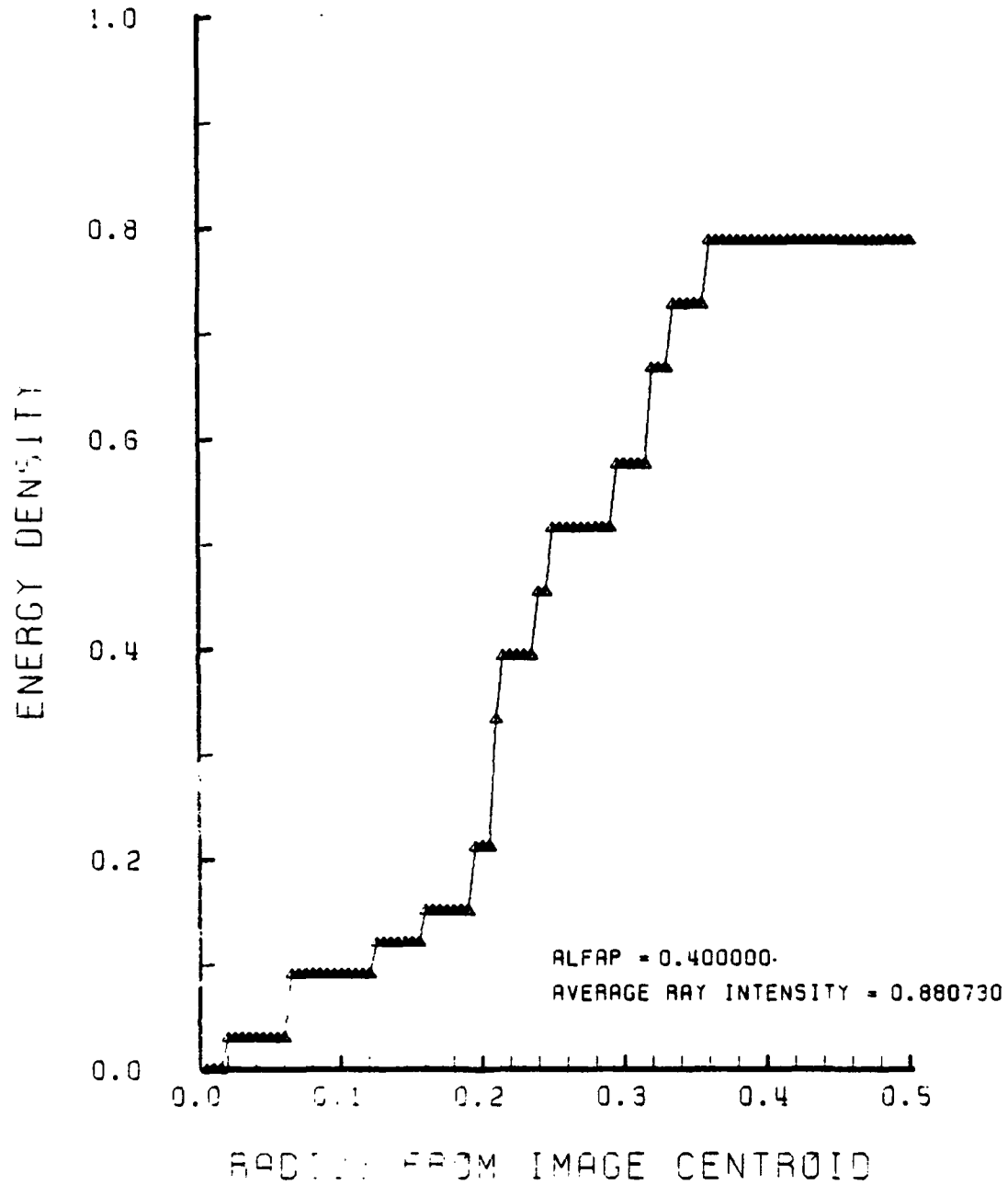

Figure 22. Example GRIN Encircled Energy Plot Corresponding to Figure 21

has been found that as the center of symmetry of the index function, O_g , is moved further away from the interior of the GRIN lens, performance deteriorates.

Two series of GRIN lens designs have been examined at the intermediate tilt angle of 0.3 radians in order to define the spectrum of lens performance. Both design series explore the GRIN lens for O_g inside, outside, and far outside the interior of the lens. The first series, Figures E-1 through E-92, are GRIN designs in the "low range" of refractive index with the index parameter "a" set at 2.25. This first set is compared to the HIN lens with $N_2 = \sqrt{a} = 1.5$. The second, or "high range" series is for $a = 9.0$, as compared to the HIN at $N_2 = 3.0$, and are displayed in Figures F-1 to F-128. Both the high and low range lenses exploit gradient changes of 5, 10, 25, and 50 percent both positive and negative, where possible. A negative 50% gradient in the low range is, of course, not possible since an index of below 1.0 would result. The center of symmetry was not located at $x \geq 0$ due to the aforementioned singularity encountered at very small angles.

The lens shapes of the GRIN designs shown vary widely. The outside surface may be either convex or concave and exhibits a thinner profile at higher values of refractive index. Although all of the resultant GRIN lens shapes are superior aerodynamically to the hemispherical seeker lenses currently in use, the convex version of the lens has more

obvious applications for a Sidewinder type tactical missile, whereas the concave lens shape is more applicable to the diffuser of a ramjet with nose inlet.

Object plane diagrams show that for lens designs exhibiting smaller spot size, fewer or none of the skew rays failed. This fact underscores the success of GRIN in controlling image deterioration contributed by the nose region of the lenses. Although the lower lens and nose regions still create the largest of the image spread, the extent is reduced.

Figures 23 and 24 are contour diagrams summarizing spot size performance of GRIN lens designs in the low and high range respectively. From these diagrams, it can be seen immediately that the best performance is obtained from lenses having the center of symmetry inside the lens. From this fact, it may be deduced that large changes in refractive index are desired along the surface of the lens rather than across. Except for isolated regions at -5%, increasing gradients produce smaller spot sizes. The positive gradient in the high range, however, has an almost constant spot size from +5% to +50% where an improvement of only 0.6% is seen. In both the low and high ranges the positive gradient at 50% and at $OB = 0.05$ has proved to be the best performing combination. Again, as in the HIN lens the high range exhibits the smaller spot size.

The best GRIN lens is now further examined over the range of obliquities up to 0.8 radians. Furthermore, since it has

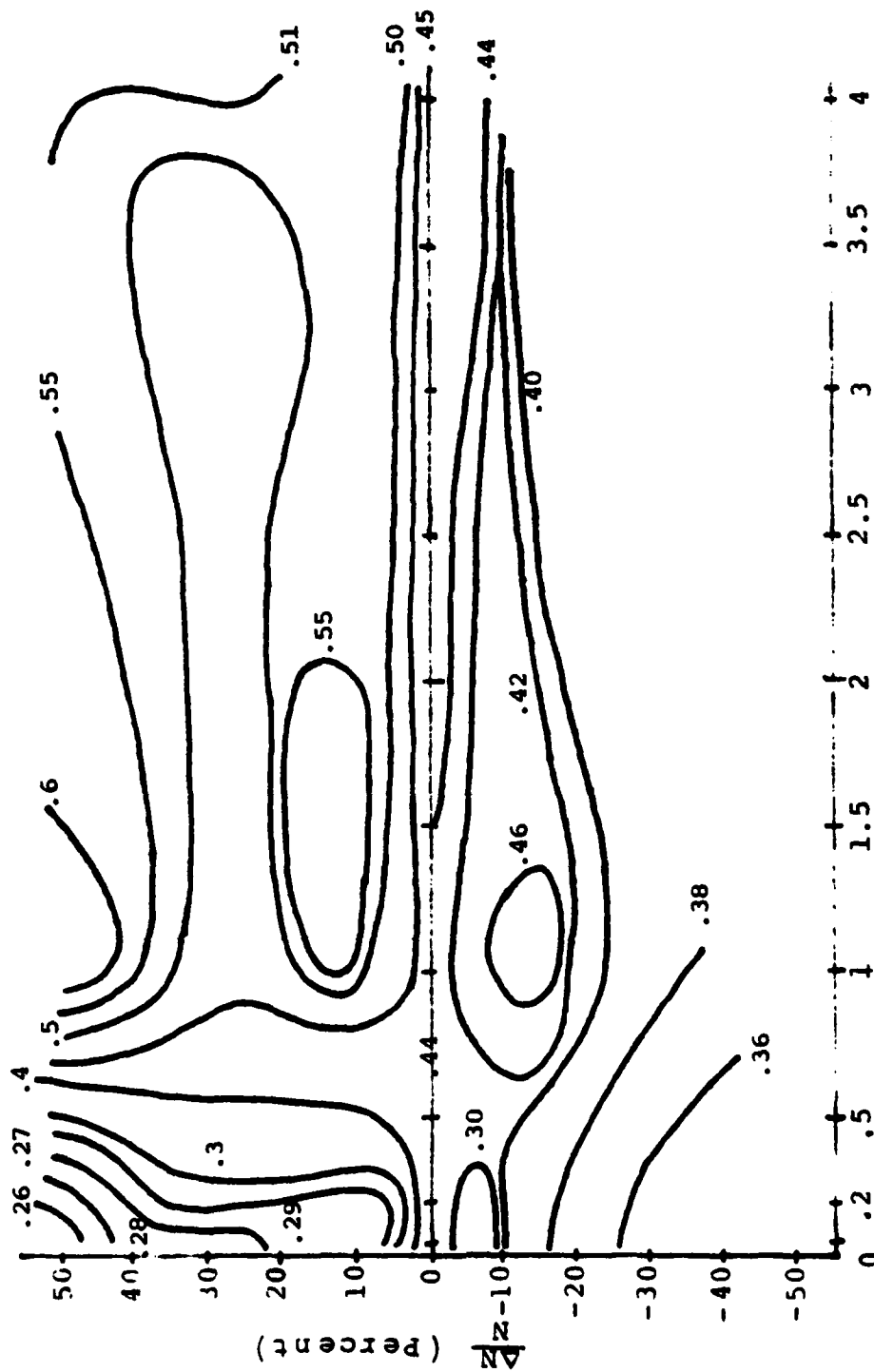

Figure 23. Contour Plot Summary of GRIN Lens Spot Size Performance
 for $\alpha_p = 0.3$ radians, $a = 2.25$

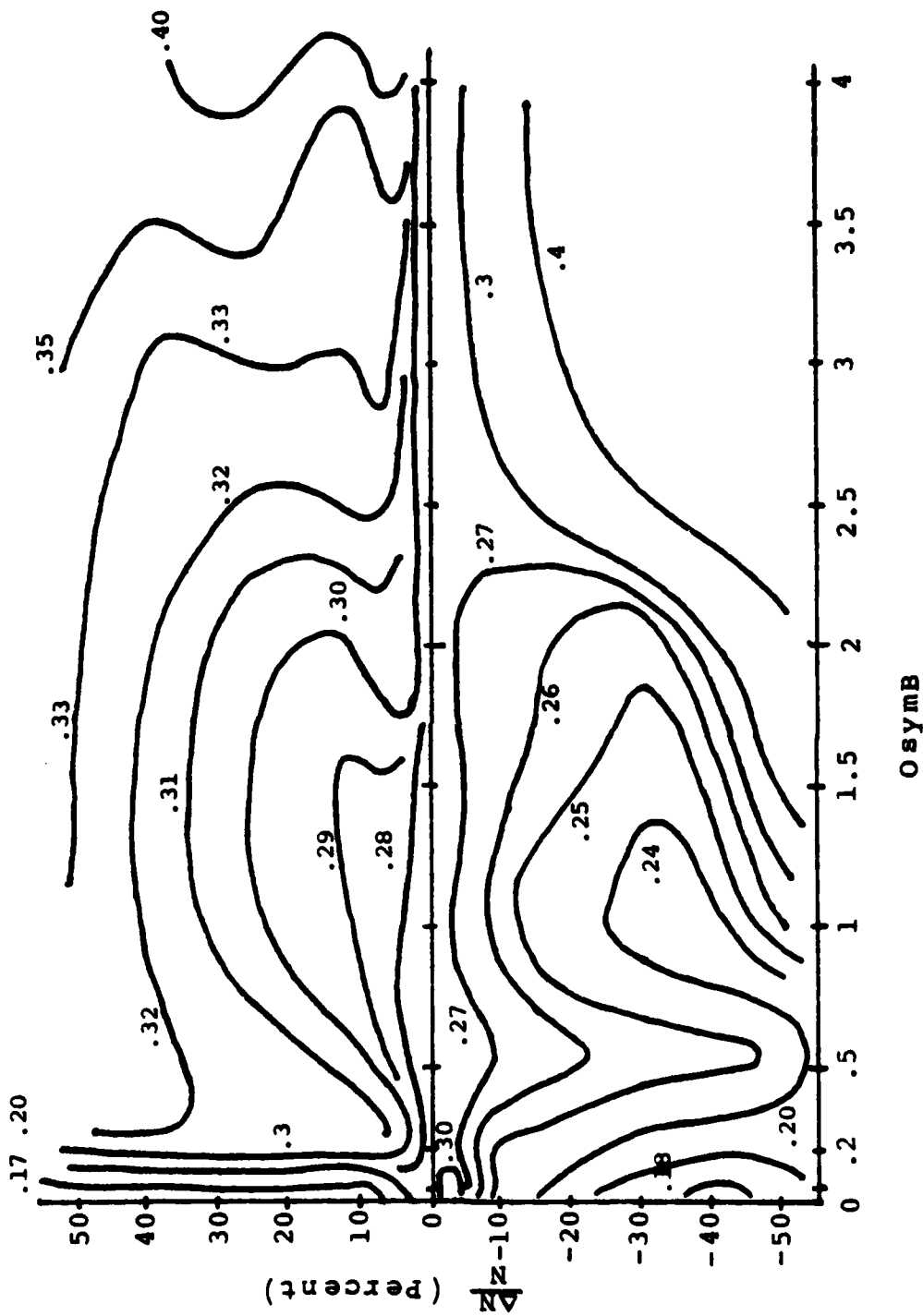

Figure 24. Contour Plot Summarizing GRIN Lens Spot Size Performance at $\alpha_p = 0.3$ radians, $a = 9.0$

been determined that placing the focal point at $x = 2.0$, improves spot size performance at lower values of α_p , another series of plots is given for $F/1$. With the focal point at $x = 1.5$, severe degradation results; for $F = 3.0$ only modest differences with $F/2$ are evident. Appendices G and H show the performance of the "best" GRIN lens at $F/1$ and $F/2$.

Here it may be fully recognized that the resulting behavior of a "good" gradient refractive index seeker lens is far superior to that of the HIN lens for $\alpha_p \leq 0.6$ radians; see Table 5. The reader will note that there are no failed rays even at 0.8 radians (45.8 degrees). Although centroid movement at $F/2$ is slightly greater than the HIN lens, by changing to $F/1$, this can be corrected; see Figure 25. The $F/1$ version, moreover, displays a range of spot sizes significantly smaller than that for the $F/2$ lens below $\alpha_p \approx 0.54$ radians or the HIN lens below 0.68 radians; see Figure 26. That the lens displays more desirable performance with a shorter focal length is a surprising but highly desired result. Since seeker optics systems are volume limited, any reduction in the lens focal length is beneficial to the final design and packaging requirements.

It is significant for the reader to note that centroid movement beyond a value of ± 1.0 exceeds the physical dimensions of the lens radius. If the interior of the lens mount is of similar dimension, it follows that the requirement for Y_{CENTR} to be less than ± 1.0 restricts the $F/1$ lens to approximately 0.65 radians of tilt whereas the $F/2$ lens is further restricted to less than 0.3 radians. The superior performance

MOVEMENT OF SPOT CENTROID

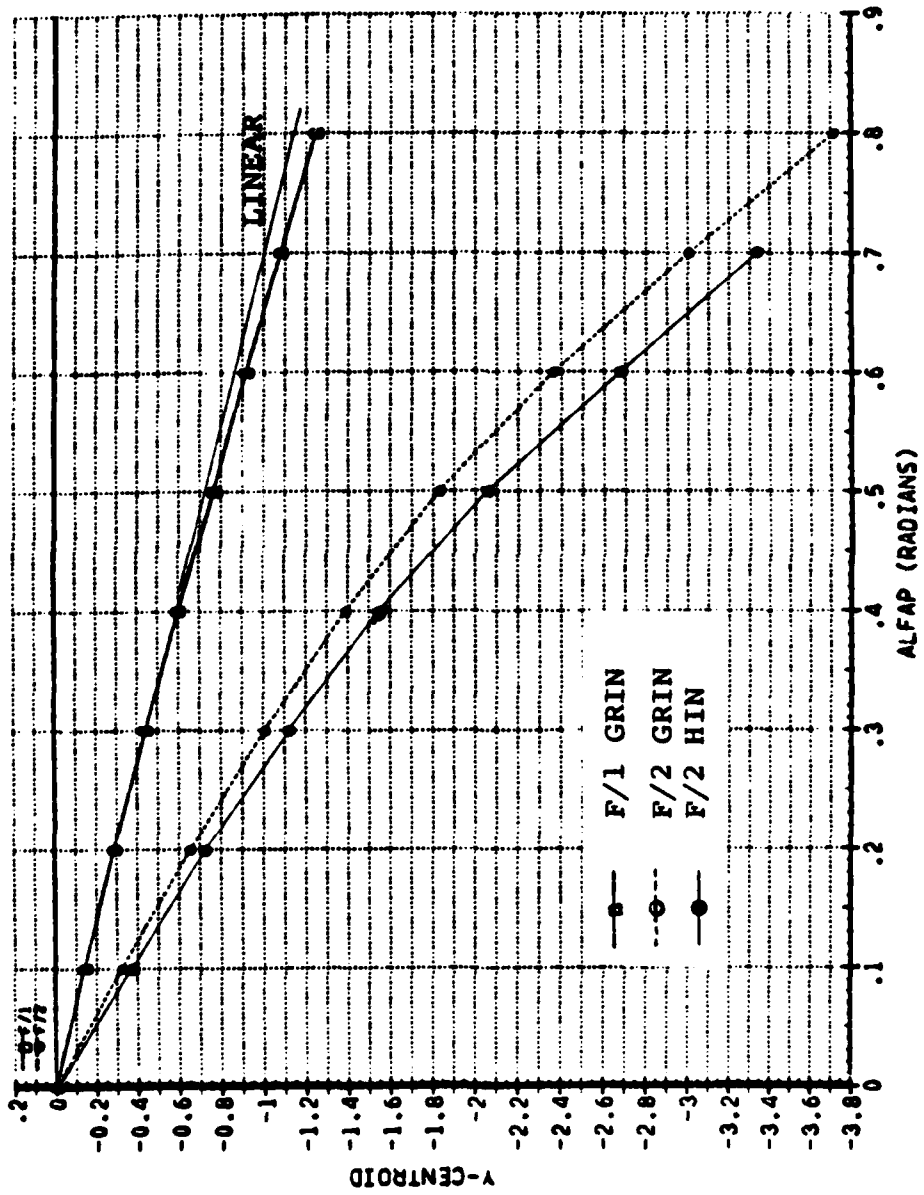

Figure 25. "Best" GRIN Lens Centroid Moment for F/Numbers of F/1 and F/2

SPOT SIZE VS. LENS TILT ANGLE

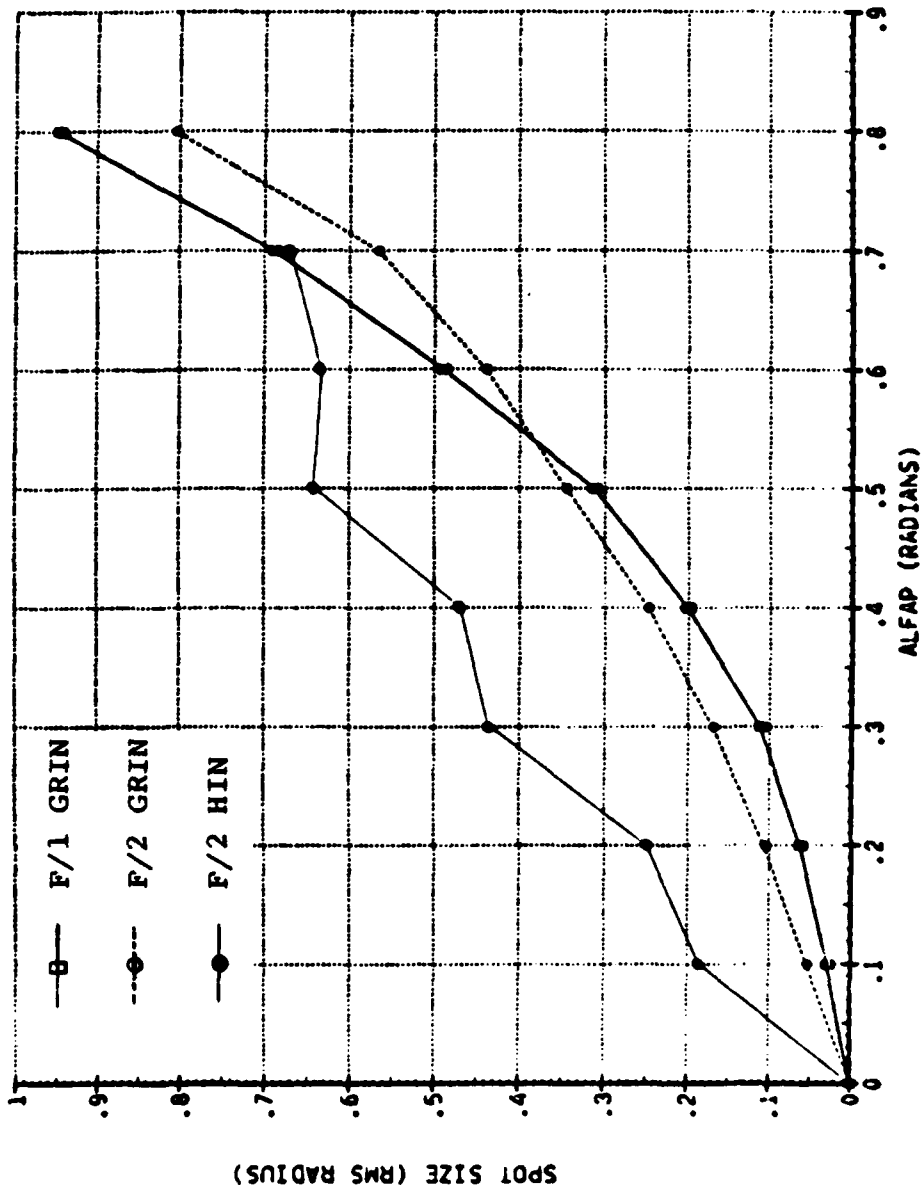

Figure 26. "Best" GRIN Lens Spot Size Performance for F/Numbers of F/1 and F/2

TABLE 5

Comparison of HIN and GRIN Lens Designs

<u>Performance Parameter or Feature</u>	<u>HIN</u>	<u>GRIN*</u>
Shape of Outer Surface	Convex	Concave
Fraction of Failed Rays at $\alpha_p = 0.7$ radians	0.143	0.0
Linearity of Centroid Motion; α_p for $\Delta y/y$ deviation of 10%	0.4 radians	0.8 radians
Spot Size for α_p		
$\alpha_p = 0.1$ radians	0.190	0.029
$\alpha_p = 0.2$ radians	0.247	0.063
$\alpha_p = 0.3$ radians	0.442	0.112
$\alpha_p = 0.4$ radians	0.466	0.201
$\alpha_p = 0.5$ radians	0.637	0.313
$\alpha_p = 0.6$ radians	0.632	0.490
$\alpha_p = 0.7$ radians	0.667	0.688
$\alpha_p = 0.8$ radians	N/A	0.947
Spot radius for 80% of energy @ $\alpha_p = 0.4$ radians	Does not attain 80% within 0.50	0.28
Average relative intensity of skew rays @ $\alpha_p = 0.4$ radians	0.82	0.44

* "Best" GRIN lens with 50% positive gradient, $O_S = 0.05$,
in the F/1 configuration.

of the $F/2$ lens above 0.54 radians is, therefore, unusable. Attempts to improve upon this performance by increasing the edge thickness, T , or by slightly adjusting the parameter U , as with the homogeneous lens only produced uniformly degraded performance in every respect.

Although the "best" GRIN lens resulted from a positive 50% gradient change in refractive index, it has been noted that this configuration was only slightly better than the same lens with a positive 5% change. Furthermore, since refractive index gradients of five percent or better have already been produced, it is entirely feasible that if the precise parabolic change could be controlled, this lens could be produced today.

Despite the obvious success of GRIN in controlling spot size growth and image centroid movement, a penalty in the form of reduced ray intensity has been paid. That increasing spot size performance is tempered by a loss of intensity may be seen by comparing "good" GRIN encircled energy plots with that of the HIN lens. Note that the HIN lens with $N_2 = 3.0$ also loses ~ 50% to intensity; see Figure 44. This loss in intensity is partially offset, however, by the GRIN lens with an increased number of rays transmitted and by the reduced spot size.

One drawback to the use of the GRIN lens as a self sufficient, single element lens is still that of the relative sizes of image and detector. Hence, even though GRIN has

significantly reduced spot size below $\alpha_p \cong 0.6$, that size is still significant at tilt angles above 0.3 radians. In order to use the lens without a secondary focusing element or mirror arrangement, a large composite sensor array would be required.

VII. CONCLUSION

Gradient refractive index materials may be employed to design a pointed seeker lens which exhibits optical performance far superior to that obtainable with conventional homogeneous optical material. A fifty percent, positive, parabolic gradient index with center of symmetry interior to the lens was found to yield the best performance although a five percent version of the same lens was only very slightly inferior; this lens may possibly be fabricated today.

For objects off-axis by more than 0.3 radians (~17.2 degrees) a secondary lens element may be required unless a large scale multiple element sensor array is employed. With such arrays, objects off-axis by more than 0.65 radians (37.2 degrees) may require Cassegrainian or other mirror elements to compensate image movement.

VIII. RECOMMENDATIONS FOR FUTURE WORK

This thesis investigated a spherically symmetric GRIN seeker lens with inside conical surface. Future studies should investigate:

- a) The elimination of the singularity problem by modification of the theoretical equations for GRIN using numerical techniques. See Reference 13.
- b) The optimization of the GRIN lens with both inside and outside curvature.
- c) The effect on lens performance due to an attached shock wave.
- d) The effect on lens performance when the object is no longer in the far field and wave front curvature must be taken into account.
- e) The performance of the lens using wavelengths corresponding to atmospheric windows.
- f) The effect of a radially symmetric gradient index on lens performance.
- g) The feasibility of adding an anamorphic gradient-index lens located on the missile body to increase off-axis tracking/acquisition capability to 90° and beyond. See Figure 1 of Reference 14.

APPENDIX A

COMPUTER LOGIC FLOW DIAGRAM FOR PROGRAM GISL

This appendix together with Appendices B and C describe the FORTRAN program GISL. GISL may be used to design either a homogeneous ($B = 0$), or a GRIN lens to the user's specifications by changing the design parameter where indicated by comments in the input section of the program. Additional software required to run GISL and plot the results are not described since these system-dependent procedures do not apply elsewhere.

The flow diagrams which follow provide the reader with the information necessary to follow the fundamental logic of the main program and subroutines of GISL. Not shown is Subroutine DIRECT which has been derived from Subroutine DIRECT as described by Amichai [5] with only slight modifications.

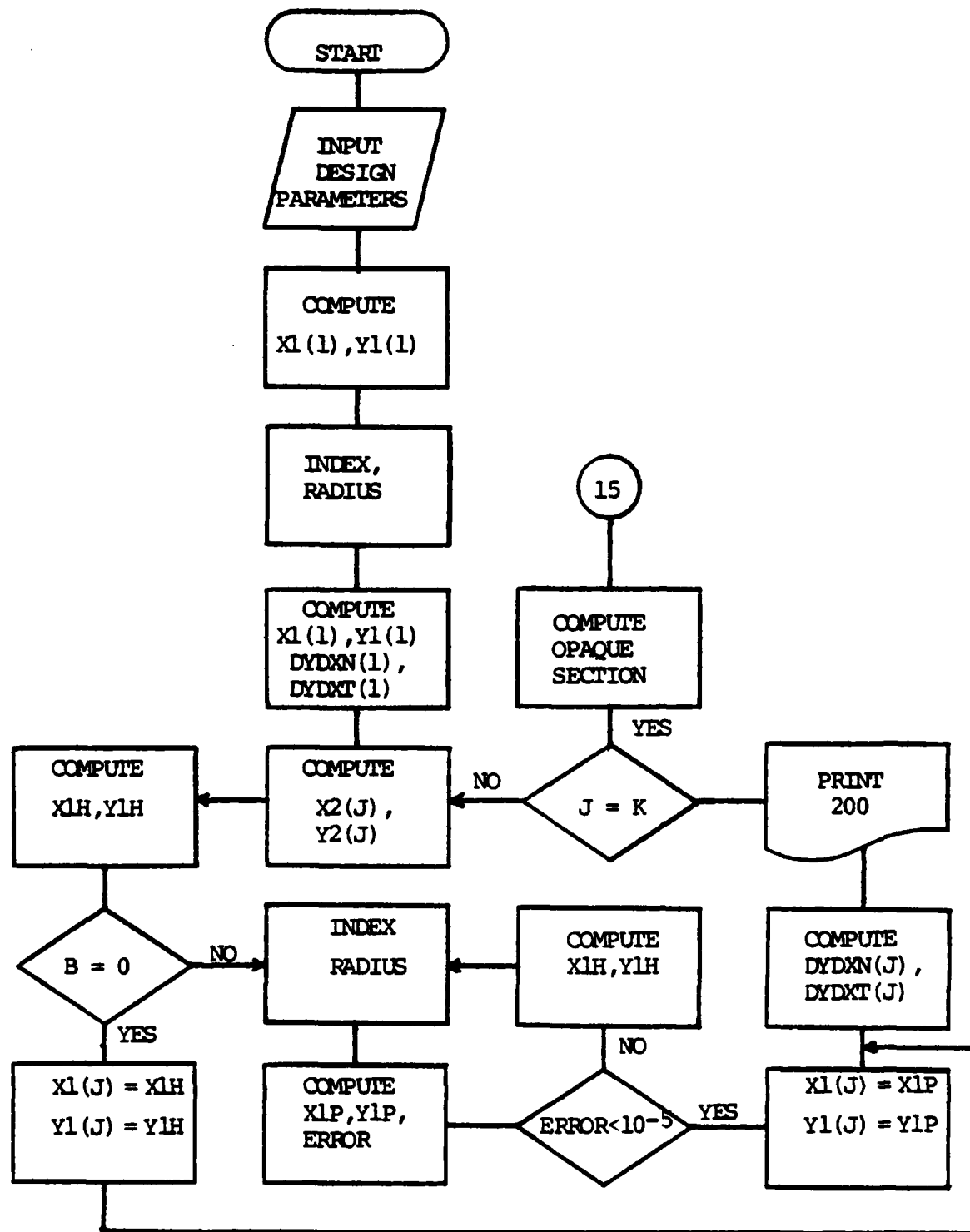

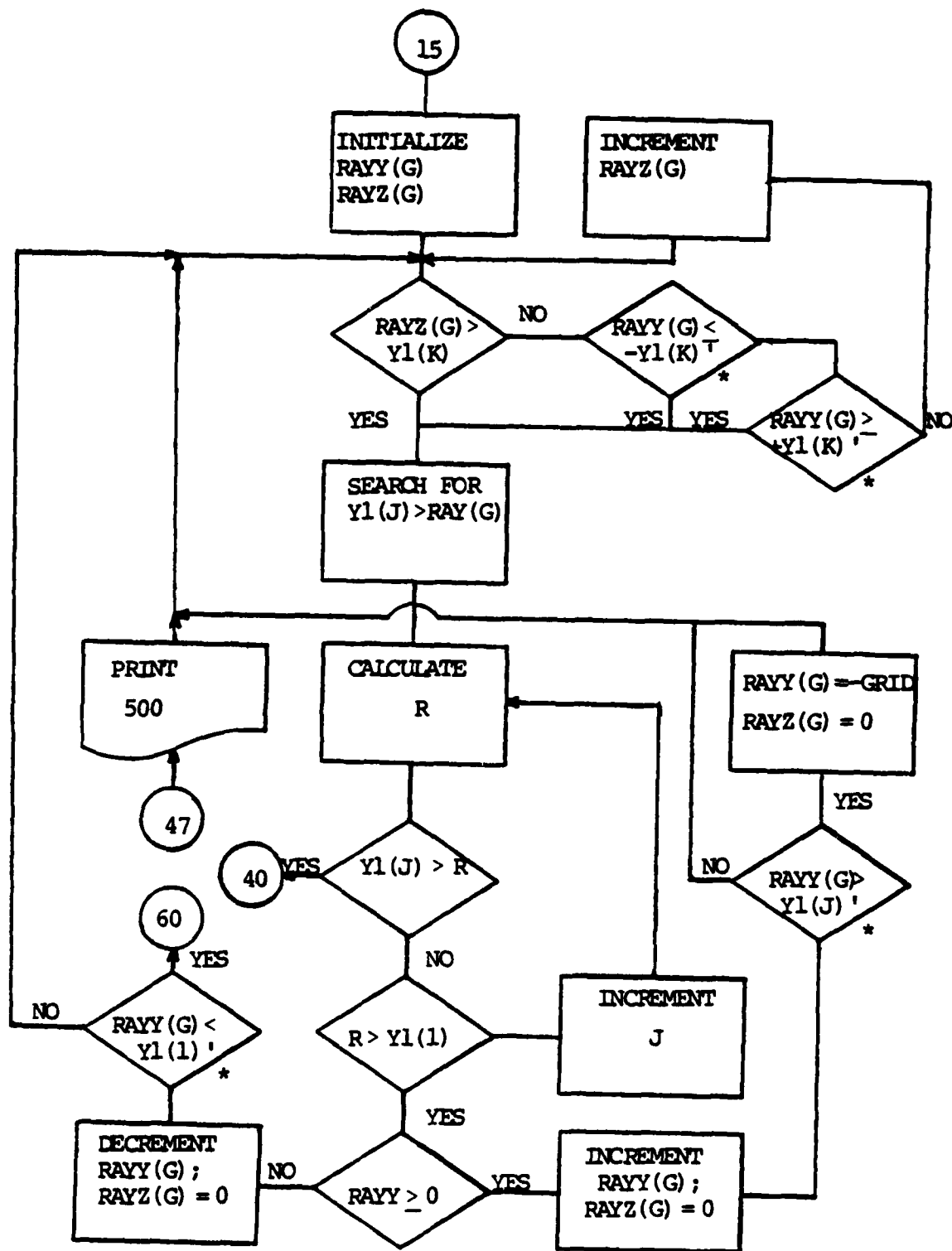

* Here, the prime indicates Y-coordinate as transformed into the grid plane.

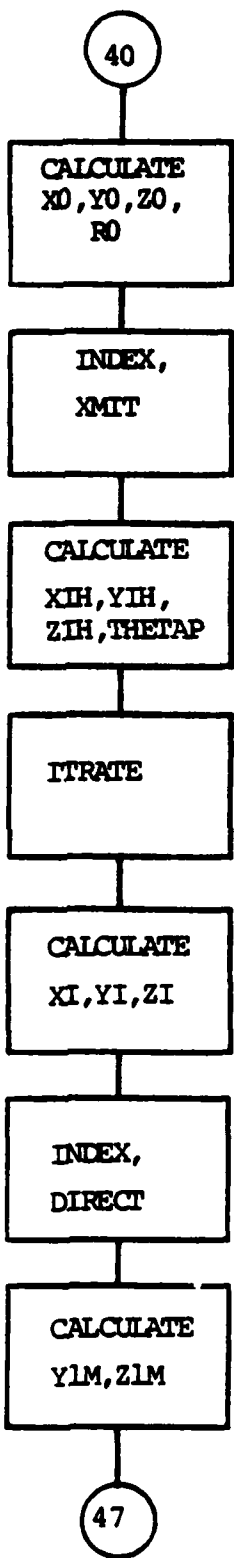

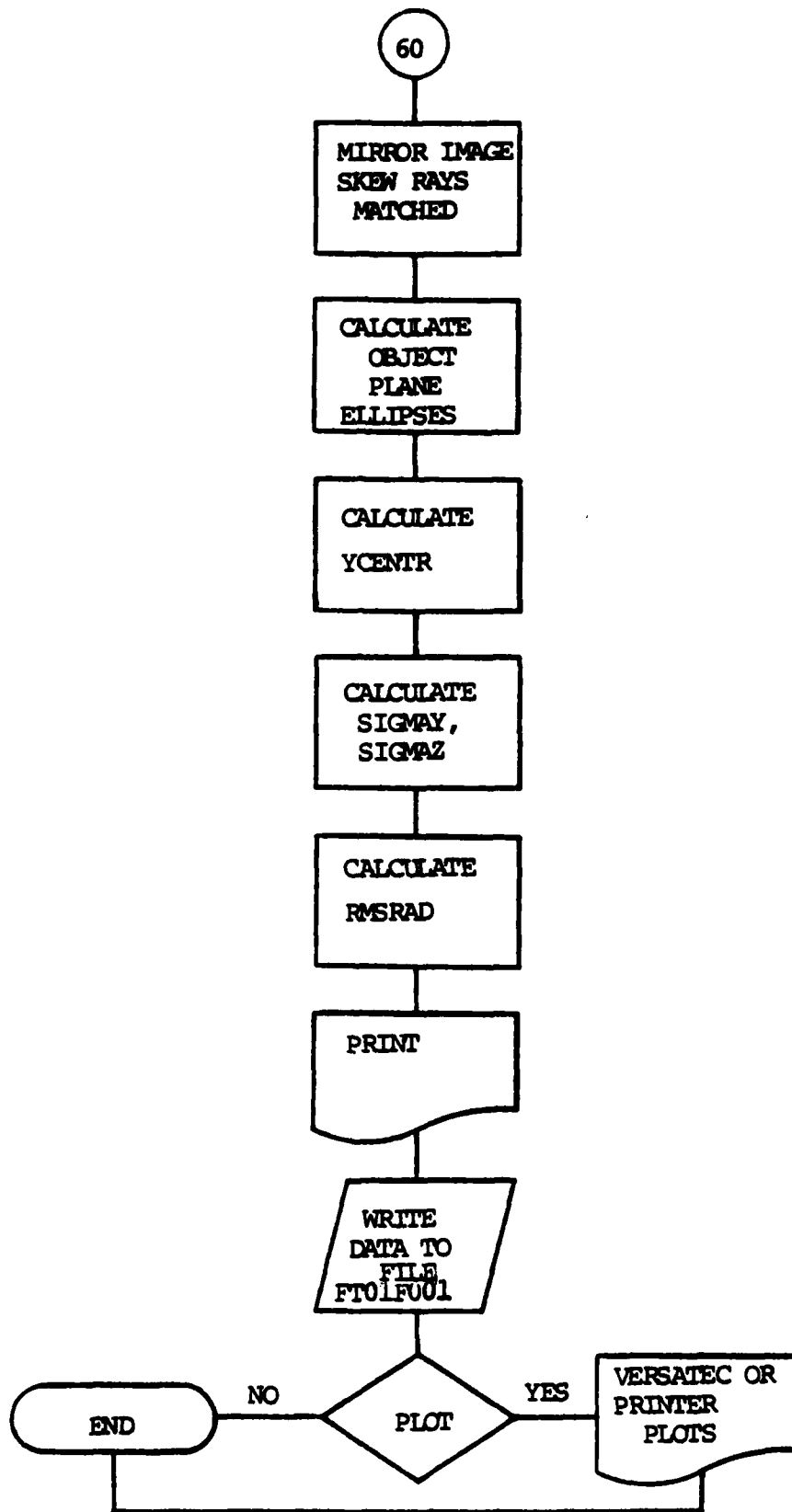

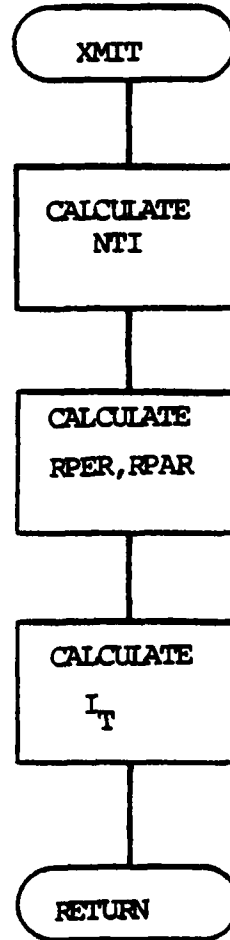
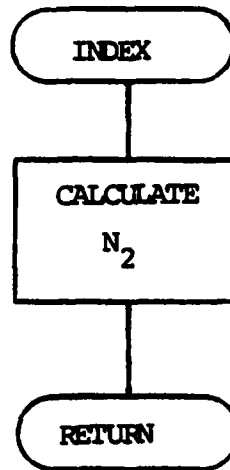

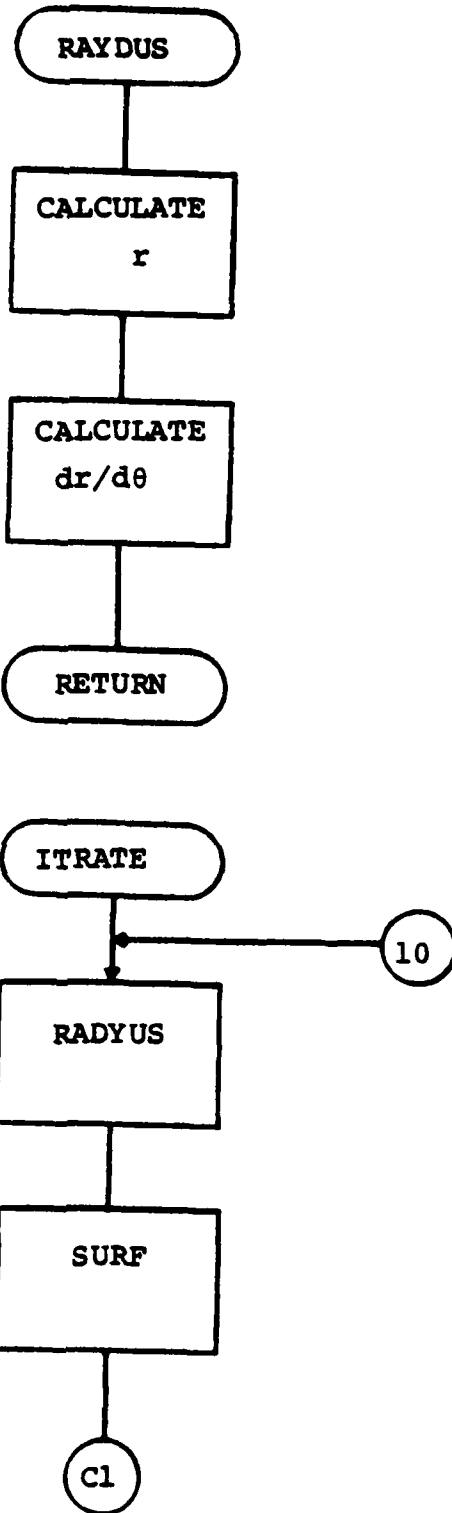

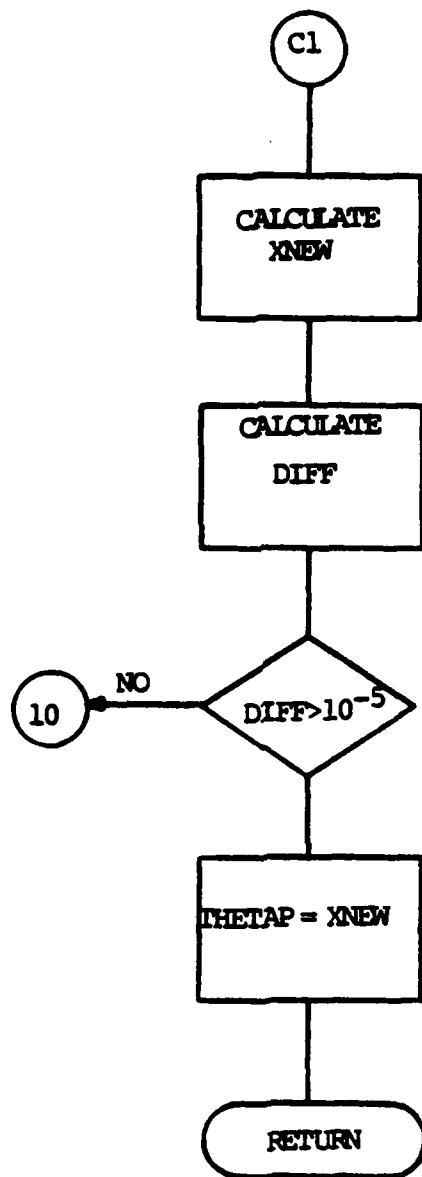

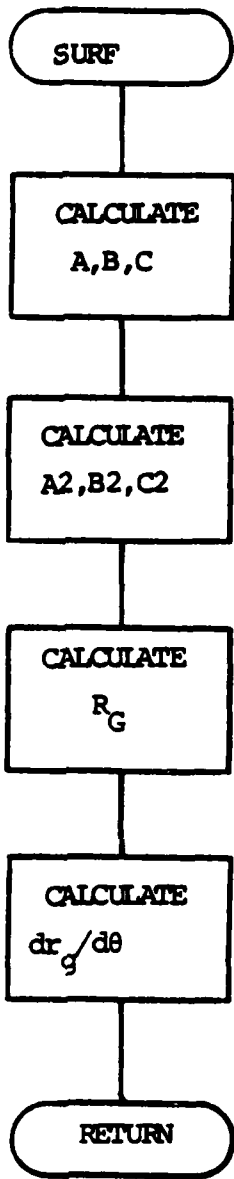



```

C C TO HAVE LENS SHAPE DATA PRINTED SET "SHAPE" TO 1. OTHERWISE
C C SET "SHAPE"=0.
C C SHAPE=1
C C TO HAVE SKEW RAY AND MIRROR IMAGE SKEW RAY DATA PRINTED SET
C C "SQURAY" TO 1. ELSE SET "SQURAY" TO 0. (INTEGER)
C C SQURAY=1
C C TO HAVE ELLIPSE SHAPE DATA PRINTED SET "ELLIP" TO 1. OTHERWISE
C C SET "ELLIP"=0.
C C ELLIP=0
C C INPUT KNOWN FOR GLY LENS SHAPE:
C C
C C FOCAL LENGTH:
C C F=4.0
C C INSIDE SURFACE CONE HALF-ANGLE:
C C ALPHA=0.7853982
C C INCIDENT RAY OFFSET ANGLE:
C C U=0.000000
C C NUMBER OF ITERATIONS (MUST BE AN EVEN INTEGER GT 750)
C C I=100
C C MAXIMUM RADIUS OF INSIDE SURFACE CONE:
C C R=1.0
C C THICKNESS OF LENS AT THE EDGE:
C C T=0.05
C C OR, IF IT IS DESIRED TO HAVE THE THICKNESS BE CHANGED FROM T=0.05
C C TO T=0.55 BY A 0.05 STEP INCREMENT, SET "THKNES" TO 1. ELSE ENSURE
C C THAT "THKNES"=0. (INTEGER)
C C THKNES=0
C C INDICES OF REFRACTION
C C N1=1.0
C C THE FOLLOWING ARE CONSTANTS A & B FOR N2(R). SEE SURR INDEX.
C C NOTE THAT IF B=0.0, N2(R) NO LONGER VARIES AS A FUNCTION OF R
C C WHICH CORRESPONDS TO THE HOMOGENEOUS LENS WITH N2=SQR(A).
C C A=9.00
C C B=+11.25
C C THE FOLLOWING IS THE DISTANCE FROM 0.0 TO THE CENTER OF
C C SYMMETRY OF THE GRADIENT INDEX ALONG THE X-AXIS. THE
C C POSITIVE SENSE IMPLIES THAT OSYM IS TO THE LEFT OF 0.0.
C C CONVERSELY, THE NEGATIVE SENSE IMPLIES THAT OSYM IS TO
C C THE RIGHT OF 0.0.
C C OSYM=+0.05
C C N3=1.0
C C BETA=A*TAN(R/(R*COTAN(ALPHA)))
C C PI=3.141592653589793
C C PIZ=PI/2.0

```

```

GI S00520
GI S00530
GI S00540
GI S00550
GI S00560
GI S00570
GI S00580
GI S00590
GI S00600
GI S00610
GI S00620
GI S00630
GI S00640
GI S00650
GI S00660
GI S00670
GI S00680
GI S00690
GI S00700
GI S00710
GI S00720
GI S00730
GI S00740
GI S00750
GI S00760
GI S00770
GI S00780
GI S00790
GI S00800
GI S00810
GI S00820
GI S00830
GI S00840
GI S00850
GI S00860
GI S00870
GI S00880
GI S00890
GI S00900
GI S00910
GI S00920
GI S00930
GI S00940
GI S00950
GI S00960
GI S00970
GI S00980
GI S00990

```



```

C INPUT KNOWN FOR TRACE RAY:
C
C INCLINATION OF OBJECT PLANE (RADIANS)
C ALFAP=0.4
C CR IF IT IS DESIRED TO HAVE ALFAP VARY BETWEEN 0.0 AND 0.7:
C SET VARY = 1, OTHERWISE SET VARY = 0
C VARY = 0
C SIZE OF GRID INCREMENT:
C GRID=0.3
C ELLNUM=4
C NUMBER OF ELLIPSES = ENUM, ELLNUM MUST BE EVEN AND
C I/ELLNUM MUST BE AN INTEGER WITH NO REMAINDER
C ENUM=ELLNUM+1
C ELL IS THE Z COORDINATE INCREMENT FOR ELLIPSE PLOTS
C ELL=GRID/7.5
C
C ALGORITHM GLM LENS SHAPE (SEE INPUT ABOVE)
C
C AT THIS POINT, IF "THKNES" IS 1, THE REMAINDER OF THE PROGRAM
C WILL BE REPEATED FOR T=0.05 TO T=0.55 BY A 0.05 INCREMENT STEP.
C IF (THKNES .EQ. 1) T=0.05
C GO TO 3
2 CONTINUE
3 T=T+0.05
4 DLUDP=BETA/I
5 BF=F/R
6 WRITE(6,1900)
7 IF (SHAPE .EQ. 1) WRITE(6,100) ALPHA,BETA,R,U,I,T,N1,
8 N3, BF, DLUDP
9 START AT THE EDGE - 1ST RAY
C FILLER=0
C J=1
C UDP(J)=BETA
C X2(J)=(BF*SIN(UDP(J)))/(SIN(UDP(J))+(TAN(ALPHA))*COS(UDP(J)))
C Y2(J)=(X2(J))*TAN(ALPHA)
C I2P(J)=-ALPHA+ATAN((BF-X2(J))/Y2(J))
C R0=SQRT((X2(J)+OSYMB)**2+Y2(J)**2)
C RZERO=R0
C IF (OSYMB .LT. 0.0) RZERO=2.0*R0
C CALL INDEX(R0,N20)
C I2(J)=ARCSIN((N3/N20)*SIN(I2P(J)))
C UP(J)=PI2-ALPHA-I2(J)
C BASE=X2(J)+CSYMB

```

```

S01000
GI S01010
GI S01020
GI S01030
GI S01040
GI S01050
GI S01060
GI S01070
GI S01080
GI S01090
GI S01100
GI S01110
GI S01120
GI S01130
GI S01140
GI S01150
GI S01160
GI S01170
GI S01180
GI S01190
GI S01200
GI S01210
GI S01220
GI S01230
GI S01240
GI S01250
GI S01260
GI S01270
GI S01280
GI S01290
GI S01300
GI S01310
GI S01320
GI S01330
GI S01340
GI S01350
GI S01360
GI S01370
GI S01380
GI S01390
GI S01400
GI S01410
GI S01420
GI S01430
GI S01440
GI S01450
GI S01460
GI S01470

```

GI S01480
 GI S01490
 GI S01500
 GI S01510
 GI S01520
 GI S01530
 GI S01540
 GI S01550
 GI S01560
 GI S01570
 GI S01580
 GI S01590
 GI S01600
 GI S01610
 GI S01620
 GI S01630
 GI S01640
 GI S01650
 GI S01660
 GI S01670
 GI S01680
 GI S01690
 GI S01700
 GI S01710
 GI S01720
 GI S01730
 GI S01740
 GI S01750
 GI S01760
 GI S01770
 GI S01780
 GI S01790
 GI S01800
 GI S01810
 GI S01820
 GI S01830
 GI S01840
 GI S01850
 GI S01860
 GI S01870
 GI S01880
 GI S01890
 GI S01900
 GI S01910
 GI S01920
 GI S01930
 GI S01940
 GI S01950

```

IF(BASE .EQ. 0.0) OSYMB=1.0000001*OSYMB
BASE=X2(J)+OSYMB
THETAO=ATAN(Y2(J)/BASE)
IF(BASE .LT. 0.0) THETAO=PI+THETAO
ED=T/R
X1H=X2(J)-ED*OS(UP(J))
Y1H=Y2(J)+ED*OSIN(UP(J))
RASI=X1H+OSYMB
IF(BASI .EQ. 0.0) OSYMB=1.0000001*OSYMB
BASI=X1H+OSYMB
THETAE=ATAN(Y1H/BASI)-THETAO
IF(BASI .LT. 0.0) THETAE=PI+THETAE
PSIO=PI-UP(J)-THE TAO
EPSLON=1.0
IF(PSIO .GT. PI2) EPSLON=-1.0
E=(EPSLON*N20*RO$IN(PSIO)
CALL SWITCH(RO,TCRIT)
CALL RADYUS(RO,THETAE,RAD,RDGTG,FILTER)
IF(FILTER .EQ. 1)WRITE(6,1800)
IF(FILTER .EQ. 1)GC TO 82
X1(J)=RAD*OS(THETAE+THETAO)-OSYMB
Y1(J)=RAD*$IN(THETAE+THETAO)
CALL INDEX(RAD,N2)
HERE TAKE PI-PSI
RETURNS AN ANGLE ALWAYS LE PI2:
PSI=PI-ARSINE/(EPSLON*N2*RAD))
IF(THETAE .GT. 0)PSI=PI-PSI
IF(EPSLON .GT. 0)PSI=PI-PSI
ZETA=PI-PSI-THETAE-THETAO
I1(J)=ARSIN(SQRT(((SIN(ZETA-U))**2)/((COS(ZETA-U))-(N1/N2))**2+
1((SIN(ZETA-U))**2)))
I1P(J)=ARSIN((N1/N2)*SIN(I1(J)))
DYDXN(J)=-TAN(I1(J)+U)
DYDXT(J)=COTAN(I1(J)+U)
IF(SHAPE .EQ. 0) GO TO 5
WRITE(6,200)J,X1(J),Y1(J),X2(J),Y2(J),UDP(J),I2P(J),UP(J),
I1P(J),I1(J),DYDXT(J)
5 CONTINUE
1 END OF TRACE FOR 1ST RAY
K=I+1
SURFL=0.0
DO 10 J=2,K
L=J-1
UDP(J)=BETA-(L)*DLUDP
X2(J)=(BF*$IN(UDP(J)))/(SIN(UDP(J))+(TAN(ALPHA))*COS(UDP(J)))
Y2(J)=(X2(J))*TAN(ALPHA)
RO=SQRT((X2(J)+OSYMB)**2+Y2(J)**2)
IF(J .EQ. K) R000=RO
  
```

C C

C

```

I2P(J)=-ALPHA+ATAN((BF-X2(J))/Y2(J))
CALL INDEX(RO,N20)
I2(J)=ARCSIN((N3/N20)*SIN(I2P(J)))
UP(J)=PI2-ALPHA-I2(J)
THETA0=ARCSIN(X2(J)+OSYMB)/RO)
PSIO=PI-UP(J)-THETA0
EPSLON=1.0
IF(PSIO.GT.PI2) EPSLON=-1.0
E=EPSLON*N20*RO*SIN(PSIO)
Y1H=((COTAN(I1(L)+U))+Y1(L)-X1(L)*COTAN(I1(L)+U))/(1.0+
(COTAN(I1(L)+U))*COTAN(UP(J)))
X1H=(COTAN(UP(J))*(-Y1H+Y2(J))+X2(J)*TAN(UP(J)))
IF(B.EQ.0.0) GO TO 8
IF(PSIO.LE.0.05.AND.PSIO.GE.-0.15) GO TO 8
TRIP=0
ZETAP=3.14
XI1P=X1H
Y11P=Y1H
IF(B.GT.0.0.AND.PSIO.GT.0.0) X1H=X1(L)
IF(B.GT.0.0.AND.PSIO.GT.0.0) Y1H=Y1(L)
CONTINUE
RH=SORT((X1H+OSYMB)**2+Y1H**2)
ARKCOS=ARCSIN(X1H+OSYMB)/RH)
TRIP=TRIP+1
THETAH(1)=THETA0
IF(OSYMB.GT.0.4) THETAH(1)=THETAH(1)+.020*TRIP)
TH=THETAH(1)
IF(B.GT.0.0.AND.PSIO.GT.0.0) THETAH(1)=THETAH(1)+.0416*TRIP)
IF(B.GT.0.0.AND.PSIO.LT.0.0) THETAH(1)=THETAH(1)*
(1.0-0.01/TRIP)
CALL SWITCH(RO,ICRIT)
CALL RADYUS(RO,THETAH(1),RAD,RDOTG,FILTER)
IF(FILTER.EQ.1) WRITE(6,1800)
IF(FILTER.EQ.1) GO TO 82
X1P=RAD*COS(THETAH(1)+THETA0)-OSYMB
Y1P=RAD*SIN(THETAH(1)+THETA0)
CALL INDEX(RAD,N2)
WE TAKE PI-PSIP BECAUSE OF THE CHARACTER OF
THE ARSIN FUNCTION IN FORTRAN.
EDNR=E/(EPSLON*N2)
IF(EDNR.GT.1.0) WRITE(6,9978)EDNR
FORMAT(10X,EDNR=,F19.16)
IF(EDNR.GT.1.0) EDNR=1.0
PSIP=PI-ARSIN(EDNR)
IF(THETAH(1).GE.TCRIT.OR.PSIO.LT.PI2.AND.PSIO.GT.-FI2) PSIP=
PI-PSIP

```

```

501960
501970
501980
501990
502000
502010
502020
502030
502040
502050
502060
502070
502080
502090
502100
502110
502120
502130
502140
502150
502160
502170
502180
502190
502200
502210
502220
502230
502240
502250
502260
502270
502280
502290
502300
502310
502320
502330
502340
502350
502360
502370
502380
502390
502400
502410
502420
502430

```

1 1

6

1

1

C C

5978

1

GI S02440
 GI S02450
 GI S02460
 GI S02470
 GI S02480
 GI S02490
 GI S02500
 GI S02510
 GI S02520
 GI S02530
 GI S02540
 GI S02550
 GI S02560
 GI S02570
 GI S02580
 GI S02590
 GI S02600
 GI S02610
 GI S02620
 GI S02630
 GI S02640
 GI S02650
 GI S02660
 GI S02670
 GI S02680
 GI S02690
 GI S02700
 GI S02710
 GI S02720
 GI S02730
 GI S02740
 GI S02750
 GI S02760
 GI S02770
 GI S02780
 GI S02790
 GI S02800
 GI S02810
 GI S02820
 GI S02830
 GI S02840
 GI S02850
 GI S02860
 GI S02870
 GI S02880
 GI S02890
 GI S02900
 GI S02910

```

ZETA=PI-PSIP-THETAH(TRIP)-THETAO
IF(B .LE. 0 .AND. ZETA .GT. ZETAP) X1P=X1PP
IF(B .LE. 0 .AND. ZETA .GT. ZETAP) Y1P=Y1PP
IF(B .LE. 0 .AND. ZETA .GT. ZETAP) GO TO 7
IF(X1P .EQ. X1PP .AND. Y1P .EQ. Y1PP) GO TO 7
ZETAP=ZETA
X1PP=X1P
Y1PP=Y1P
Y1HP=((COTAN(I1(L))+U))*(COTAN(ZETA))*(Y1P+
X1P*TAN(I1(L))-X1(L)*COTAN(I1(L)+U))/(1.0+
(COTAN(I1(L)+U))*COTAN(ZETA))
X1HP=((COTAN(ZETA))*(-Y1HP+Y1P+X1P*TAN(ZETA))
ERROR=SQRT((X1HP-X1P)**2+(Y1HP-Y1P)**2)
IF(ERROR .LE. 0.0000100) GO TO 7
X1P=X1HP
Y1P=Y1HP
GO TO 6
CONTINUE
X1(J)=X1P
Y1(J)=Y1P
GO TO 9
CONTINUE
X1(J)=X1H
Y1(J)=Y1H
ZETA=UP(J)
CONTINUE
IF(Y1(J) .LE. 0) GO TO 11
I1(J)=ARSIN((SIN(ZETA-U))**2/(COS(ZETA-U)-(N1/N2))**2+
(SIN(ZETA-U))**2))
I1P(J)=ARSIN((N1/N2)*SIN(I1(J)))
DYDXN(J)=(-TAN(I1(J)+U))
DYDXT(J)=COTAN(I1(J)+U)
SLINCR=SQRT((X1(J)-X1(L))**2+(Y1(L)-Y1(J))**2)
SURFL=SURFL+SLINCR
IF(SHAPE .EQ. 0) GO TO 10
WRITE(6,200)J,X1(J),Y1(J),X2(J),Y2(J),UDP(J),I2P(J),I2(J),
UP(J),I1P(J),I1(J),DYDXT(J)
CONTINUE
GO TO 12
C
C
C
END OF TRACE FOR RAY (I+1)
OPAQUE NOSE SECTION FOLLOWS
11 CONTINUE
K=J-1
12 CONTINUE
AB=(-X1(K))+(Y1(K))/DYDXT(K)
STATNA=-AB
  
```

GS02920
 GS02930
 GS02940
 GS02950
 GS02960
 GS02970
 GS02980
 GS02990
 GS03000
 GS03010
 GS03020
 GS03030
 GS03040
 GS03050
 GS03060
 GS03070
 GS03080
 GS03090
 GS03100
 GS03110
 GS03120
 GS03130
 GS03140
 GS03150
 GS03160
 GS03170
 GS03180
 GS03190
 GS03200
 GS03210
 GS03220
 GS03230
 GS03240
 GS03250
 GS03260
 GS03270
 GS03280
 GS03290
 GS03300
 GS03310
 GS03320
 GS03330
 GS03340
 GS03350
 GS03360
 GS03370
 GS03380
 GS03390

```

GAMMA=ATAN(DYDXT(K))
CNP=(Y1(K))/SIN(GAMMA)
TSURFL=ONP+SURFL
WRITE(6,300) GAMMA,STATNA,ONP,SURFL,TSURFL
C
C LENS INDEX OF REFRACTION DATA -- N2(R) --
BEFF=B/(RZERO**2)
N2X21=SQRT(A+B*BEFF*RZERO**2)
IF(OSYMB .LT. 0.0)N2X21=SQRT(A+B*BEFF*((RZERO/2.0)**2))
CALL INDEX(RAD,N2X1K)
CALL INDEX(R000,N2X2K)
PRCNT1=((N2X2K-N2X21)/N2X2K)*100.0
PRCNTT=-((N2X1K-N2X1K)/N2X1K)*100.0
PRCNTO=-((N2X1K-N2X21)/N2X1K)*100.0
WRITE(6,170)A,REFF,OSYMB,PRCNT1,PRCNTT,PRCNTO
END GLM LENS SHAPE
C
C ALGORITHM TRACE RAY (SEE INPUTS;X1(J),Y1(J),DYDXN(J),X2(J))
IF(VARY .EQ. 0) GO TO 15
ALFAP=0.0
GO TO 15
14 ALFAP=ALFAP+0.1
15 CONTINUE
CCOUNT=0
RAYZ(G)=0.0
RAYZ(G)=0.0
NTNCTY(G)=1.0
XMAVE=0.0
XMAVE=0.0
IF(SQRAY .EQ. 1) WRITE(6,400) ALFAP,GRID
20 CONTINUE
IF(RAYZ(G) .GE. Y1(K)) GO TO 30
CENI=(AB+X1(K))*SIN(ALFAP)
TORBI=SQRT(Y1(K)**2-RAYZ(G)**2)
BOTI=CENI-TORBI
IF(RAYZ(G) .LE. BOTI) GO TO 30
TOPI=CENI+TORBI
IF(RAYZ(G) .GE. TOPI) GO TO 30
IF(RAYZ(G)=RAYZ(G)+GRID
GO TO 20
30 CONTINUE
SEARCH FOR Y1(J) JUST GT RAYZ(G); RETRIEVE X1(J)
M=K/2
IF(Y1(M) .LT. RAYZ(G)) GO TO 32

```

S03400
 GI S03410
 GI S03420
 GI S03430
 GI S03440
 GI S03450
 GI S03460
 GI S03470
 GI S03480
 GI S03490
 GI S03500
 GI S03510
 GI S03520
 GI S03530
 GI S03540
 GI S03550
 GI S03560
 GI S03570
 GI S03580
 GI S03590
 GI S03600
 GI S03610
 GI S03620
 GI S03630
 GI S03640
 GI S03650
 GI S03660
 GI S03670
 GI S03680
 GI S03690
 GI S03700
 GI S03710
 GI S03720
 GI S03730
 GI S03740
 GI S03750
 GI S03760
 GI S03770
 GI S03780
 GI S03790
 GI S03800
 GI S03810
 GI S03820
 GI S03830
 GI S03840
 GI S03850
 GI S03860
 GI S03870

```

    IF(RAYY(G) .GT. 1.15) GO TO 32
    N=N-1
    CONTINUE
31 IF(Y1(N) .GT. RAYZ(G)) GO TO 36
    N=N-1
    IF(N .EQ. 0) GO TO 34
    GO TO 31
32 CONTINUE
    N=M
33 CONTINUE
    IF(Y1(N) .GT. RAYZ(G)) GO TO 36
    N=N-1
    IF(N .EQ. 0) GO TO 34
    GO TO 33
34 CONTINUE
    RAYZ(G)=0.0
    IF(RAYY(G) .LT. 0.0) GO TO 35
    RAYY(G)=RAYY(G)+GRID
    GO TO 20
35 CONTINUE
    RAYY(G)=RAYY(G)-GRID
    GO TO 20
36 CONTINUE
    RADIUS=SQRT(RAYZ(G)**2+((RAYY(G)/COS(ALFAP))-(X1(N)+AB)**2)
    1 TAN(ALFAP)**2)
    IF(Y1(N) .GT. RADIUS) GO TO 40
    IF(RADIUS .GT. Y1(1)) GO TO 37
    N=N-1
    GO TO 36
37 CONTINUE
    N=N-1
    IF(N .GT. 0) GO TO 36
    CEN=(X1(1)+AB)*SIN(ALFAP)
    TORB=Y1(1)*COS(ALFAP)
    RAYZ(G)=0.0
    IF(RAYY(G) .GE. 0.0) GO TO 38
    IF(RAYY(G)=RAYY(G)-GRID
    BOT=CEN-TORB
    CHECK FOR BOTTOM EDGE OF LENS, GO TO MIRROR IMAGE RAYS
    IF(RAYY(G) .LT. BOT) GO TO 60
    GO TO 20
38 CONTINUE
    RAYY(G)=RAYY(G)+GRID
    TOP=CEN+TORB
    IF(RAYY(G) .GT. TOP) GO TO 39
    GO TO 20
39 CONTINUE
    RAYY(G)=-GRID
  
```

C

IS03880
 GI503890
 GI503900
 GI503910
 GI503920
 GI503930
 GI503940
 GI503950
 GI503960
 GI503970
 GI503980
 GI503990
 GI504000
 GI504010
 GI504020
 GI504030
 GI504040
 GI504050
 GI504060
 GI504070
 GI504080
 GI504090
 GI504100
 GI504110
 GI504120
 GI504130
 GI504140
 GI504150
 GI504160
 GI504170
 GI504180
 GI504190
 GI504200
 GI504210
 GI504220
 GI504230
 GI504240
 GI504250
 GI504260
 GI504270
 GI504280
 GI504290
 GI504300
 GI504310
 GI504320
 GI504330
 GI504340
 GI504350

```

40  GO TO 20
    CCNTINUE
    P=N+1
    C  CALCULATE INTERCEPT POINT ON OUTER SURFACE
      AC=RAYY(G)/COS(ALFAP)
      BO=TAN(ALFAP)
      CO=(YI(N)-YI(P))/(X1(N)-X1(P))
      DO=X1(P)
      EO=YI(P)
      PAR1=(AO*BO+CO*EO-(CO**2)*DO-AB*(BO**2))
      PAR2=(BO**2-CO**2)
      PAR3=(AO**2+AB*(BO**2)*AB-2.0*AO*BO*AB+
      1  RAYZ(G)**2-(EO-CO*DO)**2)
      XC=(PAR1/PAR2)+SQRT((PAR1/PAR2)**2-PAR3/PAR2)
      IF((PAR1/PAR2).GT.XI(1))XC=XO-2.0*SQRT((PAR1/PAR2)**2-PAR3/PAR2)
      YO=(RAYY(G)/COS(ALFAP))-(XO+AB)*TAN(ALFAP)
      ZO=RAYZ(G)
    C  CALCULATE THE DIRECTION COSINES OF OUTSIDE SURFACE NORMAL
      DELTAX=X1(N)-X1(P)
      DELTAY=YI(N)-YI(P)
      SP=SQRT((RADIUS-YI(P))**2+(XO-X1(P))**2)
      ST=SQRT(DEL TAX**2+DEL TAY**2)
      RATIN=SP/ST
      DYDXNP=RATIO*(DYDXN(N)-DYDXN(P))+CYDXN(P)
      NPI=1.0/DYDXNP
      IF(YO.EQ.0.0) GO TO 41
      ZOYCO=(ZO/YO)
      IF(ZOYO.GE.823500) GO TO 41
      IF(ZOYO.LE.-823500) GO TO 42
      NPJ=COS(ATAN(ZO/YO))
      NPK=SIN(ATAN(ZO/YO))
      GO TO 43
    41 CONTINUE
      NPJ=0.0
      NPK=1.0
      GO TO 43
    42 CCNTINUE
      NPJ=0.0
      NPK=-1.0
    43 CONTINUE
      C  DIRECTION COSINES OF EXTERNAL RAY
      CK=COS(ALFAP)
      CL=-SIN(ALFAP)
      C  DIRECTION COSINES OF OUTSIDE SURFACE NORMAL
      LK=NPI/(SQRT(NPI**2+NPK**2+NPJ**2))
      LL=(NPK*LK)/NPI
      LM=(NPK*LK)/NPI
      IF(YO.LT.0.0) GC TO 44
  
```

S04360
 G I S04370
 G I S04380
 G I S04390
 G I S04400
 G I S04410
 G I S04420
 G I S04430
 G I S04440
 G I S04450
 G I S04460
 G I S04470
 G I S04480
 G I S04490
 G I S04500
 G I S04510
 G I S04520
 G I S04530
 G I S04540
 G I S04550
 G I S04560
 G I S04570
 G I S04580
 G I S04590
 G I S04600
 G I S04610
 G I S04620
 G I S04630
 G I S04640
 G I S04650
 G I S04660
 G I S04670
 G I S04680
 G I S04690
 G I S04700
 G I S04710
 G I S04720
 G I S04730
 G I S04740
 G I S04750
 G I S04760
 G I S04770
 G I S04780
 G I S04790
 G I S04800
 G I S04810
 G I S04820
 G I S04830

```

44 GO TO 45
    CONTINUE
    LL=-LL
    LM=-LM
45 CCNTINUE
    THETA=ARCOS(CK*LK+CL*LL)
    ANGLES OF INCIDENCE AND REFRACTION OUTSIDE SURFACE
    PHI=PI-THETA
    RO=SQRT((XO+OSYMB)**2+YO**2+ZO**2)
    CALL INDEX(RO,N20)
    PHIP=ARCSIN((N1/N20)*SIN(PHI))
    CALCULATION OF TRANSMITTED INTENSITY AT OUTSIDE SURFACE
    FACE=1
    CALL XMIT(PHI,N20,XMTC,FACE)
    IF(FACE.EQ.3) GO TO 53
    NUM=COS(PHIP)-(N1/N20)*COS(PHI)
    INITIAL DIRECTION COSINES OF INTERNAL REFRACTED RAY
    CKP=(N1/N20)*CK-NUM*LL
    CMP=-NUM*LM
    CKKP=CKP
    CLLP=CLP
    CHMP=CMP
    INTERNAL RAY LENGTH AND INSIDE SURFACE INTERCEPT
    RCX=(XO+OSYMB)/RO
    ROY=YO/RO
    ROZ=ZO/RO
    NPOX=ROY*CMP-ROZ*CLP
    NPOY=ROZ*CKP-ROX*CMP
    NPOZ=ROX*CLP-ROY*CKP
    NPO=SQRT(NPOX**2+NPOY**2+NPOZ**2)
    NPOX=NPOX/NPO
    NPOY=NPOY/NPO
    NPOZ=NPOZ/NPO
    PSIO=ARCOS(ROX*CKP+ROY*CLP+ROZ*CMP)
    EPSLON=1.0
    IF(PSIO.GE.PI2) EPSLON=-1.0
    E=EPSLON*N2C*RO*SIN(PSIO)
    NUM2=(CLP*YO+CMP*ZO-CKP*XO)*(TAN(ALPHA)**2)
    NUM3=(CLP**2+CKP**2-(CKP**2)*(TAN(ALPHA)**2))
    NUM4=(YO**2+ZO**2-(XO**2)*(TAN(ALPHA)**2))
    NUM4=NUM1**2-2*NUM2*NUM3
    CHECK FOR INTERCEPT WITH INSIDE SURFACE
    IF(NUM4.LT.0.0) GO TO 50
    D2=-NUM1/NUM2-SQRT(NUM4)/NUM2
    XIH=D2*CKP+XO
    YIH=D2*CLP+YO
    ZIH=D2*CMP+ZO
  
```



```

IF(ZIH .LT. 0.0) GO TO 50
IF(PSIO .GE. (PI-0.05)) GO TO 455
OSYMPH=SQRT((CSYMB+XIH)**2+YIH**2+ZIH**2)
OPHX=(OSYMB+XIH)/OSYMPH
OPHY=YIH/OSYMPH
OPHZ=ZIH/OSYMPH
THETA=ARCCOS(ROX*OPHX+ROY*OPHY+ROZ*OPHZ)
XINT=XO+CSYMPH*CKP
XINTD=-OSYMB .LT. 0.0 .AND. XINTD .GT. 0.0) THE TAP=-THE TAP
SIGN=+1.0
IF(THETA .LT. 0.0) SIGN=-1.0
IF(THETA .GT. 0.0) PSIO=-PSIO
CALL SURF(THETA, RADD, RDOT, SIGN, FILTER)
IF(RADD .LT. 0.0) SIGN=-SIGN
CALL RATE(SIGN, THETA, RAD, T-TAP, FILTER)
IF(PSIO .GT. PI/2 .AND. OSYMB .LT. 0.0 .AND. FILTER .EQ. 2) GO TO 455
IF(FILTER .EQ. 2) .OR. FILTER .EQ. 1) GO TO 51
IF(FILTER .EQ. 3) GO TO 50
BETA0=SIN(THETA)/SIN(PSIO)
ALFA0=CCS(THETA)-BETA0*CCS(PSIO)
XI=ALFA0*(XO+OSYMB)/RO)+BETA0*CKKP)-OSYMB
ZI=ALFA0*(YO/RO)+BETA0*CLLP)
CALL INDEX(RO, N2)
EONR=E/(EPSLN*N2)*RAD)
IF(EONR .GT. 1.0) WRITE(6,9978)EONR
IF(EONR .GT. 1.0) EONR=1.0
PSIP=ARCSIN(EONR)
IF(PSIO .LT. 0.0 .AND. (ABS(PSIO-PSIP)) .GT. PI/2) PSIP=PI-PSIP
IF(THETA .GT. 0.6 .AND. TCRIT .GT. THETA) PSIP=PI-PSIP
A1=(XI+CSYMB)/RAD
B1=ZI/RAD
C1=Z1/RAD
CALL DIRECT(CKP, CLP, CMP)
GO TO 456
455 CONTINUE
XI=XIH
ZI=ZIH
456 CONTINUE
IF(XI .LT. 0.0 .OR. XI .GT. X2(1)) GO TO 51
NUMS=SQRT((X1**2)*(TAN(ALPHA)**4)+Y1**2+Z1**2)
DIRECT(CN COSINES OF INSIDE NORMAL
LLP=YI/NUMS

```

```

504840
504850
504860
504870
504880
504890
504900
504910
504920
504930
504940
504950
504960
504970
504980
504990
505000
505010
505020
505030
505040
505050
505060
505070
505080
505090
505100
505110
505120
505130
505140
505150
505160
505170
505180
505190
505200
505210
505220
505230
505240
505250
505260
505270
505280
505290
505300
505310

```

```

LMP=ZI/NUM5
KKLLMM=CKP*LKF+CLP*LLP+CMP*LMP
IF(KKLLMM .GE. 1.0)THETA I=0.0
IF((KKLLMM .LE. -1.0)THE TAI=PI
IF((ABS(KKLLMM)) .GE. 1.0) GO TO 457
THE TAI=ARCCOS(CKP*LKP)+(CLP*LLP)+(CMP*LMP)
CONTINUE
C ANGLES CF INC IDENCE AND TOTAL INTERNAL REFLECTION
C AT THE INSIDE SURFACE:
PHI I=PI-THE TAI
TIRA=AR SIN(N3/N2) INTERNAL REFLECTION:
CHECK FOR TOTAL TIRA) GO TO 52(PHII)
IF(PHII .GE. TIRA)((N2/N3)*SIN(PHII))
PHI IP=AR SIN((N2/N3)*SIN(PHII))
CALCULATION OF TRANSMITTED INTENSITY AT INSIDE SURFACE
FACE=2
CALL XMIT(PHII,N2,XMTNCP,FACE)
NTNCTY(G)=XMTNCP*NTNCP
XMAVE T=XMAVE T+NTNCTY(G)
XMAVE=XMAVE T/(G*1.0)
NUM8=COS(PHII IP)-(N2/N3)*COS(PHII)
DIRECTION COSINES OF INSIDE EXTERNAL REFRACTEC RAY
CKPP=(N2/N3)*CKP-NU M8*LKP
CLPP=(N2/N3)*CLP-NU M8*LLP
CMPP=(N2/N3)*CMP-NU M8*LMP
LENGT F OF INSIDE EXTERNAL REFRACTEC RAY
D3=(BF-XI)/CKPP
NUM6=((XO+AB)*CK+YO*CL)
NUM7=((XO+AB)*(-CL)+YO*CK)
LENGT F OF OUTSIDE INCIDENT RAY
DI=SQRT((XJ-NU M6)**2+(YO-NU M7)**2)
TOTAL OPTICAL PATHLENGTH:
OPL(G)=N1*D1+N2*D2+N3*D3
INTERSECTION WITH THE IMAGE PLANE:
YIM(G)=((RF-XI)/CKPP)*CLPP+YI
ZIM(G)=((BF-XI)/CKPP)*CMPP+ZI
IF(CMPP .LT. 0.00000000001).AND. CMPP .GT. -0.00000000001)
GO TO 46
XDIAPT(G)=(-ZIM(G)/CMPP)*CKPP+AB
YDIAPT(G)=(-ZIM(G)/CMPP)*CLPP+YIM(G)
GO TO 47
1
46 CCNTINUE
XDIAPT(G)=99999.
YDIAPT(G)=99999.
47 CCNTINUE
IF(SURAY EQ. 1) WRITE(6,500)G,RAYY(G),RAYZ(G),XO,YO,XI,
YI,ZI,OPL(G),YIM(G),ZIM(G),NTNCTY(G),XDIAPT(G),YDIAPT(G),
FLAG(G)=0
1

```

```

GISO5320
GISO5330
GISO5340
GISO5350
GISO5360
GISO5370
GISO5380
GISO5390
GISO5400
GISO5410
GISO5420
GISO5430
GISO5440
GISO5450
GISO5460
GISO5470
GISO5480
GISO5490
GISO5500
GISO5510
GISO5520
GISO5530
GISO5540
GISO5550
GISO5560
GISO5570
GISO5580
GISO5590
GISO5600
GISO5610
GISO5620
GISO5630
GISO5640
GISO5650
GISO5660
GISO5670
GISO5680
GISO5690
GISO5700
GISO5710
GISO5720
GISO5730
GISO5740
GISO5750
GISO5760
GISO5770
GISO5780
GISO5790

```

G1S05800
 G1S05810
 G1S05820
 G1S05830
 G1S05840
 G1S05850
 G1S05860
 G1S05870
 G1S05880
 G1S05890
 G1S05900
 G1S05910
 G1S05920
 G1S05930
 G1S05940
 G1S05950
 G1S05960
 G1S05970
 G1S05980
 G1S05990
 G1S06000
 G1S06010
 G1S06020
 G1S06030
 G1S06040
 G1S06050
 G1S06060
 G1S06070
 G1S06080
 G1S06090
 G1S06100
 G1S06110
 G1S06120
 G1S06130
 G1S06140
 G1S06150
 G1S06160
 G1S06170
 G1S06180
 G1S06190
 G1S06200
 G1S06210
 G1S06220
 G1S06230
 G1S06240
 G1S06250
 G1S06260
 G1S06270

```

45 CONTINUE
   F=G
   G=H+1
   NTNCY(G)=1.0
   RAYZ(G)=RAYZ(H)+GRID
   IF(FLAG(H).EQ.0) COUNT=COUNT+1
   GO TO 30
C
50 END OF RAY TRACE
   CCNTINUE
   NTNCY(G)=0.0
   FLAG(G)=1
   IF(SOURAY .EQ. 1) WRITE(6,600)G,RAYY(G),RAYZ(G)
   GC TO 49
51 CONTINUE
   NTNCY(G)=0.0
   FLAG(G)=2
   IF(SOURAY .EQ. 1) WRITE(6,700)G,RAYY(G),RAYZ(G)
   GO TO 49
52 CONTINUE
   NTNCY(G)=0.0
   FLAG(G)=3
   IF(SOURAY .EQ. 1) WRITE(6,800)G,RAYY(G),RAYZ(G)
   GO TO 49
53 CONTINUE
   NTNCY(G)=0.0
   FLAG(G)=4
   IF(SOURAY .EQ. 1) WRITE(6,802) G,RAYY(G),RAYZ(G)
   GC TO 49
C
C MIRROR IMAGE RAY MATCHING FOLLOWS
60 CONTINUE
   IF(SOURAY .EQ.1) WRITE(6,401)
   Q=G-1
   S=G-Q
61 CONTINUE
   IF(RAYZ(S).EQ.0.0) S=S+1
   IF(S.GT.9) GO TO 70
   FLAG(G)=FLAG(S)
   IF(FLAG(G).EQ.0) COUNT=COUNT+1
   RAYZ(G)=RAYZ(S)
   IF(FLAG(S).GE.1) GO TO 63
   XDIAPT(G)=XDIAPT(S)
   YDIAPT(G)=YDIAPT(S)
   YIM(G)=YIM(S)
   ZIM(G)=ZIM(S)
  
```

```

OPL(G)=OPL(S)
NTNCTY(G)=NTNCTY(S)
IF(SQRAY.EQ.1) WRITE(6,501)G,S,RAYY(G),RAYZ(G),OPL(G),
YIM(G),ZIM(G),NTNCTY(G)
1 CCNTINUE
S=S+1
G=G+1
GO TO 61
62 CONTINUE
IF(FLAG(S).GE.2) GO TO 64
IF(SQRAY.EQ.1) WRITE(6,601)G,S,RAYY(G),RAYZ(G)
GO TO 62
63 CONTINUE
IF(FLAG(S).GE.3) GO TO 65
IF(SQRAY.EQ.1) WRITE(6,701)G,S,RAYY(G),RAYZ(G)
GO TO 62
64 CONTINUE
IF(FLAG(S).EQ.4) GO TO 67
IF(SQRAY.EQ.1) WRITE(6,801)G,S,RAYY(G),RAYZ(G)
GO TO 62
65 CONTINUE
IF(SQRAY.EQ.1) WRITE(6,803)G,S,RAYY(G),RAYZ(G)
GO TO 62
70 CONTINUE
RAYS=G-1
DRAYS=RAYS-C
IF(SQRAY.EQ.1) WRITE(6,900)RAYS,DRAYS,COUNT
GENERATE OBJECT PLANE ELLIPSES:
IF(ELLIPS.EQ.1) WRITE(6,1000)ENUM
NUMB=1
CCNTINUE
ELZ(NUMB,COORD)=-Y1(NUMBR)
71 CONTINUE
ELZ(NUMB,COORD)=(X1(NUMBR)+AB)*SIN(ALFAP)+SQRT((Y1(NUMBR))**2-
(ELZ(NUMB,COORD))**2)*COS(ALFAP)
ELZZ=ELZ(NUMB,COORD)
IF(ELLIPS.EQ.1) WRITE(6,1100)NUMBR,COORD,ELY(NUMB,COORD),
1 ELZ(NUMB,COORD)
COORD=COORD+1
ELZ(NUMB,COORD)=ELZZ+FL
IF(ELZ(NUMB,COORD).GE.Y1(NUMBR)) GO TO 73
GO TO 72
73 CONTINUE
ELZZ=ELZ(NUMB,COORD)

```

```

I 506280
GI 506290
GI 506300
GI 506310
GI 506320
GI 506330
GI 506340
GI 506350
GI 506360
GI 506370
GI 506380
GI 506390
GI 506400
GI 506410
GI 506420
GI 506430
GI 506440
GI 506450
GI 506460
GI 506470
GI 506480
GI 506490
GI 506500
GI 506510
GI 506520
GI 506530
GI 506540
GI 506550
GI 506560
GI 506570
GI 506580
GI 506590
GI 506600
GI 506610
GI 506620
GI 506630
GI 506640
GI 506650
GI 506660
GI 506670
GI 506680
GI 506690
GI 506700
GI 506710
GI 506720
GI 506730
GI 506740
GI 506750

```



```

C
C SPOT DIAGRAM ENERGY DENSITY VS. RADIUS FROM CENTROIC:
DO 79 G=1, RAYS
IF(FLAG(G) .GT. 0) GO TO 79
SDRAD(G)=SQRT((YCENTR(I,ANGLE,THICK)-YIM(G))**2+ZIM(G)**2)
75 CONTINUE
GG=1
RCC(GG)=0.005
SUM4(GG)=0.0
CCNTINUE
80 DO 81 G=1, RAYS
IF(FLAG(G) .GT. 0) GO TO 81
IF(SDRAD(G) .LE. RCC(GG)) SUM4(GG)=1+SUM4(GG)
81 CONTINUE
FRACTN(GG)=SUM4(GG)/RAYS
WRITE(6,140) GG, RCC(GG), FRACTN(GG)
HH=GG
GG=GG+1
RCC(GG)=RCC(HH)+0.005
SUM4(GG)=0.0
82 CONTINUE
IF(RCC(GG) .GT. 0.5) GO TO 82
GG=GG-1
IF(VARY .EQ. 1 .AND. ALFAP .LT. 0.65) GC TC 14
WRITE(6,150)
IF(T .LT. 0.5 .AND. THKNES .EQ. 1) GO TO 2
WRITE(6,160)

PLOT OUTPUT
WRITE OUTPUT FOR PLOT INTO FILE FT01F001
WRITE(1,83) F,ALPHA,U,I,R,T,N1,N2,N3,ALFAP,GRID,STATNA,GAMMA,RAYS,
1XCOUNT,K,GGT,I,ANGLE,THICK,OSYMB,T,SURFL,BEFF,PRCNTO,PRCNTE,PRCNTT,
1XMAVE,A,B
83 FORMAT(10F9.7,14,4F9.7/,' ',3F9.7,F9.5,F9.7/,' ',6I4,4F11.7/1X,
15F11.7)
DO 85 J=1,K
WRITE(1,84)X1(J),Y1(J),X2(J),Y2(J)
84 CONTINUE
FORMAT(10F9.7,14,4F9.7/,' ',3F9.7,F9.5,F9.7/,' ',6I4,4F11.7/1X,
DC 88 G=1, RAYS
WRITE(1,86)RAYY(G),RAYZ(G),FLAG(G)
86 CONTINUE
FORMAT(10F9.7,3X,I1)
IF(FLAG(G) .GT. 0) GO TO 88

```

```

C
C
C
C
C
C

```

```

87 WRITE(1,87)YIM(G),ZIM(G)
88 FORMAT(1,2F10.7)
CONTINUE
DO 90 GG=1,GGT
WRITE(1,89)ROC(GG),FRACTN(GG)
FORMAT(1,2F10.7,2X,F10.7)
90 CONTINUE
WRITE(1,91)YCENTR(IANGLE,THICK),SIGMAY(IANGLE,THICK),
1 SIGMAZ(IANGLE,THICK),RMSRAD(IANGLE,THICK),NUMBT
91 FCRMAT(1,4F10.7,I4)
DO 96 NUMB=1,NUMB
WRITE(1,92)COORD(NUMB)
FORMAT(1,13)
COORD=COORD+1
DO 95 COORD=1,COORD
WRITE(1,94)ELY(NUMB,COORD),ELZ(NUMB,COORD)
FORMAT(1,11.8,3X,F11.8)
94 CONTINUE
95 CONTINUE
WRITE(1,97) /**)
FCRMT(1,98)
97 FORMAT(1,6)
98 WRITE(1,98) /**)
98 TO OBTAIN PLOTS FROM THE PLOTTER OR THE PRINTER, /
1 ISSUE THE FOLLOWING COMMAND: /,8X, FOR PRINTER PLOTS,
1 T36, CENTER CHARTS PRINTER*/,8X, FOR PLOTTER GRAPHS, T36,
1 ENTER CHARTS PLOTTER*/)
99 WRITE(6,99)
FORMAT(1,99) /**) END OF PROGRAM*/)
STOP
100 FORMAT(1,1, LENS PARAMETERS: //5X, ALPHA = ,F9.7,2X,
1 BETA = ,F9.7,2X, RADIUS = ,F7.5//5X, INCIDENT ANGLE = ,
1 F9.6,2X, ITERATIONS = ,15//5X, EDGE THICKNESS = ,F9.7,2X,
1 INDICES OF REFRACTION: N1 = ,F7.5//5X, N3 = ,
1 F7.5,2X, FOCAL LENGTH FROM STATION ZERO = ,F7.5,2X,
1 DELTA UDP = ,F7.5//
11X, J I2//25X, UP I1P I1 DYDXT //)
200 FORMAT(1X,I4,7F10.7/2X,4F10.7//)
300 FORMAT(1,0,1X, NO SE SECTION DATA: //2X, NOSE HALF ANGLE = ,
1 F7.5,2X, STATION A = ,F9.5/2X, OPAQUE SURFACE LENGTH = ,
1 TRANSPARENT SURFACE LENGTH = ,F7.5/2X, TOTAL LENS SURFACE LENGTH
1 = ,F7.5//)
400 FORMAT(1,1, SKEW RAY TRACE PARAMETERS: //5X, ALFAP = ,F9.7,2X,
1 GRID = ,F9.7,2X, SEE LENS PARAMETERS ABOVE. YI //2X, RAY
1 RAYZ X0 X1 NTNCTY XDIAPT YCIAPT //)
500 FORMAT(1X,I4,7F10.7/8,9,3F10.7,2E13.3//)
600 FORMAT(1X,I4,2F10.7, NO INTERCEPT WITH 2ND SURFACE //)

```

```

GI S07720
GI S07730
GI S07740
GI S07750
GI S07760
GI S07770
GI S07780
GI S07790
GI S07800
GI S07810
GI S07820
GI S07830
GI S07840
GI S07850
GI S07860
GI S07870
GI S07880
GI S07890
GI S07900
GI S07910
GI S07920
GI S07930
GI S07940
GI S07950
GI S07960
GI S07970
GI S07980
GI S07990
GI S08000
GI S08010
GI S08020
GI S08030
GI S08040
GI S08050
GI S08060
GI S08070
GI S08080
GI S08090
GI S08100
GI S08110
GI S08120
GI S08130
GI S08140
GI S08150
GI S08160
GI S08170
GI S08180
GI S08190

```

```

700 FORMAT(IX,I4,2F10.7, INTERCEPT OUTSIDE BOUNDARY OF 2ND SURFACE'//)GIS08200
800 FCRMAT(IX,I4,2F10.7,2X, TOTAL INTERNAL REFLECTION AT 2ND SURFACE'//)GIS08210
    1) GIS08220
401 FFORMAT('1.0//MIRROR IMAGE SKEW RAYS FOLLOW'//IX, IMAGE'/2X, RAG GIS08230
    1Y, RAY RAYZ YIM NINCTGIS08240
    1Y, RAY RAYZ YIM GIS08250
501 FFORMAT(IX,I4,2F10.7,F13.9,3F10.7//)GIS08260
601 FFORMAT(IX,I4,2F10.7, NO INTERCEPT WITH 2ND SURFACE'//)GIS08270
701 FFORMAT(IX,I4,2F10.7, INTERCEPT OUTSIDE OF 2ND SURF GIS08280
    1ACE'//) GIS08290
801 FFORMAT(IX,I4,2F10.7, TOTAL INTERNAL REFLECTION'//)GIS08300
802 FFORMAT(IX,I4,2F10.7,2X, TOTAL EXTERNAL REFLECTION'//)GIS08310
803 FFORMAT(IX,I4,2F10.7, TOTAL EXTERNAL REFLECTION'//)GIS08320
900 FFORMAT(IX,I4,2F10.7,2X, TOTAL TRACE'//IX, TOTAL NUMBER OF RAYS TRACE GIS08330
    1D = , I4/3X, TOTAL NUMBER OF MIRROR IMAGE RAYS = , I4/3X, TOTAL NUG GIS08340
    1M BER OF RAYS STRIKING IMAGE PLANE = , I4//) GIS08350
1000 FFORMAT(IX,I4,2F10.7, PROJECTION OF 3-DIM LENS'//IX, 'GENERAG GIS08360
    1TED ELLIPSES ARE REFERENCED TO THE CORRESPONDING JTH COORD'//IX, 'ING GIS08370
    1GORITYH. INSIDE/OUTSIDE ELLIPSES DEFINE THE ABOVE'//IX, 'GLM LENS SHAPEAL GIS08380
    1ANSSPARENT/OPAQUE PARTS'//IX, 'THE NUMBER OF ELLIPSES = , I3//IX, ' TRGIS08390
    1J COORD I4,2F10.7) ELZ'//) GIS08400
1100 FFORMAT(IX,I4,2F10.7) GIS08410
1200 FFORMAT(IX,I4,2F10.7, CALCULATION OF ELLIPSE COORDINATES COMPLETE'//)GIS08420
1300 FFORMAT(IX,I4,2F10.7, IMAGE PLANE SPOT DIAGRAM ANALYSIS'//IX, 'THICKNESS GIS08430
    1 = , F9.7, U = , YCENTR = 0.0, SIGMAZ = , SPOT SIZE: RMS SPOT SIZE: GIS08440
    1ZCENTR = 0.0, SIGMAZ = , SPOT SIZE: RMS SPOT SIZE: SIGMAZ = , GIS08450
    1 = , F10.7//IX, SPOT DIAGRAM ENERGY DENSITY VS. RADIUS FROM CENTROID: GIS08460
    1//IX, 'GG RADIUS FROM CENTROID: GIS08470
1400 FFORMAT(IX,I4,2F10.7) GIS08480
1500 FFORMAT(IX,I4,2F10.7) SPOT DIAGRAM CALCULATIONS COMPLETE'////) GIS08490
1600 FFORMAT(IX,I4,2F10.7) SPOT DIAGRAM CALCULATIONS COMPLETE'////) GIS08500
1700 FFORMAT(IX,I4,2F10.7) SPOT DIAGRAM CALCULATIONS COMPLETE'////) GIS08510
    1) GIS08520
    1) GIS08530
    1) GIS08540
    1) GIS08550
    1) GIS08560
    1) GIS08570
    1) GIS08580
    1) GIS08590
1800 FFORMAT(IX,I4,2F10.7) IMPRCPER A TO R RATIO IN N2(R) GIS08600
1900 FFORMAT(IX,I4,2F10.7) GIS08610
    1) GIS08620
    1) GIS08630
    1) GIS08640
    1) GIS08650
    1) GIS08660
    1) GIS08670
    1) GIS08680
    1) GIS08690
    1) GIS08700
    1) GIS08710
    1) GIS08720
    1) GIS08730
    1) GIS08740
    1) GIS08750
    1) GIS08760
    1) GIS08770
    1) GIS08780
    1) GIS08790
    1) GIS08800
    1) GIS08810
    1) GIS08820
    1) GIS08830
    1) GIS08840
    1) GIS08850
    1) GIS08860
    1) GIS08870
    1) GIS08880
    1) GIS08890
    1) GIS08900
    1) GIS08910
    1) GIS08920
    1) GIS08930
    1) GIS08940
    1) GIS08950
    1) GIS08960
    1) GIS08970
    1) GIS08980
    1) GIS08990
    1) GIS09000
    1) GIS09010
    1) GIS09020
    1) GIS09030
    1) GIS09040
    1) GIS09050
    1) GIS09060
    1) GIS09070
    1) GIS09080
    1) GIS09090
    1) GIS09100
    1) GIS09110
    1) GIS09120
    1) GIS09130
    1) GIS09140
    1) GIS09150
    1) GIS09160
    1) GIS09170
    1) GIS09180
    1) GIS09190
    1) GIS09200
    1) GIS09210
    1) GIS09220
    1) GIS09230
    1) GIS09240
    1) GIS09250
    1) GIS09260
    1) GIS09270
    1) GIS09280
    1) GIS09290
    1) GIS09300
    1) GIS09310
    1) GIS09320
    1) GIS09330
    1) GIS09340
    1) GIS09350
    1) GIS09360
    1) GIS09370
    1) GIS09380
    1) GIS09390
    1) GIS09400
    1) GIS09410
    1) GIS09420
    1) GIS09430
    1) GIS09440
    1) GIS09450
    1) GIS09460
    1) GIS09470
    1) GIS09480
    1) GIS09490
    1) GIS09500
    1) GIS09510
    1) GIS09520
    1) GIS09530
    1) GIS09540
    1) GIS09550
    1) GIS09560
    1) GIS09570
    1) GIS09580
    1) GIS09590
    1) GIS09600
    1) GIS09610
    1) GIS09620
    1) GIS09630
    1) GIS09640
    1) GIS09650
    1) GIS09660
    1) GIS09670
    1) GIS09680
    1) GIS09690
    1) GIS09700
    1) GIS09710
    1) GIS09720
    1) GIS09730
    1) GIS09740
    1) GIS09750
    1) GIS09760
    1) GIS09770
    1) GIS09780
    1) GIS09790
    1) GIS09800
    1) GIS09810
    1) GIS09820
    1) GIS09830
    1) GIS09840
    1) GIS09850
    1) GIS09860
    1) GIS09870
    1) GIS09880
    1) GIS09890
    1) GIS09900
    1) GIS09910
    1) GIS09920
    1) GIS09930
    1) GIS09940
    1) GIS09950
    1) GIS09960
    1) GIS09970
    1) GIS09980
    1) GIS09990
    1) GIS10000

```

C

```

C
C
C
C
SUBROUTINE INDEX_CALCULATES THE INDEX OF REFRACTION AS A FUNCTION
OF RADIUS FROM THE CENTER OF SYMMETRY. THE VALUES OF THE INDEX
CONSTANTS A AND B ARE USER INPUTS.
SUBROUTINE INDEX(R,N)
REAL R,N,A,B,RZERO,E,EPSLON,SQRT
COMMON A,B,E,RZERC,EPSLON,P12,J
N=SQRT(A+B*(R/RZERO)**2)
RETURN
END
C
C
C
C
SUBROUTINE TRANSMIT_CALCULATES THE TRANSMITTED INTENSITY OF
EACH RAY AT BOTH THE OUTSIDE AND INSIDE SURFACES USING THE
FRESNEL EQUATIONS.
SUBROUTINE XMIT(PFI,N2,XM1,FACE)
REAL PHIN3,XM1,NTI,NI,N2,SQRT,COS
INTEGER FACE
COMMON/XM/NI,N3
NTI=N2/NI
IF (FACE .EQ. 2) NTI=N3/N2
IF (FACE=NTI)**2-(SIN(PHI)**2)
VALU=NTI**2-(SIN(PHI)**2)
IF (VALUE .LT. 0.0) GO TO 10
SQ=SQRT(VALUE)
COSP=COS(PHI)
RPAR=(COSP-SQ)/(COSP+SQ)
RPAR=((NTI**2)*COSP-SQ)/((NTI**2)*COSP+SQ)
XMI=1.0-0.5*(RPAR**2+RPAR**2)
RETLRN
CONTINUE
FACE=3
RETURN
END
10
C
C
C
C
SUBROUTINE RADYUS_CALCULATES THE RADIAL DIMENSION FROM THE CENTER
OF SYMMETRY TO THE RAY AT THE ANGLE SPECIFIED.
RADYUS ALSO FINDS D(R)/D(THETA) FOR SUBR ITRATE.
SUBROUTINE RADYUS(RC,ANGLE,R,DRDTG,FILTER)
REAL ANGLE,R,ERAT,A,B,EPSLON,ARCSYN,FRACTN,RO,SQRT,COS,SIN,ARSIN
INTEGER J,FILTER
COMMON A,B,E,RZERC,EPSLON,P12,J
RAT=SQRT(A**2+4.*B*(E**2)/RZERO**2)
ARCSYN=ARCSIN((2.0*(E/RC)**2-A)/RAT)

```

```

GISO8680
GISO8690
GISO8700
GISO8710
GISO8720
GISO8730
GISO8740
GISO8750
GISO8760
GISO8770
GISO8780
GISO8790
GISO8800
GISO8810
GISO8820
GISO8830
GISO8840
GISO8850
GISO8860
GISO8870
GISO8880
GISO8890
GISO8900
GISO8910
GISO8920
GISO8930
GISO8940
GISO8950
GISO8960
GISO8970
GISO8980
GISO8990
GISO9000
GISO9010
GISO9020
GISO9030
GISO9040
GISO9050
GISO9060
GISO9070
GISO9080
GISO9090
GISO9100
GISO9110
GISO9120
GISO9130
GISO9140
GISO9150

```

IS09160
 GISS09170
 GISS09180
 GISS09190
 GISS09200
 GISS09210
 GISS09220
 GISS09230
 GISS09240
 GISS09250
 GISS09260
 GISS09270
 GISS09280
 GISS09290
 GISS09300
 GISS09310
 GISS09320
 GISS09330
 GISS09340
 GISS09350
 GISS09360
 GISS09370
 GISS09380
 GISS09390
 GISS09400
 GISS09410
 GISS09420
 GISS09430
 GISS09440
 GISS09450
 GISS09460
 GISS09470
 GISS09480
 GISS09490
 GISS09500
 GISS09510
 GISS09520
 GISS09530
 GISS09540
 GISS09550
 GISS09560
 GISS09570
 GISS09580
 GISS09590
 GISS09600
 GISS09610
 GISS09620
 GISS09630

```

IF(ANGLE.LT.0.0) ARCSYN=2*PI2-ARCSYN
FRACFN=SIN(-EPSLON*2.0*ANGLE+ARCSYN)
IF((A+RAT*FRACFN).LE.0.0) GO TO 10
R=SQRT(2.0)*ABS(E)/SQRT(A+RAT*FRACFN)
IF(FRACFN.LE.(-C.989)) GO TO 10
DRDTHG=((EPSLON*R**3)/(2.0*E**2))*COS(-2.0*EPSLON*ANGLE+ARCSYN)
10 CONTINUE
FILTER=0
IF(FRACFN.LE.(-0.989)) FILTER=2
IF((A+RAT*FRACFN).LT.0.0) FILTER=1
RETURN
END

```

```

CC
CC
CC
CC
CC
CC

```

SUBROUTINE SWITCH CALCULATES THE POINT ON THE RAY WHERE
 D(R)/D(THETA) IS ZERO. THIS ENABLES THE MAIN ROUTINE TO
 DETERMINE WHETHER PSIP SHOULD BE EVALUATED IN THE 1ST OR 2ND
 QUADRANT.

```

SUBROUTINE SWITCH(RC,THTACR)
REAL THTACR,RAT,E,EPSLON,A2B,PI2,RO,SQRT,ARSIN
COMMON A,B,E,RZERO,EPSLON,PI2,J
RAT=SQRT(A**2+4.*B*(E**2)/RZEROC**2)
THTACR=0.5*(PI2-ARSIN((2.0*(E**2/RC**2)-A)/RAT))
IF(THTACR.LT.0.0) THTACR=THTACR+2.0*PI2
RETURN
END

```

C
 CC
 CC
 CC
 CC
 CC
 C

SUBROUTINE SURF CALCULATES BOTH THE RADIUS TO THE
 LOCUS OF THE INTERCEPT OF THE RAY PLANE AND THE IN-
 SIDE SURFACE AND THE DERIVATIVE OF THE RADIUS WRT THETA
 GIVEN THE ANGLE THETA. SURF IS DESIGNED PRIMARILY
 FOR USE WITH SUBROUTINE ITRATE.

```

SUBROUTINE SURF(THETA,R,RD0T,SIGN,FILTER)
COMMON/SUR/PSIO,X,COSYMB,YO,ZO,RO,CKKP,CLLP,CMP,N20,ALPHA
COMMON/DIR/AI,BICI,NPOX,NPOY,NPOZ,PSIP
REAL N20,COSYMB,NP CX,NPOY,NPOZ,SIN,COS,TAN,COTAN,SQRT,ATAN
INTEGER FILTER

```

```

ALFA=COS(THETA)-SIN(THETA)*COTAN(PSIO)
BETA=SIN(THETA)/SIN(PSIO)
A=ALFA*(XO+CSYMB)/RO+BETA*CKKP
P=ALFA*YO/RO+BETA*CLLP
C=ALFA*ZO/RO+BETA*CMMP
A2=B**2+C**2-(A**2)*(TAN(ALPHA)**2)
B2=B*NPOY+C*NPOZ+A*NPOX+2.0*A*OSYMB*(TAN(ALPHA)**2)

```

C

```

C2=CSYMB*APOX+(OSYMB*TAN( ALPHA ))**2+NPOX*XO+NPOY*YO+NPOZ*ZO
SQUARE=0.25*(B2/A2)**2+C2/A2
IF( SQUARE .LT. 0.0) FILTER=3
IF( FILTER .EQ. 3) RETURN
R=-B2/(2.0*A2)+SIGN*SQRT( SQUARE)
CALCULATE DR/DTHETA
DAL=-SIN( THETA )-COS( THETA )*COTAN( PSIO )
DBE=COS( THETA )/SIN( PSIO )
DA=DAL*(XC+CSYMB)/RO+LBE*CKKP
DB=DAL*YO/RO+DBE*CLLP
DC=DAL*ZO/RO+DBE*CMMP
DA2=2.0*B*DBE+2.0*C*DC-2.0*A*DA*(TAN( ALPHA ))**2)
DB2=DB*NP OY+DC*NP OZ+DA*NP OX+2.0*DA*CSYMB*(TAN( ALPHA ))**2)
A3=-0.5*(A2*DB2-B2*DA2)/(A2**2)
B3=SIGN/(2.0*SQRT(0.25*(B2/A2)**2+C2/A2))
C3=0.25*(A2**2)*2.0*B2*DB2-(B2**2)/(A2**4)-
1C2*DA2/(A2**2)
RDOT=A3+B3*C3
RETURN
END

```

C

```

SUBROUTINE DIRECT CALCULATES THE VECTOR DIRECTION COSINES OF
A SKEW RAY AT THE POINT OF INTERCEPT WITH THE INSIDE SURFACE.

```

CCCC

```

SUBROUTINE DIRECT(CKP,CLP,CMP)
COMMON/DIR/RRX,RRY,RRZ,NPFY,NPFZ,PSIR
REAL RRX,RRY,RRZ,NPFY,NPFZ,PSIR,CKP,CLP,CMPCOS,SQRT
EPS=1.0E-06
SIGN=+1.0
IF((ABS(NPFY)) .GT. EPS) GO TO 50
IF((ABS(NPFZ)) .GT. EPS) GO TO 30
IF((ABS(RRY)) .LT. EPS) GO TO 25
CMP=0.0
APP=1.0+(FRX/RRY)**2
BPP=COS(PSIR)*FRX/RRY**2
CPP=(COS(PSIR)/RRY)**2-1.0
CKP=BPP/APP+SIGN*SQRT(BPP**2-APP*CPP)/APP
CLP=(COS(PSIR)-RRX*CKP)/RRY
RETURN
25 CONTINUE
CMP=0.0
CKP=COS(PSIR)/RRX
CLP=SIGN*SQRT(1.0-CKP**2)
RETURN
30 CONTINUE
IF((ABS(NPFZ)) .GT. EPS) GO TO 40
IF((ABS(RRZ)) .LT. EPS) GO TO 35

```

25

30

IS09640
 GI509650
 GI509660
 GI509670
 GI509680
 GI509690
 GI509700
 GI509710
 GI509720
 GI509730
 GI509740
 GI509750
 GI509760
 GI509770
 GI509780
 GI509790
 GI509800
 GI509810
 GI509820
 GI509830
 GI509840
 GI509850
 GI509860
 GI509870
 GI509880
 GI509890
 GI509900
 GI509910
 GI509920
 GI509930
 GI509940
 GI509950
 GI509960
 GI509970
 GI509980
 GI509990
 GISS10000
 GISS10010
 GISS10020
 GISS10030
 GISS10040
 GISS10050
 GISS10060
 GISS10070
 GISS10080
 GISS10090
 GISS10100
 GISS10110

GISSI0120
 GISSI0130
 GISSI0140
 GISSI0150
 GISSI0160
 GISSI0170
 GISSI0180
 GISSI0190
 GISSI0200
 GISSI0210
 GISSI0220
 GISSI0230
 GISSI0240
 GISSI0250
 GISSI0260
 GISSI0270
 GISSI0280
 GISSI0290
 GISSI0300
 GISSI0310
 GISSI0320
 GISSI0330
 GISSI0340
 GISSI0350
 GISSI0360
 GISSI0370
 GISSI0380
 GISSI0390
 GISSI0400
 GISSI0410
 GISSI0420
 GISSI0430
 GISSI0440
 GISSI0450
 GISSI0460
 GISSI0470
 GISSI0480
 GISSI0490
 GISSI0500
 GISSI0510
 GISSI0520
 GISSI0530
 GISSI0540
 GISSI0550
 GISSI0560
 GISSI0570
 GISSI0580
 GISSI0590

```

CLP=0.0+(RRX/RRZ)**2
APP=1.0+(PSIR)*RRX/RRZ**2
CPP=(COS(PSIR)/RRZ)**2-1.0
CKP=BPP/APP+SQT(BPP**2-APP*CPP)/APP
CMP=(COS(PSIR)-RRX*CKP)/RRZ
RETURN
35 CONTINUE
CLP=0.0
CKP=COS(PSIR)/RRX
CMP=SIGN*SQT(1.0-CKP**2)
RETURN
40 CONTINUE
IF((ABS(RRX)) .GT. EPS) GO TO 45
CLP=COS(PSIR)/(RRY-NPFY/NPFZ*RRZ)
CMP=-NPFY/NPFZ*CLP
CKP=SIGN*SQT(1.0-CLP**2-CMP**2)
RETURN
45 CONTINUE
IF((ABS(RRY-NPFY/NPFZ*RRZ)) .GT. EPS) GO TO 47
CLP=COS(PSIR)/RRX
CMP=SIGN*SQT(1.0-CKP**2)/(1.0+(NPFY/NPFZ)**2))
CKP=-NPFY/NPFZ*CLP
RETURN
47 CONTINUE
SIGN=-1.0
IF(RRY .LT. 0.0 .OR. RRX .LT. 0.0) SIGN=+1.0
IF(RRY .LT. 0.0 .AND. RRX .LT. 0.0) SIGN=-1.0
APP=(RRY-NPFY/NPFZ*RRZ)/(RRX**2+1.0+(NPFY/NPFZ)**2)
BPP=2.0*COS(PSIR)/(RRX**2)*(RRY-NPFY/NPFZ*RRZ)
CPP=(COS(PSIR)/RRX)**2-1.0
CLP=BPP/(2.0*APP)+SIGN*SQT(BPP**2-4.0*APP*CPP)/(2.0*APP)
CMP=-NPFY/NPFZ*CLP
CKP=(COS(PSIR)-(RRY-NPFY/NPFZ*RRZ)*CLP)/RRX
RETURN
50 CONTINUE
SIGN=-1.0
IF(RRY .LT. 0.0) SIGN=+1.0
IF(RRY .LT. 0.0 .AND. NPFZ .LT. 0.0) SIGN=-1.0
AA=NPFY*RRY-NPFY*RRX
BB=NPFY*RRZ-NPFZ*RRX
CC=NPFY*COS(PSIR)
IF((ABS(BB)) .GT. EPS) GO TO 60
CLP=CC/AA
APP=(NPFZ/NPFY)**2+1.0
BPP=NPFY*NPFZ/NPFX**2*CLP
CPP=((NPFY/NPFX)**2+1.0)*CLP**2-1.0
CMP=(-BPP/APP+SIGN*SQT(BPP**2-APP*CPP))/APP
  
```

G I S I 10600
 G I S I 10610
 G I S I 10620
 G I S I 10630
 G I S I 10640
 G I S I 10650
 G I S I 10660
 G I S I 10670
 G I S I 10680
 G I S I 10690
 G I S I 10700
 G I S I 10710
 G I S I 10720
 G I S I 10730
 G I S I 10740
 G I S I 10750
 G I S I 10760
 G I S I 10770
 G I S I 10780
 G I S I 10790
 G I S I 10800
 G I S I 10810
 G I S I 10820
 G I S I 10830
 G I S I 10840
 G I S I 10850
 G I S I 10860
 G I S I 10870
 G I S I 10880
 G I S I 10890
 G I S I 10900
 G I S I 10910
 G I S I 10920
 G I S I 10930
 G I S I 10940
 G I S I 10950
 G I S I 10960
 G I S I 10970
 G I S I 10980
 G I S I 10990
 G I S I 11000
 G I S I 11010
 G I S I 11020
 G I S I 11030
 G I S I 11040
 G I S I 11050
 G I S I 11060
 G I S I 11070

```

    CKP=(-NPFY*CLP-APFZ*CMPI)/NPFZ
    RETURN
  CONTINUE
  IF(BB.GT.0.0) SIGN=-1.0
  AF=(NPFZ/NPFY)**2+1.0
  BP=(NPFZ/NPFY)**2+1.0
  CP=2.0*NPFY*NPFZ/NPFY**2
  APP=A.P+BP*(AA/BB)**2-CP*AA/BB
  BPP=2.0*AA*CC*BP/BB**2-1.0
  CFP=BP*(CC/BB)**2-1.0
  CLP=8PP/(2.0*APPI+SIGN*SQRT(BPP**2-4.0*APP*CPP))/(2.0*APP)
  CMP=CC/BB-AA/BB*CLP
  CKP=(-NPFY*CLP-APFZ*CMPI)/NPFZ
  RETURN
  END
  
```

SUBROUTINE ITRATE PERFORMS ITERATION TO FIND R AND THETA
 OF THE INTERCEPT OF THE GRIN SKEW-RAY AND THE INSIDE CONICAL
 SURFACE USING THE NEWTON-RAPHSON ITERATION PROCEDURE.

```

    SUBROUTINE ITRATE(SIGN,THETA,R,THETA,FILTER)
    COMMON A,B,E,RZER,EPSON,PI2,J
    COMMON/DIR/AL,BL,CL,NPOX,NPOY,NPOZ,PSIP
    COMMON/SUR/PSIO,XO,OSYMB,YO,ZO,RO,CKKP,CLLP,CMMP,N2O,ALPHA
    INTEGER LOOP,FILTER
  
```

```

    LOOP=0
  10 CONTINUE
    CALL RADYUS(RO,THETA,RADG,ROOTG,FILTER)
    IF(FILTER.EQ.1) RETURN
    IF(FILTER.EQ.2) RETURN
    CALL SURF(THETA,RADH,ROOTS,SIGN,FILTER)
    IF(FILTER.EQ.3) RETURN
    FX=RADG-RADH
    FXDOT=ROOTG-ROOTS
    XNEW=THETA-(FX/FXDOT)/1.3
    DIFF=ABS(THETA-XNEW)
    IF(DIFF.GT.0.00001) GO TO 20
    THETA=XNEW
    R=RADG
    RETURN
  20 CONTINUE
    GE.90) GO TO 30
    LCCP=LOOP+1
    THETA=XNEW
    GO TO 10
  30 CONTINUE
  
```

6410 IF(LOOP .GE. 90) FILTER=3
WRITE(6,641C)
FORMAT(1X,'SOLUTION NOT FOUND')
RETURN
END

GIS11080
GIS11090
GIS11100
GIS11110
GIS11120

APPENDIX C

SAMPLE TABULAR OUTPUT FROM PROGRAM GISL

 *
 * GISL TABULAR OUTPUT
 *
 *

1 LENS PARAMETERS:

ALPHA = 0.7853982 BETA = 0.3217505 RADIUS = 1.00000
 INCIDENT ANGLE = 0.0 ITERATIONS = 100
 EDGE THICKNESS = 0.0500000 INDICES OF REFRACTION: N1 = 1.00000
 N3 = 1.00000 FOCAL LENGTH FROM STATION ZERO = 4.00000 DELTA UDP = 0.00322

J	X1	Y1	X2	Y2	I1P	I1	DYDXT	UDP	I2P	I2
1	0.9616396	1.0320053	1.0000000	0.9999998	0.1720029	0.8769178	0.8318774	0.3217505	0.4636472	0.0955450
2	0.9527428	1.0245905	0.9919431	0.9919429	0.1727901	0.8770413	0.8316687	0.3185330	0.4668645	0.1006271
3	0.9438142	1.0171518	0.9838600	0.9838598	0.1735849	0.8771699	0.8314511	0.3152155	0.4700826	0.1017177
4	0.9348540	1.0096884	0.9757503	0.9757501	0.1743850	0.8772871	0.8312529	0.3120980	0.4732593	0.1028165
5	0.9258599	1.0022020	0.9676142	0.9676141	0.1751921	0.8774052	0.8310531	0.3088804	0.4765170	0.1039242
6	0.9168330	0.9946885	0.9594508	0.9594507	0.1760102	0.8775480	0.8308118	0.3056630	0.4797347	0.1050406
7	0.9077742	0.9871492	0.9512604	0.9512602	0.1768308	0.8776608	0.8306212	0.3024455	0.4829524	0.1061657
8	0.8986831	0.9795850	0.9430425	0.9430423	0.1776611	0.8777914	0.8304005	0.2992280	0.4861692	0.1072993

9 0.8895560 0.9719930 0.9347960 0.9347959 0.2960104 0.4893869 0.1084422
 0.6769556 0.1784965 0.8779076 0.83302040
 10 0.8803961 0.9643753 0.9265221 0.5265219 0.2927930 0.4926046 0.1095940
 0.6758038 0.1793403 0.8780314 0.8299952
 11 0.8712009 0.9567289 0.9182188 0.9182186 0.2855755 0.4958213 0.1107548
 0.6746430 0.1801909 0.8781521 0.8297514
 12 0.8619708 0.9490560 0.9098864 0.9098862 0.2862579 0.4990390 0.1119250
 0.6734728 0.1810462 0.8782556 0.8296165
 13 0.8527024 0.9413573 0.9015246 0.9015244 0.2831404 0.5022567 0.1131043
 0.6722935 0.1819105 0.8783699 0.8294234
 14 0.8433996 0.9336274 0.8931330 0.8931329 0.2759229 0.5054744 0.1142931
 0.6711047 0.1827840 0.8784947 0.8292129
 15 0.8340593 0.9258732 0.8847126 0.8847124 0.2767054 0.5086521 0.1154910
 0.6699068 0.1836621 0.8786031 0.8290300
 16 0.8246826 0.9180898 0.8762615 0.8762614 0.2724879 0.5119098 0.1166985
 0.6686593 0.1845482 0.8787155 0.8288405
 17 0.8152681 0.9102768 0.8677794 0.8677792 0.2702704 0.5151275 0.1179156
 0.6674823 0.1854381 0.8788039 0.8286913
 18 0.8058172 0.9024346 0.8592664 0.8592662 0.2670529 0.5183452 0.1191421
 0.6662558 0.1863384 0.8789114 0.8285100
 19 0.7963278 0.8945618 0.8507230 0.8507228 0.2638354 0.5215619 0.1203781
 0.6650197 0.1872448 0.8790098 0.8283439
 20 0.7867595 0.8866592 0.8421465 0.8421463 0.2606179 0.5247796 0.1216241
 0.6637738 0.1881607 0.8791218 0.8281551
 21 0.7772329 0.8787258 0.8335392 0.8335391 0.2574005 0.5279973 0.1228797
 0.6625181 0.1890816 0.8792174 0.8279540
 22 0.7676280 0.8707618 0.8248989 0.8248987 0.2541829 0.5312141 0.1241450
 0.6612529 0.1900077 0.8792992 0.8278561
 23 0.7579840 0.8627660 0.8162262 0.8162261 0.2509654 0.5344318 0.1254203
 0.6599776 0.1909401 0.8793746 0.8277252
 24 0.7482984 0.8547372 0.8075203 0.8075202 0.2477480 0.5376495 0.1267056
 0.6586922 0.1918799 0.8794488 0.8276040

25 0.7385736 0.8466769 0.7987810 0.7987808 0.2445304 0.5408671 C.1280009
 0.6573970 0.1928259 0.8795164 0.8274904
 26 0.7288064 0.8385835 0.7900075 0.7900074 0.2413129 0.5440835 0.1293058
 0.6560920 0.1937829 0.8796067 0.8273380
 27 0.7189997 0.8304576 0.7811996 0.7811995 0.2380954 0.5473016 C.1306210
 0.6547768 0.1947386 0.8796439 0.8272754
 28 0.7091515 0.8222976 0.7723581 0.7723579 0.2348775 0.5505193 0.1319463
 0.6534515 0.1957040 0.8796960 0.8271877
 29 0.6992603 0.8141024 0.7634806 0.7634804 0.2316604 0.5537370 0.1332816
 0.6521162 0.1966770 0.8797513 0.8270944
 30 0.6893276 0.8058743 0.7545682 0.7545680 0.2284429 0.5569547 0.1346271
 0.6507707 0.1976526 0.8797790 0.8270478
 31 0.6793501 0.7976097 0.7456194 0.7456192 0.2252254 0.5601724 0.1359826
 0.6494152 0.1986350 0.8798047 0.8270046
 32 0.6693305 0.7893112 0.7366352 0.7366350 0.2220075 0.5633891 0.1373481
 0.6480498 0.1996242 0.8798310 0.8269601
 33 0.6592678 0.7809767 0.7276143 0.7276142 0.2187904 0.5666068 0.1387237
 0.6466741 0.2006130 0.8798138 0.8269892
 34 0.6491598 0.7726042 0.7185560 0.7185559 0.2155729 0.5698245 0.1401095
 0.6452883 0.2016122 0.8798180 0.8269823
 35 0.6390076 0.7641952 0.7094607 0.7094606 0.2123554 0.5730422 0.1415054
 0.6438924 0.2026151 0.8798057 0.8270029
 36 0.6288099 0.7557480 0.7003270 0.7003269 0.2051379 0.5762599 0.1429113
 0.6424865 0.2036191 0.8797619 0.8270767
 37 0.6185674 0.7472628 0.6911556 0.6911554 0.2059204 0.5794767 0.1443270
 0.6410708 0.2046333 0.8797413 0.8271113
 38 0.6082788 0.7387393 0.6819450 0.6819448 0.2027029 0.5826944 0.1457528
 0.6396450 0.2056431 0.8796603 0.8272479
 39 0.5979443 0.7301762 0.6726955 0.6726953 0.1954854 0.5859120 0.1471885
 0.6382093 0.2066600 0.8795860 0.8273730
 40 0.5875602 0.7215751 0.6634064 0.6634063 0.1962678 0.5891297 0.1486340
 0.6367638 0.2076797 0.8794951 0.8275260

41 0.5771319 0.7129317 0.6540776 0.6540775 0.1930503 0.5923465 0.1500890
 0.6353088 0.2087043 0.8794014 0.8276839
 42 0.5666530 0.7042491 0.6447080 0.6447079 0.1858329 0.5955642 0.1515539
 0.6338440 0.2497281 0.8792736 0.8278592
 43 0.5561299 0.6955217 0.6352974 0.6352973 0.1866153 0.5987819 0.1530283
 0.6323695 0.2107540 0.8791294 0.8281425
 44 0.5455577 0.6867517 0.6258453 0.6258451 0.1832978 0.6019596 0.1545120
 0.6308858 0.2117817 0.8789694 0.8284122
 45 0.5349353 0.6779414 0.6163516 0.6163515 0.1801803 0.6052173 0.1560050
 0.6293528 0.2128095 0.8787854 0.8287225
 46 0.5242630 0.6690865 0.6068150 0.6068149 0.1769629 0.6084350 0.1575071
 0.6278507 0.2138370 0.8785779 0.8290725
 47 0.5135422 0.6601877 0.5972365 0.5972363 0.1737453 0.6116517 0.1590175
 0.6263800 0.2148613 0.8783325 0.8294867
 48 0.5027711 0.6512430 0.5876139 0.5876138 0.1705278 0.6148694 0.1605376
 0.6248602 0.2158903 0.8780947 0.8298882
 49 0.4919505 0.6422523 0.5779477 0.5779476 0.1673103 0.6180871 0.1620658
 0.6223320 0.2169136 0.8778104 0.8303685
 50 0.4810801 0.6332145 0.5682372 0.5682371 0.1640928 0.6213048 0.1636023
 0.6217955 0.2179340 0.8774970 0.8308581
 51 0.4701589 0.6241291 0.5584818 0.5584816 0.1608753 0.6245225 0.1651468
 0.6202511 0.2189507 0.8771533 0.8314753
 52 0.4591874 0.6149944 0.5486809 0.5486808 0.1576578 0.6277393 0.1666989
 0.6186990 0.2199641 0.8767840 0.8321041
 53 0.4481649 0.6058107 0.5388345 0.5388344 0.1544403 0.6309569 0.1682587
 0.6171392 0.2209763 0.8764024 0.8327499
 54 0.4370912 0.5965770 0.5289415 0.5289414 0.1512228 0.6341746 0.1698255
 0.6155723 0.2219762 0.8759543 0.8335092
 55 0.4259651 0.5872923 0.5190016 0.5190015 0.1480053 0.6373523 0.1713992
 0.6139987 0.2229703 0.8754758 0.8343204
 56 0.4147875 0.5779552 0.5090140 0.5090139 0.1447878 0.6406100 0.1729792
 0.6124186 0.2239618 0.8749874 0.8351490

57 0.4035584 0.5685652 0.4989785 0.4989784 0.1415703 0.6438268 0.1745651
0.6108327 0.2249327 0.8744001 0.8361464
58 0.3922781 0.5591206 0.4888944 0.4888943 0.1393528 0.6470445 0.1761568
0.6052411 0.2259064 0.8738380 0.8371021
59 0.3809454 0.5496220 0.4787614 0.4787613 0.1351352 0.6502622 0.1777536
0.6076442 0.2268587 0.8731809 0.8382204
60 0.3695607 0.5400661 0.4685786 0.4685785 0.1319178 0.6534799 0.1793550
0.6060428 0.2278067 0.8725201 0.8393459
61 0.3581234 0.5304537 0.4583452 0.4583451 0.1287003 0.6566976 0.1809607
0.6044372 0.2287461 0.8718379 0.8405095
62 0.3466337 0.5207826 0.4480610 0.4480609 0.1254827 0.6599143 0.1825695
0.6028283 0.2296700 0.8711029 0.8417643
63 0.3350886 0.5110562 0.4377257 0.4377256 0.1222652 0.6631320 0.1841817
0.6012161 0.2305866 0.8703625 0.8430304
64 0.3234909 0.5012654 0.4273381 0.4273379 0.1190478 0.6663497 0.1857961
0.5996017 0.2315134 0.8697081 0.8441503
65 0.3118377 0.4914232 0.4168978 0.4168977 0.1158302 0.6695674 0.1874124
0.5979854 0.2321913 0.8678473 0.8473423
66 0.3001441 0.4815053 0.4064043 0.4064041 0.1126127 0.6727841 0.1890293
0.5963685 0.2330918 0.8671477 0.8485447
67 0.2883955 0.4715261 0.3958564 0.3958563 0.1093952 0.6760018 0.1906468
0.5947511 0.2339365 0.8662193 0.8501430
68 0.2765932 0.4614829 0.3852540 0.3852539 0.1061777 0.6792195 0.1922638
0.5931340 0.2347438 0.8651602 0.8519691
69 0.2647396 0.4513741 0.3745971 0.3745970 0.1029602 0.6824372 0.1938794
0.5915185 0.2355235 0.8640264 0.8539279
70 0.2529339 0.4411972 0.3638837 0.3638836 0.0997427 0.6856549 0.1954927
0.5899051 0.2362607 0.8627505 0.8561365
71 0.2408782 0.4309509 0.3531137 0.3531135 0.0965252 0.6888726 0.1971030
0.5882948 0.2369844 0.8614810 0.8583391
72 0.2288720 0.4206347 0.3422866 0.3422865 0.0933077 0.6920894 0.1987091
0.5866887 0.2376738 0.8601224 0.8607012

73 0.2168158 0.4102467 0.3314016 0.3314016 0.090902 0.6953071 0.2003103
0.5850875 0.2383270 0.8586721 0.8632289
74 0.2047106 0.3997850 0.3204582 0.3204581 0.0868727 0.6985248 0.2019055
0.5834923 0.2389493 0.8571633 0.8658658
75 0.1925563 0.3892482 0.3094552 0.3094551 0.0836552 0.7017425 0.2034936
0.5819042 0.2395362 0.8555795 0.8686407
76 0.1803538 0.3786361 0.2983926 0.2983925 0.0804377 0.7049602 0.2050733
0.5803245 0.2400801 0.8538936 0.8716030
77 0.1681040 0.3679463 0.2872689 0.2872688 0.0772201 0.7081769 0.2066433
0.5787545 0.2405922 0.8521645 0.8746502
78 0.1558043 0.3571758 0.2760841 0.2760840 0.0740027 0.7113946 0.2082030
0.5771948 0.2410619 0.8503491 0.8778595
79 0.1434576 0.3463323 0.2648367 0.2648366 0.0707852 0.7146123 0.2097508
0.5756471 0.2414904 0.8484600 0.8812100
80 0.1310653 0.3354020 0.2535262 0.2535262 0.0675676 0.7178300 0.2112853
0.5741125 0.2418711 0.8464741 0.8847443
81 0.1186289 0.3243900 0.2421523 0.2421522 0.0643501 0.7210477 0.2128052
0.5725926 0.2422076 0.8444154 0.8884209
82 0.1061490 0.3132926 0.2307140 0.2307140 0.0611327 0.7242644 0.2143090
0.5710889 0.2424974 0.8422785 0.8922517
83 0.0936257 0.3021082 0.2192101 0.2192100 0.0575152 0.7274821 0.2157956
0.5696022 0.2427363 0.8400525 0.8962579
84 0.0810609 0.2908359 0.2076402 0.2076401 0.0546576 0.7306598 0.2172634
0.5681344 0.2429250 0.8377470 0.9004240
85 0.0684555 0.2794743 0.1960034 0.1960033 0.0514801 0.7339175 0.2187108
0.5666870 0.2430628 0.8353659 0.9047449
86 0.0558102 0.2680214 0.1842988 0.1842987 0.0482626 0.7371352 0.2201362
0.5652616 0.2431462 0.8329000 0.9092394
87 0.0431264 0.2564759 0.1725258 0.1725258 0.0450451 0.7403520 0.2215379
0.5638599 0.2431734 0.8303474 0.9139132
88 0.0304019 0.2448380 0.1606832 0.1606832 0.0418276 0.7435697 0.2229148
0.5624831 0.2431445 0.8277161 0.9187540

85 0.0176410 0.2331046 0.1487704 0.1487703 0.0386101 0.7467874 0.2242649
 0.5611330 0.2430580 0.8250054 0.5237653
 90 0.0048451 0.2212741 0.1367862 0.1367862 0.0352526 0.7500051 0.2255866
 0.55598112 0.2429150 0.8222255 0.9289307
 91-0.0079843 0.2093453 0.1247303 0.1247303 0.0321751 0.7532218 0.2268779
 0.5585199 0.2427126 0.8193703 0.9342635
 92-0.0208471 0.1973162 0.1126012 0.1126012 0.0285576 0.7564395 0.2281377
 0.5572602 0.2424498 0.8164404 0.9397660
 93-0.0337411 0.1851857 0.1003983 0.1003982 0.0257401 0.7596572 0.2293640
 0.5560338 0.2421274 0.8134441 0.9454245
 94-0.0466690 0.1729540 0.0881205 0.0881204 0.0225226 0.7628749 0.2305551
 0.5548428 0.2417436 0.8103788 0.9512465
 95-0.0596255 0.1606186 0.0757670 0.0757669 0.0193051 0.7660526 0.2317091
 0.5536888 0.2413010 0.8072599 0.9572054
 96-0.0726097 0.1481775 0.0633368 0.0633368 0.0160876 0.7693103 0.2328244
 0.5525734 0.2407974 0.8040817 0.9633141
 97-0.0856237 0.1356313 0.0508290 0.0508290 0.0128701 0.7725270 0.2338991
 0.5514987 0.2402332 0.8008499 0.9695645
 98-0.0986636 0.1229768 0.0382423 0.0382423 0.0096526 0.7757447 0.2349315
 0.5504659 0.2396098 0.7975732 0.9759415
 99-0.1117308 0.1102147 0.0255759 0.0255759 0.0064350 0.7789624 0.2359210
 0.5454769 0.2389274 0.7942556 0.9824401
 100-0.1248229 0.0973431 0.0128291 0.0128291 0.0032176 0.7821801 0.2368645
 0.5485333 0.2381868 0.7909024 0.9890516
 101-0.1379396 0.0843605 0.0000002 0.0000002 0.0000001 0.7853969 0.2377607
 0.5476371 0.2373897 0.7875214 0.9957625

NOSE SECTION DATA:

NCSE HALF ANGLE = 0.78327 STATION A = -0.22266
 OPAQUE SURFACE LENGTH = 0.11956
 TRANSPARENT SURFACE LENGTH = 1.45205
 TOTAL SURFACE LENGTH = 1.57160

LENS INDEX OF REFRACTICA DATA = SQRT((9.00)+(5.351)*R**2)
 THE INDEX GRADIENT IS: N2(R) LOCATED AT 0.050
 WITH THE CENTER OF SYMMETRY LOCATED AT 0.050
 (MINUS IMPLIES THE OSYM IS ON THE IMAGE SIDE).
 PERCENT CHANGE OF THE LENS INDEX GRADIENT:
 INSIDE SURFACE FROM CENTER TO EDGE : 49.88858
 INSIDE SURFACE TO OUTSIDE SURFACE AT THICKEST PCINT : 0.36591
 OUTSIDE SURFACE FROM CENTER TO EDGE : 49.34212

ISKE+ RAY TRACE PARAMETERS:

ALFAP= 0.400000 GRID= 0.300000 SEE LENS PARAMETERS ABOVE.

RAY	RAYY	RAYZ	XO	YO	XI	YI	ZI	OPL	YIM	ZIM	NTNCTY	XDIAPT	YDIAPT
1	0.0	0.300000	0.1307886	-0.1494352	0.2557881	-0.1287202	0.2210370	5.04583168	-2.1801453	0.1453156	0.5102614	-0.126E+01	-0.137E+01
2	0.0	0.600000	0.5384317	-0.3217840	0.6207671	-0.3018253	0.5424452	4.45555169	-1.4455128	0.2271336	0.4481558	-0.775E+00	-0.111E+01
3	0.0	0.900000	0.9583030	-0.4993026	0.9974844	-0.4872602	0.8703845	4.09892273	-1.1834154	0.2429521	0.3635889	-0.433E+00	-0.103E+01
4	0.0	0.000000	0.0109681	0.2269354	0.1305237	0.1305212	0.0	4.85042477	-1.6185007	0.0	0.5535472	0.100E+06	0.100E+06
5	0.0	0.300000	0.1424869	0.1713301	0.2579772	0.1139907	0.2314239	4.93159103	-1.9860687	0.3676555	0.5334762	-0.588E+01	0.368E+01
6	0.0	0.600000	0.4431463	0.0442133	0.5327001	0.0265410	0.5320314	4.60996151	-1.7169704	0.0316657	0.4739231	0.442E+00	-0.183E+01
7	0.0	0.900000	0.8111566	-0.1113788	0.8637780	-0.1123655	0.8564321	4.27614594	-1.4330120	0.1158373	0.3925338	-0.162E+00	-0.127E+01
8	0.0	0.000000	0.2600275	0.4473460	0.3610061	0.3610038	0.0						

4.66151619	-1.4761887	0.0	0.5169492	0.100E+06	0.100E+06
9	0.6000000	0.3000000	0.3363692	0.4150693	0.4317581
	4.65313148	-1.5641460	0.1932485	0.5009179	0.100E+06
10	0.6000000	0.6000000	0.5420605	0.3281044	0.6192006
	4.53353596	-1.5893183	0.1321886	0.4537812	0.130E+01
11	0.6000000	0.9000000	0.8309218	0.2059760	0.8806287
	4.31594181	-1.4822788	0.0079514	0.3868141	0.252E+00
12	0.9000000	0.0	0.5180798	0.6639546	0.5948910
	4.56061363	-1.3724556	0.0	0.4602101	0.100E+06
13	0.9000000	0.3000000	0.5713329	0.6414395	0.6435080
	4.53502178	-1.4060097	0.1153301	0.4473754	0.262E+01
14	0.9000000	0.6000000	0.7219925	0.5777416	0.7806184
	4.45209980	-1.4449883	0.1326690	0.4111363	0.121E+01
15	0.9000000	0.9000000	0.9483795	0.4820271	0.5865439
	4.30145073	-1.4332008	0.0648745	0.3594230	0.465E+00
16	1.1999998	0.0	0.7783279	0.8796349	0.8306387
	4.49608326	-1.3109426	0.0	0.3974670	0.100E+06
17	1.1999998	0.3000000	0.8187981	0.8625243	0.8675712
	4.47258854	-1.3300571	0.0765226	0.3879091	0.136E+01
18	1.1999998	0.6000000	0.9357986	0.8130573	0.9743750
	4.40475750	-1.3604498	0.1072606	0.3611534	0.908E+00
19	C.3000000	0.0	0.4567428	0.6129578	0.5509578
	4.38281155	-0.5380237	0.0	0.4409877	0.100E+06
20	0.3000000	0.3000000	0.6123005	0.6787266	0.6885747
	4.28067303	-0.9621467	0.2031004	0.4222168	-0.118E+01
21	0.3000000	0.6000000	0.9397941	0.8171884	0.9814265
	4.05062485	-0.9309339	0.2432328	0.3676401	-0.671E+00

1

MIRRCR IMAGE SKEW RAYS FOLLOW

IMAGE RAY	RAY	RAY	RAYZ	RAYZ	OPL	YIM	ZIM	NTACTY	
22	1	0.0	-0.3	0.00000	5.04583168	-2.1801453	0.1453156	0.5102614	
23	2	0.0	-0.6	0.00000	4.45555169	-1.4455128	0.2271336	0.4481558	
24	3	0.0	-0.9	0.00000	4.09892273	-1.1834154	0.2429521	0.3635889	
25	5	0.3	0.00000	-0.3	0.00000	4.93159103	-1.9860687	-0.3676595	0.5334762
26	6	0.3	0.00000	-0.6	0.00000	4.60996151	-1.7169704	-0.0316697	0.4739231
27	7	0.3	0.00000	-0.9	0.00000	4.27614594	-1.4330120	0.1158373	0.3925338
28	9	0.6	0.00000	-0.3	0.00000	4.65313148	-1.5641460	-0.1922485	0.5009179
29	10	0.6	0.00000	-0.6	0.00000	4.53353596	-1.5893183	-0.1321886	0.4537812
30	11	0.6	0.00000	-0.9	0.00000	4.31594181	-1.4822788	-0.0079514	0.3868141
31	13	0.9	0.00000	-0.3	0.00000	4.53502178	-1.4060097	-0.1153301	0.4473754
32	14	0.9	0.00000	-0.6	0.00000	4.45209980	-1.4449882	-0.1326690	0.4111363
33	15	0.9	0.00000	-0.9	0.00000	4.30145073	-1.4332008	-0.0648745	0.3594230
34	17	1.1	1.999958	-0.3	0.00000	4.47258854	-1.3300571	-0.0765226	0.3879091
35	18	1.1	1.999958	-0.6	0.00000	4.40475750	-1.3604498	-0.1072606	0.3611534
36	20	-0.3	0.00000	-0.3	0.00000	4.28067303	-0.9621467	0.2021004	0.4222168
37	21	-0.3	0.00000	-0.6	0.00000	4.05062485	-0.9309335	0.2422328	0.3676401

END CF SKEW RAY TRACE.

TOTAL NUMBER OF RAYS TRACED = 37
TOTAL NUMBER OF MIRROR IMAGE RAYS = 16
TOTAL NUMBER OF RAYS STRIKING IMAGE PLANE = 37

IMAGE PLANE SPOT DIAGRAM ANALYSIS:

THICKNESS = 0.050000 U = 0.0 ALFAP = 0.400000 R = 1.0000000
 CENTROID: ZCENTR = 0.0, YCENTR = -1.4490051
 STANDARD DEVIATIONS: SIGMAX = 0.0911858 SIGMAZ = 0.0264883
 PMS SPCT SIZE: RMSRAD = 0.3430366

SPOT DIAGRAM ENERGY DENSITY VS. RADIUS FROM CENTROID:

GG	RADIUS	FRACTION
1	0.0050000	0.0
2	0.0100000	0.0
3	0.0150000	0.0
4	0.0200000	0.0
5	0.0250000	0.0
6	0.0300000	0.0270270
7	0.0350000	0.0810810
8	0.0400000	0.0810810
9	0.0450000	0.0810810
10	0.0500000	0.0810810
11	0.0550000	0.0810810
12	0.0600000	0.0810810
13	0.0649999	0.0810810
14	0.0699999	0.1351351
15	0.0749999	0.1351351
16	0.0799999	0.1621621
17	0.0849999	0.1621621
18	0.0899999	0.1621621
19	0.0949999	0.1621621
20	0.0999999	0.1621621
21	0.1049999	0.1621621
22	0.1099999	0.1621621
23	0.1149999	0.1621621
24	0.1199999	0.1621621
25	0.1249999	0.2702702
26	0.1299999	0.2702702
27	0.1349999	0.3243243
28	0.1399999	0.4054054
29	0.1449999	0.4594594
30	0.1499999	0.4594594

31	0.	15499995	C.	4594554
32	0.	1599998	C.	4594594
33	0.	1649998	C.	4594594
34	0.	1699998	C.	4864864
35	0.	1749998	C.	4864864
36	0.	1799998	C.	4864864
37	0.	1849998	C.	4864864
38	0.	1899998	C.	4864864
39	0.	1949998	C.	5405405
40	0.	1999998	C.	5405405
41	0.	2049998	C.	5405405
42	0.	2099998	C.	5405405
43	0.	2149998	C.	5405405
44	0.	2199998	C.	5405405
45	0.	2249998	C.	5945545
46	0.	2299998	C.	6486486
47	0.	2349998	C.	6486486
48	0.	2399998	C.	6486486
49	0.	2449998	C.	6486486
50	0.	2499998	C.	6486486
51	0.	2549998	C.	6486486
52	0.	2599998	C.	6486486
53	C.	2649997	C.	6486486
54	0.	2699997	C.	7027027
55	0.	2749997	C.	7027027
56	0.	2799997	C.	7027027
57	0.	2849997	C.	7027027
58	0.	2899997	C.	7027027
59	0.	2949997	C.	7027027
60	0.	2999997	C.	7027027
61	0.	3049997	C.	7027027
62	0.	3099997	C.	7027027
63	0.	3149997	C.	7027027
64	0.	3199997	C.	7027027
65	0.	3249997	C.	7027027
66	0.	3299997	C.	7027027
67	0.	3349997	C.	7027027
68	0.	3399997	C.	7027027
69	0.	3449997	C.	7027027
70	0.	3499997	C.	7027027
71	0.	3549997	C.	7027027
72	0.	3599997	C.	7567567
73	0.	3649996	C.	7567567
74	0.	3699996	C.	7567567
75	0.	3749996	C.	7567567
76	0.	3799996	C.	7567567
77	0.	3849996	C.	7567567
78	0.	3899996	C.	7567567

79	0.39499996	0.7567567
80	0.39999996	0.7567567
81	0.40499996	0.7567567
82	0.40999996	0.7567567
83	0.41499996	0.7567567
84	0.41999996	0.7567567
85	0.42499996	0.7567567
86	0.42999996	0.7567567
87	0.43499996	0.7567567
88	0.43999996	0.7567567
89	0.44499996	0.7567567
90	0.44999996	0.7567567
91	0.45499996	0.7567567
92	0.45999996	0.7567567
93	0.46499996	0.7567567
94	0.46999996	0.7567567
95	0.47499995	0.7567567
96	0.47999995	0.7567567
97	0.48499995	0.7567567
98	0.48999995	0.7567567
99	0.49499995	0.7567567
100	0.49999995	0.7567567

SPOT DIAGRAM CALCULATIONS COMPLETE.

END OF PROGRAM

TO OBTAIN PLOTS FROM THE PLOTTER OR THE PRINTER,
 ISSUE THE FOLLOWING COMMAND: ENTER "CHARTS PRINTER"
 FOR PRINTER PLOTS ENTER "CHARTS PLOTTER"
 FOR PLOTTER GRAPHS
 END OF PROGRAM

APPENDIX D

HIN LENS PERFORMANCE PLOTS

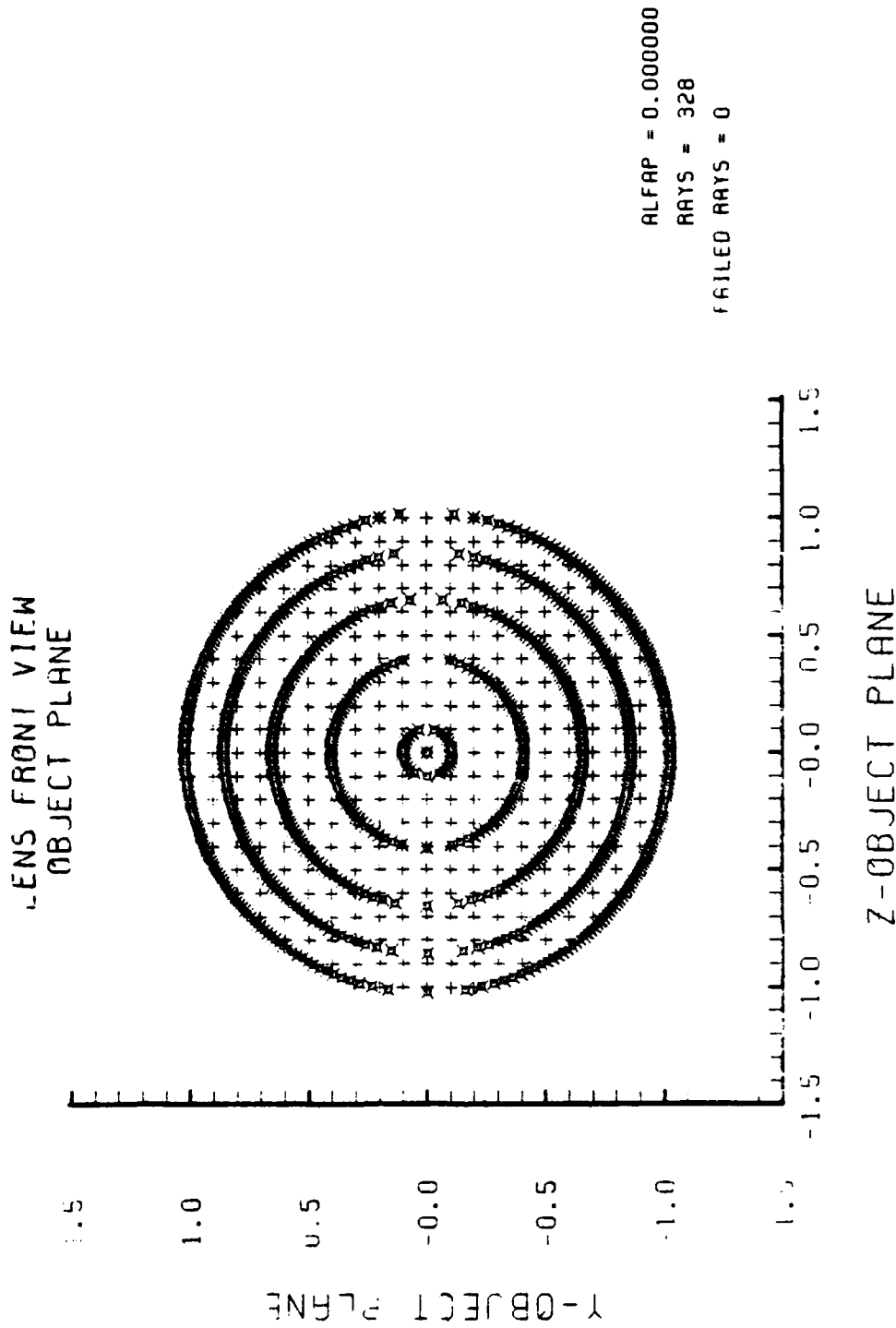

Figure D-1. Object Plane at $\alpha_p = 0.0$ Radians for Hin Lens Design Shown in Figure 11

SPOT DIAGRAM

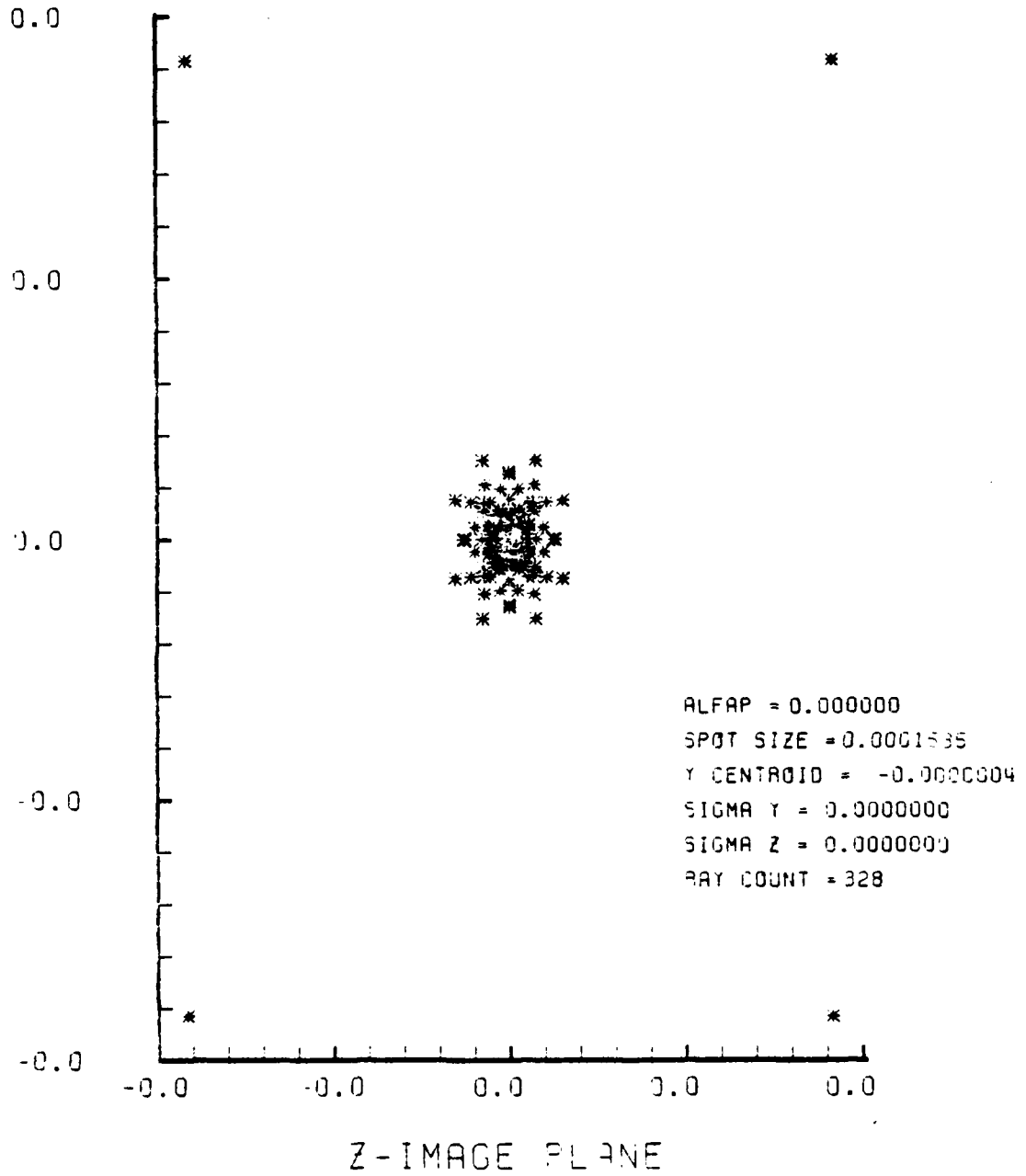
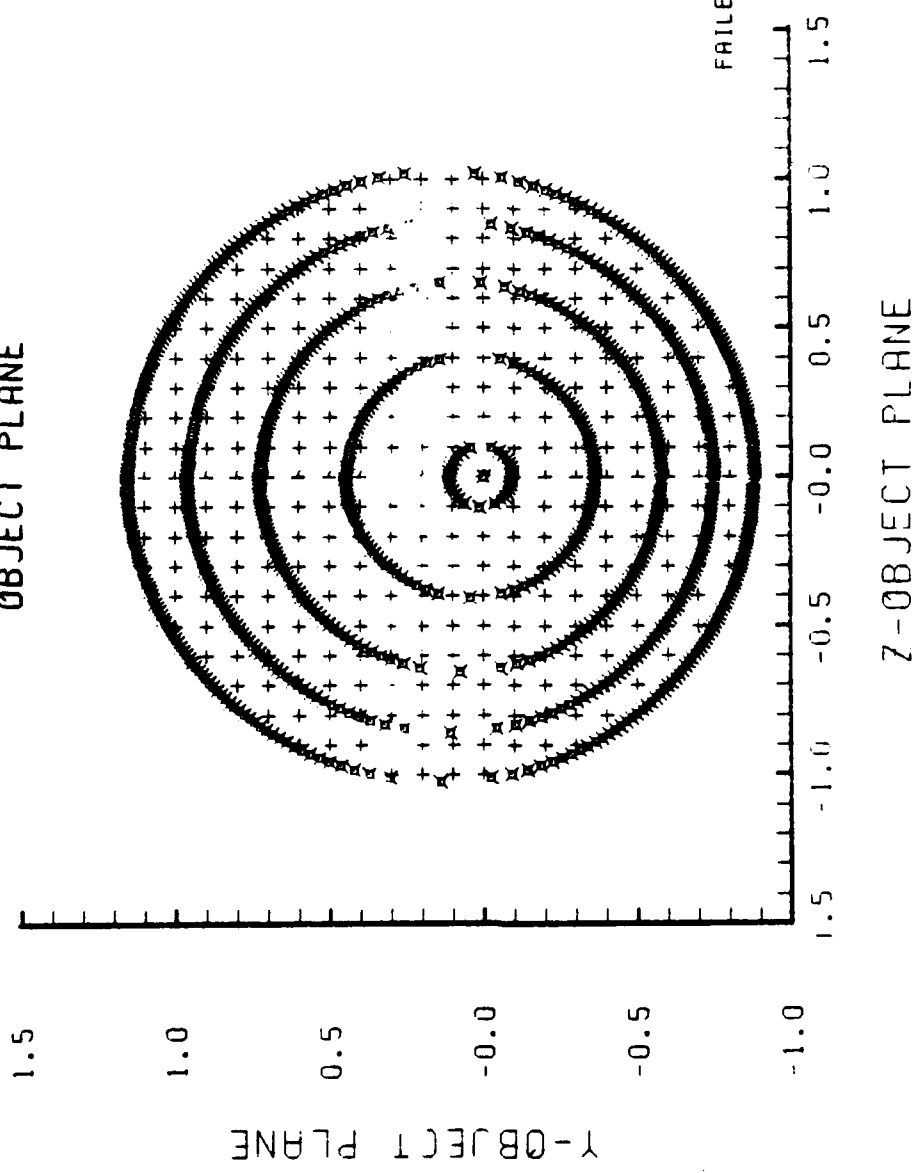

Figure D-2. Spot Diagram Corresponding to Object Plane of Figure D-1

LENS FRONT VIEW
OBJECT PLANE



ALFAP = 0.100000
RAYS = 322
FAILED RAYS = 0

Figure D-3. Object Plane at $\alpha_p = 0.1$ Radians for
HIN Lens Shown in Figure 11

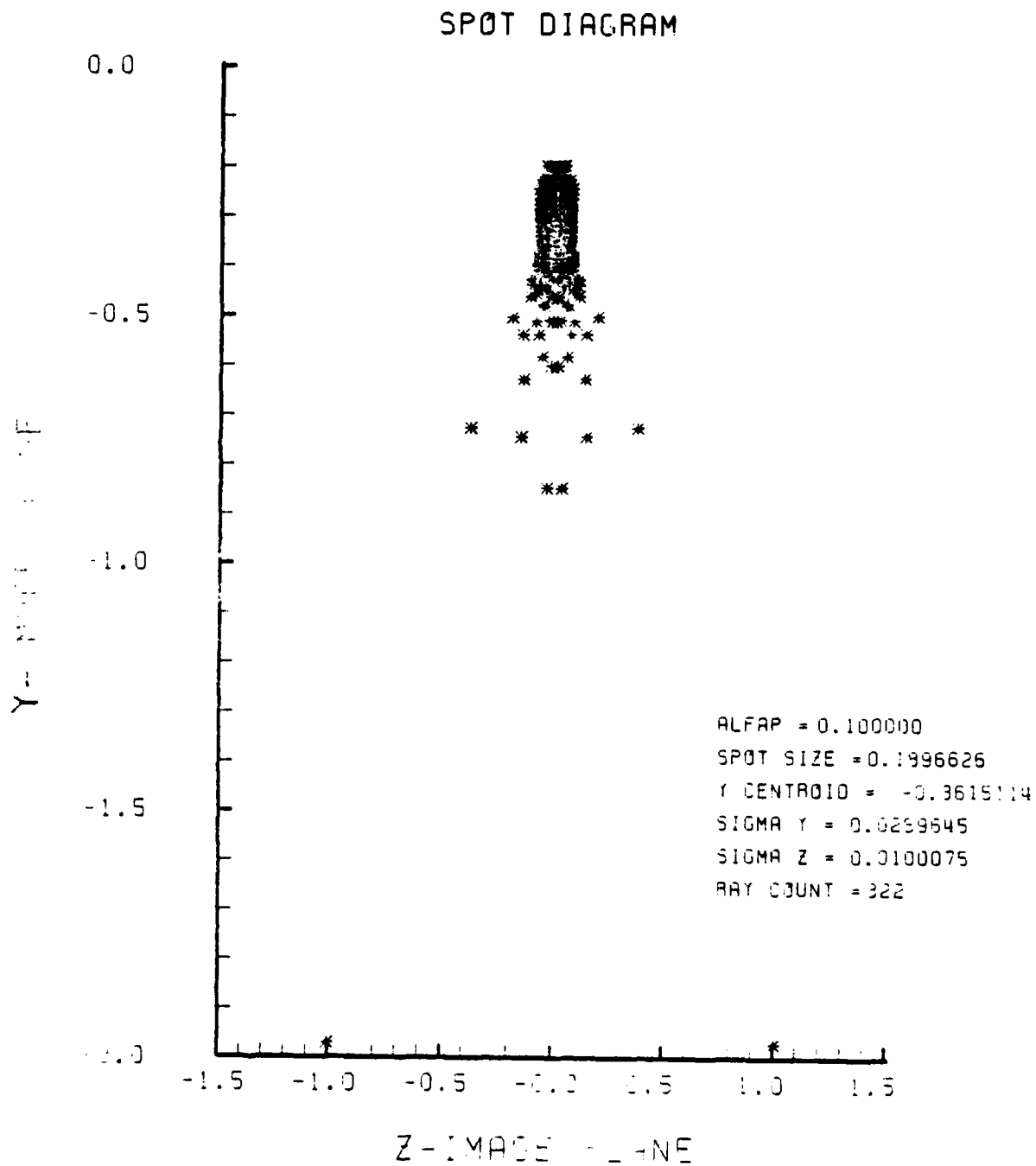

Figure D-4. Spot Diagram Corresponding to Figure D-3

SPOT DIAGRAM ENERGY DENSITY

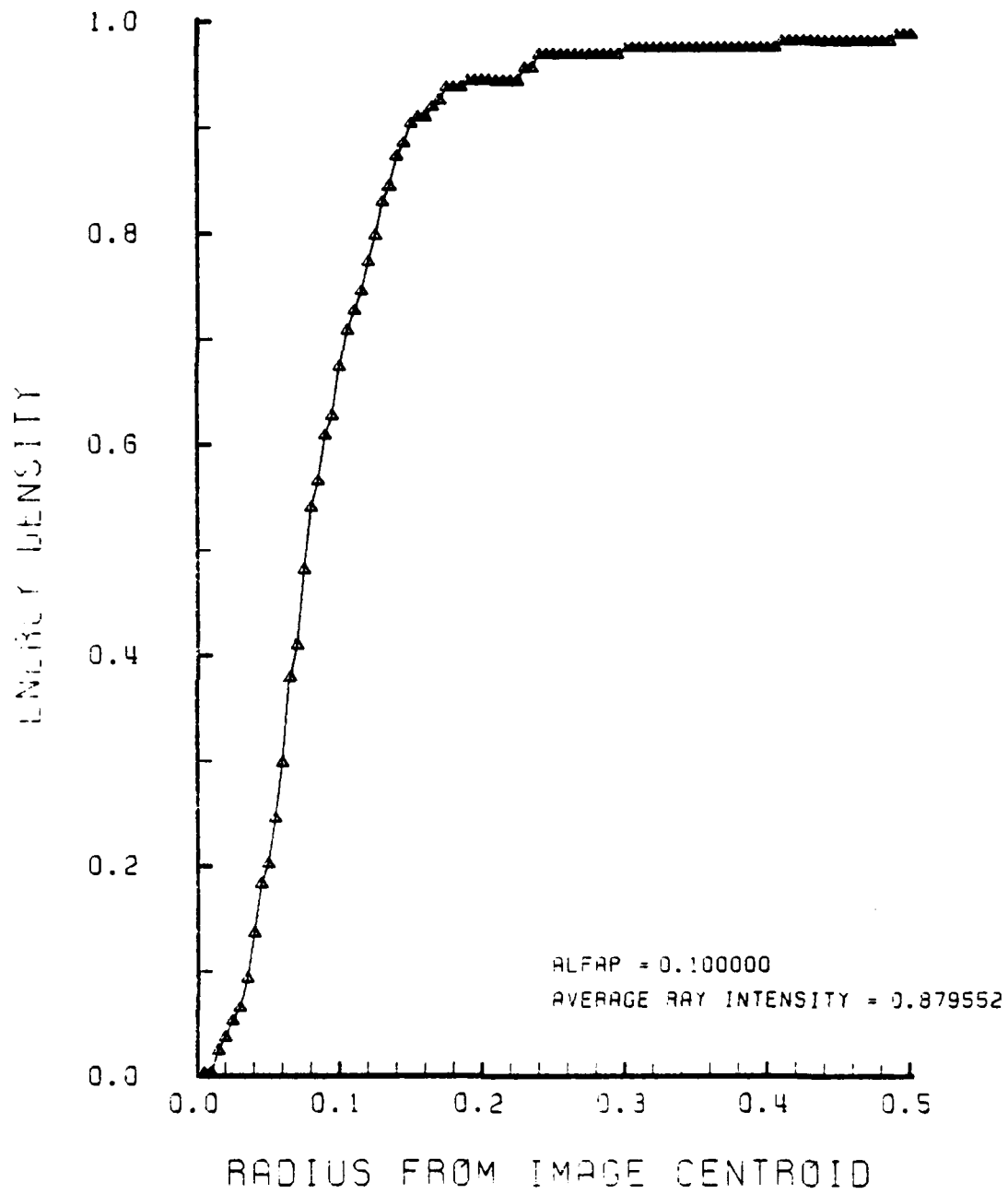

Figure D-5. Encircled Energy Plot for the Spot Diagram of Figure D-4

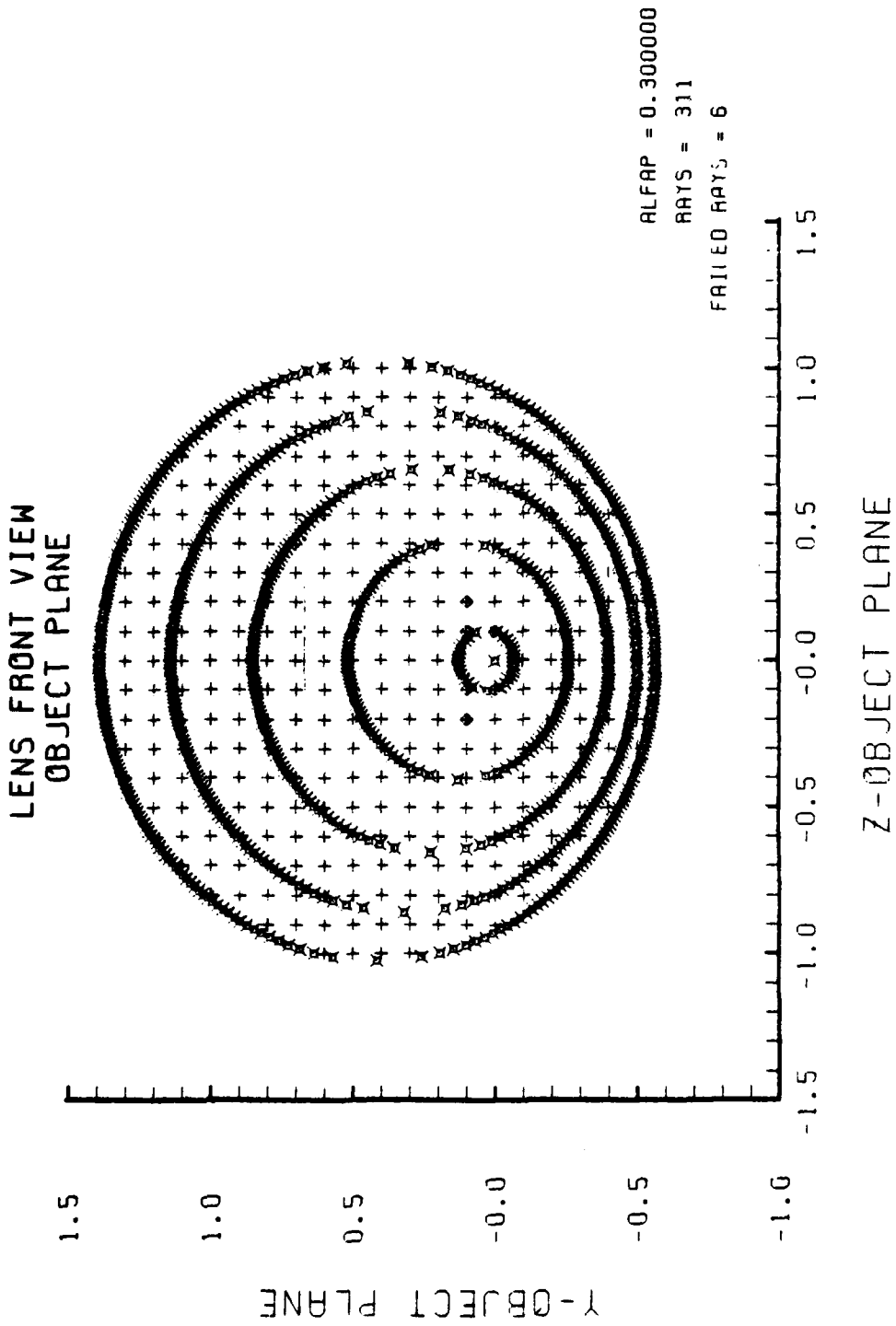

Figure D-6. HIN Object Plane at $\alpha_p = 0.2$ Radians,
 $N_2 = 1.5$

SPOT DIAGRAM

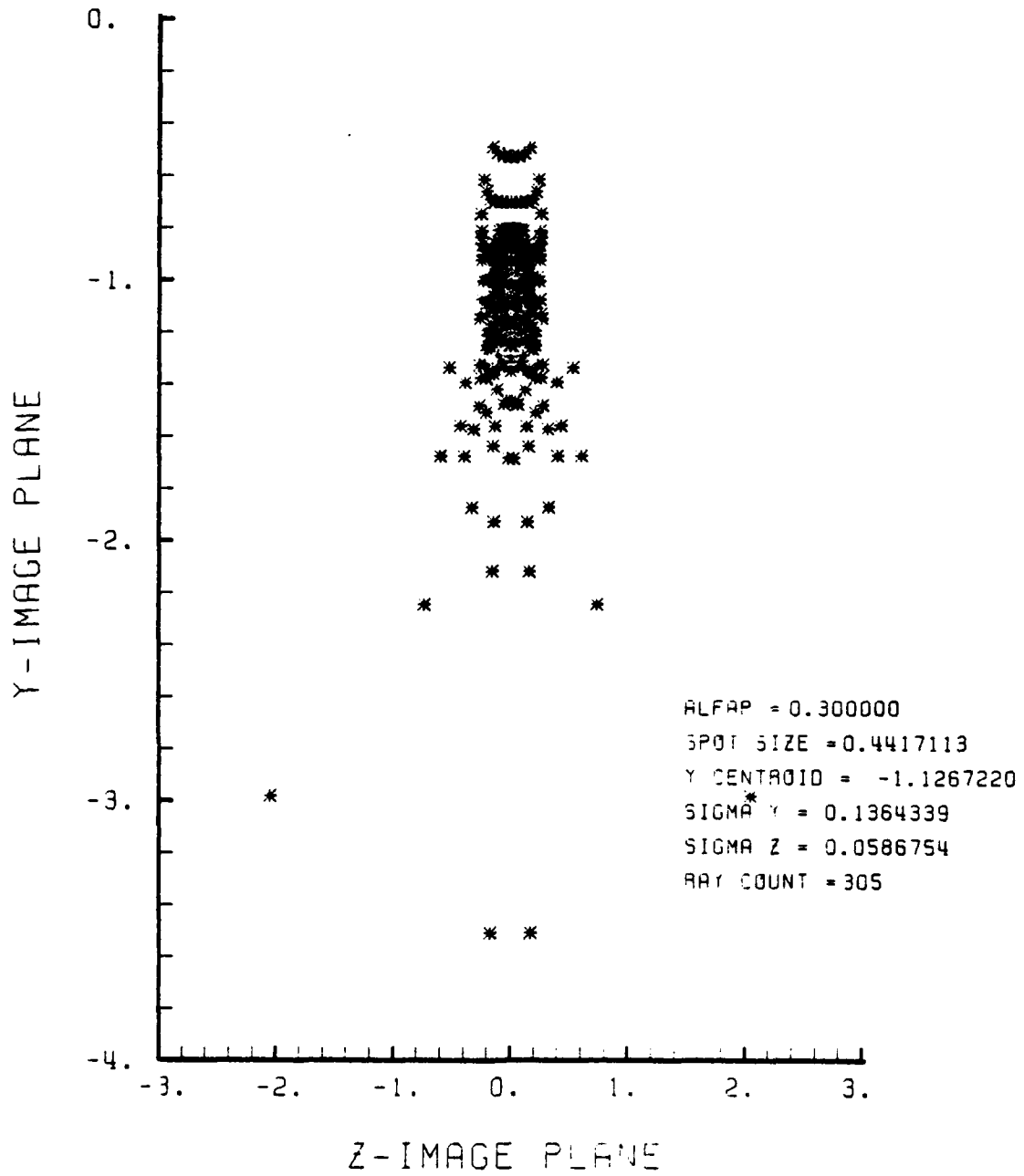

Figure D-7. Spot Diagram of HIN Lens at $\alpha_p = 0.2$ Radians, $N_2 = 1.5$

SPOT DIAGRAM ENERGY DENSITY

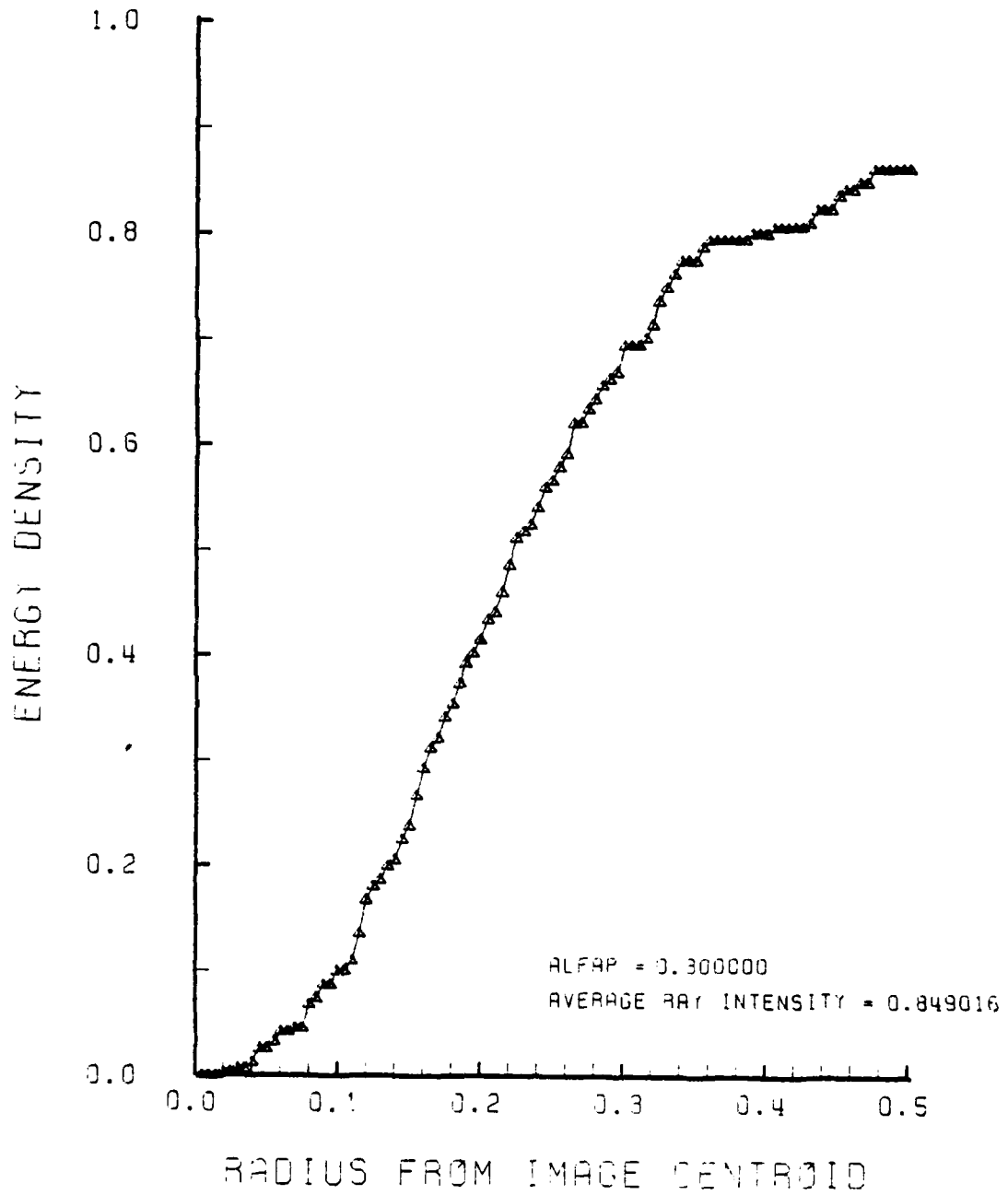

Figure D-8. Encircled Energy Plot of HIN Lens at $\alpha_p = 0.2$ Radians, $N_2 = 1.5$

9.

10.

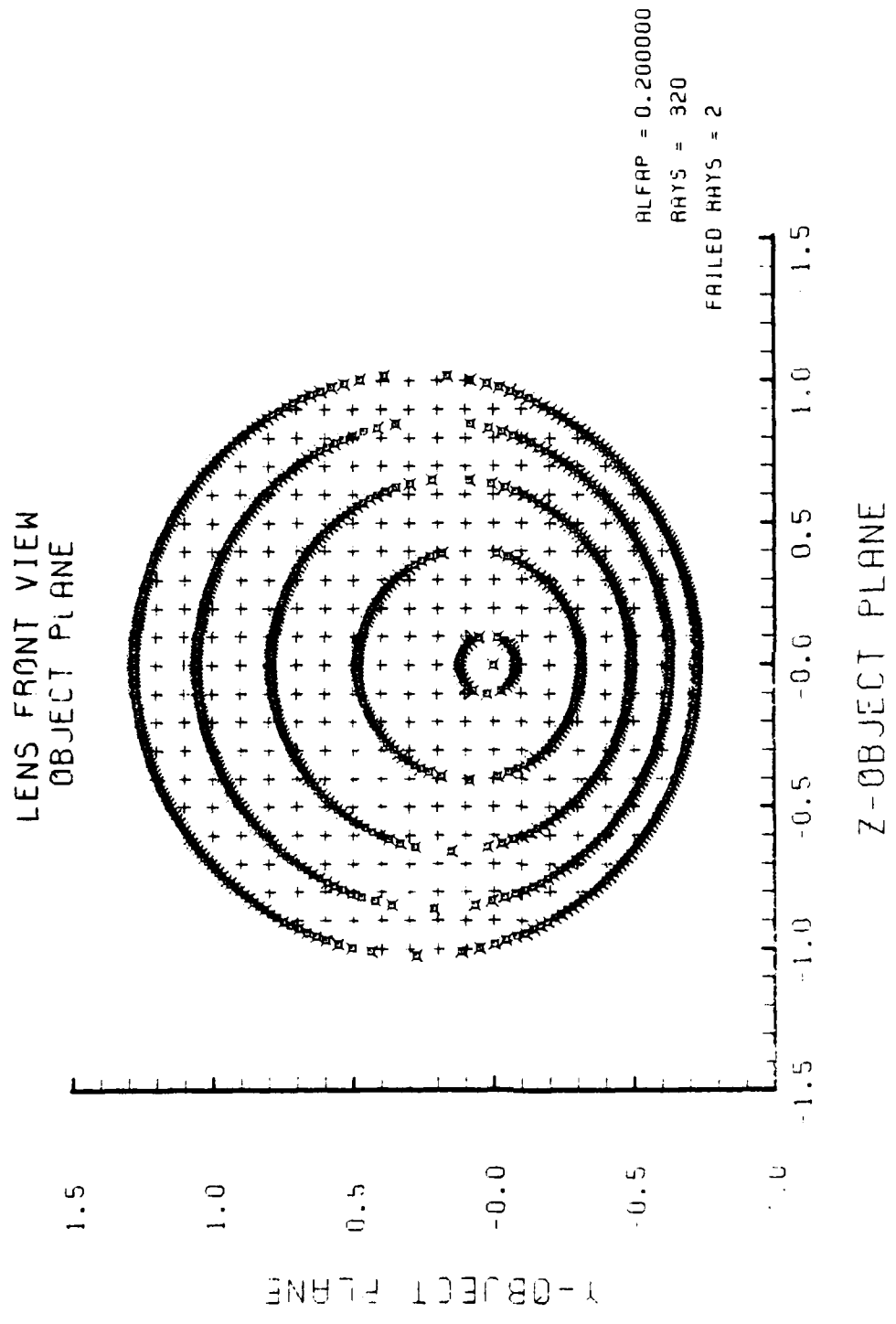

Figure D-9. HIN Object Plane at $\alpha_p = 0.3$ Radians,
 $N_2 = 1.5$

AD-A125 167

AERODYNAMICALLY EFFICIENT GRADIENT REFRACTIVE INDEX
MISSILE SEEKER LENS(U) NAVAL POSTGRADUATE SCHOOL
MONTEREY CA H M CARR OCT 82 NPS67-82-012

3/6

UNCLASSIFIED

F/G 16/4

NL

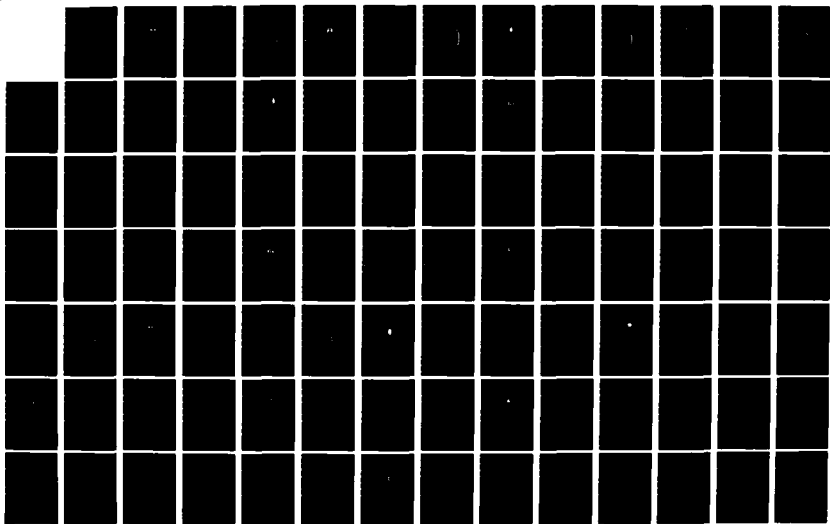

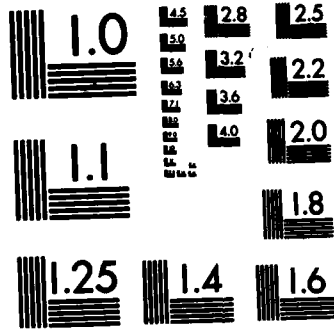

MICROCOPY RESOLUTION TEST CHART
NATIONAL BUREAU OF STANDARDS-1963-A

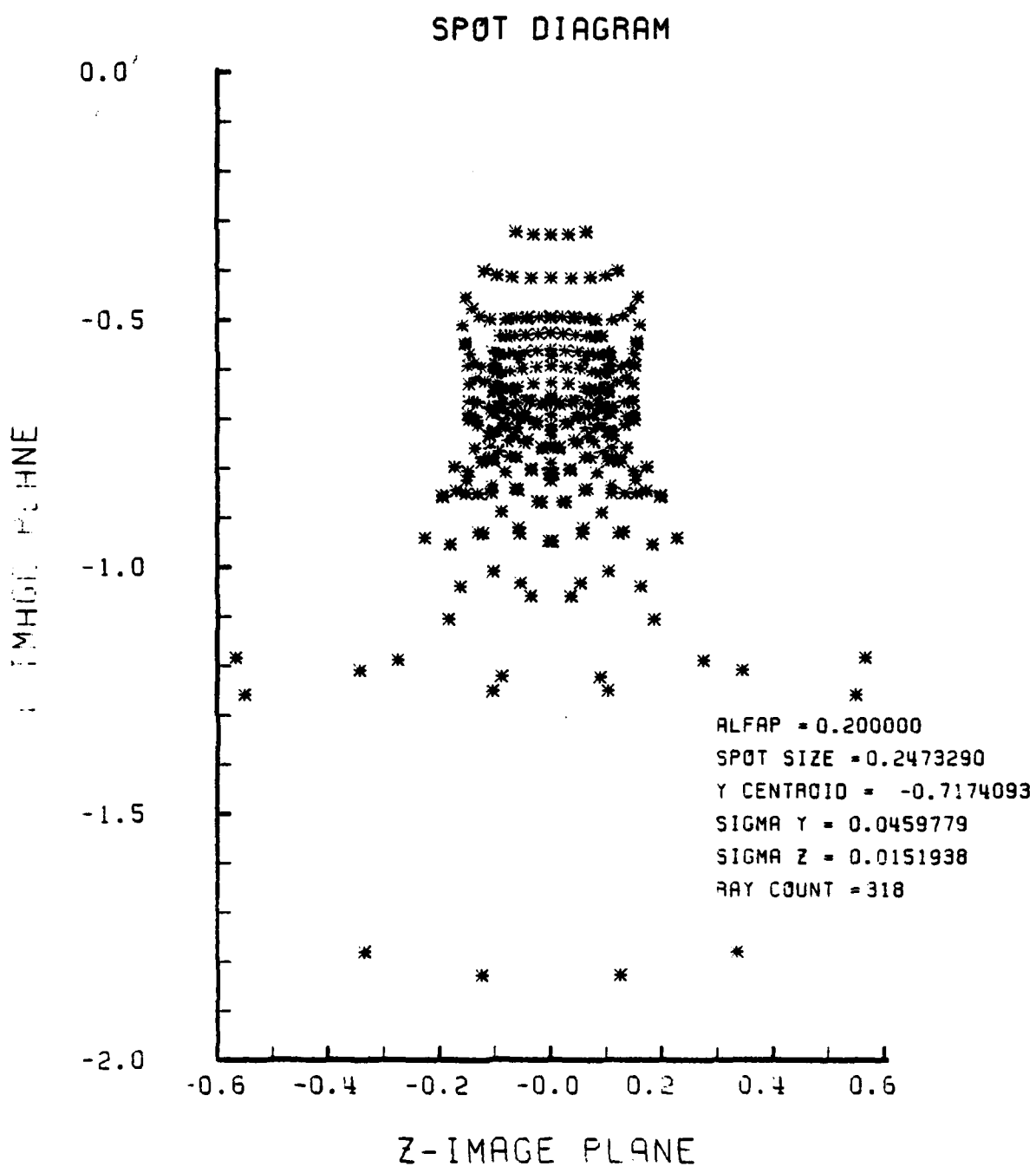

Figure D-10. Spot Diagram of HIN Lens at $\alpha_p = 0.3$ Radians, $N_2 = 1.5$

SPOT DIAGRAM ENERGY DENSITY

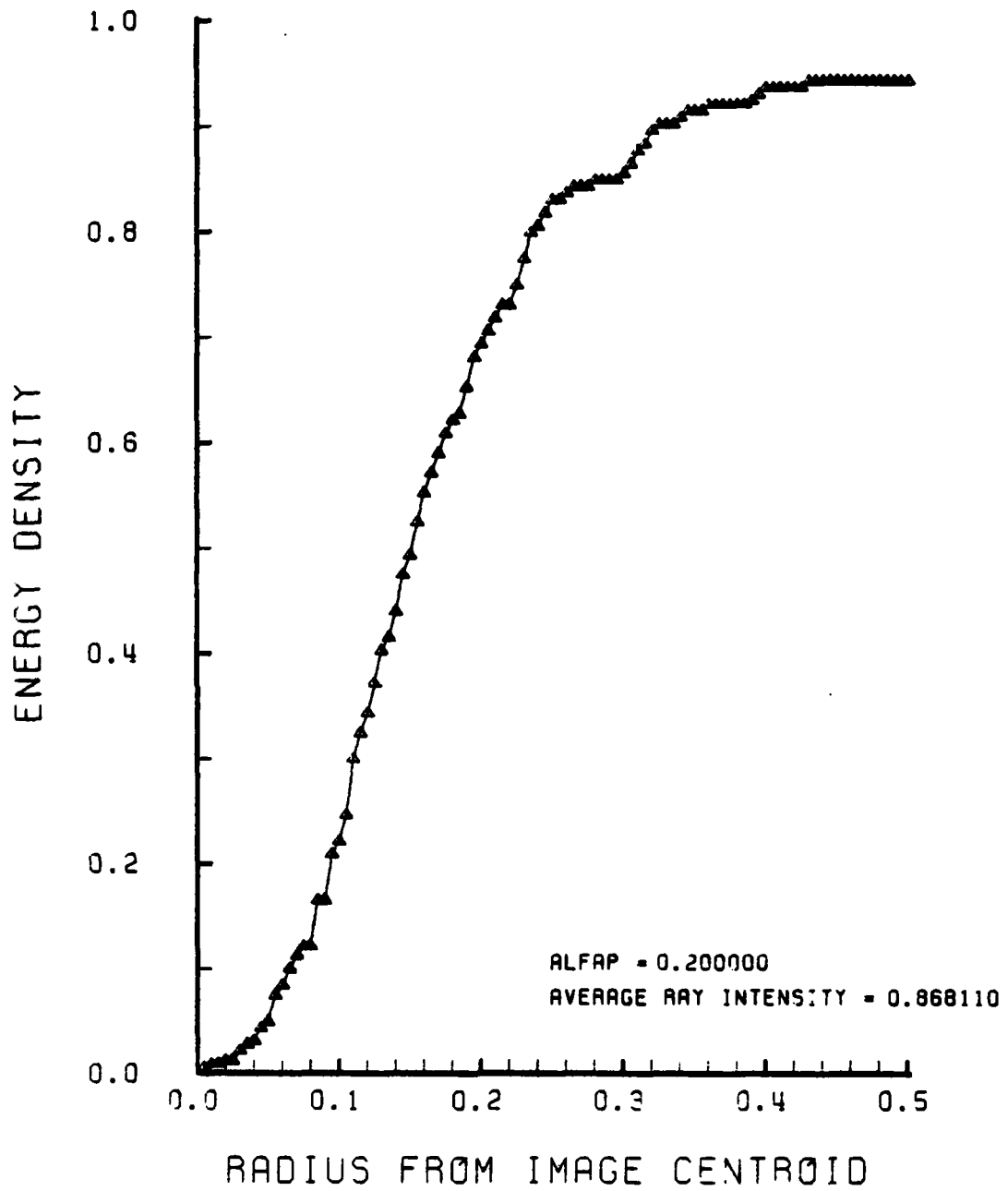

Figure D-11. HIN Lens Encircled Energy at $\alpha_p = 0.3$ Radians, $N_2 = 1.5$

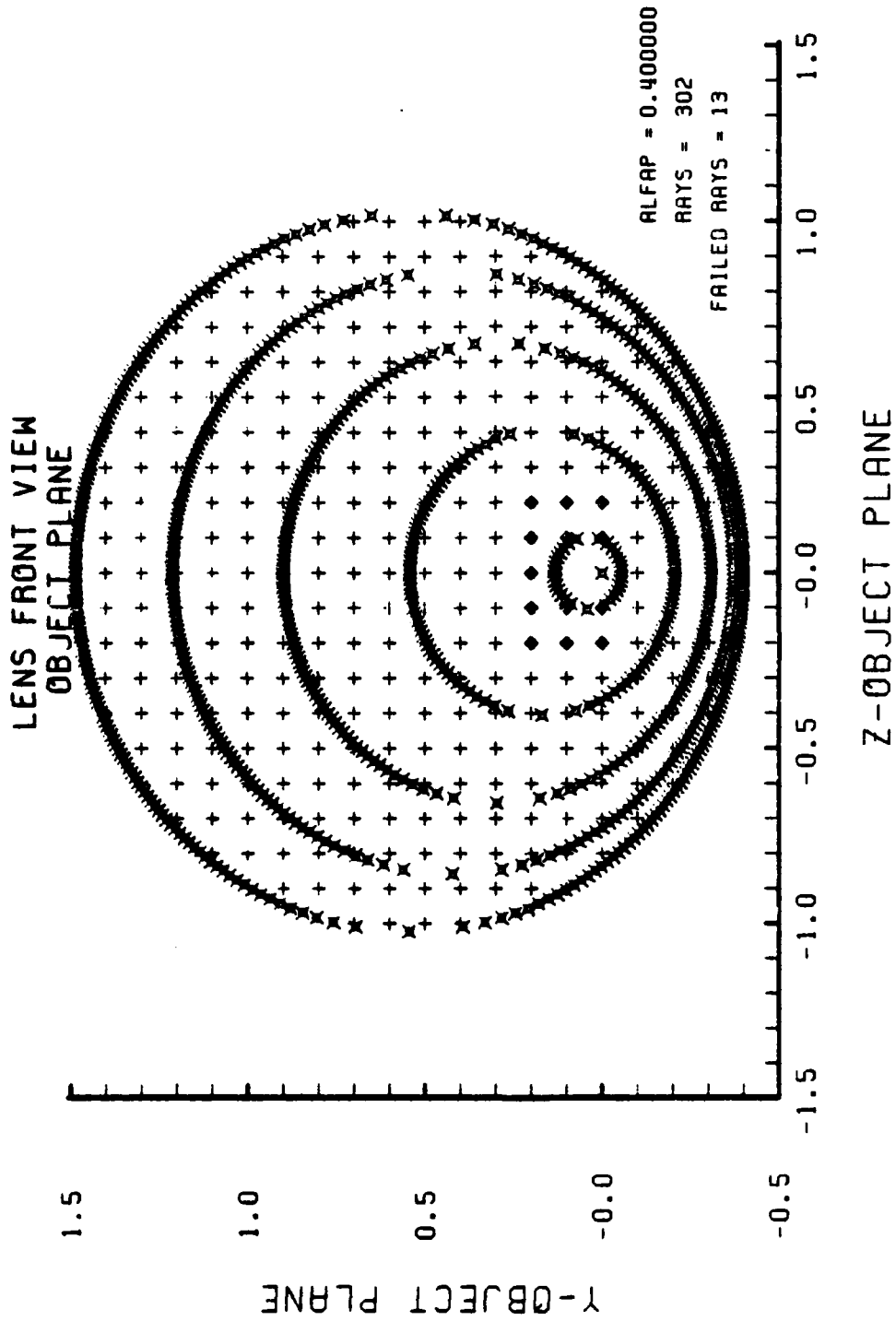

Figure D-12. HIN Object Plane at $\alpha_p = 0.4$ Radians,
 $N_2 = 1.5$

SPOT DIAGRAM

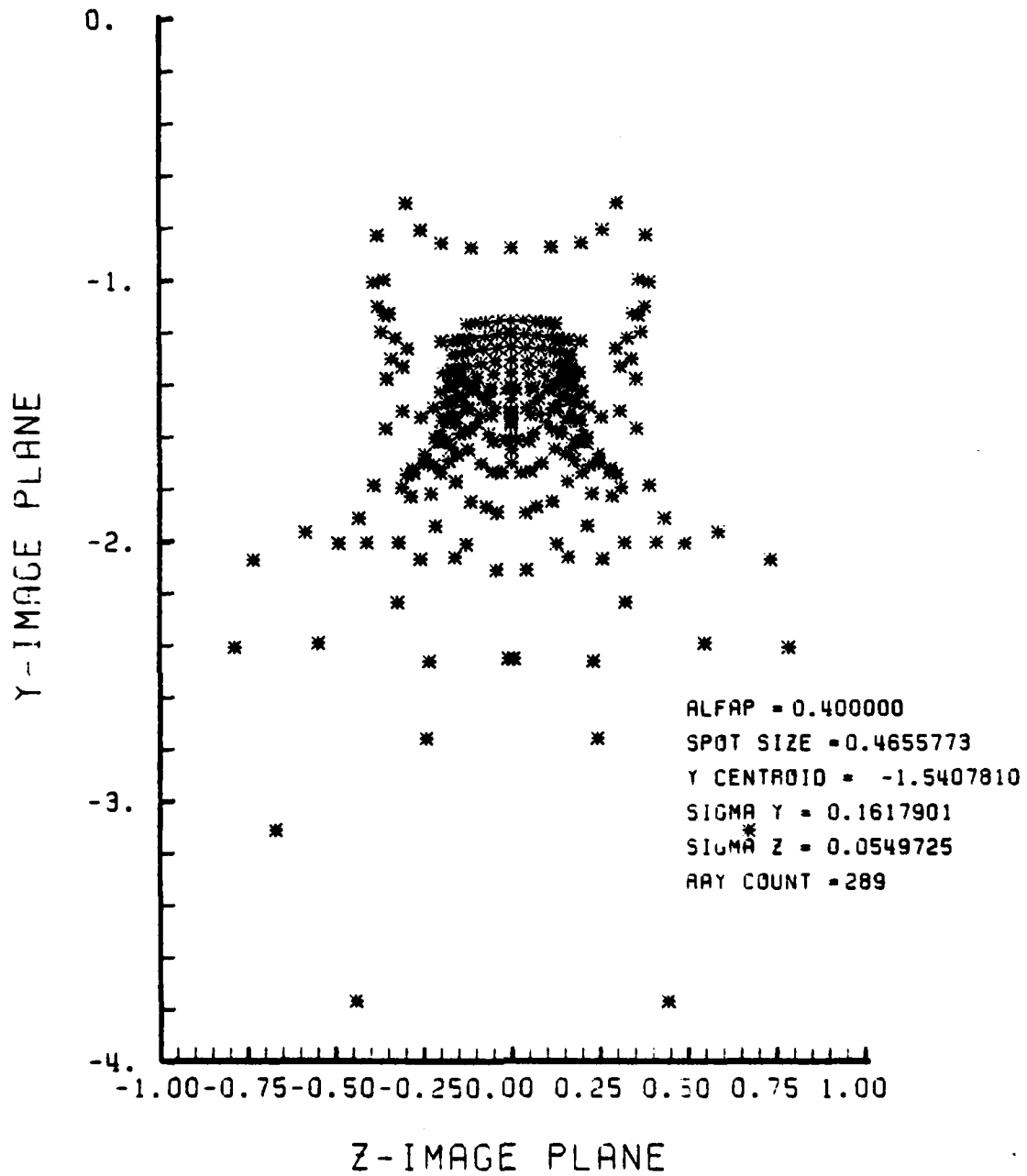

Figure D-13. Spot Diagram of HIN lens at $\alpha_p = 0.4$ Radians, $N_2 = 1.5$

SPOT DIAGRAM ENERGY DENSITY

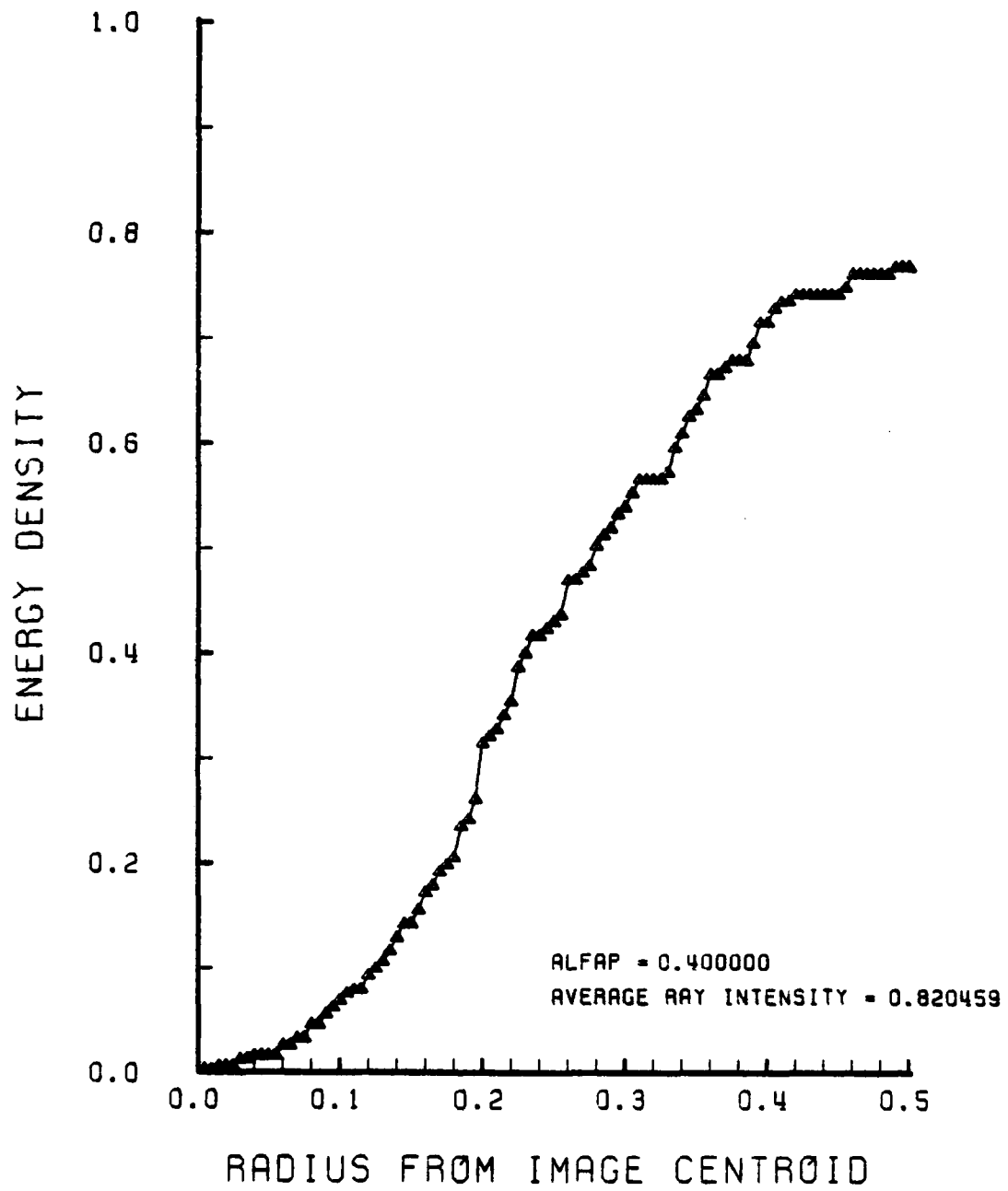

Figure D-14. Encircled Energy Plot at $\alpha_p = 0.4$
Radians, $N_2 = 1.5$

LENS FRONT VIEW
OBJECT PLANE

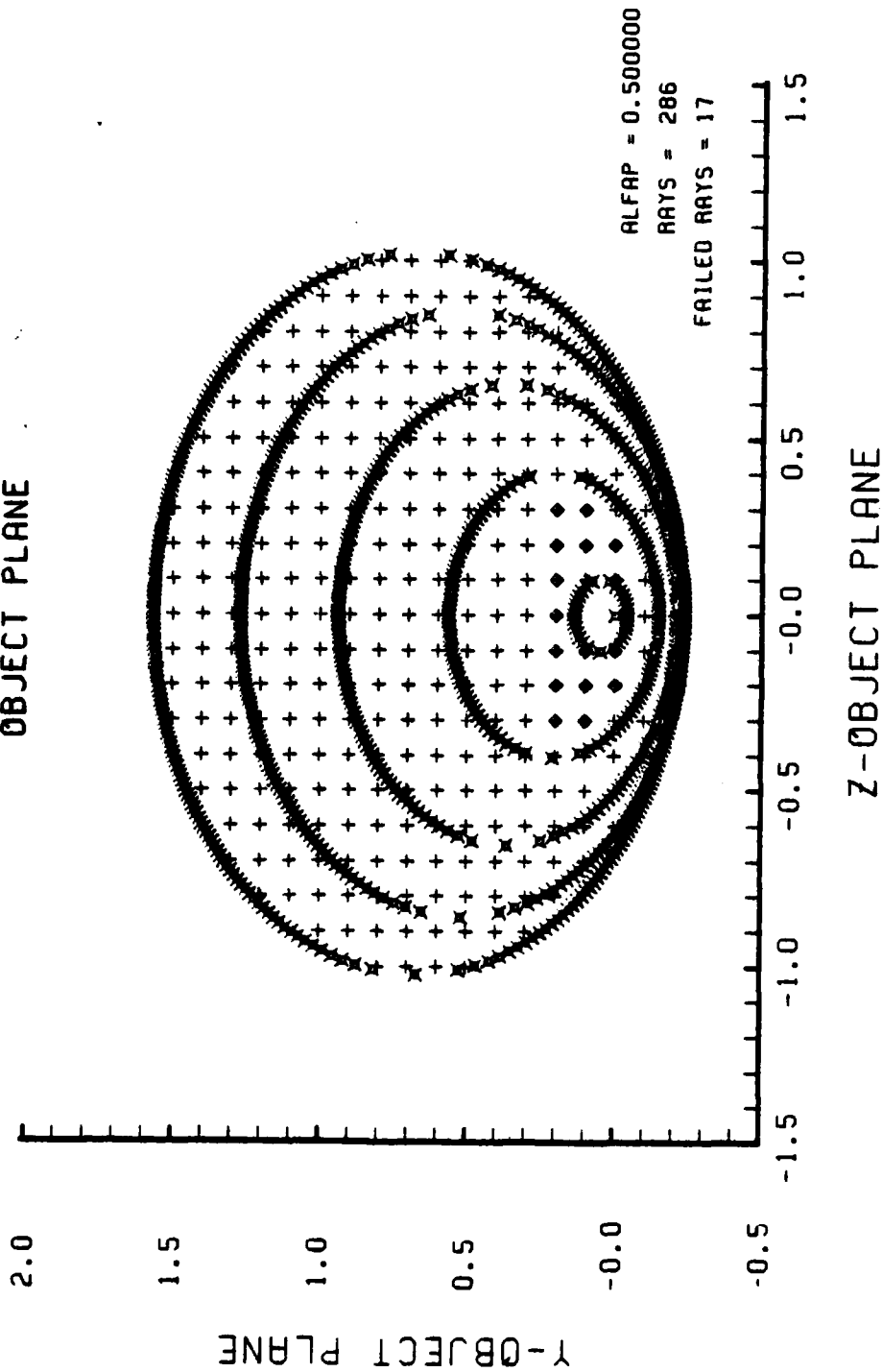

Figure D-15. HIN Lens Object Plane at $\alpha_p = 0.5$ Radians,
 $N_2 = 1.5$

SPOT DIAGRAM

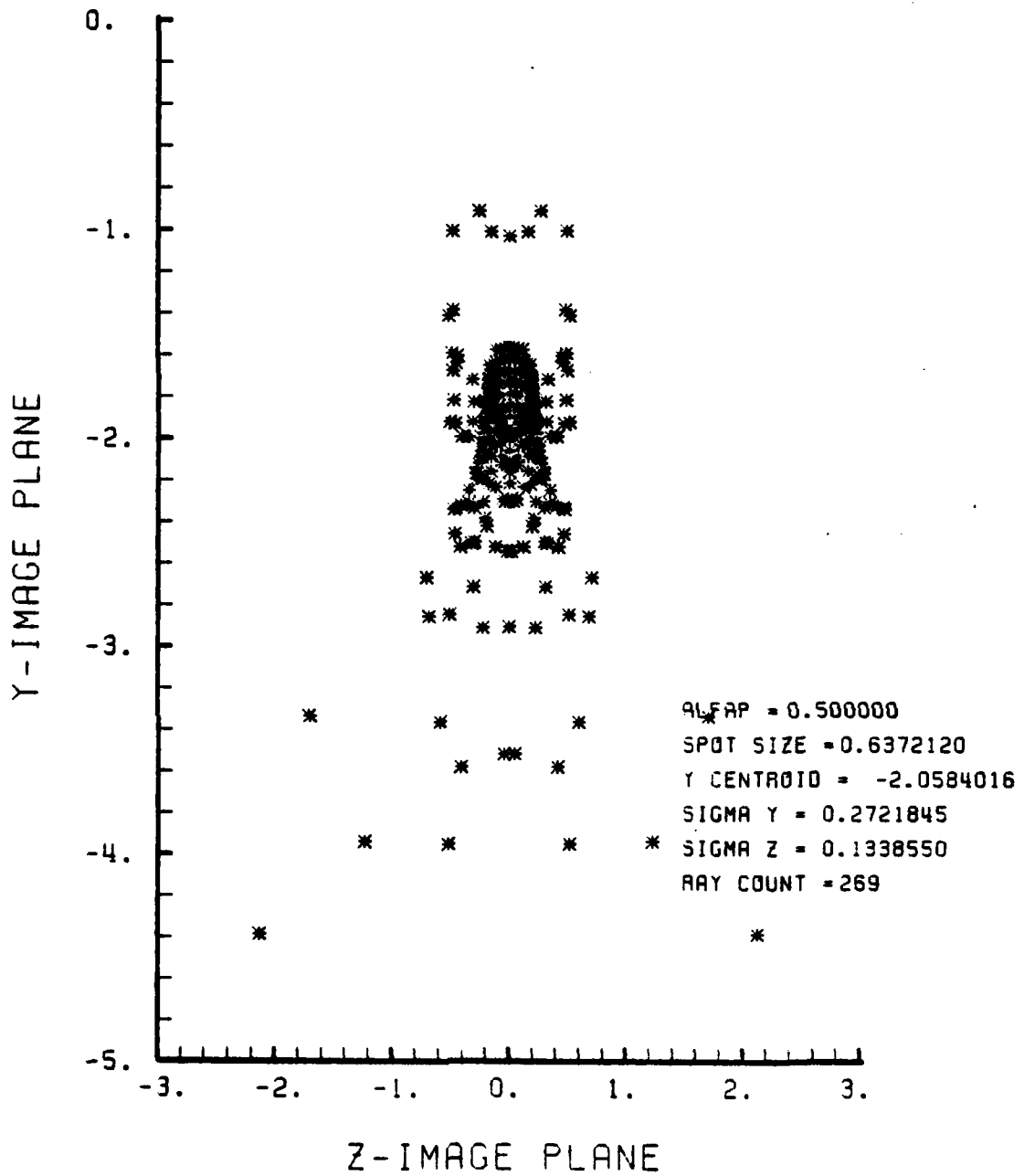

Figure D-16. Spot Diagram of HIN Lens at $\alpha_p = 0.5$ Radians, $N_2 = 1.5$

SPOT DIAGRAM ENERGY DENSITY

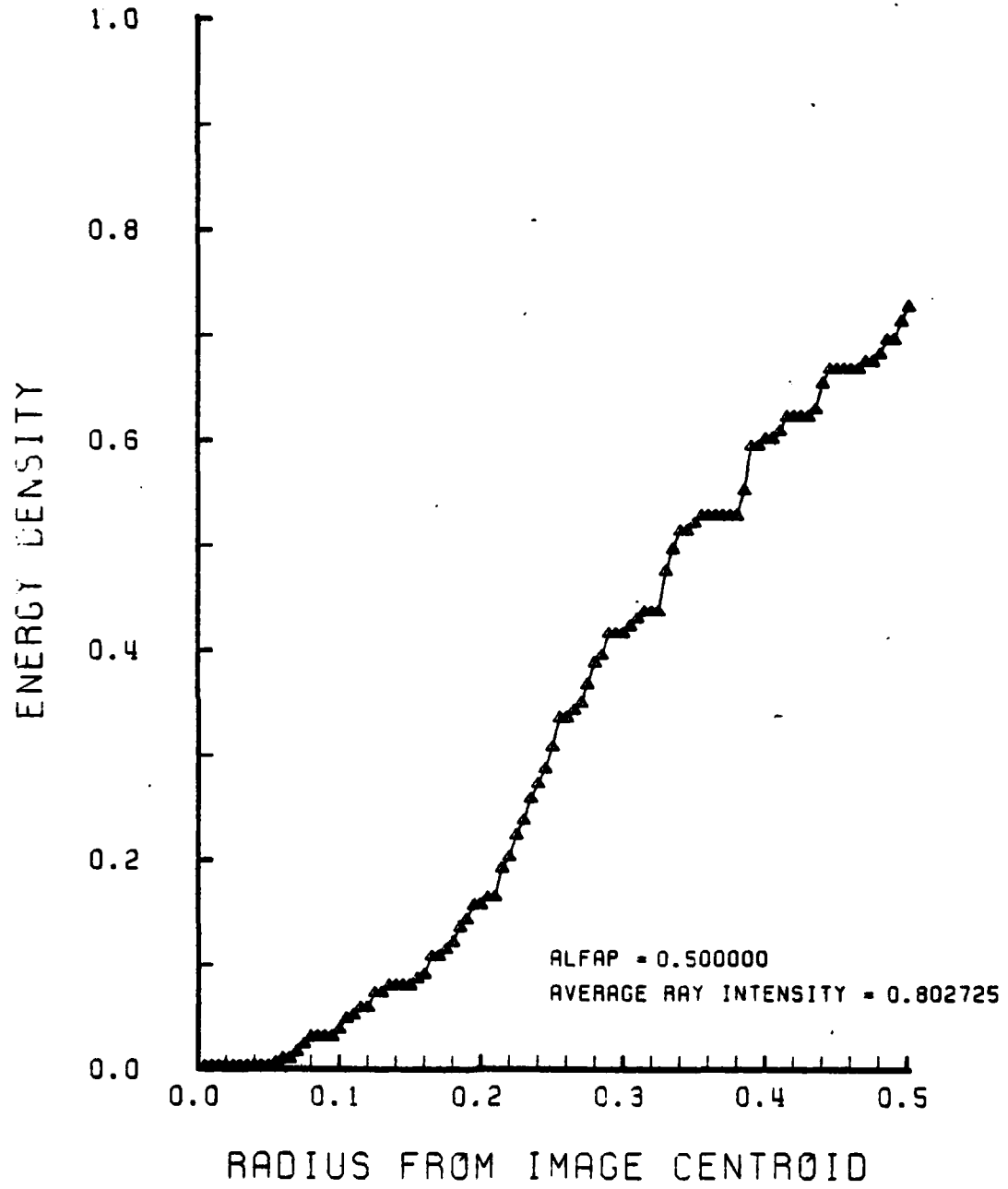

Figure D-17. Encircled Energy Plot at $\alpha_p = 0.5$
Radians, $N_2 = 1.5$

LENS FRONT VIEW
OBJECT PLANE

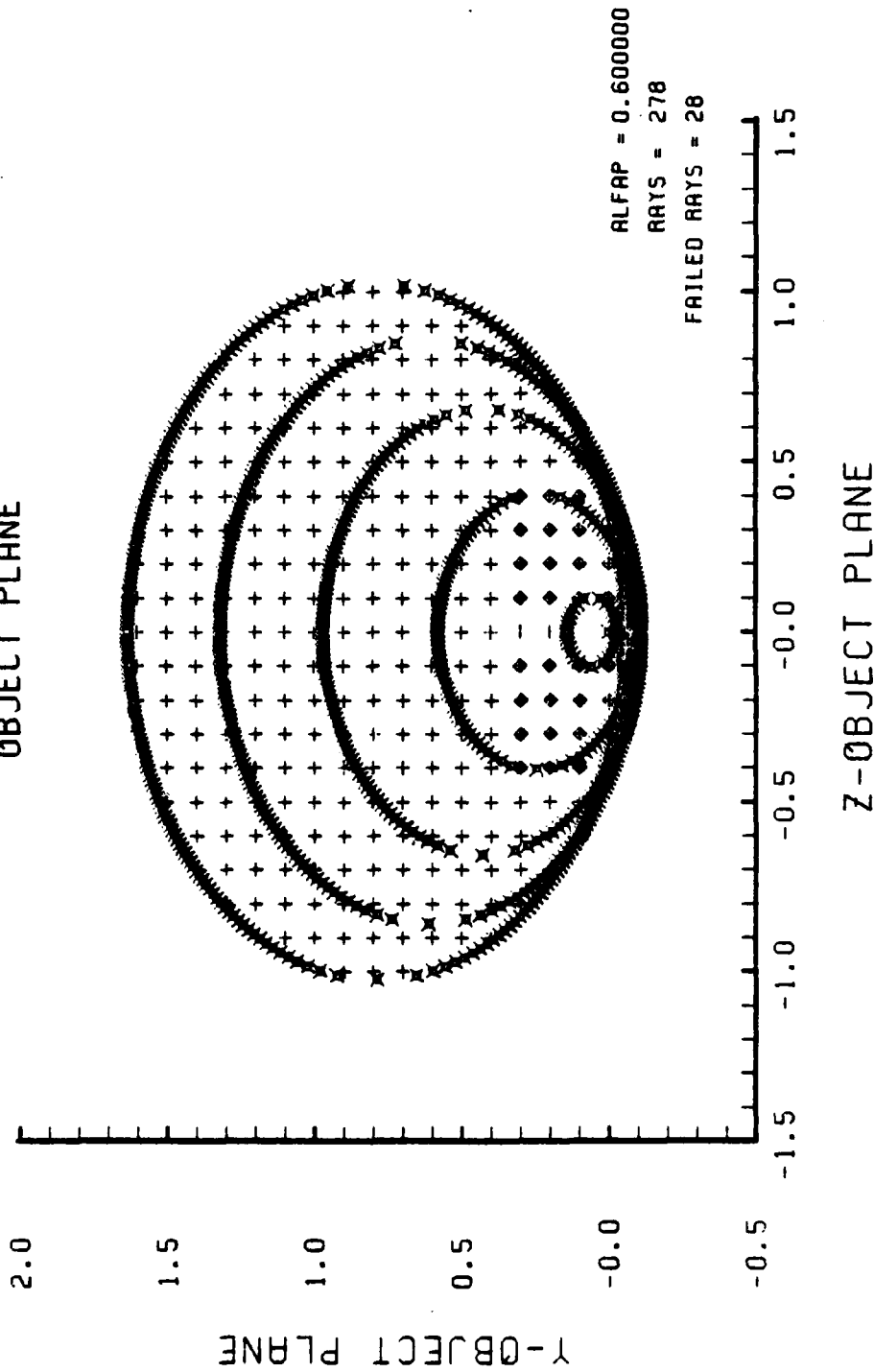

Figure D-18. HIN Object Plane at $\alpha_0 = 0.6$ Radians, $N_2 = 1.5$.
Overlapping Portions of Inner Ellipses
are hidden lines.

SPOT DIAGRAM

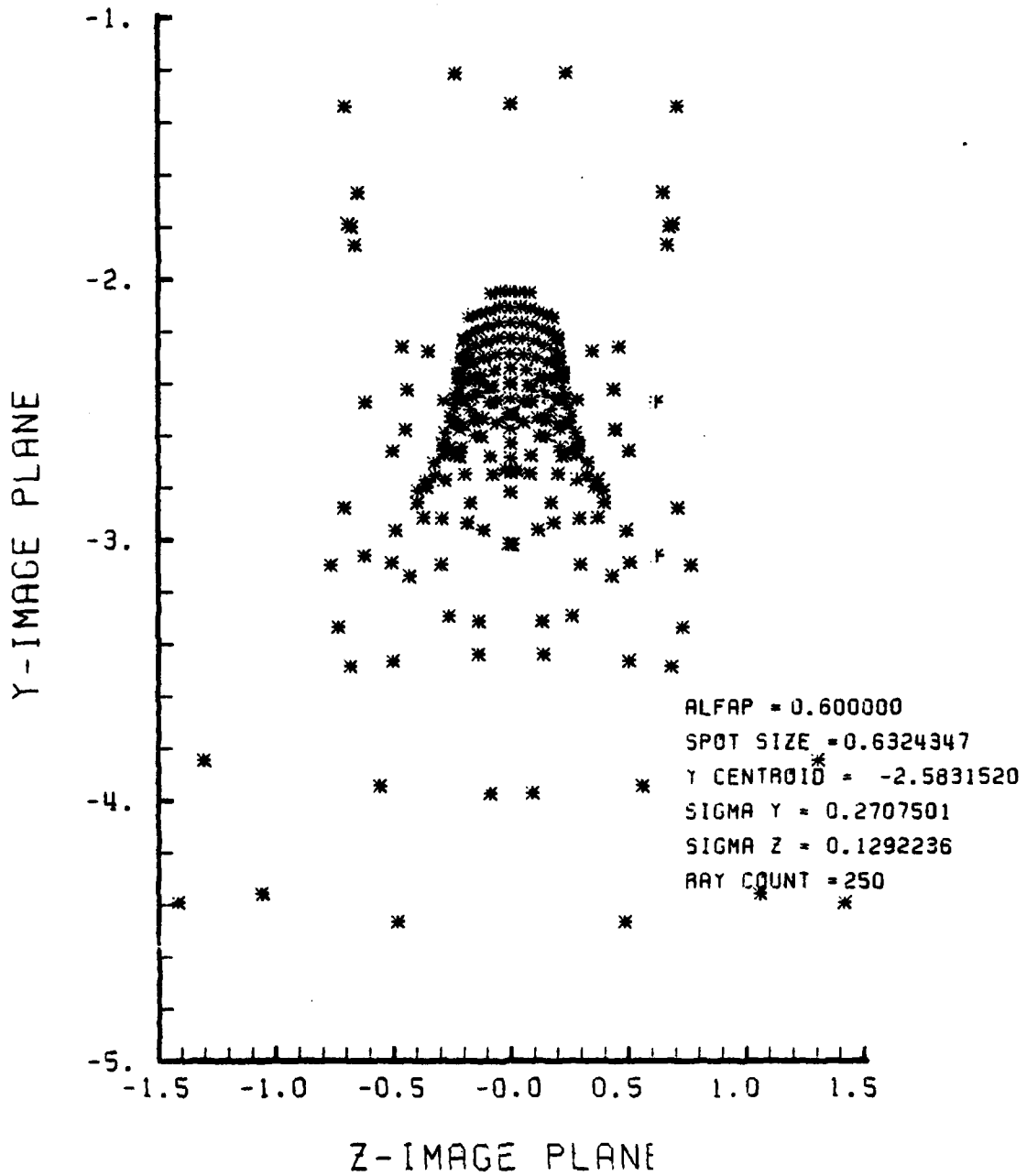

Figure D-19. Spot Diagram of HIN Lens at $\alpha_p = 0.6$ Radians, $N_2 = 1.5$

SPOT DIAGRAM ENERGY DENSITY

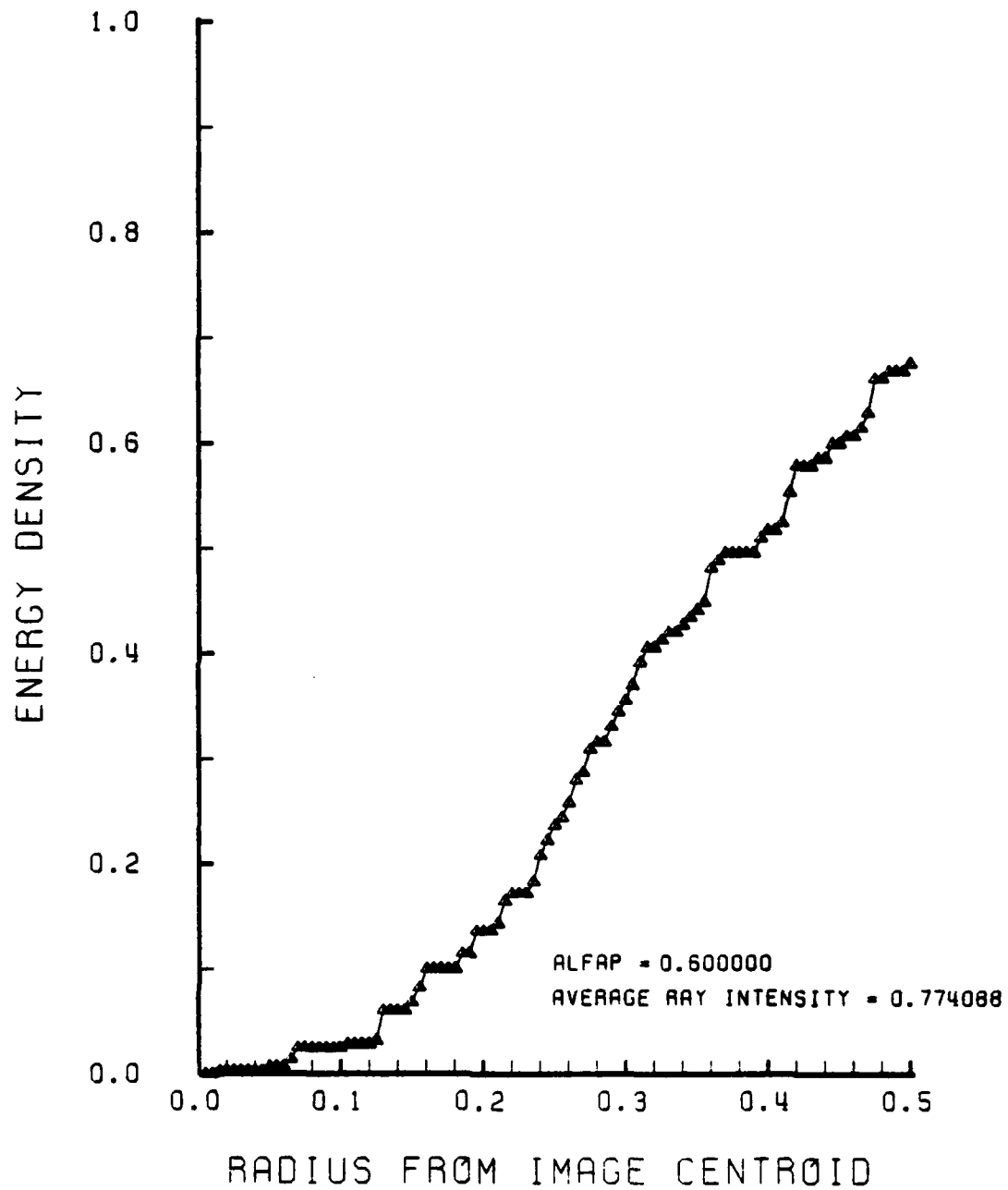

Figure D-20. Encircled Energy Plot at $\alpha_p = 0.6$ Radians, $N_2 = 1.5$

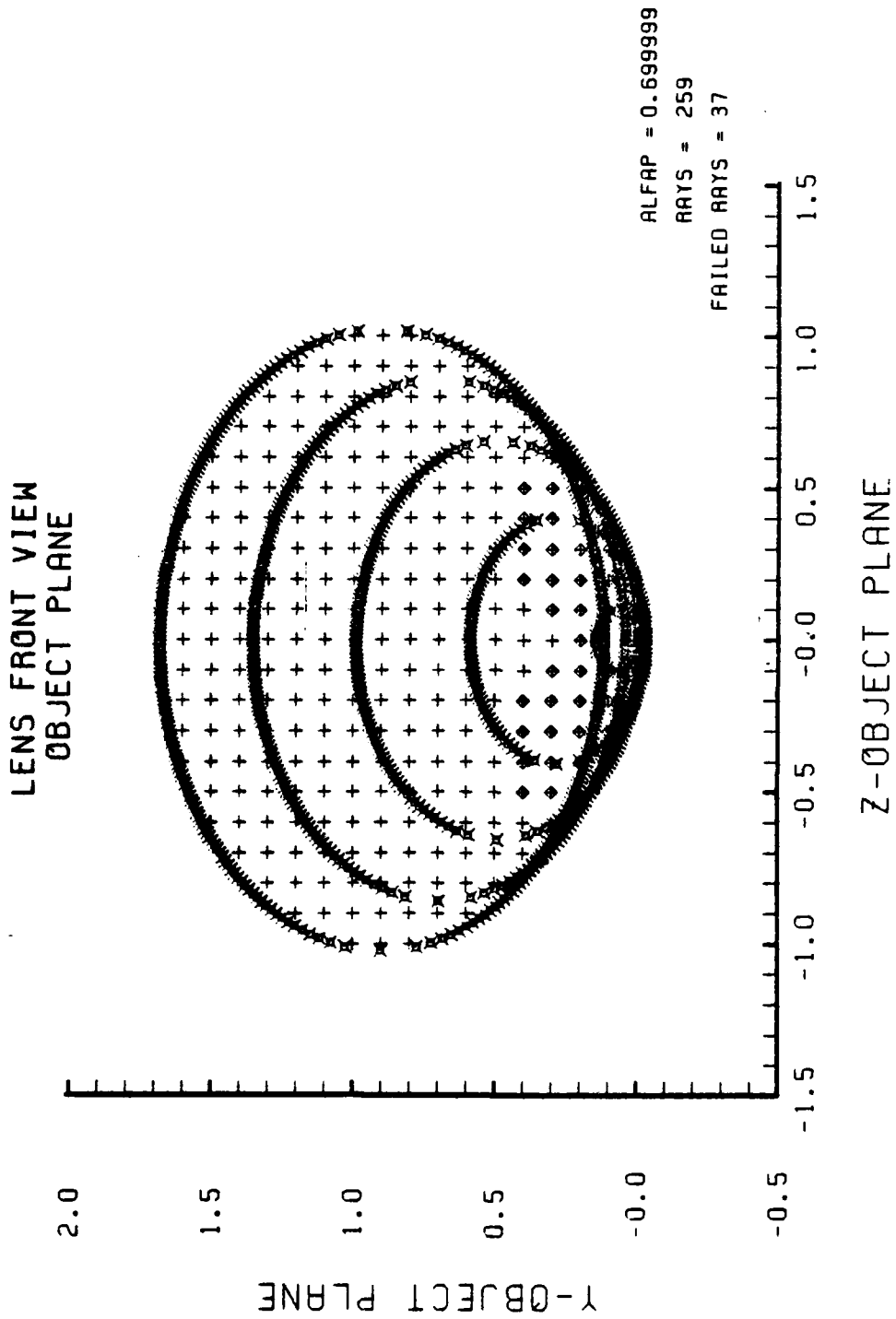

Figure D-21. HIN Object Plane at $\alpha = 0.7$ Radians, $N_2 = 1.5$.
 Overlapping Portions of Inner Ellipses
 are Hidden Lines.

SPOT DIAGRAM

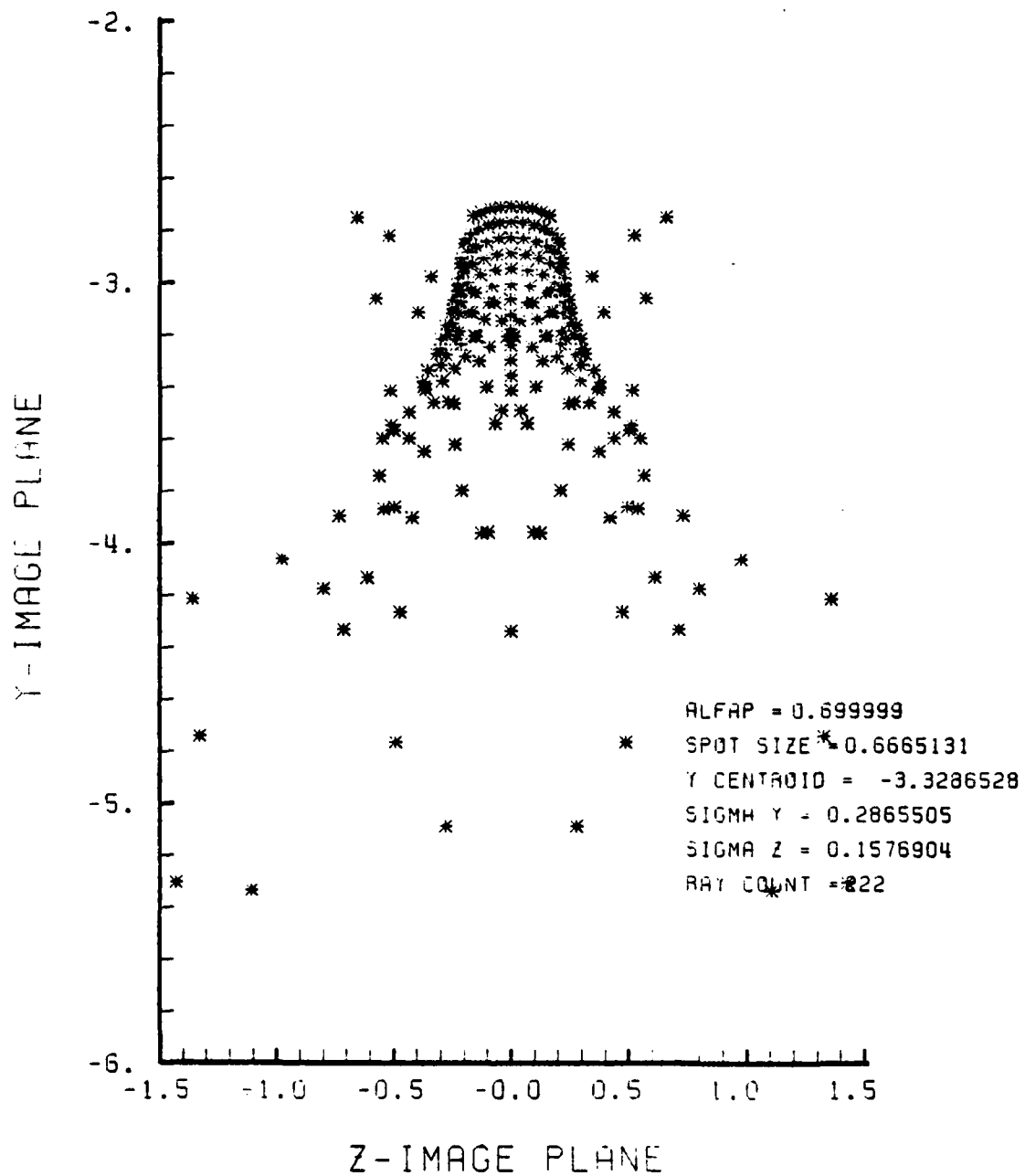

Figure D-22. Spot Diagram of HIN Lens at $\alpha_p = 0.7$ Radians, $N_2 = 1.5$

SPOT DIAGRAM ENERGY DENSITY

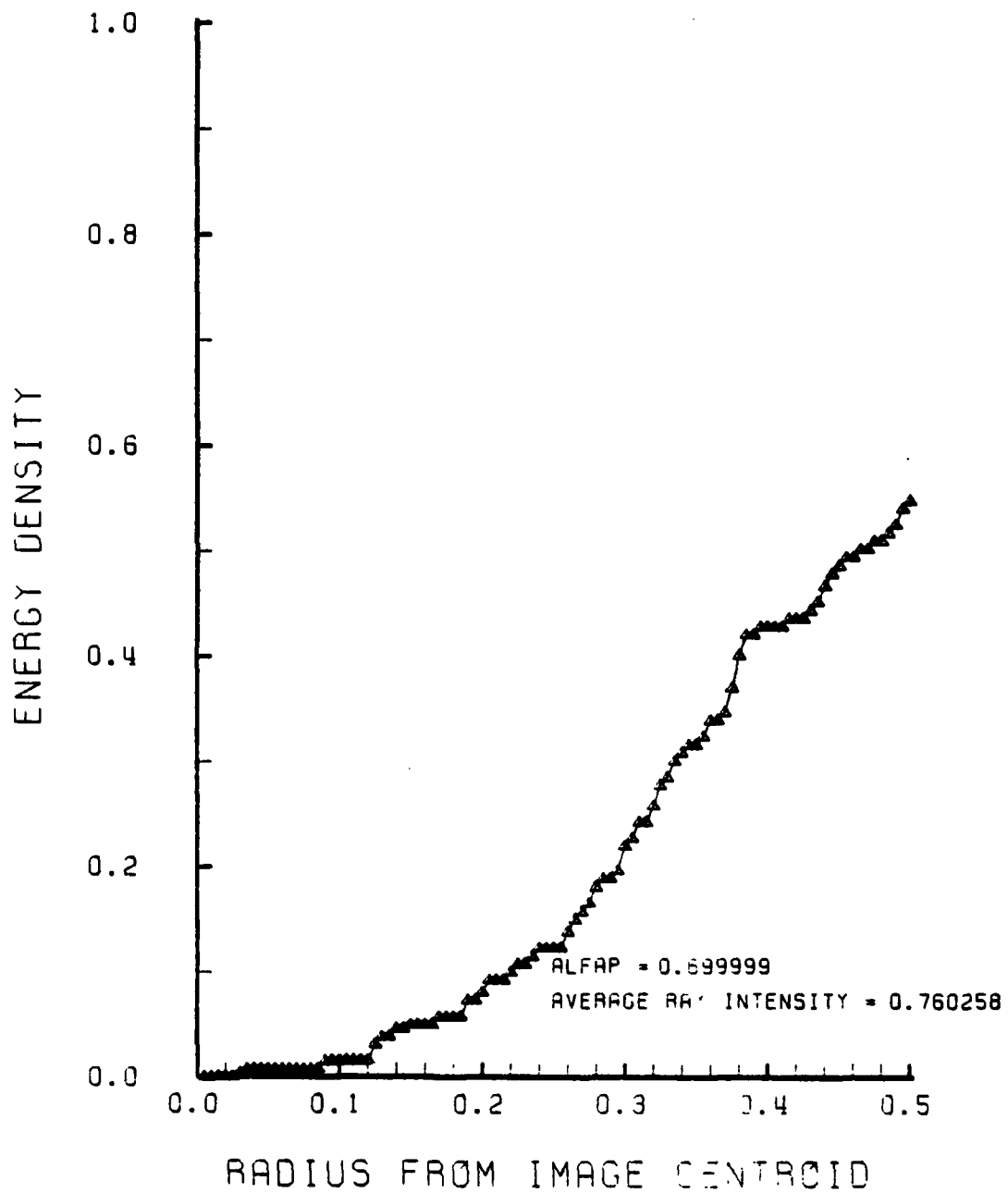

Figure D-23. Encircled Energy Plot at $\alpha_p = 0.7$ Radians, $N_2 = 1.5$

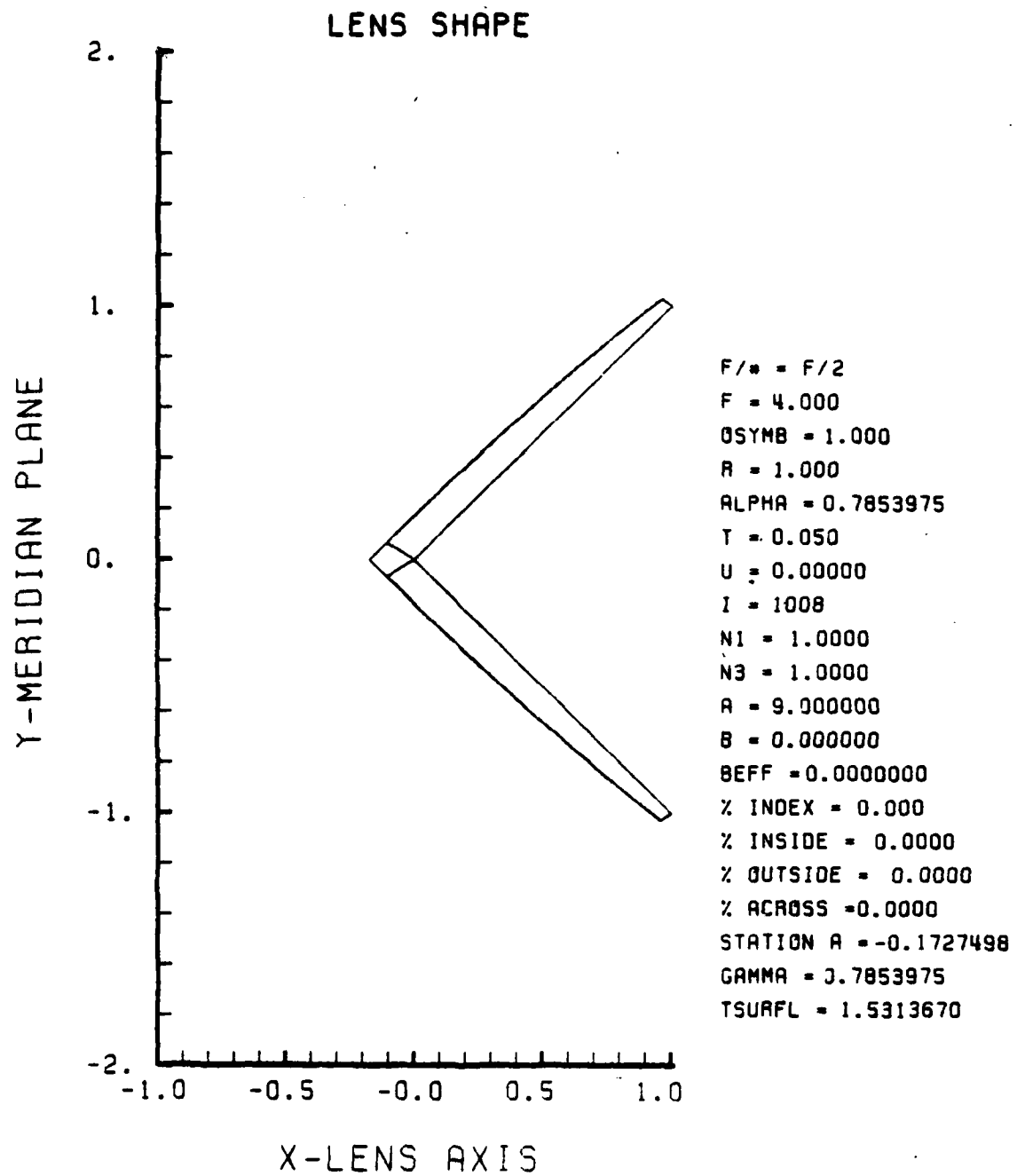

Figure D-24. HIN Lens Design for $N_2 = 3.0$

LENS FRONT VIEW
OBJECT PLANE

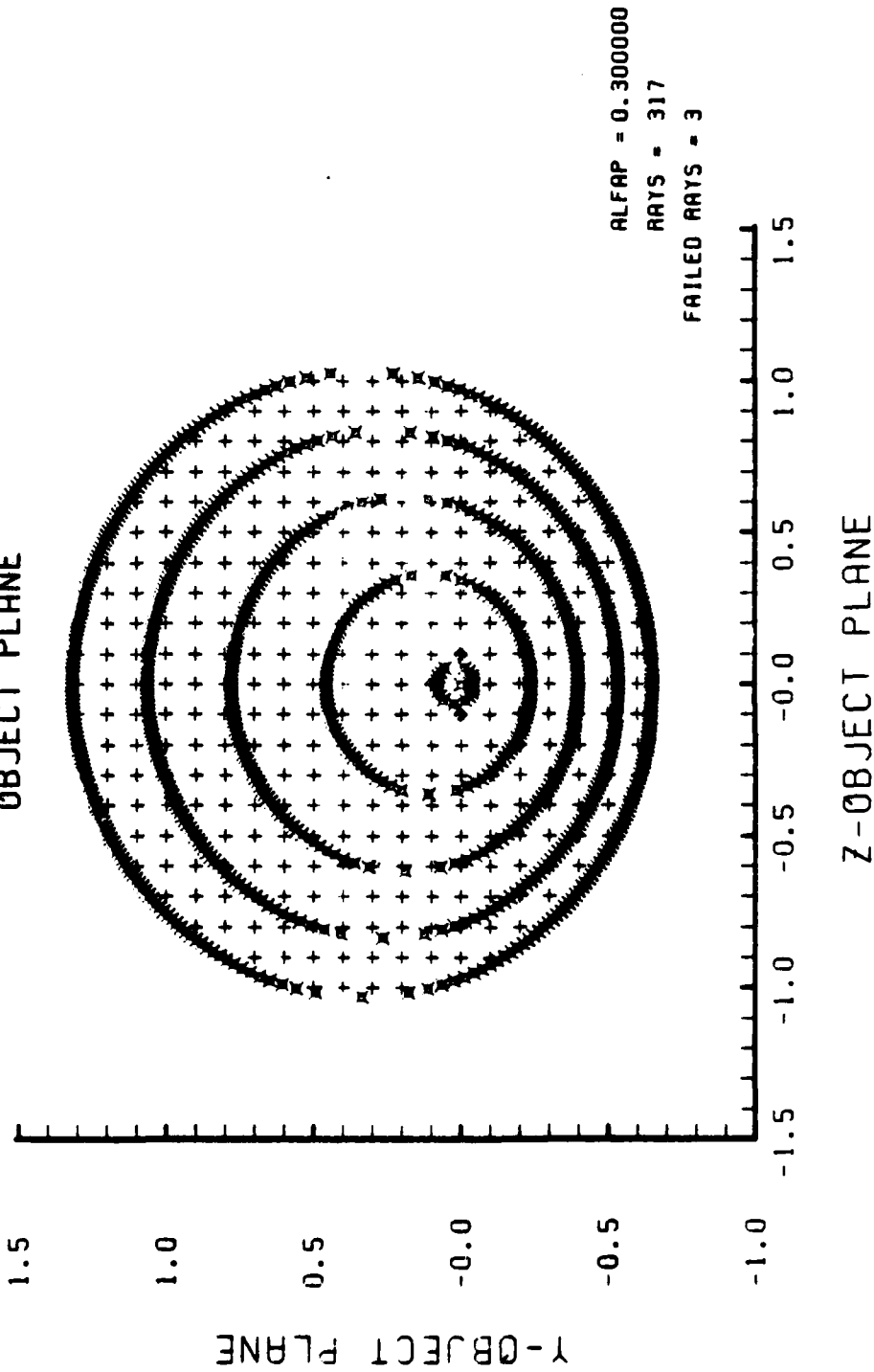

Figure D-25. Object Plane of HIN Lens in Figure D-24
at $\alpha_p = 0.3$ Radians

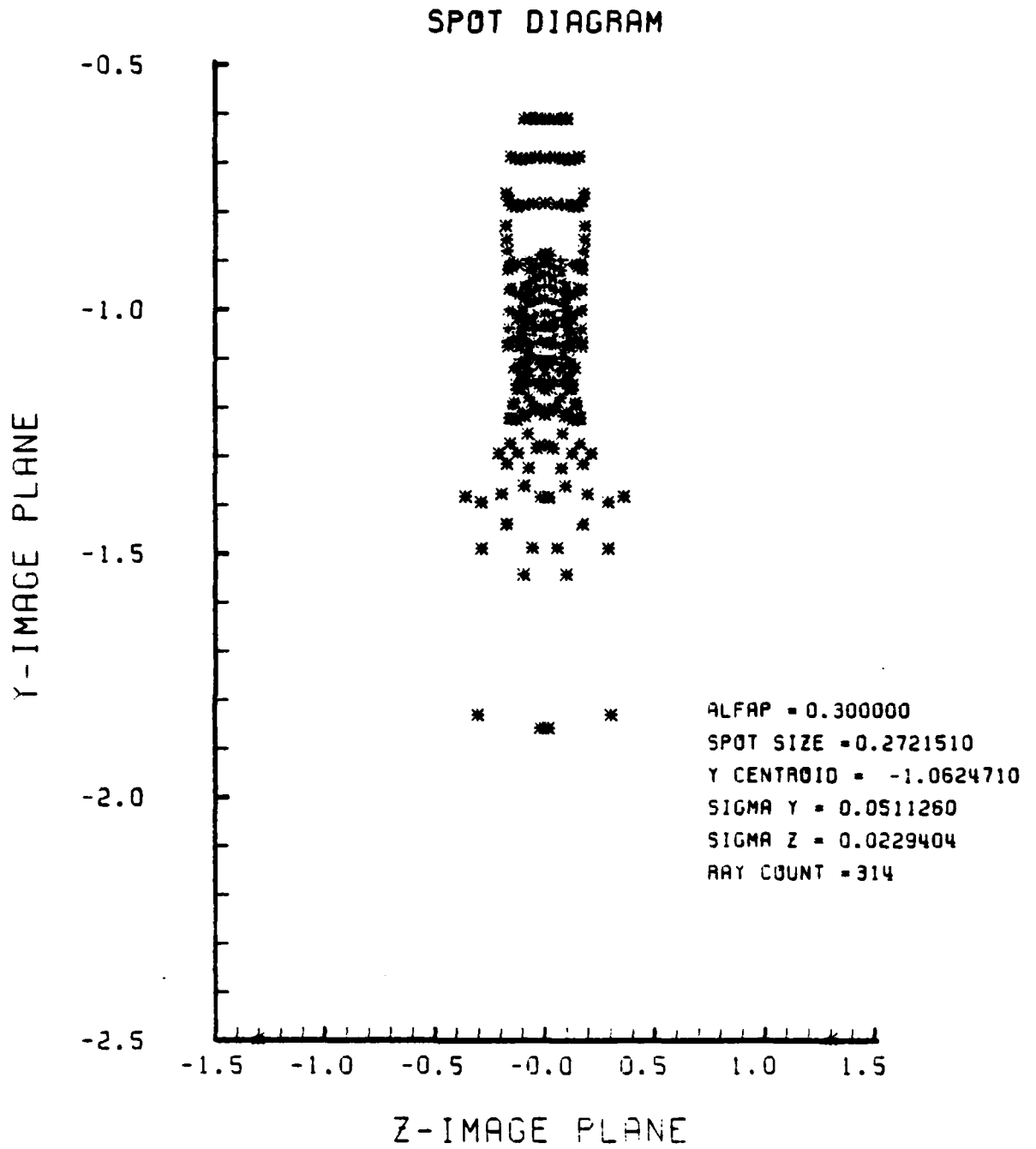

Figure D-26. Spot Diagram Corresponding to Figure D-25

SPOT DIAGRAM ENERGY DENSITY

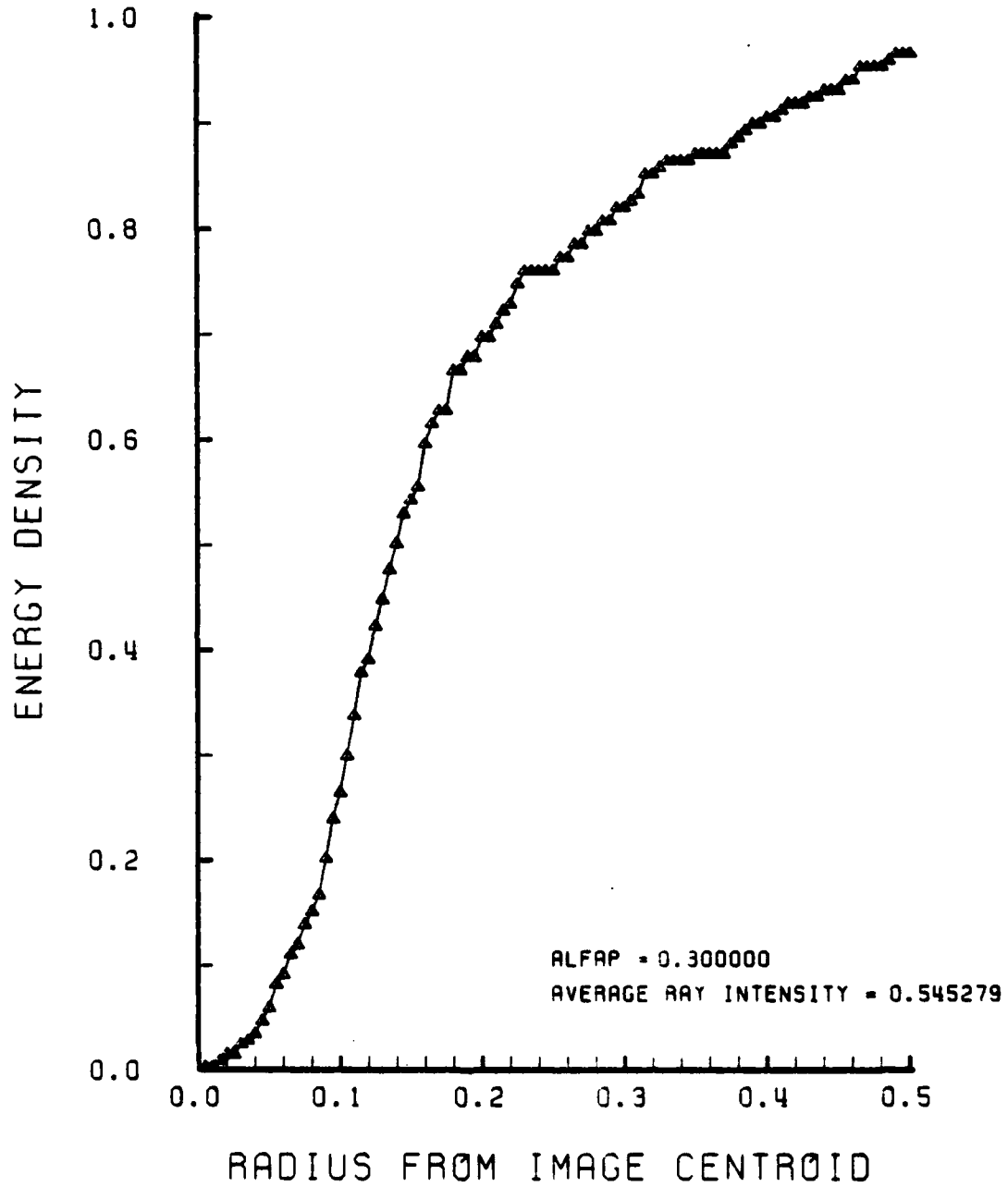

Figure D-27. Encircled Energy Plot for Spot Diagram of Figure D-26

APPENDIX E

GRIN LENS PERFORMANCE PLOTS IN THE LOW RANGE OF INDICES OF REFRACTION ($a = 2.25$)

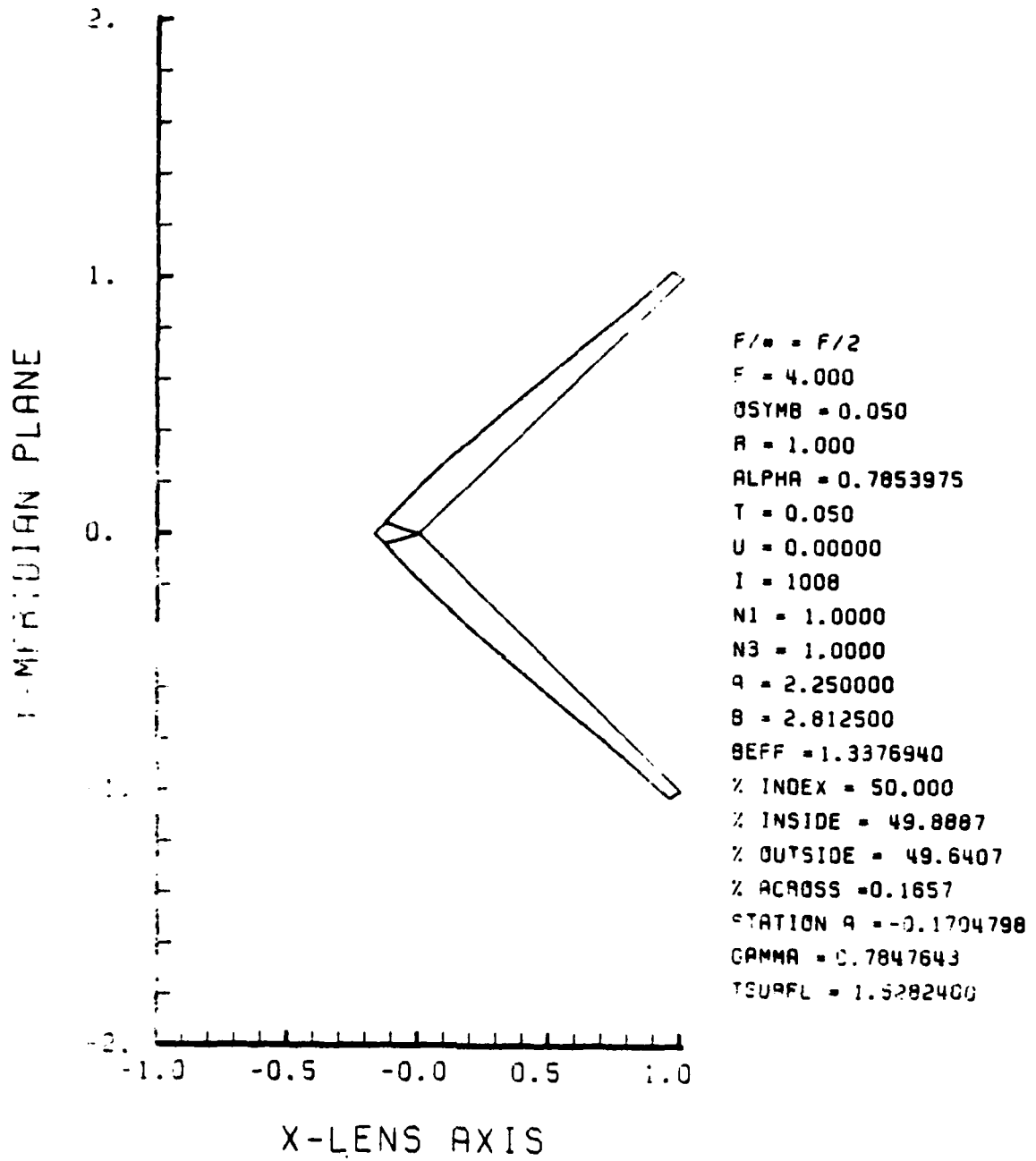

Figure E-1. GRIN Lens Shape at +50%, $OB = 0.05$,
 $a = 2.25$

B

LENS FRONT VIEW
OBJECT PLANE

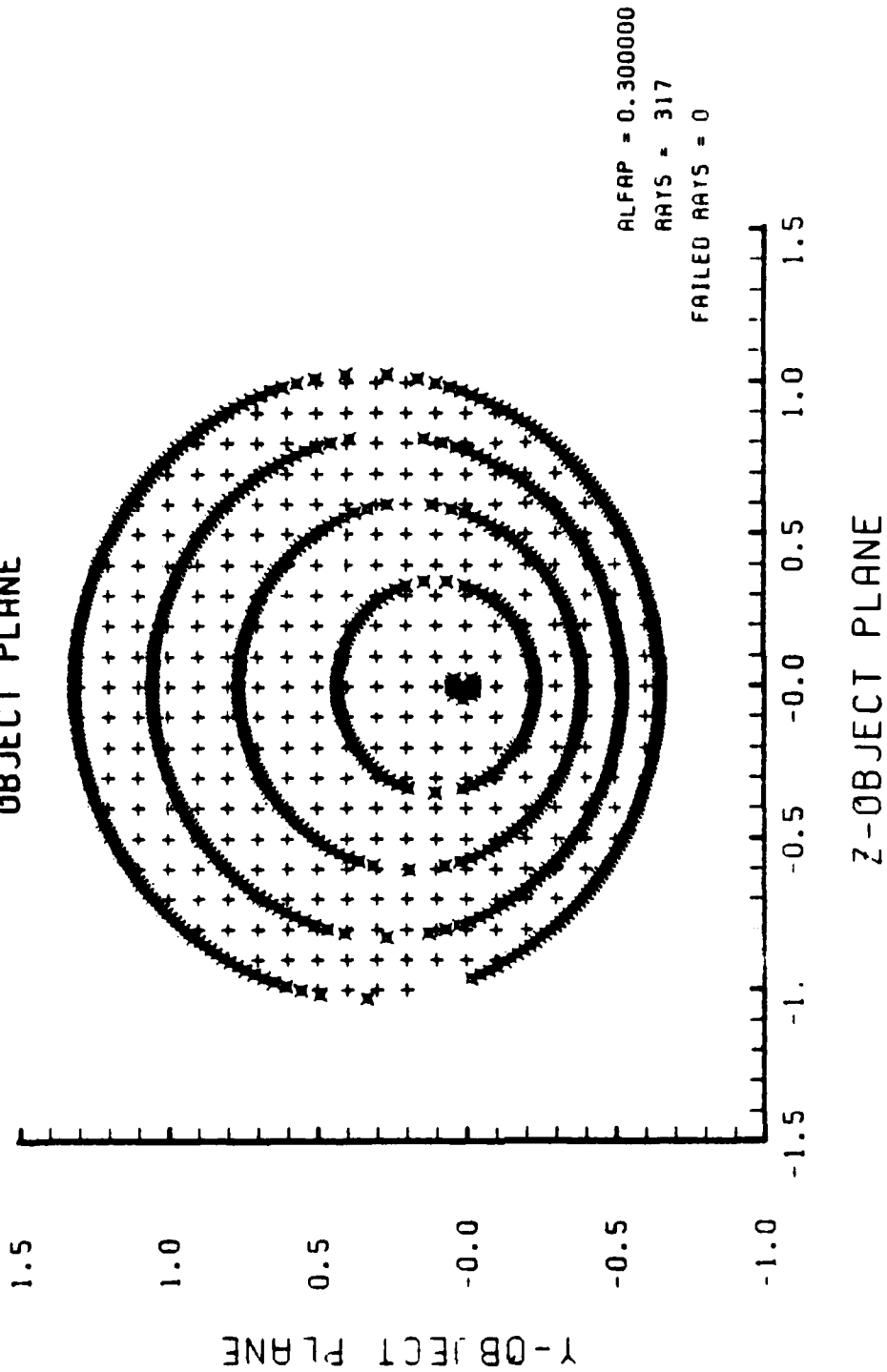

Figure E-2. Grid Plane at $\alpha_p = 0.3$ for Lens of Figure E-1

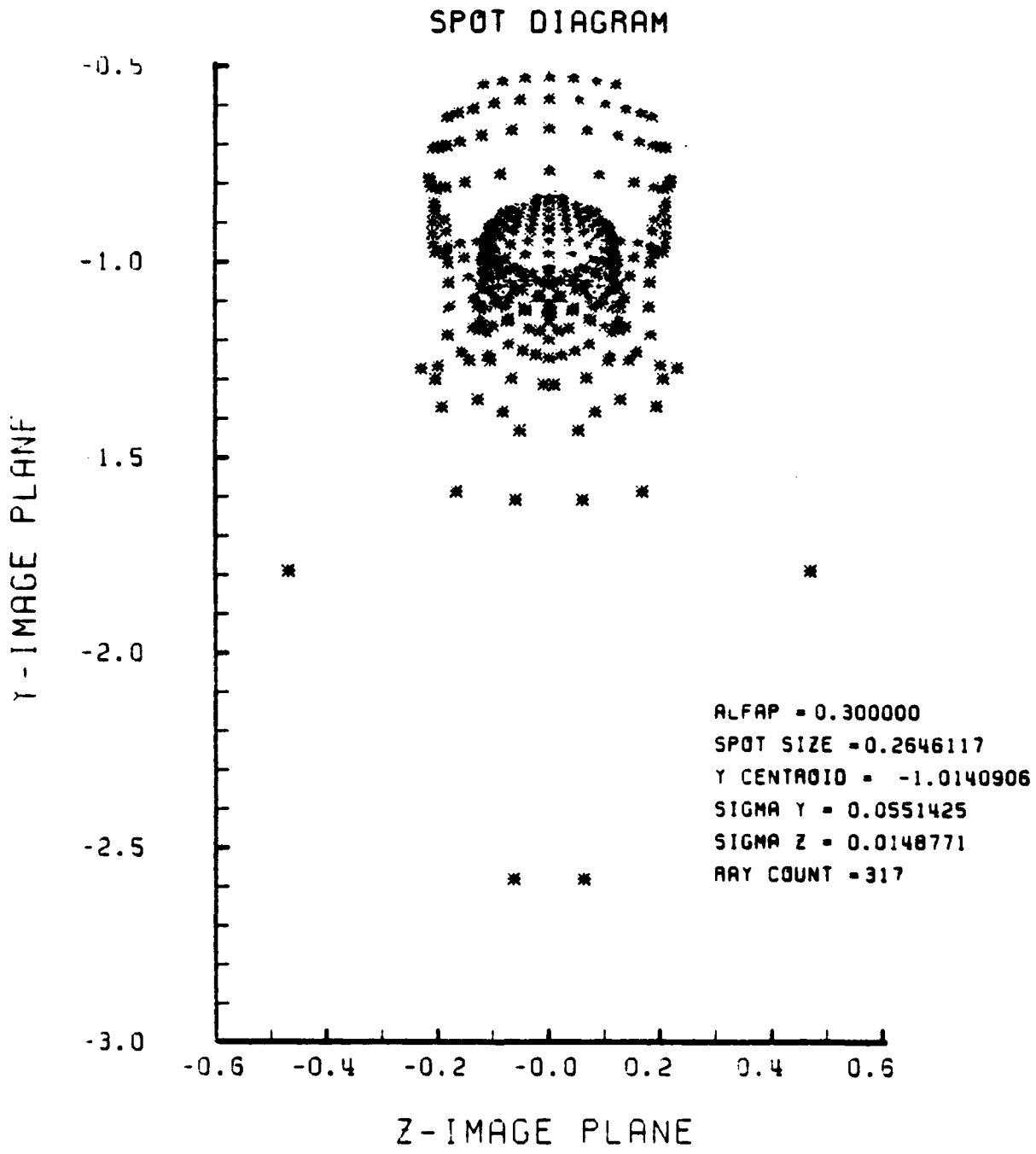

Figure E-3. Spot Diagram for Grid of Figure E-2

SPOT DIAGRAM ENERGY DENSITY

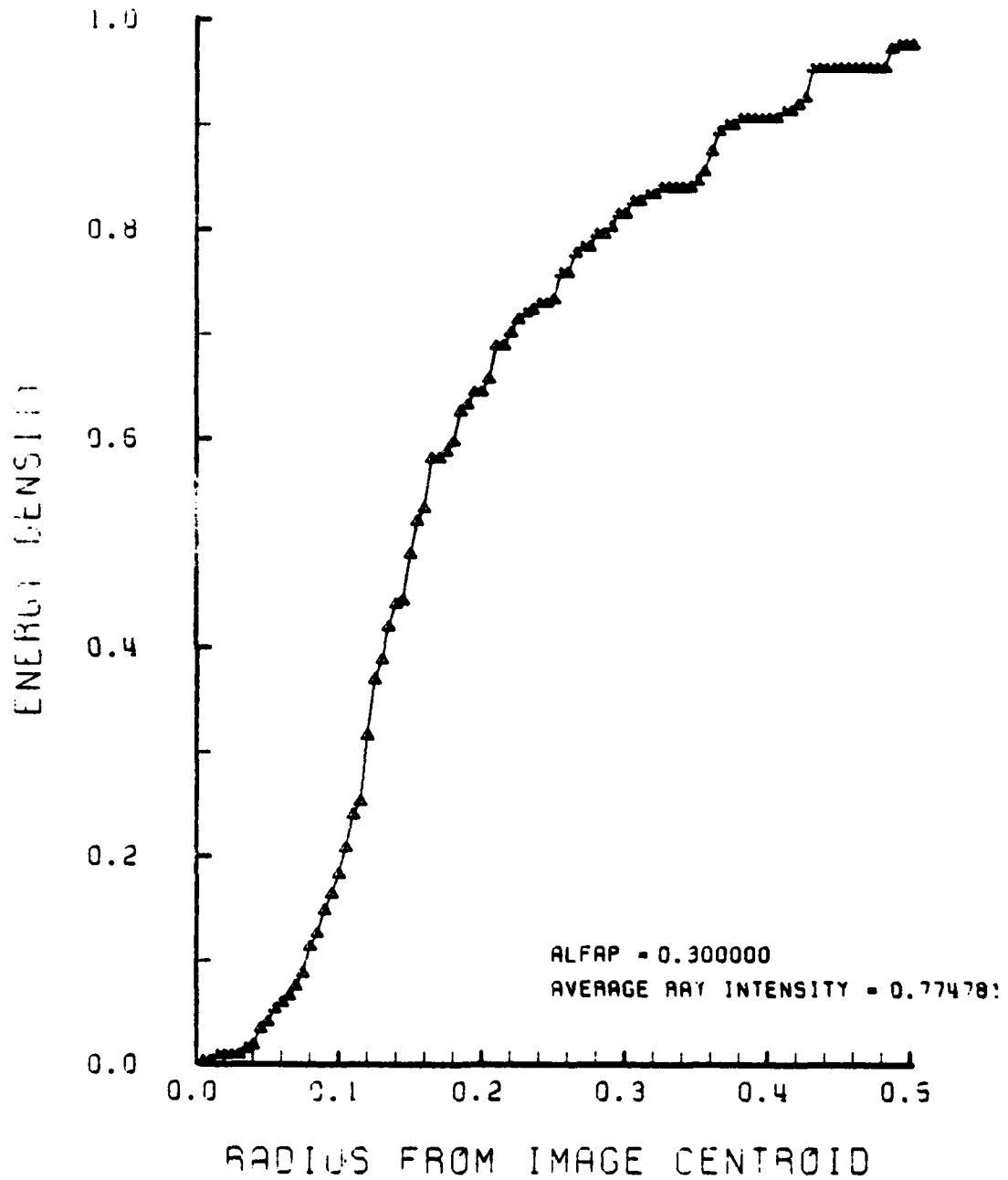

Figure E-4. Encircled Energy of Figure E-3

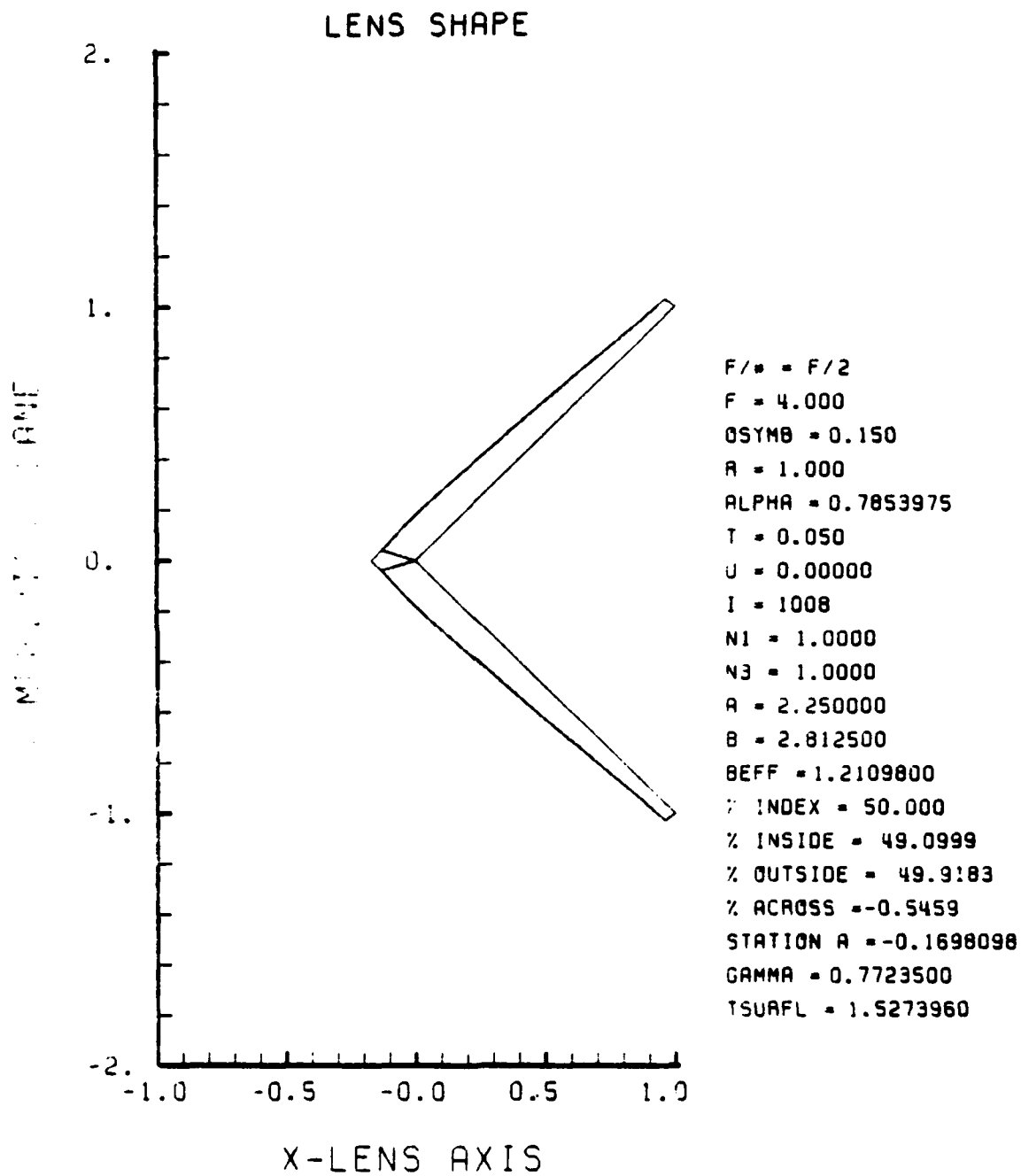

Figure E-5. GRIN Lens Shape at +50%, OB = 0.15,
a = 2.25

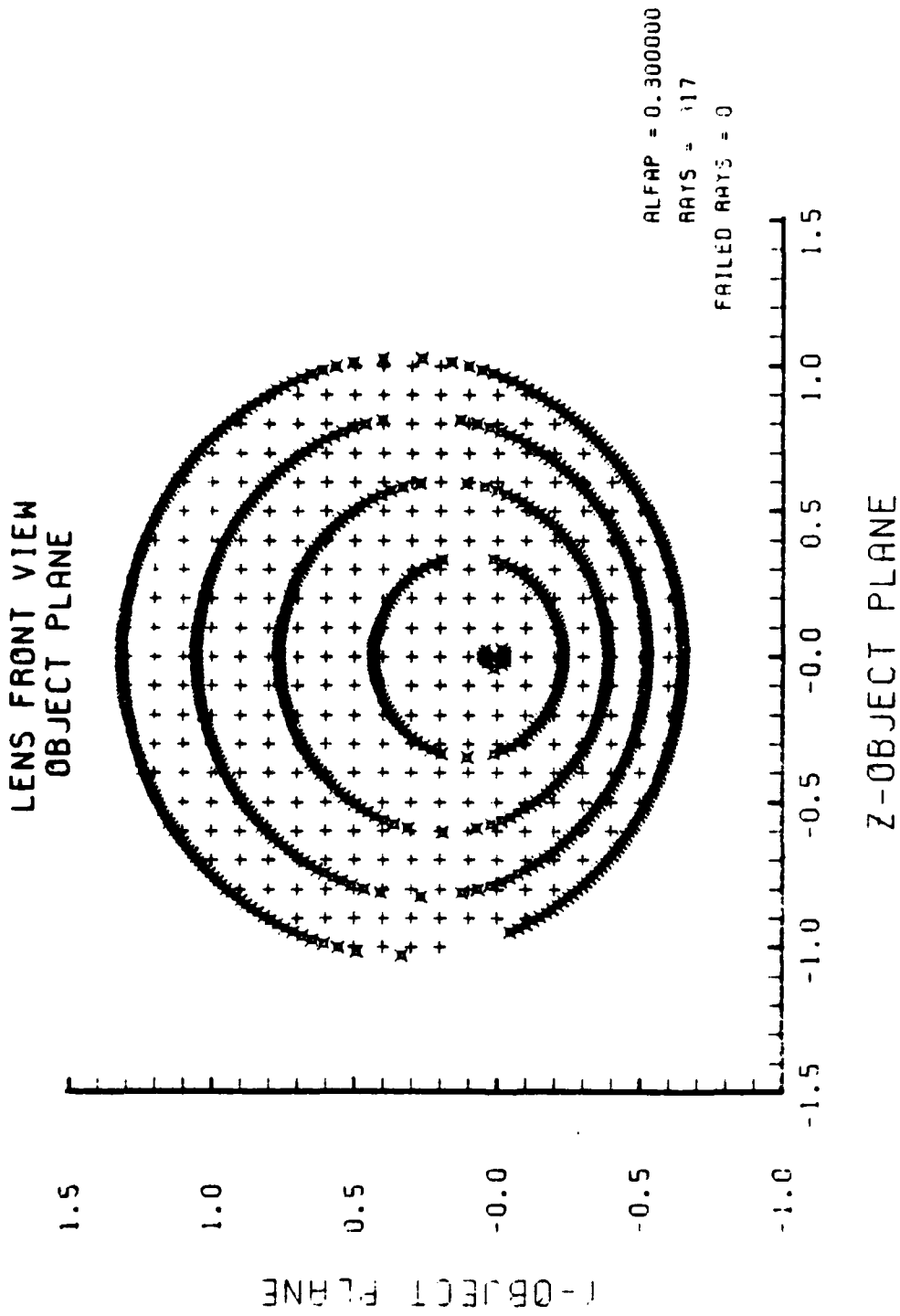

Figure E-6. Grid Plane at $\alpha_p = 0.3$ for Lens of Figure E-5

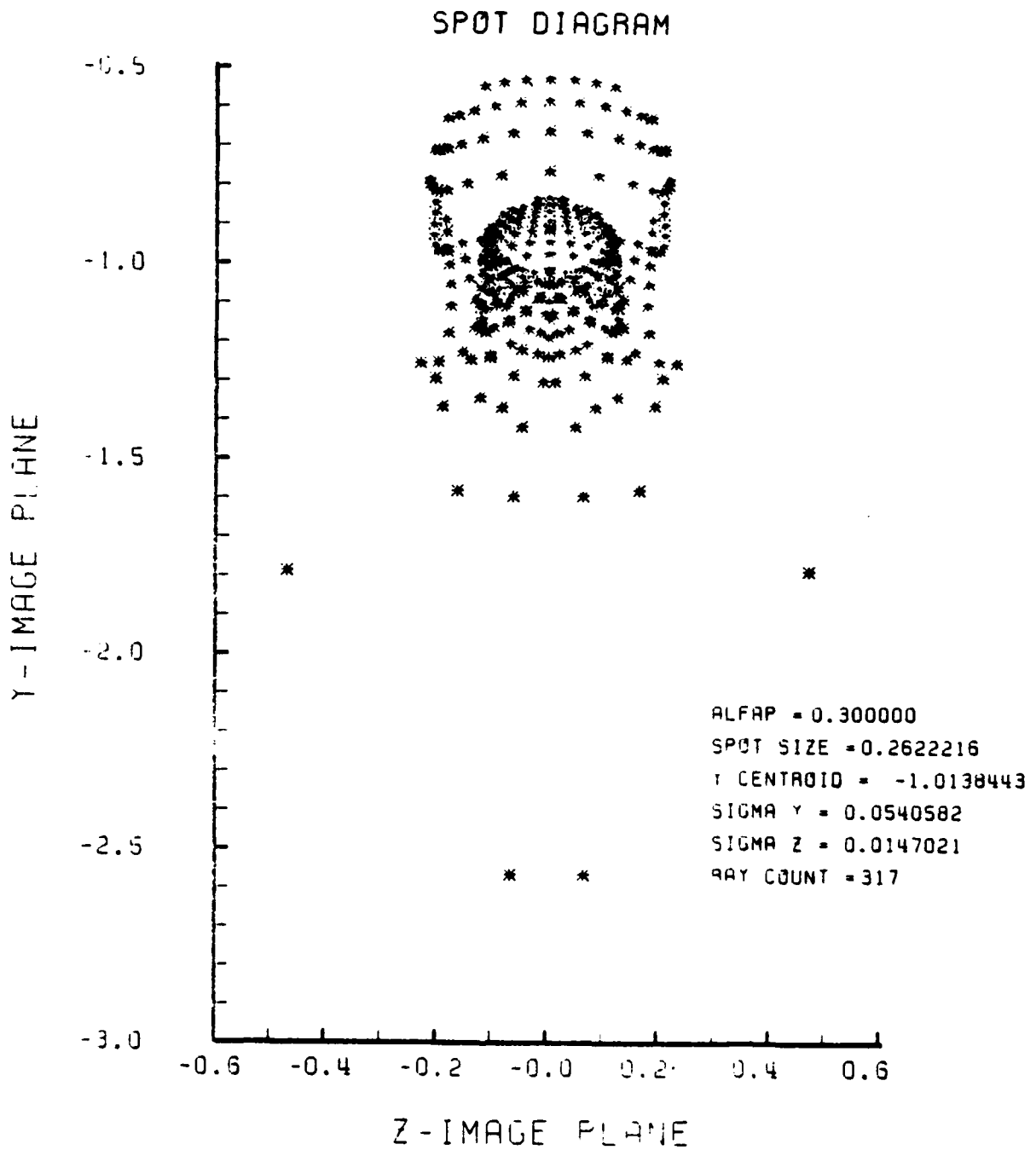

Figure E-7. Spot Diagram for Grid of Figure E-6

SPOT DIAGRAM ENERGY DENSITY

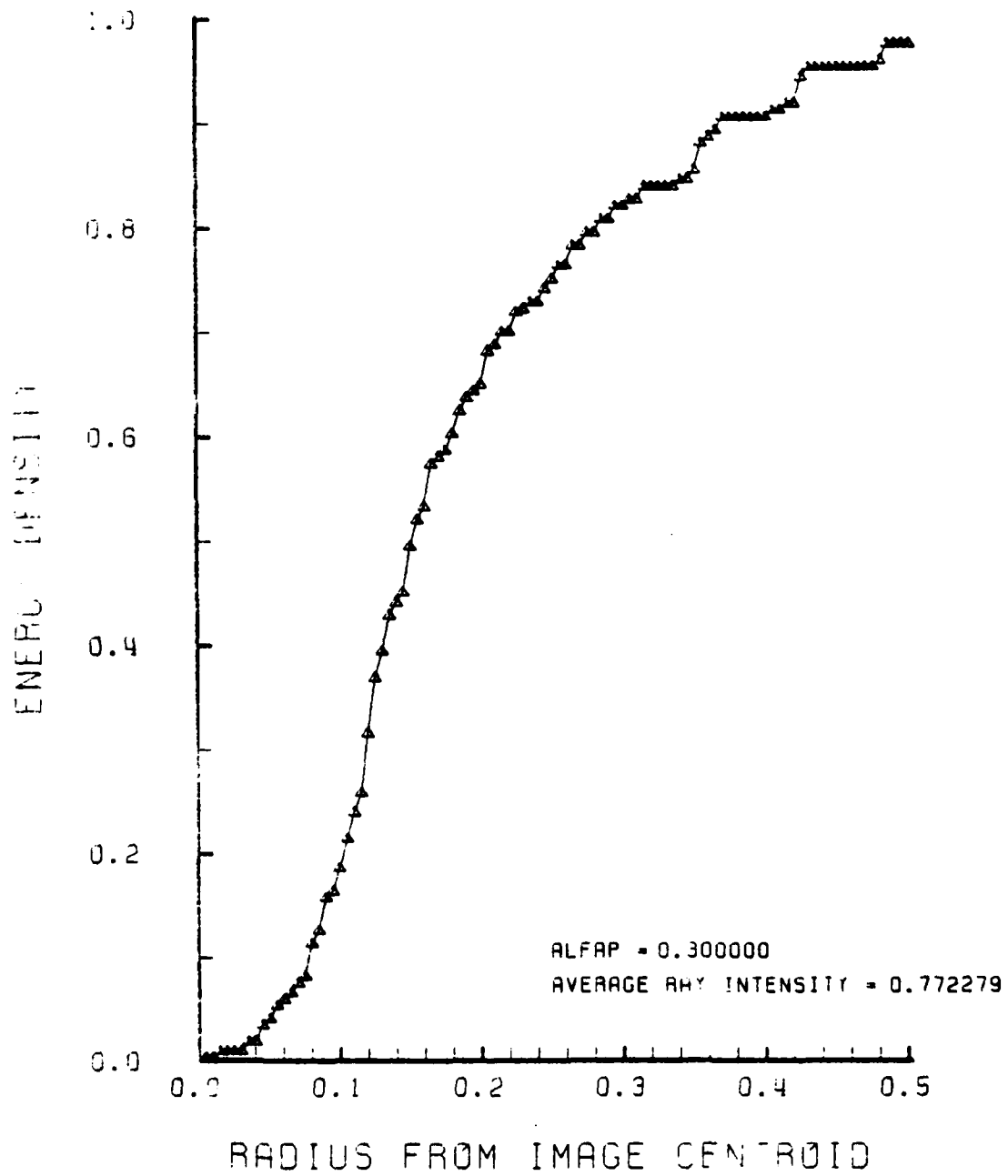

Figure E-8. Encircled Energy of Figure E-7

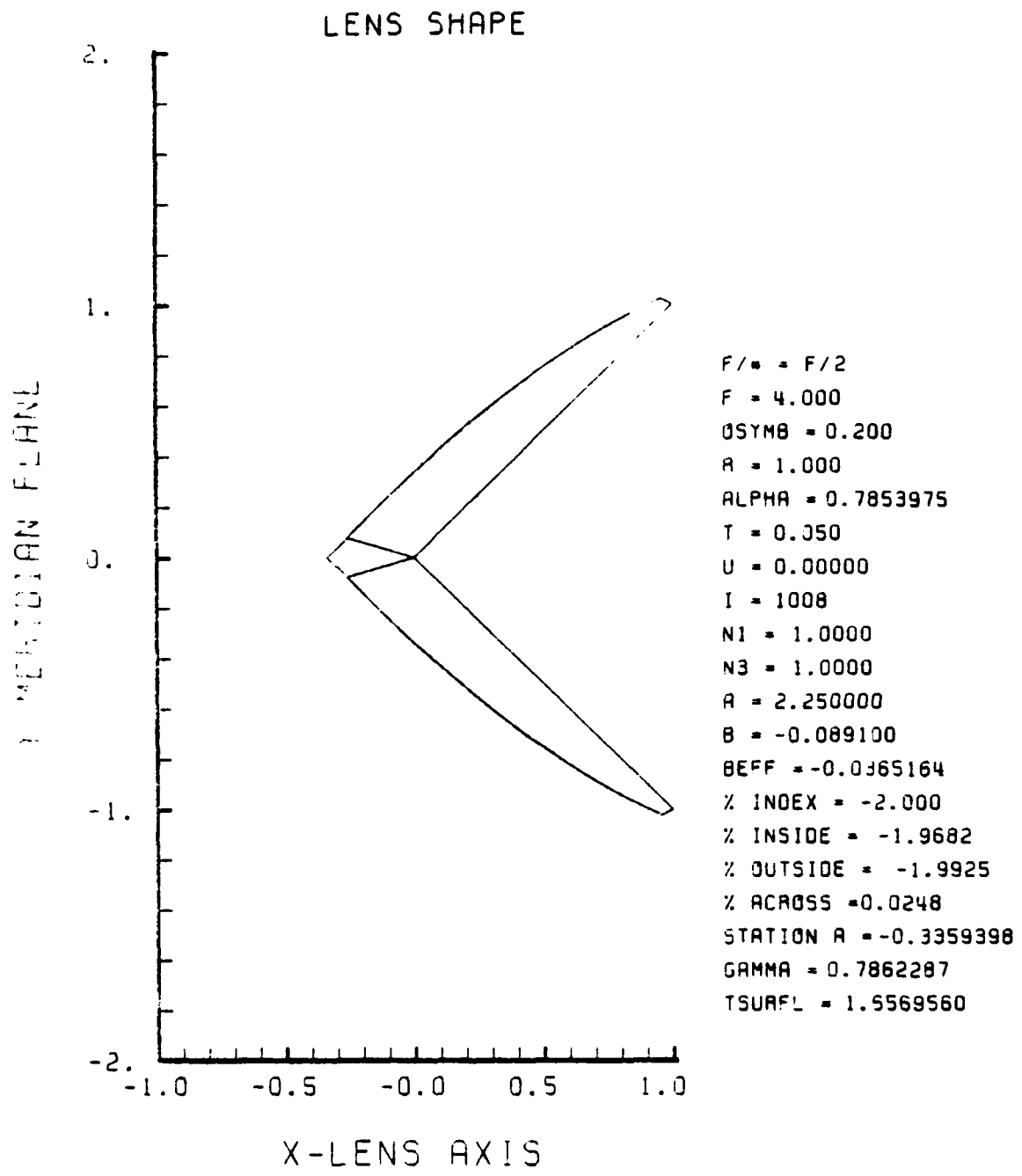
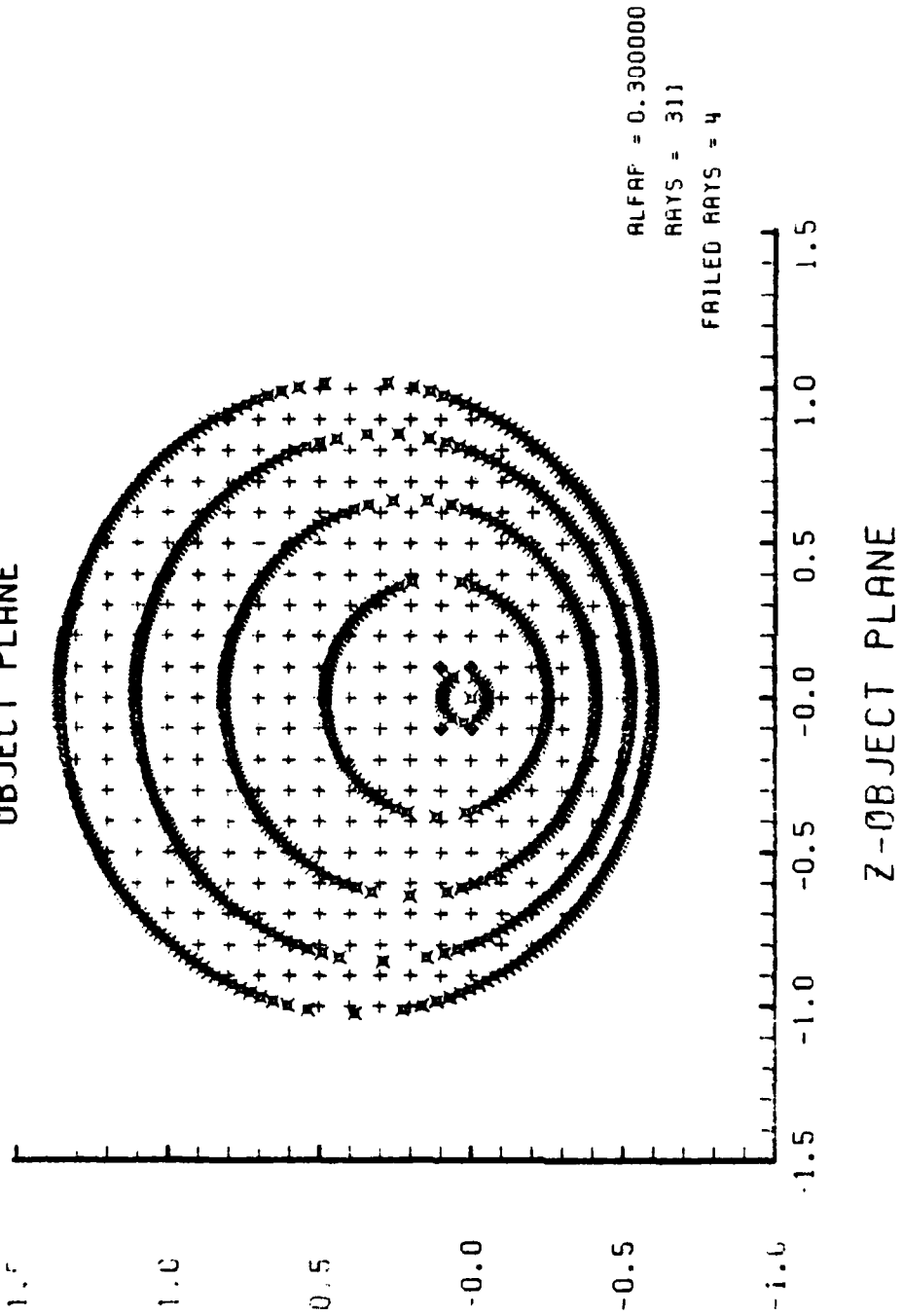

Figure E-9. GRIN Lens Shape at -2%, OB = 0.20,
a = 2.25

LENS FRONT VIEW
OBJECT PLANE



ALFAF = 0.300000
RAYS = 311
FAILED RAYS = 4

Figure E-10. Grid Plane at $\alpha_p = 0.3$ for Lens of Figure E-9

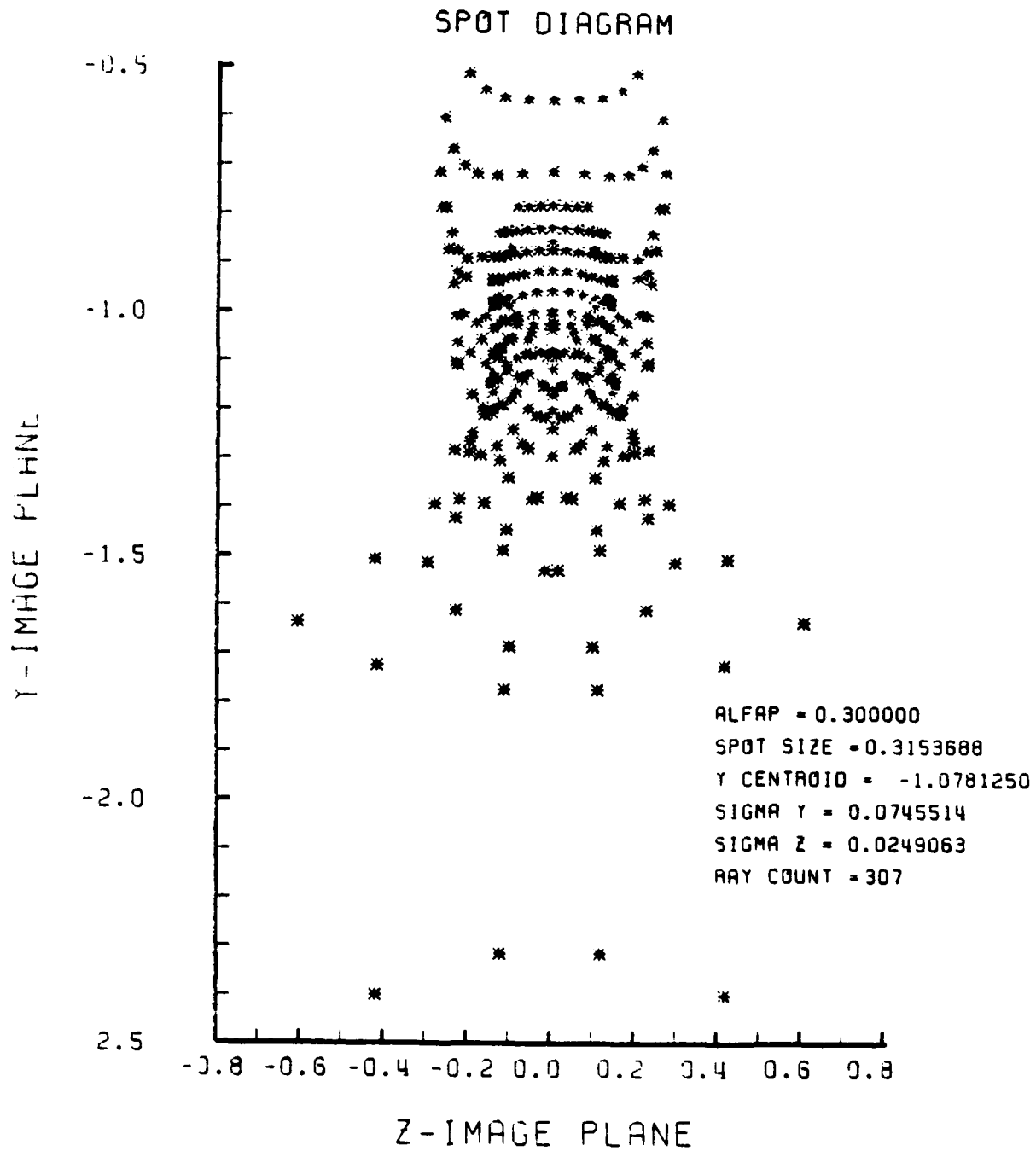

Figure E-11. Spot Diagram for Grid of Figure E-10

SPOT DIAGRAM ENERGY DENSITY

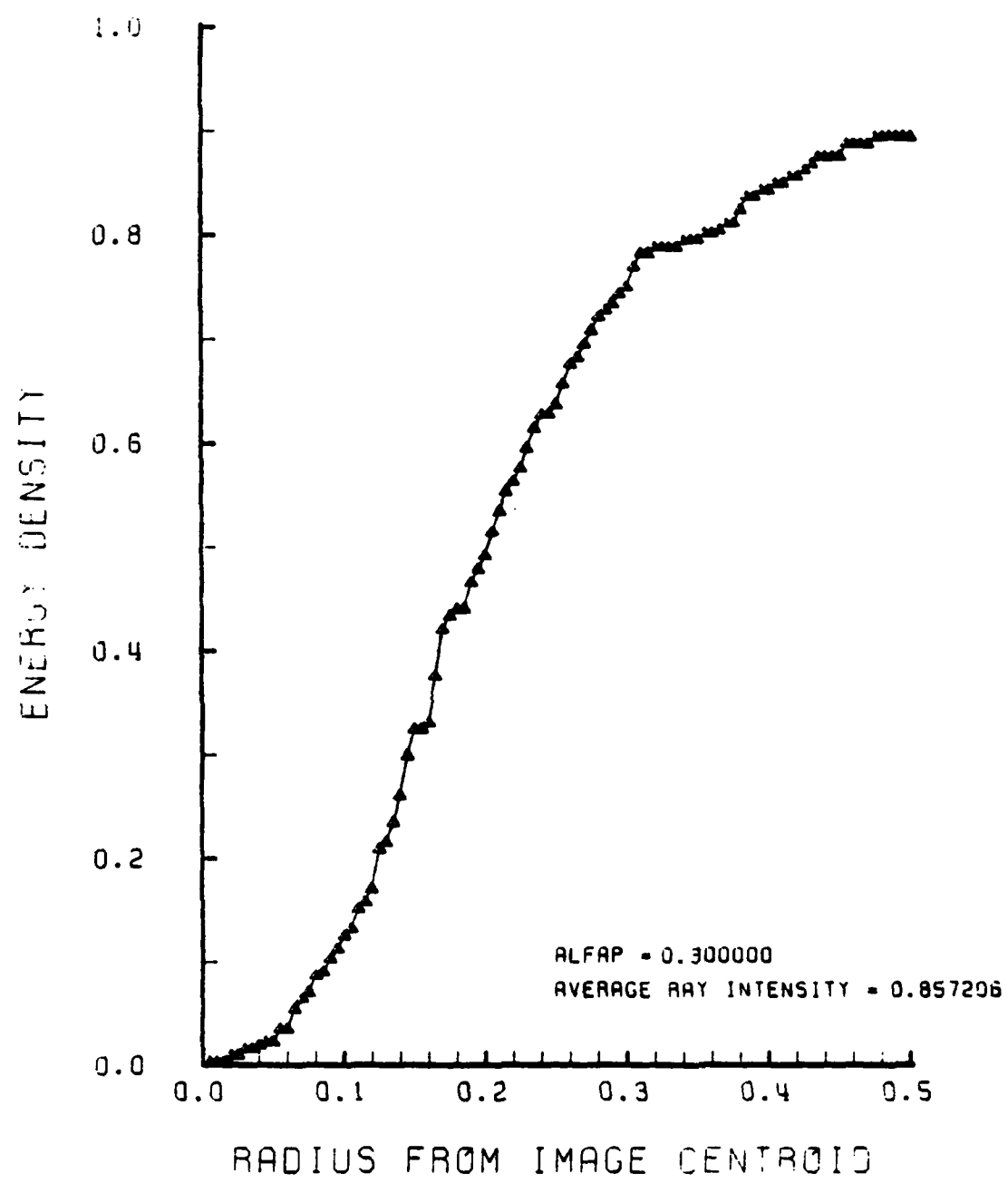

Figure E-12. Encircled Energy of Figure E-11

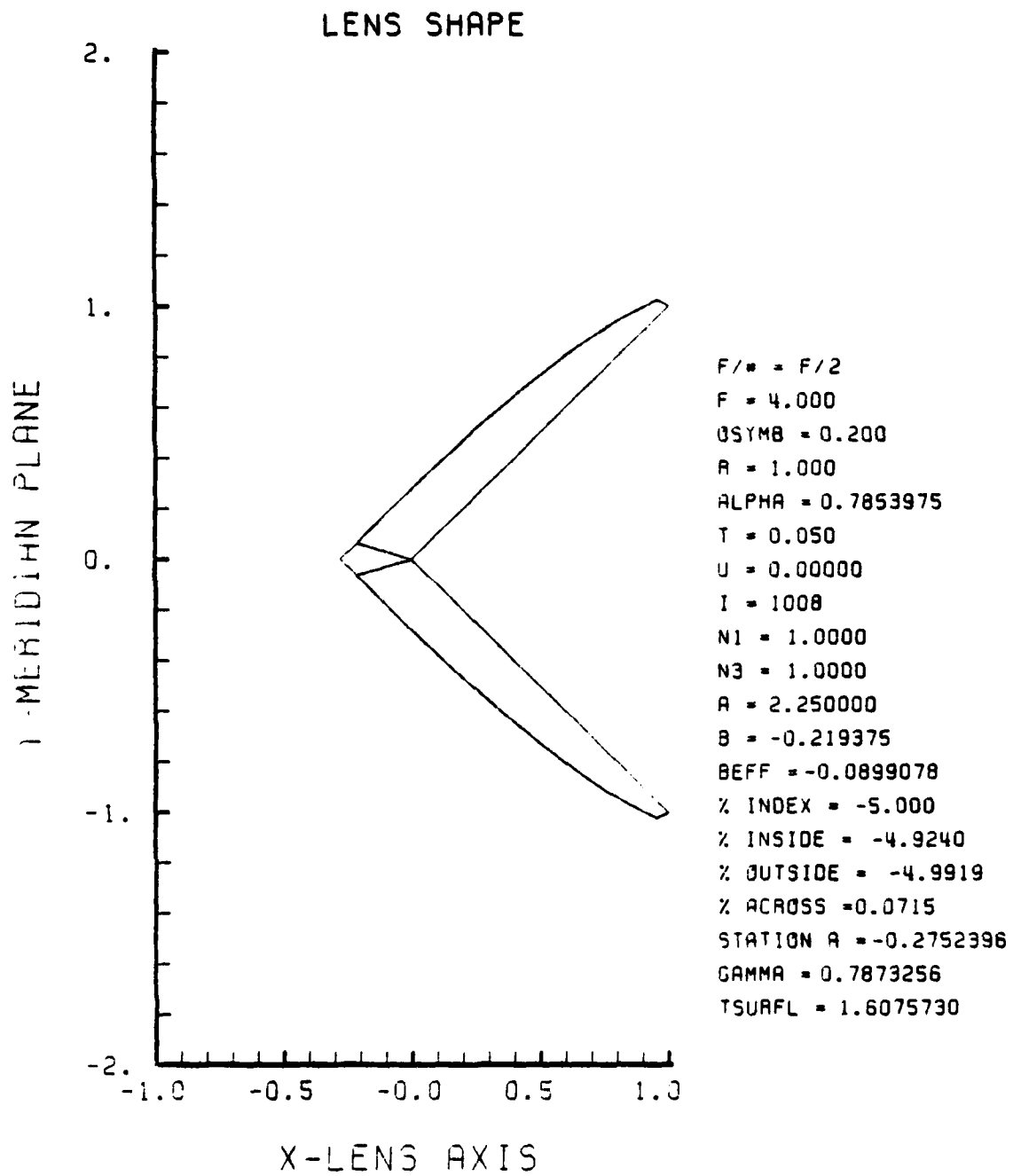

Figure E-13. GRIN Lens Shape at -5%, OB = 0.20,
a = 2.25

LENS FRONT VIEW
OBJECT PLANE

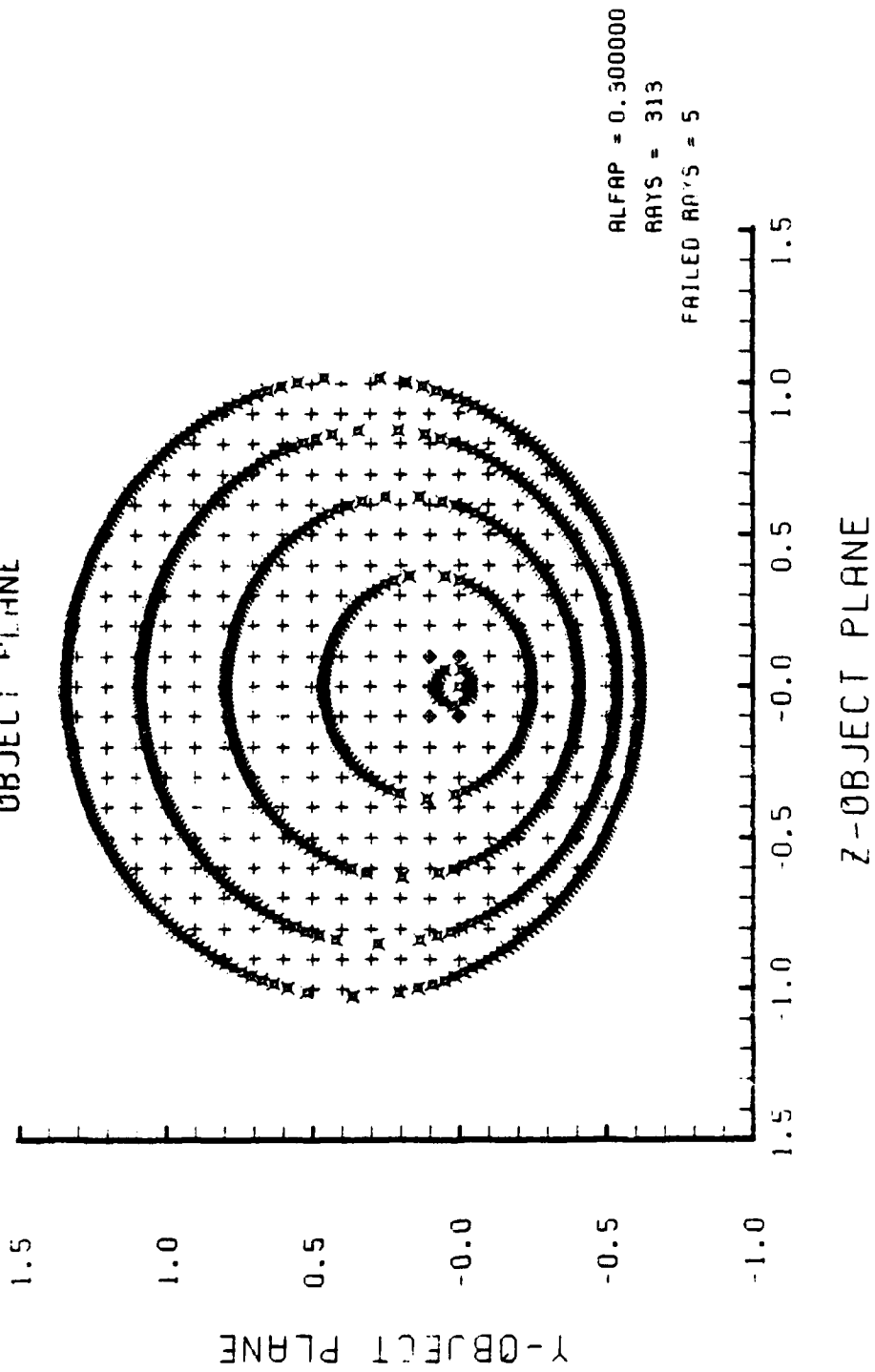

Figure E-14. Grid Plane at $\alpha_p = 0.3$ for Lens of Figure E-13

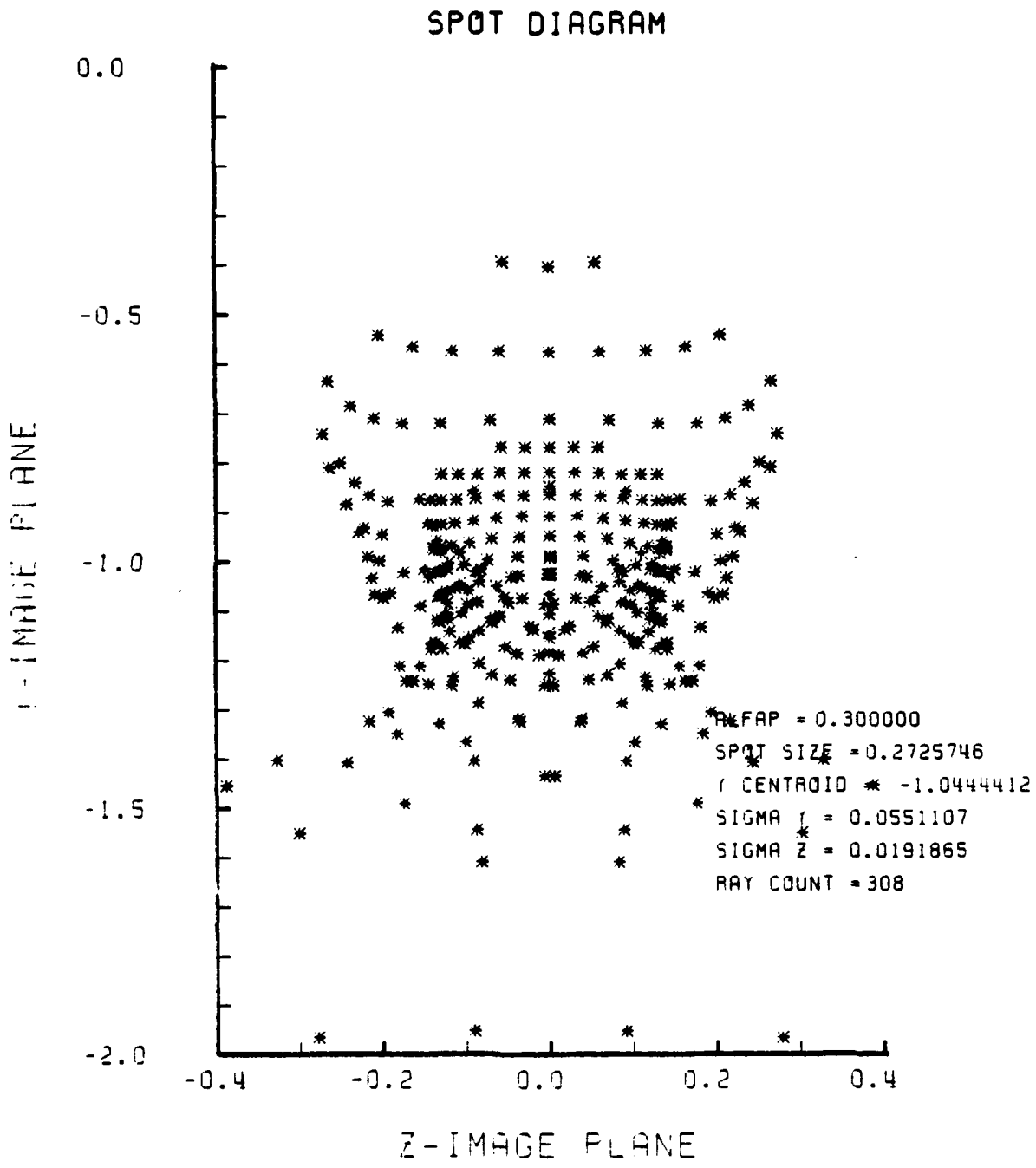

Figure E-15. Spot Diagram for Grid of Figure E-14

SPOT DIAGRAM ENERGY DENSITY

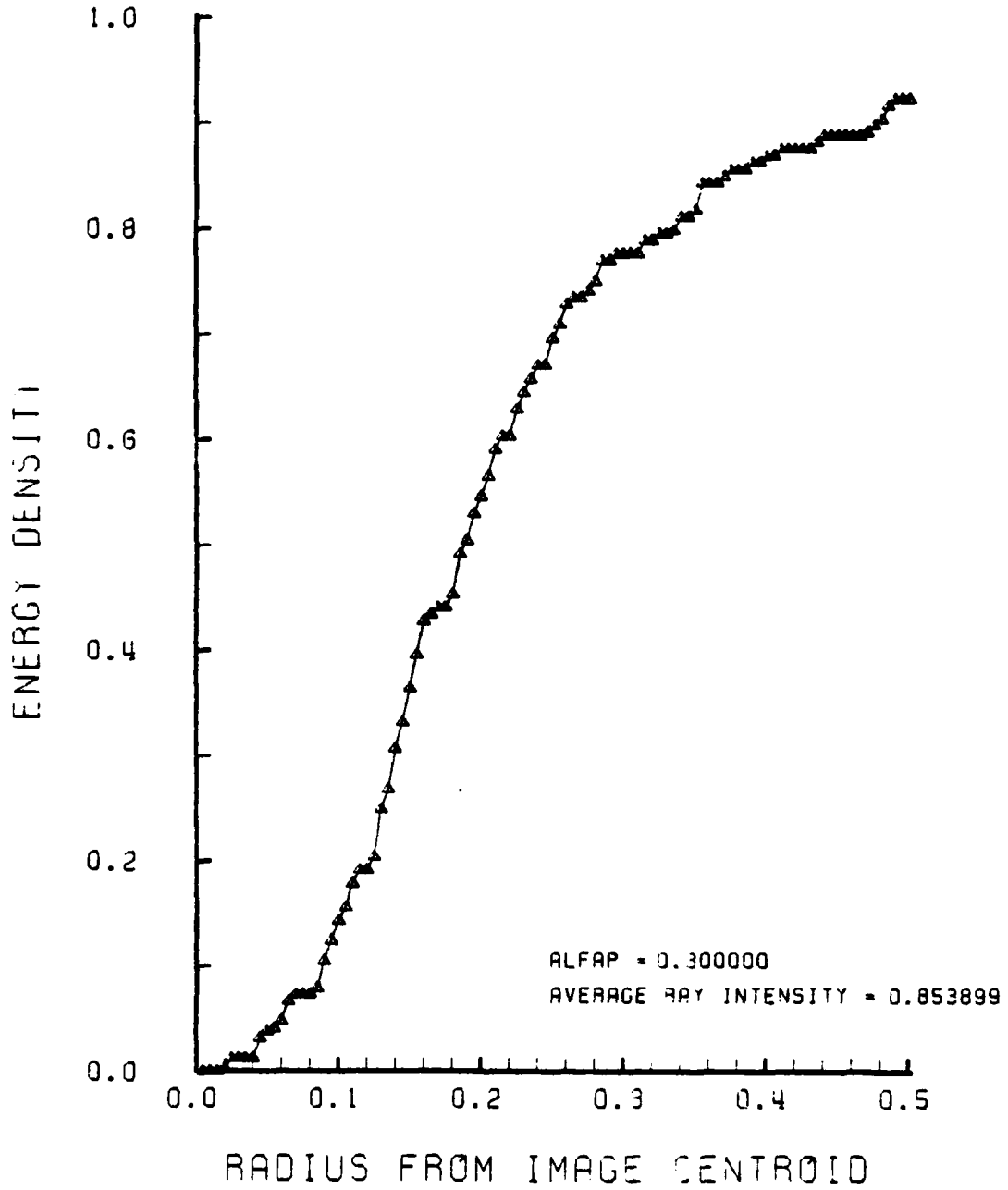

Figure E-16. Encircled Energy of Figure E-15

LENS SHAPE

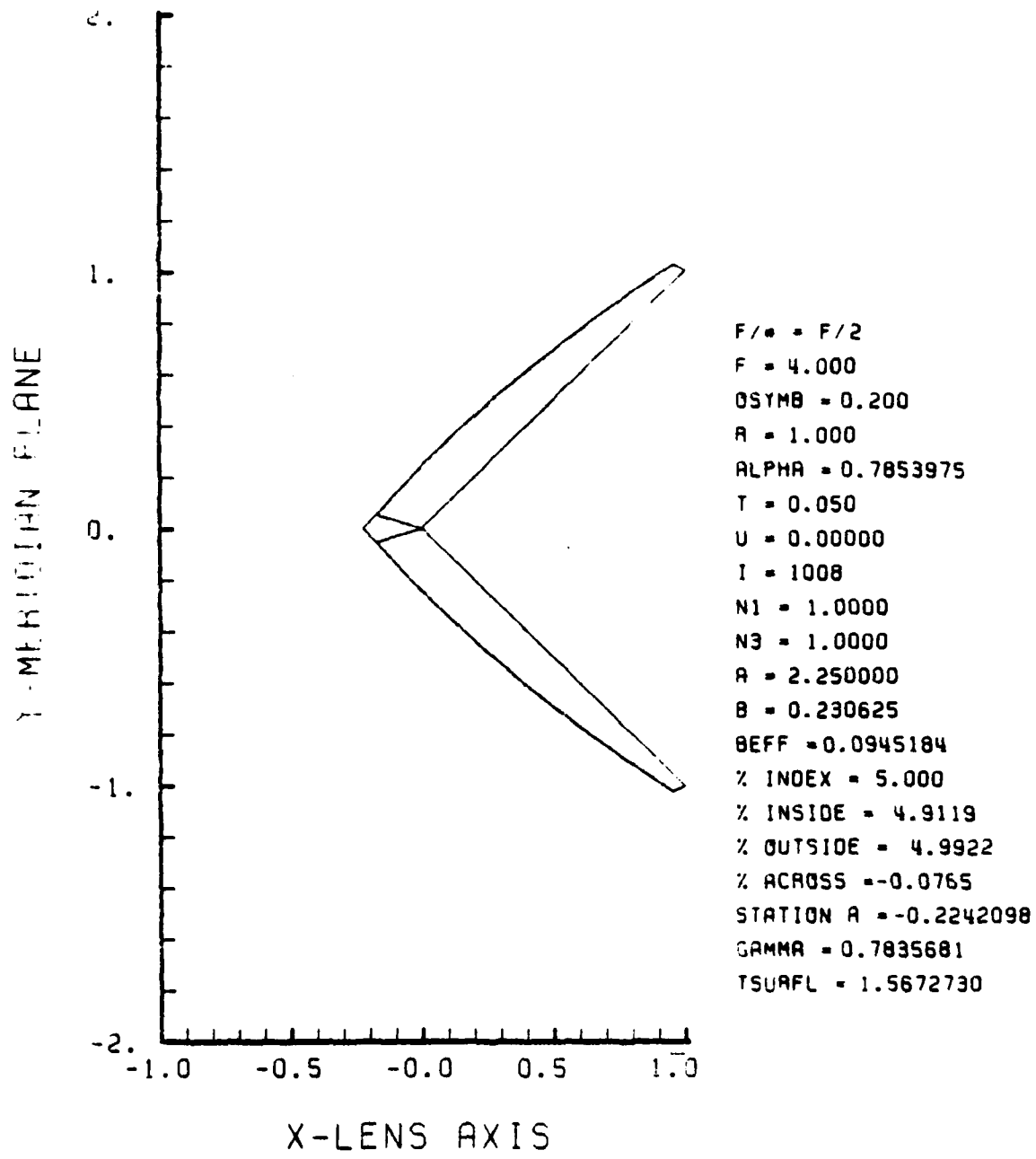

Figure E-17. GRIN Lens Shape at +5%, OB = 0.20, a = 2.25

LENS FRONT VIEW
OBJECT PLANE

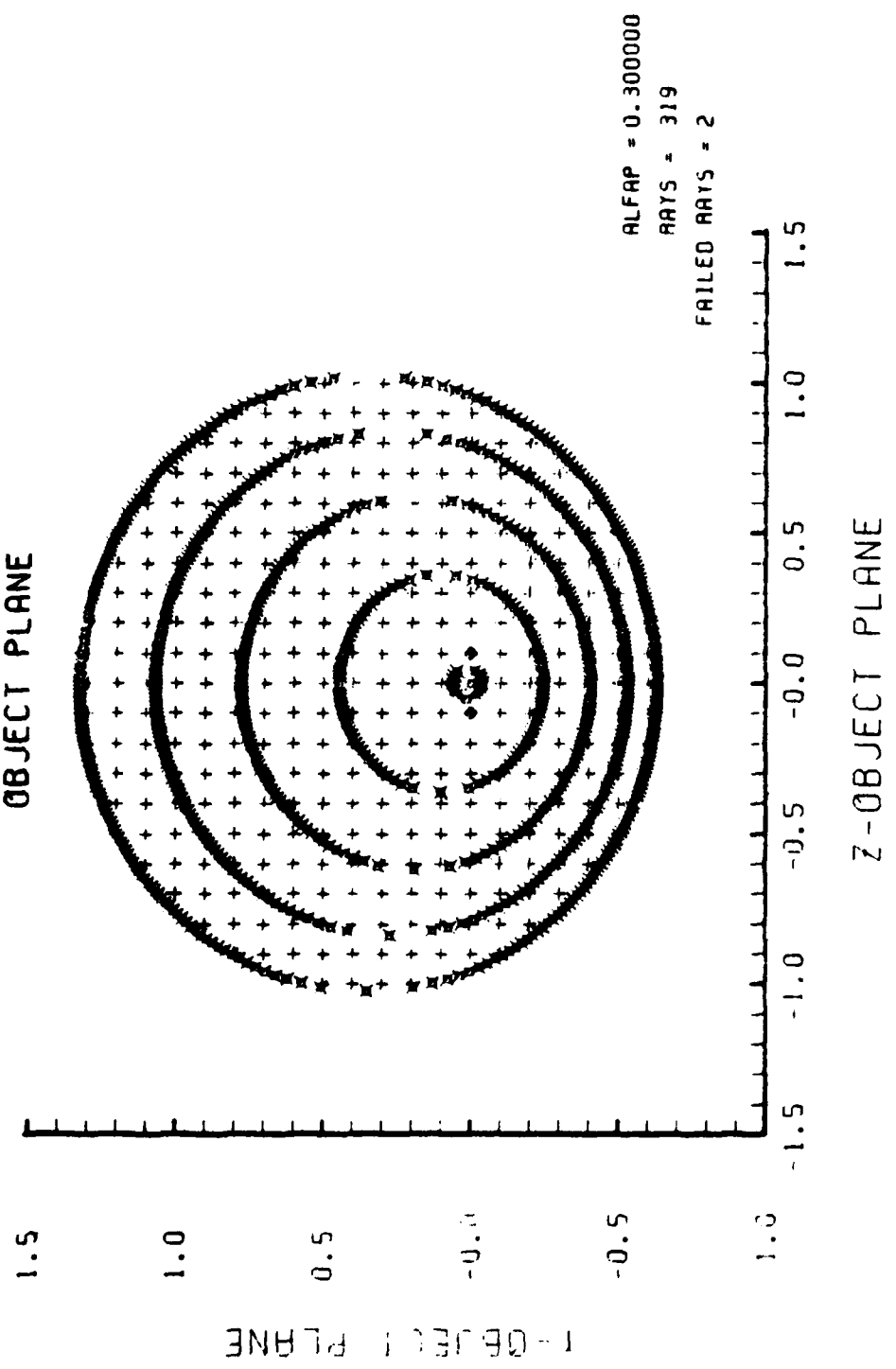

Figure E-18. Grid Plane at $\alpha_p = 0.3$ for Lens of Figure E-17

SPOT DIAGRAM

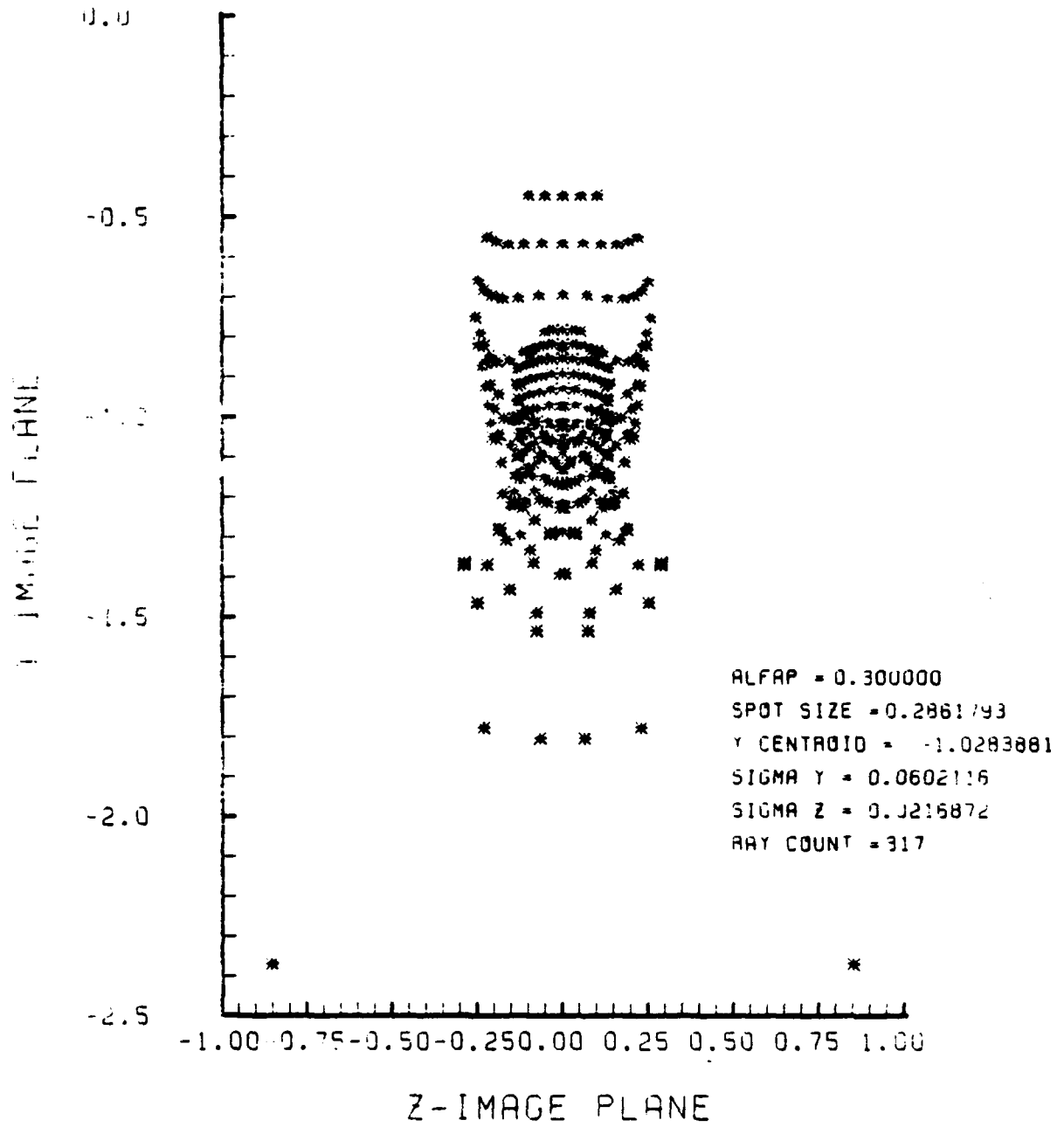

Figure E-19. Spot Diagram for Grid of Figure E-18

SPOT DIAGRAM ENERGY DENSITY

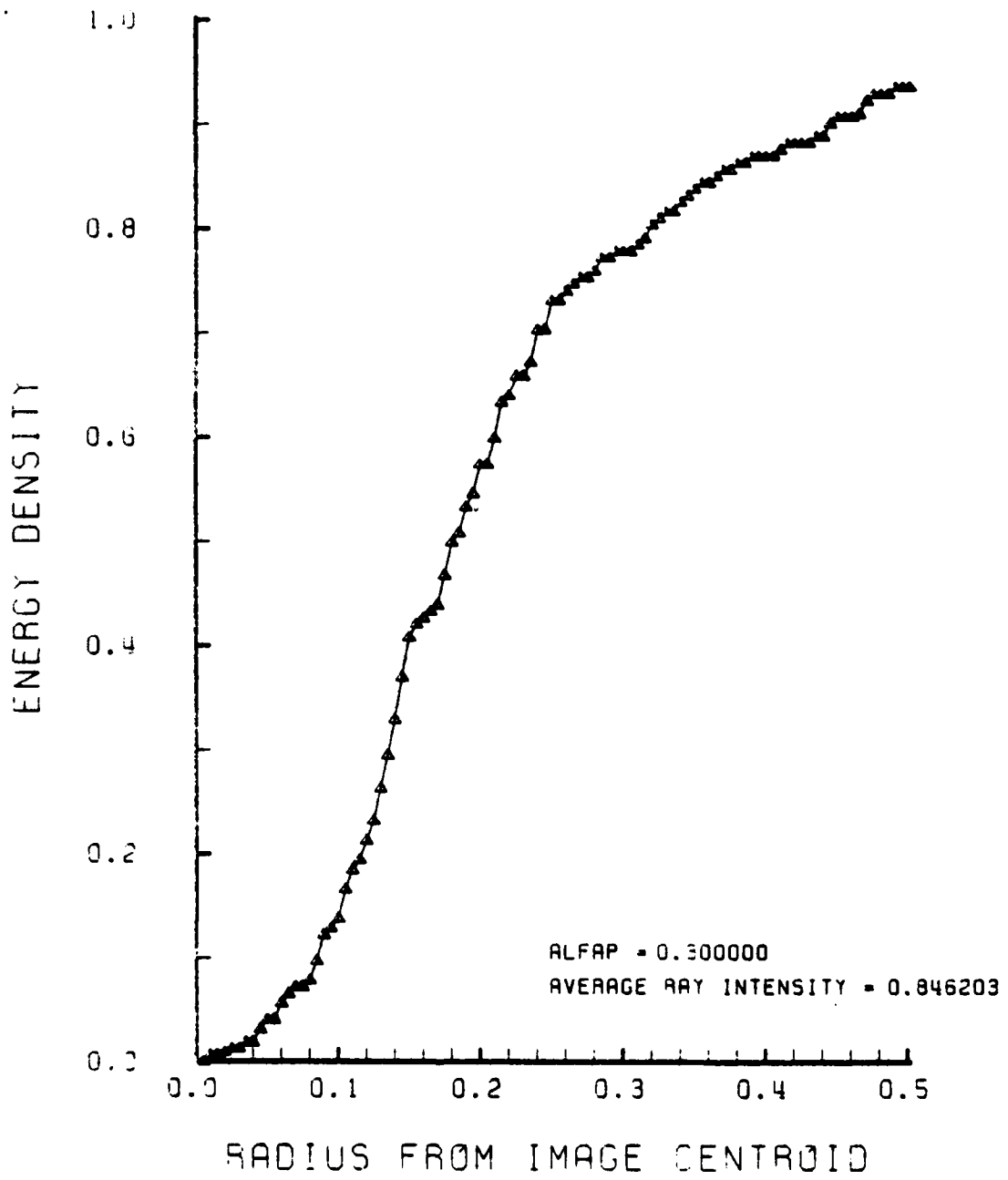

Figure E-20. Encircled Energy of Figure E-19

LENS SHAPE

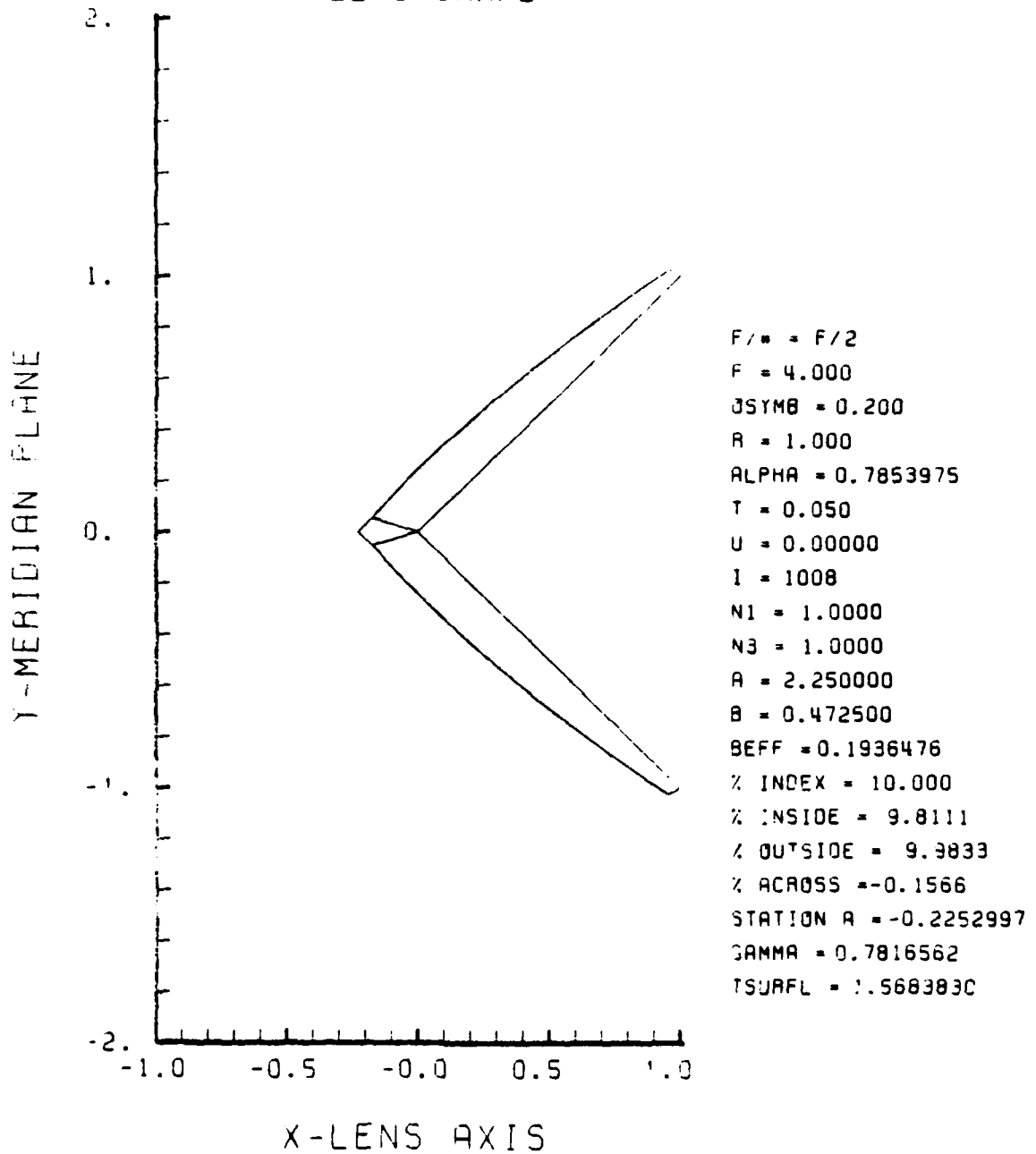

Figure E-21. GRIN Lens Shape at +10%, $\text{OB} = 0.20$,
 $a = 2.25$

LENS FRONT VIEW
OBJECT PLANE

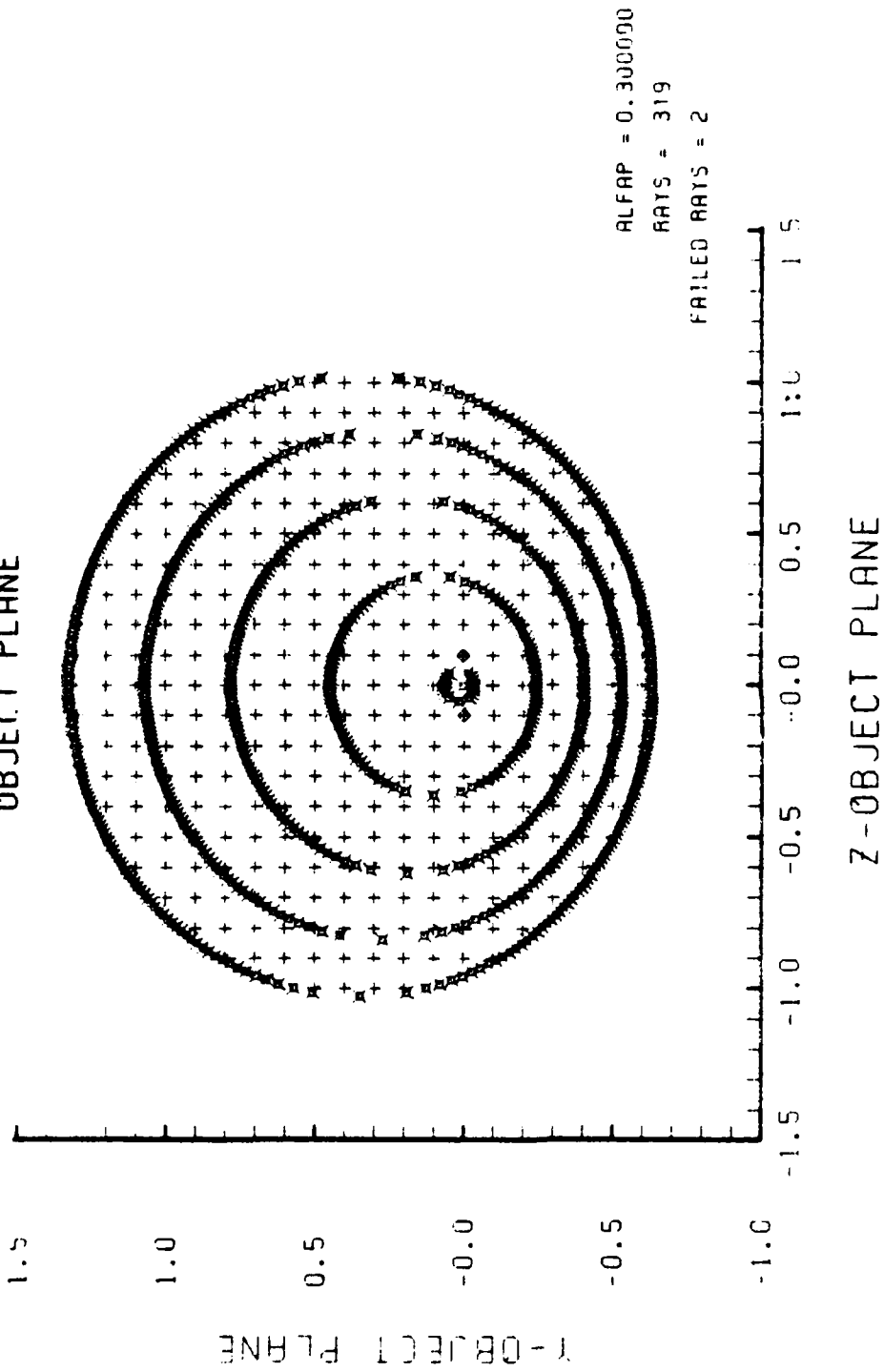

Figure E-22. Grid Plane at $\alpha_p = 0.3$ for Lens of Figure E-21

SPOT DIAGRAM

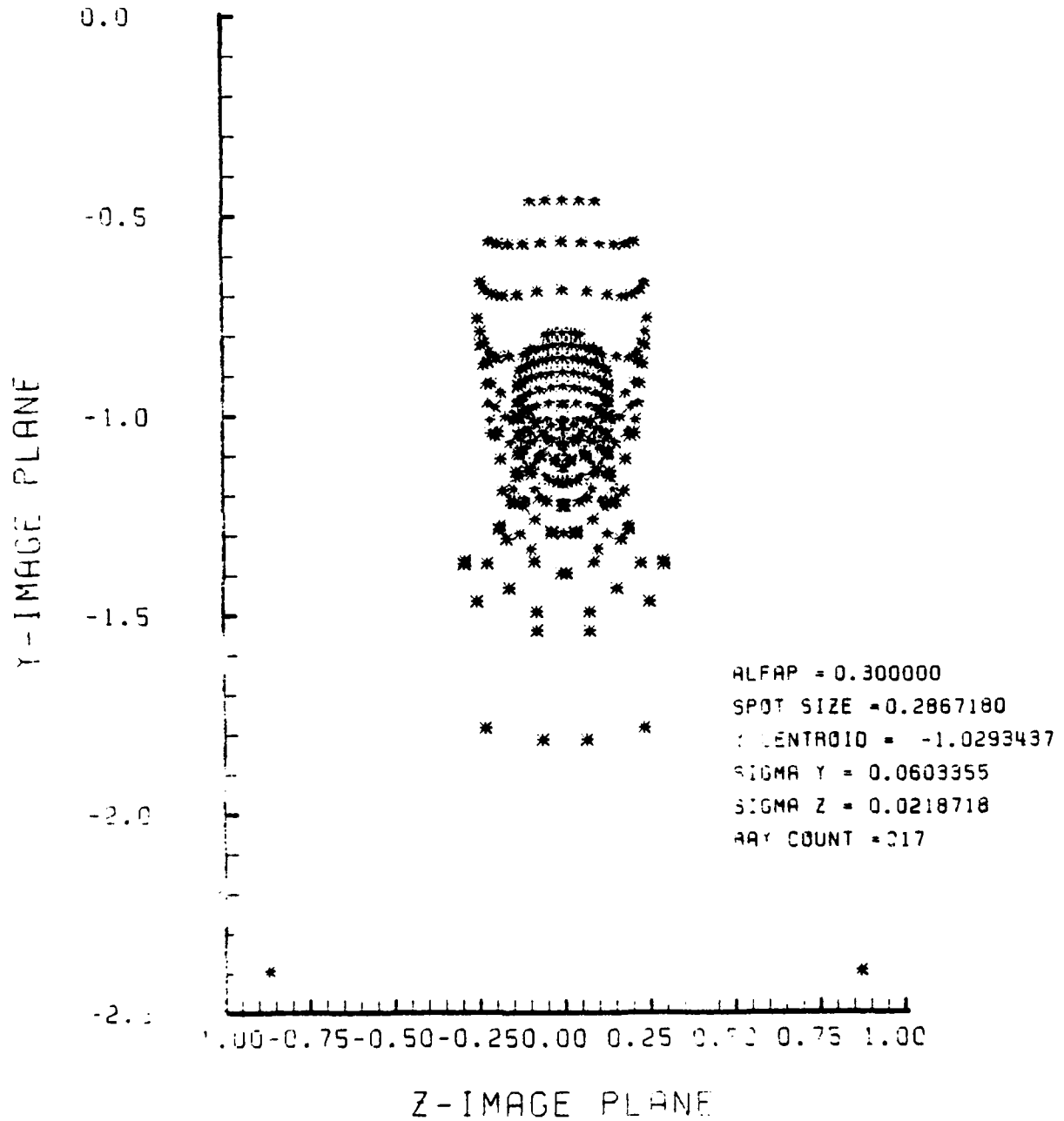

Figure E-23. Spot Diagram for Grid of Figure E-22

SPOT DIAGRAM ENERGY DENSITY

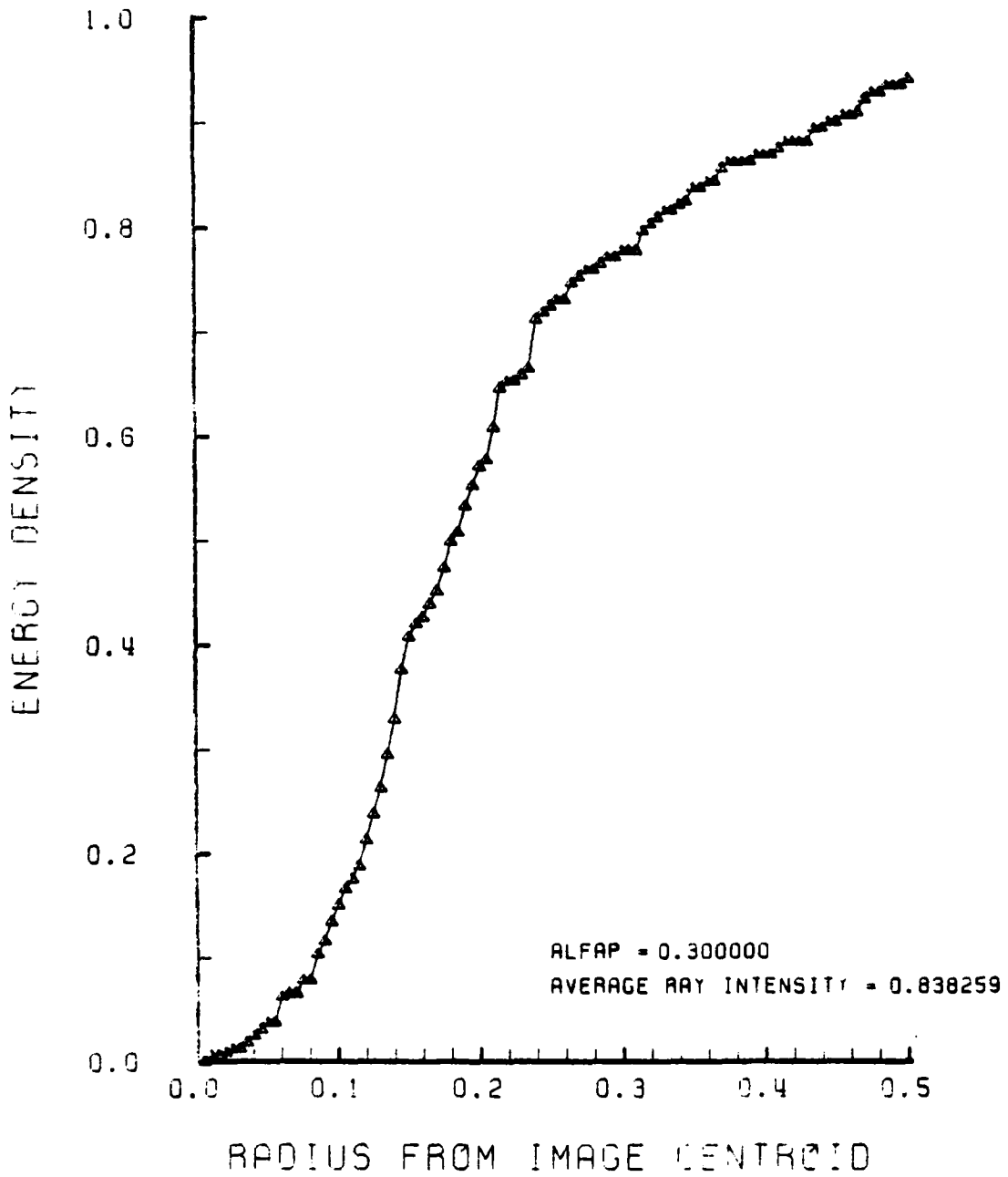

Figure E-24. Encircled Energy of Figure E-23

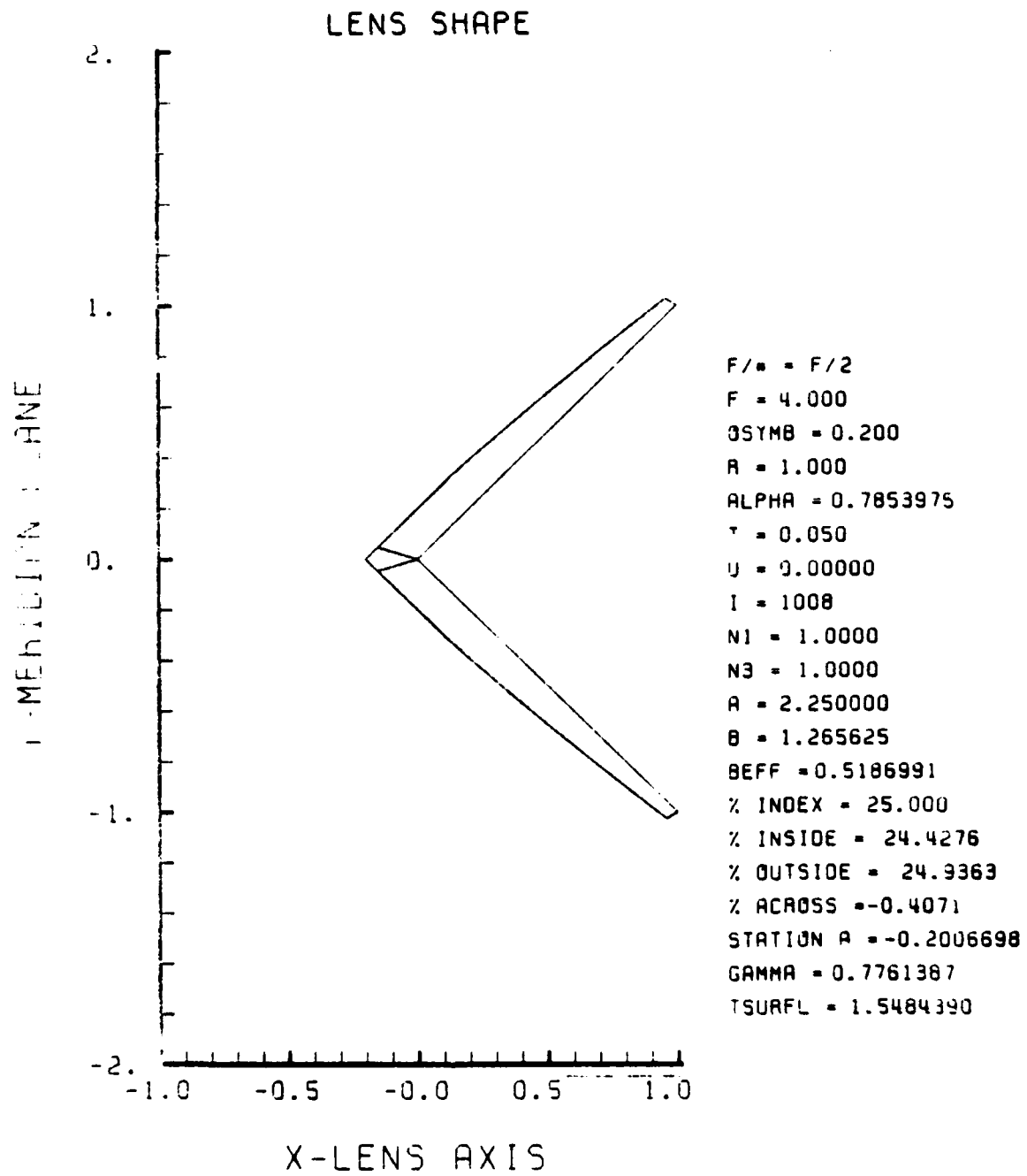

Figure E-25. GRIN Lens Shape at +25%, OB = 0.20,
a = 2.25

LENS FRONT VIEW
OBJECT PLANE

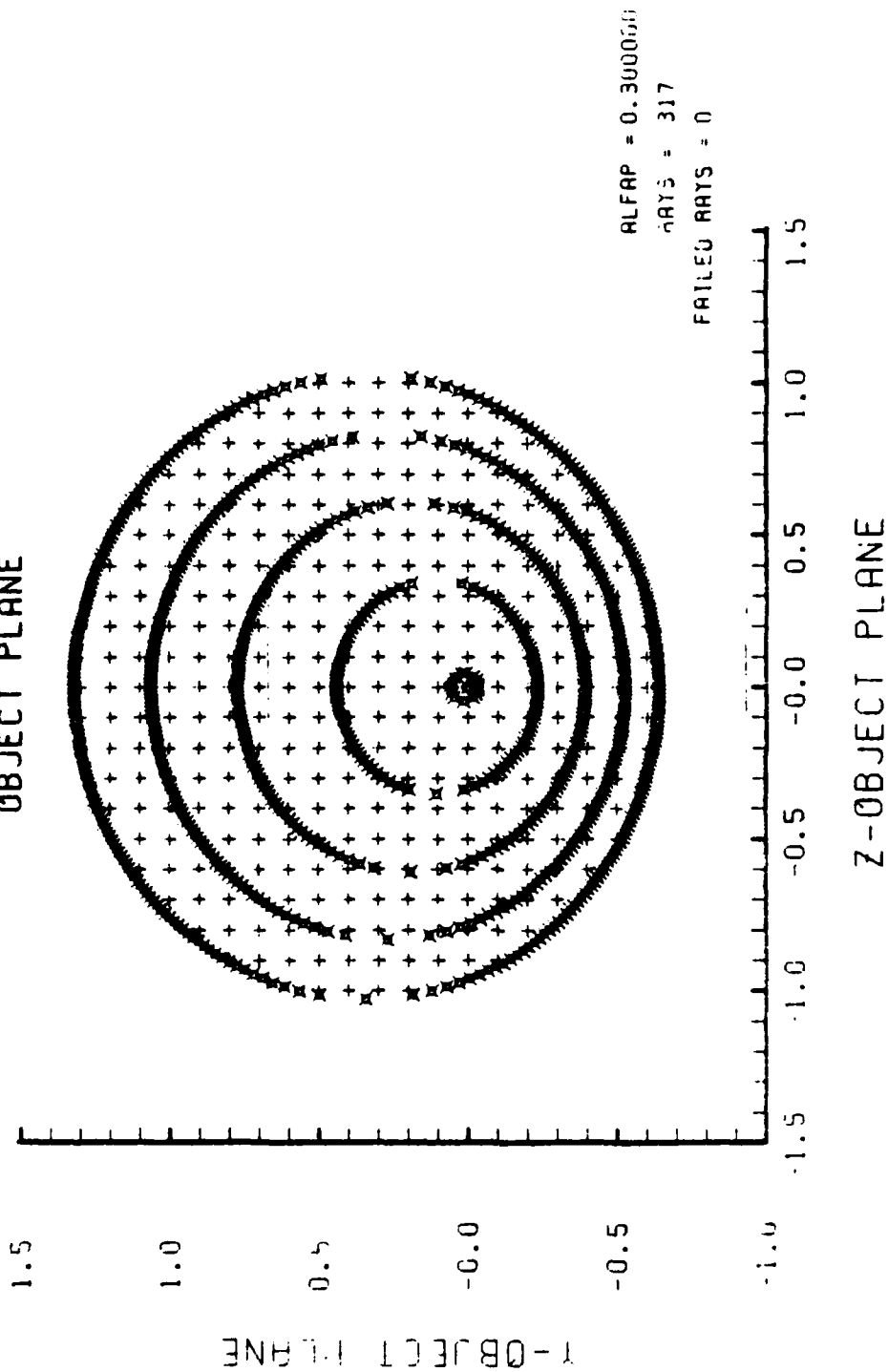

Figure E-26. Grid Plane at $\alpha_p = 0.3$ for Lens of Figure E-25

SPOT DIAGRAM

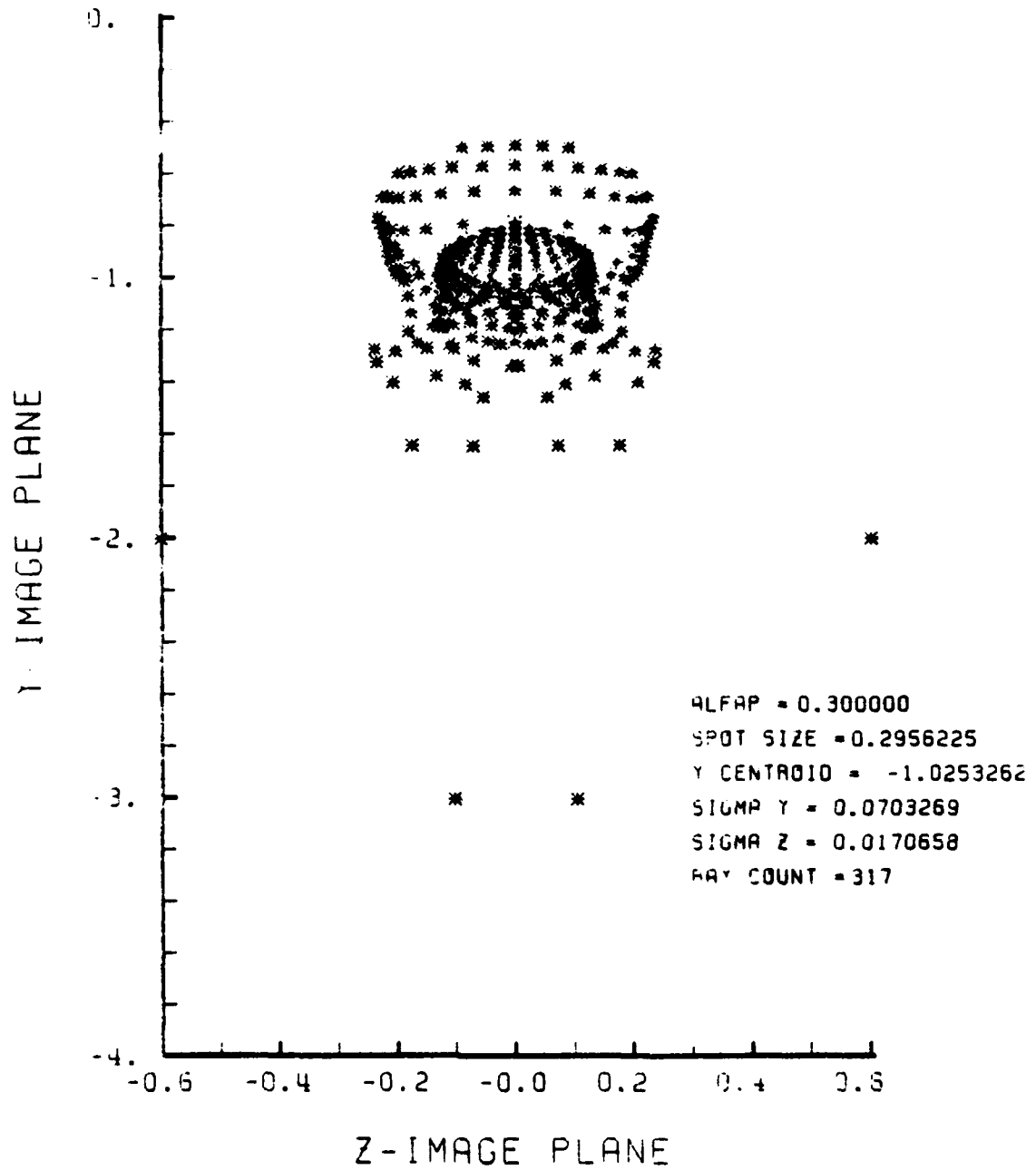

Figure E-27. Spot Diagram for Grid of Figure E-26

SPOT DIAGRAM ENERGY DENSITY

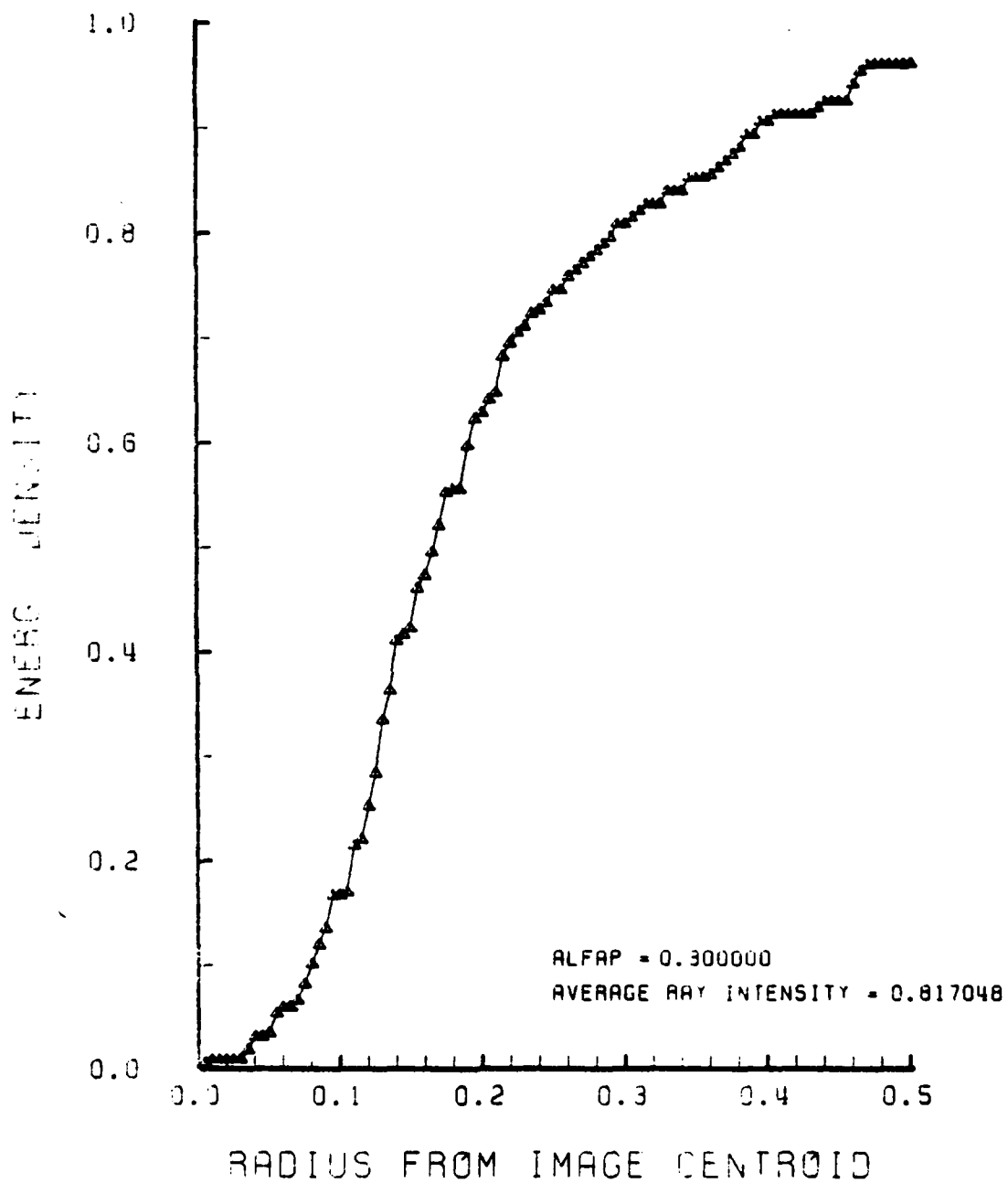

Figure E-28. Encircled Energy of Figure E-27

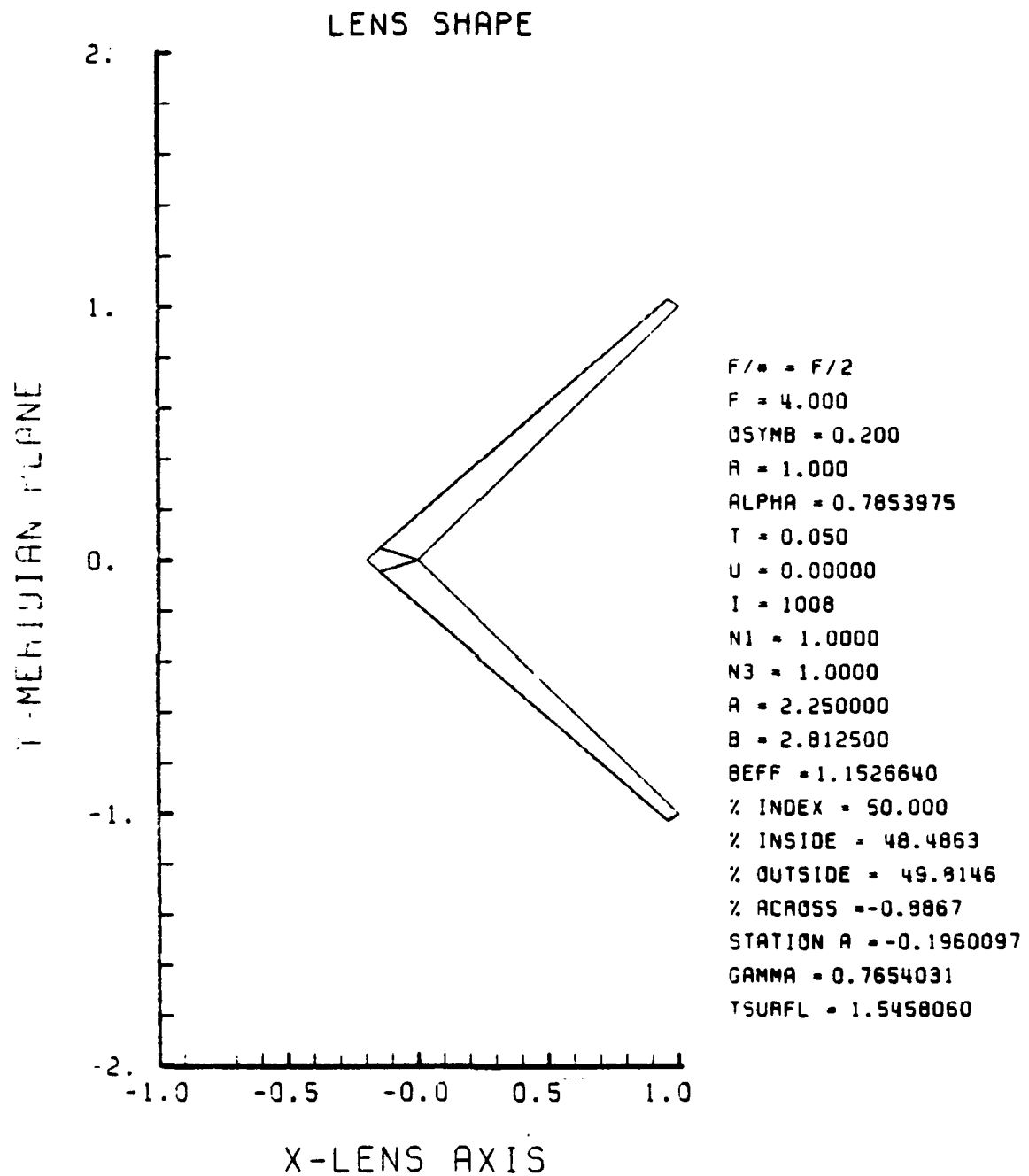

Figure E-29. GRIN Lens Shape at +50%, OB = 0.20,
a = 2.25

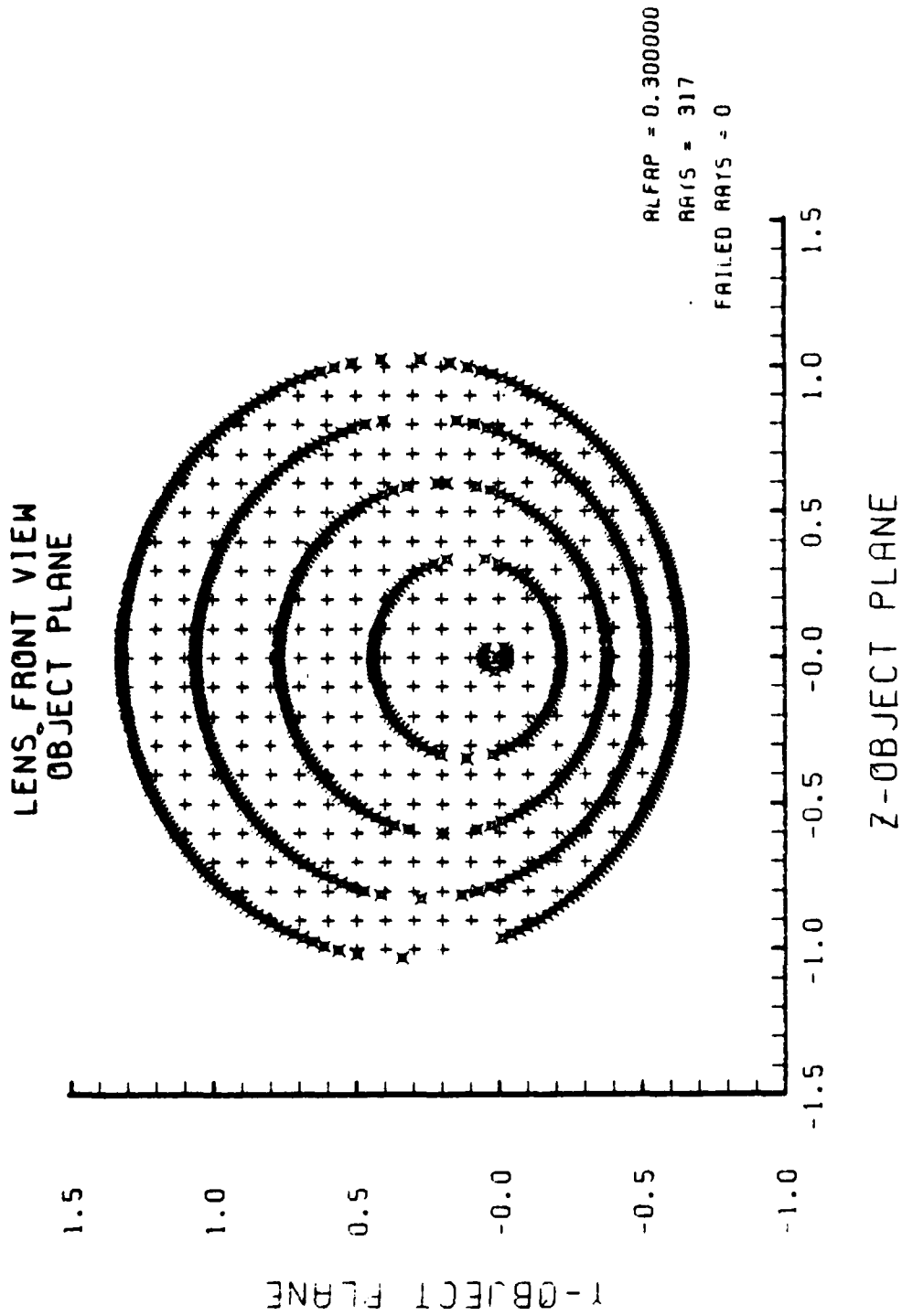

Figure E-30. Grid Plane at $\alpha_p = 0.3$ for Lens of Figure E-29

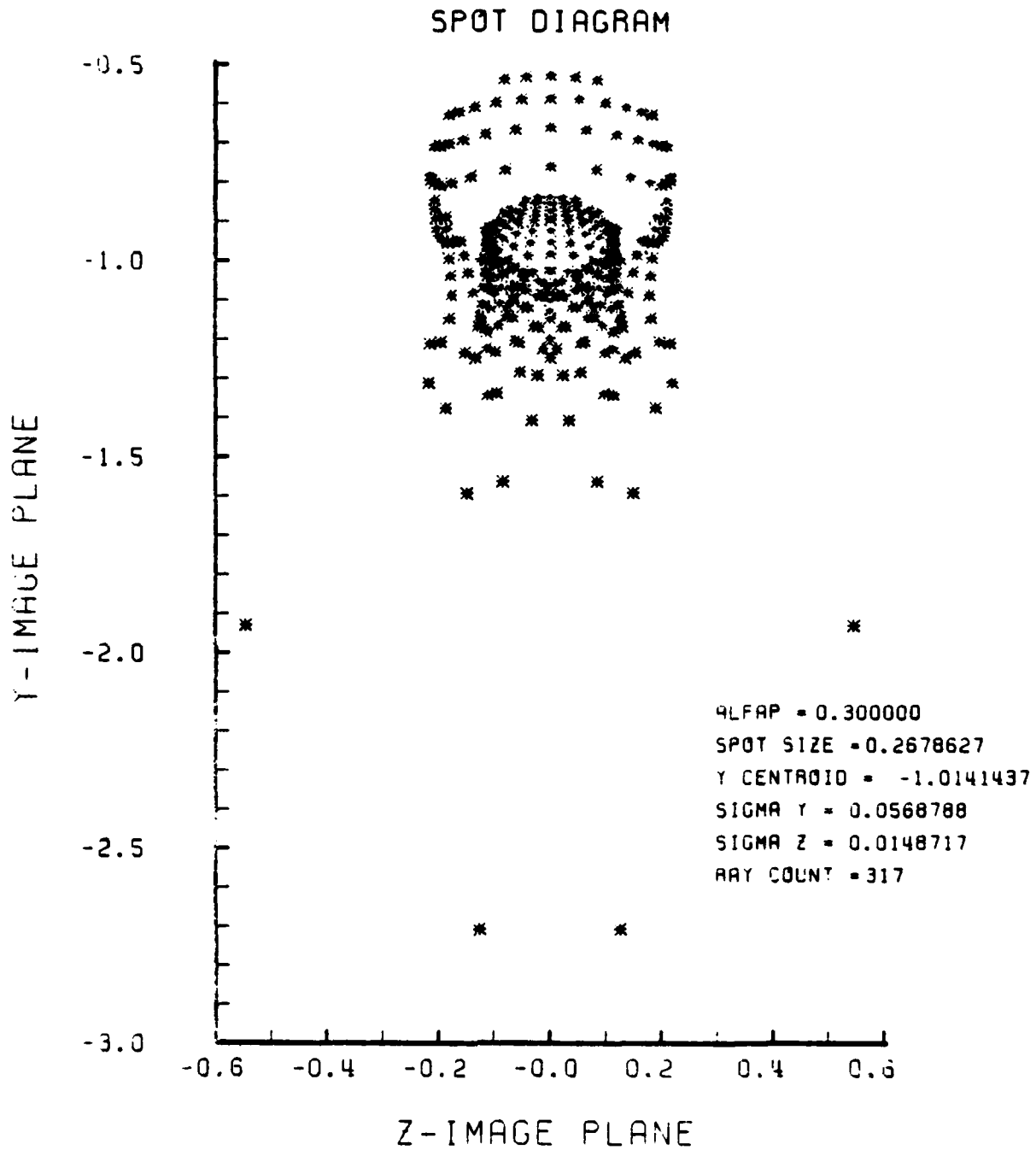

Figure E-31. Spot Diagram for Grid of Figure E-30

SPOT DIAGRAM ENERGY DENSITY

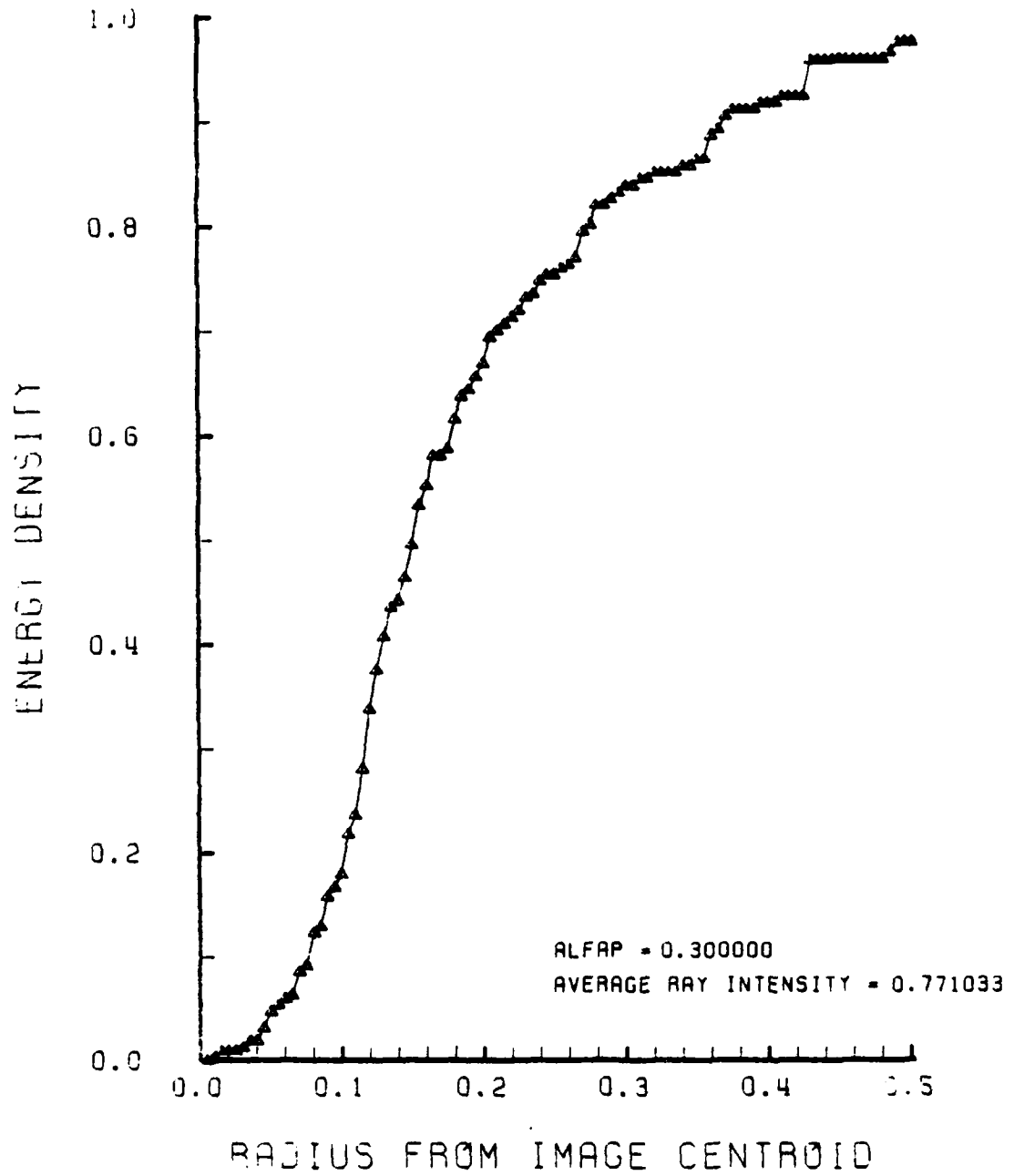

Figure E-32. Encircled Energy of Figure E-31

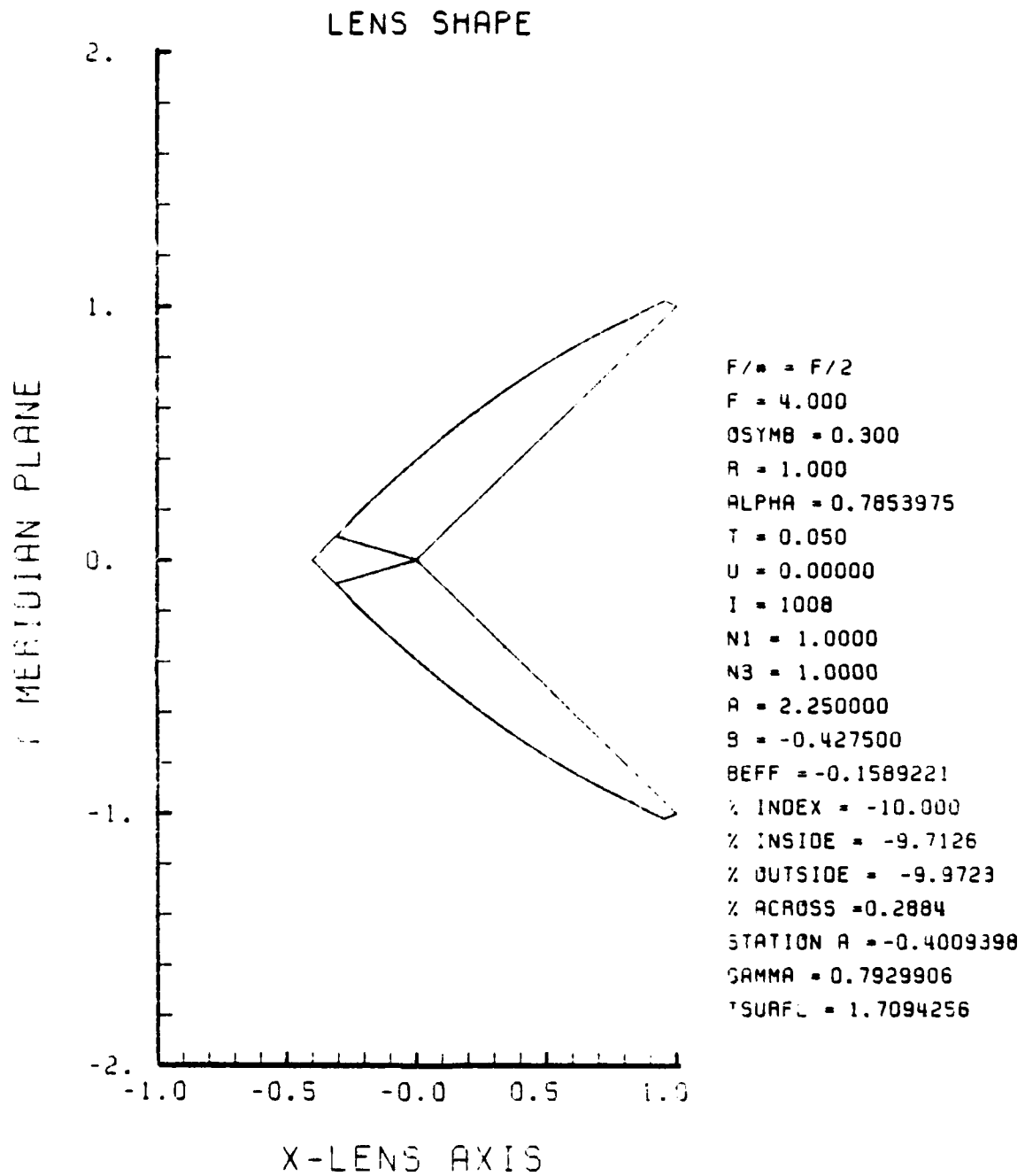

Figure E-33. GRIN Lens Shape at -10%, OB = 0.30,
a = 2.25

LENS FRONT VIEW
OBJECT PLANE

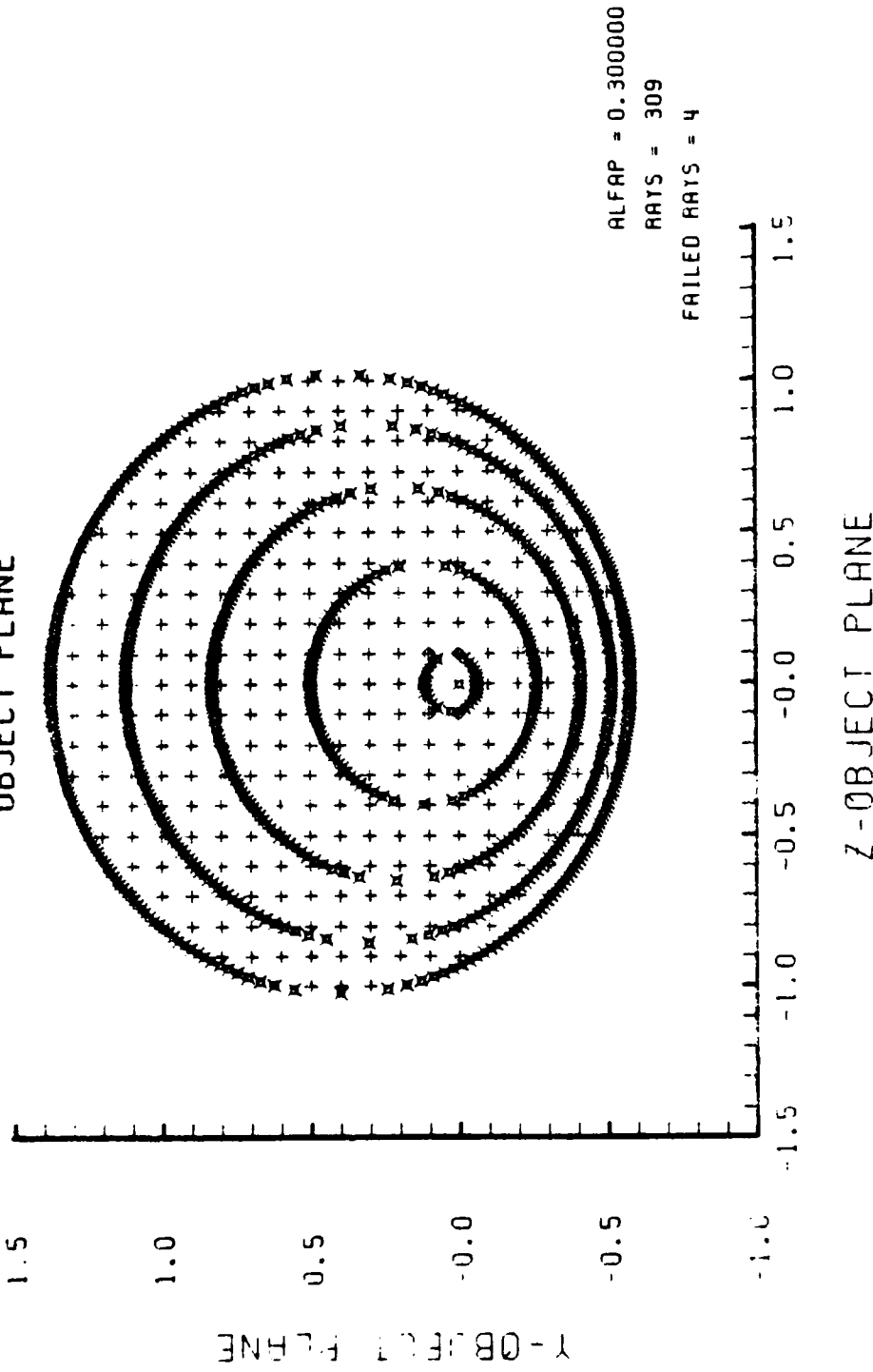

Figure E-34. Grid Plane at $\alpha_p = 0.3$ for Lens of Figure E-33

SPOT DIAGRAM

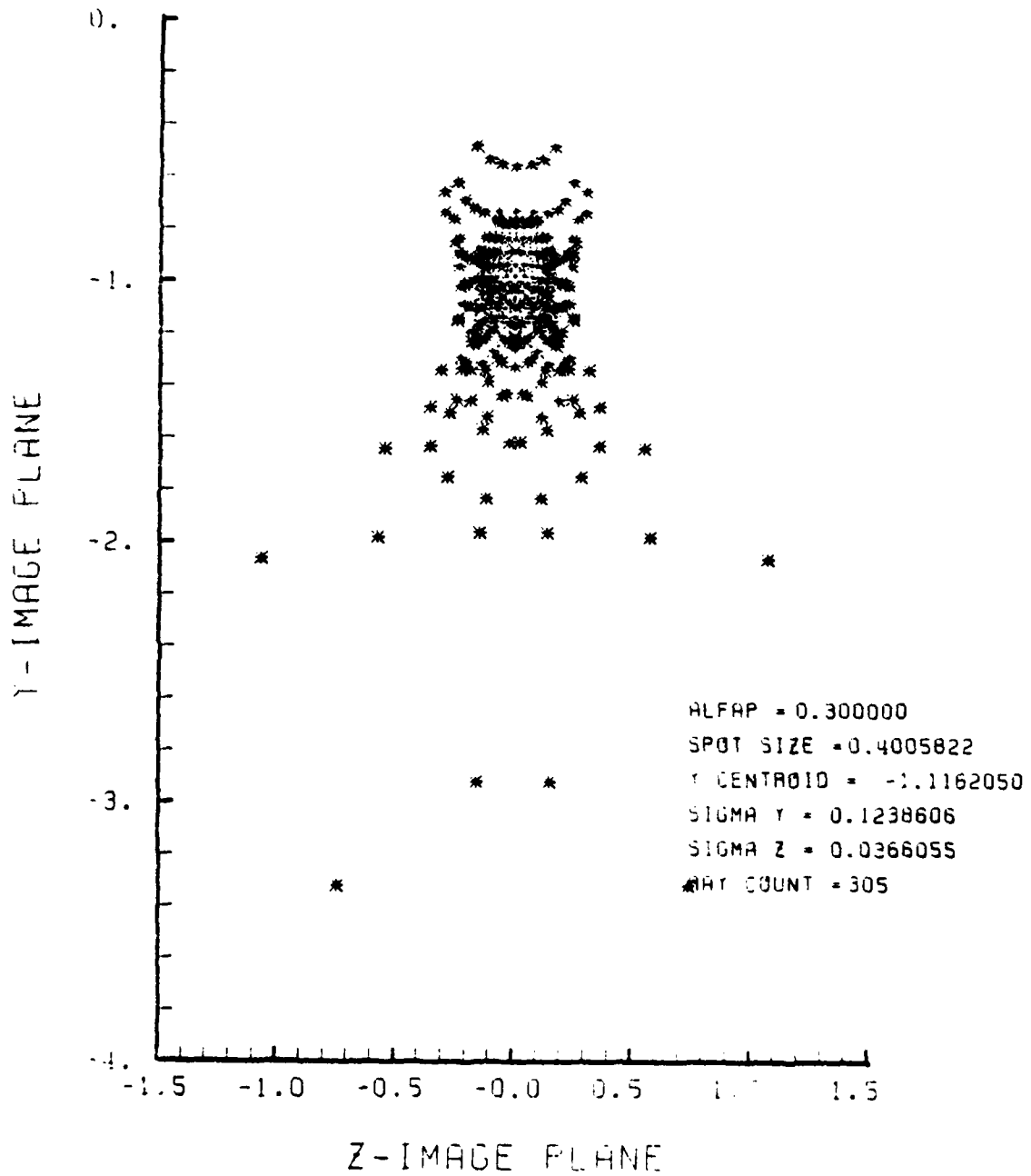

Figure E-35. Spot Diagram for Grid of Figure E-34

SPOT DIAGRAM ENERGY DENSITY

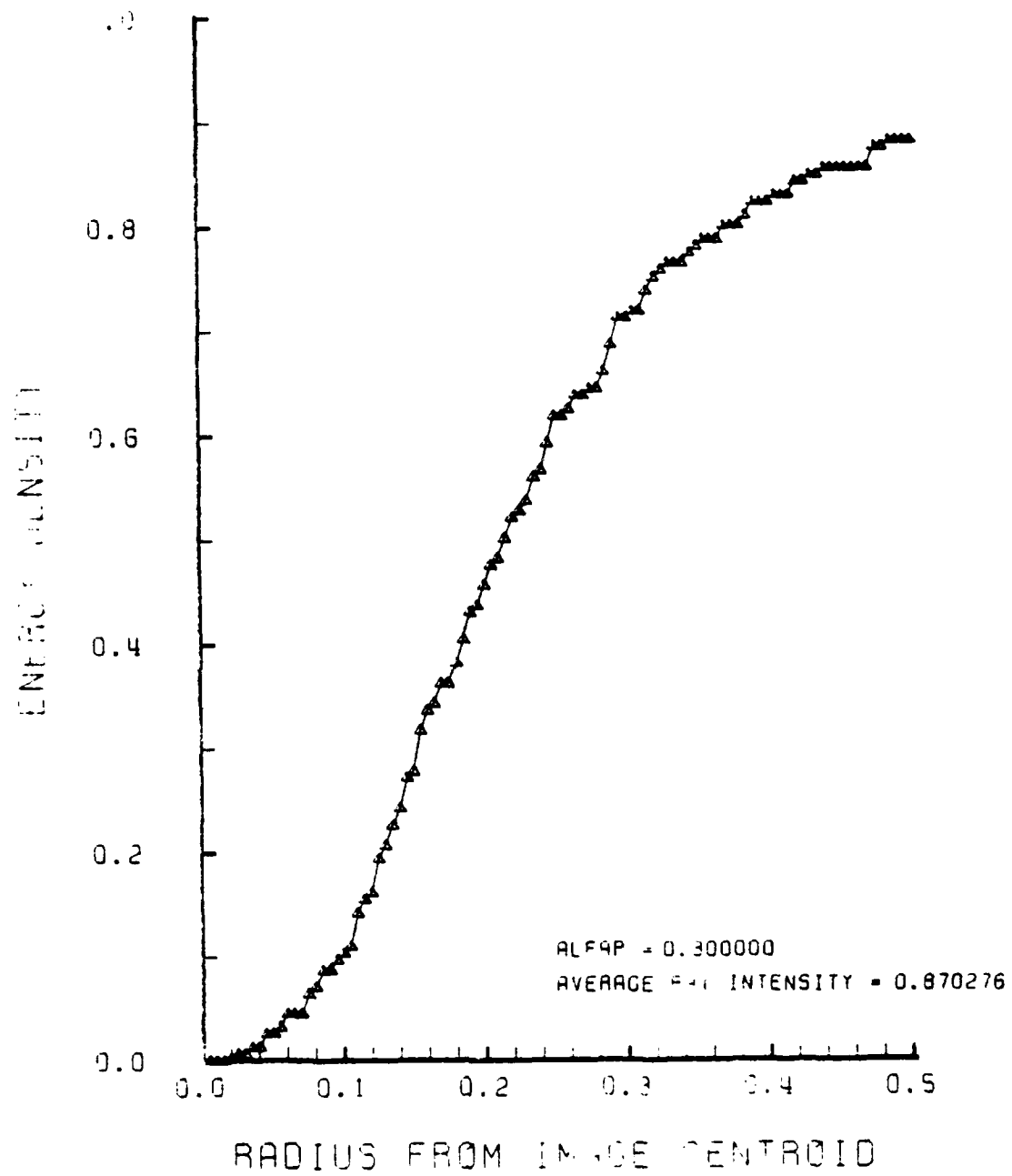

Figure E-36. Encircled Energy of Figure E-35

LENS SHAPE

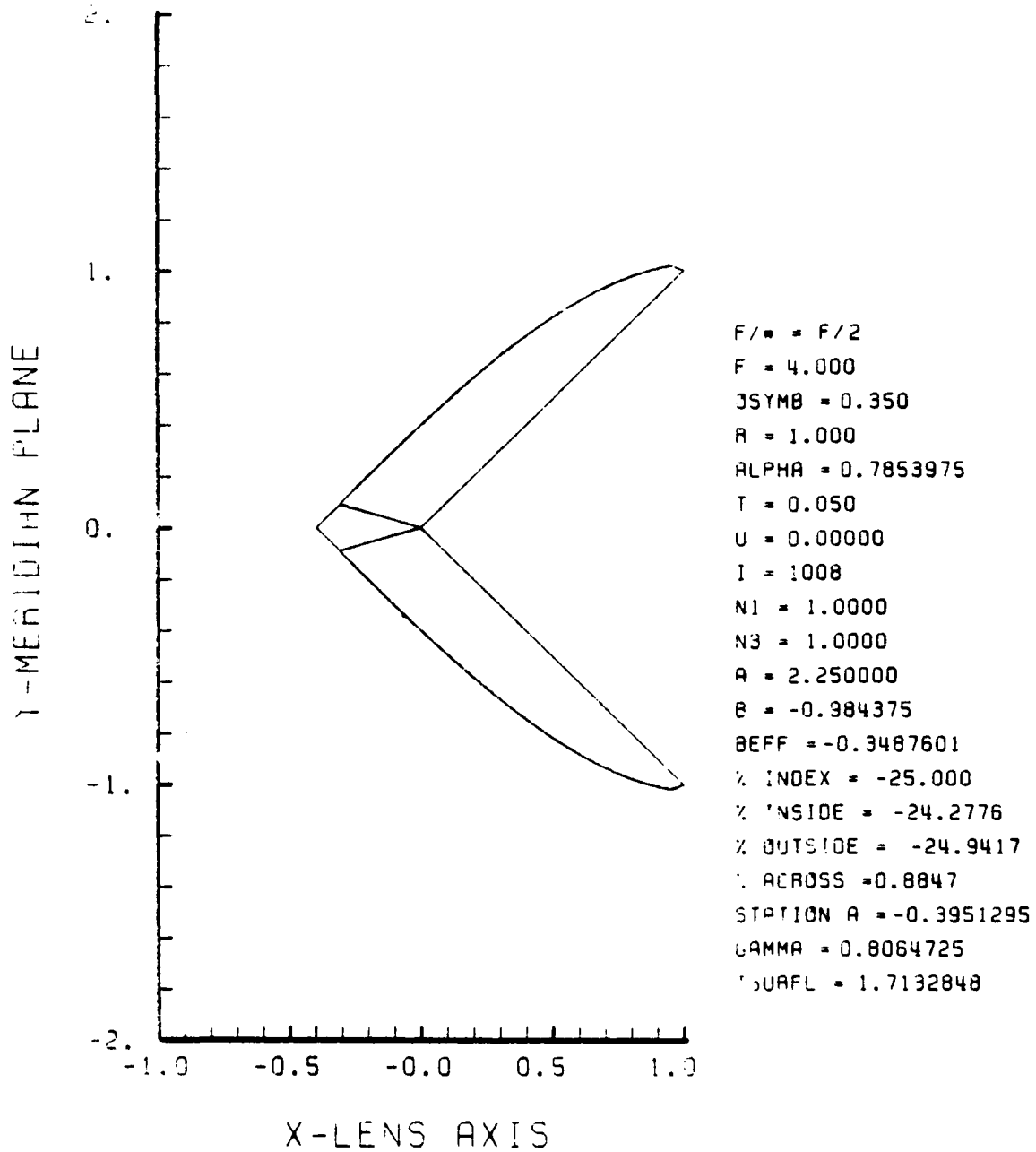
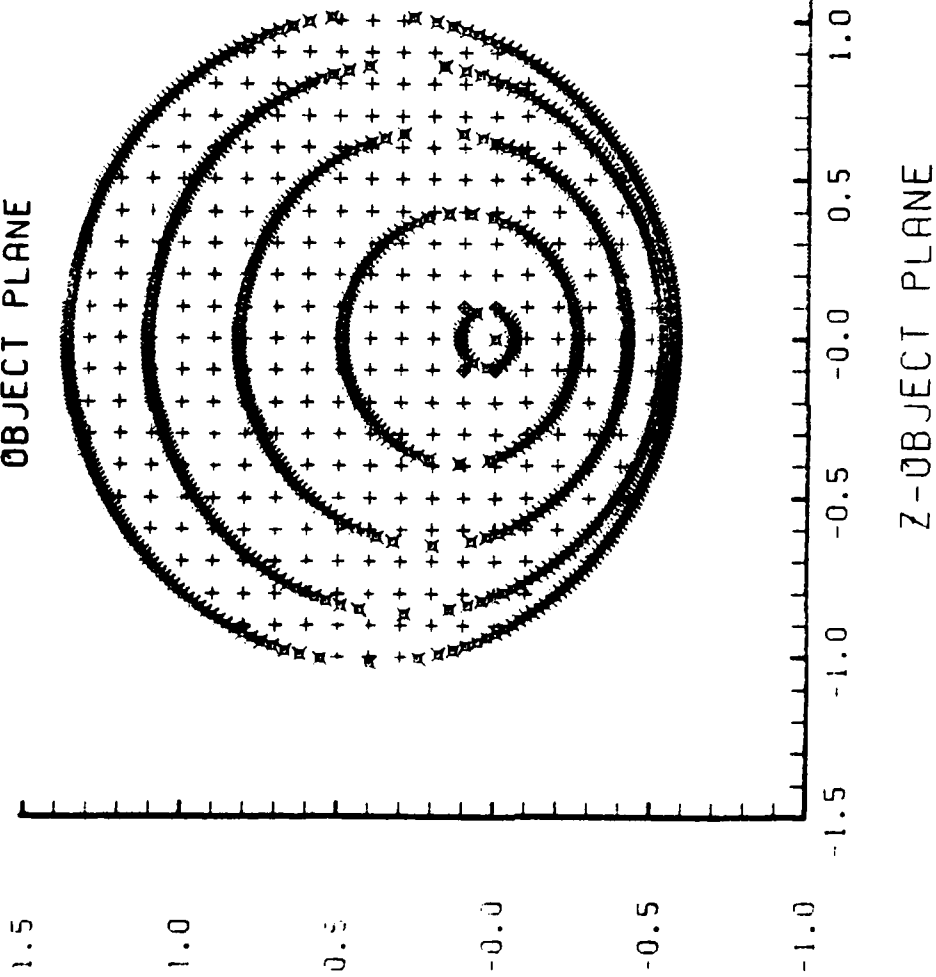

Figure E-37. GRIN Lens Shape at -25%, OB = 0.35, a = 2.25

LENS FRONT VIEW
OBJECT PLANE



ALFAP = 0.300000
RAYS = 309
FAILED RAYS = 4

Figure E-38. Grid Plane at $\alpha_p = 0.3$ for Lens of Figure E-37

SPOT DIAGRAM

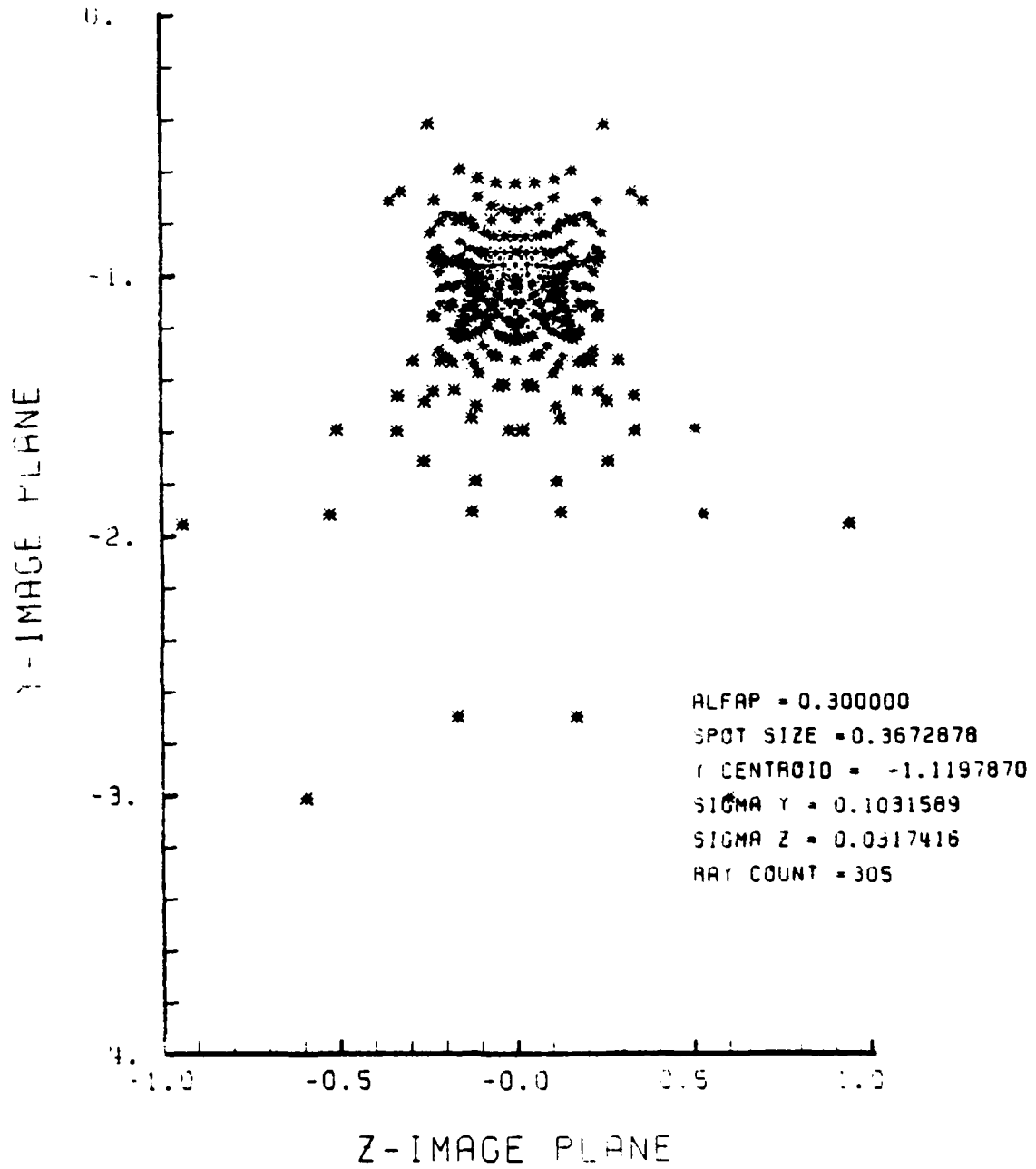

Figure E-39. Spot Diagram for Grid of Figure E-38

SPOT DIAGRAM ENERGY DENSITY

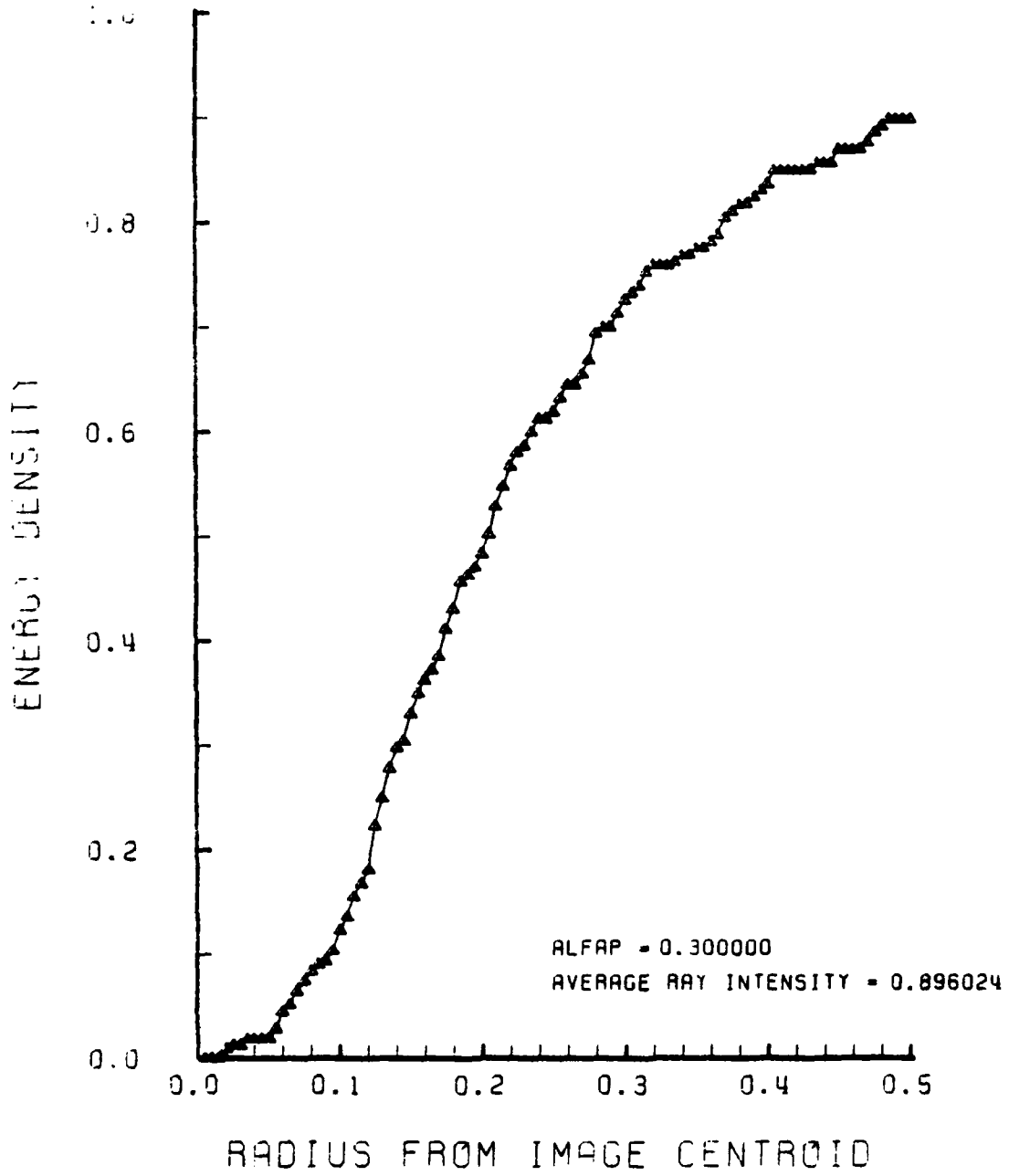

Figure E-40. Encircled Energy of Figure E-39

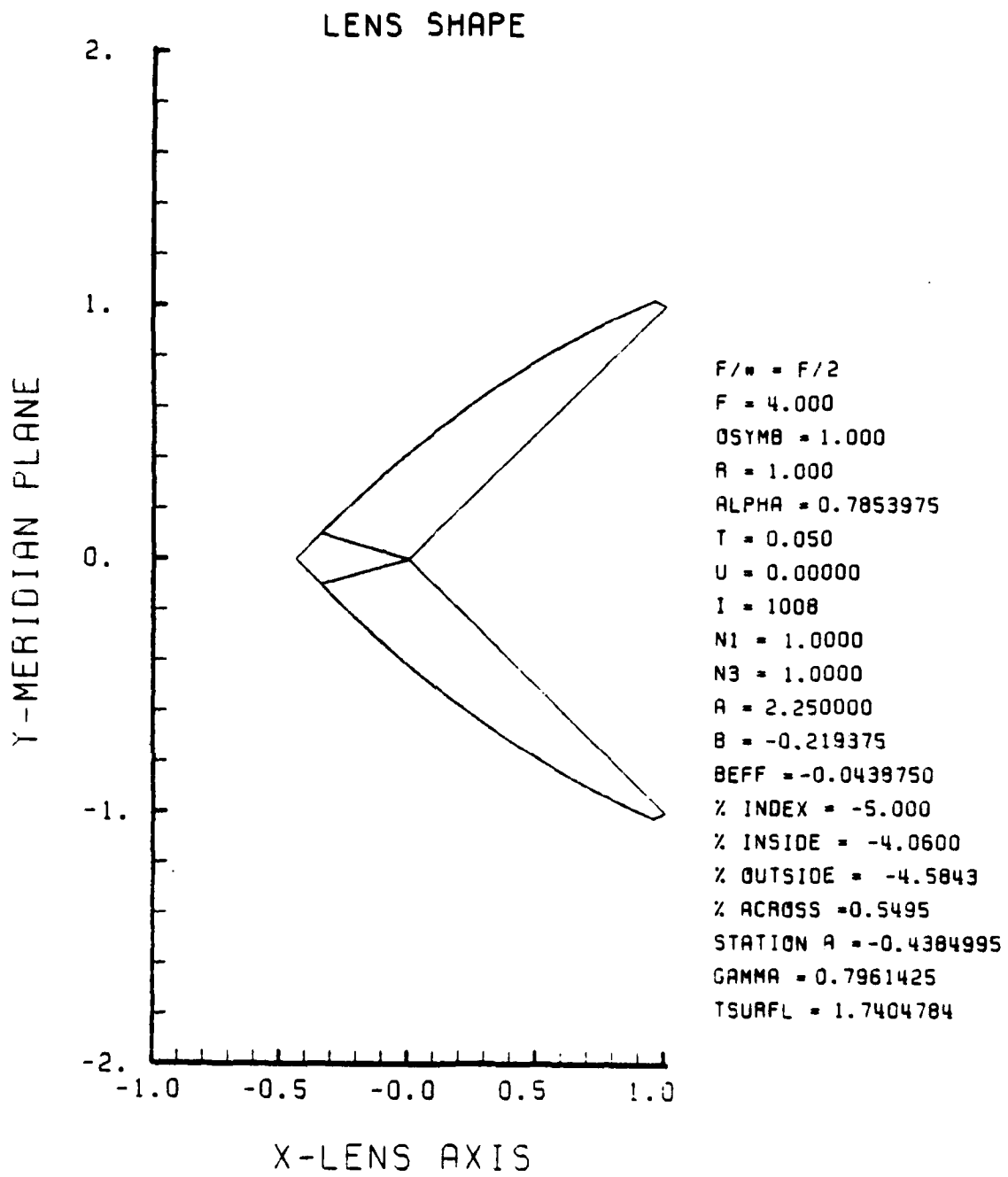
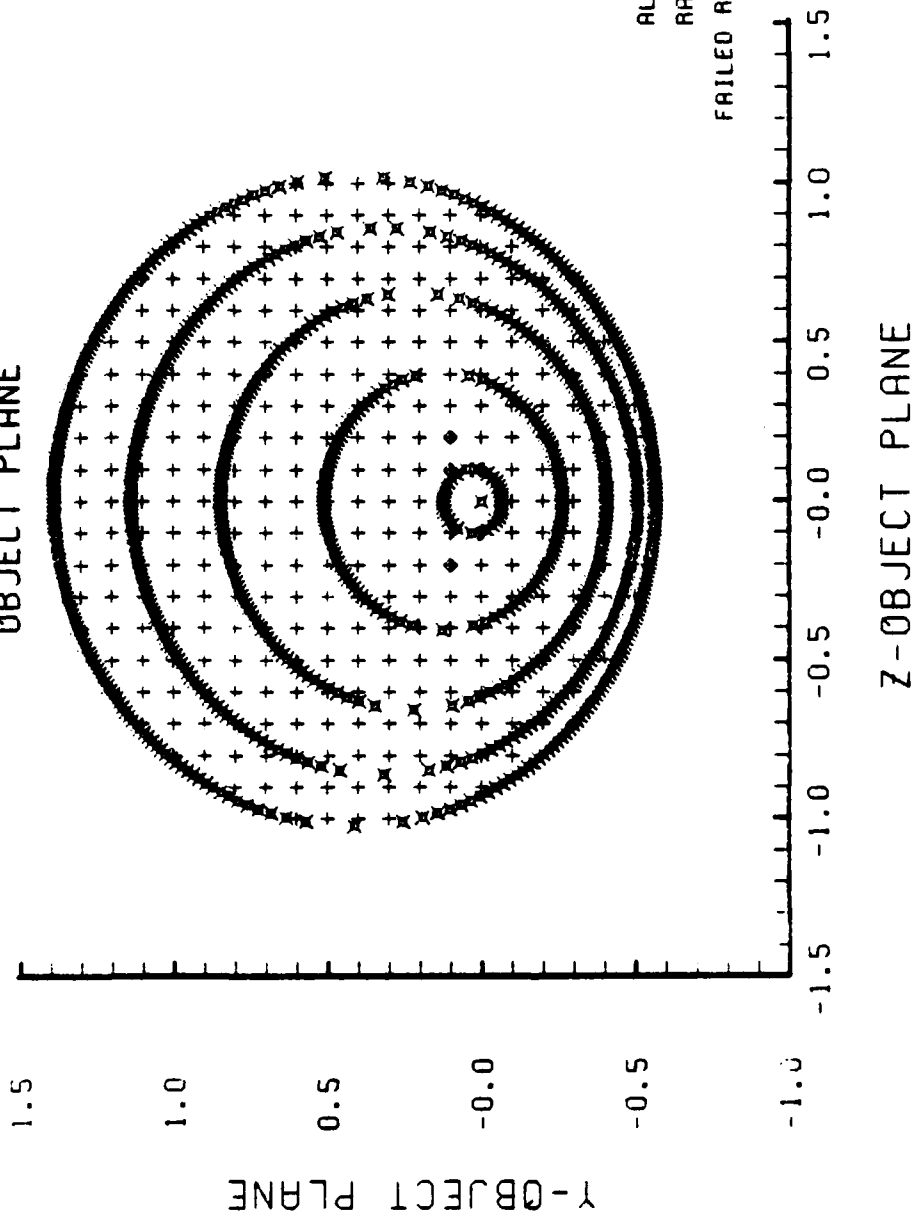

Figure E-41. GRIN Lens Shape at -5%, OB = 1.00,
a = 2.25

LENS FRONT VIEW
OBJECT PLANE



ALFAP = 0.300000
RAYS = 313
FAILED RAYS = 8

Figure E-42. Grid Plane at $\alpha_p = 0.3$ for Lens of Figure E-41

SPOT DIAGRAM

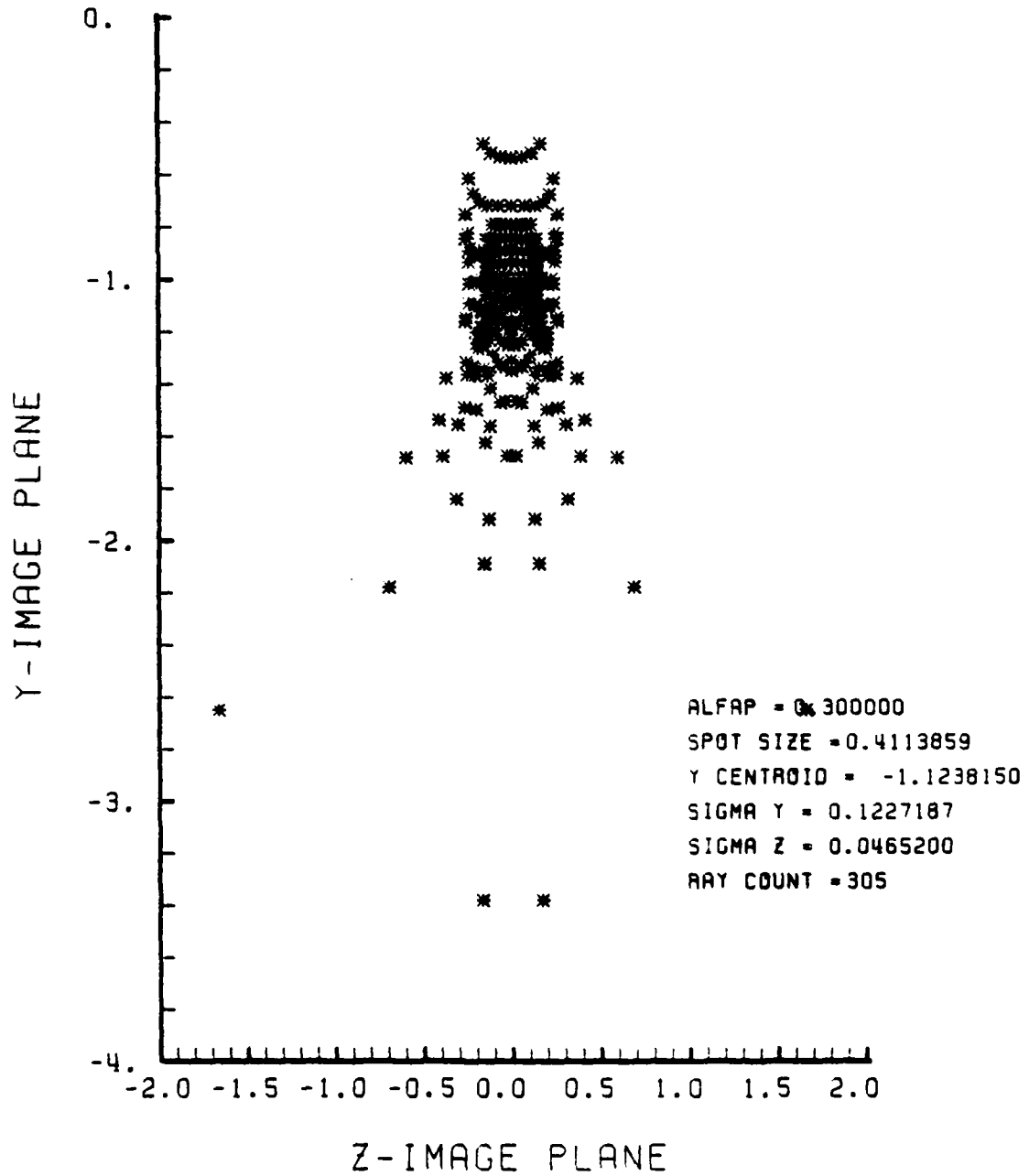

Figure E-43. Spot Diagram for Grid of Figure E-42

SPOT DIAGRAM ENERGY DENSITY

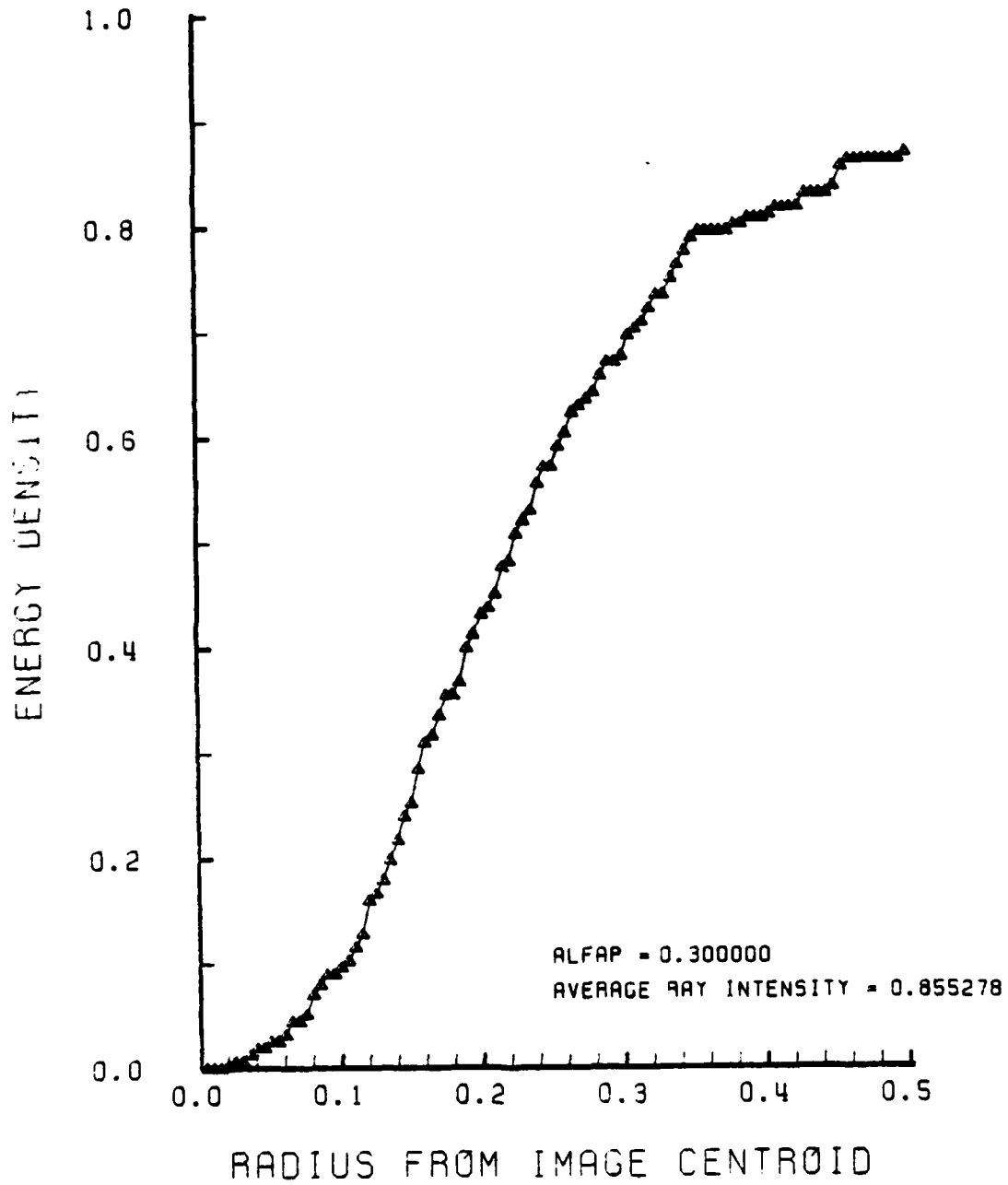

Figure E-44. Encircled Energy of Figure E-43

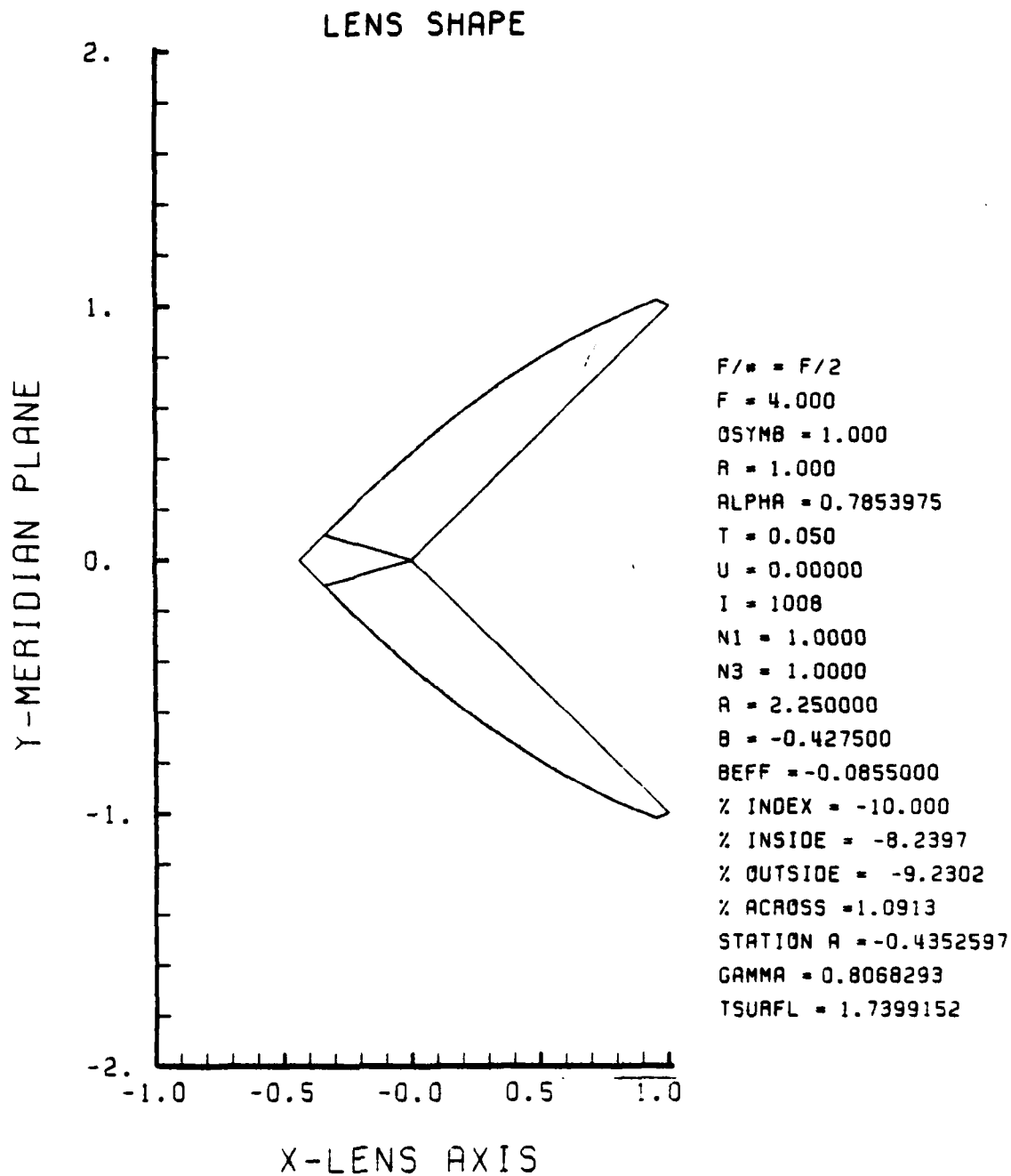

Figure E-45. GRIN Lens Shape at -10%, OB = 1.00
a = 2.25

9

LENS FRONT VIEW
OBJECT PLANE

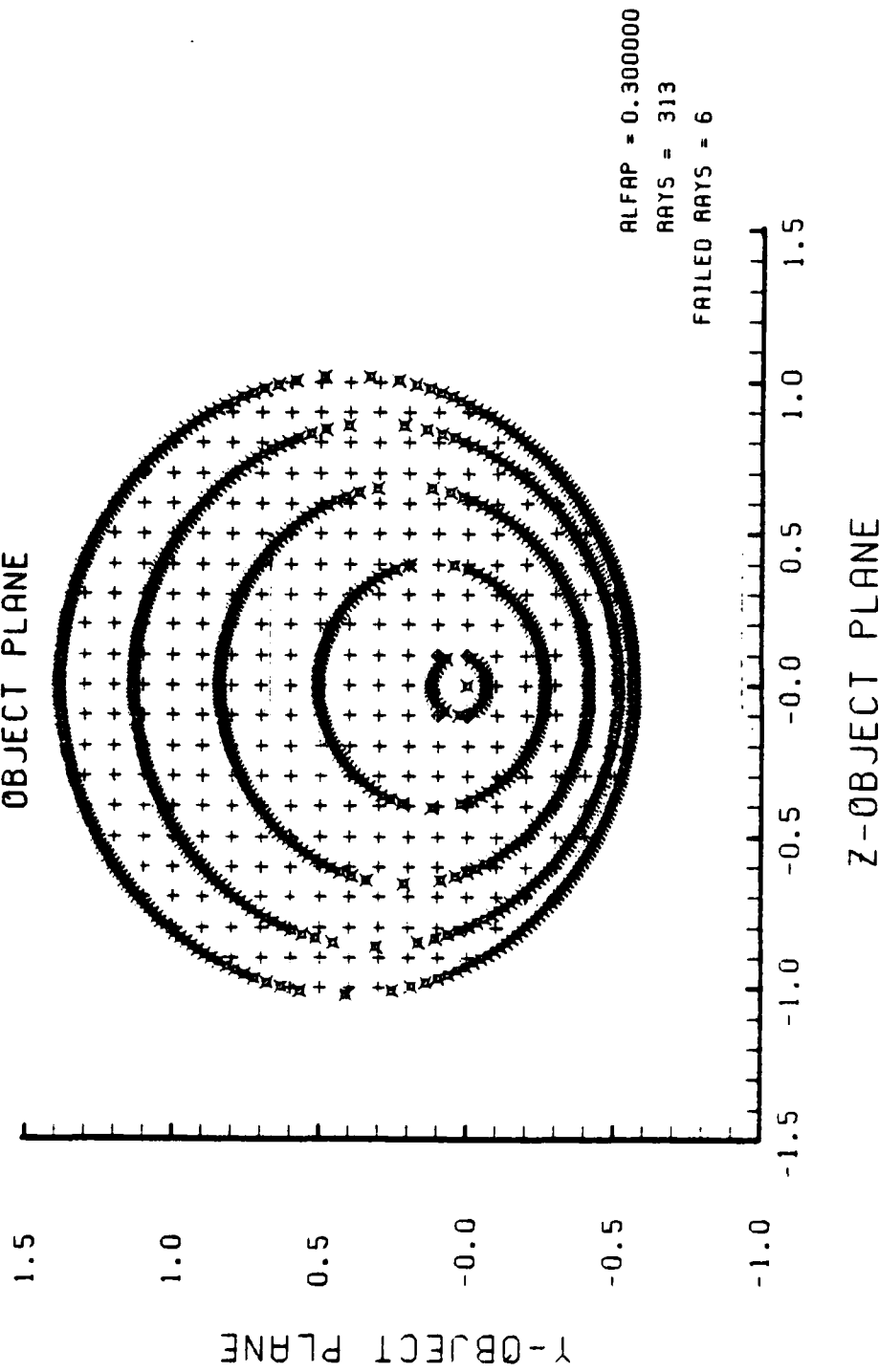

Figure E-46. Grid Plane at $\alpha_p = 0.3$ for Lens of Figure E-45

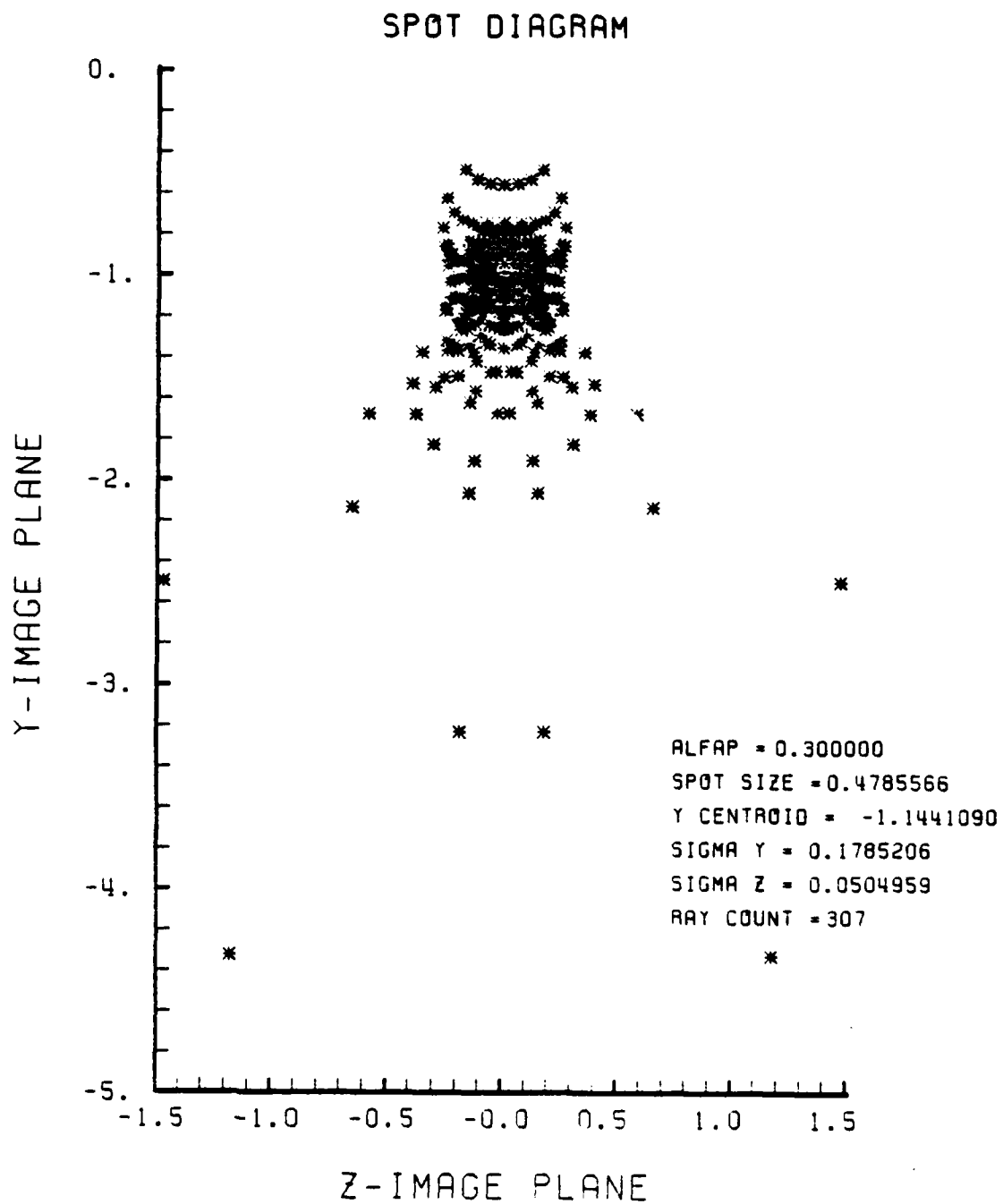

Figure E-47. Spot Diagram for Grid of Figure E-46

SPOT DIAGRAM ENERGY DENSITY

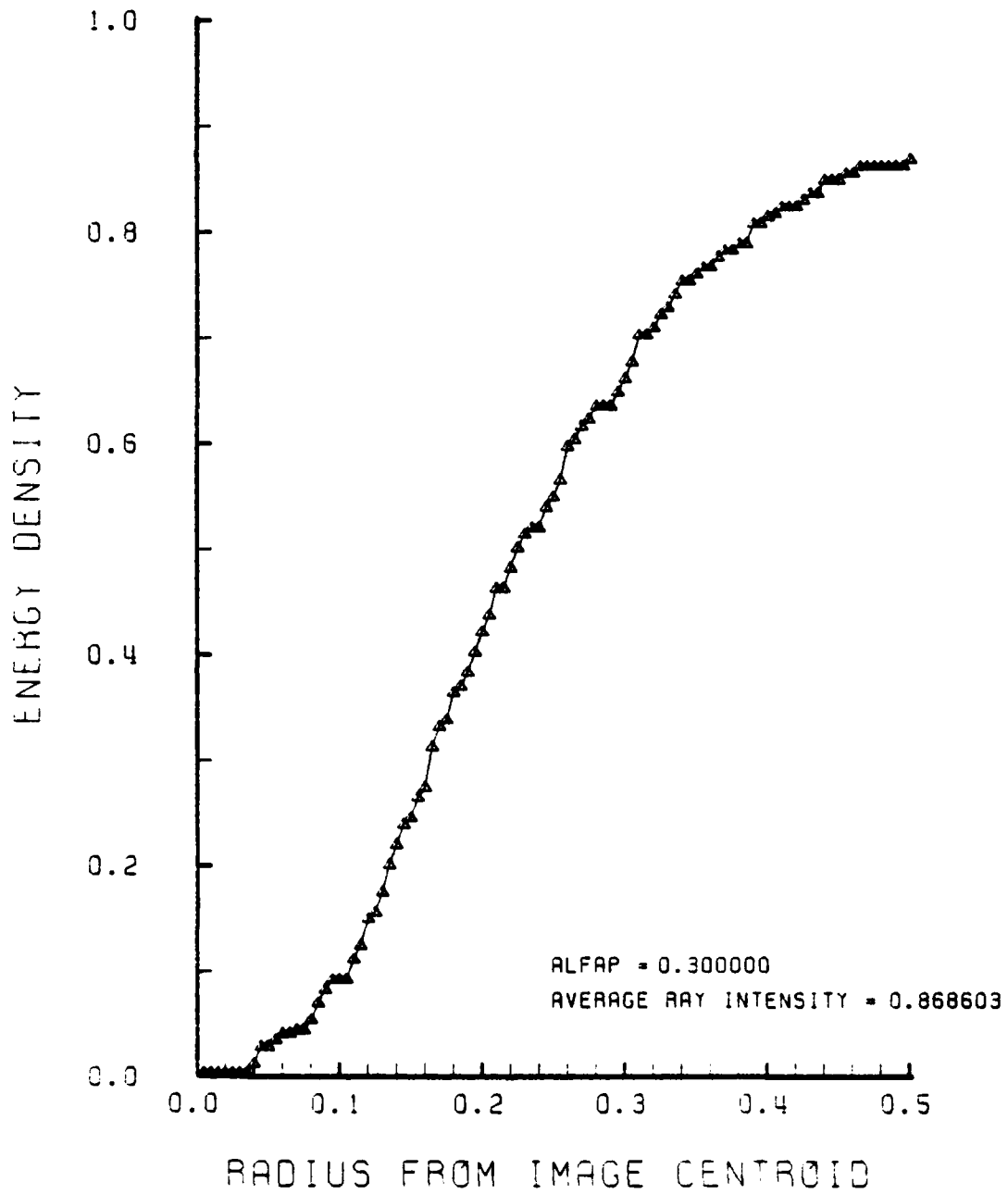

Figure E-48. Encircled Energy of Figure E-47

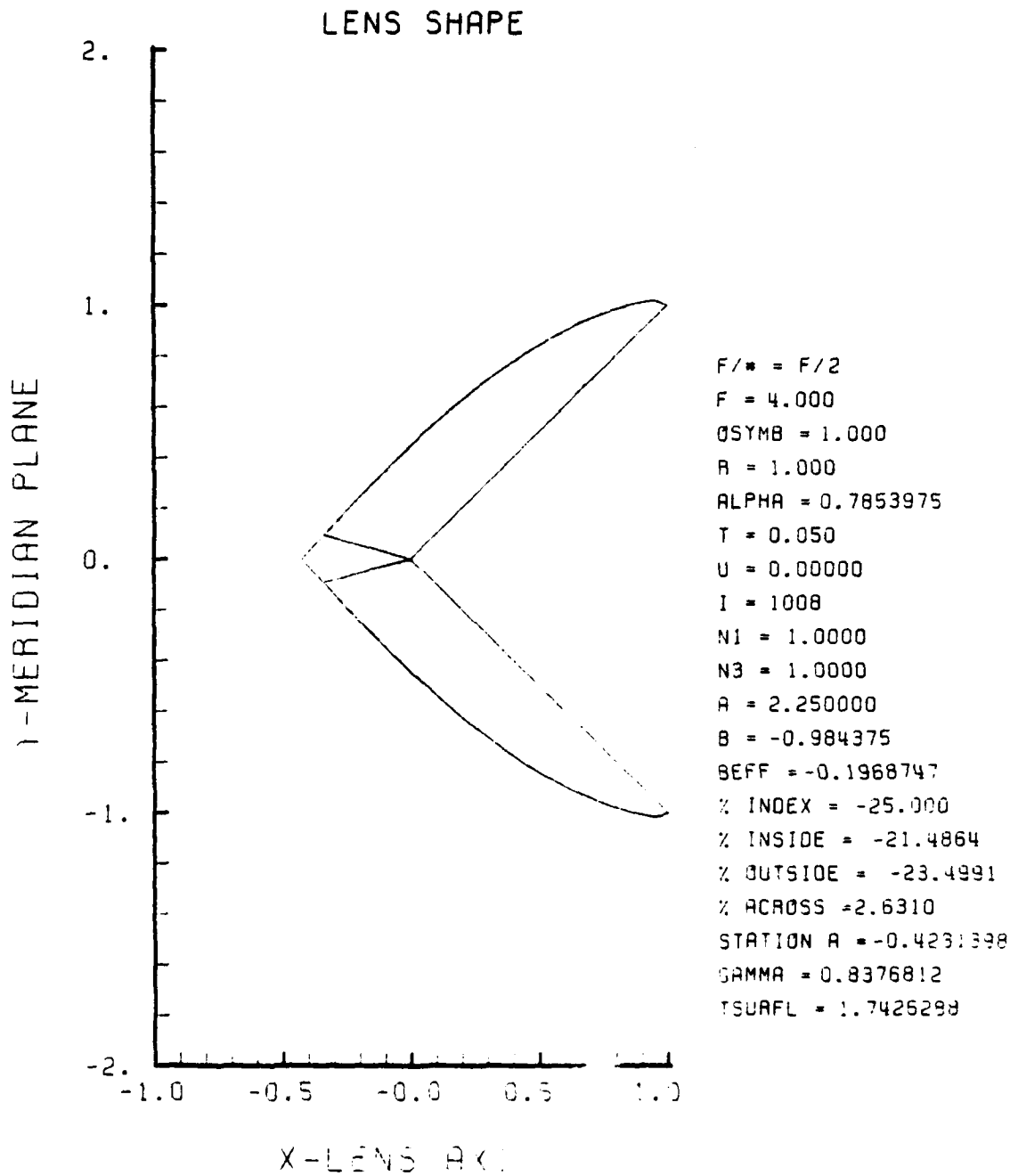

Figure E-49. GRIN Lens Shape at -25%, OB = 1.00,
a = 2.25

LENS FRONT VIEW
OBJECT PLANE

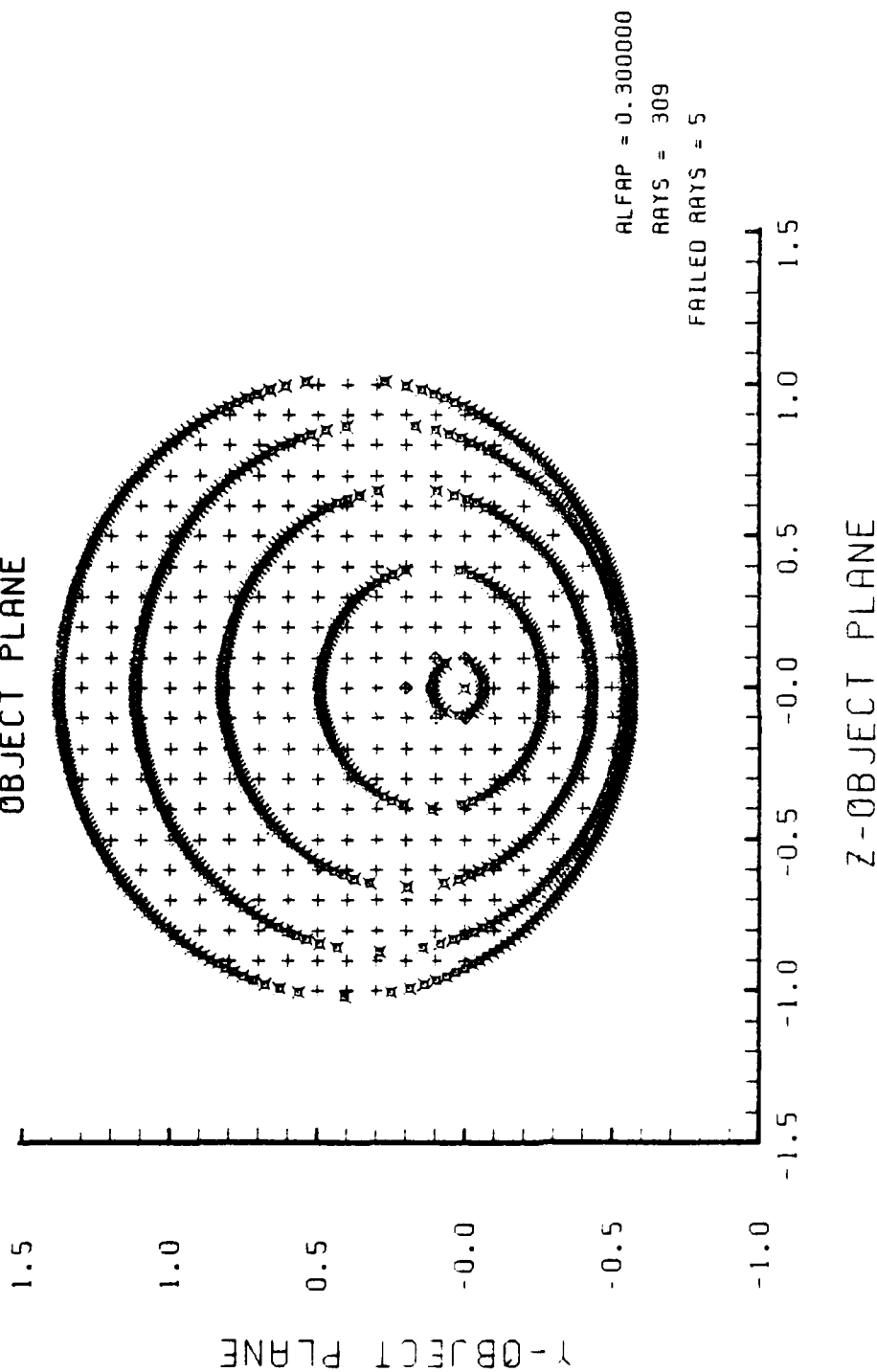

Figure E-50. Grid Plane at $\alpha_p = 0.3$ for Lens of Figure E-49

SPOT DIAGRAM

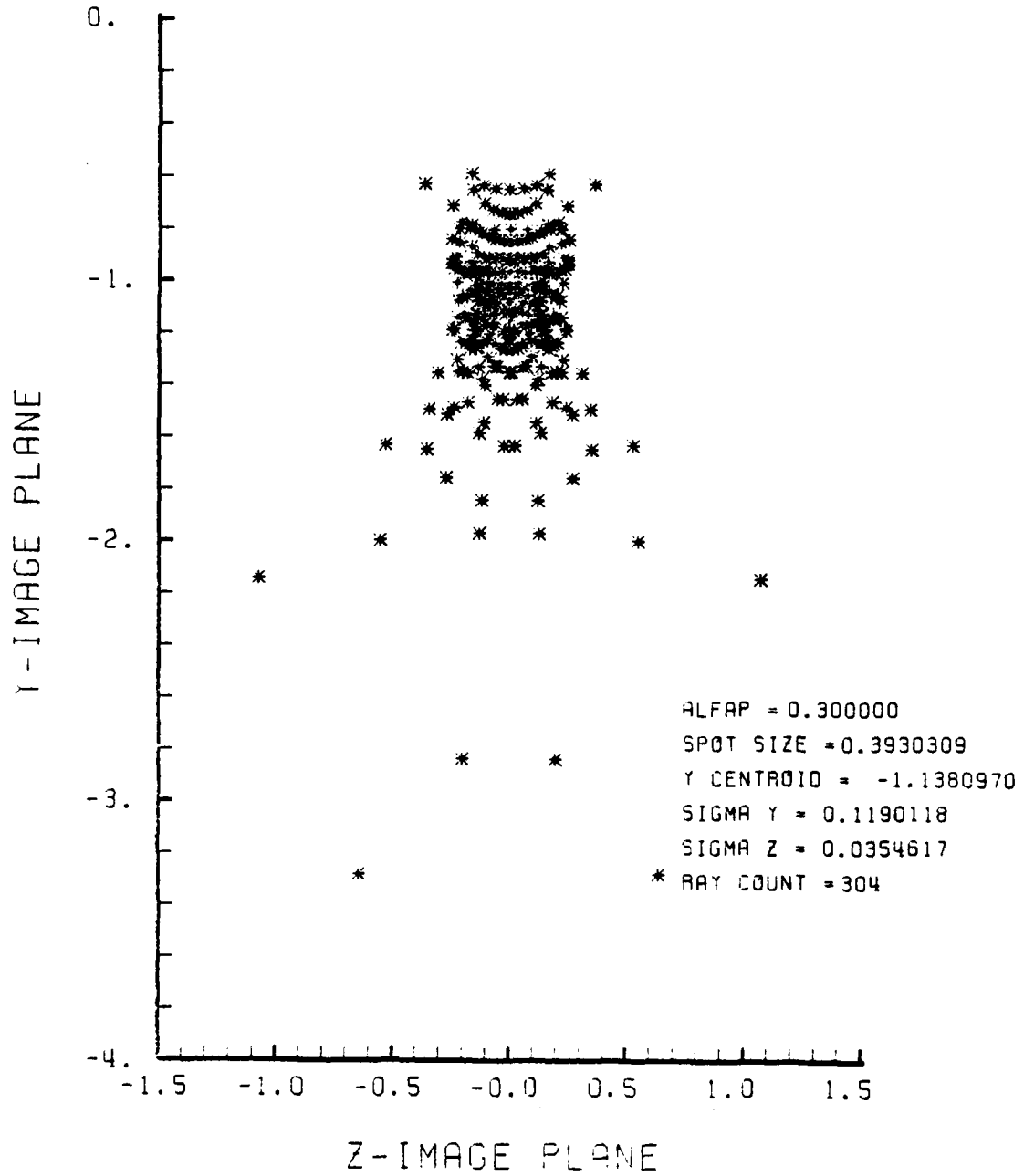

Figure E-51. Spot Diagram for Grid of Figure E-50

SPOT DIAGRAM ENERGY DENSITY

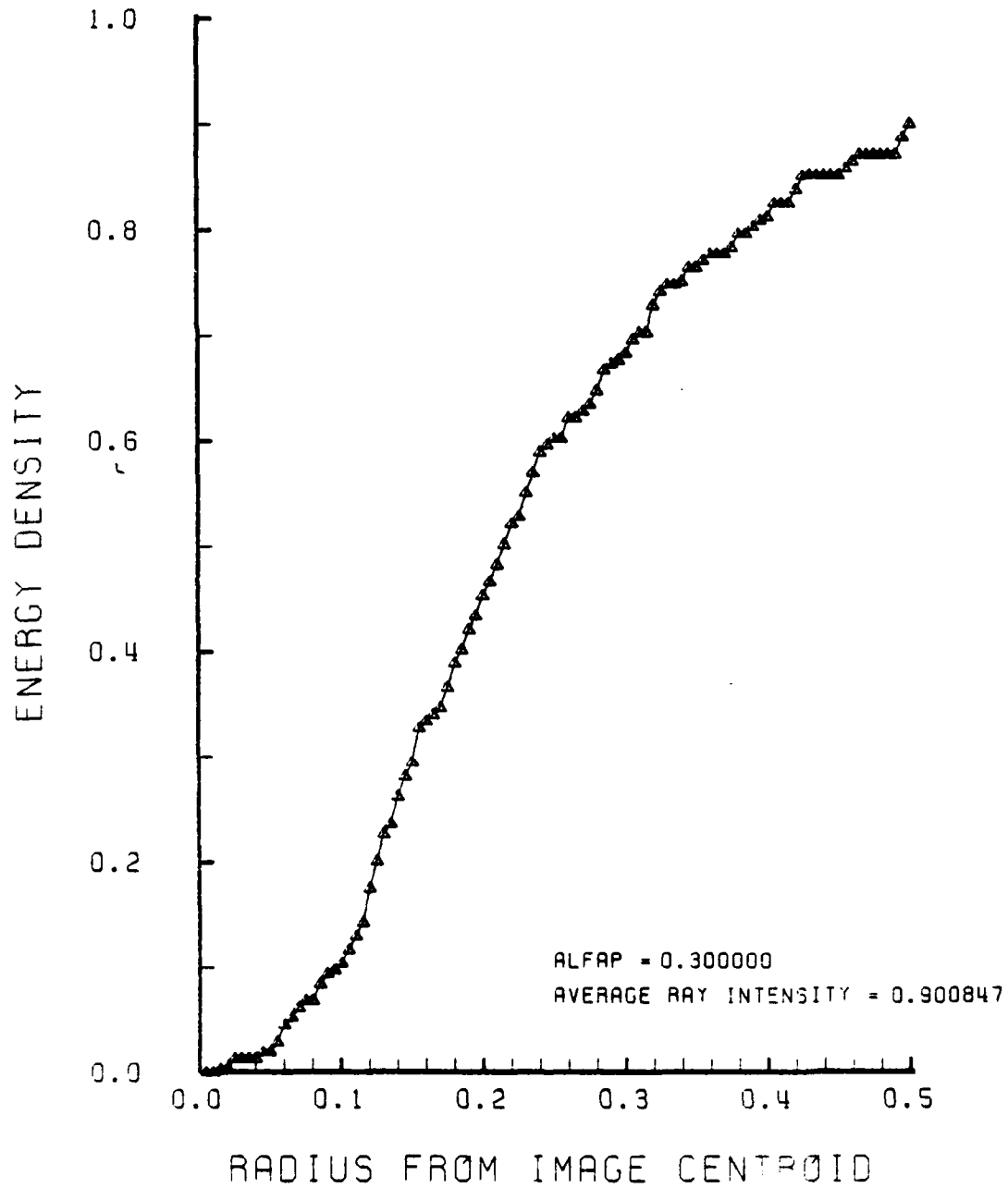

Figure E-52. Encircled Energy of Figure E-51

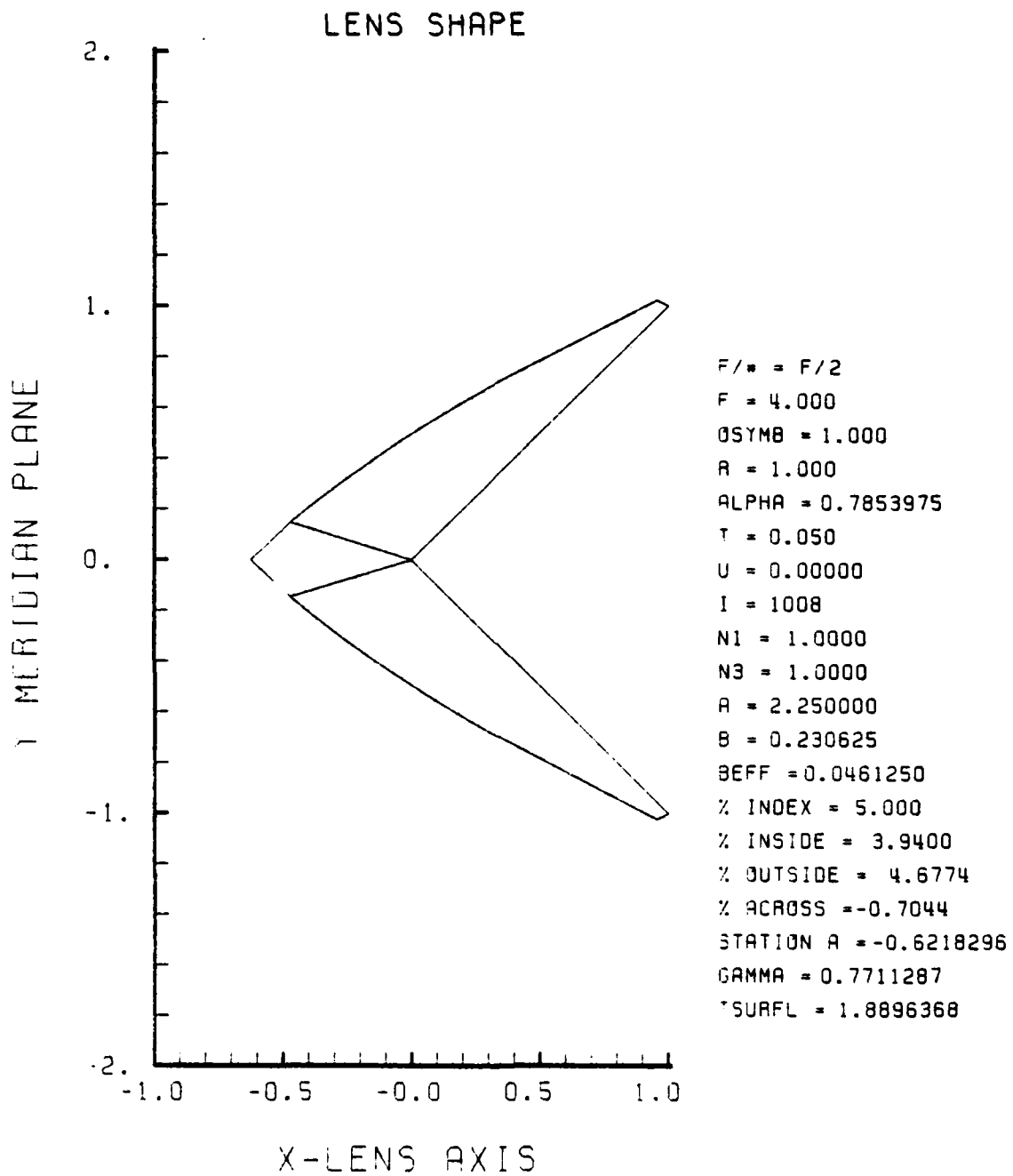

Figure E-53. GRIN Lens Shape at +5%, OB = 1.00,
a = 2.25

9

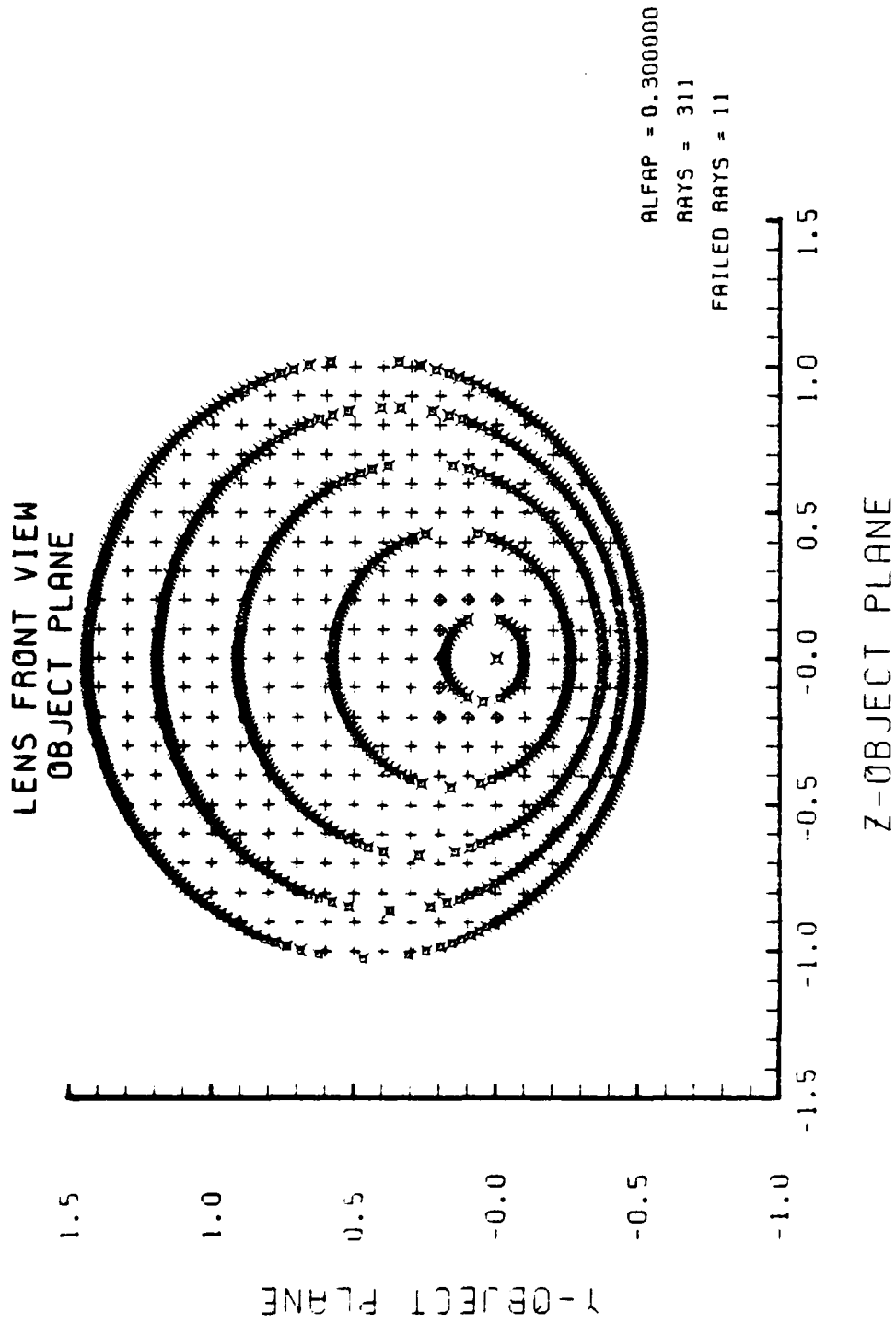

Figure E-54. Grid Plane at $\alpha_p = 0.3$ for Lens of Figure E-53

SPOT DIAGRAM

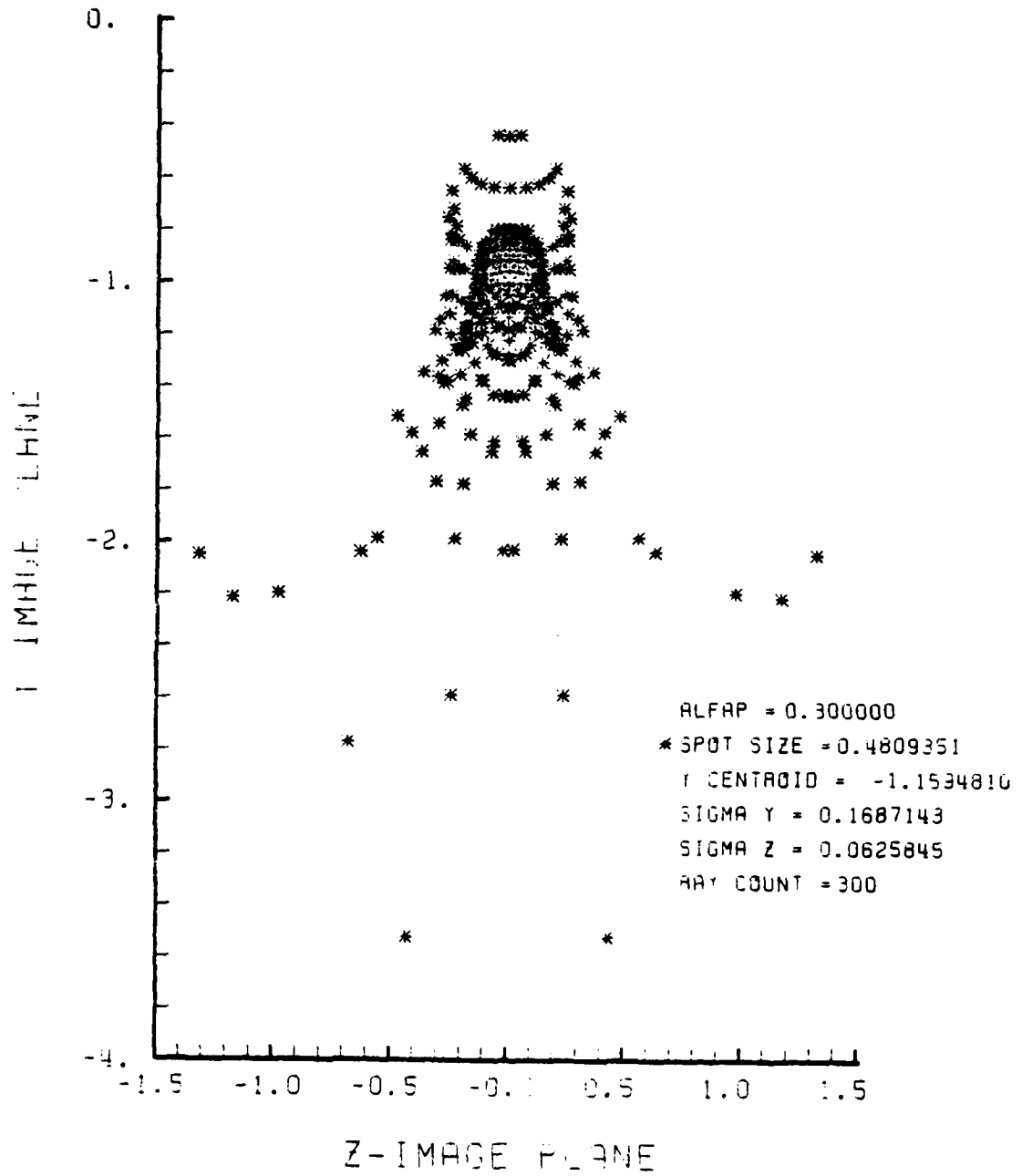

Figure E-55. Spot Diagram for Grid of Figure E-54

SPOT DIAGRAM ENERGY DENSITY

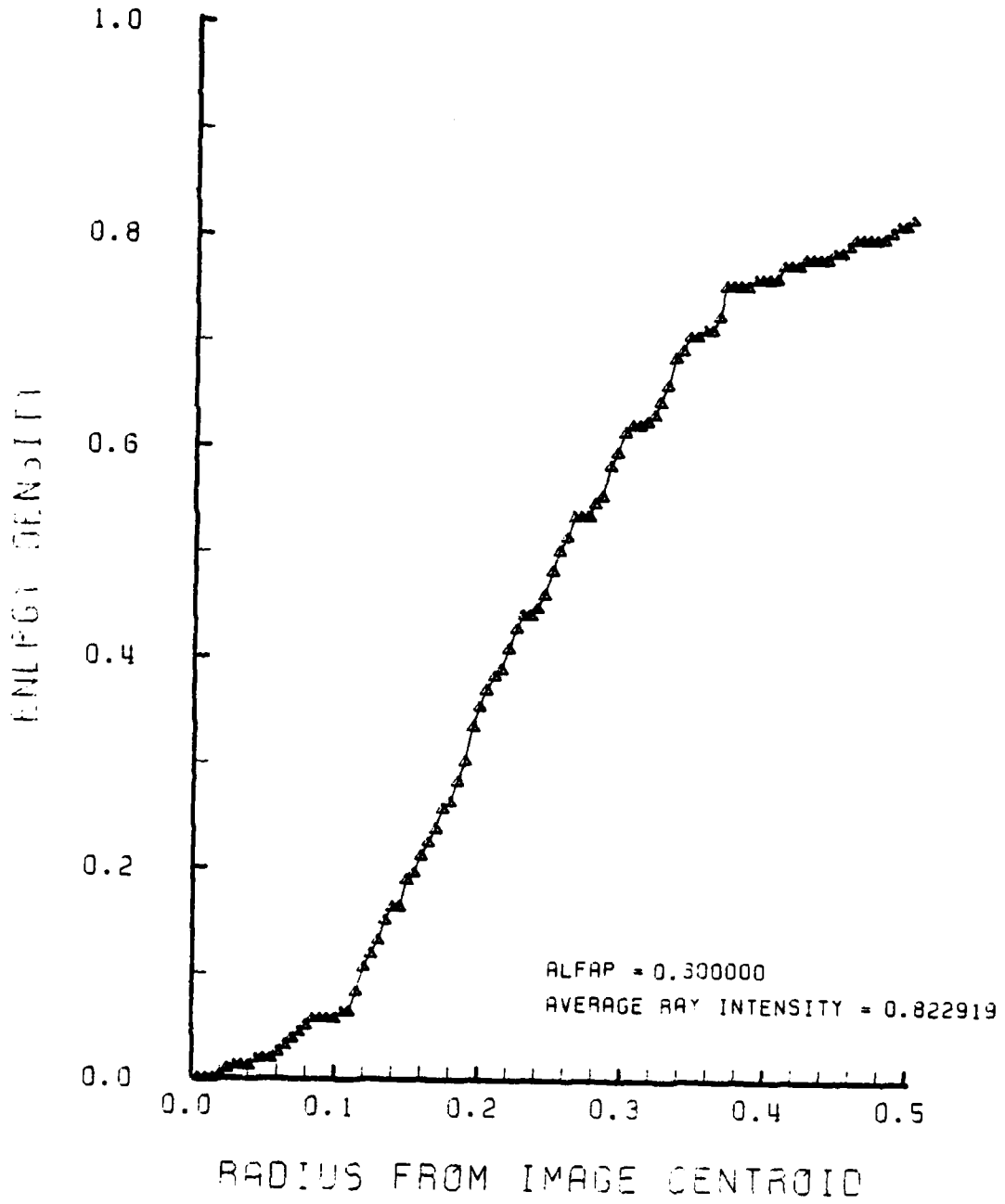

Figure E-56. Encircled Energy of Figure E-55

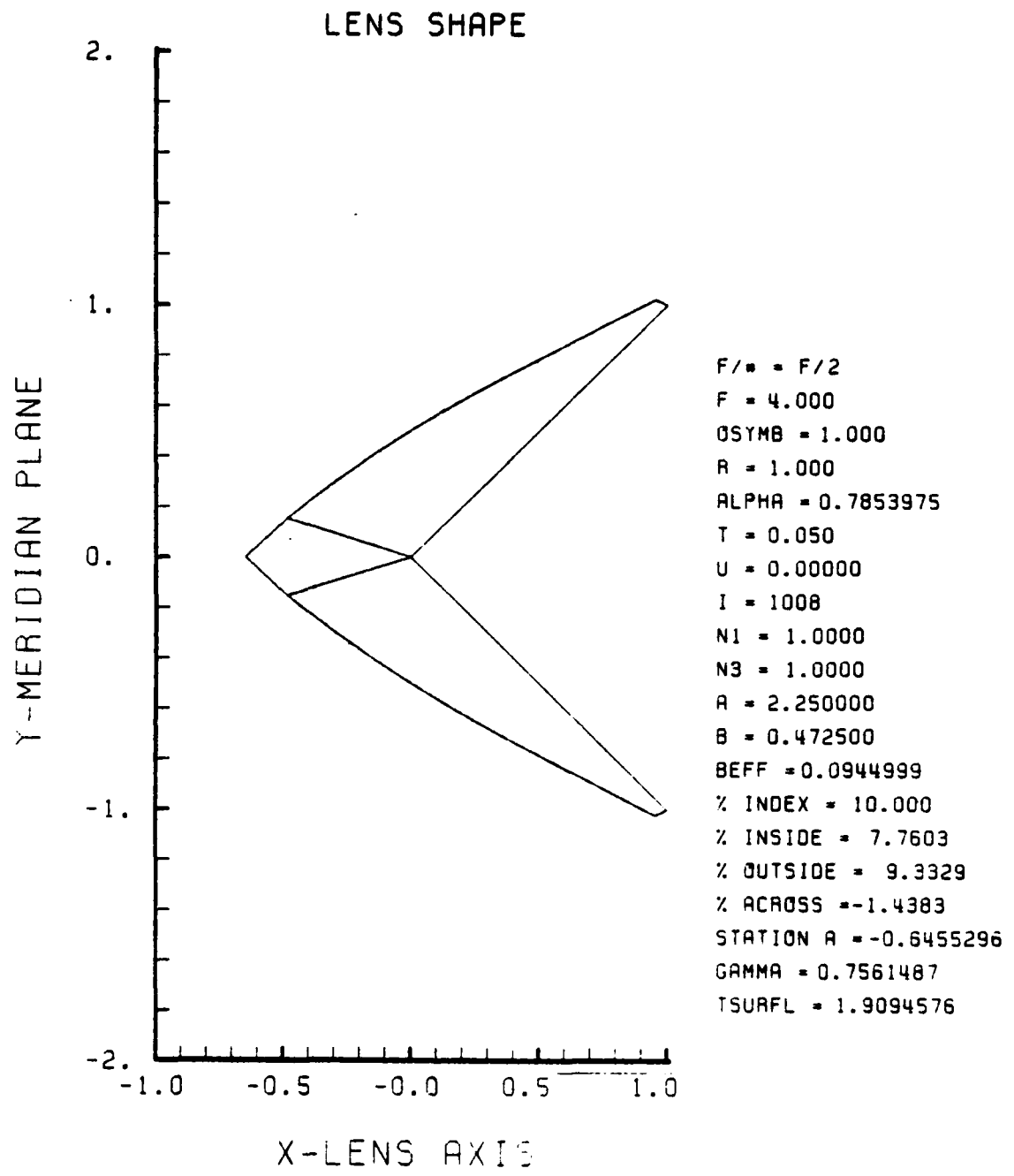

Figure E-57. GRIN Lens Shape at +10%, OB = 1.00,
a = 2.25

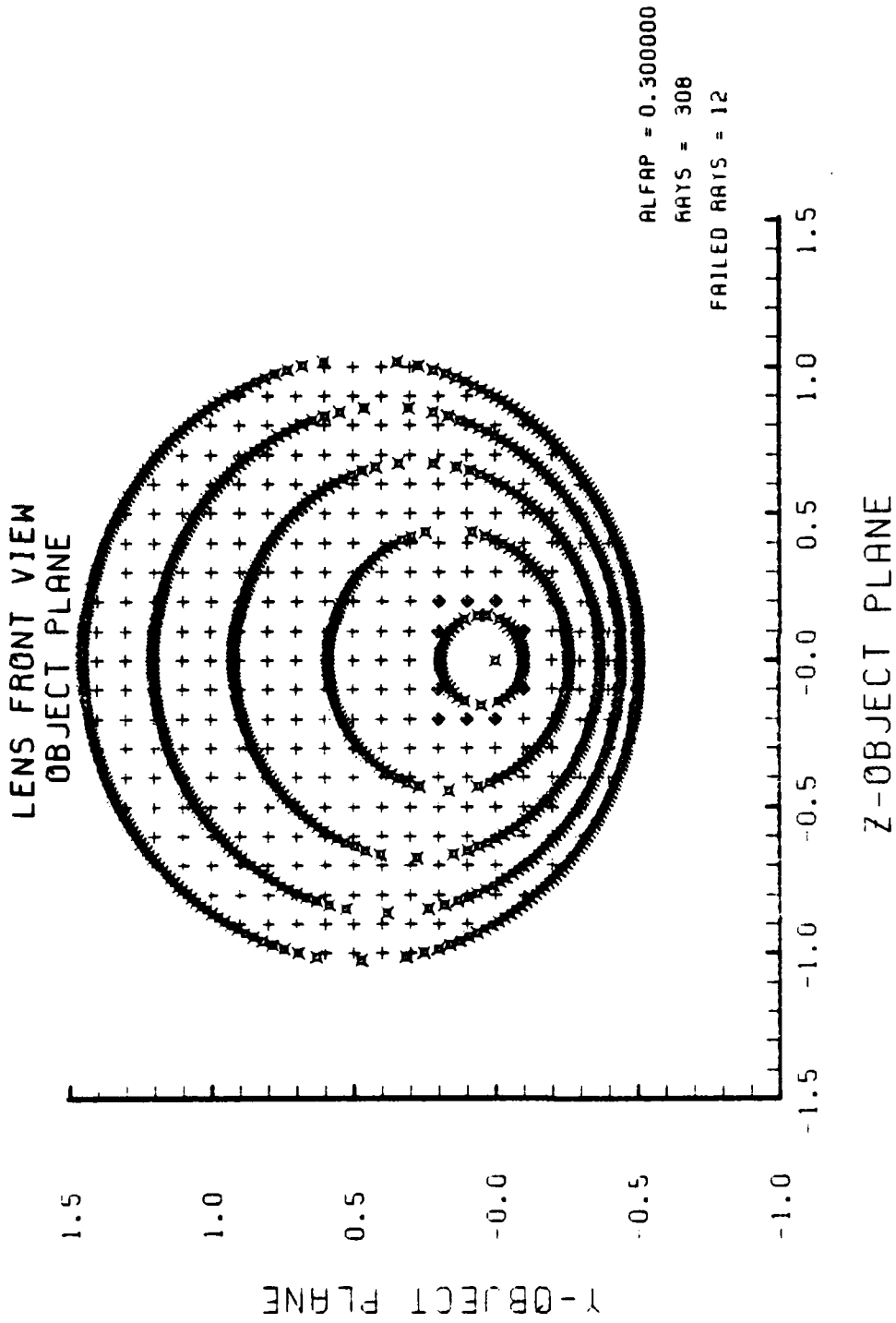

Figure E-58. Grid Plane at $\alpha_p = 0.3$ for Lens of Figure E-57

SPOT DIAGRAM

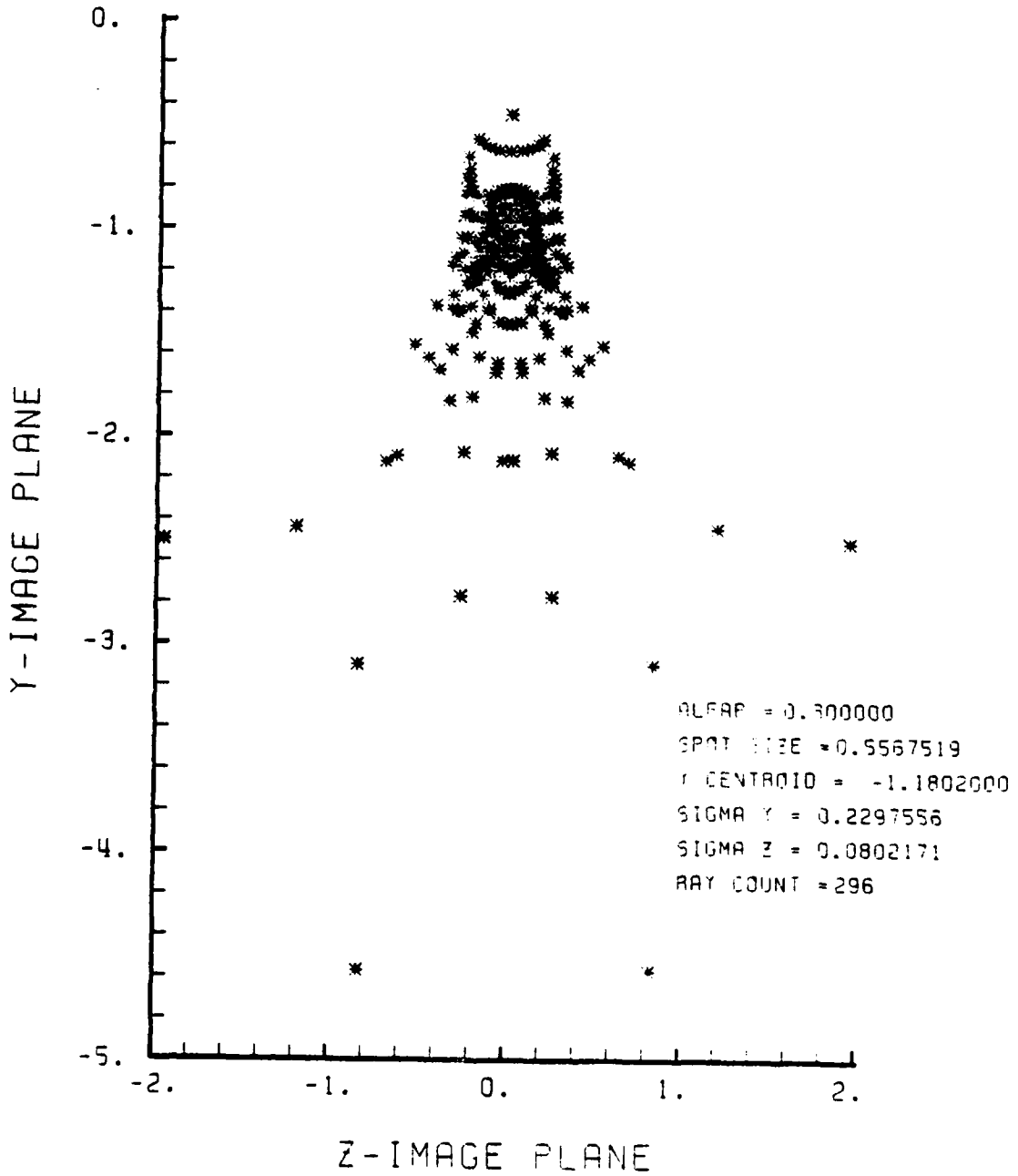

Figure E-59. Spot Diagram for Grid of Figure E-58

SPOT DIAGRAM ENERGY DENSITY

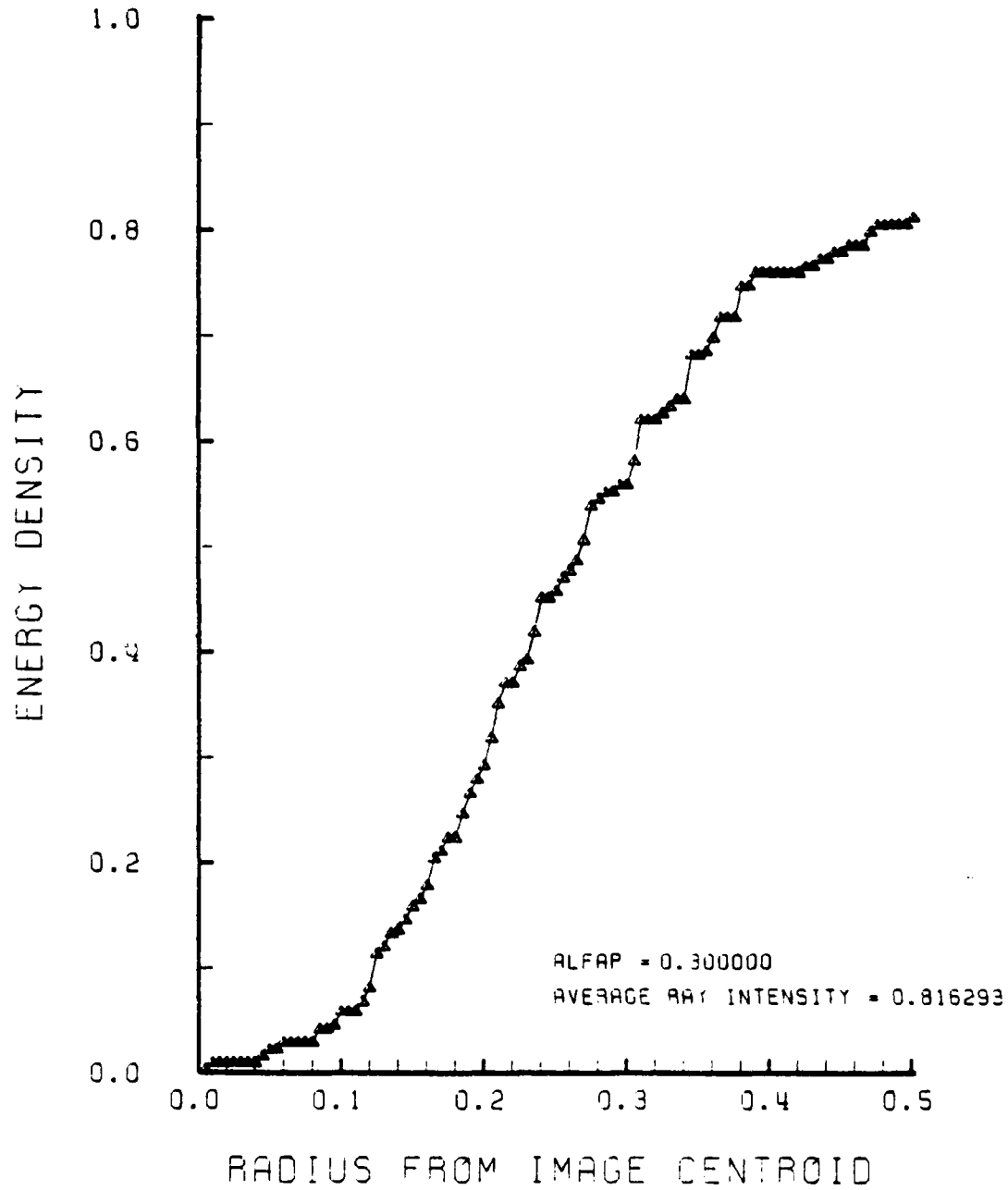

Figure E-60. Encircled Energy of Figure E-59

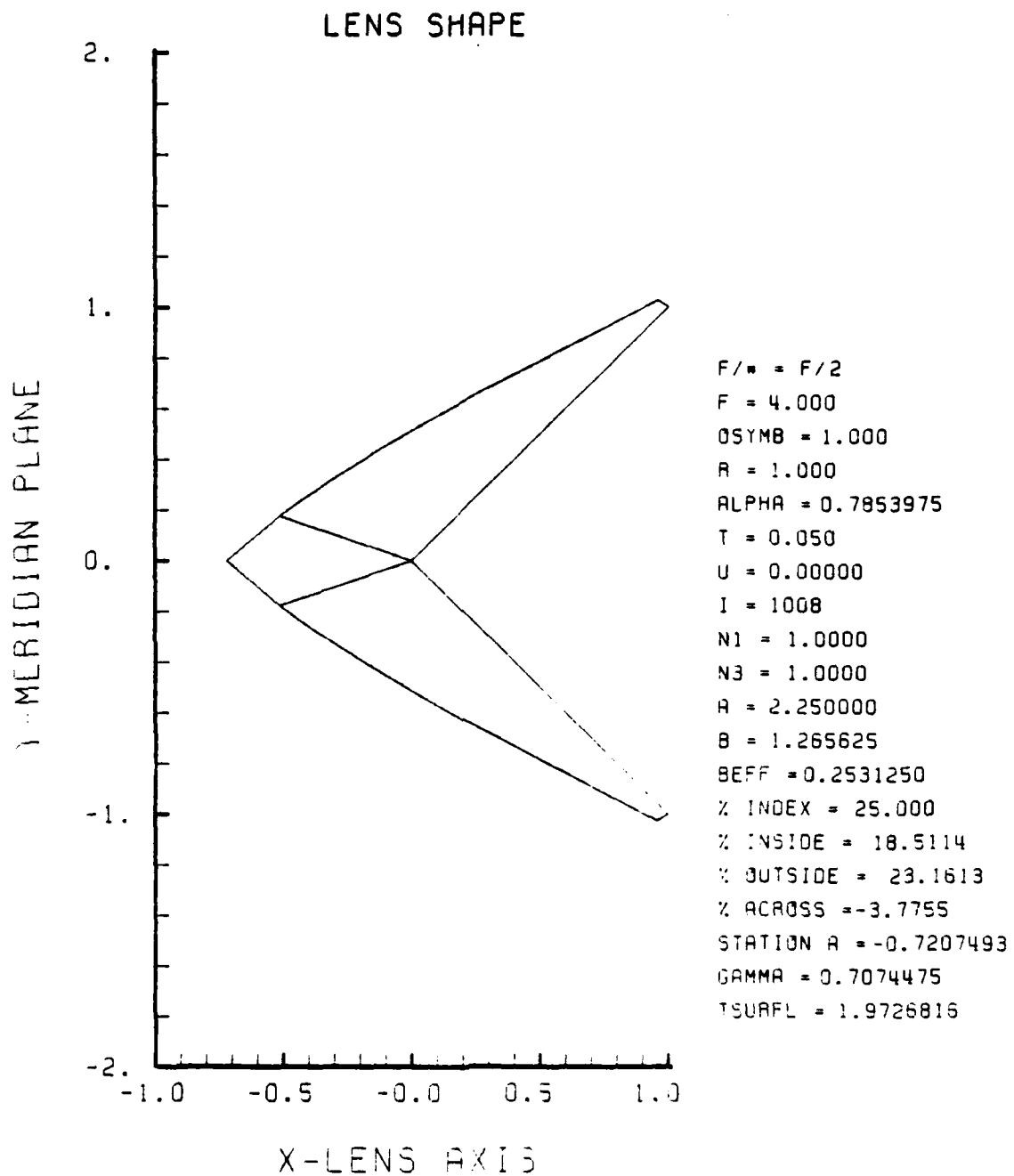

Figure E-61. GRIN Lens Shape at +25%, $OB = 1.00$,
 $a = 2.25$

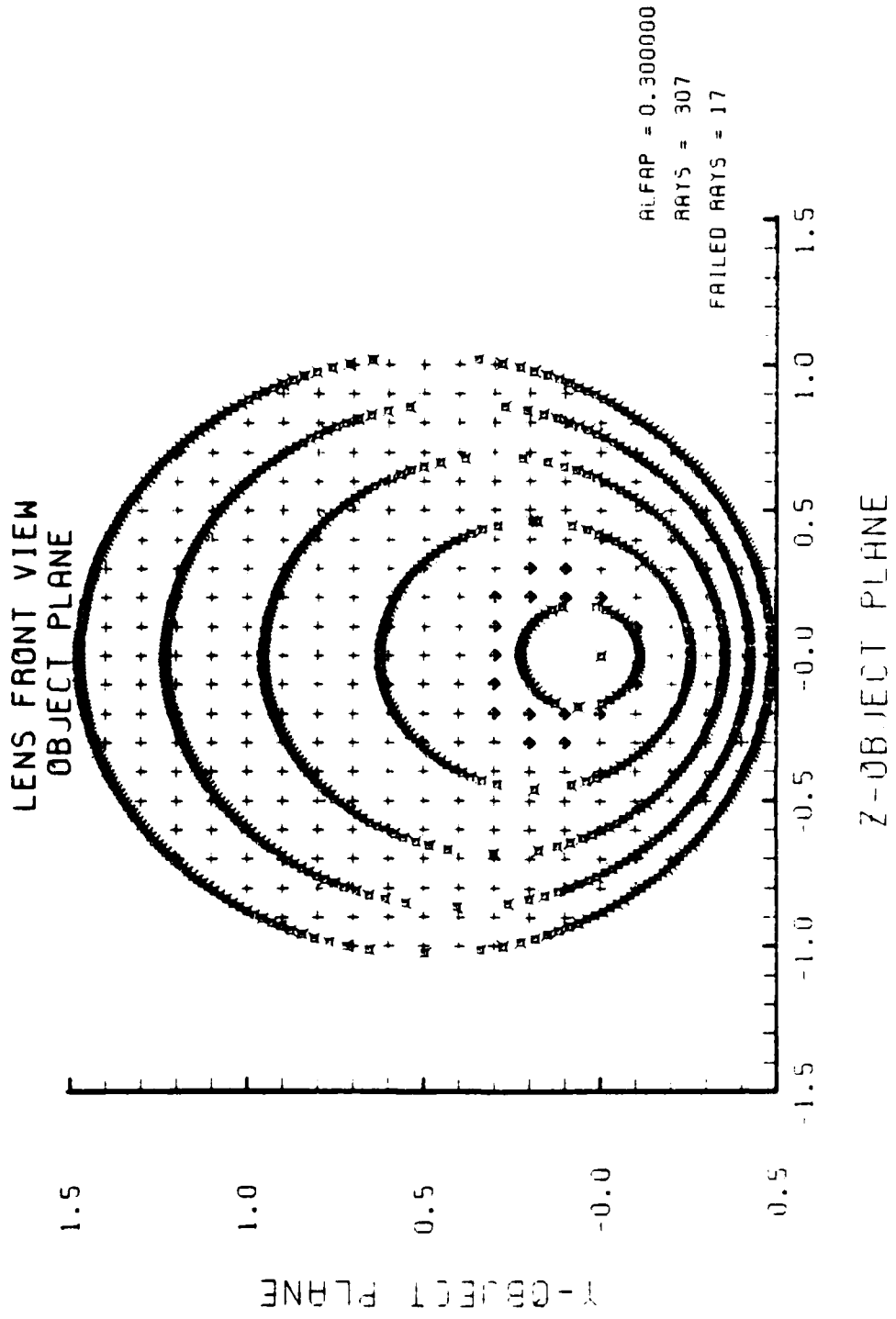

Figure E-62. Grid Plane at $\alpha_p = 0.3$ for Lens of Figure E-61

SPOT DIAGRAM

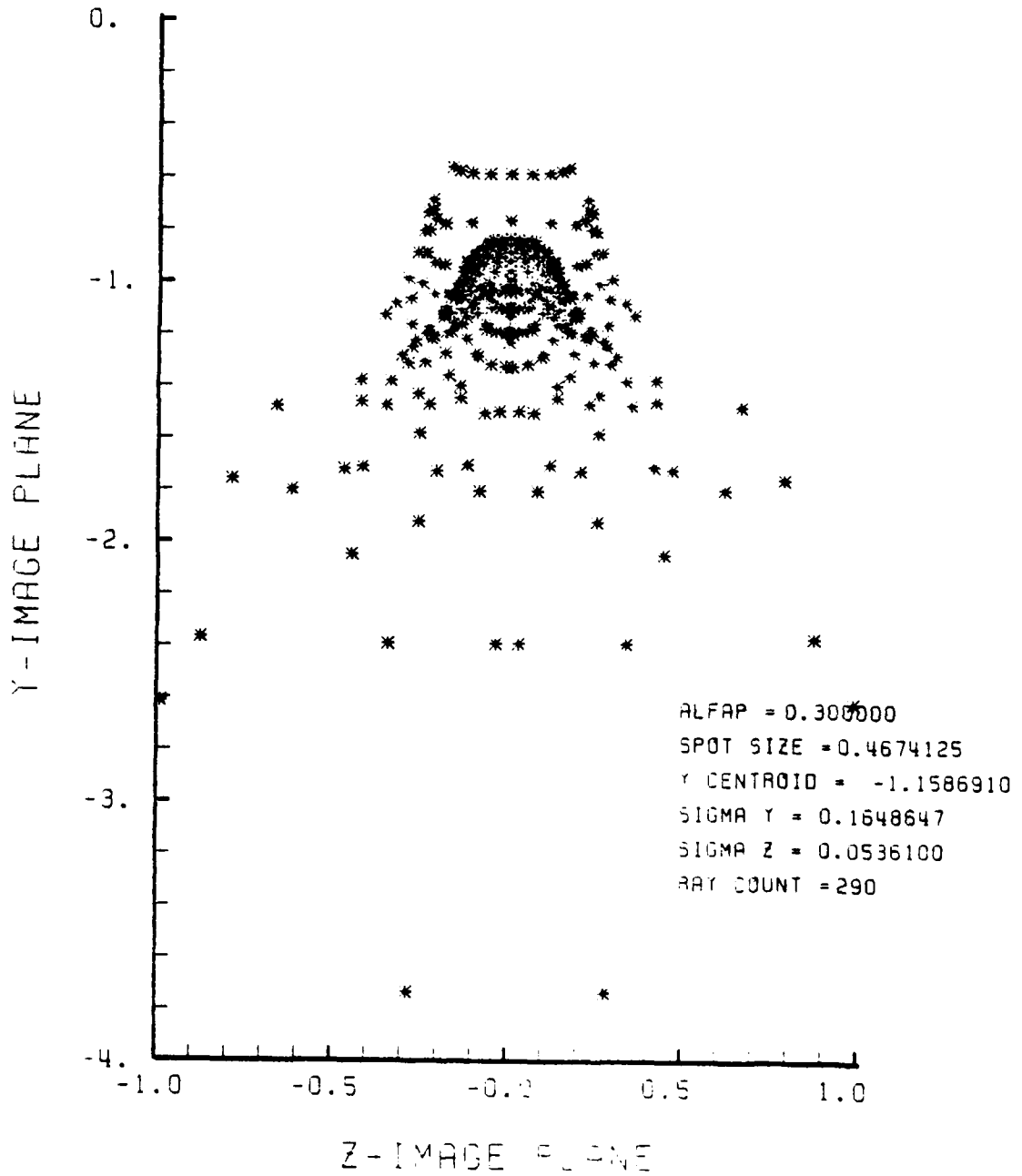

Figure E-63. Spot Diagram for Grid of Figure E-62

SPOT DIAGRAM ENERGY DENSITY

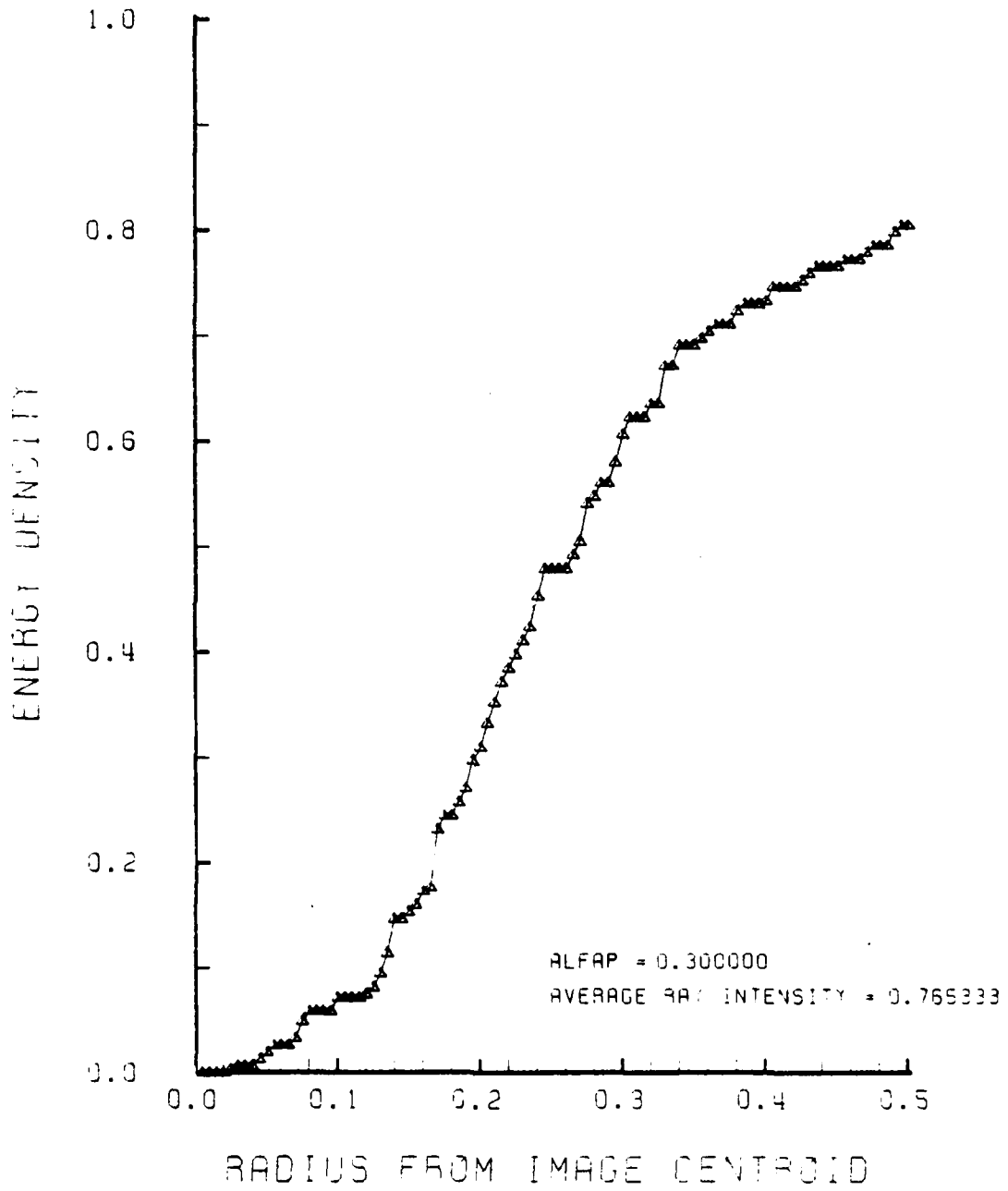

Figure E-64. Encircled Energy of Figure E-63

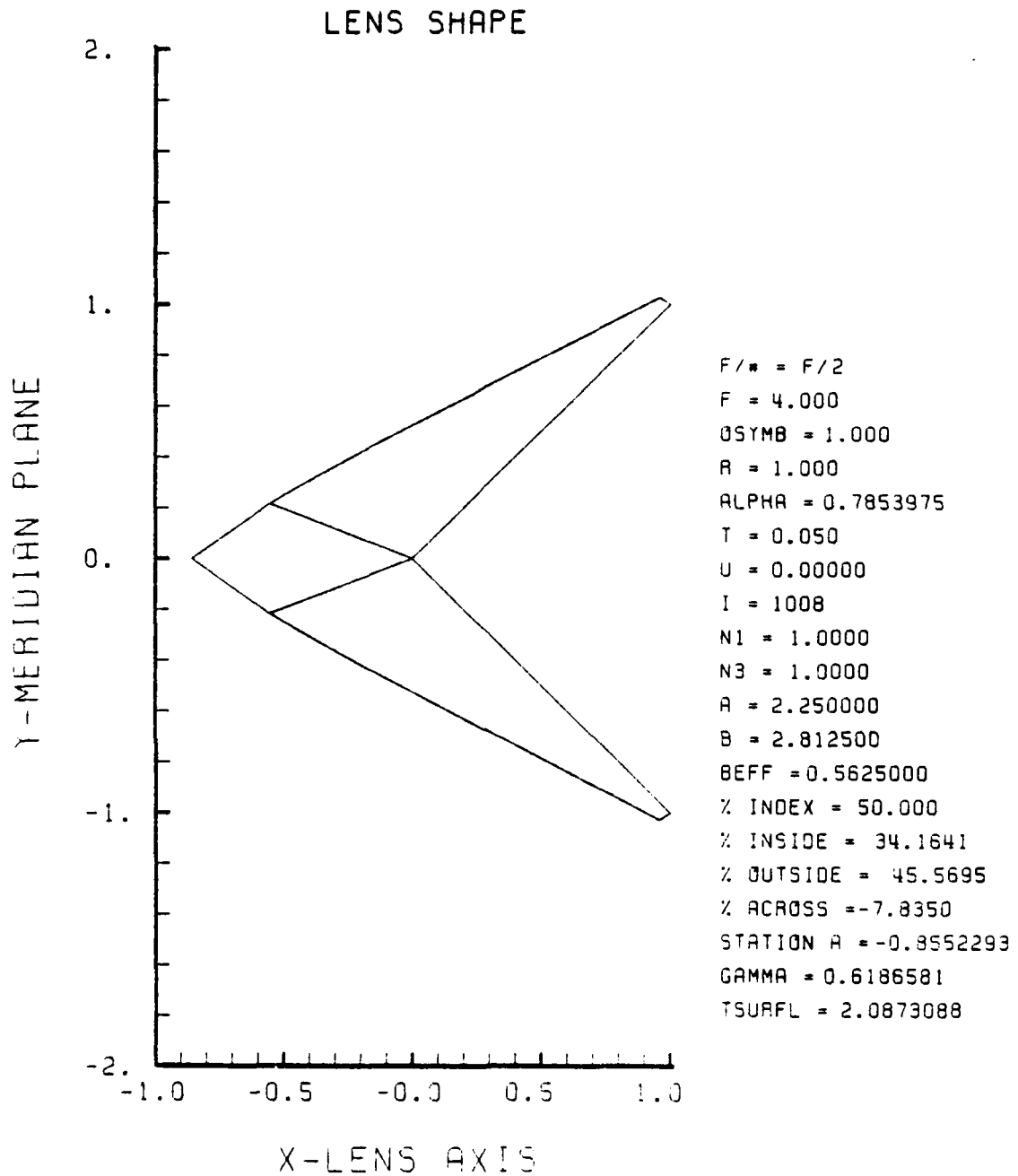

Figure E-65. GRIN Lens Shape at +50%, $\text{OB} = 1.00$,
 $a = 2.25$

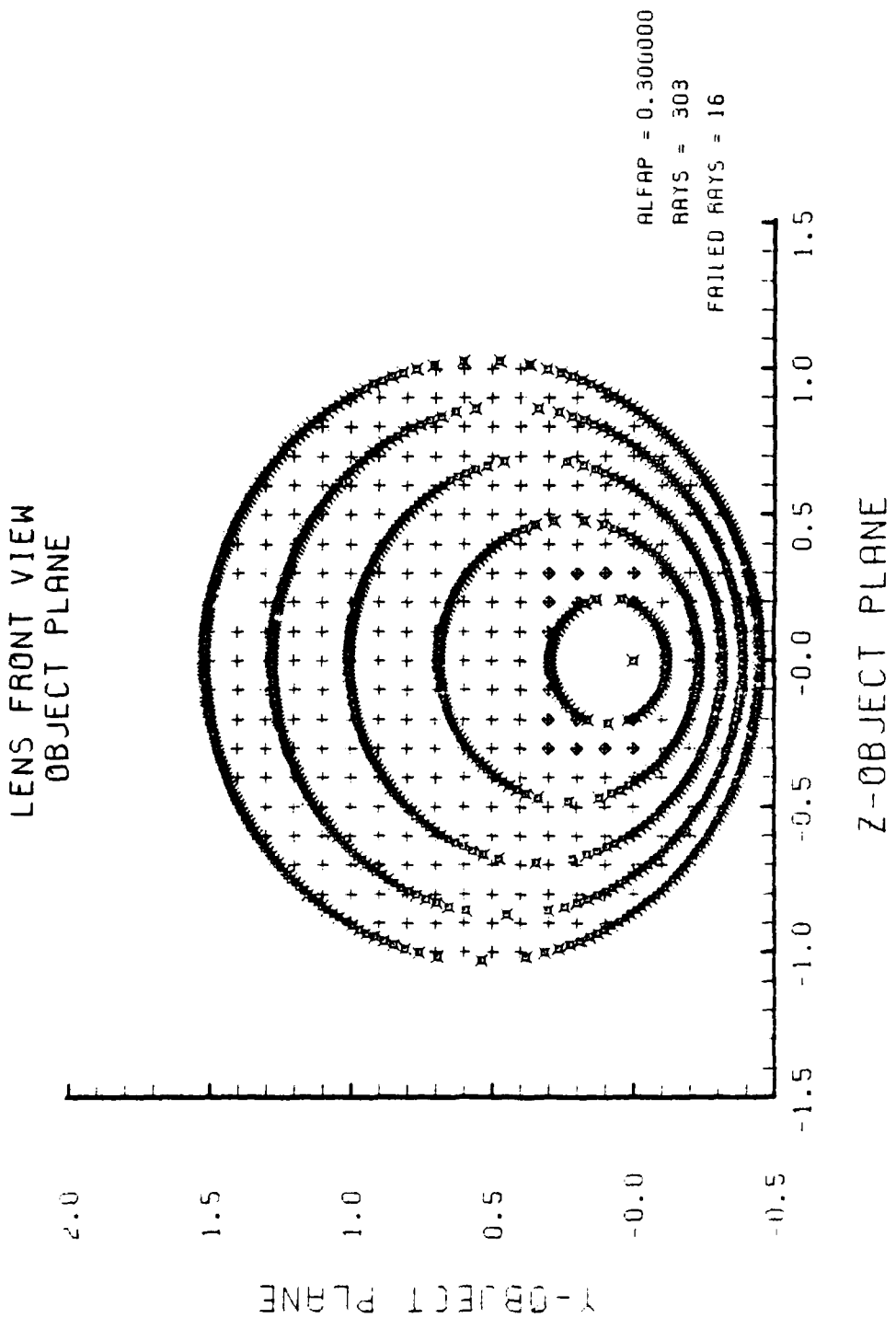

Figure E-66. Grid Plane at $\alpha_p = 0.3$ for Lens of Figure E-65

SPOT DIAGRAM

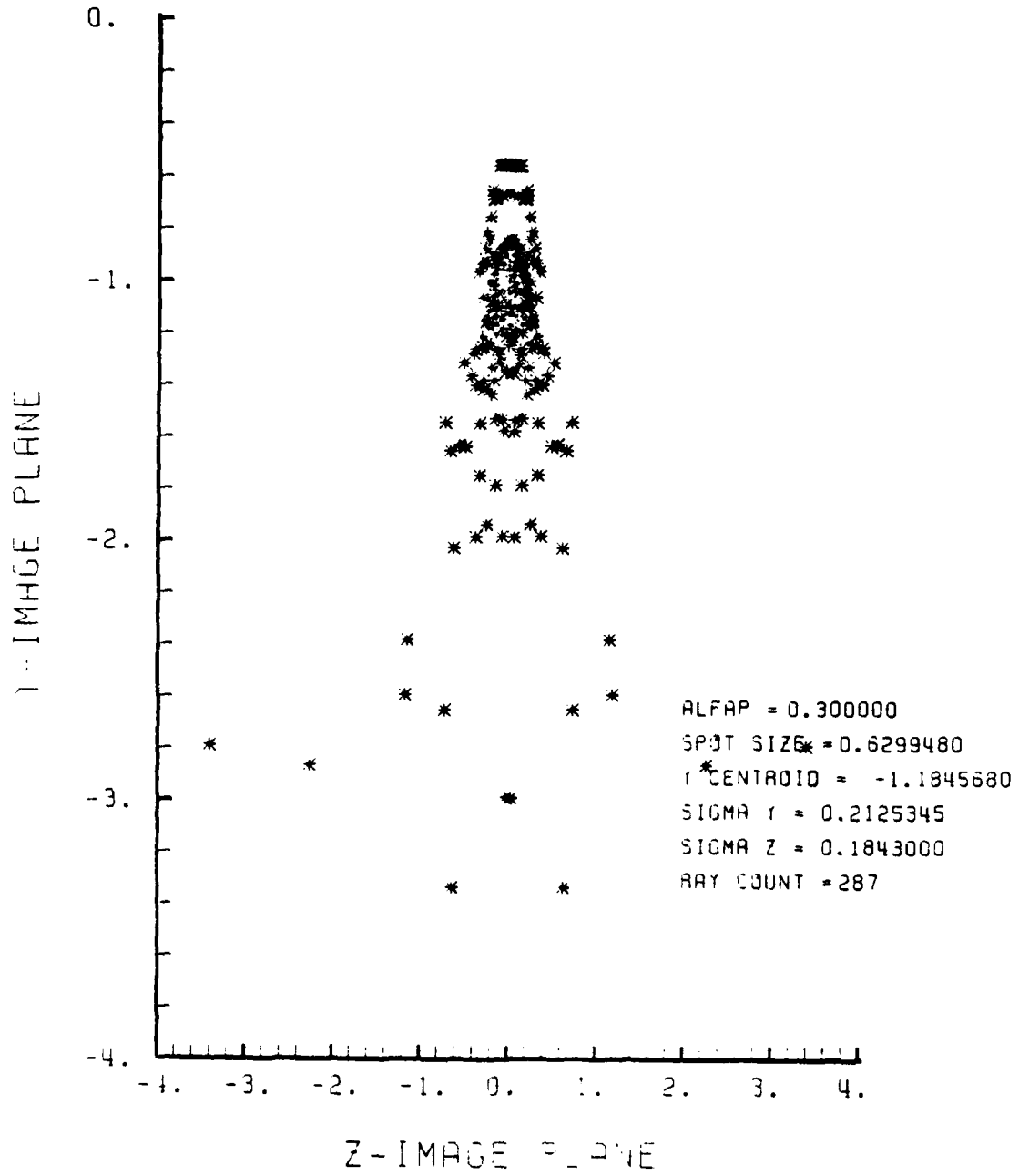

Figure E-67. Spot Diagram for Grid of Figure E-66

SPOT DIAGRAM ENERGY DENSITY

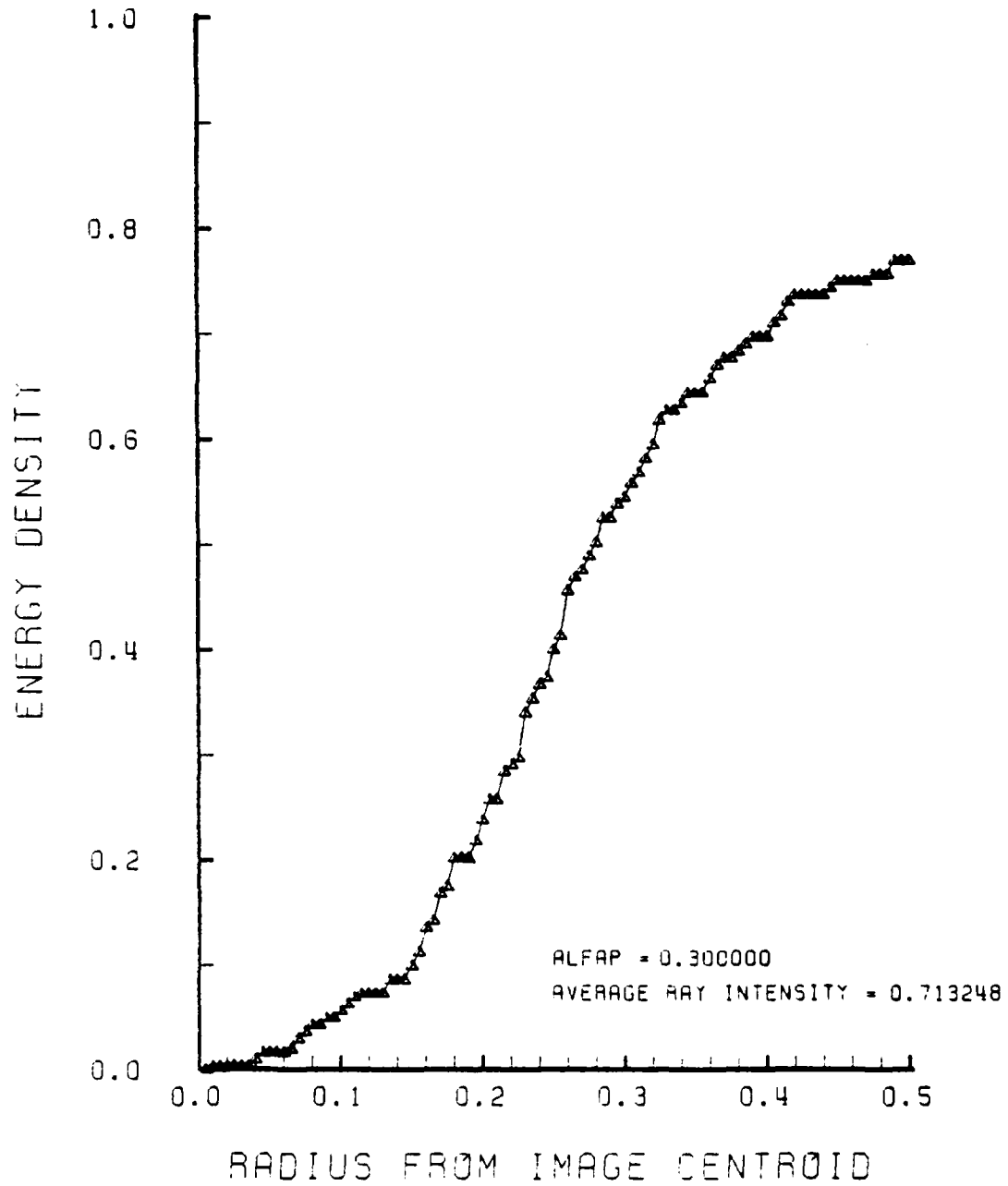

Figure E-68. Encircled Energy of Figure E-67

LENS SHAPE

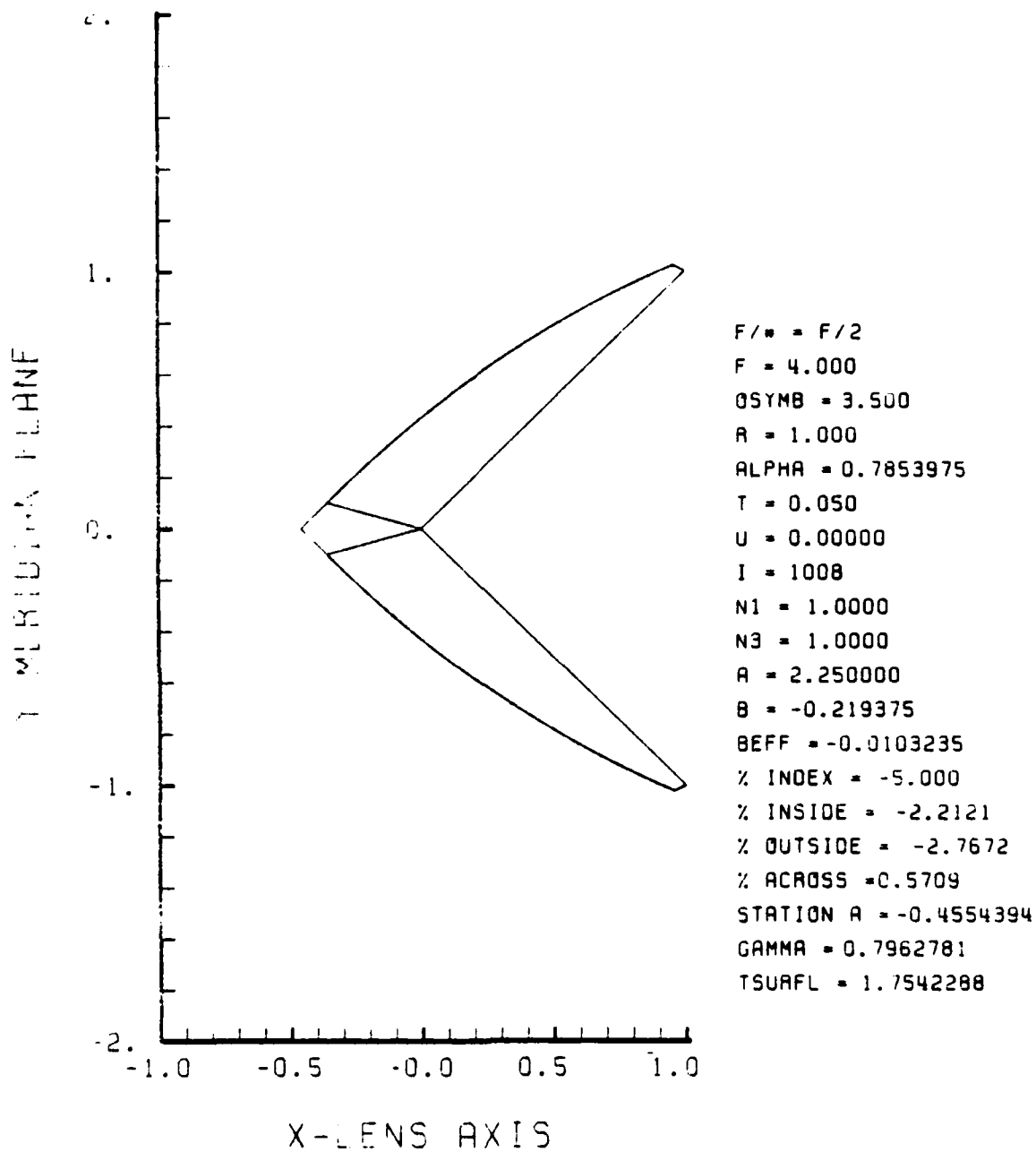

Figure E-69. GRIN Lens Shape at -5%, OB = 3.50,
a = 2.25

9

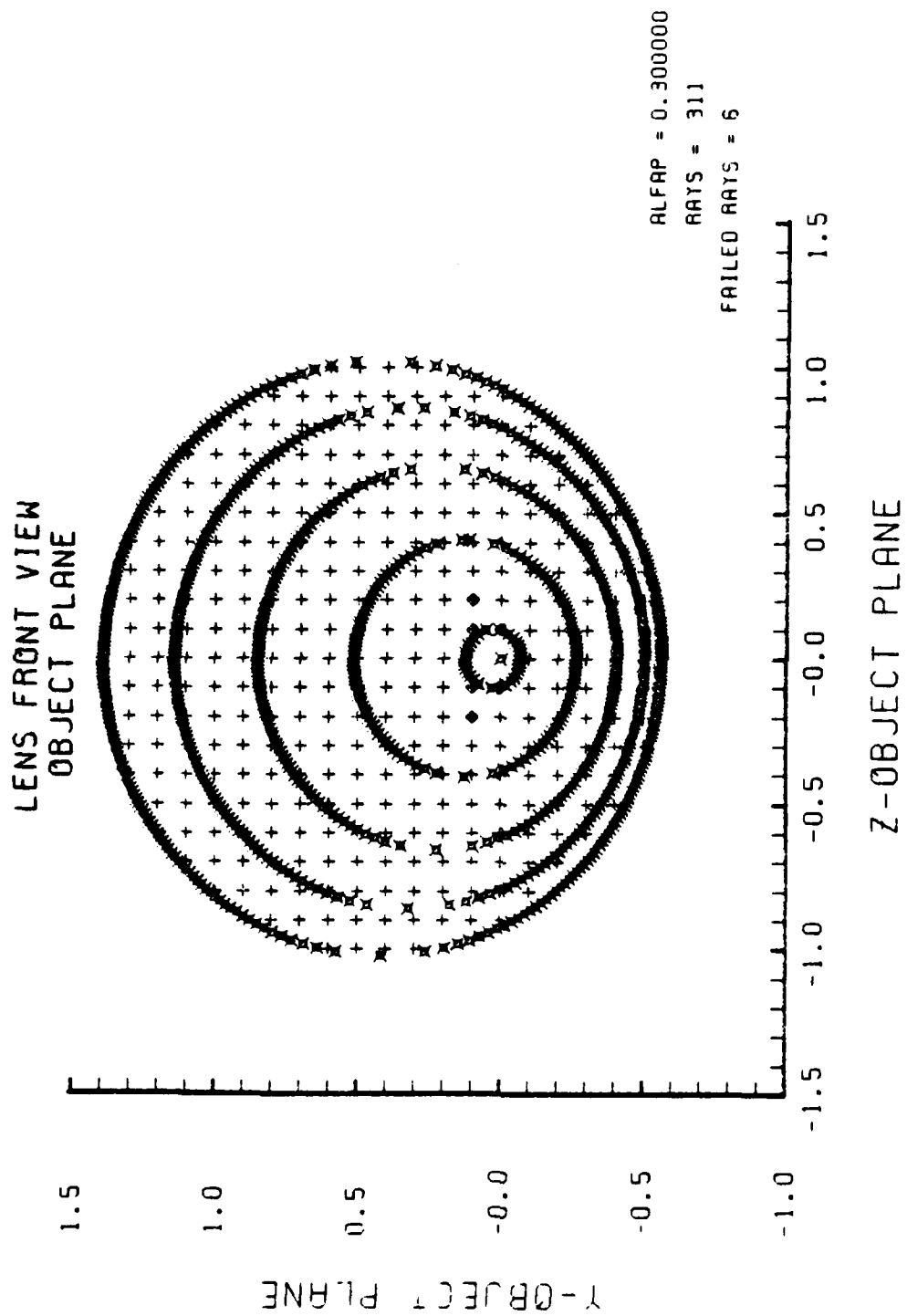

Figure E-70. Grid Plane at $\alpha_p = 0.3$ for Lens of Figure E-69

SPOT DIAGRAM

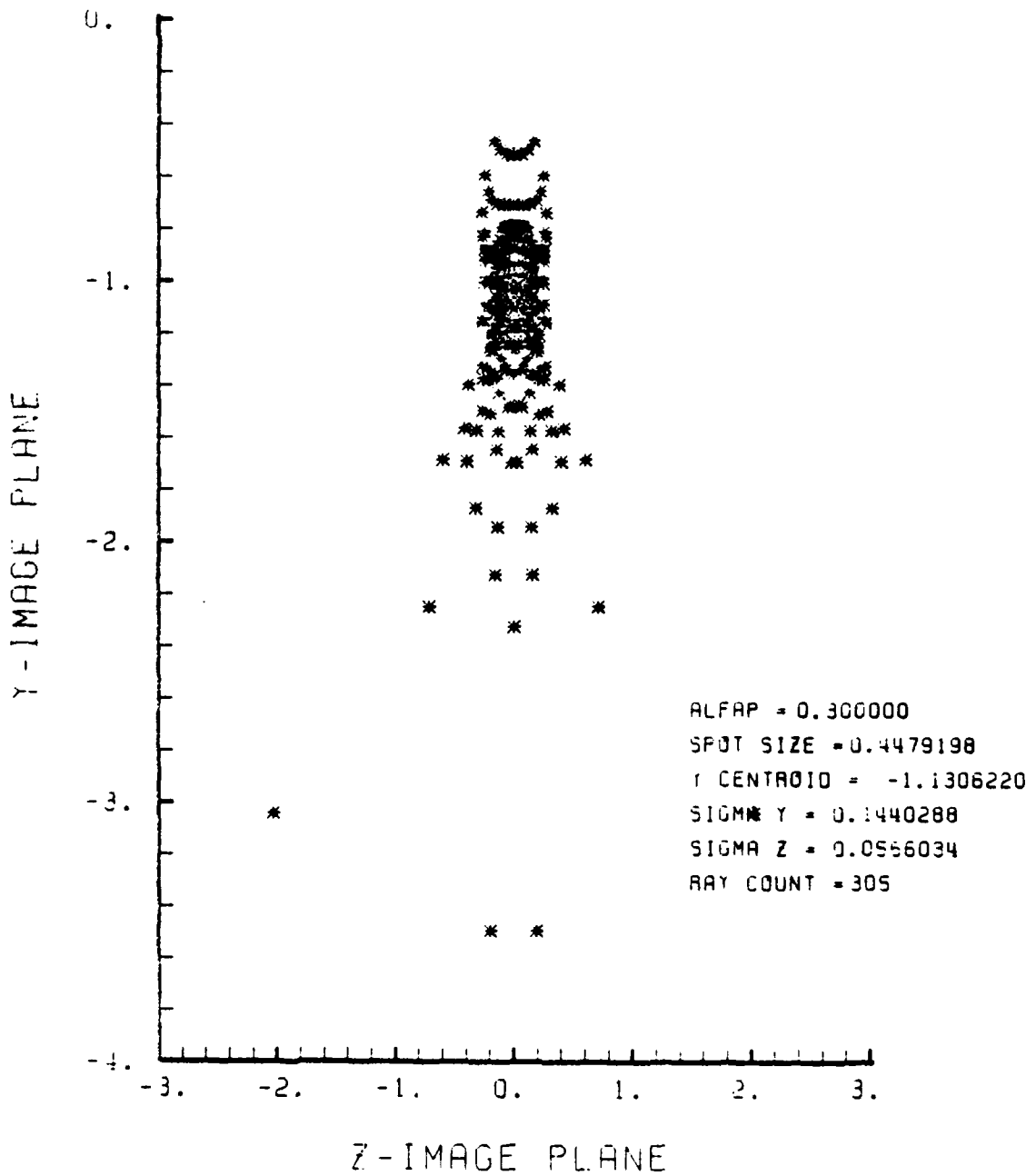

Figure E-71. Spot Diagram for Grid of Figure E-70

SPOT DIAGRAM ENERGY DENSITY

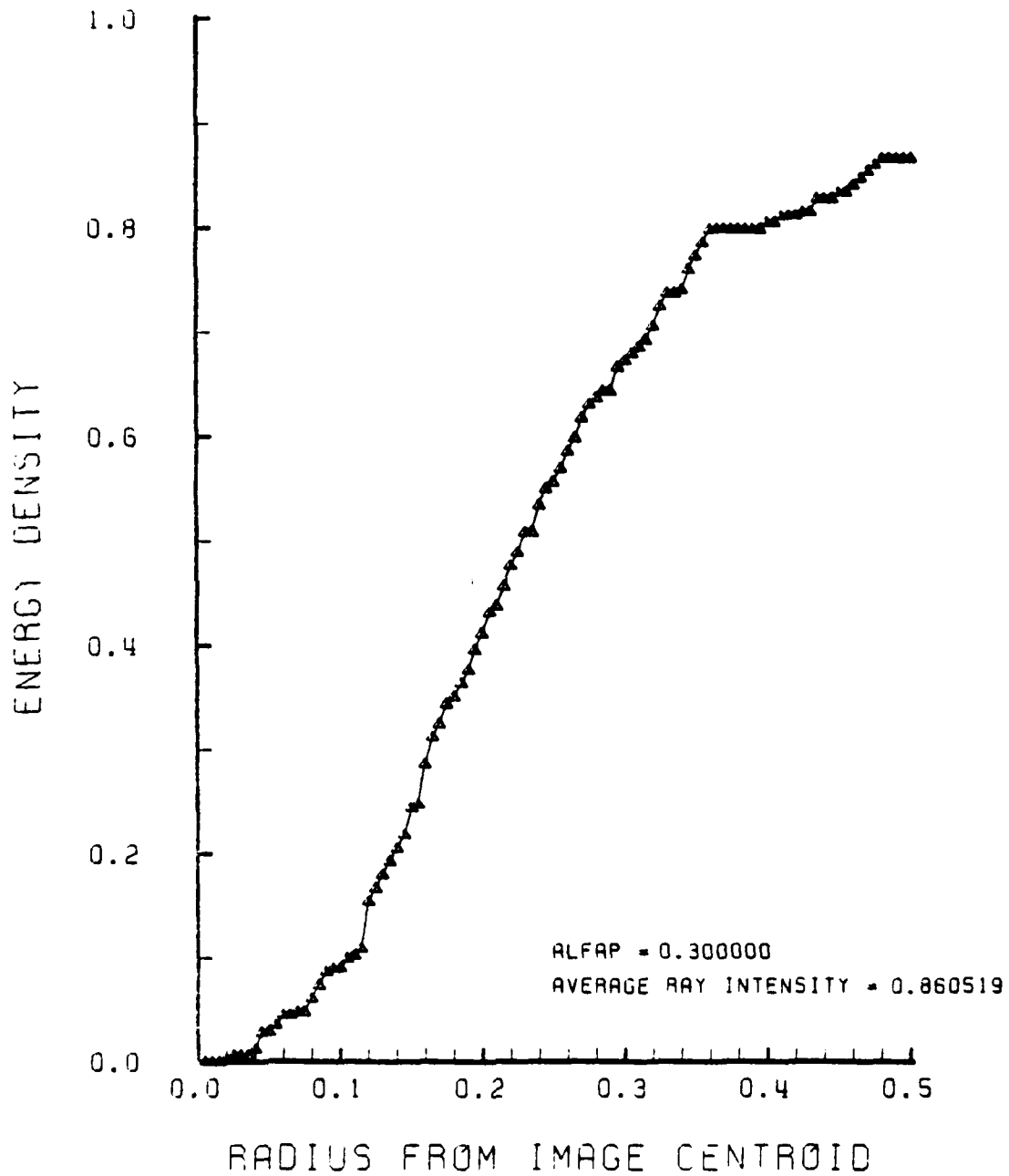

Figure E-72. Encircled Energy of Figure E-71

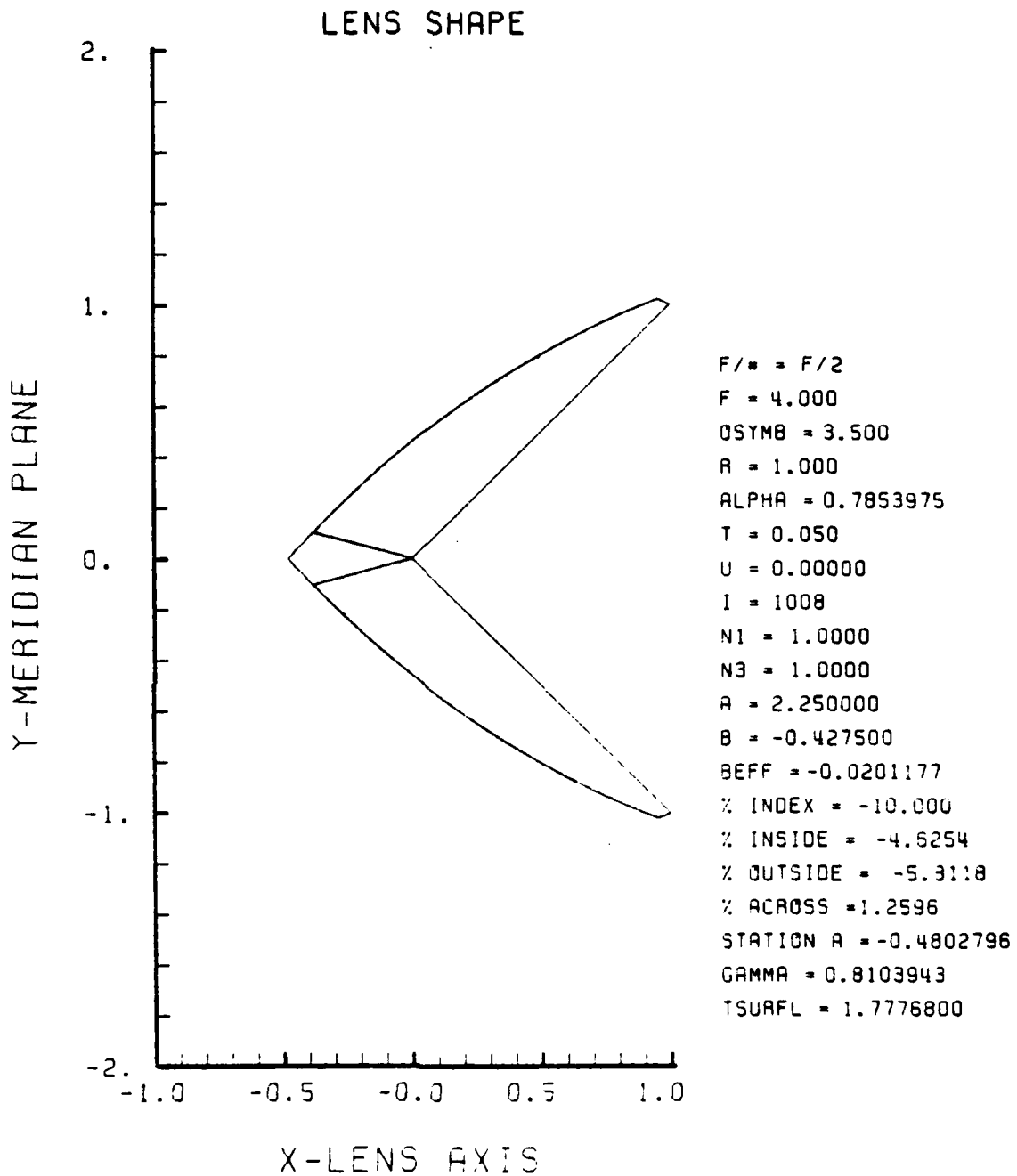
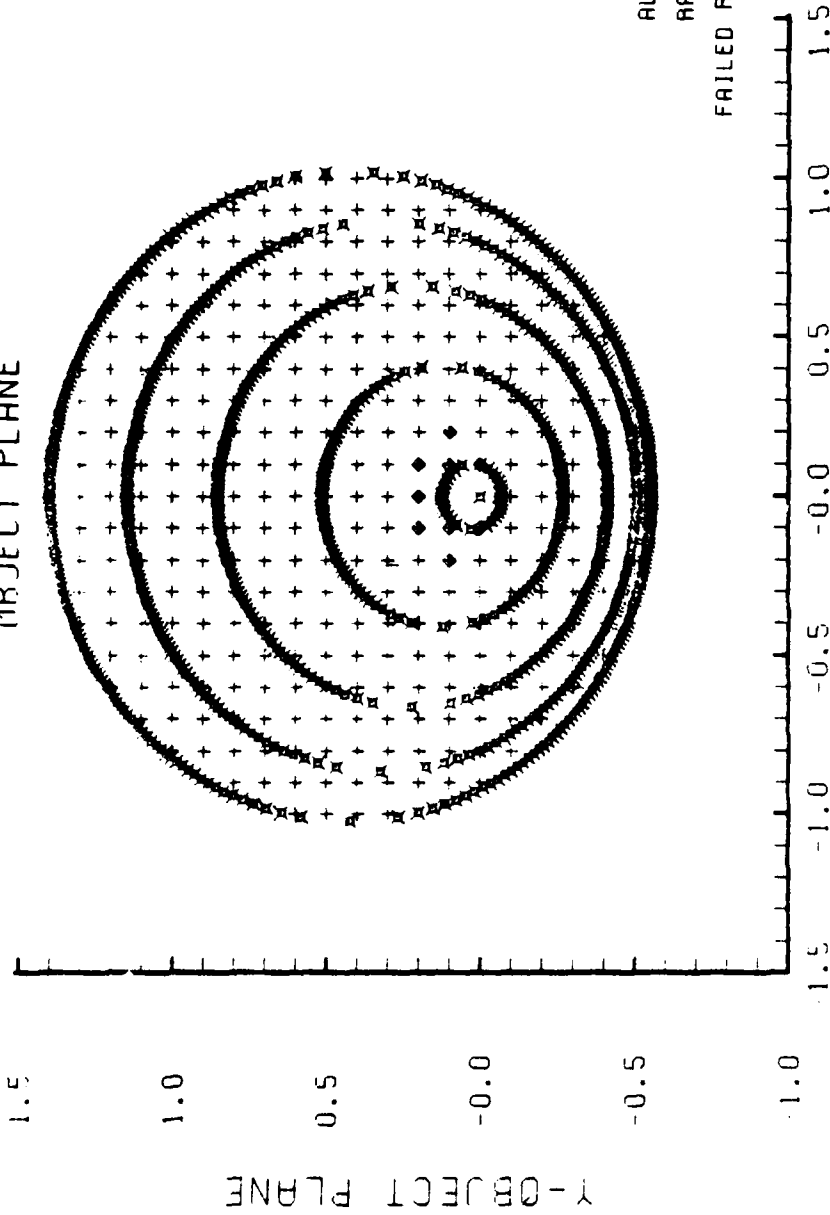

Figure E-73. GRIN Lens Shape at -10%, OB = 3.50,
a = 2.25

LENS FRONT VIEW
OBJECT PLANE



ALFAP = 0.300000
RAYS = 313
FAILED RAYS = 9

Z-OBJECT PLANE

Figure E-74. Grid Plane at $\alpha_p = 0.3$ for Lens of Figure E-73

SPOT DIAGRAM

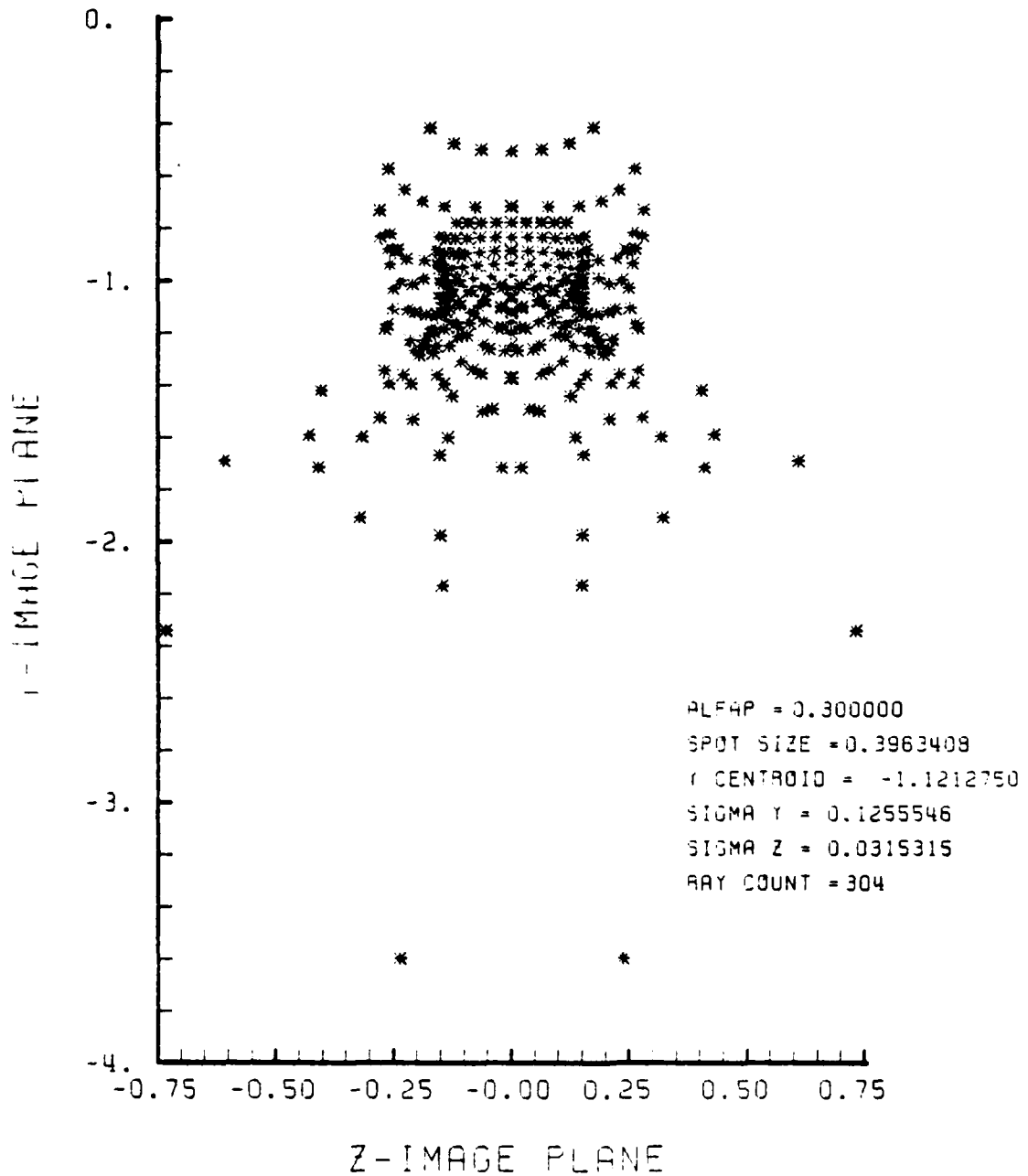

Figure E-75. Spot Diagram for Grid of Figure E-74

SPOT DIAGRAM ENERGY DENSITY

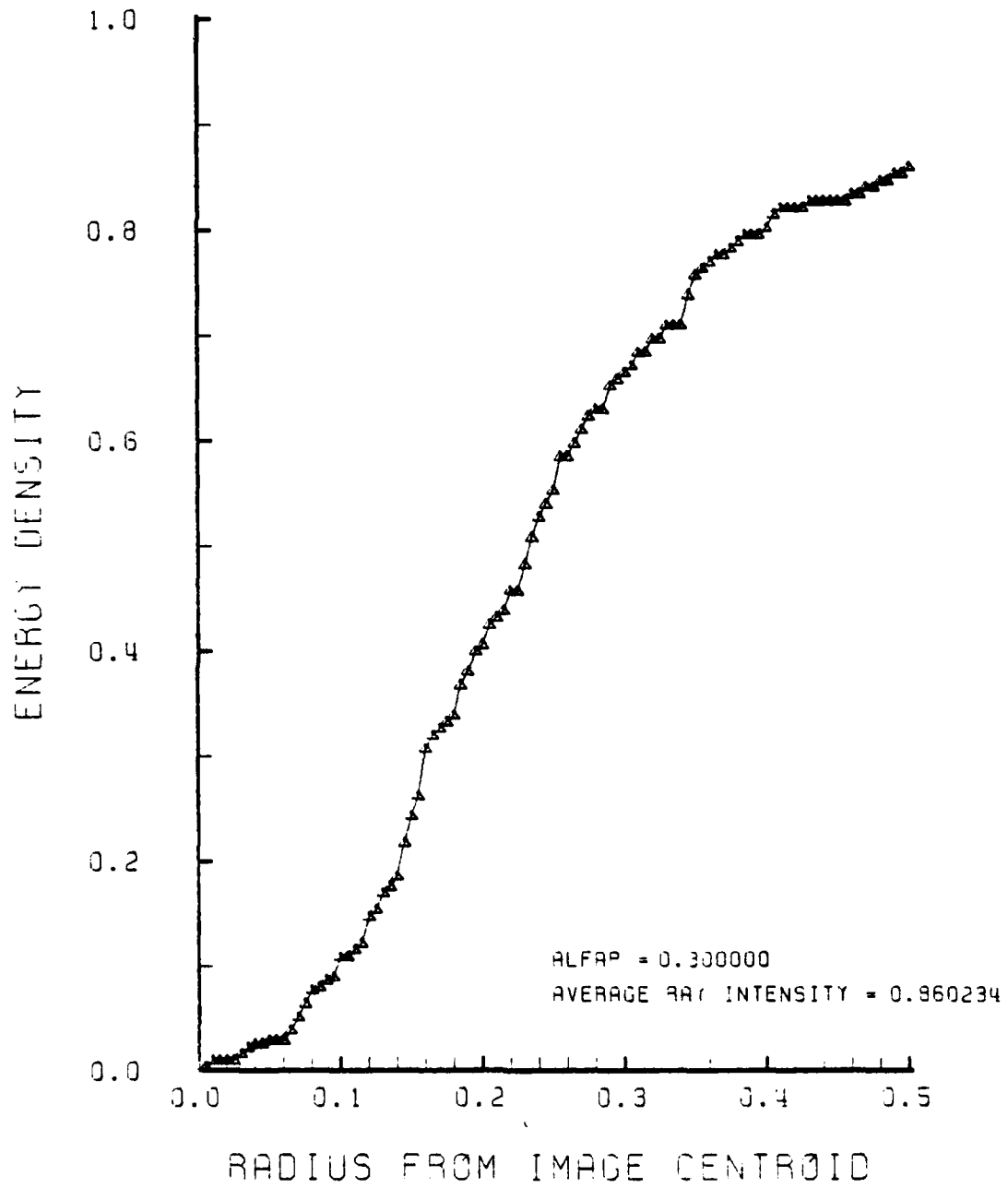

Figure E-76. Encircled Energy of Figure E-75

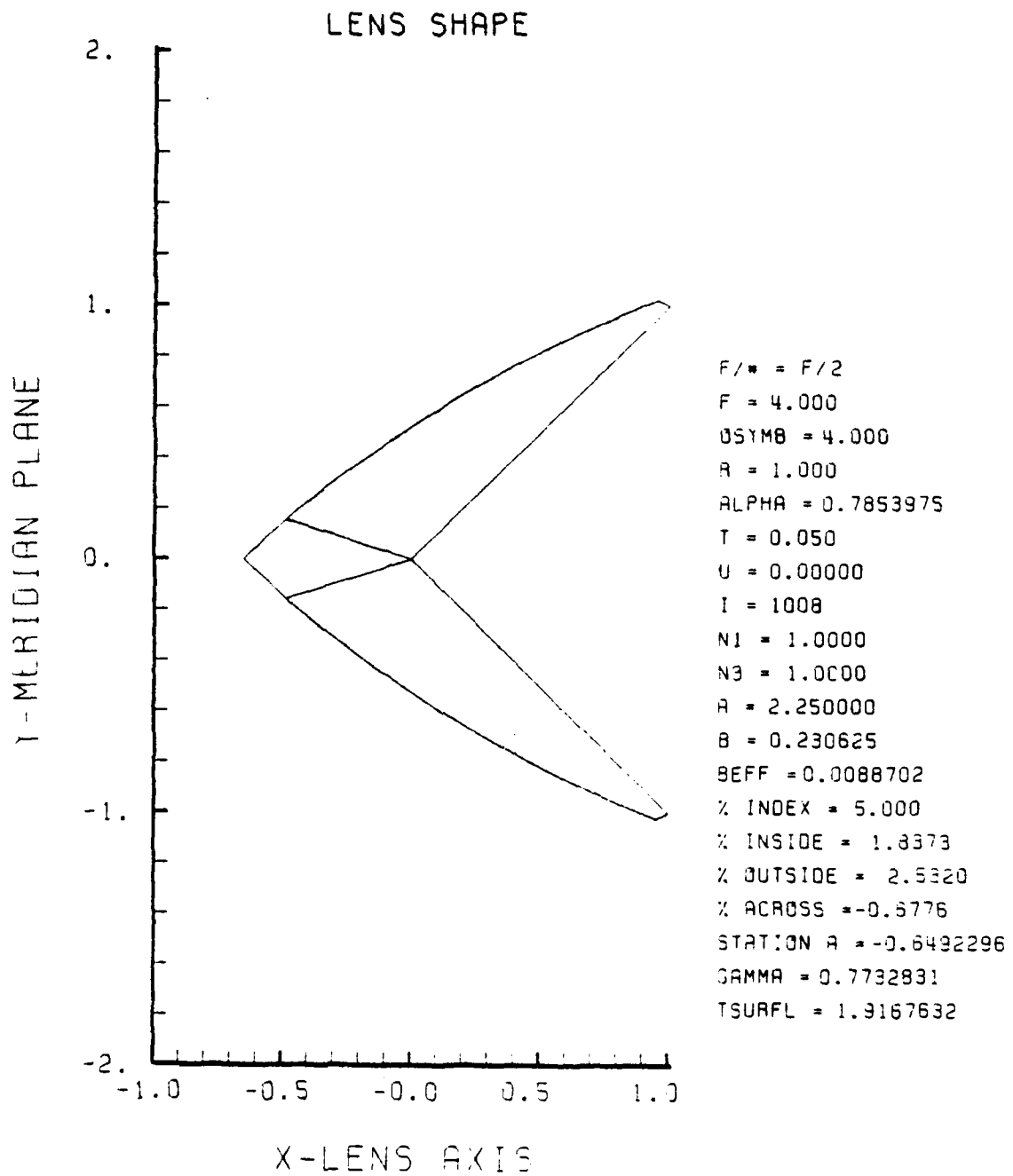

Figure E-77. GRIN Lens Shape at +5%, OB = 4.00,
a = 2.25

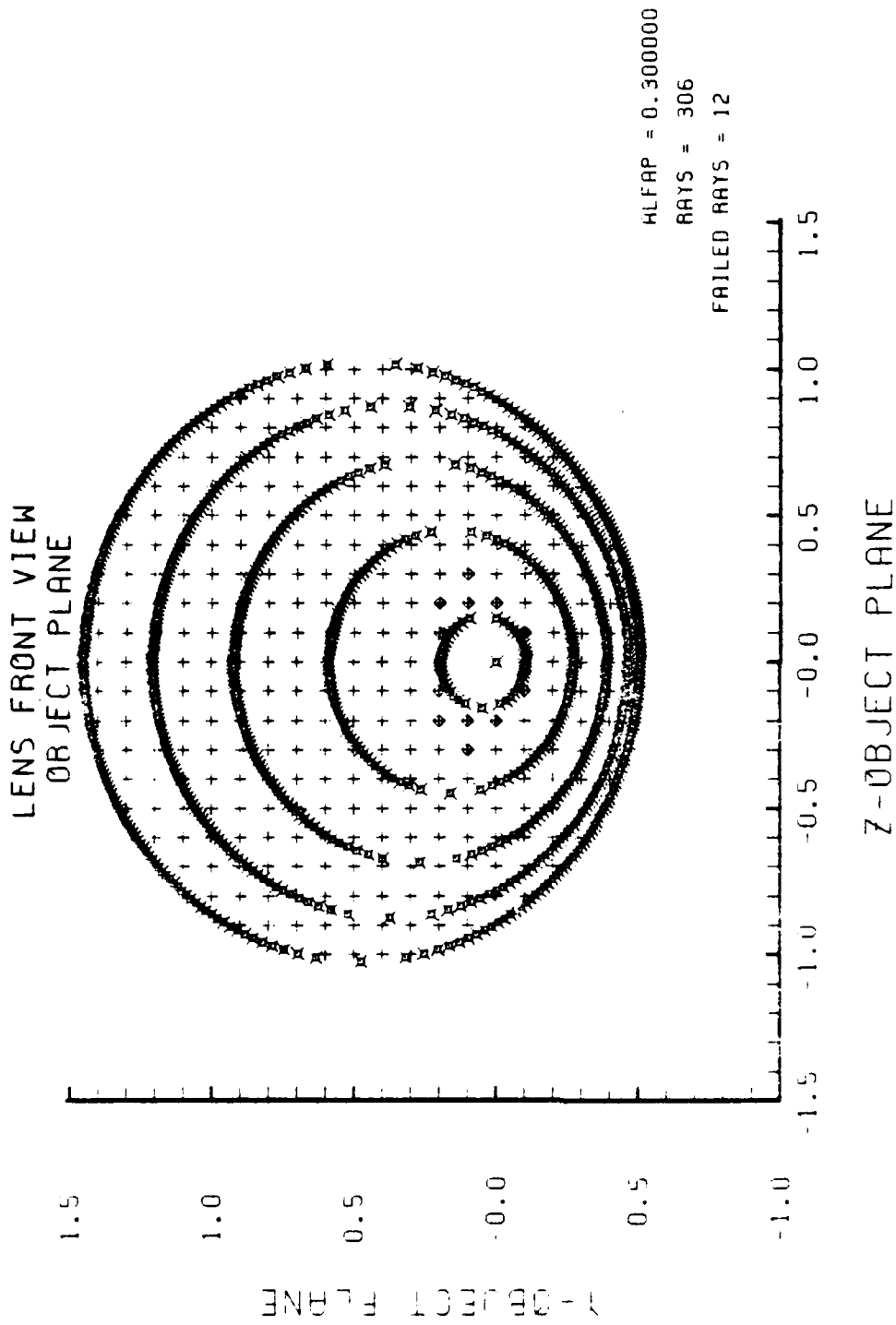

Figure E-78. Grid Plane at $\alpha_p = 0.3$ for Lens of Figure E-77

AD-A125 167

AERODYNAMICALLY EFFICIENT GRADIENT REFRACTIVE INDEX
MISSILE SEEKER LENS(U) NAVAL POSTGRADUATE SCHOOL
MONTEREV CA H M CARR OCT 82 NPS67-82-012

4/6

UNCLASSIFIED

F/G 16/4

NL

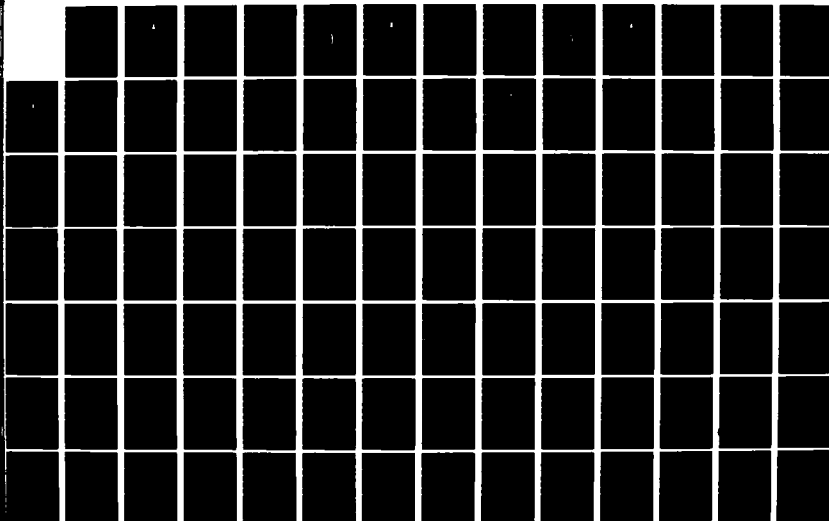

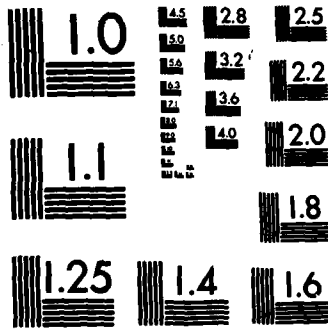

MICROCOPY RESOLUTION TEST CHART
NATIONAL BUREAU OF STANDARDS-1963-A

SPOT DIAGRAM

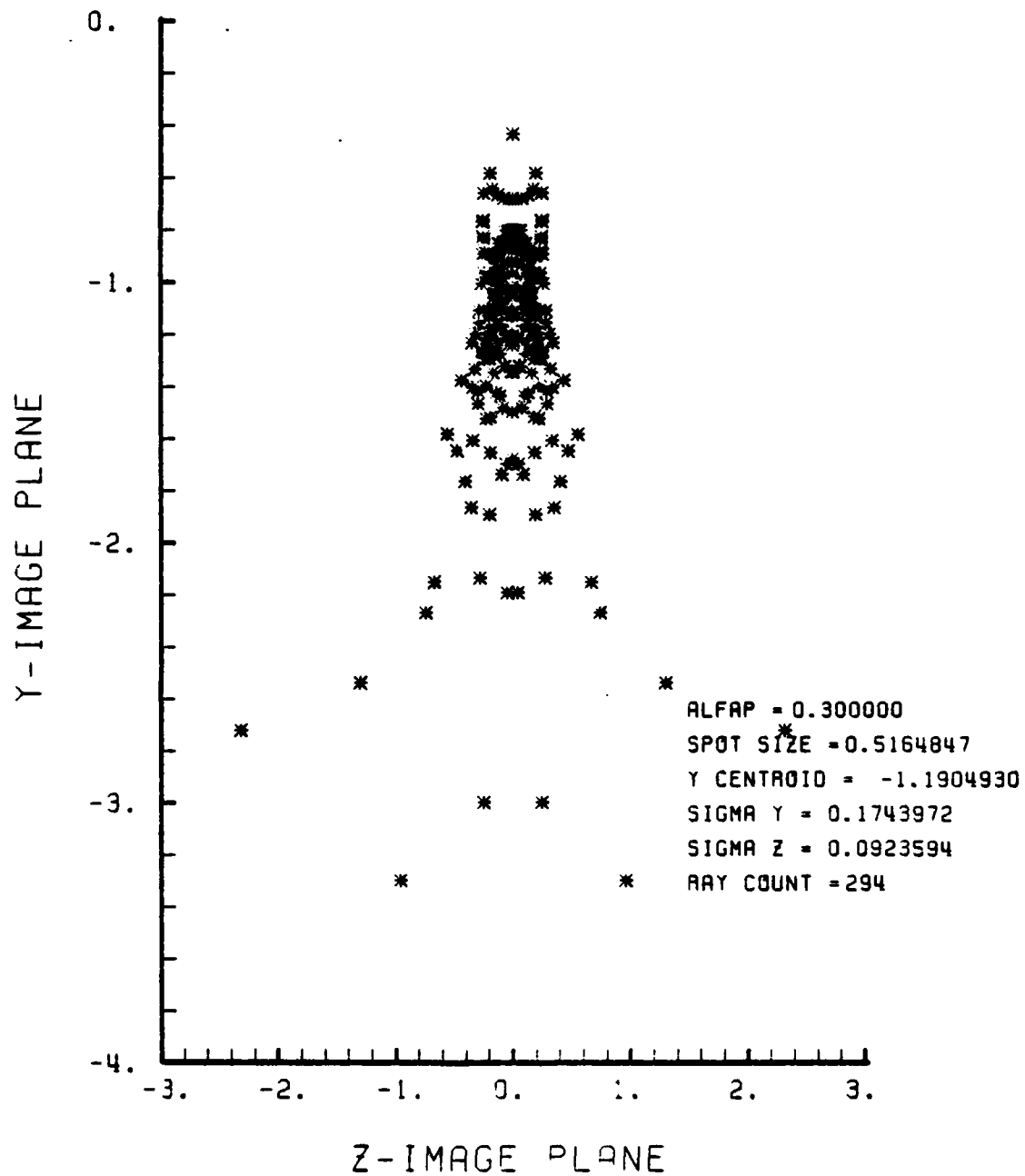

Figure E-79. Spot Diagram for Grid of Figure E-78

SPOT DIAGRAM ENERGY DENSITY

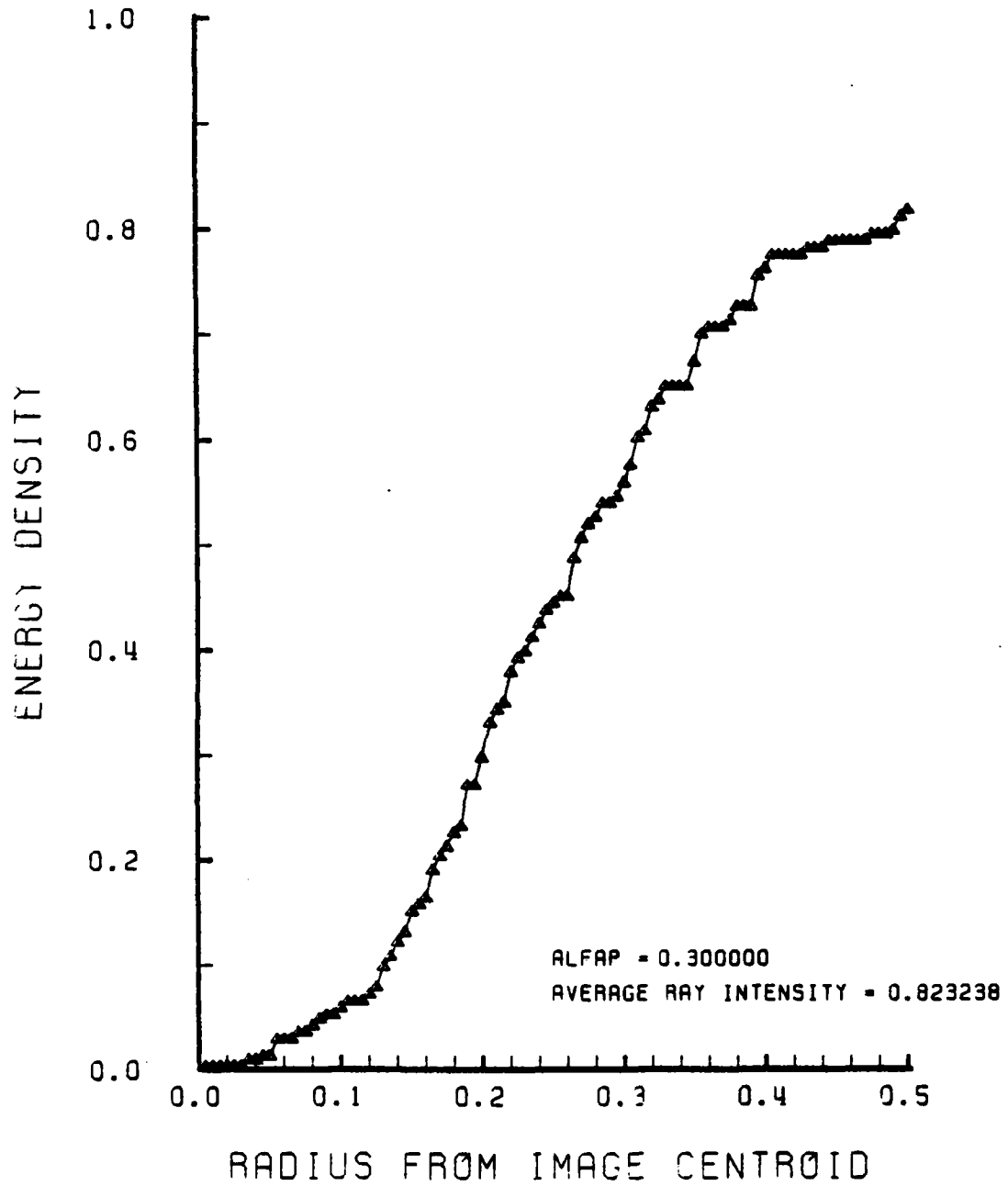

Figure E-80. Encircled Energy of Figure E-79

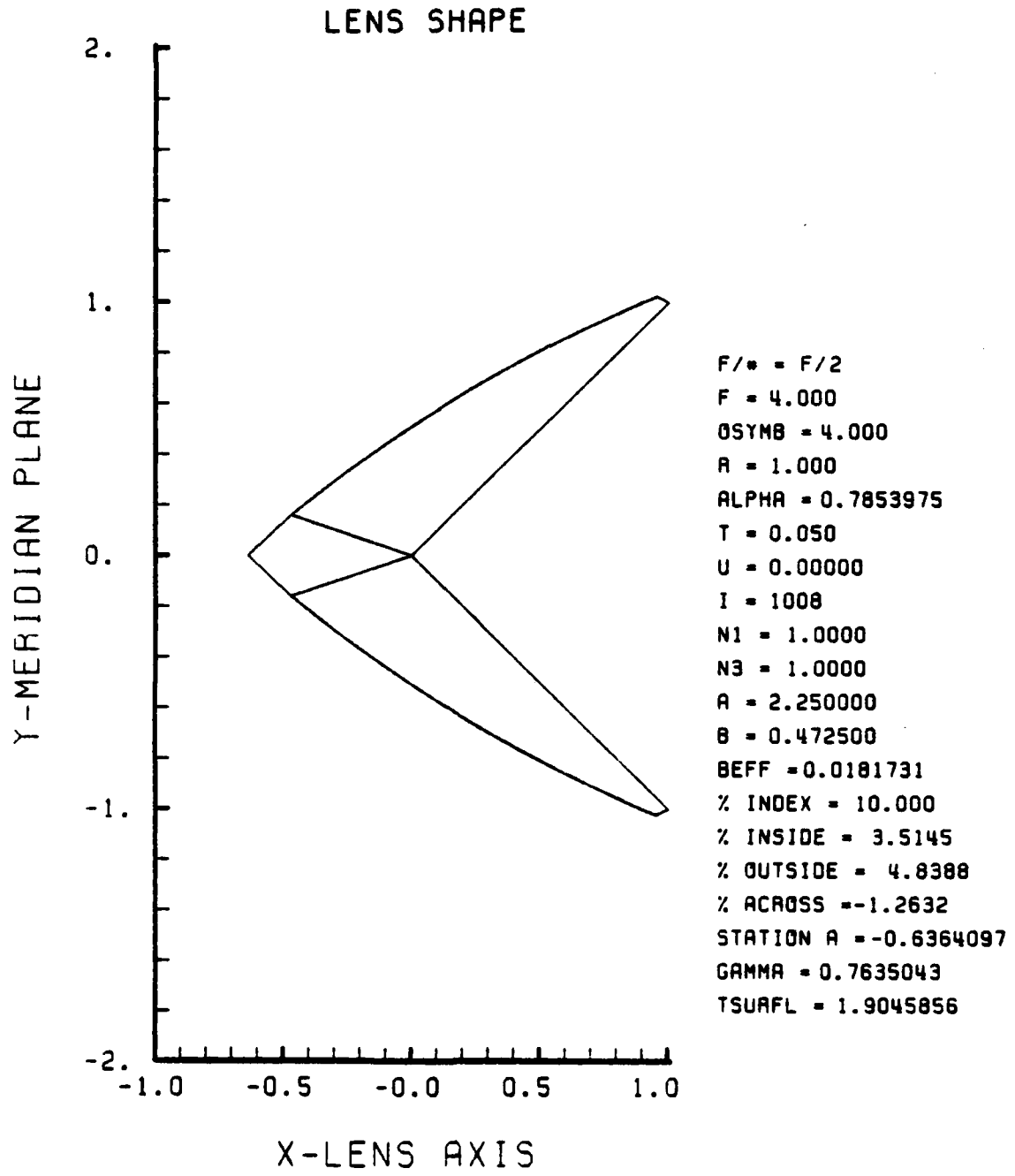

Figure E-81. GRIN Lens Shape at +10%, OB = 4.00,
a = 2.25

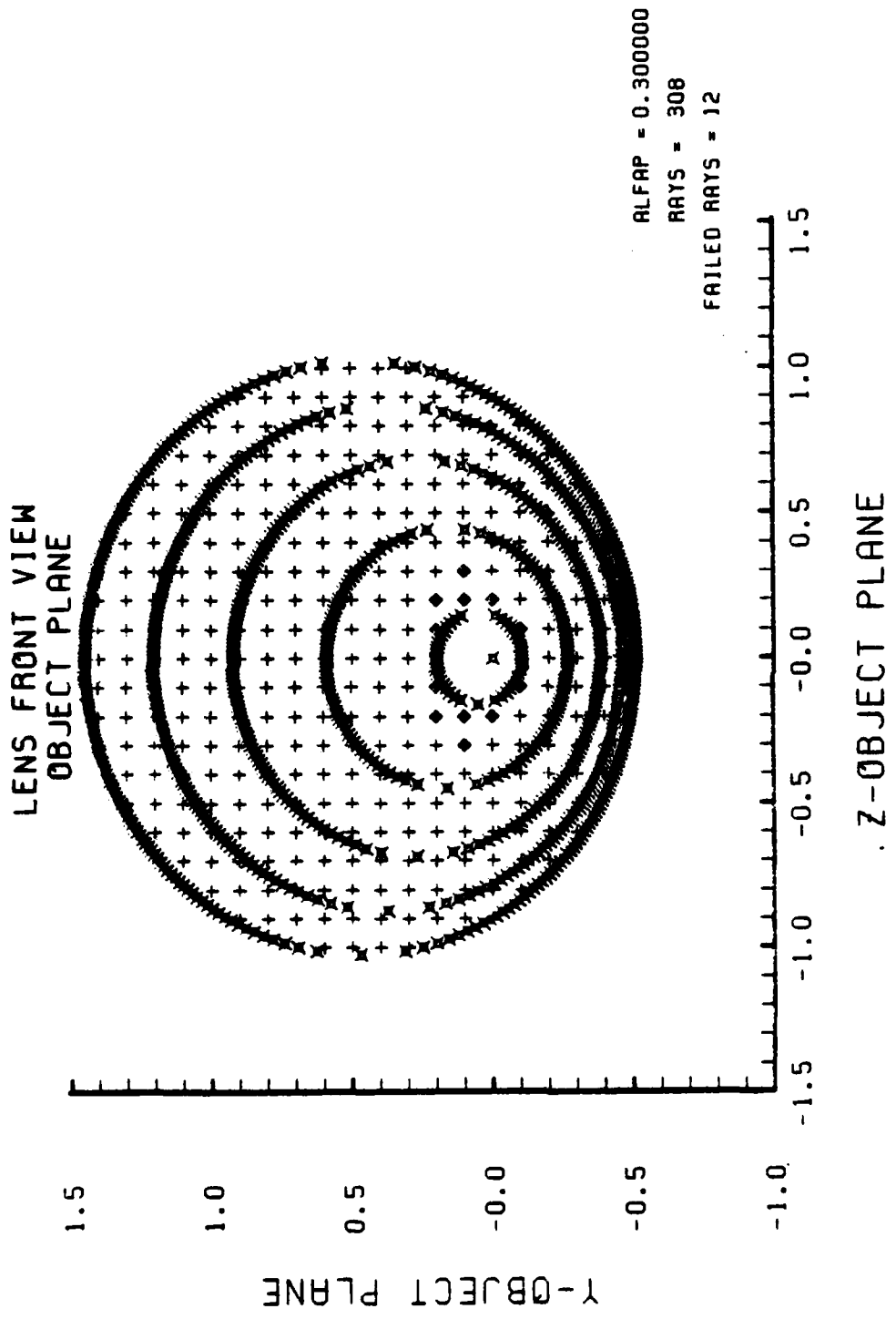

Figure E-82. Grid Plane at $\alpha_p = 0.3$ for Lens of Figure E-81

SPOT DIAGRAM

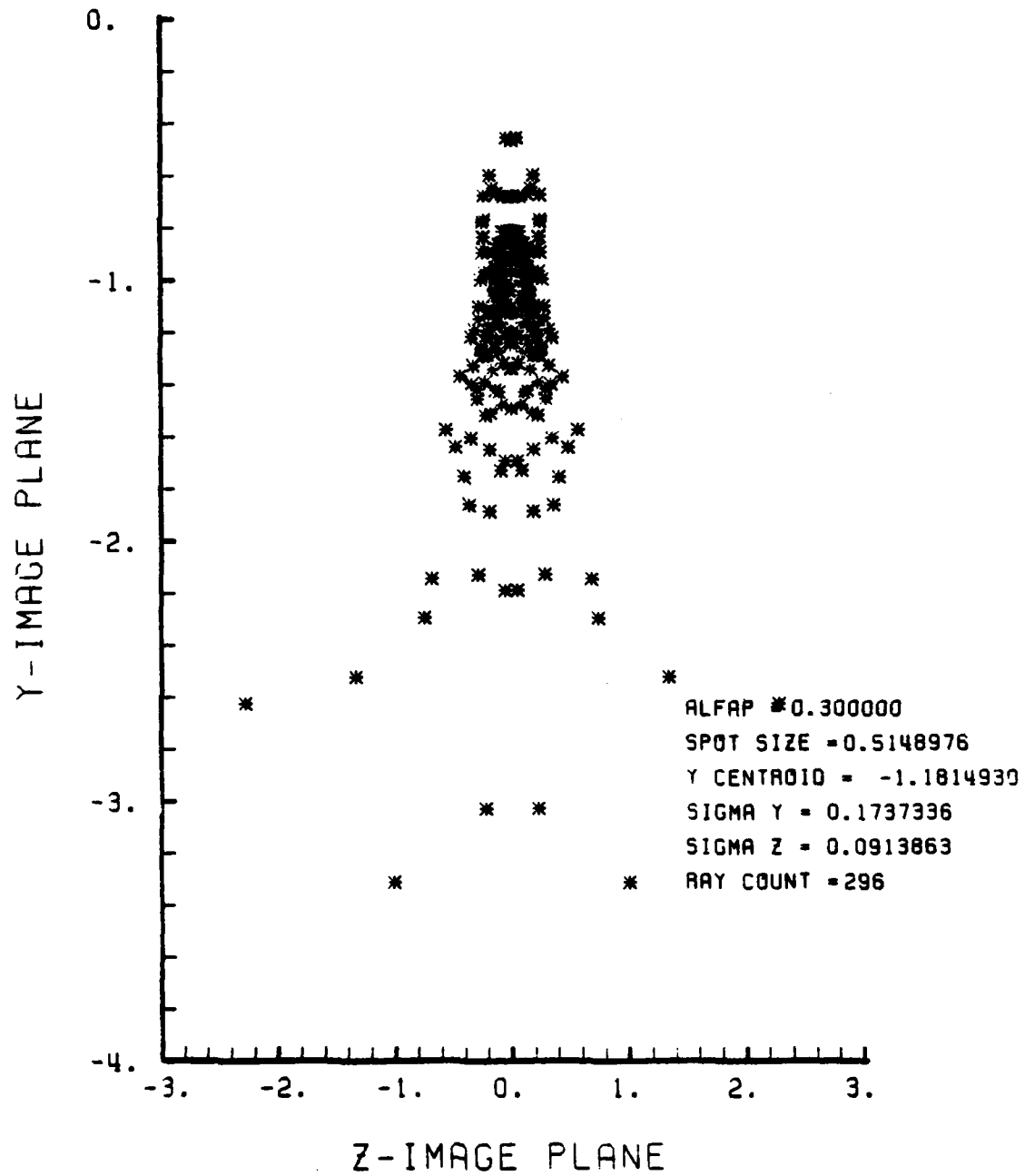

Figure E-83. Spot Diagram for Grid of Figure E-82

SPOT DIAGRAM ENERGY DENSITY

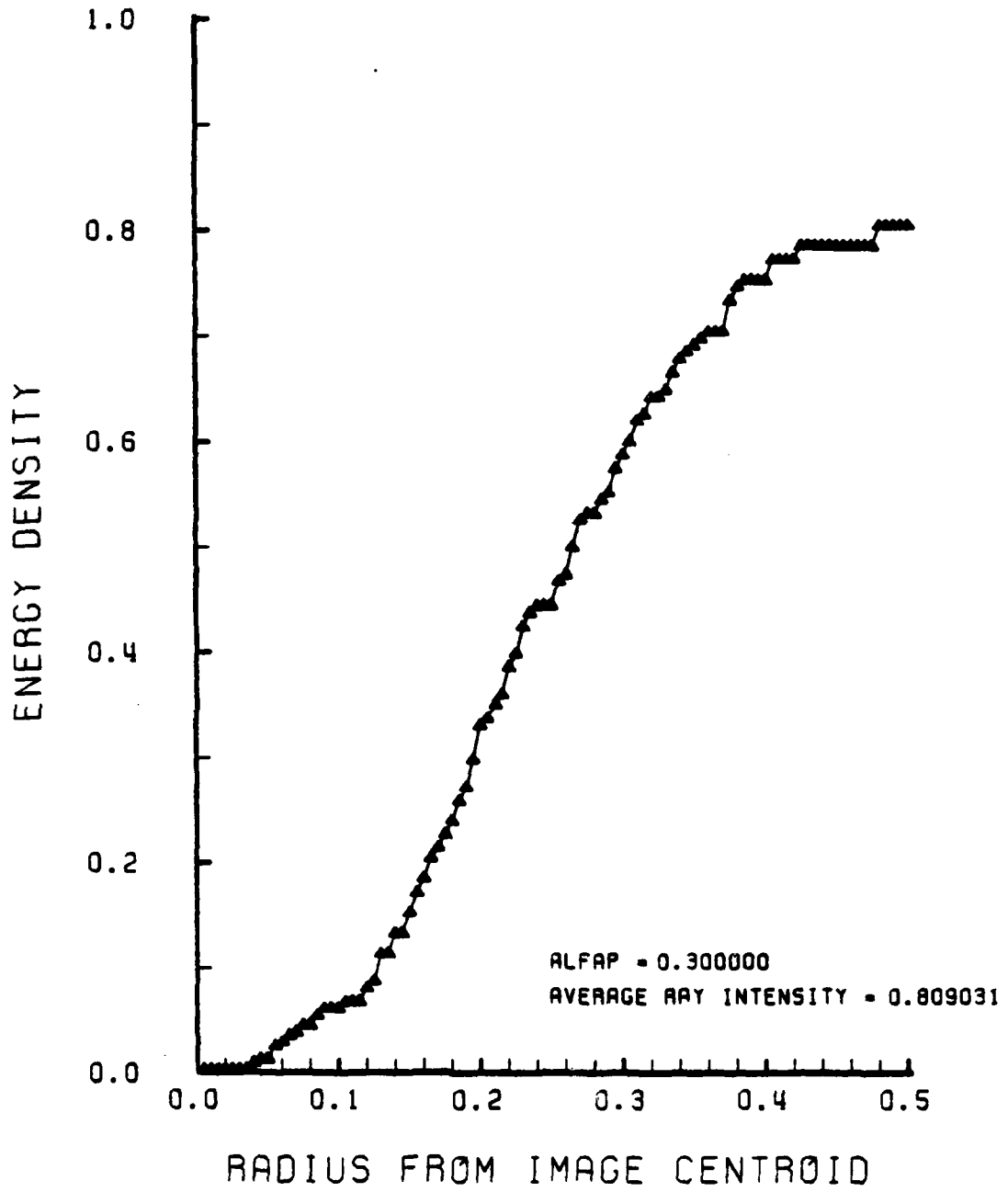

Figure E-84. Encircled Energy of Figure E-83

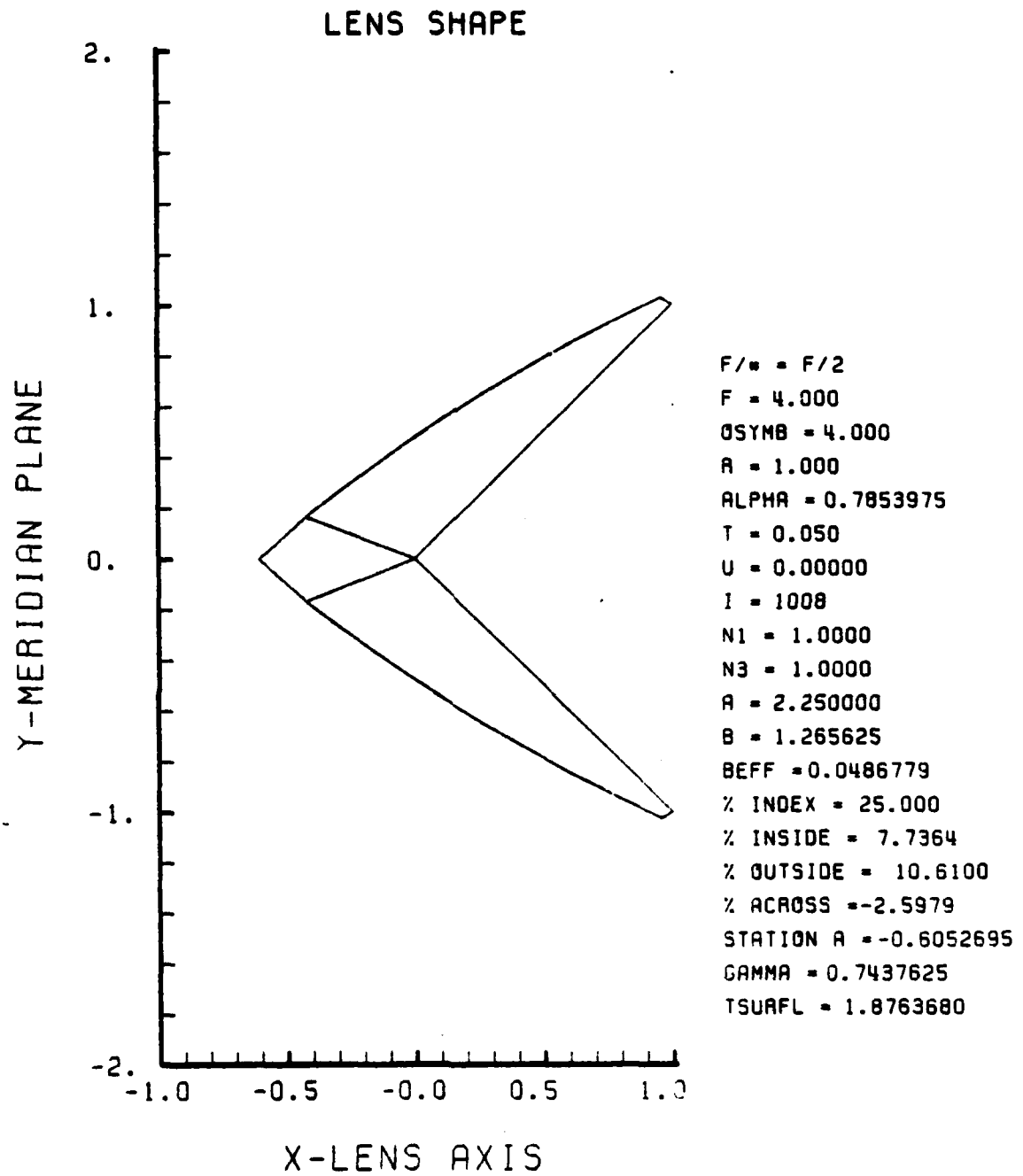

Figure E-85. GRIN Lens Shape at +25%, OB = 4.00,
a = 2.25

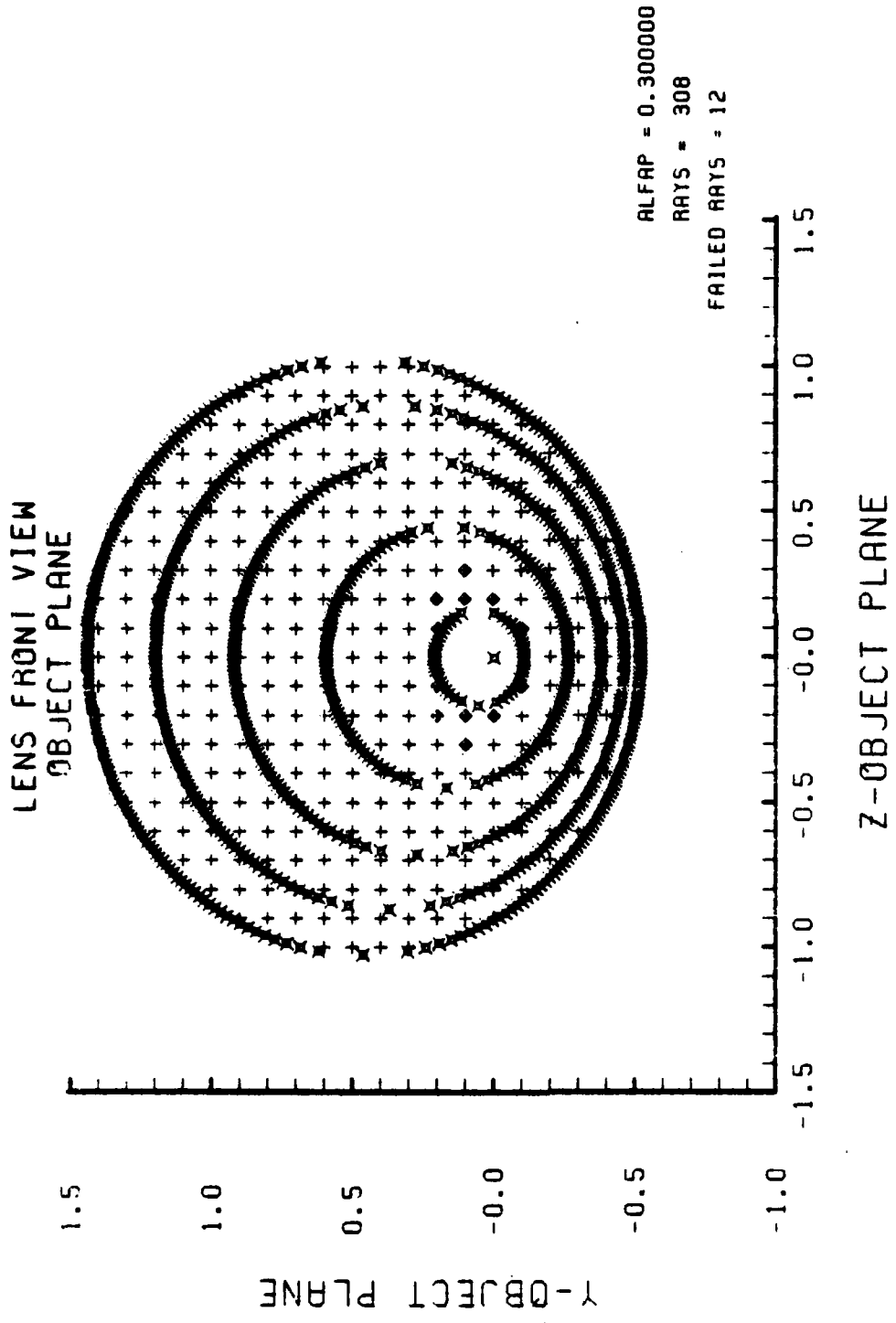

Figure E-36. Grid Plane at $\alpha_p = 0.3$ for Lens of Figure E-85

SPOT DIAGRAM

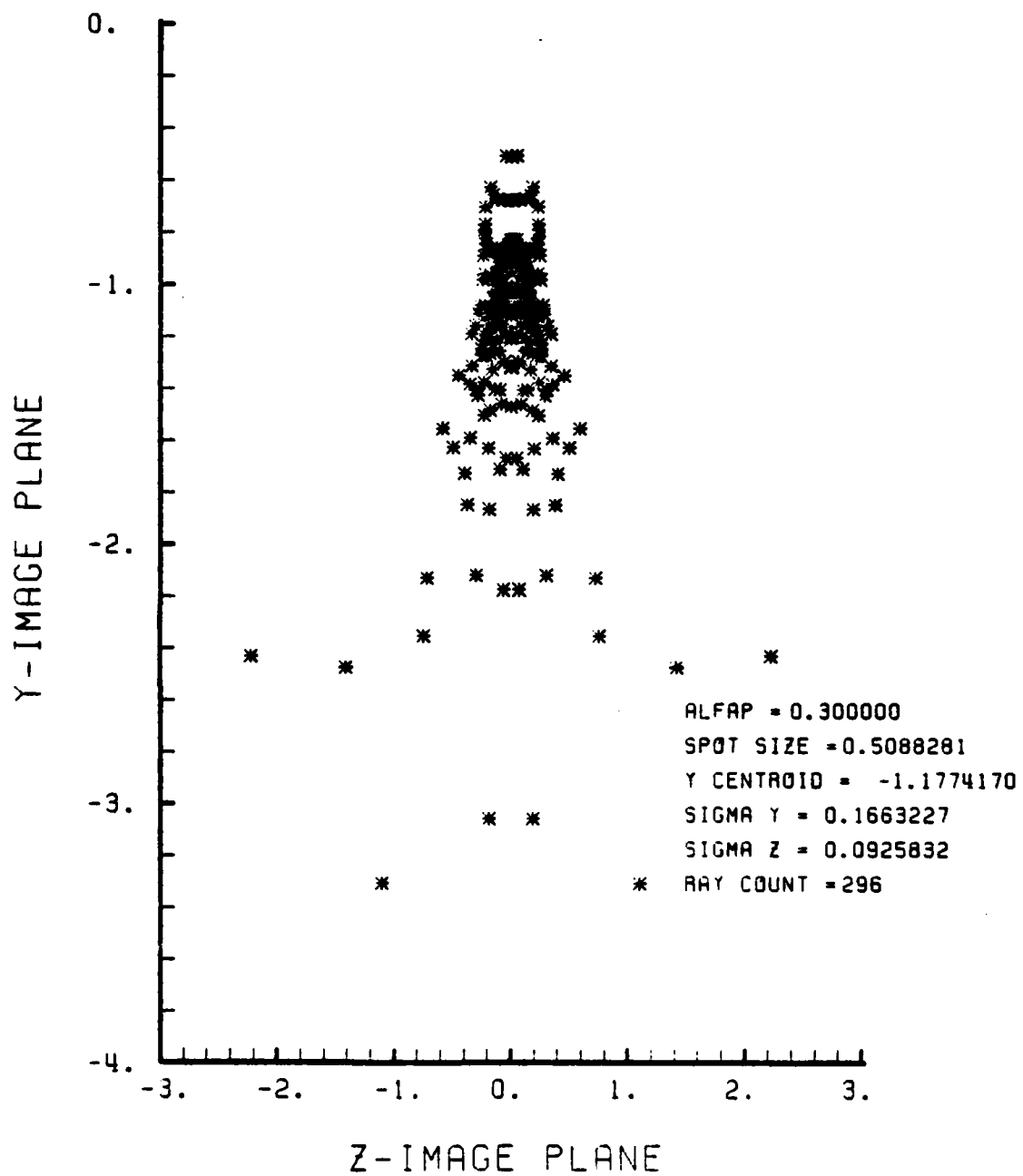

Figure E-87. Spot Diagram for Grid of Figure E-86

SPOT DIAGRAM ENERGY DENSITY

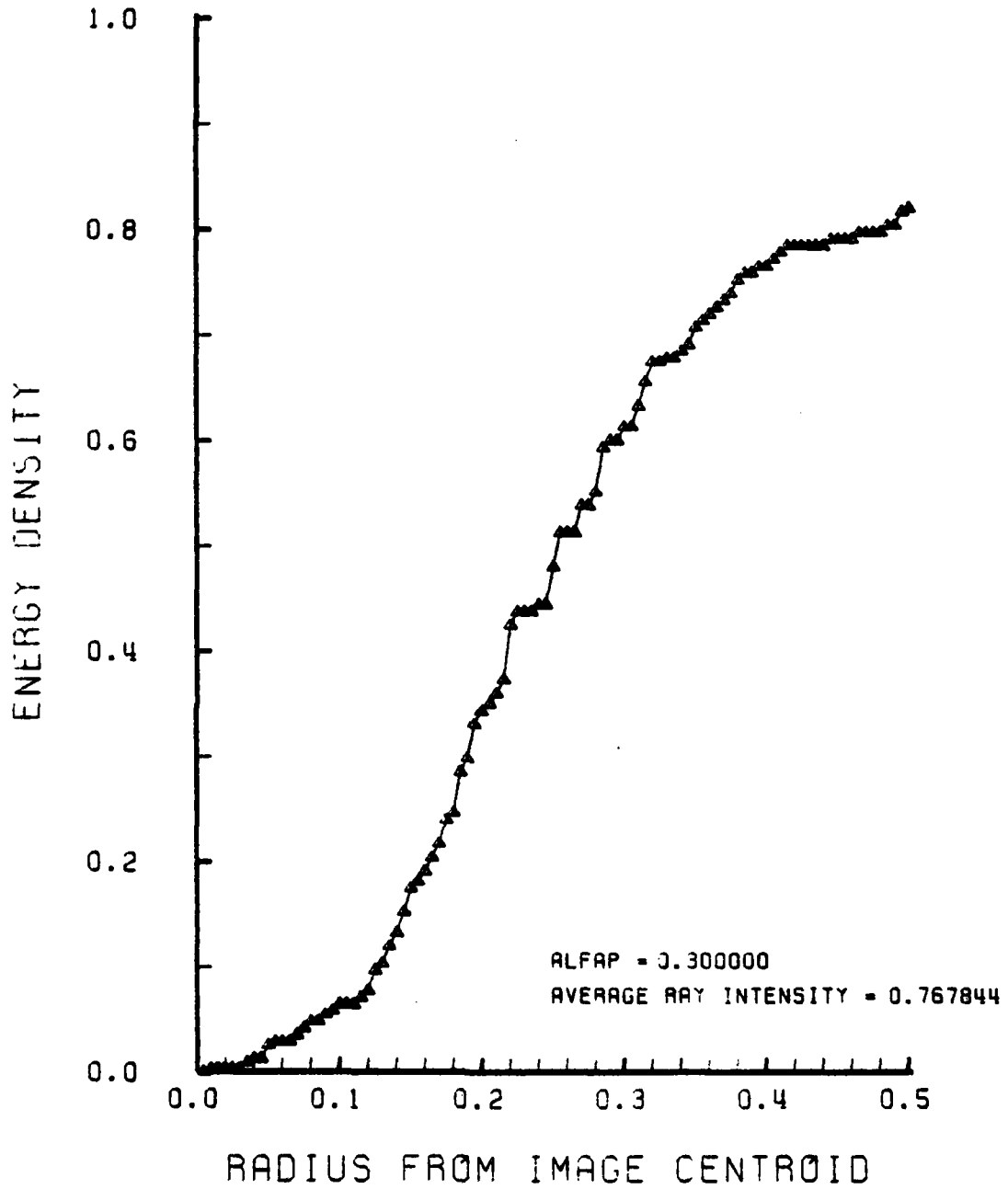

Figure E-88. Encircled Energy of Figure E-87

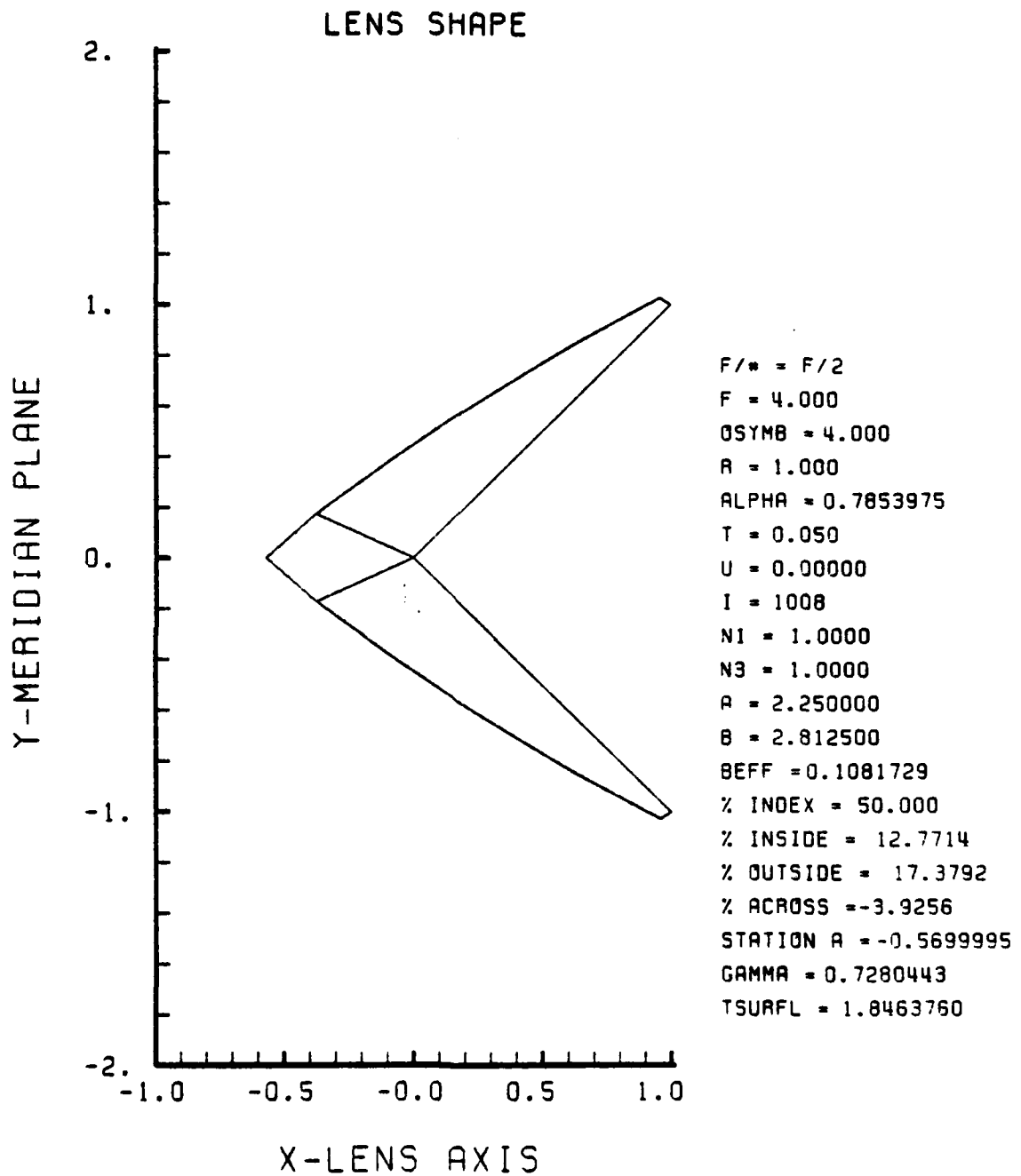
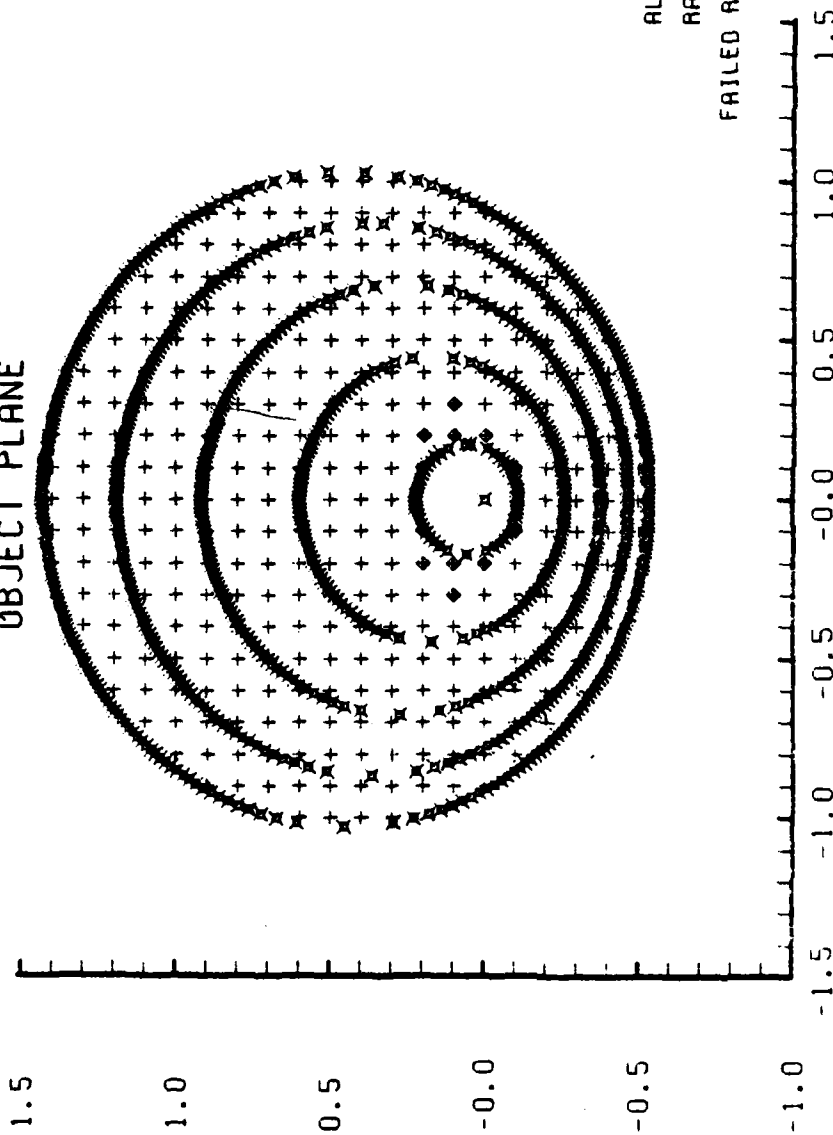

Figure E-89. GRIN Lens Shape at +50%, OB = 4.00,
a = 2.25

LENS FRONT VIEW
OBJECT PLANE



ALFAP = 0.300000

RAYS = 312

FAILED RAYS = 12

Z-OBJECT PLANE

Y-OBJECT PLANE

Figure E-90. Grid Plane at $\alpha_p = 0.3$ for Lens of Figure E-89

SPOT DIAGRAM

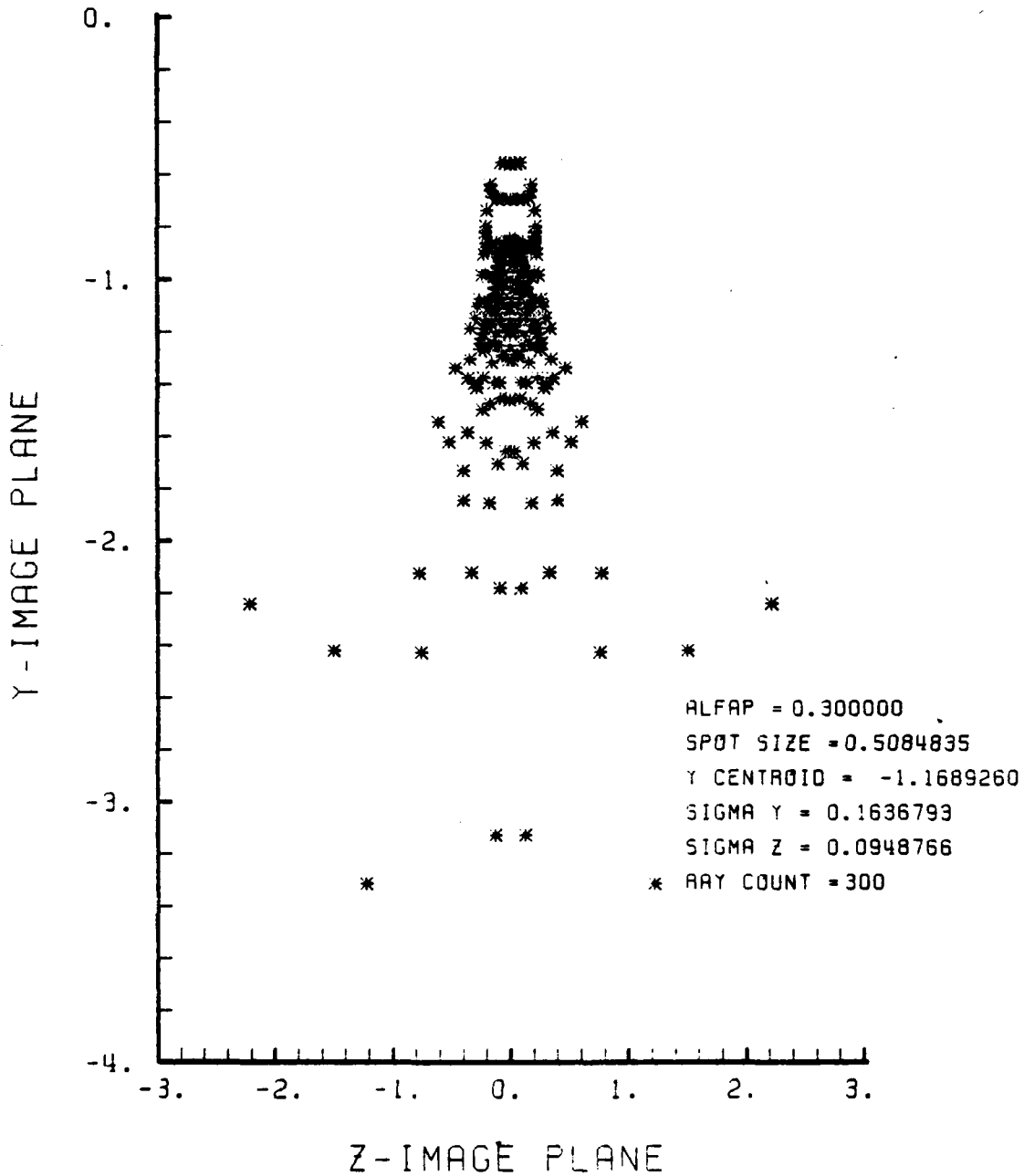

Figure E-91. Spot Diagram for Grid of Figure E-90

SPOT DIAGRAM ENERGY DENSITY

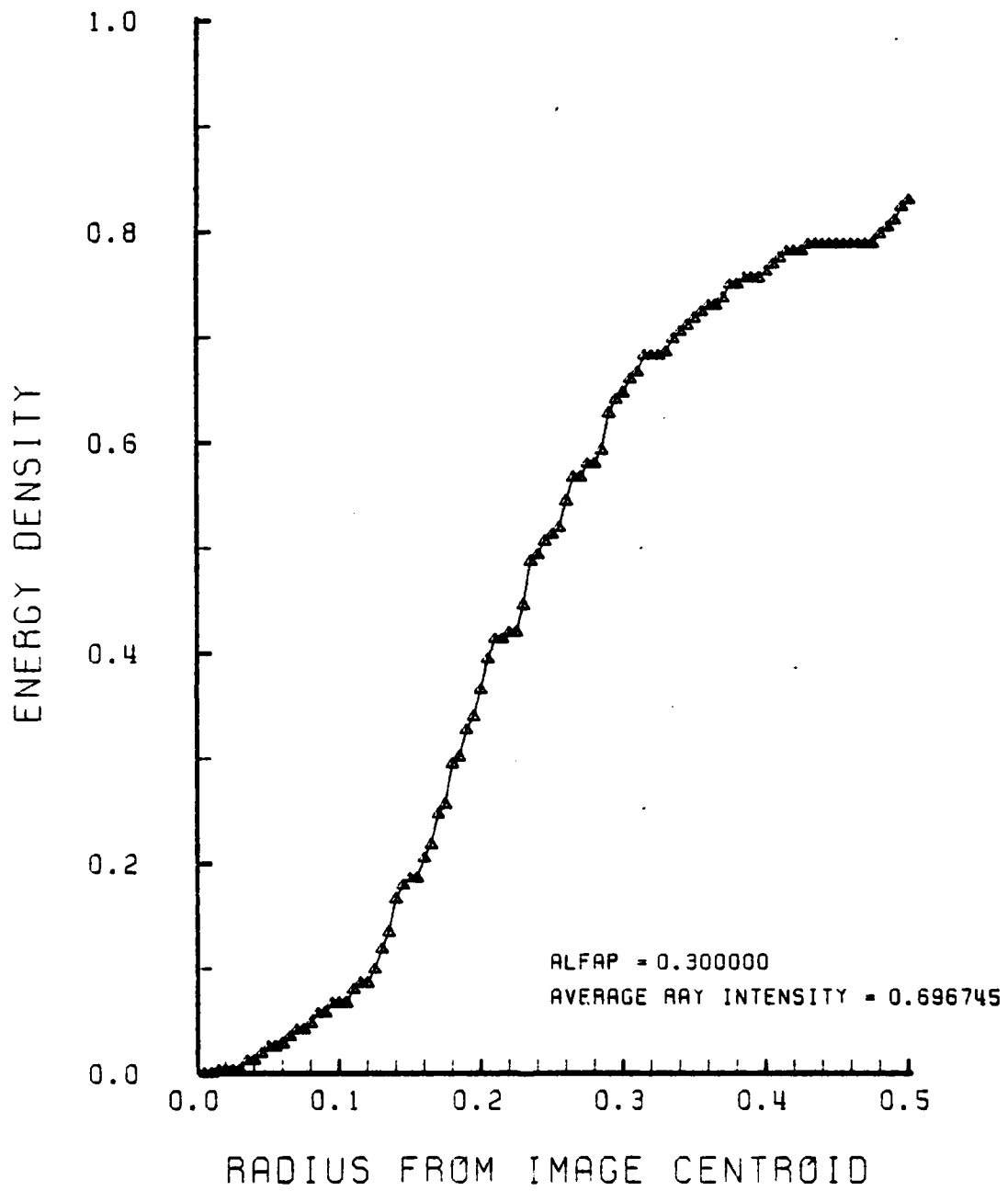

Figure E-92. Encircled Energy of Figure E-91

APPENDIX F

GRIN LENS PERFORMANCE PLOTS IN THE HIGH RANGE OF INDICES OF REFRACTION ($a = 9.00$)

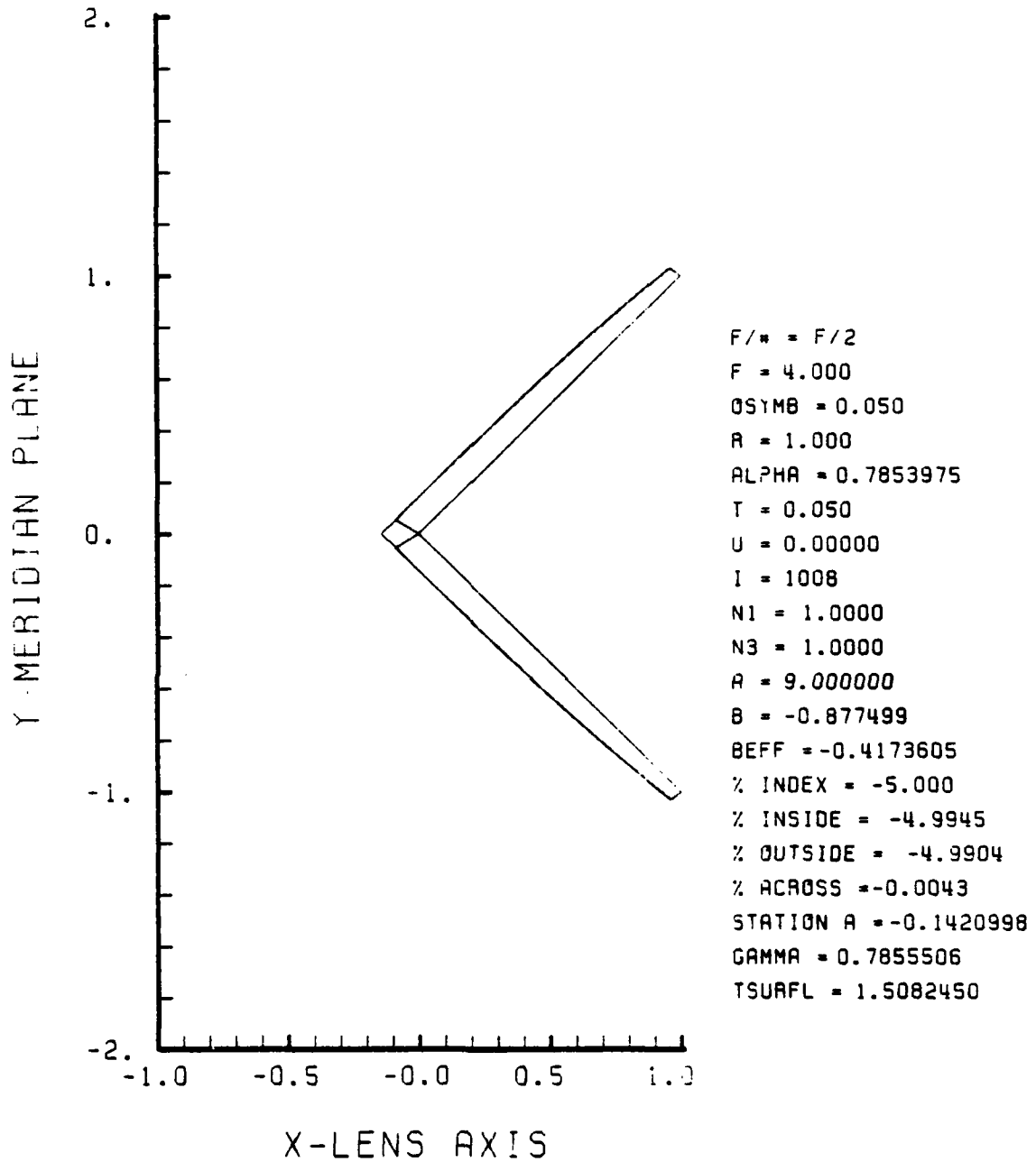

Figure F-1. GRIN Lens Shape at -5%, $OB = 0.05$,
 $a = 9.00$

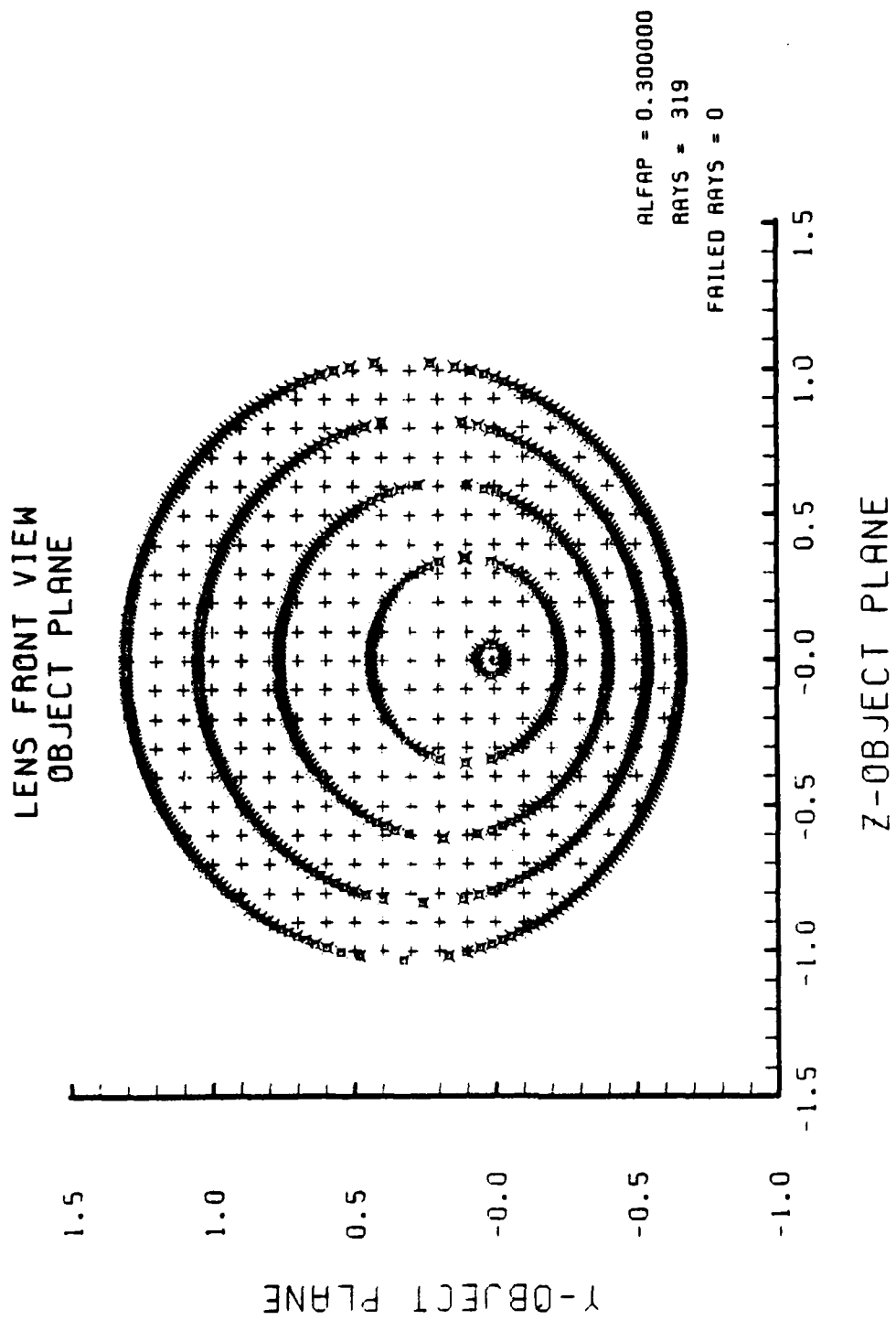

Figure F-2. Grid Plane at $\alpha_p = 0.3$ for Lens of Figure F-1

SPOT DIAGRAM

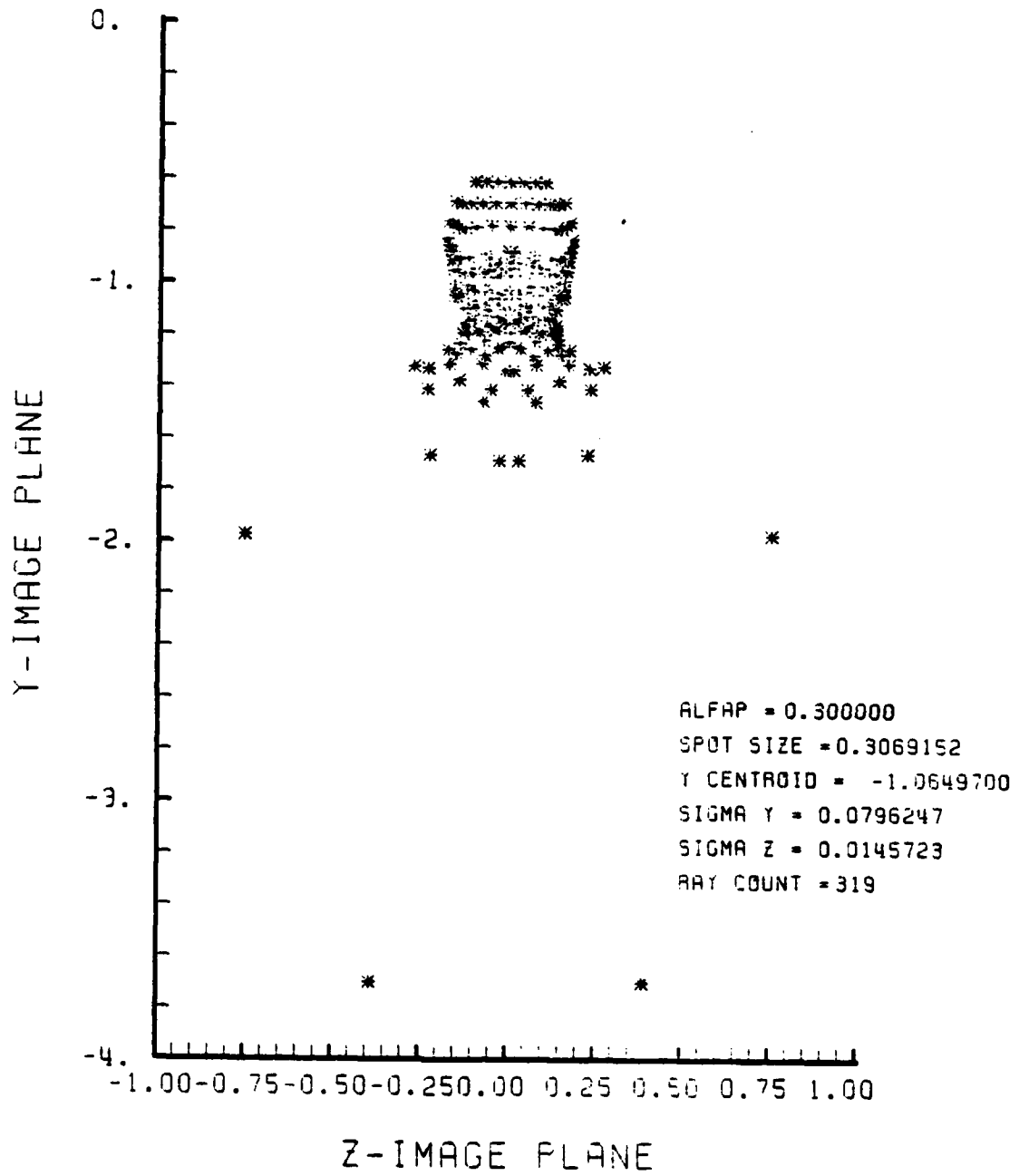

Figure F-3. Spot Diagram for Grid of Figure F-2

SPOT DIAGRAM ENERGY DENSITY

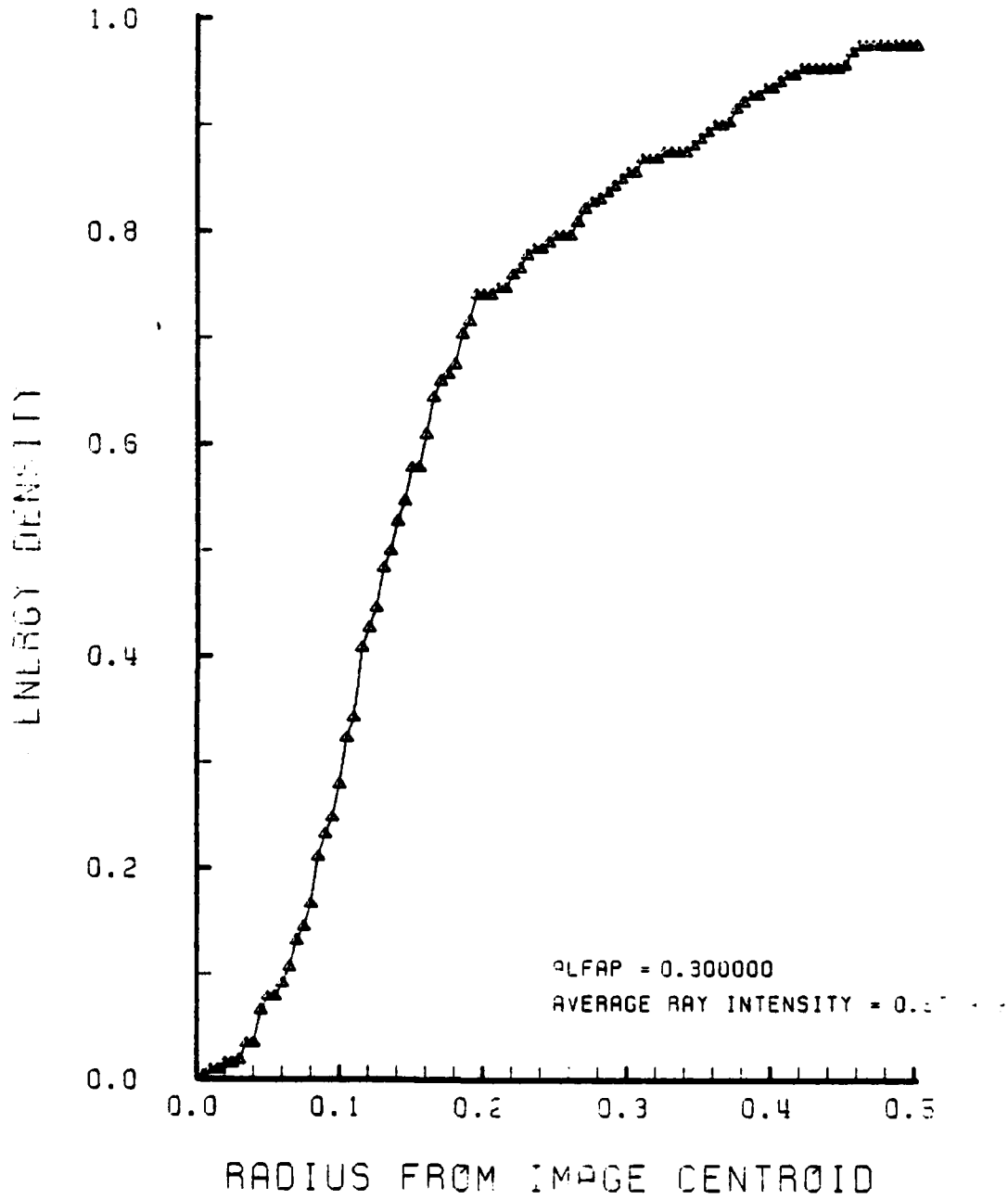

Figure F-4. Encircled Energy of Figure F-3

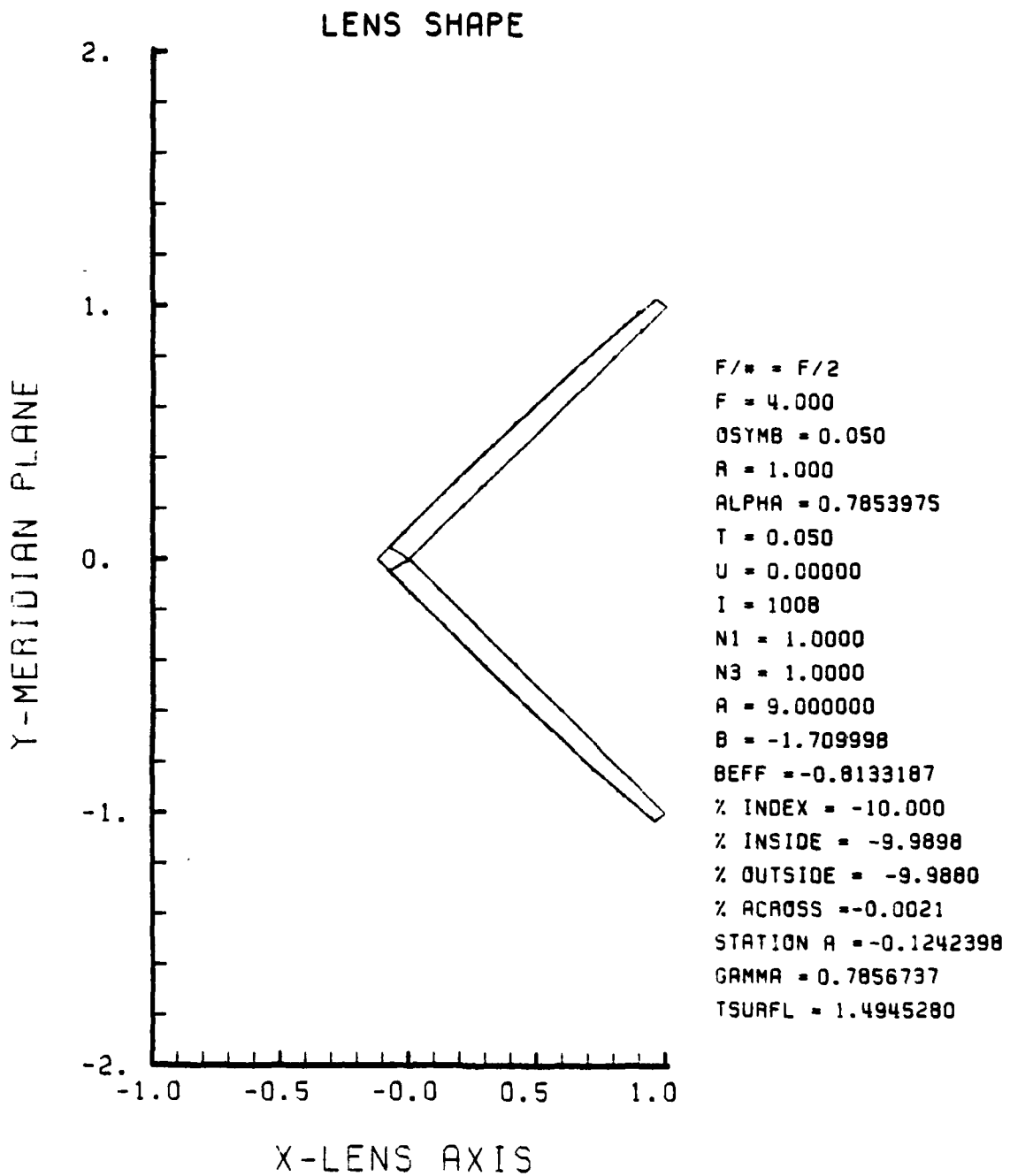

Figure F-5. GRIN Lens Shape at -10%, OB = 0.05,
a = 9.00

LENS FRONT VIEW
OBJECT PLANE

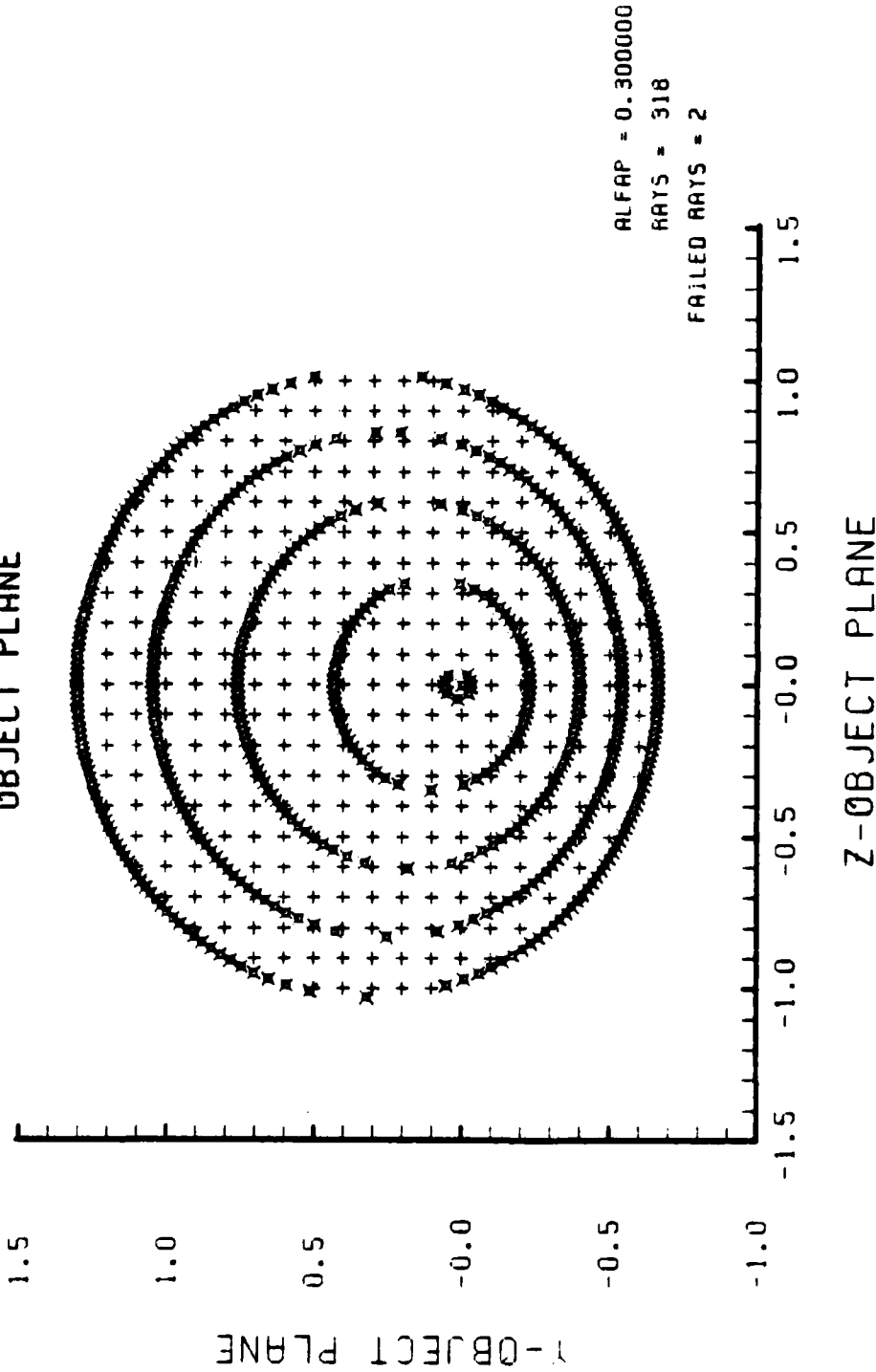

Figure F-6. Grid Plane at $\alpha_p = 0.3$ for Lens of Figure F-5

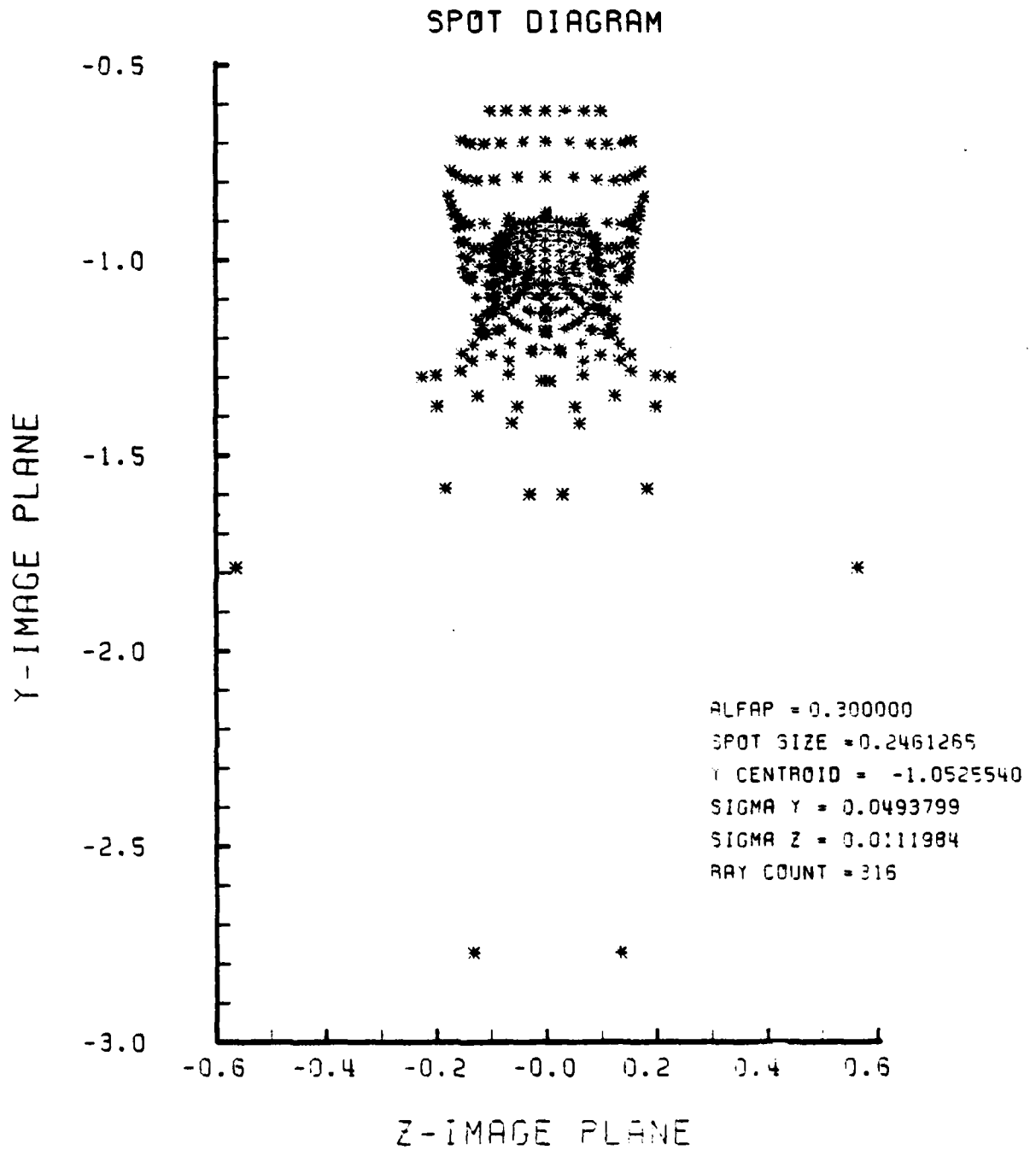

Figure F-7. Spot Diagram for Grid of Figure F-6

SPOT DIAGRAM ENERGY DENSITY

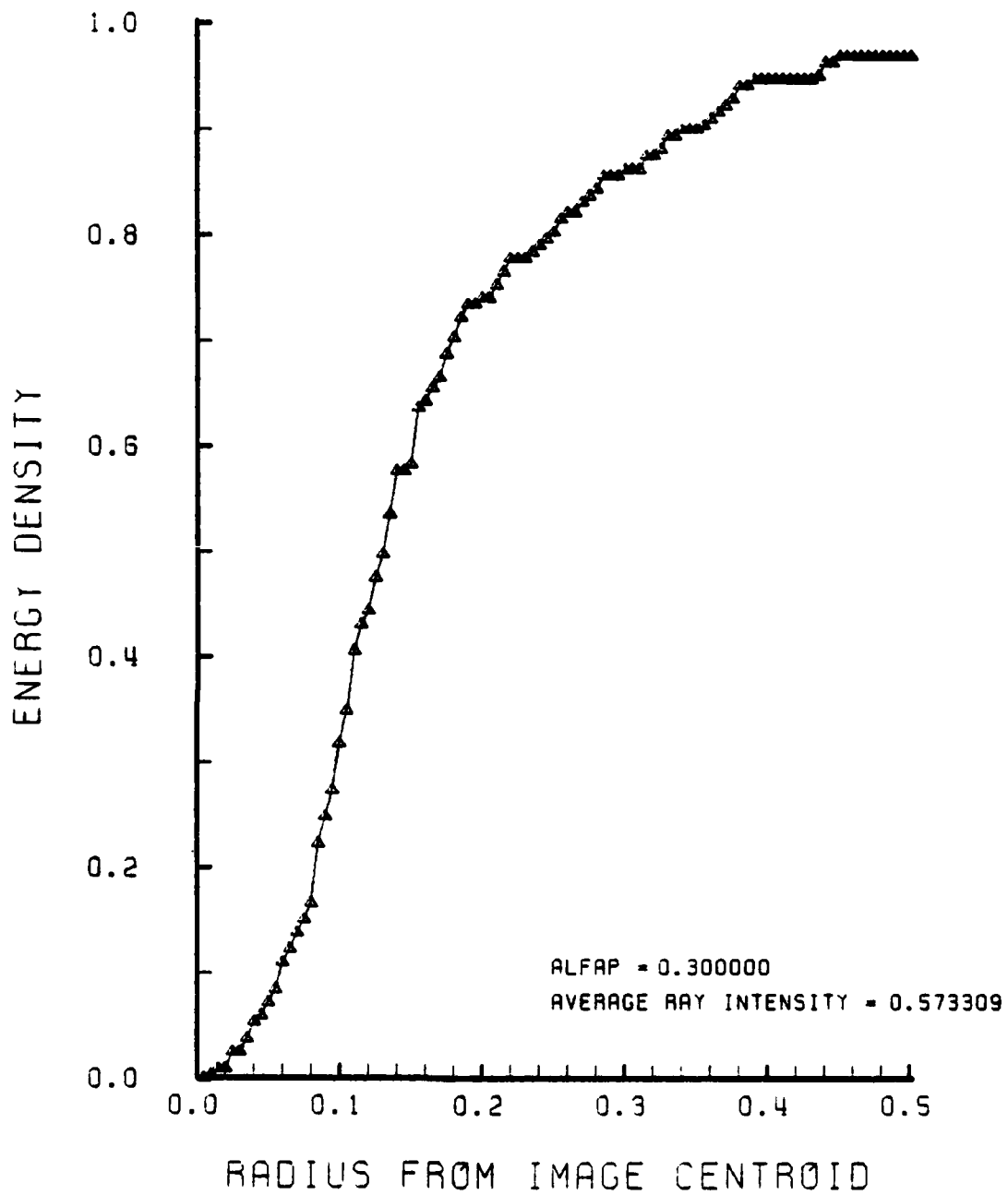

Figure F-8. Encircled Energy of Figure F-7

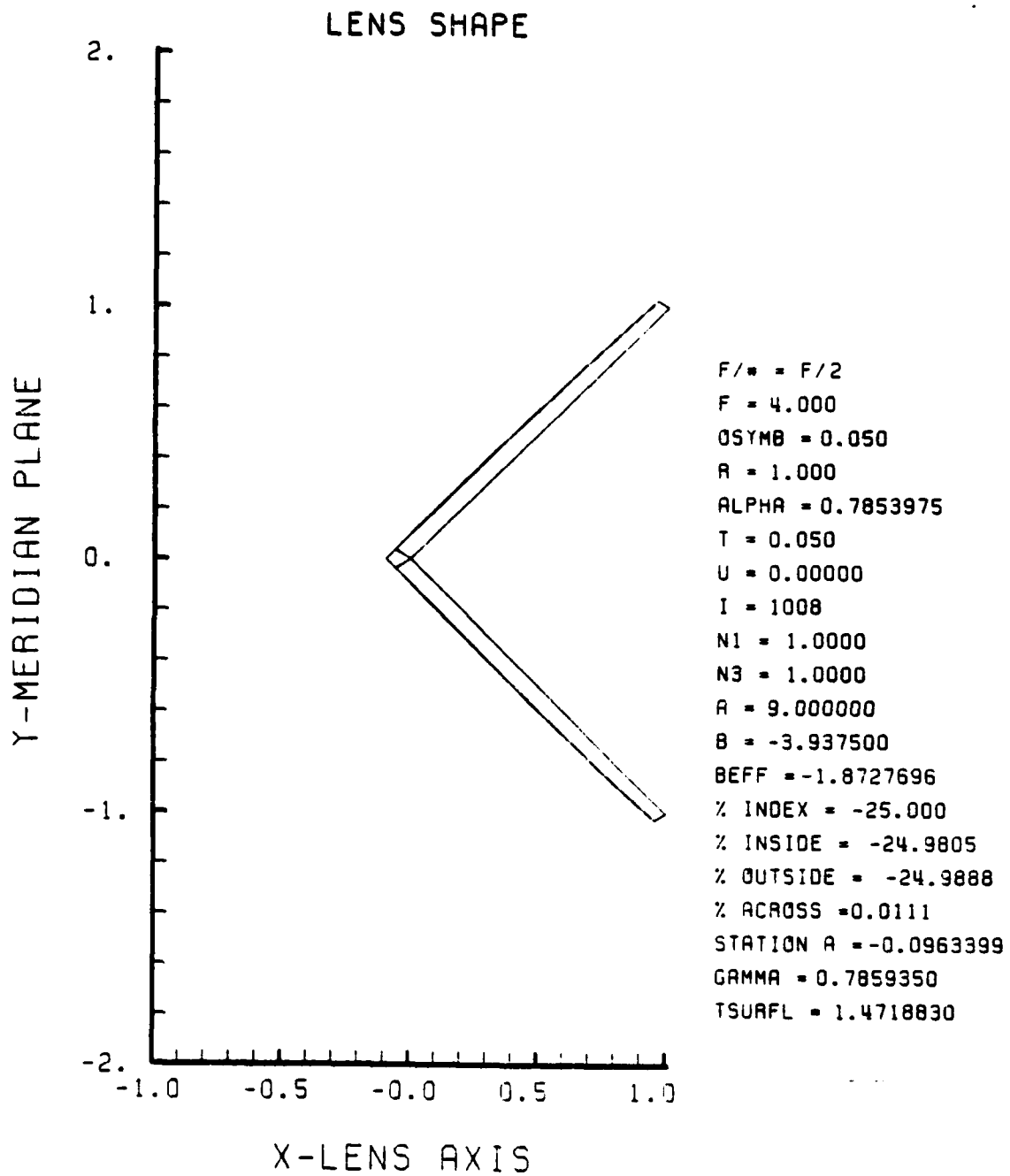

Figure F-9. GRIN Lens Shape at -25%, OB = 0.05,
a = 9.00

LENS FRONT VIEW
OBJECT PLANE

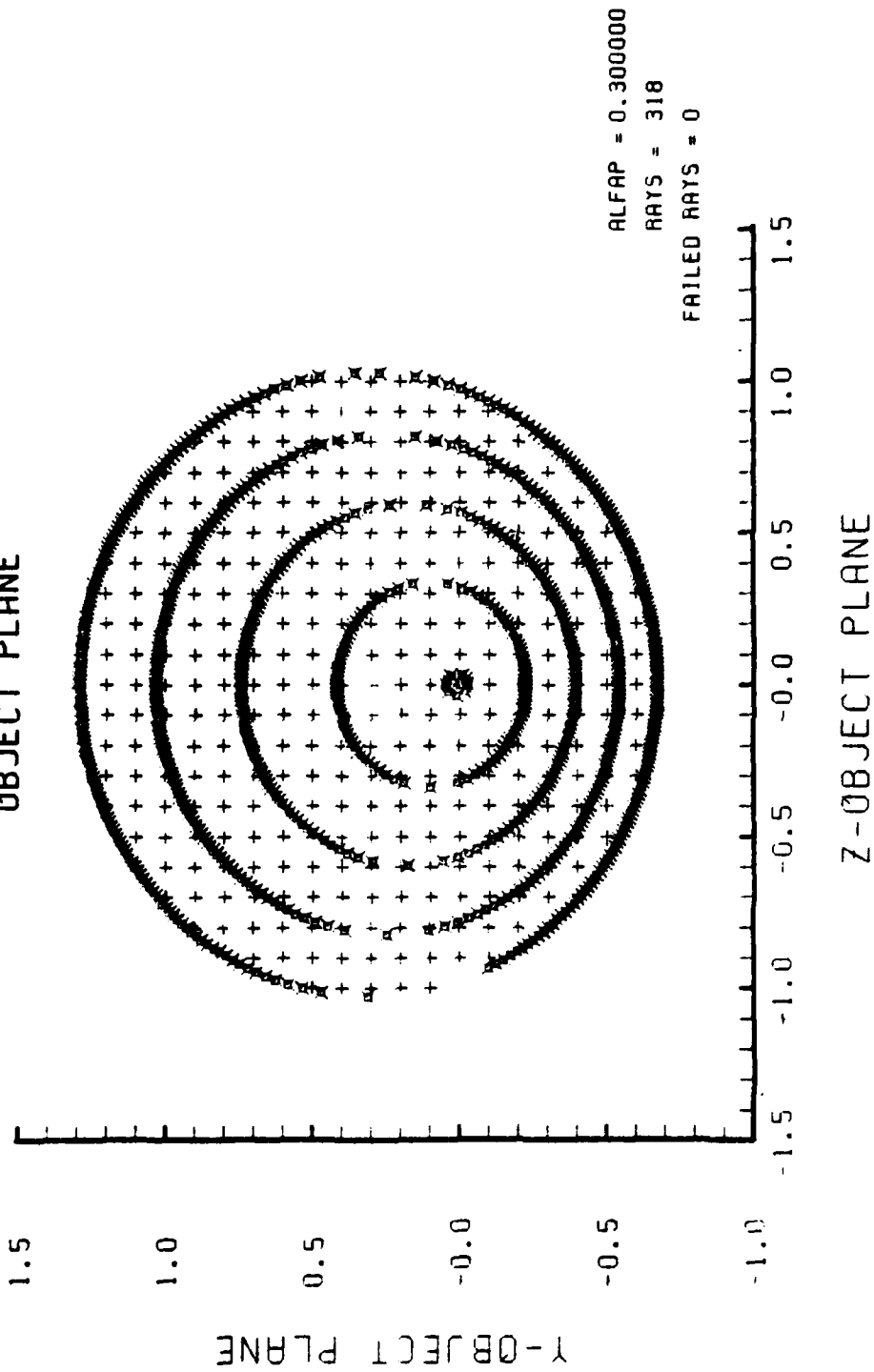

Figure F-10. Grid Plane at $\alpha_p = 0.3$ for Lens of Figure F-9

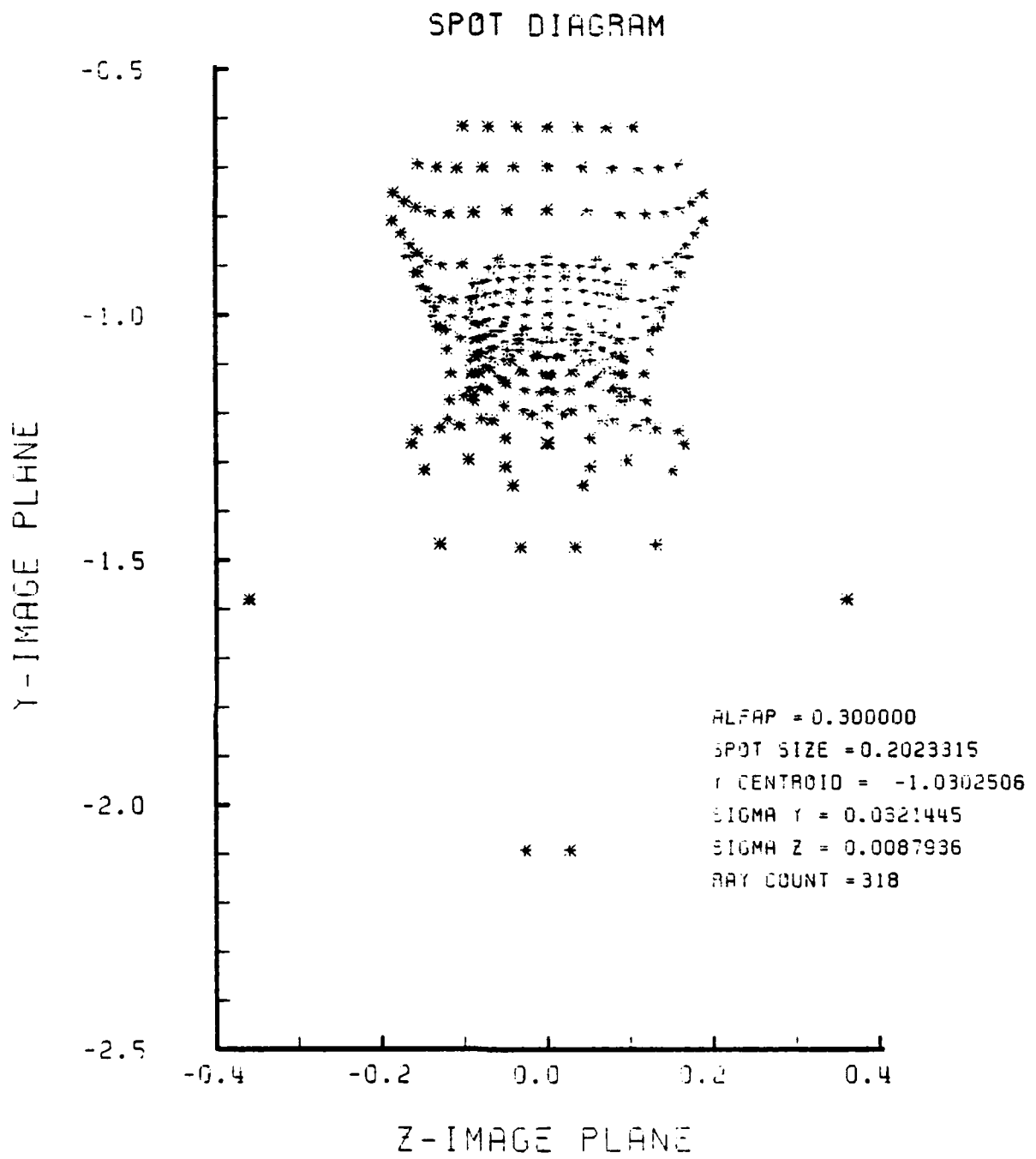

Figure F-11. Spot Diagram for Grid of Figure F-10

SPOT DIAGRAM ENERGY DENSITY

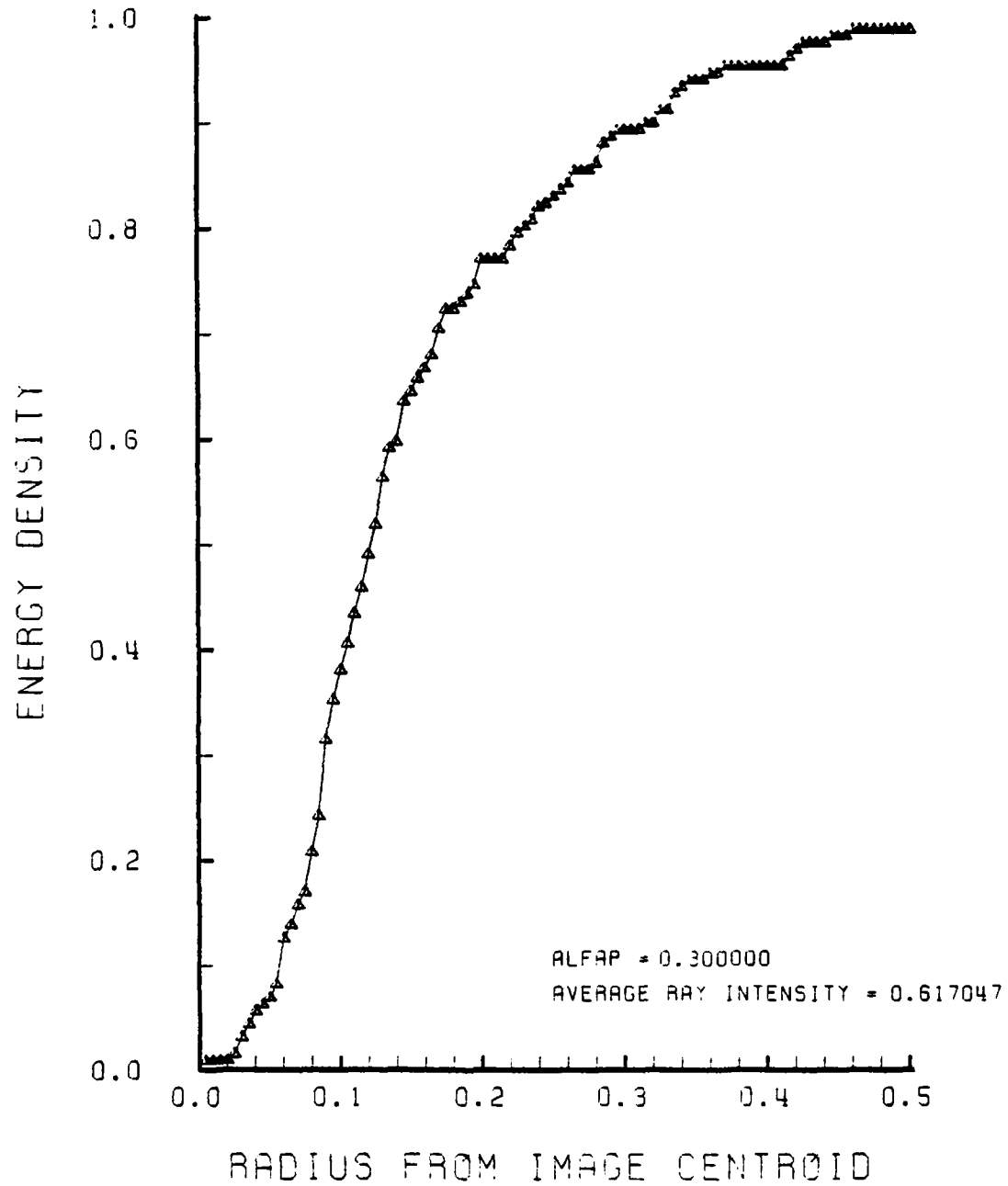

Figure F-12. Encircled Energy of Figure F-11

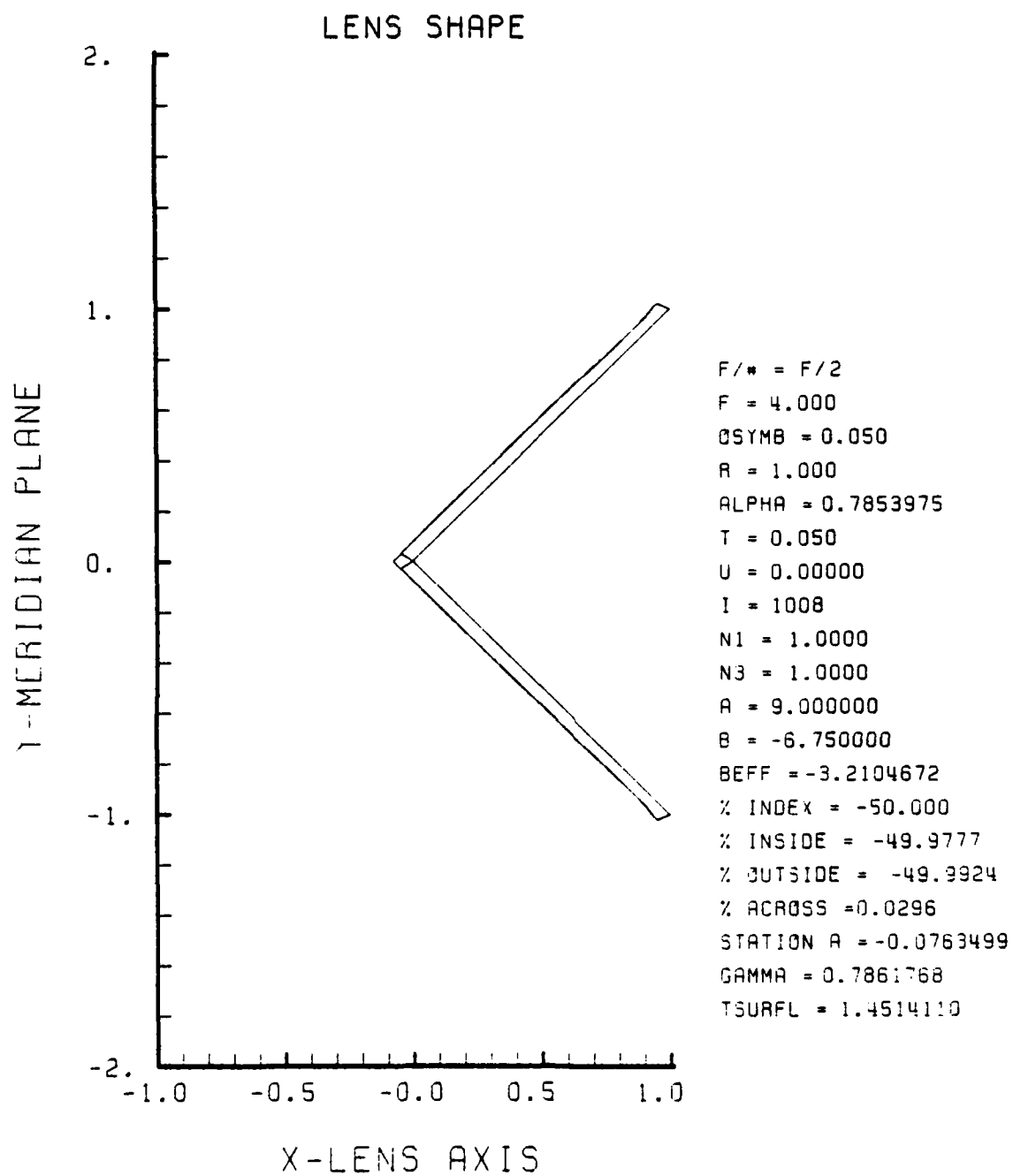

Figure F-13. GRIN Lens Shape at -50%, OB = 0.05,
a = 9.00

LENS FRONT VIEW
OBJECT PLANE

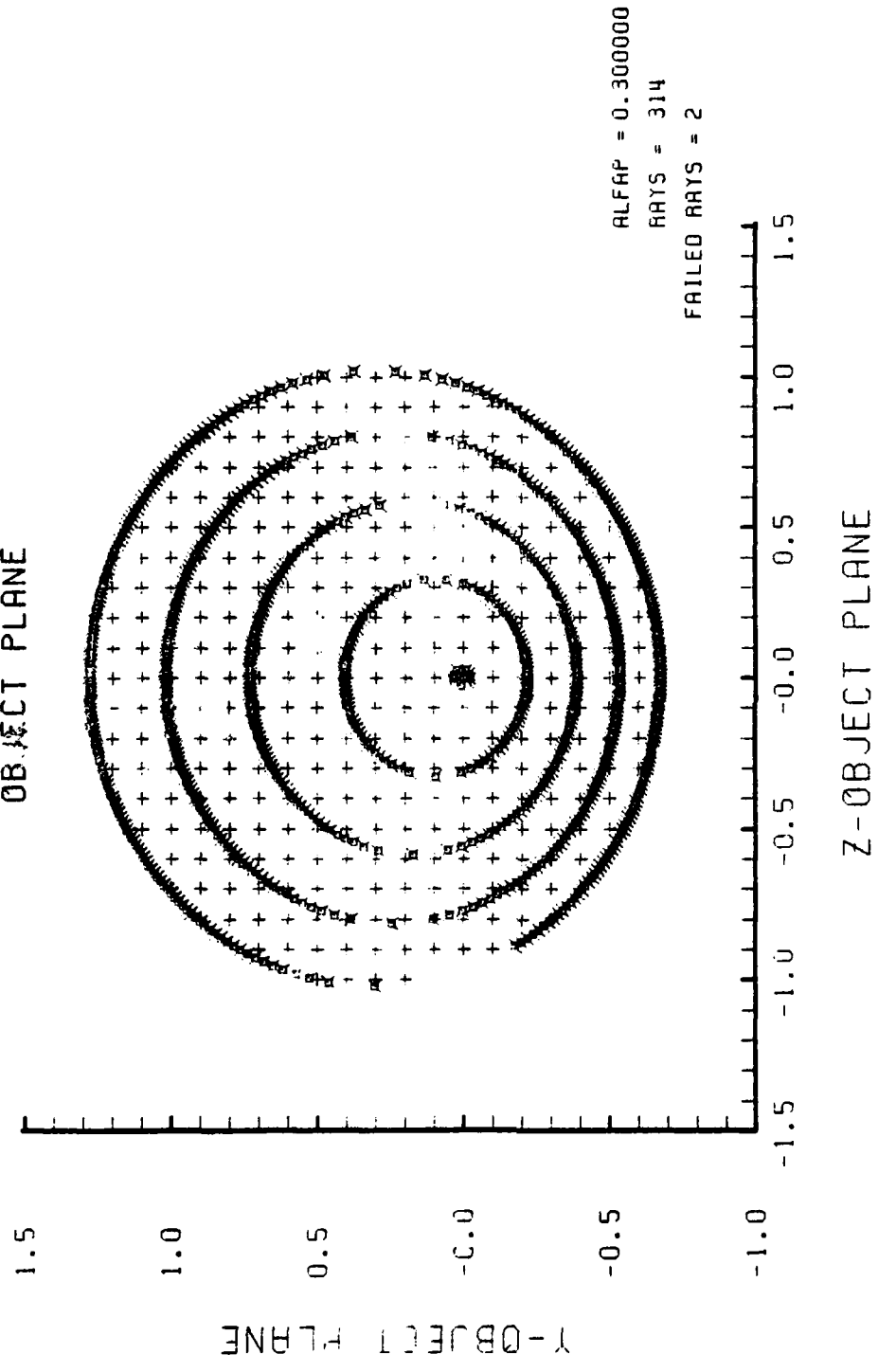

Figure F-14. Grid Plane at $\alpha_p = 0.3$ for Lens of Figure F-13

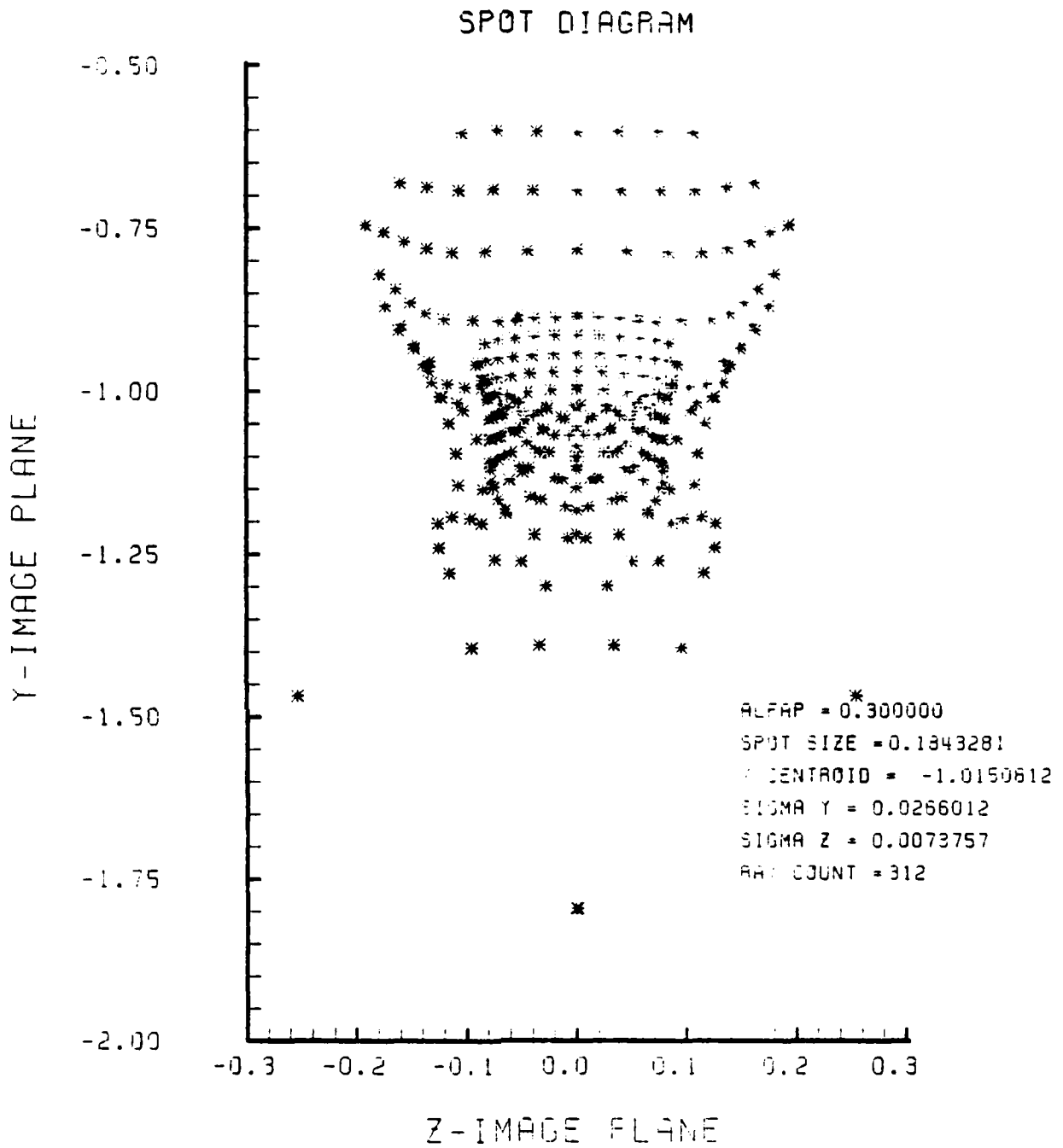

Figure F-15. Spot Diagram for Grid of Figure F-14

SPOT DIAGRAM ENERGY DENSITY

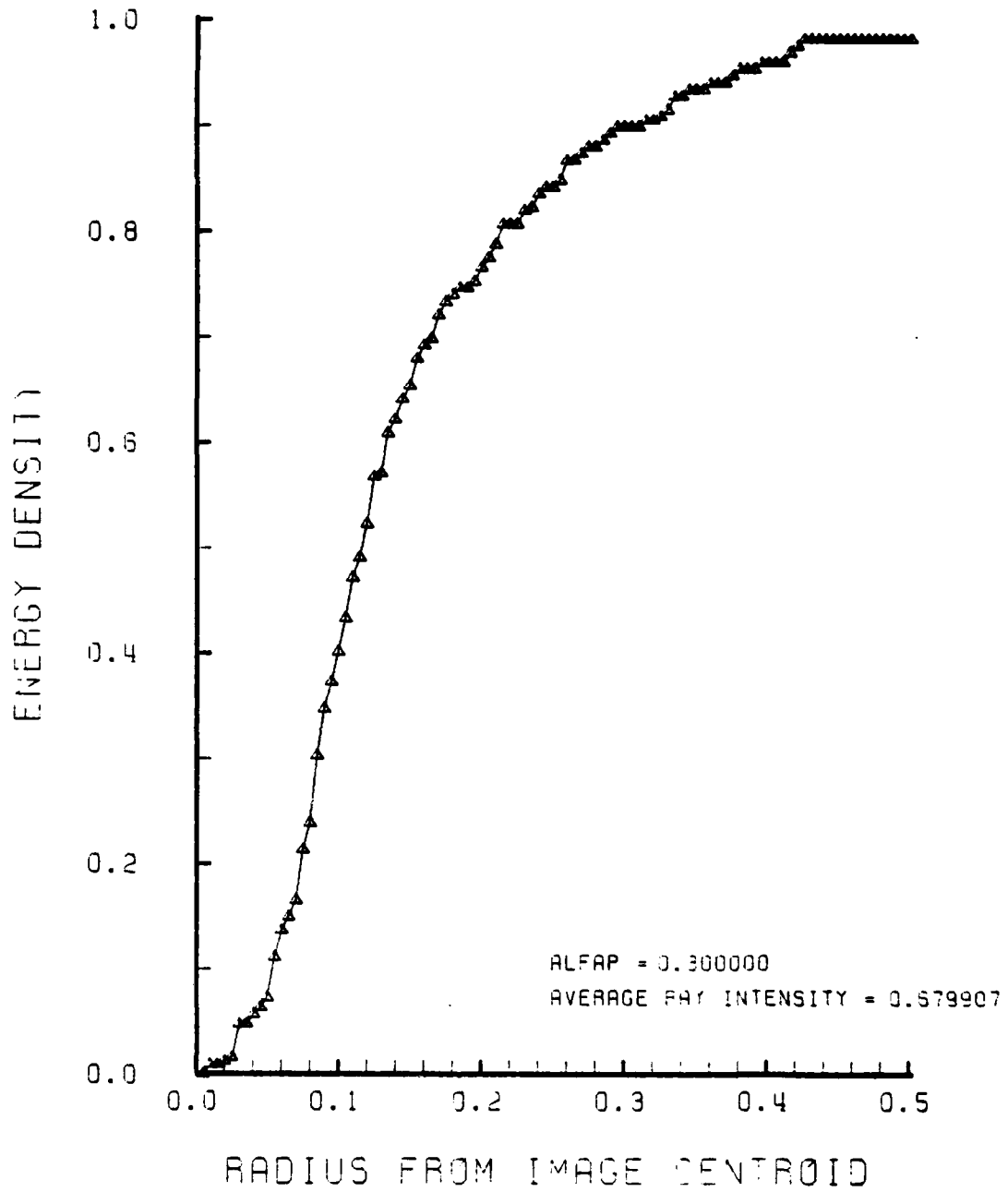

Figure F-16. Encircled Energy of Figure F-15

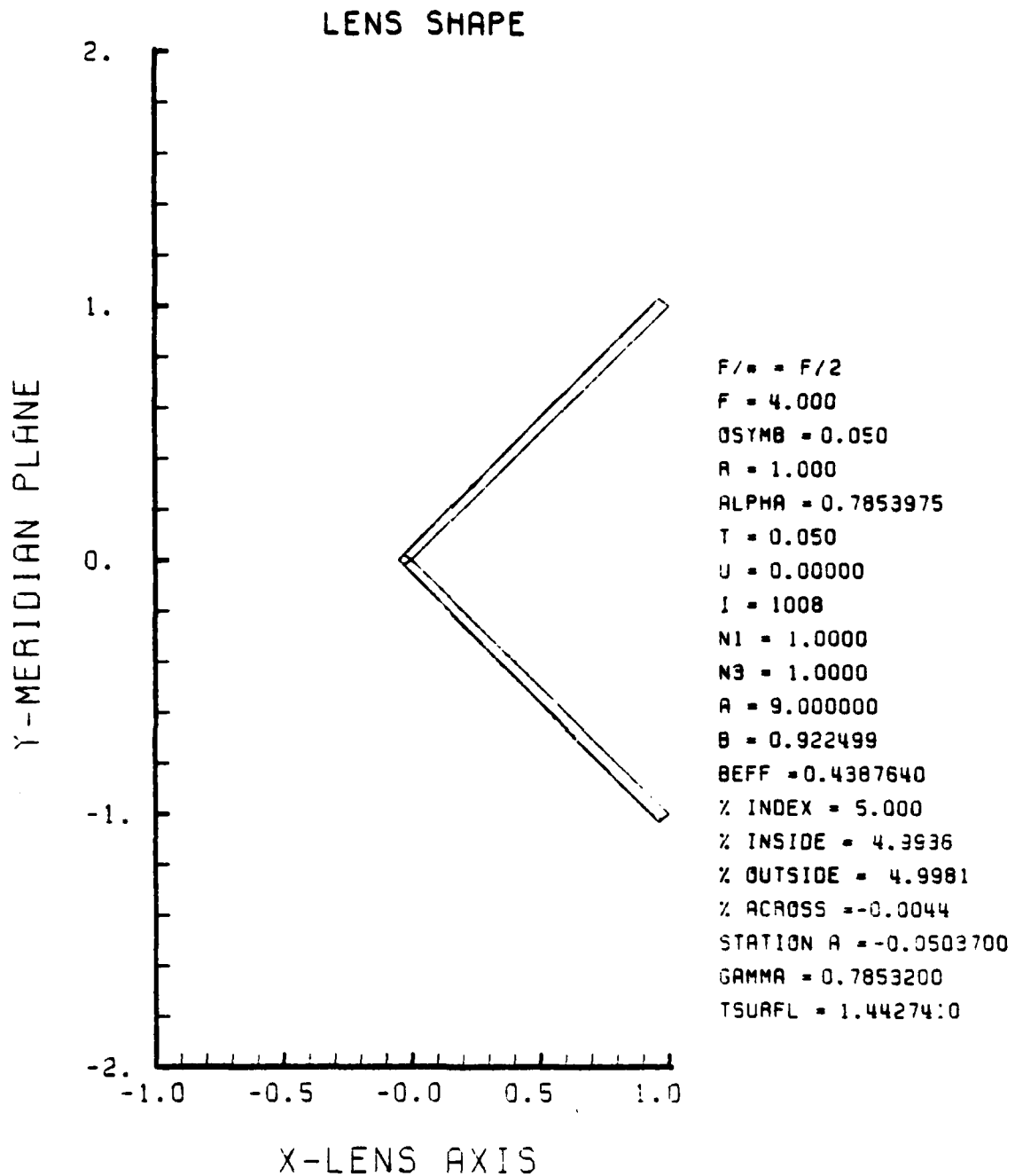

Figure F-17. GRIN Lens Shape at +5%, OB = 0.05,
a = 9.00

LENS FRONT VIEW
OBJECT PLANE

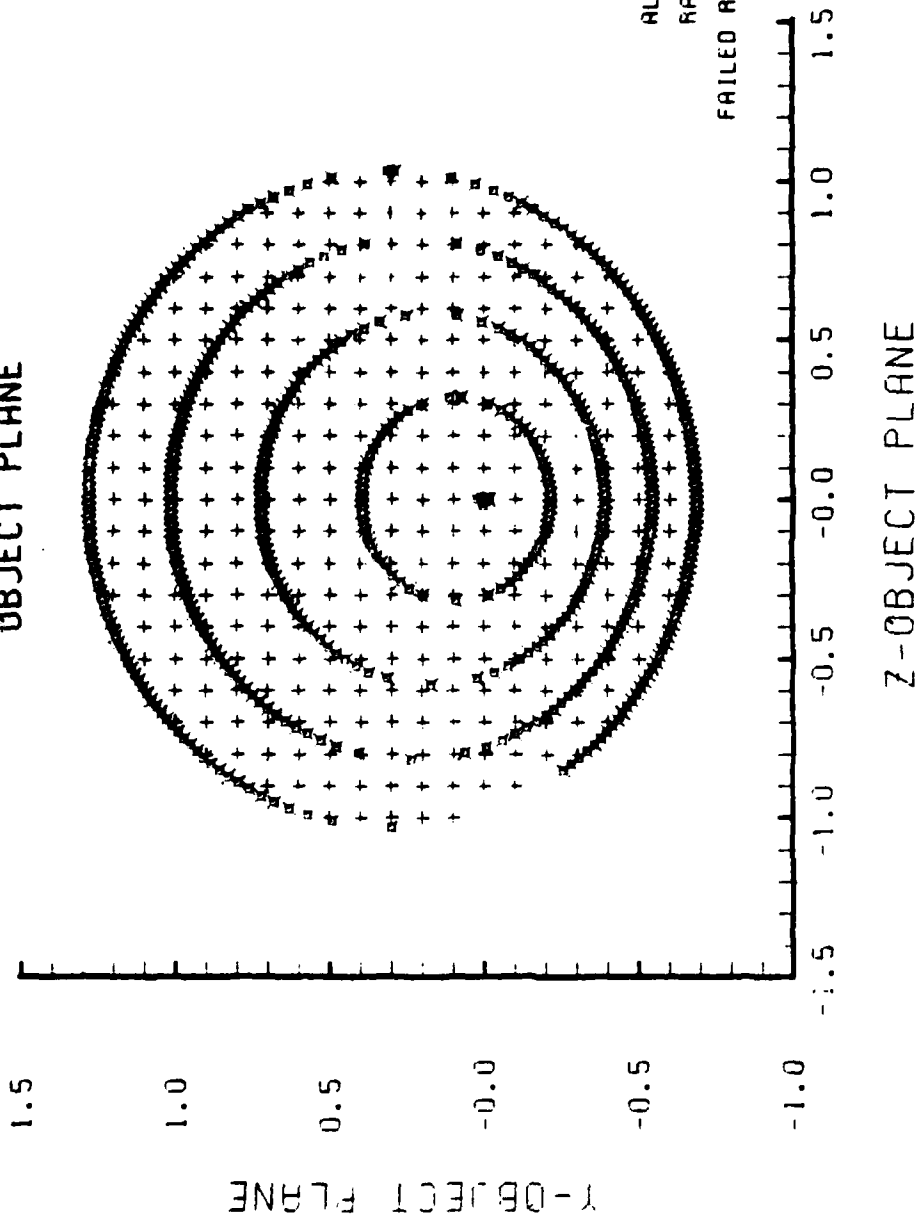

Figure F-18. Grid Plane at $\alpha_p = 0.3$ for Lens of Figure F-17

SPOT DIAGRAM

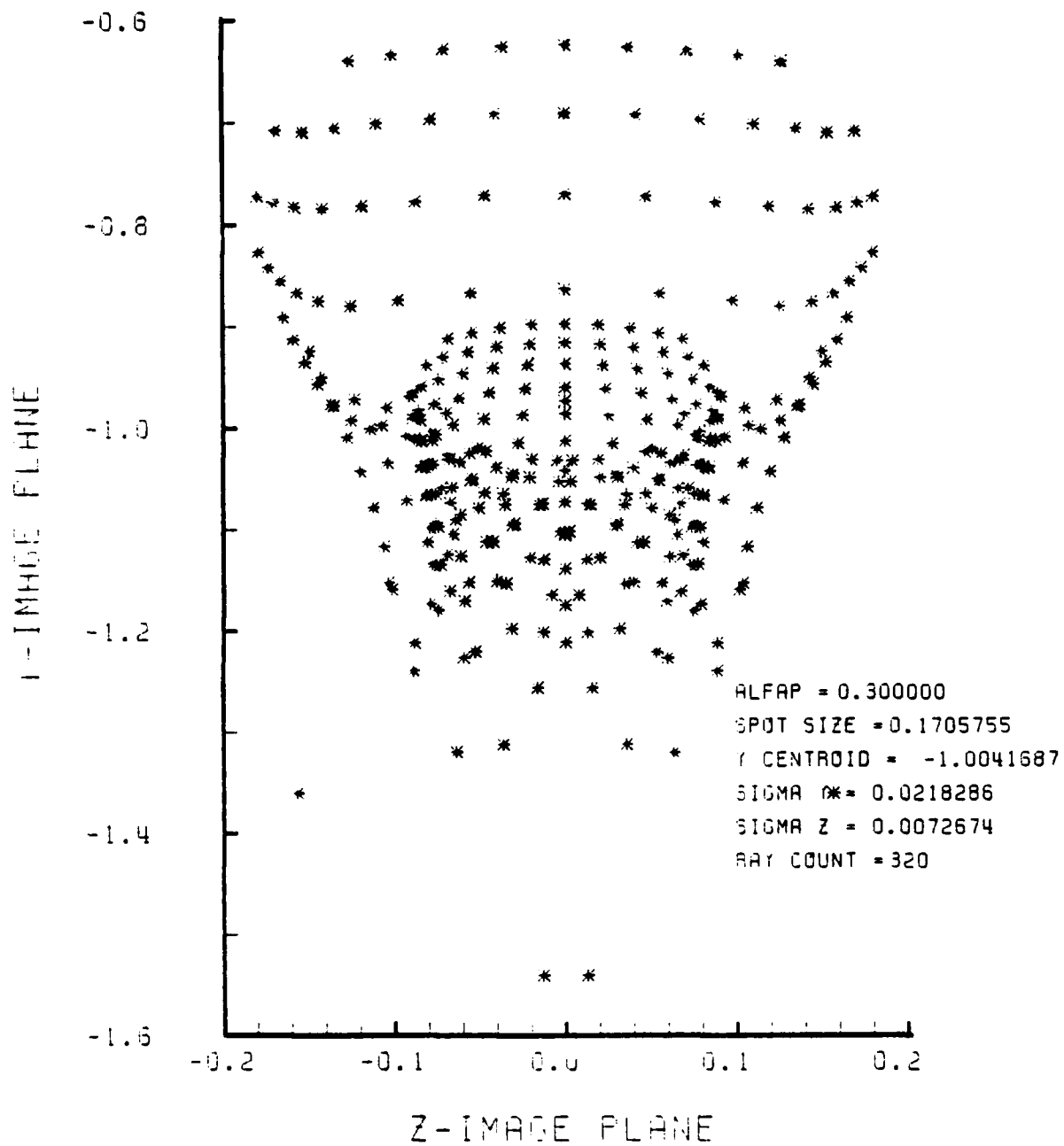

Figure F-19. Spot Diagram for Grid of Figure F-18

SPOT DIAGRAM ENERGY DENSITY

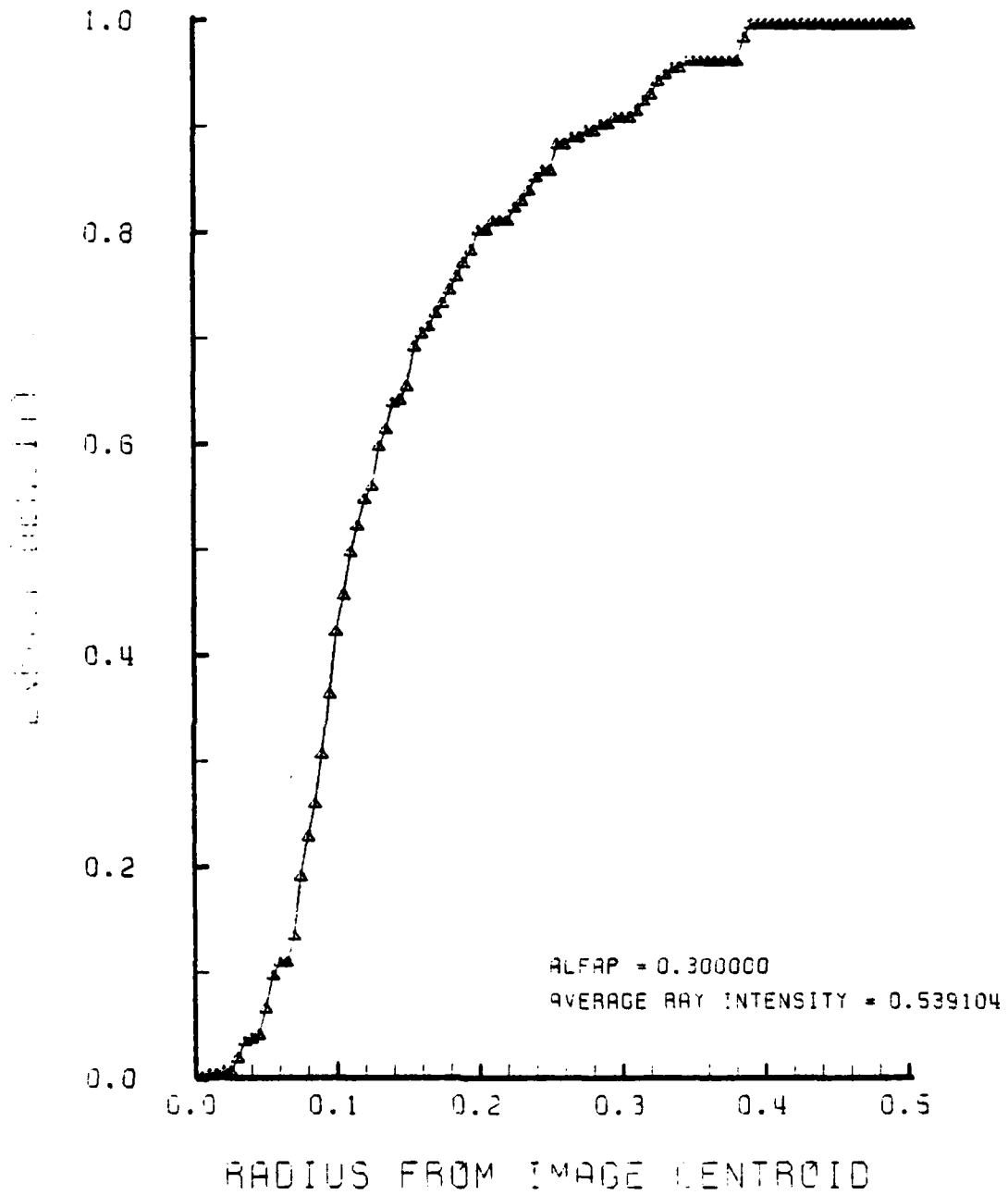

Figure F-20. Encircled Energy of Figure F-19

LENS SHAPE

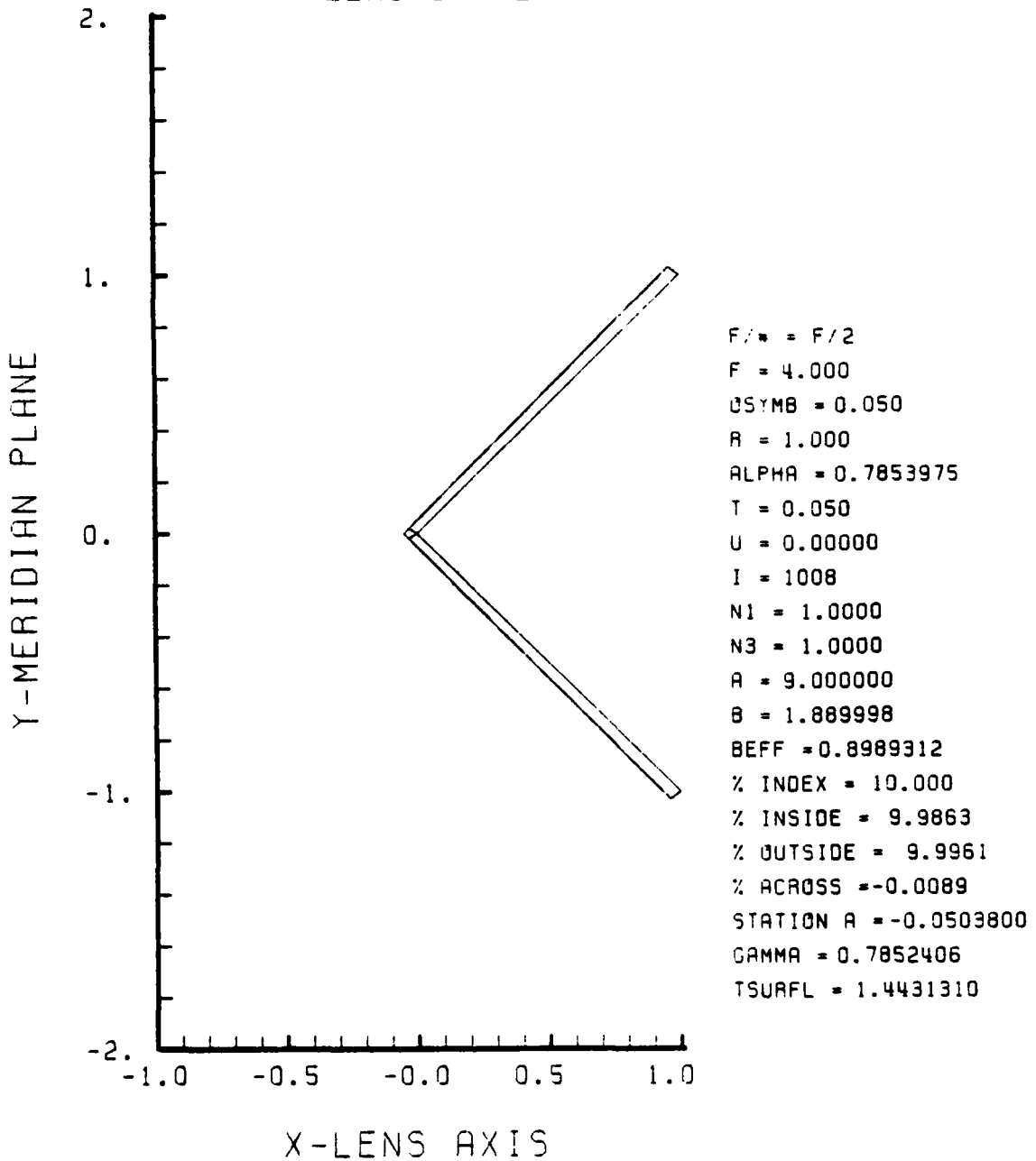

Figure F-21. GRIN Lens Shape for +10%, OB = 0.05, a = 9.00

LENS FRONT VIEW
OBJECT PLANE

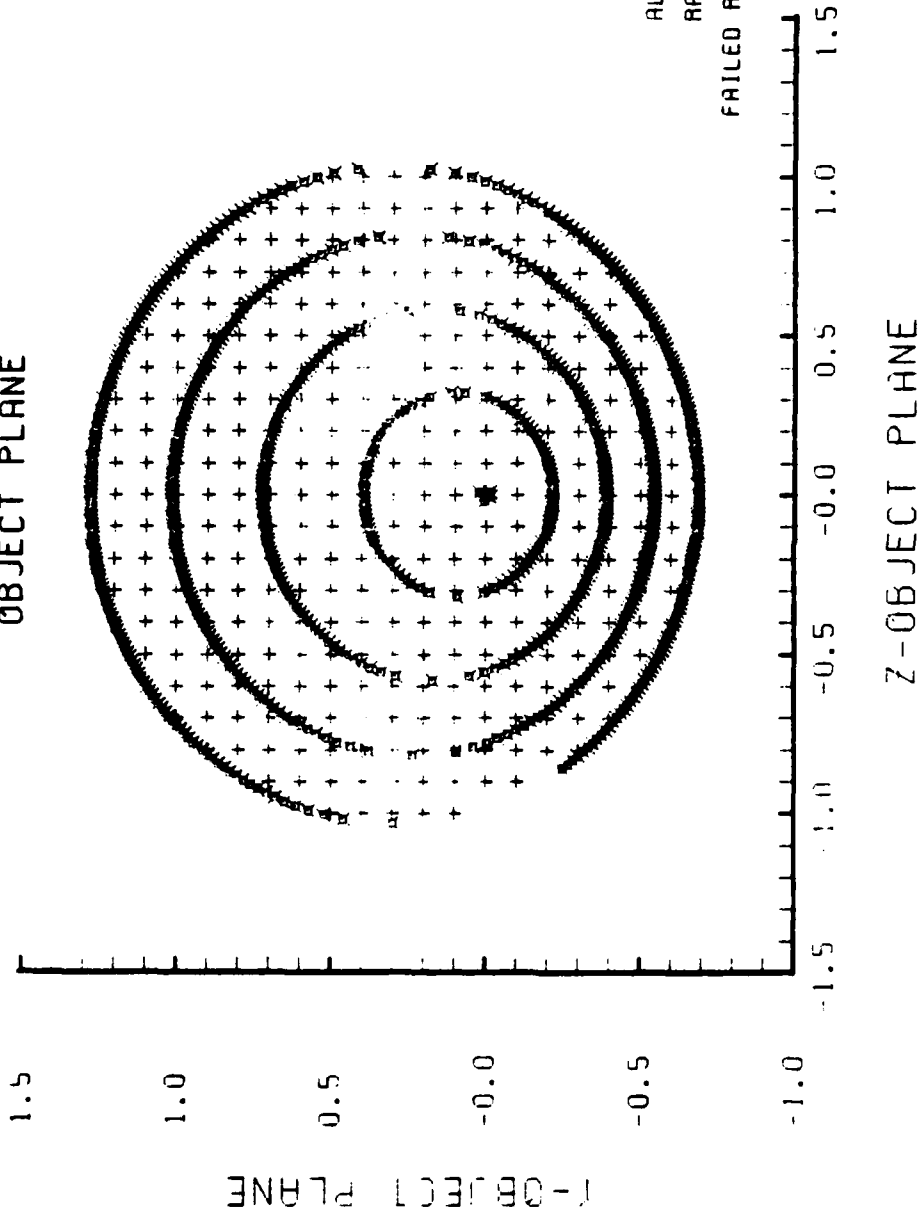

Figure F-22. Grid Plane at $\alpha_p = 0.3$ Radians for Lens of Figure F-21

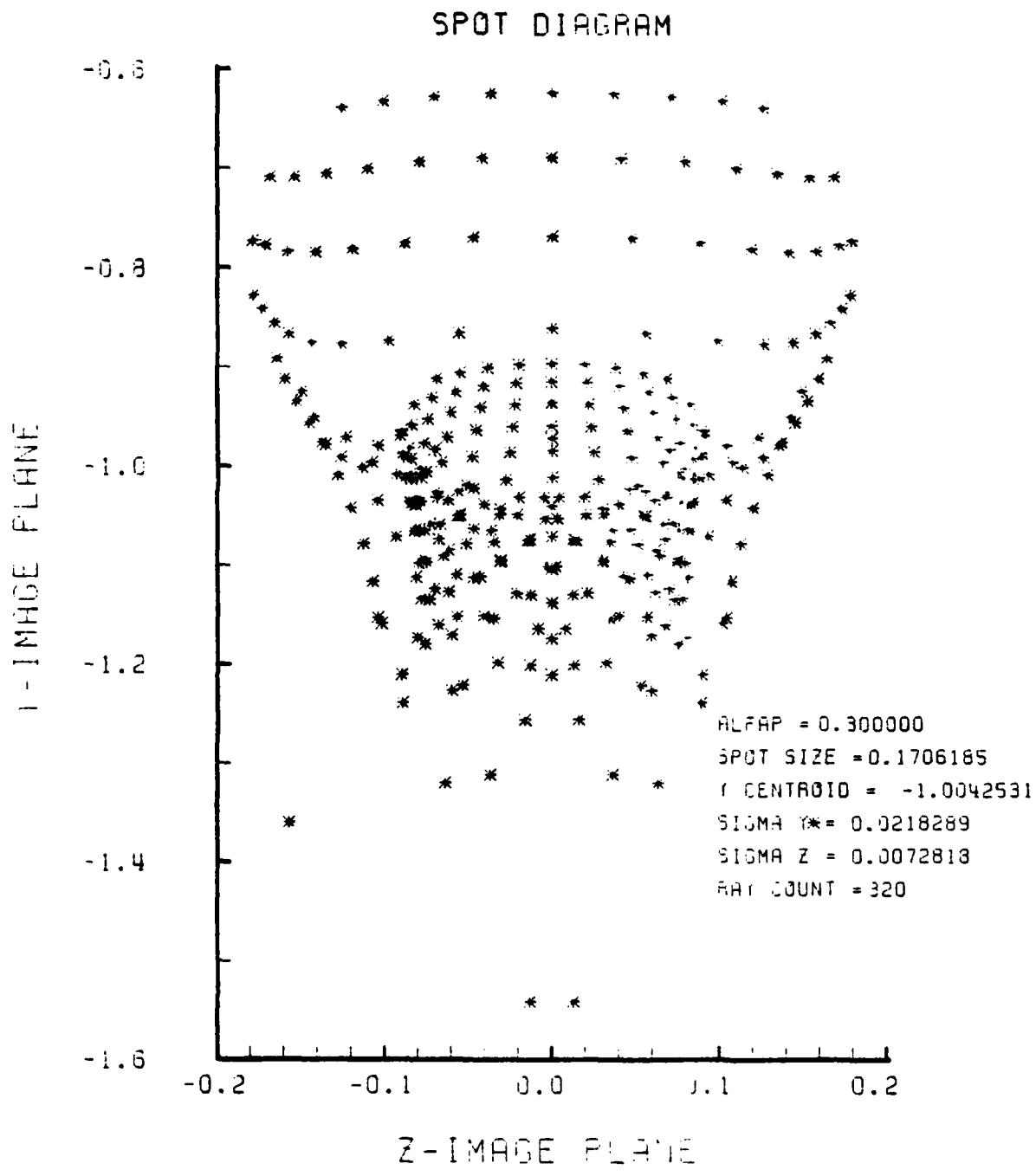

Figure F-23. Spot Diagram for Grid of Figure F-22

SPOT DIAGRAM ENERGY DENSITY

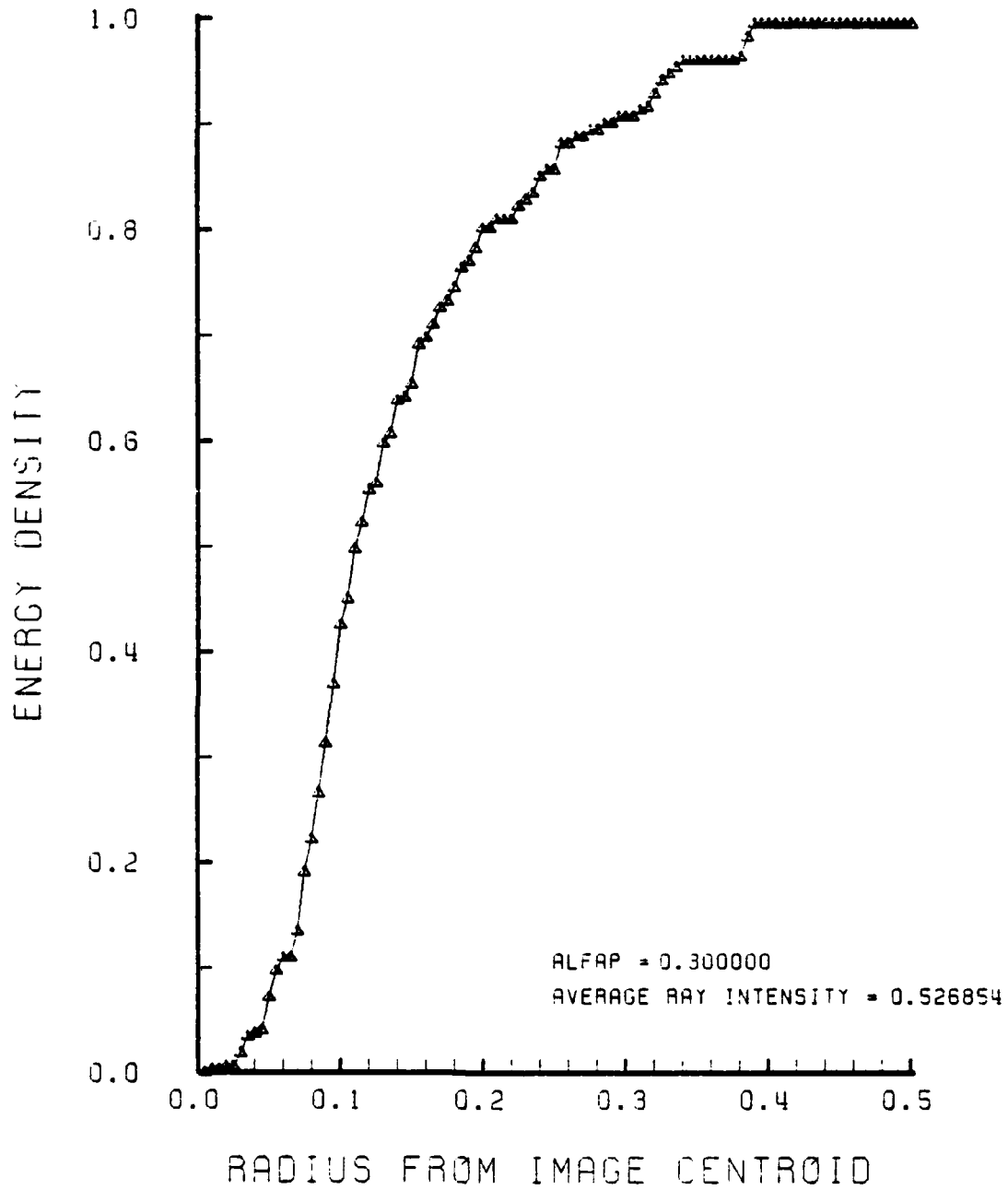

Figure F-24. Encircled Energy of Figure F-23

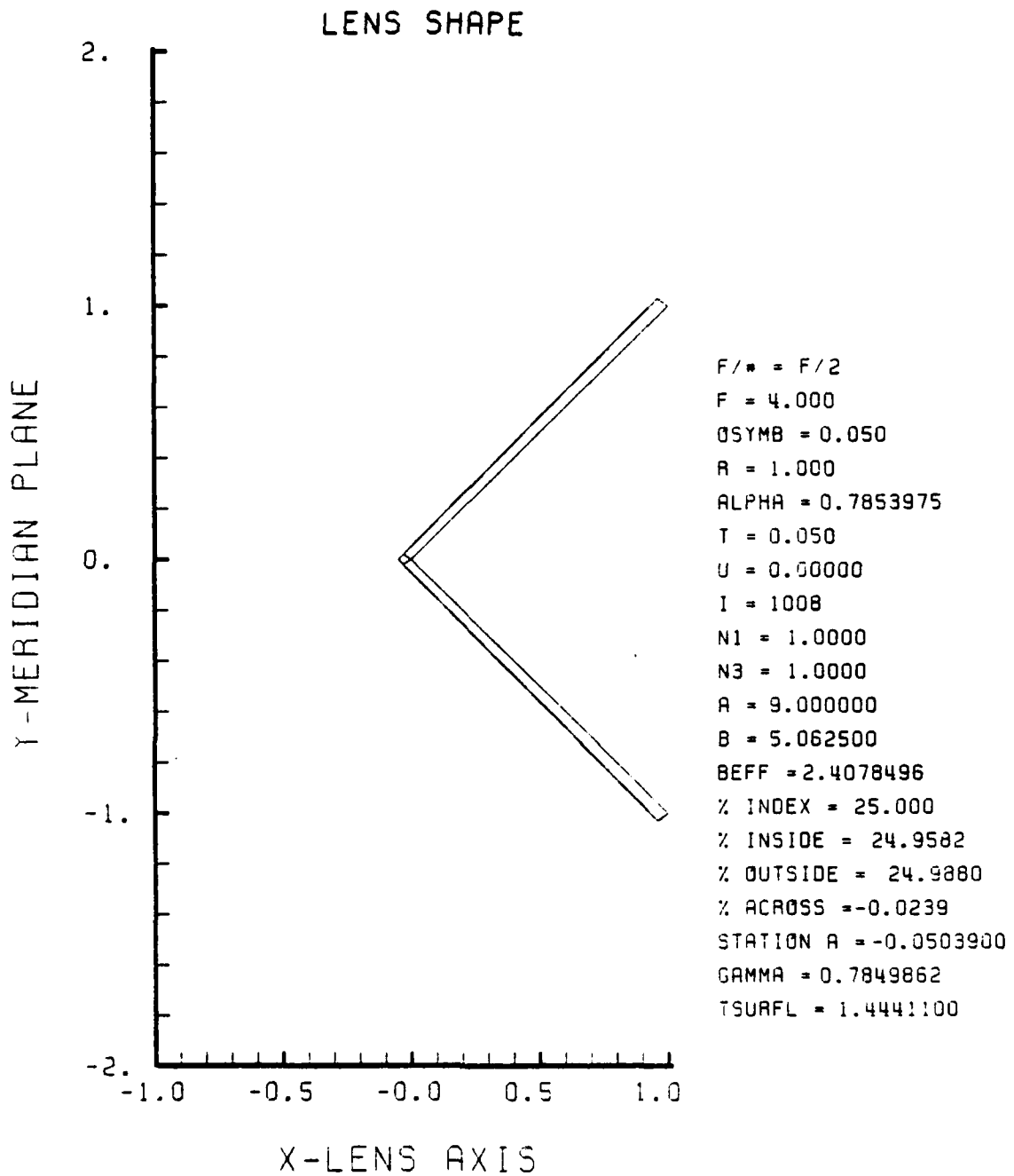

Figure F-25. GRIN Lens Shape for +25%, OB = 0.05,
a = 9.00

LENS FRONT VIEW
OBJECT PLANE

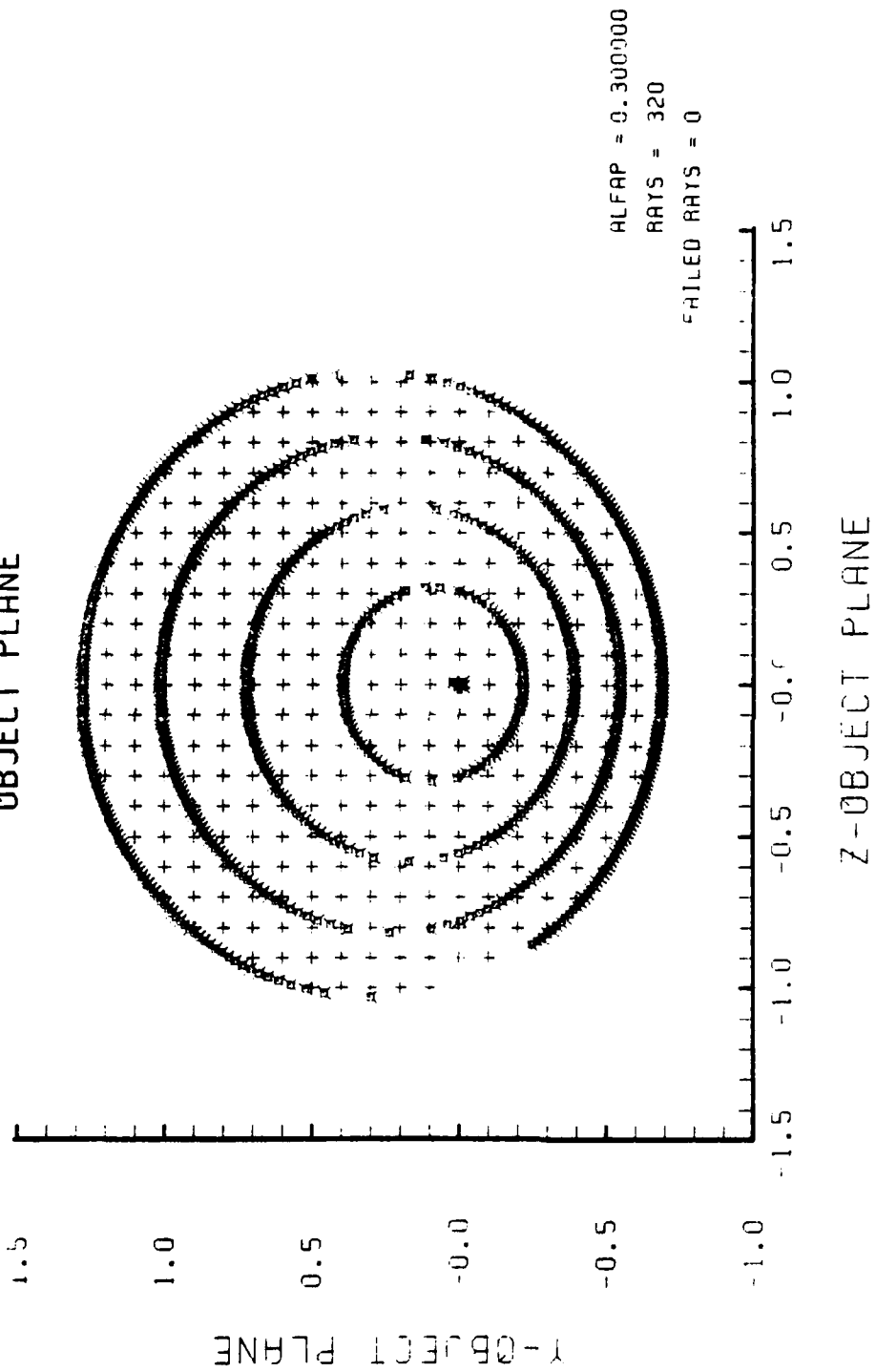

Figure F-26. Grid Plane at $\alpha_p \approx 0.3$ for Lens of Figure F-25

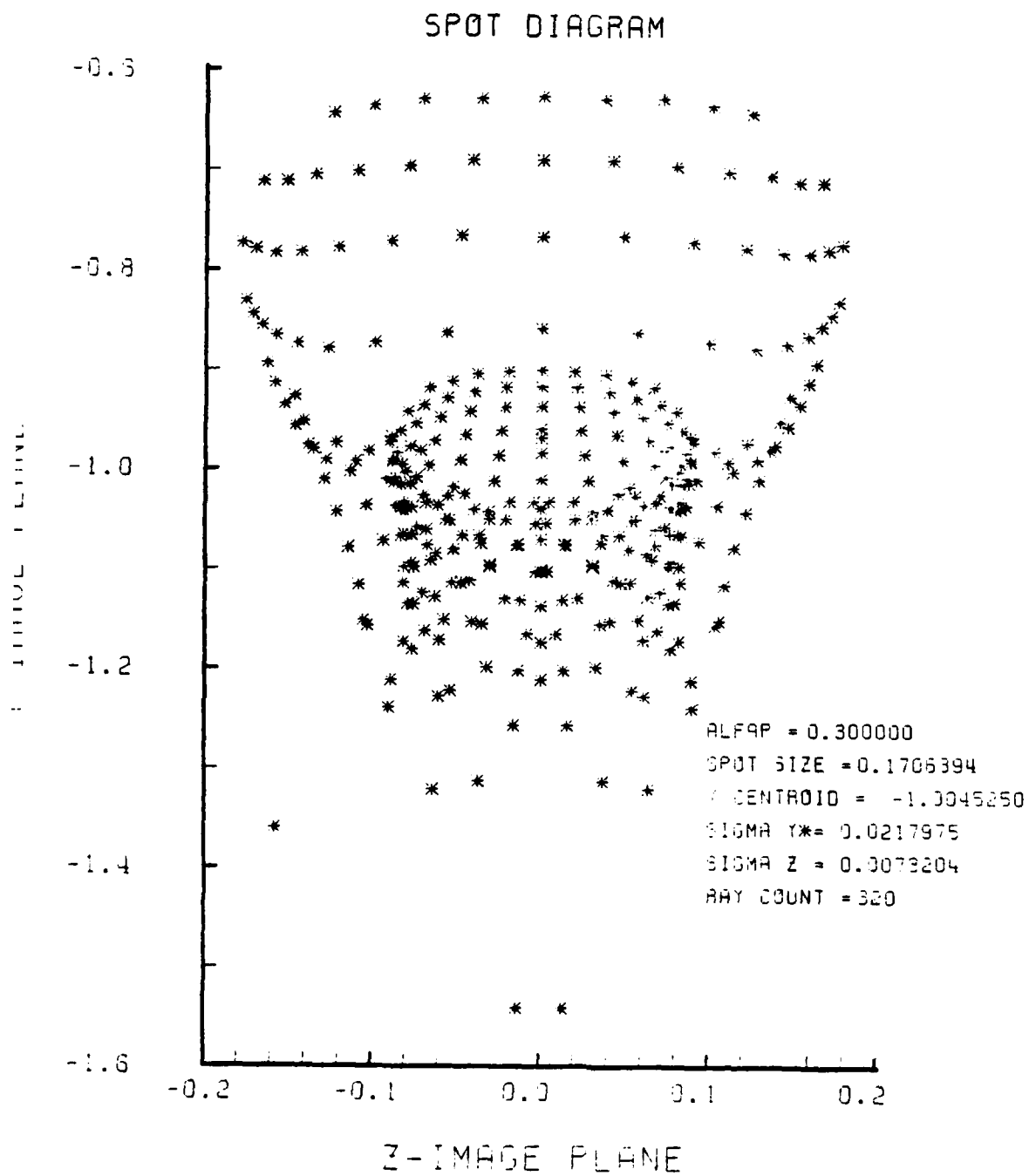

Figure F-27. Spot Diagram for Grid of Figure F-26

SPOT DIAGRAM ENERGY DENSITY

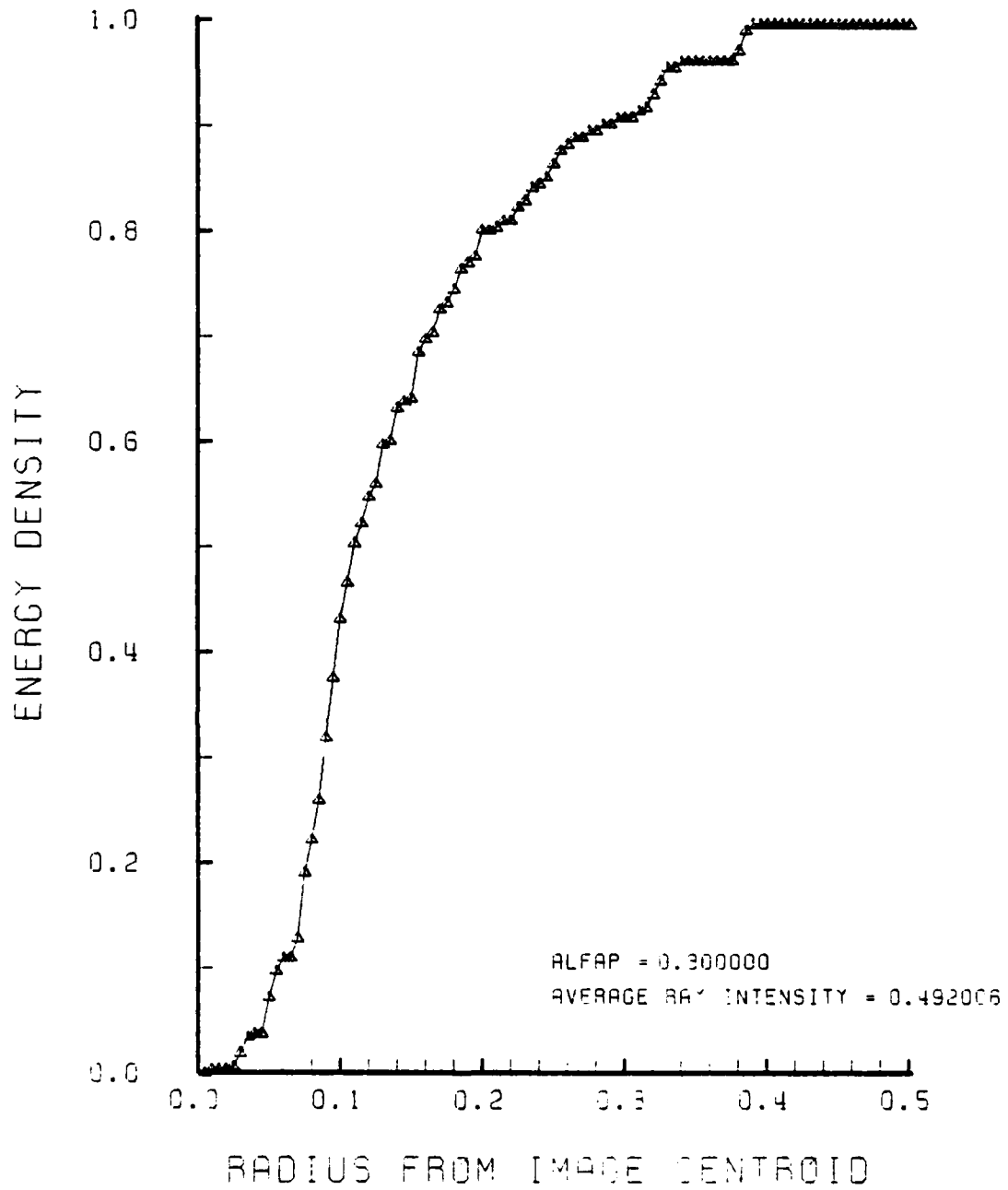

Figure F-28. Encircled Energy of Figure F-27

LENS SHAPE

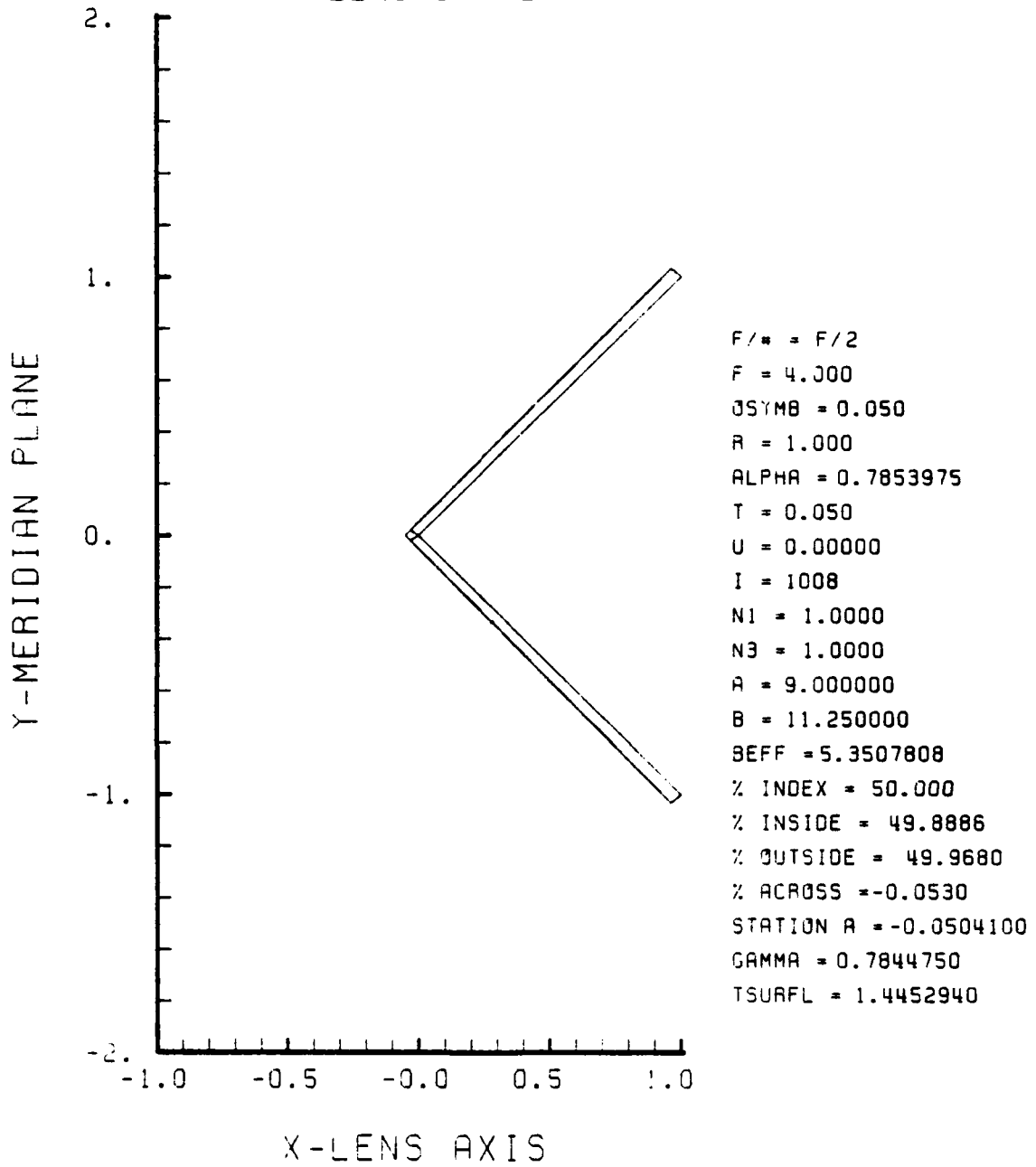

Figure F-29. GRIN Lens Shape at +50%, OB = 0.05, a = 9.00

LENS FRONT VIEW
OBJECT PLANE

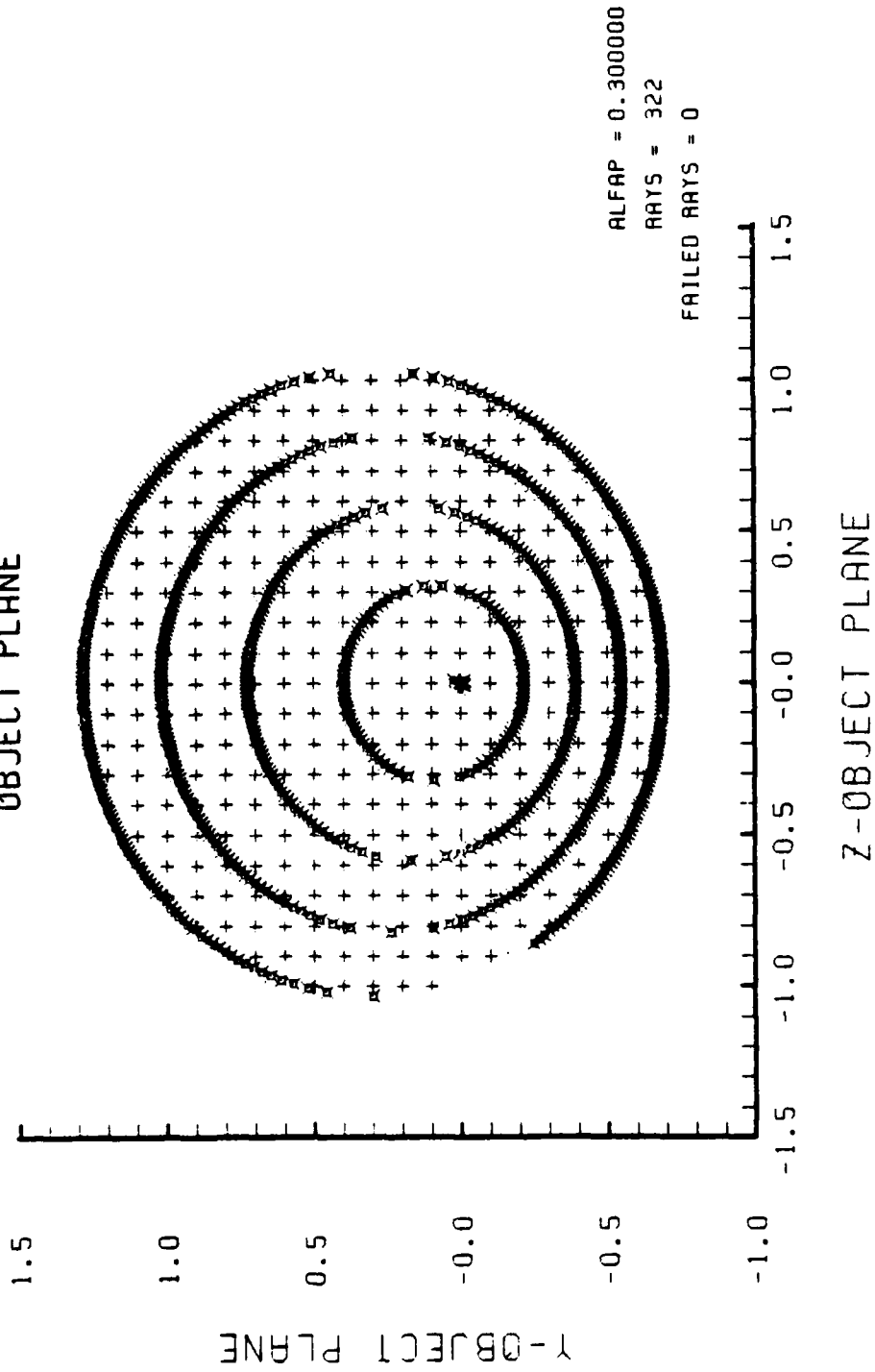

Figure F-30. Grid Plane at $\alpha_p = 0.3$ for Lens of Figure F-29

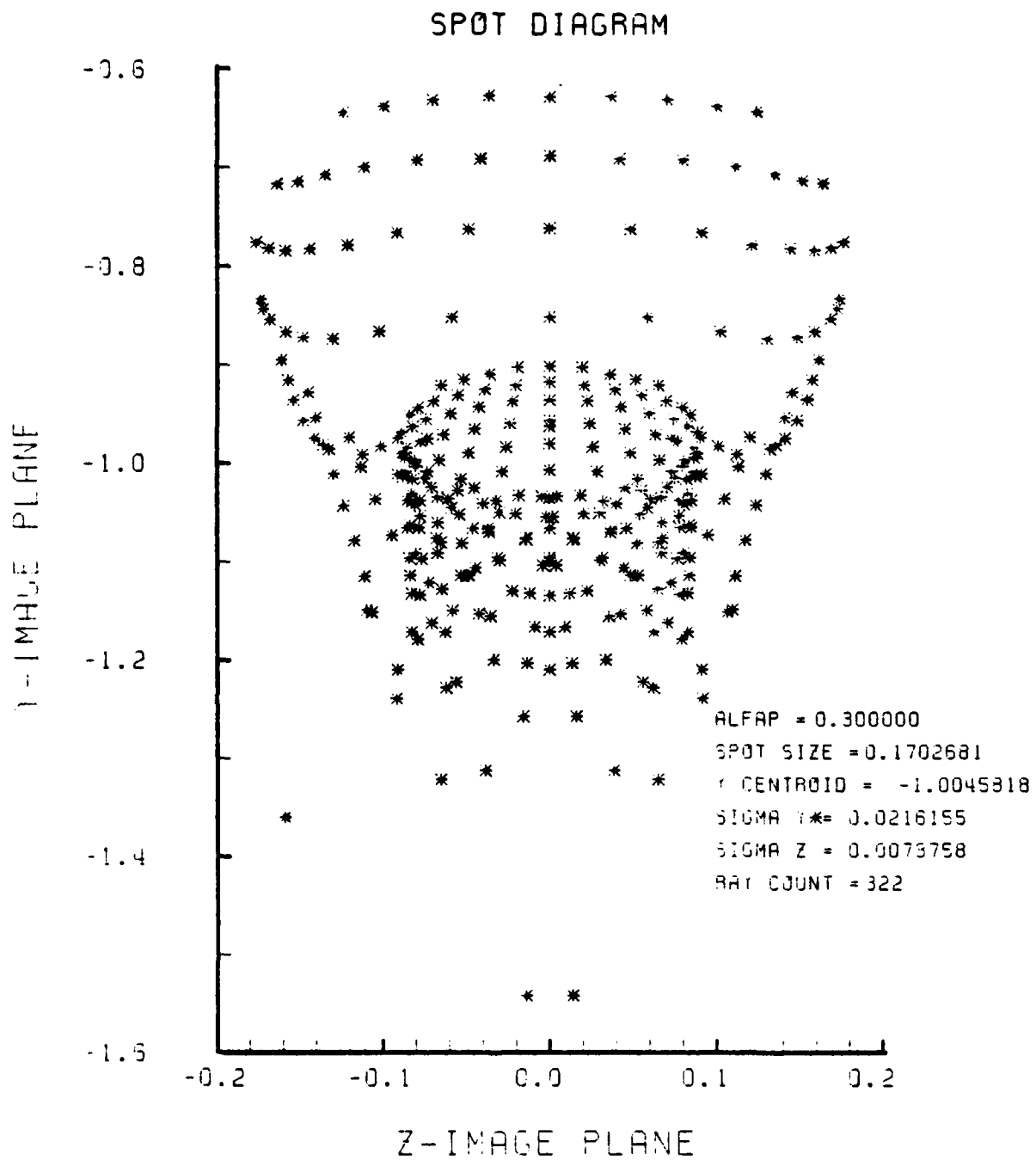

Figure F-31. Spot Diagram for Grid of Figure F-30

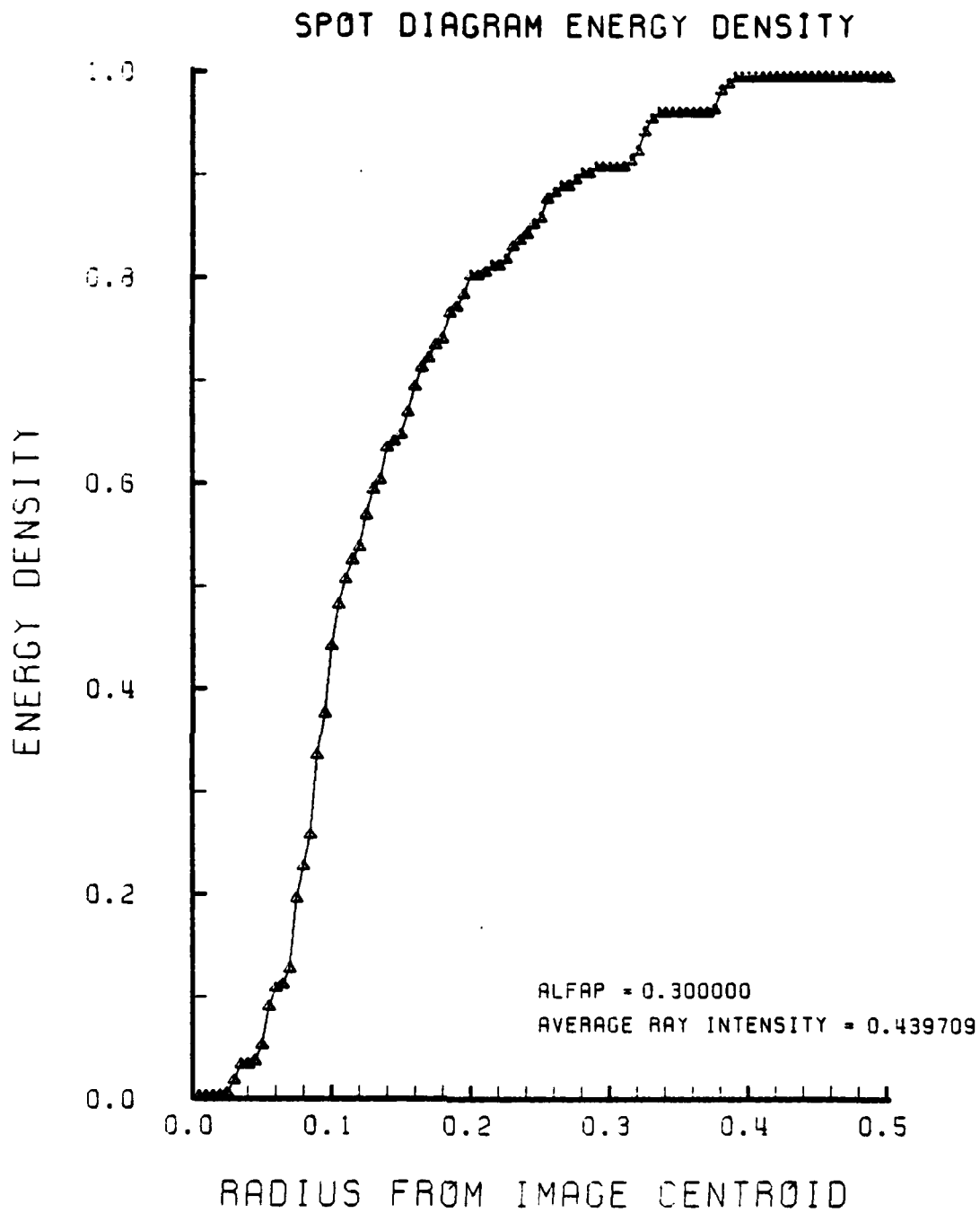

Figure F-32. Encircled Energy of Figure F-31

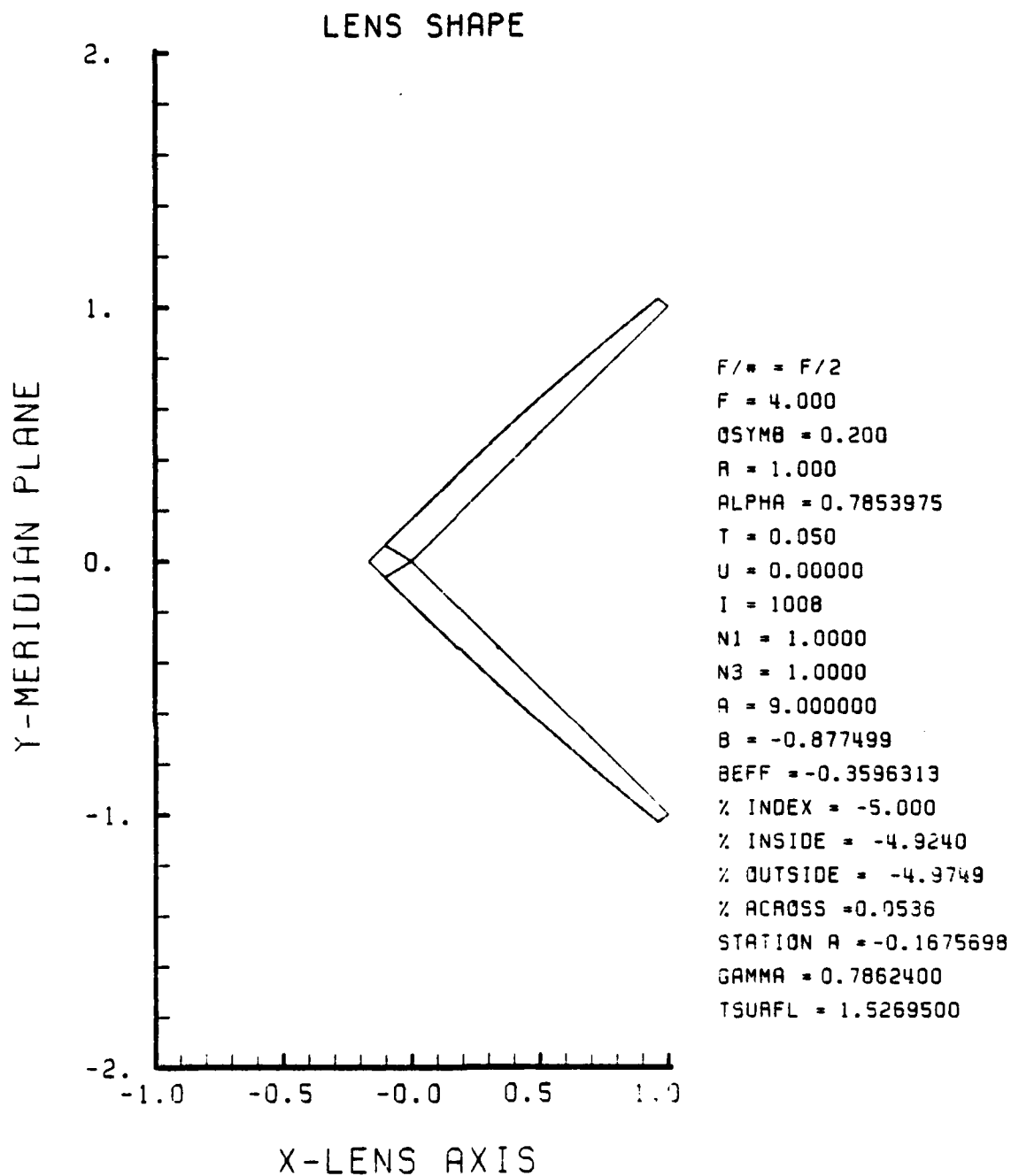

Figure F-33. GRIN Lens Shape at -5%, OB = 0.20,
a = 9.00



LENS FRONT VIEW
OBJECT PLANE

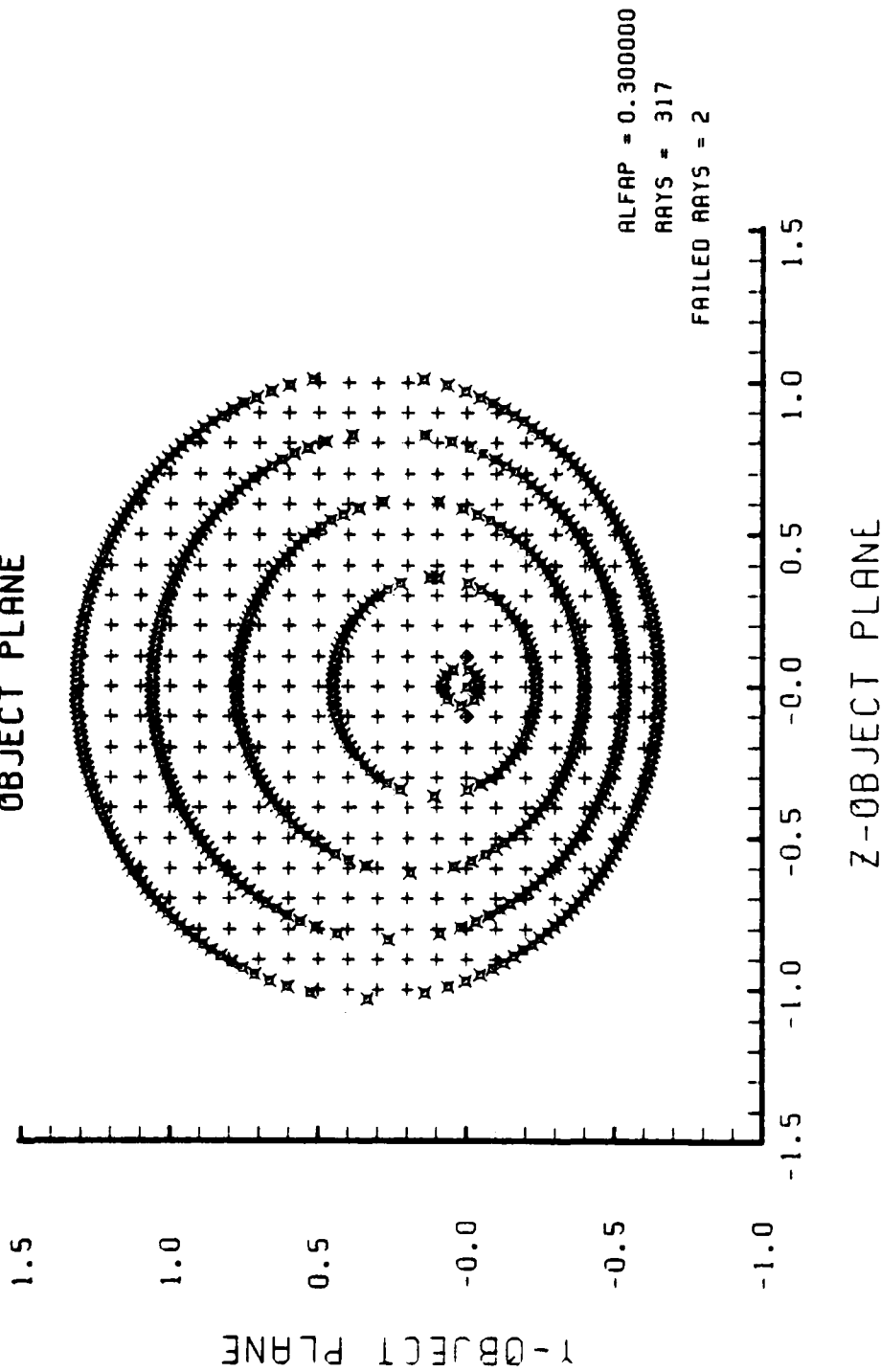

Figure F-34. Grid Plane at $\alpha_p = 0.3$ for Lens of Figure F-33

SPOT DIAGRAM

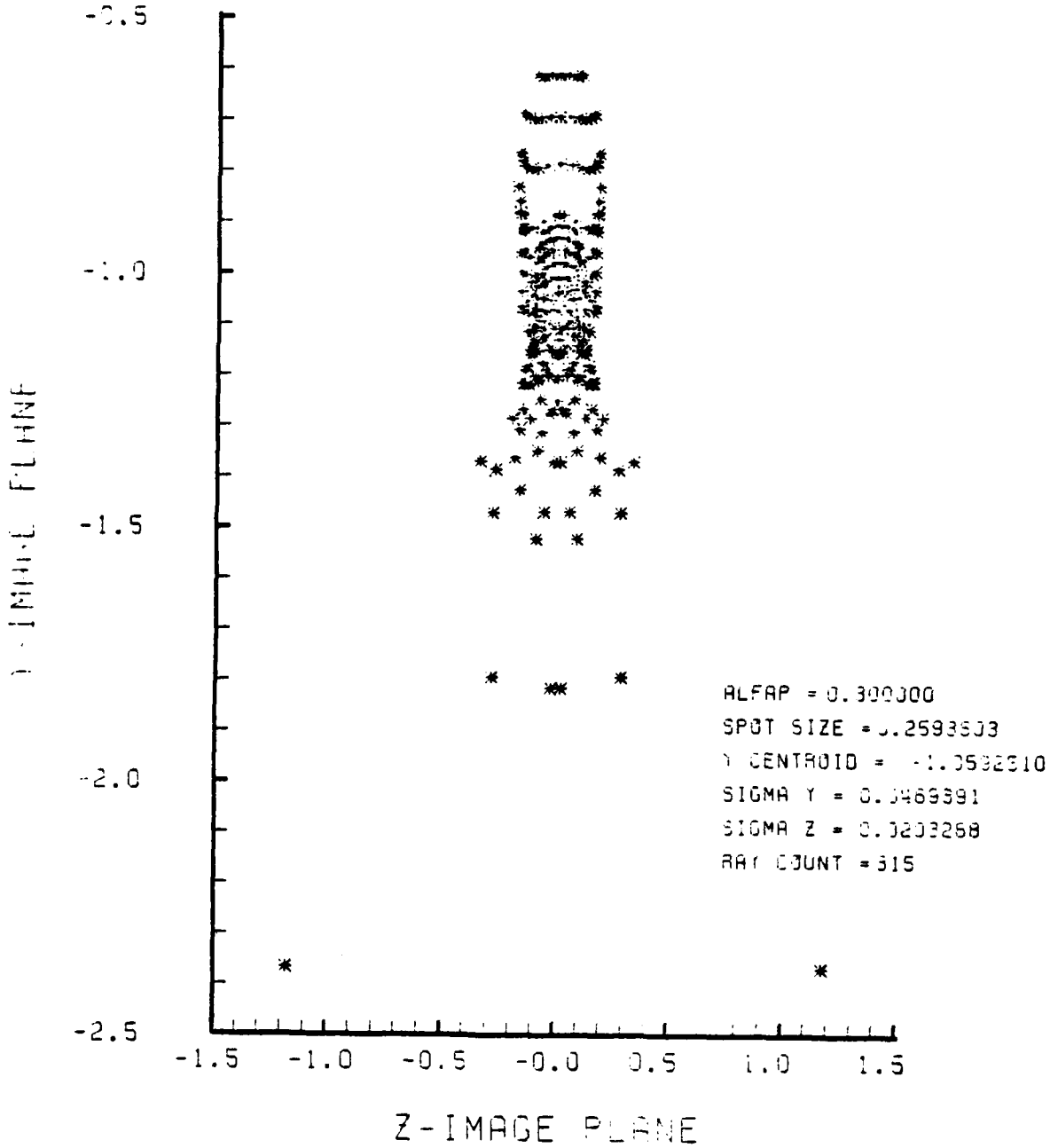

Figure F-35. Spot Diagram for Grid of Figure F-34

SPOT DIAGRAM ENERGY DENSITY

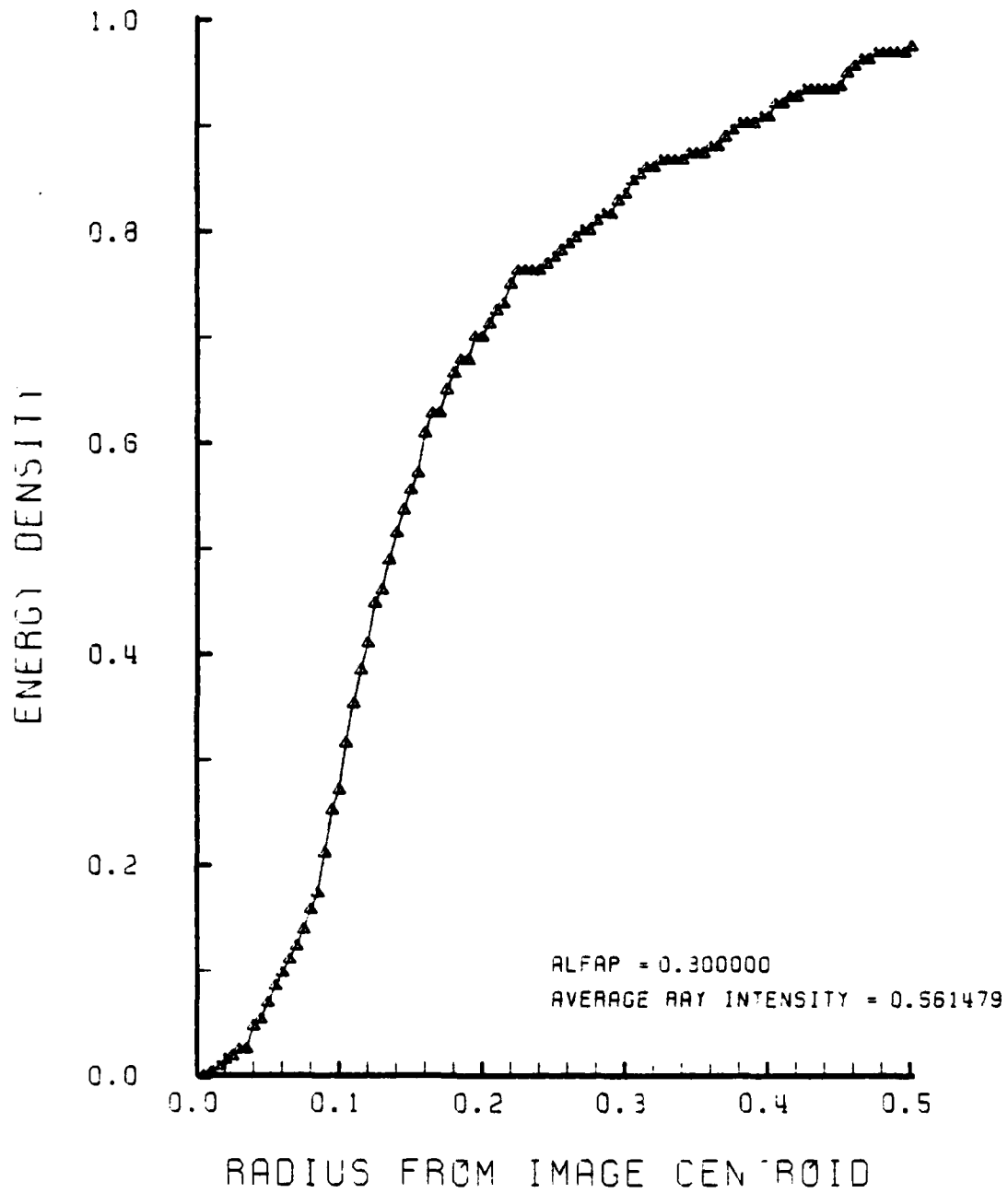

Figure F-36. Encircled Energy of Figure F-35

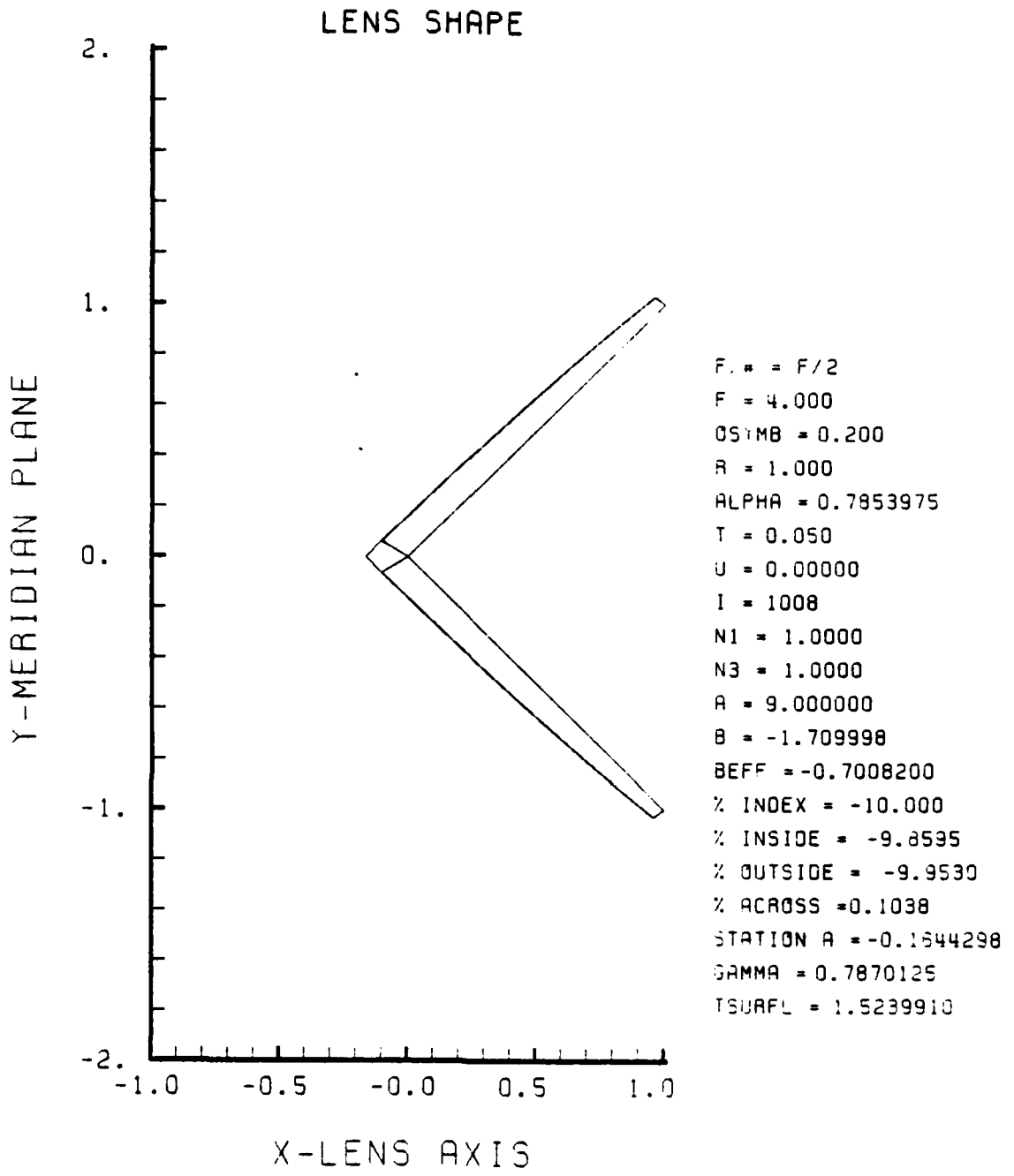

Figure F-37. GRIN Lens Shape at -10%, OB = 0.20,
a = 9.00

LENS FRONT VIEW
OBJECT PLANE

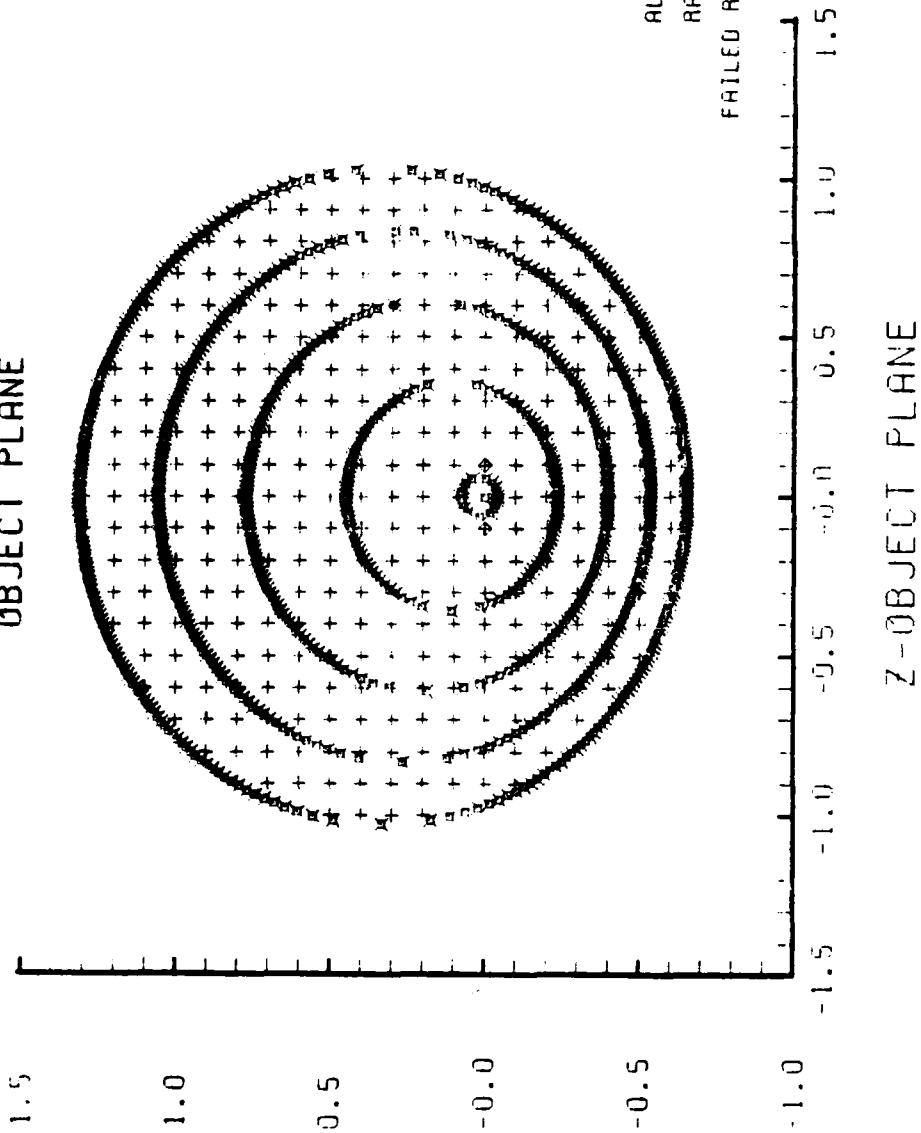

Figure F-38. Grid Plane at $\alpha_p = 0.3$ for Lens of Figure F-37

SPOT DIAGRAM

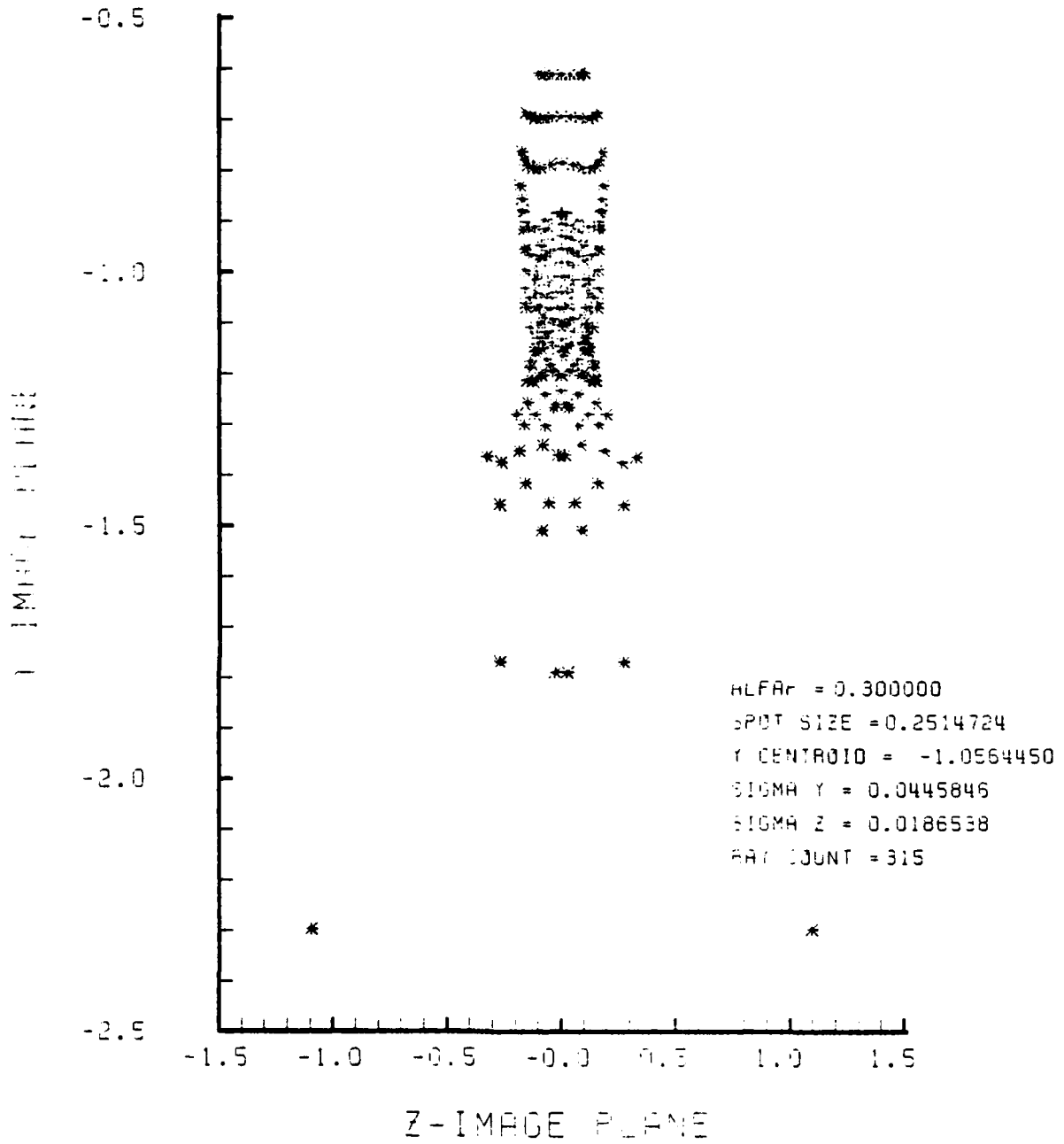

Figure F-39. Spot Diagram for Grid of Figure F-38

SPOT DIAGRAM ENERGY DENSITY

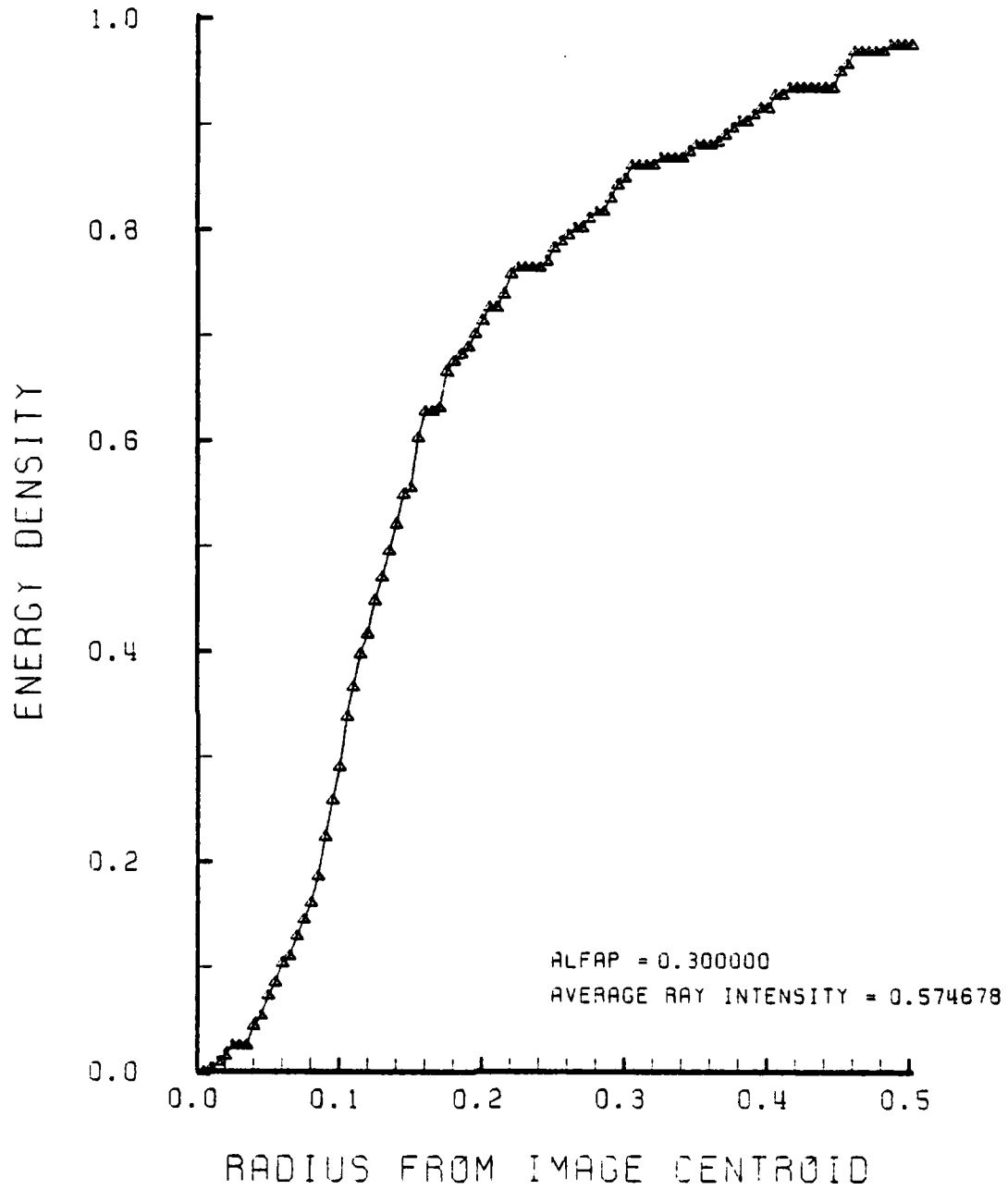

Figure F-40. Encircled Energy of Figure F-39

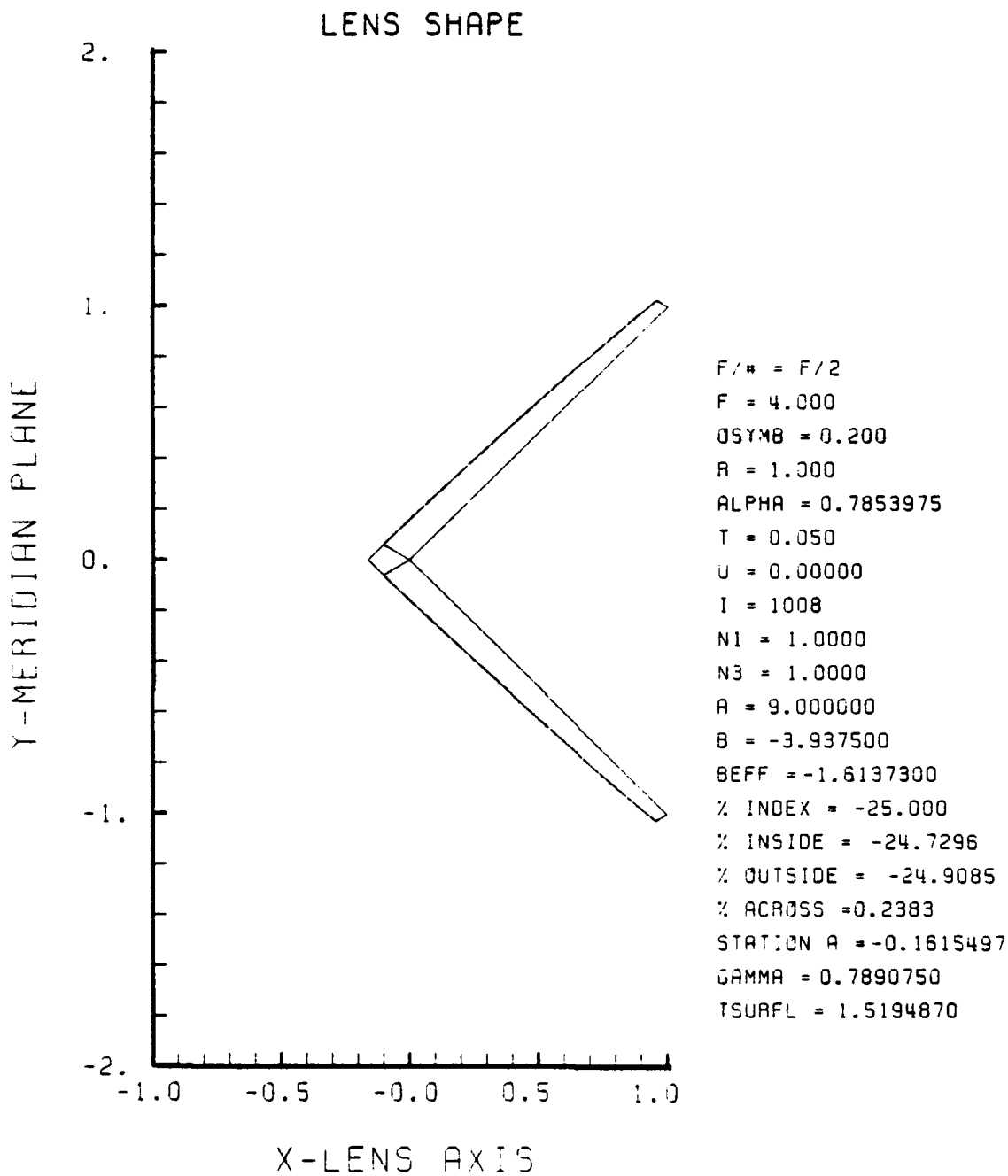

Figure F-41. GRIN Lens Shape at -25%, OB = 0.20,
a = 9.00

LENS FRONT VIEW
OBJECT PLANE

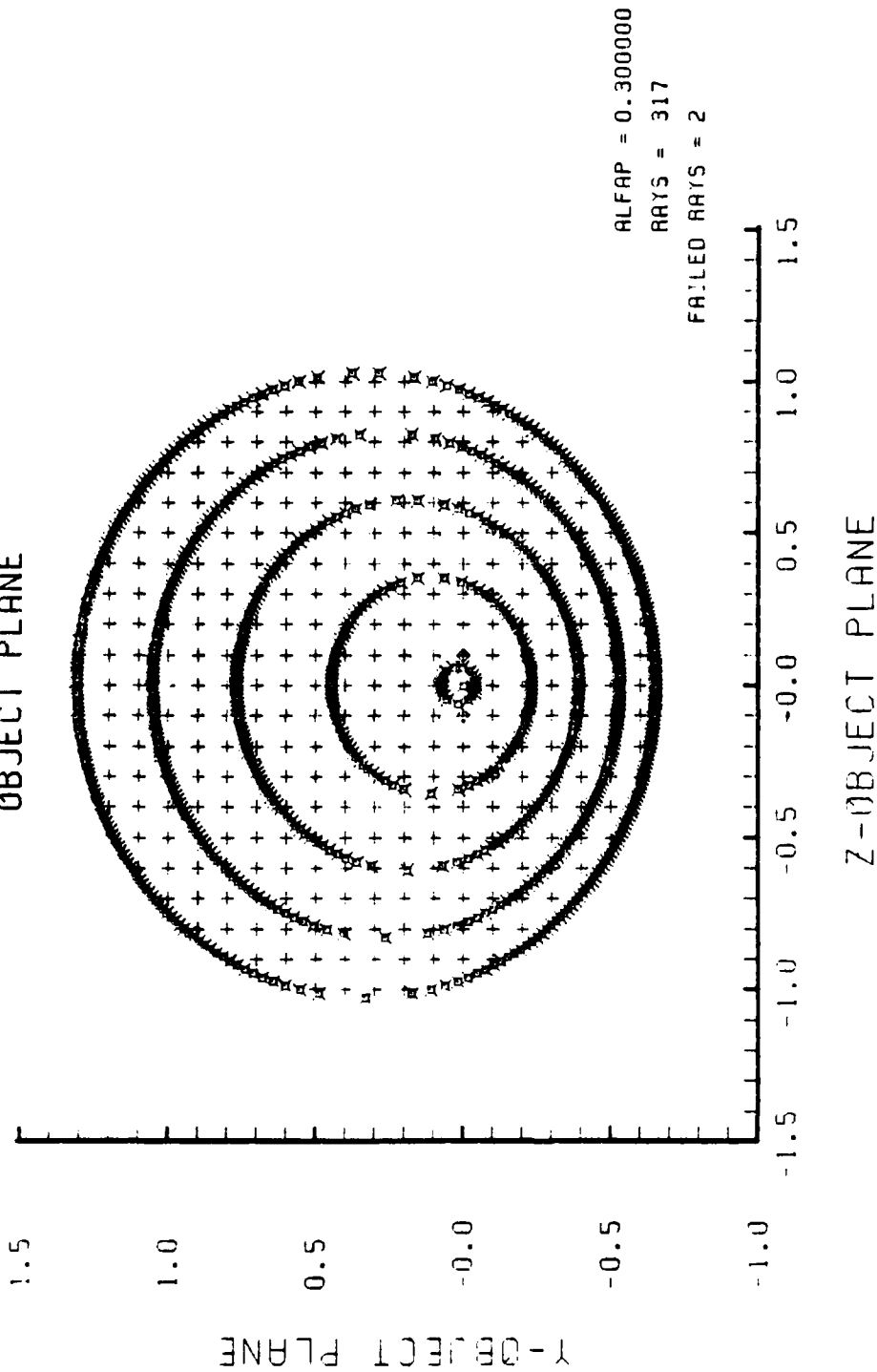

Figure F-42. Grid Plane at $\alpha_p = 0.3$ for Lens of Figure F-41

SPOT DIAGRAM

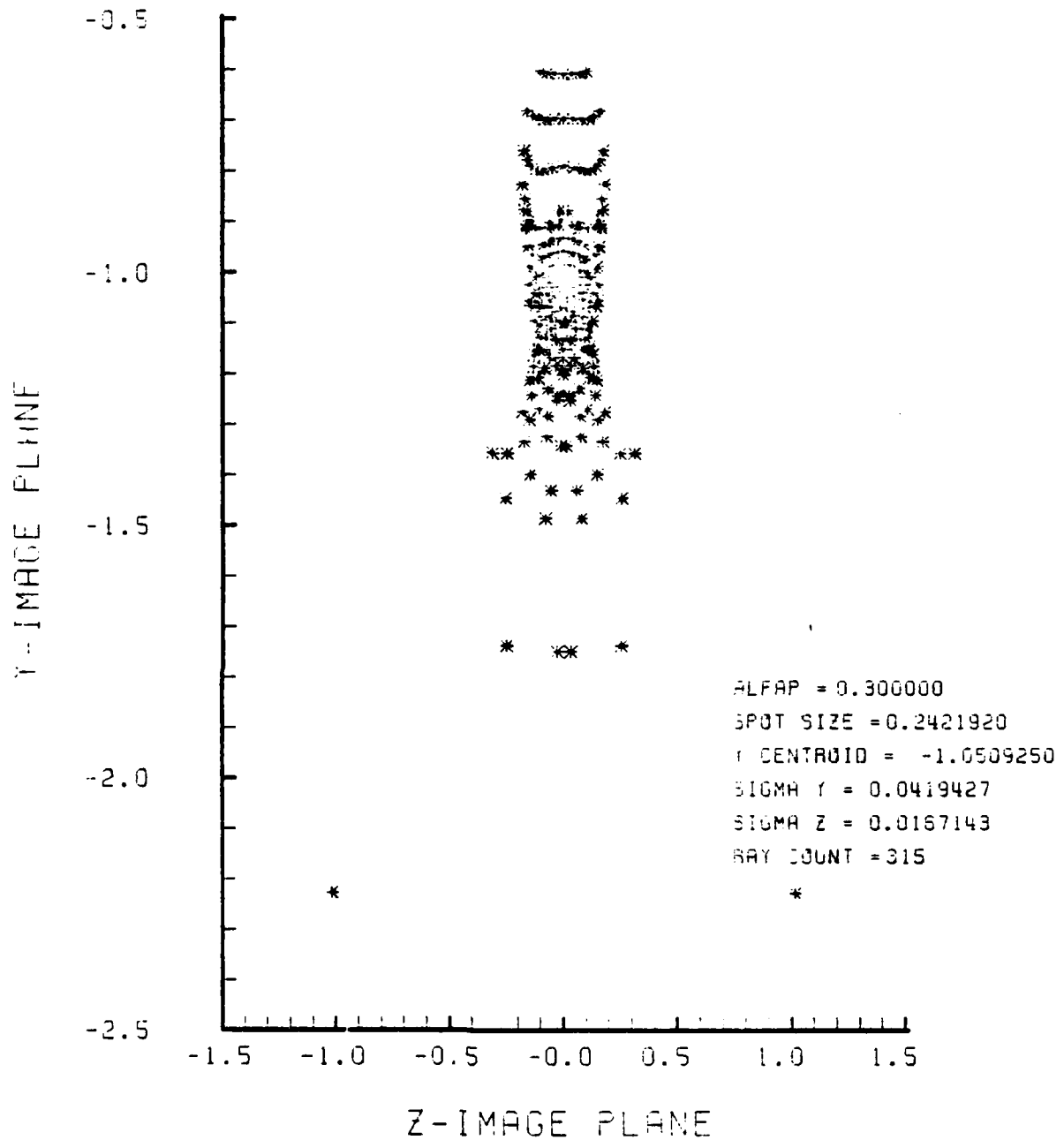

Figure F-43. Spot Diagram for Grid of Figure F-42

SPOT DIAGRAM ENERGY DENSITY

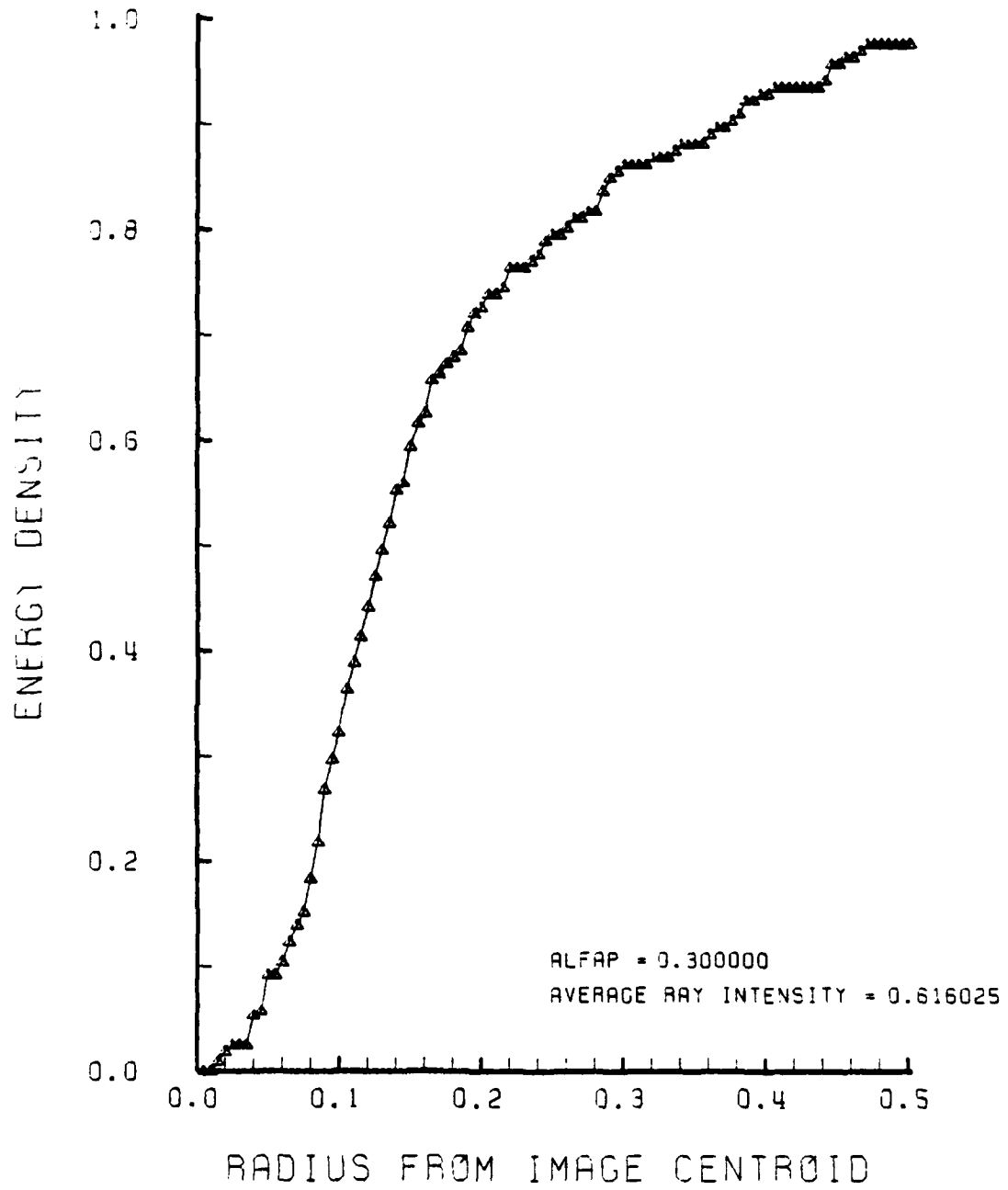

Figure F-44. Encircled Energy of Figure F-43

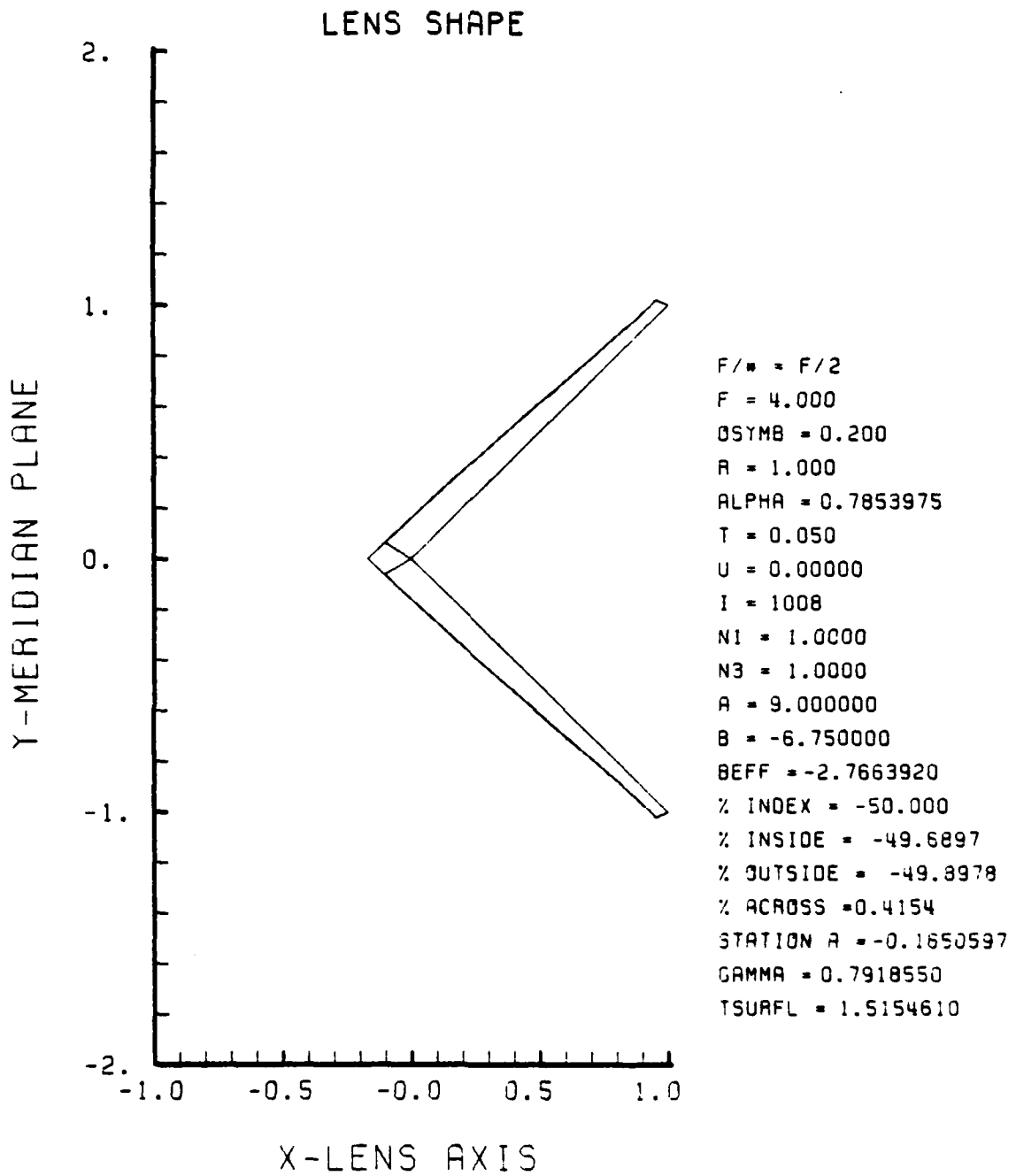

Figure F-45. GRIN Lens Shape for -50%, OB = 0.20,
a = 9.00

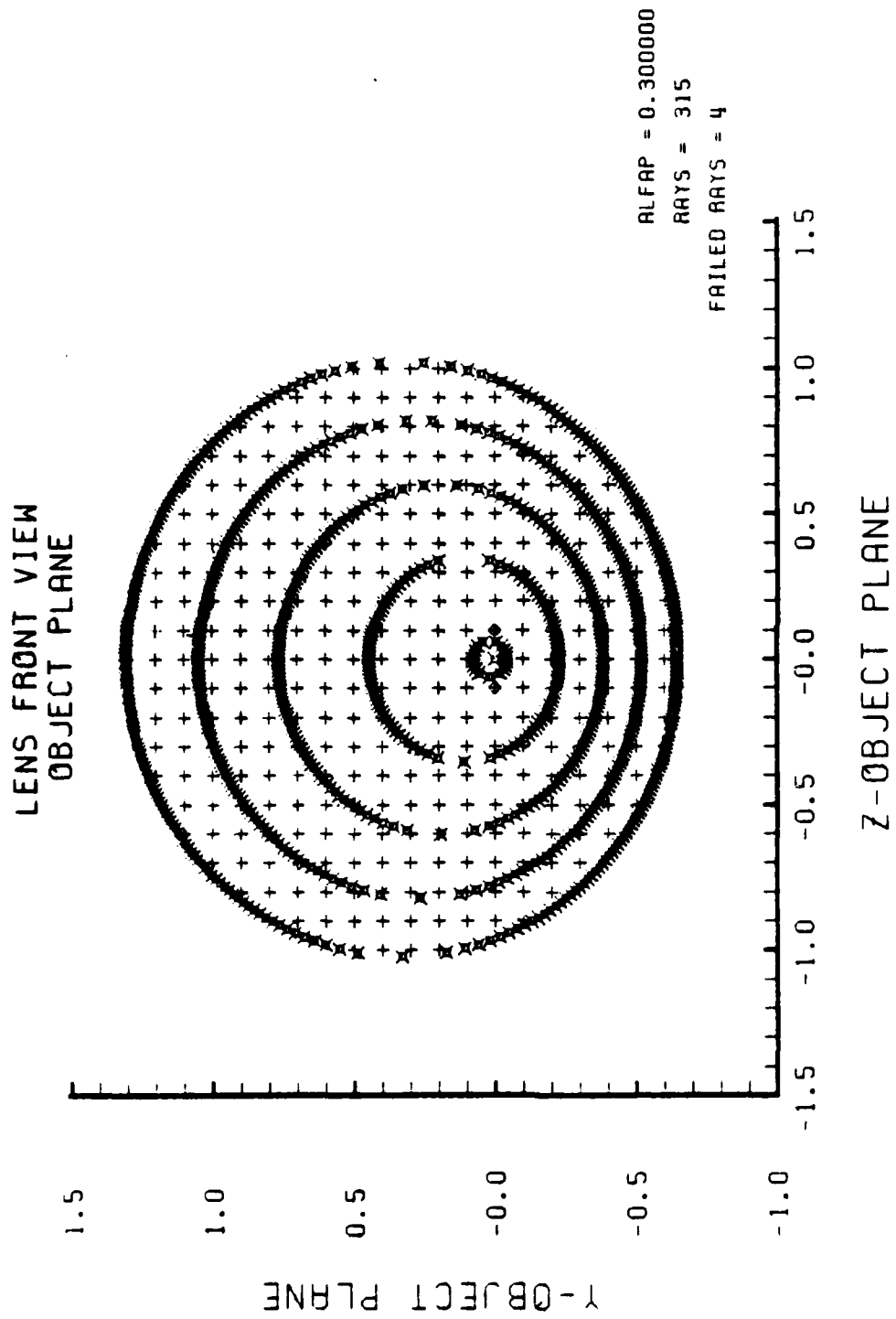

Figure F-46. Grid Plane at $\alpha_p = 0.3$ for Lens of Figure F-45

SPOT DIAGRAM

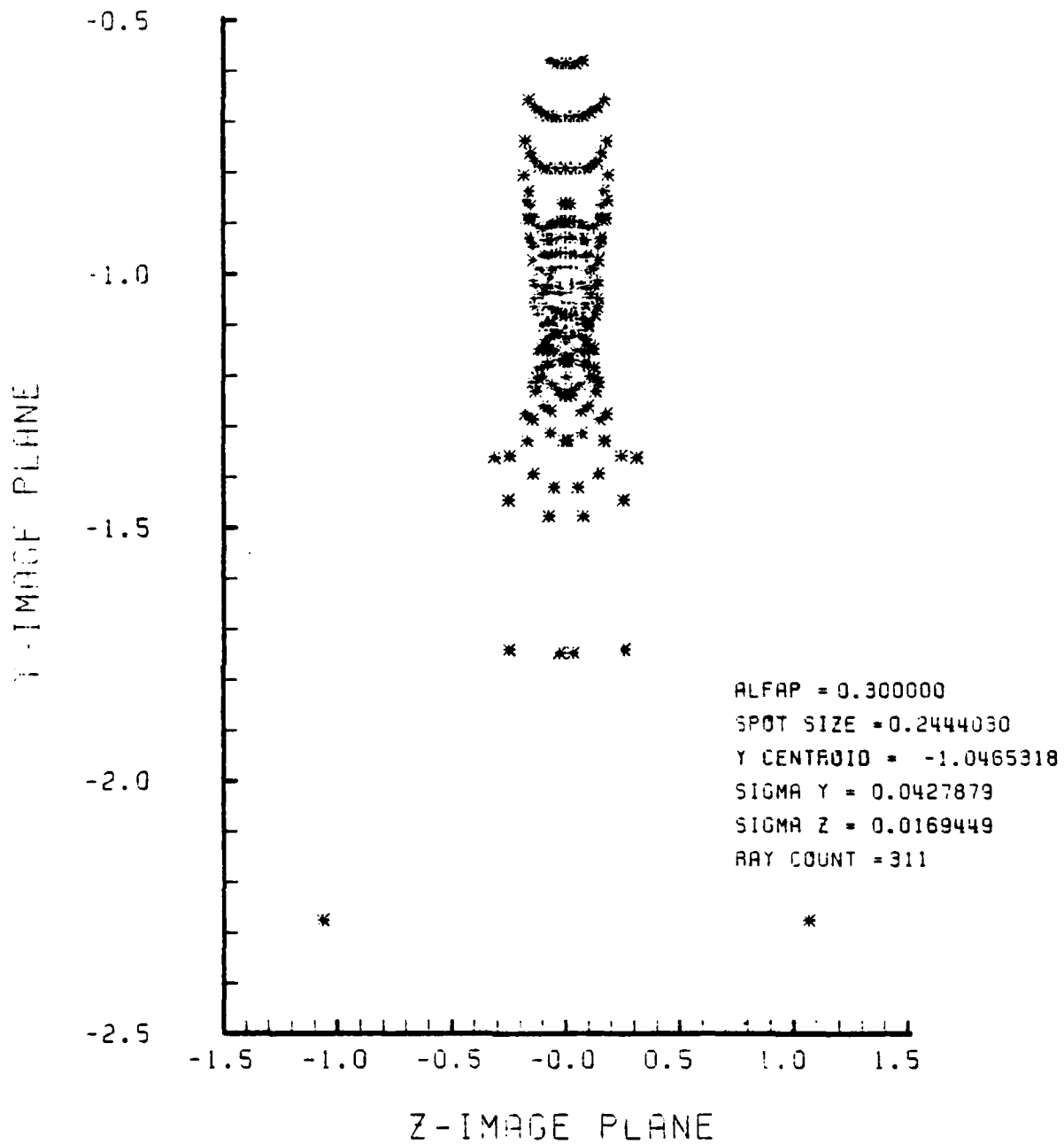

Figure F-47. Spot Diagram for Grid of Figure F-46

SPOT DIAGRAM ENERGY DENSITY

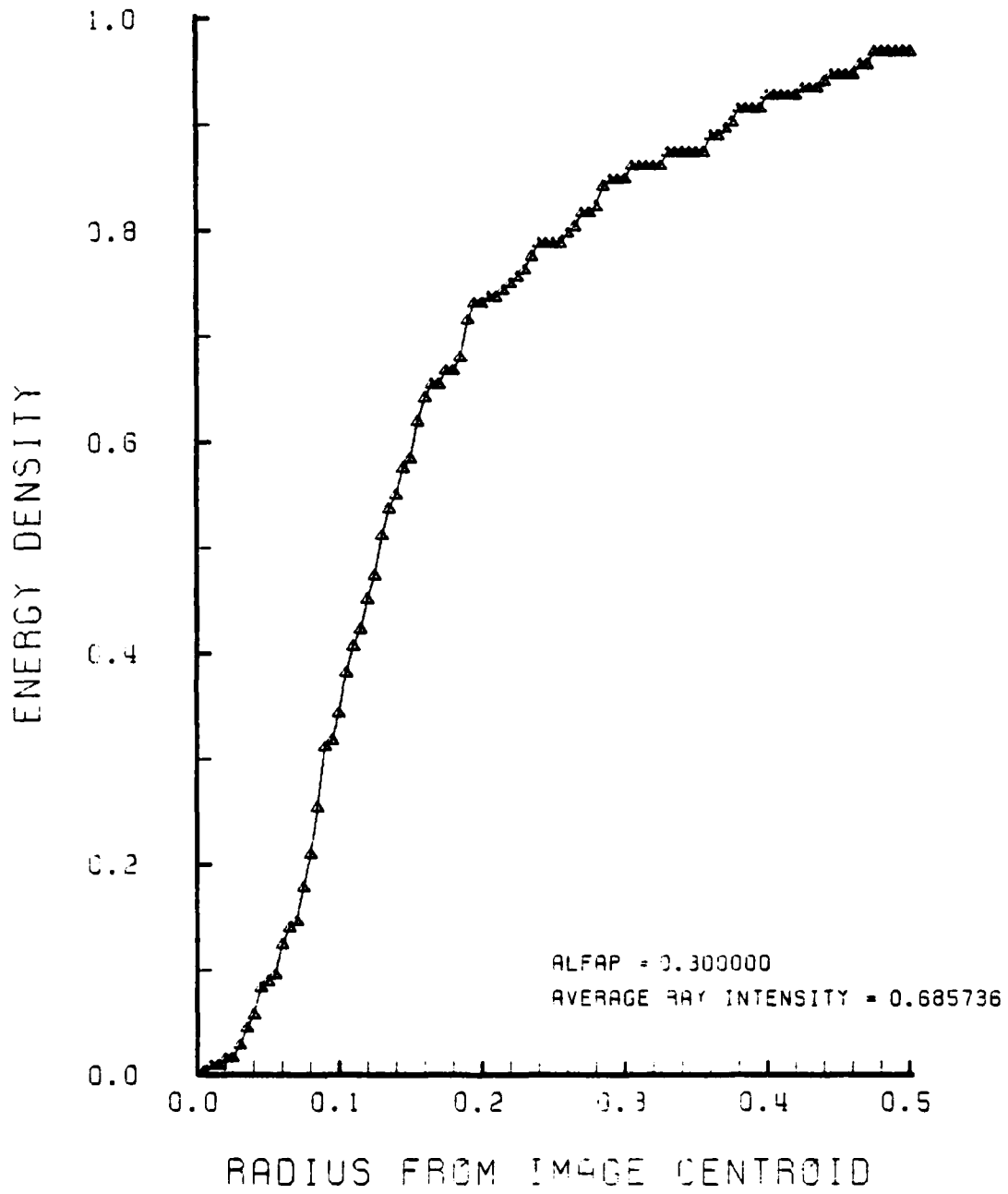

Figure F-48. Encircled Energy of Figure F-47

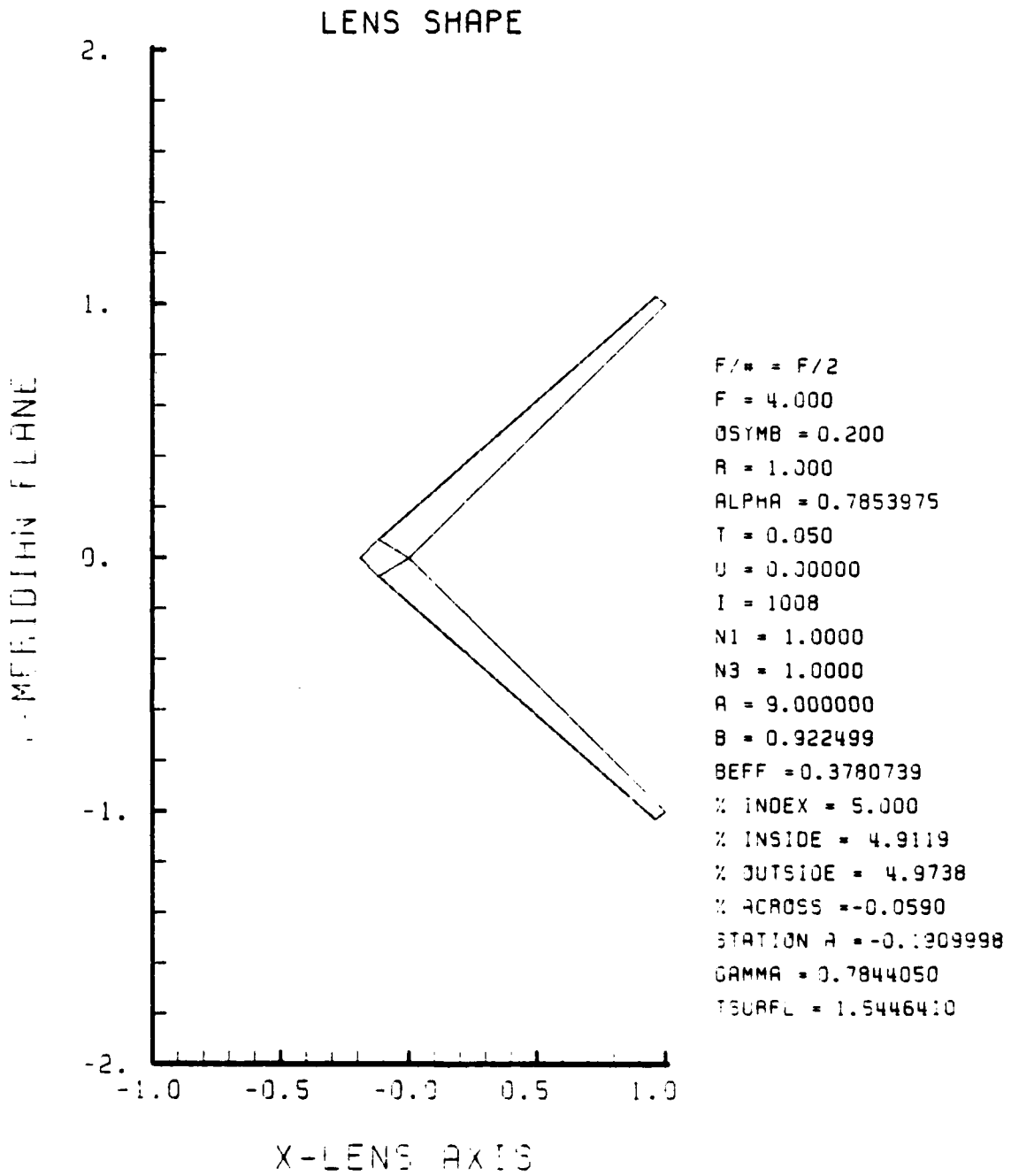

Figure F-49. GRIN Lens Shape for +5%, OB = 0.20,
a = 9.00

LENS FRONT VIEW
OBJECT PLANE

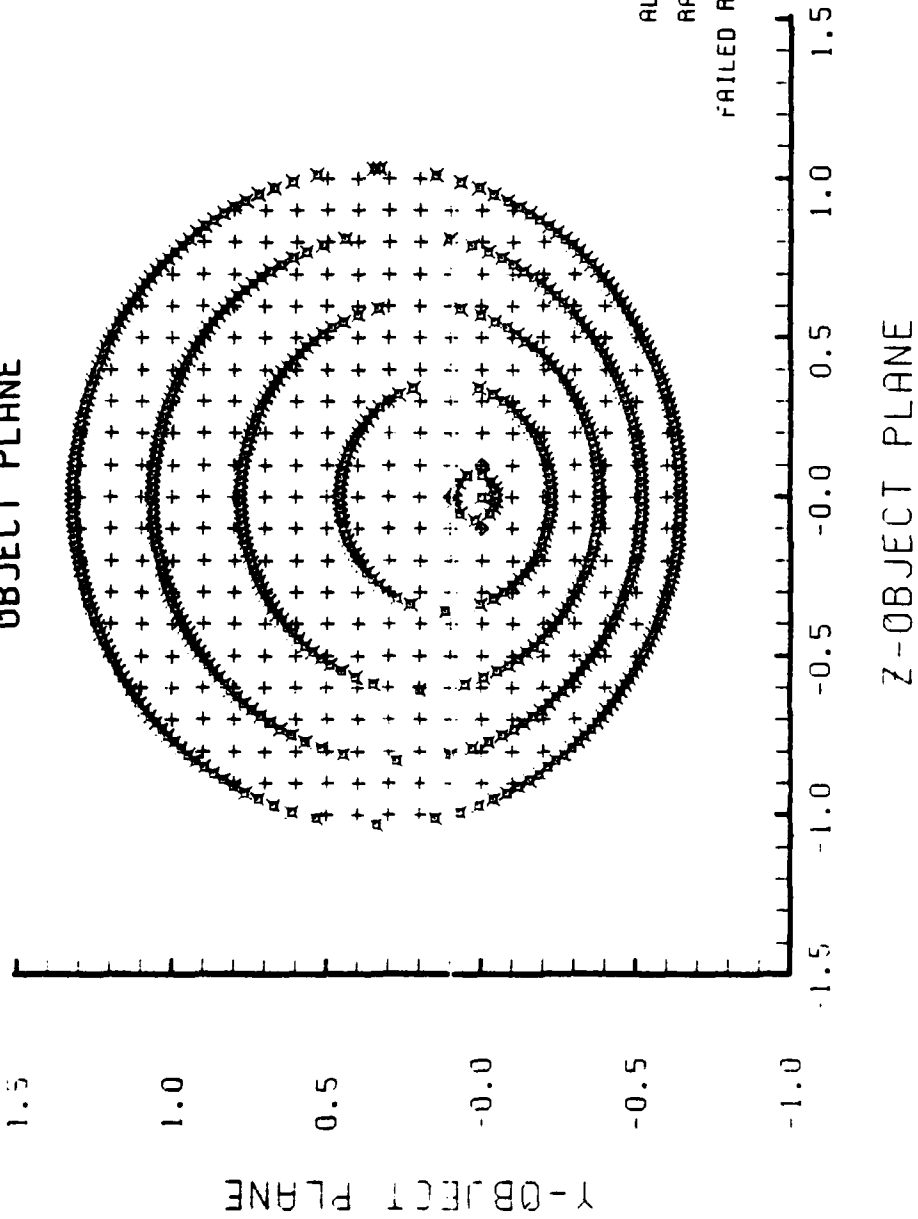

Figure F-50. Grid Plane at $\alpha_p = 0.3$ for Lens of Figure F-49

SPOT DIAGRAM

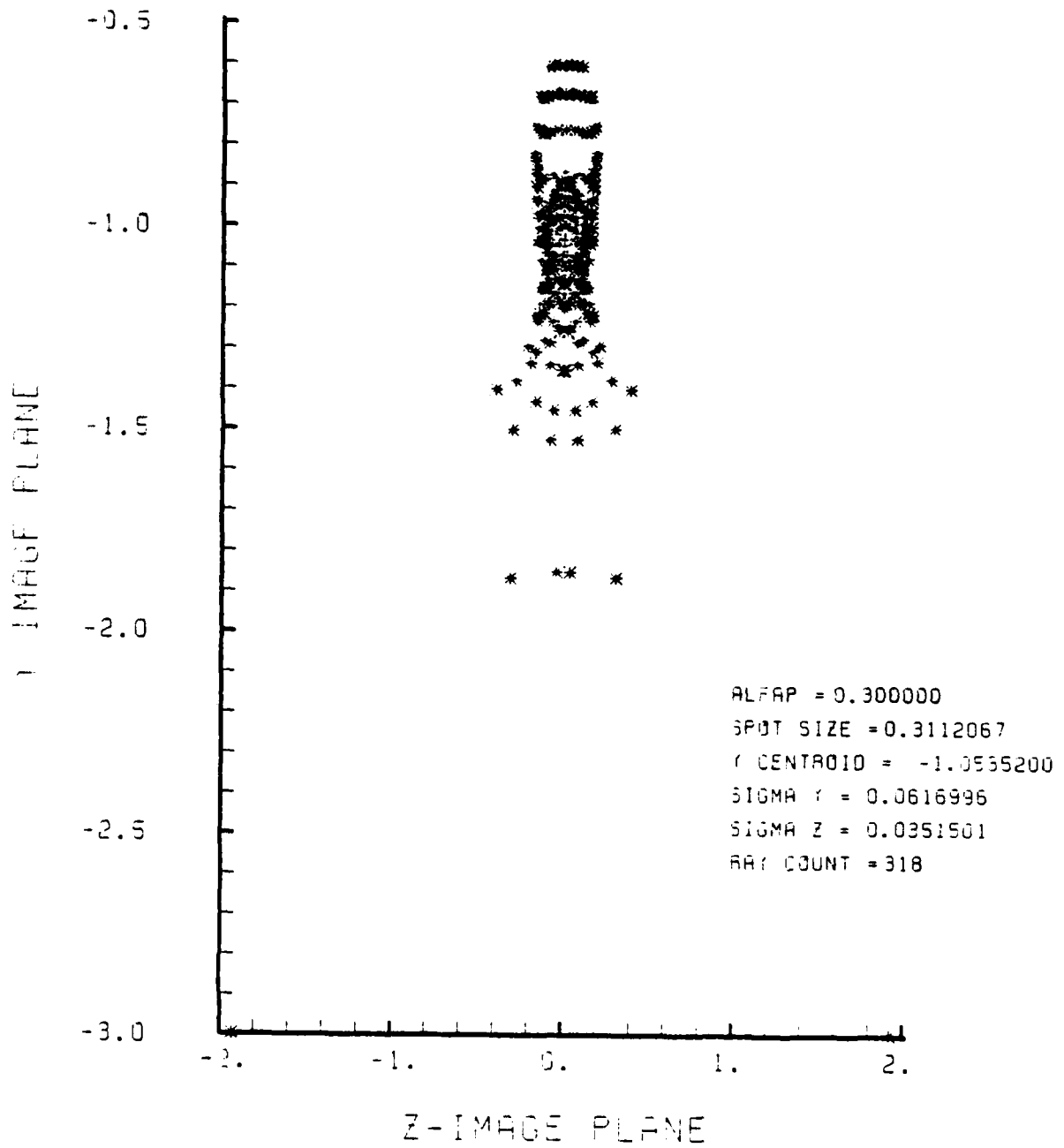

Figure F-51. Spot Diagram for Grid of Figure F-50

SPOT DIAGRAM ENERGY DENSITY

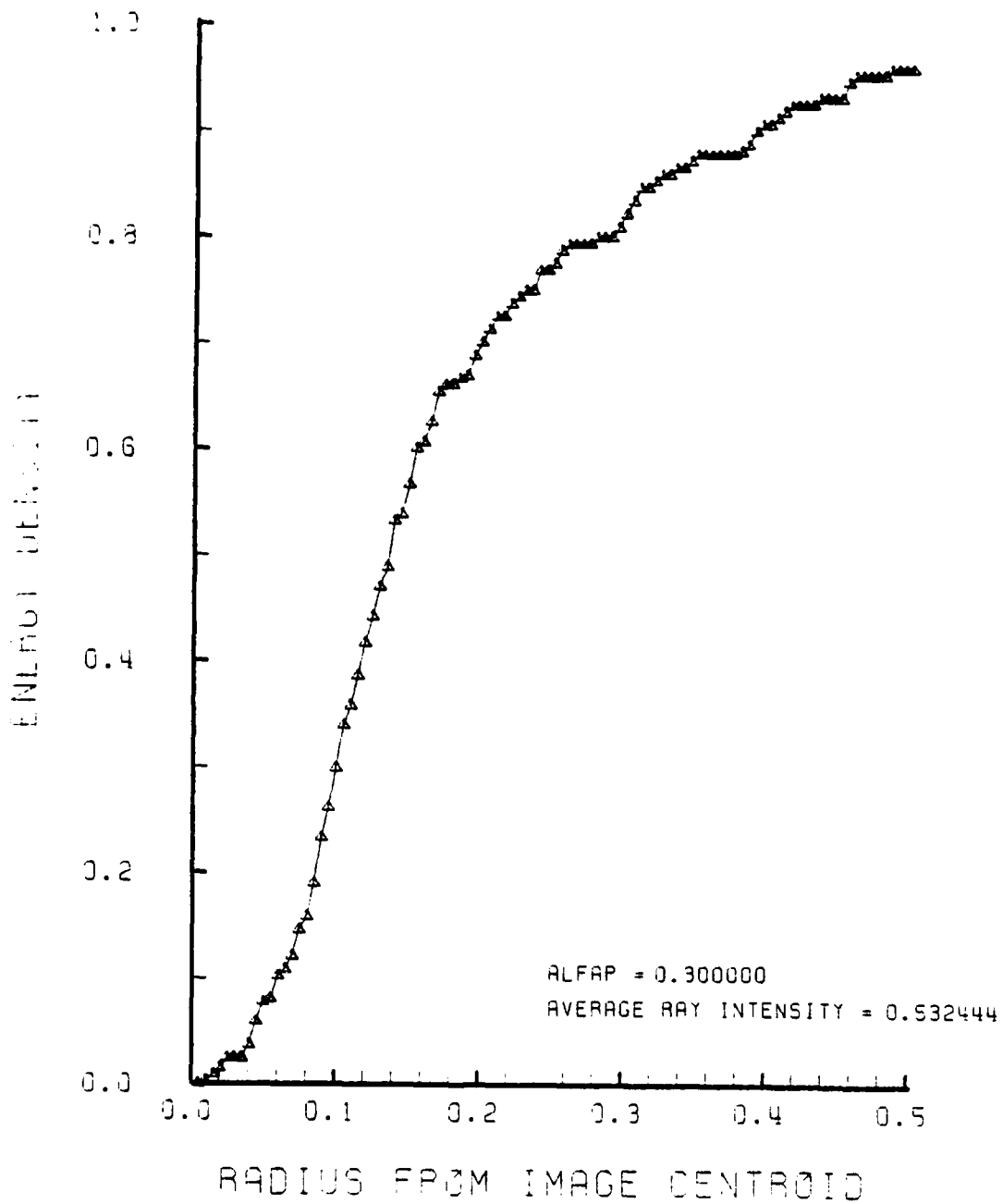

Figure F-52. Encircled Energy of Figure F-51

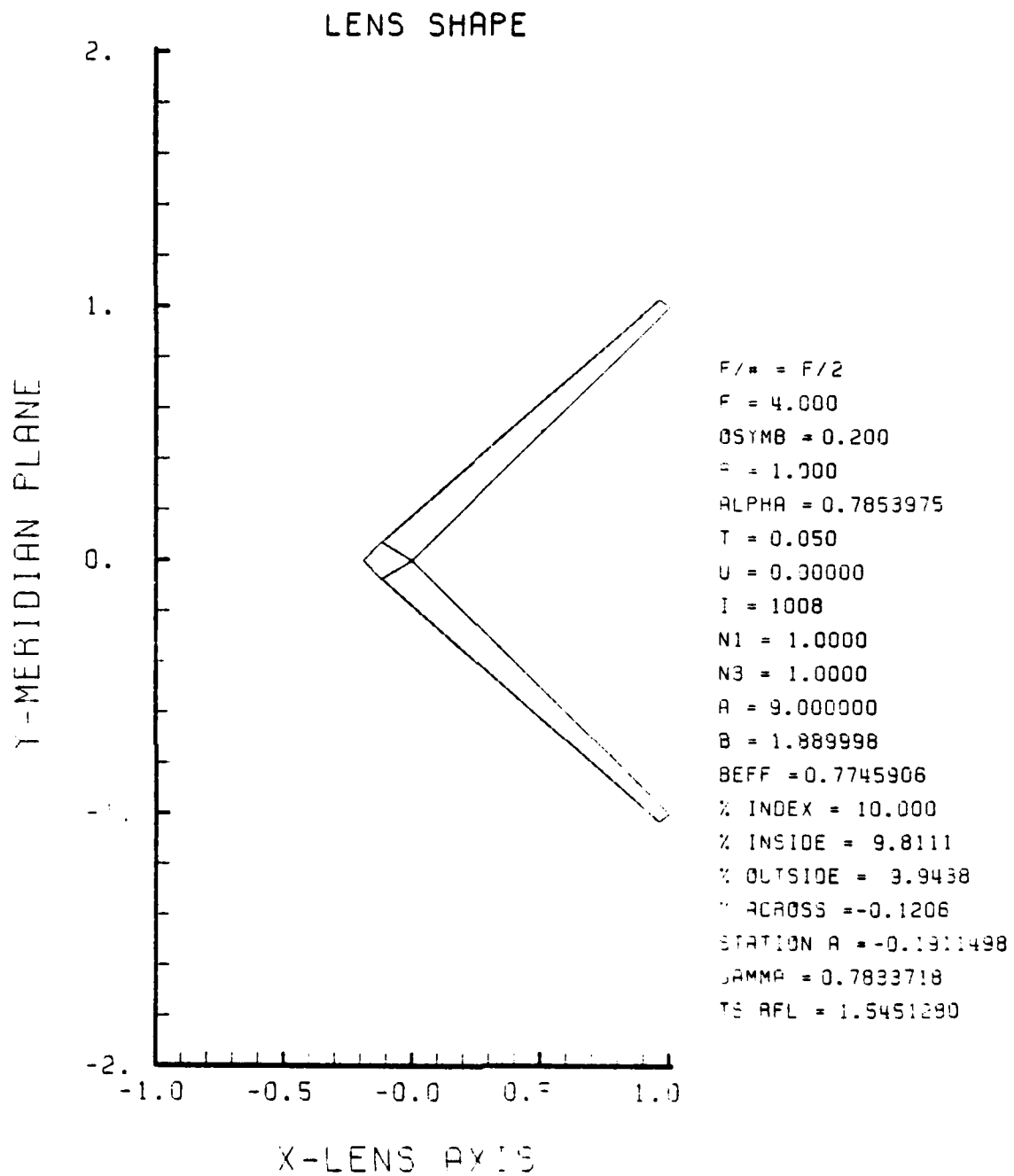

Figure F-53. GRIN Lens Shape at +10%, OB = 0.20,
a = 9.00

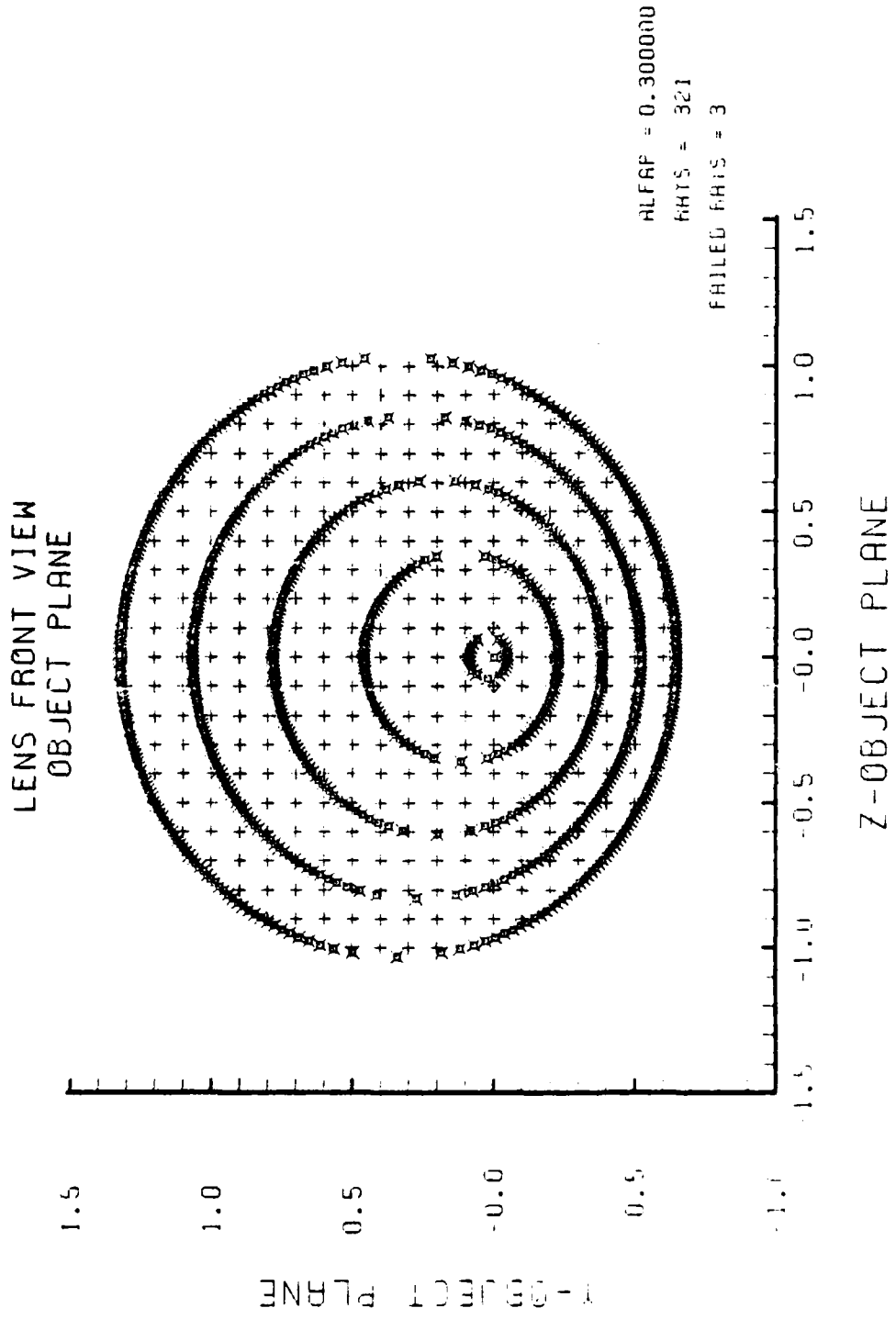

Figure F-54. Grid Plane at $\alpha_p = 0.3$ for Lens of Figure F-53

SPOT DIAGRAM

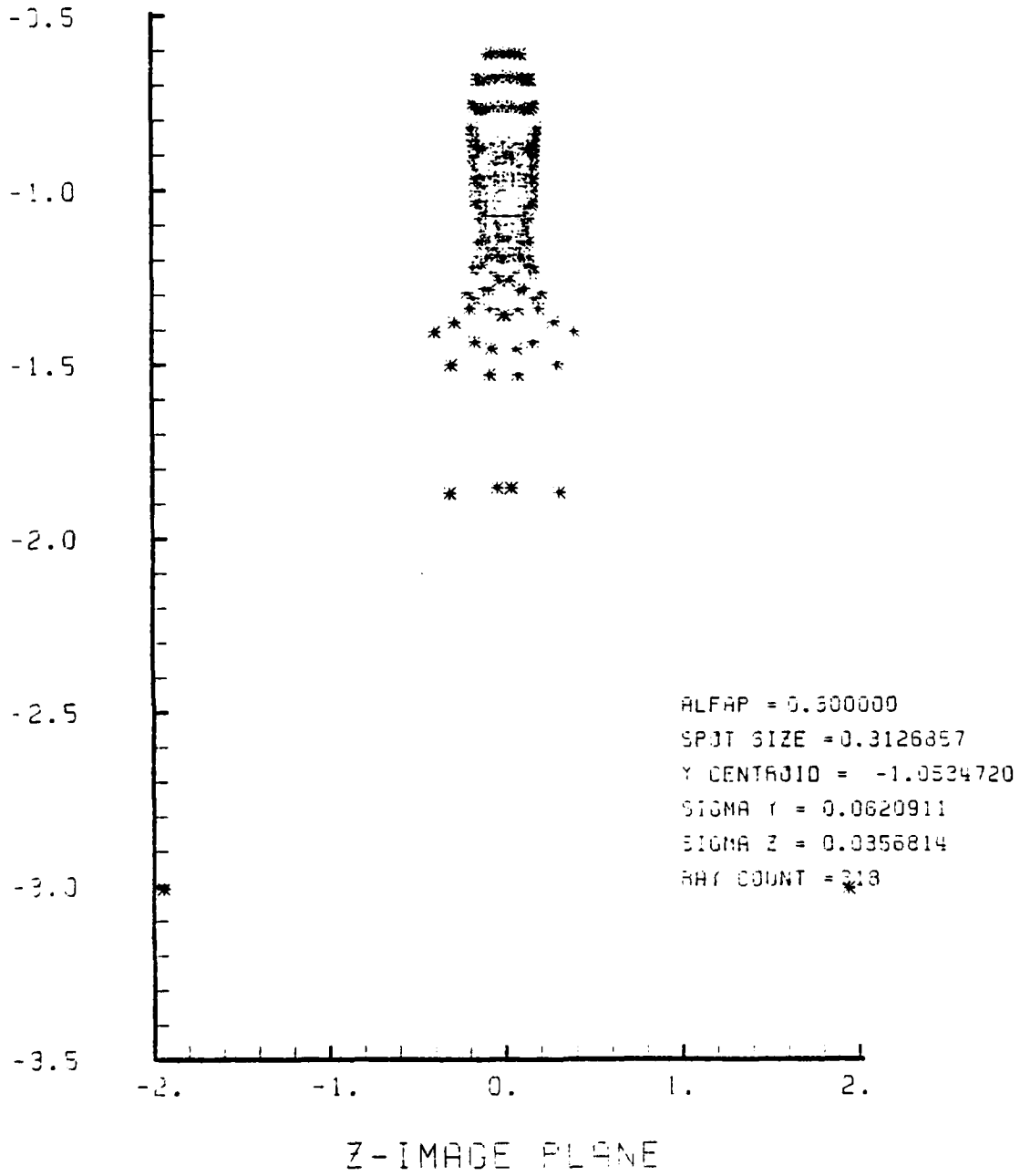

Figure F-55. Spot Diagram for Grid of Figure F-54

SPOT DIAGRAM ENERGY DENSITY

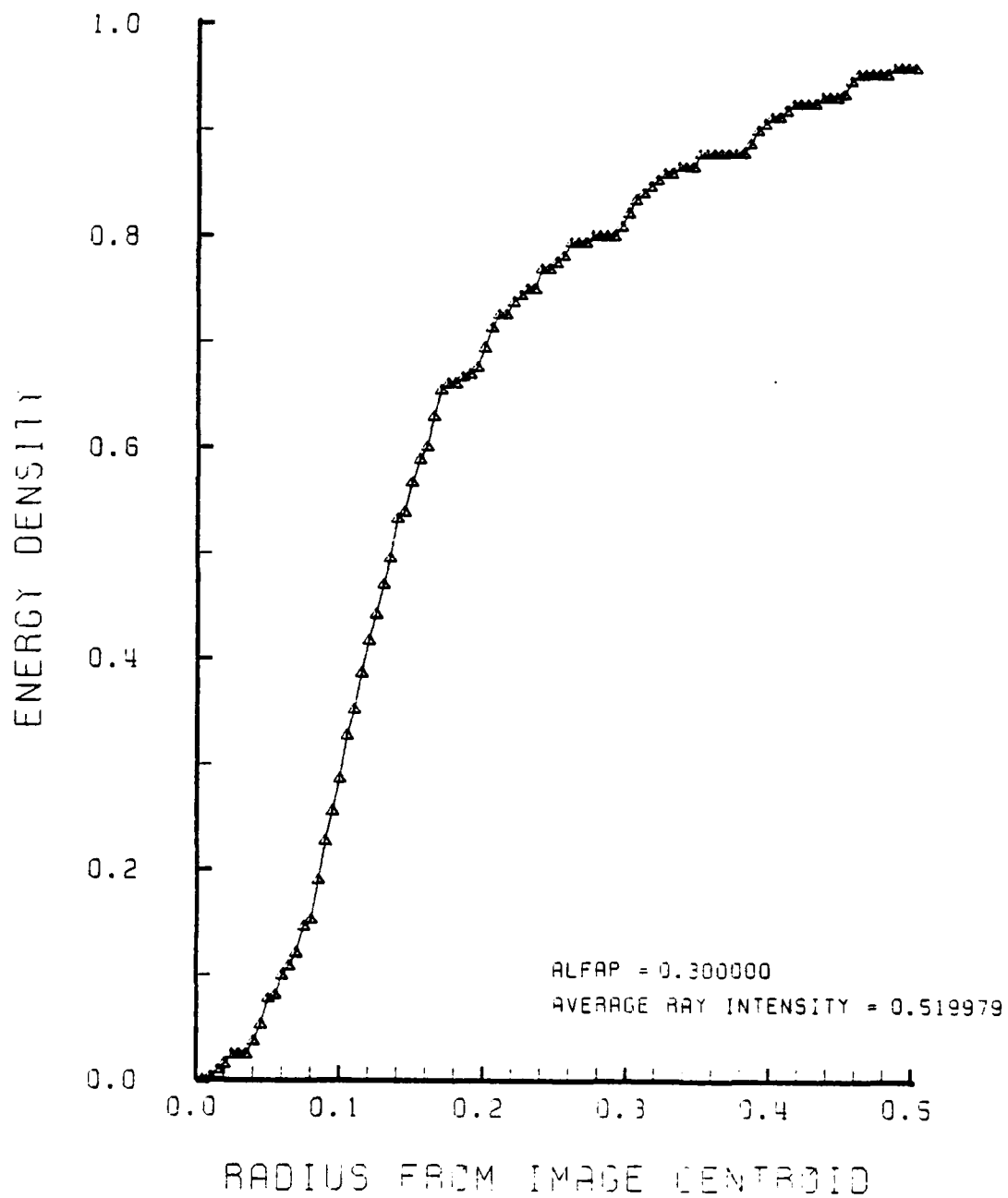

Figure F-56. Encircled Energy of Figure F-55

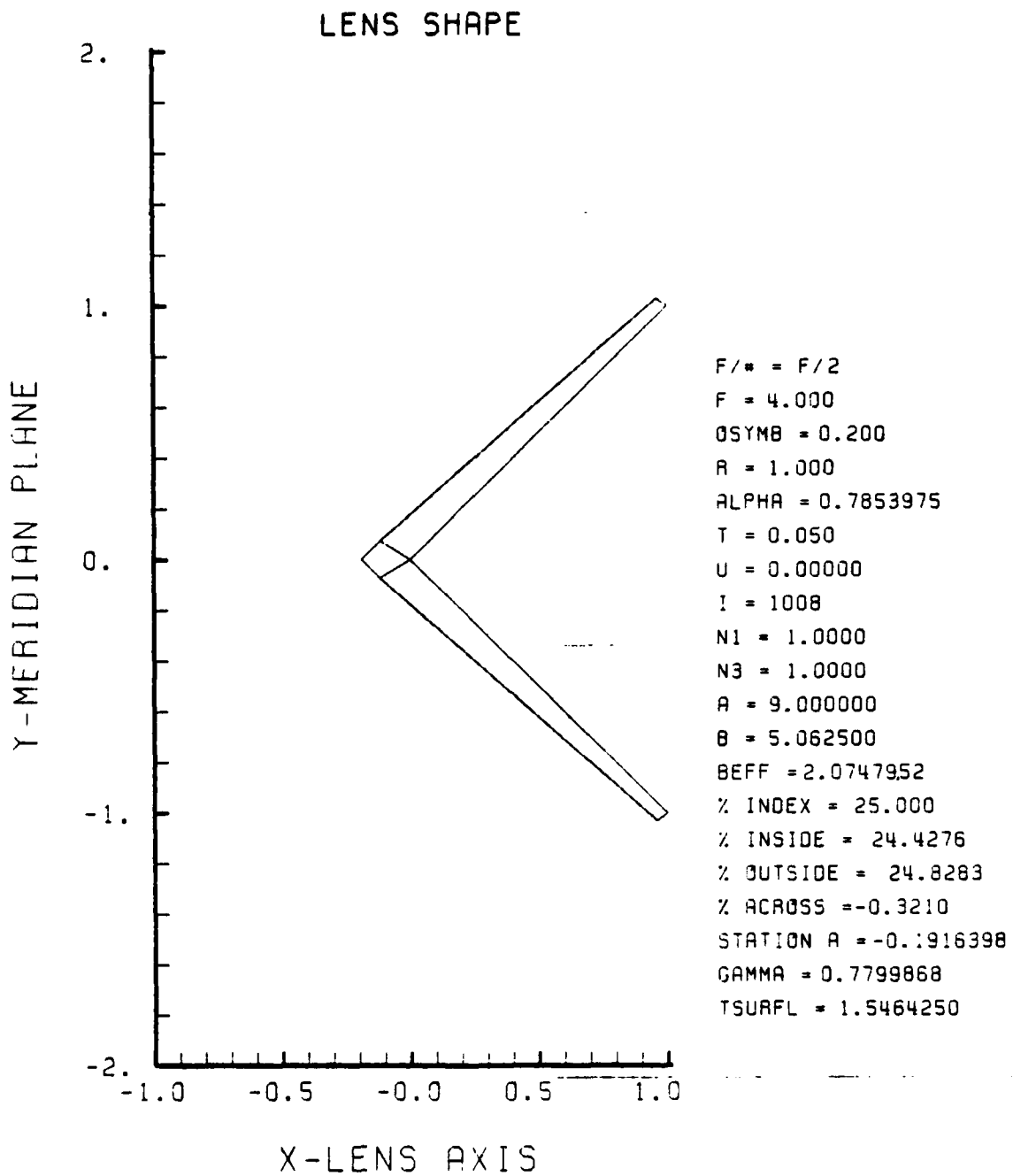

Figure F-57. GRIN Lens Shape at +25%, OB = 0.20,
a = 9.00

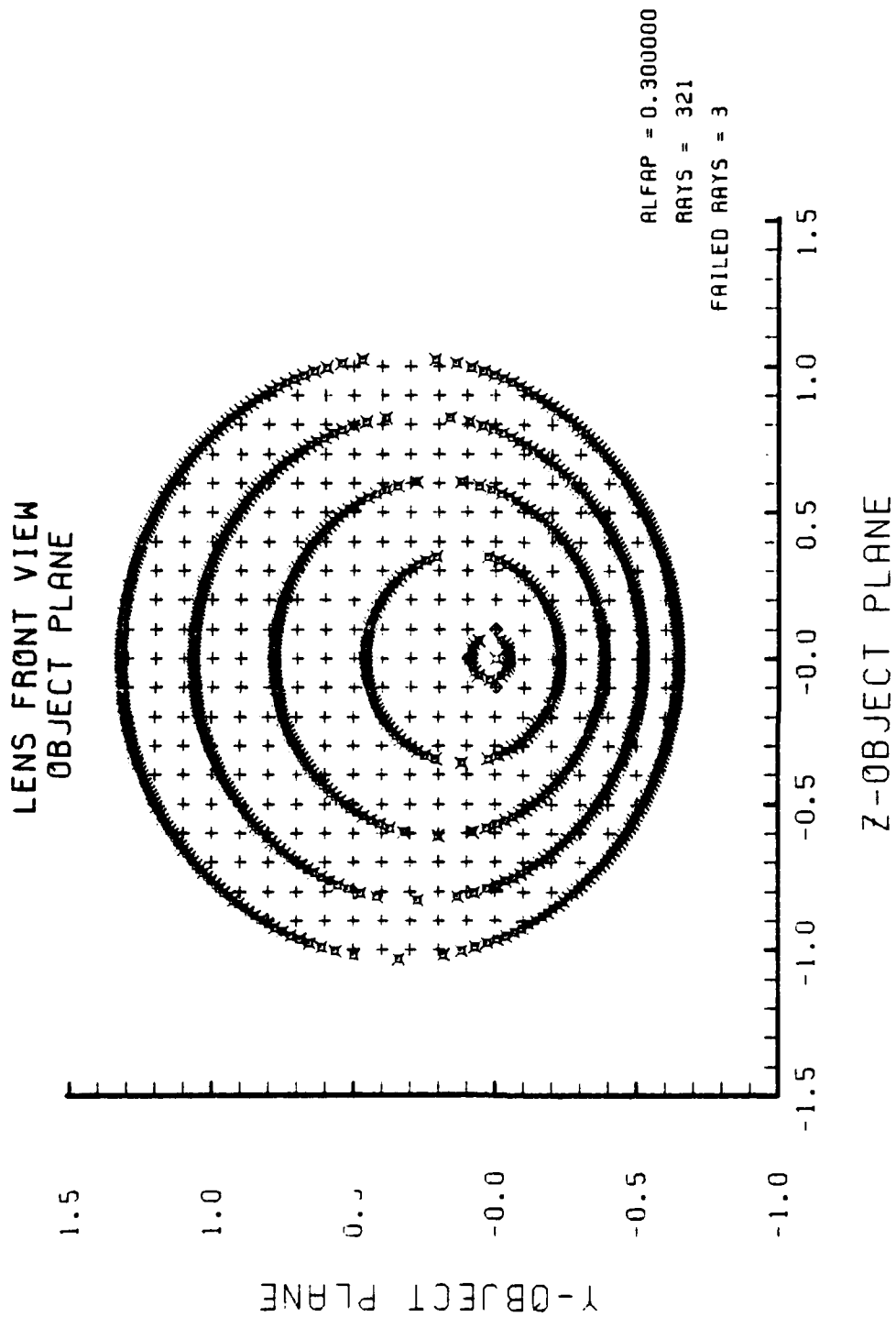

Figure F-58. Grid Plane at $\alpha_p = 0.3$ for Lens of Figure F-57

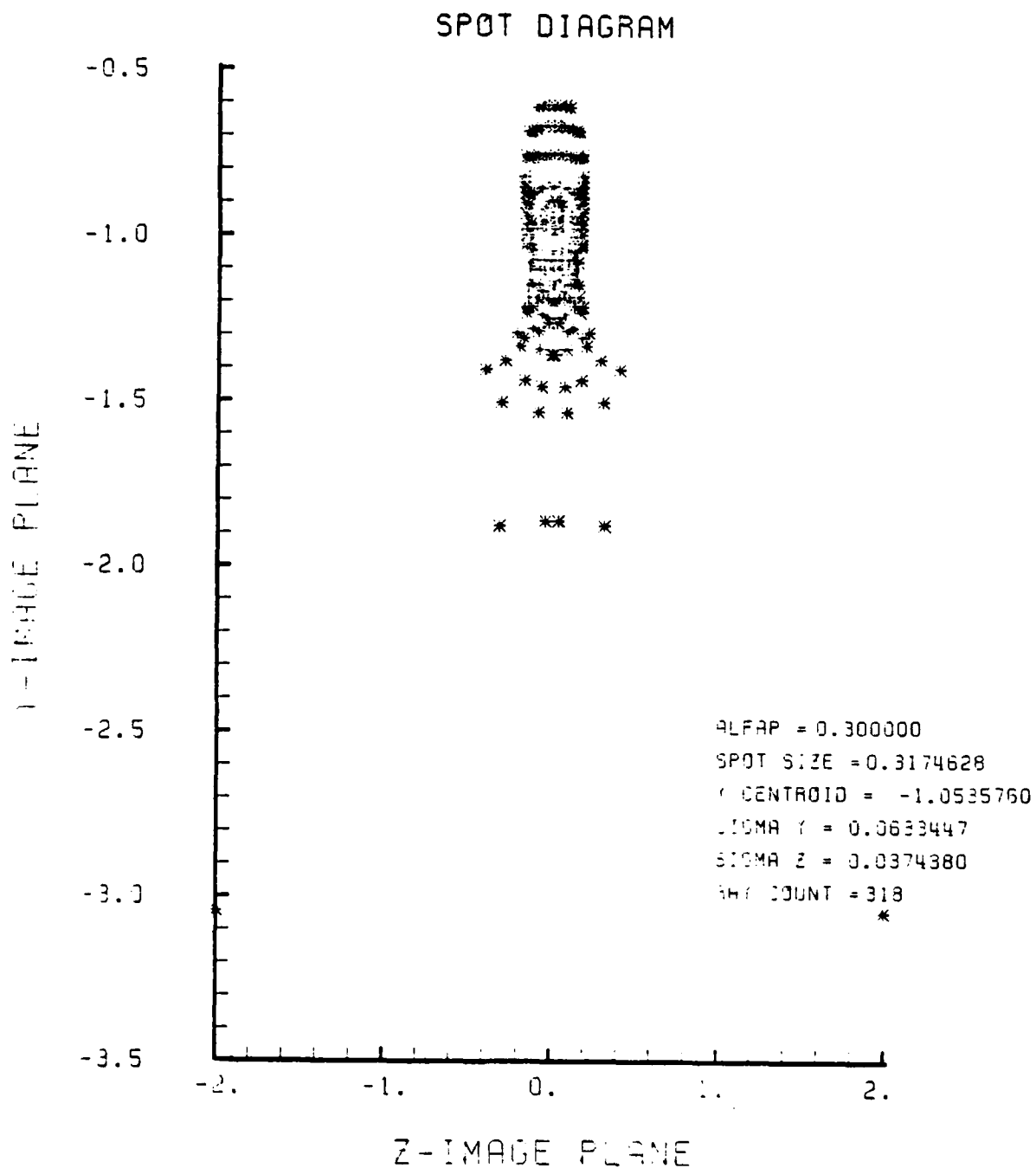

Figure F-59. Spot Diagram for Grid of Figure F-58

SPOT DIAGRAM ENERGY DENSITY

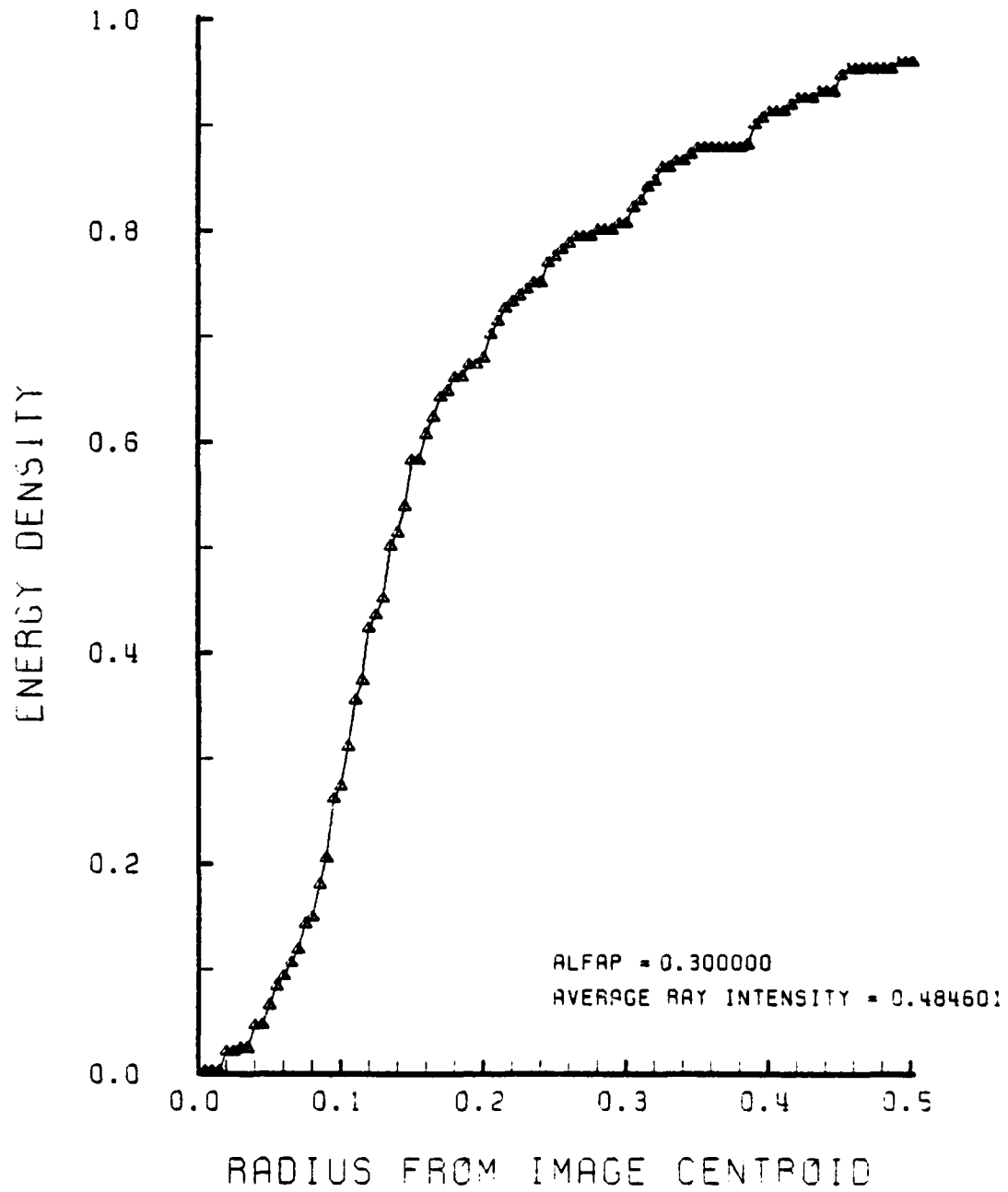

Figure F-60. Encircled Energy of Figure F-59

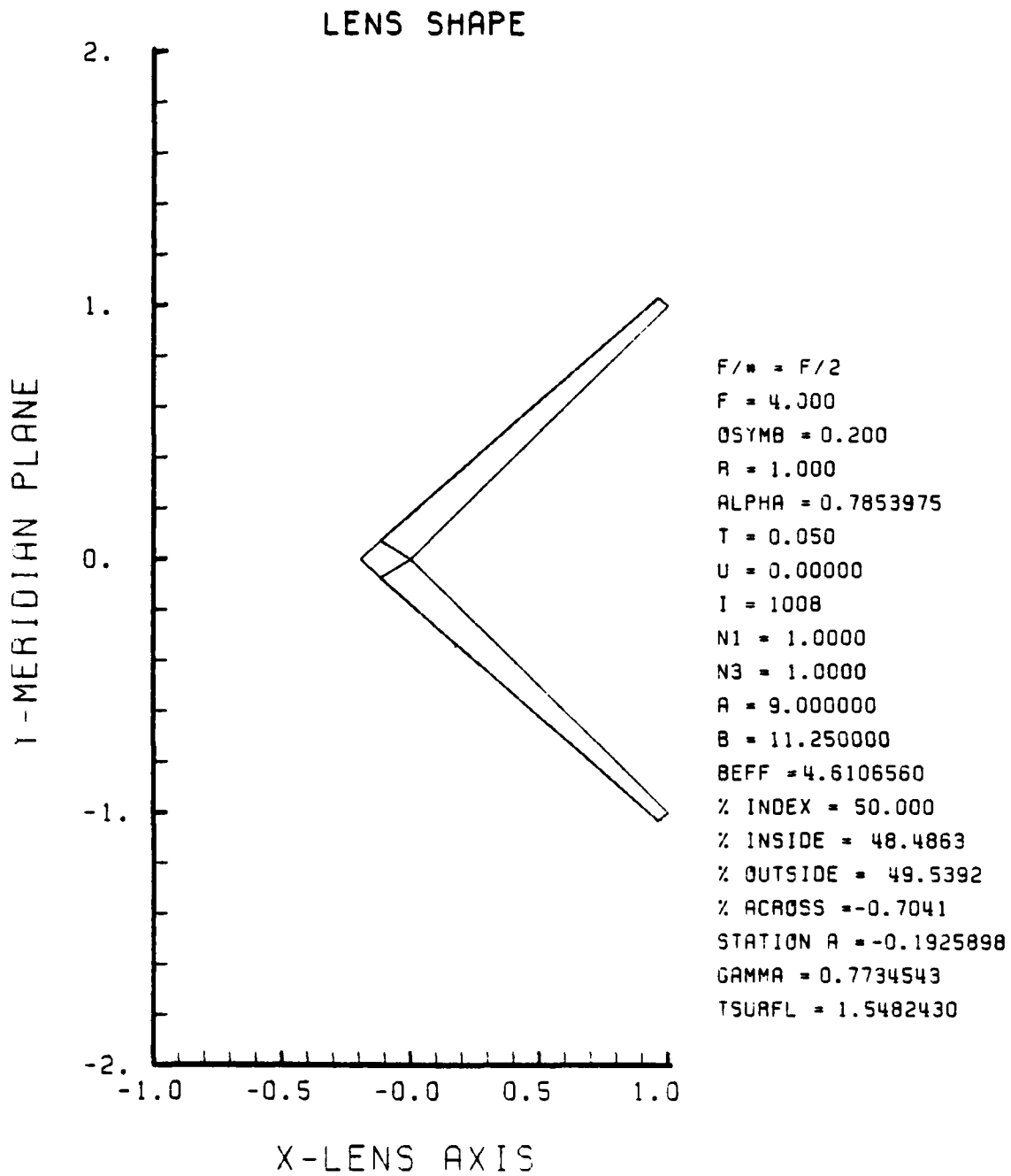

Figure F-61. GRIN Lens Shape at +50%, OB = 0.20,
a = 9.00

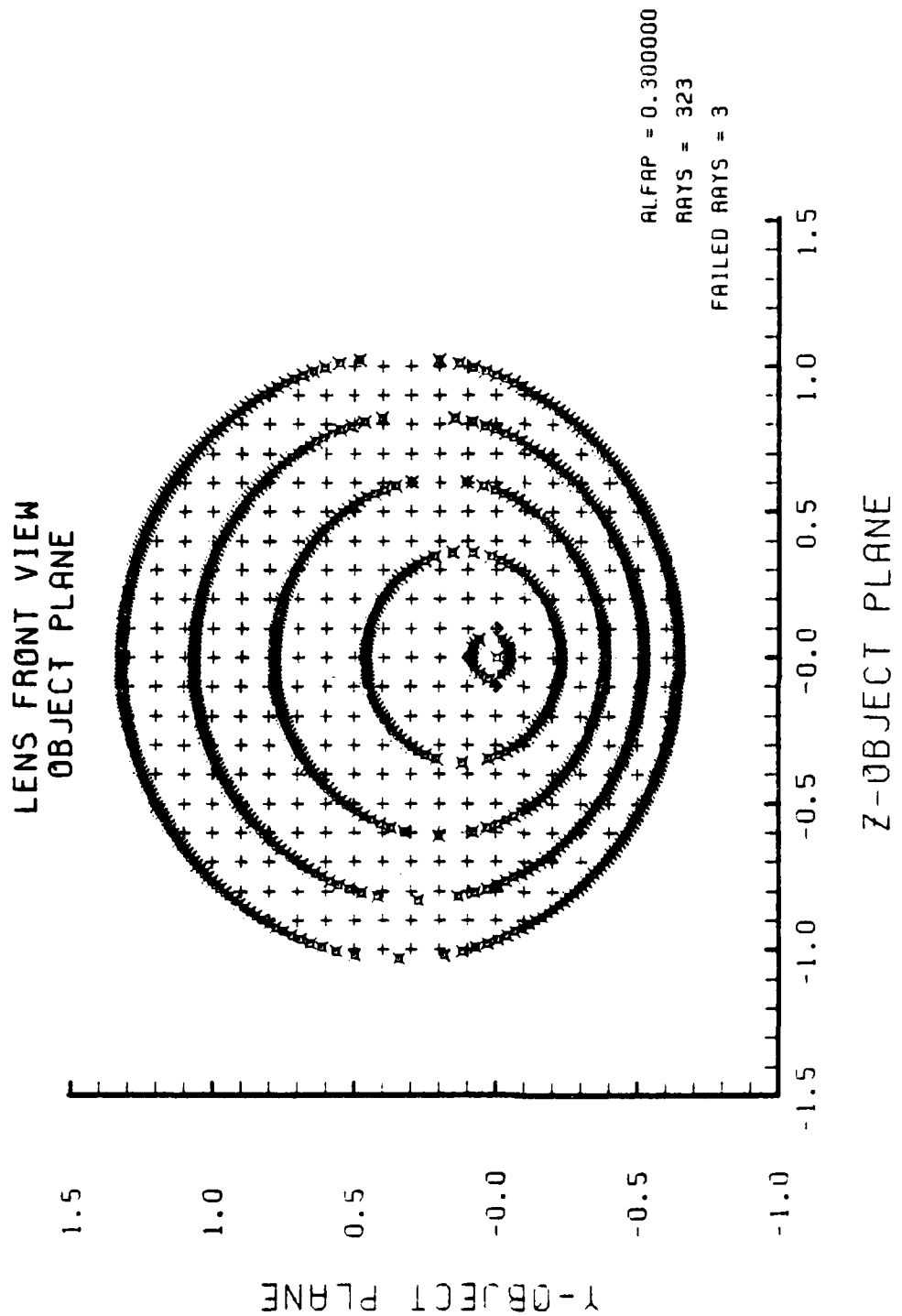

Figure F-62. Grid Plane at $\alpha_p = 0.3$ for Lens of Figure F-61

SPOT DIAGRAM

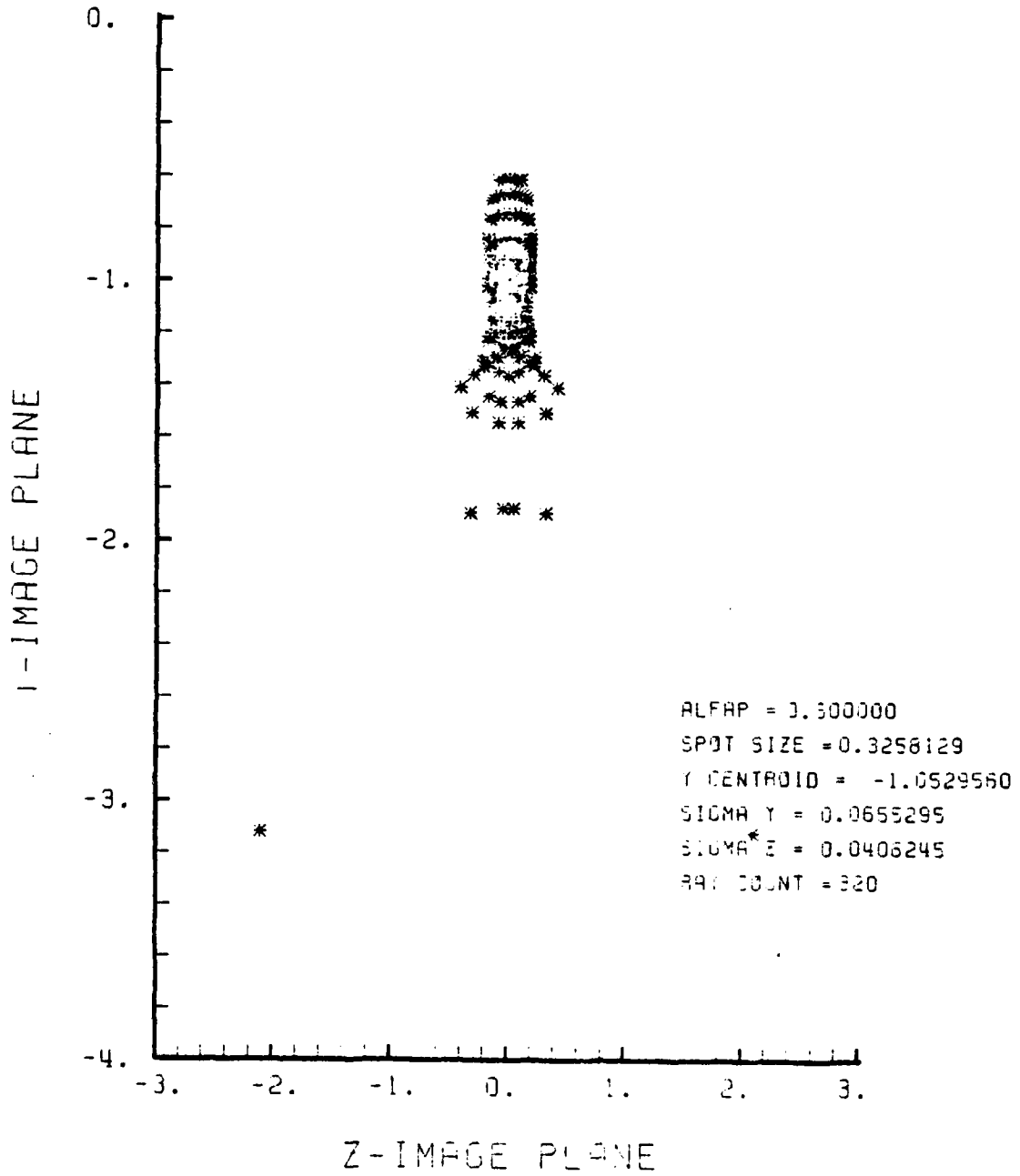

Figure F-63. Spot Diagram for Grid of Figure F-62

SPOT DIAGRAM ENERGY DENSITY

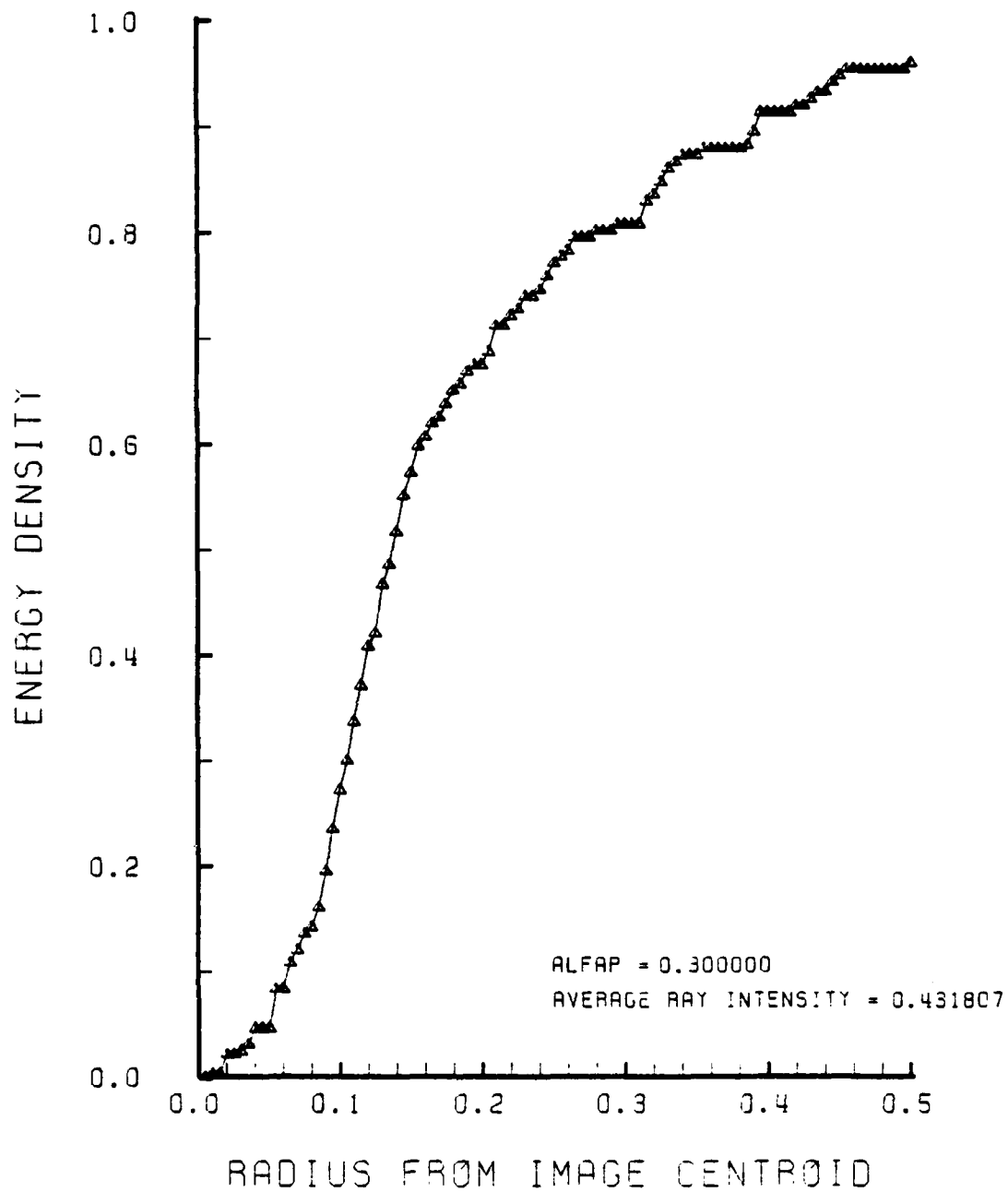

Figure F-64. Encircled Energy of Figure F-63

LENS SHAPE

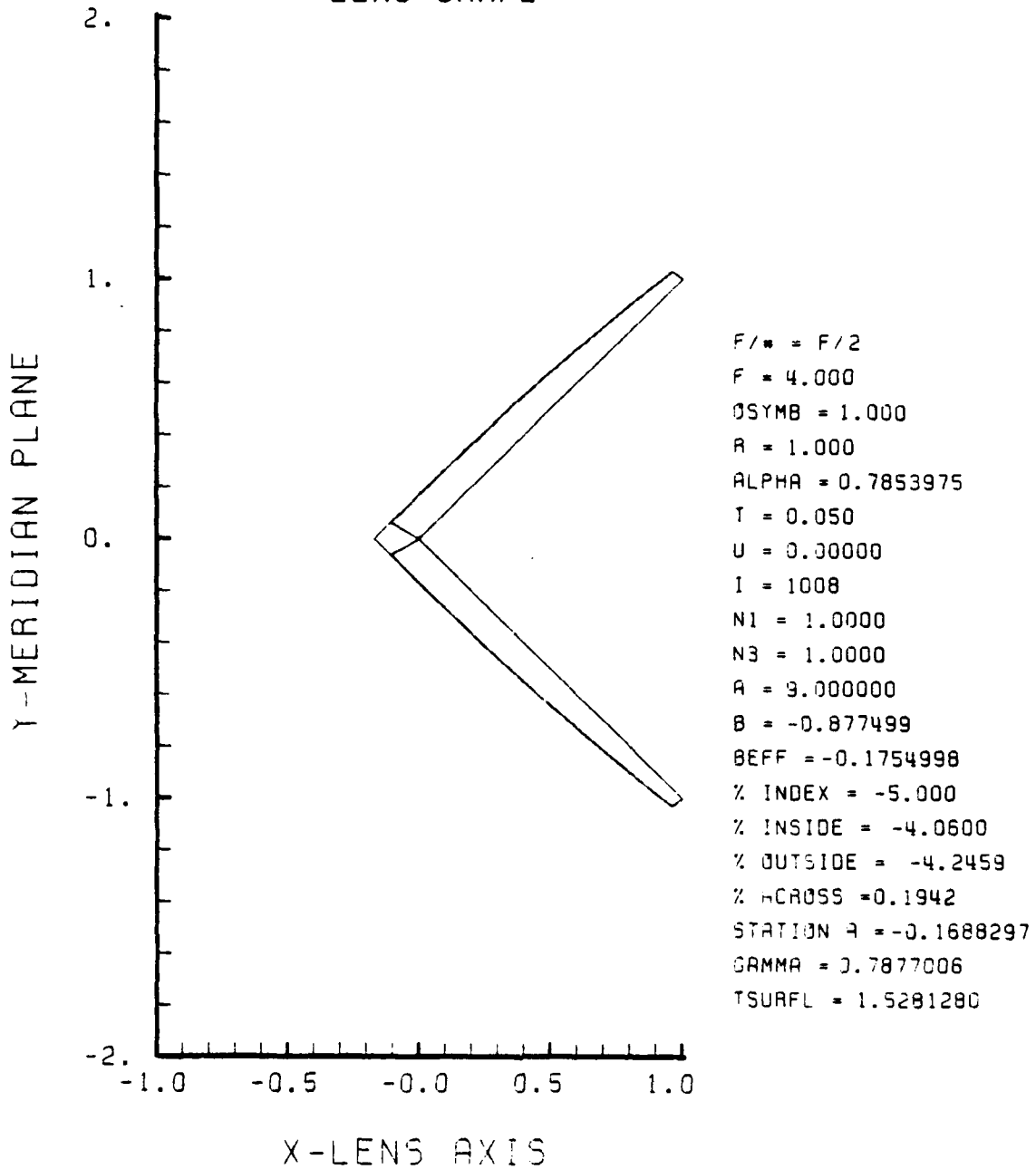

Figure F-65. GRIN Lens Shape at -5%, OB = 1.00,
a = 9.00

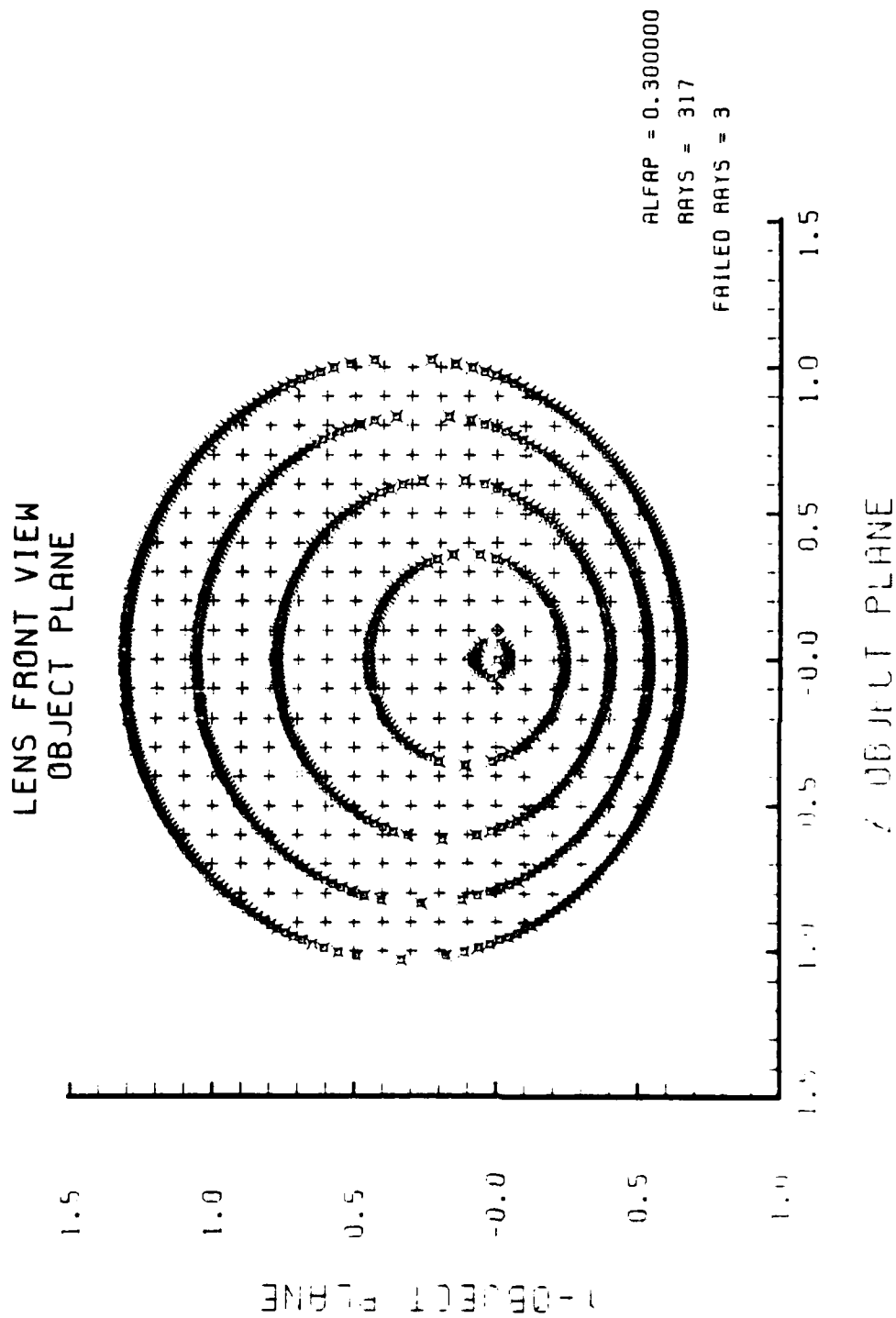

Figure F-66. Grid Plane at $\alpha_p = 0.3$ for Lens of Figure F-65

SPOT DIAGRAM

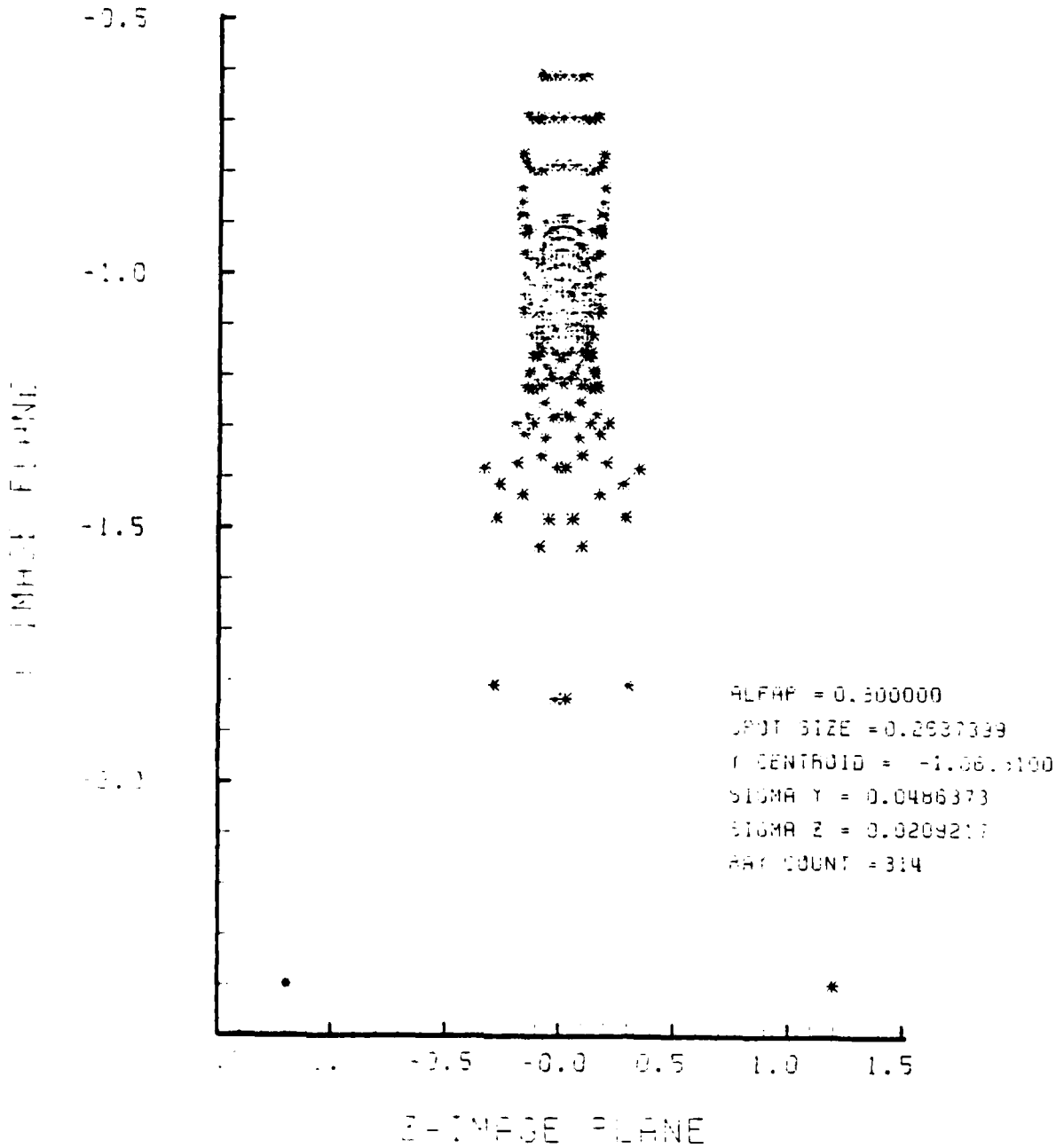

Figure F-67. Spot Diagram for Grid of Figure F-66

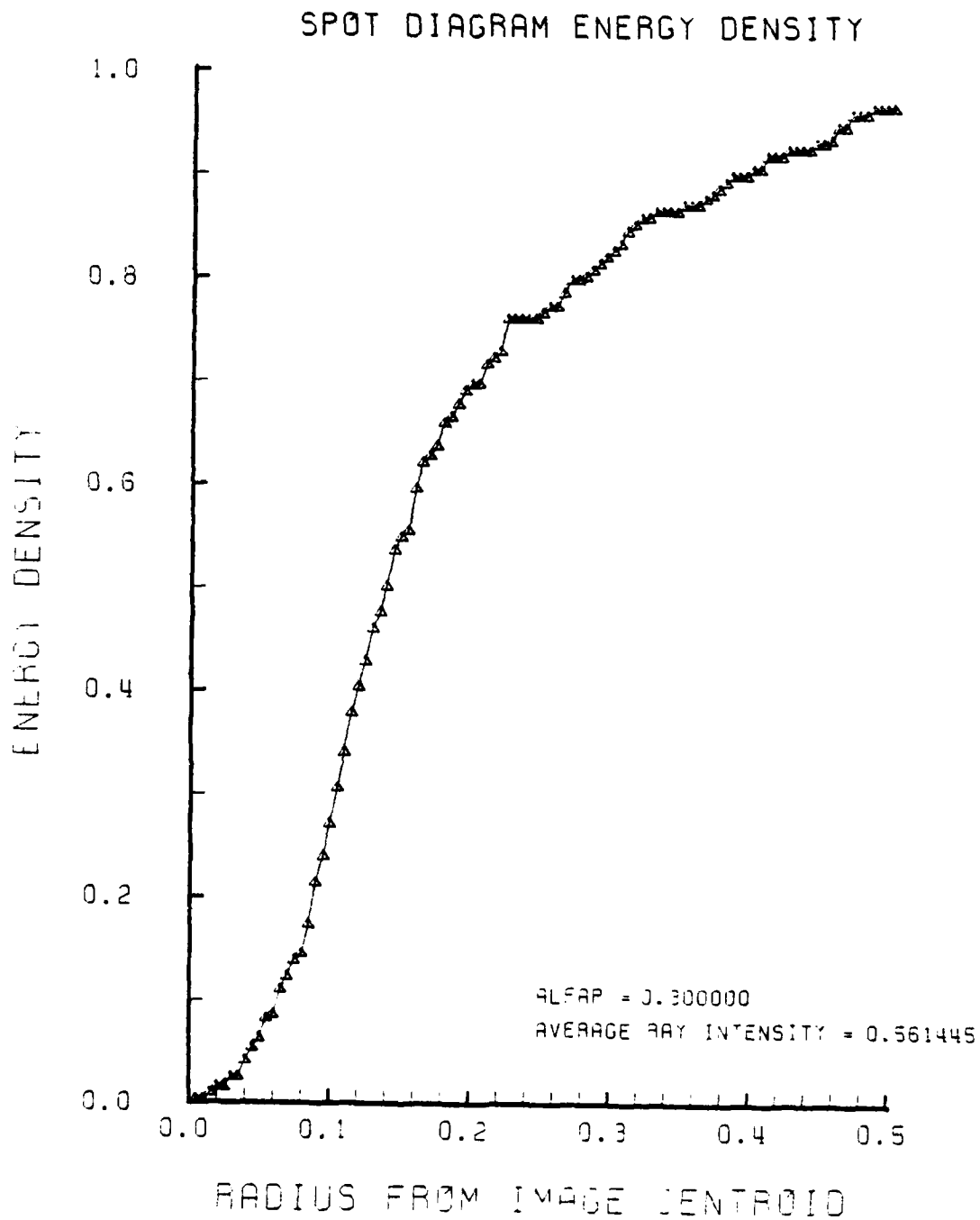

Figure F-68. Encircled Energy of Figure F-67

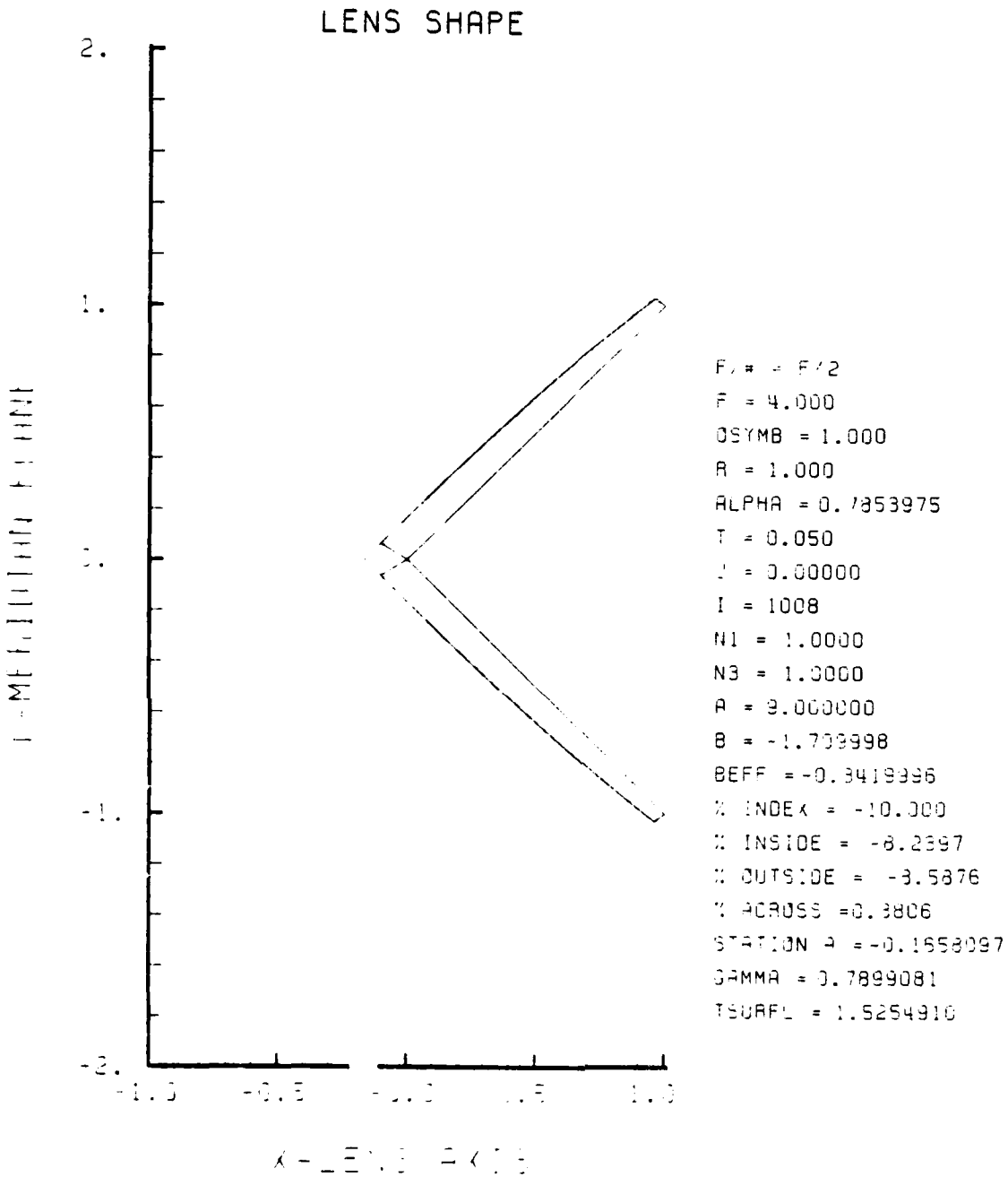

Figure F-69. GRIN Lens Shape at -10%, OB = 1.00,
a = 9.00

9

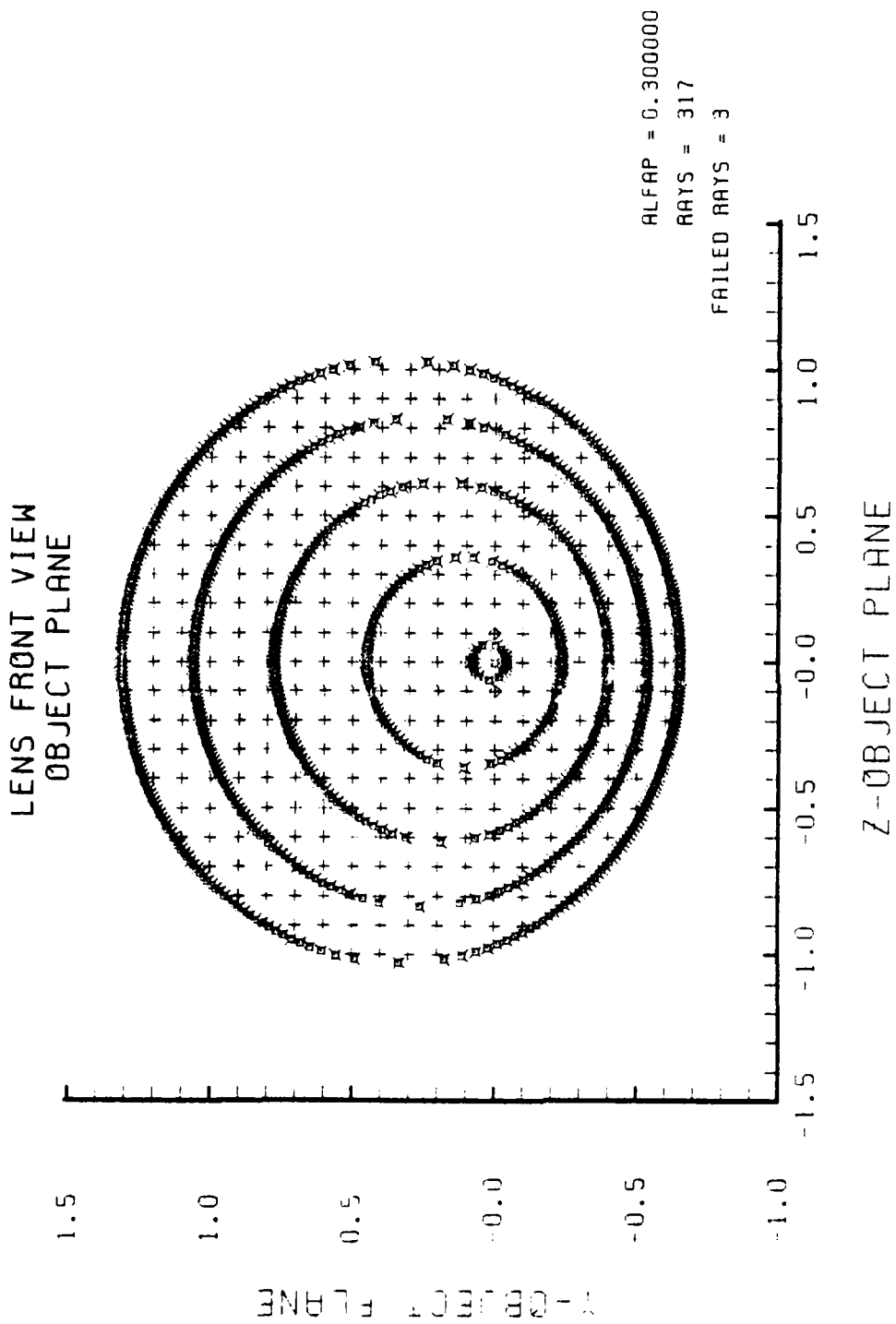

Figure F-70. Grid Plane at $\alpha_p = 0.3$ for Lens of Figure F-69

SPOT DIAGRAM

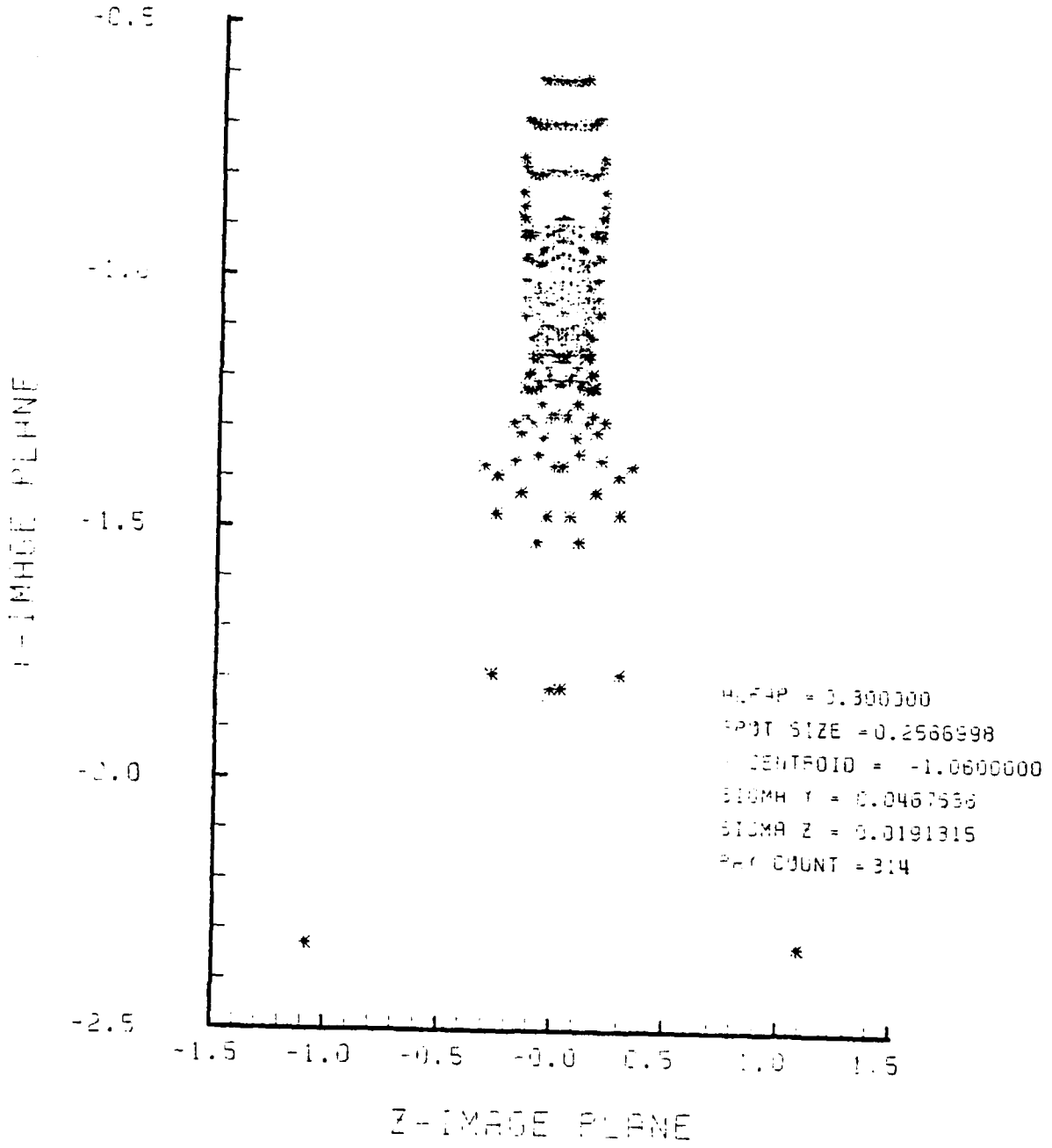

Figure F-71. Spot Diagram for Grid of Figure F-70

SPOT DIAGRAM ENERGY DENSITY

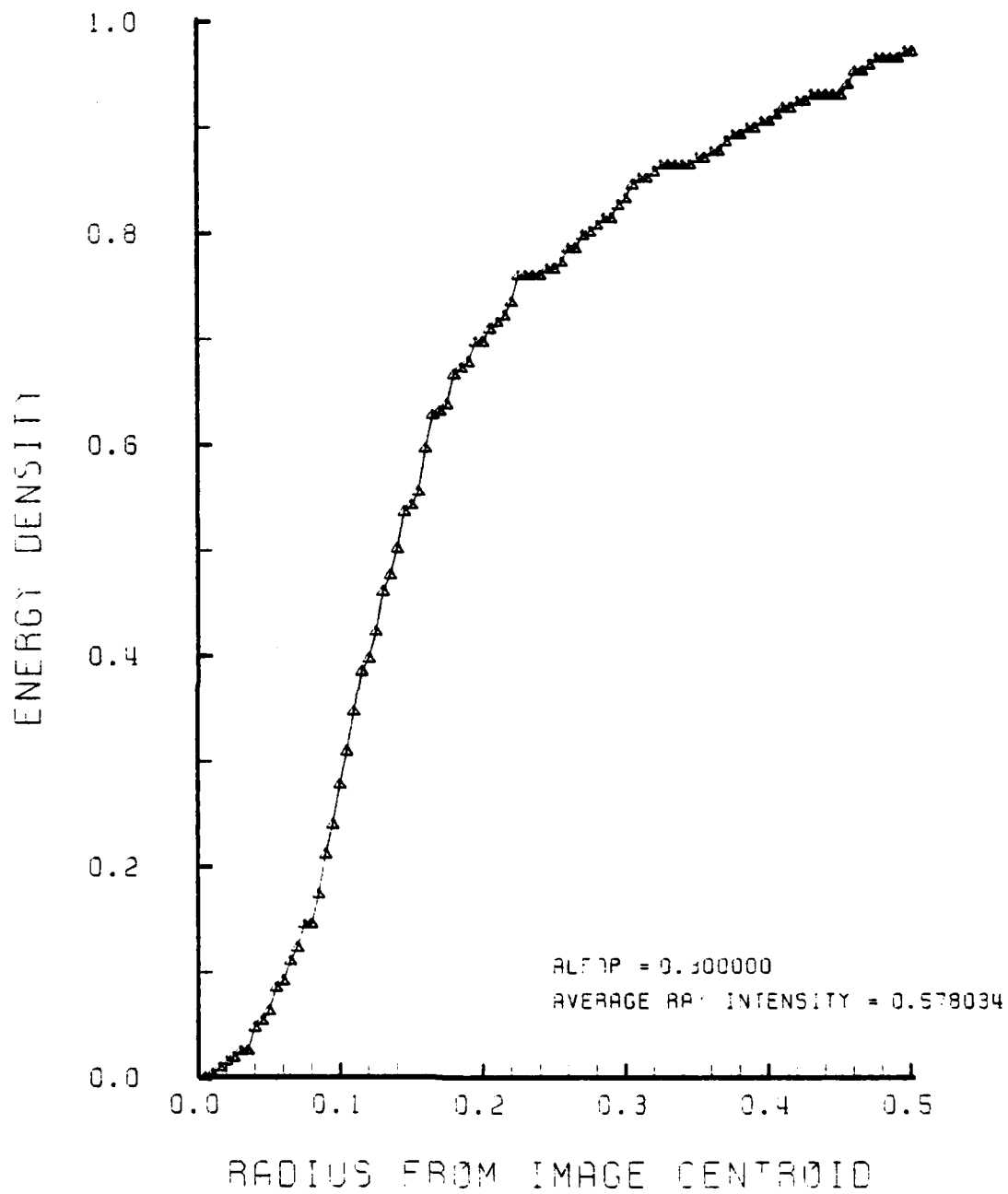

Figure F-72. Encircled Energy of Figure F-71

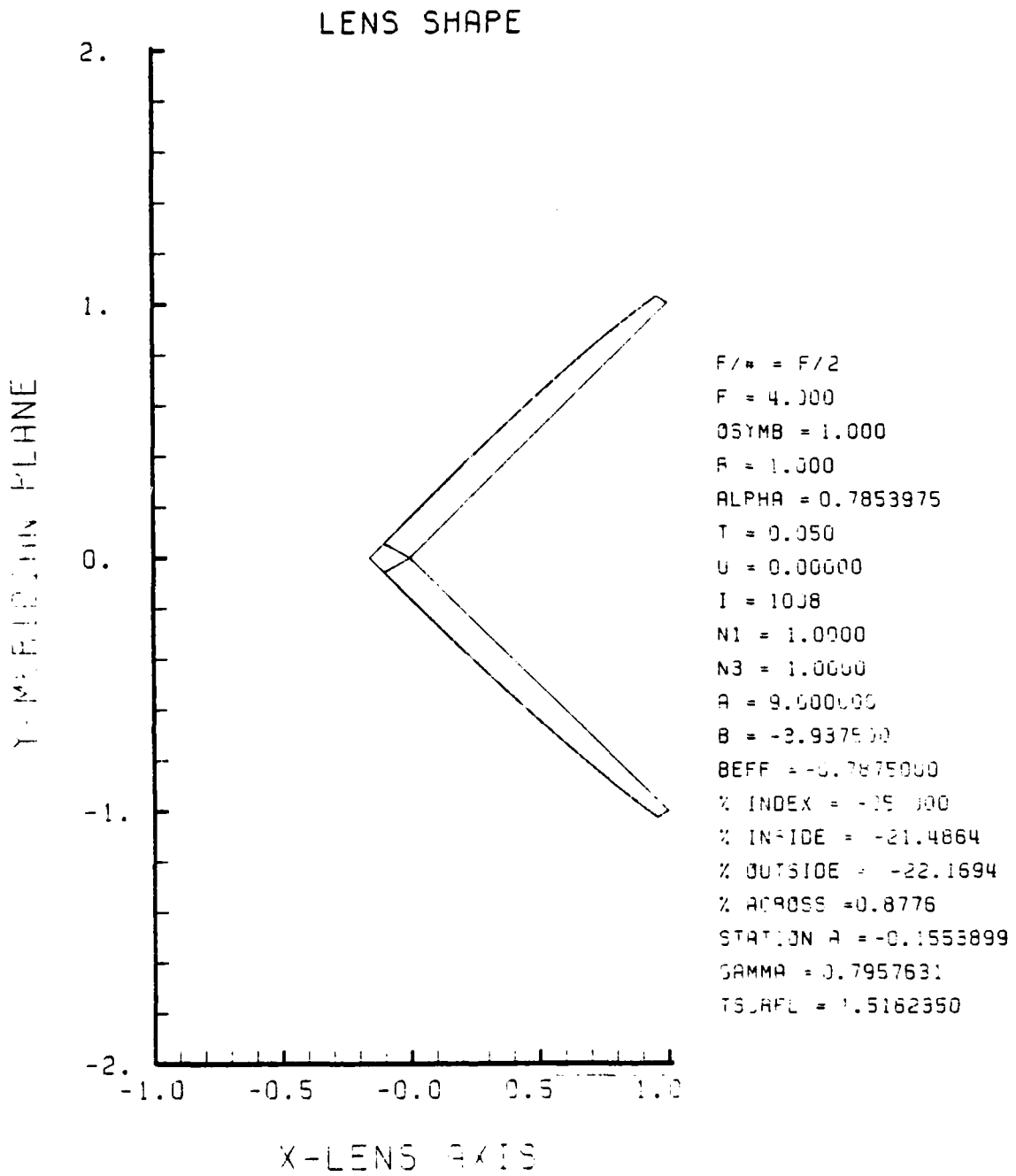

Figure F-73. GRIN Lens Shape at -25%, OB = 1.00,
a = 9.00

LENS FRONT VIEW
OBJECT PLANE

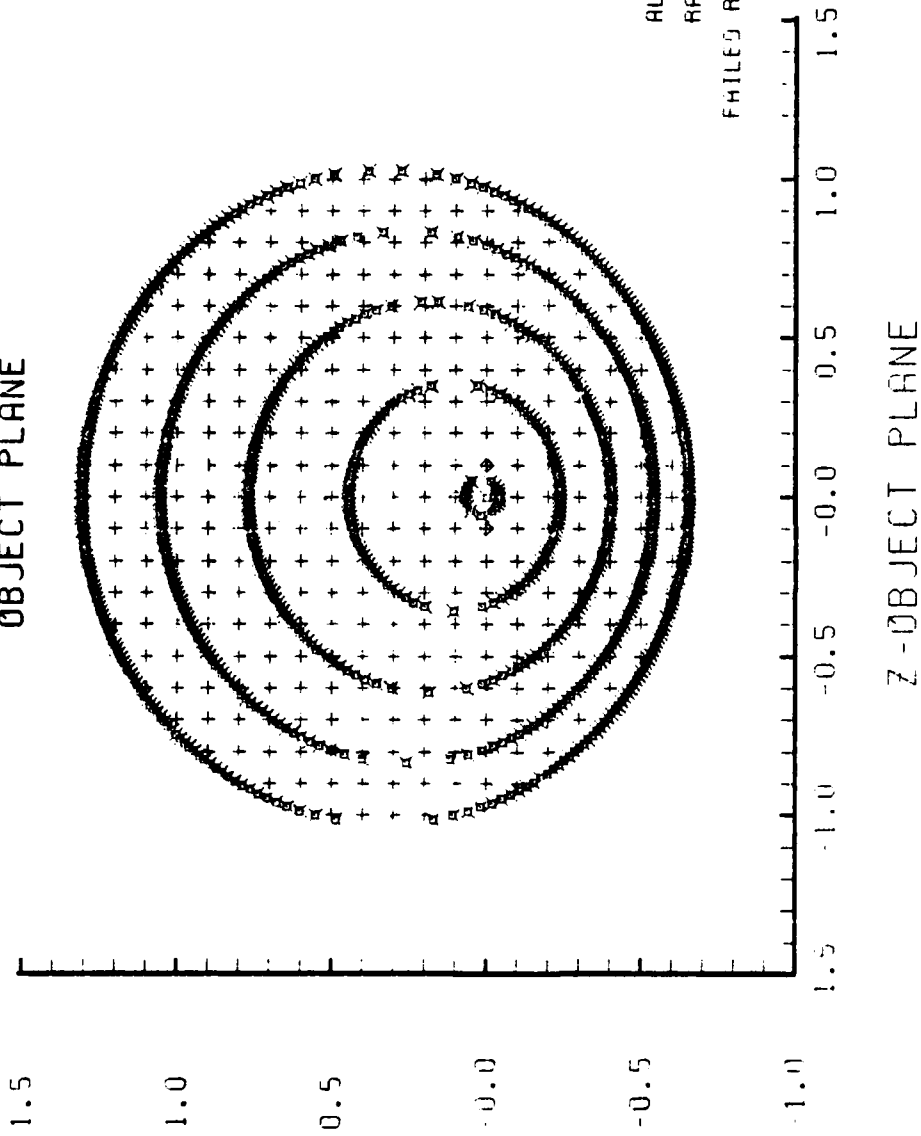

Figure F-74. Grid Plane at $\alpha_p = 0.3$ for Lens of Figure F-73

SPOT DIAGRAM

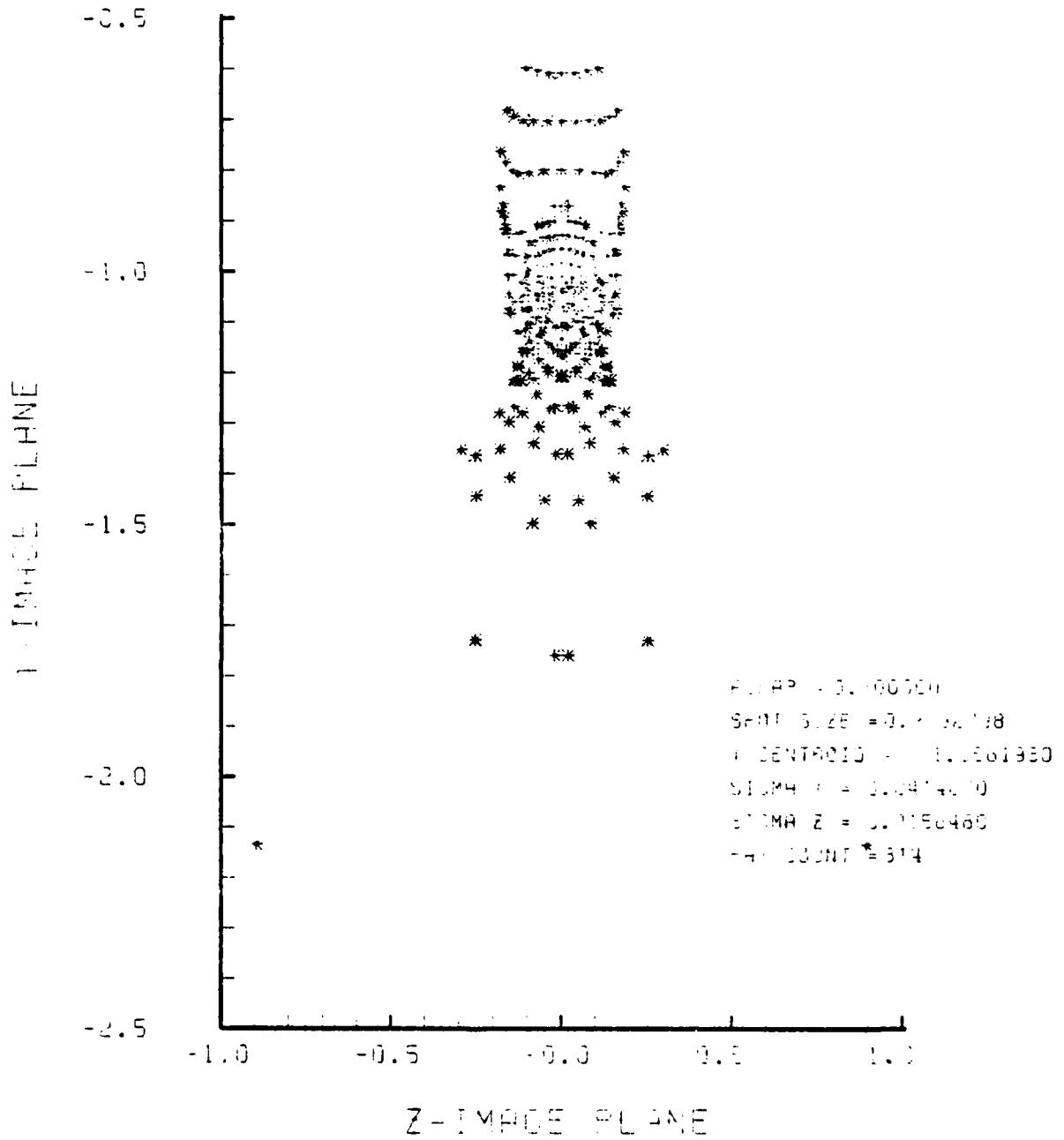

Figure F-75. Spot Diagram for Grid of Figure F-74

SPOT DIAGRAM ENERGY DENSITY

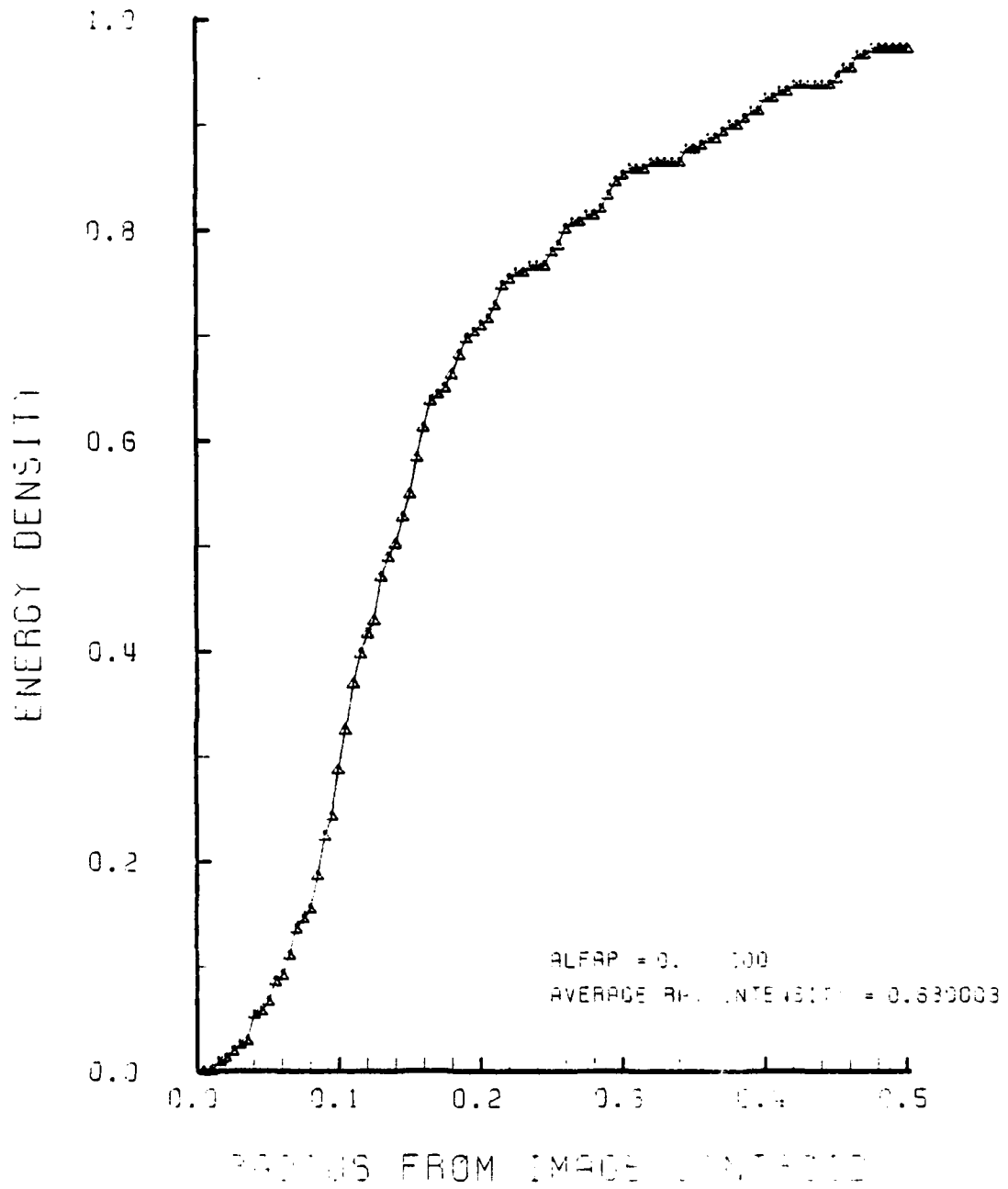

Figure F-76. Encircled Energy of Figure F-75

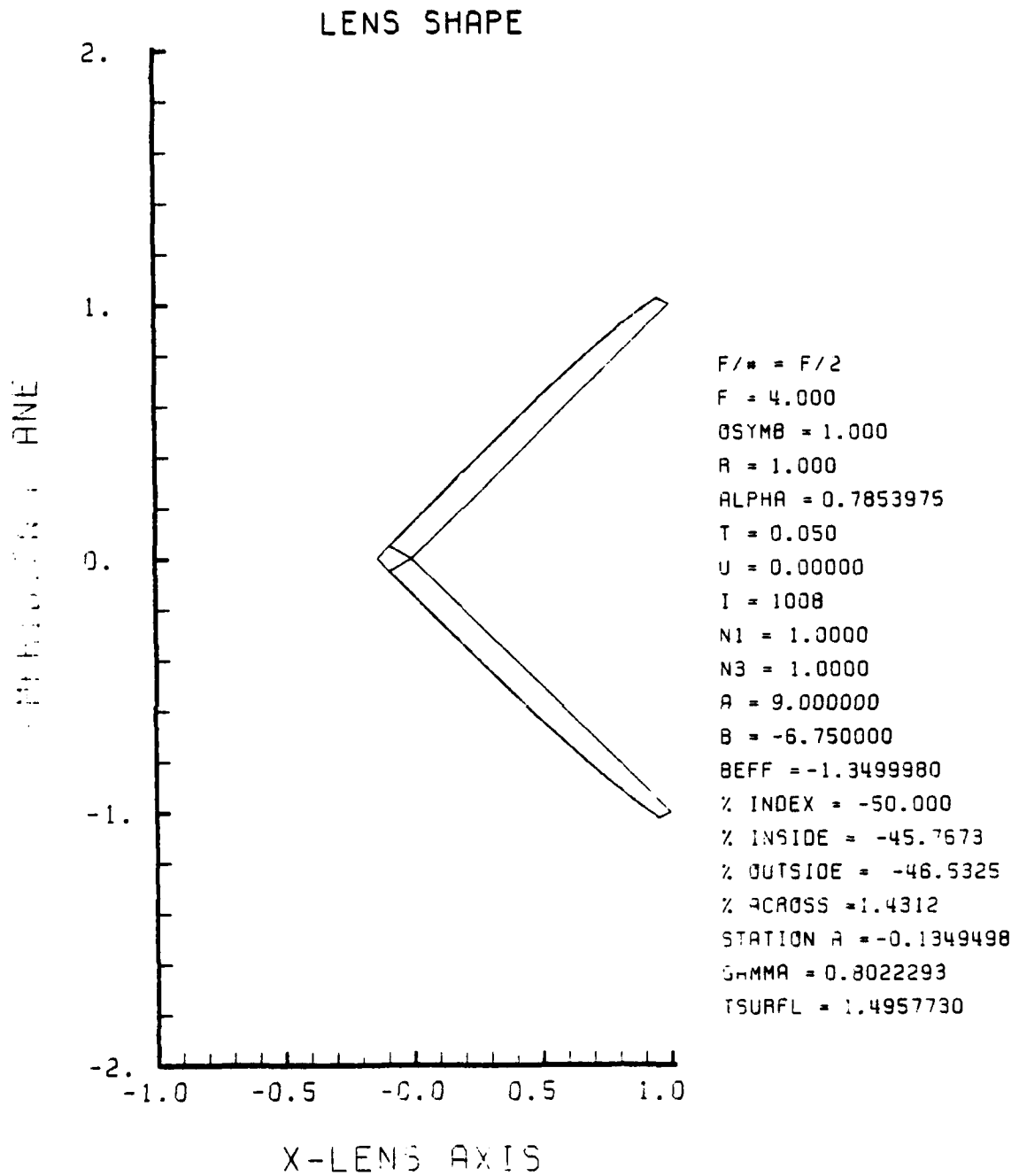

Figure F-77. GRIN Lens Shape at -50%, OB = 1.00,
a = 9.00

LENS FRONT VIEW
OBJECT PLANE

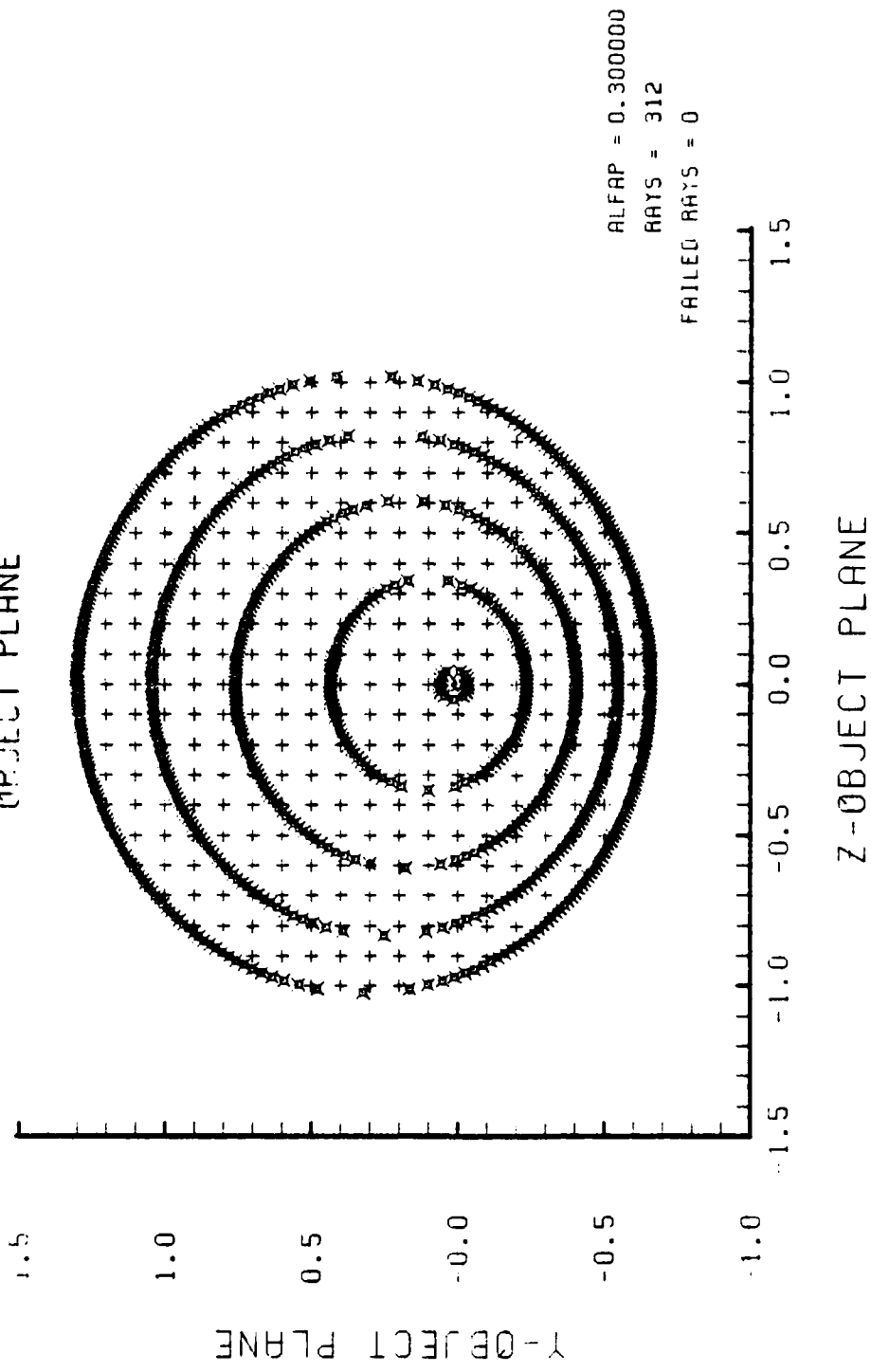

Figure F-78. Grid Plane at $\alpha_p = 0.3$ for Lens of Figure F-77

SPOT DIAGRAM

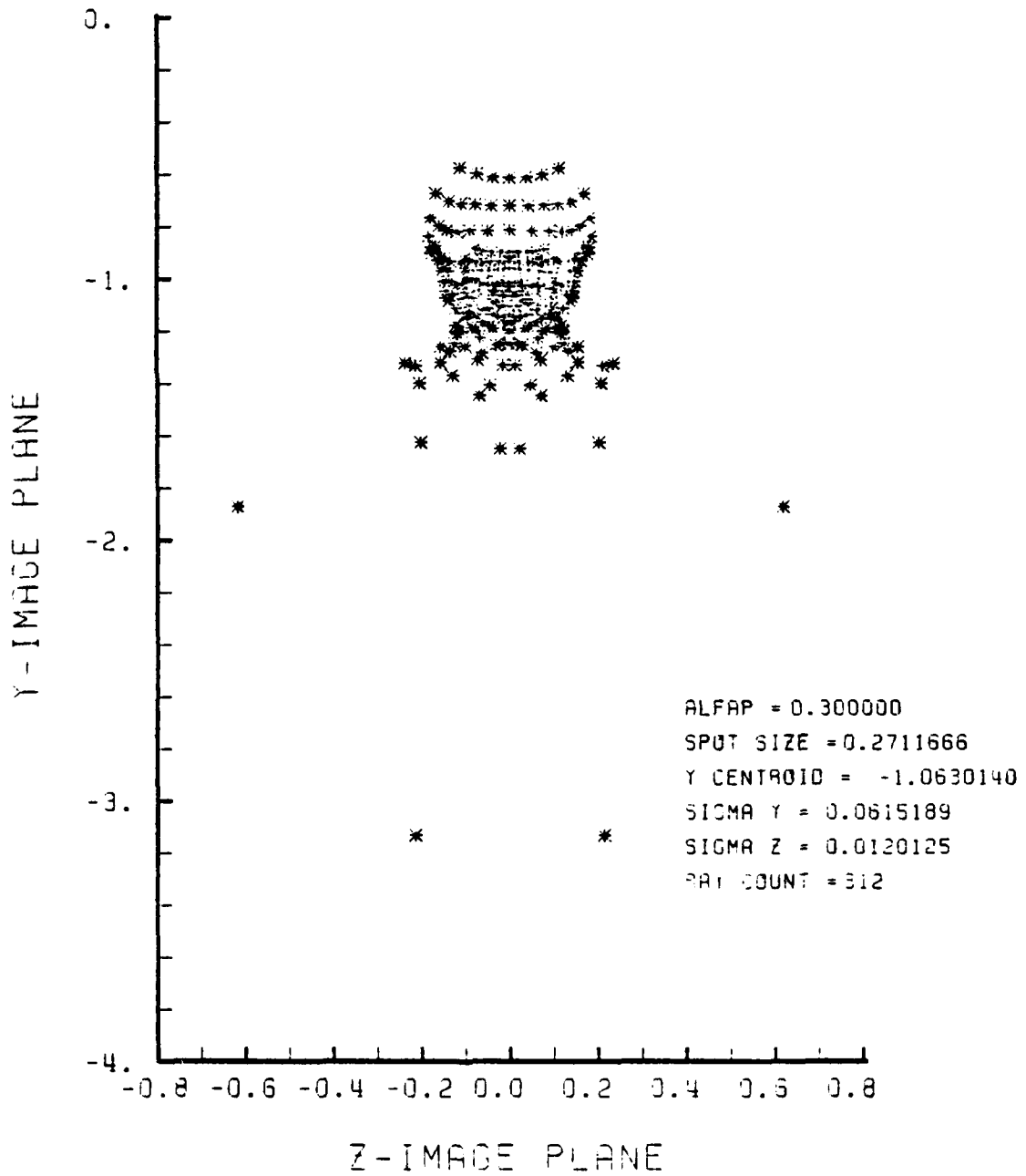

Figure F-79. Spot Diagram for Grid of Figure F-78

SPOT DIAGRAM ENERGY DENSITY

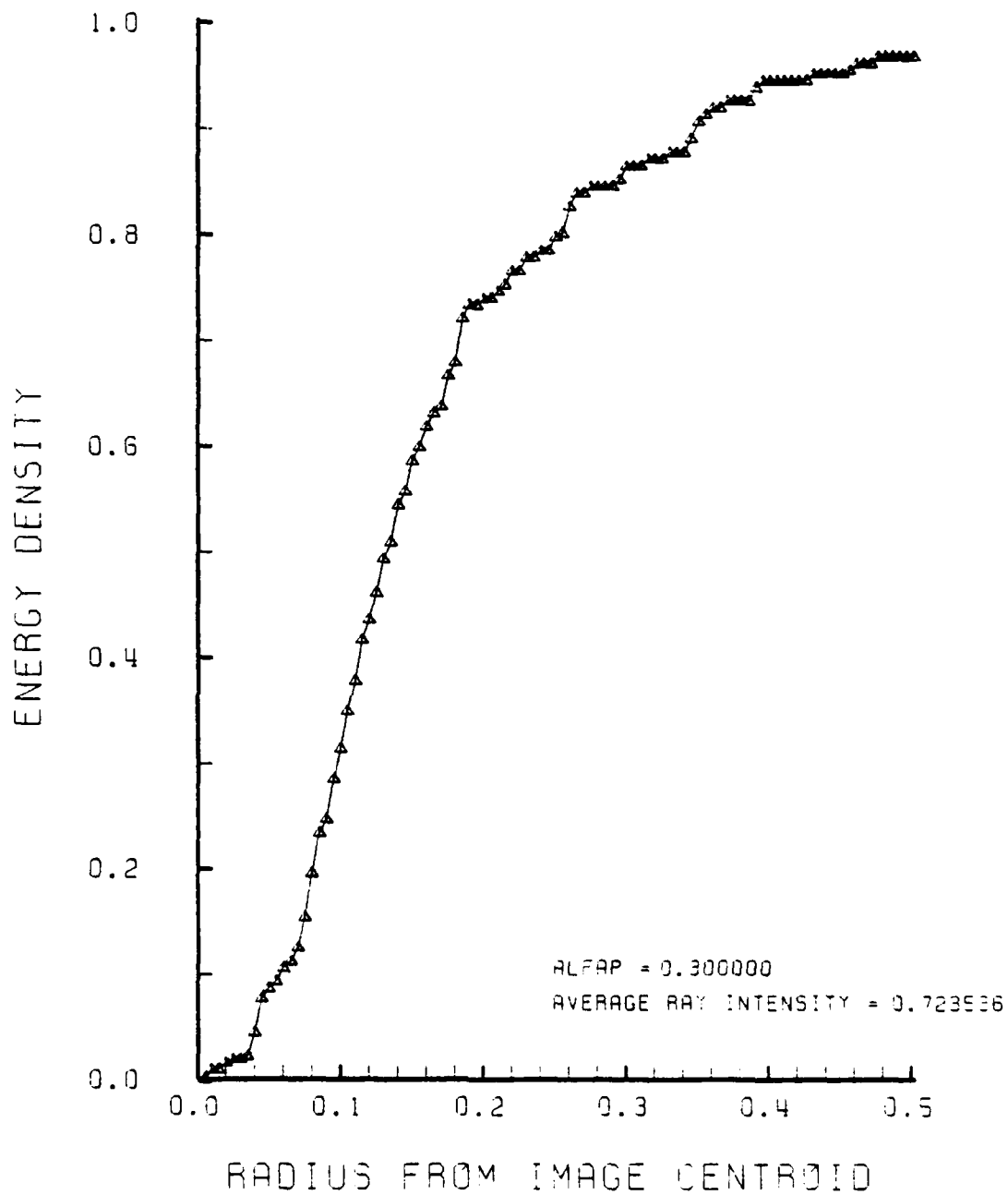
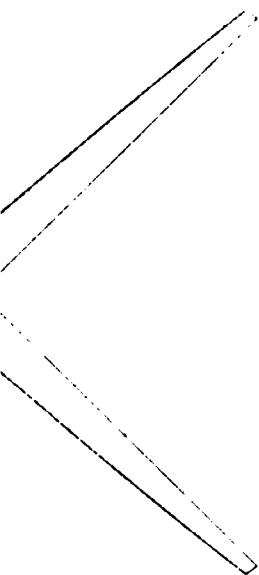
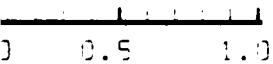

Figure F-80. Encircled Energy of Figure F-79

SHAPE



$F/\# = F/2$
 $F = 4.000$
 $OSYMB = 1.000$
 $R = 1.000$
 $ALPHA = 0.7853975$
 $T = 0.050$
 $U = 0.00000$
 $I = 1003$
 $N1 = 1.0000$
 $N3 = 1.0000$
 $A = 9.000000$
 $B = 0.922499$
 $SEFF = 0.1844997$
 $\% \text{ INDEX} = 5.000$
 $\% \text{ INSIDE} = 3.9400$
 $\% \text{ OUTSIDE} = 4.2300$
 $\% \text{ ACROSS} = -0.2782$
 $\text{STATION A} = -0.2505797$
 $\text{GAMMA} = 0.7319943$
 $\text{TSURFL} = 1.5899390$



AXIS

ns Shape at +5%, OB = 1.00,

0

LENS FRONT VIEW
OBJECT PLANE

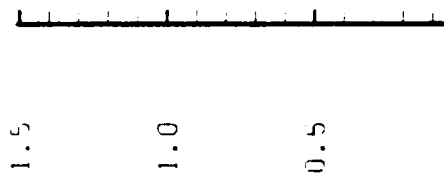
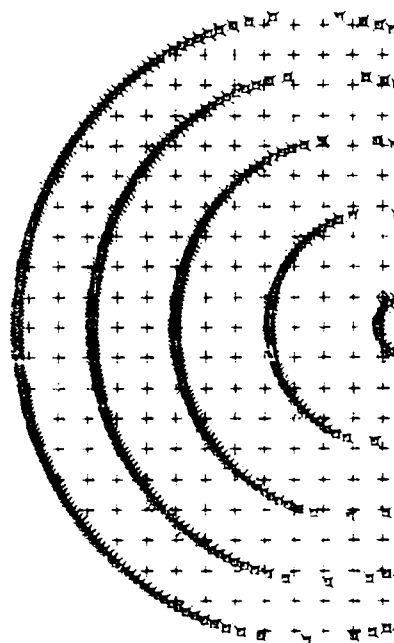

ECC. PLANE

Z-OBJECT PLANE

Figure F-82. Grid Plane at $\alpha_p = 0.3$ for Lens o

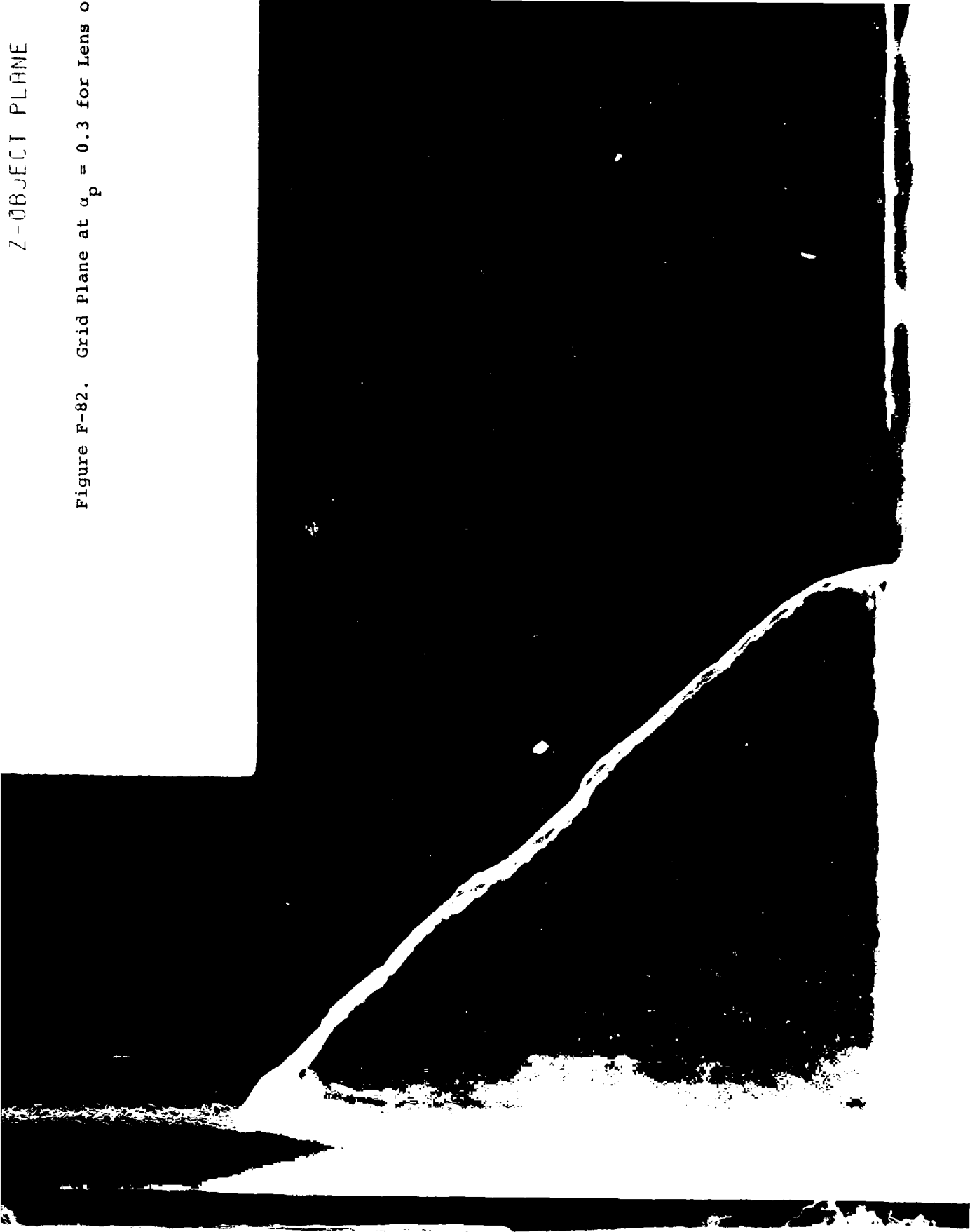

AD-A125 167

AERODYNAMICALLY EFFICIENT GRADIENT REFRACTIVE INDEX
MISSILE SEEKER LENS(U) NAVAL POSTGRADUATE SCHOOL
MONTEREY CA H M CARR OCT 82 NPS67-82-812

5/6

UNCLASSIFIED

.F/G 16/4

NL

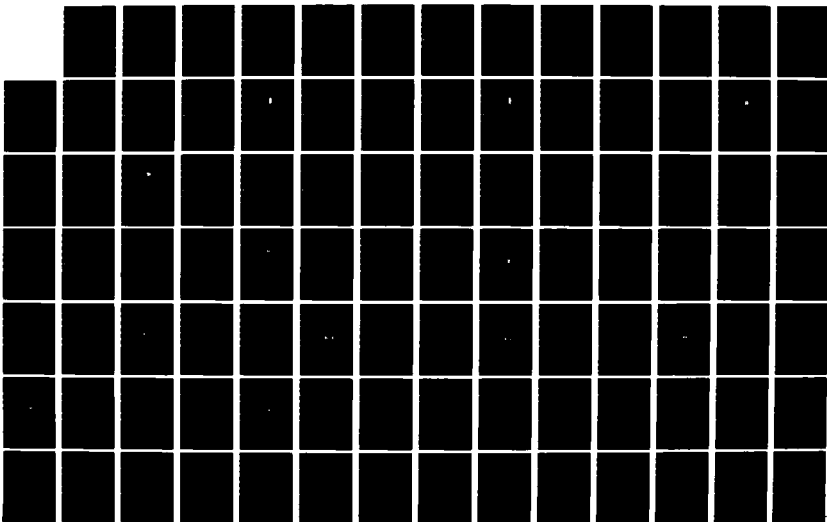

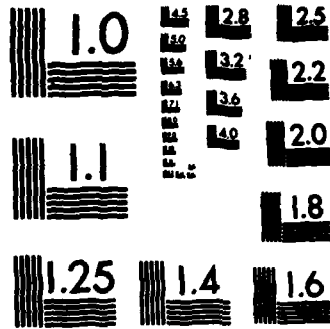

MICROCOPY RESOLUTION TEST CHART
NATIONAL BUREAU OF STANDARDS-1963-A

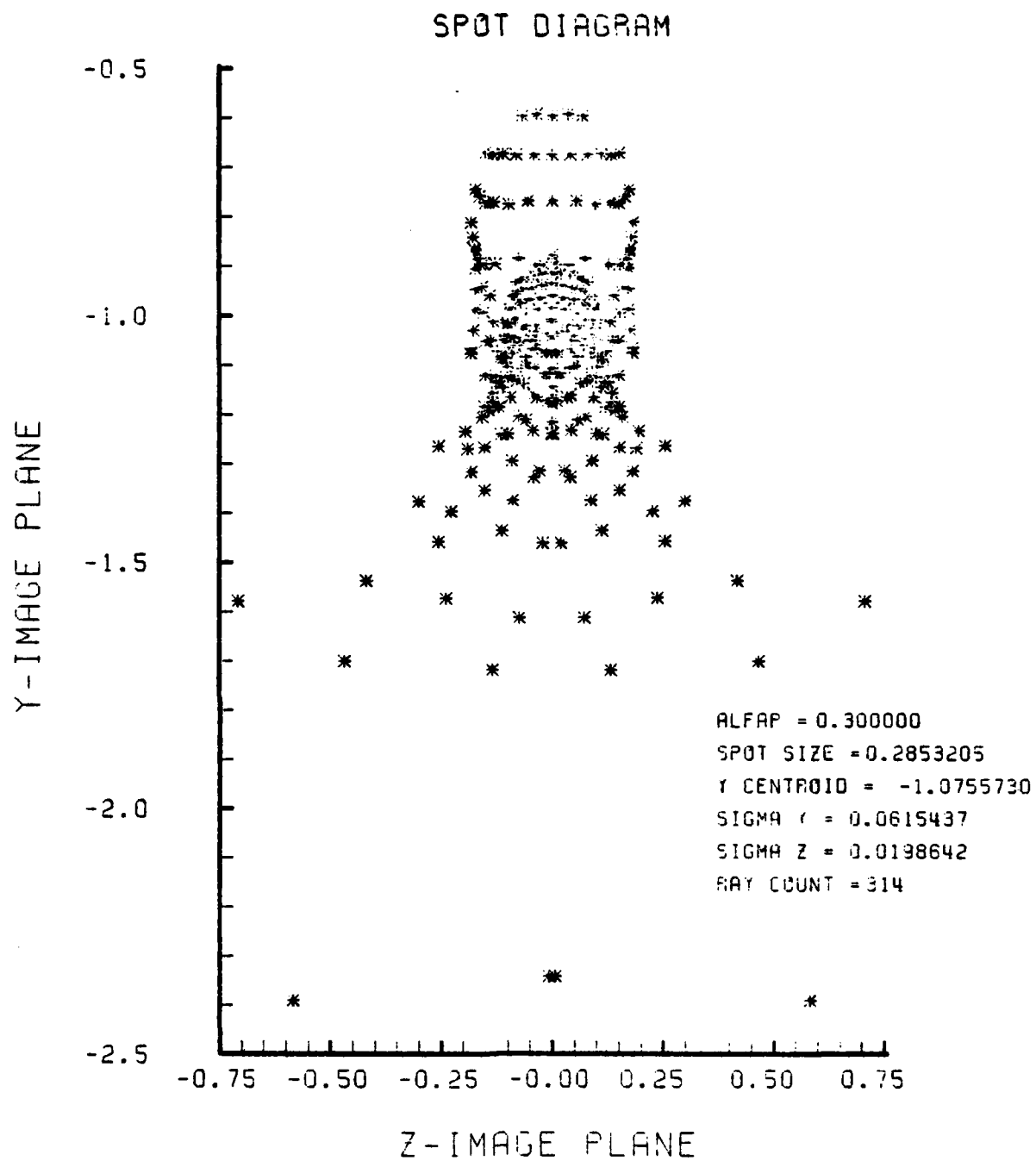

Figure F-83. Spot Diagram for Grid of Figure F-82

SPOT DIAGRAM ENERGY DENSITY

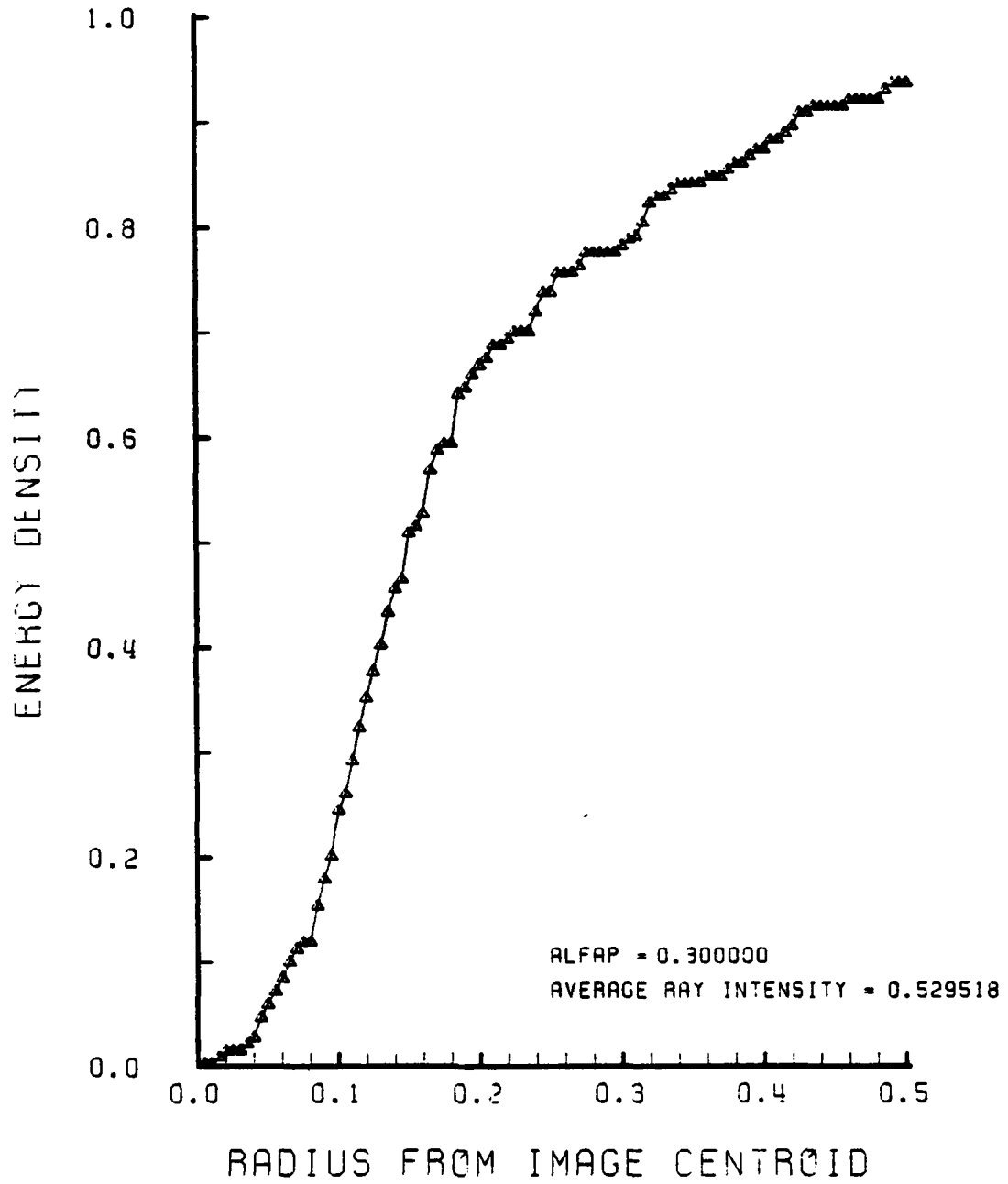

Figure F-84. Encircled Energy of Figure F-83

LENS SHAPE

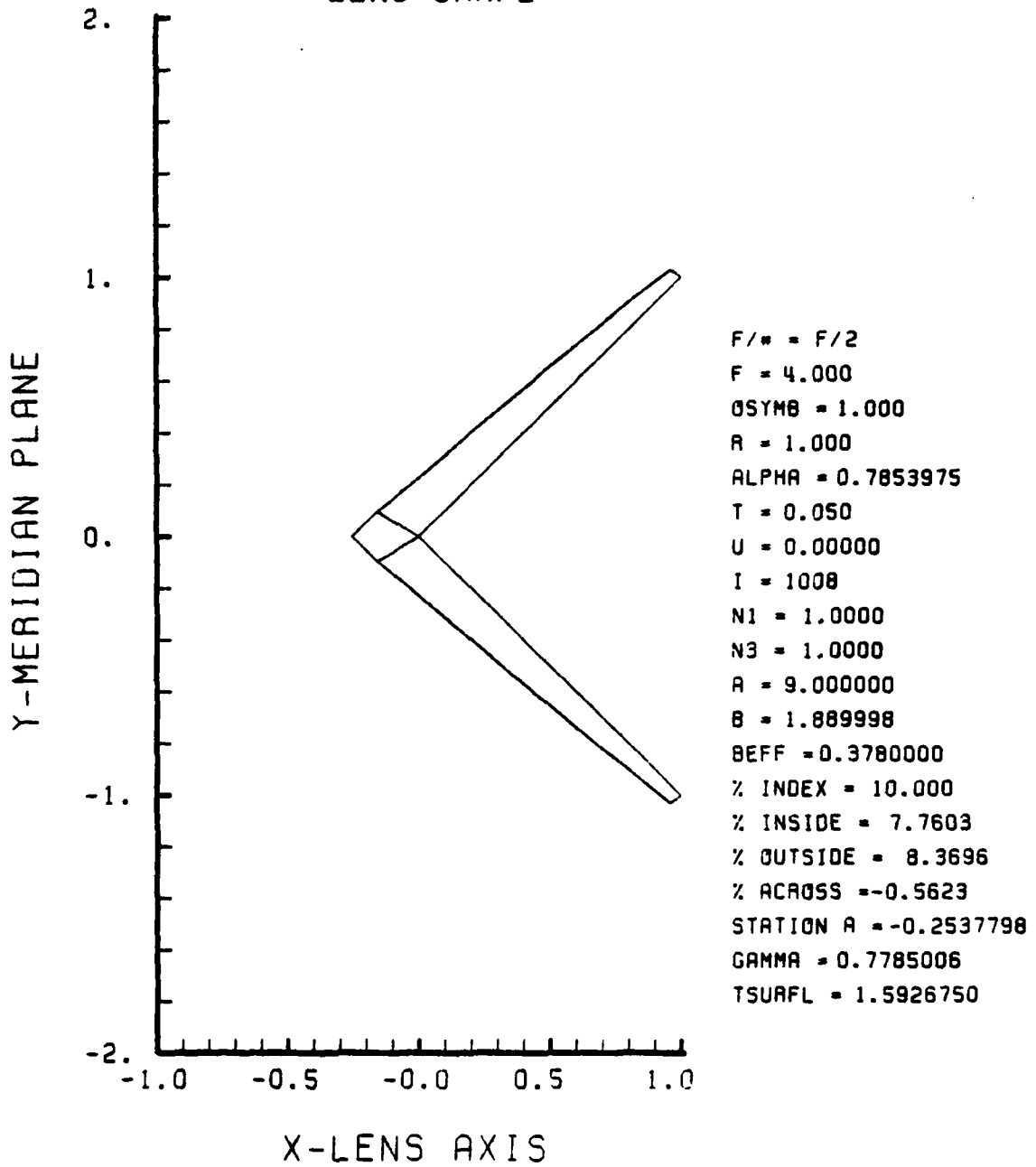

Figure F-85. GRIN Lens Shape at +10%, OB = 1.00,
a = 9.00

LENS FRONT VIEW
OBJECT PLANE

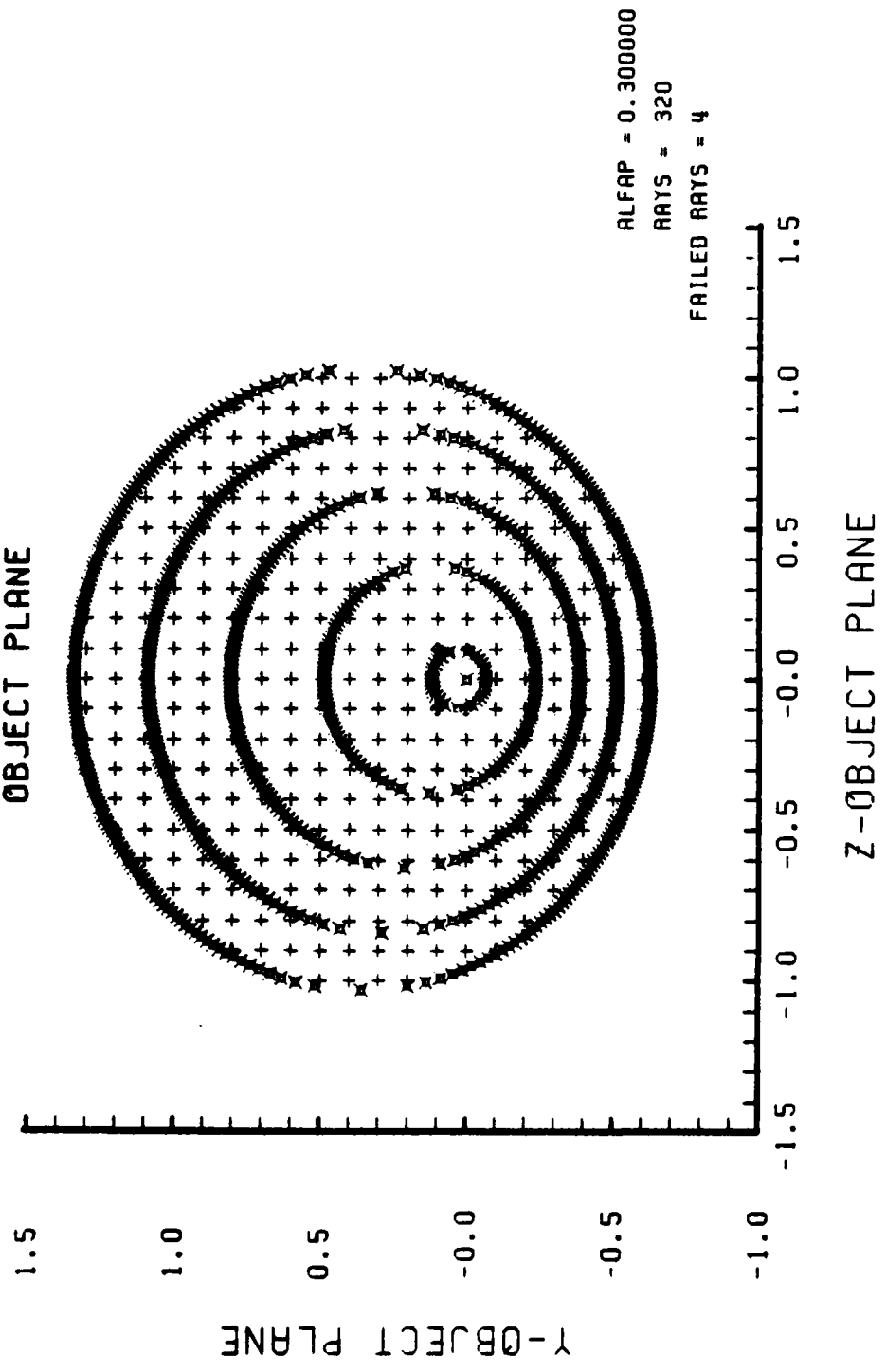

Figure F-86. Grid Plane at $\alpha_p = 0.3$ for Lens of Figure F-85

SPOT DIAGRAM

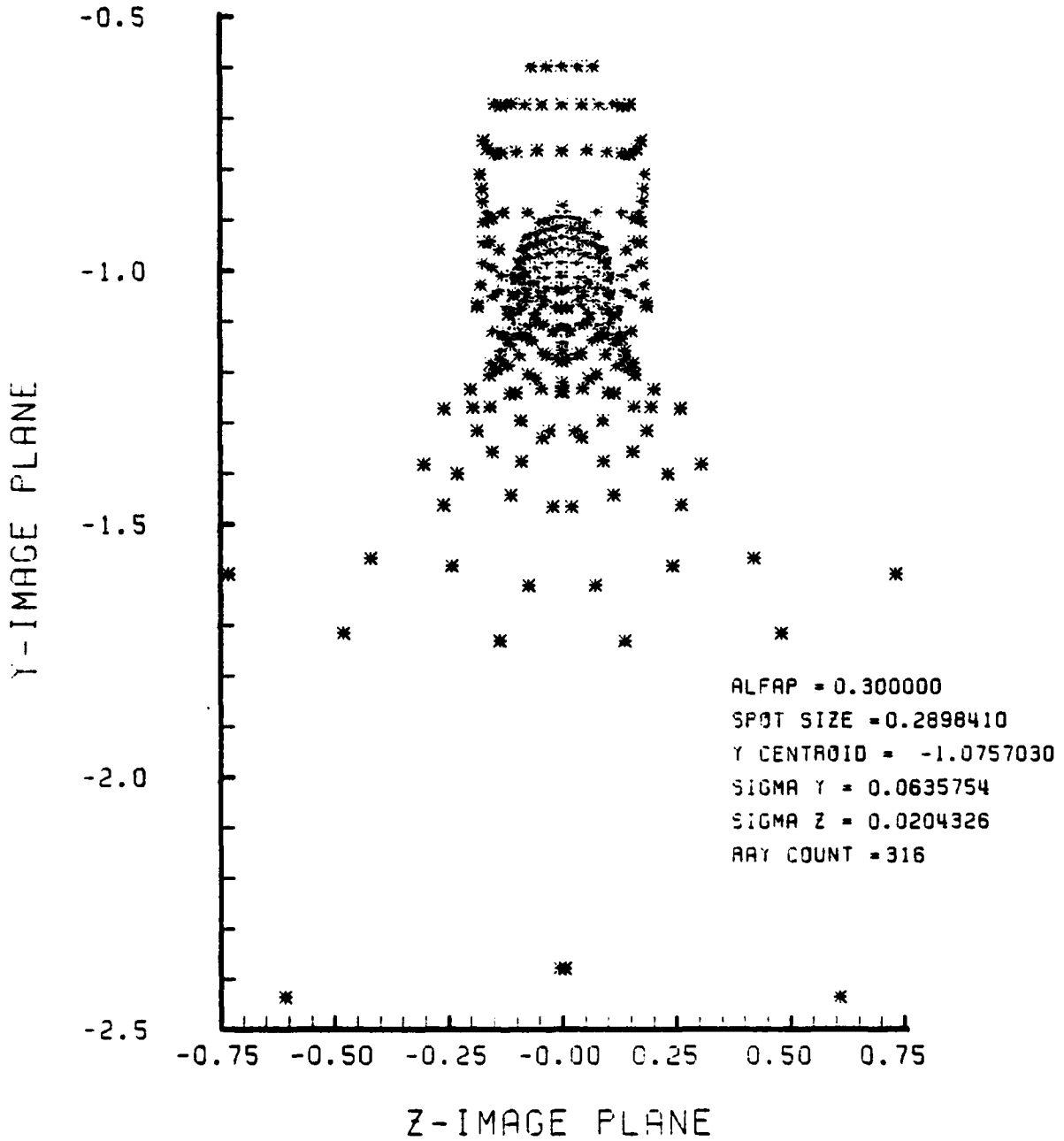

Figure F-87. Spot Diagram for Grid of Figure F-86

SPOT DIAGRAM ENERGY DENSITY

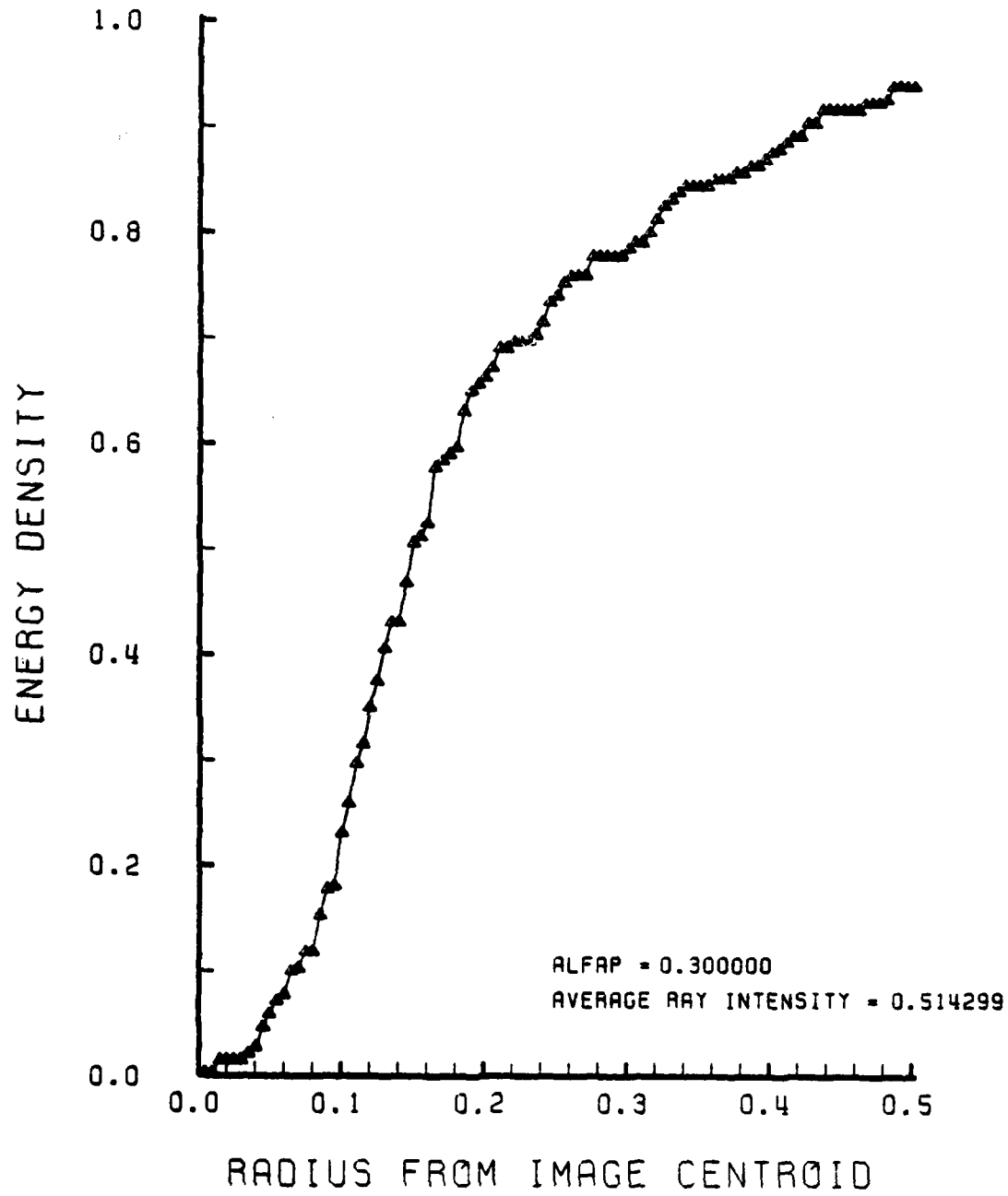

Figure F-88. Encircled Energy of Figure F-87

LENS SHAPE

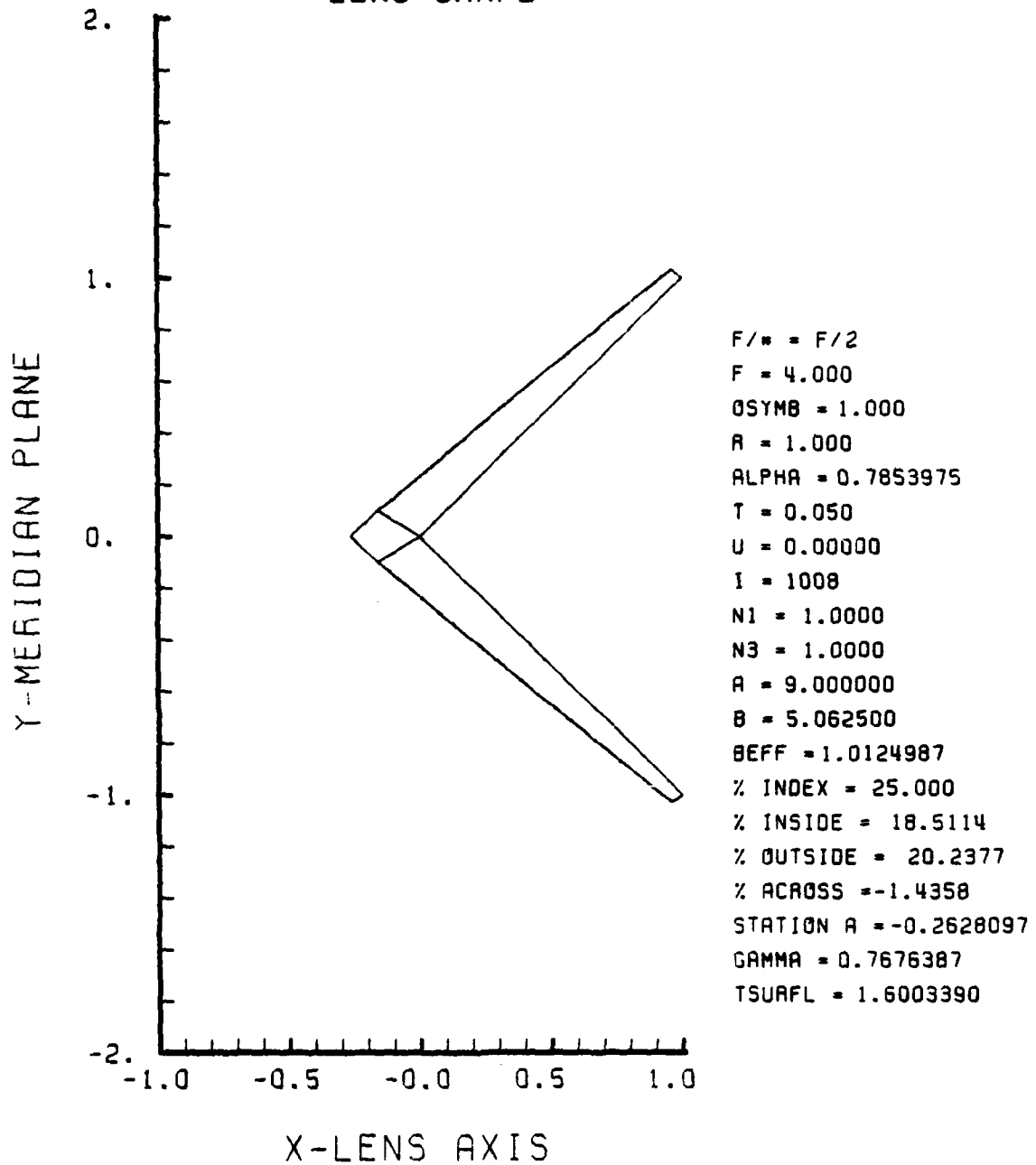

Figure F-89. GRIN Lens Shape at +25%, OB = 1.00,
a = 9.00

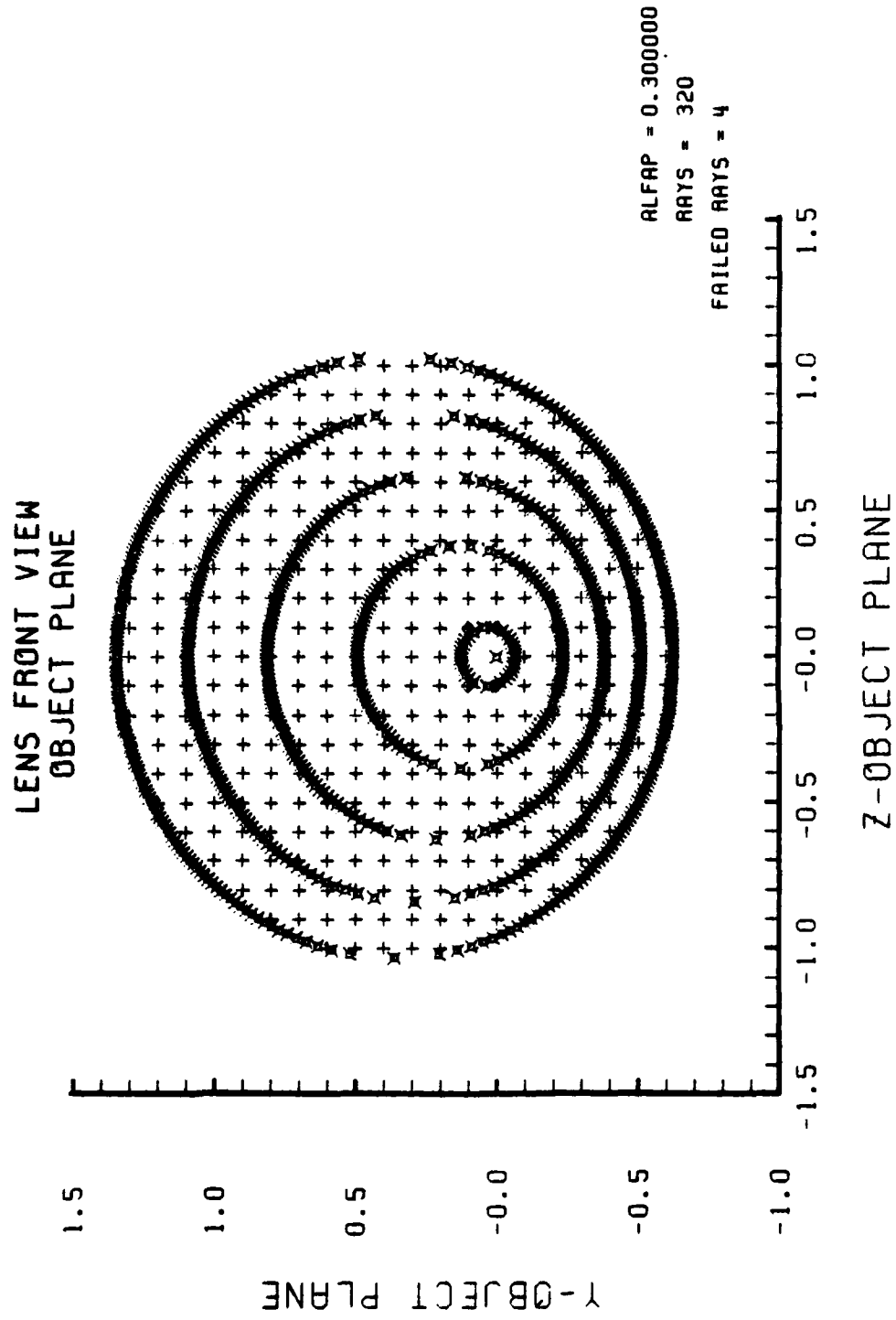

Figure F-90. Grid Plane at $\alpha_p = 0.3$ for Lens of Figure F-89

SPOT DIAGRAM

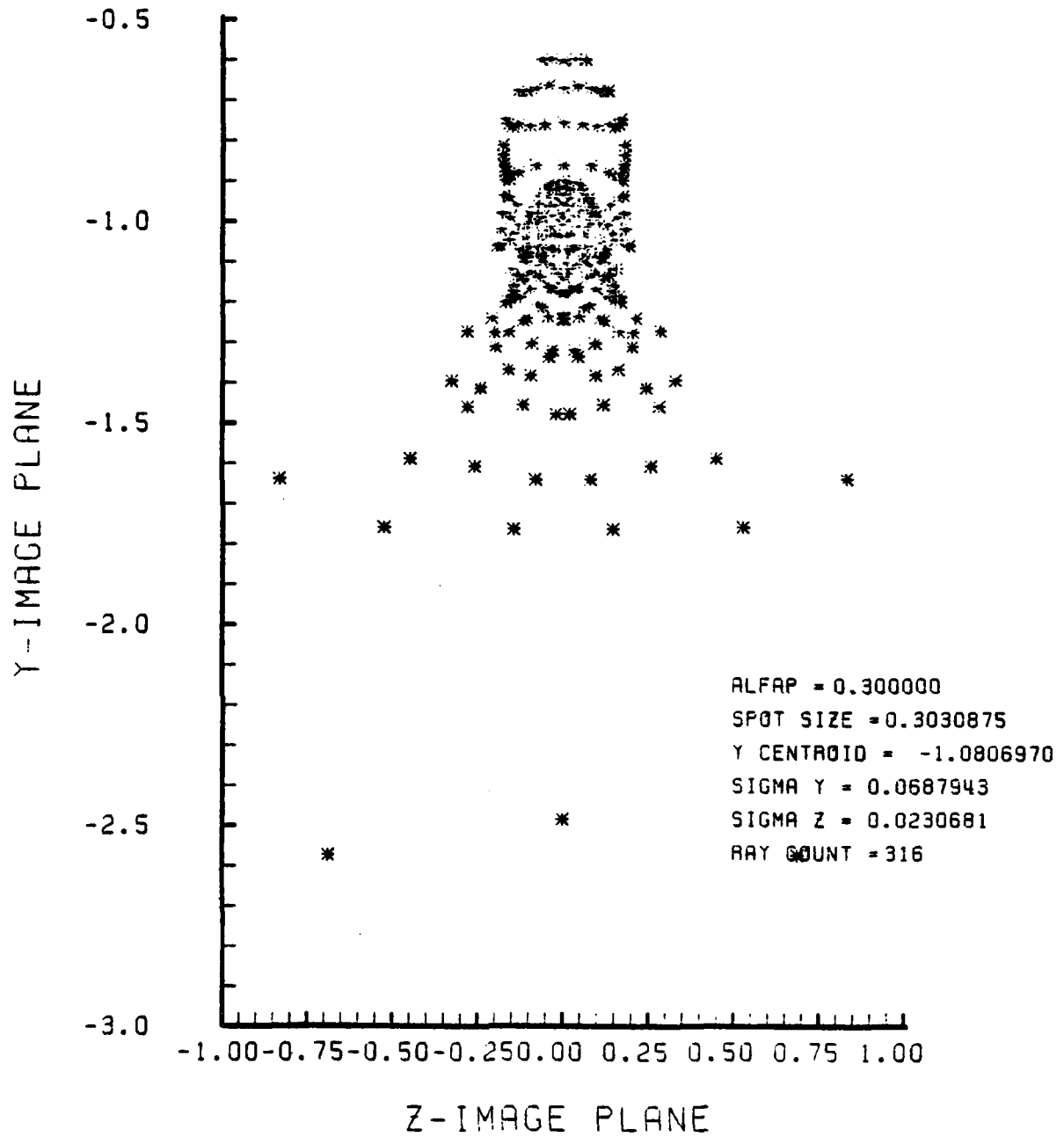

Figure F-91. Spot Diagram for Grid of Figure F-90

SPOT DIAGRAM ENERGY DENSITY

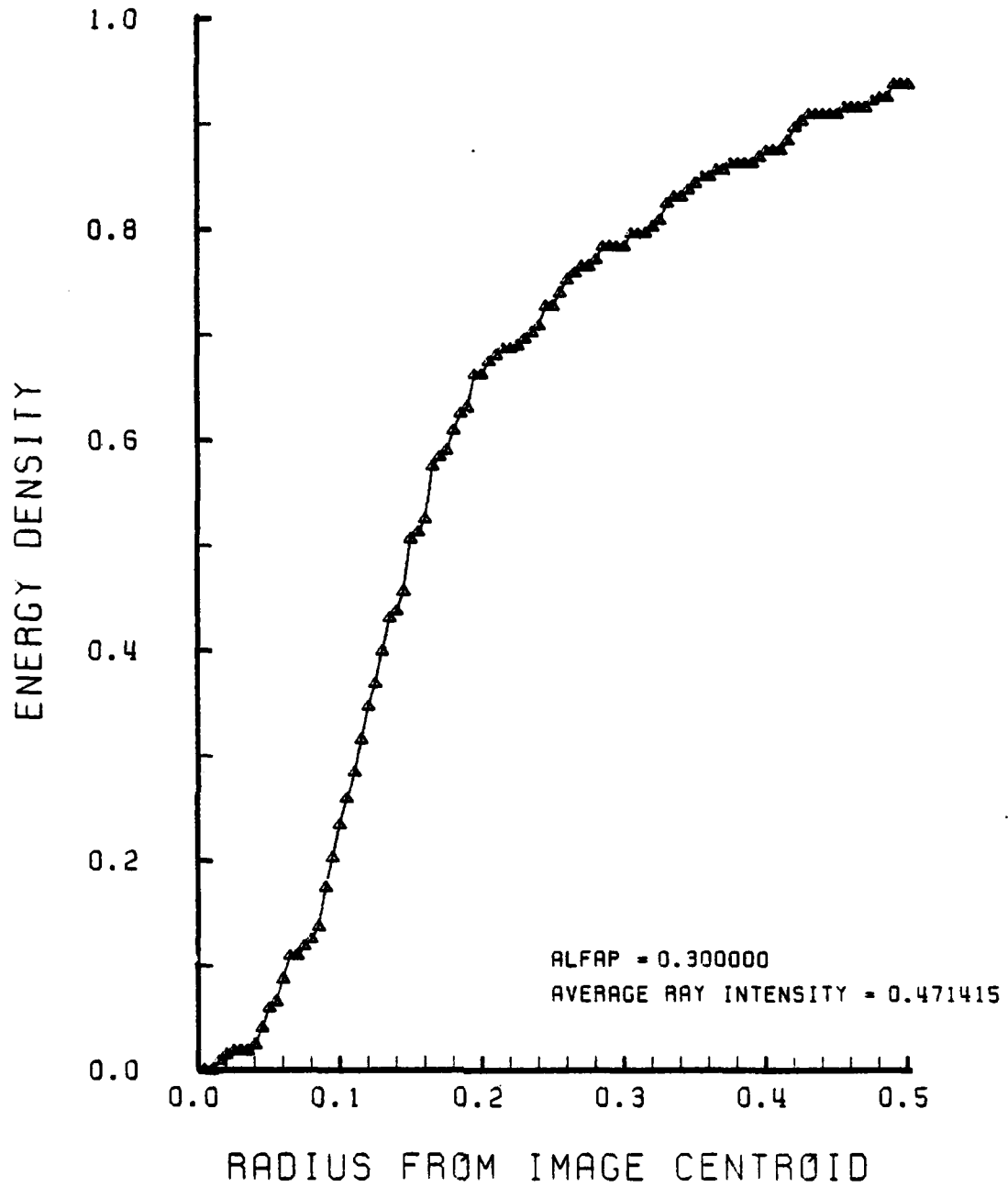
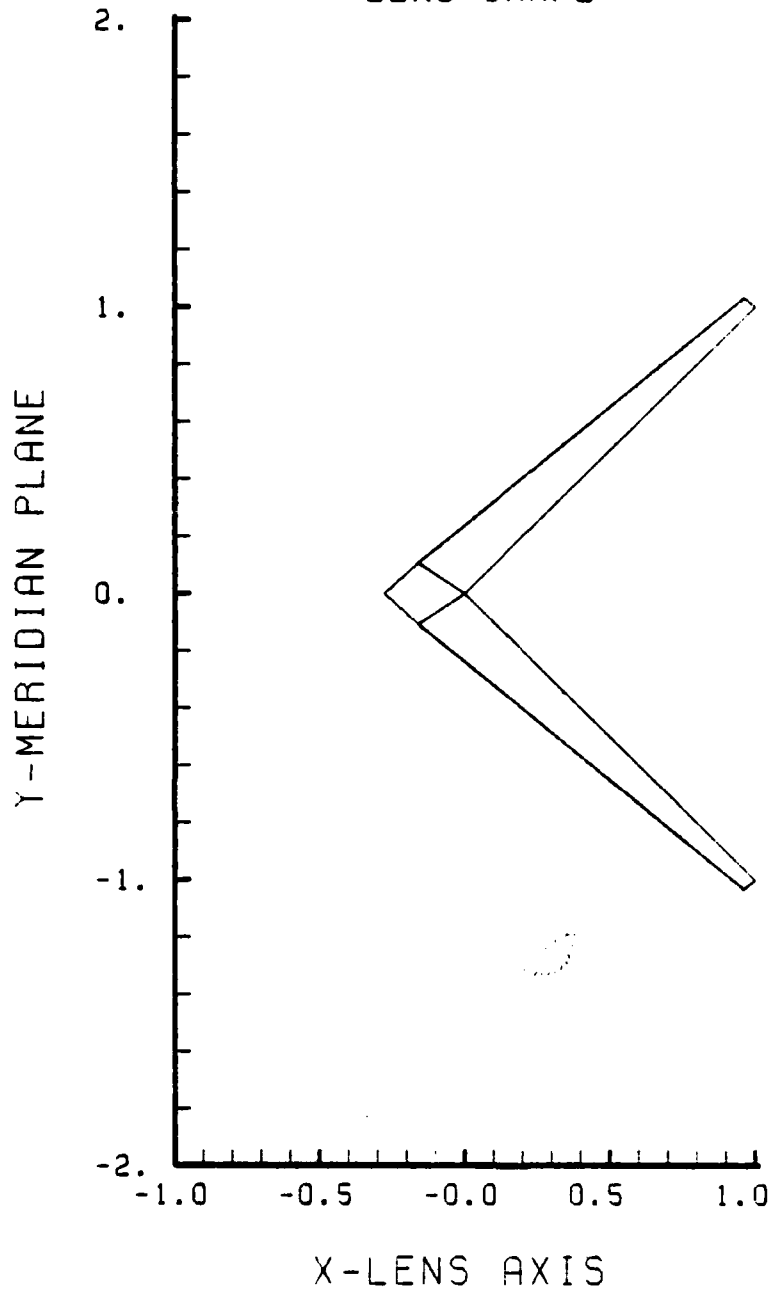

Figure F-92. Encircled Energy of Figure F-91

LENS SHAPE



F/* = F/2
F = 4.000
OSYMB = 1.000
R = 1.000
ALPHA = 0.7853975
T = 0.050
U = 0.0J000
I = 1008
N1 = 1.0000
N3 = 1.0000
A = 9.000000
B = 11.250000
BEFF = 2.2500000
% INDEX = 50.000
% INSIDE = 34.1640
% OUTSIDE = 38.1665
% ACROSS = -2.8969
STATION A = -0.2761996
GAMMA = 0.7490406
TSURFL = 1.6115560

Figure F-93. GRIN Lens Shape at +50%, OB = 1.00,
a = 9.00

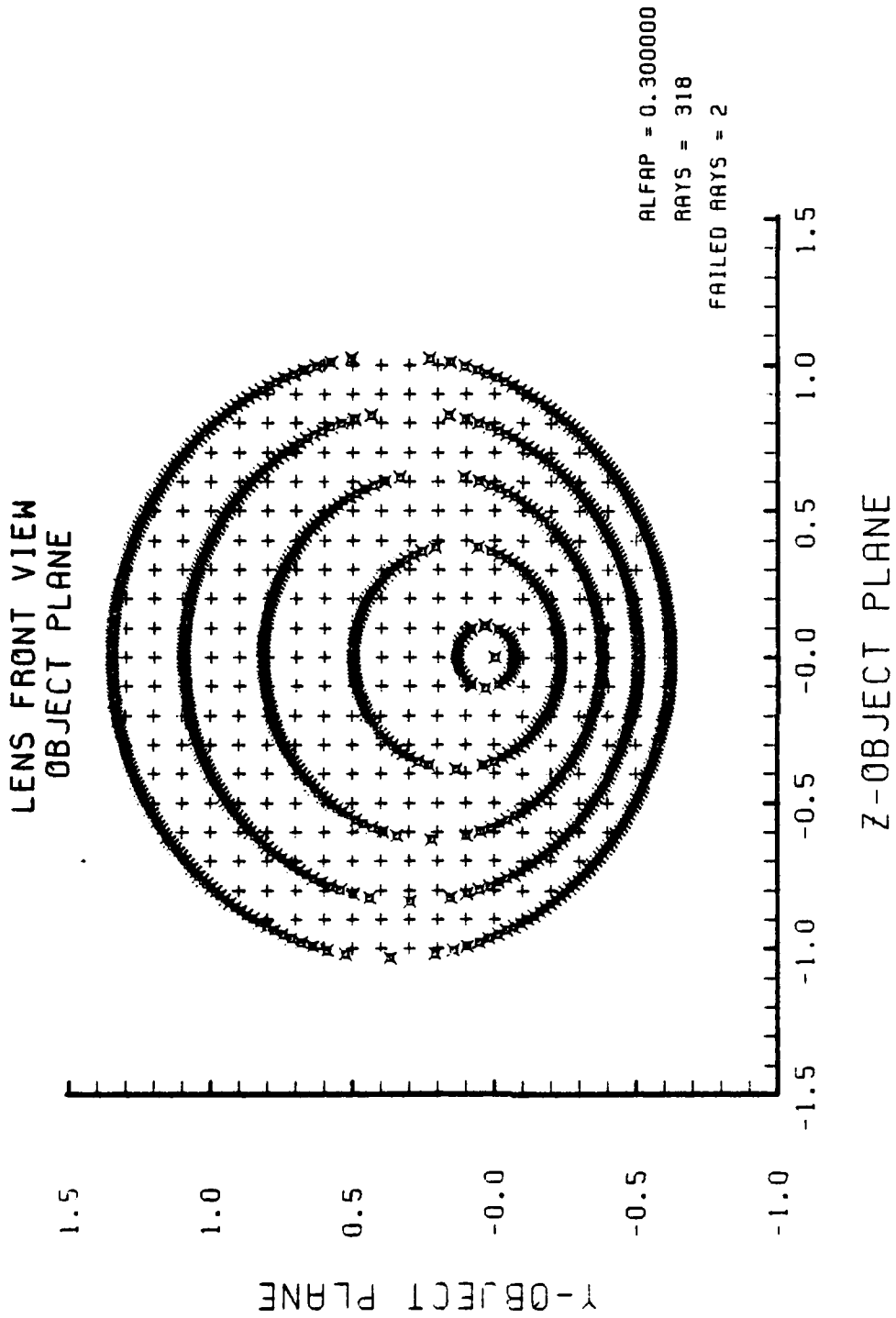

Figure F-94. Grid Plane at $\alpha_p = 0.3$ for Lens of Figure F-93

SPOT DIAGRAM

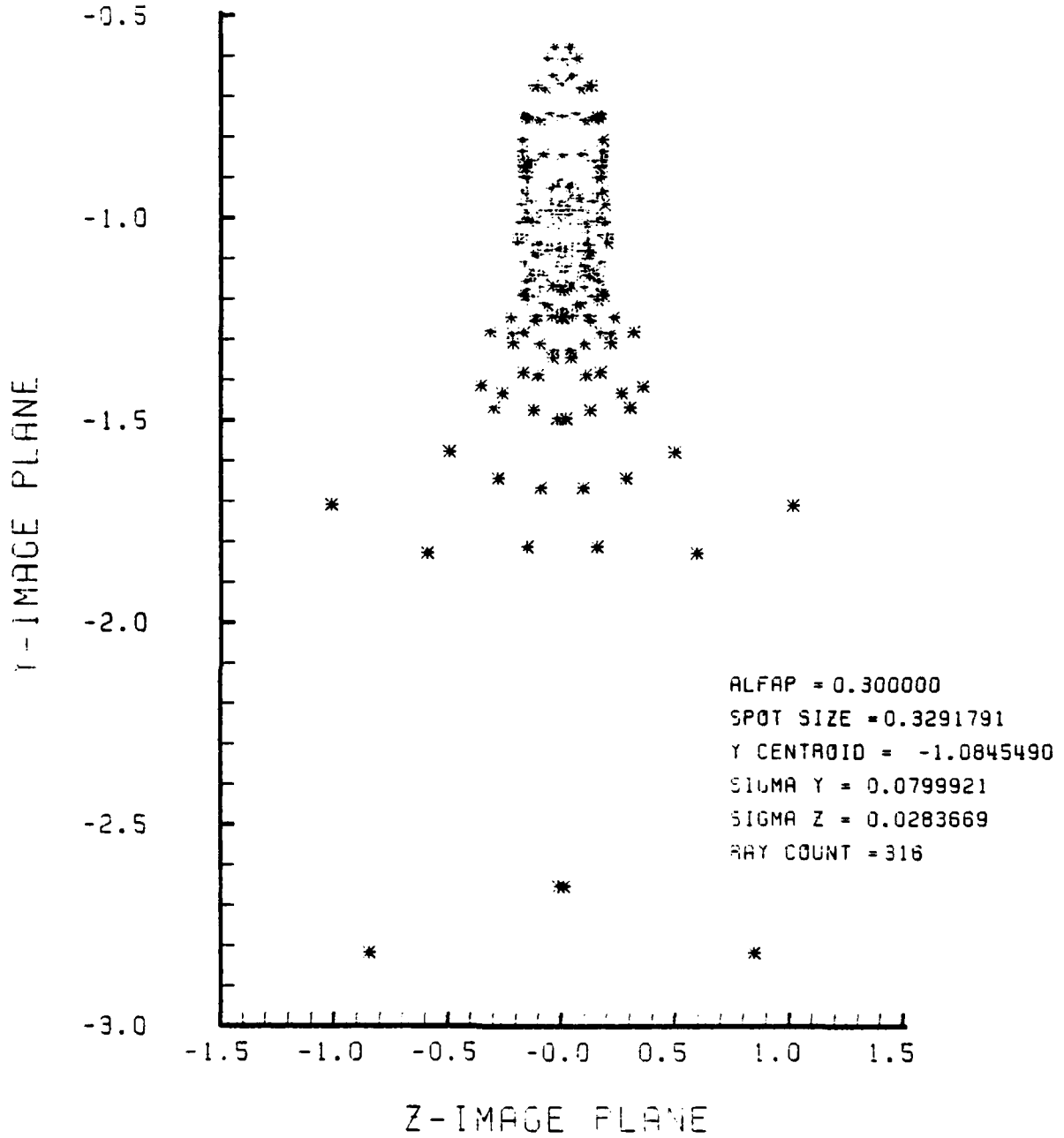

Figure F-95. Spot Diagram for Grid of Figure F-94

SPOT DIAGRAM ENERGY DENSITY

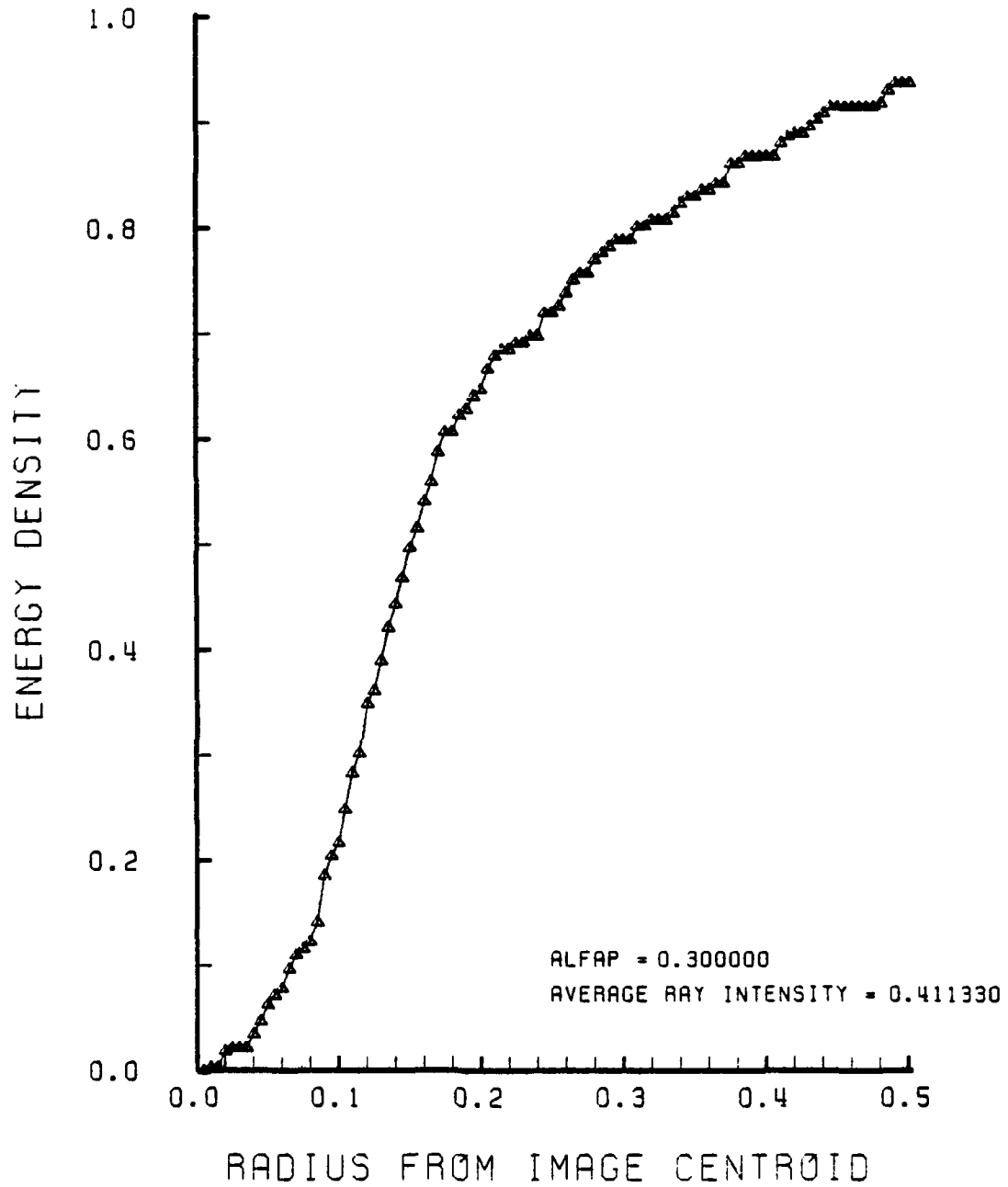

Figure F-96. Encircled Energy of Figure F-95

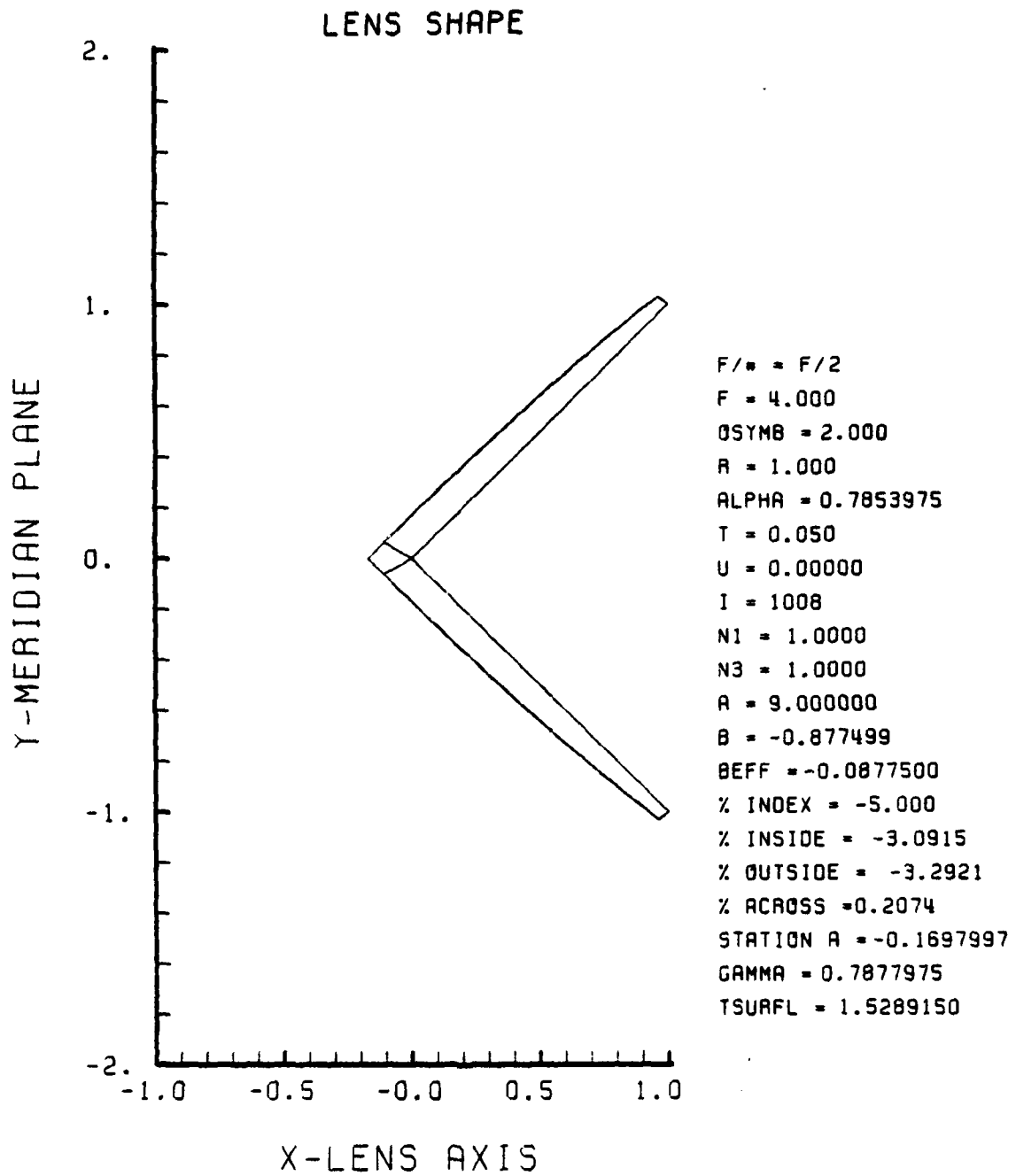

Figure F-97. GRIN Lens Shape at -5%, OB = 2.00,
a = 9.00

LENS FRONT VIEW
OBJECT PLANE

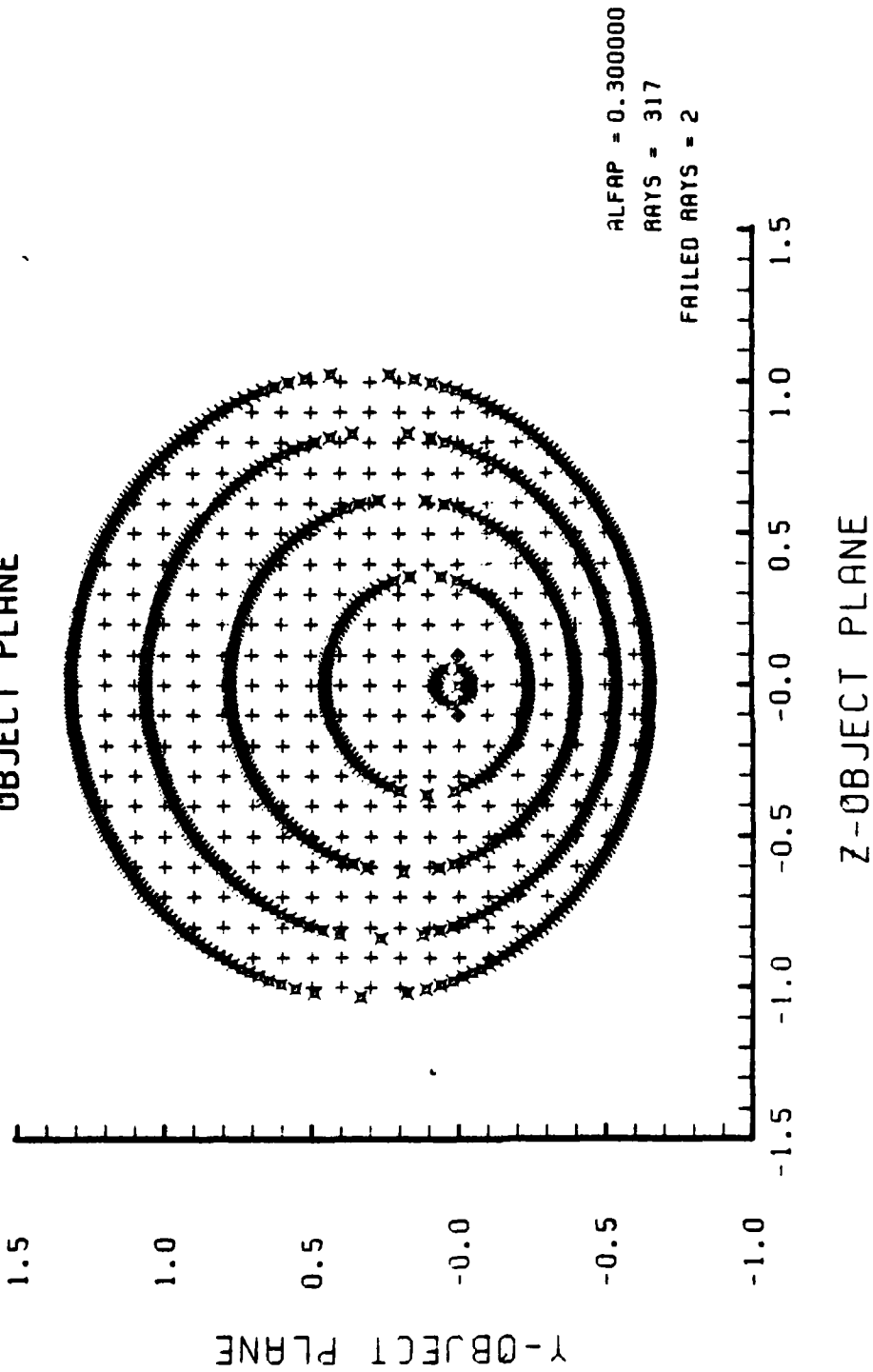

Figure F-98. Grid Plane at $\alpha_p = 0.3$ for Lens of Figure F-97

SPOT DIAGRAM

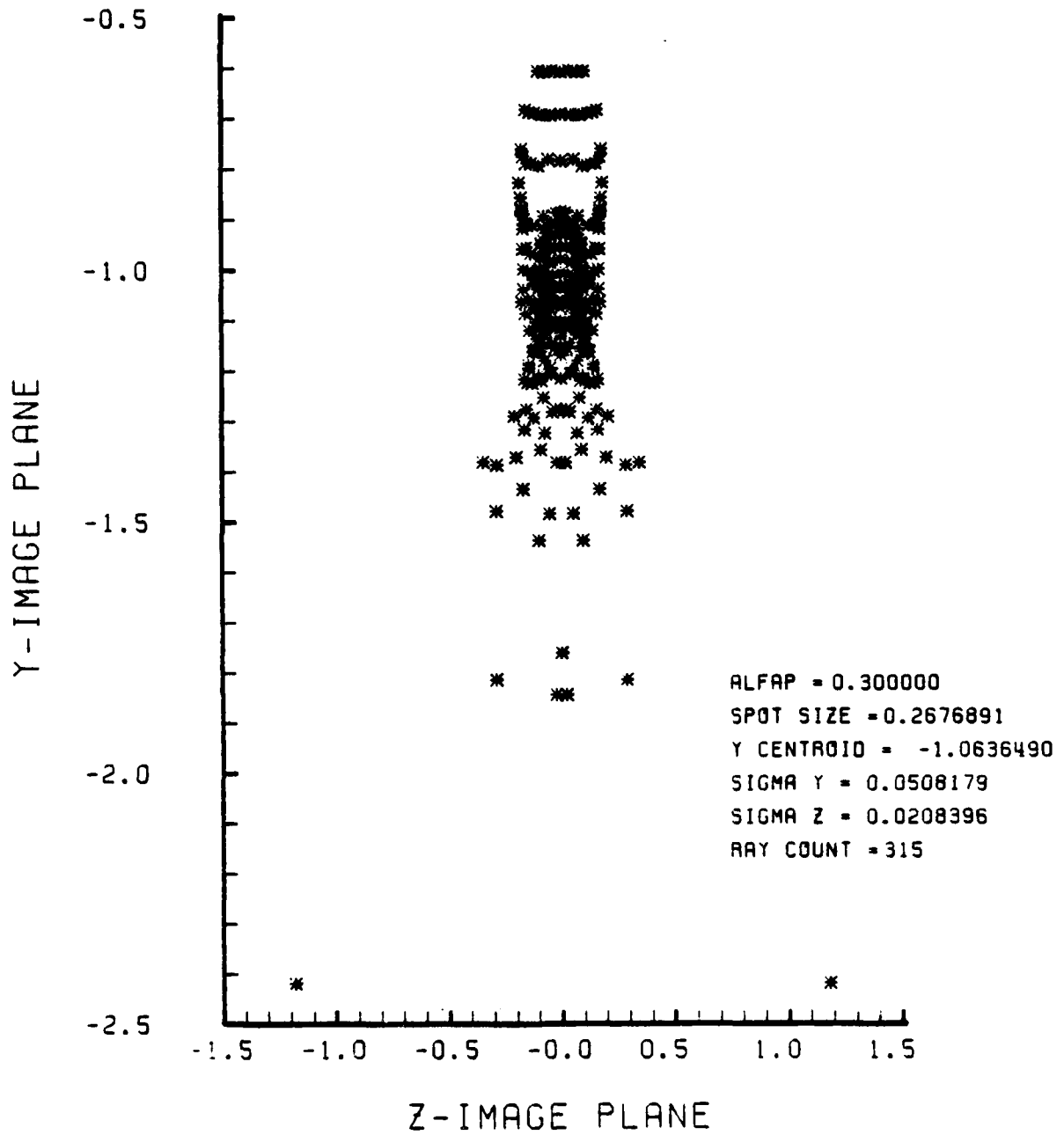

Figure F-99. Spot Diagram for Grid of Figure F-98

SPOT DIAGRAM ENERGY DENSITY

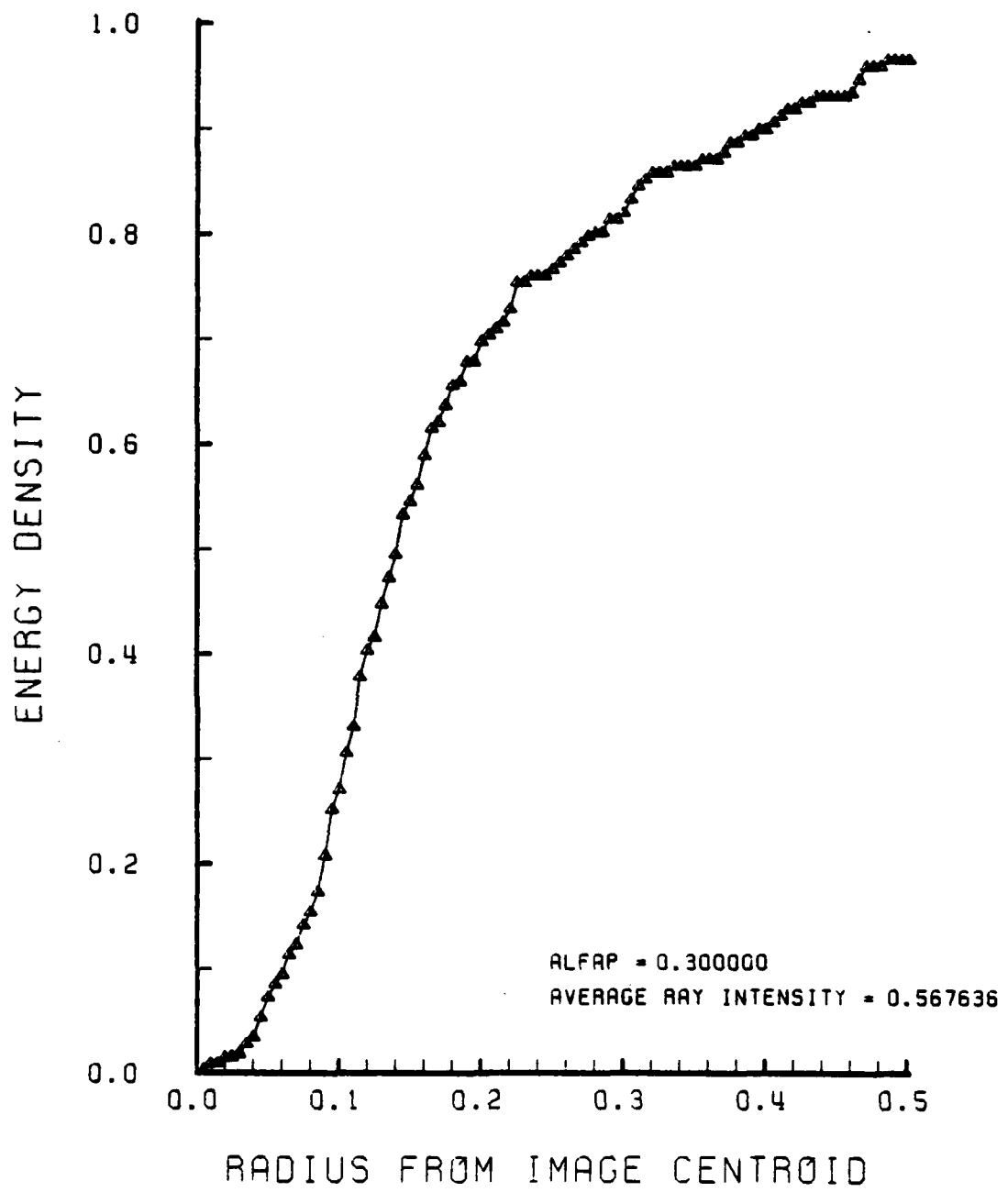

Figure F-100. Encircled Energy of Figure F-99

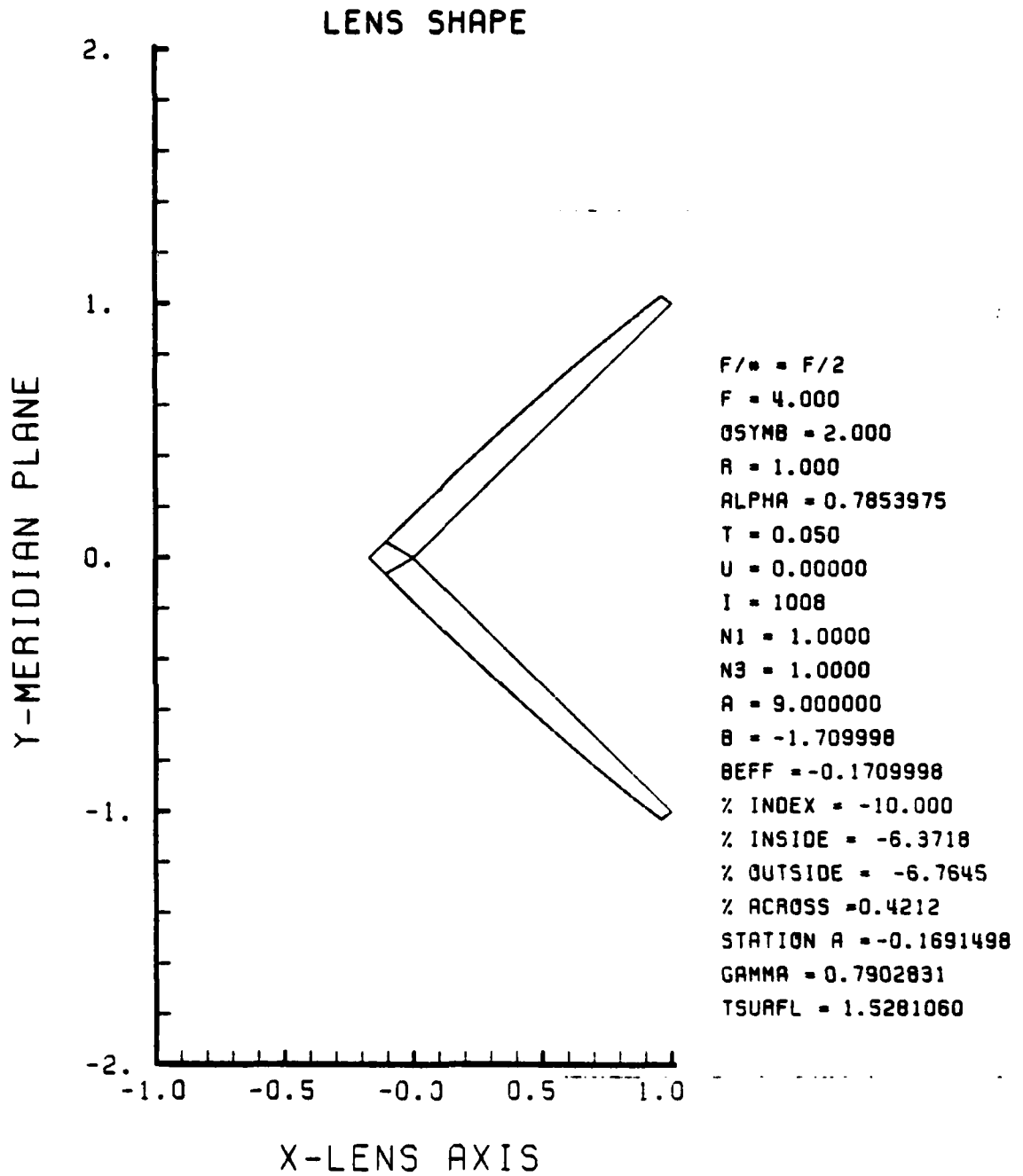

Figure F-101. GRIN Lens Shape at -10%, OB = 2.00,
a = 9.00

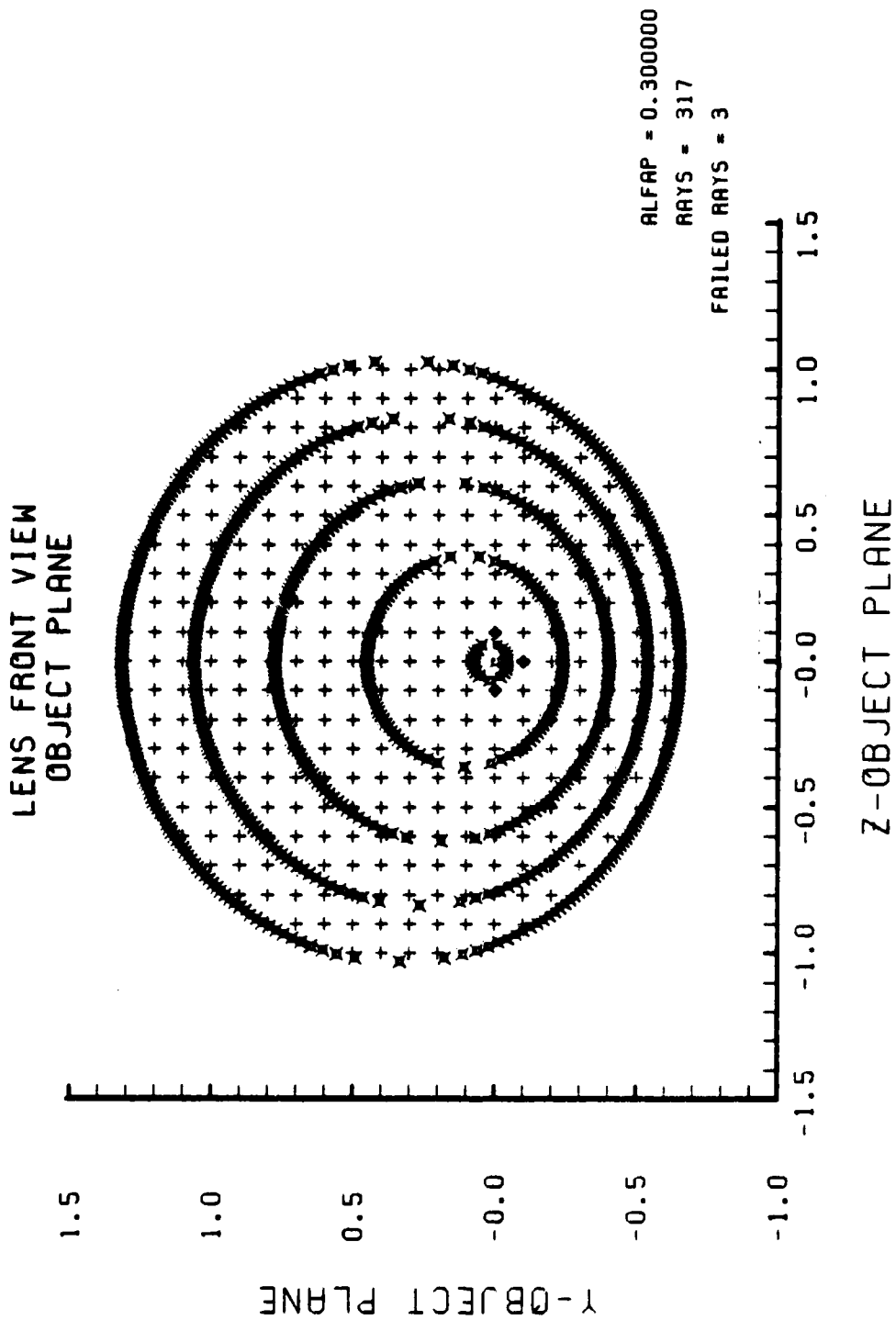

Figure F-102. Grid Plane at $\alpha_p = 0.3$ for Lens of Figure F-101

SPOT DIAGRAM

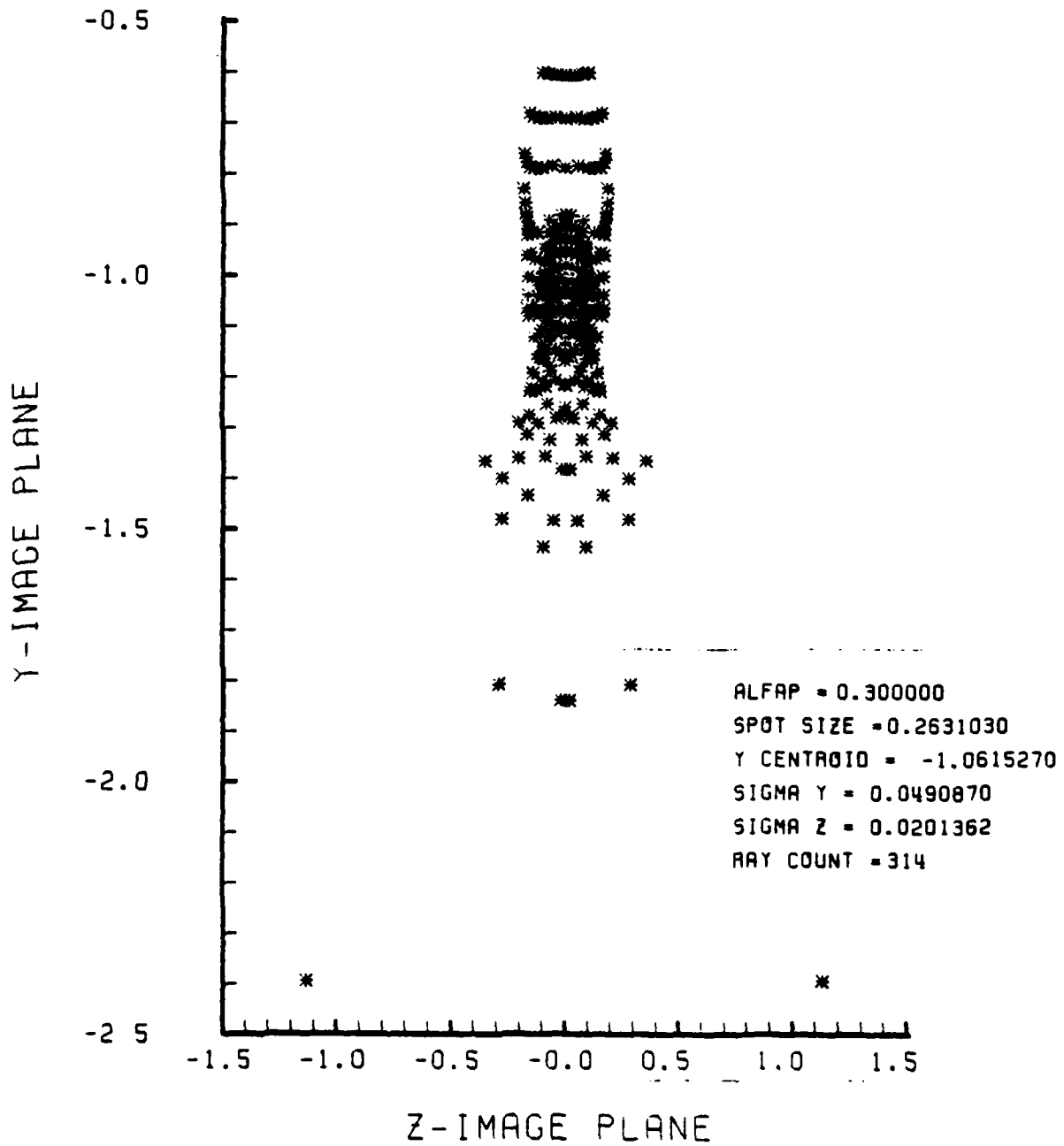

Figure F-103. Spot Diagram for Grid of Figure F-102

SPOT DIAGRAM ENERGY DENSITY

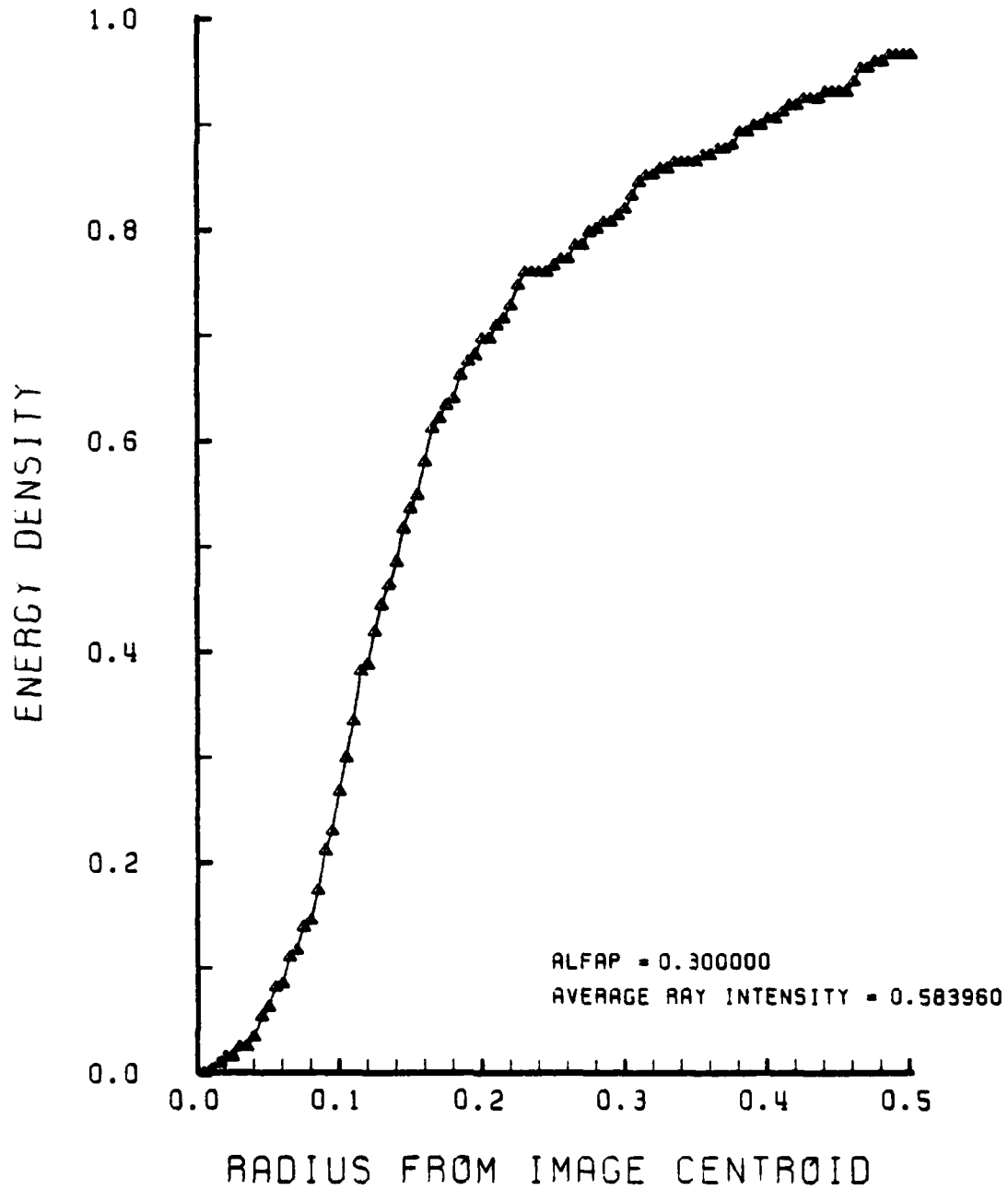

Figure F-104. Encircled Energy of Figure F-103

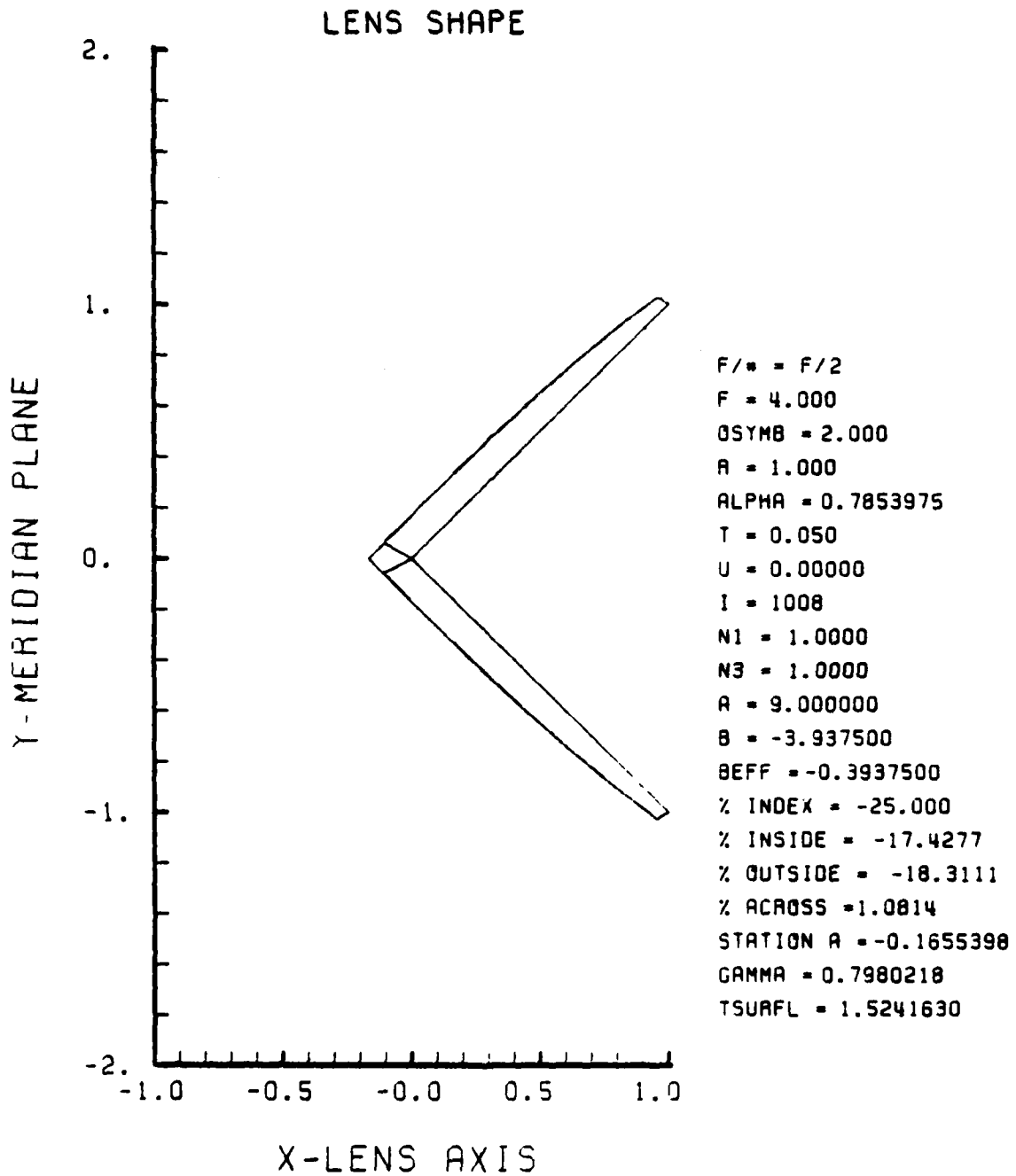

Figure F-105. GRIN Lens Shape at -25%, OB = 2.00,
a = 9.00

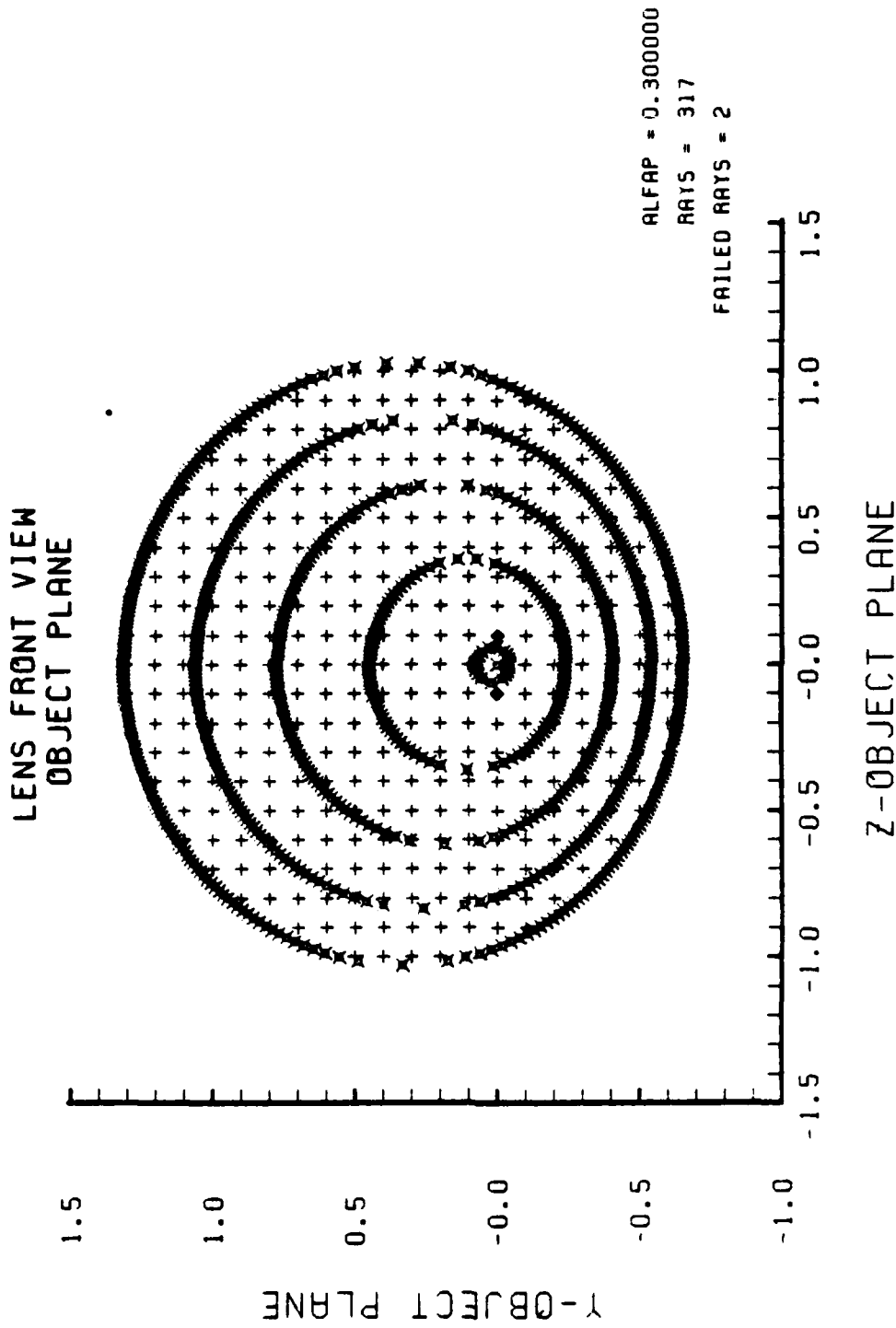

Figure F-106. Grid Plane at $\alpha_p = 0.3$ for Lens of Figure F-105

SPOT DIAGRAM

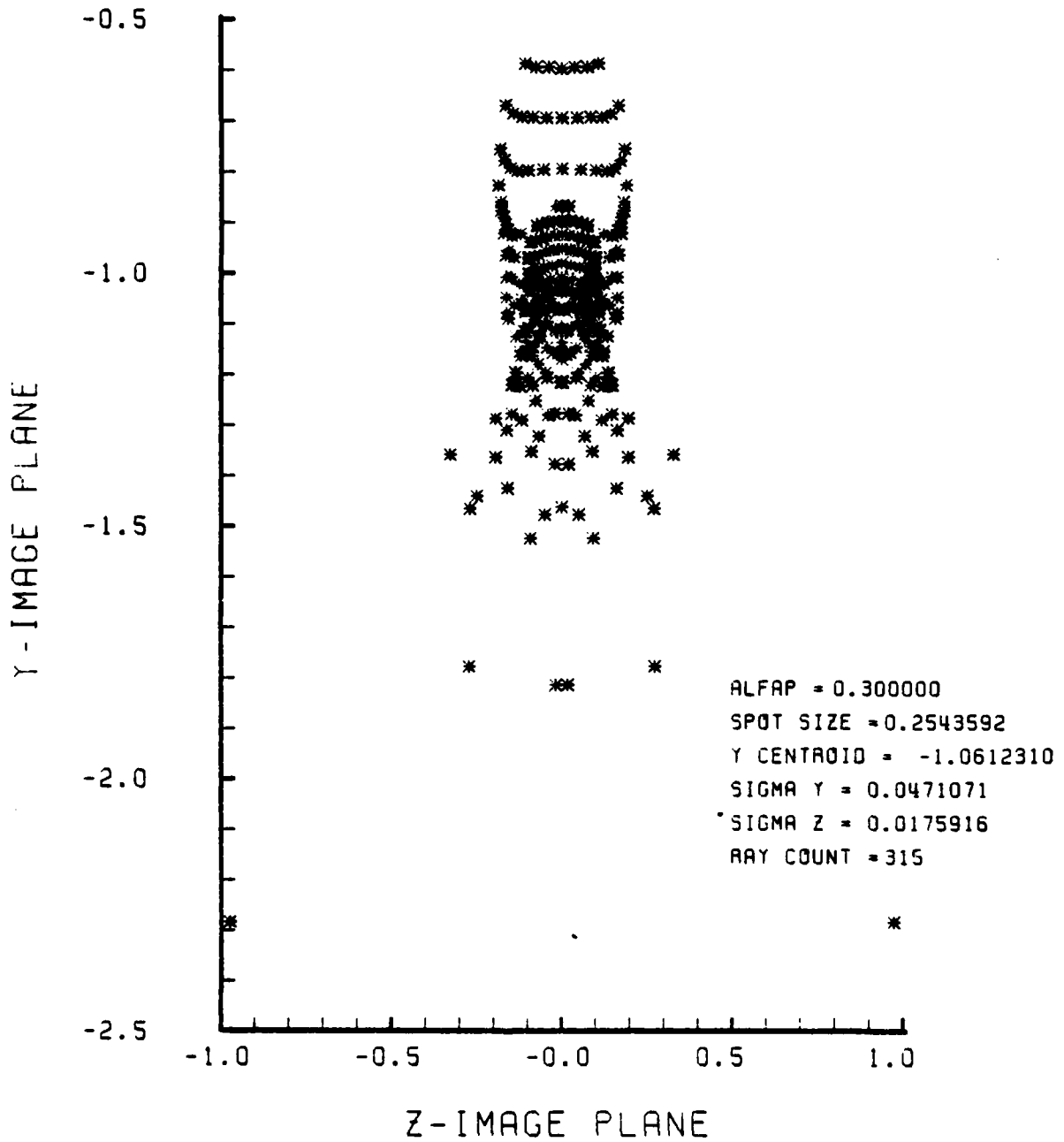

Figure F-107. Spot Diagram for Grid of Figure F-106

SPOT DIAGRAM ENERGY DENSITY

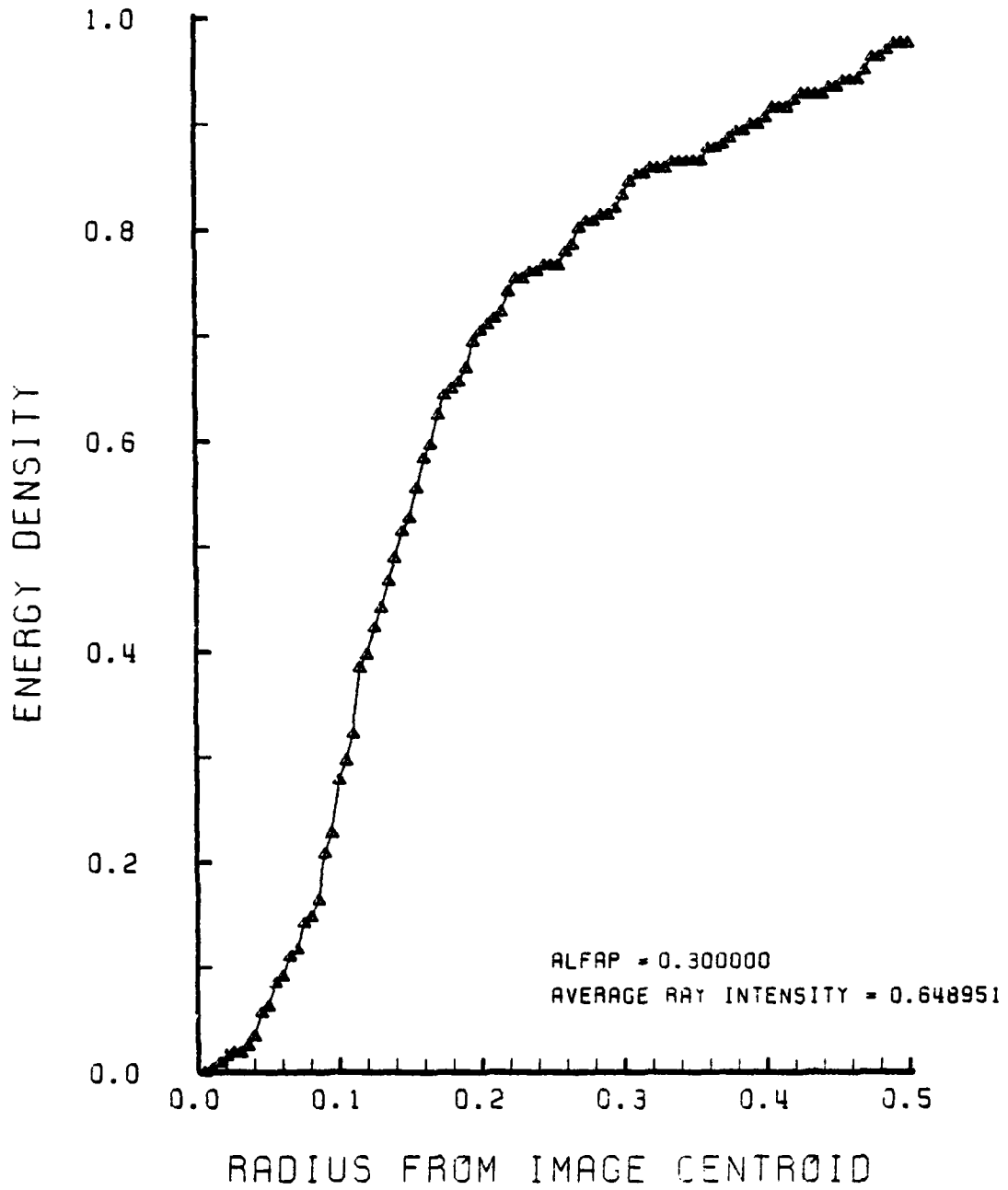

Figure F-108. Encircled Energy of Figure F-107

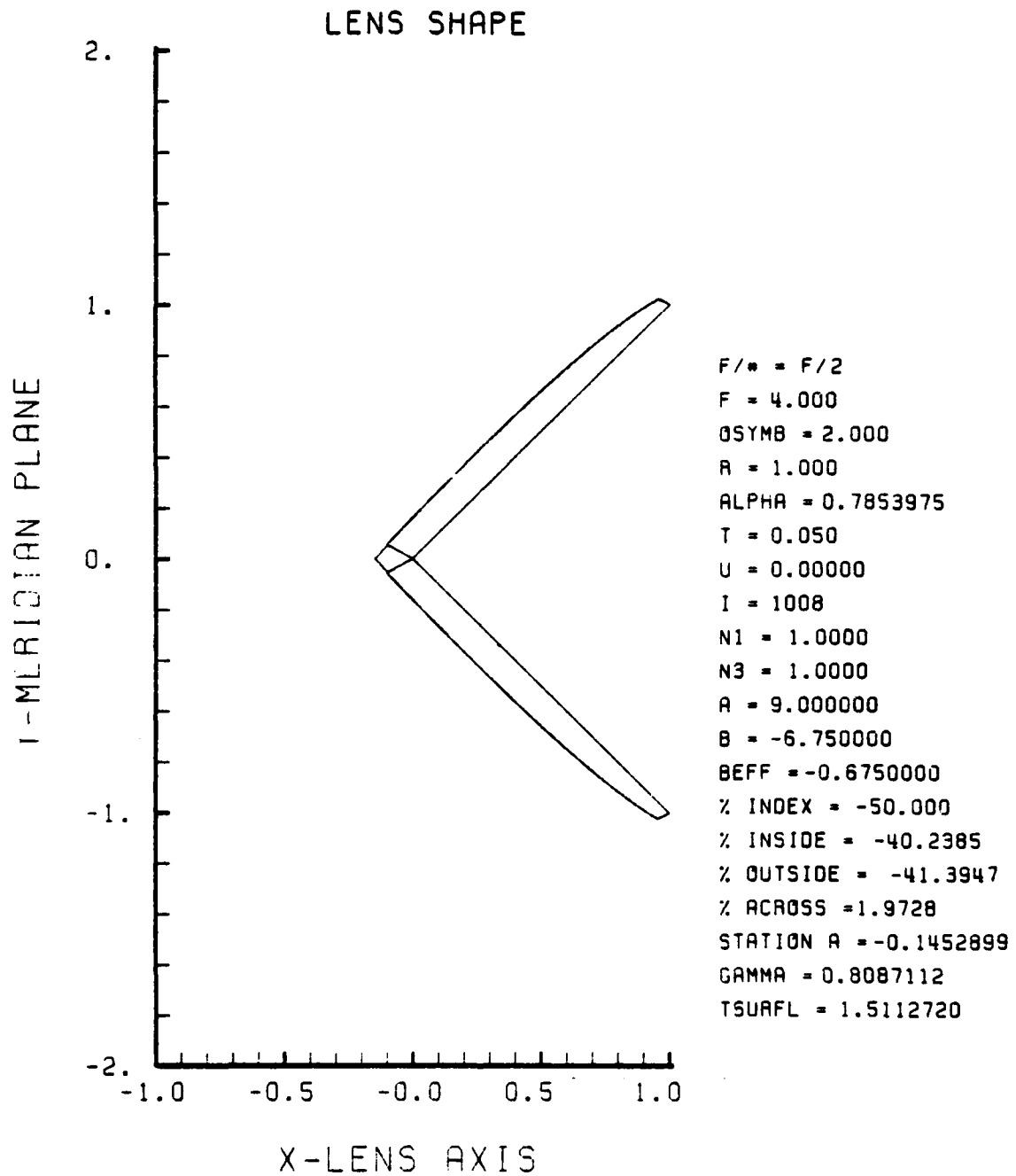

Figure F-109. GRIN Lens Shape at -50%, OB = 2.00,
a = 9.00

LENS FRONT VIEW
OBJECT PLANE

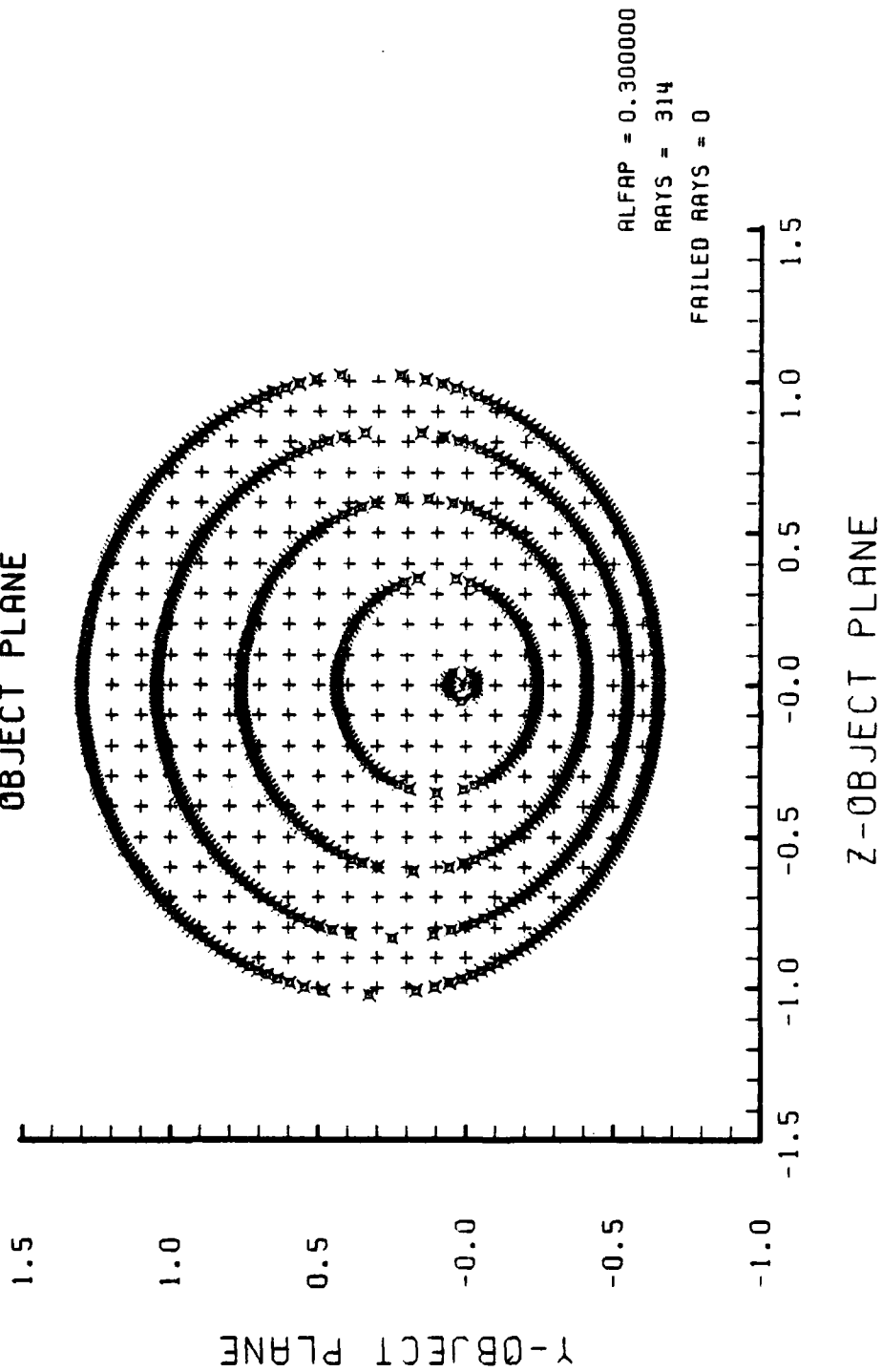

Figure F-110. Grid Plane at $\alpha_p = 0.3$ for Grid of Figure F-109

SPOT DIAGRAM

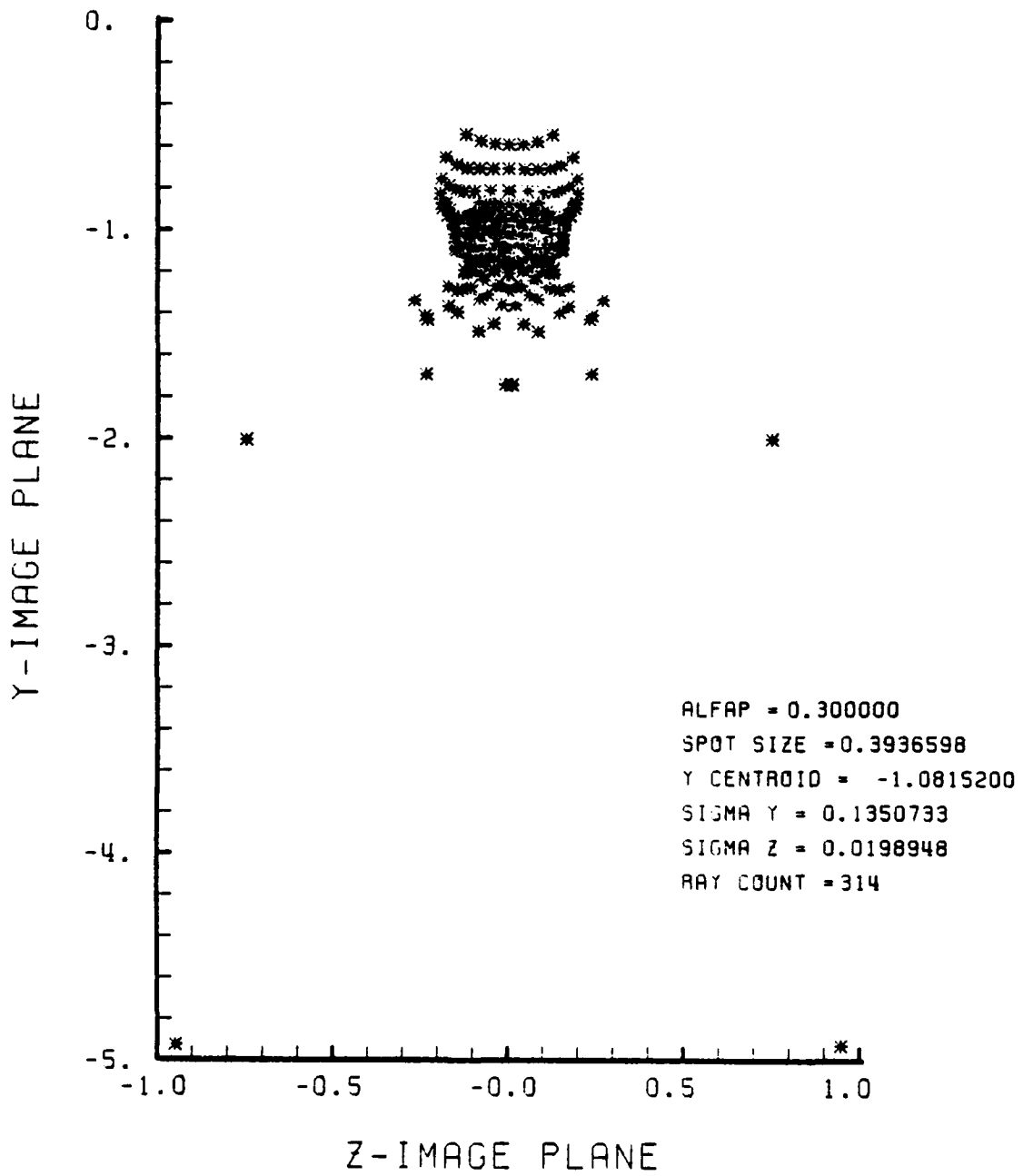

Figure F-111. Spot Diagram for Grid of Figure F-110

SPOT DIAGRAM ENERGY DENSITY

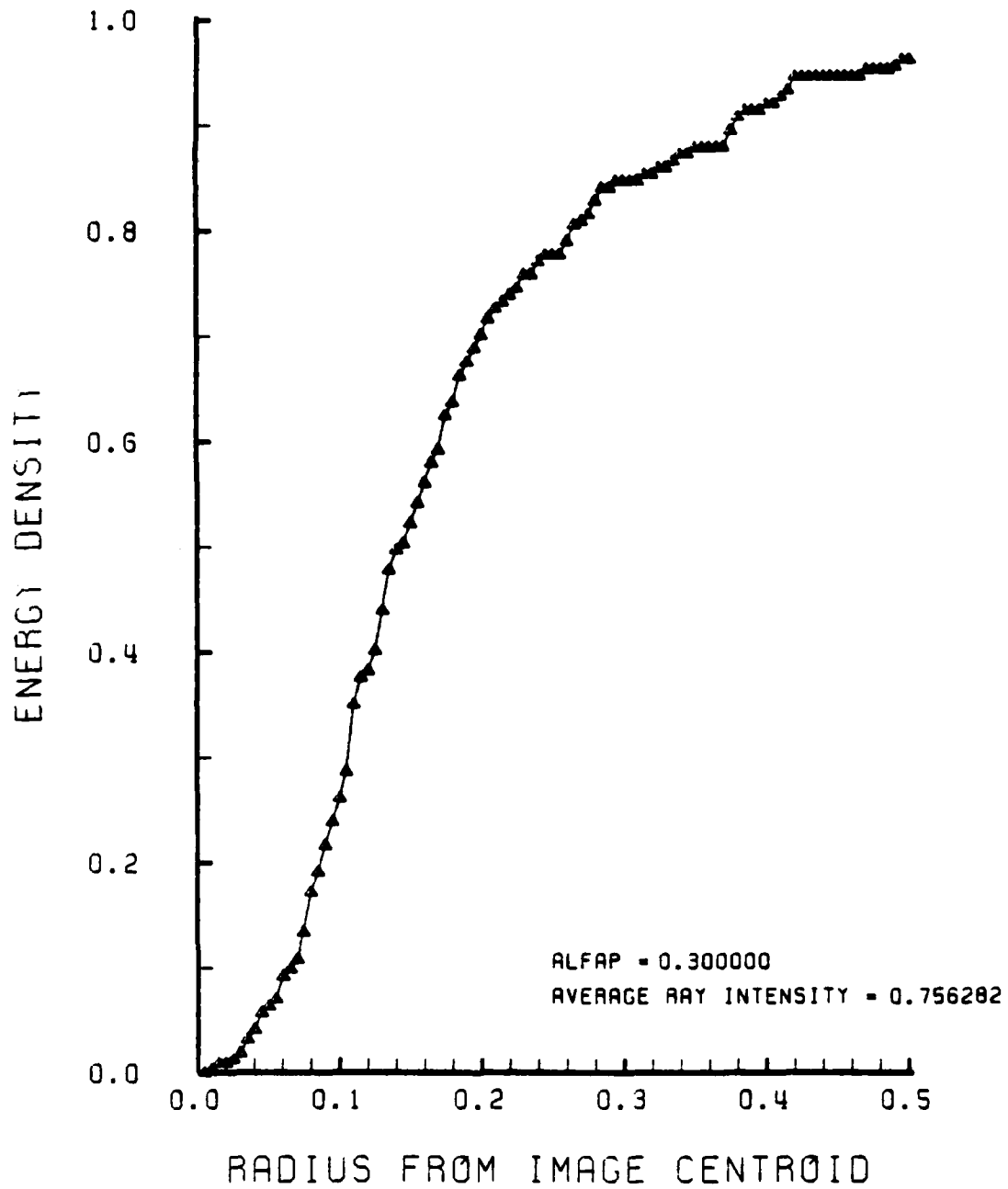

Figure F-112. Encircled Energy of Figure F-111

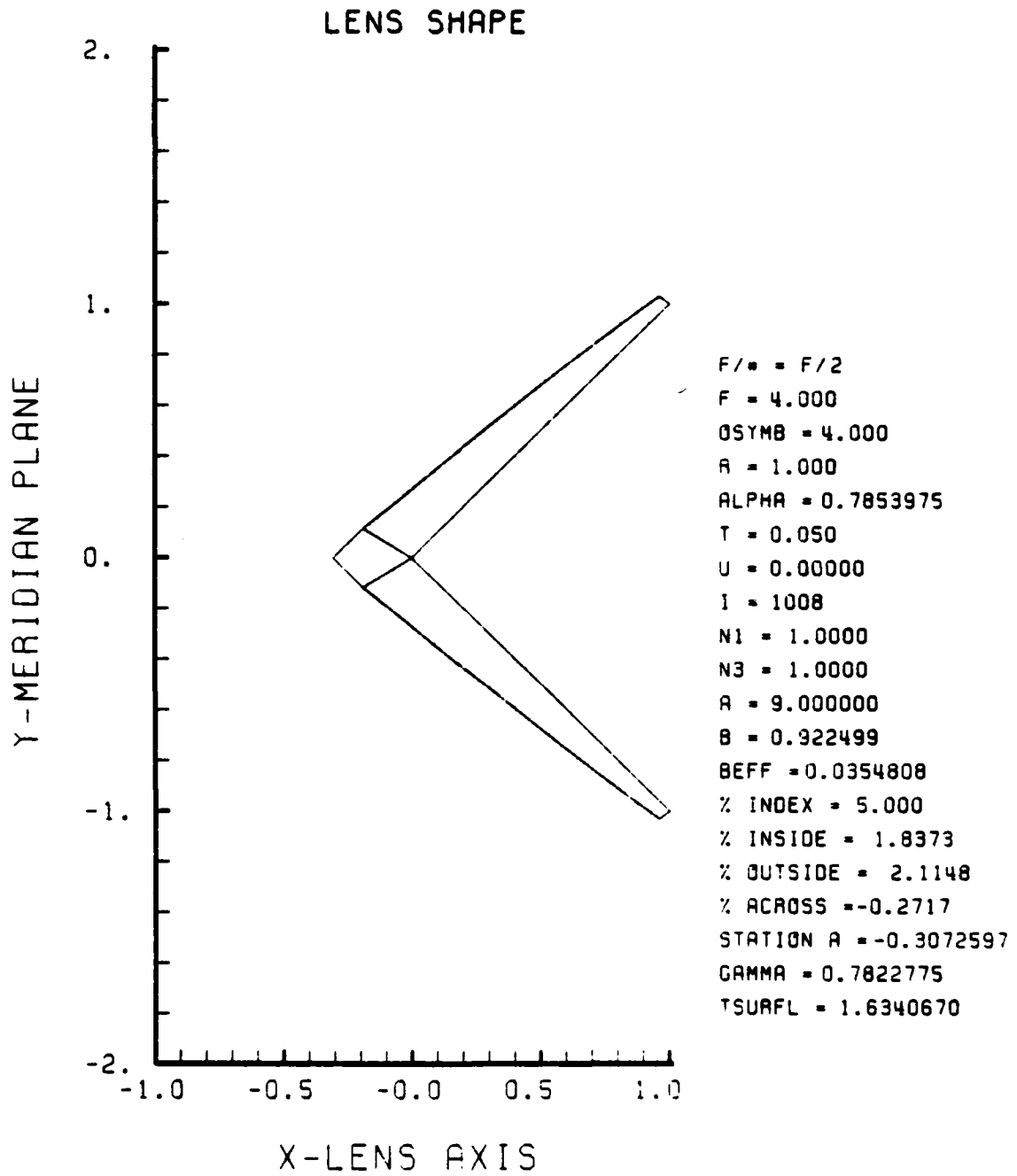

Figure F-113. GRIN Lens Shape at +5%, OB = 4.00,
a = 9.00

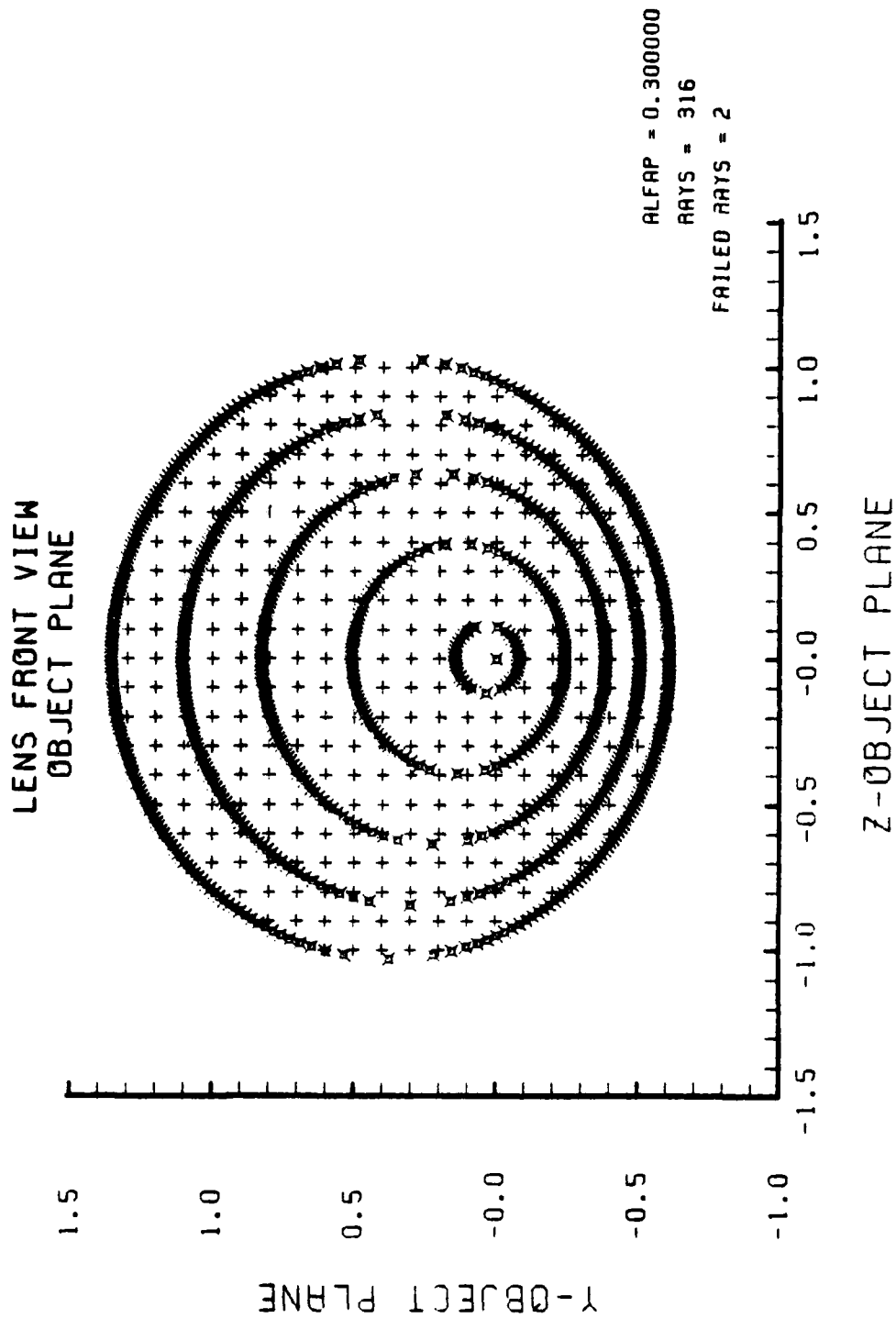

Figure F-114. Grid Plane at $\alpha_p = 0.3$ for Lens of Figure F-113

SPOT DIAGRAM

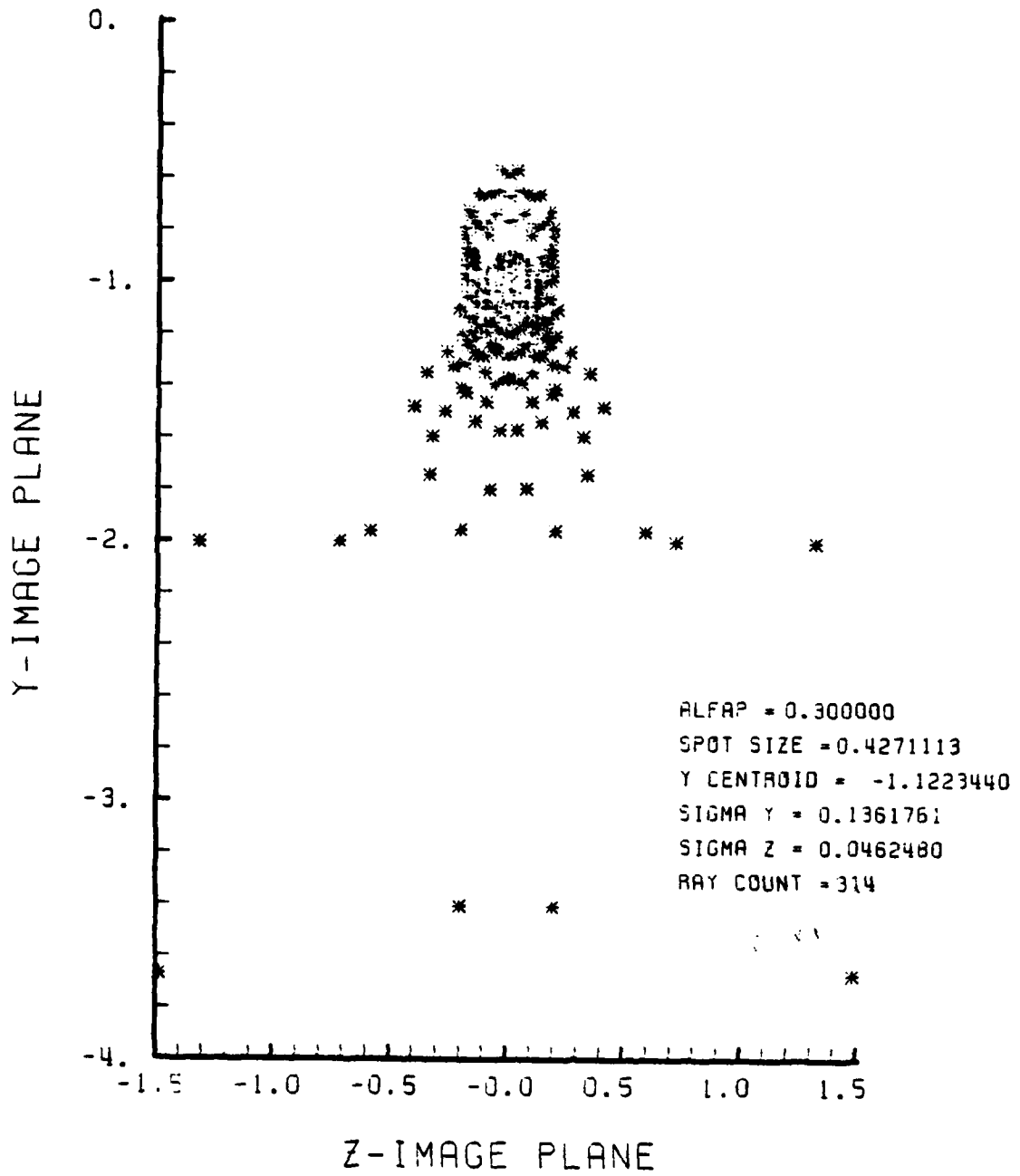

Figure F-115. Spot Diagram for Grid of Figure F-114

SPOT DIAGRAM ENERGY DENSITY

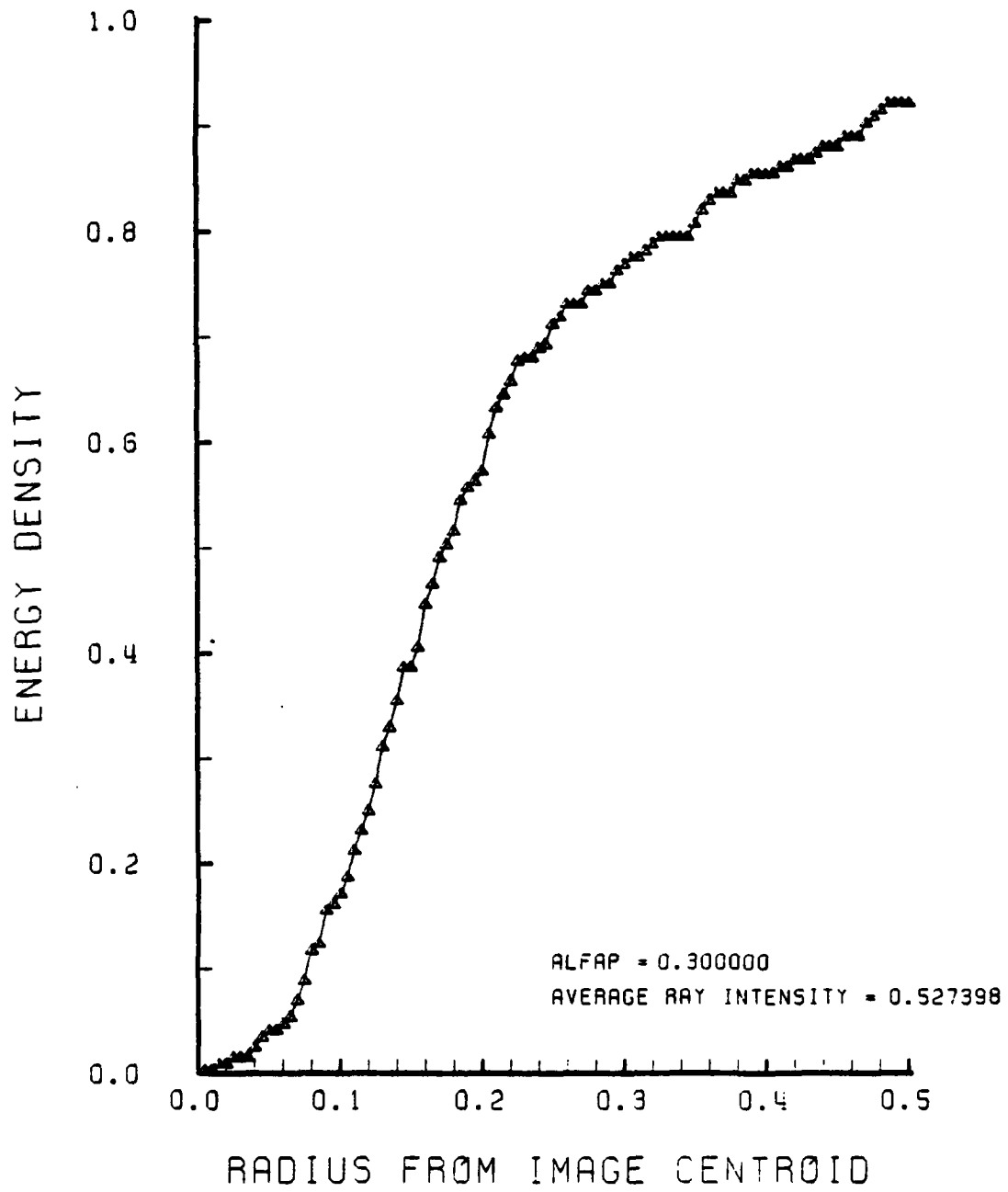

Figure F-116. Encircled Energy of Figure F-115

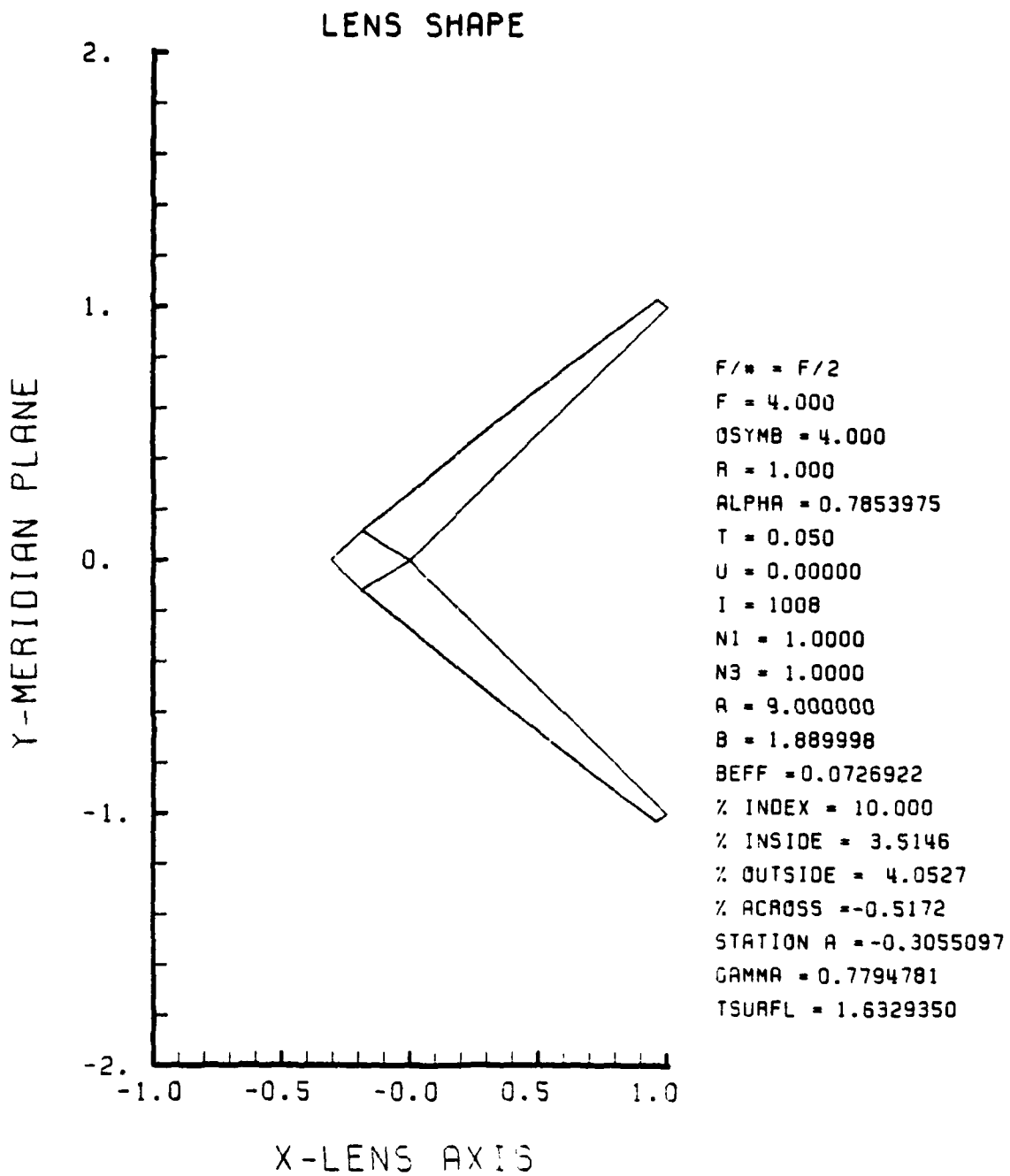

Figure F-117. GRIN Lens Shape at +10%, OB = 4.00,
a = 9.00

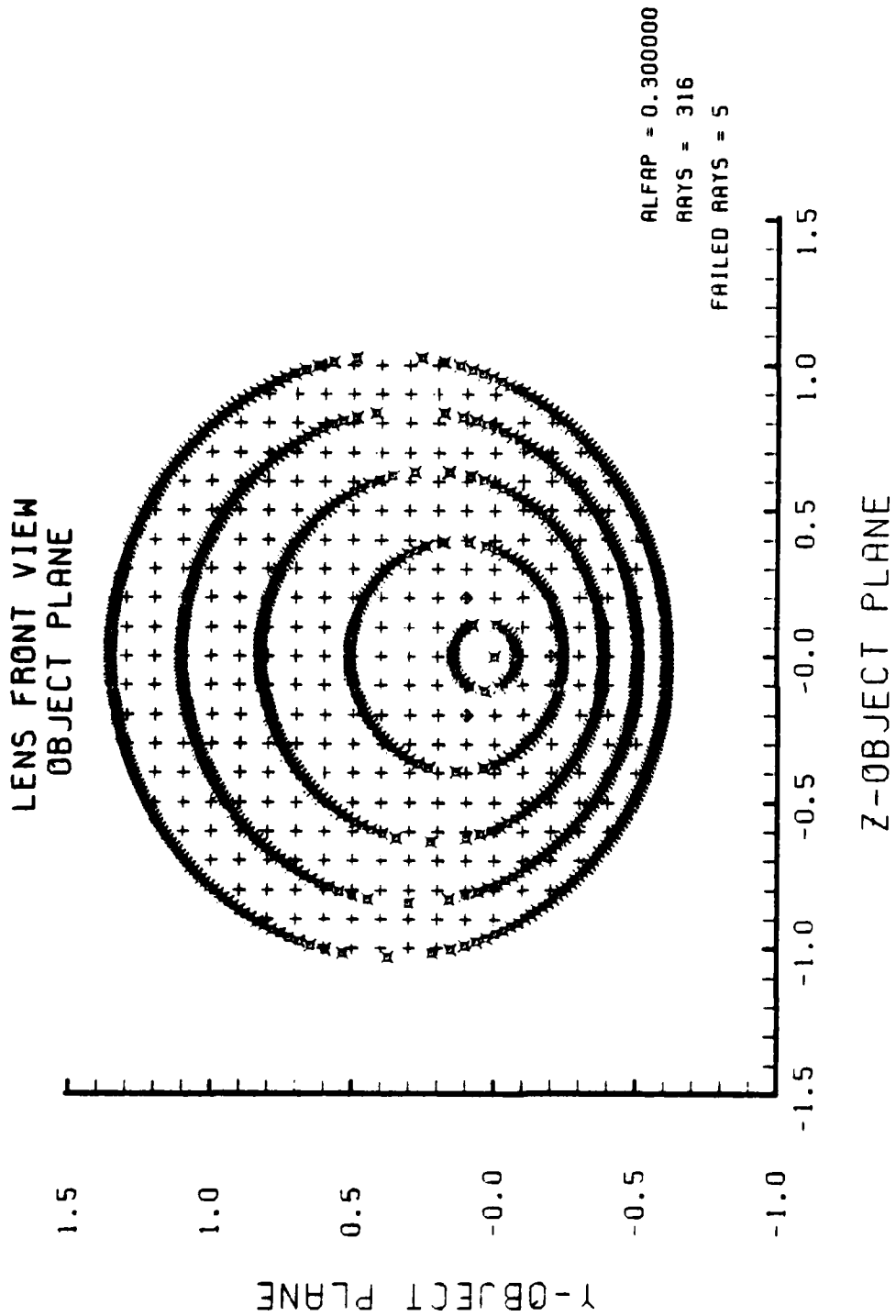

Figure F-118. Grid Plane at $\alpha_p = 0.3$ for Lens of Figure F-117

SPOT DIAGRAM

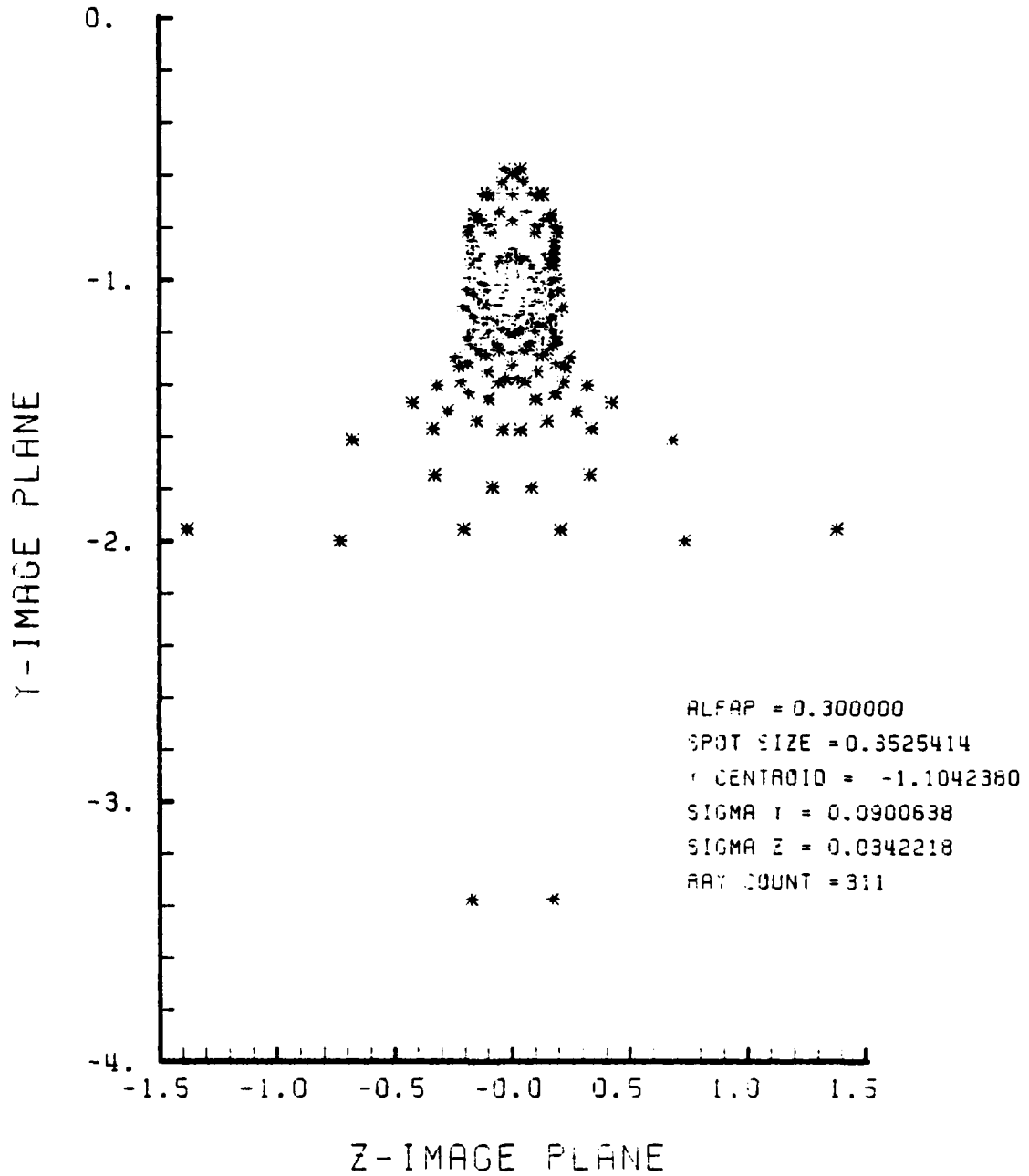

Figure F-119. Spot Diagram for Grid of Figure F-118

SPOT DIAGRAM ENERGY DENSITY

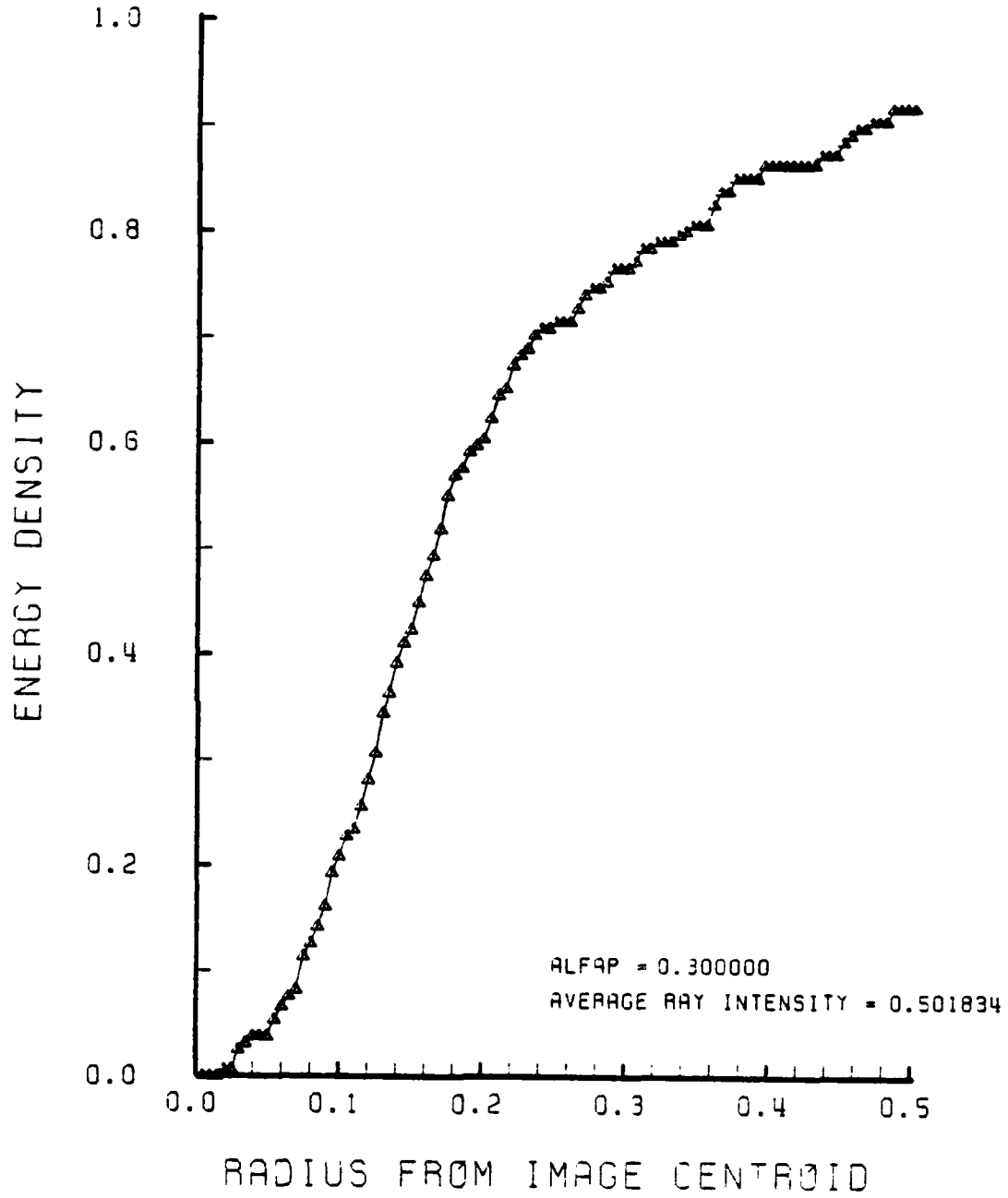

Figure F-120. Encircled Energy of Figure F-119

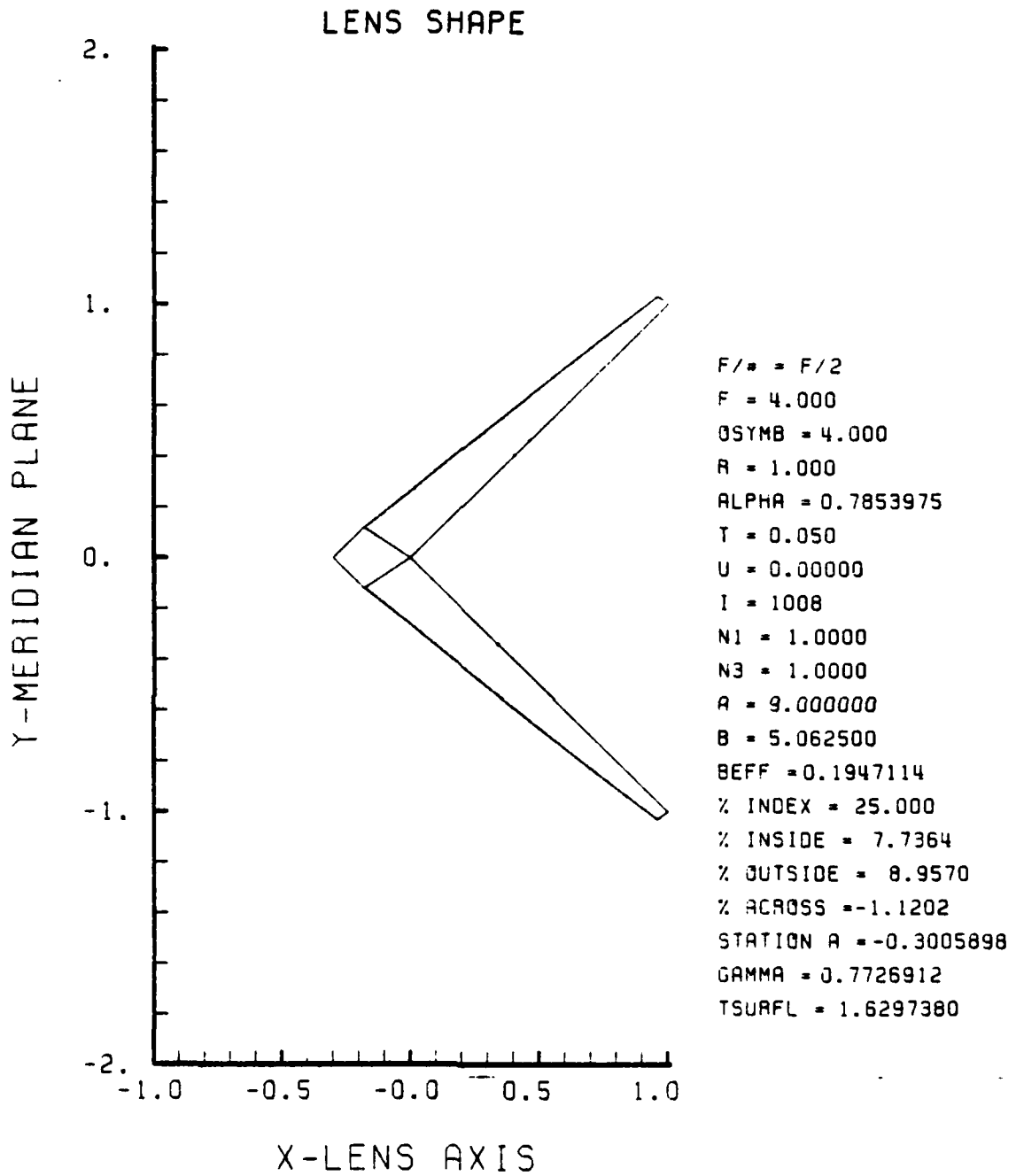

Figure F-121. GRIN Lens Shape at +25%, OB = 4.00,
a = 9.00

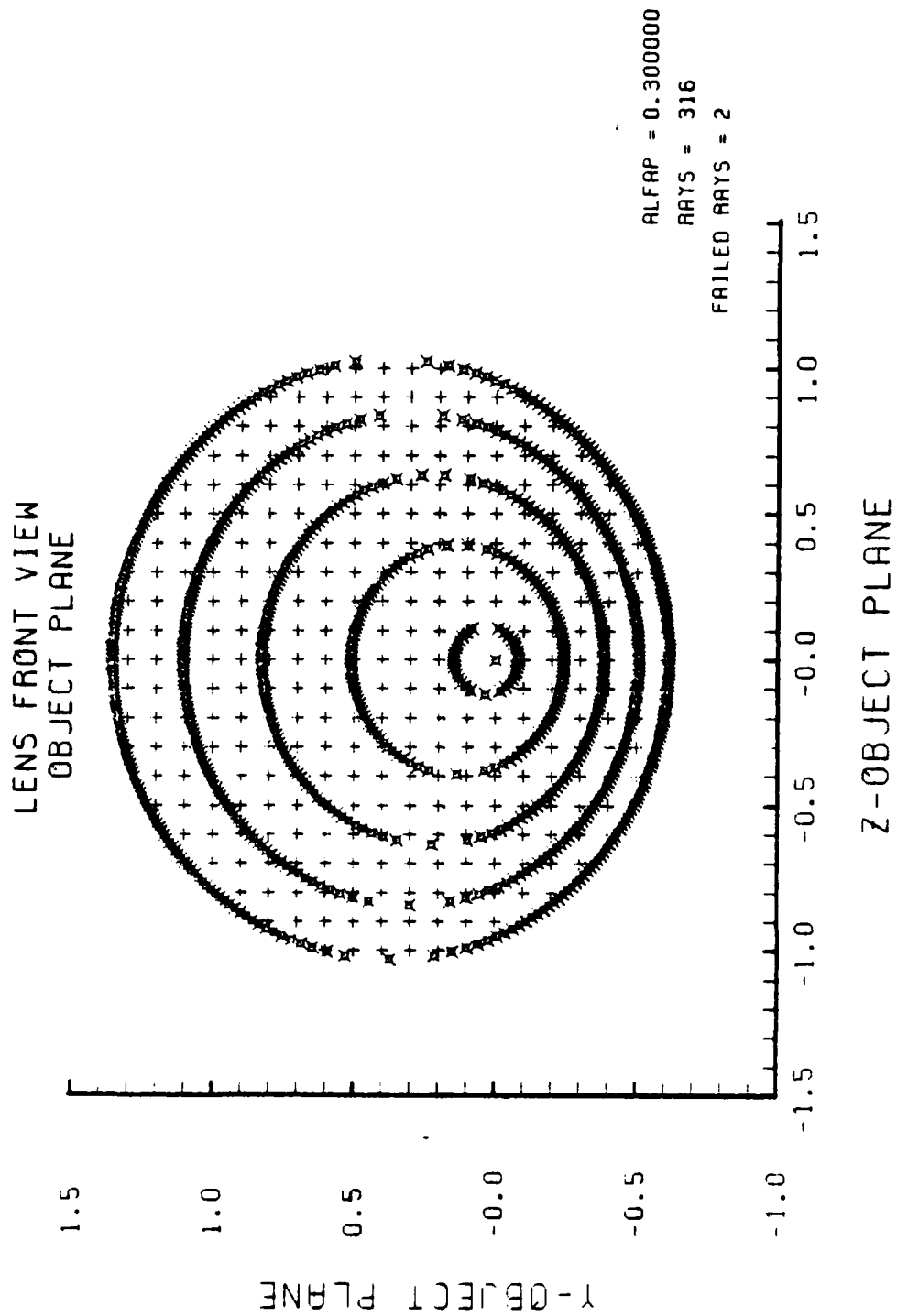

Figure F-122. Grid Plane at $\alpha_p = 0.3$ for Lens of Figure F-121

SPOT DIAGRAM

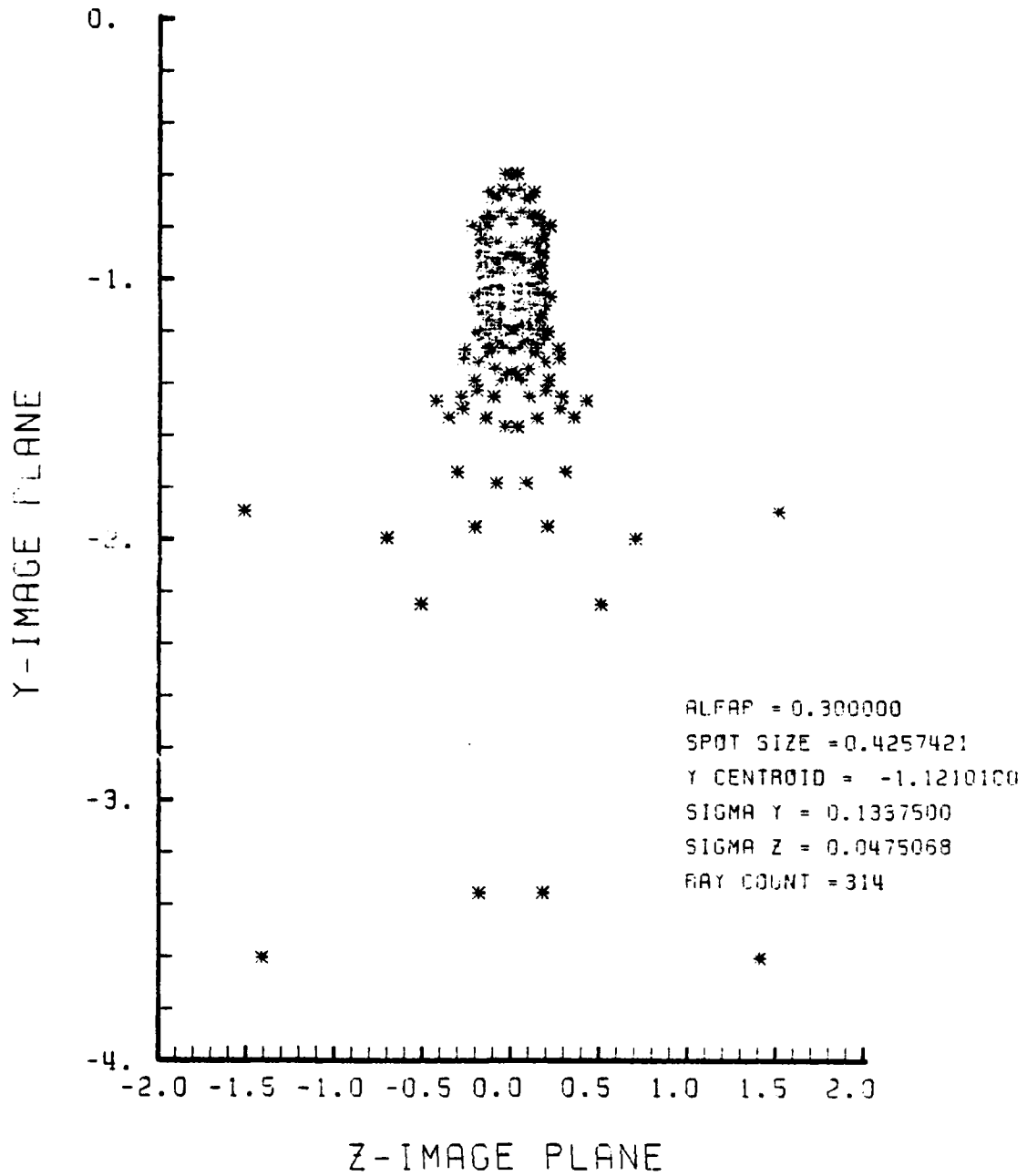

Figure F-123. Spot Diagram for Grid of Figure F-122

SPOT DIAGRAM ENERGY DENSITY

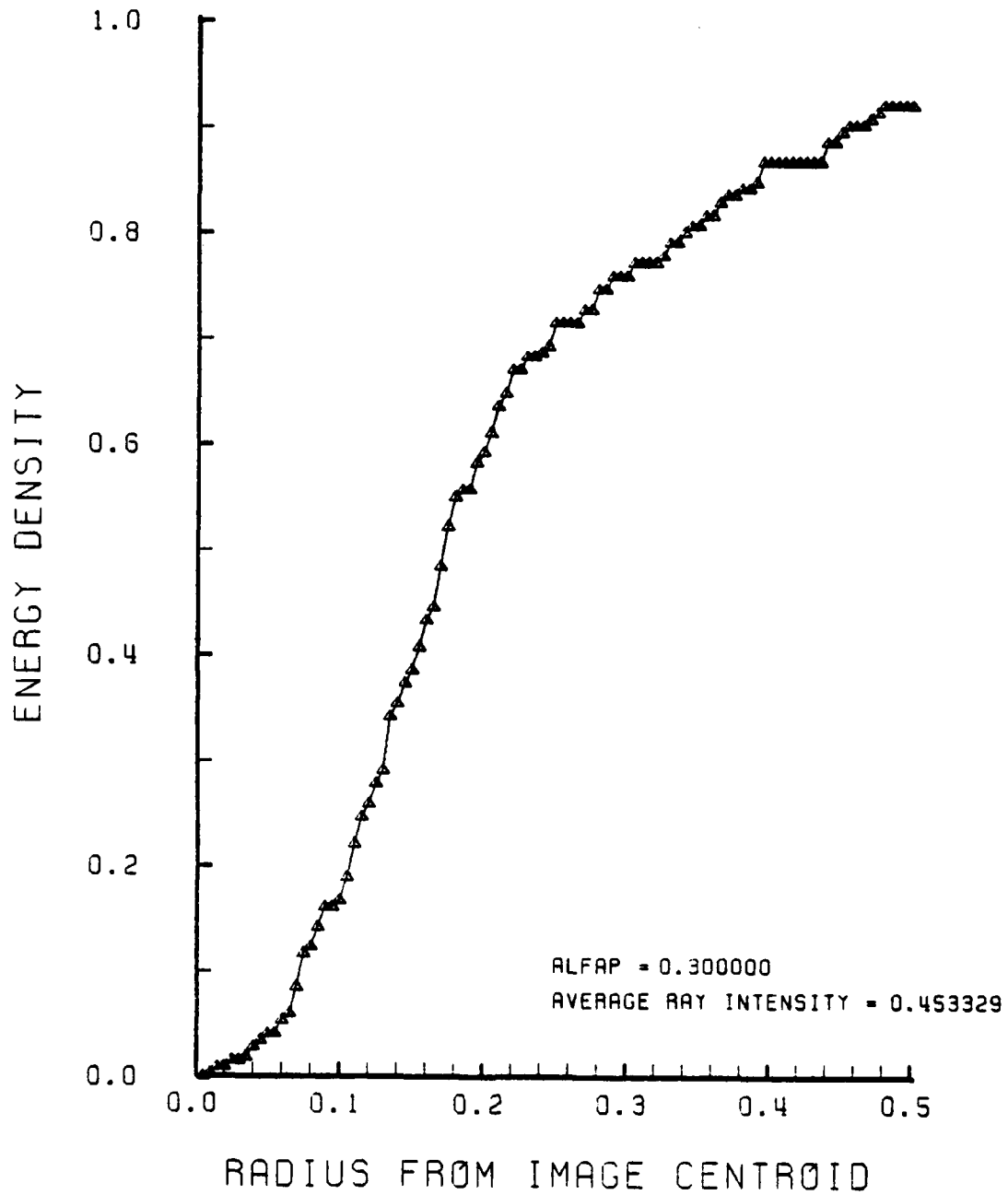

Figure F-124. Encircled Energy of Figure F-123

LENS SHAPE

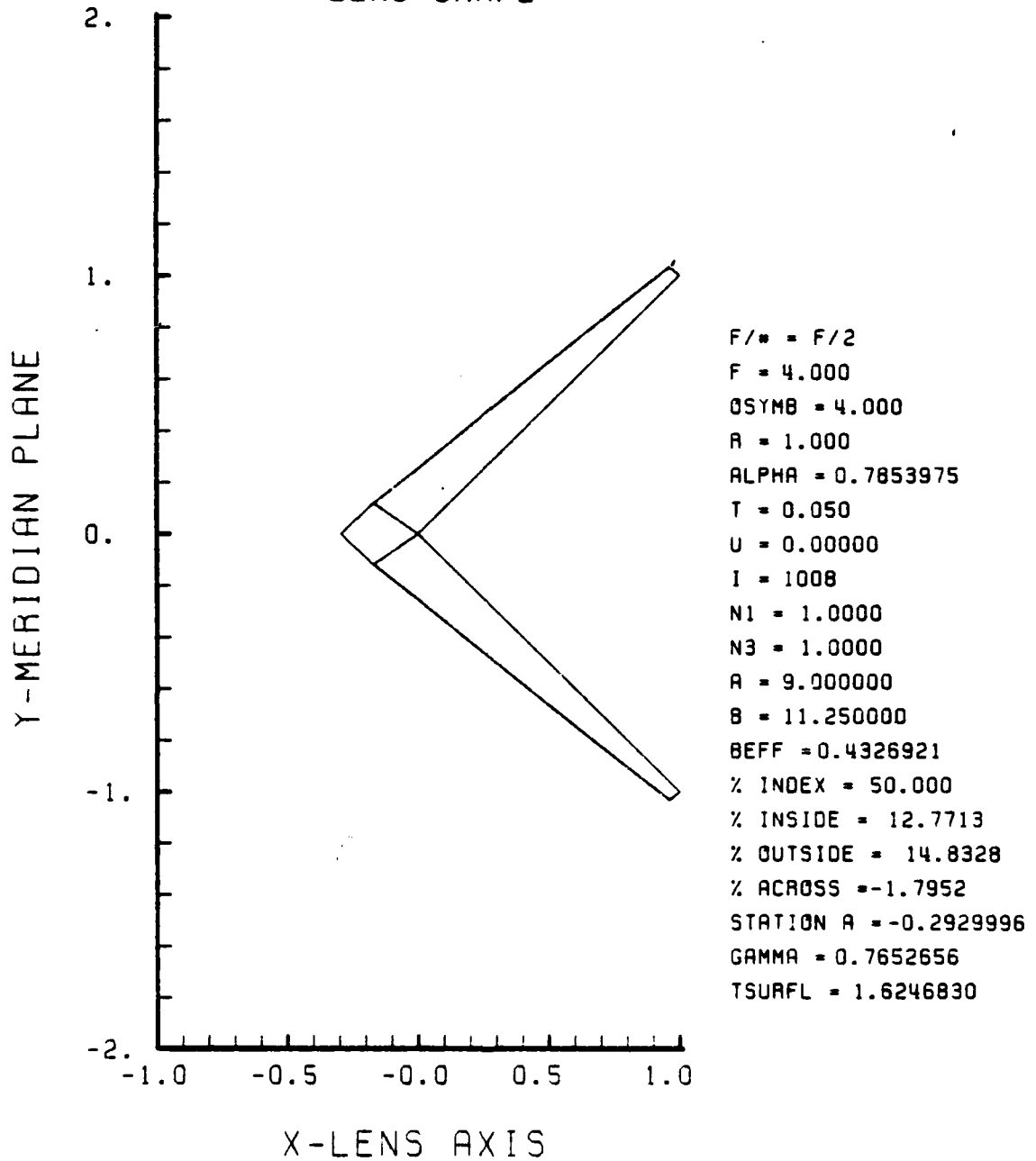

Figure F-125. GRIN Lens Shape at +50%, OB = 4.00,
a = 9.00

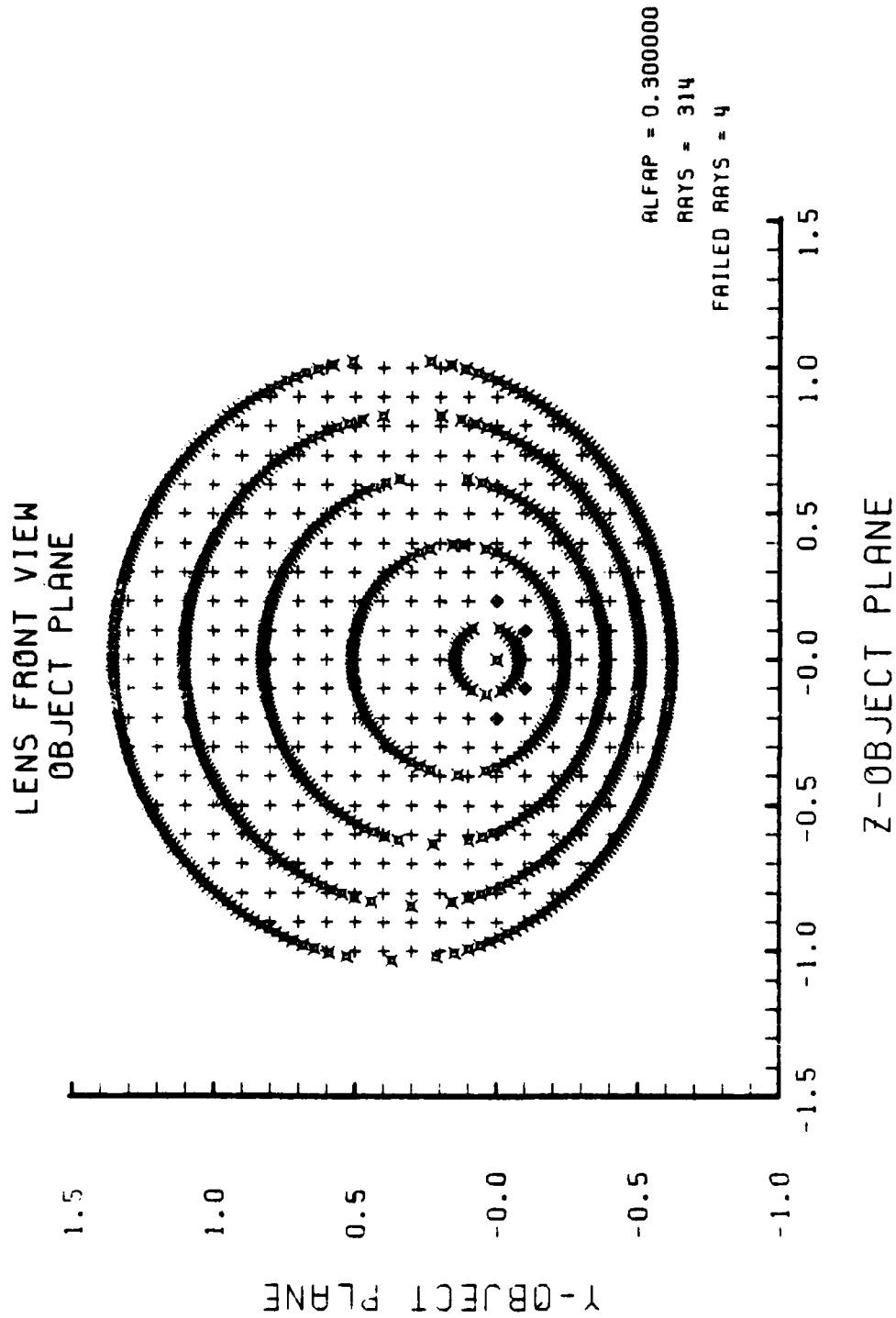

Figure F-126. Grid Plane at $\alpha_p = 0.3$ for Lens of Figure F-125

SPOT DIAGRAM

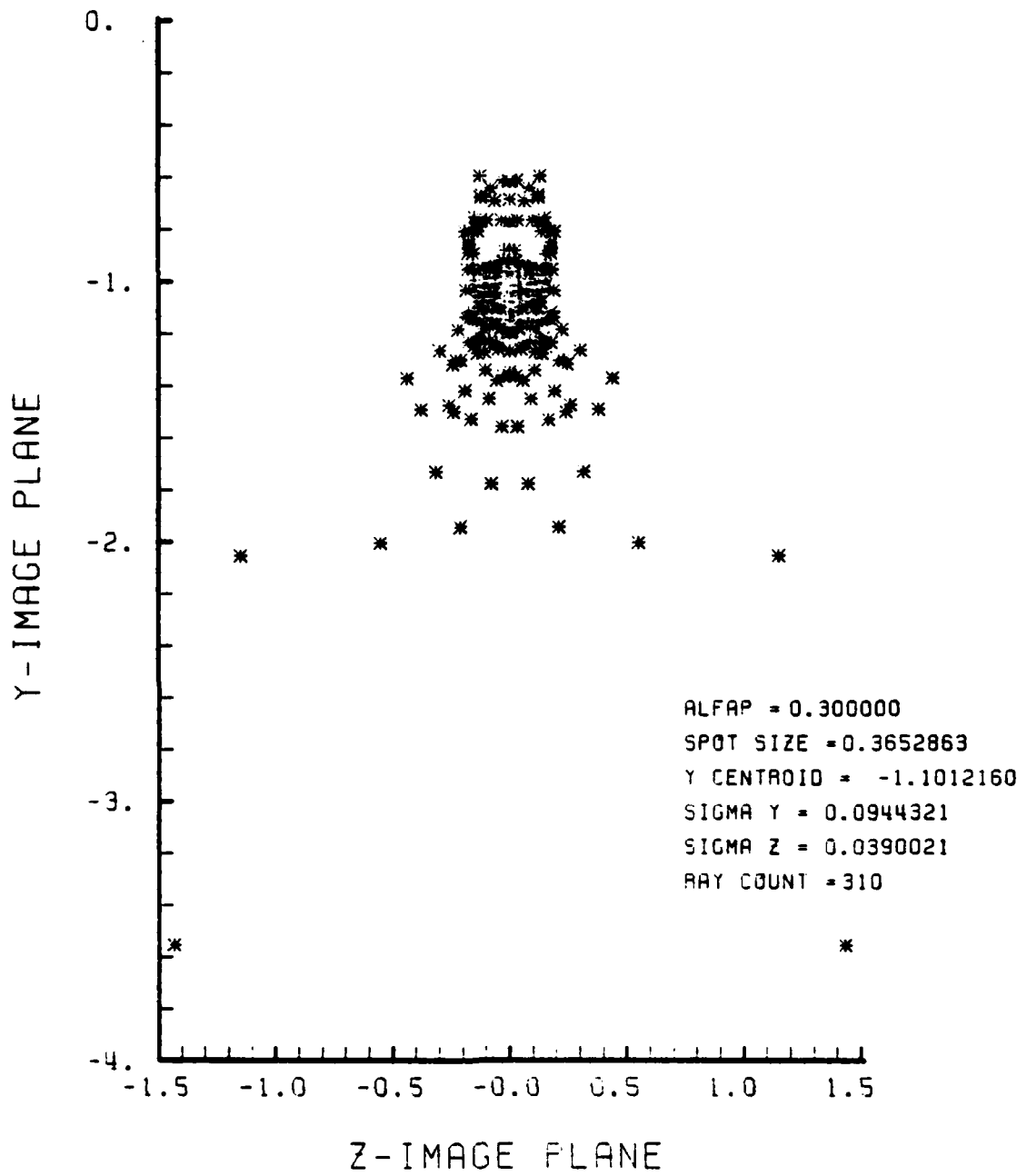

Figure F-127. Spot Diagram for Grid of Figure F-126

SPOT DIAGRAM ENERGY DENSITY

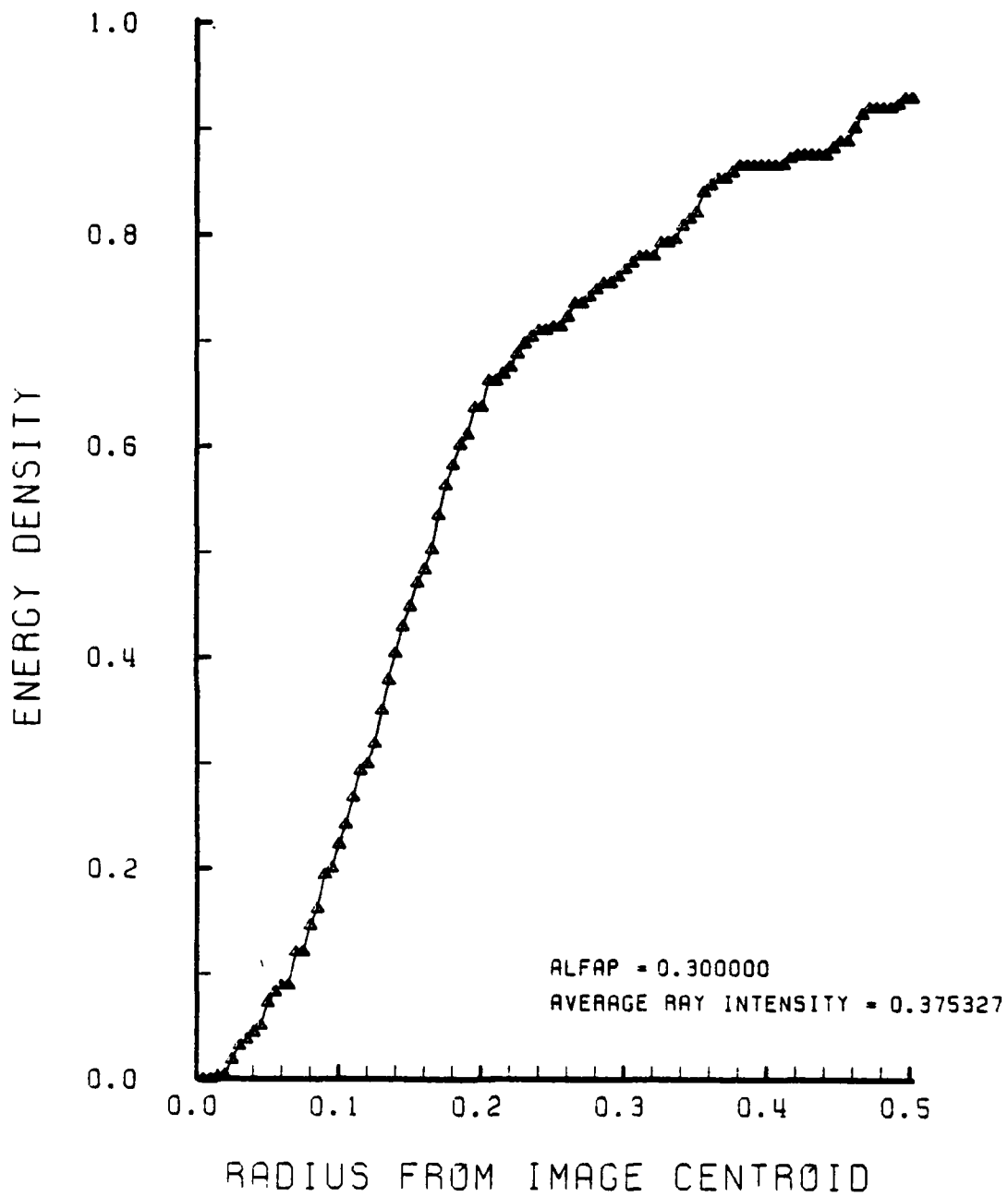

Figure F-128. Encircled Energy of Figure F-127

APPENDIX G

"BEST" GRIN LENS PERFORMANCE PLOTS IN THE F/2 CONFIGURATION

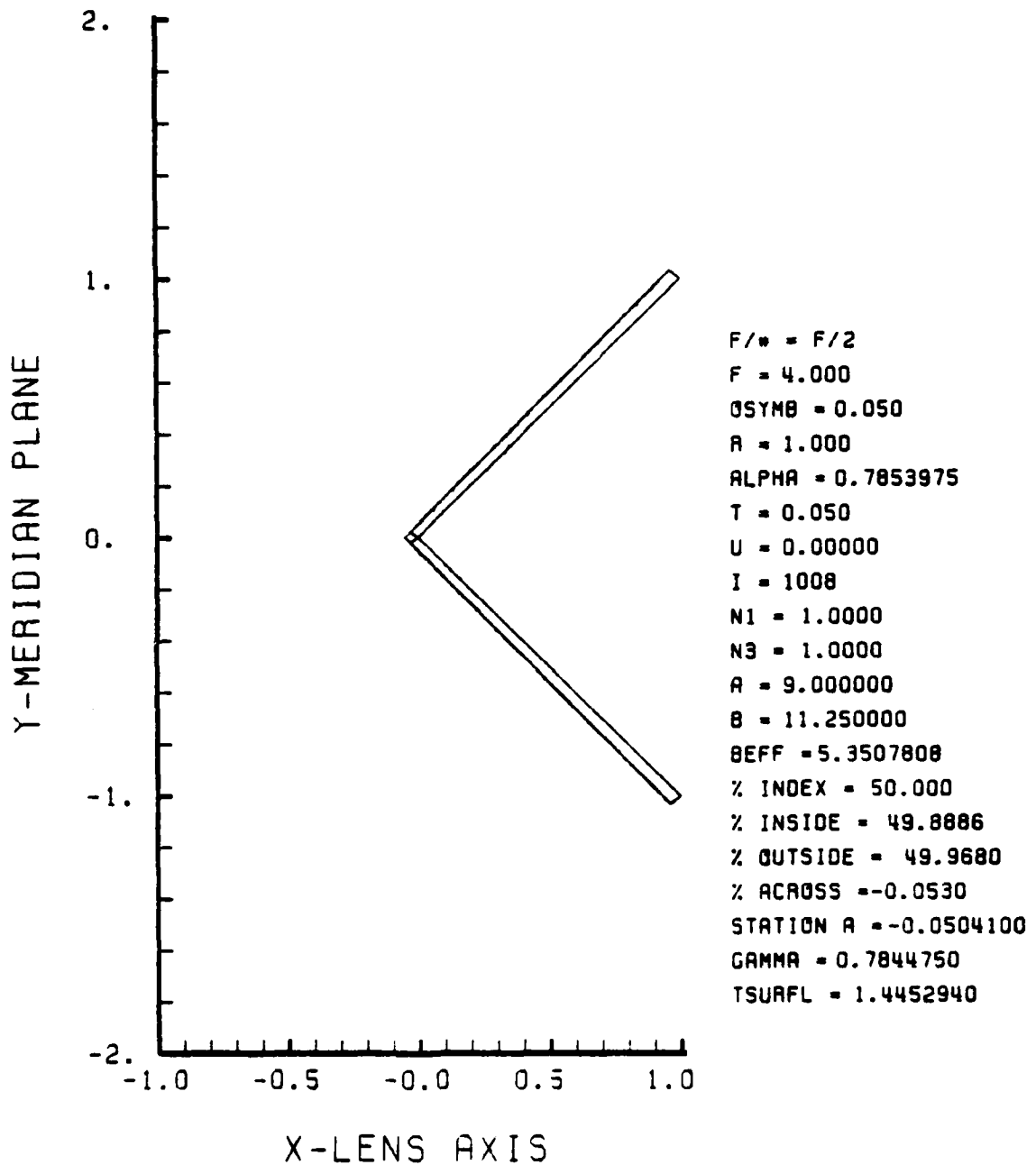

Figure G-1. "Best" GRIN Lens Shape with 50% Gradient, OB = 0.05 and a = 9.00 in the F/2 Configuration

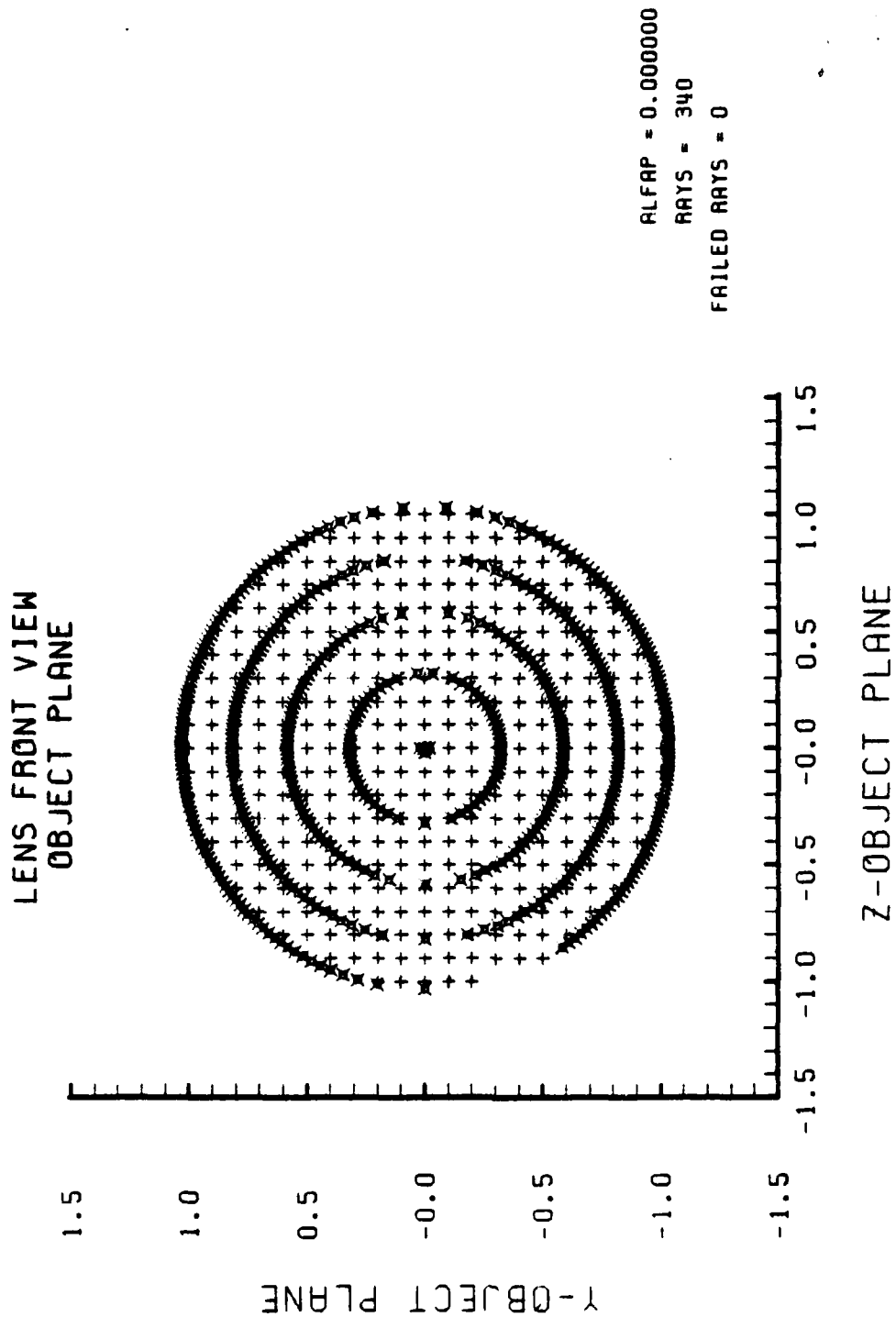

Figure G-2. Grid Plane at $\alpha_p = 0.0$ for Lens of Figure G-1

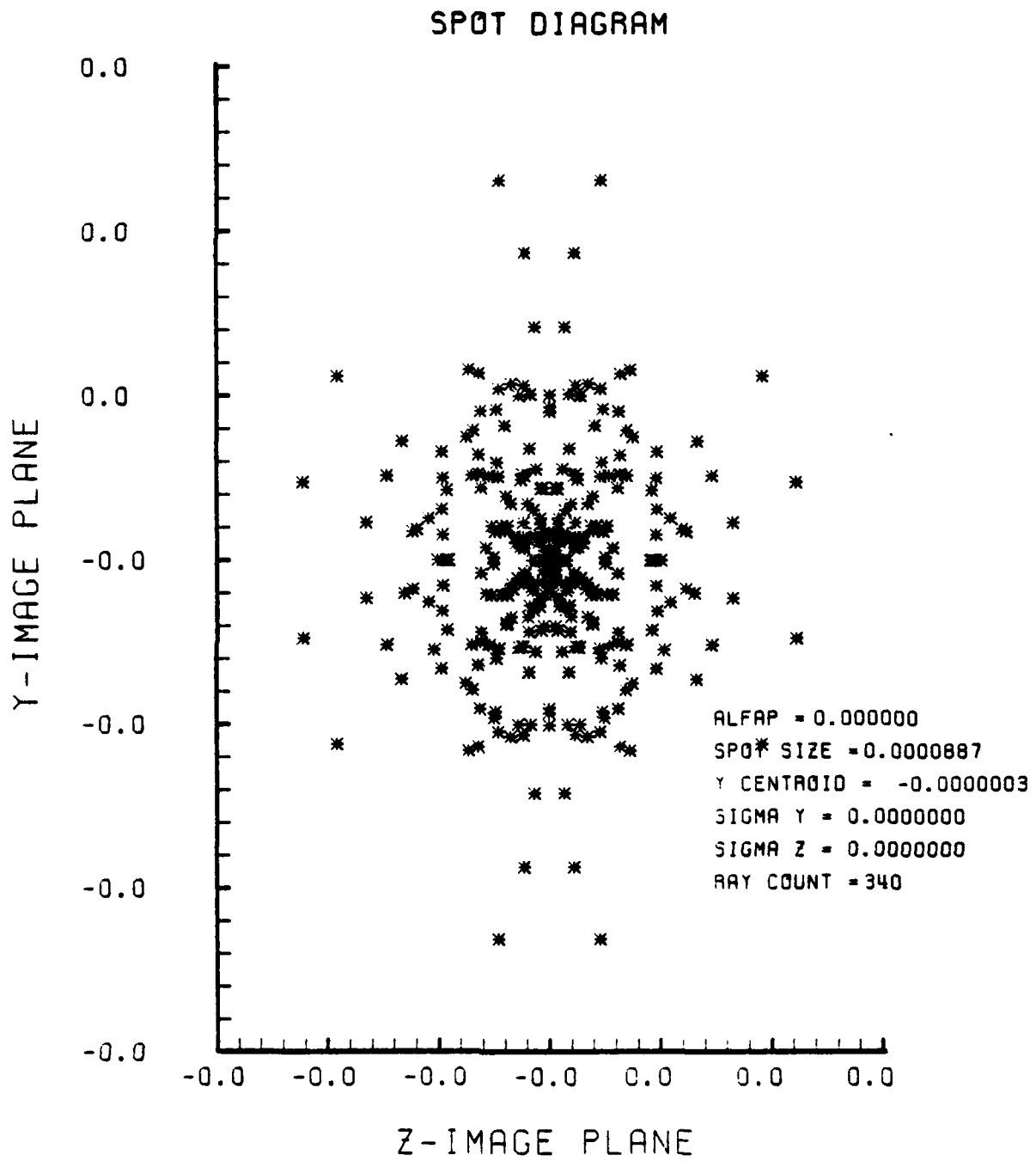

Figure G-3. Spot Diagram for Grid of Figure G-2

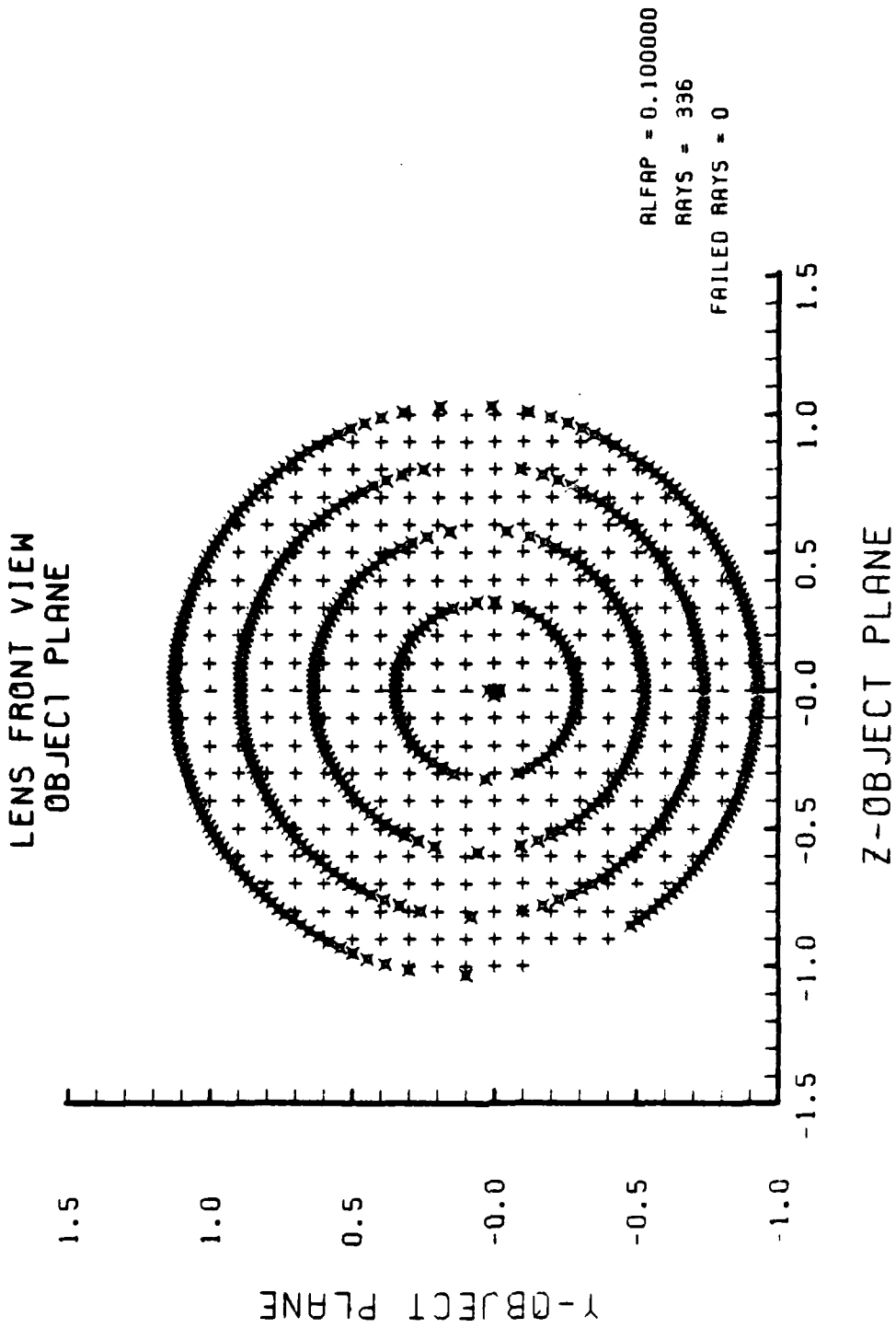

Figure G-4. Grid Plane at $\alpha_p = 0.1$ for Lens of Figure G-1

SPOT DIAGRAM

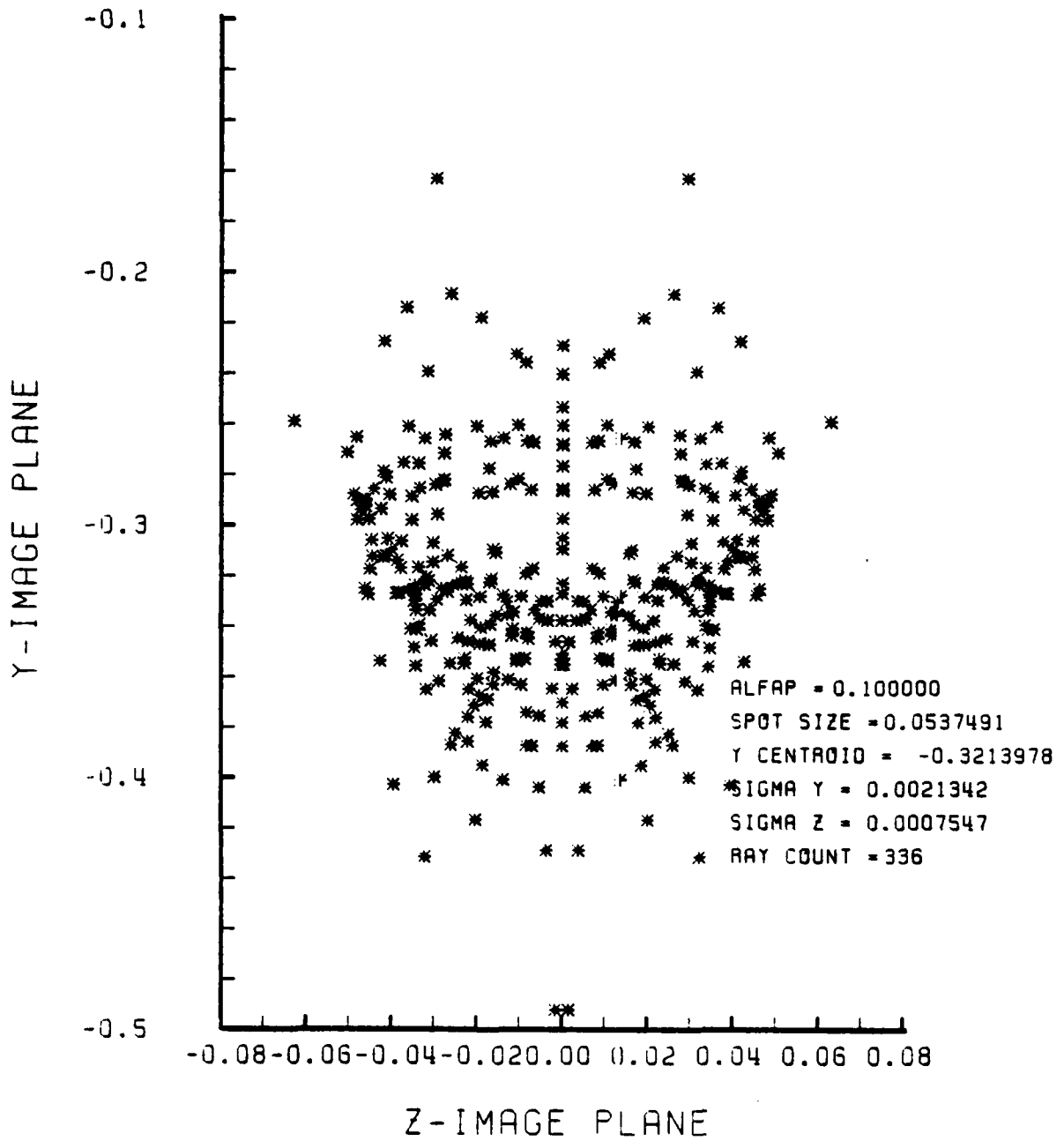

Figure G-5. Spot Diagram for Grid of Figure G-4

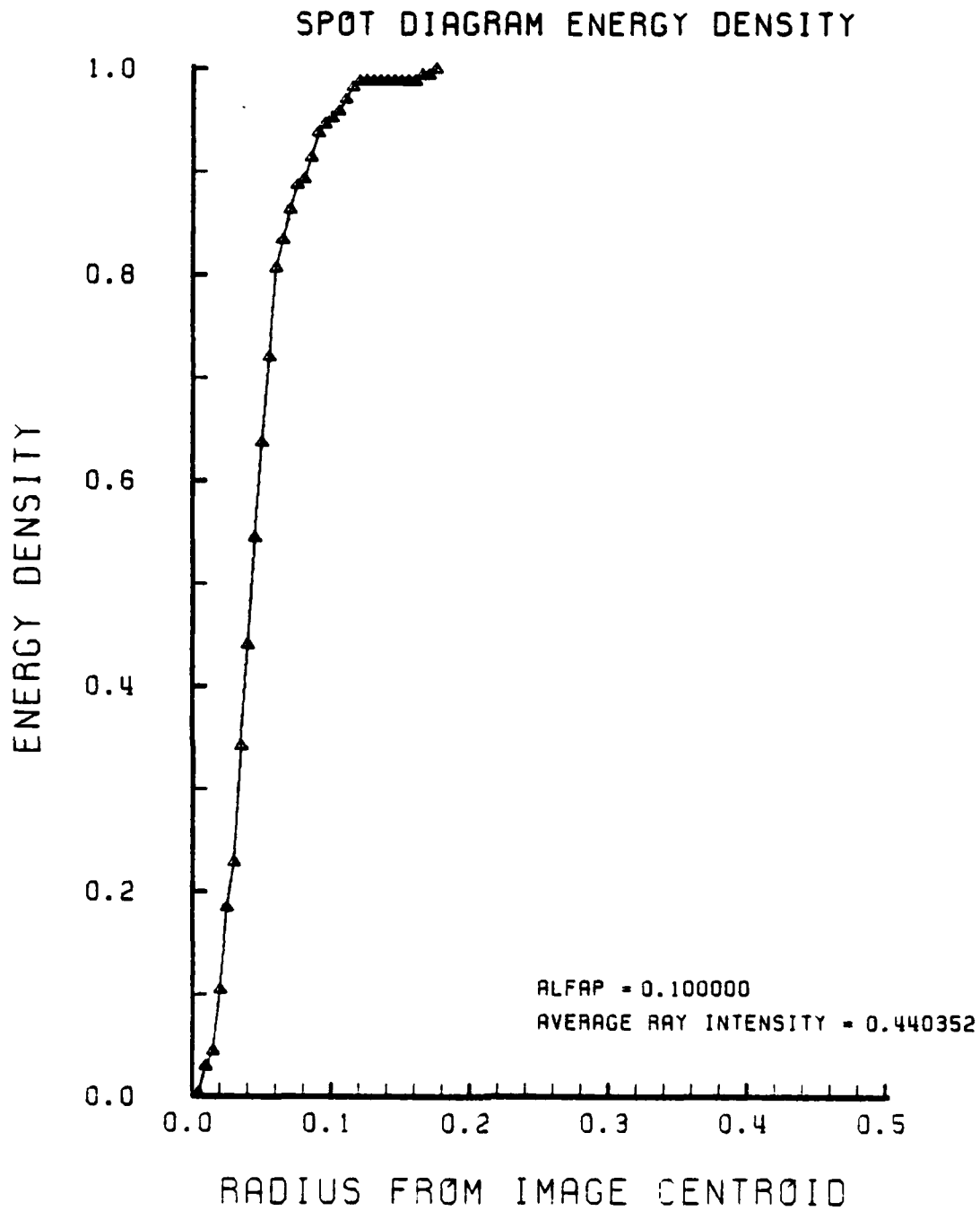

Figure G-6. Encircled Energy of Figure G-5

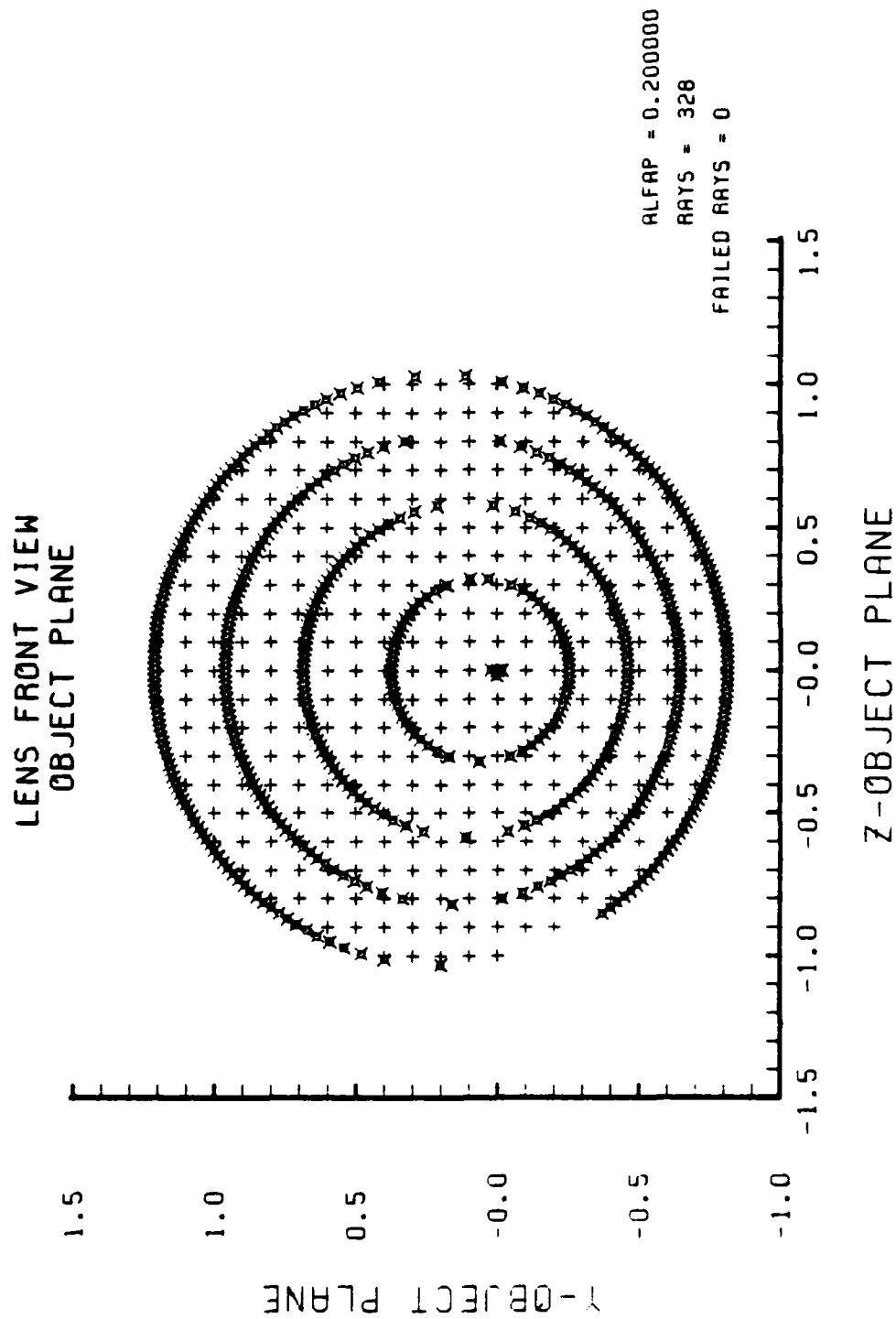

Figure G-7. Grid Plane at $\alpha_p = 0.2$ for Lens of Figure G-1

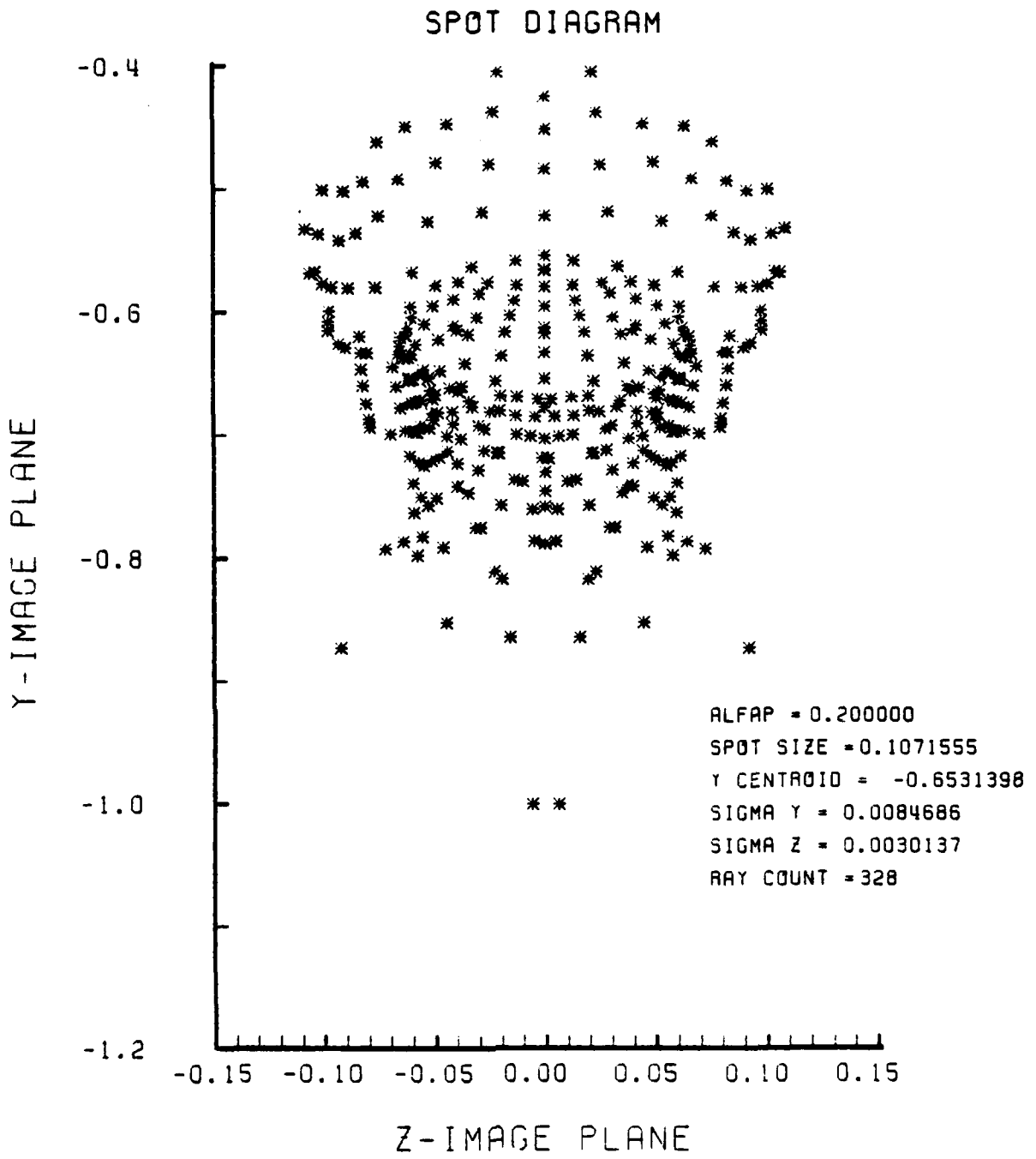

Figure G-8. Spot Diagram for Grid of Figure G-7

SPOT DIAGRAM ENERGY DENSITY

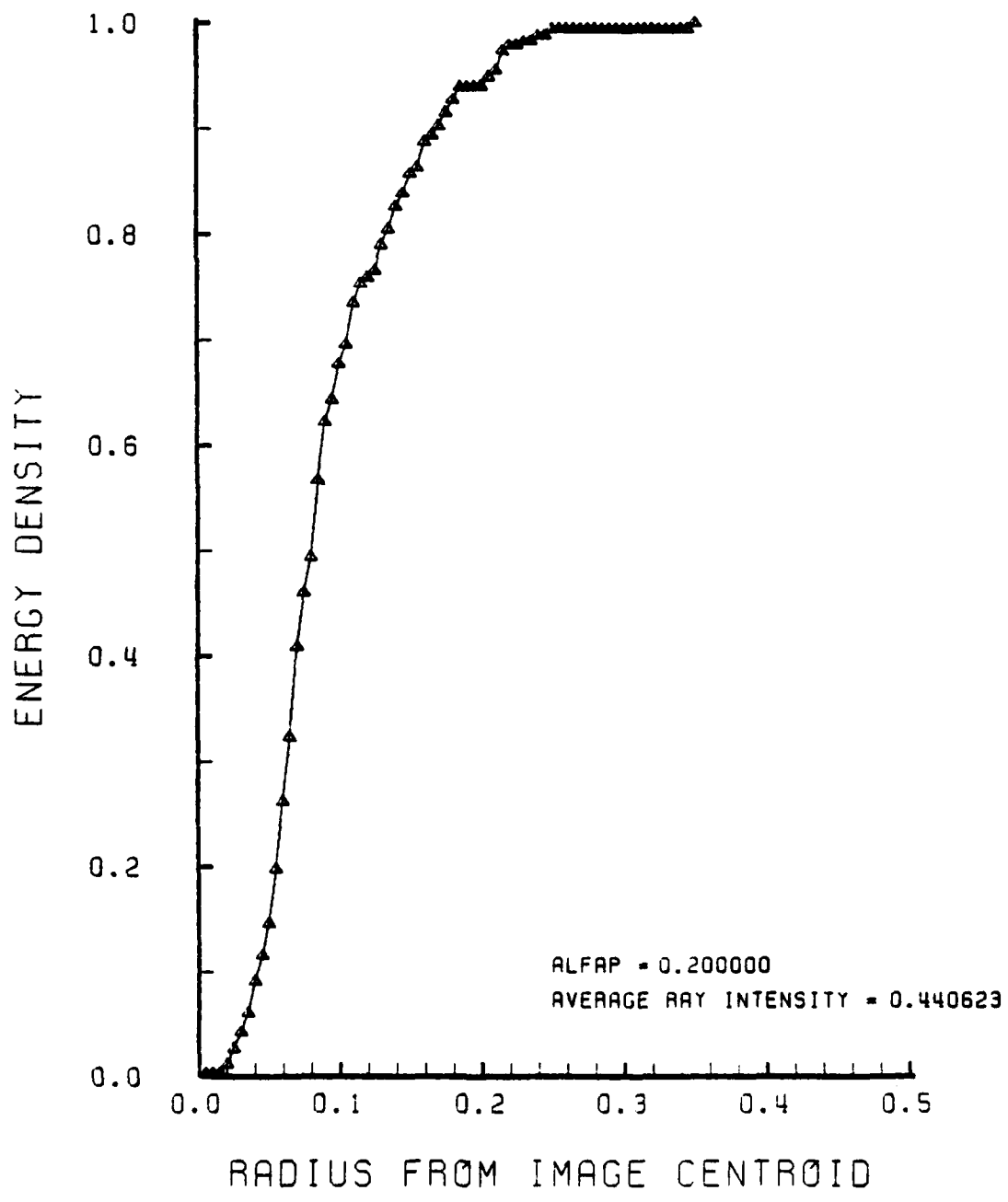

Figure G-9. Encircled Energy of Figure G-8

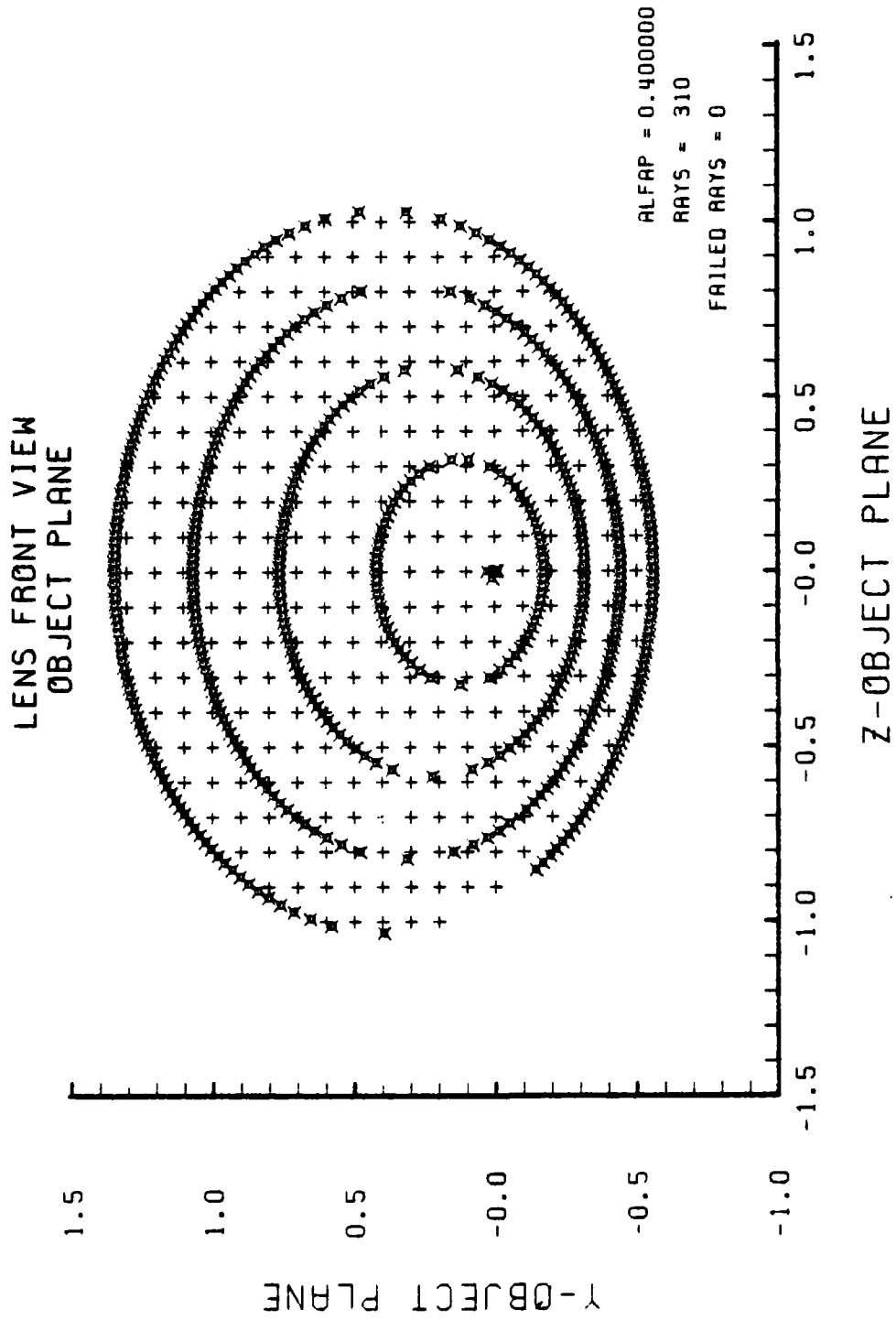

Figure G-10. Grid Plane at $\alpha_p = 0.4$ for Lens of Figure G-1

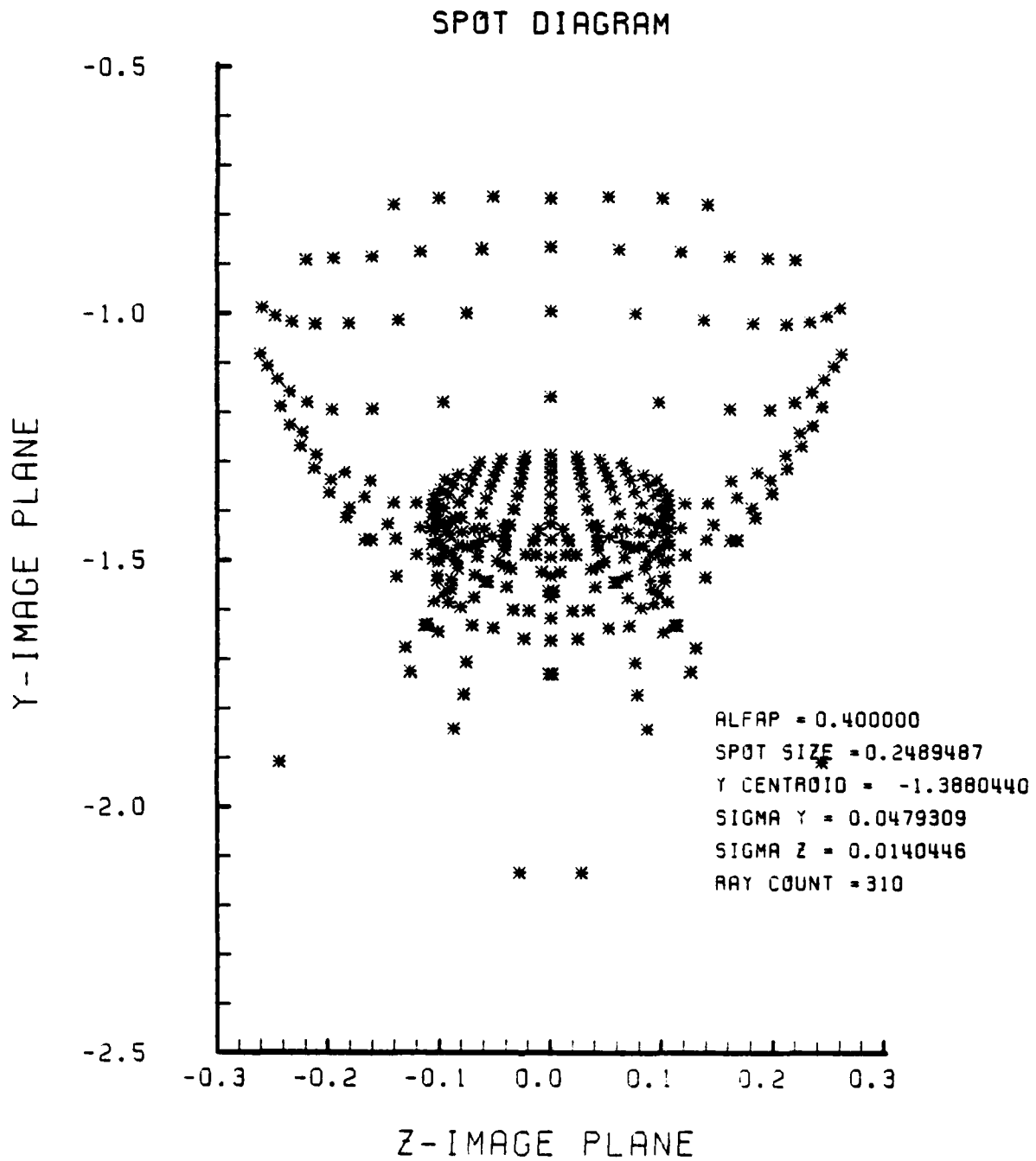

Figure G-11. Spot Diagram for Grid of Figure G-10

SPOT DIAGRAM ENERGY DENSITY

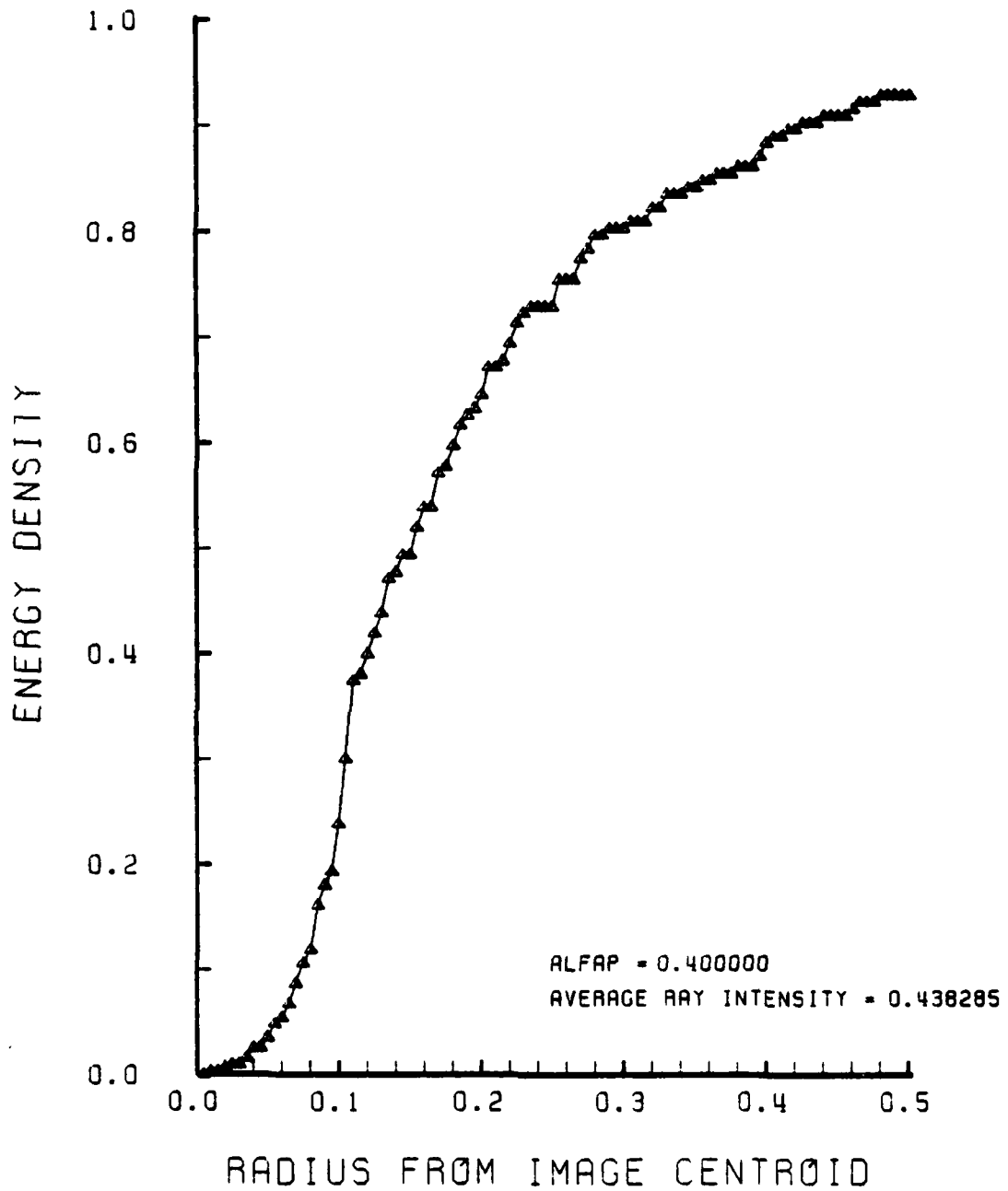

Figure G-12. Encircled Energy of Figure G-11

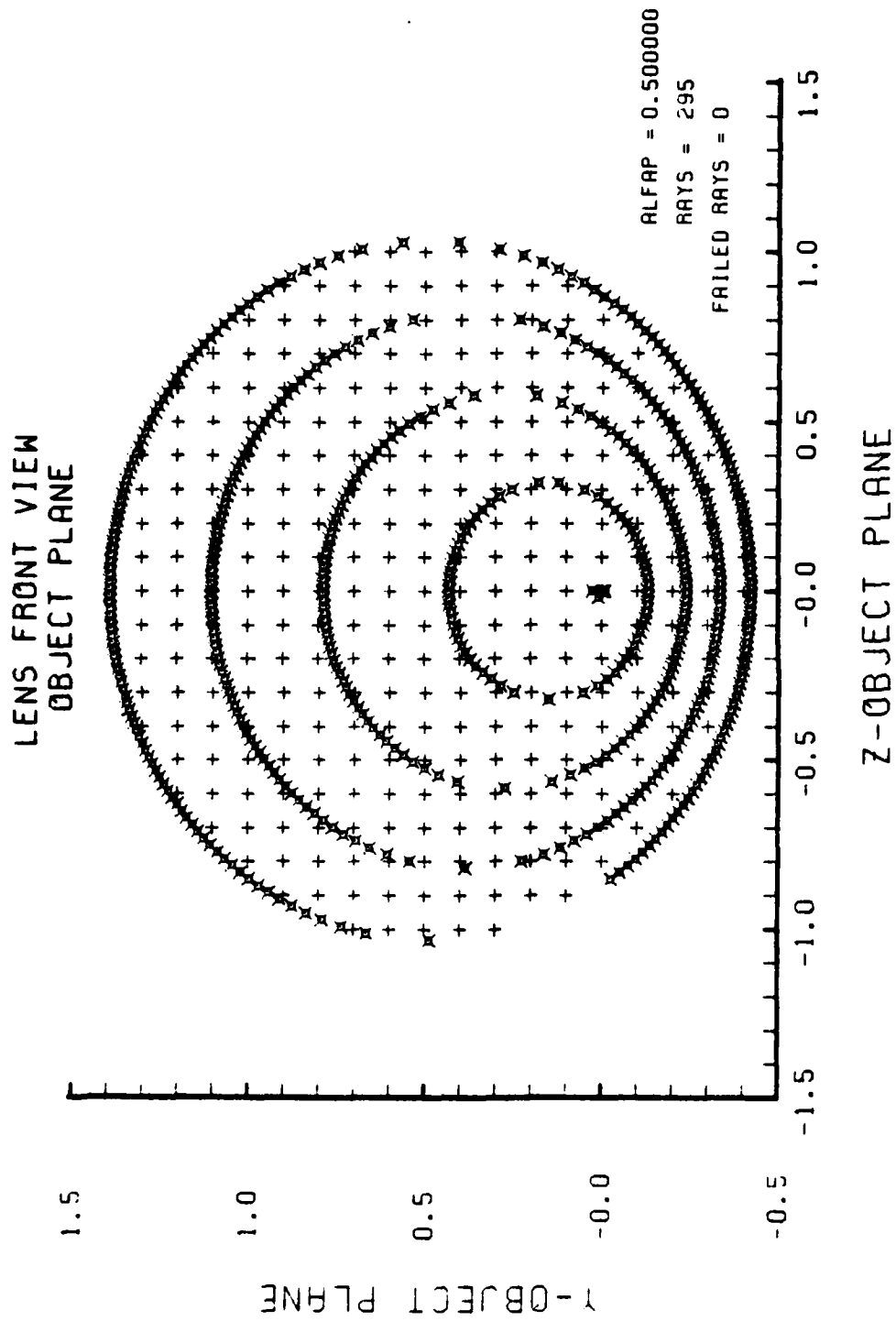

Figure G-13. Grid Plane at $\alpha_p = 0.5$ for Lens of Figure G-1

SPOT DIAGRAM

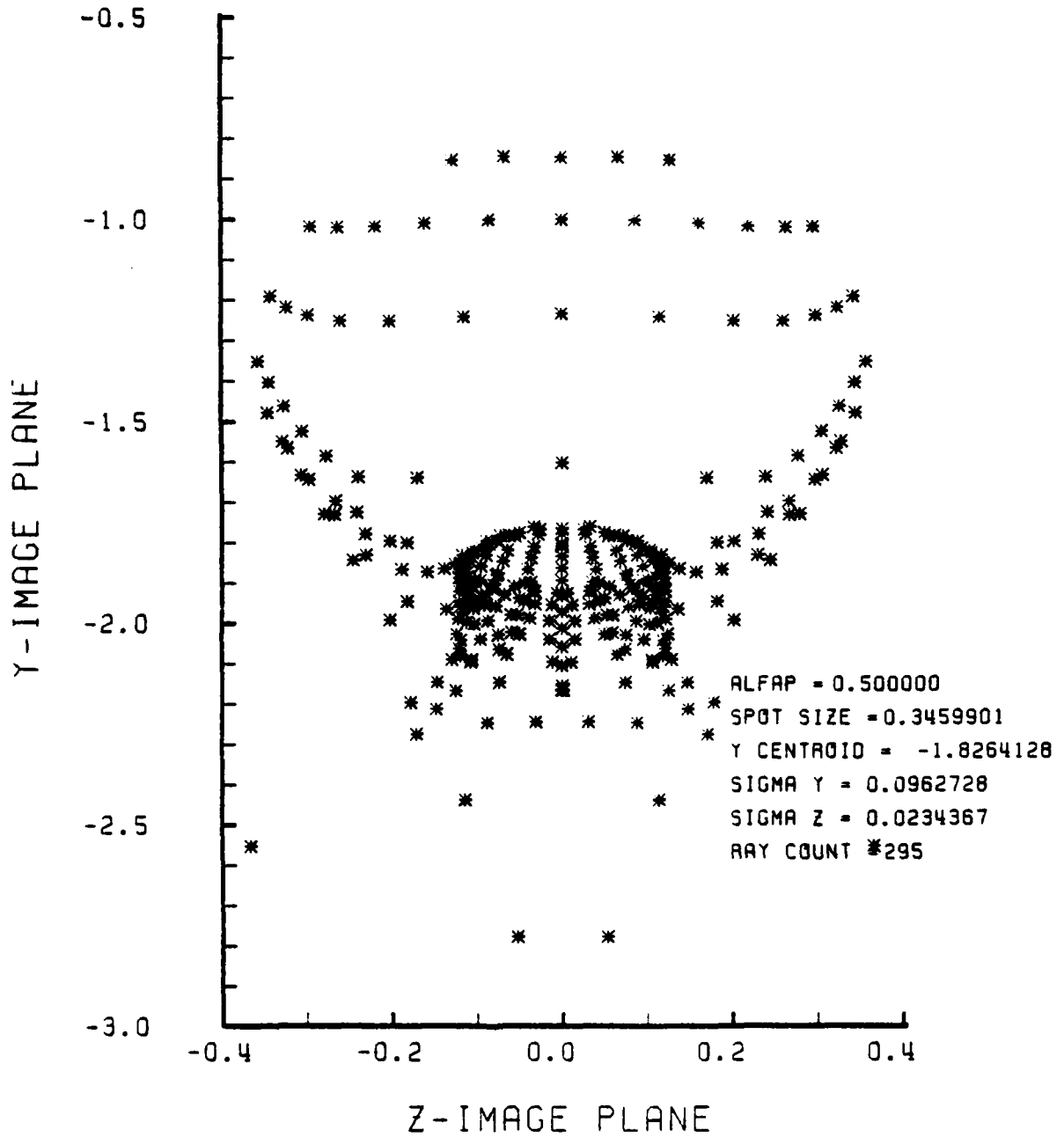

Figure G-14. Spot Diagram for Grid of Figure G-13

SPOT DIAGRAM ENERGY DENSITY

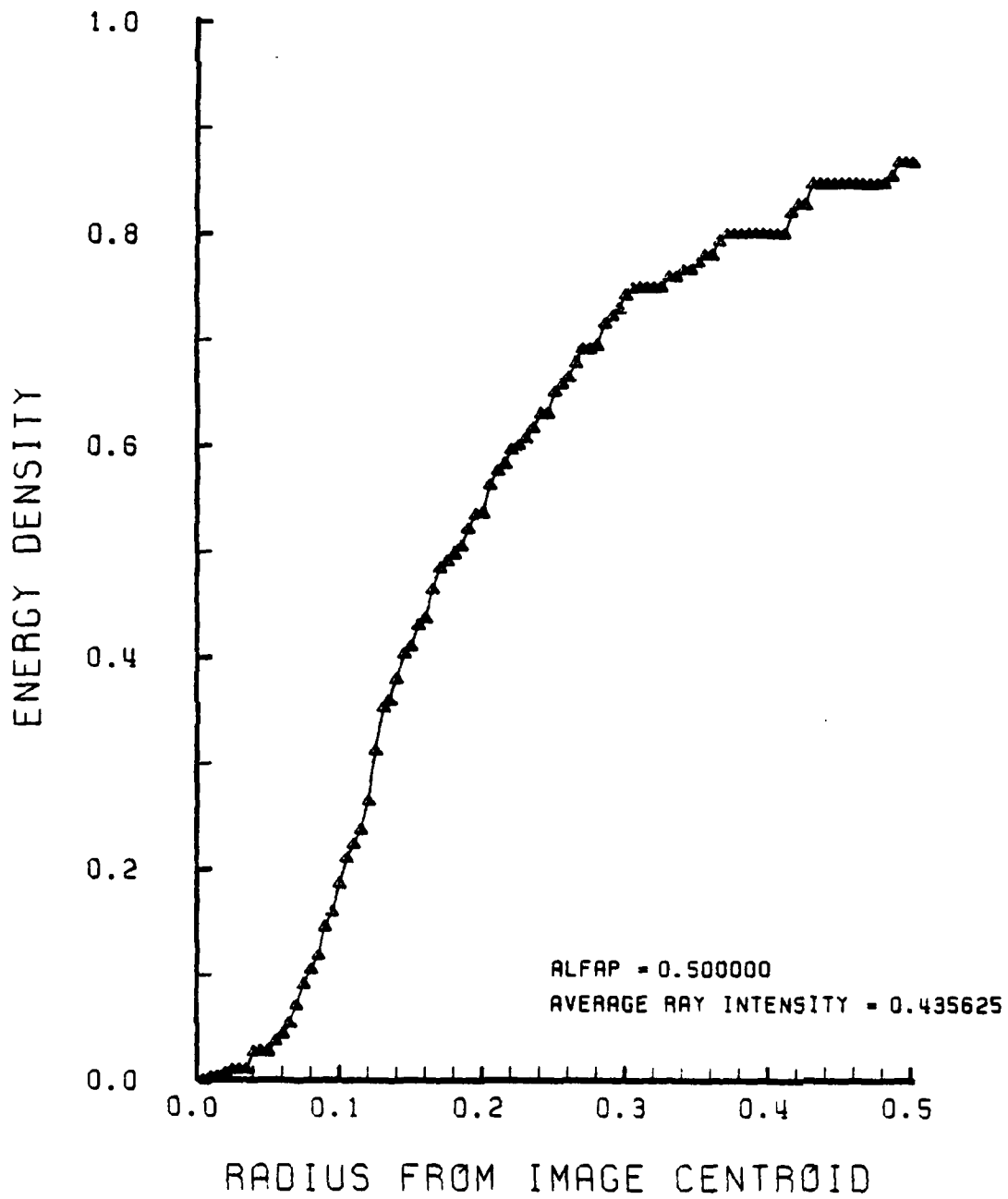

Figure G-15. Encircled Energy of Figure G-14

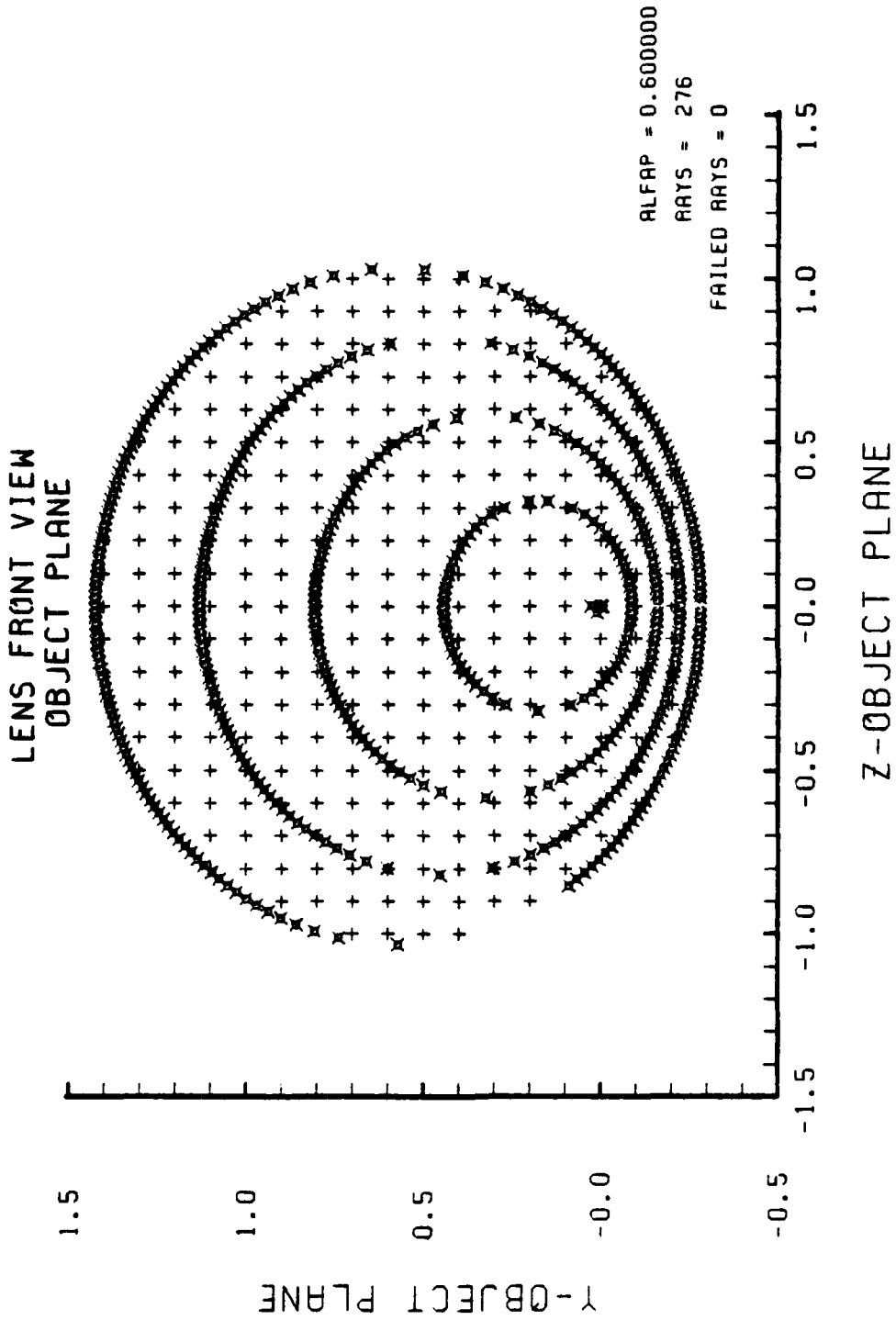

Figure G-16. Grid Plane at $\alpha_p = 0.7$ for Lens of Figure G-1

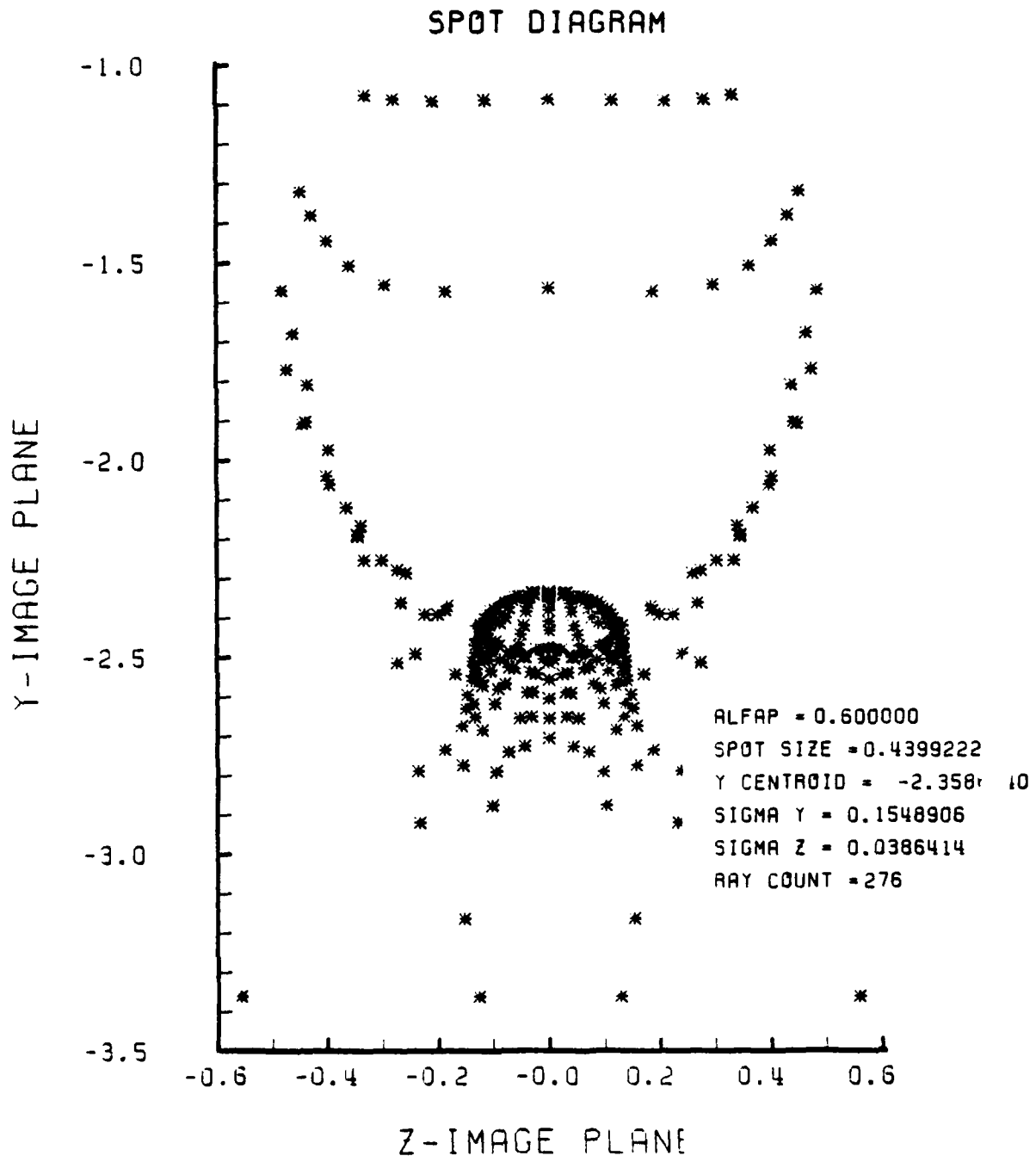

Figure G-17. Spot Diagram for Grid of Figure G-16

SPOT DIAGRAM ENERGY DENSITY

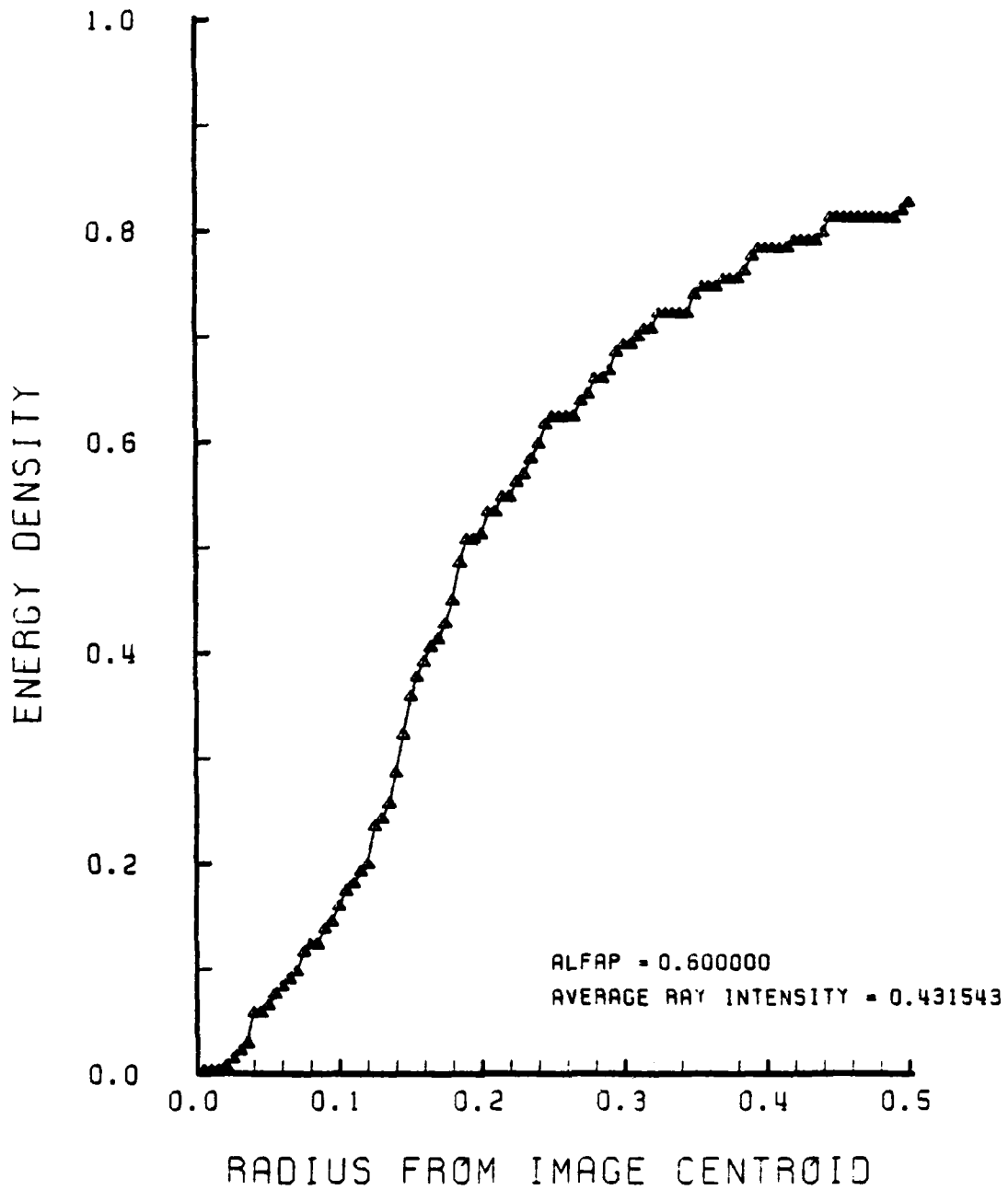

Figure G-18. Encircled Energy of Figure G-17

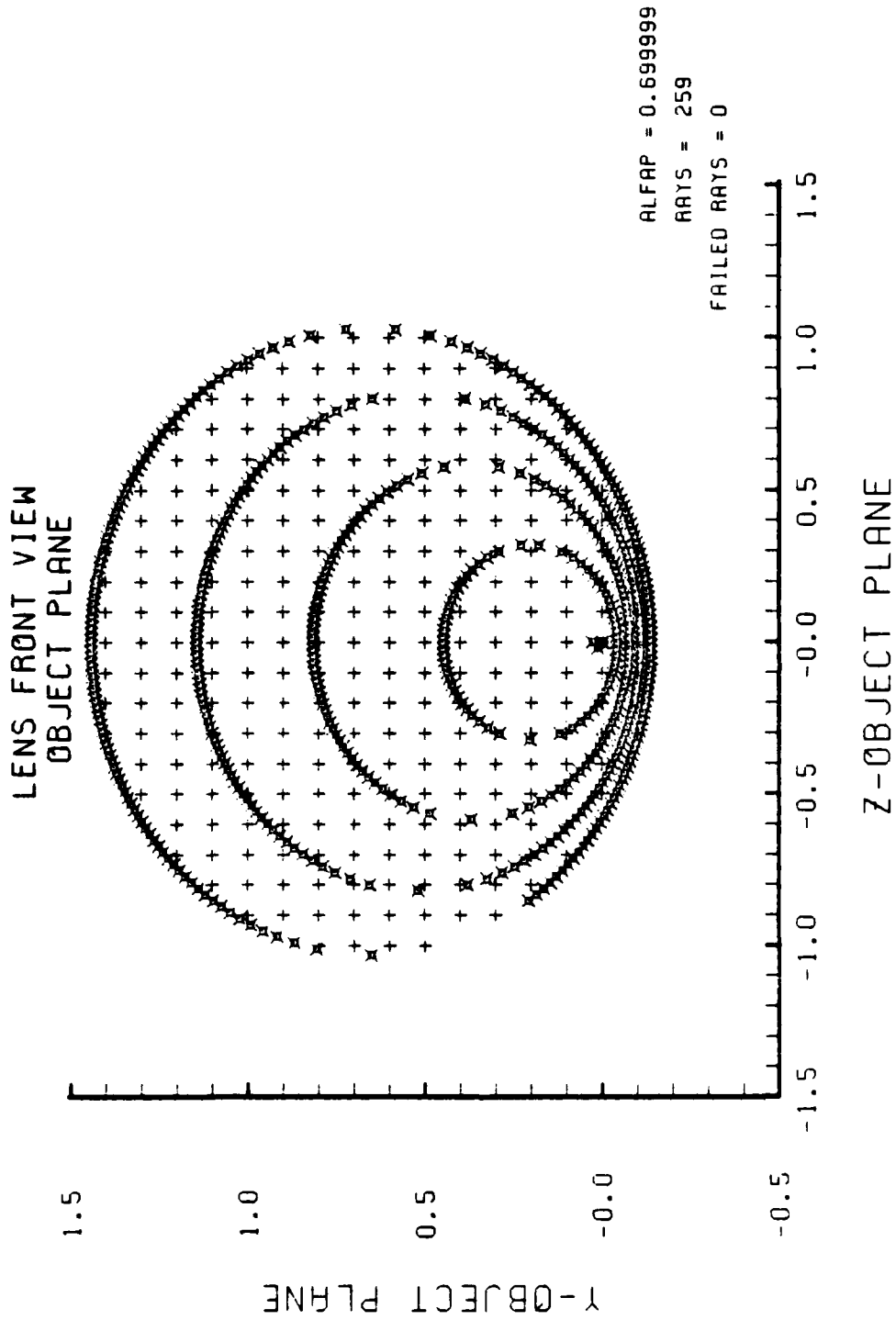

Figure G-19. Grid Plane at $\alpha_p = 0.7$ for Lens of Figure G-1

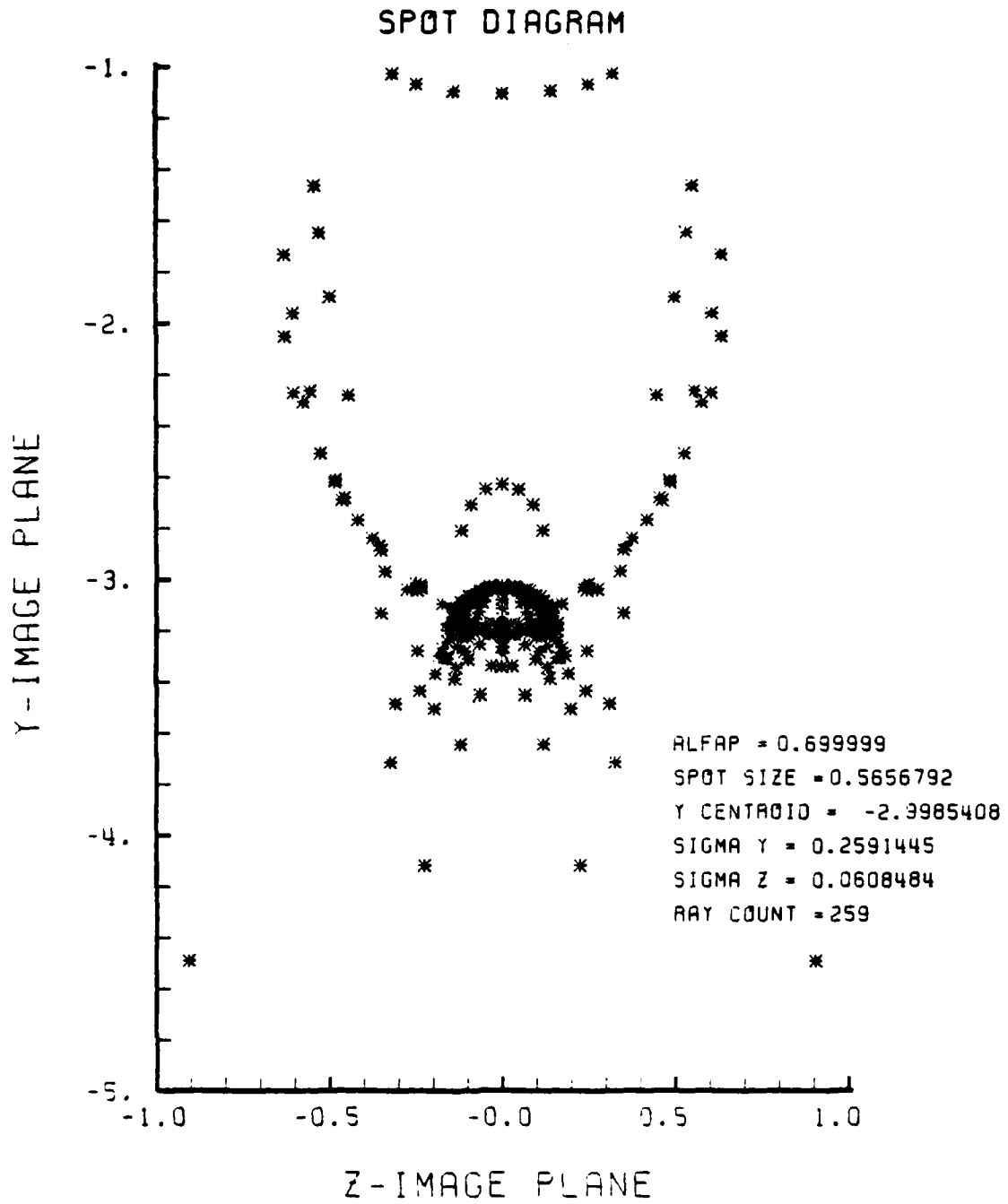

Figure G-20. Spot Diagram for Grid of Figure G-19

SPOT DIAGRAM ENERGY DENSITY

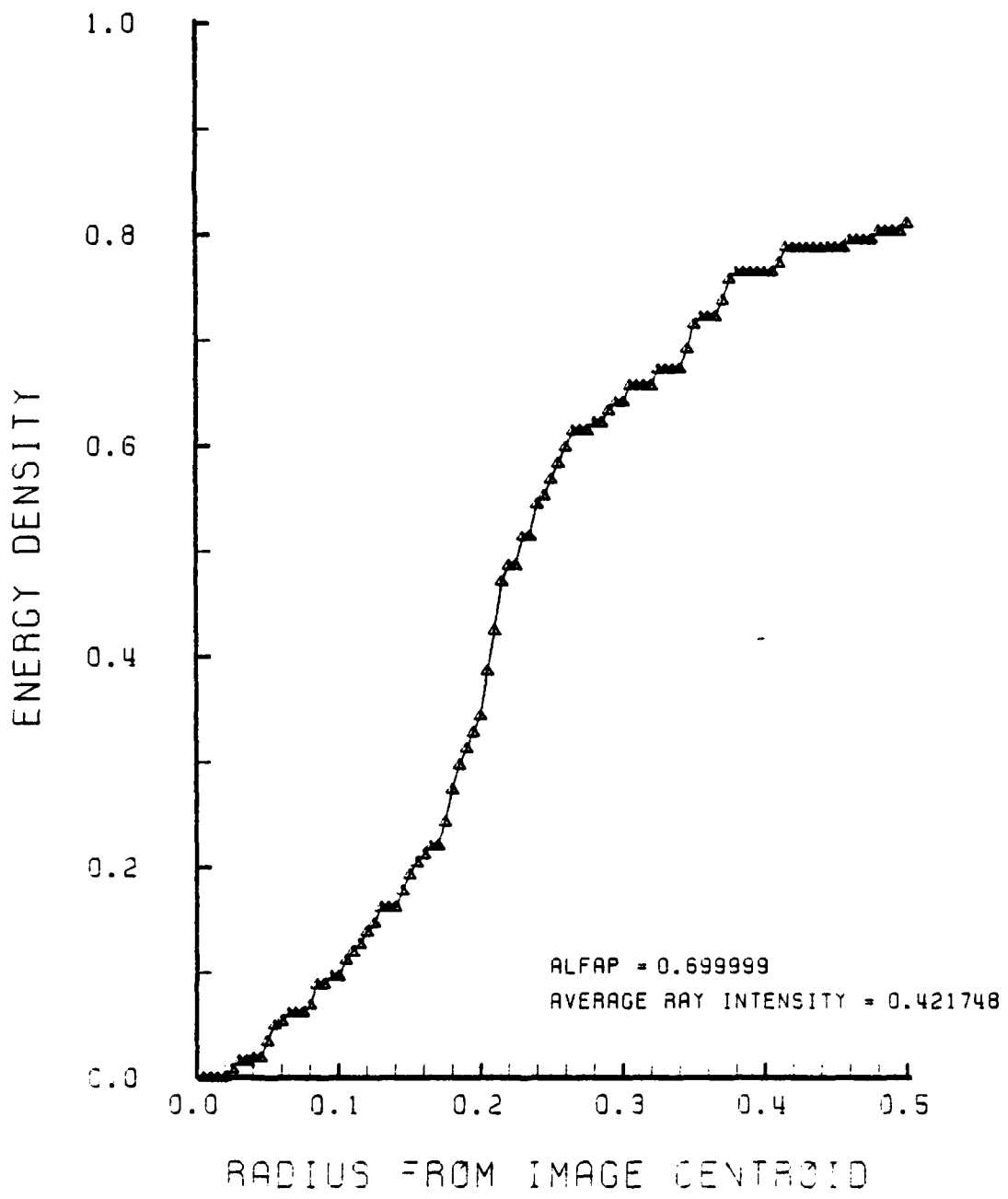

Figure G-21. Encircled Energy of Figure G-20

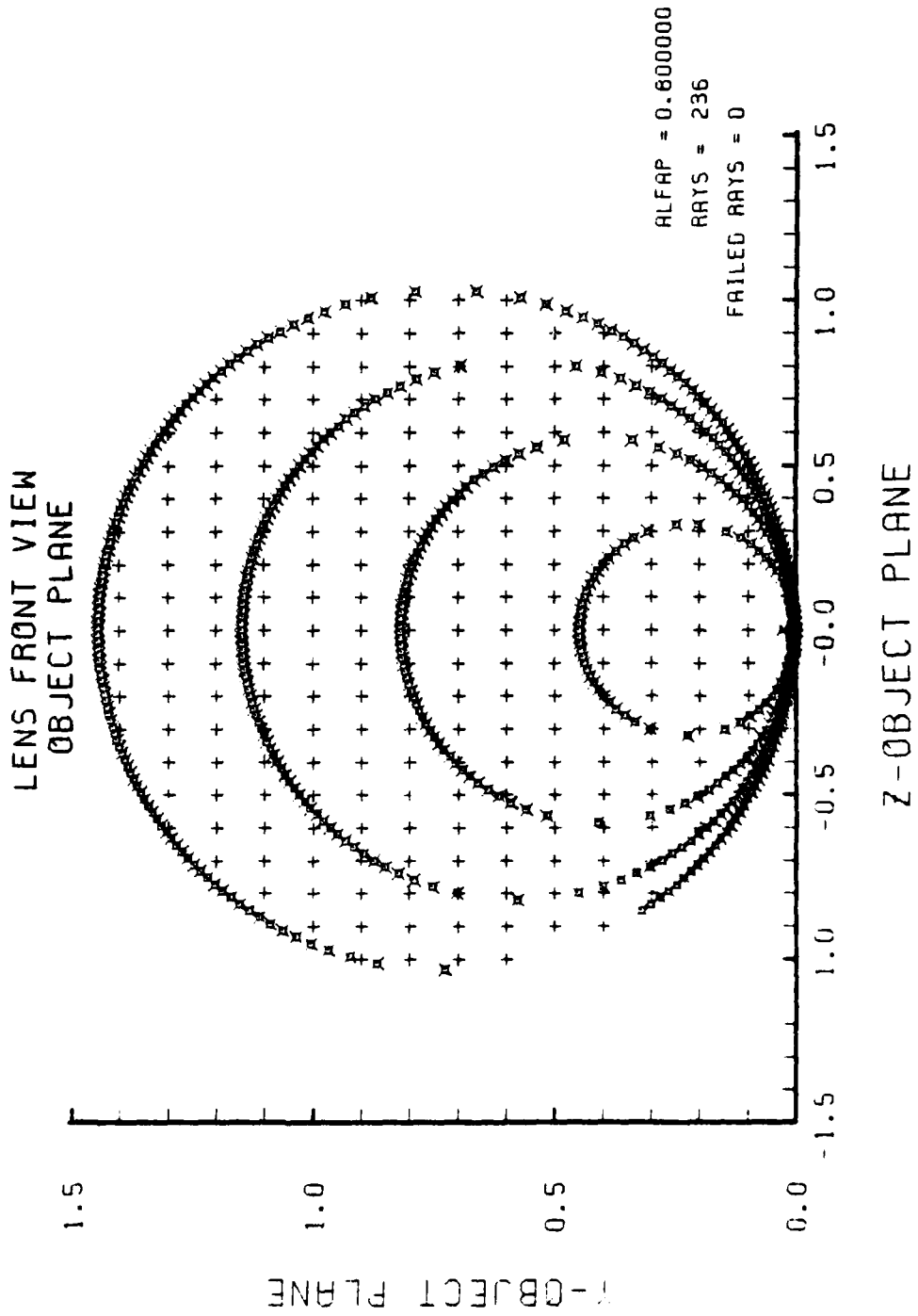

Figure G-22. Grid Plane at $\alpha_p = 0.8$ for Lens of Figure G-1

SPOT DIAGRAM

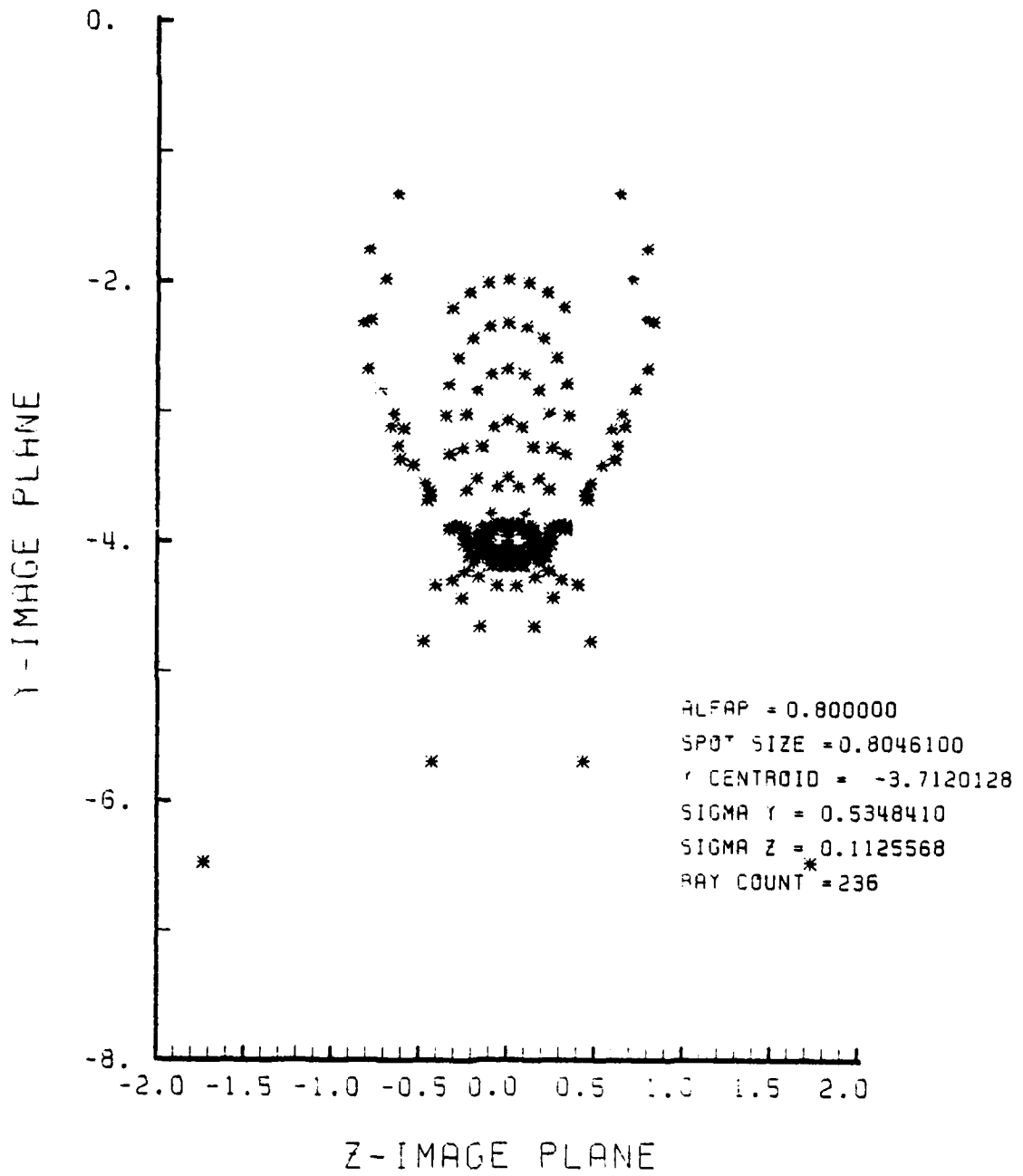

Figure G-23. Spot Diagram for Grid of Figure G-22

SPOT DIAGRAM ENERGY DENSITY

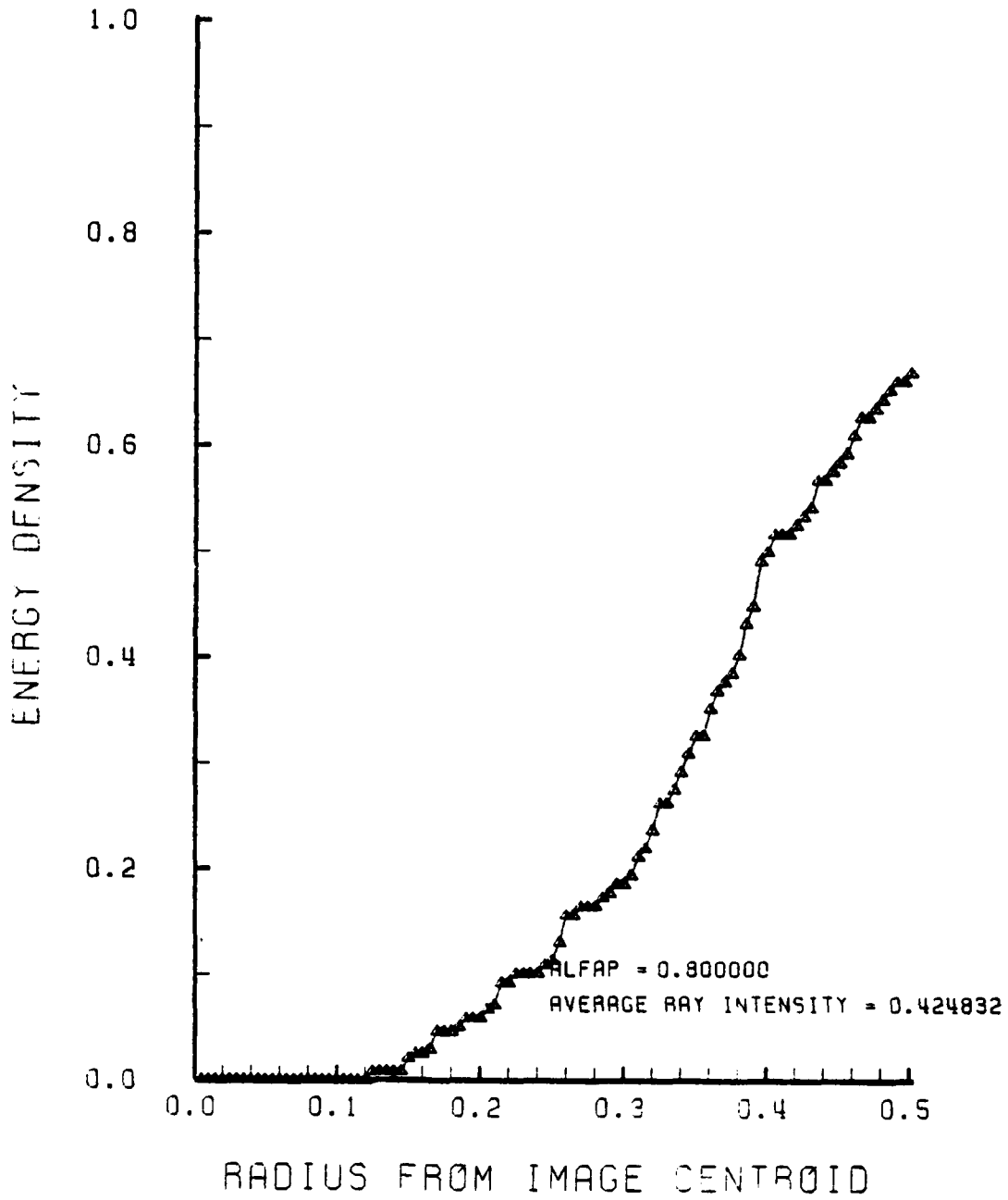

Figure G-24. Encircled Energy of Figure G-23

APPENDIX H

"BEST" GRIN LENS PERFORMANCE PLOTS IN THE F/1 CONFIGURATION

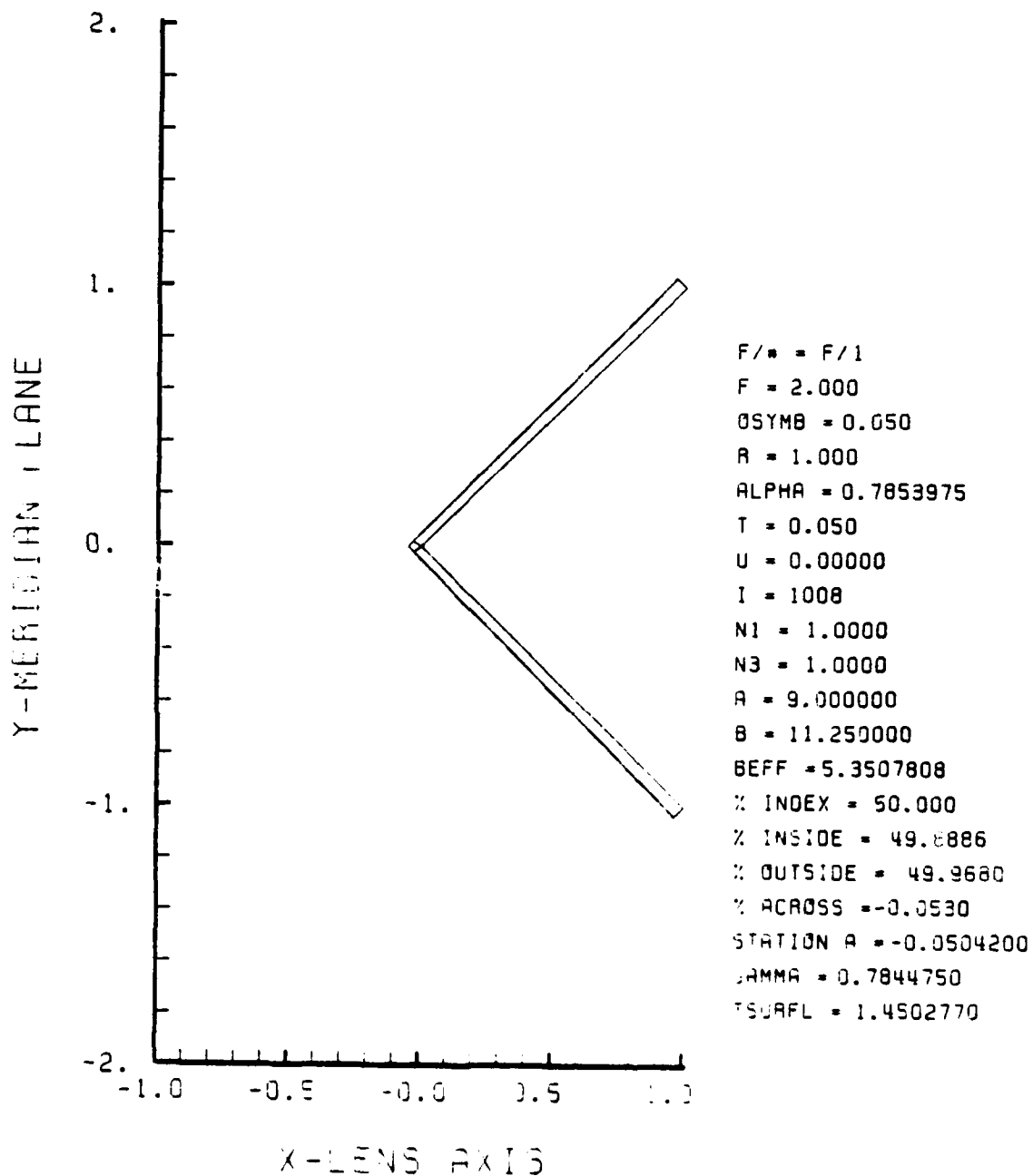
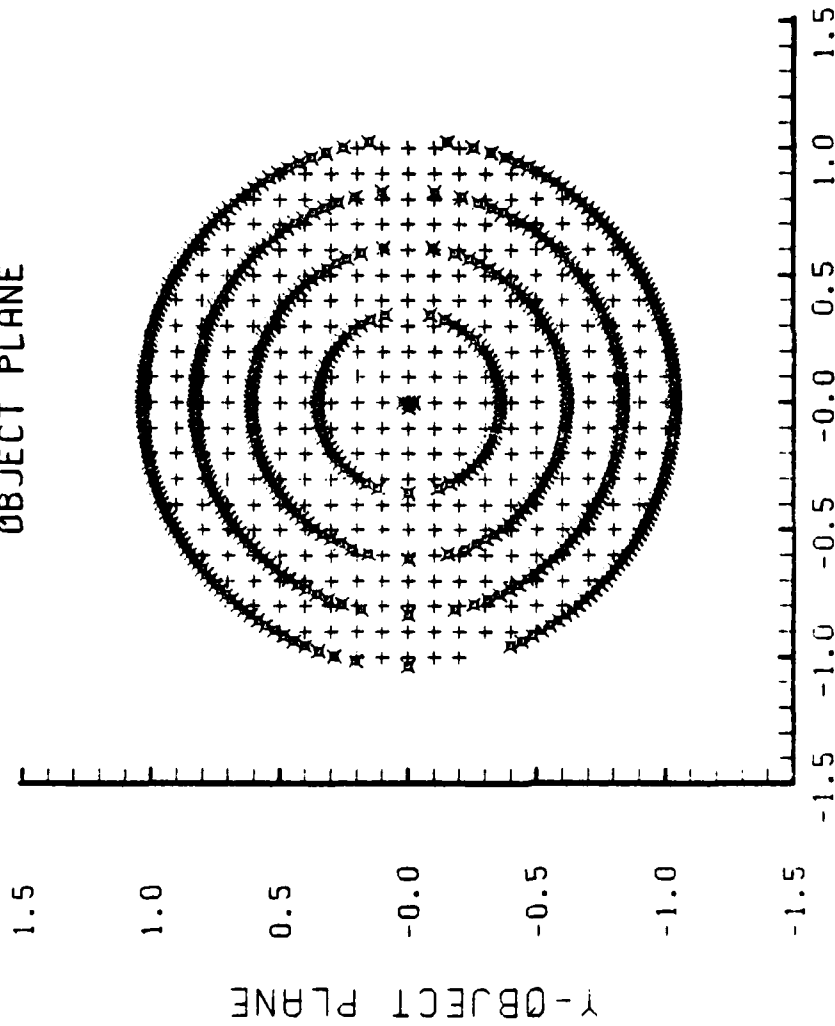

Figure H-1. "Best" GRIN Lens Shape with 50% Gradient, OB = 0.05, and a = 9.00 in the F/1 Configuration

LENS FRONT VIEW
OBJECT PLANE



ALFAP = 0.000000
RAYS = 340
FAILED RAYS = 0

Figure H-2. Grid Plane at $\alpha_p = 0.0$ for Lens of Figure H-1

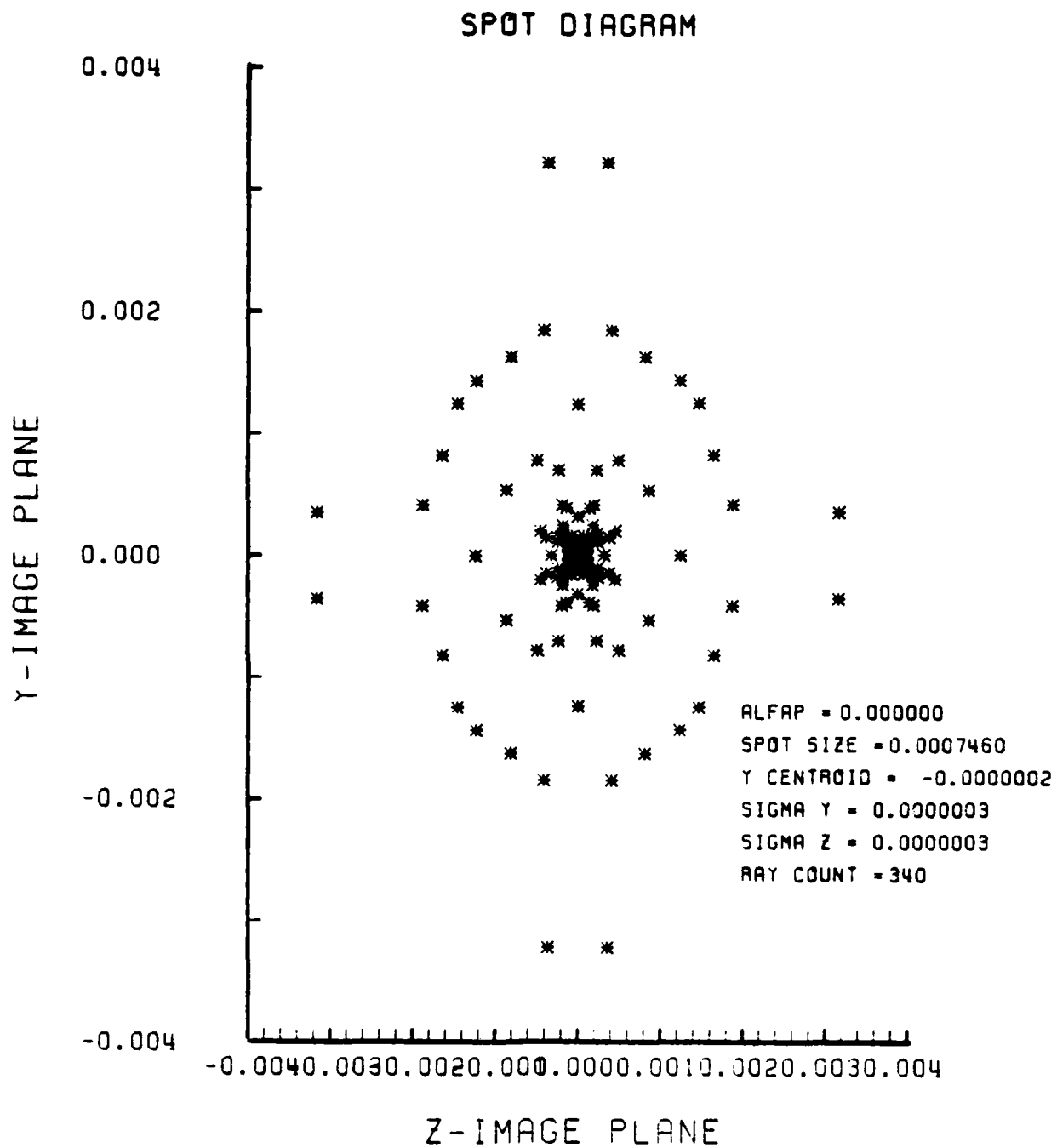

Figure H-3. Spot Diagram for Grid of Figure H-2

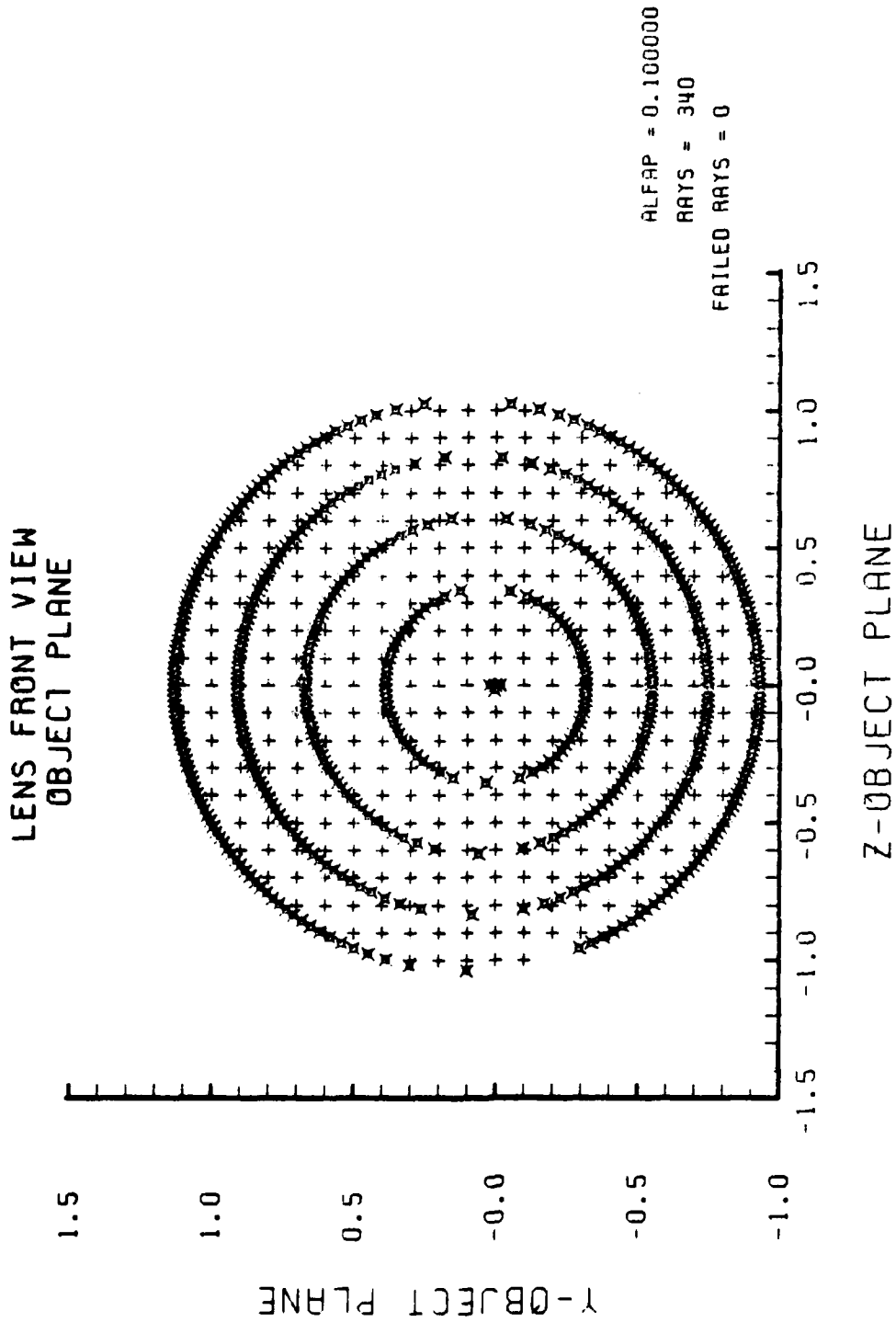

Figure H-4. Grid Plane at $\alpha_p = 0.1$ for Lens of Figure H-1

SPOT DIAGRAM

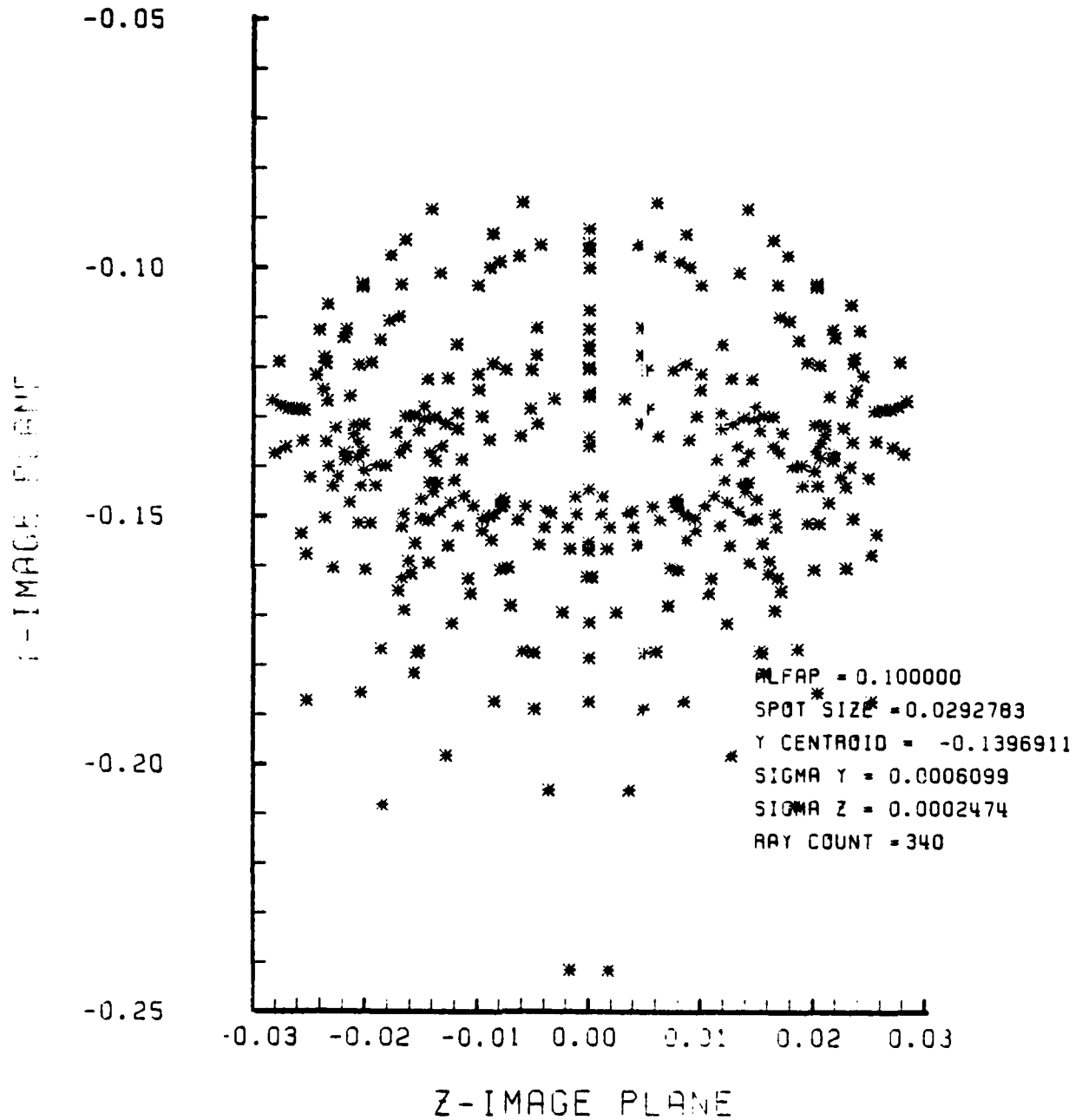

Figure H-5. Spot Diagram for Grid of Figure H-4

SPOT DIAGRAM ENERGY DENSITY

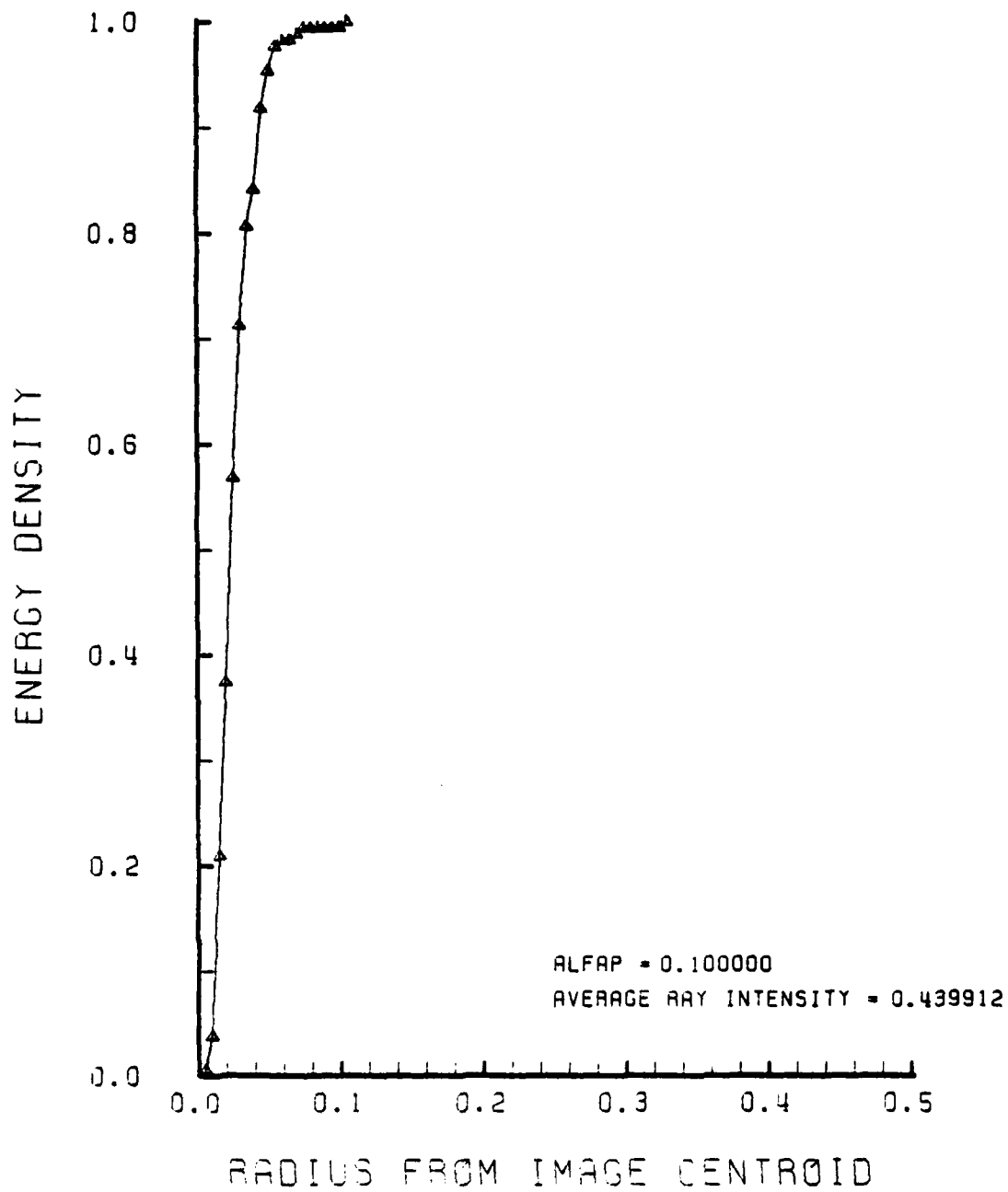

Figure H-6. Encircled Energy of Figure H-5

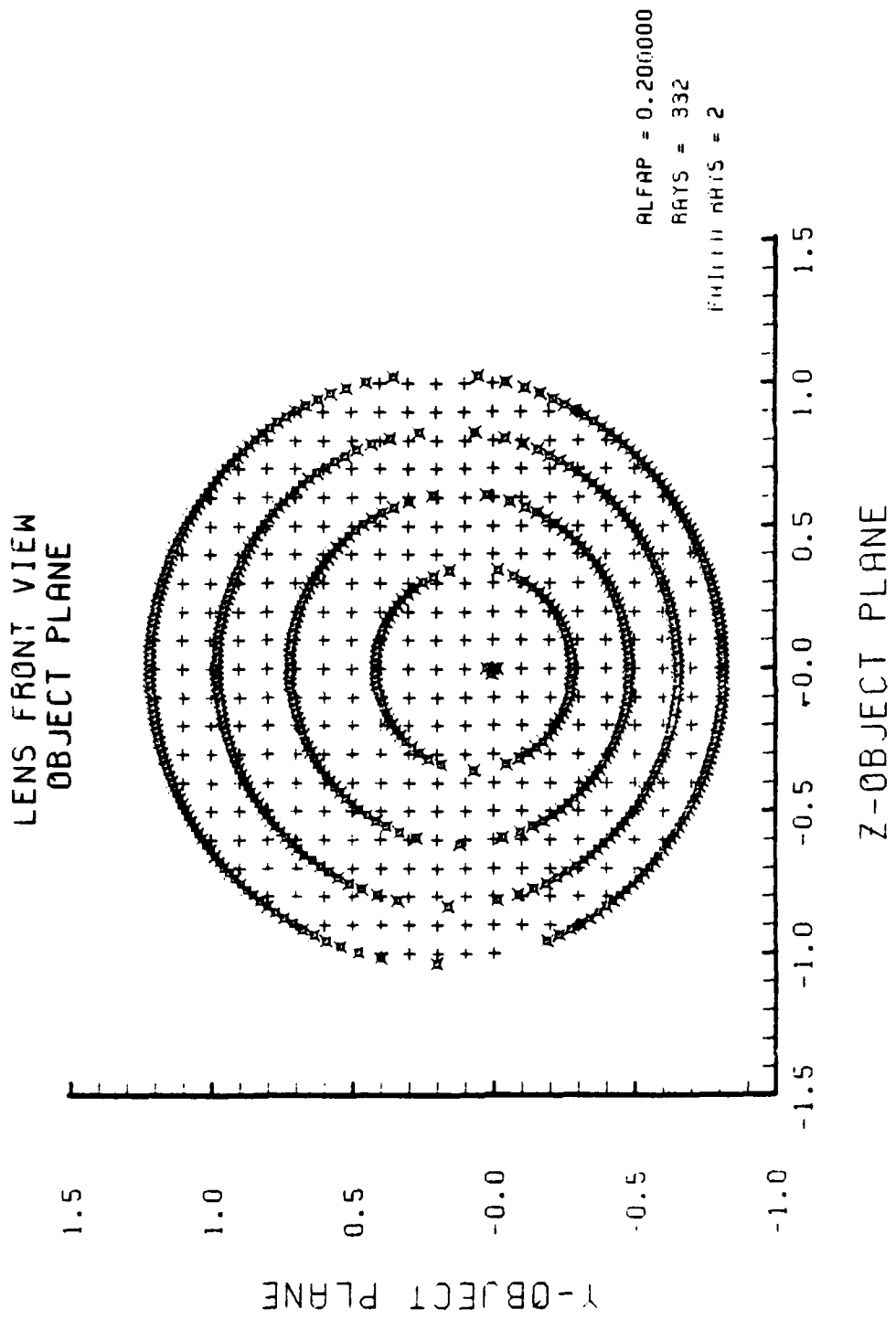

Figure H-7. Grid Plane at $\alpha_p = 0.2$ for Lens of Figure H-1

SPOT DIAGRAM

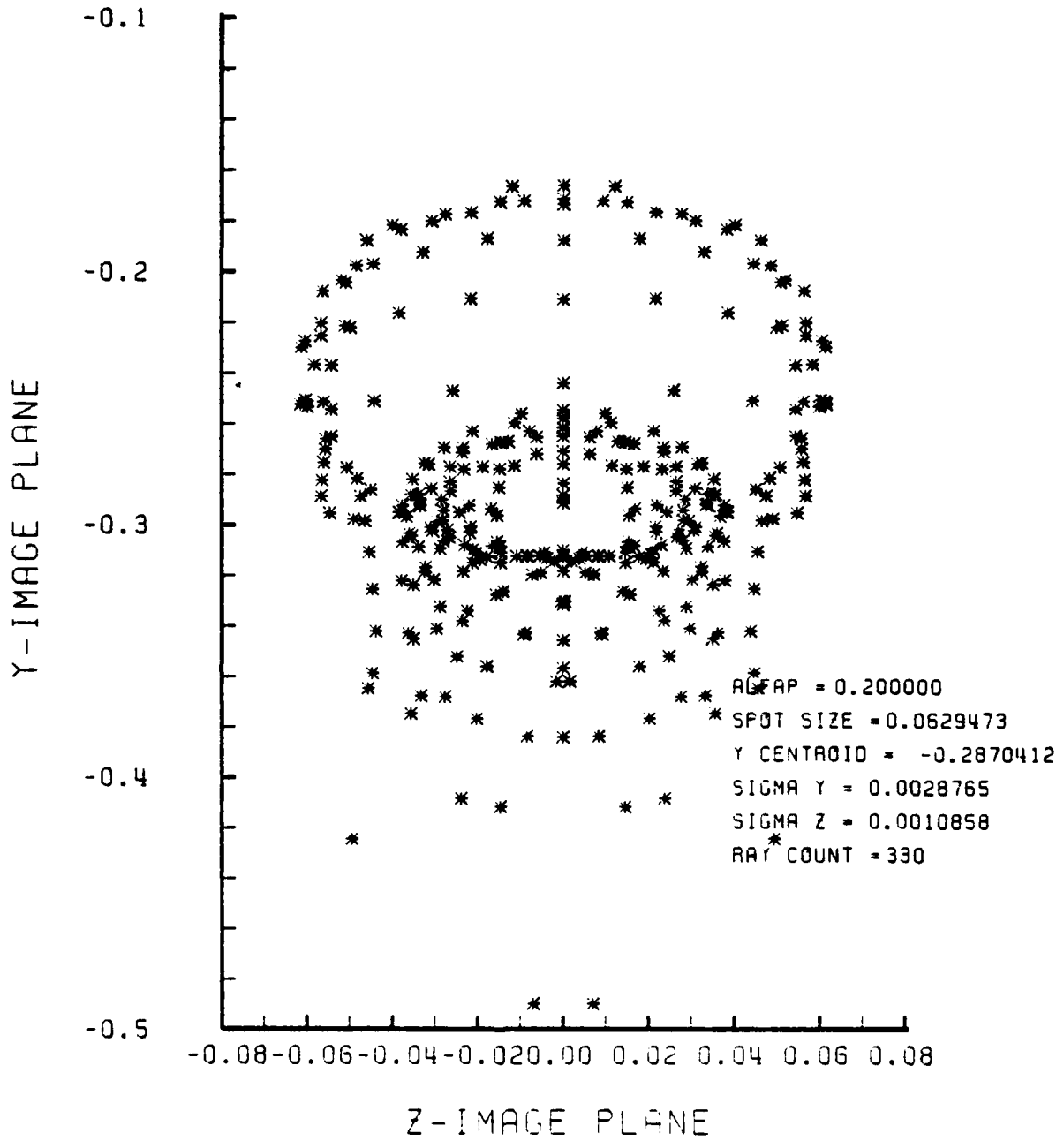

Figure H-8. Spot Diagram for Grid of Figure H-7

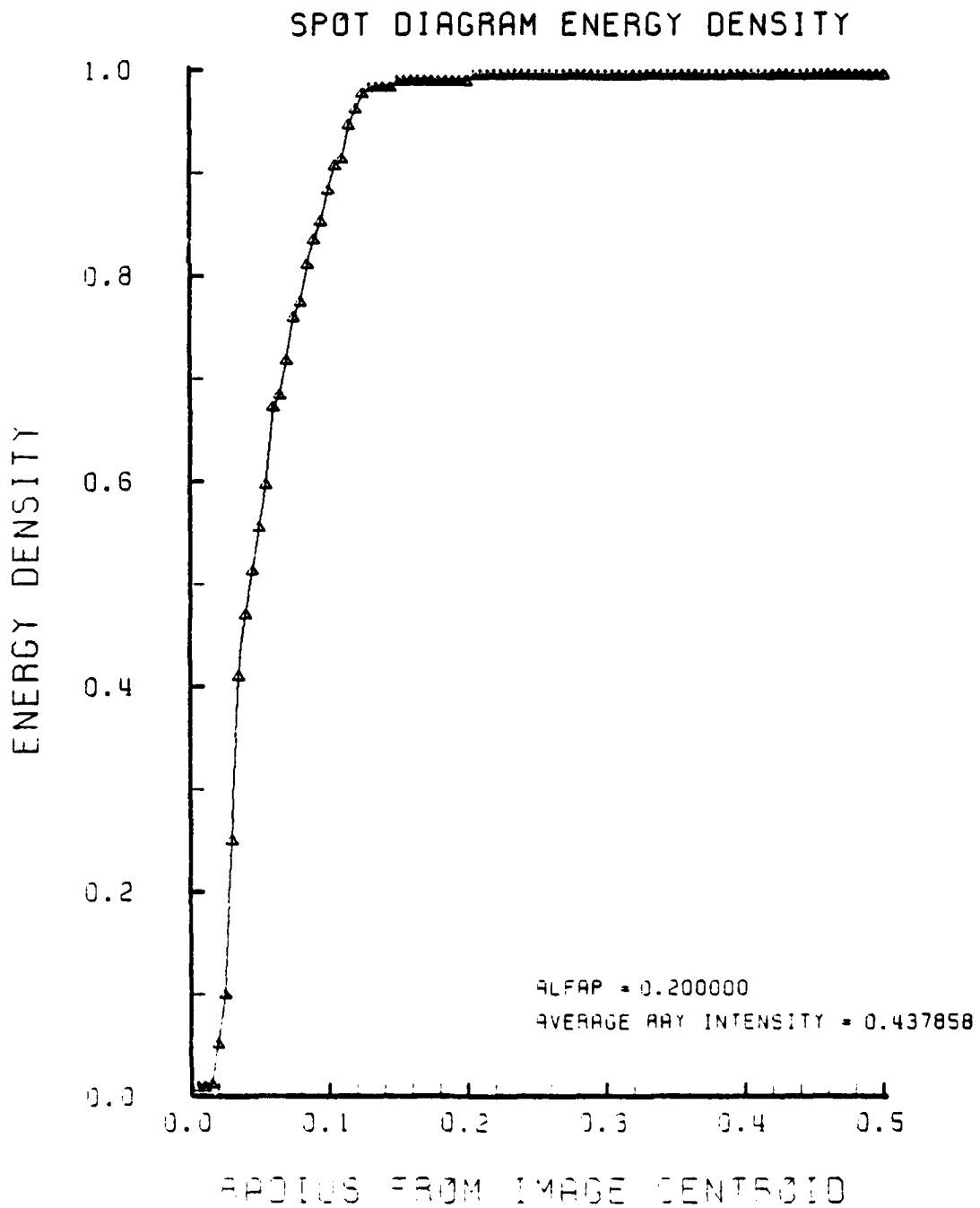

Figure H-9. Encircled Energy of Figure H-8

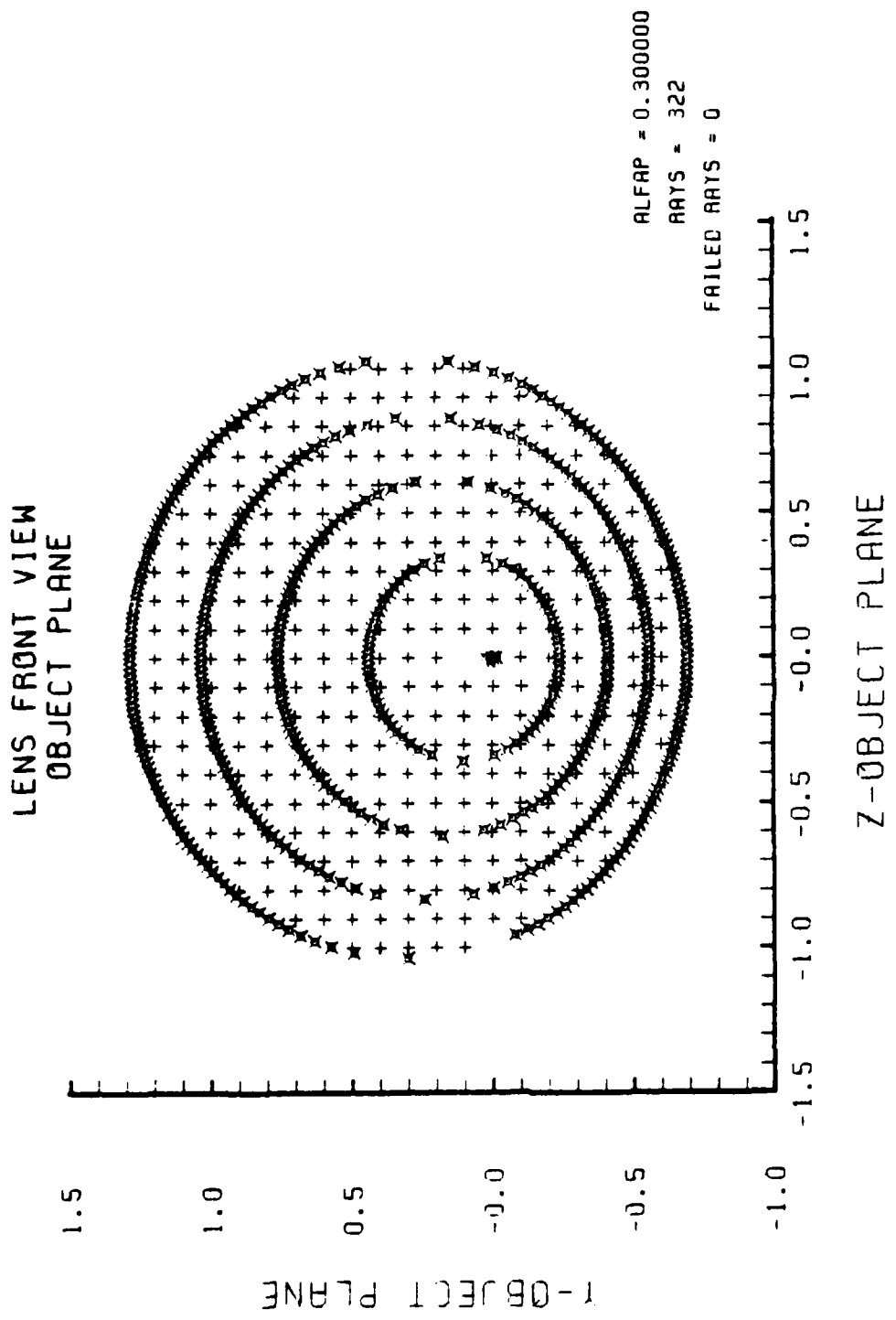

Figure H-10. Grid Plane at $\alpha_p = 0.3$ for Lens of Figure H-1

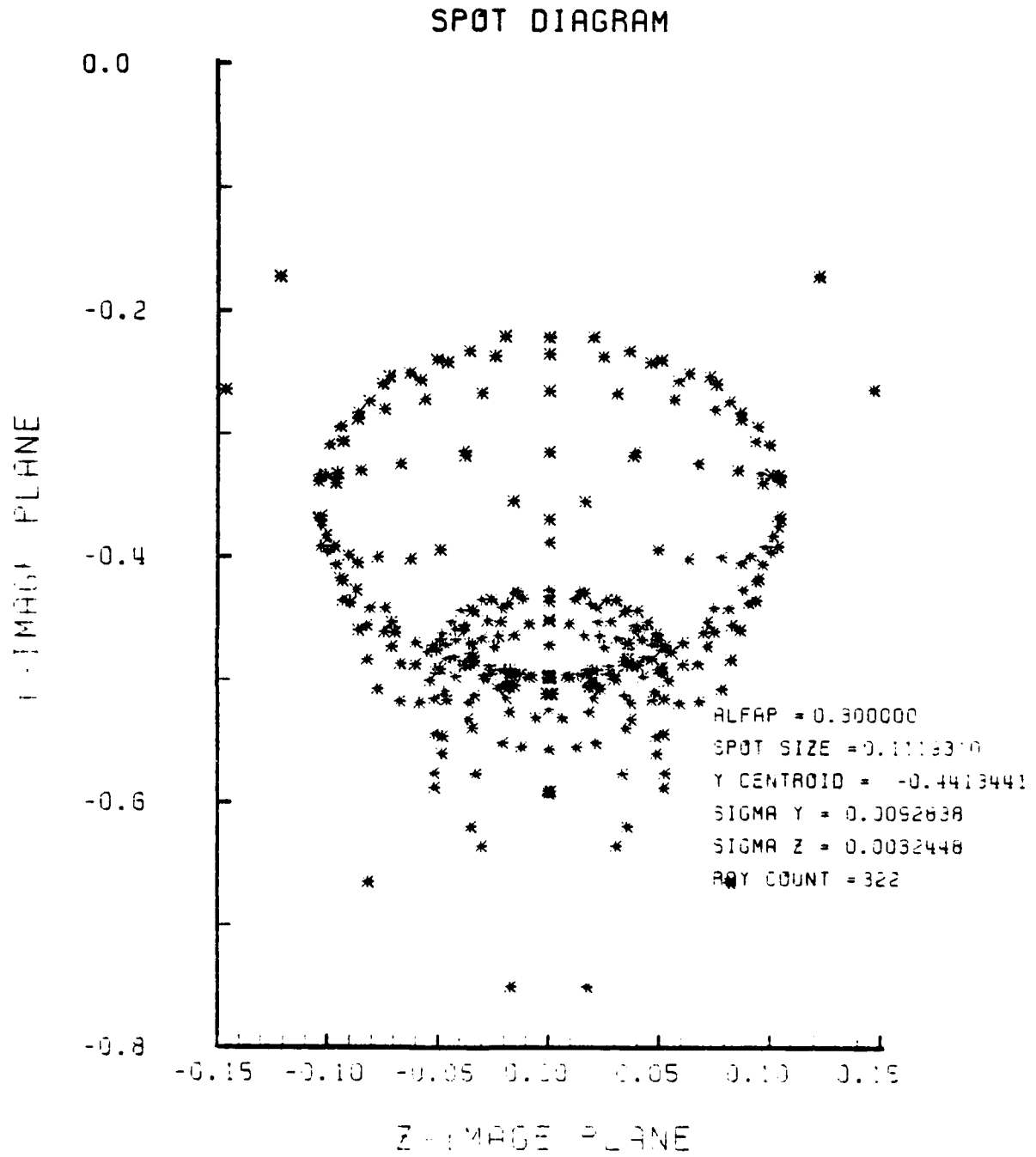

Figure H-11. Spot Diagram for Grid of Figure H-10

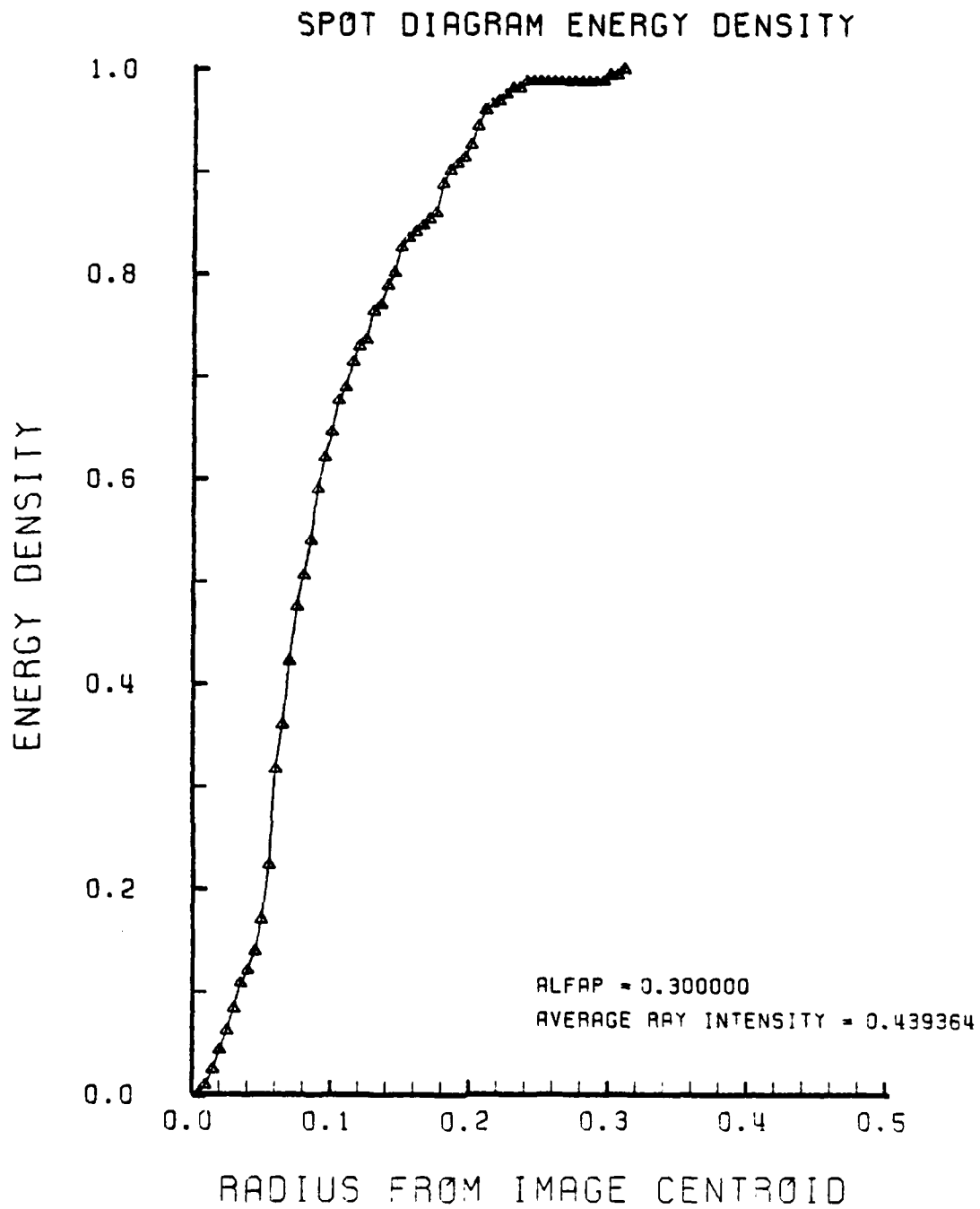

Figure H-12. Encircled Energy of Figure H-11

LENS FRONT VIEW
OBJECT PLANE

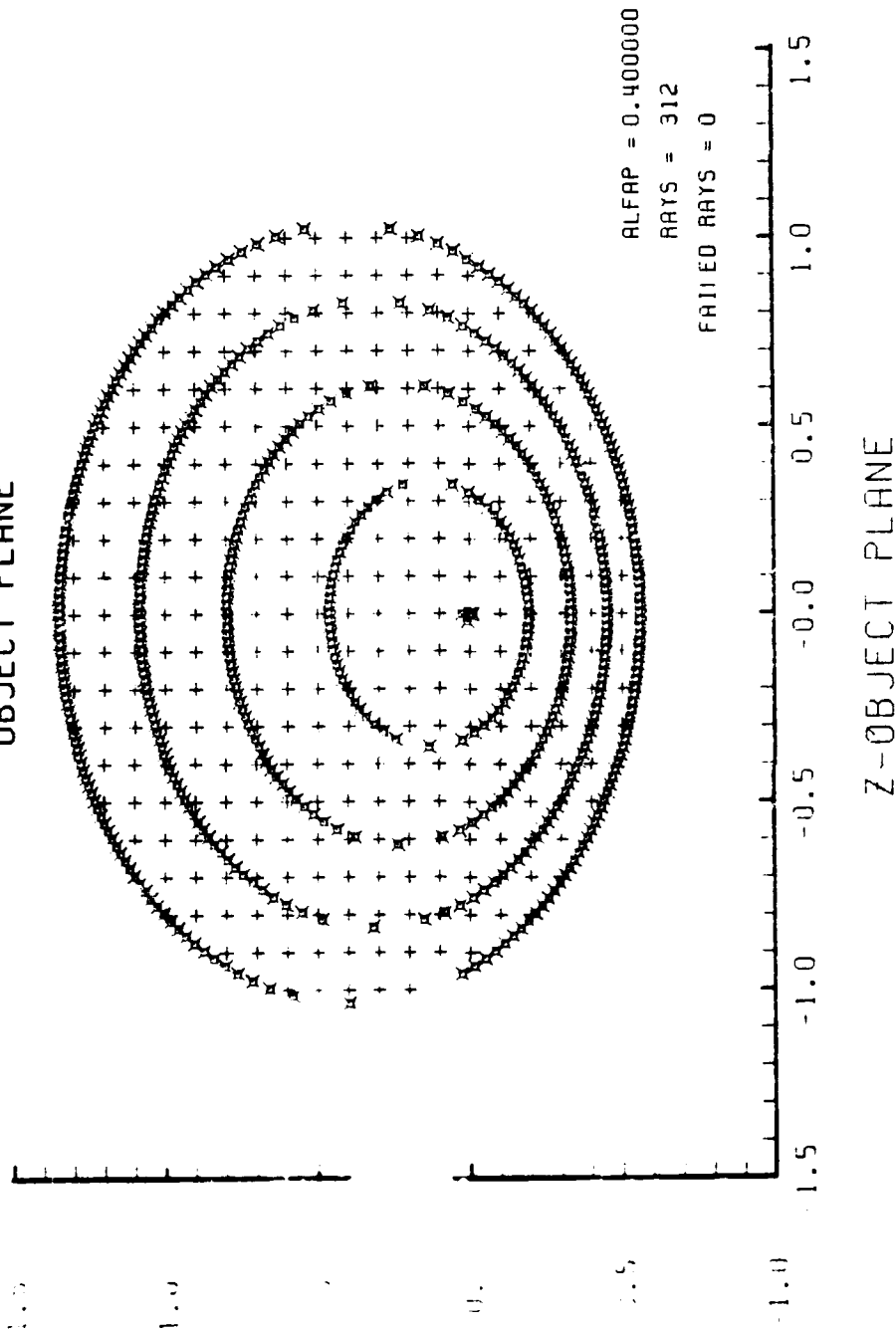

Figure H-13. Grid Plane at $\alpha_p = 0.4$ for Lens of Figure H-1

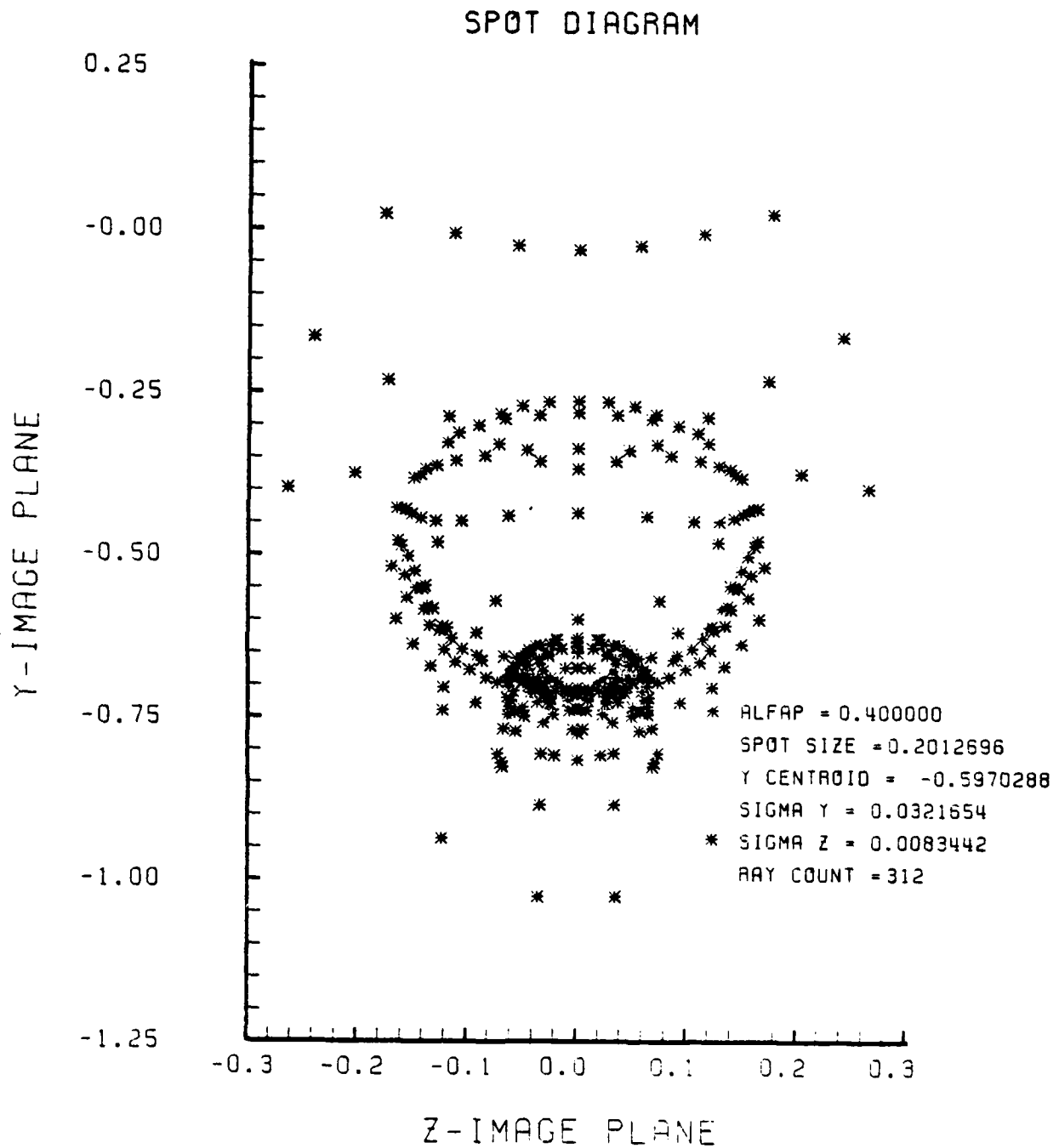

Figure H-14. Spot Diagram for Grid of Figure H-13

SPOT DIAGRAM ENERGY DENSITY

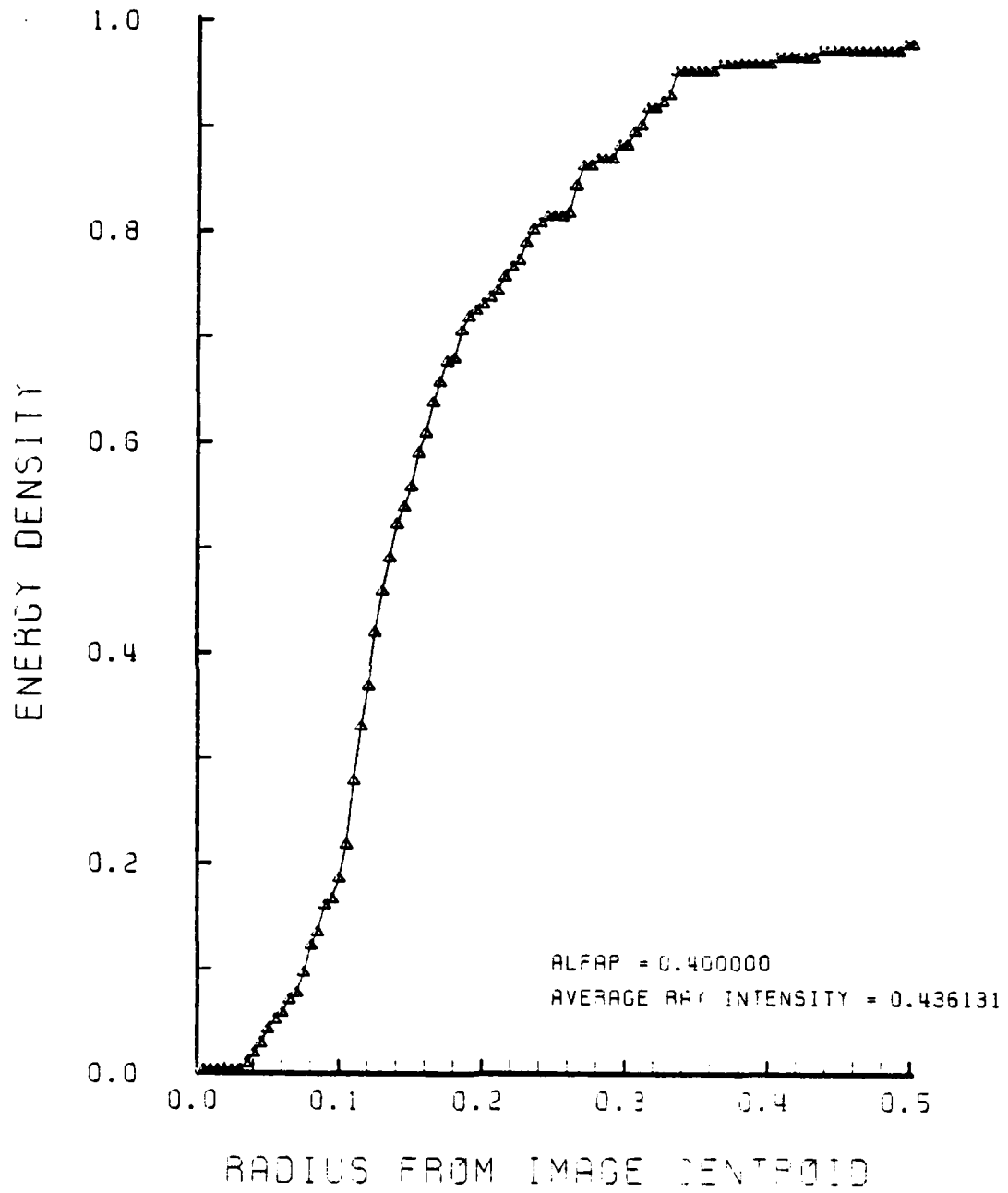

Figure H-15. Encircled Energy of Figure H-14

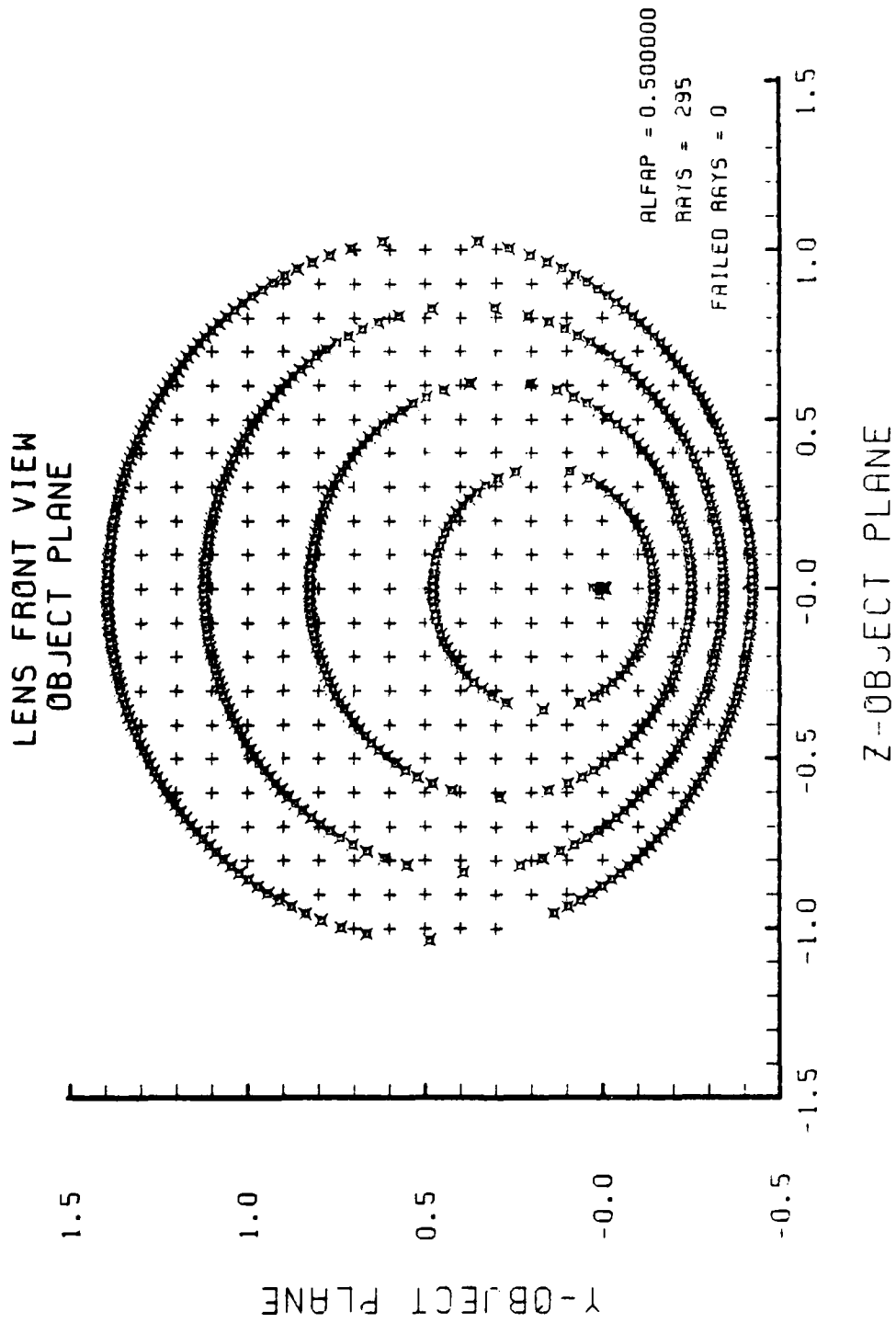

Figure H-16. Grid Plane at $\alpha_p = 0.5$ for Lens of Figure H-1

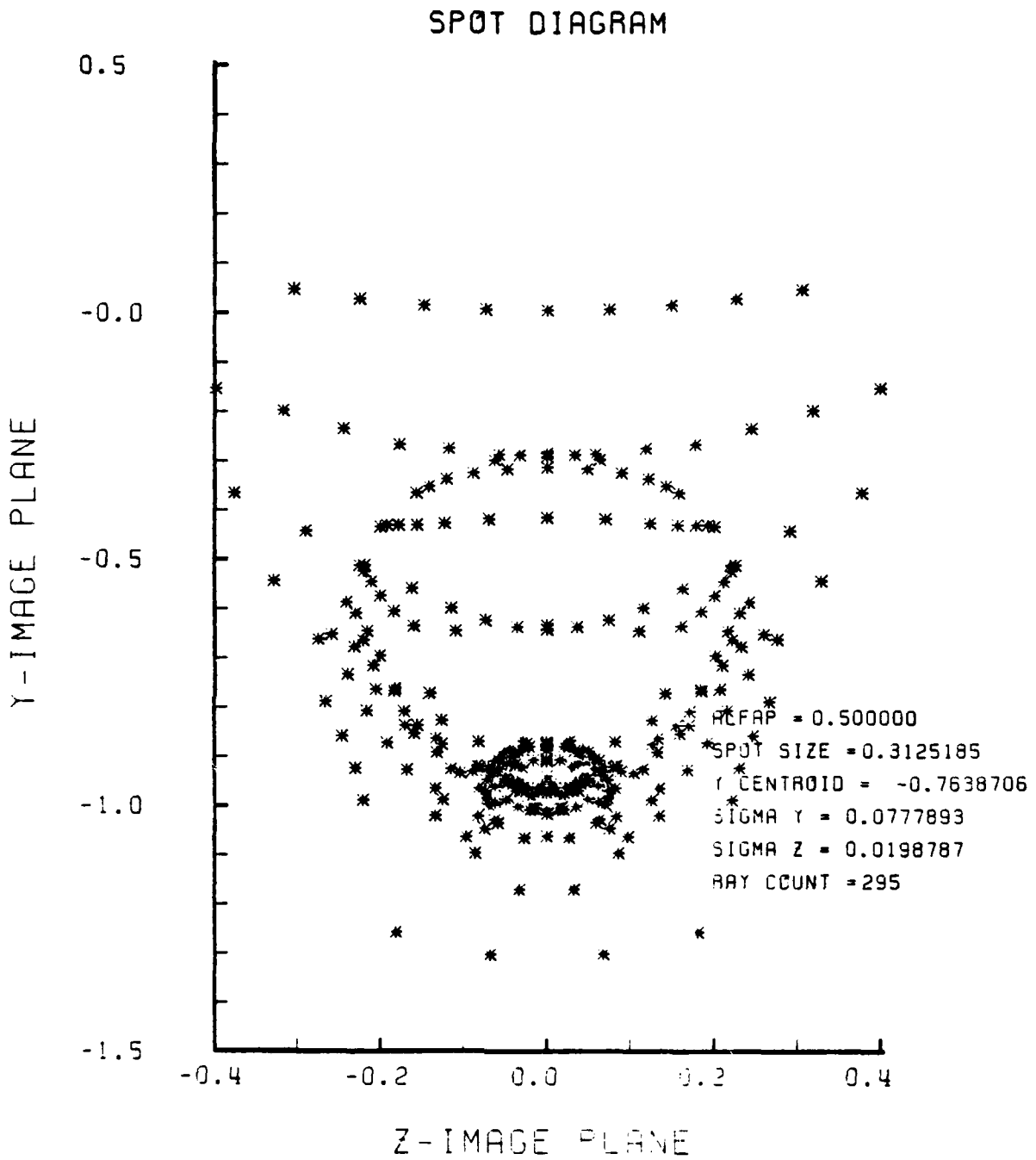

Figure H-17. Spot Diagram for Grid of Figure H-16

SPOT DIAGRAM ENERGY DENSITY

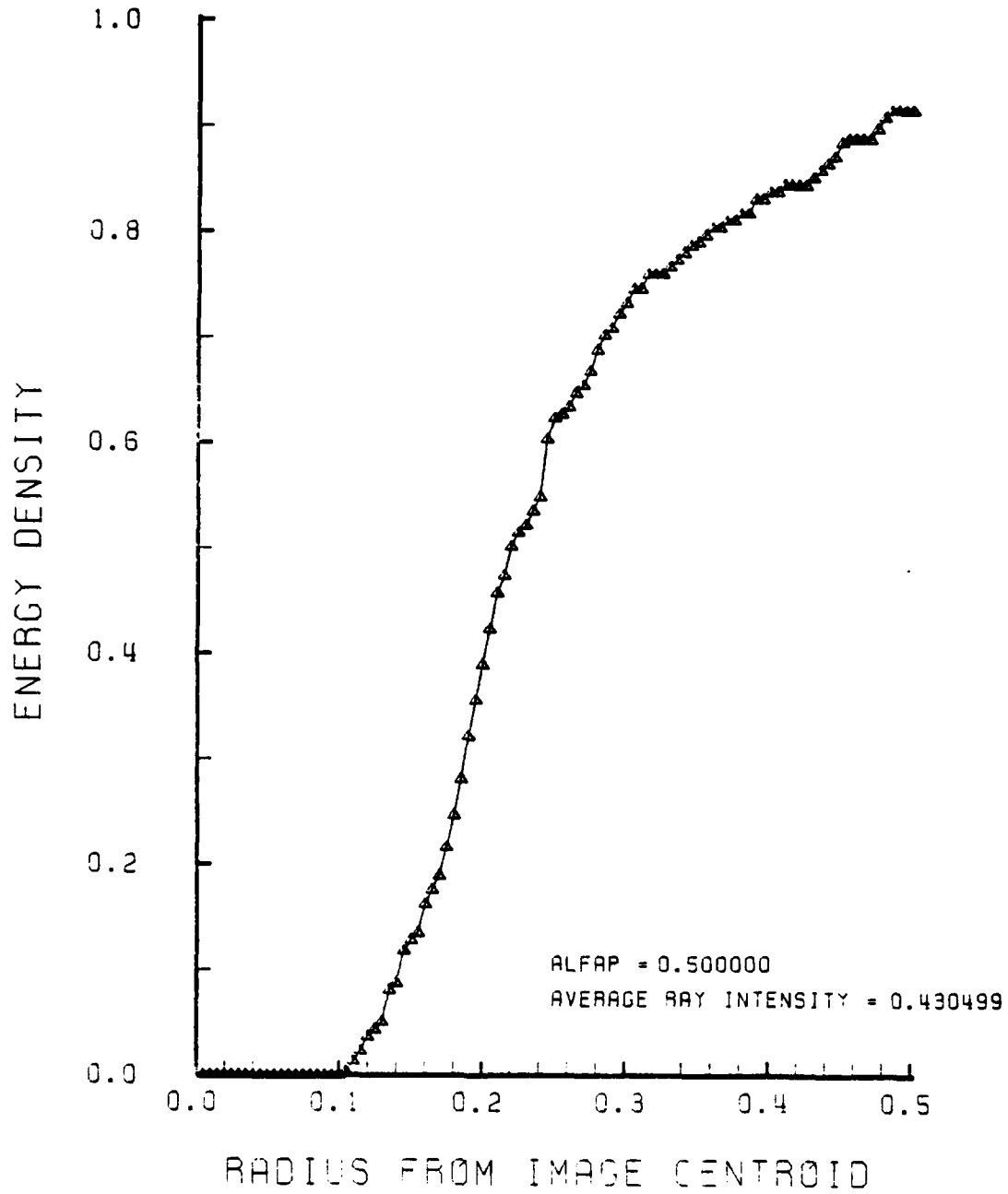

Figure H-18. Encircled Energy of Figure H-17

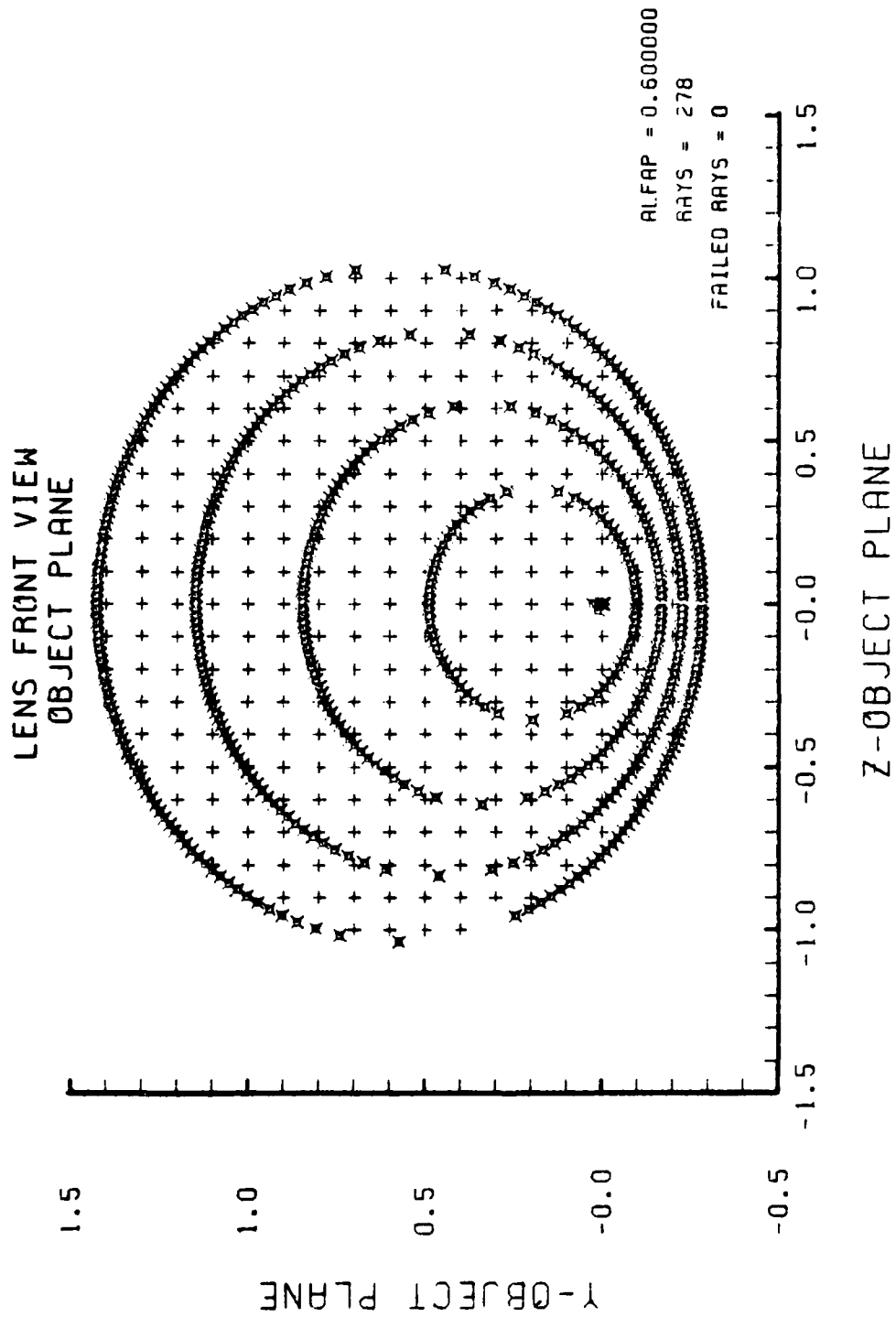

Figure H-19. Grid Plane at $\alpha_p = 0.6$ for Lens of Figure H-1

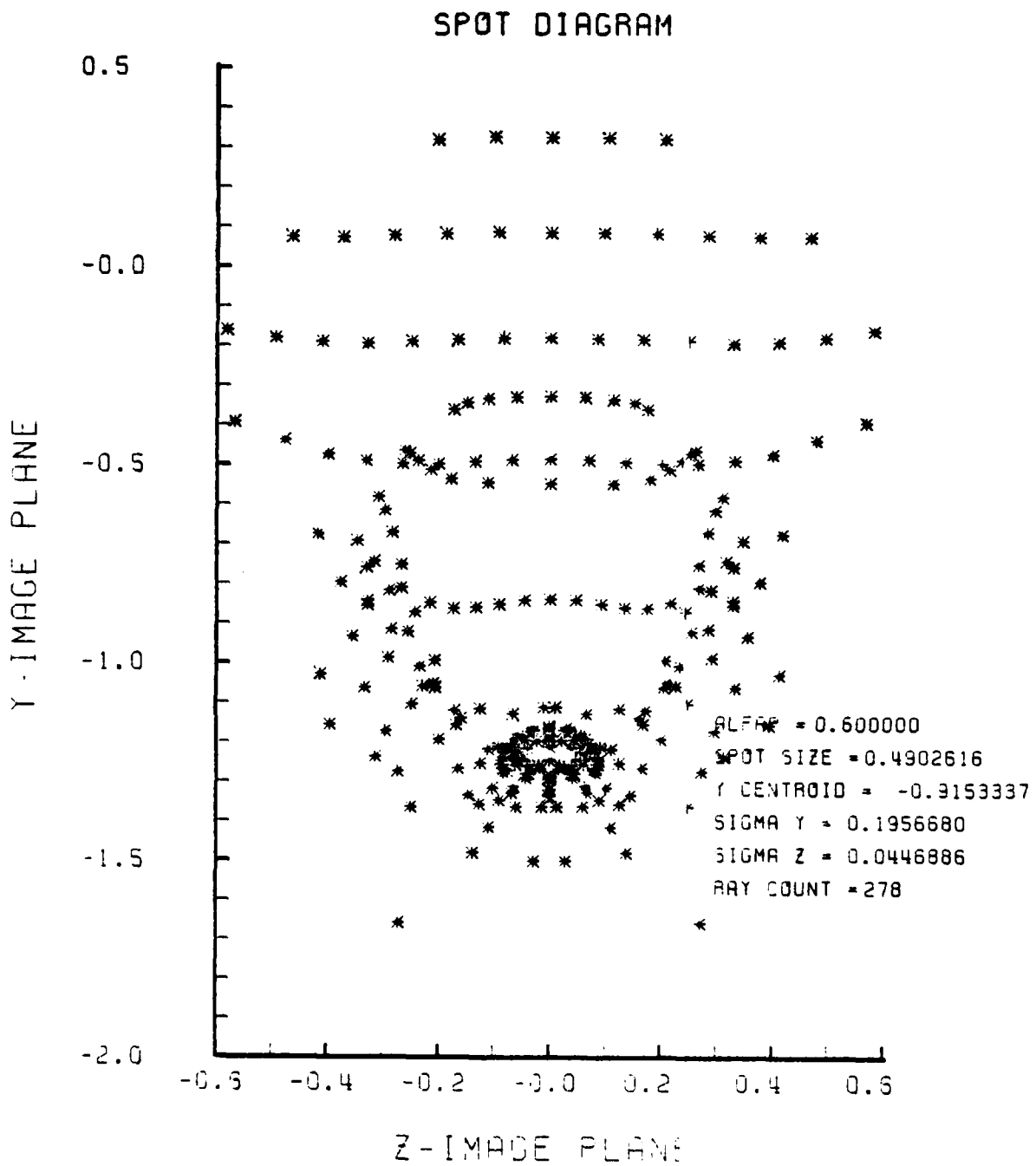

Figure H-20. Spot Diagram for Grid of Figure H-19

SPOT DIAGRAM ENERGY DENSITY

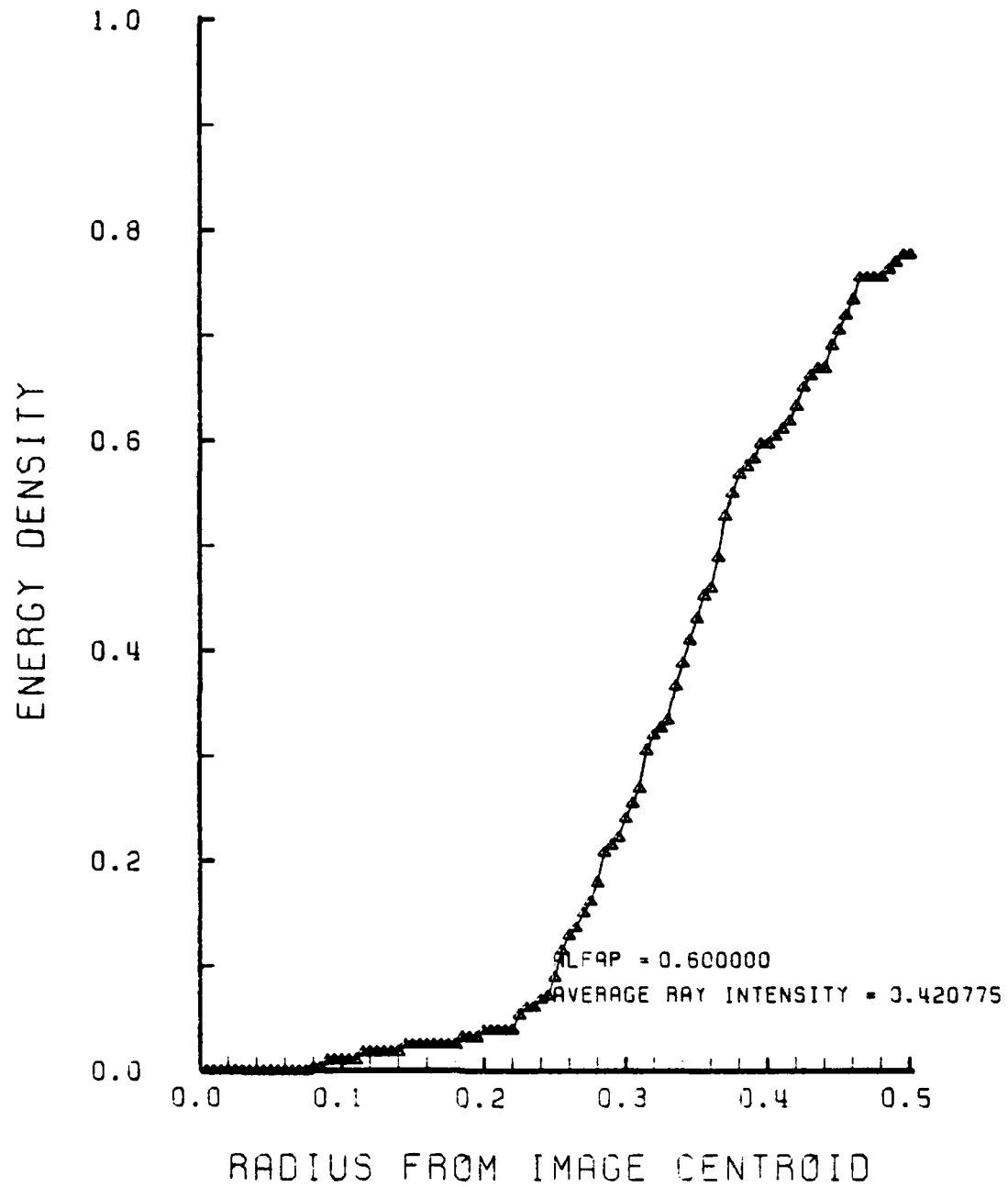

Figure H-21. Encircled Energy of Figure H-20

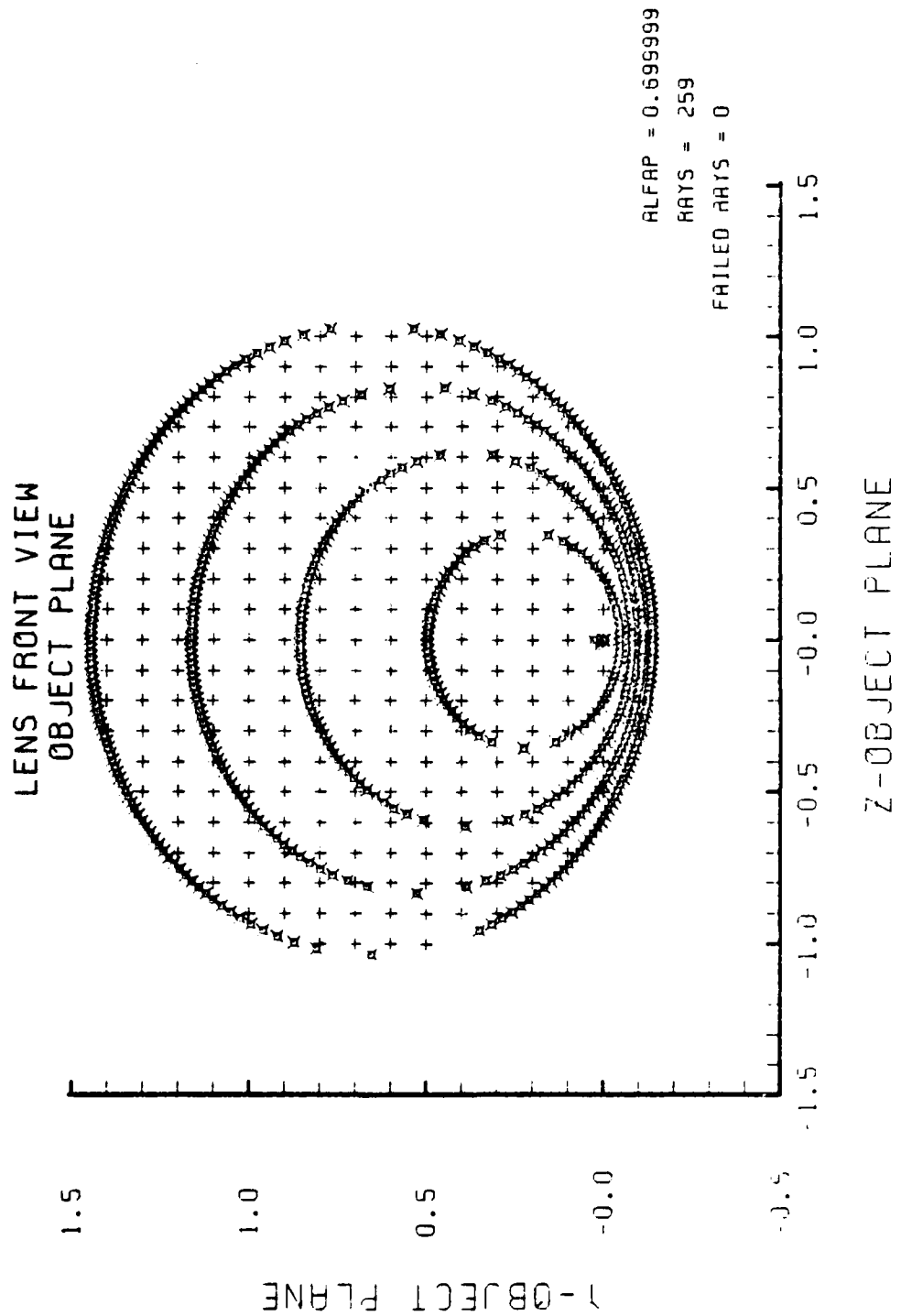

Figure H-22. Grid Plane at $\alpha_p = 0.7$ for Lens of Figure H-1

SPOT DIAGRAM

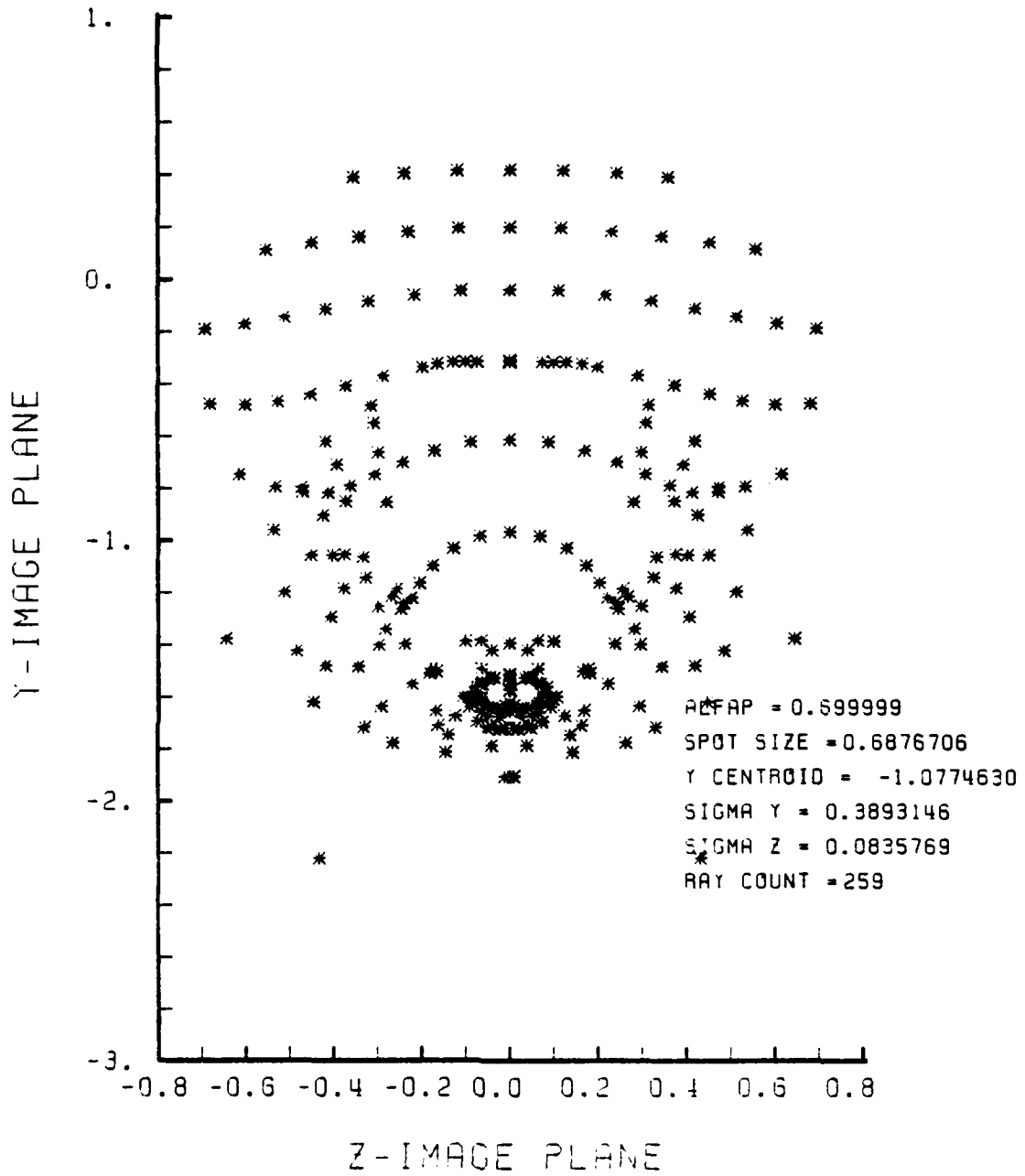

Figure H-23. Spot Diagram for Grid of Figure H-22

SPOT DIAGRAM ENERGY DENSITY

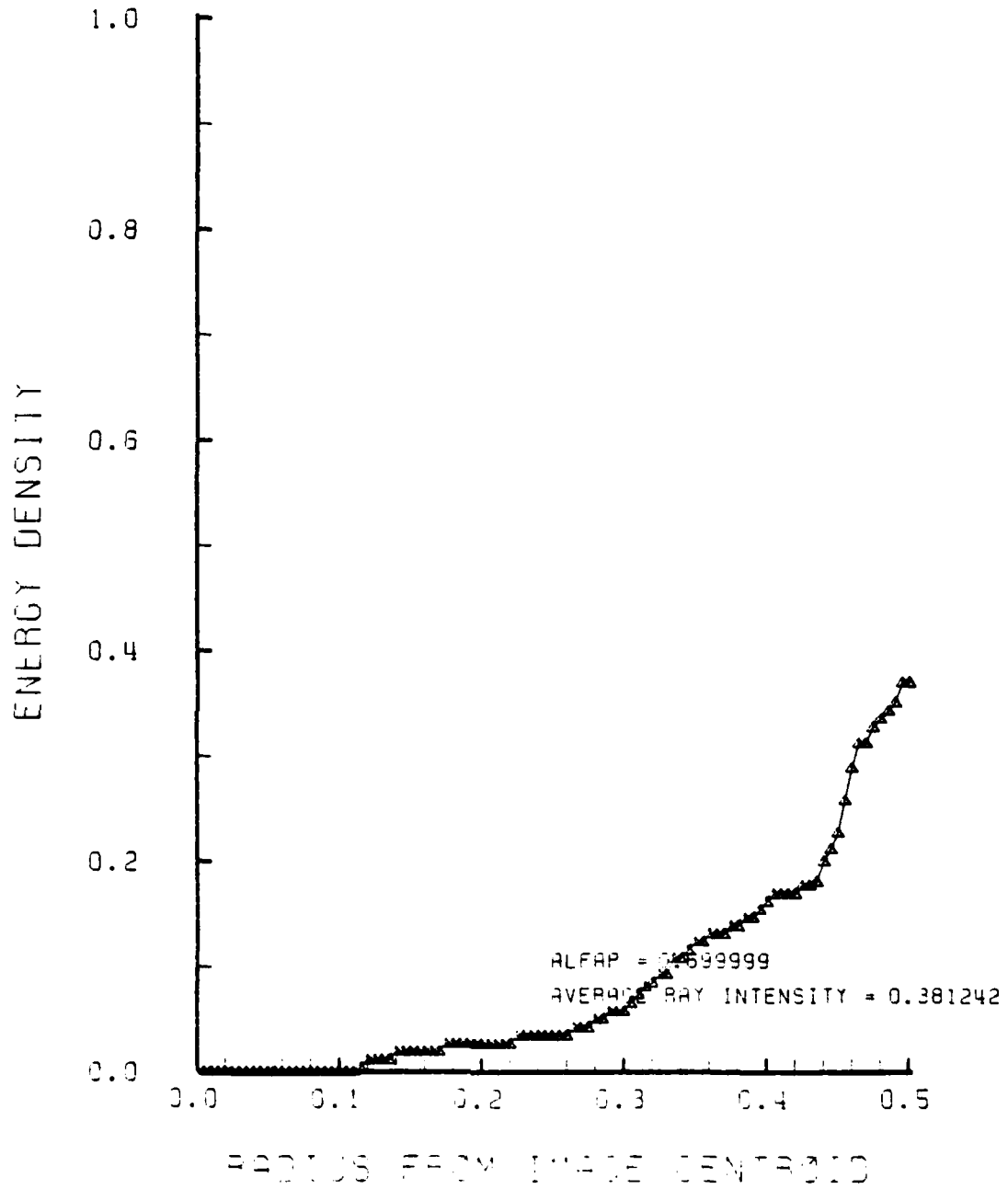

Figure H-24. Encircled Energy of Figure H-23

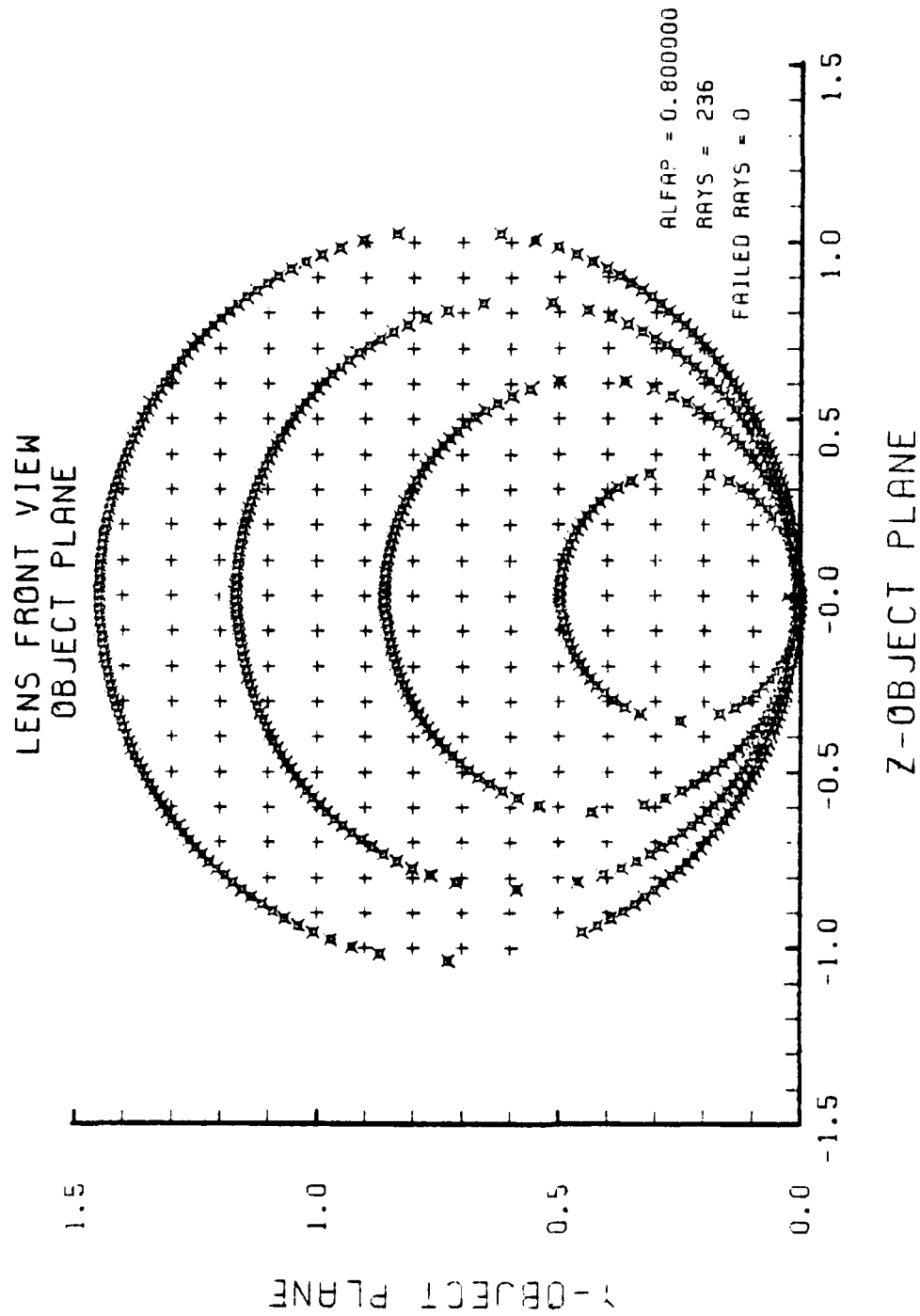

Figure H-25. Grid Plane at $\alpha_p = 0.8$ for Lens of Figure H-1

SPOT DIAGRAM

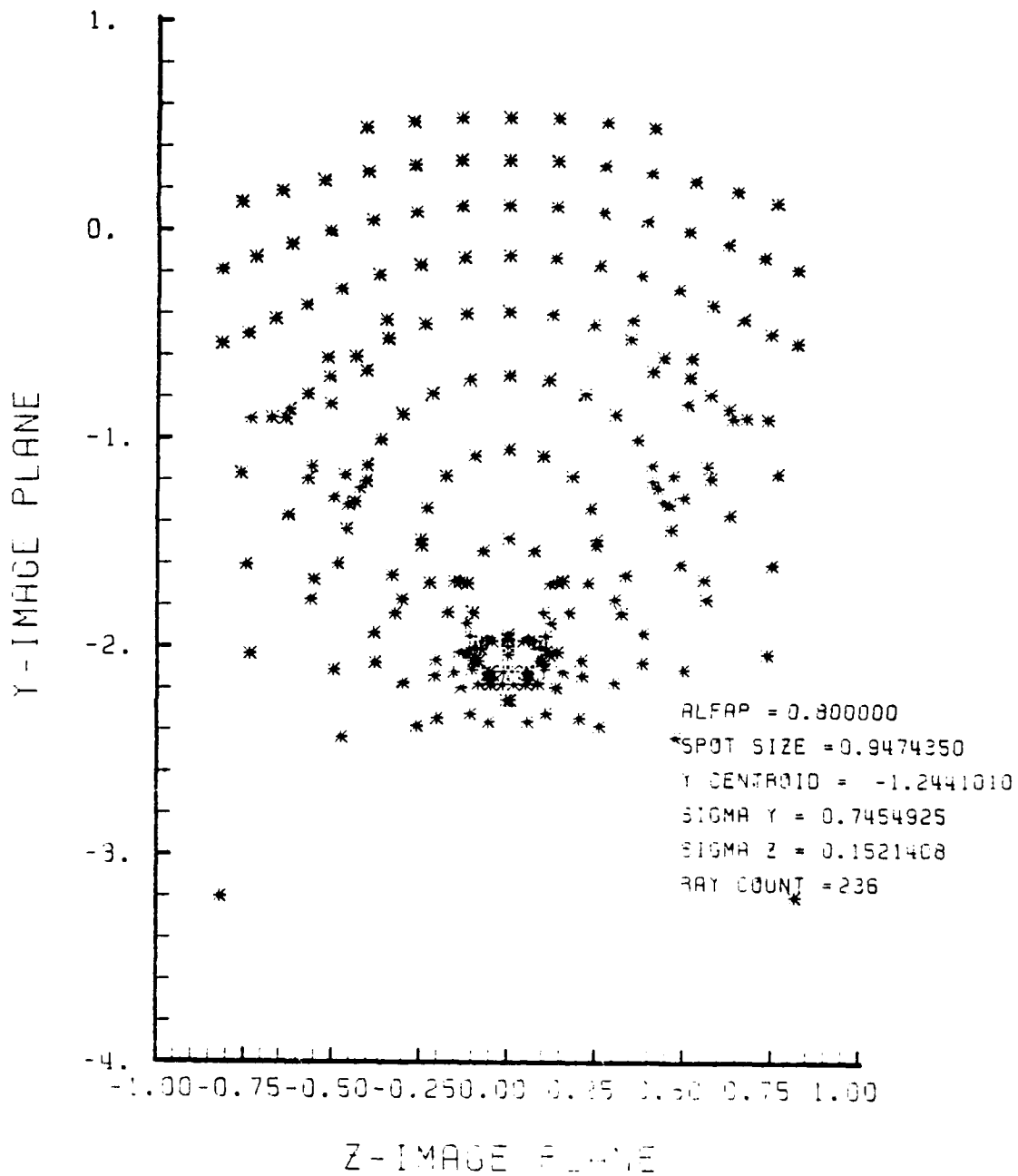

Figure H-26. Spot Diagram for Grid of Figure H-25

AD-A125 167

AERODYNAMICALLY EFFICIENT GRADIENT REFRACTIVE INDEX
MISSILE SEEKER LENS(U) NAVAL POSTGRADUATE SCHOOL
MONTEREY CA H M CARR OCT 82 NP567-82-012

6/6

UNCLASSIFIED

F/G 16/4

NL



END
FALMED
DTIC

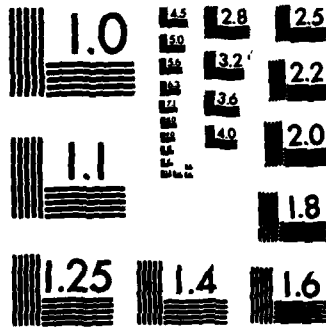

MICROCOPY RESOLUTION TEST CHART
NATIONAL BUREAU OF STANDARDS-1963-A

SPOT DIAGRAM ENERGY DENSITY

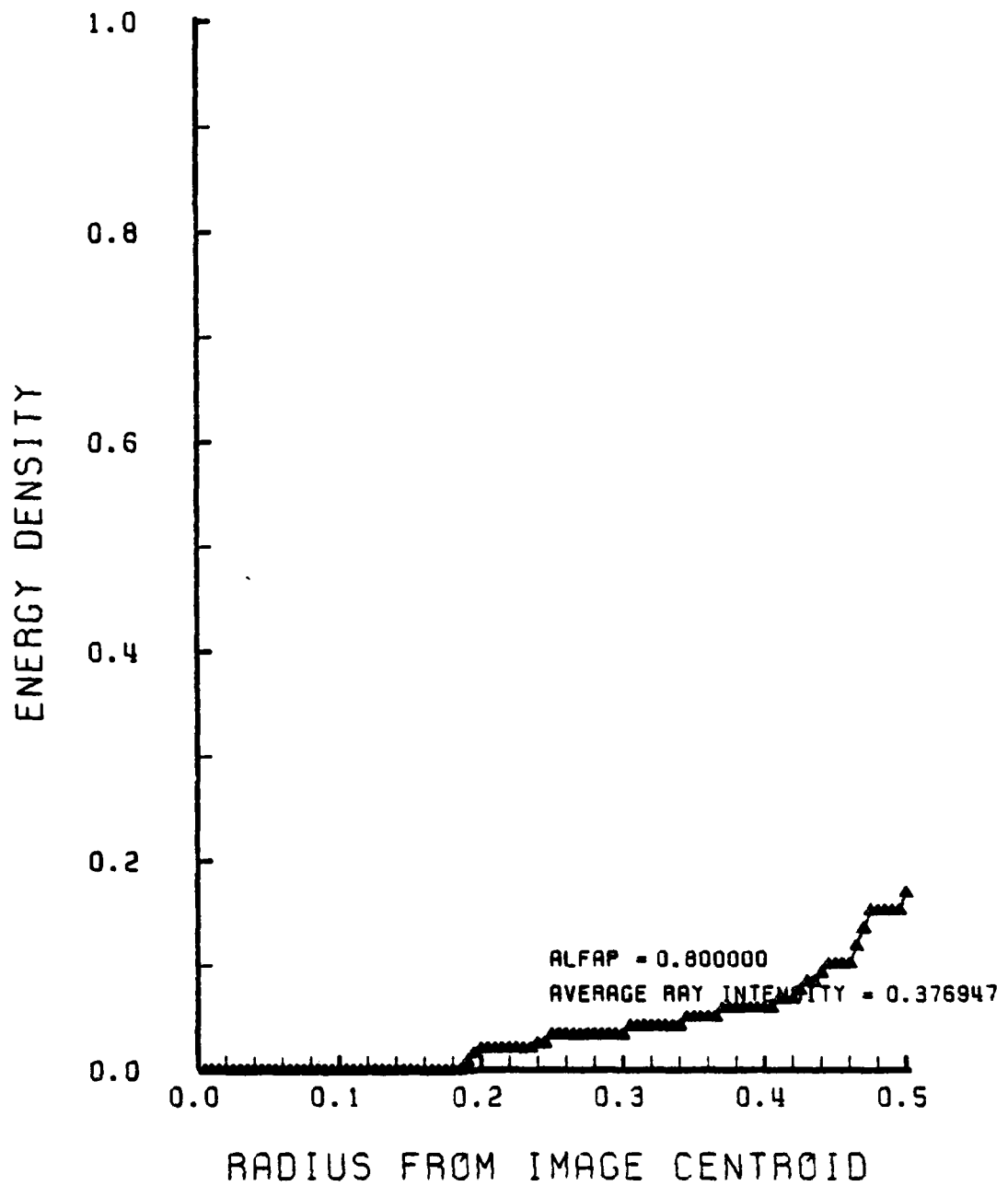

Figure H-27. Encircled Energy of Figure H-26

LIST OF REFERENCES

1. Marchand, Erich W., "Gradient-index imaging optics today", Applied Optics, V. 21, number 6, p. 983, 15 March 1982.
2. Kitano, I., Nishigawa, K., and Momokita, A., "Diffusion behavior of doped polarizable ions in glass during the ion-exchange process", Applied Optics, V. 21, number 6, p. 1017-1020, 15 March 1982.
3. Frazier, Robert L., Exterior Ballistics, Guidance Laws and Optics for a Gun-Launched Missile, M.S. Thesis, Naval Postgraduate School, Monterey, California, December 1980.
4. Terrell, James M., Conical Lens for 5"/54 Gun Launched Missile, M.S. Thesis, Naval Postgraduate School, Monterey, California, June 1981.
5. Amichai, Oded, Sharp Nose Lens Design Using Refractive Index Gradient, Contractor Report, Naval Postgraduate School, Monterey, California, June 1982.
6. Otten, L.J. and Gilbert, K.G., Aero-Optical Phenomena, V. 80, AIAA Progress Series in Astronautics and Aeronautics, 1982.
7. Kingslake, Rudolf, Lens Design Fundamentals, Academic Press, 1978.
8. Hecht, Eugene and Zajac, Alfred, Optics, Addison-Wesley, 1979.
9. Marchand, Erich W., Gradient Index Optics, Academic Press, 1978.
10. Curcio, M.E., "Precision-machined optics for reducing system complexity", Infrared Imaging Systems Technology, Society of Photo-Optical Instrumentation Engineers (SPIE), V. 226, p. 91-97, April 1980.
11. Harney, R.C., "Dual active/passive infrared imaging systems", Infrared Imaging Systems Technology, Society of Photo-Optical Instrumentation Engineers (SPIE), V. 226, p. 74-82, April 1980.

12. Robb, Paul N., "Lens design using optical aberration coefficients", Proceedings of 1980 International Lens Design Conference (OSA), Society of Photo-Optical Instrumentation Engineers (SPIE), V. 237, p. 109-118, 1980.
13. Sharma, Anurog, Kumar, D.A. Vizia, and Ghatak, A.K., "Tracing rays through graded-index media: a new method", Applied Optics, V. 21, number 6, p. 984-987, 15 March 1982.
14. Moore, Duncan T., and Stagaman, Joan M., "Ray tracing in anamorphic gradient-index media", Applied Optics, V. 21, number 6, p. 999-1003, 15 March 1982.

INITIAL DISTRIBUTION LIST

	No. Copies
1. Defense Technical Information Center Cameron Station Alexandria, Virginia 22314	2
2. Library, Code 0142 Naval Postgraduate School Monterey, California 93940	2
3. Department Chairman, Code 67 Department of Aeronautics Naval Postgraduate School Monterey, California 93940	1
4. Distinguished Professor A. E. Fuhs Code 67Fu Department of Aeronautics Naval Postgraduate School Monterey, California 93940	4
5. LTC Rene Larriva, USMC Defense Advanced Research Projects Agency 1400 Wilson Blvd. Arlington, Virginia 22209	2
6. Commander, Naval Sea Systems Command Naval Sea Systems Command Headquarters Attn: Code 62YC Washington, D.C. 20362	1
7. Mr. Conrad Brandts Naval Surface Weapons Center Dahlgren, Virginia 22448	1
8. Dr. Fred Billig Applied Physics Lab Johns Hopkins Road Laurel, Maryland 20810	1
9. Commander, U.S. Army Armament Research and Development Command (ARRAD COM) Attn: Mr. Lou Marino Dover, N.J. 07801	1
10. Deputy Chief of Staff for Research Development and Studies Headquarters USMC Washington, D.C. 20370	1

- | | | |
|-----|---|---|
| 11. | Commander
Development Command
USMC Base
Quantico, Virginia 22134 | 1 |
| 12. | Commander
Artillery Development Command
Fort Sill, Oklahoma 73503 | 1 |
| 13. | Captain Herbert M. Carr
2100 Raleigh Ave.
Austin, TX 78703 | 3 |
| 14. | Dr. Lloyd Smith
Code 3205
Naval Weapons Center
China Lake, California 93555 | 1 |
| 15. | Dr. Harold L. Bennett
Code 3272
Naval Weapons Center
China Lake, California 93555 | 1 |
| 16. | Dr. T. G. Bergman
Code 3941
Naval Weapons Center
China Lake, California 93555 | 1 |
| 17. | Dr. Oded Amichai
Ministry of Defense
P.O.B. 2250
Haifa, ISRAEL | 1 |
| 18. | Research Administration
Code 012A
Naval Postgraduate School
Monterey, California 93940 | 1 |
| 19. | Deputy Under Secretary of the Army
for Operations Research
Room 2E261, Pentagon
Washington, D.C. 20310 | 1 |
| 20. | LT James Terrell, USN
Code 290
Supervisor of Shipbuilding, Conversion,
and Repair, USN
Pascagoula, MS 39567 | 1 |

END