



Calhoun: The NPS Institutional Archive
DSpace Repository

Theses and Dissertations

Thesis and Dissertation Collection

1976

Microprogrammable data acquisition and probe control system (MIDAS IV) with application to compressor testing.

Patton, Dennis Delane

Monterey, California. Naval Postgraduate School

<http://hdl.handle.net/10945/17863>

Downloaded from NPS Archive: Calhoun



Calhoun is a project of the Dudley Knox Library at NPS, furthering the precepts and goals of open government and government transparency. All information contained herein has been approved for release by the NPS Public Affairs Officer.

Dudley Knox Library / Naval Postgraduate School
411 Dyer Road / 1 University Circle
Monterey, California USA 93943

<http://www.nps.edu/library>

MICROPROGRAMMABLE DATA ACQUISITION
AND PROBE CONTROL SYSTEM (MIDAS IV)
WITH APPLICATION TO COMPRESSOR TESTING

Dennis Delane Patton

NAVAL POSTGRADUATE SCHOOL

Monterey, California



THESIS

Microprogrammable Data Acquisition
and Probe Control System (MIDAS IV)
with Application to Compressor Testing

by

Dennis Delane Patton

Thesis Advisor

R. P. Shreeve

Approved for public release; distribution unlimited.

T173121

REPORT DOCUMENTATION PAGE

READ INSTRUCTIONS
BEFORE COMPLETING FORM

1. REPORT NUMBER		2. GOVT ACCESSION NO.	3. RECIPIENT'S CATALOG NUMBER
4. TITLE (and Subtitle) Microprogrammable Data Acquisition and Probe Control System (MIDAS IV) with Application to Compressor Testing			5. TYPE OF REPORT & PERIOD COVERED Master's Thesis March 1976
7. AUTHOR(s) Dennis Delane Patton			6. PERFORMING ORG. REPORT NUMBER
9. PERFORMING ORGANIZATION NAME AND ADDRESS Naval Postgraduate School Monterey, California 93940			8. CONTRACT OR GRANT NUMBER(s)
11. CONTROLLING OFFICE NAME AND ADDRESS Naval Postgraduate School Monterey, California 93940			10. PROGRAM ELEMENT, PROJECT, TASK AREA & WORK UNIT NUMBERS
14. MONITORING AGENCY NAME & ADDRESS (if different from Controlling Office) Naval Postgraduate School Monterey, California 93940			12. REPORT DATE March 1976
			13. NUMBER OF PAGES
			15. SECURITY CLASS. (of this report) Unclassified
			15a. DECLASSIFICATION/DOWNGRADING SCHEDULE
16. DISTRIBUTION STATEMENT (of this Report) Approved for public release; distribution unlimited.			
17. DISTRIBUTION STATEMENT (of the abstract entered in Block 20, if different from Report)			
18. SUPPLEMENTARY NOTES			
19. KEY WORDS (Continue on reverse side if necessary and identify by block number) Data acquisition system Probe control system Compressor testing Microprocessor			
20. ABSTRACT (Continue on reverse side if necessary and identify by block number) The construction and use of a programmable, fully automatic data acquisition and control system (MIDAS IV) is reported with application to probe surveys in a turbomachine. The MIDAS IV system was designed to record up to 48 channels of analog data, position and align a pneumatic probe in the direction of flow in surveys across a flow passage, and control the operation of up to four Scanivalve pneumatic			

Switches. The MIDAS IV input and output is presently via a teletypewriter keyboard and paper-tape punch. A direct interface with the Hewlett-Packard HP 9830A calculator is a logical modification of the system.

Microprogrammable Data Acquisition
and Probe Control System (MIDAS IV)
with Application to Compressor Testing

by

Dennis Delane Patton
Lieutenant, United States Navy
B.S., Purdue University, 1970

Submitted in partial fulfillment of the
requirements for the degree of

MASTER OF SCIENCE IN AERONAUTICAL ENGINEERING

from the

NAVAL POSTGRADUATE SCHOOL

March, 1976

ABSTRACT

The construction and use of a programmable, fully automatic data acquisition and control system (MIDAS IV) is reported with application to probe surveys in a turbomachine. The MIDAS IV system was designed to record up to 48 channels of analog data, position and align a pneumatic probe in the direction of flow in surveys across a flow passage, and control the operation of up to four Scanivalve pneumatic switches. The MIDAS IV input and output is presently via a teletypewriter keyboard and paper-tape punch. A direct interface with the Hewlett-Packard HP 9830A calculator is a logical modification of the system.

CONTENTS

I INTRODUCTION	12
II MIDAS IV DATA ACQUISITION AND CONTROL SYSTEM	14
A. GENERAL DESCRIPTION	14
B. HARDWARE COMPONENTS	15
1. MICROPROCESSOR	15
2. ANALOG INPUT DEVICES	15
3. SIGNAL CONDITIONERS	16
4. MULTIPLEXERS	16
5. DIGITAL VOLTMETER (DIGITEC)	16
6. INPUT/OUTPUT DEVICE	17
C. FRONT PANEL DESCRIPTION	17
1. UPPER FRONT SECTION	17
2. LOWER FRONT SECTION	19
D. REAR PANEL DESCRIPTION	19
E. SOFTWARE PROGRAMS	19
F. OPERATION VIA PROGRAM "MONITOR"	20
1. MIDAS IV MODE LISTING	20
2. CALIBRATION MODE	20
3. PROGRAM SCAN MODE	21
4. READ TAPE MODE	22
5. DATA ACQUISITION MODE	22
6. MEMORY DISPLAY AND MEMORY EDIT MODES	23
7. RESTART MODE	25
III PROBE AND TRAVERSE MECHANISM	26
A. GENERAL DESCRIPTION	26
B. HARDWARE COMPONENTS	27
1. PROBE TRAVERSE MECHANISM	27
2. CONTROL PANEL	28
C. OPERATION	28
1. SET UP	28
2. MANUAL AND SEMI-AUTOMATIC MODES	29
3. AUTOMATIC MODE USING MIDAS IV	29
IV CONCLUSIONS	30

APPENDIX A.	MIDAS IV HARDWARE MANUAL	55
A.1	PRO-LOG MPS-805 MICROPROCESSOR	55
A.2	MULTIPLEXER BOARDS	56
A.3	SIGNAL CONDITIONERS	56
A.3.1	AMPLIFIER ADJUSTMENTS	56
A.3.2	CALIBRATION OF CHANNELS 1-4	57
A.3.3	CALIBRATION OF CHANNELS 41-47	58
A.4	FREQUENCY TO VOLTAGE CONVERTER	58
A.4.1	CIRCUIT DESCRIPTION	58
A.4.2	RANGE ADJUSTMENT	59
A.5	SCANIVALVE	59
A.6	ANALOG TO DIGITAL CONVERTER (DIGITEC)	60
A.6.1	DESCRIPTION	60
A.6.2	SAMPLE RATE AND INTEGRATION TIME	60
A.7	DISPLAY CARD AND LED DISPLAY	61
A.8	TELETYPE DUPLEX CARD	62
APPENDIX B.	MIDAS IV SOFTWARE MANUAL	79
B.1	INTRODUCTION	79
B.2	TTYIN AND TTYOUT	80
B.3	HEX PAIR AND PAIROUT	80
B.4	ONEOUT, BCDHEX, AND FORMAT	81
B.5	DIGITEC	82
B.6	MULTIPLEX	82
B.7	SCANV	82
B.8	DISPLAY	83
B.9	DATAOUT	83
B.10	CONVERGE	84
B.11	START	84
B.12	CALIB	85
B.13	CHANNEL ORDER AND PROBE ORDER	85
B.14	NEXT	86
B.15	READ CORE AND WRITE CORE	86
B.16	READ TAPE	87
B.17	MONITOR	87
B.18	LISTING OF MIDAS IV SOFTWARE	88

B.19	FLOW CHARTS OF MIDAS IV SOFTWARE	113
APPENDIX C.	PROBE TRAVERSING SYSTEM	144
C.1	PROBE TRAVERSING MECHANISM	144
C.2	PROBE CONTROL PANEL	144
C.2.1	INTERFACE CABLES	144
C.2.2	ANGULAR CONTROL CIRCUIT ADJUSTMENT	145
C.2.3	LINEAR CONTROL CIRCUIT ADJUSTMENT	145
APPENDIX D.	OPERATING PROCEDURES AND PROGRAM CHANGES	150
D.1	SYSTEM OPERATION WITH EXISTING CONTROL PROGRAM	150
D.1.1	POWER ON AND POWER OFF	150
D.1.2	TO SELECT AN OPERATING MODE	151
D.1.3	TO SELECT and CALIBRATE INPUT CHANNELS (CALIBRATION MODE)	151
D.1.4	TO PROGRAM THE SCANNING SEQUENCE AND PROBE MOVEMENT	153
D.1.4.1	PROGRAMMING FROM THE KEYBOARD (PROGRAM SCAN MODE)	153
D.1.4.2	PROGRAMMING FROM PAPER TAPE (PAPER TAPE MODE)	154
D.1.4.3	PROGRAM EDITING FROM THE KEYBOARD (MEMORY DISPLAY AND MEMORY EDIT MODES)	155
D.1.5	TO OPERATE AND RECORD DATA (DATA ACQUISITION MODE)	157
D.2	PROCEDURES FOR CHANGING THE CONTROL PROGRAM ON PROM	158
D.2.1	INTRODUCTION	158
D.2.2	MINOR CHANGES (NOT REQUIRING RECOMPILATION)	158
D.2.3	MAJOR CHANGES (REQUIRING COMPLETE RECOMPILATION)	160
D.3	PROCEDURES FOR ADDING EXTRA MEMORY TO RAM	161
APPENDIX E.	GLOSSARY OF TERMS	173

LIST OF TABLES

I (a) .	OPERATIONAL SPECIFICATIONS OF MIDAS IV	32
I (b) .	TECHNICAL SPECIFICATIONS OF MIDAS IV	33
I (c) .	ESTIMATED COST OF MIDAS IV	34
II (a) .	PHYSICAL SPECIFICATIONS FOR PRO-LOG MPS-805	35
II (b) .	OPERATIONAL SPECIFICATIONS FOR PRO-LOG MPS-805	36
III .	CONNECTOR ALLOCATION	37
IV .	MODE SELECTION NUMBERS	38
V .	MIDAS IV PROGRAM SUBROUTINES	39
A.I .	I/O PORT ASSIGNMENTS FOR MIDAS IV	63
A.II .	PIN ALLOCATIONS FOR CONNECTORS	65
B.I .	SUBROUTINE CALLING LEVELS	142
C.I .	SPECIFICATIONS FOR THE PROBE TRAVERSING MECHANISM	146
D.I .	POWER ON/POWER OFF PROCEDURES	162
D.II .	MIDAS IV HEADER	163
D.III .	SCAN CONTROL AND PROBE CONTROL TABLES ENTERED AT THE KEYBOARD	164
D.IV .	SCAN CONTROL AND PROBE CONTROL TABLES ENTERED ON PAPER TAPE	165
D.V .	EXAMPLES OF THE USE OF "MEMORY DISPLAY"	166
D.VI .	EXAMPLE OF THE USE OF "MEMORY EDIT"	167
D.VII .	EXAMPLE OF THE DATA OUTPUT	168
D.VIII .	A PORTION OF THE PL/M SOURCE-MEMORY CROSS REFERENCE	169
D.IX .	A PORTION OF THE ASSEMBLY LANGUAGE VERSION OF THE MIDAS IV SOFTWARE	170
D.X .	A PORTION OF THE MACHINE LANGUAGE VERSION OF THE MIDAS IV SOFTWARE	171
D.XI .	EXAMPLE OF INSERTING A "NO-OP" INSTRUCTION	172

ILLUSTRATIONS

	PAGE
1(a). Laboratory Arrangement and Function of MIDAS IV (Schematic)	40
1(b). Test Cell	41
1(c). MIDAS IV Console and Teletype	42
1(d). HP-9830A Data Reduction Equipment	43
2. Schematic of MIDAS IV System	44
3. Upper Front Console	45
4. Lower Front Console	46
5. Rear Connector Panel	47
6. Schematic of the MIDAS IV Control Program - "MONITOR"	48
7. Memory Allocation Map for MIDAS IV	50
8(a). Pneumatic Probe for Flow Surveys- View of the Probe	51
8(b). Pneumatic Probe for Flow Surveys- Pressure Port Locations	52
9. View of the Probe Traversing Mechanism	53
10. View of the Probe Control Panel	54
A1. Signal Conditioning Circuit	67
A2. Input Devices to Signal Conditioner	68
A3. PRO-LOG 8402 Relay Card	69
A4. Front View of PRO-LOG MPS-805	70
A5. Multiplexer Board Schematic	71
A6. Magnetic Flux Cutter and Its Electrical Output	72
A7. View of the P/V Card	73
A8. Frequency to Voltage Converter	74
A9. Scanivalve "Advance" and "Home" Circuits	75
A10. DVM Integration and Sampling Rates	76
A11. Schematic of Display Card	77
A12. Schematic of Teletype Interface Card	78

C1. Probe Control Circuits	147
C2. Probe Traversing System	148
C3. Examples of Amplifier Output for Angular Control Circuit	149

ACKNOWLEDGEMENT

I wish to thank my thesis advisor, Associate Professor R.P. Shreeve, for his invaluable support and encouragement in the construction and documentation of the MIDAS IV system.

A large portion of the credit for this system belongs to Lt. J.W. Sturges, who conceived the idea and started the actual hardware.

Finally, it was through the talents and knowledge of Mr. C.E. Gordon, who assembled most of the hardware and helped to design the control circuits, that the MIDAS IV system saw its completion.

I. INTRODUCTION

The equipment described in this report was designed in answer to the particular needs of the Turbopropulsion Laboratories at the Naval Postgraduate School. In the testing of compressors and turbines, at each operating condition, data must be recorded from many channels of fixed instrumentation in steady state. Also, translational surveys of flow fields at various locations within the machines are often required. Probes are used which must be aligned with the flow direction by rotating the probe to balance the pressures sensed at two pneumatic ports before data are recorded. For safety reasons, these surveys must be remotely controlled and the data remotely recorded.

A data acquisition and control system was designed to perform these tasks and to interface with the Hewlett-Packard Model 9830A calculator system for data reduction and presentation. The design of the system was initiated by Lt. J. W. Sturges who had previously applied microprocessors to the control of data acquisition and recording [Ref. 1]. The present author completed the data system hardware, designed and constructed a traversing mechanism with linear and angular drives, and programmed the control and acquisition software in PL/M.

This document will serve both as a design report and as an operation manual. The system and its relationship to the existing test equipment are shown schematically in Fig. 1(a) with views of the equipment given in Figs. 1(b), 1(c), and 1(d). It should be noted that by programming changes only, the MIDAS IV system is applicable to a wide range of data acquisition and control tasks. In this document, however,

it is described in the context of its use in compressor testing; in particular, in acquiring data from a traversing probe system. The probe traversing mechanism mounts on the compressor case and is controlled either manually (for calibration) or automatically by the MIDAS IV system. Up to four electrically-driven rotary pneumatic switches (Scanivalves) can be used. Each Scanivalve sequentially connects 48 pressure lines from the test rig to a single strain gage transducer connected to one input channel of the MIDAS IV. Forty-four other input channels are available for electrical signals. Program inputs, program control, and data output for MIDAS IV is via a teletypewriter unit. The punched-paper tape output can be input to the Hewlett-Packard 9830A calculator for analysis. A wired interface between MIDAS IV and the HP-9830A is considered to be a feasible and practical modification of the present system.

The MIDAS IV system is described in Section II. A description of the hardware is followed by an explanation of the programs used to operate the system in Section II-E and II-F. The probe traverse mechanism and drive circuits are described in Section III. The main body of this report is intended to give a description and a general working knowledge of the complete data acquisition and control system. Details of the hardware and software needed to trouble-shoot or modify the system have been arranged in the Appendices. The operational procedures are summarized in Appendix D.

II. MIDAS IV DATA ACQUISITION AND CONTROL SYSTEM

A. GENERAL DESCRIPTION

The components of the MIDAS IV system are shown schematically in Fig. 2. At the heart of the system is a Pro-Iog Model MPS-805 microprocessor which can be programmed with programmable read-only memory units (PPOMS). These units, programmed, retain the program when power is turned off. Thus software replaces the hard-wired logic found in earlier steady-state data systems. Scanning and recording of up to forty-eight channels of input data is controlled by the software programmed onto the PROMS of the microprocessor. The control program also sends output signals to control the operation of up to four Scanivalves, and to control the motor drive units on a probe traversing mechanism.

The forty-eight inputs of analog data are multiplexed to a single Digitec digital voltmeter (DVM) under program control. The data received by the microprocessor is printed and punched onto paper tape by a teletypewriter, also under program control.

General specifications and features of the system are summarized in Tables I(a), I(b), and I(c). Views of the front panel of MIDAS IV are shown in Figures 3 and 4.

B. HARDWARE COMPONENTS

1. Microprocessor

A Pro-Log Corporation MPS-805 8-bit microprocessor is used in the MIDAS IV system. Reference 2 provides a complete description of the microprocessor and the programming requirements. The specifications summarized in Tables II(a) and II(b) are reprinted from Ref. 2. Briefly, the MPS-805 is a digital microprocessor using an 8008 CPU chip. It has extended input/output capabilities (6 input and 4 output ports), 4096 words of ROM (2048 is standard), and presently 2048 words of RAM. If more memory is required a further 2048 words of RAM can be added through the installation of RAM chips (Pro-Log #D1002) to the RAM card (Pro-Log #8117). RAM contents remain unchanged until new information is written over old, or the power to the system is turned off.

The microprocessor can be interrupted and restarted at any time by pressing the RESET button which is shown in Fig. 4.

2. Analog Input Devices

Pressure transducers, thermocouples, strain gages, and potentiometers are devices currently used in conjunction with the MIDAS IV system. The pressure transducers and strain gages are electrically similar and act as variable resistances in one leg of a Wheatstone bridge. The bridge outputs a voltage proportional to the pressure or strain. Potentiometers require a power supply and produce an output voltage depending on the potentiometer's resistance. Thermocouples require no power supply and generate only millivolts of electrical output. In order to accommodate

these various measurement devices, the analog inputs to MIDAS IV are connected to signal conditioners.

3. Signal Conditioners

The purpose of the signal conditioners is to provide power to the analog device, to accept the resulting input level of the analog signal, and to output a signal in the range required by the digital voltmeter (± 1.3999 volts). Channels 1 through 40 are available for pressure transducers, thermocouples, and strain gages, while channels 41 through 47 are designed for potentiometric inputs.

4. Multiplexers

Multiplexing allows a number of electrical inputs to be connected in succession to a single measurement device, in this case a digital voltmeter. In the MIDAS IV system three Datel (Model #MM-16) sixteen-input analog multiplexers are used [Ref. 3]. The three outputs are connected in parallel to the digital voltmeter. The outputs of the 48 signal conditioners are connected to the inputs of the three multiplexers. The desired channel (1-48) is selected when an address signal and a multiplexer enable signal are received from the microprocessor.

5. Digital Voltmeter (Digitec)

A Digitec digital voltmeter (DVM) measures the signal voltage selected by the multiplexer. The DVM converts the analog voltage into a digital value which appears in the display of the instrument. The digital value is simultaneously output on the rear of the DVM as four BCD-numbers which are read by the microprocessor [Ref. 4].

6. Input/Output Devices

An ASR-33 teletypewriter [Ref. 13] is the input/output device for the MIDAS IV system. Since the microprocessor outputs ASCII serial characters, the MIDAS IV system is compatible with other equipment using the same I/O format, such as the HP-9830A with a teletypewriter interface ROM.

C. FRONT PANEL DESCRIPTION

1. Upper Front Section

Fig. 3 is a view of the upper front section of the MIDAS IV console and shows the location of the following components:

1.1 LED Display shows the current channel and port to which the multiplexer and Scanivalve, if it is selected, are set.

1.2 Thumbwheel Switches are only active in the calibrate mode and are used to manually select a desired channel.

1.3 Port Advance Button advances the selected Scanivalve continuously until released. The advance rate permits the user to increment one port at a time. The pushbutton is only active when channels 1 through 4 are selected on the thumbwheel switches and the system is in the calibrate mode.

1.4 Probe Traverse Control moves the traverse mechanism up or down. This enables the operator to calibrate or to reposition the probe for a survey. The operation is unaffected by the program selection.

1.5 Digital Voltmeter converts the various analog inputs into digital values for the microprocessor (see Sec. II.B.6). The "on/off-repetition rate" switch and the "mode selection" switch control its operation.

1.6 Signal Conditioners, each of which are provided with "ballance" and "span" controls, allow the range of each analog input to be scaled to produce ± 1.3999 volts.

Note: Scanivalve "Home" Button (not shown in Fig. 3) advances the Scanivalve to the first port and is located to the left of the Port Advance Button.

2. Lower Front Section

Fig. 4 shows the location of the Pro-Log MPS-805 microprocessor in the lower front section of the console as well as the following components:

2.1 Preset Button which is used to interrupt the microprocessor and cause it to wait for a new program selection.

2.2 Main Power Switch is a circuit breaker type switch that controls power to the console.

2.3 Microprocessor Power Switch and Indicator Light control the power to the MPS-805 and indicate when it is on.

D. REAR PANEL DESCRIPTION

Fifty-four connectors are used to interface peripheral equipment with the MIDAS IV system. Fig. 5 shows the connectors located on the rear panel of the console. The connector allocation is given in Table III.

E. SOFTWARE PROGRAMS

MIDAS IV performs the functions of scanning, digitizing and recording data, and supplying output control signals as a result of pre-programming of the microprocessor. The programs are constructed from subroutines to allow efficient use of memory space and ease of debugging.

The construction of the control program, called "Monitor", allows the selection of one of eight possible branches or "modes" of operation. The eight modes are listed in Table IV. Operation in each mode requires the use of different subroutines as shown in Fig. 6. The function of each subroutine is summarized in Table V. Flow charts

and listings of the subroutines are given in Appendix B. Procedures for changing programs are given in Appendix D.

F. OPERATION VIA PROGRAM "MONITOR"

The operation of MIDAS IV consists of running the program, "Monitor", at the teletypewriter. Step-by-step procedures for operating the system are given in Appendix D. In this section, the available modes of operation are described. The mode is selected by entering the mode selection number at the teletype after the RESET button is pressed. A list of the mode selection numbers is given in Table IV. A summary listing of this table can be obtained by entering "0" followed by a "space" at the teletypewriter.

1. MIDAS IV Mode Listing

The operator enters "0". In this mode a list of mode selection numbers is typed on the teletypewriter. Control is automatically returned to the beginning of the "MONITOR" program, and another mode selection input can be made.

2. Calibration Mode

The operator enters "1". This mode is used to set up instrumentation and to calibrate the electrical analog signal at the DVM to the physical measurement. In the CALIBRATION mode, the operator can select any of the 48 channels and any port on each of the four Scanivalves using the thumbwheel switches and the port advance button. The selected port and channel numbers appear in the LED display and the voltage output from the signal conditioner is displayed by the DVM. Thus in this mode, the "balance" and "span" controls on the signal conditioners can be adjusted

to provide an appropriate "zero" and "range", respectively, for each input.

The CALIBRATION mode can also be used to select and monitor particular channels while testing is in progress.

To exit this mode, the RESET button is pressed.

3. Program Scan Mode

The operator enters "2". In this mode the operator first programs the sequence of channel/port combinations to be scanned when data is recorded. Second, the required increments and direction of probe movement are programmed. The required entries and format are given in Appendix D. Briefly, two tables of information are input. The first table, the Scan Control table, lists the channel and port number, the maximum difference between two successive DVM readings on this channel which can be accepted as indicating convergence has occurred, and the time in tenths of a second that the microprocessor should wait before the first DVM reading.

The Scan Control table is terminated by entering "F" in the "channel" column.

The second table, the Probe Control table, lists the amount, in hundredths of an inch, that the probe is to move and the direction of movement (0 or 1).

The Probe Control table is terminated by entering FF in the "Amt" column. During DATA ACQUISITION mode, the channels listed in the Scan Control table are scanned and recorded for each position of the probe entered in the Probe Control table. If no probe is used, a "zero" for the amount and a "zero" for the direction is entered in the Probe

Control table, which is terminated with a FF as before.

4. READ TAPE Mode

The operator enters "3". In this mode, the Scan Control and Probe Control tables can be entered from a pre-punched paper tape. The tape is punched with the teletypewriter in the "LOCAL" mode. An entry of data is always read as the number pair immediately preceding a space. Thus carriage return and line feed commands can be harmlessly included on the tape if they are followed by a number pair and a space, for example, CR, LF, 03, "space". Consequently, the entries on a paper tape can be made such that the information is simultaneously typed in a readable form. The information is entered as it is in the PROGRAM SCAN mode except that the teletypewriter does not prompt the operator. It is mandatory that the FF ending the Scan Control table be in the "channel" position. If it is not, the Probe Control table will be read as an extension of the Scan Control table. The FF ending the Probe Control table must be _ in the "Amount" position in order to terminate the table. If the tape reader continues to run after the end of the paper tape it is probable that one of the two FF's were entered in the wrong column. The last three ASCII characters on the paper tape should be the number pair, FF, followed by a "space". If additional characters follow, they are ignored.

5. DATA ACQUISITION Mode

The operator enters "4". In this mode, data scans are performed as programmed in the PROGRAM SCAN mode. When the DATA ACQUISITION mode is entered, the microprocessor first checks whether the required amount of probe movement equals FF, since this indicates the end of the run. If it is not, the probe traverse mechanism is activated in the

direction specified by the Probe Control table entry for a length of time that gives the desired incremental displacement. The microprocessor then reads the first entry in the Scan Control table. If the "channel" number is not FF, the correct channel and port are selected. After waiting the amount of time specified by the Scan Control table, the DVM is sampled on two successive scans. The two values are compared and if the magnitude of the difference is less than the tolerance given in the Scan Control table, the average of the two readings is returned. If the tolerance is not met in sixteen attempts, a value of 15000 is returned. If the DVM is overrange (the analog voltage is outside the ± 1.3999 volt range), a value of 14000 is returned. The channel number, port number, and the returned data value are output on the teletypewriter.

The microprocessor then checks the next channel number in the Scan Control table for FF and repeats the above process. The cycle is repeated until FF is read, at which time the next entry in the Probe Control table is checked for FF. If FF is read, the program is terminated and control returned to MONITOP. Otherwise the above process is repeated.

6. MEMORY DISPLAY and MEMORY EDIT Modes

The operator enters "5" for MEMORY DISPLAY and "6" for MEMORY EDIT. These modes are used together to first display and then to change what has been entered into RAM. They are available for software debugging. However, they are most frequently used to make individual changes in the Scan Control and Probe Control tables. For example, the Scan Control table is stored in RAM beginning at address 1100H. Five successive number pairs beginning with the channel number constitute one line of the table. To display a number of lines starting from the top of the table, first

"5" followed by a "space" is entered, then "11", "space", and "00","space". Following a computer printed hyphen, the address of the last line to be displayed is entered as two number pairs each followed by a space. A printout is obtained on the teletypewriter of the desired block of RAM. After noting the exact address of the number pair to be changed (note that the addresses are in hexadecimal and not decimal), the operator enters selection number "6", a "space", and the address. For example, "4, space, 11, space, 43, space". In the MEMORY EDIT mode, the existing data in RAM location specified by the entered address is printed on the teletypewriter and followed by a hyphen. The corrected data is then entered. The program automatically prints the number in the next location and a correction can be made if required. (If no data is entered before the space, a zero is written into RAM in place of the previous contents.) The RESET button is pressed to terminate the MEMORY EDIT mode. The same procedure is followed to edit entries in the Probe Control table, which is stored in RAM beginning at address 1400H. The MEMORY DISPLAY mode can be reentered following MEMORY EDIT for a final check of the entries in the tables.

An experienced operator can also enter new machine language programs using the MEMORY EDIT mode. (The organization of ROM and RAM is shown in Fig. 7.) The next section describes how microprocessor control is transferred to such a program.

7. RESTART Mode

The operator enters "7". On entering this mode, microprocessor control is transferred to the address entered following the selection number and a space. For example, a machine language program beginning at RAM location 1600H would be executed by entering the selection number "7" and a space followed by "16, space, 00, space".

The RESTART mode is terminated by pressing RESET.

III. PROBE AND TRAVERSE MECHANISM

A. GENERAL DESCRIPTION

Pneumatic probes, such as that shown in Figure 8(a), are frequently used in turbomachinery applications to determine the pressure distribution and flow direction between blade rows. The flow direction at a given location is partially determined by rotating the probe until the differential pressure between two side ports (see Fig. 8(b).) is zero ("yaw" balance). In this condition, the complete velocity vector can be determined from the pressures registered by the different probe ports with reference to calibration charts or equations. "Yaw" balanced probe readings are recorded at intervals across the flow. The Probe Traversing Mechanism (PTM), shown in Figure 9., was designed to position and balance the pneumatic probe during a survey under remote control.

The mechanism can be operated in three modes: "manual", "semi-automatic" (automatic yaw-balance and manual traverse), and "fully-automatic" operation under control of MIDAS IV. In the manual mode, the operator controls the angular and vertical positions of the probe using the control panel shown in Figure 10. This mode is used for check-out measurements. It can also be used during a test if it is safe for the operator to be in the test cell. In the semi-automatic mode, the side pressures (Fig. 8(b).) are applied to a differential pressure transducer which produces a control signal for the angular probe drive. This enables the probe to track the "yaw" direction automatically while the traversing movement is controlled manually. In the

third mode, fully-automatic, the probe is moved totally under program control of MIDAS IV. "Yaw" balance is maintained as in the semi-automatic mode, and the transverse motion is controlled by the microprocessor according to the programmed entries in the Probe Control table (see Section II-F).

B. HARDWARE COMPONENTS

1. Traverse Mechanism

The traverse mechanism was designed to accommodate probes having a shaft diameter equal to 0.25 inch with a shaft length of at least 12 inches. A variety of probe types can therefore be used. Details of the probes are not given here. The application of the mechanism is described with reference to the probe shown in Figure 8(a).

The Probe Traverse Mechanism was developed from an existing motorized probe drive of uncertain identity. It was necessary to change gearing on the transverse drive, to add position potentiometers, and to design mounting hardware for the probe and for attachment of the mechanism itself. Figure 9. shows the components of the traversing mechanism. As the probe rotates, the rotational displacement is tracked by a Cervex potentiometer. Transverse displacement is tracked by the linear potentiometer, and limit switches are provided to protect the components in event of a malfunction. Connecting cables between the traversing mechanism and the control panel can be disconnected for ease of set-up.

The mounting plate for the PTM was designed for the 4-bolt pattern used throughout the Naval Postgraduate School Turbomachinery laboratories. Thus, the PTM can be used

without modification on different pieces of test equipment. The PTM base, the angular potentiometer, and the orientation of the probe in the PTM are adjustable, which provides flexibility when space is limited.

2. Control Panel

The control panel, shown in Figure 10, is used when operating in all modes. The panel contains the drive circuits, the power supplies, and the interface connections to the MIDAS IV system. The control panel operates on 110 volt-60Hz AC power and is located within a few feet of the PTM. The connection to MIDAS IV is not necessary for manual or semi-automatic operation.

C. OPERATION

1. Set Up

The probe is held in the Probe Traversing Mechanism by three nylon-tipped, set screws in a collar at the top of the mechanism. Thus the probe can be installed in any desired position. In the semi or fully-automatic modes, the differential pressure transducer must be connected to the control panel which contains the transducer power supply. The pneumatic pressure lines must be connected without leaks, between the transducer and the #2 and #3 probe pressure outlets. (See Fig 8 (b).) For operation with the MIDAS IV system, the transverse drive and potentiometer circuits are also connected. (See Fig. C.3.) When the power switch is turned on, the PTM is ready to operate.

2. Manual and Semi-automatic Modes

Switches are provided on the Control Panel (Fig. 10.) for manual operation of the PTM. The translational and angular drive motors are controlled by the operator. In the semi-automatic mode, the angular setting of the probe is automatically controlled by a feedback circuit in which a gain adjustment is provided. If the gain is too high the probe continues to "hunt" for the balance condition. If the gain is too low the probe does not follow the flow direction accurately. The gain can be adjusted by the operator. A water-filled, U-tube manometer which measures pressure differential between the probe side ports is a good indicator of correct or incorrect adjustment.

3. Automatic Mode Using MIDAS IV

In this mode of operation the MIDAS IV provides the signal that powers the translational movement of the probe. The control program in MIDAS IV allows movement of the probe in multiples of 0.01 inches. Since the automatic angular tracking circuit also operates in this mode, the probe is maintained in alignment with the flow direction as it translates from one position to another.

IV. CONCLUSIONS

The MIDAS IV data acquisition and control system has been built, programmed and initial tests have been made with a traversing probe mechanism. While experience with the application of the system has been limited so far, several conclusions can be stated:

A wired interface between the MIDAS IV and the Hewlett-Packard 9830A calculator is a feasible and desirable modification of the present system. By bypassing the teletype printing and punching operations, the time to complete a data scan is greatly reduced. Furthermore, the need to handle paper tape is eliminated, enabling on-line reduction of data. The interface is straightforward since, as with the teletype, MIDAS IV I/O operations use ASCII serial format, and teletype interface kits are available for the HP 9830A.

A further improvement in scan rate would be obtained by replacing the present Digitec DVM with a more recent solid-state, high-speed A/D converter. This modification would involve the cost of the new converter and possibly minor changes in the present software. No changes in the present software would be necessary if the replacement converter output is in the same format as the Digitec.

More experience is needed to determine whether the motors on the probe traversing mechanism should be replaced. The high noise level of the present motors is undesirable and failure of electrical components may occur in time. Low noise, brushless motors are commercially available should this modification be necessary.

The MIDAS IV is a fully flexible system and is not limited to turbomachinery applications. Since the signal conditioners are designed to accept any Wheatstone bridge, potentiometric or thermocouple input, other applications might include structural analysis using strain gages, or wind tunnel testing.

The concept of substituting software for hardware in a data acquisition system is beneficial because of flexibility, reduced maintenance, and lack of complexity. If a system component, an A/D converter for instance, is to be replaced, changes in software can be made easily. Such a replacement could be difficult in a system using only hard-wired logic. System maintenance is simplified since there are fewer components to fail, and the difficulty of fault-finding in interconnected hard-wired logic circuits is largely eliminated.

TABLE I(a). OPERATIONAL SPECIFICATIONS OF
MIDAS IV

1. Completely self-contained system for 4 Scanivalve inputs, 36 bridge-type inputs or thermocouples, and 7 potentiometric inputs
2. Individual channel monitoring capability
3. Completely programmed for all operating functions
4. Programmable convergence specification for each channel
5. Programmable sampling time delay for damped signal input on each channel
6. Automatic non-convergence and overrange indication on all channels
7. Random channel selection and calling order
8. $4\frac{1}{2}$ digit A/D with signal conditioning capability on each channel
9. Scans and records up to 30 channels/min.
10. Self-contained F/V for RPM measurement
11. Automatic pneumatic probe positioning and yaw angle ballancing
12. Full probe-position recording capabilities
13. Serial I/O for direct connection of ASR-33 or other ASCII compatible devices
14. Self-contained power supplies for Scanivalves, bridges, and probe traverse mechanism

TABLE I(b). TECHNICAL SPECIFICATIONS OF
MIDAS IV

1. Input Points: 47
2. Measurement Functions:
 - A. Thermocouples
 - B. DC Voltages
 - C. Potentiometers
 - D. Wheatstone Bridge Applications
3. Resolution:
 - A. ± 0.2 mV for DC (after amplification)
 - B. 0.01% of full scale for Thermocouples
4. Input Impedance: Determined by amplifier gain
5. Noise Rejection: 80db
6. Digitizing Technique: Ramp
7. Display Range: ± 19999 Digits
8. Calibration: All normal adjustments are labeled on upper front panel
9. Operating Temperature: 10 to 50 C
10. Power: 115 VAC 60Hz
11. Ventilation: Small exhaust fan on rear panel
12. Size:
 - A. Height - 4 ft.
 - B. Depth - 2 ft.
 - C. Width - 2 ft.
13. Weight: 150 lb.
14. Case Construction:
 - A. 12 gage steel
 - B. 8 gage aluminum

TABLE I(c). ESTIMATED COST OF MIDAS IV

Pro-Log Equipment:

MPS-805	\$790.00	
PROM Chips (14)	490.00	
ROM Card (#8116)	95.00	
RAM Chips (8)	60.00	
I/O Card (#8113)	105.00	
Relay Card (#8402)	<u>120.00</u>	
		1660.00

MIDAS IV Hardware:

Datel F/V (VFV-10K)	59.00	
Datel Multiplexer (3) (MK-16)	387.00	
Signal Conditioning Cards (48)	1035.00	
Digitec A/D	650.00	
Thumbwheel Switch	20.00	
LED Display	10.00	
5 Pin Connectors (48)	75.00	
14 Pin Connectors (4)	8.00	
Power Supplies	190.00	
Power Switches and Circuit Breakers	10.00	
Metal Case	<u>250.00</u>	
		2694.00

Probe Traversing System:

Probe Traversing Mechanism	750.00	
Probe Control Panel	<u>285.00</u>	
		1035.00

ASR-33 Teletypewriter	<u>800.00</u>	<u>800.00</u>
-----------------------	---------------	---------------

TOTAL ESTIMATED COST:		6189.00
-----------------------	--	---------

TABLE II(a). PHYSICAL SPECIFICATIONS FOR
PRO-LOG MPS-805

Physical

Three 4.5" by 6.5" printed circuit cards

- One 8111 CPU card
- One 8114 Input card
- One 8115 Output card
- One 8116 ROM card
- One 8117 RAM card

Connector Requirement for each card

56 pin, 28 position dual row-out on 0.125 centers

CPU Card includes

- 8008 CPU
- Crystal clock
- Address latches, data buffers, and control decode circuits.
- Power-on and external restart.
- DMA buffers.

ROM Card includes

- One 1702A PROM (256 bytes) and eight PROM sockets
- Socket for card expansion circuit (up to 8 cards)

RAM Card includes

- Eight 2102 RAM (1024 bytes) and thirty-two RAM sockets
- Socket for card expansion circuit (up to 4 cards)

Input Card includes

- 32 TTL input selector circuits addressable in groups of 8
- Socket for card expansion circuit (up to 2 cards)

Output Card includes

- 32 TTL output latch circuits addressable in groups of 8
- Socket for card expansion circuit (up to 6 cards)

Operational

CPU

Executes all of the 8008 instructions.

4 microsecond time state cycle using 8008 (MPS 1805).

2.8 microsecond time state cycle using 8008-1 (MPS 805-1).

Memory for data or program storage card expandable to any combination of ROM and RAM to 16384 words

ROM, 2048 word capacity per card.

RAM, 4096 word capacity per card.

Input and Output

Input gates implement the INP instructions.

Output latches implement the OUT instructions.

Interrupt or External Restart

Single line, synchronized interrupt on CPU card can be optionally wired for multi-level interrupt or Power-on external restart.

Multi-level Interrupt Control lines available for external interrupt such as 8118 priority interrupt card.

Power-on and external restart option: CPU starts at instruction location 0000 by wiring restart output from CPU card to Interrupt Request Input.

DMA (Direct Memory Access)

Data, address, and control lines are 3 state disconnected by the CPU following a HLT instruction allowing

DMA by peripherals. The CPU must be interrupted to continue following a HALT.

Electrical Requirements

Refer to individual data sheets and schematics on the 8111, 8114, 8115, 8116, and 8117 for interface and wiring.

Power Requirements for the five card set fully loaded

+VCC = 15% @ 3.3 Amp maximum (35mA per ROM, 50mA per RAM)

GND 0 volts

VDD = 9 volts 15% @ 900 mA maximum (15 mA per ROM)

Hardware

Compatible with Series 8400 interface cards

Fits CR5, CR10 or CR19 card racks

Use M273 power supply

PROM's programmable on Series 81 programmers

Software

MPS 800 hardware is fully compatible with any 8008 software assuming I/O and interrupt can be assigned compatibly. Teletype operating system and system monitor available. Assemblers, compilers and simulators available through computer time-sharing services.

TABLE I I (b). OPERATIONAL SPECIFICATIONS FOR PRO-LOG MPS-805

TABLE III. CONNECTOR ALLOCATION

CONNECTOR NUMBER-	USE
1 - 4.....	SCANIVALVE SIGNAL INPUTS
5 - 40.....	STRAIN GAGE AND PRESSURE TRANSDUCER INPUTS
41 - 47.....	POTENTIOMETRIC INPUTS
48.....	MAGNETIC FLUX COUNTER INPUT
49.....	PROBE TRAVERSE MECHANISM CONTROL
50.....	TELETYPEWRITER I/O
51 - 54.....	SCANIVALVE CONTROL I/O

TABLE IV. MODE SELECTION NUMBERS

MODE SELECTION NUMBER	MODE	DESCRIPTION
0	MIDAS IV HEADER	TYPES OUT A LIST OF THE MODE SELECTION NUMBERS
1	CALIBRATION	ALLOWS THE SELECTION OF EACH CHANNEL FOR CALIBRATION PURPOSES
2	PROGRAM SCAN	1) THE REQUIRED SEQUENCE OF CHANNELS TO BE SCANNED CAN BE PROGRAMMED, WITH PROVISION FOR ENTERING ALLOWABLE NOISE LEVELS (SCAN CONTROL TABLE) 2) THE REQUIRED SEQUENCE OF PROBE MOVEMENTS CAN BE PROGRAMMED (PROBE CONTROL TABLE)
3	READ TAPE	ALLOWS PROGRAMMING OF RAM VIA PAPER TAPE INPUT
4	DATA ACQUISITION	PERFORMS THE SEQUENCE OF PROBE MOVEMENTS AND CHANNEL SCANS REQUIRED, OUTPUTTING DATA ON THE PAPER TAPE
5	MEMORY DISPLAY	PRINTS CONTENTS OF ROM OR RAM BETWEEN ADDRESSES REQUESTED
6	MEMORY EDIT	WRITES OVER THE CONTENTS OF RAM
7	RESTART	TRANSFERS MICROPROCESSOR CONTROL TO A DESIRED ADDRESS AND BEGINS EXECUTION THERE

TABLE V. MIDAS IV PROGRAM SUBROUTINES

1.	BCDHEX	CONVERTS DECIMAL NUMBER TO BINARY NUMBER
2.	CALIB	CALIBRATION SUBROUTINE
3.	CHANNEL ORDER	CHANNEL/PORT/ERROR/TIME INFORMATION- STARTS AT 1100H
4.	CONVERGE	CALLS "DIGITEC" UNTIL TWO SUCCESSIVE VALUES CONVERGE. RETURNS AVERAGE VALUE OR 15000 IF NO CONVERGENCE.
5.	DATAOUT	OUTPUTS CHANNEL, PORT NUMBERS AND DATA
6.	DIGITEC	READS BCD VALUE FROM DIGITEC AND RETURNS THE BINARY EQUIVALENT
7.	DISPLAY	CONTROLS THE LED DISPLAY
8.	FORMAT	AID TO OUTPUT FORMATTING
9.	HEX PAIR	CALLS TTYIN TWICE AND RETURNS A BINARY NUMBER PAIR
10.	MONITOR	PROGRAM TO SELECT THE DIFFERENT MODES OF OPERATION
11.	MULTIPLFX	OPERATES MULTIPLEXERS
12.	NEXT	TYPES "...TYPE THE NEXT SELECTION NUMBER"
13.	ONE OUT	OUTPUTS A SINGLE BINARY NUMBER
14.	PAIROUT	OUTPUTS A PAIR OF BINARY NUMBERS
15.	PROBE ORDER	PROBE INFORMATION INPUT- STARTS AT 1400H
16.	READ CORE	READS CONTENTS OF ROM OR RAM
17.	READ TAPE	READS A PAPER TAPE INTO LOCATIONS 1100H AND 1400H
18.	SCANV	OPERATES SCANIVALVES
19.	START	DATA ACQUISITION SUBROUTINE
20.	TTYIN	INPUTS ASCII BINARY CHARACTER FROM TELETYPEWRITER
21.	TTYOUT	OUTPUTS ASCII BINARY CHARACTER TO TELETYPEWRITER
22.	WRITE CORE	WRITES ONTO RAM

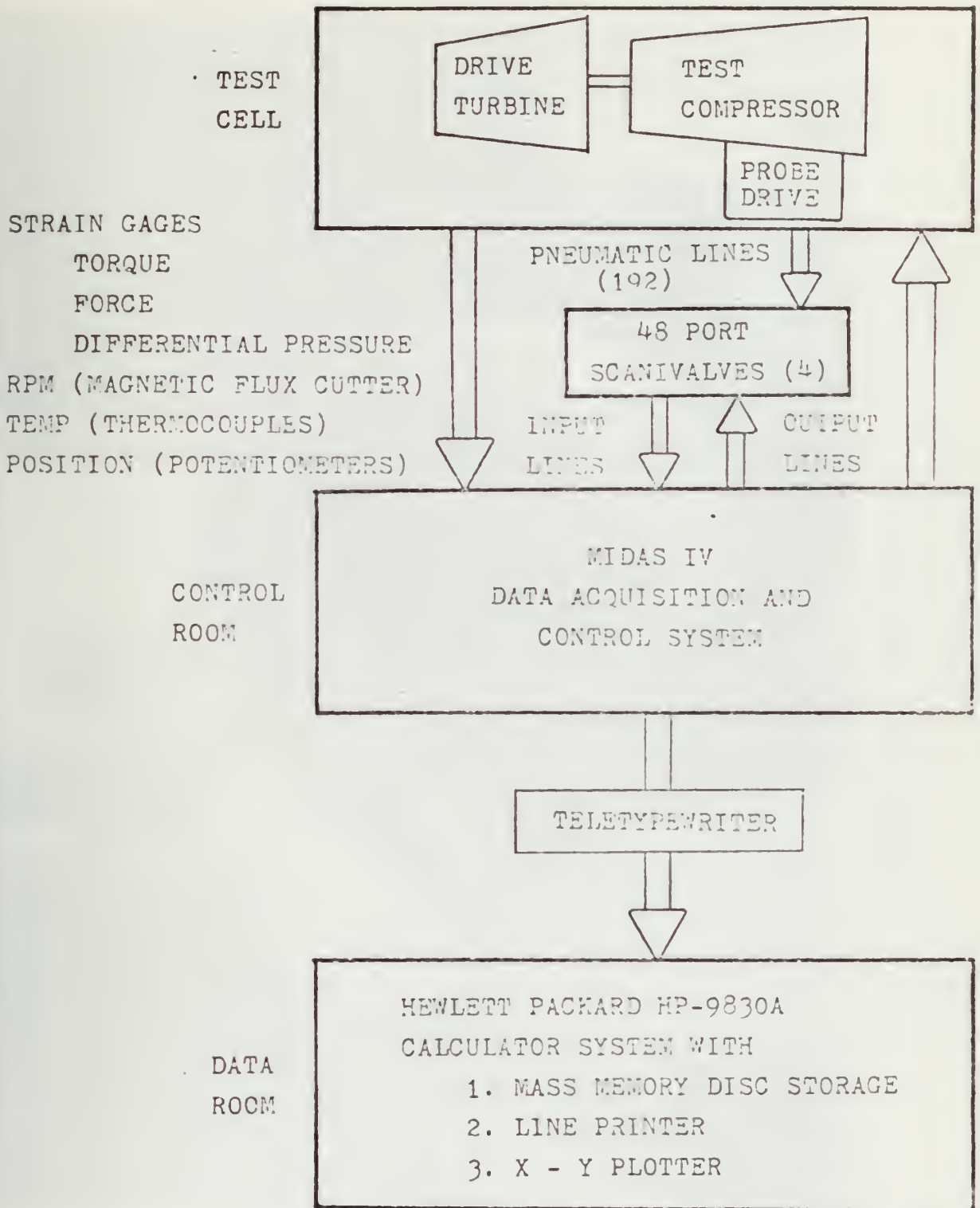

Figure 1a. Laboratory Arrangement and Function of MIDAS IV (Schematic)

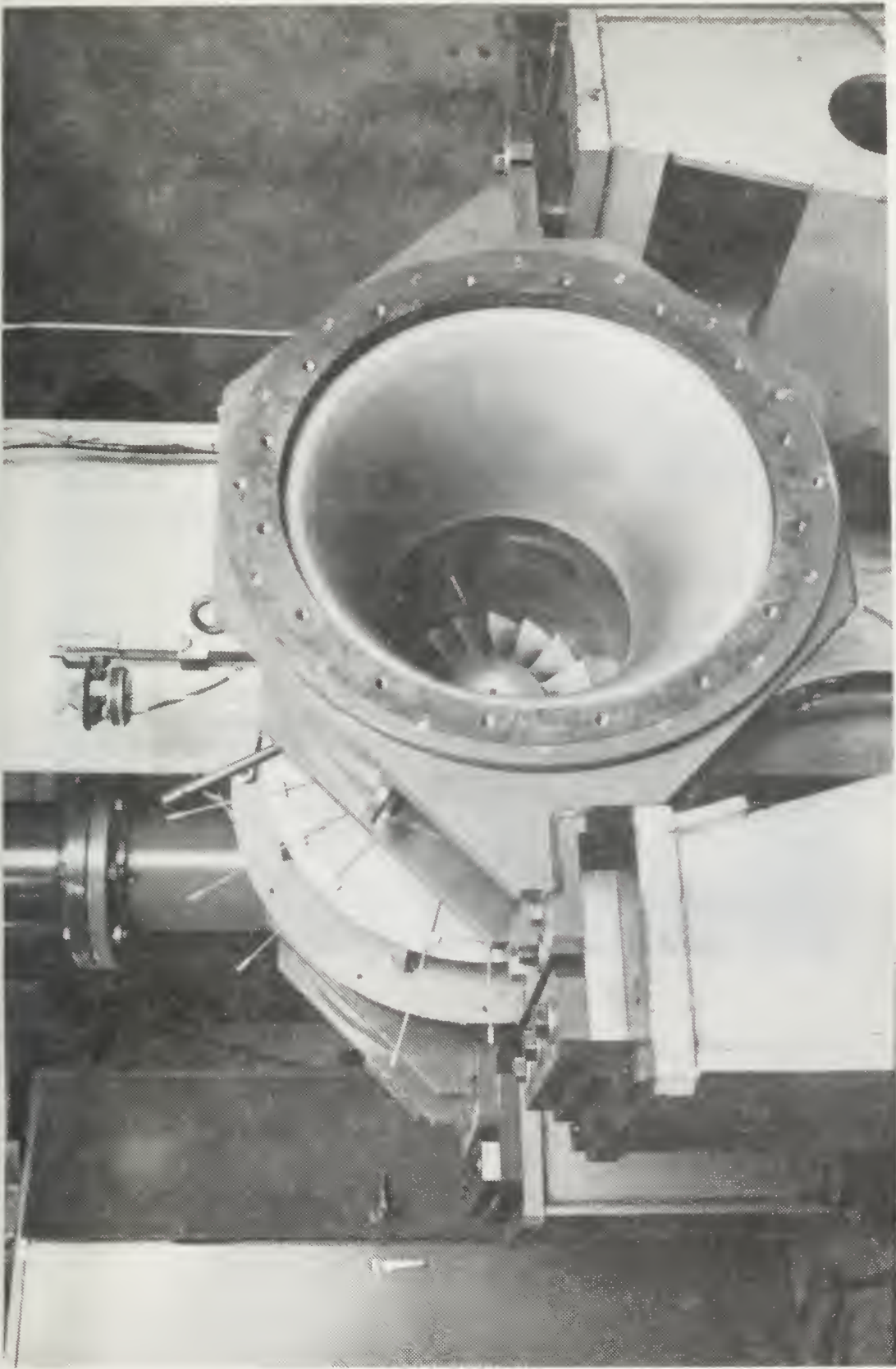

FIGURE 1(b). Test Cell

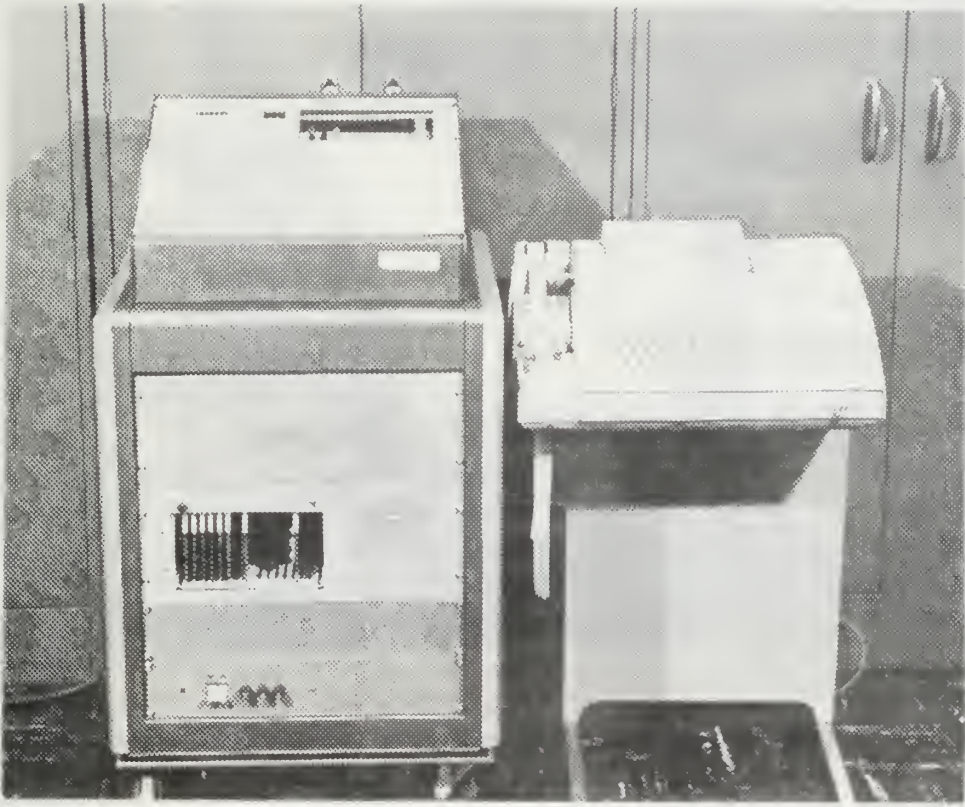

FIGURE 1(c). MIDAS IV Console
and Teletype

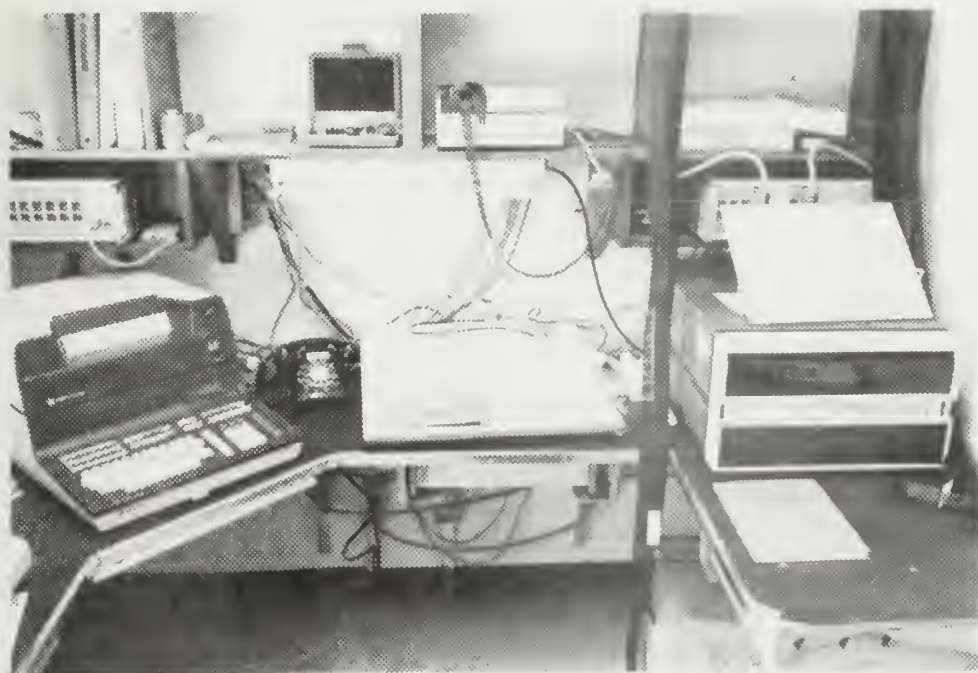
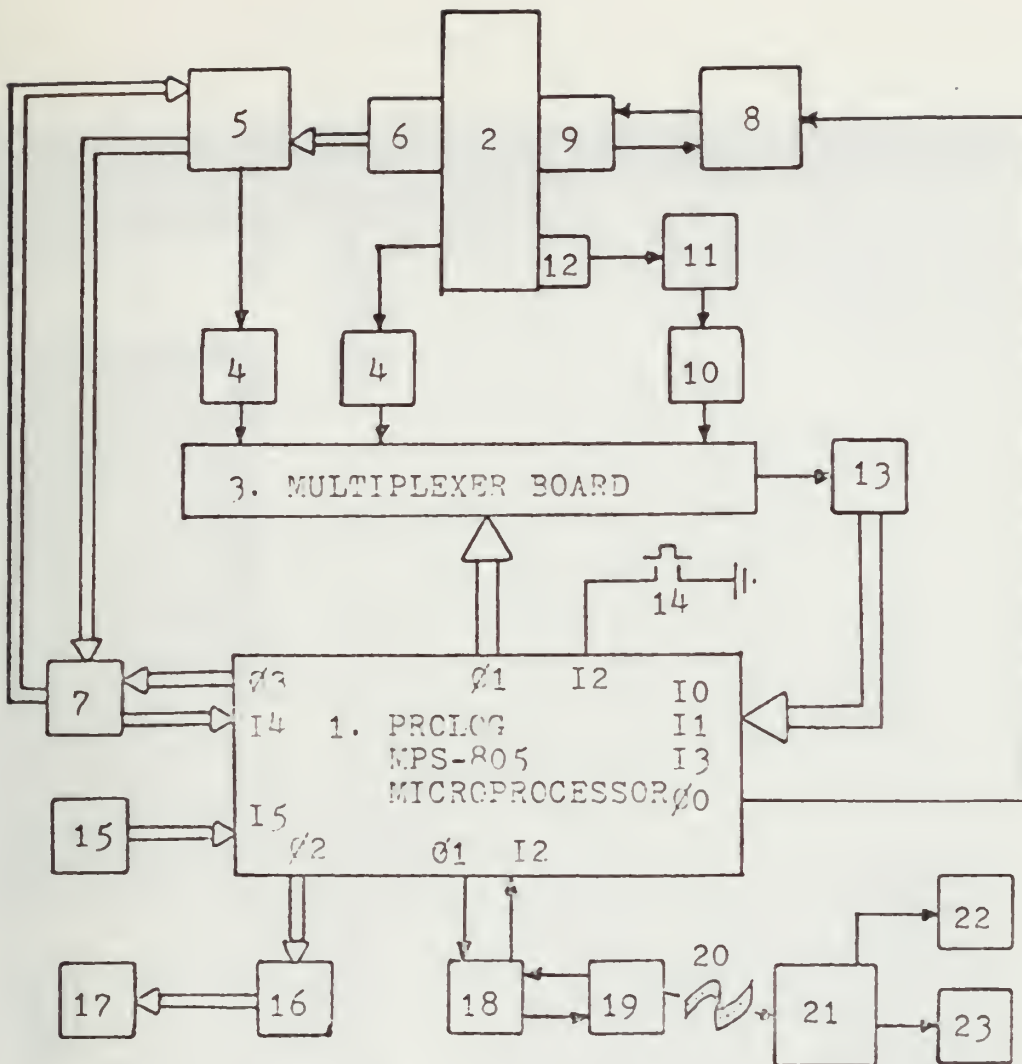

FIGURE 1(d). HP-9830A Data Reduction Equipment



- | | |
|-------------------------------|-------------------------------|
| 1. MPS-805 | 13. A to D Converter |
| 2. Compressor | 14. Scanivalve Advance Button |
| 3. Multiplexer | 15. Thumbwheel Switch |
| 4. Signal Conditioner | 16. Display Card |
| 5. Scanivalve | 17. LED Display |
| 6. Probes | 18. Teletype Card |
| 7. Relay Card | 19. ASR-33 Teletype |
| 8. PTM Panel | 20. Paper Tape Output |
| 9. Probe Traverse Mech. (PTM) | 21. HP-9830A Calculator |
| 10. Voltage Divider | 22. Line Printer |
| 11. F to V Converter | 23. X-Y Plotter |
| 12. Magnetic Flux Cutter | |

Figure 2. Schematic of MIDAS IV System

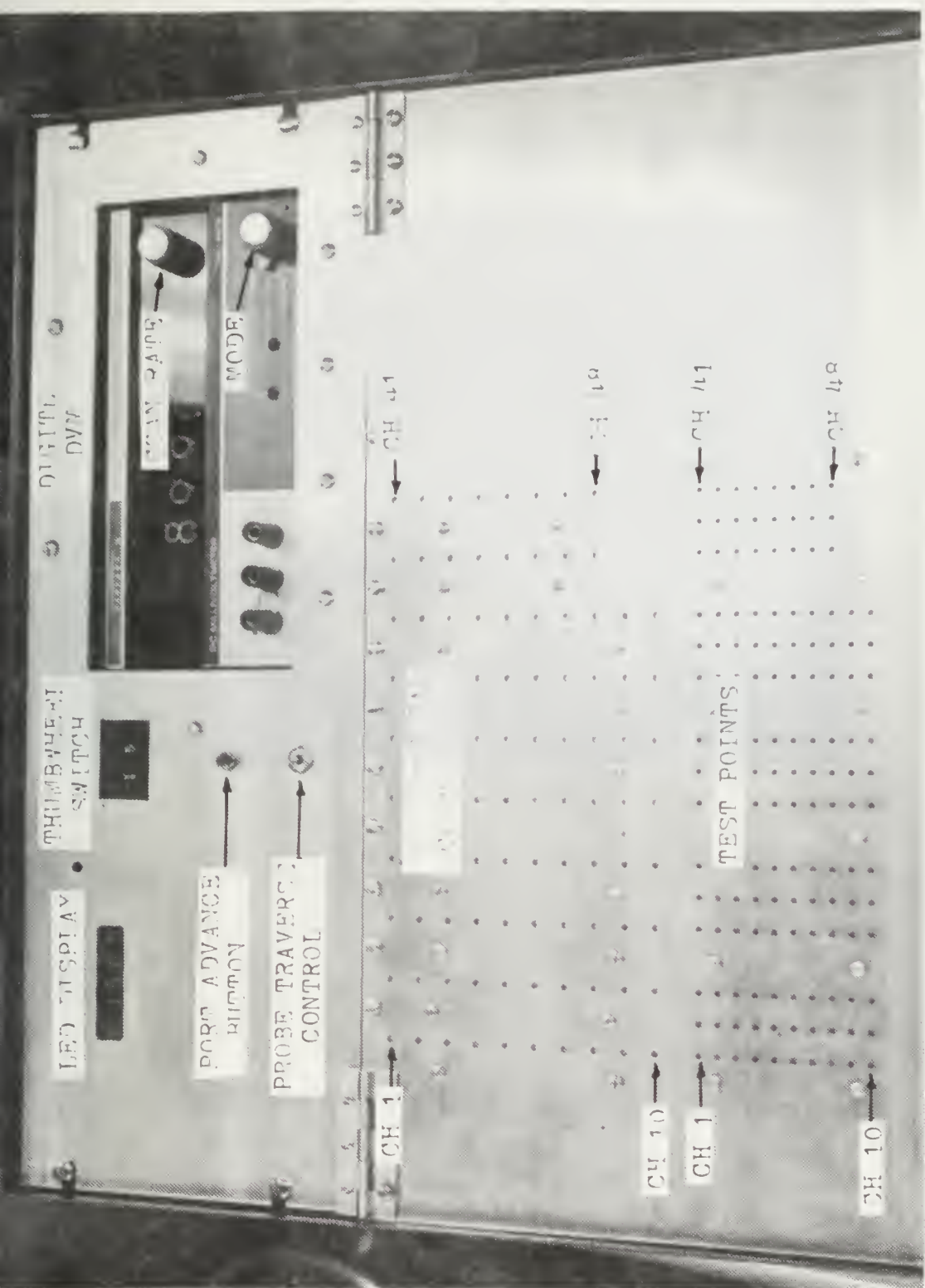

FIGURE 3. Upper Front Console

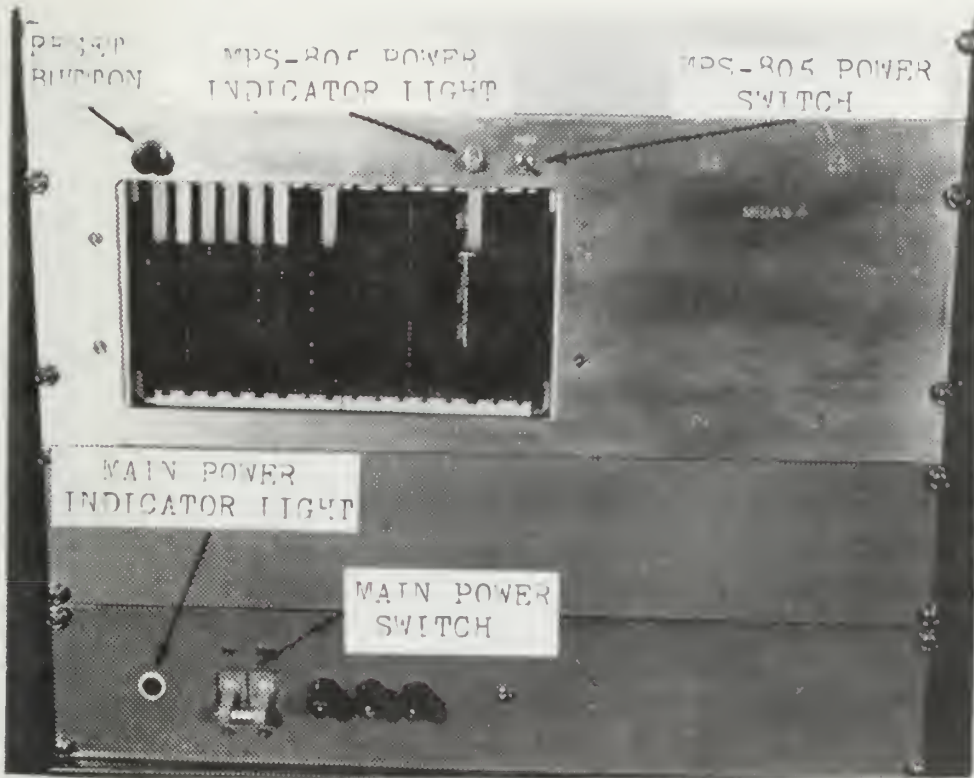

FIGURE 4. Lower Front Console

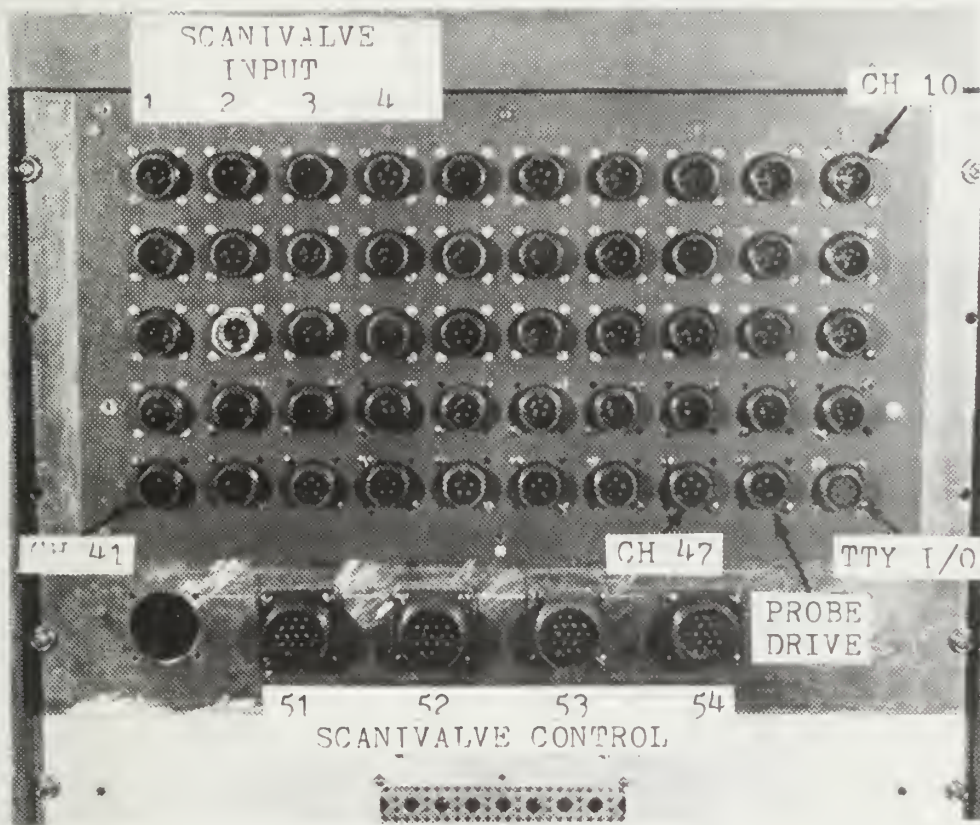

FIGURE 5. Rear Connector Panel

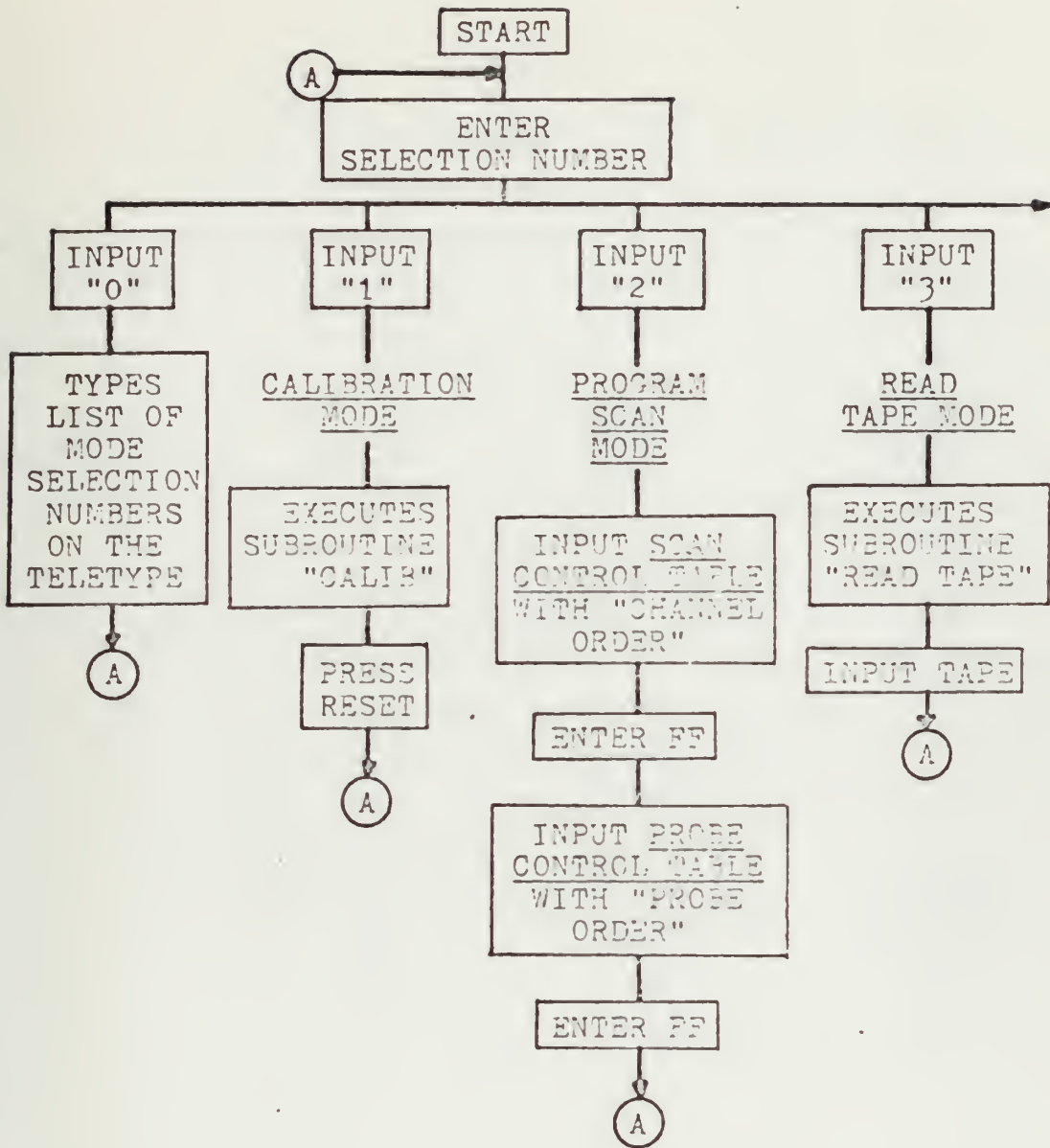

Figure 6. Schematic of the MIDAS IV Control Program - "MONITOR"

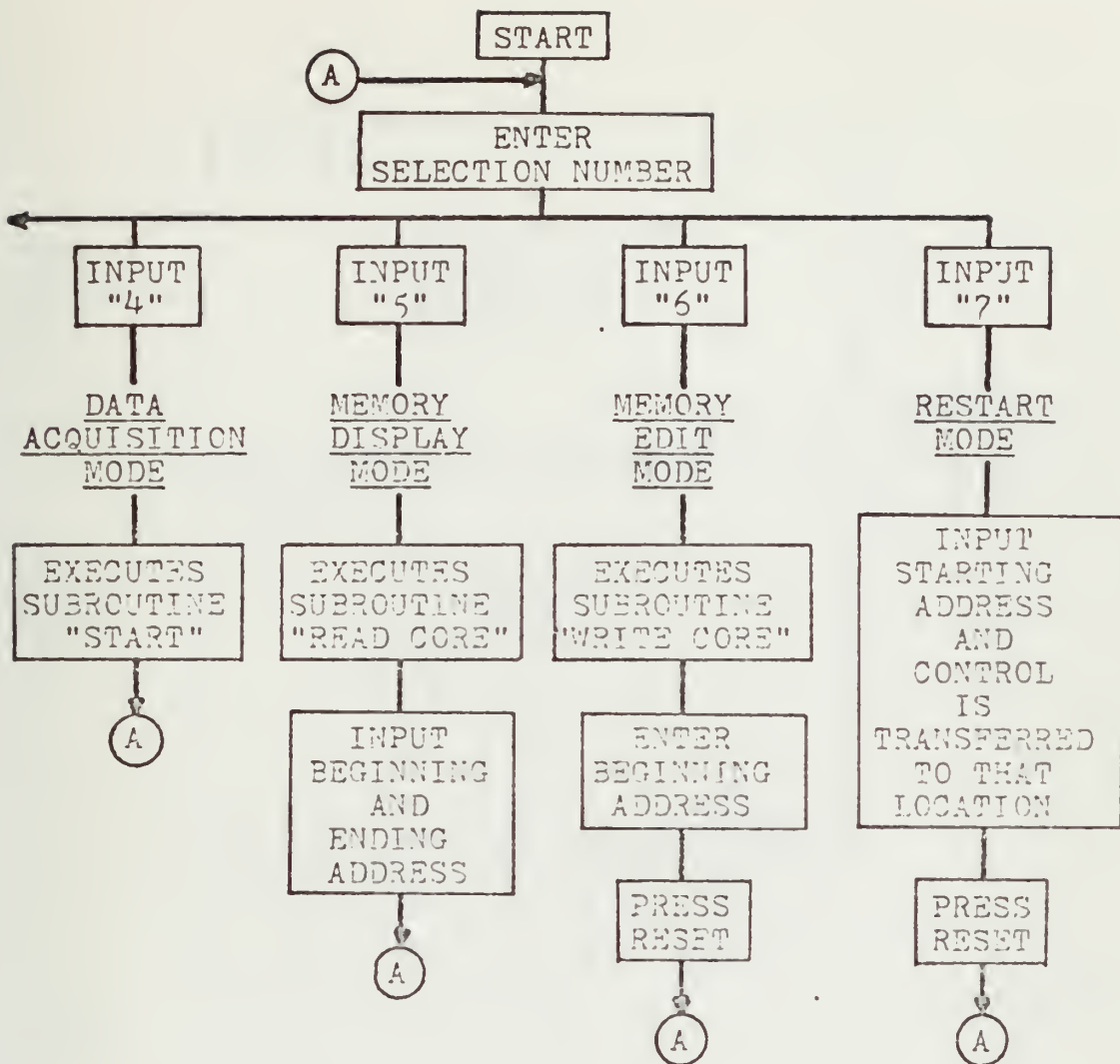

Figure 6. (cont.) Schematic of the MIDAS IV Control Program - "MONITOR"

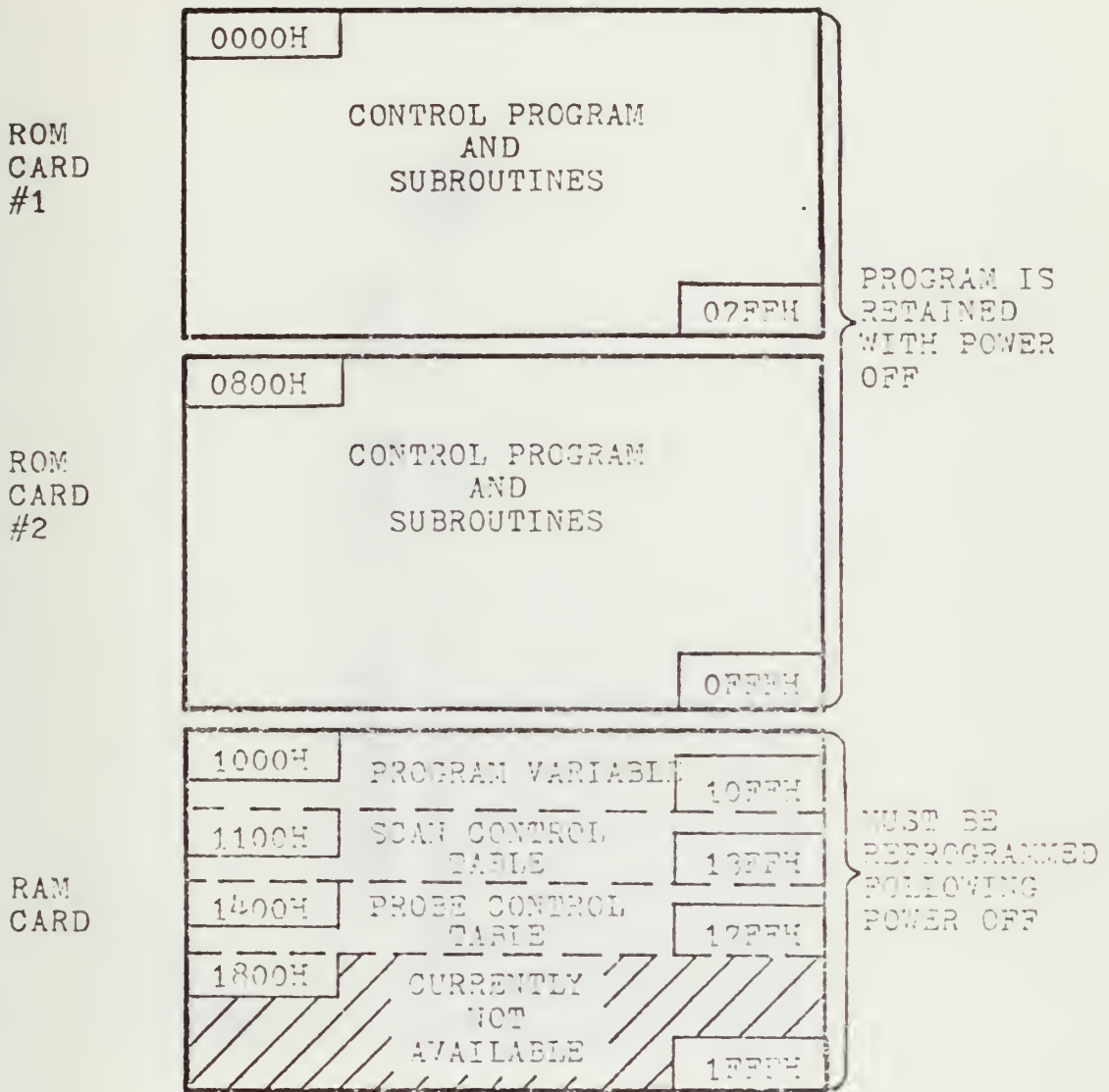
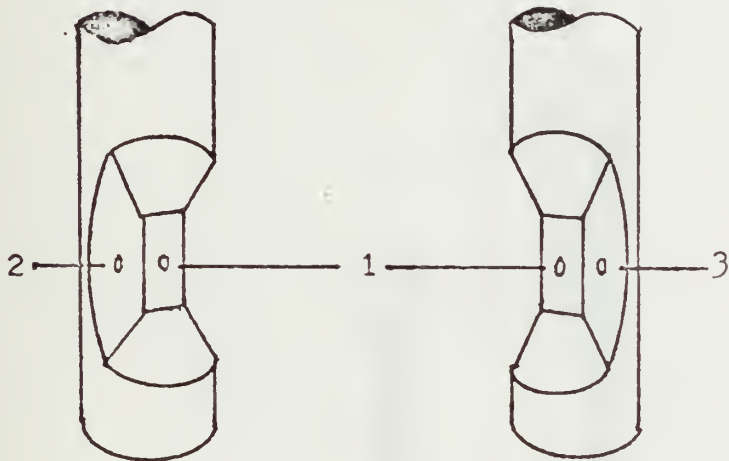

Figure 7. Memory Allocation Map for MIDAS IV



FIGURE 8(a). Pneumatic Probe for Flow Surveys-
View of the Probe

THREE HOLE PROBE: PORT #1 TOTAL PRESSURE
 PORTS #2 AND #3 YAW ANGLE INDICATORS



FIVE HOLE PROBE: PORT #1 TOTAL PRESSURE
 PORTS #2 AND #3 YAW ANGLE INDICATORS
 PORTS #4 AND #5 PITCH ANGLE INDICATORS

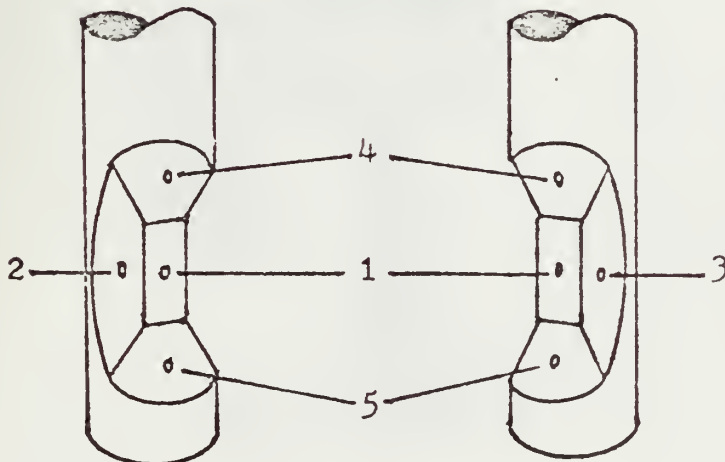

FIGURE 8(b). Pneumatic Probe for Flow Surveys-
 Pressure Port Locations

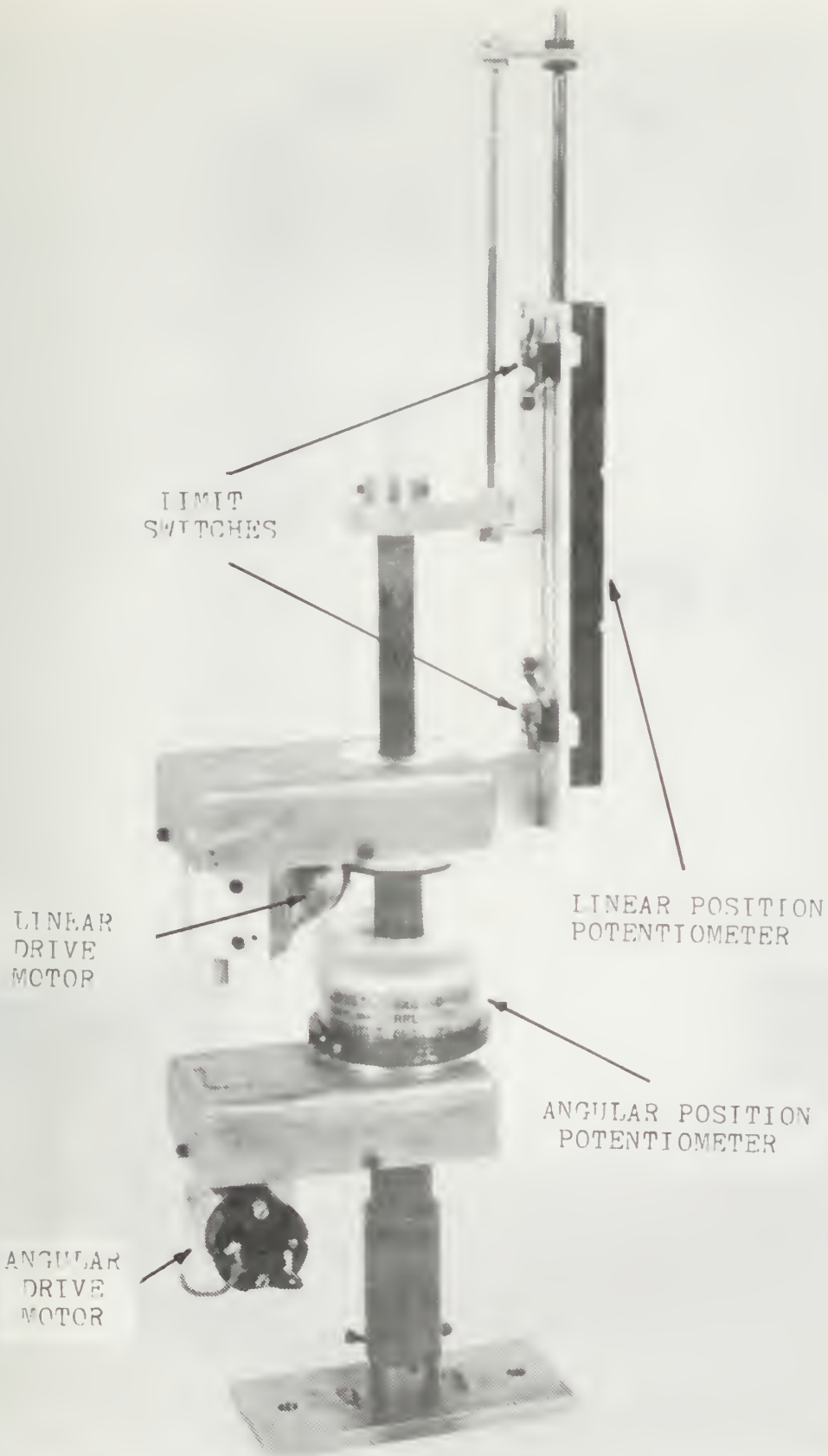

FIGURE 9. View of the Probe Traversing Mechanism

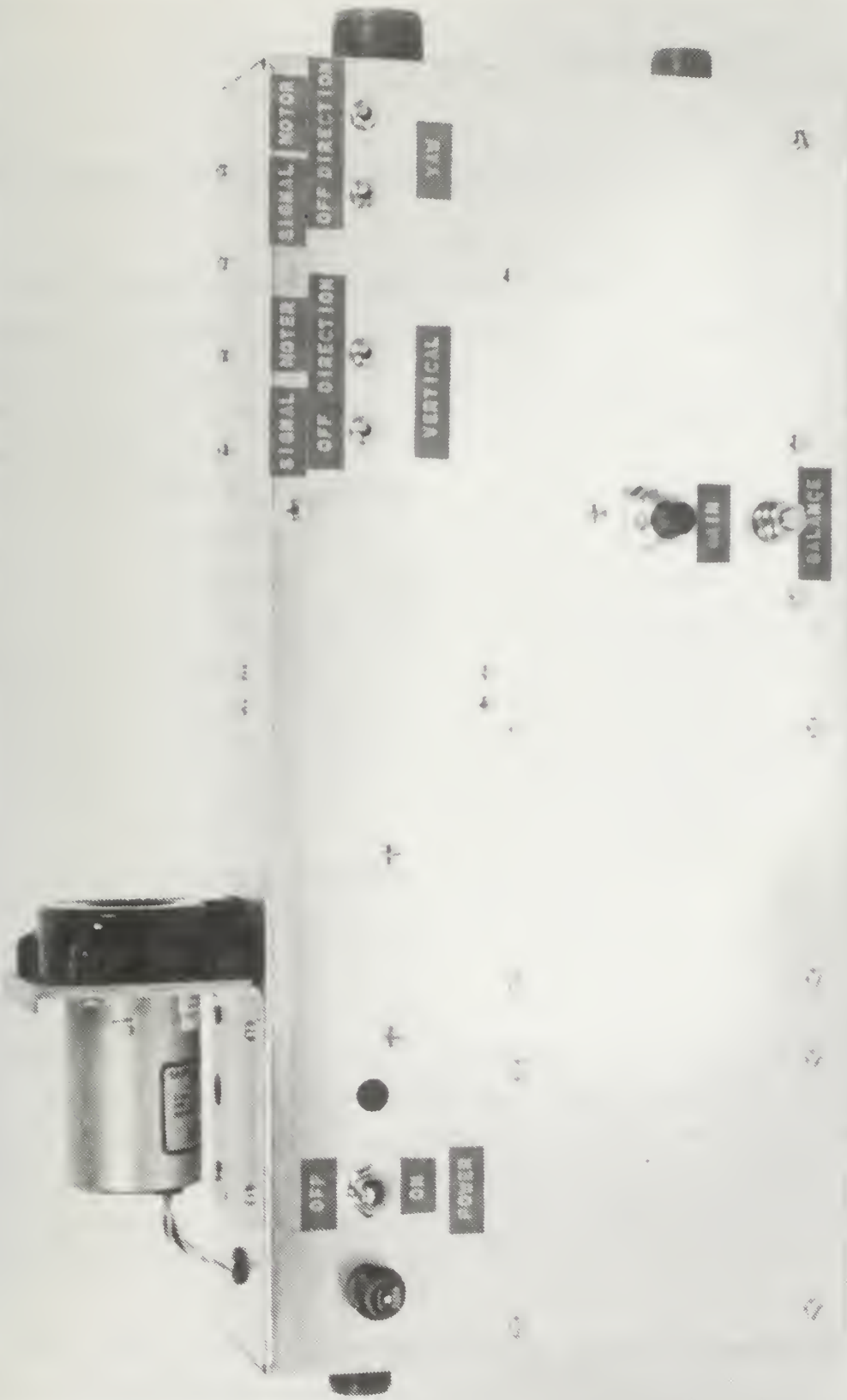

FIGURE 10. View of the Probe Control Panel

APPENDIX A. MIDAS IV HARDWARE MANUAL

A.1 PRO-LOG MPS-805 MICROPROCESSOR

The microprocessor used in MIDAS IV is a modified version of the Pro-Log Model MPS-805, the specifications of which are given in Tables II(a) and II(b). Schematics of the cards in the MIDAS IV microprocessor are contained in the following Pro-Log drawings:

- | | |
|---------------------|------------------------|
| 1. CPU CARD (8111) | 5. INPUT BOARD (8114) |
| #100308 | #100320 |
| #100305 | #100317 |
| 2. ROM CARD (8116) | 6. OUTPUT BOARD (8115) |
| #100328 | #100324 |
| #100325 | #100321 |
| 3. RAM CARD (8117) | 7. RELAY BOARD (8402) |
| #100332 | #100333 |
| #100329 | #100336 |
| 4. I/O BOARD (8113) | |
| #100316 | |
| #100313 | |

The MIDAS IV uses one additional I/O card (#8113) and one additional ROM card (#8116). The number of input ports was increased from 4 to 5. PROM capacity was increased from 2048 to 4096 words. The layout of the cards in the microprocessor is shown in Figure A1, and a side view of the relay card is shown in Figure A2.

The extra wire-wrap connections required for these cards and the original connections are listed in Ref. 5. The I/O port assignments are given in Table A.I.

A.2 MULTIPLEXER BOARDS

Three 16-input Datel Model MM-16 multiplexers are mounted on boards contained in a separate chassis above and to the right of the MPS-805. Specifications are given in Ref. 3.

Figure A3. is a schematic of the multiplexer circuit and identifies the pin allocation of the card.

A.3 SIGNAL CONDITIONERS

Signal conditioning circuits are incorporated in channels 1 to 47 to enable the analog inputs to be scaled to $\pm 1.399^{\circ}$ volts at the DVM. The circuit diagram for channels 1 to 40 is shown in Fig. A4., and notes are given in the figure for the differences in channels 41 to 47. The adjustments described in the following paragraphs are carried out in the CALIBRATION mode.

A.3.1 Amplifier Adjustments

The signal conditioners use SIGNETIC $\mu 741$ operational amplifiers [Ref.5].

1. The amplifier gain is fixed by the value of the input resistance R3 (Fig. A4.) according to the relation:

$$\text{Gain} = R4 / R3, \text{ where } R4 = 100,000 \text{ ohms}$$

2. The amplifier offset is set to zero by connecting test points 1, 2, and 3 together (Fig. 3. and Fig. A4.), and adjusting R6 to give a zero reading on the DVM.
3. The amplifier output is set to zero by

disconnecting the transducer input, shorting test points 1 and 3 together and adjusting R5 to give zero voltage.

A.3.2 Calibration of Channels 1-40

The signal conditioners on channels 1 to 40 were designed to be used with strain gage transducers (for force, torque or pressure measurements) and with thermocouples.

Strain gage inputs: A, B, C, and D (Fig. A5.) are used to complete a Wheatstone bridge circuit through the transducer.

1. The bridge is balanced to zero using R2 (labelled "bal" in the upper front panel shown in Fig. 3.)
2. The range, or span, is set using R1 (labelled "span" in the upper front panel shown in Fig. 3.)
3. A previously calibrated input can be checked using a fixed known resistance in the following way:
 - i) Connect the resistance across test points 2 and 3 (shunting one leg of the bridge) and record the DVM reading.
 - ii) Connect the resistance across test points 1 and 2 and record the DVM reading.
 - iii) If the voltages agree with established calibration values, no adjustment of R1 and R2 is necessary. Otherwise R1 and R2 must be adjusted to produce the correct calibration values.

Thermocouple Inputs: Thermocouples are connected as shown in Fig. A5. Since thermocouples are low-level voltage sources (the voltage is the analog of the temperature being

measured) the power supply is not needed. The amplifier gain required is considerably higher than for strain gage inputs.

A.3.3 Calibration of Channels 41-47

The signal conditioners on channels 41 to 47 were designed to be used with potentiometric inputs. The 20,000 ohm resistors on either side of R2 in Fig. A4. are bypassed, and pins A,C, and D are connected as shown in Fig. A5. The calibration is in two steps:

1. The potentiometer is set to one limit of travel and R2 ("bal") is adjusted to give zero voltage.
2. The potentiometer is set to the other limit of travel and P1 ("span") is set to a desired maximum voltage. (The maximum is ± 1.3999 volts, set by the DVM.)

A.4 FREQUENCY TO VOLTAGE CONVERTER

A.4.1 Circuit Description

A frequency to voltage (F/V) converter is used at the input of channel 48 to allow the measurement of RPM.

A magnetic flux cutter, consisting of an inductance sensor passed by an indented wheel mounted on the drive shaft, generates a pulsed signal at a frequency proportional to the RPM of the turbine (Fig. A6.). The F/V converter card detects the frequency and produces a voltage proportional to the frequency. A schematic of the card is shown in Fig. A8. Specifications for the Datel Model VFV-10K F/V converter are given in Ref. 8.

The F/V card produces 1 volt per 10KHz. To adjust to the range of the A/D converter (± 1.3999 volts) the F/V card output is fed through a 10:1 voltage divider to the channel 48 input. Using an indented wheel with 6 teeth, the DVM reading from 0 to 1.0 volts corresponds to a shaft rotation rate of 0 to 100,000 RPM.

A.4.2 Range Adjustment

The range adjustment procedures are:

1. Place the toggle switch shown in Fig. A7. in the "calibrate" position.
2. Select channel 48, in the CALIBRATION mode.
3. With a stationary shaft, adjust the green trim pot for zero at the DVM. (Fig. A7.)
4. Input a 10,000 Hz signal from a frequency generator on pins A and C of the 48 pin connector. Place toggle switch in the "normal" position.
5. Adjust the tan colored trim pot ("gain adj.", Fig. A7.) to give 0.1000 volts on the DVM.
6. Disconnect the frequency generator. This completes the adjustment.

A.5 SCANIVALVE CONTROLS

The Scanivalve is a commercially produced pneumatic switch that selectively connects one of several input ports to a pressure transducer contained in the unit. The Naval Postgraduate School Turbomachinery Laboratories uses two types of Scanivalves, one with 24 ports, the other with 48 ports. The MIDAS IV system can control up to four Scanivalves, thus multiplexing up to 196 pneumatic connections into four input channels.

The Scanivalve responds to two commands, "Home" and "Advance". "Home" causes the Scanivalve to be stepped until the first port is selected. "Advance" steps the Scanivalve one port at a time.

Fig A9. shows the Scanivalve "Advance" and "Home" circuitry. When MIDAS IV selects a Scanivalve, the GROUND for that Scanivalve is completed through the Pro-Log Relay Card (8402). The "Address" and "Home" signals are sent to all the Scanivalves, but only the one with the completed GROUND responds. Table A.II. lists the pin allocations for all connectors, including 51 through 54, which carry the Scanivalve control signals.

A.6 ANALOG TO DIGITAL CONVERTER (DIGITEC)

A.6.1 Description

The Digitec digital voltmeter converts an analog input voltage within the range ± 1.3999 volts into a 4 1/2 BCD output.

The specifications for the Digitec Model 251-3 used in MIDAS IV are given in Ref. 4.

A.6.2 Sample Rate and Integration Time

The sample rate of the Digitec is adjustable between 0 and 5 samples/second. The integration time (For example, the time for the analog voltage to be measured) is independent of the sample rate, and it is possible to sample at intervals shorter than the integration time.

The MIDAS IV is programmed to compare up to 16 successive readings (samples) and test for convergence

within a prescribed limit. The upper section of Fig. A10. illustrates that it is possible to sample 16 times before the analog value is measured. This is avoided in two ways:

1. By slowing the DVM sample rate (illustrated by the center section of Fig. A10.).
2. By increasing the time delay in the Scan Control table (illustrated by the lower section of Fig. A10.). Note: A delay time of 0.7 sec. (obtained by entering 07 in the "Time" column of the Scan Control table) is usually sufficient to allow the DVM to complete integration.

A.7 DISPLAY CARD AND LED MODULES

Five 5-by-7 matrix light emitting diode (LED) modules display the channel and port numbers currently selected. The information is sent to the display card from the microprocessor in BCD format. The information is "latched" by following the initial display card input with the same information "or"-ed with 000H. (This is a latch enable signal being sent to the display card and is only necessary due to hardware design.)

A schematic of the circuit of the Display Card is given in Fig. A11. Specifications for the LED modules are given in Ref. 10.

A.8 TELETYPE INTERFACE

The function of the teletype interface card is to process the output of the teletypewriter in order to eliminate transients (such as are due to bounce in the mechanical contacts) and to insure that the TTL voltage levels of 0 and 5 volts are maintained.

A schematic of the teletype interface card is given in Fig. A12.

TABLE A.I. I/O PORT ASSIGNMENTS FOR MIDAS IV

INPUT CARD 3		
0-8	Digitec	8000
0-7	"	4000
0-6	"	2000
0-5	"	1000
0-4	"	800
0-3	"	400
0-2	"	200
0-1	"	100

INPUT CARD 3		
1-8	Digitec	80
1-7	"	40
1-6	"	20
1-5	"	10
1-4	"	8
1-3	"	4
1-2	"	2
1-1	"	1

INPUT CARD 3		
2-8	TTY Input	
2-7		
2-6		
2-5		
2-4		
2-3		
2-2		
2-1	<u>Port Adv.</u>	

INPUT CARD 3		
3-8		
3-7		
3-6		
3-5		
3-4	Digitec Blanked	
3-3	New Convert Pulse	
3-2	Polarity (1=neg)	
3-1	10,000	

INPUT CARD 4		
4-8	Scanivalve	80
4-7	Position-	40
4-6	(Negative	20
4-5	Logic)	10
4-4		8
4-3		4
4-2		2
4-1		1

INPUT CARD 4		
5-8	Thumbwheel-	80
5-7	(Negative	40
5-6	Logic)	20
5-5		10
5-4		8
5-3		4
5-2		2
5-1		1

TABLE A.I.(cont) I/O PORT ASSIGNMENTS
FOR MIDAS IV

OUTPUT CARD 5		OUTPUT CARD 5	
0-8		1-8	TTY Output
0-7		1-7	MPX 3 Enable
0-6		1-6	MPX 2 Enable
0-5		1-5	MPX 1 Enable
0-4		1-4	MPX ADDR 8
0-3		1-3	MPX ADDR 4
0-2	Probe Up	1-2	MPX ADDR 2
0-1	Probe Down	1-1	MPX ADDR 1
OUTPUT CARD 5		OUTPUT CARD 5	
2-8	Display, D.P.	3-8	S.V. Home
2-7	Digit Sel. 4	3-7	Advance
2-6	" 2	3-6	S.V. Sel. 6
2-5	" 1	3-5	" 5
2-4	BCD Value 8	3-4	" 4
2-3	" 4	3-3	" 3
2-2	" 2	3-2	" 2
2-1	" 1	3-1	" 1

TABLE A.II. PIN ALLOCATION FOR CONNECTORS

CONNECTOR NUMBER	PIN	WIRE COLOR	USE
1-47	A	GRN	GROUND
	B	BLK	SIGNAL (-)
	C	WHT	SIGNAL (-)
	D	RED	BRIDGE EXCITATION
	E	YEL	SHIELD
48	A	GRN	GROUND
	B	BLK	SIGNAL (-) (NOT USED)
	C	WHT	FREQ INPUT
	D	RED	BRIDGE EXCITATION (NOT USED)
	E	-	SHIELD
49	A	RED	11 VOLTS
	B	BLK (24 ga)	"UP"
	C	WHT	"DOWN"
	D	BLK (18 ga)	GROUND
	E	-	SHIELD
50	A	BLK	OUTPUT TO TTY
	B	RED	OUTPUT TO TTY
	C	GRN	INPUT FROM TTY
	D	WHT	INPUT FROM TTY
	E	-	SHIELD
	F	-	N/C

TABLE A.II. PIN ALLOCATION FOR CONNECTORS (CONT)

CONNECTOR NUMBER	PIN	WIRE COLOR	USE
51-54	A	WHT	GROUND
	B	WHT	GROUND
	C	BLK	+24 VOLTS
	D	BLUE	ADVANCE
	E	GRN	HOME
	F	BRN	1
	G	ORG	2
	H	YEL	4
	I	-	N/C
	J	GRY	8
	K	VIO	10
	L	WHT	20
	M	RED	40
	N	GRN	ADDRESS STROBE

PROLOG CARD NO'S-

8116

8402

8111-8116-8117-8113-8114-8115

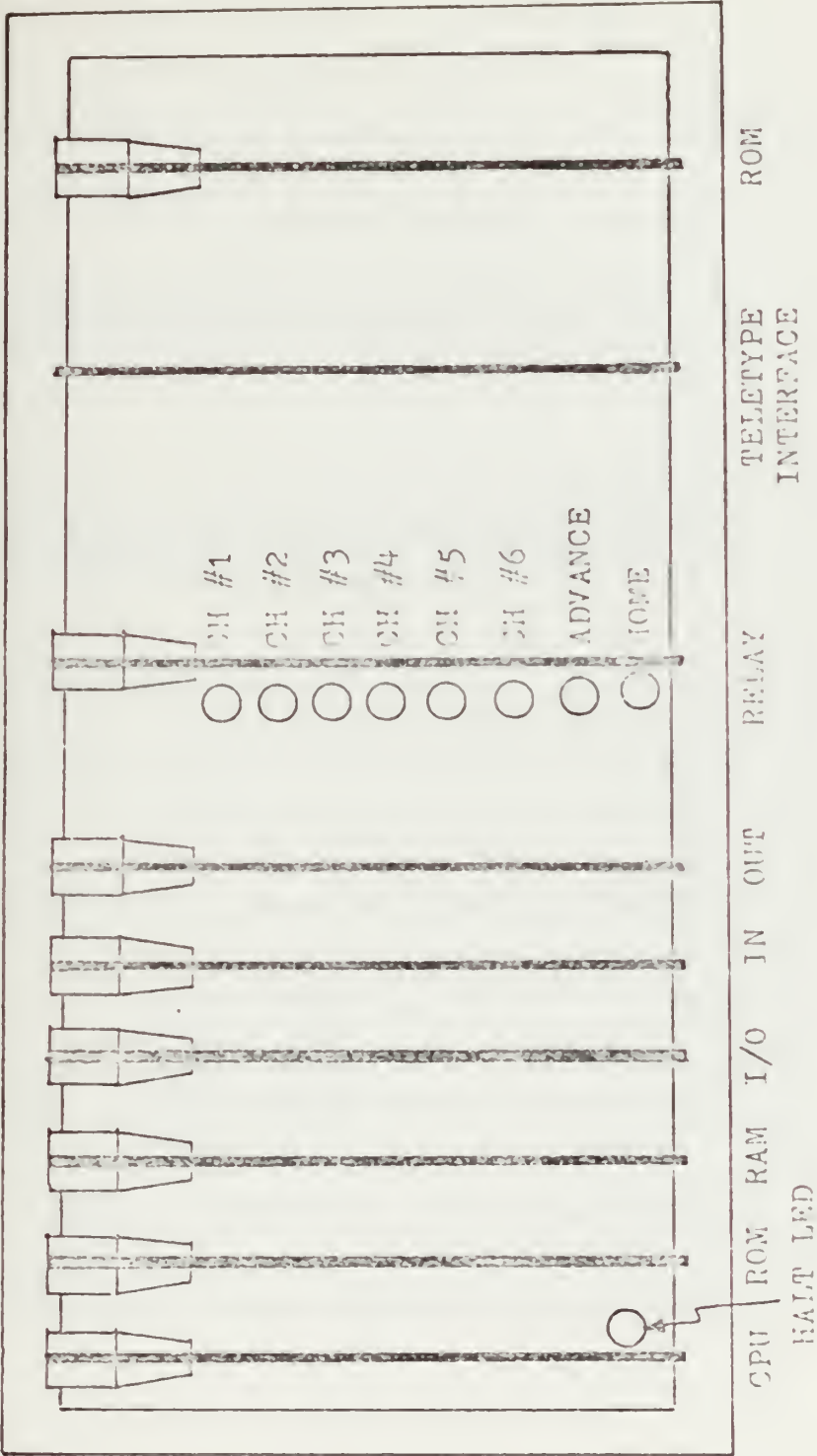

Figure A1. Front View of PROLOG MPS-805

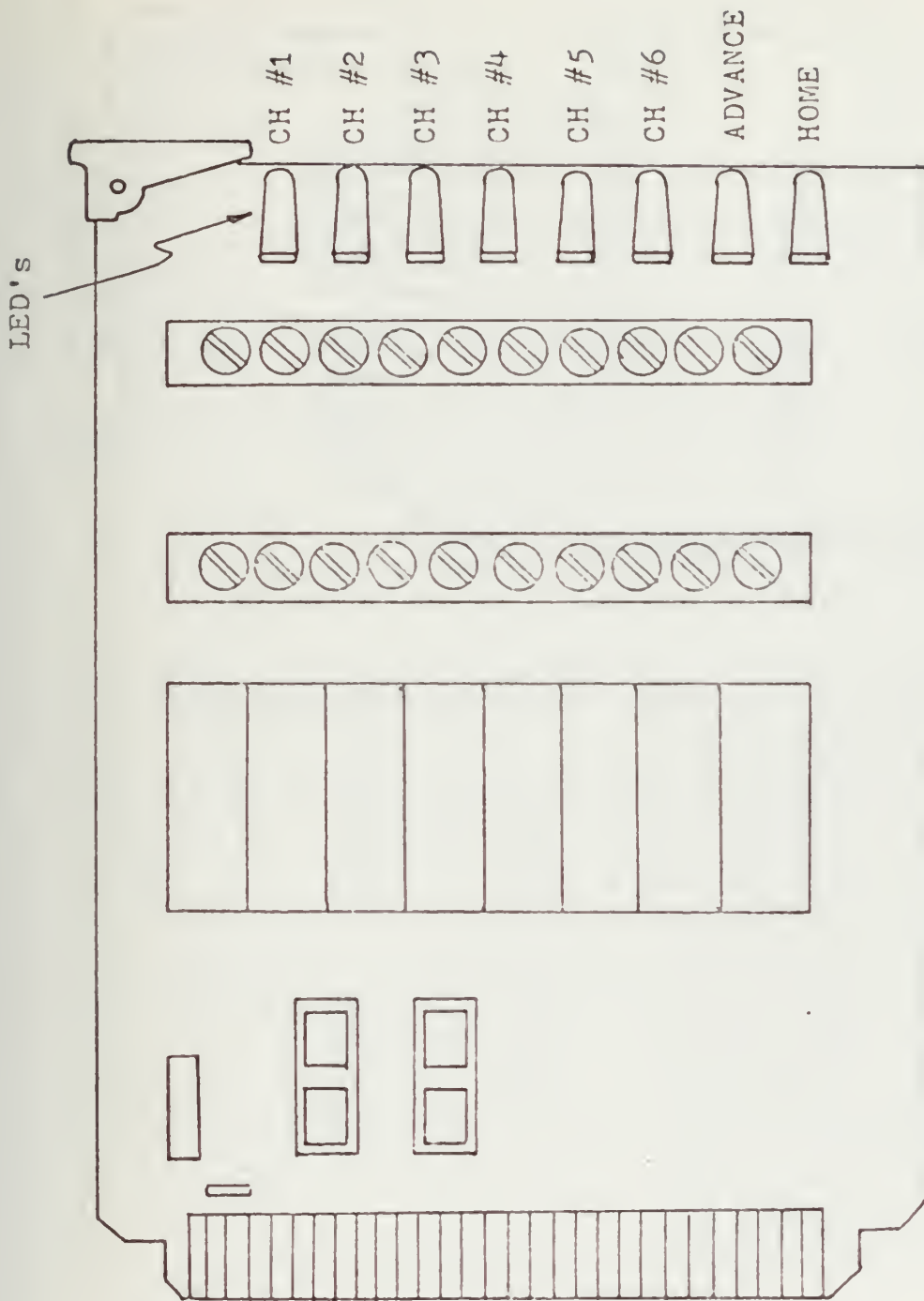

Figure A2. PROLOG-8402 Relay Card

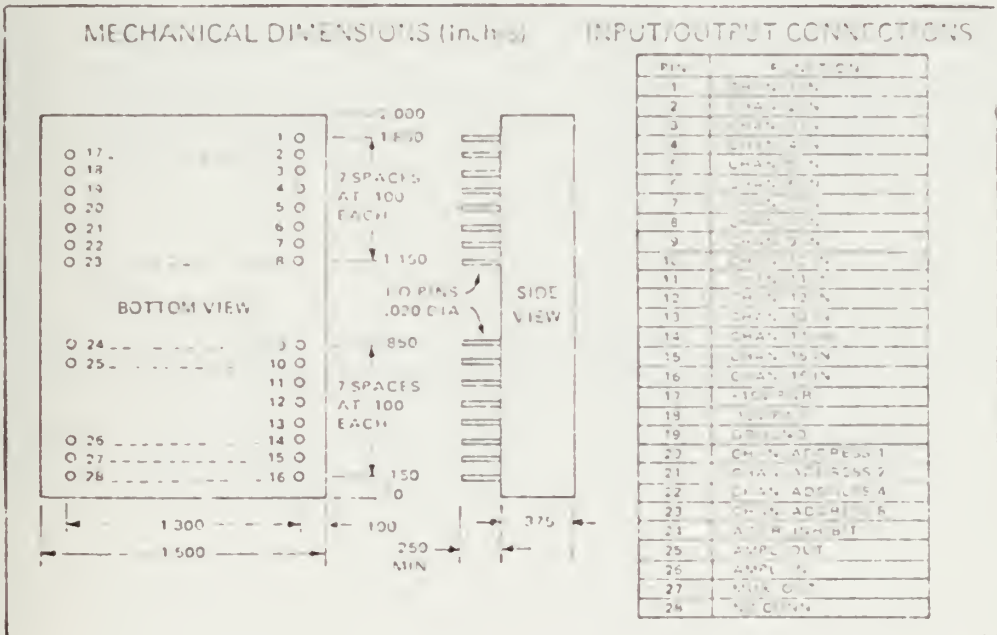
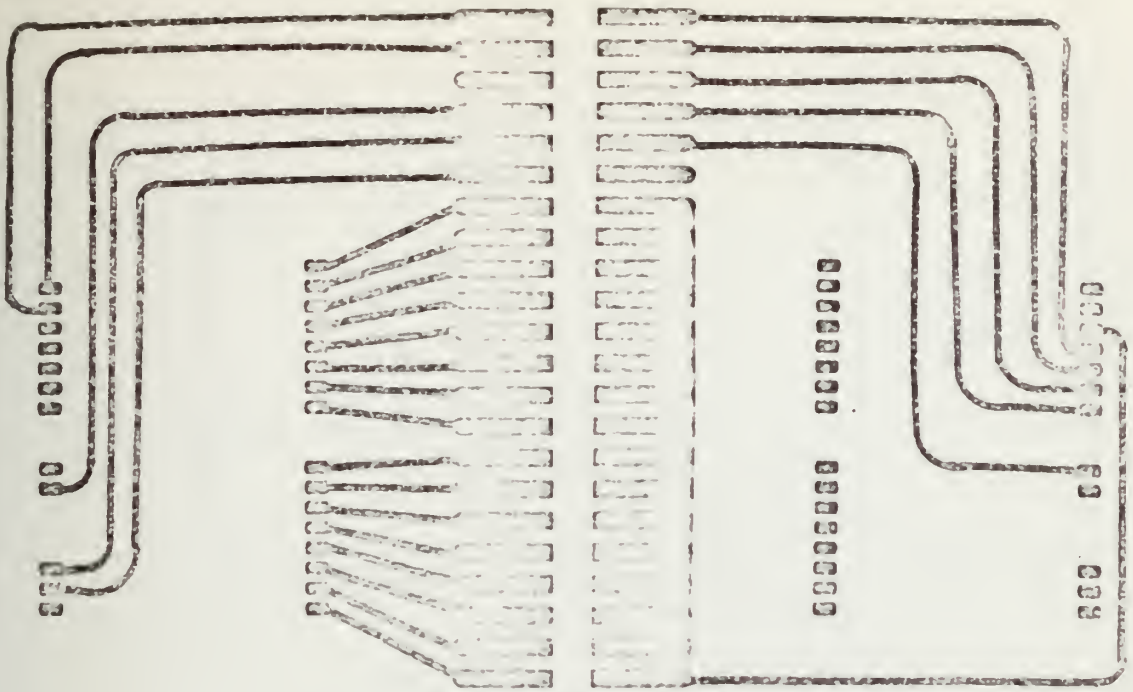
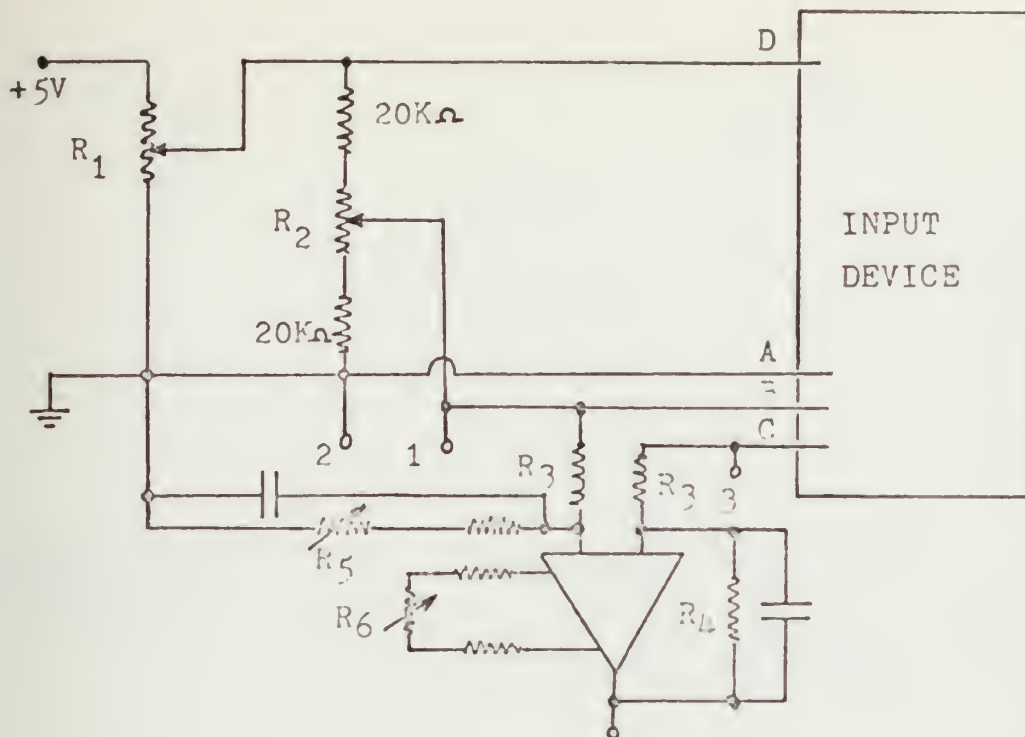

Figure A3. Multiplexer Board Schematic



- | | |
|------------------------------------|-------------------------------------|
| R ₁ : SPAN TRIM POT | R ₄ : FEEDBACK RESISTOR |
| R ₂ : BALLANCE TRIM POT | R ₅ : AMPLIFIER BALLANCE |
| R ₃ : INPUT RESISTOR | R ₆ : AMPLIFIER OFFSET |

Note 1. 1,2, and 3 Are Test Points for Amplifier Adjustment and Signal Calibration.

Note 2. For Channels 41-47, the 20K Resistors are Bypassed.

Figure A4. Signal Conditioning Circuit

PRESSURE
TRANSDUCER
OR
STRAIN GAGE

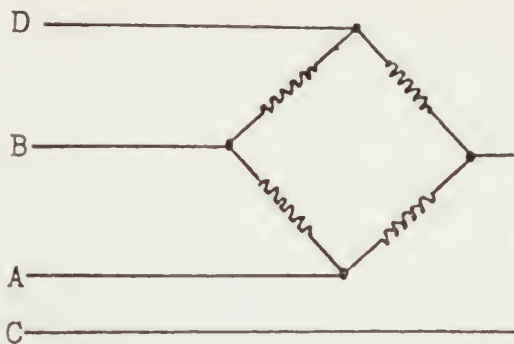

THERMOCOUPLE
(PINS A AND D
NOT USED)

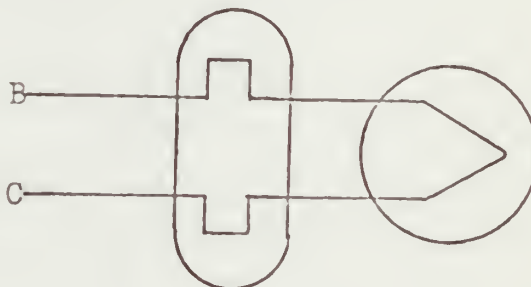

POTENTIOMETER
(PIN 3 NOT USED)

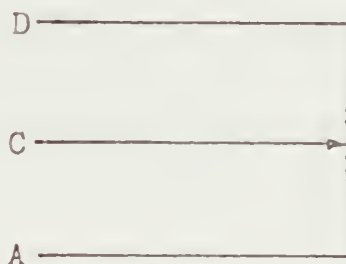

Figure A5. Input Devices to Signal Conditioner

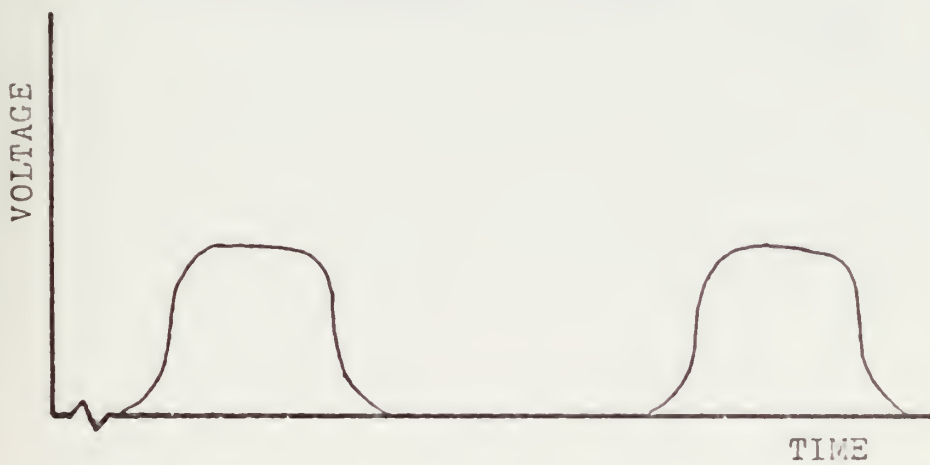
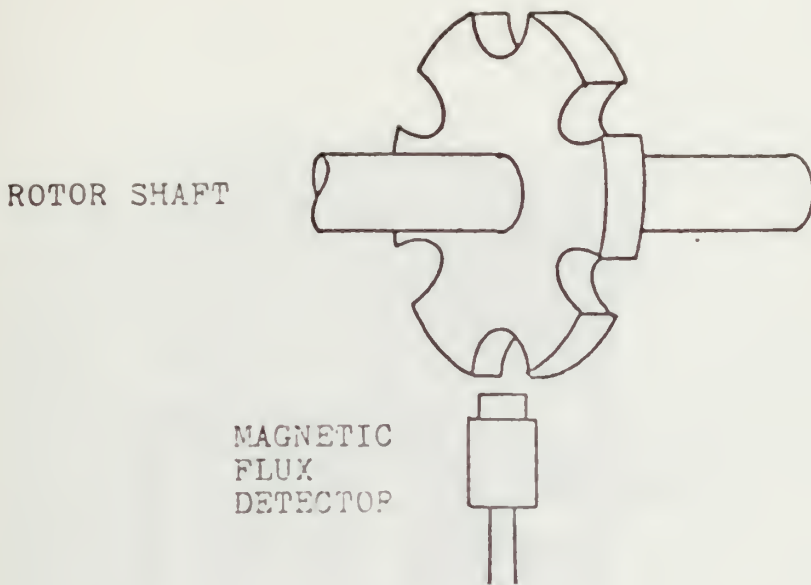

Figure A6. Magnetic Flux Cutter and Its Electrical Output

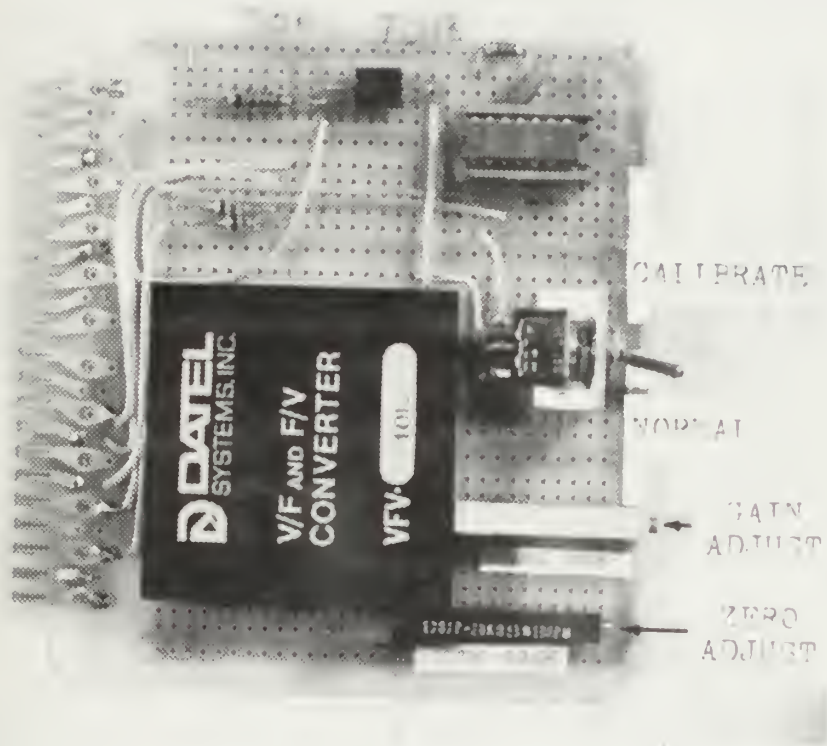

FIGURE A2. View of the F/V Card

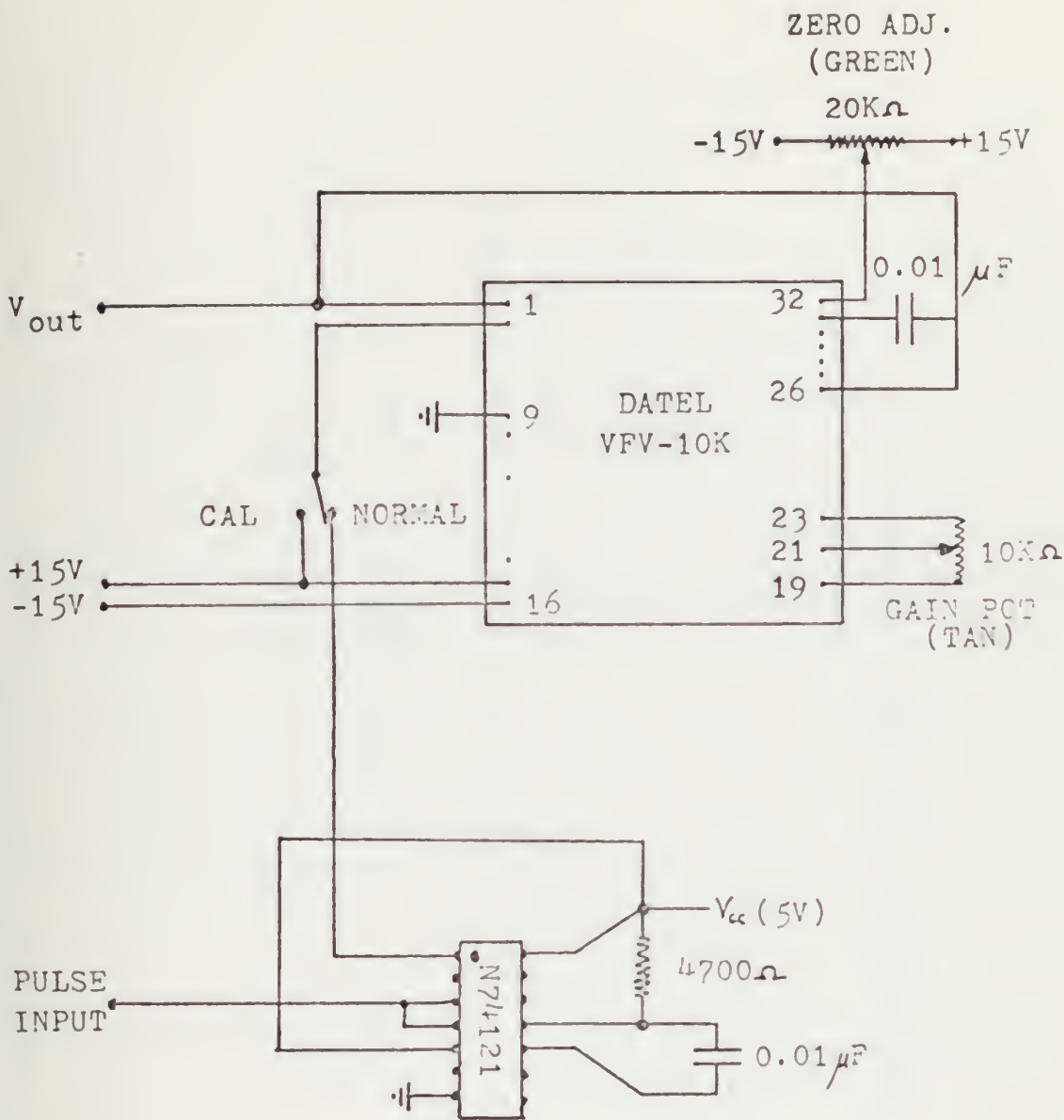

Figure A8. Frequency to Voltage Converter

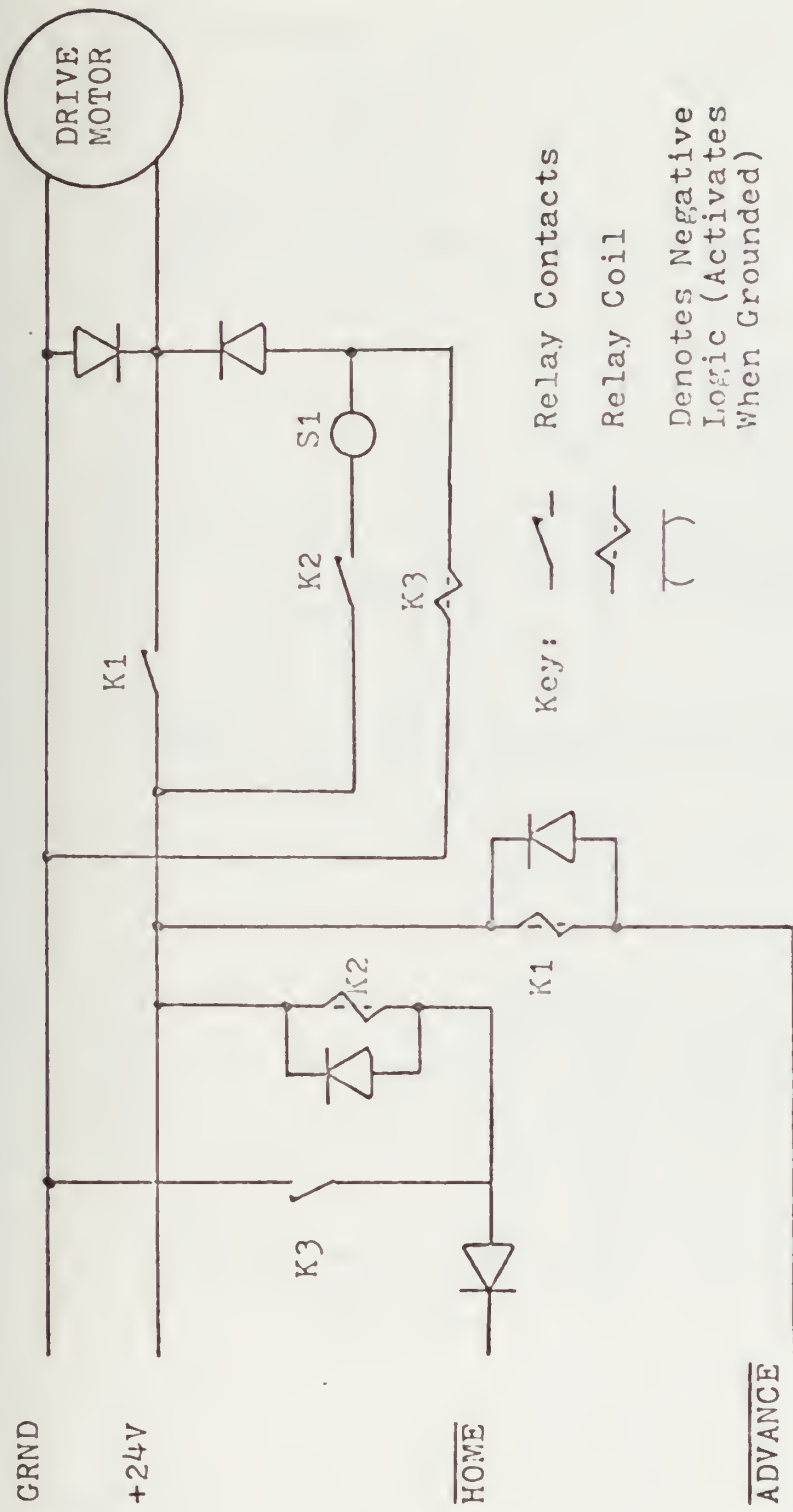

Figure A9. Scanivalve "Advance" and "Home" Circuits

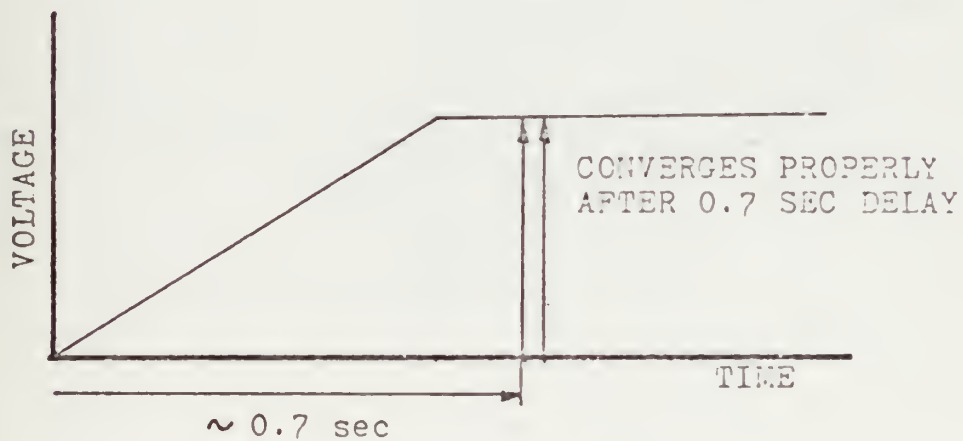
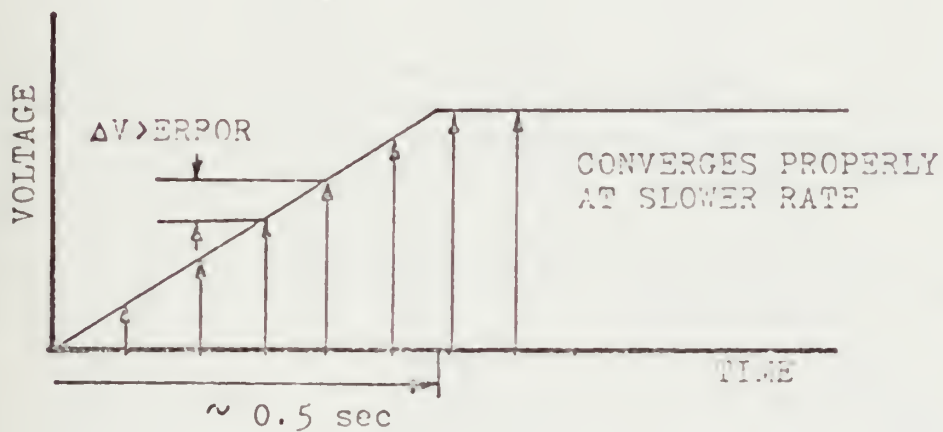
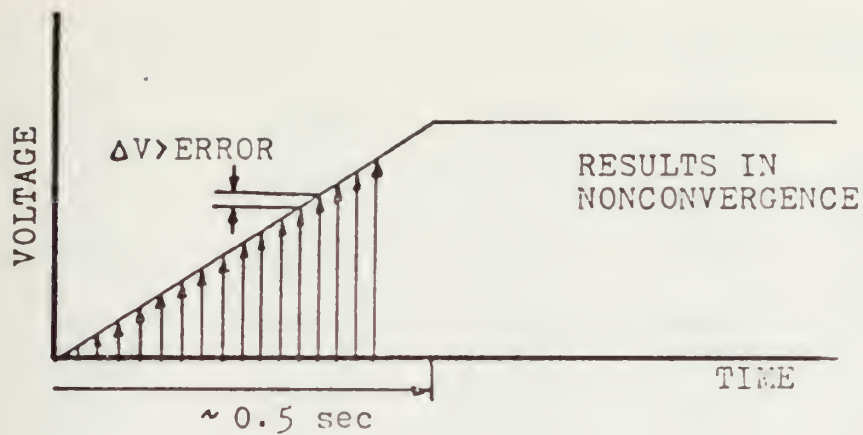

FIGURE A10. DVM Integration and Sampling Rates

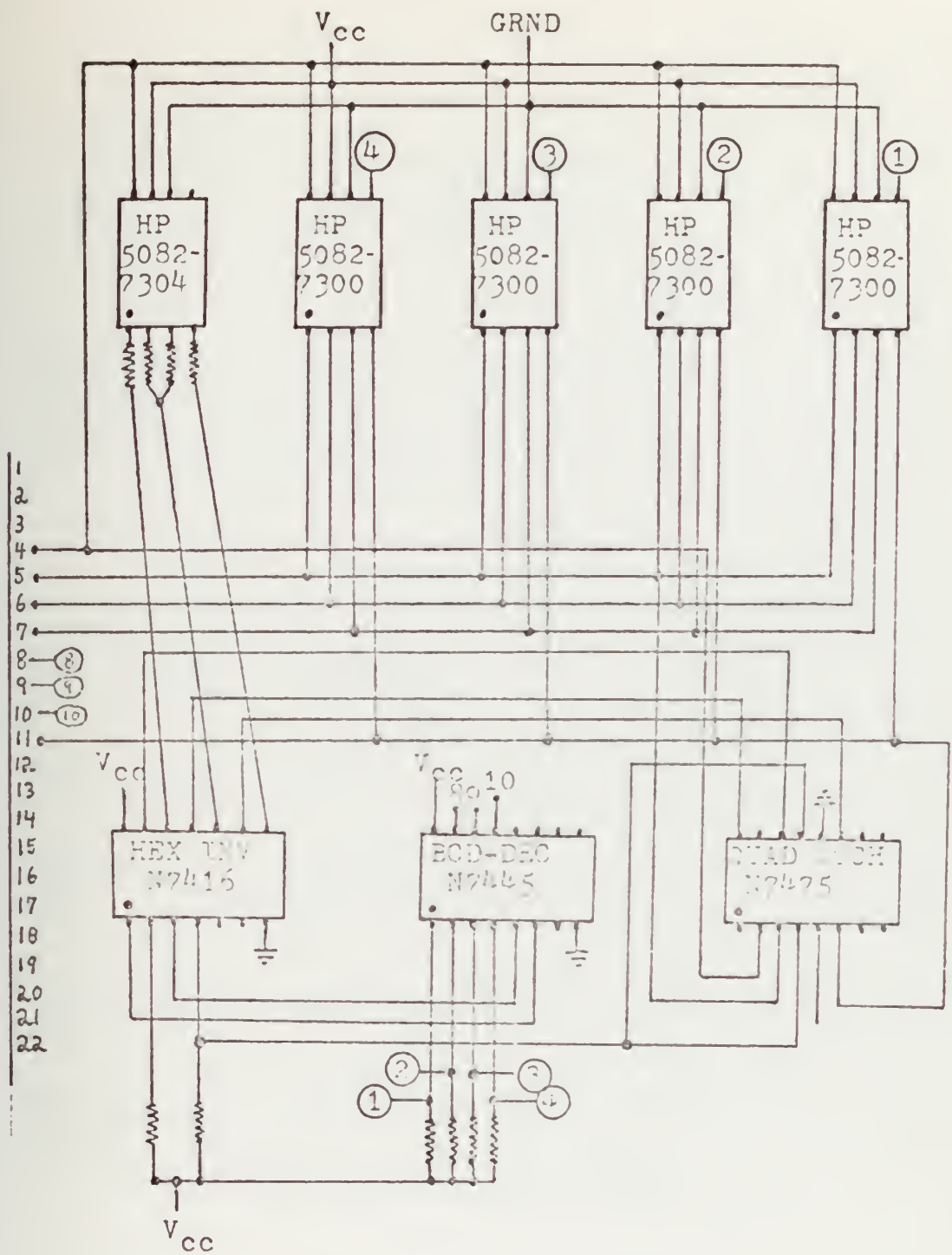
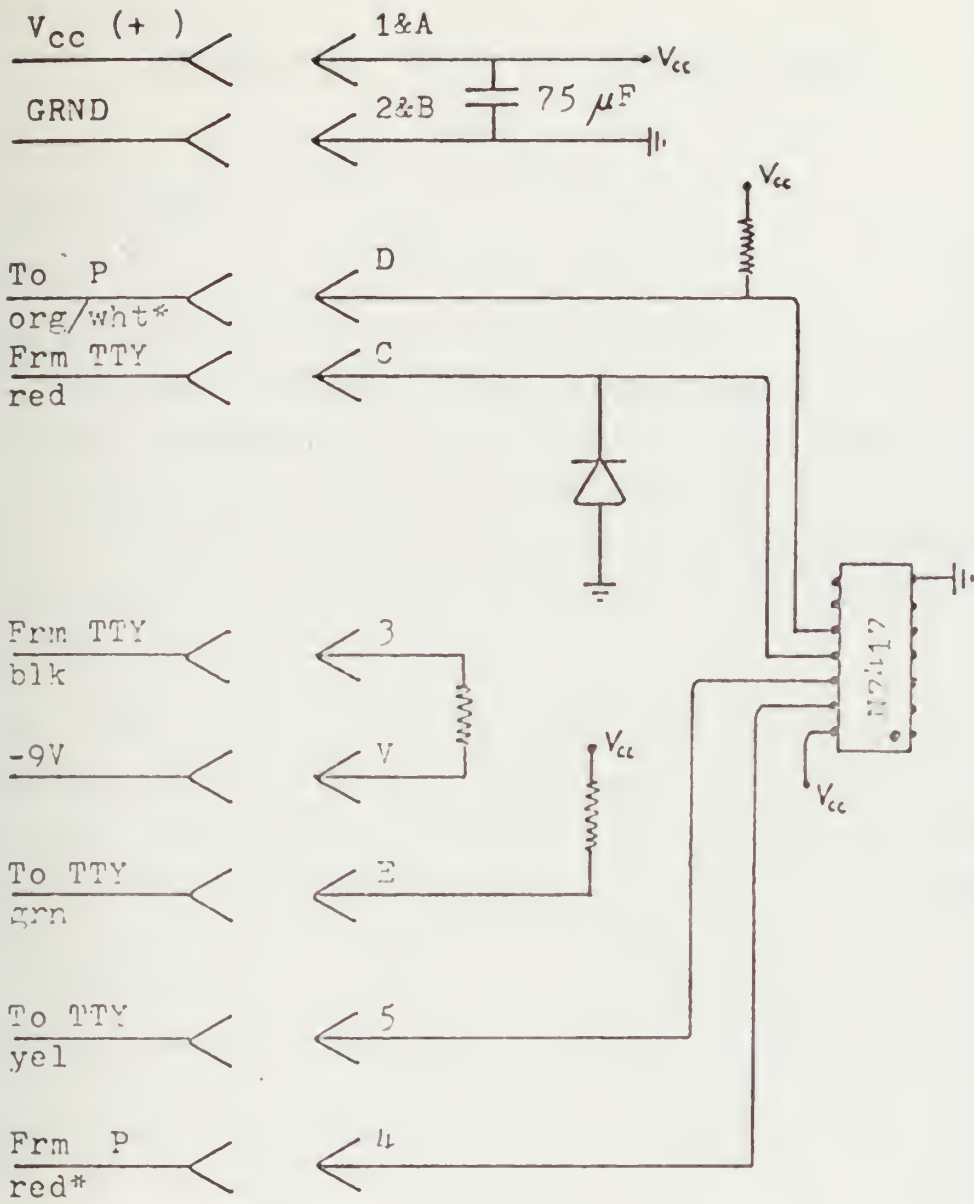

Figure A11. Schematic of Display Card



*26 AWG wires, all others 24 AWG

Figure A12. Schematic of Teletype Interface Card

APPENDIX B. MIDAS IV SOFTWARE MANUAL

B.1 INTRODUCTION

The software for MIDAS IV was written in PL/M, a higher level language developed for microprocessors by Intel Corporation. References 11. and 12. were used in the generation of the software described in the following sections. The use of PL/M rather than assembly language was intended to simplify program changes and debugging for all future users.

Each of the following sections contains a brief description of a program subroutine. Listings of the program in PL/M and schematics of the program logic are located at the end of this appendix. The subroutines are described in the order that they appear in the PL/M source file. The sequence in which the subroutines are called by the Control Program "MONITOR", and by other subroutines is shown in Table B.I. The attempt is made in the text to describe how the microprocessor carries out the separate tasks. The program listings and logic are needed if alterations to the software become necessary.

The procedures for operating the programs and for making changes to the software are given in Appendix D.

B.2 TTYIN AND TTYOUT

These subroutines are the teletypewriter I/O drivers. They are software equivalents to a serial-to-parallel and parallel-to-serial shift register, respectively. When TTYIN is called it returns an ASCII character pair to the microprocessor from the teletypewriter operating in the LINE mode. TTYOUT performs the reverse operation. As can be seen in the program listing, a time delay is included in the data transfer process to match the processor to the teletype [Ref. 13] operating at a pulse rate of 9 msec. A PL/M library subroutine is called with the statement "Call Time()", where the calling argument would normally determine the delay time in units of 0.1 msec. However, since the PL/M-8 compiler was written for microprocessors using a 4.0 micro-second time base, whereas the MPS-805 has a 2.8 micro-second time base, the "Call Time" arguments must be multiplied by $4.0/2.8$ or approximately 1.43. For example, "Call Time (100)" on a microprocessor with a 4.0 micro-second time base would give a 10 msec delay. Since the MPS-805 microprocessor with a 2.8 micro-second time base executes each instruction proportionately faster, "Call Time(143)" is required to generate a 10 msec delay.

B.3 HEX PAIR AND PAIROUT

HEX PAIR is a subroutine that converts two ASCII characters representing a hexadecimal pair into binary code. Valid inputs are 00H through FFH. If other characters are entered an error in conversion results. HEX PAIR calls TTYIN (and TTYOUT to provide a written output of what is input at the keyboard) to allow the ASCII characters to be input at the teletypewriter. The value of "word" is initialized to zero and then the input is checked to

determine if it is a space, 020H. If it is, "word" is returned; if it is not, the input is converted from ASCII to binary and "or"ed with the "word". If more characters are entered, only the two characters immediately preceding the space are taken. The others are shifted to the left and out of the register.

PAIR OUT performs the opposite function. It converts the binary code of a hexadecimal pair into two ASCII characters and outputs the result via TTYOUT to the teletypewriter.

5.4 ONFOUT, BCDHEX, AND FORMAT

ONFOUT converts the binary code of a single hexadecimal character into the corresponding ASCII code of that character. Then, by calling TTYOUT, the character is written on the teletypewriter.

BCDHEX converts a two digit BCD coded number into its binary equivalent. The maximum input is the decimal value 99.

FORMAT is a subroutine used in formatting the teletype output. The inputs are the ASCII character to be outputted and the number of times it is to be repeated. For example, FORMAT(02AH, 5) prints "*****" on the teletypewriter.

B.5 DIGITEC

DIGITEC interfaces the Digitec DVM with the MIDAS IV system. The subroutine reads a 4-digit BCD-coded decimal number, checks the high range indicator, and records the sign of the voltage. The data is then converted into binary code and a constant, "sign", is set to indicate the polarity.

The subroutine can be used with any DVM which outputs data in the format of the Digitec. If a 3 1/2 digit DVM is used, the four most significant bits of the high-half of the data should be grounded and the "high range" constant should be changed from 10000 to 1000.

If the DVM is overrange, the subroutine returns a value of 14000 since 13999 is the maximum range of the Digitec DVM.

B.6 MULTIPLEX

MULTIPLEX controls the multiplexers. The channel number is converted from decimal to binary code and the appropriate multiplexer (one of three) is selected.

B.7 SCANV

SCANV controls the Scanivalves. The calling routine specifies the Scanivalve number (1 through 4) and the port number (1 through 48). SCANV enables the selected Scanivalve and reads the current port address. If the address is not equal to the specified port number, SCANV advances the Scanivalve until the address and number match. (Note: It is possible to enter a continuous loop if the

Scanivalve does not have a port corresponding to the desired port number. For example, some Scanivalves have only even numbered ports. To avoid an endless search, odd numbers should then not be requested with this type of Scanivalve.) Since SCANV creates the advance pulse, for other scanning systems it may be necessary to change the pulse width and repetition frequency. This is a minor program change involving only the limits of the "Do" loops. The execution of the loop provides a 10 msec delay. Therefore "Do" loop limits of 1 to 8 provide about 80 msec of delay. The procedure for these changes is given in Appendix D.

B.8 DISPLAY

DISPLAY controls the LED display which shows the channel and port numbers. The calling routine specifies the sign, the channel, and the port number. Once the values are latched into the LED display, they are retained until changed by DISPLAY. The sign convention is given in the listing of the DISPLAY subroutine.

B.9 DATAOUT

DATAOUT receives the data in binary code and the channel and port numbers in BCD from the calling routine. DATAOUT converts the data from binary to BCD code, then outputs the channel, port, and data followed by carriage return and line feed commands via ONEOUT and TTYOUT.

B.10 CONVERGE

CONVERGE, when given an error tolerance and the current line number in the Scan Control table, uses the line number to locate and read the time delay entered for the selected channel and port, and delays that length of time (in tenths of a second) before calling DIGITEC. After obtaining a second DIGITEC reading, the two values are checked to see if the difference is less than the specified tolerance. If it is, the average of the two values is returned. If it is not, the subroutine tries 16 times to meet the tolerance and if unable to do so, returns 15000. If the Digitec is overrange, CONVERGE returns 14000.

B.11 START

START is the controlling routine for the DATA ACQUISITION mode. When called by MONITOR, START types 30 asterisks on the teletypewriter in order to give the operator time to turn the paper punch on and to provide a leader. The "Amount" entry in the Probe Control table is checked for FF. If not FF, the probe is moved the specified amount (in hundredths of an inch) in the direction specified by the "Direction" entry in the Probe Control table. The "Channel" entry in the Scan Control table is now checked for FF. If the entry is FF, control is transferred to where the Probe Control table is checked. If the entry in the Scan Control table is not FF, MULTIPLEX is called with arguments 0, channel number, and port number, and latches those values into the LFD display. If the channel number is between 1 and 4, SCANV selects the specified Scanivalve and port required. If the channel number is above four, SCANV has no effect. The error tolerance is read from the Scan Control table. CONVERGE and DATAOUT are called and control is transferred back to check the "Amount" entry in the Probe

Control table. When FF is encountered at this point, START ends and control is returned to MONITOR.

B.12 CALIB

CALIB is the controlling routine for the CALIBRATION mode. The routine is continuously looping and must be terminated with the RESET button. When selected, CALIB reads the thumbwheel switch and calls MULTIPLEX. If a Scanivalve is not selected by the particular thumbwheel setting, DISPLAY latches the channel number and 00 (for the port) into the LED display. If a Scanivalve is specified by the thumbwheel settings, an enable signal is sent and the port address is read from the Scanivalve. After calling DISPLAY, the current channel and port are latched into the LED's. If the Port Advance pushbutton is pressed, CALIB advances the Scanivalve and returns to read the thumbwheel switches again. The rate at which the Scanivalve is advanced when the Port Advance button is continuously pressed is determined by time delay loops as in the SCANV subroutine.

B.13 CHANNEL ORDER AND PROBE ORDER

CHANNEL ORDER is one of two controlling routines in the PROGRAM SCAN mode. It is used to write the Scan Control table into RAM beginning at address 1100H, using HEXPAIR. CHANNEL ORDER continues to fill RAM until FF is entered in the "Channel" column of the Scan Control table. PROBE ORDER is then called. PROBE ORDER, the second routine in the PROGRAM mode, writes the Probe Control table into RAM beginning at 1400H and continuing until FF is read in the "Amount" column. When PROBE ORDER is terminated with FF, control is transferred back to MONITOR.

B.14 NEXT

NEXT is a short routine which types "Enter the next selection number:" before control is transferred back to MONITOR.

B.15 READ CORE AND WRITE CORE

READ CORE is the controlling routine in the MEMORY DISPLAY mode. After calling READ CORE, a beginning and an ending address are entered. The routine types the contents of memory between the specified addresses including the line number at the beginning of each line of memory. (An example is given in Table D.VI.) If the first address is inadvertently entered to be higher than the ending address, the routine will attempt to print 256 pages of text. The process can be terminated at any point by pressing the RESET button.

WRITE CORE is the controlling routine in the MEMORY EDIT mode. After selecting this mode, the beginning address is entered. WRITE CORE types the current contents of the memory location followed by a hyphen. The correct number pair is entered at the keyboard, followed by a "space". WRITE CORE then causes the contents of the next memory location to be typed. Note that the data must either be repeated or changed, since pressing the space bar without an entry causes a "00" to be read. To exit WRITE CORE, the RESET button is pressed. (This does not effect the last uncorrected memory location.)

B.16 READ TAPE

READ TAPE is the controlling routine in the READ TAPE mode. After being selected, READ TAPE waits for a paper tape input. (The paper tape format is critical to the operation of READ TAPE. Care must be exercised that the correct format as described in APPENDIX D is used.) READ TAPE loads the Scan Control table into RAM beginning at 1100H and after encountering FF in the "channel" column, loads the Probe Control table into RAM beginning at 1400H. The end of the Probe Control table is read when FF is encountered in the "amount" column. Control is then transferred back to MONITOR.

B.17 MONITOR

MONITOR is the controlling program for the MIDAS IV system and enables the user to select one of eight operating modes. All other routines and subroutines are called as a result of the mode selection input. Table B.I gives a listing of the subroutine calling levels.

B.19 FLOW CHARTS OF MIDAS IV SOFTWARE

```
00001 1
00002 1 DECLARE DEC LITERALLY 'DECLARE';
00003 1 DEC (I,SIGN) BYTE;
00004 1 DEC CR LITERALLY '00DH';
00005 1 DEC LF LITERALLY '00AH';
00006 1 DEC SP LITERALLY '020H';
00007 1 DEC DASH LITERALLY '02DH';
00008 1 DEC INZERO LITERALLY 'INPUT(0)';
00009 1 DEC INONE LITERALLY 'INPUT(1)';
00010 1 DEC INTWO LITERALLY 'INPUT(2)';
00011 1 DEC INTHREE LITERALLY 'INPUT(3)';
00012 1 DEC INFOUR LITERALLY 'INPUT(4)';
00013 1 DEC INFIVE LITERALLY 'INPUT(5)';
00014 1 DEC OUTZERO LITERALLY 'OUTPUT(0)';
00015 1 DEC OUTONE LITERALLY 'OUTPUT(1)';
00016 1 DEC OUTTWO LITERALLY 'OUTPUT(2)';
00017 1 DEC OUTTHREE LITERALLY 'OUTPUT(3)';
00018 1 DEC M DATA(CR,LF,LF,' MIDAS IV ',CR,LF,LF,
00019 1 'TYPE THE SELECTION NUMBER FOLLOWED BY A SPACE:'
    ,CR,LF,LF,
00020 1 ' 0 - MIDAS IV HEADER',CR,LF,
00021 1 ' 1 - CALIBRATION',CR,LF,
00022 1 ' 2 - PROGRAM SCAN',CR,LF,
00023 1 ' 3 - READ TAPE',CR,LF,
00024 1 ' 4 - DATA ACQUISITION',CR,LF,
00025 1 ' 5 - MEMORY DISPLAY',CR,LF,
00026 1 ' 6 - MEMORY EDIT',CR,LF,
00027 1 ' 7 - RESTART',CR,LF,LF);
```

```
00028 1 DEC N DATA(CR,LF,LF,'ENTER THE NEXT SELECTION
        NUMBER: ',CR,LF,LF);
00029 1 DEC C$HEADER DATA(CR,LF,LF,'CH PT      ERROR  TIME
        ',CR,LF,LF);
00030 1 DEC P$HEADER DATA(CR,LF,LF,'AMT  DN=0/UP=1'
        ,CR,LF,LF);
00031 1 DEC (CHAN BASED B$CH) BYTE;
00032 1 DEC (PROBE BASED B$PB) BYTE;
00033 1 DEC (B$CH,B$PB,ADDRM) ADDRESS;
00034 1 B$CH=1100H;
00035 1 B$PB=1400H;
```

```

00036 1
00037 1 TTYIN:PROCEDURE BYTE; /* TELETYPE SERIAL INPUT */
00038 2     DEC (XTI,ITI)BYTE;
00039 2     HERE: IF (INTWO AND 080H)<>080H THEN GO TO
           HERE;
00040 2     CALL TIME(64); /* 8.5 MSEC PULSE */
00041 2     XTI = 0;
00042 2     DO ITI = 1 TO 8;
00043 2     CALL TIME(130);
00044 3     XTI = ROR(XTI,1);
00045 3     XTI = XTI OR (INTWO AND 080H);
00046 3     END;
00047 2     CALL TIME(130);
00048 2     RETURN ((NOT XTI) AND 07FH);
00049 2     END TTYIN;
00050 1
00051 1 TTYOUT:PROCEDURE(ZTO); /* TELETYPE SERIAL OUTPUT */
00052 2     DEC(ITO,ZTO)BYTE;
00053 2     ZTO=NOT ZTO;
00054 2     OUTONE = 080H; /* START PULSE */
00055 2     CALL TIME(130);
00056 2     DO ITO=1 TO 8;
00057 2     ZTO = ROR(ZTO,1);
00058 3     OUTONE = ZTO AND 080H;
00059 3     CALL TIME(130);
00060 3     END;
00061 2     OUTONE = 0;
00062 2     CALL TIME(130);
00063 2     RETURN;
00064 2     END TTYOUT;

```

```

00065 1
00066 1  HEX$PAIR:PROCEDURE BYTE; /*HEXIDEC PAIR INPUT*/
00067 2      DEC (WORD,AHP)BYTE;
00068 2      WORD = 0;
00069 2      M1:CALL TTYOUT(AHP:=TTYIN); /* ECHOS INPUT TO
          TELETYPE */
00070 2      IF AHP=20H THEN RETURN WORD; /* SPACE = END
          OF PAIR */
00071 2      IF AHP>39H THEN AHP=AHP-37H;
00072 2  /* CONVERTS ASCII TO HEX */
00073 2      ELSE AHP=AHP-30H;
00074 2      WORD=SHL(WORD,4) OR AHP;
00075 2      GO TO M1;
00076 2  END HEX$PAIR;
00077 1
00078 1  PAIROUT:PROCEDURE(ASC);
00079 2      DEC(ASC,ASC1)BYTE;
00080 2      IF (ASC1:=SHR(ASC,4))<0AH THEN ASC1=
          (ASC1 + 030H);
00081 2      ELSE ASC1=ASC1 + 037H;
00082 2      CALL TTYOUT(ASC1);
00083 2      IF (ASC1:=(ASC AND 0FH))<0AH THEN ASC1=
          (ASC1 + 030H);
00084 2      ELSE ASC1=ASC1 + 037H;
00085 2      CALL TTYOUT(ASC1);
00086 2  RETURN;
00087 2  END PAIROUT;

```

```

00088 1
00089 1 ONEOUT:PROCEDURE (NUM);
00090 2     DEC (NUM,NUM1)BYTE;
00091 2     IF (NUM1:=(NUM AND 0FH))< 10 THEN NUM1=
        (NUM1 + 030H);
00092 2     ELSE NUM1=NUM1+037H;
00093 2     CALL TTYOUT(NUM1);
00094 2     RETURN;
00095 2 END ONEOUT;
00096 1
00097 1 BCDHEX:PROCEDURE(ABH)BYTE;
00098 2     DEC (ABH,BBH)BYTE;
00099 2     BBH=((SHR(ABH,4)*00AH) + (ABH AND 0FH));
00100 2     RETURN BBH;
00101 2 END BCDHEX;
00102 1
00103 1 FORMAT:PROCEDURE (TYPE, NUM);
00104 2     DEC (TYPE,NUM,IFOR) BYTE;
00105 2     DO IFOR=1 TO NUM;
00106 2         CALL TTYOUT(TYPE);
00107 3     END;
00108 2     RETURN;
00109 2 END FORMAT;

```

```

00110 1
00111 1 DIGITEC:PROCEDURE ADDRESS;
        /* READS BCD DIGITEC OUTPUT */
00112 2     DEC (VAL,OVER)ADDRESS;
00113 2     DEC (ADC,BDC,CDC,HEXA,HEXB) BYTE;
00114 2     HERE: IF (INTHREE AND 004H)<>004H THEN
                GO TO HERE;
00115 2     /* END OF CONVERT*/
00116 2     THERE: IF (INTHREE AND 004H)=004H THEN GO TO
                THERE;
00117 2     IF ((CDC:=INTHREE) AND 008H)=008H THEN DO;
00118 2         VAL=14000;
00119 3         RETURN VAL; /* IF DIGITEC IS OVERRANGE */
00120 3     END;
00121 2     SIGN=1;
00122 2     IF (CDC AND 002H)=002H THEN SIGN=2;
                /* SIGN OUTPUT */
00123 2     OVER=0;
00124 2     IF (CDC AND 001H)=001H THEN OVER=10000;
00125 2     HEXB=BCDHEX(INONE);
00126 2     /*LOWER 2 DIGITS*/
00127 2     HEXA=BCDHEX(INZERO);
00128 2     /*UPPER 2 DIGITS*/
00129 2     VAL=(OVER + (HEXA*100) + HEXB);
00130 2     RETURN VAL;
00131 2     END DIGITEC;

```



```
00132 1
00133 1 MULTIPLEX:PROCEDURE (CHM);/* SELECTS CHANNEL */
00134 2     DEC (CHM,BM,DM) BYTE;
00135 2     BM=(BCDHEX(CHM)-1);
00136 2     DM = BM AND 00FH;
00137 2     DO CASE (SHR(BM,4));
00138 2         OUTONE = DM OR 010H;
00139 3         OUTONE = DM OR 020H;
00140 3         OUTONE = DM OR 040H;
00141 3     END;
00142 2     RETURN;
00143 2     END MULTIPLEX;
```

```

00144 1
00145 1 SCANV:PROCEDURE (CHS,PTS);
00146 2 /* SELECTS PORT ON ENABLED S.V. */
00147 2     DEC (CHS,PTS,BS,IS) BYTE;
00148 2     IF ((CHS>0) AND (CHS<5)) THEN DO;
00149 2         IF PTS > 048H THEN RETURN;
00150 3         IF PTS = 0 THEN RETURN;
00151 3 /* SCANOVALVES ARE ONLY ON CH1 TO CH4. */
00152 3     DO CASE (CHS-1);
00153 3         BS=01H;
00154 4         BS=02H;
00155 4         BS=04H;
00156 4         BS=08H;
00157 4     END;
00158 3     OUTTHREE = BS;
00159 3     DO WHILE(PTS<>(NOT(INFOUR)));
00160 3         OUTTHREE = (040H +BS);
00161 4 /* BIT 7 IS S.V. ADVANCE, BIT 8 IS S.V. HOME. */
00162 4     DO IS=1 TO 8;
00163 4         CALL TIME(143);
00164 5     END;
00165 4     OUTTHREE = BS;
00166 4     DO IS=1 TO 12;
00167 4         CALL TIME(143);
00168 5     END;
00169 4     END;
00170 3     END;
00171 2     RETURN;
00172 2     END SCANV;

```

```

00173 1
00174 1  DISPLAY:PROCEDURE(SDY,CHDY,PTDY);/*LED DISPLAY*/
00175 2      DEC (CHDY,PTDY,SDY,VDY,BDY) BYTE;
00176 2      OUTTWO = (080H OR(VDY:=(PTDY AND 00FH)));
00177 2      CALL TIME(143);
00178 2      OUTTWO = (0F0H OR VDY);
00179 2  /*MUST FOLLOW INPUT WITH 0F0H ANDED WITH INFC */
00180 2  /* INORDER TO LATCH THE INFC. */
00181 2      CALL TIME(143);
00182 2      OUTTWO = (090H OR (VDY:=SHR(PTDY,4)));
00183 2      CALL TIME(143);
00184 2      OUTTWO = (0F0H OR VDY);
00185 2      CALL TIME(143);
00186 2      OUTTWO = (0A0H OR (VDY:= (CHDY AND 00FH)));
00187 2      CALL TIME(143);
00188 2      OUTTWO = (0F0H OR VDY);
00189 2      CALL TIME(143);
00190 2      OUTTWO = (0B0H OR (VDY:= SHR(CHDY,4)));
00191 2      CALL TIME(143);
00192 2      OUTTWO = (0F0H OR VDY);
00193 2      CALL TIME(143);
00194 2      DO CASE SDY;/*SIGN CONVENTION*/
00195 2          BDY =00H;/* 00 = +0 */
00196 3          BDY= 01H;/* 01 = +1 */
00197 3          BDY= 10H;/* 10 = -0 */
00198 3          BDY= 11H;/* 11 = -1 */
00199 3      END;
00200 2      OUTTWO = (0C0H OR BDY);
00201 2      CALL TIME(143);
00202 2      OUTTWO = (0F0H OR BDY);
00203 2      CALL TIME(143);
00204 2  RETURN;
00205 2  END DISPLAY;

```

```

00206 1
00207 1  DATAOUT:PROCEDURE (DATA0,CH00,PT00);
00208 2  /* PAPER TAPE AND TTY OUTPUT.  */
00209 2  /* THE INFO IS IN CHANNEL-PORT-DATA FORMAT.  */
00210 2  /*OUTPUT FOLLOWED BY CARRIAGE RETURN/LINE FEED*/
00211 2      DEC (DATA0,DO1,DO2)ADDRESS;
00212 2      DEC (CH00,PT00,SIGNBIT,BCD1,BCD2,BCD3,
          BCD4,BCD5)BYTE;
00213 2      CALL PAIROUT(CH00);
00214 2      CALL FORMAT (SP,3);
00215 2      CALL PAIROUT (PT00);
00216 2      CALL FORMAT (SP,3);
00217 2      BCD1=0;
00218 2  /*IF THE FIRST NUMBER IN DATA0 IS BETWEEN */
00219 2  /*A AND F THEN BCD1 AND BCD2 ARE USED TO */
00220 2  /*REPRESENT THE NUMBER IN BCD.  */
00221 2      IF (BCD2:=DATA0/1000)>9 THEN DO;
00222 2          BCD1=1;
00223 3          BCD2=BCD2-10;
00224 3      END;
00225 2      BCD3=((DO1:=DATA0 MOD 1000)/100);
00226 2      BCD4=((DO2:=DO1 MOD 100)/10);
00227 2      BCD5=DO2 MOD 10;
00228 2      IF SIGN=1 THEN CALL TTYOUT('+');
00229 2      ELSE CALL TTYOUT('-');
00230 2      CALL ONEOUT(BCD1);
00231 2      CALL ONEOUT(BCD2);
00232 2      CALL ONEOUT(BCD3);
00233 2      CALL ONEOUT(BCD4);
00234 2      CALL ONEOUT(BCD5);
00235 2      CALL TTYOUT(CR);
00236 2      CALL TTYOUT(LF);
00237 2  RETURN;
00238 2  END DATAOUT;

```

```

00239 1
00240 1 CONVERGE:PROCEDURE(ERROR,VAL) ADDRESS;
00241 2 /* DIGITEC CONVERGENCE FOR SUCCESSIVE VALUES. */
00242 2 /* ERROR IS FROM TOLERANCE. */
00243 2     DEC (ERROR,A0C,A1C,A2C,A3C) ADDRESS;
00244 2     DEC (A4C,A5C,A6C,CC,VAL) BYTE;
00245 2     A4C=BCDHEX(CHAN(VAL+4));
00246 2     DO A5C=1 TC A4C;
00247 2         DO A6C=1 TO 10;
00248 3             CALL TIME(143);
00249 4             END;
00250 3     END;
00251 2     IF (A0C:=DIGITEC)=14000 THEN RETURN A0C;
00252 2     CC = 0;
00253 2     C1:IF (A1C:=DIGITEC)=14000 THEN RETURN A1C;
00254 2     IF (A2C:=A1C-A0C)<0 THEN A2C=-A2C;
00255 2     IF A2C<ERROR THEN DO;
00256 2         A3C=A0C + (A2C/2);
00257 3         RETURN A3C;
00258 3     END;
00259 2     A0C = A1C;
00260 2     IF (CC:=CC+1) = 0FH THEN RETURN 9999;
00261 2     GO TO C1;
00262 2 END CONVERGE;

```

```

00263 1
00264 1   START:PROCEDURE;
00265 2       DEC (IST,JST,KST,LST,TST,AST) BYTE;
00266 2       DEC ERROR ADDRESS;
00267 2       CALL TTYOUT(CR);
00268 2       CALL TTYOUT(LF);
00269 2       CALL FORMAT(02AH,30);
00270 2       CALL TTYOUT(CR);
00271 2       CALL TTYOUT(LF);
00272 2       LST=0;
00273 2   STO:IF (TST:=PROBE(LST))=OFFH THEN DO;
00274 2       OUTTHREE=0;
00275 3       RETURN;
00276 3   END;
00277 2   IF TST <> 0 THEN DO;
00278 2       AST=01H;
00279 3       IF PROBE(LST+1)=1 THEN AST=02H;
00280 3       OUTZERO=AST;
00281 3       DO KST=1 TO (BCDHEX(TST));
00282 3           DO JST=1 TO 50;
00283 4               CALL TIME(142);
00284 5               END;
00285 4           END;
00286 3       OUTZERO=0;
00287 3   END;
00288 2       LST=LST + 2;
00289 2       IST=0;
00290 2   ST1:IF (CHAN(IST)=OFFH) THEN GO TO STO;

```

```
00291 2      CALL MULTIPLEX(CHAN(IST));
00292 2      CALL DISPLAY(0,CHAN(IST),CHAN(IST+1));
00293 2      CALL SCANV(CHAN(IST),CHAN(IST+1));
00294 2      ERROR=(BCDHEX(CHAN(IST+2))≠100H) +
           (BCDHEX(CHAN(IST+3)));
00295 2      CALL DATAOUT(CONVERGE(ERROR,IST),
           CHAN(IST),CHAN(IST+1));
00296 2      IST=IST+5;
00297 2      GO TO ST1;
00298 2      END START;
```

```

00299  1
00300  1  CALIB:PROCEDURE;
00301  2      DEC(ACB,BCB,ICB) BYTE;
00302  2      MO:CALL MULTIPLEX((ACB:=NOT(INFIVE)));
00303  2      IF ((ACB=0) OR (ACB>4)) THEN DO;
00304  2          CALL DISPLAY(0,ACB,00);
00305  3          OUTTHREE=00;
00306  3          GO TO MO;
00307  3      END;
00308  2      DO CASE (ACB-1);
00309  2          BCB=01H;
00310  3          BCB=02H;
00311  3          BCB=04H;
00312  3          BCB=08H;
00313  3      END;
00314  2      OUTTHREE = BCB;
00315  2      CALL DISPLAY(0,ACB,NCT(INFOUR));
00316  2      M1:IF (INTWO AND 001H)<>001H THEN DO;
00317  2          OUTTHREE = (J40H OR BCB);
00318  3          DO ICB=1 TO 3;
00319  3              CALL TIME(143);
00320  4          END;
00321  3          OUTTHREE = BCB;
00322  3          DO ICB=1 TO 16;
00323  3              CALL TIME(143);
00324  4          END;
00325  3      END;
00326  2      GO TO MO;
00327  2  RETURN;
00328  2  END CALIB;

```



```

00329 1
00330 1 CHANNEL$ORDER:PROCEDURE;
00331 2     DEC (ICO,JCO) BYTE;
00332 2     DO ICO=0 TO LENGTH(C$HEADER);
00333 2         CALL TTYOUT(C$HEADER(ICO));
00334 3     END;
00335 2     ICO=0;
00336 2     CO:DO WHILE (CHAN(ICO):=HEX$PAIR)<>OFFH;
00337 2         CHAN(ICO+1)=HEX$PAIR;
00338 3         CALL FORMAT(SP,3);
00339 3         CHAN(ICO+2)=HEX$PAIR;
00340 3         CHAN(ICO+3)=HEX$PAIR;
00341 3         CALL FORMAT(SP,3);
00342 3         CHAN(ICO+4)=HEX$PAIR;
00343 3         CALL TTYOUT(CR);
00344 3         CALL TTYOUT(LF);
00345 3         ICO=ICO+5;
00346 3         GO TO CO;
00347 3     END;
00348 2 RETURN;
00349 2 END CHANNEL$ORDER;

```

```

00350 1
00351 1  PROBE$ORDER:PROCEDURE;
00352 2      DEC(IPC,JPO)BYTE;
00353 2      DO IPO=0 TO LENGTH(P$HEADER);
00354 2          CALL TTYOUT(P$HEADER(IPO));
00355 3      END;
00356 2      IPO=0;
00357 2      PO1:DO WHILE (PROBE(IPO):=HEX$PAIR)<>OFFH;
00358 2          CALL FORMAT(SP,3);
00359 3          PROBE(IPC+1)=HEX$PAIR;
00360 3          CALL TTYOUT(CR);
00361 3          CALL TTYOUT(LF);
00362 3          IPO=IPO+2;
00363 3          GO TO PO1;
00364 3      END;
00365 2  RETURN;
00366 2  END PROBE$ORDER;

```

```
00367 1
00368 1 NEXT:PROCEDURE;
00369 2     DEC IN BYTE;
00370 2     DO IN=0 TC LENGTH(N);
00371 2     CALL TTYOUT(N(IN));
00372 3     END;
00373 2 RETURN;
00374 2 END NEXT;
```

```

00375 1
00376 1 READ$CORE:PROCEDURE;
00377 2     DEC CORE BASED ADDR1 BYTE;
00378 2     DEC (ADDR1,ADDR2,PGLN,NRC)ADDRESS;
00379 2     DEC (HRC,LRC)BYTE;
00380 2     NRC=0;
00381 2     ADDR1=HEX$PAIR*100H + HEX$PAIR;
00382 2     CALL TTYOUT(SP);
00383 2     CALL TTYOUT('-');
00384 2     CALL TTYOUT(SP);
00385 2     ADDR2=HEX$PAIR*100H + HEX$PAIR;
00386 2     CALL TTYOUT(CR);
00387 2     CALL TTYOUT(LF);
00388 2     RO:PGLN=ADDR1+NRC;
00389 2     IF (PGLN AND 000FH)=0 THEN DO;
00390 2         CALL TTYOUT(CR);
00391 3         CALL TTYOUT(LF);
00392 3         CALL ONEOUT(SHR((HRC:=HIGH(PGLN)),4));
00393 3         CALL ONEOUT(HRC AND 0FH);
00394 3         CALL ONEOUT(SHR((LRC:=LOW(PGLN)),4));
00395 3         CALL ONEOUT(LRC AND 0FH);
00396 3         CALL TTYOUT(03AH);
00397 3         CALL TTYOUT(SP);
00398 3         CALL TTYOUT(SP);
00399 3     END;
00400 2     CALL PAIROUT(CORE(NRC));
00401 2     CALL TTYOUT(SP);
00402 2     NRC=NRC+1;
00403 2     IF PGLN=ADDR2 THEN RETURN;
00404 2     GO TO RO;
00405 2 END READ$CORE;

```

```

00406 1
00407 1 WRITE$CORE:PROCEDURE;
00408 2     DEC (IWC,AWC,JWC) BYTE;
00409 2     DEC WCORE BASED ADDRWC BYTE;
00410 2     DEC ADDRWC ADDRESS;
00411 2     IWC=0;
00412 2     ADDRWC=HEX$PAIR*100H + HEX$PAIR;
00413 2     WC1:JWC=0;
00414 2     WC2:CALL PAIROUT(WCORE(IWC));
00415 2     CALL TTYOUT(DASH);
00416 2     WCORE(IWC)=HEX$PAIR;
00417 2     CALL FORMAT(SP,2);
00418 2     IF (JWC:=JWC+1)=8 THEN DO;
00419 2         CALL TTYOUT(CR);
00420 3         CALL TTYOUT(LF);
00421 3         IWC=IWC+1;
00422 3         GO TO WC1;
00423 3     END;
00424 2     IWC=IWC+1;
00425 2     GO TO WC2;
00426 2 END WRITE$CORE;

```

```

00427 1
00428 1 READ$TAPE: PROCEDURE;
00429 2     DEC(RT1,RT2,RT3,RT4,RT5)BYTE;
00430 2     RT1=0;
00431 2     RT2=0;
00432 2     RT4=0;
00433 2     RT5=0;
00434 2     R1: IF (RT3:=TTYIN)=020H THEN DO CASE RT4;
00435 2         GO TO R2;
00436 3         GO TO R3;
00437 3     END;
00438 2     IF RT3>039H THEN RT3=RT3-037H;
00439 2     ELSE RT3=RT3-030H;
00440 2     RT2=SHL(RT2,4) OR RT3;
00441 2     GO TO R1;
00442 2     R2: IF (CHAN(RT1):=RT2)<>OFFH THEN DC;
00443 2         RT1=RT1+1;
00444 3         GO TO R1;
00445 3     END;
00446 2     RT4=1;
00447 2     GO TO R1;
00448 2     R3: IF (PROBE(RT5):=RT2)=OFFH THEN RETURN;
00449 2         RT5=RT5+1;
00450 2         GO TO R1;
00451 2 END READ$TAPE;

```

```

00452  1
00453  1  MONITOR:DO CASE HEX$PAIR;
00454  1          GO TO M0;
00455  2          GO TO M1;
00456  2          GO TO M2;
00457  2          GO TO M3;
00458  2          GO TO M4;
00459  2          GO TO M5;
00460  2          GO TO M6;
00461  2          GO TO M7;
00462  2          END;
00463  1  M0:DO I=0 TO LENGTH(M);
00464  1          CALL TTYOUT(M(I));
00465  2          END;
00466  1          GO TO MONITOR;
00467  1  M1:CALL CALIB;
00468  1  M2:CALL CHANNEL$ORDER;
00469  1          CALL PROBE$ORDER;
00470  1          CALL NEXT;
00471  1          GO TO MONITOR;
00472  1  M3:CALL READ$TAPE;
00473  1          CALL NEXT;
00474  1          GO TO MONITOR;
00475  1  M4:CALL START;
00476  1          CALL NEXT;
00477  1          GO TO MONITOR;
00478  1  M5:CALL READ$CORE;
00479  1          CALL NEXT;
00480  1          GO TO MONITOR;
00481  1  M6:CALL WRITE$CORE;
00482  1  M7:ADDRM=HEX$PAIR*100H + HEX$PAIR;
00483  1          GO TO ADDR;

```

S00365 M7
 S00363 M6
 S00361 M5
 S00359 M4
 S00357 M3
 S00355 M2
 S00353 M1
 S00351 M0
 S00347 MCNITOR
 S00341 R3
 S00339 R2
 S00334 R1
 S00333 RT5
 S00332 RT4
 S00331 RT3
 S00330 RT2
 S00329 RT1
 S00327 READTAPE
 S00325 O2D
 S00324 WC2
 S00323 WC1
 S00322 ADDRWC
 S00321 WCORE
 S00320 JWC
 S00319 AWC
 S00318 IWC
 S00316 WRITECORE
 S00314 O3A
 S00312 RO
 S00311 LPC
 S00310 HRC
 S00309 NRC
 S00308 PGLN
 S00307 ADDR2
 S00306 ADDR1
 S00305 CORE
 S00303 READCCRE
 S00300 IN
 S00298 NEXT
 S00295 PO1
 S00292 JPO
 S00291 IPO
 S00289 PRGBEORDER
 S00286 CO
 S00283 JCO
 S00282 ICO
 S00280 CHANNELORDER
 S00274 M1
 S00265 M0
 S00264 ICB
 S00263 BCB
 S00262 ACB
 S00260 CALIB
 S00259 100
 S00257 ST1
 S00255 50
 S00248 OFF
 S00247 STJ
 S00246 30
 S00245 C2A
 S00244 ERROR

S00243 AST
 S00242 TST
 S00241 LST
 S00240 KST
 S00239 JST
 S00238 IST
 S00236 START
 S00235 S999
 S00230 C1
 S00224 CC
 S00223 A6C
 S00222 A5C
 S00221 A4C
 S00220 A3C
 S00219 A2C
 S00218 A1C
 S00217 ACC
 S00215 VAL
 S00214 ERROR
 S00213 CONVERGE
 S00212 '-'
 S00210 '+'
 S00207 S
 S00206 1000
 S00205 BCD5
 S00204 BCD4
 S00203 BCD3
 S00202 BCD2
 S00200 SIGNBIT
 S00199 D02
 S00198 C01
 S00196 FTDO
 S00195 CHDO
 S00194 DATAO
 S00193 DATAOUT
 S00192 CCO
 S00190 11
 S00189 JBO
 S00182 OAO
 S00181 OSO
 S00180 OFO
 S00179 BOY
 S00178 VDY
 S00176 FTDY
 S00173 DISPLAY
 S00171 12
 S00174 SDY
 S00175 CHDY
 S00201 BCD1
 S00169 143
 S00155 C46
 S00153 5
 S00152 IS
 S00151 BS
 S00149 FTS
 S00148 CHS
 S00147 SCANV
 S00145 OIO
 S00139 CM
 S00138 EM
 S00136 CHM
 S00135 MULTIPLEX

S00134 100
 S00133 10000
 S00130 14000
 S00127 THERE
 S00125 3
 S00124 HERE
 S00123 HEXB
 S00122 HEXA
 S00121 CDC
 S00120 BDC
 S00119 ACC
 S00118 CVER
 S00117 VAL
 S00115 DIGITEC
 S00112 IFCR
 S00110 NUM
 S00109 TYPE
 S00108 FORMAT
 S00107 BBH
 S00105 ABH
 S00104 BCDHEX
 S00101 NUM1
 S00099 NUM
 S00098 CNEOUT
 S00095 OF
 S00092 ASC1
 S00090 ASC
 S00089 FAIROUT
 S00088 4
 S00087 30
 S00085 37
 S00083 39
 S00081 20
 S00080 M1
 S00079 AHP
 S00078 WORD
 S00076 HEXPAIR
 S00073 ITO
 S00071 ZTC
 S00070 TTYOUT
 S00069 07F
 S00068 130
 S00066 8
 S00064 1
 S00063 C
 S00062 64
 S00060 080
 S00059 2
 S00058 HERE
 S00057 ITI
 S00056 XTI
 S00054 TTYIN
 S00053 1400
 S00052 1100
 S00051 ADORM
 S00050 BPB
 S00049 PROBE
 S00048 BCH
 S00047 CHAN
 S00046 'AMT DN=0/UP=1'
 S00045 PHEADER
 S00043 'CH PT ERROR TIME'
 S00042 CHEADER
 S00040 'ENTER THE NEXT SELECTION NUMBER: '
 S00039 N

SOJC37 ' 7 - RESTART'
 SO0036 ' 6 - MEMORY EDIT'
 SO0035 ' 5 - MEMORY DISPLAY'
 SOJ034 ' 4 - DATA ACQUISITION'
 SOJC33 ' 3 - READ TAPE'
 SOJC32 ' 2 - PROGRAM SCAN'
 SOJ031 ' 1 - CALIBRATION'
 SOJC30 ' 0 - MIDAS IV HEADER'
 SO0029 'TYPE THE SELECTION NUMBER FOLLOWED BY A SPACE:'
 SO0028 ' MIDAS IV '
 SO0027 COA
 SOJC26 CCD
 SO0025 M
 SOJC23 SIGN
 SO0022 I
 SO0020 DCUBLE
 SO0019 MOVE
 SO0018 LAST
 SO0017 LENGTH
 SO0016 OUTPUT
 SO0015 INPUT
 SO0014 LOW
 SO0013 HIGH
 SO0012 TIME
 SO0011 SCR
 SO0010 SCL
 SO0009 SHR
 SO0008 SHL
 SO0007 ROR
 SOJC06 ROL
 SOJC05 MEMORY
 SO0004 PARITY
 SO0003 SIGN
 SO0002 ZERO
 SO0001 CARRY

B.18 LISTING OF MIDAS IV SOFTWARE

TTYIN

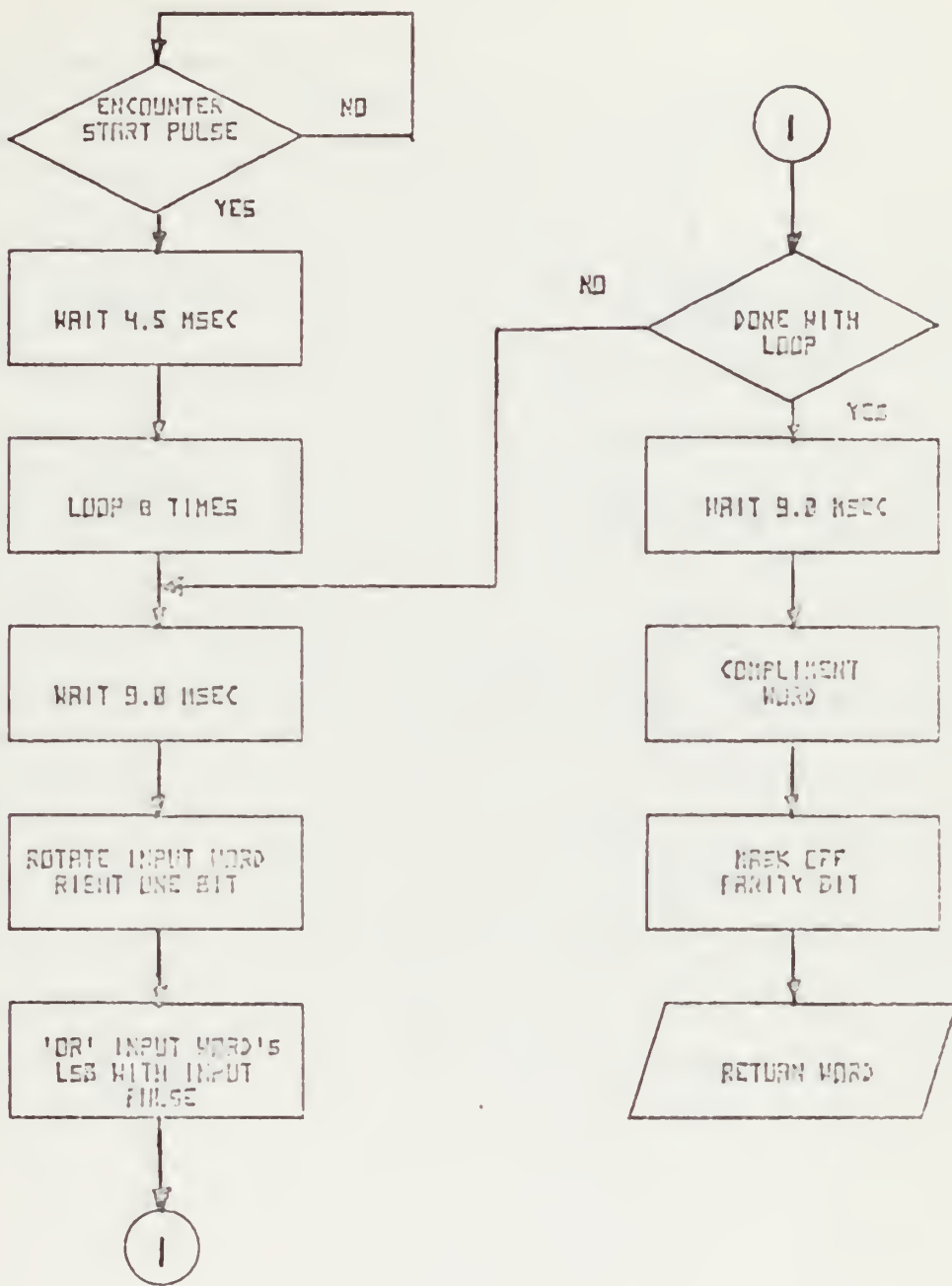

TTYOUT

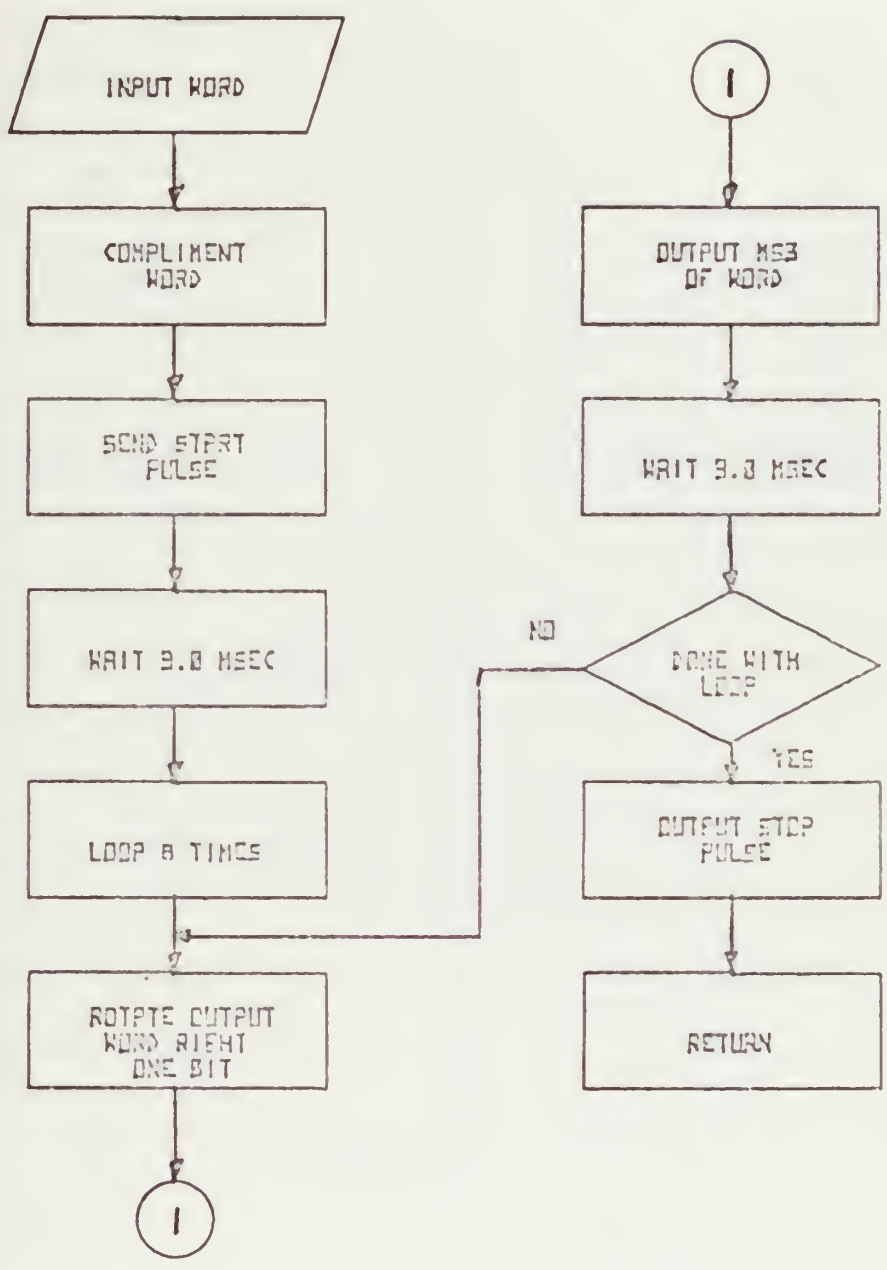

HEX PAIR

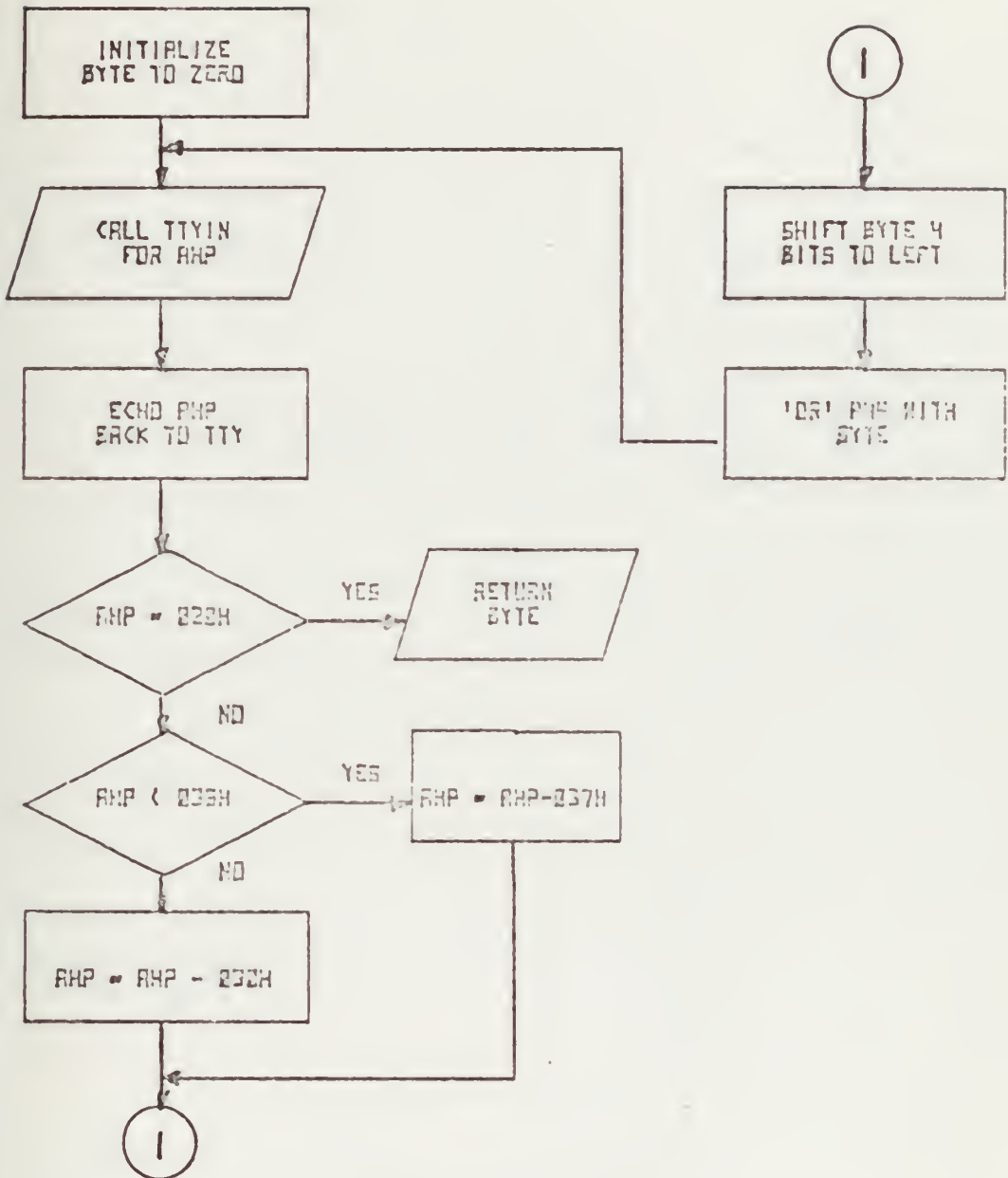

PAIROUT

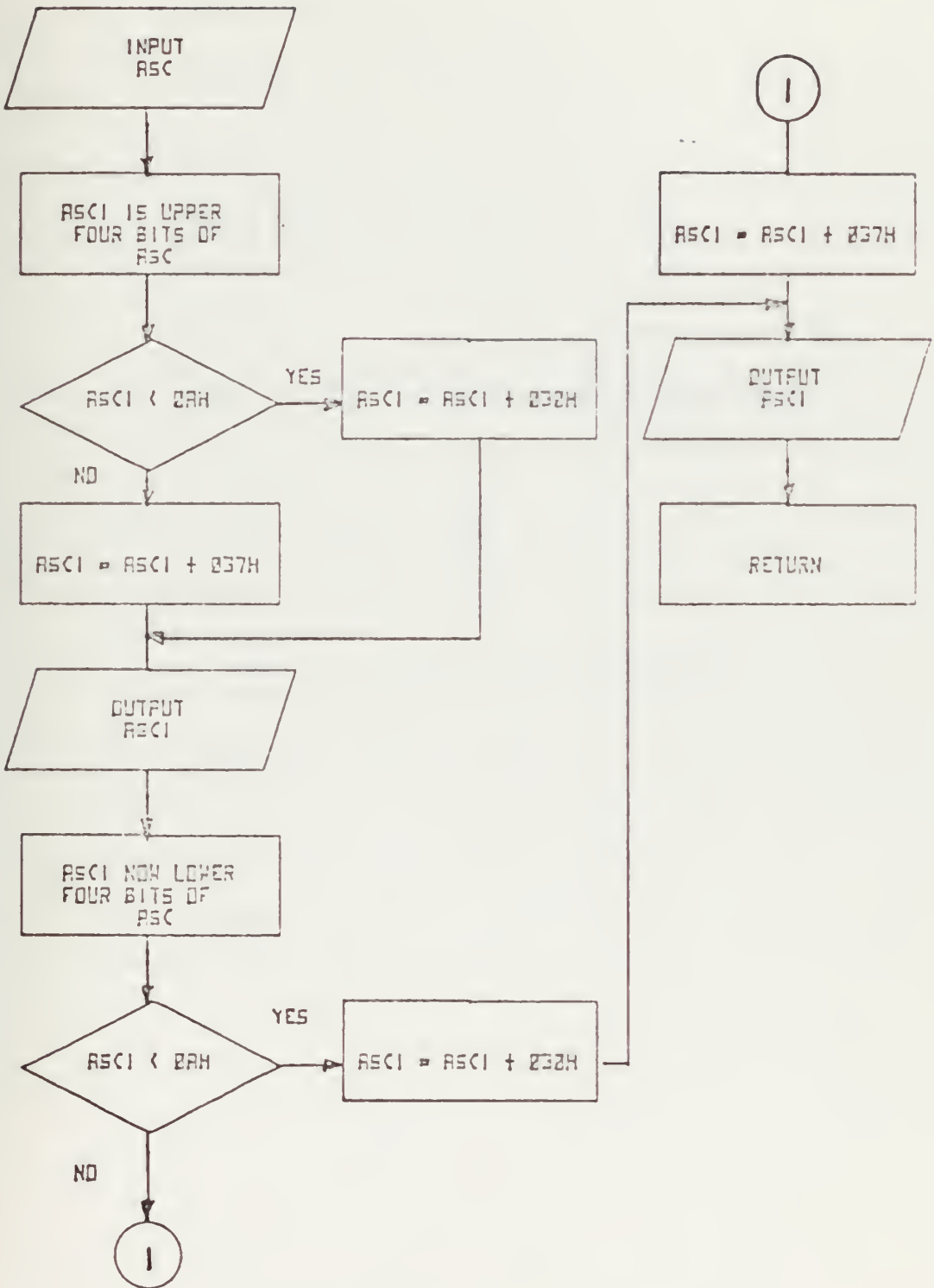

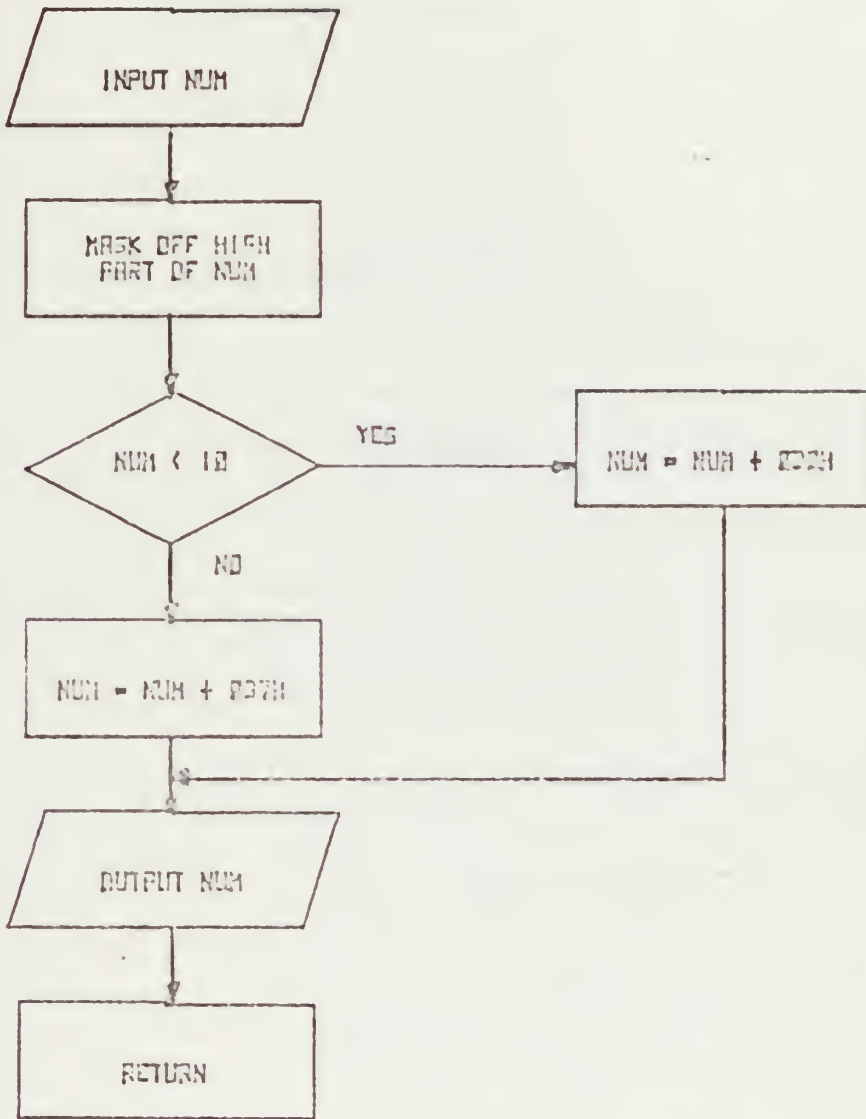

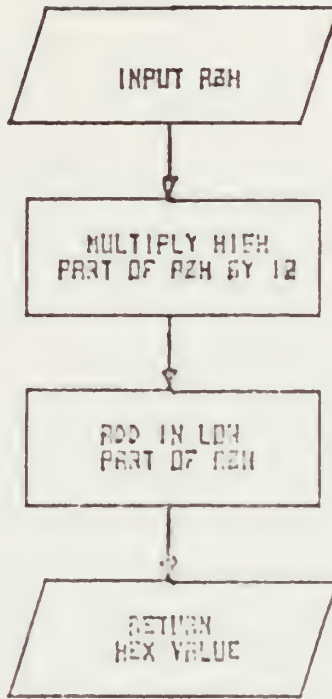

FORMAT

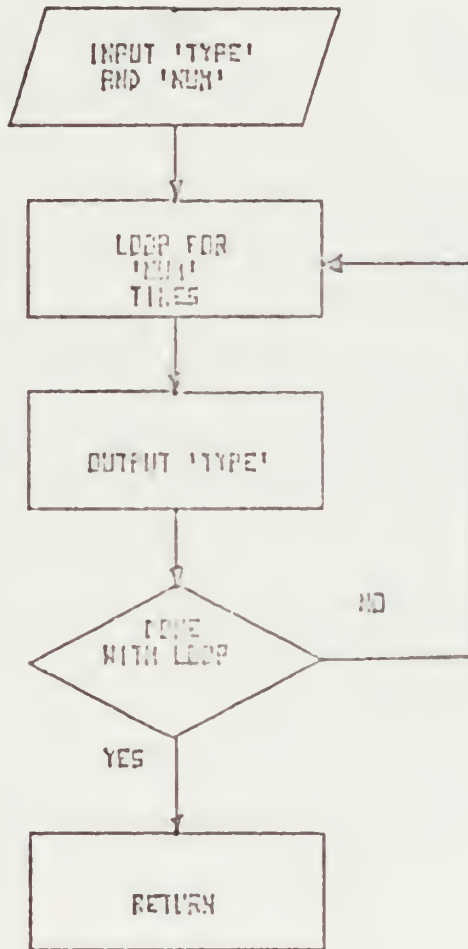

DIGITEC

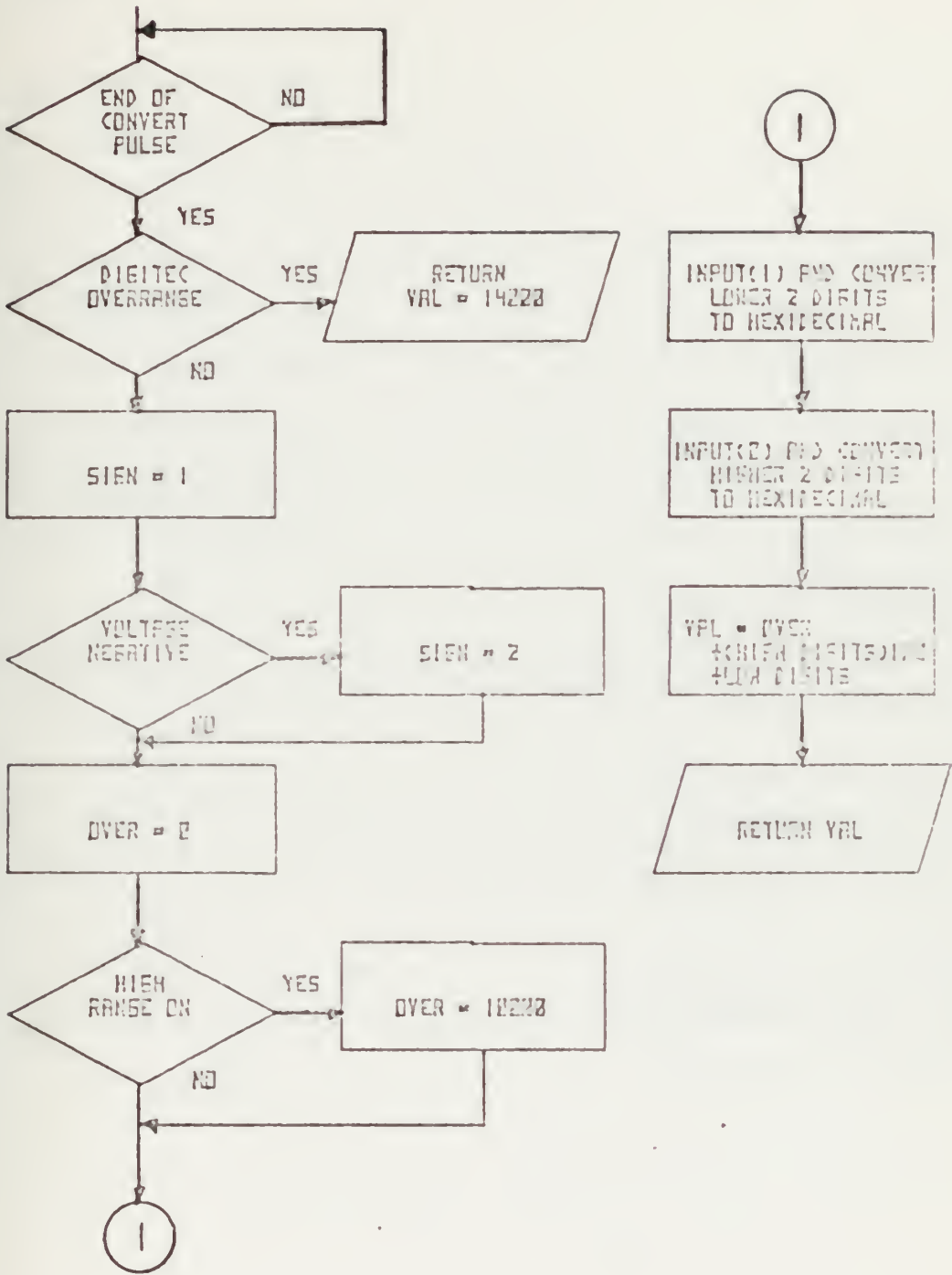

MULTIPLEX

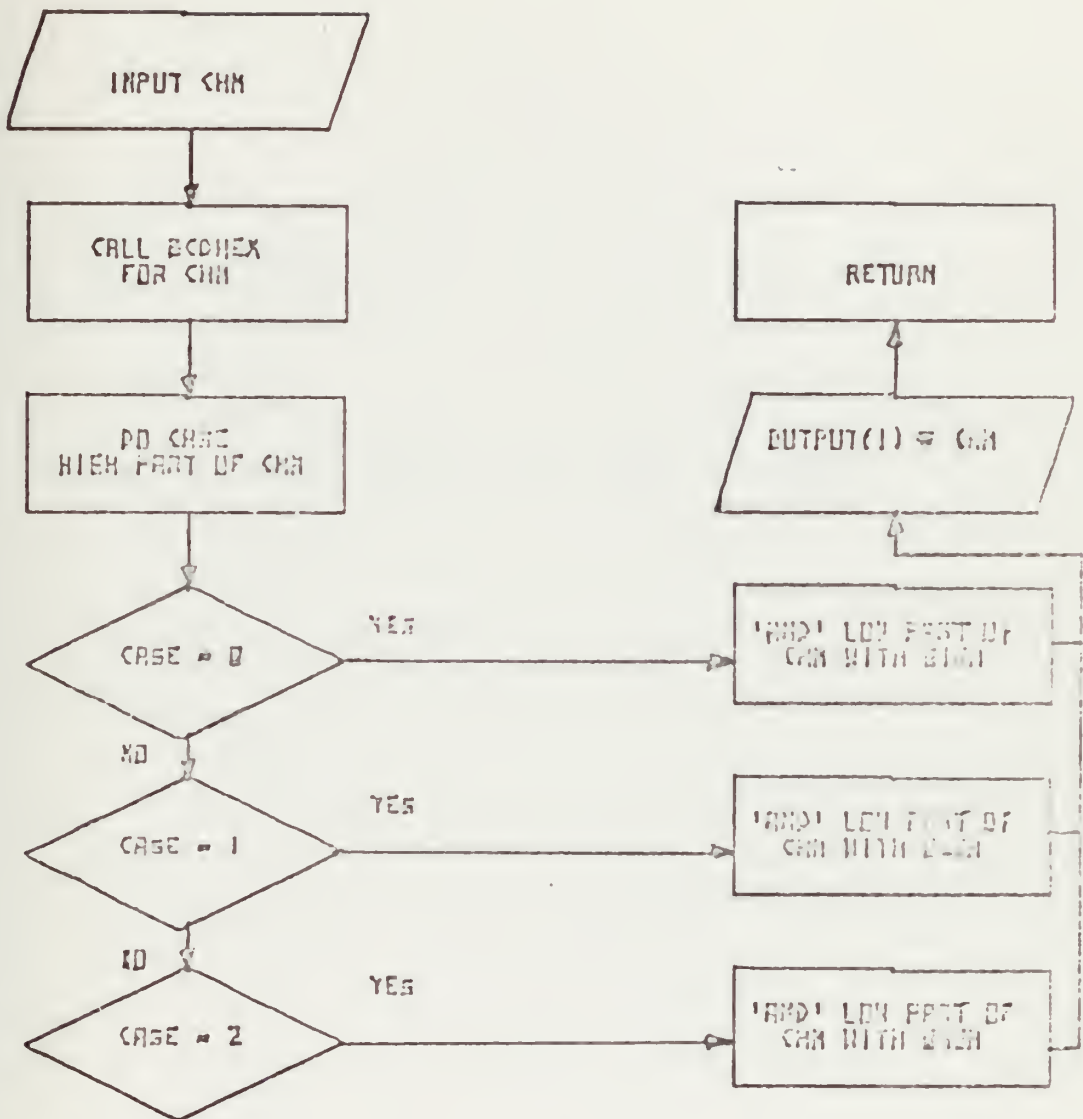

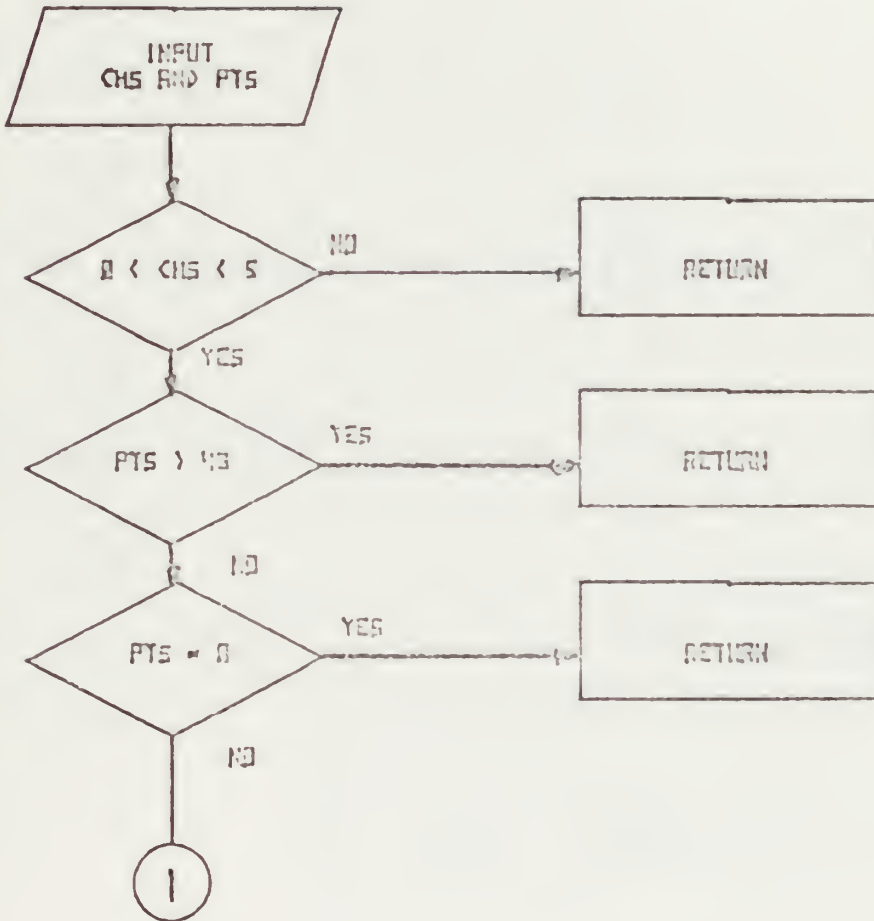

SCARY (CONT)

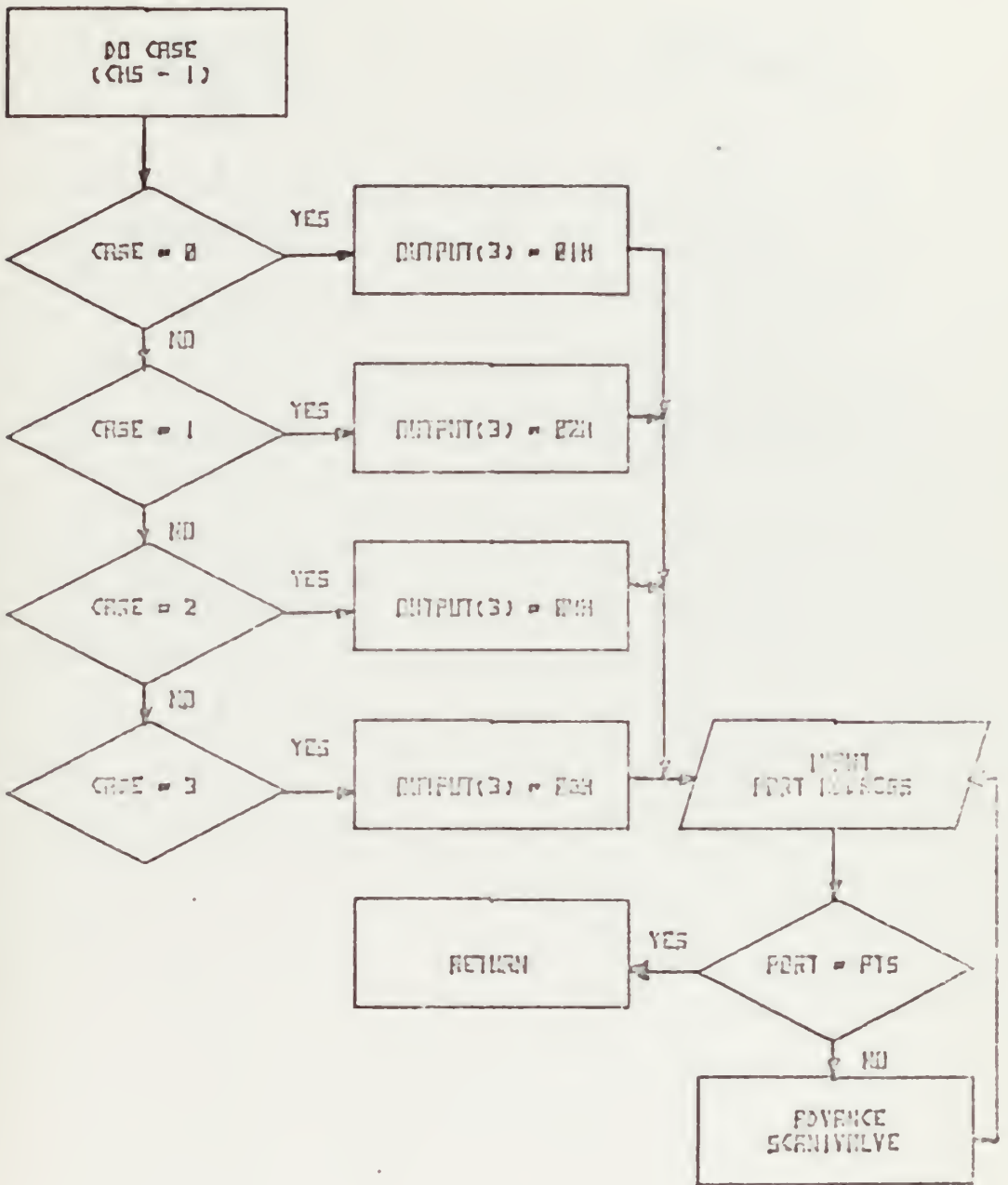

DISPLAY

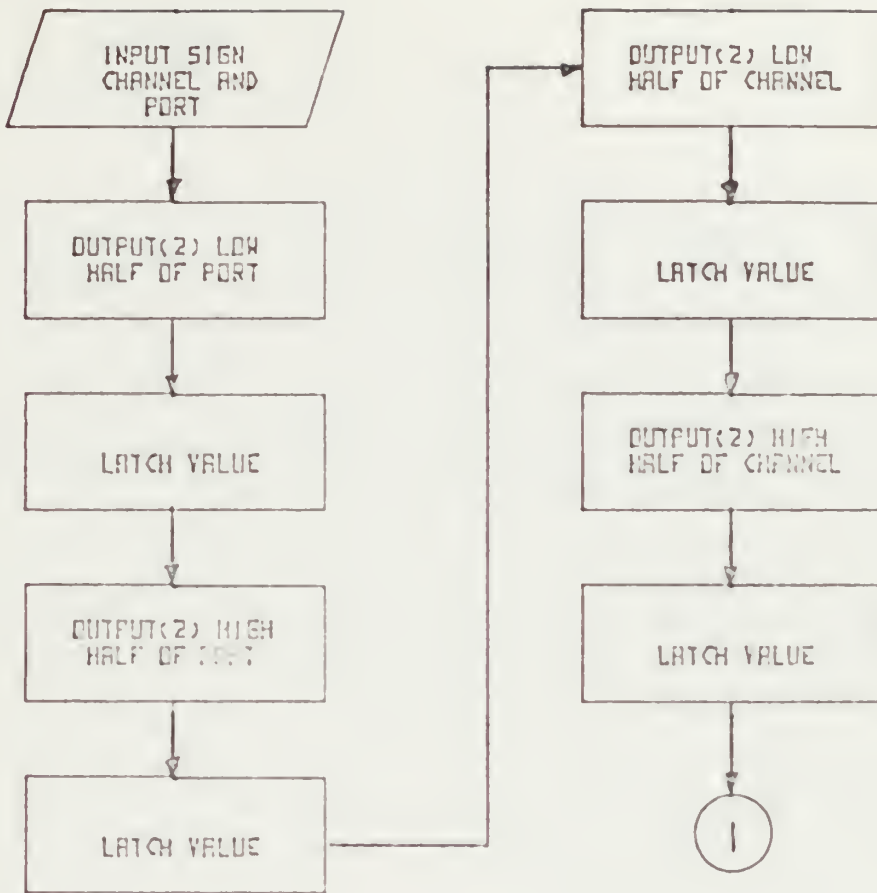

DISPLAY (CONT)

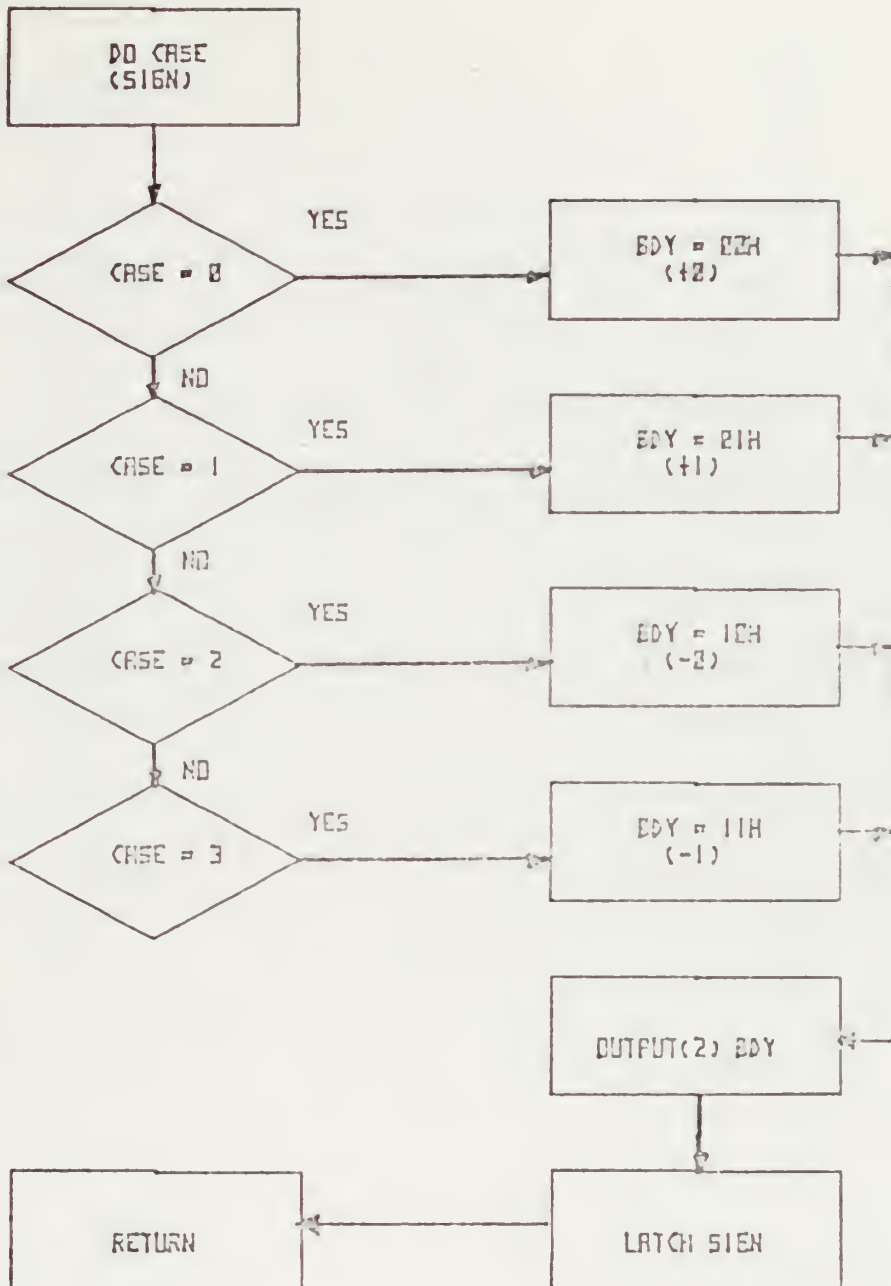

DATAOUT

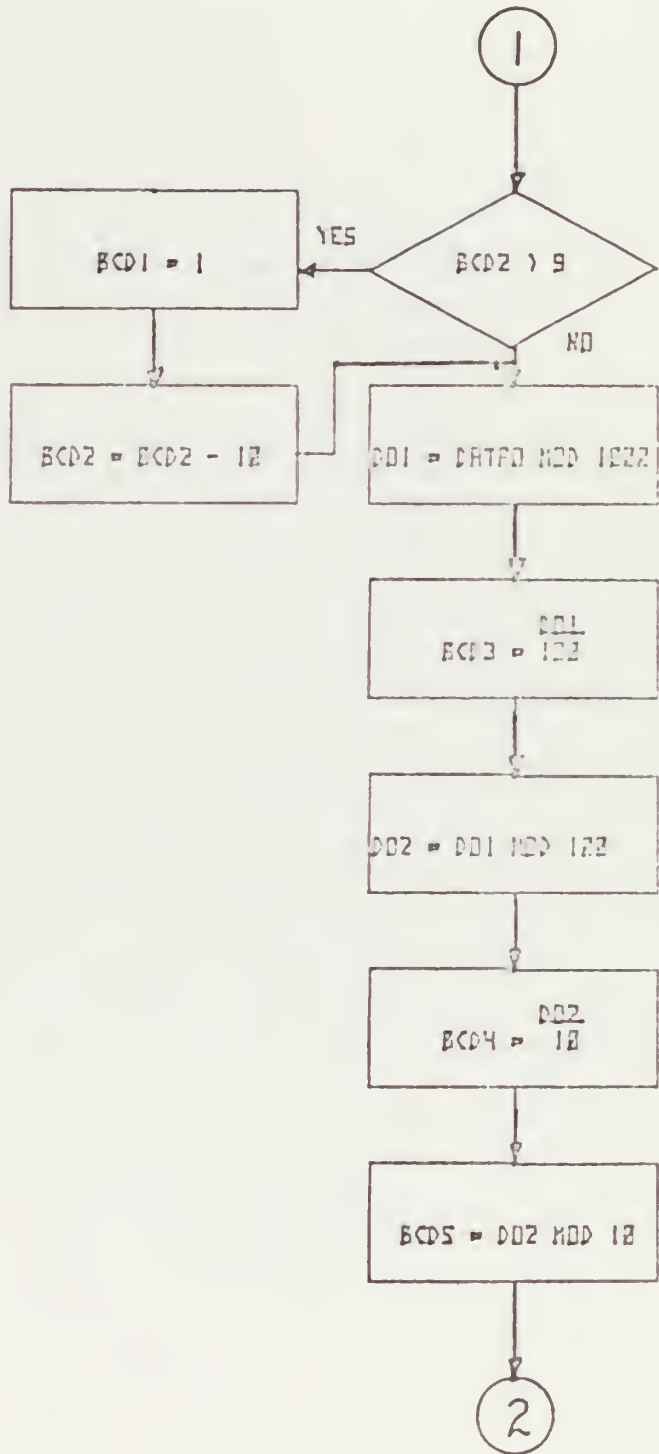
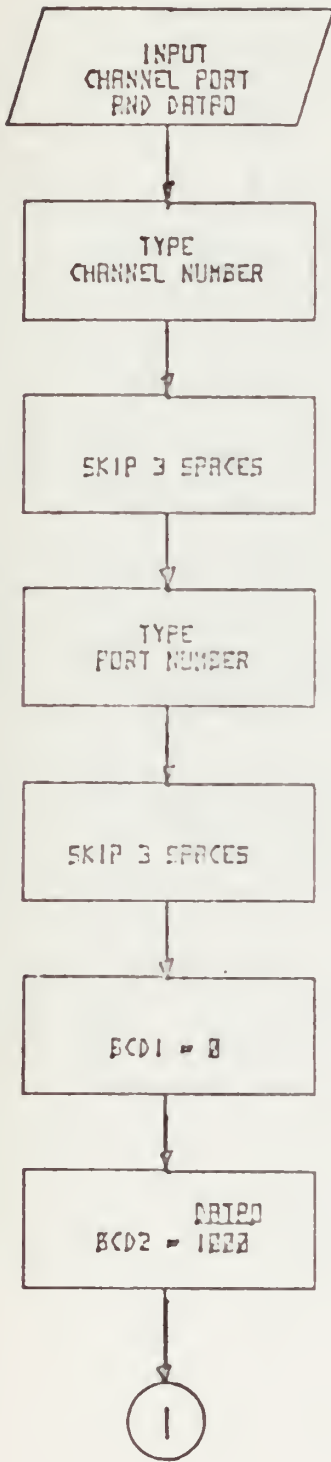

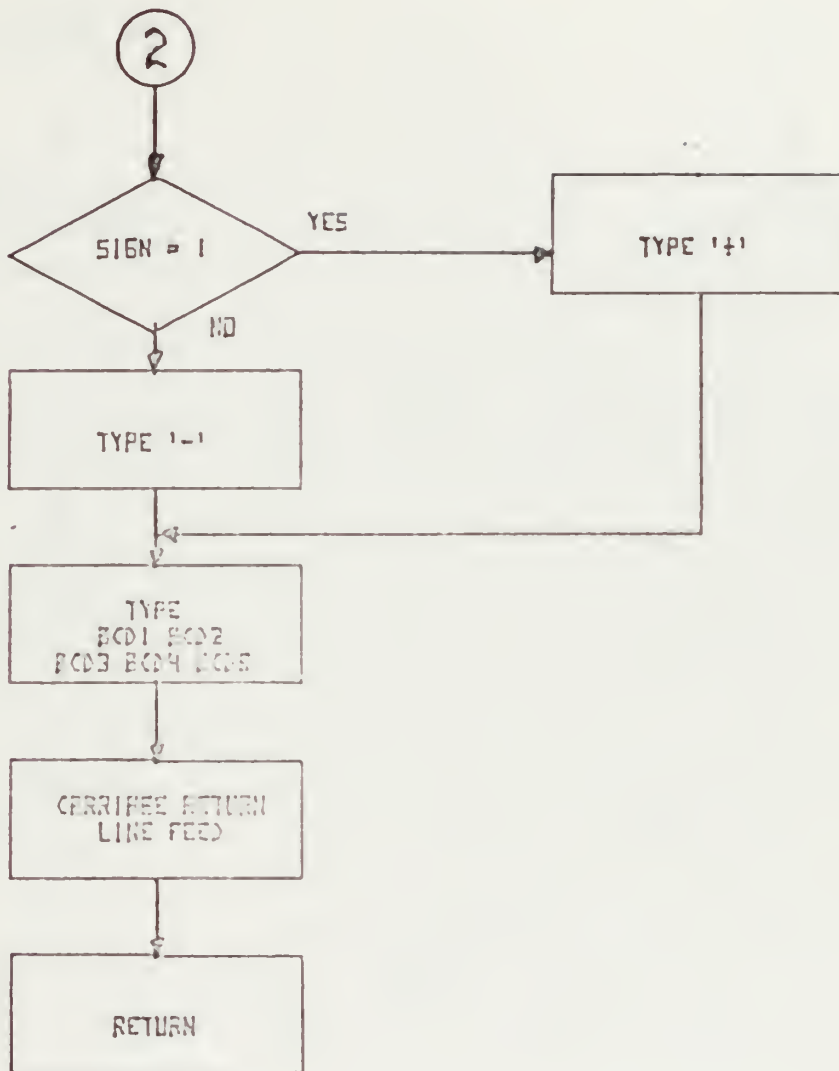

CONVERSE

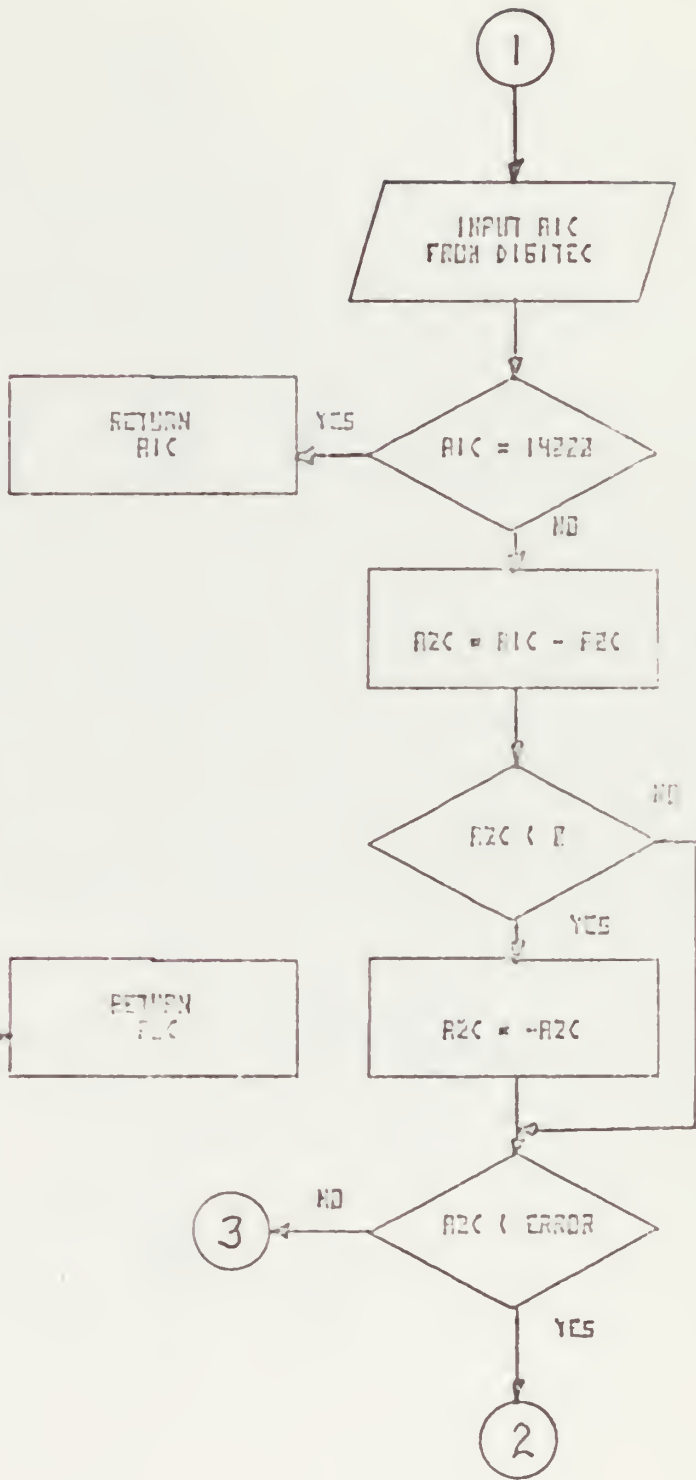
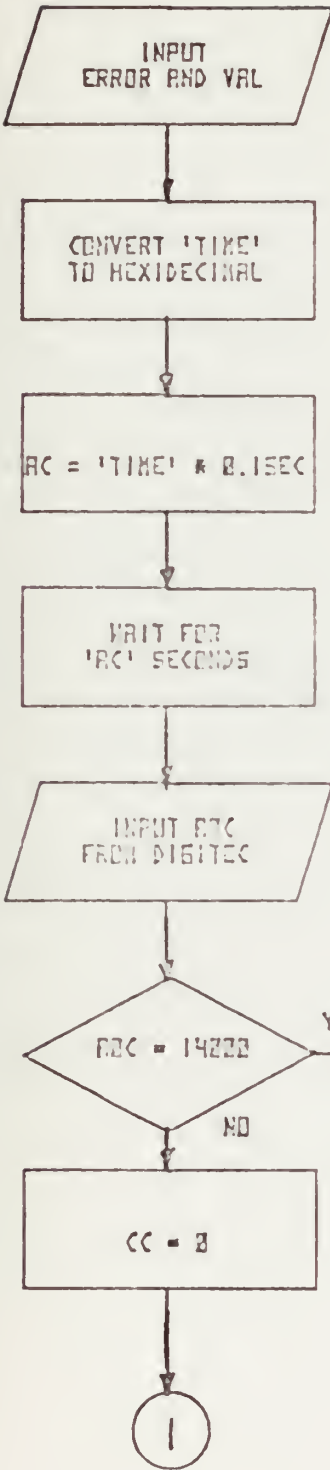

CONVERGE (CONT)

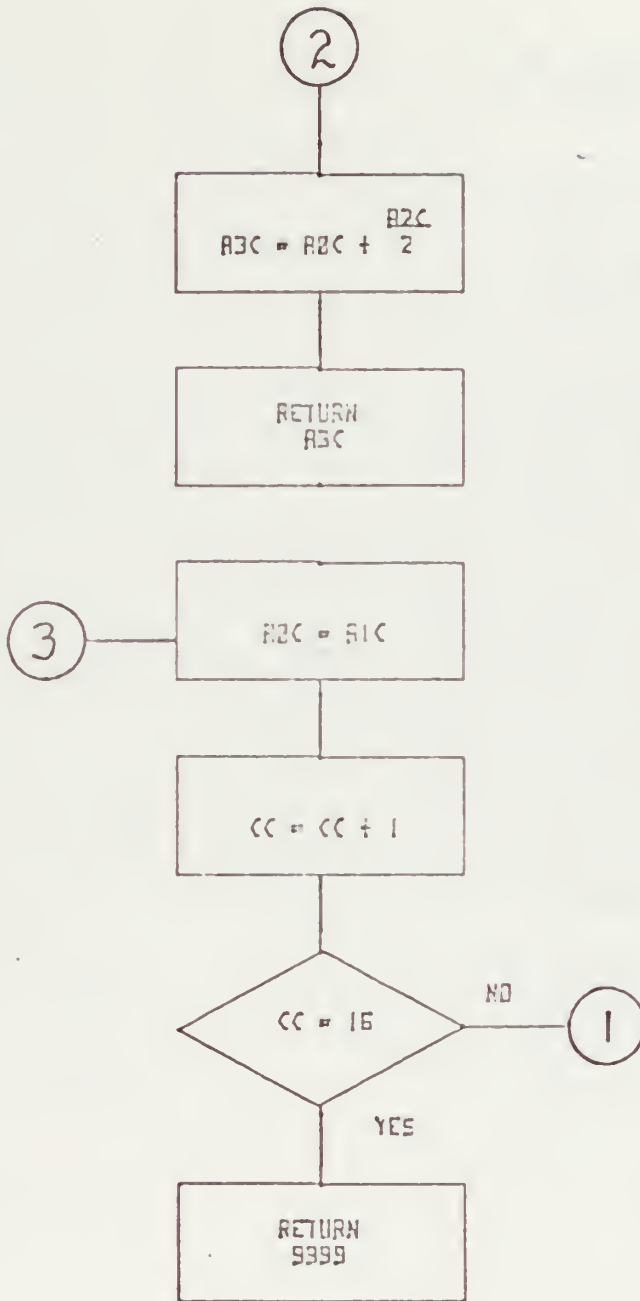

START

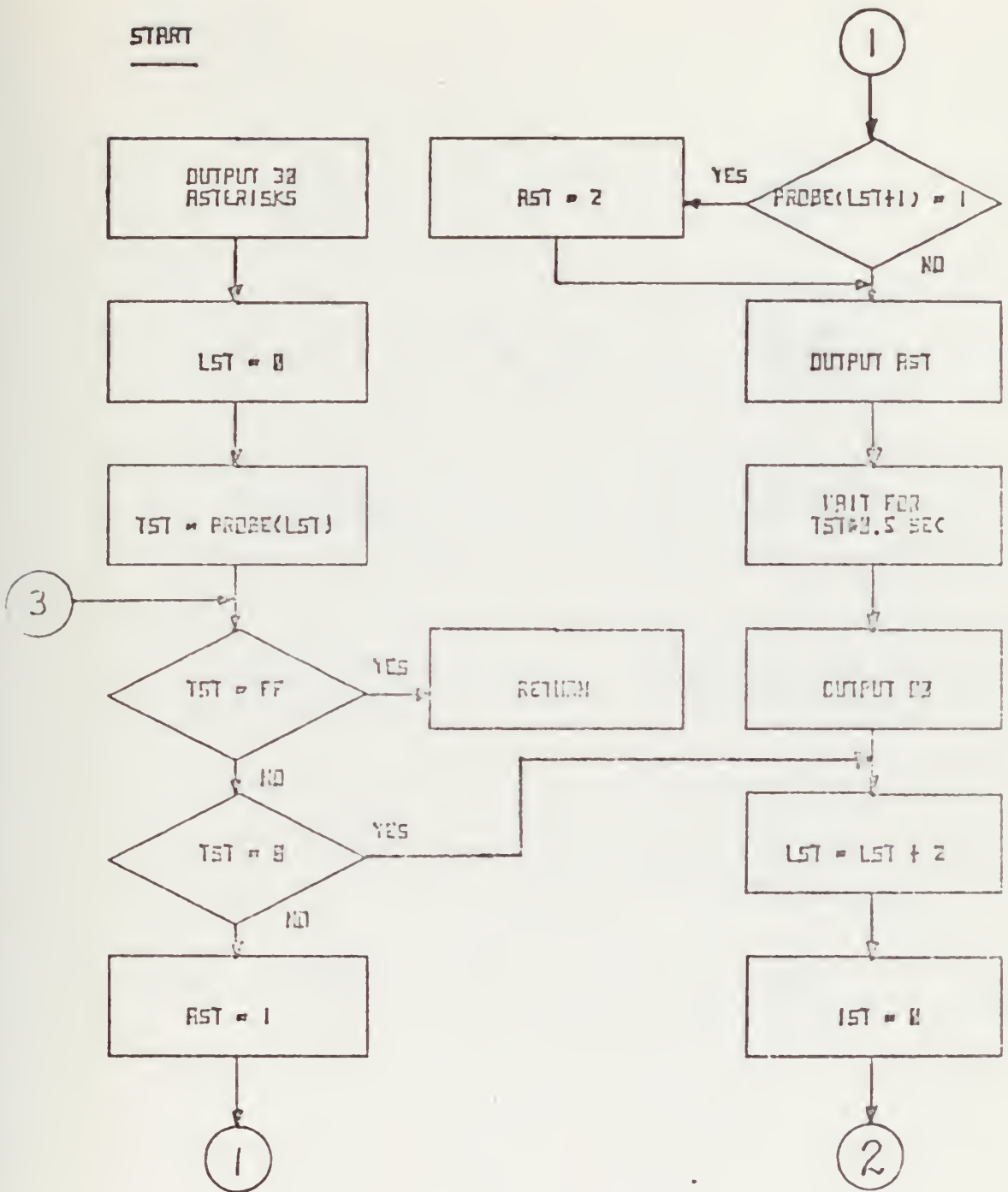

START (CONT)

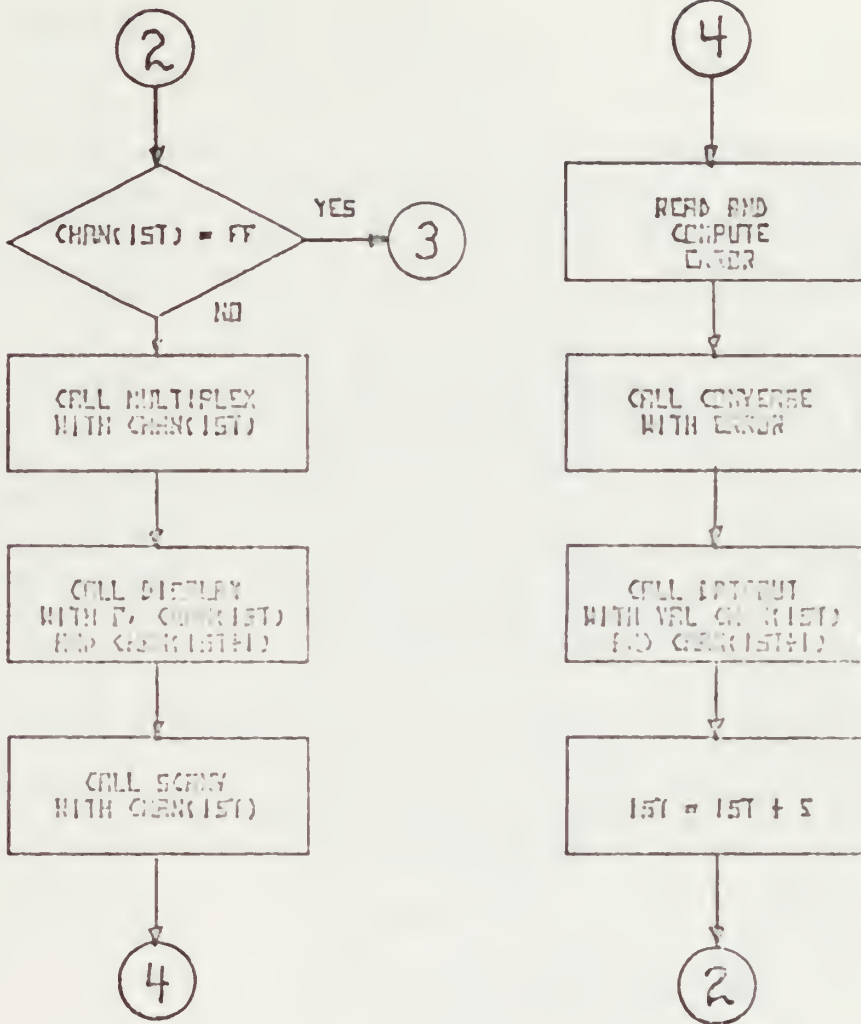

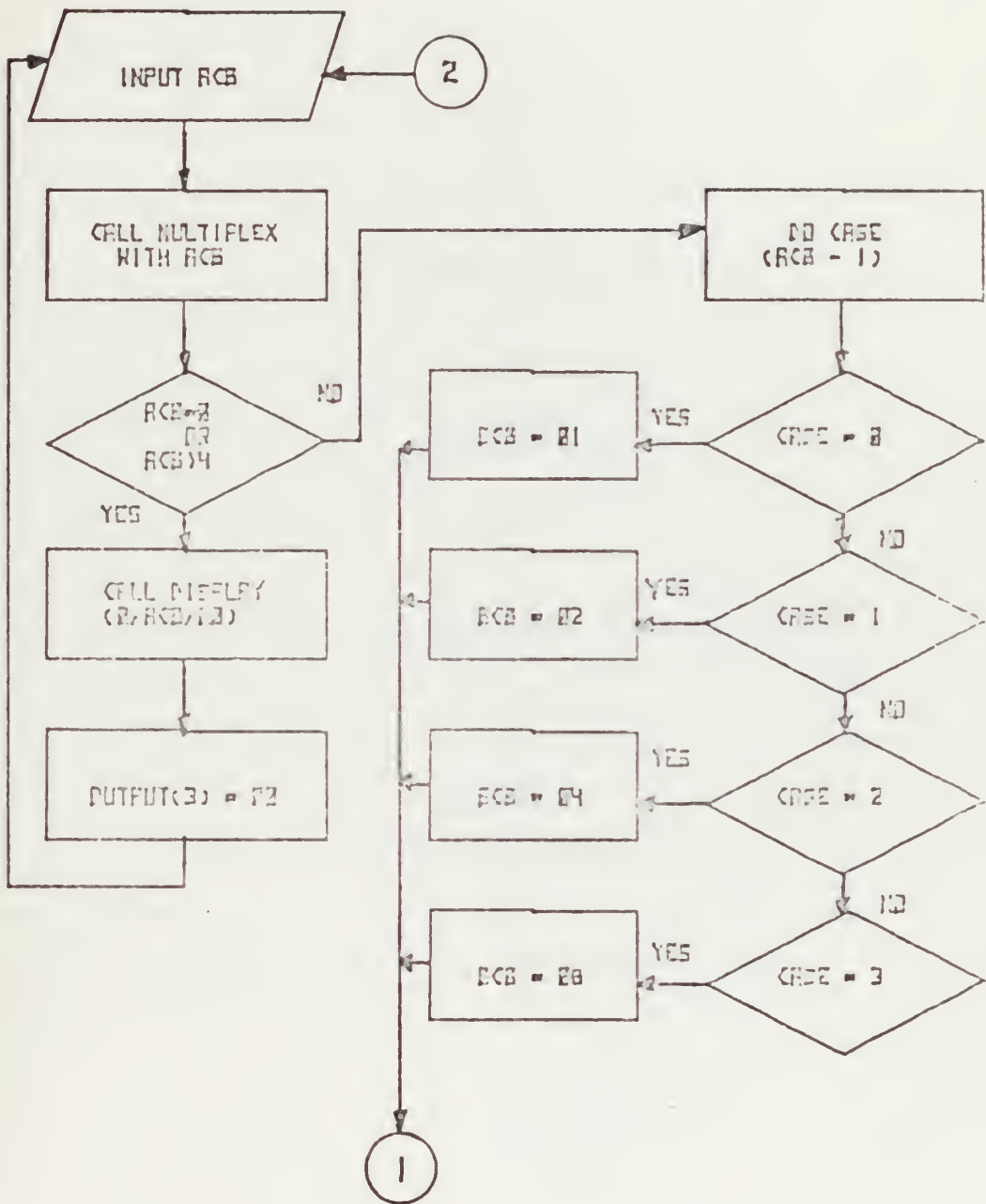

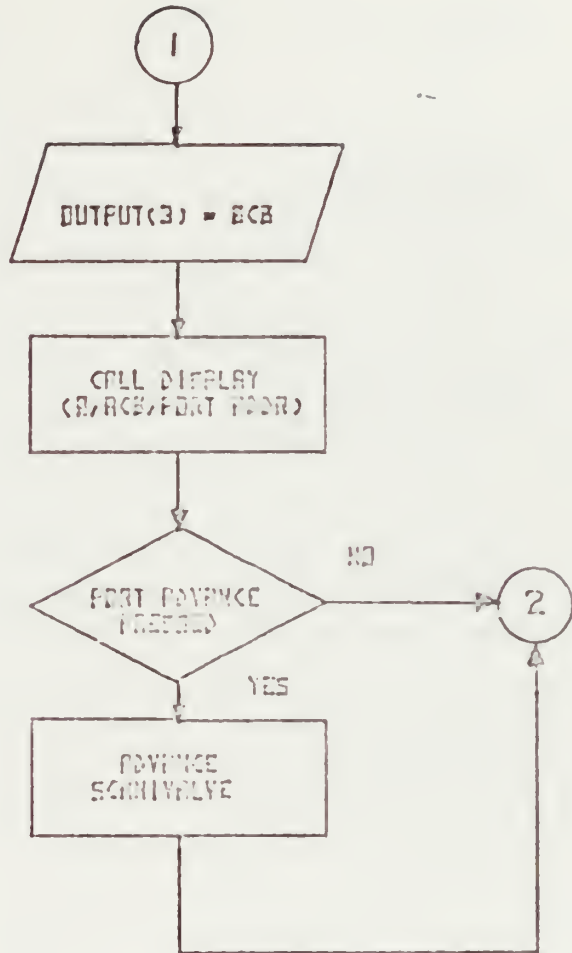

CHANNEL ORDER

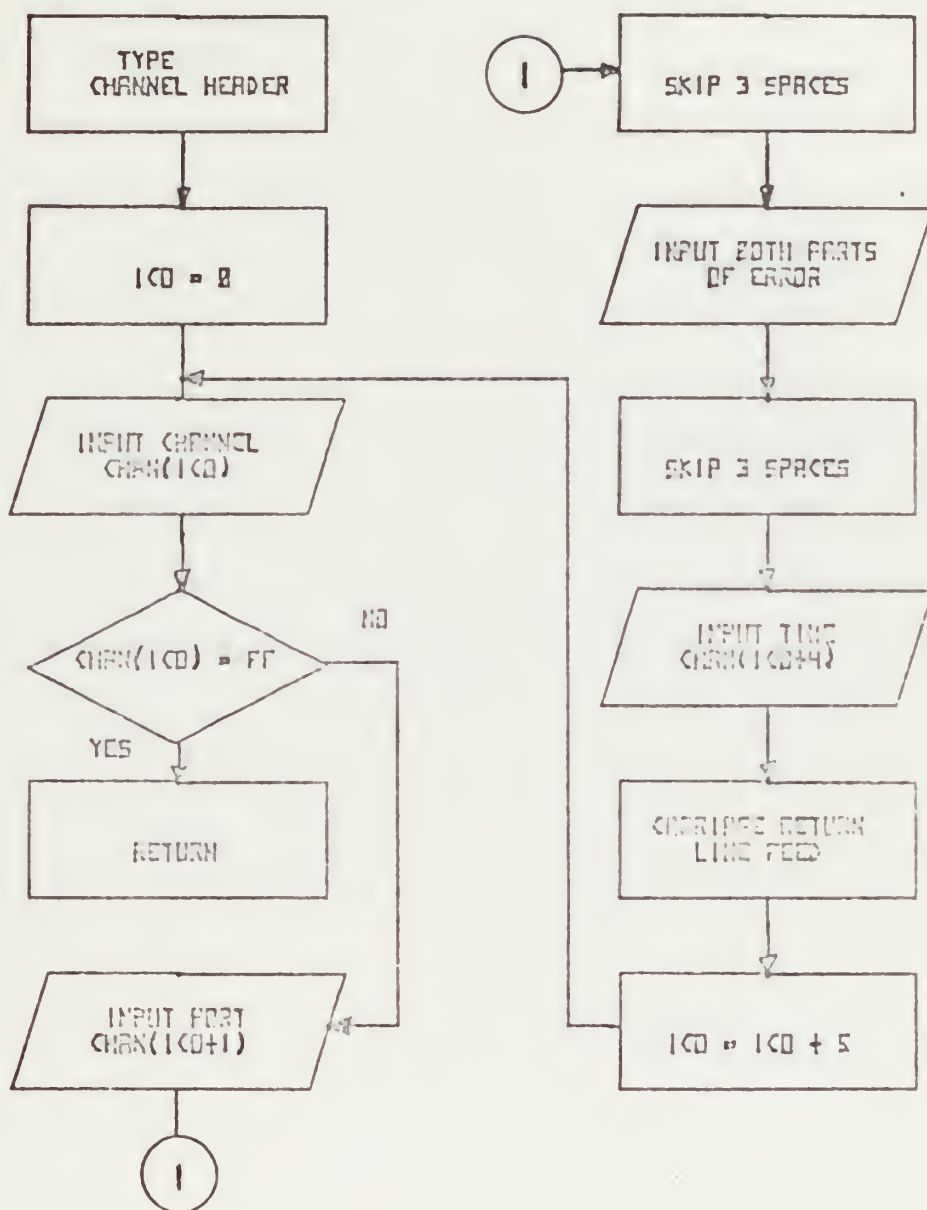

PROBE ORDER

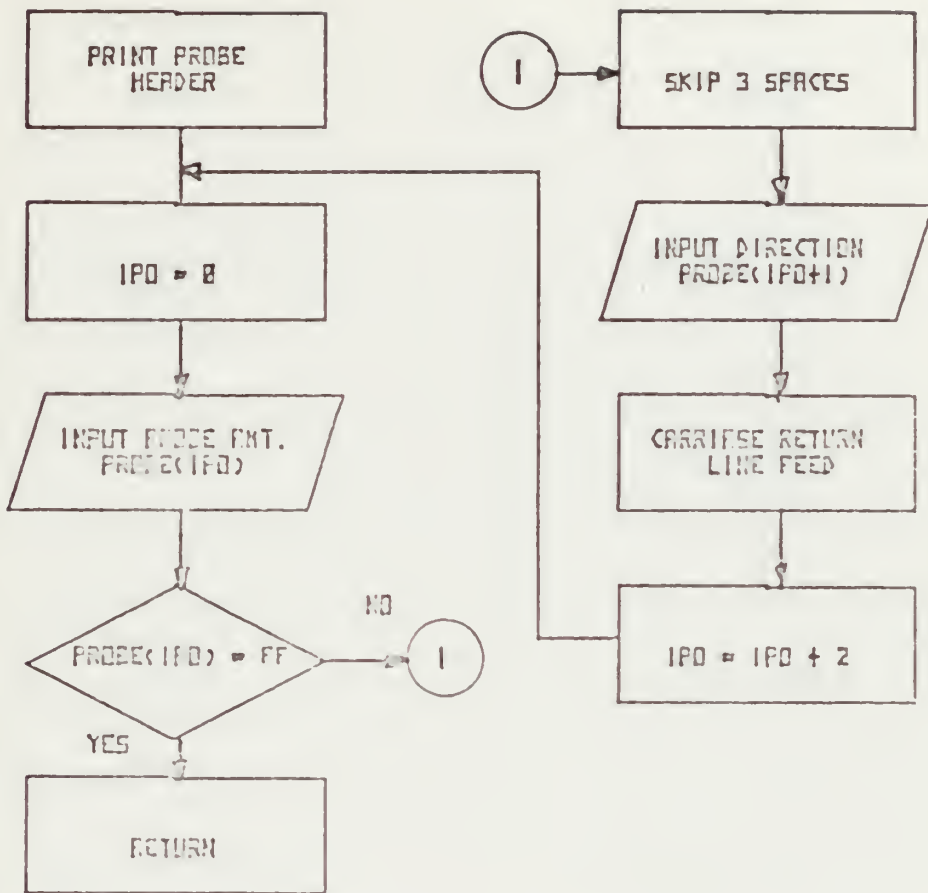

READ CORE

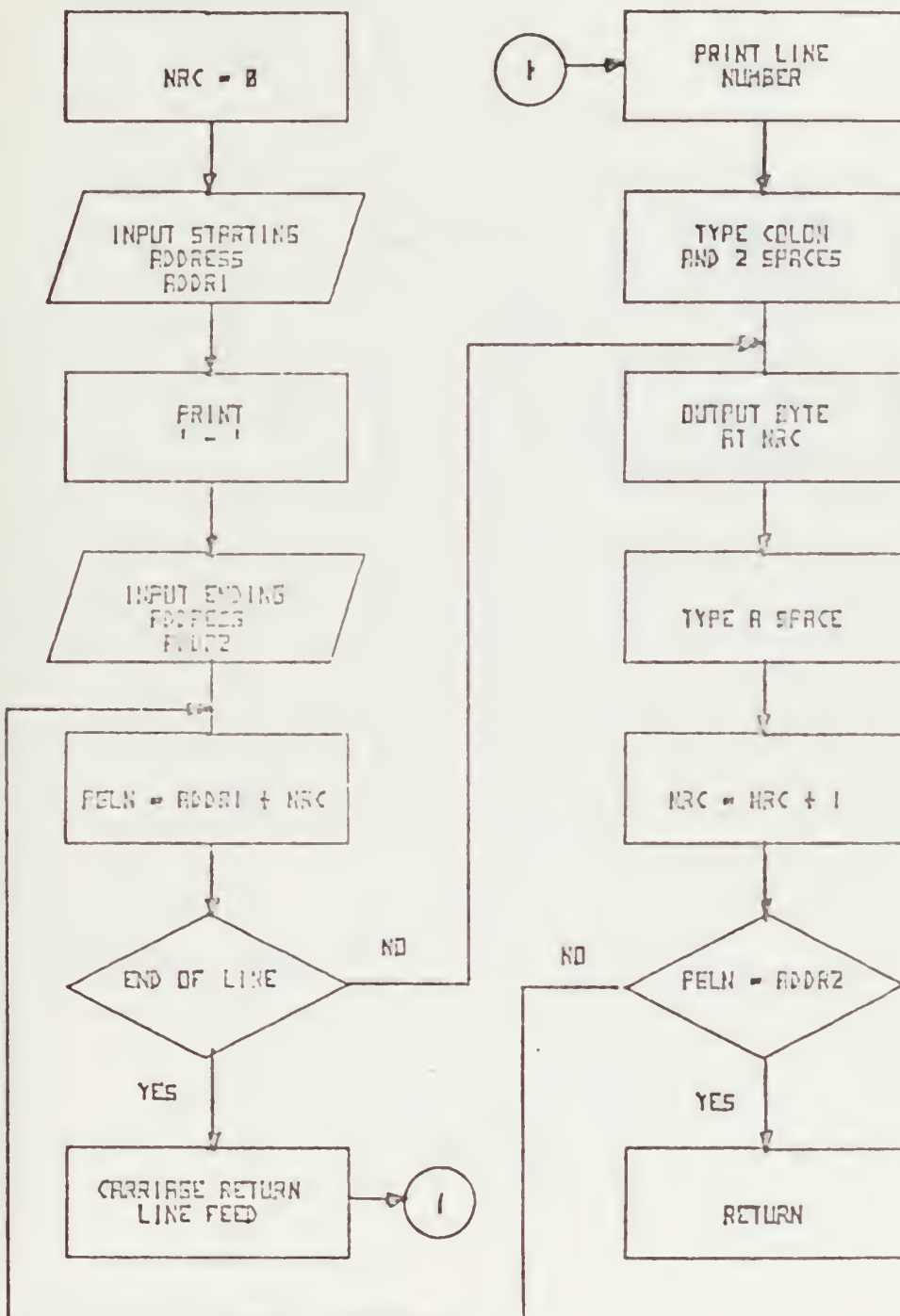

WRITE CORE

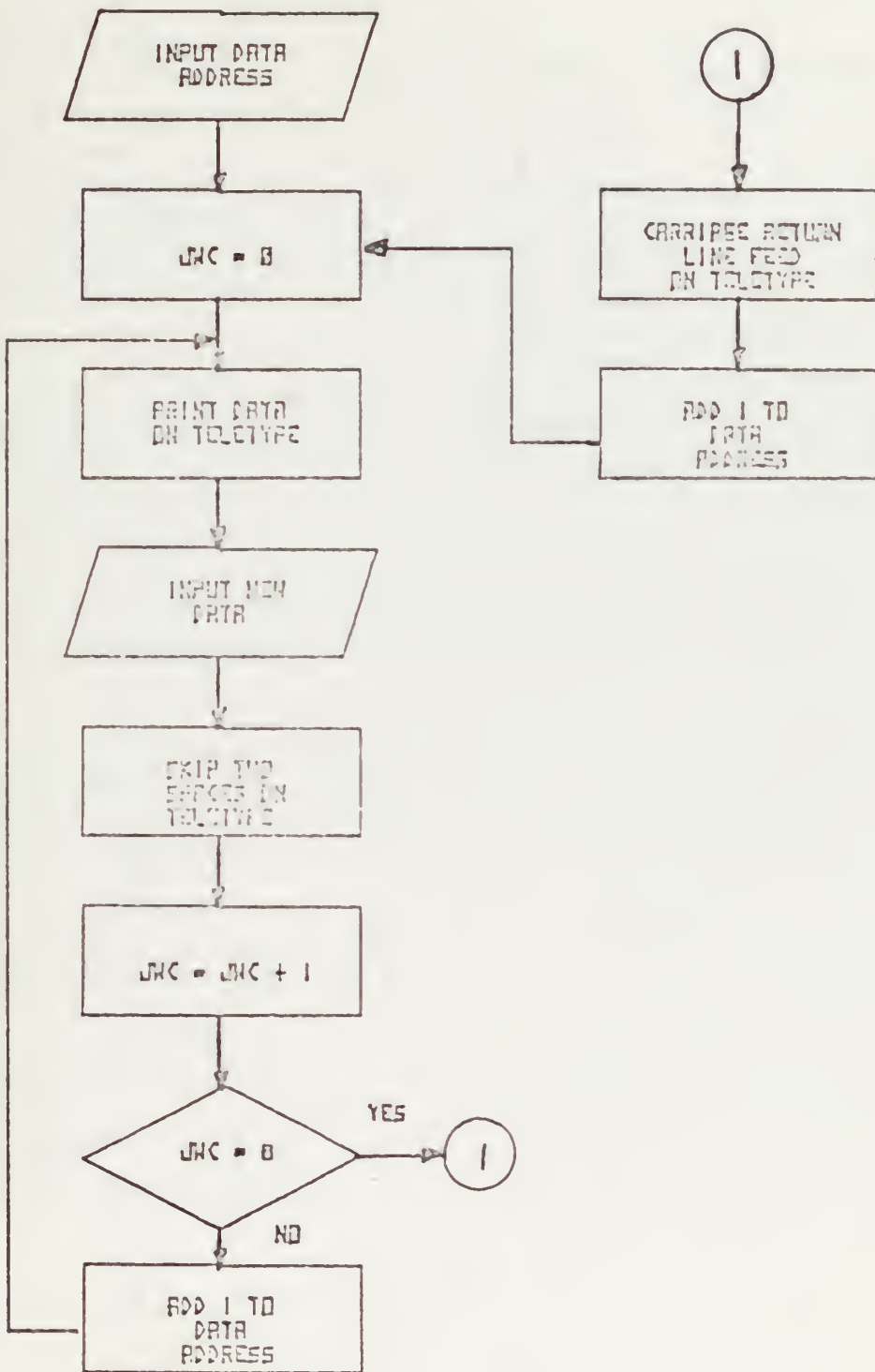

READ TAPE

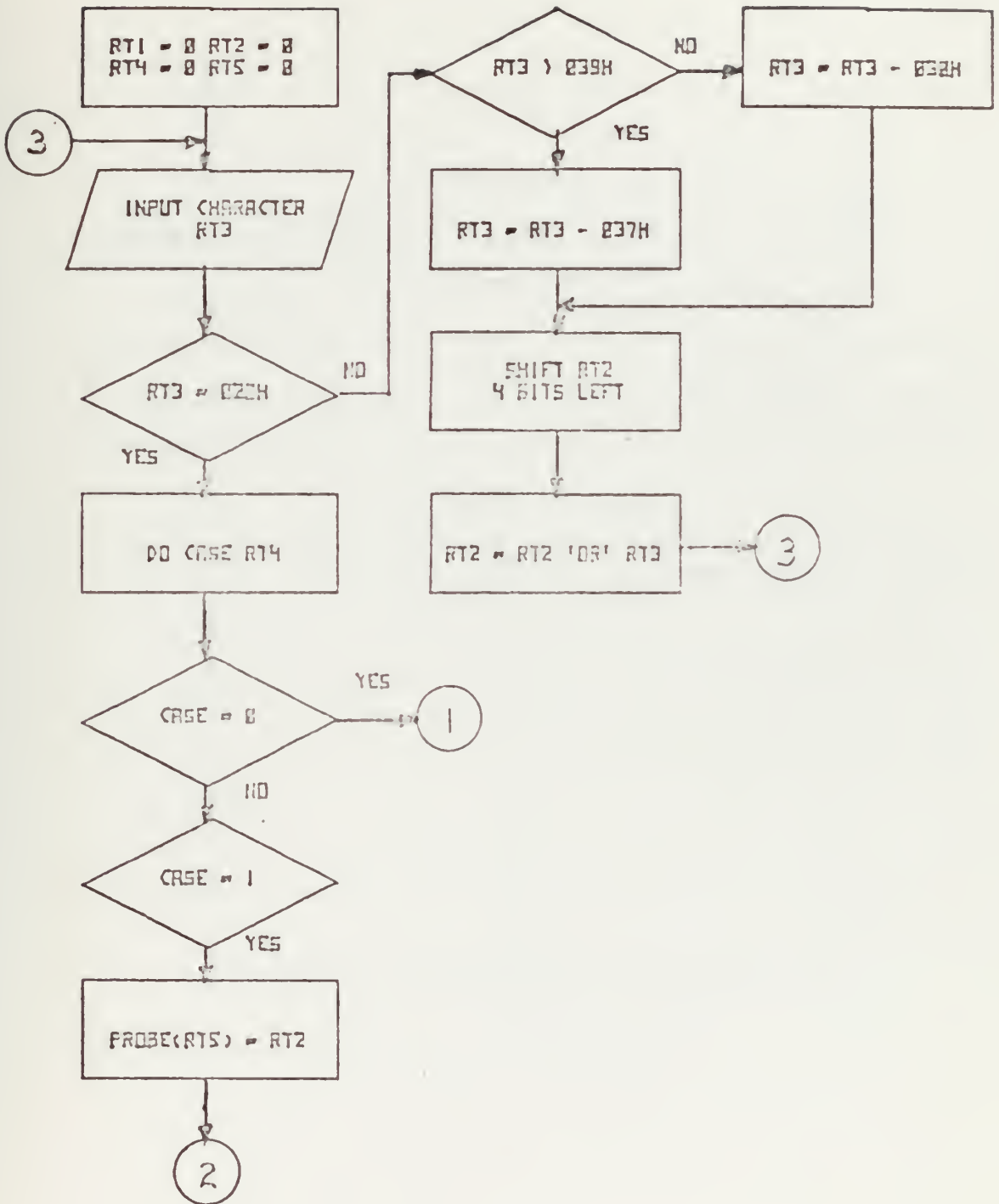

READ TAPE (CONT)

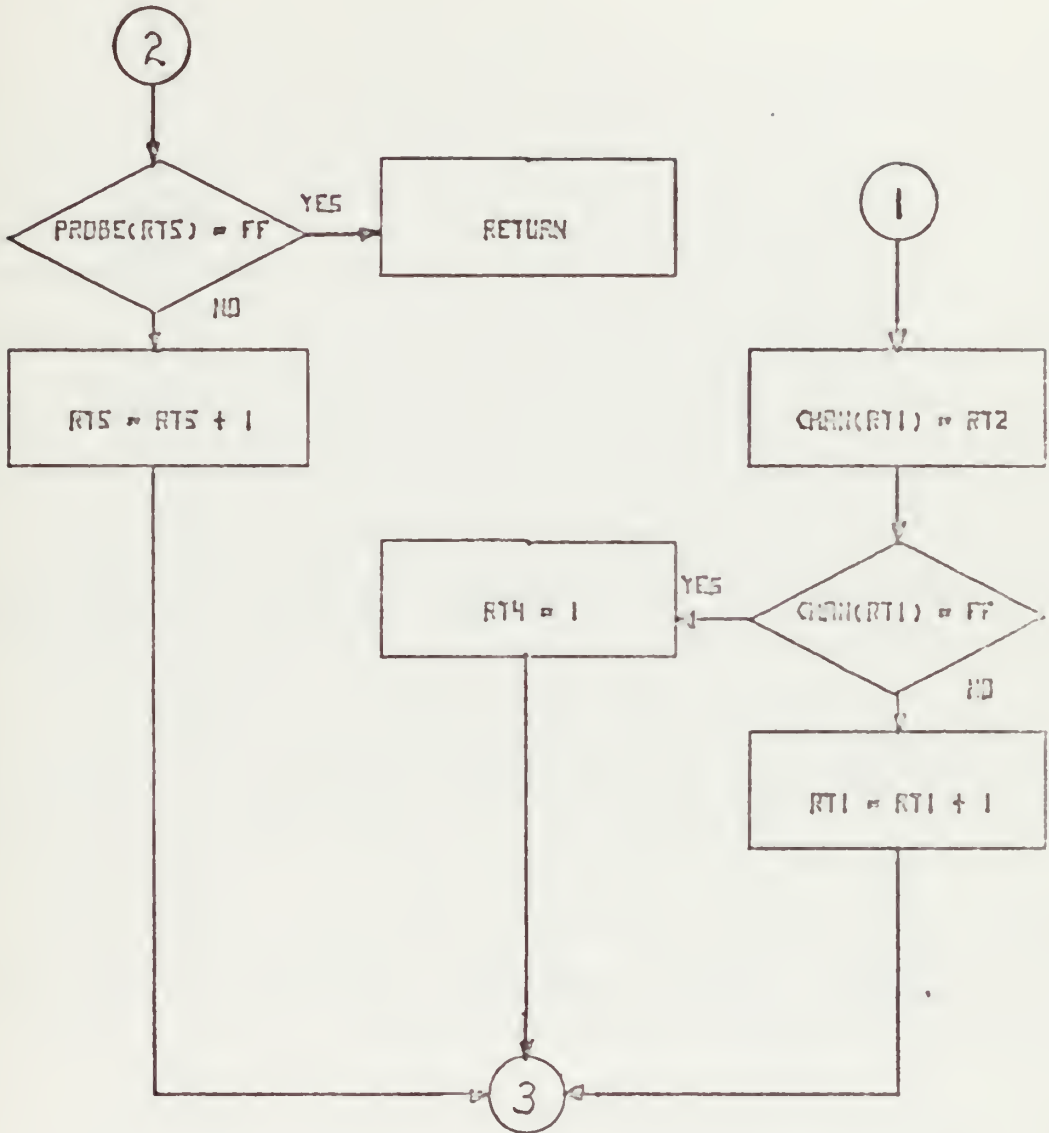

MONITOR

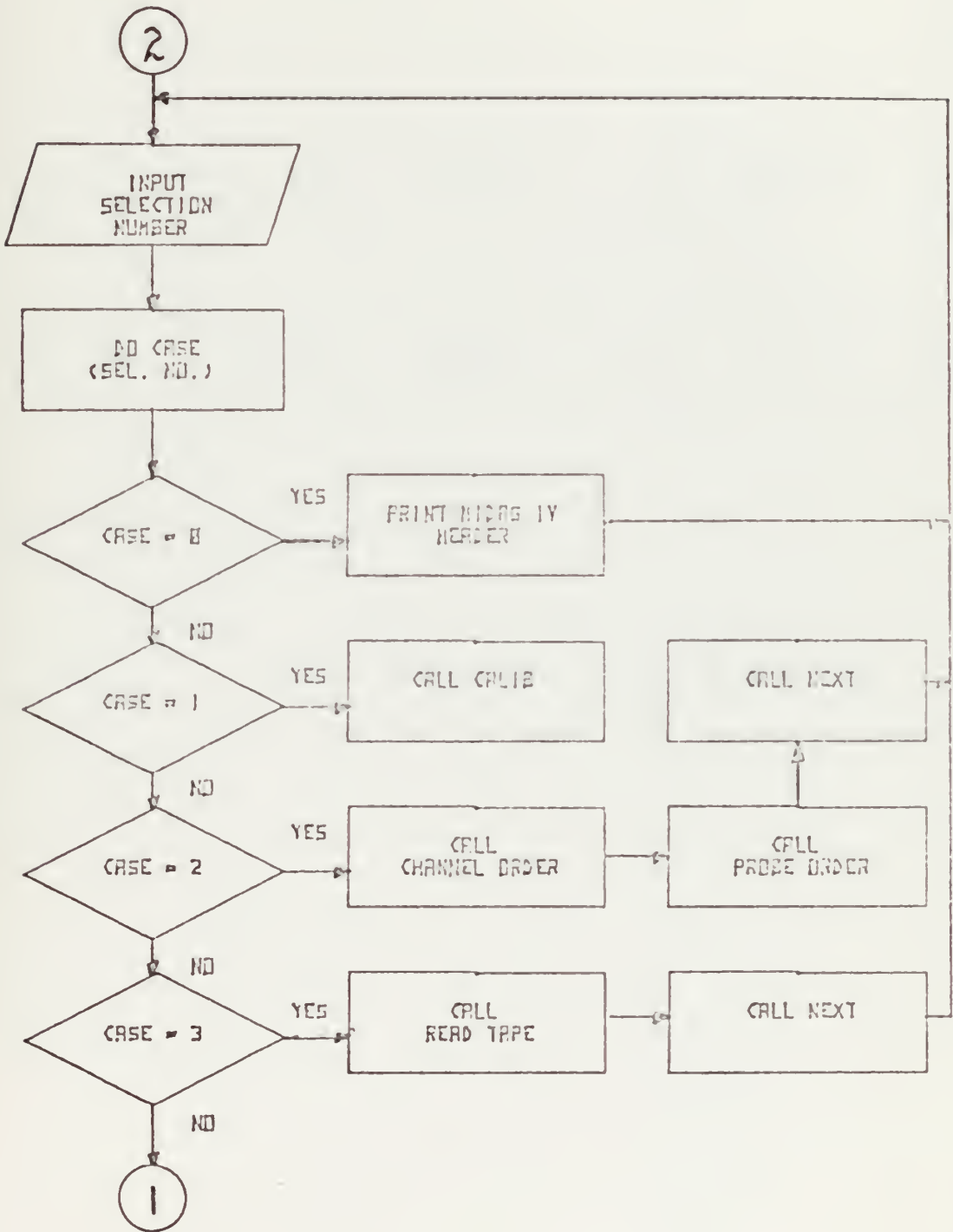

MONITOR (CONT)

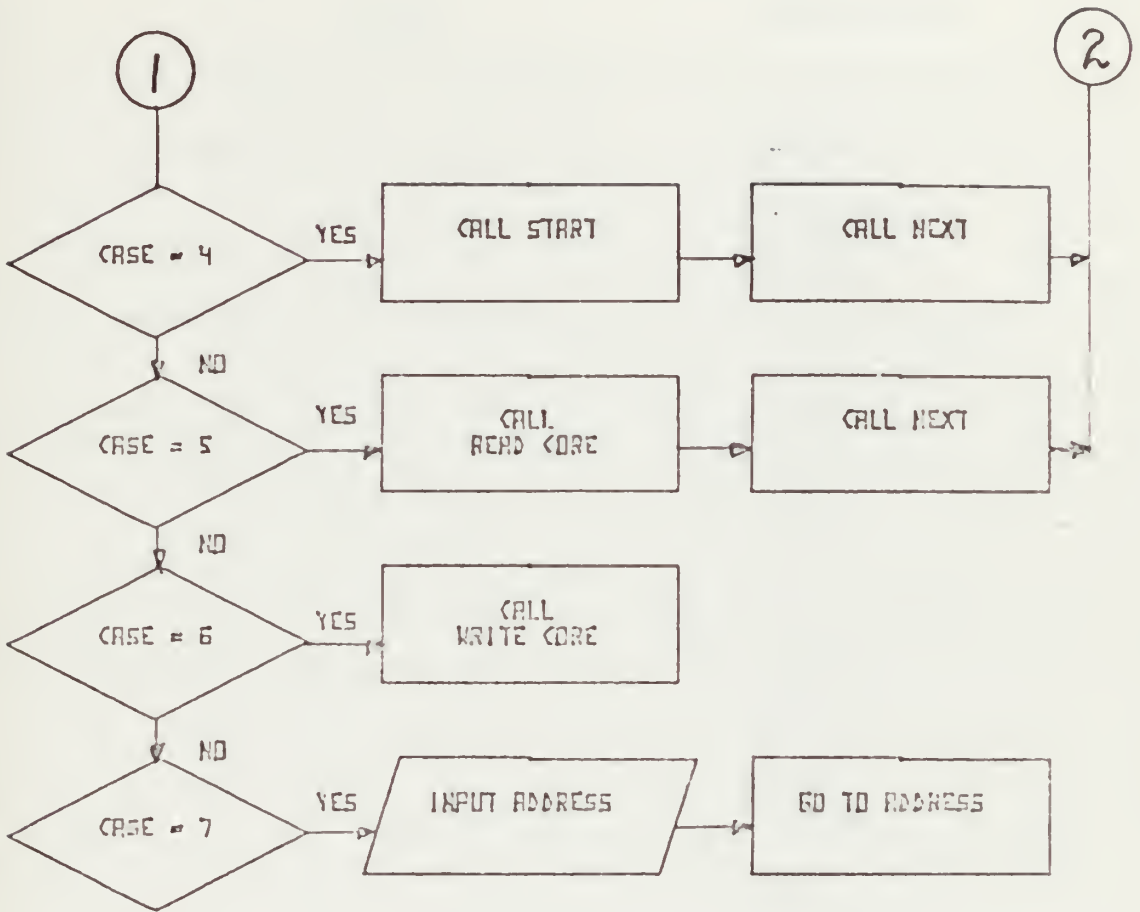

TABLE B.I. SUBROUTINE CALLING LEVELS

SELECTION NUMBER	LEVEL				SUBROUTINE
	1	2	3	4	
0	x				TTYOUT
1	x	x x	x		CALIB MULTIPLEX BCDHEX DISPLAY
2	x	x x x	x x x		CHANNEL ORDER TTYOUT HEX PAIR TTYOUT TTYIN FORMAT TTYOUT
	x	x x x	x x x		PROBE ORDER TTYOUT HEX PAIR TTYOUT TTYIN FORMAT TTYOUT
	x	x			NEXT TTYOUT
3	x	x			READ TAPE TTYIN
	x	x			NEXT TTYOUT
4	x	x x x x x x	x x		START TTYOUT FORMAT TTYOUT BCDHEX MULTIPLEX BCDHEX DISPLAY SCANV

TABLE B.I. SUBROUTINE CALLING LEVELS (CONT.)

SELECTION NUMBER	LEVEL				SUBROUTINE
	1	2	3	4	
4 (CONT.)	x	x x	x x		START (CONT.) DATAOUT CONVERGE BCDHEX DIGITEC BCDHEX
	x	x		x	NEXT TTYOUT
5	x	x	x x		READ CORE HEX PAIR TTYOUT TTYIN TTYOUT ONEOUT TTYOUT PAIROUT TTYOUT
	x	x			NEXT TTYOUT
6	x	x	x x		WRITE CORE HEX PAIR TTYOUT TTYIN PAIROUT TTYOUT FORMAT TTYOUT TTYOUT
		x x	x x		
7	x	x x			HEX PAIR TTYOUT TTYIN

APPENDIX C. PROBE TRAVERSING SYSTEM

C.1 PROBE TRAVERSING MECHANISM

The specifications for the Probe Traversing Mechanism (PTM) are listed in Table C.I.

The linear travel is limited to four inches by the linear potentiometer. Otherwise, the linear travel is limited to six inches by the cylindrical portion of the mounting base and the threaded section to which the probe is attached.

C.2 PROBE CONTROL PANEL

C.2.1 Interface Cables

The four cables used with the Probe Traversing System are:

1. Power Cable
2. Transducer Cable
3. PTM Cable
4. MIDAS IV Interface Cable

In the "manual" mode, only the Power and PTM cables are used. The Transducer cable is added for "semi-automatic" mode and all four cables are needed in the "fully-automatic" mode.

C.2.2 Angular Control Circuit Adjustment

The "balance" and "gain" for the Angular Control circuit are set as follows:

1. With the turbine not operating, connect an oscilloscope to the BNC connector on the Control Panel.
2. Adjust the "balance" control, R1, until the amplifier output, as read on the oscilloscope, is zero. (See Figs. 10 and C1.)
3. With the turbine operating, adjust the "gain", R2, (Figs. 10 and C1.) so that the signal amplitude is not causing the Probe Traversing Mechanism to oscillate. (See the top part of Fig. C3.)
4. Adjust the "balance" (if necessary) until the probe is aligned into the flow. (See the center part of Fig. C3.) This adjustment can be verified with a water-filled, U-tube manometer connected across Port #2 and Port #3 pressure lines. (See Fig.8(b).)

The Angular control circuit also has "offset" and "balance" controls (R3 and R4) that are adjusted internally and should not need further adjustment.

C.2.3 Linear Control Circuit Adjustment

Adjustments to the linear control circuit (Fig. C1.) are internal and further adjustment should not be necessary.

TABLE C.I. SPECIFICATIONS FOR THE PROBE
TRAVERSING MECHANISM

1. MOTORS: 24VDC 200-400 mA
2. LINEAR TRAVEL: 4 INCHES
3. LINEAR RATE: 0.011 INCHES/SECOND
4. LINEAR POTENTIOMETER: 5,000 OHMS
5. LIMIT SWITCHES: 2 (FULLY ADJUSTABLE LOCATION)
6. ANGULAR TRAVEL: \pm 360 DEGREES
7. ANGULAR RATE: 1.6 DEGREES/SECOND
8. ANGULAR POTENTIOMETER: 50,000 OHMS
9. PROBE DIMENSIONS:
DIAMETER: 0.25 INCHES
LENGTH: 12 INCHES (MINIMUM)
10. HEIGHT (EXTENDED, NO PROBE): 18 INCHES
11. RADIAL CLEARANCE REQUIRED: 6 INCHES

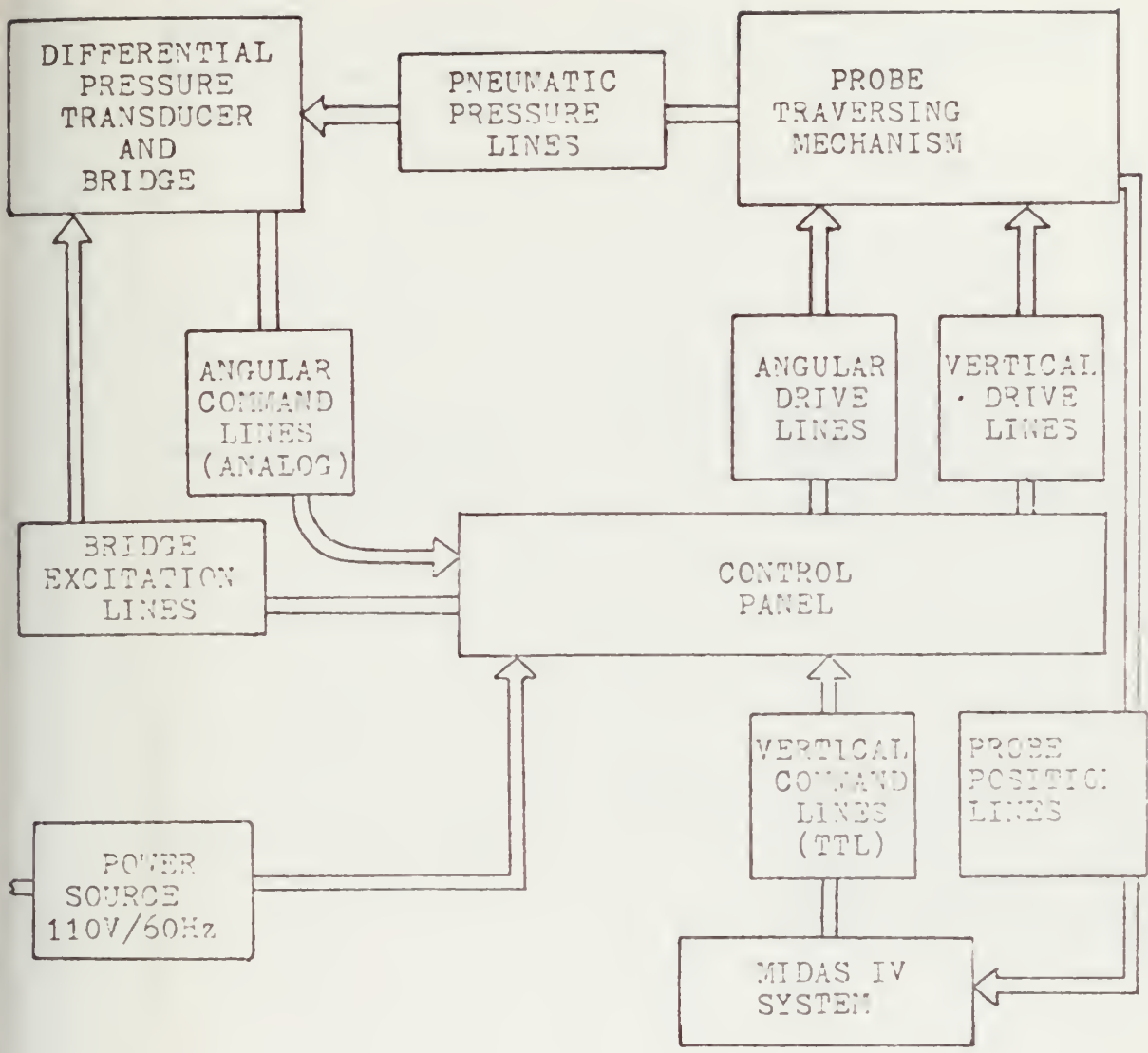
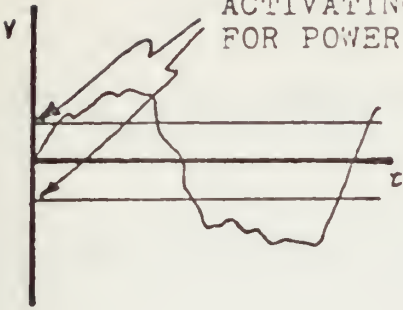
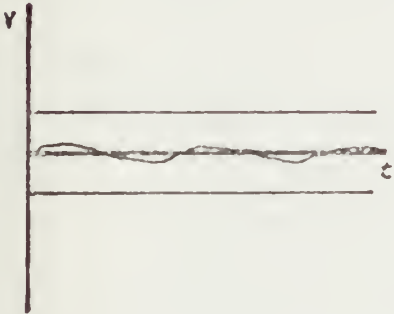

FIGURE C2. Probe Traversing System

ACTIVATING LEVEL
FOR POWER TRANSISTORS



CASE 1. GAIN NEEDS TO BE ADJUSTED



CASE 2. GAIN ADJUSTED
CORRECTLY-
BALANCED CONDITION

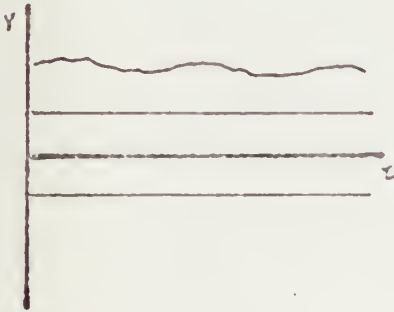

CASE 3. GAIN ADJUSTED
CORRECTLY-
UNBALANCED CONDITION
PROBE ROTATES
TOWARD FLOW DIRECTION

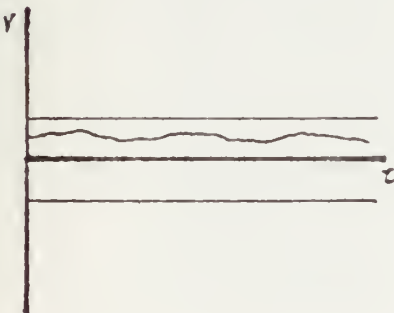

CASE 4. GAIN ADJUSTED
CORRECTLY-
PRESSURE DIFFERENCE
WITHIN LIMITS

FIGURE C3. Examples of Amplifier Output for Angular Control Circuit

APPENDIX D. OPERATING PROCEDURES AND PROGRAM CHANGES

D.1 SYSTEM OPERATION WITH PRESENT CONTROL PROGRAM

D.1.1 Power On and Power Off

The MIDAS IV system must be powered up in the following sequence of steps:

1. Insure that the MIDAS IV and teletype are connected to a 110V source and the teletype send/receive line is connected to the number 50 connector shown in Fig. 5.
2. Throw the main power switch (Fig. 4) to the "on" position. (An indicator light to the left of the main power switch comes on if the unit is operating correctly.)
3. Turn the MPS-805 power switch on. (The microprocessor power light should be on and the "halt" LED (Fig. 4) should be out.)
4. Set the teletype mode switch to "line", unless a paper tape is to be programmed of the Scan Control and Probe Control tables, in which case the mode switch on the teletype should be set to "local". Note: Whenever the teletypewriter is turned on or switched from "local" to "line" mode, the RESET button should be pressed.
5. The system is now waiting for a Mode Selection Number to be entered. To obtain a list of the Mode Selection numbers, enter "0" and press the space bar (See Section D.1.2).

The Power Off procedure is the reverse of the above steps. Both procedures are summarised in Table D.I.

D.1.2 To Select an Operating Mode

Following the Power On procedure given above, or following a "RESET", MIDAS IV waits for a Mode Selection Number to be entered. A list of the Mode Selection Numbers is given in Table V. (The list can be obtained by the operator by entering "0", followed by a space. This is the sole function of Mode 0.) Operation in a chosen mode is effected by entering the Mode Selection Number followed by a "space".

Fig. 6 shows the function of the different modes. Return from each mode is automatic except from the CALIBRATION and MEMORY EDIT modes, where RESET is required.

D.1.3 To Select and Calibrate Input Channels (CALIBRATION Mode)

The CALIBRATION mode is selected by entering "1" followed by a "space".

Channel Selection: In the CALIBRATION mode MIDAS IV continuously monitors the channel indicated by the setting of the thumbwheel switches (Fig. 3). Any channel can be selected manually using the thumbwheel switches. When addressed, the channel and port numbers appear in the LED display. If no change occurs in the LED display when the thumbwheels are turned, press RESET, enter "1" and "space".

Port selection: When a Scanivalve channel (presently 1-4) is selected, a single LED is lit on the RELAY card (Fig. A2.). The port currently selected at the Scanivalve is then indicated in the LED display in the front

panel. (On other than Scanivalve channels, zero is shown for the port number.)

Press the PORT ADVANCE button (Fig. 3) to cause the Scanivalve to advance to the next port. (The seventh LED on the RELAY CARD indicates the advance pulse transmitted to the Scanivalve.)

Press the RESET button to exit the CALIBRATION mode.

Calibration: The "zero" and "range" of the selected input channel are set using the BALANCE and SPAN adjustments on the corresponding signal conditioning card, respectively.

Adjust BALANCE to produce zero at the DVM (ballanced bridge) for:

1. zero pressure differential on a differential pressure transducer input.
2. the lower limit of a displacement measurement by a potentiometric input.
3. a shorted input for a thermocouple input.

Adjust SPAN to produce a required maximum reading at the DVM (usually, recognizable engineering units for the particular measurement) for:

1. differential pressure transducer loaded pneumatically to the desired range
2. maximum displacement of a potentiometric input

Note: 1. The DVM measures in the range ± 1.3009 volts. If no value is displayed, the voltage is outside this range.
2. The use of calibration resistors inserted into the CAL STEP section of the upper front panel to check a channel calibration is

described in APPENDIX A.

D.1.4 To Program the Scanning Sequence and Probe Movement

D.1.4.1 Programming from the Keyboard (PROGRAM SCAN Mode)

Enter "2" followed by "space" to enter the PROGRAM SCAN mode. A table heading is printed out that identifies columns of data that must be entered to form the Scan Control table. Table D.III is an example of a Scan Control table, followed by a Probe Control table.

Scan Control table: The following are entered in turn, as two numbers followed by a "space":

1. Channel number
2. Port number
3. Number of counts between successive DVM readings to be accepted as indicating that a steady reading has been reached on this channel
4. Number of tenths of a second delay before the DVM is first read on this channel

The teletype advances automatically to the required column, and CARRIAGE RETURN and LINE FEED occur at the end of each line of the table.

When the required channels have been entered, enter FF in the channel column.

A heading is printed that identifies columns of data that must be entered to form the Probe Control table.

Probe Control table: The following are entered

in turn as two numbers followed by a "space":

1. Number of hundredths of an inch the probe must be moved
2. The direction of movement (00 for down, 01 for up)

Enter one line in the table for each required probe movement. Terminate the table with FF in the "amt" column.

MIDAS IV is then ready for another mode selection to be entered. The completed tables appear as in the example shown in Table D.III.

D.1.4.2 Programming from Paper Tape (READ TAPE Mode)

The Scan Control and Probe Control tables can be entered on paper tape. There are two steps:

1. Preparation of the tape.
2. Entry of the tape using the READ TAPE mode.

To prepare the tape, switch the teletype to "local", and switch on the punch. Punch a leader that does not include a "space". (Note: In reading the tape, the program looks for data entries. An entry of data is always read as the number pair immediately preceding a space. Thus CR/LF is harmlessly included if followed by the next data entry.)

Enter the data required in the Scan Control and Probe Control tables (described in the preceding section) as a succession of number-pairs followed by a space. The inclusion of CR/LF at the end of each line in the tables results in the printout shown in Table D.IV.

The inclusion of FF to terminate each table is essential.

To enter the tape, switch the teletype to LINE, switch off the punch and ready the tape in the reader.

Press RESET. Enter "3" followed by "space" to enter the READ TAPE mode. Push MANUAL START on the tape reader. The tape is read and MIDAS IV is ready for another mode selection number to be entered.

D.1.4.3 Program Editing from the Keyboard (MEMORY DISPLAY and MEMORY EDIT Modes)

Changes can be made to the contents of RAM by:

1. using the MEMORY DISPLAY mode to print out the current contents of RAM
2. using the MEMORY EDIT mode to enter new data.

The contents of ROM can be displayed, but not edited. Thus, for example, individual entries in the Scan Control and Probe Control tables can be made after they have been entered at the keyboard or on a punched tape.

To Display Contents of Memory:

1. Enter "5" followed by "space".
2. Enter first address, to be displayed as two number pairs each followed by "space". (Teletype prints a hyphen.)
3. Enter last address, to be displayed as two number pairs each followed by a "space". (Teletype prints memory contents between the first and last addresses.)

Three examples of the use of MEMORY DISPLAY are shown in the teletype record in Table D.V. The examples illustrate:

1. A single memory location can be displayed if the first and last addresses are the same.
2. The Scan Control table is stored beginning at 1100H.
3. The Probe Control table is stored beginning at 1400H

Note: 1. All addresses are in hexadecimal.

2. If the last address is made smaller than the first address (inadvertantly), 256 pages of memory are printed. The process can be stopped by pressing RESFT.

To Edit Contents of Memory:

1. Enter "5" followed by a "space"
2. Enter beginning address of the memory section to be changed (RAM only) (Teletype prints current content followed by hyphen.)
3. Enter number pair to replace present content. (Teletype prints content of next memory location followed by a hyphen.)
4. Enter new number pair if required. Otherwise press RESFT. Step 3 can be repeated to change contents of successive memory locations. RESET exits the MEMORY EDIT mode.

Note: If "space" only is typed following the hyphen, the memory content becomes zero.

An example is shown in Table D.VI. The example illustrates how:

1. MEMORY DISPLAY mode is used to display contents of memory from 1500H to 150FH.
2. MEMORY EDIT mode is used to change memory contents to be the integers from 1 to 16.
3. MEMORY DISPLAY mode is used to display

the new contents.

An example of the procedure to change an entry in the Scan Control table is as follows:

Problem: In Table D.III, port 46 on channel 3 must be read instead of port 44.

Procedure: Enter "6, space, 14, space, 06, space".

(Teletype prints "44-")

Enter "46, space".

Press RFSET.

D.1.5 To Operate and Record Data (DATA ACQUISITION Mode)

The procedures for calibrating input channels, for programming the sequence of channels to be scanned and for programming the sequence of probe movements in a probe survey are given in Sections D.1.3 and D.1.4. When these steps are completed data is taken by selecting the DATA ACQUISITION mode. to enter this mode:

1. Enter "4" followed by a "space"

(Teletype prints 30 asterisks as a leader and to provide time to turn ON the punch.)

2. Turn on the tape punch.

(Teletype prints and punches as shown in the example in Table D.VII.)

When the data is completed a CR/LF followed by another LF are executed, and the request for a mode selection entry is typed since DATA ACQUISITION mode is exited automatically. All these characters are contained on the end of the data tape.

D.2 PROCEDURES FOR CHANGING THE CONTROL PROGRAM ON PROM

D.2.1 Introduction

Changes which might be needed in the Control Program can be classed as "minor" or "major". "Major" changes require recompilation of the complete MIDAS IV software, usually because of additions or deletions in the number of program steps. Minor changes can be effected by changing the values in particular memory locations; for example, the limits of a Do loop.

In the following section, D.2.2, making a "minor" change is illustrated by describing a particular example in detail. In Section D.2.3, in describing procedures for "major" changes, references are given for each of the steps in the programming of MIDAS IV.

D.2.2 Minor Changes (Not Requiring Recompilation)

Examples of minor changes include:

1. Alteration of the width (duration) and frequency of Scanivalve pulses
2. Changing time delays
3. Reallocation of RAM
4. Changing program constants

The steps involved in each of these examples are the same. Therefore the procedure is illustrated by describing the first example in detail.

EXAMPLE: CHANGING THE WIDTH OF A SCANIVALVE PULSE.

1. Locate the PL/M subroutine which generates the pulse (Using Fig. 6, and, when the correct branch is chosen, Appendix B.). For this particular example the Scanivalve is

advanced in both the CALIBRATION and the DATA ACQUISITION modes. Since both routines advance the Scanivalve in the same manner, only the change in DATA ACQUISITION is described. In the DATA ACQUISITION mode SCANV is the routine that controls the Scanivalves. From the SCANV logic schematic and the PL/M source file it can be seen that the pulse is initiated by outputting "040H + PS" on Output Port Three and then entering a "Do 1 to 8" loop that contains a 10 msec delay. After the 80 msec delay, "BS" is output on Output Port Three, and another time delay loop is entered. The first delay loop controls the pulse width and the second sets the time between pulses. If, for example, the pulse width is to be changed to 100 msec, the "Do 1 to 8" loop must be changed to read "Do 1 to 10".

2. The location in PROM of the value "8" is found by using the PL/M Source and Memory Cross Reference (Table D.VIII.). The line number of the "Do 1 to 8" loop is # 161 and the hexadecimal address given is 047AH. The assembly language listing of the MIDAS IV software near address 047AH, lists the implementation of the "Do 1 to 8" loop. (See Table D.IX.) The 08H value being loaded into A-register is the upper limit of the "Do" loop. By changing the content of this memory location, 047EH, from 08H to 0AH (the value must be in hexadecimal: 10 would result in looping 16 times), the pulse width is increased to 100 msec.

3. Several of the machine code values (Table D.X.) on either side of the 047EH location should be noted so that the same location can be verified at a later time on the PROM.

4. Turn off the MIDAS IV system (Appendix D) and remove the appropriate PROM card, in this case the # 2 card. (See Fig. A1.)

5. Program a new PROM, in this case # 4, with the Pro-Log PROM programmer or the Intelc-8 microprocessor [Ref. 11 or 14].

6. Reinstall the PROM, # 4 in this case, and the PROM card. This completes the change.

Note: For all changes

1. Keep the "old" PROM until the "new" PROM is verified and the system operates correctly.
2. Document the change to the software.

D.2.3 Major Changes (Requiring Recompilation)

"Major" changes are those that require recompilation of the MIDAS IV software and reprogramming of all the PROM's. Ref. 12 provides the basic PL/M background necessary to make program additions or changes to the MIDAS IV software.

Ref. 15 contains instructions on loading the MIDAS IV PL/M source deck into the IBM 360/67 and operating in the Fdit mode to change the program. The programmer should also obtain the following documentation;

1. Symbol table (see the end of the source program listing in Appendix B)
2. Assembly language representation of object code (Table D.IX.)
3. Listing of the source program (See the end of Appendix B)

The machine code listing (Table D.X.) is obtained when the paper tape is punched.

Ref. 16 contains instructions on loading the machine code program and programming the PROM's.

Note: In reprogramming, it is necessary to place a

"no-op" instruction (CO) in the first memory location. This can be done by deleting one character. For example, a "space", 020H, before the ASCII equivalent of the word MIDAS, shifts the beginning ASCII characters one space to the right and makes room for the "no-op" instruction. (See Table D.VI.) The MPS-805 requires a no-op instruction in location 0000H because of the manner in which it executes the first instruction when power is turned on.

D.3 PROCEDURES FOR ADDING EXTRA MEMORY TO RAM

In some applications, the amount of RAM allocated for the Scan Control table and the Probe Control table will not be sufficient (Fig. 7). An additional 2K of RAM can be added as described in Appendix A.

The starting address for the Probe Control table must then be changed as described in Sec. D.2.2. The memory location to be changed is 0143H.

TABLE D.I. POWER ON/POWER OFF PROCEDURES

POWER ON:

1. MIDAS IV AND TELETYPE ARE CONNECTED TO 110V 60Hz SOURCE (CHECK)
2. TELETYPE SEND/RECEIVE LINE IS PLUGGED INTO #50 CONNECTOR (CHECK)
3. MAIN POWER SWITCH - ON
4. MICROPROCESSOR POWER SWITCH - ON
5. SELECT TELETYPE MODE (LINE/LOCAL)
6. PRESS - RESET

POWER OFF:

1. TELETYPE - OFF
2. MICROPROCESSOR POWER SWITCH - OFF
3. MAIN POWER SWITCH - OFF

TABLE D.II. MIDAS IV HEADER

MIDAS IV

TYPE THE SELECTION NUMBER FOLLOWED BY A SPACE:

- 0 - MIDAS IV HEADER
- 1 - CALIBRATION
- 2 - PROGRAM SCAN
- 3 - READ TAPE
- 4 - DATA ACQUISITION
- 5 - MEMORY DISPLAY
- 6 - MEMORY EDIT
- 7 - RESTART

TABLE D.III. SCAN CONTROL AND PROBE CONTROL TABLES
ENTERED AT THE KEYBOARD

CH	PT	ERROR	TIME
01	02	00 00	10
03	44	00 05	00
18	00	00 10	05
47	00	00 50	01
FF			

AMT DN=0/MP=1

.50	00
10	01
15	00
FF	

TABLE D.IV. SCAN CONTROL AND PROBE CONTROL TABLES
ENTERED ON PAPER TAPE

01 02 00 00 10
03 44 00 05 00
15 00 00 10 05
47 00 00 50 01
FF
50 00
10 01
15 00
FF

TABLE D.V. EXAMPLE OF THE USE OF "MEMORY DISPLAY"

5 11 00 - 11 00

1100: 01

ENTER THE NEXT SELECTION NUMBER:

5 11 00 - 11 14

1100: 01 02 00 00 10 03 44 00 05 00 18 00 00 10 05 47

1110: 00 00 50 01 FF

ENTER THE NEXT SELECTION NUMBER:

5 14 00 - 14 06

1400: 50 00 10 01 15 00 FF

ENTER THE NEXT SELECTION NUMBER:

5 15 00 - 15 OF

1500: 40 9F C0 EF 40 BD 40 1F 40 FF 48 17 48 9F 48 BD

ENTER THE NEXT SELECTION NUMBER:

6 15 00	40-01	9F-02	C0-03	BF-04	40-05	BD-06	40-07	1F-08
40-09	FF-10	48-11	17-12	48-13	9F-14	48-15	BD-16	

5 15 00 - 15 OF

1500: 01 02 03 04 05 06 07 08 09 10 11 12 13 14 15 16

ENTER THE NEXT SELECTION NUMBER:

TABLE D.VI. EXAMPLE OF THE USE OF "MEMORY EDIT"

TABLE D.VII. EXAMPLE OF THE DATA OUTPUT

01	02	-15000
03	44	-00002
18	00	-14000
47	00	+06349
01	02	+15000
03	44	-00002
18	00	-14000
47	00	+06349
01	02	+15000
03	44	-00002
18	00	-14000
47	00	+06349

ENTER THE NEXT SELECTION NUMBER:

37=0147H	39=0148H	40=0158H	41=015EH	42=0161H	43=0174H
44=0177H	45=0178H	46=0187H	47=018EH	48=0194H	51=0199H
52=019CH	53=019DH	54=01A0H	55=01A9H	57=01B6H	58=01BCH
59=01BDH	60=01C0H	61=01C7H	62=01D2H	63=01D9H	68=01DFH
69=01E2H	70=01F4H	72=01F1H	73=0204H	75=020DH	76=0212H
78=0217H	80=0229H	81=0231H	82=0239H	83=0245H	84=024CH
85=0251H	86=0252H	89=0257H	91=025AH	92=0260H	93=026CH
94=0271H	97=0276H	99=027FH	100=02C7H	104=02CFH	105=02DRH
106=02E1H	107=02F9H	109=02FAH	113=02F7H	114=02F1H	115=02F5H
117=02F9H	118=0307H	119=0315H	121=0317H	122=0321H	123=0325H
124=032CH	125=0342H	126=0345H	127=0346H	128=034AH	129=0371H
130=037FH	133=0380H	134=0382H	135=0385H	136=038AH	137=038CH
138=03A3H	139=03A9H	140=03A2H	141=03A7H	142=03ECH	146=03F3H
147=03F6H	148=0401H	149=0406H	150=040FH	151=040AH	152=040DH
153=0413H	154=0419H	155=0425H	156=0429H	157=0437H	158=0468H
159=046AH	160=0479H	161=047AH	162=047FH	163=0490H	164=0496H
165=0499H	166=04A6H	167=04A1H	168=04B1H	169=04B8H	170=04B9H
175=04C0H	176=04C7H	177=04D1H	178=04D4H	180=04D5H	181=04DEF
182=04E8H	183=04F6H	184=04F9H	185=0503H	186=0508H	187=0517H
188=051AH	189=051PH	190=0534H	191=0535H	192=0541H	194=054BH
195=054EH	196=0557H	197=0560H	198=0566H	199=05A3H	200=05A6H
201=05B0H	202=0573H	203=05B4H	204=05D7H	210=05C5H	212=05C0H
213=05D1H	214=05D7H	216=05F5H	220=05E2H	221=0639H	222=063CH
223=0640H	224=0641H	225=0668H	226=0669H	227=06A2H	228=06B8H
229=06B9H	230=06C6H	231=06CCH	232=06D1H	233=06D8H	234=06DFH
235=06E3H	236=06F8H	237=06F9H	242=06F3H	244=06F6H	245=0705H

TABLE D.VIII. A PORTION OF THE PL/M SOURCE-MEMORY
CROSS REFERENCE

0415H LLI, B5H LMI, 01H JMP, 68H, 04H LHI, 10H LLI, B5H LMI, 02H JMP, 68H, 04H
0425H LHI, 10H LLI, B5H LMI, 04H JMP, 68H, 04H LHI, 10H LLI, B5H LMI, 06H JMP
0435H, 68H, 04H LHI, 10H LLI, 84H LAF, LCI, 00H AFA LRA LAC RAL LCA LAR ADM
0445H LRA LAC ACI, 00H LCA LAR ADI, 5CH LRA LAC ACI, 04H LLI, 8AH LMI, 44H
0455H INL LMB INL LMA JEF, 8AH, 10H JEF, 13H, 04H JEP, 1CH, 04H JMP, 25H, 04H
0465H JMP, 2FH, 04H LAM 011 104 XRI, 2FH LHI, 10H LLI, B4H SUM JIZ, B8H, 04H
0475H INL LAM ADI, 40H 011 LAL LMI, 01H LAI, 00H LHI, 10H LLI, RCH SUM JIC
0485H, 96H, 04H LBI, 8FH DCB JIZ, 90H, 04H JEF, 89H, 04H LPM INB LMB JIZ, 7DH
0495H, 04H DCL LAM 011 INL LBI, 01H LAI, 00H LHI, 10H LLI, BCH SUM JIC, 6AH
04A5H, 04H LBI, 8FH DCB JIZ, 6FH, 04H JEF, ACH, 04H INB LMB JIZ, 9CH, 04H
04B5H JEP, 6AH, 04H RET LHI, 10H LLI, B8H LMB INL LRA LAM NDI, 0FH INL LMA
04C5H ORI, 80H 010 LBI, 8FH DCB JIZ, D1H, 04H JEL, C8H, 04H LAM ORI, F0H 010
04D5H LBI, 8FH DCB JIZ, DEH, 04H JFI, D7H, 04H LBI, 04H DCL LAM OKA KAR DCB
04E5H JIZ, E2H, 04H INL LPA ORI, 90H 010 LBI, 8FH 1CB JIZ, F6H, 04H JMP, F6H
04F5H, 04H LAM ORI, F0H 010 LBI, 8FH 1CB JIZ, 03H, 05H JEP, FCH, 04H LLI, B8H
0505H LAM NDI, 0FH LLI, 9AH LPA ORI, A0H 010 LBI, 8FH LCB JIZ, 17H, 05H JMP
0515H, 10H, 15H LAM ORI, B0H 010 LBI, 8FH LCB JIZ, 24H, 05H LBI, 1DH, 05H LBI
0525H, 04H LLI, B8H LAM 010 LAR DCB JIZ, B2H, 05H LLI, F0H LPA ORI, B0H 010
0535H LBI, 8FH DCB JIZ, 35H, 05H JEP, 37H, 05H LAM ORI, F0H 010 LBI, 8FH DCB
0545H JIZ, 43H, 05H JFI, 44H, 05H JFI, 73H, 05H LHI, 10H LLI, B0H LMI, 00H JMP
0555H, A3H, 05H LHI, 10H LLI, B0H LFI, 01H JEF, A3H, 05H LHI, 10H LLI, B8H LMI
0565H, 10H JEP, A3H, 05H LBI, 10H LLI, B0H LBI, 11H JEP, A3H, 05H LHI, 10H LLI
0575H, B7H LAM LCI, 00H AFA LPA LAC RAL LCA LAR 00H LRA LAC ACI, 00H LCA
0585H LAR ADI, 97H LPA LAC ACI, 05H LLI, 8AH LMI, 44H INL LMB INL LMA JMP
0595H, 8AH, 10H JMP, 4EH, 05H JEP, 57H, 05H JEP, 60H, 05H JMP, 69H, 05H LAM ORI
05A5H, C0H 010 LBI, 8FH DCB JIZ, B0H, 05H JEP, A9H, 05H LAM ORI, F0H 010 LBI

TABLE D. IX. A PORTION OF THE ASSEMBLY LANGUAGE
VERSION OF THE MIDAS IV SOFTWARE

```

:1D036600C48FE0C336AF87D8C40C0036A6FR30F831C730D7072F1036R0F946710295
:1D038300140136B1F8260930F8010431C7H01A092890033C85F844BD032E1036R279
:1D03AC00C734105344E8032E1036P2C734205344E8032E1036B2C734405344ER0304
:1D03BE002E103685C7160080C8C8212F0C187C8C20C00D0C104E2C8C20C03368A3E75
:1D03DA0044305930F8448A10449C034A703448203072E1036B3F930FBA83197986F
:1D03F700C8C7140593A10A4083040648309723C714002E31CF093684F94437042F5B
:1D0414001036B53E014468082F1056F535024468042E1036B53F044468042F103639
:1D043100B53E084468042E103684C71C0080C8C212F0C187C8C20C00D0C1045CC8AB
:1D044E00229C04368A358430592058478F10441304441C1444250442E04C7574945
:1D046B002CFE2E1036B297C8F8030C7047057302F0107083F1036B697C096040F8E
:1D0488003F0968900448904CF08F9487D0431C757303E01060C2E1036B697606AFE
:1D04A500040E8F0968AF07446904CF08F9487D0431C757303E01060C2E1036B697606AFE
:1D04C2000F30F8348C550F3F0978F104446AD4C734F0550F8F09681F0444D7040F8B
:1D04DF000431C7B01A0928E20430F83490550F8F0968F0968F0968F04C734F0550F8F8FA6
:1D04FC000968030544FC04368C7240F3CBAF834F0550F8F09681705441005C734AF
:1D051900F0550E8F09682405441A050E043CF6C7F01A0948290536BAF834B0550FA4

```



LINE
PARITY

TABLE D.X. A PORTION OF THE MACHINE LANGUAGE
VERSION OF THE MIDAS IV SOFTWARE

BEFORE:

Assembly Language

0000H JMP, 35H, 01H
0003H 0DH 0AH 0AH 20H 20H 20H 4DH 49H 44H 41H 53H 20H 49H ...

Machine Language

:D0000004435010D0A0A2020204D494441532049...

AFTER:

Assembly Language

0000H NOP JMP, 35H,
0003H 01H 0DH 0AH 0AH 0AH 20H 20H 4DH 49H 44H 41H 53H 20H 49H ...

Machine Language

:D000000C04435010D0A0A20204D494441532049...

TABLE D.XI. EXAMPLE OF INSERTING A "NO-OP" INSTRUCTION

APPENDIX E. GLOSSARY

1. ASCII: American Standard Code for Information Interchange, an 8-bit binary convention originally developed to encode teletypewriter keyboard inputs. For serial data transmission the pulse width for each bit in the serial string is 9.0 msec. (See Ref. 2 for the ASCII table.)

2. BCD: Binary Coded Decimal, a system using the first ten binary numbers in a 4-bit counting scheme.

0 - 0000	5 - 0101
1 - 0001	6 - 0110
2 - 0010	7 - 0111
3 - 0011	8 - 1000
4 - 0100	9 - 1001

3. BCD Coded Number: The BCD representation digit-for-digit of a decimal number. For example, 5220 = 0101 0010 1000 0000.

4. Channel: Any of 48 inputs to the Digital Voltmeter. Each input is selected by a multiplexer controlled by either the thumbwheel switches or the DATA ACQUISITION mode.

5. CPU: Central Processing Unit, that part of a computer or microprocessor that directs the operation of the remaining components of the system. The CPU usually contains the Arithmetic Logic Unit (ALU) which performs the basic arithmetic and logic functions.

6. Digitec: A digital voltmeter produced by United Systems Corporation. MIDAS IV uses a Digitec Model 251-3.
7. DVM: Digital Voltmeter
8. Fully-automatic-mode: Refers to the mode of operation in which the Probe Traversing Mechanism is under the microprocessor's control for linear movement and in which the angular control circuit is in operation. (See Section III. C.3)
9. Hex: Hexidecimal, a number system with a base of 16. (0, 1, 2, 3, 4, 5, 6, 7, 8, 9, A, B, C, D, E, and F)
10. Hexidecimal Pair: Refers to two binary coded hexadecimal numbers. For example, 7FH = 0111 1110. (H is used as a suffix to indicate Hexidecimal.)
11. I/O: Input / Output
12. I/O Drivers: Hardware or software that creates binary signals (serial or parallel) that can be coded to convey information into or out of a system. MIDAS IV uses standard ASCII serial Input/Output format.
13. LED: Light Emitting Diode
14. Manual mode: That mode of operation in which the Probe Traversing Mechanism is moved linearly and rotated by the switches located on the Probe Traversing Panel.
15. Microprocessor: A type of computer with a design "architecture" between that of a simple calculator and a full computer. Usually contains programmable memory which can be either volatile (RAM) or non-volatile

(ROM), or both.

16. MIDAS IV: Microprogrammable Integrated Data Acquisition System, the fourth of five different data acquisition systems designed and built at the Naval Postgraduate School.
17. Mode Selection Number (0 through 7) : One of eight numbers, identifying different modes of operation for MIDAS IV.
18. Multiplexer: A device which connects one of a number of input lines to a single output line. (Section II.B.4)
19. PL/M: A high level computer language developed for use with microprocessors and copwrited by Intel Corporation.
20. Port: One of several pneumatic input lines on a Scanivalve. The port selection is controlled by the "Port Advance" button, "Home" button, or by the microprocessor in the DATA ACQUISITION mode.
21. Probe Control Table: A table programmed by the operator containing a listing of how the probe is to be moved when operating in the DATA ACQUISITION mode. (Section II.F.2)
22. Pro-Log (Corporation): (Monterey, California) manufacturers of the microprocessor and associated equipment used in MIDAS IV.
23. PROM: Programmable Read Only Memory Unit
24. PTM: Probe Traversing Mechanism (Section III. B.1)

25. RAM: Random Access Memory, memory storage used for program variables and non-permanent data. The contents of RAM are "volatile" (can be rewritten and is lost when power is removed).
26. ROM: Read Only Memory, memory storage used for permanent information. The contents of ROM are "non-volatile" (not lost when power is removed).
27. Scanivalve: Trade name for a rotary pneumatic switch produced by Scanivalve, Inc. The Naval Postgraduate School Turbopropulsion Laboratory uses 24 and 48 port Scanivalves.
28. Semi-automatic mode: A mode of operation in which the angular movement of the Probe Traversing Mechanism is automatically controlled to maintain probe alignment with the flow direction and in which the vertical movement is controlled by the operator.
29. Signal Conditioning: The electronic scaling of an analog signal to match the input requirements of a measurement system. (Section II. B.3)
30. Software: Another name for the "programs" of a computer system.
31. Subroutine: A separate program called during the execution of another program.
32. Word: Usually the contents of one memory location.
33. Yaw-balance: For a directionally sensitive probe, the condition that the pressure measured at two side ports are equal and the probe is facing into the flow.

34. N 7416: "Hex Inverter/driver", an integrated circuit that acts as a binary signal inverter and supplies current to drive other components.
35. N 7445: "BCD-to-decimal Decoder", an integrated circuit that reads a BCD number and activates one of 10 output lines.
36. N 7475: "Latch", an integrated circuit that latches a binary input so that it is not lost when the input is removed.
37. N 74121: "Schmidt One-shot", an integrated circuit that outputs a pulse when the input reaches a certain level.
38. μ 741: "Op-amp", an integrated circuit amplifier.
39. 1100D: The decimal value 1100 (the D denotes decimal representation or base 10).
39. 1100H: The hexadecimal value 1100 (the H denotes hexadecimal representation or base 16, 1100H = 4352).

REFERENCES

1. Sturges, Lt. J. W.,
A MICROPROGRAMMABLE INTEGRATED
DATA ACQUISITION SYSTEM (MIDAS),
Aeronautical Engineer Thesis,
Naval Postgraduate School,
Monterey, California,
1975.
2. Biewer, N.,
THE DESIGNER'S GUIDE TO PROGRAMMED LOGIC
FOR MPS-800 SYSTEMS,
PRO-LOG Corporation,
1974.
3. Datel Systems, Inc.,
16 Channel Analog Multiplexer: M*16,
Bulletin X150515319
4. United Systems Corporation,
Voltmeter Plug-In Module Instruction
Manual MI-9974 For Models 251-3 and 252-3.
5. Signetics Corporation,
Signetics Corporation, Digital-Linear-MOS Catalog,
High Performance Operational Amplifier (741),
p. 6-115,
6. Pro-Log Corporation,
Wire List, MPS-805 Card Pack,
A100602 by E. McCoy, 1974.
Wire List, MPS-803 Card Pack,
A100367, 1974.
7. Pro-Log Corporation,
MPS-800 series Drawings,
by E. McCoy, 1973.
8. Datel Systems, Inc.,
Model VEV-10K Frequency to Voltage Converter,
Bulletin VEVAL 10501
9. Scanivalve, Inc.,
(Product Literature).
10. Hewlett Packard,
Numeric and Hexadecimal Indicators, 5082-7300 Series,
(Technical Data), 1973.
11. Intel Corporation,
MCS-8: A Guide to PL/M Programming,
Revision 1, 1973.
12. Intel Corporation,
8008 and 8080 PL/M Programming Manual,
Revision A, 1975.
13. Teletype Corporation,
Technical Manual for 32 and 33 Teletypewriter sets,
Bulletin 273K, Vol. I.

14. Pro-Log Corporation,
Series 81 Portable PROM Programmer's Manual,
1974.
15. Naval Postgraduate School (W.R. Church Computer Center),
Technical Note No. 0211-24,
CP/CMS Users Guide at the Naval Postgraduate School,
by K.R. Strutyński,
October, 1973.
16. Intel Corporation,
Intel 8/00D8 Microcomputer
System Operator's Manual - Version II.

INITIAL DISTRIBUTION LIST

	No. Copies
1. Defense Documentation Center Cameron Station Alexandria, Virginia 22314	2
2. Library, Code 0212 Naval Postgraduate School Monterey, California 93940	2
3. Chairman, Department of Aeronautics Naval Postgraduate School Monterey, California 93940	1
4. Associate Professor R.P. Shreeve, Code 57S ^a Department of Aeronautics Naval Postgraduate School Monterey, California 93940	1
5. Mr. J. E. Hammer, Code 57 Department of Aeronautics Naval Postgraduate School Monterey, California 93940	1
6. Mr. T.B. Dunton, Code 57DTM Department of Aeronautics Naval Postgraduate School Monterey, California 93940	1
7. Mr. C. Gordon, Code 57 Department of Aeronautics Naval Postgraduate School Monterey, California 93940	1
8. Mr. W. Frutos, Code 57 Department of Aeronautics Naval Postgraduate School Monterey, California 93940	1
9. Lt. J. W. Sturges HC-3 NAS North Island San Diego, California	1
10. Dr. H. J. Mueller Research Administrator, Code 310A Naval Air Systems Command Navy Department Washington, D.C. 20360	1
11. Mr. Karl H. Guttmann Code 330C Naval Air Systems Command Navy Department Washington, D.C. 20360	1
12. Turbo-propulsion Laboratory Department of Aeronautics Naval Postgraduate School Monterey, California 93940	5
13. Lt. D. D. Patton, USN VP-19 FPO San Francisco, California	1

Microprogrammable data acquisition and p



3 2768 001 98078 2

DUDLEY KNOX LIBRARY