

SIEMENS

SIMOTION

E510

Operating Instructions

Preface

Description

1

Application planning

2

Installing and connecting

3

Commissioning

4

Service and maintenance

5

Interrupts, error and system
alarms

6

Standards and approvals

A

ESD guidelines

B



Appendix

C

Legal information

Warning notice system

This manual contains notices you have to observe in order to ensure your personal safety, as well as to prevent damage to property. The notices referring to your personal safety are highlighted in the manual by a safety alert symbol, notices referring only to property damage have no safety alert symbol. These notices shown below are graded according to the degree of danger.

 DANGER
indicates that death or severe personal injury will result if proper precautions are not taken.
 WARNING
indicates that death or severe personal injury may result if proper precautions are not taken.
 CAUTION
with a safety alert symbol, indicates that minor personal injury can result if proper precautions are not taken.
CAUTION
without a safety alert symbol, indicates that property damage can result if proper precautions are not taken.
NOTICE
indicates that an unintended result or situation can occur if the corresponding information is not taken into account.

If more than one degree of danger is present, the warning notice representing the highest degree of danger will be used. A notice warning of injury to persons with a safety alert symbol may also include a warning relating to property damage.

Qualified Personnel

The device/system may only be set up and used in conjunction with this documentation. Commissioning and operation of a device/system may only be performed by **qualified personnel**. Within the context of the safety notes in this documentation qualified persons are defined as persons who are authorized to commission, ground and label devices, systems and circuits in accordance with established safety practices and standards.

Proper use of Siemens products

Note the following:

 WARNING
Siemens products may only be used for the applications described in the catalog and in the relevant technical documentation. If products and components from other manufacturers are used, these must be recommended or approved by Siemens. Proper transport, storage, installation, assembly, commissioning, operation and maintenance are required to ensure that the products operate safely and without any problems. The permissible ambient conditions must be adhered to. The information in the relevant documentation must be observed.

Trademarks

All names identified by ® are registered trademarks of the Siemens AG. The remaining trademarks in this publication may be trademarks whose use by third parties for their own purposes could violate the rights of the owner.

Disclaimer of Liability

We have reviewed the contents of this publication to ensure consistency with the hardware and software described. Since variance cannot be precluded entirely, we cannot guarantee full consistency. However, the information in this publication is reviewed regularly and any necessary corrections are included in subsequent editions.

Preface

Contents of manual

This manual contains information about SIMOTION E510 and how it can be used as a DP slave with the SIMOTION or SIMATIC systems.

Basic knowledge requirements

To understand the manual, you should have general experience of automation engineering.

You should also be familiar with working on computers or PC-type machines (for example, programming devices) and have some knowledge of how to use the SIMATIC STEP 7 or SIMOTION SCOUT engineering software. The following manuals contain relevant information on this subject:

- *Programming with STEP 7* Manual, /2/
- *SIMOTION SCOUT* Configuration Manual, /3/

Scope of manual

The following functions described in this manual are available with firmware version 2.32 and higher, and with GSD file version 1.0 and higher:

- Digital I/O expansion module (EB DIGITAL, 32DI): Using 2 digital inputs as counter inputs
- Using the position encoder expansion module (EB MPT, 4CH)
- Max. frequency for counter inputs: 25 kHz instead of 10 kHz (for active tripping)

The following functions described in this manual are available with firmware version 2.32 and higher, and with GSD file version 1.1 and higher (on request):

- Using the EUROMAP 67-compliant handling expansion module (HAND, 16DI/16DO)
- Using the relay option module

Standards and approvals

Our products meet the requirements of EU Directive 89/336/EEC "Electromagnetic Compatibility" and the harmonized European Standards (EN) listed there.

You can find detailed information on approvals and standards in the appendix.

The current EC Declaration of Conformity can be found on the Internet at:

<http://support.automation.siemens.com/WW/view/en/15257461>

The EC Declaration of Conformity for the Low Voltage Directive can be found on the Internet at:

<http://support.automation.siemens.com/WW/view/en/22383669>

Recycling and disposal

SIMOTION E510 can be recycled because it is made with low-polluting materials.

For state-of-the art environmentally friendly recycling and disposal of your old modules, contact your Siemens representative. To locate your representative, point your browser to:

<http://www.automation.siemens.com/partner>

Hotline and Internet addresses

Technical support

If you have any technical questions, please contact our hotline:

	Europe / Africa
Phone	+49 180 5050 222 (subject to charge)
Fax	+49 180 5050 223
Internet	http://www.siemens.com/automation/support-request

	Americas
Phone	+1 423 262 2522
Fax	+1 423 262 2200
E-mail	mailto:techsupport.sea@siemens.com

	Asia / Pacific
Phone	+86 1064 719 990
Fax	+86 1064 747 474
E-mail	mailto:adsupport.asia@siemens.com

Note

Country-specific telephone numbers for technical support are provided under the following Internet address:

<http://www.siemens.com/automation/service&support>

Calls are subject to charge, e.g. 0.14 €/min. on the German landline network. Tariffs of other phone companies may differ.

Questions about this documentation

If you have any questions (suggestions, corrections) regarding this documentation, please fax or e-mail us at:

Fax	+49 9131- 98 63315
E-mail	mailto:docu.motioncontrol@siemens.com

Siemens Internet address

The latest information about SIMOTION products, product support, and FAQs can be found on the Internet at:

- General information:
 - <http://www.siemens.de/simotion> (German)
 - <http://www.siemens.com/simotion> (international)
- Product support:
 - <http://support.automation.siemens.com/WW/view/en/10805436>

Additional support

We also offer introductory courses to help you familiarize yourself with SIMOTION.

Please contact your regional training center or our main training center at D-90027 Nuremberg, phone +49 (911) 895 3202.

Information about training courses on offer can be found at:

www.sitrain.com

Table of contents

	Preface	3
1	Description.....	11
1.1	Overview of description.....	11
1.2	System overview	12
1.3	SIMOTION E510 complete units.....	17
1.4	Housing	17
1.5	Housing with 4 expansion slots.....	19
1.5.1	Illustration.....	19
1.5.2	Interfaces for housing with 4 expansion slots	20
1.5.3	Type plate	27
1.6	Housing without expansion slots.....	28
1.6.1	Illustration.....	28
1.6.2	Interfaces for housing without expansion slots	28
1.6.3	Type plate	30
1.7	Housing with 1 expansion slot	31
1.7.1	Illustration.....	31
1.7.2	Interfaces for housing with 1 expansion slot.....	31
1.7.3	Type plate	37
1.8	Head module.....	38
1.8.1	Properties of head module.....	38
1.8.2	Description of functions for analog inputs	40
1.8.3	Description of functions for analog outputs.....	40
1.8.4	Description of functions for reference outputs	40
1.8.5	Description of functions for temperature inputs	41
1.8.6	Description of functions for counter inputs.....	49
1.8.7	Fault and status indicator	54
1.8.8	DIP switch	55
1.8.9	PROFIBUS DP interface (DP slave).....	56
1.8.10	Connection for power supply	57
1.8.11	Type plate	57
1.8.12	Firmware version	58
1.9	Basic module.....	59
1.9.1	Properties of the basic module	59
1.9.2	Description of functions for digital inputs	60
1.9.3	Description of functions for digital outputs	60
1.9.4	Connection for power supply	61
1.9.5	LEDs (status indicators).....	63
1.9.6	Type plate	64
1.10	Wiring and block diagrams for devices with a head module and basic module	65
1.10.1	Overview	65
1.10.2	Digital inputs.....	66
1.10.3	Digital outputs	67
1.10.4	Temperature inputs, analog inputs, reference outputs, and analog outputs	69

1.10.5	Counter inputs.....	73
1.11	Technical data for devices with a head module and basic module.....	74
1.12	Digital I/O expansion module (EB DIGITAL, 16DI/16DO).....	85
1.12.1	Properties of EB DIGITAL, 16DI/16DO.....	85
1.12.2	Description of functions for digital inputs	86
1.12.3	Description of functions for digital outputs	87
1.12.4	Connection for power supply.....	88
1.12.5	LEDs (status indicators).....	90
1.12.6	Type plate.....	91
1.12.7	Wiring and block diagrams.....	92
1.12.8	Technical data.....	94
1.13	Digital I/O expansion module (EB DIGITAL, 32DI).....	96
1.13.1	Properties of EB DIGITAL, 32DI	96
1.13.2	Description of functions for digital inputs	97
1.13.3	Description of functions for counter inputs.....	99
1.13.4	Connection for power supply.....	100
1.13.5	LEDs (status indicators).....	101
1.13.6	Type plate.....	101
1.13.7	Wiring diagram and block diagram	102
1.13.8	Technical data.....	103
1.14	Temperature I/O expansion module (EB TEMP, 16TC/24DO).....	105
1.14.1	Properties of the EB TEMP, 16TC/24DO.....	105
1.14.2	Description of functions for temperature inputs	106
1.14.3	Description of functions for digital outputs	108
1.14.4	Connection for power supply.....	110
1.14.5	Fault and status indicators	111
1.14.6	Type plate.....	112
1.14.7	Wiring and block diagrams.....	112
1.14.8	Technical data.....	115
1.15	Position encoder expansion module (EB MPT, 4CH).....	119
1.15.1	Properties of EB MPT, 4CH	119
1.15.2	Interface for the position encoder (MPT1 to 4)	121
1.15.3	Connection for power supply.....	123
1.15.4	Fault and status indicators	124
1.15.5	Type plate.....	124
1.15.6	Technical data.....	125
1.16	EUROMAP 67-compliant handling expansion module (EB HAND, 16DI/16DO) (on request).....	126
1.16.1	Properties of EB HAND, 16DI/16DO.....	126
1.16.2	Handling interface	128
1.16.3	Connection for power supply.....	132
1.16.4	Type plate.....	133
1.16.5	Wiring diagram and block diagram	133
1.16.6	Connecting cable	136
1.16.7	Technical data.....	141
2	Application planning.....	143
2.1	Transportation and storage conditions for SIMOTION E510.....	143
2.2	Mechanical and climatic environmental conditions for operation of the SIMOTION E510	143
2.3	Specifications for insulation tests, safety class, and degree of protection.....	145
2.4	Rated voltage for operating SIMOTION E510	145

3	Installing and connecting	147
3.1	General information on installing and connecting.....	147
3.2	Installing SIMOTION E510.....	148
3.2.1	Dimension drawings.....	148
3.2.2	Installation requirements.....	151
3.2.3	Clearances.....	152
3.2.4	Dimension drawings for fixing holes.....	153
3.2.5	Installing SIMOTION E510.....	154
3.3	Installing modules in the housing.....	156
3.4	Installing the relay option module.....	157
3.5	Connecting.....	159
3.5.1	General connection requirements.....	159
3.5.2	Configuring the electrical installation.....	160
3.5.3	Overall SIMOTION E510 configuration.....	162
3.5.4	Connection overview.....	163
3.5.5	Connecting the power supply to the head module.....	164
3.5.6	Connecting PROFIBUS DP to the head module.....	167
3.5.7	Connecting the power supply to the basic module.....	169
3.5.8	Connecting inputs/outputs to the housing.....	170
3.5.9	Connecting shielded cables via the shield connection.....	173
3.5.10	Mechanical fixing of cables.....	174
3.6	Installing and connecting expansion modules.....	175
3.6.1	Overview.....	175
3.6.2	Installing expansion modules.....	175
3.6.3	Connection overview of expansion modules.....	176
3.6.4	Connecting the EB DIGITAL, 16DI/16DO.....	177
3.6.5	Connecting the EB DIGITAL, 32DI.....	178
3.6.6	Connecting the EB TEMP, 16TC/24DO.....	179
3.6.7	Connecting the EB MPT, 4CH.....	180
3.6.8	Connecting the EB HAND, 16DI/16DO.....	181
4	Commissioning.....	183
4.1	Requirements for commissioning.....	183
4.2	Installing GSD files.....	184
4.3	Configuring the DP slave (SIMOTION E510).....	184
4.4	Assigning input/output addresses.....	186
4.5	Parameterizing inputs/outputs.....	187
4.6	Assigning constant bus cycle time and isochronous mode parameters.....	200
4.7	Creating a user program.....	203
4.7.1	Overview.....	203
4.7.2	Logic addressing for inputs and outputs.....	203
4.7.3	Representation of analog values.....	210
4.7.4	Activating the outputs.....	216
4.7.5	Time synchronization for time-controlled outputs (on request) and sign-of-life monitoring.....	218
4.8	Downloading the user program to the DP master.....	232

5	Service and maintenance	233
5.1	Firmware update	233
5.2	Removing and replacing the housing or modules	236
6	Interrupts, error and system alarms	237
6.1	LED-based diagnostics	237
6.1.1	LEDs on the head module.....	237
6.1.2	LEDs on the expansion modules	241
6.2	Diagnostics via PROFIBUS DP	242
6.2.1	General information about diagnostics via PROFIBUS DP	242
6.2.2	Slave diagnostics structure	242
6.2.3	Station statuses 1 to 3.....	244
6.2.4	Master PROFIBUS address	245
6.2.5	Manufacturer's ID	246
6.2.6	Identifier-related diagnostics	246
6.2.7	Module status.....	247
6.2.8	Channel-specific diagnostics.....	248
6.2.9	Interrupts	249
6.2.10	Diagnostics data records.....	253
6.2.11	Example for decoding a diagnostics diagram	256
A	Standards and approvals	259
A.1	General rules.....	259
A.2	Safety of electronic controllers	259
A.3	Electromagnetic compatibility	261
B	ESD guidelines	263
B.1	ESD definition	263
B.2	Electrostatic charging of individuals.....	264
B.3	Basic measures for protection against discharge of static electricity	264
C	Appendix.....	265
C.1	References	265
C.2	List of abbreviations	266
	Index.....	267

Description

1.1 Overview of description

This chapter contains information on:

- System overview
- Illustration of SIMOTION E510
- Housing to contain the modules:
 - Without expansion slots
 - With 1 expansion slot
 - With 4 expansion slots
- Head module, interface module with PROFIBUS DP interface (interface module of SIMOTION E510); IM, 8AI/8AO/16TC/4CNT
- Basic module with digital inputs and outputs (DIGITAL, 32DI/48DO)
- Expansion modules for expansion slots:
 - Digital I/O expansion module (DIGITAL, 16DI/16DO)
 - Digital I/O expansion module (DIGITAL, 32DI)
 - Temperature I/O expansion module (TEMP, 16TC/24DO)
 - Position encoder expansion module (MPT, 4CH); MPT - magnetostrictive position transducer
 - EUROMAP 67-compliant handling expansion module (HAND, 16DI/16DO); on request
- Relay option module (on request)
for EUROMAP 67-compliant handling expansion module, for expansion to EUROMAP 12
- Wiring and block diagrams
- Technical data

1.2 System overview

What capabilities does SIMOTION E510 have?

SIMOTION E510 is an I/O system which enables cost-effective implementation of large I/O quantity structures within a compact unit. SIMOTION E510 offers maximum flexibility (in terms of cabling and the number of I/O) for use in a wide variety of applications - from plastics technology to equipping textile machines.

- SIMOTION E510 has an extensive range of functions based on features such as analog inputs, digital inputs, counters, position encoders, temperature inputs, analog outputs, and digital outputs.
- With its modular design, SIMOTION E510 can be adapted to suit the particular requirements of a task perfectly.
- Routing the I/O on the distribution board of the complete unit reduces the number of terminals required in the control cabinet (customer-specific terminal assignments are available on request).
- SIMOTION E510 enables tailored solutions to be found for production machine construction (individually equipped complete units or special modules are available on request).

Note

SIMOTION E510 is available from stock as a complete unit in basic variants. These basic variants can be expanded using expansion modules in order to meet your requirements.

For orders of a certain size, we can also supply expansion modules together with configured complete units on request.

Use

Typical applications for the module include:

- Plastics injection molding machine construction
- Textile machine construction
- Presses

Integration into the SIMOTION system

SIMOTION E510 can be integrated into the SIMOTION Motion Control System via the PROFIBUS DP interface (asynchronous or isochronous, equidistant) and using the following hardware platforms:

- SIMOTION C2xx
- SIMOTION P350
- SIMOTION D4xx

The figure below shows an example configuration with SIMOTION E510 and SIMOTION C2xx.

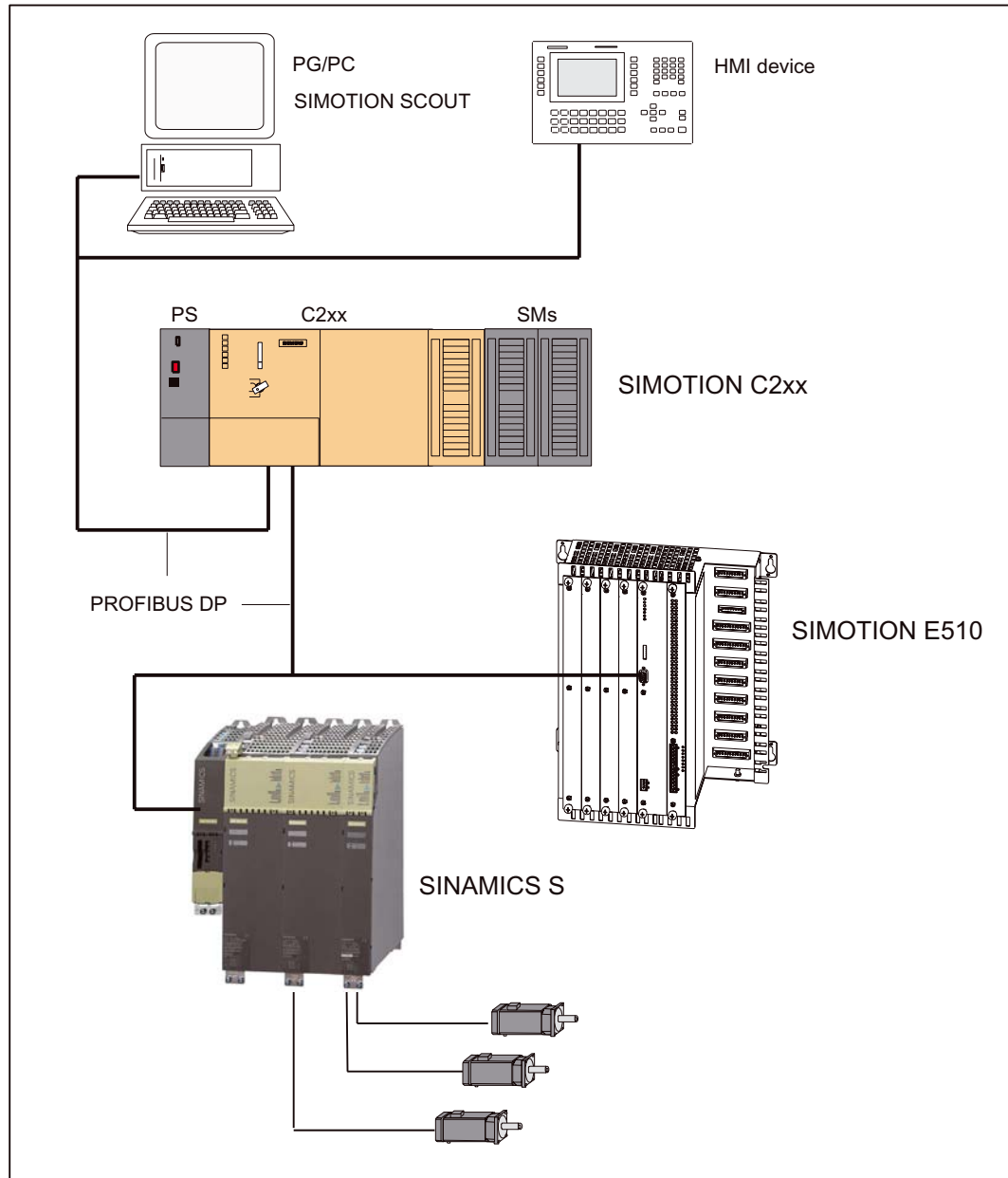

Figure 1-1 Example configuration for SIMOTION E510 and SIMOTION C2xx

The figure below shows an example configuration with SIMOTION E510 and SIMOTION P350.

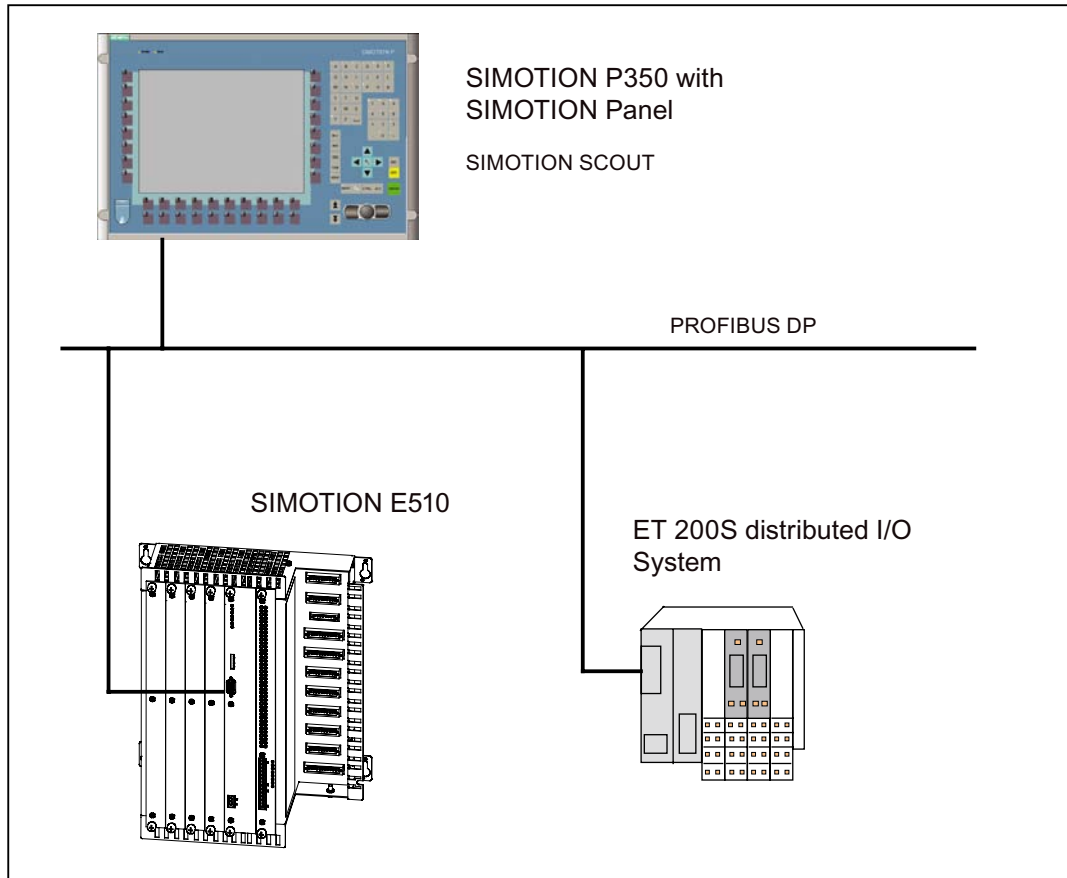

Figure 1-2 Example configuration for SIMOTION E510 and SIMOTION P350

The figure below shows an example configuration with SIMOTION E510 and SIMOTION D4xx.

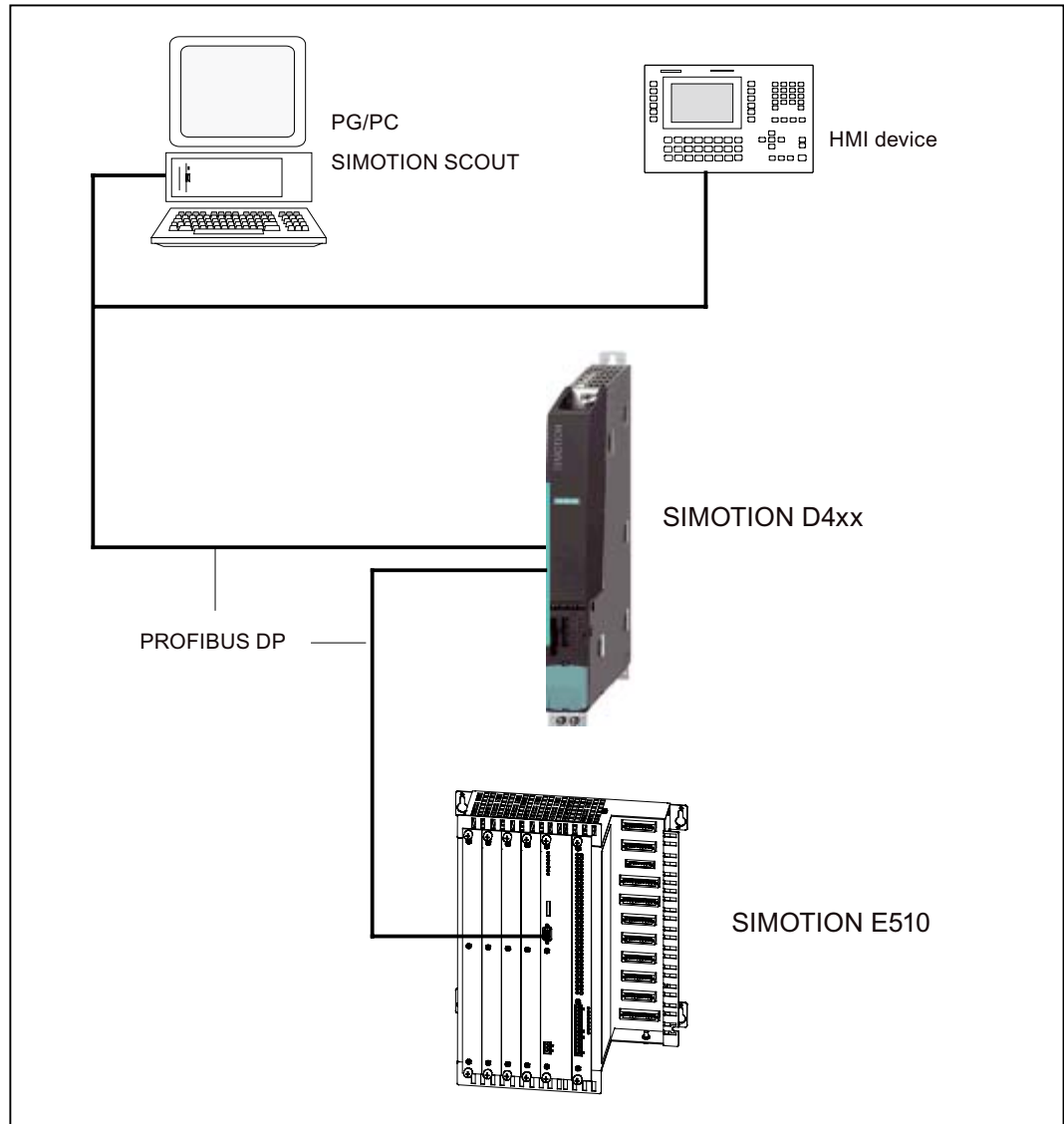

Figure 1-3 Example configuration for SIMOTION E510 and SIMOTION D4xx

Integration into the S7-300/400 automation system

SIMOTION E510 can be integrated into the S7-300/400 automation system via the PROFIBUS DP interface:

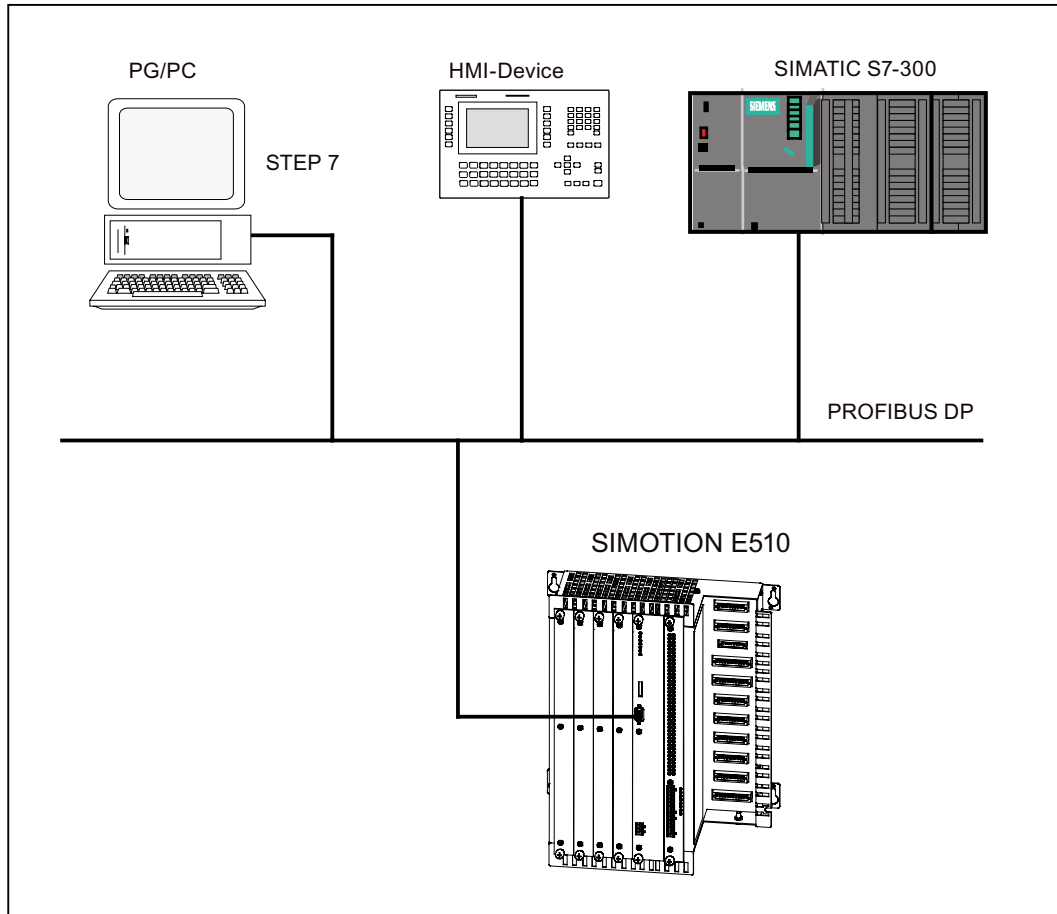

Figure 1-4 Example configuration for SIMOTION E510 and SIMATIC S7-300

1.3 SIMOTION E510 complete units

SIMOTION E510 is supplied as a complete unit. This complete unit consists of the **housing**, the **head module**, and the **basic module**. The head and basic modules are available as spare parts.

The **head module** has analog inputs/outputs as well as temperature inputs, counter inputs, and reference outputs. In addition, data exchange between the head, basic, and expansion modules is controlled. Communication with the machine control system via PROFIBUS DP also takes place via the **head module**.

The **basic module** contains 32 digital inputs and 48 digital outputs.

Expansion modules may also be equipped as an option.

The optional **expansion modules** provide additional digital and analog inputs/outputs, as well as temperature inputs. **Expansion modules** for position encoders and a handling module conforming to EUROMAP 67 or 12 are also available.

Since **head** and **basic modules** are required in every case, they are always included within the scope of delivery for complete units. In their factory state, expansion slots are supplied unequipped and with a shrouding cover. (unless agreement has been reached with SIEMENS on an individual basis regarding equipment of the complete unit).

The terminals on the housing are used for wiring the I/O channels of the **complete unit** (head and basic modules). The wiring for each **expansion module** is found on the front.

1.4 Housing

A variety of housing versions can be ordered (see table below).

Table 1- 1 Housing order numbers

Version	Order number
Housing with 4 expansion slots	<ul style="list-style-type: none"> • Can be ordered as a complete unit (order number: 6AU1 510-6XX00-1XX0) • As a spare part (order number: 6AU1 510-0EA00-0AA0)
Housing without expansion slots	Can only be ordered as a complete unit (order number: 6AU1 510-6XX01-1XX0)
Housing with 1 expansion slot	Can only be ordered as a complete unit (order number: 6AU1 510-6XX02-1XX0)

The housing with slots accommodates the wiring for the inputs/outputs, as well as the methods of adaptation to the interface. This is where the internal bus is located. The internal bus is what provides the connection between the **head module**, the **basic module**, and the optional **expansion modules**.

Modules

The components of SIMOTION E510 and their functions are described in the table below.

Table 1- 2 Components of SIMOTION E510

Module	Description
Housing <ul style="list-style-type: none"> Without expansion slots With 1 expansion slot With 4 expansion slots 	Contains the individual modules
Head module (IM, 8AI/8AO/16TC/4CNT)	<ul style="list-style-type: none"> PROFIBUS DP interface slave (isochronous, equidistant) 8 analog inputs Reference outputs 8 analog outputs 16 temperature inputs 4 counter inputs
Basic module (DIGITAL 32DI/48DO)	<ul style="list-style-type: none"> 32 digital inputs 48 digital outputs
Digital I/O expansion module (DIGITAL, 16DI/16DO)	<ul style="list-style-type: none"> 16 digital inputs 16 digital outputs
Digital I/O expansion module (DIGITAL, 32DI)	32 digital inputs
Temperature I/O expansion module (TEMP, 16TC/24DO)	<ul style="list-style-type: none"> 16 temperature channels 24 digital outputs
Position encoder expansion module (MPT, 4CH)	4 metering channels
EUROMAP 67-compliant handling expansion module (HAND, 16DI/16DO); on request	<ul style="list-style-type: none"> 16 digital inputs 16 digital outputs of which used for EUROMAP 67: <ul style="list-style-type: none"> 16 digital inputs 15 digital outputs of which used for EUROMAP 12: <ul style="list-style-type: none"> 12 digital inputs 11 digital outputs (relay option module)
Relay option module (on request) for EUROMAP 67-compliant handling expansion module, for expansion to EUROMAP 12	11 relay outputs

1.5 Housing with 4 expansion slots

1.5.1 Illustration

SIMOTION E510 with 4 expansion slots consists of a housing containing the **head module (IM)** and the **basic module (DIGITAL)**. SIMOTION E510 can be expanded to include additional modules, if required.

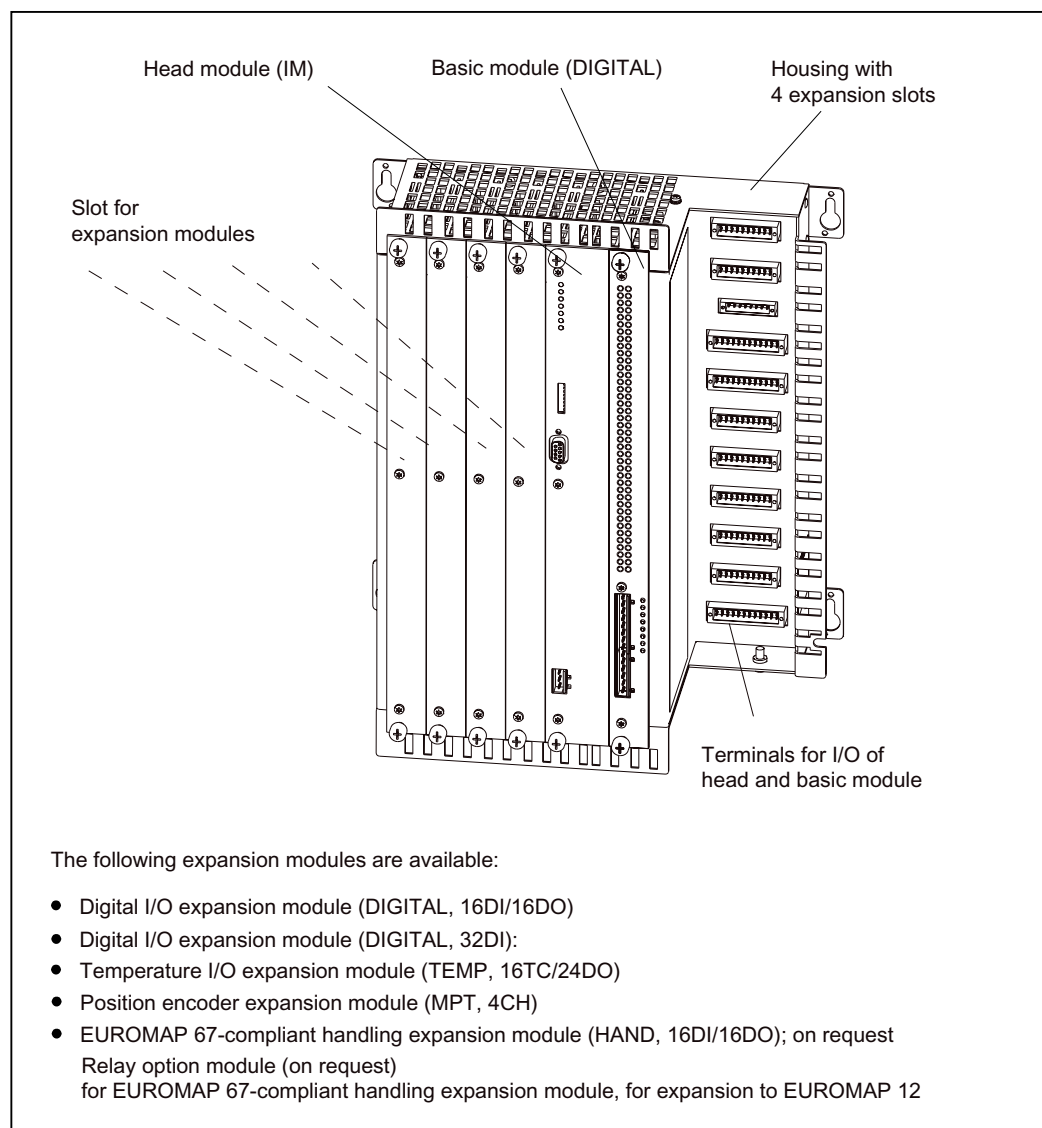

Figure 1-5 Illustration of housing with 4 expansion slots

1.5.2 Interfaces for housing with 4 expansion slots

The user can connect the inputs and outputs or plug the expansion modules into these connectors to suit the requirements of the project in question.

Note: Connectors X004 to X014 should be used for the head and basic module functions. The expansion modules have their own terminals on the front side.

Position of connectors

The figure below shows the housing and the position of the interfaces.

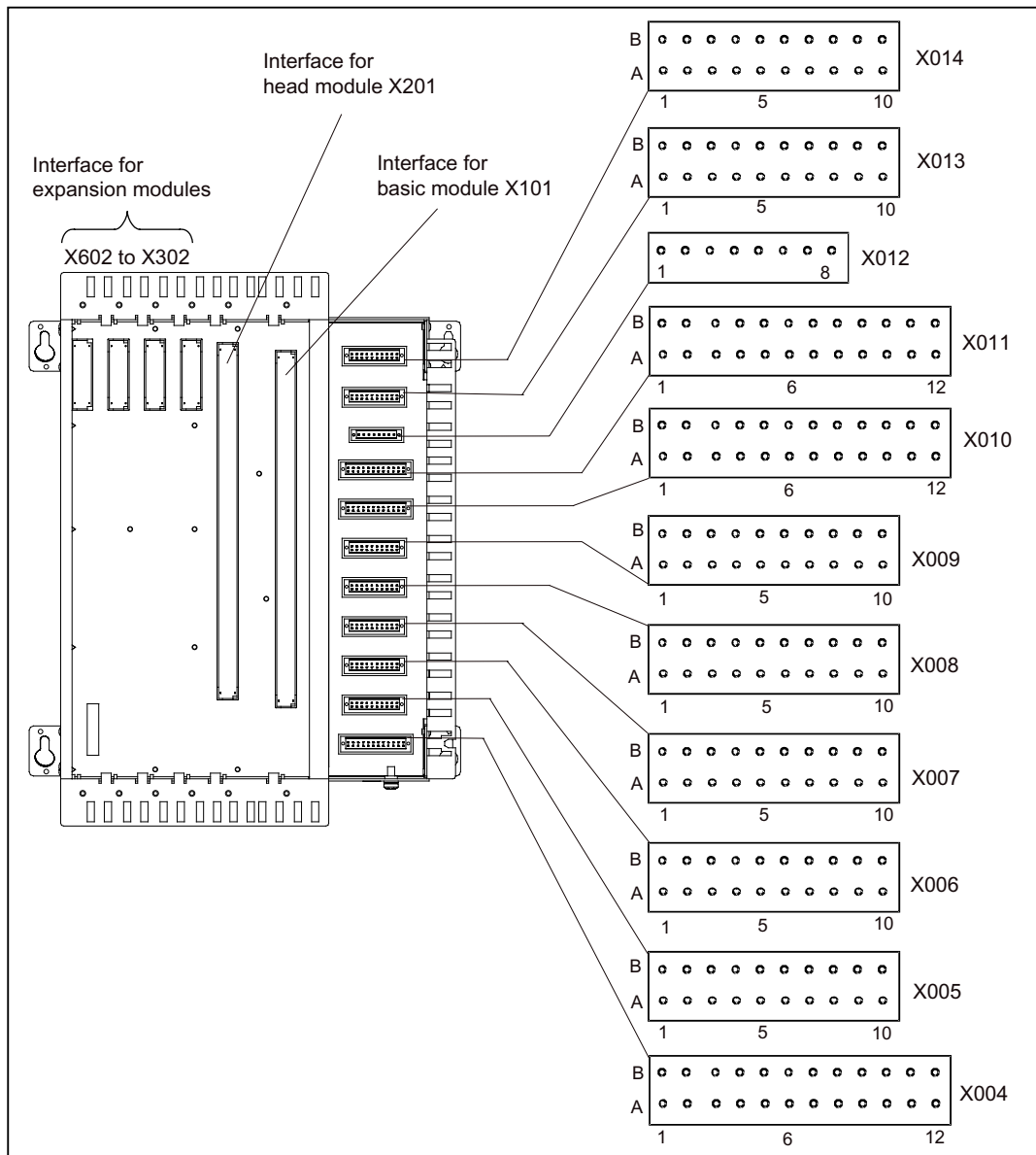

Figure 1-6 Position of connectors

Note

The 24 VDC load power supply is located on the head/basic module.

Note

The wiring and block diagrams relating to the interfaces for the housing with 4 expansion slots can be found in the section titled "Wiring and block diagrams for devices with a head module and basic module".

Technical data relating to the interfaces for the housing with 4 expansion slots can be found in the section titled "Technical data for devices with a head module and basic module".

Assignment of connectors for digital outputs

Connector designation: **X004** (4x4 digital outputs, isolated, 2 A)

Connector type: S2L-SMT3.5/24/180

Table 1-3 Assignment of connector X004

Pin A	Signal	Designation	Pin B	Signal	Designation
1	DO0	Digital output 0	1	DO1	Digital output 1
2	DO2	Digital output 2	2	DO3	Digital output 3
3	-	Not assigned	3	-	Not assigned
4	DO4	Digital output 4	4	DO5	Digital output 5
5	DO6	Digital output 6	5	DO7	Digital output 7
6	-	Not assigned	6	-	Not assigned
7	DO8	Digital output 8	7	DO9	Digital output 9
8	DO10	Digital output 10	8	DO11	Digital output 11
9	-	Not assigned	9	-	Not assigned
10	DO12	Digital output 12	10	DO13	Digital output 13
11	DO14	Digital output 14	11	DO15	Digital output 15
12	-	Not assigned	12	-	Not assigned

Description

1.5 Housing with 4 expansion slots

Connector designation: **X005** (8 digital outputs, 2 A; 8 digital outputs, 0.5 A)
Connector type: S2L-SMT3.5/20/180

The reference potential for the digital outputs is on connector X703 of the basic module.

Table 1- 4 Assignment of connector X005

Pin A	Signal	Designation	Pin B	Signal	Designation
1	DO16	Digital output 16, 2 A	1	DO17	Digital output 17, 2 A
2	DO18	Digital output 18, 2 A	2	DO19	Digital output 19, 2 A
3	DO20	Digital output 20, 2 A	3	DO21	Digital output 21, 2 A
4	DO22	Digital output 22, 2 A	4	DO23	Digital output 23, 2 A
5	-	Not assigned	5	-	Not assigned
6	-	Not assigned	6	-	Not assigned
7	DO24	Digital output 24, 0.5 A	7	DO25	Digital output 25, 0.5 A
8	DO26	Digital output 26, 0.5 A	8	DO27	Digital output 27, 0.5 A
9	DO28	Digital output 28, 0.5 A	9	DO29	Digital output 29, 0.5 A
10	DO30	Digital output 30, 0.5 A	10	DO31	Digital output 31, 0.5 A

Connector designation: **X006** (16 digital outputs, 0.5 A)
Connector type: S2L-SMT3.5/20/180

The reference potential for the digital outputs is on connector X703 of the basic module.

Table 1- 5 Assignment of connector X006

Pin A	Signal	Designation	Pin B	Signal	Designation
1	DO32	Digital output 32, 0.5 A	1	DO33	Digital output 33, 0.5 A
2	DO34	Digital output 34, 0.5 A	2	DO35	Digital output 35, 0.5 A
3	DO36	Digital output 36, 0.5 A	3	DO37	Digital output 37, 0.5 A
4	DO38	Digital output 38, 0.5 A	4	DO39	Digital output 39, 0.5 A
5	-	Not assigned	5	-	Not assigned
6	-	Not assigned	6	-	Not assigned
7	DO40	Digital output 40, 0.5 A	7	DO41	Digital output 41, 0.5 A
8	DO42	Digital output 42, 0.5 A	8	DO43	Digital output 43, 0.5 A
9	DO44	Digital output 44, 0.5 A	9	DO45	Digital output 45, 0.5 A
10	DO46	Digital output 46, 0.5 A	10	DO47	Digital output 47, 0.5 A

Assignment of connectors for temperature inputs

Connector designation: **X007** (8 temperature inputs)
 Connector type: S2L-SMT3.5/20/180

Table 1- 6 Assignment of connector X007

Pin A	Signal	Designation	Pin B	Signal	Designation
1	-	Not assigned	1	-	Not assigned
2	TC8+	Temperature input 8 (positive)	2	TC8-	Temperature input 8 (negative)
3	TC9+	Temperature input 9 (positive)	3	TC9-	Temperature input 9 (negative)
4	TC10+	Temperature input 10 (positive)	4	TC10-	Temperature input 10 (negative)
5	TC11+	Temperature input 11 (positive)	5	TC11-	Temperature input 11 (negative)
6	TC12+	Temperature input 12 (positive)	6	TC12-	Temperature input 12 (negative)
7	TC13+	Temperature input 13 (positive)	7	TC13-	Temperature input 13 (negative)
8	TC14+	Temperature input 14 (positive)	8	TC14-	Temperature input 14 (negative)
9	TC15+	Temperature input 15 (positive)	9	TC15-	Temperature input 15 (negative)
10	PE	Functional ground	10	PE	Functional ground

Connector designation: **X008** (8 temperature inputs)
 Connector type: S2L-SMT3.5/20/180

Table 1- 7 Assignment of connector X008

Pin A	Signal	Designation	Pin B	Signal	Designation
1	-	Not assigned	1	-	Not assigned
2	TC0+	Temperature input 0 (positive)	2	TC0-	Temperature input 0 (negative)
3	TC1+	Temperature input 1 (positive)	3	TC1-	Temperature input 1 (negative)
4	TC2+	Temperature input 2 (positive)	4	TC2-	Temperature input 2 (negative)
5	TC3+	Temperature input 3 (positive)	5	TC3-	Temperature input 3 (negative)
6	TC4+	Temperature input 4 (positive)	6	TC4-	Temperature input 4 (negative)
7	TC5+	Temperature input 5 (positive)	7	TC5-	Temperature input 5 (negative)
8	TC6+	Temperature input 6 (positive)	8	TC6-	Temperature input 6 (negative)
9	TC7+	Temperature input 7 (positive)	9	TC7-	Temperature input 7 (negative)
10	PE	Functional ground	10	PE	Functional ground

Description

1.5 Housing with 4 expansion slots

Assignment of connectors for analog outputs

Connector designation: **X009** (8 analog outputs)
Connector type: S2L-SMT3.5/20/180

Table 1- 8 Assignment of connector X009

Pin A	Signal	Designation	Pin B	Signal	Designation
1	-	Not assigned	1	-	Not assigned
2	AO0	Analog output channel 0	2	M _{ANA}	Reference potential analog
3	AO1	Analog output channel 1	3	M _{ANA}	Reference potential analog
4	AO2	Analog output channel 2	4	M _{ANA}	Reference potential analog
5	AO3	Analog output channel 3	5	M _{ANA}	Reference potential analog
6	AO4	Analog output channel 4	6	M _{ANA}	Reference potential analog
7	AO5	Analog output channel 5	7	M _{ANA}	Reference potential analog
8	AO6	Analog output channel 6	8	M _{ANA}	Reference potential analog
9	AO7	Analog output channel 7	9	M _{ANA}	Reference potential analog
10	PE	Functional ground	10	PE	Functional ground

Assignment of connectors for analog inputs with control

Connector designation: **X010** (4 analog inputs with control)
Connector type: S2L-SMT3.5/24/180

Table 1- 9 Assignment of connector X010

Pin A	Signal	Designation	Pin B	Signal	Designation
1	AI0	Analog input channel 0	1	M _{ANA}	Reference potential analog
2	U _{REF}	Reference output 0	2	M _{ANA}	Reference potential analog
3	-	Not assigned	3	-	Not assigned
4	AI1	Analog input channel 1	4	M _{ANA}	Reference potential analog
5	U _{REF}	Reference output 1	5	M _{ANA}	Reference potential analog
6	-	Not assigned	6	-	Not assigned
7	AI2	Analog input channel 2	7	M _{ANA}	Reference potential analog
8	U _{REF}	Reference output 2	8	M _{ANA}	Reference potential analog
9	-	Not assigned	9	-	Not assigned
10	AI3	Analog input channel 3	10	M _{ANA}	Reference potential analog
11	U _{REF}	Reference output 3	11	M _{ANA}	Reference potential analog
12	PE	Functional ground	12	PE	Functional ground

Connector designation: **X011** (4 analog inputs with control)
 Connector type: S2L-SMT3.5/24/180

Table 1- 10 Assignment of connector X011

Pin A	Signal	Designation	Pin B	Signal	Designation
1	AI4	Analog input channel 4	1	M _{ANA}	Reference potential analog
2	U _{REF}	Reference output 4	2	M _{ANA}	Reference potential analog
3	-	Not assigned	3	-	Not assigned
4	AI5	Analog input channel 5	4	M _{ANA}	Reference potential analog
5	U _{REF}	Reference output 5	5	M _{ANA}	Reference potential analog
6	-	Not assigned	6	-	Not assigned
7	AI6	Analog input channel 6	7	M _{ANA}	Reference potential analog
8	U _{REF}	Reference output 6	8	M _{ANA}	Reference potential analog
9	-	Not assigned	9	-	Not assigned
10	AI7	Analog input channel 7	10	M _{ANA}	Reference potential analog
11	U _{REF}	Reference output 7	11	M _{ANA}	Reference potential analog
12	PE	Functional ground	12	PE	Functional ground

Assignment of connectors for fast counter inputs

Connector designation: **X012**
 Connector type: SL-SMT3.5/8/180

Table 1- 11 Assignment of connector X012

Pin	Signal	Designation
1	M _{CNT}	24 V reference potential
2	CNT0	Counter input 0
3	CNT1	Counter input 1
4	CNT2	Counter input 2
5	CNT3	Counter input 3
6 to 8	-	Not assigned

Description

1.5 Housing with 4 expansion slots

Assignment of connectors for digital inputs

Connector designation: **X013** (16 digital inputs)
Connector type: S2L-SMT3.5/20/180

The reference potential for the digital inputs is on connector X703 of the basic module.

Table 1- 12 Assignment of connector X013

Pin A	Signal	Designation	Pin B	Signal	Designation
1	-	Not assigned	1	-	Not assigned
2	DI16	Digital input 16	2	DI17	Digital input 17
3	DI18	Digital input 18	3	DI19	Digital input 19
4	DI20	Digital input 20	4	DI21	Digital input 21
5	DI22	Digital input 22	5	DI23	Digital input 23
6	DI24	Digital input 24	6	DI25	Digital input 25
7	DI26	Digital input 26	7	DI27	Digital input 27
8	DI28	Digital input 28	8	DI29	Digital input 29
9	DI30	Digital input 30	9	DI31	Digital input 31
10	-	Not assigned	10	-	Not assigned

Connector designation: **X014** (16 digital inputs)
Connector type: S2L-SMT3.5/20/180

The reference potential for the digital inputs is on connector X703 of the basic module.

Table 1- 13 Assignment of connector X014

Pin A	Signal	Designation	Pin B	Signal	Designation
1	-	Not assigned	1	-	Not assigned
2	DI0	Digital input 0	2	DI1	Digital input 1
3	DI2	Digital input 2	3	DI3	Digital input 3
4	DI4	Digital input 4	4	DI5	Digital input 5
5	DI6	Digital input 6	5	DI7	Digital input 7
6	DI8	Digital input 8	6	DI9	Digital input 9
7	DI10	Digital input 10	7	DI11	Digital input 11
8	DI12	Digital input 12	8	DI13	Digital input 13
9	DI14	Digital input 14	9	DI15	Digital input 15
10	-	Not assigned	10	-	Not assigned

See also

Wiring and block diagrams for devices with a head module and basic module (Page 65)

Technical data for devices with a head module and basic module (Page 74)

1.5.3 Type plate

The housing with 4 expansion slots can be ordered as a complete unit or as a spare part. With the complete unit, there are 2 type plates on the housing.

The figure below shows all the information included on the type plates.

Note

The contents of the individual type plate fields on the current module may differ from those described in this manual (e.g. updated product status, approvals and markings not yet issued, etc.).

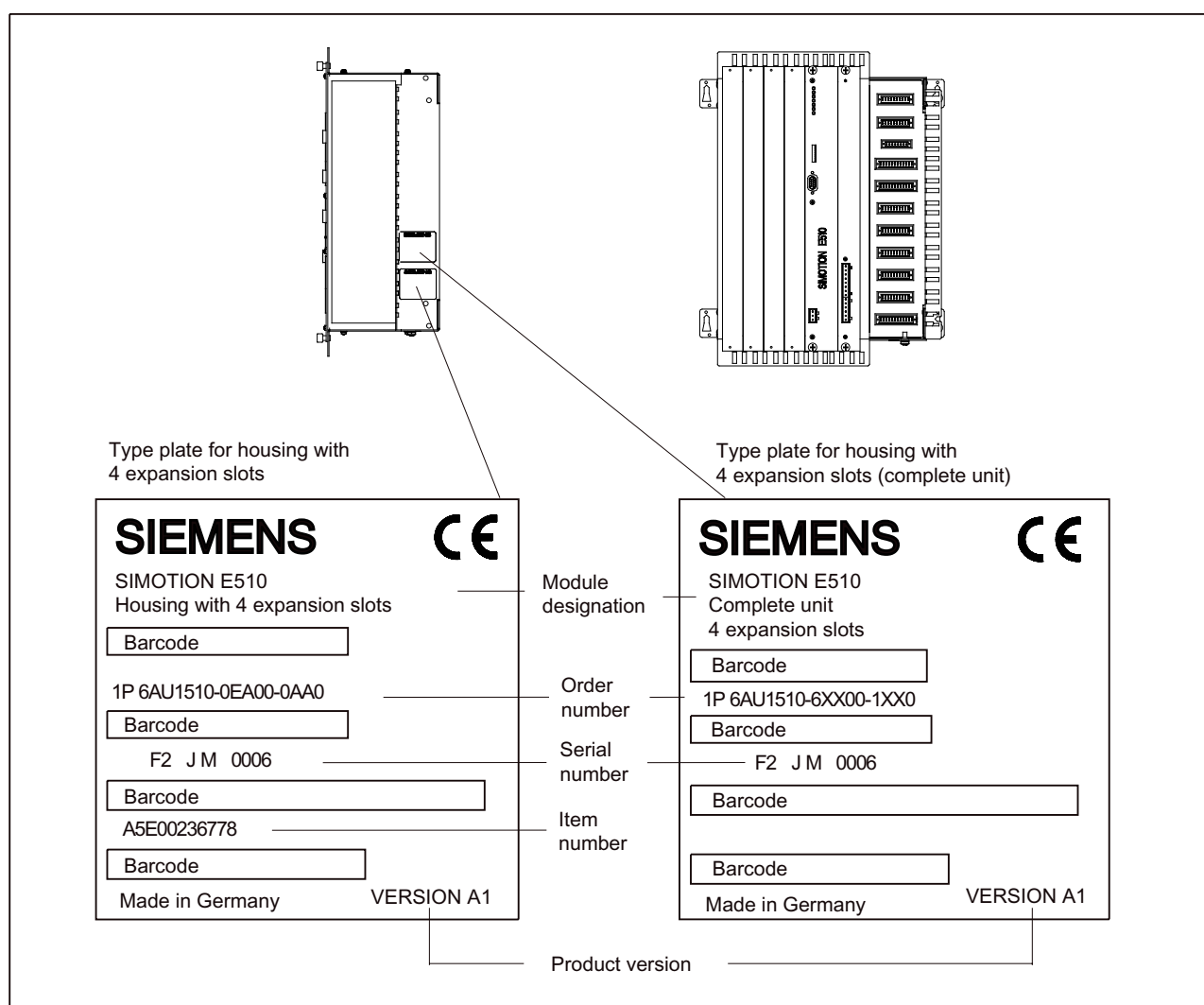

Figure 1-7 Type plates for housing with 4 expansion slots

1.6 Housing without expansion slots

1.6.1 Illustration

SIMOTION E510 without expansion slots consists of a housing containing the **head module (IM)** and the **basic module (DIGITAL)**.

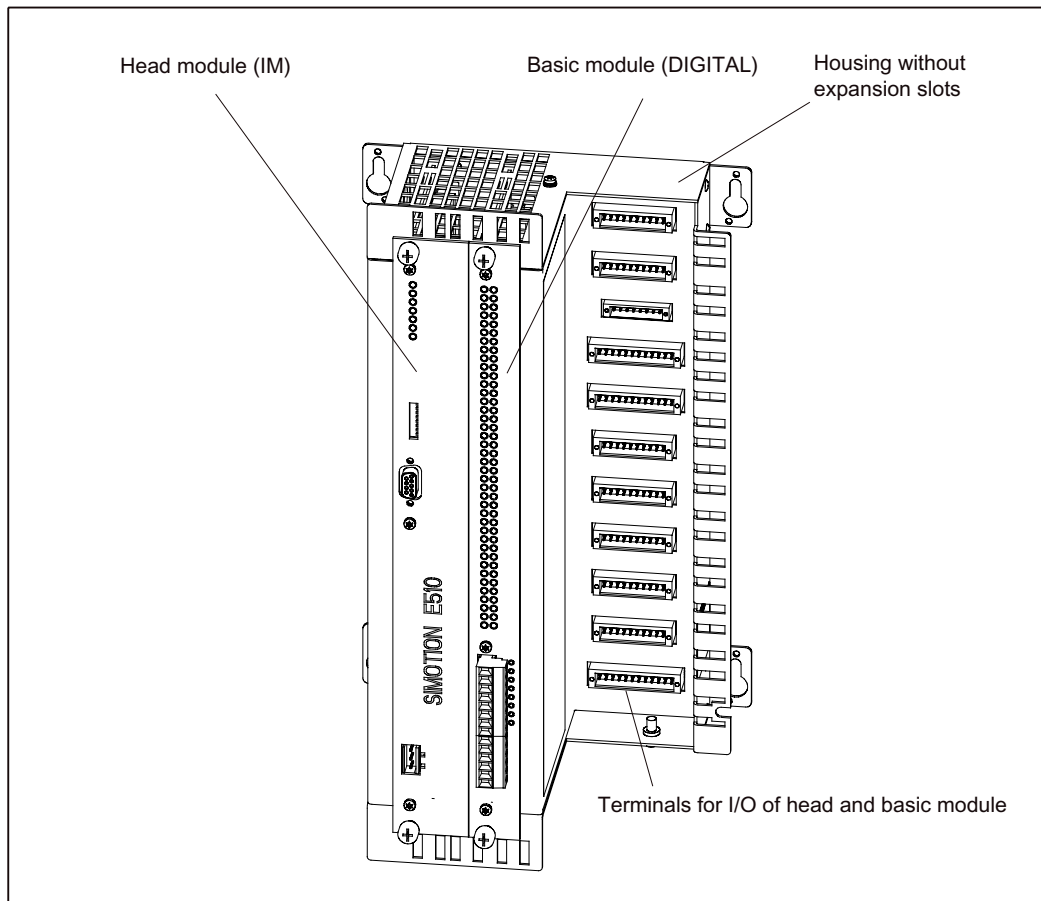

Figure 1-8 Illustration of housing without expansion slots

1.6.2 Interfaces for housing without expansion slots

The user can connect the inputs and outputs to these connectors to suit the requirements of the project in question.

Position of connectors

The figure below shows the housing and the position of the interfaces.

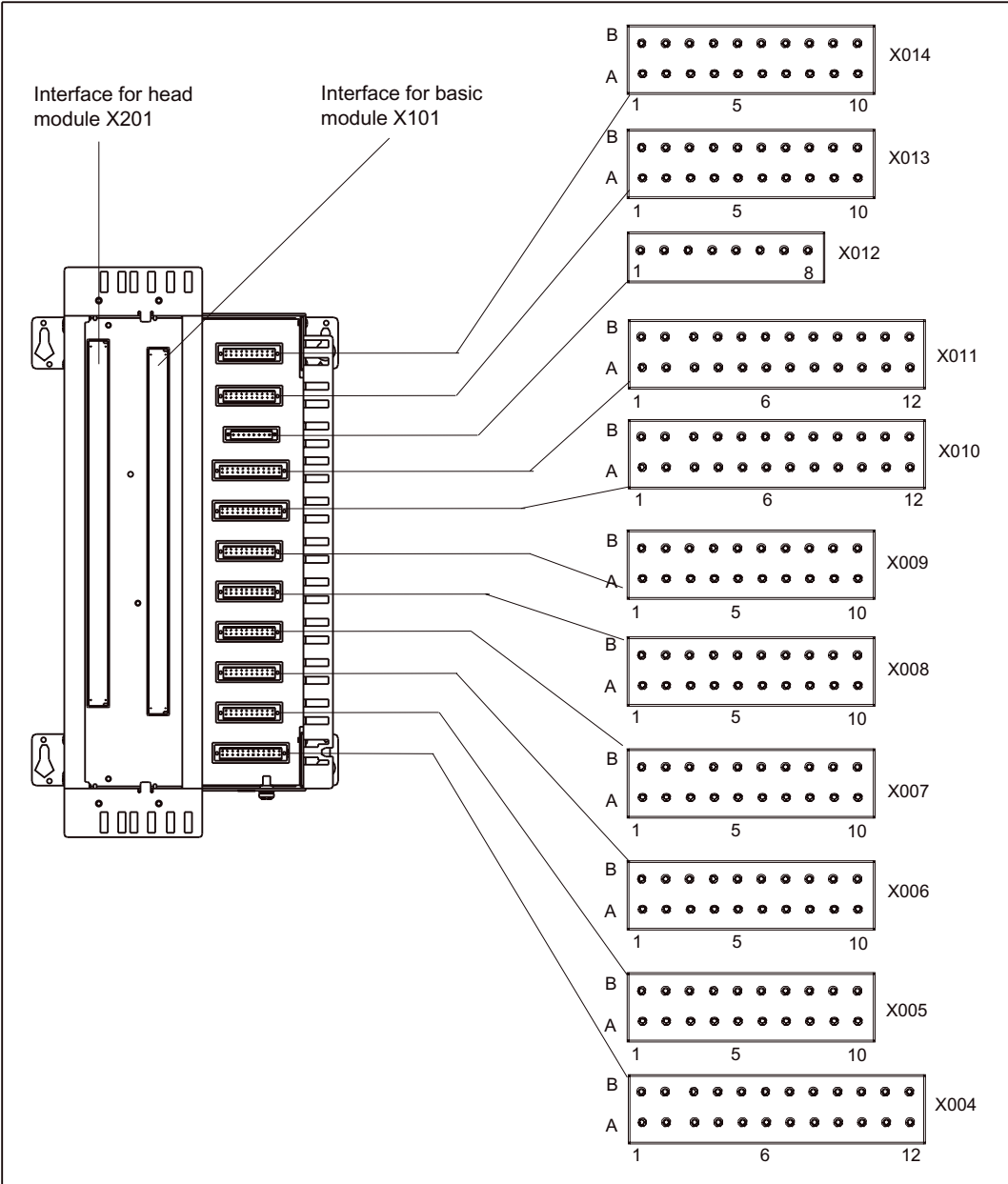

Figure 1-9 Position of connectors

Connector assignment

For the assignment of connectors X004 to X014, see the tables in the section titled "Interfaces for housing with 4 expansion slots".

See also

Interfaces for housing with 4 expansion slots (Page 20)

1.6.3 Type plate

The housing without expansion slots can only be ordered as a complete unit. There are 2 type plates on the housing.

The figure below shows all the information included on the type plates.

Note

The contents of the individual type plate fields on the current module may differ from those described in this manual (e.g. updated product status, approvals and markings not yet issued, etc.).

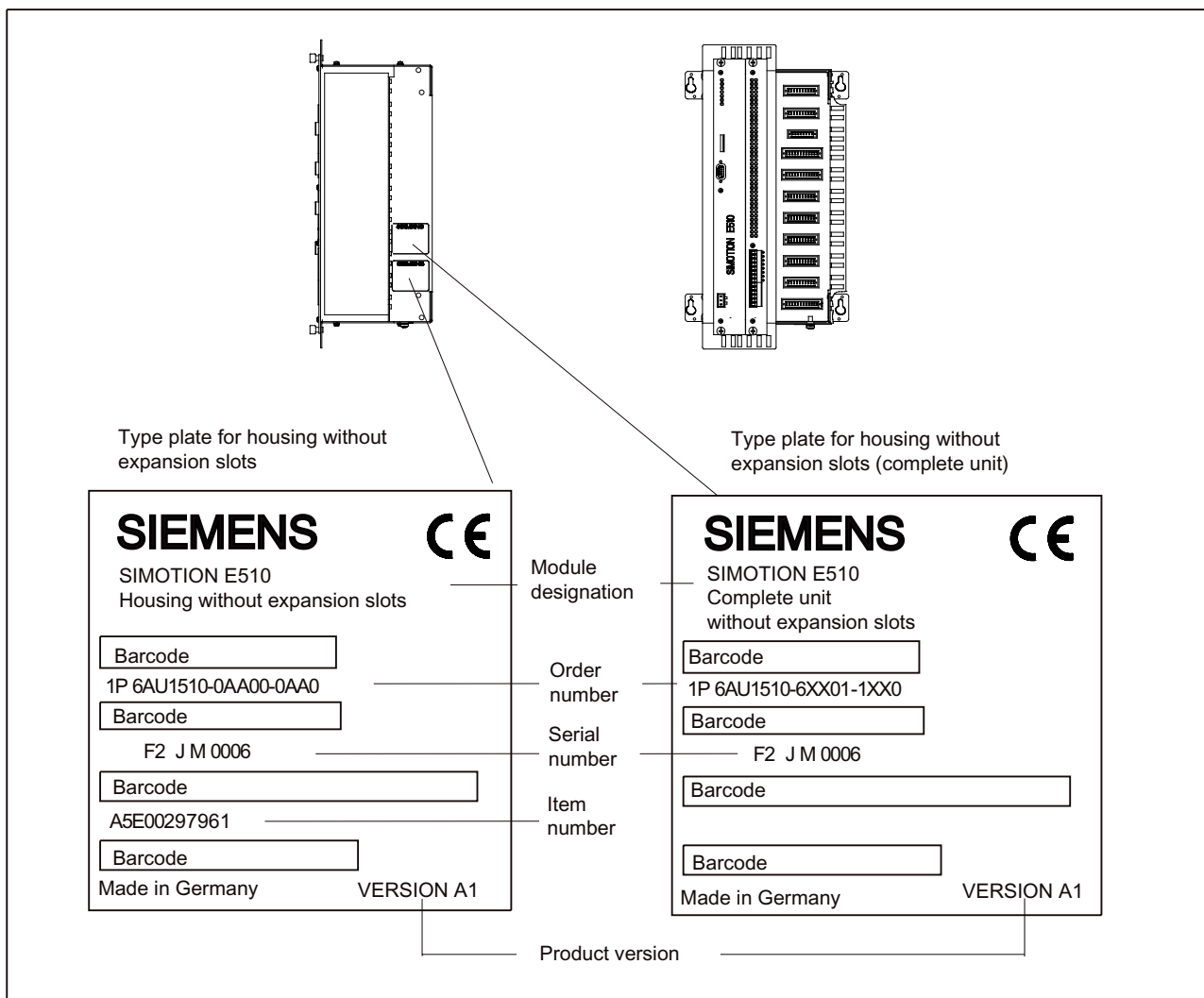

Figure 1-10 Type plates for housing without expansion slots

1.7 Housing with 1 expansion slot

1.7.1 Illustration

SIMOTION E510 with 1 expansion slot consists of housing containing the **head module (IM)** and the **basic module (DIGITAL)**. SIMOTION E510 can be expanded to include an additional module, if required.

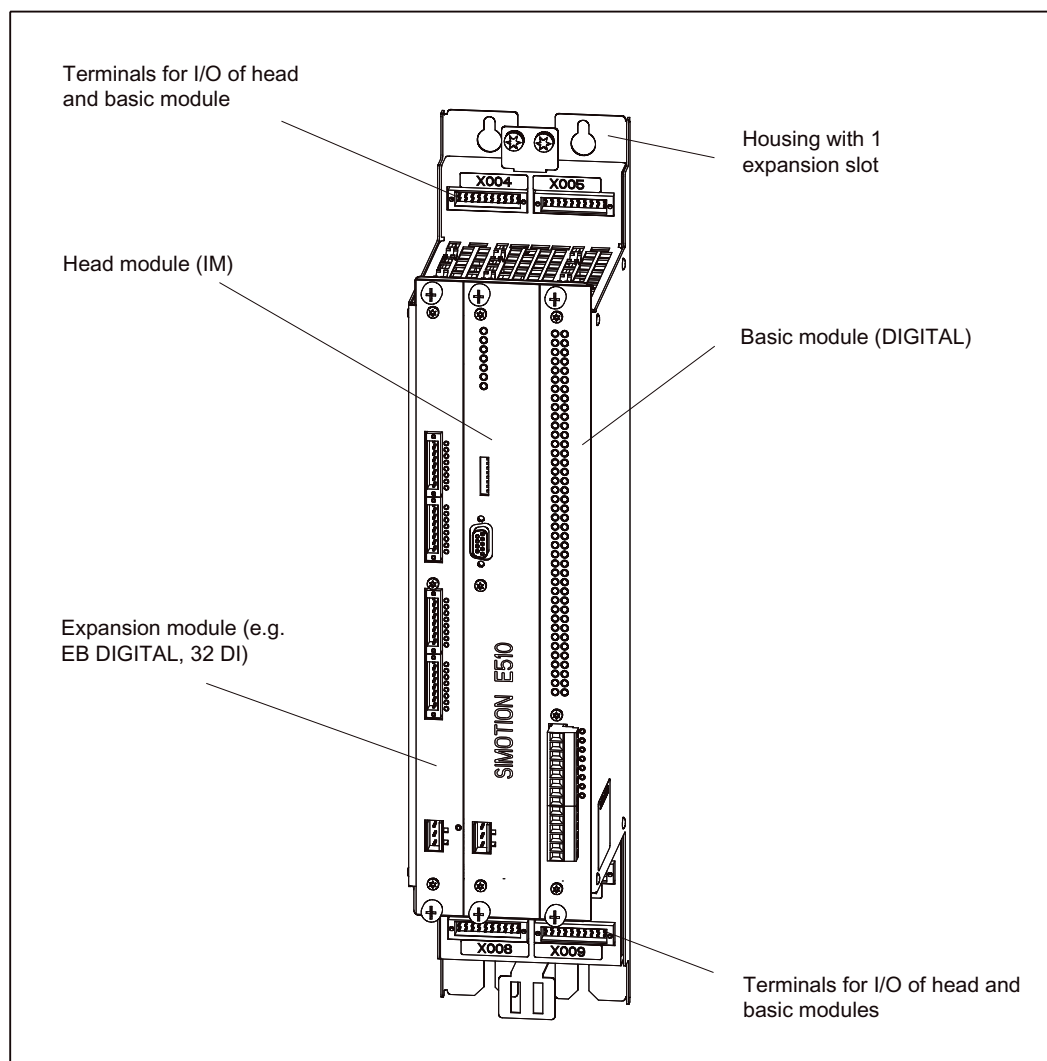

Figure 1-11 Illustration of housing with 1 expansion slot

1.7.2 Interfaces for housing with 1 expansion slot

The user can connect the inputs and outputs to these connectors to suit the requirements of the project in question.

Position of connectors

The figure below shows the housing and the position of the interfaces.

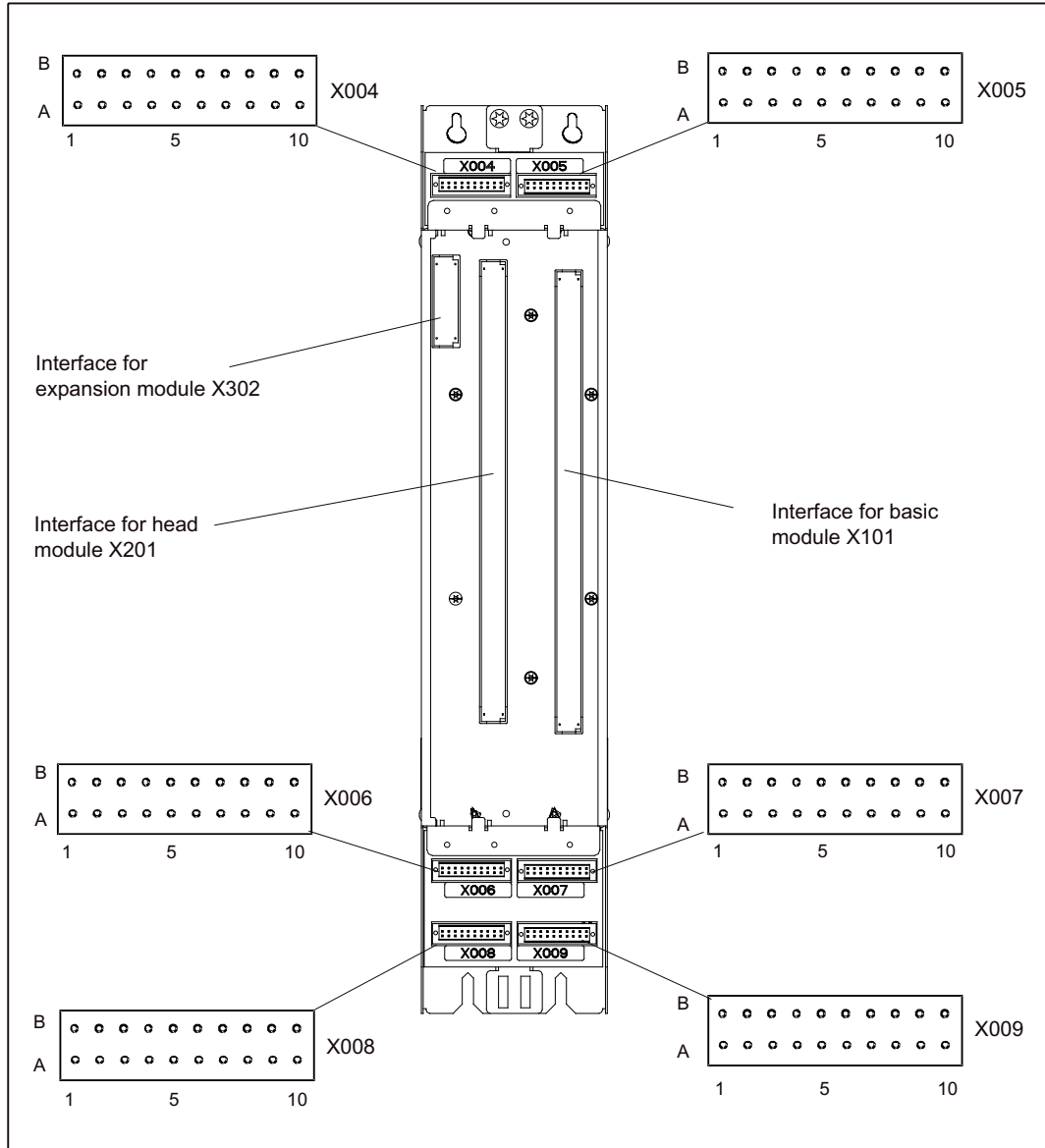

Figure 1-12 Position of connectors

Note

The 24 VDC load power supply is located on the head/basic module.

Note

Technical data relating to the interfaces for the housing with 1 expansion slot can be found in the section titled "Technical data for devices with a head module and basic module".

Assignment of connectors for digital inputs and counter inputs

Connector designation: **X004** (16 digital inputs, 2 counter inputs)
 Connector type: S2L-SMT3.5/20/180

The reference potential for the digital inputs is on connector X703 of the basic module.

Table 1- 14 Assignment of connector X004

Pin A	Signal	Designation	Pin B	Signal	Designation
1	CNT0	Counter input 0	1	M _{CNT}	24 V reference potential
2	DI0	Digital input 0	2	DI1	Digital input 1
3	DI2	Digital input 2	3	DI3	Digital input 3
4	DI4	Digital input 4	4	DI5	Digital input 5
5	DI6	Digital input 6	5	DI7	Digital input 7
6	DI8	Digital input 8	6	DI9	Digital input 9
7	DI10	Digital input 10	7	DI11	Digital input 11
8	DI12	Digital input 12	8	DI13	Digital input 13
9	DI14	Digital input 14	9	DI15	Digital input 15
10	CNT1	Counter input 1	10	M _{CNT}	24 V reference potential

Connector designation: **X005** (16 digital inputs, 2 counter inputs)
 Connector type: S2L-SMT3.5/20/180

The reference potential for the digital inputs is on connector X703 of the basic module.

Table 1- 15 Assignment of connector X005

Pin A	Signal	Designation	Pin B	Signal	Designation
1	CNT2	Counter input 2	1	M _{CNT}	24 V reference potential
2	DI16	Digital input 16	2	DI17	Digital input 17
3	DI18	Digital input 18	3	DI19	Digital input 19
4	DI20	Digital input 20	4	DI21	Digital input 21
5	DI22	Digital input 22	5	DI23	Digital input 23
6	DI24	Digital input 24	6	DI25	Digital input 25
7	DI26	Digital input 26	7	DI27	Digital input 27
8	DI28	Digital input 28	8	DI29	Digital input 29
9	DI30	Digital input 30	9	DI31	Digital input 31
10	CNT3	Counter input 3	10	M _{CNT}	24 V reference potential

Description

1.7 Housing with 1 expansion slot

Assignment of connectors for analog inputs with control

Connector designation: **X006** (8 analog inputs with control)
Connector type: S2L-SMT3.5/20/180

Table 1- 16 Assignment of connector X006

Pin A	Signal	Designation	Pin B	Signal	Designation
1	AI0	Analog input channel 0	1	M _{ANA}	Reference potential analog
2	AI1	Analog input channel 1	2	M _{ANA}	Reference potential analog
3	AI2	Analog input channel 2	3	M _{ANA}	Reference potential analog
4	AI3	Analog input channel 3	4	M _{ANA}	Reference potential analog
5	AI4	Analog input channel 4	5	M _{ANA}	Reference potential analog
6	AI5	Analog input channel 5	6	M _{ANA}	Reference potential analog
7	AI6	Analog input channel 6	7	M _{ANA}	Reference potential analog
8	AI7	Analog input channel 7	8	M _{ANA}	Reference potential analog
9	U _{REF}	Reference output 0	9	M _{ANA}	Reference potential analog
10	PE	Functional ground	10	PE	Functional ground

Note

The housing with 1 expansion slot was designed with compactness in mind, and does not have terminals for the head module's 8 analog outputs and 16 temperature inputs. The head module's analog outputs and temperature inputs cannot be used.

Note

Head modules supplied as part of complete units with 1 expansion slot must not be used in complete units with or without 4 expansion slots.

Complete units with 1 expansion slot were designed with compactness in mind. This means that their structure does not support connection of 16 TC and 8 AO channels. As such, the head modules integrated into these complete units do not have TC/AO channels, and any channels that may be present are neither checked nor adjusted.

By contrast, head modules from complete units with or without 4 expansion slots can be used in complete units with 1 expansion slot.

Assignment of connectors for digital outputs

Connector designation:	X007	(2x4 digital outputs, isolated, 2 A, 8 digital outputs, 2 A)
Connector type:	S2L-SMT3.5/20/180	

The reference potential for the digital outputs is on connector X703 of the basic module.

Table 1- 17 Assignment of connector X007

Pin A	Signal	Designation	Pin B	Signal	Designation
1	DO0	Digital output, isolated, 2 A	1	DO1	Digital output 1, isolated, 2 A
2	DO2	Digital output 2, isolated, 2 A	2	DO3	Digital output 3, isolated, 2 A
3	-	Not assigned	3	-	Not assigned
4	DO4	Digital output 4, isolated, 2 A	4	DO5	Digital output 5, isolated, 2 A
5	DO6	Digital output 6, isolated, 2 A	5	DO7	Digital output 7, isolated, 2 A
6	-	Not assigned	6	-	Not assigned
7	DO16	Digital output 16, 2 A	7	DO17	Digital output 17, 2 A
8	DO18	Digital output 18, 2 A	8	DO19	Digital output 19, 2 A
9	DO20	Digital output 20, 2 A	9	DO21	Digital output 21, 2 A
10	DO22	Digital output 22, 2 A	10	DO23	Digital output 23, 2 A

Connector designation:	X008	(20 digital outputs, 0.5 A)
Connector type:	S2L-SMT3.5/20/180	

The reference potential for the digital outputs is on connector X703 of the basic module.

Table 1- 18 Assignment of connector X008

Pin A	Signal	Designation	Pin B	Signal	Designation
1	DO24	Digital output 24, 0.5 A	1	DO25	Digital output 25, 0.5 A
2	DO26	Digital output 26, 0.5 A	2	DO27	Digital output 27, 0.5 A
3	DO28	Digital output 28, 0.5 A	3	DO29	Digital output 29, 0.5 A
4	DO30	Digital output 30, 0.5 A	4	DO31	Digital output 31, 0.5 A
5	DO32	Digital output 32, 0.5 A	5	DO33	Digital output 33, 0.5 A
6	DO34	Digital output 34, 0.5 A	6	DO35	Digital output 35, 0.5 A
7	DO36	Digital output 36, 0.5 A	7	DO37	Digital output 37, 0.5 A
8	DO38	Digital output 38, 0.5 A	8	DO39	Digital output 39, 0.5 A
9	DO40	Digital output 40, 0.5 A	9	DO41	Digital output 41, 0.5 A
10	DO42	Digital output 42, 0.5 A	10	DO43	Digital output 43, 0.5 A

Description

1.7 Housing with 1 expansion slot

Connector designation: **X009** (2x2 digital outputs, 2 A,
4 digital outputs, 0.5 A)

Connector type: S2L-SMT3.5/20/180

The reference potential for the digital outputs is on connector X703 of the basic module.

Table 1- 19 Assignment of connector X009

Pin A	Signal	Designation	Pin B	Signal	Designation
1	DO8	Digital output 8, isolated, 2 A	1	DO9	Digital output 9, isolated, 2 A
2	DO10	Digital output 10, isolated, 2 A	2	DO11	Digital output 11, isolated, 2 A
3	-	Not assigned	3	-	Not assigned
4	DO12	Digital output 12, isolated, 2 A	4	DO13	Digital output 13, isolated, 2 A
5	DO14	Digital output 14, isolated, 2 A	5	DO15	Digital output 15, isolated, 2 A
6	-	Not assigned	6	-	Not assigned
7	DO44	Digital output 44, 0.5 A	7	DO45	Digital output 45, 0.5 A
8	DO46	Digital output 46, 0.5 A	8	DO47	Digital output 47, 0.5 A
9	-	Not assigned	9	-	Not assigned
10	-	Not assigned	10	-	Not assigned

See also

Technical data for devices with a head module and basic module (Page 74)

Connection for power supply (Page 61)

1.7.3 Type plate

The housing with 1 expansion slots can only be ordered as a complete unit. There are 2 type plates on the housing.

The figure below shows all the information included on the type plates.

Note

The contents of the individual type plate fields on the current module may differ from those described in this manual (e.g. updated product status, approvals and markings not yet issued, etc.).

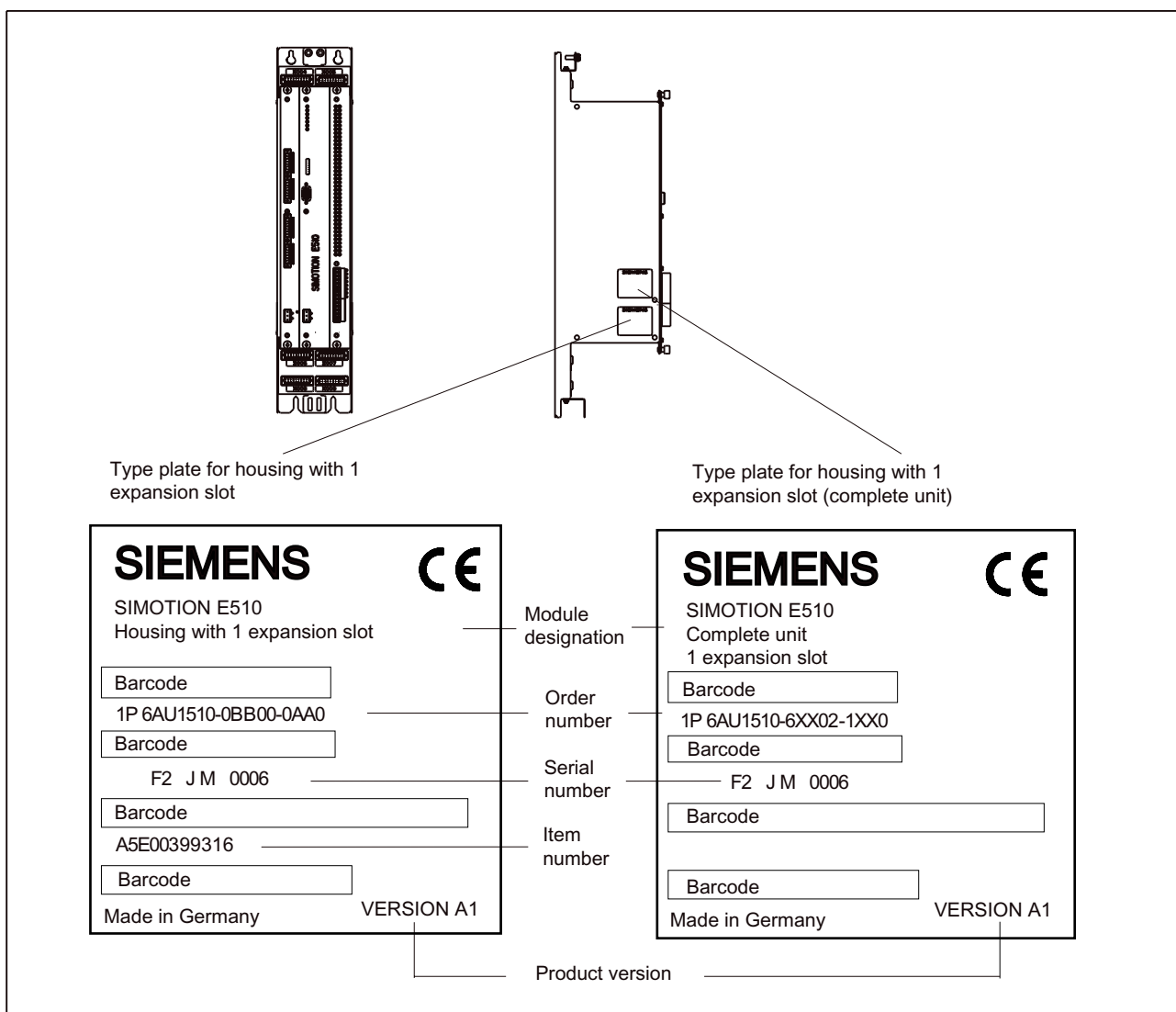

Figure 1-13 Type plates for housing with 1 expansion slot (e.g. in the figure for EB DIGITAL, 32DI)

1.8 Head module

1.8.1 Properties of head module

Head modules are included in the scope of delivery of complete units (order number 6AU1 510-6...). They only need to be ordered as individual components if they are to be used as spare parts.

Head modules are available in the following 2 versions:

- **IM, 8AI/8AO/16TC/4CNT** (designation on the head module)
Order number (spare part): 6AU1 510-1AA00-0AA0
- **IM, 8AI/4CNT** (designation on the head module)
Order number (spare part): 6AU1 510-1AB00-0AA0

Note

The more sparsely equipped head module **IM, 8AI/4CNT** is **only** supplied in conjunction with complete units with 1 expansion slot. It cannot be ordered as an individual component to be used as a spare part. The **IM, 8AI/8AO/16TC/4CNT** head module should be used as a replacement for an **IM, 8AI/4CNT** head module.

Task

The **head module** controls data exchange between the PROFIBUS DP and the **basic module**, as well as between the expansion modules. This module is also used for connecting to the PROFIBUS DP, in order to communicate with the SIMOTION or SIMATIC system.

The analog, temperature, and counter inputs, as well as the reference and analog outputs, are controlled on this module.

Illustration of the head module

The figure below shows the **head module** with the positions of the interfaces and front elements.

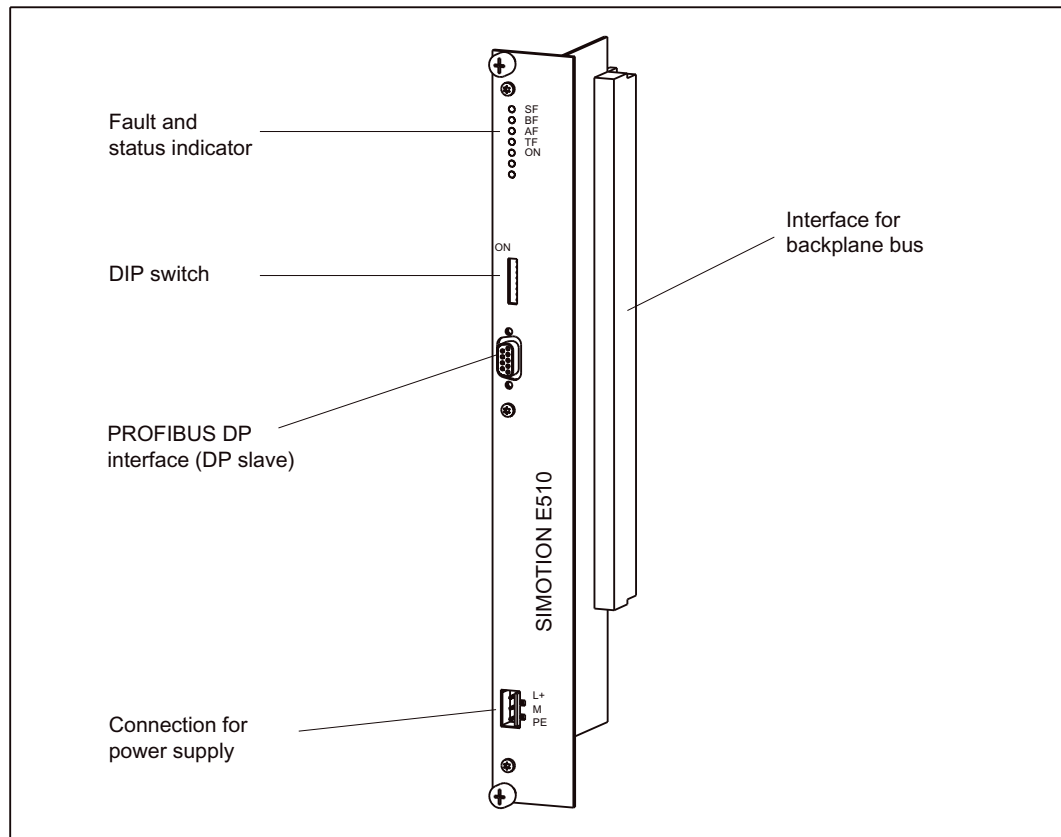

Figure 1-14 Illustration of the head module

Note

The wiring and block diagrams relating to the interfaces for the head module, as well as wiring instructions, can be found in the section titled "Wiring and block diagrams for devices with a head module and basic module".

See also

Wiring and block diagrams for devices with a head module and basic module (Page 65)

1.8.2 Description of functions for analog inputs

There are 8 analog inputs on the head module (for details of connector assignments, see the sections titled "Interfaces for housing with 4 expansion slots" or "Interfaces for housing with 1 expansion slot"). The analog inputs can be used to measure voltages from 0 V to 10 V.

The inputs can be used as freely addressable process inputs. Addresses are allocated in the hardware configuration. The inputs can be detected isochronously in the PROFIBUS DP cycle.

See also

Interfaces for housing with 4 expansion slots (Page 20)

Interfaces for housing with 1 expansion slot (Page 31)

Temperature inputs, analog inputs, reference outputs, and analog outputs (Page 69)

1.8.3 Description of functions for analog outputs

There are 8 analog outputs on the head module (for details of connector assignments, see the section titled "Interfaces for housing with 4 expansion slots"). The analog outputs can be used to supply loads/actuators with a voltage between -10 V and +10 V.

They can be used as freely addressable process outputs. Addresses are allocated in the hardware configuration.

The parameter settings can be used to determine whether a substitute value or the last value is output when communication is interrupted.

When used as process outputs, the outputs can be output isochronously in the PROFIBUS DP cycle.

See also

Interfaces for housing with 4 expansion slots (Page 20)

Temperature inputs, analog inputs, reference outputs, and analog outputs (Page 69)

1.8.4 Description of functions for reference outputs

Depending on the housing type, there are either 1 or 8 reference outputs on the head module (for details of connector assignments, see the sections titled "Interfaces for housing with 4 expansion slots" or "Interfaces for housing with 1 expansion slot"). A voltage of 10 V is output. The total current must **not** exceed 10 mA.

See also

Interfaces for housing with 4 expansion slots (Page 20)

Interfaces for housing with 1 expansion slot (Page 31)

Temperature inputs, analog inputs, reference outputs, and analog outputs (Page 69)

1.8.5 Description of functions for temperature inputs

There are 16 temperature inputs on the head module (for details of connector assignments, see the section titled "Interfaces for housing with 4 expansion slots").

The inputs can be used as freely addressable process inputs. Addresses are allocated in the hardware configuration.

The following can be connected to these inputs:

- Pt 100 resistance thermometer (RTD)
- Thermocouples of types J, K, L

Isolated measuring sensors

Isolated measuring sensors are not connected to the local ground potential. They can be operated as isolated entities. Potential differences U_{CM} (static or dynamic) may develop between the input channels as a result of local conditions or interference. However, such potential differences may not exceed the permitted value of U_{CM} . If there is a possibility that the permissible value may be exceeded, the "M" terminals of the input channels must be interconnected.

Interconnect the "M" terminals of the input channels with the "M" terminal of SIMOTION E510 if you anticipate any violation of U_{ISO} limits (inputs to the backplane bus).

The abbreviations used in the two diagrams below have the following meanings:

- M+ Measuring line (positive)
- M- Measuring line (negative)
- U_{ISO} Potential difference between the inputs and the 24 V reference potential M
- U_{CM} Potential difference between the inputs
- L+ Power supply connection 24 VDC
- M Reference potential for 24 VDC power supply

The figure below illustrates the connection of isolated measuring sensors to SIMOTION E510.

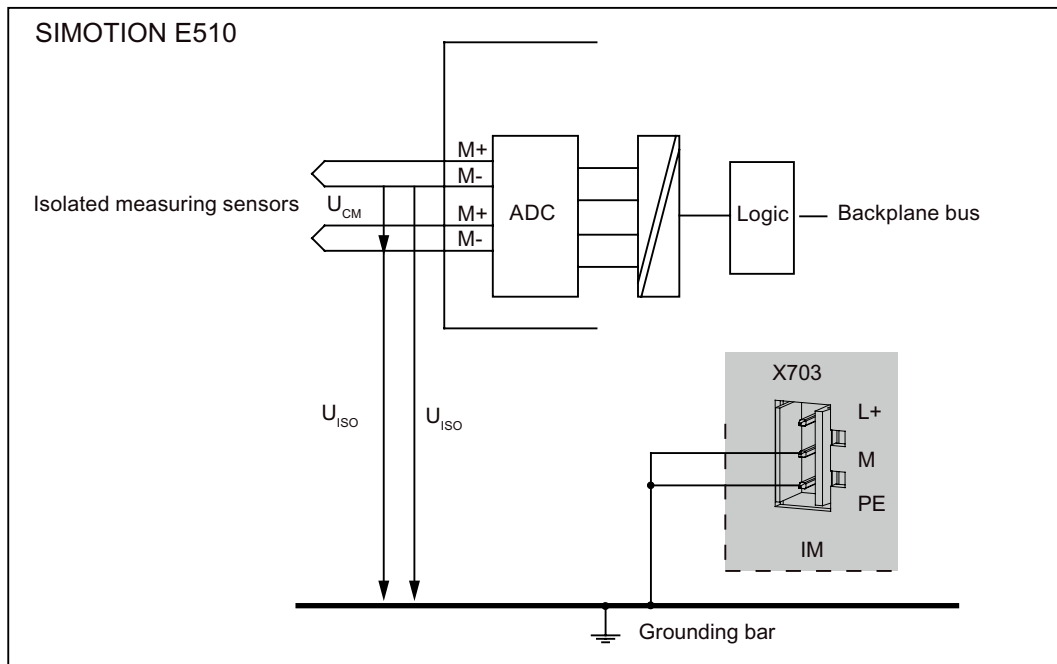

Figure 1-15 Connection of isolated measuring sensors

Non-isolated measuring sensors

Non-isolated measuring sensors are connected to the local ground potential. Potential differences (static or dynamic) may develop between locally distributed measuring points as a result of local conditions or interference. Install equipotential conductors between the measuring points in order to avoid such potential differences.

The figure below illustrates the connection of non-isolated measuring sensors to SIMOTION E510.

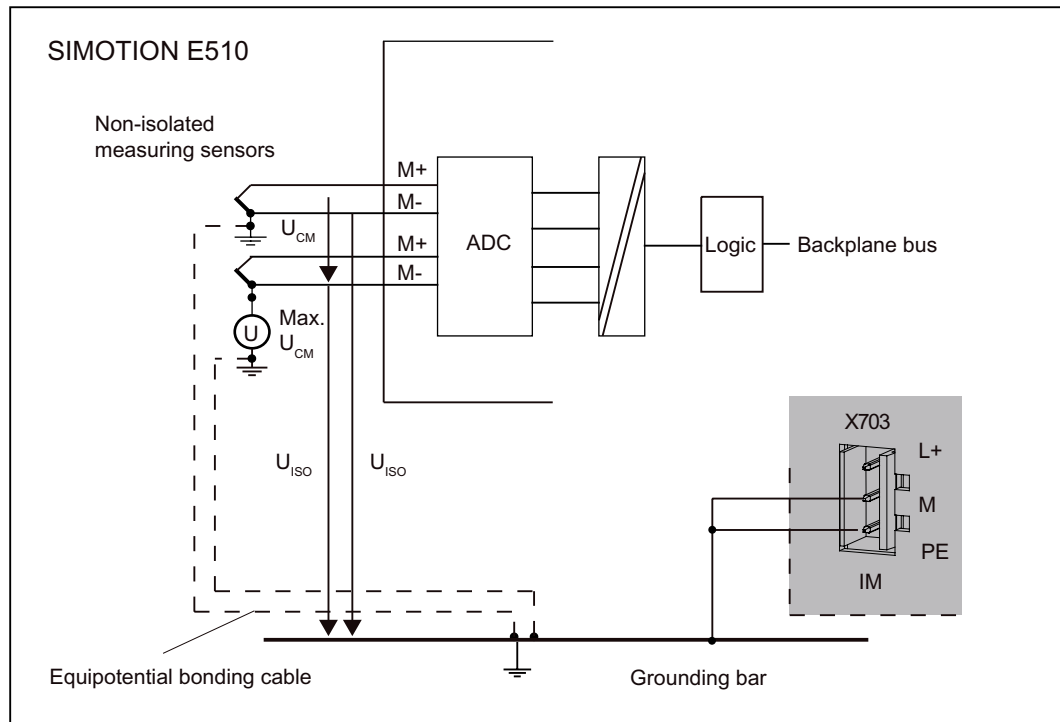

Figure 1-16 Connection of non-isolated measuring sensors

Resistance thermometer

Resistance thermometer measurement is assigned to two temperature inputs. One channel is used for the power supply, while the other is used for the voltage measurement. A maximum of 8 resistance thermometers can be connected. Two consecutive channels must be used for resistance thermometer measurement (TC0 and TC1, TC2 and TC3, ..., TC14 and TC15).

Thermocouple

Thermocouples consist of a pair of thermal probes, and all necessary installation and connecting parts. The thermocouple consists of two wire elements made of different metals or metal alloys. These are joined at their ends by means of soldering or welding.

Different types of thermocouple (for example, K, J, or L) are available depending on the composition of the material used. However, the measuring principle for all thermocouples is the same, irrespective of their type.

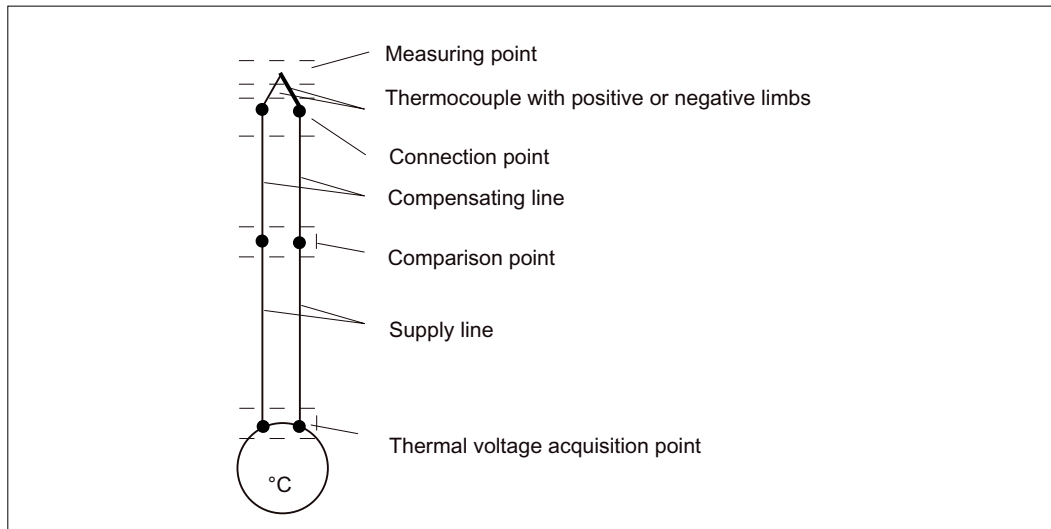

Figure 1-17 Structure of thermocouples

Operating principle of thermocouples

A difference of the temperature between the measuring point and the free ends of the thermocouple (terminal) generates a voltage at these electrodes, namely the thermal voltage. The magnitude of the thermoelectric voltage depends on the difference in temperature between the measuring point and the free ends, and on the combination of materials in the thermocouple.

As thermocouples always sense temperature differences, it is essential to maintain the free ends at the known temperature of a comparison point in order to be able to determine the temperature at the measuring point.

The thermocouples can be extended from their point of connection to the comparison point by means of compensating lines. These compensating wires are made of the same materials as the thermocouple wires. The supply lines are made of copper.

NOTICE

You must ensure the correct polarity of the connection in order to prevent substantial measuring errors from occurring (see "Wiring and block diagram for analog inputs/outputs and temperature inputs").

Compensating the comparison point temperature

You can compensate for the influence of temperature fluctuation at the comparison point by means of a compensating circuit.

There are various ways of obtaining the comparison point temperature in order to get an absolute temperature value from the temperature difference between the comparison point and measuring point.

You can use either an internal or an external compensating circuit, depending on the required location of the comparison point.

Table 1- 20 Options of compensating for the comparison point temperature

Option	Explanations
No compensation	For measurement with Pt 100
Internal compensation	If you employ internal compensation, the internal temperature of the module is used for comparison purposes.
External compensation with compensating box <ul style="list-style-type: none"> • Thermocouples with compensating box • Thermocouples with direct looping-in of compensating box 	<ul style="list-style-type: none"> • Compensation occurs via a separate temperature input, and the absolute temperature value is calculated in the module. • The compensation voltage is fed into each thermocouple or into the combined line for all the thermocouples. No further processing is required in the module.
External compensation with resistance thermometer (4-wire measurement) for recording the comparison point temperature (see "Wiring and block diagram for analog inputs/outputs and temperature inputs")	You can record the reference temperature by means of a resistance thermometer (Pt 100) and have it calculated by the module for any thermocouple.

Principle of operation of internal compensation

The internal temperature sensor measures the module's temperature and returns a compensation temperature.

Principle of operation of external compensation with compensating box

With external compensation, the temperature at the comparison point of the thermocouples is taken into consideration by means of a compensating box, for example.

The compensating box contains a bridge circuit that is adjusted for a certain comparison point temperature (compensating temperature). The terminals for the ends of the compensating line of the thermocouple form the comparison point.

Thermocouples with compensating box

If all the thermocouples connected to the inputs of a module have the same comparison point, you must compensate as shown in the figure below. The thermocouples that use a compensating box must be of the **same type** (J, K, L). Each of the thermocouples can be **grounded at any arbitrary point** (non-isolated thermocouples).

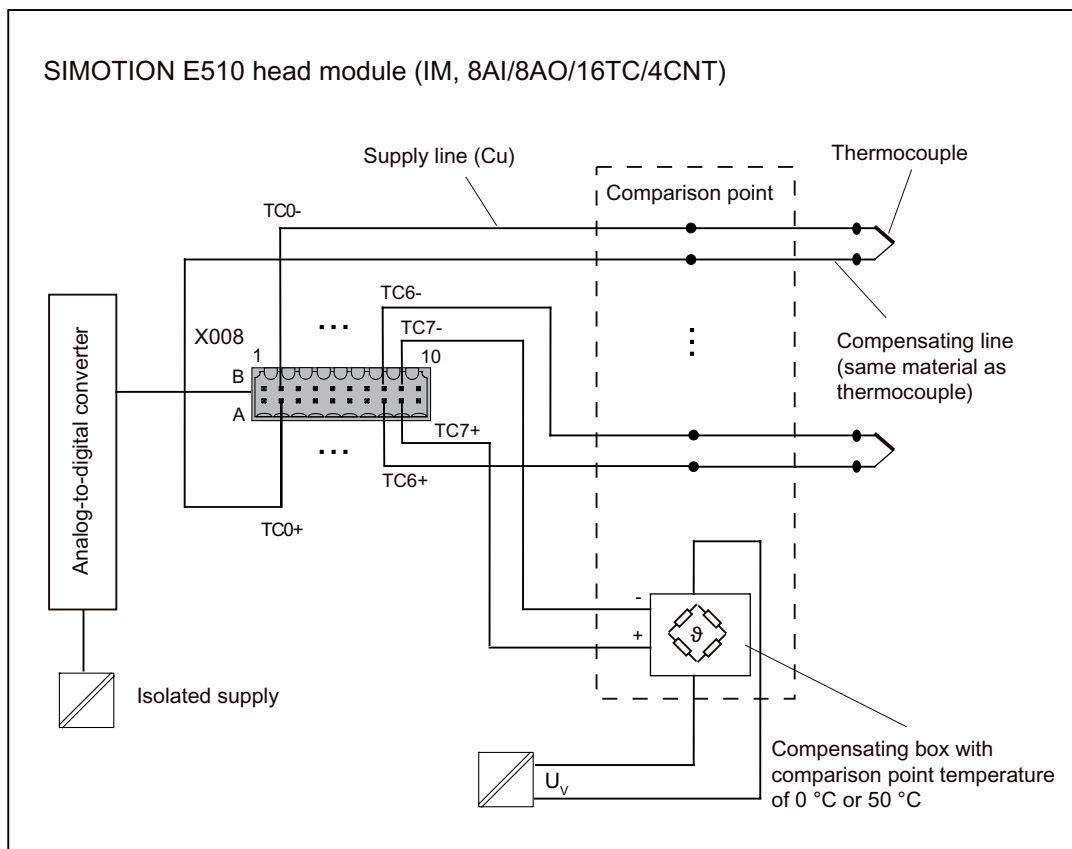

Figure 1-18 Thermocouples with compensating box

Thermocouples with direct looping-in of compensating box

The compensating box can be directly bedded into the measuring circuit if the wiring of all the thermocouples is isolated. Compensation input TC7 is not required and is now available as an additional measuring input. The **"Thermocouples with 0 °C or 50 °C compensating box"** measurement type must be set for all inputs. For this purpose, the thermocouples that use a compensating box must all be of the **same type**.

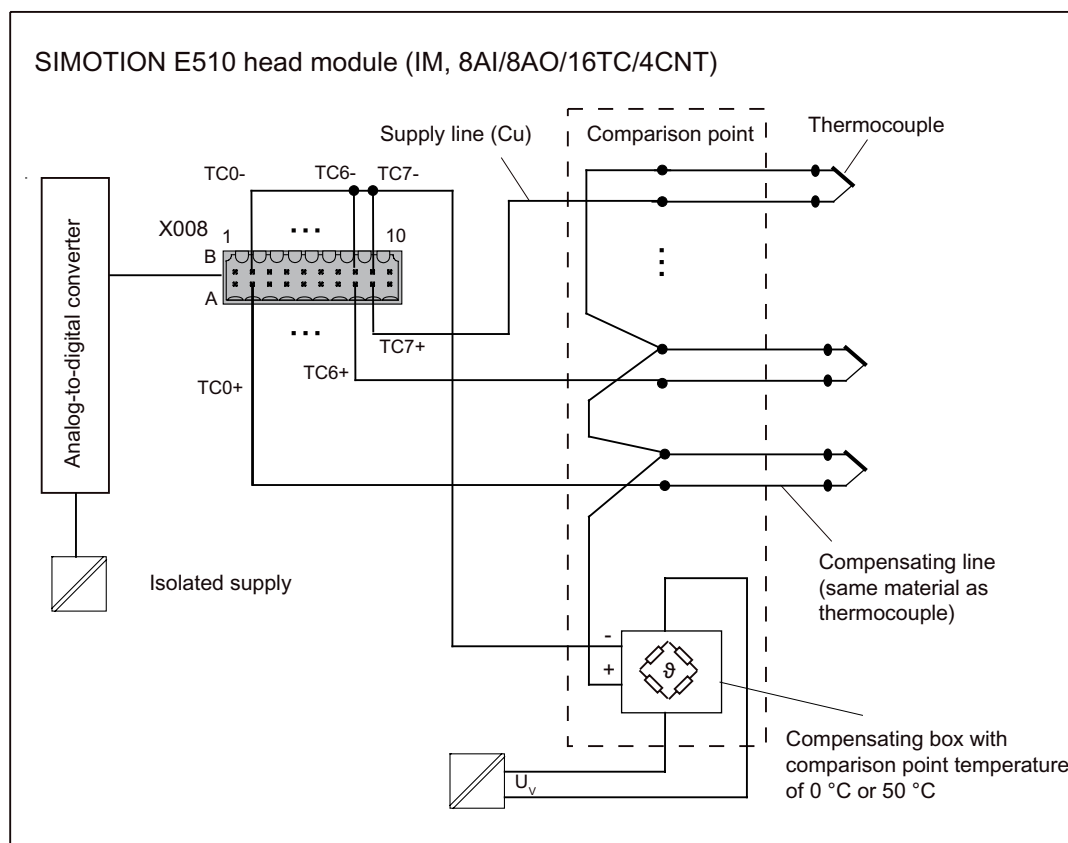

Figure 1-19 Thermocouples with direct looping-in of compensating box

Advantages:

- When using a compensating box with a comparison point temperature of 0 °C or 50 °C, the voltage corresponding to the comparison point temperature is subtracted **directly**.
- Input TC7 can be used **as an additional metering channel** with this circuit type.
- The number of connecting cables between the compensating box and the module is reduced.
- The faults that are attributed to isolated compensation measurement do not occur.

NOTICE

The thermocouples that are routed to the same compensating box **must only be grounded once at one point** (non-isolated thermocouple).

Principle of operation of external compensation with resistance thermometer

In the case of external compensation, the temperature of the comparison point is recorded by means of a resistance thermometer (4-wire measurement). This temperature is calculated internally.

Cycle time

The temperature inputs are processed one after the other without interruption. Conversion of the first temperature input starts again as soon as all the temperature inputs have been processed.

The cycle time - in other words, the time that elapses until a temperature input value is converted again - is the sum of the conversion times of all the activated temperature inputs.

Number of activated temperature inputs * 70 ms = time

For 16 active temperature inputs, for example: $16 * 70 \text{ ms} = 1.12 \text{ s}$

In order to reduce the cycle time, **deactivate** the temperature inputs that are not being used in the hardware configuration.

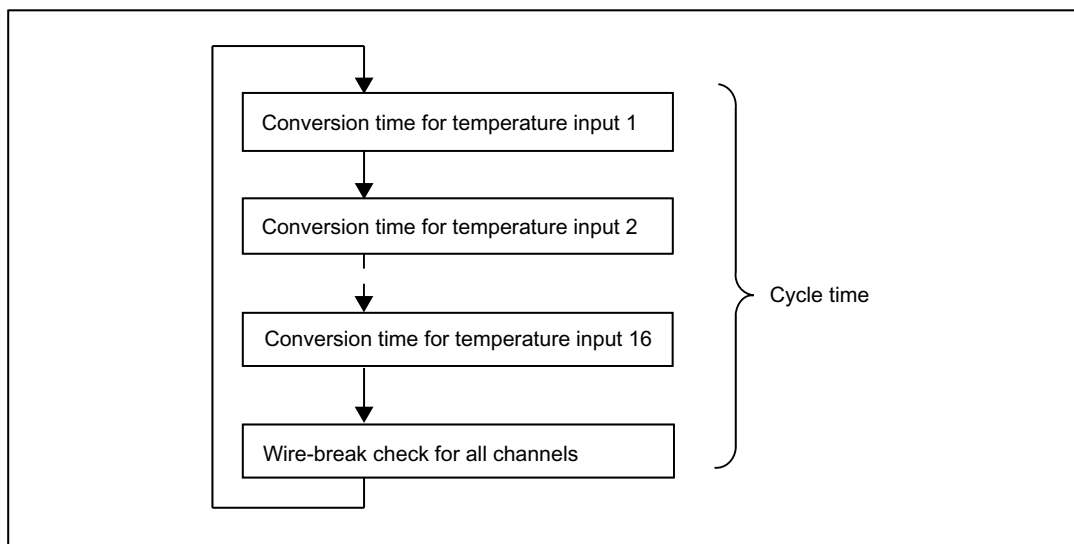

Figure 1-20 Cycle time for temperature inputs

Note

Wire-break checks for all channels are only performed once in the cycle. Once these have been performed, a false measurement result may be temporarily produced if a wire break recurs.

See also

Interfaces for housing with 4 expansion slots (Page 20)

1.8.6 Description of functions for counter inputs

There are 4 counter inputs on the head module (for details of connector assignments, see the sections titled "Interfaces for housing with 4 expansion slots" or "Interfaces for housing with 1 expansion slot"). These inputs comply with the standard IEC 1131-2/DIN EN 61131-2, characteristic type 1. They can be used as follows:

- As 4 up-counters
- As 2 up/down counters

Up-counter

Principle of a counter

A counter counts the number of time intervals. The figure below shows a simple encoder. The encoder outputs the signal "1" if the light falls through one of the slots in the disk. If the disk turns, the encoder outputs the signal shown in the figure below.

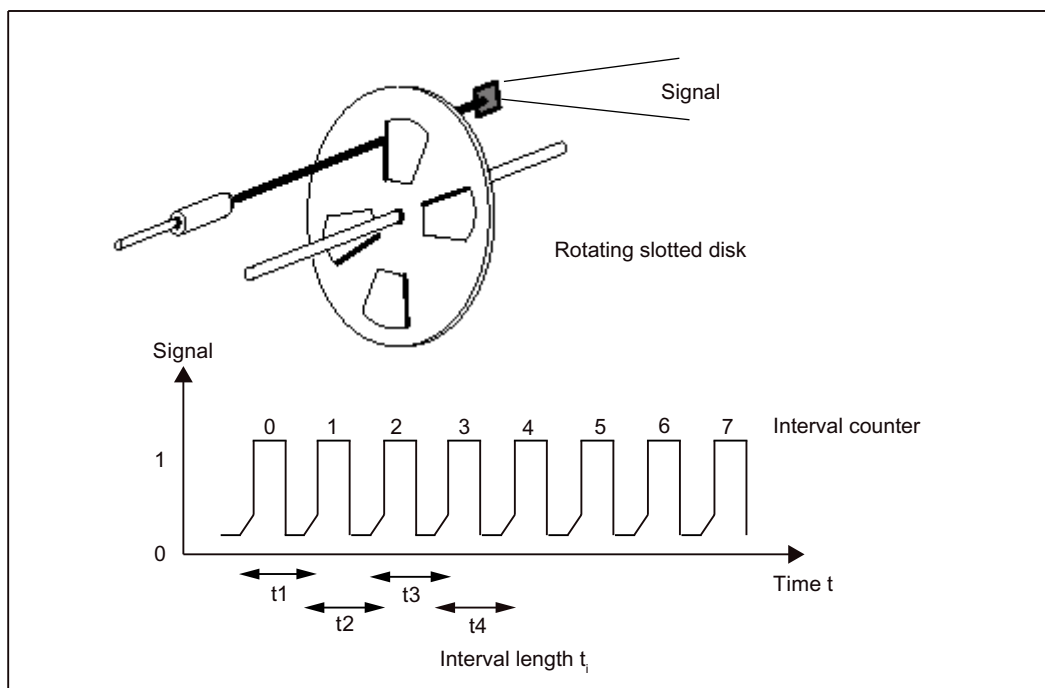

Figure 1-21 Simple encoder, e.g. slotted disk rotating on a shaft

The counter counts the number of intervals. The first interval begins when the signal changes from "0" to "1" (positive edge) for the first time. It ends with the next positive edge. This also marks the start of the next interval.

The counter also determines the duration of an interval. For this purpose, a counter is started on each positive edge. This counter increases its value by 1 on the basis of the time-base resolution (parameterized value) by the time the next positive edge occurs. We refer to this counter as the interval duration counter (IDC).

Principle of counter measurement

Pulses from a simple encoder are detected via the counter input. The encoder may be attached to the extruder worm of an injection molding machine, for example. You can determine the rotational speed of the worm on the basis of the time interval between 2 pulses.

SIMOTION E510 measures the distance in time (time interval) between 2 pulses. The time interval is determined using the time-base resolution (parameterized value). The number of intervals measured is also counted.

Once you know the number of pulses output by the encoder for each revolution of the extruder worm, you will be able to calculate the speed at which the extruder worm is revolving.

Example

$N = 16$ pulses are output for each revolution of the extruder worm (N is also referred to as the pulse number per revolution of the encoder). The duration between 2 pulses amounts to 500,000 counted increments for a parameterized time base of 41.7 ns. The rotational speed of the extruder worm is then calculated as follows:

$t = \text{counted increments} * \text{parameterized time base}$

$$v = \frac{1}{t * N} = \frac{1}{500000 * 41,7 \text{ ns} * 16} = 3 \frac{1}{s} = 180 \frac{U}{\text{min}}$$

The interval duration counter provides the count value, which is 3 bytes long. These 3 bytes can be used to represent values up to FFFFFFFF (16,777,215 in decimal format). Therefore, with a time base of 1 μs the minimum speed that can be measured for $N = 1$ is as follows:

$$v = \frac{1}{t * N} = \frac{1}{16777215 * 1 \mu\text{s}} = 0,0596 \frac{1}{s} = 3,58 \frac{U}{\text{min}}$$

The maximum speed that can be measured for encoders with passive tripping (the encoder output is open in the inactive state) is calculated from the maximum frequency (400 Hz) of the input signals at the counter inputs. If the encoder outputs 1 pulse per revolution, this will result in a maximum speed of 24,000 rpm.

If you are using encoders which output more than one pulse per revolution, you will have to reconsider the limit frequencies. Some examples are listed in the table below.

Table 1- 21 Limits for various pulses per revolution N for a time base of 1 μs (encoder with passive tripping)

N	Lower limit	Upper limit
1	3.58 rpm	24,000 rpm
4	0.89 rpm	6,000 rpm
8	0.45 rpm	3,000 rpm
16	0.22 rpm	1,500 rpm

Up-counter values

The values determined by SIMOTION E510 for operating the up-counter are stored as of the module start address + 4.

Table 1- 22 Register values for counter inputs

Signal	Module start address	Contents
CNT0	+ 4	Interval counter
	+ 5	Interval duration counter byte 1
	+ 6	Interval duration counter byte 2
	+ 7	Interval duration counter byte 3
CNT1	+ 8	Interval counter
	+ 9	Interval duration counter byte 1
	+ 10	Interval duration counter byte 2
	+ 11	Interval duration counter byte 3
CNT2	+ 12	Interval counter
	+ 13	Interval duration counter byte 1
	+ 14	Interval duration counter byte 2
	+ 15	Interval duration counter byte 3
CNT3	+ 16	Interval counter
	+ 17	Interval duration counter byte 1
	+ 18	Interval duration counter byte 2
	+ 19	Interval duration counter byte 3

The 1-byte interval counter is a ring counter for measured time intervals. The interval counter increases by "1" with every incoming pulse. No indication is given in the event of an interval counter overflow. The exact value must be calculated from the difference.

SIMOTION E510 stores the number of intervals detected so far for counter input CNT0 in the data byte with the address "Module start address + 4".

During the time it takes an interval to elapse, SIMOTION E510 counts the time until the end of the interval using parameterizable phases of 41.67 ns, 1 µs or 1 ms.

If an interval lasts longer than 16,777,215 (FFFFFF in hexadecimal format; the equivalent of 16,777.215 s where a time base of 1 ms is set), this is referred to as an overflow and is not explicitly indicated. The value indicated will be incorrect. The interval duration will be measured again with the next incoming pulse.

The value for the interval duration for counter input CNT0 is stored in 3 bytes from the module start address + 5. The "Module start address + 5" byte has a higher value than the "Module start address + 6" byte. The "Module start address + 7" byte has the lowest pulse value. The addresses for the data of the three other counter inputs (CNT1 to CNT3) are shown in the "Register values for counter inputs" table above.

Up/down counter:

Principle behind the counter

Two up/down counters can be used by combining two counter inputs. Both of the associated input signals, track A and track B, must have a phase relation of 90° and can be supplied by an incremental encoder, for example.

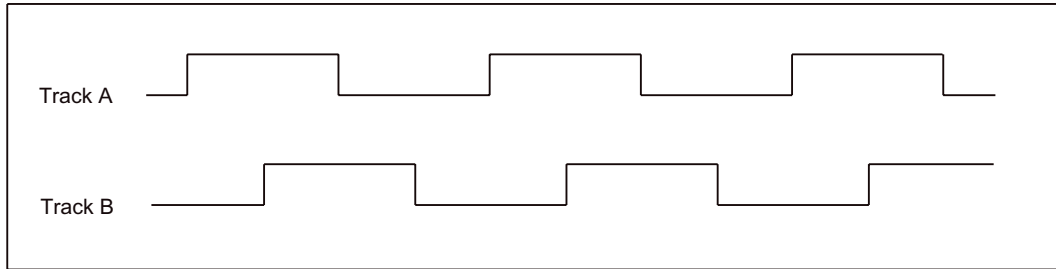

Figure 1-22 Signal wave form of the incremental encoder

It is possible to select a single, double, or quadruple detection process when setting the parameters for detecting direction. Counting frequencies of up to 25 kHz can be evaluated when using encoders with active tripping (the encoder output is connected to ground in the active state).

In total, two 4-byte pulse counters are available. These function as ring up/down counters. With every counting pulse, and depending on the direction detected, the counter is either increased or decreased by 1. As the table below shows, the counting pulses are given in terms of the type of detection parameterized.

Table 1- 23 Counting pulses

Detection parameterized	Counting pulse
Single detection	Rising edge at track A
Double detection	Rising and falling edge at track A
Quadruple detection	Rising and falling edge at track A and track B

Up/down counter values

The values determined by SIMOTION E510 for operating the up/down counter are stored as of the module start address + 4.

Table 1- 24 Register values for counter inputs

Signal	Module start address	Contents
CNT0	+ 4	Up/down counter byte 1
	+ 5	Up/down counter byte 2
	+ 6	Up/down counter byte 3
	+ 7	Up/down counter byte 4
-	+ 8 to +11	-
CNT2	+ 12	Up/down counter byte 1
	+ 13	Up/down counter byte 2
	+ 14	Up/down counter byte 3
	+ 15	Up/down counter byte 4
-	+16 to +19	-

The 4-byte pulse counter is a ring counter. No explicit indication is given in the event of an interval counter overflow. New values are only updated with incoming edges.

See also

Interfaces for housing with 4 expansion slots (Page 20)

Interfaces for housing with 1 expansion slot (Page 31)

1.8.7 Fault and status indicator

The following LEDs are situated on the front panel of the **head module**.

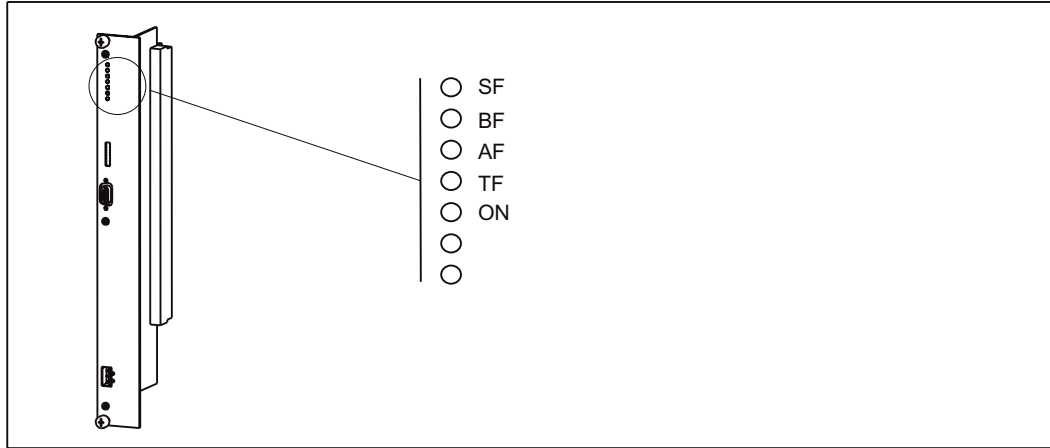

Figure 1-23 Status and fault indicators on the head module

Meaning of the status and fault indicators

The individual LEDs and their meanings are described in the table below.

Table 1- 25 Fault and status indicator

LED	Meaning	Explanations
SF (red)	Group fault (system fault)	This LED indicates a SIMOTION E510 fault.
BF (red)	PROFIBUS DP fault (bus fault)	This LED indicates a fault on the PROFIBUS DP interface.
AF (red)	Analog fault	This LED indicates a fault with the analog inputs/outputs on the head module.
TF (red)	Temperature fault	This LED indicates a fault with the temperature inputs on the head module (e.g. a wire break).
ON (green)	Power supply for the electronics	This LED indicates that the power supply is ready.

Note

The two LEDs (without labels) are used for diagnostic purposes (see section titled "Diagnostics using LEDs").

See also

LEDs on the head module (Page 237)

1.8.8 DIP switch

The PROFIBUS DP address is set in binary form using an 8-pole DIP switch.

Position of the DIP switch

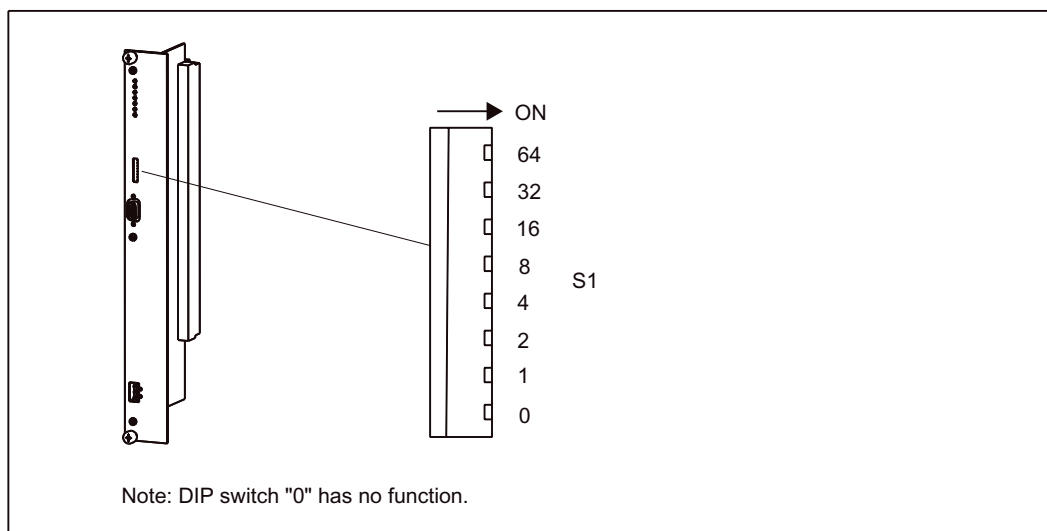

Figure 1-24 Position of the DIP switch

See the section titled "Connecting PROFIBUS DP to the head module" for information on setting the PROFIBUS DP address.

See also

Connecting PROFIBUS DP to the head module (Page 167)

1.8.9 PROFIBUS DP interface (DP slave)

SIMOTION E510 can communicate with the SIMOTION Motion Control System or the SIMATIC S7-300/400 automation system via the PROFIBUS DP interface (asynchronous or isochronous, equidistant).

The following PROFIBUS protocol is used for communication purposes: **PROFIBUS DP V2**

The maximum baud rate of the PROFIBUS DP interface is 12 Mbps.

SIMOTION E510 offers slave functionality.

Position of the connector

The figure below shows the installation position and designation of the connector on the head module.

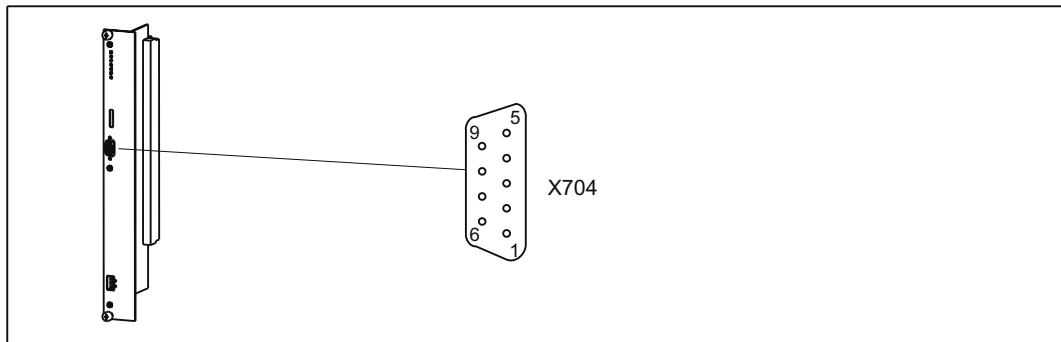

Figure 1-25 Position of connector X704

Connector assignment

Connector designation: X704
 Connector type: 9-pin sub D socket connector

Table 1- 26 Assignment of connector X704

Pin	Signal	Designation	Pin	Signal	Designation
1	-	Not assigned	6	P5	5 V power supply 60 mA, short-circuit proof
2	M24	24 V reference potential	7	P24	24 V power supply 150 mA, short-circuit proof, non-isolated
3	B	Data input/output (RS 485)	8	A	Data input/output (RS 485)
4	RTS	Transmission request	9	-	Not assigned
5	GND	Ground for 5 V voltage			

1.8.10 Connection for power supply

The following are connected to connector X703 on the **head module**:

- SIMOTION E510 logic supply
- 24 VDC load power supply for the analog outputs

Position of the connector

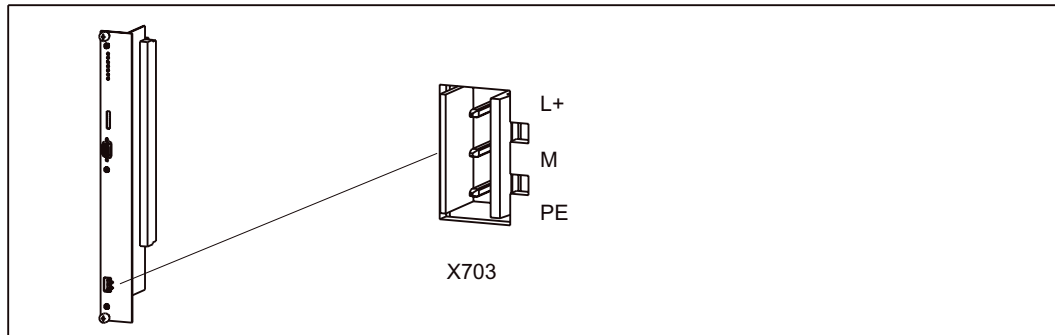

Figure 1-26 Position of connector X703

Connector assignment

Connector designation: X703
Connector type: SL-SMT3.5/90

Table 1- 27 Assignment of connector X703

Pin	Signal	Designation
1	L+	24 V power supply
2	M	24 V reference potential
3	PE	Functional ground

1.8.11 Type plate

The type plate for the **head module** is located on the printed circuit board.

The figure below contains all the information included on the type plate.

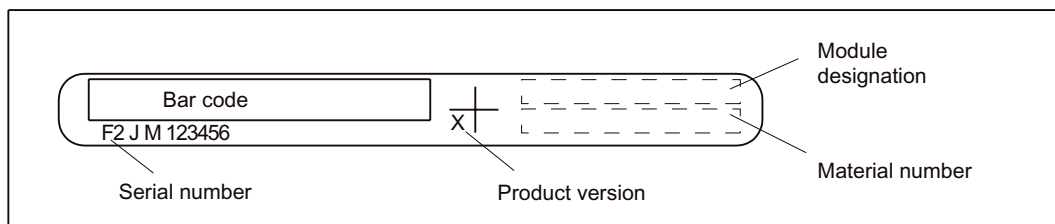

Figure 1-27 Type plate for head module

1.8.12 Firmware version

There is a label showing the SIMOTION E510 firmware version on connector X101 of the **head module**.

Note

This label indicates the firmware version on delivery. If the firmware is upgraded, make sure that you also alter the label accordingly.



Figure 1-28 Firmware version

Note

Head modules supplied as part of complete units with 1 expansion slot must not be used in complete units with or without 4 expansion slots.

Complete units with 1 expansion slot were designed with compactness in mind. This means that their structure does not support connection of 16 TC and 8 AO channels. As such, the head modules integrated into these complete units do not have TC/AO channels, and any channels that may be present are neither checked nor adjusted.

By contrast, head modules from complete units with or without 4 expansion slots can be used in complete units with 1 expansion slot.

1.9 Basic module

1.9.1 Properties of the basic module

The **basic module** is included in the scope of delivery of complete units (order number 6AU1 510-6...). It only needs to be ordered as an individual component if it is to be used as a spare part.

Order number (spare part):	6AU1 510-2AB00-0AA0
Designation of the basic module:	DIGITAL, 32DI/48DO

Task

The digital inputs and outputs are controlled on the **basic module**.

Illustration of the basic module

The figure below shows the **basic module** with the positions of the interfaces and front elements.

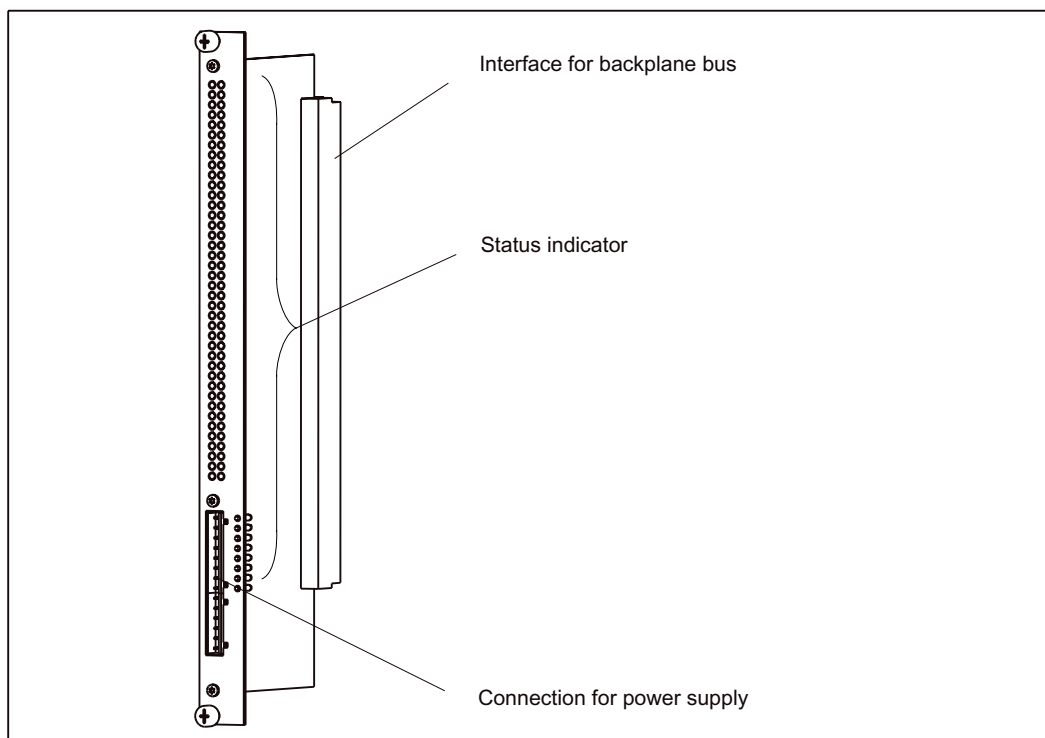

Figure 1-29 Illustration of the basic module

Note

The wiring and block diagrams relating to the interfaces for the basic module can be found in the section titled "Wiring and block diagrams for devices with a head module and basic module".

1.9.2 Description of functions for digital inputs

There are 32 digital inputs on the basic module (for details of connector assignments, see the sections titled "Interfaces for housing with 4 expansion slots" or "Interfaces for housing with 1 expansion slot"). These inputs comply with the standard IEC 1131-2/DIN EN 61131-2, characteristic type 1.

The inputs can be used as freely addressable process inputs. Addresses are allocated in the hardware configuration.

The inputs are detected in the PROFIBUS DP cycle.

See also

Digital inputs (Page 66)

1.9.3 Description of functions for digital outputs

There are 48 digital outputs on the basic module (for details of connector assignments, see the sections titled "Interfaces for housing with 4 expansion slots" or "Interfaces for housing with 1 expansion slot"). These outputs comply with the standard IEC 1131-2/DIN EN 61131-2.

The outputs can be used as freely addressable process outputs or as "time-controlled outputs" (on request). Addresses are allocated in the hardware configuration.

The parameter settings can be used to determine whether a substitute value or the last value is output when communication is interrupted.

When used as process outputs, the outputs are output in the PROFIBUS DP cycle.

Note

If the digital outputs are overloaded, the output is clocked to protect the module.

Use as time-controlled outputs (function available on request)

When using "time-controlled" outputs, you **must** set up the PROFIBUS DP interface as an isochronous, equidistant interface.

You can **only** use time-controlled outputs for the 2 A outputs (maximum of 8 outputs). These must be connected as follows:

- Housing with 4 expansion slots or no expansion slots at connector X004 (2 A digital outputs) or X005, pin A1 to A4 and pin B1 to B4 (2 A digital outputs)
- Housing with 1 expansion slot at connector X007 (2 A digital outputs) or X009, pin A1, 2, 4, 5 and pin B1, 2, 4, 5 (2 A digital outputs)

If you connect or parameterize more than 8 time-controlled outputs, a fault message will be generated.

When used as time-controlled outputs, these are output with an accuracy of approx. 64 µs.

Note

A minimum load of 2 kΩ needs to be connected to the time-controlled outputs.

Description of functions for time-controlled outputs

A time-controlled output triggers actions at specific points in time, such as switching a black/white valve, whereby the reversing point can be set to coincide with any given moment during the PROFIBUS DP cycle.

For additional information on parameterization and use, see the sections titled "Parameterizing inputs and outputs" and "Creating a user program".

See also

Digital outputs (Page 67)

Parameterizing inputs/outputs (Page 187)

Creating a user program (Page 203)

1.9.4 Connection for power supply

The following are connected to connectors X703 and X704 on the **basic module**:

- 24 VDC load power supply for the digital outputs
- Logic supply for the digital inputs

Position of connectors

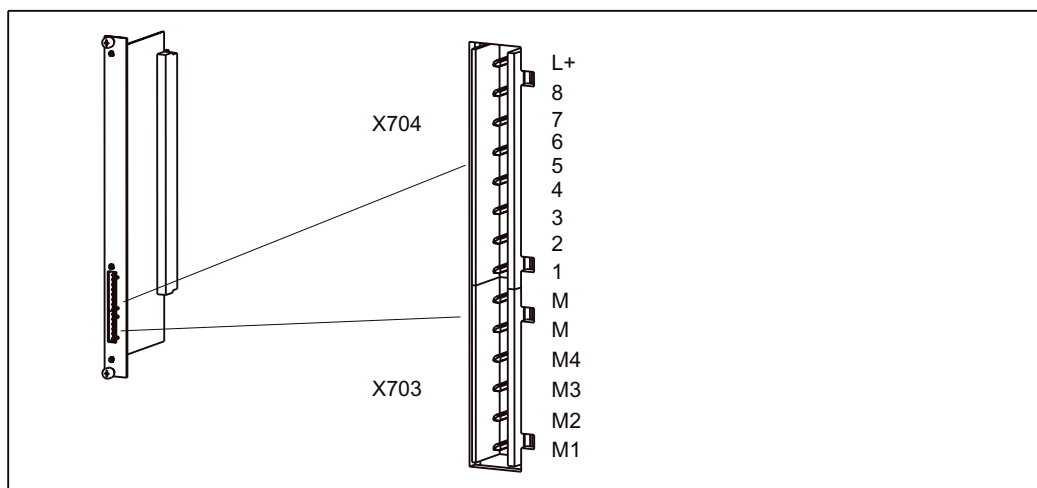

Figure 1-30 Position of connectors X703 and X704

Connector assignment

Note

For technical data on the digital inputs/outputs, see the section titled "Technical data for devices with a head module and basic module".

Connector designation: **X703/X704**
 Connector type: 1 x SL-SMT5.08/6/90
 1 x SL-SMT5.08/8/90

Table 1- 28 Assignment of connector X703/704

Pin	Signal	Designation
X704		
1	L8+	24 V supply for digital outputs 40 to 47 and digital inputs 0 to 31 ¹⁾
2	L7+	24 V supply for digital outputs 24 to 39 ¹⁾
3	L6+	24 V supply for digital outputs 20 to 23 ¹⁾
4	L5+	24 V supply for digital outputs 16 to 19 ¹⁾
5	L4+	24 V supply for digital outputs 12 to 15
6	L3+	24 V supply for digital outputs 8 to 11
7	L2+	24 V supply for digital outputs 4 to 7
8	L1+	24 V supply for digital outputs 0 to 3
X703		
1	M	24 V reference potential for digital outputs 16 to 47 and digital inputs 0 to 31
2	M	
3	M4	24 V reference potential for digital outputs 12 to 15
4	M3	24 V reference potential for digital outputs 8 to 11
5	M2	24 V reference potential for digital outputs 4 to 7
6	M1	24 V reference potential for digital outputs 0 to 3

¹⁾ In order to ensure the module has a power supply, at least one of the 24 V supplies indicated and its associated reference potential must be connected.

Supply groups

The table below shows the power supply assignments for the inputs and outputs.

Table 1- 29 Supply groups

Supply groups	Signal	Inputs/outputs	24 V reference potential
Supply group 1	L1+	DO0 to 3	M1, isolated
Supply group 2	L2+	DO4 to 7	M2, isolated
Supply group 3	L3+	DO8 to 11	M3, isolated
Supply group 4	L4+	DO12 to 15	M4, isolated
Supply group 5	L5+	DO16 to 19	M, non-isolated
Supply group 6	L6+	DO20 to 23	
Supply group 7	L7+	DO24 to 39	
Supply group 8	L8+	DO40 to 47 and DI0 to 31	

1.9.5 LEDs (status indicators)

The following LEDs are on the front panel of the **basic module**.

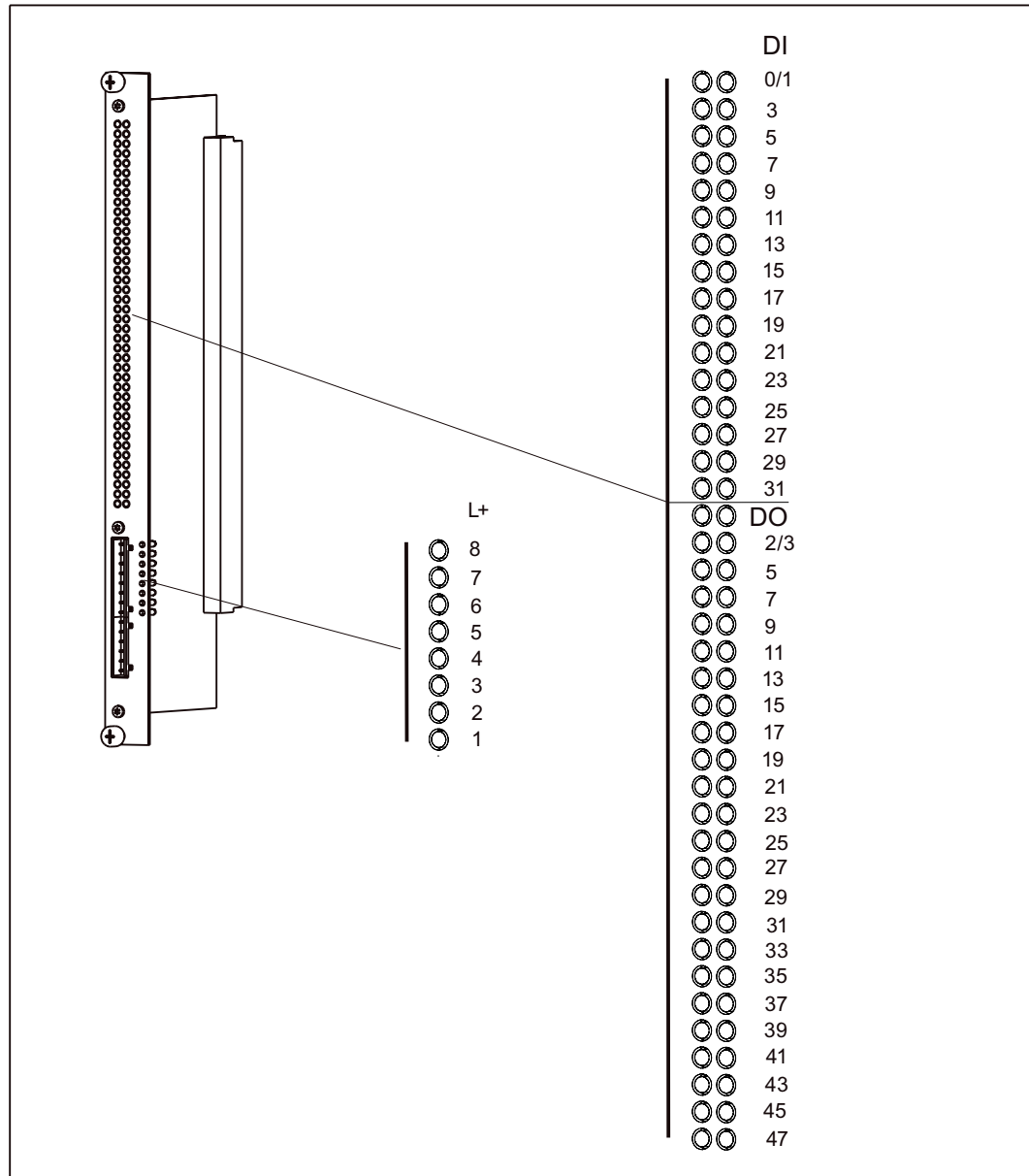

Figure 1-31 Status indicators on the basic module (DIGITAL 32DI/48DO)

Meaning of the status indicators

The individual LEDs and their meanings are described in the table below.

Table 1- 30 Status indicator

LED	Meaning	Explanations
D10 to DI31 (green)	Status of the digital inputs	These LEDs show the status of digital inputs 0 to 31.
DO0 to DO47 (green)	Status of the digital outputs	These LEDs show the status of digital outputs 0 to 47.
L1+ (green) to L7+ (green)	Power supply for the digital outputs	These LEDs show the availability of digital outputs 0 to 39.
L8+ (green)	Power supply for the digital outputs/inputs	This LED shows the availability of digital outputs 40 to 47 and digital inputs 0 to 31.

1.9.6 Type plate

The type plate for the **basic module** is located on the printed circuit board.

The figure below contains all the information included on the type plate.

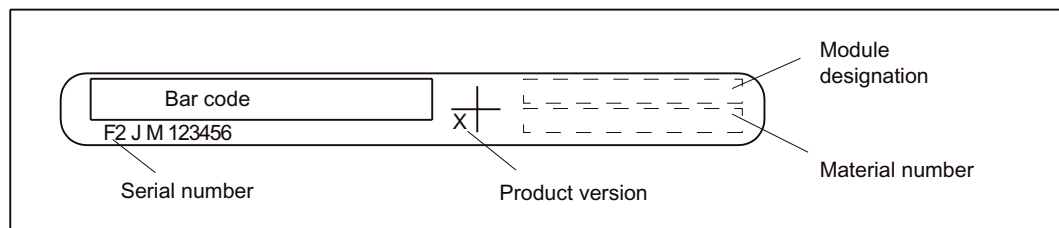

Figure 1-32 Type plate for the basic module

1.10 Wiring and block diagrams for devices with a head module and basic module

1.10.1 Overview

Note

The wiring diagrams shown in this chapter apply to the housing with 4 expansion slots or the housing with no expansion slots with a **head module** (IM, 8AI/8AO/16TC/4CNT) and a **basic module** (DIGITAL 32DI/48DO). Wiring diagrams for expansion modules can be found in the chapter for the relevant module.

1.10.2 Digital inputs

Wiring and block diagram for the basic module's DI 32, 24 VDC digital input block

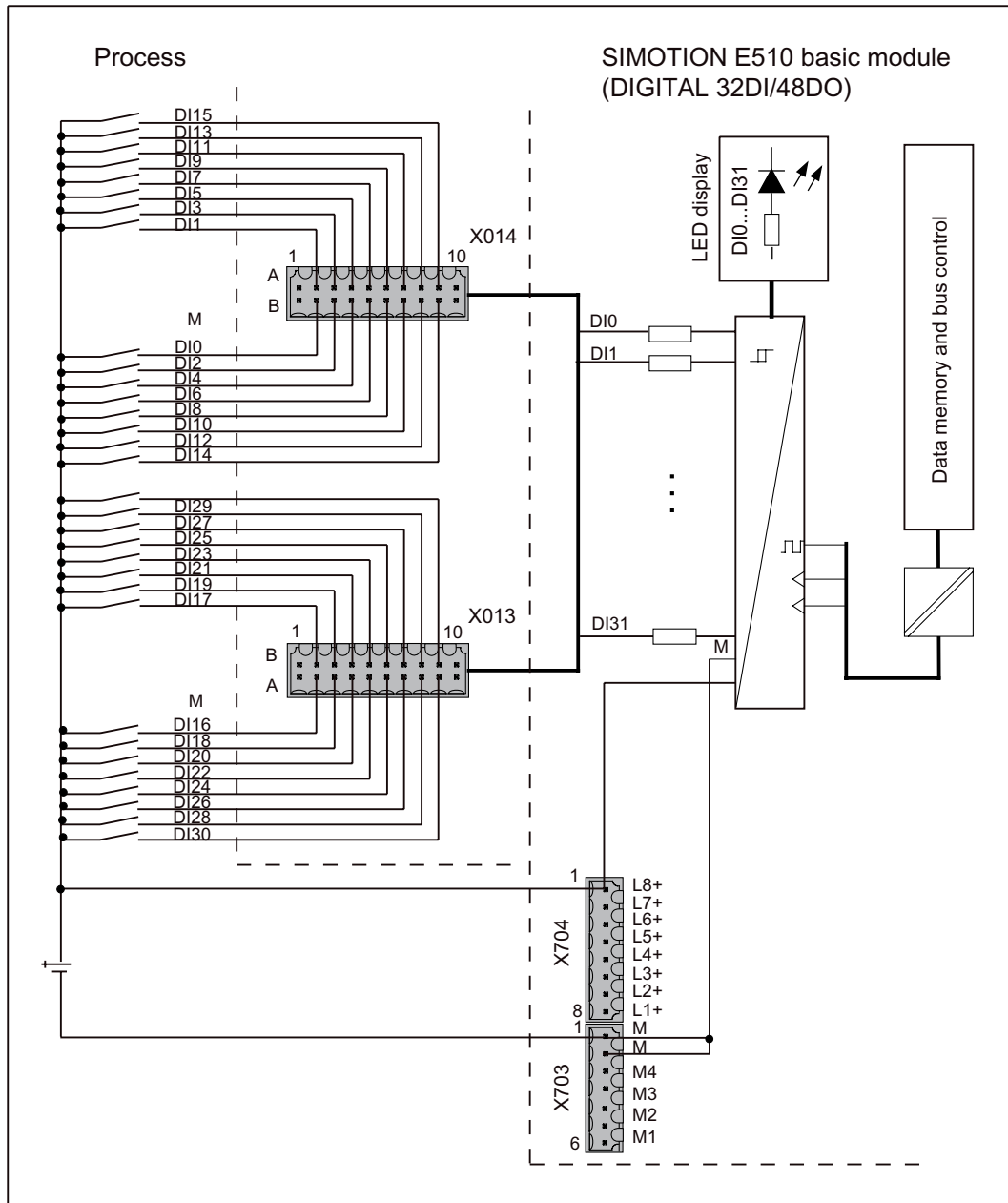

Figure 1-33 Wiring and block diagram for digital inputs

1.10.3 Digital outputs

Wiring and block diagram for the isolated DO 4 x 4 x 2 A, 24 VDC digital output block of the basic module

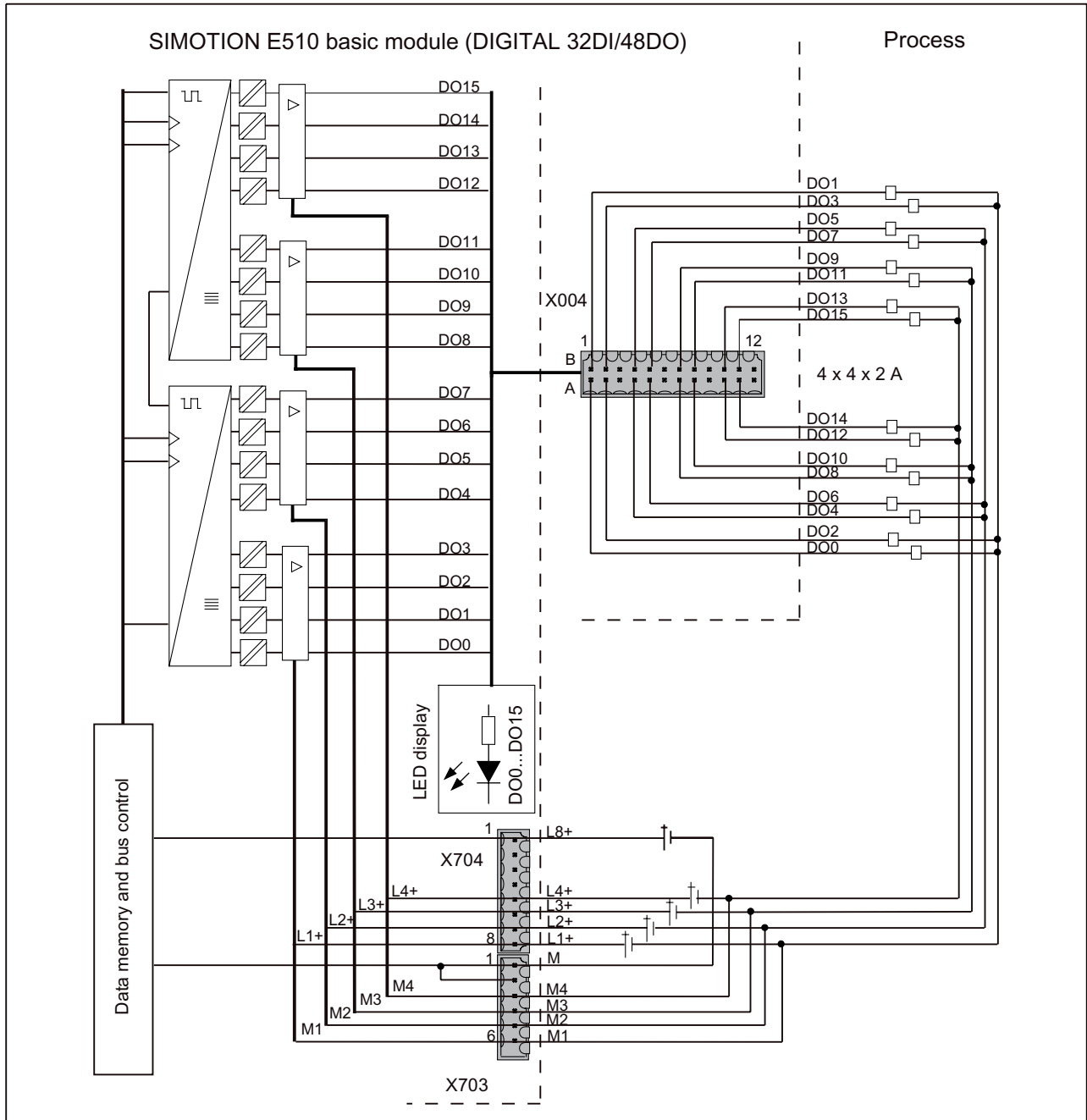

Figure 1-34 Wiring and block diagram for digital outputs DO 4 x 4 x 2 A

1.10 Wiring and block diagrams for devices with a head module and basic module

Wiring and block diagram for the DO 8 x 2 A and DO 24 x 0.5 A, 24 VDC digital output block of the basic module

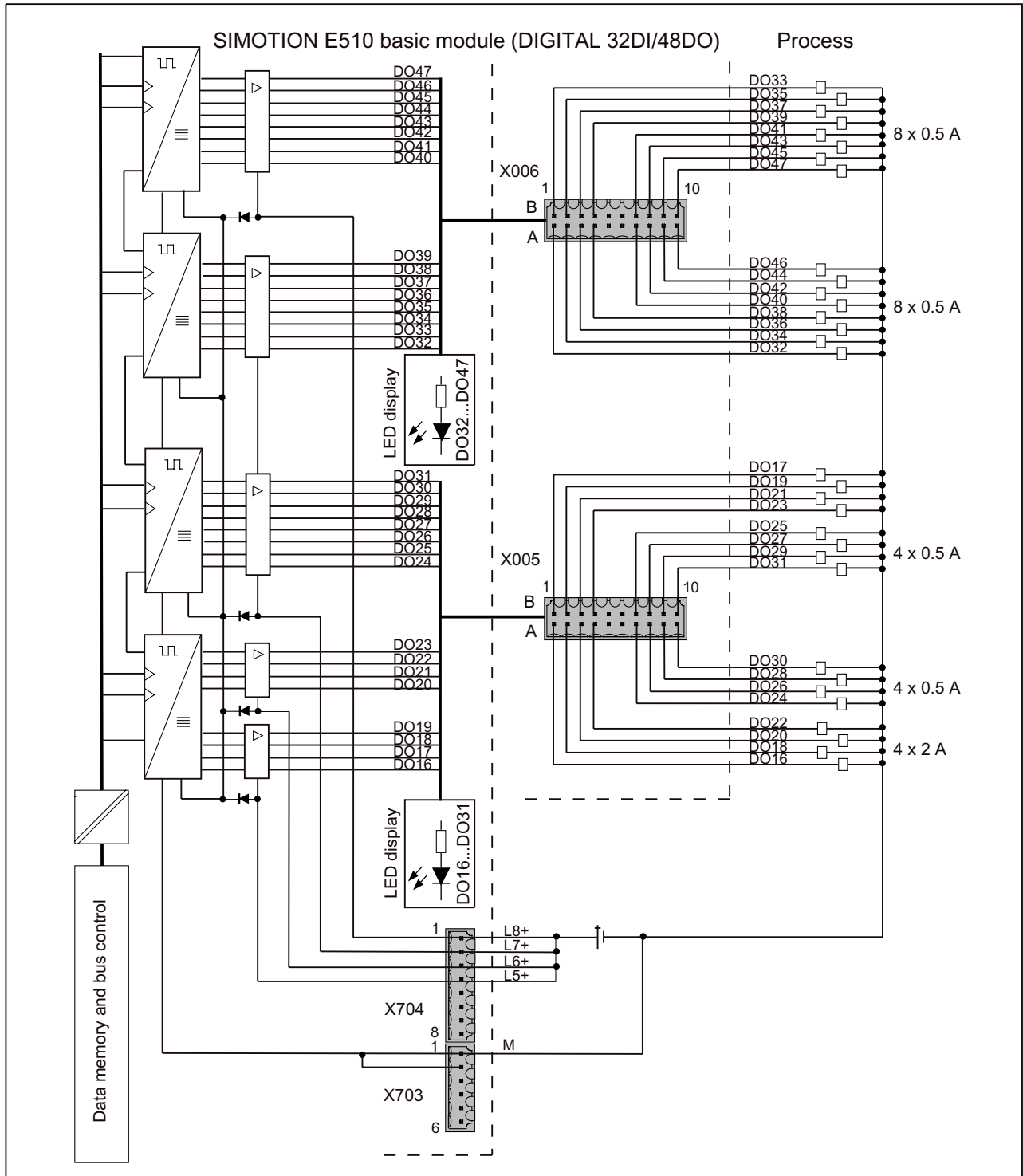

Figure 1-35 Wiring and block diagram for digital outputs DO 8 x 2 A and DO 24 x 0.5 A

1.10.4 Temperature inputs, analog inputs, reference outputs, and analog outputs

Block diagram for analog inputs/outputs

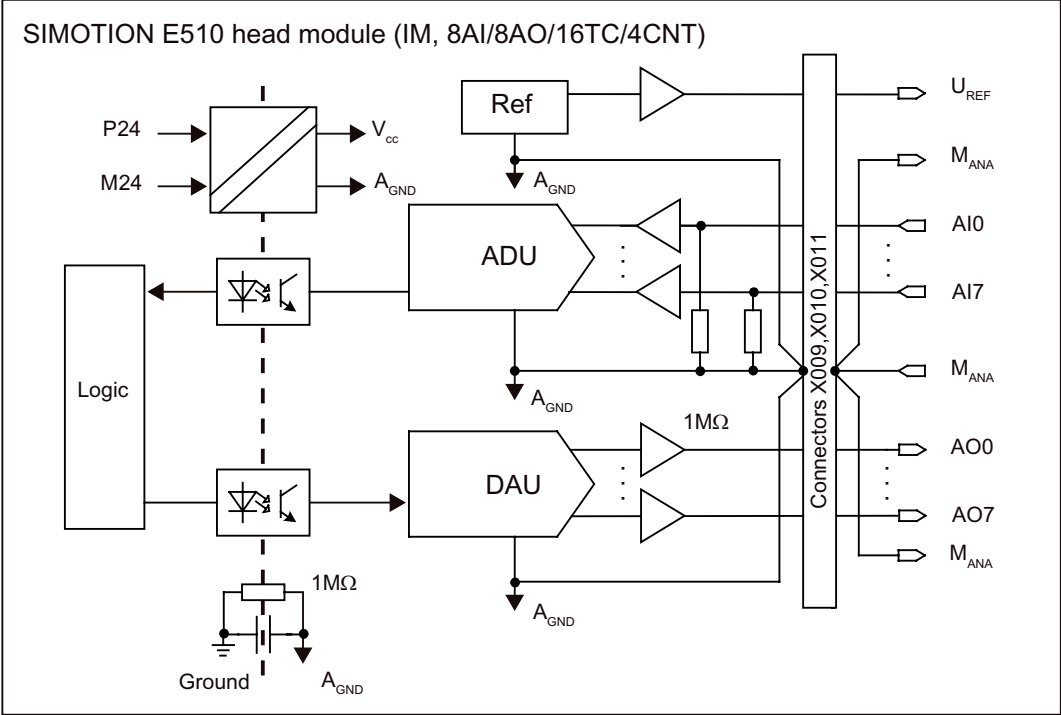

Figure 1-36 Block diagram for analog inputs/outputs

Block diagram for temperature inputs

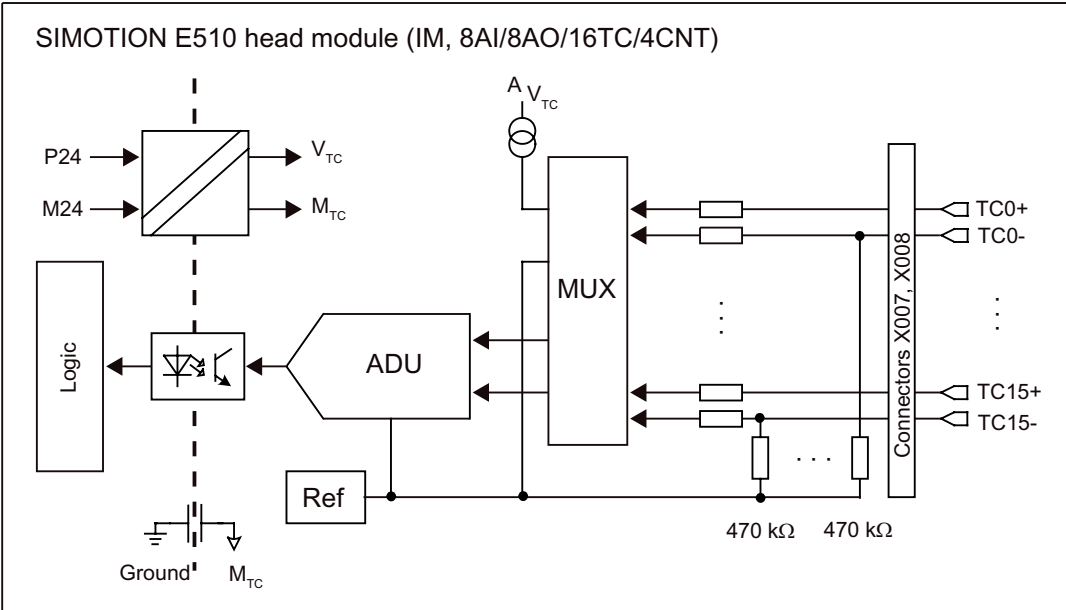

Figure 1-37 Block diagram for temperature inputs

Wiring and block diagrams for analog inputs/outputs and temperature inputs

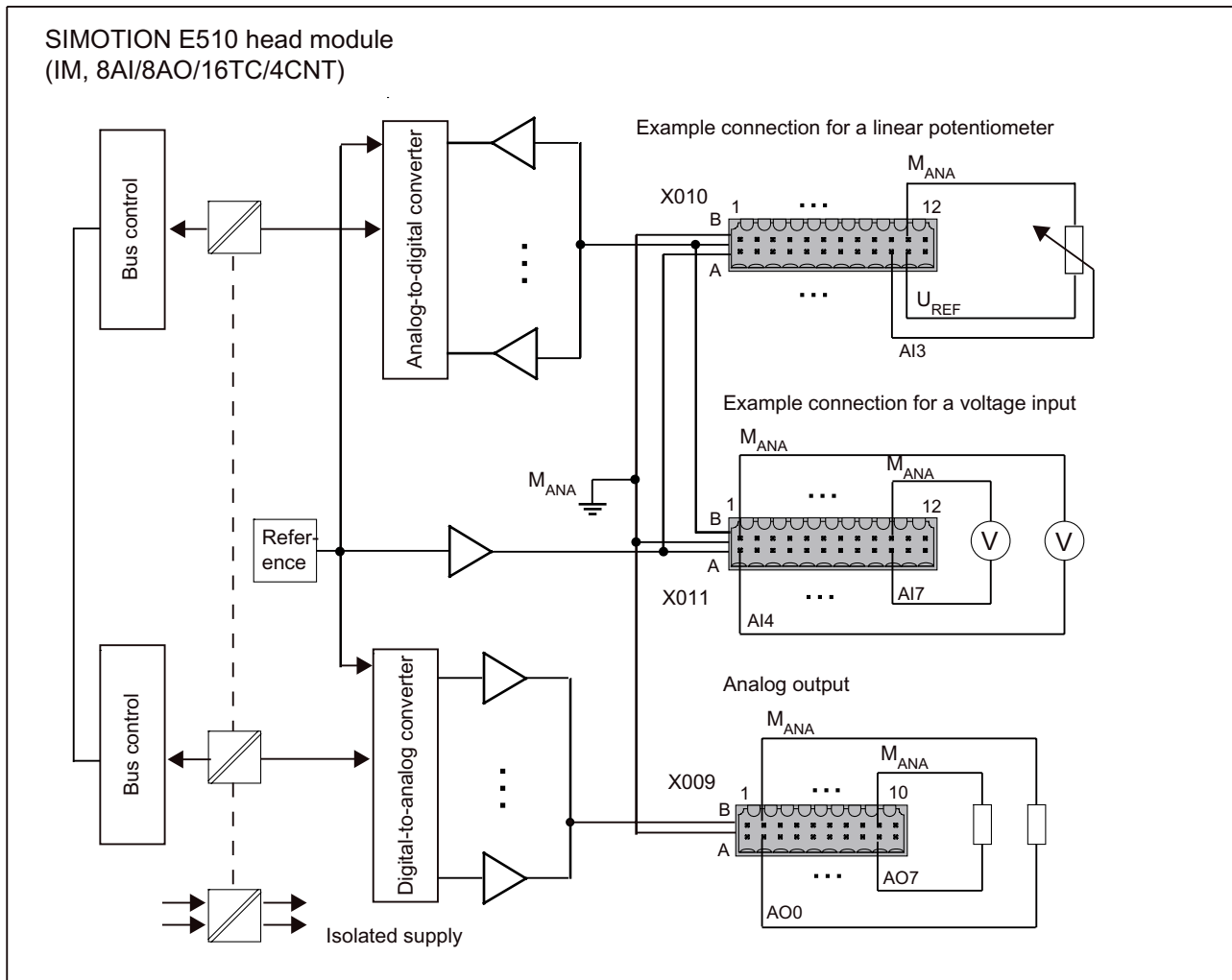

Figure 1-38 Wiring and block diagram for analog inputs/outputs

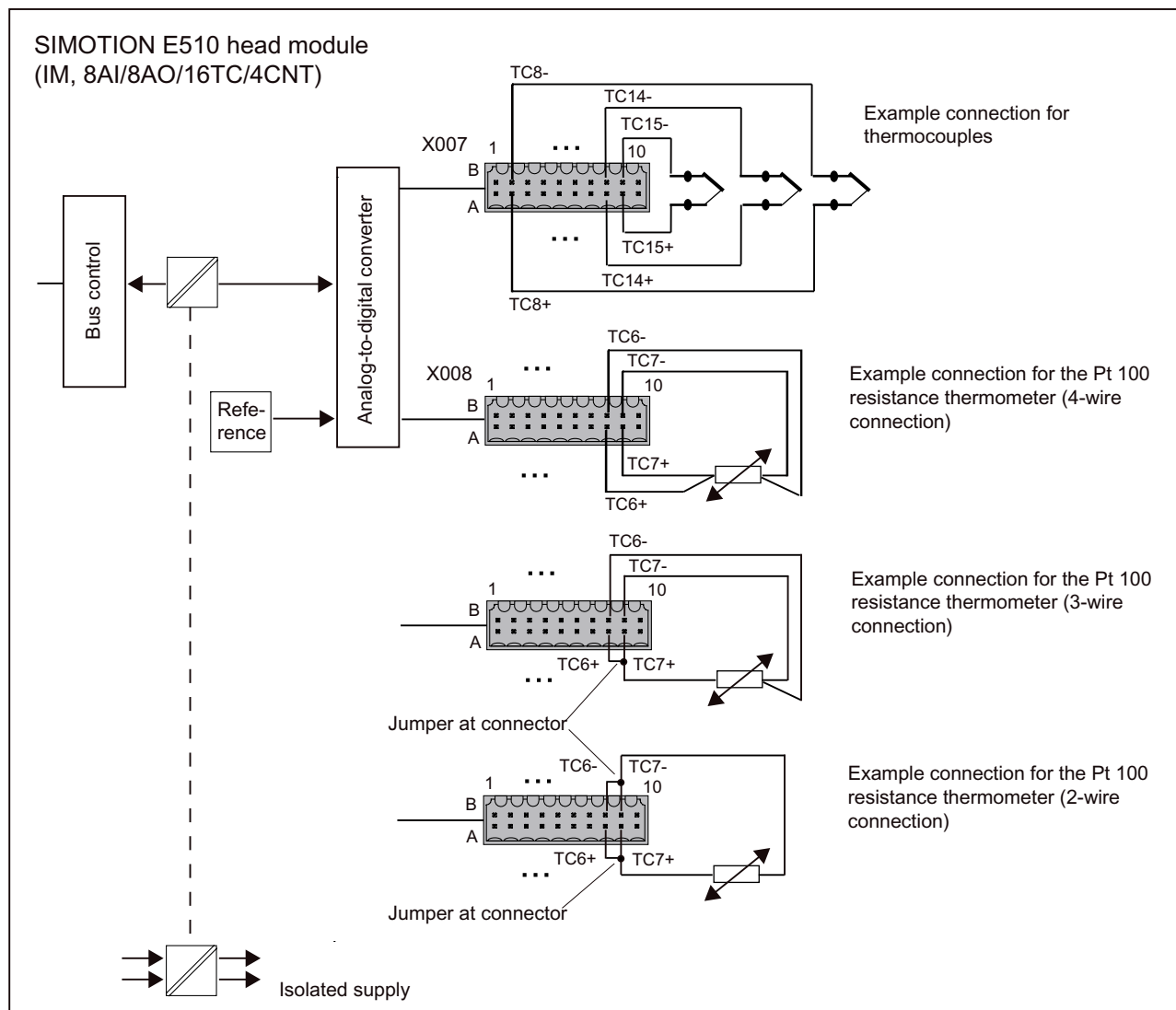

Figure 1-39 Wiring and block diagram for temperature inputs

Note

The following basic principles apply to the wiring and block diagram for analog inputs/outputs and temperature inputs:

- The cables need to be protected, shielded, and arranged as twisted pairs to prevent them from being affected by interference (see the section titled "Connecting inputs/outputs to the housing").
- The measurement accuracy required depends
 - On the load
 - On the cable between SIMOTION E510 and the load
 - On the reference voltage

Connecting the temperature inputs

You must ensure the correct polarity of the connected cable during connection work (see wiring and block diagram for analog inputs/outputs and temperature inputs).

All inputs are based on M_{ANA}. To prevent faults, all ground wires of the sensors should be routed to the terminals in a point-to-point configuration.

Connecting the analog inputs

You must not connect the sensors to a potential twice, as this creates ground loops which can introduce interference.

If you are using shielded sensors whose shield is connected to the analog ground, you will need to remove the connection between the shield and the analog ground.

All inputs are based on M_{ANA}. To prevent faults, all ground wires of the sensors should be routed to the terminals in a point-to-point configuration.

Analog inputs that are not connected must be short-circuited and connected to M_{ANA}. Deactivate the analog inputs that are not connected in the hardware configuration. Adopting this approach offers maximum resistance.

You can also use analog inputs that are not connected for monitoring reference outputs or analog outputs. This also increases resistance.

Connecting the reference output

A voltage drops out on the cable between SIMOTION E510 and the linear potentiometer. Given the high resolution of SIMOTION E510, this voltage clearly has the potential to affect signal measurement.

The voltage drop on a cable can be calculated as follows:

$$U = \frac{r_0 * I * L}{A}$$

U:	Voltage drop along a cable
r ₀ :	Specific resistance of the cable (for Cu: 0.0172 Ω mm ² /m)
I:	Current flowing through the cable in amperes
L:	Length of the cable in m
A:	Cross-section of the cable in mm ²

In light of this information, we recommend that cables are routed for as short a distance as possible and that cables with the largest possible cross-section are used.

The eight reference outputs are all supplied from **a single** source (see wiring and block diagrams for analog inputs/outputs and temperature inputs). The total current must **not** exceed 10 mA.

The housing with 1 expansion slot only has one reference output.

Connecting the analog outputs

All outputs are based on M_{ANA}. To prevent faults, all ground wires of the actuators should be routed to the terminals in a point-to-point configuration.

Shielded actuators whose shield is grounded and connected to the actuator's ground cable form a ground loop. You should, therefore, break the connection between the shield and

1.10 Wiring and block diagrams for devices with a head module and basic module

ground cable on the actuator, or use an actuator whose ground cable is not connected to ground.

To prevent unconnected analog outputs from being de-energized, they must be deactivated and left open. Analog outputs are deactivated in the hardware configuration.

1.10.5 Counter inputs

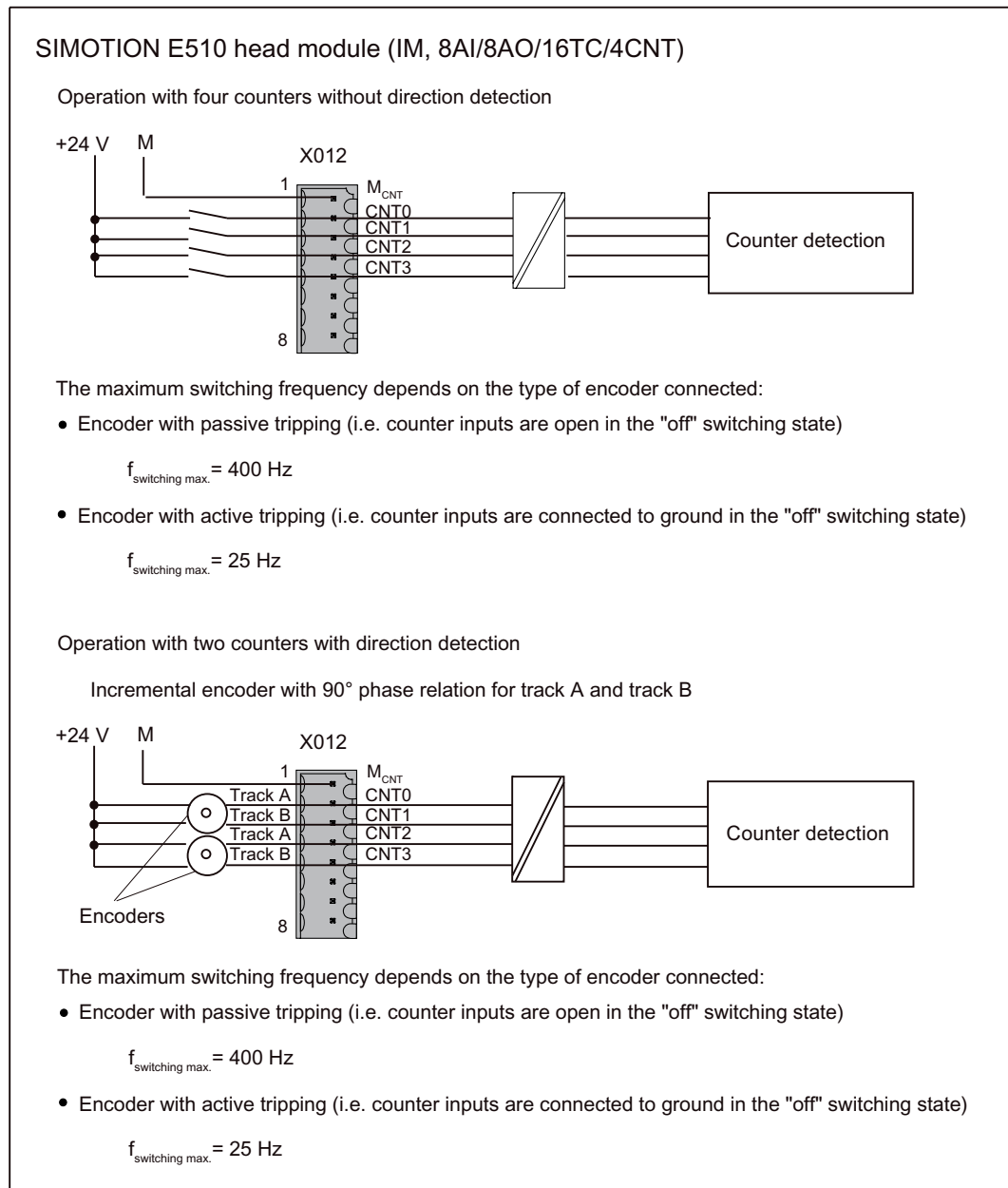

Figure 1-40 Wiring and block diagram for counter inputs

1.11 Technical data for devices with a head module and basic module

Note

The technical data listed in this chapter applies to devices with a **head module** (IM, 8AI/8AO/16TC/4CNT) and a **basic module** (DIGITAL 32DI/48DO).

Technical data for expansion modules is described in the chapter for the relevant module.

PROFIBUS DP

Table 1- 31 PROFIBUS DP

DP cycle	$1 \text{ ms} \leq \text{DP cycle} \leq 8 \text{ ms}$ $T_o \geq 0.5 \text{ ms}; T_i \geq 0.375 \text{ ms}$ See section titled "Parameterizing constant bus cycle time and isochronous mode".
Baud rate	Up to 12 Mbps

Connection values

Table 1- 32 Connection values

Supply voltage	24 VDC; permissible range: 20.4 to 28.8 V (PELV)
Current consumption of the basic variant (head module and basic module)	
Head module (supply group L+) <ul style="list-style-type: none"> • Fuse on module • Total current 	<ul style="list-style-type: none"> • 4 A, time-lag • Typ. 1 A
Basic module (supply group L1+ to L7+) <ul style="list-style-type: none"> • Fuse on module • Total current (50% output simultaneity) Basic module (supply group L8+) <ul style="list-style-type: none"> • Fuse on module • Total current (50% output simultaneity) 	<ul style="list-style-type: none"> • 10 A, quick-response • Typ. per group = 4 A • 10 A, quick-response • Typ. per group = 2 A

Dimensions and weight

Table 1- 33 Dimensions and weight

Housing (4 expansion slots)	
Dimensions W x H x D [mm]	301 × 387 × 142
Weight of complete unit with 4 empty expansion slots and grounding screws	Approx. 4,900 g
Housing (without expansion slots)	
Dimensions W x H x D [mm]	207.4 × 387 × 142
Weight of complete unit without expansion slots and grounding screws	Approx. 2,700 g
Housing (1 expansion slot)	
Dimensions W x H x D [mm]	100 × 489 × 142
Weight of complete unit with 1 empty expansion slot and grounding screws	Approx. 2,650 g
Head module (IM, 8AI/8AO/16TC/4CNT)	
Dimensions W x H x D [mm]	40.3 × 350.5 × 140.9
Weight	Approx. 480 g
Basic module (DIGITAL, 32DI/48DO)	
Dimensions W x H x D [mm]	27.1 × 350.5 × 140.9
Weight	Approx. 380 g
Holder for mounting onto standard rail (set of 4)	Approx. 120 g

Digital inputs (according to IEC 1131-2/DIN EN 61131-2, characteristic type 1)

Table 1- 34 Digital inputs

Number of inputs	32, protected against polarity reversal
Length of cable	Max. 30 m
Encoder selection data	
Input voltage <ul style="list-style-type: none"> Rated value 1 signal 0 signal 	<ul style="list-style-type: none"> 24 VDC (PELV) 15 to 30 V -3 to 5 V
Input current <ul style="list-style-type: none"> 1 signal 	<ul style="list-style-type: none"> Typ. 3 mA
Input delay until register input <ul style="list-style-type: none"> 0 → 1 signal 1 → 0 signal 1 → open 	<ul style="list-style-type: none"> Typ. 30 µs Typ. 140 µs Typ. 600 µs

Description

1.11 Technical data for devices with a head module and basic module

Voltages, currents, potentials	
Galvanic isolation	No
Non-isolated	Reference potential M
Insulation test voltage	500 VDC

Digital outputs (according to IEC 1131-2/DIN EN 61131-2)

Table 1- 35 Digital outputs

Number of outputs	48	
Length of cable	Max. 30 m	
Type of outputs	High-side driver	
Actuator selection data	DO0 to 23; 2 A	DO24 to 47; 0.5 A
Output voltage with 1 signal	L+ -0.16 V	L+ -0.16 V
Output current	<ul style="list-style-type: none"> • Rated value • 1 signal • 1 signal (for time control) • 0 signal (residual current) 	<ul style="list-style-type: none"> • 2 A • Max. 2.4 A • Min. 7 mA • Min. 12 mA • 0.3 mA
Output delay (register output to driver output)	<ul style="list-style-type: none"> • 0 → 1 signal • 1 → 0 signal 	<ul style="list-style-type: none"> • 0.5 A • Max. 0.7 A • 0.3 mA
Output delay (register output to driver output)	<ul style="list-style-type: none"> • Typ. 30 µs • Typ. 200 µs 	<ul style="list-style-type: none"> • Typ. 40 µs • Typ. 80 µs
Lamp load	Max. 5 W	
Max. switching frequency	<ul style="list-style-type: none"> • With resistive load • With inductive load in accordance with IEC 947-5-1, DC 13 • With lamp load 	
Max. switching frequency	<ul style="list-style-type: none"> • 100 Hz • 2 Hz • 11 Hz 	
Limiting of inductive cut-off voltage	47 V	53 V
Max. inductance for loads without external protective circuit	100 mH	-
Short-circuit protection of the output	<ul style="list-style-type: none"> • Yes, electronic pulsing 	<ul style="list-style-type: none"> • Yes, electronic pulsing
Response threshold	<ul style="list-style-type: none"> • > 2.5 A 	<ul style="list-style-type: none"> • > 0.7 A
Voltages, currents, potentials		
Rated load voltage	24 VDC (PELV)	
Total current of outputs	See "Connection values" table	
Galvanic isolation	<ul style="list-style-type: none"> • Non-isolated DO16 to DO47 • Isolated DO0 to DO15 	
Galvanic isolation	<ul style="list-style-type: none"> • In group of 1 x 32 • In groups of 4 x 4 	
Insulation test voltage	500 VDC	

Analog inputs

Table 1- 36 Analog inputs

Number of inputs	8
Cable length, shielded	Max. 30 m
Encoder selection data	
Input voltage (rated value)	0 to 10 V
Overflow range	0 to 12 V
Input impedance	1 M Ω
Input type	Asymmetrical
Permissible input voltage relative to M _{ANA}	Max. 15 V, long-term
Voltages, currents, potentials	
Galvanic isolation	
<ul style="list-style-type: none"> • Between channels and internal bus • Between channels 	<ul style="list-style-type: none"> • Yes • No
Insulation test voltage	500 VDC
Formation of analog values (input in relation to analog ground)	
Measuring principle	SAR (successive approximation)
Integration/conversion time/resolution	
<ul style="list-style-type: none"> • Parameters can be assigned • Basic conversion time of all 8 channels in μs • Resolution (including overshoot range) • Input filter 	<ul style="list-style-type: none"> • No • Approx. 100 μs • 14 bits without sign • Approx. 1 kHz, 2nd order
Noise suppression and error limits	
Crosstalk attenuation between inputs	> 60 dB
Operational limit (across temperature range, in relation to input range)	\pm 0.1%
Intrinsic error limit (operational limit at 25 °C in relation to input range)	\pm 0.05%

 **DANGER**

The input voltage for the analog inputs must be configured as a protective extra-low voltage (PELV).

Reference outputs

Table 1- 37 Reference outputs

Number of channels	One reference signal for: <ul style="list-style-type: none"> • 8 reference outputs (for housing with no expansion slots or with 4 expansion slots) • 1 reference output (for housing with 1 expansion slot)
Cable length, shielded	Max. 30 m
Actuator selection data	
Output voltage (rated value)	10 V
Output impedance	< 100 Ω
Output current (sum of all reference outputs)	10 mA
<ul style="list-style-type: none"> • Load resistance (for all reference outputs used) • Capacitive load (for all reference outputs used) 	<ul style="list-style-type: none"> • Min. 8 kΩ • Max. 1 μF
Voltage output <ul style="list-style-type: none"> • Short-circuit protection • Short-circuit current 	<ul style="list-style-type: none"> • Yes • 20 mA
Voltages, currents, potentials	
Galvanic isolation between channel and internal bus	Yes
Insulation test voltage	500 VDC
Error limits	
Operational limit (across temperature range, in relation to output range)	\pm 0.25%
Intrinsic error limit (operating limit at 25 °C in relation to output range)	\pm 0.24%

Note

The output voltage is configured as a protective extra-low voltage (PELV).

Analog outputs

Table 1- 38 Analog outputs

Number of outputs	8
Cable length, shielded	Max. 30 m
Actuator selection data	
Output voltage (rated value)	± 10 V
Overflow range	± 12.5 V
Output current	± 3 mA
Output impedance	$< 100 \Omega$
<ul style="list-style-type: none"> Load resistance Capacitive load 	<ul style="list-style-type: none"> Min. $3.3 \text{ k}\Omega$ Max. $1 \mu\text{F}$
Voltage output <ul style="list-style-type: none"> Short-circuit protection Short-circuit current 	<ul style="list-style-type: none"> Yes ± 21 mA
Voltages, currents, potentials	
Galvanic isolation <ul style="list-style-type: none"> Between channels and internal bus Between channels 	<ul style="list-style-type: none"> Yes No
Insulation test voltage	500 VDC
Formation of analog values	
Resolution, including sign	15 bits + 1 bit "sign"
Transient recovery time ($R_L = 3.3 \text{ k}\Omega$)	< 0.1 ms
Conversion principle	Resistor - DAC string
Noise suppression and error limits	
Crosstalk attenuation between the outputs	> 65 dB
Operational limit (across temperature range, in relation to output range)	$\pm 0.3\%$
Intrinsic error limit (operating limit at $25 \text{ }^\circ\text{C}$ in relation to output range)	$\pm 0.1\%$

Note

The output voltage is configured as a protective extra-low voltage (PELV).

Temperature inputs

Table 1- 39 Temperature inputs

Number of inputs <ul style="list-style-type: none"> • Thermocouple • Resistance thermometer 	<ul style="list-style-type: none"> • 16 • 8
Cable length, shielded	Max. 30 m
Encoder selection data	
Input range (rated values) <ul style="list-style-type: none"> • Voltage • Resistance 	Parameters cannot be assigned <ul style="list-style-type: none"> • ± 60 mV • $300 \Omega^1)$
Permissible input differential voltage	Max. 5 V
Characteristic linearization <ul style="list-style-type: none"> • For thermocouple • For resistance thermometer 	Parameters can be assigned <ul style="list-style-type: none"> • J, K, L • Pt 100 (standard range) ¹⁾
Temperature compensation <ul style="list-style-type: none"> • Internal temperature compensation • External temperature compensation with compensating box • External temperature compensation with thermoresistor (e.g. Pt 100) • Compensation for 0° C comparison point temperature • Compensation for 50° C comparison point temperature 	Parameters can be assigned <ul style="list-style-type: none"> • Possible • Possible • Possible, resistance thermometer measurement by connecting 2 temperature inputs • Possible • Possible
Measuring current for thermoresistors and wire-break checks	Approx. 0.175 mA
Input resistance (differential)	> 10 M Ω
Connection signal transmitter <ul style="list-style-type: none"> • For voltage measurement • For resistance measurement <ul style="list-style-type: none"> – With 4-wire connection ⁵⁾ – With 3-wire connection ^{2) 5)} – With 2-wire connection ^{2) 5)} 	<ul style="list-style-type: none"> • Possible • Possible
Voltages, currents, potentials	
Galvanic isolation <ul style="list-style-type: none"> • Between channels and internal bus • Between channels 	<ul style="list-style-type: none"> • Yes • No
Permissible potential difference <ul style="list-style-type: none"> • Between inputs (U_{CM}) • Between temperature input negative and central grounding point (U_{ISO}) 	<ul style="list-style-type: none"> • 3 VppAC • 3 VppAC
Insulation test voltage	500 VDC

Formation of analog values	
Measuring principle	Integrating, sigma delta
Integration time/conversion time/resolution (per channel) <ul style="list-style-type: none"> • Integration time • Basic conversion time, including integration time for two thermocouples <ul style="list-style-type: none"> – Additional conversion time for wire break monitoring for each channel • Basic conversion time, including integration time for one resistance thermometer <ul style="list-style-type: none"> – Additional conversion time for wire break monitoring for each channel • Resolution (including overshoot range) • Interference voltage suppression for interference frequency f_1 • Basic execution time (all channels enabled) 	<ul style="list-style-type: none"> • Approx. 60 ms • Approx. 132 ms • Approx. 5 ms • Approx. 66 ms • Approx. 10 ms • 16 bits • 50/60 Hz • Approx. 1,200 ms
Measured value smoothing	None
Noise suppression and error limits	
Interference voltage suppression for $f = n \times (f_1 \pm 1\%)$, ($f_1 =$ interference frequency) $n = 1, 2, \text{etc.}$ <ul style="list-style-type: none"> • Common mode interference ($U_{CM} < 2.5 \text{ V}$) • Series-mode interference (peak interference value < nominal input range value, sinusoidal) 	<ul style="list-style-type: none"> • > 90 dB • > 70 dB
Crosstalk attenuation between inputs	> 50 dB
Operational limit (across temperature range, in relation to input range) <ul style="list-style-type: none"> • Voltage measurement • Thermocouple <ul style="list-style-type: none"> – Type J – Type K – Type L • Pt 100 resistance thermometer 	<ul style="list-style-type: none"> • $\pm 0.1\%$ • Approx. $\pm 2.5 \text{ K}$ • Approx. $\pm 3 \text{ K}$ • Approx. $\pm 3 \text{ K}$ • Approx. $\pm 2 \text{ K}$
Intrinsic error limit (operational limit at 25 °C in relation to input range) <ul style="list-style-type: none"> • Voltage measurement • Thermocouple <ul style="list-style-type: none"> – Type J – Type K – Type L • Pt 100 resistance thermometer 	<ul style="list-style-type: none"> • $\pm 0.02\%$ • Approx. $\pm 1 \text{ K}$ • Approx. $\pm 1 \text{ K}$ • Approx. $\pm 1 \text{ K}$ • Approx. ± 0.5
Operational limit for internal compensation (0 to 60 °C)	$\pm 2.5 \text{ K}^4$

1.11 Technical data for devices with a head module and basic module

<p>The temperature measurement accuracy for external compensation with thermoresistors is calculated on the basis of:</p> <ul style="list-style-type: none">• Error for the temperature input of the type of thermocouple used• Accuracy ³⁾ of the type of thermoresistor used for compensation• Error ³⁾ for the compensation input
<p>The temperature measurement accuracy for external compensation with compensating box is calculated on the basis of:</p> <ul style="list-style-type: none">• Error for the temperature input of the type of thermocouple used• Accuracy ³⁾ of the compensating box• Error ³⁾ for the compensation input
<p>The temperature measurement accuracy for compensation of the external comparison point maintained at 0 °C/50 °C is calculated on the basis of:</p> <ul style="list-style-type: none">• Error for the temperature input of the type of thermocouple used• Accuracy ³⁾ of the comparison point temperature
<p>The temperature measurement accuracy for internal compensation (terminal temperature) is calculated on the basis of:</p> <ul style="list-style-type: none">• Error for the temperature input of the type of thermocouple used• Accuracy ³⁾ of the comparison point temperature ⁴⁾

1) Pt 100 measuring range up to approx. 560 °C

2) Without line resistance correction

3) Due to the constant increase in the thermocouple characteristic at higher temperatures, the compensation element error has less of an effect than at temperatures in the vicinity of the compensation temperature.

4) Module must be in a thermally settled state

Ambient temperature change < 0.3 K/min

5) Figure for the number of supply lines for power supply and voltage measurement

Note

The temperature inputs must be configured as a protective extra-low voltage (PELV).

Counter inputs (according to IEC 1131-2/DIN EN 61131-2, characteristic type 1)

Table 1- 40 Counter inputs

Number of inputs	<ul style="list-style-type: none"> • 4 (without direction detection) • 2 (with direction detection)
Cable length, shielded	Max. 30 m
Encoder selection data	
Permissible input voltage	30 V (PELV)
Input voltage (rated values)	24 V (PELV)
Permissible voltage range between the counter input (CNT0 to CNT3) and reference potential (M _{CNT}) terminals and the associated input currents with a maximum frequency of 10 kHz (for active tripping) or 400 Hz (for passive tripping) <ul style="list-style-type: none"> • 0 signal • 1 signal 	<ul style="list-style-type: none"> • -3 to 5 V (-15 to 2 mA) • 15 to 30 V (6.5 to 13 mA)
Permissible voltage range between the counter input (CNT0 to CNT3) and reference potential (M _{CNT}) terminals and the associated input currents with a maximum frequency of 25 kHz for active tripping <ul style="list-style-type: none"> • 0 signal • 1 signal Note: This function is available with product version A3/C3 and higher (see type plate).	<ul style="list-style-type: none"> • -3 to 5 V (-15 to 2 mA) • 18 to 30 V (6.5 to 13 mA)
Phase relation of the two track signals during up/down counter operation	90° electrical ± 25° electrical
Properties of the inputs	
Galvanic isolation <ul style="list-style-type: none"> • Between channels and internal bus • Between channels 	<ul style="list-style-type: none"> • Yes • No
Deceleration times (for active tripping) U _{CNT} = 24 V <ul style="list-style-type: none"> • 0 → 1 signal • 1 → 0 signal 	<ul style="list-style-type: none"> • 10 µs • 15 µs
Protected against polarity reversal	Yes
Insulation test voltage	500 VDC

Parameters for the two operating modes	
Number of up-counters <ul style="list-style-type: none"> • Time base for duration counter • Max. frequency for passive tripping • Max. frequency for active tripping 	4 <ul style="list-style-type: none"> • Parameters can be assigned for every counter: <ul style="list-style-type: none"> – 41.6666 ns – 1 µs – 1 ms • 400 Hz • 10 kHz (with 1 signal of 15 to 30 V) • 25 kHz (with 1 signal of 18 to 30 V)
Number of up/down counters <ul style="list-style-type: none"> • RLO edge detection • Max. frequency for passive tripping • Max. frequency for active tripping 	2 <ul style="list-style-type: none"> • Parameters can be assigned for every counter: <ul style="list-style-type: none"> – Single detection – Double detection – Quadruple detection • 400 Hz • 10 kHz (with 1 signal of 15 to 30 V) • 25 kHz (with 1 signal of 18 to 30 V)

1.12 Digital I/O expansion module (EB DIGITAL, 16DI/16DO)

1.12.1 Properties of EB DIGITAL, 16DI/16DO

Order number for EB DIGITAL, 16DI/16DO:	6AU1 510-3AB00-0AA0
Designation of the expansion module:	DIGITAL, 16DI/16DO

Task

There is an increase in the number of digital inputs/outputs with **EB DIGITAL, 16DI/16DO**.

Illustration of EB DIGITAL, 16DI/16DO

An illustration of the **EB DIGITAL, 16DI/16DO**, including the positions of the interfaces and front elements, is shown in the figure below.

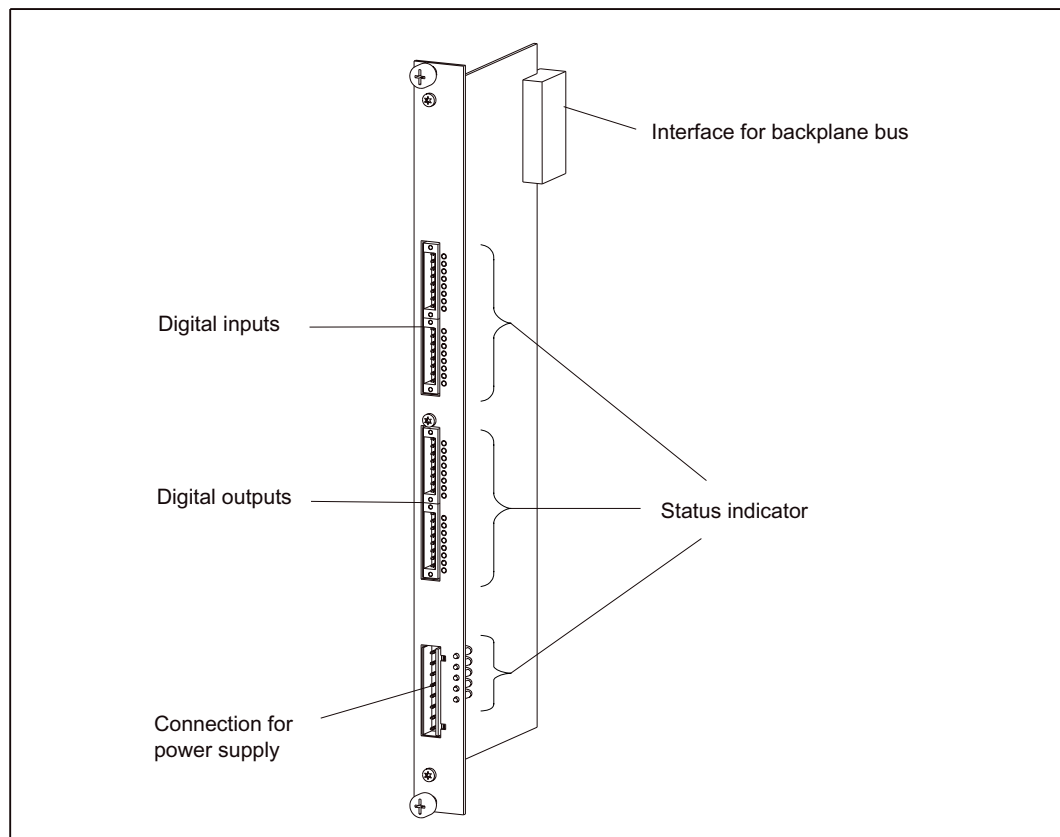

Figure 1-41 Illustration of EB DIGITAL, 16DI/16DO

1.12.2 Description of functions for digital inputs

There are 16 digital inputs on the **EB DIGITAL, 16DI/16DO**. These inputs comply with the standard IEC 1131-2/DIN EN 61131-2, characteristic type 1.

The inputs can be used as freely addressable process inputs. Addresses are allocated in the hardware configuration. The inputs are detected in the PROFIBUS DP cycle.

Position of connectors

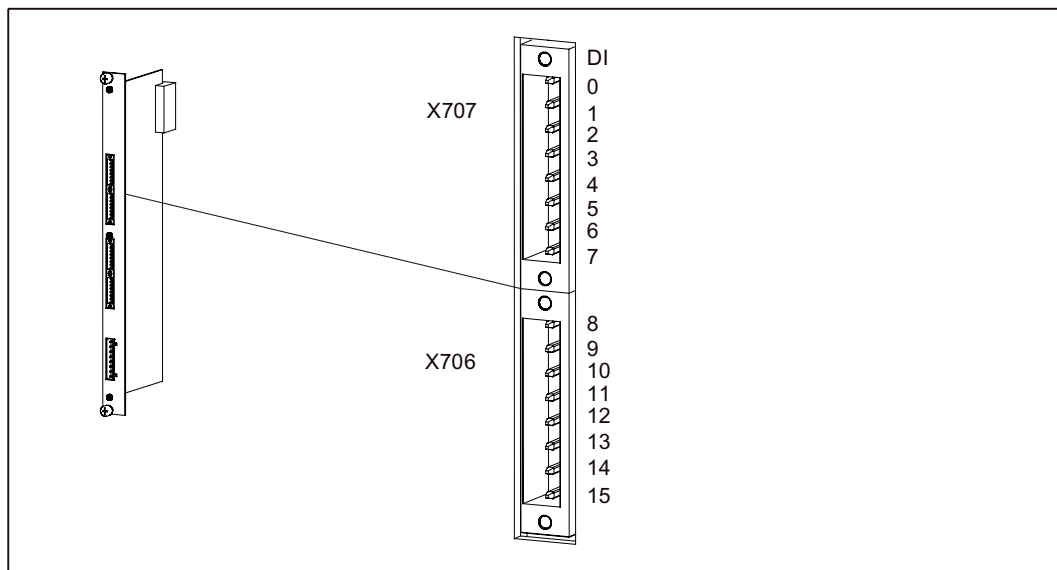

Figure 1-42 Position of connectors X706/X707

Connector assignment

Connector designation: X706/X707 (2x8 digital inputs)

Connector type: SL-SMT3.5/8/90

The reference potential for the digital inputs is M on connector X703 of the **EB DIGITAL, 16DI/16DO**.

Table 1- 41 Assignment of connector X707

Pin	Signal	Designation	Pin	Signal	Designation
1	DI0	Digital input 0	5	DI4	Digital input 4
2	DI1	Digital input 1	6	DI5	Digital input 5
3	DI2	Digital input 2	7	DI6	Digital input 6
4	DI3	Digital input 3	8	DI7	Digital input 7

Table 1- 42 Assignment of connector X706

Pin	Signal	Designation	Pin	Signal	Designation
1	DI8	Digital input 8	5	DI12	Digital input 12
2	DI9	Digital input 9	6	DI13	Digital input 13
3	DI10	Digital input 10	7	DI14	Digital input 14
4	DI11	Digital input 11	8	DI15	Digital input 15

1.12.3 Description of functions for digital outputs

There are 16 digital outputs on the **EB DIGITAL, 16DI/16DO**. These outputs comply with the standard IEC 1131-2/DIN EN 61131-2.

They can be used as freely addressable process outputs. Addresses are allocated in the hardware configuration.

The parameter settings can be used to determine whether a substitute value or the last value is output when communication is interrupted.

When used as process outputs, the outputs are output in the PROFIBUS DP cycle.

Note

If the digital outputs are overloaded, the output is clocked to protect the module.

Position of connectors

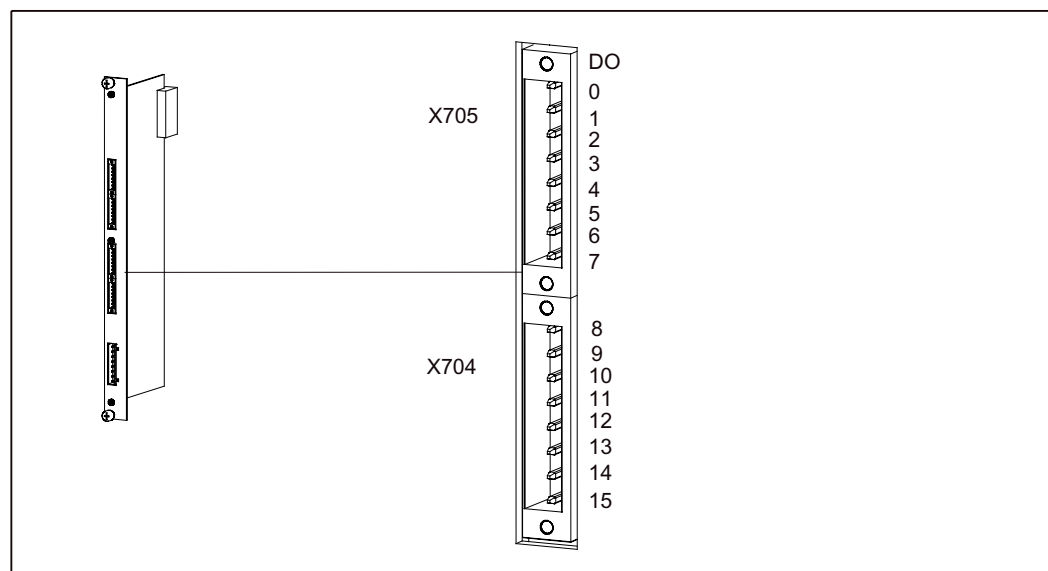

Figure 1-43 Position of connectors X704/X705

Description

1.12 Digital I/O expansion module (EB DIGITAL, 16DI/16DO)

Connector assignment

Connector designation: X704/X705 (2x8 digital outputs, isolated, 2 A)
 Connector type: SL-SMT3.5/8/90

Table 1- 43 Assignment of connector X705

Pin	Signal	Designation	Pin	Signal	Designation
1	DO0	Digital output 0	5	DO4	Digital output 4
2	DO1	Digital output 1	6	DO5	Digital output 5
3	DO2	Digital output 2	7	DO6	Digital output 6
4	DO3	Digital output 3	8	DO7	Digital output 7

Table 1- 44 Assignment of connector X704

Pin	Signal	Designation	Pin	Signal	Designation
1	DO8	Digital output 8	5	DO12	Digital output 12
2	DO9	Digital output 9	6	DO13	Digital output 13
3	DO10	Digital output 10	7	DO14	Digital output 14
4	DO11	Digital output 11	8	DO15	Digital output 15

1.12.4 Connection for power supply

The following are connected to connector X703 of the **EB DIGITAL, 16DI/16DO**:

- 24 VDC load power supply for the digital outputs
- 24 VDC logic supply for the digital inputs

Position of the connector

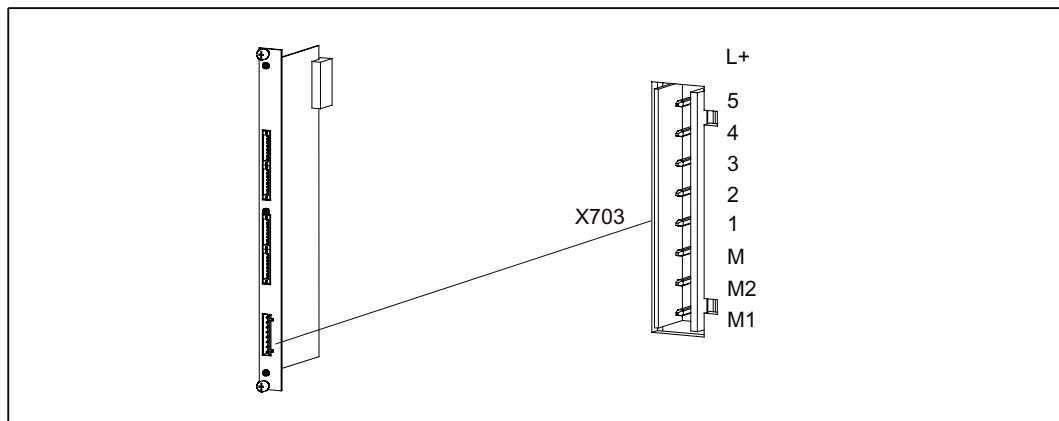

Figure 1-44 Position of connector X703 (EB DIGITAL, 16DI/16DO)

Connector assignment

Connector designation: X703
 Connector type: SL-SMT5.08/8/90

Table 1- 45 Assignment of connector X703

Pin	Signal	Designation
1	L5+	24 V supply for digital inputs 0 to 15 ¹⁾
2	L4+	24 V supply for digital outputs 12 to 15
3	L3+	24 V supply for digital outputs 8 to 11
4	L2+	24 V supply for digital outputs 4 to 7
5	L1+	24 V supply for digital outputs 0 to 3
6	M	24 V reference potential for digital inputs 0 to 15 ¹⁾
7	M2	24 V reference potential for digital outputs 8 to 15
8	M1	24 V reference potential for digital outputs 0 to 7

¹⁾ These 24 V supplies and the associated reference potential **must** be connected as a minimum requirement.

Supply groups

The table below shows the power supply assignments for the inputs and outputs.

Table 1- 46 Supply groups

Supply groups	Signal	Inputs/outputs	24 V reference potential
Supply group 1	L1+	DO0 to 3	M1, isolated
Supply group 2	L2+	DO4 to 7	M1, isolated
Supply group 3	L3+	DO8 to 11	M2, isolated
Supply group 4	L4+	DO12 to 15	M2, isolated
Supply group 5	L5+	DI0 to 15	M, non-isolated

See also

Wiring and block diagrams (Page 92)

Technical data (Page 94)

1.12.5 LEDs (status indicators)

The EB DIGITAL, 16DI/16DO has the following indicators:

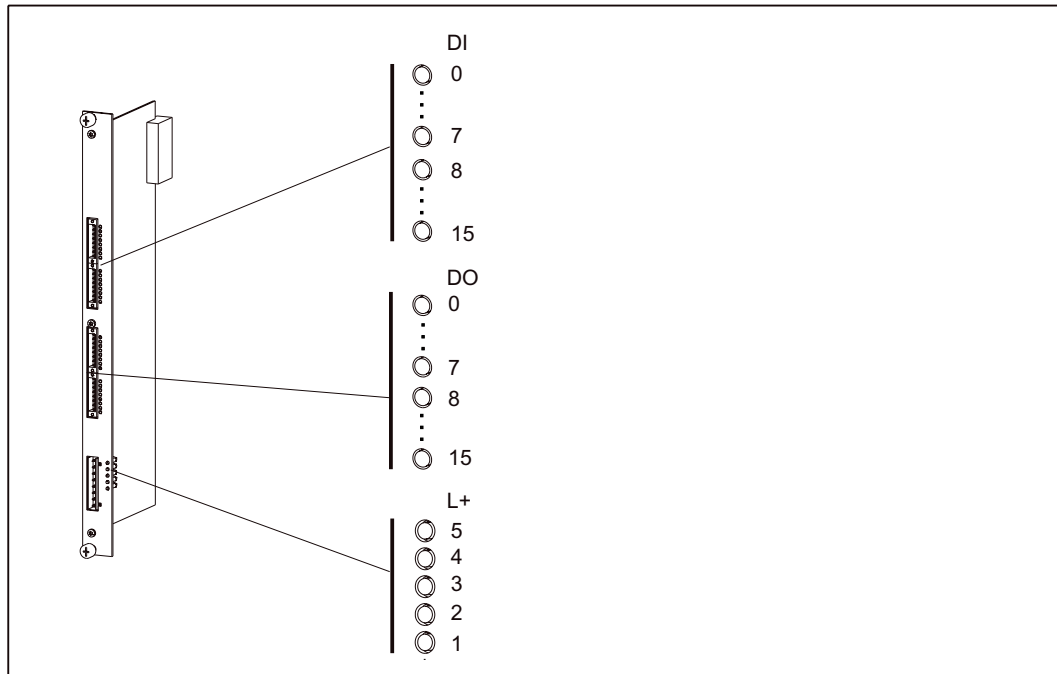

Figure 1-45 Status indicators on the EB DIGITAL, 16DI/16DO

Meaning of the status indicators

The LEDs (indicators) are explained in the order in which they are positioned on SIMOTION E510.

Table 1- 47 Status indicator (EB DIGITAL, 16DI/16DO)

LED	Meaning	Explanations
DI0 to DI15 (green)	Status of the digital inputs	These LEDs show the status of digital inputs 0 to 15.
DO0 to DO15 (green)	Status of the digital outputs	These LEDs show the status of digital outputs 0 to 15.
L1+ (green)	Power supply for the digital outputs	These LEDs show the availability of digital outputs 0 to 15.
L2+ (green)		
L3+ (green)		
L4+ (green)		
L5+ (green)	Power supply for the digital inputs	This LED shows the availability of digital inputs 0 to 15.

1.12.6 Type plate

The type plate for the **EB DIGITAL, 16DI/16DO** is located on the printed circuit board. The figure below contains all the information included on the type plate.

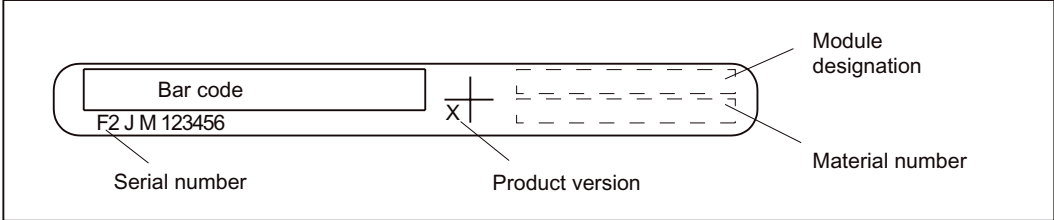

Figure 1-46 Type plate for EB DIGITAL, 16DI/16DO

1.12.7 Wiring and block diagrams

Digital inputs

Wiring and block diagram for the DI 16, 24 VDC digital input block of the **EB DIGITAL, 16DI/16DO**.

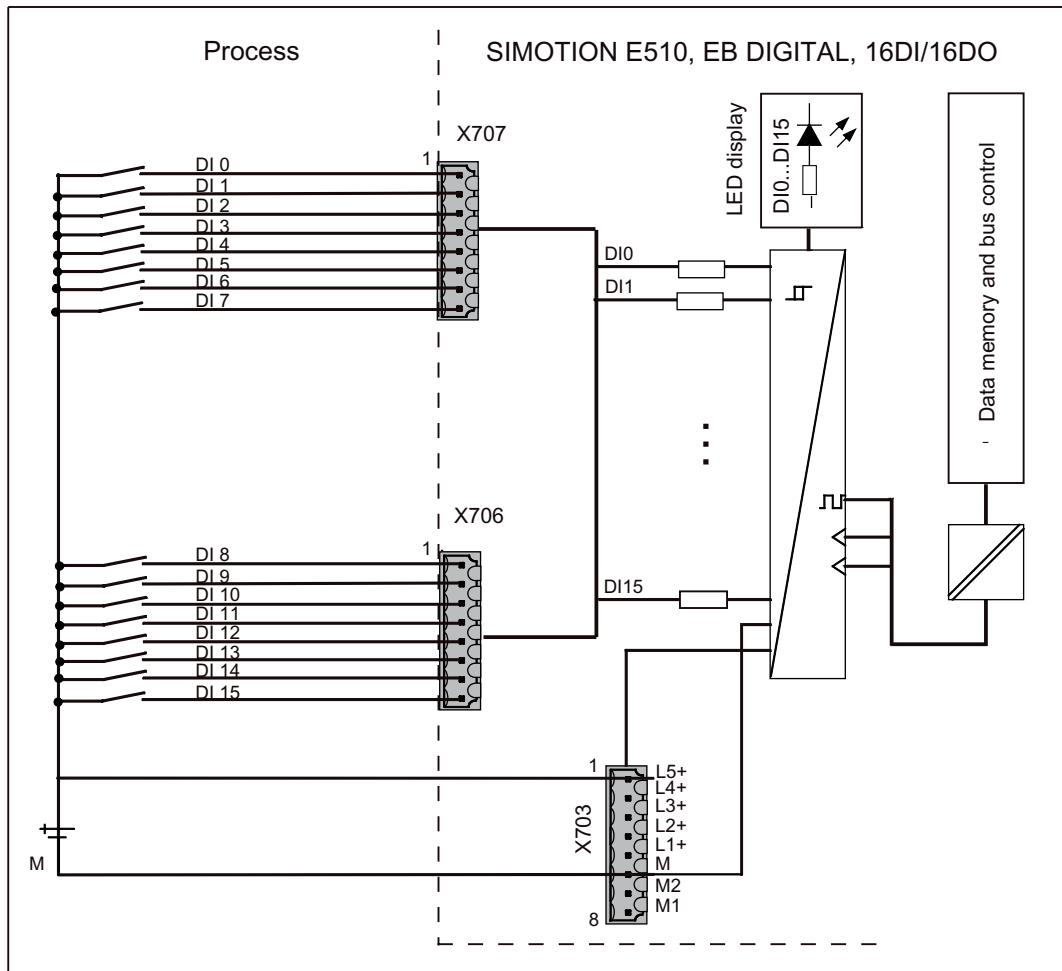

Figure 1-47 Wiring and block diagram for digital inputs

Digital outputs

Wiring and block diagram for the DO 2 x 8 x 2 A, 24 VDC digital output block of the EB DIGITAL, 16DI/16DO.

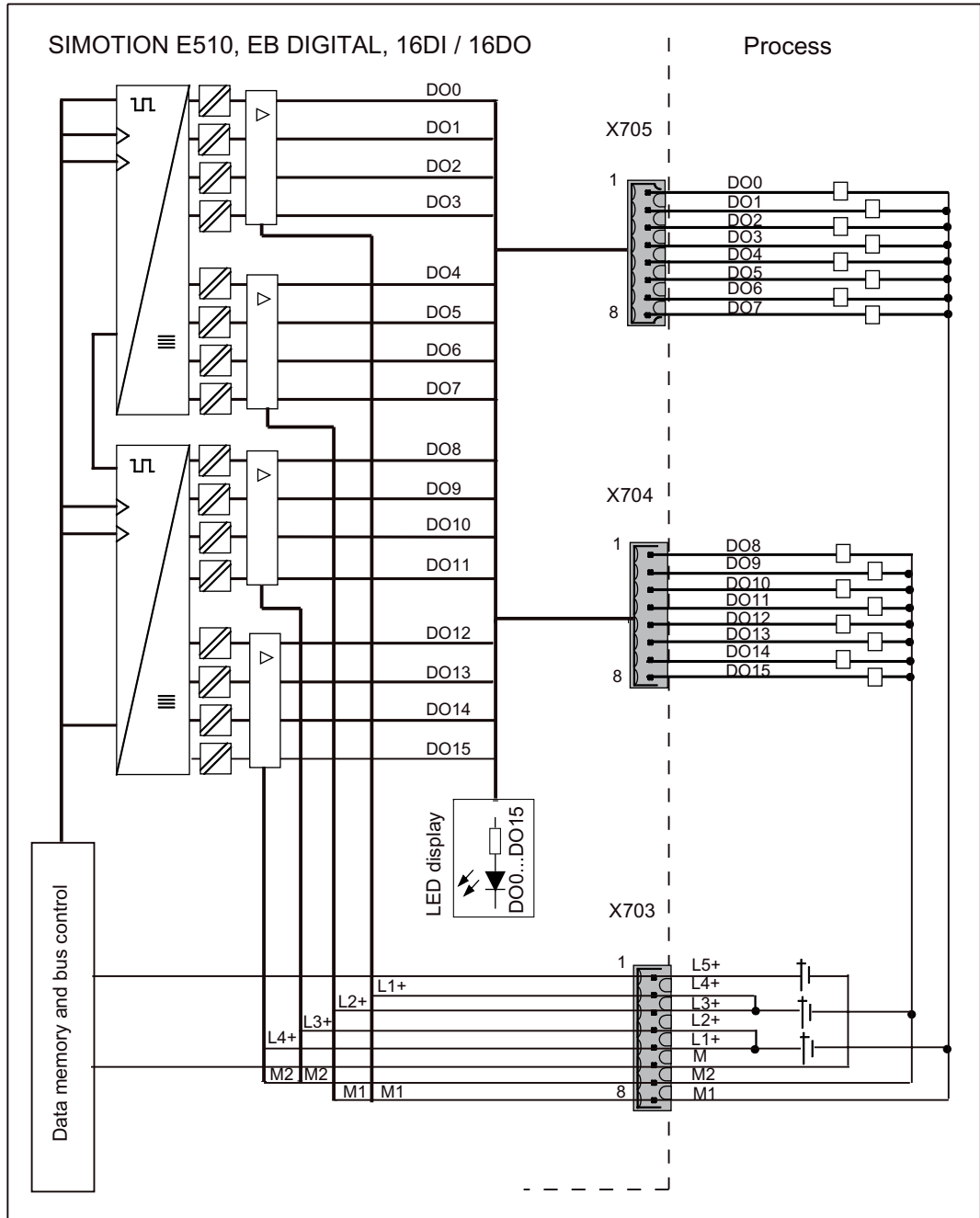

Figure 1-48 Wiring and block diagram for digital outputs DO 2 x 8 x 2 A

1.12.8 Technical data

Connection values

Table 1- 48 EB DIGITAL, 16DI/16DO connection values

Supply voltage	24 VDC; permissible range: 20.4 to 28.8 V (PELV)
Current consumption of EB DIGITAL, 16DI/16DO	
<ul style="list-style-type: none"> Total current L1+ to L5+ (50% output simultaneity) Supply group L1+ to L4+ Fuses per supply group Supply group L5+ Fuses on the module 	<ul style="list-style-type: none"> Max. 16 A 10 A, quick-response 1 A
Length of cable	Max. 10 m

Dimensions and weight

Table 1- 49 Dimensions and weight

Dimensions W x H x D [mm]	25.1 × 350.5 × 140.9
Weight	Approx. 320 g

Digital inputs (according to IEC 1131-2/DIN EN 61131-2, characteristic type 1)

Table 1- 50 Digital inputs

Number of inputs	16, protected against polarity reversal
Length of cable	Max. 30 m
Encoder selection data	
Input voltage <ul style="list-style-type: none"> Rated value 1 signal 0 signal 	<ul style="list-style-type: none"> 24 VDC (PELV) 15 to 30 V -3 to 5 V
Input current <ul style="list-style-type: none"> 1 signal 	<ul style="list-style-type: none"> Typ. 3 mA
Input delay until register output <ul style="list-style-type: none"> 0 → 1 signal 1 → 0 signal 1 → open 	<ul style="list-style-type: none"> Typ. 30 µs Typ. 140 µs Typ. 600 µs
Voltages, currents, potentials	
Galvanic isolation	No (non-isolated); reference potential M
Insulation test voltage	500 VDC

Digital outputs (according to IEC 1131-2/DIN EN 61131-2)

Table 1- 51 Digital outputs

Number of outputs	16
Length of cable	Max. 30 m
Type of outputs	High-side driver
Actuator selection data	
Output voltage with 1 signal	L+ -0.16 V
Output current <ul style="list-style-type: none"> Rated value 1 signal 0 signal (residual current) 	<ul style="list-style-type: none"> 2 A Max. 2.4 A Min. 7 mA 0.3 mA
Output delay (register output to driver output) <ul style="list-style-type: none"> 0 → 1 signal 1 → 0 signal 	<ul style="list-style-type: none"> Typ. 30 µs Typ. 200 µs
Lamp load	Max. 5 W
Max. switching frequency <ul style="list-style-type: none"> With resistive load With inductive load in accordance with IEC 947-5-1, DC 13 With lamp load 	<ul style="list-style-type: none"> 100 Hz 2 Hz 11 Hz
Limiting of inductive cut-off voltage	47 V
Max. inductance for loads without external protective circuit	100 mH
Short-circuit protection of output	Yes, electronic pulsing
Response threshold	> 2.5 A
Voltages, currents, potentials	
Rated load voltage	24 VDC (PELV)
Total current of outputs	See "Connection values" table
Isolated DO0 to DO15	In groups of 2 x 8
Insulation test voltage	500 VDC

1.13 Digital I/O expansion module (EB DIGITAL, 32DI)

1.13.1 Properties of EB DIGITAL, 32DI

Order number for EB DIGITAL, 32DI:	6AU1 510-3AB10-0AA0
Designation of the expansion module:	DIGITAL, 32DI

Task

There are 32 digital inputs on the **EB DIGITAL, 32DI**. These inputs can be used as either 32 digital inputs or 30 digital inputs and 2 counter inputs.

Illustration of the EB DIGITAL, 32DI

An illustration of the **EB DIGITAL, 32DI**, including the positions of the interfaces and front elements, is shown in the figure below.

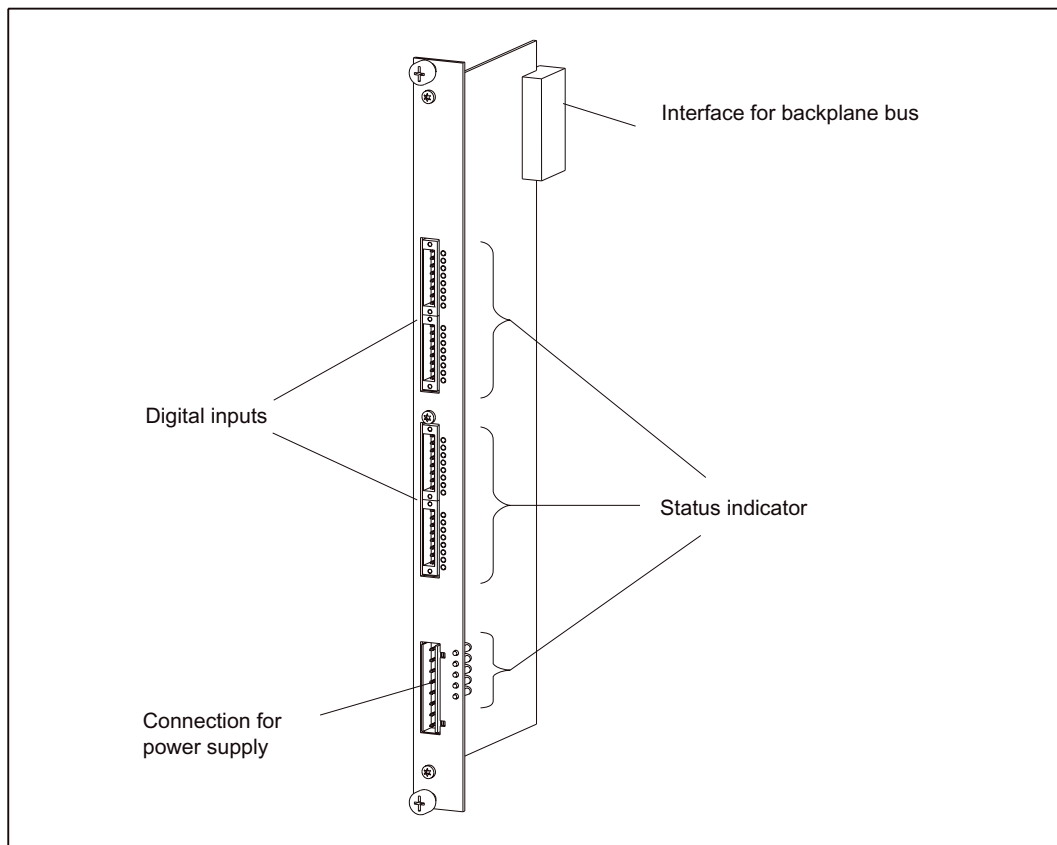

Figure 1-49 Illustration of the EB DIGITAL, 32DI

1.13.2 Description of functions for digital inputs

There are 32 digital inputs on the **EB DIGITAL, 32DI**. These inputs comply with the standard IEC 1131-2/DIN EN 61131-2, characteristic type 1.

They can be used as freely addressable process inputs. Addresses are allocated in the hardware configuration. The inputs are detected in the PROFIBUS DP cycle.

Position of connectors

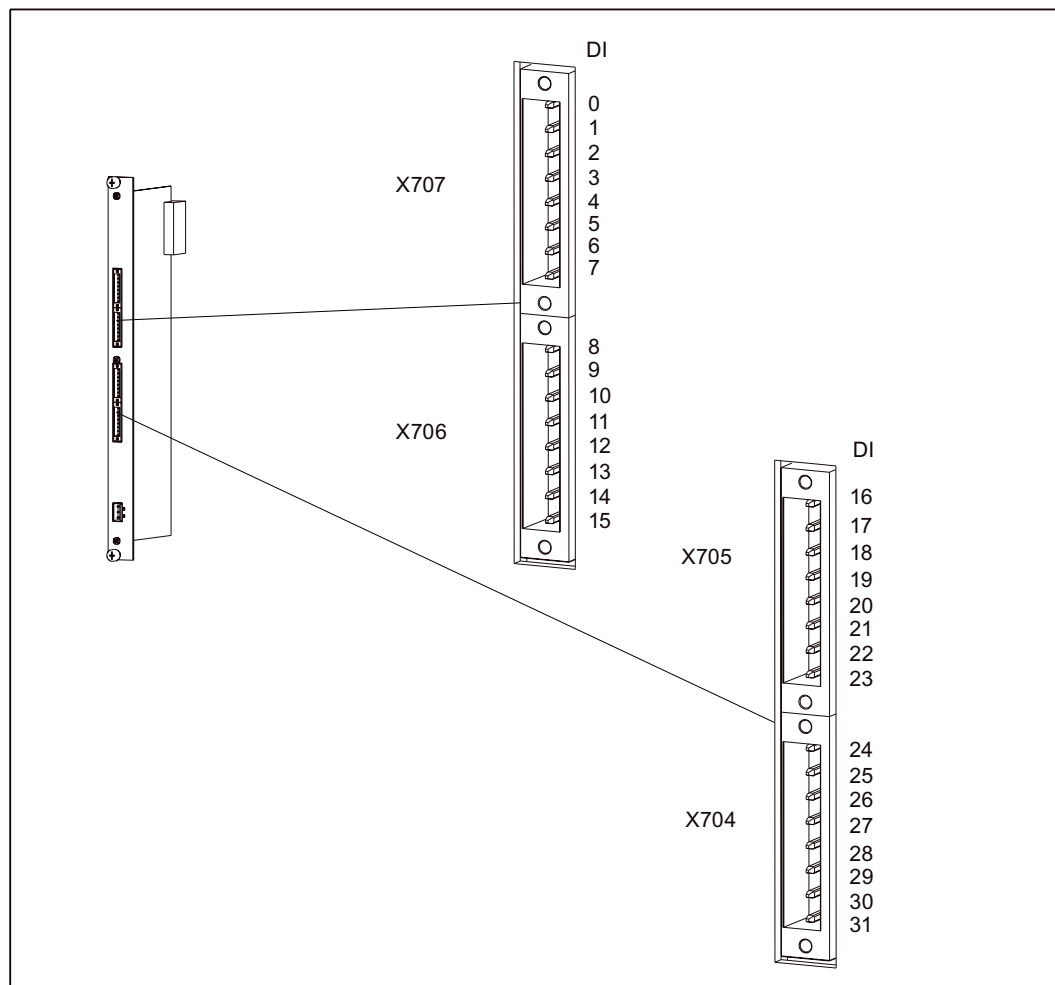

Figure 1-50 Position of connectors X704 to X707

Connector assignment

Connector designation: X704 to X707 (4 x 8 digital inputs)
 Connector type: SL-SMT3.5/8/90

The reference potential for the digital inputs is M on connector X703 of th **EB DIGITAL, 32DI**.

Table 1- 52 Assignment of connector X707

Pin	Signal	Designation	Pin	Signal	Designation
1	DI0/ CNT0	Digital input 0/ counter input 0	5	DI4	Digital input 4
2	DI1	Digital input 1	6	DI5	Digital input 5
3	DI2/ CNT1	Digital input 2/ counter input 1	7	DI6	Digital input 6
4	DI3	Digital input 3	8	DI7	Digital input 7

Table 1- 53 Assignment of connector X706

Pin	Signal	Designation	Pin	Signal	Designation
1	DI8	Digital input 8	5	DI12	Digital input 12
2	DI9	Digital input 9	6	DI13	Digital input 13
3	DI10	Digital input 10	7	DI14	Digital input 14
4	DI11	Digital input 11	8	DI15	Digital input 15

Table 1- 54 Assignment of connector X705

Pin	Signal	Designation	Pin	Signal	Designation
1	DI16	Digital input 16	5	DI20	Digital input 20
2	DI17	Digital input 17	6	DI21	Digital input 21
3	DI18	Digital input 18	7	DI22	Digital input 22
4	DI19	Digital input 19	8	DI23	Digital input 23

Table 1- 55 Assignment of connector X704

Pin	Signal	Designation	Pin	Signal	Designation
1	DI24	Digital input 24	5	DI28	Digital input 28
2	DI25	Digital input 25	6	DI29	Digital input 29
3	DI26	Digital input 26	7	DI30	Digital input 30
4	DI27	Digital input 27	8	DI31	Digital input 31

1.13.3 Description of functions for counter inputs

There are 2 counter inputs on the **EB DIGITAL, 32DI** (for connector assignment details, see the "Assignment of connector X707" table in the section titled "Description of functions for digital inputs"). These inputs comply with the standard IEC 1131-2/DIN EN 61131-2, characteristic type 1, and can be operated as up-counters. For information on the function and operating principle of an up-counter, refer to the section titled "Description of functions for counter inputs" for the head module.

Note

The 2 counter inputs may only be used on one **EB DIGITAL, 32DI** per SIMOTION E510 complete unit.

See also

Description of functions for digital inputs (Page 97)

Description of functions for counter inputs (Page 49)

1.13.4 Connection for power supply

The logic supply for the digital inputs is connected to connector X703 on the **EB DIGITAL, 32DI**.

Position of connector X703

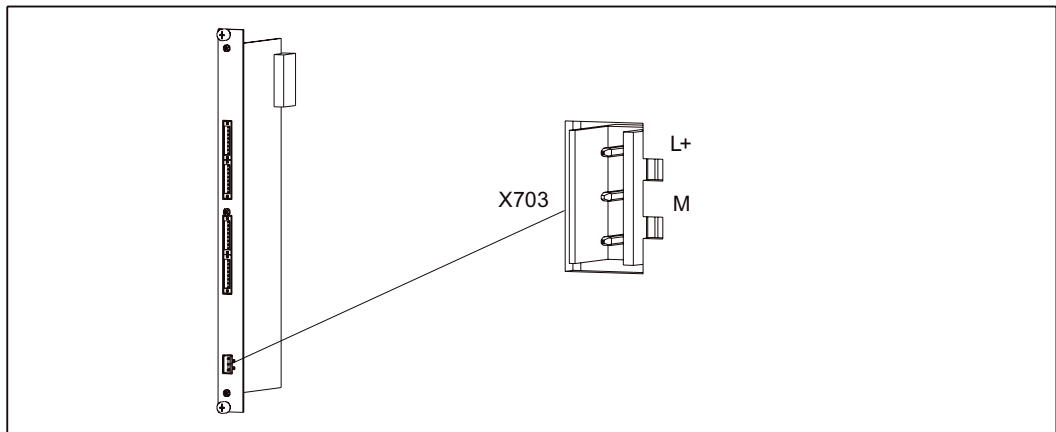

Figure 1-51 Position of connector X703 (EB DIGITAL, 32DI)

Connector assignment

Connector designation: X703
Connector type: SL-SMT5.08/3/90

Table 1- 56 Assignment of connector X703

Pin	Signal	Designation
1	L+	24 V supply for digital inputs 0 to 31
2	M	24 V reference potential
3	-	Not assigned

See also

Wiring diagram and block diagram (Page 102)

Technical data (Page 103)

1.13.5 LEDs (status indicators)

The EB DIGITAL, 32DI has the following indicators:

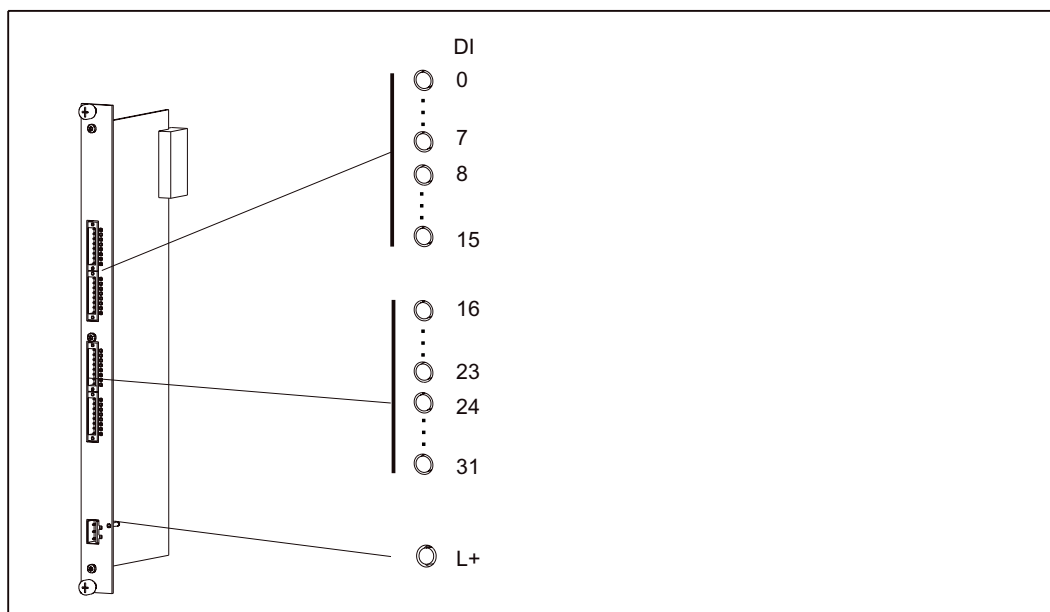

Figure 1-52 Status indicators on the EB DIGITAL, 32DI

Meaning of the status indicators

The LEDs (indicators) are explained in the order in which they are positioned on SIMOTION E510.

Table 1- 57 Status indicator (EB DIGITAL, 32DI)

LED	Meaning	Explanations
DI0 to DI31 (green)	Status of the digital inputs	These LEDs show the status of digital inputs 0 to 31.
L+ (green)	Power supply for the digital inputs	This LED shows the availability of digital inputs 0 to 31.

1.13.6 Type plate

The type plate for the **EB DIGITAL, 32DI** is located on the printed circuit board.

The figure below contains all the information included on the type plate.

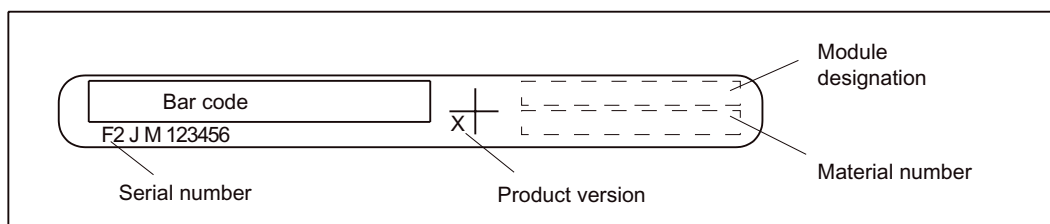

Figure 1-53 Type plate for EB DIGITAL, 32DI

1.13.7 Wiring diagram and block diagram

Digital inputs

Wiring and block diagram for the DI 32, 24 VDC digital input block of the **EB DIGITAL, 32DI**.

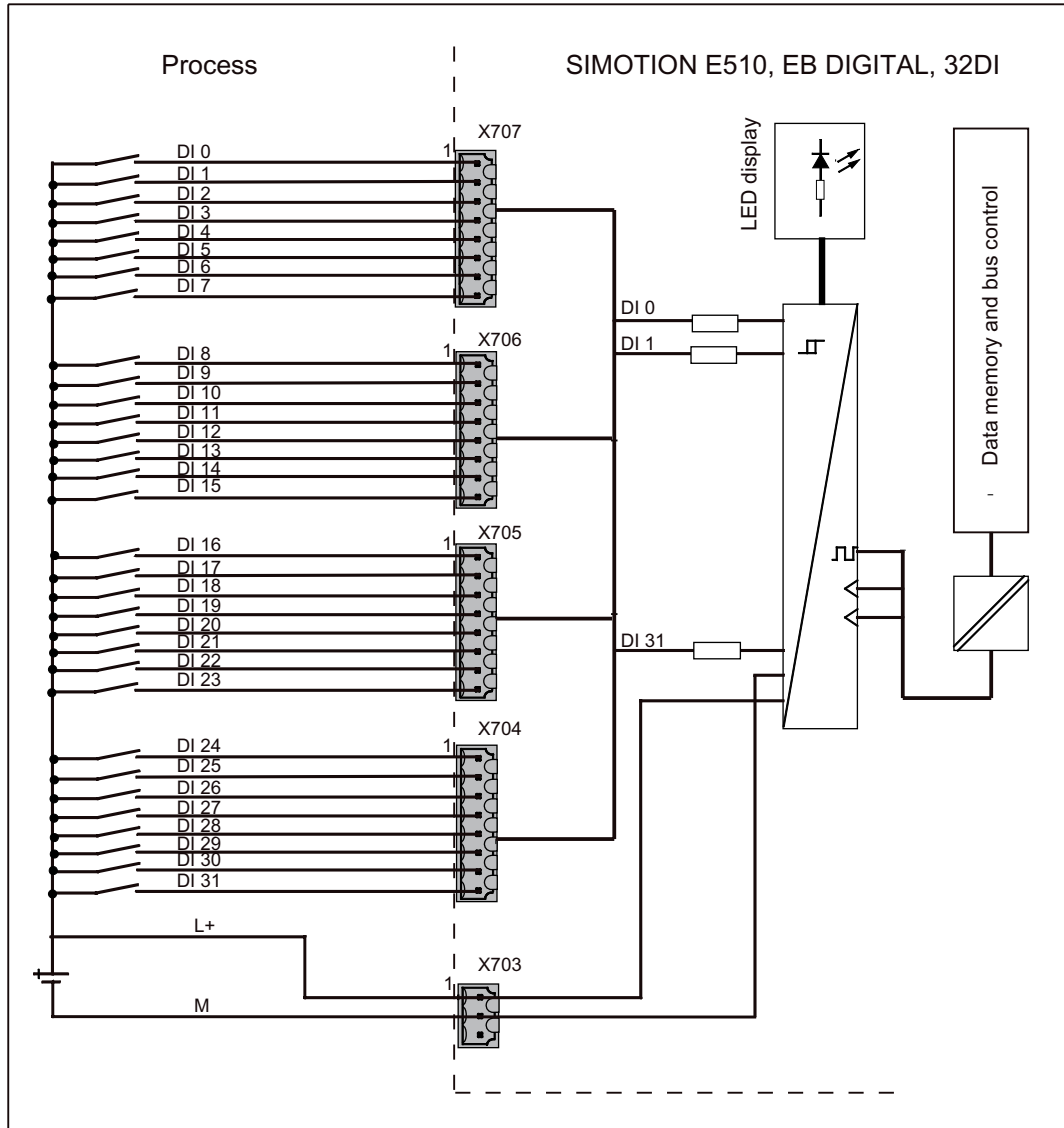

Figure 1-54 Wiring and block diagram for digital inputs

1.13.8 Technical data

Connection values

Table 1- 58 Connection values for EB DIGITAL, 32DI

Supply voltage	24 VDC; permissible range: 20.4 to 28.8 V (PELV)
Current consumption (supply group L+)	<ul style="list-style-type: none"> • Encoder power supply L+ • Fuse L+
	<ul style="list-style-type: none"> • Approx. 150 mA • 1 A, time-lag
Length of cable	Max. 10 m

Dimensions and weight

Table 1- 59 Dimensions and weight

Dimensions W x H x D [m]	25.1 × 350.5 × 140.9
Weight	Approx. 330 g

Digital inputs (according to IEC 1131-2/DIN EN 61131-2, characteristic type 1)

Table 1- 60 Digital inputs

Number of inputs	32, protected against polarity reversal
Length of cable	Max. 30 m
Encoder selection data	
Input voltage	<ul style="list-style-type: none"> • Rated value • 1 signal • 0 signal
	<ul style="list-style-type: none"> • 24 VDC (PELV) • 15 to 30 V • -3 to 5 V
Input current	<ul style="list-style-type: none"> • 1 signal (connectors X704 to X706, X707, pin 2, 4 to 8) • 1 signal (connector X707, pin 1 and 3)
	<ul style="list-style-type: none"> • Typ. 3 mA • Typ. 13 mA
Input delay until register output	<ul style="list-style-type: none"> • 0 → 1 signal • 1 → 0 signal • 1 → open
	<ul style="list-style-type: none"> • Typ. 30 µs • Typ. 140 µs • Typ. 600 µs
Voltages, currents, potentials	
Galvanic isolation	No (non-isolated); reference potential M
Insulation test voltage	500 VDC

Counter inputs (according to IEC 1131-2/DIN EN 61131-2, characteristic type 1)

Note: This function is available with product version B3 and higher (see type plate).

Table 1- 61 Counter inputs

Number of inputs	2 (without direction detection)
Cable length, shielded	Max. 30 m
Encoder selection data	
Permissible input voltage	30 V (PELV)
Input voltage (rated values)	24 V (PELV)
Permissible voltage range between the counter input (CNT0 to CNT1) and reference potential (M) terminals and the associated input currents with a maximum frequency of 10 kHz (for active tripping) or 400 Hz (for passive tripping)	<ul style="list-style-type: none"> • 0 signal • 1 signal <ul style="list-style-type: none"> • -3 to 5 V (-15 to 2 mA) • 15 to 30 V (6.5 to 13 mA)
Permissible voltage range between the counter input (CNT0 to CNT1) and reference potential (M) terminals and the associated input currents with a maximum frequency of 25 kHz for active tripping	<ul style="list-style-type: none"> • 0 signal • 1 signal <ul style="list-style-type: none"> • -3 to 5 V (-15 to 2 mA) • 18 to 30 V (6.5 to 13 mA)
Properties of the inputs	
Galvanic isolation	<ul style="list-style-type: none"> • Between channels and internal bus • Between channels <ul style="list-style-type: none"> • Yes • No
Deceleration times (for active tripping) U _{CNT} = 24 V	<ul style="list-style-type: none"> • 0 → 1 signal • 1 → 0 signal <ul style="list-style-type: none"> • 10 µs • 15 µs
Protected against polarity reversal	Yes
Insulation test voltage	500 VDC
Parameters for the two operating modes	
Number of up-counters	2
<ul style="list-style-type: none"> • Time base for duration counter • Max. frequency for passive tripping • Max. frequency for active tripping 	<ul style="list-style-type: none"> • Parameters can be assigned for every counter: <ul style="list-style-type: none"> – 41.6666 ns – 1 µs – 1 ms • 400 Hz • 10 kHz (with 1 signal of 15 to 30 V) • 25 kHz (with 1 signal of 18 to 30 V)

1.14 Temperature I/O expansion module (EB TEMP, 16TC/24DO)

1.14.1 Properties of the EB TEMP, 16TC/24DO

Order number of the EB TEMP, 16TC/24DO:	6AU1 510-3CB00-0AA0
Designation of the expansion module:	TEMP, 16TC/24DO

Task

There are 16 analog inputs on the **EB TEMP, 16TC/24DO** for connecting 16 thermocouples and 24 digital outputs. Alternatively, any two adjacent temperature inputs can be reconfigured to create a 4-wire measuring arrangement.

Illustration of the module

An illustration of the **EB TEMP, 16TC/24DO**, including the positions of the interfaces and front elements, is shown in the figure below.

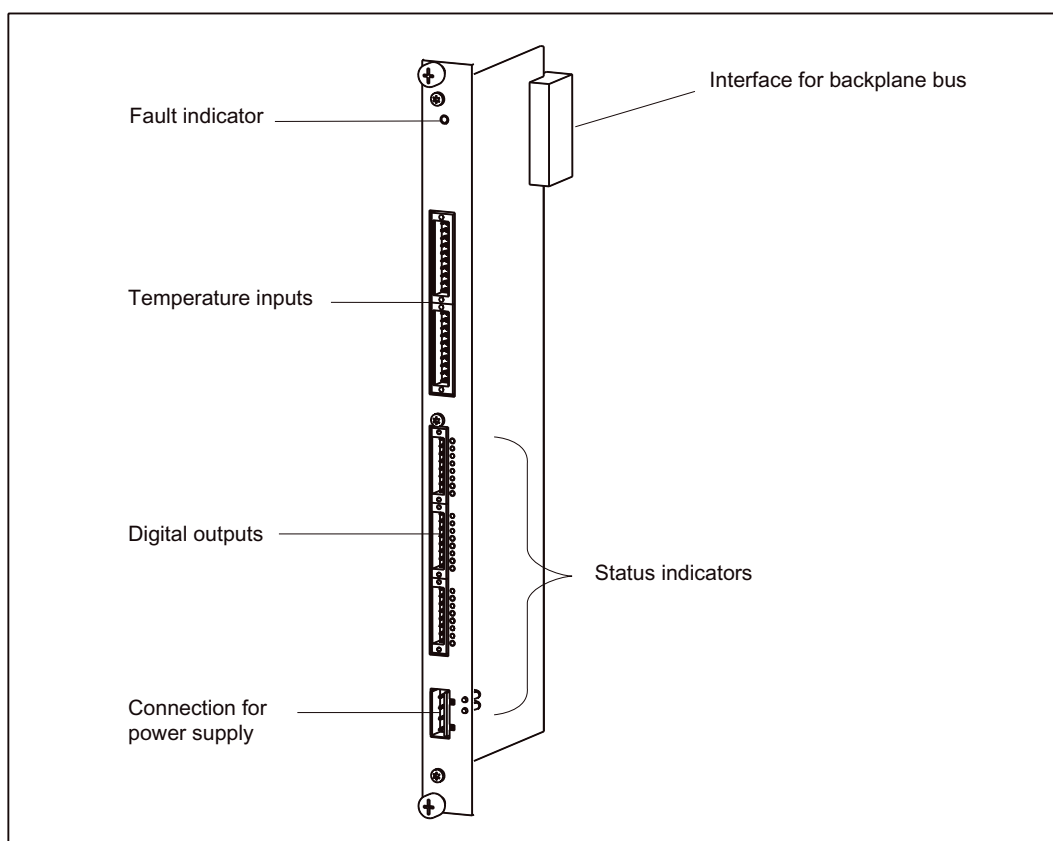

Figure 1-55 Illustration of the EB TEMP, 16TC/24DO

1.14.2 Description of functions for temperature inputs

There are 16 temperature inputs on the **EB TEMP, 16TC/24DO**.

They can be used as freely addressable process inputs. Addresses are allocated in the hardware configuration.

The following can be connected to these inputs:

- Pt 100/Pt 1000 resistance thermometer
- Thermocouples of types J, K, L

Note

For information on the function and operating principle of a resistance thermometer and a thermocouple, refer to the section titled "Description of functions for temperature inputs" for the head module.

Position of connectors

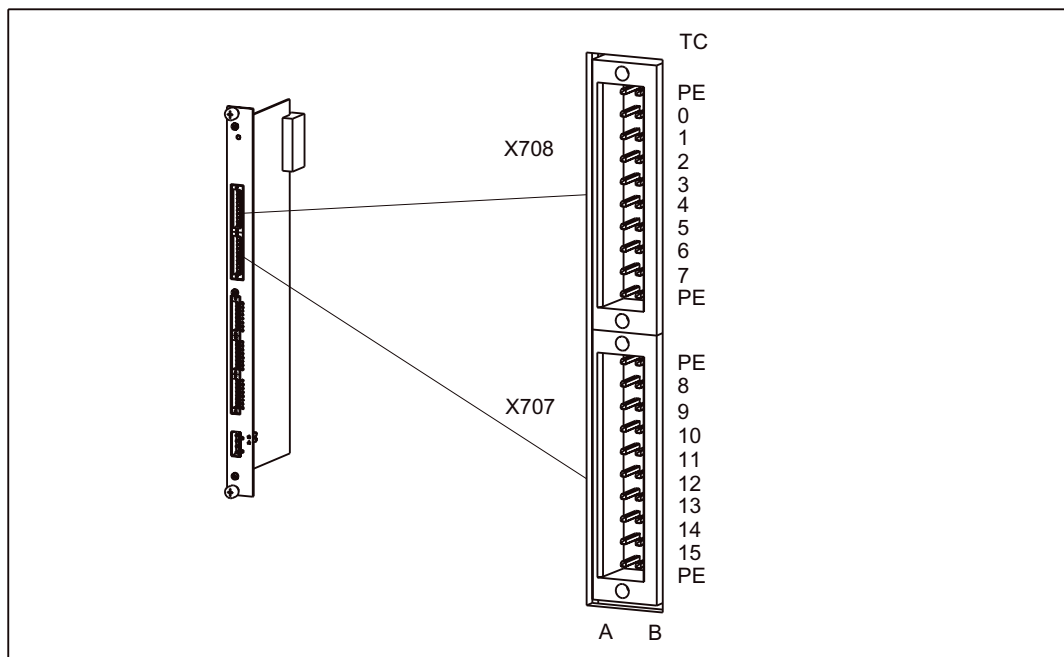

Figure 1-56 Position of connectors X707/X708 (EB TEMP, 16TC/24DO)

Connector assignment

Connector designation: X707/X708 (2x8 temperature inputs)
 Connector type: S2L-SMT3.5/20/90

Table 1- 62 Assignment of connector X708

Pin A	Signal	Designation	Pin B	Signal	Designation
1	PE	Functional ground	1	PE	Functional ground
2	TC0+	Temperature channel 0 +	2	TC0-	Temperature channel 0 -
3	TC1+	Temperature channel 1 +	3	TC1-	Temperature channel 1 -
4	TC2+	Temperature channel 2 +	4	TC2-	Temperature channel 2 -
5	TC3+	Temperature channel 3 +	5	TC3-	Temperature channel 3 -
6	TC4+	Temperature channel 4 +	6	TC4-	Temperature channel 4 -
7	TC5+	Temperature channel 5 +	7	TC5-	Temperature channel 5 -
8	TC6+	Temperature channel 6 +	8	TC6-	Temperature channel 6 -
9	TC7+	Temperature channel 7 +	9	TC7-	Temperature channel 7 -
10	PE	Functional ground	10	PE	Functional ground

Table 1- 63 Assignment of connector X707

Pin A	Signal	Designation	Pin B	Signal	Designation
1	PE	Functional ground	1	PE	Functional ground
2	TC8+	Temperature channel 8 +	2	TC8-	Temperature channel 8 -
3	TC9+	Temperature channel 9 +	3	TC9-	Temperature channel 9 -
4	TC10+	Temperature channel 10 +	4	TC10-	Temperature channel 10 -
5	TC11+	Temperature channel 11 +	5	TC11-	Temperature channel 11 -
6	TC12+	Temperature channel 12 +	6	TC12-	Temperature channel 12 -
7	TC13+	Temperature channel 13 +	7	TC13-	Temperature channel 13 -
8	TC14+	Temperature channel 14 +	8	TC14-	Temperature channel 14 -
9	TC15+	Temperature channel 15 +	9	TC15-	Temperature channel 15 -
10	PE	Functional ground	10	PE	Functional ground

See also

Description of functions for temperature inputs (Page 41)

1.14.3 Description of functions for digital outputs

There are 24 temperature outputs on the **EB TEMP, 16TC/24DO**. These outputs comply with the standard IEC 1131-2/DIN EN 61131-2.

They can be used as freely addressable process outputs. Addresses are allocated in the hardware configuration.

The parameter settings can be used to determine whether a substitute value or the last value is output when communication is interrupted.

When used as process outputs, the outputs are output in the PROFIBUS DP cycle.

Note

If the digital outputs are overloaded, the output is clocked to protect the module.

Position of connectors

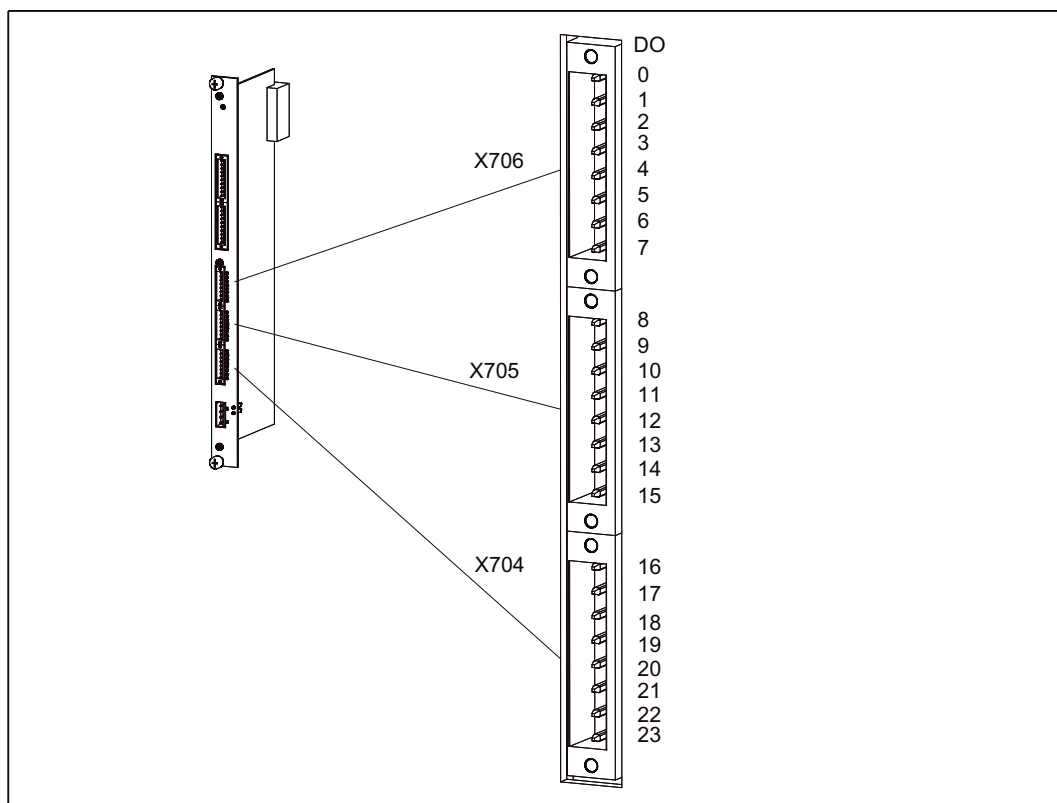

Figure 1-57 Position of connectors X704 to X706

Connector assignment

Connector designation: X704 to X706 (3 x 8 digital outputs, isolated, 0.5 A)
 Connector type: SL-SMT3.5/8/90

Table 1- 64 Assignment of connector X706

Pin	Signal	Designation	Pin	Signal	Designation
1	DO0	Digital output 0	5	DO4	Digital output 4
2	DO1	Digital output 1	6	DO5	Digital output 5
3	DO2	Digital output 2	7	DO6	Digital output 6
4	DO3	Digital output 3	8	DO7	Digital output 7

Table 1- 65 Assignment of connector X705

Pin	Signal	Designation	Pin	Signal	Designation
1	DO8	Digital output 8	5	DO12	Digital output 12
2	DO9	Digital output 9	6	DO13	Digital output 13
3	DO10	Digital output 10	7	DO14	Digital output 14
4	DO11	Digital output 11	8	DO15	Digital output 15

Table 1- 66 Assignment of connector X704

Pin	Signal	Designation	Pin	Signal	Designation
1	DO16	Digital output 16	5	DO20	Digital output 20
2	DO17	Digital output 17	6	DO21	Digital output 21
3	DO18	Digital output 18	7	DO22	Digital output 22
4	DO19	Digital output 19	8	DO23	Digital output 23

1.14.4 Connection for power supply

The 24 VDC load power supply for the digital outputs is connected to connector X703 on the EB TEMP, 16TC/24DO.

Position of the connector

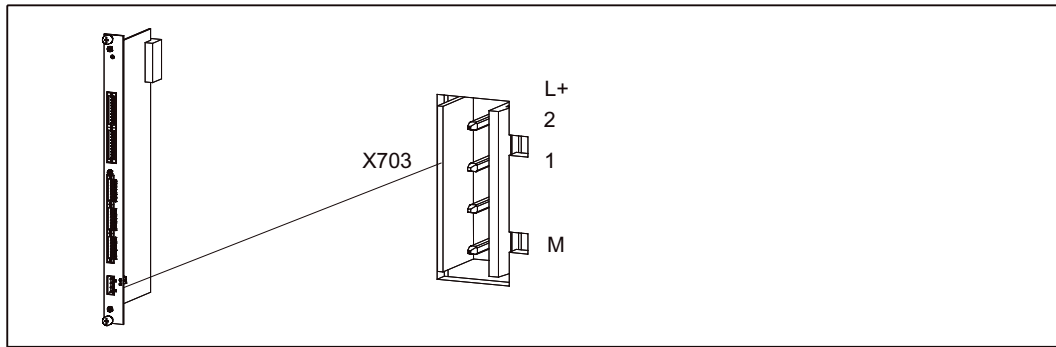

Figure 1-58 Position of connector X703

Connector assignment

Connector designation: X703
Connector type: SL-SMT5.08/4/90

Table 1- 67 Assignment of connector X703

Pin	Signal	Designation
1	L2+	24 V supply for DO16 to 23
2	L1+	24 V supply for DO0 to 15
3	-	Not assigned
4	M	24 V reference potential

1.14.5 Fault and status indicators

An LED for module faults, as well as additional status indicator LEDs for the digital outputs, are located on the front panel of the EB TEMP, 16TC/24DO.

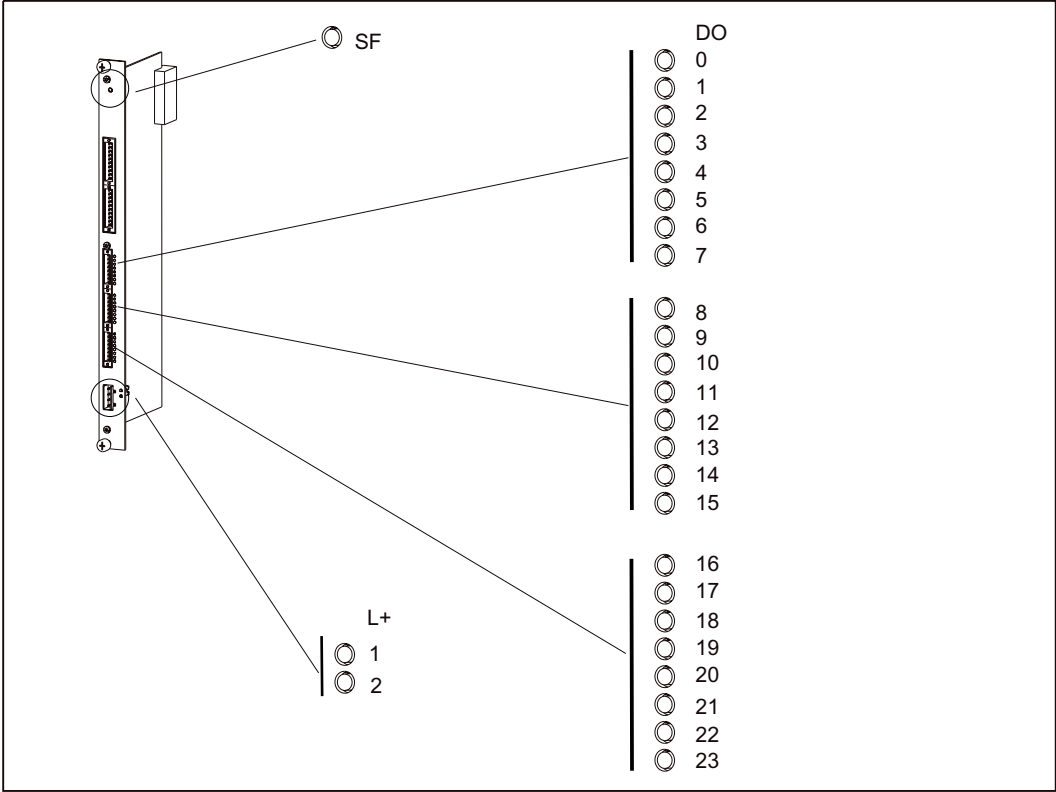

Figure 1-59 Status and fault indicators for the EB TEMP, 16TC/24DO

Meaning of the status and fault indicators

The individual LEDs and their meanings are described in the table below.

Table 1- 68 Fault and status indicators (EB TEMP, 16TC/24DO)

LED	Meaning	Explanations
SF (red)	Module error	This LED indicates a fault on the module. (see section titled "LEDs on the expansion modules")
DO0 to DO23 (green)	Status of the digital outputs	These LEDs show the status of digital outputs 0 to 23.
L1+ (green)	Power supply for the digital outputs	This LED shows the availability of digital outputs DO0 to DO15.
L2+ (green)		This LED shows the availability of digital outputs DO16 to DO23.

1.14.6 Type plate

The type plate for the **EB TEMP, 16DI/16DO** is located on the printed circuit board. The figure below contains all the information included on the type plate.

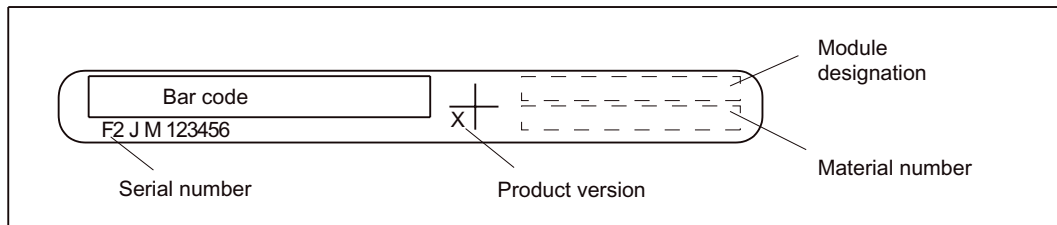

Figure 1-60 Type plate for the EB TEMP, 16TC/24DO

1.14.7 Wiring and block diagrams

Block diagram for temperature inputs

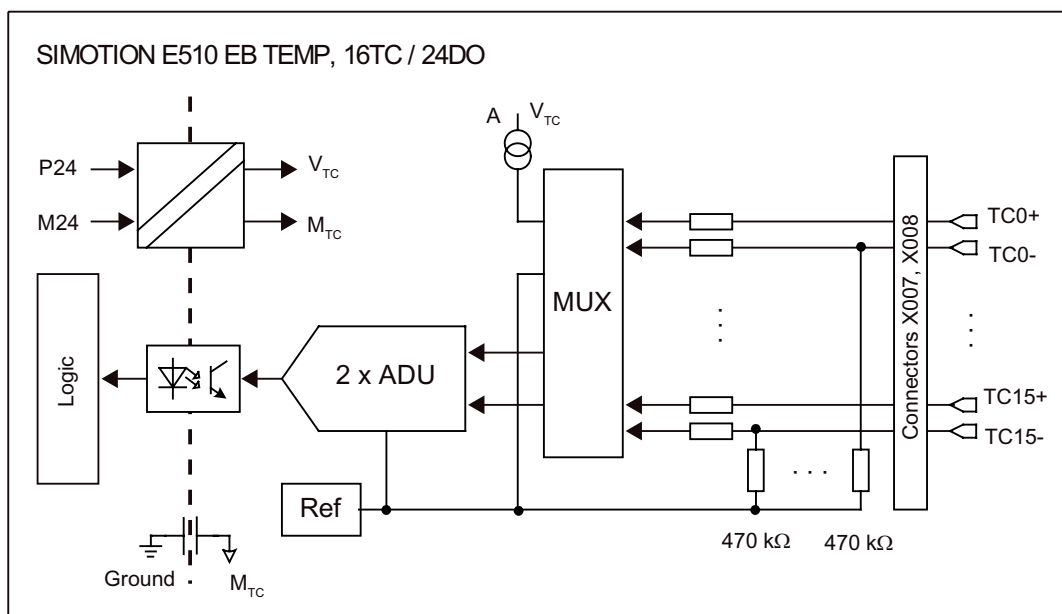

Figure 1-61 Block diagram for temperature inputs

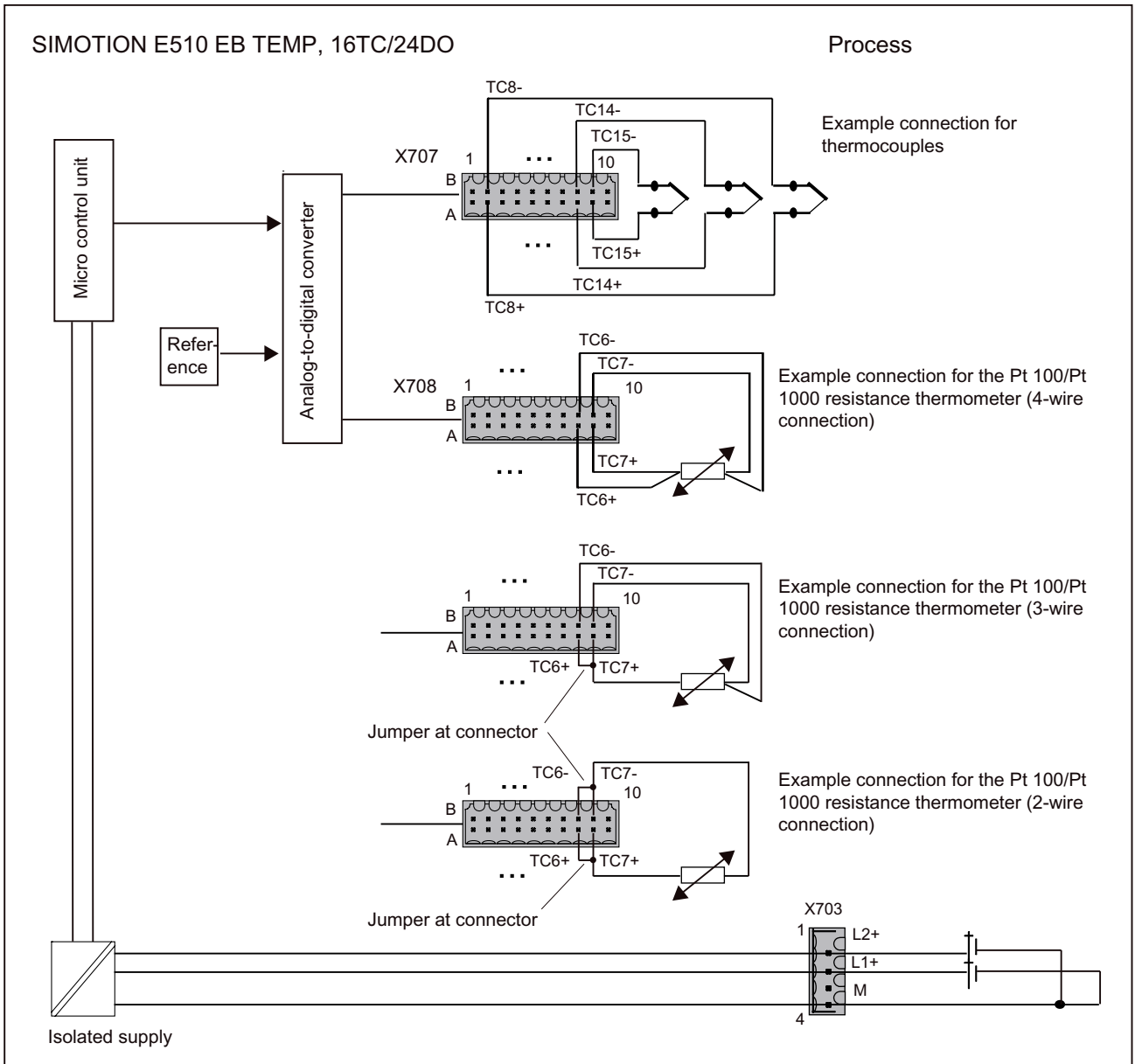

Figure 1-62 Wiring and block diagram for temperature inputs

Description

1.14 Temperature I/O expansion module (EB TEMP, 16TC/24DO)

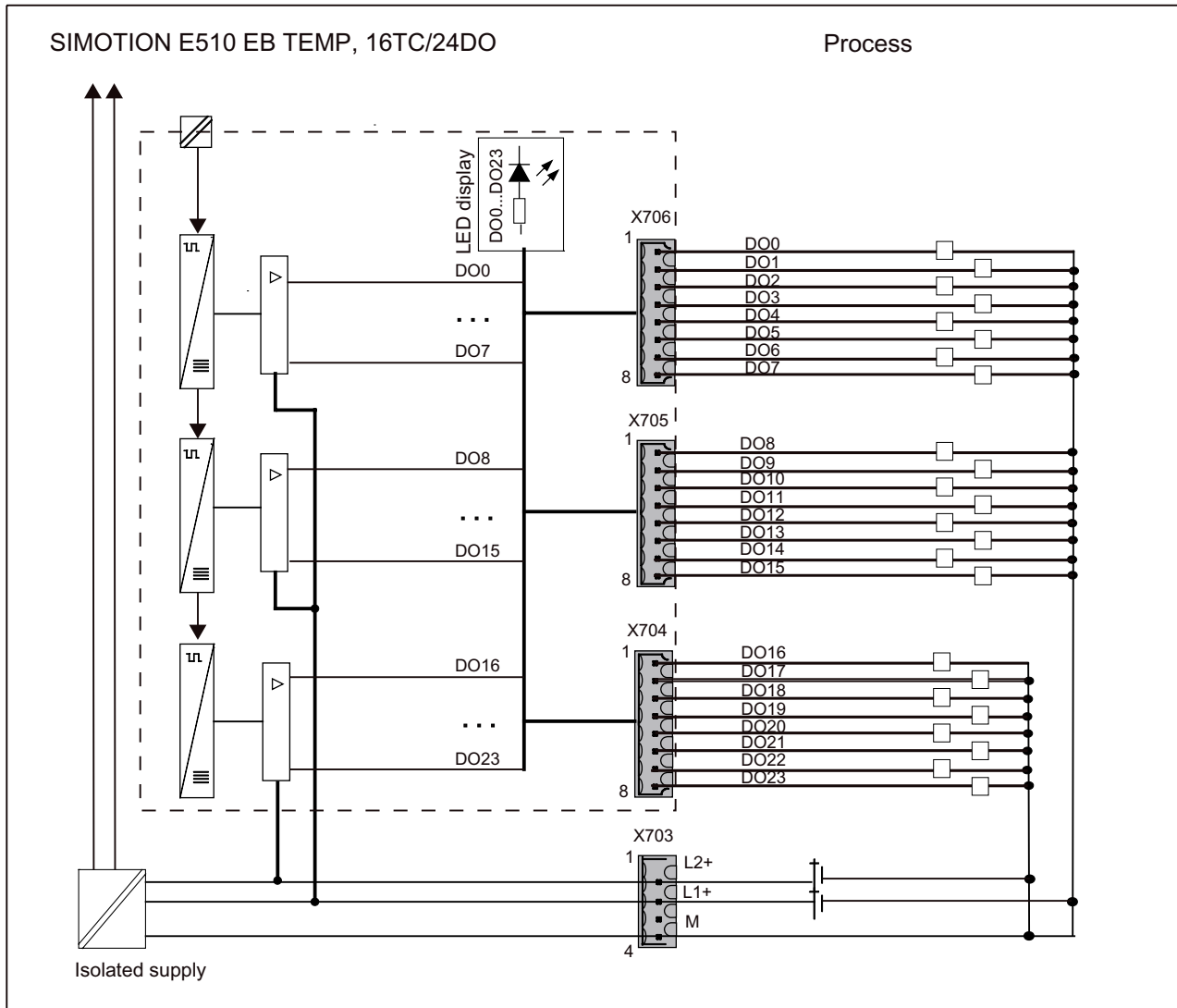

Figure 1-63 Wiring and block diagram for digital outputs

1.14.8 Technical data

Connection values

Table 1- 69 Connection values for EB TEMP, 16TC/24DO

Supply voltage	24 VDC; permissible range: 20.4 to 28.8 V (PELV)
Current consumption without load current	Approx. 100 mA
Fuse <ul style="list-style-type: none"> • L1+ • L2+ 	<ul style="list-style-type: none"> • 10 A, quick-response • 10 A, quick-response
Length of cable	Max. 10 m

Dimensions and weight

Table 1- 70 Dimensions and weight

Dimensions W x H x D [mm]	25.1 × 350.5 × 140.9
Weight	Approx. 330 g

Digital outputs (according to IEC 1131-2/DIN EN 61131-2)

Table 1- 71 Digital outputs

Number of outputs	24
Length of cable	Max. 30 m
Type of outputs	High-side driver
Data for selection	
Output voltage with 1 signal	L+ -0.16 V
Output current <ul style="list-style-type: none"> • Rated value • 1 signal • 0 signal (residual current) 	<ul style="list-style-type: none"> • 0.5 A • Max. 0.7 A • 0.3 mA
Output delay (register output to driver output) <ul style="list-style-type: none"> • 0 → 1 signal • 1 → 0 signal 	<ul style="list-style-type: none"> • Typ. 40 μs • Typ. 80 μs
Lamp load	Max. 5 W
Max. switching frequency <ul style="list-style-type: none"> • With resistive load • With inductive load in accordance with IEC 947-5-1, DC 13 • With lamp load 	<ul style="list-style-type: none"> • 100 Hz • 2 Hz • 11 Hz
Limiting of inductive cut-off voltage	53 V
Short-circuit protection of output	Yes, electronic pulsing
Response threshold	> 0.7 A

Description

1.14 Temperature I/O expansion module (EB TEMP, 16TC/24DO)

Voltages, currents, potentials	
Rated load voltage L1+, L2+	24 VDC; permissible range 20.4 to 28.8 V (PELV)
Total current of outputs per group equates to 50% simultaneity	4 A (DO0 to 15) 2 A (DO16 to 23)
Isolated DO0 to DO23	In groups of 1 x 24
Insulation test voltage	500 VDC

Temperature inputs

Table 1- 72 Temperature inputs

Number of inputs <ul style="list-style-type: none"> • Thermocouple • Resistance thermometer 	<ul style="list-style-type: none"> • 16 • 8
Cable length, shielded	Max. 30 m
Encoder selection data	
Input range (rated values) <ul style="list-style-type: none"> • Voltage • Resistance <ul style="list-style-type: none"> – Pt 100 – Pt 1000 	Parameters can be assigned <ul style="list-style-type: none"> • Approx. ±78 mV <ul style="list-style-type: none"> – Approx. 400 Ω ¹⁾ – Approx. 3,000 Ω ¹⁾
Permissible input differential voltage	Max. 5 V
Characteristic linearization <ul style="list-style-type: none"> • For thermocouple • For resistance thermometer 	Parameters can be assigned <ul style="list-style-type: none"> • J, K, L • Pt 100/Pt 1000 (standard range) ¹⁾
Temperature compensation <ul style="list-style-type: none"> • Internal temperature compensation • External temperature compensation with compensating box • External temperature compensation with thermoresistor (e.g. Pt 100/Pt 1000) • Compensation for 0 °C comparison point temperature • Compensation for 50 °C comparison point temperature 	Parameters can be assigned <ul style="list-style-type: none"> • Possible • Possible • Possible, resistance thermometer measurement by connecting 2 temperature inputs • Possible • Possible
Measuring current for thermoresistors and wire-break checks	Approx. 0.385 mA
Input resistance (differential)	> 10 MΩ
Connection signal transmitter <ul style="list-style-type: none"> • For voltage measurement • For resistance measurement <ul style="list-style-type: none"> – With 4-wire connection – With 3-wire connection ^{2) 5)} – With 2-wire connection ^{2) 5)} 	<ul style="list-style-type: none"> • Possible • Possible

Voltages, currents, potentials	
Galvanic isolation <ul style="list-style-type: none"> Between channels and internal bus Between channels 	<ul style="list-style-type: none"> Yes No
Permissible potential difference <ul style="list-style-type: none"> Between inputs (U_{CM}) Between temperature input negative and central grounding point (U_{ISO}) 	<ul style="list-style-type: none"> 3 VppAC 3 VppAC
Insulation test voltage	500 VDC
Formation of analog values	
Measuring principle	Integrating, sigma delta
Integration time/conversion time/resolution (per channel) <ul style="list-style-type: none"> Integration time Basic conversion time, including integration time for two thermocouples <ul style="list-style-type: none"> Additional conversion time for wire break monitoring for each channel Basic conversion time, including integration time for one resistance thermometer <ul style="list-style-type: none"> Additional conversion time for wire break monitoring for each channel Resolution (including overshoot range) Interference voltage suppression for interference frequency f_1 Basic execution time (all channels enabled) Additional lost time for combined use of JKL/Pt 100/Pt 1000 (transient recovery time, gain switchover, internal transmission, etc.) 	<ul style="list-style-type: none"> Approx. 60 ms Approx. 75 ms Approx. 4 ms Approx. 75 ms Approx. 8 ms 16 bits 50/60 Hz Approx. 600 ms Up to 16 DP cycles (worst-case scenario) per throughput time across all channels
Measured value smoothing	None
Noise suppression and error limits	
Noise suppression at $f = n \times (f_1 \pm 1\%)$, ($f_1 =$ interference frequency); $n = 1, 2$, etc. <ul style="list-style-type: none"> Common mode interference ($U_{CM} < 2.5$ V) Series-mode interference (peak interference value $<$ nominal input range value, sinusoidal) 	<ul style="list-style-type: none"> > 90 dB > 70 dB
Crosstalk attenuation between inputs	> 50 dB
Operational limit (across temperature range, in relation to input range) <ul style="list-style-type: none"> Voltage measurement Thermocouple <ul style="list-style-type: none"> Type J Type K Type L Resistance thermometer <ul style="list-style-type: none"> Pt 100 Pt 1000 	<ul style="list-style-type: none"> $\pm 0.1\%$ Approx. ± 2 K Approx. ± 2 K Approx. ± 2 K Approx. ± 3 K Approx. ± 3 K

Description

1.14 Temperature I/O expansion module (EB TEMP, 16TC/24DO)

<p>Intrinsic error limit (operational limit at 25 °C in relation to input range)</p> <ul style="list-style-type: none"> • Voltage measurement • Thermocouple <ul style="list-style-type: none"> – Type J – Type K – Type L • Resistance thermometer <ul style="list-style-type: none"> – Pt 100 – Pt 1000 	<ul style="list-style-type: none"> • ±0.02% • Approx. ±1 K • Approx. ±1 K • Approx. ±1 K • Approx. ±0.5 K • Approx. ±1 K
Operational limit for internal compensation (0 to 60 °C)	±2.5 K ⁴⁾
<p>The temperature measurement accuracy for external compensation with thermoresistors is calculated on the basis of:</p> <ul style="list-style-type: none"> • Error for the temperature input of the type of thermocouple used • Accuracy ³⁾ of the type of thermoresistor used for compensation • Error ³⁾ for the compensation input 	
<p>The temperature measurement accuracy for external compensation with compensating box is calculated on the basis of:</p> <ul style="list-style-type: none"> • Error for the temperature input of the type of thermocouple used • Accuracy ³⁾ of the compensating box • Error ³⁾ for the compensation input 	
<p>The temperature measurement accuracy for the compensation of the external comparison point maintained at 0 °C/50 °C is calculated on the basis of:</p> <ul style="list-style-type: none"> • Error for the temperature input of the type of thermocouple used • Accuracy ³⁾ of the comparison point temperature 	
<p>The temperature measurement accuracy for internal compensation (terminal temperature) is calculated on the basis of:</p> <ul style="list-style-type: none"> • Error for the temperature input of the type of thermocouple used • Accuracy ³⁾ of the comparison point temperature ⁴⁾ 	

1) Pt 100/Pt 1000 measuring range up to approx. 560 °C

2) Without line resistance correction

3) Due to the constant increase in the thermocouple characteristic at higher temperatures, the compensation element error has less of an effect than at temperatures in the vicinity of the compensation temperature.

4) Module must be in a thermally settled state Ambient temperature change < 0.3 K/min

5) Figure for the number of supply lines for power supply and voltage measurement

Note

The temperature inputs must be configured as a protective extra-low voltage (PELV).

1.15 Position encoder expansion module (EB MPT, 4CH)

1.15.1 Properties of EB MPT, 4CH

Order number for the expansion module:	6AU1 510-3DA00-0AA0
Designation of the expansion module:	MPT, 4CH

Task

The **EB MPT, 4CH** makes it possible to connect four magnetostrictive position transducers (MPT) with START/STOP pulse interfaces (RS 422). A maximum of two positions can be detected for each position encoder and a maximum of six positions for each expansion module.

You will need to parameterize the module (see section titled "Parameterizing inputs and outputs"), which can be configured as follows:

- As a 16-bit measured value
- As a 32-bit measured value

The 24 V supply for the sensors is monitored.

Measuring principle

An excitation pulse (START pulse) is sent by SIMOTION E510 via the RS 422 interface. A mechanical wave is generated by the superposition of the respective magnetic fields of the excitation pulse and the position encoder. This wave spreads at an ultrasonic velocity. In the sensor electronics of the measuring stick, the wave is converted into an electrical measuring pulse (STOP pulse). The wave duration, from the point at which the excitation pulse is sent to the point at which the measuring pulse is received, is proportional to the path length.

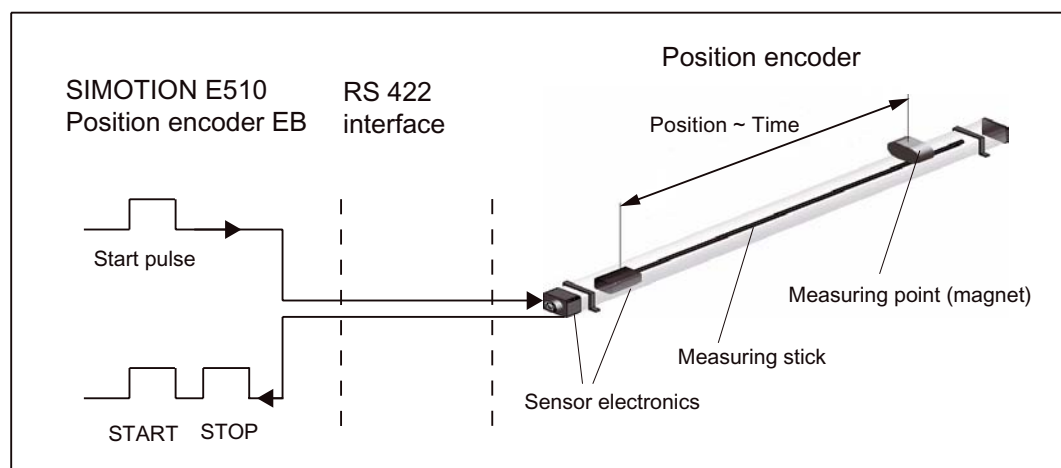

Figure 1-64 Principle of the ultrasonic position encoder

Description

1.15 Position encoder expansion module (EB MPT, 4CH)

Note

If a value is not available in each cycle, the measured values are extrapolated (refer to the section titled "Parameterizing inputs and outputs" and the details on the "Measurement: Factor" parameter).

Illustration of the module

An illustration of the **EB MPT, 4CH**, including the positions of the interfaces and front elements, is shown in the figure below.

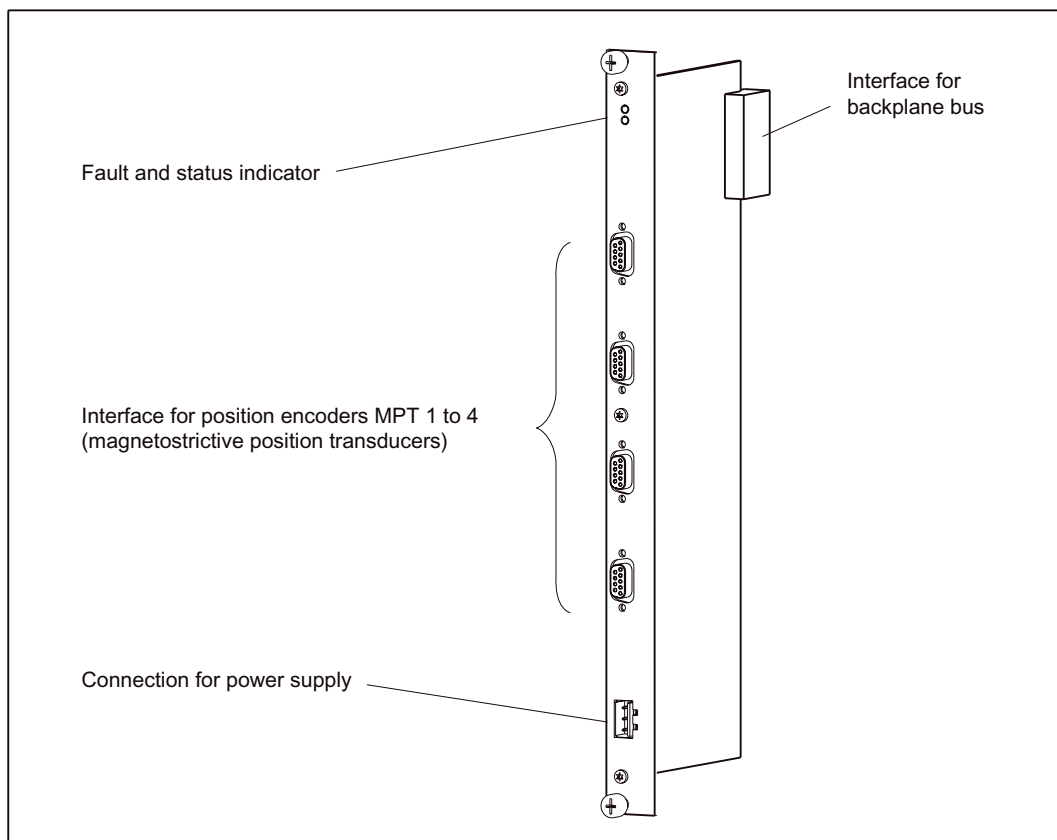

Figure 1-65 Illustration of the EB MPT, 4CH

1.15.2 Interface for the position encoder (MPT1 to 4)

Up to four position encoders can be connected.

Position of connectors

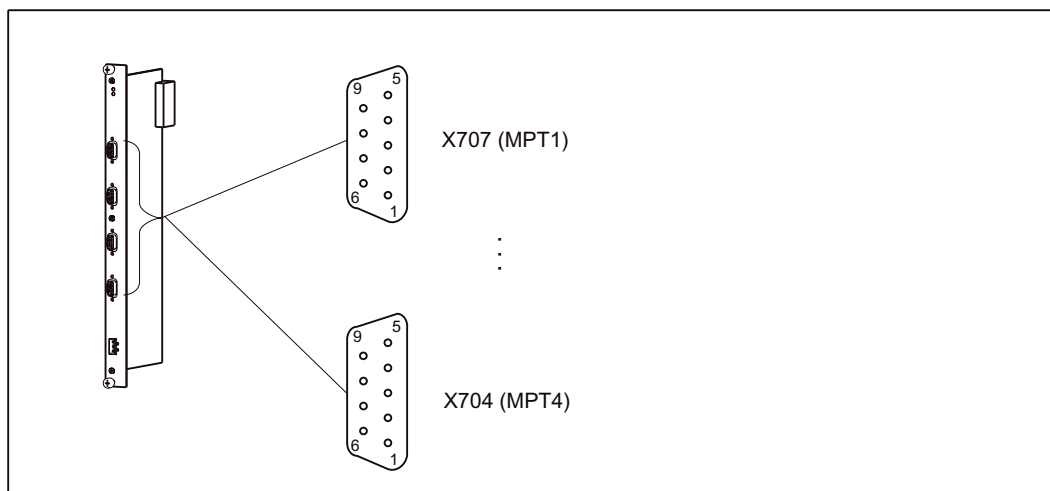

Figure 1-66 Position of connectors X704 to X707

Connector assignment

Connector designation: X704 (MPT4) / X705 (MPT3) / X706 (MPT2) / X707 (MPT1)
 Connector type: 9-pin sub D socket

Table 1- 73 Assignment of connectors X704 to X707

Pin	Signal	Designation	Pin	Signal	Designation
1	-	Not assigned	6	-	Not assigned
2	M24	Encoder supply ground	7	P24	24 V encoder supply
3	XSTART	Inverted start pulse for measurement	8	START	Start pulse for measurement
4	START/STOP	Start/stop pulse	9	XSTART/STOP	Inverted start/stop pulse
5	-	Not assigned			

Connecting cable

The figure below shows the connecting cable between the **EB MPT, 4CH** and the corresponding encoder with the RS 422 interface.

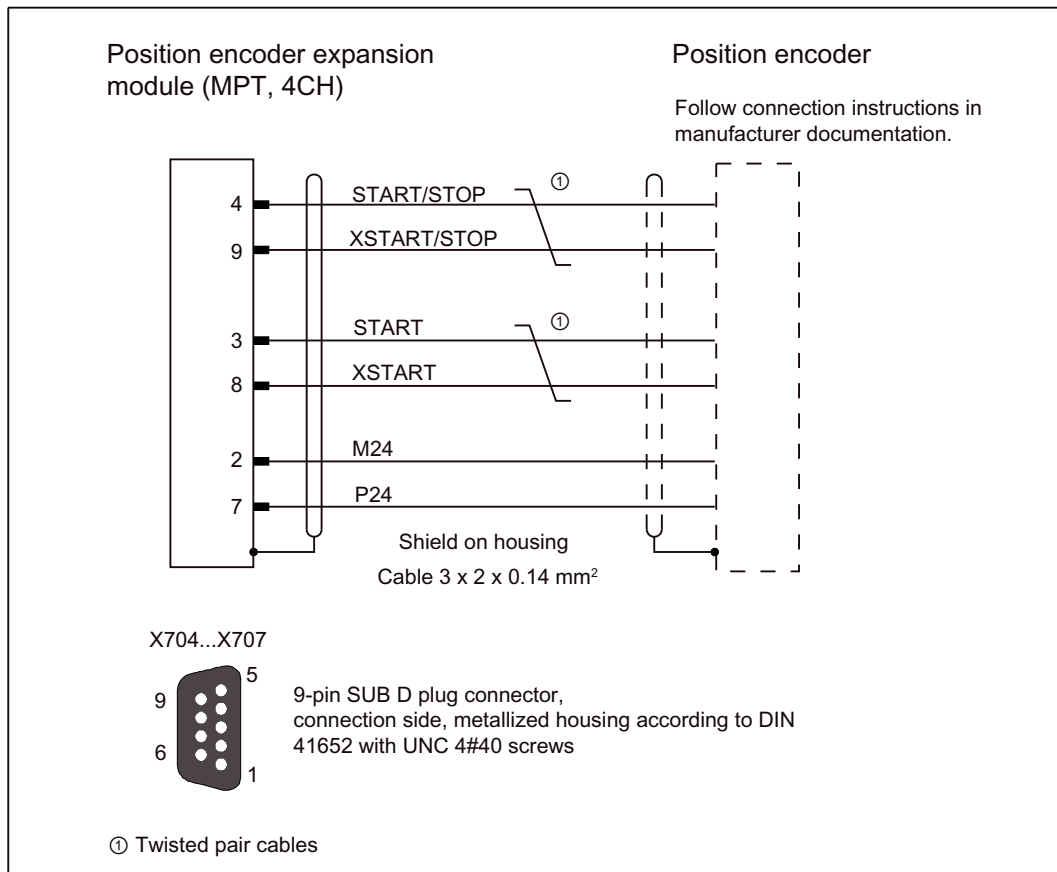

Figure 1-67 Connecting cable

NOTICE

The connecting cable must **not** be pulled out during operation.

1.15.3 Connection for power supply

The 24 VDC load power supply for the module and the encoders is connected to connector X703 on the **EB MPT, 4CH**.

Position of the connector

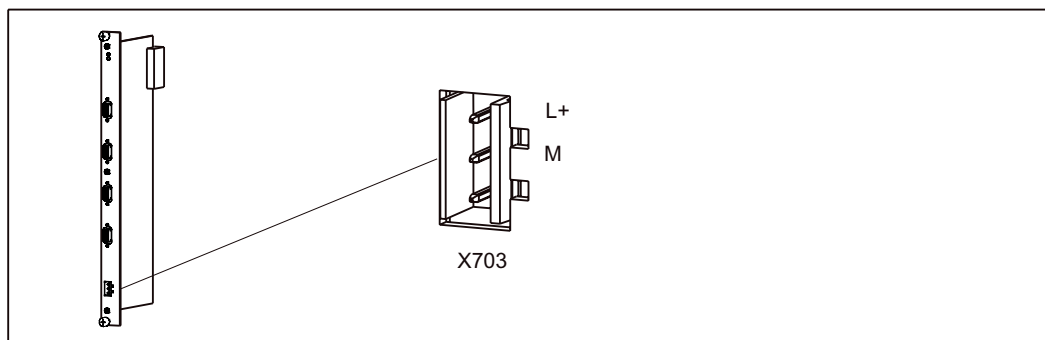

Figure 1-68 Position of connector X703

Connector assignment

Connector designation: **X703** (EB MPT, 4CH)
 Connector type: SL-SMT5.08/3/90

Table 1- 74 Assignment of connector X703

Pin	Signal	Designation
1	L+	24 V power supply
2	M	24 V reference potential
3	-	Not assigned

1.15.4 Fault and status indicators

The following LEDs are situated on the front panel of the **EB MPT, 4CH**.

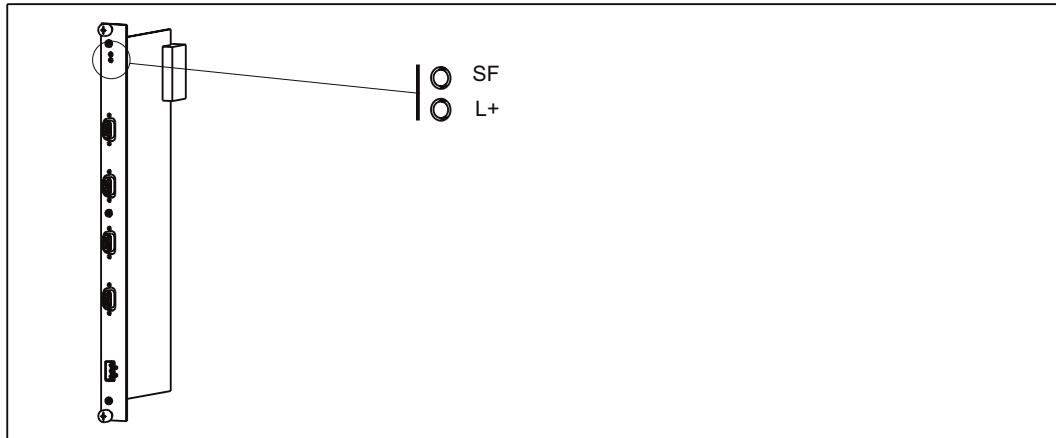

Figure 1-69 Status and fault indicators of EB MPT, 4CH

Meaning of the status and fault indicators

The individual LEDs and their meanings are described in the table below.

Table 1-75 Fault and status indicator

LED	Meaning	Explanations
SF (red)	Module error	This LED indicates a fault on the module (see section titled "LED-based diagnostics")
L+ (green)	Power supply for position encoders	This LED indicates that the power supply is available for the connected position encoders.

1.15.5 Type plate

The type plate for the **EB MPT, 4CH** is located on the printed circuit board.

The figure below contains all the information included on the type plate.

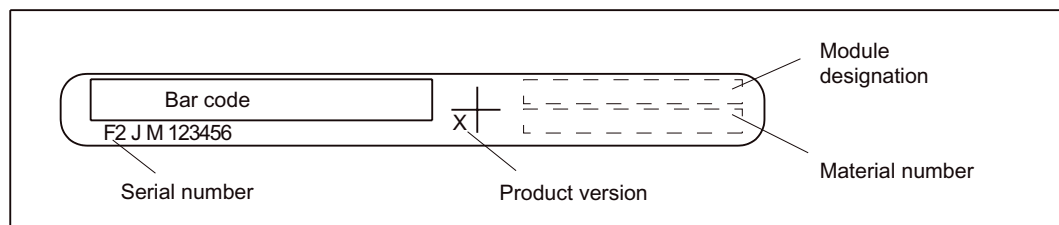

Figure 1-70 Type plate for EB MPT, 4CH

1.15.6 Technical data

Connection values

Table 1- 76 Connection values

Supply voltage	24 VDC; permissible range: 20.4 to 28.8 V (PELV)
Supply voltage for the position encoders	24 V
Current consumption per position encoder	≤ 150 mA
Galvanic isolation	No
Length of cable	Max. 10 m

Dimensions and weight

Table 1- 77 Dimensions and weight

Dimensions W x H x D [mm]	25.1 × 350.5 × 140.9
Weight	Approx. 340 g

Position encoder

Table 1- 78 Position encoder

Number of position encoders	4
Length of cable	Max. 30 m
Measuring points per position encoder	Max. 2
Total number of measuring points per module	Max. 6
Measuring cycle	Depends on the PROFIBUS DP cycle used and the factor Min. 1.25 ms
Scaling	Parameters can be assigned: 5 µm to 1,000 µm For parameterization details, see section titled "Parameterizing inputs and outputs".
Interface	RS 422 START/STOP pulse, rising edge
Automatic reading out of position encoder parameters	Possible ¹⁾

¹⁾ Position encoders from "BALLUFF" with a P111 interface are supported, as are position encoders from "MTS" with a start/stop interface able to upload sensor parameters.

Note: Please refer to the manufacturer documentation for the sensor.

1.16 EUROMAP 67-compliant handling expansion module (EB HAND, 16DI/16DO) (on request)

1.16.1 Properties of EB HAND, 16DI/16DO

Order number for EB HAND, 16DI/16DO:	6AU1 510-3EB00-0AA0 (on request)
Designation of the expansion module:	HAND, 16DI/16DO

Task

The **EB HAND, 16DI/16DO** makes it possible to connect a plastics injection molding machine to automated unloading units. This module conforms to the recommendation made by EUROMAP 12 and 67.

The following option module is required when connecting EUROMAP 12-compliant handling devices:

Relay option module

Expansion to EUROMAP 12 with 11 relay outputs

Order no.: **6AU1 510-4EA00-0AA0** (on request)

The option module can be connected to **EB HAND, 16DI/16DO** at a later point (see section titled "Installing the relay option module").

A connecting cable between the expansion module and the standardized add-on housing is used to connect the handling device.

Note

When using the relay option module, please note that either the slot to the right of the handling device with the relay module must remain unoccupied, or the permissible ambient temperature of the device with a relay module connected must not exceed 45 °C.

Hybrid solution:

The hybrid solution enables the use of both a controller conforming to EUROMAP 67 and an adapter cable for making external adaptations in line with a EUROMAP 12-compliant handling device.

The following preconditions must be fulfilled:

- A relay module must be present on the handling module.
- The required number of outputs must be ≤ 11 .
- No short-circuit proof controller outputs are required.

Refer to the section titled "Connecting cables" for connection suggestions and information on adapter cables.

 CAUTION
--

You must protect the option module's relay contacts using a 6 A quick-response fuse. Smaller fuses may also be used.
--

1.16 EUROMAP 67-compliant handling expansion module (EB HAND, 16DI/16DO) (on request)

Illustration of the module

An illustration of the EB HAND, 16DI/16DO, including the positions of the interfaces and front elements, is shown in the figure below.

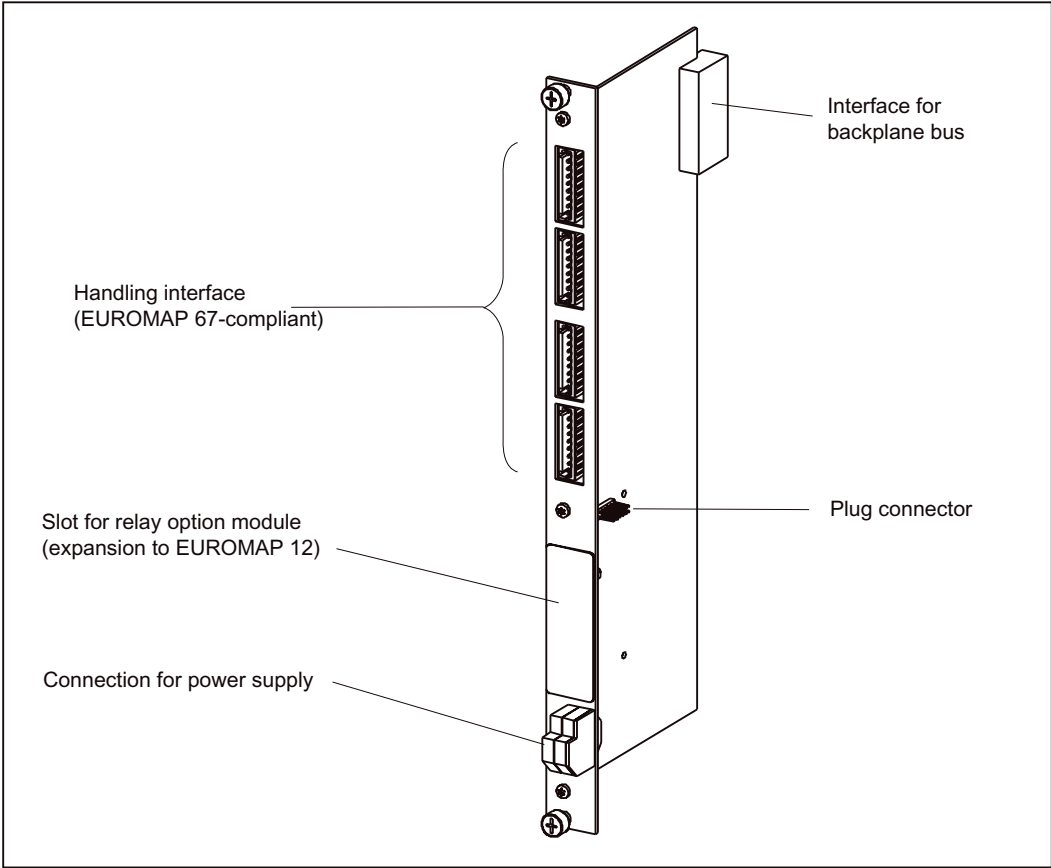

Figure 1-71 Illustration of the EB HAND, 16DI/16DO

1.16.2 Handling interface

Position of connectors

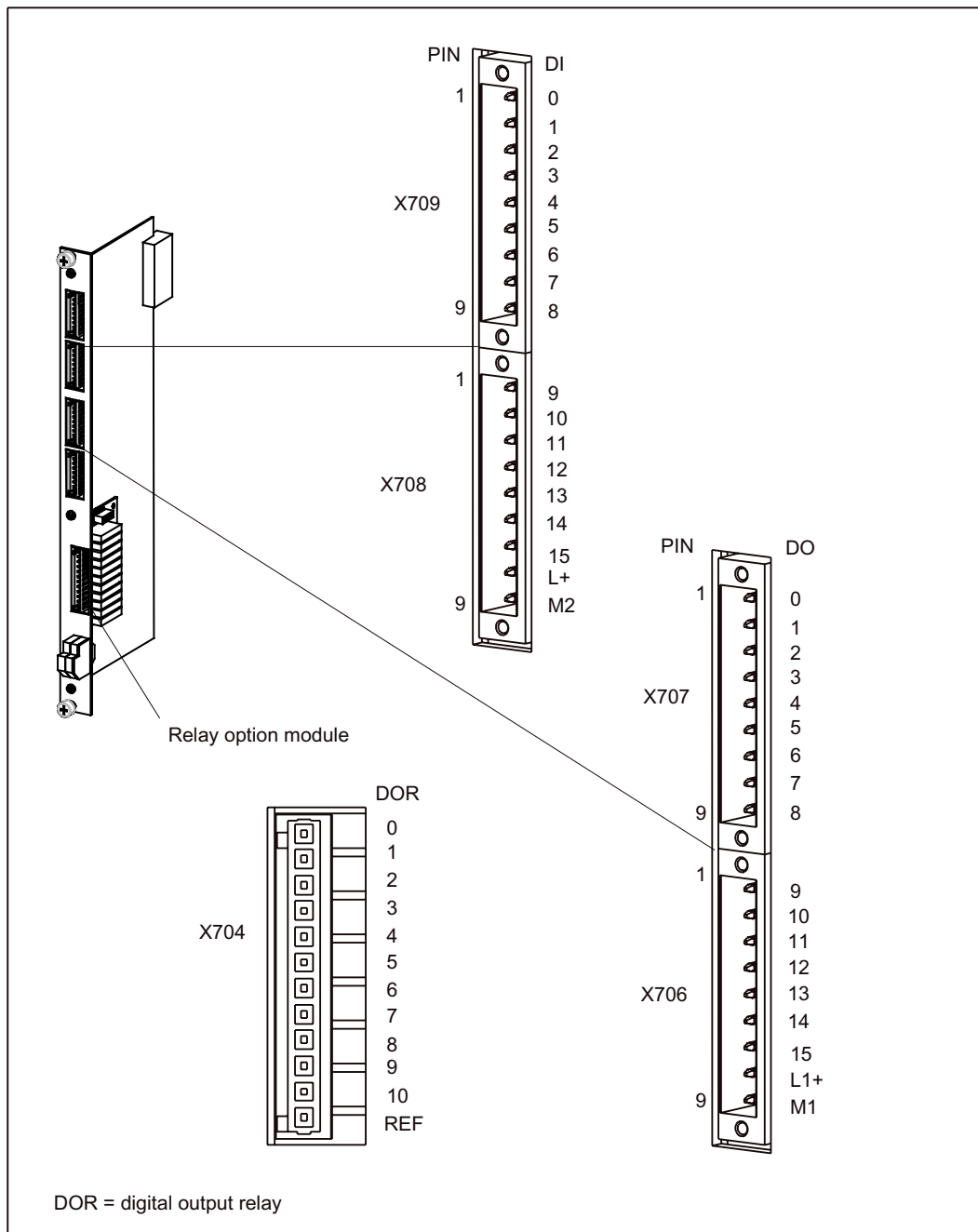

Figure 1-72 Position of connectors X704 to X707

Connector assignment

Connector designation: X706/X707 (16 digital outputs, 0.1 A)
 Connector type: 2 x 3.5MM1X1FS9P.HOR. SOLDER PIN PLUG CONNECTORS
 Order no.: 734-169 (WAGO)

Table 1- 79 Assignment of connector X706/X707

Pin	Connector	Signal	Designation	For details of the pin handling unit, refer to EUROMAP ...	
				... 12	... 67
1	X707	DO0	Digital output 0	Terminals occupied by relay outputs	ZA7
2		DO1	Digital output 1		ZB3
3		DO2	Digital output 2		ZB4
4		DO3	Digital output 3		ZB2
5		DO4	Digital output 4		ZA6
6		DO5	Digital output 5		ZB5
7		DO6	Digital output 6		ZB6
8		DO7	Digital output 7		ZA5
9		DO8	Digital output 8		ZA8
1	X706	DO9	Digital output 9	Not assigned	ZB7
2		DO10	Digital output 10		ZB8
3		DO11	Digital output 11	Not assigned	ZC8
4		DO12	Digital output 12	Not assigned	ZC5
5		DO13	Digital output 13	Not assigned	ZC6
6		DO14	Digital output 14	Not assigned	ZC7
7		DO15	Digital output 15	Not assigned	Not assigned
8		L1+	24 V power supply	24 V power supply	ZA9
9		M1	Reference potential for digital outputs	Reference potential	ZC9

Description

1.16 EUROMAP 67-compliant handling expansion module (EB HAND, 16DI/16DO) (on request)

Connector designation: X708/X709 (16 digital inputs)
 Connector type: 2 x 3.5MM1X1FS9P.HOR. SOLDER PIN PLUG CONNECTORS
 Order no.: 734-169 (WAGO)

Table 1- 80 Assignment of connector X708/X709

Pin	Connector	Signal	Designation	For details of the pin handling unit, refer to EUROMAP ...	
				... 12 ¹⁾	... 67 ¹⁾
1	X709	DI0	Digital input 0	18	A3
2		DI1	Digital input 1	17	A6
3		DI2	Digital input 2	20	B2
4		DI3	Digital input 3	21	B3
5		DI4	Digital input 4	22	B4
6		DI5	Digital input 5	23	B6
7		DI6	Digital input 6	24	B5
8		DI7	Digital input 7	28	A7
9		DI8	Digital input 8	25	B7
1	X708	DI9	Digital input 9	29	B8
2		DI10	Digital input 10	30	A5
3		DI11	Digital input 11	31	C5
4		DI12	Digital input 12	-	C8
5		DI13	Digital input 13	-	C6
6		DI14	Digital input 14	-	C7
7		DI15	Digital input 15	-	A8
8		L+	24 V power supply	32 / 26	A9/C3
9		M2	Reference potential for digital inputs	-	C9

¹⁾ See connection suggestions in the section titled "Connecting cables"

1.16 EUROMAP 67-compliant handling expansion module (EB HAND, 16DI/16DO) (on request)
Relay option module

Connector designation: X704 (11 relay contacts)
Connector type: 2 x 3.81 1X1FS12-P.HOR SOLDER PIN PLUG CONNECTORS
Order no.: 734-272 (WAGO)

Table 1- 81 Assignment of connector X704

Pin	Connector	Signal	Designation	For details of the pin handling unit, refer to	
				EUROMAP 12	EUROMAP 67 ¹⁾
1	X704	DOR0	Relay contact 0	2	ZA7
2		DOR1	Relay contact 1	4	ZB3
3		DOR2	Relay contact 2	5	ZB4
4		DOR3	Relay contact 3	10	ZB2
5		DOR4	Relay contact 4	12	ZA6
6		DOR5	Relay contact 5	6	ZB5
7		DOR6	Relay contact 6	7	ZB6
8		DOR7	Relay contact 7	8	ZA5
9		DOR8	Relay contact 8	14	ZA8
10		DOR9	Relay contact 9	13	ZB7
11		DOR10	Relay contact 10	15	ZB8
12	REF	Reference potential	16	ZA9	

¹⁾ Applies to the hybrid solution

Note

From a functional perspective, digital outputs DO0 to DO10 (X707/X706) are connected in parallel to relay outputs DOR0 to DOR10. Outputs DO0 to DO10 **may not** be used for other functions in the case of EUROMAP 12.

1.16.3 Connection for power supply

The 24 VDC load power supply is connected to terminal X703 on the **EB HAND, 16DI/16DO**:

Position of terminal

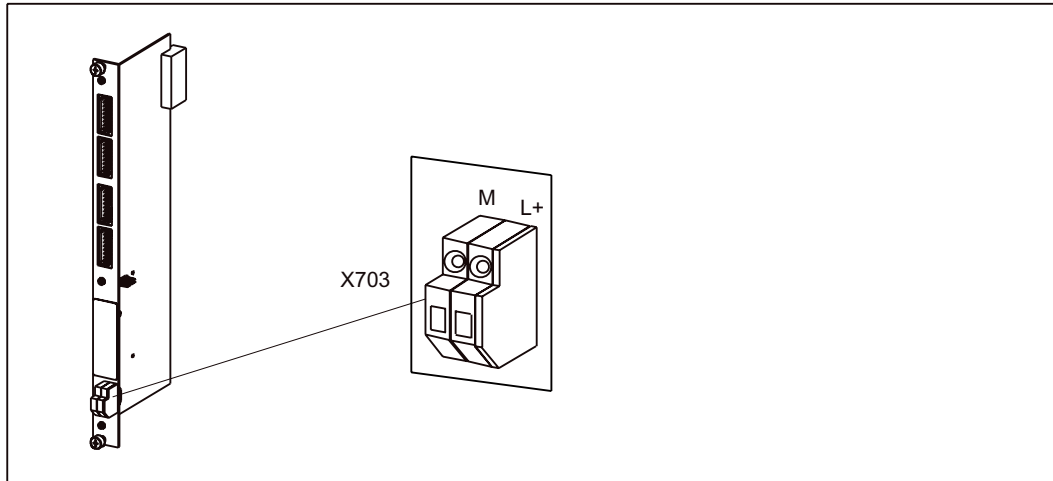

Figure 1-73 Position of terminal X703

Terminal assignment

Terminal designation: **X703**
 Terminal type: 2 x modular lead-through terminals;
 order no.: 226-111 (WAGO)

Table 1- 82 Assignment of terminal X703

Signal	Designation
L+	24 V power supply
M	24 V reference potential

Note

Double isolation exists between the potentials of plug connectors X703, X704, and X706 to X709, as well as the PELV potentials of the other modules. This ensures that handling devices which do not conform to PELV connections can be used.

Basic isolation exists between the X704 relay contacts and the potentials of plug connectors X703, X706 to X709.

Note

As far as the handling module is concerned, failure of the supply voltage at X703 **may not** be monitored by the head module.

1.16.4 Type plate

The figure below contains all the information included on the type plate.

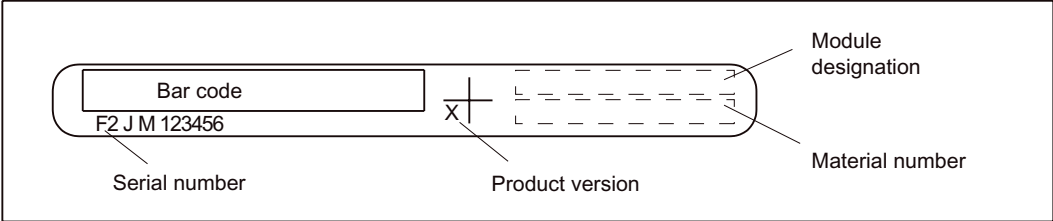

Figure 1-74 Type plate for EB HAND, 16DI/16DO

1.16.5 Wiring diagram and block diagram

Digital inputs

Wiring and block diagram for the 16DI x 24 VDC digital input block of the EUROMAP 67-compliant EB HAND, 16DI/16DO.

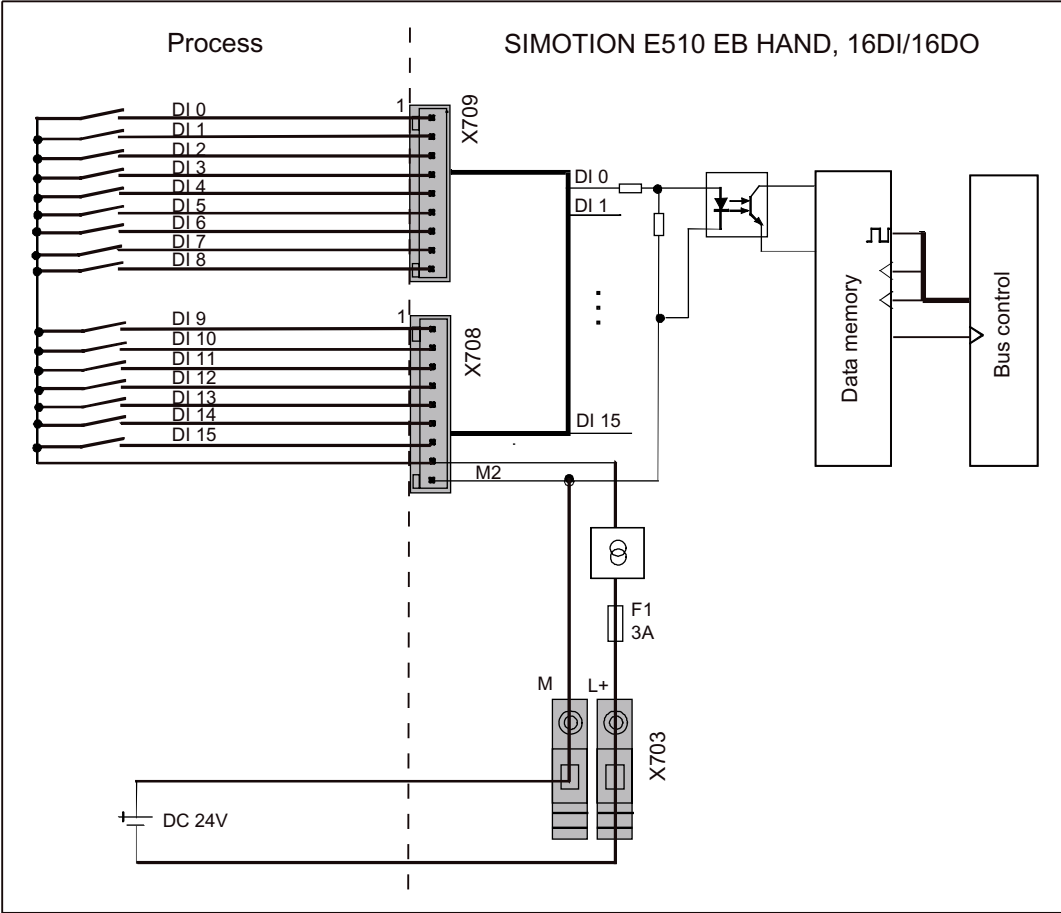

Figure 1-75 Wiring and block diagram for the EB HAND, 16DI/16DO

Description

1.16 EUROMAP 67-compliant handling expansion module (EB HAND, 16DI/16DO) (on request)

Digital outputs

Wiring and block diagram for the digital output block:

- 16DO (EUROMAP 67-compliant handling expansion module) or
- 11DOR of the relay option module (expansion to EUROMAP 12 with 11 relay outputs)

1.16 EUROMAP 67-compliant handling expansion module (EB HAND, 16DI/16DO) (on request)

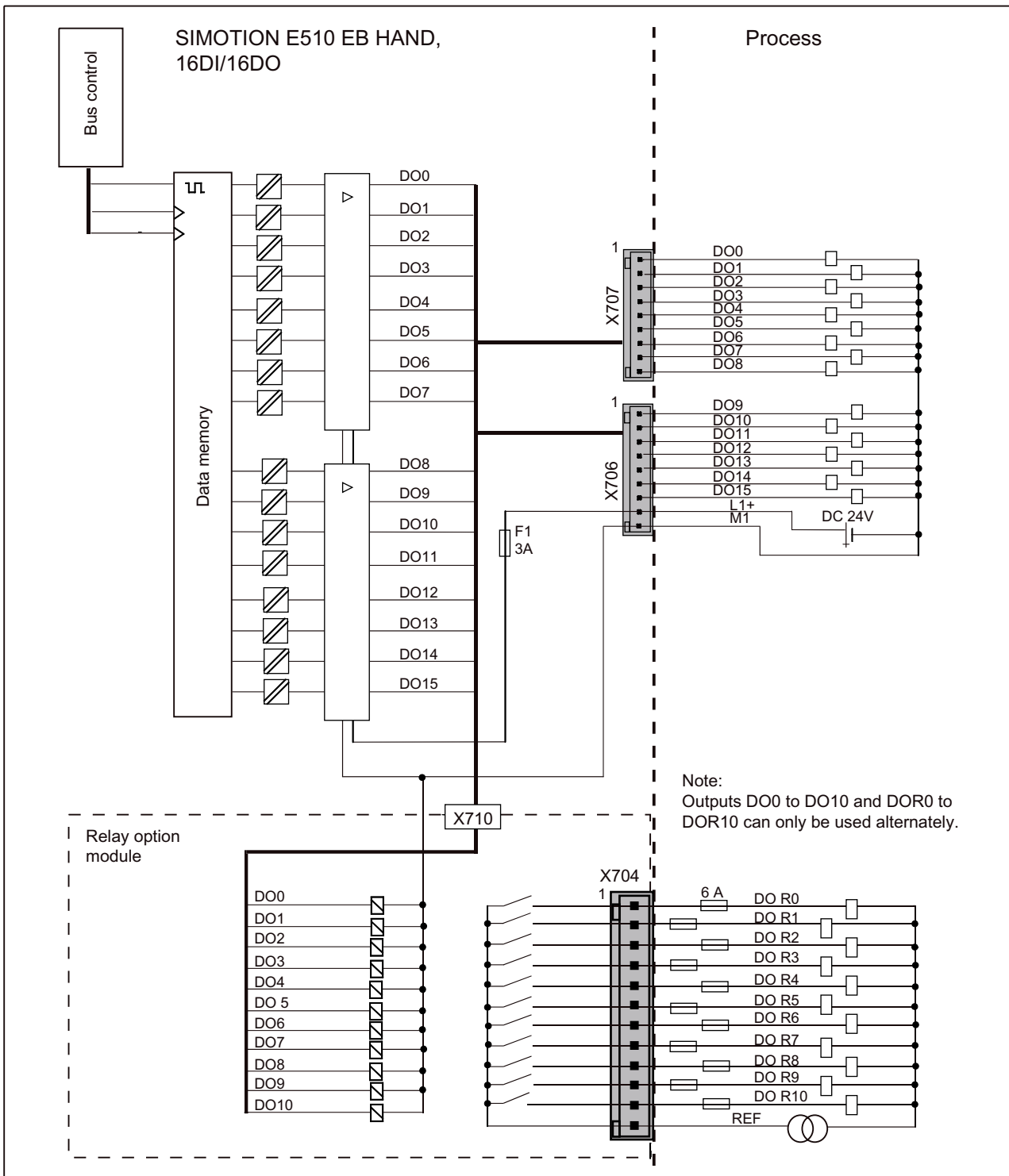

Figure 1-76 Wiring and block diagram for EB HAND, 16DI/16DO (digital output block)

Description

1.16 EUROMAP 67-compliant handling expansion module (EB HAND, 16DI/16DO) (on request)

1.16.6 Connecting cable

The figures below show connection suggestions for the **EUROMAP 67-compliant handling expansion module**.

Note

For details on the designation of the pins on the handling device, refer to EUROMAP 12 or 67
<http://www.euromap.org>.

1.16 EUROMAP 67-compliant handling expansion module (EB HAND, 16DI/16DO) (on request)

Handling connection suggestion in accordance with EUROMAP 12

EUROMAP 12-compliant connection is only possible if the relay option module is plugged into the EB HAND, 16DI/16DO.

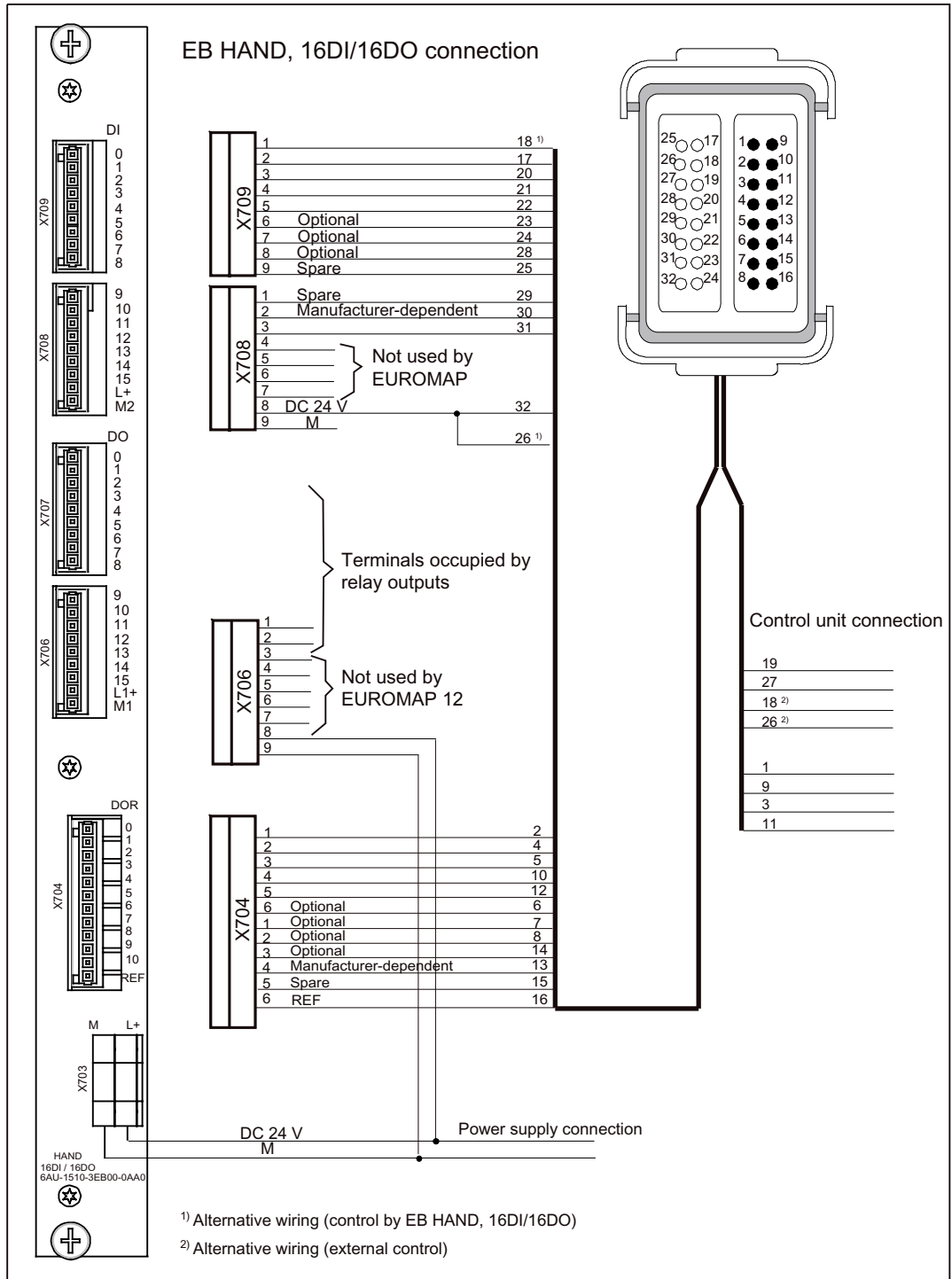

Figure 1-77 Handling connection suggestion in accordance with EUROMAP 12

Handling connection suggestion in accordance with EUROMAP 67

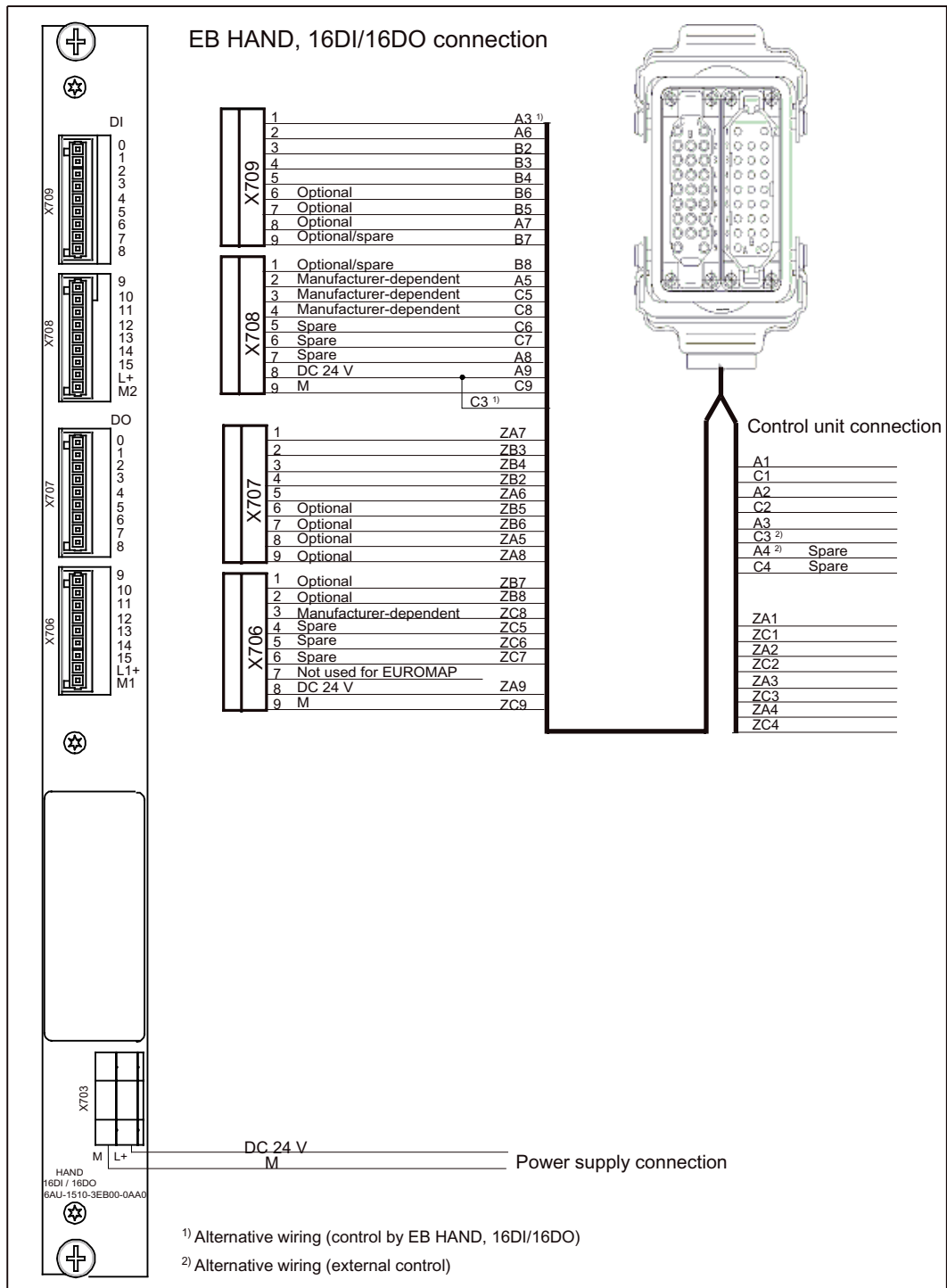

Figure 1-78 Handling connection suggestion in accordance with EUROMAP 67

1.16 EUROMAP 67-compliant handling expansion module (EB HAND, 16DI/16DO) (on request)

Hybrid-style handling connection suggestion in accordance with EUROMAP 12 or 67

EUROMAP 12- or 67-compliant connection is only possible if the relay option module is plugged into the EB HAND, 16DI/16DO.

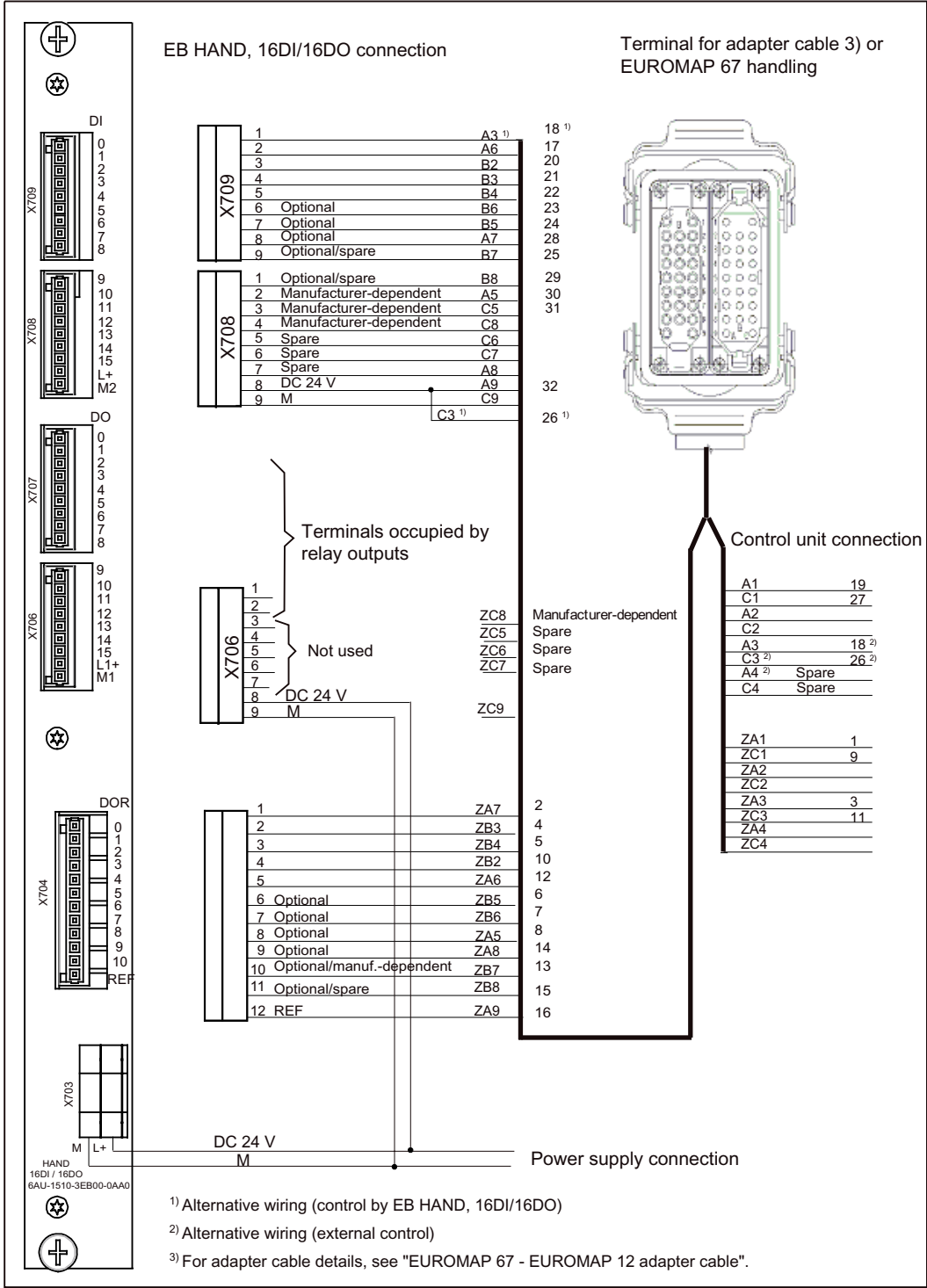

Figure 1-79 Handling connection suggestion in accordance with EUROMAP 12 or 67

Description

1.16 EUROMAP 67-compliant handling expansion module (EB HAND, 16DI/16DO) (on request)

EUROMAP 67 - EUROMAP 12 adapter cable

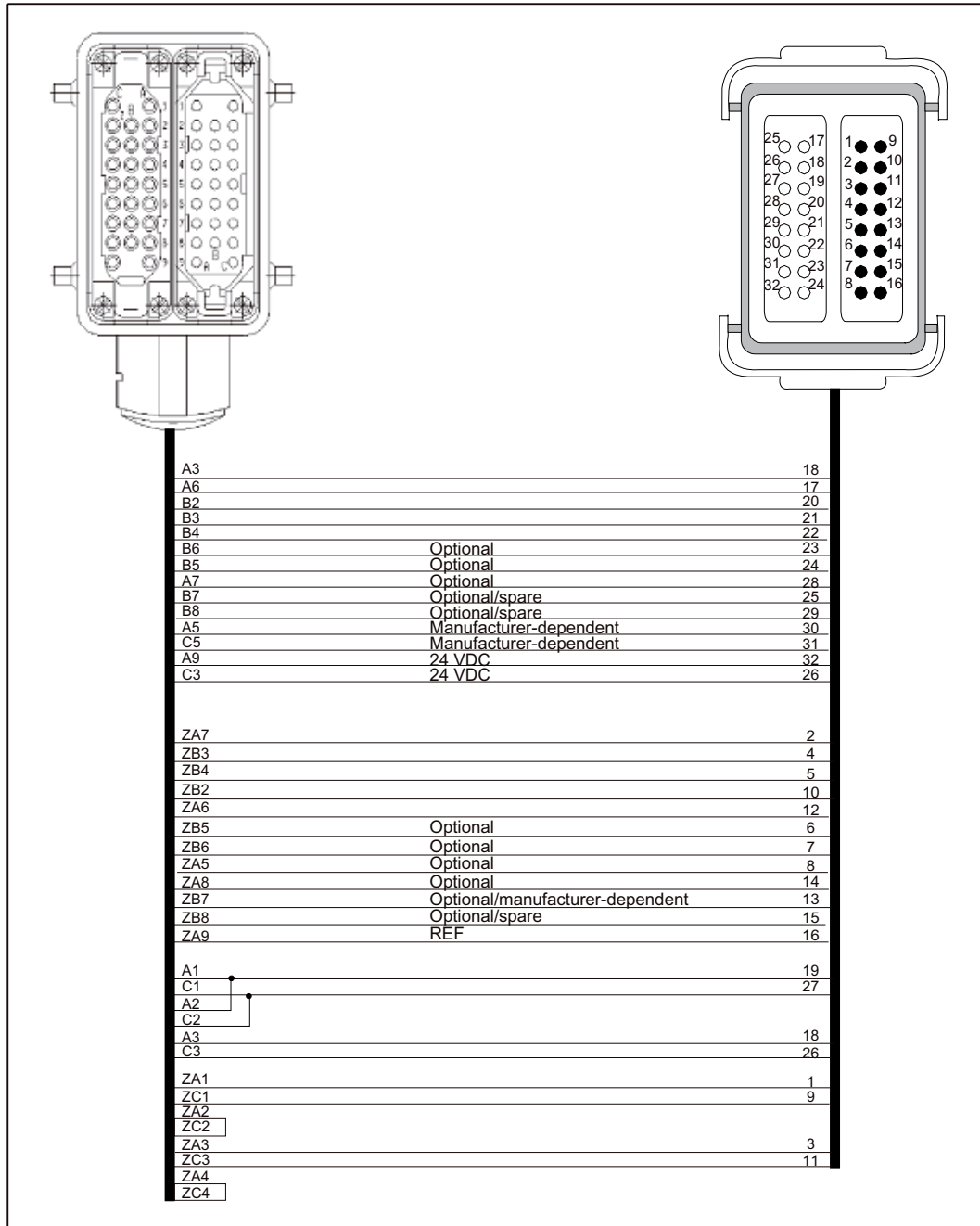

Figure 1-80 EUROMAP 67 - EUROMAP 12 adapter cable

1.16.7 Technical data

Connection values

Table 1- 83 Connection values (terminal X703)

Supply voltage	24 VDC (permissible range: 20.4 to 28.8 V)
Current consumption (supply group L+)	<ul style="list-style-type: none"> • Encoder power supply L+ • Fuse L+
Length of cable	Max. 10 m

Dimensions and weight

Table 1- 84 Dimensions and weight

Dimensions W x H x D [mm]	25.1 × 350.5 × 140.9
Weight	Approx. 310 g
Weight of relay option module	Approx. 100 g

Digital inputs (according to IEC 1131-2/DIN EN 61131-2, characteristic type 2)

Table 1- 85 Digital inputs (connector X708/X709)

Number of inputs	16 <ul style="list-style-type: none"> • 16 defined for EUROMAP 67 • 12 defined for EUROMAP 12
Length of cable	Max. 30 m
Handling device selection data	
Nominal load voltage L+	<ul style="list-style-type: none"> • Rated value • Permissible range
Input voltage	<ul style="list-style-type: none"> • 24 VDC • 20.4 to 28.8 V
Input voltage	<ul style="list-style-type: none"> • Rated value • 1 signal • 0 signal
Input current	<ul style="list-style-type: none"> • 24 VDC • 15 to 30 V • -3 to 5 V
Input current	<ul style="list-style-type: none"> • 1 signal • 6 to 12 mA
Input delay	<ul style="list-style-type: none"> • 0 → 1 signal • 1 → 0 signal
Input delay	<ul style="list-style-type: none"> • Typically 0.5 ms • Typically 3 ms
Voltages, currents, potentials	
Encoder power supply L+	<ul style="list-style-type: none"> • Voltage • Input characteristic
Encoder power supply L+	<ul style="list-style-type: none"> • 18.5 to 30 V; max. 2 A; short-circuit-proof • Type 2 in acc. with IEC 61131-2

Description

1.16 EUROMAP 67-compliant handling expansion module (EB HAND, 16DI/16DO) (on request)

Galvanic isolation <ul style="list-style-type: none"> • Non-isolated • Isolated 	<ul style="list-style-type: none"> • With L+ • Reference potential M in groups of 16
Permissible potential difference between different circuits	75 VDC/60 VAC
Insulation test voltage	500 VDC

Digital outputs (according to IEC 1131-2/DIN EN 61131-2)

Table 1- 86 Digital outputs (connector X706/X707 for EUROMAP 67, connector X704 for EUROMAP 12)

	EUROMAP 67 DO 0 to 15 DC 0.1 A	EUROMAP 12 DOR 0 to 10 relay
Number of outputs	16, 15 of which defined for EUROMAP 67	11
Length of cable	Max. 30 m	
Output voltage with 1 signal	24 VDC	Up to 250 VAC Up to 28 VDC
Output current <ul style="list-style-type: none"> • Rated value • 1 signal • 0 signal (residual current) 	<ul style="list-style-type: none"> • 0.1 A • Max. 0.5 A - • - 	<ul style="list-style-type: none"> • - • Max. 6 A Min.10 mA • -
Output delay (with resistive load) <ul style="list-style-type: none"> • 0 → 1 signal • 1 → 0 signal 	<ul style="list-style-type: none"> • Typ. 30 µs • Typ. 150 µs 	<ul style="list-style-type: none"> • Typ. 5 ms • Typ. 7 ms
Switching frequency <ul style="list-style-type: none"> • With resistive load • With inductive load in accordance with IEC 947-5-1, DC 13 	<ul style="list-style-type: none"> • Max. 50 Hz • Max. 2 Hz 	<ul style="list-style-type: none"> • 0.1 Hz • 0.1 Hz
Total current of group	Max. 3 A	Max. 10 A
Short-circuit protection of output	Yes	No
Voltages, currents, potentials		
Galvanic isolation	In groups of 16	In groups of 11
Permissible potential difference between different circuits	75 VDC/60 VAC	
Insulation test voltage	500 VDC	
Fuse L1+	3 A, quick-response	-

Note

When using the relay option module, please note that either the slot to the right of the handling device with the relay module must remain unoccupied, or the permissible ambient temperature of the device with a relay module connected must not exceed 45 °C.

Application planning

2.1 Transportation and storage conditions for SIMOTION E510

SIMOTION E510 surpasses the requirements specified in DIN EN 60068-2 with regard to transportation and storage conditions. The following conditions apply to modules that are transported and stored in their original packaging.

Type of condition	Permissible range
Free fall	≤ 1 m
Temperature (transport)	-40 °C to +70 °C
Air pressure	1,060 to 700 hPa (corresponds to an altitude of 3,000 m)
Relative humidity (transport)	10% to 95%, without condensation

2.2 Mechanical and climatic environmental conditions for operation of the SIMOTION E510

Operating conditions

SIMOTION E510 is designed for use in stationary, weatherprotected locations. The conditions of use are compliant with requirements to DIN IEC 68-2-2:

SIMOTION E510 satisfies the operating conditions for Class 3C2 in accordance with DIN EN 60721 3-3 (operating locations with high traffic densities in the immediate vicinity of industrial equipment with chemical emissions).

Unless additional measures are taken, SIMOTION E510 may **not** be used in

- Locations with a high percentage of ionizing radiation
- Aggressive environments characterized, for example, by
 - Dust accumulation
 - Corrosive vapors or gases
- Installations requiring special monitoring such as
 - Elevator installations
 - Electrical installations in highly sensitive areas

SIMOTION E510 is approved for use up to degree of pollution 2 according to EN 60664-1.

As an additional measure, SIMOTION E510 may be installed in a cabinet, for example, to ensure it is approved for use.

Climatic environmental conditions

SIMOTION E510 may be used under the following climatic environmental conditions:

Table 2- 1 Climatic environmental conditions

Environmental conditions	Operating ranges	Comments
Temperature	0 to 55 °C	Where simultaneity of the digital outputs' load per group is $\leq 50\%$
Relative humidity	5 to 95%	Without condensation, corresponds to relative humidity (RH) severity level 2 in accordance with IEC 1131-2
Air pressure	1,080 hPa to 795 hPa	-
Pollutant concentration	SO ₂ : < 0.5 ppm; Relative humidity < 60%, no condensation H ₂ S: < 0.1 ppm; Relative humidity < 60%, no condensation	Test: 10 ppm; 4 days 1 ppm; 4 days

Mechanical environmental conditions

The mechanical environmental conditions for SIMOTION E510 are listed in the following table in the form of sinusoidal vibrations.

Table 2- 2 Mechanical environmental conditions

Mechanical environmental conditions	Operation	Transport (in packaging)
Vibration tested in accordance with DIN EN 60068-2-6:1996	<ul style="list-style-type: none"> • 10 to 58 Hz: 0.15 mm • 58 to 200 Hz: 2 g 	<ul style="list-style-type: none"> • 5 to 9 Hz: 3.1 mm • 9 to 200 Hz: 10 m/s²
Shock resistance tested in accordance with DIN EN 60068-2-27	15 g peak value, 11 ms duration 3 shocks in each of 3 mutually perpendicular axes	15 g peak value, 11 ms duration 3 shocks in each of 3 mutually perpendicular axes
Installation position	There is only one possible installation position: Refer to the section titled "Installation requirements".	-

Reduction of vibrations

If SIMOTION E510 is subjected to larger shocks or vibrations, you must use suitable measures to reduce the acceleration or the amplitude.

We recommend installation on shock-absorbing material (e.g. rubber-metal vibration dampers).

2.3 Specifications for insulation tests, safety class, and degree of protection

Test voltages

During the routine test, the insulation resistance is tested at the following test voltage in accordance with IEC 1131 Part 2:

Circuits with rated voltage U_e relative to other circuits or ground	Test voltage
$0 \text{ V} < U_e \leq 50 \text{ V}$	500 VDC

Protection class

Protection class I in accordance with IEC 536 (VDE 0106, Part 1), i.e. PE/ground terminal required on housing.

Protection against foreign bodies and water

IP 20 degree of protection in accordance with IEC 529, i.e. protection against contact with standard test fingers.

Also: Protection against ingress of solid foreign bodies with diameters greater than 12.5 mm.

No special protection against ingress of water.

2.4 Rated voltage for operating SIMOTION E510

SIMOTION E510 operates at a rated voltage. The following table contains the rated voltage and the corresponding tolerance range.

Table 2- 3 SIMOTION E510 rated voltage

Rated voltage	Tolerance range
24 VDC	DC 20.4 V to 28.8 V

Installing and connecting

3.1 General information on installing and connecting

Overview

This chapter contains information on:

- Installing SIMOTION E510
- Installing modules in the housing
- Connecting

Open-type resources

SIMOTION E510 modules are a form of open-type resource. This means you may only install SIMOTION E510 in housings, cabinets, or electrical equipment rooms. These may only be accessible via key or tool. Only trained or authorized personnel should have access to the housings, cabinets, or electrical equipment rooms.

 **DANGER**

SIMOTION E510 and the individual modules may only be installed while the power is switched off.

 **DANGER**

The voltages for the inputs and outputs must be configured as protective extra-low voltages (PELV).

- According to DIN EN 60204-1, 6.4
- According to DIN EN 61800-5-1
- According to VDE 0100, Part 410
- According to DIN VDE 0800-1
- According to EN 61131-2

Packaging

 **CAUTION**

Do not remove the original packing from SIMOTION E510 until you intend to install it. SIMOTION E510 must remain in its original packing when in storage.

3.2 Installing SIMOTION E510

3.2.1 Dimension drawings

SIMOTION E510 with 4 expansion slots

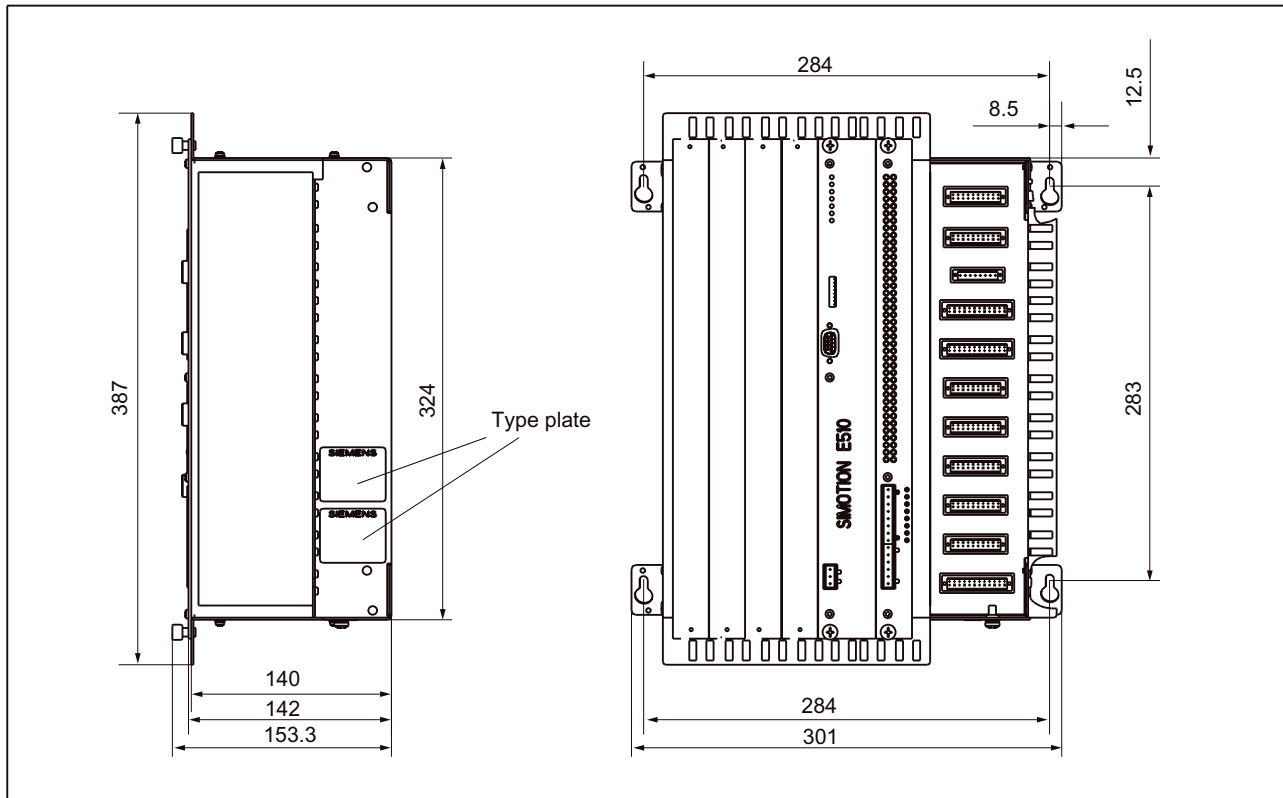

Figure 3-1 Dimensions of SIMOTION E510 (4 expansion slots)

SIMOTION E510 without expansion slots

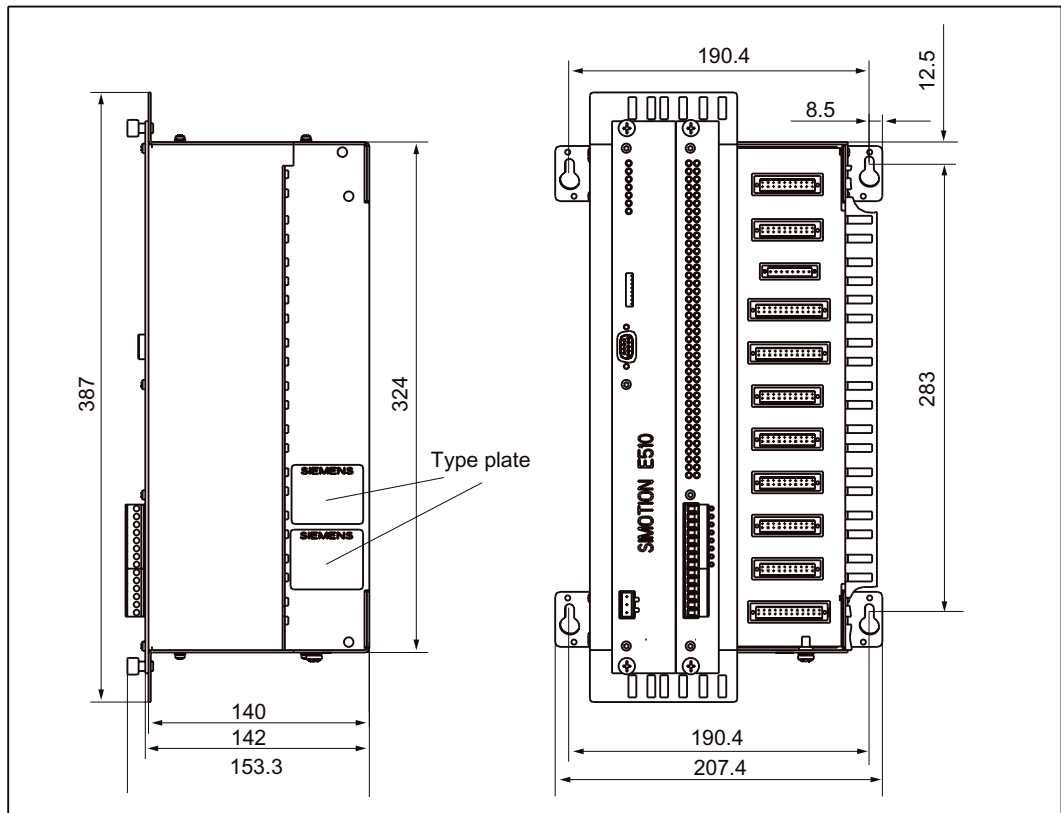

Figure 3-2 Dimensions of SIMOTION E510 (without expansion slots)

SIMOTION E510 with 1 expansion slot

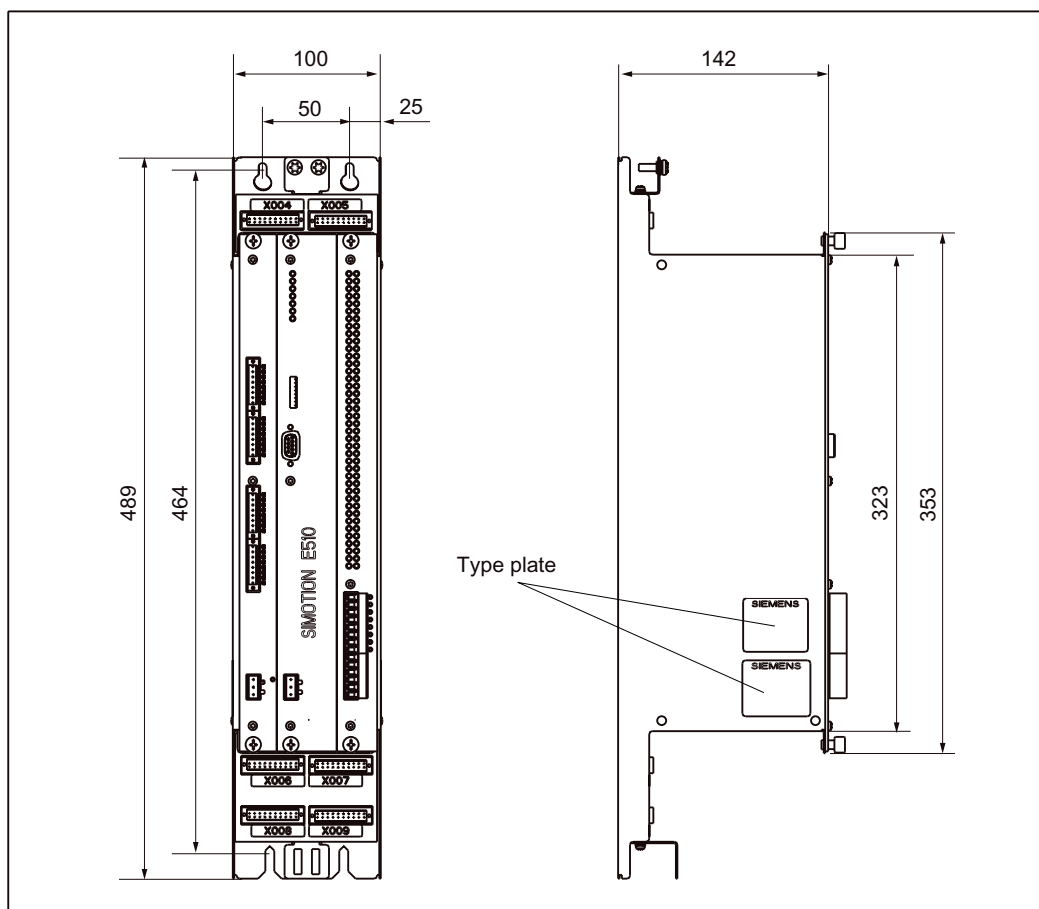

Figure 3-3 Dimensions of SIMOTION E510 (with 1 expansion slot)

3.2.2 Installation requirements

CAUTION

Ensure that no foreign bodies enter the device after installation or during operation.

Mounting plate

The limit value for unevenness must not exceed ± 1 mm for every 300 mm in length.

Installation position

SIMOTION E510 must be installed on a vertical mounting plate as follows:

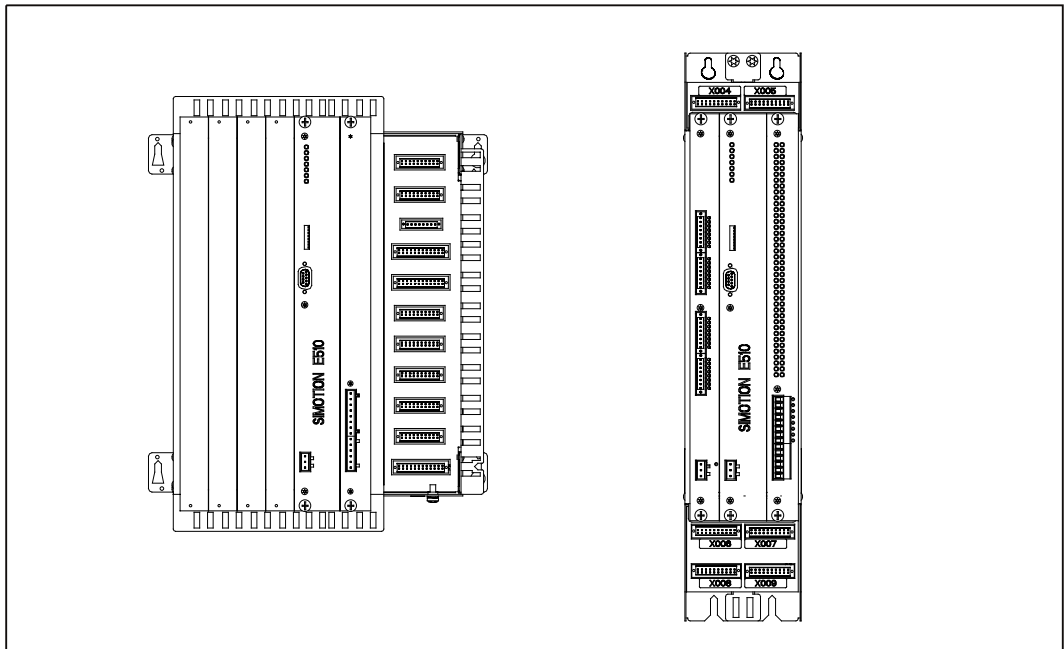

Figure 3-4 Installation position

Permissible ambient temperature

The permissible ambient temperature is 0 to 55 °C.

3.2.3 Clearances

The following figure shows you the clearances to nearby cable ducts, resources, cabinet walls, etc. for a SIMOTION E510 installation.

If you comply with the minimum clearances, you will ensure there is:

- Adequate heat dissipation for SIMOTION E510
- Sufficient room for installing and removing SIMOTION E510
- Sufficient room for laying cables

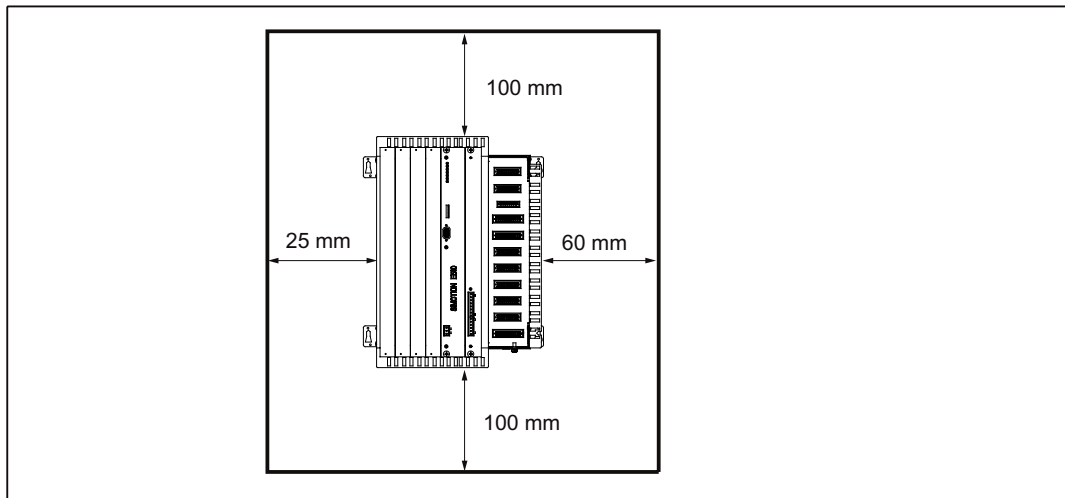

Figure 3-5 Clearances

3.2.4 Dimension drawings for fixing holes

Housing with 4 or with no expansion slots

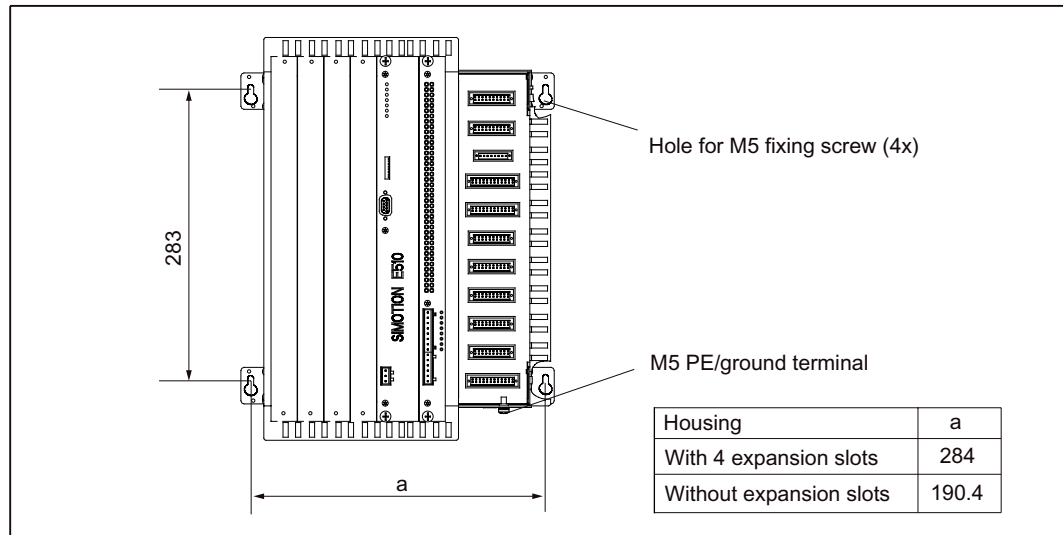

Figure 3-6 Dimension drawing for fixing holes

Housing with 1 expansion slot

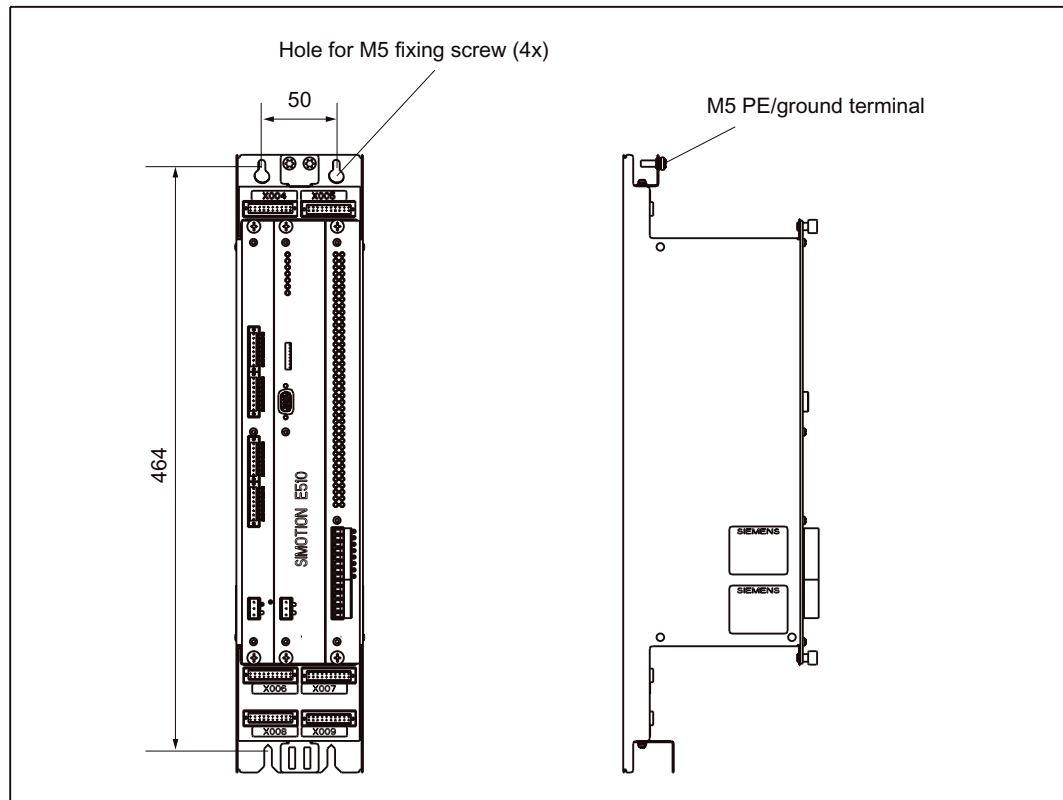

Figure 3-7 Dimension drawing for fixing holes with one expansion slot

3.2.5 Installing SIMOTION E510

Fixing screws

Use the screws provided to fix SIMOTION E510 in place.

Installing SIMOTION E510

Proceed as follows when installing SIMOTION E510:

1. Choose a position for SIMOTION E510 that affords adequate space to both install the modules (head, basic, and expansion variants) and facilitate heat dissipation.
2. Screw SIMOTION E510 onto the surface you have chosen (screw size: M5, Torx screwdriver size 25).

Connecting the protective conductor to the housing

Connect SIMOTION E510 to the protective conductor. An M5 protective conductor screw is provided on the housing for this purpose.

Minimum cross-section from the cable to the protective conductor: 10 mm²

1. Remove the M5 protective conductor screw.
2. Place the protective conductor on the housing and screw the protective conductor screw back into the insert nut (Torx screwdriver, size 25).

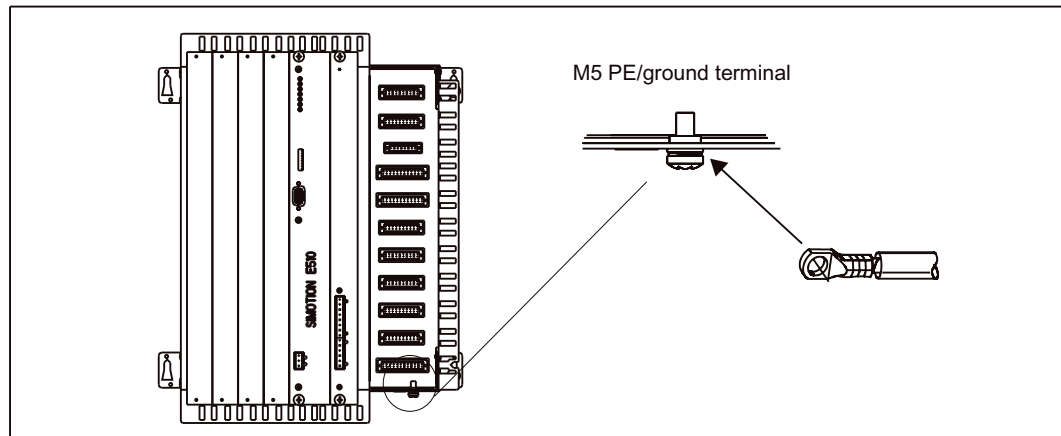

Figure 3-8 Protective conductor connection to housing

Note

Always ensure the connection to the protective conductor is a low resistance one.

If SIMOTION E510 is mounted on a movable frame, you must provide a flexible cable to the protective conductor.

Mounting onto standard rail

SIMOTION E510 can also be mounted on a standard mounting rail. You will need to order a full set of mounting supports (4 parts) to do this.

Order number: 6AU1 751-0MA00-0AA0

Note

The mounting supports are suitable for use with all 35 mm standard mounting rails according to DIN EN 50022 and have a busbar material thickness of 1 to 2.3 mm.

Please refer to the section titled "Dimension drawings for fixing holes" for mounting purposes.

3.3 Installing modules in the housing

Note

Complete units (order number 6AU1 510-6...) are delivered with both the head and basic modules already inserted into the housing.

Depending on the scope of delivery required, the expansion modules may also be equipped. Non-equipped expansion slots are provided with blanking covers.

Do not remove the original packing until you intend to install the equipment.

Slots

There are two permanently allocated slots on the SIMOTION E510 housing, for the head and basic modules. Depending on the housing type, there are also up to 4 expansion slots for expansion modules (EB) (for information on slots, refer to section titled "Illustration of housing with 4 expansion slots").

- The basic module is inserted into slot 1.
- The head module is inserted into slot 2.
- The expansion modules are inserted into slots 3 to 6 (depending on the number of expansion slots).

Module installation

 CAUTION
The plug connectors in the housing are arranged in such a way that only those modules with a correspondingly assigned slot may be inserted.
You must respect this module/slot assignment system without exception to avoid the modules or housing becoming damaged.

Proceed as follows:

1. Insert the appropriate module into the housing (without twisting it) so that it slides into the punched guideway.
2. Align the module's plug connector with its counterpart on the housing. **Take care** to ensure the contacts of the plug connectors do not become deformed during this process.
3. Screw the module to the front plate of the housing using the captive screws (Torx screwdriver, size 15).

3.4 Installing the relay option module

The relay option module can be plugged onto the **EB HAND, 16DI/16DO**. Proceed as follows:

1. Remove the blanking cover by loosening the nuts on the reverse of the **EB HAND, 16DI/16DO** front panel (SW 5.5 spanner).

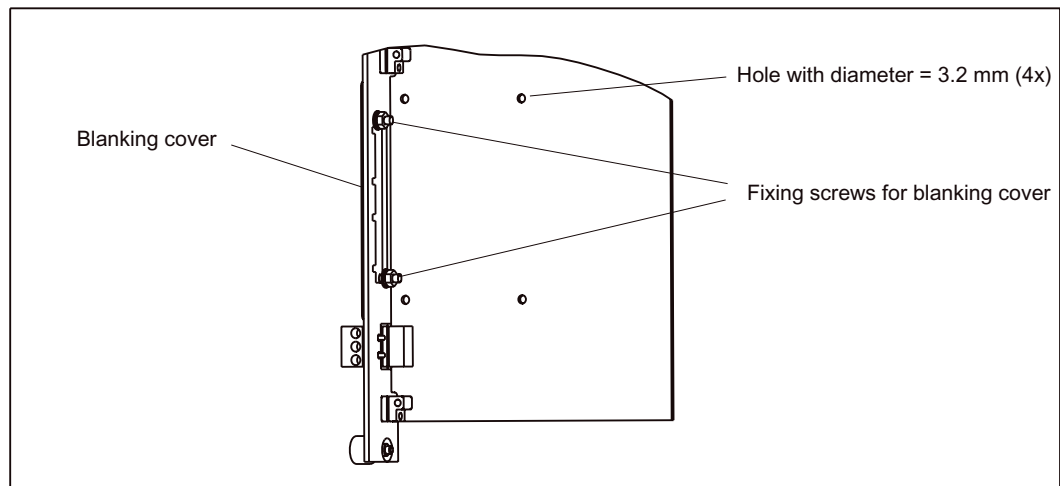

Figure 3-9 Removing the blanking cover

2. Plug the relay option module onto the **EB HAND, 16DI/16DO**.
3. Attach the relay option module to the **EB HAND, 16DI/16DO** printed circuit board. Connecting elements are provided with the option module.

3.4 Installing the relay option module

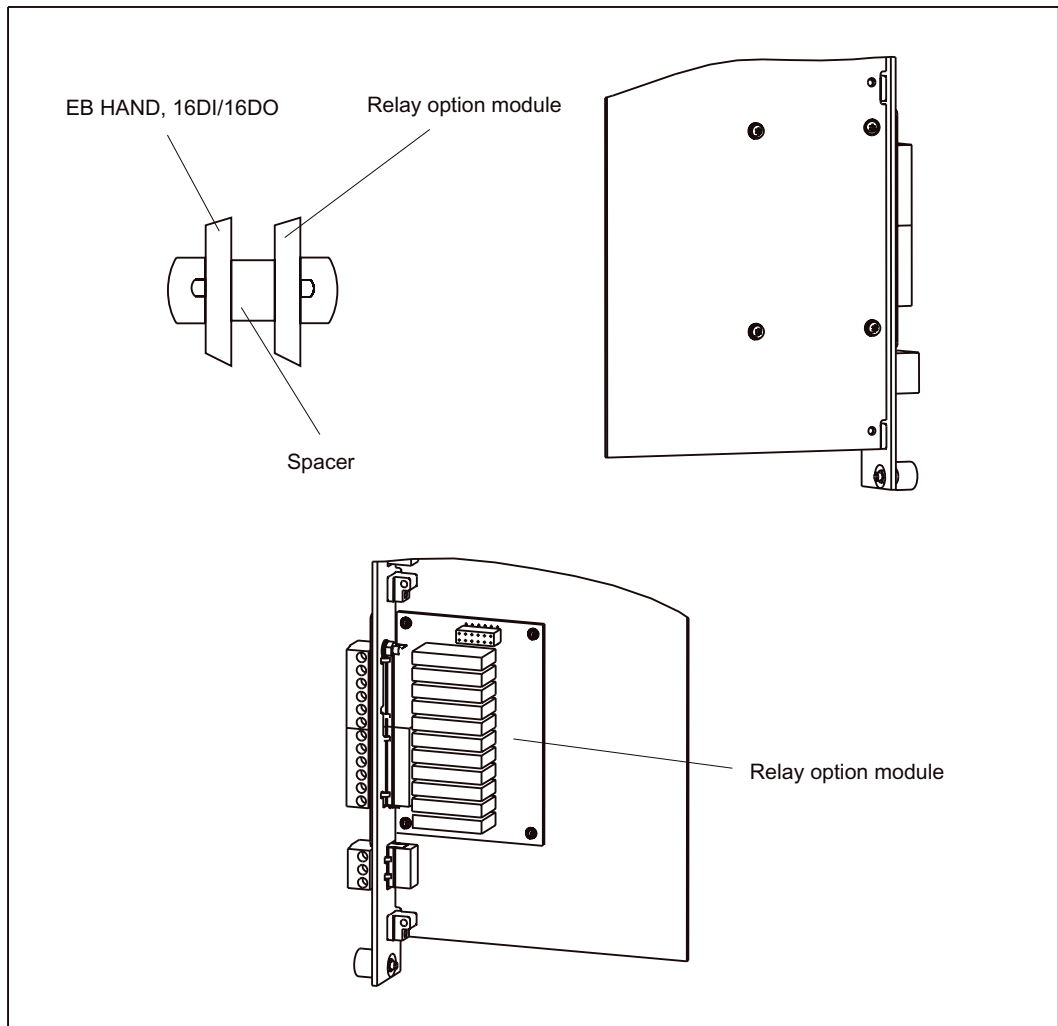

Figure 3-10 Attaching the relay option module

3.5 Connecting

3.5.1 General connection requirements

Basic rules

Because of the wide range of potential uses for SIMOTION E510, only the basic rules for electrical installation can be included in this section. As a minimum, you must comply with these basic rules to ensure problem-free operation.

Safety regulations

In order to ensure safe operation of your equipment, implement the following measures, adapting them to suit your conditions:

- An EMERGENCY OFF concept in accordance with the generally accepted rules of current engineering practice (e.g. European standards EN 60204, EN 418, and similar).
- Additional measures for end position limiting of axes (e.g. hardware limit switches).
- Equipment and measures for protection of motors and power electronics in accordance with the SIMODRIVE, MASTERDRIVES, and SINAMICS installation guidelines.

In addition, in order to identify hazards, we recommend that a risk analysis be conducted on the entire system in accordance with the basic safety requirements set out in Appendix 1 of EU Machinery Directive 89/392/EEC.

Additional references

Please also note the ESD guidelines in this manual.

For additional information on the EMC Directive, we recommend the publication:
EMC Installation Guide, Configuration Manual (HW), 111.

Standards and specifications

When connecting the SIMOTION E510, you must observe the appropriate VDE guidelines; in particular, VDE 0100 and VDE 0113 for tripping devices and short-circuit and overload protection.

3.5.2 Configuring the electrical installation

General rules for operating SIMOTION E510

You must observe the following important rules for integrating SIMOTION E510 into an automation system or plant.

System startup after certain events

The following table identifies what needs to be considered when starting up a system following certain events.

Scenario	Consideration
Startup after voltage drop or power failure	All hazardous operating conditions must be avoided. If necessary, force an EMERGENCY OFF.
Startup after releasing the EMERGENCY OFF apparatus	Any uncontrolled or undefined startups must be avoided.

Supply voltage

The following table identifies what needs to be considered in terms of the line voltage.

Arrangement	Requirement
Stationary systems or systems without all-pole line voltage disconnect switches	A power disconnect switch or a fuse must be provided in the electrical installation for the building.
Load power supplies, power supply modules	The set rated voltage range corresponds to the local supply voltage.
All electric circuits	Deviation of the line voltage from the rated value must fall within the permitted tolerance values (refer to "Technical data for the installed components").

24 VDC supply

The following table identifies what needs to be considered in terms of the 24 VDC supply.

Arrangement	Requirement	
Buildings	External lightning protection	Install lightning protection (e.g. lightning conductors).
24 VDC supply lines, signal lines	Internal lightning protection	
24 VDC supply	Safe (electrical) isolation of the extra-low voltage	

Protection against external electrical interference

The table below shows how you must protect your system against electrical interference or faults.

Arrangement	Requirement
All plants or systems in which SIMOTION or SIMATIC S7 is installed	The plant or system is connected to a protective conductor in order to divert electromagnetic interference.
Supply, signal, and bus lines	The cable routing and installation complies with EMC regulations.
Signal and bus lines	A cable or wire break cannot lead to undefined states in the plant or system.

Rules regarding current consumption and power loss of a system

The power loss of **all** the components in a cabinet must not exceed the maximum thermal rating of the cabinet.

Note

When designing the control cabinet, ensure that the temperature inside the cabinet does not exceed the permitted ambient temperature for the components even at high external temperatures.

Minimum power supply for SIMOTION E510

If the modules are **not** supplied with the required power as described below, SIMOTION E510 will not be able to start up.

Details of the minimum logic supply for the individual modules are provided below:

- **IM, 8AI/8AO/16TC/4CNT:** L+ and M
- **DIGITAL, 32DI/48DO:** L5+ or L6+ or L7+ or L8+ and M
- **EB DIGITAL, 16DI/16DO:** L5+ and M
- **EB DIGITAL, 32DI:** L+ and M
- **EB TEMP, 16TC/24DO:** L1+ or L2+ and M
- **EB MPT, 4CH:** L+ and M

3.5.3 Overall SIMOTION E510 configuration

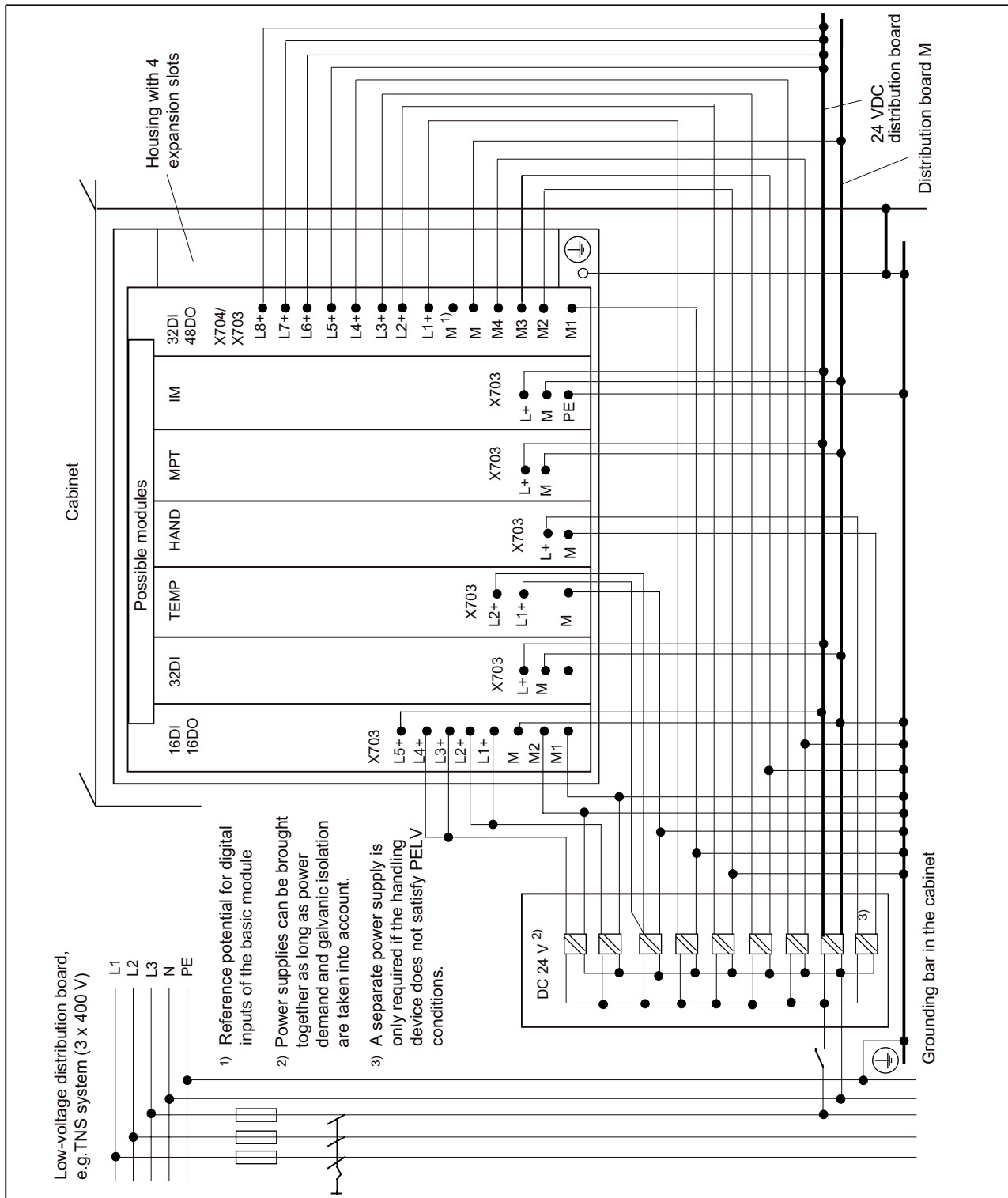

Figure 3-11 Options for supplying the modules via a grounded infeed

3.5.4 Connection overview

The figure below provides an overview of the connection options and the cables on the housing with the head and basic modules.

Note

For details of the connection overview for the expansion modules, see the section titled "Installing and connecting expansion modules".

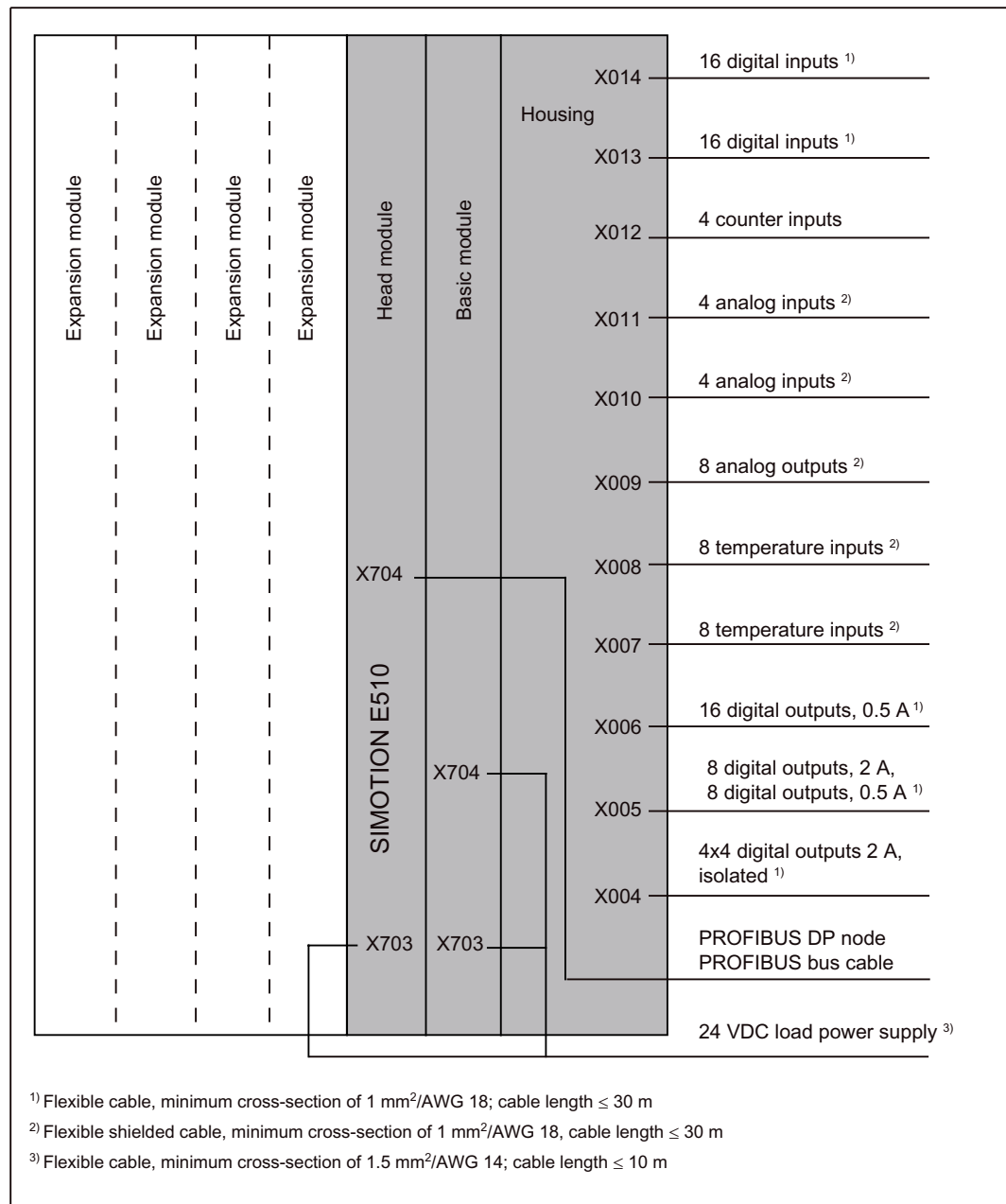



Figure 3-12 Connection overview

3.5.5 Connecting the power supply to the head module

The required 24 VDC load power supply is wired to connector X703.

Properties of the load power supply

 DANGER
The 24 VDC voltage must be configured as a protective extra-low voltage (PELV according to DIN EN 60204-1).

Note

The connecting cable between the voltage source, the load power supply connection L+, and the associated reference potential M must **not** exceed 10 m.

Table 3- 1 Electrical parameters of load power supply

Parameter	Min.	Max.	Unit	Conditions
Voltage range - mean value	20.4	28.8	V	
Ripple		3.6	Vpp	
Transient overvoltage		35	V	500 ms duration 50 s recovery time
Rated current consumption		0.4	A	
Starting current		0.7	A	

Bridging of supply failures

The power supply has to guarantee a bridging of supply failures of:

- ≤ 3 ms for transient power interruptions
- ≤ 5 ms for power switch-off

Connecting cables

For the purpose of wiring the power supply, use flexible cables with a cable cross-section of 1.5 mm²/AWG 14).

For details on the type of spring-loaded or screw terminals used, refer to <http://www.weidmueller.de>.

The maximum cable length is 10 m.

Connection element

The Weidmüller company is the manufacturer.

For information on the connection element, refer to the "Connection elements" table in the section titled "Connecting inputs/outputs to the housing".

Wiring procedure

 **WARNING**

You could come into contact with live wires if the power supply module and any additional load power supplies are switched on.

Wiring work must only be carried out on SIMOTION E510 while the power is switched off.

You can find information on how to wire the connection elements from the Weidmüller company, as well as what you need to take into account when doing so, in the online catalog on the Internet at:

<http://www.weidmueller.de>

Please also refer to the section titled "Overall SIMOTION E510 configuration".

The figures below show how to install shrouding covers (optional) for double-row or single-row connectors.

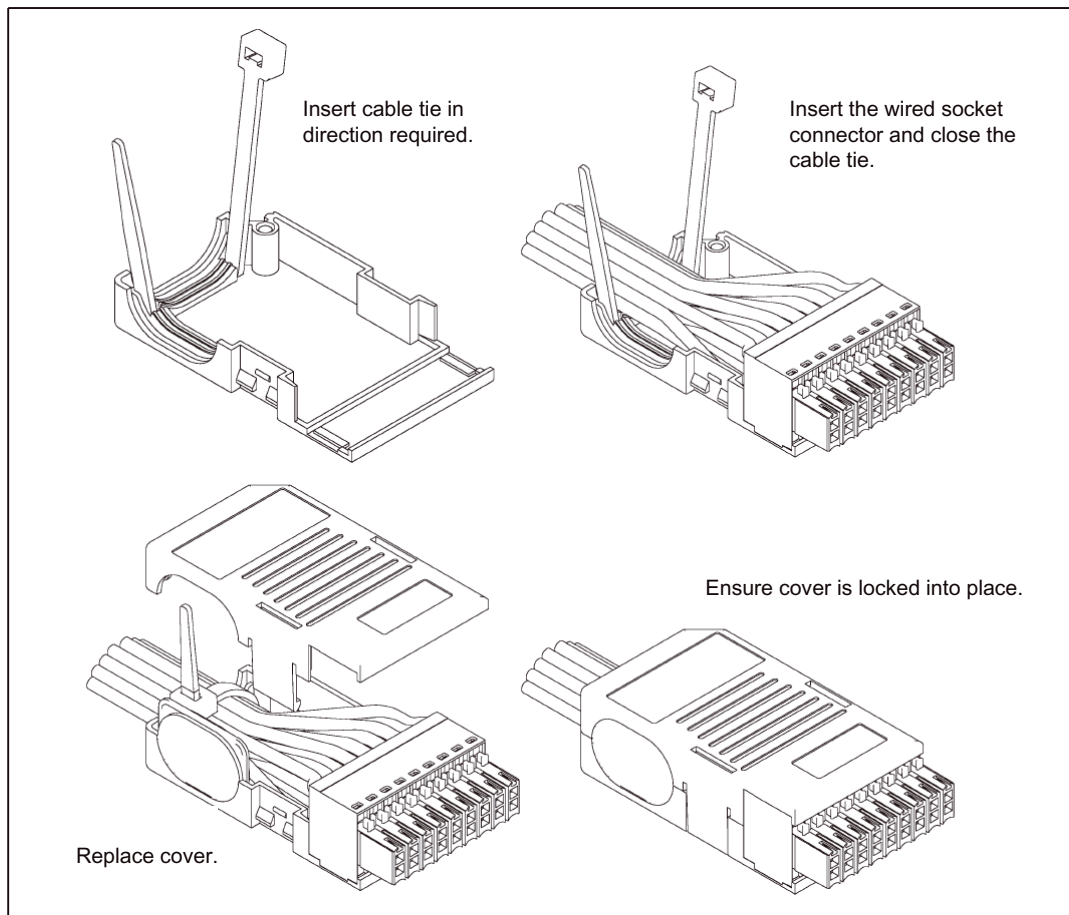

Figure 3-13 Shrouding cover for double-row connectors

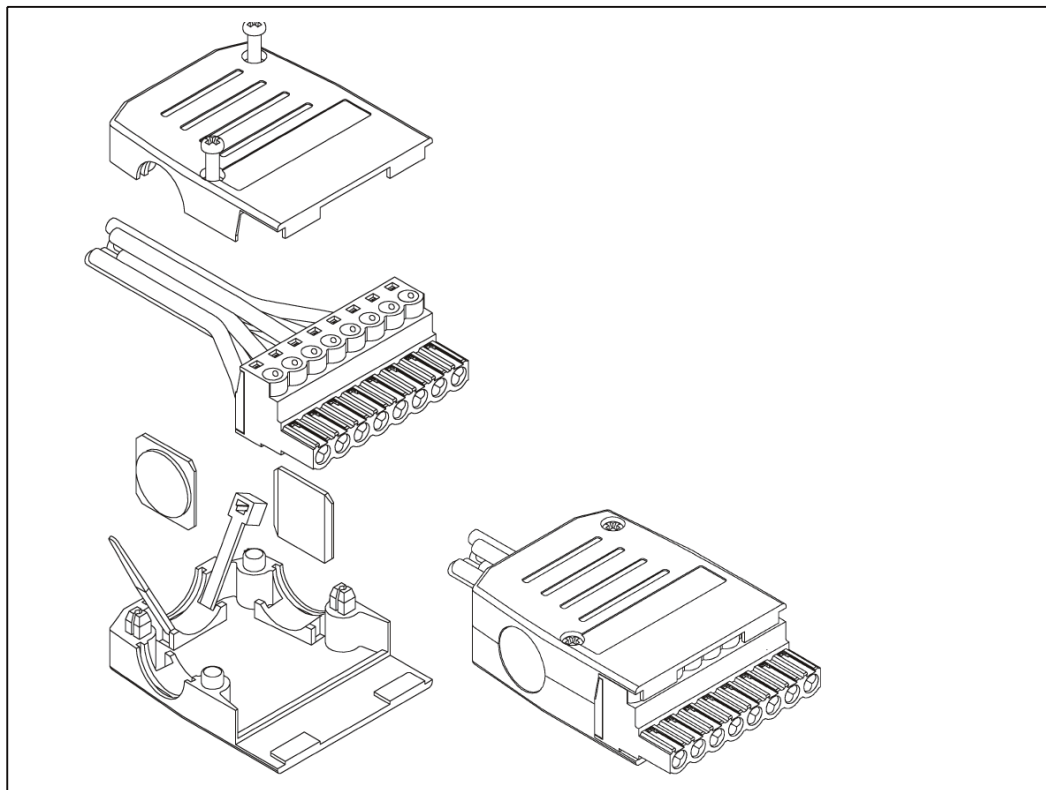

Figure 3-14 Shrouding cover for single-row connectors

Reverse polarity protection

If the connection is correct and the power supply is switched on, the "ON" LED illuminates green.

Note

SIMOTION E510 will not run if the polarity is reversed. However, a built-in reverse polarity protection will protect the electronics against damage.

Fuse

If SIMOTION E510 is defective, an internal fuse protects the electronics from consequential damage (e.g. fire). In this case, the module must be replaced.

3.5.6 Connecting PROFIBUS DP to the head module

PNO design guidelines

For electrical PROFIBUS networks, please also refer to the PROFIBUS DP/FMS design guidelines issued by the PROFIBUS user organization. These contain important information about cable routing and the commissioning of PROFIBUS networks.

Publisher: PROFIBUS-Nutzerorganisation e.V.
Haid-und-Neu-Strasse 7
76131 Karlsruhe, Germany
Phone: ++721 / 9658 590
Fax: ++721 / 9658 589
Internet: <http://www.profibus.com>

Guideline, order no. 2.112

Connecting the bus connector

Proceed as follows to connect the bus connector:

1. Plug the bus connector into connector X704 of the **head module**.
2. Screw the bus connector firmly into place.
3. If the bus connector is located at the start or the end of a segment, you must connect the terminating resistor ("ON" switch setting) (refer to the following figure).

Make sure that the stations at which the terminating resistor is located are always supplied with voltage during powering up and operation.

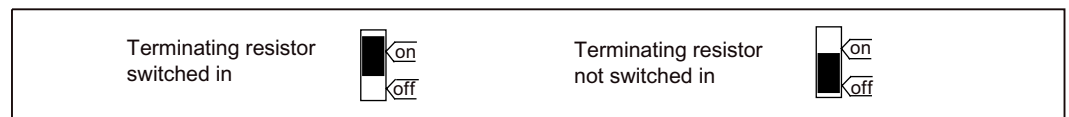



Figure 3-15 Bus connector (6ES7 ...): terminating resistor switched on and off

4. Establish a connection between the shield of the PROFIBUS cable and the housing. See the section titled "Connecting shielded cables via the shield connection" for information on how to connect a shielded cable via the shield connection.

Unplugging a bus connector

You can remove the bus connector with a **looped-through bus cable** from the PROFIBUS DP interface at any time without interrupting data exchange on the other devices connected to the bus segment.

 WARNING
Data exchange on the bus may be interrupted.
A bus segment must always be terminated with the terminating resistor at both ends. This is not the case if the last bus connector node is de-energized, for example. Because the bus connector takes its voltage from the station, this terminating resistor is ineffective.
Make sure that the stations at which the terminating resistor is connected are always energized.

Setting the PROFIBUS DP address at the S1 DIP switch on the head module.

For the purpose of unique identification on PROFIBUS[®] DP, each bus node must be given a PROFIBUS DP address. The PROFIBUS DP address can be allocated only once on the bus.

See the section titled "Configuring the DP slave (SIMOTION E510)" for details of which PROFIBUS DP address to set at the DIP switch.

Use a screwdriver to set the PROFIBUS DP address.

The PROFIBUS DP address is the addition of the switch that is located on the right ("ON" position).

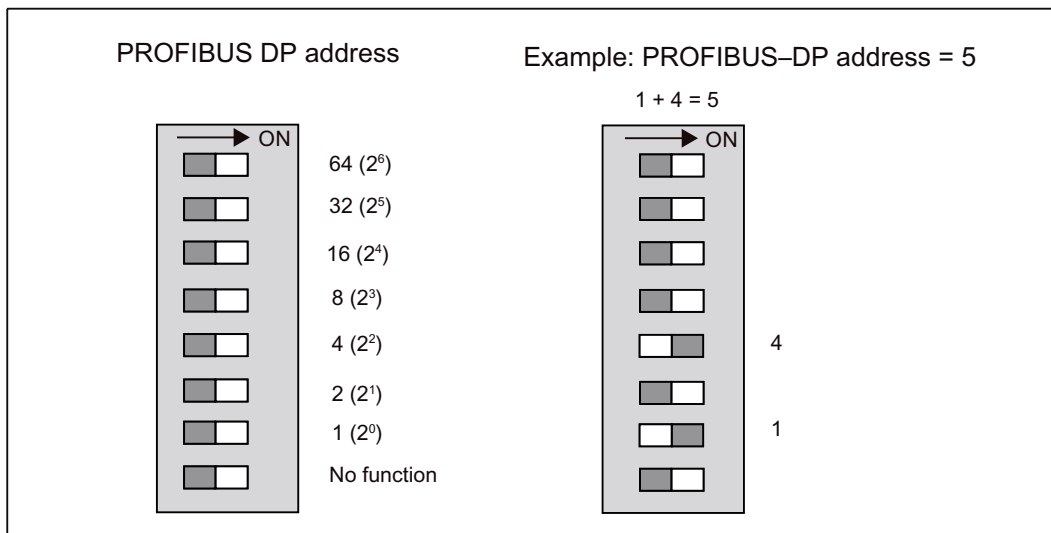

Figure 3-16 Setting the PROFIBUS DP address

Changing the PROFIBUS DP address

Once set, you can change the PROFIBUS DP address at any time. However, you will need to disconnect and reconnect the 24 VDC power supply before SIMOTION E510 can accept the newly set PROFIBUS DP address.

3.5.7 Connecting the power supply to the basic module

The required 24 VDC load power supply is wired to connectors X703 and X704.

 **DANGER**

The 24 VDC voltage must be configured as a protective extra-low voltage (PELV). In addition, one side of the circuit or one point of the energy source of the circuit must be connected to the protective conductor system.

 **CAUTION**

Power supply lines L1+ to L8+ are protected on the "basic module" by a 10 A quick-response fuse. This ensures the board has reverse polarity protection.

Connecting cables

For the purpose of wiring the power supply, use flexible cables with a minimum cable cross-section of 1.5 mm²/AWG 14).

For details on the type of spring-loaded or screw terminals used, refer to <http://www.weidmueller.de>.

The maximum cable length is 10 m.

Note

The connecting cable between the voltage source, the load power supply connection L+, and the associated reference potential M must **not** exceed 10 m.

Connection element

The Weidmüller company is the manufacturer.

For information on the connection element, refer to the "Connection elements" table in the section titled "Connecting inputs/outputs to the housing".

Wiring procedure

 **WARNING**

You could come into contact with live wires if the power supply module and any additional load power supplies are switched on.

Wiring work must only be carried out on SIMOTION E510 while the power is switched off.

You can find information on how to wire the connection elements from the Weidmüller company, as well as what you need to take into account when doing so, in the online catalog on the Internet at:

<http://www.weidmueller.de>

Please also refer to the section titled "Overall SIMOTION E510 configuration" and the connector assignment information in the "Connection for power supply" section relating to the basic module.

For information on how to install the shrouding cover, refer to the section titled "Connecting the power supply to the head module".

Reverse polarity protection

If a connection has been established correctly and the power supply has been switched on, the "L1+ to L8+" LEDs on the **basic module** will light up green.

Note

SIMOTION E510 will not run if the polarity is reversed. However, a built-in reverse polarity protection will protect the electronics against damage.

Fuse

If SIMOTION E510 is defective, an internal fuse protects the electronics from consequential damage (e.g. fire). In this case, the module must be replaced.

3.5.8 Connecting inputs/outputs to the housing

Connection overview

The table below provides an overview of the positions and assignments of the connectors on the housings.

Table 3-2 Connection overview for housing

Module	Positions of connectors, assignments of connectors
Housing without expansion slots	See the section titled "Interfaces for housing without expansion slots"
Housing with 1 expansion slot	See the section titled "Interfaces for housing with 1 expansion slot"
Housing with 4 expansion slots	See the section titled "Interfaces for housing with 4 expansion slots"



DANGER

Only a protective extra-low voltage (PELV) may be connected to the inputs/outputs.

Note

For wiring and block diagrams and connection information, refer to the section titled "Wiring and block diagrams for devices with a head module and basic module".

Connection elements

The following table lists the connectors, connection elements, and accessories for **all** modules (housing, head, basic, and expansion modules).

Table 3- 3 Connection elements

Component/ module/ designation	Connector	Quantity	Connection element	Shrouding cover (optional)	²⁾	Manufacturer
Housing with 4 or with no expansion slots	X004 X010 X011	3	B2L3.5F/24; 1748260000	B2L3.5AH/24; 1781650000	1 mm ²	Weidmüller
	X005 to X009 X013 X014	7	B2L3.5F/20; 1748240000	B2L3.5AH/20; 1781630000	1 mm ²	
	X012	1	BLZF3.5/8/180F; 1691170000	BL3.5AH/8; 1745630000	1.5 mm ²	
Housing with 1 expansion slot	X004 to X009	6	B2L3.5F/20; 1748240000	B2L3.5AH/20; 1781630000	1 mm ²	Weidmüller
Head module IM, 8A I/8AO/16TC/4CNT	X703	1	BLZF5.08/3/180; 1707700000	-	2.5 mm ²	Weidmüller
	X704	1	Sub D connector, 9-pin DIN41652, UNC Order no.: 6ES7972-0BA41-0XA0 or 6ES7972-0BB41-0XA0			Erni/Siemens
Basic module DIGITAL, 32DI/48DO	X703	1	BLZF5.08/6/180; 1707730000	BLZ5.08AH/6; 1705230000	2.5 mm ²	Weidmüller
	X704	1	BLZF5.08/8/180; 1707750000	BLZ5.08AH/8; 1705250000	2.5 mm ²	
	X703/ X704 ¹⁾	1	BLZF5.08/14/180; 1707810000	-	2.5 mm ²	
Position encoder expansion module MPT, 4CH	X703	1	BLZF5.08/3/180; 1707700000	-	2.5 mm ²	Weidmüller
	X704 to X707	4	Sub D connector, 9-pin DIN 41652, UNC, metal or metallized	SUB-D 9-pin for connectors according to DIN 41652, UNC		Erni
Digital I/O expansion module DIGITAL, 16DI/16DO	X703	1	BLZF5.08/8/180; 1707750000	BLZ5.08AH/8; 1705250000	2.5 mm ²	Weidmüller
	X704 to X707	4	BLZF3.5/8/180F; 1691170000	BL3.5AH/8; 1745630000	1.5 mm ²	
Digital I/O expansion module DIGITAL, 32DI	X703	1	BLZF5.08/3/180; 1707700000	-	2.5 mm ²	Weidmüller
	X704 to X707	4	BLZF3.5/8/180F; 1691170000	BL3.5AH/8; 1745630000	1.5 mm ²	

3.5 Connecting

Component/ module/ designation	Connector	Quantity	Connection element	Shrouding cover (optional)	2)	Manufacturer
Handling expansion module HAND, 16DI/16DO (on request)	X703	1	Available as terminal strip	-	4 mm ²	WAGO
	X706 X707 X708 X709	4	SOCKET CONNECTOR CC 3.81MM12PIN FS ORANGE; 734-212/034-000	-	1.5 mm ²	
	X704	1	SOCKET CONNECTOR.-CC 3.5MM 9PIN. FS LIGHT GRAY; 734-109/033-000	-	1.5 mm ²	
	X703	1	BLZF5.08/4/180; 1707710000	BLZ5.08AH/4; 1705210000	2.5 mm ²	
Relay option module (on request)	X704 to X706	3	BLZF3.5/8/180F; 1691170000	BL3.5AH/8; 1745630000	1.5 mm ²	Weidmüller
	X707	2	B2L3.5F/20; 1748240000	B2L3.5AH/20; 1781630000	1 mm ²	
	X708					
Temperature expansion module TEMP, 16TC/24DO						

1) Alternative to variant with separate connection elements from X703 and X704

2) Max. connectable cross-section

Connecting cables

For the purpose of wiring the inputs and outputs, use flexible cables with a minimum cable cross-section of 1 mm²/AWG 18).

For details on the type of spring-loaded or screw terminals used, refer to <http://www.weidmueller.de>.

Note

Optimum interference immunity can only be achieved if you use shielded, twisted pair cables when connecting the analog/temperature inputs and the reference/analog outputs. The shield must be connected to ground.

Signal lines with their ground in a twisted pair arrangement must be used when connecting counter inputs.

The maximum cable length is 30 m.

Wiring procedure

 WARNING
You could come into contact with live wires if the power supply module and any additional load power supplies are switched on. Wiring work must only be carried out on SIMOTION E510 while the power is switched off.

You can find information on how to wire the connection elements from the Weidmüller company, as well as what you need to take into account when doing so, in the online catalog on the Internet at: <http://www.weidmueller.de>

For information on how to install shrouding covers, refer to the section titled "Connecting the power supply to the head module".

Note

For details on connecting inputs and outputs, refer to the section titled "Wiring and block diagrams for devices with a head module and basic module".

3.5.9 Connecting shielded cables via the shield connection

The shield of shielded signal lines must be connected to ground. The connection to ground is achieved by connecting the shield connection directly to the housing.

Shield connection

The following EMC shield clips can be used as shield connections:

- EMC shield clips from SIEMENS (in packs of 15), order number: 6SY7 000-0AD60
- EMC shield clips (EMVSK 12) from Friedrich Lütze GmbH & Co. KG
<http://www.Luetze.de>

Mounting the shield connection

1. Remove the isolation from the shield as appropriate for the size of the EMC shield clip.
2. Place the shield in the appropriate place on the housing.
3. Snap the EMC shield clip into the appropriate cutout on the housing.

Ensure firm fit of the cable on the housing.

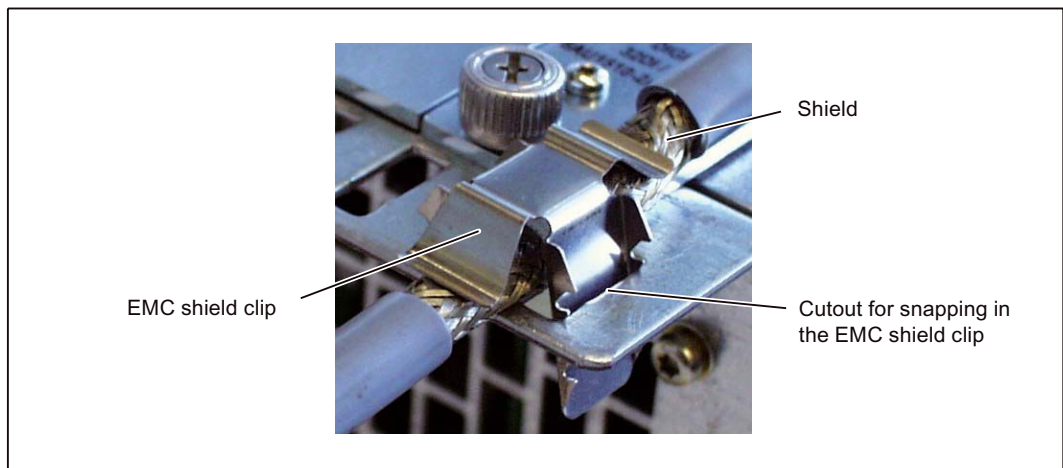

Figure 3-17 Mounting the shield connection

4. For mechanical strain relief, the cable can be fixed to the housing with cable ties (see section titled "Mechanical fixing of cables").

3.5.10 Mechanical fixing of cables

For mechanical strain relief, the cable can be fixed to the housing with cable ties.

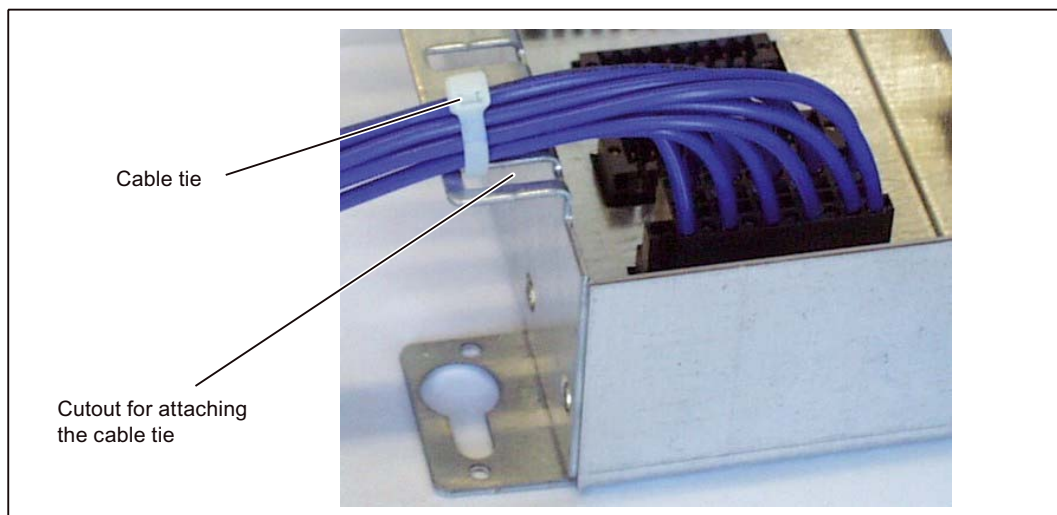

Figure 3-18 Mechanical fixing of cables

3.6 Installing and connecting expansion modules

3.6.1 Overview

Expansion modules can be ordered individually. They need to be installed and wired into the housing. Slots 3 to 6 are intended for expansion modules (as they do not have any fixed assignment).

Note

Do not remove the original packing until you intend to install the equipment.

Please refer to the sections titled "Installing modules in the housing" and "Connecting" when installing and wiring the expansion modules.

See also

Installing modules in the housing (Page 156)

Connecting (Page 159)

3.6.2 Installing expansion modules

When installing **expansion modules**, proceed as follows:

1. Remove the blanking cover of the relevant slot.
2. Insert the module into the housing (without twisting it) so that it slides into the punched guideway.
3. Align the module's plug connector with its counterpart on the housing. **Take care** to ensure the contacts of the plug connectors do not become deformed during this process.
4. Screw the module to the front plate of the housing using the captive screws.

3.6.3 Connection overview of expansion modules

The figure below provides an overview of connection options and cables on the expansion modules.

Note: For the connection overview relating to the housing, head, and basic modules, refer to the section titled "Connecting".

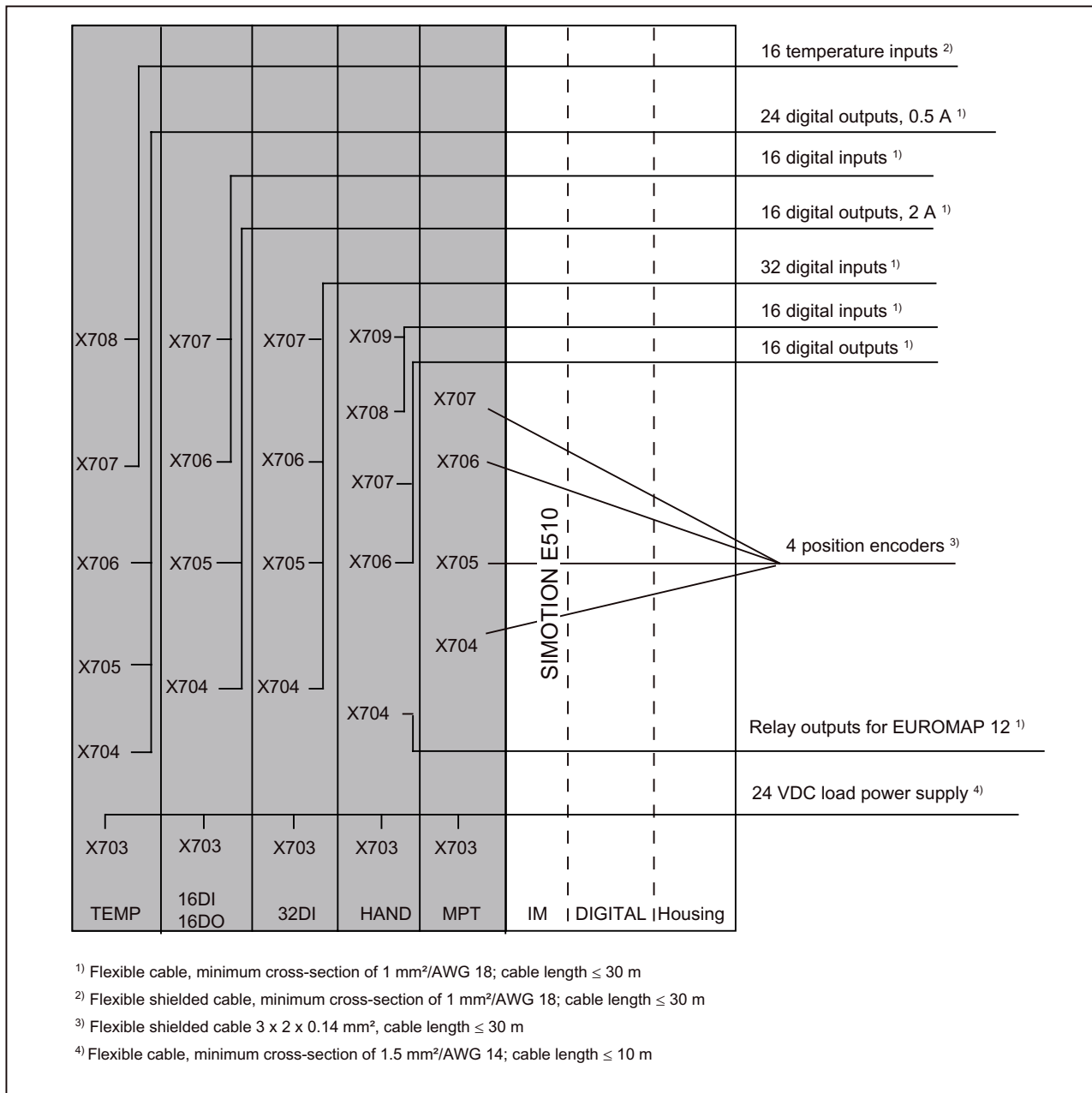

Figure 3-19 Connection overview

See also

Connection overview (Page 163)

3.6.4 Connecting the EB DIGITAL, 16DI/16DO

Connecting the power supply

The required 24 VDC load power supply is wired to connector X703.

Note

For information on how to connect the load power supply and what needs to be taken into account for this purpose, refer to the section titled "Connecting the power supply to the head module".

Please also refer to the section "Overall SIMOTION E510 configuration", as well as "Power supply connection", which relates to the digital I/O expansion module (16DI/16DO).

Connecting inputs/outputs

The digital inputs are wired to connectors X706 and X707, and the digital outputs are wired to connectors X704 and X705.

 DANGER
Only a protective extra-low voltage (PELV) may be connected to the inputs/outputs.

Note

For information on connection elements, connecting cables, and wiring procedures, refer to the section titled "Connecting inputs/outputs to the housing".

See also

- Wiring and block diagrams (Page 92)
- Mechanical fixing of cables (Page 174)
- Connecting the power supply to the head module (Page 164)
- Connection for power supply (Page 88)
- Overall SIMOTION E510 configuration (Page 162)
- Connecting inputs/outputs to the housing (Page 170)

3.6.5 Connecting the EB DIGITAL, 32DI

Connecting the power supply

The required 24 VDC load power supply is wired to connector X703.

Note

For information on how to connect the load power supply and what needs to be taken into account for this purpose, refer to the section titled "Connecting the power supply to the head module".

Please also refer to the section titled "Overall SIMOTION E510 configuration".

Connecting inputs

The digital inputs are wired to connectors X704 to X707.



Only a protective extra-low voltage (PELV) may be connected to the inputs/outputs.
--

Note

For information on connection elements, connecting cables, and wiring procedures, refer to the section titled "Connecting inputs/outputs to the housing".

See also

Connecting the power supply to the head module (Page 164)

Overall SIMOTION E510 configuration (Page 162)

Wiring diagram and block diagram (Page 102)

Mechanical fixing of cables (Page 174)

Connecting inputs/outputs to the housing (Page 170)

3.6.6 Connecting the EB TEMP, 16TC/24DO

Connecting the power supply

The required 24 VDC load power supply is wired to connector X703.

Note

For information on how to connect the load power supply and what needs to be taken into account for this purpose, refer to the section titled "Connecting the power supply to the head module".

Please also refer to the figure in the section titled "Overall SIMOTION E510 configuration".

Connecting inputs/outputs

The temperature inputs are wired to connectors X707 and X708, and the digital outputs are wired to connectors X704, X705, and X706.

 DANGER
Only a protective extra-low voltage (PELV) may be connected to the inputs/outputs.

Note

For information on connection elements, connecting cables, and wiring procedures, refer to the section titled "Connecting inputs/outputs to the housing".

See also

- Connecting the power supply to the head module (Page 164)
- Wiring and block diagrams (Page 112)
- Connecting shielded cables via the shield connection (Page 173)
- Mechanical fixing of cables (Page 174)
- Overall SIMOTION E510 configuration (Page 162)
- Connecting inputs/outputs to the housing (Page 170)

3.6.7 Connecting the EB MPT, 4CH

Connecting the power supply

The required 24 VDC load power supply is wired to connector X703.

Note

For information on how to connect the load power supply and what needs to be taken into account for this purpose, refer to the section titled "Connecting the power supply to the head module".

Please also refer to the section titled "Overall SIMOTION E510 configuration".

Connecting the position encoders

The position encoders are connected to connectors X704 to X707.

Note

For information on connection elements, refer to the section titled "Connecting inputs/outputs to the housing".

Connecting cables

When wiring position encoders, use 3 x 2 x 0.14 mm² shielded cables.

The maximum cable length is 30 m.

Wiring procedure

Proceed as follows when connecting position encoders:

1. Wire the 9-pin sub D connector as shown in the "Connecting cables" figure, which can be found in the section titled "Interface for the position encoder (MPT1 to 4)".
2. Refer to the relevant documentation when connecting to the position encoder.
3. Plug the 9-pin sub D connector into the 9-pin sub D socket of **EB MPT, 4CH**.
4. Screw the sub D connector into place.

Note

For information on mechanical fixing of cables, see the section titled "Mechanical fixing of cables".

NOTICE

The connecting cable must not be pulled out during operation.
--

See also

- Overall SIMOTION E510 configuration (Page 162)
- Connecting the power supply to the head module (Page 164)
- Connecting inputs/outputs to the housing (Page 170)
- Mechanical fixing of cables (Page 174)

3.6.8 Connecting the EB HAND, 16DI/16DO

Connecting the power supply

The required 24 VDC load power supply is wired to connector X703.

Note

For information on how to connect the load power supply and what needs to be taken into account for this purpose, refer to the section titled "Connecting the power supply to the head module".

Please also refer to the section titled "Overall SIMOTION E510 configuration".

Connecting the handling device

Handling devices conforming to EUROMAP 12 or EUROMAP 67 can also be connected. A relay option module is required when connecting a EUROMAP 12-compliant handling device (see section titled "EUROMAP 67-compliant handling expansion module").

A connecting cable between the expansion module and the standardized add-on housing is used to connect the handling device.

See the "Connecting cables" section for connection examples relating to EUROMAP 12- and EUROMAP 67-compliant handling devices, and for EUROMAP 12 or 67 hybrid connections.

Note

For information on connection elements, refer to the section titled "Connecting inputs/outputs to the housing".

For wiring and block diagrams, see the "Wiring and block diagrams" section for the handling expansion module.

Connecting cables

When wiring inputs and outputs on the **EB HAND, 16DI/16DO** or the **relay option module**, use flexible cables with a minimum cable cross-section of 1 mm²/AWG 18.

The maximum cable length is 30 m.

Note

For information on mechanical fixing of cables, see the section titled "Mechanical fixing of cables".

See also

Overall SIMOTION E510 configuration (Page 162)

Connecting the power supply to the head module (Page 164)

Wiring diagram and block diagram (Page 133)

Connecting inputs/outputs to the housing (Page 170)

Mechanical fixing of cables (Page 174)

Commissioning

4.1 Requirements for commissioning

Requirements for commissioning

Table 4- 1 Requirements for commissioning the DP slave

Prerequisite action	Refer to chapter
SIMOTION E510 has been installed.	"Installing SIMOTION E510"
SIMOTION E510 has been wired	"Connecting"
The bus connector has been connected	"Connecting PROFIBUS DP to the head module"
The terminating resistors have been switched on (at segment ends).	
A connection has been established (via PROFIBUS DP) to the DP master and the PG/PC.	

Software requirements

The **STEP 7** Engineering System program (V5.1 or higher + Service Pack 2) must be installed on the programming device (PG) or a standard PC.

If the DP master is a hardware platform from the SIMOTION system, the SIMOTION SCOUT Engineering System must be installed on the PG/PC.

Initial switching on

All the modules of a complete SIMOTION E510 device **must** be supplied with power and switched on simultaneously (see the section titled "Configuring the electrical installation").

If the modules have been supplied without any errors occurring, the "ON" LED will light up on the head module.

Commissioning steps

The following commissioning steps should be performed in the order specified:

1. Installing GSD files
2. Configuring the DP slave (SIMOTION E510)
3. Assigning input/output addresses
4. Parameterizing inputs/outputs
5. Assigning constant bus cycle time and isochronous mode parameters
6. Creating a user program
7. Downloading the user program to the DP master

These commissioning steps are described in the sections that follow.

4.2 Installing GSD files

A GSD file is used to connect SIMOTION E510 to the DP master used. The GSD file (device master data file) contains all the properties specific to a slave. The format of a GSD file is defined in IEC 61784-1:2002 Ed1 CP 3/1.

For the most recent GSD file, go to:

<http://support.automation.siemens.com/WW/view/en/20142378>

A Read Me file containing important information on the current version is also supplied with the GSD file.

Install the GSD file as follows:

1. In the *STEP 7* "Hardware Catalog", select the **Options > Install New GSD** menu command.
2. In the dialog box that appears, open the drive/directory with the corresponding GSD file.

Result: The DP slave is listed in the "Hardware Catalog" window (only in the "Standard" catalog profile) under "PROFIBUS DP\Additional Field Devices" and is available for configuration purposes.

Directory:

PROFIBUS DP\Additional Field Devices\I/O\SIMOTION\SIMOTION E510

Note

For further information about installing GSD files, refer to the *STEP 7* online help.

4.3 Configuring the DP slave (SIMOTION E510)

Requirements

The following requirements must be met:

1. You have created a project in *STEP 7* or *SIMOTION SCOUT* and inserted a DP master in the hardware configuration.
2. You have configured a PROFIBUS subnet.
3. You have opened the project.

Inserting SIMOTION E510

1. Open **HW Config**.
2. In the **HW Config** window, use the **View > Catalog** menu command to open the **Hardware Catalog**.
3. In the Hardware Catalog, select the **SIMOTION E510** module via the **PROFIBUS DP > Additional Field Devices > I/O > SIMOTION** folder path.
4. Drag and drop **SIMOTION E510** to the PROFIBUS subnet for your project (SIMOTION E510 automatically contains the head and basic modules).

The **Properties - PROFIBUS SIMOTION E510 Interface** dialog box will open. You can make the following settings here:

- Properties of the PROFIBUS subnet
- The PROFIBUS DP address of the DP slave You will be offered the addresses which are not yet assigned in the subnet. Select one of these.

Note:

You must set the PROFIBUS DP address selected here at the S1 DIP switch on the head module (see the section titled "Connecting PROFIBUS DP to the head module").

Confirm the settings by clicking **OK**.

An icon for the DP slave will be attached to the DP master system. In the lower section of the station window, a detailed view of the DP slave will appear with its available slots or DP identifiers.

5. You can still equip SIMOTION E510 with expansion modules. To do this, open the **SIMOTION E510** subfolder in the Hardware Catalog and select the relevant expansion module. Drag and drop the selected module to one of the free slots in the detailed view.

Note

When selecting expansion modules, take care to ensure that the configuration established matches the actual configuration. With the **housing with 1 expansion slot** variant, an expansion module may only be inserted into slot 6.

With the **housing with 4 expansion slots** variant, all the free slots between the head module and expansion modules must be occupied with dummy modules. A dummy module is one which can be selected from the Hardware Catalog, even though it is not physically present.

If the "Startup with inconsistent preset configuration and actual configuration" parameter (see "Hardware configuration") is activated, dummy modules can be used in order to deactivate/stop using the physically inserted expansions temporarily. In such cases, leaving the slot unoccupied is not sufficient.

If the "Startup with inconsistent preset configuration and actual configuration" parameter is deactivated, it is essential that the configuration matches.

4.4 Assigning input/output addresses

STEP 7 assigns input/output addresses as soon as modules are placed in the configuration table. This means that every module has its own start address.

Procedure

Proceed as follows to amend the modules' input/output addresses:

1. In the detailed view, select the line containing the module whose start address you wish to set and select the **Edit > Object Properties** menu command.

The **Properties - DP Slave** dialog box will open.

2. Select the **Addresses/Identifier** tab.
3. Change the preset start address.
4. Click **OK** to confirm the change.

Displaying the address overview

You can display the input/output addresses that are already in use and the address gaps as follows:

1. Open the station whose addresses you wish to see.
2. Select the **View > Address Overview** menu command.
3. In the "Address Overview" dialog box, select the module whose assigned inputs/outputs are to be displayed (e.g. head module).

4.5 Parameterizing inputs/outputs

Overview

The SIMATIC STEP 7 or SIMOTION SCOUT **HW Config** is used for parameterizing inputs/outputs.

Proceed as follows:

1. Select the line containing the module you wish to parameterize in the **HW Config** window's detailed view, followed by the **Edit > Object Properties** menu command.

The **Properties - DP Slave** dialog box will open.

2. Select the **Parameterize** tab.
3. Open the **Device-specific parameters** folder.
4. Parameterize the inputs/outputs for the relevant module. For parameter details, refer to the table below.

After you have defined all the parameters, download these from your PG to the DP master.

5. Select the **Station > Save and Compile** menu command.
6. Selecting the menu command **Target System > Download to Module** downloads the project to the DP master.

The parameters are transferred to the DP slave when the DP master is powered up.

The table below lists all the parameters (for head, basic, and expansion modules) that may be used to adapt SIMOTION E510 to the user's particular application. An explanation of the individual parameters can be found at the end of the table.

Table 4-2 Parameters for inputs/outputs

Parameter	Range of values	Default	I M	32DI/ 48DO	16DI/ 16DO	32DI	T E M P	H A N D	M P T
General parameters									
Position control cycle clock	1...2	1	x	-	-	-	-	-	-
Interpolator cycle clock	1...12	3	x	-	-	-	-	-	-
Sign-of-life monitoring	Deactivated Activated	Activated	x	-	-	-	-	-	-
Number of time-outs	0...255	0	x	-	-	-	-	-	-
Digital outputs									
Reserved DO0 to 23	Deactivated Activated	Deactivated	-	x	-	-	-	-	-
Substitute value: Retain last value DO0 to 47 DO0 to 15 DO0 to 23	No Yes	No	-	x	x	-	x	x	-

4.5 Parameterizing inputs/outputs

Parameter	Range of values	Default	I M	32DI/ 48DO	16DI/ 16DO	32DI	T E M P	H A N D	M P T
Substitute value DO0 to 47 DO0 to 15 DO0 to 23	FALSE TRUE	FALSE	-	x	x	-	x	x	-
Counter inputs									
Operating mode IDC 0 IDC 1	2 up-counters 1 up/down counter	2 up-counters	x	-	-	-	-	-	-
Operating mode IDC 2 IDC 3	2 up-counters 1 up/down counter	2 up-counters	x	-	-	-	-	-	-
RLO edge detection IDC 0 IDC 1	Single detection Double detection Quadruple detection	Single detection	x	-	-	-	-	-	-
RLO edge detection IDC 2 IDC 3	Single detection Double detection Quadruple detection	Single detection	x	-	-	-	-	-	-
Time base for duration counter IDC 0	41.67 ns ²⁾ 1 µs 1 ms	41.67 ns ²⁾	x	-	-	-	-	-	-
Time base for duration counter IDC 1	41.67 ns ²⁾ 1 µs 1 ms	41.67 ns ²⁾	x	-	-	-	-	-	-
Time base for duration counter IDC 2	41.67 ns ²⁾ 1 µs 1 ms	41.67 ns ²⁾	x	-	-	-	-	-	-
Time base for duration counter IDC 3	41.67 ns ²⁾ 1 µs 1 ms	41.67 ns ²⁾	x	-	-	-	-	-	-
Operating mode IDC 0	Up-counter ³⁾ Deactivated	Deactivated	-	-	-	x	-	-	-
Operating mode IDC 1	Up-counter ³⁾ Deactivated	Deactivated	-	-	-	x	-	-	-
Time base for duration counter	41.67 ns ³⁾ 1 µs 1 ms	41.67 ns ³⁾	-	-	-	x	-	-	-
Analog inputs									
Measurement type/measuring range AI0 to 7	Deactivated Voltage 0 to 10 V	Deactivated	x	-	-	-	-	-	-
Analog outputs									
Reserved AO0 to 7	Deactivated Activated	Deactivated	x	-	-	-	-	-	-
Substitute value: Keep last value AO0 to 7	No Yes	No	x	-	-	-	-	-	-

Parameter	Range of values	Default	I M	32DI/ 48DO	16DI/ 16DO	32DI	T E M P	H A N D	M P T
Output type/output range AO0 to 7	Deactivated Voltage -10 to +10 V	Deactivated	x	-	-	-	-	-	-
Substitute value AO0 to 7	-27,648 to +27,648 See the "Representation of analog values in the ±10 V output range" table in the section titled "Representation of analog values".	0	x	-	-	-	-	-	-
Temperature inputs									
Wire-break check TC0 to 15	No Yes	Yes	x	-	-	-	x	-	-
TC diagnostic interrupt	Deactivated Activated	Deactivated	x	-	-	-	x	-	-
Output format	Degrees Celsius Degrees Fahrenheit	Degrees Celsius	x	-	-	-	x	-	-

4.5 Parameterizing inputs/outputs

Parameter	Range of values	Default	I M	32DI/ 48DO	16DI/ 16DO	32DI	T E M P	H A N D	M P T
TCx measurement type/measuring range (x = 0, 2, 4, 6, 8, 10, 12, 14) TC = Thermocouple RTD = Resistance thermometer	Deactivated TC without compens. 0 °C type J TC without compens. 0 °C type K TC without compens. 0 °C type L TC without compens. 50 °C type J TC without compens. 50 °C type K TC without compens. 50 °C type L TC compensating box 0 °C type J TC compensating box 0 °C type K TC compensating box 0 °C type L TC compensating box 50 °C type J TC compensating box 50 °C type K TC compensating box 50 °C type L TC internal comparison type J TC internal comparison type K TC internal comparison type L TC external comparison 1 type J TC external comparison 1 type K TC external comparison 1 type L TC external comparison 2 type J TC external comparison 2 type K TC external comparison 2 type L Compensation circuit RTD 4-w-connection Pt100 std ⁶⁾ RTD 4-w-connection Pt100 std = external comparison 1 ⁶⁾ RTD 4-w-connection Pt100 std = external comparison 2 ⁶⁾ RTD 4-w-connection Pt1000 std ^{1), 6)} RTD 4-w-connection Pt1000 std = external comparison 1 ^{1), 6)} RTD 4-w-connection Pt1000 std = external comparison 2 ^{1), 6)} Note: "Thermocouple ext. comparison 1 type x or comparison 2 type x" can only be used if one input is parameterized and connected as "Resistance thermometer = ext. comparison 1 or 2".	Deactivated	x	-	-	-	x	-	-
			1)						
			1)						
			1)						

Parameter	Range of values	Default	I M	32DI/ 48DO	16DI/ 16DO	32DI	T E M P	H A N D	M P T
TCx measurement type/measuring range (x = 1, 3, 5, 7, 11, 13, 15, 19) TC = Thermocouple	Deactivated TC without compensation 0 °C type J TC without compensation 0 °C type K TC without compensation 0 °C type L TC without compensation 50 °C type J TC without compensation 50 °C type K TC without compensation 50 °C type L TC compensating box 0 °C type J TC compensating box 0 °C type K TC compensating box 0 °C type L TC compensating box 50 °C type J TC compensating box 50 °C type K TC compensating box 50 °C type L TC internal comparison type J TC internal comparison type K TC internal comparison type L TC external comparison 1 type J TC external comparison 1 type K TC external comparison 1 type L TC external comparison 2 type J TC external comparison 2 type K TC external comparison 2 type L Compensation circuit	Deactivated	x	-	-	-	x	-	-
Fault reaction TC0 to 15	Overflow Underflow	Overflow	x	-	-	-	x	-	-
Parameters for position transducers (MPT)									
Measurement: Factor (multiple of DP cycle)	1 to 8	1	-	-	-	-	-	-	x
Measurement: MPT1 resolution	5 µm 10 µm 20 µm 50 µm 100 µm 200 µm 500 µm 1,000 µm	5 µm	-	-	-	-	-	-	x
Measurement: MPT2 resolution	5 µm 10 µm 20 µm 50 µm 100 µm 200 µm 500 µm 1,000 µm	5 µm	-	-	-	-	-	-	x

4.5 Parameterizing inputs/outputs

Parameter	Range of values	Default	I M	32DI/ 48DO	16DI/ 16DO	32DI	T E M P	H A N D	M P T
Measurement: MPT3 resolution	5 µm 10 µm 20 µm 50 µm 100 µm 200 µm 500 µm 1,000 µm	5 µm	-	-	-	-	-	-	x
Measurement: MPT4 resolution	5 µm 10 µm 20 µm 50 µm 100 µm 200 µm 500 µm 1,000 µm	5 µm	-	-	-	-	-	-	x
Measurement: MPT1 sensor reading	No Yes ⁵⁾	No	-	-	-	-	-	-	x
Measurement: MPT2 sensor reading	No Yes ⁵⁾	No	-	-	-	-	-	-	x
Measurement: MPT3 sensor reading	No Yes ⁵⁾	No	-	-	-	-	-	-	x
Measurement: MPT4 sensor reading	No Yes ⁵⁾	No	-	-	-	-	-	-	x
Measurement: MPT1 number of measuring points	0...2	0	-	-	-	-	-	-	x
Measurement: MPT2 number of measuring points	0...2	0	-	-	-	-	-	-	x
Measurement: MPT3 number of measuring points	0...2	0	-	-	-	-	-	-	x
Measurement: MPT4 number of measuring points	0...2	0	-	-	-	-	-	-	x
Measurement: MPT1 offset [µm]	-3·10 ⁴ to 3·10 ⁴ for 16-bit measured value -6·10 ⁶ to 6·10 ⁶ for 32-bit measured value	0	-	-	-	-	-	-	x
Measurement: MPT2 offset [µm]	-3·10 ⁴ to 3·10 ⁴ for 16-bit measured value -6·10 ⁶ to 6·10 ⁶ for 32-bit measured value	0	-	-	-	-	-	-	x
Measurement: MPT3 offset [µm]	-3·10 ⁴ to 3·10 ⁴ for 16-bit measured value -6·10 ⁶ to 6·10 ⁶ for 32-bit measured value	0	-	-	-	-	-	-	x
Measurement: MPT4 offset [µm]	-3·10 ⁴ to 3·10 ⁴ for 16-bit measured value -6·10 ⁶ to 6·10 ⁶ for 32-bit measured value	0	-	-	-	-	-	-	x
Measurement: Wave speed (0.01 m/s) MPT1	-30,000 to 30,000 ⁴⁾	0	-	-	-	-	-	-	x
Measurement: Wave speed (0.01 m/s) MPT2	-30,000 to 30,000 ⁴⁾	0	-	-	-	-	-	-	x

Parameter	Range of values	Default	I M	32DI/ 48DO	16DI/ 16DO	32DI	T E M P	H A N D	M P T
Measurement: Wave speed (0.01 m/s) MPT3	-30,000 to 30,000 ⁴⁾	0	-	-	-	-	-	-	x
Measurement: Wave speed (m/s) MPT4	-30,000 to 30,000 ⁴⁾	0	-	-	-	-	-	-	x

¹⁾ Not for IM, 8AI/8AO/16TC/4CNT

²⁾ Exact value is 41.6666 ns

³⁾ The "Up-counter" selection can only be made on one **EB DIGITAL, 32DI** for each SIMOTION E510 complete unit.

⁴⁾ Offset for value 280,000

⁵⁾ Position encoders from "BALLUFF" with a P111 interface are supported, as are position encoders from "MTS" with a start/stop interface. **Note:** Please refer to the manufacturer documentation for the sensor.

⁶⁾ When using these parameters, we recommend activating a wire-break check at this point.

Position control cycle clock

You must enter the ratio between the PROFIBUS DP cycle and the position control cycle clock.

Note

The SIMOTION E510 **position control cycle clock** and **interpolator cycle clock** parameters must match the cycles set in SIMOTION SCOUT. If the interpolator cycle clock > 8 ms, a parameterization error will occur and the BF LED on SIMOTION E510 will flash.

Example:

- DP cycle = 2 ms
- Position control cycle clock = 4 ms
- Interpolator cycle clock = 8 ms

For this setting in SCOUT, you need to make the following parameter settings for SIMOTION E510:

- Position control cycle clock = 2
- Interpolator cycle clock = 4

Refer to the *SIMOTION SCOUT/3/* Configuration Manual or the SIMOTION SCOUT online help.

This parameter is **not** relevant for asynchronous operation.

Interpolator cycle clock

You must enter the ratio between the PROFIBUS DP cycle and the interpolator cycle clock. Interpolator cycle clocks of > 8 ms are not supported by SIMOTION E510.

This parameter is **not** relevant for asynchronous operation.

Sign-of-life monitoring

You can make settings to determine whether or not sign-of-life monitoring is activated.

In SIMOTION E510, sign-of-life monitoring can be used to define whether data exchange with the PROFIBUS master is being monitored. If a fault scenario arises, the response will depend on how the parameters were set (substitute value, substitute value: keep last value).

Number of time-outs

This parameter can be used to set the number of time-outs. Time-outs occur if processing of input or output data could not be completed properly.

The value range for setting the number of time-outs is 0 to 255.

Reserved (DO0 to 23)

This function is reserved.

Substitute value: Keep last value

Setting the parameter to "Yes" causes the last correctly transmitted value to be output if communication is interrupted.

Setting the parameter to "No" causes the value set in the "Substitute value" parameter to be output.

Substitute value

This value is output when communication is interrupted, provided that you have set the "Substitute value: Keep last value" parameter to "No".

Counter operating mode for head module

You can set parameters to determine the operating mode for the 4 counter channels:

- As 4 up-counters
- As 2 up/down counters

Refer to the section titled "Description of functions for counter inputs".

Counter operating mode for EB Digital, 32DI

You can activate the counter as an up-counter.

Refer to the section titled "Description of functions for counter inputs".

The counters may **only** be used on one **EB DIGITAL, 32 DI** per SIMOTION E510 complete unit.

RLO edge detection

You can set the edges at which counting is to occur:

- Single detection
- Double detection
- Quadruple detection

Refer to the section titled "Description of functions for counter inputs".

Time base for duration counter (interval duration counter)

You can set parameters to determine the time resolution in which the counters are to operate.

- 41.6666 ns
- 1 μ s
- 1 ms

Refer to the section titled "Description of functions for counter inputs".

Measurement type/measuring range for analog inputs

You can deactivate the analog inputs or select the input at which a voltage of 0 to 10 V will be read. Unused analog inputs must be deactivated.

Reserved (AO0 to 7)

This function is reserved.

Output type/output range for analog outputs

You can deactivate the analog outputs or select the output at which a voltage of -10 to +10 V will be output. Unused analog outputs must be deactivated.

Wire-break check for temperature inputs

Setting the parameter to "Yes" causes a wire-break check to be performed. With resistance thermometers, all 4 connecting cables are checked for wire breaks.

Diagnostic interrupt for temperature inputs

You can select whether or not a diagnostic interrupt is output in the event of a wire break. If the diagnostic interrupt facility is deactivated, the "TF" LED will **not** light up in the event of a wire break.

If the diagnostic interrupt facility is activated, an interrupt will be sent to the controller in the event of a wire break (see the section titled "Module status").

Output format for temperature inputs

You can set parameters to determine the unit in which the temperature will be output.

Measurement type/measuring range for temperature inputs

You can deactivate or select the temperature inputs:

- Sensor type
 - Thermocouple types J, K, L
 - Pt 100 resistance thermometer
 - Pt 1000 resistance thermometer (only for **EB TEMP, 16TC/24DO**)
 - Compensation circuit
- Compensation method
 - Without compensation 0 °C
 - Without compensation 50 °C
 - Compensating box 0 °C
 - Compensating box 50 °C
 - Internal comparison
 - External comparison 1
 - External comparison 2

If you have selected a Pt 100/Pt 1000 resistance thermometer, you can still specify which comparison point the resistance thermometer is to operate as (external comparison 1 or 2). The comparison point only applies to the module on which it is configured. Unused temperature inputs must be deactivated.

Note

The compensating box (TC7 in the connection example, see the "Thermocouples with compensating box" figure in the section titled "Description of functions for temperature inputs") must be parameterized as a compensation circuit. The thermocouples (TC0 to TC6 in the connection example of the figure referred to above) must be parameterized as a compensating box.

Thermocouples (for the connection example, see the "Thermocouples with direct looping-in of compensating box" figure in the section titled "Description of functions for temperature inputs") must be parameterized as thermocouples without compensation.

No realizable temperature will be shown as the value at the input where a compensating box is connected. An internal compensation value will be shown.

Fault reaction

You can set the desired reaction in the event of a fault. You have the option of displaying an overflow or underflow value (see the tables "Representation of analog values for resistance thermometers" and "Representation of analog values for thermocouples type J, K, L" in the section titled "Representation of analog values").

The following faults may occur:

- Wire break (only if open-circuit detection activated)
- Channel deactivated

Measurement: Factor

This parameter sets the number of PROFIBUS DP cycles after which a position measurement should be taken.

Any number between 1 and 8 can be selected.

The factor for position measurement is calculated using the following formula:

$$\text{Factor} = \frac{\frac{\text{Nominal length [m]}}{\text{Ultrasonic velocity [m/s]}} + 0.65 \text{ [ms]}}{\text{DP cycle [ms]}}$$

Nominal length - Available range for position encoder in m

DP_{cycle} - PROFIBUS DP cycle in ms

Factor - Specifies the number of PROFIBUS DP cycles after which a position measurement should be taken

Note: A minimum PROFIBUS DP cycle of 1.25 ms may be used with **EB MPT, 4CH**.

Example 1:

Factor = 1; ultrasonic velocity = 2,800 m/s; PROFIBUS DP cycle = 1.25 ms

Nominal length = ultrasonic velocity (DP cycle - 0.65 ms)

Nominal length = 2.8 m/ms (1.25 ms - 0.65 ms)

Nominal length = 1.68 m

Example 2:

You have a position encoder with a nominal length of 2.0 m and an ultrasonic velocity of approx. 2,800 m/s. The PROFIBUS DP cycle for SIMOTION E510 is 1.25 ms.

$$\text{Factor} = \frac{\frac{2 \text{ m}}{2.800 \text{ m/s}} + 0.65 \text{ ms}}{1.25 \text{ ms}} = 1.09$$

The factor must be rounded up to the next integer value.

This means you will need to parameterize a factor of 2.

Note

If a value is not available in every cycle, the measured values are extrapolated.

The total measuring time (PROFIBUS DP cycle * measuring factor) must not exceed 16 ms when the constant bus cycle time is active.

Measurement: MPT1 to MPT4 resolution

You can parameterize the position measurement input resolution for each position encoder separately. The maximum length that can be represented depends on the resolution.

Measurement: MPT1 to MPT4 sensor reading

You can make the following parameter settings for each position encoder separately:

- No
- Yes

Note

If the process of reading the parameters from the sensor fails, the value from the "Measurement: Wave speed (0.01 m/s) MPTx" parameter is used.

Note

The "Measurement: MPT1 to MPT4 sensor reading" parameter must only be activated for those interfaces to which a suitable position encoder is actually connected.

Note

Position encoders from the "BALLUFF" company with a P111 interface are supported, as are position encoders from the "MTS" company with a start/stop interface able to upload sensor parameters.

Please refer to the manufacturer documentation for the sensor.

Measurement: MPT1 to MPT4 number of measuring points

You can parameterize the number of measuring points for each position encoder separately as follows:

- With no sensor (0)
- Up to 2 measuring points (1 or 2) per position encoder

Measurement: MPT1 to MPT4 offset

You can parameterize the value (offset) which defines the zero point for each position encoder separately. The offset is entered as a multiple of the scaling. For example, a scaling of 5 µm and an offset of 10 will shift the zero point by 50 µm. A scaling of 20 µm and an offset of 10 will shift the zero point by 200 µm.

If automatic sensor reading is activated, the offset of the sensor itself will also be determined on the basis of the manufacturer data. During measurement, the offset used equates to the sum of the user offset and the sensor offset.

Measurement: MPT1 to MPT4 wave speed (m/s)

You can parameterize the position encoder's wave speed. The value is given as an offset to a value of 280,000 (in multiples of 0.01 m/s).

The wave speed value can be found in the documentation for the position encoder.

Note

This parameter is **only** used if automatic reading of the position encoder's wave speed is not supported.

Plausible values should be assigned to the sensor parameters at all times, so that they are suitable for use if automatic reading of sensor data fails. The user will then be notified of the fault during cyclic transmission via the sensor axis n upload status bits (see the "Logic addressing offsets for inputs and outputs (EB MPT, 4CH)" table in the section titled "Logic addressing for inputs and outputs").

Example of how to calculate a wave speed value

Based on a position encoder with a wave speed of 2,789.123 m/s, the wave speed value is calculated as follows:

$$\begin{aligned}\text{Wave speed} &= (\text{actual wave speed} - \text{offset}) * 100 \\ &= (2,789.123 \text{ m/s} - 2,800.00 \text{ m/s}) * 100 \\ &= -1,087.7\end{aligned}$$

The calculated value must be rounded up to the next integer value. This results in a value to be parameterized of -1,088.

4.6 Assigning constant bus cycle time and isochronous mode parameters

The following settings also need to be made for the DP master and DP slave when configuring isochronous mode.

The constant bus cycle time should be activated if:

- Time or phase control are being used
- I/O are used in a control loop

DP master system settings

1. Double-click the DP master system. The **Properties - DP Master System** dialog box will open.
2. Click **Properties** on the **General** tab. The **Properties-PROFIBUS** dialog box will open.
3. Select the **Network settings** tab in the **Properties-PROFIBUS** dialog box.
4. Choose a profile (e.g. "DP").
5. Click the **Options** button. The **Options** dialog box will open.
6. Select the **Constant Bus Cycle Time** tab in the **Options** dialog box and make the following settings:
 - Check the "Activate constant bus cycle" check box. This setting activates the constant DP cycle as the basis for isochronous mode.
 - Set the PROFIBUS DP cycle time under **Constant DP cycle**.
 - Do not change the default settings of the remaining parameters for the time being.
7. If you are to use a hybrid configuration, make the following settings on the **Constant Bus Cycle Time** tab:
 - Activate the "Times T_i and T_o equal for all slaves" check box.
 - Set the highest time values for T_i (reading in of process values) and T_o (output of process values) from each of the DP slaves connected (see table below).
8. Close this and all other active dialog boxes by clicking **OK**.

Settings on the DP slave (DP interface)

The isochronous input and output modules must be made known to the DP interface as isochronous components.

1. Double-click the icon for the DP slave. The **Properties - DP Slave** dialog box will open.
2. Select the **Clock-Synchronized Operation** tab in the **Properties - DP Slave** dialog box and make the following settings (only for equidistant PROFIBUS DP).
 - Activate the "Synchronize DP slave to constant DP cycle..." check box.
 - Set the times for T_i (point in time for reading in data) and T_o (point in time for output of process values) (see table below).

Note: With hybrid configurations, you will need to set the highest time values of each of the DP slaves connected for T_i and T_o .
3. Confirm your entries and close the dialog box by clicking **OK**.

Minimum times for T_i and T_o Table 4-3 Times for T_i and T_o

Modules	T_o [ms]		T_i [ms]	
	1. Module	Each additional module	1. Module	Each additional module
IM, 8AI/8AO/16TC/4CNT and DIGITAL, 32DI/48DO	0.250	-	0.345	-
IM, 8AI/8AO/16TC/4CNT and DIGITAL, 32DI/48DO with time-controlled outputs (on request)	0.500	-	0.690	-
EB DIGITAL, 16DI/16DO and EB HAND, 16DI/16DO	0.015	0.012	0.015	0.012
EB DIGITAL, 32DI (incl. CNT)	0.005	0	0.088	0.025
EB TEMP, 16TC/24DO	0.200	0.010	0.270	0.080
EB MPT, 4CH (16-bit)	0.005	0.010	0.280	0.100
EB MPT, 4CH (32-bit)	0.005	0.010	0.280	0.150

The figure below shows the sequence within the constant PROFIBUS DP cycle.

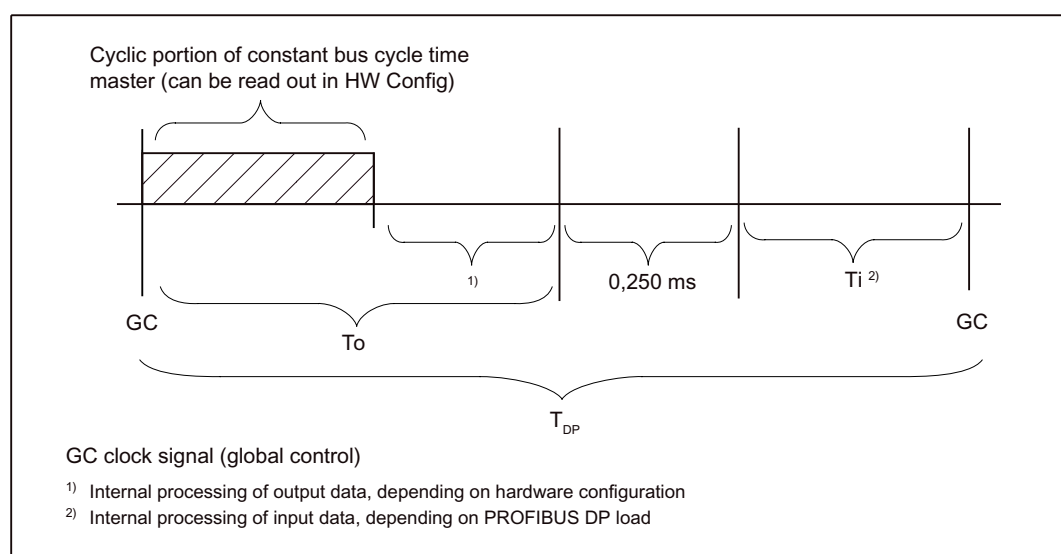

Figure 4-1 Constant PROFIBUS DP cycle

The settings on the DP slave are calculated as follows:

- T_i is derived by adding together all T_i times. The resulting time must then be rounded up to the next multiple of 0.125 ms.
- T_o is derived by adding together all T_o times and the "Cyclic portion of constant bus cycle time master" time (see figure below). The resulting time must then be rounded up to the next multiple of 0.125 ms.
- The minimum point in time T_{DP} is calculated on the basis of $T_i + T_o + 0.250$ ms.

The time for "Cyclic portion of constant bus cycle time master" can be read out in the dialog box below. To open this dialog box, select **Properties - DP Master System > Properties - PROFIBUS > Network Settings > Details**.

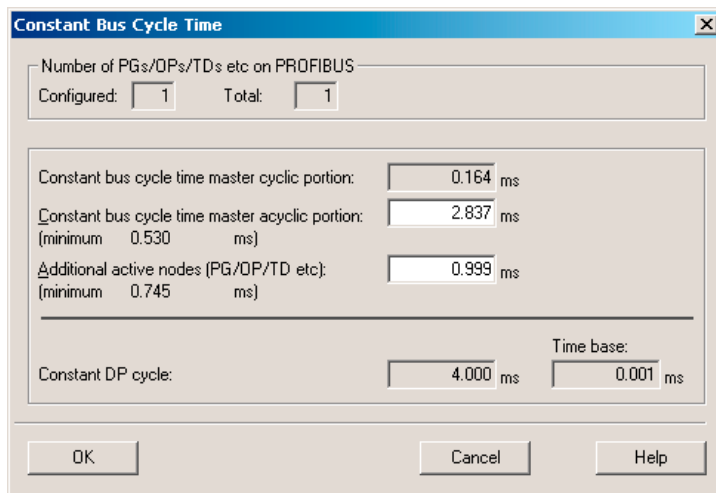

Figure 4-2 Cyclic portion of constant bus cycle time master

Note

These times should be treated as minimum times. This means, for example, that these times may prove to be insufficient for many interrupt events.

Note

For more details on parameterizing the constant bus cycle time and isochronous mode in "HW Config", refer to the *HW Config* online help.

Downloading the project to the DP master

Once you have carried out the various configuration, setting, and parameterization steps as described in the chapters you have read so far, you will need to save, compile, and download the entire project to the DP master in the "HW Config" window.

1. Select the **Station > Save and Compile** menu command.
2. Selecting the menu command **Target System > Download to Module** downloads the project to the DP master.

4.7 Creating a user program

4.7.1 Overview

Documentation on creating a user program is available from the following sources:

- For the SIMOTION Motion Control System: See the "SIMOTION SCOUT" CD-ROM
- For the SIMATIC automation system: See the "STEP 7" CD-ROM

Note

The example shown for creating a user program is based on SIMOTION.

4.7.2 Logic addressing for inputs and outputs

The tables below list the offsets for the logic addresses of the inputs and outputs.

Table 4- 4 Logic addressing offsets for inputs and outputs (basic and head module)

Logic address offset ¹⁾								
Byte	Bit 7	Bit 6	Bit 5	Bit 4	Bit 3	Bit 2	Bit 1	Bit 0
Basic module input address (I address)								
Byte 0	DI7	DI6	DI5	DI4	DI3	DI2	DI1	DI0
Byte 1	DI15	DI14	DI13	DI12	DI11	DI10	DI9	DI8
Byte 2	DI23	DI22	DI21	DI20	DI19	DI18	DI17	DI16
Byte 3	DI31	DI30	DI29	DI28	DI27	DI26	DI25	DI24
Basic module output address (O address)								
Word 0	DigitalTime0; time for digital output							
Word 2	DigitalTime1; time for digital output							
Word 4	DigitalTime2; time for digital output							
Word 6	DigitalTime3; time for digital output							
Word 8	DigitalTime4; time for digital output							
Word 10	DigitalTime5; time for digital output							
Word 12	DigitalTime6; time for digital output							
Word 14	DigitalTime7; time for digital output							
Byte 16	DO7 (2 A)	DO6 (2 A)	DO5 (2 A)	DO4 (2 A)	DO3 (2 A)	DO2 (2 A)	DO1 (2 A)	DO0 (2 A)
Byte 17	DO15 (2 A)	DO14 (2 A)	DO13 (2 A)	DO12 (2 A)	DO11 (2 A)	DO10 (2 A)	DO9 (2 A)	DO8 (2 A)
Byte 18	DO23 (2 A)	DO22 (2 A)	DO21 (2 A)	DO20 (2 A)	DO19 (2 A)	DO18 (2 A)	DO17 (2 A)	DO16 (2 A)
Byte 19	DO31 (0.5 A)	DO30 (0.5 A)	DO29 (0.5 A)	DO28 (0.5 A)	DO27 (0.5 A)	DO26 (0.5 A)	DO25 (0.5 A)	DO24 (0.5 A)
Byte 20	DO39 (0.5 A)	DO38 (0.5 A)	DO37 (0.5 A)	DO36 (0.5 A)	DO35 (0.5 A)	DO34 (0.5 A)	DO33 (0.5 A)	DO32 (0.5 A)
Byte 21	DO47 (0.5 A)	DO46 (0.5 A)	DO45 (0.5 A)	DO44 (0.5 A)	DO43 (0.5 A)	DO42 (0.5 A)	DO241 (0.5 A)	DO40 (0.5 A)

4.7 Creating a user program

Logic address offset ¹⁾								
Byte	Bit 7	Bit 6	Bit 5	Bit 4	Bit 3	Bit 2	Bit 1	Bit 0
Head module input address (I address)								
Word 0	ZSW1; status word (see "Status word 1 (ZSW1)" table in this section)							
Word 2	ZSW2; status word (see "Status word 2 (ZSW2)" table in this section)							
Up/down counter mode or up-counter mode								
Byte 4	CNT0; counter value byte 0				CNT0; pulse number			
Byte 5	CNT0; counter value byte 1				CNT0; cycle duration byte 0			
Byte 6	CNT0; counter value byte 2				CNT0; cycle duration byte 1			
Byte 7	CNT0; counter value byte 3				CNT0; cycle duration byte 2			
Byte 8	CNT1; counter value byte 0				CNT1; pulse number			
Byte 9	CNT1; counter value byte 1				CNT1; cycle duration byte 0			
Byte 10	CNT1; counter value byte 2				CNT1; cycle duration byte 1			
Byte 11	CNT1; counter value byte 3				CNT1; cycle duration byte 2			
Byte 12	CNT2; counter value byte 0				CNT2; pulse number			
Byte 13	CNT2; counter value byte 1				CNT2; cycle duration byte 0			
Byte 14	CNT2; counter value byte 2				CNT2; cycle duration byte 1			
Byte 15	CNT2; counter value byte 3				CNT2; cycle duration byte 2			
Byte 16	CNT3; counter value byte 0				CNT3; pulse number			
Byte 17	CNT3; counter value byte 1				CNT3; cycle duration byte 0			
Byte 18	CNT3; counter value byte 2				CNT3; cycle duration byte 1			
Byte 19	CNT3; counter value byte 3				CNT3; cycle duration byte 2			
Word 20	AI0; analog input 0							
Word 22	AI1; analog input 1							
Word 24	AI2; analog input 2							
Word 26	AI3; analog input 3							
Word 28	AI4; analog input 4							
Word 30	AI5; analog input 5							
Word 32	AI6; analog input 6							
Word 34	AI7; analog input 7							
Word 36	TC0; temperature input 0							
Word 38	TC1; temperature input 1							
Word 40	TC2; temperature input 2							
Word 42	TC3; temperature input 3							
Word 44	TC4; temperature input 4							
Word 46	TC5; temperature input 5							
Word 48	TC6; temperature input 6							
Word 50	TC7; temperature input 7							
Word 52	TC8; temperature input 8							
Word 54	TC9; temperature input 9							
Word 56	TC10; temperature input 10							
Word 58	TC11; temperature input 11							
Word 60	TC12; temperature input 12							

Logic address offset ¹⁾								
Byte	Bit 7	Bit 6	Bit 5	Bit 4	Bit 3	Bit 2	Bit 1	Bit 0
Word 62	TC13; temperature input 13							
Word 64	TC14; temperature input 14							
Word 66	TC15; temperature input 15							
Head module output address (O address)								
Word 0	STW1; control word (see "Control word 1 (STW1)" table in this section)							
Word 2	STW2; control word (see "Control word 2 (STW2)" table in this section)							
Word 4	Reserved							
Word 6	Reserved							
Word 8	Reserved							
Word 10	Reserved							
Word 12	Reserved							
Word 14	Reserved							
Word 16	Reserved							
Word 18	Reserved							
Word 20	AO0; analog output 0							
Word 22	AO1; analog output 1							
Word 24	AO2; analog output 2							
Word 26	AO3; analog output 3							
Word 28	AO4; analog output 4							
Word 30	AO5; analog output 5							
Word 32	AO6; analog output 6							
Word 34	AO7; analog output 7							

¹⁾ The logic address is made up of the offset and the start address from the hardware configuration. For information on start addresses for inputs and outputs, see the section titled "Assigning input/output addresses".

Table 4- 5 Logic addressing offsets for inputs and outputs (EB DIGITAL, 16DI/16DO)

Logic address offset ¹⁾								
Byte	Bit 7	Bit 6	Bit 5	Bit 4	Bit 3	Bit 2	Bit 1	Bit 0
EB DIGITAL, 16DI/16DO input address (I address)								
Byte 0	DI7	DI6	DI5	DI4	DI3	DI2	DI1	DI0
Byte 1	DI15	DI14	DI13	DI12	DI11	DI10	DI9	DI8
EB DIGITAL, 16DI/16DO output address (O address)								
Byte 0	DO7	DO6	DO5	DO4	DO3	DO2	DO1	DO0
Byte 1	DO15	DO14	DO13	DO12	DO11	DO10	DO9	DO8

¹⁾ The logic address is made up of the offset and the start address from the hardware configuration. For information on start addresses for inputs and outputs, see the section titled "Assigning input/output addresses".

4.7 Creating a user program

Table 4- 6 Logic addressing offsets for inputs and outputs (EB DIGITAL, 32DI)

Logic address offset ¹⁾								
Byte	Bit 7	Bit 6	Bit 5	Bit 4	Bit 3	Bit 2	Bit 1	Bit 0
EB DIGITAL, 32DI input address (I address)								
Byte 0	DI7	DI6	DI5	DI4	DI3	DI2	DI1	DI0
Byte 1	DI15	DI14	DI13	DI12	DI11	DI10	DI9	DI8
Byte 2	DI23	DI22	DI21	DI20	DI19	DI18	DI17	DI16
Byte 3	DI31	DI30	DI29	DI28	DI27	DI26	DI25	DI24
Up-counter mode								
Byte 4	CNT0; pulse number							
Byte 5	CNT0; cycle duration byte 0							
Byte 6	CNT0; cycle duration byte 1							
Byte 7	CNT0; cycle duration byte 2							
Byte 8	CNT1; pulse number							
Byte 9	CNT1; cycle duration byte 0							
Byte 10	CNT1; cycle duration byte 1							
Byte 11	CNT1; cycle duration byte 2							

¹⁾ The logic address is made up of the offset and the start address from the hardware configuration. For information on start addresses for inputs and outputs, see the section titled "Assigning input/output addresses".

Table 4- 7 Logic addressing offsets for inputs and outputs (EB TEMP, 16TC/24 DO)

Logic address offset ¹⁾								
Byte	Bit 7	Bit 6	Bit 5	Bit 4	Bit 3	Bit 2	Bit 1	Bit 0
EB TEMP, 16TC/24 DO input address (I address)								
Word 0	TC0; temperature input 0							
Word 2	TC1; temperature input 1							
Word 4	TC2; temperature input 2							
Word 6	TC3; temperature input 3							
Word 8	TC4; temperature input 4							
Word 10	TC5; temperature input 5							
Word 12	TC6; temperature input 6							
Word 14	TC7; temperature input 7							
Word 16	TC8; temperature input 8							
Word 18	TC9; temperature input 9							
Word 20	TC10; temperature input 10							
Word 22	TC11; temperature input 11							
Word 24	TC12; temperature input 12							
Word 26	TC13; temperature input 13							
Word 28	TC14; temperature input 14							
Word 30	TC15; temperature input 15							

Logic address offset ¹⁾								
Byte	Bit 7	Bit 6	Bit 5	Bit 4	Bit 3	Bit 2	Bit 1	Bit 0
EB TEMP, 16TC/24 DO output address (O address)								
Byte 0	DO7	DO6	DO5	DO4	DO3	DO2	DO1	DO0
Byte 1	DO15	DO14	DO13	DO12	DO11	DO10	DO9	DO8
Byte 2	DO23	DO22	DO21	DO20	DO19	DO18	DO17	DO16

¹⁾ The logic address is made up of the offset and the start address from the hardware configuration. For information on start addresses for inputs and outputs, see the section titled "Assigning input/output addresses".

Table 4- 8 Logic addressing offsets for inputs and outputs (EB HAND, 16DI/16DO)

Logic address offset ¹⁾								
Byte	Bit 7	Bit 6	Bit 5	Bit 4	Bit 3	Bit 2	Bit 1	Bit 0
EB HAND, 16DI/16DO input address (I address) ²⁾								
Byte 0	DI7	DI6	DI5	DI4	DI3	DI2	DI1	DI0
Byte 1	DI15	DI14	DI13	DI12	DI11	DI10	DI9	DI8
EB HAND, 16DI/16DO output address (O address) ²⁾								
Byte 0	DO7	DO6	DO5	DO4	DO3	DO2	DO1	DO0
Byte 1	DO15	DO14	DO13	DO12	DO11	DO10	DO9	DO8

¹⁾ The logic address is made up of the offset and the start address from the hardware configuration. For information on start addresses for inputs and outputs, see the section titled "Assigning input/output addresses".

²⁾ The following must be connected when using the relay option module:

- 16 digital inputs/15 digital outputs according to EUROMAP 67
- 12 digital inputs/11 digital outputs according to EUROMAP 12

Table 4- 9 Logic addressing offsets for inputs and outputs (EB MPT, 4CH)

Logic address offset ¹⁾								
Byte	Bit 7	Bit 6	Bit 5	Bit 4	Bit 3	Bit 2	Bit 1	Bit 0
EB MPT, 4CH 16-bit input address (I address)								
Word 0	Measured value 1, axis 1							
Word 2	Measured value 2, axis 1							
Word 4	Measured value 1, axis 2							
Word 6	Measured value 2, axis 2							
Word 8	Measured value 1, axis 3							
Word 10	Measured value 2, axis 3							
Word 12	Measured value 1, axis 4							
Word 14	Measured value 2, axis 4							
Byte 16	Number of measured values, axis 4 ⁵⁾		Number of measured values, axis 3 ⁵⁾		Number of measured values, axis 2 ⁵⁾		Number of measured values, axis 1 ⁵⁾	

Logic address offset ¹⁾								
Byte	Bit 7	Bit 6	Bit 5	Bit 4	Bit 3	Bit 2	Bit 1	Bit 0
Byte 17	Interpolation point ²⁾	24 V sensor supply failed	Measured values valid ³⁾	-	Upload status sensor axis 4 ⁴⁾	Upload status sensor axis 3 ⁴⁾	Upload status sensor axis 2 ⁴⁾	Upload status sensor axis 1 ⁴⁾
EB MPT, 4CH 32-bit input address (I address)								
DWord 0	Measured value 1, axis 1							
DWord 4	Measured value 2, axis 1							
DWord 8	Measured value 1, axis 2							
DWord 12	Measured value 2, axis 2							
DWord 16	Measured value 1, axis 3							
DWord 20	Measured value 2, axis 3							
DWord 24	Measured value 1, axis 4							
DWord 28	Measured value 2, axis 4							
Byte 32	Number of measured values, axis 4 ⁶⁾		Number of measured values, axis 3 ⁶⁾		Number of measured values, axis 2 ⁶⁾		Number of measured values, axis 1 ⁶⁾	
Byte 33	Interpolation point ²⁾	24 V sensor supply failed	Measured values valid ³⁾	-	Upload status sensor axis 4 ⁴⁾	Upload status sensor axis 3 ⁴⁾	Upload status sensor axis 2 ⁴⁾	Upload status sensor axis 1 ⁴⁾

1) The logic address is made up of the offset and the start address from the hardware configuration. For information on start addresses for inputs and outputs, see the section titled "Assigning input/output addresses".

2) If the value of the "Measurement: Factor (DP cycles)" parameter is greater than 1, this means there are cycles with original measured values (bit 7 is set) and cycles with extrapolated measured values (bit 7 is not set).

3) The bit indicates whether the measured values are valid. The bit = 0 if the parameters have not yet been transferred, for example (see the "Measurement: MPT1 to MPT4 sensor reading" parameter).

4) If 0 is showing, this means the parameters were accepted without any errors. If 1 is showing, this means the sensor parameter upload process has failed. → The values from HW Config have been set instead.

Note:

- Check that the sensor is correctly installed/wired, if one is connected.
- As the upload has failed, the measured values may also be incorrect (as a result of cable interference, for example).

Position encoders from the "BALLUFF" company with a P111 interface are supported, as are position encoders from the "MTS" company with a start/stop interface able to upload sensor parameters. Please refer to the manufacturer documentation for the sensor.

- 5) The measured values of the axis may only be used once the corresponding bit in byte 16 has been set. Example:
- If bit 0 corresponds to the value of the "Measurement: MPT1 number of measuring points" parameter (see "Parameters for inputs/outputs" table), a valid measured value will be entered in word 0 (measured value 1, axis 1).
 - If there is an encoder fault, word 0 will be set to 0 and bit 0 in byte 16 will be set to FALSE.
- 6) The measured values of the axis may only be used once the corresponding bit in byte 32 has been set. Example:
- If bit 0 corresponds to the value of the "Measurement: MPT1 number of measuring points" parameter (see "Parameters for inputs/outputs" table), a valid measured value will be entered in DWord 0 (measured value 1, axis 1).
 - If there is an encoder fault, DWord 0 will be set to 0 and bit 0 in byte 32 will be set to FALSE.

Table 4- 10 Status word 1 (ZSW1)

Bit 15 to bit 4	Bit 3	Bit 2	Bit 1	Bit 0
Reserved	Fault: Time-out	Reserved	Data set ready	Reserved

For information on the signals for activating the outputs, see the example program in the section titled "Activating the outputs".

Table 4- 11 Control word 1 (STW1)

Bit 15 to bit 8	Bit 7	Bit 6 to bit 4	Bit 3	Bit 2	Bit 1	Bit 0
Reserved	Fault: Reset time-out ¹⁾	Reserved	Enable I/O ¹⁾	Reserved	Reserved	Reserved

¹⁾ Enabled when the bit is set (0/1 edge)

For information on the signals for activating the outputs, see the example program in the section titled "Activating the outputs".

Table 4- 12 Status word 2 (ZSW2)

Bit 15	Bit 14	Bit 13	Bit 12	Bit 11 to bit 2	Bit 1	Bit 0
SSL (DP slave sign of life)				Reserved	SL_SYNC	Reserved

Table 4- 13 Control word 2 (STW2)

Bit 15	Bit 14	Bit 13	Bit 12	Bit 11 to bit 1	Bit 0
MSL (DP master sign of life)				Reserved	SYN

4.7.3 Representation of analog values

Analog to digital conversion

The DP master only processes the analog values in binary format. Analog inputs convert the analog process signal into digital format. Analog outputs convert the digital output value into an analog signal.

Representation of analog values at a resolution of 16 bits

The digitized analog value applies to input and output values of the same nominal range. Analog values are represented as fixed-point numbers in two's complement. The resulting assignment:

Bit	15	14	13	12	11	10	9	8	7	6	5	4	3	2	1	0
Bit value	S	2 ¹⁴	2 ¹³	2 ¹²	2 ¹¹	2 ¹⁰	2 ⁹	2 ⁸	2 ⁷	2 ⁶	2 ⁵	2 ⁴	2 ³	2 ²	2 ¹	2 ⁰

The sign of the analog value is always set at bit 15:

- "0" → +
- "1" → -

Resolution less than 16 bits

On analog modules with a resolution of less than 16 bits, the analog value is stored left-justified. The unused least significant bit positions are padded with "0".

Example

The example below demonstrates the "0" padding of unused bit positions for low resolution values.

Table 4- 14 Example: Bit pattern of a 16-bit and 13-bit analog value

Resolution	Analog value															
Bit	15	14	13	12	11	10	9	8	7	6	5	4	3	2	1	0
16-bit analog value	0	1	0	0	0	1	1	0	0	1	1	1	0	0	1	1
13-bit analog value	0	1	0	0	0	1	1	0	0	1	1	1	0	0	0	0

Representation of analog values of analog input channels

The "Bipolar input ranges" and "Unipolar input ranges" tables below contain the binary representation of the measured values.

As the binary representation of the measured values is always the same, the tables below showing the representation of analog values in voltage measuring ranges only contain a comparison of the measuring ranges with the units for resistance thermometers and for thermocouple types J, K, L.

Measured value resolution

At resolutions < 15 bits, all bits identified by "x" are set to "0".

Note

This resolution does not apply to temperature values. The converted temperature values are the result of a conversion in the device (see tables relating to analog value representations for resistance thermometers and for thermocouples J, K, L).

Table 4- 15 Supported analog value resolutions

Resolution in bits (+ sign)	Decimal	Hexadecimal	Analog value	
			High byte	Low byte
8	128	80	S 0 0 0 0 0 0 0	1 x x x x x x x
9	64	40	S 0 0 0 0 0 0 0	0 1 x x x x x x
10	32	20	S 0 0 0 0 0 0 0	0 0 1 x x x x x
11	16	10	S 0 0 0 0 0 0 0	0 0 0 1 x x x x
12	8	8	S 0 0 0 0 0 0 0	0 0 0 0 1 x x x
13	4	4	S 0 0 0 0 0 0 0	0 0 0 0 0 1 x x
14	2	2	S 0 0 0 0 0 0 0	0 0 0 0 0 0 1 x
15	1	1	S 0 0 0 0 0 0 0	0 0 0 0 0 0 0 1

Binary representation of input ranges

The input ranges represented in the following tables are defined in two's complement format.

Table 4- 16 Bipolar input ranges

Units	Measured value in %	Data word																Area
		2 ¹⁵	2 ¹⁴	2 ¹³	2 ¹²	2 ¹¹	2 ¹⁰	2 ⁹	2 ⁸	2 ⁷	2 ⁶	2 ⁵	2 ⁴	2 ³	2 ²	2 ¹	2 ⁰	
32767	> 118.515	0	1	1	1	1	1	1	1	1	1	1	1	1	1	1	1	Overflow
32511	117.589	0	1	1	1	1	1	1	0	1	1	1	1	1	1	1	1	Overshoot range
27649	> 100.004	0	1	1	0	1	1	0	0	0	0	0	0	0	0	0	1	
27648	100.000	0	1	1	0	1	1	0	0	0	0	0	0	0	0	0	0	Nominal range
1	0.003617	0	0	0	0	0	0	0	0	0	0	0	0	0	0	0	1	
0	0.000	0	0	0	0	0	0	0	0	0	0	0	0	0	0	0	0	
-1	-0.003617	1	1	1	1	1	1	1	1	1	1	1	1	1	1	1	1	
-27648	-100.000	1	0	0	1	0	1	0	0	0	0	0	0	0	0	0	0	
-27649	≤ -100.004	1	0	0	1	0	0	1	1	1	1	1	1	1	1	1	1	Undershoot range
-32512	-117.593	1	0	0	0	0	0	0	1	0	0	0	0	0	0	0	0	
-32768	≤ -117.596	1	0	0	0	0	0	0	0	0	0	0	0	0	0	0	0	Underflow

Table 4- 17 Unipolar input ranges

Units	Measured value in %	Data word																Area	
		2 ¹⁵	2 ¹⁴	2 ¹³	2 ¹²	2 ¹¹	2 ¹⁰	2 ⁹	2 ⁸	2 ⁷	2 ⁶	2 ⁵	2 ⁴	2 ³	2 ²	2 ¹	2 ⁰		
32,767	≥ 118.515	0	1	1	1	1	1	1	1	1	1	1	1	1	1	1	1	1	Overflow
32,511	117.589	0	1	1	1	1	1	1	0	1	1	1	1	1	1	1	1	1	Overshoot range
27,649	≥ 100.004	0	1	1	0	1	1	0	0	0	0	0	0	0	0	0	0	1	
27,648	100.000	0	1	1	0	1	1	0	0	0	0	0	0	0	0	0	0	0	Nominal range
1	0.003617	0	0	0	0	0	0	0	0	0	0	0	0	0	0	0	0	1	
0	0.000	0	0	0	0	0	0	0	0	0	0	0	0	0	0	0	0	0	
-1	-0.003617	1	1	1	1	1	1	1	1	1	1	1	1	1	1	1	1	1	Undershoot range
-4,864	-17.593	1	1	1	0	1	1	0	1	0	0	0	0	0	0	0	0	0	
-32,768	≤ -117.596	1	0	0	0	0	0	0	0	0	0	0	0	0	0	0	0	0	Underflow

Representation of analog values in voltage measuring ranges

Table 4- 18 Representation of analog values in the 0 to 10 V voltage measuring ranges

System			Voltage measurement range 0 to 10 V	
	Dec.	Hex.		
118.515%	32767	7FFF	11.852 V	Overflow
117.593%	32512	7F00		
117.589%	32511	7EFF	11.759 V	Overshoot range
	27,649	6C01		
100.000%	27,648	6C00	10 V	Nominal range
75%	20,736	5,100	7.5 V	
0.003617%	1	1	0 V + 361.7 μV	
0%	0	0	0 V	
	-1	FFFF	Negative values are not supported	Undershoot range
-17.593%	-4864	ED00		
	-4865	ECFF	Negative values are not supported	Underflow
≤ -17.596%	-32,768	8,000		

Representation of analog values for standard Pt 100/Pt 1000 resistance thermometers

Table 4- 19 Representation of analog values for Pt 100/Pt 1000 resistance thermometers

Pt x00 in °C (1 digit = 0.1 °C)	Units		Pt x00 in °F (1 digit = 0.1 °F)	Units		Pt x00 in K (1 digit = 0.1 K)	Units		Area
	Dec.	Hex.		Dec.	Hex.		Dec.	Hex.	
> 1000.0	32,767	7FFF	> 1832.0	32,767	7FFF	> 1273.2	32,767	7FFF	Overflow
1,000.0	10,000	2,710	1,832.0	18,320	4,790	1,273.2	12,732	31BC	Overshoot range
...	
850.1	8,501	2,135	1562.1	15,621	3D05	1,123.3	11,233	2BE1	Nominal range
850.0	8,500	2,134	1,562.0	15,620	3D04	1,123.2	11,232	2BE0	
...	Undershoot range
-200.0	-2,000	F830	-328.0	-3,280	F330	73.2	732	2DC	
-200.1	-2,001	F82F	-328.1	-3,281	F32F	73.1	731	2DB	Underflow
...	
-243.0	-2,430	F682	-405.4	-4,054	F02A	30.2	302	12E	
< -243.0	-32,768	8,000	< -405.4	-32,768	8,000	> 30.2	32,768	8,000	

Representation of analog values for thermocouple types J, K, L

Table 4- 20 Representation of analog values for type J thermocouples

Type J in °C	Units		Type J in °F	Units		Type J in K	Units		Area
	Dec.	Hex.		Dec.	Hex.		Dec.	Hex.	
> 1,450.0	32,767	7FFF	> 2,642.0	32,767	7FFF	> 1,723.2	32,767	7FFF	Overflow
1,450.0	14,500	38A4	2,642.0	26,420	6,734	1,723.2	17,232	4,350	Overshoot range
...	
1,201.0	12010	2EEA	21,93.8	21,938	55B2	1,474.2	14,742	3,996	Nominal range
1,200.0	12,000	2EE0	2,192.0	21,920	55A0	1,473.2	14,732	398C	
...	Underflow
-2,10.0	-2,100	F7CC	-346.0	-3,460	F27C	63.2	632	0278	
< -210.0	< -2,100	< F7CC	< -346.0	< -3,460	< F27C	< 63.2	< 632	< 0278	
Faulty wiring (polarity reversal or open inputs, for example) or encoder faults in in the negative range (wrong type of thermocouple, for example) will cause the input to signal undershooting of									
... F31C _H , and to output 8000 _H EA0C _H , and to output 8000 _H FDC8 _H , and to output 8000 _H .			

4.7 Creating a user program

Table 4- 21 Representation of analog values for type K thermocouples

Type K in °C	Units		Type K in °F	Units		Type K in K	Units		Area
	Dec.	Hex.		Dec.	Hex.		Dec.	Hex.	
> 1,622.0	32,767	7FFF	> 2,951.6	32,767	7FFF	> 1,895.2	32,767	7FFF	Overflow
1,622.0	16,220	3F5C	2,951.6	29,516	734C	1895.2	18,952	4A08	Overshoot range
...	
1,373.0	13,730	35A2	2,503.4	25,034	61CA	1646.2	16,462	404E	
1,372.0	13,720	3598	2,501.6	25,061	61B8	1,645.2	16,452	4,044	Nominal range
...	
-270.0	-2,700	F574	-454.0	-4,540	EE44	0	0	0000	
< -270.0	< -2,700	< F574	< -454.0	< -4540	< EE44	< 0	< 0	<0000	Underflow
Faulty wiring (polarity reversal or open inputs, for example) or encoder faults in in the negative range (wrong type of thermocouple, for example) will cause the input to signal undershooting of									
... F0C4 _H , and to output 8000 _H E5D4 _H , and to output 8000 _H FB70 _H , and to output 8000 _H .			

Table 4- 22 Representation of analog values for type L thermocouples

Type L in °C	Units		Type L in °F	Units		Type L in K	Units		Area
	Dec.	Hex.		Dec.	Hex.		Dec.	Hex.	
> 1,150.0	32,767	7FFF	> 2,102.0	32,767	7FFF	> 1,423.2	32,767	7FFF	Overflow
1,150.0	11,500	2CEC	2,102.0	21,020	521C	1,423.2	14,232	3,798	Overshoot range
...	
901.0	9,010	2,332	1,653.8	16,538	409A	1,174.2	11,742	2DDE	
900.0	9,000	2,328	1,652.0	16,520	4,088	1,173.2	11,732	2DD4	Nominal range
...	
-200.0	-2,000	F830	-328.0	-3,280	F330	73.2	732	02DC	
< -200.0	< -2,000	< F830	< -328.0	< -3,280	< F330	< 73.2	< 732	< 02DC	Underflow
Faulty wiring (polarity reversal or open inputs, for example) or encoder faults in in the negative range (wrong type of thermocouple, for example) will cause the input to signal undershooting of									
... F380 _H , and to output 8000 _H EAC0 _H , and to output 8000 _H FE2C _H , and to output 8000 _H .			

Representation of analog values for analog output channels

The following table contains the binary representation of the output values.

Since the binary representation of the output values is always the same, the "Representation of analog values in the ±10 V output range" table only contains the comparison of the output ranges with the units.

Binary representation of output ranges

The output ranges represented in the following table are defined in two's complement format.

Table 4- 23 Bipolar output ranges

Units	Measured value in %	Data word															Area																																																																																																																																																																		
		2 ¹⁵	2 ¹⁴	2 ¹³	2 ¹²	2 ¹¹	2 ¹⁰	2 ⁹	2 ⁸	2 ⁷	2 ⁶	2 ⁵	2 ⁴	2 ³	2 ²	2 ¹		2 ⁰																																																																																																																																																																	
≥ 32,512	0	0	1	1	1	1	1	1	1	1	x	x	x	x	x	x	x	Overflow																																																																																																																																																																	
32,511	117.589	0	1	1	1	1	1	1	0	1	1	1	1	1	1	1	1	27649	≥ 100.004	0	1	1	0	1	1	0	0	0	0	0	0	0	0	0	1	27,648	100.000	0	1	1	0	1	1	0	0	0	0	0	0	0	0	0	0	1	0.003617	0	0	0	0	0	0	0	0	0	0	0	0	0	0	0	1	0	0.000	0	0	0	0	0	0	0	0	0	0	0	0	0	0	0	0	-1	-0.003617	1	1	1	1	1	1	1	1	1	1	1	1	1	1	1	1	-27,648	-100.000	1	0	0	1	0	1	0	0	0	0	0	0	0	0	0	0	-27,649	≤ 100.004	1	0	0	1	0	0	1	1	1	1	1	1	1	1	1	1	-32,512	-117.593	1	0	0	0	0	0	0	0	1	0	0	0	0	0	0	0	≤ 32,513	0	1	0	0	0	0	0	0	0	0	x	x	x	x	x	x	Underflow
27649	≥ 100.004	0	1	1	0	1	1	0	0	0	0	0	0	0	0	0	1	27,648	100.000	0	1	1	0	1	1	0	0	0	0	0	0	0	0	0	0	1	0.003617	0	0	0	0	0	0	0	0	0	0	0	0	0	0	0	1	0	0.000	0	0	0	0	0	0	0	0	0	0	0	0	0	0	0	0	-1	-0.003617	1	1	1	1	1	1	1	1	1	1	1	1	1	1	1	1	-27,648	-100.000	1	0	0	1	0	1	0	0	0	0	0	0	0	0	0	0	-27,649	≤ 100.004	1	0	0	1	0	0	1	1	1	1	1	1	1	1	1	1	-32,512	-117.593	1	0	0	0	0	0	0	0	1	0	0	0	0	0	0	0	≤ 32,513	0	1	0	0	0	0	0	0	0	0	x	x	x	x	x	x	Underflow																		
27,648	100.000	0	1	1	0	1	1	0	0	0	0	0	0	0	0	0	0	1	0.003617	0	0	0	0	0	0	0	0	0	0	0	0	0	0	0	1	0	0.000	0	0	0	0	0	0	0	0	0	0	0	0	0	0	0	0	-1	-0.003617	1	1	1	1	1	1	1	1	1	1	1	1	1	1	1	1	-27,648	-100.000	1	0	0	1	0	1	0	0	0	0	0	0	0	0	0	0	-27,649	≤ 100.004	1	0	0	1	0	0	1	1	1	1	1	1	1	1	1	1	-32,512	-117.593	1	0	0	0	0	0	0	0	1	0	0	0	0	0	0	0	≤ 32,513	0	1	0	0	0	0	0	0	0	0	x	x	x	x	x	x	Underflow																																				
1	0.003617	0	0	0	0	0	0	0	0	0	0	0	0	0	0	0	1	0	0.000	0	0	0	0	0	0	0	0	0	0	0	0	0	0	0	0	-1	-0.003617	1	1	1	1	1	1	1	1	1	1	1	1	1	1	1	1	-27,648	-100.000	1	0	0	1	0	1	0	0	0	0	0	0	0	0	0	0	-27,649	≤ 100.004	1	0	0	1	0	0	1	1	1	1	1	1	1	1	1	1	-32,512	-117.593	1	0	0	0	0	0	0	0	1	0	0	0	0	0	0	0	≤ 32,513	0	1	0	0	0	0	0	0	0	0	x	x	x	x	x	x	Underflow																																																						
0	0.000	0	0	0	0	0	0	0	0	0	0	0	0	0	0	0	0	-1	-0.003617	1	1	1	1	1	1	1	1	1	1	1	1	1	1	1	1	-27,648	-100.000	1	0	0	1	0	1	0	0	0	0	0	0	0	0	0	0	-27,649	≤ 100.004	1	0	0	1	0	0	1	1	1	1	1	1	1	1	1	1	-32,512	-117.593	1	0	0	0	0	0	0	0	1	0	0	0	0	0	0	0	≤ 32,513	0	1	0	0	0	0	0	0	0	0	x	x	x	x	x	x	Underflow																																																																								
-1	-0.003617	1	1	1	1	1	1	1	1	1	1	1	1	1	1	1	1	-27,648	-100.000	1	0	0	1	0	1	0	0	0	0	0	0	0	0	0	0	-27,649	≤ 100.004	1	0	0	1	0	0	1	1	1	1	1	1	1	1	1	1	-32,512	-117.593	1	0	0	0	0	0	0	0	1	0	0	0	0	0	0	0	≤ 32,513	0	1	0	0	0	0	0	0	0	0	x	x	x	x	x	x	Underflow																																																																																										
-27,648	-100.000	1	0	0	1	0	1	0	0	0	0	0	0	0	0	0	0	-27,649	≤ 100.004	1	0	0	1	0	0	1	1	1	1	1	1	1	1	1	1	-32,512	-117.593	1	0	0	0	0	0	0	0	1	0	0	0	0	0	0	0	≤ 32,513	0	1	0	0	0	0	0	0	0	0	x	x	x	x	x	x	Underflow																																																																																																												
-27,649	≤ 100.004	1	0	0	1	0	0	1	1	1	1	1	1	1	1	1	1	-32,512	-117.593	1	0	0	0	0	0	0	0	1	0	0	0	0	0	0	0	≤ 32,513	0	1	0	0	0	0	0	0	0	0	x	x	x	x	x	x	Underflow																																																																																																																														
-32,512	-117.593	1	0	0	0	0	0	0	0	1	0	0	0	0	0	0	0	≤ 32,513	0	1	0	0	0	0	0	0	0	0	x	x	x	x	x	x	Underflow																																																																																																																																																
≤ 32,513	0	1	0	0	0	0	0	0	0	0	x	x	x	x	x	x	Underflow																																																																																																																																																																		

Representation of analog values in the voltage output ranges

Table 4- 24 Representation of analog values in the ±10 V output range

System			±10 V voltage measurement range	
	Dec.	Hex.		
118.515%	32,767	7FFF	0.00 V	Overflow, off power
	32,512	7F00		
117.589%	32,511	7EFF	11.76 V	Overshoot range
	27,649	6C01		
100%	27,648	6C00	10 V	Nominal range
75%	20,736	5,100	7.5 V	
0.003617%	1	1	361.7 μV	
0%	0	0	0 V	
	-1	FFFF	-361.7 μV	
-75%	-20,736	AF00	-7.5 V	
-100%	-27,648	9,400	-10 V	
	-27,649	93FF		
-117.593%	-32,512	8,100	-11.76 V	Undershoot range
	-32513	80FF		
-118.519%	-32,768	8,000	0.00 V	Underflow, no power

4.7.4 Activating the outputs

Once the device has been switched on, and in fatal fault scenarios, all outputs are switched to the safe state. Following this, they can only be controlled from the application if they have been activated.

Procedure

SIMOTION E510 uses the "Data set ready" status bit to indicate when the powering up process is complete or the fault has been dealt with. The outputs can then be activated with a rising edge at the "Enable I/O" control bit.

The table below shows the bit assignment for control word 1 (STW1).

Table 4- 25 Control word 1 (STW1)

Bit 15 to bit 4	Bit 7	Bit 6 to bit 4	Bit 3	Bit 2	Bit 1	Bit 0
Reserved	Fault: Reset time-out ¹⁾	Reserved	Enable I/O ¹⁾	Reserved	Reserved	Reserved

¹⁾ Enabled when the bit is set (0/1 edge)

The table below shows the bit assignment for status word 1 (ZSW1).

Table 4- 26 Status word 1 (ZSW1)

Bit 15 to bit 4	Bit 3	Bit 2	Bit 1	Bit 0
Reserved	Fault: Time-out	Reserved	Data set ready	Reserved

Example program for activating the outputs

This example features the "unLook" program, which is used to activate the outputs.

You can find the example, including an ST source file, in an FAQ format on the Internet at:

<http://support.automation.siemens.com/WW/view/en/21650215>

You must carry out the following steps in order to apply the example:

1. Assign parameters

Set the I/O areas:

- DIGITAL 32DI/48DO: E.g. input: 400 to 403; output: 400 to 421 (or any other range not in use)
- IM 8AI/8AO/16TC/4CNT: E.g. input: 500 to 567; output: 500...535

2. Link programs to the execution system

Assign the program to the following task:

"unLook" → **BackgroundTask**

3. Create the I/O variables in the symbol browser of SIMOTION SCOUT

Create the following I/O variables:

- bm_stw1 (e.g. PQW500)
- bm_zsw1 (e.g. PIW500)

For information on the status word (bma_zsw1) and the control word (bma_stw1), see the table "Logic addressing offsets for inputs and outputs (basic and head modules)" in the section titled "Logic addressing for inputs and outputs", head module I address, ZSW1 (status word), or head module O address, STW1 (control word).

Table 4- 27 Example program for activating the outputs

```
INTERFACE
    PROGRAM unLook
END_INTERFACE

IMPLEMENTATION
    PROGRAM unLook
        //If device-ready is FALSE set output-enable to FALSE
        IF ((bm_zsw1 AND 16#0002) <> 16#0002) THEN;
            bm_stw1 := (bm_stw1 AND 16#FFF7);
        //If device-ready is TRUE set output-enable to TRUE
        ELSE
            bm_stw1 := (bm_stw1 OR 16#0008);
        END_IF;
    END_PROGRAM
END_IMPLEMENTATION
```

4.7.5 Time synchronization for time-controlled outputs (on request) and sign-of-life monitoring

It is only possible to maintain a common system time for the DP master and DP slave in terms of switching the time-controlled outputs if this time has been synchronized. This requires the central GC (global control) clock signal and the constant bus cycle time to be set.

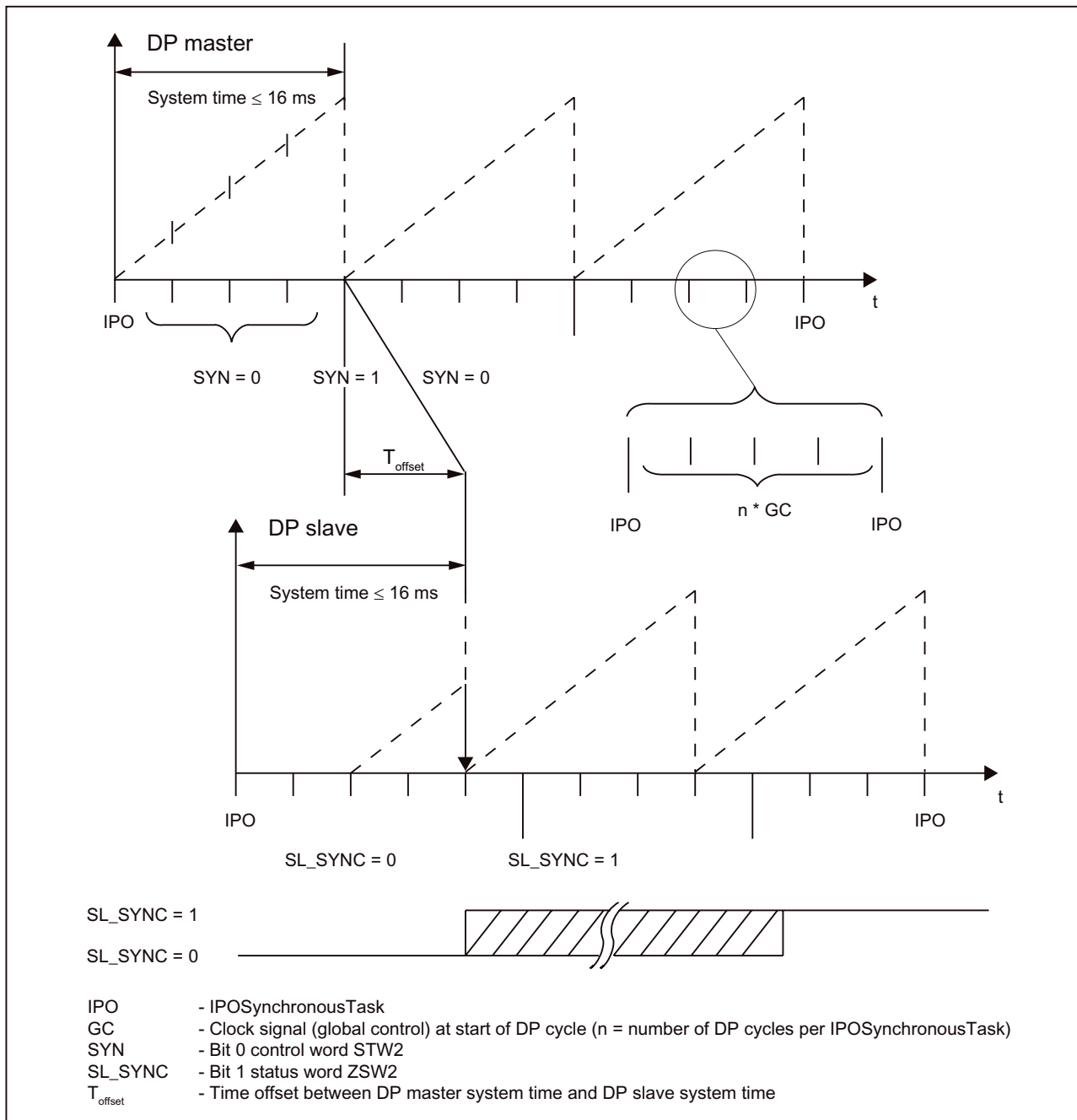

Figure 4-3 Time synchronization for time-controlled outputs

Formula for calculating system times:

System time = [rounding down (64,000/IPO cycle)] * IPO cycle

One increment of the system time = 0.25 µs

The table below contains the maximum system time based on the IPO cycle.

Table 4- 28 Maximum system time based on the IPO cycle

IPO cycle [ms]	Max. system time [ms]	IPO cycle [ms]	Max. system time [ms]	IPO cycle [ms]	Max. system time [ms]
0.5 ¹⁾	16.00	3.25	16.25	6.00	12.00
0.75 ¹⁾	15.75	3.50	14.00	6.25	12.50
1.00	16.00	3.75	15.00	6.50	13.00
1.25	16.25	4.00	16.00	6.75	13.50
1.50	15.00	4.25	12.75	7.00	14.00
1.75	15.75	4.50	13.50	7.25	14.50
2.00	16.00	4.75	14.25	7.50	15.00
2.25	15.75	5.00	15.00	7.75	15.50
2.50	15.00	5.25	15.75	8.00	16.00
2.75	13.75	5.50	11.00	-	-
3.00	15.00	5.75	11.50	-	-

¹⁾ Not supported by SIMOTION E510

DP master/DP slave sign of life

Once the system has been powered up, the DP master must manage an MSL (master sign of life) in the user program. The sign of life is a value between 1 and 15 (4 bits) which is transferred to bits 15 to 12 in control word 2 (STW2). In the first cycle, counting must begin with a value not equal to zero. In each DP cycle, the master increments its sign of life and sends it to the slave.

As soon as the DP slave is supplied with output data on a cyclic basis (DP master is in RUN mode), the slave starts to manage its own SSL (slave sign of life). This can be read out in the DP master's user program. After the DP slave has received a correct sign of life from the DP master for a period of 16 cycles, it becomes synchronized with the DP master (SL_SYNC = 1, if SYN = 1).

Note

The position control cycle clock and interpolator cycle clock may last longer than one DP cycle. This does not determine the DP cycle in which data will be exchanged.

The table below shows the bit assignment for control word 2 (STW2).

Table 4- 29 Control word 2

Bit 15	Bit 14	Bit 13	Bit 12	Bit 11 to bit 1	Bit 0
MSL (DP master sign of life)				Reserved	SYN

The table below shows the bit assignment for status word 2 (ZSW2).

Table 4- 30 Status word 2

Bit 15	Bit 14	Bit 13	Bit 12	Bit 11 to bit 2	Bit 1	Bit 0
SSL (DP slave sign of life)				Reserved	SL_SYNC	Reserved

Synchronization

If the constant bus cycle time is used on PROFIBUS DP, SIMOTION E510 must be synchronized with the DP master. This means that a DP master sign of life (see the description under "DP master/DP slave sign of life") must be generated by an isochronous user program (as an IPOSynchronousTask, for example) and a rotating system time must be managed. The system time (see above figure) is required for setting the **SYN** bit during synchronization.

Once **RUN** mode has been entered, the DP slave starts by synchronizing with the DP master (slave to master synchronization). Provided that the **SYN** has been set, the DP slave becomes synchronized with the DP master (**SYL_SYNC**) after one sign-of-life rotation has been completed without errors, or possibly even earlier.

The DP slave controls the DP master's sign of life. The sign of life must increase by 1 with every cycle of the user program (IPOSynchronousTask). A count is kept of the number of failed increments.

Each fault causes the fault counter to increase by 10. If a threshold of 50 faults is reached, the application is considered to have failed and the "Communication fault" diagnostic interrupt will be output.

After a temporary failure of the incrementing process (fewer than 5 faults), the fault counter reduces by 1 with every correctly received sign of life.

As long as the **SL_SYNC** bit is equal to 1, the system times for the DP master and DP slave will run in parallel. The absolute point in time for synchronization is randomly determined. If the **SL_SYNC** bit is equal to 0, synchronization must be performed again.

Following synchronization, a number of seconds may elapse before "Communication fault" ceases to be displayed.

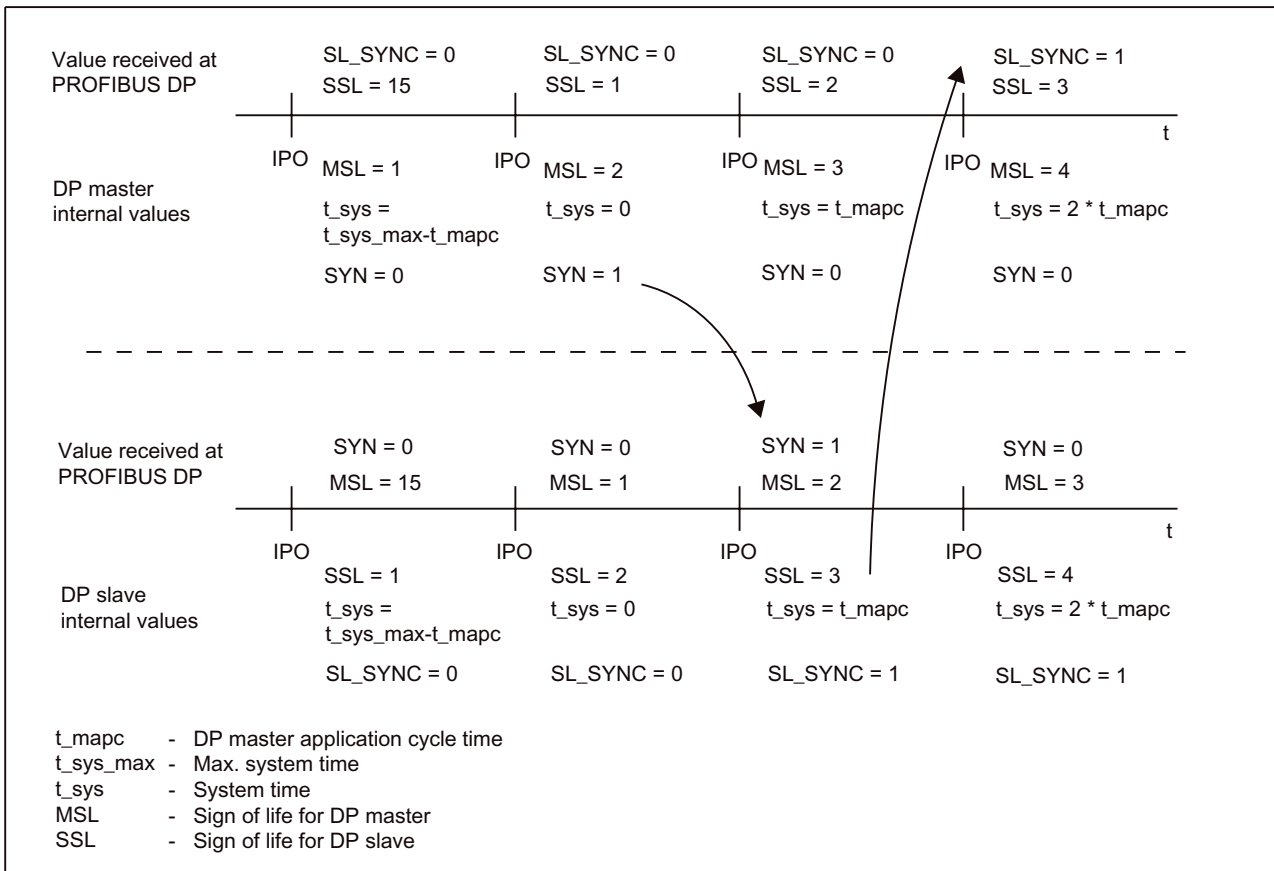

Figure 4-4 Synchronization of DP master/DP slave

Example program for synchronizing the system time between the DP master and DP slave

The example contains 3 programs.

- "startUp" program: This program is used to initialize the system time and the sign-of-life information.
- "periFault" program: Diagnostic messages (e.g. interrupts) from SIMOTION E510 should be processed in this program.
- "time_handling" program: This program updates the system time and the DP master sign of life. The current values are entered in control word 2 of SIMOTION E510. A check is performed to establish whether the DP slave has been synchronized.

You can find the example, including an ST source file, in an FAQ format on the Internet at: <http://support.automation.siemens.com/WW/view/en/21650215>

You must carry out the following steps in order to apply the example:

You will need to have created a project with equidistant PROFIBUS DP (see section titled "Commissioning requirements").

1. Assign parameters

Set the I/O areas:

- DIGITAL 32DI/48DO: E.g. input: 400 to 403; output: 400 to 421 (or any other range not in use)
- IM 8AI/8AO/16TC/4CNT: E.g. input: 500 to 567; output: 500...535

2. Link programs to the execution system

Assign the programs to the task as follows:

- "startUp" **StartupTask**
- "periFault" **PeripheralFaultTask**
- "time_handling" **IPOSynchronousTask**

3. Create the I/O variables in the symbol browser of SIMOTION SCOUT

Create the following I/O variables:

- bm_stw2 E.g. PQW502
- bm_stw2 E.g. PIW502

For information on the status word (bma_zsw2) and the control word (bma_stw2), see the table "Logic addressing offsets for inputs and outputs (basic and head modules)" in the section titled "Logic addressing for inputs and outputs", head module I address, ZSW2 (status word), or head module O address, STW2 (control word).

Note

The SIMOTION E510 **position control cycle clock** and **interpolator cycle clock** parameters must match the cycles set in SIMOTION SCOUT (see the description of the parameters for an example). Interpolator cycle clocks of > 8 ms are not supported by SIMOTION E510.

Refer to the *SIMOTION SCOUT/3/* Configuration Manual or the SIMOTION SCOUT online help.

Table 4- 31 Example program for synchronizing the system time between the DP master and DP slave

```

UNIT sync;
INTERFACE

PROGRAM startUp;
PROGRAM Time_Handling;
PROGRAM periFault;

VAR_GLOBAL
    msl      :UINT      :=0;           // master sign of life
    sl_sync  :BOOL      :=FALSE;      // synchronization state of slave
    max_cycle :UINT      :=0;           // maximum number of application
                                           // cycles per systemtime cycle
    ipo      :UINT      :=0;           // ration between iposynchronousTask
                                           // and PROFIBUS DP
    t_apcyc  :UINT      :=0;           // length of one application cycle in
                                           // steps of 0.25 µs
    t_sys_time :UINT     :=0;           // actual value of systemtime
    cycle     :UINT      :=0;           // actual cycle
END_VAR
END_INTERFACE
    
```

```

IMPLEMENTATION
PROGRAM startUp
  // init the global vars
  msl      :=0;

  // ipo = ratio between system clock/PROFIBUS DP and ipoclock
  // (iposynchronousTask)
  ipo      :=DINT_TO_UINT (ipoClock / systemClock);

  // determine the cycle time in steps of 0.25 ms
  t_apcyc  :=DINT_TO_UINT (systemClock*4*ipo);

  // determine the number of cycles per system time cycle
  max_cycle :=TRUNC(64000 / t_apcyc);

  // slave has not synchronized yet
  sl_sync  :=FALSE;

  // set system time to first value
  t_sys_time :=16#0001;

  // start with first cycle
  cycle    :=0;
END_PROGRAM

PROGRAM periFault
  // write your error handling routine here (for example if synchronization has
  //failed)
  ;
END_PROGRAM

PROGRAM Time_Handling
  //increment master sign of life mod 16
  msl:=msl+16#1000;
  IF (msl=0) THEN
    // msl must have value between 1 and 15
    msl:=16#1000;
  END_IF;

  //send new msl to slave
  bm_stw2:= (bm_stw2 AND 16#0FFF) OR UINT_TO_WORD (msl);

  // run next cycle
  cycle:=cycle+1;

  // check if actual cycle has reached maximum
  IF (cycle>=max_cycle) THEN
    // yes
    bm_stw2:= (bm_stw2 OR 16#0001); // set SYN bit if time wrapped around
    cycle:=0; // reset actual cycle number
    t_sys_time:=1; // reset system time
  ELSE
    // no
    t_sys_time:=t_sys_time+t_apcyc; // increment system time by time of one
    //application cycle
    bm_stw2:= (bm_stw2 AND 16#FFFE); // clear SYN bit
  END_IF;

```

```

//check if SL_SYNC bit was set
IF ((bm_zsw2 AND 16#0002)=16#0002) THEN
// yes => slave has reached synchronous state
sl_sync:=TRUE;
ELSE
// no => slave has not synchronized yet
sl_sync:=FALSE;
END_IF;
END_PROGRAM

```

```
END_IMPLEMENTATION
```

Time-controlled output (digital outputs; function on request)

The point in time for output ($T_{\text{Time_DO}}$) is determined by the **DigitalTime0** to **DigitalTime7** cyclic output data (see the "Logic addressing offsets for inputs and outputs (basic and head modules)" table in the section titled "Logic addressing for inputs and outputs"). One increment of **DigitalTime0 to 7** amounts to 0.25 μs . With SIMOTION E510, the resolution used for **DigitalTime0 to 7** is shortened to 64 μs (equates to 256 increments). This means, for example, that a value of 333 will be treated as 256. Values of 512 and higher only appear in the next time window.

The user program calculates points in time (in terms of the system time) at which it wishes to change the status at a time-controlled output. If periods longer than the maximum system time need to be bridged (see the table "Maximum system time based on the IPO cycle"), the user program will have to carry out higher-level time counting. This involves using the value for the maximum system time as the smallest time unit. The user program derives a timer value from its calculations, which corresponds to a specific system time status.

The DP slave must receive the timer value no later than one DP cycle before the output. If there is a delay in transmitting the timer, an output can no longer be guaranteed to be free from errors and will be deferred by a period equal to the maximum system time. The DP slave is not able to check for such scenarios, as a "far-sighted" output of this kind may also represent a desired action.

Timer values may be updated (overwritten) with each data output until one cycle before the output.

Entering a value of 0 into the timer causes the current DOx output value, together with all the "normal" outputs, to be output at time T_0 . The system time never reaches values between the maximum system time and **MAX_INT** (65,535), which means there is no status change at the output.

If the system time reaches one of the timer values, the setpoint currently present at the associated DOx output will be output.

Each output at which time control is activated is sequentially assigned to one of the cyclic values **DigitalTime0 to 7**. Timers which have not been activated remain unused.

Example program for using SIMOTION E510 time-controlled outputs:

Task description:

Digital outputs DO0 to DO7 are used as time-controlled outputs. The purpose of the example is to switch output DO2 after a trigger event has been detected. The time between the input signal and output signal is determined by the value of **time_t1**. Output DO3 should switch in the period from **time_t2** to DO2. This time can also be set by the user (see the figure "Wiring and block diagram for the basic module's DI 32, 24 VDC digital input block" in the section titled "Wiring and block diagrams for devices with a head module and basic module", and the table "Logic addressing offsets for inputs and outputs (basic and head modules)" in the section titled "Logic addressing for inputs and outputs").

Framework conditions:

- There is a minimum switching time of two DP cycles, with the maximum time only being limited by the LREAL data type.
- Repeat accuracy is reduced in the case of very large switching times, as deviations for each DP cycle have already accumulated in the DP master's hardware.
- Switching times **time_t1** and **time_t2** are specified in ms (conversion to the internal form of representation takes place in the program).
- The program must be entered as **IPOSynchronousTask** after the **Sync** program to ensure that the current system time is always used.
- The program can only be executed correctly if there is a pulse-duty factor of 1:1:1 (no level overflows) in each case.

You must carry out the following steps in order to apply the example:

You will need to have created a project with equidistant PROFIBUS DP (see section titled "Commissioning requirements").

1. Assign parameters

- Set the DP cycle within the range between 1 ms and 5.25 ms.
- Set the I/O areas:

DIGITAL 32DI/48DO: E.g. input: 400 to 403; output: 400 to 421 (or any other range not in use)

IM 8AI/8AO/16TC/4CNT: E.g. input: 500 to 567; output: 500 to 535

2. Link programs to the execution system

- Assign the programs to the tasks as follows:

"TimeDO.TimeStartUp" **StartupTask**
"TimeDO.TimeOutput" **IPOSynchronousTask**

Note: The "TimeDO.TimeOutput" program must be entered after the synchronization program (sync.st).

- Set the clocking factor for PROFIBUS DP: position control cycle clock: interpolator cycle clock to 1:1:1.

3. Create the I/O variables in the symbol browser of SIMOTION SCOUT

- Create the following I/O variables:
 - bmd_timer2 (e.g. PQW404, timer value for digital output DO2)
 - bmd_timer3 (e.g. PQW406, timer value for digital output DO3)
 - bmd_tdo0 (e.g. PQW416, digital outputs DO7 to DO0)
 - bmd_tdo2 (e.g. PQW418, digital outputs DO23 to D16)
- Outputs DO2, DO3, and DO17 are used for the example. DO17 is only used to output the trigger event so that the output process can be checked with an oscilloscope.

4. Update in the source text

Note: You need to enter the **To time** (unit is 1 ms) from the hardware configuration in the "TimeDO" program under the **time_To** variable (unit is 1 μ s).

- Save and compile the project.
- Transfer the project to the DP master.
- Switch the DP master to RUN.
- If you would like different switching times from those specified in the example, you will need to enter these under the **time_t1** and **time_t2** variables (global variables of the "TimeOutput" program).

5. Operate the example program

- After the DP master has been switched from STOP to RUN, the **test_running** variable is set to FALSE and the program waits for the **test_start** variable to be set to TRUE (this is automatically reset to FALSE again). If this action is performed, the program will be in the **test_state** 0 and will check whether the **trigger** variable is TRUE. If you are not using your own trigger condition, the condition for the example will always be fulfilled (**trigger** will always be TRUE). As soon as the above condition is fulfilled, the time-controlled output process is executed once and **test_running** is reset to FALSE. If you wish to start executing the process again, you will need to reset the "TimeOutput" program's **test_start** global variable to TRUE in the symbol browser. The **test_start** variable reinitializes the test and checks for the trigger condition once more.
- If you wish to use a different condition or query as the start event (for example, when a specific extrapolation value is reached), you will have to replace the **trigger** variable accordingly with your own condition or query.

Table 4- 32 Example program "TimeDO.st" for using SIMOTION E510 time-controlled outputs

```

INTERFACE
  USES sync;

  PROGRAM TimeOutput;
  PROGRAM TimeStartUp;

  VAR_GLOBAL
    // time in ms (including post decimal positions)
    time_t1:LREAL          :=11.75;
    time_t2:LREAL          :=4.15;

    forerun:DINT           :=0;    // when data should be transmitted to
                                   // SIMOTION E510

    // remaining time of output event1 and output event2
    macro_timer_t1:DINT    :=0;
    macro_timer_t2:DINT    :=0;

    // time of signal switch on output in relation to system time
    out_time1:DINT         :=0;
    out_time2:DINT         :=0;

    test_start:BOOL        :=FALSE;
    test_running:BOOL      :=FALSE;
    test_state:UINT        :=0;
    time_To:DINT           :=1250;    // output time of "normal" outputs
                                   // in ms (same as in HW Config)

    trigger:BOOL           :=TRUE;
    post_cycle:INT;
  END_VAR

END_INTERFACE

IMPLEMENTATION

  PROGRAM TimeStartUp
    // time of forerun
    forerun:=(systemclock+time_To)*4;
    test_state:=0;
    test_running:=FALSE;
    test_start:=FALSE;
  END_PROGRAM

  PROGRAM TimeOutput

  // problem:
  // - switch two time-controlled outputs with the following correlations
  // - first output (here we assume DO0.2) switches after a gap of time_t1 after a
  //   trigger
  // - event (for example switching of a normal output (here we assume DO17
  //   without time function))
  // - second output (here DO0.3) switches after a gap of time_t2 after output 1

  // conditions:
  // - task ratio DP:SERVO:IPO is set to 1:1:1
  // - the program TimeOutput runs as IPOSynchronousTask
  // - the program StartUp runs as StartUpTask
  // - the time-controlled outputs DO0.2 and DO0.3 are activated and the related timers
  //   are timer2 and timer3

    // start one test if wanted and no other test remaining

```

```

IF ((TRUE=test_start) AND (FALSE=test_running)) THEN
  test_running:=TRUE;
  test_state:=0;
  test_start:=FALSE;

  // set outputs to initial values/level
  bmd_timer2:=0; //output the value immediately
  bmd_timer3:=0; //output the value immediately
  bmd_tdo0:=bmd_tdo0 AND 16#F3;
ELSE
  IF (TRUE = test_running) THEN
    IF (0=test_state) THEN
      // check for trigger condition (here it is always fulfilled)
      IF (TRUE = trigger) THEN
        // set the macro timer for the outputs (increments of 0.25 ms)

        // conversion of the example input values time_t1 and
        // time_t2 (in ms)
        macro_timer_t1:=LREAL_TO_DINT(time_t1*1000*4)+time_To*4;
        macro_timer_t2:=macro_timer_t1+LREAL_TO_DINT(time_t2*1000*4);

        // output the simulated trigger signal on DO17 (offset of
        // trigger to Tdp is To)
        bmd_tdo2:=bmd_tdo2 OR 16#02;

        // set timers to a correct output time (to avoid conflicts
        // with DP cycles greater than 5.25 ms) => don't change the
        // output itself till macro timer has expired
        bmd_timer2:=1;
        bmd_timer3:=1;

        // switch to next state
        test_state:=1;
      END_IF;
    END_IF;
  END_IF;

  IF (1=test_state) THEN
    // check if enough time of macro timer 1 has elapsed, that values
    // can be set now
    IF (macro_timer_t1>=forerun) THEN
      // no=> subtract one IPO cycle from the macro timer
      // (in increments of 0.25 ms)
      macro_timer_t1:=macro_timer_t1-t_apcyc;
      macro_timer_t2:=macro_timer_t2-t_apcyc;
    ELSE
      // yes => calculate the output time and send the data
      // to SIMOTION E510

      // calculate the output time in relation to actual system time
      out_time1:=t_sys_time+macro_timer_t1;

      // check for overrun of maximum time
      IF (out_time1>=(max_cycle*t_apcyc)) THEN
        // decrease the timer value (because system time
        // doesn't run up to 2^16=65536 => else loss of precision)
        out_time1:=out_time1-(max_cycle*t_apcyc);
      END_IF;

      // set value of I/O variable
      bmd_timer2:=DINT_TO_WORD (out_time1);

      // set new level of DO0.2
      bmd_tdo0:=bmd_tdo0 OR 16#04;
    END_IF;
  END_IF;

```



```

        // switch to next state
        test_state:=2;

    END_IF;
END_IF;

IF (2=test_state) THEN
    // check if enough time of macro timer 2 has elapsed, that values
    // can be set now
    IF (macro_timer_t2>=forerun) THEN
        // no=> subtract one IPO cycle from the macro timer
        // (in increments of 0.25 ms)
        macro_timer_t2:=macro_timer_t2-t_apcyc;
    ELSE
        // yes => calculate the output time and send the data
        // to SIMOTION E510

        // calculate the output time in relation to actual system time
        out_time2:=t_sys_time+macro_timer_t2;

        // check for overrun of maximum time
        IF (out_time2>=(max_cycle*t_apcyc)) THEN
            // decrease the timer value (because system time
            // doesn't run upto 2^16=65536 => else loss of precision)
            out_time2:=out_time2-(max_cycle*t_apcyc);
        END_IF;

        // set value of I/O variable
        bmd_timer3:=DINT_TO_WORD (out_time2);

        // set new level of D00.3
        bmd_tdo0:=bmd_tdo0 OR 16#08;

        // both outputs have been handled now

        // switch to next state
        test_state:=3;
        post_cycle:=0;
    END_IF;
END_IF;

IF (3=test_state) THEN
    // ensure that the test can't be started twice
    IF (post_cycle>(2*max_cycle)) THEN
        // end of the test
        test_running:=FALSE;
        // reset the value of D017 to initial value
        bmd_tdo2:=bmd_tdo2 AND 16#FD;
    ELSE
        post_cycle:=post_cycle+1;
    END_IF;
END_IF;

END_IF;

END_IF;

END_PROGRAM

END_IMPLEMENTATION

```

Note

The SIMOTION E510 **position control cycle clock** and **interpolator cycle clock** parameters must match the cycles set in SIMOTION SCOUT (see the description of the parameters for an example).

Refer to the *SIMOTION SCOUT/3/* Configuration Manual or the SIMOTION SCOUT online help.

If you use the example with the parameters and variable settings specified below, the signal sequence shown will be generated at the outputs (measured with an oscilloscope).

- Parameters:
 - $T_{DP} = 8.00 \text{ ms}$
 - $T_o = 1.25 \text{ ms}$
 - $T_i = 0.5 \text{ ms}$
- Variables:
 - $\text{time_t1} = 11.75$
 - $\text{time_t2} = 4.15$

Channel assignment in figure:

- Channel 1 (CH1) = DO17
- Channel 2 (CH2) = DO2
- Channel 3 (CH3) = DO3
- T (rising edge of channel 1) = trigger event

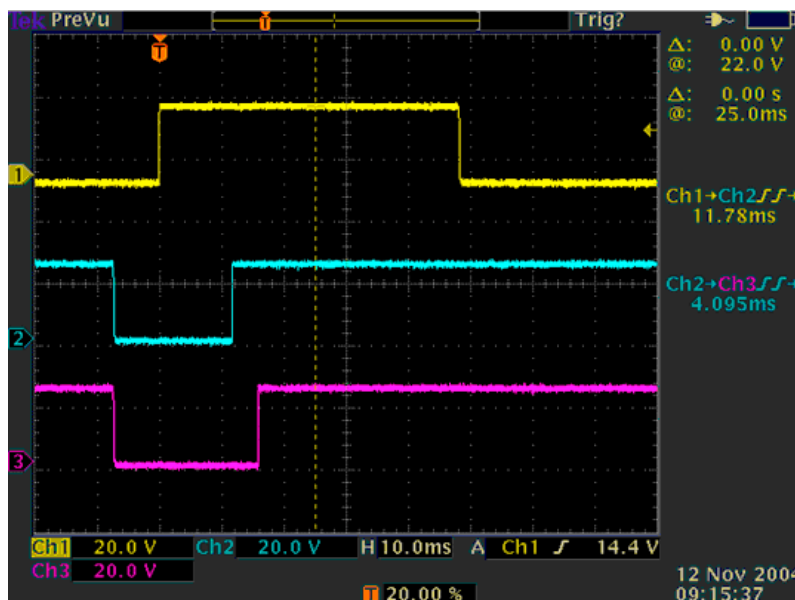

Figure 4-5 Example for time-controlled outputs

You will need to take account of the following restrictions when working with time-controlled outputs:

- To achieve the fastest possible output, the value **t_sys_time + To** (To = point in time for output) must be entered as the timer value for the other outputs, in increments of 0.25 μ s.
- The maximum system time is an integral multiple of 64 μ s. Integral multiples of 125 μ s are used for setting the DP cycle. This results in a rounding error, which is truncated to 0 each time the system time is reset.
- Entering values for **DigitalTime0 to 7** which are greater than the maximum system time causes the values of the time-controlled outputs to remain constant (1 remains as 1, 0 remains as 0).
- The program must be entered after the synchronization program in **IPOSynchronousTask**.
- The **signal level** at the output bit must be present at least until the switching instant (the application must ensure this is the case).
- Nesting (queuing) of events is not possible at an output. This type of queuing arrangement needs to be implemented on an individual application basis.
- Repeat accuracy reduces if long periods are bridged.
- Input signals with no time information are not suitable for switching time-controlled outputs, since an event at the input is only registered with a resolution of one DP cycle. If the time between an input and a directly assigned output is being measured, there will be a deviation of up to one DP cycle. Time-controlled outputs are suitable for use, particularly where extrapolations are involved, and where time differences to other outputs (switched with To) need to be implemented.
- Time-controlled outputs can only be used reliably where there is a pulse-duty factor of 1:1:1. Temporary operation is also possible with other pulse-duty factors, although unpredictable time delays (determined by the DP master's task system) occur at higher system loads.
- The output data (timer + value) must not be entered any later than ($T_{DP} + To$) before the output time. The output data must not be entered any earlier than ($T_{Timer_DO} - \text{maximum system time}$). This will result in a run-in (forerun) period during which the data should be entered in a meaningful way.

4.8 Downloading the user program to the DP master

The user program generated must be saved in SIMOTION SCOUT or SIMATIC Manager, then compiled and downloaded to the DP master.

Procedure in SIMOTION SCOUT

1. Select the **Project > Save and Compile All** menu command.
2. Establish the connection with the DP master by selecting **Project > Connect to Target System**.
3. Select **Project > Download** to download the user program to the DP master.

Procedure in SIMATIC Manager

1. Select **SIMATIC xxx > CPUxxx > S7 Program > Blocks** in SIMATIC Manager.
2. Use **Target System > Download** to download all the S7 blocks (as well as system data) contained here to your CPU (CPU in STOP state).

Service and maintenance

5.1 Firmware update

Overview

The firmware is already installed on delivery of SIMOTION E510. The user can install new versions via an update.

You can obtain firmware versions from your Siemens representative or by calling the hotline.

The update package consists of the following files:

- bg_abl.upd
- header.upd
- komp_1.upd

Note

When installing a new firmware version, the SIMOTION E510 project generated must be backed up to a data carrier before executing the firmware update.

Requirements

The requirements for executing firmware updates are as follows:

- SIMOTION E510 and the PG/PC must be in the same PROFIBUS DP segment.
- SIMOTION E510 must be configured and parameterized. There should be no bus faults present.
- The project **must** have been downloaded to the DP master without any errors occurring.
- For safety reasons, switch the DP master to **STOP** mode.

Firmware update

Proceed as follows:

1. Select the SIMOTION E510 module in **HW Config**.
2. Open the **Update Firmware** dialog box by selecting **Target System > Update Firmware ...**
3. Select the **Browse** button in this dialog box. The **Select File** window will open. Select the **header.upd** file in the window and open it.

The order number and firmware version will now appear in the **Update Firmware** dialog box.

4. Select **Activate firmware after download**.
5. Click the **Execute** button.

The module checks whether the order number and the version number are compatible. If these two numbers are compatible, the following message will appear:

"Firmware Rx.x.x has been successfully transferred to the SIMOTION_E510 module with order number 6AU1 510..."

6. Click **OK** to confirm this message. The firmware is downloaded to the module.

The following message will appear once the firmware update has been successfully completed:

"Firmware will be activated after the download is complete. If the associated CPU is in **RUN** mode, activating the firmware can lead to an access error or a CPU stop, which can cause the CPU to enter **STOP** mode."

7. Click **OK** to confirm the message. The module is rebooted.
8. Now switch the DP master back to **RUN** mode. You will then be able to run the module with the new firmware.

Reading out the firmware version

You can read out the current firmware version as follows:

1. Open the project as an online project by selecting **Station > Open Online** in the hardware configuration.
2. Double-click **E510** to open the "Module Information - SIMOTION E510" dialog box.
3. Select the "General" tab in this dialog box. The current version will be displayed here.

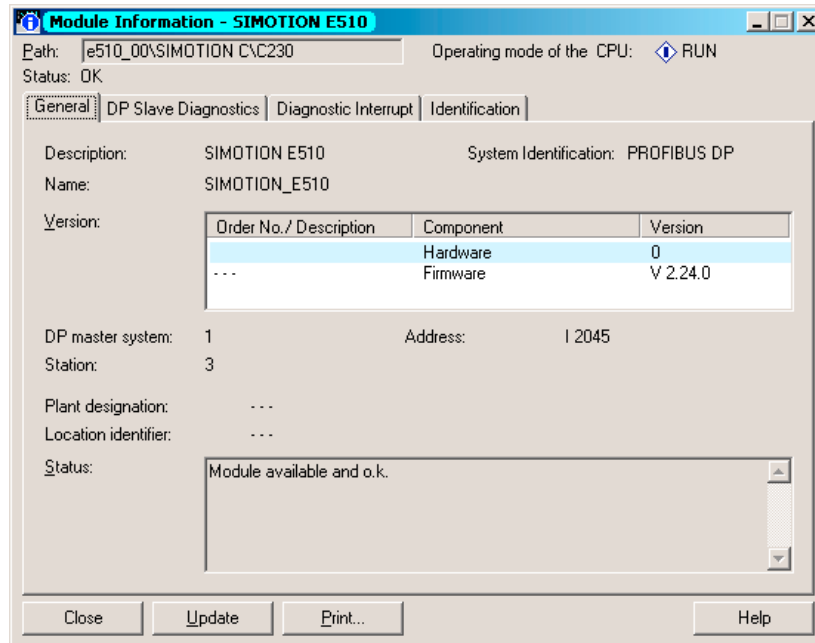

Figure 5-1 Reading out the firmware version

Firmware updates for expansion modules

If the firmware of the expansion modules is not compatible with the firmware of the head module, the firmware will be harmonized of its own accord the next time SIMOTION E510 is powered up. The "SF" LED on the head module will flash to show this process is taking place.

5.2 Removing and replacing the housing or modules

Requirements



WARNING

The **housing** or **modules** can only be replaced when the load power supply is switched off; therefore, switch off the power supply now.

Modules must **not** be removed or inserted when the power is on.

Removing a faulty module

Proceed as follows:

1. Unplug the connection to the connectors on the module to be removed.
Important: Do not pull on the cables; instead, use the connection element and its accessories to break the connection.
2. To disassemble a module, loosen the screws on its front panel using a Torx screwdriver (size 15). This enables the module to be lifted individually from the housing's plug connector.

Installing a new module

Proceed as follows:

1. Insert the new module into the housing (without twisting it) so that it slides into the punched guideway.
2. Align the module's plug connector with its counterpart on the housing. **Take care** to ensure the contacts of the plug connectors do not become deformed during this process.
3. Screw the module to the front plate of the housing using the captive screws.
The module is now ready for operation again and can be commissioned.
4. Switch the power supply on again.

Interrupts, error and system alarms

6.1 LED-based diagnostics

6.1.1 LEDs on the head module

LEDs on the head module

The status and fault indicators are explained in the order in which they are positioned on the head module.

Table 6- 1 Fault and status indicator

LED	Meaning	Explanations
SF (red) LED - ON LED - flashing (1 Hz) LED - OFF	Group fault (system fault)	This LED indicates a SIMOTION E510 fault. <ul style="list-style-type: none"> • One of the SIMOTION E510 modules is faulty (LED indicates which module is involved). • There is a wire break at one of the temperature inputs (at least). • Synchronization of system time or sign of life is faulty ("communication fault" interrupt). ¹⁾ Firmware updates for expansion modules are being executed. SIMOTION E510 is operating without error.
BF (red) LED - ON LED - flashing (0.5 Hz) LED - OFF	PROFIBUS DP fault (bus fault)	This LED indicates a fault on the PROFIBUS DP interface. Bus fault: Baud rate detection Parameterization fault: No cyclic data exchange Cyclic data exchange
AF (red) LED - ON LED - OFF	Analog fault	This LED indicates a fault with the analog inputs/outputs on the head module (IM). There is a fault with the analog inputs/outputs. Analog inputs/outputs are operating without error.

6.1 LED-based diagnostics

LED	Meaning	Explanations
TF (red) LED - ON LED - OFF	Temperature fault	This LED indicates a fault with the temperature inputs on the head module (IM). There is a fault with the temperature inputs (such as a wire break). The diagnostic interrupt must be activated. The temperature inputs are operating without error.
ON (green) LED - ON LED - OFF	Power supply for the electronics	This LED indicates that the power supply is ready. The SIMOTION E510 power supply is operating without error. If this LED is not illuminated, the reason may be: <ul style="list-style-type: none"> • No connected or switched-on network • No specified load power supply connected • SIMOTION E510 incorrectly connected • SIMOTION E510 faulty

1) When the system (DP master or/and SIMOTION E510) switches from RUN to STOP mode, a "communication fault" interrupt may arise, as synchronization of the sign of life and the system time will be stopped. As a result, it may also be normal for the SF LED to light up in the STOP state.

Diagnostics for parameterization faults

Since no diagnostic entries can be made before cyclic transmission, the two unlabeled LEDs on the head module are used for diagnostics in this state.

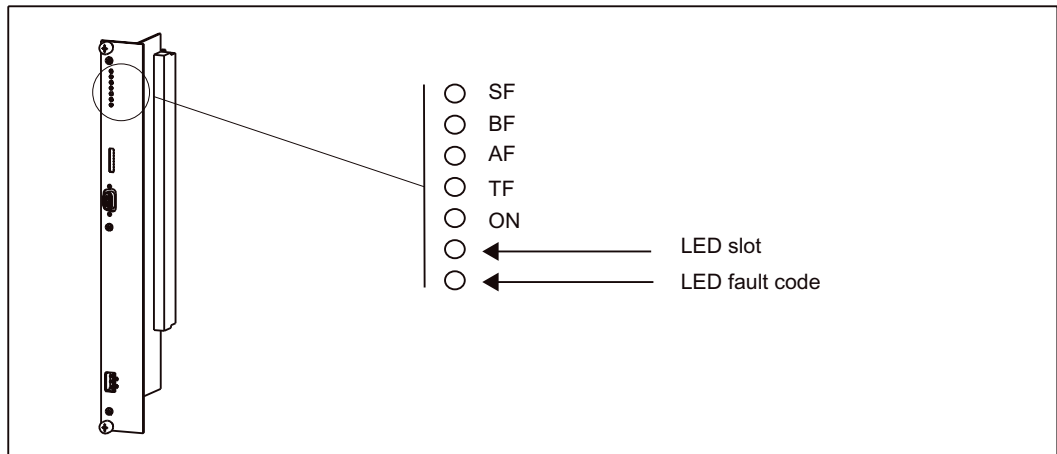

Figure 6-1 Status and fault indicators on the head module

The error code LED indicates the type of fault involved. The faults are coded as follows:

Number of flashes	Meaning
2	Incorrect cycle setting (IPO cycle/position control cycle clock ratio, impermissible Ti/To/T _{DP} setting)
3	Unknown module class
4	Actual configuration differs from preset configuration, power failure
5	Too many time-controlled digital outputs active, time control active without equidistant PROFIBUS DP
6	Reserved function selected
7	Faulty TC parameterization (for example, channel downstream of Pt 100/Pt 1000 otherwise occupied, fault when determining comparison points, etc.)
8	Parameter transfer to expansion card (EB TEMP, 16TC/24 DO or EB MPT, 4CH) failed or rejected

The slot LED indicates which slot is affected. The faults are coded as follows:

Number of flashes	Slot
1	Basic module
2	Head module
3	1st expansion slot
4	2nd expansion slot
5	3rd expansion slot
6	4th expansion slot

The counting method for both LEDs is the same. The LEDs count independently of each other. The LEDs flash with a frequency of 0.5 Hz. The start of the counting process is marked by a "gap" of 3 s. The LED will then flash with a 0.5 Hz frequency for the number of times stated above before a further "gap" occurs.

The display will only ever indicate the first fault, until this has been resolved.

6.1 LED-based diagnostics

LED combinations

The table below provides an overview of all possible LED combinations.

Table 6-2 Summary of LEDs

LEDs					Meaning	Remedy
SF (red)	BF (red)	AF (red)	TF (red)	ON (green)		
Off	Off	Off	Off	Off	<ul style="list-style-type: none"> No voltage is applied. Hardware faulty 	<ul style="list-style-type: none"> Switch on the power supply. Replace SIMOTION E510.
1)	1)	1)	1)	On	The SIMOTION E510 power supply is operating without error.	-
Off	Flashes at 0.5 Hz	Off	Off	On	SIMOTION E510 has been parameterized incorrectly. No data are being exchanged with the DP master.	<ul style="list-style-type: none"> Check configuration and parameterization. Check the PROFIBUS DP address.
Off	On	Off	Off	On	<ul style="list-style-type: none"> No connection to the DP master (baud rate detection) Bus communication to SIMOTION E510 via PROFIBUS DP is interrupted. 	<ul style="list-style-type: none"> Check bus configuration Check whether bus connector is inserted correctly. Check whether the bus cable to the master is interrupted. Check whether the master is switched on. Check whether the interpolator cycle clock is set to ≤8 ms. Switch on the terminating resistor at the start and end of the PROFIBUS DP connection. Switch off and on again.
On	1)	1)	Off	On	Group fault	<ul style="list-style-type: none"> Read out diagnostics information Replace defective modules
On	1)	On	1)	On	Analog fault	<ul style="list-style-type: none"> Read out diagnostics information. Check power supply or replace head module.
On	1)	1)	On	On	Temperature fault	<ul style="list-style-type: none"> Check the connected temperature sensors for wire breaks. Check the temperature inputs affected. Read out diagnostics information
Flashes at 1 Hz	1)	1)	1)	On	Firmware updates for expansion modules	-
Flashes at 2 Hz	Flashes at 2 Hz	Off	Flashes at 2 Hz	Flashes at 2 Hz	Module cannot be operated, internal fault	Please call the hotline (phone: +49 (180) 50 50 222)

1) Not applicable

6.1.2 LEDs on the expansion modules

The status and fault indicators are explained in the order in which they are positioned on the expansion modules.

LED	Meaning	Explanations
EB TEMP, 16TC/24 DO		
SF (red) LED - ON	Group fault (system fault)	This LED indicates a fault on the module. <ul style="list-style-type: none"> • There is a wire break at one of the temperature inputs (at least). • The module is in the RESET state.
LED - flashing (1 Hz)		Firmware updates for expansion modules are being executed.
LED - OFF		Module is operating without error
EB MPT, 4CH		
SF (red) LED - ON	Group fault (system fault)	This LED indicates a fault on the module. <ul style="list-style-type: none"> • The module has an internal error. • The module is in the RESET state. • 24 V sensor supply failed • Parameterized magnet not detected
LED - flashing (1 Hz)		Firmware updates for expansion modules are being executed.
LED - OFF		Module is operating without error

6.2 Diagnostics via PROFIBUS DP

6.2.1 General information about diagnostics via PROFIBUS DP

Diagnostics events are reported via PROFIBUS DP to the DP master, and can be read out from this point.

Diagnostics events are reported via slave diagnostics and diagnostics data records.

6.2.2 Slave diagnostics structure

Slave diagnostics structure

SIMOTION E510 provides slave diagnostics in accordance with the PROFIBUS standard. Depending on the DP master and the parameter assignment, SIMOTION E510 offers an expanded diagnostics function. Here, in the diagnostics frame you will find detailed information in the form of the module status and channel-specific diagnostics (refer to the figure below).

Calling slave diagnostics

Proceed as follows when calling slave diagnostics:

1. Open the project as an online project by selecting **Station > Open Online** in the hardware configuration.
2. Double-click **E510** to open the "Module Information - SIMOTION E510" dialog box.
3. Select the "DP Slave Diagnostics" tab in this dialog box. You can read out all the slave diagnostics by clicking the "Hex. Format..." button.

Note

The plain text messages on the "Diagnostic Interrupt" tab are not appropriate for DP masters from the SIMOTION system. The "General" and "DP Slave Diagnostics" tabs should be used for error diagnostics purposes (see the section titled "Example for decoding a diagnostic program").

Slave diagnostics structure

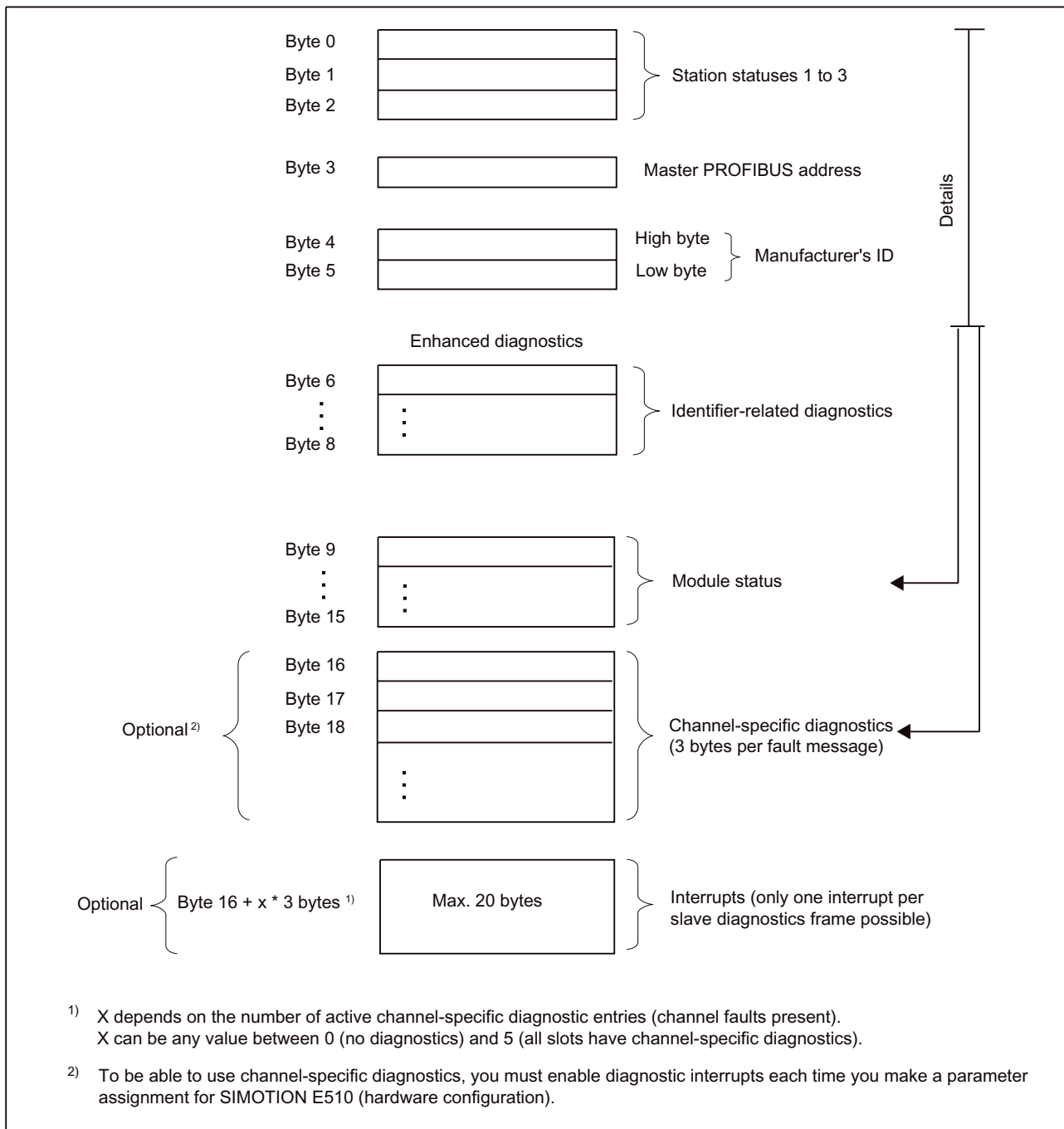

Figure 6-2 Slave diagnostics structure

6.2.3 Station statuses 1 to 3

Station statuses 1 to 3 provide an overview of the status of a DP slave.

Station status 1

Table 6- 3 Structure of station status 1 (byte 0)

Bit	Meaning	Cause/Remedy
0	1: The DP slave cannot be accessed by the DP master. The bit is always 0 at the DP slave.	<ul style="list-style-type: none"> • Is the correct PROFIBUS address set on the DP slave? • Is the bus connector connected? • Voltage at DP slave? • Is the RS 485 repeater set correctly? • Check whether the DP slave was reset (POWER OFF /POWER ON)
1	1: The DP slave is not yet ready to exchange data.	Wait, the DP slave is currently starting up.
2	1: The configuration data transferred from the DP master to the DP slave does not match the DP slave configuration.	Verify the station type or DP slave configuration in the configuration software.
3	1: External diagnostics information is pending.	Evaluate the identifier-related diagnostics information, the module status, and/or the channel-specific diagnostics information. As soon as all errors have been resolved, bit 3 will be reset. The bit will be set again when there is a new diagnostic message in the bytes of the diagnostics referred to above.
4	1: The DP slave does not support the requested function (SYNC/FREEZE, for example).	Check the configuration.
5	1: The bit is always "0".	Note: The bit is "1" when reading the station status from the DP master. The DP master cannot interpret the response of the DP slave.
6	1: The DP slave type does not correspond to the software configuration.	Compare the preset and the actual configuration.
7	1: Parameters have been assigned to the DP slave by a different DP master (not the one that currently has access to the DP slave).	The bit is always 1, for example, if you access the DP slave with the PG or another DP master. The "Master PROFIBUS address" diagnostic byte contains the PROFIBUS address of the DP master that assigned parameters to the DP slave.

Station status 2

Table 6- 4 Structure of station status 2 (byte 1)

Bit	Meaning
0	1: The DP slave parameters need to be reassigned.
1	1: The DP slave is starting up.
2	1: The bit on the DP slave is always "1".
3	1: Response monitoring is activated for this DP slave.
4	1: The DP slave has received the "FREEZE" control command.
5	1: The DP slave has received a "SYNC" control command.
6	0: Bit is always "0".
7	1: Bit is always "0". Note: When reading the station status from the DP master, the bit is "1" if the DP slave has been deactivated in the DP master. The DP slave is deactivated - in other words, it has been removed from the processing currently in progress.

Station status 3

Table 6- 5 Structure of station status 3 (byte 2)

Bit	Meaning
0 to 6	0: Bits are always set to "0".
7	1: There are more channel-specific diagnostic messages than can be represented in the diagnostics frame.

6.2.4 Master PROFIBUS address

The master PROFIBUS address diagnostics byte contains the PROFIBUS address of the DP master which:

- Assigned parameters to the DP slave and
- Has read and write access to the DP slave.

The master PROFIBUS address is located in byte 3 of the slave diagnostics.

FF_H in byte 3

If the value FF_H is entered as the master PROFIBUS address in byte 3, this means that DP slave was not assigned parameters by the DP master.

6.2.5 Manufacturer's ID

The manufacturer's ID contains a code specifying the DP slave type.

Table 6- 6 Structure of the manufacturer's ID (byte 4 and 5)

Byte 4	Byte 5	Manufacturer's ID for
81 _H	08 _H	... SIMOTION E510

6.2.6 Identifier-related diagnostics

Identifier-related diagnostics reveal whether modules of SIMOTION E510 are faulty. Identifier-related diagnostics start at byte 6 and consist of 3 bytes.

Identifier-related diagnostics are structured as follows:

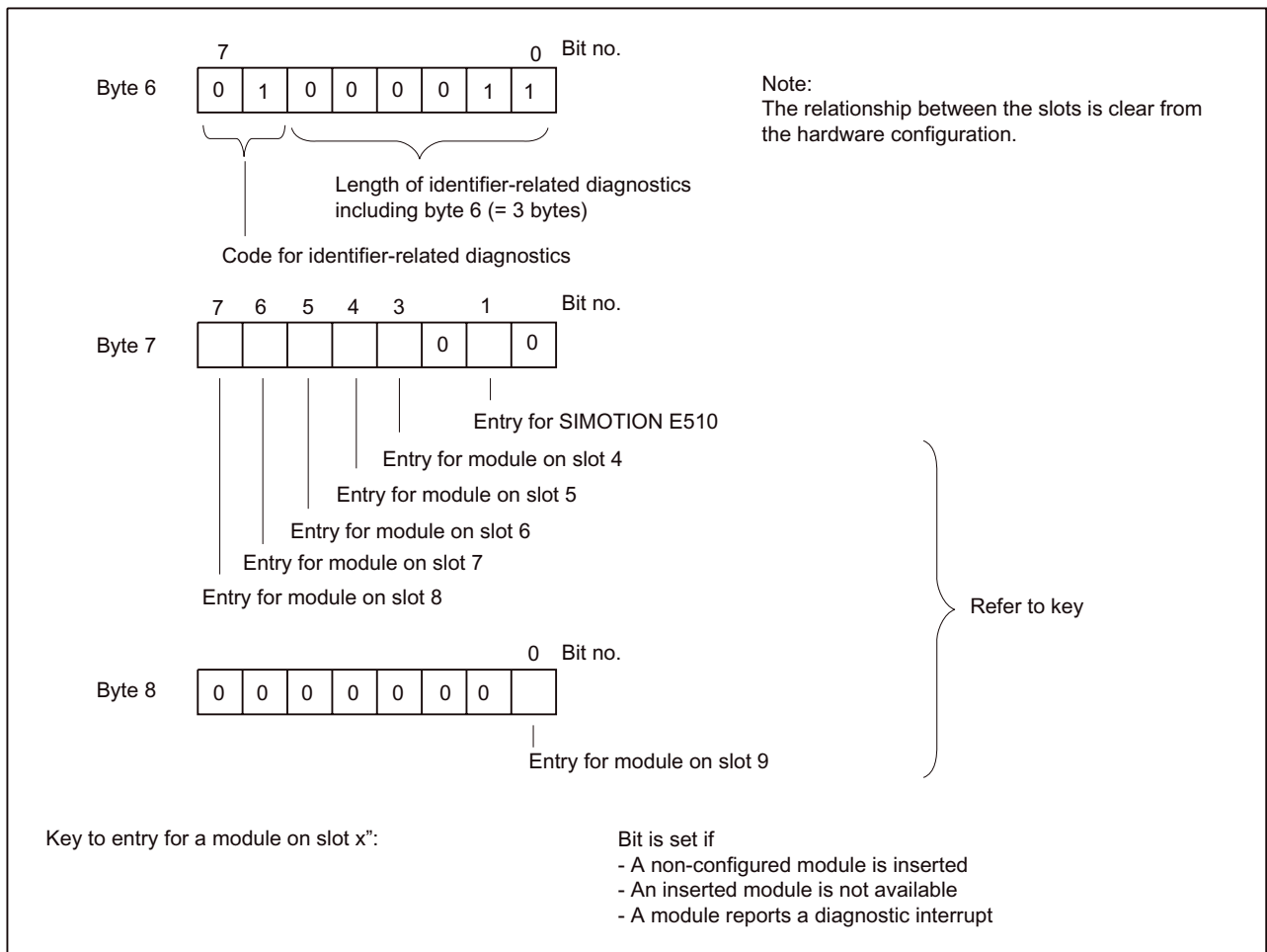

Figure 6-3 Structure of identifier-related diagnostics

6.2.7 Module status

The module status reflects the status of the configured modules and provides configuration details for identifier-related diagnostics. The module status starts after the identifier-related diagnostics and consists of 7 bytes.

The module status is structured as follows:

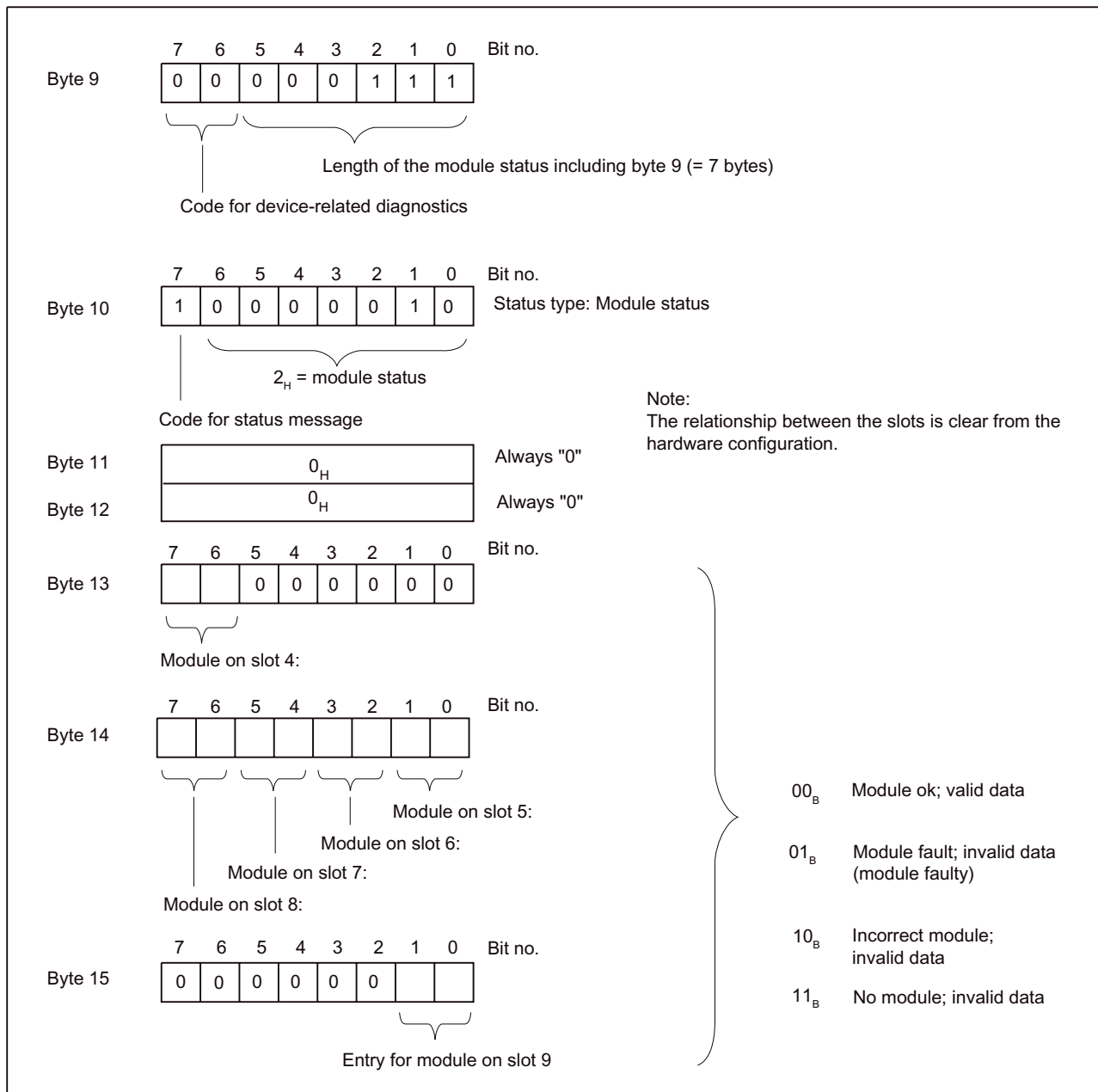

Figure 6-4 Structure of the module status

6.2.8 Channel-specific diagnostics

Channel-specific diagnostics provide information on the modules' channel faults, as well as detailed information on identifier-related diagnostics.

Channel-specific diagnostics begin after the module status.

The length of slave diagnostics data is determined by the number of current channel-specific diagnostics events. If there are more channel-specific diagnostics present than the slave diagnostics can show, bit 7 is set to "Diagnostics Overflow" in the station status 3. If no channel reports a wire break, the "Channel-specific diagnostics" block is removed from the diagnostics frame.

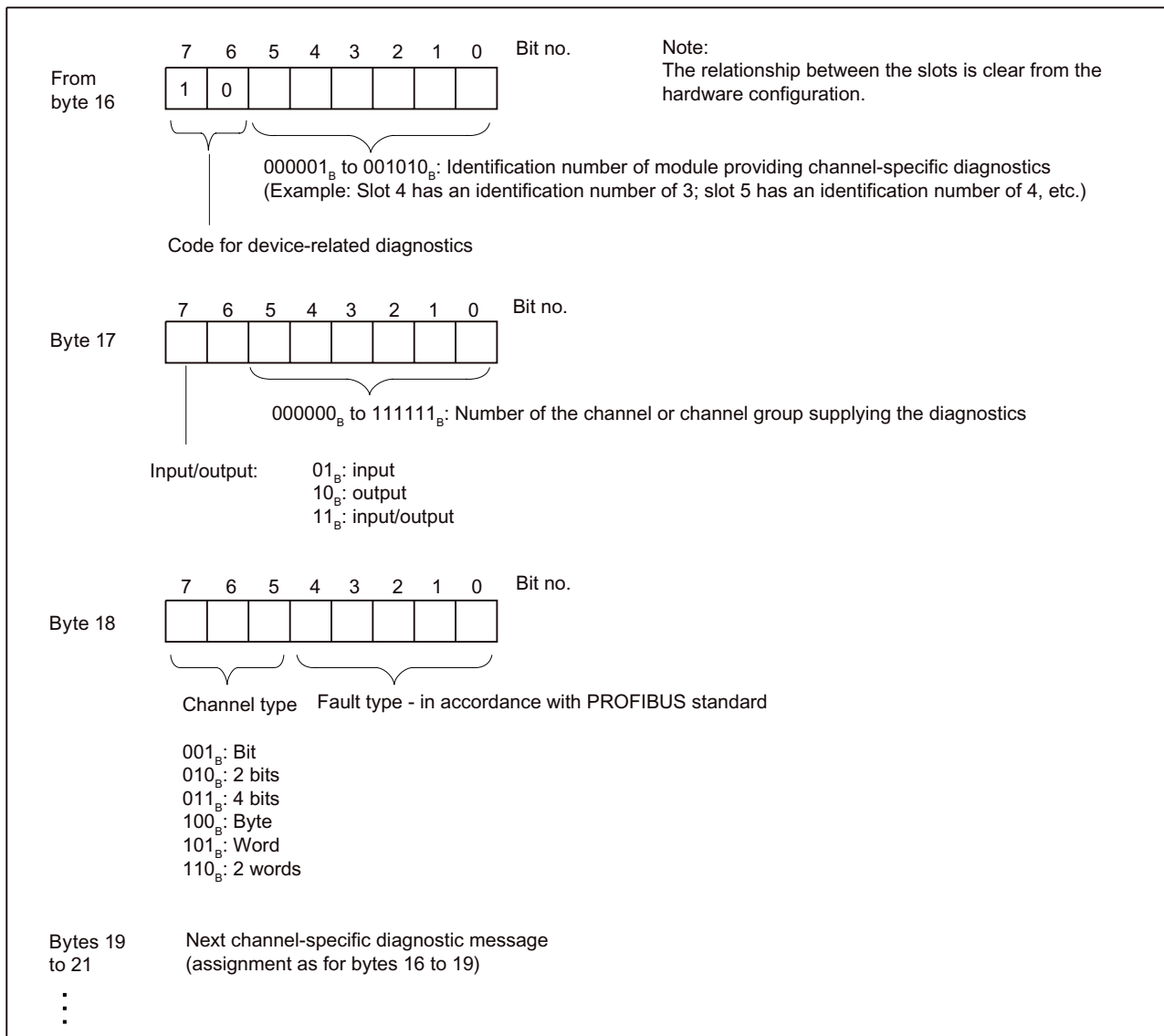

Figure 6-5 Structure of channel-specific diagnostics

Channel-specific fault messages

Table 6-7 Channel-specific fault messages in accordance with the PROFIBUS standard

Fault type		Fault type	Meaning	Remedy
00110 _B	6 _D	Wire break	Wire break caused, for example, by <ul style="list-style-type: none"> • Interruption of a signal line to a sensor • Interruption of a signal line from an actuator • Interruption of a sensor power line 	Correction of the process wiring

6.2.9 Interrupts

The interrupt section of the slave diagnostics provides information on the type of interrupt and what triggered it.

The interrupt section consists of a maximum of 20 bytes.

A maximum of 1 interrupt can be reported for each set of slave diagnostics.

Position in the diagnostics frame

The position of the interrupt section in the slave diagnostics depends on the configuration of the diagnostics frame and on the number of channel-specific diagnostics (please also see the "Structure of slave diagnostics" figure in the section of the same name). The interrupt section is always the last part in the diagnostics frame.

Contents

The contents of the interrupt information depend on the interrupt type:

With diagnosis interrupts (from byte x+4), the diagnostics data record 1 for SIMATIC S7 (e.g. 16 bytes) is sent as additional interrupt information. For digital and analog modules, the meaning of these bytes can be found in the "Structure from byte x+8 for diagnostic interrupt (analog inputs)" table.

This diagnostics data record is also sent this way in the case of SIMOTION.

Diagnostic interrupt

If there is a diagnostics event for channel/channel group 0 of a module, there may **also** be a module fault in addition to a channel fault (see data record 0 in the figure "Structure of bytes x+4 to x+7 for diagnostic interrupt").

Interrupts

The interrupt section for SIMOTION E510 is structured as follows:

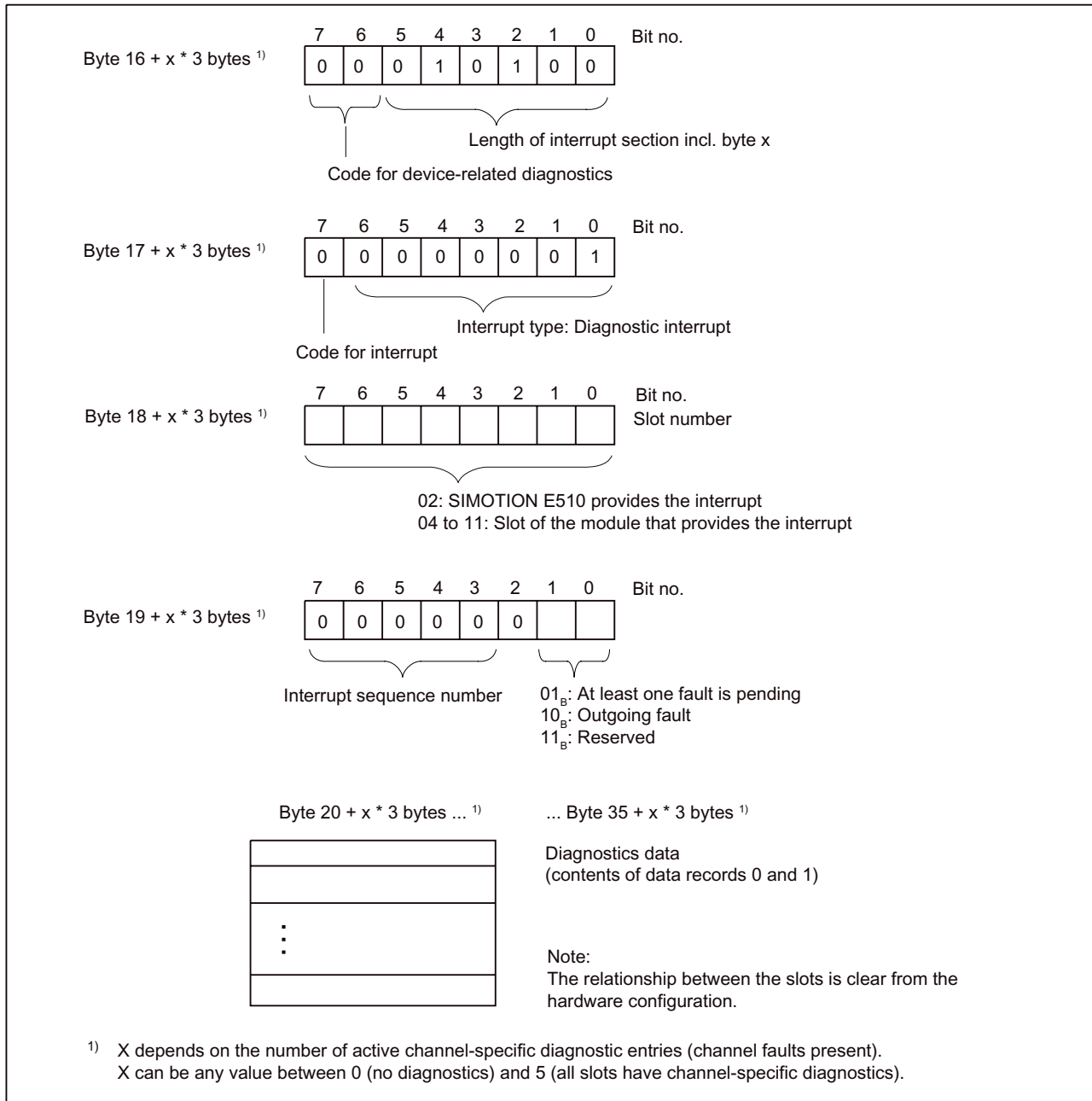

Figure 6-6 Structure of channel-specific diagnostics

Diagnostic interrupt, bytes x+4 to x+7

Bytes x+4 to x+7 correspond to the diagnostics data record 0 in STEP 7. Bytes x+8 to x+19 correspond to the diagnostics data record 1 in STEP 7.

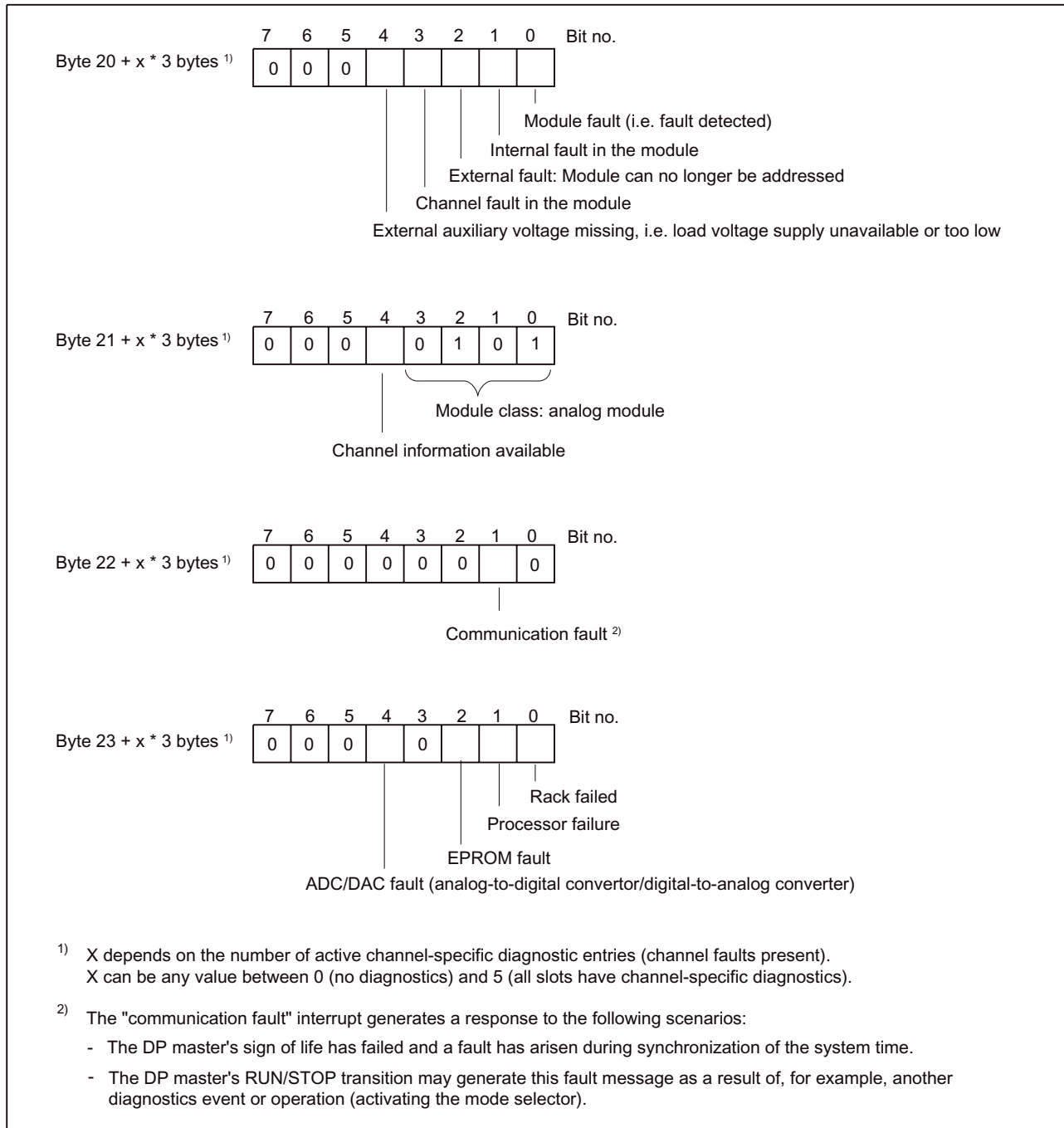

Figure 6-7 Structure of bytes x+4 to x+7 for diagnostic interrupt

Diagnostic interrupt of modules with analog inputs

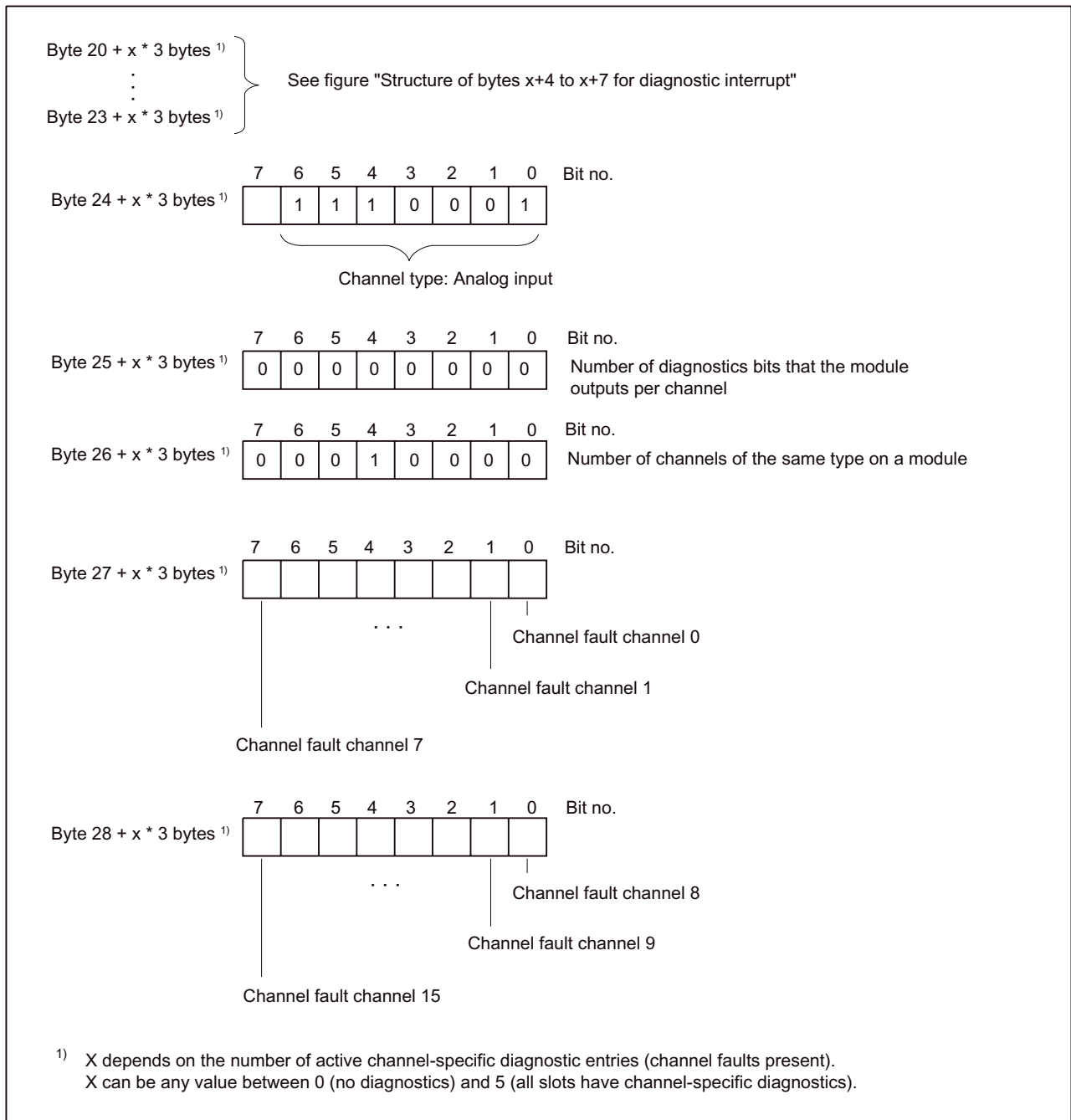

Figure 6-8 Structure from byte x+8 for diagnostic interrupt (analog inputs)

6.2.10 Diagnostics data records

The structure of diagnostics data is described in the system data. You must be familiar with this structure if you want to evaluate the diagnostics data of the signal modules in the user program.

Calling data records

Data records can be called from the user program using the following system function:

- **_readRecord** for SIMOTION (please also see the SIMOTION SCOUT online help)
- **SFB 52 RDREC** (new interface, DPV1) for SIMATIC (please also see the STEP 7 online help)

Interrupts affecting the device as a whole are displayed at slot 0 or 2.

Data records 0 and 1 are only available for the device as a whole (e.g. time-out, communication fault, rack failure), the head module (wire break), and the EB TEMP, 16TC/24 DO (wire break). The fault named "Fault during data record transfer, request cancelled" (module does not recognize data record) is reported for the other modules.

Diagnostics data stored in data records

Module diagnostics data can be as long as 16 bytes, and is contained in data records 0 and 1:

- Data record 0 contains 4 bytes of diagnostics data describing the current state of an automation system.
- Data record 1 contains the 4 bytes of diagnostics data from data record 0 and up to 12 bytes of module-specific diagnostics data.

Structure and content of diagnostics data bytes 0 to 8

The section below describes the structure and content of the individual diagnostics data bytes. General rule: If a fault occurs, the corresponding bit is set to "1".

Bytes 0 and 1

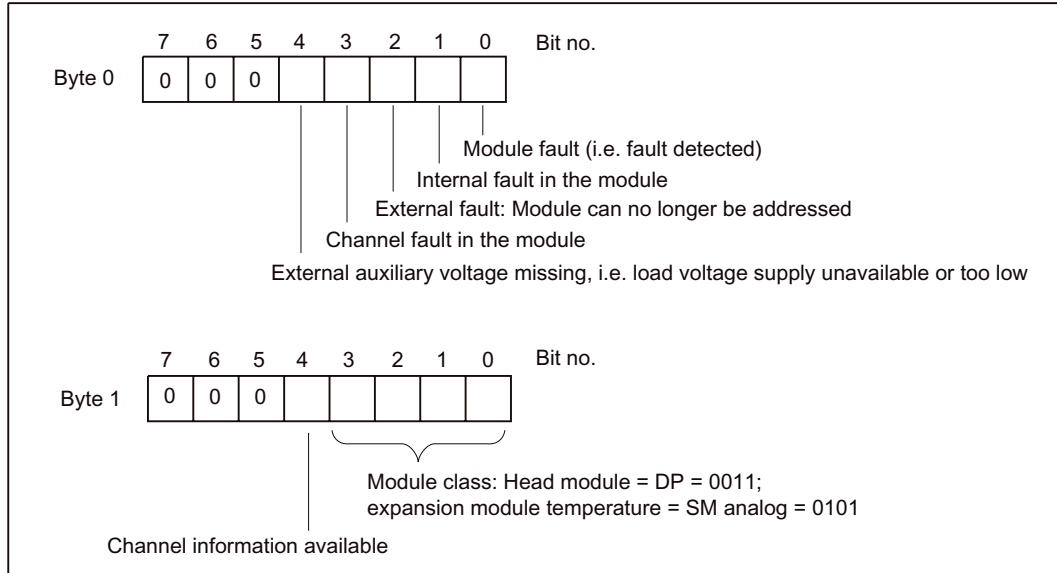

Figure 6-9 Bytes 0 and 1 of diagnostics data

Bytes 2 and 3

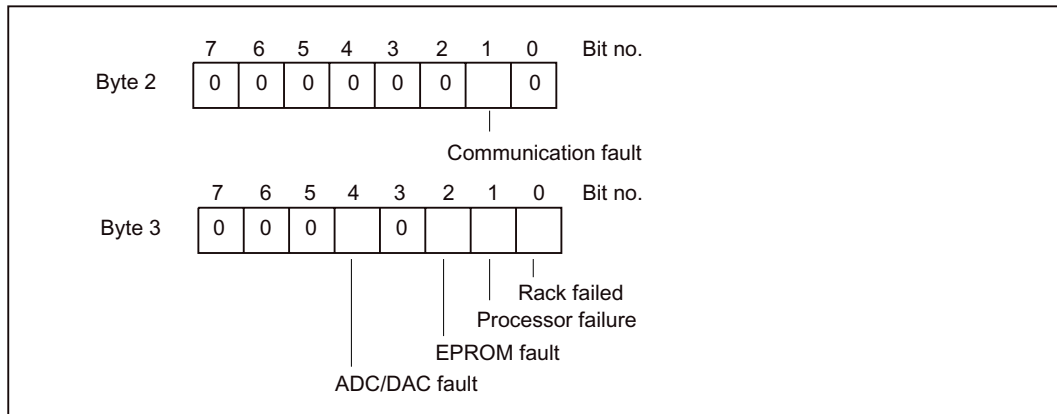

Figure 6-10 Bytes 2 and 3 of diagnostics data

Bytes 4 to 8

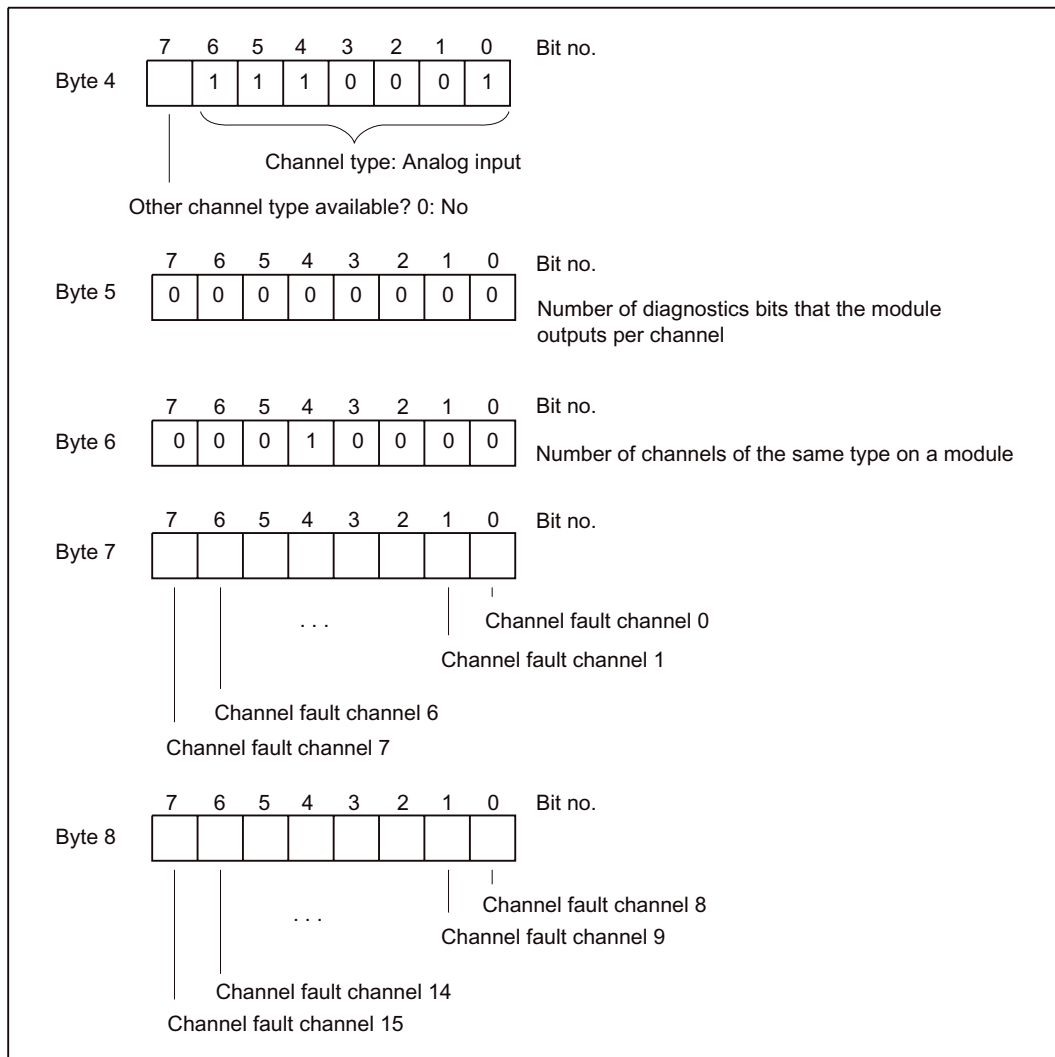

Figure 6-11 Bytes 4 to 8 of diagnostics data

6.2.11 Example for decoding a diagnostics diagram

A example of decoding is shown below. In this example, a SIMOTION E510 is connected to a SIMOTION C230-2. A wire break (open circuit) has occurred at a temperature input. The following is displayed in the hardware configuration:

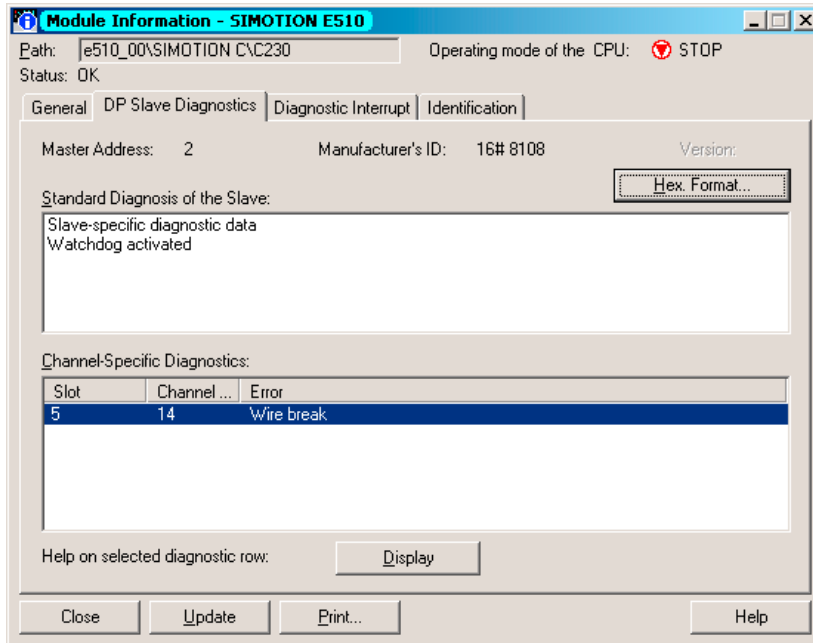

Figure 6-12 Fault message for DP slave diagnostics

Click **Hex. Format...** to display the complete diagnostics frame.

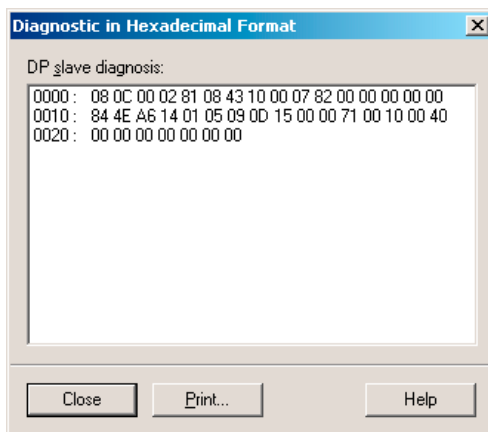

Figure 6-13 Diagnostics frame

The meaning of the diagnostics frame (see figure above) should be interpreted as follows:

08 0C 00 = Station status

- 08_H = 00001000_B → External diagnostics available
- 0C_H = 00001100_B → Response monitoring
- 00_H = 00000000_B

02 = Master PROFIBUS address

- 02_H = Address 2 (as already assigned in the project)

81 08 = Manufacturer's ID

- 81_H 08_H = SIMOTION E510

43 10 00 = Identifier-related diagnostics

- 43_H = 01000011_B → Header for identifier-related diagnostics, total length of 3 bytes
- 10_H = 00010000_B → Entry for slot 5 (head module IM)
- 00_H

07 82 00 00 00 00 00 = Module status

- 07_H = 00000111_B → Length of module status = 7 bytes
- 82_H = 10000010_B → Header identifier for module status
- 00_H...00_H → Modules are ok

84 4E A6 = Channel-specific diagnostics

- 84_H = 10000100_B → Slot 5 (head module IM) and device-related diagnostics
- 4E_H = 01001110_B → Input no. 14 has a fault
- A6_H = 10100110_B → Wire break fault type and representation in word format

14 01 05 69 = alarm header

- 14_H = 00010100_B → Device-related diagnostics with a total length of 20 bytes
- 01_H = 00000001_B → Diagnostic interrupt
- 05_H = 00000101_B → Slot 5 (head module IM) reports interrupt
- 69_H = 01101001_B → Interrupt sequence number (arbitrarily rotating);
at least one fault is present

0D 13 00 00 71 00 10 00 40 00 00 00 00 00 00 00 = Interrupt data record

0D 13 00 00 = DS0

- 0D_H = 00001101_B → Module fault, external fault, channel fault
- 13_H = 00010011_B → Module class is DP and channel information is available
- 00_H = No more relevant entries
- 00_H = No more relevant entries

71 00 10 00 40 00 00 00 00 00 00 = DS1

71_H = 01110001_B → Analog input channel type

00_H

10_H = 00010000_B → 16 channels of the same type

00_H

40_H = 01000000_B → Channel fault on channel 14

Standards and approvals

A.1 General rules

IEC 1131

SIMOTION E510 meets the requirements and criteria of standard IEC 1131, Part 2.

CE marking

Our products meet the general and safety-related requirements of the following EC guidelines and conform to the uniform standards (EN) for programmable controllers published in the official gazettes of the European Union:

89/336/EEC "Electromagnetic Compatibility" (EMC Directive)

EMC Directive

SIMOTION products are designed for industrial use.

Field of application	Requirement relating to	
	Emitted interference	Immunity to interference
Industry	EN 50081-2	EN 61000-6-2

UL approval

Recognized component mark for United States and the Canada Underwriters Laboratories (UL) according to Standard UL 508, File 16 4110.

A.2 Safety of electronic controllers

Introduction

The remarks made here relate to fundamental criteria and apply irrespective of the type of controller and the manufacturer.

Reliability

Comprehensive and cost-effective measures have been taken during development and production to increase the reliability of the devices and components as far as possible.

These include

- The selection of high-quality components
- Worst-case dimensioning of all circuits
- Systematic and computerized inspection of all supplied components
- Burn-in of all large-scale integrated circuits (e.g. processors, memory, etc.)
- Measures to prevent static discharge when handling MOS circuits
- Visual checks during various stages of manufacture
- Continuous heat testing at higher ambient temperatures for several days
- Thorough computerized final inspection
- Statistical analysis of all returned goods so that corrective measures can be initiated immediately
- Monitoring of the most important control components by means of online tests (watchdog for SIMOTION E510, etc.)

These measures are considered to be basic measures for safety engineering. They avoid or control the majority of faults that may occur.

Risk

A higher degree of safety standard applies to all applications and situations where there is a risk of material damage or injury to persons if there is a failure. Special regulations specific to the system apply to such applications. These must be taken into account for configuration of the controller (e.g. VDE 0116 for furnaces).

For electronic controllers with safety responsibility, the measures required for preventing or controlling faults depend on the hazard inherent in the plant. In this respect, the basic measures listed above are no longer adequate once the hazard exceeds a certain potential. Additional measures (e.g. double redundancy, tests, checksums, etc.) for the controller must be implemented and certified (DIN VDE 0801).

Division into safety-critical and non-safety-critical areas

Nearly all systems contain parts that perform safety-related tasks (e.g. emergency stop switch, protective grating, two-hand controls). To avoid having to apply safety-related criteria to the entire controller, it is customary to divide the controller into two areas - one that is **critical to safety** and one that is **not critical to safety**. No special demands are made concerning safety in the area that is not safety-critical as an electronic fault would not have any effect on the safety of the system. However, in the safety-critical area, only controllers and circuits that comply with the relevant regulations, may be used.

Important note

Even if an extremely high level of conceptual safety has been achieved in the design of an electronic controller - e.g. through implementation of a multi-channel design - strict adherence to all instructions in the operator's guide is mandatory, as incorrect handling could invalidate measures taken to prevent hazardous faults or create additional potential hazards.

A.3 Electromagnetic compatibility

Definition

Electromagnetic compatibility is the ability of an electrical device to function in its electromagnetic environment in a satisfactory manner without affecting this environment.

SIMOTION E510 satisfies, among other things, the requirements of the EMC regulations stipulated by the single European market.

Information on interference immunity and EMC conformance is provided below.

Pulse-shaped interference

The following table shows the electromagnetic compatibility of modules with regard to pulse-shaped interference.

Pulse-shaped interference	Tested with	Corresponds to severity
Electrostatic discharge tested in accordance with DIN EN 61000-4-2	8 kV 4 kV	3 (air discharge) 2 (contact discharge)
Burst pulses (fast transient interference) tested in accordance with DIN 61000-4-4	2 kV (supply line) 1 kV (signal line)	3
Surge tested in accordance with DIN EN 61000-4-5 asymmetrical coupling	1 kV (PROFIBUS cable)	2

Note

The following measures are required to maintain surge protection (lightning protection):

- The connecting cable between the voltage source, the load power supply connection L+, and the associated reference potential M must **not** exceed 10 m.
- DEHN FDK/2 60 surge protection terminal blocks are required to maintain lightning protection of the digital inputs and outputs.

<http://www.dehn.de>

Sinusoidal interference

HF radiation on the device in accordance with EN 61000-6-2 requirements:

- Electromagnetic HF field, amplitude-modulated
 - 80 to 1,000 MHz
 - 10 V/m
 - 80% AM (1 kHz)
- Electromagnetic HF field, pulse-modulated
 - 900 ±5 MHz
 - 10 V/m
 - 50% ED
 - 200 Hz repetition rate
- HF coupling on signal and data lines, etc. in accordance with EN 61000-6-2 requirements, high frequency, asymmetric, amplitude modulated
 - 0.15 to 80 MHz
 - 10 V rms value, unmodulated
 - 80% AM (1 kHz)
 - 150 Ω source impedance

Radio interference emission

Interference emission of electromagnetic fields in accordance with EN 55011: Limit value class A, Group 1.

20 to 230 MHz	< 30 dB (µV/m)Q
230 to 1,000 MHz	< 37 dB (µV/m)Q
Measured at a distance of 30 m	

Interference emission via network alternating current supply in accordance with EN 55011: Limit value class A, Group 1.

0.15 to 0.5 MHz	< 79 dB (µV)Q
	< 66 dB (µV)M
0.5 to 5 MHz	< 73 dB (µV)Q
	< 60 dB (µV)M
5 to 30 MHz	< 73 dB (µV)Q
	< 60 dB (µV)M

Expanded application

If you are using SIMOTION E510 in residential areas, in respect of the emission of radio interference you must ensure that you observe limit value class B in accordance with EN 55011.

Recommended: Install SIMOTION E510 in grounded metal cabinets, such as 8MC cabinets (see NV 21 Catalog). Connect filters to the supply lines.

ESD guidelines

B.1 ESD definition

What does ESD mean?

All electronic modules are equipped with highly integrated modules or components. Because of the technology used, these electronic components are very sensitive to overvoltages and thus to discharge of static electricity.

The acronym **ESD** has become the established designation for such **E**lectrostatic **S**ensitive **D**evices. The **ESD** designation is used internationally to refer to **e**lectrostatic **s**ensitive **d**evices.

Electrostatic sensitive devices are identified by the following symbol:

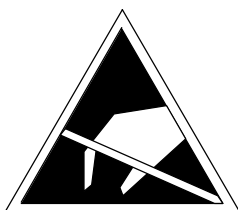



Figure B-1 Symbol for identification of electrostatic sensitive devices

 CAUTION
Electrostatic sensitive devices can be irreparably damaged by voltages that are far lower than anything a person can perceive. These voltages occur if you touch a component or the electrical connection of a module without having previously discharged any static from your body. Any damage that occurs to a module as a result of overvoltage is generally not recognized immediately and only comes to light after the equipment has been operating for some time.

B.2 Electrostatic charging of individuals

Any person who is not conductively connected to the electrical potential of the environment can accumulate an electrostatic charge.

This figure indicates the maximum electrostatic charges that can accumulate on an operator when he comes into contact with the indicated materials. These values comply with the specifications in IEC 801-2.

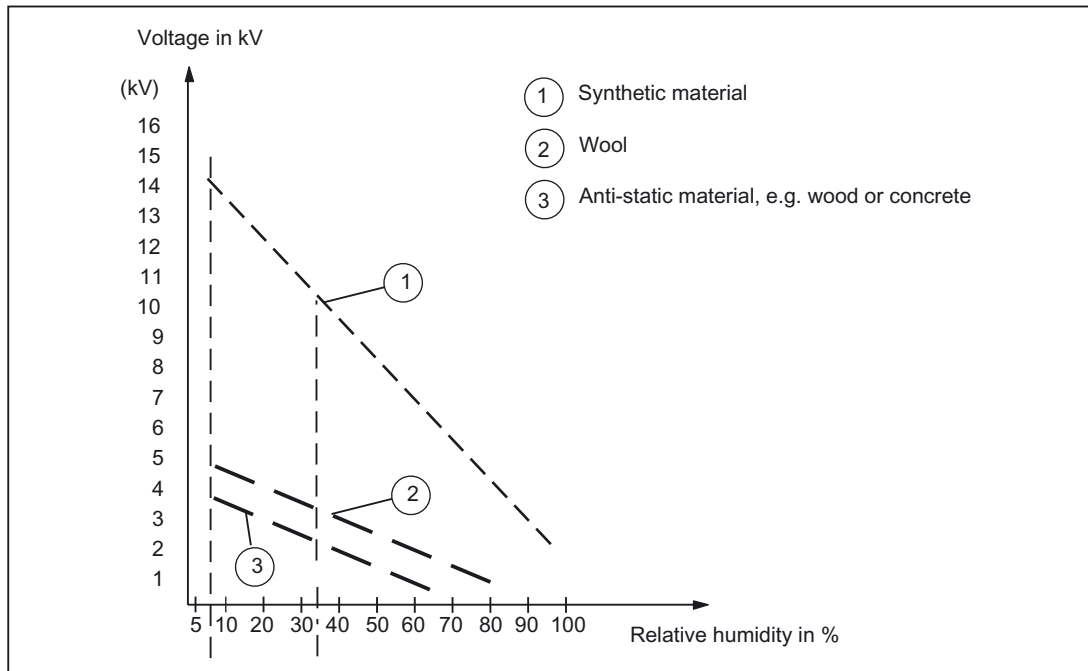

Figure B-2 Electrostatic voltage that can accumulate on operating personnel

B.3 Basic measures for protection against discharge of static electricity

Ensure sufficient grounding

When working with electrostatic sensitive devices, make sure that you, your workstation, and the packaging are properly grounded. This prevents the accumulation of static electricity.

Avoid direct contact

You should only touch ESD components if unavoidable (for example, during maintenance work). When you touch modules, make sure that you do not touch either the pins on the modules or the printed conductors. If you follow these instructions, electrostatic discharge cannot reach or damage sensitive components.

If you have to take measurements on a module, make sure that you first discharge any static that may have accumulated in your body. To do this, touch a grounded metal object. Only use grounded measuring instruments.

Appendix

C.1 References

- 1 **EMC Installation Guide, Engineering Instructions (HW)**
Order number: 6FC5 297-0AD30-0AP2 Edition 03/2004

- 2 **Programming with STEP 7 V5.4, Manual**
This manual is included in the documentation package with order number: 6ES7-810-4CA08-8AW0 Edition 03/2006

- 3 **SIMOTION SCOUT, Configuration Manual**
This documentation is part of the documentation package for SIMOTION SCOUT handling. Edition 03/2007

C.2 List of abbreviations

ADC	Analog-to-digital converter
AI	Analog input
AO	Analog output
CNT	Counter (counter input)
CPU	Central processing unit
DAC	Digital-to-analog converter
DI	Digital input
DO	Digital output
DOR	Digital output relay
DP	Distributed I/O
EB	Expansion module
EMC	Electromagnetic compatibility
ESD	Electrostatic sensitive devices
EUROMAP	European association for plastics and rubber machinery manufacturers
GC	Global control
GSD file	Device data file
Hardware	Hardware
HMI	Human machine interface
IDC	Interval duration counter
IM	Interface module (for SIMOTION E510)
LED	Light-emitting diode
MPT	Magnetostrictive position transducer
MSL	Master sign of life (sign of life for DP master)
MUX	Multiplexer
PC	Personal computer
PELV	Protective extra-low voltage
PG	Programming device
PS	Power supply (for SIMATIC S7)
RTD	Resistance thermometer
SCOUT	SIMOTION Controlling with Optimized Usability Toolbox SCOUT is the engineering system for the SIMOTION product family.
SM	Signal module (SIMATIC S7, e.g. input/output module)
SSL	Slave sign of life (sign of life of DP slave)
STW	Control word
TC	Thermo coupler (temperature input)
ZSW	Status word

Index

A

- Activating the outputs, 216
- Analog inputs, 24, 34
 - Description of functions, 40
 - Technical data, 77
 - Wiring and block diagrams, 70
- Analog output channels
 - Representation of analog values, 214
- Analog outputs, 24
 - Description of functions, 40
 - Technical data, 79
 - Wiring and block diagrams, 70
- Analog value
 - Conversion, 210
- Assigning constant bus cycle time and isochronous mode parameters, 200
- Assigning input/output addresses, 186

B

- Basic module, 59
 - Analog inputs, 24, 34
 - Analog outputs, 24
 - Connection for power supply, 61
 - Connection values, 74
 - Counter inputs, 25
 - Designation, 59
 - Digital inputs, 26, 33
 - Digital outputs, 21, 35
 - Dimensions and weight, 75
 - LED display, 63
 - Order number, 59
 - Technical data, 74
 - Temperature inputs, 23
 - Type plate, 64
- Bridging of supply failures, 164
- Bus connector
 - Connecting to the head module, 167
 - Removing, 168
 - Setting the terminating resistor, 167

C

- CE
 - Marking, 259

- Channel-specific diagnostics, 248
- Clearances, 152
- Commissioning steps, 183
- Configuring a DP slave, 184
- Configuring the electrical installation, 160
- Connecting
 - Connecting PROFIBUS DP, 167
 - Inputs/outputs for EB DIGITAL 32DI, 178
 - Inputs/outputs for EB TEMP, 16TC/24DO, 179
 - Inputs/outputs to the housing, 170
 - Position encoder, 180
 - Power supply inputs/outputs for EB DIGITAL, 16DI/16DO, 177
 - Power supply to EB TEMP, 16TC/24DO, 179
 - Power supply to the basic module, 169
 - Power supply to the EB DIGITAL, 16DI/16DO, 177
 - Power supply to the EB DIGITAL, 32DI, 178
 - Power supply to the EB HAND, 16DI/16 DO, 181
 - Power supply to the EB MPT, 4CH, 180
 - Power supply to the head module, 164
 - Shielded cables, 173
- Connecting cable, 122
- Connecting cables, 164, 169, 172
- Connecting expansion modules, 177, 179, 180, 181
- Connecting inputs/outputs to the housing, 170
- Connecting PROFIBUS DP to the head module, 167
- Connecting the power supply to the basic module, 169
- Connecting the power supply to the head module, 164
- Connection element, 164, 169, 171
- Connection for power supply, 57, 61, 88, 100, 110, 123, 132
- Connection overview, 163, 176
- Connection values, 74, 94, 103, 115, 125, 141
- Conversion
 - Of analog values, 210
- Counter inputs, 25, 33, 99
 - Description of functions, 49
 - Technical data, 83, 104
 - Wiring and block diagrams, 73
- Creating a user program, 203

D

- Declaration of conformity, 3
- Degree of protection, 145
 - IP 20, 145
- Description of the E510 module, 11
- Designation

- Basic module, 59
- EB DIGITAL, 16DI/16DO, 85
- EB DIGITAL, 32DI, 96
- EB HAND, 16DI/16DO, 126
- EB MPT, 4CH, 119
- EB TEMP, 16TC/24DO, 105
- Diagnostics data records, 253
 - Calling, 253
 - Structure and content, 254
- Diagnostics diagram
 - Example, 256
- Diagnostics for parameterization faults, 238
- Diagnostics via PROFIBUS DP, 242
- Digital I/O expansion module (EB DIGITAL, 16DI/16DO), 85
- Digital I/O expansion module (EB DIGITAL, 32DI), 96
- Digital inputs, 26, 33, 86, 97, 141
 - Description of functions, 60, 86, 97
 - Technical data, 75, 94, 103, 141, 142
 - Wiring and block diagrams, 66, 92, 102
- Digital outputs, 21, 35, 87, 108, 142
 - Description of functions, 60, 87, 108
 - Technical data, 76, 95, 115
 - Wiring and block diagrams, 67, 93, 114
- Dimension drawing for fixing holes, 153
- Dimension drawings, 148
- Dimensions, 75, 94, 103, 115, 125, 141, 148
- DIP switch, 55

E

- EB DIGITAL, 16DI/16DO
 - Connecting, 177
 - Connection for power supply, 88
 - Connection values, 94
 - Designation, 85
 - Digital inputs, 86
 - Digital outputs, 87
 - Dimensions and weight, 94
 - Installing, 175
 - LED display, 90
 - Order number, 85
 - Technical data, 94
 - Type plate, 91
 - Wiring diagram and block diagram, 92
- EB DIGITAL, 32DI
 - Connecting, 178
 - Connection for power supply, 100
 - Connection values, 103
 - Counter inputs, 99
 - Designation, 96
 - Digital inputs, 97

- Dimensions and weight, 103
- Installing, 175
- LED display, 101
- Order number, 96
- Technical data, 103
- Type plate, 101
- Wiring diagram and block diagram, 102
- EB HAND, 16DI/16DO
 - Connecting, 181
 - Connecting cable, 137
 - Connection for power supply, 132
 - Connection values, 141
 - Designation, 126
 - Dimensions and weight, 141
 - Handling interface, 128
 - Installing, 175
 - Order number, 126
 - Technical data, 141
 - Type plate, 133
 - Wiring diagram and block diagram, 133
- EB MPT, 4CH
 - Connecting, 180
 - Connecting cable, 122
 - Connection for power supply, 123
 - Connection values, 125
 - Designation, 119
 - Dimensions and weight, 125
 - Fault and status indicator, 124
 - Installing, 175
 - Order number, 119
 - Technical data, 125
 - Type plate, 124
- EB TEMP, 16TC/24DO
 - Connecting, 179
 - Connection for power supply, 110
 - Connection values, 115
 - Description of functions, 106
 - Designation, 105
 - Digital outputs, 108
 - Dimensions and weight, 115
 - Fault and status indicators, 111
 - Installing, 175
 - Order number, 105
 - Technical data, 115
 - Temperature inputs, 106
 - Type plate, 112
 - Wiring and block diagrams, 112
- Electrical interference, 161
- Electromagnetic compatibility, 261
- EMC Directive, 159, 259
- EMERGENCY OFF concept, 159
- Environmental conditions, 143
 - Mechanical, 144

ESD guideline, 263
 EUROMAP 67-compliant handling expansion module (EB HAND, 16DI/16DO), 126
 EUROMAP adapter cable, 140
 EUROMAP connecting cable
 Adapter cable, 140
 EUROMAP 12 connection suggestion, 137
 EUROMAP 12 or 67 hybrid connection suggestion, 139
 EUROMAP 67 connection suggestion, 138
 EUROMAP connection suggestions, 137
 Example configuration, 13, 14, 15, 16

F

Fault and status indicator, 54, 124
 Fault and status indicators, 111
 Firmware update, 233, 235
 Firmware version, 58
 Fixing holes, 153

G

Guideline
 ESD, 263

H

Head module, 38
 Analog inputs, 40
 Analog outputs, 40
 Connection for power supply, 57
 Connection values, 74
 Counter inputs, 49
 Dimensions and weight, 75
 DIP switch, 55
 Fault and status indicator, 54
 Order number, 38
 PROFIBUS DP interface as slave, 56
 Reference outputs, 40
 Technical data, 74
 Temperature inputs, 41
 Type plate, 57
 Housing, 17
 Housing with slots
 Connecting, 159
 Connection overview, 163
 Connection values, 74
 Connector assignment, 21, 33
 Dimensions and weight, 75
 Interfaces, 20, 28, 31

Type plate, 27

I

Identifier-related diagnostics, 246
 IEC 1131, 259
 Illustration of housing
 With 1 expansion slot, 31
 With 4 expansion slots, 19
 Without expansion slots, 28
 Initial switching on, 183
 Installation position, 151
 Installing
 Housing, 154
 Modules in housing, 156
 Relay option module, 157
 Shield connection, 174
 Installing GSD files, 184
 Insulation test, 145
 Interference
 Pulse-shaped, 261
 Sinusoidal, 262
 Interpolator cycle clock, 193, 219, 222, 230
 Interrupts, 249
 IP 20, 145

L

LED display, 54, 63, 90, 101, 111, 124
 LED-based diagnostics, 237
 Expansion modules, 241
 Head module, 237

M

Master PROFIBUS address, 245
 Minimum power supply, 161
 Module overview, 18
 Module status, 247
 Module supply, 162
 Modules
 Transport and storage conditions, 143
 Mounting onto standard rail, 155

O

Operating conditions, 143
 Order number
 Basic module, 59
 EB DIGITAL, 16DI/16DO, 85
 EB DIGITAL, 32DI, 96

EB HAND, 16DI/16DO, 126
 EB MPT, 4CH, 119
 EB TEMP, 16TC/24DO, 105
 Head module, 38
 Housing, 17

P

Parameterizing inputs/outputs, 187
 PELV (Protective Extra-Low Voltage), 77, 78, 79, 82, 118, 147, 164, 169, 170, 177, 178, 179
 Position control cycle clock, 193, 219, 222, 230
 Position encoder, 121
 Connecting, 180
 Technical data, 125
 Position encoder expansion module (EB MPT, 4CH), 119
 Interface for position encoder, 121
 PROFIBUS DP, 74
 PROFIBUS DP address
 Setting, 168, 185
 PROFIBUS DP interface as slave, 56
 Protection against electrical interference, 161
 Protection class, 145
 Protective conductor connection, 154
 Pulse-shaped interference, 261

Radio interference
 Emission, 262

R

Rated voltages, 145
 Reading out the firmware version, 235
 Reference outputs, 24, 34
 Description of functions, 40
 Technical data, 78
 Wiring and block diagrams, 70
 Relay option module, 126
 Installing, 157
 Removing and replacing, 236
 Housing, 236
 Modules, 236
 Representation of analog values, 210
 For analog input channels, 210
 For analog output channels, 214
 For resistance thermometer, 213
 For thermocouple, 213
 In voltage measuring ranges, 212

Resistance thermometer, 43

S

Safety of electronic controllers, 259
 Safety regulations, 159
 EMERGENCY OFF apparatus, 159
 Sample program
 System time synchronization, 221
 Time-controlled outputs, 225
 Shield connection, 173
 Shielded cables, 173
 Sign of life
 DP master, 219
 DP slave, 219
 Sign-of-life monitoring, 218
 SIMOTION E510 complete units, 17
 SIMOTION E510, installing, 148
 Sinusoidal interference, 262
 Slave diagnostics, 242
 Calling, 242
 Channel-specific diagnostics, 248
 Diagnostic interrupts, 251
 Identifier-related diagnostics, 246
 Interrupts, 249
 Manufacturer's ID, 246
 Module status, 247
 Station status, 244
 Structure, 243
 Standards and approvals, 3
 Station statuses 1 to 3, 244
 Switching on, 183
 System integration
 SIMATIC, 16
 SIMOTION, 13
 System overview, 12

T

Technical data, 74, 94, 103, 115, 125, 141
 Temperature I/O expansion module (EB TEMP, 16TC/24DO), 105
 Temperature inputs, 23, 106
 Description of functions, 41
 Technical data, 80, 116
 Wiring and block diagrams, 71, 113
 Terminating resistor
 Adjusting to bus connector, 167
 Test voltages, 145
 Thermocouple, 44
 Comparison point, 45
 Operating principle, 44

- Structure, 44
- Types, 44
- Time synchronization for time-controlled outputs (digital outputs), 218
- Time-controlled output, 224
- Time-controlled outputs, 61
- Type plate
 - Basic module, 64
 - EB DIGITAL, 16DI/16DO, 91
 - EB DIGITAL, 32DI, 101
 - EB MPT, 4CH, 124
 - EB TEMP, 16TC/24DO, 112
 - Head module, 57
 - Housing, 27, 30, 37

U

- UL approval, 259
- Up/down counter, 52
- Up-counter, 49
- User program
 - Downloading to the DP master, 232

V

- Vibration, 144
- Voltages
 - Rated, 145

W

- Weight, 75, 94, 103, 115, 125, 141
- Wiring and block diagrams, 65, 92, 102, 112, 133
 - Notes, 71
- Wiring procedure, 165, 169, 173