

Acorn World '97  
Guide Inside

The best-selling Acorn magazine in the world

# ACORN USER

Essential for all users of 32-bit RISC OS computers

## Better type

Making  
your  
text  
**bolder**  
and  
*brighter*

Acorn  **97**  
World

**THE BIG  
SHOW  
PREVIEW**

Embolden

November 1997 Issue 187 £3.95

IDG  
MEDIA



11



PHONE ORDERS:  
01728 621222



CASTLE TECHNOLOGY

FAX ORDERS (24HR):  
01728 621179

120Mb  
from only  
£90

## IDE HARD DRIVES



## SPECIAL PROMOTION FOR THE NEW ACADEMIC YEAR 120MB HARD DRIVES FROM ONLY £90 (£105.75 inc VAT)

Get one of our IDE hard drives and increase the power of your Acorn. Fit it yourself - no special knowledge is required and no extra parts are needed. Just connect and go!

- ◆ Risc OS 3.1 required for A310 / A400 / A3000
- ◆ Uses Risc OS 3.1 for full compatibility
- ◆ All drives formatted and soak tested
- ◆ Full 1 year guarantee

	Computer	120Mb inc interface		400Mb inc interface		Interface only	
		ex VAT	inc VAT	ex VAT	inc VAT	ex VAT	inc VAT
2.5"	A3020	£90	£105.75	£120	£141.00	£8	£9.40
	A310/A400	£138	£162.15	£168	£197.40	£72	£84.60
	A3010	£129	£151.58	£159	£186.83	£60	£70.50
	A3000	£129	£151.58	£159	£186.83	£60	£70.50

	Computer	500Mb		1Gb		2Gb	
		ex VAT	inc VAT	ex VAT	inc VAT	ex VAT	inc VAT
3.5"	A4000/S000	£99	£116.33	n/a		n/a	
	A7000, RiscPC	£99	£116.33	£129	£151.56	£179	£210.33

## SCANFLAT II SCSI SCANNER

High quality  
flatbed scanner



Scanflat II 600 & 800

FROM  
£179

The single pass high quality Scanflat II range of A4 flatbed scanners is a new and improved version of the highly successful Scanflat series. With a new compact footprint to save space, improved scanning speeds and quiet operation, the Scanflat II provides both quality and ease of use for the busy office or classroom. Available now in 600dpi and 800dpi versions.

- ◆ Scanflat II has 400x290mm footprint
- ◆ Line art, grey or 24-bit colour modes
- ◆ Pre-scan colour/brightness control
- ◆ Free ImageMaster Software & TWAIN driver
- ◆ PC SCSI interface & software kit £45 extra
- ◆ SCSI cable included
- ◆ Full 1 year guarantee
- ◆ New! Parallel port versions now available

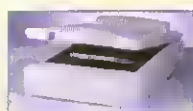

Scanflat II Transparency adaptor



Scanflat II 200

Price in brackets Includes VAT	Scanner (excl. interface)	Trans. Adaptor
£179 <small>(£210.33)</small>	Scanflat II 600 (600dpi)	£149 <small>(£175.08)</small>
£229 <small>(£269.08)</small>	Scanflat II 800 (800dpi)	£149 <small>(£175.08)</small>
£299 <small>(£351.33)</small>	Scanflat II 200 (1200dpi)	£199 <small>(£233.83)</small>

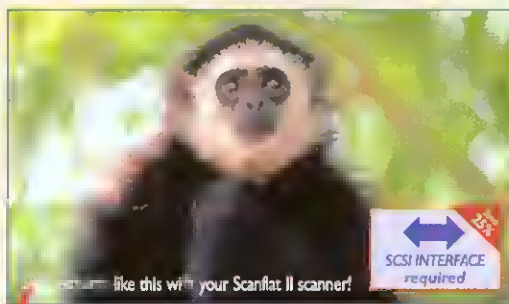

like this with your Scanflat II scanner!

SCSI INTERFACE  
required

## COMBO CASE FOR SCSI DEVICES

£60



The unique expandability of SCSI makes it so easy to install extra SCSI hardware, and Castle Technology is delighted to be able to make this product available to the Acorn user. The Combo Case's two standard 5.25" size bays and robust construction provide a flexible and long-lasting carrier for your SCSI peripherals.



Suitable SCSI devices include: hard drives, CD-ROM, MaxIT, SyQuest, Panasonic PD, Zip etc

**FREE  
INSTALLATION!**  
When Combo Case is purchased  
we will install SCSI devices  
absolutely FREE!

- Slot 1
- Slot 2
- SCSI terminator
- 25/50 way SCSI cable
- Own internal PSU
- SCSI in & expansion
- SCSI ID selectors
- Daisychain power
- Whisper-quiet fan
- Phono output (to hi-fi etc)

Combo Case £60  
(£70.50 inc VAT)

Illustration shows Combo Case with CD-ROM



Front



Back

**FREE!**  
HEADPHONES



CASTLE TECHNOLOGY  
01728 621222

Delivery: £10 (**£11.75 inc VAT**) per order.  
Cheques (allow 5 working days to clear), debit cards (Switch & Delta), credit cards (2% charge may apply), and educational orders accepted. All trademarks acknowledged. E&OE



CASTLE TECHNOLOGY  
Ore Trading Estate Woodbridge Road  
Framlingham Suffolk IP13 9LL  
e-mail: sales@castle-technology.co.uk  
Web: http://www.castle-technology.co.uk

## • regulars

- 6 News**  
Find out what's new in the Acorn world
- 13 Graphics**  
The latest from Aspek
- 15 Comms**  
Introducing Twisted Spires BBS
- 16 Public Domain**  
Catch up on all the latest PD news
- 19 Business page**  
Hardware on the move
- 21 Portables**  
The PC card-modem adaptor

- 23 Cover disc**  
Software to keep you busy for hours

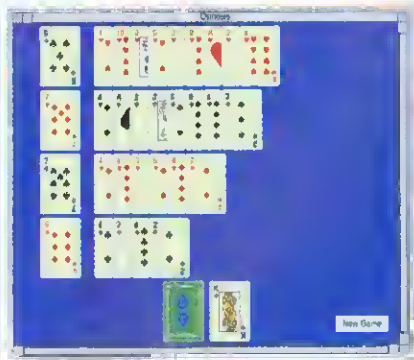

**'Get Online' now  
for only £89**

**A fantastic special offer  
with Argonet  
See page 84  
for full details**

## • reviews

- 48 Armchair surfing**  
The NetStation from another perspective

## • features

- 27 Font handling**  
Font design made easy

**Acorn World 97**

**All you need to know  
before your visit to  
Wembley - turn to  
page 33**

**Managing Editor** Pam Turnbull  
**Editor** Steve Turnbull  
**Assistant Editor** Karen Peach  
**Art Editor** Ed Burke  
**Sub Editor** Justine Bowden

### Contributors

Dave Acton, Ian Burley, Mike Cook, David Dade, Simon Kiff, Jack Kreindler, Dave Lawrence, David Mathewman, Steve Mumford, Graham Nelson, Geoff Preston, Jiff Regan, Clive Semmens, Mark Taylor, Mike Tomkinson, Paul Wheatley

**Group Advertisement Manager**  
Elaine Prescott

**Account Manager** Ian Antrobus

**Account Executive** Carl Jackson

**Ad Production** Barbara Newall

**Ad Typesetting** Malcolm Thorley

**Marketing Manager** Steve Tagger

**Marketing Assistant** Jane Comber

**Production Manager** Alan Capper

**Production Assistant** Joanne Clifford

**Circulation Director** David Wren

**Distribution** COMAG (01895) 444055

### Subscriptions & Back Issues

Database Direct 0151-357 1275

**Email:** database@dbdirect.demon.co.uk

**Managing Director** Ian Bloomfield

**Cover** Tym Lecky/Ed Burke

Member of the Audit Bureau of Circulation  
Acorn User is an independent publication and Acorn is  
not responsible for any of the articles in this issue or  
for any of the opinions expressed



Published by IDG Media Ltd,  
Media House, Adlington Park, Macclesfield SK10 4NP  
e-mail [aueditor@idg.co.uk](mailto:aueditor@idg.co.uk)  
<http://www.idg.co.uk/acornuser/>  
Tel: (01625) 878888 Fax: (01625) 850652  
Printed by Apple Web Offset, Warrington

13 issue subscription rate: £39.99 (UK),  
£53.99 (EU), £68.99 (World)

©1997 IDG Media Ltd.  
No material may be reproduced in whole or in part without written  
permission. While every care is taken, the publishers cannot be held  
legally responsible for any errors in articles, listings or advertisements  
and the views of contributors do not necessarily reflect the views  
of the publishers

- 61 Game Show**  
Get up-to-date with our games news

- 86 Back issues**  
Buy now to complete your  
collection of *Acorn User*

- 87 Letters**  
Air your views on the pages of *Acorn User*

- 90 The Regan Files**  
Alexander Streater and the Acorn  
scene in Japan

## • hands on

- 65 \*INFO**  
Are you a winner of the Spooky  
competition? Find out here

- 77 Rambles through  
Acorn Wood**  
Mike Cook tackles more of your  
problems

- 81 Checking the instruction**  
Using a software PIC simulator

- 85 C for yourself**  
Get in control of your fonts

## • education

- 57 Education news**  
Including the latest from Anglia

- 58 At last - Advance Level 4**  
A look at this new fileserver software

**NEW  
SUBSCRIPTION  
OFFER**

See page 74 for more details

### The Acorn User Web site

Check it out at:  
<http://www.idg.co.uk/acornuser/>

### Advertisers index

See page 83 for details

### Next month in **Acorn User**

**Acorn User CD-ROM 3**  
On the next issue of *Acorn User* get your free CD-ROM  
packed with the latest  
software and information -  
don't miss it

**Next issue** on sale 30 October 1997







## Computer Concepts, Xara and now Zyris

It's an unofficial fact that Computer Concepts has now virtually ceased software development for the Acorn platform, however, Acorn roots refuse to dock. The Xara side of the Computer Concepts group has been working in the PC software market for nearly five years.

Many expected the company would wash their hands of the Acorn connection once and for all, but the latest venture to emanate from Gaddesden Place maintains one more link with Acorn. The new company, called Zyris, is a joint venture between Computer Concepts founder, Charles Moir and Nova Fisher - who heads up Minerva Software and the Zynet Internet service provider. If that wasn't enough, Acorn former technical supremo, Malcolm Bird, has also joined the new venture as a non-executive director.

So what is Zyris all about? When we spoke to Charles Moir he was being somewhat coy about the potential of Zyris. After all, his plans are not unique and there are some competitors to watch out for.

Basically, Moir believes the future lies on the World Wide Web. Software Computer Concepts and Xara have developed almost entirely products which are designed to run inside the computer in front of you. Zyris is all about software on world-wide world servers, powerful computers which can be accessed from anywhere where there is a suitable Internet access point. This brings us to another Acorn link - NCs. Zyris-hosted services on the World Wide Web will be ideal for so called thin clients, Network Computers or NCs.

The opportunities are almost limitless. There are already several examples of diverse services being hosted by servers on the World Wide Web, for example, Web e-mail, search engines, catalogues, news services and video conferencing. Some of these services require software to be run on the 'client' side - your computer in other words. However, Zyris are banking on the success of the now ubiquitous Web browser.

Zyris applications will run entirely on the central server without the need for specialist software on the client. For example, the latest Xara software release is a 3D application. A Xara customer can buy and download this application over the World Wide Web, but the software must be run on the user's own computer. If you are not within reach of your computer you don't have access to that software.

Today, to avoid this situation, many people resort to using computers they carry with them. Charles Moir sees a future where you will not need portable computers - you will simply use the nearest computer connected to the Internet via a standard World

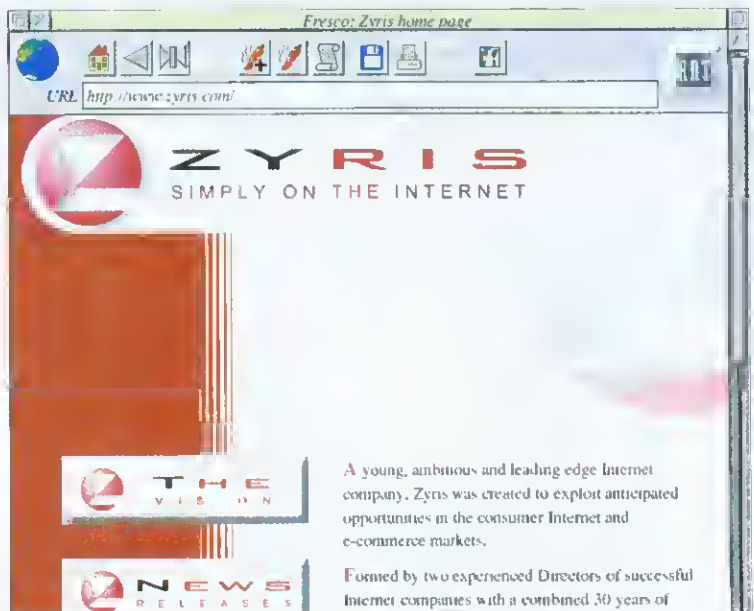

Wide Web browser. Of course many of these computers will be NCs. Zyris are scheduling their official launch in November or thereabouts, and will start by hosting a selection of services themselves. Later it is expected the software developed for these services will be made available to other Internet or intranet service providers. Meanwhile Zyris are recruiting staff for the new company.

While Nova Fisher and Charles Moir will be on the board of directors, they are also looking for a candidate for the position of managing director. 'Alas, the Zyris software has no direct Acorn link. Zyris will be supporting Windows NT and Unix'. Sales will be supporting Microsoft Windows NT and Unix. There isn't even a connection to Java. The basic common denominator is HTML 3.2 - as long as your browser supports this level of HTML you should be able to use Zyris services.

Payment is likely to be via a subscription and when a standard for electronic payment over the Internet is agreed upon it is likely that Zyris will be able to charge per use without the need for an account. At the time of writing Zyris had not yet been officially launched. However, there is a Zyris home page on the Web at <http://www.zyris.com>

## Acorn World show rescued

Serious problems hit the Acorn World show just two months before the event was scheduled to take place. The good news is that Acorn have stepped in and saved the day. Problems became apparent when people found they were not able to purchase advance tickets for the show and there were even reports that the Wembley ticket office was telling enquirers that the show had been postponed.

Behind the scenes, the contracted organiser of the show - EPS Events - had apparently begun to experience difficulties in their business relationship with the Wembley venue. Eventually it was clear that neither EPS nor their sister company

EPS HOYS (Horse of the Year Show), would be able to organise Acorn World 97 at Wembley. Acorn have since stepped into the fray and assumed the role of organiser.

Unfortunately, at the time of writing, there was concern that deposits paid by exhibitors to the former organisers might be lost. It also seems Acorn were not able to obtain details of exhibitors who had

previously booked stand space with the original organisers. This meant a lot of hard work contacting dozens of companies to find whether they had previously booked space and whether or not they had paid deposits.

The encouraging news is that as we went to press, Acorn confirmed the show would take place as originally planned. Advance ticket sales have re-started and Acorn are working hard to address the situation regarding exhibitors. With a bit of luck these problems will not have any effect on the end product in any major way. If you have not yet ordered your advance tickets the number to ring is: 0181-982 6500.





## Eesox ships new SCSI-2 card

Last month it was Castle technology who launched a new SCSI-2 card. This month it is the turn of Eesox to launch their own. The new Eesox card is capable of transferring data at up to seven megabytes per second in asynchronous mode and ten megabytes per second in synchronous mode using DMA on a Risc PC.

Other features include background transfers, a cached filing system and enhanced SCSI driver software from Eesox. The card is auto-configuring so there is no need to enter awkward configuration commands every time you change, add or remove a device. Eesox said that software is provided with the card to enable any hard disc or CD-ROM drive to be used.

Additional drivers may be required for specific devices, such as scanners or CD-writers. The card is also supplied with a program called *SCSI*

*Director*, which is designed to maintain SCSI peripherals – formatting and verifying, etc.

Four gigabyte partitions are possible using the Eesox card and up to eight partitions per device can be set up. The card can be used with all Archimedes and recent Acorn RISC computers which have standard 16-bit full size podule slots. Risc PC and A7000 models make best use of the cards performance because they support DMA.

Eesox is charging £125 plus VAT for the SCSI-2 card. There is also a £25 discount on the card if you buy a SCSI peripheral from Eesox at the same time.

Eesox

Tel: 01954 208208

E-mail: [sales@eesox.demon.co.uk](mailto:sales@eesox.demon.co.uk)

WWW:<http://www.eesox.demon.co.uk>

## Portable doubts

It was with some frustration that the Acorn Products Group learned that it is now unlikely that they will be able to market a consumer version of the portable computer which was shown at the Wakefield show earlier in the year.

Acorn have never tried to avoid the fact that the prototype portable shown at Wakefield was primarily a development project for an unnamed US company. The Acorn Products Business were banking on the portable project being put into production so that a version of the computer could have been produced for the consumer market. However, Acorn's US client has decided that the portable form factor for the

device they ultimately required is not the answer. Unless, the same client revives the portable project or another client takes an interest in it, it is unlikely that a consumer version will be possible.

The news is frustrating and removes one of the forthcoming highlights of the Acorn World show. However, we understand that Chris Cox, who heads the Product Business section, is working on another attraction to replace the portable at the show. Unfortunately, we were not able to find out precisely what this might be – so perhaps there's another good reason for visiting the show!

## New integrated StrongARM from Digital

It had to happen sooner or later – Digital Semiconductor has produced an integrated version of the StrongARM processor which includes practically everything a system designer would require for a portable battery-powered device with a LCD screen and PC card slots.

The new SA-1100 chip includes system support logic, multiple serial communication channels, a colour/grey scale LCD controller, PCMCIA support for up to two sockets and general purpose I/O ports. Sounds familiar? The new chip is practically a StrongARM version of the older ARM 7500, though without external monitor drivers, or more closely the ARM 7800 as used in the new Pision Series 5 palmtop computer.

The Series 5 chugs along at a relatively sedate 18MHz, so a StrongARM version of the Series 5 would see a dramatic performance improvement – even at the SA1100's slower speed option of 133MHz. The faster option is 200MHz. The only component missing appears to be a floating point arithmetic processor, but if the ARM 7500

FE can have one, so can the SA-1100, one day. Digital says the SA-1100 is aimed at handheld personal computers or HPCs, smart phones, digital cameras, subnotebook computers, wallet personal computers, screen and Web phones and portable NCs. The only item on that list Acorn haven't publicly revealed that they have worked on is the wallet computer. The maximum heat dissipation of the SA-1100 is still minuscule at half a watt.

To put this into perspective, Cyrix, which recently introduced a Pentium MMX clone, were singing the praises of its product's sub-15 watt figure. Digital are also highlighting the potential of the SA-1100 for voice recognition and Java performance.

A list of nine supported operating systems can be found in Digital's literature, though oddly there is no mention of either RISC OS or NCOS. This is odd because RISC OS patently will work on the SA-1100, and NCOS version 1 is RISC OS by another name, plus NCOS 2 is a Digital NC operating system which runs on the StrongARM platform.

## Acorn licenses Java

It is certainly no secret that Acorn are developing a Java Virtual Machine (VM) – it's a vital ingredient for the long term viability of Acorn's NC product line and it's called RISCafé. The news is that Acorn have finally paid up front for a Java licence, which suggests that RISCafé is nearing its debut as a full commercial product, likely to be made available to NC customers and, of course, Acorn's third party NC clients. RISCafé is a run-time environment for executing Java applications which operates on top of RISC OS.

## 233MHz StrongARMS

Digital Semiconductor have started to produce 233MHz StrongARMS, replacing production of the original and familiar 200MHz parts which have been used in the flagship Risc PC until now. In fact some StrongARM Risc PCs have already started to ship with the faster StrongARM fitted because the summer Risc PC promotion was more successful than anticipated, exhausting stocks of the 200MHz model.

It had originally been planned to launch the faster StrongARM Risc PC at Acorn World 97. StrongARM upgrade kits are still being supplied with the old chip, but 233MHz upgrades will be available from Acorn World 97. Despite the slight performance boost there is no change to pricing.

## ARM Club events coming up

The National Motorcycle Museum will be the venue for The ARM Club's Midlands Show on December 6th. More details on this event can be found at <http://www.armclub.org.uk/shows/midlands.html> and anyone wishing to exhibit there should contact [ralph@armclub.org.uk](mailto:ralph@armclub.org.uk) for details. The club will also be returning to Merton Court School in Sidcup, Kent on March 1 1998. Details of this event can be found on the Web at <http://www.armclub.org.uk/shows/sidcup/index.html>



## Rewritable DVD news



CD-ROM as we know it is definitely old hat now. Who needs a 24X drive if it only holds a paltry 650 megabytes? That was obviously a tongue in cheek observation, but with the imminent arrival of DVD-ROM and DVD-RAM (rewritable), good old CD-ROM is going to look very ordinary indeed.

DVD-ROM drives are already filtering onto the market. Commercial content on DVD-ROM promises over two hours of top quality video and stereo sound courtesy of MPEG-2 A/V compression – there will be no need to swap CDs in the middle of a movie. A single-sided single density DVD-ROM has the space for nearly five gigabytes of data, enough to store the contents of more than seven 650Mb CD-ROMs. Ultimately, a single double-sided, double-layered DVD-ROM will contain 17Gb of storage space – that's 26 CDs or about 12,000 floppy discs! The big news is that some of the

most important CD-ROM players have agreed on a specification for phase change rewritable CDs which will be compatible with the DVD standard.

The companies which have announced the agreement include Hewlett-Packard, Philips Electronics, Sony, Mitsubishi, Ricoh and Yamaha. Conspicuous by its absence from the ranks are Panasonic, who pioneered the original PD format phase change standard which marketed as a CD-ROM drive enhancement, but wasn't actually CD-ROM compatible.

Phase change describes the two optical states of the recording medium which can be written using a single-pass laser system, unlike magneto-optical (MO) drives, which require two passes per write. Phase change is purely optical and the blank media is considerably cheaper to produce than MO.

The new phase-change rewritable specification presented by the group of companies is based on a standard 120mm disc format designed to be read by future DVD-ROM drives. This data-storage format specifies an initial capacity of 3.0Gb per disc surface. In the Constant Angular Velocity (CAV)(1) mode high-performance random access and transfer rates are achieved by using techniques similar to those used in hard disc drives. The official name for these new devices will be 'DVD+RW' drives.

As yet there is no firm idea of when DVD+RW drives will appear in quantity or how much the drives will cost. However, the possible uses are clear. Five hours of CD-quality audio could be recorded on a 3Gb disc, or a little more than five hours of MPEG-1 video. Or how about 125 uncompressed 600dpi 24-bit 6x4 inch photo scans? 3Gb is larger than many hard disc drives too, so drive hack-ups could be a doddle. SCSI is likely to be one of the main interface options for these DVD drives, so the Acorn platform looks well equipped to embrace the new technology.

## Calling all would-be butlers

A Psion Series 3, or the Acorn Pocket Book equivalent, is now one of the recommended tools for learning to be a successful butler. Welsh butler, John Thomas, says life wouldn't be the same without his Psion Series 3a. 'I know it's not exactly in keeping with a butler's image, but I'd be lost without my Psion,' he explained. Thomas, a butler of eight years now runs his own

training school for butlers and household personnel. He added: 'I use mine daily to make appointments, write class notes, or send and receive faxes.'

A Series 3 is now included in the syllabus of his butler training course in order to encourage trainees to use the technology. He explained: 'Apart from training students how to clean silver, lay tables and serve

food, I also introduce them to the advantages of owning a Psion.'

The main uses a 21st century-style butler will put his pocket computer to include stock control – the wine list, for example, surfing the Net, e-mail and sending faxes. 'I've even been known to take it to bed with me, to tap in some last-minute notes,' said Thomas.

## Acorn sets up shop in Taiwan

Taiwan is to computers as Hong Kong is to plastic toys or Japan is to cars. Taiwan is the busiest computer manufacturing country in the world. A few other countries may exceed Taiwan's bottom-line computer manufacturing volume and value in a given year, but Taiwan single-handedly produces more different brands, makes and models of computers and component parts than anywhere else.

With this knowledge, it's not difficult to understand why Acorn have tied a deal with Lumax Technology Inc., based in Taiwan's capital city of Taipei, to act as its Taiwanese agent. Lumax Technology are no strangers to Acorn, as they have been promoting the Digital StrongARM in this market for some time.

Eric Chou, executive vice president of Lumax Technology Inc. commented: 'Since our founding in 1975, Lumax have excelled as a solution supplier of high-tech products in Taiwan and China. Utilising our established technical background and familiarity with the Asian

high-tech industry, we are confident that we will be an outstanding representative for Acorn.' Peter Bondar, Acorn's senior vice president of technologies and engineering, commented: 'Our Asian presence is getting stronger by the day. We are already working with Samsung in Korea, and NTT in Japan, so this is the next logical step forward. The Taiwanese market is an exciting place to be, and the fact that we're working with a recognised leader in this market to promote all design and licensing opportunities for Acorn's technology is just fantastic. We look forward to a long and successful relationship with Lumax.'

It's still early days for the NC or thin Internet client market, but if and when this market takes off, the myriad of small and medium-sized computer manufacturers in Taiwan will move to ride the market. Acorn's deal with Lumax is designed to ensure that Acorn technology will be at the top of the shopping list among the Taiwanese manufacturers when the big day finally arrives.





## Oregan serves up the mail

Like the new Zyris venture from Computer Concepts founder, Charles Moir, Oregan's new *NC-Mail* product adopts the Internet server as a centralised and universally accessible service. *NC-Mail* is a server-side e-mail processor, mailbox and transmission tool. It was developed primarily for the Acorn-based NC or NetStation and is designed to integrate with the ROM-based *NCFresco* web browser, by providing browser "mailto:" URL support, as well as conventional e-mail sending and receiving capability.

Rather than use the server as a temporary store for your messages which are then downloaded to your local computer via a mail client program, the Oregan system simply needs a browser to view and edit received mail as well as prepare new mail and then send it. All the action happens on the server, with the browser serving as a remote display.

*NC-Mail* supports customised signature attachments and address books, e-mail save, print and forwarding, provides "mailto:" URL processing capability, optional quoting of original mail, minimal client processing – virtually no overheads on an NC plus extensive customi-

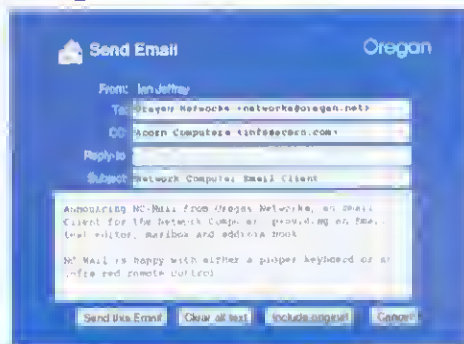

sation available via an extra client-side handler. The beauty of the system is that you don't need a specific computer to access your e-mail, which is certainly the case with most Internet e-mail users at present. You could, in theory, wander up to any old NC or PC with a standard browser and Internet connection, log-in to your mail server site on the Web and then carry out mail actions remotely.

Oregan

Tel: 0121 353 6044

E-mail: [networks@oregan.net](mailto:networks@oregan.net)

## Image processing on your NC

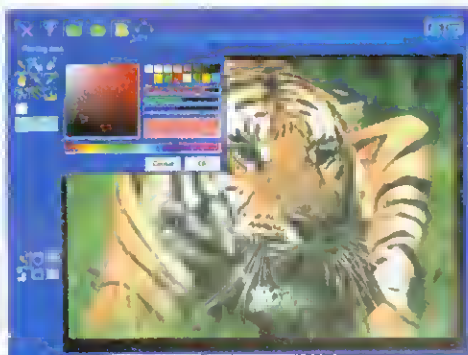

Oregan are taking on the brave new world of Network Computing with products on both sides of the client/server divide. In another story this month we bring news of a server-side e-mail facility for NCs from the Midlands company. At the same time, Oregan have introduced an image processing package for NCs called *NC-Photo*.

Oregan describes *NC-Photo* as an image processing, photo-retouching and colour painting tool all in one package. *NC-Photo* has been designed specifically for the Network Computer, with a consistent NC look and feel, integrating seamlessly with other NC tools. The package includes dozens of filters, special-effects and image controls and it is able to import and export industry standard image file types, like JPEG, GIF and TIFF.

All special effects, image enhancement, and filter operations may be applied globally, or may be gradually applied using any of the *NC-Photo* painting tools. There is a cloning brush, airbrush, a texture builder, transparency, translucency, colour correction, linear and gradient fills, morphing and other distortions, scratching, rippling, embossing and protection masking.

Oregan

Tel: 0121 353 6044

E-mail: [networks@oregan.net](mailto:networks@oregan.net)

## Teething problems

The Internet is a wonderful thing and people are trying out new and increasingly clever applications across the Internet. Some might say that one day you will be able to do anything on the Internet using an NC, within reason. BT's latest smart idea is to use the Internet as a virtual slide projector to accompany telephone conferences.

Basically, you log onto the host website which displays the 'projection' screen and a conference moderator on the phone introduces speakers who can display their electronic slides to all the participants through their Web browsers. So you're

listening to the person giving the talk on the phone and watching their presentation on the Web.

Nice idea BT, but it would be better to make sure it works before trying to demonstrate it live. Myself and 15 other journalists were literally hanging around on the Internet twiddling our thumbs while BT tried to jump-start the Internet 'projector'. After an hour's delay and a second abortive re-start, the demonstration was abandoned. Apparently BT's network was experiencing problems. The Internet is a wonder, but it also has teeth to bite you with!

## Get the DARC bus to Acorn World

Derbyshire Acorn Risc Club (DARC) are offering a limited number of places on their special coach which will take both members and non-members to the Acorn World show this year.

The coach will start at Matlock, but people will also have the opportunity of joining the coach at several pick up points during the journey. St.Helens House in Derby and also Thulston are definite pick-up points and it's possible the coach will be able to stop at other points on the A6 through to Junction 24 of the M1.

Anyone who is interested can get the latest details of cost and pick-up points from the club secretary, Margaret Barefoot, e-mail: [barefoot@btinternet.com](mailto:barefoot@btinternet.com)

## Werewolf's new number

Werewolf Software's new phone number is 0181 289 6003. The old one still works, but it's now best to use the new one.

Werewolf will also have their own independent stand at Acorn World for the first time. One of the highlights will be none other than the new game *Sheep Racing Deluxe*, plus various special offers.

Werewolf Software

<http://www.werewolf.demon.co.uk/>

## ESP takes on Audio Dynamics MIDI

ESP have announced they have taken over the licence of the Audio Dynamics DMI MIDI card along with its associated range of XG Synthesiser and Sampler options.

ESP says they are committed to the long-term support and development of MIDI and Sound on the Acorn platform, including extended software support for the DMI cards. Any orders for equipment and upgrades placed with Beebug have now been passed on to ESP.

ESP

Tel: 0115 944 4140

Fax: 0115 944 4150

E-mail:

[sales@exsoftpr.demon.co.uk](mailto:sales@exsoftpr.demon.co.uk)

WWW:

<http://www.cybervillage.co.uk/acorn/esp/>



## Acorn dangles the NC carrot

Acorn believes the NC's market's proverbial 'big bang' is now just waiting to be ignited. Much of the hard work in researching and designing the NC platform is finished. All Acorn and their many partners and competitors need is some strong market growth.

In a bold move to deliver just that, Acorn have decided to offer their Network Computer hardware production and reference designs free of charge to licensees of RISC OS, the same operating system we all use in our desktop Acorns which is at the heart of Acorn NCs. A tailored version of RISC OS was licensed to Oracle to form their ARM-processor-based NCOS (Network Computer OS) operating system.

By charging only for the operating system licence, Acorn are simplifying the deal and hopefully encouraging more players to take the plunge with them. The designs being offered free of charge include updated and lower cost versions of the NC reference designs that were originally developed by Acorn for Oracle. Acorn's existing customers for these

designs include RCA, Zenith, Akai and NetProducts. Peter Bondar, Acorn's senior vice president of technologies and engineering, commented: 'These changes in the license pricing structure will ultimately benefit the consumer, because Acorn will now be able to offer more companies the NC technology at lower costs. This will spur the growth of the market, making the final products less expensive and more widely available to the public.'

He added: 'This is a fantastic opportunity, both for Acorn and our RISC OS licensees. We have the hardware designs, the operating system, and excellent relationships with content providers and manufacturers. This allows Acorn to be a one-stop shopping centre for anyone hoping to create a digital product, or enhance one they already have.'

By licensing RISC OS, Acorn can open avenues to lucrative development contracts which will involve designing, developing and production-engineering RISC OS-based devices for their clients. Acorn also believes

that they can bring designs to fruition more quickly than anyone else because they have most of the technology on the shelf already.

Projects will often require the relatively simple job of cementing some of the Acorn library or 'kit bag' as Bondar likes to put it, building blocks together with production in mind. With NCs, you're not just talking about a standalone product. Network providers and content providers become important partners as well. Acorn have these in their armoury as well, with the likes of Curtis Mathes Xpressway(tm), NetChannel and Argonet to provide services to include such features as managed access (providing secure storage space for online users) and the integration of Acorn's flashDisplay(TM) technology.

Acorn's own press release unashamedly declares that Acorn network computer technology is at the heart of more Original Equipment Manufacturer (OEM) NC products than any other technology. Making its reference designs free of charge should help Acorn to keep this advantage.

### Siren TECHNOLOGIES



### Siren Technologies

Siren Technologies Ltd is a newly created company incorporating Siren Software Systems and will continue to market and support their product portfolio. Siren Technologies will trade under two operating divisions - SirenSOFT and SirenNET.

The role of SirenSOFT will be to continue to market Siren Software Systems' product range in particular the Neos, Time and Attendance System and to continue to support the Acorn platform.

SirenNET will aim to provide Internet consultancy and design services for small to medium sized businesses. The new contact details are as follows:

All correspondence to Siren Technologies Ltd, 11 Eastville, Birmingham, B31 3UJ. Tel: 0121-683 8440 (Siren Technologies and SirenSOFT), tel: 0121-683 8441 (SirenNET). Fax: 0121-683 8444. E-mail: sirentech@argonet.co.uk (Siren Technologies Ltd), sirensoft@argonet.co.uk (SirenSOFT), sirennet@argonet.co.uk (SirenNET). The URL for their Web site is now: <http://www.siren.co.uk>

## New products/upgrades

Product	New features/Product details	Price	Contact
ClipNET	*Network clip art browser to work alongside Mr Clippy	£31 50 incl p&p & full site licence (Mr Clippy costs £20)	iSV Products Tel: 01344 55769
PDCD5	*Latest demos *Over 1000 utilities * Games * Rasmol plus scripts and PDB files * Zip2000 adventure system and adventure files * Flight Sims * Internet Software * Animations * Educational Software	£17 50 incl VAT & postage	The Datafile Tel: 01934 644048
DrawWorks Designer	* New version of DrawWorks package * Will include named colours, definable text styles, selection of default font, path moulding and more * New interface	Not fixed yet. Upgrades from DrawWorks2 available at AW — take master disc to iSV stand	iSV Products Tel: 01344 55769
*Fast* SCSI interface	* Designed to make using SCSI simple and easy * For use with many different SCSI devices * Simple to install & auto-configuring * SCSI Director provided	£125 (ex VAT and carriage)	Eesox Tel: 01954 208208
Rocks, Minerals & Fossils Picturebase CD-ROM	* Origin & properties of common rocks and minerals * Mining * Identifying fossils & more * Covers KS3 & 4 requirements	£69 + VAT	AVP Tel: 01291 625439
Physical Processes Picturebase CD-ROM	* For KS2 and 3 science * Covers forces and motion, light and sound, the earth and beyond, energy resources and transfer and electricity and magnetism	£69 + VAT	AVP Tel: 01291 625439
Mathsbook 2	* To help children improve their multiplication and division * On screen help * Monitors progress * Tailors itself to the changing needs of the child * Progress recorded * Fully configurable	£35 + VAT Site licence: £70 + VAT Half price to existing MathsBook1 owners 'til Dec 31 1997	Topologika Tel: 01326 377771
Simple Circuits	* A simple simulation to help students learn about electrical circuits * Includes worksheets and notes	A3000 - A5000 & Risc PC site licence - £25 + VAT & P&P	SoftTeach Tel: 01965 840329

### Contacting me

You can contact the news page by writing to me Ian Burley at the usual Acorn User address or by e-mail: [aunews@idg.co.uk](mailto:aunews@idg.co.uk)

Acorn 

# BEEBUG

Acorn 

## StrongARM Risc PC Upgrades

See below for BEEBUG Special Offers when you purchase a Risc PC

**PLUS**

**Free RISC User Magazine Subscription & Free Ovation DTP**

**Plus 0% Finance** (subject to status, phone for details)

VisionMaster 15" add	£34.63
VisionMaster 17" add	£311.37
VisionMaster Pro 17" add	£395.62

8Mb SIMM	£40.00
16Mb SIMM	£68.00
32Mb SIMM	£140.00
1Mb VRAM (expandable)	£70.00
2Mb VRAM	£105.00

CD Drive Twelve Speed IDE	£99.00
CD Drive Twenty Four Speed IDE	£116.33
CD Drive Twelve Speed SCSI	£170.38
CD Drive Writable PD Drive	£398.33

StrongARM Upgrade (for old style RPC's)	£292.58
SCSI I Interface	£116.33
SCSI II Interface	£175.00
PC DX4-100 Card with Risc PC (£351.33 without)	£233.83
PC 5x86 Card with Risc PC (£468.83 without)	£351.33
2 Slot Backplane (for 4Mb Risc PC)	£35.19
2nd Slice (inc. 4 slot Backplane)	£90.00
!PC Pro Upgrade (incl PC Exchange)	£49.00

If upgrading the original 1.2Gb hard drive, deduct £100 from the following prices:

2GB Drive IDE	£205.00
2GB Drive SCSI	£434.75
4GB Drive SCSI	£787.25

Windows 95 OEM (CD)	£79.00
Windows Workgroups 3.11 OEM (CD)	£64.63

## StrongARM 200MHz Risc PC

This is the most flexible machine in Acorn's range and has a wide range of cost effective upgrades. Please phone for our full listing. All hardware upgrades are fitted free of charge.

Have your Risc PC system tailor-made to meet your requirements. All systems are supplied with 1 year warranty, including 1 year free technical support. Trade-in discount available.

<b>Risc PC 4Mb HD1.2Gb/AKF60</b> . . . . .	<b>£1397.70</b>
<b>Risc PC 4Mb HD1.2Gb x8CD/AKF60</b> . . .	<b>£1482.96</b>
<b>Risc PC 10Mb HD1.2Gb/AKF60</b> . . . . .	<b>£1697.70</b>
<b>Risc PC 10Mb HD1.2Gb x8CD/AKF60</b> . .	<b>£1782.95</b>



## NEW Acorn A7000+

This is the first production Acorn computer with an integrated Floating Point Accelerator. The combination of a fast 7500FE processor and high-speed EDO DRAM give a dramatic improvement in desktop performance, but

with no increase in price! The A7000+ offers: 8Mb EDO RAM, 1.2Gb IDE hard drive, RISC OS 3.71, Floating Point Accelerator, Integrated 16-bit digital stereo sound, 1.6Mb floppy drive, VGA, SVGA, and other resolutions

<b>A7000+ 8Mb HD1.2Gb</b> . . . . .	<b>£1099.00</b>
<b>A7000+ 8Mb HD1.2Gb 8xCD</b> . . . . .	<b>£1199.00</b>



## BEEBUG OFFERS

Choose one offer per Risc PC purchased.

Offer valid 1st Sept to 25th Oct 1997, subject to availability.

And you still get the Beebug offers of FREE Ovation DTP & RISC User Magazine Subscription

### OFFER 1

FREE Canon  
BJC4200 Bubblejet  
Colour Printer  
RRP £210

### OFFER 2

USR 33,600 external  
modem, ANT Internet  
Suite & Internet  
Survival Guide  
Only £150  
(normally £276)

### OR

£140 off  
any other  
purchase from  
BEEBUG

### OFFER 3

FREE 12 speed  
CD-ROM Drive &  
15W Speakers  
Worth £141

### OFFER 4

Beebug  
Multimedia Pack  
Only £400  
(normally £515)

BEEBUG Ltd., 117 Hatfield Road, St Albans, Herts AL1 4JS

Tel: 01727 840303 Fax: 01727 860263 Email: sales@beebug.co.uk

Prices & Specifications maybe subject to change Prices include VAT Courier Delivery from £11.75

# Videodesk

Full-frame, True-Colour, Non-Linear Video Editing System.

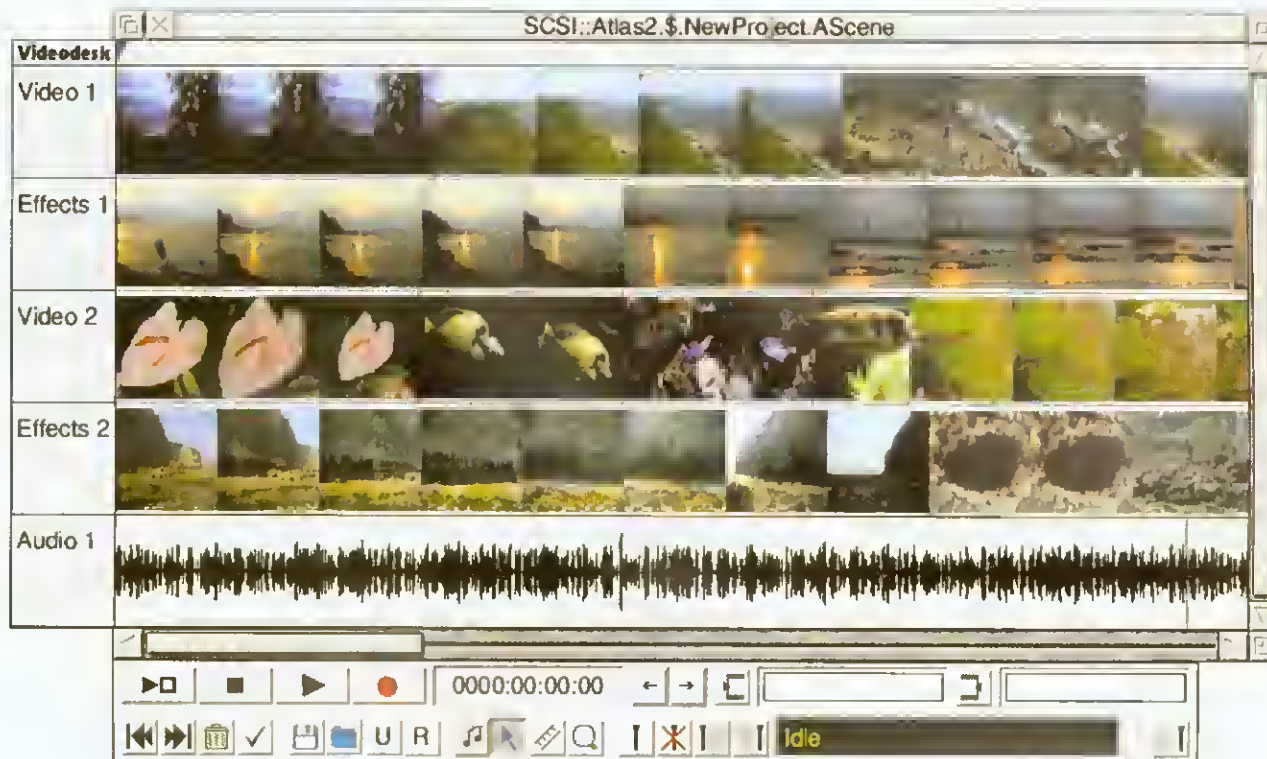

## Videodesk

- Frame accurate editing.
- Separate audio and video tracks.
- Instant playback of edits.
- Effects include mix, fade and wipes etc.
- Multi-level undo and redo.
- User selectable quality factor up to S-VHS\*.
- Composite and S-Video inputs and outputs.
- Resolution of up to 768 pixels x 576 lines.
- 50 fields per second capture and playback.
- 24 bit colour range.
- 16 bit stereo inputs and outputs.
- Audio sampling up to CD and DAT rates.
- Direct-to-disc recording.
- Built-in hardware Moving JPEG (MJPEG) Codec.
- Contrast, Brightness and Saturation adjustment.

Videodesk is a significant advance in video editing for Acorn machines. It allows full-size, full-colour and full-motion video to be compressed to disc in real-time using MJPEG hardware. The compressed data can be edited frame accurately and output back to video. Unlike tape-based editing systems there is no generation loss or waiting for tapes to rewind.

Complete video editing software is supplied as standard, which is sophisticated, flexible and simple-to-use. Editing is done on a multi-track time-line with separate audio and video tracks. Effects are generated digitally and include mixes, wipes and fades. Sequences of clips can be played back continuously without waiting for them to be assembled into a single file. So there is no waiting to preview an edit and disc space is not wasted. **RiscTV** is supported for real-time desktop display up to full-screen size.

Videodesk is available now direct from Irlam Instruments Ltd.



For the Complete Picture...

**Irlam Instruments Ltd**, Brunel Institute for Bioengineering, Brunel University, Uxbridge, Middlesex, UBB 3PH. Tel/Fax 01895 811401. Email: sales@irlam.co.uk  
Website: [www.irlam-instruments.co.uk](http://www.irlam-instruments.co.uk)

Please note: Videodesk requires a RISC PC, large fast hard disc and 8Mb RAM minimum. A StrongARM processor is recommended. Check suitability for your computer before ordering. 1 years guarantee. E & OE.

\*To obtain good quality video requires storage of around 1.5Mb per second (5.4Gb per hour).

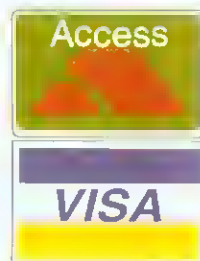

# graphics



## 3D engine - to render all others obsolete?

Aspex, authors of *DaVinci 90*, the 3D graphics package, have given *Acorn User* an exclusive demo application of their latest developments. Aspex see the Virtual Reality Modelling Language, or VRML as their key interest.

VRML is probably the most comprehensive 3D graphics standard used on the Internet, and with many Acorn HTML (web page) authoring packages on the market, there seems to be a considerable market for a powerful 3D graphics editor specialising in this area.

Aspex have developed the new graphics engine from scratch and will be incorpo-

rated into *DaVinci 180*, the successor to *DaVinci 90*. The engine supports the latest revision of the VRML2 standard, VRML97, with an impressive specification including 8 to 32-bit Z buffered rendering modes; yaw, pitch and roll, walk, fly and examine; rendering modes from points to phong shading, texture, bump, chrome, environment mappings and transparency. Glowing lights, 'depth of field' and interactive, 'point and click' animation are other features *180* will support.

Aspex's demonstration program clearly illustrated the power and stability of their VRML97 engine and incorporated into a



simple to use but powerful editor as it will be in *DaVinci 180* - it may prove to be an unparalleled tool for 3D Internet graphics origination. It is as yet unclear whether *DaVinci's* modelling tools will ever match Sincronia's *TapModel* 3D application but hoards of users are now awaiting a more VRML angled application which Aspex's looks certain to deliver.

The future of the *DaVinci* series will continue on VRML lines with fuller support of the VRML.xx standard including sound and sound editing in the planned *DaVinci 270*. Sadly, because of being booked for another event, Aspex regret they will not be at Acorn World.

Aspex

Tel: 01822 611060

<http://www.aspexsoftware.com>



## Even more ViVid

iSV Products have announced an upgraded version of their software-only video performance upgrade for A7000 and Risc PC machines without VRAM.

The program costs a mere £11.50 all in, and now works for higher specification monitors than the low-medium grain 14in screens which previous versions were limited to. For anyone who cannot afford a hardware Video RAM upgrade, iSV's ViVid solutions are a must. Additionally, iSV's new version of *DrawWorks Designer*

will be released at Acorn World '97. I have not had any hands-on experience of the package yet, but as an evolution of its predecessor, *DrawWorks 2, Designer* should be another very useful addition to your vector graphics design suite. Features include multi-level undo and antialiased GIF file export for website imagery.

iSV

Tel: 01344 757769

E-mail: [atimbrell@aol.com](mailto:atimbrell@aol.com)

## Picture of the month

Kell Gatherer is this month's winner with probably the most detailed and intricate map yet submitted to the magazine. The *ArtWorks* file weighed in at a hefty 578K, and even on a StrongARM Risc PC it took well over 30 seconds to redraw.

Apart from the sheer complexity of the file, Kell has managed to liven up a two-dimensional, monochrome street map, something which has the potential of being very drab, and turn it into a very appealing design.

Kell has achieved this by a careful choice of fonts and by limiting the extent of the streets so they do not bleed into the grid, room was made for the attractive Location Works film location services logo. The map, created using the *!Streetmap* program makes up one side of a complimentary A5 road-finder of Soho, notorious in many ways, not just for its difficulty to navigate by foot or by car. On the other side are printed all the street names and their grid reference, and it all folds up into a credit card size - essential for anyone travelling through the streets of London.

Congratulations to Kell to whom the grand sum of £20 makes its way, providing the postman can find the address.



## Apologies

In last month's issue, the phone number for Akalat Publishing should have read 01582-881614. Apologies for any inconvenience caused.

## Contacting me

You can contact the graphics and DTP page by writing to me, Jack Kreindler, at *Acorn User*, Media House, Adlington Park, Macclesfield SK10 4NP, or by e-mail to [augrafix@idg.co.uk](mailto:augrafix@idg.co.uk).





## Twisted Spires – the last best BBS hope for East Anglia?

East Anglia was once served well by Acorn Bulletin Boards, and most have featured on this page at some time. Names like Archive, StarNet, Archipelago and Archiboard Central have passed into BBS history, but if you consider Peterborough to be in the East Anglian province, Mossoft and ARM Pit BBSs are still very much with us.

So it's good to be able to report the East Anglian

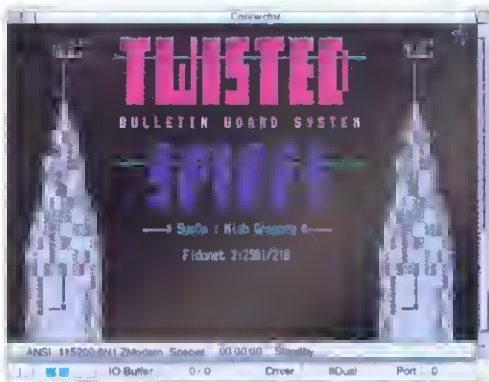

A new BBS to call between times?

birth of Twisted Spires BBS, run by Sysop Miah Gregory from the village of Gooderstone, midway between Swaffham and Downham Market in Norfolk. Miah is an A-level student at present and a keen Acorn computer user. He and a small group of friends are writing Acorn software, and projects in hand include a Net management system and a BBS server.

Twisted Spires' BBS runs NewsFlash software on

a Risc PC 600, with 17Mb of RAM and two hard discs totalling 1.4Gb, a 16 speed CD-ROM drive and a US Robotics Sportster 28k8 Fax modem. Miah says of the NewsFlash software, 'It's quite old, but up to the job and after a few additions is running better than ever'. In spite of this enthusiasm, he hopes to move over to his group's BBS server software eventually.

The BBS concentrates on its filebases and downloading as the main online activity. Point messaging is encouraged, where subscribers call in briefly to download their mail and choice message areas for reading offline on their own machines and a fully pre-configured mail package is available from Twisted Spires for this purpose.

The BBS is linked to five FidoNet-type BBS networks and gives users access to Internet e-mail and all the Acorn newsgroups cross-networked via FidoNet from other BBSs. Miah is working on an interesting development to allow World Wide Web type access to the BBS. This illustrates the kind of adapt-to-survive thinking that is needed to keep Bulletin Boards alive.

Miah says the name Twisted Spires was suggested by a friend, referring to the nearby village of Oxborough, which not only boasts moated Oxburgh Hall (1482), but a church with no spire at all – its wooden one fell down in 1879 to be replaced by a stone spire that also fell down in 1948. With luck Twisted Spires' BBS will stay up a bit longer.

*Twisted Spires BBS  
01366 328725 Ringback system – let ring once, then  
call back within one minute*

## The Acorn Webring – roses or noses?

David Horman's Acorn Webring seems to have created quite a stir in the Acorn newsgroups, but not in quite the way he expected. His idea is to link an expanding number of Acorn-interest World Wide Web sites, such as Acorn computer enthusiasts' home pages and software writers' freeware and shareware download sites by using a simple clickable icon set added to their pages, that takes you and your browser around the ring.

Webrings are not new and can be found linking websites specialising in many minority group subjects. David is the first to implement this idea for Acorn enthusiast websites though, and the Webring CGI software that creates the ring links runs on a server at the University of Bath. Joining is free and requires only a site ID number supplied by David and an HTML fragment to create the images and links.

What seems a fairly reasonable idea to help rationalise the mind-engulfing enormity of the Internet has not however left the Acorn Webring smelling of roses. Great enmity and name-calling has been rife in the newsgroups and it's been suggested as just being a way of dragging visitors by the nose to sites that don't deserve attention, and

that no-one with anything worth showing on their pages would want to join.

There are hundreds of Acorn users' websites with long lists of 'Acorn Links' which some people think offer you a more individual and considered choice of where to go next than being sent off to a randomly-selected site. But if you have never visited a particular site in one of these lists of links, what's the difference?

In fact, David couldn't have wished for a better advertising campaign if he'd tried, because the number of news articles with 'Acorn Webring' in their subject lines far exceeds the number of subscribing sites to the Webring, and no-one reading the newsgroups regularly could have missed at least one reference to it, and here's another:

*The Acorn Webring  
<http://www.bath.ac.uk/~ua6djuh/webrings/acorn/>*

### Contacting me

Keep sending me interesting URLs for the next yoUR List  
by e-mail to [david@arcade.demon.co.uk](mailto:david@arcade.demon.co.uk),  
or mail #2 on Arcade BBS 0181-654 2212.

### Werewolf bows out

Reluctantly Dane Koekoek has decided to close The Werewolf BBS after a run of over two years operation. An enthusiastic exponent of FidoNet BBS operation, Dane had become a well-known figure in the London FidoNet scene and demand built for 24 hour operation of The Werewolf BBS in April 1996.

A year later, the Internet has enticed away so many of those callers that Dane has decided to concentrate on his Werewolf Software business, but will remain as an observer of the BBS scene. We wish him well.

*Werewolf Software  
[dane@werewolf.demon.co.uk](mailto:dane@werewolf.demon.co.uk)*

### FreeNet moves

Stewart Brodie, author of ArcWeb and other excellent Internet applications, has now left Southampton University where the FreeNet software archive which he co-ordinated was hosted. The archive has now been moved to Barnet College, London, UK and the new site maintainer is Joseph Heenan (author of NewsHound).

Also from Barnet College, Carol Carpenter has assembled a new up-to-date version of the FreeNet Internet Suite Acornet. Discussions are in progress with Demon Internet to host a mirror of this site on their FTP service.

*FreeNet FTP site  
<ftp://freenet.barnet.ac.uk/pub/>  
[Acorn/freenet/](http://Acorn/freenet/)*

### It could be Mossoft

Mike Mostowjy of the 24 hour Peterborough-based Mossoft BBS now enters a line in the National Lottery each week on behalf of all his registered users who have added their names free of charge to his list for a share in any winnings he might get.

Mossoft BBS offers FidoNet Point mail, Netmail and Echo message areas, Internet E-mail, web space and all the other friendly features that only bulletin boards can offer.

*Mossoft BBS  
01733 701501*

## PD games

For the latest in games news, check out Alasdair Bailey's new website, featuring reviews of all the latest PD games. The site also holds Alasdair's photographic backgrounds. You can contact Alasdair at [jpb@le.ac.uk](mailto:jpb@le.ac.uk) and access the website at [http://sun2.botany.le.ac.uk/bo\\_docs/johnb/ali.htm](http://sun2.botany.le.ac.uk/bo_docs/johnb/ali.htm)

## Kulture website

Following the recent release of Kulture's *Freestyle* demo, the group have produced a complete set of stylish web pages detailing the members, aims and productions. A special section on the *Freestyle* demo features scanned plans of the demo.

The site also includes some more unusual sections including music charts by the group's members and the rather cheeky inXperienced web pages. The group plans to update the site every month with the latest news on games, demos and the QTM music player.

## AutoVCache

Following last month's mention of the rather nifty *AutoVCache* module I've had chance to do a few speed tests. The module enables the screen memory to be cached on StrongARM machines, giving a large speed increase to graphics software like games and demos. Running speed tests with the *Vcache* module and some Gourard shading plot routines, I was able to obtain a massive 30 per cent speed increase.

Without *AutoVCache*, plotting multiples of four words to the screen at a time is no faster than individual word stores. With caching enabled the speed increase is considerable. Note that the tests involved only plotting to the screen, with no reading back – as is necessary with routines like blurring or transparency which produces even bigger speed increases with the caching enabled. Why didn't Acorn at least give us the option of turning on caching in RISC OS 3.7?

*AutoVCache* has recently been updated providing facilities to flush the cache allowing the last screen plots to be visible on the screen. You can also turn the caching on and off. Expect to see *AutoVCache* in all the forthcoming demos. I'd recommend anyone writing graphics software for the StrongARM to check this module out immediately.

# Reisnac

I've finally managed to catch up with the spate of recent demo releases with a review of one of my favourite demos from the year. Icebird have always been a scene orientated group, and *Reisnac*, their second place entry at Siliconvention '97, has a strong scene feel. This demo has the style of the Amiga

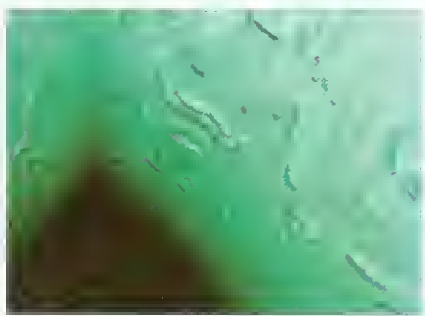

demo scene at its peak, mixed with the speed of the StrongARM processor.

The demo begins with an introduction picture that's ripped onto the screen rather smoothly. A 3D tunnel launches



you into the main part of the demo and, as with the rest of the production, it's both technically impressive and very nice to look at. The tunnel walls are hump-mapped and light-sourced to produce the best effect of the demo. The only minor niggle is the texture itself



– if only a bit of time had been spent to ensure that it wrapped around properly. The noticeable edges do spoil the appearance a little.

The name of the group and demo are then introduced with some nice 3D

texture-mapped words that spin round on an unusual and very stylish background made up of a kind of flared star effect. Unfortunately a bug in the background effect creates odd flashes of white every so often. This is flashed into the next effect with a few

palette changes by way of a very quick tunnel transition effect. You only get a second or two to see it, but it looks gorgeous.

Next up is an effect taken straight from a classic Amiga demo, updated for the Acorn. What you see on screen is a bouncing ball that has several holes cut in it and appears to have a light inside it. The holes cast beams of light that shine out of the ball as it spins round. To really show off, the beams of light are actually transparently texture-mapped tubes. Nice.

Following that coding extravaganza a still graphic and a slow down in the music drop the pace to a laid back feel.

Icebird's artist who has produced some dithous graphics in the past is on top form in *Reisnac* with several quality hand-drawn pictures.

The demo is then rounded off with a 3D scene featuring a character looking suspiciously like

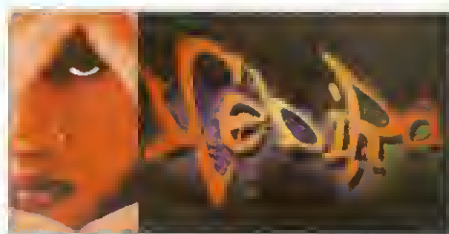

Rayman standing on a rocky outcrop. After a few spins to view the scene everything turns black and white and the usual credits and greetings are scrolled past.

As with the improvement in still graphics by artist Gizmo, Icebird's musician Skid has also come a long way since their last demo. The *Reisnac* music is a dark and brooding drum 'n' bass number that's been crafted



into the production very well. This seems to have been said too many times before, but you really need to hear demo music from a proper pair of speakers. This is particularly true for the

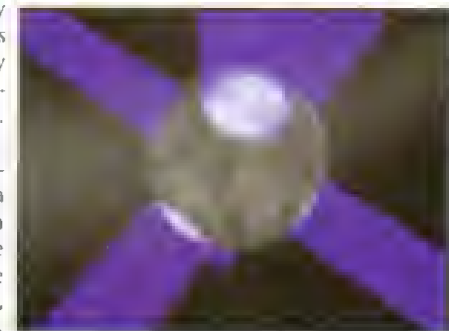

*Reisnac* music which is based around bass samples that just aren't audible on the computer's speaker. They really prod buttock from a proper stereo system though.

To sum up, this is a very cool demo. It's as simple as that. *Reisnac* is available from the Icebird website at <http://www.germany.net/teilnehmer/100,160485/>



# MAME

MAME or the Multiple Arcade Machine Emulator is the new emulator program to arrive on the scene. ARM MAME has been ported from the MS DOS version by Gareth Long and provides game emulation for a variety of classic arcade machines.

The code provides emulation for over a hundred different games including everything from 1942 to *Commando* and *Yie Ar Kung Fu*. The only problem is getting hold of the games.

Several sites on the Internet hold disc images of the game ROMs, but playing these on your Risc

PC without owning the original games machines is technically breaking the law. Emulation is surprisingly accurate but you'll need a fast machine to get the games running at a playable speed. Even with a StrongARM and *AutoVCache* running, the frame rate can still be a little slow.

Not really my cup of tea, but if you can get round the problems it may just satisfy your appetite for games until *Iron Dignity* is available. The RISC OS version of MAME is available from <http://www.eleclns.demon.co.uk/MAME> or from Arcade BBS on 0181 654 2212.

# OptPal

Andreas Dehmel has put together a rather nifty little palette optimisation routine that takes 24-bit colour sprites and outputs a 2, 4, or 8bpp sprite with an optimised palette. It has been possible to do this with *ChangeFSI* and a PD utility, but *OptPal* is a little easier to use and has a much greater range of features.

For example, the iterative process used to select the best palette can average the colours

around the mid range of the palette. *OptPal* supports the method of using Fixpoints to 'secure' the RGB values of certain colours, thus ensuring a good colour balance across the image.

Results with the program are a little varied. Some test images were a little disappointing but others produced perfect colours that couldn't be bettered after several days work by hand. Fortunately

*OptPal* uses dithering to improve the output images, so even if you use an input image with a big range of colours the output won't be too disastrous.

Unfortunately *OptPal* is usable from the command line only, but hopefully someone will knock up a nice RISC OS front end for us (if you do, please let me know). You can find *OptPal* on the August Subs disc from APDL.

# Shuffle Puck

*Shuffle Puck* is a 3D wireframe version of the classic pub game - *Air Hockey*. The game is played on a low friction air table. The idea is to knock a puck into your opponent's goal using a circular bat and prevent them from scoring goals against you. This simple game implementation pits you against a computer player who competes with progressive skill levels. The start is very easy but it

soon gets hard. I had trouble making it past level five and much higher than that and it all becomes quite intense.

Not a game with great stability but it certainly achieves the author's aim of demonstrating what you can knock up in BASIC on a rainy afternoon. Comments by e-mail to the author at [fdupont@irisa.fr](mailto:fdupont@irisa.fr)

## Recommended PD Libraries

- APDL, 39 Knighton Park Road, Sydenham, London SE26 5RN
- Arch Angel PD, PO Box 41, Exeter EX4 3EN
- ARM Club PD Library, Freepost ND6573, London N12 0BR
- Beebware PD, B3 Forrest Road, Huncote, Leicester LE9 3BH
- Five Star Marketing, 4 Shepherds Walk, Bushey, Hertfordshire WD2 1LZ
- Naked PD, 'Fayence', Fulford Road, Stoke-on-Trent, Staffs ST11 9QT
- The Datafile, Willoughby House, 89 Woodville Road, Boston PE21 8BB

## Contacting me

You can contact the PD page by writing to me, Paul Wheatley, at *Acorn User*, IDG Media, Media House, Adlington Park, Macclesfield, SK10 4NP. Or preferably, by e-mail to [aupdp@idg.co.uk](mailto:aupdp@idg.co.uk).

## RiscWorld

RiscWorld PD is no longer owned by Daniel Hayes and has been bought out by PD enthusiast Tony Bonner. The library is currently in stasis as Tony rearranges the catalogue and prepares for a re-launch. Expect full details here when RiscWorld becomes operational again.

## Lipsum

*Lipsum* is Tony Howat's Lorem ipsum generator for RISC OS. No idea what I'm talking about? Here's Tony to explain: 'It means nothing whatsoever, but it's surprisingly useful. The main idea behind *lorem ipsum* is to have 'convincing' text, separated into words, paragraphs and with punctuation etc. This 'text' is then used by DTP bureaux and designers for roughing out document designs, it helps the design of flow boxes and run arounds before the final text arrives. It allows designers to show their proposals without having clients distracted by meaningful text'.

Not the most essential of programs but certainly something you'd only ever find in the Public Domain. *Lipsum* can be located on the August APDL subs disc.

## DrawRot

*DrawRot* is a handy design utility that accepts drawfile outlines as its input and produces rather attractive rotated patterns with just a few clicks of your mouse - an essential tool for every DTP enthusiast. *DrawRot* can be found on the APDL subs disc for August.

## Feedback

What do you think of the PD pages? Am I covering the right software? Have I missed any programs which should have been endorsed by the PD column? Am I too obsessed with computer graphics? I'd love to hear your comments on the column, so please drop me a line at the address below. As always PD software authors are welcome to send in their software for review, or pass on the latest news about their up and coming projects.





# business

## Hardware on the move

It is quite rare, even among computer users, to find a piece of new hardware that literally revolutionises the way we work. Even rarer that I recommend any. Like most Acorn business users I split my computing between sites - this involves the transfer of files from one place to another and from one computer to another.

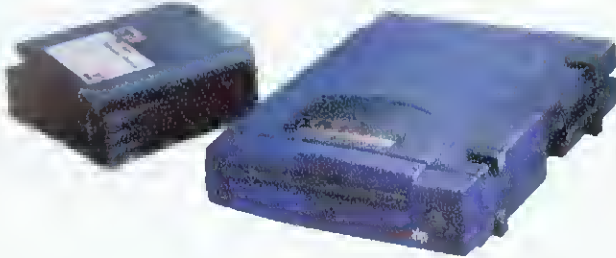

It has caused me a certain amount of concern in recent years that, despite all the advances made in other areas of hardware the humble floppy disc drive seems to have gained little in speed. I will concede that high density drives and the ability to store up to 1.6Mb on a single floppy did help for a certain time. That time has passed as I now regularly generate files bigger than this capacity and can be working on files which would require a box of floppies.

Compression of files can and does help but I have never felt very comfortable with this as a method. There is always the worry that one computer may not be able to read the compressed files or that something may go wrong between compression and expansion. Experience has also taught me that floppies are unreliable and always likely to fail just at the point where no backup exists.

Other alternatives have existed for some time - removable hard drives, magneto-optical drives and so on but these have always seemed to be expensive both in terms of the hardware and the storage media. They become even more expensive when you consider that many such devices require SCSI interfaces. SCSI is an excellent option in terms of speed and expandability but expensive for the average user.

I am now happy to report that all such problems are resolved, and relatively cheaply with my discovery of the wonderful device called a Zip drive, manufactured by Iomega.

These little blue boxes now sit alongside my computer at home and my computer at work. Their chunky floppies hold 100Mb and are simply transferred between the two.

100Mb will be, for many Acorn users, greater than the capacity of their hard drives. This means that they are also a very good backup medium, whatever size of hard drive you have. As the external Zip drive does plug into the parallel port I assume it requires a machine with a bi-directional printer port.

So no more worries about capacity, no more unreliable floppies - but always back up your work as insurance against loss or accidental damage to the Zip floppy - and no more compression. Zip

drives are internal or external but the internal version seems to defeat the whole object. As mentioned, the external version plugs into the parallel port and a second connector on the back of the Zip drive then connects through to the printer. In use this has presented absolutely no problems although I do not use the special dangled leads required by Turbo drivers.

On an A7000, which has no joystick port, I was able to connect a joystick via the Zip drive and use it as normal. This was using SOLO from Stuart Tyrrell Developments. The only problems Zip drives present, in my experience, are the need for another plug point near your computer and the fact that it did not like my using an *Impression* dangle on my older version of *Impression Publisher* - an upgrade to *Publisher* solved that problem. Has anyone got a good (clean), suggestion what to do with old *Impression* dongles?

The only down side for Acorn users appears to be that Zip drives come with driver and utility software for PCs and even the Mac, but nothing for the Acorn. You may see them around with a street price of considerably less than £100, but if you want one to work with your Acorn you must expect to pay more as you are also buying the Acorn drivers.

The current price from Argo of a Zip drive plus Acorn drivers is £139 plus VAT. The drivers alone cost £29 plus VAT. A little simple arithmetic seems to indicate that if you can buy a Zip drive elsewhere for less than £129 including VAT, you would be saving money but probably at the expense of having to shop around. Personally I think we should support the Acorn market as much as our wallets allow.

The actual prices of the Zip discs seems to vary enormously but I have seen them as low as £10 when bought in packs of 6.

Argo Interactive  
Tel: 01243 815815 (Sales).  
Stuart Tyrrell Developments  
PO Box 183, Oldham, OL2 8FB  
E-mail: Solo@STDevel.demon.co.uk

### To softly go...

A recent correspondent berated me for saying that we lacked relational databases in the Acorn world. He stated that if we substituted the word relational for programmable we have a good choice of such databases. I disagree but that is not the point I wish to make on this subject.

My correspondent then went on to talk about a potentially good database which appears to have stopped being both developed and supported by its manufacturer. I am not going to mention names here, but this situation can leave users in the lurch.

Many products could have been excellent but for the final lack of development and support. A look at back issues of Acorn magazines reveals a wealth of these nearly great pieces of software.

I believe that the software scene is now significantly behind the hardware scene. We are in danger of having excellent hardware and nothing to run on it. For this reason I was particularly pleased when Chris Cox mentioned the revival of AcornSoft at the Wakefield Show. (See News section September AU).

It seems to me that if some of the larger software houses wish to reposition themselves in the market then only Acorn themselves can take up the mantle.

What has this to do with the original problem? Well, what about this? As well as AcornSoft developing new software, of which I am firmly in favour, how about it taking on some of the software currently in existence and continuing to develop, support and sell that?

I know there would be problems of licensing and so on but if they sold off the business to Superior Software then surely it would make sound economic sense to actually acquire some software titles which are currently in abeyance.

For that reason please e-mail or write to me with lists or titles of software that you think should still be being developed and supported. I am willing to start the ball rolling with Advance. Perhaps AcornSoft could be persuaded the idea has some commercial merit.

### Almanac

On the subject of software development and support Stallion Software have announced, via their web page, some planned upgrades to their organiser software Almanac. This was a classic case of an excellent piece of software gaining a bad reputation. One hopes that Stallion can rescue the situation and provide us with a much needed organiser and I speak as someone who recently forgot his wedding anniversary. Thankfully so did my wife.

[www.stallion.demon.co.uk](http://www.stallion.demon.co.uk)

### Contacting me

You can contact me, Mike Tomkinson, by post at the usual Acorn User address or by dropping me an e-mail at: [aubzniz@idg.co.uk](mailto:aubzniz@idg.co.uk)

## The Zetnet Solution to the Internet for Acorn Users *(and PC users, and Mac users .....)*

### Features

#### Performance

- 33,600bps modem access
- USR x2 access
- ISDN access

#### Affordability

- 100% UK local call access
- Free connection
- Free technical support
- Unlimited access

#### Standard Account

- £8.50 per month *or*  
£90.00 per annum
- 33,600bps modem access
- Free 5Mb web space

#### Enhanced Account

- £10.00 per month *or*  
£100.00 per annum
- USR x2 or ISDN access
- Free 10Mb web space
- Unlimited email addresses
- Free access to Internet  
games server

At Zetnet we believe that you should be able to connect to the Internet when you want to. We believe in bringing the Internet to everybody, whether you're a technowizard or a techno-phobe. We'll help you contact the world, and help you establish your presence on the Internet.

As you become familiar with the Internet, you'll have the peace of mind knowing you're subscribing to a quality service,

backed by a company who will be with you every step of the way.

As well as providing full Internet access, Zetnet also provide a wide range of additional services, and can tailor connections to your requirements.

We have specially written software for users of Windows, allowing the first time user to access the Internet with the minimum of effort. It even allows you to read and write

messages without being connected to the telephone line, saving money on call charges.

It is well known that the Internet can be a haven for subversive material, causing concern for families wishing to exploit the benefits of the Internet. With our unique filter system, families can connect to the Internet safe in the knowledge that any such material can be blocked by Zetnet if desired.

Unlike some service providers we do not charge for online time. We'll connect you to the Internet for the cost of a local telephone call and a nominal subscription charge.

Technical Support is provided free of charge between 9.00 a.m. and 8.00 p.m. Monday - Saturday as well as there being comprehensive help in our dedicated newsgroup for Acorn customers.

\* Enhanced account only, standard account has 5Mb free space

- Accessed by local call nationwide
- Supports all modem speeds
- Up to 10Mb of free space for your Internet pages\*



Zetnet Services Ltd.  
Garthspool  
Lerwick  
Shetland ZE1 0NY

<http://www.zetnet.co.uk>  
[info@zetnet.net](mailto:info@zetnet.net)

**Freefone 0800 938638**

# portables



## The PC Card-modem adaptor

Until recently the modem support for the Psion range has been very limited, with only the 3-Fax system being available. This all changed about a year ago with the release of a 14.4K Psion Travel modem and perhaps more excitingly the release of a PC Card-modem adaptor. Both are currently only available for the 3c and S5 but versions for the 3a/PBH will become available in time.

The travel modem is rather slow and only really suitable for faxing and e-mailing not Web browsing, but it is the cheaper of the two options.

The PC Card-modem adaptor allows you to hook up any PC Card modem (formerly



PCMCIA) to your Psion and communicate at speeds of up to 56.6K.

PC Card-modems are quite remarkable devices – they are about the same size as a credit card and only slightly thicker – and yet perform all the functions of a normal desktop modem.

The PC Card-modem I looked at was the Hayes Accura 336 + Fax which supports modem speeds of up to 33.6K and fax speeds of up to 14.4K. This modem costs £99

+ VAT and is one of the cheaper options but still has an excellent specification.

The adaptor is just slightly bigger than a Post-It note pad and is powered by four AA batteries to save draining the Psion's bat-

tery. An optional mains adaptor is available but this somewhat reduces its portability.

The PC Card-modem plugs into the adaptor and a phone socket and the adaptor is then connected to the Psion and really that's about it. The Psion communications software doesn't need to be specially configured and the set-up works well.

I haven't yet had the chance to try out Psion's Internet software as the S5 version is not yet available and I don't own a 3c.

The Fax system is very easy-to-use and works in a similar way to *ArcFAX*. The document you want to fax is printed as a fax-file which can then be viewed in *EasyFax*. From here you dial the fax number, configure any options and then it takes over and does the rest. The system can also be set up to receive incoming faxes.

Overall, the PC Card modem adaptor is an excellent product and if your Psion is used a lot for communications it is a much better option than the travel modem despite the extra cost. The travel modem costs £199 inc VAT and the PC Card-modem adaptor costs £116 inc VAT.

## Series 5 backlight

One of the most useful features of the S5 is its backlight which allows you to use the machine in almost all conditions. The backlight control built into the S5, however, is very limited – on or er... off!

Two programs have recently been released which improve this situation allowing you to specify times of the day when you want the backlight to come on automatically.

*Backlite*, as well as controlling the hours in which the backlight is on, also allows you to configure the 'backlight off' time, make

notes on a jotter, check the battery levels and more. The program is downloadable from <http://www.kneen.demon.co.uk/>

*InteliScrn* is the simpler of the two programs, allowing you to specify the times of the day when the backlight should be on and off. *InteliScrn* can be found at <http://www.geocities.com/SiliconValley/Lakes/4917/>

Both programs are freeware so if you think either would be useful I'd download both and give each a try.

## The 'No Nags' page

Fed up with downloading software from the Web only to find it's shareware and an annoying screen keeps popping up reminding you of this fact? Well, if so, the 'No Nags' pages is for you.

This 'no nags' page lists a selection of the true freeware software that is available for the Psion S3 and S5. The software has been categorised and the majority of it has been reviewed by the Webmaster before it gets onto the list.

If you're looking for some new software for your Pocket Book, whether it be games or utilities, and you don't want to pay for it, check out the 'No-Nags' site at: <http://3lib.ukonline.co.uk/noonags.htm>

## Acorn World

Well, it's Acorn World time again and this year show promises to be quite exciting from a portable perspective.

Acorn plan to have a prototype of their new portable on-show (yes, I know they had

one at Wakefield but that was a technology demonstrator and not the true Acorn portable...), so we should finally get to see if the machine lives up to expectations.

Xemplar will be demonstrating the Apple e-mate and the Acorn Pocket Book – maybe with some news on a replacement – who knows?

What I do know is that I'll be there either on the Saturday or Sunday so, if you see me, stop and say hello, and if you want to test my brain I'll make sure it's switched on for that weekend!

## This page

With the release of the Series 5 from Psion and the imminent arrival of Acorn's new Portable, I thought it is about time I outlined what I intend to cover on this page in future. My current plan is to cover all Acorn portables – the Pocket Book, A4 and the new laptop – as well as covering the Psion Series 3 and 5.

My reasoning behind covering the S5 is that a lot of Acorn users have always owned

Psion machines – especially after Acorn produced a link suitable for the S3. Many of these Acorn users may now wish to upgrade their Psion to the new S5, especially if they have access to a PC or if Xemplar produce an Acorn link, and will want to keep up-to-date with any developments that occur.

I do not, at the present time, intend to cover either the e-mate or the Newton despite the fact that they are ARM-powered as I feel the user base within the Acorn market is too small. However, if anyone disagrees with this, yell loudly and if enough people do then I'll undertake a re-think.

If anyone has any suggestions about topics they would like to see covered on this page then please contact me at the usual *Acorn User* address.

### Contacting me

You can contact the Portables page by writing to me, Mark Taylor at *Acorn User*, Media House, Adlington Park, Macclesfield SK10 4NP, or by e-mail to [aupt@idg.co.uk](mailto:aupt@idg.co.uk)

# MidiWorks



Oregon

## Hard Disc Recording

### Sound Editing and Audio Processing

ProSound is a fully integrated hard disc recording, sound editing and audio processing suite. The extendable modular design of ProSound allows it to be tailored to the users own application.

ProSound utilises a fast virtual memory system making it possible to edit enough audio to fill a typical audio CD, using just a 4Mb machine.

ProSound offers an eight track mixing desk. Each track may be assigned somewhere between the left and right stereo positions, at varying volume levels. The tracks are then mixed in real-time when the project is played.

ProSound is able to import and export most industry standard audio file formats, as well as the familiar Acom native formats, thus solving any platform portability problems.

ProSound offers a comprehensive portfolio of audio effects and processing options, permitting flexible manipulation of audio samples. Tools such as bandpass filters, and frequency analysis diagrams may be used to improve sample quality, whilst special effects may be utilised for the production of a synthesized sample.

ProSound supports multiple projects, to allow editing to take place on several different projects simultaneously, just as you would expect a desktop publisher to allow you to edit multiple documents and move data around between them.

ProSound enables many of the currently available audio capture cards to record directly to disc, and so recording duration may be virtually unlimited.

ProSound - RRP £119.95 - Special £99.95

MidiWorks - RRP £159.95

Special £119.95 to ProSound or StudioSound Users

## Acoru MIDI Sequencing Studio

MidiWorks is a highly sophisticated MIDI sequencing and composing studio, designed for the serious professional musician.

The pattern arranger allows up to 64 channel output, using an intuitive drag and drop system as used throughout the studio. Arranging and composing could not be quicker or easier.

The piano roll, event list, and drum map editors offer fast and efficient editing of any aspect of a score, including features such as system exclusive, key pressure, and pattern tempo. All are represented graphically, and may be fluidly drawn as a graph with the pencil tool.

A unique and powerful feature is the meta controller, enabling the creative multimedia designer to sequence non MIDI events. This provides a powerful method of synchronising multimedia presentations to music by triggering audio samples and video movies, and for controlling external hardware.

The flexible processing tools include several types of quantisation, as well as data transformation, non-linear timestretch, and data reduction. All processing tools can be applied to an accurately defined selection of notes or events.

MidiWorks is equipped with internal and external MTC/SMPTE synchronisation via the Acom TimeCode system. This permits synchronisation with any compliant external hardware, and allows comprehensive control of other applications such as hard disc recording software within the desktop.

Many useful studio utilities and gadgets are provided such as a patch bay, MIDI filter, MIDI channel monitor, desktop keyboard, user definable instrument lists, VU meters, and studio clocks.

Above all MidiWorks provides an intuitive and relaxing environment, where the musician is encouraged to channel all his effort into composing.

Lite version also available soon

ProSound



Oregon

## Oregon Developments

36 Grosvenor Avenue : Streetly : Sutton Coldfield : B74 3PE

Tel : 0121 353 6044 / Fax : 0121 353 6472

<http://www.oregon.demon.co.uk>

# cover disc

## Osmosis

John Pettigrew

*Osmosis* is a slightly different slant on the desktop-patience-game theme. Not only are the games different, it also uses a larger screen mode than normal – 800 x 600 is the minimum. This allows those of us with more powerful computers to see the cards when using these large screen modes, as most patience games use small sprites to cater for the small screen modes. The game was written on an A5000, and has been tested on a Risc PC with and without StrongARM, so it should work on most machines (although, as I said, large screen modes are really needed).

The two games that the program plays are *Osmosis* and *Pyramid*. *Osmosis* is similar to the kind of patience games you will be familiar with – the object of the game is to move

all the cards from the pack and four piles (see screenshot) onto the layout in suit. However, unlike most games, the cards do not move in number order.

All the piles must start with the same number card as the top pile, but thereafter the only restriction on moving cards to the layout is that the number must have already appeared in the layer above, hence the name – the card numbers 'diffuse' down from the top to the bottom layer.

*Pyramid* is rather different – although the aim is to move the cards from the (triangular) layout onto the foundation pile, in pairs that add up to 13, the game involves much more skill and strategy than *Osmosis*. Indeed, this game has one feature that most patience



games do not – a score. This is added up after six games, and an overall score of zero means that you have done well, if your score is negative, more work is needed.

Playing six games means that the random effect of the cards tends to be removed, as some games do turn out to be impossible to finish. My best score so far is 32. See if you can do better!

Full instructions on how to play the games are included in the Help file, and remember – practice makes perfect.

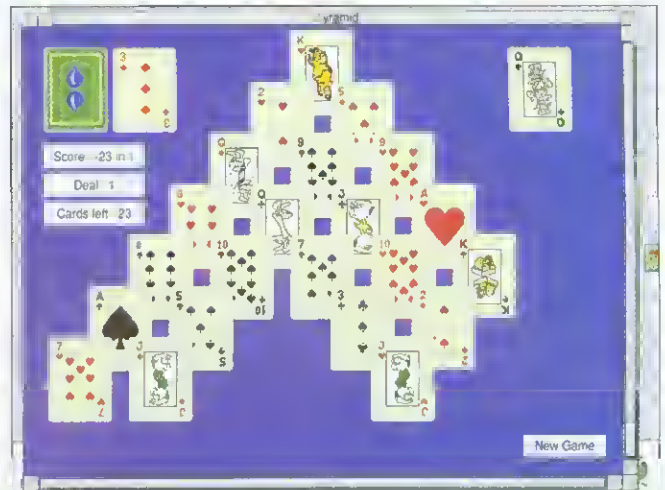

## Tizzy's Toybox demo

Sherston Software

Try out the demo of this new title from Sherston Software, contact details in the Help file.

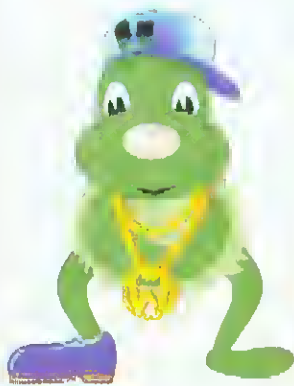

Hello. I'm Tizzy. Welcome to my toybox.

## Poly-plot?

Fortran Friends

Demos of two new programs from Fortran Friends demonstrating the power of the language. *!PolyDraw* is an interactive program which displays a polyhedron in two forms, a 3D solid and a planar net from prestored datafiles. The full version allows you to save Draw files of the 3D solids and planar nets; you cannot save any files with this demo version and can only use the supplied datafiles.

*!PolyNet* allows you to create planar nets from files containing data on how to draw

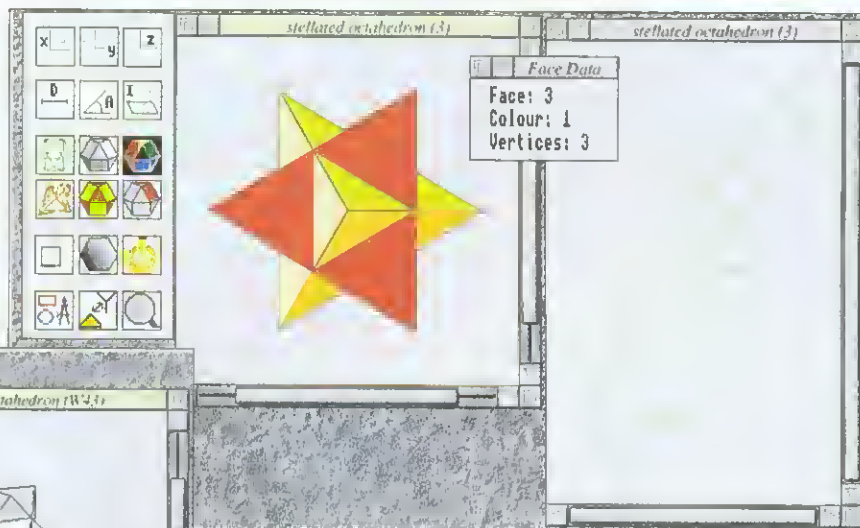

polyhedra. The full version allows you to save Draw and datafiles; you cannot save any files with

this demo version, you can only use the supplied datafiles, and cannot change the Choices file.

Contact details and further information are in the ReadMe and help files.

### Regular items

- Mike Cook's PIC simulator
- Free Ads — all our Free Ads on disc
- All the \*INFO programs

### Extras

- *!Embolden*, *!Fontician* and *!PathWays*
- Font creation grids
- A complete font

## Disc information

The software on these discs has been compressed using *ArcFS 2* from VTi, and are opened by running a copy of *ArcFS* then double-clicking on the archive to open it. There is a copy of *ArcFS* on each disc.

Most software will run straight from the archive, but some programs may need to be copied out of the archive before being run, uncompressing them in the process. Any program that saves a file to disc, for instance, will be unable to do so into the archives on the disc.

## Faulty disc?

If your disc is faulty, test whether it will verify by clicking with Menu on the floppy drive icon and choosing Verify.

If it fails to verify or is physically damaged you should return it to TIB, TIB House, 11 Edward Street, Bradford, Yorkshire BD4 7BH. If it verifies successfully return it to the *Acorn User* editorial office at the usual address.

The *Acorn User* cover discs have been checked for viruses using *Killer* version 2.700 from Pineapple Software.



# Special Purchase

Warranty:- NEW=1 Year, S/H=3 Months

NEW A3010's from £ 150  
 NEW A4000's from £ 390  
 S/H RPC's Mk1 9MB £ 550  
 S/H A5000's from £ 375

Monitors not included with above

NEW 17" AKF85 £ 450  
 NEW 14" SVGA from £ 160  
 S/H AKF18 Monitors £ 150

JOB Vacancies  
 Sales/Support  
 & Trade Sales  
 Send CV to  
 C Evans

S/H AKF17 Monitors £ 120  
 New Pocket Books from £ 150  
 A4 Concept Keyboard £ 80  
 BJC4100's Printers(Rtrns) £ 150  
 Phone for full list of specials

## Risc PC's

RiscPC's Built to your specification.

### Example 1 :

RiscPC StrongARM, 8MB RAM  
 1.2GB HD. & 14" Monitor  
 Quad speed CD & Delivery

**£ 1320 inc. VAT**

### Example 2 :

RiscPC StrongARM, 16MB RAM  
 2MB Vram, 1.2GB, 15" FST Mon.  
 8 speed CD & Delivery

**£ 1600 inc. VAT**

Plus

0% finance on SA RiscPC's & A7000+

## RiscPC RAM

4MB	£ 16	128MB	<b>Reduced</b> £ 849
8MB	£ 29	1MB V-RAM	£ 65
16MB	<b>Reduced</b> £ 56	2MB V-RAM	£ 110
32MB	<b>Reduced</b> £ 100	1-2MB V-RAM	£ 90
64MB	<b>Reduced</b> £ 375	For DRAM Part Exchange prices please Call.	

## Monitors

14" SVGA (AKF 60 equiv.)	<b>Reduced</b> £ 180
15" SVGA (0.28mm FST MPC 1280 x 1024)	<b>Reduced</b> £ 250
17" Acorn AKF85 (0.28mm FST MPC 1600 x 1200)	£ 450
17" Iiyama 8617e (0.26mm FST MPC 1600 x 1200)	<b>Reduced</b> £ 550
17" Iiyama 9017e Pro 0.25mm FST MPC 1600 x 1200	<b>Down</b> £ 600

## Hard Disc Drives

210MB Conner 3.5" IDE	<b>Reduced</b> £ 60
1.2GB Quantum/Fujitsu TM 3.5" IDE	<b>Reduced</b> £ 120
2.1GB Quantum/Fujitsu 3.5" IDE	<b>Reduced</b> £ 160
2.5GB Quantum/Fujitsu 3.5" IDE	<b>Reduced</b> £ 190
3.2GB Quantum Fireball 3.5" IDE	<b>Reduced</b> £ 220
3.8GB Quantum Fireball 3.5" IDE	<b>Reduced</b> £ 250
6.4GB Quantum Fireball 3.5" IDE	<b>NEW</b> £ 360
2.0GB 3.5" SCSI	<b>Reduced</b> £ 250
4.3GB 3.5" SCSI	<b>Reduced</b> £ 450
Hard Disc Kits for A3000 from (A3020 from £ 90)	£ 175
Syquest EZ230MB 3.5" Drive (removable cartridge)	£ 220
Xyratex 540MB Drive (removable cartridge) external	£ 320
Iomega 1GB JAZ Drive (removable cartridge)	<b>Reduced</b> £ 320

## Printers

BJ30 Black	£ 155	BJC620 Col.	<b>Reduced</b> £ 260
BJC240 Colour	£ 180	Stylus Colour 500	£ 220
BJC4200Col.	<b>Reduced</b> £ 200	Stylus Colour 600	£ 260
BJC4550Col. A3	£ 350	HP6L 6ppm	<b>NEW</b> £ 380

## RiscPC CD Rom Systems

### IDE CD ROM Drives

Eight Speed **Reduced** £ 75  
 Twelve Speed **Reduced** £ 90  
**NEW** Panasonic  
 24 Speed Maximum £ 110  
 (Average speed 17)  
 6Speed 4Disk Autochange £ 175

For details on drives for other systems,  
 please call

(Please add £ 15 for IDE CD Drivers if  
 using RiscOS 3.5 computer).

### SCSI CD ROM Drives

Double Speed - tray £ 95  
 6.7 Speed - tray £ 170  
 Eight Speed - tray £ 200

**Combined Quad Speed SCSI CD Rom  
 Drive AND 650MB Optical Read/Write  
 Drive £ 360\***

SCSI I Mini Podule Int. (e.g. A3020)	£ 115
SCSI I Podule Int. (e.g. RiscPC)	£ 90
SCSI II Podule Int. Cumana	£ 175
SCSI II Podule Int. PowerTec	£ 195
Cases for External CD Rom Drives from	£ 47
*Optical Discs for PD Drive	£ 46

Call for prices on:

- Interfaces
- Digital Cameras
- Scanners
- Modems
- Speakers
- Arc. Hardware
- Printer Ribbons & Cartridges

Post from £ 2.50 Courier from £ 7.00  
 Credit Cards & Official Orders Welcome.

**0%**

RiscPC's from £ 48 p.m.  
 20% deposit.  
 20 Months to pay.  
 Call for further details.

All prices  
**Include VAT**  
 @ 17.5%



The Fastest RiscPC PC Card is now even faster!  
 The 'CJE 133MHz 5x86' with **512K Cache!**

Now Available £ 390 inc VAT Please phone for Part Exchange details.



Acorn  **CJE** micro's  Acorn

78 Brighton Road, Worthing, West Sussex, BN11 2EN Telephone : 01903 523666 Fax : 01903 523679

Email : sales@cje.co.uk or info@cje.co.uk Web : http://www.cje.co.uk/

**NEW FONTEFX  
FA6**

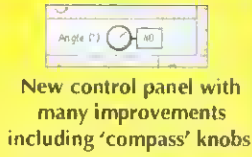

New control panel with many improvements including 'compass' knobs

**FONTEFX**  
Choose from 16 million colours



New 3D Shadow effect

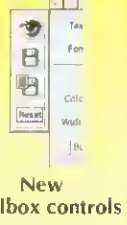

New toolbox controls

**FONTEFX VERSION 6**  
New grow and shrink feature

**FONTEFX**  
New rainbow fill option

**FONTEFX**  
New border effect

**FONTEFX**  
User-definable shadow length and direction

RELEASED AT ACORN WORLD 97 - SEE US ON STAND 128!  
PRICE £29.95 INC. VAT - SITE LICENCES AVAILABLE  
Upgrades at special prices for owners of earlier versions.

**THE DATA STORE**  
microcomputers



6 CHATTERTON ROAD BROMLEY KENT BR2 9QN  
Tel 0181-460 8991 Fax 0181-313 0400  
Email info@datstore.demon.co.uk  
Web http://www.datstore.demon.co.uk/

OPEN TILL 7.30 ON THURSDAY, BUT CLOSED ALL DAY WEDNESDAY

# texttease

Simply the Best  
Word Processor and  
Desktop Publisher

Just click anywhere  
and start to type

**BETT 97  
Gold Award**

Talking *texttease*

**Best Primary  
Software**

Softease Limited,  
The Old Courthouse,  
St Peters Church Yard,  
Derby, DE1 1NN  
Tel 01332 204911 Fax 01332 609224  
Email sales@softease.co.uk

For Windows 3.11 and '95 or Acorn RISC OS3.1

Produced on / C.V.F. /

# Rainbow's Edge

Two new CD-ROMs from RESOURCE!

## Much Ado at Rainbow's Edge

Much, much more than Talking Stories. Over 100 daft and different characters live in Rainbow's Edge. Follow any of them through their adventures. From Helmut, the sausage-mad dog, to G. Porgie, the village bully, there's a feast of interlocking stories. Plus PSE topics, map work, comprehension, treasure trails and puzzles.

**SPECIAL OFFERS!**  
STAND 52  
ACORN  
WORLD

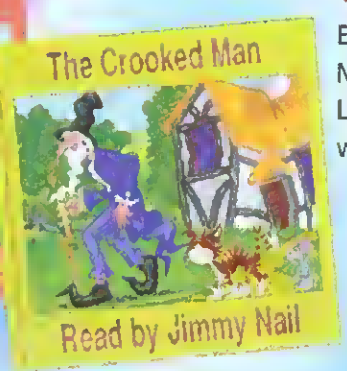
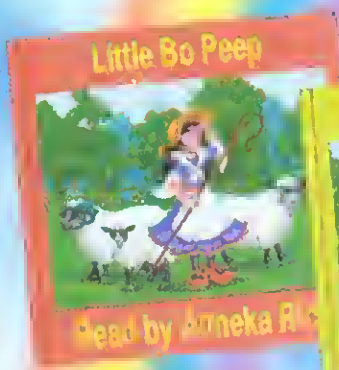

## Rainbow Stories

Eighteen talking and singing books of your favourite stories. Narrators include Anneka Rice, Victoria Wood, Julie Walters, Gary Lineker and Jimmy Nail. High quality animations and sound effects will appeal to all ages and are guaranteed to make you smile.

The **RESOURCE** Centre  
51 High Street, Kegworth, Derby DE74 2DA  
Telephone: (01509) 672222 Fax: (01509) 672267  
E-mail: info@resourcekt.co.uk

# Font handling

Clive Semmens

introduces the ins and outs of font design

One of the real beauties of RISC OS is that it is relatively easy to design your own fonts. And, if you have the expertise, the standard can be at least as high as on any other computer system.

At first I designed fonts using nothing more than Acorn's own *!FontEd*, which is much better than some people would have you believe. Its weakest feature is its inability to handle kerning tables, but there are a couple of applications available quite cheaply from other software houses that make up that particular deficiency admirably.

The other significant weakness is the main reason for this article: Thickness.

If you look inside a font directory, you will see two files: *IntMetrics* and *Outlines* (or *IntMetric0* and *Outlines0*). They will usually be typed as Font files, but some *Outlines* – *Homerton.Medium.Oblique* for example – are text. If you open one you will see that all it contains is a reference to another font, and a matrix of numbers. This tells the font manager to use the outlines from this other font, transformed according to the matrix. *Homerton.Medium.Oblique* is exactly the same as *Homerton.Medium*, except that it leans over by 12 degrees.

The only transformations possible using this system are horizontal and vertical scaling, shearing (leaning over), rotations, reflections and translations (horizontal and vertical shifts). Some software vendors will sell you a package that makes a 'new' font which is simply a transformed ver-

sion of an existing font, done in this way. This is all very well as far as it goes, but what if you want a bolder version of a font?

It simply won't do to stretch a font out in the x direction and call it bolder – the same percentage of the paper is covered with ink as was before. You can't make a lighter weight of font this way either. Horizontally stretched out fonts are really called *extended*, and horizontally squeezed

different weights – demi-bold, ultra-bold, light and so on? These are much harder, and definitely need separate fonts.

In theory, *!FontEd* has a facility to adjust the weight of a font. If you click Menu over the Font Index window, move through Alter and then Thickness, you can change the thickness by positive (bolder) or negative (lighter) numbers. The numbers correspond to Design Units, one five-hundredth of the nominal size of the font when the Design Size is 50.

Unfortunately this facility is badly flawed. It works well enough for straight lines and angles, but there's something seriously wrong with the way it handles curves and tangents unless the change of weight is very slight, and sometimes even then. The examples show the effect of a +5 alteration of thickness on a few Trinity Medium Italic characters.

Apart from these occasional wild errors, there is a general tendency for Alter Thickness to change the thickness of curved strokes by somewhat less than it changes the thickness of straight strokes. This means that fonts emboldened or lightened

using the facility have a tendency to look uneven, and a great deal of editing is necessary afterwards to get them looking right.

## Embolden

There are difficulties in principle with changing the weight of fonts in software. There are details which need to alter as the weight changes, but for which there is no simple algorithm to decide how they will change, so that input from the designer is

Medium

Bold

Bold Extended

Medium Extended

Bold Condensed

Medium Condensed

Figure 1: Extending and condensing is not the same as a weight change

ones, *condensed*. It's a quite separate issue from font weight.

Ideally, as you extend a font you should make it a little lighter – Figure 1 shows how the 60 per cent extended version of Medium looks a little bolder than ordinary Medium – but it doesn't look like Bold, even though it's very much extended. Most DTP software, and even *Draw*, allows you to produce text extended or condensed to any degree without having to have a special font at all. But what about

# Font handling

► needed. However, it is certainly possible to do a lot better than *FontEd* does: *!Embolden* is my offering, it isn't perfect, but it's much better than *FontEd*.

Most characters in most fonts can be emboldened or lightened to a considerable degree using *Embolden*, without needing any post-editing at all. A few characters with particular features may need a bit of tweaking, but usually this only involves moving a couple of control points and can be done quickly. It's also easy to spot the likely places where problems may occur.

Figure 11 shows the outline of a Trinity.Medium n and an emboldened version around it. The error is at the point where the top edge of the thin stroke at the top meets the vertical in a reflex angle: See how the gap between the two outlines is wider here. The problem occurs at reflex angles if either or both of the adjacent lines are curved. This area might need a bit

of tweaking in any case, as it is a place where there is a difficulty in principle: If the gap between the two outlines was constant, the short length of upright above the attachment of the thin stroke would get shorter as the character got bolder. For small changes this probably could be ignored, but it would look very silly if it got very small, and what happens when it becomes negative?

*!Embolden* works on draw files, not font files. It could be upgraded to be able to do either, but I usually work on fonts in *!Draw* in the early stages anyway, finding it better for designing the outlines. I then move the outlines into font files for applying scaffolding and autokerning. The second utility, *!Fontician*, does the conversion to a font file. It can also do the reverse, as well as a number of other things.

Lastly, *!Embolden* doesn't know the inside of a curve from the outside! This is sad and I'd like to fix it, but it would be quite a big job. The effect is that whether an outline is emboldened or lightened depends on the *winding* – whether the outline was created clockwise or anticlockwise – as well as the sign of the Amount. *Embolden* offers an option to do both sides, leaving you to delete the unwanted variant. Alternatively you can do what I do: Ensure

that the outer outlines of characters all go clockwise, and the outlines of any holes go anticlockwise. The third utility, *!PathWays*, can help you with this.

## !Fontician

*!FontEd* does some things very well, but I find it much easier to do the initial creation of characters in *!Draw*, and some editing is easier in *!Draw* too. *!Fontician* provides a quick and easy way to convert back and forth between fonts and draw files.

To use it, drag a font directory or a suitable draw file on to the icon on the icon bar. A save window will appear, containing two icons, one a font file icon and one a draw file icon. If you drag the font file icon, a font directory (containing *IntMetrics* and *Outlines* files) will be produced; if you drag the draw file icon, a draw file will be produced.

Suitable draw files may either be produced using *!Fontician*, then edited as required, or you can start from *Grid256* or *Grid416* provided on the cover disc, and add your own outlines.

When *Fontician* makes a draw file, it puts a blue line under each character. The length of the blue line is the width of the character taken from the *IntMetrics* file, and the left hand end marks the position of the origin (0,0 point) of the character. You can edit the length of these blue lines, and the *IntMetrics* file will reflect the change. However, the position of the origin is absolute, so don't move the left hand end of the line.

You probably already know about *!Draw's* little quirk, but it's worth mentioning here: You can't get hold of the bottom handle of a selected horizontal line to drag the length! The trick is to edit the line instead, and move the control ►

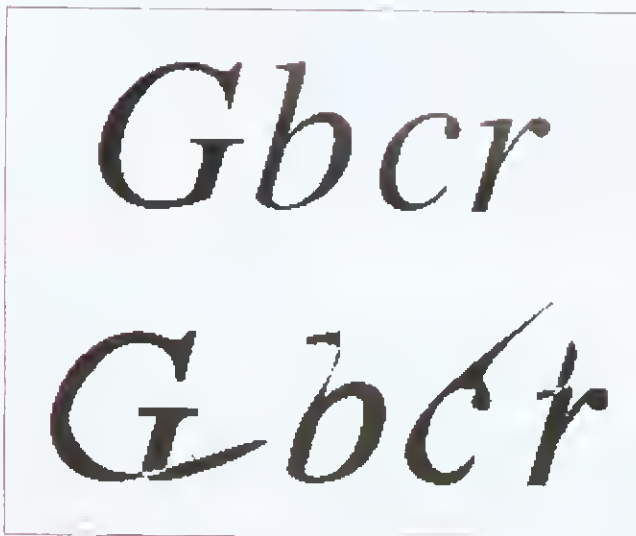

Figure 11: *!FontEd* has real trouble emboldening curves

IT'S HERE!!

# Sheep Racing Deluxe

See us on stand #68 at Acorn World '97



Sheep Racing Deluxe runs on any Acorn computer with RISC OS 3.10+ and 2MB RAM. It has been optimised for use on a StrongARM Risc PC.

Featuring: 256 colour VGA graphics at 50Hz (needs RPC & 1Mb VRAM) • Five wacky and varied levels chock full of hilarious surprises 2-5 player serial link up option! • Easy to use WIMP interface • Four way parallax scrolling  
*It's thwogging brilliant!*

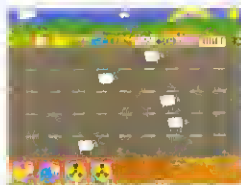

All this and more

for only **£25.95!** (plus £1.50 carriage in the UK) (single user)

Werewolf Software • 23 The Spinneys, Bromley, Kent, BR1 2NT • Tel: 0181-289 6003  
Email: info@werewlf.demon.co.uk • WWW: <http://www.werewlf.demon.co.uk/>

## AJS Computers Ltd

E-mail: [sales@ajscomps.demon.co.uk](mailto:sales@ajscomps.demon.co.uk)

### StrongARM RiscPC Special Package

- 16Mb RAM + 1Mb VRAM
  - StrongARM Processor
  - 15" AOC Monitor
  - 1.2Gb Hard drive
  - x8 CD ROM
  - Stereo speakers
- ..upgrades: DX4-100 PC Card £199.00  
1.7Gb Hard Drive upgrade £45.00

**£1225.00**

### Acorn A7000+ Multimedia system

- ARM 7500FE Processor
- 8Mb Ram
- 14" AOC Digital Monitor
- x8 CD ROM

**£865.00**

### Clearance Sale: (12 Months warranty)

- |                        |         |
|------------------------|---------|
| EESOX PD System        | £225.00 |
| SCSI Podule            | £50.00  |
| Epson Stylus Colour II | £100.00 |
| HP DeskJet 340 + SF    | £100.00 |
| Acorn RiscPC 700       | £750.00 |

### Second Hand Items:\*

- |                        |         |
|------------------------|---------|
| BBC Master 128         | £40.00  |
| A3000 (2Mb, ROS 3)     | £125.00 |
| A4000 (2Mb, HD80)      | £250.00 |
| A5000 (4Mb, HD160)     | £325.00 |
| RiscPC600 (9Mb, HD210) | £550.00 |
| 486SX40 PC Card (S/H)  | £50.00  |
| Microvitec CUB Monitor | £60.00  |
| Acorn AKF12 Monitor    | £50.00  |
| Acorn AKF18 Monitor    | £125.00 |
| Acorn AKF60 Monitor    | £100.00 |
| CC Laser Direct LBP4   | £300.00 |



Systems  
Part-Exchange  
Second-Hand  
Upgrades



Millstone House,  
51 Heath Drive,  
Chelmsford,  
Essex.  
CM2 9HE

Tel: 01245 345263  
Fax: 01245 345233

\* 3 month warranty on all S/H goods.

All prices plus VAT and carriage

# Over 10,000 Vector Images!

## £34.95 (inc. VAT)

*The Clip Art You've Always Wanted*

Meet some of the many hundreds of colourful people who will be on the Akalat Publishing stand at Acorn World.

Alternatively you can meet them now when you buy the Task Force Clip Art Collection. This contains 1088 different clip art images of people – just one of twenty different categories.

Write or phone for more information

# Task Force Clip Art™

Produced by New Vision Technologies Inc., Canada

Check out Task Force at <http://www.nvtech.com>

The Task Force Clip Art Collection consists of 10,000 vector graphic images and 500 photographic images on CD-ROM together with a 386-page full colour catalogue showing every clip art image. Conversion software to use images on an Acorn system included. The Task Force Collection costs £34.95 including VAT plus £3 p&p (UK) from:

Akalat Publishing, P.O.Box 231, Barton, Bedford MK45 4HQ  
Tel. 01582 881614, email [akalat@kbnnet.co.uk](mailto:akalat@kbnnet.co.uk)

# WHAT'S COMING OUT AT ACORN WORLD

**Acorn™**  
Registered Developer



Acorn User Awards 1995  
Runner up Best Business  
Software - TableCalc



Acorn User Awards 1996  
Runner up Best Network  
Software - SerialNET

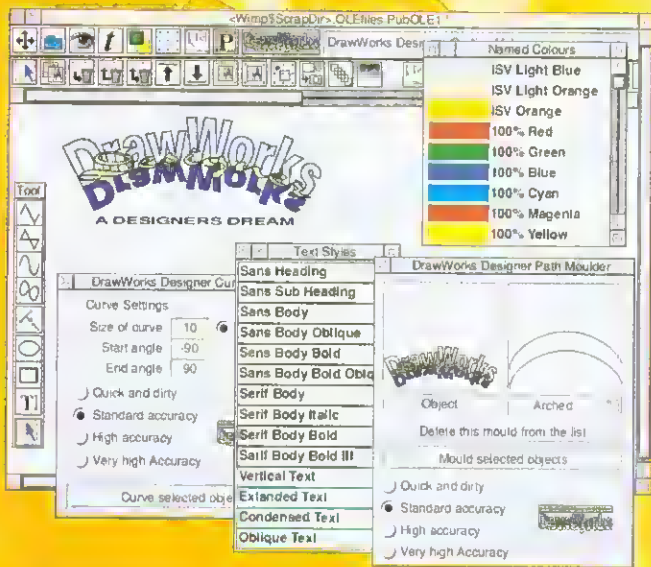

## DrawWorks DESIGNER

A DESIGNER'S DREAM

The latest version in the best selling DrawWorks series. Includes a completely redesigned user interface with on-line help. Buttons are now split into separate toolbars grouped by function.

New features include fitting objects to moulds, named colours, wrapping text or objects around a curve, user definable named text styles, full on-line help. DrawWorks Designer also has three users levels, from Student up to Designer. Objects can be exported as anti-aliased sprites and as JPEG and GIFF files. DrawWorks designer comes with a 60+ page fully illustrated on-line manual.

DrawWorks Designer requires Risc OS 3.1, 2Mb of RAM and a hard disk.

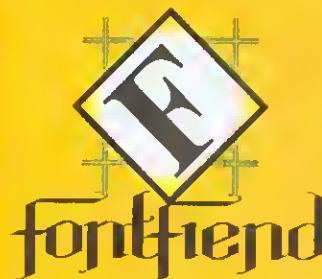

## The Font Designer

After 4 years work iSV Products is finally ready to release FontFiend. FontFiend is the intelligent font designer. FontFiend can make fonts with Latin 1,2,3 or 4 character sets. Automatically make accented letters and symbols in your font. Worried about the "black arts" of hinting a font. FontFiend can do this for you automatically.

FontFiend can also repair damaged fonts that won't load into FontED as well as loading many fonts that FontED cannot cope with. Supplied with a comprehensive printed manual and full on-line help FontFiend is the professional font designer. To quote one of iSV Products beta testers "...it's EXCELLENT!"

Requires RiscPC with 8Mb of RAM

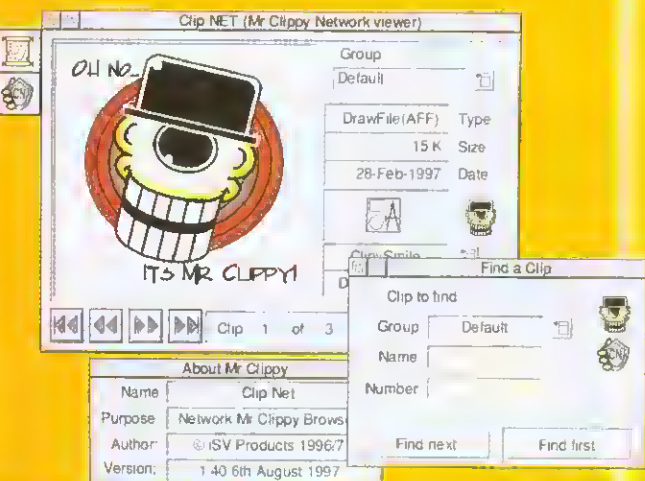
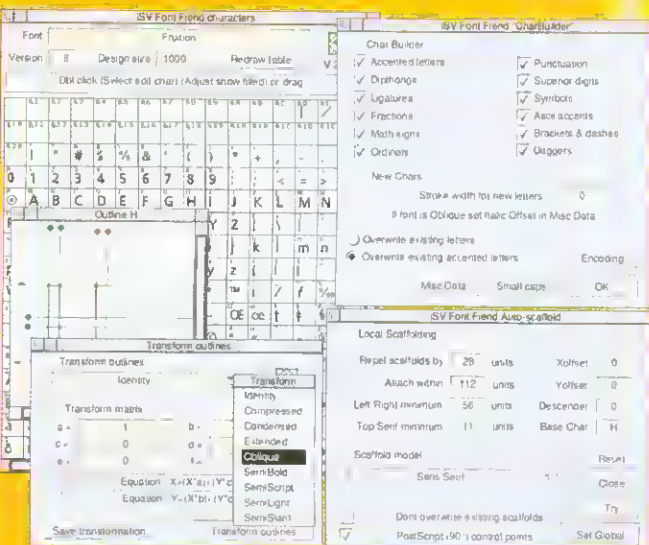

## The Network ClipArt Browser

ClipNET is the all purpose network clip art browser. ClipNET works in conjunction with Mr Clippy to deliver compressed clips over your network quickly and simply.

Users can see all of the clips stored in Mr Clippy on the file server. If a user wants a clip all they have to do is drag out a file, or just double click on the large thumbnail in the ClipNET window.

Users can locate clips by name using the "Find-a-Clip" system or from a menu. All Clips are presented in the same way as they would be from the main Mr Clippy application, except that users cannot modify or delete any of the clips. ClipNET requires Risc OS 3.1 or later and 2Mb of RAM in order to work.

**Don't  
Forget all  
the other  
Products  
we have  
released  
over the  
last 12  
months!**

**XStitch2**  
"...amazing...highly  
recommended...a  
class product..."  
Acorn User  
£36.50  
Upgrada from V1  
£16.50

**Report  
Generator**  
...difficult to separate  
from the  
competition, the  
diferrence is that it is  
about half the price!  
Acorn User  
£21.50 single user  
£41.50 alta licence

**SerialNET  
V1.5**  
"...half the price and  
four times the  
speed..."  
Archive  
£21.50 no cable  
£36.50 inc cable

**Typography  
Font CD**  
"...good quality  
fonts...excellant  
valua for money..."  
Archimadas World  
"...NDT es used by  
iSV Produces  
superior results."  
Acorn Publishar  
£31.50

**Mr Clippy**  
"...gets high marks...  
good valua for  
money..."  
Archive  
"Value 5 out of 5"  
Archimedes World  
£21.50

**ClassDesks**  
The protected  
desktop for  
educational  
astabishments  
5 Machine £31.50  
Site Licence £61.50

### ISV Special Offers

Font Designers Toolkit  
£21.50 aava £10.00!  
FontTrix PRO  
£16.50 save £10.00!  
Font PscK 312  
£14.00 HALF PRICE!  
TableCalc  
£21.50 save £10.00 from old rrp

VIVID 5000  
£11.50 SAVE 33%  
VIVID 20  
£11.50 SAVE 33%  
Publish Art 2  
£15.50 UNDER HALF PRICE  
DrawWorks2  
£16.50 SAVE 25%

Overseas orders please add £2.00 carriage  
86 Turnberry • Home Farm  
Bracknell • Berks • RG12 8ZH  
Tel 01344 55769

**iSV  
Products**

This advert was produced using NDT fonts  
stored on the Typograhly CD & DrawWorks2

All details correct at the time of going to press E&OE  
NDT & Typography are trademarks of iSV Products. All other trademarks are acknowledged

# Font handling

- ▶ point with Adjust-drag. The exact vertical position doesn't matter to *!Fontician*, but in other circumstances you can always realign the control points by applying a 'Transform-Y scale' of zero.

There are several other things that *!Fontician* can do, too.

Occasionally I find that I want to completely restart the scaffolding from scratch. This is because it's horribly easy to get the scaffold tree – the family tree of the scaffold lines – into a terrible tangle.



Figure III: An emboldened n

Going through every character in *!FontEd* to remove them all is tedious in the extreme. *!Fontician* will do this for you. All you have to do is click on the 'Toggle Size' icon, and then on the 'Remove scaffolding' button.

Making an oblique font by applying a matrix to another font is all very well, but you might not want every character in the font to lean. Many publications like to keep brackets, mathematical symbols, punctuation and the like upright even within oblique text, and it's a dreadful nuisance to have to change in and out of a font or style all the time. Also, you might want to change the form of some of the characters for the oblique font. A matrix transformation applied to a whole font doesn't allow this.

In contrast with oblique fonts, italic fonts usually aren't anything like their Roman counterparts. Even then, you might want some of the special characters to be simply leaning versions of the roman ones. For example, although the

*JPhysiol.italic* font is completely independently designed in the lower case, the upper case letters are simply sloping copies of the Roman font.

*!Fontician* allows you to apply a matrix to a font, producing a real Outlines file rather than just a reference to the parent font. You can then edit this font with *!FontEd* – in particular you can copy characters from one font into another. All you have to do is drag them from the first Font Index window to the second.

This means that you could make an oblique version of a font, then replace the characters that you wanted to leave upright with the upright versions from the original font. Similarly, you could make an oblique font, and then just use a few special characters from it, with the remainder being independently drawn italic characters or copies of the original upright characters.

Rather than you having to calculate the matrix you need for the effect you are trying to achieve, *Fontician* expects you to enter it in terms of X and Y scales, X and Y shifts, shear angles and rotations. The one item that may not be immediately obvious is *Truck*. This increases the width of every character by the given amount, that is the space allocated for the character in a line of text. For small amounts of emholding, having a little less space between the characters looks right, but for larger amounts you have to increase the widths or the characters start to collide excessively.

Another particular use I've made of these applications was to make proper Small Caps and Inferior/Superior fonts. Although most DTP software provides for subscripts and superscripts by applying a scaling and

a vertical shift to the ordinary characters, really the end result is that the subscripts and superscripts look too light and finely detailed in relation to the main font. In the days of metal type, a smaller type size was used, which was independently designed to match the larger. One particular detail of such smaller type is that the ratio of X-height to Caps height is usually larger.

Similarly, small capitals are often produced simply by using capitals and reducing the point size. Again, the result is that the characters look too light in relation to the main font. Ideally they should be adjusted in weight. They also look bet-

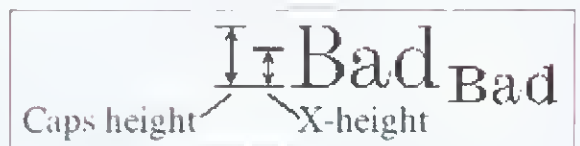

Figure IV: A real subscript font has a bigger x-height

ter with a slightly wider aspect ratio. *The Journal of Physiology* uses a font that we call *JPhysiol.SmallCaps*, which is identical to the *JPhysiol* font except that the lower case letters are carefully produced small capitals. This makes it possible for us to do lists of authors' names in caps and small caps without changing style all the time.

You can use any combination of *!Fontician's* facilities in a single operation. The various transformation will be performed in the order of the list in the Save window. If you want to do them in a different order, you'll have to process your font more than once.

*!Fontician* will accept Format Version 6 or 8 fonts as input, but always produces Format Version 8 fonts.

Next month we'll delve a little further into how to process fonts files to produce good quality lettering. **AU**

# Get the latest in technology

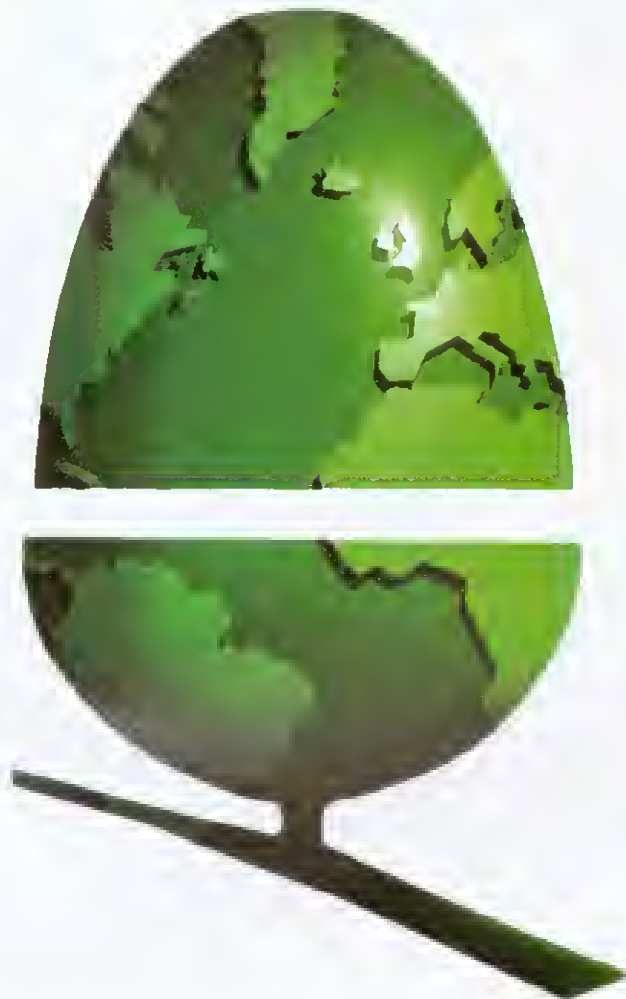

## FREE

Claim a full range of AcornSoft  
beta Software completely  
FREE of charge when you visit  
Acorn World 97

Acorn   
WORLD

31 October - 2 November 1997

Wembley Conference and Exhibition Centre  
HALL 3

Ticket prices:

	Advance	On the door
Adult:	£6.00	£9.50
Child: (under 16)	£5.00	£7.00
Family: (2 adults and 2 children)	£16.00	£22.00

**Ticket Hotline Number: 0181 982 6500**



# Acorn World '97 Show Guide

Hall 3, Wembley Exhibition  
and Conference Centre  
31 Oct – 2 Nov 1997

Acorn World is the largest annual Acorn computer exhibition and attracts visitors from all around the world.

It is an opportunity for Acorn users to see, try and buy the latest hardware and software, attend seminars and demonstrations of a wide range of products covering education, publishing, design, process control, games, business applications, networking, communications and the Internet.

Research carried out by EPS, last years organisers indicated that, over the three days of the event, an estimated £2 million was spent by visitors to the show. They also discovered that many Acorn enthusiasts and schools make their major annual equipment and software purchases at Acorn World.

As announced last issue EPS have withdrawn from the organisation of this year's show and Acorn themselves have stepped in to ensure that the show is as successful as in previous years. Due to the recent takeover only limited information was available about the event as we went to press but Kerri Davies at Acorn said that they were putting lots of resources and effort into the show, however, they were unable to confirm promotions, competitions or any further details at this stage.

Contact Kerri Davies on 01223 725267 or e-mail [k.davies@acorn.co.uk](mailto:k.davies@acorn.co.uk)

## Acorn highlights – stand 58

Two of the highlights of the show include Java enabled Acorn prod-

ucts and a sneak look at a prototype of the Risc PC II (to be launched in 1998). The first public showing will be accompanied by the Acorn Technology Showcase Cinema, where Acorn's latest and next generation technology will be revealed on the big screen to show attendees.

One of the main thrusts from Acorn's technology division will be their TVCentric(TM) technology, incorporating Network Computers (NC's), set-top boxes and LAN TV – bringing the next generation of home entertainment into the market today. As further commitment to this market, an expansion of the gaming titles available on the Acorn format will also be unveiled.

A new tables & frames browser (name still to be announced) will be launched – commercially available to Acorn users for the first time, this browser

will cope with the latest Internet technology, eliminating no-go areas of the World-Wide Web for all Acorn users.

## Meet the Acorn User team – stand 104

Visit the *Acorn User* stand where you can meet members of the editorial team – Mike Cook will be showing off one of his projects and Steve Turnbull will be on hand to answer any technical queries. We'll also have back issues for sale and a range of other AU goodies. Of course, it's an ideal time to take out or renew a subscription to *Acorn User* – so take advantage of our special show offer and sign up at Acorn World.

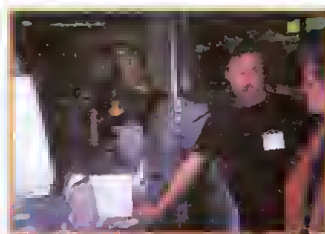
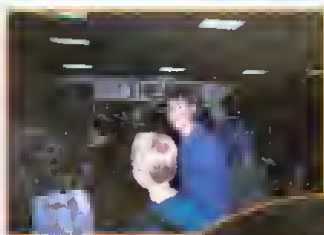

## TRAVELLING TO WEMBLEY

### By rail

Wembley Park underground station is a few minutes walk from the Conference Centre, and is on the Metropolitan and Jubilee Underground Lines.

In addition there is a British Rail connection from Marylebone to the Wembley Complex BR station.

### By road

Wembley Conference Centre is just 20 minutes by road from London's West End. The Conference Centre is close to the A406 North Circular Road, and there is easy access from the M25, the M1, and M40. 'Wembley' signs will help direct you from the M1 and North Circular. There is ample car parking space at the rear of the Conference Centre.

## Charity lucky dip – stand 48

*Acorn User* are once again organising a lucky dip to raise money for charity. Opening times will be announced at the show so come along and try your luck – there'll be prizes large and small donated by Acorn dealers and developers.

## OPENING TIMES

Friday 31 Oct/Saturday 1 Nov 10.00 - 18.00  
Sunday 2 Nov 10.00 - 17.00

## TICKET DETAILS

	On the door	In advance
Adults	£9.50	£6.00
Minors (under-16)	£7.00	£5.00
Families (2 adults & 2 children)	£22.00	£16.00

Advance ticket holders will be admitted to the show 30 minutes before the official opening time to the general public.

Ticket Hotline number: 0181 982 6500

## Education seminars – Friday 31 October

Friday			
Times	Seminar title	Speaker(s)	Further info
10.30	What's New?	Chris Cox	Hot news on the latest from Acorn
11.30	Data Management and Reporting for the National Curriculum	Stuart Forbes	How National Curriculum pupil data can be easily and effectively managed using NStore the award-winning package for Pocket Book and Acorn RISC machines
12.30	Why Internet your school?	Ian Goodall	For primary and secondary teachers who are considering a school internet connection
1.30	Security and the Classroom Computer	Alan Bennett and Roger Young	Xemplar's new classroom management system for RISC OS computers provides a sensible level of security and makes the machine even more teacher friendly and child compatible
2.30	IT in the Secondary Curriculum	Chris Morley	Details to be confirmed
3.30	Turnkey Solutions for RISC OS	Alan Bennett and Roger Young	See how Xemplar Infant and Junior Toolboxes for RISC OS can be used to deliver the key elements of the IT curriculum at Key Stages One and Two
4.30	The Docklands Project	Glen Franklin	Introducing the innovative work of the National Literacy Association Docklands Project using nearly 600 Acorn Pocket Book computers with Primary schoolchildren and their parents and carers in London Docklands, with the aim of increasing achievement in literacy

Education day sponsored by



*Details correct as of 12 September 1997. Please check on day for any changes to programme.*

## Demo theatre – Sat 1 & Sun 2 November

Saturday			
Times	Seminar Subject	Company(C)/Expert(E)	Product/Subject
1015 - 1130	The Internet	Argo Interactive PLC (C) RComp (C) David Matthewman (E)	Voyager HTMLedit3 WWW Page creation
1145 - 1445	DTP, Design and Graphics	Beebug (C) Computer Concepts (C) Spaceteck (C) Mike Williams of Akalat Publishing (E) Clive Semems of The Journal of Physiology (E) Tony Tolver of T-J Reproductions (E)	OvationPro ArtWorks and its Plugs-ins Photodesk2 Design Importation Printing
1500 - 1615	Video	Oregan (C) WSS (C)	CineWorks MovieFS
1630 - 1745	The Future	Acorn	Chris Cox Peter Bondar

Sunday			
Times	Seminar Subject	Company/Expert	Product/Subject
1015 - 1145	Music	Oregan (C) Sibelius (C) Expert -TBC	Prosound Sibelius 6/7
1200 - 1315	Business Applications	Clares (C) Circle Software (C) Apricote Studios (C)	Schema2 Impact Professional Prophet
1330 - 1445	Software Tools	WSS (C) Acorn/ARM Research and Development (C) Expert - TBC	Dr Smiths Toolkit New C/C++ Package
1500 - 1630	The Future	Acorn	Chris Cox Peter Bondar

*Programme correct as at 10:09:97.*

Admission – Entry to the seminars on Saturday and Sunday will be on a first come, first seated basis with one exception – The ART of Future Gazing with Chris Cox and Peter Bondar will be ticket only. Tickets will cost £2

# Power for performance

Available at  
Acorn World '97

Ultra  
**SCSI III**

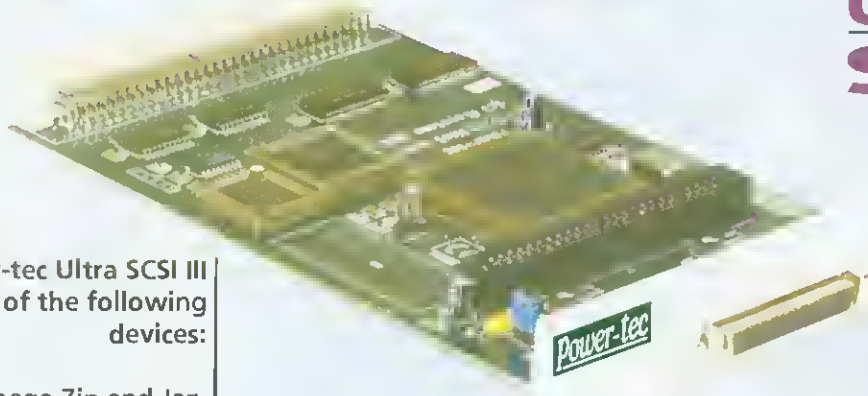

The new Power-tec Ultra SCSI III supports all of the following devices:

Iomega Zip and Jaz,  
Mag Optical,  
Panasonic PD (eg Proteus),  
SyQuest (including SyJet)...

ALL sizes of hard discs of ALL leading manufacturers such as Fujitsu, Quantum, Conner, Micropolis, IBM, Seagate.

Scanners from Epson, Canon, Umax, Mustek, Microtek and other leading brands.

Includes SCSI CD Drivers for NEC, Pioneer, Plextor, Aiwa, Toshiba, Sony, Sanyo & recordables too!

ATAPI Drivers for ALL leading makes up to 12/20x as well as Multi-Changer Drives.

Also included - Backup Software, 8 drive icons on the icon bar, drive spin down, support for up to 4 Power-tec SCSI cards in one machine giving a possible 32 devices on ONE machine, user configurable LFAU and icon order on icon bar.

Ultra SCSI III is backwards compatible with SCSI I and SCSI II.

All Power-tec products now come with 90 days FREE technical support which includes software updates, telephone support and access to our Support Web Pages and Power-tec Chat Mailing List.

## Leading Edge Power-tec ULTRA SCSI III card...

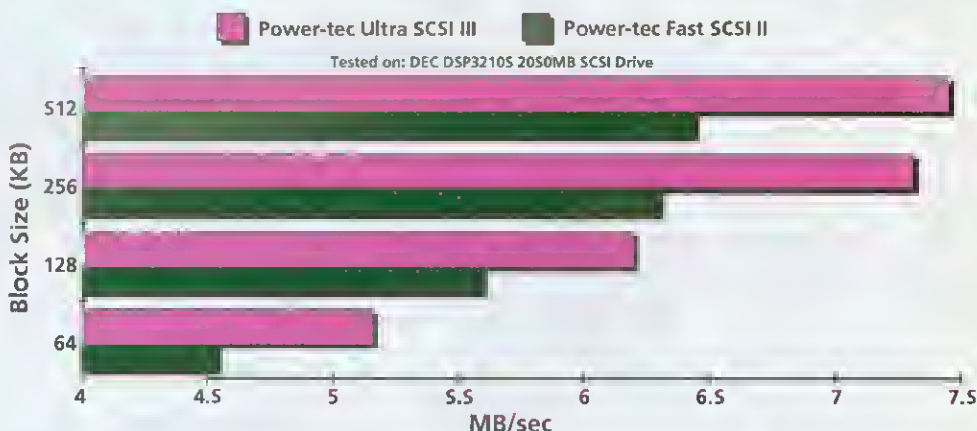

### Power-tec Price List:

Ultra SCSI III card: £175

Fast SCSI II card: £135

Upgrade to Ultra SCSI III: Without Tech Support      With Tech Support\*

v1.00 or v1.01 SCSI II card: £110      £90

v2.00 or v2.01 SCSI II card: £49      £29

Optional Extended Technical Support and Upgrades: £20

NB: All prices exclude VAT and carriage.

\*This price applies to customers with Tech Support current at 1st September 1997.

47 Winchester Road, Four Marks, Alton,  
Hampshire, GU34 5HG UK.

Please call or e-mail us  
for more details...

**Power-tec**



Tel: +44 (0)1420 561111  
Fax: +44 (0)1420 561100  
E-Mail: sales@alsystems.co.uk  
WWW: <http://www.alsystems.co.uk>

**Alsystems**

# Liquid Silicon

## Sibelius V3.5

New Features!  
New Prices!

- Junior Sibelius -- £49.00
- Sibelius 6 -- £99.95
- Sibelius 7 Student -- £399.95
- Sibelius 7 -- £899.00

Complete MIDI sound expansion £229.00

(Dealer enquiries welcome)

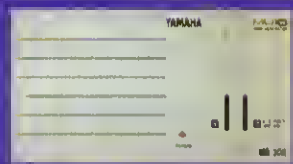

- MU10 MIDI sound module (976 sounds in total, 21 drum kits, 11 reverb, 11 chorus & 42 variation effects (with audio inputs for microphones etc.), Absolutely superb sounds for the price.
- Serial driver connects the MU10 to a fast serial port (Risc PC, A7000, AS000 or multiple serial card) and turns it into a 1 in, 1 out MIDI interface as well as a sound module. **No need for a separate MIDI interface** - you can plug a keyboard straight into the MU10. Ideal if you already use your parallel port etc.
- Excellent results with MIDI, Sibelius (you can hear playback when recording with Flexi-Time) and other MIDI applications.
- Requires either headphones, a HiFi hook-up or a pair of powered speakers (superb results with the Yamaha YST series).

• Computers & Music Hardware • Upgrades • Software • Cables etc.

### Computer Systems

Call for a 'DIY' price.

- Risc PC SA 4+0Mb 1.2Gb HD -- £1087.99
- Risc PC SA 9+2Mb 1.2Gb HD -- £1375.99
- A7000+ 4Mb, Natwork, AKF60 -- £939.24
- A7600+ 8Mb, 1.2Gb, AKF60 -- £1095.04
- Modem (29.9) Network Computer -- £450.08
- Ethernet (10BaseT) Net. Comp. -- £450.00

### Monitor options when buying a Risc PC

- Acorn AKF60 (14") -- add £253.00
- Acorn AKF91 (17") -- add £614.78
- Iiyama 350 (MF-8515G 15") -- add £263.80
- Iiyama MF-9617E (17") -- add £498.00
- Iiyama MF-8817ES (17") -- add £543.50
- Iiyama MF-9017E Pro (17") -- add £546.00
- Iiyama MF-9221T (21") -- add £1082.80
- Iiyama 500 (MF-8721T 21") -- add £1140.50
- Iiyama MF-9021T Pro (21") -- add £1127.50

### PC cards:

- DX4-100 -- £233.00
- 5x86-100 -- £349.00
- 5x86-133, 128K cache -- £349.00
- 5x86-133, 512K cache -- £390.00
- PC Pro (includes PC Exchange) -- £47.95
- PC Sound Pro -- £20.50

### Other options (with machine):

- 8 speed CD ROM drive (RPC) -- add £81.84
- 9 speed CD drive (A7000+) -- add £95.00

### Pision Series 5

- Drool over the new ARM-powered palmtop
- 4Mb, with PC connection kit -- £429.95
- 8Mb, with PC connection kit -- £487.45

### Memory Upgrades

Please call to check prices. Others available.

- A3000 1-4 Mb -- £74.00
- A3010 1-4 Mb -- £81.00
- A3020/A4000 2-4 Mb -- £63.45
- A5000 2-4 Mb -- £69.30

### Risc PC/A7000 SIMMs:

- 4Mb -- £18.00
- 9Mb -- £29.70
- 18Mb -- £61.85
- 32Mb -- £97.95
- 1Mb VRAM -- £82.85
- 2Mb VRAM -- £97.50

### Music & Sound Section

Call for other musical items

### MIDI Interfaced:

- A30x0/A4000 Internal 1x1x1 -- £57.00
- MIDI Max Internal 1x1x1 -- £82.00
- Parallel Port 1x1x1 -- £80.00
- Serial Port -- £Call
- Synth 8 -- £44.60
- Basic Synth -- £44.60
- Synth Plus -- £55.75

### Other hardware:

- Fatar Studio Logic Pianos -- £Call
- SPDIF interface -- £Call
- Yamaha MU10 module -- £195.00
- Yamaha YST-M7 speakers -- £44.60
- YST-M28 DSP speakers -- £68.00
- YST-MS25 speakers & sub. -- £Call
- YST-MSW5 subwoofer -- £Call
- YST-MSW10 subwoofer -- £88.00
- Sound Byte Recorder -- £47.95

### Other software:

- MIDI Support -- £18.50
- MIDI Mapper -- £22.75
- MU10 serial driver -- £37.95
- Prosound -- £116.95

### Other Hardware

- ARM Switcher -- £119.00
- Connect 32 SCSI 2 RPC card -- £211.50
- 3.2Gb IDE drives -- £200.00
- Hard drives & kits -- £Call
- HP 8L laser printer -- £320.00
- Pocket Book & Link -- £59.50
- Risc PC second disc -- £118.30
- RPC second disc (no PSU) -- £90.00

### Other Software

- ANT Internet Suite 2 -- £112.00
- Bitfiddle 7 CD -- £47.95
- Blindle -- £24.95
- Brutal Horse Power -- £Call
- The Cobalt Seed -- £22.00
- DarkWood -- £22.00
- DataPower 2 -- £165.00
- DrawWorks 2 -- £20.40
- Driftin -- £30.00
- Dune II -- £51.00
- Dune II CD -- £45.00

- Empire Soccer 94 -- £22.90
- Kaystrokes -- £34.95
- Kingstuner Ch. Micropedia -- £64.95
- Klykeo -- £35.00
- My 1st Incredible Amaz. Dict. -- £39.00
- Ovation Pro -- £174.50
- Personal Accounts 3 -- £43.00
- Photodesk Light -- £128.00
- Photodesk 2 -- £247.95
- Premier Manager -- £22.00
- Prophet 3 -- £160.00
- Shuggy -- £22.00
- Tanks -- £22.00
- Textaxe 2 -- £54.50
- Tanks -- £22.00
- The Ultimate Human Body -- £40.50
- Undelete -- £10.25
- The Way Things Work -- £49.50

### Books & Manuals

- BBC BASIC Manual -- £21.95
- Impression Tutorial Guide -- £7.95
- RISC OS 3 PRM -- £104.00
- RISC OS 3 PRM V5a -- £32.75

### Cables

- We do hundreds of different cables. Data switches are also available. 3.5mm stereo jack to same (2m) audio lead for additional output to Yamaha speakers etc. -- £4.05
- MIDI cable (4m) -- £5.25
- MIDI cable (5m) -- £5.95
- MIDI gender changer - joins two MIDI cables together -- £2.40
- Multimodem cable (2m) -- £8.95
- Multimodem cable (5m) -- £10.95
- Two Phono plugs to same (e.g. PowerWave to Hi Fi) -- £3.95
- As above (5m) -- £5.95
- As above (10m) -- £6.05
- 8 or 15-pin Scart & audio leads -- £10.95

### Bargains

- Other bargains are available.
- Acorn 14" mon. nylon cover -- £49.50
- 10/10 Dinosaurs -- £10.00
- Carnage Inc -- £10.00

# MELIDI

MelIDI is a powerful pattern-based MIDI sequencer for all Acorn machines. It supports any MIDI interface (including parallel and serial) and requires RISC OS 3 and 2Mb of memory. A Risc PC and large monitor are not essential.

A demo disc is available on request, or visit the MelIDI web site at <http://www1.cableinet.co.uk/liquid/melidi>.

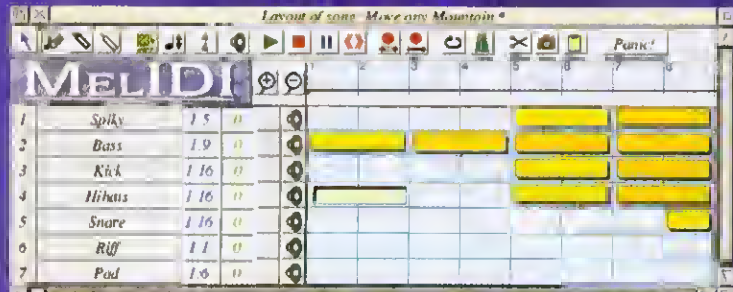

Despite being powerful and flexible, MelIDI has a simple to use and straightforward drag & drop interface - you can move sequences around as you wish and drag and drop other songs and patterns in to merge them. Patterns can be linked together (orange sequences), so that if you change the master pattern, the other patterns will be updated accordingly.

You can have any number of tracks your computer will allow - you are not limited to 64 tracks. MelIDI also supports up to 12 MIDI OUTs, giving you access to 192 MIDI channels.

You can apply basic transpositions or completely definable on-the-fly note mappings to sequences. For example, this can allow you to play GM files on a non-GM instrument.

Powerful quantisation and transformation functions are also available which are accessed via the piano roll, drum editor and map windows and the powerful event editor gives you fine control over your data (and can handle System Exclusive messages effortlessly).

With the addition of a separate plugin module, you can also sequence sound samples - there is no need to buy a completely separate package!

### What you say:

- "I do like the way that MelIDI detects the type of Controller command you are sending. MelIDI is a joy to use and is a lot more flexible and user friendly than any other MIDI sequencer that I have ever used. A great bit of software!" - J. Reil, Guild Entertainment
- "MelIDI's pattern handling is lovely - much nicer than a separate window which forces you to be aware of the pattern name, even if you don't want to be. MelIDI is very neat." - Name withheld by request
- "I'm still finding my way through MelIDI but the combination with the [Yamaha] MU10 seems really amazing." - Peter Roberts
- "Also, I love the drag'n'drop facilities of MelIDI. From rearranging the drum list to moving patterns, it's just so beautifully intuitive and elegant, and extremely impressive - I'm sure it must have taken a huge amount of work to implement." - Gareth Long
- "Very classy. Very good, clear manual!" - Martin Eastwell
- "This is clearly the best and most comprehensive sequencing package available on the Archimedes. I was impressed by its clear and straightforward user interface, it is both intuitive and accurate. A pleasure to use. At last we have something on the Arc to rival Cubase and Cakewalk, it's about time!" - Neil Martin
- "Can I first of all say that MelIDI is a brilliant program far ahead of anything available on the Acorn! Keep up the good work!" - Rob Ives
- "I'm a user of MelIDI, and it's a cracking package. MelIDI has all the features you'd expect from a top quality professional sequencer (I use Notator, Cakewalk Pro and Logic Audio on a regular basis) with some nice little additions like incredibly quick MIDI file loading, three playback modes for those with less able computers as well as its incredible all-round speed - I don't think it's ever taken control for more than half a second on any operation; and I've got an A3010!
- There are the windows which are some of the best around: I particularly like the map window in which you can have graphic displays of changes in tempo, velocity, controllers (picked by name or number) and control of plug-in extensions. For all these, you can simply draw in a controller change and use the powerful transform function to change it all sorts of ways. Then there's the controller sliders. Beautifully compact and go all the way up to track number 'infini!' I'm more than pleased with MelIDI and completely overwhelmed by the support I'm getting - definitely unparalleled!" - Matthew Burke

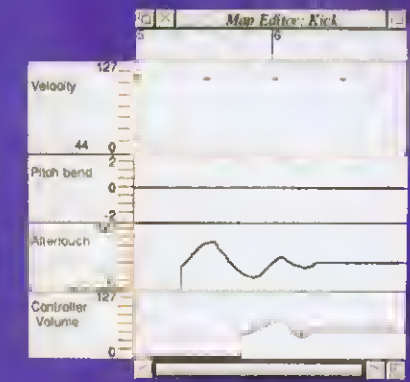

This example map window shows four of the possible controller maps which are available. These are easily alterable by drawing with the mouse.

Maps available include tempo, velocity, aftertouch and pitch bend, plus continuous and bilinear plugin controllers for any unique devices (MIDI Support is required for using plugins).

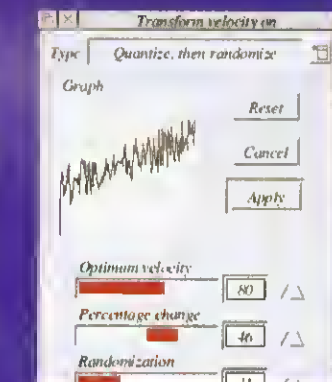

From a map display, you can transform any event using various graphical transformation functions, including quantize, percentage or constant change and reversing.

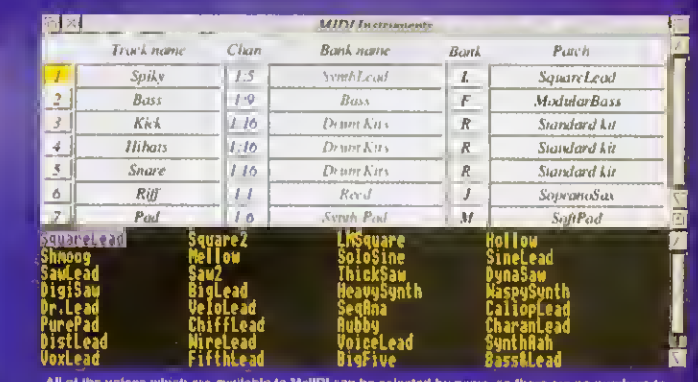

All of the voices which are available to MelIDI can be selected by name, so there are no numbers to remember. A large number of pre-defined instruments from many manufacturers are supplied so setting up is straightforward. MelIDI can also make use of MIDI Support-compatible devices for even easier configuration.

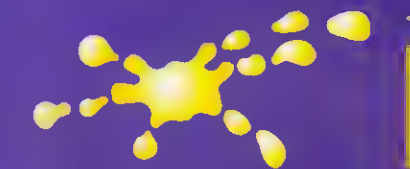

We will attempt to match or beat any advertised price - even special offers.

Liquid Silicon, FREEPOST EH2725, Kirkcaldy, Fife, KY2 5BR, United Kingdom  
Tel: (01592) 592265, Fax: (01592) 596102  
email: [Liquid@Cableinet.co.uk](mailto:Liquid@Cableinet.co.uk), <http://www.cybervillage.co.uk/acorn/liquid/>  
All prices INCLUDE VAT & UK carriage  
Official orders and callers welcome. Finance available

THE  
COMPANIES  
INVOLVED**4th Dimension**

Stand 124  
PO Box 4444  
Port St Mary  
Isle of Man IM99 7RS  
Tel: 01624 836744  
Fax: 01624 836745  
E-mail:  
4d@rsmtcr.dcmom.co.uk  
WWW:  
www.rsmtcr.dcmom.co.uk/d4.htm  
With the VFM range, that's 26 games at only £39.99 each; a new release at that price *Pushy*; a playable demo of a new RPG *Worldly Wise* (working title); a *Drifter* Competition and all the usual bargains to boot, can you afford to miss the 4D stand this year?

**Acorn Group plc**

Stand 58  
Acorn House  
645 Newmarket Road  
Cambridge CB5 8PB  
Tel: 01223 725000  
E-mail: info@acorn.com  
WWW:  
http://www.acorn.com/acorn/  
Further details on previous page.

**Acorn Archimedes World**

Stand 108  
Nexus House  
Boundary Way  
Hemel Hempstead HP2 7ST  
Tel: 01442 66551  
Fax: 01442 66889  
E-mail:  
editor@arcworld.co.uk  
Situated outside the Demonstration Theatre, the *Archimedes World* stand (108) will host Question and Answer sessions following the theatre seminars. Visit the *Arc World* stand to see the latest issue and to take advantage of the special subscription offer.

**Acorn User**

Stand 104  
IDG Media  
Media House  
Adlington Park  
Macclesfield  
Cheshire SK10 4NP  
Tel: 01625 878888  
Fax: 01625 850652  
E-mail: aeditor@idg.co.uk  
WWW:  
http://www.idg.co.uk/acornuser/

Further details on previous page.

**Acorn User Lucky Dip**

Stand 48  
Further details on previous page.

**AJS Computers Ltd**

Stand 19  
Millstone House  
51 Heath Drive  
Chelmsford  
Essex CM2 9HE  
Tel: 01245 345263  
Fax: 01245 345233  
E-mail:  
sales@ajscomps.demon.co.uk  
One of the first Centres of Technology. Specialising in custom configured packages based on the Risc PC and special value for money configurations based on the A7000+. Upgrades for memory, CD-ROMs, hard drives, monitors and of course computers are all available. Second-hand systems, ranging from A3000s to Risc PCs often available.

**Akalat Publishing**

Stand 80  
P.O.Box 231  
Barton  
Bedford MK45 4HQ  
Tel: 01582 881614  
Fax: 01582 881614  
E-mail: akalat@kbnet.co.uk  
WWW:  
http://huns.co.uk/ucornpub  
A major feature of Akalat Publishing's stand will be the *Task Force Clip Art Collection* on CD-ROM. Akalat Publishing are the UK distributors for this Canadian product which has been widely praised in the Acorn press. We will also have on sale the latest issue of *Acorn Publisher*, plus back issues and a varied selection of books on dtp, design, graphics and the Internet.

**Alsystems**

Stand 10  
47 Winchester Road  
Four Marks  
Alton  
Hampshire GU34 5HG  
Tel: 01420 561111  
Fax: 01420 561100  
E-mail:  
keith@alsystems.co.uk  
WWW: http://www.alsys-

tems.co.uk  
We'll be releasing some great new products. Our Ultra SCSI 3 card is ready at last and we'll have plenty of cards available. Performance is fabulous so don't miss it! Released too will be low cost Parallel Port Zip Driver software with identical format to SCSI media.

**Alternative Publishing Ltd**

Stand 34  
30 Clyde Place  
Glasgow G5 8AQ  
Tel: 0141-418 0881  
Fax: 0141-418 0889  
E-mail: sales@apsoft.co.uk  
WWW: www.apsoft.co.uk  
Alternative Publishing will be offering special discounts on the ever-popular *ImageFS* graphics conversion software. *ImageFS* now supports 21 major graphics formats, giving a range of over 100 sub-formats. AP will also be demonstrating innovative new software to allow support for *PostScript*, *Illustrator* and *Acrobat/PDF* documents on Acorn technology; with performance unparalleled on any computer platform.

**Anglia Multimedia**

Stand 120  
Anglia House  
Norwich NR1 3JG  
Tel: 01603 615151  
Fax: 01603 622191  
Orders & enquiries: 01268 755811  
E-mail: angliamail@aol.com  
WWW:  
www.anglia.co.uk/education/  
At this year's show there will be an opportunity to see the latest titles: *Ancient Egyptians*, *Cabot and the Merchant Venturers* and the new disc for KS1 — *Through my Window*. This will also be your first chance to preview *Introducing the Internet*, two new CD-ROMs for primary and secondary schools providing a wealth of internet resources for the classroom — without the phone charges!

**ANT Ltd**

Stand 60  
PO Box 300  
Cambridge CB1 1HZ  
Tel: 01223 567 808

Fax: 01223 567 801  
E-mail: sales@ant.co.uk  
WWW: http://www.ant.co.uk  
ANT's new products will include *WebTool*, a utility which allows users to download entire websites and store them locally, and RISC OS Internet Servers, which allow complete websites to run from a RISC OS server. Other highlights will include the latest version of the *ANT Internet Suite* as well as versions of *ANT Fresco*. ANT also anticipate having on sale the *ANT Fresco Web Browser* as stand alone software.

A CD-ROM will be available for new users, developed in association with UK-Online and *Computer Shopper* magazine, enabling people who have never used the Internet to get online using their Acorn machine, without the worry of finding an ISP or the appropriate software. There will be the special price for the *ANT Internet Suite* of £99 (inc VAT) and for £20 (inc VAT).

**A.P.D.L.**

Stand 112  
39 Knighton Park Road  
Sydenham  
London SE26 5RN  
Tel: 0181 778 2659  
Fax: 0181 488 0487  
E-mail: info@apdl.co.uk  
WWW: www.apdl.co.uk  
APDL will have new versions of the PD CDs at special prices, and the ever popular clip art CDs. Plus lots of software and hardware bargains, including hard discs and Syquest drives and a new, fast, low cost IDE interface.

**Apricote Studios**

Stand TBC  
2 Purls Bridge Farm  
Manca  
Cambs PE15 0ND  
Tel/Fax: 01354 680432  
E-mail:  
apricote@enterprise.net  
WWW:  
http://homepages.enterprise.net/apricote/  
We will be demonstrating our multi-award winning business accounts application — *Prophet3*, as well as the best-selling *Personal Accounts* and *Shares* appli-

cations. If you need to stay in control of your finances a visit to our stand is a must.

**Argo Interactive Group plc**

Stand 106  
7 Dukes Court  
Chichester  
W Sussex PO19 2FX  
Tel: 01243 815 815  
Fax: 01243 815 805  
E-mail: info@argonet.co.uk  
WWW: www.argonet.co.uk  
New products include the new sub-£300 *NetProducts* *NetStation*, *ArgoNet's* easy-to-use *Voyager* Internet suite with frames and tables, and a *Voyager* file server designed for networks. Argo also supply Zip drives and 100Mb cartridges for Acorn, Windows, Macs and Acorn *NetStations*.

**Atomwide Limited**

Stand 59  
7 The Metro Centre  
Bridge Road  
Orpington  
Kent BR5 2BE  
Tel: 01689 814500  
Fax: 01689 814501  
E-mail:  
sales@atomwide.co.uk  
WWW: http://www.atomwide.co.uk  
Atomwide will be exhibiting their range of cross-platform network services and solutions, hardware products and training courses. Notably, the show will be the first outing for Atomwide's new range of network utility software *NT Filer*, *NT Users* and *NPA Spooler*.

**AVP**

Stand 2  
School Hill Centre  
Chepstow  
Monmouthshire  
NP6 5PH  
Tel: 01291 625439  
Fax: 01291 629671  
E-mail: avp@compuserve.com  
WWW: http://ourworld.compuserve.com/homepages/avp  
Four CD-ROMs in AVP's *PictureBase* range of integrated educational CD-ROMs will be launched at the show — *Rocks Minerals and Fossils*, *Physical Processes, Materials*, the new *Art In The National Curriculum*. The *PictureBase* range is now the largest

THE  
COMPANIES  
INVOLVED

integrated range of Acorn educational CD-ROMs. Available at a special show discount.

**BEEBUG Limited**

Stand 12  
117 Hatfield Road  
St Albans AL1 4JS  
Tel: 01727 840303  
Fax: 01727 860263  
E-mail: sales@beebug.co.uk  
WWW: www.beebug.com  
BEEBUG will be selling and demonstrating *Ovation Pro* with Colour Supplement. Also on demonstration will be the leading OCR package *Slenth 3*. Come to BEEBUG for your Risc PC and A7000+ special offers at the show. Networking is the future, and who better to talk to than the specialists. We have reference sites large and small.

**Cannon Computing**

Stand 117  
Whitegate  
Hatfield Heath  
Bishop's Stortford  
Hertfordshire CM22 7ED  
Tel: 01279 730800 (Sales and general enquiries, 3 lines)  
Fax: 01279 730809  
E-mail: sales@cannonco.demon.co.uk  
Special offers on Acorn computers and peripherals for educational, home, and business users. Exclusive show offers in collaboration with SEMERC on a selection of their most popular software and hardware, including YITM CDs. Prize draws for customers throughout the show.

**Castle Technology**

Stand 56  
Ore Trading Estate  
Woodbridge Road  
Framlingham  
Suffolk, IP13 9LL  
Tel: 01728 621222  
Fax: 01728 621179  
E-mail: jack@castle-technology.co.uk  
WWW: http://www.castle-technology.co.uk  
The new Storm DMA32 SCSI card will be available at the show for purchase. Also available for purchase will be: Scanners, IDE & SCSI hard drives, keyboards,

CD-ROM drives, removable drives, memory, Acorn computers and monitors.

**Circle Software**

Stand 76  
PO Box 36  
Bodnini PL30 4YY  
Tel: 01208 850790  
E-mail: sales@circlesw.demon.co.uk  
Circle Software will be demonstrating the latest versions of their *Impact* relational database range, which will be available at special offer prices. *Impact* will, as ever, be greatly enhanced with many new and innovative features.

**CJE Micro's**

Stand 126  
78 Brighton Road  
Worthing  
West Sussex BN11 2EN  
Tel: 01903 523666  
Fax: 01903 523679  
E-mail: chris@cje.co.uk  
WWW: http://www.cje.co.uk/  
On demonstration will be CJE Micro's large range of peripherals, as well as Risc PC's themselves. This will be the first opportunity for many to see the 'Fastest Risc PC Card' available, the 'CJE 5x86 133MHz with 512k Level 2 Cache'. CJE's wide range of CD-ROM drives and memory will also be on display. All of CJE Micro's products will be available for purchase from their stand at very favourable prices!

**Clares Micro Supplies**

Stand 98  
98 Middlewich Road  
Northwich  
Cheshire CW9 7DA  
Tel: 01606 48511  
Fax: 01606 48512  
E-mail: sales@clares.demon.co.uk  
WWW: http://www.stcoll.ac.uk/clares/  
Clares will be showing version 2 of *WimpBasic*, *Rhapsody 4* and maybe a few surprises. Lots of special show prices available.

**Cumana (A division of Economatics Education Ltd)**

Stand 114  
Boundary House  
The Pines  
Broad Street  
Guildford  
Surrey GU3 3BH  
Tel: 01483 503121  
Fax: 01483 451371  
E-mail: sales@cumana.co.uk  
WWW: www.cumana.demon.co.uk  
On show for the first time the Acorn versions of the Syquest EZFlyer 230Mb and the SyJet 1.5Gb Parallel port devices. Also the new twelve-speed replacement for Cumana's hugely popular CD-ROM drive, which can give full CD multimedia capability to all Acorn computers fitted with a bi-directional parallel port. We will also be showing a range of other CD-ROM drives, the successful SCSI II card, the latest SCSI CD-ROM drives and the range of Casio Digital cameras. Special offers will be announced at the show.

**Dalriada Data Technology**

Stand 100  
74 Greville Road  
Warwick CV34 5PJ  
Tel: 01926 492459  
Fax: 01926 492459  
E-mail: sales@dalriad.demon.co.uk  
WWW: www.dalriad.demon.co.uk  
Acorn World will see the latest versions of *WebSpider*, Dalriada's leading visual HTML editor, plus *DiagramIt* and *TableMate*, our popular diagramming and tabling tools. Whether you are into electronic or paper publishing, this stand is a "must see".

**Desktop Projects Ltd**

Stand 28  
Unit 2a Heapriding Business Park  
Ford Street  
Stockport SK3 0BT  
Tel: 0161-474 0778  
Fax: 0161-474 0781  
E-mail: info@desktopp.demon.co.uk  
WWW: http://www.desk-

topp.demon.co.uk  
We will be selling Risc PC's, StrongARM's, SIMM's, VRAM, ATAPI/SCSI CD-ROM drives, Zip/Jaz drives with our new *JazZip* tools (also available separately), Printers, Modems, Speakers, CD-ROM titles, and other software with some very special offers. *QuickLink*, a serial port file transfer utility for direct cable link between two local computers or over the telephone network using modems. *TopicArt* CD, the CD-ROM version of our popular clipart in three formats, plus high quality Replay movies. Finally, *QuickTile*, the only utility that allows you to create tiled posters from any RISC OS application using *Printers*. Come and visit our stand even if it is just for a chat!

**Economatics (Education) Ltd**

Stand 116  
Epic House  
Darnall Road  
Attercliffe  
Sheffield S9 5AA  
Tel: 0114 281 3311 (Sales Office)  
Fax: 0114 243 9306  
E-mail: davidlr@economat-ics.co.uk  
WWW: www.economatics.co.uk  
Economatics will be showing their range of computer control equipment including *Smart Box*, *Discovery* and *Logicator* flowsheet control software. New for '97 is our HACCP software for Food Technology. Come along and get hands-on experience of our products and pick up our Special Offers leaflet.

**Electronic Font Foundry**

Stand 70  
11 Silwood Road  
Ascot  
Berkshire SL5 0PY  
Tel: 01344 875201  
Fax: 1344 875202  
E-mail: sales@efffounts.demon.co.uk  
The only supplier of exclusively high quality, professionally designed and fully hand-tinted typefaces on floppies and CDs. Over

1,200 typefaces for over 50 languages, including Russian, Greek, Hebrew and Indic. Special exhibition offers. New products. 4,000 PD Fonts CD GIVE AWAY.

**Eesox**

Stand 40  
Century Hoase  
1st Floor  
Market Street  
Swavesey  
Cambridgeshire  
CB4 5QG  
Tel: 01954 208208  
Fax: 01954 208208  
E-mail: info@eesox.demon.co.uk  
WWW: www.eesox.demon.co.uk  
Eesox will be demonstrating and selling their new 'Fast' SCSI-2 interface. There will be special offers on CD-Writer kits and CD-ROM kits. They will also be demonstrating their range of graphic tablets.

**ExplAN Computers Ltd/ MW Software**

Stand 50  
PO Box 32  
Tavistock  
Devon PL19 8YU  
Tel: 01822 613868  
Fax: 01822 610868  
E-mail: explan@explan.demon.co.uk  
WWW: http://www.explan.demon.co.uk/  
ExplAN are showing two new releases for their multimedia *HolyBible* project, the *Lion Electronic Library* and the *IVP New Bible Commentary*. Both of these are extensive reference works, one for education/home and the other for semi-professional use. Each is freshly coded to use *HolyBible's* hotlinks rather than being just a PC port.  
MW Software of Stuttgart will be selling their extensive range of *ArtWorks* add-on modules released this year.

**Expressive Software Projects**

Stand TBC  
21 Beech Lane  
West Hallam  
Derbyshire DE7 6GP  
Tel: 0115 9441140

• Continued on page 45



# OVATION

## Pro

### THE PROFESSIONAL DESKTOP PUBLISHER



#### New features!!!

- Colour palette
- Definable multi-row button bar
- Style palette
- Instant highlight of misspelt words

#### Package includes:

- 300 page reference guide
- Step-by-step tutorial
- Quick reference card
- 50 high-quality fonts
- Selection of clipart
- Desktop Thesaurus
- Bubble help

## NEW!

### Colour Supplement



This fully integrated extension allows professional designers to produce output for high quality commercial litho printing. Both full colour and spot colour separations are supported, with options to view separations on-screen and to control PostScript screen angles, frequency etc.

Also included is a powerful image processing facility which allows brightness, contrast and gamma levels of images to be adjusted using slider controls. Custom contrast settings may be defined on the colour map, and images can be converted to duotones.

**Ovation Pro Colour Supplement costs £57.58**

Note that all registered users who have bought Ovation Pro before May 1st 1997 will be sent the colour supplement free-of-charge.

For more information on Ovation Pro, including up-to-date news, specifications, latest applets etc., why not visit our web site at:  
<http://www.beebug.com>

Ovation Pro combines fast, responsive word processing with state-of-the-art page layout features to deliver the ultimate desktop publishing system. Packed with a staggering range of features – many available on the Acorn platform for the first time – Ovation Pro opens up a whole new world of document design. At last you can flow text inside and outside irregular frames or rotate them to any angle – in both cases the text remaining fully editable. Even with such a vast range of features Ovation Pro is still easy-to-use, thanks to its superb user interface.

- Definable Button Bar
- Irregular frames with Bézier curves
- Rotated text frames with editable text
- Multi-step Undo & Redo
- Drag & Drop for text and objects
- Drag & Drop between documents
- Named colours & definable colour charts
- Automatic drop caps
- Justification with letter spacing
- Multi-column frames
- Frames with skew & rounded corners
- Vertical justification
- Frame borders and drop shadows
- Straight and curved line drawing
- Auto flow around irregular graphics
- Easy-to-use master pages
- Context sensitive info palette
- Reads Ovation, RTE, DDF, Artworks files
- Macro handling and script language

## BEEBUG

Beebug Ltd. 117 Hatfield Road,  
St.Albans, Herts. AL1 4JS  
Tel: +44 (0) 1727 840303  
Fax: +44 (0) 1727 860263  
Email: sales@beebug.co.uk

All prices include VAT, but please add £3.50 carriage. Airmail will be charged at cost to overseas customers.

Ovation Pro is fully expandable using extension modules called Applets. Over 30 of these are supplied, including applets to automatically insert ligatures, generate fractions and expand abbreviations.

**Ovation Pro costs £193.88**

**Upgrade from Ovation £116.33**

**Upgrade from another desktop publisher or word processor\* £139.83**

\*includes Style, Publisher, EasiWriter, TechWriter, PenDown+ and Advance. Site licences and upgrades are available – please phone for details. To upgrade you must return your original program disc with payment (discs will be returned).

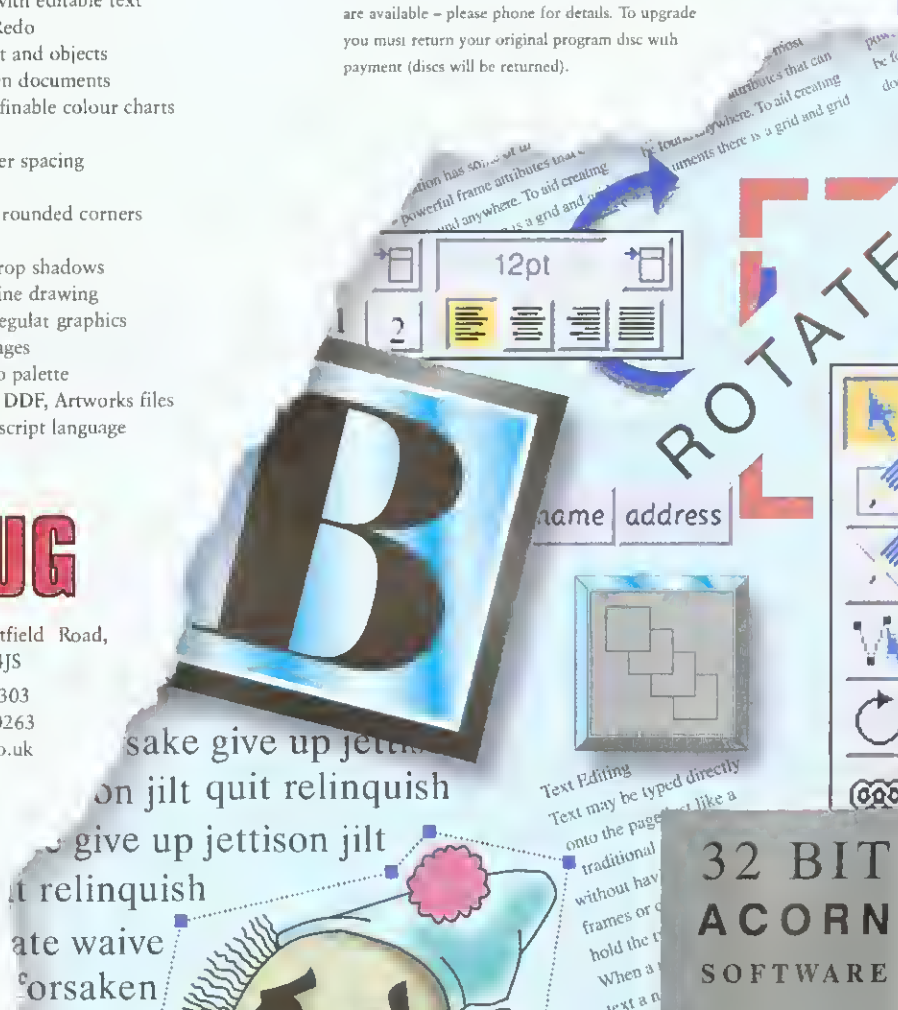

32 BIT  
ACORN  
SOFTWARE

**STAND  
GUIDE**



**HALL 3,  
WEMBLEY EXHIBITION  
AND  
CONFERENCE CENTRE**

**31 Oct - 2 Nov 1997**



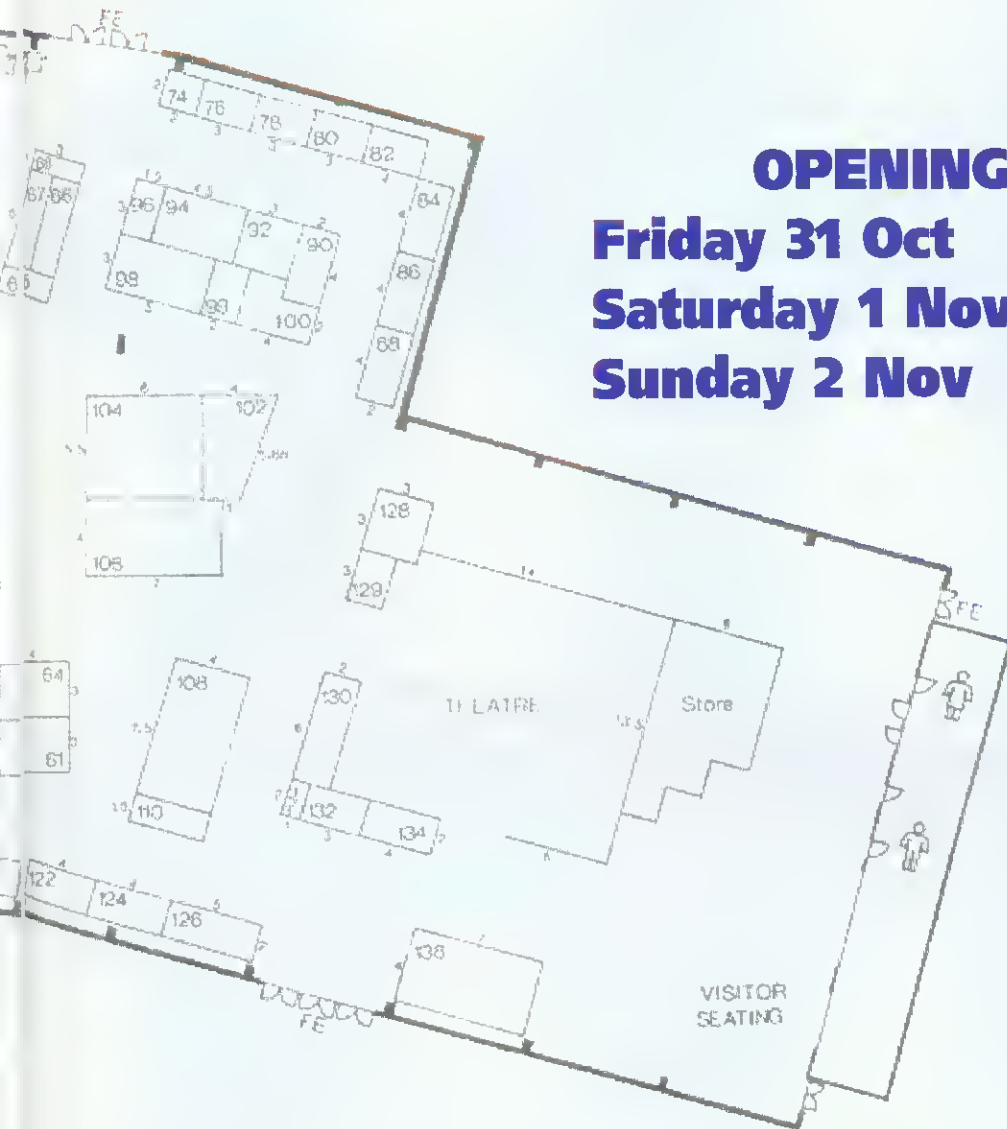

**OPENING TIMES:**

**Friday 31 Oct 10.00-18.00**

**Saturday 1 Nov 10.00-18.00**

**Sunday 2 Nov 10.00-17.00**

**LIST OF EXHIBITORS**

4th Dimension	124	Clares Micro Supplies	98	Serious Statistical Software	131
Acorn	58	CTA	24	Sherston Software Limited	62
Acorn Archimedes World	108	Cumana	114	Sibelius Software Ltd	46
Acorn User	104	Dalriada Data Technology	100	Softease Ltd	26
Acorn User lucky dip	48	Desktop Projects	28	Spacotech Ltd	44
AJS Computers Ltd	19	Economatics	116	System Insight	88
Akalat Publishing	80	Electronic Font Foundry	70	T8A Software	23
Alsystems	10	Eesox	40	The ARM Club	8
Alternative Publishing Ltd	34	ExplAN Computers Ltd	50	The Clan area	TBC
Anglia Multimedia	120	Expressive Software Projects	T8C	The Datafile	T8C
ANT Ltd	60	Fabis Computing	65	The Data Store	128
A.P.D.L.	112	H.S. Software	TBC	The Guardian Newspaper	14
Apricote Studios	T8C	Icon Technology Ltd	54	Uniqueway Ltd	32
Argo Interactive Group plc	106	Iota Software Ltd	96	Warm Silence Software	16
Atomwide Limited	59	Insight Training	122	Werewolf Software	68
AVP	2	Irlam Instruments Ltd	61	Xemplar Education Ltd	58
BEEBUG Limited	12	Norwich Computer Services	30	Yellowstone	6
Cannon Computing	117	Pineapple Software	64	YITM	118
Castle Technology	56	R-Comp & R-Comp Interactive	110	Zenta Multimedia	T8C
Circle Software	76	RESOURCE	52		
CJE Micro's	126	SEMERC	118		

ACORN WORLD '97 SHOW GUIDE





## A3000 upgrades

### Memory

1-4Mb	£63 (74.02)
(See also the "2nd user" section)	
2-4Mb upgrade pack	£45 (52.87)
4-8Mb	£125 (146.87)

The above upgrades are all constructed on four-layer boards, as recommended by Acorn. Gold plated connectors are used for reliable contact with the A3000 main board. There are no clips or wires, and no soldering is required (except 8Mb). Full instructions supplied. Some older types of 2Mb board cannot be upgraded to 4Mb, but we offer a trade-in allowance. Please phone for details.

### Hard drives

A range of internal hard disc upgrades is available. The upgrades simply plug into the internal expansion slot. Also suitable for the A3010.

120Mb	£124 (145.70)
210Mb	£135 (158.62)
340Mb	£142 (166.85)
420Mb	£152 (178.60)
540Mb	£165 (193.87)
RISC OS 3	£39 (45.82)
ARM3 (25MHz)	£109 (128.07)
(Dealer fitting recommended for the ARM3)	

**A3000 4Mb RAM £63 (74.02)**

**RISC PC 16Mb SIMM £41 (48.17)**

## A5000

### Memory

2-4Mb	£59 (69.32)
4-8Mb	£125 (146.87)

Dealer fitting for the 8Mb upgrade is recommended for the 25MHz A5000.

## A3020/A4000

### Memory

2-4Mb	£54 (63.45)
-------	-------------

### Hard drives

210Mb	£79 (92.82)
340Mb	£89 (104.57)
420Mb	£99 (116.32)

## A400/1

### Memory

Per Mb (up to 4Mb)	£30 (35.25)
4-8Mb	£125 (146.87)
RISC OS 3	£39 (45.82)
ARM3 (25MHz)	£109 (128.07)

**Hard drives.** For prices, refer to the A310 section.

## Various

Alsystems SCSI 2	£170 (199.75)
ARM3	£109 (128.07)
RISC OS 3	£39 (45.82)
MEMC 1a	£35 (41.12)
MEMC 1a (2nd User)	£20 (23.50)
Hard disc cradle	£6 (7.05)
Fan filters (pack of 5)	£3 (3.52)
RISC OS manuals, no vat	£22
Dongle dangle	£6 (7.05)
Chip extractor tool	£4 (4.70)
(for eg MEMC, ARM2)	
CDFS upgrade for Oak SCSI card	£25 (29.37)

**The following item is reduced to clear. Please phone to check availability.**

Wordworks	£23 (27.02)
-----------	-------------

**How to order:** The VAT inclusive amount is shown in brackets. Cheques made payable to IFEL. Most Credit cards accepted, and Switch. Official orders welcome.

**Educational and quantity discount available. Dealer enquiries welcome.**

**IFEL**

21, Glenfield Road, Glenholt, Plymouth PL6 7LJ. Tel (01752) 777106. Fax (01752) 777830

## A3010 upgrades

### Memory

1-4Mb	£69 (81.07)
1-2Mb	£32 (37.60)
2-4Mb	£55 (64.62)

The 4Mb upgrade is constructed on a compact four-layer board. No soldering is required. Full instructions supplied.

### Hard drives

A range of internal hard disc upgrades is available. The upgrades simply plug into the internal expansion slot. For prices, refer to the A3000 section.

## RISC PC

### SIMMs...(please phone for latest prices)

4Mb	£13 (15.27)
8Mb	£25 (29.37)
16Mb	£41 (48.17)
<b>32Mb</b>	<b>£75 (88.12)</b>

**16Mb SIMM to 32Mb upgrade**  
**£49 (57.57)**

(By upgrading your 16Mb SIMM to 32Mb you don't lose a SIMM socket. Original 16Mb SIMM must be returned to IFEL and the type must be suitable - most are. Please phone to check first or ask for our free leaflet.)

### RAM packs for upgradable SIMMs

4Mb-8Mb	£19 (22.32)
16Mb-32Mb	£55 (64.62)

Each pack consists of 8 chips which simply plug into empty sockets. Instructions supplied, no soldering needed.

### VRAM modules...

1Mb	£45 (52.87)
<b>2Mb</b>	<b>£83 (97.52)</b>
<b>1Mb-2Mb upgrade</b>	<b>£45 (52.87)</b>

## A310

### Memory

4Mb	£69 (81.07)
4-8Mb	£125 (146.87)

### Backplane (4-slot, four-layer)

	£35 (41.12)
Fan for above	£8 (9.40)
RISC OS 3	£39 (45.82)
RISC OS carrier board	£12 (14.10)
ARM3 25MHz	£109 (128.07)
MEMC 1a	£35 (41.12)

### Hard drives

850Mb IDE	£125 (146.87)
1Gb IDE	£135 (158.62)
IDE controller	£65 (76.37)

## 2nd User

Please phone to check availability.

A3000 1-2Mb	£15 (17.62)
A3000 RAM board (ie bare board, no chips)	£5 (5.87)
A5000 2-4Mb	£38 (44.65)

## Spares/Repairs

We carry stocks of most replacement chips for the Acorn range. (MEMC, VIDC, IOC and most memory devices). We can also fit any upgrades and offer a computer repair service.

All products (except some marked "2nd User") are fully guaranteed for 12 months. All items normally carried in stock have a 14-day money-back guarantee. Please note that the cost of memory products varies - please phone for the latest pricing.



THE  
COMPANIES  
INVOLVED

Fax: 0115 9444150

E-mail: [sales@ExSoftPractemum.co.uk](mailto:sales@ExSoftPractemum.co.uk)  
 WWW: <http://www.cybervil-lage.co.uk/acorn/esp/>  
 MIDI devices: Audio Dynamics DMI, Parallel and Serial Port and Software Synthesiser. The ESP Synthesiser includes instrument editing and CD's of new instruments. The MIDI Support pack includes new composition tools that enhance the use of MIDI hardware and software.

**Fabis Computing**

Stand 65  
 48 Charles Street  
 Church Gresley  
 Swallincoate  
 Derbyshire DE11 9QD  
 On the Fabis computing stand there's something for everyone — at some very special prices too. There's the launch of *AddressIt* which gives you access to the Royal Mails Postcode Address File (PAF), making finding an address fast, easy and accurate. Ever deleted a file and wished you hadn't? You need *Recycler* — there's no easier way to recover deleted files. For graphics fans, *EasyClip* makes sorting a clipart collection a snap. And why not check out our superb graphics CD with over 10,000 images. If fonts are your scene then you should take a look at what *EasyFont Professional* can do for you? It's more than just a directory for fonts!

**H.S. Software**

Stand TBC  
 56 Hyldefield Avenue  
 Sketty  
 Swansea SA2 7NB  
 Tel: 01792 204519  
 Fax: 01792 298283  
 E-mail: [h.s.soft@argonet.co.uk](mailto:h.s.soft@argonet.co.uk)  
 WWW: <http://www.argonet.co.uk/h.s.soft>  
 Special show discounts of up to 70 per cent on — *NSTORE* our National Curriculum report writing software for teachers, winner of a 1996 *Acorn User* Award and a wide range of fun educational games for primary age/special needs and dyslexia.

**Icon Technology Ltd**

Stand 54  
 Church House  
 Church Street  
 Carlby  
 Stamford  
 Lincs PE9 4NB  
 Tel: 01778 590 563  
 Fax: 01778 590 563  
 E-mail: [mike@iconsupport.demon.co.uk](mailto:mike@iconsupport.demon.co.uk)  
 Icon will be showing the latest versions of *EasiWriter* and *TechWriter* professional. In addition to reading and writing Microsoft Word documents the versions launched at the show will be able to read and write HTML and read RTF. Icon will be offering 'professional versions' for the cost of the standard version — a saving of up to £58.75.

**Iota Software Ltd**

Stand 96  
 Iota House  
 Willington Court  
 Cambridge  
 CB1 1HZ  
 Tel: 01223 566789  
 Fax: 01223 566788  
 E-mail: [sales@iota.co.uk](mailto:sales@iota.co.uk)  
 WWW: <http://www.iota.co.uk>  
 The long-awaited *DutyPower 2*, designed to be as easy-to-use as its predecessor, but with the power of a relational database behind it, and the second CD-ROM in the popular *Cambridge Primary Maths* series will be available, along with all our other products at discounted prices.

**Insight Training**

Stand 122  
 P O Box 864  
 Cambridge  
 CB5 9RX  
 Tel/Fax: 01223 812927  
 E-mail: [insight@argonet.co.uk](mailto:insight@argonet.co.uk)  
 WWW: [www.argonet.co.uk/business/insight/](http://www.argonet.co.uk/business/insight/)  
 Insight specialises in Acorn-based quality training for education, home and business users. Visit the stand for full details of introductory courses and software training, as well as specialist courses for network managers, technicians and service engineers.

**Irlam Instruments Ltd**

Stand 61  
 Brunel Institute for Biengineering  
 Brunel University  
 Uxbridge  
 Middlesex  
 UB8 3PH  
 Tel/Fax: 01895 811401  
 E-mail: [sales@irlam.co.uk](mailto:sales@irlam.co.uk)  
 WWW: [www.irlam-instruments.co.uk](http://www.irlam-instruments.co.uk)  
 Irlam Instruments specialise in imaging products including flatbed scanners and multimedia cards. The *Videodesk* non-linear video editing system will be demonstrated. Two major upgrades to *RiscTV* will be shown for the first time. Special offers will be announced on the stand.

**Norwich Computer Services**

Stand 30  
 96a Vanxhall Street  
 Norwich  
 NR2 2SD  
 Tel: 01603 766592  
 Fax: 01603 764011  
 E-mail: [paul.NCS@paston.co.uk](mailto:paul.NCS@paston.co.uk)  
 WWW: <http://www.paston.co.uk/nics/>  
*Archive* isn't just a magazine, it's an interactive user group, and it can be relied upon to provide the most up-to-date Acorn news outside of the Net. *Archive* CD-ROM, 1997 edition, is a goldmine of information.

**Pineapple Software**

Stand 64  
 352 Green Lane  
 Ilford  
 Essex IG3 9JS  
 Tel: 0181 599 1476  
 Fax: 0181 598 2343  
 E-mail: [sales@pineapple.demon.co.uk](mailto:sales@pineapple.demon.co.uk)  
 WWW: <http://www.pineapple.demon.co.uk>  
 At this years show Pineapple will be demonstrating all of their usual products plus a few new ones. There will be special deals on virtually all products and demonstrations of scanners, PAL Coders and many other items of hardware and software.

**R-Comp & R-Comp Interactive**

Stand 110  
 22 Robert Moffat  
 High Legh  
 Knutsford  
 Cheshire WA16 6PS  
 Tel: 01925 755043  
 Fax: 01925 757377  
 E-mail: [rcomp@rcomp.co.uk](mailto:rcomp@rcomp.co.uk)  
 WWW: <http://www.rcomp.co.uk/>  
 Development of our award winning Web authoring software continues apace. See the latest versions of *HTMLedit* and *Web Designer's Toolkit*, with spell-checking, Java support, link/image checking, auto-uploading of pages, plus sophisticated site-management system for all webmasters. *PCSound Professional 2* will be making its debut, and much more!

**RESOURCE**

Stand 52  
 51 High Street  
 Kegworth DE74 2DA  
 Tel: 01509 672222  
 Fax: 01509 672267  
 E-mail: [info@resourcekt.co.uk](mailto:info@resourcekt.co.uk)  
 RESOURCE will be offering substantial savings on a range of new software for youngsters, including special pre-Christmas offers on popular CDs *Rainbow Stories*, *Minch Ato at Rainbow's Edge* and *Albert's House*.

**SEMERC**

Stand 118  
 1 Broadbent Road  
 Watersheddings  
 Oldham OL1 4LB  
 Tel: 0161-627 4469  
 Fax: 0161-627 2381  
 WWW: [www.semec.com](http://www.semec.com)  
 See *Wellington Square* which consists of five interactive CD-ROMs. Each contains six talking books, two cartoon stories and over 250 educational activities linked to the books. It also gives the teacher a concise well-presented analysis of each student's progress. *All about Weather and Seasons* is the first in a series of CDs designed for KS1 learners. It enhances the children's understanding of the effects of the weather on people and their surroundings. The CD contains simple writing

screens, games, activities and a talking story and has audio support on all pages. Both CDs will be available on all three platforms. Also watch out for *All About Shape and Space*.

**Serious Statistical Software**

Stand 131  
 Lynwood  
 Bnty Heath Lane  
 Williston  
 S. Wirral L64 1SD  
 Tel: 0151 327 4268  
 E-mail: [SSS@argonet.co.uk](mailto:SSS@argonet.co.uk)  
 WWW: <http://www.serious-stats.co.uk>  
 SSS will be demonstrating the latest versions of their well-known and versatile statistical data analysis software. Emphasis will be on graphical capabilities and particularly use in the analysis of school performance data. This will especially interest school principals and governors.

**Sherston Software Limited**

Stand 62  
 Angel House  
 Sherston  
 Near Mahersbury  
 Wiltshire SN16 0LH  
 Tel: 01666 840433  
 Fax: 01666 840048  
 E-mail: [sales@sherstun.co.uk](mailto:sales@sherstun.co.uk)  
 WWW: <http://www.sherstun.com>  
 Award winning Sherston Software are releasing two new CD-ROMs at the exhibition. *Matti Mole's Summer Holiday* is an interactive story CD which addresses the basic reading skills and *Map Detectives* is a multimedia CD designed to develop geographical skills.

**Sibelius Software Ltd**

Stand 46  
 75 Bnrleigh Street  
 Cambridge CB1 1DJ  
 Tel: 01223 302765  
 Fax: 01223 351947  
 E-mail: [info@sibelius-soft-ware.com](mailto:info@sibelius-soft-ware.com)  
 WWW: [www.sibelius-soft-ware.com](http://www.sibelius-soft-ware.com)  
 Sibelius Software produce world class programs that

THE COMPANIES INVOLVED

allow anyone to compose, arrange, print and publish their own music. We have four types of software with hundreds of brand new features and new, exceptionally low prices. Come to our stand and be amazed!

**Softease Ltd**

Stand 26  
*The Old Courthouse  
 St Peters Church Yard  
 Derby DE1 1NN  
 Tel: 01332 204911  
 Fax: 01332 609224  
 E-mail: sales@softease.co.uk  
 WWW: www.softease.ro.uk*  
 Softease will again be demonstrating its award winning *textease* and *textease multimedia*. Also we will be offering special resource packs that bring out the best in *textease*. Our long awaited *My World* reader and HTML reader will also be on show.

**Spacetech Ltd**

Stand 44  
*21 West Woods Ltd  
 Portland  
 Dorset DT5 2EA  
 Tel: 01305 822753  
 Fax: 01305-860483  
 E-mail: rachel@spacetech.co.uk  
 WWW: http://www.spacetech.co.uk*  
 Our usual display of imaging software (*Platodisk*, plug-ins, *TopModel* etc). PhotoReal drivers for both Canon and Epson Stylus Photo. A new range of stunning digital cameras from Olympus with our superb *PhotoLuk* software. Many discounts for show purchases.

**System Insight**

Stand 88  
*Hillcrest House  
 Shirell Heath  
 Southampton SO32 2JS  
 Tel: 01329 835500  
 Fax: 01329 835501*  
 A complete range of all you need to run your inkjet printer. All the latest models are covered by an economical range of refill kits and compatible papers. Bring this page to the stand and if you buy two refill kits you will receive a THIRD one

free! Only one free kit per customer.

**TBA Software**

Stand 23  
*Mead Furn  
 North Road  
 Timsbury  
 Bath  
 Somerset BA3 1JU  
 Tel: 01761 470003  
 Fax: 01761 479011  
 WWW: http://www.tba-software.co.uk/*  
 A high quality range of games and accessories are available from TBA Software. Come and see *TBAFS*, the fastest compressed filing system on the Acorn platform, and *Brutal Horse Power (BHP)*, the latest superb TAG game for the StrongARM Risc PC.

Look out for demos showing the next generation of Acorn gaming, and be prepared for crazy show deals on the entire range of TBA products.

**The ARM Club**

Stand 8  
*FREEPOST ND6573  
 London N12 0BR  
 Tel: 07010 709849  
 Fax: 0171-288 3451  
 E-mail: info@armclub.org.uk*  
 This year, The ARM Club will be teaming up with the newly formed Association of Acorn User Groups to host clubs from around the country, so if you would like to find out what's going on in your area, come along and find out. As usual we will also be selling the club's range of fund raising products, including *StrongGuard!*, *Game On!*, *SmartCD+* and *TypeTutor*.

**The Datafile**

Stand TBC  
*PO Box 175  
 Weston-Super-Mare  
 BS23 4DE  
 Tel/Fax: 01934 644046  
 E-mail: sales@datafile.demon.co.uk  
 WWW: datafile.demon.co.uk*  
 Release of *Wizard Apprentice* from Fantasia Software. A great 100 level puzzle game featuring great graphics and music. We will also be releasing *Flying High* a

budget two game pack from GEK programs, this pack has two great games for Risc PC owners.

**The Data Store**

Stand 128  
*6 Chatterton Road  
 Bromley  
 Kent  
 BR2 9QN  
 Tel: 0181-460 8991  
 Fax: 0181-313 0400  
 E-mail: sales@datstore.demon.co.uk  
 WWW: http://www.datstore.demon.co.uk/*  
 We are launching *FontFX* Version 6, a brand new version of our best-selling graphics application. There will also be a whole host of special show offers.

**The Guardian Newspaper**

Stand 14  
*119 Farringdon Road  
 London EC1R 3ER  
 Tel: 0171-278 2332  
 Fax: 0171-278 1449  
 WWW: www.guardian.co.uk*  
 The Guardian Newspapers Limited welcomes visitors and other exhibitors to view a number of products in its portfolio. On display will be *The Guardian Education* and *Online*, *The Guardian's* weekly computer section.

There will also be a great opportunity to enter a competition to win £3000 worth of prizes from Xemplar. Visitors to the stand are invited to take a complimentary copy of the day's newspaper.

**Uniqueway Ltd**

Stand 32  
*3 Churendon Road  
 Cyncoed  
 Cardiff CF3 7JD  
 Tel: 01222 464020  
 Fax: 01222 440071  
 E-mail: sales@uniqueway.co.uk  
 WWW: www.uniqueway.co.uk*  
 Uniqueway will be showing their latest CD-ROMs including the *Risc Disc* series and a new religious clip art collection, *RiScript Pro* the Postscript and PDE viewer will also be

on sale along with the usual selection of special show offers.

**Warm Silence Software**

Stand 16  
*P.O.Box 28  
 Woodstock  
 Oxfordshire OX20 1XX  
 Tel: 0585 487642  
 Fax: 01608 737172  
 E-mail: info@wss.co.uk  
 WWW: http://www.wss.co.uk/*  
 WSS will be launching several new applications, including *Win95FS*, drivers for CD writers, a printer accelerator, *Dr Smiths Professional* and even more yet to be announced. Stop by for more information and take advantage of our special show offers!

**Werewolf Software**

Stand 68  
*23 The Spinnerys  
 Bromley  
 Kent BR1 2NT  
 Tel: 0181-289 6003  
 E-mail: info@werewolf.demon.co.uk  
 WWW: http://www.werewolf.demon.co.uk*  
 Check out our stand for our new games release, *Sheep Racing Deluxe*, which will be on sale and on demonstration, along with *Shuggy* and *TANKS*. We will also be supplying joypads/joysticks and various titles from the ProAction range of products.

**Xemplar Education Ltd**

Stand 58  
*The Quorum  
 Barwell Road  
 Cambridge CB5 8RE  
 Tel: 01223 724724  
 Fax: 01223 724324  
 E-mail: @xemplar.co.uk  
 WWW: http://www.xemplar.co.uk/*  
 The Xemplar Education area on the Acorn stand will feature *Infant* and *Junior Toolboxes* for RISC OS, StrongArm Risc PC, Network Computers and the eMate all displaying the latest primary and secondary software solutions for education.

**Yellowstone Electronic Solutions Ltd**

Stand 6  
*Brauningham Park Business Centre  
 Enterprise Way  
 Luton  
 Bedfordshire LU3 4BU  
 Tel: 01582 584828  
 Fax: 01582 654440  
 E-mail: sales@yellowstone.co.uk  
 WWW: http://www.yellowstone.co.uk*  
 We shall be demonstrating several new applications, including *Replay* movies as well as still sprites at the show along with the *RaplDE32* Interface with its new enhanced features. Most products will be on sale at special show prices.

**YITM**

Stand 118  
*1 Broadbent Road  
 Witherheadings  
 Oldham OL1 4LB  
 Tel: 0161-627 4469  
 Fax: 0161-627 2381  
 WWW: www.semec.com*  
 YITM is dedicated to providing products and solutions for learners, which not only stimulate but inform and educate. YITM have developed three unique tools. *Assessment Manager*, *Trailsave* and *Scripthook* which allow you to customise your CD-ROM. Please visit our stand for a demonstration.

**Zenta Multimedia**

Stand TBC  
*10 Ravnhurst Drive  
 Birningham  
 B43 7RS  
 Tel: 0121 358 3054  
 Fax: 0121 358 5969  
 E-mail: sales@zenta.demon.co.uk  
 WWW: http://www.zenta.demon.co.uk*  
 Zenta will be bring along its range of ten Acorn CD-ROMs, which features seven new ones, including two Mega Shareware CDs. Plus there's a chance to buy last years best sellers *The Clip Art Collection* and *The Font Emporium* at special prices.

# Acorn publisher

The magazine for all interested in publishing

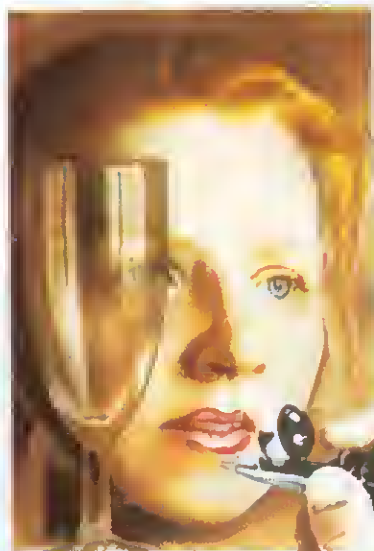

Inspiration  
Information  
Acorn Publisher

## LOOK INTO ACORN PUBLISHER

ArtWorks, Impression, Ovation Pro, Draw, Font Directory, Photodesk, Image Outliner, Studio 24 Pro, ImageMaster, digital cameras, graphics tablets, scanners, printers: if you use software and hardware like this then you need Acorn Publisher. Ask for your free sample copy and see for yourself, or visit our stand at Acorn World

**AKALAT Publishing**

P.O. Box 231, Barton, Bedford MK45 4HQ  
Tel. 01582 881614  
Email: akalat@kbnnet.co.uk  
http://www.nms.co.uk/acornpub

## APDL

As well as a huge range of P.D. and Shareware APDL offers all types of low cost software and hardware for Acorn computers

### APDL PD CD-1 and PD CD-2 £14.50 each

A massive collection of P.D. and Shareware at a realistic price. PD-1 contains serious and educational, PD-2 games and novelties.

Issue 2, both PD CDs for just £27.50

### APDL Clip Art CDs

DTP-1 and DTP-2 - £17.50 each, DTP-3 - £19.50  
DTP-1 + DTP-2 £33, all three for just £49

All in Acorn format, Sprite, Drawfile and Artworks. Ideal for schools. DTP-1 and DTP-2 have around 500 Mb, DTP-3 more than 720 Mb

#### A3010/A3000 IDE

including interface  
60 Mb - £114  
120 Mb - £134  
170 Mb - £149  
250 Mb - £159  
340 Mb - £172  
420 Mb - £184  
512 Mb - £204  
800 Mb - £229

#### Hard discs

A310/A400 IDE  
including interface  
210 Mb - £119  
420 Mb - £149  
512 Mb - £162  
850 Mb - £169  
1.2 Gb - £178  
1.6 Gb - £192  
2.1 Gb - £203

#### Drives only

2.5 Gb IDE - £154  
3.2 Gb IDE - £172  
4.2 Gb IDE - £186  
100 Mb SCSI - £44  
280 Mb SCSI - £74  
1 Gb SCSI - £158  
2 Gb SCSI - £257  
3.2 Gb SCSI - £309

Others available

Syquest and ZIP removable, SCSI or IDE, internal or external  
Solve your backup and security problems from £139, discs from £13.50

Bargain offers. £80 oIT - Syquest 230Mb removable SCSI drive complete with TWO discs and SCSI interface. All for just £214  
SCSI ZIP drive with TWO discs and SCSI interface only £229  
SyJet 1.5 Gb removable drive, SCSI or IDE, from just £299

PLUS

Rise PC RAM upgrades. (32 Mb just £98) the famous APDL part-exchange scheme if you need a bigger hard disc (eg. 420Mb to 2.5 Gb for only £149) and more!

For a full catalogue on HD or DD disc send 50p or two 1st class stamps to APDL, 39 Knighton Park Road, Sydenham, London SE26 5RN

Phone: 0181 778 2659 Fax: 0181 488 0487 www.apdl.co.uk



All prices include VAT and UK carriage



## EFF Professional Typography CD

500 highest quality fonts

ELECTRONIC  
**font**  
FOUNDRY

Samples of some of the fonts on the CD:

- 500 original EFF Latin typefaces of original EFF quality
- Fonts grouped into eight traditional categories: Old Style, Transitional, Modern, Slab Serif, Sans Serif, Script, Display and Monospaced
- Fonts can be run straight from the CD or installed on the Hard Disk
- Full Latin 1 character set - for all West European languages
- All fonts supplied in standard Risc OS3 and special Publisher format for PostScript printers and imagesetters
- All fonts are hand hinted and contain all the appropriate links and skeletons for maximum performance
- On-screen scalable sample viewer
- On-line catalogue of complete EFF type library, full of additional information about typography
- Great value for money - just over 11p per font for private users
- Free 4,000 PD Fonts CD with every order

### Professional Typography CD costs:

- Private User Licence **£69 incl.** (£58.72+VAT)
- School Site Licence **£99 incl.** (£84.26+VAT)
- Business User Licence **£149 incl.** (£126.81+VAT)

Ask for EFF1 Professional typography leaflet for more information, including the samples of all the fonts available on the EFF1 CD.

**EFF FREE 4,000 Public Domain Fonts CD** is still available for the handling charge of **£2.35** and a self-addressed label (orders by post only, £3.00 Europe, £5 world), or free with every order from us.

Also available from EFF:

- Fonts for over 50 foreign languages (West, Central and East European, Greek, Hebrew, Indic, etc)
- Keyboard Drivers for foreign languages
- Specialist, symbolic and scientific fonts
- Wide range of educational fonts (easy reading, primary and real joined-writing fonts)
- All fonts are available individually - each standard OS3 Latin 1 font is just £5+VAT

Please contact us for EFF 1997 Font Poster, EFF 1997 Price List, EFF 1997 Professional Typography leaflet, Educational Fonts leaflet or Indic Fonts catalogue.

The **Electronic Font Foundry**

11 Silwood Road • Ascot • SL5 0PY

e-mail sales@efffonts.demon.co.uk

tel 01344 875 201

fax 01344 875 202

**eff**

See us on Stand 70  
at Acorn World '97

### EFF Katie Title

EFF King

EFF LIPA

EFF Liz

EFF LondonA

EFF LONDONA SMALL CAPS

EFF LONDONA TITLE

EFF Marilyn

EFF Michael

EFF Mike

EFF Modern Gothic

EFF Modern Times

EFF Mont

EFF Mr Jones

EFF Multivac

EFF New Katie

EFF New Schbook

EFF New Swiss

EFF New Times

EFF Old Adrian

EFF Old English

EFF Old Solid

EFF Old Windsor

EFF Outline

EFF Oxford

EFF PETERS

EFF Pimpuc

EFF Remington

EFF Rivers

EFF Rounded

EFF SciFi

EFF SHARAKU

EFF Shel

EFF SHERIFF

EFF SMOKE

EFF Simple

EFF Sky

EFF Small Times

EFF Soft Touch

EFF Solo

EFF Sophie

EFF Spike

EFF STAMP

EFF Staszek

EFF Stewart

EFF Straight

EFF Streak

EFF Swiss

EFF Swiss Inserat

EFF Swiss Mono

EFF Sword

EFF Tamsin

EFF Times

EFF Tuwim

EFF UTAMARU

EFF Venice

EFF Veronica

EFF Windsor

EFF Wedding

EFF Wild West

EFF X Script

EFF Xmas

EFF Yates

**David Matthewman** looks at Acorn's Network Computer in the last of our three-part series



# Armchair

The NC is a slim, black box that looks like a satellite receiver, but is in fact a far more significant development. Satellite receivers allow Rupert Murdoch onto your TV set – you get more TV channels, to be sure, but they're really just more of the same. The NC allows *the world* onto your TV set and, if that's not enough for you, it gives you a voice with which to talk back to the world.

In this, it doesn't do anything that more traditional computers haven't been able to do for several years, but does it with considerably less fuss. Granted, by the time I got to review the NC it had already been through Stuart Tyrrell and David Dade, so any teething problems had been sorted out, but the NC is pretty much 'plug-in and play'. You plug one end into the phone, the other end into your video recorder (or TV, if it has the appropriate inputs), and away you go.

### The smart card

It's not quite that simple. You also have a smart card which identifies you to the NC. The first time you insert this, there's a delay of a couple of minutes as the NC connects to your ISP (Argonet, in this case) and verifies your account details. This is a first time only delay – the next time you connect it's usually quick.

The smart card is a wonderful concept, whose potential will only be fully realised if the NC becomes a global feature. In theory, you'll be able to fly to the other side of the world carrying the smart card in your wallet, walk into a hotel, slip the

*All the lines jam up with graphics,  
And there's nothing you can do.  
'Cos it's all just bits of data,  
Flying away from you.  
Oh look out world, take a good look  
What goes down here?  
You must learn this lesson soon and learn it well.  
This ain't no Information Superhighway,  
Oh no,  
This is the road to hell.*

Apologies to Chris Rea

smart card into the NC in your room and log straight into your own personal account. You'll be able to read and answer your e-mail and work on your own documents just as though you were sitting in the comfort of your own home.

Not only is this far cheaper for the hotels of the world than putting a full-blown PC in every room, it's a lot more secure for the user. It will require a leap of faith by some very influential people if this is to become a reality, but leaps of faith abound in the world of the NC. Several have already been made to get where we are today.

### The NC in use

Once you've connected, surfing the Web is conceptually easy. Your ISP will provide you with a starting page, and you just follow links. You can also enter a URL directly, although this is a lot more awkward than it should be, because you never get the current URL to edit in this field. It's always truncated to 'http://www', which is annoying if you've just mistyped a long URL and would like to edit it.

To browse, I deliberately used only the infra-red remote control provided. You can plug a keyboard and a mouse into it,



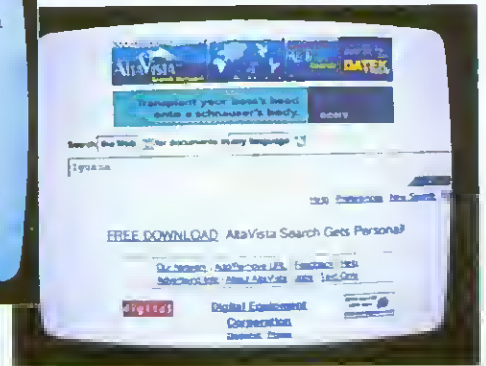
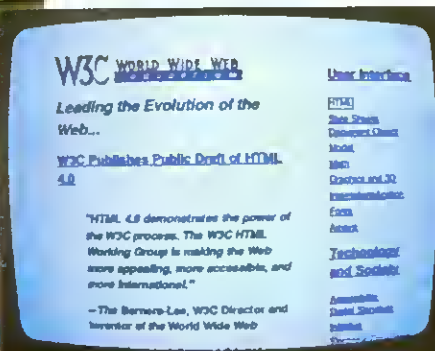

# surfing

but that felt like cheating to me somehow. The keypad has a full set of alphanumeric characters and various other useful buttons. The letters are arranged alphabetically, and so aren't ideal for finding your way around. It's the weakest part of the remote control, but that's inevitable really. A version with a full infra-red keyboard should be available soon, and will be well worth it, in my opinion.

Central to the keypad is a compass of four arrow keys surrounding the Enter/Select button. These are used for navigation. Anyone who's used the text-only Lynx browser will be quite at home navigating with the NC's remote control. The way you move through links is exactly the same; by using the up/down arrow. Once you've got the hang of this it's easy – a lot easier than I was expecting actually. You can also page up and down, or scroll a page a line at a time.

Frames do present a slight problem. The only way to move the cursor out of one frame and into the next is to scroll though

all the links in that frame. On sites like the Xara one where the first frame has a collection of navigation buttons (and there are several that use this general design), this quickly becomes tedious as you can need to hit the down button 10 to 20 times before you're in the main frame. And you can't scroll the main frame until you're in it – irritating.

This is a minor quibble – otherwise the NC performs well. Text on web pages is easily readable a reasonable distance away from the TV screen. The only problem tends to come on custom graphic buttons where the Web designer has made the text as small as possible; it's readable on a monitor but hard to read on a TV display.

My extensive user tests indicate that even people unfamiliar with browsing the Web should find the NC easy to get the hang of. In fact, if you're more used to a video remote control than a traditional keyboard, you'll probably find the NC's remote control straightforward as well.

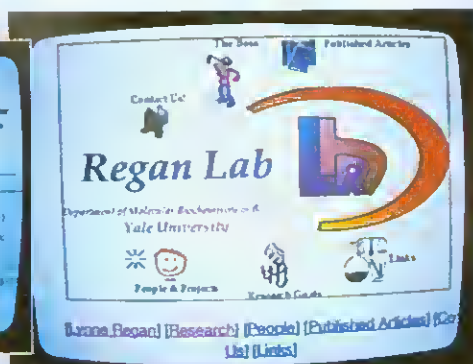
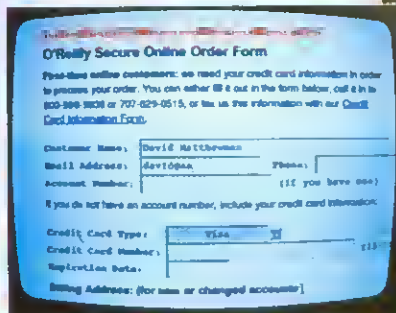

## Beyond the Web

The NC has a wordprocessor built-in, based on Icon Technology's *EasiWriter*. This is, as you might expect, a nightmare to use with the remote control, but with a keyboard and mouse would be very useful. All documents are stored on the ISP's server.

E-mail is not handled natively by the NC, but is accessed via a Web-based interface at the ISP. Again, actually composing an e-mail via the remote control is awkward, but it works as well as possible under the circumstances. Usenet news is not currently supported.

You can also attach a printer to the back of your NC for a hard copy; all popular printer makes and models are supported.

## The NC in business

I've said hardly anything about the Acorn NC's use in a business environment as a client to a central server. This is an important part of the NC concept, especially to Larry Ellison – but I don't think the Acorn NC as it stands is designed to attack this market. There are simply too few programs that will run on it and few, if any, that properly follow the client/server model.

Java may change all this. On the plus side, Java has a lot of features built into the language to make the client/server model easy to write for. On the down side it's undeniably slow. The NC will probably be better off running custom-written C++ applications, and these will appear if there's the demand for them (for all I know, they're being written now).

## But will it sell?

The bottom line has to be whether the Acorn NC will actually become a regular feature of people's homes in the millennium. The first thing to say is that anyone with a PC already connected to the Internet won't need one. Until the smart card system becomes popular enough to be useful, the NC doesn't really offer enough over the standard Windows (or Mac) and Netscape combination.

What of Acorn owners? This ought to be just as clear cut, but it's a reflection on

### What does the NC support?

Just under a year ago, I wrote an article describing how the NC stood with respect to the then current Internet technology. It's perhaps a little alarming that little has changed since then. Java, for example, was 'coming soon' then, and it's 'coming soon' now. It would be helpful if it were to arrive at some point, however slow it might be. The lack of it is the aspect most seriously damaging the NC's credibility on the Net at present.

Some technologies have changed in importance since I wrote the original article. ActiveX – in the absence of implementation on non-Windows platforms – has become a specialist technology, used most in Windows-only Intranets. The lack of ActiveX isn't likely to affect the NC much. JavaScript on the other hand has gained in credibility. It's becoming more stable, and is used on many pages as a faster, more friendly alternative to CGI scripts. However, sensible sites provide non-JavaScript alternatives. This is just as well, because JavaScript is unlikely to appear on the NC.

The NC implements the HTML 3.2 standard. 'Implements' needs a little clarification – for instance, the `<applet>` tag used to embed Java applets is in the HTML 3.2 standard, and the NC implements it to the extent of ignoring it (correctly, as it doesn't support Java). This is perfectly reasonable, but worth noting.

The HTML 3.2 standard, although it's the most recent stable standard for HTML, is a little behind current Web design in some areas. For a start, it doesn't mention frames. The NC does support frames, although it doesn't support the enhanced version of frames where the frame borders can be turned off.

The NC doesn't support `<font face="">`, which is fair enough because it isn't part of the HTML 3.2 spec (it's mentioned in a comment) and no page was ever made unreadable by being displayed in the wrong font. However, it doesn't support the `<font color="">` tag either, which changes the colour of a font used on a page.

Not only is this tag in the HTML 3.2 spec but its omission is odd, because the NC does support the global colouring of text, background and links on a page using attributes in the `<body>` tag. It also supports background colours on tables, and this can lead to a problem on some pages, where text is locally coloured white in a table with a black background. The NC doesn't colour the text white, and it can be hard or impossible to read as a result. Thankfully this doesn't happen very often.

The HTML 3.2 spec may be current, but let's be honest about this – browsing the Web with the NC now is like browsing it over a year ago using *Netscape Navigator* and *Microsoft Internet Explorer*. That's how quickly these things date. This wouldn't matter so much if it weren't for the fact that there are a couple of key Web revolutions that the NC looks likely to miss out on: CSS and PICS. CSS (Cascading Style Sheets) are a

way of separating all the presentation information from the content in HTML. There's not room here to describe why this is a good thing but trust me, it is.

What's more, CSS are easy-to-use and Web-designer-friendly, so if they do catch on, websites will start using them extensively. Actually, this may not matter too much; the whole point of CSS is that they are separate from the content, so non-CSS browsers like NCFresco will still be able to see the web page content with no problems.

PICS on the other hand, should really be not just supported by the NC, but embraced by it. PICS started out as a system that allowed people to rate sites as unsuitable for children, and has blossomed into a general, all-purpose system for categorising websites. If Acorn really intend to sell NCs to families, they should take a long, hard look at how PICS is developing. If it catches on, and PC browsers implement it, the NC will be seriously disadvantaged by not supporting it.

I emphasise that neither CSS nor PICS are used to any great extent on the Web at the moment, as they're both developing technologies.

Plug-ins are a problem. Currently the NC has a plug-in for Macromedia *Director 4* multimedia files. Macromedia is now on to *Director 6*, and the number of files still in *Director 4* format that the NC can play is approximately zero. Worse, the NC still doesn't have a *RealAudio* plug-in, let alone one for *Flash*, *AVIs*, *PDF* or any of the other odd file formats you're likely to find scattered on the Web.

I'm less worried about this, though, because Acorn are working hard to rectify it. It's unfair to blame them for being a little behind; once the NC becomes popular, it's reasonable to expect the plug-in manufacturers to write NC versions as a matter of priority.

One feature that I was relieved to see built into the NC browser is secure transactions. These allow you to connect to a website securely and transmit, say, credit-card information. Without secure transactions, much of the on-line shopping experience on the Web is closed; however, the NC supports them so you can shop around the clock, should you so wish.

It's also worth pointing out that the NC is state-of-the-art in a couple of areas. The on-screen anti-aliasing which Acorn users are almost blasé about, is way ahead of the display on Macs and PCs. In fact, the display on my ordinary, 10-year-old TV set is remarkably good. I doubt it could be significantly improved, and anti-aliasing is probably the only reason Web browsing on a TV screen is possible at all.

A smaller kudos point is the display of PNGs. PNG is a touted replacement for GIF that's slowly gaining acceptance on the Web. The NC will display PNGs (as most Acorn browsers have been able to for a while, in fact) – Netscape Navigator and MSIE are only just supporting the format in their latest browsers.

how fragile the Acorn Desktop market has become that it isn't. It's possible that the mass-market NC may quickly overtake Desktop Acorn machines in terms of supported features and software development. A StrongARM Risc PC is faster than the NC, and of course does a lot more, but has no SSL implementation or Director plug-in at the moment, so already the NC has some advantages.

However, there's still a large market out there for the NC. Many families don't have a computer, but would still like access to the Web and e-mail. The Acorn NC fits this niche very well. I'm slightly worried about the price – it's too expensive for what it is to my mind.

The Acorn NC may not sell at all. It's a

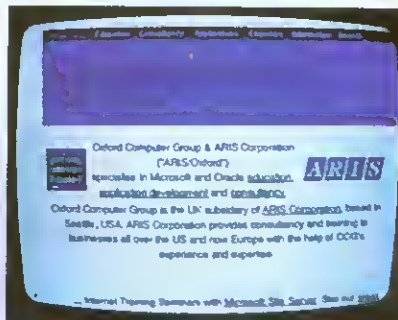

little hard to envisage it crowding out the video recorders and laser disc players on the shelves at Dixon's, although we can all hope. In a sense though, that's not the point. If the Acorn NC sells, that's a bonus. The machine *really* feels like a

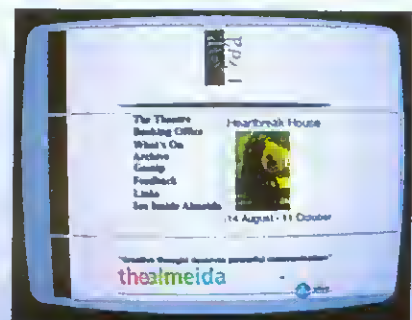

'proof of concept' on Acorn's behalf. The fact that something like this could even have been built to be usable would have (and was) hotly disputed two years ago, and it's all credit to Acorn that it's here and it works.

excellent value  
**CD ROMS**

Zenta Brand

**10,000**  
VECTOR DRAW FORMAT IMAGES

WARNING  
Supplied as  
Acorn Format  
NO conversion  
needed. Watch  
out other CDs  
are not like this!



Just a taste of this massive collection

Thumbnail quick viewer supplied

THE  
CLIP ART  
COLLECTION CD  
£29.95

**NEW HIGH RESOLUTION**

Images ideal for Photodesk or full colour publishing



250 24bit royalty free images

The  
**PHOTO**  
Album CD  
£29.95

**BEST ONE THOUSAND FONTS SELLER**

The Font Emporium is the all time best selling Acorn CD

Paradox Dark Ages Home Away  
DINOSAUR

The  
**FONT**  
Emporium CD  
£29.95

Great selector application included



Quality music with player

**3000**  
TRACKS

3000  
Symphony  
Masterpieces Collection CD  
£29.95

Buy Three Zenta Brand CDs and get the 4th \*FREE\*

**NEW Lowcost PD CD ROMS**

**Skyfall AUDIO**

This CD contains a wealth of music in all formats imaginable. Included are Maestro files, Module samples for your own programs, Mini SciFi Blasters and Mega icon bar samples.

£12.95

**Skyfall MOVIES**

A great set of Replay Movies are included on this CD, all are of very high quality. Plus as a bonus there are MPEG, AVI, ACE and FLI movies all supplied together with the required players.

£12.95

**Skyfall GRAPHIX**

This CD contains lots of Slideshow covering many interesting topics, plus many 24bit JPEG images. Also included on the disc are Digital Quarter mini sprites ideal for art packages.

£12.95

**Skyfall DEMOS**

Crammed with the latest in Acorn ARM demos, and a nice selection of old classics. Plus Music Videos with a selection of Video walls, Amazing very funny Morphs and some cartoon fun.

£12.95

Buy Three Lowcost PD CDs and get the 4th \*FREE\*

**NEW Mega Shareware CD ROMS**

**APPLICATIONS CD**

This CD contains plenty of really useful app's. For starters how about a full spreadsheet, a handy database or an impressive image processing application. Hundreds more app's are also featured, including ray tracing, fractals, disc tools, programming tools, a tracker type sound editor, a full sample editor and lots of DTP tools. A truly amazing disc which is literally worth hundreds of pounds. StrongARM checked (as all our discs are).

**SUPER VALUE JUST**

£15.95

**FUN 'N' GAMES CD**

You'll have lots of good times with this bumper fun packed CD. It contains over one hundred games including arcade, puzzles and adventure games. Featured games like Gyriums, Invaders and Yaig are arguable better than games costing £30 or more. Plus there's a big collection of playable commercial game demos and a set of great disc magazines.

**SUPER VALUE JUST**

£15.95

\*SAVE\* Both Mega Shareware together for £24.95

PRICES INCLUDE VAT & POSTAGE. PLEASE ASK IF YOU REQUIRE MORE INFORMATION.

Zenta Multimedia  
10 Ravenhurst Drive / Birmingham / B43 7RS  
Tel 0121 358 3054 Fax 0121 358 5969  
email sales@zenta.demon.co.uk



WWW.ZENTA.DEMON.CO.UK

ZENTA

**CANNON COMPUTING**



Educational specialist in supply of Acorn Computers to Schools for 13 Years

Cumana and Semerc Approved Suppliers

**Come to us for**

- ☛ Special Educational Prices
- ☛ Home Use
- ☛ Business Use
- ☛ Networking (including NT servers)
- ☛ Printers, scanners & peripherals

**Exclusive Show Offers\***

In collaboration with Semerc on a selection of their most popular software and hardware including YITM CDs

Cumana show offers on stand 117!

**Don't miss out!**

We will have extra special pricing on Acorn equipment for the three days only

See us at \*Acorn World, Stand 117

or call on 01279 730800, fax 01279 730809  
email sales@cannonco.demon.co.uk

-----Cut out----- ✂ -----Cut out-----

**Acorn World Show Vouchers Save £££'s**

Register at stand 117 for your money off vouchers (available with this form). Simply complete this form & drop to the stand.

Name:.....  
Establishment (if applicable).....  
Address:.....  
.....  
.....  
Tel.....

Areas of interest to you?

- 1) Acorn Computer systems ..... 2) Printers (Acorn, PC, Apple).....  
3) Peripherals ..... 4) Other (please state).....

aw11/97



# Blowing away the cobwebs

## Part two

**Simon Kiff** looks at how to get visitors to your website and to keep them coming back for more

Last issue, I addressed some of the technicalities of setting up a website – such as getting web space and getting your site into this space. This issue I want to look at the elements which make a good website, getting feedback on your web pages and how to bring in visitors to your site.

### Designing a website

Designing a website is very similar to laying out a page. You want to grab the reader's attention and then inspire them to read on. If you are faced with a page which consists entirely of black and white text, then unless you need some information buried within, you are unlikely to sit and read the whole thing.

If the page has a few catchy graphics, a splash of colour and is split up into manageable chunks you are far more likely to stop and take note. With the Internet, however, you need to take some time and care making sure that your graphics will download at a reasonable speed. So many pages include a huge title image, and peo-

ple click back before they see any of the page just because the title graphic is so slow. The simple solution to this problem is to always include the height and width information in the image tag, so that the browser can leave a gap.

The image/text ratio is quite important. There is no hard and fast rule as to the number of graphics to include on a page

ones. The trend is to include some sort of logo at the top or bottom of every page. The advantage of this is that once the image has downloaded from the server, the user's browser stores it in a cache, so it appears instantaneously on each subsequent page. This also means that the user always knows which site they are using.

Another important consideration is the

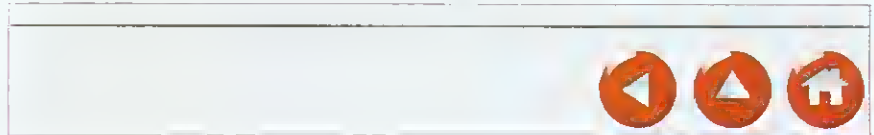

Navigation tools, present at the bottom of every page

but it should look balanced and should not be swamped with text. Conversely, a page with four words on is unlikely to be particularly useful reference material – unless it is designed to just hold a large image.

Good websites tend to be those with a consistent feel, particularly commercial

structure of the site. It is useful to include navigation tools on each page, such as a back arrow and a home icon. Again, these can be common graphics so that once downloaded they appear immediately. They allow the user to jump around the site easily without getting lost, and resorting to the browser's history list.

Careful consideration needs to be given to the backgrounds and colours used for web pages. Background images can be very useful, giving the page a nice finish, but they can also completely destroy a page. If the background is too three-dimensional or too bright it will dominate the page and, more dangerously, make the text unreadable.

When you select a background colour,

### Introduction To IRC

*rough*  
**IRC Guide**

**connect - irc**

Before you can do anything else you need to connect to the IRC network. There are basically two main choices for Acorn users - connecting to a server, or using custom software known as an IRC client.

Demon users are able to telnet to their own server, diana01, by first connecting by telnet to `acorn.acorn.com`, port 23. Here they are prompted for a nickname, and a terminal type - this should be entered as vt100.

**The IRC client**

A more pleasant, user friendly way of using IRC is with a client. There is a freeware client available which is compatible with Acornet, ANI and Argonet. Terminal users

Before you can do anything else you need to connect to the IRC network. There are basically two main choices for Acorn users - connecting to a server, or using custom software known as an IRC client.

Demon users are able to telnet to their own server, diana01, by first connecting by telnet to `acorn.acorn.com`, port 23. Here they are prompted for a nickname, and a terminal type - this should be entered as vt100.

A more pleasant, user friendly way of using IRC is with a client. There is a freeware client available which is compatible with Acornet, ANI and Argonet. Terminal users

So, you've connected to IRC, telling the server a nickname and a terminal type (vt100) - how do you start? The first thing you need to do is understand the principle of channels. On the IRC network, there are several hundred channels, which each have a name up to 6 characters long. Each channel is like a room, and the name is like a name on the door. Every name begins with a hash (#), and signifies the topic for the chat which takes place inside the room.

The same page, split into sections with some simple graphics

## Introduction To IRC

Before you can do anything else you need to connect to the IRC network. There are basically two main choices for Acorn users - telnetting to a server, or using custom software known as an IRC client.

Demon users are able to telnet to their own server, dismay!, by first connecting by telnet to `irc-client.demon.co.uk` port 23. There they are prompted for a nickname, and a terminal type - this should be entered as vt100.

A more pleasant, user friendly way of using IRC is with a client. There is a freeware client available which is compatible with Acornet, ANT and Argonet. Termitte users must use telnet. This client, 'IRCClient', by Matthew Godbolt, can be downloaded for free from his [website](#). Also under development and beta testing is a new commercial client from [QuadWorld](#). Both clients, and a number of others being written allow you to choose a server to connect to - and enter preferences such as nickname into a RiscOS window. All common commands are accessible from menus.

So, you've connected to IRC, telling the server a nickname and a terminal type (vt100) - how do you start? The first thing you need to do is understand the principle of channels. On the IRC network, there are several hundred channels, which each have a name up to 8 characters long. Each channel is like a room, and the name is like a name on the door. Every name begins with a hash (#), and

Horribly clashing backgrounds and colours



choose one which is similar to the overall colour of the background image you are using, so that the RISC OS web browsers can anti-alias to the right colour. If you choose completely the wrong colour, the text appears to have 'fur' growing around it.

I recommend you get someone to check your colour matching and choice of background. I once made an embarrassing mistake with the *Acorn User* website. I chose a background which I considered to be quite pleasant but as soon as I put it online I received e-mails complaining that it was making people go cross-eyed look-

ing at it, and made the text look like it was sloping up or down the page. Needless to say, I changed it as soon as possible.

### Feedback

It is very important to communicate with your readers. The best way to do this is to provide your e-mail address on the website, somewhere obvious. A popular choice is to put the address (as a link) at the bottom of every page.

An alternative approach is to have a 'feedback' logo on the end of your navigation tools, which takes you to a separate page with appropriate e-mail addresses,

possibly a postal address, and if possible a web form. Users are far more likely to respond by using a form, because all they need do is type a few words into the web page and click send, rather than having to run their e-mail program and type a formal response. Make sure one of the fields on the form asks for their e-mail address, so that you can respond to them about any points they raise.

If they do not want to be contacted they will just leave this field blank. Respond swiftly and the reader is more likely to pass comment again, and the more constructive feedback you can get the better. ▶

I am always interested in your views on this website, without your feedback I could not possibly hope to keep the site fresh and interesting. Please take the time to fill in the form below, which will be posted to me when you click *submit* at the bottom.

Full Name

Email Address

Location

Which computer do you own?

General Comments

A nice simple web form lets people send you feedback quickly and easily

# Blowing away the cobwebs

## Part two



► It will also give you an indication of the number of visitors you are getting and what information they want you to provide. It would be a waste of effort continually updating a page if nobody reads it. Plus, it is a real 'buzz' to discover someone is actually reading your site!

### Bringing in visitors

If you are going to put time and effort into creating and maintaining a website, you want to make sure an adequate number of people are actually visiting it. The simplest way of knowing how many visitors you are getting is to use a web counter. These are provided via scripts on many Web servers and allow you to display the num-

ber of new visitors, or keep people coming back.

Firstly, do not let people forget that your site exists. If you are a commercial company, make sure you print your website address on adverts, on letters and any documentation you produce. Make sure you are keeping the site up-to-date, and that people know it is. If you do have time to update regularly, put a 'last updated' line on your main index.

All that is required is 'last updated 28.7.97'. If you have time, you could have a latest updates page, where you list all the changes you have made. If you do not have time to update, do not advertise this fact. Do not tell everyone on your main

index page that you have updated. If you want visitors on your site to stay for any length of time, you need to let them know exactly what useful information you carry. I have seen many sites which have fascinating articles hidden deep inside the website, inside an archive or which are just not given justice in their description.

For example, a complete guide to BASIC programming for beginners, including diagrams, example programs and a reference section is sold short by describing it as 'an article on BASIC'.

Sadly, this happens all too often, and information we could all benefit from goes to waste. In the same way, do not sell your site short when you describe it for the search engines such as Alta Vista or Yahoo. There is a size limit on your description, but a three word description is not very inspiring for the tired Web surfer.

If there are other websites related to yours, persuade them to add a link to you. People with a specific interest do not stick to just one site, they build up a list of places to visit, so if they happen to arrive from someone else's site then you may have gained another regular visitor. You can return the favour by putting some links to other sites on yours.

However, do not make them sound so attractive that they leave your site instantly to go to one you recommend, unless you intend to make yourself just a launching point to hundreds of sites about a specific interest. There is certainly space for lists of recommended sites on the Internet, as you will undoubtedly have discovered if you have spent any time searching for specific information on the Web. Be warned that keeping such a list up-to-date is extremely time consuming.

Next month I'll look at using images on websites and site maintenance techniques.

AU

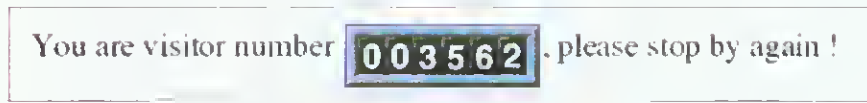

A typical web counter

ber of visitors to any website, as an image. If you have used the Web for any length of time you will have come across numerous versions and variations on the theme.

Commercial web space may allow you to view access statistics, including logs of all the visitors, the browser they were using (web browsers send identification every time they access a web page) and the pages they viewed. You will be able to identify people returning for more, or if people visit once and never again. If people are just visiting once, how can you make them return for more?

Well assuming you have information on your page which interests them, you can first of all follow all the points I have made already - such as thinking about design, use of colour, breaking up text and making the site more navigable. There are however, some things you can do to bring

index that your site was last updated in June 1994. If people think the information is out-of-date they may just hit that back arrow.

When you make a major update, for example if you add a new version of some software to download, you can announce this on an appropriate usenet newsgroup.

It is important to get your website registered with as many search engines as possible. There is now software available (thought not for the Acorn) which will register you with a huge number of engines automatically. If people want information that your site holds, but cannot find it, what use is it to them?

There is no harm in reminding people to add your site to their 'favourites' list. They will either ignore the advice or it may prompt them to add it to their hotlist, and then you stand a much larger



## A Powerful Page Editor

- Point-and-click editing of ruleoffs, images, lists, etc
- Drag-and-drop import of images and creation of links!
- Automatic conversion of Acorn graphics to Internet formats
- Set text styles just like in a wordprocessor/DTP package
- Imagemap editor included - table editing built in
- Automatic encoding of extended characters
- Search-and-replace, drag-and-drop and undo
- Named colours for consistency across the whole site
- Extensive forms facilities - multiple forms included
- No need to learn web jargon



## WebSpider

*The fast-track to website creation!*

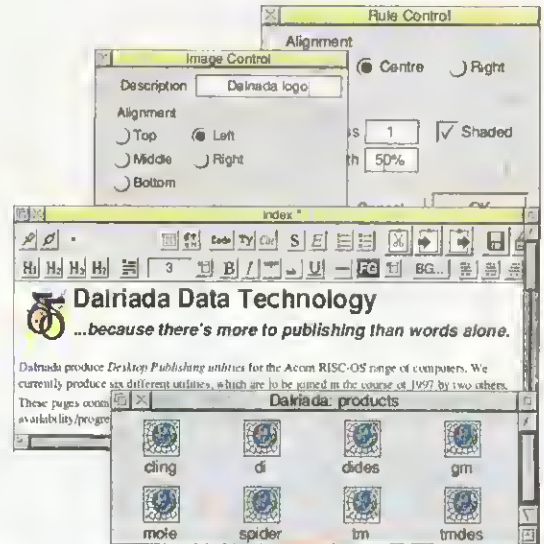

## Sophisticated Site Management

- Directories and sub-directories to organise your site
- Links automatically updated when files renamed etc
- Publishing management - all files or changed files
- Full site management
- Import of existing webpages and graphics

*WebSpider costs just £60*



**DALRIADA DATA TECHNOLOGY**

74 Greville Road, WARWICK, CV34 5PJ.

Phone/Fax: 01926 492459

e-Mail: sales@dalriad.demon.co.uk

WWW: <http://www.dalriad.demon.co.uk/>

## TableMate

*The Ultimate Table Editor!*

*Designer*

**See us at  
Acorn World**

TableMate Designer is the latest in the popular TableMate family of products - it offers the most comprehensive range of facilities yet - with more new features than TableMate 2 and 3 put together. A short extract is given below. TableMate 3 is available for those with simpler needs.

- Variable fonts inside cells
- Super- & sub- scripts, bold and italic effects
- Export/import HTML tables for the Internet
- Yet more line and row controls!
- Global cut-and-paste
- Named colours & styles

Single User - £60, Upgrade from Impression Style/Publisher £45, Upgrade from TableMate 3 - £27-50

## HOW GOOD IS YOUR GRAPH DRAWING PACKAGE?



*Does it support OLE with the latest packages?*

*Is it simple to mix different graph types?*

*Has it got extensive presentation controls?*

*Can you put text anywhere you want?*

*Are key areas fully under your control?*



We could go on for much, much longer, nag about shadows, backdrops, automatic table generation etc...

## GraphMate

*Presentation graphics without tears.*

*GraphMate costs £45 for a Single User pack*

## -Diagram-It-

Diagrams of all sorts - in a flash!

- Flowcharts, organisational charts, annotated diagrams spider diagrams, process diagrams - and more!
- Automatic connection of symbols using Artificial Intelligence, with Anchor points for precise control.
- Full presentation control - of colours, text, line widths etc
- Word-wrapping text or scaled graphics inside symbols
- Tiled printing for larger charts
- A wide variety of flowcharting and other popular symbols
- OLE compatible for all the latest DTP/WP applications

The fastest, easiest and most powerful way to create all those time-consuming structured diagrams.

Single User - £50. TableMate 3 User - £45.





# Anglia's latest

CD-ROMs continue to come out of Anglia Multimedia like water out of a tap!

## John Cabot and the Merchant Adventurers

This CD focuses on the voyages of John Cabot but also contains information about other merchant explorers. The disc is in five sections - all of which are accessed from the Quayside. The user can click on various shops or on the display board to find out more information.



The Grocer's shop contains information about the food supplies that Cabot and his crew would have

taken on board and at the Chandler's you can explore the shop and collect things for John Cabot's voyage.

The Library contains information relating to different explorers. There are three areas of the library which can be selected - the bookshelf, the globe and the map chest.

If you choose to enter John Cabot's ship *The Matthew*, from the Quayside then you can explore the ship and find out more about Cabot's voyage.

An interesting feature first used in one of Anglia's earlier CD-ROMs is the documentary where you simply sit back and listen to the story of how the replica of *The Matthew* was built and the

preparations for its voyage to Newfoundland earlier this year.

John Cabot is available for Acorn, PC and Mac and costs £50+VAT.

## British Countrysides

This explores the work of the National Trust by focusing on the landscapes and historic buildings it protects.

In the documentaries section there is a choice of five documentaries to sit back and watch - Historic Buildings and Gardens, Nature Conservation, Countryside, People and The Coast. Tony Robinson narrates and an on-screen button allows the user to view the script as it is read.

British Countrysides is available for Acorn, PC and Mac and costs £40+VAT.

As with all of Anglia's CD-ROMs, the subject matter has been thoroughly researched and presented in a clear and interesting fashion.

Anglia Multimedia  
Tel: 01268 755811



## Unlimited expansion

A question from Alan Roberts in Leeds prompted me to investigate the growing phenomena of removable hard discs and, in particular, two budget devices which hit the market at almost the same time. One of the advantages of devices with removable cartridges is that the cartridge, like a floppy disc, is transportable and hence can be used on more than one drive.

However, I found that transporting cartridges is a very uncertain business as any knocks could cause problems when later trying to read it. They are generally slower than sealed hard discs but because the cartridges are changeable, the total capacity is unlimited.

### Syquest ezFlyer

The Syquest drive has been around for some time but has recently been revamped and is now being marketed exclusively for the Acorn market by Cumana. Syquest drives are currently available as either IDE, SCSI or in the format Cumana is highlighting - par-

allel devices. The cartridge size has now increased to 230MBytes.

### Omega Zip drive

Marketed by Argo, this portable hard disc offers users low-cost storage which is ideal for transferring data between home, school and work. Again, this is available in various formats, although the best selling device is likely to be the external parallel unit.

### Verdict

Of the two, the Zip drive is said to have better access time while the Syquest has better read/write times. This means that for moving lots of small files the Zip drive is better, while moving one big file is best done on the Syquest. In practice I couldn't see any difference, but for those of you capable of detecting millionth parts of a second, please feel free to tell me which you think is the fastest.

### Who could use these?

For the home user, either would be an

	Zip Drive	Syquest Drive
Supplier	Argo	Cumana
Cost of Drive	£139.99+VAT	£159+VAT
Cost of Cartridge	£12.00+VAT	£17+VAT
Size	100 MBytes	230 MBytes
Cost per MByte	12p	7.5p
Fitting	External	External
Interface	Parallel	Parallel
Power Supply	Own PSU	Own PSU
Cartridge Supplied	Yes	Yes
Acorn Driver	Yes	Yes
PC Driver	Yes	Yes

excellent investment and certainly something to consider instead of buying a second 'conventional' hard drive. For backing up networks, which was the basis of Alan's question, either would be appropriate for a class or year group. The 100MByte capacity of the Zip drive might be a little small for very large networks, although at only £12 per cartridge you could probably afford to store each class on a separate cartridge.

Argo  
Tel: 01243 815815  
Cumana  
Tel: 01483 503121

## Contacting me

You can contact the Education page by writing to me, Geoff Preston at Acorn User, IDG Media, Media House, Adlington Park, Macclesfield SK10 4NP or by e-mail to: [aeduc@idg.co.uk](mailto:aeduc@idg.co.uk)

# At last - Adv

Unless you've been able to buy PC file servers running OmniClient, your Acorn network probably hasn't changed much during the past three to four years. **Geoff Preston** looks at some new fileserver software

**L**evel 4, the program that manages a network is rather long in the tooth. It started life in 1989 and was first published in 1991 with a couple of modifications to bring us up to *Level 4 Release 3* in about 1994/5, but its roots go back further.

In fact it is little more than a modified version of *Level 3* which was originally used to run Econet with BBC Micros. If you look inside the *Level 4* application you'll still find Econet drivers. Perfectly adequate for running Econet but not really

Stephenson, the original author of *Level 4*. The specifications for the *Advanced Level 4* server upgrade is impressive to say the very least. Twice as fast for single clients, up to 10 times faster when used with multiple clients, faster log on, shared Scrap rather than one for each user, 32-bit client software – the claims go on and on.

### The Fileserver software

The software comes on two discs, the contents of which are installed onto the

have to be outstanding to beat it. I'm pleased to say that it is as good as *Admin*, which is just as well because *Admin* won't work with this fileserver software – also the case with any other management utility which attempts to read the user profile file.

Client software for such tasks as changing the password will still work though. Although I felt it was as good as *Admin*, it is totally different and took me a while to get used to. If you've used *Manager* supplied with *Level 4*, you'll recognise it, although this version is a great deal faster.

To use it, as always the manager must log on as a privileged user and then load the software. *Manager II* displays a screen showing all the current groups on that fileserver. Clicking on a group displays all the clients within that group. The first thing you'll notice is that there is rather more information about each client than was previously the case. Apart from the usual exported root, user name and password, there's information about the users' use of the system – when s/he last logged on and onto which computer.

Changing details is easy, although the menu system by the password panel is a little annoying if you're looking up lots of passwords. Increasing user space, on the other hand, is very straightforward.

Users can be added directly from the key-

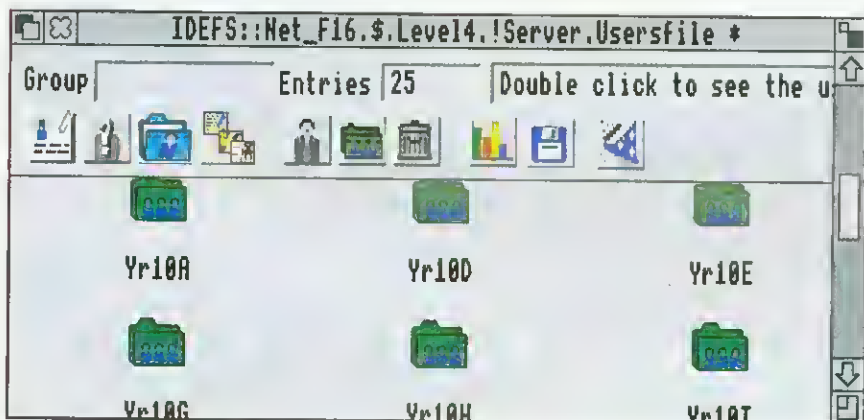

Not just new icons, but a whole range of features on a button bar. The window acts in much the same way as a filer window and supports many of the same features like drag and drop, copy, double click to open and so on

ideal for the newer and faster Ethernet.

Like many others who run an Acorn network, I have been waiting for better fileserver software ever since I first installed the network, but its development seemed like the kiss of death to anyone who touched it. First was Acorn network specialist Digital Services who came up with *Vector*. Having demonstrated it at various shows, the company went feet-up without the software actually hitting the market.

Cumana eventually took it over and they too had to call in the receivers. Economatics took control of Cumana and they didn't seem very keen to continue with it. Quite what the current state of that program is, I've no idea, and apparently neither does anyone else.

Having got to the point of abandoning any hope of new software, out of the blue came a press release from Network Solutions – a company owned by Gary

fileserver's hard disc. The original files containing the user profiles (*Users*) and the list of exported servers (*Exports*) are copied into the new application thus keeping existing settings. The existing version of *NetUtils* must also be replaced with the new version supplied on one of the discs.

### Management software

For me, the most tiresome job is network management. I don't mind spending a day each year creating user areas for the new intake and printing new profile slips for 1200+ students, but the daily chore of looking up passwords for those who've lost it or forgotten it or changed it and forgotten it or given it to his friend who has changed it, drives me to despair. So I want a system which will enable me to look up passwords very quickly.

At present I use *Admin* by Room J Software which is superb and so this would

User file statistics	
Users	45
Groups	3
Total entries	48
System users	6
Lost users	0
Free entries	2000

Statistics can be accessed very easily enabling the manager to know who is doing what and where they are doing it

# Advanced Level 4

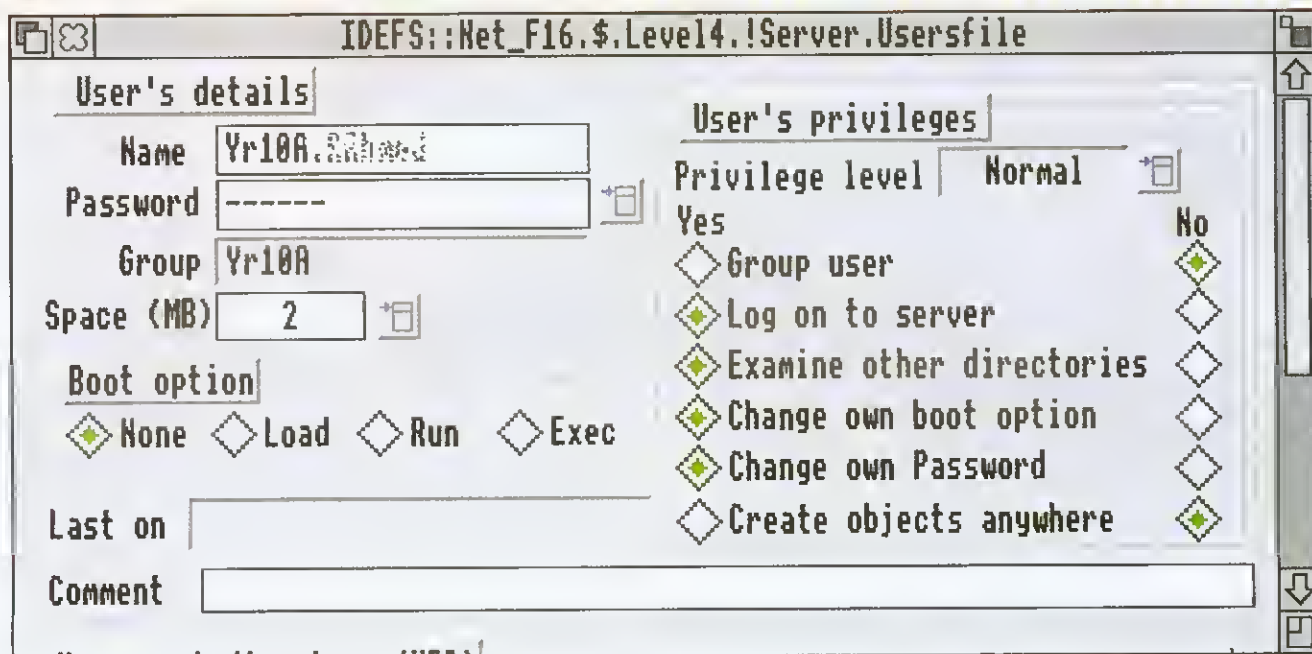

The user profile window contains many additional features relating to privileges. I'm not sure why there is a 'Examine other directories' option

board, but for creating multiple users a Comma Separated Value (CSV) file can be dropped in. A CSV file can be pulled off the school's administration network (running SIMs or something similar) and then edited in *Edit* before being used to create the user profiles.

This is a very comprehensive utility, but what I would really like is an extremely simple program where on typing in a user name (with wild cards) the password is displayed or printed.

## Application server

*Advanced Level 4* comes with an application server but at present this is little faster than the existing *AAserver* (supplied with Level 4), and nowhere near as fast as *AppFS*. Network Solutions are working on the product and upgrades will be sent to customers as soon as it is ready.

## Printer spooler

This is an enhanced version of the existing *Spooler* and is installed in the computer with the printer attached. The spooling computer and the client computers use *Printers*. I haven't tried this application because it won't support direct drive laser printers.

## Upgrading from Level 4

By comparison with *Level 4*, the Advanced version is very fast indeed, especially when the system is under load. However, before rushing out with a fist full of dollars, let's look at the real cost.

If, like me, you're running multiple servers, you may need to buy more than one Advanced pack because the licence is for three file servers, each running up to 2048 clients.

Although I only have 1200 students, the layout of the school dictates that I have seven file servers. The improvements in the software mean that I could now dispense with two and those computers are now in the classrooms and in use as client machines.

The five file servers in use means two Advanced packs at £249 +VAT each. Then you must consider the computers which are in use as file servers. I was running Level 4 on 33MHz A5000s which were also doubling up as application servers and occasionally servers for the network version of Iota's *DataPower* data management program. That arrangement is not suitable for *Advanced Level 4*.

Because the new software caches data in the file server's RAM, 4Mb will soon get gobbled up. If doubling up really is essential, then 8Mb is a minimum, 16Mb is better.

The best arrangement would be a 16Mb Risc PC with StrongARM and SCSI hard discs. That really will set the world on fire. If, like me, you're running A5000s, an upgrade from 4Mb to 8Mb will cost £120 + VAT from IFEL.

They will also fit it for you for £20 plus £20 carriage. For most schools, this arrangement will be quite adequate and will be noticeably quicker than *Level 4*.

## Compatibility

It seems that *Advanced Level 4* is compatible with all other network (software specifically for the network). For reference, for anyone considering this route, I can vouch for the fact that it is compatible with XOB's Teletext server, Iota's *DataPower* server, Cumana's *CD Net II*, Computer Concepts Laser Direct/Turbo Spooler and Acorn's application server. I've also run it with Atomwide, Acorn and i-cubed network cards.

## Cost

For about £400 for one file server, it's certainly well worth doing, but a few words of caution. Before attempting to upgrade, first make a full backup of each file server. Not just the user areas, but the existing *Level 4* software including the Users files and the Exports file (which should be done regularly anyway).

Ensure also that you've made a note of the file server's configuration and the software that is exported to the clients. Should anything go wrong (which is unlikely but possible – especially if you haven't taken precautions) then the system can be reinstated exactly to its previous state. Ignore this advice at your peril.

## Contact details

Network Solutions	Tel: 01487 843763
IFEL	Tel: 01752 777106
Room J Software	Tel: 01736 762541

**spacetechn**  
imaging technology

**spacetechn Ltd**

21 West Woods, Portland, Dorset, DT5 2EA. UK

Tel: 01305 822753

Fax: 01305 860483

Email: sales@spacetechn.co.uk

Web: http://www.spacetechn.co.uk



camera driver for Acorn

**PhotoLink** is an Acorn multi-driver for the most popular makes of Digital camera. Cameras currently supported are the **Olympus 400, 400L, 410L & 800L, the Sanyo Image PC** and the **Epson PhotoPC 500**. Higher spec. replacements for the current Olympus models should be available in Sept.. please phone us re availability.

"...if you buy a digital camera at all it should be an Olympus; personally I would also opt for the Spacetechn driver" *Richard Hallas, Risc User.* "...the results from the Olympus/Spacetechn combination are stunning... Spacetechn's offering is by far the most comprehensive..." *Stuart Tyrrell, Acorn User.*

Superb hard copy can be obtained via our **FotoFun** printer or Canon **PhotoReal**.

Prices (inc VAT): **PhotoLink £69.00.**

Camera + PhotoLink: **Sanyo ImagePC £434.75, Olympus C400 £299.00, C410L £587.49, C800L £949.99, Epson PhotoPC 500 £499.00.**



**PHOTODESK (v.2)** is the package which defines studio quality image editing and artwork on RISC OS machines. It has many powerful features, including a sophisticated colour management system for the full-time graphics professional. Most of the extensive programming effort invested in this project has been concentrated upon making it **easy to use** and to give the **highest quality** results. **£269.50**

**PHOTODESK LIGHT**, an economic alternative to PHOTODESK2 retains most of its creative features apart from those essential for the professional user. **£134.75**

**Plug-in Effects Packs** are available for both packages. A pack containing 10 special effects, or 5 extra loader/savers is available at **£19.95**

*all prices include UK VAT and UK P&P*



## Impact Professional

*More than just a database*

- ✓ Fully relational
- ✓ Programmable
- ✓ Easy to use

Fast becoming the standard Acorn database. Buy nothing until you've checked it out!

Now available from all good dealers - ask for a demo.

★ See us on stand 76 at Acorn World

Example.Main			
Company	Acme Engineering	Date last contacted	12 Oct 1996
Contact	Fred Bloggs	By	Phone / Δ Accounts...
Address	Unit 5	<input type="radio"/> Customer	Letter...
	Industrial Estate Town Centre	<input checked="" type="radio"/> Supplier	Fax...
Phone	0171 592 4789	Log call	Show calls
Fax	0170 592 4752	<input checked="" type="checkbox"/> Action needed	Queue Label
			Display notes

Create data cards like this, using familiar desktop features. Programmable buttons combine many complex actions into single button clicks, to make life even simpler!

**£125.00**  
+ VAT

PHONE, WRITE, or EMAIL -  
for full details, to -

P.O. Box 36  
BODMIN  
PL30 4YY 01208 850790

sales@circlesw.demon.co.uk



**Circle Software**

The easy choice

# GAME SHOW



**Steve Mumford** reports with more info on Marsquake and details of promising developments in the Acorn world

Let's start off with some good news for all those people out there who have been enjoying Paul Taylor's *Bombermen* rendition, *Marsquake*, included on one of our September cover discs. There's been a fair amount of activity on the comp.sys.acorn.games newsgroup - some have hailed it as a classic, others have wondered why it wasn't released as a full-price game, and yet more have posted suggestions for features that they'd like to see included in the future version. The most popular request was for network and Internet play, with computer-controlled adversaries and level designers coming close behind.

Paul has informed me that an updated release will be making an appearance later on this year - a few bugs will have been fixed and he's got some ideas for additional features he might implement. Depending upon the number of extras (a level editor is planned), *Marsquake Gold*, for want of a better name, could well be a shareware release. Paul is looking into network support, not just for *Marsquake*, but for the games he's currently planning.

The only information I have at the present is that it's going to be 3D - more news as it happens. For further information about the game itself, keep your eyes on the official *Marsquake* website at: <http://www.cyplexia.demon.co.uk/mq.html>

## Sheep racing

Dene Koakok of Werewolf Software has informed me that they'll be releasing a new game written by Quintin Parker at the Acorn World show, with the rather improbable name *Sheep Racing Deluxe*. For those in the know, it's a sequel to the similarly-titled public domain game, penned by Gilbert the Hamster Software. More details as and when they arrive, but Dana promises me the Werewolf website will be kept up-to-date - you'll find it at <http://www.werewolf.demon.co.uk/>

## FastQuake and Iron Dignity

As I write, full versions of Rob Templin's *Destiny* or TBA's *BHP* are still tightly under wraps, but there's hope that they'll be released in the near future. Things are looking promising for the StrongARM game market - although the chip has only been able to run what could euphemistically be described as a streamlined collection of



Acorn games, programmers out there seem to be making better use of the power on offer.

You might already have seen *FastQuake* by Jen Vlatinck and *Iron Dignity* by Frank Föhl, both available at [http://aldonis.lmeg.fr/AcornDemos/FtpArea/3D\\_engines](http://aldonis.lmeg.fr/AcornDemos/FtpArea/3D_engines) - the Acorn Demo server. Although these are really just graphical demos, the fact remains that they're based around rudimentary game engines that could be developed into full-blown products.

TBA have been talking to the people at id Software about their own version of the Quake engine, and we might even see a distributable player that would allow high-end machines to load *Quake* executable - all you'd need would be an original copy of the game for the PC, and the Acorn player could then extract and use the appropriate maps.

*Iron Dignity* is already being developed as a full-blown game, and although the documentation included with the demo outlines a lot of work that still remains to be done, some of the graphical effects already on display are remarkable. The style reminds me of *Mechwarrior* - a blend of arcade and strategy as you take control of futuristic walking robots and attempt to complete various missions. Frank and his team have obviously thought long and hard about the game mechanics, and as well as being able to control each unit individually in first person perspective in the style

of *Mechwarrior*, it will also be possible to control groups of units remotely.

The list of 'things to do' makes impressive reading in its own right - I'm pleased to see that as well as working to improve the 3D engine (the cannon fire and jet engine effects are already superb), there's a whole stack of gameplay ideas waiting to be implemented. These include 'droid logic' for individual units that give them a slight degree of



autonomy, allowing them to carry out such tasks as guarding an area, following a set path, obeying aversion and of course self-defence.

A deeper form of artificial intelligence will be required by each of the computer-controlled 'Clans', enabling them to control a whole range of individual droids and make tactical decisions. It all goes well, we might be looking at a game to rival the popularity of *Star Fighter 3000* and possibly become a hot product for high-end RISC PCs - I certainly hope so.



## GAME SHOW



## Gruesome

Graham Nelson reports on a turn-up for the books

The shock news in adventure-game circles is that Infocom have a new one out. This is a little like Eivils emerging from the shadows for just one comeback gig. Infocom, handsomely the world's best text adventure company from 1979 onward, left a conspicuous gap when they were wound up. In fan mythology the Infocom era was the golden age, and Infocom's 35 works overshadow anything else of the period. To the new generation of 1990s fans, the collapse of Infocom seems as remote and inevitable as the fall of the Roman Empire.

But it happened only in 1989, and although Infocom had reduced to a staff of 30 and still lost \$800,000 a year, they never went to the wall – instead they were bought out by a rival firm, Activision, and closed down. This means that the Infocom name, trademarks and back catalogue are still legally alive. Activision put out the so-so graphical *Return To Zork* in 1993, signing it 'Infocom' – though fans were unconvinced – and followed it with the much more interesting *Zork: Nemesis* in 1996.

Now, with *Zork: The Grand Inquisitor* on the way, the team at Activision have been building bridges to fans of the 'old' Infocom. Since a text game can be to a graphical game as a script to a film, *Zork:TGI* began as a textual prototype. Now Activision have commissioned a new textual *Zork* from two of the original Infocom authors, Marc Blank (*Zork I to III*, *Deadline*, *Enchanter*, *Border Zone*, *Journey*) and Mike Berlyn (*Suspended*, *Infidel*, *Cutthroats*). Ironically, the compiler they used was Inform, written by the fan community (well, by me on my old A5000, in fact) after years of reverse-engineering Infocom's

old games, a process that's now gone full circle.

*Zork* remains the most famous Infocom work, a trilogy (1980/1) divided up from only the second mainframe-based adventure game written (1977). 'Zork' itself is a nonsense-word used by MIT students, of whom Blank was one.

The player explores the derelict Great Underground Empire, once presided over by the Flathead dynasty (notably Lord Dimwit Flathead the Excessive, who has a penchant for stupendously over-the-top building works) but now abandoned to 'grueas', never-seen creatures repelled by any form of light.

## So is it any good?

Yes, it is. To my great relief, because expectations were high, *Zork: The Undiscovered Underground* is a positive delight. This time the basic aim is not to collect treasure but to get out alive, which means solving a dense mass-full of puzzles. What do the red and blue lines on the projector mean? Why are there five sculptured models and only four circles beside them? Is it possible to gain entry to the conference of grueas?

I hope it won't give too much away to say that it is good.

Inside, delegates worried by the recent 'adventurer famine' are listening to a paper called 'Surviving the Lean Years: Is Lurking Enough?'. Outside, you can buy souvenir postcards which are, of course, entirely bleak.

So this game has all the *Zork* hallmarks: A puzzle involving

grueas, another to do with zorkmids – the zorkmid is the unit of currency – a not-entirely reliable lantern, Flathead Jokea and a hidden algnsture. It's also beautifully written – and it's free. Activision are distributing it to promote the *Zork* name, along with the original *Zork* trilogy, on their FTP site:

<ftp://west.ftp.activision.com/activision/zork/legacy/>

## Other IF news...

Entries for the *Third Annual Interactive Fiction Competition* are just due in. See:

<http://www.afn.org/~efn55673/con-test/>

This contest has so absorbed the Internet newsgroup rec.arts.int-fiction that the summer months go by with no game released, and then in the autumn 40 arrive at once. We hope to include some of last year's best on the next *Acom User* cover CD.

The reverse-engineering of Infocom's object code format (the 'Z-machine'), mentioned above, has at long last resulted in a definitive committee-written specification. This can be accessed, along with a new HTML version of the Inform manual, from the Inform Home Page:

<http://www.gnelson.demon.co.uk/inform.html>

The fanzine *XYZZYnews*, now up to leave 13, has gone online at:

<http://www.xyzzynews.com/>

Version 2.4 of *Hugo*, another design system, has been ported to RISC OS with an improved front end. See:

<ftp://ftp.gmd.de/if-archive/programming/hugo>

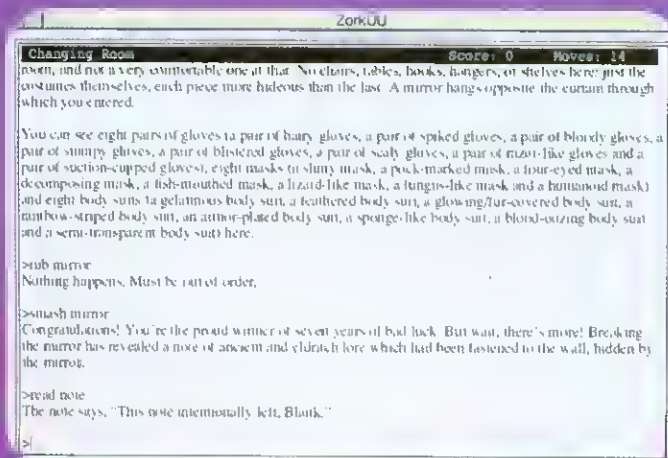

**The Fourth Dimension Presents  
A Game by Andrew Docking**

Compatible with all Acorn RiscOS Machines with 2Mb RAM  
Including StrongARM RiscPC

# DRIFTER

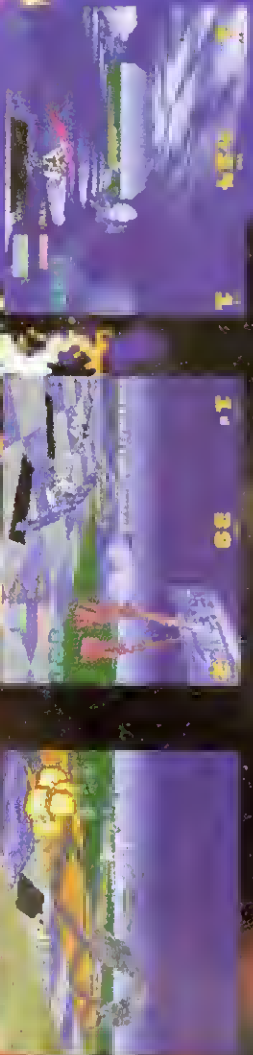

**£34.95**

The Fourth Dimension. P.O. Box 4444, Port St. Mary, Isle of Man. IM99 7RS  
Credit Card Hotline Tel: 01624 836744 Fax: 01624 836745

## The Fourth Dimension

are happy to announce the release of their first NEW game to be added to the popular *VFM Range*. Pushy is the first game from a new programming team, based in Norwich, which will be providing a further 4 games for publication over the next 12 months. Each of them for **ONLY £9.99 + £1. p&p.**

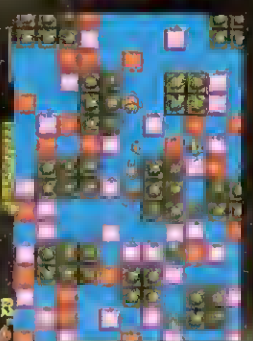

Pushy is added to the following list:

- |                                    |                                     |
|------------------------------------|-------------------------------------|
| Apocalypse... (Previous RRP 29.95) | Galactic Dan... (19.95)             |
| Anagram Genius... (19.95)          | Grievous Bodily Arm... (19.95)      |
| ARCticulate... (25.95)             | Holed Out Comp... (25.95)           |
| ARClst... (25.95)                  | Nevryon... (19.95)                  |
| Black Angel... (34.95)             | Pandora's Box... (25.95)            |
| Carnage Inc... (25.95)             | Powerband... (25.95)                |
| Cataclysm... (19.95)               | Saloon Cars Extra Tracks.. (19.95)  |
| Chopper Force... (29.95)           | Stereoworld... (29.95)              |
| Cyber Chess... (34.95)             | Stunt Racer Extra Tracks... (19.95) |
| Demon's Lair... (19.95)            | Sylvia Layne Adventure... (19.95)   |
| Drop Ship... (19.95)               | Virtual Golf AUGUSTA... (19.95)     |
| Enter The Realm... (25.95)         | WIMP game... (19.95)                |
| E-Type Comp.. (25.95)              | W-Fire... (19.95)                   |

SO THAT'S ANY OF THE ABOVE FOR ONLY £9.99 EACH + £1. p&p  
ONLY AVAILABLE FROM THE FOLLOWING ADDRESS

The Fourth Dimension

P.O. Box 4444

Port St Mary

Isle of Man

IM99 7RS

Tel: 01624 836744 Fax: 01624 836745

E-Mail 4D@rsenter.demon.co.uk

or why not visit Stand 124 at Acorn World



# Rcomp

See us on stand 110 at Acorn World!



## HTMLEdit v3

Next Generation

WWW Authoring

For RiscOS

£49

Why bother playing catch-up? HTMLEdit v3 and the Web Designer's Toolkit offer Acorn owners everything needed to make top notch WWW sites. Forms, frames, tables, pictures? No problem! And with HTMLEdit v3, you don't have to worry about making mistakes, as it includes a full error checker to do the hard work! With Macroing; URL and Image databasing; shared, dynamic files, and fully supporting HTML 3.2, it's the only choice for managing a professional WWW site. **Now!**

## The Web Designer's Toolkit

£30

## Textures Professional Edition

Every graphic designer knows that the right background shows off your message, be it on paper, or on the WWW. Make your mark - design your effects in Textures Pro - the complete texture studio

£20

R-Comp, 22 Robert Moffat, High Legh, Knutsford, Cheshire WA16 6PS

Tel: 01925 755043 Fax: 01925 757377

Email: rcomp@rcomp.co.uk rck@rcomp.co.uk

Check out http://www.rcomp.co.uk

Check out http://www.rcomp.co.uk

e esox

## New - 'Fast' SCSI-2 INTERFACE

NEWS

www.eesox.demon.co.uk

### THE NEXT GENERATION

Eesox now have their own 'fast' SCSI-2 interface card for the Acorn platform. This SCSI-2 card is the fastest card available at a sensible price; and has many unique performance enhancements specific only to this card.

### INNOVATIVE DESIGN

Capable of transferring data up to 7Mb/sec in Asynchronous mode and 10Mb/sec in Synchronous mode, using DMA. The SCSI interface fully supports the 'fast' SCSI-2 standard and is also backward compatible with SCSI-1 devices.

£125.00

+ VAT & Postage.

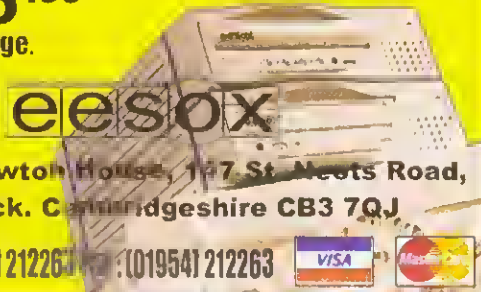

Suite 8c, Newton House, 147 St. Neots Road, Hardwick, Cambridgeshire CB3 7QJ

Telephone: (01954) 212263 Fax: (01954) 212263



## 24 Speed IDE CD-ROM Drive £95.00

+ VAT & Postage.

CD-Recorders  
£499.00



Parallel Port  
CD-ROM Drives  
£169.00

CD-ROM Drives,  
Towers, Recorders

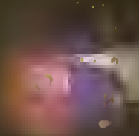

Harddrives



Audio Boards



Speakers



CD-ROM  
Mastering



Graphic Tablets



Memory

e esox

Suite 8c, Newton House, 147 St. Neots Road, Hardwick, Cambridgeshire CB3 7QJ

Telephone: (01954) 212263 Fax: (01954) 212263





**Dave Acton**  
and **Dave Lawrence**  
present this month's  
spooky submissions

# st★r info

## Don't spook to soon

And with no more ado, to the moment you've all been waiting for. The eerie, creepy, crawly conclusion to our spookiest challenge yet. You will remember the brief we gave back in the August issue – simply to write the spookiest program you can. We had an excellent response – thank you to all who took the trouble to enter.

First, the obligatory honourable mentions. **Scott Boham** who has featured prominently in past challenges put in another sterling performance, only narrowly missing out on a prize. Undaunted by the proverb 'less is more', Scott packed just about every item of spooky imagery into his demo – witches, bats, black cats with hair on end – even a UFO making mysterious sorties into a graveyard. **Adrian King** provided perhaps the funniest entry, but for legal reasons we are unable to publish it!

Fourth prize goes to **Thomas Simmons**. The author describes it as a 'sort of wind in the graveyard in the middle of the night simulator' which we think is a more than fair description. It is a multi-tasking number which just uses sound-effects to add a creepy atmosphere to your desktop. In fact there are only two samples involved – 'wind' and 'owl'. I'm sure there is scope here to make a dreadful pun about owling wind but I shall resist. The overall effect is similar to that of the sound effects of *Populous* (anyone remember that one?)

The bronze medal is awarded to **Philip Mellor** for his program –

*Bats*. In fact, Philip sent us a whole host of good demos, most of which were more in the gruesome ballpark rather than spooky. We hope to be able to bring them to you in future months, but meanwhile, *Bats* illustrates how effective a couple of black triangles can be!

Optional extras include spooky sky, spooky ground and spooky tree. You can also choose the number of bats (15 to 20 is good). Of course, since bats are a protected species, once you have run the demo you are forbidden by law to press Escape...

The silver medal goes to a particularly imaginative entry from **Tom Thorne** of Fritham. Tom hasn't provided many details about his program, other than the fact that it will require a Risc PC to run since it needs a changeable 256 colour palette. When we set the challenge we anticipated the usual stream of cartoon ghosts, shrieks and howls (and owls for that matter) and so forth. We did hope that a few intrepid souls might create something really

different, and Tom came up trumps with *Dust*. Basically, it's one of those 'keep track of lots of dots' demos, made much prettier by the fact that the dots in question have fading blue trails.

It may not be immediate obvious as to why this is an entry to the spooky challenge, but after watching the demo for a couple of minutes, you will be able to make out the spooky images that the dots morph in and out of – ghosts, skulls and the like. In between spooky images, the dots revert to their usual swirling maelstrom. ▶



From: Denis Howe <dhowe@linklaters.com>  
Date: Mon, 02 Jun 1997 13:30:35 +0100  
To: paul.NCS@paston.co.uk  
Subject: Archive magazine

I just had to email you to say how excellent I think Archive is. I've known of it for years but only recently subscribed in response to the ad I received through the post.

I wish I'd subscribed ages ago, I guess I always imagined it was one of those sad little "This is \*your\* magazine, please send an article" fanzines, but now I discover it's stuffed with a wealth of authoritative, professionally presented articles, several of which were of immediate relevance to me.

Thanks and keep up the great work.

Denis Howe

The offer that Denis took up was: **£15 for 12 issues of Archive and a free copy of the Archive CD-ROM**. That offer is open to you as long as you've never subscribed before.

Send a cheque or credit card details to: Norwich Computer Services, 96a Vauxhall Street, Norwich, NR2 2SD. Phone 01603-765073, fax 764011, email <paul.NCS@paston.co.uk>

## Don't spook to soon (cont.)

- ▶ The effect is made all the creepier by the fact that only single pixels are used – no pre-rendered ghost sprites in sight!

And talking of pre-rendered ghost sprites, we come on to the winners. **Mark Adcock** is a name not new to these pages, but he has an accomplice in this challenge in the shape of **Ben Spencer**. Together they produced *!Spook* (don't heat around the bush with your application names now lads). Now I know I said 'less is more' and all that, but we couldn't resist giving this demo first prize.

The authors give the following accurate description of their work: 'This program simulates several floating apparitions haunting a derelict hilltop castle by the light of a full moon.' The demo features several distinct elements:

'The bloody text uses a procedure:

```
PROCBlood_Text(text$,X,Y,Xtextsize,Ytextsize,t,t,t)
```

which plots the string `text$` centred around `X` at height `Y`. The text (size `Xtextsize,Ytextsize`) is plotted, blurred `t` times, then, after a pause of `t` centiseconds, is blurred another `t` times.

The main body of the demo relies heavily on ARM code. The reflection in the lake is performed by a routine which takes every fourth line of the top 4/5ths of the screen and reproduces it in the bottom fifth. To add movement to the reflection, tables of vertical offsets are used.

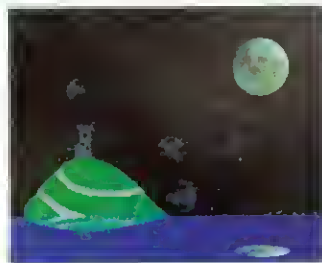

The fact that the stars zoom across the screen at such speed is perhaps the most spookiest feature of the demo, and far more worrying than the vaporous creatures flitting about in the foreground.

'The stars are only plotted over a blank pixel, which means the sprite plotters don't have to

use masks. The locations in screen memory of the stars are not calculated every time they are plotted: stars start off in random positions and move along the screen memory until they hit the end. When this happens they are put back to the start (thanks to the *AU* demo writing series for the technique).

'Before the main loop begins, the ghost sprite from the file *Sprites* is rotated and scaled according to the variables `NumberOfSteps%` and `NumberOfSpooks%`. For `<NumberOfSpooks%>` different sizes



of ghost `<NumberOfSteps%>` copies are made, each one rotated `360/NumberOfSteps%` degrees more than the previous one.

'During the main loop each ghost is moved (using a BASIC procedure) and plotted (using an ARM code one). There are two versions of the spook-plotter. The fast one simply increases the tint of pixels it is plotting over, whereas the slower one increases the red, green and blue elements of the pixel. How much they are increased by depends upon the colour of the sprite at that particular point, which is why the sprite is composed of colours 0-3 only.

'You can change the following to suit your machine's speed/memory \*and\* your preference.

<code>NumberOfSteps%</code>	see above
<code>NumberOfSpooks%</code>	see above
<code>fast%</code>	if TRUE, then use the faster sprite plotter
<code>GN%</code>	the number of ghosts haunting your screen
<code>ReflectionSpeed</code>	how fast the water ripples (I have included this because when you increase the number of ghosts, the ripple speed decreases – this, at least, gives you some control)

The jolly tune is reminiscent of *Ghostbusters* (who ya gonna call etc. etc.) and was written by Ben. Well done again chaps – now, onto the next challenge...

## On the tiles

Author: Jan Vibe

Our old friend **Jan Vibe** returns with a utility ideal for any Roman artists out there. Or any stationary ones for that matter. *Mosaic* converts a 256 colour sprite into a mosaic made up of irregular tiles.

'The program asks for a sprite file and the name for the new sprite file it is going to make. You don't need to supply the new name – press Return and the program just makes the mosaic on the screen.

'The sprite file is examined, and a sprite area which is 1.3 times larger than the original is initiated. Now the sprite file is loaded, and the name of the first sprite in this file is determined.

This sprite is examined and the width and height of the sprite are found. This information is used to make a new sprite with the same width and height, but only in black and white. This new sprite is filled with a irregular grid. This grid is to be used as the skeleton for the tiling process.

'The tiling process works like this: Each point in the sprite with

the grid is examined and if it is black, a special fill procedure is invoked. The fill procedure fills the tile, but also stores the co-ordinates of the filled points. These co-ordinates are used to examine the corresponding points in the loaded sprite. The colour number of these points is being split up in RGB and tint values, and added in separate registers.

When all the points in the tile have been examined in this way, the values of the registers is divided by the number of pixels in this particular tile, thus obtaining an average colour for the tile. The RGB and tint values are now used to select a colour in the 256 colour palette for the finished tile.

'The finished mosaic works like a pointillist picture. When viewed at close range, you only see a rough outline of the picture, but if viewed from a distance, new details seem to enter the picture.'

A small sample called *pic* is provided on the disc. As with many of Jan's demos, the original uses Colour Card mode 103. Risc PC users will find their own version on the cover disc.



## Winter challenge

Your next challenge is simply to write the most wintry program you can. The best will be carried in the February issue which, by our reckoning, should still be pretty chilly, even with global warming and all.

The brief is an open one, and we have carried a few wintry demos in the past – snowflakes, snowstorms and snow on. Have a look through back issues for some ideas to get you going – Jan Vibe's *Snowflake* from

February 1996 or Keith Wood's *Snowfall* from March 1997 for example.

Extra credit will be given for imagination, originality, simplicity and possibly humour – if it's not the sort that might get us into trouble.

The deadline is **Friday 28th November 1997**. So that we can feature as many programs as possible on the cover disc, each entry **must not be more than 50K**. You

may of course send as many entries as you like, and any other programs you'd like to submit.

Post your disc to the usual address, marking the envelope **Winter Challenge**. Please include the standard text file with your name, address, e-mail address etc., as well as details of your entry. See **\*quit** for details about e-mailing your programs to us. And of course, the judges' decisions are final.

## Doing the rounds

Author: Christopher Bradburne

This is one of those programs that does something very specific which would be completely impossible to do if you didn't have the very program to do it. If you know what I mean. *Spiral*, by **Christopher Bradburne** takes a text file and winds the text in a spiral, producing a draw file of the result.

'The program is run in the usual way. To produce a file you have to proceed as follows:

- Drag a text file to the window. This indicates the text file to be used. Note that the text file is not loaded, just its position noted.
- Click Menu over the font field to select a font for use in the draw file.



- Either click the Auto Size button or enter a text size in the appropriate box. If you select the Auto Size option the file will take considerably longer to produce.

- Drag the draw file icon to the appropriate filer/application window. The hourglass will then appear and the program will generate the draw file.

'The program can take a long time if the file is big and you don't have a StrongARM. Also the resulting file will need a lot of font cache to speed up the rendering of it. The first time it will be slow, but after that faster if enough memory is available.'

## Pi-man

Author: Jean van Mourik

**Jean van Mourik** continues his mathematical theme with a trio of programs.

*PI*, no surprises here, calculates that most magical, nay transcendental of numbers using a particularly nice iterative method devised by Peter Borwein.

The convergence is, it seems, quicker than with any other method, but you will

need to read *Science News* (28 Oct 1995) if you want to know why.

*Factorise* is a quick BASIC program to factorise numbers. The sieve of Eratosthenes (which I believe he kept in the kitchen drawer of Eratosthenes, next to the tin-opener of Eratosthenes) is used to 'harvest' all the primes from 2 to 46333.

Any number you enter is then checked for divisibility by the primes in the array, which saves having to divide by lots of unnecessary values.

*Mind-read* is really just a simple demonstration of the binary system. You are left to work out how the program guesses your number.

## Latoocarf

Author: Jan van Mourik



...was a word unfamiliar to me before **Jean van Mourik** sent us a program to plot a graph of it.

I did a search of the Internet for more info but to no avail. So, since Jean lives in Dyfed, we guess it must be a local, Welsh fractal.

No matter – it's a jolly nice one, and moreover, you can experiment with the parameters in real time using Jean's program. Just hold down Select and move the mouse around.



## Palin into significance

Author: Royston Palin

More significant and original contributions to the world of electronic music from **Royston Palin**. It is refreshing to feature styles of music not always associated with computers, and the fact that

Royston's compositions are original works makes them all the more special. So crank up your copy of *Rhapsody3* and enjoy six more ragtime masterpieces in the syncopated style...

Acorn User Award - Best Pocket Book Software

# **n** THE SOLUTION to the NATIONAL CURRICULUM for ALL YOU BUSY TEACHERS!

Version 5 of our award winning National Curriculum Record Keeping and Report Writing software is now available for:

- ▷ Acorn RISC machines @ £44.95
- ▷ Pocket Book II @ £49.95\*
- ▷ New PSION Series 5 @ £49.95\* \*£28 with Acorn version

Here are just a few of Nstore's many powerful facilities:

- ▷ All the NC Level Descriptions
- ▷ 750 Teacher Comments
- ▷ Automated Report Writing
- ▷ Targets

For details of Nstore, our £5 demo disc and our full range of Special Needs Software write to: H.S. Software, FREEPOST, Swansea SA2 9ZZ  
 tel.: (01792) 204519 e-mail: h.s.soft@argonet.co.uk  
 FREE demos at: <http://www.argonet.co.uk/h.s.soft>



Educational Software

Maths History  
 Animation Primary  
 Language Adventures  
 Early Years Graphics  
 Safety Time Spelling

**4MATION**  
 Publishers of quality educational software since 1983

ACORN PC & MAC

FREE CATALOGUE AVAILABLE

4Mation, 14 Castle Park Road,  
 Barnstaple, Devon EX32 8PA.  
 Phone: 01271 25353 FAX: 01271 22974

# Statistics with Graphics

# 1st

1st now seriously upgraded version 2 products give a choice of user interfaces with even more statistics and graphics.

1st provides UNEQUALLED statistical facilities. Drawfile graphics. Easy CSV interface. Spreadsheet type data entry with extensive manipulation features. Automatic, context sensitive manual. Mouse driven, with optional keyboard shortcuts.

Our products cover statistical requirements at levels from GCSE to advanced research. Education prices from £50 to £164 depending on the version.

New, unique features for Value Added Analysis in School Administration.

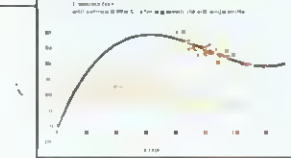
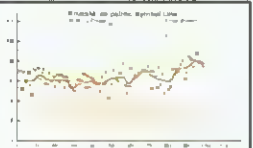
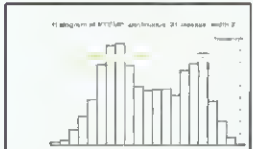

FREE loan copies. Further info available from:  
**Serious Statistical Software**  
 Lynwood  
 Benty Heath Lane  
 Willaston  
 S. Wirral, L64 1SD  
 Tel: 0151 327 4268

The established statistical packages.

# picture book 2

**6** high-quality programs specially designed to help pre-school, primary school and special needs children with Reading, Spelling and Counting - enjoyably and very effectively!

- AlphaBook • Snap • WordMatch
- Count 'em • Spell It • FlashCard

Each program uses Alphabet files with professionally drawn graphics, sound effects and spoken words and offers many setting choices to suit each child's ability.

For RISC OS 3.1 or later. **£35.00**  
 Site licence: £105.

## Draggie The Professional Application Launcher

For easy on-screen access to your most frequently used files and applications **Draggie** is the professional answer. Cut out constant clicking with these easy to install pull-down menus. The best way yet to organise your computer screen, your files and your time. **£12.00**

## Notice Board

"..for rolling presentations Notice Board excels."

Acorn User

Using Draw and Artworks files **Notice Board** enables you to create multi-page, poster-like presentations to run unattended in any location. Widely used in schools, **Notice Board** provides a colourful, constantly changing information point that is also ideal for information/sales messages at conferences and exhibitions, libraries, reception areas, etc. **£35.00**

For use with RISC OS 3.1 or later.

## Montage Creative Fractal Art

"...decidedly the most original and unusual package I have seen for a very long time.....once you've digested what the instructions say, **Montage** is a fascinating and enthralling program." *RISC User*

Create your own stunning fractal art pictures quickly and easily with **Montage**. Working in interactive mode **Montage** builds the images as you work. Requires RISC OS 3.1 minimum 2mb, 4mb for hi-res pictures. **£45.00**

**MultiLink** Transfers data effortlessly between 8-bit BBC and all RISC OS 32-bit computers. Easy to use click and drag operation. *With serial cable* **£29.95**

## The Really Good Software Company

39 Carisbrooke Road, Harpenden, Herts. UK AL5 5QS  
 Tel/Fax: 01582 761 395 Email:rgsc@turnbull.compulink.co.uk  
 No VAT or post/packing. Cheques, with order please, made payable to the company. Official orders welcomed.

Scottish

Acorn

Show

23rd November 1997

The Marriott Hotel  
500 Argyle Street, Glasgow

10 am - 5 pm

Adults £2

Concession £1

Acorn 

Simtec Electronics

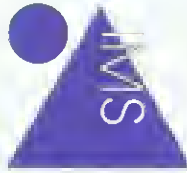

Design IT



Todd  
Education  
Computer  
Services

R-Comp

Icon Technology

*Acorn Education*

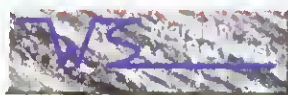

Dalriada Data Technology

CTA Direct

APDL



Creative Curriculum Software

QUANTUM  
SOFTWARE



Learning Through Computing

AKALAT  
Publishing

Contact TECS on 0141 644 4952 For details

WWW <http://www.argonet.co.uk/tecs/show97>

E-mail : [sacs@argonet.co.uk](mailto:sacs@argonet.co.uk)

## In the shade

Author: Alex Holloway

Alex Holloway of Edware has come up with a funky shading program. We will let him explain what it does and how it works:

'Shade is a program which allows you to



draw using the 'shade bobs' effect seen in demos such as *Xtreme*. *Shade* is Risc PC only (24-bit colour), and requires at least 1Mb VRAM to work (a version for machines without VRAM is of course technically possible, but the display would be very small).

The keys are as follows:

mouse	draw (click Select)
Insert	shows menu
Delete	clears screen
Print	saves screen

The menu offers the following options:

- *Change colour shift* allows you to specify how much of each colour to be added to or removed from the screen while drawing, and takes integer values between -10 and

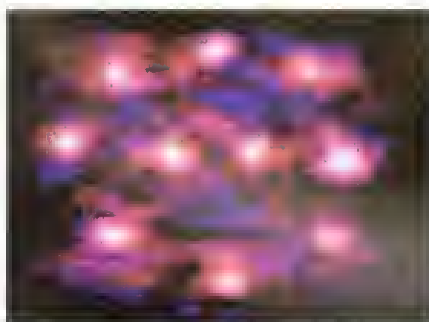

+10 (higher values are possible but don't give the effect).

- *Change brush type* allows you to select which sprite to use as a brush shape. Extra brushes can be created by adding sprites to the *Brushes* sprite file inside *!Shade*. These should be 20x20 pixels in two colours, and

will be recognised automatically by the program.

- *Change background colour* takes input of values between 0 and 255 for red, green and blue. Note – this clears the screen, all previous drawings are lost.

- *Change filename for screen save* allows you to specify a pathname to save to when Print is pressed.

### Haw Shade works

'Lines up to 430 are for setting up and mainly involve getting the brush sprites sorted out, the main loop is lines 430 to 510. *x%* is the current *x* position of the mouse, *x2%* is the previous *x* position of the mouse. (Similarly for *y%* and *y2%*).

'When drawing, *Shade* takes points two at a time, and interpolates between them to create a continuous line – this is done by **PROCdraw\_across** and **PROCdraw\_up**.



This is done with respect to either the horizontal or the vertical depending on whether the gradient of the line is greater or less than 1 (decided by **PROCdraw**).

'For each position on the line, the assembler plot routine is called. Registers at the start are as follows:

- R0 – start address of screen memory
- R1, R2 – *x*, *y* location of plot
- R3, R4 – width and height of plot respectively

(Originally different sized brushes were planned, however I never got round to implementing this)

- R5 – start address of mask, generated from sprite data when program is started up by **PROCsetup\_pixtable**

- R6 – address of block containing colour information (**cols%**)

- R7 – brush type

'Lines 900 to 1050 do setup, translate the co-ordinates information into addresses to start and end the plot; the remainder is the actual plot code. This section goes through

each memory location to be changed, checks if it isn't masked out, and if not, splits out the colour components and adds (or subtracts) in the colour shift. During the



plotting process, registers are used as follows:

- R1 – shift for current colour (red/green/blue)
- R2 – 8-bit value of current colour component of pixel

- R6 – address of current position in colour info block

- R7 – bit offset from 0 of current colour in pixel data

- R8 – mask for current pixel loaded here
- R9 – start address of position in plot, incremented with each pixel

- R10 – end address of plot

- R11 – colour data of current pixel

- R12 – end address of current line to plot

'Lines 1490 onwards are the user inter-



face, this should be fairly self-explanatory; a user sprite area, starting at **sprite%**, is used to store the current picture while the menu is being used. **PROCsetcols** makes sure that the text is in a readable colour no matter what the background colour is.'

## Race against the machine

Author: Scott Boham



A 'nice little car game' now, from 16 year old **Scott Boham**. First design the track using Z, X, ? and ". When complete, press Space to start the race and use the same keys to control your car.

The program can easily be

customised to increase (or reduce) the number of cars – just change the first line.

And if you fancy some night-driving, try the one-player *Race2* – only the road ahead is shown, illuminated by your headlights.



Star info

# Let's twist again

Author: Mark Adcock

Not one, but four variations on the old Spirograph theme from (spooky) Mark Adcock now.

Whereas the original toy featured only one pencil, Mark's electronic version has three.

There are colour and grey-scale variants in both 16 and 256 colour modes and you will easily be able to deduce which is which from the program names.

For that 'chalky' effect, the screen memory is accessed directly and 1 is simply added to the colour. Press Space at any time to skip to a new pattern.



# Spin city

Author: Thomas Madams



It seems Alex wasn't the only one influenced by the Xtreme demo – our old chum Thomas Madams emulates one of the effects from it with *Spinaway*.

*Spinaway* simply spins a sprite around and moves away from the screen as it does so. The trailing effect is accomplished by instead of clearing the screen before plotting the

next frame, subtracting one from the colour of each pixel every frame – the opposite to what Alex's *Shade* program does really.

At the moment, it is not particular easy to change the text or sprite used – the data is stored as a bitmap in a file called *spindata*.

## \*QUIT

All submissions be they programs, hints, tips, music or madness to the following please:  
\*INFO, Acorn User, IDG Media, Media House, Adlington Park, Macclesfield SK10 4NP  
or, if your submission is about 100K or less, e-mail us (including your real address please) at:  
[austarinfo@idg.co.uk](mailto:austarinfo@idg.co.uk)

You needn't include a letter but please put your name, address and program title on every disc and include a text file containing your name, address, disc contents and program details. An SAE will ensure your discs are returned. \*info submissions only please – if you are also submitting material to another section of the magazine it is best to do so separately.

## Compatibility table

Program	RO 2	RO 3	RO 3.1	RO 3.5+
SPIRO 16C	Yes	Yes	Yes	Yes
SPIRO 16G	Yes	Yes	Yes	Yes
SPIRO 256C	No	Yes	Yes	Yes
SPIRO 256G	No	Yes	Yes	Yes
Race	Yes	Yes	Yes	Yes
Race2	Yes	Yes	Yes	Yes
!Spiral	No	No	Yes	Yes
!Shade	No	No	No	Yes
!Spinaway	Yes	Yes	Yes	Yes
Spooky!				
!Spook	Yes	Yes	Yes	Yes
Buts	No	Yes	Yes	Yes
IWind	Yes	Yes	Yes	Yes
Dust	No	No	No	Yes
FACTORISE	Yes	Yes	Yes	Yes
LATOOCARF	Yes	Yes	Yes	Yes
MIND-READ	Yes	Yes	Yes	Yes
PI	Yes	Yes	Yes	Yes
Mosaic	Yes	Yes	Yes	Yes
Mosaic-RPC	No	No	No	Yes





Amazing free gifts and special offers!!!  
**Over £100 worth of magazines and software for just £39.99**

# ACORN USER

the world's number 1 Acorn magazine

**Y**ou already know what a great magazine ACORN USER is. It is the only Acorn magazine with up-to-the-minute Acorn news, in-depth hardware and software reviews, and without doubt the best cover discs available.

What you might not know is that by taking out a subscription today, not only are you guaranteed never to miss an issue of the biggest and best Acorn magazine in the world, but you can also claim an excellent free gift or special offer, available exclusively to all new ACORN USER subscribers.

\*All our software offers are StrongARM compatible.

## TEXTEASE



Only £20 rrp £49

Software Limited

### CURRENT SUBSCRIBERS

- you can take advantage of these offers by renewing your subscription at any time

The most flexible, straightforward and comprehensive wordprocessor and desktop publisher ever. Use it to make letters, invitations cards, banners, notices, posters, overhead foils, in fact any kind of text and graphics. It is designed to be ideal for children and is invaluable for older children and adults.

**Acorn WORLD**

**SPECIAL OFFER 1 Month only!**

Why wait until Acorn World to re-subscribe when you can take advantage of this fantastic offer today?

Subscribe before 30 October and you will receive a FREE copy of "Notes" from *The Really Good Software Company* PLUS any one of our other fantastic subscription gifts.

**FREE RHAPSODY**

**New stocks now available**

Your chance to compose your own musical score. Rhapsody allows you to modify and manipulate music as a wordprocessor does text. You can enter score by hand, note by note, or, if a MIDI Interface is fitted to your computer, you can play a tune using a MIDI keyboard and capture the music in Rhapsody. The music can then be transcribed ready for editing, replaying, etc.

In the shops £59.99 as an Acorn User subscriber you can claim it for free!

### SUBSCRIBING HAS NEVER BEEN EASIER



Why not make your subscription even easier and subscribe by direct debit, spreading the cost of your subscription over quarterly hassle-free payments. What's more, you need never worry about missing an issue again, as the subscription continues until you decide to cancel.

**CRYSTAL MAZE**

**New offer**  
rrp £16.95



Pit your wits against TV's most famous maze! Discover the secrets of the maze as you take up the challenges of the Aztec, Medieval, Futuristic and Ocean zones. Solve the ingenious games and fiendish puzzles to win precious seconds in the ultimate challenge - the Crystal Dome.

**FREE**

**PERSONAL ACCOUNTS 3**

**Just £10**  
rrp £49.95

The most popular home and club accounts package. Multiple accounts, standing orders and forecasting are just some of its features. We gave it top marks in the Jan '95 issue. See the demo on the AU CD-ROM 2.

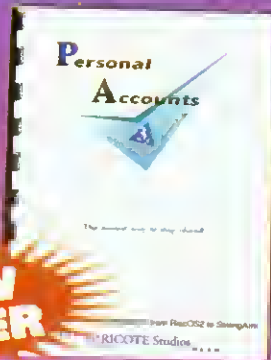

**NEW OFFER**

**HIGH RISC RACING**



**PLUS A £5 OFF VOUCHER FOR LAST OFFENCE**  
Fast, furious and fatal, the ultimate racing game. You'll need nerves of steel and lightning fast reflexes to win. Runs on any 32-bit Acorn Machine with 2Mb of memory and RISC OS 2+.

**FREE**  
rrp £30

**BINDER & TWO FREE MAGAZINES**

Comprehensive and accurate, our new binder will hold up to 12 issues of your favourite magazine. PLUS receive an extra two magazines absolutely FREE!

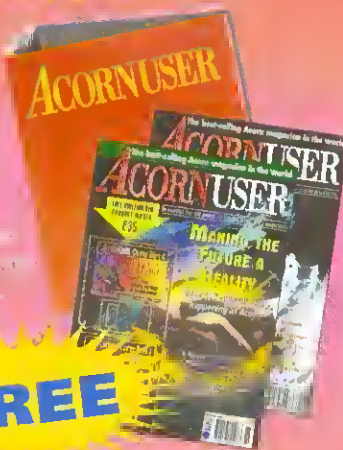

**FREE**

**Subscription Hotline numbers**

**Tel: 0151-357 1275**

**Fax: 0151-357 2813**

**Email: database@dbdirect.demon.co.uk**

**Yes! I will subscribe...**

**1a** There's never been a better time to subscribe so take advantage of one of these offers TODAY. See section 2

4234  UK £39.99    4202  EU £53.99    4203  World £68.99\*

To renew subscription please tick:

4235  UK £39.99    4224  EU £53.99    4225  World £68.99\*

\*Unfortunately World subscribers are not eligible to receive the free gift/special offer

I wish to pay by:  Cheque/postal order made payable to IDG Media  
 Credit card (Visa/Access/Barclaycard/Mastercard/Eurocard/Connect)

Expiry date  /

Card No.

**1b** Please enrol me as a subscriber to Acorn User.

4210  with payments of £9.49 by continuous quarterly direct debit See section 2.

Your subscription will continue until you cancel. Over a year you will receive 13 issues.

Name of Bank/Building Society .....

Address .....

.....

Name of Account .....

Your Account No. .... Sort Code .....

Date ..... Signature(s) .....

Your instructions to the bank/building society:  Originator's ID No. 851412

I instruct you to pay direct debits from my account at the request of IDG Media. The amounts are variable and may be debited on various dates. No acknowledgement required. I understand that IDG Media may change the amounts and dates only after giving me prior notice. I will inform the bank/building society in writing if I wish to cancel this instruction. I understand that if any direct debit is paid which breaks the terms of the instruction, the bank/building society will make a refund. Bank/building society may decline to accept instructions to pay direct debit from some types of accounts.

**2** Please send me the following FREE Gift/Special Offer (tick one):

4247  Rhapsody **FREE**    4705  Binder & 2 magazines **FREE**

4249  Crystal Maze **FREE**    4770  High RISC Racing **FREE**

4248  TextEase **£20**    4250  Personal Accounts 3 **£10**

**3** Name (Mr/Mrs/Ms/Miss) .....

Address .....

.....

.....

Postcode ..... Tel. ....

**4** Now send your completed form and payment to Acorn User, Database Direct, FREEPOST, South Wirral L65 3EB. Tel: 0151-357 1275. Please state if credit card billing address is different from the delivery address. Photocopies or handwritten versions of the above information are acceptable.

# SILICON VISION®

DESKTOP SOLUTIONS FOR ACORN COMPUTERS

1987 - 1997

10

YEARS OF  
EXCELLENCE

## SolidCAD®

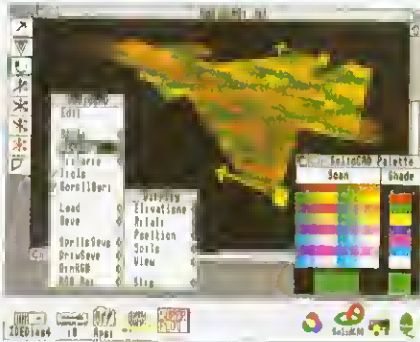

Comprehensive 3D CAD & Visualisation with fast rendering & animation. £49.95

## SolidsRENDER®



Advanced Ray-Tracing package for photo-realistic images of SolidCAD designs. £49.95

## SolidTOOLS®

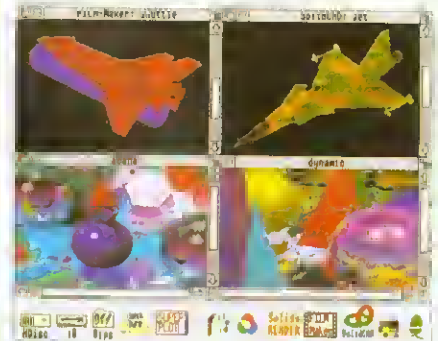

Fully integrated environment for 3D Conceptual Design and High Quality Presentations. £125

## ArcPCB™

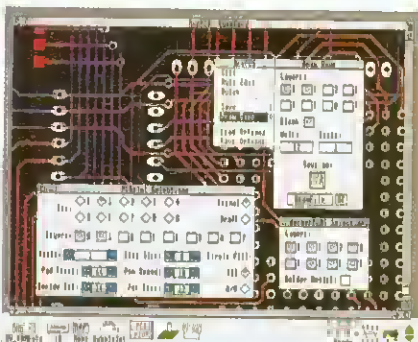

The most comprehensive Electronic Design Automation Tools starting at only: £49.95

## LOGIX™

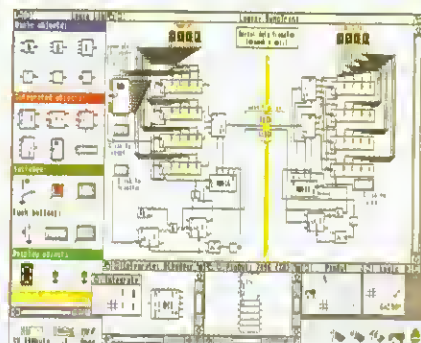

Digital Design and Simulation Tools with extensive customisable libraries. £49.95

## AlphaTracks™

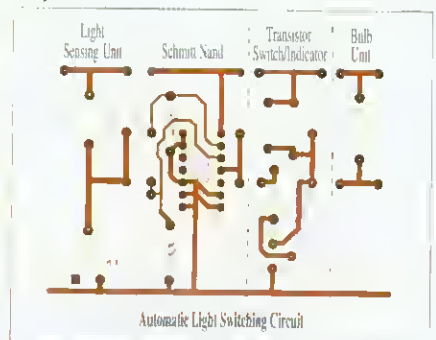

The complete Electronics Teaching Course for Schools based on ArcPCB. Site License: £40

## WimpGEN™



RISC OS User Interface Design and Generation tool for rapid applications development. £49.95

## RiscBASIC™ Compiler

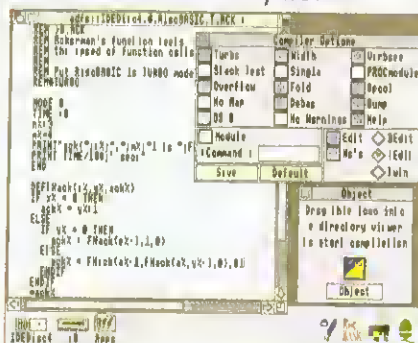

Unrivalled BASIC V & VI Compiler for creating secure high-speed applications. £49.95

## RoboLOGO®

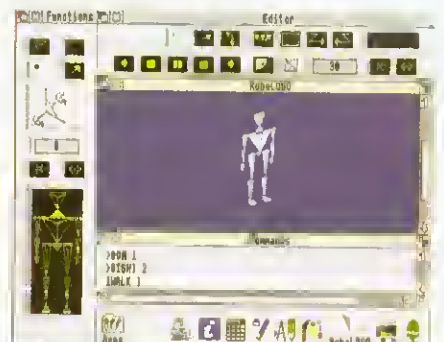

The ideal introduction to computing with 2D & 3D Turtlegraphics plus Robot control. £29.95

## ProSHEET™

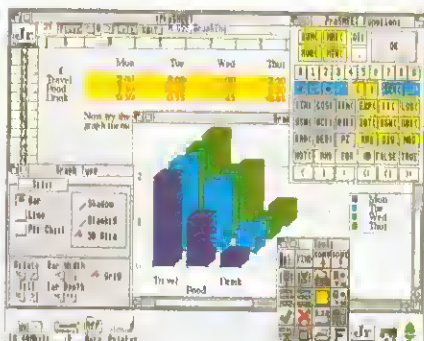

Combines ease of use with full featured functionality at an affordable price. £29.95

## ShareHolder™

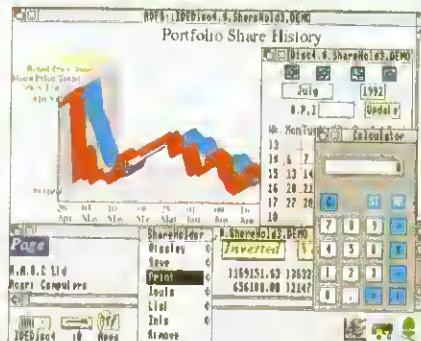

Comprehensive Share Portfolio Management for £49, or £75 with Teletext/Prestel links.

## Payroll Manager™

Employee		General Manager 11/19/1991		Calculation Control	
Members	0 1 0	3548		* Consult List	
Name	Mr. J. Sandrain	3548		* Week/Month	
Tax Period	4	Mar 8	May 8	* Book Values	
Date Paid	05/05/91	15	May 5	* Personal	
Earnings		Units	Rate	Deductions	To Date
Hours	1.90	875.00	875.00	PAVE	121.75
Hours	1.90	875.00	875.00	PAVE	121.75
Hours	1.90	875.00	875.00	PAVE	121.75
G.S.P.	Search	Conf/Len	Pay Advice	Print	10.00
Net Pay	Lock	Worksheet	Missed	5.00	5.00
G.S.P.	Print				
Total		875.00	Total	214.50	Net Pay

Complete & easy to use Payroll Manager handling the latest budget changes. Use standalone or integrate with Prophet Accounts. £49.95

## 10th Anniversary Offers

To celebrate 10 years of trading, the prices quoted are substantially discounted up to 50% off RRP. Offer valid for this issue.

All products are available now. Prices exclude Carriage @ £3 & VAT. Educational official orders accepted.

**SILICON VISION LTD, SIGNAL HOUSE, LYON ROAD, HARROW, MIDDLESEX, HA1 2AG, UK. TEL: 0181-422 3556, FAX: 0181-248 3589.**

Software Site Licenses are 2 times the RRP for use on up to 10 stations or individual machines. Enquire for specific cases.

All product titles are registered trademarks or trademarks of Silicon Vision Ltd. All other trademarks acknowledged.

Copyright © 1997 Silicon Vision Limited. All rights reserved. All software support RISC OS 2, 3 and the Risc PC.

# Rambles through Acorn Wood

Another question and answer session from **Mike Cook**

Many people think that if an application has been placed on the cover disc of a magazine then it is in the public domain – not so. The copyright of that application has not been relinquished – it is owned by someone. The arrangement I have with *Acorn User* for my own hardware column is for the publishers, IDG Media, to have first publication rights lasting six months but after that time the sole copyright of my programs reverts back to me.

Other authors may have other arrangements but what is certain is that you can't just stick an application on your website just because it has been on a magazine cover disc. This goes for modifications too. If you want to modify an author's program then you own the copyright for the modifications but the author still retains the copyright for the original. That means you can't just go and distribute the modified application as if it were your own.

At the very least there should be a note somewhere in the application to the effect of describing your modifications. However, the best way to distribute your modifications is as a patch file that will alter a copy of the original program that the user already has. This is what I did when I wanted to add some effects to *Slide Show* demo that came with the Risc PC.

I wrote some extra code that would cycle through the colour palette of each image giving a psychedelic look to it. As I did not own the copyright to *Slide Show* I incorporated all the modifications into an update application that created a new program from *Slide Show*. The fact that everyone who could use my modified version already had a legitimate copy of *Slide Show* was no reason to say that I could distribute a modified copy. Most of the problems like this can be resolved with a modicum of common sense and courtesy.

*Alan Metcalfe from Accrington, just a bit further up the road from where I live, comes up with a helpful utility:*

In reply to your request for info for Cannon BJ130 printer drivers for Glenn Burgess I have enclosed a copy of a driver written for me by Gary Forrest at DeskTop Projects fame when I bought a BJ130e from him many moons ago. I found it worked well under both RISC OS 2 & 3 but later I moved on to the Turbo drivers by Computer Concepts through the various revisions released.

I have included a text file 'DipSw's' which should solve the jumper links problem he is experiencing. My old faithful BJ130e now resides in my workshop as the ink drawing pump no longer works and the head has started to show hanging problems. It has got to the age where its repair is no longer 'economically viable', so if anyone would like to collect it for spares, I would be more

than willing to donate it (including spare ink cartridges, tractor feed and manuals etc).

Thanks for that Alan, the Charity stand run by Norwich Computer Services at the London and Wakefield Acorn shows would be a good place to donate your printer. No sooner have we solved one printer driver problem than we are faced with another.

*Ben Geach from Cobham has been eyeing up an interesting new product, he writes:*

I would like to find out if there is a printer driver for the Acorn that will support the Hewlett Packard OfficeJet Pro 1150C's printing function on my A5000. I have looked through the drivers on the July cover disc but am unable to find any mention an HP Office Jet. Has such a driver been produced and if so please can you tell me where I can get hold of it?

Ben sent me a small leaflet about this piece of kit, it appears to be an inkjet printer combined with a flatbed scanner so it can act as either/or, by putting the two together a copier. It doesn't sound like the sort of thing you could knock up overnight but is any dealer out there looking to support it?

*Alex Heys from Billinge writes to me to make a plea for a small LCD display to be included as one of my future projects, but he also has this advice for a topic that appeared in these pages recently:*

In response to Peter Peertinat's request for a device to check whether his other phone is in use, I appear to have found just what he is looking for in the latest *Innovations* catalogue. Costing £6.95, the 'Privacy Fute' replaces your socket doubler and it simply allocates your line on a first come first served basis.

It also includes a 'line in use' LED. You can contact Innovations via the Web on <http://www.innovations.co.uk> and look under communications, alternatively if you don't have Net access, then the telephone can be used on 01793 432365. Finally would it be possible to write some software to decode RDS information via your radio tuner?

Thanks Alex, I have seen a copy of the catalogue but must have missed that. I always find their products tempting but not tempting enough for me to purchase.

As to your last point, the RDS (Radio Data System) transmits information on top of the radio signal that allows suitably equipped radios to display short text messages. These are mainly simply the name of the station, although in Switzerland I did notice that one station had a scrolling message and another appeared to be displaying the

artist of the record they were playing.

My understanding of the system is that the information is carried in the radio frequency part of the signal and so could not be extracted from simply the audio signal. That means there would need to be more hardware, and as the radio is a discontinued discounted mass produced item it would inevitably cost more than the radio itself.

Also the RDS system is useful in cars when you are in a strange location and want to know what radio stations are what. In a fixed location they don't change that often so I don't see it being so useful.

*Martin Wilson has a whole ship load of questions to fire at me so I will split them up:*

My questions all relate to my A3010 model. It's not the more common variety as it has separate main chips on a daughterboard. On the original Archimedes A3000 there was a feature where the top end of the sound was reduced so that the built-in speaker was less likely to distort. Does the A3010 have this and can it also be worked round to get better high frequency sound?

All computers have a low pass filter on the sound system, this is to reduce the sampling noise and computer interference. If you do any modifications to this then it is more than likely you will induce buzzing and interference noise.

However these filters are just simple second order filters so if you want to give the top end of your sound a boost then simply fit a high pass filter or graphics equaliser between the sound output and the amplifier. Normally you can compensate for any internal filters by adjusting the tone controls on your Hi-Fi. Having said all that, it really doesn't make much of a difference.

The motherboard/memory system is run at 12MHz I believe, can this be increased to 14 or even 16MHz and how will this effect the monitor display (I have a true variable multisync), serial and parallel ports? Hardware-wise I have an ICS internal IDE interface and both internal and external hard drives plus an Atomwide printer SCSI interface.

Your system is running at 12MHz because this is the fastest speed that design will work at dependably. Sure, there are tolerances on production runs and it might be possible to tweak an individual system up by a small amount but you are going to make it much less reliable and have less tolerance to things like increased temperature.

For the extra speed increase it is simply not worth the effort, you will not notice that your computer runs any faster. It won't make any difference to the serial port but would throw off the

# Acorn Wood

timing on the serial port. You can compensate for this by writing different values into some chip registers but, without delving into it more deeply, I can't be more specific.

I believe my A3010 can be upgraded to ARM3 and would like to fit one. I've read that, speed-wise, there's not much difference between the slowest ARM3 at 20MHz and the fastest at 40MHz. Why is this and is it related to the speed of the memory system?

It is common now for the processor to run faster than the memory because it is expensive to make fast memory and relatively cheap to make a fast processor. Ultimately the speed of the machine is governed by how many instructions it can process per second. These come from the memory and so the memory access time will be a crucial factor. However, processors like the ARM3 and the StrongARM have a cache or onboard memory so that when an instruction is fetched it is stored on the processor chip - if it is needed again it can be accessed much faster.

This means programs that use tight loops execute much faster than ones with no looping. Therefore the speed of the machine depends very much on what sort of program it is executing and that makes comparisons difficult, if not impossible.

The secret of why the StrongARM is so fast with BASIC programs is that the whole of the BASIC interpreter can sit inside the cache, whereas with the ARM3 processor the cache is not that big and so the extra processor speed is not that much of an advantage when executing interpretative BASIC.

Lastly, what is the safest maximum speed of the serial port and will this be improved by an ARM3? Why does something like Connector allow speeds far higher than RISC OS itself? P.S. I've done lots of soldering in the past but no surface mount work.

The RISC OS has to work on all sorts of machines and so has to be compatible with the slower hardware found in earlier machines, that is why newer plug-in cards can work faster. To be fair to the designers the need for faster serial port speeds is quite new, until a few years ago anything above 9600 baud was not needed.

The question of the maximum reliable speed is almost impossible to predict because it depends on what else your computer is doing at the time. Basically the computer has to respond to an interrupt, get the character from the serial port and put it in a buffer at a rate of one tenth the speed of the serial port.

For example, with a speed of 32,000 baud you need to be able to respond at a speed of 3.3 KHz. That's fine if the computer is doing nothing else but with the requirements of video refresh and sound production you begin to push what you can achieve.

The only way is to try it and see - if you don't get the speed you want, try to reduce the processor load. Incidentally, surface mounting work is virtually impossible to do without the correct equipment, such as vacuum picks and hot air irons. A surface mount work station will cost you about the same as a Risc PC so it's not an activity for the amateur.

*James Stevens is hoping to save money on his monitor, he writes:*

Recently I have decided to upgrade from my ageing A3010 to a Risc PC. Being an A-Level Computing student on a tight budget I would prefer to use my existing AKF52 monitor. However, I am confused.

As the AKF52 is a Multiscan monitor, will it be able to display many of the Risc PC's high resolution screen modes, as a SVGA monitor can? Also, will the amount of VRAM make a difference? Currently I usually use mode 31 (800 X 600, 16 colours), but find it a pain to have to change to mode 28 (640 X 480, 256 colours) whenever I use any applications which require a 256 colour mode. Would the AKF52 be able to display an 800 X 600 mode with 256 colours, or even 16 and 24-bit colours?

The number of colours a monitor can display is only dependent on whether it is an analogue or digital monitor. The early 8-bit monitors were digital but all the 32-bit machines have used analogue monitors, you can therefore use your monitor to display any colour depth.

As to the resolution, the Risc PC comes with an AKF52 driver and offers resolution up to 1600 X 600. However, having said that you can't expect a razor sharp picture at that resolution. The amount of VRAM you have available will limit you to the combination of screen resolution and colour depth. Without any VRAM you can only get a 256 colour mode. For higher depth modes simply multiply the horizontal and vertical resolution together and multiply this by two for 16-bit colour and four for 24-bit colour.

*James continues to look to the future and asks:*

I am in the process of choosing a University to follow Computer Science. Many Universities offer their students access to the campus network from their bedrooms, using a dreadful Wintel PC. Would you see any problems connecting a Risc PC to the network using a PC Card and appropriate version of Windows?

Yep, I would see lots of problems. Not with the basic setup but with the Internet software you will probably want to run - most is a bit flaky to say the least. However, if you have a proper ethernet connection for the computer there is no need to resort to PC technology at all. The whole point about the Internet is that it does not matter what sort of computer you have, so with the correct software and interface card you can run it all from the Acorn side.

*David Cload from Hayes has been reading my hardware column and has a bit of a wish list, he says:*

After seeing your recent article on a PIC programmer for the Archimedes I was wondering if you had any plans to do an article on a universal device programmer that could program most types of programmable logic devices, EPROMS, PALs, GALs and PICs as well as some of the more popular single chip computers, as this facility is seriously lacking on the Arc and although I have the ability to design the hardware, my programming skill would not be up to the task.

I did look at the possibility of making a GAL programmer a few years ago. A GAL by the way is Generic Array Logic and allows you to make all

sorts of chip functions from a single chip. The only problem is that chip manufacturers will not release the programming algorithms to anyone who isn't a licensed registered developer with them.

Their excuse is that they want to be able to ensure the reliability and reputation of their chips but I suspect the real reason was to keep the price of the programmers up. I did have several attempts at trying to worm it out of them but they all failed. The other problem is that with device specifications changing all the time a lot of effort has to be put into keeping such a project up-to-date and with the size of the Acorn market for this sort of device being so small, I am sorry the answer has to be no.

*Last month Chris Bell from Llanbedr had a problem about seeing if his printer was online. Following my suggested solution he writes back:*

I've tried your SYS"Parallel Op" suggestion and it does indeed give various results depending upon the printer state. However my setup (a Risc PC 600 and HP LaserJet 5L) gives different results to those that you said you got from yours.

`SYS"Parallel Op" IO %S% PRIN -%S% yields the following..`

```
printer cable disconnected %S% 3D 878
printer connected, switched off %S% 3D 880
printer connected, switched on, no paper %S%
3D 860
printer connected, switched on, paper loaded
%S% 3D 8D8
```

Perhaps you can see a pattern, but I can't. Obviously I could just look for %S% 3D 8D8 on my setup, but this wouldn't necessarily work for other people. I'd appreciate your further thoughts.

Well let's look at the bits in the status register, bits 0 to 3 are not used so we are left with five bits that are brought out to the port, these are: 7 - Not Busy, 6 - Not Ack, 5 - Paper Error, 4 - Select, 3 - Not Error. The important thing to remember is that while some of the signal names are preceded by Not, only bit 7 is actually inverting input.

So with nothing connected, logic inputs will float high and read as ones, hence you will get &78, bits 0 to 2 always read zero and bit 7 is the inverse of the input and hence a one. I get the same value on my computer. Now with the cable connected but printer not switched on there is a path to earth for the signals and it looks like all those that were floating high have now gone low as this is the inverse of the not connected bit pattern.

When you switch on with no paper your printer is indicating that it is busy, bit 7 low and it has an error - bit 3 low, it is not selected - bit 4 low and finally it has a paper error - bit 5 high. So it looks like your printer is pulling out all the stops to indicate it is not ready to go and not just singling a paper error. I would think you would be safe in looking at the top five bits for all setups remember bits 0 to 2 should not be relied upon and should be masked out of any test. If you are worried about other setups then offer the user an option to ignore the status bits and go ahead anyway.

AU

## Contacting me

You can contact me, Mike Cook, by post at the usual address or by e-mail at: [auqanda@idg.co.uk](mailto:auqanda@idg.co.uk)



## High speed FIFO Midi Interface

Internal fitting  
for all Systems with a backplane

# Midi Connect

16 Channels IN  
32 Channels OUT  
+ 16 Thru Channels

Tested with:

*Sibelius*  
Software



**£75** Incl.



## Midi Thru Box

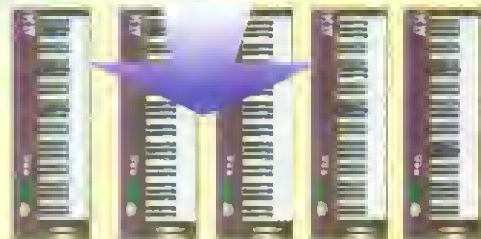

**£39** Incl.

The MTB is designed to  
provide you with 5x Midi Outs,  
thus giving you access to further sound modules

## CONNECT 32

100% Acorn SCSES Compatible uses Recognised Rise & DOS formats

High Data-Transfer-Rate

fast SCSI II Upto 6.5 MB/s

**SCSI POWER**



**£129** Incl.

Email: [acesales@plaza-project.de](mailto:acesales@plaza-project.de)

**ACE** Baroper Bahnhof Str 55  
44225 Dortmund Germany  
T. 0049 231 7274260  
F. 0049 231 7274261



<http://www.acebase.de>

# ACORN USER GUIDE TO LOCAL DEALERS

## NOTTINGHAMSHIRE

– Arnold Computer Supplies. Home enquiries welcome. Repairs & Service. Tel: 0115 9264973

## ESSEX

– GeneSys for all your Acorn needs, serving Education, Business & Home. Contact Richard Brown 01702 462385. E-mail: genesys@argonet.co.uk

## HIGHLANDS

– Wardlaw Surveys, Authorised Acorn Dealer, for all your needs from supply, service, repair & full after sales. Tel/Fax: 01463 831214

## DEVON

– West Devon Electronics covers Devon and Cornwall, supplies and repairs Acorn computers. Tel: 01822 853434. Fax: 01822 853542

## SCOTLAND

**Tecs**  
Todd Education Computer Services

Sales, Technical Support, Networking  
Sibelius Agents  
Acorn Dealers Xemplar Agents

Telephone  
0141 644 4952  
e-mail : tecs@argonet.co.uk

## DERBYSHIRE

Selective Computer Services  
Acorn Specialist Dealer  
Acorn Centre of Technology

StrongARM Risc PC  
A7000+

Sales  
Tuition  
Peripherals  
Repairs  
Software  
Internet Solutions

Phone 01332 690691  
8 Oldgate Avenue - Westlan on Trent - Derby - DE72 2B2  
email: selective@globalnet.co.uk

## SURREY

**Calancraft Ltd.**  
THE COMPLETE ACORN DEALER

- Showroom open 9.00 - 5.30 six days and to 8.00 on Thursday.
- Acorn range on display, and full demonstrations given.
- Lots of programs, games and education software for you to try.
- Full service and repair facilities.
- Network Dealer and Training Centre for Education and Home.
- Printers, Upgrades, Internet, CD ROM, etc. etc.

*"Very helpful people"*  
with a 13 year long reputation for exceptional service and support.

Easy parking.

96 High Road, Byfleet, Surrey KT14 7QT

Tel: (01932) 342137 Fax: (01932) 336435

## SOUTH WALES

**UNIQUEway**  
SOUTH WALES' ONLY DEDICATED ACORN DEALER AND ACORN CENTRE OF TECHNOLOGY

Technical Support - Repairs - Hire - Internet Connections  
Low cost finance available on all systems.

3 Clarendon Road, Cyncoed, Cardiff - CF11 7JD  
Tel 01222-464020 Fax 01222-440071  
<http://www.uniqueway.co.uk>

## WEST YORKSHIRE

THE CHOICE OF EXPERIENCE  
**DAVYN**  
Davyn Computer Services

For the best service in Yorkshire (we think)  
CALL US for A7000, RisePC & Pocket Book II  
Visit our Showroom  
Open 9.30 to 5.30 Mon, Tues, Weds, Sat.  
9.30 to 7.30 Thurs & Fri

Printers, Ribbons, Ink Cartridges, Refills  
Expert Advice & After Sales Service  
Mail Order Master Card, Visa, Switch  
Ring for Prices  
Service & Repair to all Equipment  
Full Range of Acorn Hardware & Software  
(We operate the Acorn Finance Schemes)  
Full Range of Educational Software  
Tel. 01924 254800 Fax. 01924 258036  
e-mail sales@davyn.demon.co.uk

WE ARE HERE The Workshop  
off Princess Street  
Sandel Wakefield WF1 5NY

How to find us

Acorn CENTRES OF TECHNOLOGY

Acorn RISC PC hp HEWLETT PACKARD Canon

## MIDLANDS AND OXFORD

**DACO**  
459-465 Warwick Road, Tyseley, Birmingham B11 2JP  
XEMPLAR EDUCATION AGENT  
Tel: 0121 706 8933 Fax: 0121 706 4306

- Home use
- Business
- Education
- Special Needs
- Software Training
- Acorn approved network installers
- Complete range of Acorn equipment
- Consultancy

For expert advice & friendly service come and see us.  
We are open Monday - Friday 9.00am - 5.30pm

## EAST MIDLANDS

**RESOURCE**  
ACORN Centre of Technology

For your new  
**233 MHz StrongArm Risc PC**

FREE upgrade to 15" monitor and FREE CD-ROM drive for orders placed before 25th October

Visit our showrom - half a mile from M1 J24  
Open Mon-Fri 9.00 - 6.00 • Sat 9.30 - 1.00  
51 High Street, Kegworth, Derby DE74 2DA  
Telephone: (01509) 672222

## CUMBRIA

**XEMPLAR**  
Cumbria Software Systems  
Specialist Acorn Dealer

Risc PC700, A7000  
Sales, Repairs, Software, Peripherals

Network design and installation  
Ethernet, Nexus ATM, Multi-platform networks

Semerc Authorised Dealer

CSS Ltd., Unit 3A, Townfoot Industrial Estate  
Brampton, Cumbria, CA8 1SW  
Tel: 016977 3779



# Checking the instruction

In the third part of this project **Mike Cook** explains the uses of a software PIC simulator

Over the last two months I have presented software to program the Maplin 16C84 PIC blower and an assembler to generate the source code. This month, to complete the trilogy, I will look at a software PIC simulator. The first thing you might think is 'why bother?' – and I do have some sympathy with that point of view. There is nothing to beat sitting down and thinking about a problem. However, most problems you will encounter when learning an instruction set stem from a misunderstanding of it.

Computer manual writers have not got the best of reputations when it comes to clarity and accuracy of expression. This is mainly because the topic is quite complex and often authors assume knowledge that you don't have. Mind you, this is better than wading through tons of turgid prose explaining absolutely everything, so that by the time you have read it it is difficult to extract the information you need.

Computer manual writers have not got the best of reputations when it comes to clarity and accuracy of expression. This is mainly because the topic is quite complex and often authors assume knowledge that you don't have. Mind you, this is better than wading through tons of turgid prose explaining absolutely everything, so that by the time you have read it it is difficult to extract the information you need.

There is a difference between a simulator and an emulator. A simulator is a piece of software that will behave like a device whereas an emulator also has real inputs and outputs and can be plugged into the final circuit to test out the interaction of the hardware. An emulator is another step up in complexity from a simulator and unless it can be made to run in real time is of little use.

Most emulators use specialised hardware and are quite complex. That's not to say the simulator isn't complex – it's the most complex application I have written for quite a few years. The trick to writing complex applications is to start simply and then build up, but here I want to concentrate more on how to use it rather than how I wrote it.

Load up the simulator from the cover disc and drag a hex file onto the icon bar. You should get the control window bristling with controls and information. Like seeing an oscilloscope for the first time, it could be that

there is too much to take in at once but it is not so daunting if you take it slowly. At the top is the path name of the file you are simulating, when you drag it into this window you simulate a power up reset. This is different from the normal reset you get from the reset line on the chip as some registers are preset to certain values.

The next row of icons show you the current address, op-code and mnemonic – this is the instruction that is about to be executed. Clicking on GO will execute that instruction and you can see the results reflected in the other indicators. The simulator will now be in a paused state with a new instruction displayed waiting to be executed. The heart of the simulator is a disassembler – a program that takes the raw op-codes and translates them into mnemonics.

I decided not to use the original assembler syntax but rather pad it out a bit so the meaning of the mnemonic was made clearer. For example, in the assembler a mnemonic can have an extra number that is used as file storage location or a numeric value. Which it is depends on the type of instruction being used and there is no need to specify if the number is a file or a value.

However, this is often the cause of confusion with beginners, so in the simulator the instruction will specifically have the word file or value in the mnemonic as appropriate. The PIC 16C84 has only one accumulator called W and its value is shown under the op-code. You can change this, and most other values, at any time by typing a new value in. Note you have to

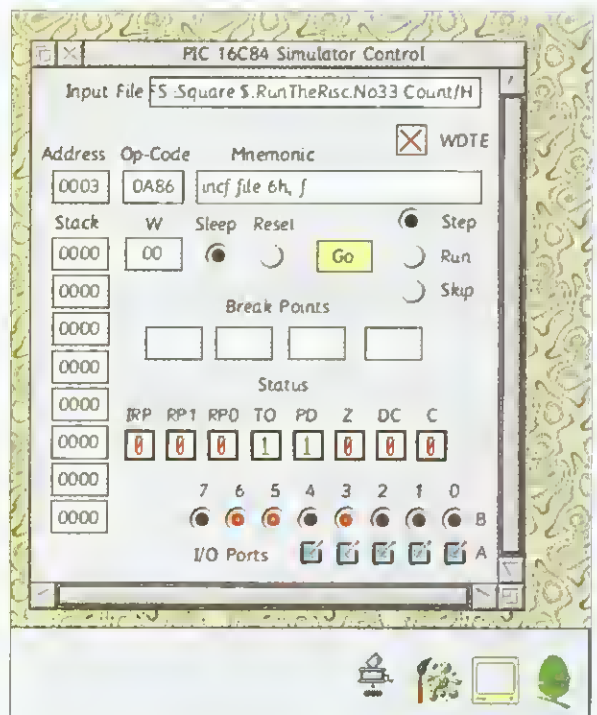

# Checking the instruction

press Return before the simulator uses this updated value.

In this way you can check a whole host of operations without having to rely on the code you are simulating to put the correct values in files. For example, you can type in another address and skip over a section of code to the part that is giving you trouble. Having said that, remember that the code you skip might have done something that affects your problem code.

On the real chip the status register is actually file location 3, here it is shown as individual bits which you can click on to change their values. The bits TO and PD can be changed by clicking on them but as far as the real chip and the simulator are concerned, they are not writable. That is because they reflect various events going on in the processor, however, they are changed by these events.

The eight indicators under the word Stack represent the sub-routine return address stack. As a sub-routine is called, the address of the next instruction is pushed onto the stack. When a return from sub-routine is executed, the processor goes to the address stored at the top of the stack and all the other values move up. On the chip this is a hardware stack and there is no way you can access it – here you can.

I have not made an indicator for a stack overflow or underflow as I wanted to make it behave like the real chip. When an overflow or underflow occurs, the stack simply wraps round. Similarly, when a reset occurs the stack is not cleared. This is so that 'clever' programmers can continue to be clever – the more sensible among us will ensure that this never happens.

Next to the GO button you have a choice of whether to execute just that one instruction with STEP, the default, continuously execute instructions with RUN or miss out the instruction with SKIP. When running you can stop at any time but if you are interested in the state of the machine at a particular time you need to use the break points.

You can set up to four of these and when a running simulation encounters an address that is the same as one of the break points, it will stop and go into the single step mode. To clear a break point simply type a number greater than the biggest address – say 1000. At the bottom of the control window there are two rows of indicators representing the input/output ports. On power up these will be inputs, represented by switches set at logic one. Clicking on the switches will change the value.

However, if bits in the two TRIST registers are cleared, these inputs will change to outputs and be shown as LEDs. The TRIST registers along with all the other registers can be accessed from

the monitor window. You get the monitor window from the menu. Note here that ticks against the windows don't change when you close the window – they indicate the windows that will be opened on an iconbar click. For an uncluttered appearance, values only appear here when they are used by the program so you can easily see what registers (or files) you have initialised.

Some of the registers concerned with interrupts are displayed as individual bits that can be changed with a click. There are also some pseudo registers here as well, these are values used in the simulation that you might want to change. For example, if you have the watchdog timer enabled this will time out and cause an interrupt approximately every 18mS. However, this is not precise and depends on things like the temperature of the chip.

The watchdog timeout is a number that the watchdog timer must reach before generating an interrupt. It is preset to the number of cycles representing 18mS if you have a 4MHz clock. As the simulator does not work in real time this can be too much for testing, so you can simply type a lower number in here. See the help file for further details.

Learning to use a simulator is like learning to use an oscilloscope or any other complex instrument – the more you practice the more you can get out of it. The basic trick is to be able to predict what will happen – in that way you get your surprises and learn. I have sent out a few copies of the simulator for beta testing and I would like to thank Bill Jeffs for spotting a few mistakes in the original.

However, I would not be surprised if a few subtle bugs are still in there, so if you come across any differences in behaviour between the simulator and the actual chip please let me know and I will see about correcting it in a later version. In the meantime I think we have all the tools needed to be able to make full use of this remarkable chip. Best of luck in your exploration.

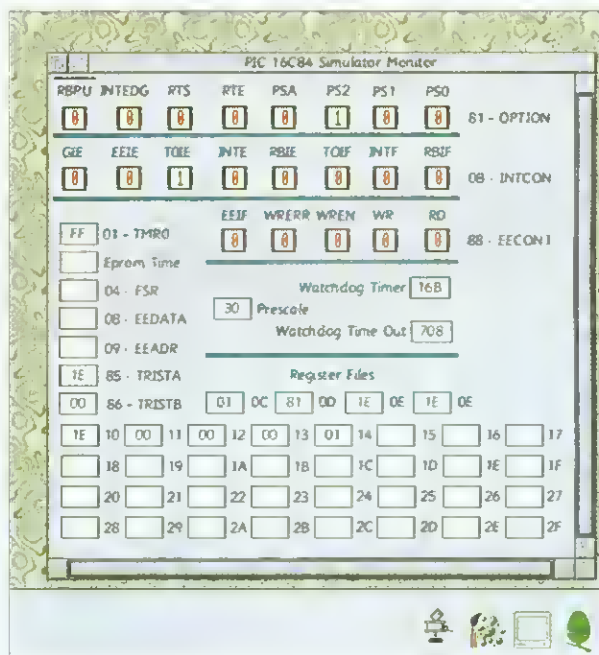

# SOFTWARE SHOWCASE

## BUSINESS SOFTWARE

**DSL SUPPLIES**

**SQUIRREL**  
Single-User £90.35. Save £18.65!  
Multi-User £361.40. Save £74.60!

**ARMLOCK**  
Single-User £27.75. Save £12.25!  
Multi-User £90.35. Save £48.65!  
excl. P&P

**35% OFF!**

**ST MARGARET'S LANE  
FAREHAM  
HANTS PO14 4BQ  
TEL/FAX 01329 841600**



## GAME HARDWARE

**STD**

Phone write off  
email for a free  
product information  
sheet!

**Quality!**  
Use high quality PC-style joysticks with your Acorn machine. Also works under the PC card. PCJoy interface £39.95

**Quality!**  
Use high quality PS/2 (round connector) mice, trackerballs etc. with your Acorn machines. PS2Mouse interface £24.95

**FREE!**  
Buy our SOLO digital joystick interface And get a FREE Cheetah 125+ joystick! A complete solution for only £14.95

Stuart Tyrrell Developments  
PO Box 183, Oldham OL2 9FB  
Orange 01625 2211 (am 9am)  
Info@STDdevelop.com.co.uk Web: www.stdev.com.co.uk  
All prices include P&P. All trademarks acknowledged. E&OE

**PRINTMAKER**  
Word/printer-kit pack

**ACORN FRIENDLY  
SCREEN PRINTER  
& VINYL GRAPHICS  
BUREAU**

Contact Chris Meister  
1016 Eidan Terrace  
Reading Berkshire  
RG1 4BX  
printmaker@argonet.co.uk  
**0118 956 7947**



**14 DAY  
HOME TRIAL**

What we will do is send you our latest five quality budget games for you to try in the comfort of your own home.

**Any Risc OS  
including  
StrongARM**

**GENERATION DESIGN**  
2 Whitecliff Gardens, Blandford  
Forum, Dorset DT11 7BU  
Tel: 01258 452507  
Email: genden@argonet.co.uk

**FIVE STAR MARKETING**

Our \*NEW\* demo/catalogue disc for just £1 or buy any pack and get our demo disc free. Sorry, no credit card facilities available.

**OUTSTANDING HIGH QUALITY PUBLIC DOMAIN SOFTWARE**

**EXCELLENT PACK OFFERS**

Games 1 : Games 2 : Games 3 : Games 4 : Draw Clipart 1  
Draw Clipart 2 : Draw Clipart 3 : Draw Clipart 4 : \*NEW\*  
Draw Clipart 5 : Educational 1 : \*NEW\* Educational 2  
Utils 1 : Utils 2 : Utils 3 : \*NEW\* Utils 4 : Sound1 : Sound2

Each pack has three fully archived discs. One pack for £3.75 -  
Two packs for £7.20 - Three packs or more at £3.50 for each pack.

We are distributors of educational software from Sherston and 10 out of 10. We offer at least 10% saving on their recommended prices. Official orders are welcome. For free educational catalogues and further information write to the address below or call 0181 950 4973.

**Five Star Marketing, 4 Shepherds Walk  
Bushey, Herts. WD2 1LZ.**

**Exhibition - Acorn Into the Future**

Exhibitors include:  
Acorn - Arm Club - Acorn Publisher Magazine - Computer Concepts - Camana - Dalriada - Fabis  
Eesox - Sherston Software - ISV Products - Oregon - Smart DTP - Sibolus Software - Spacetec - et al

**Venue - Kegworth Hotel on the A6 in  
Kegworth Village (near J24 M1)**  
Drinks, snacks and meals available in the hotel

**Date - Sunday 16th November 1997**  
**Time - 10.00am until 4.00pm**  
**Admission £2**

**SELECTIVE  
COMPUTER  
SERVICES**

Telephone  
**01332 690691**  
email: selective@globalnet.co.uk



# ACORN USER ADVERTISERS INDEX

1st Computer Centre.....	55
4th Dimension .....	63
5 Star Marketing.....	80
ACE .....	79
AJS Computers.....	29
Akalat .....	29, 47
Alsystems .....	35
A P D L .....	47
Arnold Computer Supplies.....	80
Atomwide.....	OBC
Beebug.....	11, 39
Calancraft .....	80
Canon Computing.....	51
Castle Tech.....	IFC
Circle Software.....	60
CJE Micros .....	25
CSS .....	80
CTA .....	42 & 43
Daco Systems .....	80
Dalriada Data.....	56
Davyn Computer Services.....	18, 80
Desktop Projects.....	14
DSL Supplies.....	83
Eesox .....	64
Electronic Font .....	47
Generation Design.....	83
Genesys .....	80
I.C.S. (Ian Copestake Ltd) .....	2, 4 & 5
IFEL.....	44
Irlam Instruments .....	12
ISV Products.....	30
Liquid Silicon.....	36
Micro Laser Design.....	73
Oregon Developments .....	22
Norwich Computer Services .....	66
Pineapple Software .....	IBC
Printmaker .....	83
R Comp .....	64
Really Good.....	64
Resource .....	26, 80
Selective Computer .....	80
Selective Computer Shows.....	83
Softase .....	26
Spacetec.....	60
Stuart Tyrrell.....	83
Todd Education.....	80
Todd Show Ad.....	32
The Datastore .....	26
Uniqueway.....	80
Wardlaw Surveys.....	80
Werewolf .....	60
West Devon .....	80
Zenta.....	51
Zetnet Internet .....	20

Get online

# ACORN USER

Brings you the most amazing  
"Get Online" offer in the UK today



Argo have dramatically reduced the cost of coming online to the Internet



For only £89 including VAT, this new ArgoNet pack contains everything needed for existing Acorn users to get online quickly and easily.

Available for all Acorn RISC OS users the "Get connected to ArgoNet" pack includes:

- Full use of the ArgoNet Internet service for one month
- A Dynalink fast 33.6K Voice/Fax/Data external modem (please note that this modem is not upgradeable to 56K)
- Stereo headset (headphones and microphone)
- Voyager, Argo's easy-to-use Internet access software
- Connecting cables from modem to computer and telephone

The ArgoNet Internet service provides:

- Full Internet access including e-mail
- Unlimited access with no additional charges
- 100% UK local telephone call rates
- 5Mb FREE Web space
- Up to 5 e-mail addresses
- FREE phone technical support

**COLLECT 3  
VOUCHERS AND GET  
AN EXTRA MONTH  
FREE!!!**



Current ArgoNet subscription rates inc VAT (monthly rate ex VAT in brackets) are:

- **Monthly £14.69 (£12.50)**
- **6-monthly £77.55 (£11.00pm)**
- **12-monthly £141.00 (£10.00pm)**

Vouchers will be printed in each issue of Acorn User for the next three months. Purchasers of this reader offer can receive FREE Internet service for an extra month by collecting three vouchers and sending them to Argo Interactive Ltd

Please send your completed order form to:

Argo Interactive Ltd,  
7 Dukas Court, Chichester,  
W. Sussex, PO19 2FX

Any queries, contact:

Tel: 01 243 815 815

E-mail: sales@argonet.co.uk

Fax: 01 243 815 805

**ORDER FORM**

Personal Details: The address below is your invoice or credit card address.  
If your delivery address is different please attach a separate sheet of paper and tick here.

Name: ..... My computer is: .....

Address: .....

Postcode: ..... Tel: .....

To ensure we can allocate a unique e-mail address to you, please give three names in order of preference (e.g. for John Smith you could be - jsmith, johnsm and jnsmth).

E-mail choices:  
1.....  
2.....  
3.....

I would like to pay by:

Cheque/Postal order (Payable to Argo Interactive Ltd) for £89 +£2.94 UK carriage - a total of £91.94

Credit card (Visa / Access / Barclaycard / Mastercard)

Card Number:

Expiry Date:  /  Signature: ..... Date: / /

Please invoice my Official Order no.: .....

**VOUCHER 3  
OF 3**

AU



JACK KREINDLER

## Steve Mumford explains how you can exert greater control when plotting fonts

**W**e're now at a stage where we can paint a string of text to the screen in a chosen font without too much trouble. As I mentioned last time round, this can be handy but it's definitely not the end of the story. This month I'll introduce some of the other SWI calls available for more sophisticated manipulation of text prior to display.

First, it's important to be able to convert between OS units and millipoints, as some of the more flexible font manipulation commands, such as **Font\_ScanString**, only take input in the form of the latter. Two SWI calls are provided to ease this process, and these are **Font\_ConverttoOS** and **Font\_Converttopoints**.

They're simple to use – just set registers 1 and 2 to the *x* and *y* coordinates you wish to translate, and a call to the appropriate SWI will convert and return the values in the same registers. The default 'exchange rate' is 400 millipoints per OS unit, but this can be altered if you're really desperate.

**Font\_StringWidth** can also be particularly useful – its function is to calculate the length of a string as it would appear on the screen when plotted in the current font. If you know the dimensions of the area you want to paint the text into, this call can predict where you'd need to split a long string to fit it into the available space. It takes values in

registers 1 to 5 – the first is a pointer to the string you wish to analyse, the second and third hold the maximum *x* and *y* sizes of the area the text is to fit into, the fourth holds the numeric code of the character at which a line-split may take place (normally '32', which represents a space) and the fifth stores the number of characters you wish to process – normally the length of the string.

Armed with this information, **Font\_StringWidth** will take a note of the font currently in use and scan through the given string, character by character, until one of several criteria is met, taking note of the positions of the assigned 'split' characters on the way. Obviously, if the string comes to an end before its on-screen size exceeds those values in R2 and R3, the call will terminate and will calculate sizes based on the whole string.

However, if the predicted size of the painted text exceeds those given in R2 and R3, the function will return early. In this case, the SWI will return the length and the dimensions of the string as it would be plotted, up to but not including the last successfully scanned 'split' character. In most situations, a space will be used as the separation character, so **Font\_StringWidth** will just discard the last interrupted word.

On returning, the call will give you five values, again in registers 1 to 5. R1 is

a pointer to the last character that was reached in the scan, R2 and R3 give the *x* and *y* offsets that would result if the string was actually printed to screen, R4 holds the number of occurrences of the 'split' character specified, and R5 gives the position of the character within the string at which the scan stopped – the character before the last 'split' character if the text had to be broken over more than one line.

One way of using this call is to partition a long bit of text into smaller chunks that will all fit within a certain width – by taking the returned values and re-submitting the modified string, it's possible to work through and format a complete column of text.

**Font\_ScanString** is a more powerful relative of the above SWI, and is only available in RISC OS 3 or later. It closely mirrors the format of **Font\_Paint**, so it can give details about most of the effects of a **Font\_Paint** call without having to display the text on-screen.

As well as more sophisticated termination criteria, it can deal with text being painted in different directions and help you discover where to insert a caret following a mouse-click within a region of text. In the later versions of the operating system, this call replaces **Font\_StringWidth** as well as a couple of other system calls, and provides all their functionality within one SWI. **AU**

# BACK ISSUES

Missed out on one of our previous issues? Now's your opportunity to bring your collection up to date. But hurry – stocks are limited



### Issue 186-October 1997

- MidiWorks
- Using Net Computers
- Psion 5
- Apple IIe emulator on disc

### Issue 185-September 1997

- NetStation
- Website designers
- Music Studio 32
- Marsquake on disc



### Issue 184-August 1997

- TopModel2
- Acorn interviews
- Acorn Club scene
- Iron Lord on disc

### Issue 176 - Christmas 1996

- AU awards
- StrongARM compatibility table
- SCSI vs IDE
- Nstore for the pocketbook

### Issue 177 - January 1997

- Acorn in New Zealand
- Risc TV ● New Psions
- HTML creation tools
- Bett'97 Show

### Issue 178 - February 1997

- Acorn Internet Relay
- Spreadsheets compared
- Upgrading to Hard Drive or CD
- Acorn Portables

### Issue 179 - March 1997

- Flatbed scanners reviewed
- Oregon's SoundStudio
- Control your business payroll
- HTML oddments examined

### Issue 180 - April 1997

- Creating your own 3D games
- The new Zip drives
- Public Domain software CDs
- C++ books reviewed

### Issue 181 - May 1997

- Politics & I.T.
- Real programming
- Acorn User survey
- Quick time VR

### Issue 182 - June 1997

- Digital Cameras
- ARMSwitcher
- Game Creation
- Apocalypse on disc

### Issue 183 - July 1997

- New A7000+
- Publish Art
- TBA FS
- Drifter

## Order form

<input type="checkbox"/>	Issue 176, Christmas 1996 .....	£3.25	Name .....
<input type="checkbox"/>	Issue 177, January 1997 .....	£3.75	Address .....
<input type="checkbox"/>	Issue 178, February 1997 .....	£3.75	.....
<input type="checkbox"/>	Issue 179, March 1997 .....	£3.75	.....
<input type="checkbox"/>	Issue 180, April 1997 .....	£3.75	.....
<input type="checkbox"/>	Issue 181, May 1997 .....	£3.75	.....
<input type="checkbox"/>	Issue 182, June 1997 .....	£3.75	.....
<input type="checkbox"/>	Issue 183, July 1997 .....	£3.95	.....
<input type="checkbox"/>	Issue 184, August 1997 .....	£3.95	.....
<input type="checkbox"/>	Issue 185, September 1997 .....	£3.95	.....
<input type="checkbox"/>	Issue 186, October 1997 .....	£3.95	.....

Please allow 14 days for delivery. Send cheques payable to IDG Media to: Acorn User Back Issues, Database Direct, FREEPOST, South Wirral L65 3EB or phone 0151 357 1275 Fax: 0151 357 2813 E-mail: database@dbdirect.demon.co.uk

Please tick if you do NOT wish to receive further information or special offers

**FREE  
ADS ARE  
ON  
THIS  
MONTH'S  
COVER  
DISC**

## Acorn User Free Ads Service

Why not take advantage of our free reader ad service? Fill in your details on this coupon (25 words maximum, one word per box below) and send it to Free Ads, Acorn User, IDG Media Ltd, Media House, Adlington Park, Macclesfield SK10 4NP or by e-mail to: aufreeads@idg.co.uk. Only one ad per reader, please. Although we try to publish every ad we receive, we can make no guarantees; publication is entirely dependent on space and time constraints. We may also publish free ads on the cover disc if magazine space is short. Please fill in your name and telephone number below: these will not be published, but they enable us to contact you in case of any queries.

Your name: ..... Telephone no: .....



Write to Acorn User, Media House, Adlington Park, Macclesfield, SK10 4NP. E-mail: auleters@idg.co.uk



# l e t t e r s

## The pernicky pessimist

In response to the letter written by Wilf Beeson (September 1997) and the comment of Steve Turnbull, the Editor (July 1997), I feel it is important to clarify one point – without promotional means, a company is in no small difficulty.

Certainly, I agree that every Acorn user should do what they can to help advertise, such as creating their own websites and so on. Unfortunately, I am not, at present, on the Internet but have every intention of launching my own little magazine – well, more of a pamphlet really – with a disc per issue. Naturally, I shall do everything I can to elevate the public opinion about Acorns.

However, if a company remains so dependent on its relatively few loyal customers, the progress will be an uphill fight. If that is how it must be, we will all have to get our act together and force the disbelieving world to swallow the simple fact that Acorn is the best.

So called 'quibbling' in this case, is merely an attempt to elucidate a problem. The refinement and development of a company depends on the illumination of these faults. Therefore I would urge anyone with any 'quibbles' to make them known. Yes, I am a constant critic and I will try to find positive things to say in the future.

Another thing I would like to comment on is Acorn's ability to maintain company interest. Hewlett Packard refuse to produce any

printer drivers for their latest range of deskjets and other printers. When I inquired as to why they had shut off this area of the market, the simple reply was that they felt Acorn wasn't worth their while anymore.

They are not the only company who will not cooperate. In my attempts to find the appropriate software to download the images of my RC260 Canon Camera, the only things available were for PCs priced at around five hundred pounds. Incidentally, does anyone know what I need? The software I have seen seems to focus on other cameras.

If everyone is so keen on the idea of the consumer being the advertiser, that's great. But programming skills are required to create software and websites. *The Programmers Reference Manual* is not exactly cheap. I haven't got it, much as I need it. It can only be purchased through Acorn dealers or magazines. There are no programming books for the Acorn in any of the libraries in Lincoln. I asked the librarian to dig up what they had access to, internally and externally. She found two books – both on the Acorn Electron and not exactly what I had in mind. There were plenty of PC manuals, but Acorn, not a hope.

It seems that if you want to do real serious programming a step beyond Lee Calcraft and Alan Wrigley's *Wimp Programming for All*, you need over one hundred pounds spare cash to start.

William Simpson  
Lincoln

## Acorn virtuality update

Just to let you know, I have been adding a few more decent features to the engine and hope to be doing something *commercial* with it soon. The screenshot shows the running engine which now has floor and ceiling texturing and variable detail levels. I've also fixed that stupid occurrence when the walls look squished if you walked too close to them.

Greg Scott  
AUThreeD@aol.com

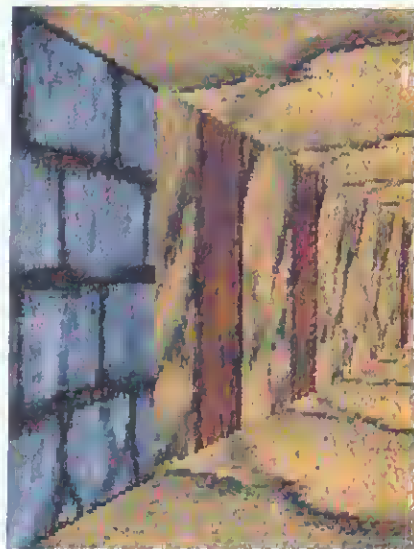



## 2000 more rumbles

I agree with Paul Dunning that just because the OS doesn't fall over at year 2000, you shouldn't assume that programs running on it don't. If you're writing a proper application you should ask the OS for the year as a number and store it as a number, rather than

System	Time stored as	Epoch Start	Epoch Length	Epoch End
UNIX	32-bit seconds	1970	68	2038
DOS	7-bit years	1980	128	2107
NIS	7-bit years	1981	128	2108
HADES	5-bit years	1981	32	2012
RISC OS	40-bit centiseconds	1900	348	2248

ask for it as a string and chop it up. Even in MS DOS where most of the problems are appearing, the year is returned as a 7-bit offset from 1980, so it's where people process that number incorrectly that problems arise.

As a comparison, this table shows some comparative epoch definitions in various systems.

In the news section in September 1997 it was stated that 'early versions of the NFS as used in the Bees expired a while ago'. The NFS knows nothing about dates, it's the file-server that sends them and any application that asks for them that interprets them. While it is true that early file servers only returned the year as a 4-bit number giving a

way forward is by online communication there must be some point in small businesses going online.

Phillip Webster (aged 15)  
phillweb@argonet.co.uk

## Another day nearer

In reply to Paul Dunning about the year 2000 problem. You wondered if there are any significant RISC OS applications built before 1996 that would have problems.

Well, yes and no. *Eureka*, the excellent spreadsheet from Logotron, as supplied (even version 3.05 the last release) cannot display 2000+ dates unless the user creates a new Template to get around the problem. The default Template within the App, which is not user modifiable, has not been given the extra yy attributes required to display this date.

That's not to say it cannot present the 2000+ date, the underlying application can. But without manual intervention by the user it cannot. What needs to be done is create a new Template file, to be stored in: !Eureka.Templates.

Then bring up the Number Formats window (Menu-Format-Number), scroll to the bottom of the formats list and create a new one, in the form: dd-mm-yyyy. Click on

range from 1981 to 1996, versions of file-server code released from the late 1980's onwards returned the full 7-bit year.

True, early programs that only used the bottom four bits did fall over and in January this year I had a number of phone calls from people whose programs were saying that it

was 1981. Most of these were fixed by changing bits of code from something like:  
yr%=1981+(blk%?5)DIV16  
to:  
yr%=1981+(blk%?5)DIV16+((blk%?4)AND&E0)DIV2

It's surprising to think that the early programmers who tried to save space by putting a year into two characters as 1900+'97' instead of '1997' and created a 100-year date range didn't realise that they could have put the year into one byte as a number, used half the space and more than doubled the range.

Jonathan Harston  
JGH@digihank.demon.co.uk

Add, then re-save the Template.

If the user always uses this template as their default, 2000+ dates should be no problem.

Dave Symes  
df.symes@argonet.co.uk

## Don't bug me

William Simpson isn't the first person I've seen scoffing at Intel's hardware bugs and their reaction to them (AU letters, October 1997). I've even done it myself. But think: What about Digital? Did not a great many Risc PC owners buy huggled StrongARMS? What have Digital done to address the matter? It's all very well Acorn patching the OS to sweep it under the carpet (and well done to them), but I hear the bug causes serious performance problems with RiscBSD.

Tony Houghton  
tonyh@tcp.co.uk

## TV star quality

Did anyone notice it? The highlight of Saturday (30 August) evening's television. Yes you've guessed what it is I'm talking about - the Archimedes at 9pm in *A Mind To Kill* on Channel 5. Isn't this just the best sort of advertising Acorn can get?

Now I, like many Acorn users, know that Acorn cannot afford to launch a multi-million

## Internet business

I was recently looking over some *Acorn User* mags from earlier in the year and came across Alex Singleton's letter about how he thought the Internet was only useful to certain businesses.

I have to disagree with this because some people will put their business websites on the Internet and some people will look there for ideas. As more businesses get on the Web, more people will be aware that they will be able to find what they want on there. Basically whatever you want to know, you can probably find several pages on the Internet about it.

At the end of Alex's letter he says that he thinks that online communication is the way forward but if small businesses decide not to go online because they don't think it will give them enough business the general public may think it wouldn't be worth looking online either because the information they require may not be there. So if the





pond advertising campaign that has been designed by top advertising gurus, but one way of achieving a great deal of advertising at a much lesser cost would be to offer A7000 and Risc PCs to television companies for inclusion in their productions. For example a few Acorns most certainly wouldn't look out of place in programmes such as *BUGS* - BBC1's techno programme where the *BUGS* team can do anything with a computer.

**Paul Stewart**  
xaj86@dial.pipex.com

### Not that bad

Having read the review of our product, *WinRisc*, in the August issue of *Acorn User*, I have to say it gives an entirely misleading view of the product. It states categorically that the program is useless due to the speed at which it operates. The reviewers have attempted to use *WinRisc* for things which it is simply not designed to do, for example, we make it clear that *WinRisc* is not designed for graphically intensive tasks such as full motion video, yet they complain that it does not render video quickly enough.

They have also given several exact timings for *WinRisc* to perform certain tasks, and I have compared these with timings on another identical system, and found that the timings in the review are up to 20 times slower than the actual time taken to perform the tasks. I can only assume that the reviewer's computer system had a serious software or hardware fault.

Several other major Acorn magazines have reviewed *WinRisc* and none has found the speed of the program to be a significant problem, yet you claim that it is *entirely useless for any serious work*. There are hundreds of regular users of *WinRisc* who would disagree, unless you are implying that their work is not serious?

Your reviewers seem to expect *WinRisc* to run faster than the ordinary PC card software, which is of course impossible, since it runs on top of this software. In fact it is around 20 per cent slower than !PC for most tasks, which I think is perfectly acceptable. Obviously if the PC card itself is *Faster than a speeding glacier* so will *WinRisc* be, but there is no other justification for that title.

The difficulties your second reviewer had in installing *WinRisc* were entirely due to a failure to read the documentation supplied. We always recommend to customers that they use Windows 3.1 since it is considerably faster, however *WinRisc* still runs at a perfectly acceptable speed under Windows 95. I was given a copy of the article before it went to press and informed you of the errors, and was told that steps would be taken to check the article before it went to press, however it was not checked and I was not told that it was going to press until I saw the article in the magazine, hence the delay between the publication of the review and of this letter.

If any reader would like to see for themselves how fast *WinRisc* operates, please visit your local Acorn dealer and ask to see it. Over 100 people came to see it at the

Wakefield show, running on an SX33 PC card, and not one of them was disappointed by the speed, even on that very slow system. If any buyer finds *WinRisc* to be 'useless' we will naturally offer them a full refund.

**Chris Claydon,**  
AF Software

### The best

I've been an Acorn user since about 1986 when I bought an Electron, partly because it was the cheapest way of playing Elite at the time. Even before this I used to pick up Acorn magazines when I aspired to owning a BBC Micro.

I think the time has come for Acorn to licence RISC OS to other manufacturers who can sell their own computers with ARM processors - perhaps not matching the speed of Acorn's more prestigious machines, but sold at a sub-£500 price point. The StrongARM could be the basis of a superb games console.

**Martin Wilson**  
Yeovil, Somerset

*Acorn will licence their technologies to anyone who wants to buy - and that's precisely what they are doing again and again. Mostly it's in the guise of the NCOS but as I've said before, make no mistake, NCOS is RISC OS.*

*Of course that's "only" for the NC, but with Acorn's new global positioning other, very large, companies are licencing their software for a multitude of different products and who's to say that a StrongARM-powered games console featuring RISC OS, isn't among the forthcoming products?*



# Vote in the ACORN USER Awards 1997

It's time to cast your vote in the *Acorn User Awards 1997*. So take a little time to look back over the year and let us know who and what you think has stood out from the rest in the Acorn marketplace.

Just fill in the form opposite with your votes in the Best Product, Best Advert, Best *Acorn User* Article/Series and Best Dealer categories and post it to:

*Acorn User Awards 1997, Acorn User, IDG Media, Media House, Adlington Park, Macclesfield, Cheshire, SK10 4NP* or e-mail your vote to [auspecial@idg.co.uk](mailto:auspecial@idg.co.uk)

Best Product:	<input type="text"/>
Best Advert*:	<input type="text"/>
Best Article*:	<input type="text"/>
Best Dealer:	<input type="text"/>
*Best Article and Best Advert from the November 1996 to October 1997 issue (inclusive). Best Article can be a series or a one-off article.	

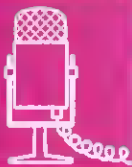

## the Regan files

Alexander and Sapphire Streater  
photographed by Jill Regan

**H**ercules was given 12 labours to complete. If he had been around today, one of them might have been selling Acorn computers and accompanying software to the Japanese domestic market. This task actually falls on Alexander Streater, who explains a little about Japan.

'Such is the wealth in Japan,' he says, 'that more and more people are tending to have more than one platform. People may have a PC running a Japanese version of Windows 95 and a Mac, or they will have one of these machines and a dedicated laptop wordprocessor. The good thing is that they are all absolutely incompatible; non-compatibility is very normal in Japanese society. Because of this, Acorn machines could find themselves a niche at the expensive end of this trend. This too is possibly the way into areas such as the network computer.'

It was about 13 years ago when Alexander first saw this niche. He'd been invited by a Japanese corporation to research automation control. When he came back to England, Acorn had just produced their first RISC machines.

'Even though I was not working for the corporation any more, I knew the Acorn computer was definitely something they would be interested in. I managed to sell them one. You have to realise that at this time it was "old" Acorn and not "new" Acorn, so the Japanese found it very difficult to communicate with people back at Acorn even though they tried. If it had been new Acorn, I think it would have been different. I decided it was something which could work out, so I flew out and started showing some people. Unfortunately I think I had just missed the boat because by this time all the big Japanese corporations had tied up with Sun.'

Even with this initiative, Alexander found that showing good technology in Japan does

not make you any money – you really have to build contacts, and that meant moving to Japan. Then, after 10 years drinking with someone, that someone might trust you enough to make the right kind of introductions. This is the way Japanese corporations act when buying. So Alexander and his wife set up a school in Japan to teach English.

'The school pays for the bread and butter. It only takes 20 hours a week of our time, so we are virtually retired,' grins Alexander wickedly. 'The rest of the time we do whatever interests

**The good thing is that they are all absolutely incompatible; non-compatibility is very normal in Japanese society**

us. We have spent a lot of time travelling around Japan demonstrating the Acorn system running programs like *ArtWorks* in Japanese. This always gets a good reception.

'The system is not quite complete and it is not hacked by Acorn – we would like an Acorn solution. There was no support in the operating system for Japanese – it was not until a couple of years ago we managed to solve this problem.

'We have not made any major deals yet, but what we are doing as well is trying to make people aware of the technology. Now we have a front-end processor so we can type in all the characters. Most software works straight away

in Japanese without any changes. If there are any developers out there who are interested in the potential of the Japanese or far-eastern market, they should get in touch with me.'

Japanese engineers are particularly impressed. They are always amazed how beautifully well-designed everything is, how good the operating system is and how nice the interface is.

'For the first 18 months we were using the industry standard font, which is the equivalent to Homerton in English. We realised that this is simply because all the characters are flat there are not many curves – this means the font is easy to display on low resolution monitors when nothing is anti-aliased.

'It occurred to us to try the equivalent of a serif font like Trinity. When we announced this, we were met with dismay and concern; people said that it would never work and it would be too difficult to read. When a group came to see it and we switched the computer on, booted up and opened a document their mouths actually dropped open – they were amazed that every horizontal line appeared to be visible. Some characters are very similar and they look almost identical, but with this you could distinguish them all.'

Alexander hasn't made his millions yet, although he's well on his way. If he gets there, he'll probably carry on what he's doing at the moment, but build and design houses 'as a hobby'.

'I would design one, build it, live in it to see how it works and then get on with the next one. An idea which interests me is having an ordinary looking house and walking in to find that the floor is a huge piece of glass under which goldfish are swimming.'

Alexander Streater can be contacted via e-mail at [donquiri@scorpius.hekkoame.or.jp](mailto:donquiri@scorpius.hekkoame.or.jp)

Jill Regan **AU**

# Big Summer Price Reductions

RFD prices = at least 10%  
RED '\* = at least 25%!  
(Since July 97 Prices)



# StrongARM RiscPCs



Picture by Walter Briggs  
using Studio24Pro

The cheapest way to buy the RiscPC of your choice. Let Pineapple install the upgrades you require into a basic StrongARM RiscPC and save money!

**StrongARM RiscPC (233Mhz) (4Mb 1.2Gb HD) Base Price - £ 1099.00 inc vat**

General Upgrades	
CDROMs - (when bought with a RiscPC)	
x8 speed CDROM	£ 50.00
x24 speed CDROM	£ 75.00
Harddrives - (exchange for RiscPC 1.2Gb HD)	
1.7Gb Harddrive	£ 99.00
2.5Gb Harddrive	£ 129.00
3.8Gb Harddrive	£ 199.00
5.1Gb Harddrive	£ 299.00
Other sizes available - please ask	
Backplanes	
2 slot backplane	£ 34.00
2nd Slice (inc 4 slot backplane)	£ 89.00

RiscPC Memory	
1Mb VRam	£ 80.00
2Mb VRam	£ 115.00
8Mb SIMM	£ 39.00
16Mb SIMM	£ 59.00
32Mb SIMM	£ 105.00
Other sizes available - please ask	

Monitors	
Acorn 14" AKF60	£ 264.00
Acorn 17" AKF91	£ 639.00
Iiyama 17" 8617E	£ 515.00
Iiyama 17" 9017E Pro	£ 549.00
CTX 14"	£ 189.00
CTX 15"	£ 279.00
CTX 17" .28mm 30-70Khz	£ 449.00
CTX 17" .26mm 30-85Khz	£ 549.00

PC Cards & Software	
DX2-66 PC Card	£ 169.00
DX4-100 PC Card	£ 229.00
586-100 (or 133Mhz) PC Card	£ 351.33
PC Pro & PC Exchange	£ 49.95
Windows 95 (Installed for you)	£ 79.00

Internet	
33.600 Ext Voice Modem BABT	£85.00
33.600 US Robotics Voice	£169.00
Ant Internet Suite software	£116.33

## Pineapple Computer Offers

### Buy a new RiscPC and have an extra £200 to spend!

From the 1st September if you buy a RiscPC we will give you a voucher which allows you to spend £200 on any goods purchased from Pineapple Software. This can include any of our normal stock items or any third party products we can obtain for you. This offer is in addition to our FREE gifts shown opposite! Limited period only!

### Pineapple FREE gifts

With every new RiscPC you receive -  
1 year subscription to the Virus Scheme.  
Studio24 v1 Art & photo-retouch software.



**20:20 Finance available on all RiscPCs (subject to status). 20% deposit and 20 monthly payments at 0%**

### Flatbed Colour Scanners



There are now a growing number of scanners which will work on RiscOS. Most of these need a SCSI interface though, so the Epson GT5000 parallel is still our most popular model.  
A new inexpensive parallel port scanner which works just on the PCcard is now available at £169.00 !!  
All our scanner prices include Twain and Imagemaster software. SCSI scanner prices do not include the SCSI connecting cable.

Epson GT5000 parallel	★ £299.00
Epson GT5000 SCSI	★ £349.00
Epson GT8500 par&SCSI	★ £459.00
Epson GT9500 par&SCSI	★ £599.00
Umax Vista S6E - SCSI	£269.00
Umax Astra - SCSI	£269.00
Agfa Snapscan - SCSI	£259.00
NIW - Trust (parallel) ***	★ ★ ★ £169.00
<small>(PC Card use Only)</small>	
<b>SCSI Cards &amp; Cables</b>	
Cumana SCSI II Card	£189.00
EESOX SCSI II Card	£145.00
50 mini 'D' to 50 Centronics	£19.00
50 mini 'D' to 25 'D' plug	£19.00
25 'D' plug to 50 Centronics	£16.99
50 Centronics plug to plug	£15.99
50 Centronics plug to skt	£16.99
<b>Switch Boxes</b>	
These are ideal for parallel port switching between a printer & scanner	
Parallel 2 way	£16.99
Parallel 4 way	£19.99
25 'D' plug to 25 'D' plug	£4.99
25 'D' plug to 36 Centronics	£4.99
Monitor and keyboard switch boxes also available	

### Hard Drives



Pineapples removable drive system is available for both IDE and SCSI systems. Provides total data protection!

IDE mounting kit (tine cable)	£15.00
IDE removable case	£10.00
SCSI mounting kit (tine cable)	£19.00
SCSI removable case	£10.00
<b>Bare IDE harddrives</b>	
1.2Gb IDE	£145.00
1.7Gb IDE	£158.00
2.0Gb IDE	★ £169.00
2.5Gb IDE	★ £179.00
3.2Gb IDE	★ £209.00
3.8Gb IDE	★ £249.00
4.3Gb IDE (Fireball ST)	★ £319.00
4.3Gb IDE (Cyclone 5.25")	★ £239.00
5.1Gb IDE	£349.00
6.4Gb IDE (Fireball ST)	★ £399.00
<b>IDE Expansion</b>	
x4 IDE Expansion card	£69.00
<b>Bare SCSI harddrives</b>	
1.0Gb SCSI	£169.00
2.0Gb SCSI	★ £329.00
3.2Gb SCSI (Quantum ST)	★ £289.00
4.2Gb SCSI	★ £459.00

### PAL TV Coders



We have a range of PAL TV coders available which allow the output of any Acorn Computer to be displayed on a normal TV or recorded onto a video recorder. All models have S-VHS as well as standard video outputs. Please ask for more details.

PLC/3 PAL Coder	★ £79.00
AVK/3 PAL Coder	£289.00
AVK/5 PAL Coder	★ £379.00
Monitor adapter 9-15pin	£4.11
Monitor adapter 15-9 pin	£4.11

### Colour Printers



Canon B130 - portable mono	£159.00
Canon BJC70 - portable col	£199.00
Canon BJC240 - promo pack	£169.00
Canon BJC620 - colour	£289.00
Canon BJC4200 - promo pack	£209.00
Canon BJC4550 1A3	£364.00
Canon BJC5500 1A2	£698.00
Epson Stylus 200 mono	£139.00
Epson Stylus 2100 colour	£179.00
Epson Stylus Colour 400	£219.00
Epson Stylus Colour 600	£279.00
Epson Stylus Colour 800	£399.00
Epson Stylus Colour 1520 (A3)	£729.00
HP Deskjet 690C	£259.00
HP Deskjet 870C	£369.00
HP Laserjet 6L	£399.00

### Other Items

Artworks video tutorial	★ £14.99
Casio QV100a Digital Camera	£376.00
Casio QV100 Digital Camera	£528.00
Sibelius 6 software	£180.95
Sibelius 7 Student	£493.50
Sibelius 7 software	£940.00
Studio24 version 1	£35.00
Acorn Netstation (Ethernet)	£467.00
Acorn Netstation (Modem)	£467.00
A7000 upgrade to A7000+	£249.00

We have many items in stock which are not shown in this advert. Please ask for anything you require which may not be shown. We also undertake repairs and upgrades in all Acorn computer models. Collectium can be arranged if necessary.

### Studio24Pro



Many Acorn User Front covers have been created from scratch using this program alone. concrete proof of the power of this creative tool! - Acorn User Mar 96

**Now just ★ £99.00 ★**

Users note: FREE! update v2.16 is now available.

### Pineapples Virus Protection Scheme



has been running for over five years and is still being updated with new viruses on a regular basis. New software versions are sent out to members every three months and the total number of viruses which can be removed is over 100.

**Joining fee just £28.20**  
Inexpensive multi-user licences

*If you're interested in virus protection, join the Pineapple virus protection scheme and buy Killer. Accept no alternative - Acorn User Feb 96*

As an Acorn Centre of Technology Pineapple Software can help you with ALL your Acorn computer related problems.

## Pineapple Software

352 Green Lane, ILFORD  
Essex IG3 9JS

Tel 0181 599 1476 Fax 0181 598 2343

email:- sales@pineapple.demon.co.uk

www:- http://www.pineapple.demon.co.uk

**Terms:-** All prices include 17.5% vat. Carriage £15 on computer systems. £5 on all other hardware. Other items free. Phone for quote outside UK. Official orders, cheques and all major credit cards accepted at no extra charge.

**'Pineapple offer same of the finest and friendliest after sales support you will find' - Acorn User Mar 96**

Why not come and visit us (easy parking) where you can see most of the Acorn range of computers and other hardware in action. Monday - Saturday 0900 - 1730



# Completing The Jigsaw

**Puzzled by the complexities  
of networking?**

Atomwide can help you out. From a two workstation peer to peer network, to a very large site comprising hundreds of network points.

Atomwide have been designing and building networks for many years now. We can help you every step of the way, to ensure that your network is assembled correctly right up to the last piece in the jigsaw.

All Atomwide networks are designed to meet EEC specifications giving you the choice of using both Acorn and other industry standard equipment. All installations software training, and after sales hot line support are carried out by our fully qualified team of experts.

Contact us now for a network quotation designed to meet your specific requirements.

# A T O M W I D E

7 The Mall, London, W1A 0AB  
Tel 01 689 814500 Fax 01 689 814501  
<http://www.ant.co.uk/com/atomwide.html> FIP: 7777 ant.co.uk/