

mRNA Editing, Processing and Quality Control in *Caenorhabditis elegans*

Joshua A. Arribere,^{*1} Hidehito Kuroyanagi,^{†1} and Heather A. Hundley^{*1}

^{*}Department of MCD Biology, UC Santa Cruz, California 95064, [†]Laboratory of Gene Expression, Medical Research Institute, Tokyo Medical and Dental University, Tokyo 113-8510, Japan, and ^{*}Medical Sciences Program, Indiana University School of Medicine-Bloomington, Indiana 47405

ABSTRACT While DNA serves as the blueprint of life, the distinct functions of each cell are determined by the dynamic expression of genes from the static genome. The amount and specific sequences of RNAs expressed in a given cell involves a number of regulated processes including RNA synthesis (transcription), processing, splicing, modification, polyadenylation, stability, translation, and degradation. As errors during mRNA production can create gene products that are deleterious to the organism, quality control mechanisms exist to survey and remove errors in mRNA expression and processing. Here, we will provide an overview of mRNA processing and quality control mechanisms that occur in *Caenorhabditis elegans*, with a focus on those that occur on protein-coding genes after transcription initiation. In addition, we will describe the genetic and technical approaches that have allowed studies in *C. elegans* to reveal important mechanistic insight into these processes.

KEYWORDS *Caenorhabditis elegans*; splicing; RNA editing; RNA modification; polyadenylation; quality control; WormBook

TABLE OF CONTENTS

Abstract	531
RNA Editing and Modification	533
<i>Adenosine-to-inosine RNA editing</i>	533
<i>The C. elegans A-to-I editing machinery</i>	534
<i>RNA editing in space and time</i>	535
<i>ADARs regulate the levels and fates of endogenous dsRNA</i>	537
<i>Are other modifications present in C. elegans mRNAs?</i>	537
Splicing	538
<i>Operons and trans-splicing</i>	538
<i>cis-splicing</i>	539
<i>Alternative splicing</i>	540
Processing and 3' End Formation of mRNAs	545
<i>mRNA 3' end formation and polyadenylation machinery and genetics</i>	546
<i>Termination of RNA polymerase II transcription</i>	546

Continued

Copyright © 2020 by the Genetics Society of America

doi: <https://doi.org/10.1534/genetics.119.301807>

Manuscript received September 18, 2019; accepted for publication May 3, 2020

¹Corresponding authors: Sinsheimer Labs, S424, Molecular, Cell, and Developmental Biology, 1156 High St., Santa Cruz, CA 95064. E-mail: jarriber@ucsc.edu; Tokyo Medical and Dental University, M&D Tower, Room S2452, 1-5-45 Yushima, Bunkyo-ku, Tokyo 113-8510, Japan. E-mail: kuroyana.end@tmd.ac.jp; and Medical Sciences Program, Jordan Hall 104, 1001 E Third St., Bloomington, IN 47405. E-mail: hahundle@indiana.edu

CONTENTS, continued

<i>Alternative polyadenylation</i>	547
<i>Does length matter? Insights into poly(A) tails from genome-wide studies</i>	549
<i>Processing of histone mRNAs</i>	549
mRNA Quality Control: Counteracting Errors and Regulating Gene Expression	550
<i>Nonsense-mediated mRNA decay discovery and genetics</i>	550
<i>Mechanism of NMD</i>	551
<i>Endogenous roles for NMD</i>	553
<i>No-Go/Nonstop mRNA decay</i>	555
<i>Endogenous roles for No-Go/Nonstop Decay</i>	556
<i>Concluding Remarks and Perspective</i>	557

MATURE mRNAs are born from a series of co- and post-transcriptional processing events that act on a precursor mRNA (pre-mRNA) transcribed by RNA polymerase II (Pol II) (Figure 1). The majority of known eukaryotic mRNA processing events occur in *Caenorhabditis elegans*, including capping of the mRNA at the 5' end soon after nascent RNA synthesis, splicing, modification, and polyadenylation. Additionally, many nascent mRNA molecules in *C. elegans* undergo RNA processing events not observed in other common metazoan model organisms. In particular, 84% of *C. elegans* genes are *trans*-spliced (Tourasse *et al.* 2017), a process where a capped 22 nucleotide (nt) RNA (referred to as a splice leader) is covalently attached to the 5' end of the pre-mRNA [reviewed in Blumenthal (2012) and discussed in detail later in this chapter]. The presence of a *trans*-splicing pathway in *C. elegans* has permitted the evolution of operons throughout the nematode genome (Morton and Blumenthal 2011b). While eukaryotes typically transcribe genes in a monocistronic fashion (*i.e.*, one gene per one mRNA), the *C. elegans* genome has ~15% of protein-coding genes arranged in operons (Zorio *et al.* 1994; Blumenthal *et al.* 2002). These clusters of genes are transcribed from a single promoter as a polycistronic pre-mRNA which are cotranscriptionally processed into multiple mature mRNAs.

The processing events of both monocistronic and polycistronic mRNAs are affected by the interaction of RNA binding proteins (RBPs) and other regulatory factors with sequence and structural elements located in noncoding regions of the mRNA, including the intron and untranslated regions (UTRs). In the Wormbase database, the gene sequence information contains the entire transcribed region, while the transcript sequence information contains the exonic information as well as the 5' and 3' UTRs to model the mature mRNA (Spieth *et al.* 2014). While these annotations are sufficient for many uses, the accuracy of transcript boundaries and structures is often improved by consulting the primary data. Several recent studies have annotated specific transcript features including 5' ends (Saito *et al.* 2013), spliced

leaders (Allen *et al.* 2011), spliced mRNA isoforms (Tourasse *et al.* 2017), 3' ends (Mangone *et al.* 2010; Jan *et al.* 2011), and poly(A) tails (Lima *et al.* 2017).

As errors in RNA processing events and transcription can lead to misexpression of proteins and/or aberrant protein function, cells employ a number of mRNA quality control pathways (Isken and Maquat 2007). The cellular machinery for mRNA processing and quality control is conserved in *C. elegans*. However, the nonessential nature of some of this machinery is unique to *C. elegans*, and provides a vantage point for determining important mechanistic insights, as well as an exploration of genetic interactions between individual gene regulatory processes and cellular pathways.

In addition to genetic screens, technical advances in exploring tissue- and cell-specific gene regulation have allowed these processes to be carefully dissected in *C. elegans*. For example, the combination of promoters that provide tissue- and/or cell-specific transcription, the compact genome organization, and the transparent nature of *C. elegans* allows for spatiotemporal analysis of the effects of RNA processing using fluorescent reporters in living animals (reviewed extensively in Gracida *et al.* 2016; Wani and Kuroyanagi 2017). Multichromatic reporters that are translated into different fluorescent proteins based on splicing of upstream exons have been particularly insightful in determining alternative splicing events that occur for specific transcripts in individual *C. elegans* neurons (Kuroyanagi *et al.* 2006, 2010; Norris *et al.* 2014).

Transcriptome-wide approaches to study effects of RNA processing and modification on gene expression in specific cells and/or tissues have also been extensively used in *C. elegans*. One approach uses animals with tissue/cell-type specific expression of an epitope-tagged poly(A) binding protein (PABP), which binds to the poly(A) tail of mRNAs (Roy *et al.* 2002). Immunoprecipitation of the tagged PABP from these animals followed by high-throughput sequencing has been used in *C. elegans* to identify alternative polyadenylation events that occur in transcripts expressed in intestines,

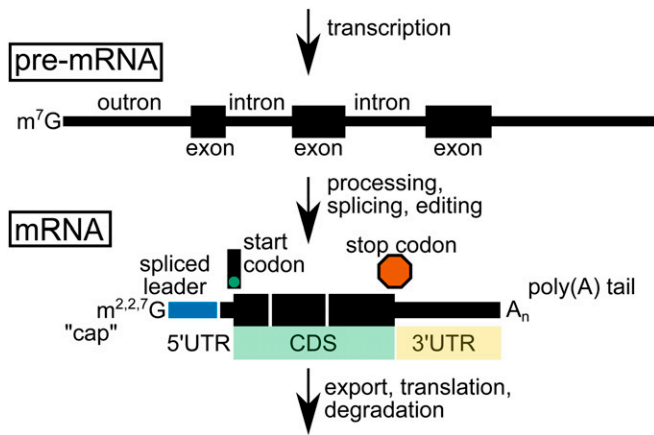

Figure 1 Commonly used terms in the study of mRNA biogenesis and regulation. An mRNA begins its life with transcription and initially exists as a premature mRNA (pre-mRNA). The pre-mRNA includes more sequence than the mature mRNA will contain. The pre-mRNA is processed, spliced, and edited to give rise to the mature mRNA. Several commonly described features of the mature mRNA are indicated, including the trimethylguanosine “cap,” spliced leader (blue, which is appended after excision of the outtron), 5' UTR (the portion of the mRNA upstream of the start codon), CDS (green, coding DNA sequencing also called open reading frame (ORF), 3' UTR (yellow, the region of mRNA downstream of the stop codon) and untemplated poly(A) tail. For simplicity, the pre-mRNA and mRNA are shown as discrete entities, though there is evidence that mRNA maturation occurs cotranscriptionally. The mature mRNA is exported from the nucleus, possibly translated, and eventually degraded.

muscle, neurons, seam cells, and hypodermal tissue (Blazie *et al.* 2015, 2017). A second global approach to identify transcripts present in specific cell- or tissue-types uses chemo-mechanical dissociation of animals expressing a fluorescent protein in the cell/tissue type of interest and fluorescence-assisted cell sorting to isolate those cells (Spencer *et al.* 2011, 2014). High-throughput sequencing of RNA has revealed splicing events that occur in a number of tissues in both larval and adult animals (Kaletsky *et al.* 2016, 2018) as well as RNA modification events that occur in neurons of larval animals (Deffit *et al.* 2017).

Together with behavioral and other genetic analyses, these techniques are providing a mechanistic understanding of how cell/tissue-specific splicing, modification, and polyadenylation contribute to organismal physiology. In this chapter, we will provide an introduction to each of these processes as well as the mRNA quality control pathways that help mitigate errors in mRNA processing.

RNA Editing and Modification

The central dogma suggests that mRNAs are simply faithful copies of the genome that serve as molecular instructions for protein production. However, there are a number of cellular processes that act on newly synthesized mRNA to alter genetic information. In addition to removal of large intronic sequences from nascent mRNA, individual nucleosides in RNA can be inserted, deleted, undergo base conversions, or be chemically modified. The processes of base insertion,

deletion, and conversion were originally referred to as “RNA editing” to describe that the information in the RNA molecule is edited/changed from the genomic sequence (Gott and Emeson 2000). RNA editing can occur to varying extents both during development and in a cell/tissue-specific manner. This process is an important mechanism to regulate gene expression and function from a constant genome. Furthermore, as these events insert, delete, or alter base-pairing of nucleotides, RNA editing can effectively rewire genomic information to generate molecular and phenotypic diversity.

Chemical modification of RNA nucleosides occurs in all organisms (Frye *et al.* 2018). Over 100 chemically distinct and naturally occurring RNA modifications have been known for several decades. Many of these were initially identified in abundant RNA species such as ribosomal RNA (rRNA) and transfer RNA (tRNA), likely due to the abundance of these RNAs in cells. These modifications serve important functions in such RNAs (reviewed in (Sarin and Leidel 2014; Roundtree *et al.* 2017)), but here our focus will be on modifications in mRNAs. Due to advances in enrichment techniques and high-throughput sequencing, the identification of RNA modifications within mRNA have expanded greatly in recent years (reviewed in Helm and Motorin 2017; Peer *et al.* 2017). Thus far, the majority of RNA modifications identified in mRNA involve methylation of a specific nucleoside, such as N⁶-methyladenosine (m⁶A) and 5-methylcytosine (m⁵C) (Bohnsack *et al.* 2019; Shi *et al.* 2019). The biological consequences of these modifications are just beginning to be identified. Some modifications alter base-pairing of mRNA and directly impact gene expression, and some modifications have reader proteins that recognize the chemically altered nucleoside, and relay this information for gene regulatory and cell fate changes (Roundtree *et al.* 2017; Covelo-Molares *et al.* 2018; Casella *et al.* 2019).

While the identification of editing events and modifications present in the transcriptomes of human cells has expanded exponentially in recent years, the *in vivo* RNA modification landscape of animals is largely unknown. In this chapter, we will focus on the most well-established nucleoside changes that occur in *C. elegans* mRNA, which are adenosine (A)-to-inosine (I) RNA editing events. The machinery that catalyzes deamination of adenosine, as well as the biological and gene regulatory consequences of A-to-I editing, will be discussed (Table 1). In addition, we will describe a handful of reports of other RNA modifications in *C. elegans* and highlight future areas for expansion.

Adenosine-to-inosine RNA editing

The adenosine deaminases that act on the RNA (ADAR) family of enzymes catalyze A-to-I RNA editing in all animals (Figure 2). These enzymes were first uncovered during studies of antisense RNA techniques in the developing *Xenopus laevis* embryo (Bass and Weintraub 1987; Rebagliati and Melton 1987). When double-stranded RNA (dsRNA) was injected into developing *Xenopus* embryos, the dsRNA appeared to unwind. It was later revealed that this “unwinding activity”

Table 1 Brief summary of RNA editing and modification factors in *C. elegans*

<i>C. elegans</i>	Human Ortholog	Domains	Description
Adenosine to inosine RNA editing			
<i>adr-1</i>	ADAD1	dsRBD, adenosine deaminase	ADR-1 physically interacts with ADR-2 and promotes editing of certain transcripts, ADR-1 can also inhibit editing by an unknown mechanism
<i>adr-2</i>	ADAR2	dsRBD, adenosine deaminase	ADR-2 is the sole adenosine deaminase acting on mRNA in <i>C. elegans</i>
<i>adbp-1</i>		None identified	ADBP-1 is important for nuclear localization of ADR-2 and RNA editing
Possible mRNA editing and mRNA modification enzymes in <i>C. elegans</i>			
<i>cdd-1</i>	CDA	Cytidine deaminase	Loss of <i>cdd-1</i> affects uridine metabolism, may also be involved in C-U editing of mRNA
<i>cdd-2</i>	CDA	Cytidine deaminase	Loss of <i>cdd-2</i> affects uridine metabolism, may also be involved in C-U editing of mRNA
<i>nsun-2</i>	NSUN2	RNA C5-methyltransferase, SAM- dependent methyltransferase	Based on homology, NSUN-2 is predicted to have cytosine methyltransferase activity on tRNA and mRNA
<i>B0024.11</i>	PUS7	Pseudouridine synthase	Based on homology, <i>B0024.11</i> is predicted to have pseudouridylation activity on RNA
—	METTL3	Adenine-N6-methyltransferase	No known homolog
—	METTL14	Adenine-N6-methyltransferase	No known homolog
<i>mett-10</i>	METTL16	Adenine-N6-methyltransferase	Based on homology, <i>METT-10</i> is predicted to have N6-methyltransferase activity on rRNA

This table describes factors that are currently known to act in adenosine-to-inosine RNA editing in *C. elegans*. In addition, this table includes factors that are predicted to function in different types of RNA modification of mRNA.

was due to adenosine deamination to inosine (Bass and Weintraub 1988). As adenosine and inosine have different base-pairing capabilities (Figure 2), the conversion of adenosine to inosine results in mismatches in perfectly base-paired dsRNA, and the presence of multiple A-to-I editing events leads to decreased stability of dsRNA and can affect the cellular function of dsRNA. In *C. elegans*, editing can prevent entry of dsRNA into the RNA interference (RNAi) pathway, thus inhibiting silencing of gene expression (Knight and Bass 2002). In addition, as dsRNA signals the presence of foreign invaders to the vertebrate immune system, ADARs in vertebrates and *C. elegans* have been proposed to function in immunity as markers of endogenous (“self”) dsRNA (Eisenberg and Levanon 2018; Reich *et al.* 2018). These data, and the role of ADARs in regulating gene expression in both development and tissue-specific manners, will be described below.

The *C. elegans* A-to-I editing machinery

The *C. elegans* *adr-2* gene was identified through homology soon after the first mammalian A-to-I editing enzyme was cloned (Kim *et al.* 1994). Similar to all ADARs (Savva *et al.* 2012), *C. elegans* ADR-2 contains an N-terminal dsRNA binding domain (dsRBD) and a C-terminal deaminase domain (Hough *et al.* 1999). Interestingly, a recent biochemical study suggests that ADR-2 has an ~100-fold weaker *in vitro* affinity for dsRNA compared to all other ADARs characterized to date (Rajendren *et al.* 2018). Despite this reduced affinity for dsRNA, it is well established that ADR-2 is responsible for all A-to-I editing events in *C. elegans*. The initial characterization of an *adr-2* genetic mutant (*gv42*) revealed loss of *in vitro* dsRNA editing as well as complete loss of editing

for a handful of endogenous mRNAs (Tonkin *et al.* 2002), a finding that was corroborated by more recent high-throughput sequencing studies using another *adr-2* deletion [*adr-2(ok735)*] (Washburn *et al.* 2014). Together, these studies support the idea that ADR-2 is the only A-to-I mRNA editing enzyme in *C. elegans*.

Although ADR-2 is the only enzyme that catalyzes adenosine deamination in *C. elegans*, ADR-2 activity is regulated by ADR-1 (Tonkin *et al.* 2002; Washburn *et al.* 2014; Rajendren *et al.* 2018). As suggested by the name, *C. elegans* *adr-1* has sequence similarity with the ADAR family. ADR-1 contains two N-terminal dsRBDs and a C-terminal domain that is homologous with the ADAR deaminase domain, though the C-terminal domain lacks the essential amino acids required for catalyzing adenosine deamination (Tonkin *et al.* 2002). Thus, ADR-1 is an editing-deficient member of the ADAR family. It is important to note that the numbering of the *C. elegans* ADR proteins does not relate directly to the mammalian ADAR proteins. In addition, both ADR-1 and ADR-2 are referred to as ADARs due to the conserved domain structure, not necessarily the ability to deaminate dsRNA.

The initial characterization of animals lacking *adr-1* [*adr-1(gv6)*] revealed decreased editing of dsRNA *in vitro* (Tonkin *et al.* 2002). High-throughput sequencing approaches of a second *adr-1* allele [*adr-1(tm668)*] and biochemical studies have indicated that ADR-1 binds to ADR-2 directly and ADR-2 target mRNAs to promote A-to-I editing at many sites in the transcriptome (Washburn *et al.* 2014; Rajendren *et al.* 2018). In addition, RNA-immunoprecipitation studies of ADR-2 from wild-type animals and those lacking *adr-1* suggest that the ability of ADR-2 to interact with most mRNAs requires

ADR-1 (Rajendren *et al.* 2018). Together, these data suggest a model in which ADR-1 binds to both ADR-2 and cellular mRNAs to deliver ADR-2 to specific adenosines to promote editing (Figure 3). However, it remains to be shown whether the ADR-1/ADR-2 complex exists on mRNAs *in vivo*, and, more specifically, whether the binding of ADR-2 binding to dsRNA is compatible with simultaneous binding to ADR-1. Future studies need to focus on identifying binding sites of ADR-1 and ADR-2 on cellular mRNAs and correlating that information with the extent of editing of specific adenosines in those mRNAs.

It is well-established that ADR-1 and ADR-2 function together for efficient editing of many mRNAs; however, ADR-1 is also known to inhibit ADR-2 activity at specific sites (Tonkin *et al.* 2002; Washburn *et al.* 2014). Interestingly, in the nervous system, where ADR-1 and ADR-2 function together to efficiently edit and regulate expression of important neural mRNAs (Deffit *et al.* 2017), ADR-1 has also been shown to inhibit editing of specific reporter mRNAs (Washburn and Hundley 2016). The ability of ADARs, and most RBPs, to use different modes of substrate recognition at different points in development, and in different tissues, is underexplored. Biochemical studies of RBPs indicate that *in vitro* recognition of RNA targets can be altered when multiple proteins are in a complex (Campbell *et al.* 2012); however, similar *in vivo* studies are lacking. Due to the technical advances to examine tissue-specific gene regulation and transgenic systems to express RBPs in specific cell and tissue types [described above and reviewed in Nance and Frokjaer-Jensen (2019)], studies in *C. elegans* will likely lead the field in addressing tissue- and developmental-specific functions of ADARs and RBPs in general.

The expression pattern of ADR-1 has been determined primarily by translational reporter fusions. Transgenic expression of an ADR-1::GFP fusion containing the *adr-1* promoter and an N-terminal portion of ADR-1 fused to GFP is expressed in most cells of the nervous system throughout development (Tonkin *et al.* 2002). In addition, ADR-1 is expressed in the developing vulva of L4 animals, and loss of *adr-1* leads to a protruding vulva phenotype in a small portion of animals (<10%) (Tonkin *et al.* 2002; Ganem *et al.* 2019). Historically, expression studies with the *adr-2* promoter were lacking due to the inability to generate *adr-2* transgenes, presumably because *adr-2* exists in a six-gene operon (Hough *et al.* 1999; Tonkin *et al.* 2002), but, with the recent expansion in modern genome engineering technologies [*i.e.*, CRISPR, reviewed in Dickinson and Goldstein (2016)], the technical hurdles to ADR-2 expression studies will likely be overcome. In a recent global analysis of single-cell transcriptome profiling of L2 animals, expression of *adr-1* and *adr-2* mRNA was reported to be expressed in neurons, muscle, hypodermis, intestine, and the germline (Cao *et al.* 2017), suggesting ADR-1 may be expressed more broadly than observed with the ADR-1::GFP fusion.

The role of editing and ADARs in many of these tissues is currently unknown. However, as animals individually lacking

adr-1 or *adr-2* and an animal lacking both genes are viable (Tonkin *et al.* 2002), *C. elegans* will be an important contributor to determining how tissue-specific gene regulation contributes to organismal function and development. In this regard, *C. elegans* *adr* mutants exhibit defects in chemotaxis (Tonkin *et al.* 2002), and recent high-throughput sequencing of isolated neural cells, combined with functional assays of genetic mutants, led to an identification of an edited mRNA (*clec-41*) that was critical for this behavioral defect (Deffit *et al.* 2017). It is important to note that in these same genetic mutants, namely *adr-1(-)* animals, altered editing and gene expression of *clec-41* mRNA was not observed in RNA isolated from whole larval animals. Similar tissue-specific approaches may also prove informative for understanding the role of ADR-1 and ADR-2 in lifespan (Sebastiani *et al.* 2009; Ganem *et al.* 2019).

RNA editing in space and time

High-throughput sequencing studies of the *C. elegans* transcriptome have revealed tens of thousands of editing sites in protein-coding genes and long-noncoding RNAs (Wu *et al.* 2011; Washburn *et al.* 2014; Whipple *et al.* 2015; Zhao *et al.* 2015; Deffit *et al.* 2017; Goldstein *et al.* 2017; Reich *et al.* 2018; Ganem *et al.* 2019). These studies have used a number of different technical and computational approaches, including enriching for dsRNA (Reich and Bass 2019). All of these studies take advantage of the nonessential nature of A-to-I editing in *C. elegans*. Parallel analyses of sequencing data from the *adr-2(-)* animals facilitates accurate identification of A-to-I editing events from technical errors in sequencing data, including errors introduced by PCR, sequencing, and/or strain differences (Bass *et al.* 2012; Reich and Bass 2019). Two general trends that have emerged from these high-throughput studies are that editing levels are developmentally regulated (Zhao *et al.* 2015; Goldstein *et al.* 2017; Reich *et al.* 2018; Ganem *et al.* 2019) and that most editing events occur in noncoding regions of the transcriptome (Washburn *et al.* 2014; Whipple *et al.* 2015; Deffit *et al.* 2017).

High-throughput sequencing studies have identified most editing events in RNA isolated from animals early in development (Zhao *et al.* 2015; Reich *et al.* 2018), which is also when expression of *adr-1* and *adr-2* mRNA levels peak (Hundley *et al.* 2008). There are some reported differences in the exact “peak” of RNA editing (embryos vs. L1s), which may relate to secondary effects of starvation-induced transcript changes and/or differences in recovery time after L1 arrest. Interestingly, it has been shown that some mRNAs are expressed throughout development, but edited only at a specific stage. An example is *egl-2*, which is edited in embryos, but not L4 animals (Goldstein *et al.* 2017). In addition, it was recently shown that the ability of ADR-1 to promote ADR-2 editing of mRNAs is developmentally regulated, with ADR-1 regulatory function contributing to higher editing of specific mRNAs in L4 animals compared to embryos (Ganem *et al.* 2019). The consequences of ADARs and RNA editing for gene

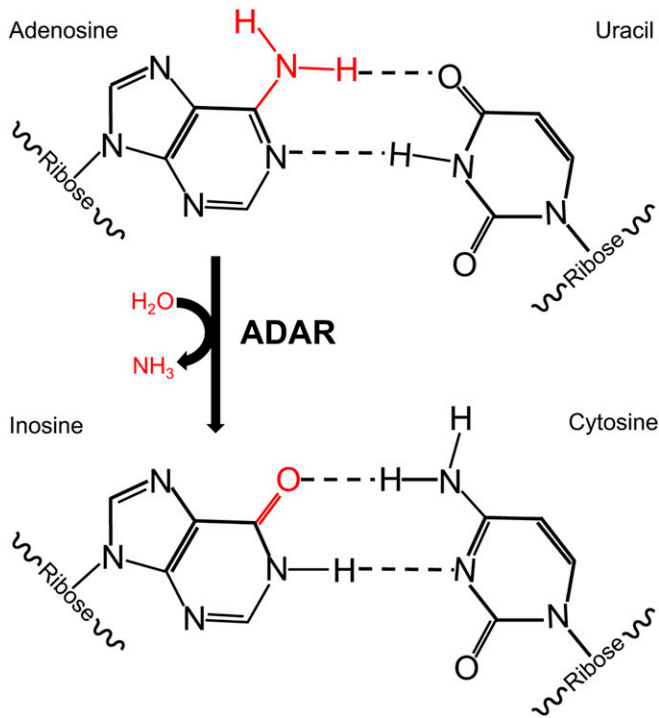

Figure 2 The impact of ADARs on RNA. ADARs use water (H_2O) to catalyze the removal of an amine group (red) from adenosine, resulting in inosine. While adenosine in RNA base-pairs with uracil, inosine base-pairs with cytosine.

expression at specific developmental stages is beginning to emerge (Zhao *et al.* 2015; Reich *et al.* 2018; Ganem *et al.* 2019). However, as tissue-specific effects may be masked when examining RNA isolated from whole animals of different developmental stages, it will be important to combine the tools of tissue-specific studies with development to obtain a clear picture of the function of RNA editing on development.

The impact of A-to-I RNA editing on gene expression is not relayed by specific “reader” proteins, but rather is dictated by the location of the editing event within an RNA species. As the base-pairing properties of inosine mimic those of guanosine (Figure 2), A-to-I editing events alter the structure and sequence-specific interactions of the edited RNA. Editing events in open reading frames (ORFs) of mRNAs can alter base-pairing with tRNAs, thus changing the genetic code (referred to as recoding events), and, ultimately, the amino acid sequence of the protein. Recoding events play critical roles in proteomic diversity of ion channels and receptors in mammals, flies, and cephalopods (Tariq and Jantsch 2012; Rosenthal 2015; Keegan *et al.* 2017). However, only a handful of editing sites have been identified within the coding regions of *C. elegans* mRNAs [e.g., eight validated recoding events identified in one study (Zhao *et al.* 2015)], and there is currently no evidence that *C. elegans* recoding sites have functional consequences. The lack of identification of *C. elegans* recoding sites does not appear to be due to tissue-specific effects, as recent transcriptome-wide sequencing of mRNAs from isolated neural cells did not detect novel

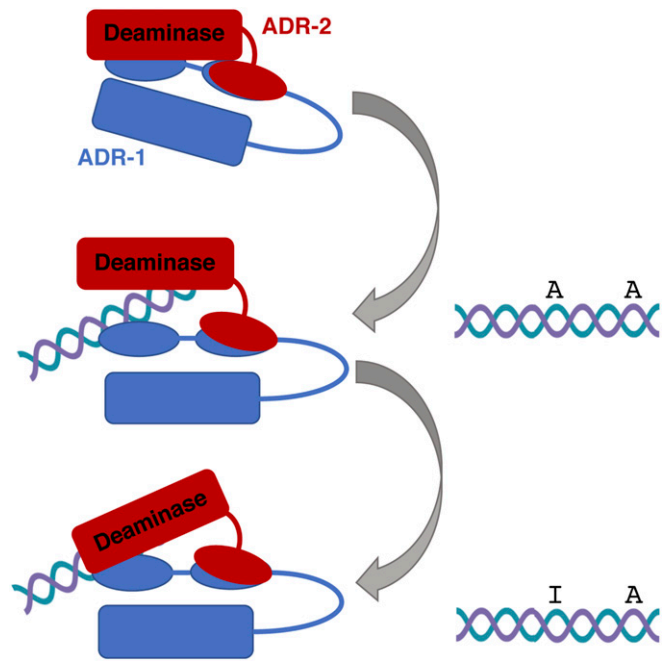

Figure 3 Substrate recognition by the *C. elegans* ADARs. *C. elegans* ADR-1 (blue) contains two dsRNA binding domains (ovals) and a deaminase domain (red), but lacks critical amino acids to perform deamination. ADR-1 interacts physically with both ADR-2 (red) and target mRNAs (teal/purple dsRNA) to promote editing by ADR-2 at specific sites.

recoding editing sites, suggesting that the major role of A-to-I editing in the *C. elegans* nervous system is not to generate proteome diversity (Deffit *et al.* 2017).

A number of recent high-throughput sequencing studies have revealed that a majority of A-to-I editing events in the *C. elegans* transcriptome occur within introns (Zhao *et al.* 2015; Deffit *et al.* 2017; Reich *et al.* 2018). As ADR-2 is present in the nucleus (Ohta *et al.* 2008), and the important sequences for splicing (*i.e.*, the branch point adenosine, splice donor, splice acceptor) all contain adenosines or guanosines, A-to-I editing within intronic regions has the potential to both create and disrupt splicing, though, to date, no studies have addressed the impact of RNA editing on splicing in *C. elegans*. With the many elegant technical tools available to study splicing, such as fluorescent splicing reporters for tissue-specific analysis, as well as the *adr* mutants, this is an emerging and important area for investigation.

Additionally, it has been shown recently that circular RNA species can be formed from back-splicing of intronic sequences (Wilusz 2018). High-throughput sequencing studies identified at least 1166 circular RNAs (circRNAs) in *C. elegans*, some of which accumulate during aging (Cortés-López *et al.* 2018). Studies from human cells indicate that A-to-I editing and ADARs influence circular RNA production (Ivanov *et al.* 2015). It was recently reported that regions of the *C. elegans* genome that are enriched for editing (identified by immunoprecipitation and high-throughput sequencing) significantly overlap with circular RNAs (Reich *et al.* 2018). However, the functional consequences of RNA editing

and ADARs on *C. elegans* circRNAs, as well as the biological impact of circRNAs on *C. elegans* development and organismal function, are unknown.

As the 3' UTRs of cellular mRNAs contain elements for post-transcriptional gene regulation, and thousands of editing sites in *C. elegans* occur in 3' UTRs, these editing events have the potential to alter mRNA stability, localization, and translation (Hundley and Bass 2010). Global expression analyses have revealed small, but reproducible, decreases in mRNA expression of genes with edited 3' UTRs in *adr* mutant embryos compared with wild-type embryos (Goldstein *et al.* 2017; Reich *et al.* 2018). These gene regulatory effects were not observed in later stage animals, suggesting developmental-specific roles for editing in gene regulation. However, it is also possible that A-to-I editing in 3' UTRs regulates gene expression in specific tissues, and is masked by analysis of RNA isolated from whole animals, as described above. Moreover, in large part, functional studies of the role of individual editing events in noncoding regions serving to regulate *C. elegans* gene expression are lacking. With recent advances in the use of CRISPR to modify specific nucleotides of the *C. elegans* genome (Dickinson and Goldstein 2016), as well as techniques to analyze tissue-specific gene expression, it is now possible to start directly assessing the consequences of specific 3' UTR editing events on gene expression.

ADARs regulate the levels and fates of endogenous dsRNA

In addition to the role of individual editing events in regulating gene expression, the ability of ADARs to bind and modify dsRNA impacts dsRNA recognition by other dsRBPs. The helical structure of dsRNA is A-form, and, thus, has a narrow major groove that prevents sequence-specific contacts with proteins. Therefore, dsRBPs recognize primarily the shape of dsRNA, and all characterized dsRBPs bind to dsRNA of any sequence (Bass 2006). The lack of specific binding by dsRBPs can result in an intersection of dsRNA-mediated pathways *in vivo*. For ADARs, this intersection has been well documented to impact the production of small RNAs and silencing of cellular RNAs, both of which are fields where *C. elegans* research has been at the forefront (Youngman and Claycomb 2014).

The biogenesis of most classes of small RNAs requires the action of nucleases that act on longer dsRNA precursors (Fischer 2010; Billi *et al.* 2014). In some instances, ADARs can bind and edit these dsRNA precursors, which can alter small RNA sequence and/or production (Nishikura 2016). The first evidence of this antagonistic function came from studies of transgene expression in *C. elegans adr* mutants (Knight and Bass 2002). Highly repetitive extrachromosomal arrays can give rise to dsRNA through overlapping sense and antisense transcription. Editing of these dsRNA molecules prevents recognition by Dicer, thus decreasing small interfering RNA (siRNA) production and allowing expression of the transgene. Repetitive transgenes expressed in a number of tissues, including muscle, intestine, and hypodermis, can be acted upon by ADR-2 to prevent silencing (Knight and Bass

2002; Ohta *et al.* 2008). Loss of nuclear localization of ADR-2 increases somatic transgene silencing (Ohta *et al.* 2008), while loss of RNA interference (RNAi) factors leads to reduced silencing (Knight and Bass 2002).

The ability of ADARs to protect cellular transcripts from small RNA processing is not limited to transgenes. Loss of ADARs affects the levels of mature microRNAs (miRNAs) (Warf *et al.* 2012). Interestingly, these effects are more prominent upon loss of *adr-1* than *adr-2*, suggesting that ADAR binding to miRNA precursors antagonizes processing more than editing. The increases in mature miRNAs and consequent changes in the mRNA levels of miRNA target genes in the absence of ADARs has also been observed in mouse embryos (Vesely *et al.* 2012), suggesting a conserved role for ADARs in antagonizing small RNA processing.

Recently, a striking phenotype of frequent adult bursting was observed when *C. elegans adr* mutants were in an Enhanced RNAi (Eri) background (Reich *et al.* 2018). This synthetic genetic interaction was alleviated when core RNAi factors were absent. The rescue of *adr* phenotypes by loss of RNAi factors is consistent with previous studies that indicated loss of RNAi factors could restore the chemotaxis and lifespan defects of *C. elegans adr* mutants (Tonkin and Bass 2003; Sebastiani *et al.* 2009). Mechanistically, these data suggest that ADARs protect endogenous dsRNA from destruction by siRNA silencing pathways, and that aberrant destruction of endogenous dsRNA has developmental and neurological consequences (Pasquinelli 2018). Consistent with this model, loss of another *C. elegans* RNA binding protein, TDP-1, leads to increased dsRNA production and chemotaxis defects, the latter of which can be rescued by loss of RNAi factors (Saldi *et al.* 2014). Furthermore, recent high-throughput sequencing of small RNAs identified a class of 23 nt siRNAs that are homologous to the double-stranded regions of *C. elegans* edited mRNAs, and loss of *adrs* resulted in downregulation of these mRNAs (Reich *et al.* 2018). A previous study also identified small RNAs (22, 23, and 24 nt siRNAs) regulated by *adr* expression (Wu *et al.* 2011). However, in large part, the two studies do not overlap in identification of genomic loci, suggesting that ADARs may participate in regulating multiple, distinct small RNA generating pathways. These studies in *C. elegans* showcase the role of ADARs in counteracting immune responses to dsRNA, and are also consistent with the emerging view in mammals of ADARs in preventing aberrant recognition of endogenous dsRNA by the innate immune system (Samuel 2019). Together, these data suggest that the conserved, and perhaps primary, function of A-to-I editing is to protect self dsRNA.

Are other modifications present in *C. elegans* mRNAs?

The identification of mammalian ADARs coincided with sequencing of the *C. elegans* genome and stimulated the study of A-to-I editing in *C. elegans*. The other major class of deaminases in mammals, cytidine deaminases, have a handful of RNA targets, such as apolipoprotein B mRNA, but the majority of C-U edits occur at the DNA level (Salter *et al.* 2016).

There has been one report of a C-U edited mRNA in *C. elegans* (Wang *et al.* 2004). The serendipitous discovery of C-U editing of the *gld-2* mRNA occurred when researchers noticed discrepancy between cDNA sequences and genomic sequences. Further analysis indicated that C-U editing of *gld-2* mRNA occurred in the germline, but not the soma (Wang *et al.* 2004). The biological function of the cytidine deamination of *gld-2* mRNA is unknown. Interestingly, it was shown recently that two *C. elegans* cytidine deaminases, *cdd-1* and *cdd-2*, are important for germline proliferation (Chi *et al.* 2016). This effect is likely due to changes in the cellular pyrimidine pool and the action of these enzymes on free nucleotides (Table 1). However, a direct role for these two enzymes and the seven other predicted cytidine deaminases in *C. elegans* (Wang *et al.* 2004) in modifying *gld-2* mRNA has not been examined.

In contrast to the well-established editing enzymes that act on mRNA, the enzymes that deposit many other mRNA modifications have only recently been identified in mammals, flies, and yeast (Frye *et al.* 2018). Database searches of enzymes that catalyze some modifications (*e.g.*, pseudouridylation and 5-methylcytosine) reveal potential homologous *C. elegans* genes (Dezi *et al.* 2016) (Table 1). Interestingly, for some modifications present in human mRNAs, such as m⁶A, the major modification enzymes are absent from the *C. elegans* genome, while homologs of enzymes that play a more minor role in humans are present in *C. elegans*, but not characterized to date (Table 1). Some RNA modifications, such as 5-hydroxymethylcytidine (hm⁵C), have been detected in *C. elegans* RNA, but the enzyme that performs this modification in humans, TET, does not have an easily identifiable homolog in *C. elegans* (Huber *et al.* 2015). Metabolic labeling experiments coupled to mass spectrometry have also identified several RNA modifications that occur in *C. elegans* (van Delft *et al.* 2017). These modifications responded dynamically to cellular and environmental stress, and were identified in both large (>200 nt) and small (<200 nt) RNAs. A functional consequence on gene expression in starved animals was identified for one of these modifications, 5-methoxycarbonylmethyl-2-thiouridine (mcm⁵s²U), which occurs in the anticodon of select tRNAs. As tRNA and rRNA are much more abundant than mRNA, information about mRNA modification will be more difficult to obtain from global metabolic studies. Future studies using enrichment techniques for specific modifications (Helm and Motorin 2017), as well as genetic mutants, will be important to understand the *C. elegans* mRNA modification landscape. In addition, with the emerging use of technologies that allow direct sequencing of RNA (Kono and Arakawa 2019), detection of modifications in *C. elegans* mRNAs will increase over the coming years.

Splicing

RNA splicing is a process that removes introns from a primary transcript and ligates exons. Eukaryotic pre-mRNA splicing entails two sequential transesterification reactions (branching

and exon ligation) and is catalyzed by a large ribonucleoprotein complex termed the spliceosome. The spliceosome comprises five uridine-rich small nuclear RNAs (U snRNAs) and nearly 200 proteins that are highly conserved from yeast to humans (Shi 2017). The spliceosome assembles on pre-mRNAs and undergoes numerous conformational changes mediated by *trans*-acting proteins such as adenosine triphosphatases (ATPases)/RNA helicases. Near-atomic resolution structures of *Saccharomyces cerevisiae* and human spliceosomes at different stages of assembly, catalysis, and disassembly have been solved by cryoelectron microscopy (cryo-EM) in the last couple of years, and provide considerable mechanistic insight into how the spliceosome achieves the two transesterification reactions (Galej *et al.* 2016; Rauhut *et al.* 2016; Wan *et al.* 2016, 2017, 2018; Yan *et al.* 2016, 2017; Bai *et al.* 2017, 2018; Bertram *et al.* 2017a,b; Fica *et al.* 2017, 2019; Liu *et al.* 2017; Plaschka *et al.* 2017; Wilkinson *et al.* 2017; Zhang *et al.* 2017, 2018, 2019; Haselbach *et al.* 2018; Zhan *et al.* 2018a,b). In *C. elegans*, there are two categories of spliceosomal splicing: *trans*-splicing and *cis*-splicing (Blumenthal 2012) (Figure 4). *Trans*-splicing precisely joins exons from two discontinuous primary transcripts (Figure 4A), whereas *cis*-splicing precisely joins two exons from the same primary transcript (Figure 4B) (discussed in detail below).

Operons and *trans*-splicing

mRNAs of >84% of *C. elegans* protein-coding genes begin with a spliced leader (SL), one of two common extragenetically derived 22 nt sequences (SL1 or SL2) (Allen *et al.* 2011; Tourasse *et al.* 2017). The SL is donated by a ~100 nt RNA, SL1 or SL2 RNA, in a process termed spliced leader *trans*-splicing (Figure 4A). The SL RNA forms a small nuclear ribonucleoprotein particle (snRNP), which is structurally and functionally similar to the U snRNAs (U1, U2, U4, U5, and U6) that play key roles in *cis*-splicing or intron removal (Van Doren and Hirsh 1988). The *trans*-splicing event is very closely related to *cis*-splicing: the 5' splice site (5' SS) is on the SL RNA and the 3' splice site (3' SS) is the *trans*-splice site or the site of SL addition on the pre-mRNA (Figure 4A). Unlike the U snRNAs, the SL RNA is consumed in every *trans*-splicing event (Van Doren and Hirsh 1988). The *C. elegans* genome contains 110–150 tandem repeats of SL1 RNA gene loci (Krause and Hirsh 1987; Yoshimura *et al.* 2019) and 18 SL2 RNA genes, including a variety of variant SL2 RNAs at dispersed loci (Evans *et al.* 1997). As the SL RNAs have a 2,2,7-trimethylguanosine (TMG) cap, mRNAs processed by *trans*-splicing also have a TMG cap rather than the usual 7-methylguanosine (m⁷G) cap (Figure 4) (Van Doren and Hirsh 1988). The TMG cap is considered to stimulate translation of the *trans*-spliced mRNAs (Maroney *et al.* 1995; Lall *et al.* 2004; Wallace *et al.* 2010). Detailed mechanisms of *trans*-splicing in *C. elegans* are documented in a previous article in WormBook (Blumenthal 2012).

More than half of pre-mRNAs are subject to SL1 *trans*-splicing, which trims off the 5' ends of pre-mRNAs and

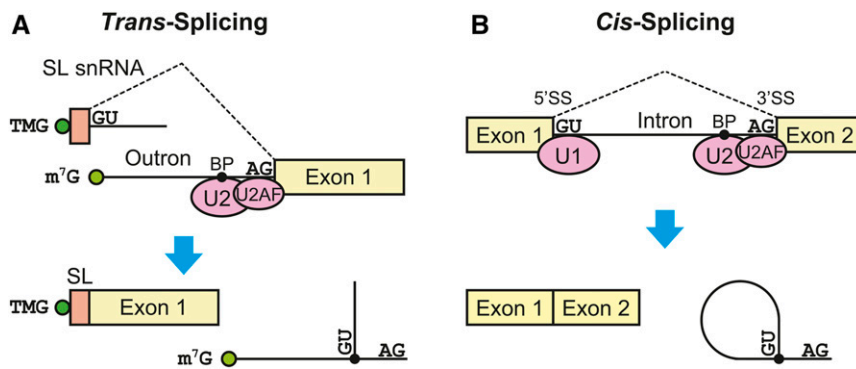

Figure 4 Schematic representations of *trans*-splicing and *cis*-splicing in *C. elegans*. (A) Spliced leader *trans*-splicing. A 2,2,7-trimethylguanosine (TMG)-capped 22-nt spliced leader (SL) sequence derived from an SL snRNA in SL snRNP replaces a 7-methylguanosine (m⁷G)-capped outon in a pre-mRNA. A y-shaped outon is excised. (B) *Cis*-splicing. A lariat-shaped intron is excised and the upstream and downstream exons are ligated. The 5'-splice site (5'SS), 3'-splice site (3'SS) and branch point (BP) are recognized by U1 snRNP (U1), U2 auxiliary factor (U2AF) and U2 snRNP (U2), respectively. Boxes represent exons and solid lines indicate introns and outons. Dashed lines connect exons that are ligated in the splicing reactions. Cap structures and branch points are indicated with green and black circles, respectively. Almost invariable nucleotide sequences of the splice sites are indicated.

replaces them with the SL1 sequence. The region between the transcription start site (TSS) or the 5' cap and the *trans*-splice site is called the outon. As *trans*-splicing is very efficient, pre-mRNAs with outon sequences are hardly detected, which makes it difficult to determine the TSSs for *trans*-spliced genes in *C. elegans*. RNA-seq analysis of captured 5' ends of nuclear RNAs revealed a collection of TSSs for 7351 *trans*-spliced genes, often with multiple TSS clusters per gene (Kruesi *et al.* 2013; Saito *et al.* 2013). Lengths of the outons range from <10 to >3000 nt, with a median of 369 nt (Saito *et al.* 2013).

The other splice leader, SL2, is *trans*-spliced to mRNAs derived from downstream genes in operons (Spieth *et al.* 1993; Blumenthal *et al.* 2002; Allen *et al.* 2011). In *C. elegans*, there are 1255 verified operons containing 3193 genes, representing ~15% of all protein-coding genes (Allen *et al.* 2011; Blumenthal 2012). Half of the operons contain only two genes, whereas the other half contain three to eight genes (Allen *et al.* 2011). The distance between the genes in an operon is typically ~100 bp, but can be up to >2 kb-pairs (kb) (Morton and Blumenthal 2011a). First genes in the operons are either *trans*-spliced to SL1 or not *trans*-spliced. Downstream genes are *trans*-spliced predominantly to SL2, but some of them are also *trans*-spliced to SL1 at the same *trans*-splice site as SL2, and the ratio of SL2 is negatively correlated with the intergenic distance (Allen *et al.* 2011; Tourasse *et al.* 2017). Some downstream genes in operons are predominantly *trans*-spliced to SL1 due to transcription from intergenic promoters, and such operons are termed “hybrid” operons (Huang *et al.* 2007; Allen *et al.* 2011). Further variations in the structure of gene clusters and detailed lists of their examples are summarized in a previous article in WormBook (Blumenthal *et al.* 2015). Information about the positions of the *trans*-splice sites, as well as the ratio of SL1/SL2 *trans*-splicing for each gene, derived from a compendium of 1682 publicly available *C. elegans* RNA-seq data sets are now available (Tourasse *et al.* 2017). Operons appear to be highly stable in the genus *Caenorhabditis*; 96% of *C. elegans* operons are conserved in

Caenorhabditis briggsae (Stein *et al.* 2003). Features of *trans*-splicing and operons in nematodes and other organisms are summarized in a previous review article (Lasda and Blumenthal 2011).

cis-splicing

Similar to other multicellular organisms, *C. elegans* has an intron-rich genome, and intron excision from pre-mRNAs by the spliceosome—a process referred to as *cis*-splicing—is a fundamental step of gene expression (Figure 4B) (reviewed in a previous WormBook article (Zahler 2012)). A notable peculiarity of *C. elegans* introns is that many of them are relatively short compared to other metazoan introns; around half of *C. elegans* introns are <65 nt long, with 47 nt being the most commonly observed intron length (Lander *et al.* 2001; Spieth *et al.* 2014). Similar to other eukaryotes, *cis*-splicing in *C. elegans* involves base-pairing between the U1 snRNA and the 5' splice donor site (Figure 4B) (Thomas *et al.* 1990; Zahler *et al.* 2004) with a consensus sequence of AG/GUAAGUU (where / indicates the intron/exon boundary) (Figure 5A). It is important to note that in *C. elegans* (as in humans) a small portion of introns (<1%) begins with GC instead of GU (Farrer *et al.* 2002) (Burset *et al.* 2001). In addition, at least one intron begins with GA (H.K., unpublished data). The consensus sequence of the *C. elegans* 3' splice acceptor site—UUUUCAG/R (Figure 5B)—is recognized by U2 auxiliary factor (U2AF) (Figure 4B) (Zorio and Blumenthal 1999a; Hollins *et al.* 2005). U2AF is a heterodimer composed of U2AF⁶⁵ and U2AF³⁵ (UAF-1 and UAF-2, respectively, in *C. elegans*) (Zorio *et al.* 1997; Zorio and Blumenthal 1999b). In most metazoans, U2AF⁶⁵ recognizes the polypyrimidine tract separated from the 3'SS (Sickmier *et al.* 2006; Mackereth *et al.* 2011). In contrast, *C. elegans* lacks the polypyrimidine tract (Blumenthal and Steward 1997; Schwartz *et al.* 2008) and UAF-1 and UAF-2 recognize the U stretch and the AG dinucleotide, respectively, in the conserved octamer sequence of the 3'SS (Zorio and Blumenthal 1999a; Hollins *et al.* 2005). It is assumed that lariat formation occurs during splicing in *C. elegans* like in

other eukaryotes, but few studies experimentally addressed the branchpoints (Zahler 2012; Ragle *et al.* 2015) due to the very short and AU-rich nature of the introns. Unlike in budding yeast, branchpoint consensus is not found in sequence analysis of *C. elegans* introns, even though branchpoint binding protein ortholog *SFA-1* is essential for embryonic development (Mazroui *et al.* 1999).

A compendium of the publicly available *C. elegans* RNA-seq data sets from 96 individual studies, including >6.6 billion exon-exon junction reads, identified as many as 667,779 junctions in the genome (Tourasse *et al.* 2017). However, 78.8% of these splice junctions were detected only rarely (<100 reads over the datasets). In contrast, 97.6% of the reads came from 63,156 robustly detected junctions (>10,000 reads). Rare splice junctions (including those predicted in gene models in WormBase) may be derived from alternative splicing (discussed below), while some of these transcripts may represent sequencing errors or biological noise. In support of the latter idea, the total number of detected junctions per gene increases with the gene expression level (top 5% genes having on average ~70 junctions) and “rare” junctions are less evolutionarily conserved than more frequently used ones (Tourasse *et al.* 2017).

It is generally assumed that homologs of human and yeast splicing machinery components also function in splicing in *C. elegans* (Table 2). As *cis*-splicing is a critical step of pre-mRNA processing, crucial components of the splicing machinery are essential for embryonic development (Hebeisen *et al.* 2008). Forward and reverse genetic screens revealed that loss of function of many splicing machinery proteins leads to the Masculinization of Germline (Mog) phenotype (Puoti and Kimble 1999, 2000; Kasturi *et al.* 2010; Zanetti *et al.* 2011), germline overproliferation (Kerins *et al.* 2010), or distal tip cell migration phenotypes (Doherty *et al.* 2014). Recent extensive forward and reverse genetic studies of cryptic splicing in the *unc-73(e936)* allele that harbor a 5' SS mutation demonstrated functional roles for a conserved 27 kDa component of U4/U6-U5 tri-snRNP-specific proteins (SNRP-27) and a conserved U5 snRNP protein PRP-8 in maintaining the position of the 5' SS defined by U1 snRNA during rearrangements of the spliceosome (Zahler *et al.* 2018; Mayerle *et al.* 2019).

Mutations in splicing machinery genes can cause human diseases with specific symptoms such as autosomal dominant retinitis pigmentosa and spinal muscular atrophy (Daguenet *et al.* 2015; Carey and Wickramasinghe 2018), and *C. elegans* has been utilized as a model organism to study pathogenesis and potential therapeutics for such diseases (Briese *et al.* 2009; Sleight *et al.* 2011; Gao *et al.* 2014, 2019; Rubio-Peña *et al.* 2015; Wheway *et al.* 2015; Dimitriadis *et al.* 2016). RNA-seq analyses have identified many genes affected in such conditions, though how reduction of splicing machinery function leads to such specific phenotypes in *C. elegans* and other organisms is unknown.

There is an increasing appreciation for roles for pre-mRNA splicing homeostasis in aging. Expression of fluorescent *ret-1*

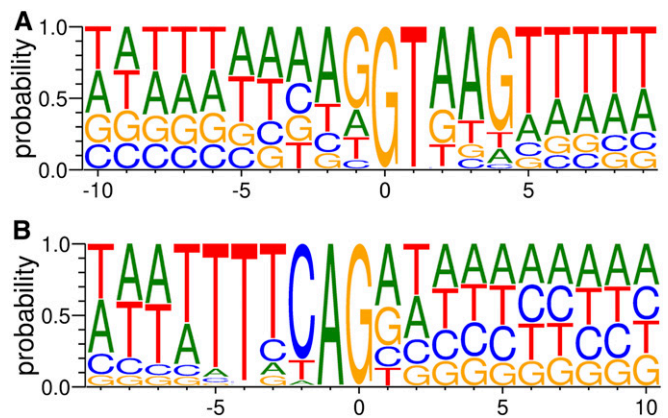

Figure 5 Sequence motifs of the 5' (A) and 3' (B) splice sites. Probability of the nucleotides at each position is displayed by using Weblogo version 3.7.1 (Crooks *et al.* 2004). The sequences of the introns are derived from 114,417 (5') and 114,006 (3') unique splice sites in 20-nt or longer introns annotated in WormBase (WS254). Position 0 indicates the beginning (A) and the end (B) of the introns.

splicing reporter minigenes (Kuroyanagi *et al.* 2013b) is deregulated with age, and dietary restriction (which extends lifespan) prolongs proper splicing regulation (Heintz *et al.* 2017). In addition, *sfa-1*, which encodes the *C. elegans* ortholog of branchpoint binding protein [BBP, also known as splicing factor 1 (SF1)], is required for maintenance of youthful splicing of the *ret-1* reporters as well as lifespan extension by dietary restriction (Heintz *et al.* 2017). RNA-seq analyses of endogenous mRNAs confirmed age-induced splicing deregulation, which is suppressed by dietary restriction in an *sfa-1*-dependent manner (Heintz *et al.* 2017). Although *SFA-1* is essential for embryonic development, and considered to be involved in branchpoint recognition in *C. elegans cis*-splicing (Mazroui *et al.* 1999), it is unclear whether *SFA-1* is globally required for intron excision because consensus sequences of the yeast/vertebrate branchpoint have not been found in *C. elegans* introns (Blumenthal and Steward 1997; Schwartz *et al.* 2008). Indeed, RNA-seq analyses revealed that genes whose splicing is affected by *sfa-1* knockdown upon dietary restriction are functionally enriched for metabolic processes, including lipid catabolism and carbohydrate transport (Heintz *et al.* 2017). Although the link between the longevity signals upon dietary restriction and *SFA-1* function is still unclear, this study provided functional relevance of splicing homeostasis and healthy aging.

Alternative splicing

Alternative pre-mRNA splicing is a process by which the exons of primary transcripts are joined in different combinations of splice sites to produce structurally and functionally distinct mRNA and protein variants and enables organisms to generate vast protein diversity from a limited number of genes (Matlin *et al.* 2005; Nilsen and Graveley 2010). In humans, ~95% of multi-exon genes undergo alternative splicing, most of which are regulated in a tissue- or cell-type-specific manner (Pan *et al.* 2008; Wang *et al.* 2008). Elementary alternative

Table 2 C. elegans orthologs of human spliceosome component proteins

<i>C. elegans</i>	Human Ortholog	Domains	Description
<i>snr-2</i>	SNRPB/Sm B/B'	L5m	Sm protein (Common in U1, U2, U4 and U5 snRNPs)
<i>snr-3</i>	SNRPDI/Sm D1	L5m	Sm protein (Common in U1, U2, U4 and U5 snRNPs)
<i>snr-4</i>	SNRPD2/Sm D2	L5m	Sm protein (Common in U1, U2, U4 and U5 snRNPs)
<i>snr-1</i>	SNRPD3/Sm D3	L5m	Sm protein (Common in U1, U2, U4 and U5 snRNPs)
<i>snr-6</i>	SNRPE/Sm E	L5m	Sm protein (Common in U1, U2, U4 and U5 snRNPs)
<i>snr-5</i>	SNRPF/Sm F	L5m	Sm protein (Common in U1, U2, U4 and U5 snRNPs)
<i>snr-7</i>	SNRPG/Sm G	L5m	Sm protein (Common in U1, U2, U4 and U5 snRNPs)
<i>gut-2</i>	LSM2/Lsm2	L5m	L5m protein (U6 snRNP)
<i>lsm-3</i>	LSM3/Lsm3	L5m	L5m protein (U6 snRNP)
<i>lsm-4</i>	LSM4/Lsm4	L5m	L5m protein (U6 snRNP)
<i>lsm-5</i>	LSM5/Lsm5	L5m	L5m protein (U6 snRNP)
<i>lsm-6</i>	LSM6/Lsm6	L5m	L5m protein (U6 snRNP)
<i>lsm-7</i>	LSM7/Lsm7	L5m	L5m protein (U6 snRNP)
<i>lsm-8</i>	LSM8/Lsm8	L5m	L5m protein (U6 snRNP)
<i>rnpl-7</i>	SNRNP70/U1-70K	U1 snRNP70, RRM	U1 snRNP
<i>rnpl-2</i>	SNRPA/U1A	RRM	U1 snRNP
<i>snrp-3</i>	SNRPC/U1C	U1 Zn finger	U1 snRNP
<i>prp-40</i>	PRPF40A/FBP11	WW, FF	U1 snRNP
<i>rbm-25</i>	RBM25/S164	RRM, PWI	U1 snRNP
<i>ddx-17</i>	DDX5/p68	DEAD-box helicase	U1 snRNP
<i>tcer-1, tcer-2</i>	TCERG1/CA150	WW, FF	U1 snRNP
<i>mog-2</i>	SNRPA1/U2A'	Leucine-rich repeat	U2 snRNP
<i>rnpl-3</i>	SNRPB2/U2B''	RRM	U2 snRNP
<i>prp-21</i>	SF3A1/SF3a120	SWAP, PRP21-like, Ubiquitin	U2 snRNP
<i>repo-1</i>	SF3A2/SF3a66	C2H2 Zn finger	U2 snRNP
<i>prp-9</i>	SF3A3/SF3a60	SF3a60 binding	U2 snRNP
<i>sftb-1</i>	SF3B1/SF3b155	Sf3b1	U2 snRNP
<i>sftb-2</i>	SF3B2/SF3b150	Proline-rich	U2 snRNP
<i>teg-4</i>	SF3B3/SF3b130	MMS1, CPSF A subunit region	U2 snRNP
<i>sap-49</i>	SF3B4/SF3b49	RRM	U2 snRNP
<i>moa-2</i>	SF3B5/SF3b10	SF3b10	U2 snRNP
<i>sftb-6</i>	SF3B6/SF3b14a	RRM	U2 snRNP
<i>phf-5</i>	PHF5A/SF3b14b	PHD-finger	U2 snRNP
<i>snu-13</i>	SNU13/hSnu13	L7Ae	U4/U6 snRNP
<i>prp-31</i>	PRPF31/hPrp31	snoRNA binding, Prp31	U4/U6 snRNP
<i>prp-3</i>	PRPF3/hPrp3	PWI, PRP3	U4/U6 snRNP
<i>prp-4</i>	PRPF4/hPrp4	PRP4-like, WD40 repeat	U4/U6 snRNP
<i>cyn-11</i>	PPIH/hCypH	Peptidyl-prolyl <i>cis-trans</i> isomerase	U4/U6 snRNP
<i>prp-8</i>	PRPF8/hPrp8	PROCN, RRM, U5-snRNA binding, U6-snRNA interacting, PRP8 domain IV, MPN, PROCT	U5 snRNP
<i>snrp-200</i>	SNRNP200/hBrr2	DEAD/DEAH box helicase	U5 snRNP
<i>eftu-2</i>	EFTUD2/hSnu114	GTP-binding, Elongation factor Tu, Elongation factor G	U5 snRNP
<i>snrp-40.1, snrp-40.2</i>	SNRNP40/U5-40K	WD40 repeat	U5 snRNP
<i>prp-6</i>	PRPF6/hPrp6	PRP1, TPR	U5 snRNP
<i>teg-1</i>	CD2BP2/hLin1	GYF	U5 snRNP
<i>dib-1</i>	TXNL4A/hDib1	DIM1	U5 snRNP
<i>ddx-23</i>	DDX23/hPrp28	DEAD-box helicase	U5 snRNP
<i>snrp-27</i>	SNRNP27/U4/U6.U5-27K		U4/U6.U5 tri-snRNP
<i>usp-39</i>	USP39/hSad1	Ubiquitin-hydrolases Zn finger, Ubiquitin carboxyl-terminal hydrolase	U4/U6.U5 tri-snRNP
<i>sart-1</i>	SART1/hSnu66	SART-1	U4/U6.U5 tri-snRNP
<i>rbm-42</i>	RBM42	RRM	U4/U6.U5 tri-snRNP

(continued)

Table 2 continued

<i>C. elegans</i>	Human Ortholog	Domains	Description
<i>uaf-1</i>	U2AF2/U2AF ⁶⁵	RRM	U2 related
<i>uaf-2</i>	U2AF1/U2AF ³⁵	CCCH Zn finger, RRM	U2 related
<i>rnp-6</i>	PUF60	RRM	U2 related
<i>smr-1</i>	SMNDC1/SPF30	SMN	U2 related
<i>dnj-30</i>	DNAJC8/SPF31	DnaJ	U2 related
<i>rbm-17</i>	RBM17/SPF45	G-patch, RRM	U2 related
<i>tag-65</i>	CHERP	SWAP, CTD-binding, G-patch	U2 related
<i>sap-140</i>	U2SURP/SR140	RRM, SWAP, cwf21	U2 related
<i>ddx-15</i>	DHX15/PRP43	DEAH-box helicase	U2 related
<i>ddx-46</i>	DDX46	DEAD-box helicase	U2 related
<i>hel-1</i>	DDX39B/UAP56	DEAD/H-box helicase	Transcription and export (TREX) complex
<i>aly-1, aly-2, aly-3</i>	ALYREF/Aly/REF	RRM, Fop	Transcription and export (TREX) complex
<i>thoc-1</i>	THOC1	Thoc1, Death domain	Transcription and export (TREX) complex
<i>thoc-2</i>	THOC2	Thoc2	Transcription and export (TREX) complex
<i>thoc-3</i>	THOC3	WD40 repeat, WD40-like beta propeller repeat	Transcription and export (TREX) complex
<i>luc-7L</i>	LUC7L	LUC7	A complex protein
<i>prp-39</i>	PRPF39	PRP39	A complex protein
<i>tiar-1, tiar-2, tiar-3</i>	TIA1	RRM, Q-rich	A complex protein
<i>bub-3</i>	BUB3	WD40 repeat	A complex protein
-	TRIR/MGC2803	TRIR	A complex protein
-	SUGP1/SF4	SWAP, G-patch	A complex protein
<i>ccar-1</i>	CCAR1/FU10839	S1-like RNA binding, DBC1, SAP	A complex protein
<i>cdk-11.1, cdk-11.2</i>	CDK11A/CDC2L2	Protein kinase	A complex protein
<i>cus-2</i>	HTATSF1/Tat SF1	RRM	A complex protein
<i>fust-1</i>	FUS/TLS	RRM, RanBP Zn finger	A complex protein
<i>rbm-5</i>	RBM5	RRM, RanBP Zn finger, G-patch	A complex protein
<i>rbm-5</i>	RBM10	RRM, RanBP Zn finger, G-patch	A complex protein
<i>sfa-1</i>	SF1	KH, CCHC Zn finger	A complex protein
<i>bud-13</i>	BUD13/MGC13125	Bud13	RES complex
<i>pmlr-1</i>	SNIP1	FHA	RES complex
<i>rbmx-2</i>	RBMX2/CGI-79	RRM	RES complex
<i>snu-23</i>	ZMAT2/hSnu23	dsRNA-binding Zn finger	B complex protein
<i>prp-38</i>	PRPF38A/hPrp38	PRP38	B complex protein
<i>mfap-1</i>	MFAP1	MFAP1	B complex protein
<i>ubl-5</i>	UBL5	Ubiquitin	B complex protein
<i>smu-2</i>	IK/RED	RED-like	B complex protein
<i>smu-1</i>	SMU1	WD40 repeat	B complex protein
<i>multiple genes</i>	HSPB1/HSP27	Hsp20	B complex protein
<i>dxbp-1</i>	KIN/HsKin17	Kin17 curved DNA-binding	B complex protein
<i>mtr-4</i>	MTREX/Skiv2L2	DEAD/DEAH box helicase	B complex protein
<i>prpf-4</i>	PRPF4B/hPrp4 kinase	Protein kinase	B complex protein
<i>pqbp-1.1, pqbp-1.2</i>	PQBP1/NPW38	WW	B complex protein
<i>wbp-11</i>	WBP11/NPW38BP	WBP11	B complex protein
<i>wbp-4</i>	WBP4/FBP21	U1 Zn finger, WW	B complex protein
<i>mog-4</i>	DHX16/hPrp2	DEAD/DEAH box helicase	B ^{act} complex protein
<i>let-858</i>	CWC22/KIAA1604	MIF4G, MA3	B ^{act} complex protein
<i>rf-113</i>	RNF113A	CCCH Zn finger, RING finger	B ^{act} complex protein
<i>cyn-16</i>	CWC27/NY-CO-10	Peptidyl-prolyl <i>cis-trans</i> isomerase	B ^{act} complex protein
<i>cyn-4</i>	PPIL2	Rtf2 RING finger, Peptidyl-prolyl <i>cis-trans</i> isomerase	B ^{act} complex protein
<i>ccdc-12</i>	CCDC12	cwf18	B ^{act} complex protein
<i>cyn-10</i>	PPIL3/PPIL3b	Peptidyl-prolyl <i>cis-trans</i> isomerase	B ^{act} complex protein
<i>gkow-1</i>	GPKOW/hSPP2	G-patch, KOW	B ^{act} complex protein
<i>prp-19</i>	PRPF19/Prp19	U-box, PRP19-like, WD40 repeat	Prp19 complex (nineteen complex, NTC)
<i>cdc-5L</i>	CDC5L/CDC5	Myb-like DNA-binding, Cdc5p/Cef1	Prp19 complex (nineteen complex, NTC)
<i>bcas-2</i>	BCAS2/SPF27	BCAS2	Prp19 complex (nineteen complex, NTC)
<i>syf-1</i>	XAB2/hSyf1	TPR	Prp19 complex (nineteen complex, NTC)
<i>syf-2</i>	SYF2/GCIP p29	SYF2	Prp19 complex (nineteen complex, NTC)
<i>syf-3</i>	CRNKL1/hSyf3	HAT repeat	Prp19 complex (nineteen complex, NTC)
<i>isy-1</i>	ISY1/hIsy1	Isy1-like	Prp19 complex (nineteen complex, NTC)

(continued)

Table 2 continued

<i>C. elegans</i>	Human Ortholog	Domains	Description
<i>ctnb-1</i>	CTNNB1/catenin beta like 1	Catenin-beta-like	Prp19 complex (nineteen complex, NTC)
<i>hsp-1, hsp-70, F44E5.4, F44E5.5, F11F1.1</i>	HSPA8/Hsp73	Hsp70	Prp19 complex (nineteen complex, NTC)
<i>rbm-22</i>	RBM22	RRM	NTC-related (NTR) complex
<i>skp-1</i>	SNW1/SKIP	SKIP/SNW	NTC-related (NTR) complex
<i>bud-31</i>	BUD31/G10	G10	NTC-related (NTR) complex
<i>cyn-12</i>	PPIL1	Peptidyl-prolyl <i>cis-trans</i> isomerase	NTC-related (NTR) complex
<i>cwc-15</i>	CWC15/AD-002	Cwf15/Cwc15	NTC-related (NTR) complex
<i>plrg-1</i>	PLRG1/PRL1	WD40 repeat	NTC-related (NTR) complex
<i>emb-4</i>	AQR/Aquarius	AAA	NTC-related (NTR) complex
<i>sel-13</i>	ZNF830/CCDC16	C2H2 Zn finger	Intron-binding complex (IBC)
<i>cyn-13</i>	PIIE/CypE	RRM, Peptidyl-prolyl <i>cis-trans</i> isomerase	Intron-binding complex (IBC)
<i>cwf-19L2</i>	CWF19L2	CwfJ	Intron-binding complex (IBC)
<i>F33D11.10, Y65B4A.6</i>	EIF4A3/eIF4A3	DEAD/DEAH box helicase	Exon junction complex (EJC)
<i>mag-1</i>	MAGOH	Mago nashi	Exon junction complex (EJC)
<i>mnp-4</i>	RBM8A/Y14	RRM	Exon junction complex (EJC)
<i>casc-3</i>	CASC3/MLN51	Btz	Exon junction complex (EJC)
<i>mog-1</i>	DHX38/hPrp16	DEAH-box helicase	Step 1 factor
<i>yju-2</i>	YJU2/CCDC94	YJU2	Step 1 factor
<i>mog-3</i>	CWC25/CCDC49	CIR, CWC25	Step 1 factor
<i>sacy-1</i>	DDX41/Abstrakt	DEAD-box helicase	C complex protein
<i>cacn-1</i>	CACTIN	Cactin	C complex protein
<i>ddx-35</i>	DHX35/DDX35	DEAH-box helicase	C complex protein
<i>gpch-1</i>	GPATCH1/Q9BRR8	G-patch	C complex protein
<i>cyn-15</i>	PPWD1	WD40 repeat, Peptidyl-prolyl <i>cis-trans</i> isomerase	C complex protein
<i>Y66D12A.8</i>	CXorf56	UPF0428	C complex protein
<i>T23G11.4</i>	C9orf78	HCA59	C complex protein
<i>cyn-8</i>	PIIG	Peptidyl-prolyl <i>cis-trans</i> isomerase	C complex protein
<i>C08H9.16</i>	FRA10AC1	Fra10Ac1	C complex protein
<i>frg-1</i>	FRG1	FRG1-like	C complex protein
<i>wdr-83</i>	WDR83/MORG1	WD40 repeat	C complex protein
<i>ess-2</i>	ESS2/DGCR14	Es2	C complex protein
<i>R05G6.4</i>	NOSIP	NOSIP	C complex protein
<i>sde-2</i>	SDE2/C1orf55	Sde2	C complex protein
<i>C47E8.4</i>	FAM50A, FAM50B	XAP5	C complex protein
<i>K01G5.8</i>	FAM32A	FA32A	C complex protein
<i>rsr-2</i>	SRRM2/SRm300	cwf21, SRRM	C complex protein
<i>prp-17</i>	CDC40/hPrp17	WD40 repeat	Step 2 factor
<i>prp-18</i>	PRPF18/hPrp18	PRP18	Step 2 factor
<i>mog-5</i>	DHX8/hPrp22	DEAH-box helicase	Step 2 factor
<i>sluh-7</i>	SLU7	Pre-mRNA splicing Prp18-interacting factor	Step 2 factor
<i>F37A4.2</i>	PRKRIP1	PRKRIP1	Step 2 factor

This table describes *C. elegans* orthologs or closest homologs of human spliceosomal protein components described in Wahl and Luhrmann (2015) with some updates.

splicing events can be classified into several types (Figure 6). A cassette exon is a discrete exon and can be either included in, or excluded from, an mRNA (Figure 6A); this is the most widely appreciated type of alternative splicing in humans as well as in *C. elegans* (Wang *et al.* 2008; Ramani *et al.* 2011). One splice site may be selected from two or more competitive 5' (Figure 6B) or 3' (Figure 6C) SSs in an exon. For mutually exclusive exons, only one out of two or more discrete exons is selected at a time in a mutually exclusive manner (Figure 6D). An intron can be either excised from, or included in, an mRNA (Figure 6E). Back splicing generates a circular

RNA by ligating a 5' SS of an exon to a 3' SS of the same or an upstream exon (Figure 6F). Alternative first exons (Figure 6G) are regulated by transcription start site selection, and alternative last exons (Figure 6H) are coupled with alternative polyadenylation (discussed below). Multiple elementary alternative splicing events within a gene, and even within an exon, can combinatorially expand the number of isoforms potentially produced by a single gene.

Alternative splicing occurs in ~23.5–35% of *C. elegans* genes, depending on the read cutoffs used for detection (Ramani *et al.* 2011; Tourasse *et al.* 2017). To visualize the

relative expression levels of possible splice variants, Tourasse *et al.* (2017) diagrammed the abundance of supporting reads for all splicing junctions for each of the 20,335 protein-coding genes in *C. elegans* (Tourasse *et al.* 2017). For instance, usage of each of four mutually exclusive exons in the *mrp-1* gene (Yabe *et al.* 2005) is supported by at least 7% of junction reads (Tourasse *et al.* 2017). In contrast, only one isoform is considered to be expressed for the *ant-1.1* gene, one of the most highly expressed genes in *C. elegans*, even though >50 isoforms were predicted in WormBase (WS251) and 170 other junctions were actually detected (Tourasse *et al.* 2017). RNA-seq analysis of *C. briggsae* suggested limited conservation of the alternative splicing events between *C. elegans* and *C. briggsae* (Uyar *et al.* 2012), although this result could also be explained readily by differences in the read depth and annotation quality between *C. elegans* and *C. briggsae*.

Early findings about splicing regulatory factors in *C. elegans* came from genetic suppressor screenings that unexpectedly identified mutations in U1 snRNA genes (Zahler *et al.* 2004) and RBP genes (Lundquist *et al.* 1996; Spike *et al.* 2001, 2002; Spartz *et al.* 2004; Dassah *et al.* 2009) as allele-specific suppressors. Our current understanding of factors and elements that influence specific alternative splicing events in *C. elegans* came from a number of technical advantages, such as the fact that *trans*-acting factors and *cis*-acting elements can be identified by genetic analysis with fluorescent reporter animals (Kuroyanagi *et al.* 2007, 2013a; Ohno *et al.* 2008), and the evolutionary conservation of *trans*-acting factors and their binding sequences (Kabat *et al.* 2006; Ray *et al.* 2013; Soufari and Mackereth 2017). The nonessential nature of many splicing regulators allows for analysis of partially spliced pre-mRNAs and insight into the specific order of intron excision (Ohno *et al.* 2008, 2012; Kuroyanagi *et al.* 2013a). RNA-seq analysis of splicing regulator mutants, as well as crosslinking and immunoprecipitation coupled with deep sequencing (CLIP-seq) analysis of the regulators, allow a global search for alternative splicing events and target genes in *C. elegans* (Kuroyanagi *et al.* 2013b; Norris *et al.* 2014; Ragle *et al.* 2015; Chen *et al.* 2016). With these advantages, it is now clear that alternative splicing events are coordinately regulated by multiple splicing regulators (Barberan-Soler *et al.* 2011; Amrane *et al.* 2014; Kuwasako *et al.* 2014; Norris *et al.* 2014; Tomioka *et al.* 2016; Tan and Fraser 2017).

Regulation of alternative splicing events and/or isoform-specific functions in *C. elegans* was discussed extensively in previous review articles (Zahler 2012; Gracida *et al.* 2016; Wani and Kuroyanagi 2017). Some highlights of those reviews include that regulatory mechanisms for tissue-specific mutually exclusive exons vary from gene to gene (Kuroyanagi *et al.* 2006, 2007, 2013a, 2014; Ohno *et al.* 2008), a fraction of the alternative splicing events are coupled with nonsense-mediated mRNA decay (NMD) (see below for details) (Barberan-Soler *et al.* 2011; Takei *et al.* 2016; Muir *et al.* 2018), a weak GC splice site can be used in alternative splicing regulation (Farrer *et al.* 2002; Ohno *et al.* 2008), and germlines tend to utilize proximal 3' splice sites that are

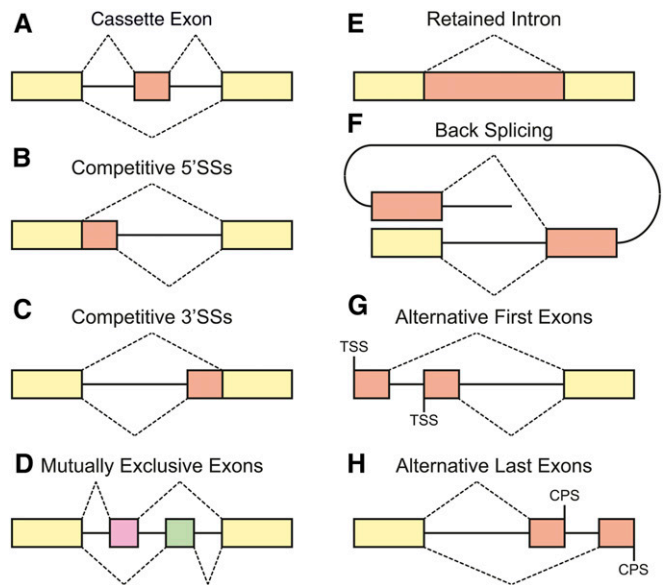

Figure 6 Schematic representations of elementary alternative splicing events. (A) Cassette exon. (B and C) Competitive 5'- (B) and 3'- (C) splice sites. (D) Mutually exclusive exons. (E) Retained intron. (F) Back splicing. (G) Alternative first exons. The first exon of an mRNA is selected by alternative promoters. TSS, transcription start site. (H) Alternative last exons. The last exon of an mRNA is selected in conjunction with alternative polyadenylation sites. CPS, cleavage and polyadenylation site.

not accompanied by pyrimidine stretches (Ragle *et al.* 2015). Here, we summarize alternative splicing regulation of genes that are not discussed in previous review articles.

Splice site usage can be affected by core components of the splicing machinery, and such events help illuminate mechanisms of splice site selection fidelity. *tos-1* (*target of splicing-1*) was originally identified as a gene whose pre-mRNA splicing pattern was altered in a temperature-sensitive mutant of *uaf-1* encoding U2AF large subunit U2AF⁶⁵; UAF-1 and SFA-1 facilitate recognition of weak 3' SSs of intron 1 and intron 2 of the *tos-1* gene (Ma *et al.* 2011). A B-complex-specific protein homolog MFAP-1 (Table 2) also affects splicing of *tos-1* intron 2 and exon 3 (Ma *et al.* 2012). Despite detailed analysis of its alternative splicing, the function of the *tos-1* gene is still unknown. Aging-induced changes in alternative splicing of the *tos-1* gene were used as a readout of SFA-1-mediated pre-mRNA splicing homeostasis (Heintz *et al.* 2017). Because overexpression of SFA-1 extends lifespan (Heintz *et al.* 2017), identification of critical target(s) for SFA-1 in alternative or constitutive splicing is of particular interest. Aging-induced splicing changes were confirmed for *ret-1* exon 5, *lip1-7* intron 4, *slo-2* cassette exon, and *lea-1* exon 10 (Heintz *et al.* 2017), yet their relevance to longevity is yet to be elucidated.

Neuron-type-specific alternative splicing can be achieved by specific combinations of splicing regulatory proteins that are regulated by transcription factors specifying the fate of the neurons. *sad-1* (*synapses of amphids defective-1*) encodes a conserved neuronal protein serine/threonine kinase that regulates axonal identity and synapse formation (Crump *et al.*

2001; Hung *et al.* 2007). Inclusion of *sad-1* exon 15, which carries a termination codon, leads to truncation of the SAD-1 C-terminus that includes the PDZ domain binding sequence (Hung *et al.* 2007). Only full-length SAD-1 protein, SAD-1(L), can physically interact with an F-actin binding scaffolding protein Neurabin (NAB-1) to control neuronal polarity, and with a pseudokinase STRD-1 to mediate synaptogenesis (Hung *et al.* 2007; Kim *et al.* 2010a,b). A dichromatic fluorescent reporter revealed that *sad-1* exon 15 is regulated in a neuron-type specific manner; motor neurons in the ventral nerve cord express both isoforms, a touch-sensing neuron ALM expresses only the inclusion isoform, and its sister neuron BDU expresses only the skipped isoform (Thompson *et al.* 2019). The neuron-type-specific alternative splicing of *sad-1* exon 15 is mediated by differential expression of multiple RBPs that are regulated by multiple neuron-type-specific transcription factors; co-expression of transcription factors UNC-86, MEC-3, and ALR-1 specifies the identity of ALM and controls expression of MEC-8 and a Muscleblind homolog MBL-1, leading to complete inclusion of exon 15 (Thompson *et al.* 2019). In excitatory motor neurons, MBL-1, and not MEC-8, is expressed, and exon 15 of *sad-1* is partially included, whereas in inhibitory motor neurons, another RBP, a Musashi homolog, MSI-1, is responsible for the partial inclusion of *sad-1* exon 15 (Thompson *et al.* 2019).

Although alternative splicing can, in theory, generate a large number of isoforms, depending on the locus, only a handful of isoforms may be observed. *lev-11* (*levamisole resistant-11*) is the sole gene encoding tropomyosin, an evolutionarily conserved actin-binding protein that influences actomyosin contractility and actin filament dynamics. It has two tissue-specific promoters, and two, three, two, and three mutually exclusive splicing events for exons 4, 5, 7, and 9, respectively (Kagawa *et al.* 1995; Anyanful *et al.* 2001). With this complex gene structure, the *lev-11* locus can potentially produce up to 72 distinct mRNAs/proteins and WormBase (WS271) predicts >20 distinct gene models. Extensive analyses of RT-PCR products, however, detected only six isoforms (Watabe *et al.* 2018). Dichromatic and trichromatic fluorescent splicing reporters revealed tissue-specific expression patterns; body wall muscles in the main body express *lev-11a* and *lev-11d*; pharynx and an excretory cell express *lev-11e*; the intestine and neurons express *lev-11c*; head muscles express *lev-11o*; and an unidentified tissue expresses *lev-11t* (Barnes *et al.* 2018; Watabe *et al.* 2018). We expect that future work using long-read RNA sequencing will clarify the observable populations in genes such as *lev-11* where only a subset of possible mRNA isoforms is expressed.

CircRNAs have recently been appreciated as common products of many eukaryotic protein-coding genes (Wilusz 2018). They are produced by a kind of alternative splicing termed back splicing (Figure 6F), which is facilitated by short intronic repeat sequences flanking an upstream 3' SS and a downstream 5' SS (Liang and Wilusz 2014). CircRNAs are highly stable and accumulate in cells (Zhang *et al.* 2016) because they are resistant to exonucleases. Certain vertebrate

circRNAs have multiple binding sites for specific miRNAs, and, thus, negatively regulate miRNA function by serving as a sponge (Hansen *et al.* 2013; Memczak *et al.* 2013). In *C. elegans*, at least 1166 circRNAs from 797 genes have been identified, and some of them accumulate with age (Memczak *et al.* 2013; Cortés-López *et al.* 2018), yet their functions remain to be elucidated.

Some alternative splicing events are conserved between *C. elegans* and mammals. PTB-1 is the sole *C. elegans* homolog of mammalian hnRNP proteins PTBP1 (also known as PTB) and PTBP2 (also known as neural PTB, nPTB). PTBP1 negatively auto-regulates its own expression by repressing splicing of the 34-nt exon 11 to elicit NMD (Wollerton *et al.* 2004), and negatively cross-regulates splicing of its paralogue PTBP2 by repressing a paralogous 34-nt exon (Boutz *et al.* 2007; Spellman *et al.* 2007). In *C. elegans*, PTB-1 represses inclusion of its own 34 nt orthologous exon to elicit NMD (Tomioka *et al.* 2016), demonstrating conservation of the gene structure and autoregulation of the PTB family. While it is known that PTB family proteins have four RNA-recognition motif (RRM) domains and binds to UC-rich sequences (Oberstrass *et al.* 2005), *cis*-elements for the *ptb-1* autoregulation remain to be identified.

These examples illustrate that alternative splicing in *C. elegans* is regulated in a cell-type-specific manner by multiple RBPs. The RBPs responsible may vary from gene to gene in the same cell type, as well as from cell type to cell type for the same gene. In order to elucidate the entire network of RBPs that regulates all the alternative pre-mRNA processing events in all the cell types in this organism, high-throughput analysis of cell-type-specific transcriptomes, as well as systematic characterization of conditional RBP mutant strains, will be needed. High-throughput genome-editing (Norris *et al.* 2017), deep single-cell RNA sequencing (Cao *et al.* 2017), isolation of intact RNAs from single tissues (Kunitomo *et al.* 2005; Spencer *et al.* 2011; Kaletsky *et al.* 2016), and long-read RNA sequencing will contribute to this ultimate goal.

Processing and 3' End Formation of mRNAs

Eventually, an elongating RNA polymerase II (Pol II) transcription complex reaches the end of the gene and transcription termination must occur. The 3' end of eukaryotic mRNAs are not formed simply by transcription termination, but rather by RNA processing. These RNA processing events include cleavage of the nascent transcript and poly(A) tail formation, both of which typically precede transcription termination. The poly(A) tails of eukaryotic mRNAs are important elements for nuclear export, translation, and stability (Mangus *et al.* 2003; Goldstrohm and Wickens 2008; Roy and Jacobson 2013). As with splicing, 3' end formation and polyadenylation can be regulated to generate mRNAs with different 3' UTRs, which can impact post-transcriptional gene regulation. While our understanding of the molecular mechanisms underlying 3' end formation and polyadenylation are more completely worked out in mammalian and yeast

systems, genetic screens, reporter analysis, and transcriptomics in *C. elegans* have revealed important insights into these regulatory steps, and will be the focus of this section.

mRNA 3' end formation and polyadenylation machinery and genetics

An evolutionarily conserved protein complex forms the poly (A) tail through endonucleolytic cleavage and template-independent polyadenylation of nascent pre-mRNAs (Table 3) (Chan *et al.* 2011; Shi and Manley 2015). Although there is considerable deviation in individual genes, the current consensus sequences for cleavage and polyadenylation in mammals consist of an upstream sequence conforming to the consensus UGUA, a U-rich upstream element (USE), AAUAAA or similar sequences 15–30 nt upstream of the cleavage and polyadenylation site (CPS), a CA dinucleotide immediately 5' to the CPS, and the U/GU-rich downstream element (DSE) (Figure 7) (Proudfoot 2011; Gruber *et al.* 2014; Shi and Manley 2015). Cleavage and polyadenylation specificity factor (CPSF) and cleavage stimulation factor (CstF) synergistically bind to the USE-AAUAAA hexamer and the DSE, respectively (MacDonald *et al.* 1994; Schönemann *et al.* 2014; Casañal *et al.* 2017; Clerici *et al.* 2018). Cleavage factor I (CF I_m) binds to the UGUA motif (Brown and Gilmartin 2003). These factors directly bind to the pre-mRNA to form a core complex, which, in turn, recruits other factors, including cleavage factor II (CFII_m), a scaffolding protein symplekin, and the poly(A) polymerase (PAP) to assemble the active 3' end processing complex (Chan *et al.* 2011; Shi and Manley 2015). The C-terminal domain (CTD) of the largest subunit of Pol II, which comprises tandem repeats of YSPTSPS heptads, facilitates cotranscriptional assembly of these factors (Hirose and Manley 2000; Proudfoot *et al.* 2002; Bentley 2005). Recently, a minimal machinery for cleavage and polyadenylation in yeast was reconstituted *in vitro*, and the cryo-EM structure of the complex was solved (Hill *et al.* 2019).

Factors functionally involved in cleavage and/or polyadenylation in *C. elegans* were first identified in an RNAi screen for suppressors of a Synthetic Multi-Vulva (SynMuv) phenotype of the *lin-15AB* (*n765*) mutant (Cui *et al.* 2008). The *Lin* phenotype of the *n765* allele is caused by premature transcription termination in a transposon integrated into the *lin-15AB* operon. Suppressors that restored expression of *lin-15A* (the downstream gene of the operon) were recovered and proposed to function by compromising transcription termination within the inserted transposon (Cui *et al.* 2008). This screen identified functional homologs of much of the eukaryotic cleavage and polyadenylation machinery, including CPSF subunit genes: *cpsf-1*, *cpsf-2*, and *cpsf-4*; CstF subunit genes: *cpf-1* and *cpf-2*; a symplekin gene *symk-1*; and a poly(A) polymerase gene *pap-1* (Table 3) (Cui *et al.* 2008). This screen also identified another group of genes, *cids-1*, *cids-2*, and *nrd-1*, encoding proteins with a Pol II CTD interacting domain (CID), although their function in 3' end formation remains to be elucidated. A *dpy-13* transcriptional readthrough

reporter that carries a GFP-fused tubulin cDNA downstream from the CPS was also used to identify cleavage and polyadenylation factors (Miki *et al.* 2017). Efficient repression of the *dpy-13* reporter readthrough requires the CPSF subunit genes *cpsf-1*, *cpsf-2*, *cpsf-3*, *cpsf-4*, *fipp-1*, and *pfs-2*, CstF subunit genes *cpf-2* and *suf-1*, a CFII_m subunit gene *pcf-11*, and *symk-1*, likely due to the functions of these proteins in 3' end cleavage (Miki *et al.* 2017). Chromatin immunoprecipitation coupled with high-throughput sequencing (ChIP-seq) analysis revealed peaks of CstF subunit proteins CPF-1 and CPF-2 almost overlapping with that of Pol II with Ser2-phosphorylated CTD at 0.5–0.6 kb downstream from the CPSs (Garrido-Lecca *et al.* 2016). These results indicated that functions of the factors involved in the 3' end processing of pre-mRNAs and termination of Pol II transcription are conserved, and that these processes are also coupled in *C. elegans*.

Termination of RNA polymerase II transcription

In eukaryotes, termination of Pol II transcription is not necessary for mRNA 3' end formation. Rather, efficient transcription termination requires 3' end processing of pre-mRNAs because these processes are functionally coupled. Here, we summarize the current models of this mechanism and the fate of pre-mRNAs downstream from the CPS. Two, nonmutually exclusive models for transcription termination have been proposed in mammals and yeast. In the “torpedo” model, pre-mRNA is first cleaved at the CPS (Kim *et al.* 2004b). For a subset of genes, the pre-mRNA is cleaved within the cotranscriptional cleavage (CoTC) site located downstream from the CPS (Teixeira *et al.* 2004; Nojima *et al.* 2013). Then, a processive 5'-to-3' exoribonuclease XRN2 (*Rat1p* in budding yeast) degrades the nascent RNA from a new 5' end and catches up with and disassembles the transcription elongation complex (Kim *et al.* 2004b; Teixeira *et al.* 2004; West *et al.* 2004; Nojima *et al.* 2013). In the alternative “conformational change” model, the transcription elongation complex is disassembled by factors associated with, and/or dissociated from, the Pol II CTD in a polyadenylation signal (PAS)-dependent, yet cleavage-independent, manner (Kim *et al.* 2004a; Zhang *et al.* 2005, 2015). As phosphorylation status of the YSPTSPS heptad repeats in the Pol II CTD is regulated dynamically during transcription cycles, CTD phosphatases are implicated in transcription termination (see below).

Experiments in *C. elegans* support both models of transcription termination. ChIP-seq analysis, revealed that Pol II with Ser2-phosphorylated CTD peaked ~0.5 kb downstream from the CPS (Garrido-Lecca *et al.* 2016), suggesting that Pol II pauses in this region to facilitate 3' end formation and transcription termination. Consistent with the “torpedo” model, temperature-sensitive alleles of *xrn-2* (an ortholog of human XRN2) were recovered in a forward genetic screen for mutants that allow transcriptional readthrough of the *dpy-13* reporter (described above) (Miki *et al.* 2017). However, additional experiments revealed two types of genes: those that depend on *xrn-2* for transcription termination and those that do not (Miki *et al.* 2017). When *xrn-2* was inhibited, pre-mRNAs of some genes, including *dpy-13*, were cleaved at

Table 3 Brief summary of factors considered to act in cleavage and polyadenylation in *C. elegans*

<i>C. elegans</i>	Human Ortholog	Domains	Description
Cleavage and polyadenylation specificity factor (CPSF)			
<i>cpsf-1</i>	CPSF160	MMS1_N, CPSF_A	Cleavage and polyadenylation specificity factor 160 kDa subunit
<i>cpsf-2</i>	CPSF100	Lactamase_B, Beta-Casp, RMMBL, CPSF100_C	Cleavage and polyadenylation specificity factor 100 kDa subunit, homologous to CPSF73
<i>cpsf-3</i>	CPSF73	Lactamase_B, Beta-Casp, RMMBL, CPSF73-100_C	Cleavage and polyadenylation specificity factor 73 kDa subunit, considered to be an endonuclease that cleaves pre-mRNAs at CPSs
<i>cpsf-4</i>	CPSF30	zf-CCCH, zf-CCHC	Cleavage and polyadenylation specificity factor 30 kDa subunit, ZF2 and ZF3 directly recognize AAUAAA
<i>fipp-1</i>	Fip1	Fip1	Pre-mRNA 3'-end-processing factor FIP1, binds to U-rich RNA
<i>pfs-2</i>	WDR33	six WD40 domains	Directly recognizes AAUAAA
<i>symk-1</i>	Symplekin	DUF3453, Symplekin C	Scaffold protein that functions as a component of a multimolecular complex involved in histone mRNA 3'-end processing. Is involved in pre-mRNA polyadenylation.
Cleavage stimulatory factor (CstF)			
<i>cpf-1</i>	CstF-50	CSTF1 dimer, five WD40 domains	Cleavage stimulation factor 50 kDa subunit
<i>cpf-2</i>	CstF-64	RRM, CSTF2 hinge, CSTF C	Cleavage stimulation factor 64 kDa subunit, recognizes DSE
<i>suf-1</i>	CstF-77	Suf	Cleavage stimulation factor 77 kDa subunit, stimulates CstF-64
Cleavage factor I _m (CF I _m)			
<i>cfim-1</i>	CF _m 25	NUDIX	Cleavage factor I _m complex 25 kDa subunit
<i>cfim-2</i>	CF _m 68, CF _m 59	RRM	Cleavage factor I _m complex 68 kDa subunit, Cleavage factor I _m complex 59 kDa subunit
Cleavage factor II _m (CF II _m)			
<i>pcf-11</i>	PCF11	CTD bind	Enhances transcription termination and 3' end processing, genome-wide in human cells
<i>clpf-1</i>	CLP1	CLP1 N, CLP1 P, Clp1	Polyribonucleotide 5'-hydroxyl-kinase
Poly(A) polymerase (PAP)			
<i>pap-1</i>	PAP-alpha, beta, gamma	PAP central, NTP transf 2, PAP RNA-bind	Poly(A) Polymerase
<i>pap-2</i>	PAP-alpha, beta, gamma	PAP central, NTP transf 2, PAP RNA-bind	Poly(A) Polymerase
<i>pap-3</i>	PAP-alpha, beta, gamma	PAP central, NTP transf 2, PAP RNA-bind	Poly(A) Polymerase

This table describes *C. elegans* orthologs of human proteins involved in 3' end processing.

the CPSs, yet Pol II did not terminate transcription, and some downstream genes in the same direction were processed into mature mRNAs (Miki *et al.* 2017). In the same experiments, other genes exhibited no transcription termination defect. CHIP-seq analysis of *XRN-2::GFP* suggested that, in both types of genes, *XRN-2* is recruited to promoter regions, travels along the gene bodies, and pauses just downstream from the CPSs together with Pol II (Miki *et al.* 2017). Fragment swapping of readthrough reporter minigenes suggested that it is the promoter regions that determine whether or not the transcription termination depends on *XRN-2* (Miki *et al.* 2017), although detailed mechanisms are yet to be determined. Interestingly, transcription termination of transcripts from *XRN-2*-independent genes requires a CPS downstream element of unknown composition (Miki *et al.* 2017).

A unique property of pre-mRNA processing of operon genes is that 3' end formation of the upstream genes is coupled with *trans*-splicing of the downstream genes and not with transcription termination (Blumenthal 2012; Blumenthal *et al.* 2015). Briefly, cleavage and polyadenylation of the upstream

mRNA occurs by a conventional mechanism (Garrido-Lecca *et al.* 2016), and the resulting 5'-phosphate end of the nascent RNA is subjected to *XRN-2*-mediated degradation (Miki *et al.* 2016). The downstream pre-mRNA is, however, protected from *XRN-2* by a U-rich (Ur) element proposed to recruit SL2 snRNP for *trans*-splicing (Graber *et al.* 2007; Lasda *et al.* 2010). Recently, it has been shown that expression of *xrn-2*, a downstream gene of the *rpl-43~xrn-2* operon, is negatively auto-regulated by *XRN-2* activity *in vivo* (Miki *et al.* 2016); *XRN-2* may compete with transcribing Pol II and/or the *trans*-splicing machinery to terminate transcription by the "torpedo" mechanism without affecting expression of the upstream *rpl-43* gene (Miki *et al.* 2016). *XRN-2* activity also affects expression of downstream genes in other operons, including *clpf-1*, by the same mechanism (Miki *et al.* 2016).

Alternative polyadenylation

Selection of an appropriate CPS can regulate gene expression. A diversity of techniques have been used to annotate *C. elegans* CPSs genome-wide, which has led to a more

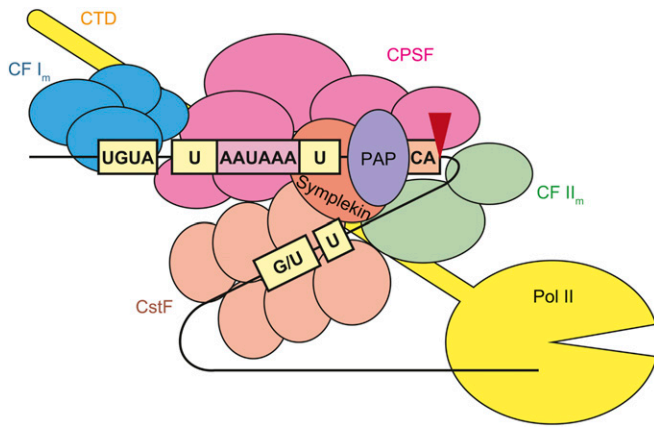

Figure 7 Schematic representations of core sequence elements and factors involved in cleavage and polyadenylation of mRNAs in mammals. Red arrowhead indicates CPS. CA, CA dinucleotide immediately 5' to the CPS; CTD, C-terminal domain of Pol II; CF I_m, mammalian cleavage factor I; CF II_m, mammalian cleavage factor II; CPSF, cleavage and polyadenylation specificity factor; CstF, cleavage stimulation factor; PAP, poly(A) polymerase; U, U-rich upstream element (USE); UGUA, upstream elements with UGUA consensus.

complete picture of cleavage and polyadenylation than would be possible from single reporter analyses (Mangone *et al.* 2010; Jan *et al.* 2011). At least one representative CPS has been identified in 83% of RefSeq mRNAs so far, and most CPSs in individual mRNAs are clustered within 4 nt of the representative CPS (Mangone *et al.* 2010; Jan *et al.* 2011). Searches for the most likely PAS within 50 nt upstream of each of the CPSs identified the canonical PAS motif AAUAAA in 39% of the CPSs and many PAS variants that differ by 1–2 nt in 48% of the CPSs (Mangone *et al.* 2010). The positions of both the canonical PAS motif and the PAS variants peaked 19 nt upstream of the CPS and were embedded within a U-rich region that extends ~20 nt beyond the CPS (Mangone *et al.* 2010; Jan *et al.* 2011) (Figure 8A). Surprisingly, ~13% of the CPSs lacked a detectable PAS motif (Mangone *et al.* 2010); such “no PAS” CPSs are within a U-rich region (Jan *et al.* 2011). The canonical PAS motifs were much more frequently found in nontrans-spliced (43% of 5131 CPSs) than in trans-spliced transcripts (30% of 14,873 CPSs), and more frequently in SL1-spliced nonoperon genes (32% of 10,879 CPSs) than in SL1-spliced operon genes (22% of 1409 sites), implying some correlation between 5'- and 3'-end processing.

About half of genes have more than one CPS (Mangone *et al.* 2010; Jan *et al.* 2011). Two or more closely spaced (usually 12–22 nt) CPSs may form an overlapping end region (OER) (Figure 8B), in which each of the CPSs contains a PAS motif; such PAS motifs are separated by a U-rich region that can serve as either an upstream or a downstream element depending on the CPS used (Jan *et al.* 2011). In total, 17,596 CPSs from 7116 OERs represent the largest currently known class of alternative mRNA isoforms in *C. elegans* (Jan *et al.* 2011). The end regions of 2448 genes even overlap with

those of convergent genes, contributing to genome compaction without significantly impacting regulatory autonomy (Jan *et al.* 2011).

Multiple CPSs in a single gene may be separated by 40 nt or more; 11,285 such upstream CPSs were identified in 31% of the Entrez genes with sequencing information (Jan *et al.* 2011) (Figure 8C). Among them, 8148 CPSs (72%) are within the same last exon as the 3'-most CPSs to form tandem CPSs (Jan *et al.* 2011). As miRNAs recognize complementary elements in 3' UTRs of their target mRNAs (Zisoulis *et al.* 2010), alternative choice of tandem CPSs may affect regulation by miRNAs (Jan *et al.* 2011; Blazie *et al.* 2017). The 3'-most or distal CPSs prefer a common PAS, whereas the proximal CPSs more often show no PAS (Mangone *et al.* 2010; Jan *et al.* 2011), consistent with the fact that the cleavage and polyadenylation machinery sometimes bypasses the proximal CPSs. Some of the upstream “no PAS” CPSs may be used upon physical constraint, such as queuing of Pol II (Mangone *et al.* 2010). In the rest of the multi-CPS genes, choice of the CPS is coupled with choice of alternative last exons (ALEs), often with distinct termination codons, thereby affecting the function of the protein products (Figure 8D). So far, 1398 ALEs have been identified across 1277 Entrez genes (Jan *et al.* 2011). Recent polyA-tagging and sequencing (PAT-Seq) analysis of mRNAs from eight somatic tissues revealed widespread tissue-specific alternative polyadenylation (Blazie *et al.* 2015, 2017). Regulation mechanisms for the alternative polyadenylation events coupled with ALEs are reported for *unc-60*, *unc-64*, and *cha-1/unc-17*; tissue-specific RBPs and/or RNA secondary structure have been shown to play switch-like roles (Ohno *et al.* 2012; Kuroyanagi 2013; Mathews *et al.* 2015; Chen *et al.* 2016).

Regulators of alternative polyadenylation have been identified in a suppressor screen for synaptogenesis and axon development phenotypes of a *sydn-1* null mutant (Van Epps *et al.* 2010; Chen *et al.* 2015). The neuronal phenotypes of the *sydn-1* mutant were suppressed by loss-/reduction-of-function or knockdown of *pfs-2*, *cpf-1*, *cpf-2*, *cpvf-2*, *pap-2* (*T15H9.6*), *cpvf-4*, *zfp-3* (encoding a zinc finger protein that can interact with CPF-2), *ssup-72* (encoding an ortholog of human and yeast CTD phosphatase SSU72), *symk-1*, *cids-1*, and *cids-2* (Van Epps *et al.* 2010; Chen *et al.* 2015), indicating that these genes are specifically required for the *sydn-1* neuronal phenotypes. Pol II occupancy analysis by ChIP-seq and reporter analysis revealed that inhibition of SSUP-72 activity by a nuclear protein, SYDN-1, at a strong internal PAS region of the endogenous *unc-44* locus is required for producing a neuron-specific isoform of *unc-44* (*unc-44f*) that utilizes the 3'-most PAS (Chen *et al.* 2015). Paradoxically, SYDN-1 inhibition of SSUP-72 promotes neuron-specific expression of an isoform of the *dlk-1* gene (*dlk-1S*) that utilizes a weak intronic PAS (Chen *et al.* 2015), indicating that the function of SSUP-72 is context-dependent. A *dlk-1* null mutation suppressed the axonal phenotype of the *sydn-1* null mutant (Chen *et al.* 2015), suggesting that this *sydn-1* phenotype is due to dysregulation of *dlk-1* alternative polyadenylation.

A Cleavage and Polyadenylation Signals

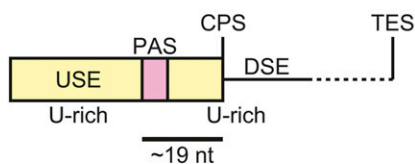

B Overlapping End Region

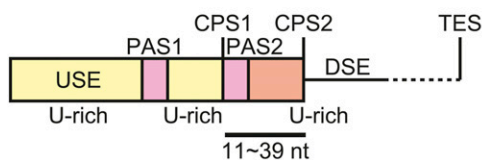

C Tandem CPSs

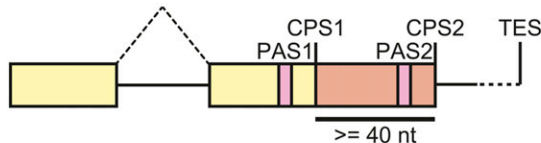

D Alternative Last Exons

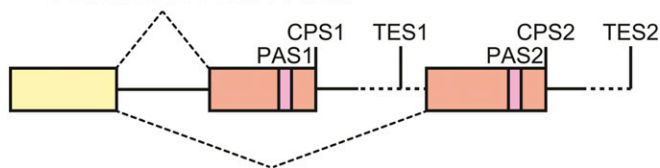

Figure 8 Schematic representations of *cis*-elements for 3' end processing of mRNAs in *C. elegans*. (A) Typical cleavage and polyadenylation signals. AAUAAA or related sequences embedded in a U-rich region functions as a polyadenylation signal (PAS). CPS, cleavage and polyadenylation site; DSE, downstream element; TES, transcription end site; USE, upstream element. (B) Overlapping end region (ORE). Two closely located (11–39 nt apart) CPSs have their own PAS and share a U-rich region as either DSE or USE. (C) Tandem cleavage and polyadenylation sites (CPSs). Two or more PASs and CPSs are located in the same last exon but are ≥ 40 nt apart. (D) Alternative last exons (ALEs). Choice of the CPS is coupled with choice of the last exon of an mRNA. Boxes represent exons and solid lines indicate introns or 3' flanking regions.

This study thus revealed mechanisms for neuron-specific alternative polyadenylation as well as the functions of neuron-specific protein isoforms.

Does length matter? Insights into poly(A) tails from genome-wide studies

Since poly(A) tails of eukaryotic mRNAs are important for nuclear export, translation, and stability, it has long been believed that longer poly(A) tails contribute more to mRNA stabilization and efficient translation, and that is true at pregastrulation stages of frog, zebrafish, and fruit fly embryos (Subtelny *et al.* 2014; Eichhorn *et al.* 2016; Lim *et al.* 2016). However, recent poly(A) tail profiling with TAIL-seq or PAL-seq protocols in eukaryotes, including *C. elegans*, reveal that short poly(A) tails are a feature of abundant and well-translated mRNAs (Chang *et al.* 2014; Subtelny *et al.* 2014; Park *et al.* 2016; Lima *et al.* 2017). For example, at the L4 stage,

90% of mRNA molecules had tail lengths between 26 and 132 nt, with the most abundant species of poly(A) tails being 33–34 nt (Lima *et al.* 2017); 33–34 nt is the size of one PABP footprint (Lima *et al.* 2017). In addition, a phasing pattern was observed, with peaks at the poly(A) tail lengths consistent with serial PABP binding (Lima *et al.* 2017), suggesting that unprotected 3' adenosines are trimmed. When looking at median overall poly(A) lengths of 13,601 individual protein-coding genes, the most frequent median length was 82 nt, with 90% of mRNAs having median tails ranging from 53 to 115 nt (Lima *et al.* 2017). Gene ontology (GO) analysis revealed that short-tailed transcripts were highly enriched for genes involved in translation, nucleosome components, and cuticular collagens, whereas long-tailed transcripts were enriched for genes with regulatory functions, such as transcription factors, signal transduction proteins, mediators of neuronal activity, and hormone receptors (Lima *et al.* 2017).

Processing of histone mRNAs

In metazoans, mRNAs of canonical, replication-dependent histone genes (H2a, H2b, H3, and H4) are not polyadenylated, but end in a 26-nt conserved structure with a stem-loop (Marzluff *et al.* 2008). During formation of the 3' end, the stem-loop is recognized by stem-loop binding protein (SLBP), and the pre-mRNAs are cleaved by the endonuclease subunit CPSF73 in CPSF with the help of the U7 snRNP, which binds to the histone downstream element (HDE) located downstream from the cleavage site (Strub and Birnstiel 1986; Mowry and Steitz 1987; Wang *et al.* 1996; Dominski *et al.* 2005; Kolev and Steitz 2005).

C. elegans has 64 histone genes that all harbor conserved 3' end sequences with a stem-loop structure and a highly conserved AATCC element immediately followed by at least one canonical PAS element (Pettitt *et al.* 2002; Keall *et al.* 2007). The majority of *C. elegans* histone mRNAs end 3–6 nt downstream from the hairpin structure and lack a poly(A) tail, as revealed by poly(A) selection, RNase protection assays, and sequencing analysis (Keall *et al.* 2007). The sole SLBP homolog in *C. elegans*, *CDL-1*, specifically binds to the conserved 16-nt hairpin sequence (Michel *et al.* 2000; Kodama *et al.* 2002). While knockdown of *cdl-1* does not significantly affect histone mRNA levels, it does severely deplete histone protein levels (Pettitt *et al.* 2002; Keall *et al.* 2007), consistent with the role of *CDL-1* in post-transcriptional control of histone gene expression. Surprisingly, the *C. elegans* genome lacks a U7 snRNA gene (Davila Lopez and Samuelsson 2008). Instead, CSR-1-bound endogenous small interfering RNAs (endo-siRNAs) produced by the RNA-dependent RNA polymerase (RdRP) *EGO-1* and the dicer-related helicase *DRH-3* are proposed to be involved in the processing of histone mRNAs (Avgousti *et al.* 2012).

Even though the majority of *C. elegans* histone mRNAs lack poly(A) tails (Keall *et al.* 2007), poly(A) profiling analyses revealed polyadenylated transcripts for 57 of the 64 histone genes (Mangone *et al.* 2010; Jan *et al.* 2011). These observations lend support to models in which the canonical

PAS elements ensure transcription termination, *i.e.*, *C. elegans* histone mRNAs are initially 3'-end-processed via cleavage and polyadenylation at the conserved PAS sites, followed by further processing to remove sequences downstream of the stem-loop (Mangone *et al.* 2010). Recently, it has been shown that total and polyadenylated mRNAs are upregulated for most of the replication-dependent and -independent histone genes in an *smn-1* null mutant (Gao *et al.* 2019). *C. elegans smn-1* is the sole ortholog of mammalian SMN proteins, which facilitate assembly of snRNPs, implying that some snRNPs may be involved in histone mRNA processing.

mRNA Quality Control: Counteracting Errors and Regulating Gene Expression

There is ample room for errors during mRNA processing and maturation. For example, the frequency of transcriptional errors in *C. elegans* has been estimated at $\sim 4 \times 10^{-6}$ (Gout *et al.* 2013). While this error frequency may seem low, the number and size of mRNA molecules produced in each cell guarantees some number of errors. For example, a cell with 10,000 mRNAs of an average length of 1500 nt and a transcriptional error frequency of 4×10^{-6} would be expected to harbor ~ 60 mRNAs with errors from transcription alone. The spliceosome is also not perfect: a meta-analysis of over 1000 *C. elegans* RNA-seq samples identified a persistent, low level of novel splice junctions (deemed “biological noise”), especially in highly transcribed mRNAs, where sensitivity to detect low-abundance isoforms would be expected to be greatest (Tourasse *et al.* 2017). As with errors that arise during DNA replication (*i.e.*, mutations), errors during mRNA production may be benign, or they may alter the encoded information, leading to gene products deleterious to the organism.

To ensure the fidelity of gene expression, and to mitigate the deleterious consequences of mistakes in mRNA production, *C. elegans* has quality control mechanisms that act on the intermediates and products of gene expression. The intermediates (mRNAs) and products (proteins) of gene expression are tested for certain properties, and a molecule that fails a test is often destroyed. In this manner, cells constantly scrutinize gene expression, prune errors, and effectively heighten the fidelity of gene expression. Many of these quality control pathways are conserved throughout eukaryotes. Here, we will focus on quality control pathways relating to protein-coding genes, though we note there is also quality control of ncRNAs, including ribosomal RNAs, tRNAs, and telomerase RNA (for reviews, see de la Cruz *et al.* 2015; Hopper and Huang 2015; Zinder and Lima 2017).

There are several distinct quality control pathways that collectively attenuate the levels and effects of a wide variety of errors. For example, mRNAs that are inefficiently spliced are often retained in the nucleus, effectively preventing their translation (*e.g.*, Shiimori *et al.* 2013). Misfolded proteins are recognized by chaperones, and either refolded or degraded (reviewed in Voisine *et al.* 2010). Double-stranded

RNAs are produced by some viruses, selfish genetic elements, and repetitive sequences and are edited or silenced, altering the encoded protein or preventing protein production altogether (Fire *et al.* 1998; Morse *et al.* 2002). Many quality control processes act cell-autonomously, though some can communicate across tissues (Prahlad *et al.* 2008; Sun *et al.* 2011). While these pathways collectively capture the products of a great diversity of errors, they are not perfect and they do have blind spots: some proteins escape or overwhelm quality control, misfold, and accumulate, leading to cellular and organismal dysfunction (Satyal *et al.* 2000; Parker *et al.* 2001).

It should be noted that, while many quality control processes have defined roles in mitigating the production and consequences of errors in gene expression, they serve other conserved functions as well, including regulation of endogenous gene expression. For example, NMD (discussed in detail in the next section) affects mRNA expression for a large fraction of the genome, including many apparently “normal” (*i.e.*, “error-free”) transcripts (Morrison *et al.* 1997; Barberan-Soler *et al.* 2009; Muir *et al.* 2018). In fungi, mammals, and plants, some quality control components and pathways function as antiviral factors, to help cells distinguish between “self” and “nonself” and fight invasions (Toh *et al.* 1978; Balistreri *et al.* 2014; Garcia *et al.* 2014). This remains an area of active research, and *C. elegans* will continue to contribute to the appreciation of the biological functions that quality control pathways provide.

One important class of quality control pathways are those acting at the level of translation. Collectively, these pathways are known as translation surveillance and involve communication between a ribosome and mRNA decay machinery. A schematic of the translational surveillance pathways we will overview in this chapter are depicted in Figure 9, and the names, domains, and functions of specific factors are tabulated (Table 4). These pathways prevent protein production from mRNAs with an early stop codon (NMD), mRNAs that lack a stop codon (Nonstop Decay), or mRNAs with a block to translation elongation (No-Go Decay). A theme of all three pathways is that failure of a ribosome to transit an mRNA in a timely or “normal” manner is coupled to mRNA decay. This has led to the view of translational surveillance pathways as enforcing a “translate or perish” rule on mRNAs (Brognia *et al.* 2016).

Nonsense-mediated mRNA decay discovery and genetics

NMD in *C. elegans* was discovered as an allele-specific, gene-nonspecific informational suppression phenomenon (Hodgkin *et al.* 1989). This origin is reflected in the naming of proteins that carry out NMD: Suppressor with Morphogenetic effect on Genitalia (*smg*, pronounced “smug”) are genes that, when inactivated, suppress certain alleles in unrelated genes (*dpy-5*, *lin-29*, *unc-54*, *tra-1*, *tra-2*) and also exhibit abnormal genitalia (a protruding vulva in the hermaphrodite and a swollen bursa in males). At least some *smg*-suppressible alleles are mutations of the 3' UTR downstream of an otherwise normal ORF (Hodgkin *et al.* 1989; Pulak and Anderson 1993). At the time of its discovery, this distinguished *smg*

from other informational suppression mechanisms, all of which directly altered the nature of information transfer in coding regions (e.g., nonsense suppressor tRNAs that recode some stop codons to an amino acid). Instead, it was suggested that SMGs act in mRNA metabolism.

This turned out to be the case, with an interesting twist: the SMG machinery acts to destabilize certain mRNAs in a translation-dependent manner (Losson and Lacroute 1979; Daar and Maquat 1988; Peltz *et al.* 1993; Pulak and Anderson 1993). *smg*-suppressible alleles produce mRNAs that encode functional proteins, but the mRNA is destabilized by the SMG machinery. In such cases, the mutant phenotype arises from decreased levels of functional protein rather than an mRNA that encodes a nonfunctional protein. Loss of a SMG protein allows for derepression of the mRNA (i.e., normal mRNA levels), and sufficient protein production for suppression of the mutant phenotype. A distinguishing feature of many *smg*-suppressible alleles is the presence of a premature stop codon, which can arise from mutation, frameshifts, and/or an abnormally long 3' UTR, to name but a few (Pulak and Anderson 1993; Longman *et al.* 2007). In such cases, the C-terminally truncated protein is apparently still functional. This is where the name NMD comes from (which we will hereafter use interchangeably with SMG): NMD is an mRNA decay process acting on certain nonsense (early stop codon) alleles. In at least one case, phenotypic suppression by *smg* may yield full-length protein via spontaneous readthrough of an early stop codon (*tra-3* (Hodgkin *et al.* 1989)); loss of NMD leads to an increase in mRNA levels and readthrough of stop codons in *S. cerevisiae* (Wang *et al.* 2001; Keeling *et al.* 2004). We note that while many early stop codon mutations will trigger degradation by NMD, not all such early stop codons will be phenotypically *smg*-suppressible; phenotypic *smg* suppression requires the truncated polypeptide be functional [for several examples of this, see *unc-54* (Pulak and Anderson 1993)].

A surprising feature of *C. elegans* is that its NMD system is nonessential, in contrast to other metazoans where loss of NMD is lethal (Medghalchi *et al.* 2001; Metzstein and Krasnow 2006; Wittkopp *et al.* 2009). This fact allows *C. elegans*' *smg* suppressors to be easily isolated via genetic screens or as spontaneous suppressors, both of which contributed to the isolation of *smg* genes in *C. elegans* (Hodgkin *et al.* 1989; Cali *et al.* 1999). It is not uncommon to unintentionally obtain spontaneous *smg* suppressors when growing large populations of mutant animals, where a mutation can suppress the mutant phenotype and improve growth and/or health of the animal. It is an outstanding question why NMD is essential in most animals but not in *C. elegans*; recent work suggests many metazoans (but not *C. elegans*) contain an apoptosis-promoting factor (GAD45Beta) that NMD must constitutively repress for viability (Nelson *et al.* 2016). Whatever the cause, the nonessential nature of *C. elegans*' NMD has had many positive outcomes, including:

(1) The ability to study and characterize functional effectors of NMD to learn how the NMD pathway works (see next section).

- (2) A view of mRNA metabolism in the absence of NMD, useful for analyzing more directly the products of transcription and splicing divorced from cellular efforts to erase errors in these processes (Morrison *et al.* 1997; Mitrovich and Anderson 2000; Barberan-Soler *et al.* 2009; Tourasse *et al.* 2017; Muir *et al.* 2018).
- (3) Reverse genetic tools to dissect gene function and expression, by combining *smg* mutants with construction of *smg*-suppressible alleles of a gene-of-interest (Wilkinson *et al.* 1994; Getz *et al.* 1997; Maher *et al.* 2013).

Many of the above studies have served as a genesis for models and studies in other organisms, and also benefited from discoveries in other species—a trend that we expect will continue into the future.

Mechanism of NMD

Soon after its discovery, it was appreciated that NMD is a widely conserved process throughout eukaryotes, including humans (Chang and Kan 1979; Losson and Lacroute 1979; Maquat *et al.* 1981; Hodgkin *et al.* 1989). The observation that a large fraction (~11–20%) of human inherited genetic diseases results from mutations that create an early stop codon pointed to NMD as an important player in a diverse swath of human health and disease (Mort *et al.* 2008). This realization stimulated much interest in understanding how NMD (Figure 9B) identifies target mRNAs and destroys them. However, there still is no consensus on many questions one might consider fundamental to an understanding of NMD. Below we describe observations and models in *C. elegans* and other systems, highlighting areas for future work.

One question central to NMD is how SMG proteins identify their targets. Translation is required for NMD, and all known NMD targets contain an early stop codon. These two observations spatiotemporally align translation termination and NMD and have led to the idea that some stop codons are deemed “premature” and are targeted by NMD. Consistent with the idea that there are qualitative or quantitative differences in recognition of premature and normal stop codons, ribosomal toeprints in *S. cerevisiae* and mammalian extracts are slightly longer on at least some NMD targets (Amrani *et al.* 2004; Peixeiro *et al.* 2012), and ribosomes in *C. elegans* protect different footprint sizes on NMD targets compared to non-NMD targets (Arribere and Fire 2018). While the physical basis for such effects remains unclear, these studies provide evidence that differences between premature and normal stop codons indeed exist at the level of translation.

One approach to address how premature stop codons are defined has been to analyze NMD targets and mutate features of interest. These studies point to the 3' UTR as being critical for NMD target definition, and we provide some exemplary alleles that do or do not elicit NMD in Figure 10.

One model for premature stop codon recognition is that NMD detects stop codons with downstream splicing events. In

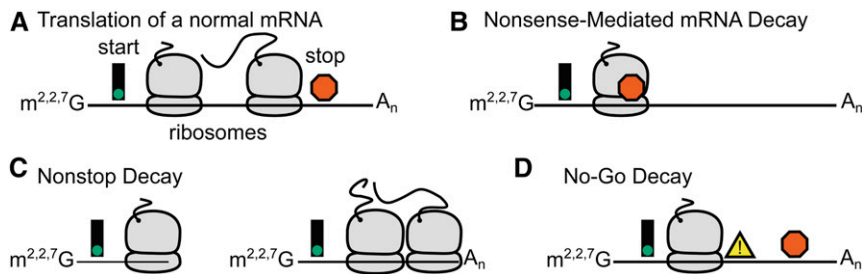

Figure 9 Translational surveillance pathways under consideration. (A) Translation of a normal mRNA. Ribosomes (gray) load near the trimethylguanosine cap (m^{2,2,7}G) and locate a start codon (green stop-light). Ribosomes elongate until they terminate at a stop codon (red octagon). Upon termination, protein is released, and ribosomes are recycled for further rounds of translation. (B) Nonsense-mediated mRNA decay (NMD) arises from translation termination at a premature stop codon. The mRNA is destabilized through the action of at least seven SMG

proteins. (C) Nonstop Decay arises from translation to the 3' end of an mRNA, which can arise from mRNA cleavage (left) or polyadenylation upstream of a stop codon (right). The mRNA and nascent protein are degraded, and the ribosome is rescued. (D) No-Go Decay arises when a ribosome stalls as a result of a roadblock during elongation (yellow triangle). Such roadblocks include RNA hairpins, rare codons, and polybasic (Arg or Lys) amino acid runs. As with Nonstop Decay, the mRNA and nascent protein are degraded, and the ribosome is rescued.

this model, translation termination upstream of an exon junction complex [deposited ~20–24 nt upstream of an exon junction (Le Hir *et al.* 2000)] gives rise to NMD. While this model has proven useful for understanding NMD targeting of some human mRNAs (Cheng *et al.* 1990; Zhang *et al.* 1998a,b), it cannot explain NMD in *S. cerevisiae*, which is thought to lack an exon junction complex. Furthermore, it cannot explain all NMD targeting in *C. elegans*, as NMD in *C. elegans* has been shown to act on mono-exonic transcripts [where splicing is not thought to happen, *e.g.*, *dpy-5* (Figure 10B)], and splicing downstream of a stop codon is neither necessary (Longman *et al.* 2007) nor sufficient (Figure 10D) (Roller *et al.* 2000) for NMD.

A second model from NMD substrate recognition is that premature stop codons are distinguished from normal stop codons by virtue of the length of the downstream 3' UTR. It is unclear what factors might sense 3' UTR length. Two overlapping possibilities are: (1) one or more SMG proteins detect 3' UTR length, and (2) 3' UTR length is sensed by interactions between a terminating ribosome and the PABP (Behm-Ansmant *et al.* 2007; Ivanov *et al.* 2008; Silva *et al.* 2008). However, an argument against a role for the PABP is that NMD can occur even on transcripts that lack a poly(A) tail (Meaux *et al.* 2008). Furthermore, in humans, there is a relatively poor correlation between 3' UTR length and susceptibility to NMD genome-wide, with many long 3' UTRs apparently resistant to NMD (Hurt *et al.* 2013; Toma *et al.* 2015). Interestingly, SMG-2 binds throughout the 3' UTR of NMD targets in mammals, though binding also occurs throughout the 3' UTRs of normal mRNAs, suggesting that the mere presence of SMG-2 is insufficient to discriminate NMD targets from nontargets (Hogg and Goff 2010; Hurt *et al.* 2013; Zund and Muhlemann 2013; Kurosaki *et al.* 2014).

Cellular identification of NMD targets requires the action of each of at least seven different SMG proteins, SMG-1 through SMG-7 (Hodgkin *et al.* 1989; Cali *et al.* 1999). SMG-1 through SMG-7 have functional homologs throughout metazoans, and at least SMG-2, SMG-3, and SMG-4 are conserved to *S. cerevisiae* (Upf1, Upf2, Upf3, respectively). Loss of any one of the seven *smg* genes yields nearly identical phenotypes

with respect to NMD, consistent with the idea that action of all seven SMG proteins is required for the NMD pathway (Pulak and Anderson 1993). Curiously, complete knockout of *smg-6* appears to be lethal, though the reasons for this are currently unknown (Cali and Anderson 1998). One possibility is that SMG-6 has essential functions outside of NMD; at least some SMG proteins have additional functions outside the NMD pathway [*e.g.*, SMG-2/Upf1 in Staufen-mediated decay (reviewed in Kim and Maquat 2019)]. Additionally, there may be other genes with a *smg* phenotype (Longman *et al.* 2007, 2013; Yamashita *et al.* 2009; Hug and Caceres 2014; Melero *et al.* 2016), but the role of at least some of these factors in NMD remains controversial (Rosains and Mango 2012).

The SMG proteins include several conserved domains that are known to act in RNA metabolism and in protein–protein interactions, suggesting SMGs act directly on RNA and interact with one another. Targeted studies of particular SMG proteins have provided glimpses of the NMD pathway in *C. elegans*. SMG-1 has a PIK3 kinase domain that is required for NMD, possibly via phosphorylation of SMG-2 (Page *et al.* 1999; Grimson *et al.* 2004). SMG-5/7 interact with SMG-2 and are required for its efficient dephosphorylation (Anders *et al.* 2003). Phospho-SMG-2 is bound preferentially to NMD targets (Johns *et al.* 2007; Muir *et al.* 2018), though it is unclear how this binding relates to other steps in the pathway (coming before/after NMD target identification) (Grimson *et al.* 2004). In humans, the phosphorylation state of SMG-2 changes during NMD and affects interactions with other SMG proteins and translational components, and it has been proposed that phospho-SMG-2 may serve as a binding site for mRNA decay effectors (Ohnishi *et al.* 2003; Kashima *et al.* 2006; Okada-Katsuhata *et al.* 2012). For more information on SMG proteins, their domains, and their functions, see Karousis *et al.* (2016).

Eventually, the SMG proteins bring about the demise of an NMD target mRNA by stimulating RNA decay. There are several possible mRNA decay pathways, with many of them reported as active on NMD targets in diverse eukaryotes including 3'→5' exonucleolytic decay, decapping and 5'→3' exonucleolytic decay, and endonucleolytic cleavage (*e.g.*,

Table 4 Brief summary of factors known to act in *C. elegans* translational surveillance

<i>C. elegans</i>	Human Ortholog	Domains	Description
Nonsense-mediated decay			
<i>smg-1</i>	SMG1	PI3Kinase	SMG-1 encodes a huge protein with a PI3K domain required for NMD, presumably via phosphorylation of SMG-2
<i>smg-2</i>	UPF1	RNA helicase, AAA	Binds mRNAs and is dynamically phosphorylated/dephosphorylated, with the phosphorylated form exhibiting a preference for NMD targets. Binding observed throughout 3'UTRs.
<i>smg-3</i>	UPF2	MIF4G, Upf2	SMG-2/3/4 interact and are thought to constitute a "core" NMD complex conserved in most eukaryotes.
<i>smg-4</i>	UPF3A and UPF3B	Upf3	SMG-2/3/4 interact and are thought to constitute a "core" NMD complex conserved in most eukaryotes.
<i>smg-5</i>	SMG5	PIN (catalytically inactive)	With SMG-7, required for efficient dephosphorylation of SMG-2
<i>smg-6</i>	SMG6	EST1, PIN	SMG-6 contains a PIN endoribonuclease domain required for NMD
<i>smg-7</i>	SMG7	EST1	With SMG-5, required for efficient dephosphorylation of SMG-2
<i>smgl-1</i>	NBAS	WD40	Identified alongside <i>smgl-2</i> ; loss-of-function via RNAi stabilizes some NMD targets. Complete loss-of-function thought to be lethal.
<i>smgl-2</i>	DHX34	DExH-box helicase	Identified alongside <i>smgl-1</i> ; loss-of-function via RNAi stabilizes some NMD targets. Complete loss-of-function thought to be lethal.
Nonstop/no-go decay			
<i>skih-2</i>	SKIV2L	DEAD-box helicase, rRNA processing Arch	Catalytic subunit of the SKI RNA helicase and is required for 3'>5' decay of Nonstop mRNAs
<i>ttc-37</i>	TTC37	Tetratricopeptide repeat	Scaffolding subunit of the SKI RNA helicase and is required for 3'>5' decay of Nonstop mRNAs
<i>pelo-1</i>	PELO	eRF1 domains 1, 2, and 3	Ribosome rescue factor required for release of ribosomes from Nonstop mRNAs; homologous to eRF1
<i>nonu-1</i>	N4BP2	P-loop Kinase, Cue, Smr	Putative endoribonuclease required for repression of Nonstop and No-Go mRNAs

This table describes factors currently known to act in translational surveillance in *C. elegans*. This list is not exhaustive, esp. for Nonstop/No-Go Decay where genetic screens for factors are far from saturated and several more factors are known in systems other than *C. elegans*. There is an extensive literature for many of these individual factors, and readers are referred to references and reviews for further reading (see main text).

Muhlrad and Parker 1994; Mitchell and Tollervey 2003; Gatfield and Izaurralde 2004). One technical hurdle to the study of NMD target decay mechanisms is the essential nature of much of the decay machinery: the exonucleolytic machinery implicated in NMD target removal is essential for mRNA decay generally, and inactivating mutations are largely lethal across metazoans, confounding experimental interpretation.

There is at least one RNA decay factor that is clearly genetically required for NMD target degradation: **SMG-6**. Fly and mammalian **SMG-6** proteins contain a PIN endonuclease domain with catalytic activity required for NMD, and it has been suggested that **SMG-6** directly cleaves NMD targets in those systems (Gatfield and Izaurralde 2004; Glavan *et al.* 2006; Huntzinger *et al.* 2008; Eberle *et al.* 2009). The **SMG-6** protein of *C. elegans* also contains a PIN domain, and catalytic residues of *C. elegans* **SMG-6** are also required for NMD (J.A., unpublished data). Cleavage activity of **SMG-6** is thus a central conserved feature of metazoan NMD, and it is possible this is an initiating event in degradation of NMD targets. We note that this is in contrast to *S. cerevisiae*, where the dominant model has long been that NMD triggers decapping followed by 5'>3' degradation of mRNA targets (Muhlrad and Parker 1994). However, other work identified a homolog of **SMG-6** in *S. cerevisiae* (Nmd4) that acts during NMD of at least some transcripts (He and Jacobson 1995; Dehecq *et al.* 2018). After cleavage, NMD target mRNA fragments are

further digested by exonucleases. As part of this in *C. elegans* and flies, the RNA helicase SKI and 3'>5' exosome are thought to degrade the mRNA 3'>5', and, with the help of the ribosome rescue factor PELO-1, dissociate any upstream straggling ribosomes (see section of endogenous roles for Nonstop/No-Go; Hashimoto *et al.* 2017; Arribere and Fire 2018).

Endogenous roles for NMD

Soon after its discovery, the idea emerged that NMD is a quality control pathway to prevent the accumulation of deleterious, and potentially dominantly acting, truncated proteins. Consistent with this idea, NMD changes the mode of inheritance of some premature stop codon-containing alleles from dominant to recessive. For example, in an NMD-deficient background (*smg(-)*), certain nonsense mutations in *unc-54* are dominant over wild-type *unc-54*, whereas, in an NMD-competent background (*smg(+)*), the same *unc-54* mutations are recessive (Cali and Anderson 1998). The effect depends on the position of the premature stop codon in relation to the domains of the **UNC-54** protein, as would be expected if the mechanism depended on the nature of the encoded protein. An explanation for these observations is that alleles encoding truncated proteins can be dominant negatives (antimorphs) and are normally kept in check by NMD-dependent destabilization of their mRNA. This model has proven useful to understand the mode of inheritance of certain disease-causing

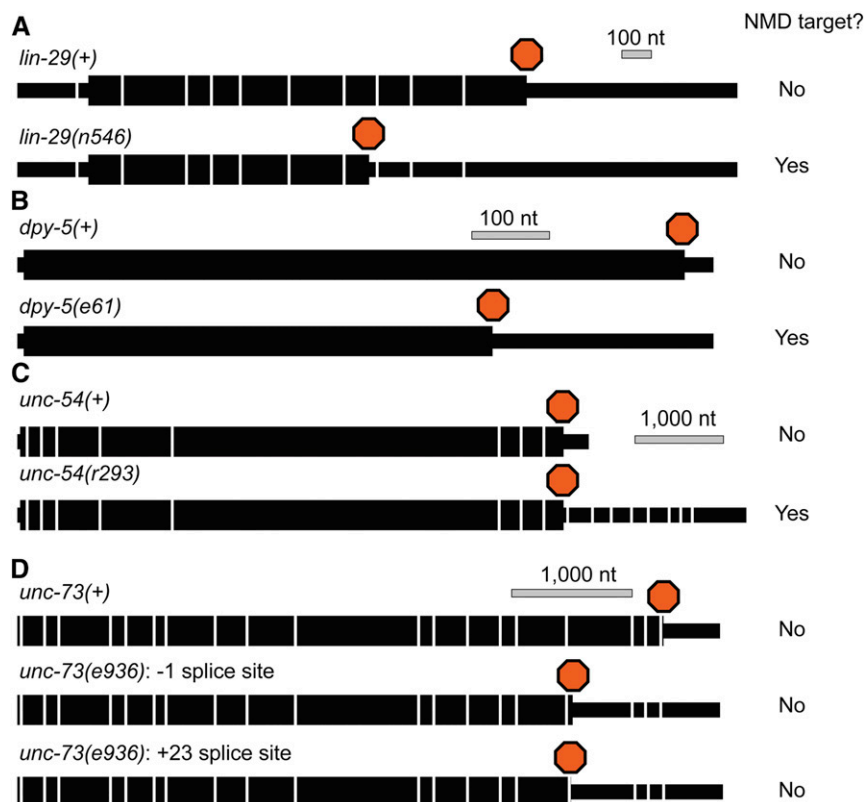

Figure 10 Schematic of mRNAs that do, or do not, trigger NMD. For each gene, the wild-type allele is diagrammed above a mutant allele. In the diagrams, exons are indicated by boxes, coding regions by thicker boxes, stop codons by red octagons and exon-exon junctions by white gaps. The scale bar shows 100 or 1000 nt for each mRNA. The far-right column indicates whether the allele is an NMD target or not. Examples were chosen to illustrate different classes of NMD targets and are not exhaustive (see text for further examples). Annotations were taken from Ensembl, with 3' UTR annotations from (Jan *et al.* 2011). (A) An example of a premature stop codon upstream of exon-exon junctions. *lin-29(n546)* is a smg-suppressible allele of *lin-29* (Hodgkin *et al.* 1989) that encodes an Arg > Stop mutation in the *lin-29* ORF (Rougvie and Ambros 1995). (B) An example of an NMD target from a mono-exonic gene. *dpy-5(e61)* is a Gly > Stop mutation (Thacker *et al.* 2006) that confers a smg-suppressible Dpy phenotype (Hodgkin *et al.* 1989). (C) An example of an allele that converts a normal stop codon to a premature stop codon. *unc-54(r293)* is a 256 bp deletion spanning the *unc-54* 3' UTR and poly(A) site that results in a fusion of the *unc-54* transcript with the downstream *aex-5* transcript. The *unc-54(r293)* allele is smg-suppressible (Hodgkin *et al.* 1989). The exact positions of the exon-exon junctions in the *unc-54(r293)* transcript are not known; the diagram represents a “best guess” based on the work of Pulak and Anderson

(1993), Loepold and Ahmed (2014) and the *aex-5* transcript. (D) An example of an allele that creates premature stop codons but does not elicit NMD. *unc-73(e936)* is a splice site mutation that leads to usage of two cryptic splice sites (–1 and +23 nt relative to the normal splice site) generating out-of-frame premature stop codons. Neither transcript is an NMD target, though the reasons for this are not known (Roller *et al.* 2000).

premature stop codon-containing alleles in humans (Miller and Pearce 2014).

A major source of NMD targets in wild-type organisms is pseudogenes. Pseudogenes are generally thought to be non-functional and imperfect copies of normal genes, and accumulate inactivating mutations and rearrangements through genetic drift. Many such mutations in pseudogenes shift the reading frame or introduce stop codons, making the pseudogene an NMD target. There are ~1600 annotated pseudogenes in *C. elegans* (Yates *et al.* 2016), with at least 131 pseudogene mRNAs destabilized in a smg-dependent manner (Mitrovich and Anderson 2005; Muir *et al.* 2018). Thus, a major function of NMD is to buffer cells from pseudogene-encoded products that might otherwise interfere with the functions of normal genes.

In addition to truncating mutations and pseudogenes, NMD affects expression of mRNAs from ~20% of genes in *C. elegans* (Ramani *et al.* 2009). The fraction of genes with mRNAs affected by NMD is similar in other eukaryotes (He *et al.* 2003; Mendell *et al.* 2004). A major challenge in analyzing gene expression differences in NMD-deficient strains is identifying what mRNA changes are the direct result of NMD vs. secondary effects. A better understanding of the NMD pathway will facilitate the identification of direct NMD targets from indirect effects, with recent work leveraging an evolving understanding of SMG-2 binding and RNA decay

processes toward this end (Arribere and Fire 2018; Muir *et al.* 2018).

The consensus from both genome-wide and individual gene studies is that NMD targets include many endogenous mRNAs that have an upstream ORF (uORF), a long 3' UTR, one or more 3' UTR-contained introns, or a splicing event that introduces a premature stop codon (Ramani *et al.* 2009). In such cases, NMD can serve a regulatory role. For example, mRNA expressed from *gna-2* contains two uORFs that elicit NMD (Lee and Schedl 2004). *gna-2* mRNA is also a target of the RNA binding protein GLD-1, which can act as a translational repressor. Upon GLD-1 binding, translation of the *gna-2* mRNA is blocked, NMD is prevented, and the mRNA is thus stabilized. In this example, NMD enables GLD-1-dependent mRNA stabilization of *gna-2* mRNA.

An important class of endogenous NMD targets are mRNAs with premature stop codons introduced by splicing. Such transcripts can arise from errors in splicing, and the ability to knockout the NMD pathway has led to a more complete picture of these events (Barberan-Soler *et al.* 2009; Tourasse *et al.* 2017). Spliced transcripts with premature stop codons can also be programmed, intentional, alternative splicing events. RBPs such as some ribosomal proteins and mRNA splicing factors can regulate the splicing of a premature stop-codon-containing exon in their own transcripts as a means to autoregulate functional protein levels (Morrison

et al. 1997; Mitrovich and Anderson 2000; Takei *et al.* 2016). The model of alternative splicing coupled to NMD has proven mutually beneficial to understand the regulation, substrates, and functions of both splicing and NMD in *C. elegans* and throughout metazoans (Lareau *et al.* 2007; Barberan-Soler *et al.* 2009; Hansen *et al.* 2009; Tourasse *et al.* 2017).

Organisms have co-opted NMD to regulate several endogenous mRNAs, involving NMD in many biological functions. While some examples are understood in molecular detail (*e.g.*, Lee and Schedl 2004), there are several known functions of NMD with an incompletely understood molecular basis. For example, *smg* mutants exhibit a protruding vulva (Pvl) phenotype, often associated with cellular proliferation defects, though the basis for this is unknown (Hodgkin *et al.* 1989). Work has shown that NMD is influenced by, or required for, normal aging and insulin signaling (Son *et al.* 2017). At least some SMG proteins also act in pathways other than NMD [SMG-2/UPF1 in staufen-mediated mRNA decay (Kim and Maquat 2019)]. We expect that the experimental tractability of *C. elegans* in general, and its NMD system in particular, coupled with its powerful research tools and a rich literature, will continue to enable insight on the intersection of NMD and organism function and physiology.

No-Go/Nonstop mRNA decay

While NMD is the most well-studied translational surveillance pathway, it is not the only one, and here we will discuss two additional pathways: Nonstop and No-Go Decay (Figure 9, C and D). Because of the close relationship between No-Go and Nonstop Decay, we will discuss them together. To date, *C. elegans* has sat on the sidelines while much of the discovery and characterization of No-Go and Nonstop Decay pathways has taken place in yeast and mammalian systems. We will describe the current models of No-Go and Nonstop Decay developed from these systems, and mention what is known about *C. elegans* in particular at the end. There has been a flood of molecular detail of No-Go/Nonstop discovered even since relatively recent reviews (Joazeiro 2017).

Nonstop Decay refers to the mRNA and protein loss that results from ribosomal stalling at the 3' end of an mRNA (Frischmeyer *et al.* 2002). No-Go Decay refers to the mRNA and protein loss that results from ribosomal stalling during translation elongation, *e.g.*, from a stretch of rare codons, polybasic amino acids, or structured RNAs (Doma and Parker 2006). No-Go and Nonstop Decay overlap substantially. For example, translation of the poly(A) tail during Nonstop Decay gives rise to polylysine, which can stall ribosomes and elicit No-Go Decay (Ito-Harashima *et al.* 2007). Both No-Go and Nonstop Decay elicit mRNA degradation as well as ubiquitination and degradation of the nascent protein chain (Dimitrova *et al.* 2009; Bengtson and Joazeiro 2010). A commonality between No-Go and Nonstop Decay is a failure of the ribosome to leave the mRNA in a timely fashion. In such cases, the ribosome does not fall off but remains bound at the stall site, even if the stall is simply a free 3' end. The stalled ribosome::mRNA complex marks the mRNA, and

recruits cellular machinery to the site to degrade the mRNA and nascent peptide.

How does a cell distinguish a terminally stalled ribosome from a ribosome that has transiently paused? One idea that has recently emerged from *S. cerevisiae* is that it is not a stalled ribosome that is recognized but rather a pile-up of ribosomes on an mRNA (Simms *et al.* 2017). As translation can occur on polyribosomes (multiple ribosomes bound on a single mRNA), if one ribosome stalls, the ribosomes that lie upstream will collide with it, forming a ribosomal traffic jam. Recent work supports the idea that the interface between collided ribosomes may recruit cellular decay machinery, with Cryo-EM structures of collided diribosomes highlighting a conserved interface between the small ribosomal subunits (Juszkiewicz and Hegde 2018; Ikeuchi *et al.* 2019).

After recognition of ribosomal stalling, three things take place (the temporal relationship of the first two processes is still unclear):

- (1) The mRNA is degraded. Both No-Go and Nonstop are thought to involve endonucleolytic cleavage in the vicinity of stalled ribosomes, as well as 3'>5' exonucleolytic decay facilitated by the SKI RNA helicase and the 3'>5' exosome (van Hoof *et al.* 2002; Doma and Parker 2006; Tsuboi *et al.* 2012; D'Orazio *et al.* 2019).
- (2) The ribosome is rescued. A specialized ribosome rescue factor (Dom34/Pelota with Hbs1) recognizes the stalled ribosome and recruits ABCE-1 for ribosomal splitting (Shoemaker *et al.* 2010; Pisareva *et al.* 2011; Young *et al.* 2015).
- (3) The nascent peptide chain is degraded in a process deemed "Ribosome Quality Control." After ribosomal subunit splitting, the peptidyl-tRNA remains bound to the 60S. Factors elongate the nascent chain with alanine and threonine, ubiquitinate the nascent peptide, and eventually degrade the protein (Bengtson and Joazeiro 2010; Shao and Hegde 2014; Shen *et al.* 2015; Kostova *et al.* 2017).

An initial study in *C. elegans* demonstrated that Nonstop Decay exists in this organism, though the machinery that executes repression was not able to be identified (Parvaz and Anderson 2007). At least one reason for this is that, in *C. elegans*, translation of many 3' UTRs is sufficient to repress protein expression through a poorly understood mechanism independent of No-Go and Nonstop Decay (Arribere *et al.* 2016). This added layer of repression may have caused early screens for Nonstop Decay factors to fail (Parvaz and Anderson 2007). An appreciation of the repressive effect of translation of the 3' UTR allowed subsequent work to remove the effect, leading to identification of functional homologs of the SKI RNA helicase (*skih-2* and *ttc-37*) as well as the pelota ribosome rescue factor (*pelo-1*) (Arribere and Fire 2018). Knockout of *skih-2* stabilizes Nonstop mRNA reporter levels, and knockout of *pelo-1* leads to an accumulation of stalled ribosomes on the same Nonstop mRNA reporter. It thus appears that *C. elegans* contains a Nonstop mRNA Decay

pathway mechanistically similar to that in yeast and mammals. Recent work also suggests *C. elegans* has a No-Go mRNA Decay pathway, and has identified a putative endoribonuclease (*nonu-1*) acting in both Nonstop and No-Go mRNA Decay (Glover *et al.* 2020), similar to work in *S. cerevisiae* (D'Orazio *et al.* 2019). There have been no reports to date on the fate of nascent peptides during No-Go/Nonstop Decay in *C. elegans*, though *C. elegans* contains homologs of factors known to act in these pathways in yeast and mammals.

Endogenous roles for No-Go/Nonstop Decay

As with NMD, cells have co-opted No-Go/Nonstop Decay to repress and regulate endogenous mRNAs. Because at least some mutants of Nonstop Decay factors are viable in *C. elegans*, translation can be examined in their absence and used to define endogenous Nonstop Decay targets (as is done with *smg* mutants to define targets of that pathway). While NMD targets can be examined by looking for changes in RNA-seq between *smg* and wild-type strains, with No-Go/Nonstop Decay targets, a modified ribosome footprint profiling technique is used to capture the ribosomes that stall in the absence of *skih-2* and *pelo-1* (Ingolia *et al.* 2009; Guydosh and Green 2014; Arribere and Fire 2018). This approach has revealed that endogenous Nonstop Decay targets include mRNAs that are endonucleolytically cleaved, for example the mRNA *xbp-1/hac1* in *C. elegans/S. cerevisiae* that regulates the unfolded protein response (Guydosh and Green 2014; Arribere and Fire 2018). mRNAs undergoing RNAi would also be expected to experience mRNA cleavage within their ORF, and recent work has shown these mRNAs are also targeted by Nonstop Decay in *C. elegans* (Pule *et al.* 2019), consistent with earlier findings in flies and plants (Orban and Izaurralde 2005; Hashimoto *et al.* 2017; Szádeczky-Kardoss *et al.* 2018). These studies illustrate that one function of Nonstop Decay is to efficiently dismantle ribosomes on an mRNA undergoing cotranslational degradation.

One function of the Nonstop Decay pathway in *C. elegans* and *Drosophila melanogaster* is to clear the degradation products of NMD (Hashimoto *et al.* 2017; Arribere and Fire 2018). In animals deficient for Nonstop Decay factors (lacking the RNA helicase *skih-2* and the ribosome rescue factor *pelo-1*), ribosomes accumulate at premature stop codons. The link between NMD and Nonstop Decay occurs after a committed step of mRNA decay in NMD: mutations in Nonstop factors do not appreciably derepress steady state levels of NMD targets, and *smg* mutations are epistatic to ribosomal stalling at premature stop codons (Arribere and Fire 2018). This work suggests that NMD funnels into Nonstop Decay, an axis that may inform an understanding of the NMD pathway as well as functions of Nonstop Decay. The relationship between NMD and Nonstop Decay is conserved between *C. elegans* and *D. melanogaster* (Hashimoto *et al.* 2017).

The picture attained so far shows important roles for Nonstop Decay in *C. elegans*. However, the study of endogenous

functions and targets for No-Go/Nonstop Decay has lagged behind similar studies of NMD targets. There are a number of technical issues that have stymied the study of endogenous No-Go/Nonstop functions, including:

1. Nonstop Decay targets have been systematically ignored by annotation software. Virtually all gene annotation programs require protein coding genes to have start and stop codons. Nonstop mRNA targets would violate this rule as they lack a stop codon. Historically, techniques to annotate polyadenylation sites suffered from high false positive rates inside coding regions [due to internal priming artifacts (Nam *et al.* 2002)], leading to skepticism about the existence of *bona fide* premature polyadenylation. However, other work has shown that Nonstop Decay targets can arise from premature polyadenylation in a coding region, generating stop-codon-less transcripts (Sparks and Dieckmann 1998; Ozsolak *et al.* 2010). The absence of a stop codon would cause Nonstop Decay targets to be either discarded or annotated as nonprotein-coding. An appreciation of this effect has led to manual annotation of Nonstop Decay mRNA targets in humans, but such efforts have not yet occurred in *C. elegans*.
2. There is still a relatively poor understanding of which endogenous mRNAs elicit No-Go Decay. This is in part because most No-Go Decay reporters include translational stalls, which are hyperbolic examples of what is observed in the genome. For example, No-Go Decay reporters in yeast and mammals often include 12 consecutive rare codons encoding basic amino acids, though such runs are rare in normal proteins. As No-Go Decay is not yet well studied in *C. elegans*, it remains unclear what structures or sequences stall ribosomes in a reporter context, let alone endogenous mRNAs. There are a few endogenous genes known to trigger No-Go Decay in *S. cerevisiae* (e.g., Brandman *et al.* 2012), and we expect that as an understanding of No-Go Decay evolves so too will the understanding of how No-Go acts on endogenous mRNAs.
3. Currently the experimental identification of endogenous No-Go/Nonstop Decay targets is more difficult than the identification of NMD targets. For NMD, a *smg* mutation confers a large-fold increase in the levels of NMD targets, as much as 10- to 20-fold, which can be detected readily by any number of techniques (RT-qPCR, northern, RNA-seq). For No-Go/Nonstop Decay, there are multiple redundant mechanisms acting to repress mRNA levels, and loss of any one mechanism has little, if any, detectable effect on total mRNA levels for its targets. For this reason, No-Go/Nonstop Decay targets are defined by monitoring the ribosomes that stall on them. As the understanding of No-Go/Nonstop Decay improves, it may become easier to experimentally identify targets.

Once these issues are resolved, we expect there will be greater insight into the role of No-Go/Nonstop Decay in normal animal physiology and function.

Concluding Remarks and Perspective

In the above sections, we have briefly outlined what is known about mRNA editing, splicing, and quality control in *C. elegans*. Historically, the rich literature and physiology of *C. elegans*, its vibrant research community, and the genetic tractability of *C. elegans* has proven to be powerful assets toward attaining insight into mRNA processing and regulation *in vivo*. We expect this trend to continue. We now have a greater appreciation for the complexity of mRNA processing and quality control, and expect that this view will facilitate deeper insight into the individual pathways of mRNA metabolism, as well as their combined effects on all mRNAs in the cell. Moving forward, the development and application of novel enrichment and high throughput techniques will be an exciting area with new discoveries. The genetic tractability, well-annotated cell types, and rich physiology of *C. elegans* will provide an important setting in which to apply such techniques, and to rigorously explore the role of mRNA metabolism in the normal health and life of an organism.

Acknowledgments

Work in the laboratory of J.A.A. is supported by the National Institutes of Health (NIH) (R01GM131012), the Searle Scholars Foundation, and startup funds from the University of California, Santa Cruz. Work in the laboratory of H.K. is supported by KAKENHI from Ministry of Education, Culture, Sports, Science and Technology of Japan (MEXT) or the Japan Society for the Promotion of Science (JSPS) [grant numbers JP20112004, JP25118506, JP26291003, JP15H01350, JP15H01467, JP15KK0252, JP17H03633, JP17H05596, JP20H03181, JP221S0002 and JP16H06279 (PAGS)], Precursory Research for Embryonic Science and Technology (PRESTO) from Japan Science and Technology Agency (JST) and Nanken-Kyoten from Tokyo Medical and Dental University (TMDU). Work in the laboratory of H.A.H. is supported by the American Cancer Society (RSG-15-051 RMC), the National Science Foundation (Award Number 1917050) and the NIH (R01GM130759).

Literature Cited

- Allen, M. A., L. W. Hillier, R. H. Waterston, and T. Blumenthal, 2011 A global analysis of *C. elegans* trans-splicing. *Genome Res.* 21: 255–264. <https://doi.org/10.1101/gr.113811.110>
- Amrane, S., K. Rebora, I. Zniber, D. Dupuy, and C. D. Mackereth, 2014 Backbone-independent nucleic acid binding by splicing factor SUP-12 reveals key aspects of molecular recognition. *Nat. Commun.* 5: 4595. <https://doi.org/10.1038/ncomms5595>
- Amrani, N., R. Ganesan, S. Kervestin, D. A. Mangus, S. Ghosh *et al.*, 2004 A faux 3'-UTR promotes aberrant termination and triggers nonsense-mediated mRNA decay. *Nature* 432: 112–118. <https://doi.org/10.1038/nature03060>
- Anders, K. R., A. Grimson, and P. Anderson, 2003 SMG-5, required for *C. elegans* nonsense-mediated mRNA decay, associates with SMG-2 and protein phosphatase 2A. *EMBO J.* 22: 641–650. <https://doi.org/10.1093/emboj/cdg056>

- Anyanful, A., Y. Sakube, K. Takuwa, and H. Kagawa, 2001 The third and fourth tropomyosin isoforms of *Caenorhabditis elegans* are expressed in the pharynx and intestines and are essential for development and morphology. *J. Mol. Biol.* 313: 525–537. <https://doi.org/10.1006/jmbi.2001.5052>
- Arribere, J. A., and A. Z. Fire, 2018 Nonsense mRNA suppression via nonstop decay. *eLife* 7: pii: e33292. <https://doi.org/10.7554/eLife.33292>
- Arribere, J. A., E. S. Cenik, N. Jain, G. T. Hess, C. H. Lee *et al.*, 2016 Translation readthrough mitigation. *Nature* 534: 719–723. <https://doi.org/10.1038/nature18308>
- Avgousti, D. C., S. Palani, Y. Sherman, and A. Grishok, 2012 CSR-1 RNAi pathway positively regulates histone expression in *C. elegans*. *EMBO J.* 31: 3821–3832. <https://doi.org/10.1038/emboj.2012.216>
- Bai, R., C. Yan, R. Wan, J. Lei and Y. Shi, 2017 Structure of the post-catalytic spliceosome from *Saccharomyces cerevisiae*. *Cell* 171: 1589–1598.e8. <https://doi.org/10.1016/j.cell.2017.10.038>
- Bai, R., R. Wan, C. Yan, J. Lei, and Y. Shi, 2018 Structures of the fully assembled *Saccharomyces cerevisiae* spliceosome before activation. *Science* 360: 1423–1429. <https://doi.org/10.1126/science.aau0325>
- Balistreri, G., P. Horvath, C. Schweingruber, D. Zund, G. McInerney *et al.*, 2014 The host nonsense-mediated mRNA decay pathway restricts Mammalian RNA virus replication. *Cell Host Microbe* 16: 403–411. <https://doi.org/10.1016/j.chom.2014.08.007>
- Barberan-Soler, S., N. J. Lambert, and A. M. Zahler, 2009 Global analysis of alternative splicing uncovers developmental regulation of nonsense-mediated decay in *C. elegans*. *RNA* 15: 1652–1660. <https://doi.org/10.1261/rna.1711109>
- Barberan-Soler, S., P. Medina, J. Estella, J. Williams, and A. M. Zahler, 2011 Co-regulation of alternative splicing by diverse splicing factors in *Caenorhabditis elegans*. *Nucleic Acids Res.* 39: 666–674. <https://doi.org/10.1093/nar/gkq767>
- Barnes, D. E., E. Watabe, K. Ono, E. Kwak, H. Kuroyanagi *et al.*, 2018 Tropomyosin isoforms differentially affect muscle contractility in the head and body regions of the nematode *Caenorhabditis elegans*. *Mol. Biol. Cell* 29: 1075–1088. <https://doi.org/10.1091/mbc.E17-03-0152>
- Bass, B., H. Hundley, J. B. Li, Z. Peng, J. Pickrell *et al.*, 2012 The difficult calls in RNA editing. Interviewed by H Craig Mak. *Nat. Biotechnol.* 30: 1207–1209. <https://doi.org/10.1038/nbt.2452>
- Bass, B. L., 2006 How does RNA editing affect dsRNA-mediated gene silencing? *Cold Spring Harb. Symp. Quant. Biol.* 71: 285–292. <https://doi.org/10.1101/sqb.2006.71.037>
- Bass, B. L., and H. Weintraub, 1987 A developmentally regulated activity that unwinds RNA duplexes. *Cell* 48: 607–613. [https://doi.org/10.1016/0092-8674\(87\)90239-X](https://doi.org/10.1016/0092-8674(87)90239-X)
- Bass, B. L., and H. Weintraub, 1988 An unwinding activity that covalently modifies its double-stranded RNA substrate. *Cell* 55: 1089–1098. [https://doi.org/10.1016/0092-8674\(88\)90253-X](https://doi.org/10.1016/0092-8674(88)90253-X)
- Behm-Ansmant, I., D. Gatfield, J. Rehwinkel, V. Hilgers, and E. Izaurralde, 2007 A conserved role for cytoplasmic poly(A)-binding protein 1 (PABPC1) in nonsense-mediated mRNA decay. *EMBO J.* 26: 1591–1601. <https://doi.org/10.1038/sj.emboj.7601588>
- Bengtson, M. H., and C. A. Joazeiro, 2010 Role of a ribosome-associated E3 ubiquitin ligase in protein quality control. *Nature* 467: 470–473. <https://doi.org/10.1038/nature09371>
- Bentley, D. L., 2005 Rules of engagement: co-transcriptional recruitment of pre-mRNA processing factors. *Curr. Opin. Cell Biol.* 17: 251–256. <https://doi.org/10.1016/j.ceb.2005.04.006>
- Bertram, K., D. E. Agafonov, O. Dybkov, D. Haselbach, M. N. Leelaram *et al.*, 2017a Cryo-EM structure of a pre-catalytic human spliceosome primed for activation. *Cell* 170: 701–713.e11. <https://doi.org/10.1016/j.cell.2017.07.011>

- Bertram, K., D. E. Agafonov, W. T. Liu, O. Dybkov, C. L. Will *et al.*, 2017b Cryo-EM structure of a human spliceosome activated for step 2 of splicing. *Nature* 542: 318–323. <https://doi.org/10.1038/nature21079>
- Billi, A. C., S. E. Fischer, and J. K. Kim, 2014 Endogenous RNAi pathways in *C. elegans* (May 7, 2014), *WormBook*, ed. The *C. elegans* Research Community, WormBook, doi/10.1895/wormbook.1.170.1, <http://www.wormbook.org>. <https://doi.org/10.1895/wormbook.1.170.1>
- Blazie, S. M., C. Babb, H. Wilky, A. Rawls, J. G. Park *et al.*, 2015 Comparative RNA-Seq analysis reveals pervasive tissue-specific alternative polyadenylation in *Caenorhabditis elegans* intestine and muscles. *BMC Biol.* 13: 4. <https://doi.org/10.1186/s12915-015-0116-6>
- Blazie, S. M., H. C. Geissel, H. Wilky, R. Joshi, J. Newbern *et al.*, 2017 Alternative polyadenylation directs tissue-specific miRNA targeting in *Caenorhabditis elegans* somatic tissues. *Genetics* 206: 757–774. <https://doi.org/10.1534/genetics.116.196774>
- Blumenthal, T., 2012 Trans-splicing and operons in *C. elegans* (November 20, 2012), *WormBook*, ed. The *C. elegans* Research Community, WormBook, doi/10.1895/wormbook.1.5.2, <http://www.wormbook.org>.
- Blumenthal, T., and K. Steward, 1997 RNA processing and gene structure in *C. elegans II*, edited by D. L. Riddle, T. Blumenthal, B. J. Meyer, and J. R. Priess. Cold Spring Harbor Laboratory Press, Cold Spring Harbor, NY.
- Blumenthal, T., D. Evans, C. D. Link, A. Guffanti, D. Lawson *et al.*, 2002 A global analysis of *Caenorhabditis elegans* operons. *Nature* 417: 851–854. <https://doi.org/10.1038/nature00831>
- Blumenthal, T., P. Davis, and A. Garrido-Lecca, 2015 Operon and non-operon gene clusters in the *C. elegans* genome (April 28, 2015), *WormBook*, ed. The *C. elegans* Research Community, WormBook, doi/10.1895/wormbook.1.175.1, <http://www.wormbook.org>.
- Bohnsack, K. E., C. Hobartner, and M. T. Bohnsack, 2019 Eukaryotic 5-methylcytosine (m⁵C) RNA methyltransferases: mechanisms, cellular functions, and links to disease. *Genes (Basel)* 10: pii: E102. <https://doi.org/10.3390/genes10020102>
- Boutz, P. L., P. Stoilov, Q. Li, C. H. Lin, G. Chawla *et al.*, 2007 A post-transcriptional regulatory switch in polypyrimidine tract-binding proteins reprograms alternative splicing in developing neurons. *Genes Dev.* 21: 1636–1652. <https://doi.org/10.1101/gad.1558107>
- Brandman, O., J. Stewart-Ornstein, D. Wong, A. Larson, C. C. Williams *et al.*, 2012 A ribosome-bound quality control complex triggers degradation of nascent peptides and signals translation stress. *Cell* 151: 1042–1054. <https://doi.org/10.1016/j.cell.2012.10.044>
- Briese, M., B. Esmaeili, S. Fraboulet, E. C. Burt, S. Christodoulou *et al.*, 2009 Deletion of *smn-1*, the *Caenorhabditis elegans* ortholog of the spinal muscular atrophy gene, results in locomotor dysfunction and reduced lifespan. *Hum. Mol. Genet.* 18: 97–104. <https://doi.org/10.1093/hmg/ddn320>
- Brogna, S., T. McLeod, and M. Petric, 2016 The meaning of NMD: translate or perish. *Trends Genet.* 32: 395–407. <https://doi.org/10.1016/j.tig.2016.04.007>
- Brown, K. M., and G. M. Gilmartin, 2003 A mechanism for the regulation of pre-mRNA 3' processing by human cleavage factor Im. *Mol. Cell* 12: 1467–1476. [https://doi.org/10.1016/S1097-2765\(03\)00453-2](https://doi.org/10.1016/S1097-2765(03)00453-2)
- Burset, M., I. A. Seledtsov, and V. V. Solovyev, 2001 SpliceDB: database of canonical and non-canonical mammalian splice sites. *Nucleic Acids Res.* 29: 255–259. <https://doi.org/10.1093/nar/29.1.255>
- Cali, B. M., and P. Anderson, 1998 mRNA surveillance mitigates genetic dominance in *Caenorhabditis elegans*. *Mol. Gen. Genet.* 260: 176–184. <https://doi.org/10.1007/s004380050883>
- Cali, B. M., S. L. Kuchma, J. Latham, and P. Anderson, 1999 smg-7 is required for mRNA surveillance in *Caenorhabditis elegans*. *Genetics* 151: 605–616.
- Campbell, Z. T., D. Bhimsaria, C. T. Valley, J. A. Rodriguez-Martinez, E. Menichelli *et al.*, 2012 Cooperativity in RNA-protein interactions: global analysis of RNA binding specificity. *Cell Rep.* 1: 570–581. <https://doi.org/10.1016/j.celrep.2012.04.003>
- Cao, J., J. S. Packer, V. Ramani, D. A. Cusanovich, C. Huynh *et al.*, 2017 Comprehensive single-cell transcriptional profiling of a multicellular organism. *Science* 357: 661–667. <https://doi.org/10.1126/science.aam8940>
- Carey, K. T., and V. O. Wickramasinghe, 2018 Regulatory potential of the RNA processing machinery: implications for human disease. *Trends Genet.* 34: 279–290. <https://doi.org/10.1016/j.tig.2017.12.012>
- Casañal, A., A. Kumar, C. H. Hill, A. D. Easter, P. Emsley *et al.*, 2017 Architecture of eukaryotic mRNA 3'-end processing machinery. *Science* 358: 1056–1059. <https://doi.org/10.1126/science.aao6535>
- Casella, G., D. Tsitsipatis, K. Abdelmohsen, and M. Gorospe, 2019 mRNA methylation in cell senescence. *Wiley Interdiscip. Rev. RNA* 10: e1547. <https://doi.org/10.1002/wrna.1547>
- Chan, S., E. A. Choi, and Y. Shi, 2011 Pre-mRNA 3'-end processing complex assembly and function. *Wiley Interdiscip. Rev. RNA* 2: 321–335. <https://doi.org/10.1002/wrna.54>
- Chang, H., J. Lim, M. Ha, and V. N. Kim, 2014 TAIL-seq: genome-wide determination of poly(A) tail length and 3' end modifications. *Mol. Cell* 53: 1044–1052. <https://doi.org/10.1016/j.molcel.2014.02.007>
- Chang, J. C., and Y. W. Kan, 1979 beta 0 thalassemia, a nonsense mutation in man. *Proc. Natl. Acad. Sci. USA* 76: 2886–2889. <https://doi.org/10.1073/pnas.76.6.2886>
- Cheng, J., M. Fogel-Petrovic, and L. E. Maquat, 1990 Translation to near the distal end of the penultimate exon is required for normal levels of spliced triosephosphate isomerase mRNA. *Mol. Cell. Biol.* 10: 5215–5225. <https://doi.org/10.1128/MCB.10.10.5215>
- Chen, L., Z. Liu, B. Zhou, C. Wei, Y. Zhou *et al.*, 2016 CELF RNA binding proteins promote axon regeneration in *C. elegans* and mammals through alternative splicing of Syntaxins. *eLife* 5: pii: e16072. <https://doi.org/10.7554/eLife.16072>
- Chen, F., Y. Zhou, Y. B. Qi, V. Khivansara, H. Li *et al.*, 2015 Context-dependent modulation of Pol II CTD phosphatase SSUP-72 regulates alternative polyadenylation in neuronal development. *Genes Dev.* 29: 2377–2390. <https://doi.org/10.1101/gad.266650.115>
- Chi, C., D. Ronai, M. T. Than, C. J. Walker, A. K. Sewell *et al.*, 2016 Nucleotide levels regulate germline proliferation through modulating GLP-1/Notch signaling in *C. elegans*. *Genes Dev.* 30: 307–320. <https://doi.org/10.1101/gad.275107.115>
- Clerici, M., M. Faini, L. M. Muckenfuss, R. Aebersold, and M. Jinek, 2018 Structural basis of AAUAAA polyadenylation signal recognition by the human CPSF complex. *Nat. Struct. Mol. Biol.* 25: 135–138 (erratum: *Nat. Struct. Mol. Biol.* 25: 355). <https://doi.org/10.1038/s41594-017-0020-6>
- Cortés-López, M., M. R. Gruner, D. A. Cooper, H. N. Gruner, A. I. Voda *et al.*, 2018 Global accumulation of circRNAs during aging in *Caenorhabditis elegans*. *BMC Genomics* 19: 8. <https://doi.org/10.1186/s12864-017-4386-y>
- Covelo-Molares, H., M. Bartosovic, and S. Vanacova, 2018 RNA methylation in nuclear pre-mRNA processing. *Wiley Interdiscip. Rev. RNA* 9: e1489. <https://doi.org/10.1002/wrna.1489>
- Crooks, G. E., G. Hon, J. M. Chandonia, and S. E. Brenner, 2004 WebLogo: a sequence logo generator. *Genome Res.* 14: 1188–1190. <https://doi.org/10.1101/gr.849004>
- Crump, J. G., M. Zhen, Y. Jin, and C. I. Bargmann, 2001 The SAD-1 kinase regulates presynaptic vesicle clustering and axon termination. *Neuron* 29: 115–129. [https://doi.org/10.1016/S0896-6273\(01\)00184-2](https://doi.org/10.1016/S0896-6273(01)00184-2)

- Cui, M., M. A. Allen, A. Larsen, M. Macmorris, M. Han *et al.*, 2008 Genes involved in pre-mRNA 3'-end formation and transcription termination revealed by a lin-15 operon Muv suppressor screen. *Proc. Natl. Acad. Sci. USA* 105: 16665–16670. <https://doi.org/10.1073/pnas.0807104105>
- Daar, I. O., and L. E. Maquat, 1988 Premature translation termination mediates triosephosphate isomerase mRNA degradation. *Mol. Cell. Biol.* 8: 802–813. <https://doi.org/10.1128/MCB.8.2.802>
- Daguenet, E., G. Dujardin, and J. Valcarcel, 2015 The pathogenicity of splicing defects: mechanistic insights into pre-mRNA processing inform novel therapeutic approaches. *EMBO Rep.* 16: 1640–1655. <https://doi.org/10.15252/embr.201541116>
- Dassah, M., S. Patzek, V. M. Hunt, P. E. Medina, and A. M. Zahler, 2009 A genetic screen for suppressors of a mutated 5' splice site identifies factors associated with later steps of spliceosome assembly. *Genetics* 182: 725–734. <https://doi.org/10.1534/genetics.109.103473>
- Davila Lopez, M., and T. Samuelsson, 2008 Early evolution of histone mRNA 3' end processing. *RNA* 14: 1–10. <https://doi.org/10.1261/rna.782308>
- Deffit, S. N., B. A. Yee, A. C. Manning, S. Rajendren, P. Vadlamani *et al.*, 2017 The *C. elegans* neural editome reveals an ADAR target mRNA required for proper chemotaxis. *eLife* 6: pii: e28625. <https://doi.org/10.7554/eLife.28625>
- Dehecq, M., L. Decourty, A. Namane, C. Proux, J. Kanaan *et al.*, 2018 Nonsense-mediated mRNA decay involves two distinct Upf1-bound complexes. *EMBO J.* 37: pii: e99278. <https://doi.org/10.15252/embj.201899278>
- de la Cruz, J., K. Karbstein, and J. L. Woolford, Jr., 2015 Functions of ribosomal proteins in assembly of eukaryotic ribosomes in vivo. *Annu. Rev. Biochem.* 84: 93–129. <https://doi.org/10.1146/annurev-biochem-060614-033917>
- Dezi, V., C. Ivanov, I. U. Haussmann, and M. Soller, 2016 Nucleotide modifications in messenger RNA and their role in development and disease. *Biochem. Soc. Trans.* 44: 1385–1393 [corrigenda: *Biochem. Soc. Trans.* 47: 957 (2019)]. <https://doi.org/10.1042/BST20160110>
- Dickinson, D. J., and B. Goldstein, 2016 CRISPR-based methods for *Caenorhabditis elegans* genome engineering. *Genetics* 202: 885–901. <https://doi.org/10.1534/genetics.115.182162>
- Dimitriadis, M., A. Derdowski, G. Kallou, M. S. Maginnis, P. O'Hern *et al.*, 2016 Decreased function of survival motor neuron protein impairs endocytic pathways. *Proc. Natl. Acad. Sci. USA* 113: E4377–E4386. <https://doi.org/10.1073/pnas.1600015113>
- Dimitrova, L. N., K. Kuroha, T. Tatematsu, and T. Inada, 2009 Nascent peptide-dependent translation arrest leads to Not4p-mediated protein degradation by the proteasome. *J. Biol. Chem.* 284: 10343–10352. <https://doi.org/10.1074/jbc.M808840200>
- Doherty, M. F., G. Adelmant, A. D. Cecchetelli, J. A. Marto, and E. J. Cram, 2014 Proteomic analysis reveals CACN-1 is a component of the spliceosome in *Caenorhabditis elegans*. *G3 (Bethesda)* 4: 1555–1564. <https://doi.org/10.1534/g3.114.012013>
- Doma, M. K., and R. Parker, 2006 Endonucleolytic cleavage of eukaryotic mRNAs with stalls in translation elongation. *Nature* 440: 561–564. <https://doi.org/10.1038/nature04530>
- Dominski, Z., X. C. Yang, and W. F. Marzluff, 2005 The polyadenylation factor CPSF-73 is involved in histone-pre-mRNA processing. *Cell* 123: 37–48. <https://doi.org/10.1016/j.cell.2005.08.002>
- D'Orazio, K. N., C. C. Wu, N. Sinha, R. Loll-Krippelber, G. W. Brown *et al.*, 2019 The endonuclease Cue2 cleaves mRNAs at stalled ribosomes during No Go Decay. *eLife* 8: pii: e49117. <https://doi.org/10.7554/eLife.49117>
- Eberle, A. B., S. Lykke-Andersen, O. Muhlemann, and T. H. Jensen, 2009 SMG6 promotes endonucleolytic cleavage of nonsense mRNA in human cells. *Nat. Struct. Mol. Biol.* 16: 49–55. <https://doi.org/10.1038/nsmb.1530>
- Eichhorn, S. W., A. O. Subtelny, I. Kronja, J. C. Kwasniewski, T. L. Orr-Weaver *et al.*, 2016 mRNA poly(A)-tail changes specified by deadenylation broadly reshape translation in *Drosophila* oocytes and early embryos. *eLife* 5: pii: e16955. <https://doi.org/10.7554/eLife.16955>
- Eisenberg, E., and E. Y. Levanon, 2018 A-to-I RNA editing - immune protector and transcriptome diversifier. *Nat. Rev. Genet.* 19: 473–490. <https://doi.org/10.1038/s41576-018-0006-1>
- Evans, D., D. Zorio, M. MacMorris, C. E. Winter, K. Lea *et al.*, 1997 Operons and SL2 trans-splicing exist in nematodes outside the genus *Caenorhabditis*. *Proc. Natl. Acad. Sci. USA* 94: 9751–9756. <https://doi.org/10.1073/pnas.94.18.9751>
- Farrer, T., A. B. Roller, W. J. Kent, and A. M. Zahler, 2002 Analysis of the role of *Caenorhabditis elegans* GC-AG introns in regulated splicing. *Nucleic Acids Res.* 30: 3360–3367. <https://doi.org/10.1093/nar/gkf465>
- Fica, S. M., C. Oubridge, W. P. Galej, M. E. Wilkinson, X. C. Bai *et al.*, 2017 Structure of a spliceosome remodelled for exon ligation. *Nature* 542: 377–380. <https://doi.org/10.1038/nature21078>
- Fica, S. M., C. Oubridge, M. E. Wilkinson, A. J. Newman, and K. Nagai, 2019 A human postcatalytic spliceosome structure reveals essential roles of metazoan factors for exon ligation. *Science* 363: 710–714. <https://doi.org/10.1126/science.aaw5569>
- Fire, A., S. Xu, M. K. Montgomery, S. A. Kostas, S. E. Driver *et al.*, 1998 Potent and specific genetic interference by double-stranded RNA in *Caenorhabditis elegans*. *Nature* 391: 806–811. <https://doi.org/10.1038/35888>
- Fischer, S. E., 2010 Small RNA-mediated gene silencing pathways in *C. elegans*. *Int. J. Biochem. Cell Biol.* 42: 1306–1315. <https://doi.org/10.1016/j.biocel.2010.03.006>
- Frischmeyer, P. A., A. van Hoof, K. O'Donnell, A. L. Guerrero, R. Parker *et al.*, 2002 An mRNA surveillance mechanism that eliminates transcripts lacking termination codons. *Science* 295: 2258–2261. <https://doi.org/10.1126/science.1067338>
- Frye, M., B. T. Harada, M. Behm, and C. He, 2018 RNA modifications modulate gene expression during development. *Science* 361: 1346–1349. <https://doi.org/10.1126/science.aau1646>
- Galej, W. P., M. E. Wilkinson, S. M. Fica, C. Oubridge, A. J. Newman *et al.*, 2016 Cryo-EM structure of the spliceosome immediately after branching. *Nature* 537: 197–201. <https://doi.org/10.1038/nature19316>
- Ganem, N. S., N. Ben-Asher, A. C. Manning, S. N. Deffit, M. C. Washburn *et al.*, 2019 Disruption in A-to-I editing levels affects *C. elegans* development more than a complete lack of editing. *Cell Rep.* 27: 1244–1253.e4. <https://doi.org/10.1016/j.celrep.2019.03.095>
- Gao, X., Y. Teng, J. Luo, L. Huang, M. Li *et al.*, 2014 The survival motor neuron gene *smn-1* interacts with the U2AF large subunit gene *uaf-1* to regulate *Caenorhabditis elegans* lifespan and motor functions. *RNA Biol.* 11: 1148–1160. <https://doi.org/10.4161/rna.36100>
- Gao, X., J. Xu, H. Chen, D. Xue, W. Pan *et al.*, 2019 Defective expression of mitochondrial, vacuolar H⁺-ATPase and histone genes in a *C. elegans* model of SMA. *Front. Genet.* 10: 410. <https://doi.org/10.3389/fgene.2019.00410>
- Garcia, D., S. Garcia, and O. Voinnet, 2014 Nonsense-mediated decay serves as a general viral restriction mechanism in plants. *Cell Host Microbe* 16: 391–402. <https://doi.org/10.1016/j.chom.2014.08.001>
- Garrido-Lecca, A., T. Saldi, and T. Blumenthal, 2016 Localization of RNAPII and 3' end formation factor CstF subunits on *C. elegans* genes and operons. *Transcription* 7: 96–110. <https://doi.org/10.1080/21541264.2016.1168509>

- Garfield, D., and E. Izaurralde, 2004 Nonsense-mediated messenger RNA decay is initiated by endonucleolytic cleavage in *Drosophila*. *Nature* 429: 575–578. <https://doi.org/10.1038/nature02559>
- Getz, S., S. Xu, and A. Fire, 1997 Temperature sensitive smg mutations as a tool to engineer conditional expression. ...a progress report. *Worm Breed. Gaz.* 14: 26.
- Glavan, F., I. Behm-Ansmant, E. Izaurralde, and E. Conti, 2006 Structures of the PIN domains of SMG6 and SMG5 reveal a nucleosome within the mRNA surveillance complex. *EMBO J.* 25: 5117–5125. <https://doi.org/10.1038/sj.emboj.7601377>
- Glover, M. L., A. M. Burroughs, P. C. Monem, T. A. Egelhofer, M. N. Pule *et al.*, 2020 NONU-1 encodes a conserved endonuclease required for mRNA translation surveillance. *Cell Rep.* 30: 4321–4331.e4. <https://doi.org/10.1016/j.celrep.2020.03.023>
- Goldstein, B., L. Agranat-Tamir, D. Light, O. Ben-Naim Zgayer, A. Fishman *et al.*, 2017 A-to-I RNA editing promotes developmental stage-specific gene and lncRNA expression. *Genome Res.* 27: 462–470. <https://doi.org/10.1101/gr.211169.116>
- Goldstrohm, A. C., and M. Wickens, 2008 Multifunctional deadenylase complexes diversify mRNA control. *Nat. Rev. Mol. Cell Biol.* 9: 337–344. <https://doi.org/10.1038/nrm2370>
- Gott, J. M., and R. B. Emeson, 2000 Functions and mechanisms of RNA editing. *Annu. Rev. Genet.* 34: 499–531. <https://doi.org/10.1146/annurev.genet.34.1.499>
- Gout, J. F., W. K. Thomas, Z. Smith, K. Okamoto, and M. Lynch, 2013 Large-scale detection of in vivo transcription errors. *Proc. Natl. Acad. Sci. USA* 110: 18584–18589. <https://doi.org/10.1073/pnas.1309843110>
- Graber, J. H., J. Salisbury, L. N. Hutchins, and T. Blumenthal, 2007 *C. elegans* sequences that control trans-splicing and operon pre-mRNA processing. *RNA* 13: 1409–1426. <https://doi.org/10.1261/rna.596707>
- Gracida, X., A. D. Norris, and J. A. Calarco, 2016 Regulation of tissue-specific alternative splicing: *C. elegans* as a model system. *Adv. Exp. Med. Biol.* 907: 229–261. https://doi.org/10.1007/978-3-319-29073-7_10
- Grimson, A., S. O'Connor, C. L. Newman, and P. Anderson, 2004 SMG-1 is a phosphatidylinositol kinase-related protein kinase required for nonsense-mediated mRNA Decay in *Caenorhabditis elegans*. *Mol. Cell. Biol.* 24: 7483–7490. <https://doi.org/10.1128/MCB.24.17.7483-7490.2004>
- Gruber, A. R., G. Martin, W. Keller, and M. Zavolan, 2014 Means to an end: mechanisms of alternative polyadenylation of messenger RNA precursors. *Wiley Interdiscip. Rev. RNA* 5: 183–196. <https://doi.org/10.1002/wrna.1206>
- Guydosh, N. R., and R. Green, 2014 Dom34 rescues ribosomes in 3' untranslated regions. *Cell* 156: 950–962. <https://doi.org/10.1016/j.cell.2014.02.006>
- Hansen, K. D., L. F. Lareau, M. Blanchette, R. E. Green, Q. Meng *et al.*, 2009 Genome-wide identification of alternative splice forms down-regulated by nonsense-mediated mRNA decay in *Drosophila*. *PLoS Genet.* 5: e1000525. <https://doi.org/10.1371/journal.pgen.1000525>
- Hansen, T. B., T. I. Jensen, B. H. Clausen, J. B. Bramsen, B. Finsen *et al.*, 2013 Natural RNA circles function as efficient microRNA sponges. *Nature* 495: 384–388. <https://doi.org/10.1038/nature11993>
- Haselbach, D., I. Komarov, D. E. Agafonov, K. Hartmuth, B. Graf *et al.*, 2018 Structure and conformational dynamics of the human spliceosomal B^{act} complex. *Cell* 172: 454–464.e11. <https://doi.org/10.1016/j.cell.2018.01.010>
- Hashimoto, Y., M. Takahashi, E. Sakota, and Y. Nakamura, 2017 Nonstop-mRNA decay machinery is involved in the clearance of mRNA 5'-fragments produced by RNAi and NMD in *Drosophila melanogaster* cells. *Biochem. Biophys. Res. Commun.* 484: 1–7. <https://doi.org/10.1016/j.bbrc.2017.01.092>
- Hebeisen, M., J. Drysdale, and R. Roy, 2008 Suppressors of the cdc-25.1(gf)-associated intestinal hyperplasia reveal important maternal roles for prp-8 and a subset of splicing factors in *C. elegans*. *RNA* 14: 2618–2633. <https://doi.org/10.1261/rna.1168408>
- Heintz, C., T. K. Doktor, A. Lanjuin, C. Escoubas, Y. Zhang *et al.*, 2017 Splicing factor 1 modulates dietary restriction and TORC1 pathway longevity in *C. elegans*. *Nature* 541: 102–106 (erratum: *Nature* 547: 476). <https://doi.org/10.1038/nature20789>
- He, F., and A. Jacobson, 1995 Identification of a novel component of the nonsense-mediated mRNA decay pathway by use of an interacting protein screen. *Genes Dev.* 9: 437–454. <https://doi.org/10.1101/gad.9.4.437>
- He, F., X. Li, P. Spatrick, R. Casillo, S. Dong *et al.*, 2003 Genome-wide analysis of mRNAs regulated by the nonsense-mediated and 5' to 3' mRNA decay pathways in yeast. *Mol. Cell* 12: 1439–1452. [https://doi.org/10.1016/S1097-2765\(03\)00446-5](https://doi.org/10.1016/S1097-2765(03)00446-5)
- Helm, M., and Y. Motorin, 2017 Detecting RNA modifications in the epitranscriptome: predict and validate. *Nat. Rev. Genet.* 18: 275–291. <https://doi.org/10.1038/nrg.2016.169>
- Hill, C. H., V. Boreikaite, A. Kumar, A. Casanal, P. Kubik *et al.*, 2019 Activation of the endonuclease that defines mRNA 3' ends requires incorporation into an 8-subunit core cleavage and polyadenylation factor complex. *Mol. Cell* 73: 1217–1231.e11. <https://doi.org/10.1016/j.molcel.2018.12.023>
- Hirose, Y., and J. L. Manley, 2000 RNA polymerase II and the integration of nuclear events. *Genes Dev.* 14: 1415–1429.
- Hodgkin, J., A. Papp, R. Pulak, V. Ambros, and P. Anderson, 1989 A new kind of informational suppression in the nematode *Caenorhabditis elegans*. *Genetics* 123: 301–313.
- Hogg, J. R., and S. P. Goff, 2010 Upf1 senses 3'UTR length to potentiate mRNA decay. *Cell* 143: 379–389. <https://doi.org/10.1016/j.cell.2010.10.005>
- Hollins, C., D. A. Zorio, M. MacMorris, and T. Blumenthal, 2005 U2AF binding selects for the high conservation of the *C. elegans* 3' splice site. *RNA* 11: 248–253. <https://doi.org/10.1261/rna.7221605>
- Hopper, A. K., and H. Y. Huang, 2015 Quality Control Pathways for Nucleus-Encoded Eukaryotic tRNA Biosynthesis and Subcellular Trafficking. *Mol. Cell. Biol.* 35: 2052–2058. <https://doi.org/10.1128/MCB.00131-15>
- Hough, R. F., A. T. Lingam, and B. L. Bass, 1999 *Caenorhabditis elegans* mRNAs that encode a protein similar to ADARs derive from an operon containing six genes. *Nucleic Acids Res.* 27: 3424–3432. <https://doi.org/10.1093/nar/27.17.3424>
- Huang, P., E. D. Pleasance, J. S. Maydan, R. Hunt-Newbury, N. J. O'Neil *et al.*, 2007 Identification and analysis of internal promoters in *Caenorhabditis elegans* operons. *Genome Res.* 17: 1478–1485. <https://doi.org/10.1101/gr.6824707>
- Huber, S. M., P. van Delft, L. Mendil, M. Bachman, K. Smollett *et al.*, 2015 Formation and abundance of 5-hydroxymethylcytosine in RNA. *ChemBioChem* 16: 752–755. <https://doi.org/10.1002/cbic.201500013>
- Hug, N., and J. F. Caceres, 2014 The RNA helicase DHX34 activates NMD by promoting a transition from the surveillance to the decay-inducing complex. *Cell Rep.* 8: 1845–1856. <https://doi.org/10.1016/j.celrep.2014.08.020>
- Hundley, H. A., and B. L. Bass, 2010 ADAR editing in double-stranded UTRs and other noncoding RNA sequences. *Trends Biochem. Sci.* 35: 377–383. <https://doi.org/10.1016/j.tibs.2010.02.008>
- Hundley, H. A., A. A. Krauchuk, and B. L. Bass, 2008 *C. elegans* and *H. sapiens* mRNAs with edited 3' UTRs are present on polysomes. *RNA* 14: 2050–2060. <https://doi.org/10.1261/rna.1165008>

- Hung, W., C. Hwang, M. D. Po, and M. Zhen, 2007 Neuronal polarity is regulated by a direct interaction between a scaffolding protein, Neurabin, and a presynaptic SAD-1 kinase in *Caenorhabditis elegans*. *Development* 134: 237–249. <https://doi.org/10.1242/dev.02725>
- Huntzinger, E., I. Kashima, M. Fauser, J. Sauliere, and E. Izaurralde, 2008 SMG6 is the catalytic endonuclease that cleaves mRNAs containing nonsense codons in metazoan. *RNA* 14: 2609–2617. <https://doi.org/10.1261/rna.1386208>
- Hurt, J. A., A. D. Robertson, and C. B. Burge, 2013 Global analyses of UPF1 binding and function reveal expanded scope of nonsense-mediated mRNA decay. *Genome Res.* 23: 1636–1650. <https://doi.org/10.1101/gr.157354.113>
- Ikeuchi, K., P. Tesina, Y. Matsuo, T. Sugiyama, J. Cheng *et al.*, 2019 Collided ribosomes form a unique structural interface to induce Hel2-driven quality control pathways. *EMBO J.* 38: pii: e100276. <https://doi.org/10.15252/embj.2018100276>
- Ingolia, N. T., S. Ghaemmaghami, J. R. Newman, and J. S. Weissman, 2009 Genome-wide analysis in vivo of translation with nucleotide resolution using ribosome profiling. *Science* 324: 218–223. <https://doi.org/10.1126/science.1168978>
- Isken, O., and L. E. Maquat, 2007 Quality control of eukaryotic mRNA: safeguarding cells from abnormal mRNA function. *Genes Dev.* 21: 1833–1856. <https://doi.org/10.1101/gad.1566807>
- Ito-Harashima, S., K. Kuroha, T. Tatematsu, and T. Inada, 2007 Translation of the poly(A) tail plays crucial roles in non-stop mRNA surveillance via translation repression and protein destabilization by proteasome in yeast. *Genes Dev.* 21: 519–524. <https://doi.org/10.1101/gad.1490207>
- Ivanov, A., S. Memczak, E. Wyler, F. Torti, H. T. Porath *et al.*, 2015 Analysis of intron sequences reveals hallmarks of circular RNA biogenesis in animals. *Cell Rep.* 10: 170–177. <https://doi.org/10.1016/j.celrep.2014.12.019>
- Ivanov, P. V., N. H. Gehring, J. B. Kunz, M. W. Hentze, and A. E. Kulozik, 2008 Interactions between UPF1, eRFs, PABP and the exon junction complex suggest an integrated model for mammalian NMD pathways. *EMBO J.* 27: 736–747. <https://doi.org/10.1038/emboj.2008.17>
- Jan, C. H., R. C. Friedman, J. G. Ruby, and D. P. Bartel, 2011 Formation, regulation and evolution of *Caenorhabditis elegans* 3'UTRs. *Nature* 469: 97–101. <https://doi.org/10.1038/nature09616>
- Joazeiro, C. A. P., 2017 Ribosomal stalling during translation: providing substrates for ribosome-associated protein quality control. *Annu. Rev. Cell Dev. Biol.* 33: 343–368. <https://doi.org/10.1146/annurev-cellbio-111315-125249>
- Johns, L., A. Grimson, S. L. Kuchma, C. L. Newman, and P. Anderson, 2007 *Caenorhabditis elegans* SMG-2 selectively marks mRNAs containing premature translation termination codons. *Mol. Cell. Biol.* 27: 5630–5638. <https://doi.org/10.1128/MCB.00410-07>
- Juszkiewicz, S., and R. S. Hegde, 2018 Quality control of orphaned proteins. *Mol. Cell* 71: 443–457. <https://doi.org/10.1016/j.molcel.2018.07.001>
- Kabat, J. L., S. Barberan-Soler, P. McKenna, H. Clawson, T. Farrer *et al.*, 2006 Intronic alternative splicing regulators identified by comparative genomics in nematodes. *PLoS Comput. Biol.* 2: e86. <https://doi.org/10.1371/journal.pcbi.0020086>
- Kagawa, H., K. Sugimoto, H. Matsumoto, T. Inoue, H. Imadzu *et al.*, 1995 Genome structure, mapping and expression of the tropomyosin gene *tmy-1* of *Caenorhabditis elegans*. *J. Mol. Biol.* 251: 603–613. <https://doi.org/10.1006/jmbi.1995.0459>
- Kaletsky, R., V. Lakhina, R. Arey, A. Williams, J. Landis *et al.*, 2016 The *C. elegans* adult neuronal IIS/FOXO transcriptome reveals adult phenotype regulators. *Nature* 529: 92–96. <https://doi.org/10.1038/nature16483>
- Kaletsky, R., V. Yao, A. Williams, A. M. Runnels, A. Tadych *et al.*, 2018 Transcriptome analysis of adult *Caenorhabditis elegans* cells reveals tissue-specific gene and isoform expression. *PLoS Genet.* 14: e1007559. <https://doi.org/10.1371/journal.pgen.1007559>
- Karousis, E. D., S. Nasif, and O. Muhlemann, 2016 Nonsense-mediated mRNA decay: novel mechanistic insights and biological impact. *Wiley Interdiscip. Rev. RNA* 7: 661–682. <https://doi.org/10.1002/wrna.1357>
- Kashima, I., A. Yamashita, N. Izumi, N. Kataoka, R. Morishita *et al.*, 2006 Binding of a novel SMG-1-Upf1-eRF1-eRF3 complex (SURF) to the exon junction complex triggers Upf1 phosphorylation and nonsense-mediated mRNA decay. *Genes Dev.* 20: 355–367. <https://doi.org/10.1101/gad.1389006>
- Kasturi, P., S. Zanetti, M. Passannante, Z. Saudan, F. Muller *et al.*, 2010 The *C. elegans* sex determination protein MOG-3 functions in meiosis and binds to the CSL co-repressor CIR-1. *Dev. Biol.* 344: 593–602. <https://doi.org/10.1016/j.ydbio.2010.05.009>
- Keall, R., S. Whitelaw, J. Pettitt, and B. Muller, 2007 Histone gene expression and histone mRNA 3' end structure in *Caenorhabditis elegans*. *BMC Mol. Biol.* 8: 51. <https://doi.org/10.1186/1471-2199-8-51>
- Keegan, L., A. Khan, D. Vukic, and M. O'Connell, 2017 ADAR RNA editing below the backbone. *RNA* 23: 1317–1328. <https://doi.org/10.1261/rna.060921.117>
- Keeling, K. M., J. Lanier, M. Du, J. Salas-Marco, L. Gao *et al.*, 2004 Leaky termination at premature stop codons antagonizes nonsense-mediated mRNA decay in *S. cerevisiae*. *RNA* 10: 691–703. <https://doi.org/10.1261/rna.5147804>
- Kerins, J. A., M. Hanazawa, M. Dorsett, and T. Schedl, 2010 PRP-17 and the pre-mRNA splicing pathway are preferentially required for the proliferation vs. meiotic development decision and germline sex determination in *Caenorhabditis elegans*. *Dev. Dyn.* 239: 1555–1572. <https://doi.org/10.1002/dvdy.22274>
- Kim, M., S. H. Ahn, N. J. Krogan, J. F. Greenblatt, and S. Buratowski, 2004a Transitions in RNA polymerase II elongation complexes at the 3' ends of genes. *EMBO J.* 23: 354–364. <https://doi.org/10.1038/sj.emboj.7600053>
- Kim, J. S., W. Hung, P. Narbonne, R. Roy, and M. Zhen, 2010a *C. elegans* STRADalpha and SAD cooperatively regulate neuronal polarity and synaptic organization. *Development* 137: 93–102. <https://doi.org/10.1242/dev.041459>
- Kim, J. S., W. Hung, and M. Zhen, 2010b The long and the short of SAD-1 kinase. *Commun. Integr. Biol.* 3: 251–255. <https://doi.org/10.4161/cib.3.3.11455>
- Kim, M., N. J. Krogan, L. Vasiljeva, O. J. Rando, E. Nedeja *et al.*, 2004b The yeast Rat1 exonuclease promotes transcription termination by RNA polymerase II. *Nature* 432: 517–522 [corrigenda: *Nature* 433: 661 (2005)]. <https://doi.org/10.1038/nature03041>
- Kim, U., Y. Wang, T. Sanford, Y. Zeng, and K. Nishikura, 1994 Molecular cloning of cDNA for double-stranded RNA adenosine deaminase, a candidate enzyme for nuclear RNA editing. *Proc. Natl. Acad. Sci. USA* 91: 11457–11461. <https://doi.org/10.1073/pnas.91.24.11457>
- Kim, Y. K., and L. E. Maquat, 2019 UPFront and center in RNA decay: UPF1 in nonsense-mediated mRNA decay and beyond. *RNA* 25: 407–422. <https://doi.org/10.1261/rna.070136.118>
- Knight, S. W., and B. L. Bass, 2002 The role of RNA editing by ADARs in RNAi. *Mol. Cell* 10: 809–817. [https://doi.org/10.1016/S1097-2765\(02\)00649-4](https://doi.org/10.1016/S1097-2765(02)00649-4)
- Kodama, Y., J. H. Rothman, A. Sugimoto, and M. Yamamoto, 2002 The stem-loop binding protein CDL-1 is required for chromosome condensation, progression of cell death and morphogenesis in *Caenorhabditis elegans*. *Development* 129: 187–196.

- Kolev, N. G., and J. A. Steitz, 2005 Symplekin and multiple other polyadenylation factors participate in 3'-end maturation of histone mRNAs. *Genes Dev.* 19: 2583–2592. <https://doi.org/10.1101/gad.1371105>
- Kono, N., and K. Arakawa, 2019 Nanopore sequencing: Review of potential applications in functional genomics. *Dev. Growth Differ.* 61: 316–326. <https://doi.org/10.1111/dgd.12608>
- Kostova, K. K., K. L. Hickey, B. A. Osuna, J. A. Hussmann, A. Frost *et al.*, 2017 CAT-tailing as a fail-safe mechanism for efficient degradation of stalled nascent polypeptides. *Science* 357: 414–417. <https://doi.org/10.1126/science.aam7787>
- Krause, M., and D. Hirsh, 1987 A trans-spliced leader sequence on actin mRNA in *C. elegans*. *Cell* 49: 753–761. [https://doi.org/10.1016/0092-8674\(87\)90613-1](https://doi.org/10.1016/0092-8674(87)90613-1)
- Kruesi, W. S., L. J. Core, C. T. Waters, J. T. Lis, and B. J. Meyer, 2013 Condensin controls recruitment of RNA polymerase II to achieve nematode X-chromosome dosage compensation. *eLife* 2: e00808. <https://doi.org/10.7554/eLife.00808>
- Kunitomo, H., H. Uesugi, Y. Kohara, and Y. Iino, 2005 Identification of ciliated sensory neuron-expressed genes in *Caenorhabditis elegans* using targeted pull-down of poly(A) tails. *Genome Biol.* 6: R17. <https://doi.org/10.1186/gb-2005-6-2-r17>
- Kurosaki, T., W. Li, M. Hoque, M. W. Popp, D. N. Ermolenko *et al.*, 2014 A post-translational regulatory switch on UPF1 controls targeted mRNA degradation. *Genes Dev.* 28: 1900–1916. <https://doi.org/10.1101/gad.245506.114>
- Kuroyanagi, H., 2013 Switch-like regulation of tissue-specific alternative pre-mRNA processing patterns revealed by customized fluorescence reporters. *Worm* 2: e23834. <https://doi.org/10.4161/worm.23834>
- Kuroyanagi, H., T. Kobayashi, S. Mitani, and M. Hagiwara, 2006 Transgenic alternative-splicing reporters reveal tissue-specific expression profiles and regulation mechanisms in vivo. *Nat. Methods* 3: 909–915. <https://doi.org/10.1038/nmeth944>
- Kuroyanagi, H., G. Ohno, S. Mitani, and M. Hagiwara, 2007 The Fox-1 family and SUP-12 coordinately regulate tissue-specific alternative splicing in vivo. *Mol. Cell. Biol.* 27: 8612–8621. <https://doi.org/10.1128/MCB.01508-07>
- Kuroyanagi, H., G. Ohno, H. Sakane, H. Maruoka, and M. Hagiwara, 2010 Visualization and genetic analysis of alternative splicing regulation in vivo using fluorescence reporters in transgenic *Caenorhabditis elegans*. *Nat. Protoc.* 5: 1495–1517. <https://doi.org/10.1038/nprot.2010.107>
- Kuroyanagi, H., Y. Watanabe, and M. Hagiwara, 2013a CELF family RNA-binding protein UNC-75 regulates two sets of mutually exclusive exons of the unc-32 gene in neuron-specific manners in *Caenorhabditis elegans*. *PLoS Genet.* 9: e1003337. <https://doi.org/10.1371/journal.pgen.1003337>
- Kuroyanagi, H., Y. Watanabe, Y. Suzuki, and M. Hagiwara, 2013b Position-dependent and neuron-specific splicing regulation by the CELF family RNA-binding protein UNC-75 in *Caenorhabditis elegans*. *Nucleic Acids Res.* 41: 4015–4025. <https://doi.org/10.1093/nar/gkt097>
- Kuroyanagi, H., S. Takei, and Y. Suzuki, 2014 Comprehensive analysis of mutually exclusive alternative splicing in *C. elegans*. *Worm* 3: e28459. <https://doi.org/10.4161/worm.28459>
- Kuwasako, K., M. Takahashi, S. Unzai, K. Tsuda, S. Yoshikawa *et al.*, 2014 RBFOX and SUP-12 sandwich a G base to cooperatively regulate tissue-specific splicing. *Nat. Struct. Mol. Biol.* 21: 778–786. <https://doi.org/10.1038/nsmb.2870>
- Lall, S., C. C. Friedman, M. Jankowska-Anyszka, J. Stepinski, E. Darzynkiewicz *et al.*, 2004 Contribution of trans-splicing, 5' -leader length, cap-poly(A) synergism, and initiation factors to nematode translation in an *Ascaris suum* embryo cell-free system. *J. Biol. Chem.* 279: 45573–45585. <https://doi.org/10.1074/jbc.M407475200>
- Lander, E. S., L. M. Linton, B. Birren, C. Nusbaum, M. C. Zody *et al.*, 2001 Initial sequencing and analysis of the human genome. *Nature* 409: 860–921. <https://doi.org/10.1038/35057062>
- Lareau, L. F., A. N. Brooks, D. A. Soergel, Q. Meng, and S. E. Brenner, 2007 The coupling of alternative splicing and nonsense-mediated mRNA decay. *Adv. Exp. Med. Biol.* 623: 190–211. <http://compbio.berkeley.edu/people/brenner/pubs/lareau-2007-eurekah-nmd.pdf>
- Lasda, E. L., and T. Blumenthal, 2011 Trans-splicing. *Wiley Interdiscip. Rev. RNA* 2: 417–434. <https://doi.org/10.1002/wrna.71>
- Lasda, E. L., M. A. Allen, and T. Blumenthal, 2010 Polycistronic pre-mRNA processing in vitro: snRNP and pre-mRNA role reversal in trans-splicing. *Genes Dev.* 24: 1645–1658. <https://doi.org/10.1101/gad.1940010>
- Lee, M. H., and T. Schedl, 2004 Translation repression by GLD-1 protects its mRNA targets from nonsense-mediated mRNA decay in *C. elegans*. *Genes Dev.* 18: 1047–1059. <https://doi.org/10.1101/gad.1188404>
- Le Hir, H., E. Izaurralde, L. E. Maquat, and M. J. Moore, 2000 The spliceosome deposits multiple proteins 20–24 nucleotides upstream of mRNA exon-exon junctions. *EMBO J.* 19: 6860–6869. <https://doi.org/10.1093/emboj/19.24.6860>
- Liang, D., and J. E. Wilusz, 2014 Short intronic repeat sequences facilitate circular RNA production. *Genes Dev.* 28: 2233–2247. <https://doi.org/10.1101/gad.251926.114>
- Lim, J., M. Lee, A. Son, H. Chang, and V. N. Kim, 2016 mTAIL-seq reveals dynamic poly(A) tail regulation in oocyte-to-embryo development. *Genes Dev.* 30: 1671–1682. <https://doi.org/10.1101/gad.284802.116>
- Lima, S. A., L. B. Chipman, A. L. Nicholson, Y. H. Chen, B. A. Yee *et al.*, 2017 Short poly(A) tails are a conserved feature of highly expressed genes. *Nat. Struct. Mol. Biol.* 24: 1057–1063. <https://doi.org/10.1038/nsmb.3499>
- Liu, S., X. Li, L. Zhang, J. Jiang, R. C. Hill *et al.*, 2017 Structure of the yeast spliceosomal postcatalytic P complex. *Science* 358: 1278–1283. <https://doi.org/10.1126/science.aar3462>
- Loepold, L., and S. Ahmed, 2014 *Surveillance and Targeting of Aberrant Transcripts in Caenorhabditis elegans*. UNC, Chapel Hill, NY.
- Longman, D., R. H. Plasterk, I. L. Johnstone, and J. F. Caceres, 2007 Mechanistic insights and identification of two novel factors in the *C. elegans* NMD pathway. *Genes Dev.* 21: 1075–1085. <https://doi.org/10.1101/gad.417707>
- Longman, D., N. Hug, M. Keith, C. Anastasaki, E. E. Patton *et al.*, 2013 DHX34 and NBAS form part of an autoregulatory NMD circuit that regulates endogenous RNA targets in human cells, zebrafish and *Caenorhabditis elegans*. *Nucleic Acids Res.* 41: 8319–8331. <https://doi.org/10.1093/nar/gkt585>
- Losson, R., and F. Lacroute, 1979 Interference of nonsense mutations with eukaryotic messenger RNA stability. *Proc. Natl. Acad. Sci. USA* 76: 5134–5137. <https://doi.org/10.1073/pnas.76.10.5134>
- Lundquist, E. A., R. K. Herman, T. M. Rogalski, G. P. Mullen, D. G. Moerman *et al.*, 1996 The mec-8 gene of *C. elegans* encodes a protein with two RNA recognition motifs and regulates alternative splicing of unc-52 transcripts. *Development* 122: 1601–1610.
- Ma, L., Z. Tan, Y. Teng, S. Hoersch, and H. R. Horvitz, 2011 In vivo effects on intron retention and exon skipping by the U2AF large subunit and SF1/BBP in the nematode *Caenorhabditis elegans*. *RNA* 17: 2201–2211. <https://doi.org/10.1261/rna.027458.111>
- Ma, L., X. Gao, J. Luo, L. Huang, Y. Teng *et al.*, 2012 The *Caenorhabditis elegans* gene mfab-1 encodes a nuclear protein that affects alternative splicing. *PLoS Genet.* 8: e1002827. <https://doi.org/10.1371/journal.pgen.1002827>

- MacDonald, C. C., J. Wilusz, and T. Shenk, 1994 The 64-kilodalton subunit of the CstF polyadenylation factor binds to pre-mRNAs downstream of the cleavage site and influences cleavage site location. *Mol. Cell. Biol.* 14: 6647–6654. <https://doi.org/10.1128/MCB.14.10.6647>
- Mackereth, C. D., T. Madl, S. Bonnal, B. Simon, K. Zanier *et al.*, 2011 Multi-domain conformational selection underlies pre-mRNA splicing regulation by U2AF. *Nature* 475: 408–411. <https://doi.org/10.1038/nature10171>
- Maher, K. N., M. Catanese, and D. L. Chase, 2013 Large-scale gene knockdown in *C. elegans* using dsRNA feeding libraries to generate robust loss-of-function phenotypes. *J. Vis. Exp.* 79: e50693. <https://doi.org/10.3791/50693>
- Mangone, M., A. P. Manoharan, D. Thierry-Mieg, J. Thierry-Mieg, T. Han *et al.*, 2010 The landscape of *C. elegans* 3'UTRs. *Science* 329: 432–435. <https://doi.org/10.1126/science.1191244>
- Mangus, D. A., M. C. Evans, and A. Jacobson, 2003 Poly(A)-binding proteins: multifunctional scaffolds for the post-transcriptional control of gene expression. *Genome Biol.* 4: 223. <https://doi.org/10.1186/gb-2003-4-7-223>
- Maquat, L. E., A. J. Kinniburgh, E. A. Rachmilewitz, and J. Ross, 1981 Unstable beta-globin mRNA in mRNA-deficient beta o thalassemia. *Cell* 27: 543–553. [https://doi.org/10.1016/0092-8674\(81\)90396-2](https://doi.org/10.1016/0092-8674(81)90396-2)
- Maroney, P. A., J. A. Denker, E. Darzynkiewicz, R. Laneve, and T. W. Nilsen, 1995 Most mRNAs in the nematode *Ascaris lumbricoide*s are trans-spliced: a role for spliced leader addition in translational efficiency. *RNA* 1: 714–723.
- Marzluff, W. F., E. J. Wagner, and R. J. Duronio, 2008 Metabolism and regulation of canonical histone mRNAs: life without a poly(A) tail. *Nat. Rev. Genet.* 9: 843–854. <https://doi.org/10.1038/nrg2438>
- Mathews, E. A., G. P. Mullen, J. R. Manjarrez, and J. B. Rand, 2015 Unusual regulation of splicing of the cholinergic locus in *Caenorhabditis elegans*. *Genetics* 199: 729–737. <https://doi.org/10.1534/genetics.114.173765>
- Matlin, A. J., F. Clark, and C. W. Smith, 2005 Understanding alternative splicing: towards a cellular code. *Nat. Rev. Mol. Cell Biol.* 6: 386–398. <https://doi.org/10.1038/nrm1645>
- Mayerle, M., S. Yitiz, C. Soulette, L. E. Rogel, A. Ramirez *et al.*, 2019 Prp8 impacts cryptic but not alternative splicing frequency. *Proc. Natl. Acad. Sci. USA* 116: 2193–2199. <https://doi.org/10.1073/pnas.1819020116>
- Mazroui, R., A. Puoti, and A. Kramer, 1999 Splicing factor SF1 from *Drosophila* and *Caenorhabditis*: presence of an N-terminal RS domain and requirement for viability. *RNA* 5: 1615–1631. <https://doi.org/10.1017/S1355838299991872>
- Meaux, S., A. van Hoof, and K. E. Baker, 2008 Nonsense-mediated mRNA decay in yeast does not require PAB1 or a poly(A) tail. *Mol. Cell* 29: 134–140. <https://doi.org/10.1016/j.molcel.2007.10.031>
- Medghalchi, S. M., P. A. Frischmeyer, J. T. Mendell, A. G. Kelly, A. M. Lawler *et al.*, 2001 Rent1, a trans-effector of nonsense-mediated mRNA decay, is essential for mammalian embryonic viability. *Hum. Mol. Genet.* 10: 99–105. <https://doi.org/10.1093/hmg/10.2.99>
- Melero, R., N. Hug, A. Lopez-Perrote, A. Yamashita, J. F. Caceres *et al.*, 2016 The RNA helicase DHX34 functions as a scaffold for SMG1-mediated UPF1 phosphorylation. *Nat. Commun.* 7: 10585. <https://doi.org/10.1038/ncomms10585>
- Memczak, S., M. Jens, A. Elefsinioti, F. Torti, J. Krueger *et al.*, 2013 Circular RNAs are a large class of animal RNAs with regulatory potency. *Nature* 495: 333–338. <https://doi.org/10.1038/nature11928>
- Mendell, J. T., N. A. Sharifi, J. L. Meyers, F. Martinez-Murillo, and H. C. Dietz, 2004 Nonsense surveillance regulates expression of diverse classes of mammalian transcripts and mutes genomic noise. *Nat. Genet.* 36: 1073–1078 (erratum: *Nat. Genet.* 36: 1238). <https://doi.org/10.1038/ng1429>
- Metzstein, M. M., and M. A. Krasnow, 2006 Functions of the nonsense-mediated mRNA decay pathway in *Drosophila* development. *PLoS Genet.* 2: e180. <https://doi.org/10.1371/journal.pgen.0020180>
- Michel, F., D. Schumperli, and B. Muller, 2000 Specificities of *Caenorhabditis elegans* and human hairpin binding proteins for the first nucleotide in the histone mRNA hairpin loop. *RNA* 6: 1539–1550. <https://doi.org/10.1017/S135583820000056X>
- Miki, T. S., S. H. Carl, M. B. Stadler, and H. Grosshans, 2016 XRN2 autoregulation and control of polycistronic gene expression in *Caenorhabditis elegans*. *PLoS Genet.* 12: e1006313. <https://doi.org/10.1371/journal.pgen.1006313>
- Miki, T. S., S. H. Carl, and H. Grosshans, 2017 Two distinct transcription termination modes dictated by promoters. *Genes Dev.* 31: 1870–1879. <https://doi.org/10.1101/gad.301093.117>
- Miller, J. N., and D. A. Pearce, 2014 Nonsense-mediated decay in genetic disease: friend or foe? *Mutat. Res. Rev. Mutat. Res.* 762: 52–64. <https://doi.org/10.1016/j.mrrrev.2014.05.001>
- Mitchell, P., and D. Tollervey, 2003 An NMD pathway in yeast involving accelerated deadenylation and exosome-mediated 3'→5' degradation. *Mol. Cell* 11: 1405–1413. [https://doi.org/10.1016/S1097-2765\(03\)00190-4](https://doi.org/10.1016/S1097-2765(03)00190-4)
- Mitrovich, Q. M., and P. Anderson, 2000 Unproductively spliced ribosomal protein mRNAs are natural targets of mRNA surveillance in *C. elegans*. *Genes Dev.* 14: 2173–2184. <https://doi.org/10.1101/gad.819900>
- Mitrovich, Q. M., and P. Anderson, 2005 mRNA surveillance of expressed pseudogenes in *C. elegans*. *Curr. Biol.* 15: 963–967. <https://doi.org/10.1016/j.cub.2005.04.055>
- Morrison, M., K. S. Harris, and M. B. Roth, 1997 smg mutants affect the expression of alternatively spliced SR protein mRNAs in *Caenorhabditis elegans*. *Proc. Natl. Acad. Sci. USA* 94: 9782–9785. <https://doi.org/10.1073/pnas.94.18.9782>
- Morse, D. P., P. J. Aruscavage, and B. L. Bass, 2002 RNA hairpins in noncoding regions of human brain and *Caenorhabditis elegans* mRNA are edited by adenosine deaminases that act on RNA. *Proc. Natl. Acad. Sci. USA* 99: 7906–7911. <https://doi.org/10.1073/pnas.112704299>
- Mort, M., D. Ivanov, D. N. Cooper, and N. A. Chuzhanova, 2008 A meta-analysis of nonsense mutations causing human genetic disease. *Hum. Mutat.* 29: 1037–1047. <https://doi.org/10.1002/humu.20763>
- Morton, J. J., and T. Blumenthal, 2011a Identification of transcription start sites of trans-spliced genes: uncovering unusual operon arrangements. *RNA* 17: 327–337. <https://doi.org/10.1261/rna.2447111>
- Morton, J. J., and T. Blumenthal, 2011b RNA processing in *C. elegans*. *Methods Cell Biol.* 106: 187–217. <https://doi.org/10.1016/B978-0-12-544172-8.00007-4>
- Mowry, K. L., and J. A. Steitz, 1987 Identification of the human U7 snRNP as one of several factors involved in the 3' end maturation of histone pre-messenger RNAs. *Science* 238: 1682–1687. <https://doi.org/10.1126/science.2825355>
- Muhlrad, D., and R. Parker, 1994 Premature translational termination triggers mRNA decapping. *Nature* 370: 578–581. <https://doi.org/10.1038/370578a0>
- Muir, V. S., A. P. Gasch, and P. Anderson, 2018 The Substrates of Nonsense-Mediated mRNA Decay in *Caenorhabditis elegans*. *G3 (Bethesda)* 8: 195–205. <https://doi.org/10.1534/g3.117.300254>
- Nam, D. K., S. Lee, G. Zhou, X. Cao, C. Wang *et al.*, 2002 Oligo(-dT) primer generates a high frequency of truncated cDNAs through internal poly(A) priming during reverse transcription. *Proc. Natl. Acad. Sci. USA* 99: 6152–6156. <https://doi.org/10.1073/pnas.092140899>

- Nance, J., and C. Frokjaer-Jensen, 2019 The *Caenorhabditis elegans* transgenic toolbox. *Genetics* 212: 959–990. <https://doi.org/10.1534/genetics.119.301506>
- Nelson, J. O., K. A. Moore, A. Chapin, J. Hollien, and M. M. Metzstein, 2016 Degradation of Gadd45 mRNA by non-sense-mediated decay is essential for viability. *eLife* 5: pii: e12876. <https://doi.org/10.7554/eLife.12876>
- Nilsen, T. W., and B. R. Graveley, 2010 Expansion of the eukaryotic proteome by alternative splicing. *Nature* 463: 457–463. <https://doi.org/10.1038/nature08909>
- Nishikura, K., 2016 A-to-I editing of coding and non-coding RNAs by ADARs. *Nat. Rev. Mol. Cell Biol.* 17: 83–96. <https://doi.org/10.1038/nrm.2015.4>
- Nojima, T., M. Dienstbier, S. Murphy, N. J. Proudfoot, and M. J. Dye, 2013 Definition of RNA polymerase II CoTC terminator elements in the human genome. *Cell Rep.* 3: 1080–1092. <https://doi.org/10.1016/j.celrep.2013.03.012>
- Norris, A. D., S. Gao, M. L. Norris, D. Ray, A. K. Ramani *et al.*, 2014 A pair of RNA-binding proteins controls networks of splicing events contributing to specialization of neural cell types. *Mol. Cell* 54: 946–959. <https://doi.org/10.1016/j.molcel.2014.05.004>
- Norris, A. D., X. Gracida, and J. A. Calarco, 2017 CRISPR-mediated genetic interaction profiling identifies RNA binding proteins controlling metazoan fitness. *eLife* 6: pii: e28129. <https://doi.org/10.7554/eLife.28129>
- Oberstrass, F. C., S. D. Auweter, M. Erat, Y. Hargous, A. Henning *et al.*, 2005 Structure of PTB bound to RNA: specific binding and implications for splicing regulation. *Science* 309: 2054–2057. <https://doi.org/10.1126/science.1114066>
- Ohnishi, T., A. Yamashita, I. Kashima, T. Schell, K. R. Anders *et al.*, 2003 Phosphorylation of hUPF1 induces formation of mRNA surveillance complexes containing hSMG-5 and hSMG-7. *Mol. Cell* 12: 1187–1200. [https://doi.org/10.1016/S1097-2765\(03\)00443-X](https://doi.org/10.1016/S1097-2765(03)00443-X)
- Ohno, G., M. Hagiwara, and H. Kuroyanagi, 2008 STAR family RNA-binding protein ASD-2 regulates developmental switching of mutually exclusive alternative splicing in vivo. *Genes Dev.* 22: 360–374. <https://doi.org/10.1101/gad.1620608>
- Ohno, G., K. Ono, M. Togo, Y. Watanabe, S. Ono *et al.*, 2012 Muscle-specific splicing factors ASD-2 and SUP-12 cooperatively switch alternative pre-mRNA processing patterns of the ADF/cofilin gene in *Caenorhabditis elegans*. *PLoS Genet.* 8: e1002991. <https://doi.org/10.1371/journal.pgen.1002991>
- Ohta, H., M. Fujiwara, Y. Ohshima, and T. Ishihara, 2008 ADBP-1 regulates an ADAR RNA-editing enzyme to antagonize RNA-interference-mediated gene silencing in *Caenorhabditis elegans*. *Genetics* 180: 785–796. <https://doi.org/10.1534/genetics.108.093310>
- Okada-Katsuhata, Y., A. Yamashita, K. Kutsuzawa, N. Izumi, F. Hirahara *et al.*, 2012 N- and C-terminal Upf1 phosphorylations create binding platforms for SMG-6 and SMG-5:SMG-7 during NMD. *Nucleic Acids Res.* 40: 1251–1266. <https://doi.org/10.1093/nar/gkr791>
- Orban, T. I., and E. Izaurralde, 2005 Decay of mRNAs targeted by RISC requires XRN1, the Ski complex, and the exosome. *RNA* 11: 459–469. <https://doi.org/10.1261/rna.7231505>
- Ozsolak, F., P. Kapranov, S. Foissac, S. W. Kim, E. Fishilevich *et al.*, 2010 Comprehensive polyadenylation site maps in yeast and human reveal pervasive alternative polyadenylation. *Cell* 143: 1018–1029. <https://doi.org/10.1016/j.cell.2010.11.020>
- Page, M. F., B. Carr, K. R. Anders, A. Grimson, and P. Anderson, 1999 SMG-2 is a phosphorylated protein required for mRNA surveillance in *Caenorhabditis elegans* and related to Upf1p of yeast. *Mol. Cell. Biol.* 19: 5943–5951. <https://doi.org/10.1128/MCB.19.9.5943>
- Pan, Q., O. Shai, L. J. Lee, B. J. Frey, and B. J. Blencowe, 2008 Deep surveying of alternative splicing complexity in the human transcriptome by high-throughput sequencing. *Nat. Genet.* 40: 1413–1415 [corrigenda: *Nat. Genet.* 41: 762 (2009)]. <https://doi.org/10.1038/ng.259>
- Park, J. E., H. Yi, Y. Kim, H. Chang, and V. N. Kim, 2016 Regulation of Poly(A) Tail and Translation during the Somatic Cell Cycle. *Mol. Cell* 62: 462–471. <https://doi.org/10.1016/j.molcel.2016.04.007>
- Parker, J. A., J. B. Connolly, C. Wellington, M. Hayden, J. Dausset *et al.*, 2001 Expanded polyglutamines in *Caenorhabditis elegans* cause axonal abnormalities and severe dysfunction of PLM mechanosensory neurons without cell death. *Proc. Natl. Acad. Sci. USA* 98: 13318–13323. <https://doi.org/10.1073/pnas.231476398>
- Parvaz, J. B., and P. Anderson, 2007 *Analysis of Nonstop mRNA Decay in Caenorhabditis elegans*. University of Wisconsin, Madison, WI.
- Pasquinelli, A. E., 2018 A rADAR defense against RNAi. *Genes Dev.* 32: 199–201. <https://doi.org/10.1101/gad.313049.118>
- Peer, E., G. Rechavi, and D. Dominissini, 2017 Epitranscriptomics: regulation of mRNA metabolism through modifications. *Curr. Opin. Chem. Biol.* 41: 93–98. <https://doi.org/10.1016/j.cbpa.2017.10.008>
- Peixeiro, I., A. Inacio, C. Barbosa, A. L. Silva, S. A. Liebhaber *et al.*, 2012 Interaction of PABPC1 with the translation initiation complex is critical to the NMD resistance of AUG-proximal nonsense mutations. *Nucleic Acids Res.* 40: 1160–1173. <https://doi.org/10.1093/nar/gkr820>
- Peltz, S. W., A. H. Brown, and A. Jacobson, 1993 mRNA destabilization triggered by premature translational termination depends on at least three cis-acting sequence elements and one trans-acting factor. *Genes Dev.* 7: 1737–1754. <https://doi.org/10.1101/gad.7.9.1737>
- Pettitt, J., C. Crombie, D. Schumperli, and B. Muller, 2002 The *Caenorhabditis elegans* histone hairpin-binding protein is required for core histone gene expression and is essential for embryonic and postembryonic cell division. *J. Cell Sci.* 115: 857–866.
- Pisareva, V. P., M. A. Skabkin, C. U. Hellen, T. V. Pestova, and A. V. Pisarev, 2011 Dissociation by Pelota, Hbs1 and ABCE1 of mammalian vacant 80S ribosomes and stalled elongation complexes. *EMBO J.* 30: 1804–1817. <https://doi.org/10.1038/emboj.2011.93>
- Plaschka, C., P. C. Lin, and K. Nagai, 2017 Structure of a pre-catalytic spliceosome. *Nature* 546: 617–621. <https://doi.org/10.1038/nature22799>
- Prahlad, V., T. Cornelius, and R. I. Morimoto, 2008 Regulation of the cellular heat shock response in *Caenorhabditis elegans* by thermosensory neurons. *Science* 320: 811–814. <https://doi.org/10.1126/science.1156093>
- Proudfoot, N. J., 2011 Ending the message: poly(A) signals then and now. *Genes Dev.* 25: 1770–1782. <https://doi.org/10.1101/gad.17268411>
- Proudfoot, N. J., A. Furger, and M. J. Dye, 2002 Integrating mRNA processing with transcription. *Cell* 108: 501–512. [https://doi.org/10.1016/S0092-8674\(02\)00617-7](https://doi.org/10.1016/S0092-8674(02)00617-7)
- Pulak, R., and P. Anderson, 1993 mRNA surveillance by the *Caenorhabditis elegans* smg genes. *Genes Dev.* 7: 1885–1897. <https://doi.org/10.1101/gad.7.10.1885>
- Pule, M. N., M. L. Glover, A. Z. Fire, and J. A. Arribere, 2019 Ribosome clearance during RNA interference. *RNA* 25: 963–974. <https://doi.org/10.1261/rna.070813.119>
- Puoti, A., and J. Kimble, 1999 The *Caenorhabditis elegans* sex determination gene *mog-1* encodes a member of the DEAH-Box protein family. *Mol. Cell. Biol.* 19: 2189–2197. <https://doi.org/10.1128/MCB.19.3.2189>
- Puoti, A., and J. Kimble, 2000 The hermaphrodite sperm/oocyte switch requires the *Caenorhabditis elegans* homologs of PRP2 and PRP22. *Proc. Natl. Acad. Sci. USA* 97: 3276–3281. <https://doi.org/10.1073/pnas.97.7.3276>

- Ragle, J. M., S. Katzman, T. F. Akers, S. Barberan-Soler, and A. M. Zahler, 2015 Coordinated tissue-specific regulation of adjacent alternative 3' splice sites in *C. elegans*. *Genome Res.* 25: 982–994. <https://doi.org/10.1101/gr.186783.114>
- Rajendren, S., A. C. Manning, H. Al-Awadi, K. Yamada, Y. Takagi *et al.*, 2018 A protein-protein interaction underlies the molecular basis for substrate recognition by an adenosine-to-inosine RNA-editing enzyme. *Nucleic Acids Res.* 46: 9647–9659. <https://doi.org/10.1093/nar/gky800>
- Ramani, A. K., A. C. Nelson, P. Kapranov, I. Bell, T. R. Gingeras *et al.*, 2009 High resolution transcriptome maps for wild-type and nonsense-mediated decay-defective *Caenorhabditis elegans*. *Genome Biol.* 10: R101. <https://doi.org/10.1186/gb-2009-10-9-r101>
- Ramani, A. K., J. A. Calarco, Q. Pan, S. Mavandadi, Y. Wang *et al.*, 2011 Genome-wide analysis of alternative splicing in *Caenorhabditis elegans*. *Genome Res.* 21: 342–348. <https://doi.org/10.1101/gr.114645.110>
- Rauhut, R., P. Fabrizio, O. Dybkov, K. Hartmuth, V. Pena *et al.*, 2016 Molecular architecture of the *Saccharomyces cerevisiae* activated spliceosome. *Science* 353: 1399–1405. <https://doi.org/10.1126/science.aag1906>
- Ray, D., H. Kazan, K. B. Cook, M. T. Weirauch, H. S. Najafabadi *et al.*, 2013 A compendium of RNA-binding motifs for decoding gene regulation. *Nature* 499: 172–177. <https://doi.org/10.1038/nature12311>
- Rebagliati, M. R., and D. A. Melton, 1987 Antisense RNA injections in fertilized frog eggs reveal an RNA duplex unwinding activity. *Cell* 48: 599–605. [https://doi.org/10.1016/0092-8674\(87\)90238-8](https://doi.org/10.1016/0092-8674(87)90238-8)
- Reich, D. P., and B. L. Bass, 2019 Mapping the dsRNA world. *Cold Spring Harb. Perspect. Biol.* 11: pii: a035352. <https://doi.org/10.1101/cshperspect.a035352>
- Reich, D. P., K. M. Tyc, and B. L. Bass, 2018 *C. elegans* ADARs antagonize silencing of cellular dsRNAs by the antiviral RNAi pathway. *Genes Dev.* 32: 271–282. <https://doi.org/10.1101/gad.310672.117>
- Roller, A. B., D. C. Hoffman, and A. M. Zahler, 2000 The allele-specific suppressor sup-39 alters use of cryptic splice sites in *Caenorhabditis elegans*. *Genetics* 154: 1169–1179.
- Rosales, J., and S. E. Mango, 2012 Genetic characterization of smg-8 mutants reveals no role in *C. elegans* nonsense mediated decay. *PLoS One* 7: e49490. <https://doi.org/10.1371/journal.pone.0049490>
- Rosenthal, J. J., 2015 The emerging role of RNA editing in plasticity. *J. Exp. Biol.* 218: 1812–1821. <https://doi.org/10.1242/jeb.119065>
- Rougvie, A. E., and V. Ambros, 1995 The heterochronic gene lin-29 encodes a zinc finger protein that controls a terminal differentiation event in *Caenorhabditis elegans*. *Development* 121: 2491–2500.
- Roundtree, I. A., M. E. Evans, T. Pan, and C. He, 2017 Dynamic RNA modifications in gene expression regulation. *Cell* 169: 1187–1200. <https://doi.org/10.1016/j.cell.2017.05.045>
- Roy, B., and A. Jacobson, 2013 The intimate relationships of mRNA decay and translation. *Trends Genet.* 29: 691–699. <https://doi.org/10.1016/j.tig.2013.09.002>
- Roy, P. J., J. M. Stuart, J. Lund, and S. K. Kim, 2002 Chromosomal clustering of muscle-expressed genes in *Caenorhabditis elegans*. *Nature* 418: 975–979 [corrigenda: *Nature* 450: 128 (2007)]. <https://doi.org/10.1038/nature01012>
- Rubio-Peña, K., L. Fontrodona, D. Aristizabal-Corrales, S. Torres, E. Cornes *et al.*, 2015 Modeling of autosomal-dominant retinitis pigmentosa in *Caenorhabditis elegans* uncovers a nexus between global impaired functioning of certain splicing factors and cell type-specific apoptosis. *RNA* 21: 2119–2131. <https://doi.org/10.1261/rna.053397.115>
- Saito, T. L., S. Hashimoto, S. G. Gu, J. J. Morton, M. Stadler *et al.*, 2013 The transcription start site landscape of *C. elegans*. *Genome Res.* 23: 1348–1361. <https://doi.org/10.1101/gr.151571.112>
- Saldi, T. K., P. E. Ash, G. Wilson, P. Gonzales, A. Garrido-Lecca *et al.*, 2014 TDP-1, the *Caenorhabditis elegans* ortholog of TDP-43, limits the accumulation of double-stranded RNA. *EMBO J.* 33: 2947–2966. <https://doi.org/10.15252/embj.201488740>
- Salter, J. D., R. P. Bennett, and H. C. Smith, 2016 The APOBEC Protein Family: United by Structure, Divergent in Function. *Trends Biochem. Sci.* 41: 578–594. <https://doi.org/10.1016/j.tibs.2016.05.001>
- Samuel, C. E., 2019 Adenosine deaminase acting on RNA (ADAR1), a suppressor of double-stranded RNA-triggered innate immune responses. *J. Biol. Chem.* 294: 1710–1720. <https://doi.org/10.1074/jbc.TM118.004166>
- Sarin, L. P., and S. A. Leidel, 2014 Modify or die?—RNA modification defects in metazoans. *RNA Biol.* 11: 1555–1567. <https://doi.org/10.4161/15476286.2014.992279>
- Satyal, S. H., E. Schmidt, K. Kitagawa, N. Sondheimer, S. Lindquist *et al.*, 2000 Polyglutamine aggregates alter protein folding homeostasis in *Caenorhabditis elegans*. *Proc. Natl. Acad. Sci. USA* 97: 5750–5755. <https://doi.org/10.1073/pnas.100107297>
- Savva, Y. A., L. E. Rieder, and R. A. Reenan, 2012 The ADAR protein family. *Genome Biol.* 13: 252. <https://doi.org/10.1186/gb-2012-13-12-252>
- Schönemann, L., U. Kuhn, G. Martin, P. Schafer, A. R. Gruber *et al.*, 2014 Reconstitution of CPSF active in polyadenylation: recognition of the polyadenylation signal by WDR33. *Genes Dev.* 28: 2381–2393. <https://doi.org/10.1101/gad.250985.114>
- Schwartz, S. H., J. Silva, D. Burstein, T. Pupko, E. Eyraas *et al.*, 2008 Large-scale comparative analysis of splicing signals and their corresponding splicing factors in eukaryotes. *Genome Res.* 18: 88–103. <https://doi.org/10.1101/gr.6818908>
- Sebastiani, P., M. Montano, A. Puca, N. Solovieff, T. Kojima *et al.*, 2009 RNA editing genes associated with extreme old age in humans and with lifespan in *C. elegans*. *PLoS One* 4: e8210. <https://doi.org/10.1371/journal.pone.0008210>
- Shao, S., and R. S. Hegde, 2014 Reconstitution of a minimal ribosome-associated ubiquitination pathway with purified factors. *Mol. Cell* 55: 880–890. <https://doi.org/10.1016/j.molcel.2014.07.006>
- Shen, P. S., J. Park, Y. Qin, X. Li, K. Parsawar *et al.*, 2015 Protein synthesis. Rqc2p and 60S ribosomal subunits mediate mRNA-independent elongation of nascent chains. *Science* 347: 75–78. <https://doi.org/10.1126/science.1259724>
- Shi, H., J. Wei, and C. He, 2019 Where, When, and How: Context-Dependent Functions of RNA Methylation Writers, Readers, and Erasers. *Mol. Cell* 74: 640–650. <https://doi.org/10.1016/j.molcel.2019.04.025>
- Shi, Y., 2017 Mechanistic insights into precursor messenger RNA splicing by the spliceosome. *Nat. Rev. Mol. Cell Biol.* 18: 655–670. <https://doi.org/10.1038/nrm.2017.86>
- Shi, Y., and J. L. Manley, 2015 The end of the message: multiple protein-RNA interactions define the mRNA polyadenylation site. *Genes Dev.* 29: 889–897. <https://doi.org/10.1101/gad.261974.115>
- Shimori, M., K. Inoue, and H. Sakamoto, 2013 A specific set of exon junction complex subunits is required for the nuclear retention of unspliced RNAs in *Caenorhabditis elegans*. *Mol. Cell Biol.* 33: 444–456. <https://doi.org/10.1128/MCB.01298-12>
- Shoemaker, C. J., D. E. Eyler, and R. Green, 2010 Dom34:Hbs1 promotes subunit dissociation and peptidyl-tRNA drop-off to initiate no-go decay. *Science* 330: 369–372. <https://doi.org/10.1126/science.1192430>
- Sickmier, E. A., K. E. Frato, H. Shen, S. R. Paranawithana, M. R. Green *et al.*, 2006 Structural basis for polypyrimidine tract recognition

- by the essential pre-mRNA splicing factor U2AF65. *Mol. Cell* 23: 49–59. <https://doi.org/10.1016/j.molcel.2006.05.025>
- Silva, A. L., P. Ribeiro, A. Inacio, S. A. Liebhaber, and L. Romao, 2008 Proximity of the poly(A)-binding protein to a premature termination codon inhibits mammalian nonsense-mediated mRNA decay. *RNA* 14: 563–576. <https://doi.org/10.1261/rna.815108>
- Simms, C. L., L. L. Yan, and H. S. Zaher, 2017 Ribosome collision is critical for quality control during no-go decay. *Mol. Cell* 68: 361–373.e5. <https://doi.org/10.1016/j.molcel.2017.08.019>
- Sleigh, J. N., S. D. Buckingham, B. Esmaeili, M. Viswanathan, E. Cuppen *et al.*, 2011 A novel *Caenorhabditis elegans* allele, *smn-1(cb131)*, mimicking a mild form of spinal muscular atrophy, provides a convenient drug screening platform highlighting new and pre-approved compounds. *Hum. Mol. Genet.* 20: 245–260. <https://doi.org/10.1093/hmg/ddq459>
- Son, H. G., M. Seo, S. Ham, W. Hwang, D. Lee *et al.*, 2017 RNA surveillance via nonsense-mediated mRNA decay is crucial for longevity in *daf-2/insulin/IGF-1* mutant *C. elegans*. *Nat. Commun.* 8: 14749. <https://doi.org/10.1038/ncomms14749>
- Soufari, H., and C. D. Mackereth, 2017 Conserved binding of GCAC motifs by MEC-8, couch potato, and the RBPMS protein family. *RNA* 23: 308–316. <https://doi.org/10.1261/rna.059733.116>
- Sparks, K. A., and C. L. Dieckmann, 1998 Regulation of poly(A) site choice of several yeast mRNAs. *Nucleic Acids Res.* 26: 4676–4687. <https://doi.org/10.1093/nar/26.20.4676>
- Spartz, A. K., R. K. Herman, and J. E. Shaw, 2004 SMU-2 and SMU-1, *Caenorhabditis elegans* homologs of mammalian spliceosome-associated proteins RED and fSAP57, work together to affect splice site choice. *Mol. Cell Biol.* 24: 6811–6823. <https://doi.org/10.1128/MCB.24.15.6811-6823.2004>
- Spellman, R., M. Llorian, and C. W. Smith, 2007 Crossregulation and functional redundancy between the splicing regulator PTB and its paralogs nPTB and ROD1. *Mol. Cell* 27: 420–434. <https://doi.org/10.1016/j.molcel.2007.06.016>
- Spencer, W. C., G. Zeller, J. D. Watson, S. R. Henz, K. L. Watkins *et al.*, 2011 A spatial and temporal map of *C. elegans* gene expression. *Genome Res.* 21: 325–341. <https://doi.org/10.1101/gr.114595.110>
- Spencer, W. C., R. McWhirter, T. Miller, P. Strasbourger, O. Thompson *et al.*, 2014 Isolation of specific neurons from *C. elegans* larvae for gene expression profiling. *PLoS One* 9: e112102. <https://doi.org/10.1371/journal.pone.0112102>
- Spieth, J., G. Brooke, S. Kuersten, K. Lea, and T. Blumenthal, 1993 Operons in *C. elegans*: polycistronic mRNA precursors are processed by trans-splicing of SL2 to downstream coding regions. *Cell* 73: 521–532. [https://doi.org/10.1016/0092-8674\(93\)90139-H](https://doi.org/10.1016/0092-8674(93)90139-H)
- Spieth, J., D. Lawson, P. Davis, G. Williams, and K. Howe, 2014 Overview of gene structure in *C. elegans* (October 29, 2014), *WormBook*, ed. The *C. elegans* Research Community, *WormBook*, doi/10.1895/wormbook.1.65.2, <http://www.wormbook.org>. <https://doi.org/10.1895/wormbook.1.65.2>
- Spike, C. A., J. E. Shaw, and R. K. Herman, 2001 Analysis of *smu-1*, a gene that regulates the alternative splicing of *unc-52* pre-mRNA in *Caenorhabditis elegans*. *Mol. Cell Biol.* 21: 4985–4995. <https://doi.org/10.1128/MCB.21.15.4985-4995.2001>
- Spike, C. A., A. G. Davies, J. E. Shaw, and R. K. Herman, 2002 MEC-8 regulates alternative splicing of *unc-52* transcripts in *C. elegans* hypodermal cells. *Development* 129: 4999–5008.
- Stein, L. D., Z. Bao, D. Blasiar, T. Blumenthal, M. R. Brent *et al.*, 2003 The genome sequence of *Caenorhabditis briggsae*: a platform for comparative genomics. *PLoS Biol.* 1: E45. <https://doi.org/10.1371/journal.pbio.0000045>
- Strub, K., and M. L. Birnstiel, 1986 Genetic complementation in the *Xenopus* oocyte: co-expression of sea urchin histone and U7 RNAs restores 3' processing of H3 pre-mRNA in the oocyte. *EMBO J.* 5: 1675–1682. <https://doi.org/10.1002/j.1460-2075.1986.tb04411.x>
- Subtelny, A. O., S. W. Eichhorn, G. R. Chen, H. Sive, and D. P. Bartel, 2014 Poly(A)-tail profiling reveals an embryonic switch in translational control. *Nature* 508: 66–71. <https://doi.org/10.1038/nature13007>
- Sun, J., V. Singh, R. Kajino-Sakamoto, and A. Aballay, 2011 Neuronal GPCR controls innate immunity by regulating noncanonical unfolded protein response genes. *Science* 332: 729–732. <https://doi.org/10.1126/science.1203411>
- Szádeczky-Kardoss, I., T. Csorba, A. Auber, A. Schamberger, T. Nyiko *et al.*, 2018 The nonstop decay and the RNA silencing systems operate cooperatively in plants. *Nucleic Acids Res.* 46: 4632–4648. <https://doi.org/10.1093/nar/gky279>
- Takei, S., M. Togo-Ohno, Y. Suzuki and H. Kuroyanagi, 2016 Evolutionarily conserved autoregulation of alternative pre-mRNA splicing by ribosomal protein L10a. *Nucleic Acids Res.* 44: 5585–5598. <https://doi.org/10.1093/nar/gkw152>
- Tan, J. H., and A. G. Fraser, 2017 The combinatorial control of alternative splicing in *C. elegans*. *PLoS Genet.* 13: e1007033. <https://doi.org/10.1371/journal.pgen.1007033>
- Tariq, A., and M. F. Jantsch, 2012 Transcript diversification in the nervous system: a to I RNA editing in CNS function and disease development. *Front. Neurosci.* 6: 99. <https://doi.org/10.3389/fnins.2012.00099>
- Teixeira, A., A. Tahiri-Alaoui, S. West, B. Thomas, A. Ramadass *et al.*, 2004 Autocatalytic RNA cleavage in the human beta-globin pre-mRNA promotes transcription termination. *Nature* 432: 526–530. <https://doi.org/10.1038/nature03032>
- Thacker, C., J. A. Sheps, and A. M. Rose, 2006 *Caenorhabditis elegans dpy-5* is a cuticle procollagen processed by a proprotein convertase. *Cell Mol. Life Sci.* 63: 1193–1204. <https://doi.org/10.1007/s00018-006-6012-z>
- Thomas, J., K. Lea, E. Zucker-Aprison, and T. Blumenthal, 1990 The spliceosomal snRNAs of *Caenorhabditis elegans*. *Nucleic Acids Res.* 18: 2633–2642. <https://doi.org/10.1093/nar/18.9.2633>
- Thompson, M., R. Bixby, R. Dalton, A. Vandenburg, J. A. Calarco *et al.*, 2019 Splicing in a single neuron is coordinately controlled by RNA binding proteins and transcription factors. *eLife* 8: pii: e46726. <https://doi.org/10.7554/eLife.46726>
- Toh, E. A., P. Guerry, and R. B. Wickner, 1978 Chromosomal superkiller mutants of *Saccharomyces cerevisiae*. *J. Bacteriol.* 136: 1002–1007. <https://doi.org/10.1128/JB.136.3.1002-1007.1978>
- Toma, K. G., I. Rebbapragada, S. Durand, and J. Lykke-Andersen, 2015 Identification of elements in human long 3' UTRs that inhibit nonsense-mediated decay. *RNA* 21: 887–897. <https://doi.org/10.1261/rna.048637.114>
- Tomioka, M., Y. Naito, H. Kuroyanagi, and Y. Iino, 2016 Splicing factors control *C. elegans* behavioural learning in a single neuron by producing DAF-2c receptor. *Nat. Commun.* 7: 11645. <https://doi.org/10.1038/ncomms11645>
- Tonkin, L. A., and B. L. Bass, 2003 Mutations in RNAi rescue aberrant chemotaxis of ADAR mutants. *Science* 302: 1725. <https://doi.org/10.1126/science.1091340>
- Tonkin, L. A., L. Saccomanno, D. P. Morse, T. Brodigan, M. Krause *et al.*, 2002 RNA editing by ADARs is important for normal behavior in *Caenorhabditis elegans*. *EMBO J.* 21: 6025–6035. <https://doi.org/10.1093/emboj/cdf607>
- Tourasse, N. J., J. R. M. Millet, and D. Dupuy, 2017 Quantitative RNA-seq meta-analysis of alternative exon usage in *C. elegans*. *Genome Res.* 27: 2120–2128. <https://doi.org/10.1101/gr.224626.117>

- Tsuboi, T., K. Kuroha, K. Kudo, S. Makino, E. Inoue *et al.*, 2012 Dom34:hbs1 plays a general role in quality-control systems by dissociation of a stalled ribosome at the 3' end of aberrant mRNA. *Mol. Cell* 46: 518–529. <https://doi.org/10.1016/j.molcel.2012.03.013>
- Uyar, B., J. S. Chu, I. A. Vergara, S. Y. Chua, M. R. Jones *et al.*, 2012 RNA-seq analysis of the *C. briggsae* transcriptome. *Genome Res.* 22: 1567–1580. <https://doi.org/10.1101/gr.134601.111>
- van Delft, P., A. Akay, S. M. Huber, C. Bueschl, K. L. M. Rudolph *et al.*, 2017 The Profile and Dynamics of RNA Modifications in Animals. *ChemBioChem* 18: 979–984. <https://doi.org/10.1002/cbic.201700093>
- Van Doren, K., and D. Hirsh, 1988 Trans-spliced leader RNA exists as small nuclear ribonucleoprotein particles in *Caenorhabditis elegans*. *Nature* 335: 556–559. <https://doi.org/10.1038/335556a0>
- Van Epps, H., Y. Dai, Y. Qi, A. Goncharov, and Y. Jin, 2010 Nuclear pre-mRNA 3'-end processing regulates synapse and axon development in *C. elegans*. *Development* 137: 2237–2250. <https://doi.org/10.1242/dev.049692>
- van Hoof, A., P. A. Frischmeyer, H. C. Dietz, and R. Parker, 2002 Exosome-mediated recognition and degradation of mRNAs lacking a termination codon. *Science* 295: 2262–2264. <https://doi.org/10.1126/science.1067272>
- Vesely, C., S. Tauber, F. J. Sedlazeck, A. von Haeseler, and M. F. Jantsch, 2012 Adenosine deaminases that act on RNA induce reproducible changes in abundance and sequence of embryonic miRNAs. *Genome Res.* 22: 1468–1476. <https://doi.org/10.1101/gr.133025.111>
- Voisine, C., J. S. Pedersen, and R. I. Morimoto, 2010 Chaperone networks: tipping the balance in protein folding diseases. *Neurobiol. Dis.* 40: 12–20. <https://doi.org/10.1016/j.nbd.2010.05.007>
- Wahl, M. C., and R. Luhrmann, 2015 SnapShot: spliceosome dynamics I. *Cell* 161: 1474–e1. <https://doi.org/10.1016/j.cell.2015.05.050>
- Wallace, A., M. E. Filbin, B. Veo, C. McFarland, J. Stepinski *et al.*, 2010 The nematode eukaryotic translation initiation factor 4E/G complex works with a trans-spliced leader stem-loop to enable efficient translation of trimethylguanosine-capped RNAs. *Mol. Cell. Biol.* 30: 1958–1970. <https://doi.org/10.1128/MCB.01437-09>
- Wan, R., C. Yan, R. Bai, G. Huang, and Y. Shi, 2016 Structure of a yeast catalytic step I spliceosome at 3.4 Å resolution. *Science* 353: 895–904. <https://doi.org/10.1126/science.aag2235>
- Wan, R., C. Yan, R. Bai, J. Lei and Y. Shi, 2017 Structure of an intron lariat spliceosome from *Saccharomyces cerevisiae*. *Cell* 171: 120–132.e12. <https://doi.org/10.1016/j.cell.2017.08.029>
- Wang, E. T., R. Sandberg, S. Luo, I. Khrebtkova, L. Zhang *et al.*, 2008 Alternative isoform regulation in human tissue transcriptomes. *Nature* 456: 470–476. <https://doi.org/10.1038/nature07509>
- Wang, L., J. Kimble, and M. Wickens, 2004 Tissue-specific modification of *gld-2* mRNA in *C. elegans*: likely C-to-U editing. *RNA* 10: 1444–1448. <https://doi.org/10.1261/rna.7570804>
- Wang, W., K. Czaplinski, Y. Rao, and S. W. Peltz, 2001 The role of Upf proteins in modulating the translation read-through of nonsense-containing transcripts. *EMBO J.* 20: 880–890. <https://doi.org/10.1093/emboj/20.4.880>
- Wang, Z. F., M. L. Whitfield, T. C. Ingledue, 3rd, Z. Dominski, and W. F. Marzluff, 1996 The protein that binds the 3' end of histone mRNA: a novel RNA-binding protein required for histone pre-mRNA processing. *Genes Dev.* 10: 3028–3040. <https://doi.org/10.1101/gad.10.23.3028>
- Wani, S., and H. Kuroyanagi, 2017 An emerging model organism *Caenorhabditis elegans* for alternative pre-mRNA processing in vivo. *Wiley Interdiscip. Rev. RNA* 8: pmid:28703462. <https://doi.org/10.1002/wrna.1428>
- Warf, M. B., B. A. Shepherd, W. E. Johnson, and B. L. Bass, 2012 Effects of ADARs on small RNA processing pathways in *C. elegans*. *Genome Res.* 22: 1488–1498. <https://doi.org/10.1101/gr.134841.111>
- Washburn, M. C., and H. A. Hundley, 2016 Trans and cis factors affecting A-to-I RNA editing efficiency of a noncoding editing target in *C. elegans*. *RNA* 22: 722–728. <https://doi.org/10.1261/rna.055079.115>
- Washburn, M. C., B. Kakaradov, B. Sundararaman, E. Wheeler, S. Hoon *et al.*, 2014 The dsRBP and inactive editor ADR-1 utilizes dsRNA binding to regulate A-to-I RNA editing across the *C. elegans* transcriptome. *Cell Rep.* 6: 599–607. <https://doi.org/10.1016/j.celrep.2014.01.011>
- Watabe, E., S. Ono, and H. Kuroyanagi, 2018 Alternative splicing of the *Caenorhabditis elegans* lev-11 tropomyosin gene is regulated in a tissue-specific manner. *Cytoskeleton (Hoboken)* 75: 427–436. <https://doi.org/10.1002/cm.21489>
- West, S., N. Gromak, and N. J. Proudfoot, 2004 Human 5' → 3' exonuclease Xrn2 promotes transcription termination at co-transcriptional cleavage sites. *Nature* 432: 522–525. <https://doi.org/10.1038/nature03035>
- Whewy, G., M. Schmidts, D. A. Mans, K. Szymanska, T. T. Nguyen *et al.*, 2015 An siRNA-based functional genomics screen for the identification of regulators of ciliogenesis and ciliopathy genes. *Nat. Cell Biol.* 17: 1074–1087. <https://doi.org/10.1038/ncb3201>
- Whipple, J. M., O. A. Youssef, P. J. Aruscavage, D. A. Nix, C. Hong *et al.*, 2015 Genome-wide profiling of the *C. elegans* dsRNAome. *RNA* 21: 786–800. <https://doi.org/10.1261/rna.048801.114>
- Wilkinson, H. A., K. Fitzgerald, and I. Greenwald, 1994 Reciprocal changes in expression of the receptor lin-12 and its ligand lag-2 prior to commitment in a *C. elegans* cell fate decision. *Cell* 79: 1187–1198. [https://doi.org/10.1016/0092-8674\(94\)90010-8](https://doi.org/10.1016/0092-8674(94)90010-8)
- Wilkinson, M. E., S. M. Fica, W. P. Galej, C. M. Norman, A. J. Newman *et al.*, 2017 Postcatalytic spliceosome structure reveals mechanism of 3'-splice site selection. *Science* 358: 1283–1288. <https://doi.org/10.1126/science.aar3729>
- Wilusz, J. E., 2018 A 360° view of circular RNAs: from biogenesis to functions. *Wiley Interdiscip. Rev. RNA* 9: e1478. <https://doi.org/10.1002/wrna.1478>
- Wittkopp, N., E. Huntzinger, C. Weiler, J. Sauliere, S. Schmidt *et al.*, 2009 Nonsense-mediated mRNA decay effectors are essential for zebrafish embryonic development and survival. *Mol. Cell. Biol.* 29: 3517–3528. <https://doi.org/10.1128/MCB.00177-09>
- Wollerton, M. C., C. Gooding, E. J. Wagner, M. A. Garcia-Blanco, and C. W. Smith, 2004 Autoregulation of polypyrimidine tract binding protein by alternative splicing leading to nonsense-mediated decay. *Mol. Cell* 13: 91–100. [https://doi.org/10.1016/S1097-2765\(03\)00502-1](https://doi.org/10.1016/S1097-2765(03)00502-1)
- Wu, D., A. T. Lamm, and A. Z. Fire, 2011 Competition between ADAR and RNAi pathways for an extensive class of RNA targets. *Nat. Struct. Mol. Biol.* 18: 1094–1101. <https://doi.org/10.1038/nsmb.2129>
- Yabe, T., N. Suzuki, T. Furukawa, T. Ishihara, and I. Katsura, 2005 Multidrug resistance-associated protein MRP-1 regulates dauer diapause by its export activity in *Caenorhabditis elegans*. *Development* 132: 3197–3207. <https://doi.org/10.1242/dev.01909>
- Yamashita, A., N. Izumi, I. Kashima, T. Ohnishi, B. Saari *et al.*, 2009 SMG-8 and SMG-9, two novel subunits of the SMG-1 complex, regulate remodeling of the mRNA surveillance complex during nonsense-mediated mRNA decay. *Genes Dev.* 23: 1091–1105. <https://doi.org/10.1101/gad.1767209>
- Yan, C., R. Wan, R. Bai, G. Huang, and Y. Shi, 2016 Structure of a yeast activated spliceosome at 3.5 Å resolution. *Science* 353: 904–911. <https://doi.org/10.1126/science.aag0291>

- Yan, C., R. Wan, R. Bai, G. Huang, and Y. Shi, 2017 Structure of a yeast step II catalytically activated spliceosome. *Science* 355: 149–155. <https://doi.org/10.1126/science.aak9979>
- Yates, A., W. Akanni, M. R. Amodé, D. Barrell, K. Billis *et al.*, 2016 Ensembl 2016. *Nucleic Acids Res.* 44: D710–D716. <https://doi.org/10.1093/nar/gkv1157>
- Yoshimura, J., K. Ichikawa, M. J. Shoura, K. L. Artilles, I. Gabdank *et al.*, 2019 Recompleting the *Caenorhabditis elegans* genome. *Genome Res.* 29: 1009–1022. <https://doi.org/10.1101/gr.244830.118>
- Young, D. J., N. R. Guydosh, F. Zhang, A. G. Hinnebusch, and R. Green, 2015 Rli1/ABCE1 recycles terminating ribosomes and controls translation reinitiation in 3'UTRs in vivo. *Cell* 162: 872–884. <https://doi.org/10.1016/j.cell.2015.07.041>
- Youngman, E. M., and J. M. Claycomb, 2014 From early lessons to new frontiers: the worm as a treasure trove of small RNA biology. *Front. Genet.* 5: 416. <https://doi.org/10.3389/fgene.2014.00416>
- Zahler, A. M., 2012 Pre-mRNA splicing and its regulation in *Caenorhabditis elegans* (March 21, 2012), *WormBook*, ed. The *C. elegans* Research Community, WormBook, doi/10.1895/wormbook.1.31.2, <http://www.wormbook.org>.
- Zahler, A. M., L. E. Rogel, M. L. Glover, S. Yitiz, J. M. Ragle *et al.*, 2018 SNRP-27, the *C. elegans* homolog of the tri-snRNP 27K protein, has a role in 5' splice site positioning in the spliceosome. *RNA* 24: 1314–1325. <https://doi.org/10.1261/rna.066878.118>
- Zahler, A. M., J. D. Tuttle, and A. D. Chisholm, 2004 Genetic suppression of intronic +1G mutations by compensatory U1 snRNA changes in *Caenorhabditis elegans*. *Genetics* 167: 1689–1696. <https://doi.org/10.1534/genetics.104.028746>
- Zanetti, S., M. Meola, A. Bochud, and A. Puoti, 2011 Role of the *C. elegans* U2 snRNP protein MOG-2 in sex determination, meiosis, and splice site selection. *Dev. Biol.* 354: 232–241. <https://doi.org/10.1016/j.ydbio.2011.04.001>
- Zhan, X., C. Yan, X. Zhang, J. Lei, and Y. Shi, 2018a Structure of a human catalytic step I spliceosome. *Science* 359: 537–545. <https://doi.org/10.1126/science.aar6401>
- Zhan, X., C. Yan, X. Zhang, J. Lei, and Y. Shi, 2018b Structures of the human pre-catalytic spliceosome and its precursor spliceosome. *Cell Res.* 28: 1129–1140. <https://doi.org/10.1038/s41422-018-0094-7>
- Zhang, H., F. Rigo, and H. G. Martinson, 2015 Poly(A) signal-dependent transcription termination occurs through a conformational change mechanism that does not require cleavage at the Poly(A) Site. *Mol. Cell* 59: 437–448. <https://doi.org/10.1016/j.molcel.2015.06.008>
- Zhang, J., X. Sun, Y. Qian, J. P. LaDuca, and L. E. Maquat, 1998a At least one intron is required for the nonsense-mediated decay of triosephosphate isomerase mRNA: a possible link between nuclear splicing and cytoplasmic translation. *Mol. Cell. Biol.* 18: 5272–5283. <https://doi.org/10.1128/MCB.18.9.5272>
- Zhang, J., X. Sun, Y. Qian, and L. E. Maquat, 1998b Intron function in the nonsense-mediated decay of beta-globin mRNA: indications that pre-mRNA splicing in the nucleus can influence mRNA translation in the cytoplasm. *RNA* 4: 801–815. <https://doi.org/10.1017/S1355838298971849>
- Zhang, X., C. Yan, J. Hang, L. I. Finci, J. Lei *et al.*, 2017 An atomic structure of the human spliceosome. *Cell* 169: 918–929.e14. <https://doi.org/10.1016/j.cell.2017.04.033>
- Zhang, X., C. Yan, X. Zhan, L. Li, J. Lei *et al.*, 2018 Structure of the human activated spliceosome in three conformational states. *Cell Res.* 28: 307–322. <https://doi.org/10.1038/cr.2018.14>
- Zhang, X., X. Zhan, C. Yan, W. Zhang, D. Liu *et al.*, 2019 Structures of the human spliceosomes before and after release of the ligated exon. *Cell Res.* 29: 274–285. <https://doi.org/10.1038/s41422-019-0143-x>
- Zhang, Y., W. Xue, X. Li, J. Zhang, S. Chen *et al.*, 2016 The biogenesis of nascent circular RNAs. *Cell Rep.* 15: 611–624. <https://doi.org/10.1016/j.celrep.2016.03.058>
- Zhang, Z., J. Fu, and D. S. Gilmour, 2005 CTD-dependent dismantling of the RNA polymerase II elongation complex by the pre-mRNA 3'-end processing factor, Pcf11. *Genes Dev.* 19: 1572–1580. <https://doi.org/10.1101/gad.1296305>
- Zhao, H. Q., P. Zhang, H. Gao, X. He, Y. Dou *et al.*, 2015 Profiling the RNA editomes of wild-type *C. elegans* and ADAR mutants. *Genome Res.* 25: 66–75. <https://doi.org/10.1101/gr.176107.114>
- Zinder, J. C., and C. D. Lima, 2017 Targeting RNA for processing or destruction by the eukaryotic RNA exosome and its cofactors. *Genes Dev.* 31: 88–100. <https://doi.org/10.1101/gad.294769.116>
- Zisoulis, D. G., M. T. Lovci, M. L. Wilbert, K. R. Hutt, T. Y. Liang *et al.*, 2010 Comprehensive discovery of endogenous Argonaute binding sites in *Caenorhabditis elegans*. *Nat. Struct. Mol. Biol.* 17: 173–179. <https://doi.org/10.1038/nsmb.1745>
- Zorio, D. A., and T. Blumenthal, 1999a Both subunits of U2AF recognize the 3' splice site in *Caenorhabditis elegans*. *Nature* 402: 835–838. <https://doi.org/10.1038/45597>
- Zorio, D. A., and T. Blumenthal, 1999b U2AF35 is encoded by an essential gene clustered in an operon with RRM/cyclophilin in *Caenorhabditis elegans*. *RNA* 5: 487–494. <https://doi.org/10.1017/S1355838299982225>
- Zorio, D. A., N. N. Cheng, T. Blumenthal, and J. Spieth, 1994 Operons as a common form of chromosomal organization in *C. elegans*. *Nature* 372: 270–272. <https://doi.org/10.1038/372270a0>
- Zorio, D. A., K. Lea, and T. Blumenthal, 1997 Cloning of *Caenorhabditis* U2AF65: an alternatively spliced RNA containing a novel exon. *Mol. Cell. Biol.* 17: 946–953. <https://doi.org/10.1128/MCB.17.2.946>
- Zund, D., and O. Muhlemann, 2013 Recent transcriptome-wide mapping of UPF1 binding sites reveals evidence for its recruitment to mRNA before translation. *Translation (Austin)* 1: e26977. <https://doi.org/10.4161/trla.26977>

Communicating editor: J. Kim