

## Flex System Enterprise Chassis Product Guide

Flex System is the next generation of blade technology with more performance and bandwidth and far more capability to consolidate and virtualize than previous systems. Flex System is anchored by the Flex System Enterprise Chassis which enables high-speed performance with integrated servers and networking. Furthermore, its flexible design can meet the needs of varying workloads with independently scalable IT resource pools for higher utilization and lower cost per workload.

The Flex System Enterprise Chassis is shown in Figure 1.



Figure 1. The Flex System Enterprise Chassis

### Did you know?

In addition to the Flex System Enterprise Chassis, Lenovo also offers the Carrier-Grade Chassis for installations requiring tolerance to higher temperatures or for use in environments without filtered air. For information about the Carrier-Grade Chassis, see <https://lenovopress.com/tips1285>.

## **Key features**

The Flex System Enterprise Chassis is a simple, integrated infrastructure platform that supports a mix of compute, storage, and networking resources to meet the demands of your applications. The solution is easily scalable with the addition of another chassis with the required nodes. With Lenovo XClarity Administrator, multiple chassis can be monitored from a single screen. This flexible 14 node, 10U chassis is designed for a simple deployment now and to scale to meet your needs in the future.

### **Flexibility and efficiency**

The 14 bays in the chassis allow the installation of compute or management nodes, with networking modules in the rear. A single chassis or a group of chassis can be fully customized to the specific needs of the computing environment. IT can meet the needs of the business using a single system across multiple operating environments.

The system monitors and manages power usage on all major chassis components so you have total control over power consumption. AC power options can be configurable in either a single or three-phase power domain. The chassis supports N+N or N+1 redundant power supplies and an entirely passive mid-plane to meet your reliability needs. The power supplies are 80 PLUS Platinum-certified indicating high energy efficiency. The chassis design also optimizes cooling with cooling zones within the chassis. The system manages the fan modules based on node configuration within the chassis. So, the system can increase the speed of certain fan modules to cool potential hot spots, and use lower speeds for other fan modules where appropriate.

### **Easily scalable with simple administration**

Because the Flex System Enterprise Chassis is an all-in-one solution, it is designed for growth from a single chassis to many. Adding compute, or networking capability is as simple as adding additional nodes or modules. Compute nodes and I/O modules connect to a midplane and are designed to be inserted or removed while the chassis is running. The use of the midplane means that the compute nodes and I/O modules do not need their own power cables and do not need network cables or transceivers to connect to each other within the chassis. These features make it easy to add or replace compute nodes and get them operational quickly.

The simple, highly integrated management system allows you to use the Chassis Management Modules integrated into each chassis to administer a single chassis, and the new Lenovo XClarity Administrator offers agent-free hardware management for compute nodes and networking.

### **Designed for multiple generations of technology**

The Flex System Enterprise Chassis is designed to be the foundation of your IT infrastructure now and into the future. Compute performance requirements are always on the rise and networking demands continue to grow with rising bandwidth needs and a shrinking tolerance for latency. The chassis is designed to scale to meet the needs of your future workloads, offering the flexibility to support current and future innovations in compute, storage, and networking technology.

## Locations of key components and connectors

The following figure shows the front of the Enterprise Chassis.

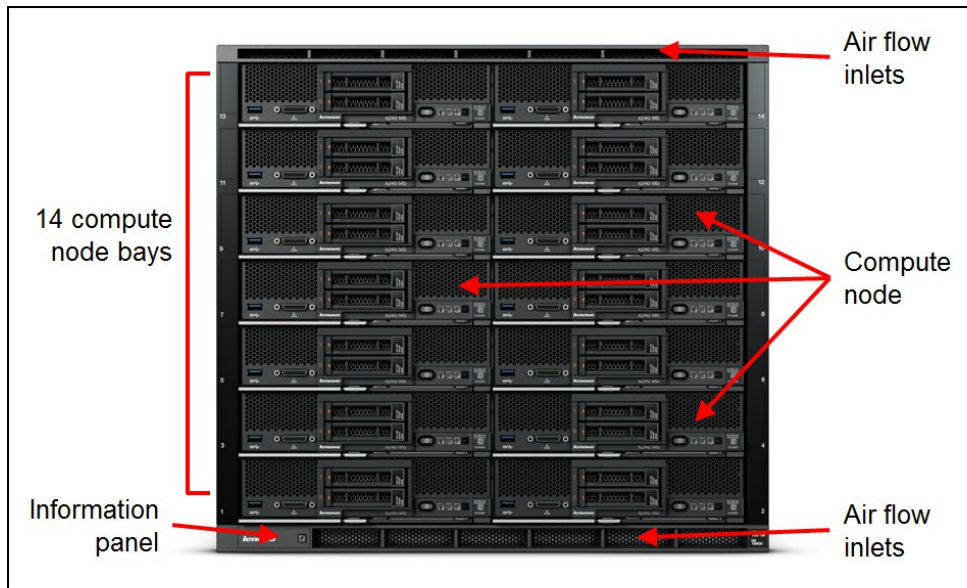

Figure 2. Front of the Flex System Enterprise Chassis

The following figure shows the rear of the Enterprise Chassis.

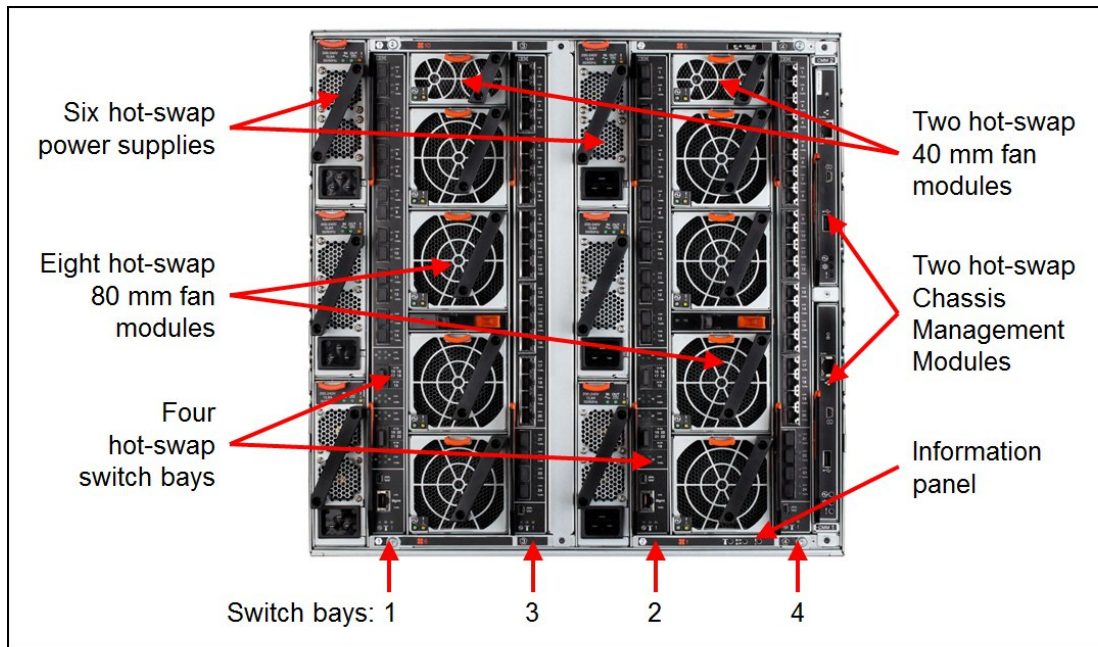

Figure 3. Rear of the Flex System Enterprise Chassis

## Standard specifications

The following table lists the standard specifications.

Table 1. Standard specifications

Components	Specification
Machine type	8721
Firmware	Chassis with first generation Chassis Management Module (68Y7030): IBM-signed firmware Chassis with Chassis Management Module 2 (00FJ669): Lenovo-signed firmware
Form factor	10U rack-mounted unit.
Maximum number of compute nodes	14 half-wide (single bay), seven full-wide (two bays), three double-height full-wide (four bays) or one quadruple-height full-wide (8 bays). Mixing is supported.
Chassis per 42U rack	Four.
Nodes per 42U rack	56 half-wide, or 28 full-wide.
Management	Chassis Management Modules 2 (CMM2) modules provide chassis management. One or two CMM2s standard, depending on the model and the use of two provides redundancy. Earlier models of the Enterprise Chassis use the first generation CMM. The CMM2 interfaces with the integrated management module (IMM2) integrated in each compute node in the chassis. Optional Lenovo XClarity Administrator for hardware resource management with integrators to VMware vCenter and Microsoft System Center, including virtualization, networking, and storage management. Chassis with first generation CMM can be upgraded to CMM2 however CMM and CMM2 cannot be mixed.
I/O architecture	Up to eight lanes of I/O to an I/O adapter card, with each lane capable of up to 25 Gbps bandwidth. Up to 16 lanes of I/O to a half-wide node with two adapters. A wide variety of networking solutions, including Ethernet, Fibre Channel, Fibre Channel over Ethernet (FCoE), and InfiniBand.
Power supplies	Up to six power supplies that can provide N+N or N+1 redundant power. AC power supplies are 80 PLUS Platinum certified and provide over 94% efficiency at 50% load and 20% load. Each power supply contains two independently powered 40 mm cooling fan modules. All installed power supplies must be identical.
Fan modules	Ten fan modules (eight 80 mm fan modules and two 40 mm fan modules); Four 80 mm and two 40 mm fan modules standard.
Dimensions	Height: 440 mm (17.3 in) Width: 447 mm (17.6 in) Depth: 800 mm (31.5 in) (measured from front bezel to rear of chassis), 840 mm (33.1 in) (measured from node latch handle to the power supply handle)
Weight	Minimum configuration: 96.62 kg (213 lb) Maximum configuration: 220.45 kg (486 lb)
Sound level	7.5 bels (declared)
Temperature	Operating air temperature 10°C to 40°C
Electrical power	AC Input power: 200 - 240 V ac (nominal), 50 or 60 Hz -48 V DC Input power: -48V to -60 V dc (nominal) Minimum configuration: 0.51 kVA (two power supplies) Maximum configuration: 13 kVA (six power supplies)
Power consumption	12,900 watts maximum

The following table lists what each standard model, Express model and TopSeller model includes. In addition, each model ships with:

- One C19 to C20 two-meter power cable for each power supply
- One Rack Mount Kit

## Models

The Flex System Enterprise Chassis can be configured by using the [Lenovo Data Center Solution Configurator \(DCSC\)](#).

Configure-to-order (CTO) models are used to create models with factory-integrated server customizations. For CTO models, the base CTO models are listed in the following table.

- Model HC2 is for chassis orders with an FC5022 switch configured
- Model HC3 is for chassis orders without an FC5022 switch configured

Table 2. Base CTO models

Description	Machine Type/Model
Flex System Enterprise Chassis with CMM2 - 3 year Warranty	8721HC2
Flex System Enterprise Chassis with CMM2 - 3 year Warranty (no FC5022 Fibre Channel switches)	8721HC3

Preconfigured chassis models are also available as listed in the following table.

The following table lists the specifications of the standard Enterprise Chassis models.

Table 3. Models

Model	Node bays	CMM* (2 max)	I/O bays (used / max)	I/O modules included	Power supplies (6 max)	40mm fans (2 max)	80mm fan (8 max)	Console breakout cable
Standard models - World wide								
8721-ALx	14	1x CMM2	0 / 4	None	2x 2500W	2	4	1
Standard models - EMEA								
8721-17A	14	1x CMM2	0 / 4	None	2x 2500W	2	4	1
TopSeller models – North America								
8721-E3U	14	2x CMM2	2 / 4	2x SI4093#	6x 2500W	2	8	1
8721-E4U	14	2x CMM2	2 / 4	2x CN4093#	6x 2500W	2	8	1
8721-E5U	14	1x CMM2	0 / 4	None	2x 2500W	2	4	1
TopSeller models – Latin America & Brazil								
8721-E3U	14	2x CMM2	2 / 4	2x SI4093#	6x 2500W	2	8	1
8721-E4U	14	2x CMM2	2 / 4	2x CN4093#	6x 2500W	2	8	1

\* CMM1 = first generation Chassis Management Module (68Y7030), CMM2 = Chassis Management Module 2 (00FJ669)

† Model B1x includes two Flex System EN4023 10Gb Scalable Switches, 94Y5212 and two Flex System EN4023 10Gb Scalable Switch (FoD 3) upgrades, 47C9993. The FoD 3 upgrade enables FCoE on all active ports of the switches.

‡ Model B2x includes two Flex System EN4023 10Gb Scalable Switches, 94Y5212 and two Lenovo Flex System FC5022 24-port 16Gb SAN Scalable Switch, 00Y3324.

# Models E3U and E4U include two Flex System Fabric SI4093 System Interconnect Modules, 00FM518 or two Flex System Fabric CN4093 10Gb Converged Scalable Switches, 00FM510, respectively.

## Supported compute nodes

The following table lists the compute nodes that are supported in the Flex System Enterprise Chassis. The table also lists the maximum number installable.

Table 4. Supported compute nodes and maximum quantities

Description	Machine type	Firmware code base	Supported in chassis		Maximum per chassis*
			8721 with CMM1 (IBM signed)	8721 with CMM2 (Lenovo signed)	
<b>Lenovo ThinkSystem servers</b>					
ThinkSystem SN550 V2	7Z69	Lenovo signed	No	Supported	14
ThinkSystem SN550	7X16	Lenovo signed	No	Supported	14
ThinkSystem SN850	7X15	Lenovo signed	No	Supported	7
<b>Lenovo Flex System compute nodes</b>					
Flex System x220	7906	IBM signed	Supported	Supported	14
Flex System x222	7916	IBM signed	Supported	Supported	14
Flex System x240	7162	Lenovo signed	No	Supported	14
Flex System x240	8737	IBM signed	Supported	Supported	14
Flex System x240 M5 (E5-2600 v3)	9532	Lenovo signed	Supported	Supported	14
Flex System x240 M5 (E5-2600 v4)	9532	Lenovo signed	No	Supported	14
Flex System x440	7917	IBM signed	Supported	Supported	7
Flex System x440	7167	Lenovo signed	Supported	Supported	7
Flex System x280 X6	7196	Lenovo signed	No	Supported	7
Flex System x480 X6	7196	Lenovo signed	Supported	Supported	7
Flex System x880 X6	7196	Lenovo signed	Supported	Supported	7
Flex System x280 X6	7903	IBM signed	Supported	Supported	7
Flex System x480 X6	7903	IBM signed	Supported	Supported	7
Flex System x880 X6	7903	IBM signed	Supported	Supported	7
Flex System Manager	8731-A1x	IBM signed	Supported	Supported	1**
<b>IBM Power Systems servers</b>					
Flex System p24L	1457	IBM signed	Supported	No	14
Flex System p260	7895-22X	IBM signed	Supported	No	14
Flex System p270	7954-24X	IBM signed	Supported	No	14
Flex System p460	7895-42X	IBM signed	Supported	No	7

† The maximum number of compute nodes supported depends on a number of factors. See below.

\*\* A single Flex System Manager appliance can manage up to 16 chassis

The actual number of compute nodes systems that can be powered on in a chassis depends on these factors:

- The TDP power rating for the processors that are installed in the compute nodes (x86 servers)
- The number of power supplies installed in the chassis
- The capacity of the power supplies installed in the chassis (2100 W or 2500 W)

- The power redundancy policy used in the chassis (N+1 or N+N)

For the x480 X6 or x880 X6, if two compute nodes are scaled together, then a maximum of 3 scaled complexes can be installed. For the x880 X6, if four compute nodes are scaled together, then a maximum of 1 scaled x880 X6 complexes can be installed. Other bays can be filled with other compute nodes.

The table in the [Power Supplies](#) section provides guidelines about what number of compute nodes can be powered on in the Enterprise Chassis, based on the type and number of power supplies installed.

See ServerProven® for the latest information about the supported servers:  
<http://www.lenovo.com/us/en/serverproven/flexsystem.shtml>

## Supported I/O modules

The Flex System Enterprise Chassis has four high-speed switch bays that are capable of supporting a variety of I/O architectures.

The switches are installed in switch bays in the rear of the Flex System Enterprise Chassis as shown in the following figure. Switches are normally installed in pairs (bays 1 & 2, and bays 3 & 4), because I/O adapter cards installed in the compute nodes route to two switch bays for performance and redundancy.

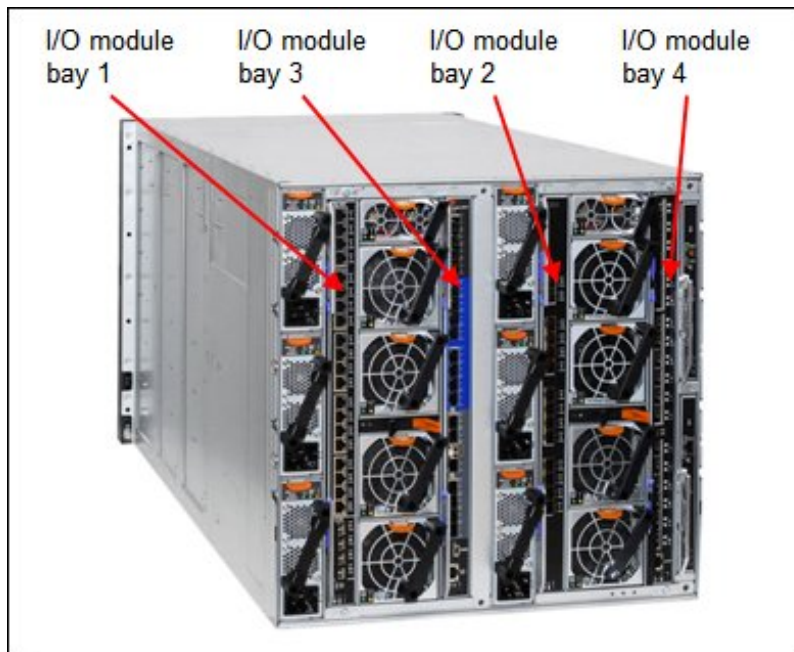

Figure 4. Location of the switch bays in the Flex System Enterprise Chassis

The following tables list the switches that are supported by the chassis.

**Note:** Some switches are withdrawn from marketing.



Table 5. I/O modules (currently available)

Description	Part number	Firmware code base	Supported in chassis	
			8721 with CMM (IBM signed)	8721 with CMM2 (Lenovo signed)
<b>25 Gb Ethernet module</b>				
ThinkSystem NE2552E Flex Switch	4SG7A08868	Lenovo†	No	Supported
<b>10 Gb Ethernet modules</b>				
EN4093R 10Gb Scalable Switch	00FM514	Lenovo†	No	Supported
SI4091 10Gb System Interconnect Module	00FE327	Lenovo†	No	Supported
SI4093 System Interconnect Module	00FM518	Lenovo†	No	Supported
EN4091 10Gb Ethernet Pass-thru	88Y6043	IBM	Supported	Supported

† For these switches, IBM signed switch firmware is up to Version 7.x and Lenovo signed switch firmware is Version 8.x onwards

Table 6. I/O modules (withdrawn)

Description	Part number	Firmware code base	Supported in chassis	
			8721 with CMM (IBM signed)	8721 with CMM2 (Lenovo signed)
<b>40 Gb Ethernet module (withdrawn)</b>				
EN6131 40Gb Ethernet Switch	90Y9346*	Vendor	Supported	Supported
<b>10 Gb Ethernet modules (withdrawn)</b>				
CN4093 10Gb Converged Scalable Switch	00FM510*	Lenovo†	No	Supported
EN4093 10Gb Scalable Switch	49Y4270*	IBM†	Supported	Supported
EN4093R 10Gb Scalable Switch	95Y3309*	IBM†	Supported	Supported
CN4093 10Gb Converged Scalable Switch	00D5823*	IBM†	Supported	Supported
SI4093 System Interconnect Module	95Y3313*	IBM†	Supported	Supported
Cisco Nexus B22 Fabric Extender	94Y5350*	Vendor	Supported	Supported
EN4023 10Gb Scalable Switch	94Y5212*	Vendor	Supported	Supported
<b>1 Gb Ethernet switch (withdrawn)</b>				
EN2092 1Gb Ethernet Scalable Switch	49Y4294*	IBM†	Supported	Supported
<b>Fibre Channel switches (withdrawn)</b>				
FC5022 16Gb SAN Scalable Switch	88Y6374	Vendor	Supported	Supported
FC5022 24-port 16Gb SAN Scalable Switch	00Y3324	Vendor	Supported	Supported
FC5022 24-port 16Gb ESB SAN Scalable Switch	90Y9356*	Vendor	Supported	Supported
FC3171 8Gb SAN Switch	69Y1930*	Vendor	Supported	Supported
FC3171 8Gb SAN Pass-thru	69Y1934*	Vendor	Supported	Supported
<b>InfiniBand switches (withdrawn)</b>				
IB6131 InfiniBand Switch (QDR/FDR)	90Y3450*	Vendor	Supported	Supported

\* Withdrawn from marketing

† For these switches, IBM signed switch firmware is up to Version 7.x and Lenovo signed switch firmware is Version 8.x onwards

## I/O architecture

Each half-wide compute node (such as the ThinkSystem SN550) has two adapter slots, and each full-wide compute node (such as the ThinkSystem SN850) has four adapter slots. The adapter slots in each compute node route through the chassis midplane to the switch bays. The architecture supports up to eight ports per adapter.

The following figure shows how two-port adapters are connected to switches installed in the chassis.

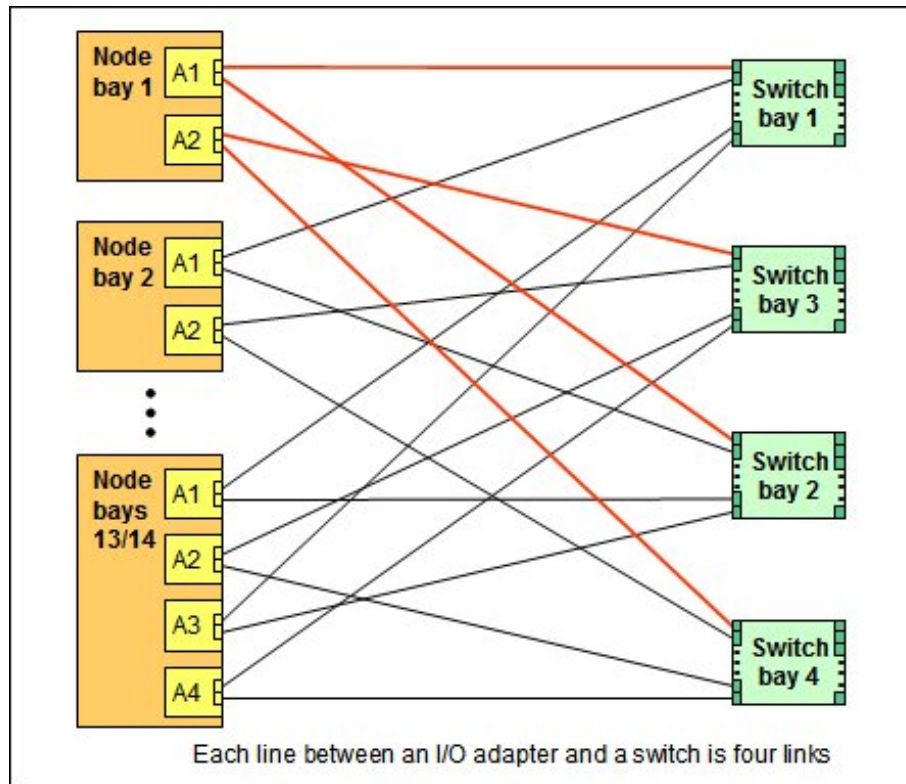

Figure 5. Logical layout of the interconnects between two-port I/O adapters and I/O modules

A four-port adapter doubles the connections between each adapter and switch pair (for example, a four-port adapter in A1 in each compute node routes two connections to switch 1 and two connections to switch 2).

The following figure shows how four-port adapters are connected to switches that are installed in the chassis.

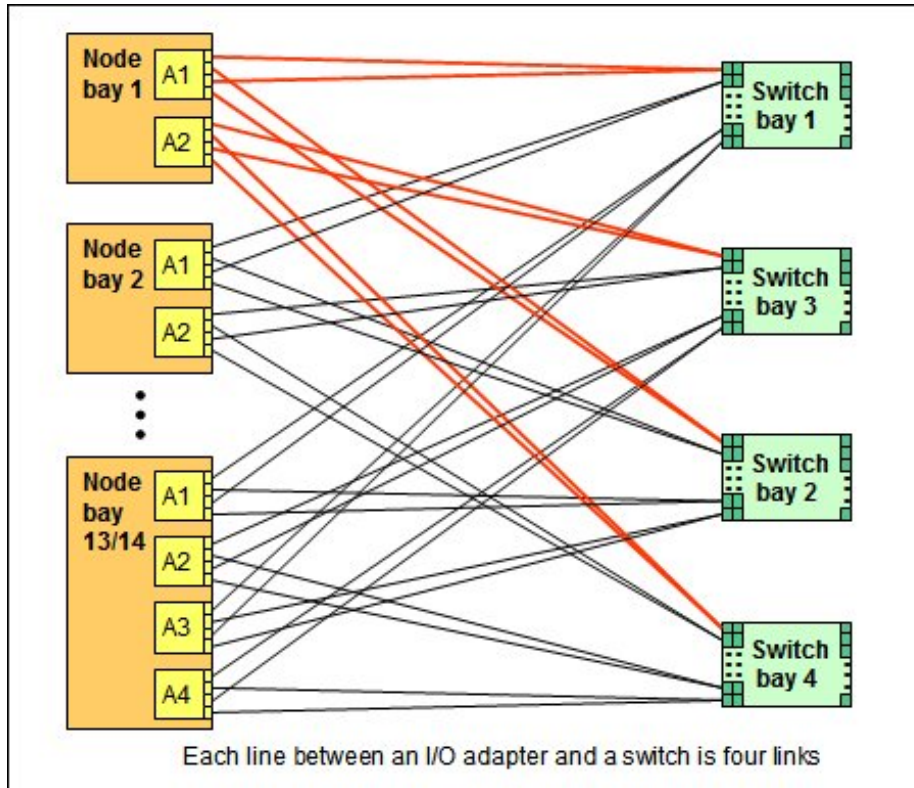

Figure 6. Logical layout of the inter-connections between four-port I/O adapters and I/O modules

The following table shows the connections between adapter slots in the compute nodes to the switch bays in the chassis.

Notes:

- To make use of all four ports of a four-port adapter across all blade servers, the switch must have 28 internal ports enabled, and two switches must be installed in the bays as indicated.
- To make use of six ports of a eight-port adapter across all blade servers, the switch must have 42 internal ports enabled, and two switches must be installed in the bays as indicated. Ports 7 and 8 of an eight-port adapter are reserved for future use. The chassis supports all eight ports, but there are no switches that are available that connect to these ports.

Table 7. Adapter to I/O bay correspondence

I/O adapter slot in the server	Port on the adapter*	Corresponding I/O module bay in the chassis			
		Bay 1	Bay 2	Bay 3	Bay 4
Slot 1	Port 1	Yes	No	No	No
	Port 2	No	Yes	No	No
	Port 3 (for 4 & 8-port cards)	Yes	No	No	No
	Port 4 (for 4 & 8-port cards)	No	Yes	No	No
	Port 5 (for 8-port cards)	Yes	No	No	No
	Port 6 (for 8-port cards)	No	Yes	No	No
	Port 7 (for 8-port cards)	Yes	No	No	No
	Port 8 (for 8-port cards)	No	Yes	No	No
Slot 2	Port 1	No	No	Yes	No
	Port 2	No	No	No	Yes
	Port 3 (for 4 & 8-port cards)	No	No	Yes	No
	Port 4 (for 4 & 8-port cards)	No	No	No	Yes
	Port 5 (for 8-port cards)	No	No	Yes	No
	Port 6 (for 8-port cards)	No	No	No	Yes
	Port 7 (for 8-port cards)	No	No	Yes	No
	Port 8 (for 8-port cards)	No	No	No	Yes

## Chassis Management Module

The Chassis Management Module (CMM) provides single-chassis management in the Enterprise Chassis. The CMM is used to communicate with the integrated management module (IMM) controller in each compute node to provide system monitoring, event recording and alerts, and to manage the chassis, its devices, and the compute nodes.

The chassis has one CMM installed standard but supports two CMMs for redundancy. If one CMM fails, the second CMM can detect its inactivity and activate itself to take control of the system without any disruption. The CMM is central to the management of the chassis and is required in the Enterprise Chassis.

There are two versions of the Chassis Management Module available:

- Chassis Management Module 2 (00FJ669) -- contains a Trusted Platform Module (TPM) v2.0 chip and has a Lenovo-signed firmware codebase. This module is recommended for new installation.
- First generation Chassis Management Module (68Y7030) -- contains a Trusted Platform Module (TPM) v1.1 chip and has an IBM-signed firmware codebase

Standard and TopSeller models of the chassis contain either a CMM (68Y7030) or a CMM2 (00FJ669) as listed in Table 2. The selection of CMM determines which compute nodes and I/O modules are supported in the chassis. See Tables 3 and 4 respectively for details. You can replace a CMM with a CMM2, however mixing is not supported -- you cannot have a chassis with one CMM (68Y7030) and one CMM2 (00FJ669).

The following table shows the ordering information.

Table 8. Chassis Management Module

Part number	Feature codes**	Description	Standard / Maximum
68Y7030*	A0TM / A0UE	Flex System Chassis Management Module	1 / 2
00FJ669	ASPT / ASQ8	Flex System Chassis Management Module 2	1 / 2

\* Withdrawn from marketing

\*\* The first feature code corresponds to the base CMM installed in the chassis. The second feature code corresponds to the optional second CMM which provides redundancy.

The following figure shows the Chassis Management Module. See Figure 3 for the location of the CMM in the chassis.

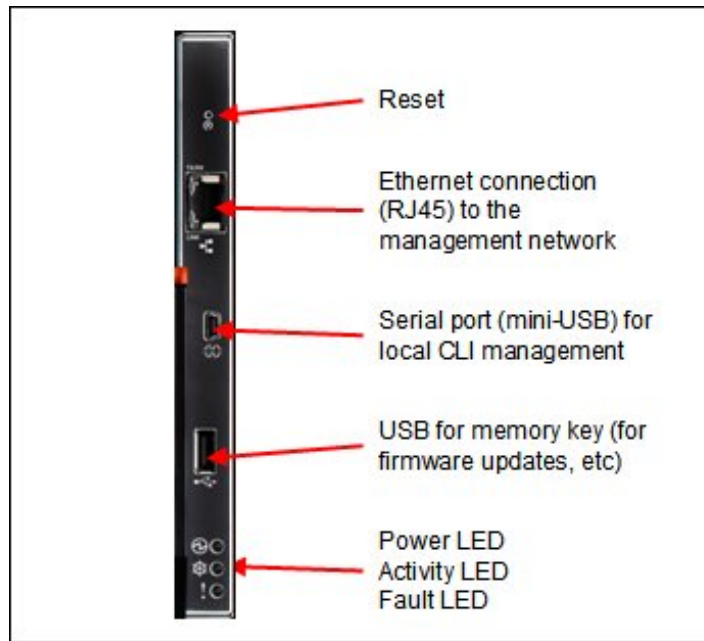

Figure 7. Chassis Management Module

The CMM provides these functions:

- Power control
- Fan management
- Chassis and compute node initialization
- Switch management
- Diagnostics: chassis, I/O options, and compute nodes
- Resource discovery and inventory management
- Resource alerts and monitoring management
- Chassis and compute node power management
- Security policy management
- Role-based access control
- Support for up to 84 local CMM user accounts
- Support for up to 32 simultaneous sessions

The CMM has the following connectors:

- USB connection. This connection can be used for insertion of a USB media key for tasks, such as firmware updates.
- 10/100/1000 Mbps RJ45 Ethernet connection to connect to a management network. The CMM can be managed via this Ethernet port.
- Serial port (mini-USB) for local command-line interface (CLI) management. Use serial cable 90Y9338 for connectivity.

The CMM has the following light-emitting diodes (LEDs) that provide the following information:

- Power-on LED
- Activity LED
- Error LED
- Ethernet port link and port activity LEDs

The CMM also incorporates a reset button, which, when pressed, resets the CMM back to its default condition. It has two functions, depending on how long the button is pressed:

- When pressed for less than 5 seconds, the CMM restarts.
- When pressed for more than 5 seconds (for example, 10 or 15 seconds), the CMM configuration is reset to the manufacturing defaults, and then the CMM restarts.

The CMM supports a web-based graphical user interface (GUI) that provides a way to perform CMM functions within a supported web browser. You can also perform management functions through the CMM command-line interface (CLI). Both the web-based GUI and the CLI are accessible via the single RJ45 Ethernet connector on the CMM or from any other system that is connected to the same (management) network.

The CMM has the following default static IPv4 address. By default, the CMM is configured to respond to Dynamic Host Configuration Protocol (DHCP) first before using its static IPv4 address:

- IP address: 192.168.70.100
- Subnet: 255.255.255.0
- User ID: USERID (all capital letters)
- Password: PASSWORD (all capital letters, with a zero instead of the letter O)

The CMM does not have a fixed static IPv6 IP address, by default. Initial access to the CMM in an IPv6 environment can be performed by either using the IPv4 IP address or the IPv6 link-local address. The IPv6 link-local address is automatically generated based on the Media Access Control (MAC) address of the CMM.

The CMM is the key component enabling the integrated management network. Internally, the CMM has a multiple port L2 1Gigabit Ethernet switch with dedicated links to all 14 node bays, all four switch bays, and the second CMM, if installed. These connections are all point-to-point, ensuring dedicated bandwidth. The 1GbE links are full-duplex, fixed speed (not auto-negotiate) links. The 1 GbE management network is only accessible by each node's management controller (IMMv2 or FSP), each switch module's management interfaces, the CMM, and the Flex System Manager (FSM) management appliance. This design permits the separation of the management network from the data network.

The CMM has a high-security policy that is enabled by default, which means that the following policies are enabled by default:

- Strong password policies with automatic validation and verification checks
- Required update of the default passwords after the initial setup
- Only secure communication protocols, such as SSH and SSL. Unencrypted protocols, such as HTTP, Telnet, and SNMPv1, are disabled.
- Certificates to establish secure, trusted connections for applications that run on the management processors

## Lenovo XClarity Administrator

Lenovo XClarity Administrator is centralized resource management solution aimed at reducing complexity, speeding response and enhancing availability of both Lenovo server systems and solutions.

Lenovo XClarity Administrator provides agent-free hardware management for System x rack servers and Flex System compute nodes and components, including the Chassis Management Module and Flex System I/O modules. The following figure shows the Lenovo XClarity Administrator interface, where both Flex System components and rack servers are being managed and can be seen on the dashboard.

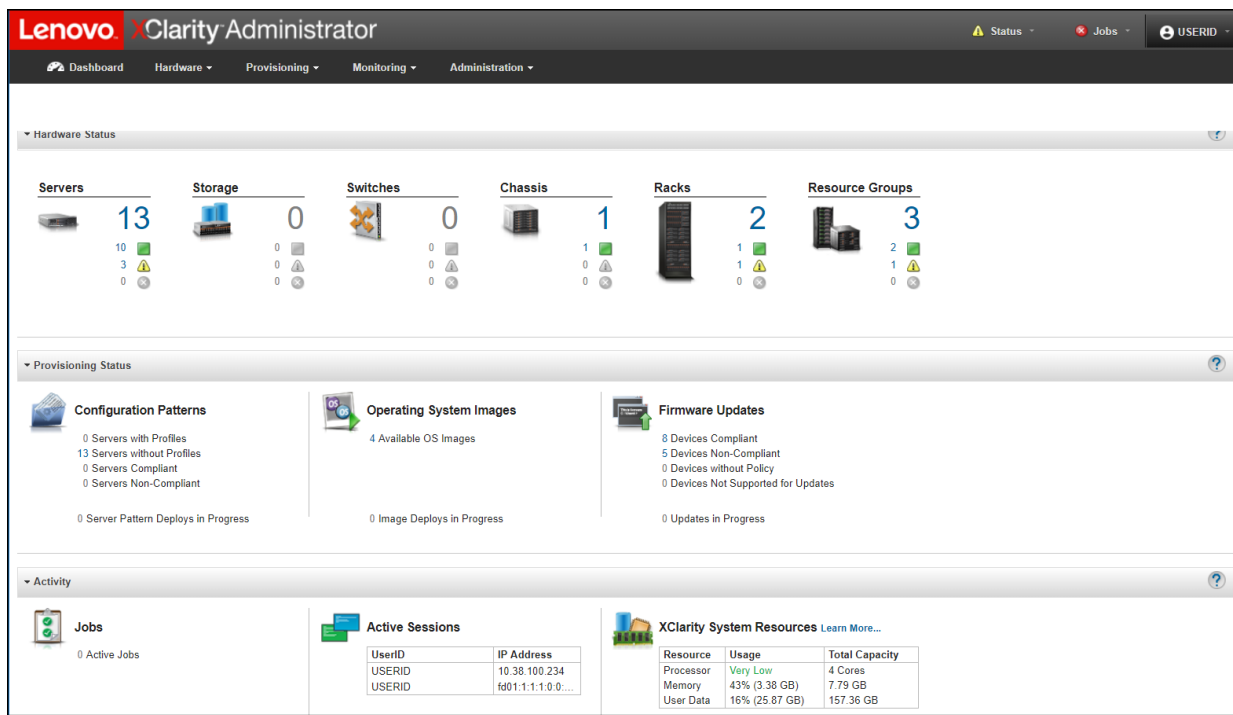

Figure 8. Lenovo XClarity Administrator dashboard

For information about Lenovo XClarity Administrator, see the Lenovo Press Product Guide: <http://lenovopress.com/tips1200>

## Power supplies

A maximum of six hot-swap power supplies can be installed in the Enterprise Chassis. In models where only two power supplies are standard, additional power supplies are orderable per the following table. All installed power supplies must be the same.

**Note:** The following power supplies are withdrawn from marketing:

- 2100W Power Module, 47C7633
- HVDC 2500W Power Module, 00AM765

Table 9. Ordering part number and feature code

Description	Part number	Feature code*
Flex System Enterprise Chassis 2500W Power Module	43W9049	A0UC / A0UD
Flex System Enterprise Chassis -48V DC 2500W Power Module	00FJ635	A5VB / A5VC

\* Use the first feature code for the first 2 power supplies, and use the second feature code for any additional power supplies, up to a total of 6

Each AC power supply part number ships with one 2.0m (6.5 ft) 16A/100-250V, C19 to IEC 320-C20 rack power cable, feature 6292. Other supported AC line cords including three-way split line cords, are listed in the following table.

Table 10. Supported AC line cords

Description	Part number	Feature code
4.3m, 16A/208V, C19 to NEMA L6-20P (US) Line Cord	40K9772	6275
2.5m, 16A/100-240V, C19 to IEC 320-C20 Rack Power Cable	39Y7916	6252
2m, 16A/100-250V, C19 to IEC 320-C20 Rack Power Cable	None	6292
4.3m, US/CAN, NEMA L15-30P - (3P+Gnd) to 3X IEC 320 C19	00D7192	A2Y3
4.3m, EMEA/AP, IEC 309 32A (3P+N+Gnd) to 3X IEC 320 C19	00D7193	A2Y4
4.3m, A/NZ, (PDL/Clipsal) 32A (3P+N+Gnd) to 3X IEC 320 C19	00D7194	A2Y5

The -48V DC power supply operates at -48V to -60 V dc (nominal) and has a Molex 1060 Power Connector. The power supply ships with one 2.0m DC power cord (FRU part number 69Y1652)

The following figure shows the power supply and highlights the light-emitting diodes (LEDs).



Figure 9. Power supply option

The AC power supplies are 80 PLUS Platinum-certified. The 2500W modules are 2500 Watts output rated at 200VAC to 208VAC (nominal), and 2750W at 220VAC to 240VAC (nominal). The power supply has an oversubscription rating of up to 3538 Watts output at 200VAC. The power supply operating range is 200-240 VAC. The power supplies also contain two dual independently powered 40mm cooling fan modules that are powered not from the power supply itself, but from the chassis midplane. The fan modules are variable speed and controlled by the chassis fan logic.



80 PLUS is a performance specification for power supplies used within servers and computers. To meet the 80 PLUS standard, the power supply must have an efficiency of 80% or greater, at 20%, 50%, and 100% of rated load with PF of .09 or greater. The standard has several grades, such as Bronze, Silver, Gold, and Platinum.

The chassis allows configurations of power supplies to give N+N or N+1 redundancy. A chassis can operate on only three power-supply units (PSUs) with no redundancy, but N+1 or N+N is advised. Three power supplies (or six with N+N redundancy) allow for a balanced three-phase configuration.

All power supply modules are combined into a single power domain within the chassis, which distributes power to each of the compute nodes, I/O modules, and ancillary components through the Enterprise Chassis midplane. The midplane is a highly reliable design with no active components. Each power supply is designed to provide fault isolation and is hot swappable.

In the case of the 2500W supplies, power monitoring of both the DC and AC signals allows the Chassis Management Module to accurately monitor the power supplies.

The following figure shows the compute node bay numbering (left) and power supply bay numbering (right).

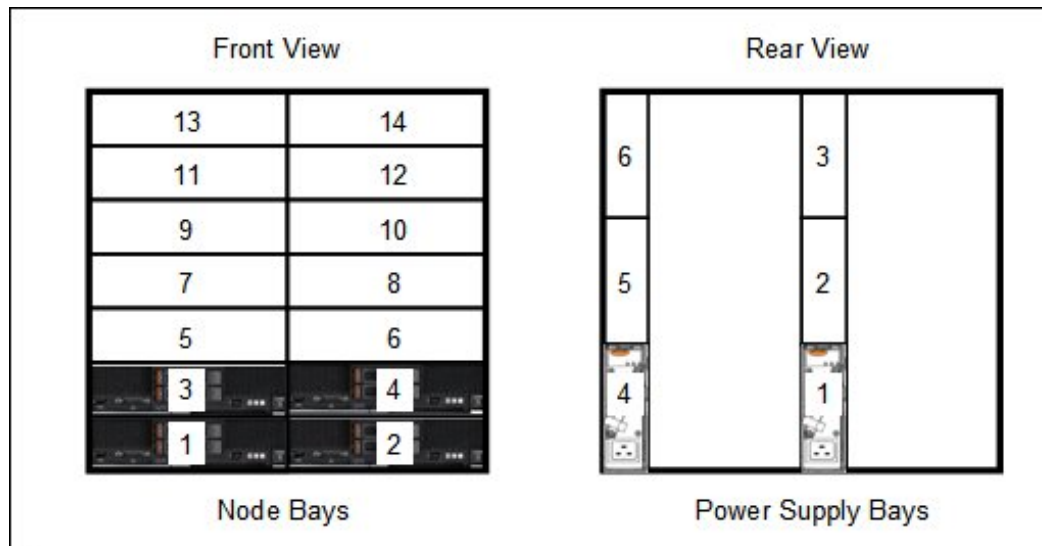

Figure 10. Power supply bay numbering

## Fan modules

The Enterprise Chassis supports up to a total of ten hot-swap fan modules: two 40 mm (1.57 in) fan modules and eight 80 mm (3.14 in) fan modules. Fans are redundant and the chassis will continue to operate in the event that a fan module fails.

The two 40 mm fan modules distribute airflow to the I/O modules and chassis management modules. Both of these fan modules ship with the chassis. The 80 mm fan modules distribute airflow to the compute nodes through the chassis from front to rear. Each 80 mm fan module actually contains two 80 mm fan modules, back to back at each end of the module, which are counter-rotating. The following figure shows the 80 mm fan module.

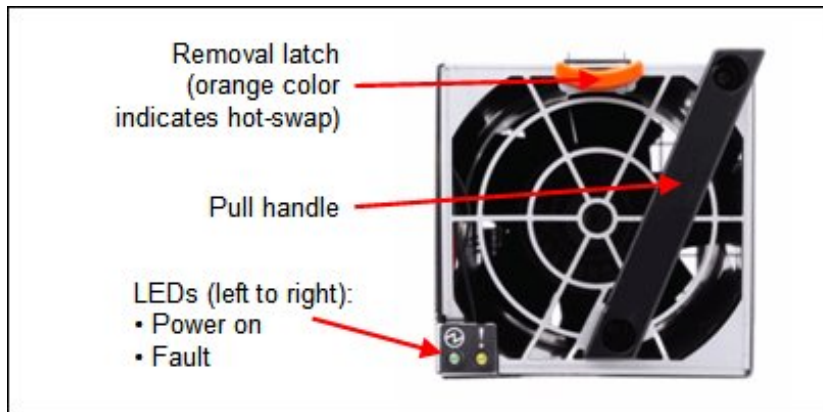

Figure 11. 80 mm fan module

Four 80 mm fan modules are installed standard in chassis model 8721-A1x and CTO orders. The maximum number of 80 mm fan modules that can be installed is eight. Ordering information is shown in the following table. When the modules are ordered as a part number, they are supplied as a pair. The feature codes is comprised of one fan.

Table 11. Fan module ordering information

Description	Part number	Feature code
Flex System Enterprise Chassis 80mm Fan Module	43W9078 (2 fan modules)	A0UA (1 fan module)

The 80 mm fan modules are populated, depending on the nodes installed. To support the base configuration and up to four nodes, chassis model 8721-A1x ships with four 80 mm fan modules and two 40 mm fan modules preinstalled. There are two cooling zones for the nodes: a left zone and a right zone. Fan modules must be installed in pairs as shown in the following figure. If there are insufficient fan modules for the number of nodes installed, the compute nodes might be throttled to balance heat generation and cooling capacity.

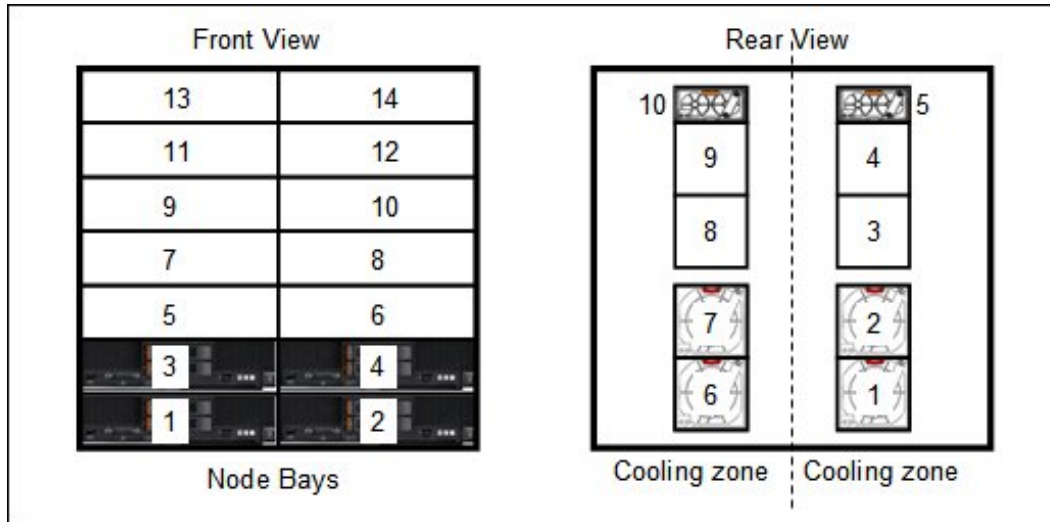

Figure 12. Fan module locations and cooling zones

The 40 mm fan modules are always required. Additional 80 mm fan modules are required as listed in the following table.

Table 12. 80 mm fan module requirements

Description	80 mm fan module requirements
Up to four half-wide compute nodes (node bays 1 - 4)	4 fan modules (fan bays 1, 2, and 6, 7)
Up to eight half-wide compute nodes (node bays 1 - 8)	6 fan modules (fan bays 1, 2, 3 and 6, 7, 8)
All 14 compute node bays (node bays 1 - 14)	8 fan modules (fan bays 1, 2, 3, 4 and 6, 7, 8, 9)

## Physical specifications

Dimensions:

- Height: 440 mm (17.3 inches)
- Width: 447 mm (17.6 in)
- Depth, measured from front bezel to rear of chassis: 800 mm (31.5 in)
- Depth, measured from node latch handle to the power supply handle: 840 mm (33.1 in)

Weight:

- Minimum configuration: 96.62 kg (213 lb)
- Maximum configuration: 220.45 kg (486 lb)

Shipping dimensions (approximate):

- Height: 81 cm (32 in)
- Length: 102 cm (40 in)
- Width: 71 cm (24 in)

## Supported environment

The Flex System Enterprise Chassis complies with ASHRAE Class A2 specifications.

The following environment is the supported operating environment.

Temperature:

- 0 - 914 m (0 - 3,000 ft): 10 - 40 °C (50 - 104 °F)
- 914 m - 3048 m (3,000 - 10,000 ft): The maximum ambient temperature drops 1 °C for every additional 178 m (584 ft) increase in altitude until the maximum temperature is 28 °C at 3,048 m (10,000 ft)

Relative humidity: 8% - 85%

Maximum altitude: 3,048 m (10,000 ft)

Electrical power:

- 200 - 240 V ac (nominal), 50 or 60 Hz
- Minimum configuration: 0.51 kVA (two power supplies)
- Maximum configuration: 13 kVA (six power supplies)

Power consumption: 12,900 watts maximum

Thermal output, full configuration - 12,900 watts (43,900 Btu/hr)

Acoustical noise emissions for Flex Chassis:

- 7.5 bels operating
- 7.5 bels idling

The noise emission level stated is the declared (upper limit) sound power level, in bels, for a random sample of machines. All measurements are made in accordance with ISO 7779 and reported in conformance with ISO 9296.

## Warranty and Support

The Flex System Enterprise Chassis, 8721, has a three-year warranty.

The standard warranty terms are customer-replaceable unit (CRU) and onsite (for field-replaceable units FRUs only) with standard call center support during normal business hours and 9x5 Next Business Day Parts Delivered.

Lenovo's additional support services provide a sophisticated, unified support structure for your data center, with an experience consistently ranked number one in customer satisfaction worldwide. Available offerings include:

- **Premier Support**

Premier Support provides a Lenovo-owned customer experience and delivers direct access to technicians skilled in hardware, software, and advanced troubleshooting, in addition to the following:

- Direct technician-to-technician access through a dedicated phone line
- 24x7x365 remote support
- Single point of contact service
- End to end case management
- Third-party collaborative software support
- Online case tools and live chat support
- On-demand remote system analysis

- **Warranty Upgrade (Preconfigured Support)**

Services are available to meet the on-site response time targets that match the criticality of your systems.

- 3, 4, or 5 years of service coverage
- 1-year or 2-year post-warranty extensions
- **Foundation Service:** 9x5 service coverage with next business day onsite response
- **Essential Service:** 24x7 service coverage with 4-hour onsite response or 24-hour committed repair (available only in select markets)
- **Advanced Service:** 24x7 service coverage with 2-hour onsite response or 6-hour committed repair (available only in select markets)

- **Managed Services**

Lenovo Managed Services provides continuous 24x7 remote monitoring (plus 24x7 call center availability) and proactive management of your data center using state-of-the-art tools, systems, and practices by a team of highly skilled and experienced Lenovo services professionals.

Quarterly reviews check error logs, verify firmware & OS device driver levels, and software as needed. We'll also maintain records of latest patches, critical updates, and firmware levels, to ensure you systems are providing business value through optimized performance.

- **Technical Account Management (TAM)**

A Lenovo Technical Account Manager helps you optimize the operation of your data center based on a deep understanding of your business. You gain direct access to your Lenovo TAM, who serves as your single point of contact to expedite service requests, provide status updates, and furnish reports to track incidents over time. In addition, your TAM will help proactively make service recommendations and manage your service relationship with Lenovo to make certain your needs are met.

- **Enterprise Server Software Support**

Enterprise Software Support is an additional support service providing customers with software support on Microsoft, Red Hat, SUSE, and VMware applications and systems. Around the clock availability for critical problems plus unlimited calls and incidents helps customers address challenges fast, without incremental costs. Support staff can answer troubleshooting and diagnostic questions, address product comparability and interoperability issues, isolate causes of problems, report defects to software vendors, and more.

- **Health Check**

Having a trusted partner who can perform regular and detailed health checks is central to maintaining efficiency and ensuring that your systems and business are always running at their best. Health Check supports Lenovo-branded server, storage, and networking devices, as well as select Lenovo-supported products from other vendors that are sold by Lenovo or a Lenovo-Authorized Reseller.

Examples of region-specific warranty terms are second or longer business day parts delivery or parts-only base warranty.

If warranty terms and conditions include onsite labor for repair or replacement of parts, Lenovo will dispatch a service technician to the customer site to perform the replacement. Onsite labor under base warranty is limited to labor for replacement of parts that have been determined to be field-replaceable units (FRUs). Parts that are determined to be customer-replaceable units (CRUs) do not include onsite labor under base warranty.

If warranty terms include parts-only base warranty, Lenovo is responsible for delivering only replacement parts that are under base warranty (including FRUs) that will be sent to a requested location for self-service. Parts-only service does not include a service technician being dispatched onsite. Parts must be changed at customer's own cost and labor and defective parts must be returned following the instructions supplied with the spare parts.

Lenovo Service offerings are region-specific. Not all preconfigured support and upgrade options are available in every region. For information about Lenovo service upgrade offerings that are available in your region, refer to the following resources:

- Service part numbers in Lenovo Data Center Solution Configurator (DCSC):  
<http://dcsc.lenovo.com/#/services>
- Lenovo Services Availability Locator  
<http://lenovolocator.com/>

For service definitions, region-specific details, and service limitations, please refer to the following documents:

- Lenovo Statement of Limited Warranty for Infrastructure Solutions Group (ISG) Servers and System Storage  
<http://pcsupport.lenovo.com/us/en/solutions/ht503310>
- Lenovo Data Center Services Agreement  
<http://support.lenovo.com/us/en/solutions/ht116628>

## Services

Lenovo Services is a dedicated partner to your success. Our goal is to reduce your capital outlays, mitigate your IT risks, and accelerate your time to productivity.

**Note:** Some service options may not be available in all markets or regions. For more information, go to <https://www.lenovo.com/services>. For information about Lenovo service upgrade offerings that are available in your region, contact your local Lenovo sales representative or business partner.

Here's a more in-depth look at what we can do for you:

- **Asset Recovery Services**

Asset Recovery Services (ARS) helps customers recover the maximum value from their end-of-life equipment in a cost-effective and secure way. On top of simplifying the transition from old to new equipment, ARS mitigates environmental and data security risks associated with data center equipment disposal. Lenovo ARS is a cash-back solution for equipment based on its remaining market value, yielding maximum value from aging assets and lowering total cost of ownership for your customers. For more information, see the ARS page, <https://lenovopress.com/lp1266-reduce-e-waste-and-grow-your-bottom-line-with-lenovo-ars>.

- **Assessment Services**

An Assessment helps solve your IT challenges through an onsite, multi-day session with a Lenovo technology expert. We perform a tools-based assessment which provides a comprehensive and thorough review of a company's environment and technology systems. In addition to the technology based functional requirements, the consultant also discusses and records the non-functional business requirements, challenges, and constraints. Assessments help organizations like yours, no matter how large or small, get a better return on your IT investment and overcome challenges in the ever-changing technology landscape.

- **Design Services**

Professional Services consultants perform infrastructure design and implementation planning to support your strategy. The high-level architectures provided by the assessment service are turned into low level designs and wiring diagrams, which are reviewed and approved prior to implementation. The implementation plan will demonstrate an outcome-based proposal to provide business capabilities through infrastructure with a risk-mitigated project plan.

- **Basic Hardware Installation**

Lenovo experts can seamlessly manage the physical installation of your server, storage, or networking hardware. Working at a time convenient for you (business hours or off shift), the technician will unpack and inspect the systems on your site, install options, mount in a rack cabinet, connect to power and network, check and update firmware to the latest levels, verify operation, and dispose of the packaging, allowing your team to focus on other priorities.

- **Deployment Services**

When investing in new IT infrastructures, you need to ensure your business will see quick time to value with little to no disruption. Lenovo deployments are designed by development and engineering teams who know our Products & Solutions better than anyone else, and our technicians own the process from delivery to completion. Lenovo will conduct remote preparation and planning, configure & integrate systems, validate systems, verify and update appliance firmware, train on administrative tasks, and provide post-deployment documentation. Customer's IT teams leverage our skills to enable IT staff to transform with higher level roles and tasks.

- **Integration, Migration, and Expansion Services**

Move existing physical & virtual workloads easily, or determine technical requirements to support increased workloads while maximizing performance. Includes tuning, validation, and documenting ongoing run processes. Leverage migration assessment planning documents to perform necessary migrations.

## Regulatory compliance

The server conforms to the following standards:

- ASHRAE Class A2
- FCC - Verified to comply with Part 15 of the FCC Rules Class A
- Canada ICES-004, issue 3 Class A
- UL/IEC 60950-1
- CSA C22.2 No. 60950-1
- NOM-019
- Argentina IEC 60950-1
- Japan VCCI, Class A
- IEC 60950-1 (CB Certificate and CB Test Report)
- China CCC (GB4943); (GB9254, Class A); (GB17625.1)
- Taiwan BSMI CNS13438, Class A; CNS14336
- Australia/New Zealand AS/NZS CISPR 22, Class A
- Korea KN22, Class A, KN24
- Russia/GOST ME01, IEC 60950-1, GOST R 51318.22, GOST R 51318.249, GOST R 51317.3.2, GOST R 51317.3.3
- CE Mark (EN55022 Class A, EN60950-1, EN55024, EN61000-3-2, EN61000-3-3)
- CISPR 22, Class A
- TUV-GS (EN60950-1/IEC 60950-1, EK1-ITB2000)

## Top-of-rack Ethernet switches

For enterprise-class installations with multiple Flex System Enterprise Chassis configurations, a top-of-rack Ethernet switch from Lenovo provides the necessary level of networking between racks of systems and the rest of your production network.

## Fibre Channel SAN switches

Lenovo offers the ThinkSystem DB Series of Fibre Channel SAN switches for high-performance storage expansion. See the DB Series product guides for models and configuration options:

- ThinkSystem DB Series SAN Switches:  
<https://lenovopress.com/storage/switches/rack#rt=product-guide>



## Power distribution units

Power planning for an Flex System Enterprise Chassis is essential.

The Enterprise Chassis has a maximum of six power supplies installed. So, careful consideration must be given to providing the best power-optimized source. Both N+N and N+1 configurations are supported for maximum flexibility in power redundancy. Each AC power supply in the chassis has a 16A C20 three-pin socket and can be fed by a C19 power cable, from a suitable supply.

The chassis has the ability to accommodate a maximum of six power supplies, so it is possible to balance a three-phase power input into a single chassis or a group of chassis. The chassis power system is designed for efficiency using data center power consisting of three-phase, 60A Delta 200 VAC (North America) or three-phase 32A wye 380-415 VAC (international). The chassis can also be fed from single-phase 200 - 240VAC supplies, if required.

For further details, see the *Flex System Enterprise Chassis Power Requirements Guide*, available from: <https://support.lenovo.com/documents/LNVO-POWINF>

Table 13. Power distribution units

Part number	Description
Switched and monitored AC PDUs	
46M4002	1U 9 C19/3 C13 Active Energy Manager DPI PDU
46M4003	1U 9 C19/3 C13 Active Energy Manager 60A 3 Phase PDU
46M4167	1U 9 C19/3 C13 Switched and Monitored 30A 3 Phase PDU
46M4134	0U 12 C19/12 C13 Switched and Monitored 50A 3 Phase PDU
46M4140	0U 12 C19/12 C13 50A 3 Phase PDU
Enterprise AC PDUs	
71762MX	Ultra Density Enterprise PDU C19 PDU+ (WW)
71762NX	Ultra Density Enterprise PDU C19 PDU (WW)
71763MU	Ultra Density Enterprise PDU C19 3 phase 60A PDU+ (NA)
71763NU	Ultra Density Enterprise PDU C19 3 phase 60A PDU (NA)
39Y8923	DPI 60A Three Phase C19 Enterprise PDU with IEC309 3P+G (208 V) fixed line cord
39Y8948	DPI Single Phase C19 Enterprise PDU without line cord
Front-end AC PDUs	
39Y8934	DPI 32amp/250V Front-end PDU with IEC 309 2P+Gnd connector
39Y8938	30amp/125V Front-end PDU with NEMA L5-30P connector
39Y8939	30amp/250V Front-end PDU with NEMA L6-30P connector
39Y8940	60amp/250V Front-end PDU with IEC 309 60A 2P+N+Gnd connector
DC PDUs	
44T0966	1U Higher Voltage DC PDU (240V/380V)

## Uninterruptible power supply units

The Flex System Enterprise Chassis supports attachments to the uninterruptible power supply units listed in the following table.

Table 14. Uninterruptible power supply units

Part number	Description
55946KX	RT6kVA 3U Rack or Tower UPS (200-240VAC)
55948KX	RT8kVA 6U Rack or Tower UPS (200-240VAC)
55949KX	RT11kVA 6U Rack or Tower UPS (200-240VAC)
55948PX	RT8kVA 6U 3:1 Phase Rack or Tower UPS (380-415VAC)
55949PX	RT11kVA 6U 3:1 Phase Rack or Tower UPS (380-415VAC)

For more information, see the related Lenovo Press Product Guides in the UPS category:

<https://lenovopress.com/servers/options/ups>

## Rack cabinets

The Flex System Enterprise Chassis is supported in the rack cabinets as listed in the following table. The suggested rack for Flex System is the 42U 1100 mm Enterprise V2 Deep Dynamic Rack, 93634PX.

Table 15. Rack cabinets

Part number	Feature code	Rack cabinet	Supported
93634PX	A1RC	42U 1100 mm Enterprise V2 Deep Dynamic Rack	Recommended
93634EX	A1RD	42U 1100 mm Dynamic Enterprise V2 Expansion Rack	Recommended
93634CX	A3GR	PureFlex System 42U Rack	Recommended
93634DX	A3GS	PureFlex System 42U Expansion Rack	Recommended
93634AX	A31F	PureFlex System 42U Rack	Recommended
93634BX	A31G	PureFlex System 42U Expansion Rack	Recommended
201886X	2731	11U Office Enablement Kit	Yes*
93072PX	6690	S2 25U Static Standard Rack	Yes
93072RX	1042	S2 25U Dynamic Standard Rack	Yes
93074RX	1043	S2 42U Standard Rack	Yes
99564RX	5629	S2 42U Dynamic Standard Rack	Yes
99564XX	5631	S2 42U Dynamic Standard Expansion Rack	Yes
93084PX	5621	42U Enterprise Rack	Yes
93084EX	5622	42U Enterprise Expansion Rack	Yes
93604PX	7649	42U 1200 mm Deep Dynamic Rack	Yes
93604EX	7650	42U 1200 mm Deep Dynamic Expansion Rack	Yes
93614PX	7651	42U 1200 mm Deep Static Rack	Yes
93614EX	7652	42U 1200 mm Deep Static Expansion Rack	Yes
93624PX	7653	47U 1200 mm Deep Static Rack	Yes
93624EX	7654	47U 1200 mm Deep Static Expansion Rack	Yes
14102RX	1047	eServer™ Cluster 25U Rack	Yes
14104RX	1048	Linux Cluster 42U Rack	Yes
9306-900	None	Netfinity® Rack	No
9306-910	None	Netfinity Rack	No
9306-42P	None	Netfinity Enterprise Rack	No
9306-42X	None	Netfinity Enterprise Rack Expansion Cabinet	No
9306-200	None	Netfinity NetBAY 22	No

\* This Office Enablement kit is specifically designed for the BladeCenter S Chassis. The Flex System Enterprise Chassis can be installed in this kit with 1U of space remaining, however the noise generated by the chassis may not be acceptable for office use.

## Lenovo Financial Services

Lenovo Financial Services reinforces Lenovo's commitment to deliver pioneering products and services that are recognized for their quality, excellence, and trustworthiness. Lenovo Financial Services offers financing solutions and services that complement your technology solution anywhere in the world.

We are dedicated to delivering a positive finance experience for customers like you who want to maximize your purchase power by obtaining the technology you need today, protect against technology obsolescence, and preserve your capital for other uses.

We work with businesses, non-profit organizations, governments and educational institutions to finance their entire technology solution. We focus on making it easy to do business with us. Our highly experienced team of finance professionals operates in a work culture that emphasizes the importance of providing outstanding customer service. Our systems, processes and flexible policies support our goal of providing customers with a positive experience.

We finance your entire solution. Unlike others, we allow you to bundle everything you need from hardware and software to service contracts, installation costs, training fees, and sales tax. If you decide weeks or months later to add to your solution, we can consolidate everything into a single invoice.

Our Premier Client services provide large accounts with special handling services to ensure these complex transactions are serviced properly. As a premier client, you have a dedicated finance specialist who manages your account through its life, from first invoice through asset return or purchase. This specialist develops an in-depth understanding of your invoice and payment requirements. For you, this dedication provides a high-quality, easy, and positive financing experience.

For your region-specific offers, please ask your Lenovo sales representative or your technology provider about the use of Lenovo Financial Services. For more information, see the following Lenovo website:

<https://www.lenovo.com/us/en/landingpage/lenovo-financial-services/>

## Related publications and links

For more information, see the following resources:

- Flex System product page  
<https://www.lenovo.com/us/en/c/data-center/servers/blades-flex>
- Flex System Information Center  
<http://flexsystem.lenovofiles.com/help/index.jsp>
- *Flex System Enterprise Chassis Installation and Service Guide*  
[http://flexsystem.lenovofiles.com/help/topic/com.lenovo.acc.8721.doc/printable\\_doc.html?cp=0\\_4\\_0\\_0](http://flexsystem.lenovofiles.com/help/topic/com.lenovo.acc.8721.doc/printable_doc.html?cp=0_4_0_0)
- ServerProven hardware compatibility page for Flex System  
<http://www.lenovo.com/us/en/serverproven>
- *Flex System Interoperability Guide*  
<http://lenovopress.com/fsig>
- Power Configurator (for Flex System nodes)  
<https://support.lenovo.com/documents/LNVO-PWRCONF>
- Lenovo Capacity Planner (for ThinkSystem nodes)  
<https://datacentersupport.lenovo.com/us/en/solutions/Invo-lcp>
- *Flex System Enterprise Chassis Power Requirements Guide*  
<https://support.lenovo.com/documents/LNVO-POWINF>
- *Lenovo Flex System Products and Technology*, SG24-8255  
<http://lenovopress.com/sg248255>
- IBM System Storage® Interoperation Center  
<http://www.ibm.com/systems/support/storage/ssic>

## Related product families

Product families related to this document are the following:

- Blade Chassis
- ThinkSystem SN550 V2 Server
- ThinkSystem SN850 Server
- ThinkSystem SN550 Server

## Notices

Lenovo may not offer the products, services, or features discussed in this document in all countries. Consult your local Lenovo representative for information on the products and services currently available in your area. Any reference to a Lenovo product, program, or service is not intended to state or imply that only that Lenovo product, program, or service may be used. Any functionally equivalent product, program, or service that does not infringe any Lenovo intellectual property right may be used instead. However, it is the user's responsibility to evaluate and verify the operation of any other product, program, or service. Lenovo may have patents or pending patent applications covering subject matter described in this document. The furnishing of this document does not give you any license to these patents. You can send license inquiries, in writing, to:

Lenovo (United States), Inc.  
8001 Development Drive  
Morrisville, NC 27560  
U.S.A.  
Attention: Lenovo Director of Licensing

LENOVO PROVIDES THIS PUBLICATION "AS IS" WITHOUT WARRANTY OF ANY KIND, EITHER EXPRESS OR IMPLIED, INCLUDING, BUT NOT LIMITED TO, THE IMPLIED WARRANTIES OF NON-INFRINGEMENT, MERCHANTABILITY OR FITNESS FOR A PARTICULAR PURPOSE. Some jurisdictions do not allow disclaimer of express or implied warranties in certain transactions, therefore, this statement may not apply to you.

This information could include technical inaccuracies or typographical errors. Changes are periodically made to the information herein; these changes will be incorporated in new editions of the publication. Lenovo may make improvements and/or changes in the product(s) and/or the program(s) described in this publication at any time without notice.

The products described in this document are not intended for use in implantation or other life support applications where malfunction may result in injury or death to persons. The information contained in this document does not affect or change Lenovo product specifications or warranties. Nothing in this document shall operate as an express or implied license or indemnity under the intellectual property rights of Lenovo or third parties. All information contained in this document was obtained in specific environments and is presented as an illustration. The result obtained in other operating environments may vary. Lenovo may use or distribute any of the information you supply in any way it believes appropriate without incurring any obligation to you.

Any references in this publication to non-Lenovo Web sites are provided for convenience only and do not in any manner serve as an endorsement of those Web sites. The materials at those Web sites are not part of the materials for this Lenovo product, and use of those Web sites is at your own risk. Any performance data contained herein was determined in a controlled environment. Therefore, the result obtained in other operating environments may vary significantly. Some measurements may have been made on development-level systems and there is no guarantee that these measurements will be the same on generally available systems. Furthermore, some measurements may have been estimated through extrapolation. Actual results may vary. Users of this document should verify the applicable data for their specific environment.

© Copyright Lenovo 2022. All rights reserved.

This document, TIPS0863, was created or updated on October 12, 2021.

Send us your comments in one of the following ways:

- Use the online Contact us review form found at:  
<https://lenovopress.lenovo.com/TIPS0863>
- Send your comments in an e-mail to:  
[comments@lenovopress.com](mailto:comments@lenovopress.com)

This document is available online at <https://lenovopress.lenovo.com/TIPS0863>.

## Trademarks

Lenovo and the Lenovo logo are trademarks or registered trademarks of Lenovo in the United States, other countries, or both. A current list of Lenovo trademarks is available on the Web at <https://www.lenovo.com/us/en/legal/copytrade/>.

The following terms are trademarks of Lenovo in the United States, other countries, or both:

Lenovo®  
BladeCenter®  
Flex System  
Lenovo Services  
Netfinity®  
RackSwitch  
ServerProven®  
System x®  
ThinkSystem  
TopSeller  
XClarity®

The following terms are trademarks of other companies:

Linux® is the trademark of Linus Torvalds in the U.S. and other countries.

Microsoft® is a trademark of Microsoft Corporation in the United States, other countries, or both.

Other company, product, or service names may be trademarks or service marks of others.