

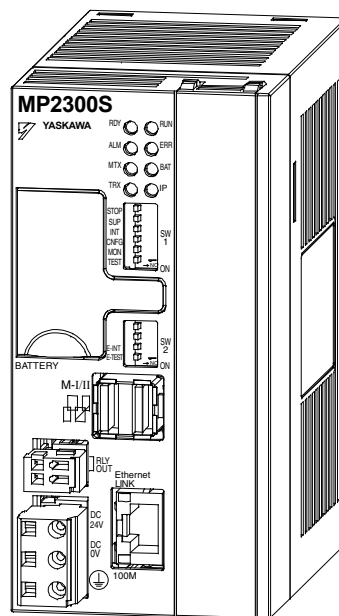

YASKAWA

Machine Controller MP2300S Basic Module USER'S MANUAL

Model: JEPMC-MP2300S-E



Overview	1
Specifications and Functions	2
Mounting and Wiring	3
System Start Up and Easy Programming	4
Outline of Motion Control Systems	5
Ethernet Communications	6
Slave CPU Synchronous Function	7
Maintenance, Inspection, and Troubleshooting	8
Appendices	A

Copyright © 2007 YASKAWA ELECTRIC CORPORATION

All rights reserved. No part of this publication may be reproduced, stored in a retrieval system, or transmitted, in any form, or by any means, mechanical, electronic, photocopying, recording, or otherwise, without the prior written permission of Yaskawa. No patent liability is assumed with respect to the use of the information contained herein. Moreover, because Yaskawa is constantly striving to improve its high-quality products, the information contained in this manual is subject to change without notice. Every precaution has been taken in the preparation of this manual. Nevertheless, Yaskawa assumes no responsibility for errors or omissions. Neither is any liability assumed for damages resulting from the use of the information contained in this publication.

Using this Manual

The MP2300S is a compact Machine Controller that contains the power supply, the CPU, I/O, and the communication functions in one single unit.

Please read this manual to ensure correct usage of the MP2300S system and apply to your manufacturing system for control. Keep this manual in a safe place for future reference.

■ Basic Terms

Unless otherwise specified, the following definitions are used:

- MP2300S: MP2300S Machine Controller
- MPE720: The Programming Device Software or a Programming Device (i.e., a personal computer) running the Programming Device Software
- PLC: Programmable Logic Controller

■ Manual Configuration

Read the chapters of this manual as required by the purpose.

Chapter	Selecting Models and Peripheral Devices	Studying Specifications and Ratings	Designing the System	Installation and Wiring	Trial Operation	Maintenance and Inspection
Chapter 1 Overview	√	–	–	–	–	–
Chapter 2 Specifications and Functions	√	√	√	√	–	–
Chapter 3 Mounting and Wiring	–	√	√	√	–	–
Chapter 4 System Start Up and Easy Programming	√	–	–	–	√	–
Chapter 5 Outline of Motion Control Systems	–	–	√	–	√	–
Chapter 6 Ethernet Communications	–	–	√	–	√	–
Chapter 7 Slave CPU Synchronous Function	–	–	√	–	√	–
Chapter 8 Maintenance, Inspection, and Troubleshooting	–	–	–	–	√	√
Appendices A to G	–	–	√	–	√	√

For information on motion parameters and motion commands, refer to *Machine Controller MP2000-series SVB/SVB-01 Motion Module User's Manual* (Manual no.: SIEPC88070033).

■ Indication of Reverse Signals

In this manual, the names of reverse signals (ones that are valid when low) are written with a forward slash (/) before the signal name, as shown in the following example:

Notation Examples

- $\overline{S-ON}$ = /S-ON
- $\overline{P-CON}$ = /P-CON

■ Related Manuals

The following table lists the manuals relating to the MP2300S. Refer to these manuals as required.

Manual Name	Manual Number	Contents
Machine Controller MP2000 series SVB/SVB-01 Motion Module User's Manual	SIEPC88070033	Describes the functions, specifications, and application methods of the MP2000-series Motion Module that is built into the SVB, SVB-01, and SVR Module.
Machine Controller MP2300 Basic Module User's Manual	SIEPC88070003	Describes the application methods and modules to be connected.
Machine Controller MP2□00 Communication Module User's Manual	SIEP C880700 04	Describes the functions, specifications, and application methods of the MP2□00 Communication Modules (217IF, 218IF, 260IF, 261IF).
Machine Controller MP900/MP2000 Series User's Manual, Ladder Programming	SIEZ-C887-1.2	Describes the instructions used in MP900/MP2000 ladder programming.
Machine Controller MP900/MP2000 Series User's Manual Motion Programming	SIEZ-C887-1.3	Describes the instructions used in MP900/MP2000 motion programming.
Engineering Tool for MP2000-series Machine Controller MPE720 Version 6 User's Manual	SIEPC88070030	Describes the installation and operation of the engineering tools for MP2000-series Machine Controller MPE720 Version 6.
Machine Controller MP900/MP2000 Series MPE720 Software for Programming Device User's Manual	SIEP C880700 05	Describes how to install and operate the MP900/MP2000-series programming system (MPE720).
Σ Series SGM□/SGD User's Manual High-speed Field Network MECHATROLINK-compatible AC Servo Drivers	SIEZ-S800-26.4	Describes the Σ Series SERVOPACK models, specifications, and capacity selection methods.
Σ-II Series SGM□H/SGDM User's Manual	SIEP S800000 15	Describes the installation, wiring, trial operation, function applications methods, maintenance, and inspection of the Σ-II Series SERVOPACKs.
Σ-III Series SGM□H/SGDS User's Manual	SIEP S800000 00	Describes the models, specifications, wiring, trial operation, adjustment, function application methods, maintenance, and inspection of the Σ-III Series SERVOPACKs and Servomotors.
Σ-III Series SGM□S/SGDS Digital Operator Operating Instructions	TOBEP S800000 01	Describes the operating methods of the JUSP-OP05A Digital Operator.
Σ-III Series SGM□S/SGDS MECHATROLINK-II SERVOPACKs with Communication User's Manual	SIEP S800000 11	Describes the models, specifications, wiring, trial operation, adjustment, function application methods, maintenance, inspection, and MECHATROLINK communication of the Σ-III Series SERVOPACKs and Servomotors.
Machine Controller MP900/MP2000 Series Linear Servomotor Manual	SIEP C880700 06	Describes the connection methods, setting methods, and other information for Linear Servomotors.
Machine Controller MP900/MP2000 Series New Ladder Editor User's Manual Programming Manual	SIEZ-C887-13.1	Describes the programming instructions of the New Ladder Editor, which assists MP900/MP2000-series design and maintenance.
Machine Controller MP900/MP2000 Series New Ladder Editor User's Manual Operation	SIEZ-C887-13.2	Describes the operating methods of the New Ladder Editor, which assists MP900/MP2000-series design and maintenance.
Machine Controller MP900/MP2000 Series User's Manual, MECHATROLINK System	SIEZ-C887-5.1	Describes MECHATROLINK distributed I/O for MP900/MP2000-series Machine Controllers.

■ Copyrights

- DeviceNet is a registered trademark of the ODVA (Open DeviceNet Venders Association).
- PROFIBUS is a trademark of the PROFIBUS User Organization.
- Ethernet is a registered trademark of the Xerox Corporation.
- Microsoft, Windows, Windows NT, and Internet Explorer are registered trademarks of the Microsoft Corporation.
- Pentium is a registered trademark of the Intel Corporation.
- Other product names and company names are the trademarks or registered trademarks of the respective company. "TM" and the ® mark do not appear with product or company names in this manual.

Safety Information

The following conventions are used to indicate precautions in this manual. These precautions are provided to ensure the safe operation of the MP2300S and connected devices. Information marked as shown below is important for the safety of the user. Always read this information and heed the precautions that are provided.

The conventions are as follows:



Indicates precautions that, if not heeded, could possibly result in loss of life, serious injury, or property damage.



Indicates precautions that, if not heeded, could result in relatively serious or minor injury, or property damage.

If not heeded, even precautions classified under  CAUTION can lead to serious results depending on circumstances.



Indicates prohibited actions. Specific prohibitions are indicated inside .

For example,  indicates prohibition of open flame.



Indicates mandatory actions. Specific actions are indicated inside .

For example,  indicates mandatory grounding.

Safety Precautions

The following precautions are for checking products on delivery, storage, transportation, installation, wiring, operation, application, inspection, and disposal. These precautions are important and must be observed.

■ General Precautions

WARNING

- ♦ Before connecting the machine and starting operation, ensure that an emergency stop procedure has been provided and is working correctly.
There is a risk of injury.
- ♦ Do not touch anything inside the MP2300S.
There is a risk of electrical shock.
- ♦ Always keep the front cover attached when power is being supplied.
There is a risk of electrical shock.
- ♦ Observe all procedures and precautions given in this manual for trial operation.
Operating mistakes while the servomotor and machine are connected may damage the machine or even cause accidents resulting in injury or death.
There is a risk of electrical shock.
- ♦ Do not remove the front cover, cables, connector, or options while power is being supplied.
There is a risk of electrical shock.
- ♦ Do not damage, pull on, apply excessive force to, place heavy objects on, or pinch cables.
There is a risk of electrical shock, operational failure or burning of the MP2300S.
- ♦ Do not attempt to modify the MP2300S in any way.
There is a risk of injury or device damage.
- ♦ Do not approach the machine when there is a momentary interruption to the power supply. When power is restored, the MP2300S and the device connected to it may start operation suddenly. Provide safety measures in advance to ensure human safety in the event that operation restarts suddenly.
There is a risk of injury.
- ♦ Do not allow installation, disassembly, or repairs to be performed by anyone other than specified personnel.
There is a risk of electrical shock or injury.

■ Storage and Transportation

CAUTION

- ♦ Do not store or install the MP2300S in the following locations.
There is a risk of fire, electrical shock, or device damage.
 - ♦ Direct sunlight
 - ♦ Ambient temperature exceeds the storage or operating conditions
 - ♦ Ambient humidity exceeds the storage or operating conditions
 - ♦ Rapid changes in temperature or locations subject to condensation
 - ♦ Corrosive or flammable gas
 - ♦ Excessive dust, dirt, salt, or metallic powder
 - ♦ Water, oil, or chemicals
 - ♦ Vibration or shock
- ♦ Do not overload the MP2300S during transportation.
There is a risk of injury or an accident.
- ♦ If disinfectants or insecticides must be used to treat packing materials such as wooden frames, pallets, or plywood, the packing materials must be treated before the product is packaged, and methods other than fumigation must be used.
Example: Heat treatment, where materials are kiln-dried to a core temperature of 56°C for 30 minutes or more.

If the electronic products, which include stand-alone products and products installed in machines, are packed with fumigated wooden materials, the electrical components may be greatly damaged by the gases or fumes resulting from the fumigation process. In particular, disinfectants containing halogen, which includes chlorine, fluorine, bromine, or iodine can contribute to the erosion of the capacitors.

■ Installation

CAUTION

- ♦ Never use the MP2300S in locations subject to water, corrosive atmospheres, or flammable gas, or near burnable objects.
There is a risk of electrical shock or fire.
- ♦ Do not step on the MP2300S or place heavy objects on the MP2300S.
There is a risk of injury.
- ♦ Do not block the air exhaust port or allow foreign objects to enter the MP2300S.
There is a risk of element deterioration inside, an accident, or fire.
- ♦ Always mount the MP2300S in the specified orientation.
There is a risk of an accident.
- ♦ Do not subject the MP2300S to strong shock.
There is a risk of an accident.

■ Wiring

⚠ CAUTION

- ♦ Check the wiring to be sure it has been performed correctly.
There is a risk of motor run-away, injury, or an accident.
- ♦ Always use a power supply of the specified voltage.
There is a risk of burning.
- ♦ In places with poor power supply conditions, take all steps necessary to ensure that the input power supply is within the specified voltage range.
There is a risk of device damage.
- ♦ Install breakers and other safety measure to provide protection against shorts in external wiring.
There is a risk of fire.
- ♦ Provide sufficient shielding when using the MP2300S in the following locations.
There is a risk of device damage.
 - ♦ Noise, such as from static electricity
 - ♦ Strong electromagnetic or magnetic fields
 - ♦ Radiation
 - ♦ Near to power lines
- ♦ When connecting the battery, connect the polarity correctly.
There is a risk of battery damage or explosion.

■ Selecting, Separating, and Laying External Cables

⚠ CAUTION

- ♦ Consider the following items when selecting the I/O signal lines (external cables) to connect the MP2300S to external devices.
 - ♦ Mechanical strength
 - ♦ Noise interference
 - ♦ Wiring distance
 - ♦ Signal voltage, etc.
- ♦ Separate the I/O signal lines from the power lines both inside and outside the control box to reduce the influence of noise from the power lines.
If the I/O signal lines and power lines are not separated properly, malfunctioning may result.

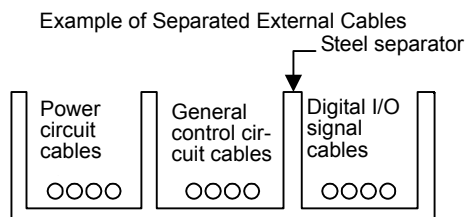

■ Maintenance and Inspection Precautions

 CAUTION

- ♦ Do not attempt to disassemble the MP2300S.
There is a risk of electrical shock or injury.
- ♦ Do not change wiring while power is being supplied.
There is a risk of electrical shock or injury.
- ♦ When replacing the MP2300S, restart operation only after transferring the programs and parameters from the old Module to the new Module.
There is a risk of device damage.

■ Disposal Precautions

 CAUTION

- ♦ Dispose of the MP2300S as general industrial waste.

Contents

Using this Manual	iii
Safety Information	v
Safety Precautions	vi
1 Overview	1-1
1.1 MP2300S Features	1-2
1.2 MP2300S Configuration	1-3
1.2.1 Basic Module Appearance	1-3
1.2.2 MP2300S Modules	1-4
1.3 System Configuration	1-5
1.3.1 Example	1-5
1.3.2 Example of Distributed Synchronizing System	1-6
1.4 MECHATROLINK-compatible Devices	1-7
1.4.1 SERVOPACKs	1-7
1.4.2 Modules	1-7
1.5 Cables and Accessories	1-8
1.5.1 Cables	1-8
1.5.2 Accessories and Options	1-9
1.5.3 Software (Programming Tool)	1-9
2 Specifications and Functions	2-1
2.1 Specifications	2-2
2.1.1 General Specifications	2-2
2.1.2 Product Specifications	2-3
2.1.3 Function Lists	2-4
2.2 Basic Module	2-7
2.2.1 Outline of Functions	2-7
2.2.2 External Appearance, LED Indicators, and Switch Settings	2-8
2.2.3 Specifications	2-11
2.2.4 218IFA Module (Ethernet)	2-12
2.2.5 Built-in SVB Module	2-30
2.2.6 SVR Virtual Motion Module	2-47
2.2.7 M-EXECUTOR Module (Motion Program Executor)	2-50
2.3 Option Module	2-61
2.3.1 Option Module Overview List	2-61
2.4 External Appearance	2-63
2.4.1 Basic Module	2-63
2.4.2 Basic Module with Metal Fittings	2-64
3 Mounting and Wiring	3-1
3.1 Mounting MP2300S	3-2
3.1.1 Method	3-2
3.1.2 MP2300S Mount Direction	3-7
3.1.3 Space Required for Mounting MP2300S	3-8
3.1.4 Replacing and Adding Optional Modules	3-9
3.2 Basic Module Connections	3-12
3.2.1 Connectors	3-12
3.2.2 Power Supply Connector	3-13

3.2.3	MECHATROLINK Connectors	3-14
3.2.4	Ethernet Connector Details	3-19
3.2.5	RLY OUT Connector Details	3-23
3.2.6	System Connection Example	3-25
4	System Start Up and Easy Programming	4-1
4.1	System Startup Overview	4-2
4.2	Preparation (step 1)	4-3
4.2.1	Wiring	4-3
4.2.2	Self Configuration	4-5
4.2.3	Test Operation	4-6
4.3	Programming (step 2)	4-9
4.3.1	Programming Procedure	4-9
4.4	Executing Motion (step 3)	4-11
4.4.1	Registering Program Execution	4-11
4.4.2	Starting a Motion Program Using the Operation Control Panel	4-12
4.5	Starting Motion Program from an External Signal	4-13
4.5.1	Overview	4-13
4.5.2	Required Equipment	4-13
4.5.3	Creation Procedure	4-15
5	Outline of Motion Control Systems	5-1
5.1	Startup Sequence and Basic Operation	5-2
5.1.1	DIP Switch Settings	5-2
5.1.2	Startup Sequence	5-3
5.1.3	Startup Sequence Operation Details	5-4
5.1.4	LED Indicator Details	5-5
5.2	User Programs	5-6
5.2.1	Types and Execution Timing of User Program	5-6
5.2.2	Motion Programs	5-7
5.2.3	Sequence Program	5-28
5.2.4	Ladder Drawings (DWG)	5-31
5.3	Registers	5-36
5.3.1	Types of Registers	5-36
5.3.2	Data Types	5-39
5.3.3	How to Use Subscripts i, j	5-40
5.3.4	Register Designation	5-41
5.4	Self-configuration	5-42
5.4.1	How to Execute Self-Configuration	5-43
5.4.2	Definition Information Updated with Self-Configuration	5-51
5.5	Precaution on Using MP2300S	5-54
5.5.1	Precautions when User Definition File is Configured/Changed	5-54
5.5.2	Setting or Changing Module Configuration Definition Files	5-55
5.5.3	Setting and Changing the Scan Time	5-56
6	Ethernet Communications	6-1
6.1	Communication Methods	6-2
6.2	Communication with Other MP Series	6-3
6.2.1	When the MP2300S Acts as Slave (automatic receive function is used)	6-3
6.2.2	When the MP2300S Acts as a Slave (ladder program which uses a MSG-RCV function)	6-17

6.2.3	When MP2300S Acts as Master (I/O message communication function is used)	6-36
6.2.4	When the MP2300S Acts as Master (ladder program which uses MSG-SND function)	6-49
6.3	Communication with Touch Panel	6-65
6.3.1	When MP2300S Acts as Slave	6-65
6.4	Communication with PLC Manufactured by Mitsubishi Electric Corporation (MELSEC protocol)	6-75
6.4.1	When the MP2300S Acts as Slave (automatic receive function is used)	6-75
6.4.2	When the MP2300S Acts as Master (I/O message communication function is used)	6-83
7	Slave CPU Synchronous Function	7-1
7.1	Function	7-2
7.1.1	Overview	7-2
7.2	Requirements and Setting of Execution	7-3
7.2.1	Supported Version	7-3
7.2.2	Requirements to Execute Slave CPU Synchronous Function	7-3
7.2.3	How to Set up Slave CPU Synchronous Function	7-4
7.2.4	How to Execute Slave CPU Synchronous Function	7-7
7.3	Operation	7-9
7.3.1	Input/Output Register	7-9
7.3.2	How to Determine Slave CPU Synchronous State	7-15
7.3.3	Calculation of Slave CPU Synchronous Delay Time	7-16
7.3.4	How to Use Scan Counter	7-17
7.3.5	How to Determine Input Error	7-18
7.3.6	Management to Resume Slave CPU Synchronization	7-24
7.4	Precautions	7-28
7.4.1	Precautions on Usage	7-28
7.4.2	Effect of Error on Slave CPU Synchronous Operation	7-29
8	Maintenance, Inspection, and Troubleshooting	8-1
8.1	Inspection Items	8-2
8.1.1	Daily Inspections	8-2
8.1.2	Regular Inspections	8-3
8.1.3	Replacing the Basic Module Battery	8-4
8.2	Troubleshooting	8-5
8.2.1	Basic Flow of Troubleshooting	8-5
8.2.2	MP2300S Error Check Flowchart	8-6
8.2.3	LED Indicators	8-6
8.2.4	Troubleshooting System Errors	8-8
8.2.5	Motion Program Alarms	8-25
8.2.6	List of Causes for Command Error Completed Status	8-30
8.2.7	Troubleshooting Motion Errors	8-33
Appendices		
Appendix A	System Registers Lists	A-2
A.1	System Service Registers	A-2
A.2	Scan Execution Status and Calendar	A-4
A.3	Program Software Numbers and Remaining Program Memory Capacity	A-4
Appendix B	SERVOPACK Parameter Data Flow	A-5
B.1	Operations and Parameter Data Flow	A-5
Appendix C	Initializing SERVOPACKs	A-14

Appendix D Initializing the Absolute Encoder	A-15
D.1 Σ -III SERVOPACK	A-15
D.2 Σ -II SERVOPACK	A-16
D.3 Σ -I SERVOPACK	A-18
Appendix E Motion Parameter Details	A-20
E.1 Fixed Parameter List	A-20
E.2 Setting Parameter List	A-22
E.3 Monitoring Parameter List	A-27
Appendix F How to Set up Communication Process	A-31
F.1 Preparation	A-31
F.2 Procedure	A-31
Appendix G MSG-SND/ MSG-RCV Functions	A-35
G.1 Message Transmit Function (MSG-SND)	A-35
G.2 Message Receive Function (MSG-RCV)	A-70
G.3 Communication Buffer Channel	A-102

INDEX

Revision History

MEMO

Overview

This chapter explains an overview and features of the MP2300S Machine Controller.

1.1 MP2300S Features	1-2
1.2 MP2300S Configuration	1-3
1.2.1 Basic Module Appearance	1-3
1.2.2 MP2300S Modules	1-4
1.3 System Configuration	1-5
1.3.1 Example	1-5
1.3.2 Example of Distributed Synchronizing System	1-6
1.4 MECHATROLINK-compatible Devices	1-7
1.4.1 SERVOPACKs	1-7
1.4.2 Modules	1-7
1.5 Cables and Accessories	1-8
1.5.1 Cables	1-8
1.5.2 Accessories and Options	1-9
1.5.3 Software (Programming Tool)	1-9

1.1 MP2300S Features

The MP2300S is a small all-in-one machine controller, and successor to the MP2000 series in function and performance. It is characterized by the following standard features:

■ Standard Feature Motion Network MECHATROLINK-II

- Controls up to 16 axes of servos supporting MECHATROLINK-II.
- Connects up to 21 stations including I/Os.

■ Standard Feature Ethernet (100Mbps)

- Allows high-speed communications with the engineering tool MPE720.
- Enables communication without a ladder program by using a touch panel (automatic receive function).
- Enables communication without a ladder program by using an upper PLC (I/O message communication function).

■ Scalability Ensured in Preparation for Single Optional Slot

- Single optional slot ensures scalability. The existing optional modules of MP2000 series are available.
- An optional module allows the use of various open networks, such as CC-Link, DeviceNet, and PROFIBUS.
- Connecting an SVB-01 module to the optional slot allows the synchronized control of up to 32 axes of servos.

■ Capable of a Synchronous Distributed System with MECHATROLINK

- The MP2300S has a CPU synchronous function using MECHATROLINK communications. This is a new function in the MP2000 series Machine Controllers.
- A sync operation between slave controllers is made possible by connecting the MP2300S as a slave with an MP2000 series model as a master via MECHATROLINK-II.
- The controller's load balancing affords a high-speed synchronization of multi-axis motions.

■ Simple Programming

- The operation procedures needed before performing a motion operation are significantly reduced.
- You can start up a motion program from an upper PLC without the need for programming, simply by creating the motion program and registering execution orders.

1.2 MP2300S Configuration

The MP2300S is configured with one Basic Module and an optional slot.

1.2.1 Basic Module Appearance

The following figure shows the external appearance of the Basic Module with metal fittings for attachment. Also, the values in the figure do not include the length of metal fittings.

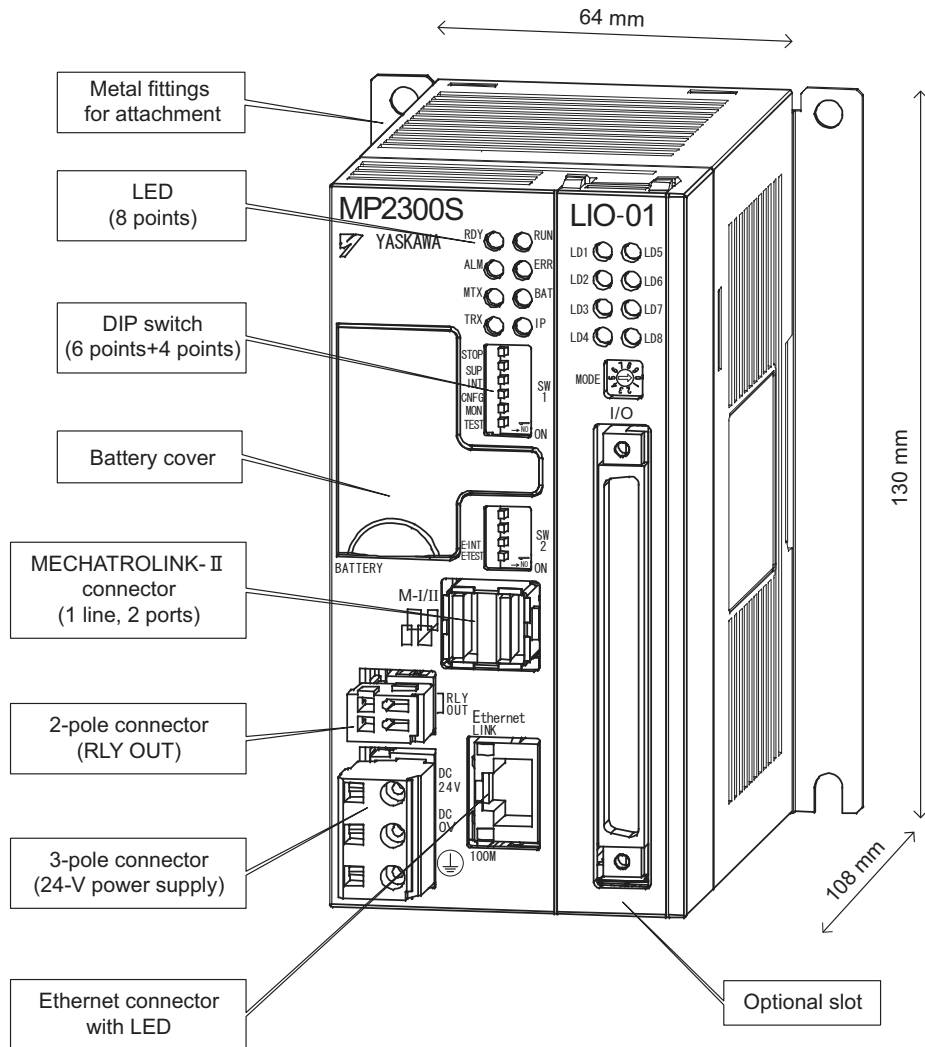

1.2.2 MP2300S Modules

The following table shows the names and specifications of the Basic Module and Optional Modules.

Group	Name	Description	Model	Specifications	
Basic Module	Basic Module	MP2300S	JAPMC-MP2300S-E	MECHATROLINK-I and -II Interface Ethernet communications	
Optional Modules	Motion Modules	MECHATROLINK Motion Module	SVB-01	JAPMC-MC2310	MECHATROLINK-I and -II, Interface 16 axes maximum
		Analog Output Motion Module	SVA-01	JAPMC-MC2300	Analog output, 2 axes maximum
		Pulse Output Motion Module	PO-01	JAPMC-PL2310	Pulse output, max. 4 axes
	I/O Modules	I/O Module	LIO-01	JAPMC-IO2300	16 inputs, 16 outputs (sink mode output) 1 pulse input
		I/O Module	LIO-02	JAPMC-IO2301	16 inputs, 16 outputs (source mode output) 1 pulse input
		I/O Module	LIO-04	JAPMC-IO2303	32 inputs, 32 outputs (sink mode output)
		I/O Module	LIO-05	JAPMC-IO2304	32 inputs, 32 outputs (source mode output)
		Output Module	DO-01	JAPMC-DO2300	64 outputs (sink mode output)
		Analog Input Module	AI-01	JAPMC-AN2300	Analog input, 8 channels
		Analog Output Module	AO-01	JAPMC-AN2310	Analog input, 4 channels
	Counter Module	CNTR-01	JAPMC-PL2300-E	Reversible counter, 2 channels	
	Communication Modules	Ethernet Communication Module	218IF-01	JAPMC-CM2300	RS-232C and Ethernet communication
		General-purpose Serial Communication Module	217IF-01	JAPMC-CM2310	RS-232C and RS422/485 communication
		DeviceNet Communication Module	260IF-01	JAPMC-CM2320	RS-232C and DeviceNet communication
		PROFIBUS Communication Module	261IF-01	JAPMC-CM2330	RS-232C and PROFIBUS communication
MPLINK/CP-215 Communication Module		215AIF-01	JAPMC-CM2330 JAPMC-CM2361	RS-232C, MPLINK, and CP-215 communications	

1.3 System Configuration

1.3.1 Example

The following diagram shows an example of system configuration.

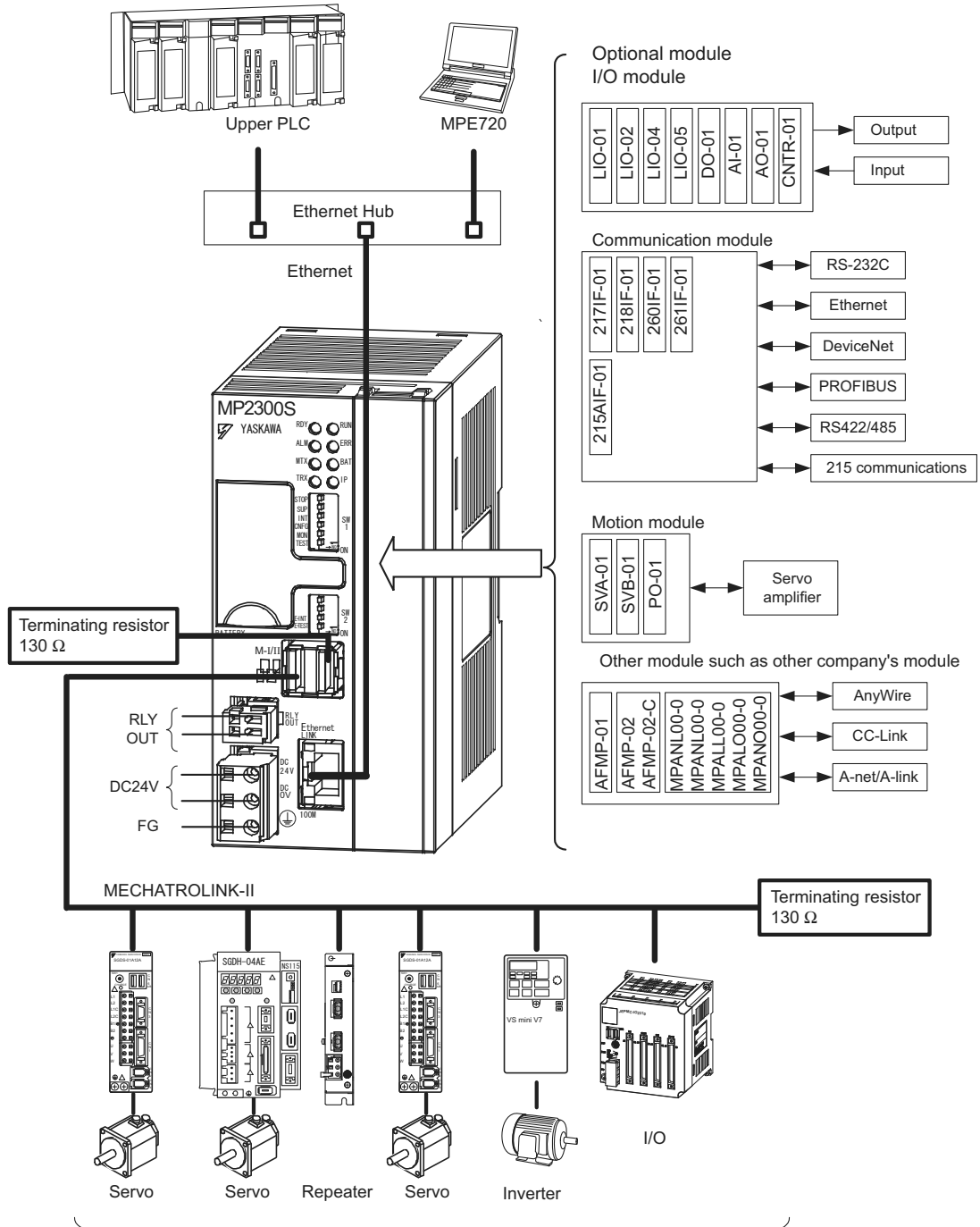

Max. 21 stations including I/O.
(Max. 16 stations servo can be included.)

- For the details on the system configuration example, refer to 4.2.1 (1) *System Layout Model* on page 4-3.
- Use the connecting cables and connectors recommended by Yaskawa. Always check the device to be used and select the correct cable for the device.
- Different SERVOPACKs are connected to MECHATROLINK-I (4 Mbps) and MECHATROLINK-II (10 Mbps). Refer to 1.4.1 *SERVOPACKs* on page 1-7 and select the appropriate SERVOPACKs.
- If devices compatible with MECHATROLINK-I and with MECHATROLINK-II are used together, make the settings for MECHATROLINK-I.
- The user must supply the 24-VDC power supply.
- When connecting SERVOPACKs via MECHATROLINK, connect the overtravel, zero point return deceleration limit switch, and external latch signals to the SERVOPACKs. For connection, refer to the SERVOPACK's manual.

1.3.2 Example of Distributed Synchronizing System

If some MP2300S are connected as slaves and other MP2000-series Machine Controllers are connected via MECHATROLINK-II, slaves can operate synchronously.

Distribution of the load realizes the high-speed synchronization of multiple axes.

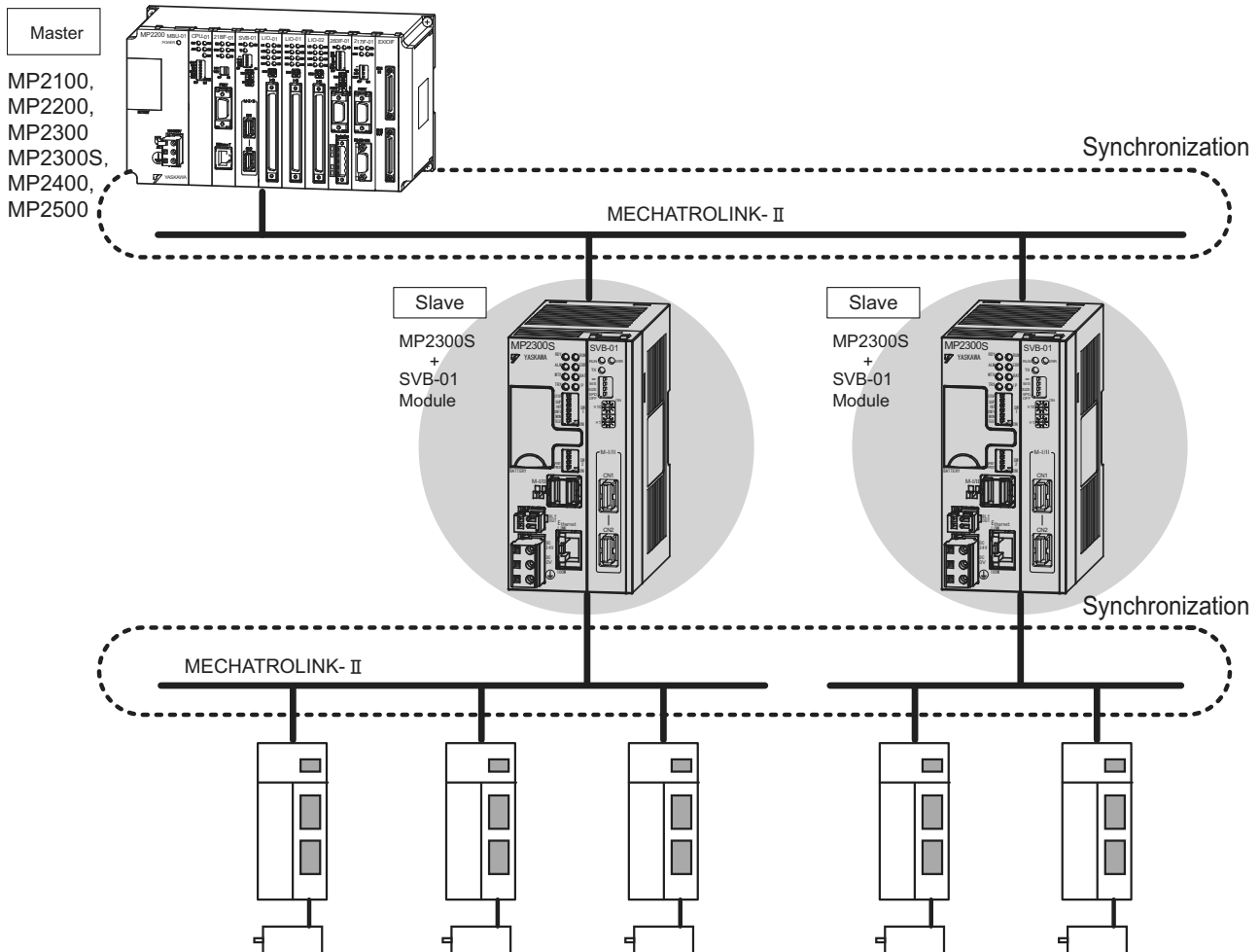

1.4 MECHATROLINK-compatible Devices

The devices that are compatible with MECHATROLINK and can be connected to the MP2300S and the SVB-01 Module are listed below.

1.4.1 SERVOPACKS

Model Number	Details	MECHATROLINK-I	MECHATROLINK-II
SGDV-□□□1□□	SGDV SERVOPACK	Yes	Yes
SGDS-□□□1□□	SGDS SERVOPACK	Yes	Yes
SGDH-□□□E JUSP-NS115	SGDH SERVOPACK NS115 MECHATROLINK-II Interface Unit	Yes	Yes
SGDH-□□□E JUSP-NS100	SGDH SERVOPACK NS110 MECHATROLINK-I Interface Units	Yes	No
SGD-□□□N SGDB-□□AN	MECHATROLINK compatible AC SERVO- PACKs	Yes	No

1.4.2 Modules

Model Number	Details	MECHATROLINK-I	MECHATROLINK-II
JEPMC-IO2310	64-point I/O Module 24 VDC, 64 inputs, 64 outputs (sink mode output)	Yes	Yes
JEPMC-IO2330	64-point I/O Module 24 VDC, 64 inputs, 64 outputs (source mode output)	Yes	Yes
JEPMC-PL2900	Counter Module Reversible counter, 2 channels	Yes	Yes
JEPMC-PL2910	Pulse Output Module Pulse output, 2 channels	Yes	Yes
JEPMC-AN2900	A/D Module Analog inputs, -10 to 10 V, 4 channels	Yes	Yes
JEPMC-AN2910	D/A Module Analog outputs, -10 to 10 V, 2 channels	Yes	Yes
JEPMC-IO350	64-point I/O Module 24 VDC, 64 inputs, 64 outputs	Yes	No
JAMSC-120DDI34330	DC Input Module 12/24 VDC, 16 inputs	Yes	No
JAMSC-120DDO34340	DC Output Module 12/24 VDC, 16 outputs	Yes	No
JAMSC-120DAI53330	AC Input Module 100 VAC, 8 inputs	Yes	No
JAMSC-120DAI73330	AC Input Module 200 VAC, 8 inputs	Yes	No
JAMSC-120DAO83330	AC Output Module 100/200 VAC, 8 outputs	Yes	No
JAMSC-120DRA83030	Relay Module Wide voltage range relay contacts, 8 contact outputs	Yes	No
JAMSC-120AVI02030	A/D Module Analog inputs, -10 to 10 V, 4 channels	Yes	No
JAMSC-120AVO01030	D/A Module Analog outputs, -10 to 10 V, 2 channels	Yes	No
JAMSC-120EHC21140	Counter Module Reversible counter, 2 channels	Yes	No
JAMSC-120MMB20230	Pulse Output Module Pulse output, 2 channels	Yes	No
JEPMC-REP2000	MECHATROLINK-II Repeater	No	Yes
JEVSA-YV250	MYVIS (image processing device)	Yes	Yes

1.5 Cables and Accessories

1.5.1 Cables

The following table shows the cables that can be connected to the MP2300S Basic Module and Optional Modules.

Module	Connector Name	Application	Model	Specifications	
MP2300S Basic Module	Ethernet	Ethernet communication cable	Provided by customers.	–	
MP2300S Basic Module and SVB-01	M-I/II	MECHATROLINK-I, MECHATROLINK-II cable	JEPMC-W6002-□□ *with MECHATROLINK connectors on both ends	Used between the devices listed below SVB-01 and I/O Unit, SVB-01 and SGD-□□E+NS100 SVB-01 and SGD-□□E+NS115 SVB-01 and SGDS-□□□1□□	
			JEPMC-W6003-□□ *with MECHATROLINK connectors on both ends *with ferrite core		
			JEPMC-W6011-□□ *with a MECHATROLINK connector and loose wires	Used between the devices listed below SVB-01 and SGD-□□□N SVB-01 and SGDB-□□AN	
			JEPMC-W6022	Terminator	
SVA-01	CN/1 CN/2	Cable for analog reference input SERVOPACK	JEPMC-W2040-□□	Used between the devices listed below SVA-01 and SGDM/SGDH SVA-01 and SGDS-□□□01□ SVA-01 and SGDS-□□□02□	
LIO-01 LIO-02	I/O	External I/O cable	JEPMC-W2061-□□ *Loose wires on one end	Used between LIO-01/02 and external I/O device	
LIO-04 LIO-05	CN/1, CN/2	External I/O cable	JEPMC-W6060-□□ *Loose wires on one end	Used between LIO-04/05 and external I/O device	
DO-01	CN/1, CN/2	External output cable	JEPMC-W6060-□□ *Loose wires on one end	Used between DO-01 and external I/O device	
AI-01	CN/1, CN/2	Analog input cable	JEPMC-W6080-□□ *Loose wires on one end	Used between AI-01 and analog external input device	
AO-01	CN/1	Analog output cable	JEPMC-W6090-□□ *Loose wires on one end	Used between AO-01 and analog external output device	
CNTR-01	CN/1	Cable for CNTR-01 Module	JEPMC-W2063E-□□ *Loose wires on one end	Used between CNTR-01 and external I/O device	
Communication Module	PORT (Common to all communication modules)	RS-232C communication cable	JEPMC-W5310-□□	Used between RS-232C port and 25-pin male D-sub connector	
			JEPMC-W5311-□□	Used between RS-232C port and DOS/V	
	218IF-01	10Base-T	Ethernet communication cable	Use a commercially available cable.	Cross cable (Category 3 min.)
	217IF-01	RS422/485	RS422/485 communication cable		Module-side connector: 1010214-52A2JL (manufactured by Sumitomo 3M)
					Cable-side connector: 10114-3000VE (manufactured by Sumitomo 3M)
260IF-01	DeviceNet	DeviceNet communication cable	Shell: 10314-52A0-008 (manufactured by Sumitomo 3M)		
261IF-01	PROFIBUS	PROFIBUS communication cable	Module-side connector: MSTB2-5/5-GF-5.08AM (manufactured by Phoenix Contact K.K.)		
				Module-side connector: 17LE-13090-27(D33C) (manufactured by DDK Ltd.)	

1.5.2 Accessories and Options

Name	Accessory/Optional	Model	Remarks
Battery	Accessory	JZSP-BA01	ER3VC + exclusive use connector (BA000517)
Power Supply Connector	Accessory	721-203/026	Cable side
RLY OUT Connector	Accessory	734-YE102	Cable side
DIN Rail Mounting Parts	Accessory	JEPMC-OP300	1 pair
Terminator (Terminating Resistor)	Accessory	JEPMC-W6022	Q'ty: 1
Metal Fittings for Attachment	Optional	JEPMC-OP2300S-E	–

1.5.3 Software (Programming Tool)

The MPE720, programming tool for MP2300S, is available.

Name	Model	Remarks
MPE720	CPMC-MPE720 (Ver. 5.38 or later)	CD-ROM (1 disk)
MPE720 Version 6	CPMC-MPE720 (Ver. 6.04 or later)	CD-ROM (1 disk)

MEMO

Specifications and Functions

This chapter explains detailed specifications for the Basic Module and Optional Modules of the MP2300S.

2.1 Specifications	2-2
2.1.1 General Specifications	2-2
2.1.2 Product Specifications	2-3
2.1.3 Function Lists	2-4
2.2 Basic Module	2-7
2.2.1 Outline of Functions	2-7
2.2.2 External Appearance, LED Indicators, and Switch Settings	2-8
2.2.3 Specifications	2-11
2.2.4 218IFA Module (Ethernet)	2-12
2.2.5 Built-in SVB Module	2-30
2.2.6 SVR Virtual Motion Module	2-47
2.2.7 M-EXECUTOR Module (Motion Program Executor)	2-50
2.3 Option Module	2-61
2.3.1 Option Module Overview List	2-61
2.4 External Appearance	2-63
2.4.1 Basic Module	2-63
2.4.2 Basic Module with Metal Fittings	2-64

2.1 Specifications

2.1.1 General Specifications

Item		Specifications
Environmental Conditions	Ambient Operating Temperature	0°C to 55°C
	Ambient Storage Temperature	-25°C to 85°C
	Ambient Operating Humidity	30% to 95% (with no condensation)
	Ambient Storage Humidity	5% to 95% (with no condensation)
	Pollution Level	Pollution level 1 (conforming to JIS B 3501)
	Corrosive Gas	There must be no combustible or corrosive gas.
	Operating Altitude	2,000 m above sea level or lower
Mechanical Operating Conditions	Vibration Resistance	Conforming to JIS B 3502: <ul style="list-style-type: none"> • 10 to 57 Hz with single-amplitude of 0.075 mm • 57 to 150 Hz with fixed acceleration of 9.8 m/s² • 10 sweeps each in X, Y, and Z directions (sweep time: 1 octave/min.)
	Shock Resistance	Conforming to JIS B 3502: Peak acceleration of 147 m/s ² (15 G) twice for 11 ms each in the X, Y, and Z directions
Electrical Operating Conditions	Noise Resistance	Conforming to EN 61000-6-2, EN 55011 (Group 1, Class A) Power supply noise (FT noise): 2 Kv min., for one minute Radiation noise (FT noise): 1 Kv min., for one minute
Installation Requirements	Ground	Ground to 100 Ω max.
	Cooling Method	Natural cooling

2.1.2 Product Specifications

The following table shows the product specifications of the MP2300S.

Items		MP2300S
External Dimensions		64 mm × 130 mm × 108 mm
Number of Optional Slots		1 slot
Number of Control Axes	Number of Basic Control Axes	16 axes
	Maximum Number of Control Axes	32 axes (when one SVB-01 is added.)
	Number of Virtual Axis Controlling Axes	16 axes
MECHATROLINK	Communication System	MECHATROLINK-I, MECHATROLINK-II (32 byte), or MECHATROLINK-II (17 byte)
	Communication Cycle (M-II)	0.5 ms, 1 ms, 1.5 ms, or 2 ms
	Maximum Number of Connectable Stations (M-II)	21 stations (up to 16 servo stations)
	Slave Function	√
	Slave Synchronous Function	√
Scan Interval Setting	High-speed Scan	0.5 ms to 32 ms (per 0.5 ms)
	Low-speed Scan	2.0 ms to 300 ms (per 0.5 ms)
Communication I/F	Ethernet	100Base-TX 1 port
I/O	On-board I/O	– (Optional)
	Output Signal during RUN	√
Memory Capacity	SDRAM	32 MB
	SRAM	512 KB (Battery backup)
	FLASH	8 MB
	Program Capacity	5.5 MB
Programming Language	Ladder Language	√
	Motion Language	√
	Sequence Program	√
	C Language	√

- Symbols in the table mean as follows.
M-I: MECHATROLINK-I, M-II: MECHATROLINK-II
√: Available, –: Not available

2.1.3 Function Lists

(1) PLC Function Specifications

The following table shows the PLC function specifications.

Item	Specifications
Control Method	Sequence: High-speed and low-speed scan methods
Programming Language	Ladder diagram: Relay circuit Text-type language: Numeric operations, logic operations, etc.
Scan	Two scan levels: High-speed scan and low-speed scan High-speed scan time setting: 0.5 to 32 ms (Integral multiple of MECHATROLINK communication cycle) Low-speed scan time setting: 2 to 300 ms (Integral multiple of MECHATROLINK communication cycle)
User Drawings, Functions and Motion Programs	Startup drawings (DWGA): 64 drawings max. Up to three hierarchical drawing levels Interrupt processing drawings (DWGI): 64 drawings max. Up to three hierarchical drawing levels High-speed scan process drawings (DWG.H): 200 drawings max. Up to three hierarchical drawing levels Low-speed scan process drawings (DWGL): 500 drawings max. Up to three hierarchical drawing levels Number of steps: Up to 1,000 steps per drawing User functions: Up to 500 functions Motion programs and sequence programs: A total of up to 256 Revision history of drawings and motion programs Security function for drawings and motion programs
Data Memory	Common data (M) registers: 64 kwords System (S) registers: 8 kwords Drawing local (D) registers: Up to 16 kwords per drawing Drawing constant (#) registers: Up to 16 kwords per drawing Input (I) registers: 32 kwords (including internal input registers) Output (O) registers: 32 kwords (including internal output registers) Constant (C) registers: 16 kwords
Trace Memory	Data trace: 128 kwords (32 kwords × 4 groups), 16 points defined
Memory Backup	Program memory: Flash memory: 8 MBytes (User area: 5.5 MBytes) definition files, ladder programs, motion programs, etc. Data other than battery backup data Data memory: Battery backup: 512 kbytes, M registers, S registers, alarm history, trace data
Data Types	Bit (relay): ON/OFF Integer: -32768 to +32767 Double-length integer: -2147483648 to +2147483647 Real number: ± (1.175E-38 to 3.402E+38)
Register Designation Method	Register number: Direct designation of register number Symbolic designation: Up to 8 alphanumeric characters (up to 200 symbols per drawing) With automatic number or symbol assignment
Instructions	Program control instructions: 14 instructions Direct I/O instructions: 2 instructions Relay circuit instructions: 14 instructions (including set and reset coils) Logic operation instructions: 3 instructions Numeric operation instructions: 16 instructions Numeric conversion instructions: 9 instructions Numeric comparison instructions: 7 instructions Data manipulation instructions: 14 instructions Basic function instructions: 10 instructions Table data manipulation instructions: 11 instructions DDC instructions: 13 instructions System functions: 9 instructions

(2) Motion Control Function Specifications

The following table lists the motion control function specifications for the MP2300S.

Item		Specifications		
Interface		MECHATROLINK-I, MECHATROLINK-II		
Number of Controlled Axes/Module		Up to 16 axes (up to 32 axes when an SVB Modules are mounted)		
Control Specifications	PTP Control		Linear, rotary, and infinite-length	
	Interpolation		Up to 16 linear axes, 2 circular axes, and 3 helical axes	
	Speed Reference Output		Yes (Only with MECHATROLINK-II)	
	Torque Reference Output		Yes (Only with MECHATROLINK-II)	
	Phase Control		Yes (Only with MECHATROLINK-II)	
	Position Control	Positioning		Yes
		External positioning		Yes
		Zero point return		Yes
		Interpolation		Yes
		Interpolation with position detection function		Yes
		JOG operation		Yes
		STEP operation		Yes
Parameter changes during motion command execution		Yes (Only with MECHATROLINK-II in 32-byte mode)		
Reference Unit		mm, inch, deg, or pulse		
Reference Unit Minimum Setting		1, 0.1, 0.01, 0.001, 0.0001, 0.00001		
Maximum Programmable Value		-2147483648 to +2147483647 (signed 32-bit value)		
Speed Reference Unit		Reference unit/s designation: mm/s, inch/s, deg/s, pulse/s Reference unit/min. designation: mm/min., inch/min., deg/min., pulse/min. Percentage designation: Percentage of rated speed		
Acceleration/Deceleration Type		Linear, asymmetric, S-curve, exponent		
Acceleration/Deceleration Reference Unit		Reference unit/s ² designation: mm/s ² , inch/s ² , deg/s ² , pulse/s ² Acceleration/deceleration time constant: Time from 0 to rated speed (ms)		
Override Function		Positioning: 0.01% to 327.67% by axis		
Coordinate System		Rectangular coordinates		
Zero Point Return	DEC1+ Phase-C pulse		Yes	
	ZERO signal		Yes	
	DEC1+ ZERO signal		Yes	
	Phase-C pulse		Yes	
	Only Phase-C pulse		Yes	
	POT and Phase-C pulse		Yes	
	POT		Yes	
	Home limit switch and Phase-C pulse		Yes	
	HOME		Yes	
	NOT and Phase-C pulse		Yes	
	NOT		Yes	
	INPUT and Phase-C pulse		Yes	
	INPUT		Yes	

2.1 Specifications

2.1.3 Function Lists

Item	Specifications	
Applicable SERVOPACKs	<ul style="list-style-type: none"> ■ MECHATROLINK-I • SERVOPACKs SGD-□□□N SGDB-□□AN SGDH-□□□E + NS100 SGDS-□□□1□□ SGDV-□□□1□□ 	<ul style="list-style-type: none"> ■ MECHATROLINK-II • SERVOPACKs SGDH-□□□E + NS115 SGDS-□□□1□□ SGDV-□□□1□□
Encoders	<ul style="list-style-type: none"> • Incremental Encoder • Yaskawa Absolute Encoder 	

2.2 Basic Module

This section describes the functions, the external appearance, the LED indicators, the setting switches, and the hardware specifications of the MP2300S Basic Module and also describes the virtual motion module (SVR).

2.2.1 Outline of Functions

The Basic Module is an all-in-one, compact module that combines power supply, CPU, and 218IFA in one module. The Basic Module has both motion control and sequence control functions. With a slot option slot configuration, Optional Modules can be selected freely and the optimum system can be built for your machine. An outline of the Basic Module functions is shown in the following diagram.

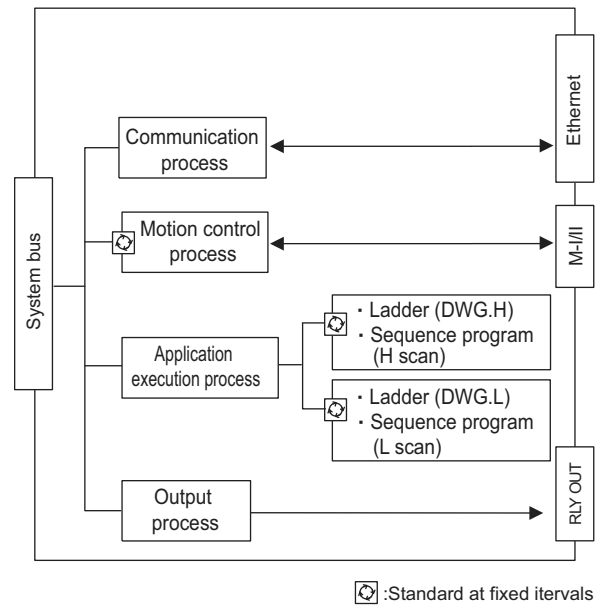

2.2.2 External Appearance, LED Indicators, and Switch Settings

(1) External Appearance

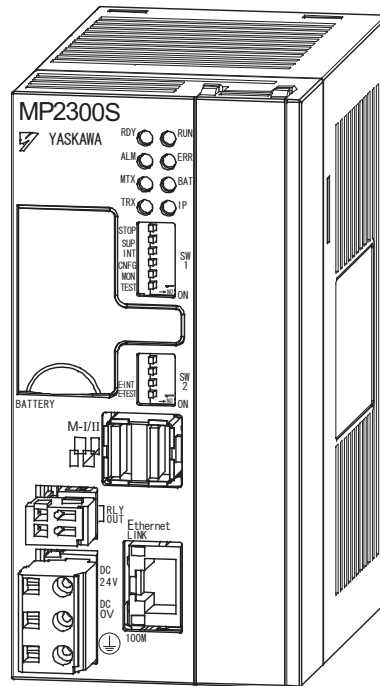

(2) Indicators

The following table shows the indicators that show the operating status of the Basic Module and error information.

	Indicator	Color	Status
RDY ○ ○ RUN ALM ○ ○ ERR MTX ○ ○ BAT TRX ○ ○ IP	RDY	Green	Lit during normal operation.
	RUN	Green	Lit during execution of user program.
	ALM	Red	Lit/blinking when warning occurs.
	ERR	Red	Lit/blinking when malfunction occurs.
	MTX	Green	Lights up when submitting MECHATROLINK-I/ MECHATROLINK-II data
	BAT	Red	Lit during battery alarm.
	TRX	Green	Lights up when transmitting and receiving Ethernet data
	IP	Green	Lights up when an IP address setting is completed

- For details on indicator meanings, refer to 8.2.3 (2) LED Indicator Meanings on page 8-7.

(3) Switch Settings

The DIP switch sets the operating conditions for the Basic Module when the power is turned ON.

[a] SW1

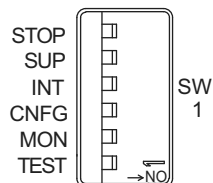

No.	Name	Setting	Operating Mode	Default	Details
S1-6	STOP	ON	User program stopped	OFF	Stops the user program execution. Enabled only when the power is turned ON.
		OFF	User program running		
S1-5	SUP	ON	System load	OFF	If set to ON, starts in a mode that can change the version.
		OFF	Normal operation		
S1-4	INIT	ON	Memory clear	OFF	Set to ON to clear the memory. If this switch is set to OFF, the program stored in flash memory will be executed.
		OFF	Normal operation		
S1-3	CNFG	ON	Self-configuration mode	OFF	Set to ON to execute self-configuration for connected devices.
		OFF	Normal operation		
S1-2	MON	ON	System use	OFF	Always leave set to OFF.
		OFF	Normal operation		
S1-1	TEST	ON	System use	OFF	Always leave set to OFF.
		OFF	Normal operation		

[b] SW2

Sets the Ethernet port condition and other operating conditions.

The change of switch setting is invalid after the power is turned ON (read only when the module is initialized by software).

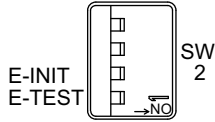

No.	Switch Name	State	Operation Mode	Default	Description
S2-4	-	ON	Reserved	OFF	Reserved for future use
		OFF			
S2-3	-	ON	Reserved	OFF	Reserved for future use
		OFF			
S2-2	E-INIT	ON	Transmission parameter for Ethernet, default	OFF	When ON, transmission parameters such as an IP address are set to default at startup.
		OFF	Normal operation		
S2-1	E-TEST	ON	System use	OFF	Always leave set to OFF
		OFF	Normal operation		

2.2.3 Specifications

(1) Hardware Specifications

The following table shows hardware specifications for the basic module:

Item	Specifications	
Classification	Basic Module	
Name	MP2300S	
Model Number	JEPMC-MP2300S-E	
Power Unit	Input Voltage	24 VDC (± 20%)
	Input Current*	1 A max. (during input/output rating)
	Inrush Current*	40 A max. (full discharge state, during output rating, or the secondary output of the external 24 V power supply is turned ON)
	Rated Voltage	5.0 V
	Rated Current	2.0 A
	Output Current Range	0.0 to 2.0 A
	Constant Voltage Precision	±2% max. (including input voltage and output load fluctuations)
Battery	Battery for memory retention attachable	
Flash Memory	8 MBytes (User area 5.5 MBytes)	
SDRAM	32 MBytes	
SRAM	512 kBytes: M registers, S registers, trace memory, alarm history (battery backup)	
Motion Network	MECHATROLINK: 1 channel SERVOPACK and I/O for up to 21 stations connectable (SERVOPACK for up to 16 axes) Baud rate: 4 Mbps (MECHATROLINK-I) or 10 Mbps (MECHATROLINK-II)	
Communication Function	Ethernet: 100BASE-TX/10BASE-T	
Calendar	Seconds to year timer (Battery backup)	
Connectors	POWER: Power supply connector M-I/II: MECHATROLINK connector Ethernet: Ethernet connector RLY OUT: RLY OUT connector	
Indicators	RDY(green), RUN(green), ALM(red), ERR(red), MTX(green), BAT(red), TRX(green), IP(green), LINK(yellow), 100M(green)	
Switches	STOP, SUP, INIT, CNFG, MON, TEST, E-INIT, and E-TEST	
Current Consumption	1A max.	
Dimensions (mm)	64 × 130 × 108 (W × H × D)	
Mass	390 g	

* For the external 24V power supply, select a power supply which satisfies the specifications below as well as the rated current (not more than 1A):

- ◆ Allowable output load capacity: 1200μF or more
- ◆ Overcurrent detection is automatically restored by removing causes

However, except that the primary side (AC side) of the external 24V power supply is turned ON/OFF.

Note: Recommended external 24V power supply: RTW24-2R2 (manufactured by TDK)

2.2.4 218IFA Module (Ethernet)

(1) Overview of 218IFA Module Functions

MP2300S built-in 218IFA module is a 10Base-T/100Base-TX Ethernet interface and a communication interface equipped as standard in MP2300S.

- 100Mbps transmission speed is supported (100Base-TX).
- Supports the following various communication protocols:
 - Support for MEMOBUS protocol, Extended MEMOBUS protocol
 - Support for MELSEC protocol
 - Support for MODBUS/TCP protocol
 - Support for non-procedure communication
- An I/O message communication function enables you the data exchange in the form of I/O image when communicating with upper PLC, eliminating you from creating a ladder program.
- An automatic receive function eliminates you from creating a ladder program when connected to the indicator and the like.
- Enables you to use as a standard interface with the engineering tool MPE720. In addition, provides a simple function for connecting with the engineering tool, allowing you to connect to MPE720 without the knowledge of MP2300S IP address.

(2) Specification of 218IFA Module

The following table shows the specification of the 218IFA Module.

Items		MP2300S/218IFA
Communication Interface (Note1)		10Base-T/100Base-TX
Communication Protocol (Note2)		TCP/UDP/IP/ARP/ICMP
Maximum Number of Communication Connections		4+2 (I/O Message communication)
Maximum Number of Communication Channels		4+2 (I/O Message communication)
Message Communication (maximum)	MEMOBUS	Write: 100W Read: 125W
	Extended MEMOBUS	Write: 2043W Read: 2044W
	MELSEC	Write: 1017W Read: 1017W
	MODBUS/TCP	Write: 100W Read: 125W
	Non-procedure	Write: 2046W
I/O Message Communication (maximum)	MEMOBUS	Write: 100W Read: 125W
	Extended MEMOBUS	Write: 1024W Read: 1024W
	MELSEC	Write: 256W Read: 256W
	MODBUS/TCP	Write: 100W Read: 125W
Automatic Receive	MEMOBUS	○
	Extended MEMOBUS	○
	MELSEC	○
	MODBUS/TCP	○
Simple Function for Connecting with Engineering Tool		○

Note: 1. Communication Interface

The discrimination between 10Base-T/100Base-TX and full-duplex/half-duplex is done by 218IFA based on the remote equipment. When connecting to an equipment without automatic negotiation function, set the remote equipment to half-duplex mode.

Correspondence of Communication Mode

218IFA Module	Device to be connected				
	Automatic Negotiation	10Base-T Half-duplex	10Base-T Full-duplex	100Base-TX Half-duplex	100Base-TX Full-duplex
Automatic Negotiation	Depends on the remote equipment	Communicates in 10Base-T half-duplex mode	Unable to communicate	Communicates in 100Base-TX half-duplex mode	Unable to communicate

2. Communication protocols

- TCP(Transmission Control Protocol): Connection-oriented transport layer protocol
- UDP(User Datagram Protocol): Connectionless transport layer protocol
- IP(Internet Protocol): Protocol for establishing a communication link between computers
- ICMP(Internet Control Message Protocol): Error control protocol for IP protocol
- ARP(Address Resolution Protocol): Address resolving protocol. Protocol for converting IP address into MAC address

(3) Module Configuration Definition

(a) Module Configuration Definition Screen Details

Click **MP2300S** in the **Controller** area to display the details of the Basic Modules' functions in the **Module Details** area. The cell No.2 provides a detailed definition of 218IFA.

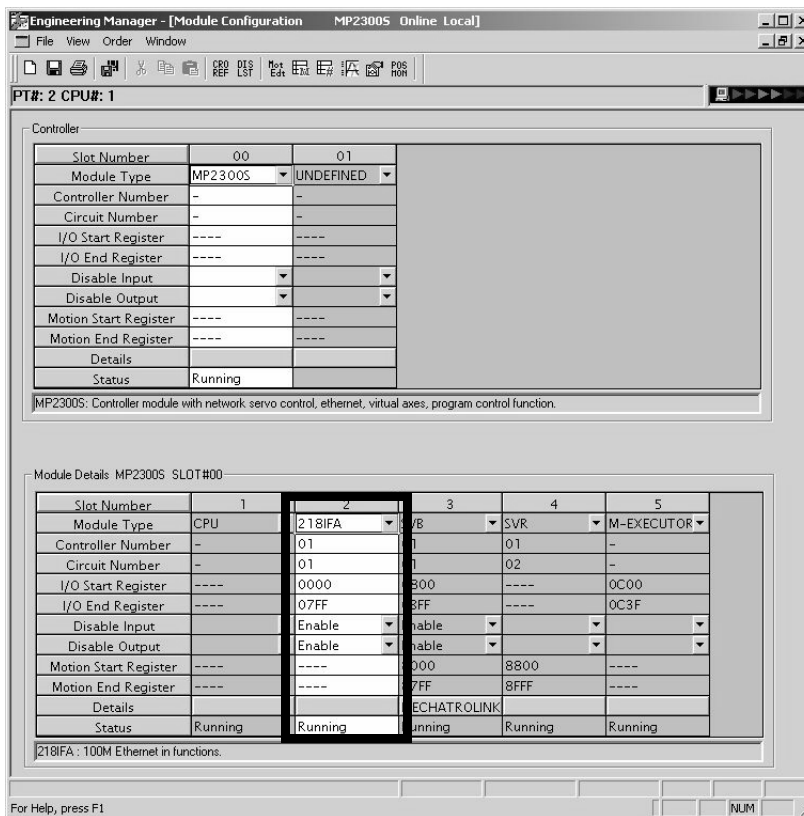

Items displayed in the **Module Details** area show the following meanings:

Items	Descriptions	Change
Slot Number	Sub-slot number. Double-click it to open the 218IFA detailed definition window.	-
Module Type	A module name is shown. Changing the name to UNDEFINED enables you to disable 218IFA functions.	√
Controller Number	Not used. Fixed at “-”.	-
Circuit Number	Module's line number (valid range: 01-08)	√
I/O Start Register	Start register of the I/O register used in the I/O message communication of 218IFA (valid range: 0000-7FFFh, size: 800h words)	√
I/O End Register	End register of the I/O register used in the I/O message communication of 218IFA (valid range: 0000-7FFFh, size: 800h words)	√
Disable Input	Input Enable/Disable.	√
Disable Output	Output Enable/Disable.	√
Motion Start Register	Not used. Fixed at “- - - -”.	-
Motion End Register	Not used. Fixed at “- - - -”.	-
Details	Not used.	-
Status	218IFA module status in online mode.	-

√: Available, -: Not available

(4) 218IFA Module Detailed Screen

(a) Displaying the 218IFA Module Detailed Window

The 218IFA Module Detailed Window is displayed by selecting **MP2300S** in the **Controller** area of the **Module Configuration** Window and double-clicking the cell No.2 in the **Module Details** field.

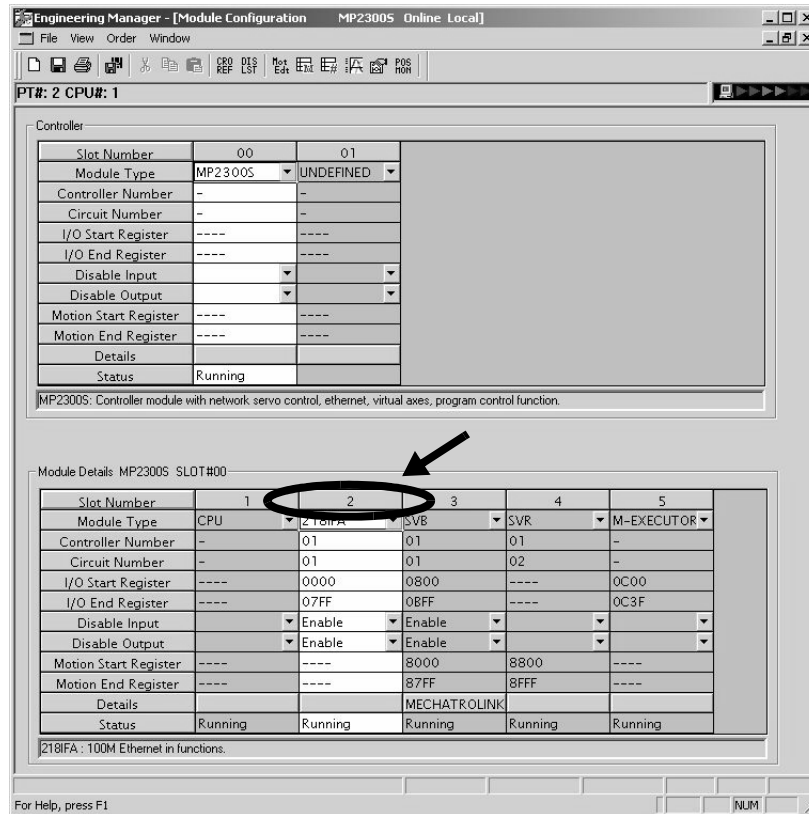

(b) 218IFA Module Detailed Window

The 218IFA Module Detailed Window is composed of **Transmission Parameter** and **Status** Tabs, and each tab is changed with a click.

1. Parameter Setting Tab

The **Transmission Parameters** Tab sets 218IFA transmission parameters. The setting details are as follows:

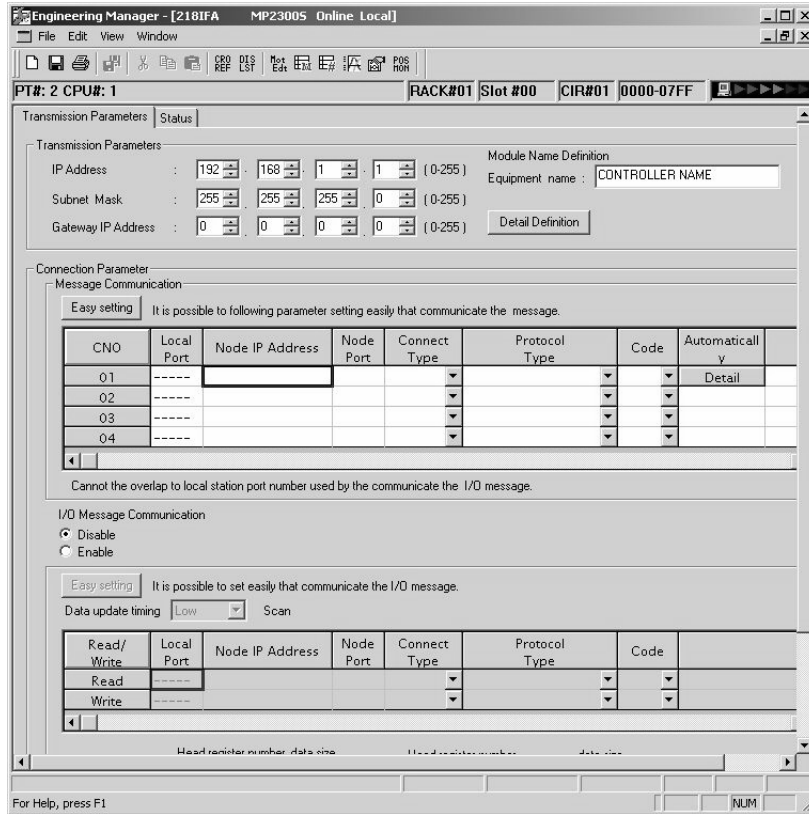

■ Transmission Parameter Setting Items

Sets local transmission parameters for 218IFA.

The screenshot shows a configuration window titled 'Transmission Parameters' with a 'Status' tab. Under 'Transmission Parameters', there are three rows of IP address settings, each with four spinners and a range '(0-255)'. The first row is IP Address (192, 168, 1, 1), the second is Subnet Mask (255, 255, 255, 0), and the third is Gateway IP Address (0, 0, 0, 0). To the right, under 'Module Name Definition', there is a text field for 'Equipment name' containing 'CONTROLLER NAME' and a 'Detail Definition' button.

The following table shows each setting item.

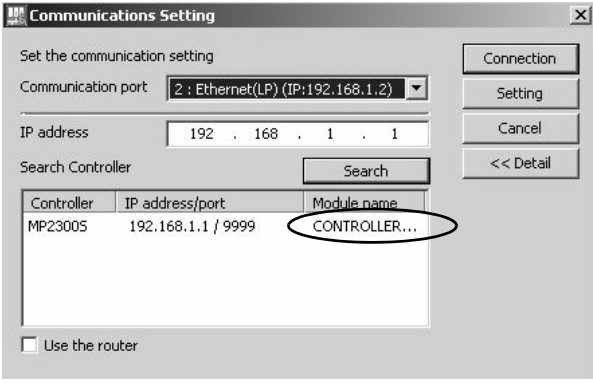
Item	Setting Range	Details	Default
IP Address	0.0.0.1 to 255.255.255.254	Sets 218IFA IP address. However, the following addresses are excluded: 127.xxx.xxx.xxx xxx.xxx.xxx.000 xxx.xxx.xxx.255	192.168.001.001
Subnet Mask	0.0.0.0 to 255.255.255.254	Sets the 218IFA subnet mask.	255.255.255.000
Gateway IP Address	0.0.0.0 to 255.255.255.254	Sets the 218IFA default gateway IP address. However, the following addresses are excluded: 127.xxx.xxx.xxx xxx.xxx.xxx.000 (except 000.000.000.000) xxx.xxx.xxx.255 When you do not use it, set it to 000.000.000.000.	000.000.000.000
Equipment Name	Up to 16 single-byte characters	218IFA can be any name. The name specified here is displayed as a search result in the module name field of controller search list when running the Search in the communications setting dialog box of MPE720 Ver.6. 	CONTROLLER NAME
Detailed Definition	–	Opens the screen for setting the engineering communication with MPE720 and the MEMOBUS communication.	–

■ Detailed Setting Screen of Transmission Parameter Setting

Sets the engineering communication with MPE720 and the message communication.

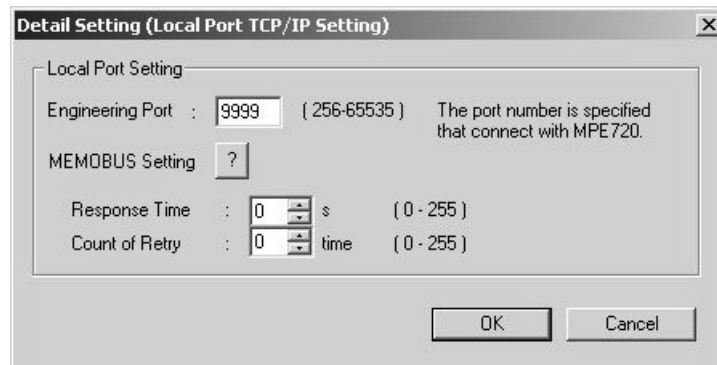

The following table shows each setting item.

Item	Setting Range	Details	Default
Engineering Port	256 to 65535	Specify the 218IFA port number used in the engineering communication with MPE720. Note: When changing this setting, you must also change the engineering port value in the logical port setting detailed screen of the MPE720 communication process. The port number cannot be 9998 or 10000.	9999
Response Time	0 to 255 (sec)	Specify the wait time until a remote response is returned after sending a command, when carrying out a message communication using MSG-SND function. (value zero waits infinitely.) If the retransmit number of times is zero, set response monitor period to zero. Note: If no response is returned after the setting period expires, a timeout occurs, retry the transmission the number of times specified by resend number of times.	0
Count of Retry	0 to 255 (time)	Specify the command retransmit number of times when a timeout is detected after response monitor period expires. Note: If no response is returned after as many retries as the retransmit number of times, an error is returned to the MSG-SND function.	0

■ Message Communication Item of Connection Parameter Setting

Sets the connection parameters for the message communication using MSG-SND/MSG-RCV function and the message communication using automatic receive function.

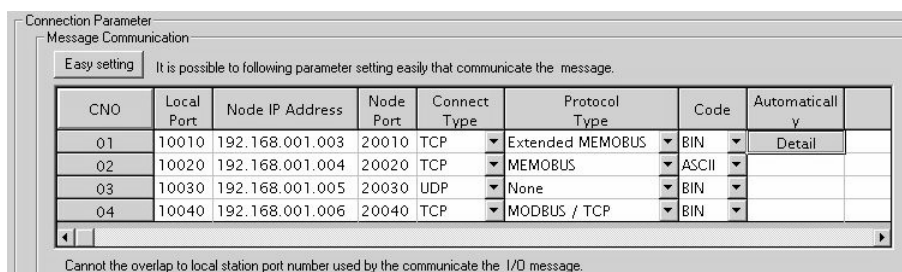

The following table shows each setting item.

Item	Setting Range	Details	Default												
Easy Setting	—	Opens the easy setting screen for the connection parameters. The content of the selected connection is shown.	—												
Connection Number (CNO)	1 to 4	In 218IFA Ethernet communication, remote stations are distinguished by their connection numbers. This connection number is used in remote connection number (PARAM02) of the parameter list (PARAM) of the MSG-SND/MSG-RCV function.	—												
Local Port	256 to 65535	Specify the 218IFA port number for each connection. 218IFA establishes a message communication with the connection with this port number only. Set an unique channel number for the port number of this connections. Also, to delete the port number, enter zero. Note: When the connection type = UDP, the port number cannot be 9998 or 10000.	0												
Node IP Address	0.0.0.0 to 255.255.255.254	Set the remote IP address for each connection. However, the following addresses are excluded: 127.xxx.xxx.xxx xxx.xxx.xxx.000 (except 000.000.000.000) xxx.xxx.xxx.255 Note: When 0.0.0.0 is set, it will enter into “Unpassive open mode.” When 218IFA is within the network specified by the subnet mask, it responds to the connection request from the remote station regardless of the remote IP address setting.	000.000.000.000												
Node Port	0 and 256 to 65535	Specify the remote port number for each connection. A pair of remote IP address and remote port number must not be duplicated. Note: In case of “Unpassive open mode,” set it to zero.	0												
Connect Type	TCP, UDP	Select a transport layer protocol. TCP: Transmission control protocol UDP: User datagram protocol	TCP												
Protocol Type	Extended MEMOBUS, MEMOBUS, MELSEC, None, MODBUS/TCP	Select an application layer protocol. <table border="1"> <thead> <tr> <th>Protocol Type</th> <th>Overview</th> </tr> </thead> <tbody> <tr> <td>Extended MEMOBUS</td> <td>Yaskawa’s Extended MEMOBUS protocol.</td> </tr> <tr> <td>MEMOBUS</td> <td>Yaskawa’s MEMOBUS protocol.</td> </tr> <tr> <td>MELSEC</td> <td>Ethernet I/F protocol for the sequencer (A series) manufactured by Mitsubishi Electric Corporation.</td> </tr> <tr> <td>Non-procedure</td> <td>General-purpose message communication. Transmits and receives continuous data intact in the specified register.</td> </tr> <tr> <td>MODBUS/TCP</td> <td>Industrial Ethernet protocol proposed by Modicon, Inc.</td> </tr> </tbody> </table>	Protocol Type	Overview	Extended MEMOBUS	Yaskawa’s Extended MEMOBUS protocol.	MEMOBUS	Yaskawa’s MEMOBUS protocol.	MELSEC	Ethernet I/F protocol for the sequencer (A series) manufactured by Mitsubishi Electric Corporation.	Non-procedure	General-purpose message communication. Transmits and receives continuous data intact in the specified register.	MODBUS/TCP	Industrial Ethernet protocol proposed by Modicon, Inc.	Extended MEMOBUS
Protocol Type	Overview														
Extended MEMOBUS	Yaskawa’s Extended MEMOBUS protocol.														
MEMOBUS	Yaskawa’s MEMOBUS protocol.														
MELSEC	Ethernet I/F protocol for the sequencer (A series) manufactured by Mitsubishi Electric Corporation.														
Non-procedure	General-purpose message communication. Transmits and receives continuous data intact in the specified register.														
MODBUS/TCP	Industrial Ethernet protocol proposed by Modicon, Inc.														

Item	Setting Range	Details	Default																											
Code	ASCII BIN RTU	<p>Select a code type for the message communication data. Depending on protocol type, available codes are restricted as follows:</p> <table border="1"> <thead> <tr> <th rowspan="2">Protocol Type</th> <th colspan="3">Code</th> </tr> <tr> <th>ASCII</th> <th>BIN</th> <th>RTU</th> </tr> </thead> <tbody> <tr> <td>Extended MEMOBUS</td> <td>√</td> <td>√</td> <td>–</td> </tr> <tr> <td>MEMOBUS</td> <td>√</td> <td>–</td> <td>√</td> </tr> <tr> <td>MELSEC</td> <td>√</td> <td>√</td> <td>–</td> </tr> <tr> <td>Non-procedure</td> <td>√</td> <td>√</td> <td>–</td> </tr> <tr> <td>MODBUS/TCP</td> <td>–</td> <td>√</td> <td>–</td> </tr> </tbody> </table> <p>√ : Available, – : Not available</p>	Protocol Type	Code			ASCII	BIN	RTU	Extended MEMOBUS	√	√	–	MEMOBUS	√	–	√	MELSEC	√	√	–	Non-procedure	√	√	–	MODBUS/TCP	–	√	–	ASCII
Protocol Type	Code																													
	ASCII	BIN	RTU																											
Extended MEMOBUS	√	√	–																											
MEMOBUS	√	–	√																											
MELSEC	√	√	–																											
Non-procedure	√	√	–																											
MODBUS/TCP	–	√	–																											
Automatically	–	<p>Opens the automatic receive setting screen. To open the screen, double-click this button.</p> <p>Note: The automatic receive function is valid only for a connection when the connection number = 1.</p>	–																											
Remote Station Name	Up to 32 single-byte characters (16 double-byte characters)	Any text can be entered as a connection comment.	Blank																											

■ Simple Setting Screen for Message Communication

Graphically sets connection parameters for each connection.

Basically, the same content as with message communication items in connection parameter setting can be set.

When connection parameters are not yet set and this screen is opened, the default value for each connection will be automatically stored.

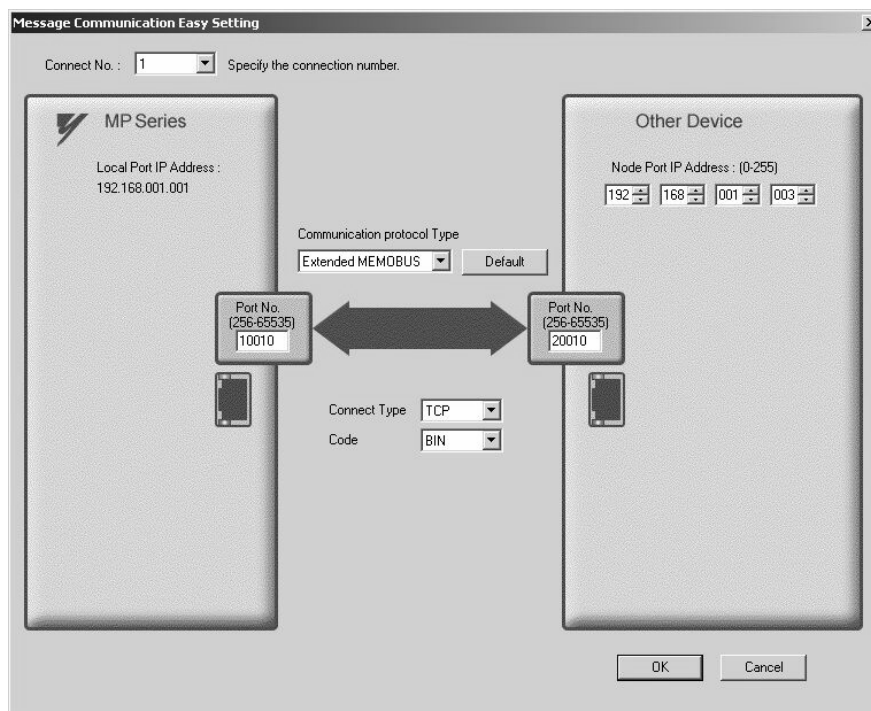

The following table provides the default values for each connection stored when the connection parameters are not yet set and this screen is opened.

Item	Default			
	Connection Number 01	Connection Number 02	Connection Number 03	Connection Number 04
Local Port	10001	10002	10003	10004
Node IP Address	192.168.1.2	192.168.1.3	192.168.1.4	192.168.1.5
Node Port Number	10001	10002	10003	10004
Communication Protocol Type	Extended MEMOBUS			
Connect Type	TCP			
Code	BIN			

By clicking the **Default** Button, default values are set for each data code type according to the selected communication protocol type.

The following table shows the default values for each data code type.

Communication Protocol Type	Default for Data Code Type
Extended MEMOBUS	BIN
MEMOBUS	RTU
MELSEC	BIN
Non-procedure	BIN
MODBUS/TCP	BIN

■ Automatic Receive Setting Screen for Message Communication

The automatic receive function can be enabled only for connections where the connection number = 1.

The automatic receive function enables you to automatically run a function equivalent to the MSG-RCV function.

The following table explains each setting item.

Item	Setting Range	Details	Default
Automatic Reception Enable/Disable	Enable/Disable	Select whether to enable automatic reception. Note: When the local port number is not yet set, it becomes invalid regardless of the enable/disable selection.	Enable
The setting items below can only be set when the Automatic Reception is set to "Enable."			
Transmission Buffer Channel	Cannot be set (fixed at one)	The communication buffer channel is usually used for data exchanged between the MSG-SND/MSG-RCV function and 218IFA. The communication buffer channel is associated with the connection according to the input item "CH-NO" for the MSG-SND/MSG-RCV function and node connection number (PARAM02) setting for the parameter list (PARAM). When automatic reception is running, the function equivalent to the MSG-RCV function is realized by using the communication buffer channel number "1."	1
Readout of Input Relay	IW0000 to IWFFFF	Set a start register of the input relay used for the automatic reception.	IW0000
Readout of Input Register	IW0000 to IWFFFF	Set a start register of the input register used for the automatic reception.	IW0000
Readout/Write-in of Coil	MW00000 to MW65534	Set a start read/write register of the coil used for the automatic reception.	MW00000
Readout/Write-in of Hold Register	MW00000 to MW65534	Set a start read/write register of the holding register used for automatic reception.	MW00000
Write-in Width of Coil/Hold Register (LO)	MW00000 to MW65534	Set a write range (LO) of the coil/holding registers used for automatic reception.	MW00000
Write-in Width of Coil/Hold Register (HI)	MW00000 to MW65534	Set a write range (HI) of the coil/holding registers used for the automatic reception.	MW65534

The following table provides the valid setting items for each communication protocol type.

Setting Item	Communication Protocol Type				
	Extended MEMOBUS	MEMOBUS	MELSEC	Non-procedure	MODBUS/TCP
Readout of Input Relay	√	√	–	–	√
Readout of Input Register	√	√	–	–	√
Readout/Write-in of Coil	√	√	–	–	√
Readout/Write-in of Hold Register	√	√	√	–	√
Write-in Width of Coil/Hold Register (LO)	√	√	√	–	√
Write-in Width of Coil/Hold Register (HI)	√	√	√	–	√

Note: √ : Enable

– : Disable

■ I/O Message Communication Item Connection Parameter Setting

Sets connection parameters for I/O message communication.

I/O message communication exchanges the data using I/O images with the remote equipment.

I/O Message Communication

Disable
 Enable

Easy setting It is possible to set easily that communicate the I/O message.

Data update timing Low Scan

Read/Write	Local Port	Node IP Address	Node Port	Connect Type	Protocol Type	Code
Read	10005	192.168.001.007	10005	TCP	Extended MEMOBUS	BIN
Write	10006	192.168.001.007	10006	TCP	Extended MEMOBUS	BIN

Head register number data size

MP2300S input disable [rw0000] 4 W<- [Hold register(MW)] 00000 4 W

output disable [0w0004] 4 W-> [Hold register(MW)] 00004 4 W Node equipment

The following table explains each setting item.

Item	Setting Range	Details	Default
I/O Message Communication Enable/Disable	Enable/Disable	Select whether to enable I/O message communications.	Disable
The setting items below can only be set when the I/O Message Communication is set to "Enable."			
Easy Setting	—	Opens the Simple Setting screen for the read/write connection parameters.	—
Data Update Timing	H Scan/ L Scan	Set when to update the I/O data for the controller side when the I/O message communication is established.	L Scan
Read/Write	—	In 218IFA Ethernet communications, remote stations are distinguished by their connection numbers. I/O message communications have a connection for each read/write.	
Local Port	256 to 65535	Specify the 218IFA port number for each read/write connection. To delete the port number setting, enter zero. To use only a read or a write connection, set the other port number to zero to delete the connection. Note: When the connection type = UDP, the port number cannot be 9998 or 10000.	0
Node IP Address	0.0.0.1 to 255.255.255.254	Set a remote IP address for both read and write connections. Set a common value for both read and write. However, the following addresses cannot be used: 127.xxx.xxx.xxx xxx.xxx.xxx.000 xxx.xxx.xxx.255	000.000.000.000
Node Port	256 to 65535	Specify the remote port number for each read/write connection. A pair of a remote IP address and remote port number must not be duplicated.	0
Connect Type	TCP UDP	Select a transport layer protocol. TCP: Transmission control protocol UP: User datagram protocol	TCP

Item	Setting Range	Details	Default																							
Protocol Type	Extended MEMOBUS MEMOBUS	Select an application layer protocol.	Extended MEMOBUS																							
		<table border="1"> <thead> <tr> <th>Protocol Type</th> <th>Overview</th> </tr> </thead> <tbody> <tr> <td>Extended MEMOBUS</td> <td>Yaskawa's Extended MEMOBUS protocol.</td> </tr> <tr> <td>MEMOBUS</td> <td>Yaskawa's MEMOBUS protocol.</td> </tr> <tr> <td>MELSEC</td> <td>Ethernet I/F protocol for the sequencer (A series) manufactured by Mitsubishi Electric Corporation.</td> </tr> <tr> <td>MODBUS/TCP</td> <td>Industrial Ethernet protocol proposed by Modieon, Inc.</td> </tr> </tbody> </table>		Protocol Type	Overview	Extended MEMOBUS	Yaskawa's Extended MEMOBUS protocol.	MEMOBUS	Yaskawa's MEMOBUS protocol.	MELSEC	Ethernet I/F protocol for the sequencer (A series) manufactured by Mitsubishi Electric Corporation.	MODBUS/TCP	Industrial Ethernet protocol proposed by Modieon, Inc.													
		Protocol Type		Overview																						
		Extended MEMOBUS		Yaskawa's Extended MEMOBUS protocol.																						
		MEMOBUS		Yaskawa's MEMOBUS protocol.																						
MELSEC	Ethernet I/F protocol for the sequencer (A series) manufactured by Mitsubishi Electric Corporation.																									
MODBUS/TCP	Industrial Ethernet protocol proposed by Modieon, Inc.																									
Code	ASCII BIN RTU	Select a code type for the message communication data. Depending on protocol type, available codes are restricted as follows:	ASCII																							
		<table border="1"> <thead> <tr> <th rowspan="2">Protocol Type</th> <th colspan="3">Code</th> </tr> <tr> <th>ASCII</th> <th>BIN</th> <th>RTU</th> </tr> </thead> <tbody> <tr> <td>Extended MEMOBUS</td> <td>√</td> <td>√</td> <td>–</td> </tr> <tr> <td>MEMOBUS</td> <td>√</td> <td>–</td> <td>√</td> </tr> <tr> <td>MELSEC</td> <td>√</td> <td>√</td> <td>–</td> </tr> <tr> <td>MODBUS/TCP</td> <td>–</td> <td>√</td> <td>–</td> </tr> </tbody> </table>		Protocol Type	Code			ASCII	BIN	RTU	Extended MEMOBUS	√	√	–	MEMOBUS	√	–	√	MELSEC	√	√	–	MODBUS/TCP	–	√	–
Protocol Type	Code																									
	ASCII	BIN		RTU																						
Extended MEMOBUS	√	√		–																						
MEMOBUS	√	–	√																							
MELSEC	√	√	–																							
MODBUS/TCP	–	√	–																							
		√: Available –: Not available																								
Remote Station Name	Up to 32 single-byte characters (16 double-byte characters)	Any text can be entered as a connection comment.	Blank																							
Input Disable	Enable/disable	Select whether to update the input data in the I/O message communication.	enable																							
Output Disable	Enable/disable	Select whether to update the output data in the I/O message communication.	enable																							
MP2300S Head Register Number Data Size	IW0000 to IW7FFF	Set a start address of the input register of the MP2300S side for storing the data read from the remote equipment. Note1: "xxxx" represents a start I/O register number specified by the 218IFA cell in the detailed field of the module configuration definition screen.	IW xxxx (Note1)																							
	OW0000 to OW7FFF	Set a start address of the MP2300S side output register for referencing the data written in the remote equipment. Note2: "xxxx" represents a start I/O register number specified by the 218IFA cell in the detailed field of the module configuration definition screen.	OWxxxx + 4 (Note2)																							
Data Size	Varies according to protocol type	Specify the data size (word) read from the remote equipment.	4																							
		Specify the data size (word) written in the remote equipment.	4																							
Head Register Number for the Node Equipment	Varies according to protocol type	Specify the register type and the start register address for the remote equipment to read.	Varies according to protocol type.																							
		Specify the register type and the start register address for the remote equipment to write.																								
Data Size of the Node Equipment	Display only	Generally, the same value specified in MP2300S data size is shown. By way of exception, when MELSEC is selected for communication protocol type and a bit device such as input relay (X)/ output relay (Y)/ internal relay (M)/ link relay (B) is selected for read register, the display is shown in bit size.	4																							
		Generally, the same value specified in MP2300S data size is shown. By way of exception, when MELSEC is selected for communication protocol type and a bit device such as input relay (X)/ output relay (Y)/ internal relay (M)/ link relay (B) is selected for read register, the display is shown in bit size.	4																							

■ Easy Setting Window for I/O Message Communication

Graphically adjusts the setting for the read/write connection parameters.

Generally, the contents are similar to I/O message communication items in connection parameter setting.

When the connection parameters are not yet set and this dialog box is opened, the default values for read/write connection will be automatically stored.

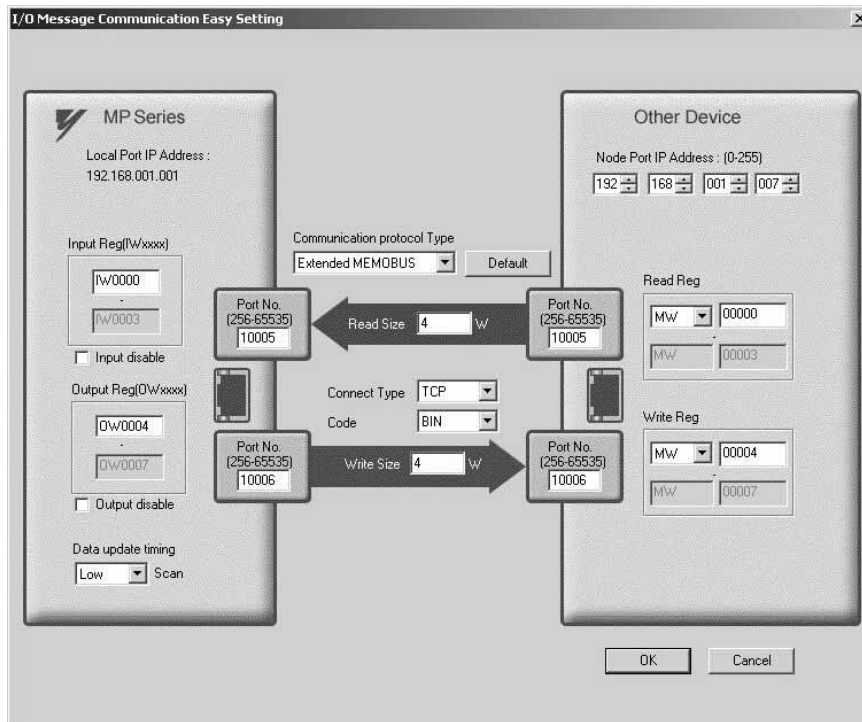

The following table provides the default values for each connection stored when the connection parameters are not yet set and this screen is opened.

Item		Default	
MP Series	Local IP Address		Values set in transmission parameter setting items are shown.
	Local Port	Read	10005
		Write	10006
	Input Register (IW xxxx)		Start I/O register number specified by the 218IFA cell in the detailed field of the module configuration definition screen.
	Input Disable		Not checked (enable)
	Output Register (OW xxxx)		Start I/O register number specified by the 218IFA cell in the detailed field of the module configuration definition screen + 4.
Data Update Timing		Low	
Other Device	Node IP Address		192.168.1.7
	Node Port Number	Read	10005
		Write	10006
	Read Register		MW00000
Write Register		MW00004	
Communication Protocol Type		Extended MEMOBUS	
Read Size		4	
Write Size		4	
Connect Type		TCP	
Code		BIN	

In addition, click the **Default** Button to set the default values for data code type, local I/O register setting, read/write size, and node read/write register setting according to the selected communication protocol type.

The following table provides these default values.

Communication Protocol Type	Default			
	Data Code Type	Local Input/Output Register Setting	Read/Write Size	Node Read/Write Register Setting
Extended MEMOBUS	BIN	IW□□□□ to IW□□□□+ 3 (input) OW□□□□+ 4 to OW□□□□+7 (output)	4 (read) 4 (write)	MW0000 to MW0003 (read) MW0004 to MW0007 (write)
MEMOBUS	RTU	Same as above	Same as above	Same as above
MELSEC	BIN	Same as above	Same as above	D0000 to D0003 (read) D0004 to D0007 (write)
MODBUS/TCP	BIN	Same as above	Same as above	4X00001 to 4X00004 (read) 4X00005 to 4X00008 (write)

2. Status tab

In the **Status** Tab, each setting for 218IFA transmission definition and transmission status is shown. The displayed contents are as follows:

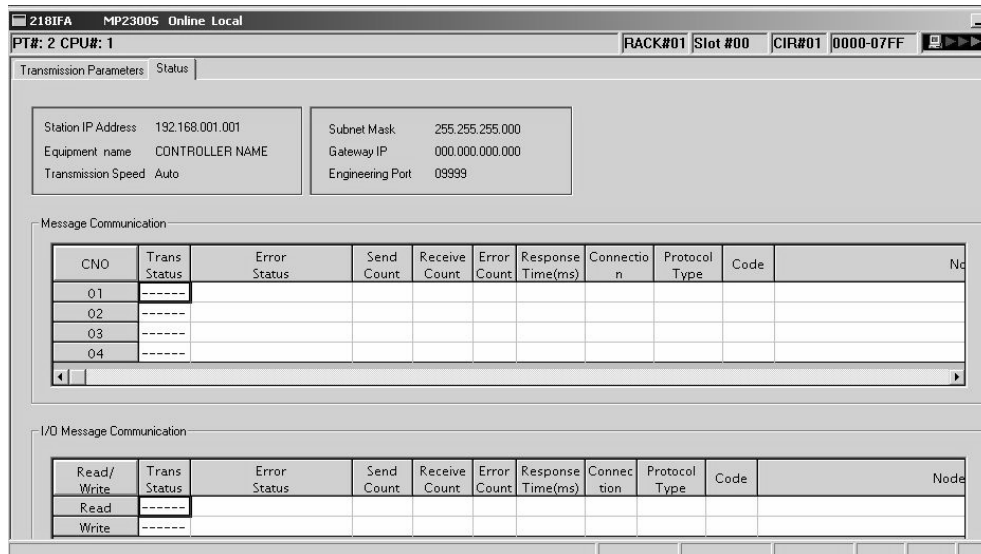

■ Transmission Parameter Item

Item	Displayed Content	Default
Station IP Address	Displays local IP address specified in the Transmission Parameter Tab.	000.000.000.000
Equipment Name	Displays equipment name specified in the Transmission Parameter Tab. When the equipment name is not yet set, nothing is shown.	NULL
Transmission Speed	Displays transmission rate retrieved from the status information. (Fixed at Automatic)	Automatic
Subnet Mask	Displays a subnet mask set in the Transmission Parameter Tab.	000.000.000.000
Gateway IP	Displays a default gateway IP address set in the Transmission Parameter Tab.	000.000.000.000
Engineering Port	Displays a port number set in the detailed definition of the Transmission Parameter Tab.	9999

■ Message Communication and I/O Message Communication Items

Item	Displayed Content	Default
Trans Status	Displays the transmission status for each connection.	—
Error Status	If an error is indicated in the transmission status, the error details are shown.	—
Send Count	Displays the number of packets transmitted to the remote station.	—
Receive Count	Displays the number of packets received from the remote station.	—
Error Count	Displays the number of errors that occurred in each connection.	—
Response Time (ms)	Displays the time taken to receive a response after issuing a command in the MSG-SND function of the message communication and the I/O message communication.	—
Connection	Displays the connection type set in the Transmission Parameter Tab.	—
Protocol Type	Displays the protocol of the connection parameter set in the Transmission Parameter Tab.	—
Code	Displays the code type of the data set in the Transmission Parameter Tab.	—
Node Station Name	Displays the remote station name set in the Transmission Parameter Tab.	—

Note: 1. Transmission status

In online mode, displays the transmission status for each connection.

Transmission Status	State
IDLE	IDLE
WAIT	WAIT (waiting for connection)
CONNECT	CONNECT (capable of transmitting and receiving data)
–	Unused connection

2. Error status

If an error is indicated in the transmission status, the error details are shown.

Error Status	State	Remarks
No Error	Normal	–
Socket Generation Error	System error	Socket generation failed
Local Port Number Error	Error in setting the local port number (the same address is bound while disconnecting the TCP connection)	Bind error (duplicated port number)
		A bind error occurred while aborting using the MSG function and ending the connection. The error occurs if Execute is turned ON within one minute after an Abort is completed. Before the connection was completed, another function issued a command to the same remote station.
Socket Attribute Change Error	System error (in TCP)	An error occurred while setting a socket attribute.
Connection Error (M-SND)	Connection error (when actively open in TCP, a connection is rejected by the node station)	Tried to connect using the MSG-SND function, but the connection was rejected by the remote station, and the command was reset.
		When disconnecting the cable, retried connecting for one minute (default value) without a response.
Connection Error (M-RCV)	Connection error (when passively open in TCP)	An error occurred while receiving the connection from the MSG-RCV function.
System Error	System error	A socket polling (select specification) error occurred while receiving data.
Data Transmit Error (TCP)	Data transmit error (in TCP, either there is no node station or a node station did not startup.)	A response transmit error occurred in the MSG-RCV function. An error also occurred in the MSG-SND function. An error occurred only in TCP when there was no node station to transmit or a node station was rebooted.
Data Transmit Error (UDP)	Data transmit error (in UDP)	A transmit request was issued to a nonexistent socket.
Data Receive Error (TCP)	Data receive error (in TCP, a request to disconnect the connection is received from the node station)	An error occurred when disconnecting the connection from the node station. It also may occur even when close is processed properly.
Data Receive Error (UDP)	Data receive error (in UDP)	A data receive command was issued to a nonexistent socket.
Socket Option Change Error	System error	Error when changing a socket option
Data Change Error	Data change error	Protocol change error

2.2.5 Built-in SVB Module

(1) Overview

[a] About SVB Module

The SVB Module is a motion module used to control SERVOPACKs, stepping motor drivers, inverters, distributed I/O devices, etc. via MECHATROLINK interface MECHATROLINK-I or -II.

The MECHATROLINK-II enables position, speed, torque, and phase control for highly accurate synchronized control. In addition, sophisticated machine operations can be performed by switching the control mode while the axis is moving.

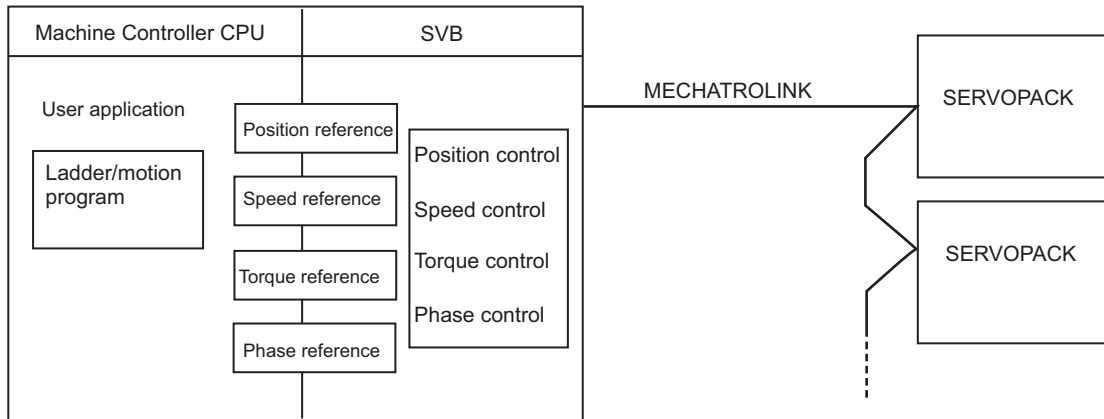

[b] Built-in SVB and Slot-mounting Optional SVB

The SVB Modules are of two types: The built-in SVB (hereinafter referred to as Built-in SVB) and the Slot-mounting Optional SVB (hereinafter referred to as Optional SVB)

A built-in SVB Module is incorporated in the MP2300S.

The Optional SVB is one of the optional modules for the Machine Controller. The SVB-01 Module is an Optional SVB that can be mounted on the optional slot of the MP2300S.

[c] Features

- Up to 21 slave stations can be connected to a single Module (the SERVOPACKs can be connected up to 16 axes).
MP2300S: Only an SVB-01 Module can be mounted in optional slot.
Including the MP2300S's built-in SVB, a total of 32 axes can be controlled.
- Synchronization between Modules is also supported, making it suitable for both synchronous control and interpolation across Modules.
- An SVB-01 Module used as a slave can be connected to a host controller equipped with MECHATROLINK communication functions.
- Self-configuration enables automatic allocation of setting data for the slave device that is connected to MECHATROLINK.
- SERVOPACK parameters can be managed over networks.
- When using MECHATROLINK-II, MP2300S built-in SVB is available as a slave.

[d] System Configuration Example

The following diagram shows a system configuration example.

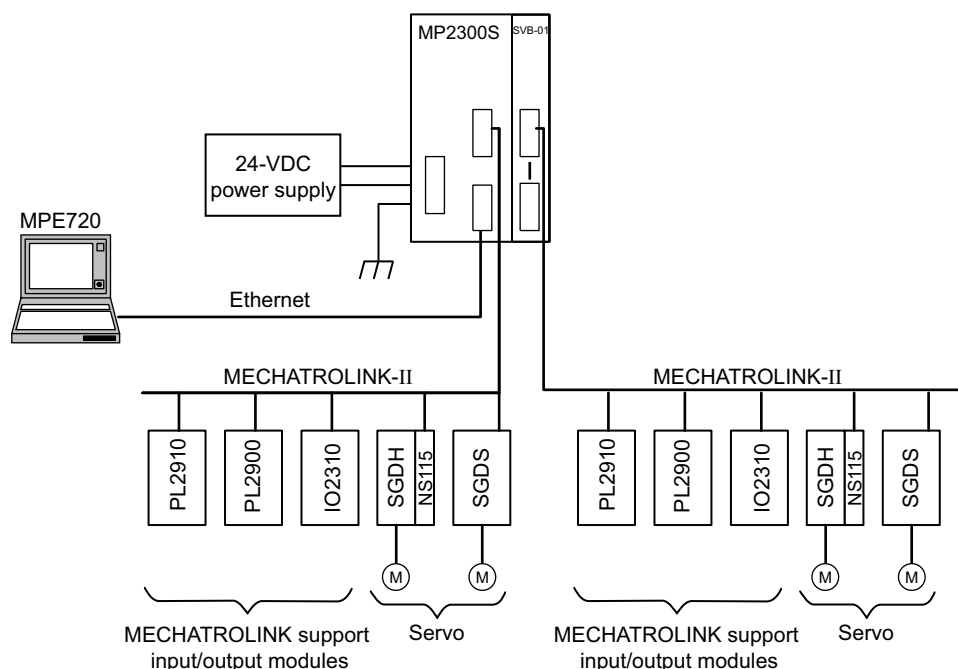

- Use the specified cables and connectors. Refer to 1.1.5 (3) *Cables* in the *Machine Controller MP2000-series SVB/ SVB-01 Motion Module User's Manual (manual no.: SIEPC88070033)* to select appropriate cables and connectors to connect each device.
- The SERVOPACK models that can be connected through MECHATROLINK-I differ from those connected through MECHATROLINK-II. Refer to 1.4 *MECHATROLINK-compatible Devices* on page 1-7 to select appropriate SERVOPACK models for the MECHATROLINK interface to be used.
- If both MECHATROLINK-I (4 Mbps) compatible devices and MECHATROLINK-II (10 Mbps) compatible devices are connected in a system, make the settings in accordance with MECHATROLINK-I specifications.
- When connecting a servo to an SVB Module via MECHATROLINK, connect signals such as overtravel, zero-point return deceleration limit switch, and external latch to the servo. Refer to the relevant SERVOPACK manual for details on the connections.
- When connecting Σ -II series SERVOPACKs (SGDH+NS100 or SGDH+NS115), do not connect a hand-held type digital operator and SigmaWin+. If connected, alarms A.95 (command warning) and A.ED (execution not completed) will occur for the commands sent from the SVB Module, and normal operation will be interrupted. If a digital operator or SigmaWin+ must be connected to a Σ -II series SERVOPACK, disconnect the SERVOPACK from the SVB Module.

[e] Synchronization between Modules

1. Overview

MP2200 and MP2300 Machine Controllers have a function that can synchronize hardware between the CPU and an optional module. This function enables MECHATROLINK communications in synchronization with high-speed scans. As a result, synchronization between a built-in SVB Module and an SVB-01 Module, or among multiple SVB-01 Modules, can be enabled.

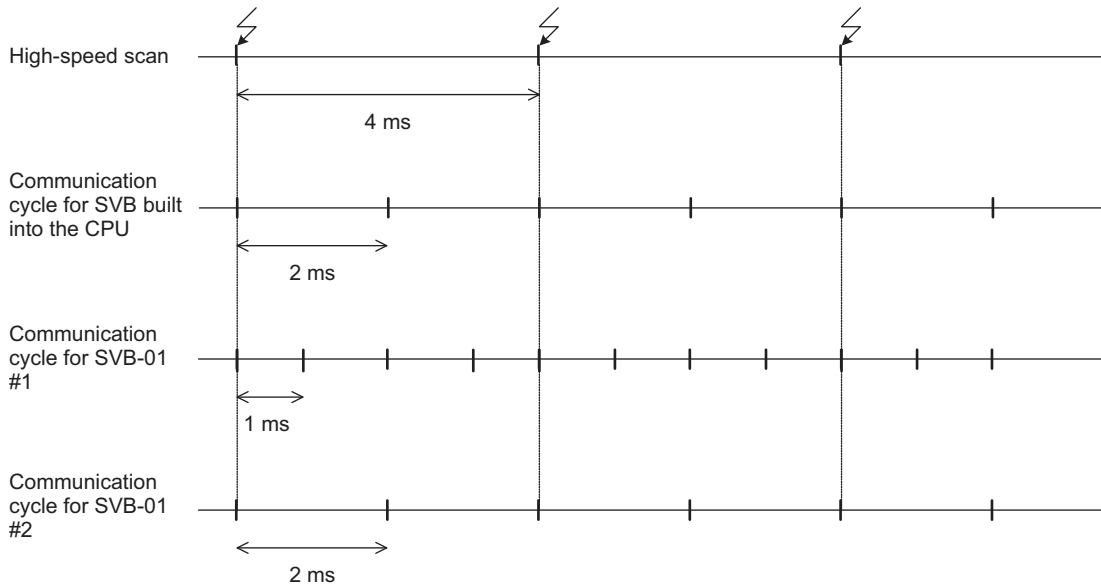

When synchronized mode is used, the start of the high-speed scan and the various communication cycles are synchronized. This means that commands from the high-speed scan will be sent at consistent points in communication cycle processing and simplifies distribution processing for interpolation commands.

2. Conditions Under Which Synchronization Is Possible

The following table shows the combinations of high-speed scan times and MECHATROLINK communication cycles that allow synchronization between modules in the synchronization mode.

High-speed Scan (RTC: 0.5 ms)	MECHATROLINK Communication Cycle			
	0.5 ms	1 ms	1.5 ms	2 ms
1.0 ms	Yes	Yes	–	Yes
1.5 ms	Yes	–	Yes	–
2.0 ms	Yes	Yes	–	Yes
2.5 ms	Yes	–	–	–
3.0 ms	Yes	Yes	Yes	–
3.5 ms	Yes	–	–	–
4.0 ms	Yes	Yes	–	Yes
4.5 ms	Yes	–	Yes	–
5.0 ms	Yes	Yes	–	–
5.5 ms	Yes	–	–	–
6.0 ms	Yes	Yes	Yes	Yes
:				

3. Timing At Which Modules Are Synchronized

Modules are automatically synchronized when the power supply is turned OFF and ON again.

4. Operation when High-speed Scan Cycle Is Changed

MECHATROLINK communication with SVB Modules will continue even if the high-speed scan cycle is changed. However, the speed waveform at execution of interpolation command will be disordered. When changing the high-speed scan cycle, do so either with the CPU stopped or when motion commands are not being executed.

Change the high-speed scan setting and then save the settings to flash memory and turn the power supply OFF and ON when operation changes from synchronized to asynchronous or from asynchronous to synchronized.

5. Operation When the MECHATROLINK Communication Cycle Is Changed

- Changing the MECHATROLINK communication cycle of the SVB in the CPU
Synchronization may be lost when a change is made even if synchronization is possible for the high-speed scan and communication cycle combination. When a change is made, save the settings to flash memory and then turn the power supply OFF and ON.
- Changing the MECHATROLINK communication cycle of the SVB-01 Module
Operation will be automatically synchronized when a change is made if synchronization is possible for the high-speed scan and communication cycle combination. It is not necessary to turn the power supply OFF and ON.

6. Conditions when the Power Supply Must Be Turned OFF and ON

When any of the following operations is performed, save the settings to flash memory and then turn the power supply OFF and ON.

- After executing a self-configuration command from the MPE720 after turning ON the power supply
- After loading a Module definition after turning ON the power supply
- After changing the SVB communication cycle in the CPU after turning ON the power supply
- After operation changes from synchronized to asynchronous or from asynchronous to synchronized when the high-speed scan setting is changed

(2) Specifications

The specifications of built-in and optional SVB Modules are as follows.

[a] Motion Control Function

Item		Details		
MECHATROLINK Communication	Number of Communication Lines	One line		
	Number of Communication Ports (Connectors)	2 ports		
	Terminating Resistor	JEPMC-W6022 terminator must be purchased separately.		
	Transmission Distance	MECHATROLINK-II Min. distance between stations: 0.5 m Total network length: 50 m (can be extended to 100 m by connecting repeaters) MECHATROLINK-I Min. distance between stations: 0.3 m Total network length: 50 m (can be extended to 100 m by connecting repeaters)		
	Master Functions	Communication Interface	MECHATROLINK-II (2:N synchronous)	MECHATROLINK-I (1:N synchronous)
		Baud Rate	10 Mbps	4 Mbps
		Transmission Cycle	0.5 ms, 1 ms, 1.5 ms, or 2 ms	2 ms
		Number of Link Communication Bytes	17 bytes or 32 bytes	17 bytes
		Number of Connectable Stations	Up to 21 stations (SERVOPACK for up to 16 axes)	Up to 14 stations
		C1 Messaging (Master Function)	Provided (selectable).	Not provided.
		C2 Messaging (Allocations)	Provided (selectable).	Not provided.
		Retry Function	Provided (selectable).	Not provided.
		Supported Slave Devices	For details, refer to <i>1.4.2 Modules</i> on page 1-7.	
	Slave Functions*	Communication Interface	MECHATROLINK-II	
		Baud Rate	10 Mbps	
		Transmission Cycle	The transmission cycle of the master station (0.5 ms min.)	
Number of Link Communication Bytes		17 bytes or 32 bytes		
Messaging (Slave Function)		Supported.		

* Only with MECHATROLINK-II

(cont'd)

	Item	Details
Servo Control	Communication Method	Single-send (communication cycle = transmission cycle) synchronous communication Transmission/communication error detection (hardware) provided. Synchronous communication error detection (software) provided. Automatic recovery function not provided (recovery when alarm is cleared).
	I/O Registers	Input/output using motion registers (synchronized on high-speed scan)
	Command Mode	Motion Command Mode/MECHATROLINK Transparent Command Mode
	Supported Servomotors	Standard motors, linear motors, and direct-drive motors
	Control Type	Position control, speed control, torque control, and phase control
	Motion Commands	Positioning, External Positioning, Zero Point Return, Interpolation, Interpolation with Position Detection, JOG operation, STEP operation, Speed Reference*, Torque Reference*, Phase Control*, etc.
	Acceleration/Deceleration Method	One-step asymmetric trapezoidal acceleration/deceleration, exponential acceleration/deceleration filter, moving average filter
	Position Unit	pulse, mm, inch, degree, μm
	Speed Unit	Reference units/s, 10^n reference units/min, percentage of rated speed
	Acceleration Unit	Reference units/s ² , ms (acceleration from 0 until rated speed reached)
	Torque Unit	Percentage of rated torque
	Electronic Gear	Provided.
	Position Control Method	Finite length position control, infinite length position control, absolute system infinite length position control, and simple absolute system infinite length position control
	Software Limit	Positive/negative direction for each point
Zero Point Return Method	13 types	
SERVOPACK Parameter Management	Parameters can be managed in the MPE720's SERVOPACK Parameter Window.	
Inverter Control	Communication Method	Single-send (communication cycle = transmission cycle) asynchronous communication Transmission/communication error detection (hardware) provided. Synchronous communication error detection (software) not provided. Automatic recovery function not provided (recovery when alarm cleared).
	I/O Registers	Input/output using motion registers (synchronized on high-speed scan)
	Command Mode	Motion Command Mode/MECHATROLINK Transparent Command Mode
	Control Type	Speed control only (V/F, vector control and other control methods use inverter settings.)
	Motion Commands	Inverter I/O control, etc.
	Speed Unit	The speed unit depends on the inverter settings.
I/O Control	Communication Method	Single-send (communication cycle = transmission cycle) asynchronous communication Transmission/communication error detection (hardware) provided. Synchronous communication error detection not provided. Automatic recovery function provided.
	I/O Registers	Input/output using I/O registers and synchronized on the high-speed scan or low-speed scan (selectable).
	Self-configuration Function	Module and slave devices can be automatically allocated.
	Synchronization between Modules	Synchronization supported (enabled when power is cycled) when high-speed scan cycle = communication cycle times n

* Only with MECHATROLINK-II

[b] MECHATROLINK Communication Specifications

Item	MECHATROLINK-I	MECHATROLINK-II
Topology	Bus	Bus
Transmission Media	Twisted-pair cable	Twisted-pair cable
Transmission Distance	50 m max. (can be extended to 100 m by connecting repeaters)	50 m max. (can be extended to 100 m by connecting repeaters)
Minimum Distance between Stations	0.3 m	0.5 m
Baud Rate	4 Mbps	10 Mbps
Communication Cycle	2 ms	0.5 ms, 1 ms, 1.5 ms, or 2 ms
Number of Connectable Stations	Up to 14 stations	Up to 21 stations * (SERVOPACK for up to 16 axes)
Communication Control Method	Cyclic	Cyclic
Media Access Control Method	1:N	2:N
Communication Mode	Control communication	Control communication
Error Control	CRC check	CRC check

* Up to 16 stations can be connected if a JEPMC-REP2000 MECHATROLINK-II Repeater is not used. Refer to *Chapter 8 MECHATROLINK-II Repeater of the Machine Controller MP900/MP2000 Series User's Manual MECHATROLINK System* (Manual No.: SIEZ-887-5.1) for details.

[c] Maximum Number of Slave Stations

The maximum numbers of slave stations that can be connected to the SVB-01 Module are listed below.

■ MECHATROLINK Communication Setting and Maximum No. of Slave Stations

MECHATROLINK Communication Setting			Maximum Number of Slave Stations
Communication Method	Baud Rate	Communication Cycle	
MECHATROLINK-I	4 Mbps	2 ms	14
MECHATROLINK-II (17-byte Mode)	10 Mbps	0.5 ms	6
		1 ms	15
MECHATROLINK-II (32-byte Mode)	10 Mbps	0.5 ms	4
		1 ms	9
		1.5 ms	15
		2 ms	21 (SERVOPACK for up to 16 axes)

♦ Refer to 8.8.6 MECHATROLINK Definitions of Machine Controller MP900/MP2000 Series MPE720 Software for Programming Device User's Manual (Manual No.: SIEPC88070005) for information on the settings for MECHATROLINK transmission.

■ Transmission Distance and Maximum No. of Slave Stations

Communication Method	Transmission Distance (Total Network Length)	Maximum Number of Slave Stations
MECHATROLINK-I	50 m (can be extended to 100 m by connecting repeaters)	14
MECHATROLINK-II	30 m (can be extended to 100 m by connecting repeaters)	16 (21)*
	50 m (can be extended to 100 m by connecting repeaters)	15 (21)*

* The values in parentheses apply when a JEPMC-REP2000 Repeater is used.
JEPMC-REP2000 Repeater must be used if 17 or more slave stations are connected when using MECHATROLINK-II communication.

(3) Module Configuration

[a] Module Configuration Window

Click **MP2300S** in the **Controller** area to display the details of the basic module functions in the **Module Details** area.
The cell No.3 provides a detailed definition of built-in SVB.

The screenshot shows the 'Module Configuration' window for 'MP2300S Online Local' with 'PT#: 2 CPU#: 1'. It is divided into two main sections: 'Controller' and 'Module Details'.

Controller Section:

Slot Number	00	01
Module Type	MP2300S	UNDEFINED
Controller Number	-	-
Circuit Number	-	-
I/O Start Register	----	----
I/O End Register	----	----
Disable Input		
Disable Output		
Motion Start Register	----	----
Motion End Register	----	----
Details		
Status	Running	

MP2300S: Controller module with network servo control, ethernet, virtual axes, program control function.

Module Details Section (MP2300S SLOT#00):

Slot Number	1	2	3	4	5
Module Type	CPU	218IFA	SVB	SVR	M-EXECUTOR
Controller Number	-	01	01	01	-
Circuit Number	-	01	01	02	-
I/O Start Register	----	0000	0800	----	0C00
I/O End Register	----	07FF	08FF	----	0C3F
Disable Input		Enable	Enable		
Disable Output		Enable	Enable		
Motion Start Register	----	----	8000	8800	----
Motion End Register	----	----	87FF	8FFF	----
Details			MECHATROLINK		
Status	Running	Running	Running	Running	Running

SVB: Network servo control function.

The following table lists the items shown in the **Module Configuration** Window.

Item	Description	Modification
Slot Number	Slot number	Not possible
Module Type	Module detected in the slot	Possible
Controller Number	Fixed to 01	Not possible
Circuit Number	Module circuit number	Possible
I/O Start Register	I/O start register number of the I/O Module to be connected to MECHATROLINK (Setting range: 0000 to 7FFFh, max. 400h words per SVB Module)	Possible
I/O End Register	I/O last register number of the I/O Module to be connected to MECHATROLINK (Setting range: 0000 to 7FFFh, max. 400h words per SVB Module)	Possible
Disable Input	Input enabled (Enable)/disabled (Disable)	Possible (Not possible if the cell is blank)
Disable Output	Output enabled (Enable)/disabled (Disable)	Possible (Not possible if the cell is blank)
Motion Start Register	Start register number of the motion parameters (Automatically sets according to the circuit number)	Not possible
Motion End Register	Last register number of the motion parameters (Automatically sets according to the circuit number)	Not possible
Details	Opens the MECHATROLINK Transmission Definition Window. (Double-click the MECHATROLINK cell to open the window.)	–
Status	Status of each module in online mode	Not possible

- ♦ “Possible” in the Modification line in the above table means that it is possible to change the setting of the item. Always save the setting to the flash memory after having changed the setting.
 - ♦ When changing the setting, be careful not to set the register numbers overlapped with another module.
 - ♦ I/O Start Register and I/O End Register must be set even though the I/O Module is connected or not connected to MECHATROLINK.

(4) MECHATROLINK Transmission Definition

[a] How to Open the MECHATROLINK Transmission Definition Window

In the Module Configuration Window, select the **SVB** Module in the **Controller** field and double-click the **MECHATROLINK** cell in the Module **Details** field. The MECHATROLINK Transmission Definition Window will open.

- If several SVB Modules are mounted, select the SVB Module to be checked or set in the **Controller** field.
- To check or set the built-in SVB Module, select slot number **00** in the **Controller** field.

The screenshot shows the 'Module Configuration' window for 'MP2300S Online Local' with 'PT#: 2 CPU#: 1'. It is divided into two main sections: 'Controller' and 'Module Details: MP2300S SLOT#00'.

Controller Section:

Slot Number	00	01
Module Type	MP2300S	UNDEFINED
Controller Number	-	-
Circuit Number	-	-
I/O Start Register	----	----
I/O End Register	----	----
Disable Input		
Disable Output		
Motion Start Register	----	----
Motion End Register	----	----
Details		
Status	Running	

MP2300S: Controller module with network servo control, ethernet, virtual axes, program control function.

Module Details: MP2300S SLOT#00

Slot Number	1	2	3	4	5
Module Type	CPU	218IFA	SVB	SVR	M-EXECUTOR
Controller Number	-	01	01	01	-
Circuit Number	-	01	01	02	-
I/O Start Register	----	0000	0800	----	0C00
I/O End Register	----	07FF	0BFF	----	0C3F
Disable Input		Enable	Enable		
Disable Output		Enable	Enable		
Motion Start Register	----	----	8000	8800	----
Motion End Register	----	----	82FF	8FFF	----
Details			MECHATROLINK		
Status	Running	Running	Running	Running	Running

SVB: Network servo control function.

[b] MECHATROLINK Transmission Definition Window Details

The MECHATROLINK Transmission Definition Window has four tabs: **Transmission Parameters**, **Link Assignment**, **I/O Map**, and **Status**. Click the tab to view each.

1. Transmission Parameters Tab

The parameters required to use the MECHATROLINK transmission system are displayed.

<Communication Method in MECHATROLINK-II>

<Communication Method in MECHATROLINK-I>

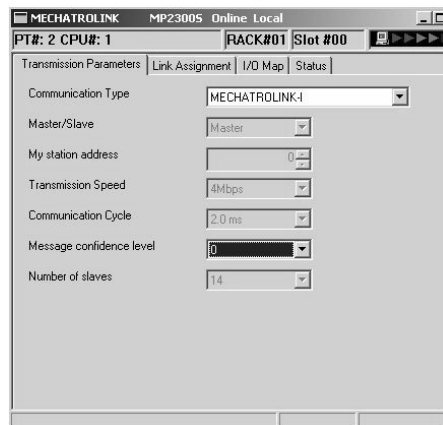
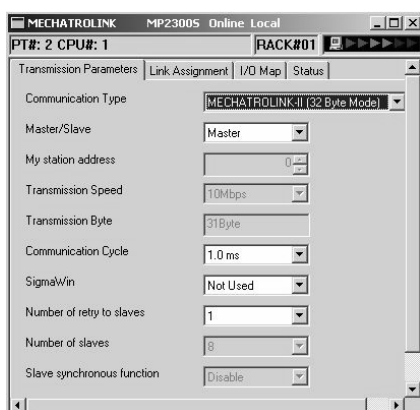

The items shown on the **Transmission Parameters** Tab are described in the following table. For items whose input fields are available, the settings can be changed. Always save the settings to the flash memory after changing them.

Item	Display during Self-configuration	Options and Precautions on Settings
Communication Type	Displays the detected communication method.	Select MECHATROLINK-II (32 Byte Mode) , MECHATROLINK-II (17 Byte Mode) , or MECHATROLINK-I .
Master/Slave	Displays whether the selected SVB Module is used as a Master station or Slave station.	Select either Master or Slave .
My station address (Local station address)	Displays the local station address set by using the rotary switches.	For Master station, fixed to 0. For slave stations, set a number between 1 and the number of slave stations.
Transmission Speed	Displays the transmission speed: MECHATROLINK-II (32-byte mode): 10 Mbps MECHATROLINK-II (17-byte mode): 10 Mbps MECHATROLINK-I: 4 Mbps	Cannot be set.
Transmission Byte (Hidden for MECHATROLINK -I)	Displays the number of transmission bytes. The number of transmission bytes depends on the communication type and the station type, Master or Slave. Refer to <i>n Transmission Bytes</i> , <i>Communication Cycle</i> , <i>Number of Retries to Slaves</i> , <i>Number of Slaves</i> for details.	Cannot be set.
Communication Cycle	Displays the communication cycle. The number of transmission bytes depends on the communication type and the station type, Master or Slave. Refer to <i>n Transmission Bytes</i> , <i>Communication Cycle</i> , <i>Number of Retries to Slaves</i> , <i>Number of Slaves</i> for details.	Can be set only for the Master station and when MECHATROLINK-II is selected as the communication type. The value that can be set differs depending on whether the SVB Module is a built-in SVB Module or optional SVB Module. Refer to <i>n Communication Cycle That Can be Set</i> for details.
Message Confidence Level (Hidden for MECHATROLINK -II)	Not used for MECHATROLINK transmission.	Set to 0 (default).

(cont'd)

Item	Display during Self-configuration	Options and Precautions on Settings
SigmaWin (Hidden for MECHATROLINK -I)	For MECHATROLINK-II communications, displays whether or not to use SigmaWin+ for communication via MECHATROLINK-II adapter such as JUSP-NP115.	Select either use or not use .
Number of Retry to Slaves (Hidden for MECHATROLINK -I)	Displays the maximum number of slave stations to which the Master can retry transmission in one transmission cycle when the Master has not received a normal response from a slave.	Only for Master station. Set a number between 0 and 7. Cannot set for Slaves.
Number of Slaves	Displays the number of slave stations that can be connected. The number of slave stations that can be connected is determined by communication type, communication cycle, SigmaWin+ use/not use, and number of retry to slaves.	Cannot be set.
Slave Synchrono- us Function	When using a built-in SVB as a slave station, select whether to synchronize with a master station.	Select either Enable or Disable . For more information about the process, refer to <i>Chapter 7 Slave CPU Synchronous Function</i> .

■ Transmission Bytes, Communication Cycle, Number of Retries to Slaves, Number of Slaves

Transmission bytes, communication cycle, number of retries to slaves, and number of slaves at execution of self-configuration will be automatically set according to conditions including communication type, station type (Master or Slave), and the largest slave station number (the largest number among the detected slave station numbers).

<For Master Station>

Item	MECHATROLINK-II (32-byte mode)				MECHATROLINK-II (17-byte mode)		MECHATRO- LINK-I
	1 to 8	9	10 to 16	17 to 21	1 to 14	15	
Largest Slave Station Number	1 to 8	9	10 to 16	17 to 21	1 to 14	15	
Transmission Byte	31 bytes				16 bytes		–
Communication Cycle	1 ms	1 ms	2 ms	2 ms	1 ms	1 ms	2 ms
Number of Retry to Slaves	1	0	5	21 (The largest slave station number)	1	0	14
Number of Slaves	8	9	16	The largest slave station number	14	15	14

<For Slave Stations>

Item	MECHATROLINK-II (32-byte mode)	MECHATROLINK-II (17-byte mode)	MECHATROLINK-I
Transmission Byte	–	–	–
Communication Cycle	1 ms	1 ms	2 ms
Number of Retry to Slaves	30	30	15
Number of Slaves	30	30	15

■ Communication Cycle That Can be Set

The communication cycle that can be set will differ depending on the communication type as follows.

MECHATROLINK-II Communication Mode	32-byte mode	17-byte mode
Communication Cycle That Can be Set	0.5 ms, 1 ms, 1.5 ms, or 2 ms	0.5 ms or 1 ms

- Communication Cycle can only be set for Master.
- The communication cycle for MECHATROLINK-I is fixed to 2 ms.

2. Link Assignment Tab Page

The data of the slave devices (MECHATROLINK connected devices such as SERVOPACK, inverter, and distributed I/O) are displayed on the **Link Assignment Tab**.

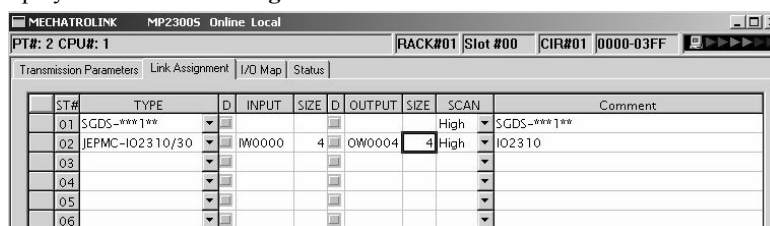

The items shown on the **Link Assignment Tab** are as follows. You can change the settings or delete the data station by station on this tab. Always save the settings to the flash memory after changing them.

Item	Description	Options and Precautions on Settings
ST #	Station number	The station number set here must be the same as the number set using rotary switches.
TYPE	Slave device connected at the station	Select the device type from the pull-down list.
D	I/O register's enable/disable status <input type="checkbox"/> : Enabled <input checked="" type="checkbox"/> : Disabled	Click the button to switch the status.
INPUT, SIZE	The leading input register number (INPUT) and the number of input registers in words (SIZE). The maximum number of input registers will be automatically set in SIZE .	When setting, be careful not to overlap the register range among stations. The register numbers that can be set are in the range between the leading register number and the ending register number in the Module Configuration Definition Window.
OUTPUT, SIZE	The leading output register number (OUTPUT) and the number of input registers in words (SIZE). The maximum number of output registers will be automatically set in SIZE .	When setting, be careful not to overlap the register range among stations. The register numbers that can be set are in the range between the leading register number and the ending register number in the Module Configuration Definition Window.
SCAN	Scan type used for synchronization with CPU. High : High-speed scan Low : Low-speed scan	Select either High or Low . When TYPE is set to a SERVOPACK, fixed to High .
Comment (Station name)	–	Enter a comment of up to 32 characters for each station.

■ Deleting a Station Assignment

Click any cell in the row of the station to be deleted, and select **Edit - Assignment Delete** from the main menu.

- Care must be taken when deleting a station assignment. The deletion is irreversible.

■ *****I/O and *****SERVO in Type

The following slave devices (I/O Modules) do not have model codes. Therefore, “*****I/O”(wild card I/O) will be displayed in **TYPE** for these devices after execution of self-configuration.

- JEPMC-IO350
- JAMSC-120DAI53330
- JAMSC-120DAI73330
- JAMSC-120DAO83330
- JAMSC-120DRA83030

For a servo with customized specifications that could not be recognized by self-configuration, “*****SERVO” (wild card servo) will be displayed in **TYPE**.

Select a correct device type in the Link Assignment Tab Page for the devices with *****I/O or *****SERVO displayed in **TYPE**.

3. I/O Map Tab

The status allocated to I/O registers is displayed.

- The **I/O Map** Tab is used for monitoring (read-only). Do not change the displayed settings.

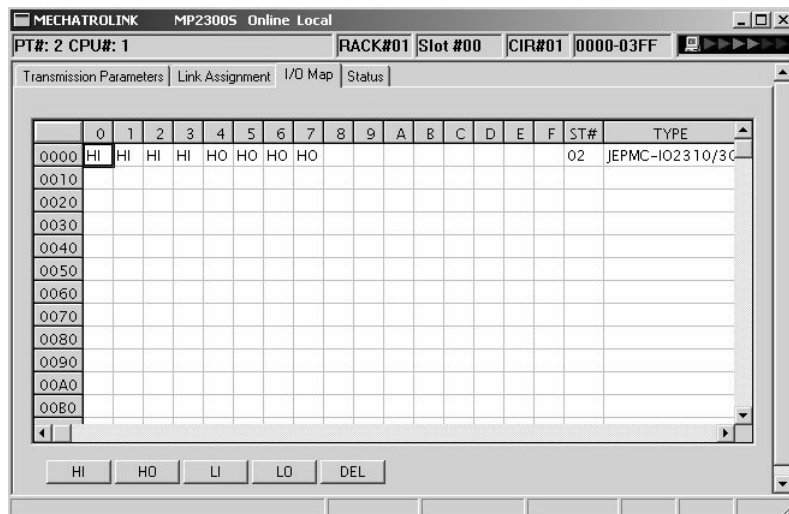

[c] Status Tab Page

The MECHATROLINK transmission status is displayed. The displayed settings cannot be changed.

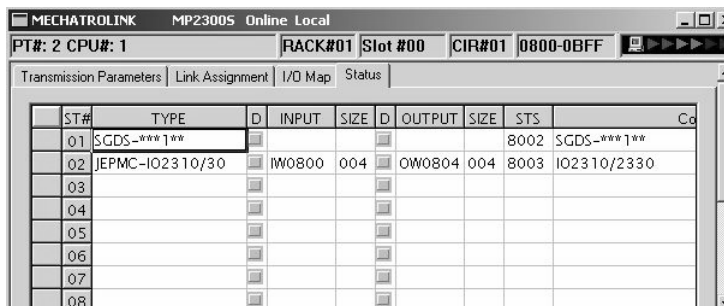

The items shown on the **Status** Tab are the same as those on the **Link Assignment** Tab except for STS.

■ STS

In online mode MECHATROLINK transmission status information is displayed in hexadecimal.

- In offline mode, nothing will be displayed.

The meaning of each bit is shown below.

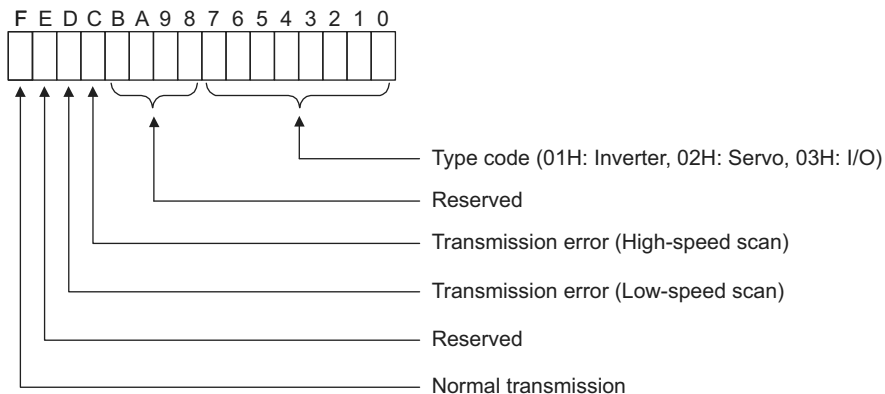

(5) SVB Definition

The SVB Definition file defines the motion parameters (motion fixed parameters, motion setting parameters, and motion monitoring parameters) to control motion axes such as the SERVOPACK, inverter, and stepper.

- Refer to *Appendix E Motion Parameter Details* for details on motion parameters.

[a] Opening the SVB Definition Window

Open the SVB Definition Window by the following procedure.

1. Select **MP2300S** in the Controller area, then double-click the slot number cell of the SVB Module in the **Module Details** field in the **Module Configuration** Window.

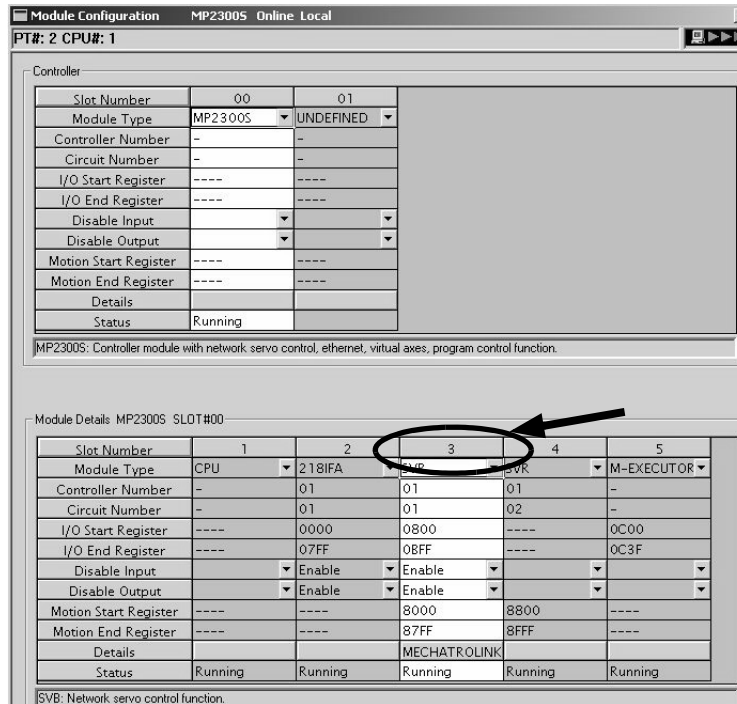

The Create New Confirmation Dialog Box will open. Click **OK** to display the **Fixed Parameters** Tab of the **SVB Definition** Window.

2. Select the axis to be set or monitored from the **Axis** pull-down list.

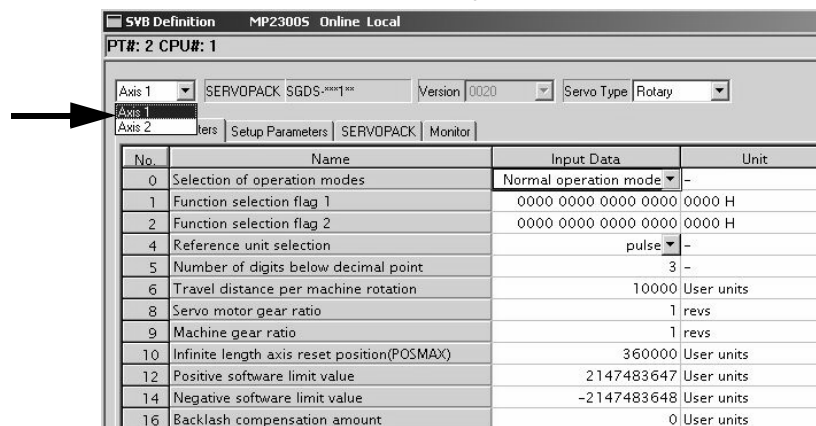

- **Axis** corresponds to **ST#** (station number) in the **Link Assignment** Tab of the **MECHATROLINK** Transmission Definition Window.

3. Click the **Fixed Parameters**, **Setup Parameters**, or **Monitor** Tab to display the desired page.

- If the setting in **Servo Type** is switched from Rotary to Linear, or vice-versa, some of the displayed parameters will change. Refer to *4.2.2 Motor Type and Related Alarms in the Machine Controller MP2000-series SVB/ SVB-01 Motion Module User's manual* (manual no.: SIEPC88070033) for details.

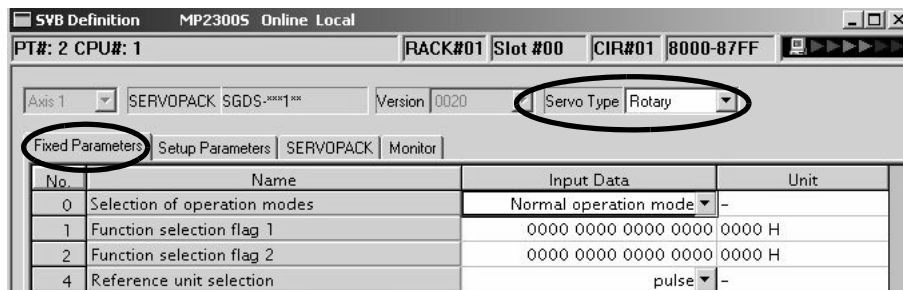

Fig. 2.1 Fixed Parameters Tab

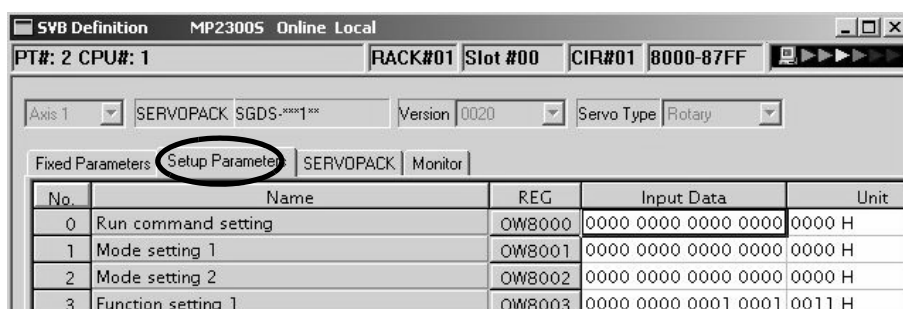

Fig. 2.2 Setup Parameters Tab

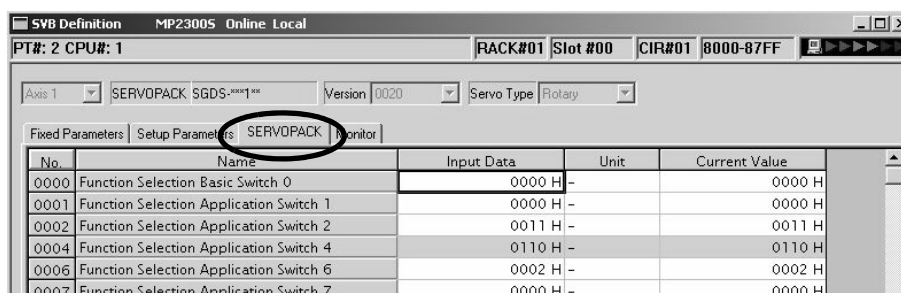

Fig. 2.3 SERVOPACK Parameters Tab

- Refer to the relevant SERVOPACK user's manual for information on SERVOPACK parameters.
- Refer to *Appendix B SERVOPACK Parameter Data Flow*.

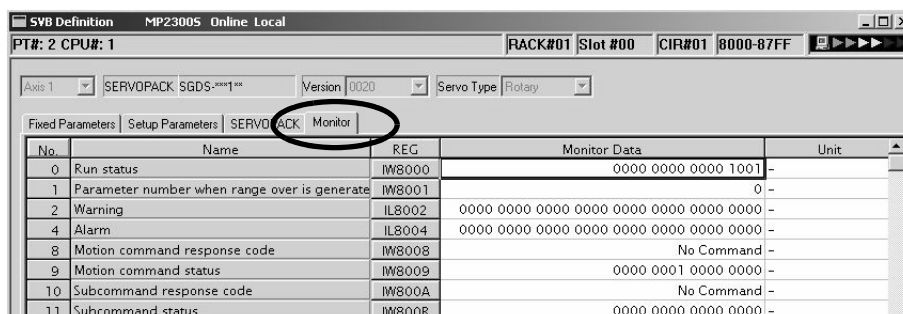

Fig. 2.4 Monitor Parameters Tab (read-only)

(6) Precautions when Saving the Servo User Constant

To save it in the SERVOPACK parameter screen except when SERVOPACK is changed, make sure in advance to select *Edit (E) - SERVOPACK Current Value* and *To Setting Value (V)* menus in order.

2.2.6 SVR Virtual Motion Module

(1) Outline

The Virtual Motion Module is a software module provided as a standard feature with the MP2300S. It is not connected to a motor, but provides a virtual axis interface.

The SVR is configured in the same way as the MP2300S built-in SVB with fixed parameters, setting parameters, and monitoring parameters, and can be accessed from application programs using I/O registers.

The SVR can be used to control up to 16 virtual axes in the high-speed scan control cycle.

Note: For information on how to use SVR motion parameters and motion commands, refer to *Machine Controller MP2000-series SVB/SVB-01 Motion Module User's Manual* (manual no.: SIEPC88070033).

In the MP2300S Basic Module, slot 4 in the default **Module Configuration** Window is for SVR.

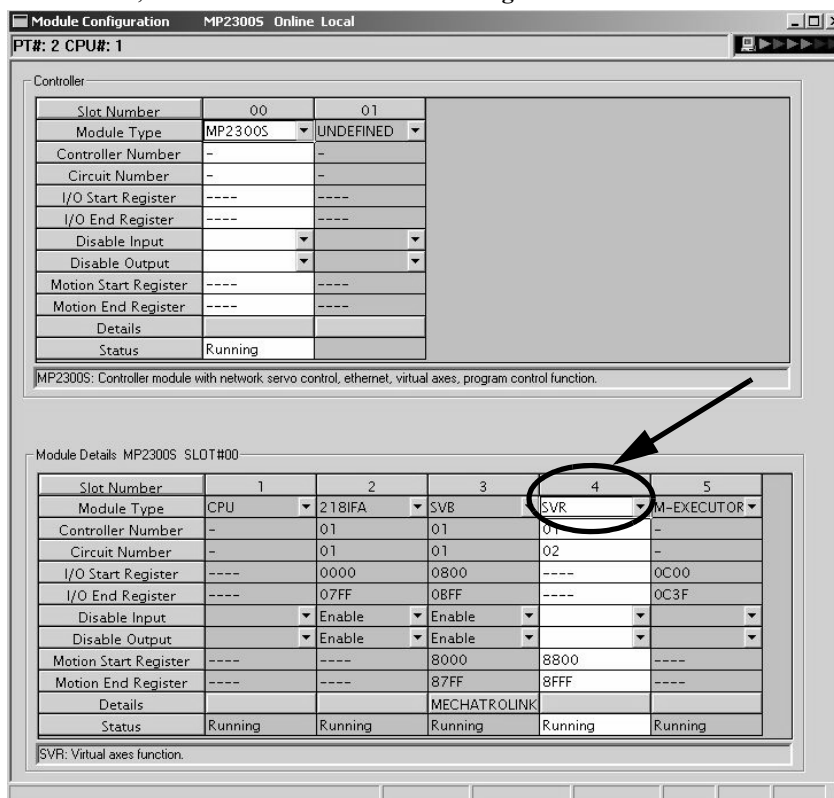

- If the SVR is not used, MP2300S processing time can be reduced by setting the *Module Type* for SVR to **UNDEFINED** in the **Module Configuration** Window.

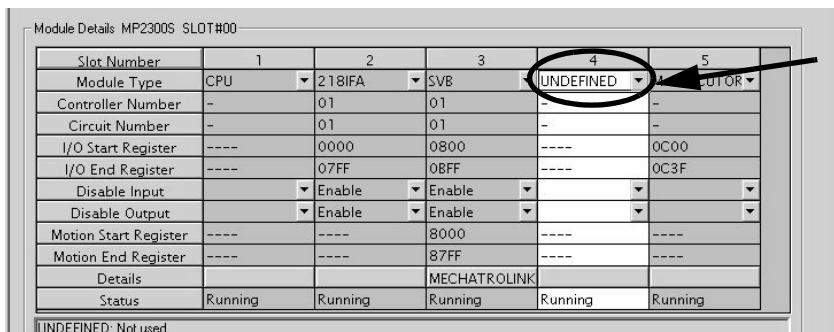

(2) Example SVR Usage

The SVR is used in the following two applications.

- **Program testing:** Results are easily obtained without mounting a motor.
- **Generating commands:** If the SVR is used in applications where motion modules are required only for generating commands, such as master axis for phase control or multi-axis synchronous control, then Motion Modules on real axes are no longer required.

The following table lists application examples of the SVR.

Slot Number	Application Example	Application Method
1	Master axis for phase control	Electronic cam or shaft operation can be achieved by using the SVR for the virtual master axis.
2	Multi-axis synchronous control	Multi-axis synchronous control can be achieved by controlling the SVR from a motion program and then using the ladder program to copy position commands of the SVR to other axes.
3	Sine curve commands	If the motion program is used to perform circular interpolation with the SVR, the axis will operate with a sine curve command.

- ♦ The software limit function and machine lock function cannot be used with the SVR. The position error will always be 0.

(3) System Configuration Example

The following figure shows an example system configuration using SVR.

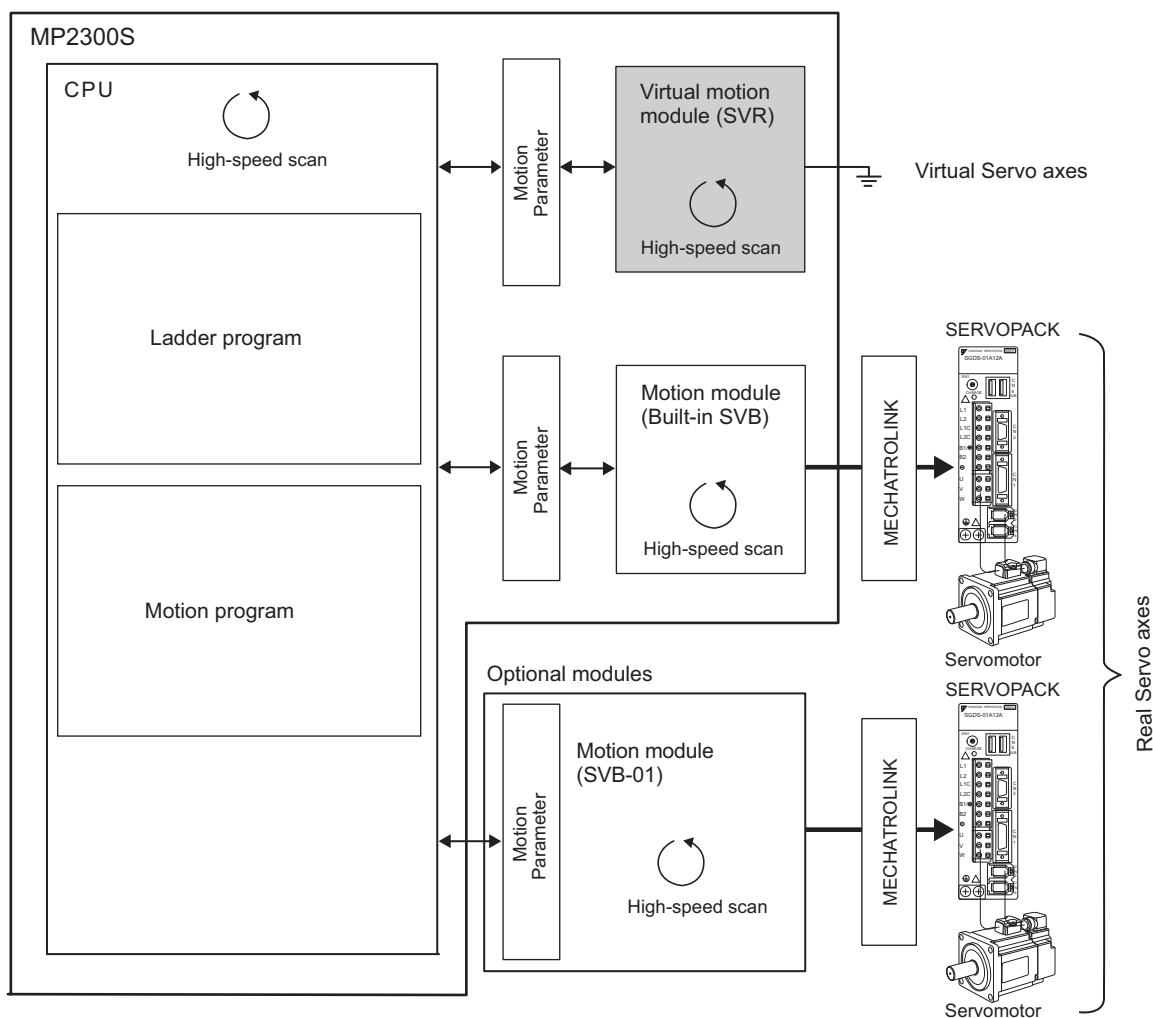

(4) SVR Operation

[a] SVR Execution Timing

The SVR is processed at the beginning of the high-speed scan. SVR processing is performed in the next scan after specifying and the processing results are reflected in the monitoring parameters.

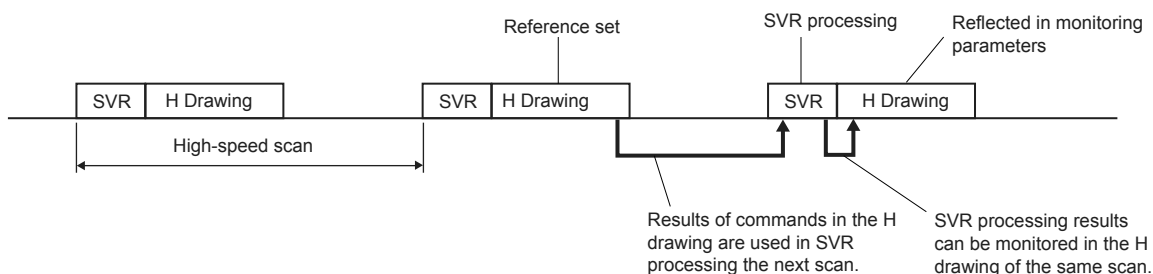

[b] Processing Time

When fixed parameter 0 (Selection of Operation Modes) is set to 0 (Normal Operation Mode), services are started for each of the 16 SVR Module virtual axes.

- The default for the Selection of Operation Modes parameter is 1 (Axis Unused).

The following table gives guidelines for the processing time required for each SVR axis.

Command	MP2300S
NOP	$35 + 14 \times \text{Number of axes } (\mu\text{s})$
POSING	$35 + 36 \times \text{Number of axes } (\mu\text{s})$

- Number of axes: The number of axes (1 to 16) when Selection of Operation Modes (fixed parameter 0) is set to Normal Operation Mode (0). The formula listed above do not apply when the number of axes is 0.

■ Differences from SVB Simulation Mode

Simulation mode does not have a positioning function, so the position data is refreshed in one scan to the final target position. The SVR has its own positioning function that performs distribution, so like a real module, position data is refreshed each scan for the final target position.

2.2.7 M-EXECUTOR Module (Motion Program Executor)

This section explains the M-EXECUTOR Module (motion program executor) function and its detail screen.

(1) M-EXECUTOR Module Function Overview

The M-EXECUTOR Module is a software module that executes a motion or sequence program.

The M-EXECUTOR Module enables the following features:

■ Executing a motion program without using a ladder program

Conventionally, in order to execute a motion program, you need to incorporate an MSEE command into a ladder program. The M-EXECUTOR Module allows you to execute the motion program without incorporating the MSEE command into the ladder program.

Note: You can incorporate a MSEE command into the ladder program as ever.

■ Controlling a motion program without using a ladder program

You can map any register to the control signal of the motion program registered in the M-EXECUTOR Module.

So, without a ladder program, this allows you to directly control a motion program from a host PLC or other device.

■ Describing sequence control in motion language

As a new programming method, a sequence program has been added to the MP2300S.

A sequence program is a scan execution type program where a process is completed with one scan. It employs a text language similar to a motion program.

You can use the sequence program as an alternative to the ladder program.

For information about commands available in the sequence program, see *Machine Controller MP900/MP2000 Series Users Manual Motion Programming* (manual number: SIE-C887-1.3).

(2) M-EXECUTOR Module Specification

[a] Programs Capable of Registration in M-EXECUTOR

The following table shows programs capable of registration in M-EXECUTOR.

Program Type		Number of Registrations	Remarks
Motion Program		16	Up to 16 programs in total
Sequence Program	Startup	1	
	Interrupt	Disable	
	H Scan	16	
	L Scan	16	

[b] Program Control Method

The following table shows the program control methods registered in M-EXECUTOR.

Item	Motion Program	Sequence Program										
Execution Method	Sequential Execution	Startup: Event driven H Scan: Scan execution L Scan: Scan execution										
System Work	1:1 correspondence between the definition number and system work (The number of program definitions is set in the MPE720 screen.)											
	<table border="1"> <thead> <tr> <th>Definition No.</th> <th>System Work Number</th> </tr> </thead> <tbody> <tr> <td>No. 1</td> <td>1</td> </tr> <tr> <td>No. 2</td> <td>2</td> </tr> <tr> <td>.</td> <td>.</td> </tr> <tr> <td>No. 16</td> <td>16</td> </tr> </tbody> </table>		Definition No.	System Work Number	No. 1	1	No. 2	2	.	.	No. 16	16
Definition No.	System Work Number											
No. 1	1											
No. 2	2											
.	.											
No. 16	16											
Program Designation Method	Direct or indirect designation	Direct designation										
Program Startup Method	Registered in the definition, turns start signal ON	Starts up when registered in the definition										
Override Setting for Interpolation	Yes	No										
I/O Link Definition	Yes	No										
S Register Report Function of Motion Program Status	Yes											
Number of Parallels	1 to 8 (4 main parallels × 2 sub parallels)	1										
Execute an Error Drawing when Operation Error Occurred	Yes											

(3) Module Configuration Definition

(a) Details of Module Configuration Definition Window

Click **MP2300S** in the **Controller** area to display the details of the basic module functions in the **Module Details** area. The cell No.5 provides a detailed definition of M-EXECUTOR.

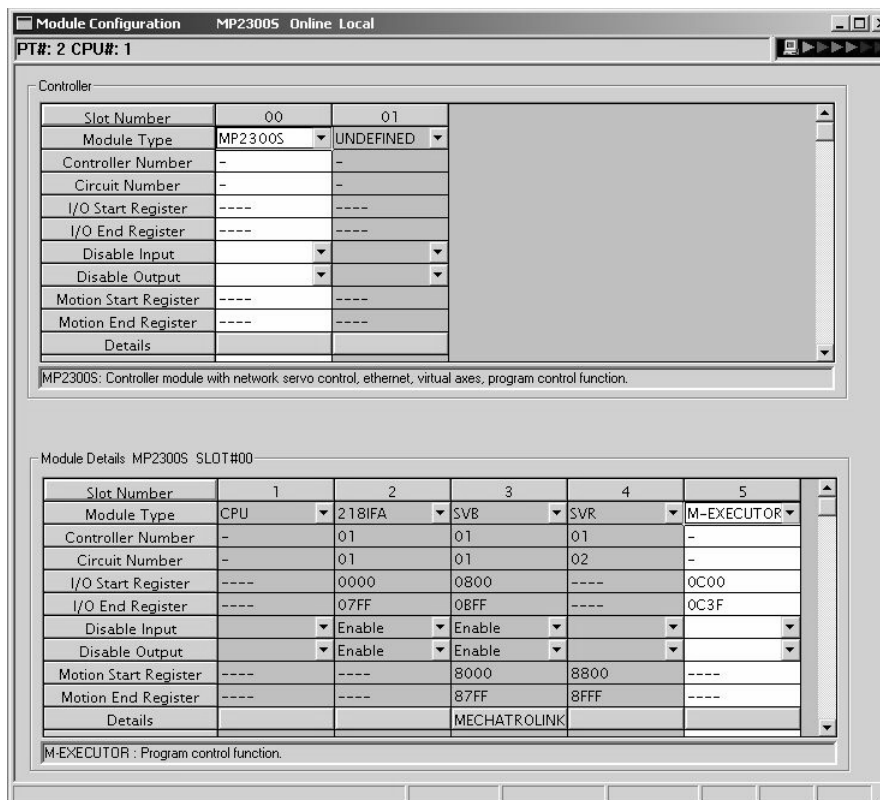

Items displayed in the **Module Details** area show the following:

Item	Description	Change
Slot Number	Sub-slot number. Double-click to open the M-EXECUTOR detailed definition screen.	–
Module Type	A module name appears. Changing the name to UNDEFINED enables you to disable M-EXECUTOR functions.	√
Controller Number	Not used. Fixed to “–”.	–
Circuit Number	Not used. Fixed to “–”.	–
I/O Start Register	Start register of the M-EXECUTOR I/O register (valid range: 0000-7FFFh, size: 40h words)	√
I/O End Register	End register of the M-EXECUTOR I/O register (valid range: 0000-7FFFh, size: 40h words)	√
Disable Input	Not used. Fixed at “blank”.	–
Disable Output	Not used. Fixed at “blank”.	–
Motion Start Register	Not used. Fixed at “– – – –”.	–
Motion End Register	Not used. Fixed at “– – – –”.	–
Details	Not used.	–
Status	M-EXECUTOR Module status in online mode.	–

√ : Available, – : Not available

■ I/O Register Details

An I/O register assigned to M-EXECUTOR is used to run a motion program and sequence program, and to monitor a sequence program.

M-EXECUTOR I/O register details are as follows:

M-EXECUTOR Input Register

M-EXECUTOR Input Register	Item	
lwxxxx + 0	Definition No.1	Status
lwxxxx + 1		Spare
lwxxxx + 2		Spare
lwxxxx + 3		Spare
lwxxxx + 4	Definition No.2	Status
lwxxxx + 5		Spare
lwxxxx + 6		Spare
lwxxxx + 7		Spare
	.	
	.	
	.	
lwxxxx + 3C	Definition No.16	Status
lwxxxx + 3D		Spare
lwxxxx + 3E		Spare
lwxxxx + 3F		Spare

M-EXECUTOR Output Register

M-EXECUTOR Output Register	Item	
owxxxx + 0	Definition No.1	Program number
owxxxx + 1		Control signal
owxxxx + 2		Override
owxxxx + 3		Spare
owxxxx + 4	Definition No.2	Program number
owxxxx + 5		Control signal
owxxxx + 6		Override
owxxxx + 7		Spare
	.	
	.	
	.	
owxxxx + 3C	Definition No.16	Program number
owxxxx + 3D		Control signal
owxxxx + 3E		Override
owxxxx + 3F		Spare

(4) Detailed Screen

This section describes the M-EXECUTOR detail screen.

■ Program Definition Screen (M-EXECUTOR (list display) screen)

The program definition screen allows you to register a motion or sequence program to run.

Programs are executed according to the scan, in ascending numeric order.

A white cell can be set by the user, and a grey cell cannot be set by the user.

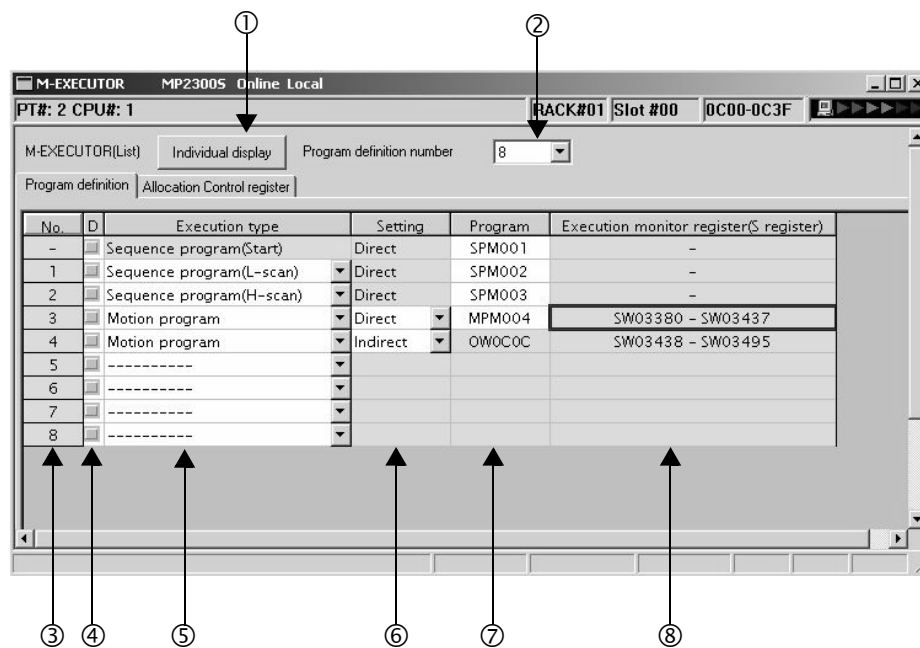

- ① Individual display
Shows M-EXECUTOR (individual display) screen.
- ② Program definition number
Sets the number of program definitions registered in the M-EXECUTOR Module.
The valid range is 0-16 (8 by default).
- ③ No.
Shows the program execution order. Processed according to the scan in ascending numeric order.
- ④ D
Enables/disables the definition. Uncheck to enable the definition.

⑤ Execution type

Sets the program execution type.

Execution Type	Program to Execute	Execution Condition
-----	None	None (select this to delete the definition)
Sequence Program (startup)	Sequence program	Power-up (during power-up, run only once)
Sequence Program (L scan)		Periodical startup (run each time a low-speed scan is performed)
Sequence Program (H scan)		Periodical startup (run each time a high-speed scan is performed)
Motion Program	Motion program	Turns ON the program operation start request of the control signal (runs when the program operation start request is ON).

⑥ Setting

Sets the a program designation.

The way to designate a program may differ according to the program.

Designation Method	Motion Program	Sequence Program	Remarks
Direct Designation	Enable	Enable	The way to designate the program number Example: MPM001, SPM002, and so on
Indirect Designation	Enable	Disable	The way to designate the register for storing the program number Example: OW0C0C, and so on (refers to MPM001 by storing one in OW0C0C)

⑦ Program

Sets a program number.

Execution Type	Remarks
Sequence Program (startup, L scan, H scan)	Enter "1" and press ENT to automatically input "SPM001." You can save an unregistered program or exit this screen without setting (blank), but in these cases, the program will not be executed.
Motion Program	Direct designation: Enter "1" and press ENT to automatically input "MPM001." You can save an unregistered program or exit this screen without setting (blank), but in these cases, the program will not be executed. Indirect designation: O register of M-EXECUTOR Module is automatically set. It cannot be set by the user.

⑧ Execution monitor register (S Register)

When the execution type is set to motion program, the range of the execution monitor registers (S registers) is shown. For more information on the execution monitor register, refer to (6) *Monitoring the Execution Information of Motion Program Using S Register of 5.2.2 Motion Programs* on page 5-7.

■ Control Register Mapping Window

The control register mapping screen sets a mapping register.

A white cell can be set by the user, and a shaded cell cannot be set by the user.

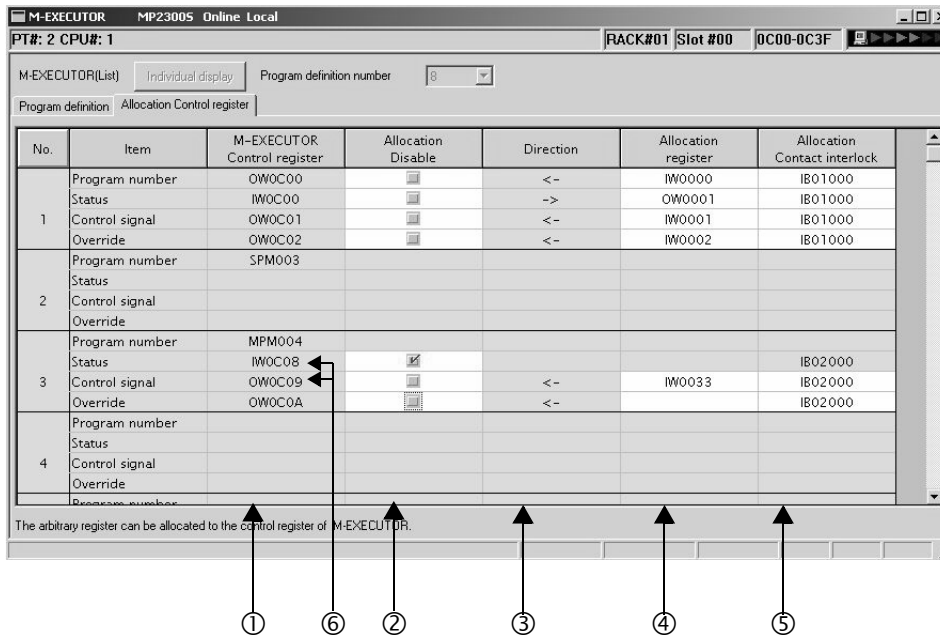

① M-EXECUTOR Control register

Displays an I/O register mapped to the M-EXECUTOR Module.

Controls the motion program and monitors the state, using the M-EXECUTOR control register.

M-EXECUTOR Control Register	Usage
Program Number	Sets a program number. This register is used only when set to an indirect designation.
Status	Monitors the program execution status.
Control Signal	Controls the program.
Override	Sets an override value when running a move command for the interpolation system.

Note: For more information on the M-EXECUTOR control register, refer to 2.2.7 (1) M-EXECUTOR Module Function Overview.

② Allocation Disable

Enables/disables the mapping register. Uncheck to enable the definition.

③ Direction

Displays the data I/O direction.

④ Allocation register

Data is exchanged between mapping and M-EXECUTOR control registers in real-time.
Any register can be mapped to the mapping register.

Registers that can be set as a Mapping Register
Word type I, O, M (except the motion register)

⑤ Allocation Contact interlock

An allocation contact interlock is used to control the data exchange between the allocation register and M-EXECUTOR control registers. When the allocation contact interlock is ON, data can be exchanged between the allocation register and M-EXECUTOR control registers.
Any register bit can be mapped to the allocation contact interlock.

Registers that can be set as an Allocation Contact Interlock
Bit type I, O, S, M, C (except the motion register)

■ Caution

An allocation contact interlock is used to interlock the operation of a motion program.
When setting an allocation register, be sure to set the allocation contact interlock.

⑥ Status, Control Signal Details

Double-click the status and control register to display the bit detail.
You can check the signal sequence and status here.

Control signal	M-EXECUTOR Control register	Allocation register	Status
Program start request	OB0C090	IB00330	<input type="radio"/> : ON <input checked="" type="radio"/> : OFF
Program pause request	OB0C091	IB00331	<input type="radio"/> : ON <input checked="" type="radio"/> : OFF
Program stop request	OB0C092	IB00332	<input type="radio"/> : ON <input checked="" type="radio"/> : OFF
Program single block mode selection	OB0C093	IB00333	<input type="radio"/> : ON <input checked="" type="radio"/> : OFF
Program single block start request	OB0C094	IB00334	<input type="radio"/> : ON <input checked="" type="radio"/> : OFF
Alarm reset request	OB0C095	IB00335	<input type="radio"/> : ON <input checked="" type="radio"/> : OFF
Program continuous operation start	OB0C096	IB00336	<input type="radio"/> : ON <input checked="" type="radio"/> : OFF
Skip 1 information	OB0C098	IB00338	<input type="radio"/> : ON <input checked="" type="radio"/> : OFF
Skip 2 information	OB0C099	IB00339	<input type="radio"/> : ON <input checked="" type="radio"/> : OFF
System work number setting	OB0C09D	IB0033D	<input type="radio"/> : ON <input checked="" type="radio"/> : OFF
...	OB0C09E	IB0033E	<input type="radio"/> : ON <input checked="" type="radio"/> : OFF

Control signal	M-EXECUTOR Control register	Allocation register	Status
Program is running	IB0C080	----	<input type="radio"/> : ON <input checked="" type="radio"/> : OFF
Program is pausing	IB0C081	----	<input type="radio"/> : ON <input checked="" type="radio"/> : OFF
Program stopped with program stop	IB0C082	----	<input type="radio"/> : ON <input checked="" type="radio"/> : OFF
Program stopped under single block	IB0C084	----	<input type="radio"/> : ON <input checked="" type="radio"/> : OFF
Program alarm has been generated	IB0C088	----	<input type="radio"/> : ON <input checked="" type="radio"/> : OFF
Stopped at break point	IB0C089	----	<input type="radio"/> : ON <input checked="" type="radio"/> : OFF
Debugging mode(CMS, debugging)	IB0C08B	----	<input type="radio"/> : ON <input checked="" type="radio"/> : OFF
Start request signal history	IB0C08D	----	<input type="radio"/> : ON <input checked="" type="radio"/> : OFF
No system work error	IB0C08E	----	<input type="radio"/> : ON <input checked="" type="radio"/> : OFF
Main program number limit error	IB0C08F	----	<input type="radio"/> : ON <input checked="" type="radio"/> : OFF

■ Program Execution Registration Screen (M-EXECUTOR (individual display) screen)

Click the **Individual Display** Button in the M-EXECUTOR (list display) dialog box to display this dialog box.

The items that can be set are similar to those in the program definition window and the control register mapping window.

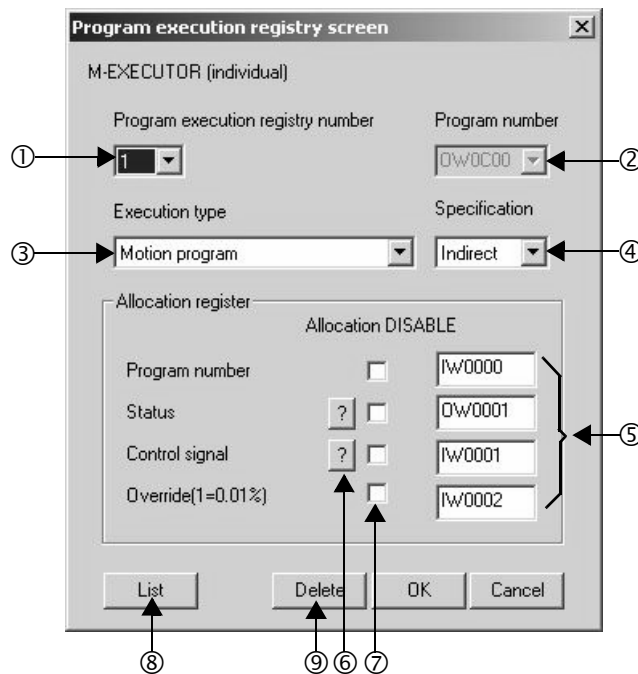

- ① Program execution registry number
Selects a program execution registration No.
- ② Program number
Sets a program number.
- ③ Execution type
Sets the program execution type.
- ④ Specification
Sets the method of designating a program.
- ⑤ Allocation register
Sets a mapping register.
- ⑥ Status, Control signal
Displays the status and the signal sequence of the control register.
- ⑦ Allocation DISABLE
Enables/disables the allocation register. Uncheck to enable the definition.
- ⑧ List
Displays the M-EXECUTOR (list display) screen.
- ⑨ Delete
Deletes a definition.

(5) Execution Scheduling

Programs registered in M-EXECUTOR are executed on the basis of their priorities (execution type).
 Programs registered in M-EXECUTOR are executed just before the ladder process.

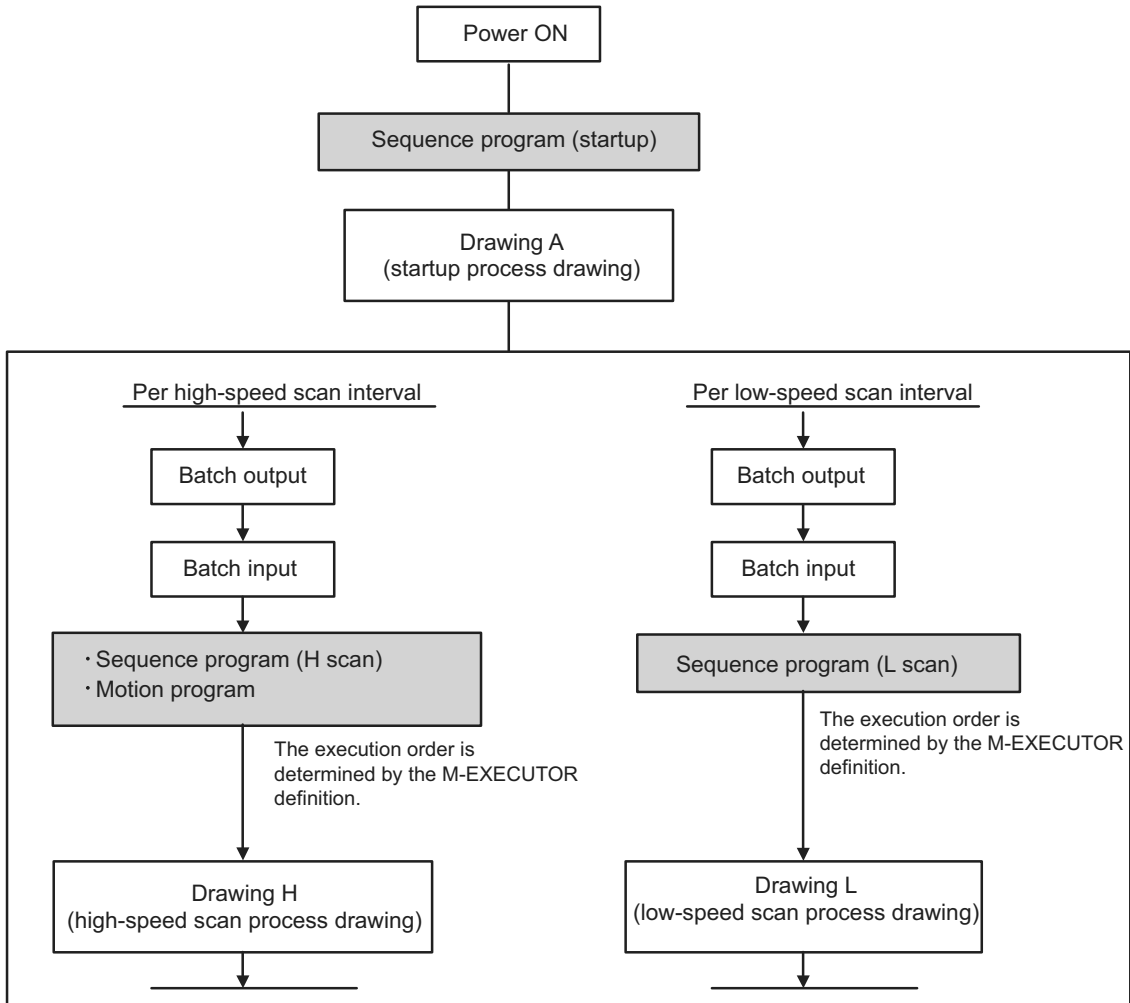

An execution example is as follows:

- M-EXECUTOR program definition

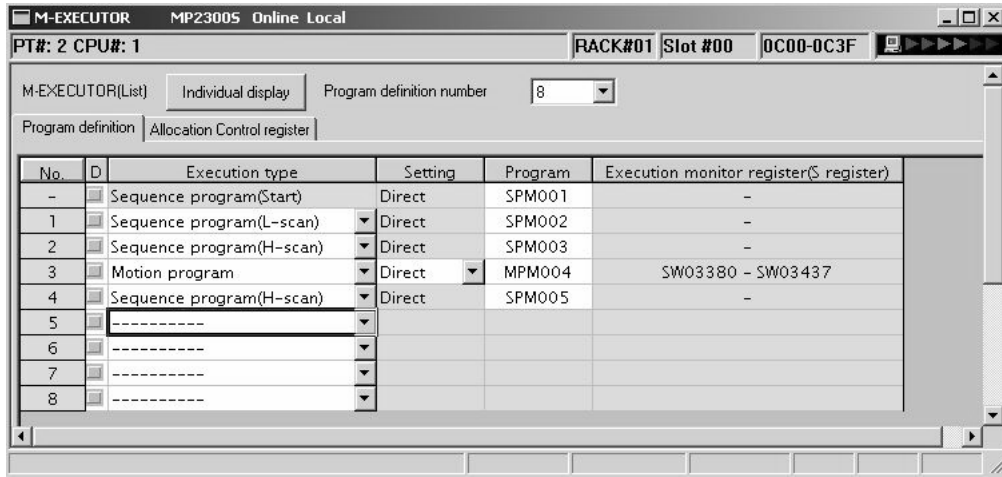

- Execution scheduling

The following diagram shows the execution scheduling when set in the screen above.

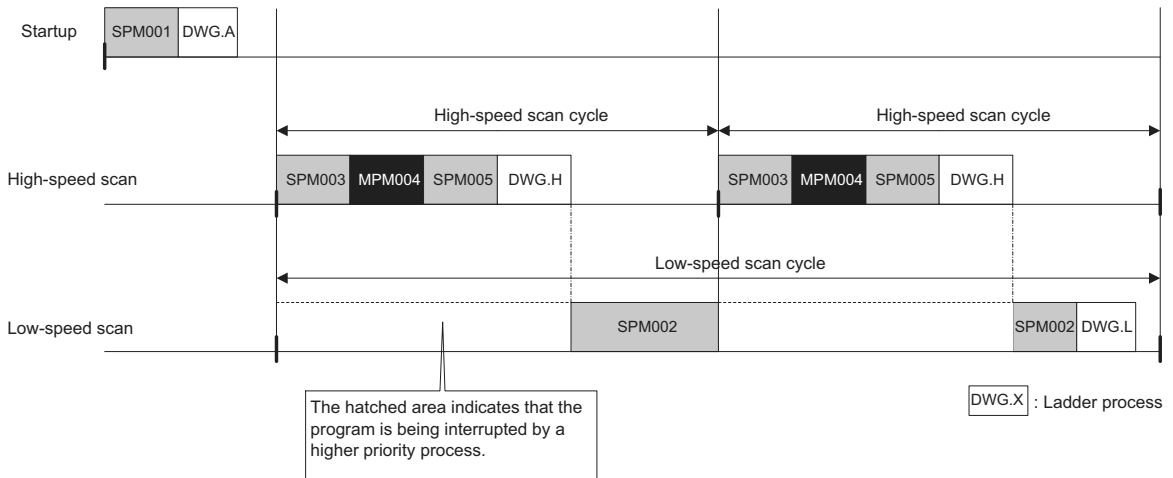

2.3 Option Module

This section provides an option module overview. For more information on its specifications, functions, connections, settings, etc., refer to the following documents separately.

2.3.1 Option Module Overview List

Classification	Option Module Name	Module Overview	Reference Manual
Motion Module	SVB-01 Module	<p>The SVB-01 Module is a motion module equipped with a MECHATROLINK supporting interface.</p> <p>The adoption of MECHATROLINK enables reduced wiring and multi-axis control. In addition, the support for MECHATROLINK-II standard allows you to control position, speed, torque, and phase, realizing precise synchronous control. Also, complex mechanical operation can be achieved by changing the control mode during axis operation.</p> <p>■ Features</p> <ul style="list-style-type: none"> • Up to 21 slave stations per module are connectable (up to 16 servo axes are controllable) • Because synchronization between modules is enabled, adaptable to interpolation and synchronous control between modules • With the SVB-01 Module as a slave, connectable to an upper controller with the MECHATROLINK communication function • Self-configuration function allows you to automatically map slave devices connected to MECHATROLINK. • SERVOPACK parameters are manageable over the network 	<p><i>Machine Controller MP2000 Series SVB/SVB-01 Motion Module User's Manual</i> (manual number: SIEPC88070033)</p>
	SVA-01 Module	<p>The SVA-01 Module is a motion control module with analog output. Capable of controlling a two-axes servo per module or an inverter. The module has two connectors (CN1, CN2) for connection to a SERVOPACK and an external I/O. Each connector is equipped with an analogue output to command speed and torque, an analogue input to monitor feedback speed and torque, a pulse input phase-A, B, and C (5V differential), and a general-purpose digital input/output.</p> <p>The control cycle is fixed at 500μs, so precise control is enabled regardless of high-speed scan cycles.</p> <p>■ Features</p> <ul style="list-style-type: none"> • Two axes servo module with analogue output • Each axis can independently perform position control, speed command output, torque command output, and phase control functions. • Self-configuration function allows you to automatically map modules. 	<p><i>Machine Controller MP2000 Series Motion Module SVA-01 User's Manual</i> (manual number: SIEPC88070032)</p>
	PO-01 Module	<p>The PO-01 Module is a motion module with pulse output and a four-axes interface. Applicable to connection to a stepping motor or SERVOPACK.</p>	<p><i>Machine Controller MP2000 Series Pulse Output Motion Module PO-01 User's Manual</i> (manual number: SIEPC88070028)</p>

Classification	Option Module Name	Module Overview	Reference Manual
Input/Output Module	LIO-01/ LIO-02 Module	Digital I/O and pulse counter functions. As a digital I/O function, equipped with 16 digital inputs (DI), 16 digital outputs (DO) (LIO-01: sink output, LIO-02: source output). As a pulse counter function, one pulse input (PI). As for when to input/output for digital I/O and pulse counter functions, input/output for each MP2300S high-speed (High)/ low-speed (Low) scan is carried out at a constant cycle.	<i>Machine Controller MP2300S Basic Module User's Manual</i> (manual number: SIEPC88070003)
	LIO-04/ LIO-05 Module	As a digital I/O function, equipped with 32 digital inputs (DI), and 32 digital outputs (DO) (LIO-04: sink output, LIO-05: source output).	
	DO-01 Module	As a digital output function, equipped with 64 digital outputs (DO) (sink output).	
	AI-01 Module	8 channel analogue input module. For the input, capable of selecting from three options: -10V to +10V, 0V to +10V, or 0 to 20 mA.	<i>Machine Controller MP2000 Series Analogue Input/Output Module AI-01/AO-01 User's Manual</i> (manual number: SIEPC88070026)
	AO-01 Module	4 channel analogue output module. For the output, select one from two options: -10V to +10V, or 0V to +10V.	
		CNTR-01 Module	2 channel reversible counter module. 5V differential/ 12V input is optional, and phase-A or -B/ sign/ add-subtract method is optional.
Communication Module	2181F-01 Module	Equipped with serial interface (RS-232C) and Ethernet interface. Allows you to connect to a personal computer, HMI equipment, or controller by other makers via PORT or 10Base-T connector.	<i>Machine Controller MP2300 Communication Module User's Manual</i> (manual number: SIEPC88070004)
	2171F-01 Module	Equipped with serial interfaces (RS-232C and RS422/485). Allows you to connect to a personal computer, HMI equipment, or controller by other makers via PORT or RS422/485 connector.	
	2601F-01 Module	Equipped with serial interface (RS-232C) and DeviceNet interface. Allows you to connect to a controller by other makers via DeviceNet connector. Also, allows you to connect to a personal computer or HMI equipment by other makers via the PORT connector.	
	2611F-01 Module	Equipped with serial interface (RS-232C) and PROFIBUS interface. Allows you to connect to a controller by other makers via the PROFIBUS connector. Also, allows you to connect to a personal computer or HMI equipment by other makers via the PORT connector.	
	215AIF-01 Module	MPLINK and CP-215 specifications. MPLINK specification is equipped with one line of our original real-time core network interface MPLINK transmission and a serial interface (RS-232C). CP-215 specification is equipped with one line of our original real-time core network interface CP-215 transmission and a serial interface (RS-232C).	

2.4 External Appearance

The external appearance of the basic module is as follows:

2.4.1 Basic Module

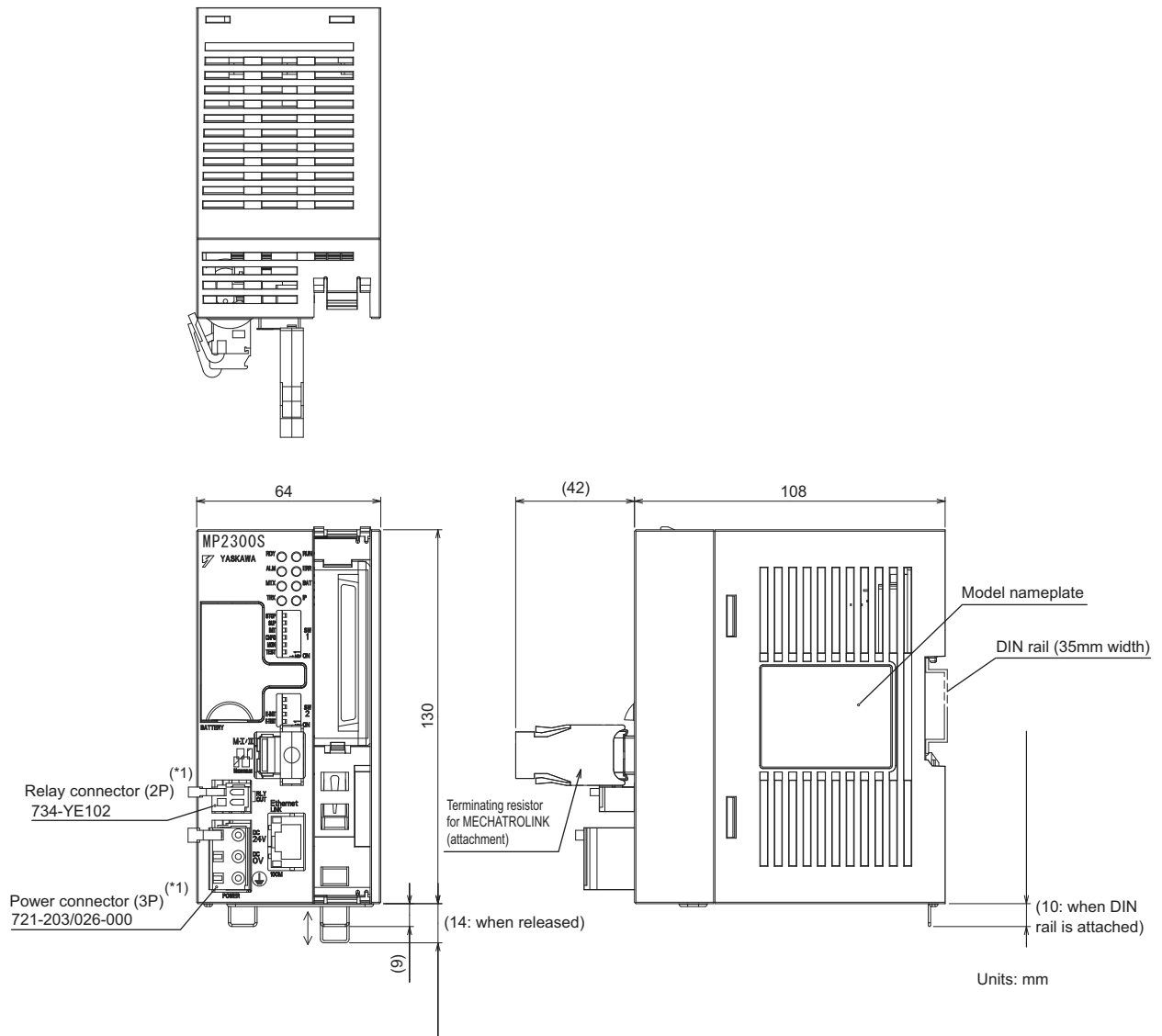

* 1. The following cable-side connectors are attached to the power and relay connectors.

- Power connector: 721-203 / 026-000
- Relay connector: 734-YE102

Note: Attachment

- Handle for power connector (model: 231-131)
- Handle for relay connector (model: 734-230)
 - * These handles are used when connecting a cable to the cable-side connector.
- Terminating resistor for MECHATROLINK (JEPMC-W6022-E)

2.4.2 Basic Module with Metal Fittings

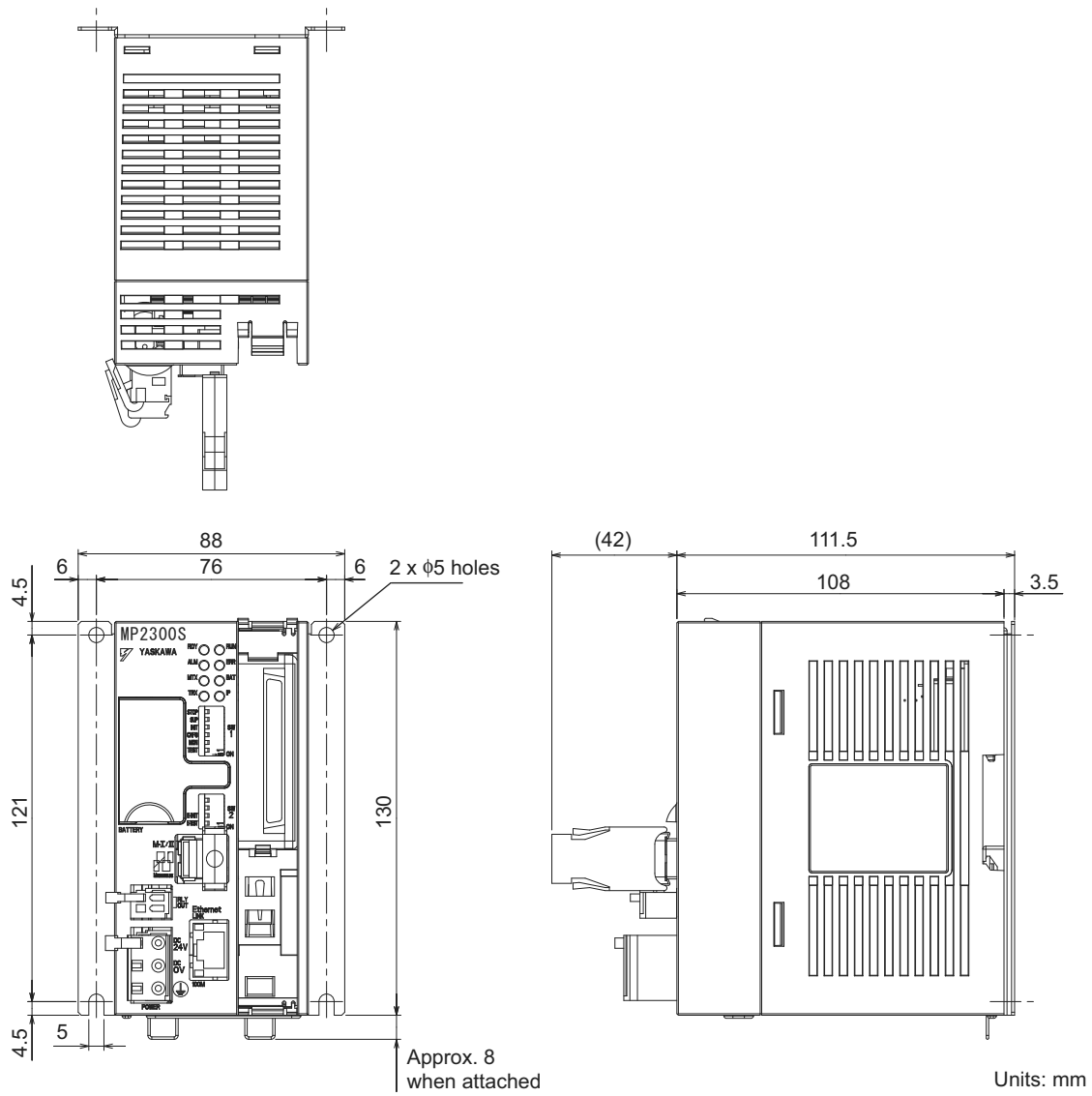

Mounting and Wiring

This chapter explains how to handle MP2300S and the connection methods for each module.

3.1 Mounting MP2300S	3-2
3.1.1 Method	3-2
3.1.2 MP2300S Mount Direction	3-7
3.1.3 Space Required for Mounting MP2300S	3-8
3.1.4 Replacing and Adding Optional Modules	3-9
3.2 Basic Module Connections	3-12
3.2.1 Connectors	3-12
3.2.2 Power Supply Connector	3-13
3.2.3 MECHATROLINK Connectors	3-14
3.2.4 Ethernet Connector Details	3-19
3.2.5 RLY OUT Connector Details	3-23
3.2.6 System Connection Example	3-25

3.1 Mounting MP2300S

3.1.1 Method

There are two methods for mounting MP2300S.

- Using DIN rail (standard)
- Using screws

(1) DIN Rail Mounting

[a] DIN Rails and Spacer

Several types of DIN rails are available: with 7-mm to 15-mm gap from the mounting base as shown in the following diagram. If mounting a MP2300S using DIN rail with 10 mm gap, install a spacer on the rear of the MP2300S near the bottom to protect the MP2300S from vibration and shock.

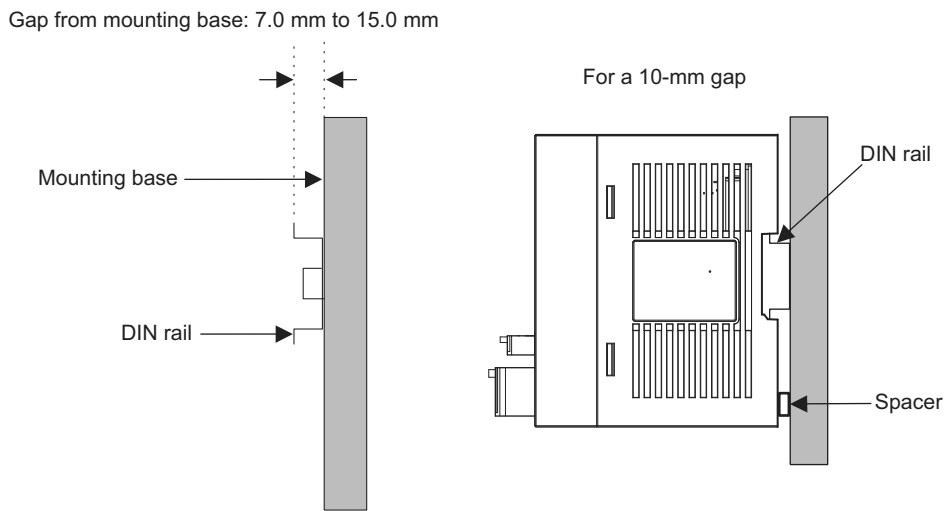

[b] Procedure for Mounting to DIN Rail

Use the following procedure to attach the DIN rail mounting parts to the MP2300S and then mount the MP2300S to the DIN rail.

1. Insert the DIN rails to the dotted line in the two slots on the rear of the MP2300S as shown in the following figure.

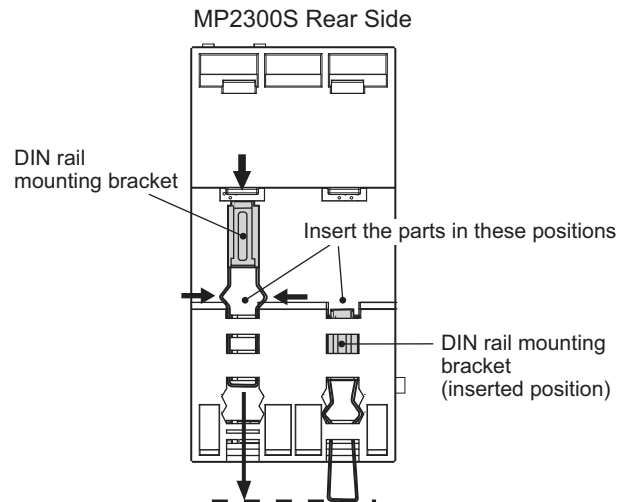

- The following figure shows the front and back of a mounting clip. Insert each clip so that its front faces outward.

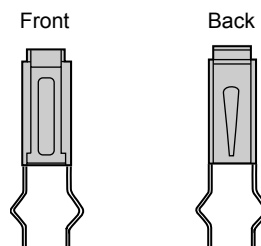

2. Pull the DIN rail mounting clips down to release them.

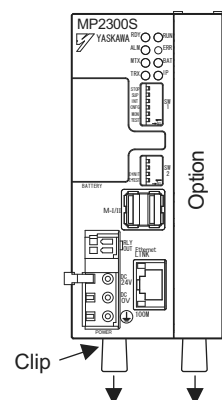

■ Fixing a DIN Rail

Make sure to fix a DIN rail at 300mm or less pitch as shown in the figure below.

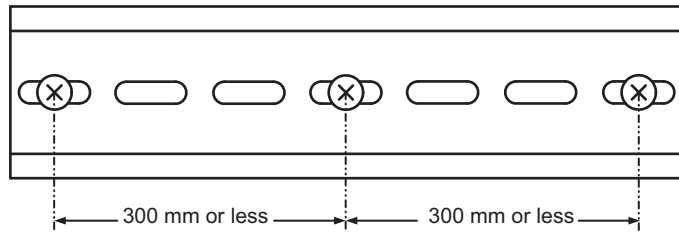

- Hook the MP2300S to the top of the DIN rail (a), and then push the MP2300S towards the mounting base to secure it in place (b).

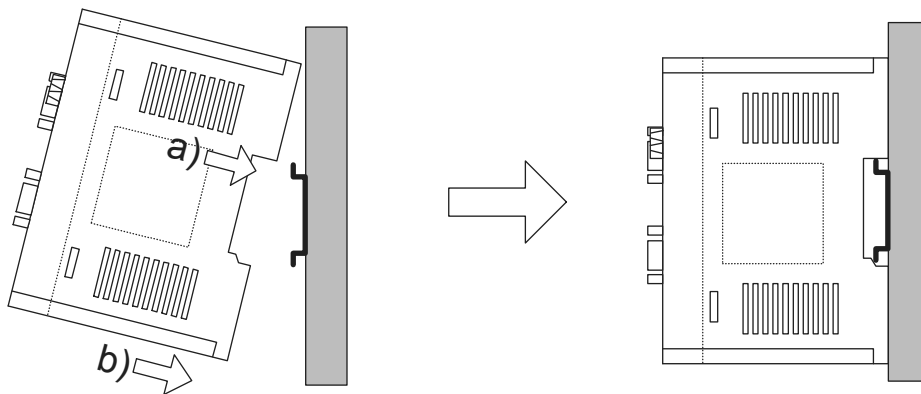

- Push the DIN rail mounting clips to lock them in place.

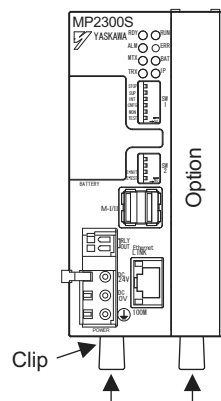

- Place end plates on both sides of the MP2300S to secure it to the DIN rail.

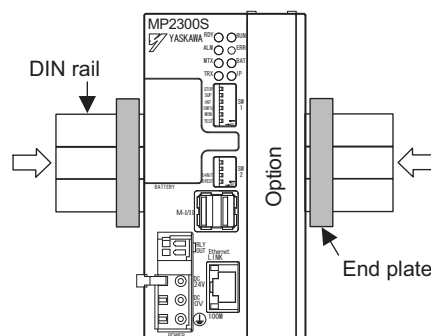

This completes the installation procedure.

(2) Screwed Method

Use a panel mounting clamp (optional) by the following procedure to mount MP2300S on the panel.

1. Release DIN fixing locks (two) at the center of the panel mounting clamp.

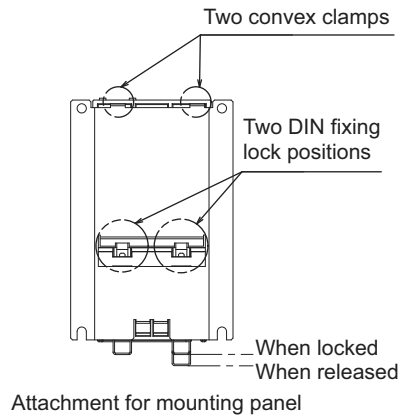

2. Insert two convex portions at the top of the panel mounting clamp into holes of the MP2300S case.

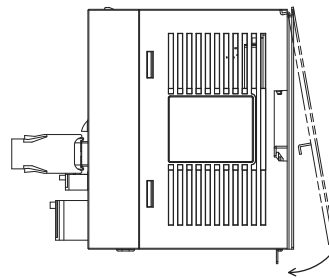

3. Push the clamp as indicated by an arrow above onto the MP2300S case and use DIN fixing locks to fix MP2300S.

3.1.2 MP2300S Mount Direction

Be sure to mount the MP2300S using DIN rail or metal fittings.

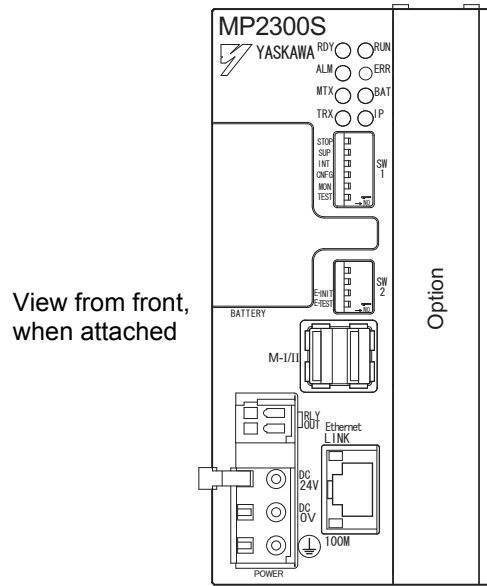

3.1.3 Space Required for Mounting MP2300S

Install MP2300S so that enough space is left around it as shown in the following figure:

■ Mount condition

- Vertical direction: 40 mm or more
- Horizontal direction: 10 mm or more

Note: However, ambient temperature should be 55°C or less.

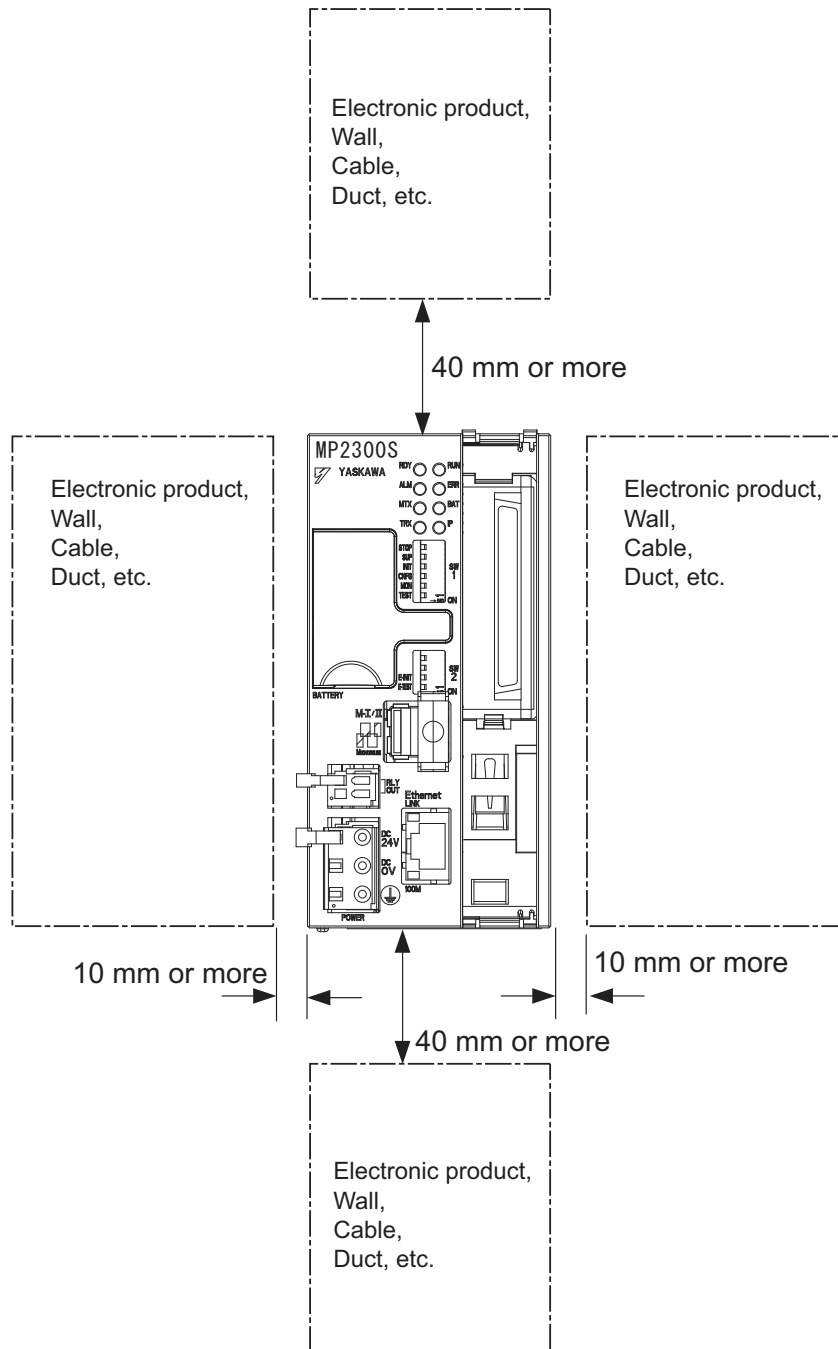

3.1.4 Replacing and Adding Optional Modules

Use the following procedures to replace and add Optional Modules.

(1) Preparations

1. Create a backup data file.

Use the MPE720 to save the MP2300S program on a computer (right-click the **PLC**, and select **Transfer - All Files - From Controller to MPE720.**)

2. Remove the MP2300S.

Turn OFF the power supply and disconnect all cables from the MP2300S. Then remove the MP2300S from the panel or rack and place on a workbench or other area with sufficient space.

(2) Removing Optional Modules

1. Remove the battery cover.

Pull the notch on the side of the MP2300S towards you to remove the battery cover.



2. Remove the panel of Optional Module.

Insert the protruding part of the battery cover into the slot on top of the panel of Optional Module to unhook, as shown in the diagram. Face the front of the battery cover towards you for this operation.

- ♦ Remove the front cover (optional) from the empty slot before mounting an Optional Module in an empty slot.



Unhook the bottom in the same way.

3. Remove the Optional Module from the mounting base.

Pull the top of the panel of the Optional Module towards you to remove it. A notch on the Optional Module will be visible from the gap in the cover. Hook the round knob on the battery cover, shown in the diagram, into the notch in the Optional Module.

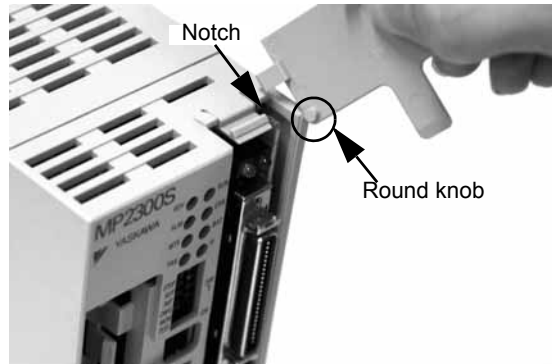

Hold the center of the battery cover as shown in the following diagram. Push the battery cover down and out, rotating from the round knob to disconnect the Module and mounting base connectors, and then pull the Optional Module forward.

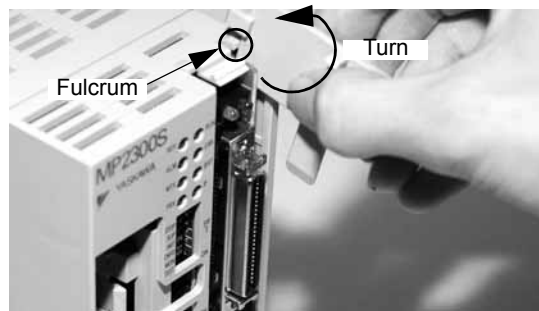
**4. Pull out the Optional Module.**

Hold the Module on the top and bottom and pull it out straight. Hold the edges of the Module and avoid touching the parts on the Module.

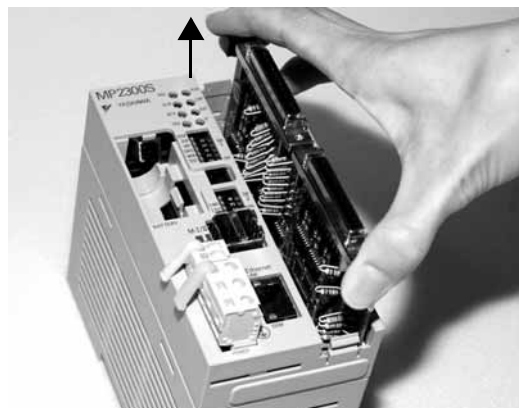

Put the removed Module into the bag that was supplied with and store the Module in this bag.

(3) Installing Optional Modules

1. Insert Optional Modules.

Hold the top and bottom of the Module to be installed, line up the Module on the left-side guide rail inside the Option Slot, and then insert it straight.

- The FG bar on the inside bottom of the Unit Case may be damaged if the Module is not inserted straight.

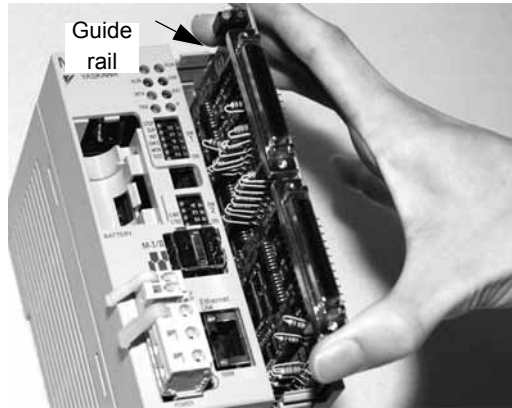

2. Mount on to the mounting base.

Once the Optional Module has been completely inserted, place your hand on the front face of the Optional Module and push hard until the Optional Module has been inserted into the mounting base connectors. The front face of the Optional Module and the hook will be aligned when the Optional Module has been installed properly.

3. Install the panel of the Optional Module.

Place the hole on the bottom of the panel of the Optional Module onto the hook on the bottom of the MP2300S. Next, hook the hole at the top of the panel of the Optional Module onto the hook at the top of the MP2300S.



This completes the Optional Module mounting procedure.

Be sure to attach the optional cover (model: JEPMC-OP2300) on the empty slot.

3.2 Basic Module Connections

3.2.1 Connectors

The following diagram shows the connectors for the Basic Module.

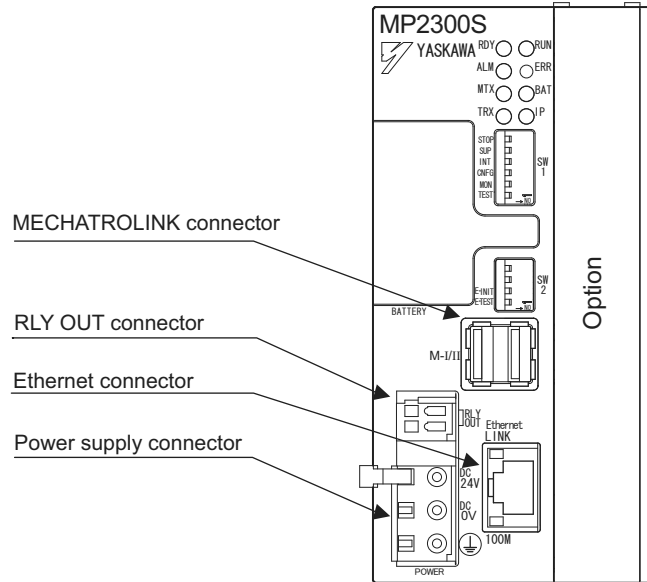

3.2.2 Power Supply Connector

(1) Specifications, Pin Arrangement, and Connection Procedure

Supply a 24-VDC to the MP2300S. Connect the power supply connector as shown in the diagram below.

Name	Connector Name	No. of Pins	Connector Model		
			Module	Cable	Manufacturer
Power Supply Connector	POWER	3	721-863	721-203/026	WAGO

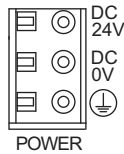

Symbol	Signal Name	Description
	24 V	24 VDC input
	0 V	0 V input
	FG	Frame ground (Ground to 100 Ω or less.)

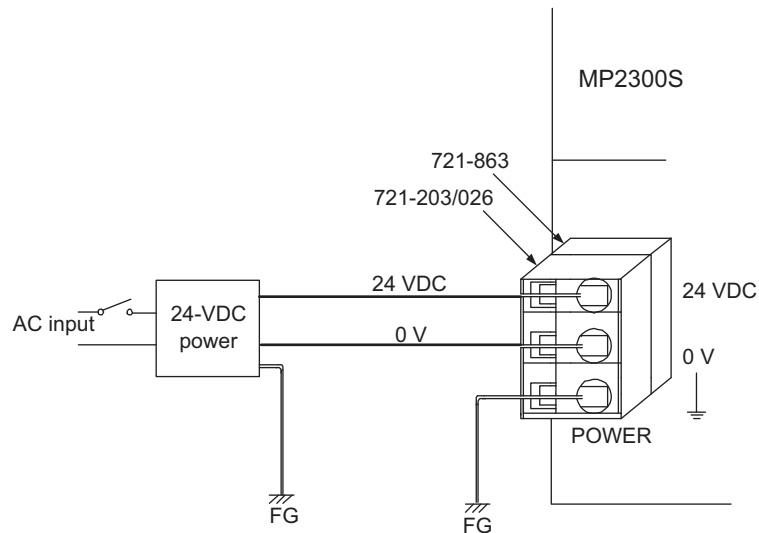

- Use an insulated 24-VDC power supply. Attach the power supply switch on the AC side. If the switch is attached on the 24-VDC side, there will be an inrush current of approximately 40 A when the power is turned ON.

(2) Connection Procedure

The power supply terminal has a removable connector. Use the following procedure to wire the terminal to the power supply connector. Use 0.2 mm² to 0.51 mm² (AWG24 to AWG20) twisted-pair cable.

1. Strip approx. 6.5 mm the end of the wire.

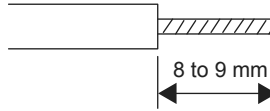

2. Open the wire insert opening on the terminal with the tool shown in Fig. A or Fig. B.

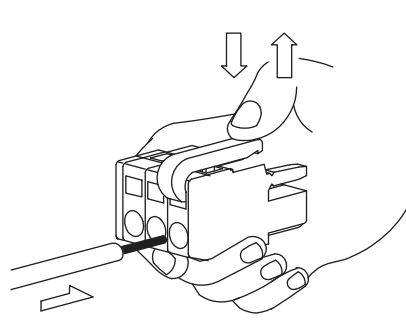

Fig. A (with lever)

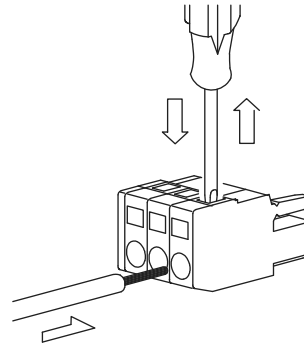

Fig. B (with screwdriver)

3. Insert the wire into the opening and then close the opening by releasing the lever or removing the screwdriver.

3.2.3 MECHATROLINK Connectors

MECHATROLINK connector is used to connect the MP2300S and the SERVOPACKs and distributed I/O via MECHATROLINK cables.

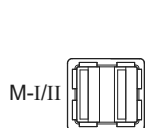

(1) Specifications and Pin Arrangement

Name	Connector Name	No. of Pins	Connector Model		
			Module	Cable	Manufacturer
MECHATROLINK Connector	M-I/II	8	DUSB-ARB82-T11A-FA	DUSB-APA42-B1-C50	DDK Ltd.

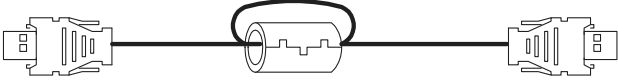

No.	Signal Name	Description	No.	Signal Name	Description
A1	-	-	B1	-	-
A2	SRD-	Signal -	B2	SRD-	Signal -
A3	SRD+	Signal +	B3	SRD+	Signal +
A4	SLD	Shield	B4	SLD	Shield

(2) Cables

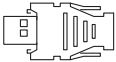
Name and Specification	Model Number	Length
MECHATROLINK Cable MECHATROLINK Connector – MECHATROLINK Connector 	JEPMC-W6002-A5	0.5 m
	JEPMC-W6002-01	1 m
	JEPMC-W6002-03	3 m
	JEPMC-W6002-05	5 m
	JEPMC-W6002-10	10 m
	JEPMC-W6002-20	20 m
	JEPMC-W6002-30	30 m
	JEPMC-W6002-40	40 m
	JEPMC-W6002-50	50 m
MECHATROLINK Cable MECHATROLINK Connector – MECHATROLINK Connector (with Ferrite Core) 	JEPMC-W6003-A5	0.5 m
	JEPMC-W6003-01	1 m
	JEPMC-W6003-03	3 m
	JEPMC-W6003-05	5 m
	JEPMC-W6003-10	10 m
	JEPMC-W6003-20	20 m
	JEPMC-W6003-30	30 m
	JEPMC-W6003-40	40 m
	JEPMC-W6003-50	50 m
MECHATROLINK Cable MECHATROLINK Connector – Loose Wire 	JEPMC-W6011-A5	0.5m
	JEPMC-W6011-01	1 m
	JEPMC-W6011-03	3 m
	JEPMC-W6011-05	5 m
	JEPMC-W6011-10	10 m
	JEPMC-W6011-20	20 m
	JEPMC-W6011-30	30 m
	JEPMC-W6011-40	40 m
	JEPMC-W6011-50	50 m
Terminator 	JEPMC-W6022	-

(3) Cable Connections between the MP2300S and I/O Units and the MP2300S and SERVO-PACKs

Use the MECHATROLINK cable JEPMC-W6002-□□ or JEPMC-W6003-□□ with a ferrite core for connection between the MP2300S and I/O units or SERVOPACKs.

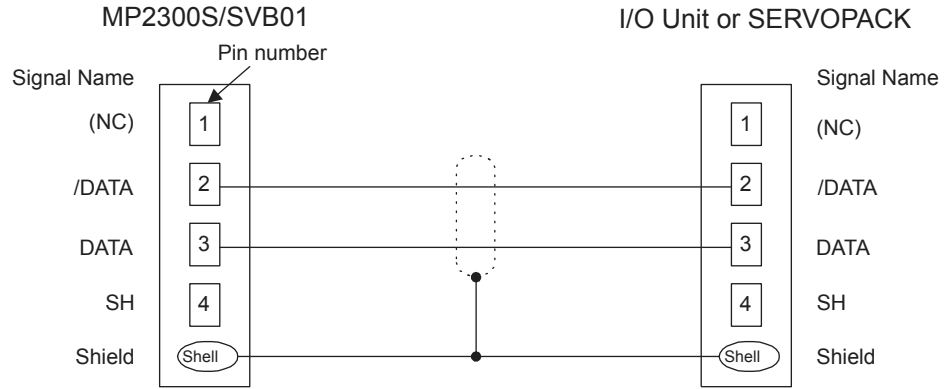

Standard model: JEPMC-W6002-□□ and JEPMC-W6003-□□

(4) Cable Connections between the MP2300S and SGD-□□□N and SGDB-□□AN SERVOPACKs

Use the MECHATROLINK cable JEPMC-W611-□□ for the connections between the MP2300S and SGD-□□□N or SGDB-□□AN SERVOPACK and between these SERVOPACKs.

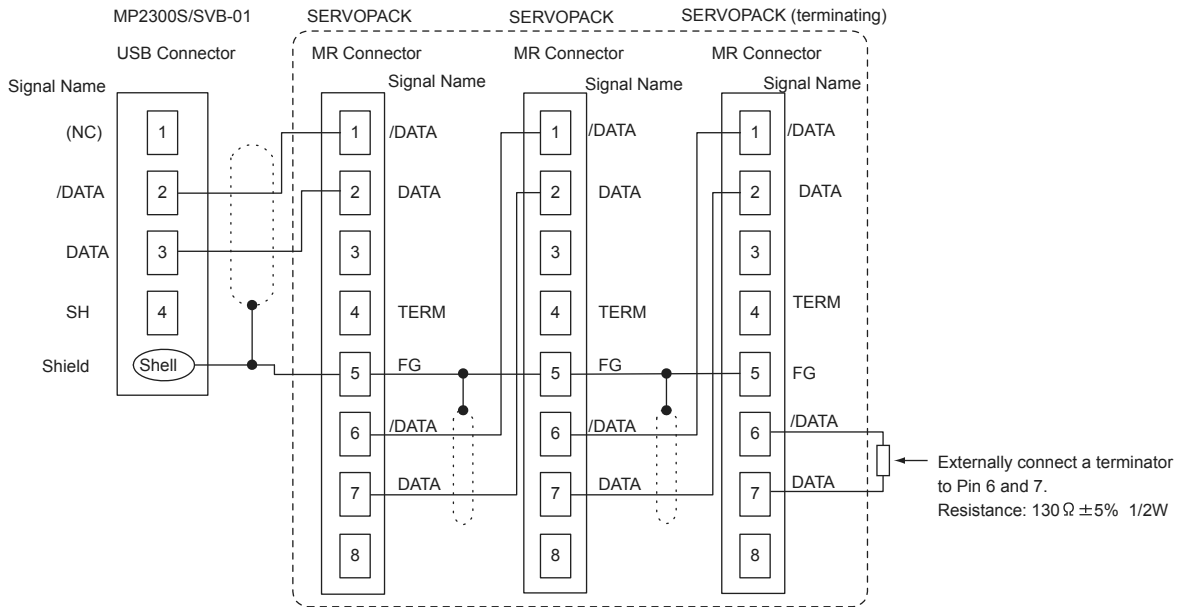

- Note: 1. The JEPMC-6011-□□ has a USB connector on one end and loose wires on the other end. Use an MR connector and wiring material to create a 1:N cable. The terminator must be provided by the user.
2. The shield wire can be connected as instructed in the SERVOPACK's manual. However, the connections shown in the above diagram is recommended when using the MP2300S in combination with a SVB-01 Module.
3. Prepare the cables according to MECHATROLINK-I specifications. Connections that do not meet the specifications will prevent normal communication due to the influence of reflected waves or other factors.

MECHATROLINK-I Specifications

- Total network length: 50 m max.
- Maximum number of slave stations: 14 stations max.
- Minimum distance between stations: 0.3 m min.

(5) Terminator Connections

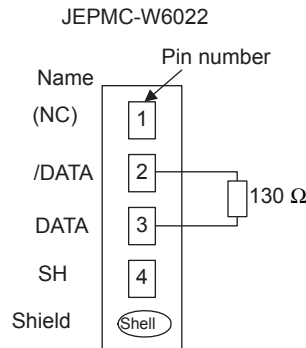

(6) Connection Example between MP2300S, SERVOPACK, and IO2310

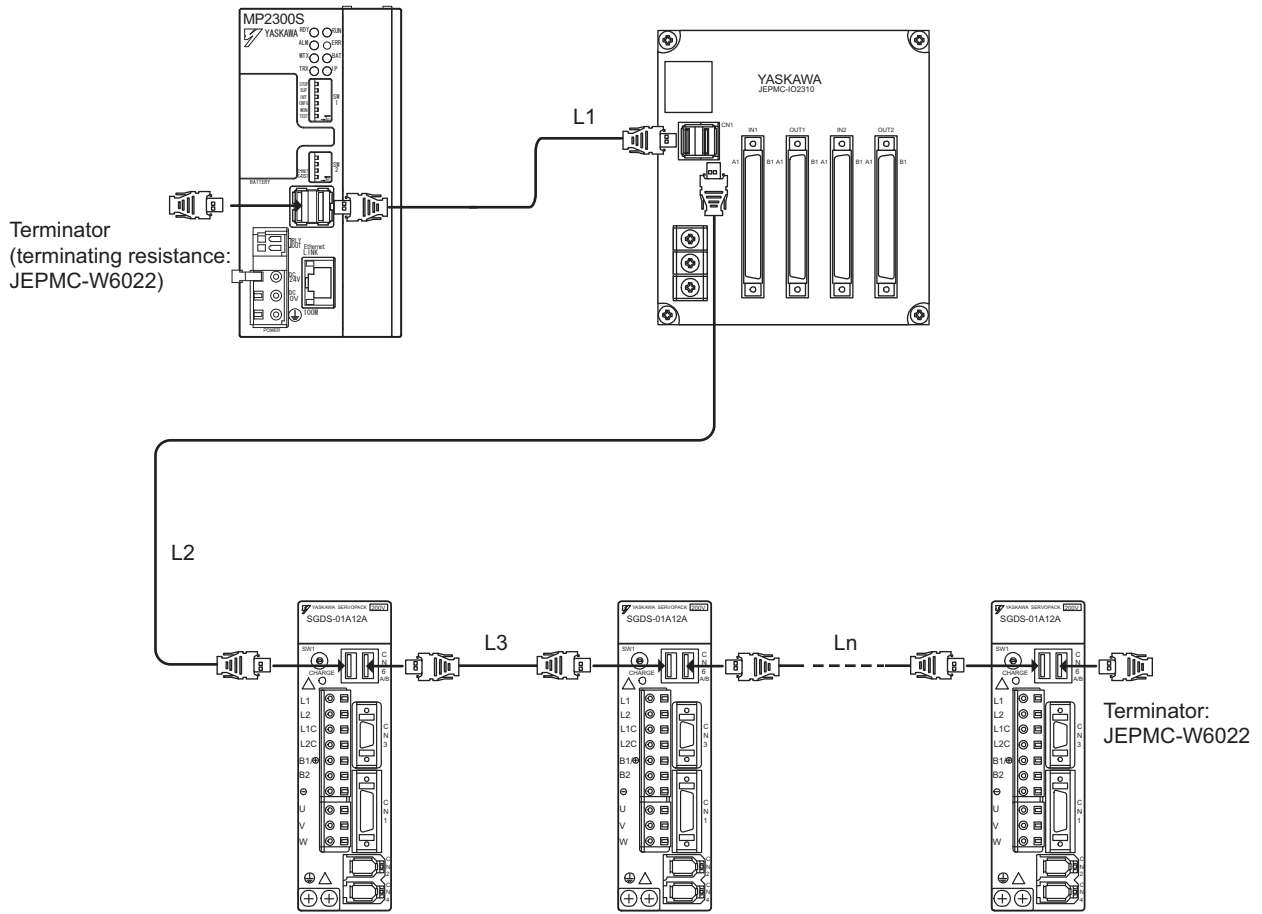

- Use MECHATROLINK cables between modules.
- Use under the conditions that $L1 + L2 + L3 + \dots + Ln \leq 50 \text{ m}$

3.2.4 Ethernet Connector Details

Connects to a personal computer or HMI device by Ethernet (100Base-TX /10Base-T).

(1) Ethernet Connector Specification and Pin Arrangement/ Indicator Light

The following table provides the Ethernet connector specifications.

Name	Connector Name	Number of Pins	Connector Model		
			Module Side	Cable Side	Manufacturer
Ethernet	Ethernet	8	RJ-45 CAT5 Socket	RJ-45 CAT5 Plug	Pulse Engineering

The following table provides Ethernet connector pin arrangement/ indicator light details.

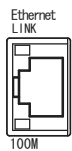

Pin Number	Signal Name	Description
1	TXD+	Transmitted data + side
2	TXD-	Transmitted data – side
3	RXD+	Received data + side
4	–	–
5	–	–
6	RXD-	Received data – side
7	–	–
8	–	–

Display Name	Display Color	Description
LINK	Yellow	Lit: Connect Unlit: Unconnected
100M	Green	Lit: Connected at 100Mbps, or automatically negotiating Unlit: Connected at 10Mbps

(2) Ethernet Cable

For the Ethernet cable, use a twisted pair cable with RJ-45 connector.

Ethernet Type	Category	Remarks
10Base-T	Category 3 or more	<ul style="list-style-type: none"> • When connecting to remote equipment through a hub: Straight cable • When connecting to remote equipment without using a hub: Cross cable
100Base-TX	Category 5 or more	

(3) Ethernet Connection Example

The following are examples of Ethernet network connections via 10Base-T cable:

■ Connection Example 1

When using a repeater HUB:

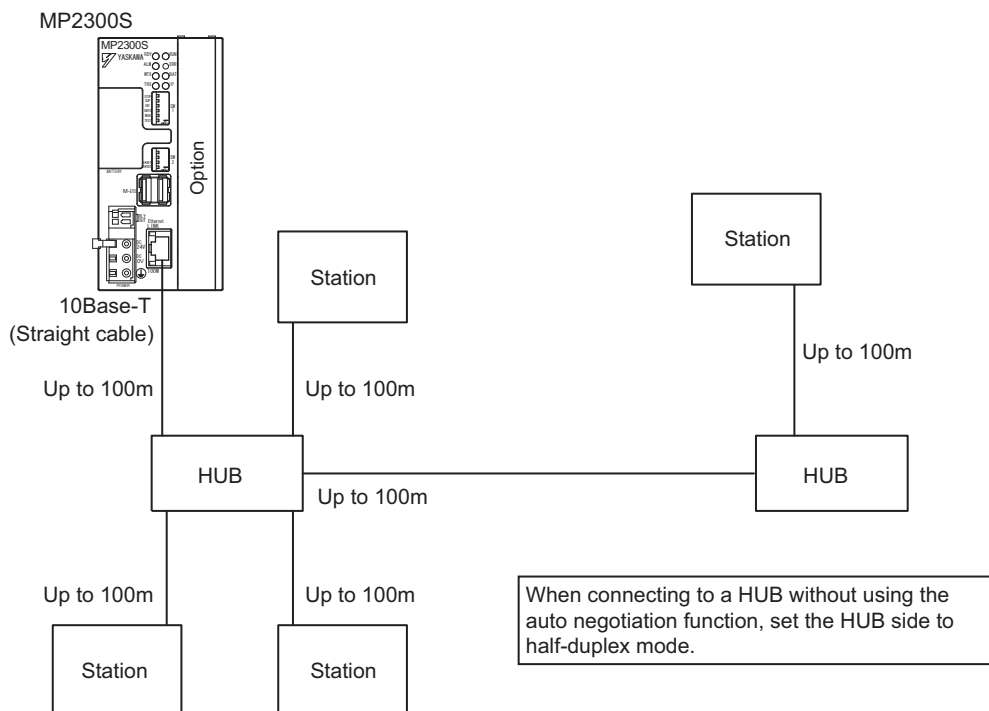

Specification

Item	When Connecting to a Repeater HUB	When Connecting to a Switching HUB
Cable Length between Node-HUB	100 m or less	100 m or less
Cable Length between HUBs	100 m or less	100 m or less
Number of HUBs between Nodes	Up to four	Unlimited

■ Connection Example 2

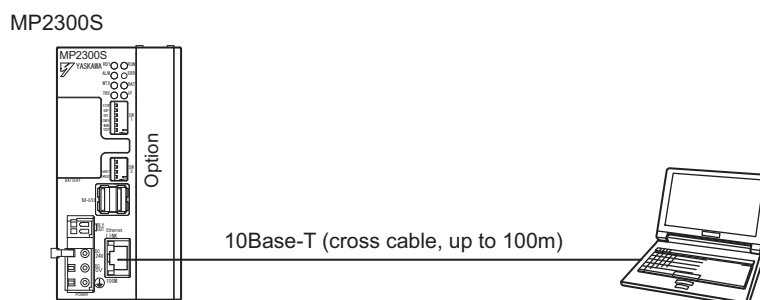

The following are examples of Ethernet network connections via 100Base-Tx cable:

■ Connection Example 1

When using a repeater HUB:

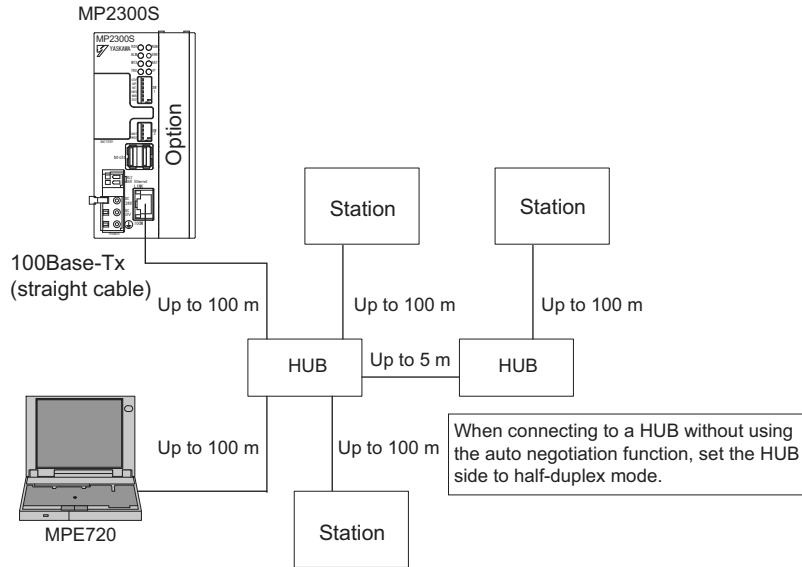

Specification

Item	When Connecting to a Repeater HUB	When Connecting to a Switching HUB
Cable Length between Node-HUB	100 m or less	100 m or less
Cable Length between HUBS	5 m or less	100 m or less
Number of HUBS between Nodes	Up to two	Unlimited

■ Connection Example 2

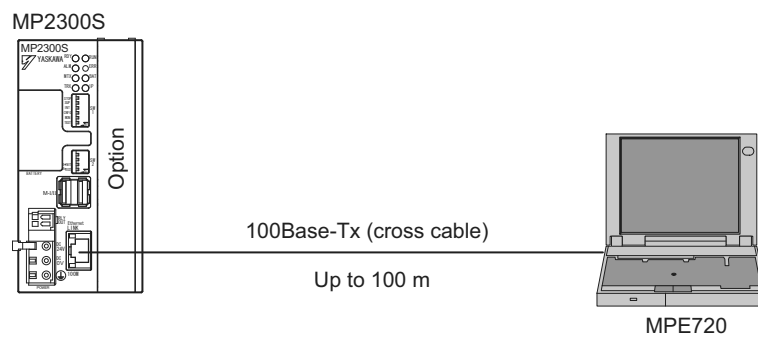

■ Caution

High frequency wave noise from other devices in the installation environment may cause error in communications using 100 BASE-Tx or MECHATROLINK connections. When constructing a system, use MP2300S protective measures to avoid the influence of high frequency wave noise as follows:

1 Wiring

Wire Ethernet or MECHATROLINK cables so that they are well-separated from other cable systems such as the main circuit or power lines.

2 Communication system (100BASE-TX)

- Communicate data to a remote device through TCP/IP communication.
- If necessary, increase the number of communication retries.

3 Attach a ferrite core.

Attach a ferrite core in the manner described below:

Ethernet : Attach it to the communication port side and the external equipment side of the MP2300S main unit.

MECHATROLINK : Attach it only to the communication port side of the MP2300S main unit.
(We will provide a standard cable with core. Model: JEPMC-W6003-□□)

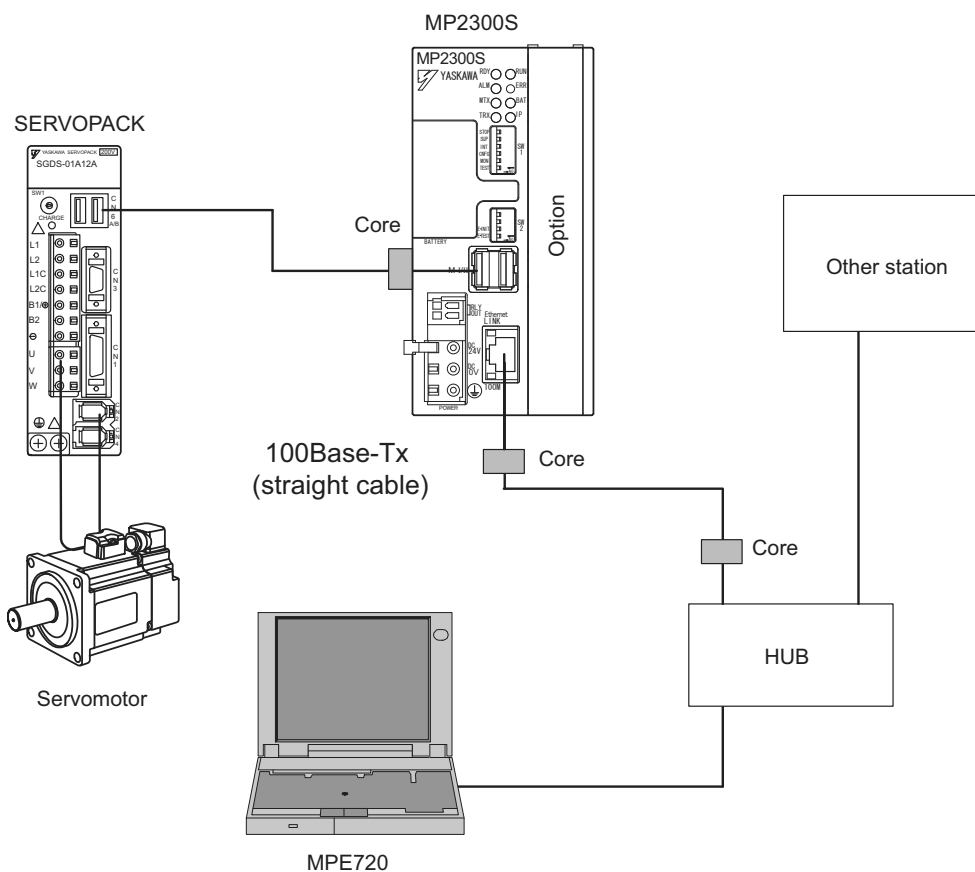

Note: Recommended ferrite core

Model:	Manufacturer
E04SR301334	Seiwa Electric Mfg. Co., Ltd

3.2.5 RLY OUT Connector Details

The RLY OUT connector is a terminal for outputting state and NO contact relay output. A circuit between terminals is short-circuited when RDY LED is lit, and opens when it is unlit.

Note: A state when RDY LED is lit indicates that a controller is operating normally. It does not indicate that an user program is running.

(1) RLY OUT Connector Specifications and Pin Arrangement

The following table provides the RLY OUT connector specifications.

Name	Connector Name	Number of Pins	Connector Model		
			Module Side	Cable Side	Manufacturer
RLY OUT	RLY OUT	2	734-162	734-YE102	Wago Corporation

The following table shows the RLY OUT connector pin arrangement.



Pin Number	Signal Name	Description
1	OUT	<ul style="list-style-type: none"> • Operating normally: Short-circuit • Error occurred: Opened
2	OUT	

The following table provides the RLY OUT connector contact ratings.

Input Voltage	Current Capacity
24 VDC	0.5 A (resistance load)
	0.25 A (induced load)
125 VAC	0.4A (resistance load)
	0.2A (induced load)

(2) RLY OUT Connection Cable

For the RLY OUT connection cable, use a cable of line size AWG28 to AWG14 (0.08 mm² to 1.5 mm²), maximum sheath diameter ϕ 3.4 mm.

The RLY OUT connector cable is similar in manufacture to the 24-VDC power supply cable.

(3) RLY OUT Connection Example

The following figure shows how to connect the RLY OUT connector:

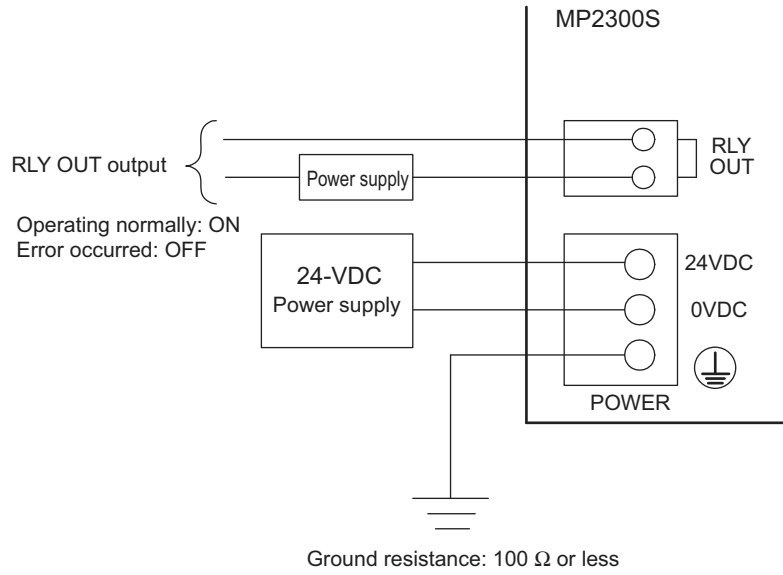

3.2.6 System Connection Example

The following diagram shows a connection example of a system using the MP2300S.

The following diagram shows a 200-VAC power supply example.

Note: elect the SERVOPACK, 24-VDC power supply to use in accordance with the input power supply specification.

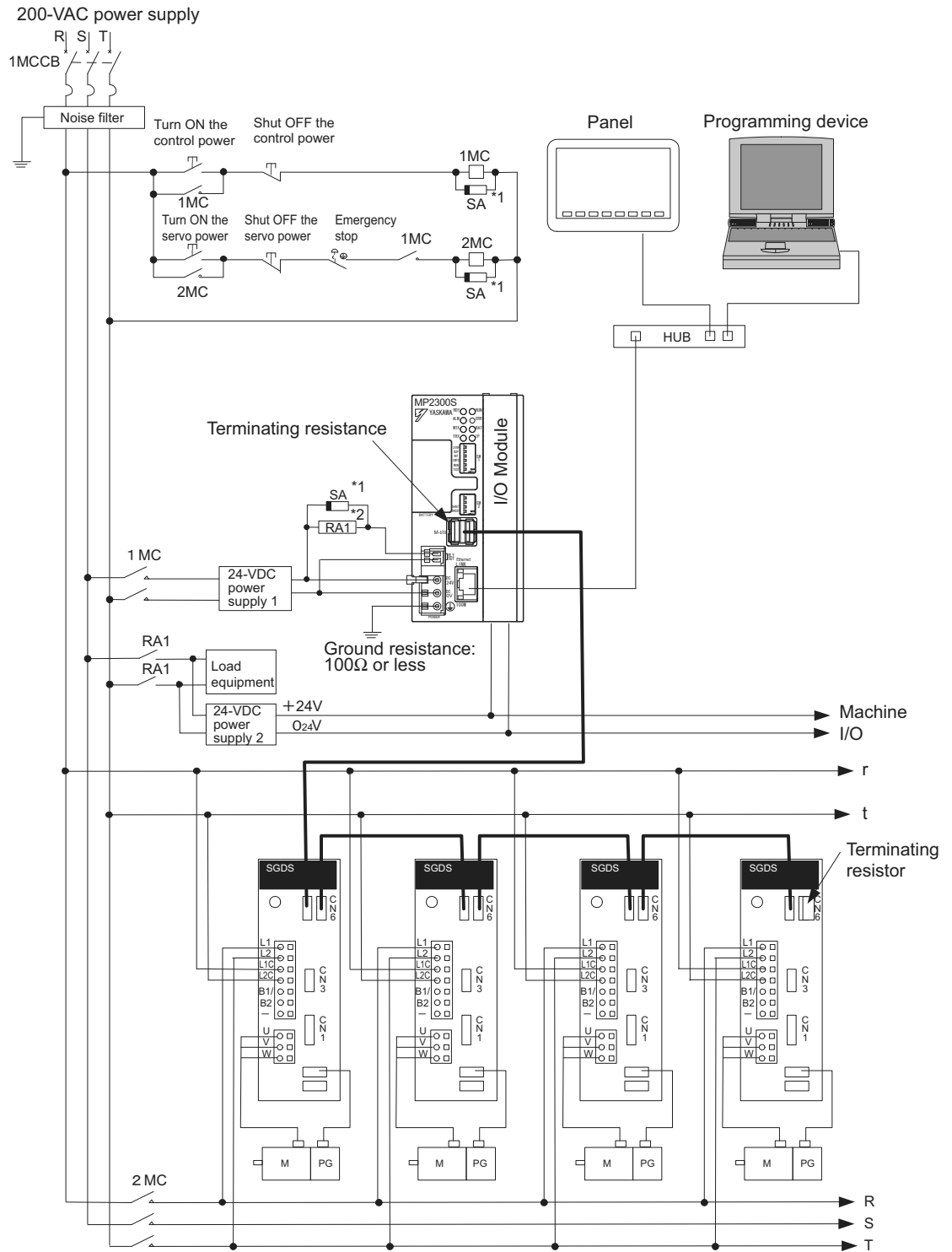

*1 SA: Surge absorber (for switching surge)
 *2 RA1: CPU RUN output

MEMO

System Start Up and Easy Programming

This chapter explains how to start up a model system using the programming tool MPE720 Ver.6.
Note that the procedure for designing a mechanical system has been omitted here.

4.1 System Startup Overview	4-2
4.2 Preparation (step 1)	4-3
4.2.1 Wiring	4-3
4.2.2 Self Configuration	4-5
4.2.3 Test Operation	4-6
4.3 Programming (step 2)	4-9
4.3.1 Programming Procedure	4-9
4.4 Executing Motion (step 3)	4-11
4.4.1 Registering Program Execution	4-11
4.4.2 Starting a Motion Program Using the Operation Control Panel	4-12
4.5 Starting Motion Program from an External Signal	4-13
4.5.1 Overview	4-13
4.5.2 Required Equipment	4-13
4.5.3 Creation Procedure	4-15

4.1 System Startup Overview

The start-up procedure for a model system is as follows. For detailed information of each step, refer to the cited references.

This chapter explains a procedure where you can easily run and check a program without external signals.

The simple motion program which you create has three lines only, moving and stopping 150,000 pulses from the current position.

INC;	Specify an incremental mode
MOV	[A1]150000, [B1]150000;Position two-axes 150,000 pulses
END;	



4.2 Preparation (step 1)

This section explains the steps of “wiring,” “self-configuration,” and “test operation” for starting up the model system.

4.2.1 Wiring

We use the following layout model to explain the startup of the model system. Prepare each device listed on the next page and connect them as shown in the figure below.

(1) System Layout Model

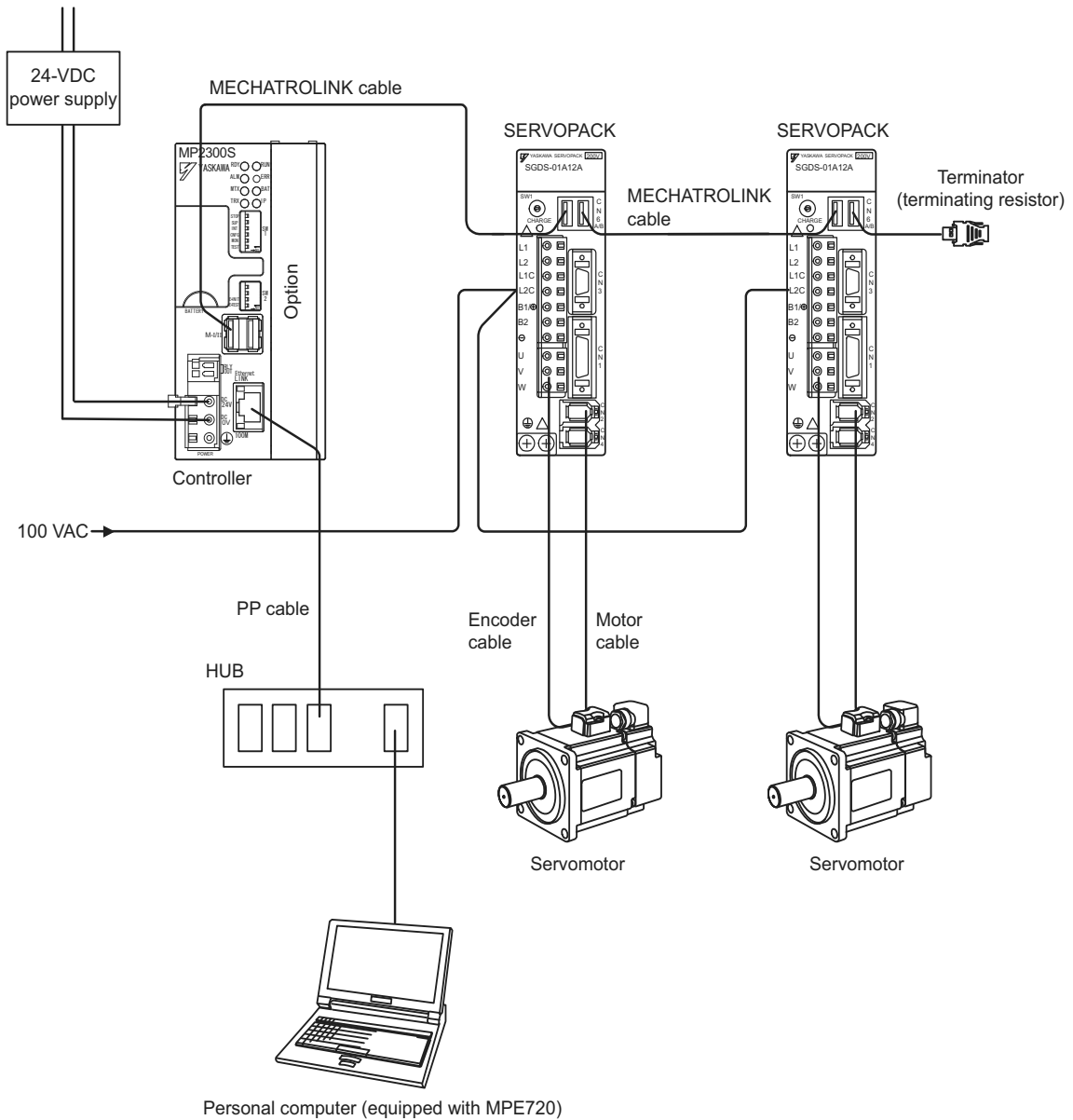

[a] Required Equipment

Product Name	Model	Q'ty
MP2300S	JEPMC-MP2300S-E	1
MECHATROLINK cable (0.5m)	JEPMC-W6002-A5	2
Terminator (terminating resistor)	JEPMC-W6022	2
Σ -III SERVOPACK	SGDS-A5F12A	2
Σ -III servomotor	SGMAS-A5A2A21	2
Motor cable (3m)	JZSP-CSM01-03	2
Encoder cable (3m)	JZSP-CSP05-03	2
HUB (commercial product)	LSW-TX-8EP	1
MPE720 Ver.6	CPMC-MPE770	1
LAN cable (for Ethernet connection)	Commercial straight cable	2
Personal computer (main unit)	Commercial product	1
24-VDC	Current capacity of power supply 2A or more	1

■ Caution

- Install MPE720 Ver.6 in the personal computer before starting step 1.
For information on its installation, refer to “MP2000 Series MPE720Ver.6.0 Users Manual” (manual number: SIEPC88070030).
 - Set the PC Ethernet port in advance. For information on the setup, refer to *Appendix F How to Set up Communication Process* on page A-31.
 - The SERVOPACK station number (SW1) is set to 1 and 2.
 - In a 1:1 connection without HUB, use a cross cable as a LAN cable.
-

4.2.2 Self Configuration

Run the self configuration to automatically recognize devices connected to the MECHATROLINK connector.
Steps for self configuration are as follows.

1. Check that the Σ -III SERVOPACK power supply is ON.
2. Turn OFF the MP2300S 24-V power supply.
3. Turn ON "INIT" and "CONFIG" of DIP switch (SW1) on the MP2300S main unit.
4. Turn ON the 24-VDC power supply on the MP2300S main unit, and confirm the LED display changes as follows:

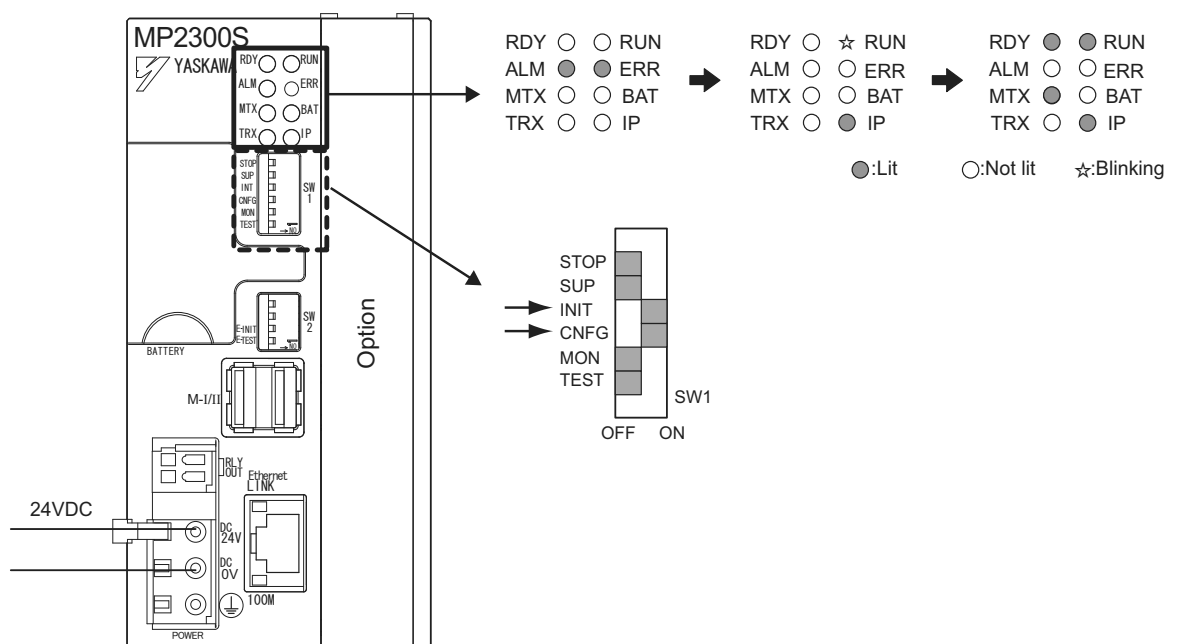

5. Self configuration is complete, and MECHATROLINK slave device information has been written to a definition information file.

4.2.3 Test Operation

Confirm that the machine controller can command axis servo ON/OFF and jog operation.

(1) Starting and Connecting MPE720 Ver.6

Launch MPE720Ver.6 and click “1:Ethernet(LP)192.168.1.1” to connect to the controller.

For more information on the communications settings, refer to *Appendix F How to Set up Communication Process* on page A-31.

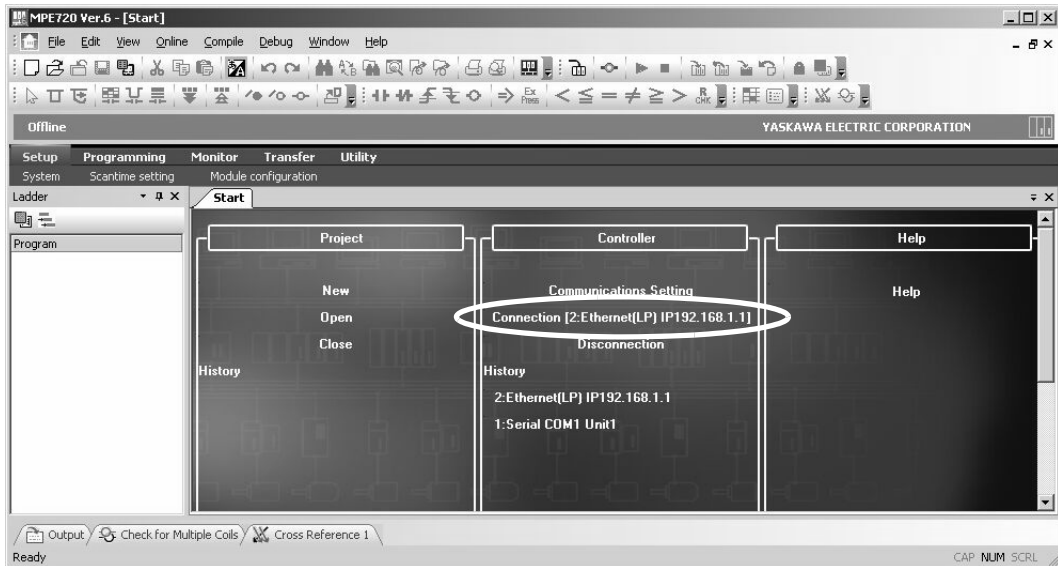

When the connection is complete, the display will change from offline to online.

(2) Operating Manually in the Test Operation Screen

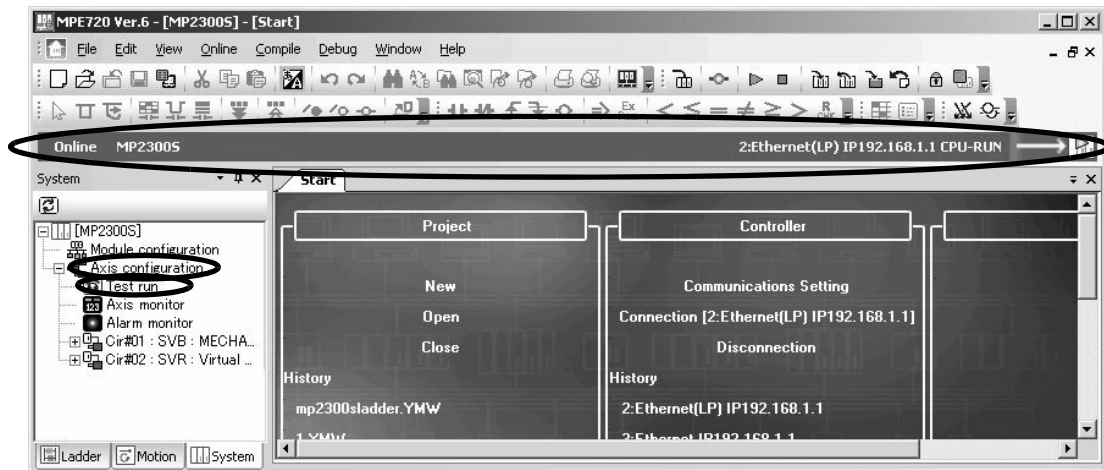

1. Click **System** in the subwindow and double-click **Axis Configuration - Test Run** to display a warning dialog a box for the test run. Click the **Accept** Button.

2. Axis Selection and Servo ON

Set an axis number in the **Axis** Window and click the **Enable (Servo ON)** Button in the **Test Run** Window.

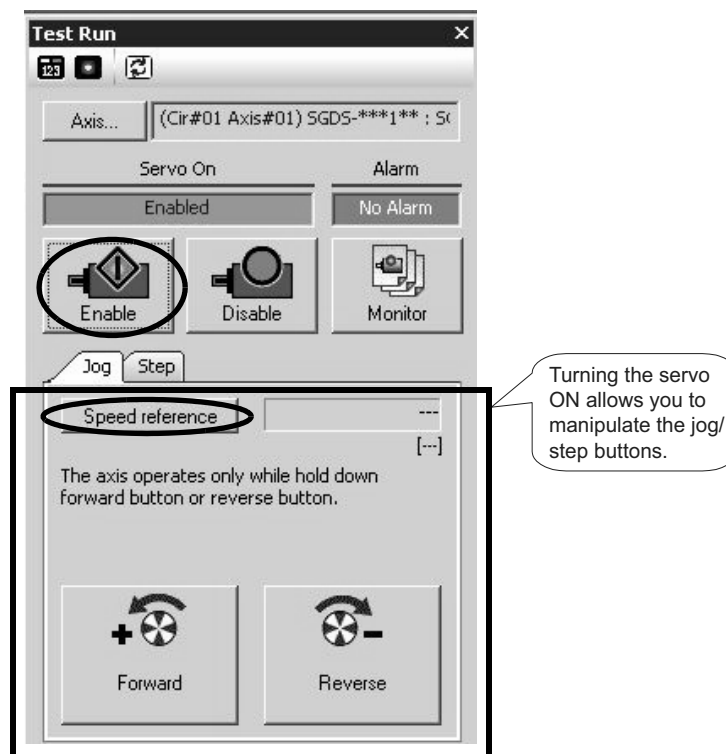
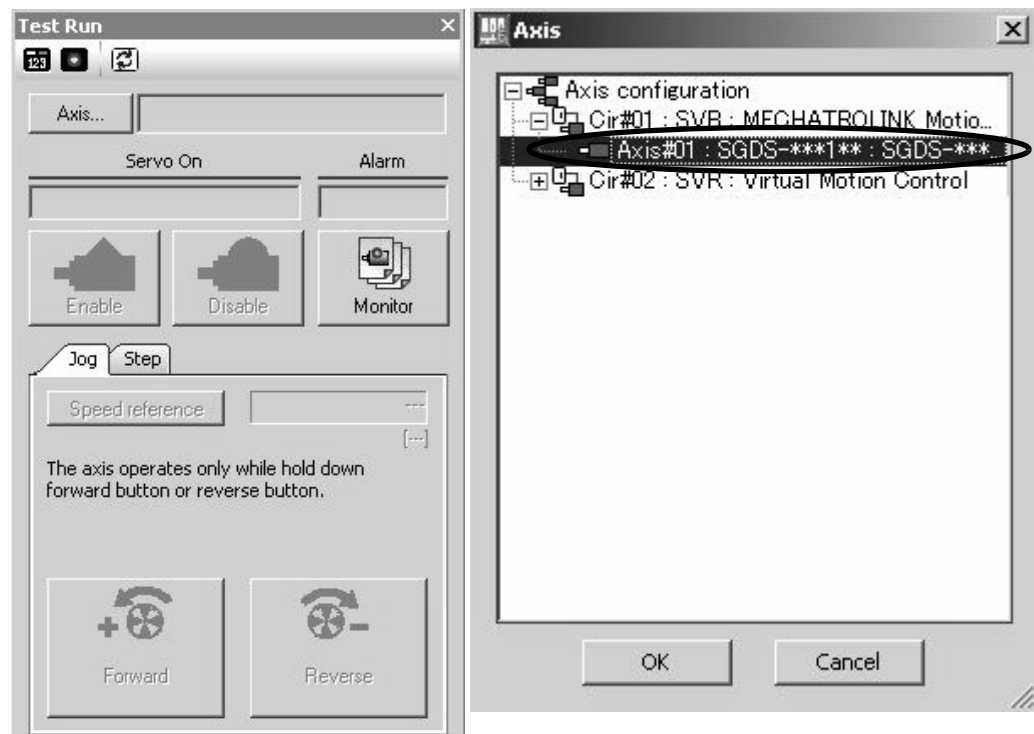

3. Jog Operation

Click the Speed reference icon and set a speed reference value, and check that the axis rotates normally while the **Forward** Button or **Reverse** Button is pressed.

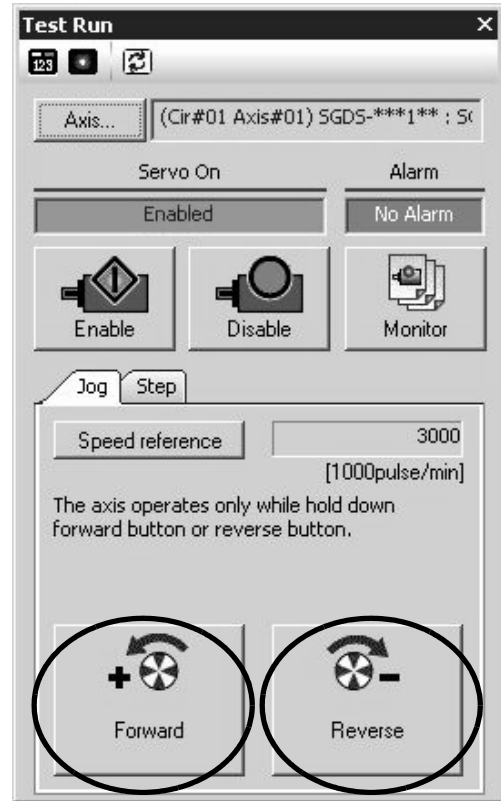
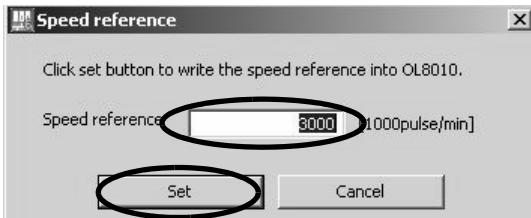

The operation check of the first axis is complete.

Press the **Axis ...** Button to change to "Axis #02" in the axis select screen, and perform the steps 1 to 3 above.

4.3 Programming (step 2)

This section describes the procedure from creating to saving a motion program.

4.3.1 Programming Procedure

1. Click the **Motion** Tag in the subwindow.

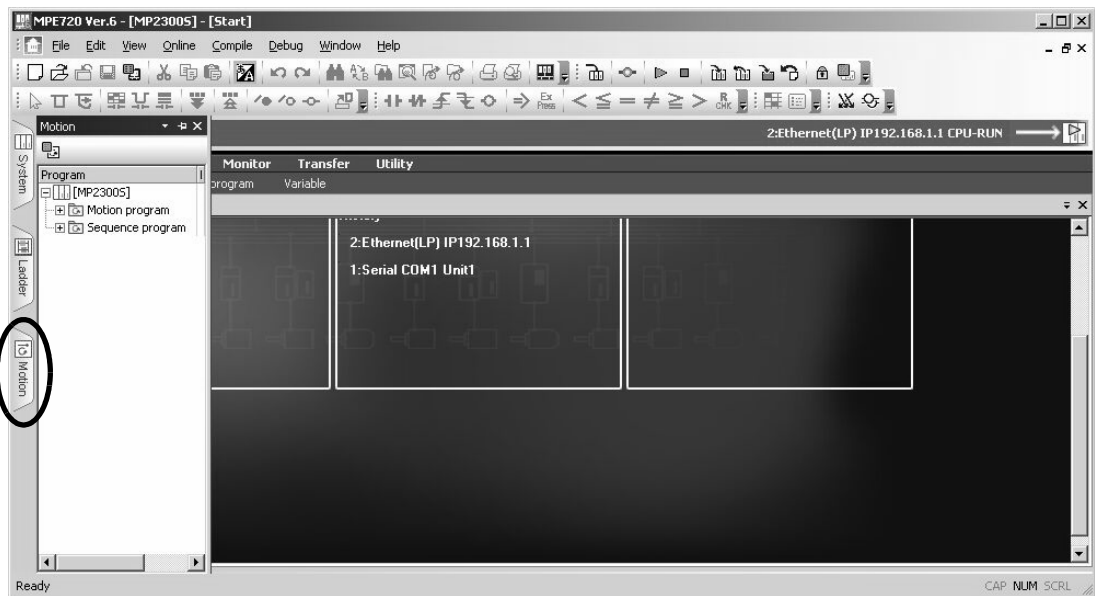

2. The motion program subwindow will appear.

When you double-click **Motion Program** and there is not any group definition, the group definition screen will be shown. For this setting example, you do not need to change it, so accept the default setting and click the **OK** Button. Note that if a group definition already exists, the group definition screen will not be shown.

3. Right-click **Main Program** and select **Create New** to display the **Create New Program** Dialog Box. Then click the **OK** Button.

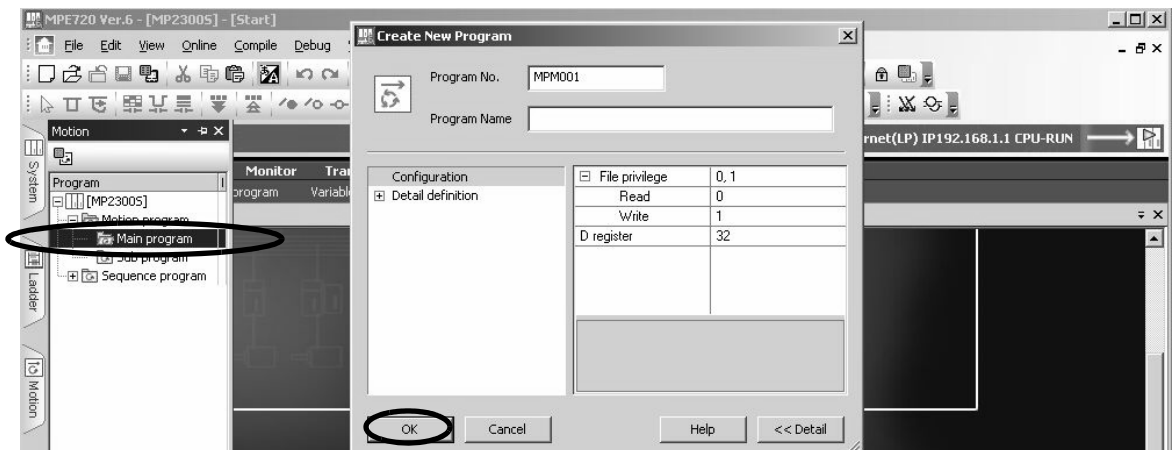

4. Editing Motion Program

Use the command input assist feature to insert INC and MOV Commands into the motion program.

The command input assist feature is made accessible by right-clicking the mouse on the **Motion Editor** Window.

- Call the command input assist feature

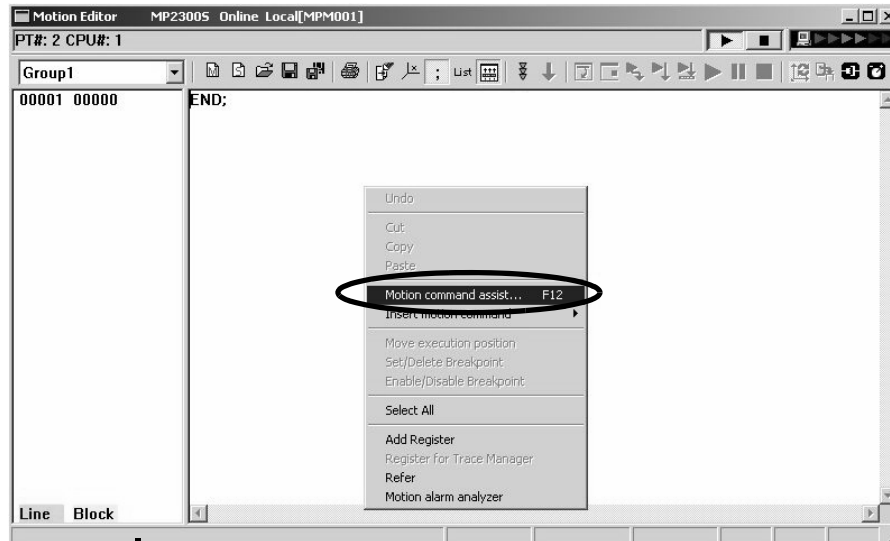

- Insert an INC Command

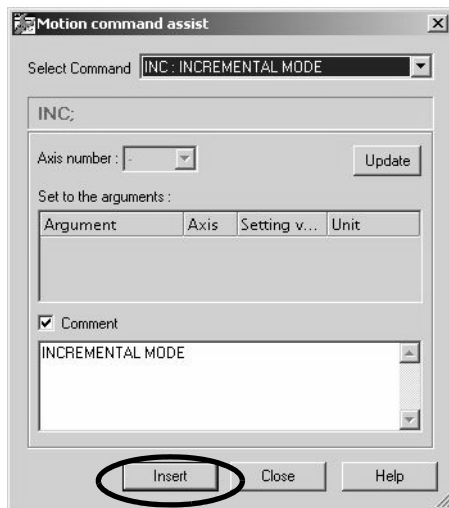

- Insert a MOV Command

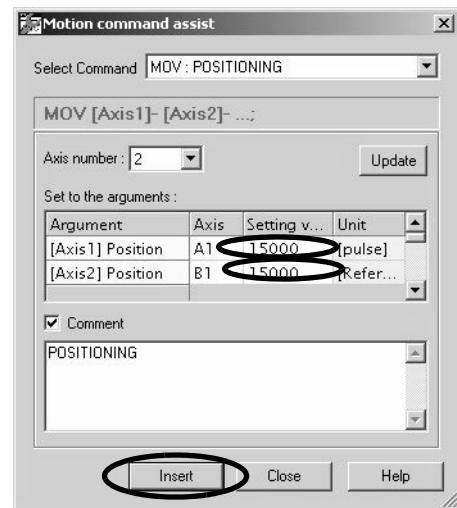

Click the save icon to save the motion program.



4.4 Executing Motion (step 3)

4.4.1 Registering Program Execution

1. Click the **Execution Registration** Icon.

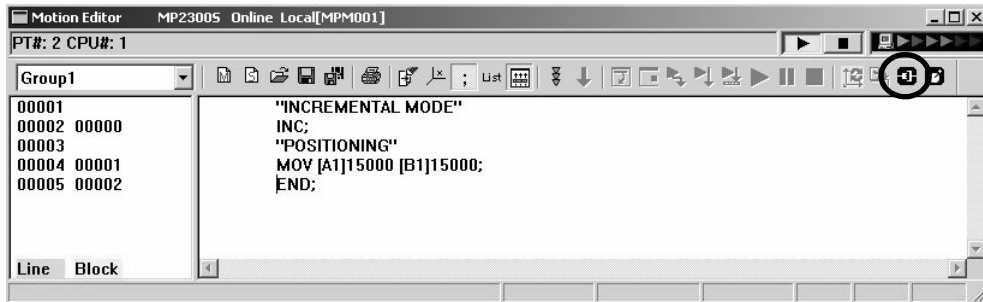

The **Program Execution Registry Screen** Dialog Box will appear.

2. Check Program Number and click **OK** to save the registered contents.

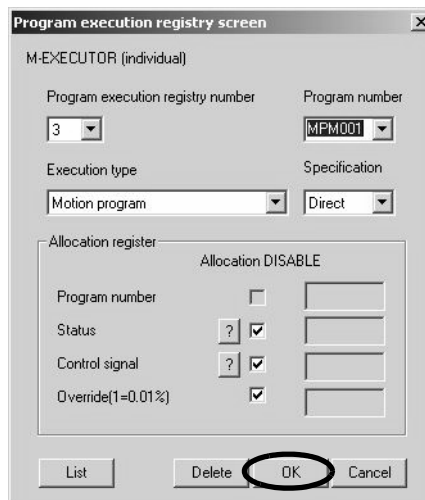

4.4.2 Starting a Motion Program Using the Operation Control Panel

1. Click the **Operation Control Panel** Icon.

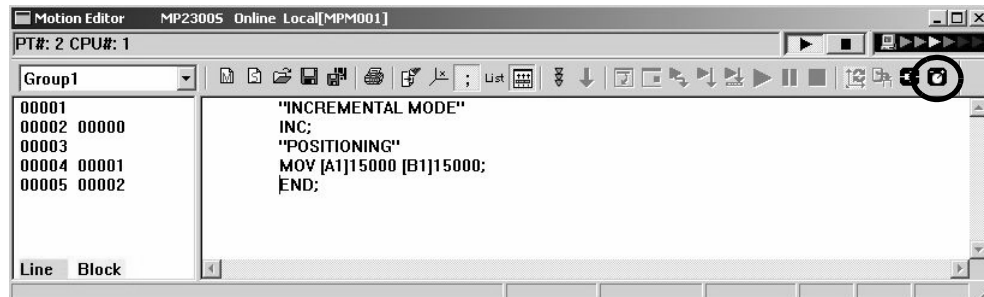

The **Device Control Panel** Dialog Box will appear.

2. Check Program to run, and click the **START** Button.

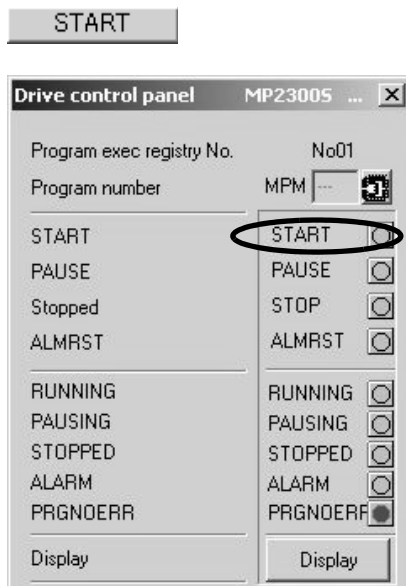

The MPM001's motion program is executed.

■ Caution

- This chapter explains the simple procedure where you can easily run and check a program without external signals. In practice, you need to connect to external signals and create a sequence.
- Registering a program execution enables the M-EXECUTOR definition. The MP2300S automatically controls the motion program, so be aware that changing registers registered in ladder and sequence programs may cause problems.

4.5 Starting Motion Program from an External Signal

4.5.1 Overview

This section explains how to start a motion program created in 4.3 Programming (step 2) from external signals. Note that in this section, we show an example which substitutes a touch panel for the external signal.

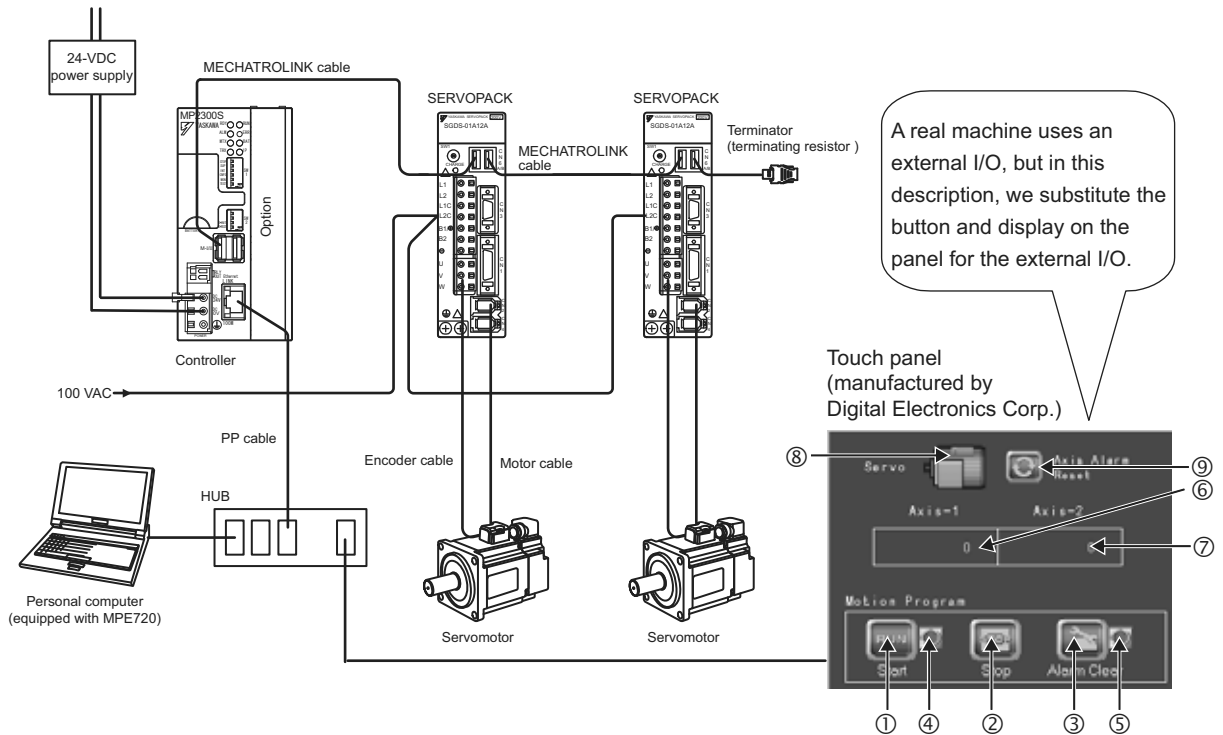

4.5.2 Required Equipment

Product Name	Model	Q'ty
MP2300S	JEPMC-MP2300S-E	1
MECHATROLINK cable (0.5 m)	JEPMC-W6002-A5	2
Terminator (terminating resistor)	JEPMC-W6022	2
Σ -III SERVOPACK	SGDS-A5F12A	2
Σ -III servomotor	SGMAS-A5A2A21	2
Motor cable (3 m)	JZSP-CSM01-03	2
Encoder cable (3 m)	JZSP-CSP05-03	2
Touch panel (manufactured by Digital Electronics Corp.)	AGP3300-T1-D24	1
HUB (commercial product)	LSW-TX-8EP	1
MPE720 Ver.6	CPMC-MPE770	1
LAN cable (for Ethernet connection)	Commercial straight cable	3
Personal computer (main unit)	Commercial product	1
24-VDC power supply	Current capacity of power supply 2 A or more	1

Mapping of the panel manufactured by Digital Electronics Corp.

No.	Name	Mapping	Category	Description	MP2300S Operation
①	Start	MB5000	Control signal	Starts up a motion program	Sets in M-EXECUTOR
②	Stop	MB5002	Control signal	Displays the running of a motion program	
③	Clear Alarm	MB5005	Control signal	Stops a motion program	
④	Running Program	MB5010	Status	Clears an alarm of a motion program	
⑤	Alarm	MB5018	Status	Indicates an alarm is occurring in a motion program	
⑥	Axis 1 (current position)	IL8016	Monitor parameter	Displays current axis 1 position	Automatic receive function
⑦	Axis 2 (current position)	IL8096	Monitor parameter	Displays current axis 2 position	
⑧	Servo (ON/OFF)	MB5020	External signal	Axis 1, axis 2 servo ON signal	Sequence program is needed
⑨	Reset Axis Alarm	MB5021	External signal	Axis 1, axis 2 alarm reset signal	

- Note: 1. You do not need to create a program for signals and data in ① to ⑦.
 2. You need to create a sequence program for outputting signals of ⑧ and ⑨ to the motion parameters.
 3. For information on creating a program for the panel side, refer to 6.2.1 *When the MP2300S Acts as Slave (automatic receive function is used)*.

4.5.3 Creation Procedure

1. Creating a Sequence Program

Now create a sequence program which copies the M register content mapped to “**Ⓢ Servo (ON/OFF)**” and “**Ⓢ Axis Alarm Reset**” Buttons on the touch panel to the relevant registers in the motion setting parameter of the embedded SVB.

Follow a procedure similar to creating a motion program from the motion program subwindow.

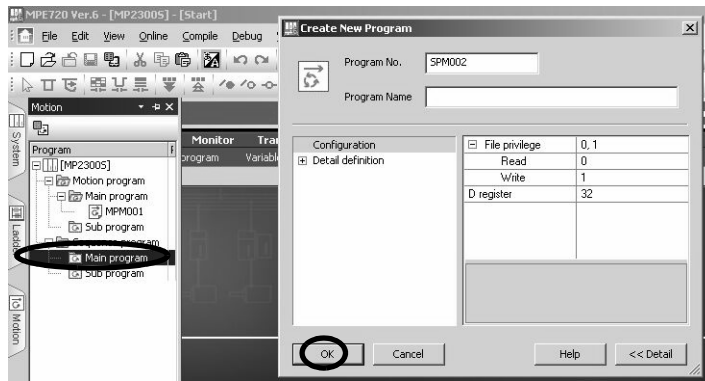

Output the information of the "Ⓢ Servo (ON/OFF)" button on the touch panel to the motion setting parameter "Axis 1 and axis 2 servo ON" of the built-in SVB.

```

00001 "panel <-> MP2000 data reception and transmission";
00002
00003 00000 ob80000=mb5020; "servo on axis 1"
00004 00001 ob80800=mb5020; "servo on axis 2"
00005
00006 00002 ob8000f=mb5021; "alarm reset axis 1"
00007 00003 ob8080f=mb5021; "alarm reset axis 2"
00008
00009
00010 00004 END;
00011
    
```

Output the information of the "Ⓢ Axis Alarm Reset" Button on the touch panel to the motion setting parameter "Axis 1 and axis 2 alarm reset" of the built-in SVB.

Click the **Execution Registration Icon**.



2. Registering Program Execution

- A **Program Execution Registry Screen** Dialog Box will appear.
- Click the **List** Button to set a program definition in the **M-EXECUTOR** Window.
→ Then register the MPM001, SPM001 executions.

For more information on how to set the **M-EXECUTOR** Window, refer to 2.2.7 *M-EXECUTOR Module (Motion Program Executor)* on page 2-50.

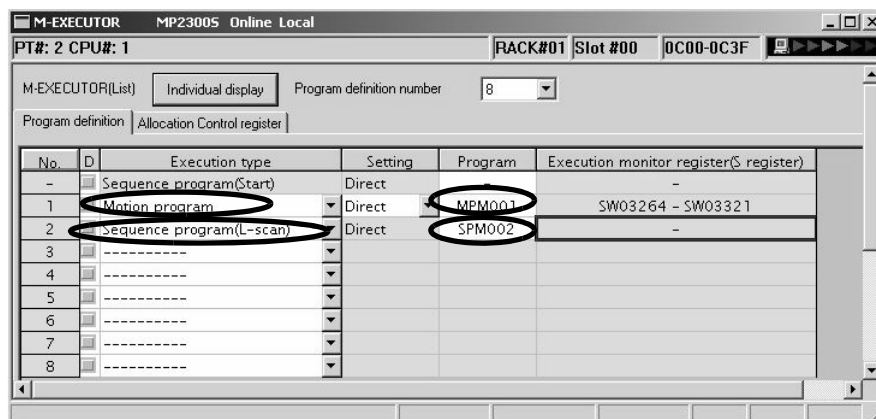
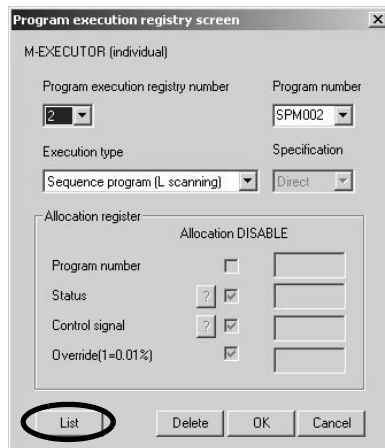

- In the **Allocation Control Register** Window, map the M registers allocated to control signals (① **Start** / ② **Stop** / ③ **Alarm Clear**) and status (④ **Running Program** / ⑤ **Alarm**) on the touch panel as an M-EXECUTOR allocation register for the motion program created in 4.3 *Programming (step 2)*.
Status=MW00501, control signal=MW00500, allocation contact interlock =SB000004

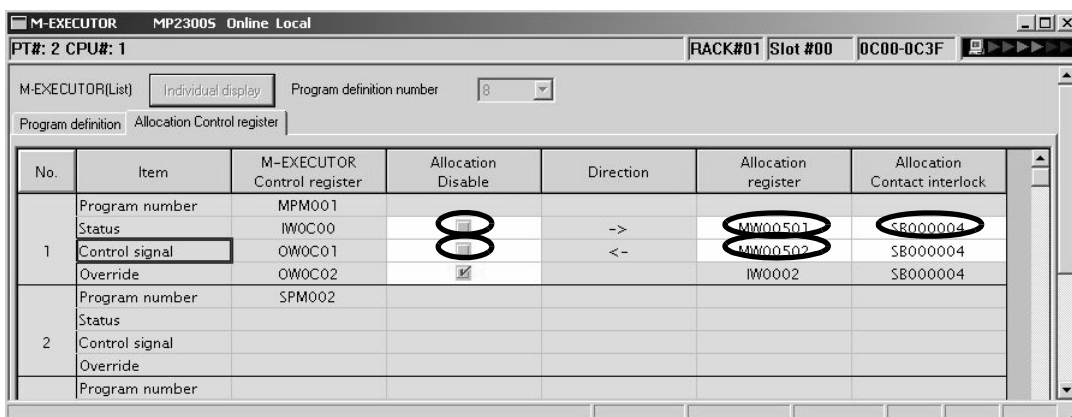

- Click the **Save** Icon to save the M-EXECUTOR definition.

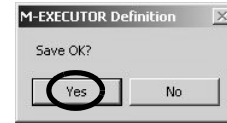

3. Communication Setting with Touch Panel

For information on communication setting with the touch panel, refer to *6.2.1 Automatic Receive Example Using Touch Panel*.

4. FLASH Save

When all settings are completed, click the **FLASH Save** Icon to save the data to the flash memory.

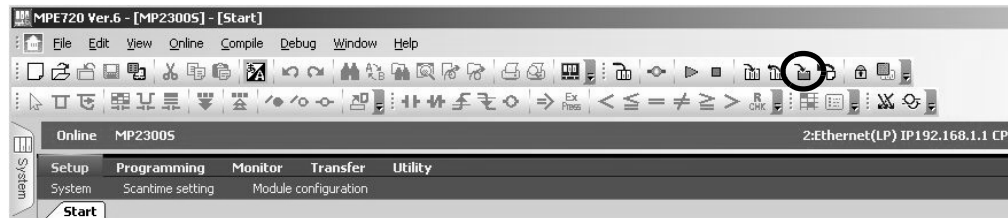

5. Operation Check

Turn ON MP2300S power again and press “① **Servo**” and “② **Start**” on the panel screen.

Then check that the motion program starts and the two-axes motor begins to operate to change the current position of the axis.

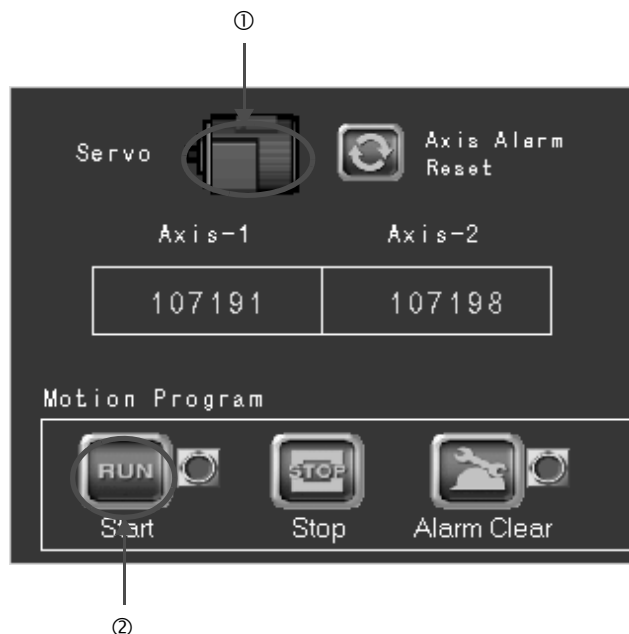

MEMO

Outline of Motion Control Systems

This chapter describes the basic operation of MP2300S Motion Control Systems and provides an outline of user programs and registers.

5.1 Startup Sequence and Basic Operation	5-2
5.1.1 DIP Switch Settings	5-2
5.1.2 Startup Sequence	5-3
5.1.3 Startup Sequence Operation Details	5-4
5.1.4 LED Indicator Details	5-5
5.2 User Programs	5-6
5.2.1 Types and Execution Timing of User Program	5-6
5.2.2 Motion Programs	5-7
5.2.3 Sequence Program	5-28
5.2.4 Ladder Drawings (DWG)	5-31
5.3 Registers	5-36
5.3.1 Types of Registers	5-36
5.3.2 Data Types	5-39
5.3.3 How to Use Subscripts i, j	5-40
5.3.4 Register Designation	5-41
5.4 Self-configuration	5-42
5.4.1 How to Execute Self-Configuration	5-43
5.4.2 Definition Information Updated with Self-Configuration	5-51
5.5 Precaution on Using MP2300S	5-54
5.5.1 Precautions when User Definition File is Configured/Changed	5-54
5.5.2 Setting or Changing Module Configuration Definition Files	5-55
5.5.3 Setting and Changing the Scan Time	5-56

5.1 Startup Sequence and Basic Operation

This section describes the MP2300S startup sequence and basic operation together with the DIP switch settings, self-diagnosis at startup, and LED indicator patterns.

5.1.1 DIP Switch Settings

Set the DIP switch (SW1) on the Basic Module to control operations of the startup sequence. The six switches are provided on the DIP switch (SW1) on the Basic Module as shown in the following figure. The following table lists the functions of six switches.

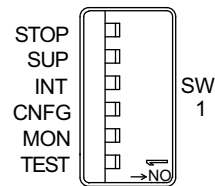

No.	Switch Name	Status	Operating Mode	Default Setting	Remarks
S1-6	STOP	ON	User program stops	OFF	Set to ON to stop user program operation.
		OFF	User program operation		
S1-5	SUP	ON	System load	OFF	If set to ON, starts up in the mode that can renew the version of the firmware.
		OFF	Normal operation		
S1-4	INIT	ON	Memory clear	OFF	Set to ON to clear memory. Programs stored in flash memory will be run when Memory Clear is set to OFF. S and M registers are cleared to all zeros.
		OFF	Normal operation		
S1-3	CNFG	ON	Self-configuration mode	OFF	Set to ON for self-configuration of connected devices.
		OFF	Normal operation		
S1-2	MON	ON	System use	OFF	Always set to OFF.
		OFF	Normal operation		
S1-1	TEST	ON	System use Adjusted before Shipment	OFF	Always set to OFF.
		OFF	Normal operation		

5.1.2 Startup Sequence

The startup sequence for the MP2300S from the moment when the power has been turned ON is shown in the following flowchart.

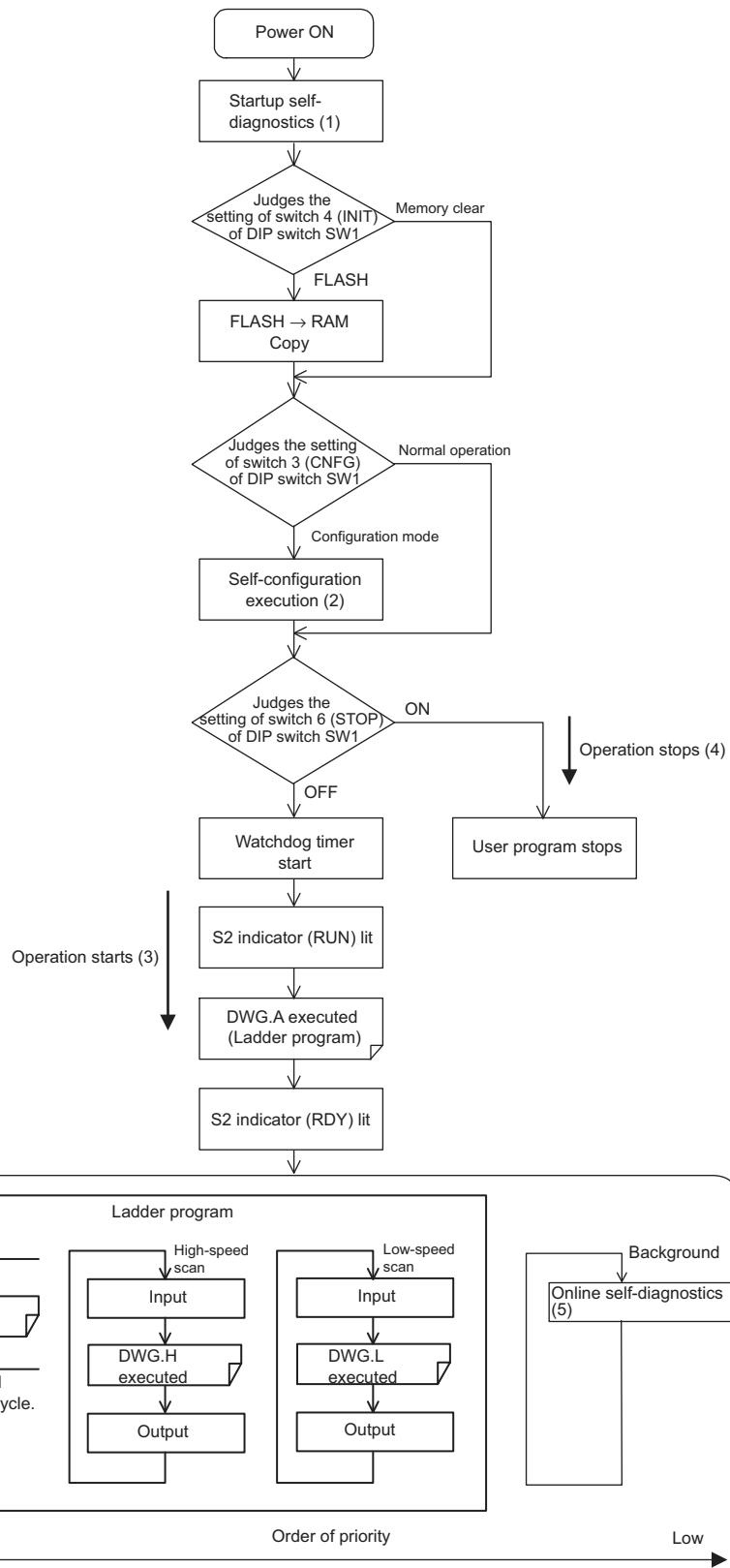

* Refer to 5.1.3 Startup Sequence Operation Details on the next page for details on (1) to (5).

5.1.3 Startup Sequence Operation Details

(1) Self-diagnosis at Startup

Self-diagnosis is performed on the following items after the power is turned ON.

- Read/write diagnosis of memory (RAM)
- System program (ROM) diagnosis
- Main processor (CPU) function diagnosis
- Floating Point Unit (FPU) function diagnosis

If diagnosis results in an error, the ALM and ERR LED indicators will blink red for the specified number of times.

Refer to *5.1.4 LED Indicator Details* on page 5-5.

(2) Self-configuration

Self-configuration automatically recognizes the connected Optional Modules, and automatically creates a definitions file. For details, refer to *5.4 Self-configuration* on page 5-42.

The RUN LED indicator will blink green during execution of self-configuration.

(3) Operation Start

When the STOP switch is set to OFF (RUN) or changes from ON (STOP) to OFF (RUN), the CPU starts the watchdog timer and then executes DWG.A in the ladder program. Refer to the startup processing drawing and *5.2.2 Motion Programs* on page 5-7.

First scan processing is executed once DWG.A has been completed and the high-speed or low-speed scan time has elapsed. System I/O are executed from the first scan.

(4) Operation Stop

MP2300S stops motion control operation when the STOP switch is ON (STOP) and in the following circumstances.

Cause	Restart method
Power supply turned OFF	Turn ON the power again.
Power interruption	
Fatal error	Check the LED indicator for the cause of the error and then turn the power OFF then ON.
STOP executed from MPE720	Execute RUN from MPE720.

(5) Online Self-diagnosis

Self-diagnosis is performed on the following items when the user logs on online.

- System program (ROM) diagnosis
- Main processor (CPU) function diagnosis
- Floating Point Unit (FPU) function diagnosis

If diagnosis results in an error, the ALM and ERR LED indicators will blink red for the specified number of times.

Refer to *5.1.4 LED Indicator Details* on page 5-5.

5.1.4 LED Indicator Details

The MP2300S performs a variety of diagnostics at startup. If an error is found, the ERR LED indicator blinks red. The number of times the indicators blink differs depending on the error details, so error details can be determined from counting the number of blinks. The following table shows details of MP2300S LED indicator.

- ♦ MPE720 cannot be operated when the indicators are blinking.
- ♦ For information on errors and countermeasures, refer to *Chapter 8 Maintenance, Inspection, and Troubleshooting*.

Type	LED Indicator Name					Indicator Details	Remarks
	RDY	FUN	ALM	ERR	BAT		
Normal	Not lit	Not lit	Lit	Lit	Not lit	Hardware reset status	–
	Not lit	Not lit	Not lit	Not lit	Not lit	Initializing	
	Not lit	Lit	Not lit	Not lit	Not lit	Executing DWGA	
	Lit	Not lit	Not lit	Not lit	Not lit	User program stopped (Offline stop mode)	User program stops when the DIP switch or MPE720 is used to execute the STOP operation.
	Lit	Lit	Not lit	Not lit	Not lit	User program executing normally (Online operation mode)	–
Error	Not lit	Not lit	Not lit	Lit	Not lit	Major damage has occurred	The ERR LED indicator is lit red when the CPU is down.
	Not lit	Not lit	Not lit	Blinking	Not lit	(Software error) No. of blinks 3: Address error (read) exception 4: Address error (write) exception 5: FPU exception 6: Illegal general command error 7: Illegal slot command error 8: General FPU inhibited error 9: Slot FPU inhibited error 10: TLB duplicated bit error 11: LTB mistake (read) 12: LTB mistake (write) 13: LTB protection violation (read) 14: LTB protection violation (write) 15: Initial page write error	The ERR LED indicator will blink red when an exception error has occurred.
	Not lit	Not lit	Blinking	Blinking	Not lit	(Hardware errors) No. of blinks 2: RAM diagnosis error 3: ROM diagnosis error 4: CPU function diagnosis error 5: FPU function diagnosis error	The ALM and ERR LED indicators will blink red if there is a self-diagnosis failure.
Alarm	–	–	–	–	Lit	Battery alarm	The BAT LED indicator will be lit when the battery voltage drops.
	Lit	Not lit	Lit	Not lit	Not lit	Operation error I/O error	The ALM LED indicator will be lit red when an operation or I/O error is detected.

5.2 User Programs

User programs for executing machine control using the MP2300S include ladder programs and motion programs. This section describes the basic operation and other information about user programs.

- For programming details, refer to the following manuals.
 - Machine Controller MP900/MP2000 Series User's Manual Ladder Programming (SIEZ-C887-1.2)*
 - Machine Controller MP900/MP2000 Series User's Manual Motion Programming (SIEZ-C887-1.3)*
 - Machine Controller MP900/MP2000 Series New Ladder Editor Programming Manual (SIEZ-C887-13.1)*
 - Machine Controller MP900/MP2000 Series New Ladder Editor User's Manual (SIEZ-C887-13.2)*

5.2.1 Types and Execution Timing of User Program

The following table shows the types and execution timing of MP2300S user program.

User Program		Execution Timing
Motion Program	High-speed Scan Process	Turns ON the program operation start request of the control signal (runs when program operation start request is ON)
Sequence Program	Startup Process	Power-up (during power-up, runs only once)
	High-speed Scan Process	Periodical startup (runs each time a high-speed scan is performed)
	Low-speed Scan Process	Periodical startup (runs each time a low-speed scan is performed)
Ladder Program	Startup Process	Power-up (during power-up, runs only once)
	Interrupt Process	Runs on external interrupt (runs on DI interrupt of option module and counter match interrupt)
	High-speed Scan Process	Periodical startup (runs each time a high-speed scan is performed)
	Low-speed Scan Process	Periodical startup (runs each time a low-speed scan is performed)

For more information on the user program, refer to the next page and after.

5.2.2 Motion Programs

Motion programs are programs written in a text-based language called motion language.

The following table shows the two types of motion programs.

Type	Specification Method	Features	No. of Programs
Main Program	MPM□□□ (□□□ = 1 to 256)	Accessed from DWG.H	Up to 256 programs (including main and sub programs) can be created.
Sub-program	MPS□□□ (□□□ = 1 to 256)	Can be called from main programs	

- The program numbers of motion programs are managed in the same manner as the sequence program numbers. Assign a unique number for each program number.
 - Program number of Motion program MPM □□□, MPS □□□
 - Program number of Sequence program SPM □□□, SPS □□□
- The MP2300S can execute up to 16 motion programs simultaneously. An alarm (no system work error) will occur if 17 or more programs are executed simultaneously.
 - No system work error: Bit E of the leading word in the MSEE work registers

(1) Groups

A group of axes with related operations can be treated as one group by motion programs and programs can be executed for each group. This allows one MP2300S to independently control multiple machines using group operation. Group operation can be single group operation or multiple group operation.

Definitions for axes to be grouped together are made under *Group Definitions*.

(a) Single Group Operation

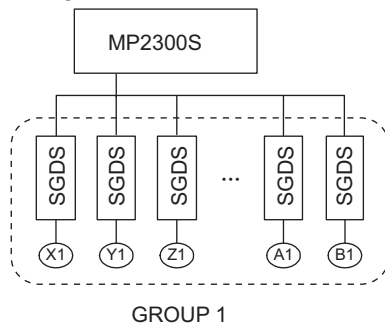

(b) Multiple Group Operation

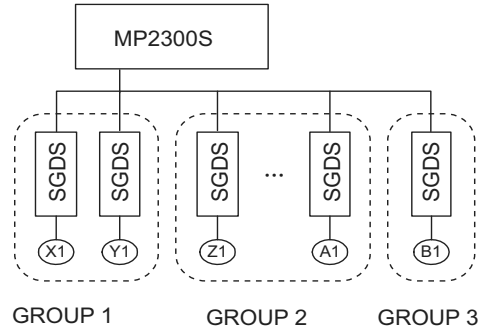

This section explains the Group Definition screen.

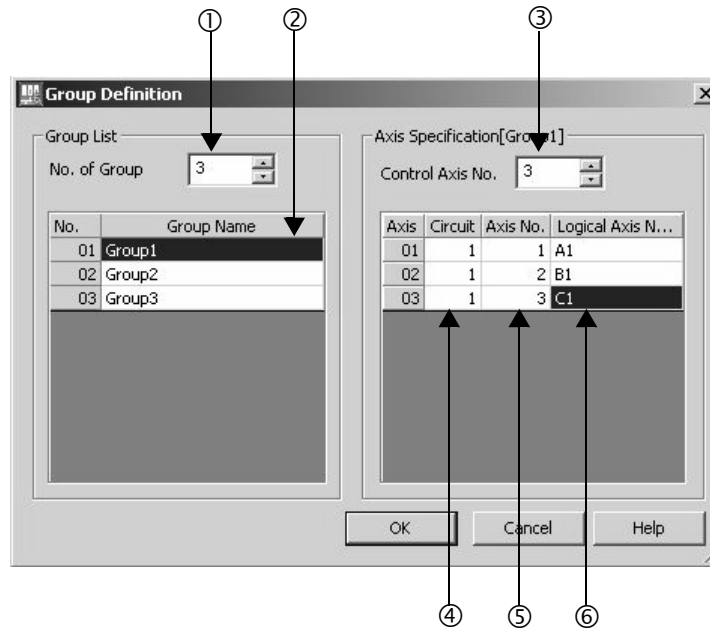

- ① **No. of Group**
Set a number for the operation as a group.
Set it to 1 for the operation as one group.
Set it to the number of groups for the operation with multiple groups.
- ② **Group Name**
Define a group name.
- ③ **Control Axis No.**
Set the number of axes controlled in the group.
- ④ **Circuit**
Set a line number for the used motion module.
The line number can be checked in the module configuration definition.

Line number

Slot Number	1	2	3	4	5
Module Type	CPU	218IFA	SVB	SVR	M-EXECUTOR
Controller Number	-	01	01	01	-
Circuit Number	-	01	01	02	-
I/O Start Register	----	0000	0800	----	0C00
I/O End Register	----	07FF	0BFF	----	0C3F
Disable Input		Enable	Enable		
Disable Output		Enable	Enable		
Motion Start Register	----	----	8000	8800	----
Motion End Register	----	----	87FF	8FFF	----
Details			MECHATROLINK		
Status	Running	Running	Running	Running	Running

⑤ Axis No.

Set an axis number for the used axis.

The axis number can be checked in the detailed screen of the used motion module.

Axis number

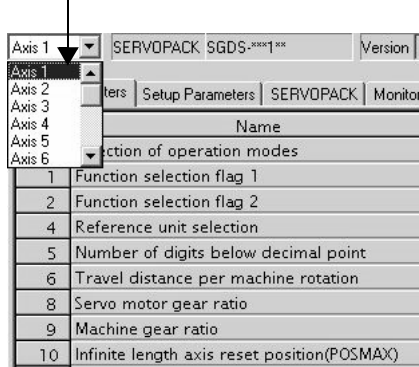

Double-click

Slot Number	1	2	3	4	5
Module Type	CPU	218IFA	SVR	SVR	M-EXECUTOR
Controller Number	-	01	01	01	-
Circuit Number	-	01	01	02	-
I/O Start Register	----	0000	0800	----	0C00
I/O End Register	----	07FF	0BFF	----	0C3F
Disable Input		Enable	Enable		
Disable Output		Enable	Enable		
Motion Start Register	----	----	8000	8800	----
Motion End Register	----	----	87FF	8FFF	----
Details			MECHATROLINK		
Status	Running	Running	Running	Running	Running

⑥ Logical Axis Name

Define a name for the specified axis number.

The name defined here is used when programming a motion program.

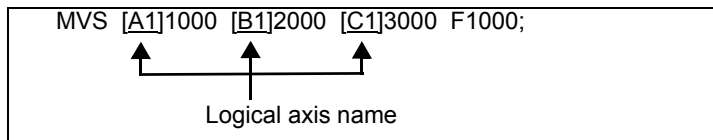

(2) How to Run a Motion Program

The following two methods are available for running a motion program.

- Registering it to the M-EXECUTOR program execution definition
- Executing it using a MSEE command from a ladder program of H drawing

Now, this section explains each way to run a motion program:

[a] Registering it to the M-EXECUTOR Program Execution Definition

After creating a motion program, register it in the M-EXECUTOR program execution definition screen.

The programs registered in the M-EXECUTOR program execution definition screen are executed in ascending numeric order.

The execution example is shown in the figure below.

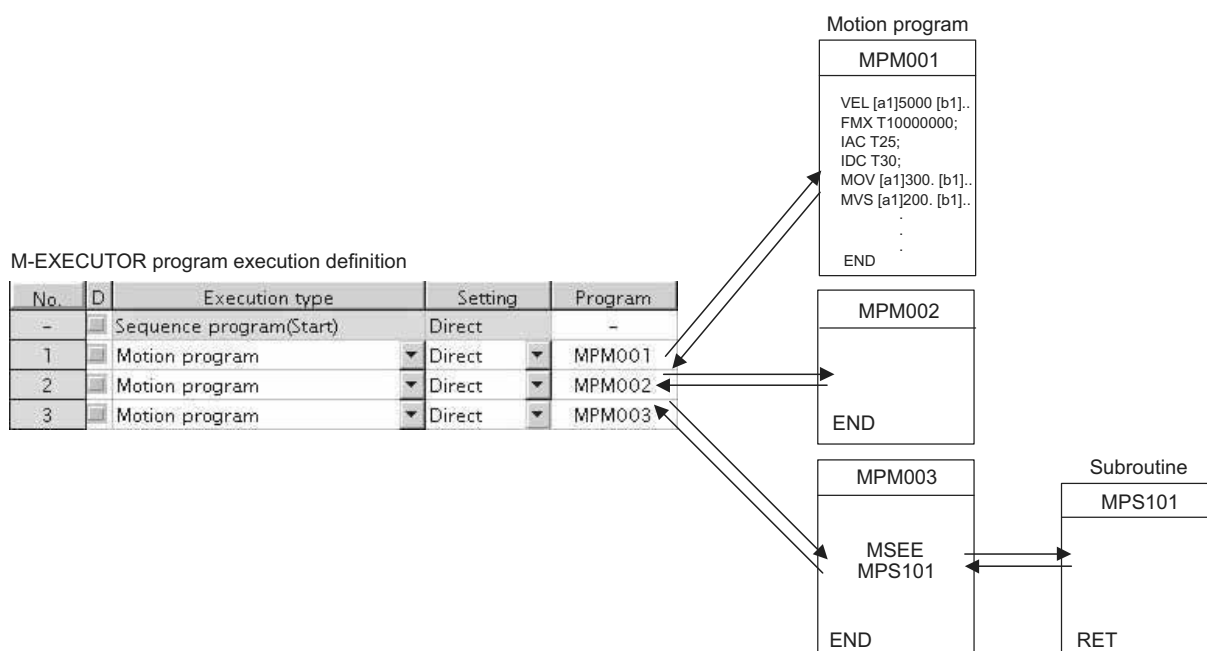

The above method is a preparation for running a motion program. When registered in the M-EXECUTOR program execution definition, a motion program does not start up. To start up the motion program, after the motion program registration, use a control signal to turn ON the request for the program operation startup.

The motion program registered in M-EXECUTOR is executed at a scan cycle, but similar to a ladder, the whole program cannot be executed at a single scan. In case of the motion program, a motion management function in the system carries out an execution control exclusive for the motion programs.

■ Caution

When registering a motion program to M-EXECUTOR, pay attention to the followings:

- Multiple motion programs with the same number cannot be registered.
- Multiple motion programs with the same number cannot be referenced using an indirect designation.

[b] Executing H Drawings by MSEE Command

Motion programs are always called from H drawings using the MSEE command (motion program call command).

Motion programs can be called from any parent, child, or grandchild drawing in an H drawing.

The following figure shows an example of motion program execution.

System programs are started according to execution conditions.

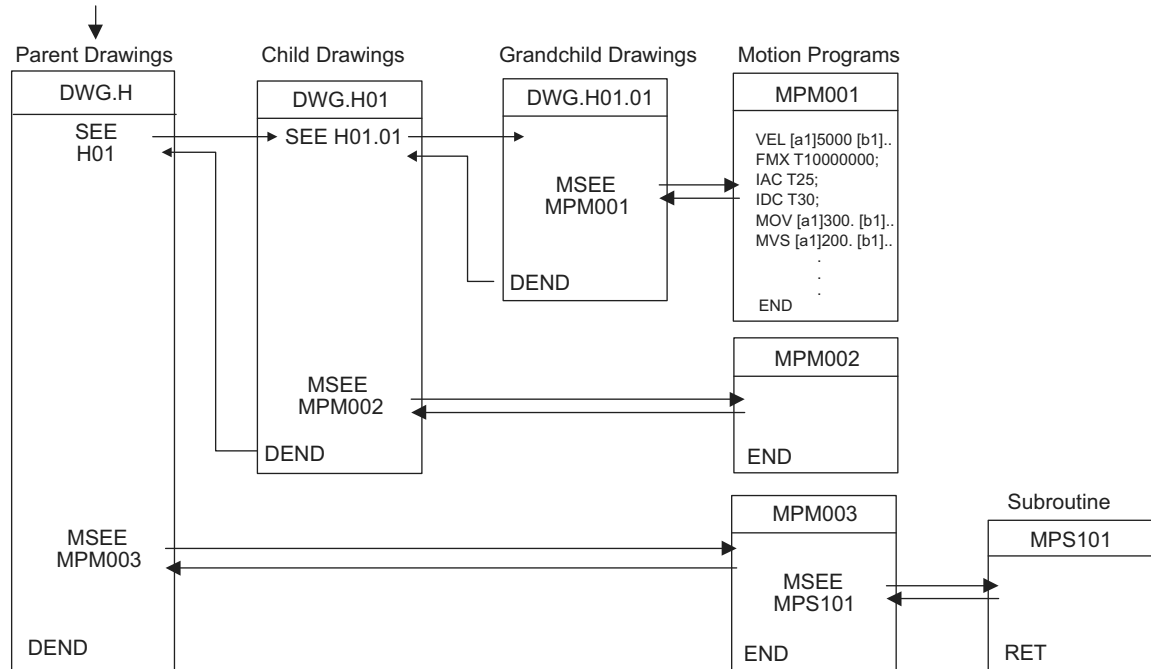

H drawing ladder commands are executed in hierarchical order i.e., parent drawings, child drawings, then grandchild drawings each high-speed scan cycle.

The above method is a preparation for running a motion program. When a MSEE command is built in, the motion program does not start up. To start up the motion program, after the MSEE command is incorporated, use a control signal to turn on the request for the program operation startup.

Motion programs are also called each scan cycle, but unlike ladder programs, all motion programs cannot be executed in one scan. For this reason, motion programs are executed and controlled by special system's motion management function.

■ Caution

When running a motion program, pay attention to the followings:

- The motion program registered in M-EXECUTOR cannot be executed using a MSEE command.
- Multiple motion programs with the same number cannot be executed using a MSEE command.
- A subroutine (MPS □□□) cannot be executed from a MSEE command in a ladder. It can only be referenced from a motion program (MPM □□□, MPS □□□).
- A sequence program (SPM □□□, SPS □□□) cannot be executed from a MSEE command in a ladder.
- The same subroutine cannot be referenced at the same time.

(3) How to Designate a Motion Program

The following two methods are available for designating a motion program.

- Using a direct designation to invoke a motion program
- Using a indirect designation to invoke a motion program

Now, this section explains each way to designate a motion program.

[a] Using a Direct Designation to Call a Motion Program

A direct designation method designates a motion program to call using a program number (MPM □□□).

■ A motion program registered in the M-EXECUTOR program execution definition

Select **Direct** for the Setting and set a program number (MPM □□□).

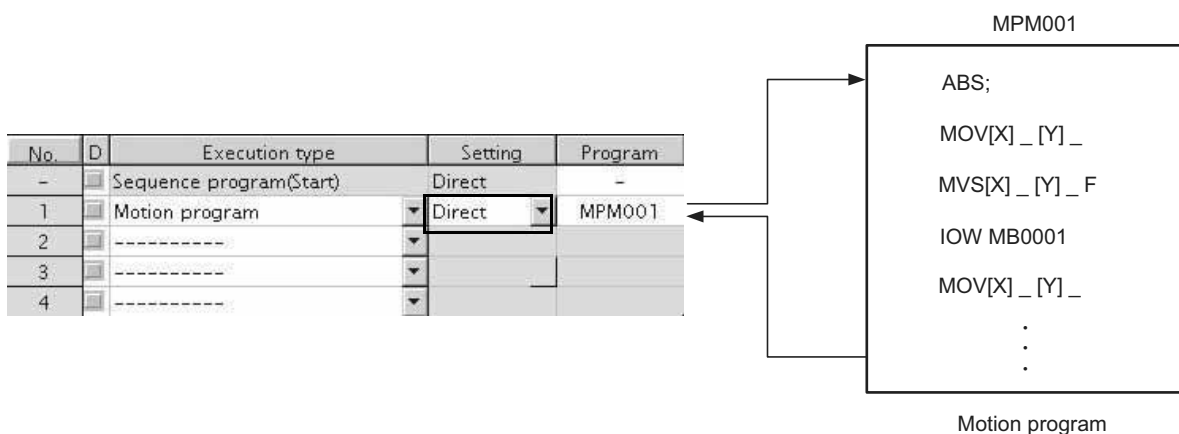

Fig. 5.1 Calling a Motion Program Using a Direct Designation - 1

■ A motion program referenced by a MSEE command from a ladder program

Set a program number to Program No. (□□□□□) in the MSEE command.

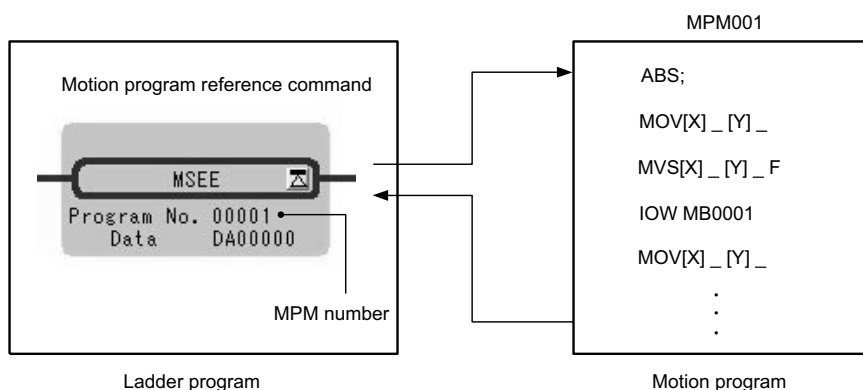

Fig. 5.2 Calling a Motion Program Using a Direct Designation -2

[b] Using an Indirect Designation to Call a Motion Program

An indirect designation method designates a motion program to call using a register.
 In this method, a program (MPM □□□) coinciding with value stored in the register is called.

■ A motion program registered in the M-EXECUTOR program execution definition

Select **Indirect** for the Setting. A register for the indirect designation is automatically mapped.

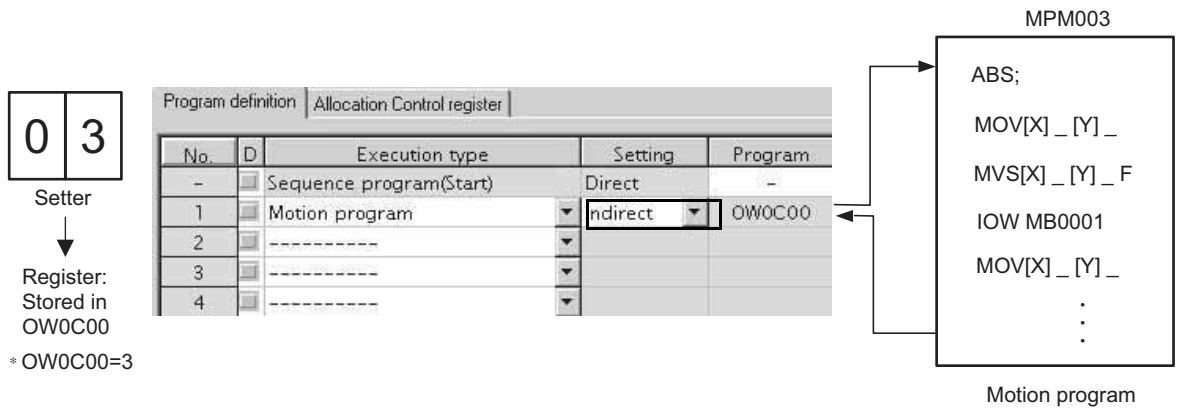

Fig. 5.3 Calling a Motion Program Using an Indirect Designation - 1

■ A motion program referenced by a MSEE command from a ladder program

Specify any register (M or D register) used for an indirect designation for Program No. in the MSEE command.

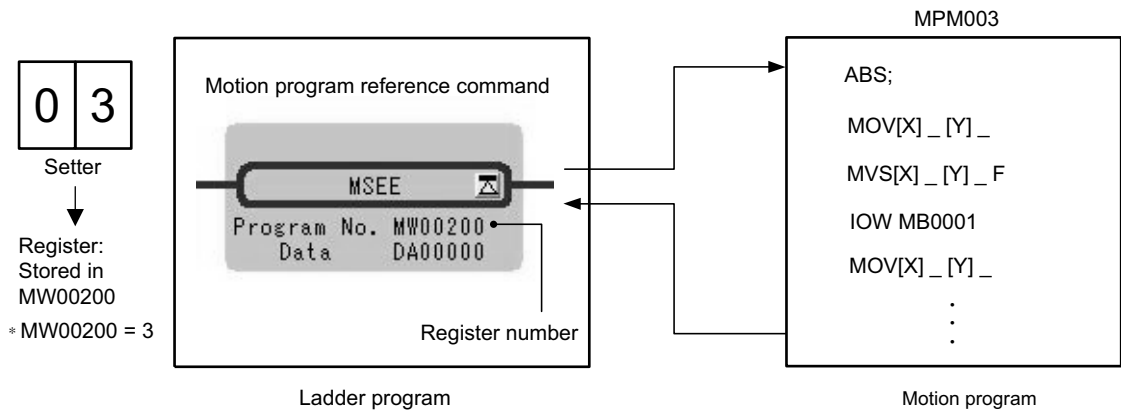

Fig. 5.4 Calling a Motion Program Using an Indirect Designation - 2

(4) Work Register

Configure and monitor a motion program via a work register.

The work register constitution for motion programs registered in the M-EXECUTOR program execution definition differs from that for motion programs referenced by a MSEE command from a ladder program.

The work register constitution in each case is as follows:

■ A motion program registered in the M-EXECUTOR program execution definition

The work register is assigned to a M-EXECUTOR control register. (automatically defined by system)

The M-EXECUTOR control register constitution is as follows:

No.	Item	M-EXECUTOR Control register
1	Program number	MPM001
	Status	IW0C00
	Control signal	OW0C01
	Override	OW0C02

← Work register (automatically defined by system)

M-EXECUTOR Control Register	Description
Status	Status flag of a motion program
Control Signal	Control Signal of a motion program
Override	Override for interpolation

■ A motion program executed by a MSEE command from a ladder program

Use a MSEE command of a ladder program to designate the work register (M or D register).

The work register constitution is as follows:

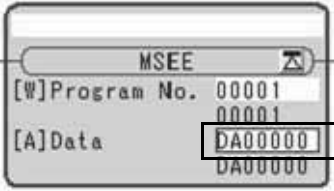

← Work register (designate M or D register)

Work Register	Description
First word	Status flag of a motion program
Second word	Control signal of a motion program
Third word	Override for interpolation
Fourth word	System work number

For more information on the work register, refer to the subsequent pages.

[a] Status Flag of a Motion Program

The motion program status flag shows the execution status of the motion program. The following table shows details of status flag.

[Status Flag]

Bit No.	Status
0	Program running
1	Program paused
2	Program stopped by stop request (used by system)
3	(Reserved)
4	Single program block operation stopped
5	(Reserved)
6	(Reserved)
7	(Reserved)
8	Program alarm
9	Stopped by brake point
A	(Reserved)
B	In debug mode (EWS debugging operation)
C	Program type 0: Motion program
D	Start request signal history
E	No system work error
F	Main program number exceeded error

- When program alarm has occurred, the error details of the motion program are stored in the error information screen and S registers.

[b] Control Signal

Program control signals (e.g., program operation start requests and program stop requests) need to be entered to execute the motion program.

The following types of signals for controlling motion programs are available.

Bit No.	Signal Name	Signal Type
0	Program operation start request	Differential or NO contact input
1	Program pause request	NO contact
2	Program stop request	NO contact
3	Program single block mode selection	NO contact
4	Program single block start request	Differential or NO contact input
5	Alarm reset request	NO contact
6	Program continuous operation start request	Differential or NO contact input
7	(Reserved)	
8	Skip 1 information	NO contact
9	Skip 2 information	NO contact
A	(Reserved)	
B	(Reserved)	
C	(Reserved)	
D	System work number setting* ¹	NO contact
E	Override setting for interpolation* ²	NO contact
F	(reserved)	

* 1. System work number setting

- When a motion program is registered in M-EXECUTOR:
Unable to designate it. The same system work number as No. defined in the system is used.
- When a motion program is invoked by a MSEE command from a ladder program:
OFF: A system work automatically retrieved by system is used. The system work number may differ in each case.
ON: A work with the designated system work number is used.
However, when a work occupied by M-EXECUTOR is designated, "BitE: Error without a system work" is reported to the status.

* 2. Override setting for interpolation

- OFF: 100% fixed at an override for interpolation
- ON: Depends on the designated override for interpolation.

Use signals conforming to the above signal types when writing ladder programs.

Note: Motion programs are executed if the program operation start request signal is ON when the power is turned ON.

■ Timing Chart for Motion Program Control Signals

The following figure shows an example of a timing chart for motion program control signals.

• Program Operation Start Request

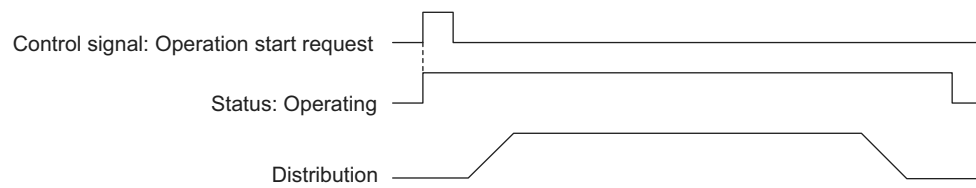

• Pause Request

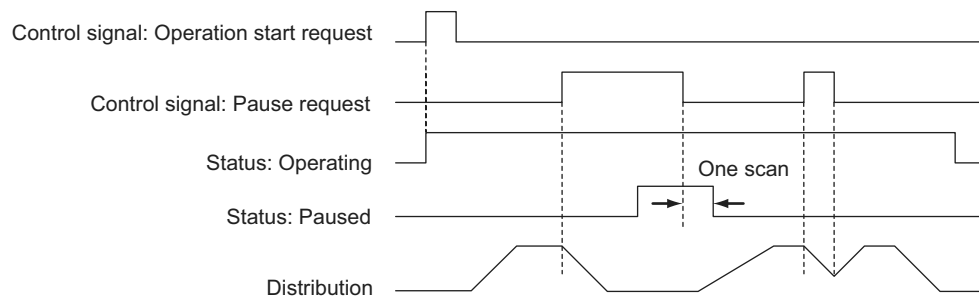

• Stop Request

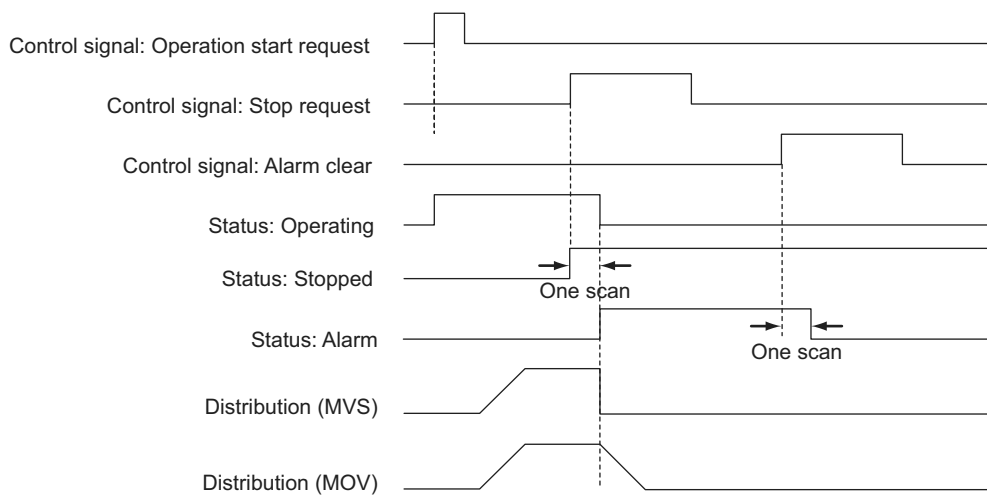

- An alarm will occur if the stop request is turned ON during axis operation using a motion command.

[c] Interpolation Override

The override when executing interpolation travel commands (setting; unit: 1 = 0.01%) is set.

This interpolation override is enabled only when the motion program control signal bit E (interpolation override setting) is ON.

[d] System Work Number

The system work number n (setting range: 1 to 16) used when executing motion programs is set by the MSEE work registers.

This system work number is enabled only when the motion program control signal bit D (system work number setting) is ON. The status bit, bit E (No system work error), will turn ON if the work number setting is outside the setting range or the specified system work is in use.

- The total number of system works of a motion program is 16 for both M-EXECUTOR and ladder. The number configured in the number of program definitions of the M-EXECUTOR detailed screen is set for the system work for M-EXECUTOR.

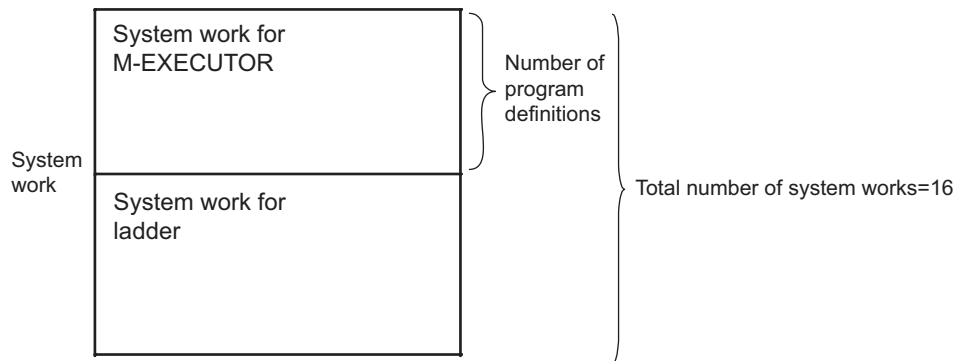

1. A work not occupied by M-EXECUTOR can execute a motion program using a MSEE command from a ladder program.
2. When the number of a system work occupied by M-EXECUTOR is specified by a ladder program, an alarm (Error without a system work) occurs. Therefore, when the number of program definitions is set to 16 in the M-EXECUTOR detailed screen, a motion program cannot be executed by a ladder MSEE command.
 - Error without a system work: Status flag Bit E of the motion program

(5) How to Operate a Work Register

The way to operate a work register of a motion program registered in the M-EXECUTOR program execution definition differs from that of a motion program referenced by a MSEE command from a ladder program.

The way to operate it in each case is shown as follows:

[a] A motion program registered in the M-EXECUTOR program execution definition

When a motion program is registered in M-EXECUTOR program execution definition, select one from the following two execution processings.

- A way to immediately control a motion program from external equipment
- A way to control a motion program via a sequence or ladder program

Now, this section explains each execution processing in the subsequent pages.

■ A Way to Immediately Control a Motion Program from External Equipment

M-EXECUTOR has a function which allocates any register to an M-EXECUTOR control register.

Using this function allows you to automatically exchange data between an M-EXECUTOR control register and an I/O register connected to an external equipment. This allows you to immediately control the motion program from the external equipment.

The following figure shows a setting example in this method.

Figure for allocating the M-EXECUTOR register

No.	Item	M-EXECUTOR Control register	Allocation Disable	Direction	Allocation register	Allocation Contact interlock
1	Program number	MPM001				
	Status	IW0C00	<input type="checkbox"/>	->	OW0000	IB00020
	Control signal	OW0C01	<input type="checkbox"/>	<-	IW0000	IB00020
	Override	OW0C02	<input type="checkbox"/>	<-	IW0001	IB00020

Specify any registers for mapping register and mapping interlock contact.

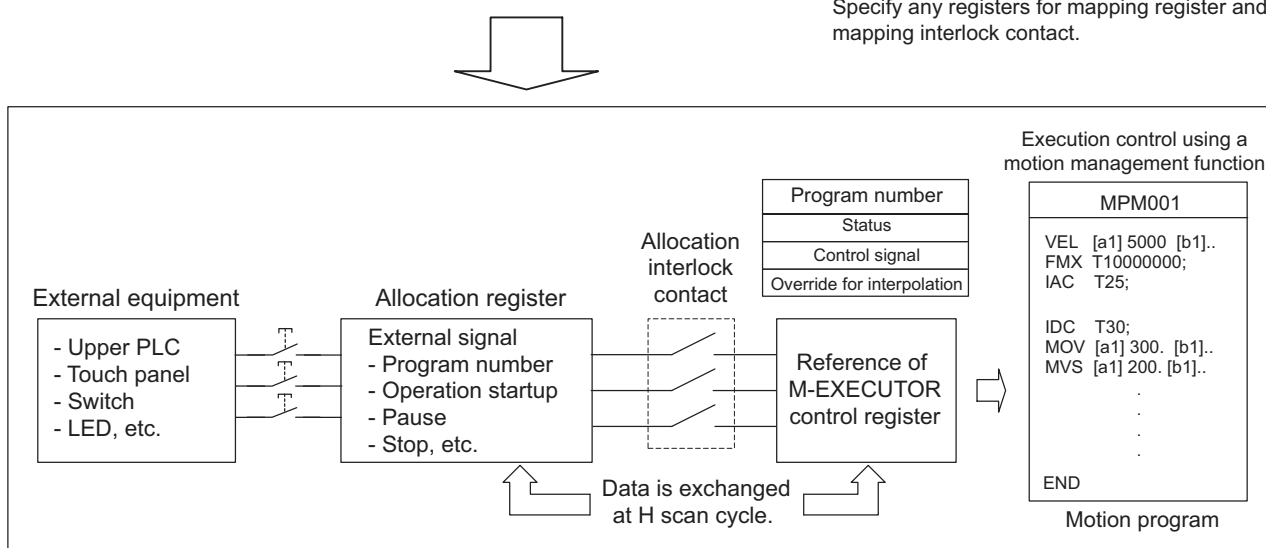

- An allocation contact interlock is used to interlock the operation of a motion program. When setting an allocation register, be sure to set an allocation contact interlock.

It is processed, as shown below, by turning ON/OFF an allocation contact interlock:

- When an allocation contact interlock contact is ON, data is exchanged between an allocation register and M-EXECUTOR control register at H scan cycle. Now, the motion program becomes executable.
- When an allocation contact interlock is OFF, data is not exchanged between an allocation register and M-EXECUTOR control register. Now, the motion program becomes unexecutable.
- When an allocation contact interlock is switched from ON to OFF while running a motion program, the running motion program stops and an axis in operation also stops. Now, the motion program falls into the alarm "1Bh: Executing an emergency stop command" state, and the status "Bit8: Program alarm is occurring" is turned ON.

Again, to execute a motion program, follow the procedure below for operation:

1. Switch the interlock contact from OFF to ON.
2. Turn ON a control signal "Bit5: Alarm reset request."
3. Make sure that the status "Bit8: Program alarm is occurring" is turned OFF.
4. Turn OFF the control signal "Bit5: Alarm reset request."
5. Turn ON a control signal "Bit0: Request for the program operation startup."

■ A Way to Control a Motion Program via a Sequence or Ladder Program

Without using the allocating function of the above mentioned M-EXECUTOR control register, controls a motion program via a sequence or ladder program.

To use this execution processing, save the blank Allocation register and the blank Allocation interlock contact as a blank.

In this case, the M-EXECUTOR control register configures and monitors the motion program.

The following figure shows a setting example in this method.

M-EXECUTOR program execution definition

No.	Item	M-EXECUTOR Control register	Allocation Disable	Direction	Allocation register	Allocation Contact interlock
1	Program number	MPM001				
	Status	IWOC00	<input type="checkbox"/>	->		
	Control signal	OWOC01	<input type="checkbox"/>	<-		
	Override	OWOC02	<input type="checkbox"/>	<-		

Save the mapping register and the mapping interlock contact as a blank.

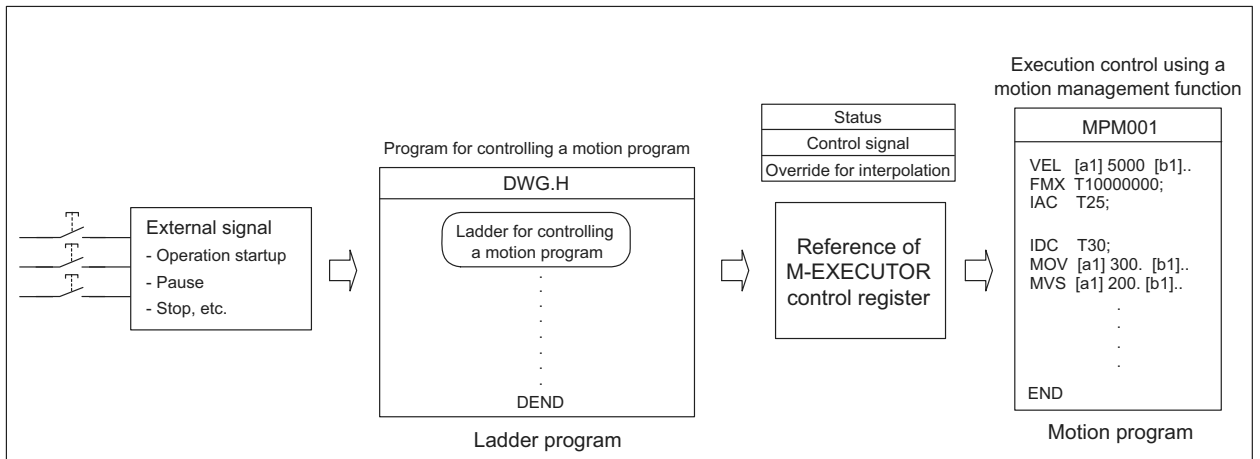
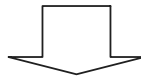

Each example which uses a sequence program and ladder program respectively as a program for controlling the motion program is shown as follows:

1. Example using a sequence program

```

OB80000 = IB00000;           "axis 1 servo on"
OB0C010 = PON( IB00001 DB000000 ); "program start"
OB0C011 = IB00002;         "hold"
OB0C012 = IB00003;         "program stop"
OB0C015 = IB00004;         "alarm reset"
OB8000F = IB00005;         "Turn ON a single axis servo"
IF NON( IB0C000 DB000001 ) == 1; "Is the program operation OFF?"
;                             "Process when program operation is stopped"
IEND;

END;
    
```

2. Example using a ladder program

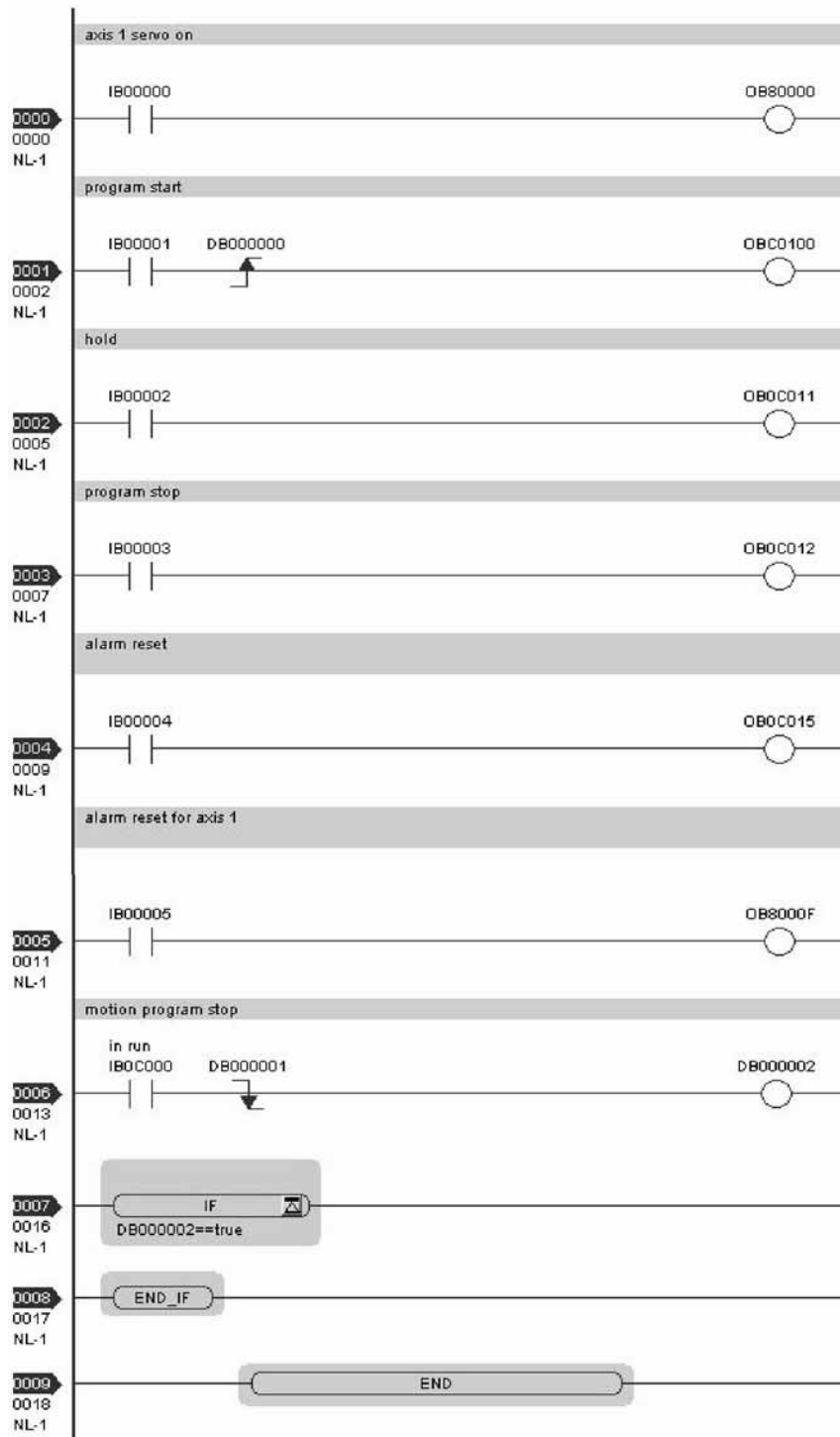

[b] A motion program referenced by a MSEE command from a ladder program

When a motion program is referenced by a MSEE command from a ladder program, control the motion program via a sequence or ladder program.

To use this execution processing, incorporate a MSEE command in the ladder H drawing. In this case, MSEE work register configures and monitors the motion program.

The following figure shows a setting example in this method.

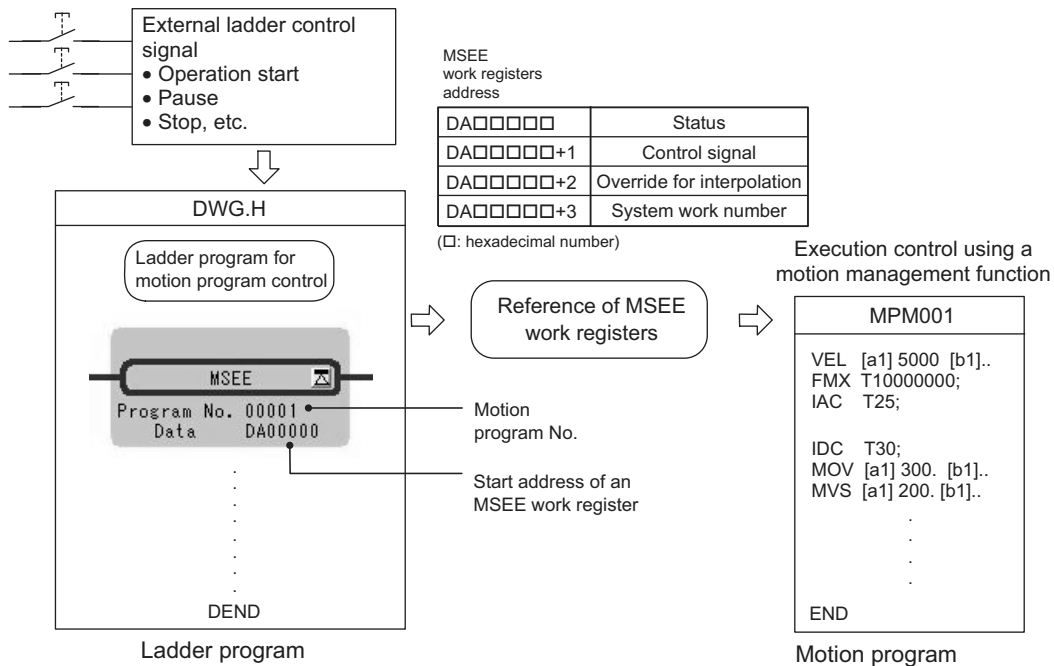

- For information about the meaning and estimation of the register number, refer to 5.3 *Registers* on page 5-36.

Each example which uses a sequence program and ladder program respectively as a program for controlling the motion program is shown as follows:

1. Example using a sequence program

```

OB80000 = IB00000;           "axis 1 servo on"
MB00010 = PON( IB00001 DB000000 ); "program start"
MB00011 = IB00002;         "hold"
MB00012 = IB00003;         "program stop"
MB00015 = IB00004;         "alarm reset"
OB8000F = IB00005;         "alarm reset for axis 1"
IF NON( MB00000 DB000001 ) == 1; "motion program stop"
;                             "Process when program operation is stopped"
IEND;

END;
  
```

Note: An MSEE command cannot be incorporated into a sequence program. Incorporate an MSEE command separately into a ladder H drawing.

2. Example using a ladder program

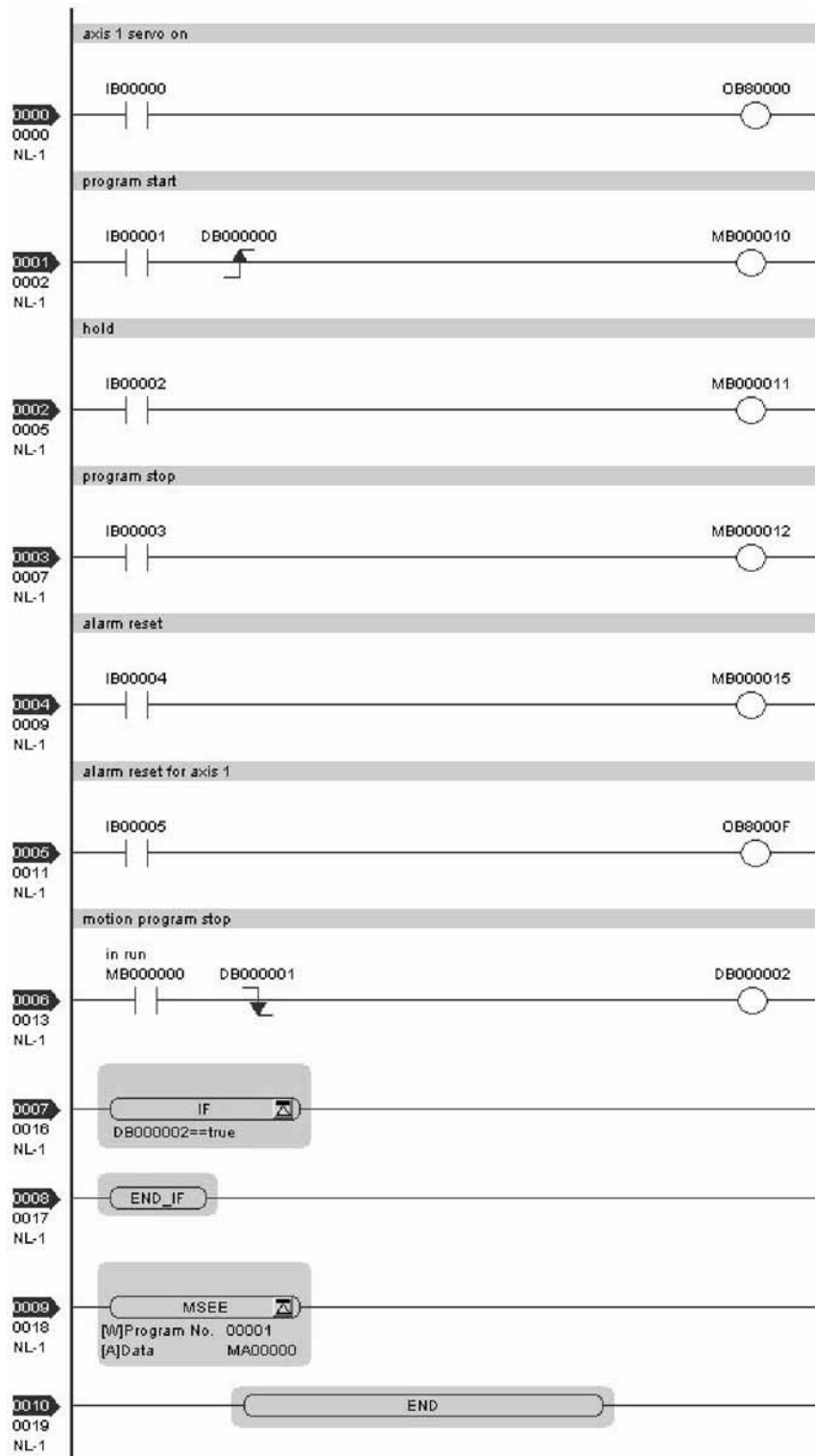

(6) Monitor the motion program execution information using S register

Using S register (SW03200 to SW04191) allows you to monitor the motion program execution information.

The way to monitor the execution information for a motion program registered in the M-EXECUTOR program execution definition differs from that for a motion program referenced by an MSEE command from a ladder program.

The way to monitor it in each case is shown as follows:

[a] A motion program registered in the M-EXECUTOR program execution definition

When a motion program is registered in the M-EXECUTOR program execution definition, the same system work number as the definition No. is used.

For example, a motion program is registered as “Definition No.”=3, the used system work number is “System Work”=3. In this case, the execution information for the motion program can be monitored in “Program Information Using Work 3” (=SW03380 to SW03437).

[b] A motion program referenced by an MSEE command from a ladder program

When a motion program is referenced by an MSEE command from a ladder program, the way differs, depending on the “BitD” setting (system work number setting) of the motion program control signal, as follows:

■ The motion program control signal “BitD, System Work Number Setting” = ON

The execution information is reported to “Program Information Using Work n” register (SW03264-SW04191).

For example, when “System Work Number”=1, the motion program execution information can be monitored in SW03264-SW03321 “Program Information Using Work 1”.

■ The motion program control signal “BitD, System Work Number Setting” = OFF

The used system work is automatically decided by system. Thus, to check which work is used, refer to “Running Program Number” (=SW03200 to SW03215).

For example, when you want to monitor the motion program MPM001 and SW03202=001, as used the work number=3, the execution information for the motion program MPM001 can be monitored in “Program Information Using Work 3” (=SW03380 to SW03437).

For more information on the register area of the motion program execution information, refer to the subsequent pages.

■ Register Areas for Motion Program Execution Information

Motion program execution information		Executing program number	
SW03200	Executing program number (No. of main program currently executing) 16W	SW03200	Program number used by work 1
SW03216	Reserved by the system. 16W	SW03201	Program number used by work 2
SW03232	Executing Program Bit (Executing when corresponding bit is ON) 16W	SW03202	Program number used by work 3
SW03248	Reserved by the system. 16W	SW03203	Program number used by work 4
SW03264	Program information used by work 1 58W	SW03204	Program number used by work 5
SW03222	Program information used by work 2 58W	SW03205	Program number used by work 6
SW03380	Program information used by work 3 58W	SW03206	Program number used by work 7
SW03438	Program information used by work 4 58W	SW03207	Program number used by work 8
SW03496	Program information used by work 5 58W	SW03208	Program number used by work 9
SW03554	Program information used by work 6 58W	SW03209	Program number used by work 10
SW03612	Program information used by work 7 58W	SW03210	Program number used by work 11
SW03670	Program information used by work 8 58W	SW03211	Program number used by work 12
SW03728	Program information used by work 9 58W	SW03212	Program number used by work 13
SW03786	Program information used by work 10 58W	SW03213	Program number used by work 14
SW03844	Program information used by work 11 58W	SW03214	Program number used by work 15
SW03902	Program information used by work 12 58W	SW03215	Program number used by work 16
SW03960	Program information used by work 13 58W		
SW04018	Program information used by work 14 58W		
SW04076	Program information used by work 15 58W		
SW04134	Program information used by work 16 58W		
SW04192	Reserved by the system. 928W		
SW05120	Reserved by the system. 64W		

Executing program bit	
SW03232	MP□016 (Bit15) to MP□001 (Bit0)
SW03233	MP□032 (Bit15) to MP□017 (Bit0)
SW03234	MP□048 (Bit15) to MP□033 (Bit0)
SW03235	MP□054 (Bit15) to MP□049 (Bit0)
SW03236	MP□080 (Bit15) to MP□055 (Bit0)
SW03237	MP□096 (Bit15) to MP□081 (Bit0)
SW03238	MP□112 (Bit15) to MP□097 (Bit0)
SW03239	MP□128 (Bit15) to MP□113 (Bit0)
SW03240	MP□144 (Bit15) to MP□129 (Bit0)
SW03241	MP□160 (Bit15) to MP□145 (Bit0)
SW03242	MP□176 (Bit15) to MP□161 (Bit0)
SW03243	MP□192 (Bit15) to MP□177 (Bit0)
SW03244	MP□208 (Bit15) to MP□193 (Bit0)
SW03245	MP□224 (Bit15) to MP□209 (Bit0)
SW03246	MP□240 (Bit15) to MP□225 (Bit0)
SW03247	MP□256 (Bit15) to MP□241 (Bit0)

Note: □ indicates M or S.

■ Details of Program Information Used by Work n

Program information used by work n

+0	Program status	
+1	Program control signal	
+2	Parallel 0 information	3W
+5	Parallel 1 information	3W
+8	Parallel 2 information	3W
+11	Parallel 3 information	3W
+14	Parallel 4 information	3W
+17	Parallel 5 information	3W
+20	Parallel 6 information	3W
+23	Parallel 7 information	3W
+26	Logical axis #1 program current position	2W
+28	Logical axis #2 program current position	2W
+30	Logical axis #3 program current position	2W
+32	Logical axis #4 program current position	2W
+34	Logical axis #5 program current position	2W
+36	Logical axis #6 program current position	2W
+38	Logical axis #7 program current position	2W
+40	Logical axis #8 program current position	2W
+42	Logical axis #9 program current position	2W
+44	Logical axis #10 program current position	2W
+46	Logical axis #11 program current position	2W
+48	Logical axis #12 program current position	2W
+50	Logical axis #13 program current position	2W
+52	Logical axis #14 program current position	2W
+54	Logical axis #15 program current position	2W
+56	Logical axis #16 program current position	2W

Executing program number
Executing block number
Error code

5.2.3 Sequence Program

A sequence program is a program described with motion language of text format.

The following table shows two types of sequence programs.

Category	Designation Method	Features	Number of Programs
Main program	SPM□□□ (□□□=1 to 256)	Calling from the M-EXECUTOR program execution definition	Up to 256 programs of the following types can be created: <ul style="list-style-type: none"> • Main motion program • Sub motion program • Main sequence program • Sub sequence program
Sub program	SPS□□□ (□□□=1 to 256)	Calling from the main program	

■ The program numbers of sequence programs are managed in the same manner as the motion program numbers. Assign a different number for each program number.

- Motion program MPM□□□: Program number of MPS□□□
- Sequence program SPM□□□: Program number of SPS□□□

(1) How to Run a Sequence Program

A sequence program is executed by registering it in the M-EXECUTOR program execution definition.

Sequence programs are executed in ascending numeric order.

The following figure shows an execution example.

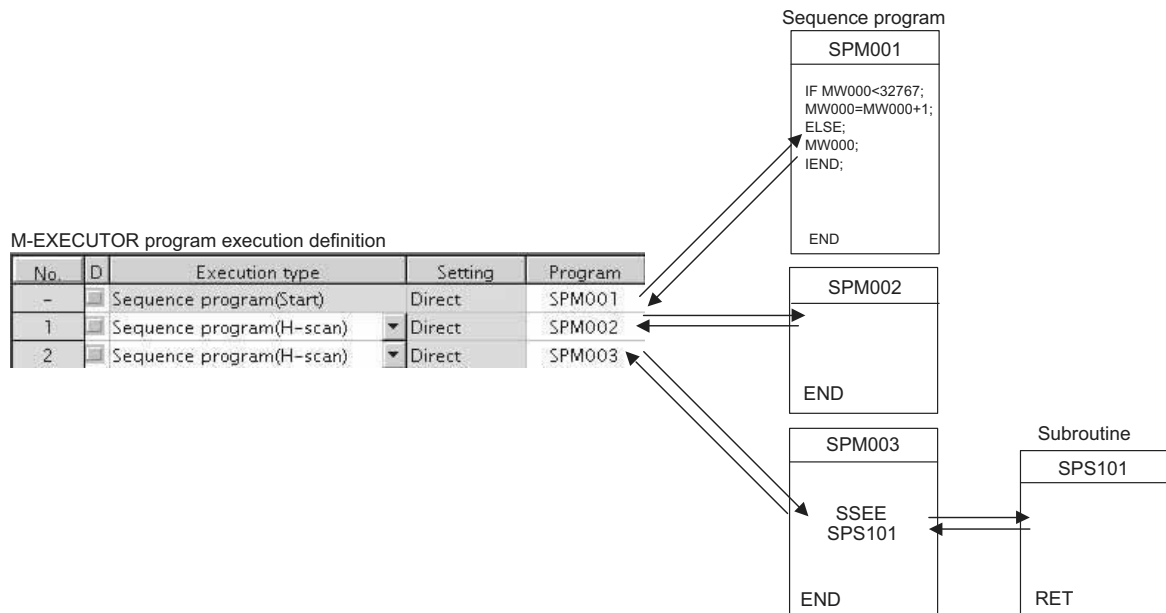

When the execution type is set to “**Sequence Program (H scan)**” or “**Sequence Program (L scan)**”, the program is executed at the time the definition is saved. When the execution type is set to **Sequence Program (Start)**, the program is executed when the power supply is turned ON again next time.

(2) How to Designate a Sequence Program

You can only designate a sequence program directly. Indirect designation is unavailable.
Use the program number (SPM□□□) when designating a sequence program to execute.

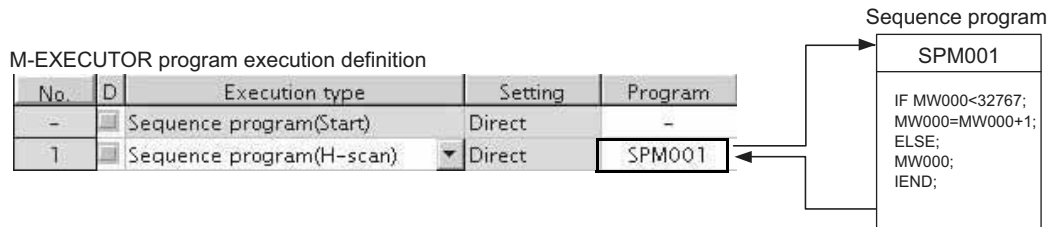

Fig. 5.5 Calling a Sequence Program

(3) Work Register

Monitor a sequence program through a work register.

A work register, similar to the motion program registered in M-EXECUTOR, has status flags in the M-EXECUTOR control register.

The following table shows the work register configuration of the sequence program.

Work Register	Content
Status	Status flag of a sequence program

[a] Status Flag of Sequence Program

The status flags of a sequence program allow you to know the execution status of the sequence program.

The following table explains the detailed contents of status flags.

[Status]

Bit No.	Status
0	Program running
1	(Reserved)
2	(Reserved)
3	(Reserved)
4	(Reserved)
5	(Reserved)
6	(Reserved)
7	(Reserved)
8	Program alarm is occurring
9	Stopping at breakpoint
A	(reserved)
B	In debug mode (EWS debug operation)
C	Program type 1: Sequence program
D	Start request history
E	(Reserved)
F	(Reserved)

■ Sequence program alarm

When referencing a sub sequence program (SSEE command execution) and an error is detected, “Bit8: Program alarm is occurring” is turned ON. If the error is cleared, it is turned OFF.

Error details are as follows:

Error Details
Called program is unregistered
Called program is not a sequence program
Called program is not a sub program (main program is called)
Called program number is over
Nest over error

5.2.4 Ladder Drawings (DWG)

(1) Types of Drawings

Ladder programs are managed in units of ladder drawings, which are identified by drawing numbers. These drawings form the basis of user programs.

Ladder drawings include parent drawings, child drawings, grandchild drawings, and operation error processing drawings. In addition to drawings, there are functions that can be freely accessed from each drawing.

- Parent Drawings

Parent drawings are automatically executed by the system program when the execution conditions, outlined in the table below, are met.

- Child Drawings

Child drawings are accessed using a SEE command from a parent drawing.

- Grandchild Drawings

Grandchild drawings are accessed using a SEE command from a child drawing.

- Operation Error Processing Drawings

Operation error processing drawings are automatically executed by the system program when an operation error occurs.

- Functions

Functions are accessed and executed from parent, child, and grandchild drawings using the FSTART command.

[a] Drawing Types and Order of Priority

Drawings are classified by their first letter (A, I, H, or L) based on the processing purpose. The following table outlines the order of priority and execution conditions for these drawings.

Type of Parent Drawing	Function	Priority	Execution Conditions	Max. No. of Drawings
DWG.A (Drawing A)	Startup processing	1	Power ON (Executed once only, when power turned ON)	64
DWG.I (Drawing I)	Interrupt processing	2	External interrupt (executed by Option Module DI interrupt or counter match interrupt)	64
DWG.H (Drawing H)	High-speed scan processing	3	Scheduled cycle startup (Executed each high-speed scan)	200
DWG.L (Drawing L)	Low-speed scan	4	Scheduled cycle startup (Executed each low-speed scan)	500

The following table provides details of the number of drawings for each drawing.

Drawing	Number of Drawings			
	DWG.A	DWG.I	DWG.H	DWG.L
Parent Drawings	1 (A)	1 (I)	1 (H)	1 (L)
Operation Error Processing Drawings	1 (A00)	1 (I00)	1 (H00)	1 (L00)
Child Drawings	Total: 62 max.	Total: 62 max.	Total: 198 max.	Total: 498 max.
Grandchild Drawings				

(2) Execution Control of Drawings

[a] Execution Control

The following table shows when each drawing is executed based on the order of priority.

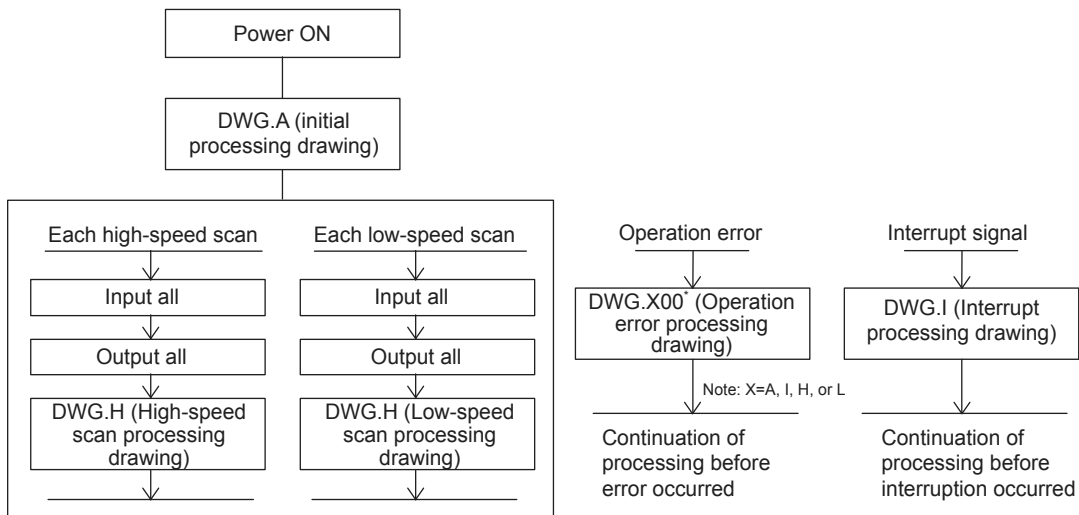

[b] Execution Schedule for Scan Processing Drawings

The scan processing drawings are not executed simultaneously. As shown in the following figure, the execution of each drawing is scheduled based on the order of priority and time sharing.



* Background processing is used to execute internal system processing, e.g., communication processing.

Low-speed scan processing is executed in spare processing time of the high-speed scan. Set the time of the high-speed scan to approximately double the total execution time for DWG.H.

[c] Hierarchical Structure of Drawings

Each processing program is made up of parent drawings, child drawings, and grandchild drawings. Parent drawings cannot call child drawings from a different type of drawing and child drawings cannot call grandchild drawings from a different type of drawing. Also, parent drawings cannot directly call grandchild drawings. Child drawings are always called from parent drawings and grandchild drawings are always called from child drawings. This is the hierarchical structure of drawings.

As shown in the following figure, each processing program is created from a hierarchy of parent, child, and grandchild drawings.

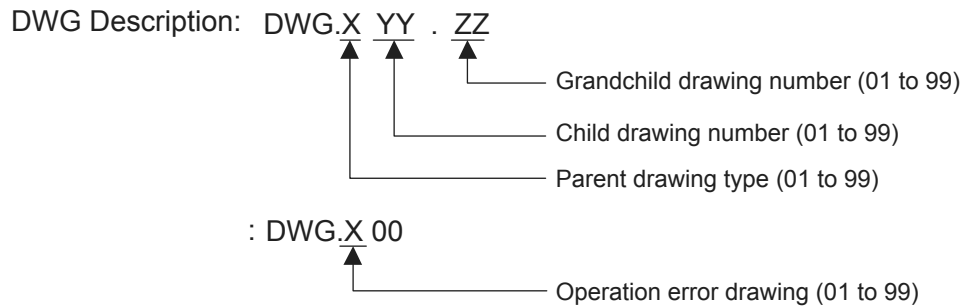
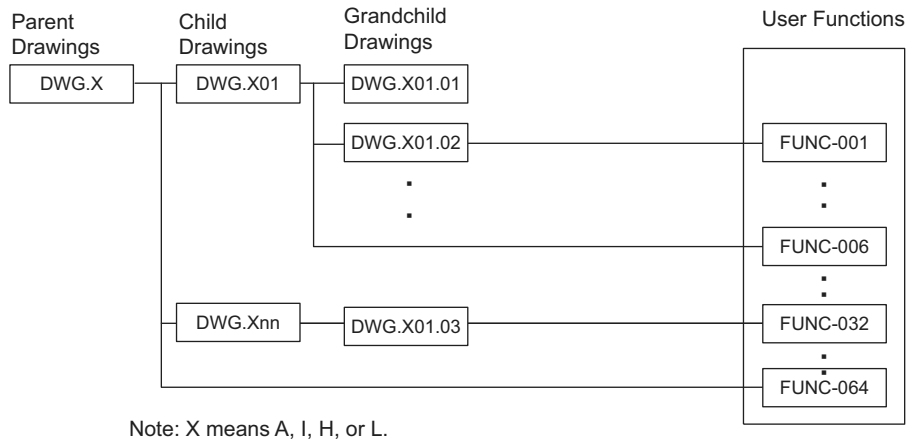

[d] Drawing Execution Processing Method

The execution processing of hierarchical drawings are performed by calling lower-level drawings from higher-level drawings.

The following figure shows the execution processing for drawings, using DWG.A as an example.

System programs are started according to execution conditions.

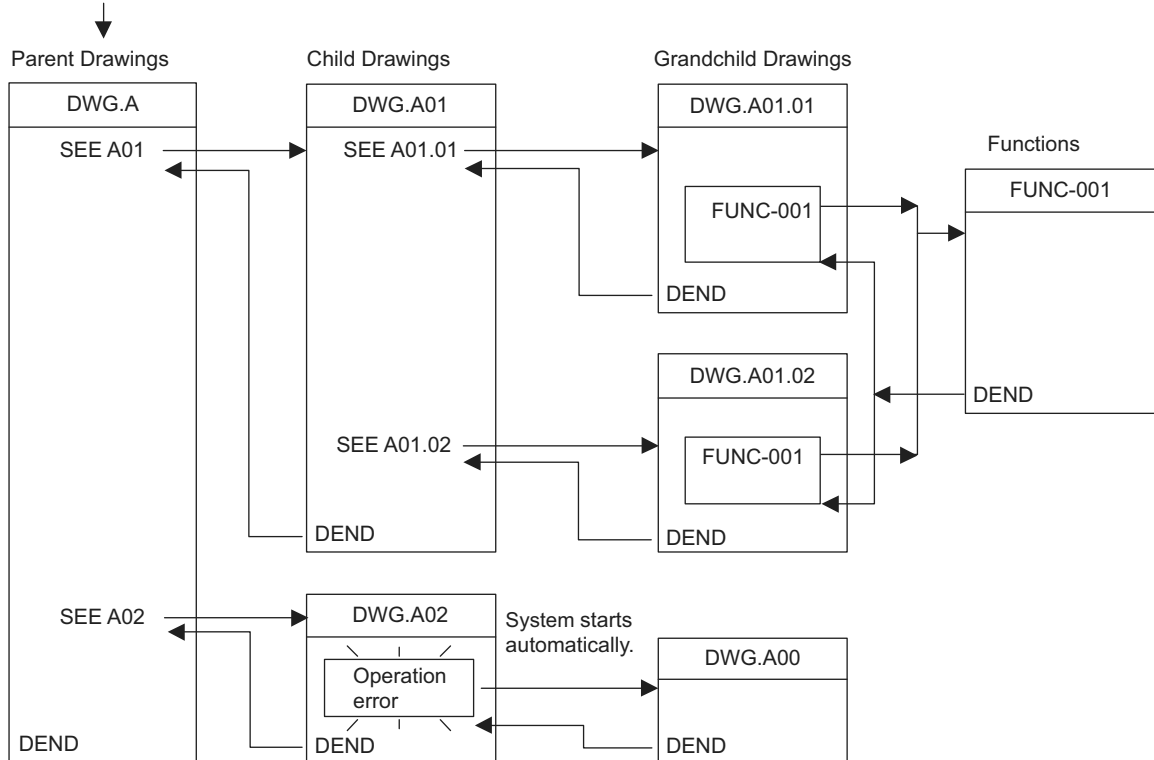

- Note: 1. Parent drawing is automatically called and executed by system. Therefore, you can execute the child and grandchild drawings by programming a DWG reference command (SEE command) in the parent and child drawings.
2. Functions can be referenced from any drawing. Functions can also be referenced from other functions.
3. When an operation error occurs, the operation error processing drawing for that drawing will be started.

(3) Functions

Functions are executed by calling them from parent, child, or grandchild drawings using the FSTART command. Functions can be called from any drawing, and the same function can be called at the same time from different types of drawings and from different levels of drawings. Another completed functions can also be called from functions. Using functions has the following advantages.

- Easier creation of user program components
- Easier writing and maintenance of user programs

Functions include standard system functions that are already in the system and user functions that are defined by the user.

[a] Standard System Functions

The transmission and other functions listed below are already created as standard system functions. Standard system functions cannot be changed by users.

Type	Name	Symbol	Contents
System functions	Counter	COUNTER	Incremental/decremental counter
	First in/first out	FINFOUT	First in/first out
	Trace function	TRACE	Data trace execution control
	Data trace read	DTRC-RD	Reads data from data trace memory to user memory
	Inverter trace read function	ITRC-RD	Reads trace data from inverter trace memory to user memory
	Message send	MSG-SND	Sends messages to external communication devices
	Message receive	MSG-RCV	Receives messages from external communication devices

[b] User Functions

The functions (programs) and the function definitions can be changed (programmed) freely by users. The maximum number of user functions that can be defined is 500 drawings.

- Refer to the following manual for information on defining functions.
 - *Machine Controller MP900/MP2000 Series User's Manual Ladder Programming*
(manual number: SIEZ-C887-1.2)
 - *Machine Controller MP900/MP2000 Series User's Manual Motion Programming*
(manual number: SIEZ-C887-1.3)
 - *Machine Controller MP900/MP2000 Series New Ladder Editor Programming Manual*
(manual number: SIEZ-C887-13.1)
 - *Machine Controller MP900/MP2000 Series New Ladder Editor User's Manual*
(manual number: SIEZ-C887-13.2)
 - *MP2000 Series Engineering Tool for Controller MPE720 Ver.6.0 User's Manual*
(manual number: SIEPC88070030)

5.3 Registers

This section describes the types of registers used in MP2300S user programs (mainly ladder programs) and how to use them.

5.3.1 Types of Registers

(1) DWG Registers

Registers used by ladder programs (ladder drawings; DWG). Each drawing can use the registers outlined in the following table.

Type	Name	Specification Method	Range	Details	Characteristics
S	System registers	SB, SW, SL, SFnnnnn (SAnnnnn)	SW00000 to SW08191	Registers provided by the system. SW00000 to SW00049 are cleared to all zeros when the system starts.	Common to all drawings
M	Data registers	MB, MW, ML, MFnnnnn (MAnnnnn)	MW00000 to MW65534	Registers shared by all drawings. Used, e.g., as an interface between drawings.	
I	Input registers	IB, IW, IL, IFhhhh (IAhhhh)	IW0000 to IW13FFF	Registers used for input data.	
O	Output registers	OB, OW, OL, OFhhhh (OAhhhh)	OW0000 to OW13FFF	Registers used for output data.	
C	Constants registers	CB, CW, CL, CFnnnnn (CAnnnnn)	CW00000 to CW16383	Registers that can only be called from programs.	
#	# registers	#B, #W, #L, #Fnnnnn (#Annnnn)	#W00000 to #W16383	Call-only registers Can be called only by corresponding drawing. The usage range is set by the user using MPE720.	Unique to each drawing
D	D registers	DB, DW, DL, DFnnnnn (DAnnnnn)	DW00000 to DW16383	Internal registers unique to each drawing. Can be used only by corresponding drawing. The usage range is set by the user using MPE720.	

Note: 1. n: Decimal number; h: Hexadecimal number

2. B, W, L, F, and A: Data type (B: Bit, W: Integer, L: Double-length integer, F: Real number, A: Address. Refer to 5.3.2 *Data Types* on page 5-39.)
3. Up to 32 D registers (32 words, DW0000 to DW0031) can be used when creating drawings, but this can be changed in the MPE720 Drawings Properties Window. Refer to the *Machine Controller MP900/MP2000 Series User's Manual MPE720 Software for Programming Device (SIEPC88070005□)* or, refer to *MP2000 Series Engineering Tool for Controller MPE720 Ver.6.0 User's Manual* (manual number: SIEPC88070030) for details.
4. S and M register data has a battery backup to ensure the data is held even if the MP2300S power is turned OFF and ON. Other register data is saved to flash memory, so when the MP2300S power is turned OFF to ON, data saved to flash memory is read and data not saved to flash memory is lost. It is recommended, therefore, that data to be held regardless of whether or not the power is turned OFF to ON should be written to M registers if possible.

(2) Function Registers

The following table shows the registers that can be used with each function.

Type	Name	Specification Method	Range	Details	Characteristics
X	Function input registers	XB, XW, XL, XFnnnnn	XW00000 to XW00016	Input to functions Bit input: XB000000 to XB00000F Integer input: XW00001 to XW00016 Double-length integer input: XL00001 to XL00015	Unique to each function
Y	Function output registers	YB, YW, YL, YFnnnnn	YW00000 to YW00016	Output from functions Bit output: YB000000 to YB00000F Integer output: YW00001 to YW00016 Double-length integer output: YL00001 to YL00015	
Z	Internal function registers	ZB, ZW, ZL, ZFnnnnn	ZW0000 to ZW00063	Internal registers unique to each function Can be used for function internal processing.	
A	External function registers	AB, AW, AL, AFhhhh	AW0000 to AW32767	External registers with the address input value as the base address. For linking with S, M, I, O, #, and DANnnnn.	
#	# registers	#B, #W, #L, #Fnnnnn (#Annnnn)	#W00000 to #W16383	Call-only registers Can be called only from the relevant function. The usage range is set by the user using MPE720.	
D	D registers	DB, DW, DL, DFnnnnn (DAnnnnn)	DW00000 to DW16383	Internal registers unique to each function. Can be called only the relevant function. The usage range is set by the user using MPE720.	
S	System registers	SB, SW, SL, SFnnnnn (SAnnnnn)	Same as DWG registers These registers are shared by drawings and functions. Pay attention to how these registers are to be used when calling the same function from a drawing of a different priority level.		
M	Data registers	MB, MW, ML, MFnnnnn (MAnnnnn)			
I	Input registers	IB, IW, IL, IFhhhh (IAhhhh)			
O	Output registers	OB, OW, OL, OFhhhh (OAhhhh)			
C	Constants registers	CB, CW, CL, CFhhhh (CAnnnn)			

- n: Decimal number; h: Hexadecimal number
- B, W, L, F, and A: Data type (B: Bit, W: Integer, L: Double-length integer, F: Real number, A: Address. Refer to 5.3.2 *Data Types* on page 5-39.)
- SA, MA, IA, OA, DA, #A, and CA registers can be used within functions.

(3) Register Ranges in Programs

The following figure shows DWG programs, function programs, and register call ranges.

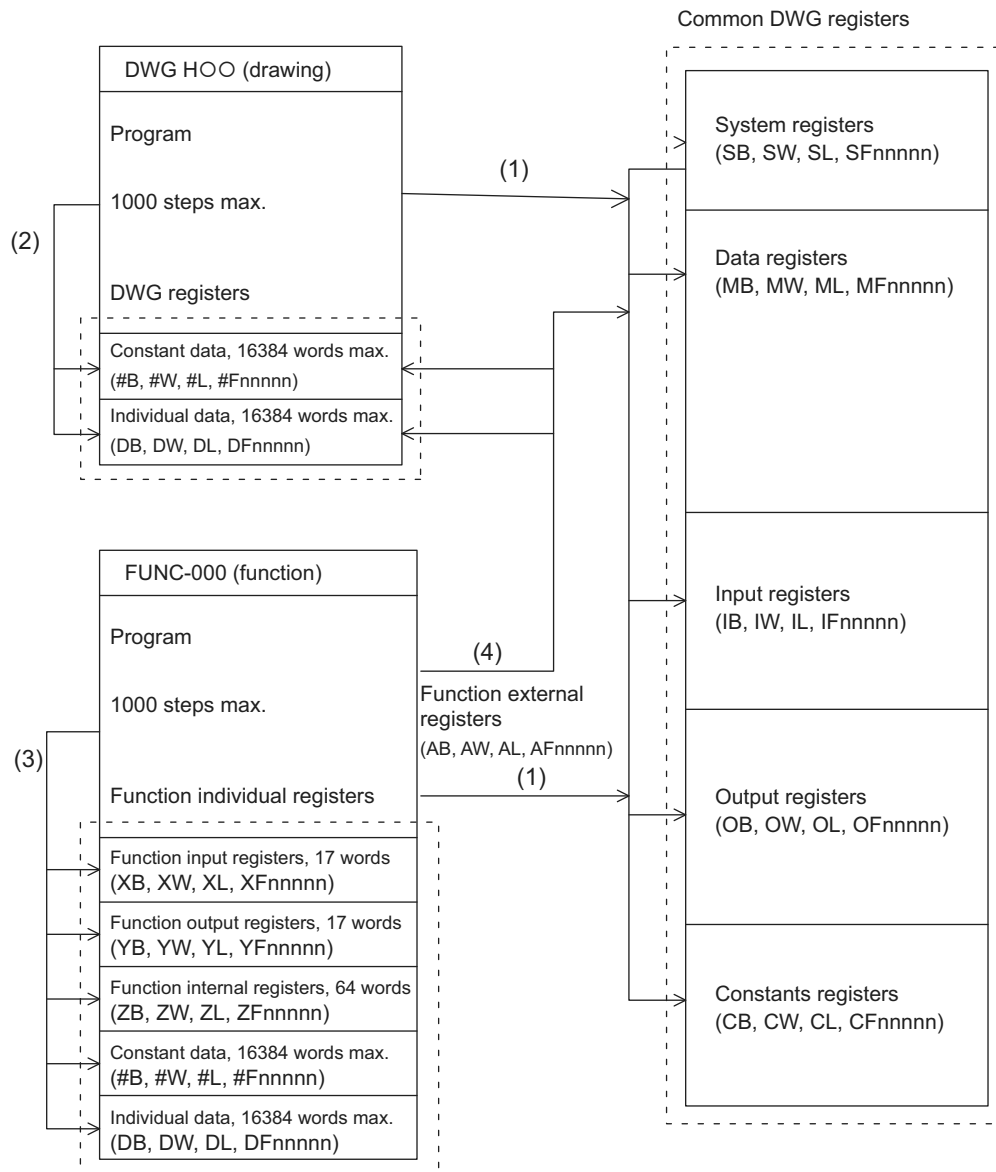

(1): Registers that are common to all drawings can be called from any drawing or function.

(2): Registers that are unique to each drawing can be called only from within the drawing.

(3): Registers that are unique to each function can be called only from within the function.

(4): Registers that are common to all drawings and registers that are unique to each drawing can be called from functions using the external function registers.

5.3.2 Data Types

There are five kinds of data: Bit, integer, double-length integer, real number, and address data. Each is used differently depending on the application. Address data, however, is used only inside functions when specifying pointers. The following table shows the types of data.

Type	Data types	Numeric Value Range	Remarks
B	Bit	0, 1	Used by relay circuits.
W	Integer	-32768 to +32767 (8000H) (7FFFH)	Used for numeric value operations. The values in parentheses () indicate use with logical operations.
L	Double-length integer	-2147483648 to +2147483647 (80000000H) (7FFFFFFFH)	Used for numeric value operations. The values in parentheses () are for use with logical operations.
F	Real number	$\pm (1.175E-38 \text{ to } 3.402E+38), 0$	Used for numeric value operations.
A	Address	0 to 32767	Used only when specifying pointers.

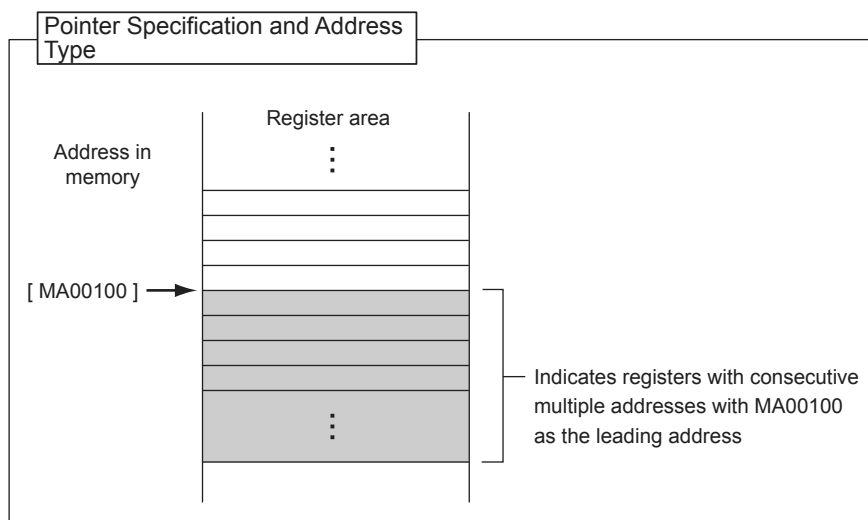
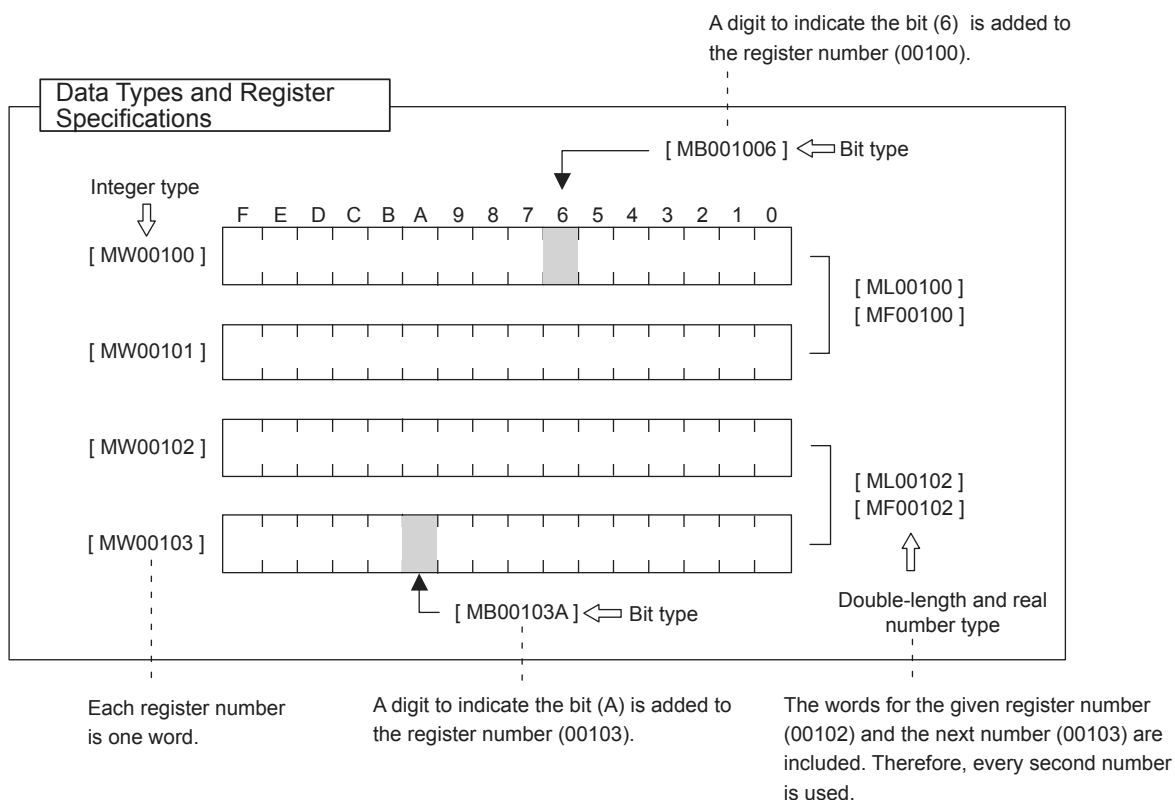

5.3.3 How to Use Subscripts i, j

Two type of registers (i, j) are available as dedicated registers to modify the relay and register numbers. Both i and j have the same function. They are used when you want to handle a register number as a variable. An example for each register data type is given as explanation.

(1) Bit Type Attached with a Subscript

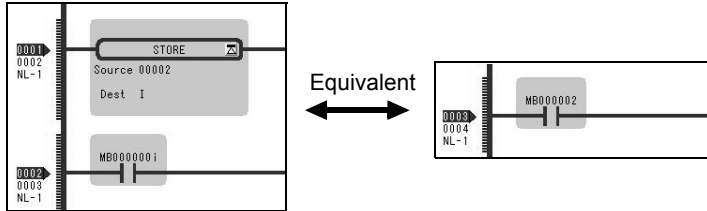

The result is a relay number added with i or j value. For example, MB000000i for i=2 is the same as MB000002. Also, MB000000j for j=27 is the same as MB00001B.

(2) Integer Type Attached with a Subscript

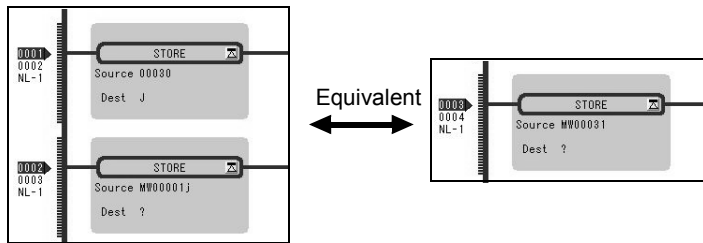

The result is a register number added with i or j value. For example, MW00010i for i=3 is the same as MW00013. Also, MW00001j for j=30 is the same as MW00031.

(3) Long Integer or Real Type Attached with a Subscript

Long integer type	Upper word	Lower word
ML00000j for j = 0: ML00000	MW00001	MW00000
ML00000j for j = 1: ML00001	MW00002	MW00001
Real type	Upper word	Lower word
MF00000j for j = 0: MF00000	MW00001	MW00000
MF00000j for j = 1: MF00001	MW00002	MW00001

The result is a register number with an added i or j value.

For example, “ML00000j for j=1” is the same as ML00001. Also, “MF00000j for j=1” is the same as MF00001.

However, as a word indicated by a register number is the lower word for a long integer/real type, for the same ML00001 and MF00001, be aware that an upper/lower word of ML00001 and MF00001 for j=0 may differ from those of

Program example using subscript

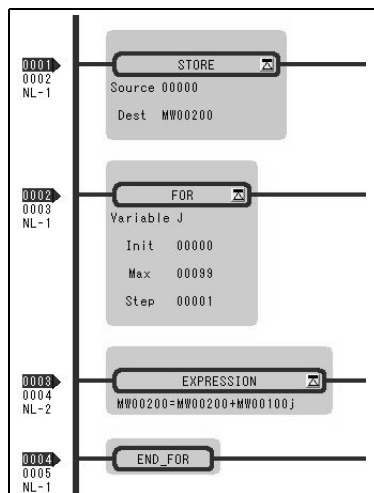

The left program uses a subscript j and calculates the total amount of a hundred registers from MW00100 to MW00199, and stores the total amount in MW00200.

5.3.4 Register Designation

Registers can be specified directly by register number or by symbol (register name). A combination of both of these register designation methods can be used in ladder programs. When using the symbol specification method, the relationship between symbols and register numbers must be defined. The following table shows the register specification methods.

Designation Method	Designation Example for Each Data Type
Register Number Direct Designation	Bit register: MB00100AX Integer register: MW00100X Double-length integer register: ML00100X Real number register: MF00100X Address register: MA00100X X: When specifying subscripts, subscript i or j is added after the register number.
Symbol Designation	Bit register: RESET1-A.X Integer register: STIME-H.X Double-length integer registers: POS-REF.X Real number registers: IN-DEF.X Address registers: PID-DATA.X ↓ 8 alphanumeric characters max. X: When specifying subscripts, a period (.) is added after the symbol (8 alphanumeric characters max.) and then a subscript i or j is added.

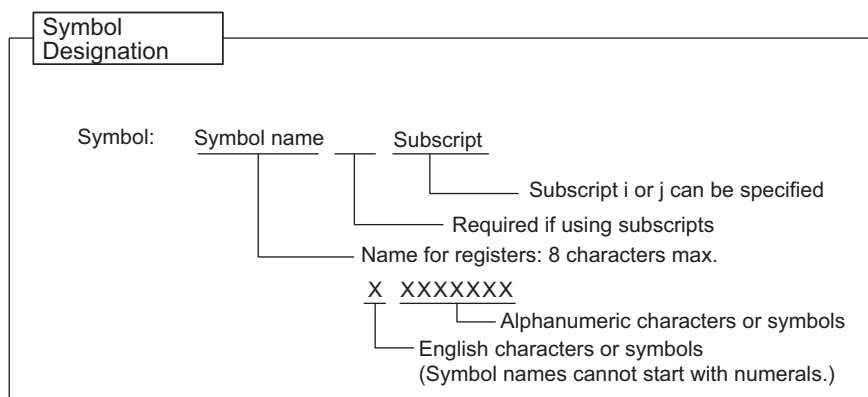
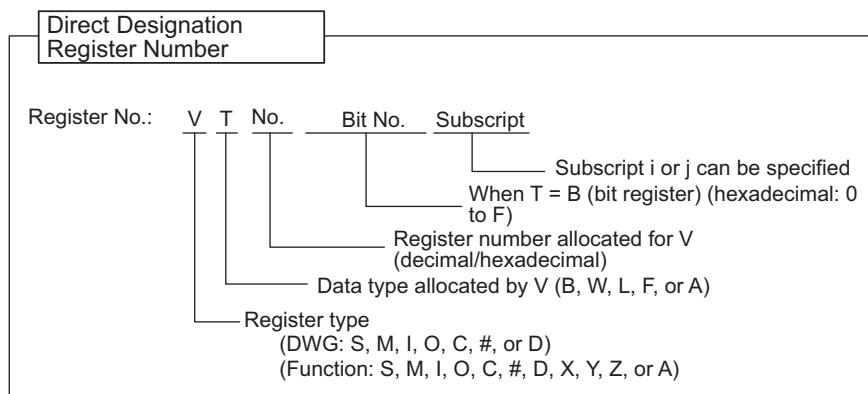

5.4 Self-configuration

The self-configuration function automatically recognizes the Optional Modules mounted to the MP2300S Basic Module and all slave data for slaves connected to the MECHATROLINK network, and automatically generates a definition file.

Self-configuration greatly simplifies the procedure needed to start the system.

Refer to 5.4.2 *Definition Information Updated with Self-Configuration* for items that are automatically generated.

[Execute Self-Configuration]

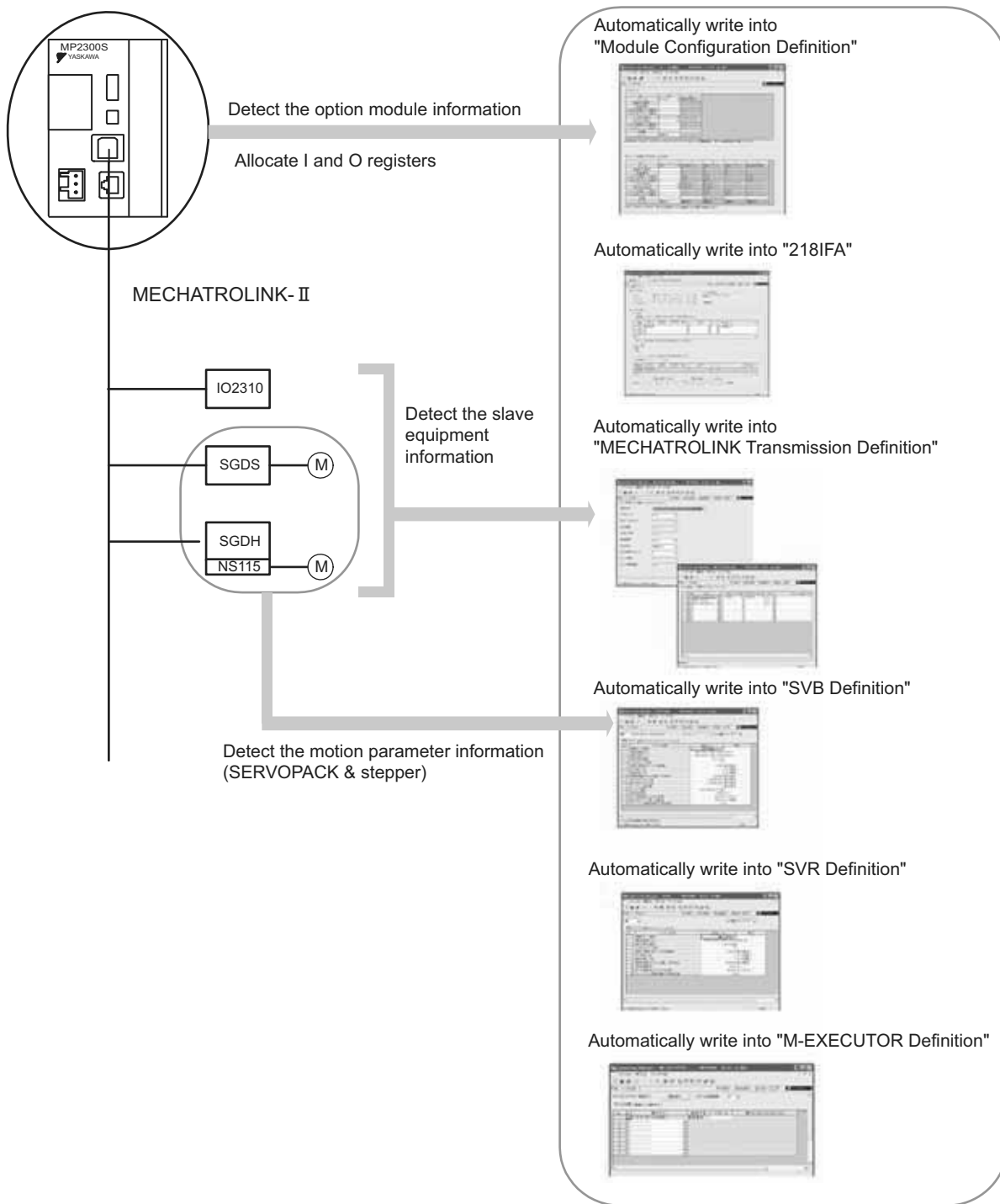

5.4.1 How to Execute Self-Configuration

The following two methods are available for executing the self-configuration.

- Execute the self-configuration (from DIP switch)
- Execute the self configuration (from MPE720)

Now, this section explains each way to execute the self-configuration:

(1) Procedure Using the DIP Switch

Self-configuration can be executed from the Basic Module DIP switch.

[a] When Executing the Self-Configuration First Time after Connecting Equipment

By performing the operation below, the self-configuration for all modules is newly executed, and all new definition files are created.

Before performing the operation, turn ON the power supply of equipment such as SERVOPACK.

■ Caution

Note that this operation can clear the following data in MP2300S.

- All definition files, all user programs, and all registers

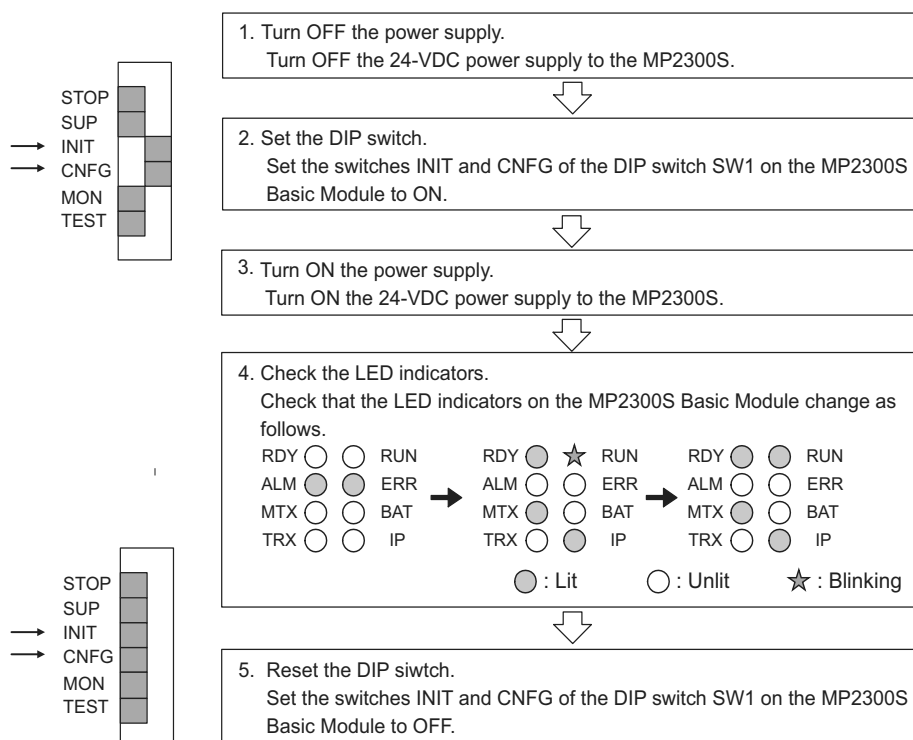

[b] Self-configuration after Adding Devices Such as SERVOPACKs

By performing the following operation, a definition for an axis newly detected in the MECHATROLINK transmission is created. The definitions for already mapped axes are not updated.

Before performing the operation, turn ON the power supply of devices such as SERVOPACK.

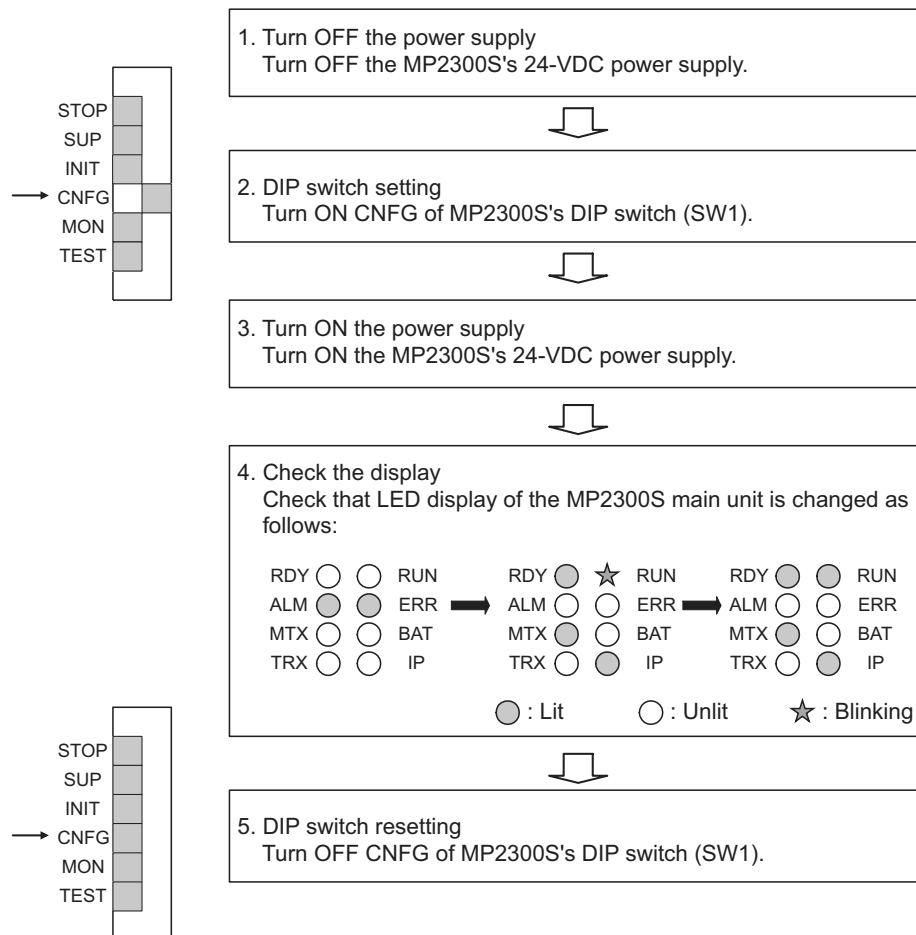

Note: Since a register mapping was manually changed after the self-configuration was last executed last time, input/output addresses may be changed by executing subsequent self-configurations. Also, when SVR is set to Disable, SVR may be reset to Enable. To retain the changed register mapping, etc., manually map a register to the additional devices instead of using self-configuration, and then update the definition file.

■ INIT Switch and RAM Data

RAM data will be cleared if the INIT switch of the DIP switch on the MP2300S Basic Module is ON and the power is turned ON. Flash memory data is read and overwritten when the INIT switch is OFF and the power is turned ON. Therefore, to protect RAM data, always save data to the MP2300S flash memory before turning OFF the power when writing or editing programs.

■ Turning OFF Power After Executing Self-configuration

Do not turn OFF the 24-VDC power supply to the MP2300S after executing self-configuration until the definitions data has been saved to flash memory in the MP2300S. If the power is somehow turned OFF before the data is saved to flash memory, re-execute the self-configuration.

(2) Procedure Using MPE720

Executing self-configuration from MPE720 allows self-configuration for individual Modules as well as for all modules.

When self-configuration is carried out from MPE720, a definition for any axis newly detected in the MECHATROLINK transmission is created. The definitions for already mapped axes are not updated.

This section explains each way to execute the self-configuration:

[a] Self-configuration for All the Modules

By performing the following operation, the self-configuration for MP2300S basic and option modules is executed. Before performing the operation, turn ON the power supply of equipment such as SERVOPACK.

1. Double-click **System - Module Configuration**.

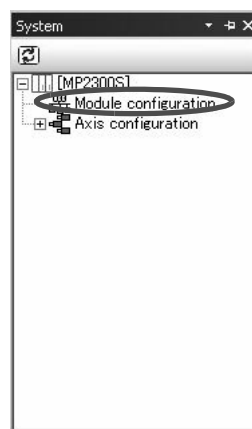

The **Engineering Manager** Window will open and the **Module Configuration** Window will appear.

2. Select **Order - Self Configure All Modules** to execute self-configuration.

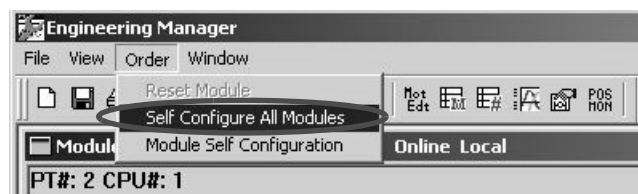

3. Click **Yes** for the following message.

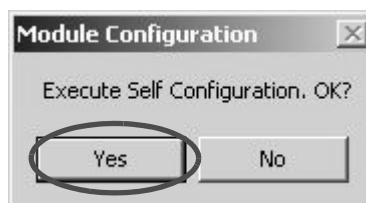

4. While running the self-configuration, the following message is shown.

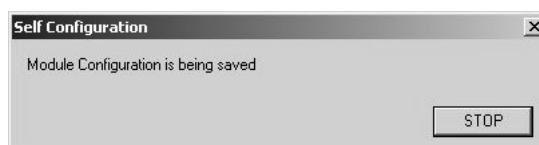

5. If the following warning message is shown after performing step 4, the module configuration definitions for CPU and MPE720 may differ from each other. Continue to perform step 6. When the message is not shown, go to step 9.



6. Select **Online(O) - Read from Controller(A)**.

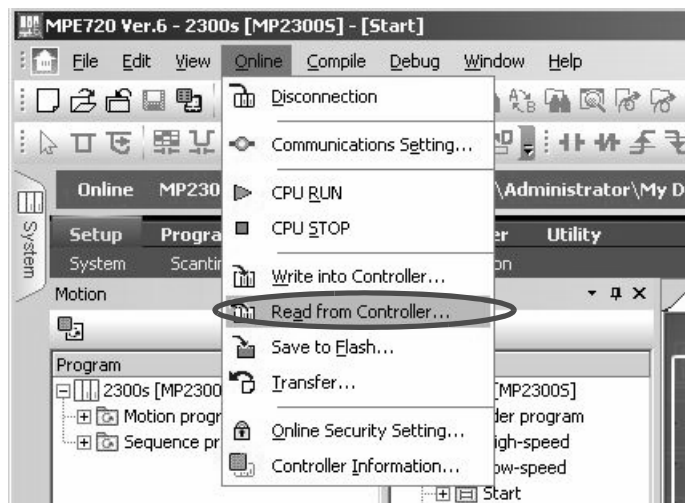

7. Click **Individual**, and only check **Module Configuration**.

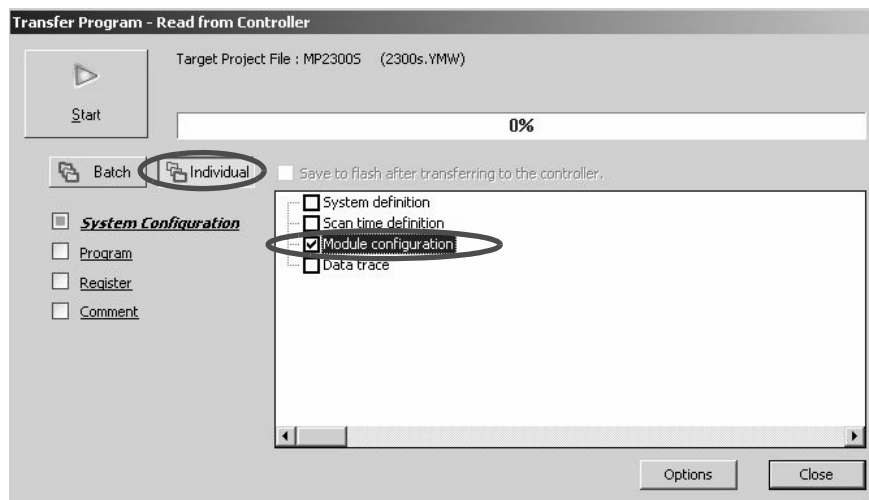

- Click **Start** to read the module configuration definition from a controller.

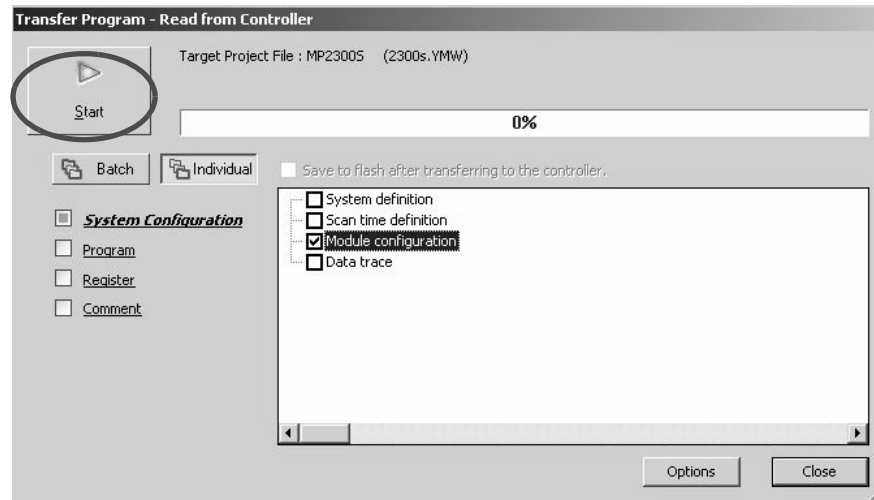

- Click the **Save & FLASH Save** Button to flash save the definition information.

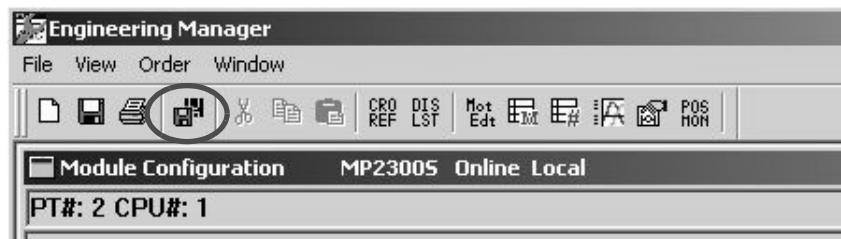

- Check that the definition is successfully created in the **Module Configuration** Window.

[b] Self Configuration of Each Module

If modules or devices are added, self-configuration can be executed separately for the Module (port) that has been changed.

By performing the following operation, self-configuration will be executed for the selected slot.

Before performing the operation, turn ON the power supply of devices such as SERVOPACK.

1. Double-click **System - Module Configuration**.

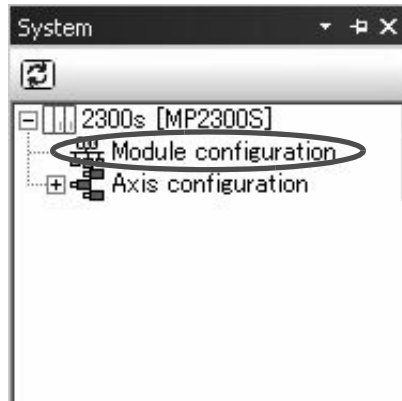

The **Engineering Manager** Window will start and the **Module Configuration** Window will appear.

2. Right-click the Module for which devices have been added and select **Module Self Configuration** from the pop menu to execute self-configuration.

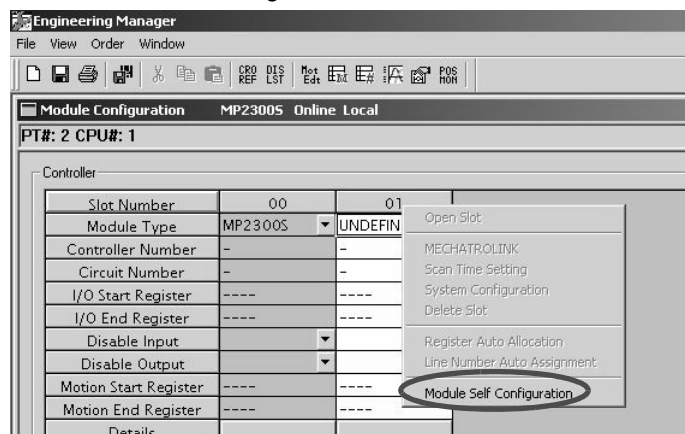

3. Click **Yes** for the following message.

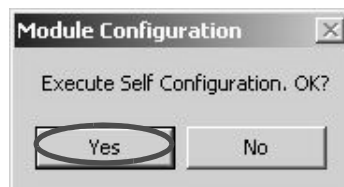

4. While running the self-configuration, the following message is shown.

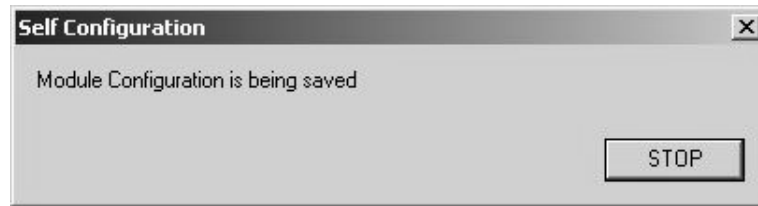

5. If the following warning message is shown after performing step 4, the module configuration definitions for CPU and MPE720 may differ from each other. Continue to perform step 6. When the message is not shown, go to step 9.



6. Select **Online(O) - Read from Controller(A)**.

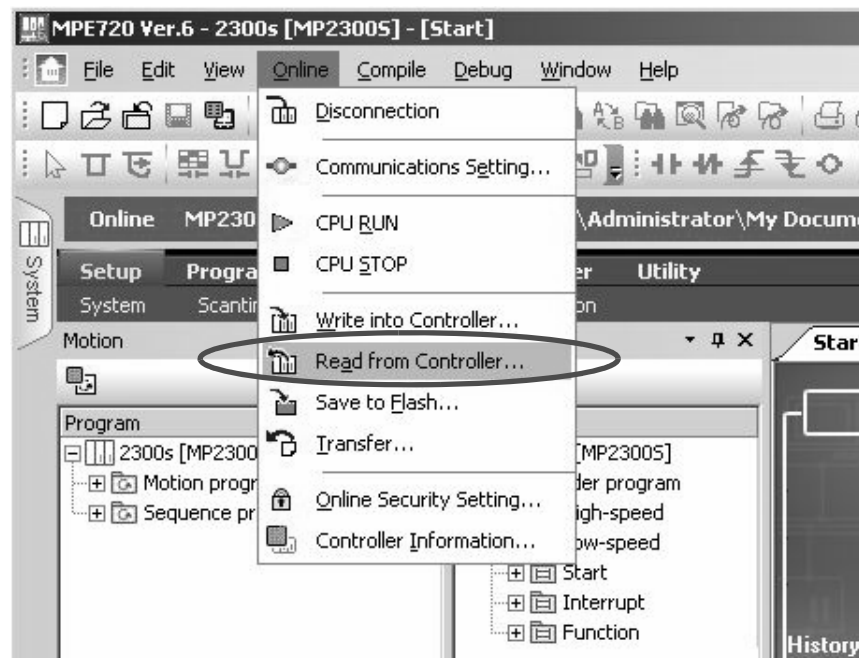

7. Click **Individual**, and only check **Module Configuration**.

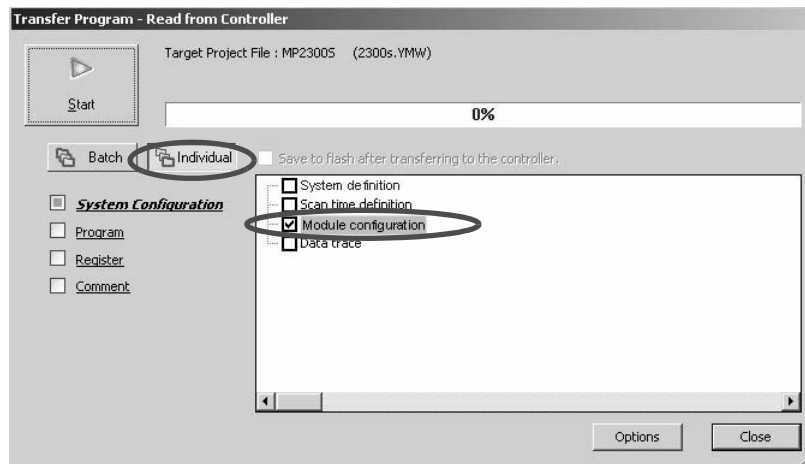

8. Click **Start** to read the module configuration definition from a controller.

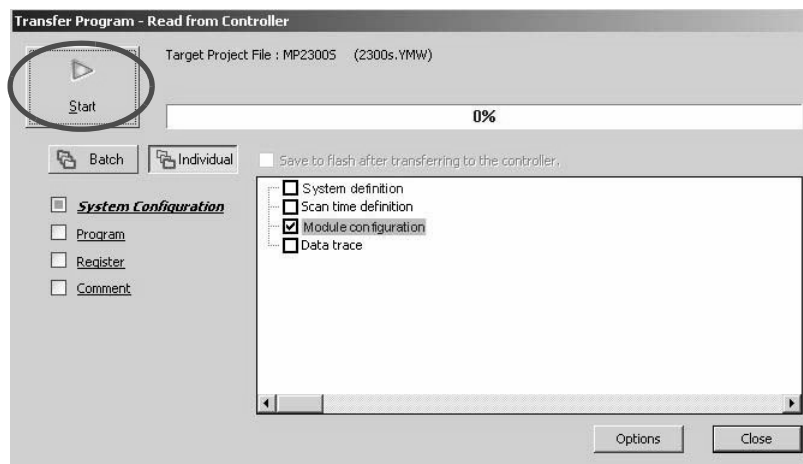

9. Click the **Save & FLASH Save** Button to flash save the definition information.

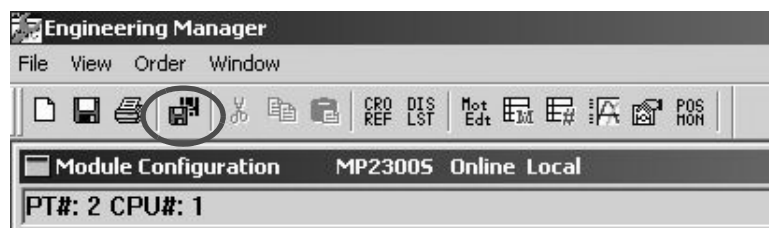

10. In the **Module Configuration Definition** Window, check that the definition has been created.

5.4.2 Definition Information Updated with Self-Configuration

Now, the definition information updated during executing the self-configuration and the module configuration definition example based on the module combination are as follows:

(1) Definition Data of MP2300S Basic Module

[a] I/O Allocations

Item		Allocation
218IFA		<ul style="list-style-type: none"> Start I/O register: IW0000/OW0000 End I/O register: IW07FF/OW07FF (Input register: IW0000 to IW07FF Output register: OW0000 to OW07FF)
SVB	MECHATROLINK	<ul style="list-style-type: none"> Start I/O register: IW0800/OW0800 End I/O register: IW0BFF/OW0BFF (Input register: IW0800 to IW0BFF Output register: OW0800 to OW0BFF)
	Motion Parameter	<ul style="list-style-type: none"> Start motion register: IW8000/OW8000 End motion register: IW87FF/OW87FF (Input register: IW8000 to IW87FF Output register: OW8000 to OW87FF)
SVR	Motion Parameter	<ul style="list-style-type: none"> Start motion register: IW8800/OW8800 End motion register: IW8FFF/OW8FFF (Input register: IW8800 to IW8FFF Output register: OW8800 to OW8FFF)
M-EXECUTOR		<ul style="list-style-type: none"> Start I/O register: IW0C00/OW0C00 End I/O register: IW0C3F/OW0C3F (Input register: IW0C00 to IW0C3F Output register: OW0C00 to OW0C3F)

[b] 218IFA Definition

Item	Allocation
Local IP Address	192.168.1.1
Subnet Mask	255.255.255.0
Gateway IP Address	0.0.0.0
Module Name Definition	“CONTROLLER NAME”
System Port (engineering port)	9999 (UDP)
Check & Monitor Time of MEMOBUS response	0 s
Retransmit Count	0

Note: The self-configuration allows you to connect with MPE720 for engineering transmission. In order to carry out MEMOBUS message transmission, manually use an automatic reception and I/O message communication separately, or MSG-SND/MSG-RCV functions are required.

[c] SVB Module Definitions

MECHATROLINK transmission definitions are automatically set according to the detected communication method and the number of slaves.

For more information on self-configuration for SVB module, refer to Chapter 3 of *Machine Controller MP2000-series SVB/SVB-01 Motion Module User's Manual* (manual number: SIEPC88070033).

■ Master

Item	MECHATROLINK-II (32-byte mode)				MECHATROLINK-II (17-byte mode)		MECHATROLINK-I
	Maximum Slave Station Number	1 to 8	9	10 to 16	17 to 21	1 to 14	
Number of Transmit Bytes	31 bytes				16 bytes		—
Communication Cycle	1ms	1ms	2ms	2ms	1ms	1ms	2ms
Number of Retry Stations	1	0	5	21: Maximum station number	1	0	14
Number of Slave Stations	8	9	16	Maximum station number	14	15	14

■ Slave

Item	MECHATROLINK-II (32-byte mode)	MECHATROLINK-II (17-byte mode)	MECHATROLINK-I
Number of Transmit Bytes	—	—	—
Communication Cycle	1ms	1ms	2ms
Number of Slave Stations	30	30	15

Note: To use MP2300S/SVB as a Slave, before executing the self-configuration, the parameter setting for MECHATROLINK transmission definition must be set to Slave in MPE720.

[d] SVR Definition

Type	No.	Name	Allocation
Fixed Parameter	0	Selection of Operation Modes	Axis unused
	1	Function Selection Flag 1	0000h
	4	Reference Unit Selection	pulse
	5	Number of Digits below Decimal Point	3
	6	Travel Distance per Machine Rotation	10000 reference unit
	8	Servo Motor Gear Ratio	1 rev (rotation)
	9	Machine Gear Ratio	1 rev (rotation)
	10	Infinite Length Axis Reset Position (POSMAX)	360000 reference unit
	34	Rated Motor Speed	3000 min ⁻¹
	36	Number of Pulses per Motor Rotation	65536 pulse/rev
	42	Feedback Speed Movement Averaging Time Constant	10 ms
Setting Parameter	OW□□00	RUN Command Setting	0000h
	OW□□03	Function Setting 1	0011h
	OW□□08	Motion Command	0: No command
	OW□□09	Motion Command Control Flag	0000h
	OW□□0A	Motion Subcommand	0: No command
	OL□□0C	Torque/Thrust Reference Setting	0.00 %
	OL□□10	Speed Reference Setting	3000 10**n reference unit/min
	OL□□16	Secondly Speed Compensation	0.00 %
	OL□□1C	Position Reference Setting	0 reference unit
	OW□□31	Speed Compensation	0.00 %
	OL□□36	Straight Line Acceleration/ Acceleration Time Constant	0 ms
	OL□□38	Straight Line Deceleration/ Deceleration Time Constant	0 ms
	OW□□3A	Filter Time Constant	0.0 ms
	OW□□3B	Bias Speed for Index Deceleration/ Acceleration Filter	0 reference unit/s
	OW□□3D	Width of Starting Point Position Output	100 reference unit
	OL□□44	STEP Travel Distance	1000 reference unit
	OL□□48	Zero Point Position in Machine Coordinate System Offset	0 reference unit
	OL□□4A	Work Coordinate System Offset	0 reference unit
OL□□4C	Number of POSMAX Turns Presetting Data	0 turn	
OW□□5C	Fixed Parameter Number	0	

[e] M-EXECUTOR Definition

Item	Allocation
Number of Program Definitions	8
Program Allocation	None
Control Register Allocation	None

5.5 Precaution on Using MP2300S

This section explains precautions when a user definition file is configured/changed and when setting a scan time.

5.5.1 Precautions when User Definition File is Configured/Changed

System settings, scan time settings, and module configuration definitions must be saved in flash memory (flash save). When a system setting, scan time setting, or module configuration definition is configured/changed, be sure to use MPE720 to flash save it. Note that when the MP2300S power supply is turn ON again without flash saving, the configured/changed data may be lost.

- System Setting

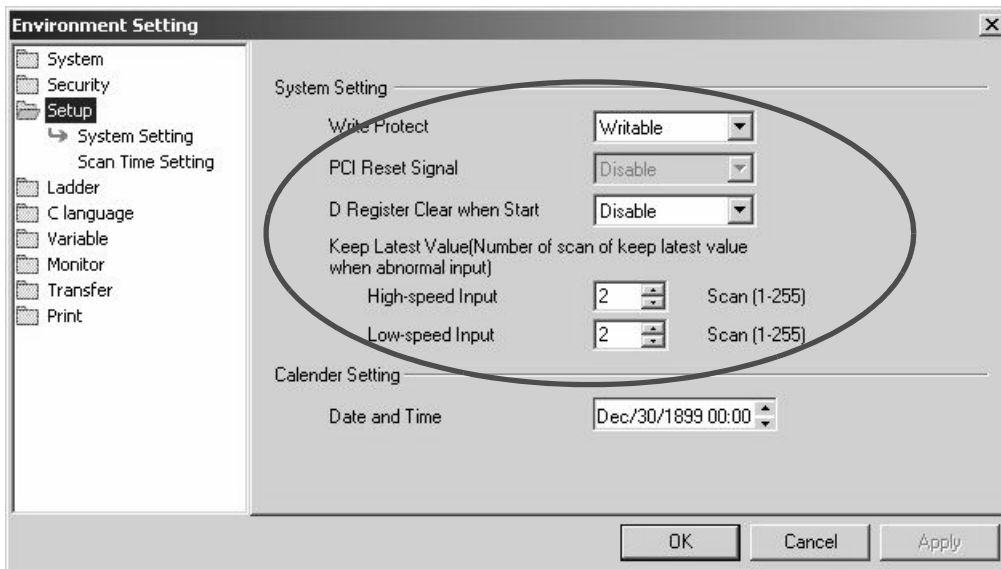

- Scan Time Setting

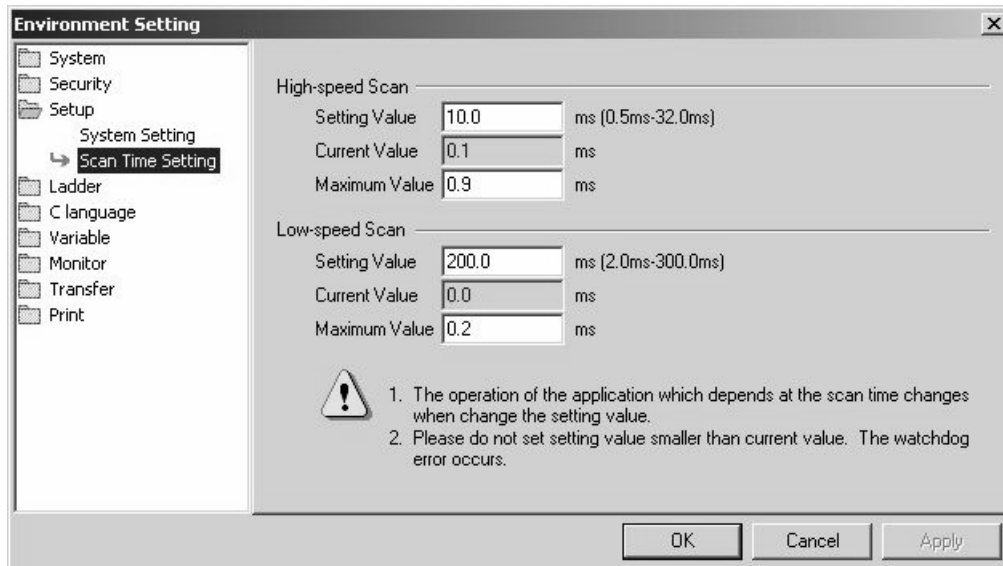

- Module Configuration Definition

The screenshot shows the 'Module Configuration' software interface. The title bar indicates 'MP2300S Online Local' and 'PT#: 2 CPU#: 1'. The interface is divided into two main sections: 'Controller' and 'Module Details'.

Controller Section:

Slot Number	00	01
Module Type	MP2300S	UNDEFINED
Controller Number	-	-
Circuit Number	-	-
I/O Start Register	----	----
I/O End Register	----	----
Disable Input		
Disable Output		
Motion Start Register	----	----
Motion End Register	----	----
Details		
Status	Running	

MP2300S: Controller module with network servo control, ethernet, virtual axes, program control function.

Module Details Section (MP2300S SLOT#00):

Slot Number	1	2	3	4	5
Module Type	CPU	218IFA	SVB	SVR	M-EXECUTOR
Controller Number	-	01	01	01	-
Circuit Number	-	01	01	02	-
I/O Start Register	----	0000	0800	----	0C00
I/O End Register	----	07FF	0BFF	----	0C3F
Disable Input		Enable	Enable		
Disable Output		Enable	Enable		
Motion Start Register	----	----	8000	8800	----
Motion End Register	----	----	87FF	8FFF	----
Details			MECHATROLINK		
Status	Running	Running	Running	Running	Running

CPU: CPU module. CPU operation, such as a scan time setup and a system definition, is set up.

5.5.2 Setting or Changing Module Configuration Definition Files

Observe the following precautions when setting or changing module configuration definition files.

- Always check to make sure that the mounted Module is the one that is defined.
- Be sure to save any new settings or changes to flash memory.
- After the settings or changes have been completed, turn the power supply to the MP2300S OFF and ON.

5.5.3 Setting and Changing the Scan Time

(1) Precautions When Setting or Changing the Scan Time

The scan time can be set and changed in the **Scan Time Setting** Window in the **Environmental Setting** Dialog Box on the MPE720.

Observe the following precautions when setting or changing the scan time.

- Set the set values of the scan time for both the high-speed (H) and low-speed (L) scans to at least the maximum time required to execute the scans. We recommend setting the set values of the scan time using the formula (set value – maximum time to execute scan) $\geq (0.2 \times \text{set values of the scan time})$, i.e., setting the set values of the scan time to at least 1.25 times the maximum times required to execute the scans.

Note: If the scan time is set too close to the maximum execution time for the scan, the refresh time for the screen on the MPE720 will be very slow and communication timeouts may occur. If the maximum execution time exceeds the scan time set value, a watchdog timer timeout error will occur and the MP2300S system will stop.

- Set the set values of the high-speed (H) and low-speed (L) scan time to an integral multiple of the MECHATROLINK communication cycle (1 or 2 ms) set in the MP2300S. Always check the set values of the scan time after changing the MECHATROLINK communication cycle.
- Do not change the scan time set value while the Servo is ON. Never change the setting while the axis is moving (while the motor is running). Otherwise an error may occur during motor operation (e.g., high-speed rotation).
- When the scan time is set or changed, be sure to save the data to flash memory.

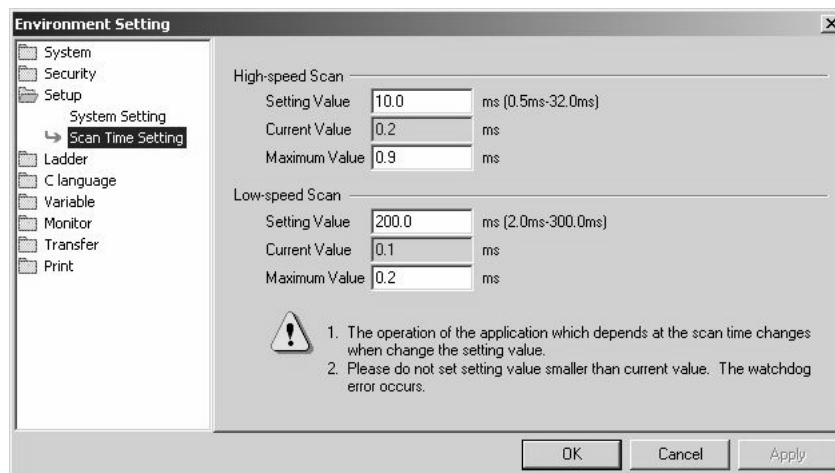

(2) Scan Time Set Value Examples

■ 0.8-ms Maximum Scan Time and 1-ms Communication Cycle (MECHATROLINK-II Only)

High-speed (or low-speed) scan set value $\geq 1.25 \times 0.8 (= 1 \text{ ms})$

High-speed (or low-speed) scan set value = 1 ms, 2 ms, 3 ms, etc. (an integral multiple of at least 1 ms)

■ 1.4-ms Maximum Scan Time and 1-ms Communication Cycle (MECHATROLINK-II Only)

High-speed (or low-speed) scan set value $\geq 1.25 \times 1.4 (= 1.75 \text{ ms})$

High-speed (or low-speed) scan set value = 2 ms, 3 ms, etc. (an integral multiple of at least 2 ms)

■ 0.8-ms Maximum Scan Time and 2-ms Communication Cycle (MECHATROLINK-I or MECHATROLINK-II)

High-speed (or low-speed) scan set value $\geq 1.25 \times 0.8 (= 1 \text{ ms})$

High-speed (or low-speed) scan set value = 1 ms, 2 ms, 4 ms, etc. (an integral multiple of 2 ms at 1 ms and 2 ms or higher)

■ 1.4-ms Maximum Scan Time and 2-ms Communication Cycle (MECHATROLINK-I or MECHATROLINK-II)

High-speed (or low-speed) scan set value $\geq 1.25 \times 1.4 (= 1.75 \text{ ms})$

High-speed (or low-speed) scan set value = 2 ms, 4 ms, etc. (an integral multiple of 2 ms at 2 ms or higher)

MEMO

Ethernet Communications

This chapter explains how to communicate with devices (PLC, touch panel, etc.) connected to the MP2300S by Ethernet.

6.1 Communication Methods	6-2
6.2 Communication with Other MP Series	6-3
6.2.1 When the MP2300S Acts as Slave (automatic receive function is used)	6-3
6.2.2 When the MP2300S Acts as a Slave (ladder program which uses a MSG-RCV function)	6-17
6.2.3 When MP2300S Acts as Master (I/O message communication function is used)	6-36
6.2.4 When the MP2300S Acts as Master (ladder program which uses MSG-SND function)	6-49
6.3 Communication with Touch Panel	6-65
6.3.1 When MP2300S Acts as Slave	6-65
6.4 Communication with PLC Manufactured by Mitsubishi Electric Corporation (MELSEC protocol)	6-75
6.4.1 When the MP2300S Acts as Slave (automatic receive function is used)	6-75
6.4.2 When the MP2300S Acts as Master (I/O message communication function is used)	6-83

6.1 Communication Methods

The following table provides the appropriate mode of communication for each remote device and purpose.

Remote Equipment	Purpose	Communication Method	Remarks
Other MP Series	When other MP series equipment reads/writes the coil state or register content of MP2300S	Uses the Extended MEMOBUS communication protocol. The remote equipment (master) side creates a ladder program using a MSG-SND function. The MP2300S (slave) side uses an automatic receive function. (You do not need to create a ladder program.) ⇒ Refer to 6.2.1 <i>When the MP2300S Acts as Slave (automatic receive function is used)</i>	MP2300S can communicate with only one master using the automatic receive function.
		Uses the Extended MEMOBUS communication protocol. The remote equipment (master) side creates a ladder program using a MSG-SND function. The MP2300S (slave) side creates a ladder program using a MSG-RCV function. ⇒ Refer to 6.2.2 <i>When the MP2300S Acts as a Slave (ladder program which uses a MSG-RCV function)</i>	Communication with multiple masters is possible.
	When MP2300S reads/writes the coil state or register content of other MP series equipment	Uses the Extended MEMOBUS communication protocol. The MP2300S (master) side uses an I/O message communication function. (You do not need to create a ladder program.) The remote equipment (slave) side creates a ladder program using a MSG-RCV function. ⇒ Refer to 6.2.3 <i>When MP2300S Acts as Master (I/O message communication function is used)</i>	Only the holding register (M register) is capable of reading/writing using an I/O message communication function. It can communicate with only one slave.
		Uses the Extended MEMOBUS communication protocol. The MP2300S (master) side uses an I/O message communication function. (You do not need to create a ladder program.) The remote equipment (slave) side creates a ladder program using a MSG-RCV function. ⇒ Refer to 6.2.4 <i>When the MP2300S Acts as Master (ladder program which uses MSG-SND function)</i>	Registers other than the holding register are capable of reading/writing. Communication with multiple slaves is enabled.
Touch Panel	When a touch panel reads/writes the coil state or register content of MP2300S	Uses the Extended MEMOBUS communication protocol. Set the protocol for the touch panel side to the Extended MEMOBUS protocol. The MP2300S (slave) side uses an automatic receive function. (You do not need to create a ladder program.) ⇒ Refer to 6.3 <i>Communication with Touch Panel.</i>	
PLC Manufactured by Mitsubishi Electric Corporation	When a PLC Manufactured by Mitsubishi Electric Corporation reads/writes the MP2300S register content.	Uses the MELSEC communication protocol. The remote equipment (master) side creates a ladder program using a BUFSND function. The MP2300S (slave) side uses an automatic receive function. (You do not need to create a ladder program.) ⇒ Refer to 6.4.1 <i>When the MP2300S Acts as Slave (automatic receive function is used)</i>	The MP2300S can communicate with only one master when using the automatic receive function.
	When an MP2300S reads/writes the relay state or register content of PLC Manufactured by Mitsubishi Electric Corporation.	Uses the MELSEC communication protocol. The MP2300S (master) side uses an I/O message communication function. (You do not need to create a ladder program.) The remote equipment (slave) side needs to set the network parameters. (You do not need to create a ladder program.) ⇒ Refer to 6.4.2 <i>When the MP2300S Acts as Master (I/O message communication function is used)</i>	The MP2300S can communicate with only one slave when using the I/O message communication function.

6.2 Communication with Other MP Series

When Ethernet communication is carried out between the MP2300S and other MP series, the Extended MEMOBUS protocol is used as a communication protocol. The Extended MEMOBUS protocol allows the master to read/write the slave register contents.

This chapter explains communications when an MP2300S acts as a slave and a master respectively.

When the MP2300S acts as a slave, this chapter explains communications using an automatic receive function and a ladder program with the MSG-RCV function.

When the MP2300S acts as a master, this chapter explains communications using an I/O message communication function and a ladder program with the MSG-SND function.

6.2.1 When the MP2300S Acts as Slave (automatic receive function is used)

This section explains how to communicate with the MP2300 message transmit function (MSG-SND) using the MP2300S automatic receive function.

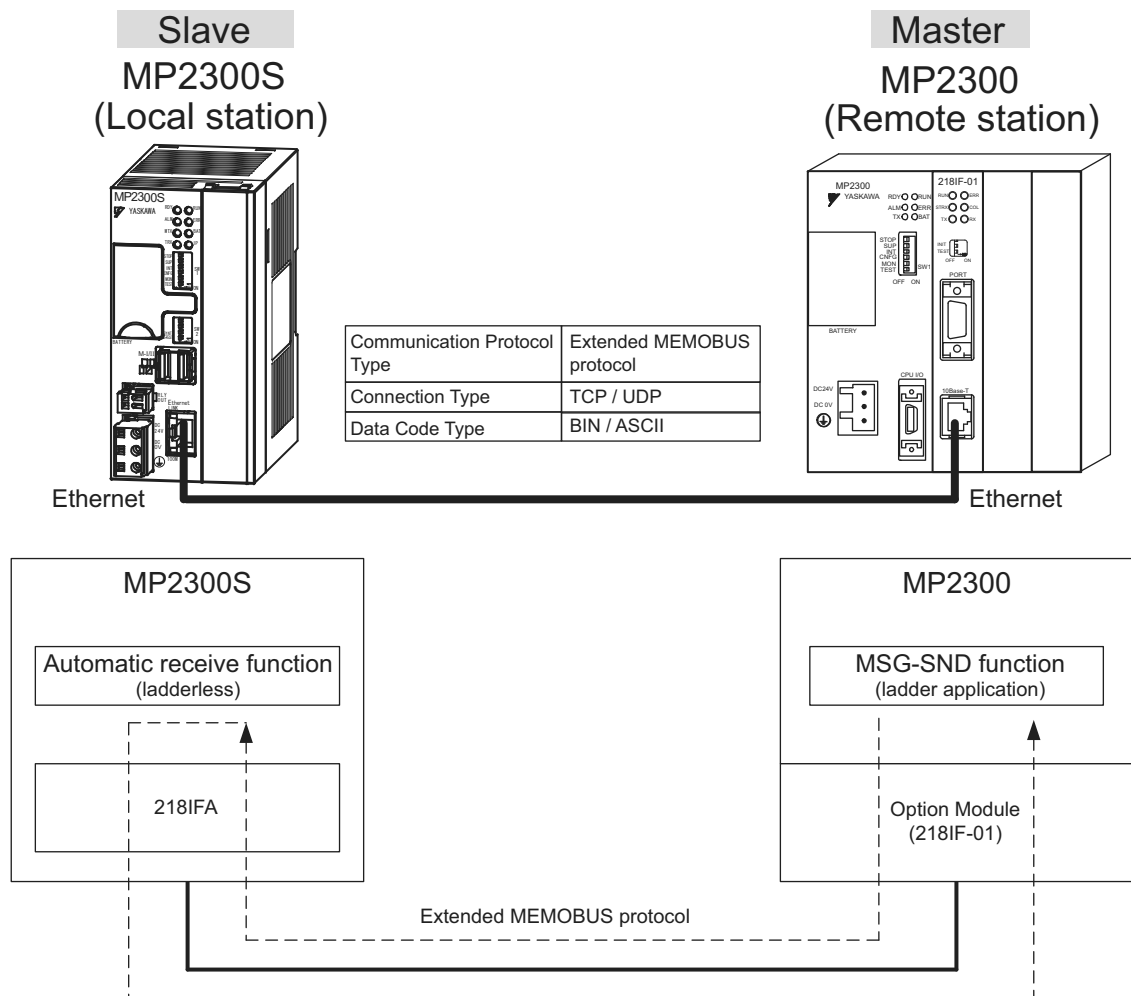
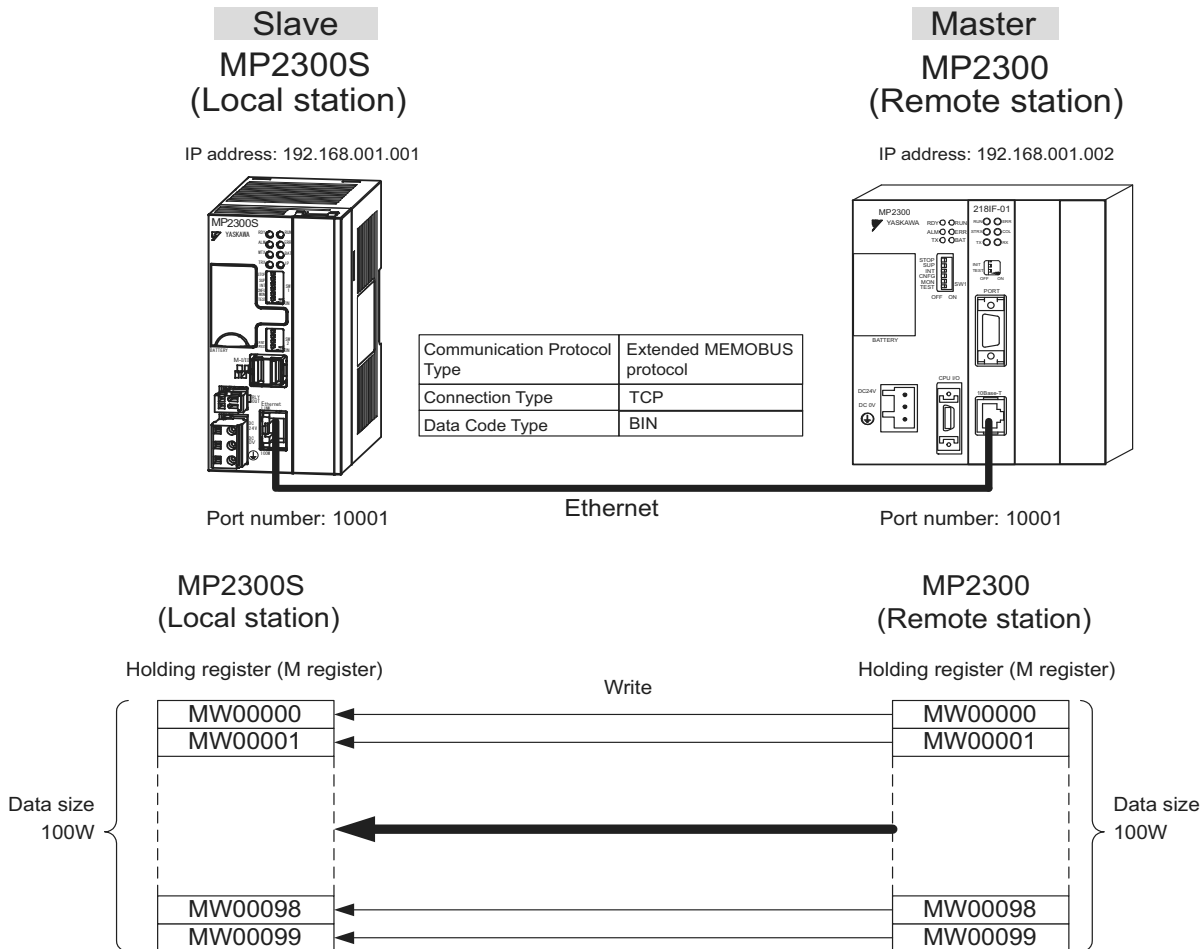

Fig. 6.1 Message Flow with MP2300 when Automatic Receive Function Is Used

■ Setting Example

The following figure illustrates how the content of the MP2300S (master) holding register (MW00000 to MW00099) is written into the MP2300S (slave) holding register (MW00000 to MW00099).



The setup procedure is explained in the following pages.

(1) How to Set up the MP2300S Side

If the setting of transmission parameters (IP address, subnet mask) is already completed, start from step 3.

1. Double-click the **2181FA** Tab in the **Module Details** Window of the module configuration definition.

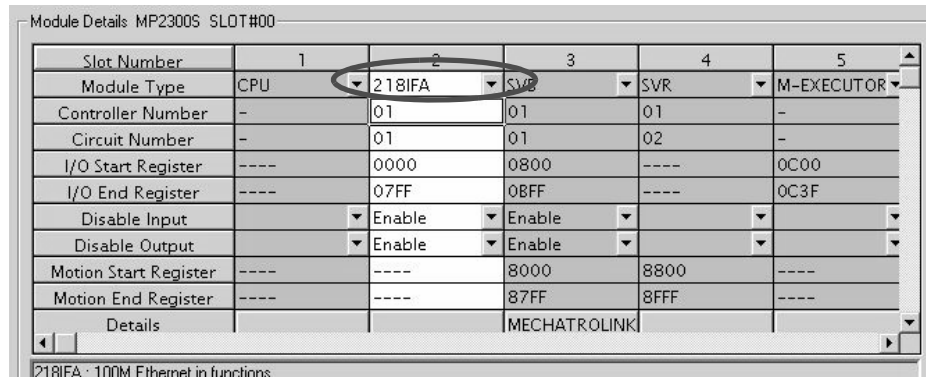

2. Set transmission parameters.

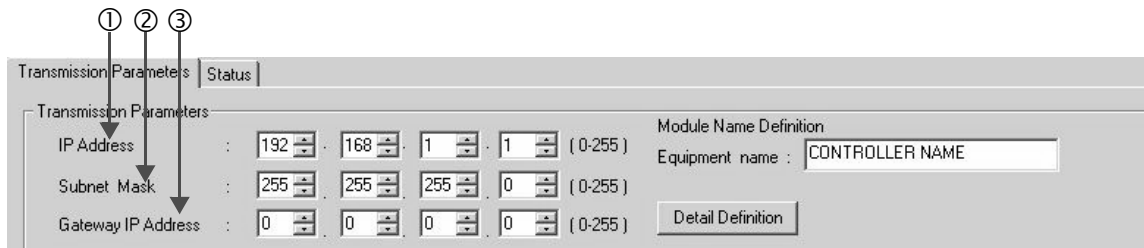

■ How to set up transmission parameters

- ① Set **IP Address** (to “192.168.001.001,” for example).
- ② Set **Subnet Mask** (to “255.255.255.000,” for example).
- ③ Set **Gateway IP Address** (to “000.000.000.000,” for example).

■ Caution

Set up a unique IP address in the network.
For the IP address, check with your network administrator.

3. Click the **Easy Setting** Button in the **Message Communication** area of the connection parameter setting.

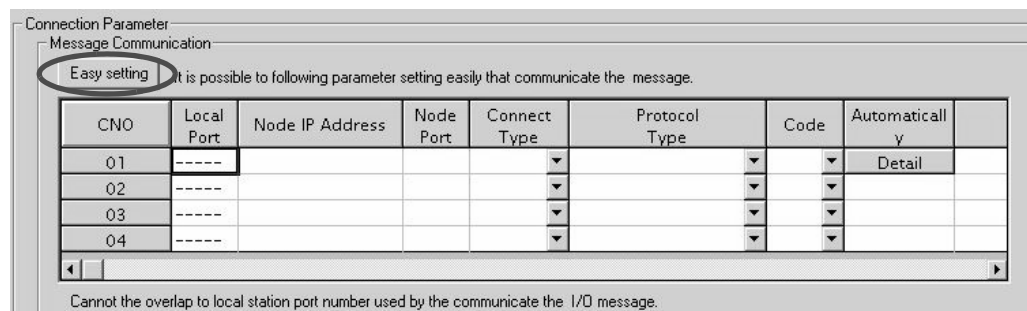

4. Set a communication setting in the **Message Communication Easy Setting** Window.

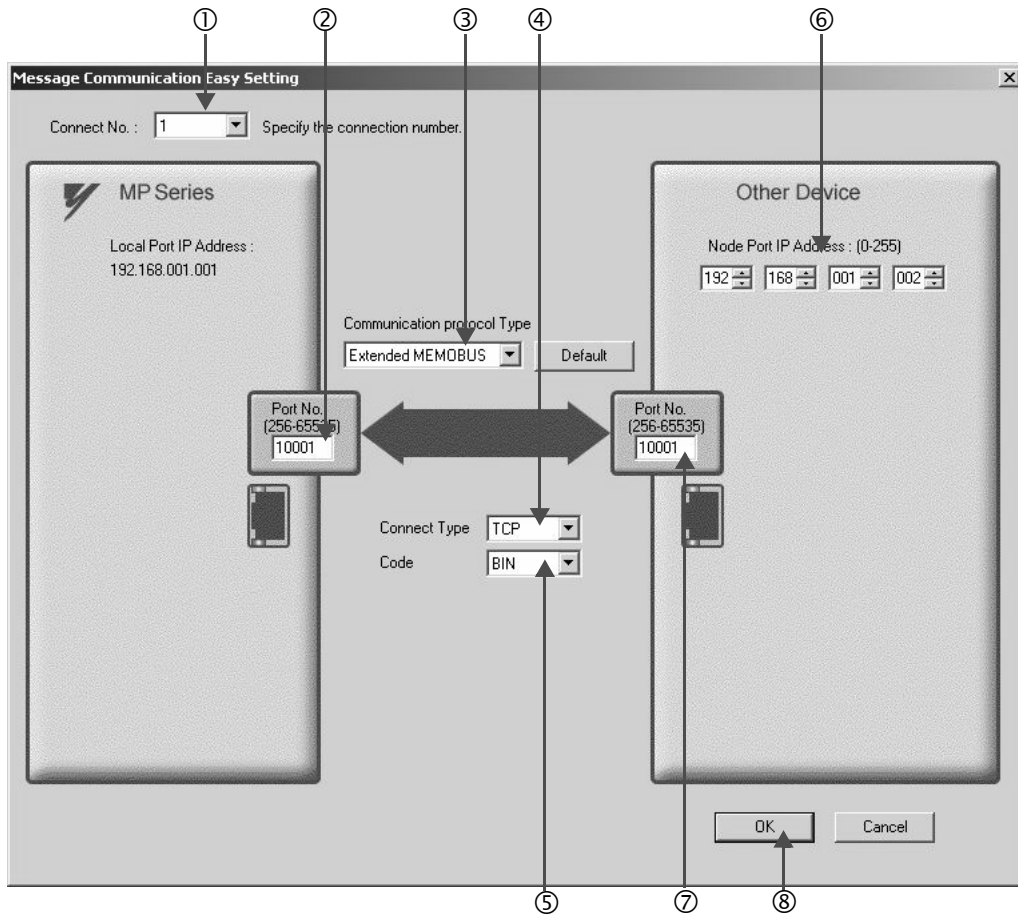

■ How to set up in the **Message Communication Easy Setting** Window

- ① When automatic receive is used, select “1” for the **Connect No.**
- ② Set **Port No.** of the MP2300S side (“10001,” for example).
- ③ Select **Extended MEMOBUS** for the **Communication Protocol Type**, and click **Default** Button.
- ④ Select **Connect Type** (TCP, for example).
- ⑤ Select **Code** (BIN, for example).
- ⑥ Set **Node Port IP Address** for the other device (MP2300) to be connected (to “192.168.001.002,” for example).
- ⑦ Set **Port No.** of the other device (MP2300) to be connected (to “10001,” X for example).
- ⑧ Click **OK** Button.

■ Caution

When message functions (MSG-SND, MSG-RCV) are used with the connection number 01, disable the automatic receive function. If message functions are used while the automatic receive function is enabled, communications will not function properly.

Note: The automatic receive function with a connection number 01 is set to “Enable” by default.

- Click **Yes** in the confirmation dialog of the parameter setting.

■ **Caution**

Note that when a parameter with the same connection number is already set and you click **Yes** in the confirmation dialog of the parameter setting, the setting will be overwritten by the parameter configured in the **Message Communication Easy Setting** Window.

- Check the setting value and click the **Detail** Button of the **Automatically**.

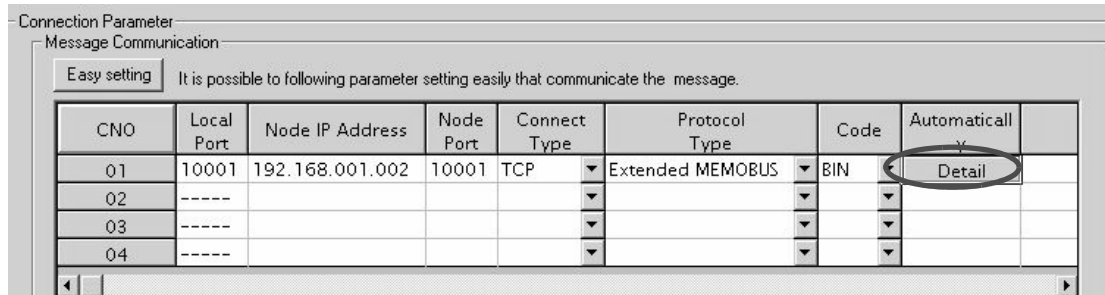

7. Click **Enable** in the **Automatically Reception Setting** Dialog Box and then click the **OK** Button.

Automatically Reception Setting

Automatically Reception Unable to automated reception, when the protocol type is no control sequence.

Disable
 Enable

Transmission Buffer Channel 1 The automatic reception is fixed 1ch.

Slave I/F Register Settings Head REG

Readout of Input Relay Iw0000

Readout of Input Register Iw0000

Readout / Write-in of Coil Mw00000

Readout / Write-in of Hold Register Mw00000

Write - in width of Coil/Hold Register LD: Mw00000
 HI: Mw65534

Automatic input processing delay time 0 ms (0-100)

The influence on a low-speed scanning can be adjusted according to this parameter.
 [Attention] It is not in the setting of the communication period of an automatic reception.

OK Cancel

Note: For more information on Slave Side I/F Register Settings and Automatic input precessing delay time, refer to 2.2.4 (4) (b) ■ *Automatic Receive Setting Screen for Message Communication* on page 2-22.

Now, the automatic receive function is set up when the MP2300S acts as a slave.

■ **Caution**

When any transmission or connection parameter is changed, the change will be reflected after FLASH has been saved and the power is turned ON again.

(2) How to Set up the Remote Device (MP2300) to Be Connected

If the setting of transmission parameters (IP address, subnet mask) is already completed, start from step 3.

1. Double-click the **218IF** Tab in the **Module Details** of the module configuration definition.

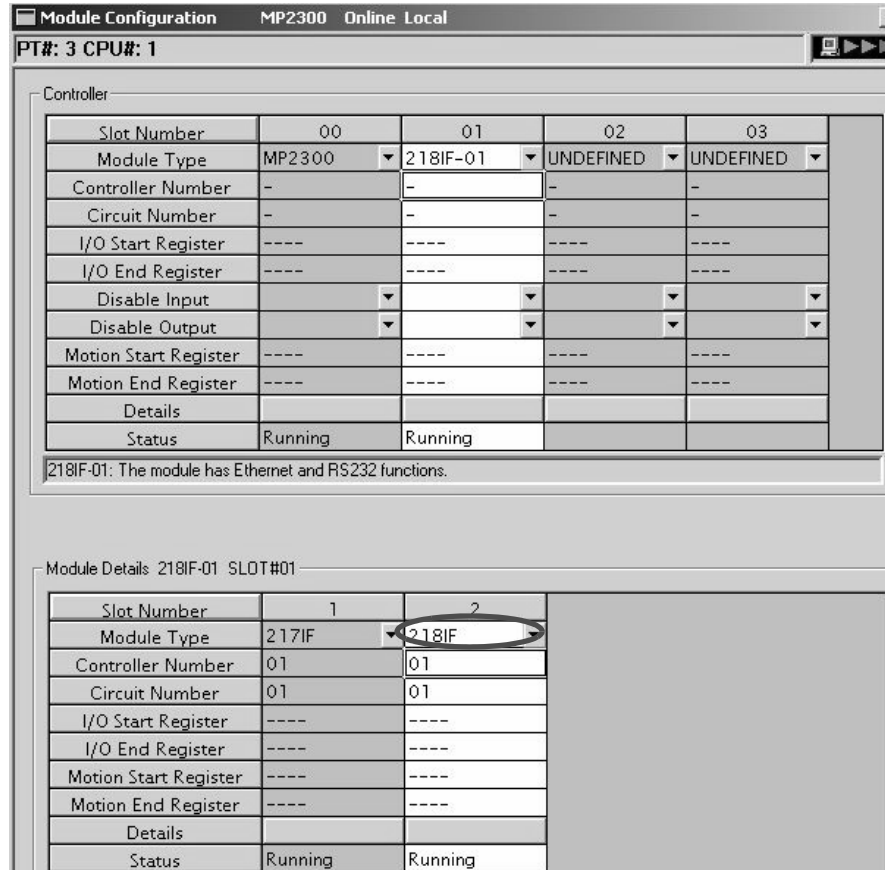

2. Set transmission parameters.

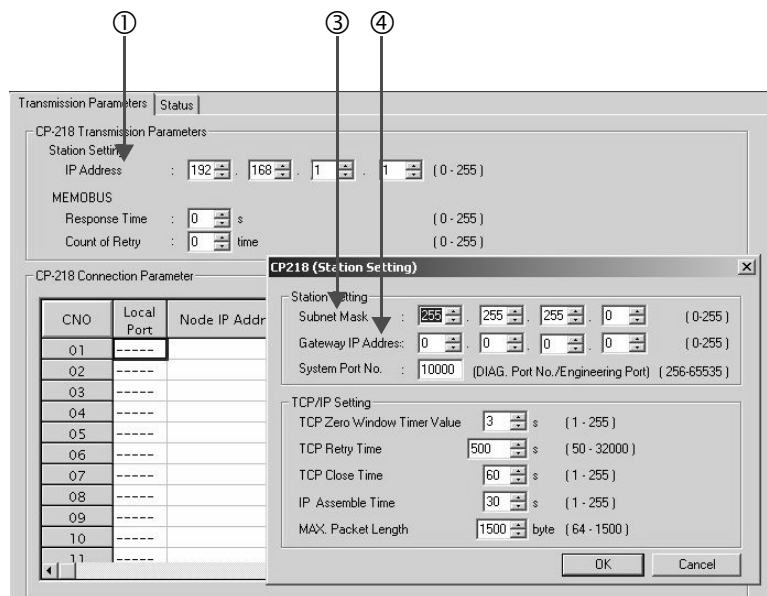

■ How to set up transmission parameters

- ① Set **IP Address** ("192.168.001.001," for example).
- ② Click **Edit**, and then click **Local Station: TCP/IP Setting** in the Engineering Manager Window.

6.2.1 When the MP2300S Acts as Slave (automatic receive function is used)

- ③ Set **Subnet Mask** (“255.255.255.000,” for example).
- ④ Set **Gateway IP Address** (“000.000.000.000,” for example).

■ Caution

Set up a unique IP address in the network.
For the IP address, check with your network administrator.

3. Set connection parameters.

CNO	Local Port	Node IP Address	Node Port	Connect Type	Protocol Type	Code
01	10001	192.168.001.001	10001	TCP	Extended MEMOBUS	BIN
02	10002	192.168.001.001	10002	TCP	Extended MEMOBUS	BIN
03	10003	192.168.001.001	10003	TCP	Extended MEMOBUS	BIN
04	-----					
05	10005	192.168.001.001	10005	TCP	Extended MEMOBUS	BIN
06	10006	192.168.001.001	10006	TCP	Extended MEMOBUS	BIN
07	-----					
08	-----					
09	-----					

■ How to set up with a connection number 01 in the connection parameter setting screen

- ① Set **Local Port** to the port number used in the MP2300 side (“10001,” for example).
- ② Set **Node IP Address** to the IP address configured in the MP2300S side.
- ③ Set **Node Port** to the port number configured in the MP2300S side (“10001,” for example).
- ④ Select **Connect Type** (TCP, for example).
- ⑤ Select **Extended MEMOBUS** for **Protocol Type**.
- ⑥ Select **Code** (BIN, for example).

■ Caution

When any transmission or connection parameter is changed, the change will be reflected after FLASH has been saved and the power turned ON again.

4. Create a ladder program with a message transmit function (MSG-SND).

A ladder program for transmitting messages to/from the remote equipment (MP2300) side is shown as follows:

■ Message transmit function (MSG-SND)

Required for transmitting messages. Message transmission is carried out by describing and executing this message transmit function in a ladder program.

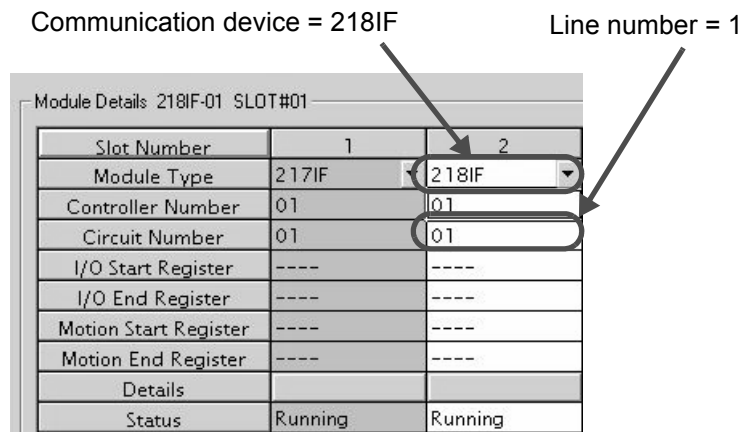
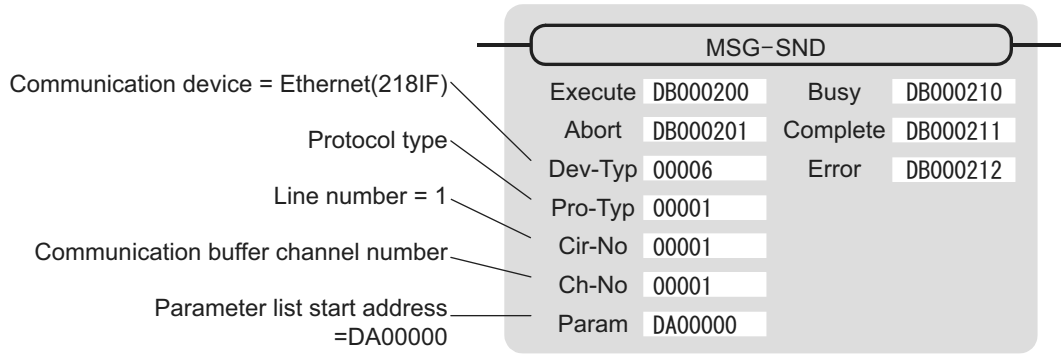

Fig. 6.2 MPE720 Module Configuration Definition Window

■ Input/output definitions for message transmit functions

The input/output definitions for the message transmit function are explained as follows:

Table 6.1 Input/Output Definitions for Message Transmit Functions

I/O Definition	No.	Name	Setting Example	Explanation
Input Item	1	Execute	DB000200	Executes a transmission When the Execute bit is ON, the message is transmitted.
	2	Abort	DB000201	Aborts a transmission When the Abort bit is ON, the message transmission is forcibly stopped.
	3	Dev-Typ	00006	Communication device type Specify the type of the communication device used in transmission. When Ethernet (218IF) is used, specify "6".
	4	Pro-Typ	00001	Communication protocol Specify the type of the communication protocol. MEMOBUS(*1) = 1, non-procedure 1(*2) = 2, non-procedure 2(*2) = 3
	5	Cir-No	00001	Circuit number Specify the circuit number of the communication device. Specify it in accordance with the circuit number displayed in the MPE720 module configuration definition screen.
	6	Ch-No	00001	Communication buffer channel number Specify the channel number of the communication buffer. When Ethernet (218IF) is used, specify it in the range between "1" and "10". * Set up a unique channel number in the circuit.
	7	Param	DA00000	Parameter list start address Specify the start address of the parameter list. For the Parameter List, 17 words are automatically assigned from the configured address.
Output Item	1	Busy	DB000210	In process Busy is turned ON while executing a message transmission or forced abort process.
	2	Complete	DB000211	Process completed When a message transmission or abort process is properly completed properly, Complete will turn ON only for one scan.
	3	Error	DB000212	Error occurred When an error occurs, the Error bit will turn ON only for one scan.

* 1. When transmitting in MEMOBUS, Extended MEMOBUS, MELSEC, or MODBUS/TCP protocol, set the communication protocol (Pro-Typ) to MEMOBUS(=1). The communication device automatically converts the protocol.

* 2. Non-procedure 1: In non-procedural communications, data is transmitted on a per-word basis.
Non-procedure 2: In non-procedural communications, data is transmitted on a per-byte basis.

■ Parameter list setting example for the message transmit function

An example of a parameter list setting when writing 100 words of data from MW00000 to the destination using the connection with a connection number = 1 follows:

Table 6.2 Sample Parameter List Setting (parameter list start address Param=DA00000)

Register Number	Setting Value	Parameter Number	IN/OUT	Remarks
DW00000	–	PARAM00	OUT	Process result
DW00001	–	PARAM01	OUT	Status
DW00002	00001	PARAM02	IN	Connection number = 1
DW00003	–	PARAM03	IN	Option (Setting unnecessary)
DW00004	000BH	PARAM04	IN	Function code = 0BH (Writes to holding register)
DW00005	00000	PARAM05	IN	Data address = 0 (Starting from MW00000)
DW00006	00100	PARAM06	IN	Data size = 100 (100 words)
DW00007	00001	PARAM07	IN	Remote CPU number = 1
DW00008	00000	PARAM08	IN	Coil offset = 0 word
DW00009	00000	PARAM09	IN	Input relay offset = 0 word
DW00010	00000	PARAM10	IN	Input register offset = 0 word
DW00011	00000	PARAM11	IN	Holding register offset = 0 word
DW00012	–	PARAM12	SYS	Reserved by the system. (Zero clear at startup)
DW00013	–	PARAM13	SYS	Reserved by the system.
DW00014	–	PARAM14	SYS	Reserved by the system.
DW00015	–	PARAM15	SYS	Reserved by the system.
DW00016	–	PARAM16	SYS	Reserved by the system.

Note: N: Input, OUT: Output, SYS: For system use

■ Example of Using the Message Transmit Function in a Ladder Program

Here is one example of the message transmit function through Ethernet (218IF).

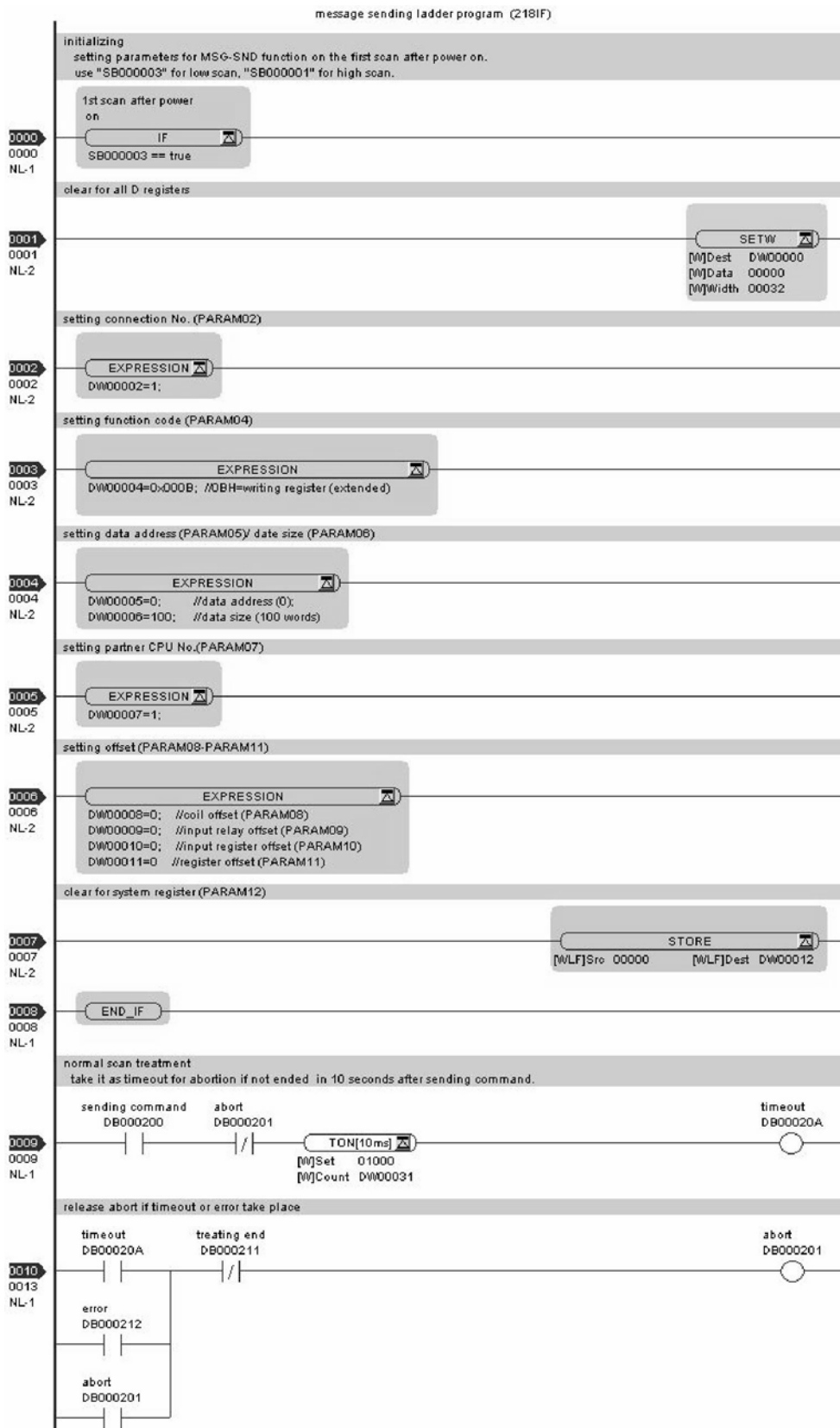

6.2.1 When the MP2300S Acts as Slave (automatic receive function is used)

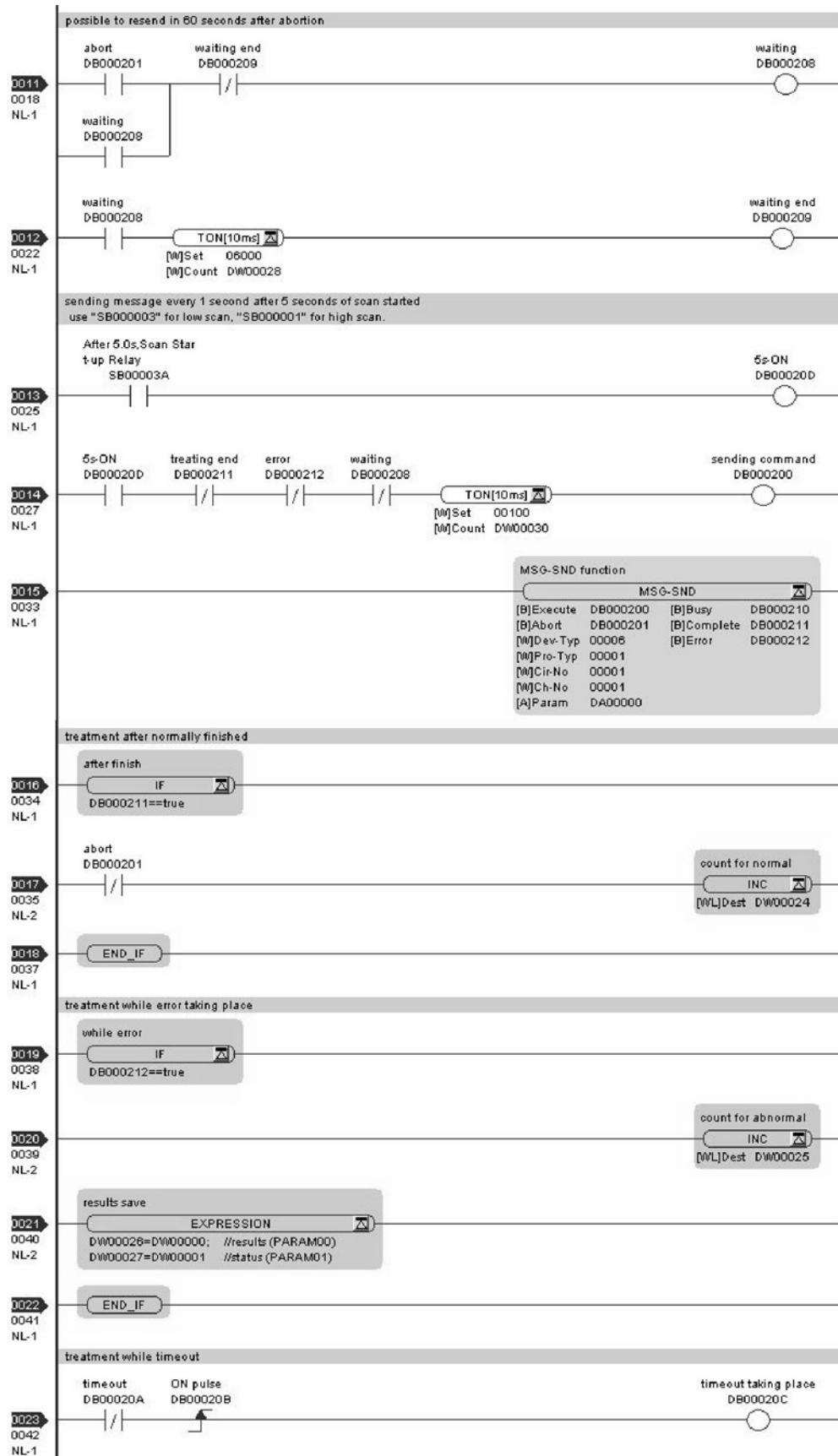

6.2.1 When the MP2300S Acts as Slave (automatic receive function is used)

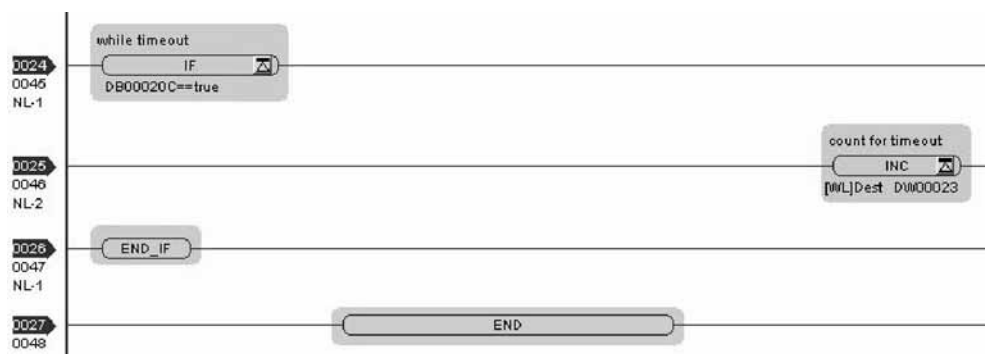

The communication setting and the ladder program creation are now finished, when MP2300 acts as a master.

(3) How to Start Communications

1. The MP2300S side starts to receive the messages.

When the automatic receive function is used, the message receive operation starts automatically.

2. Turn Execute ON for the message transmit function in the MP2300 side to transmit messages.

Messages are transmitted by turning ON the register (DB000200, for example), configured in Execute of the message transmit function, starting communication with the MP2300S.

Table 6.3 Input/Output Definition for Message Transmit Function

I/O Definition	No.	Name	Setting Example	Content
Input Item	1	Execute	DB000200	Executes a transmission When Execute is ON, the message transmission will be carried out.

The sample ladder program is created to transmit a message every one second when five seconds have elapsed after the low-speed scan (or high-speed scan) startup.

To change the message transmission interval, change the timer value ①.

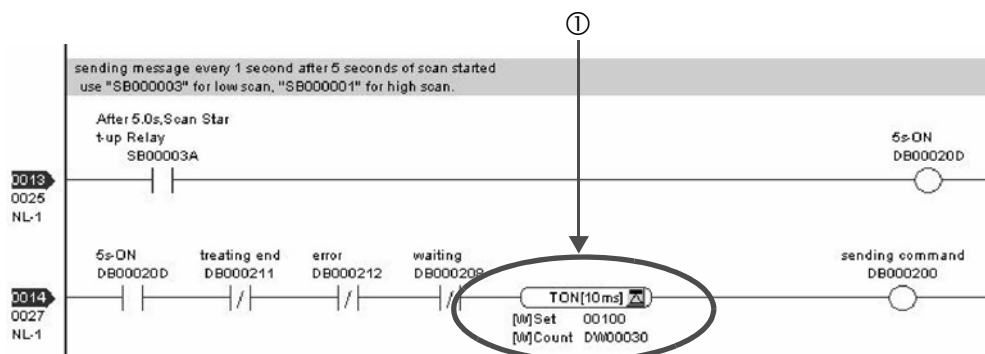

6.2.2 When the MP2300S Acts as a Slave (ladder program which uses a MSG-RCV function)

The MP2300S can communicate with only one master when using the automatic receive function. To communicate with more than one master, use a ladder program with a message receive function (MSG-RCV) at the MP2300S end. You can use the message receive function (MSG-RCV) as well as the automatic receive function by keeping connections separate from each other.

This section explains how to communicate with an MP2300 message transmit function (MSG-SND) using the MP2300S message receive function (MSG-RCV).

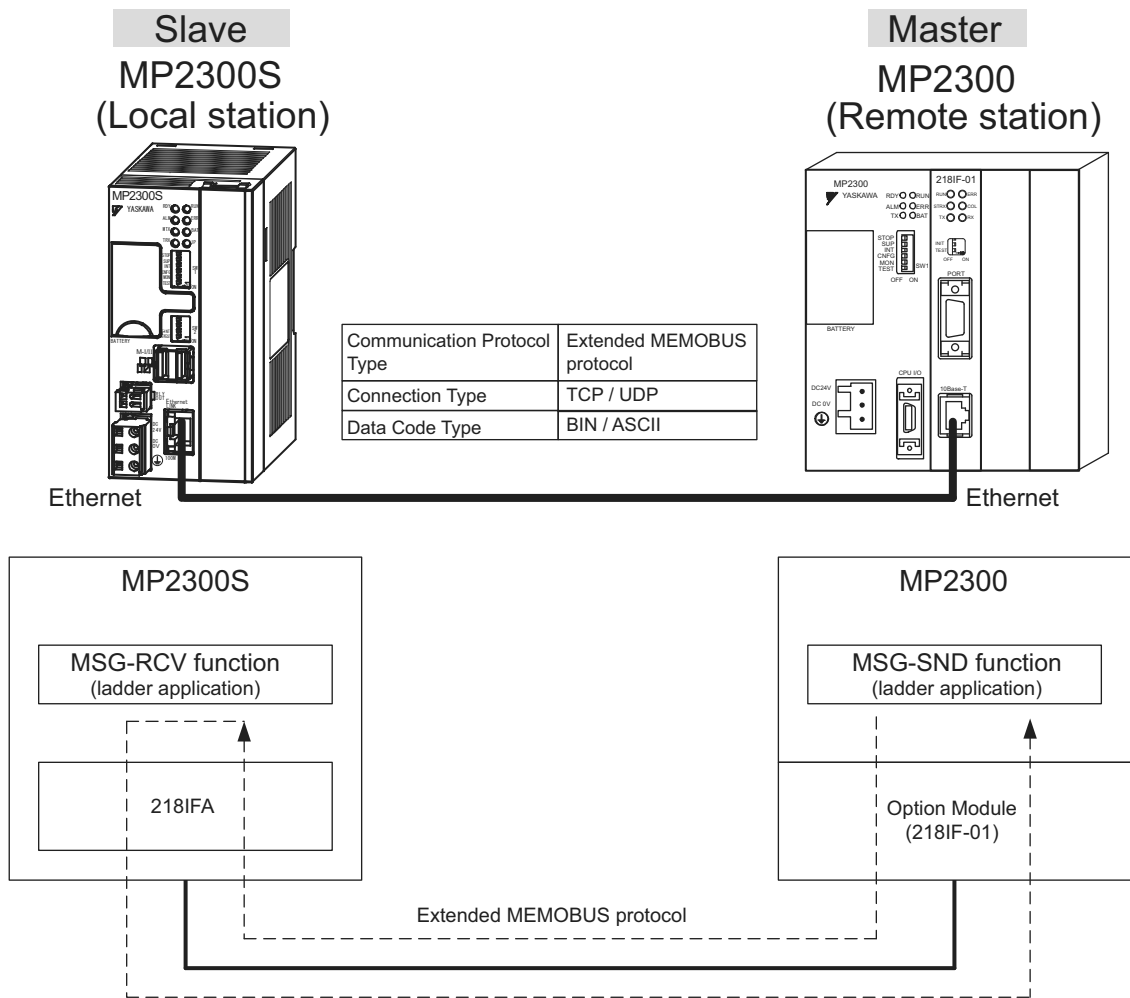
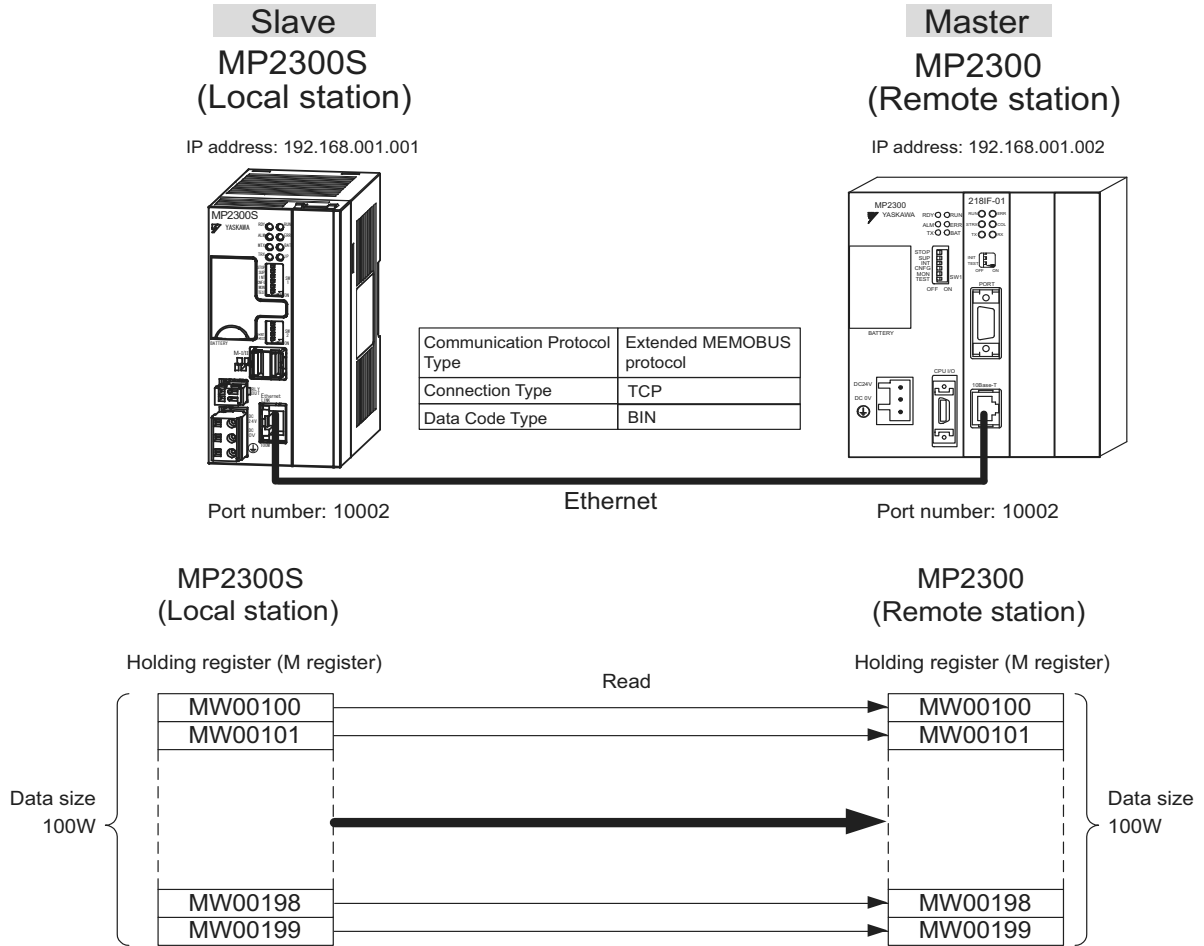

Fig. 6.3 Message Flow with MP2300 when Message Receive Function (MSG-RCV) Is Used

■ Setting Example

The following figure illustrates one example of writing the contents of the MP2300 (master) holding register (MW00100 to MW00199) into the MP2300S (slave) holding register (MW00100 to MW00199).



The particular setup procedure is explained in the subsequent pages.

(1) How to Set up the MP2300S Side

If the setting of transmission parameters (IP address, subnet mask) is already completed, start from step 3.

1. Double-click the **218IFA** Tab in the **Module Details** of the module configuration definition.



2. Set transmission parameters.

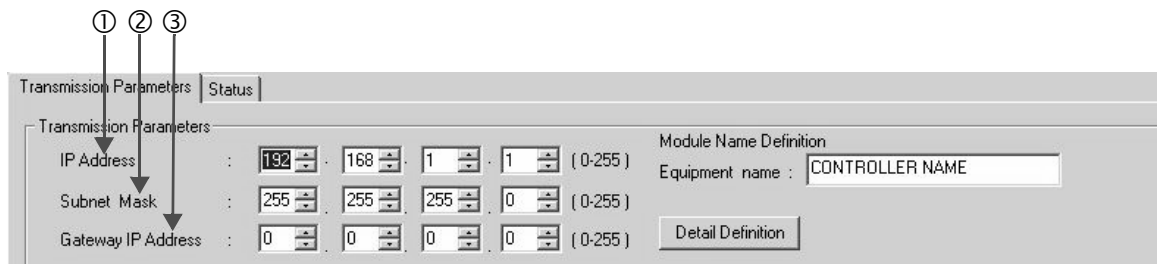

■ How to set up transmission parameters

- ① Set **IP Address** (“192.168.001.001,” for example).
- ② Set **Subnet Mask** (“255.255.255.000,” for example).
- ③ Set **Gateway IP Address** (“000.000.000.000,” for example).

■ Caution

Set up a unique IP address in the network.
For the IP address, check with your network administrator.

- Click the **Easy Setting** Button in the **Message Communication** area of the connection parameter setting.

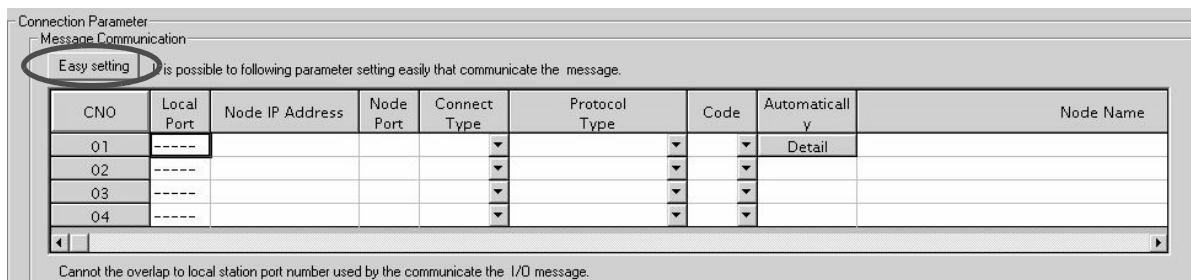

- Set a communication setting in the **Message Communication Easy Setting** Window.

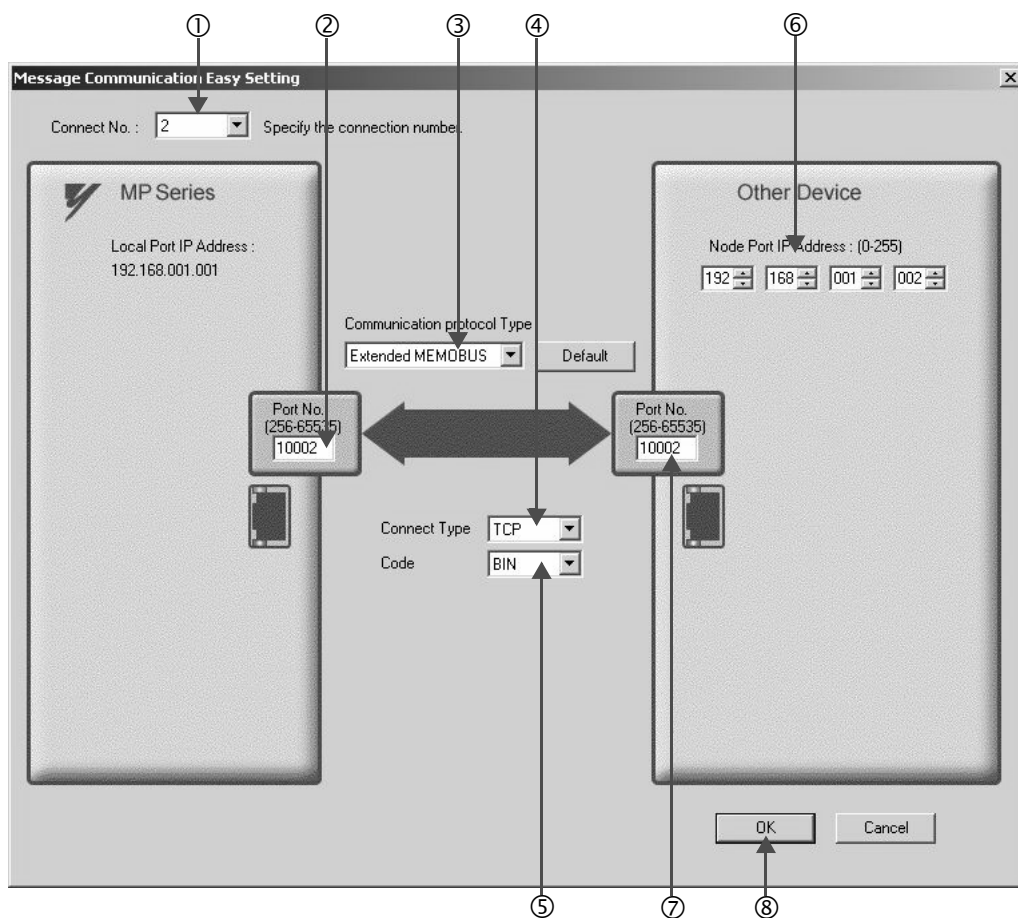

■ How to set up in the **Message Communication Easy Setting** Window

- When automatic receive is used, select “2” for the **Connect No.**
- Set **Port No.** of the MP2300S side (“10002,” for example).
- Select **Extended MEMOBUS** for **Communication Protocol Type**, and click the **Default** Button.
- Select **Connect Type** (TCP, for example).
- Select **Code** (BIN, for example).
- Set **Node Port IP Address** for the other device (MP2300) to be connected (to “192.168.001.002,” for example).
- Set **Port No.** of the other device (MP2300) to be connected (to “10002,” for example).
- Click **OK**.

■ Caution

When message functions (MSG-SND, MSG-RCV) are used with the connection number 01, disable the automatic receive function. If message functions are used while the automatic receive function is enabled, communications will not function properly.

Note: By default, the automatic receive function with a connection number 01 is set to "Enable."

5. Click **Yes in the parameter setting confirmation dialog.**

■ Caution

Note that when a parameter with the same connection number is already set and you click **Yes** in the parameter setting confirmation dialog, the setting will be overwritten by the parameter configured in the **Message Communication Easy Setting** Window.

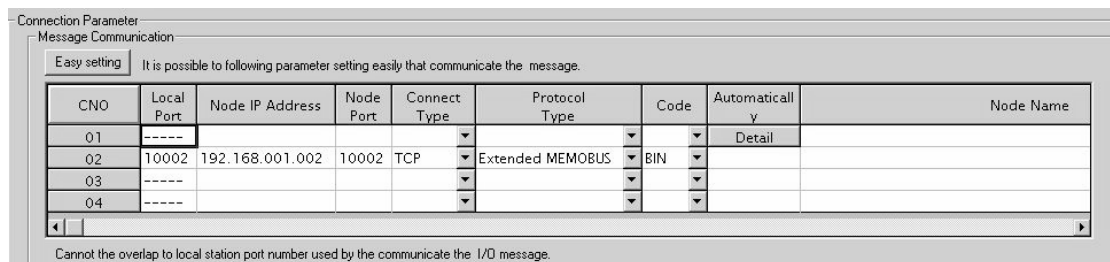
6. Check the setting values.

CNO	Local Port	Node IP Address	Node Port	Connect Type	Protocol Type	Code	Automatically	Node Name
01	-----						Detail	
02	10002	192.168.001.002	10002	TCP	Extended MEMOBUS	BIN		
03	-----							
04	-----							

Cannot the overlap to local station port number used by the communicate the I/O message.

■ Caution

When any transmission or connection parameter is changed, the change will be reflected after FLASH has been saved and the power supply is turned ON again.

7. Create a ladder program with a message receive function (MSG-RCV) in it.

An example of a ladder program for receiving messages in the MP2300S side is as follows:

■ Message receive function (MSG-RCV)

Required for receiving messages. A message reception is carried out by inputting and executing this message receive function in a ladder program.

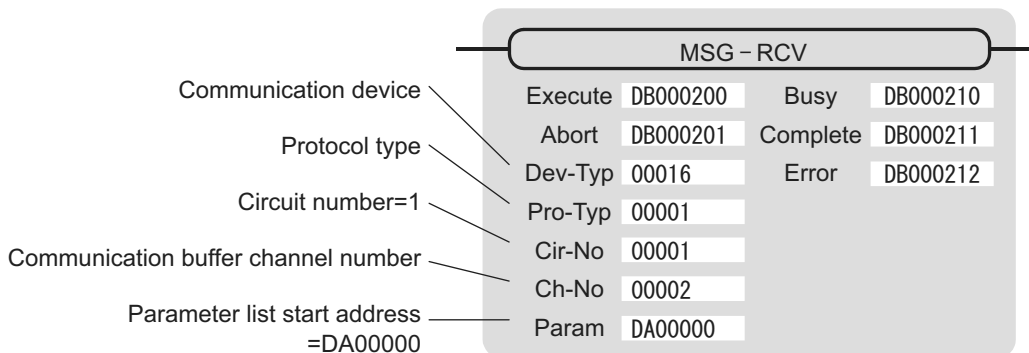

Communication device

Circuit number=1

Module Details MP2300S SLOT#00

Slot Number	1	2	3	4	5
Module Type	CPU	2181FA	SVB	SVR	M-EXECUTOR
Controller Number	-	01	01	01	-
Circuit Number	-	01	01	02	-
I/O Start Register	----	0000	0800	----	0C00
I/O End Register	----	07FF	0BFF	----	0C3F
Disable Input		Enable	Enable		
Disable Output		Enable	Enable		
Motion Start Register	----	----	8000	8800	----
Motion End Register	----	----	87FF	8FFF	----
Details			MECHATROLINK		
Status	Running	Running	Running	Running	Running

2181FA: 100M Ethernet in functions.

Fig. 6.4 MPE720 Module Configuration Definition Window

■ Input/output definition contents for message receive functions

The input/output definition content for message receive function is as follows:

Table 6.4 Input/Output Definitions for Message Receive Functions

I/O Definition	No.	Name	Setting Example	Contents
Input Item	1	Execute	DB000200	Executes a reception When Execute is ON, message reception will be carried out.
	2	Abort	DB000201	Aborts a reception When Abort is ON, message reception is forcibly stopped.
	3	Dev-Typ	00016	Communication device type Specify the type of the communication device used in reception. When Ethernet (218IF) is used, specify "16."
	4	Pro-Typ	00001	Communication protocol Specify the type of the communication protocol. MEMOBUS(*1) = 1, non-procedure 1(*2) = 2, non-procedure 2(*2) = 3
	5	Cir-No	00001	Circuit number Specify a circuit number of the communication device. Specify it in accordance with the circuit number displayed in the MPE720 Module Configuration Definition Window.
	6	Ch-No	00002	Communication buffer channel number Specify the channel number of the communication buffer. When Ethernet (218IF) is used, specify it in the range between "1" and "4." * Set up a unique channel number in the line.
	7	Param	DA00000	Parameter list start address Specify the start address of the parameter list. For the Parameter List, 17 words are automatically assigned from the configured address.
Output Item	1	Busy	DB000210	In process Busy will be ON while executing a message reception or forced abort process.
	2	Complete	DB000211	Process completed When a message reception or forced abort process is properly completed, Complete will turn ON only for one scan.
	3	Error	DB000212	Error When an error occurs, Error will turn ON only for one scan.

* 1. When transmitting in MEMOBUS, Extended MEMOBUS, MELSEC, or MODBUS/TCP protocol, set the communication protocol (Pro-Typ) to MEMOBUS(=1). The communication device automatically converts the protocol.

* 2. Non-procedure 1: In non-procedural communication, data is received on a per-word basis.
Non-procedure 2: In non-procedural communication, data is received on a per-byte basis.

■ Parameter list setting example for message receive function

An example of a parameter list setting when receiving messages from a transmit source using the connection with a connection number = 2 follows:

Table 6.5 Parameter List Setting Example (parameter list start address Param=DA00000)

Register Number	Setting Value	Parameter Number	IN/OUT	Remarks
DW00000	-	PARAM00	OUT	Process result
DW00001	-	PARAM01	OUT	Status
DW00002	00002	PARAM02	IN	Connection number = 2
DW00003	-	PARAM03	OUT	Option
DW00004	-	PARAM04	OUT	Function code
DW00005	-	PARAM05	OUT	Data address
DW00006	-	PARAM06	OUT	Data size
DW00007	-	PARAM07	OUT	Remote CPU number
DW00008	00000	PARAM08	IN	Coil offset = 0 word
DW00009	00000	PARAM09	IN	Input relay offset = 0 word
DW00010	00000	PARAM10	IN	Input register offset = 0 word
DW00011	00000	PARAM11	IN	Holding register offset = 0 word
DW00012	00000	PARAM12	IN	Writable address lower limit = MW00000
DW00013	65534	PARAM13	IN	Writable address upper limit = MW65534
DW00014	-	PARAM14	SYS	Reserved by the system. (Zero clear at startup)
DW00015	-	PARAM15	SYS	Reserved by the system.
DW00016	-	PARAM16	SYS	Reserved by the system.

Note: IN: Input, OUT: Output, SYS: For system use

■ Example of Using the Message Receive Function in a Ladder Program

Here is an example of the message receive function through Ethernet (2181FA).

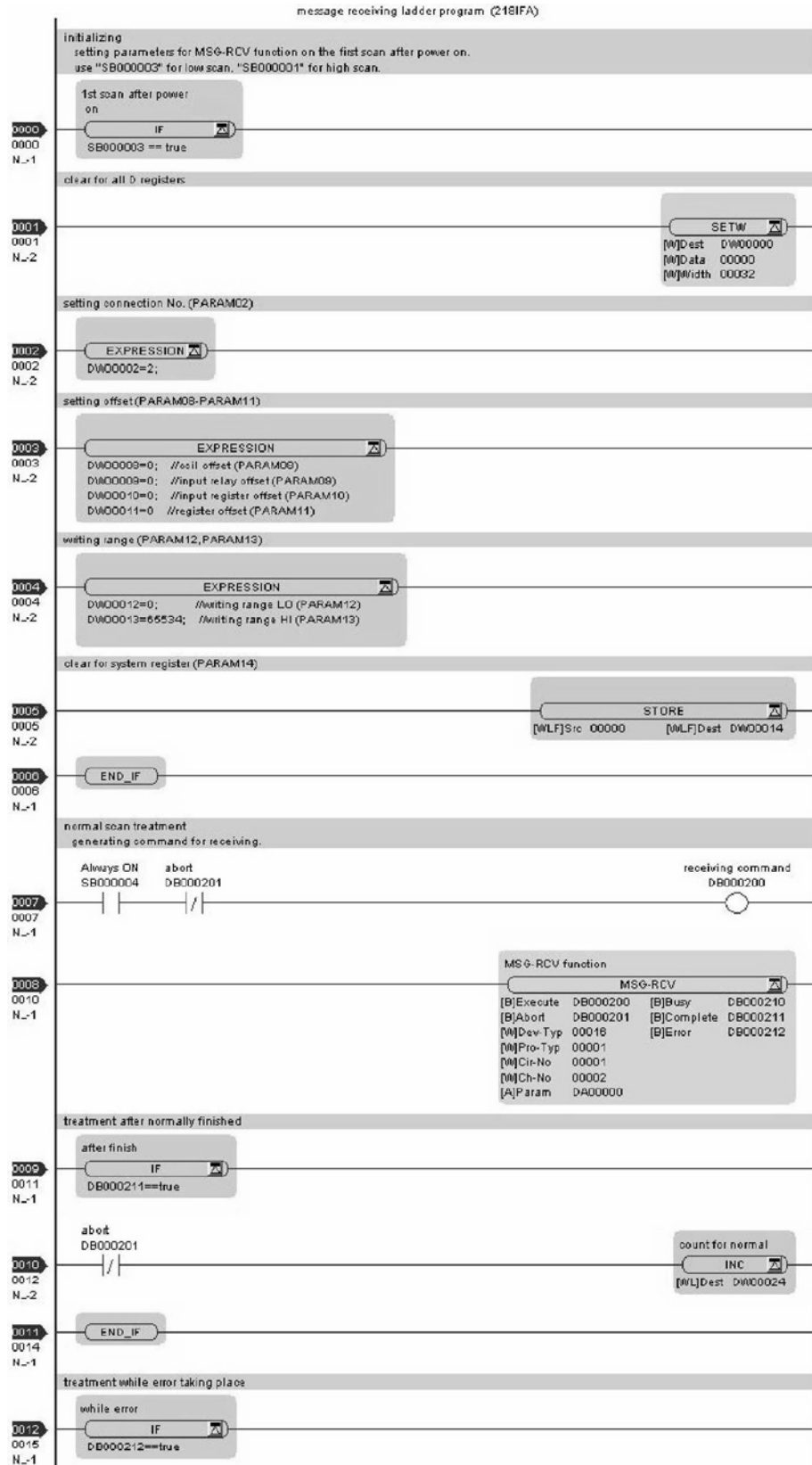

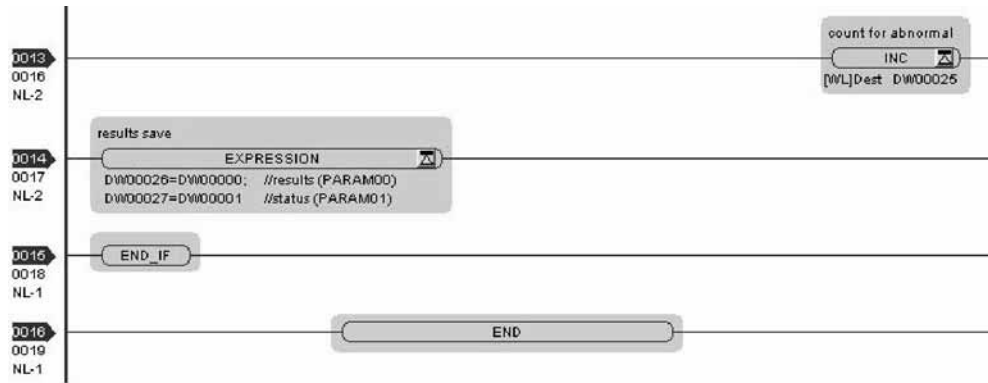

The communication setting and the ladder program creation are now finished, when the MP2300S acts as a slave.

(2) How to Set up the Remote Device (MP2300) to Be Connected

If the setting of transmission parameters (IP address, subnet mask) is already completed, start from step 3.

1. Double-click the **218IF** Tab in the **Module Details** of the module configuration definition.

The screenshot shows the 'Module Configuration' window for 'MP2300 Online Local'. The 'PT#: 3 CPU#: 1' is displayed. The 'Controller' section contains a table with columns for Slot Numbers 00, 01, 02, and 03. The 'Module Type' for Slot 01 is set to '218IF-01'. Below this table, a note states: '218IF-01: The module has Ethernet and RS232 functions.'

The 'Module Details 218IF-01 SLOT#01' section shows a table with two columns for Slot Numbers 1 and 2. The 'Module Type' for Slot 2 is set to '218IF', which is circled in red. The 'Controller Number' and 'Circuit Number' are both set to '01' for Slot 2.

Slot Number	00	01	02	03
Module Type	MP2300	218IF-01	UNDEFINED	UNDEFINED
Controller Number	-	-	-	-
Circuit Number	-	-	-	-
I/O Start Register	----	----	----	----
I/O End Register	----	----	----	----
Disable Input				
Disable Output				
Motion Start Register	----	----	----	----
Motion End Register	----	----	----	----
Details				
Status	Running	Running		

Slot Number	1	2
Module Type	217IF	218IF
Controller Number	01	01
Circuit Number	01	01
I/O Start Register	----	----
I/O End Register	----	----
Motion Start Register	----	----
Motion End Register	----	----
Details		
Status	Running	Running

2. Set transmission parameters.

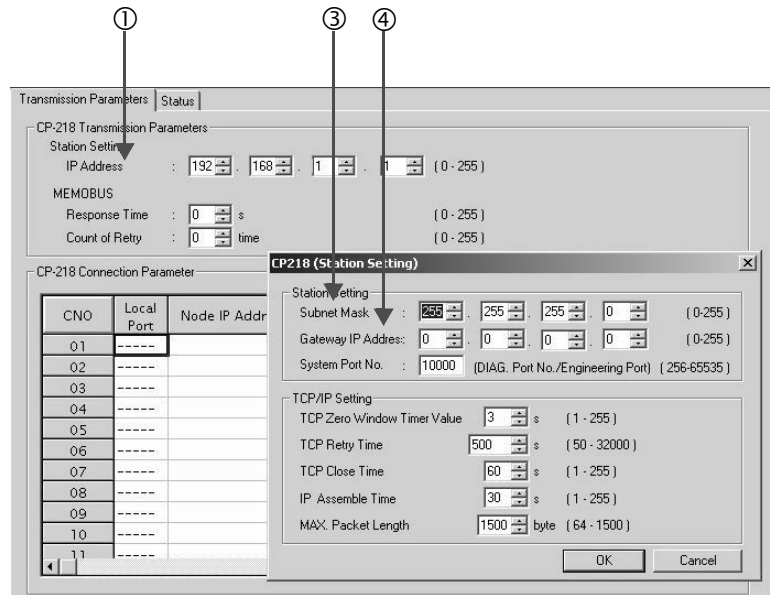

■ How to set up transmission parameters

- ① Set **IP Address** (“192.168.001.001,” for example).
- ② Click **Edit**, and then click **Local Station: TCP/IP Setting** in the **Engineering Manager** Window.
- ③ Set **Subnet Mask** (“255.255.255.000,” for example).
- ④ Set **Gateway IP Address** (“000.000.000.000,” for example).

■ Caution

Set up a unique IP address in the network.
For the IP address, check with your network administrator.

3. Set connection parameters.

CNO	Local Port	Node IP Address	Node Port	Connect Type	Protocol Type	Code
01	10001	192.168.001.001	10001	TCP	Extended MEMOBUS	BIN
02	10002	192.168.001.001	10002	TCP	Extended MEMOBUS	BIN
03	10003	192.168.001.001	10003	TCP	Extended MEMOBUS	BIN
04	-----					
05	10005	192.168.001.001	10005	TCP	Extended MEMOBUS	BIN
06	10006	192.168.001.001	10006	TCP	Extended MEMOBUS	BIN
07	-----					
08	-----					
09	-----					

■ How to set up with a connection number 02 in the **CP-218 Connection Parameter** Window

- ① Set **Local Port** (to the port number “10002” used in the MP2300 side, for example).
- ② Set the **Node IP Address** (to the IP address “192.168.001.001” configured in the MP2300S side, for example).
- ③ Set the **Node Port** (to the port number “10002” configured in the MP2300S side, for example).
- ④ Select **Connect Type** (TCP, for example).
- ⑤ Select **Extended MEMOBUS** for **Protocol Type**.
- ⑥ Select **Code** (BIN, for example).

■ Caution

When any transmission or connection parameter is changed, the change will be reflected after FLASH has been saved and the power supply is turned ON again.

4. Create a ladder program containing a message transmit function (MSG-SND).

An example of a ladder program for transmitting messages in the remote device (MP2300S) side follows:

■ Message transmit function (MSG-SND)

Required for transmitting messages. Message transmission is carried out by describing and executing this message transmit function in a ladder program.

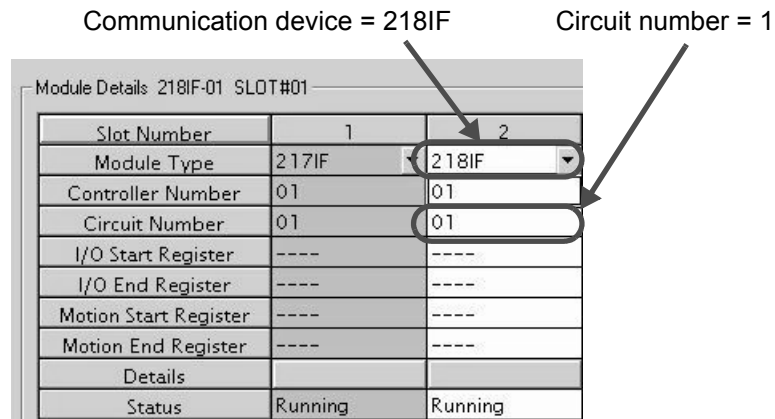
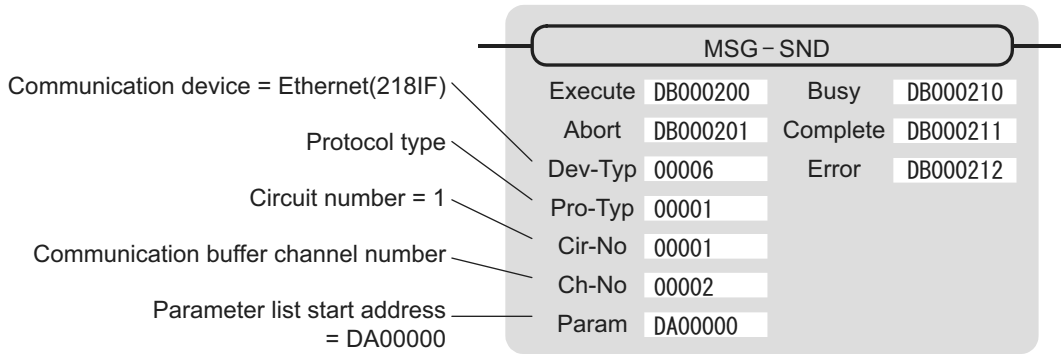

Fig. 6.5 MPE720 Module Configuration Definition Screen

■ Input/output definitions contents for message transmit functions

The input/output definition content for the message transmit function is as follows:

Table 6.6 Input/Output Definitions for Message Transmit Functions

I/O Definition	No.	Name	Setting Example	Contents
Input Item	1	Execute	DB000200	Executes a transmission When Execute is ON, the message transmission will be carried out.
	2	Abort	DB000201	Forcibly aborts a transmission When Abort is ON, the message transmission is forcibly stopped.
	3	Dev-Typ	00006	Communication device type Specify the type of the communication device used in transmission. When Ethernet (218IF) is used, specify "6."
	4	Pro-Typ	00001	Communication protocol Specify the type of the communication protocol. MEMOBUS(*1) = 1, non-procedure 1(*2) = 2, non-procedure 2(*2) = 3
	5	Cir-No	00001	Circuit number Specify a circuit number of the communication device. Specify it in accordance with the circuit number displayed in the MPE720 module configuration definition screen.
	6	Ch-No	00002	Communication buffer channel number Specify the channel number of the communication buffer. When Ethernet (218IF) is used, specify it in the range between "1" and "10." * Set up a unique channel number in the line.
	7	Param	DA00000	Parameter list start address Specify the start address of the parameter list. For the Parameter List, 17 words are automatically assigned from the configured address.
Output Item	1	Busy	DB000210	In process Busy will be ON while executing a message transmission or forced abort process.
	2	Complete	DB000211	Process completed When a message transmission or forced abort process is properly completed, Complete will turn ON only for one scan.
	3	Error	DB000212	Error When an error occurs, Error will turn ON only for one scan.

* 1. When transmitting in MEMOBUS, Extended MEMOBUS, MELSEC, or MODBUS/TCP protocol, set the communication protocol (Pro-Typ) to MEMOBUS(=1). The communication device automatically converts the protocol.

* 2. Non-procedure 1: In non-procedural communication, data is transmitted on a per-word basis.
Non-procedure 2: In non-procedural communication, data is transmitted on a per-byte basis.

■ Parameter list setting for the message transmit function

An example of a parameter list setting when reading 100 words of data from MW00100 from the destination using the connection with a connection number = 2 follows:

Table 6.7 Parameter List Setting Example (parameter list start address Param=DA00000)

Register Number	Setting Value	Parameter Number	IN/OUT	Remarks
DW00000	–	PARAM00	OUT	Process result
DW00001	–	PARAM01	OUT	Status
DW00002	00002	PARAM02	IN	Connection number = 2
DW00003	–	PARAM03	IN	Option (Setting unnecessary)
DW00004	0009H	PARAM04	IN	Function code = 09H (Reads a holding register)
DW00005	00100	PARAM05	IN	Data address = 100 (Starting from MW00100)
DW00006	00100	PARAM06	IN	Data size = 100 (100 words)
DW00007	00001	PARAM07	IN	Remote CPU number = 1
DW00008	00000	PARAM08	IN	Coil offset = 0 word
DW00009	00000	PARAM09	IN	Input relay offset = 0 word
DW00010	00000	PARAM10	IN	Input register offset = 0 word
DW00011	00000	PARAM11	IN	Holding register offset = 0 word
DW00012	–	PARAM12	SYS	Reserved by the system. (Zero clear at startup)
DW00013	–	PARAM13	SYS	Reserved by the system.
DW00014	–	PARAM14	SYS	Reserved by the system.
DW00015	–	PARAM15	SYS	Reserved by the system.
DW00016	–	PARAM16	SYS	Reserved by the system.

Note: IN: Input, OUT: Output, SYS: For system use

■ Example of Using the Message Transmit Function in a Ladder Program

Here is one example of the message transmit function through Ethernet (218IF).

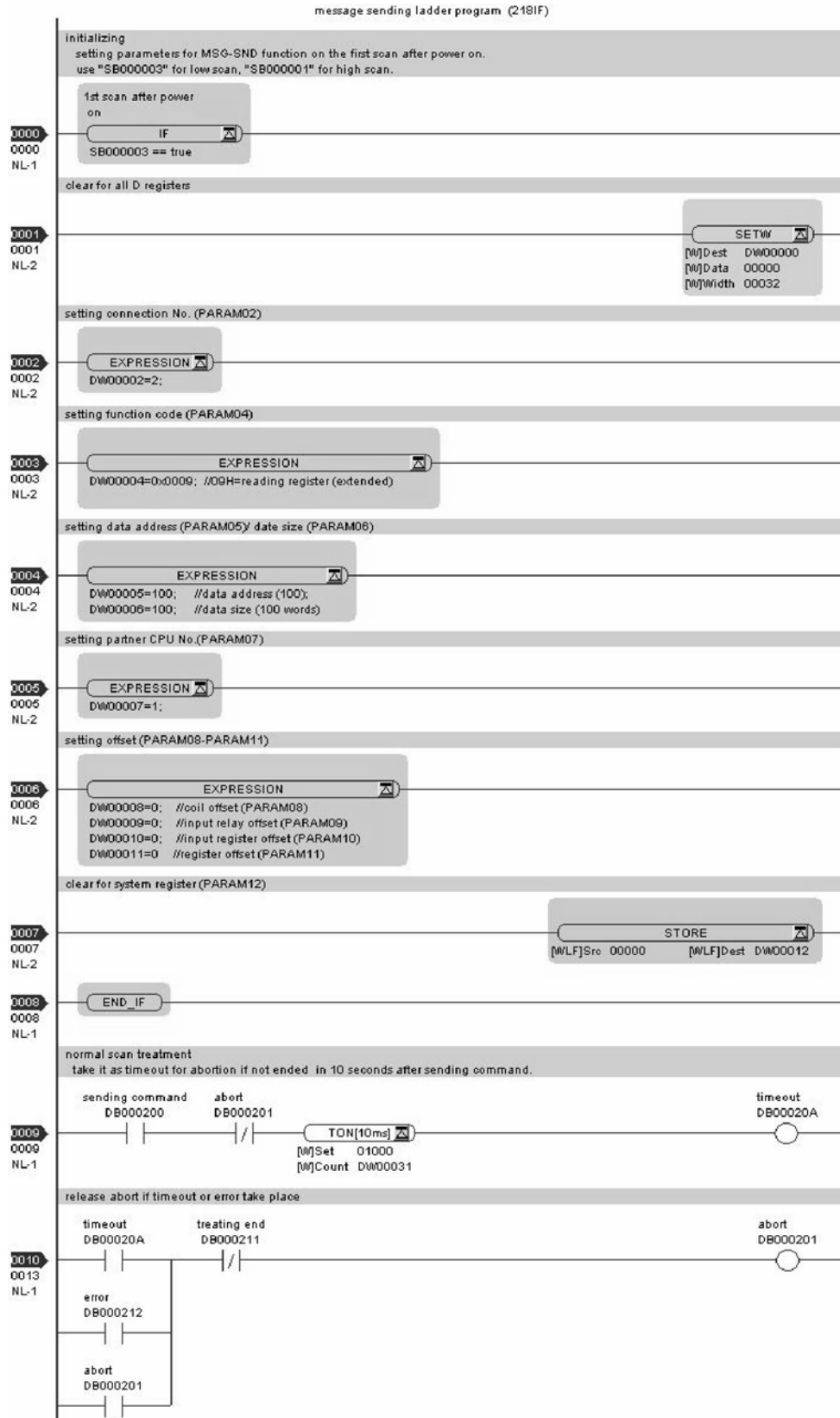

6.2.2 When the MP2300S Acts as a Slave (ladder program which uses a MSG-RCV function)

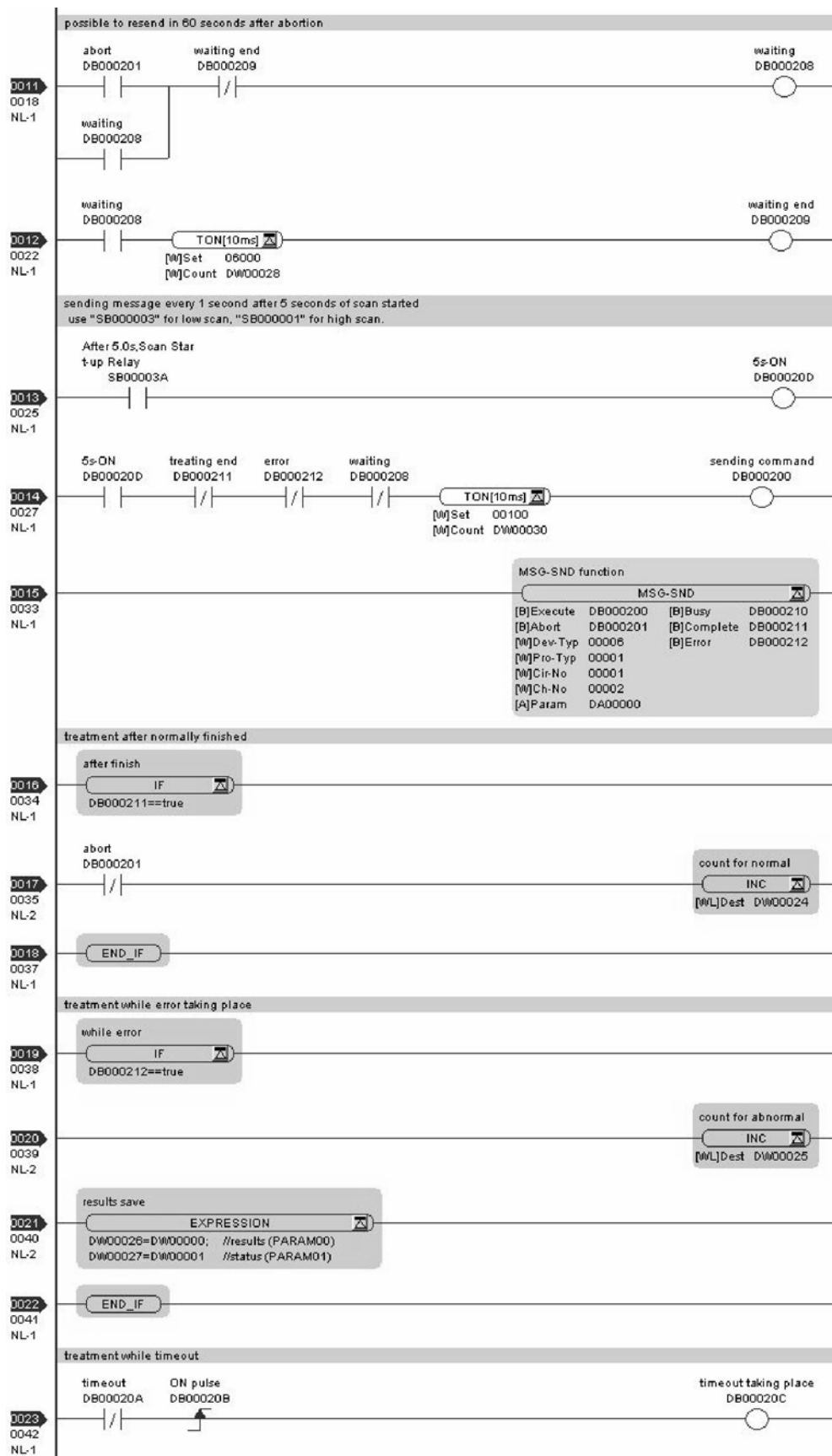

6.2.2 When the MP2300S Acts as a Slave (ladder program which uses a MSG-RCV function)

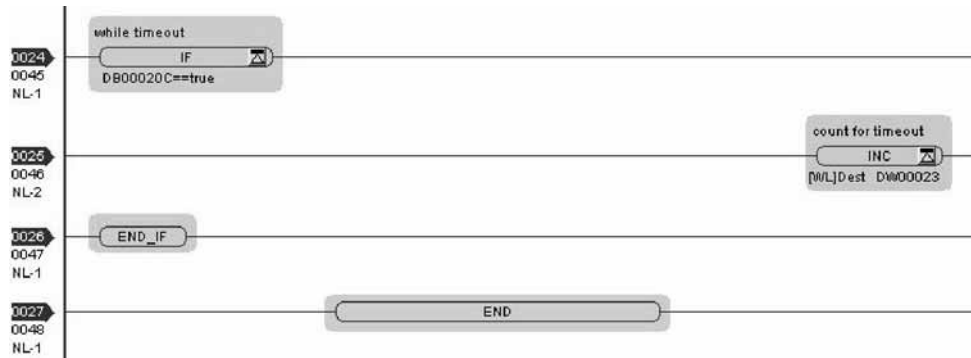

The communication setting and the ladder program creation are now finished, when MP2300 acts as a master.

(3) How to Start Communications

1. The MP2300S side starts to receive the messages.

As the sample ladder program automatically starts the message receive operation just after system startup, you are not required to do anything. In normal operation, accept the default.

2. Turn Execute ON for the message transmit function in the MP2300 side to transmit messages.

Messages are transmitted by turning on the register DB000200 configured in Execute of the message transmit function, for example, starting communication with MP2300S.

Table 6.8 Input/Output Definition for Message Transmit Function

I/O Definition	No.	Name	Setting Example	Contents
Input Item	1	Execute	DB000200	Executes a transmission When Execute is ON, the message transmission is carried out.

The sample ladder program is created to transmit a message every one second when five seconds have elapsed after the low-speed scan (or high-speed scan) startup.

To change the message transmission interval, change the timer value ①.

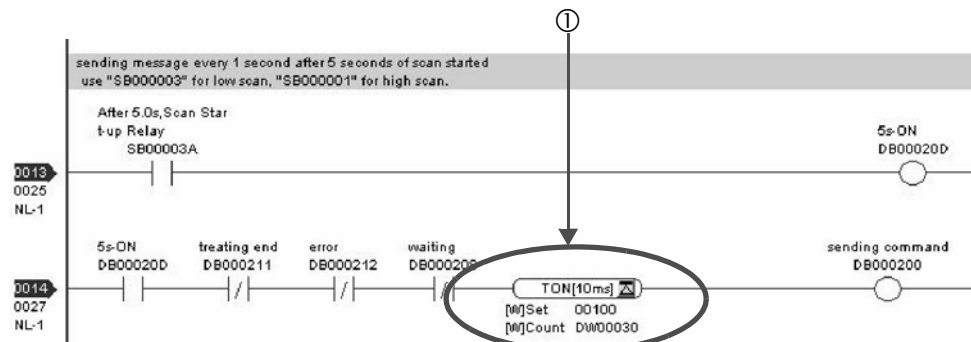

6.2.3 When MP2300S Acts as Master (I/O message communication function is used)

This section explains how to communicate with the MP2300 message receive function (MSG-RCV) using the MP2300S I/O message communication function.

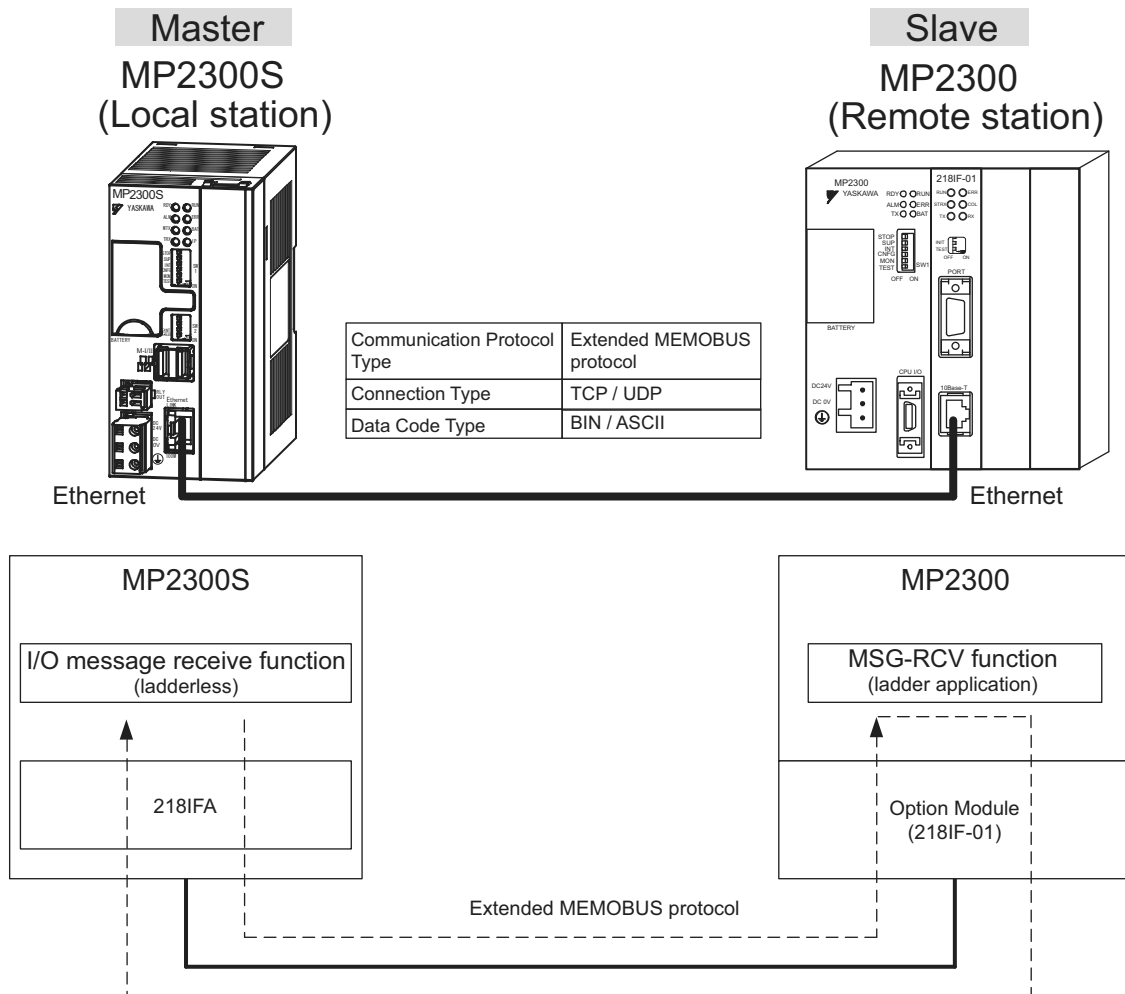

Fig. 6.6 Message Flow with MP2300 when I/O Message Communication Function Is Used

■ I/O Message Communication

I/O message communication implements out 1:1 communication.

In addition, you can read and write only the holding register in the case of “Communication Protocol Type: Extended MEMOBUS” used in the communication with MP series.

When you communicate with multiple remote devices, or when you need to read a coil state or input relay, or change a coil state as well as read/write a holding register, use the message transmit function (MSG-SND).

■ Setting Example

The following figure illustrates one example of reading the contents of the holding register (MW00200 to MW00299) of MP2300 (slave) into an input register (IW0000 to IW0063) of MP2300S (master) and writing the contents of an output register (OW0064 to OW00C7) of MP2300S (master) into a holding register (MW00300 to MW00399) of MP2300 (slave).

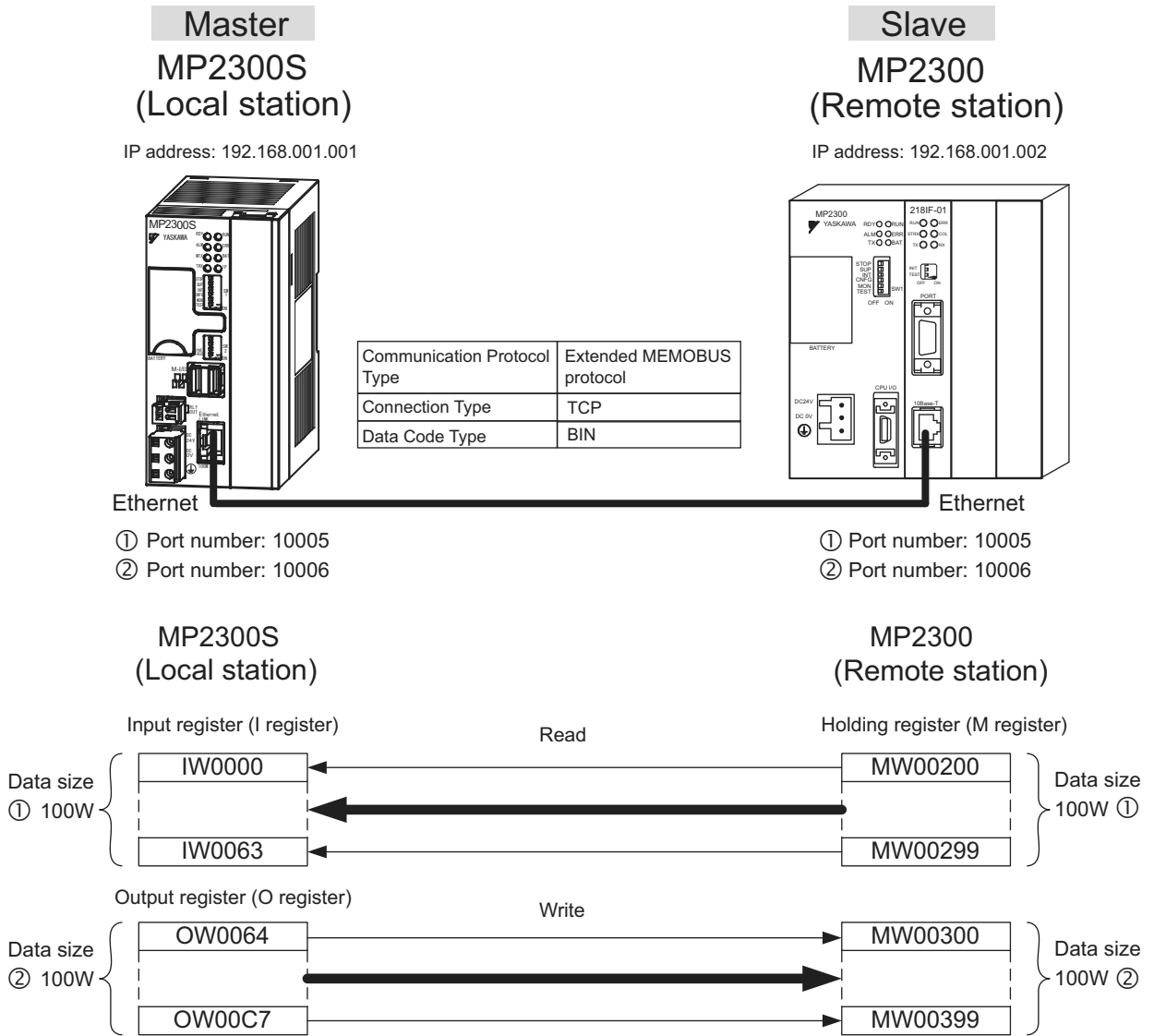

The particular setup procedure is explained in the subsequent pages.

(1) How to Set up the MP2300S Side

If the setting of transmission parameters (IP address, subnet mask) is already completed, start from step 3.

1. Double-click the 218IFA Tab in the **Module Details** of the module configuration definition.

Slot Number	1	2	3	4	5
Module Type	CPU	218IFA	SVR	SVR	M-EXECUTOR
Controller Number	-	01	01	01	-
Circuit Number	-	01	01	02	-
I/O Start Register	----	0000	0800	----	0C00
I/O End Register	----	07FF	0BFF	----	0C3F
Disable Input		Enable	Enable		
Disable Output		Enable	Enable		
Motion Start Register	----	----	8000	8800	----
Motion End Register	----	----	87FF	8FFF	----
Details			MECHATROLINK		
Status	Running	Running	Running	Running	Running

2. Set transmission parameters.

How to set up transmission parameters

- ① Set **IP Address** (“192.168.001.001,” for example).
- ② Set **Subnet Mask** (“255.255.255.000,” for example).
- ③ Set **Gateway IP Address** (“000.000.000.000,” for example).

Caution

Set up a unique IP address in the network.
For the IP address, check with your network administrator.

3. Click **Enable** in the **I/O Message Communication** of the connection parameter setting.

4. Set a communication setting in the **I/O Message Communication Easy Setting** Window.

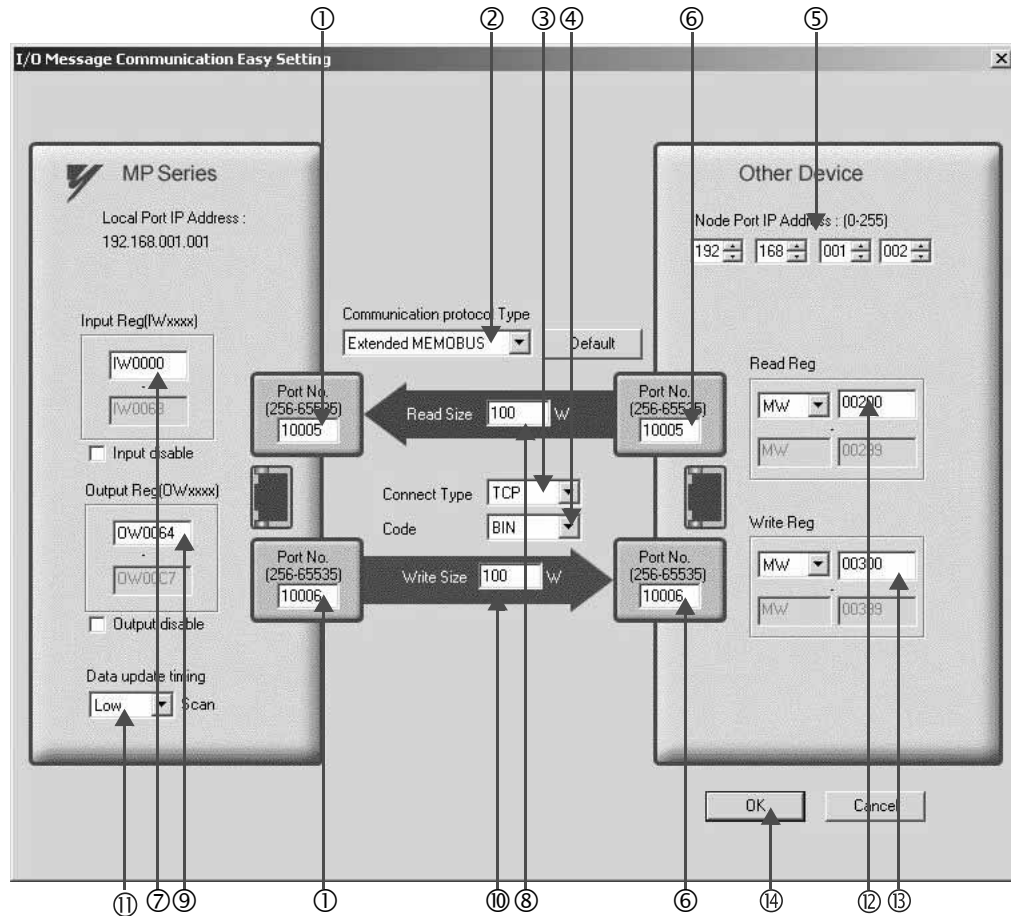

■ How to set up in the **I/O Message Communication Easy Setting** Window

- ① Set **Port No.** of the MP2300S side (“10005, 10006,” X for example).
- ② Select **Extended MEMOBUS** for **Communication Protocol Type**, and click the **Default** Button.

■ Caution

When the communication protocol is Extended MEMOBUS, the register type that can select both read and write is fixed at the Holding Register (MW).

- ③ Select **Connect Type** (TCP, for example).
- ④ Select **Code** (BIN, for example).
- ⑤ Set **Remote IP Address** for the other device (MP2300) to be connected (“192.168.001.002,” for example).
- ⑥ Set **Port No.** of the other device (MP2300) to be connected (“10005, 10006,” for example).

■ Caution

In I/O message communication, as a message is transmitted from each port number for register read/write, a connected remote device needs the message receive functions to receive two messages.

6.2.3 When MP2300S Acts as Master (I/O message communication function is used)

- ⑦ Set a storage area (**Input Reg**) of data read by MP2300S (IW0000, for example).
- ⑧ Set the **Read Size** of data to be the read by the MP2300S (“100” W, for example).
- ⑨ Set a storage area (**Output Reg**) of data written by the MP2300S (OW0064, for example).
- ⑩ Set the **Write Size** of data written by the MP2300S (“100” W, for example).
- ⑪ Set an I/O data update timing (**Data update timing**) for CPU and built-in Ethernet (“Low” scan, for example).

■ Data Update Timing

Data update timing indicates when to send and receive data between the CPU and built-in Ethernet. Communication with the remote device is carried out asynchronously, so note that a message is not necessarily transmitted to the remote equipment at each set data update time.

- ⑫ Set the register type and start address (**Read Reg**) of the remote device (MP2300) read by the MP2300S (“MW00200,” for example).
- ⑬ Set the register type and start address (**Write Reg**) of the remote device (MP2300) written by the MP2300S (“MW00300,” for example).
- ⑭ Click **OK**.

5. Click Yes in the parameter setting confirmation window.

■ Caution

Note that when a parameter with the same connection number is already set and you click **Yes** in the parameter setting confirmation window, the setting will be overwritten by the parameter configured in the **Message Communication Easy Setting** Window.

6. Check the setting values.

I/O Message Communication

Disable
 Enable

Easy setting It is possible to set easily that communicate the I/O message.

Data update timing: Low Scan

Read/Write	Local Port	Node IP Address	Node Port	Connect Type	Protocol Type	Code
Read	10005	192.168.001.002	10005	TCP	Extended MEMO8US	BIN
Write	10006	192.168.001.002	10006	TCP	Extended MEMO8US	BIN

MP2300S

Head register number data size

input disable IW0000 100 W<- Hold register(MW) 00200 100 W

output disable OW0064 100 W-> Hold register(MW) 00300 100 W

Node equipment

The I/O message communication is now set up, when MP2300S acts as a master.

■ Caution

When any transmission or connection parameter is changed, the change will be not reflected after FLASH has been saved and the power supply is turned ON again.

(2) How to Set up the Remote Device (MP2300) to Be Connected

When the setting of transmission parameters (IP address, subnet mask) is already completed, start from step 3.

1. Double-click the **218IF** Tab in the **Module Details** of the module configuration definition.

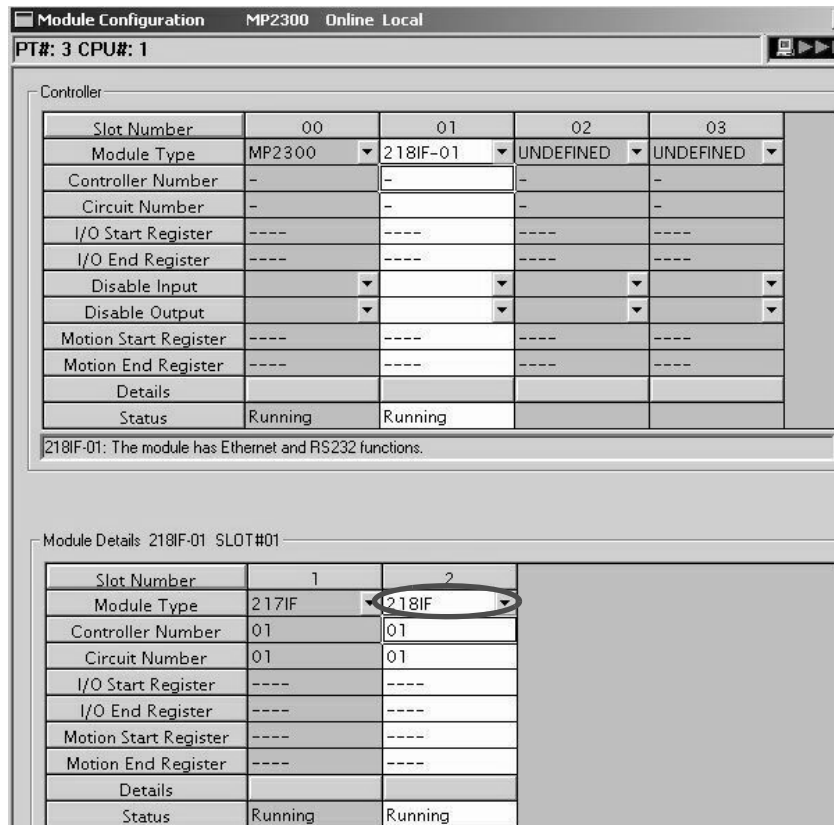

2. Set transmission parameters.

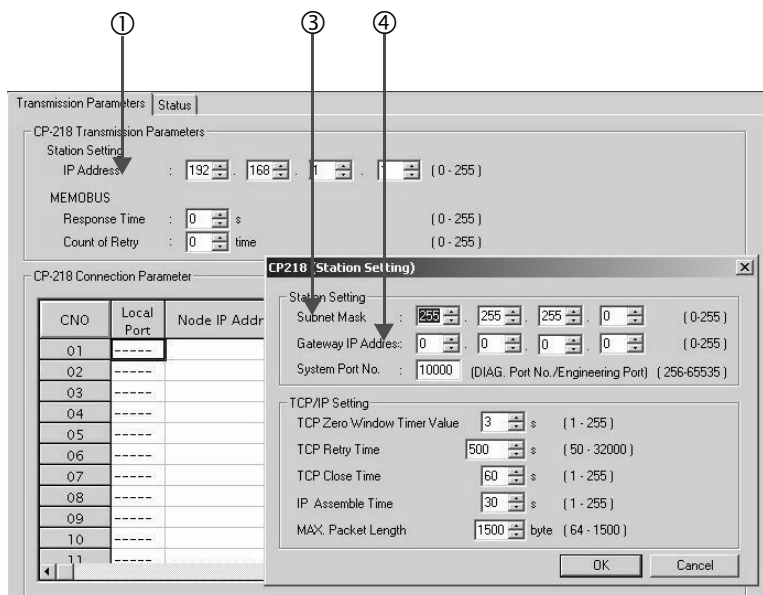

■ How to set up transmission parameters

- ① Set **IP Address** (“192.168.001.001”, for example).
- ② Click **Edit**, and then click **Local Station: TCP/IP Setting** in the **Engineering Manager** Window.
- ③ Set **Subnet Mask** (“255.255.255.000”, for example).
- ④ Set **Gateway IP Address** (“000.000.000.000”, for example).

■ Caution

Set up a unique IP address in the network.
For the IP address, check with your network administrator.

3. Set connection parameters.

CNO	Local Port	Node IP Address	Node Port	Connect Type	Protocol Type	Code
01	10001	192.168.001.001	10001	TCP	Extended MEMOBUS	BIN
02	10002	192.168.001.001	10002	TCP	Extended MEMOBUS	BIN
03	10003	192.168.001.001	10003	TCP	Extended MEMOBUS	BIN
04	----					
05	10005	192.168.001.001	10005	TCP	Extended MEMOBUS	BIN
06	10006	192.168.001.001	10006	TCP	Extended MEMOBUS	BIN
07	----					
08	----					
09	----					

■ How to set up in the CP-218 Connection Parameter Window with connection numbers 05, 06

- ① Set **Local Port** (the port number “10005, 10006” used in the MP2300 side, for example).
- ② Set **Node IP Address** (the IP address “192.168.001.001” configured in the MP2300S side, for example).
- ③ Set **Node Port** (the port number “10005, 10006” configured in the MP2300S side, for example).
- ④ Select **Connect Type** (TCP, for example).
- ⑤ Select **Extended MEMOBUS** for **Protocol Type**.
- ⑥ Select **Code** (BIN, for example).

■ Caution

When any transmission or connection parameter is changed, the change will be reflected after FLASH has been saved and the power supply is turned ON again.

4. Create a ladder program with a message receive function (MSG-RCV) in it.

An example of a ladder program for receiving messages in the remote equipment (MP2300) side follows:

■ **Message receive function (MSG-RCV)**

Required for receiving messages. Message reception is carried out by inputting and executing this message receive function in a ladder program.

In addition, in order to support Read and Write by MP2300S, two message receive functions should be provided. Here, the input item and parameters (Communication buffer channel number and Connection number) of the message receive function need to accord with the MP2300S side settings.

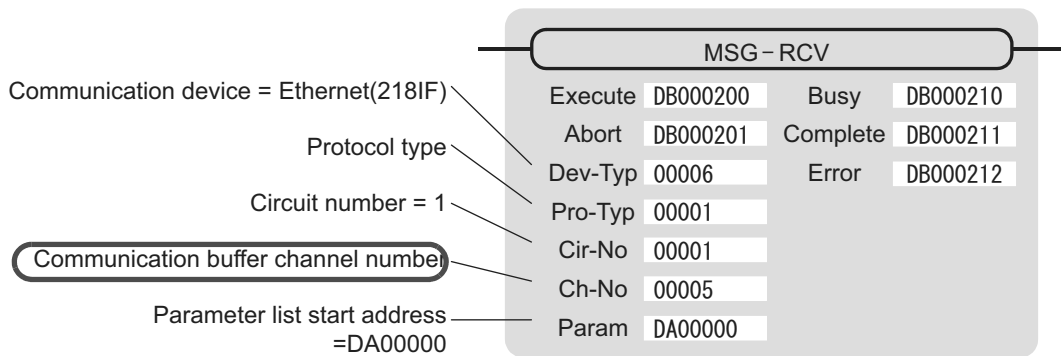

Note: Similarly, a message receive function with the communication buffer channel number = 6 is required.

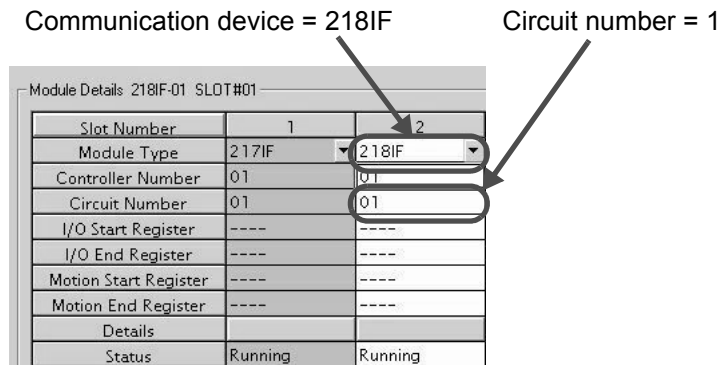

Fig. 6.7 MPE720 Module Configuration Definition Window

■ Input/output definition contents for message receive functions

The input/output definition content for message receive function is as follows:

Table 6.9 Input/Output Definitions for Message Receive Functions

I/O Definition	No.	Name	Setting Example	Content
Input Item	1	Execute	DB000200	Executes a reception When Execute is ON, message reception is carried out.
	2	Abort	DB000201	Forcibly aborts a reception When Abort is ON, the message reception is forcibly stopped.
	3	Dev-Typ	00006	Communication device type Specify the type of the communication device used in reception. When Ethernet (218IF) is used, specify "6."
	4	Pro-Typ	00001	Communication protocol Specify the type of the communication protocol. MEMOBUS(*1) = 1, non-procedure 1(*2) = 2, non-procedure 2(*2) = 3
	5	Cir-No	00001	Circuit number Specify a circuit number of the communication device. Specify it in accordance with the circuit number displayed in the MPE720 module configuration definition screen.
	6	Ch-No	00005 & 00006	Communication buffer channel number Specify the channel number of a communication buffer. When Ethernet (218IF) is used, specify it in the range between "1" and "10." * Set up a unique channel number in the line.
	7	Param	DA00000	Parameter list start address Specify the start address of the parameter list. For the Parameter List, 17 words are automatically assigned from the configured address.
Output Item	1	Busy	DB000210	In process Busy will be ON while executing a message reception or forced abort process.
	2	Complete	DB000211	Process completed When a message reception or forced abort process is properly completed, Complete will turn ON only for one scan.
	3	Error	DB000212	Error When an error occurs, Error will turn ON only for one scan.

* 1. When transmitting in MEMOBUS, Extended MEMOBUS, MELSEC, or MODBUS/TCP protocol, set the communication protocol (Pro-Typ) to MEMOBUS (=1). The communication device automatically converts the protocol.

* 2. Non-procedure 1: In non-procedural communication, data is received on a per-word basis.
Non-procedure 2: In non-procedural communication, data is received on a per-byte basis.

■ Parameter list setting example for message receive function

An example of a parameter list setting when receiving messages from a transmit source using the connection with connection numbers = 5 and 6 follows:

Table 6.10 Parameter List Setting Example 1 (parameter list start address Param = DA00000)

Register Number	Setting Value	Parameter Number	IN/OUT	Remarks
DW00000	–	PARAM00	OUT	Process result
DW00001	–	PARAM01	OUT	Status
DW00002	00005	PARAM02	IN	Connection number = 5 (For receiving read operation)
DW00003	–	PARAM03	OUT	Option
DW00004	–	PARAM04	OUT	Function code
DW00005	–	PARAM05	OUT	Data address
DW00006	–	PARAM06	OUT	Data size
DW00007	–	PARAM07	OUT	Remote CPU number
DW00008	00000	PARAM08	IN	Coil offset = 0 word
DW00009	00000	PARAM09	IN	Input relay offset = 0 word
DW00010	00000	PARAM10	IN	Input register offset = 0 word
DW00011	00000	PARAM11	IN	Holding register offset = 0 word
DW00012	00000	PARAM12	IN	Writable address lower limit = MW00000
DW00013	65534	PARAM13	IN	Writable address upper limit = MW65534
DW00014	–	PARAM14	SYS	Reserved by the system. (Zero clear at startup)
DW00015	–	PARAM15	SYS	Reserved by the system.
DW00016	–	PARAM16	SYS	Reserved by the system.

Note: N: Input, OUT: Output, SYS: For system use

Table 6.11 Parameter List Setting Example 2 (parameter list start address Param = DA00000)

Register Number	Setting Value	Parameter Number	IN/OUT	Remarks
DW00000	–	PARAM00	OUT	Process result
DW00001	–	PARAM01	OUT	Status
DW00002	00006	PARAM02	IN	Connection number = 6 (For receiving write operation)
DW00003	–	PARAM03	OUT	Option
DW00004	–	PARAM04	OUT	Function code
DW00005	–	PARAM05	OUT	Data address
DW00006	–	PARAM06	OUT	Data size
DW00007	–	PARAM07	OUT	Remote CPU number
DW00008	00000	PARAM08	IN	Coil offset = 0 word
DW00009	00000	PARAM09	IN	Input relay offset = 0 word
DW00010	00000	PARAM10	IN	Input register offset = 0 word
DW00011	00000	PARAM11	IN	Holding register offset = 0 word
DW00012	00000	PARAM12	IN	Writable address lower limit = MW00000
DW00013	65534	PARAM13	IN	Writable address upper limit = MW65534
DW00014	–	PARAM14	SYS	Reserved by the system. (Zero clear at startup)
DW00015	–	PARAM15	SYS	Reserved by the system.
DW00016	–	PARAM16	SYS	Reserved by the system.

Note: N: Input, OUT: Output, SYS: For system use

■ Example of Using the Message Receive Function in a Ladder Program

Here is one example of using the message receive function through Ethernet (218IF). In addition, this ladder program is for receiving read operation. A ladder program for receiving write operations is required separately.

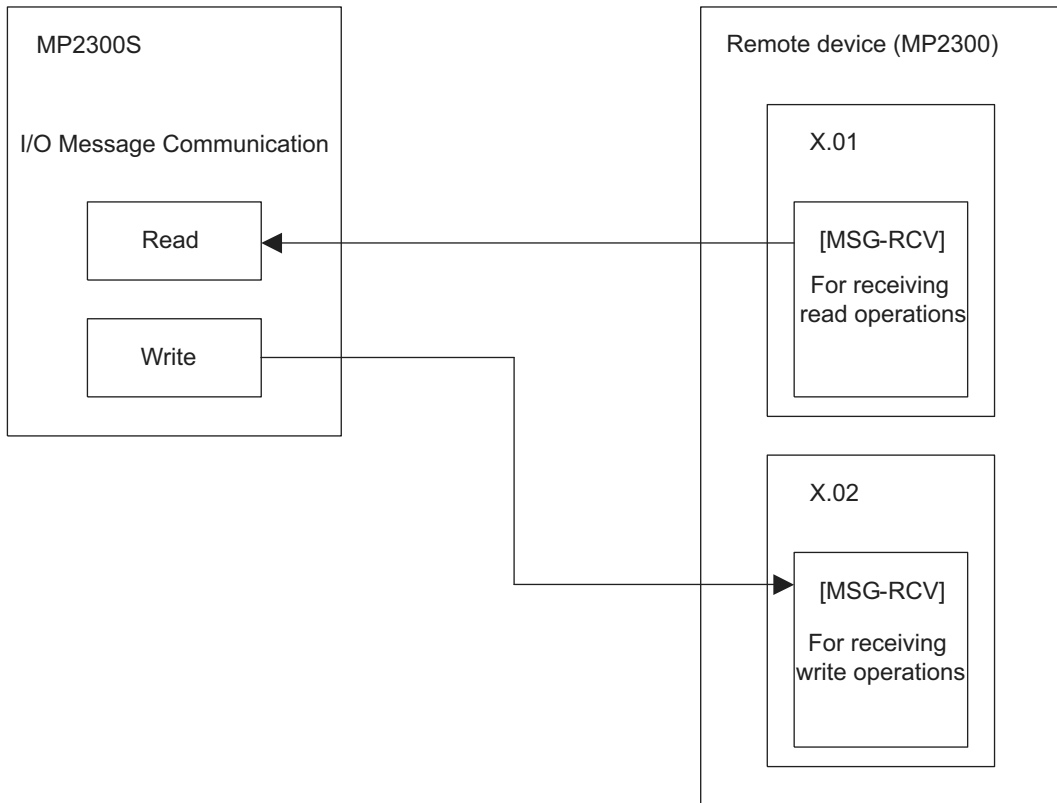

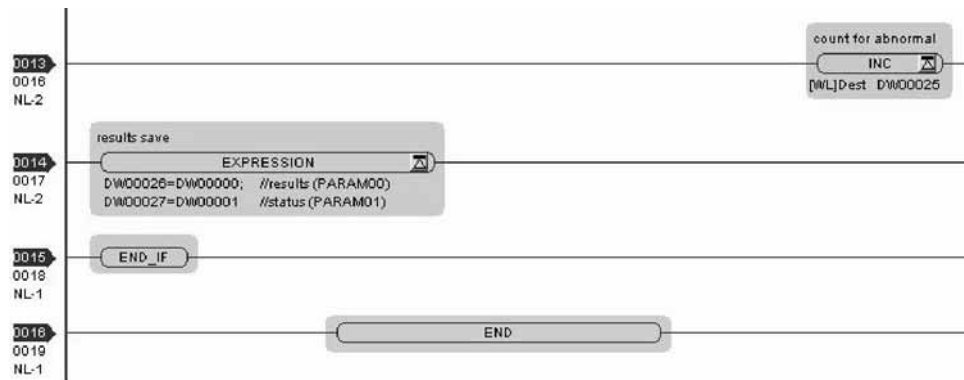

The communication setting and the ladder program creation are now finished, when MP2300 acts as a slave.

(3) How to Start Communication

1. The MP2300 side starts to receive the messages.

As the sample ladder program starts the message receive operation just after the system startup, you are not required to do anything. In normal operation, accept the default.

2. The MP2300S side transmits messages.

When an I/O message communication function is used, message transmit operation status automatically.

6.2.4 When the MP2300S Acts as Master (ladder program which uses MSG-SND function)

The I/O message communication function cannot operate any registers other than the holding register (M register). Note that it can communicate with only one slave.

To communicate with more than one slave, use a ladder program with a message transmit function (MSG-SND) on the MP2300S side. You can use the message transmit (MSG-SND) function as well as the I/O message communication function by keeping connections separate from each other.

This section explains how to communicate with the MP2300 message receive function (MSG-RCV) using the MP2300S message transmit function (MSG-SND).

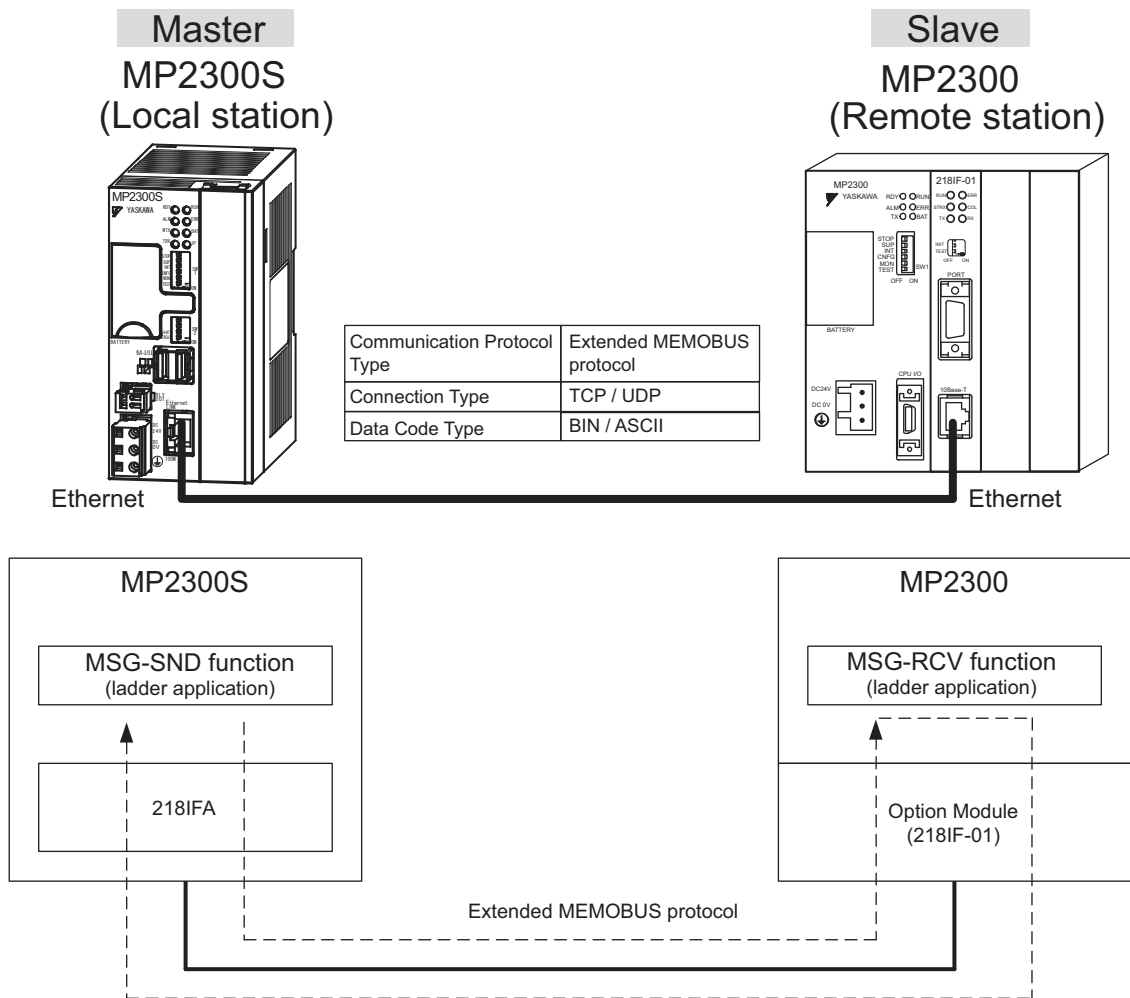
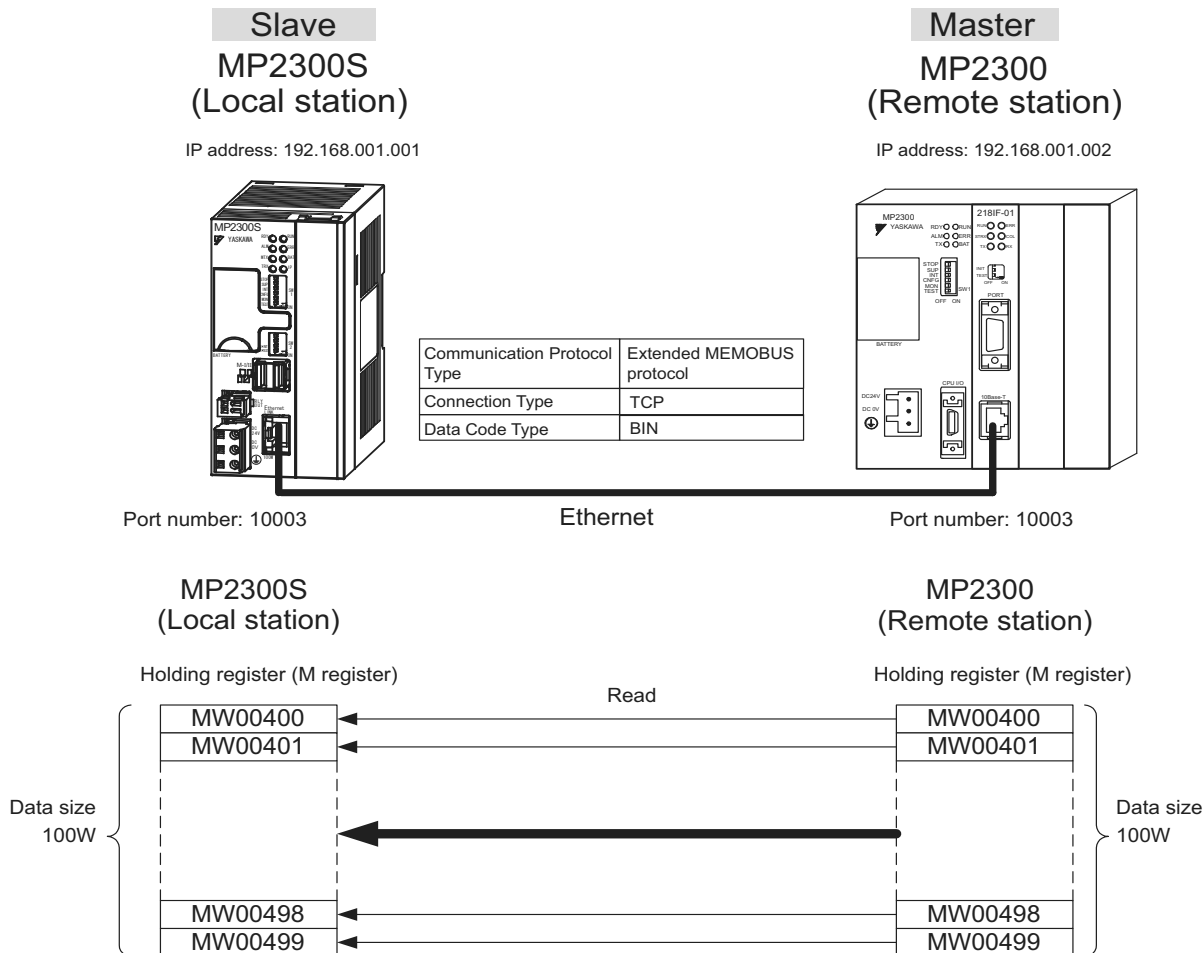

Fig. 6.8 Message Flow with MP2300 when Message Transmit Function (MSG-SND) Is Used

■ Setting Example

The following figure illustrates one example of reading the content of the MP2300 (slave) holding register (MW00400 to MW00499) into the MP2300S (master) holding register (MW00400 to MW00499).



The particular setup procedure is explained in the subsequent pages.

(1) How to Set up the MP2300S Side

When the setting of transmission parameters (IP address, subnet mask) is already completed, start from step 3.

1. Double-click the **2181FA** Tab in the **Module Details** of the module configuration definition.

Slot Number	1	2	3	4	5
Module Type	CPU	2181FA	SVR	SVR	M-EXECUTOR
Controller Number	-	01	01	01	-
Circuit Number	-	01	01	02	-
I/O Start Register	----	0000	0800	----	0C00
I/O End Register	----	07FF	0BFF	----	0C3F
Disable Input		Enable	Enable		
Disable Output		Enable	Enable		
Motion Start Register	----	----	8000	8800	----
Motion End Register	----	----	87FF	8FFF	----
Details			MECHATROLINK		
Status	Running	Running	Running	Running	Running

2. Set transmission parameters.

Transmission Parameters Status

Transmission Parameters

IP Address : 192 . 168 . 1 . 1 (0-255)

Subnet Mask : 255 . 255 . 255 . 0 (0-255)

Gateway IP Address : 0 . 0 . 0 . 0 (0-255)

Module Name Definition

Equipment name : CONTROLLER NAME

Detail Definition

■ How to set up transmission parameters

- ① Set **IP Address** (“192.168.001.001,” for example).
- ② Set **Subnet Mask** (“255.255.255.000,” for example).
- ③ Set **Gateway IP Address** (“000.000.000.000,” for example).

■ Caution

Set up a unique IP address in the network.
For the IP address, check with your network administrator.

3. Click the **Easy Setting** Button in the **Message Communication** area of the connection parameter setting.

Connection Parameter

Message Communication

Easy setting is possible to following parameter setting easily that communicate the message.

CNO	Local Port	Node IP Address	Node Port	Connect Type	Protocol Type	Code	Automaticall y	Node Name
01	----							Detail
02	----							
03	----							
04	----							

Cannot the overlap to local station port number used by the communicate the I/O message.

4. Set a communication setting in the **Message Communication Easy Setting** Window.

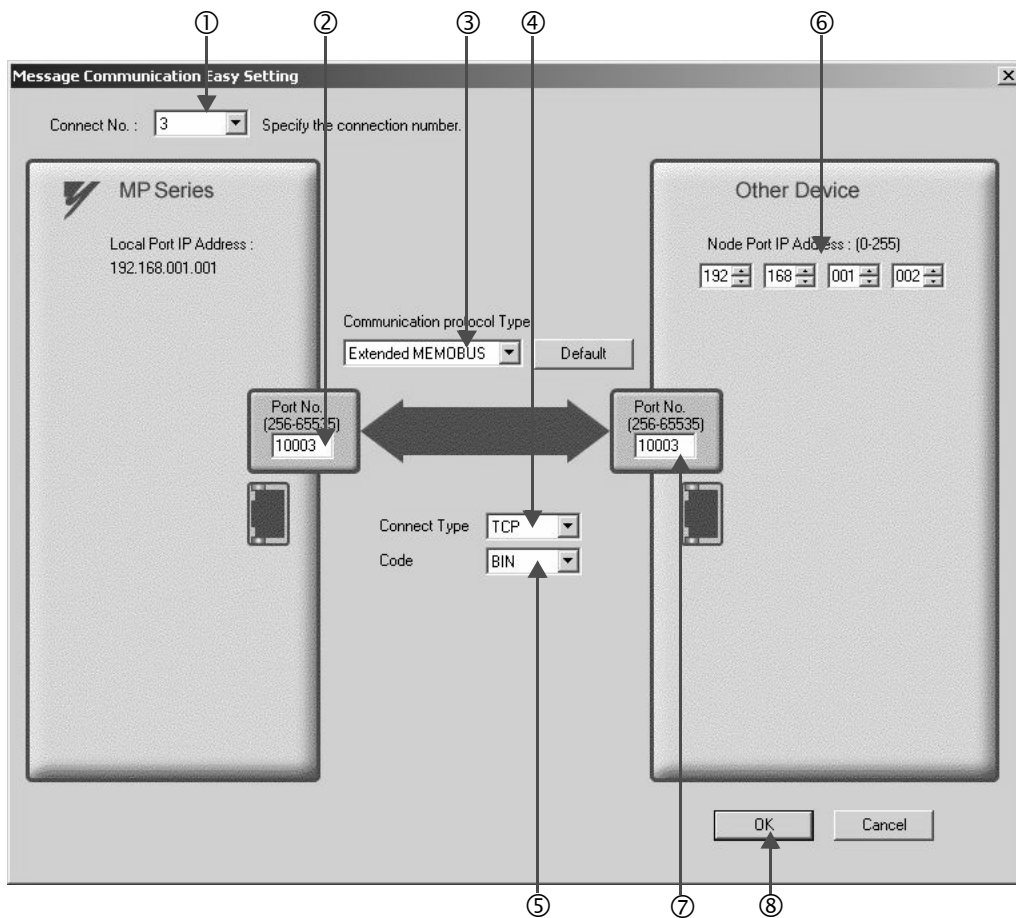

■ How to set up in the **Message Communication Easy Setting** Window

- ① When automatic receive is used, select “3” for the **Connect No.**
- ② Set **Port No.** of the MP2300S side (“10003,” for example).
- ③ Select **Extended MEMOBUS** for **Communication Protocol Type**, and click the **Default** Button.
- ④ Select **Connect Type** (TCP, for example).
- ⑤ Select **Code** (BIN, for example).
- ⑥ Set **Node Port IP Address** for the other device (MP2300) to be connected (“192.168.001.002,” for example).
- ⑦ Set **Port No.** of the other device (MP2300S) to be connected (“10003,” for example).
- ⑧ Click **OK**.

■ Caution

When message functions (MSG-SND, MSG-RCV) are used with the connection number 01, disable the automatic receive function. If message functions are used while the automatic receive function is enabled, the communication will not function properly.

Note: By default, the automatic receive function with a connection number 01 is set to “Enable.”

5. Click **Yes** in the parameter setting confirmation dialog box.

■ **Caution**

Note that when a parameter with the same connection number is already set and you click **Yes** in the parameter setting confirmation dialog, the setting will be overwritten by the parameter configured in the **Message Communication Easy Setting** Window.

6. Check the setting values.

Connection Parameter
Message Communication

Easy setting It is possible to following parameter setting easily that communicate the message.

CNO	Local Port	Node IP Address	Node Port	Connect Type	Protocol Type	Code	Automaticall y	
01	-----			▼	▼	▼	Detail	
02	-----			▼	▼	▼		
03	10003	192.168.001.002	10003	TCP	Extended MEMOBUS	BIN		
04	-----			▼	▼	▼		

Cannot the overlap to local station port number used by the communicate the I/O message.

■ **Caution**

When any transmission or connection parameter is changed, the change will be reflected after FLASH has been saved and the power supply is turned ON again.

7. Create a ladder program containing a message transmit function (MSG-SND).

An example of a ladder program example for transmitting messages from the MP2300S side follows:

Message transmit function (MSG-SND)

Required for transmitting messages. A message transmission is carried out by describing and executing this message transmit function in a ladder program.

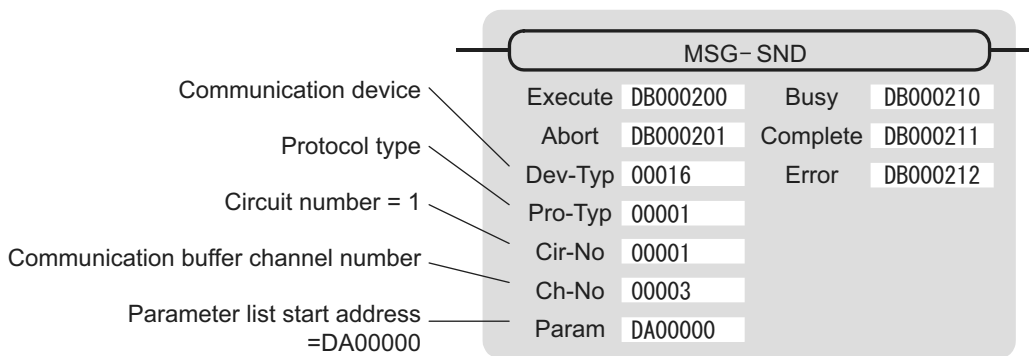

Communication device Circuit number = 1

Module Details MP2300S SLOT#00					
Slot Number	1	2	3	4	5
Module Type	CPU	2181FA	SVB	SVR	M-EXECUTOR
Controller Number	-	01	01	01	-
Circuit Number	-	01	01	02	-
I/O Start Register	----	0000	0800	----	0C00
I/O End Register	----	07FF	0BFF	----	0C3F
Disable Input		Enable	Enable		
Disable Output		Enable	Enable		
Motion Start Register	----	----	8000	8800	----
Motion End Register	----	----	87FF	8FFF	----
Details			MECHATROLINK		
Status	Running	Running	Running	Running	Running

2181FA : 100M Ethernet in functions.

Fig. 6.9 MPE720 Module Configuration Definition Window

■ Input/output definition contents for message transmit functions

The input/output definition content for the message transmit function is as follows:

Table 6.12 Input/Output Definitions for Message Transmit Functions

I/O Definition	No.	Name	Setting Example	Contents
Input Item	1	Execute	DB000200	Executes a transmission When Execute turns ON, the message transmission is carried out.
	2	Abort	DB000201	Aborts a transmission When the Abort bit turns ON, message transmission is forcibly stopped.
	3	Dev-Typ	00016	Communication device type Specify the type of the communication device used in transmission. When Ethernet (218IF) is used, specify "16."
	4	Pro-Typ	00001	Communication protocol Specify the type of the communication protocol. MEMOBUS(*1) = 1, non-procedure 1(*2) = 2, non-procedure 2(*2) = 3
	5	Cir-No	00001	Circuit number Specify a circuit number of the communication device. Specify it in accordance with the circuit number displayed in the MPE720 module configuration definition screen.
	6	Ch-No	00003	Communication buffer channel number Specify the channel number of a communication buffer. When Ethernet (218IF) is used, specify it in the range between "1" and "4." * Set up a unique channel number in the line.
	7	Param	DA00000	Parameter list start address Specify the start address of the parameter list. For the Parameter List, 17 words are automatically assigned from the configured address.
Output Item	1	Busy	DB000210	In process Busy is ON while executing a message transmission or forced abort process.
	2	Complete	DB000211	Process completed When a message transmission or abort process is properly completed, Complete will turn ON only for one scan.
	3	Error	DB000212	Error occurred When an error occurs, Error will turn ON only for one scan.

* 1. When transmitting in MEMOBUS, Extended MEMOBUS, MELSEC, or MODBUS/TCP protocol, set the communication protocol (Pro-Typ) to MEMOBUS(=1). The communication device automatically converts the protocol.

* 2. Non-procedure 1: In non-procedural communication, data is transmitted on a per-word basis.
Non-procedure 2: In non-procedural communication, data is transmitted on a per-byte basis.

■ Parameter list setting example for the message transmit function

An example of a parameter list setting when writing 100 words of data from MW00000 to the destination using the connection with a connection number = 1 follows:

Table 6.13 Parameter List Setting Example (parameter list start address Param = DA00000)

Register Number	Setting Value	Parameter Number	IN/OUT	Remarks
DW00000	–	PARAM00	OUT	Process result
DW00001	–	PARAM01	OUT	Status
DW00002	00003	PARAM02	IN	Connection number = 3
DW00003	–	PARAM03	IN	Option (Setting unnecessary)
DW00004	0009H	PARAM04	IN	Function code = 09H (Reads a holding register)
DW00005	00400	PARAM05	IN	Data address = 400 (Starting from MW00400)
DW00006	00100	PARAM06	IN	Data size = 100 (100 words)
DW00007	00001	PARAM07	IN	Remote CPU number = 1
DW00008	00000	PARAM08	IN	Coil offset = 0 word
DW00009	00000	PARAM09	IN	Input relay offset = 0 word
DW00010	00000	PARAM10	IN	Input register offset = 0 word
DW00011	00000	PARAM11	IN	Holding register offset = 0 word
DW00012	–	PARAM12	SYS	Reserved by the system. (Zero clear at startup)
DW00013	–	PARAM13	SYS	Reserved by the system.
DW00014	–	PARAM14	SYS	Reserved by the system.
DW00015	–	PARAM15	SYS	Reserved by the system.
DW00016	–	PARAM16	SYS	Reserved by the system.

Note: N: Input, OUT: Output, SYS: For system use

■ Example of Using the Message Transmit Function in a Ladder Program

Here is one example of using the message transmit function through Ethernet (218IFA).

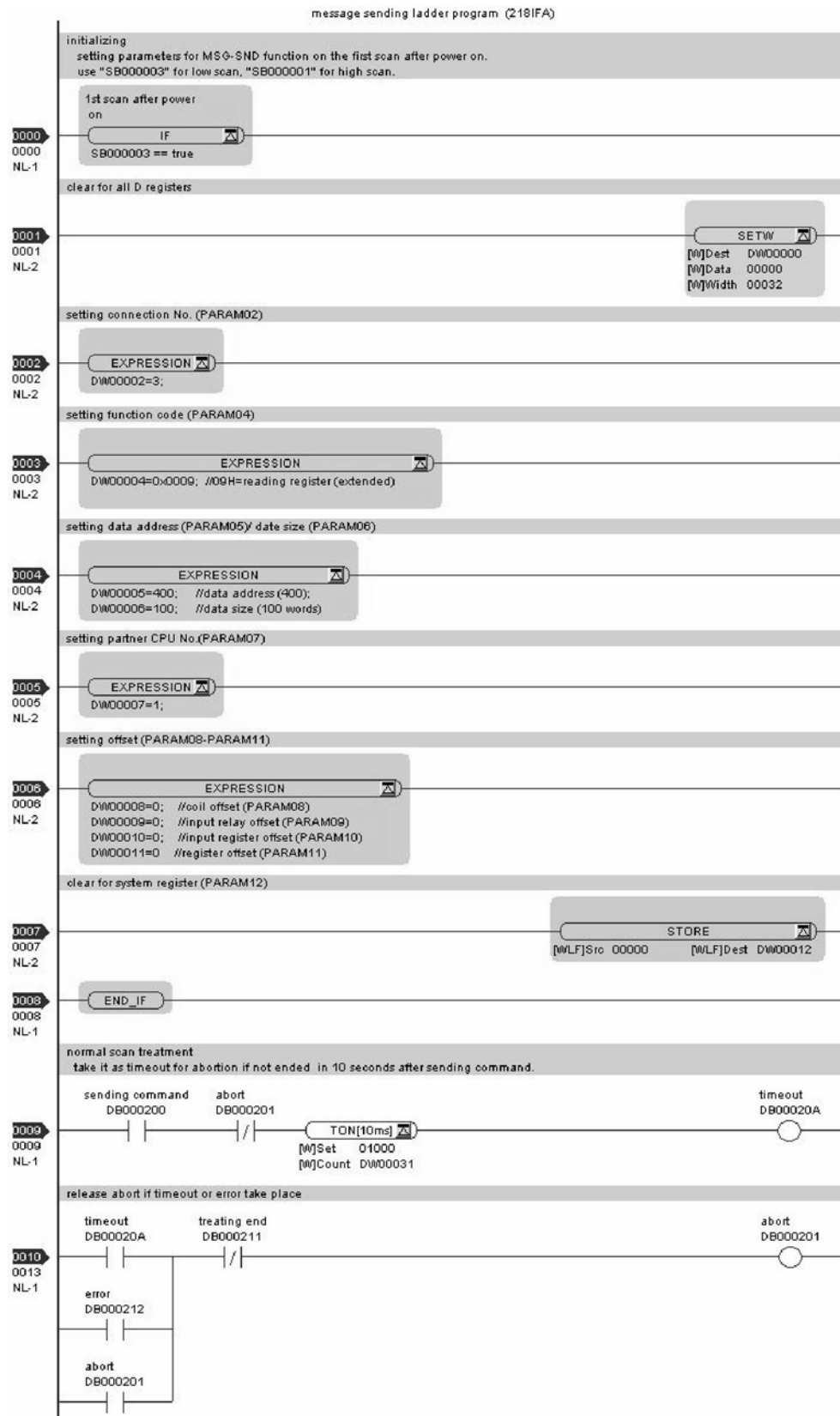

6.2.4 When the MP2300S Acts as Master (ladder program which uses MSG-SND function)

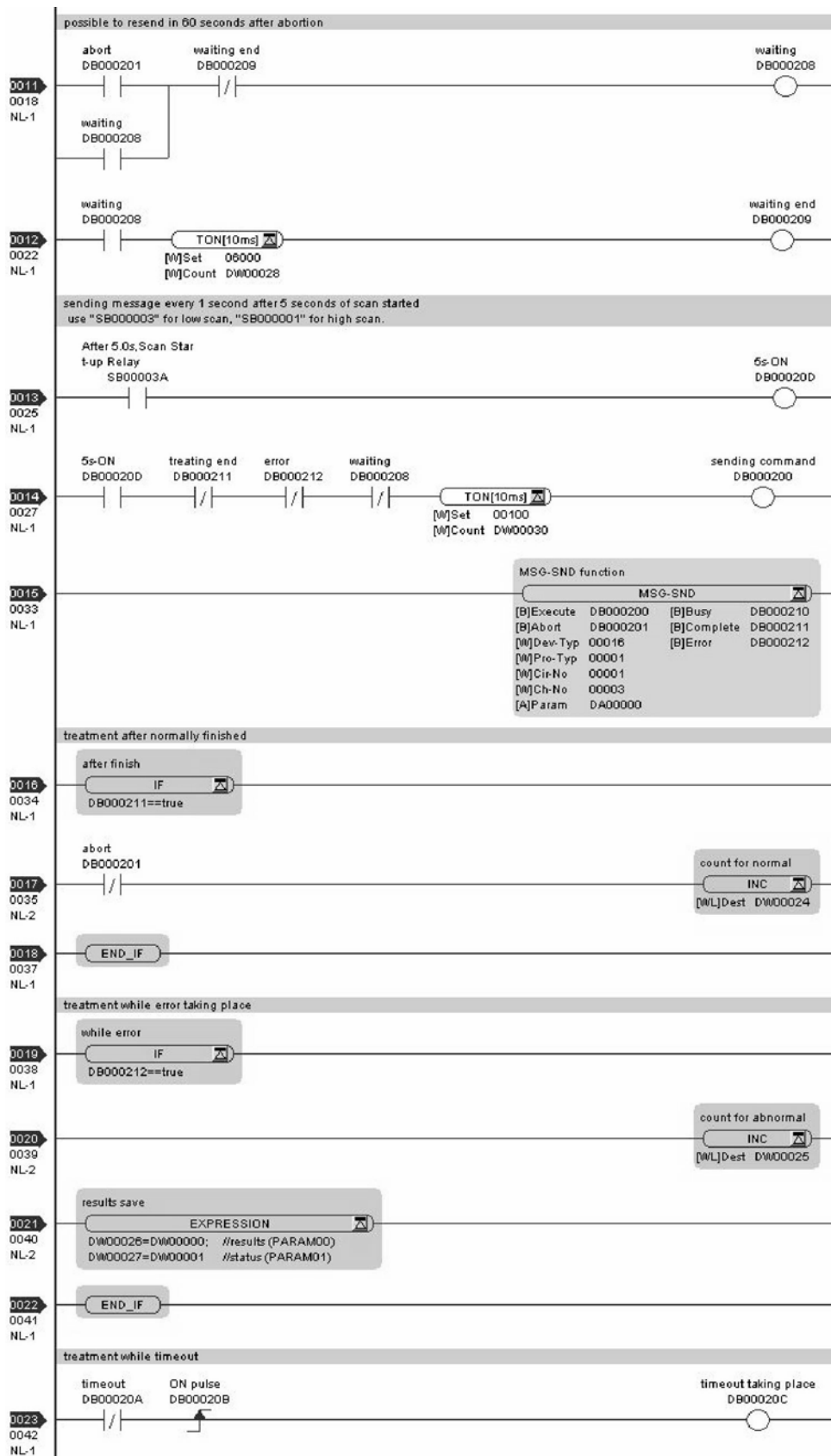

6.2.4 When the MP2300S Acts as Master (ladder program which uses MSG-SND function)

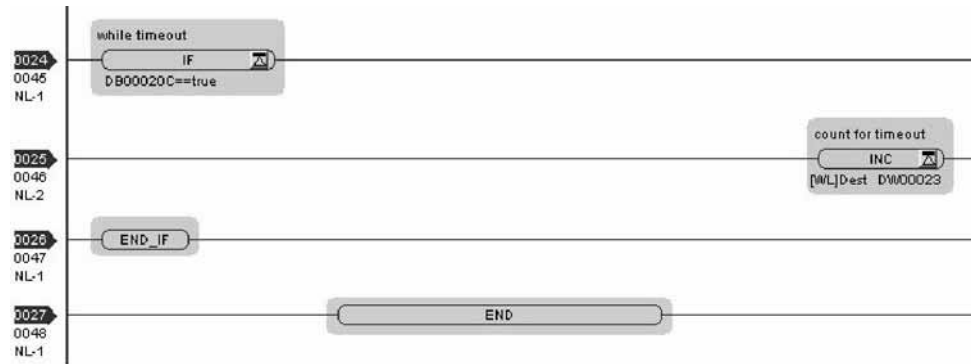

The communication setting and the ladder program creation are now finished, when MP2300S acts as a master.

(2) How to Set up the Remote Equipment (MP2300) to Be Connected

If the setting of transmission parameters (IP address, subnet mask) is already completed, start from step 3.

1. Double-click the **218IF** Tab in the **Module Details** of the module configuration definition.

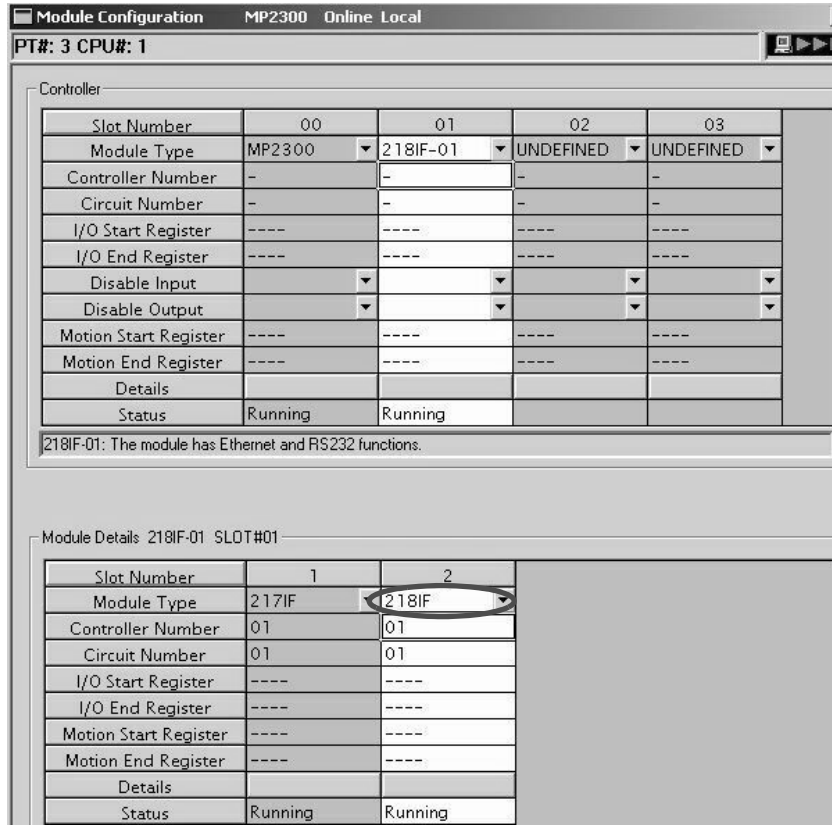

2. Set transmission parameters.

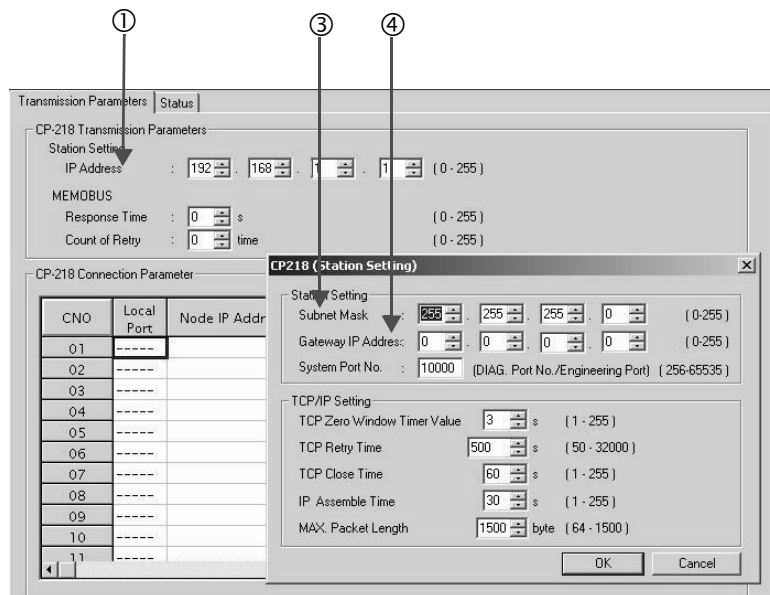

■ How to set up transmission parameters

- ① Set **IP Address** (“192.168.001.001,” for example).
- ② Click **Edit**, and then click **Local Station: TCP/IP Setting** in the **Engineering Manager** Window.
- ③ Set **Subnet Mask** (“255.255.255.000,” for example).
- ④ Set **Gateway IP Address** (“000.000.000.000,” for example).

■ Caution

Set up a unique IP address in the network.
For the IP address, check with your network administrator.

3. Set connection parameters.

CNO	Local Port	Node IP Address	Node Port	Connect Type	Protocol Type	Code
01	10001	192.168.001.001	10001	TCP	Extended MEMOBUS	BIN
02	10002	192.168.001.001	10002	TCP	Extended MEMOBUS	BIN
03	10003	192.168.001.001	10003	TCP	Extended MEMOBUS	BIN
04	----					
05	10005	192.168.001.001	10005	TCP	Extended MEMOBUS	BIN
06	10006	192.168.001.001	10006	TCP	Extended MEMOBUS	BIN
07	----					
08	----					
09	----					

■ Procedure to set up in the **CP-218 Connection Parameter** Window, for example, with a connection number 03

- ① Set **Local Port** (the port number “10003” used in the MP2300 side, for example).
- ② Set **Node IP Address** (the IP address “192.168.001.001” configured in the MP2300S side, for example).
- ③ Set **Node Port** (the port number “10003” configured in the MP2300S side, for example).
- ④ Select **Connect Type**, (TCP, for example).
- ⑤ Select **Extended MEMOBUS** for **Protocol Type**.
- ⑥ Select **Code** (BIN, for example).

■ Caution

When any transmission or connection parameter is changed, the change will be reflected after FLASH has been saved and the power supply is turned ON again.

4. Create a ladder program with a message receive function (MSG-RCV) in it.

An example of a ladder program for receiving messages in the remote equipment (MP2300) side follows:

■ Message receive function (MSG-RCV)

Required for receiving messages. Message reception is carried out by describing and executing this message receive function in a ladder program.

In addition, in order to support Read and Write by MP2300S, two message receive functions should be provided. Here, the input item and parameters (communication buffer channel number and connection number) of the message receive function need to accord with the MP2300S side settings.

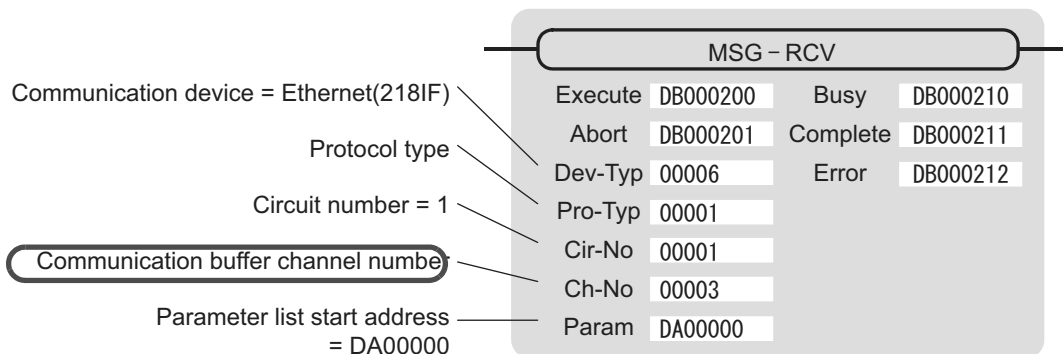

Note: Similarly, a message receive function with the communication buffer channel number=6 is required.

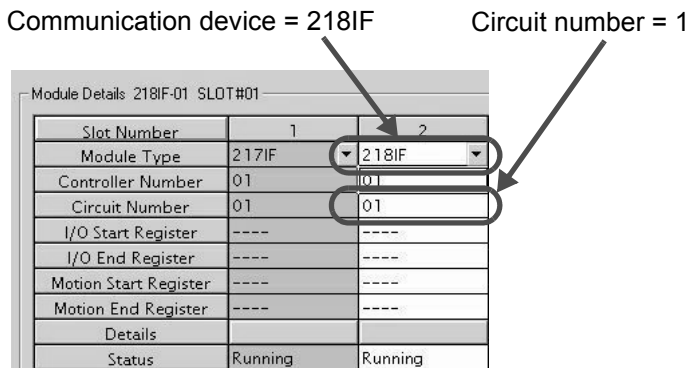

Fig. 6.10 MPE720 Module Configuration Definition Screen

■ Input/output definitions contents for message receive functions

The input/output definition content for message receive function is as follows:

Table 6.14 Input/Output Definitions for Message Receive Functions

I/O Definition	No.	Name	Setting Example	Contents
Input Item	1	Execute	DB000200	Executes a reception When Execute turns ON, the message reception is carried out.
	2	Abort	DB000201	Aborts a reception When Abort turns ON, the message reception is forcibly stopped.
	3	Dev-Typ	00006	Communication device type Specify the type of the communication device used in reception. When Ethernet (218IF) is used, specify "6."
	4	Pro-Typ	00001	Communication protocol Specify the type of the communication protocol. MEMOBUS(*1) = 1, non-procedure 1(*2) = 2, non-procedure 2(*2) = 3
	5	Cir-No	00001	Circuit number Specify a circuit number of the communication device. Specify it in accordance with the circuit number displayed in the MPE720 module configuration definition screen.
	6	Ch-No	00003	Communication buffer channel number Specify the channel number of a communication buffer. When Ethernet (218IF) is used, specify it in the range between "1" and "10." * Set up a unique channel number in the line.
	7	Param	DA00000	Parameter list start address Specify the start address of the parameter list. For the Parameter List, 17 words are automatically assigned from the configured address.
Output Item	1	Busy	DB000210	In process Busy will be ON while executing a message reception or forced abort process.
	2	Complete	DB000211	Process completed When a message reception or forced abort process is properly completed, Complete will turn ON only for one scan.
	3	Error	DB000212	Error occurred When an error occurs, Error will turn ON only for one scan.

* 1. When transmitting in MEMOBUS, Extended MEMOBUS, MELSEC, or MODBUS/TCP protocol, set the communication protocol (Pro-Typ) to MEMOBUS(=1). The communication device automatically converts the protocol.

* 2. Non-procedure 1: In non-procedural communication, data is received on a per-word basis.
Non-procedure 2: In non-procedural communication, data is received on a per-byte basis.

■ Parameter list setting example for message receive function

A parameter list setting example is as follows when receiving messages from a transmit source using the connection with a connection number = 3:

Table 6.15 Parameter List Setting Example1 (parameter list start address Param = DA00000)

Register Number	Setting Value	Parameter Number	IN/OUT	Remarks
DW00000	–	PARAM00	OUT	Process result
DW00001	–	PARAM01	OUT	Status
DW00002	00003	PARAM02	IN	Connection number = 3 (For receiving read operation)
DW00003	–	PARAM03	OUT	Option
DW00004	–	PARAM04	OUT	Function code
DW00005	–	PARAM05	OUT	Data address
DW00006	–	PARAM06	OUT	Data size
DW00007	–	PARAM07	OUT	Remote CPU number
DW00008	00000	PARAM08	IN	Coil offset = 0 word
DW00009	00000	PARAM09	IN	Input relay offset = 0 word
DW00010	00000	PARAM10	IN	Input register offset = 0 word
DW00011	00000	PARAM11	IN	Holding register offset = 0 word
DW00012	00000	PARAM12	IN	Writable address lower limit = MW00000
DW00013	65534	PARAM13	IN	Writable address upper limit = MW65534
DW00014	–	PARAM14	SYS	Reserved by the system. (Zero clear at startup)
DW00015	–	PARAM15	SYS	Reserved by the system.
DW00016	–	PARAM16	SYS	Reserved by the system.

Note: N: Input, OUT: Output, SYS: For system use

■ Example of Using the Message Receive Function in a Ladder Program

A ladder program for receiving messages in the remote equipment (MP2300) side is similar to that in (2) *How to Set up the Remote Device (MP2300) to Be Connected* of 6.2.3 *When MP2300S Acts as Master (I/O message communication function is used)*.

However, change Communication buffer channel number and Connection number respectively based on the I/O definition and parameter list settings.

(3) How to Start Communication

1. MP2300 side starts to receive the messages.

As the sample ladder program starts the message receive operation just after the system startup, you don't need to operate it particularly. Normally, accept the default.

2. Turn Execute ON for the message transmit function in the MP2300S side to transmit messages.

The sample ladder program is created to transmit a message every one second when five seconds elapsed after the low-speed scan (or high-speed scan) startup.

The way to change the message transmission interval is similar to that in (3) *How to Start Communications* of 6.2.1 *When the MP2300S Acts as Slave (automatic receive function is used)*.

6.3 Communication with Touch Panel

This section explains how to communicate with a touch panel supporting for the Extended MEMOBUS protocol using the MP2300S automatic receive function.

In this section, GP3000 series manufactured by Digital Electronics Corp. is used as a touch panel supporting for the Extended MEMOBUS protocol.

6.3.1 When MP2300S Acts as Slave

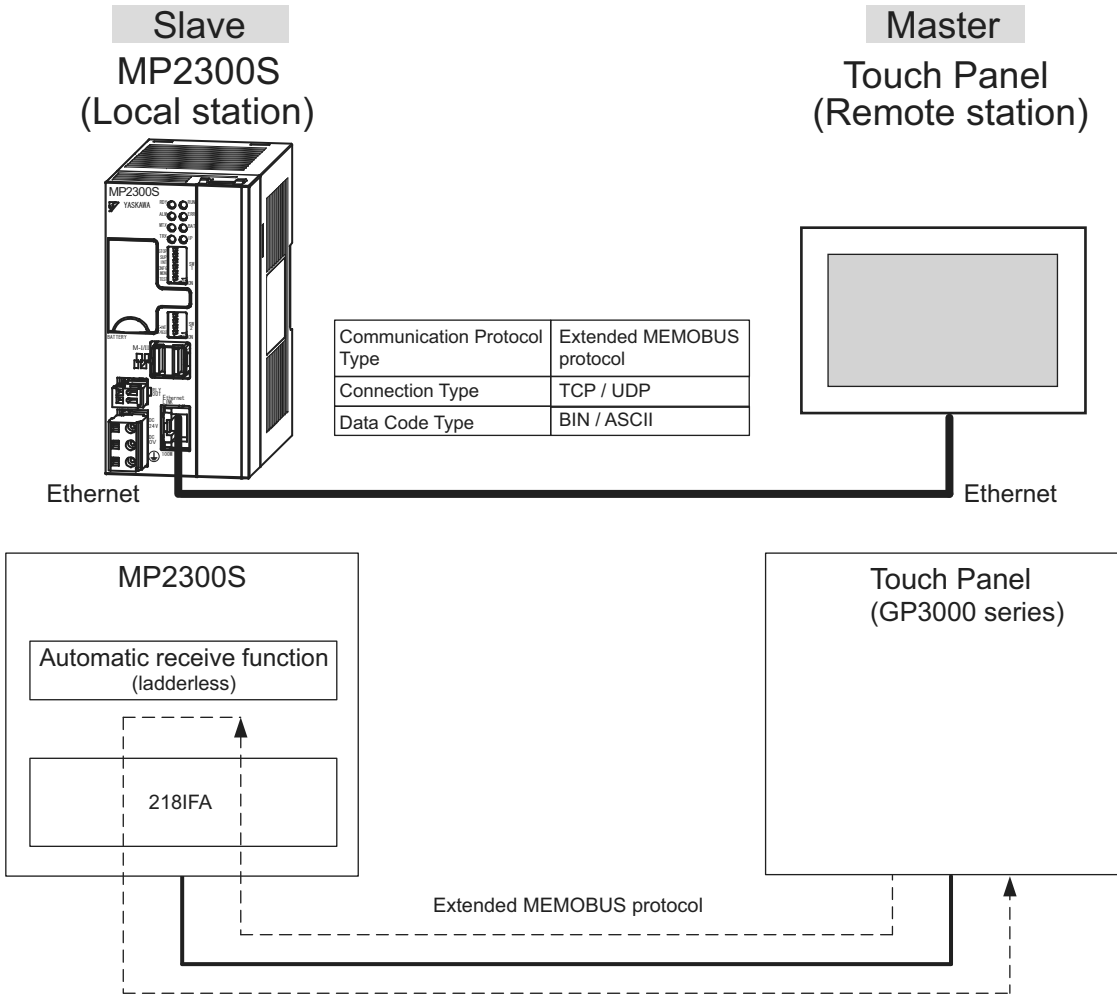
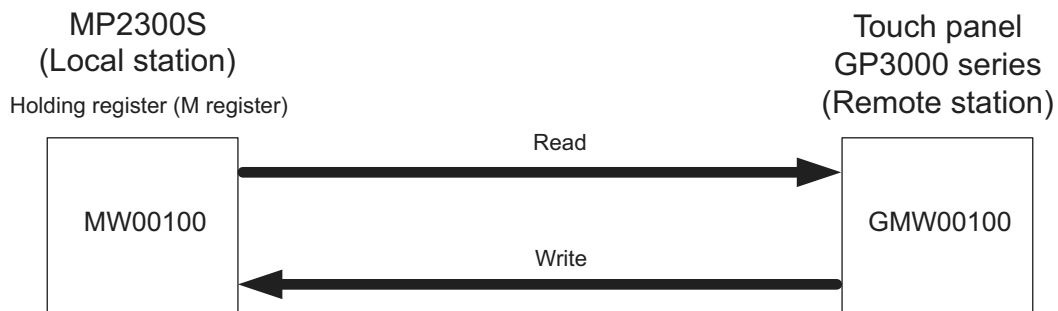
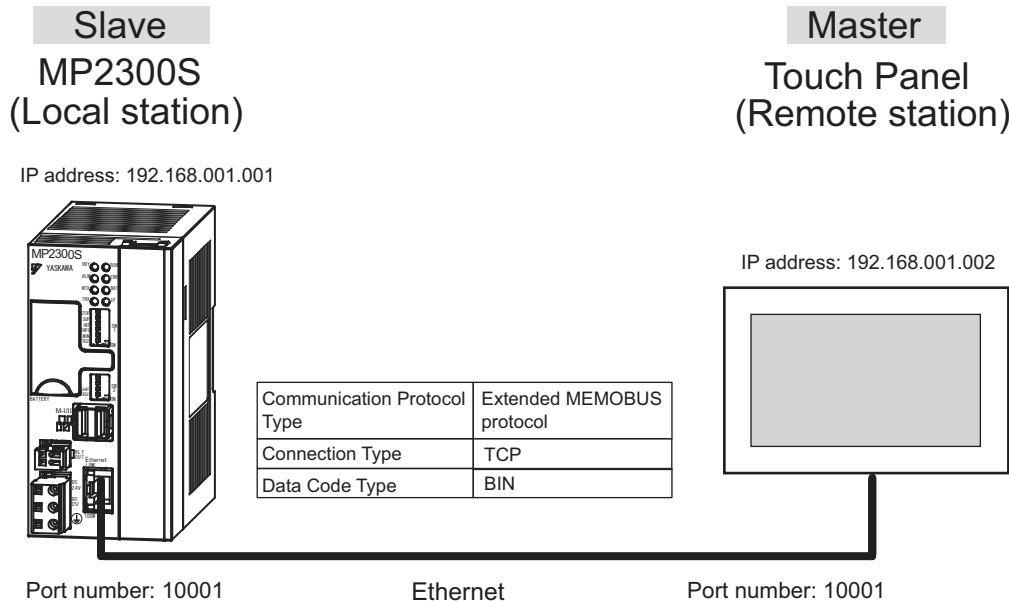

Fig. 6.11 Message Flow with Touch Panel (GP3000 series) when Automatic Receive Function Is Used

Note: Here, communication with the touch panel is carried out using the automatic receive function, but it can also use the message receive function (MSG-RCV). For information on how to set up when the message receive function (MSG-RCV) is used, refer to (2) *How to Set up the Remote Device (MP2300) to Be Connected* of 6.2.2 *When the MP2300S Acts as a Slave (ladder program which uses a MSG-RCV function)*.

■ Setting Example

The following figure shows an example which displays the content of the MP2300S (slave) holding register (MW00100) on a touch panel and writes values from the touch panel to the same register.



(1) How to Set up the MP2300S Side

1. Double-click the **2181FA** Tab in the **Module Details** of the module configuration definition.

Slot Number	1	2	3	4	5
Module Type	CPU	2181FA	SVR	SVR	M-EXECUTOR
Controller Number	-	01	01	01	-
Circuit Number	-	01	01	02	-
I/O Start Register	----	0000	0800	----	0C00
I/O End Register	----	07FF	08FF	----	0C3F
Disable Input		Enable	Enable		
Disable Output		Enable	Enable		
Motion Start Register	----	----	8000	8800	----
Motion End Register	----	----	87FF	8FFF	----
Details			MECHATROLINK		
Status	Running	Running	Running	Running	Running

2. Set transmission parameters.

Transmission Parameters | Status

Transmission Parameters

IP Address : 192 . 168 . 1 . 1 (0-255)

Subnet Mask : 255 . 255 . 255 . 0 (0-255)

Gateway IP Address : 0 . 0 . 0 . 0 (0-255)

Module Name Definition
Equipment name : CONTROLLER NAME

Detail Definition

How to set up transmission parameters

- ① Set **IP Address** (“192.168.001.001,” for example).
- ② Set **Subnet Mask** (“255.255.255.000,” for example).
- ③ Set **Gateway IP Address** (“000.000.000.000,” for example).

Caution

Set up a unique IP address in the network.
For the IP address, check with your network administrator.

3. Click the **Easy Setting** Button in the **Message Communication** area of the connection parameter setting.

Connection Parameter
Message Communication

Easy setting It is possible to following parameter setting easily that communicate the message.

CNO	Local Port	Node IP Address	Node Port	Connect Type	Protocol Type	Code	Automaticall y	Node Name
01	----						Detail	
02	----							
03	----							
04	----							

Cannot the overlap to local station port number used by the communicate the I/O message.

4. Set a communication setting in the **Message Communication Easy Setting** Window.

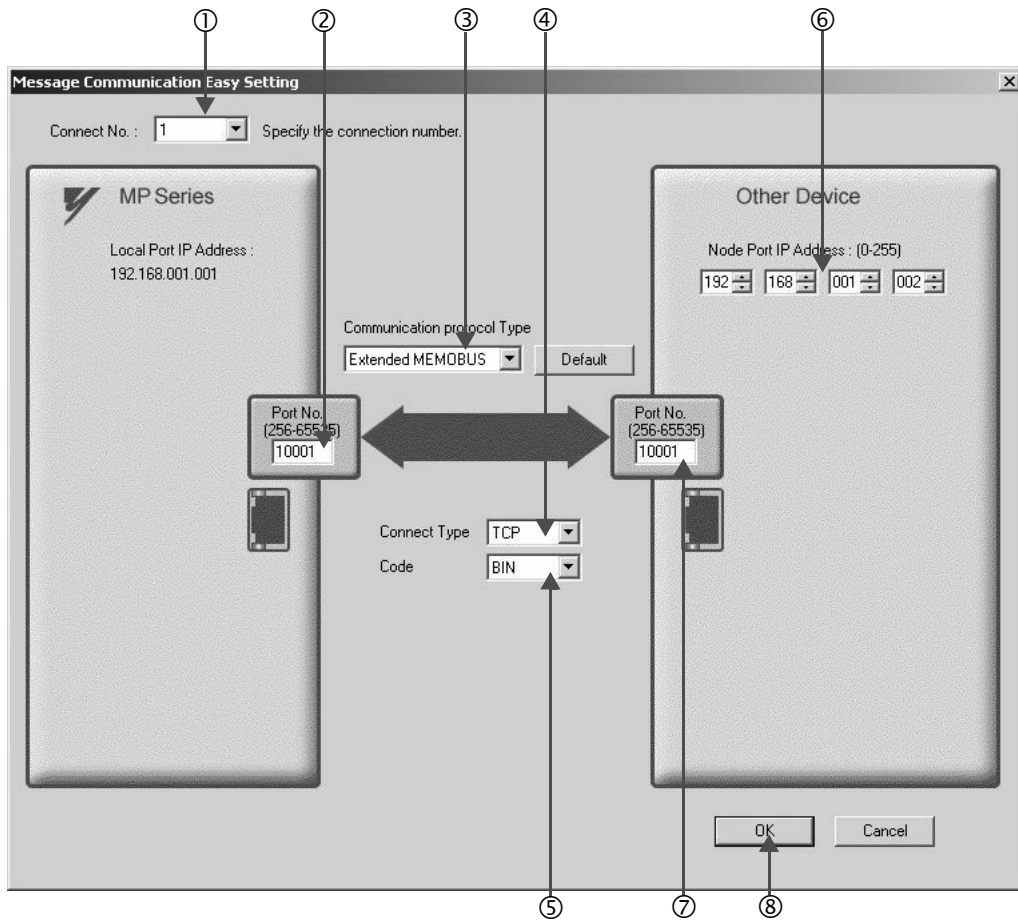

■ How to set up in the **Message Communication Easy Setting** Window

- ① When automatic receive is used, select "1" for the **Connect No.**
- ② Set **Port No.** of MP2300S side ("10001," for example).
- ③ Select **Extended MEMOBUS** for **Communication Protocol Type**, and click the **Default** Button.
- ④ Select **Connect Type** (TCP, for example).
- ⑤ Select **Code** (BIN, for example).
- ⑥ Set **Node Port IP Address** for the other device (MP2300) to be connected ("192.168.001.002," for example).
- ⑦ Set **Port No.** of the other device (MP2300) to be connected ("10001," for example).
- ⑧ Click **OK**.

■ Caution

When message functions (MSG-SND, MSG-RCV) are used with the connection number 01, disable the automatic receive function. If message functions are used while the automatic receive function is enabled, the communications will not function properly.

Note: By default, the automatic receive function with a connection number 01 is set to "Enable."

- Click **Yes** in the parameter setting confirmation dialog box.

■ **Caution**

Note that when a parameter with the same connection number is already set and you click **Yes** in the parameter setting confirmation dialog, the setting will be overwritten by the parameter configured in the **Message Communication Easy Setting** Window.

- Check the setting value and click the **Detail** Button in the **Automatically** column.

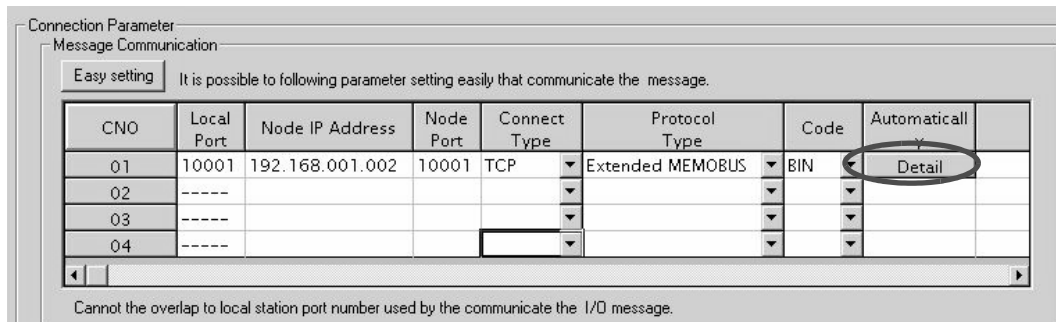

- Check **Enable** in the **Automatically Reception Setting** Window and then click the **OK** Button.

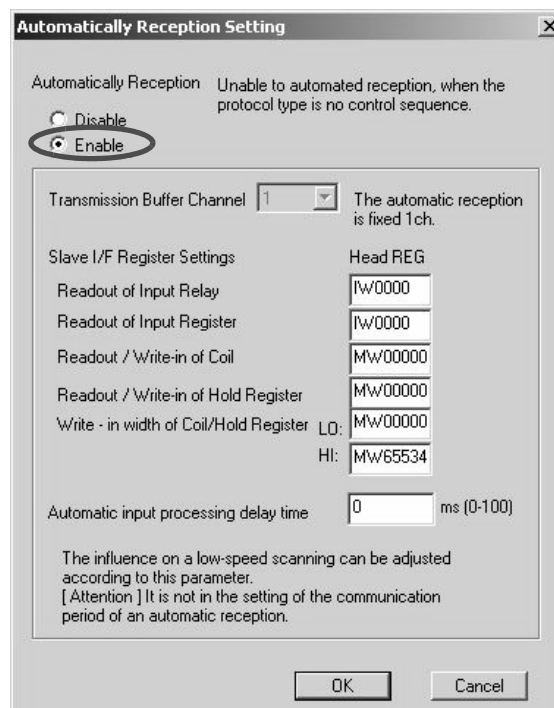

Note: For more information on Slave Side I/F Register Setting and Automatic Receive Process Delay Time, refer to 2.2.4 (4) (b) ■ *Automatic Receive Setting Screen for Message Communication* on page 2-22. The automatic receive function for connecting the MP2300S to the touch panel is now set up.

■ **Caution**

When any transmission or connection parameter is changed, the change will be reflected after FLASH has been saved and the power supply is turned ON again.

(2) How to set up a touch panel

This section explains the GP-Pro EX side set up procedure for connecting the MP2300S to an indicator (GP3000 series) and the screen creation example.

Note: The indicator (GP3000 series) and GP-Pro EX are manufactured by Digital Electronics Corp. Contact Digital Electronics Corp. for more information.

[a] How to Set up GP-Pro EX

1. Start up GP-Pro EX.
2. Create a new project.
3. Set its indicator type. Set the indicator type in accordance with the model in use.

Here, we explain the setting when AGP-3600T is used.

Table 6.16 Indicator Type Setting (example)

Series	GP3000 series
	AGP33** series
Model	AGP-3600T
Installation Method	Horizontal model

4. Set up connected equipment.

Table 6.17 Connected Equipment

Manufacturer	YASKAWA Electric Corporation
Series	MEMOBUS Ethernet

5. Set up the way to connect.

Table 6.18 Connection Method

Port	Ethernet (TCP)
------	----------------

6. Select the **Connected Equipment Setting** from the **System** Tab to display the connected equipment setting screen.
7. Set the communication setting.

Table 6.19 Communication Setting

Port Number*	10001
Timeout	3(sec)
Retry	0
Transmit Weight	0(ms)

* For more information on the port number, refer to the following.

■ Port Number

- If you don't check Automatic Assignment of the port number in the communication setting screen, the automatic assignment will be disabled, and the GP3000 series port number will be fixed at the setting value.
- If you check Automatic Assignment of the port number in the communication setting screen, automatic assignment will be enabled, and the GP3000 series port number will be assigned in each case.
When you use Automatic Assignment, set *Unpassive open mode* in the 2181FA screen of MPE720.
For more information about *Unpassive open mode*, refer to 2.2.4 (b) *2181FA Module Detailed Window* on page 2-16.
For information on the relationship between GP-Pro EX and MPE720 settings, see the table below.

MPE720 Side Setting \ GP-Pro EX Side Setting	Unpassive open Mode	Fixed Value Setting
Automatic Assignment Enable	√	–
Automatic Assignment Disable	√	√

Note: √: connectable, –: unconnectable

- How to set up *Unpassive open mode* of the MP2300S (reference)
Set **Node IP Address** to 000.000.000.000 and the **Node Port** to 0 to enter into the *Unpassive open mode*.

Transmission Parameters | Status

Transmission Parameters

IP Address : 192 . 168 . 1 . 1 (0-255)

Subnet Mask : 255 . 255 . 255 . 0 (0-255)

Gateway IP Address : 0 . 0 . 0 . 0 (0-255)

Module Name Definition

Equipment name : CONTROLLER NAME

Detail Definition

Connection Parameter

Message Communication

Easy setting It is possible to following parameter setting easily that communicate the message.

CNO	Local Port	Node IP Address	Node Port	Connect Type	Protocol Type	Code	Automatically
01	10001	000.000.000.000	00000	TCP	Extended MEMOBUS	BIN	Detail
02	----						
03	----						
04	----						

Cannot the overlap to local station port number used by the communicate the I/O message.

8. Click the setup button of the connected PLC1 for each device setting to display the setting screen for each device.
9. Set up the setting screen for each device.

In the setting screen for each device, set up a connected device (in this case, the MP2300S).

Set the IP address, port number and data code in the same manner as the 218IFA screen of the MP2300S.

Table 6.20 Each Device Setting

IP Address	192.168.001.001
Port Number	10001
Data Code	binary

- 218IFA screen (reference)

The screenshot shows the configuration interface for the 218IFA screen. It is divided into two main sections: 'Transmission Parameters' and 'Connection Parameter'.

Transmission Parameters:

- IP Address:** 192.168.1.1 (0-255)
- Subnet Mask:** 255.255.255.0 (0-255)
- Gateway IP Address:** 0.0.0.0 (0-255)
- Module Name Definition:** Equipment name: CONTROLLER NAME

Connection Parameter:

Message Communication

Easy setting It is possible to following parameter setting easily that communicate the message.

CNO	Local Port	Node IP Address	Node Port	Connect Type	Protocol Type	Code	Automaticall y
01	10001	192.168.001.002	10001	TCP	Extended MEMOBUS	BIN	Detail
02	----						
03	----						
04	----						

Cannot the overlap to local station port number used by the communicate the I/O message.

The setting is finished for now.

Create a screen and transfer the project to an indicator as required.

■ Caution

- Set up a unique IP address in the network.
The MP2300S side IP address is set to "192.168.1.1" in self-configuration.
For the IP address, check with your network administrator.

Note: Set the GP3000 series IP address in the off-line mode of the indicator.
Contact Digital Electronics Corp. for more information.

[b] Screen Creation Example

1. Create a base screen.
2. Select Data Indicator from the toolbar to paste it on the screen.

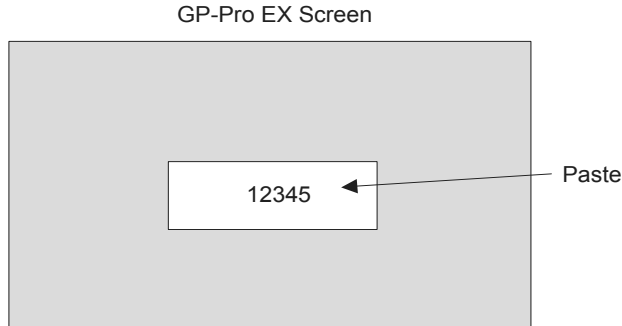

3. Double-click the Data Indicator pasted on the screen.

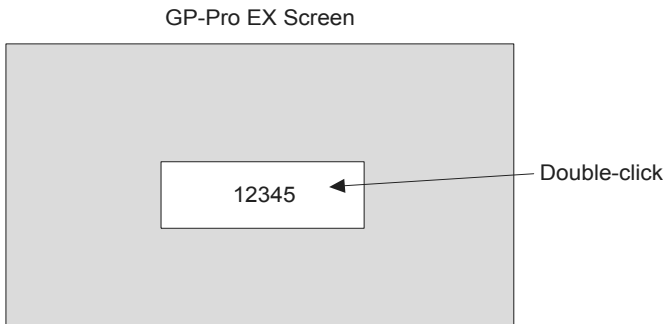

4. Set as follows in the detailed setting screen of Data Indicator and click OK.

Table 6.21 Data Indicator Detailed Setting

Display Data	Numeric display
Monitor Word Address	GMW00100

■ Relationship between GP-Pro EX address display and MP2300S register

Device	GP-Pro EX Address Display	MP2300S Register
Coil (bit)	GMB□□□□□□	MB□□□□□□
Coil (word)	GMW□□□□□□	MW□□□□□□
Input Relay (bit)	GIB□□□□□□	IB□□□□□□
Input Relay (word)	GIW□□□□□□	IW□□□□□□

(3) How to Start Communication

- 1.** The MP2300S side starts to receive the messages.

When the automatic receive function is used, the message receive operation starts automatically, and you are not required to do anything.

- 2.** Start up the touch panel (GP3000 series) to display the main screen.

After the system startup of the touch panel, communication with MP2300S will start.

Note: Contact Digital Electronics Corp. for more information.

6.4 Communication with PLC Manufactured by Mitsubishi Electric Corporation (MELSEC protocol)

In Ethernet communication between the MP2300S and MELSEC (Q, A series) general-purpose PLC manufactured by Mitsubishi Electric Corporation, the MELSEC protocol (MELSEC ACPU common command) is used as a communication protocol.

Using the MELSEC protocol allows a master to read/write the slave register content.

This chapter explains communication when the MP2300S acts as a slave and a master respectively.

For using the MP2300S as a slave, we explain communication using the automatic receive function.

For using the MP2300S as a master, we explain communication using the I/O message communication function.

6.4.1 When the MP2300S Acts as Slave (automatic receive function is used)

This section explains how to carry out a fixed buffer communication with the BUFSND command (with procedure) of the MELSEC Q series using the MP2300S automatic receive function.

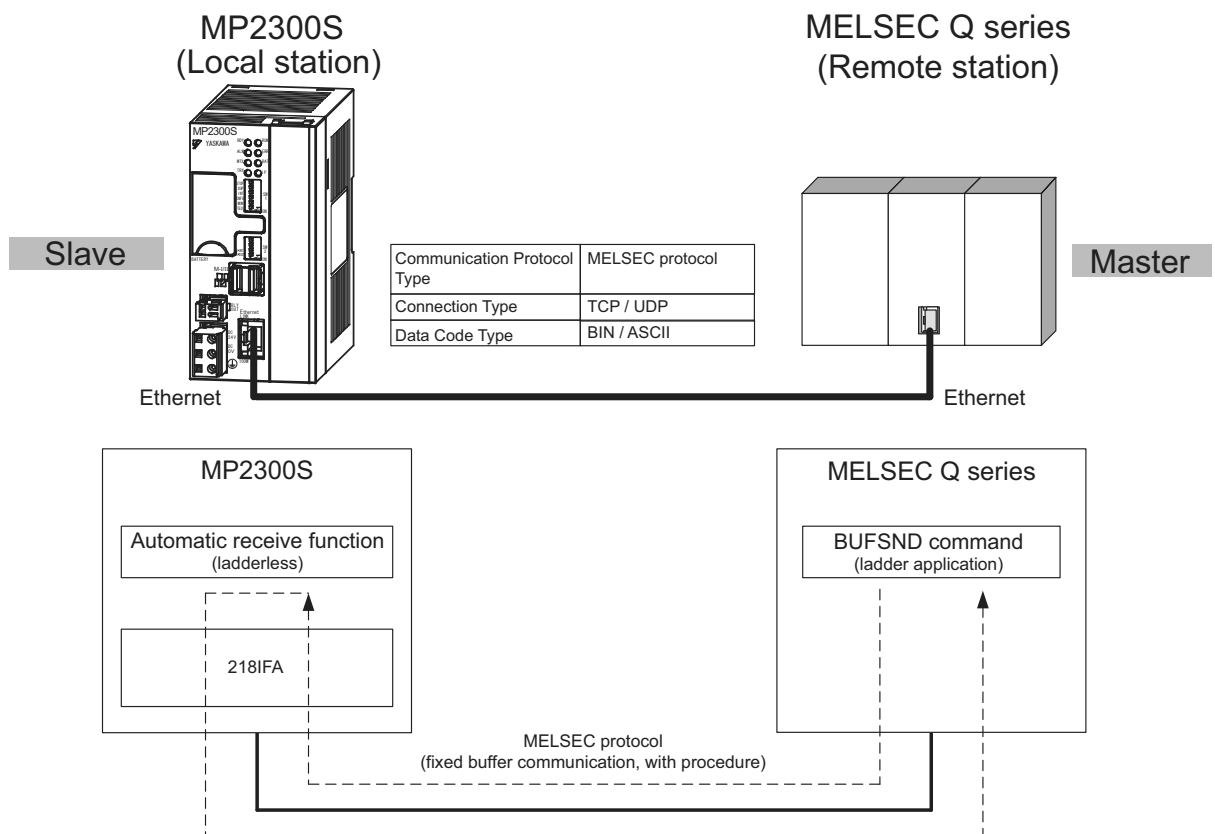

Fig. 6.12 Message Flow with the MELSEC Q Series when the Automatic Receive Function Is Used

6.4.1 When the MP2300S Acts as Slave (automatic receive function is used)

■ Caution

Communication using the automatic receive function is 1:1 communication.

Also, when “Communication Protocol Type: MELSEC” is used in communication with the MELSEC Q series, the MELSEC Q series (master) side can read/write the holding register of the MP2300S (slave) using fixed buffer communication.

However, when the MP2300S acts as a slave, you cannot use the inter-CPU or random access communication, because of the MELSEC specifications.

In addition, use the message receive function (MSG-RCV) when communicating with multiple remote devices.

■ Setting Example

The following figure illustrates one example of writing the contents of the data register (D00201 to D00300) of MELSEC Q series (master) into the MP2300S (slave) holding register (MW00000 to MW00099).

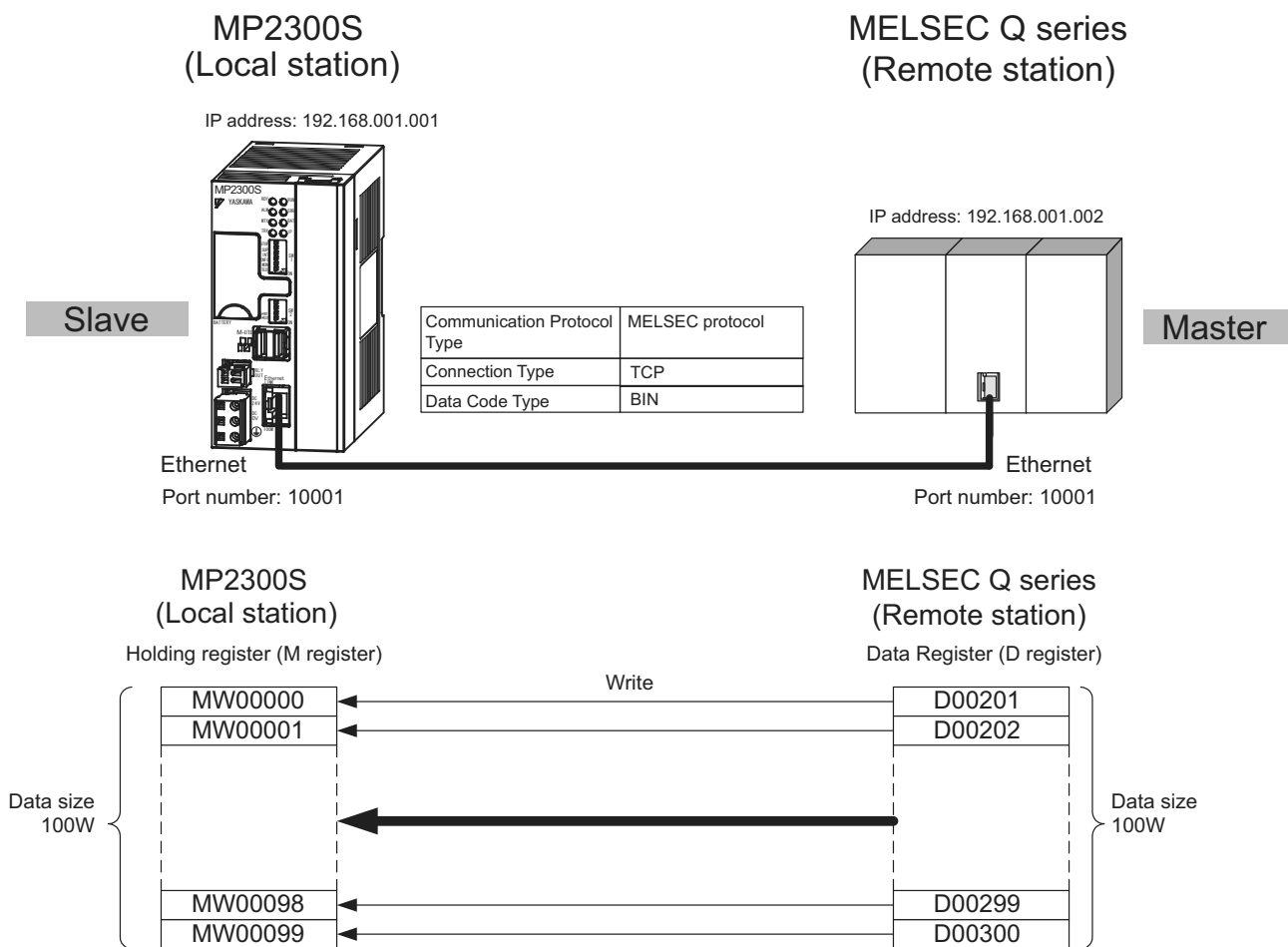

The particular setup procedure is explained in the subsequent pages.

(1) How to Set up the MP2300S Side

If the setting of transmission parameters (IP address, subnet mask) is already completed, start from step 3.

1. Double-click the **218IFA** Tab in the **Module Details** of the module configuration definition.

Slot Number	1	2	3	4	5
Module Type	CPU	218IFA	SVP	SVR	M-EXECUTOR
Controller Number	-	01	01	01	-
Circuit Number	-	01	01	02	-
I/O Start Register	----	0000	0800	----	0C00
I/O End Register	----	07FF	0BFF	----	0C3F
Disable Input		Enable	Enable		
Disable Output		Enable	Enable		
Motion Start Register	----	----	8000	8800	----
Motion End Register	----	----	87FF	8FFF	----
Details			MECHATROLINK		
Status	Running	Running	Running	Running	Running

2. Set transmission parameters.

■ How to set up transmission parameters

- ① Set **IP Address** (“192.168.001.001,” for example).
- ② Set **Subnet Mask** (“255.255.255.000,” for example).
- ③ Set **Gateway IP Address** (“000.000.000.000,” for example).

■ Caution

Set up a unique IP address in the network.
For the IP address, check with your network administrator.

- Click the **Easy Setting** Button in the **Message Communication** area of the connection parameter setting.

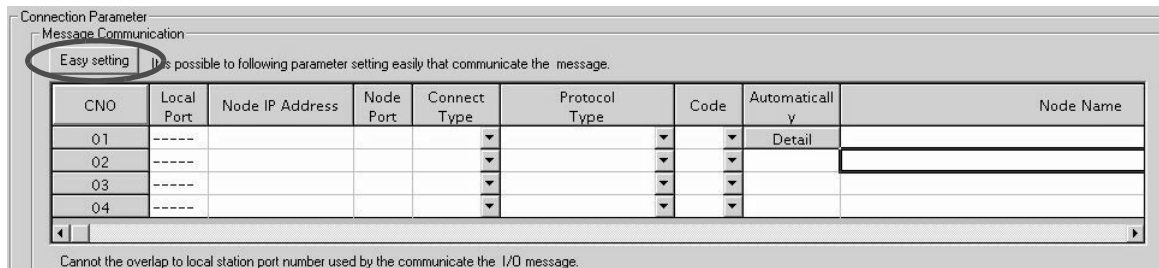

- Set up the communication settings in the **Message Communication Easy Setting** Window.

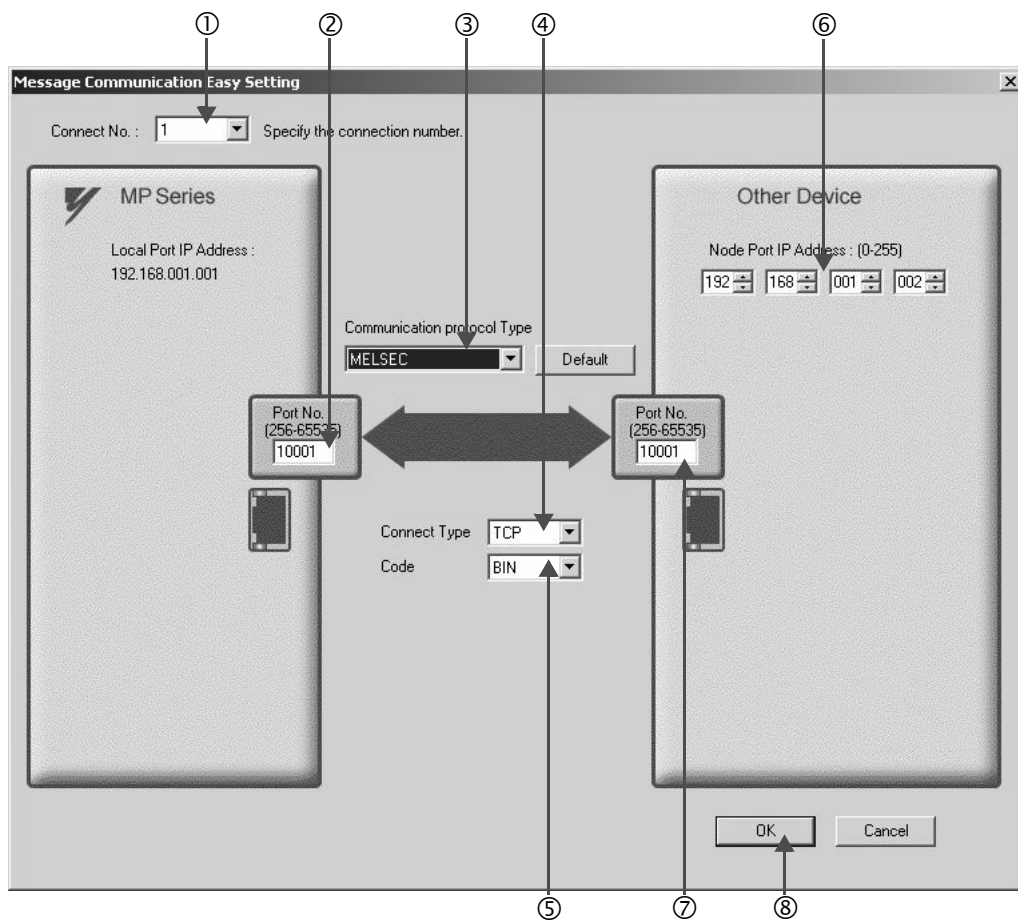

■ How to set up in the **Message Communication Easy Setting** Window

- When automatic receive is used, select “1” for the **Connect No.**
- Set **Port No.** of MP2300S side (“10001,” for example).
- Select **MELSEC** for **Communication Protocol Type**, and click the **Default** Button.
- Select **Connect Type** (TCP, for example).
- Select **Code** (BIN, for example).
- Set **Node port IP Address** for the other device (MELSEC Q series) to be connected (“192.168.001.002,” for example).
- Set **Port No.** of the other device (MELSEC Q series) to be connected (“10001,” for example).
- Click **OK**.

■ Caution

When message functions (MSG-SND, MSG-RCV) are used with the connection number 01, disable the automatic receive function. If message functions are used while the automatic receive function is enabled, the communications will not function properly.

Note: By default, the automatic receive function with a connection number 01 is set to "Enable."

5. Click **Yes in the parameter setting confirmation dialog box.**

■ Caution

Note that when a parameter with the same connection number is already set and you click **Yes** in the parameter setting confirmation dialog, the setting will be overwritten by the parameter configured in the **Message Communication Easy Setting** Window.

6. Check the setting value and click the **Detail Button in the **Automatically** column.**

Message Communication

Easy setting It is possible to following parameter setting easily that communicate the message.

CNO	Local Port	Node IP Address	Node Port	Connect Type	Protocol Type	Code	Automatically
01	10001	192.168.001.002	10001	TCP	MELSEC	BIN	Detail
02	-----						
03	-----						
04	-----						

Cannot the overlap to local station port number used by the communicate the I/O message.

7. Click **Enable** in the **Automatically Reception Setting** Window and then click the **OK** Button.

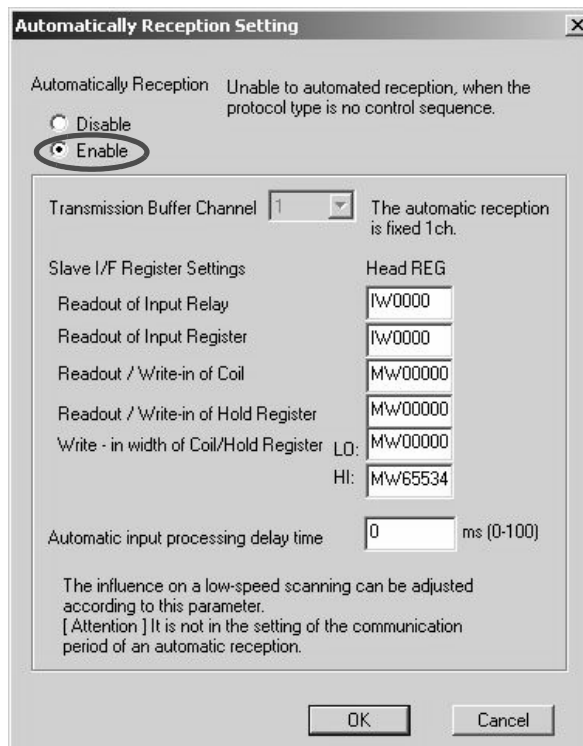

Note: For more information on Slave Side I/F Register Setting and Automatic Receive Process Delay Time, refer to 2.2.4 (4) (b) ■ *Automatic Receive Setting Screen for Message Communication* on page 2-22.

The automatic receive function is now set up, when MP2300S acts as a slave.

■ **Caution**

When any transmission or connection parameter is changed, the change will be reflected after FLASH has been saved and the power supply is turned ON again.

(2) How to Set up the Remote Device (MELSEC Q series) to Be Connected

This section explains the MELSEC Q series side procedure to set up for connecting the MP2300S with the MELSEC Q series.

Note: MELSEC Q series are manufactured by Mitsubishi Electric Corporation.
Contact Mitsubishi Electric Corporation for more information.

1. Start up GX Developer.
2. Create a new project.
3. Set up network parameters (MELSECNET/Ethernet).

Table 6.22 Network Parameter Setting (example)

Setting Item	Setting Details
Network Type	Ethernet
Start I/O No.	Any
Network No.	Any
Group No.	Any
Exchange Number	Any
Mode	Online

4. Set up Ethernet operation.

Table 6.23 Ethernet Operation Setting (example)

Setting Item	Setting Details
Communication Data Code Setting	Binary code communication
Initial Timing Setting	Any
IP Address	192.168.1.2
Transmit Frame Setting	Ethernet (V2.0)
TCP Alive Check Setting	Any
Permit Writing during RUN	Permitted

5. Set the open setting.

Table 6.24 Open Setting (example)

Setting Item	Setting Details (connection number=1)
Protocol	TCP
Open System	Active
Fixed Buffer	Transmit
Procedure to Communicate with Fixed Buffer	With procedure
Pairing Open	Any
Check Alive	Any
Local Port Number	2711H (10001)
Remote IP Address for Communication	192.168.1.1
Remote Port Number for Update	2711H (10001)

■ **Caution**

Set up a unique IP address in the network.
For the IP address, check with your network administrator.

■ **Complement**

Set up an initial setting and a router relay parameter below, if needed:

- Initial setting
Set a timer relevant configuration when TCP is selected as a protocol. In most cases, accept the default.
Set up if changes such as a shortened a TCP retransmit timer are required.
 - Router relay parameter
Set up when you use a subnet mask pattern or default gateway.
-

6. Create a ladder program for communication.

■ **Procedure overview to communicate using a ladder program**

- ① Use an OPEN command to establish a connection with the remote device.
- ② Use a BUFSND command to write the register content configured by parameters below to the MP2300S holding register (M register).
Setting example: When the BUFSND command is used to set the device start number for storing the transmit data to "D00200"
D00200 (transmit data length): 100W
D00201 to D00300 (transmit data): Written into MW00000 to MW00099
- ③ If necessary, use a CLOSE command to close the operation.

Note: Contact Mitsubishi Electric Corporation for more information on the ladder program.

The setting is finished for now. If necessary, transfer the settings to the PLC after setting all parameters.

(3) How to Start Communication

1. The MP2300S side starts to receive the messages.

When an automatic receive function is used, the message receive operation starts automatically, so you are not required to do anything.

2. Use an OPEN command in the MELSEC Q series side to establish a connection with the MP2300S, and use a BUFSND command to transmit messages.

When messages are transmitted from the MELSEC Q series, communication with the MP2300S will start.

6.4.2 When the MP2300S Acts as Master (I/O message communication function is used)

This section explains how to carry out the communications between CPU and the MELSEC Q series using the MP2300S I/O message communication function.

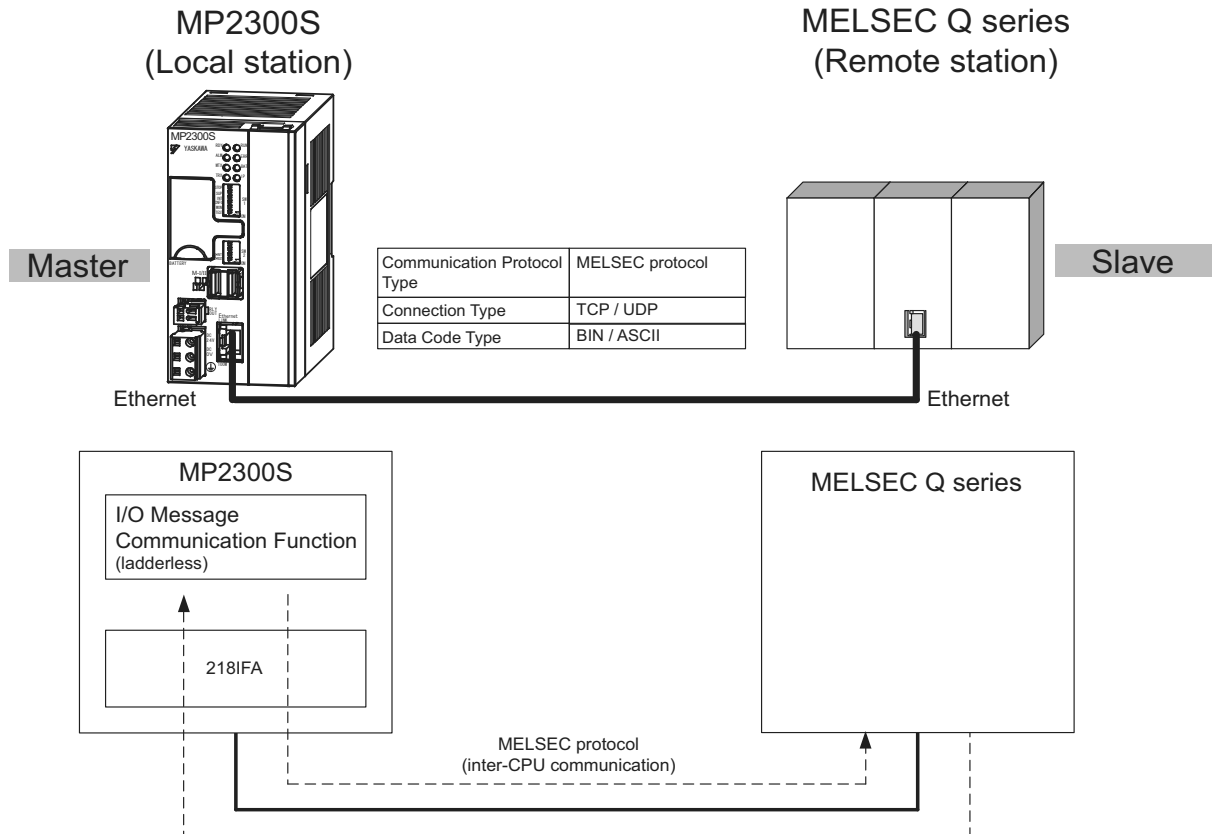

Fig. 6.13 Message Flow with MELSEC Q series when I/O Message Communication Function Is Used

■ Caution

I/O message communication is 1:1 communication.

In addition, you can read and write the registers below using inter-CPU communication when “Communication Protocol Type: MELSEC” is used in the communication with the MELSEC series.

- Bit device register - - - X, Y (read only), M, B
- Word device register - - - D, W, R

Note: A bit device register reads or writes on a per-word (16 bit) basis.

When communicating with multiple remote devices.

To carry out a fixed buffer/random access buffer communication when reading/writing registers other than those mentioned above, use the message transmit function (MSG-SND).

■ Setting Example

The following figure illustrates one example of reading the content of the data register (D00000 to D00099) of the MELSEC Q series (slave) into an input register (IW0000 to IW0063) of the MP2300S (master) and writing the content of an output register (OW0064 to OW00C7) of the MP2300S (master) in a data register (D00100 to D00199) of the MELSEC Q series (slave).

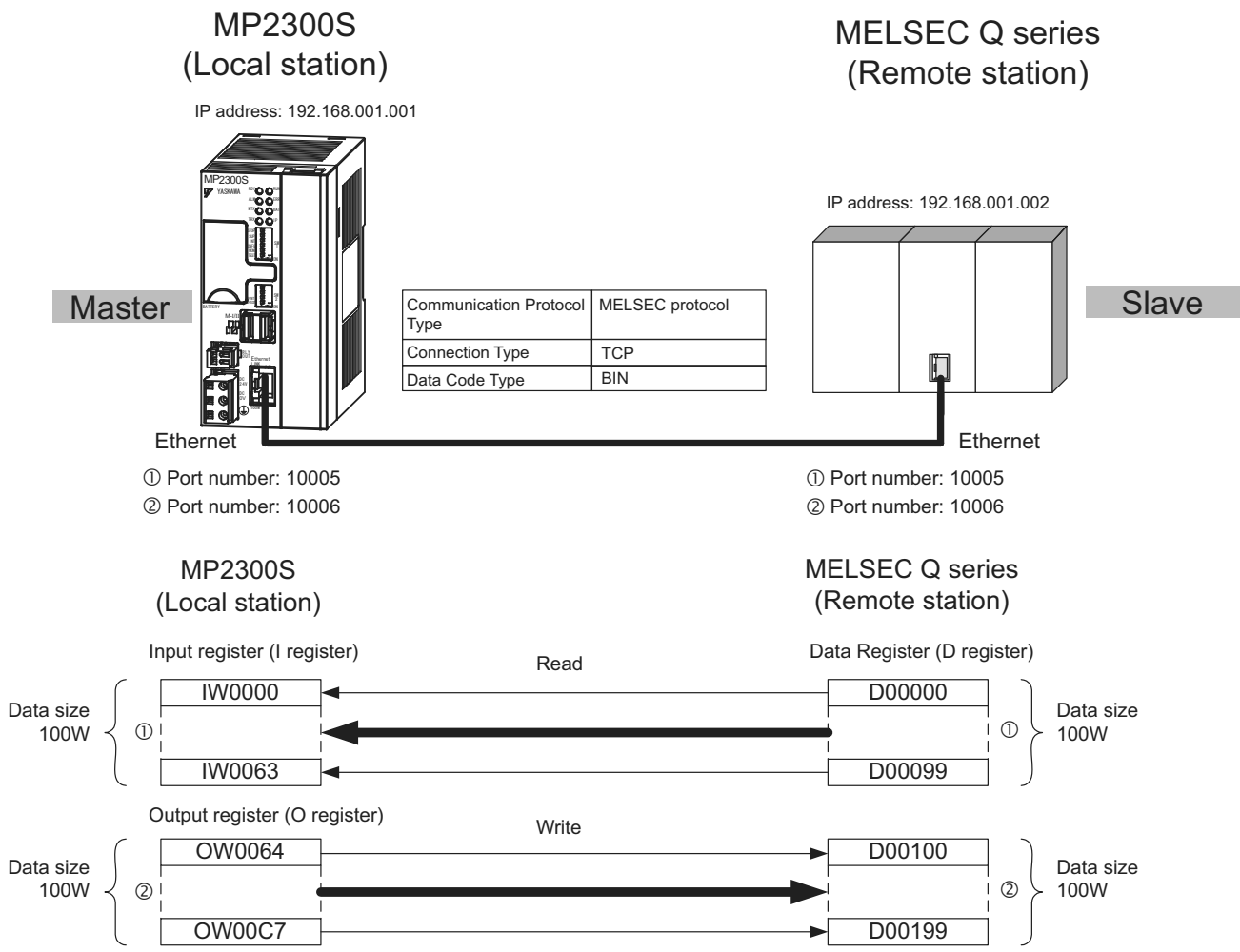

A particular setup procedure is explained in the subsequent pages.

(1) How to Set up the MP2300S Side

If the setting of transmission parameters (IP address, subnet mask) is already completed, start from step 3.

1. Double-click the **218IFA** Tab in the **Module Details** of the module configuration definition.

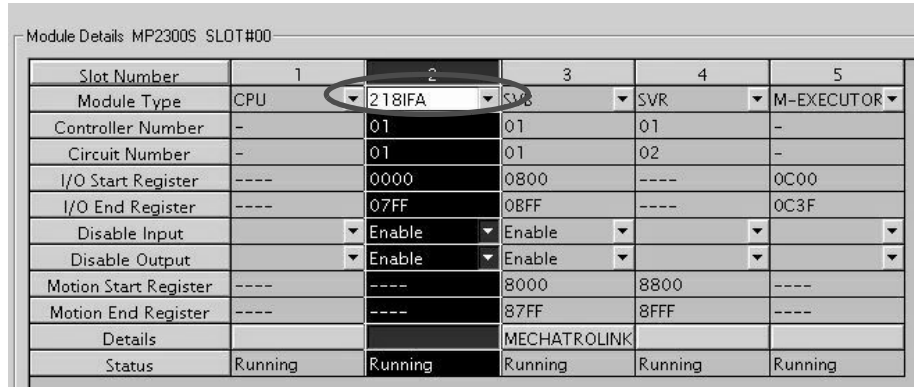

2. Set transmission parameters.

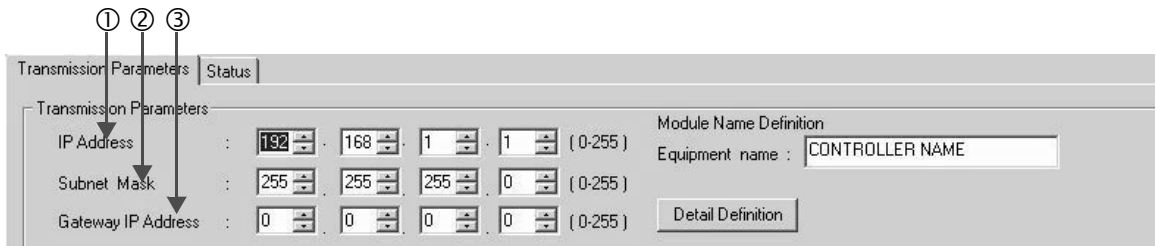

■ How to set up transmission parameters

- ① Set **IP Address** (“192.168.001.001,” for example).
- ② Set **Subnet Mask** (“255.255.255.000,” for example).
- ③ Set **Gateway IP Address** (“000.000.000.000,” for example).

■ Caution

Set up a unique IP address in the network.
For the IP address, check with your network administrator.

3. Click **Enable** in the **I/O Message Communication** of the connection parameter setting.

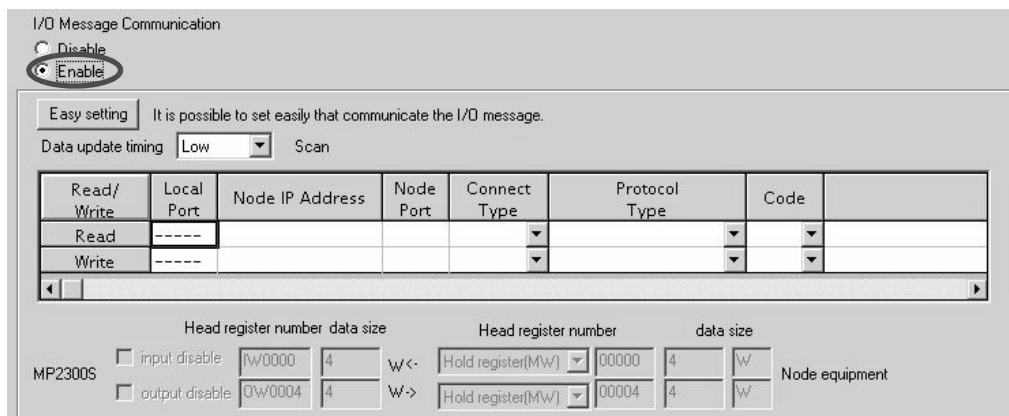

4. Set-up a communication settings in the **I/O Message Communication Easy Setting** Window.

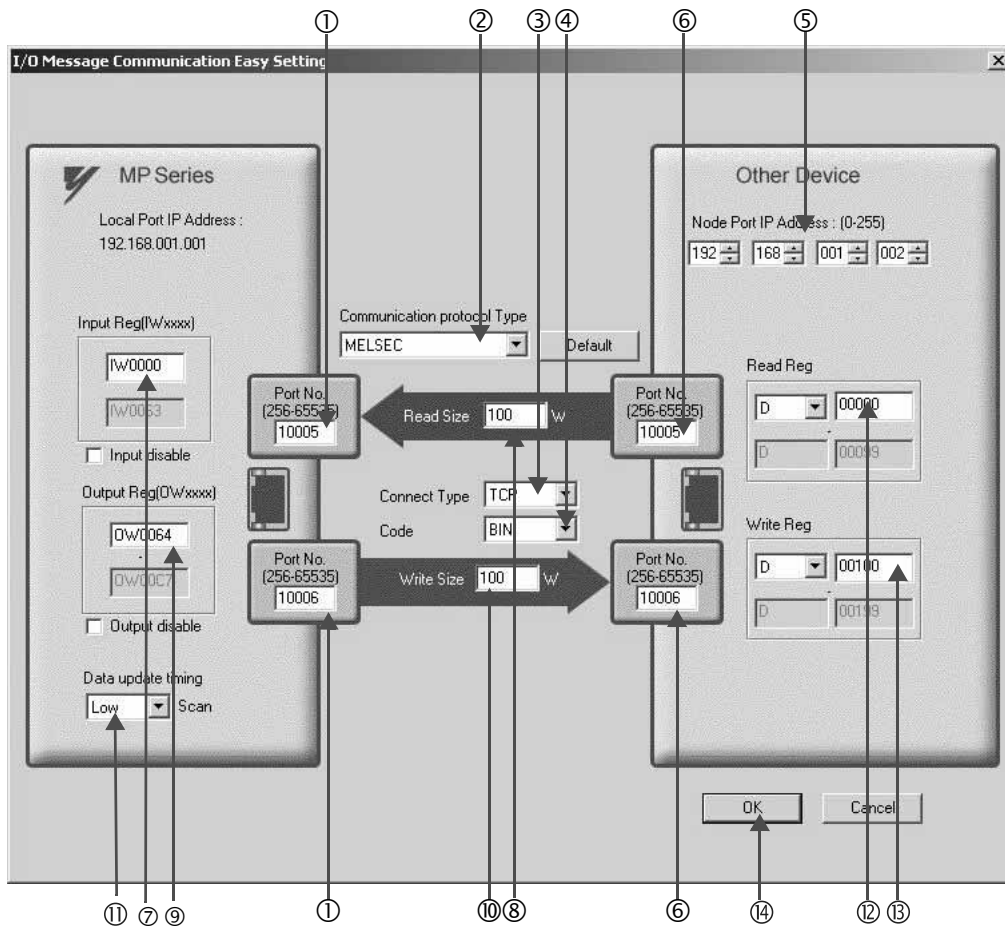

■ How to set up in the **I/O Message Communication Easy Setting** Window

- ① Set **Port No.** of MP2300S side (“10005, 10006,” for example).
- ② Select **MELSEC** for **Communication Protocol Type**, and click the **Default** Button.

■ Caution

When the communication protocol is MELSEC, the register type for the default read/write is “Word Device Register: D.”

- ③ Select **Connect Type** (TCP, for example).
 - ④ Select **Code** (BIN, for example).
 - ⑤ Set **Node Port IP Address** for the other device (MELSEC Q series) to be connected (“192.168.001.002,” for example).
 - ⑥ Set **Port No.** of the other device (MELSEC Q series) to be connected (“10005, 10006,” for example).
-

■ Caution

In I/O message communications, since a message is transmitted from each port number for register read/write, a connected remote device needs the two receive connections for receiving messages.

- ⑦ Set a storage area (**Input Reg**) for data read by the MP2300S (IW0000, for example).
 - ⑧ Set **Read Size** of data to be read by the MP2300S (“100” W, for example).
 - ⑨ Set a storage area (**Output Reg**) for data written by MP2300S (OW0064, for example).
 - ⑩ Set **Write Size** of data written by the MP2300S (“100” W, for example).
 - ⑪ Set an I/O data update timing (**Data update timing**) for the CPU and built-in Ethernet (“Low” scan, for example).
-

■ Data Update Timing

Data update timing indicates when to give and receive data between the CPU and built-in Ethernet. Communication with the remote device is carried out asynchronously, so note that a message is not necessarily transmitted to the remote device at each data update timing.

- ⑫ Set the register type and start address (**Read Reg**) of the remote device (MELSEC Q series) read by the MP2300S (“D00000,” for example).
- ⑬ Set the register type and start address (**Write Reg**) of the remote device (MELSEC Q series) written by the MP2300S (“D00100,” for example).
- ⑭ Click **OK**.

5. Click **Yes in the parameter setting confirmation dialog box.**

■ Caution

Note that when a parameter with the same connection number is already set and you click **Yes** in the parameter setting confirmation dialog, the setting will be overwritten by the parameter configured in the **Message Communication Easy Setting Window**.

6. Check the setting values.

I/O Message Communication

Disable
 Enable

Easy setting It is possible to set easily that communicate the I/O message.

Data update timing Low Scan

Read/Write	Local Port	Node IP Address	Node Port	Connect Type	Protocol Type	Code
Read	10005	192.168.001.002	10005	TCP	MELSEC	BIN
Write	10006	192.168.001.002	10006	TCP	MELSEC	BIN

Head register number data size

MP2300S input disable |w0000 100 w<- Data register(D) 00000 100 w

output disable |0w0064 100 W-> Data register(D) 00100 100 w Node equipment

The I/O message communication is now set up, when the MP2300S acts as a master.

■ Caution

When any transmission or connection parameter is changed, the change will be reflected after FLASH has been saved and the power supply is turned ON again.

(2) How to Set up the Remote Equipment (MELSEC Q series) to Be Connected

This section explains the MELSEC Q series side procedure to set up for connecting the MP2300S with the MELSEC Q series.

Note: MELSEC Q series are products manufactured by Mitsubishi Electric Corporation.
Contact Mitsubishi Electric Corporation for more information.

1. Start up GX Developer.
2. Create a new project.
3. Set up network parameters (MELSECNET/Ethernet).

Table 6.25 Network Parameter Setting (example)

Setting Item	Setting Details
Network Type	Ethernet
Start I/O No.	Any
Network No.	Any
Group No.	Any
Exchange Number	Any
Mode	Online

4. Set up Ethernet operation.

Table 6.26 Ethernet Operation Setting (example)

Setting Item	Setting Details
Communication Data Code Setting	Binary mode communication
Initial Timing Setting	Always waiting OPEN
IP Address	192.168.1.2
Transmit Frame Setting	Ethernet (V2.0)
TCP Alive Check Setting	Any
Permit Writing during RUN	Permitted

5. Set the open setting.

Table 6.27 Open Setting (example)

Setting Item	Setting Details (connection number=1)	Setting Details (connection number=2)
Protocol	TCP	TCP
Open System	Fullpassive	Fullpassive
Fixed Buffer	Any	Any
Procedure to Communicate with Fixed Buffer	Any	Any
Pairing Open	Any	Any
Check Alive	Any	Any
Local Port Number	2715H (10005)	2716H (10006)
Remote IP Address for Communication	192.168.1.1	192.168.1.1
Remote Port Number for Update	2715H (10005)	2716H (10006)

■ Caution

Set up a unique IP address in the network.
For the IP address, check with your network administrator.

The setting is finished for now. If necessary, transfer the settings to the PLC after setting all parameters.

■ Complement

Set up an initial setting and a router relay parameter below, if needed:

- Initial setting
Set a timer relevant configuration when TCP is selected as a protocol. In most cases, accept the default.
Set up if changes such as a shortened TCP retransmit timer are required.
- Router relay parameter
Set up when you use a subnet mask pattern or default gateway.

(3) How to Start Communication**1. The MELSEC Q series starts to receive messages.**

The message receive operation starts automatically, so you are not required to do anything.

2. The MP2300S side transmits messages.

When an I/O message communication function is used, the message transmit operation starts automatically, so you are not required to do anything.

MEMO

Slave CPU Synchronous Function

This chapter explains the slave CPU synchronous function details and the precautions for using it.

7.1 Function	7-2
7.1.1 Overview	7-2
7.2 Requirements and Setting of Execution	7-3
7.2.1 Supported Version	7-3
7.2.2 Requirements to Execute Slave CPU Synchronous Function	7-3
7.2.3 How to Set up Slave CPU Synchronous Function	7-4
7.2.4 How to Execute Slave CPU Synchronous Function	7-7
7.3 Operation	7-9
7.3.1 Input/Output Register	7-9
7.3.2 How to Determine Slave CPU Synchronous State	7-15
7.3.3 Calculation of Slave CPU Synchronous Delay Time	7-16
7.3.4 How to Use Scan Counter	7-17
7.3.5 How to Determine Input Error	7-18
7.3.6 Management to Resume Slave CPU Synchronization	7-24
7.4 Precautions	7-28
7.4.1 Precautions on Usage	7-28
7.4.2 Effect of Error on Slave CPU Synchronous Operation	7-29

7.1 Function

7.1.1 Overview

A slave CPU synchronous function synchronizes the master side high-speed scan cycle with the MP2300S high-speed scan cycle, in a configuration where another MP2300S series controller acts as a MECHATROLINK master and the MP2300S with a built-in SVB acts as a MECHATROLINK slave.

This function automatically allows you the synchronization among slave CPUs and the distribution of application programs by connecting multiple MP2300Ss as a slave.

The following figure shows a schematic diagram of the slave CPU synchronous function of MECHATROLINK-II.

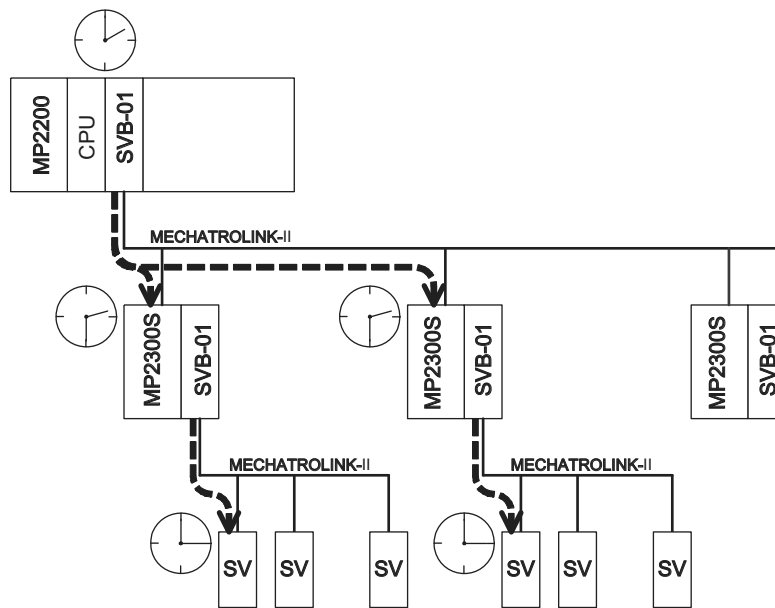

Here, there is a communication delay in MECHATROLINK-II as shown above, until a command from a master side application program is transmitted to a slave.

Since, the delay time is constant, you can use an application program to manage the timing between the master and slave. Note that you don't need to control the timing between slave CPUs.

■ Caution

A precaution is given to safely use the slave CPU synchronous function.
For more information on the precautions, refer to *7.4 Precautions*.

7.2 Requirements and Setting of Execution

7.2.1 Supported Version

In order to use the slave CPU synchronous function, the master side must support the MP2300S.

The following table shows supported versions:

Controller	Model	Version
MP2100	JAPMC-MC2100(-E)	Ver.2.60 or later
MP2100M	JAPMC-MC2140(-E)	
MP2300	JEPMC-MP2300(-E)	
MP2300S	JEPMC-MP2300S-E	
MP2400	JEPMC-MP2400-E	
MP2000 series SVB-01	JAPMC-MC2310(-E)	Ver.1.21 or later

7.2.2 Requirements to Execute Slave CPU Synchronous Function

In order to use the slave CPU synchronous function, both master and slave sides must meet all the following requirements:

(1) Master Side Requirements

- Supports the slave synchronous function (the versions mentioned above and later)
- H scan setting is either an integer multiple or an integer fraction of the MECHATROLINK communication cycle
- Communication system is MECHATROLINK-II (17Byte, 32Byte)

(2) Slave Side Requirements

- Selects “Slave Synchronous Function = Enable” as a MECHATROLINK communication parameter
- H scan setting is either an integer multiple or an integer fraction of the MECHATROLINK communication cycle setting
- H scan setting is either an integer multiple or an integer fraction of the master side H scan setting
- Sets “Resume Control of Slave Synchronization = OFF” as an output register assigned to MP2300S/SVB

(3) Setting Example

- Master side

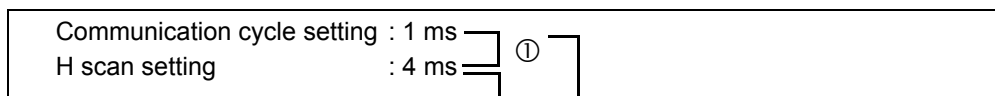

- Slave side

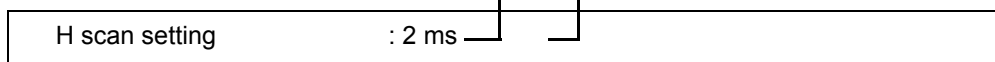

① The master side H scan setting is an integral multiple of the MECHATROLINK communication cycle

② The slave side H scan setting is an integer fraction of the master side H scan setting

③ The slave side H scan setting is an integral multiple of the communication cycle setting

→ If requirements are met, a slave CPU synchronization can be executed.

7.2.3 How to Set up Slave CPU Synchronous Function

The way to set up the slave CPU synchronous function is as follows:

(1) Master Side Setting

The master side does not need to enable/disable the slave CPU synchronous function.

Set the synchronous scan of MP2300S/SVB to "High" as a MECHATROLINK link assignment.

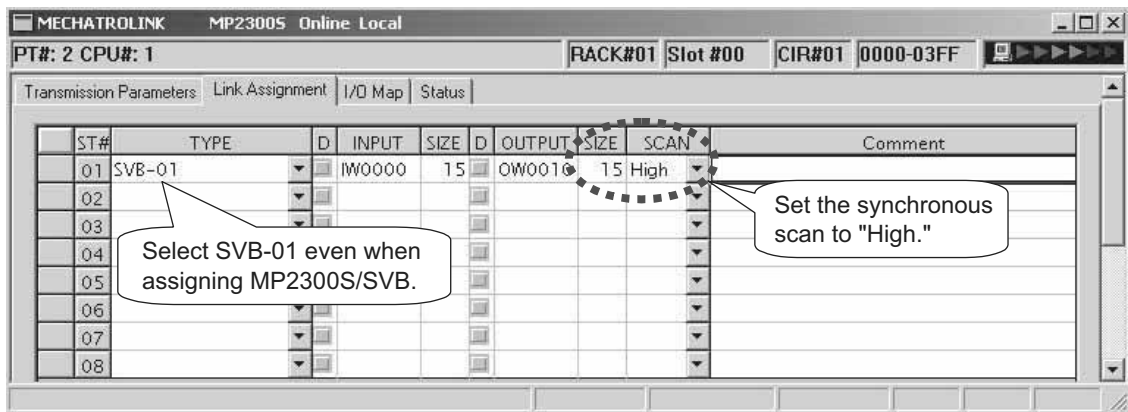

(2) Slave Side Setting

1. Select "Slave synchronous function = Enable" as a MECHATROLINK communication parameter.

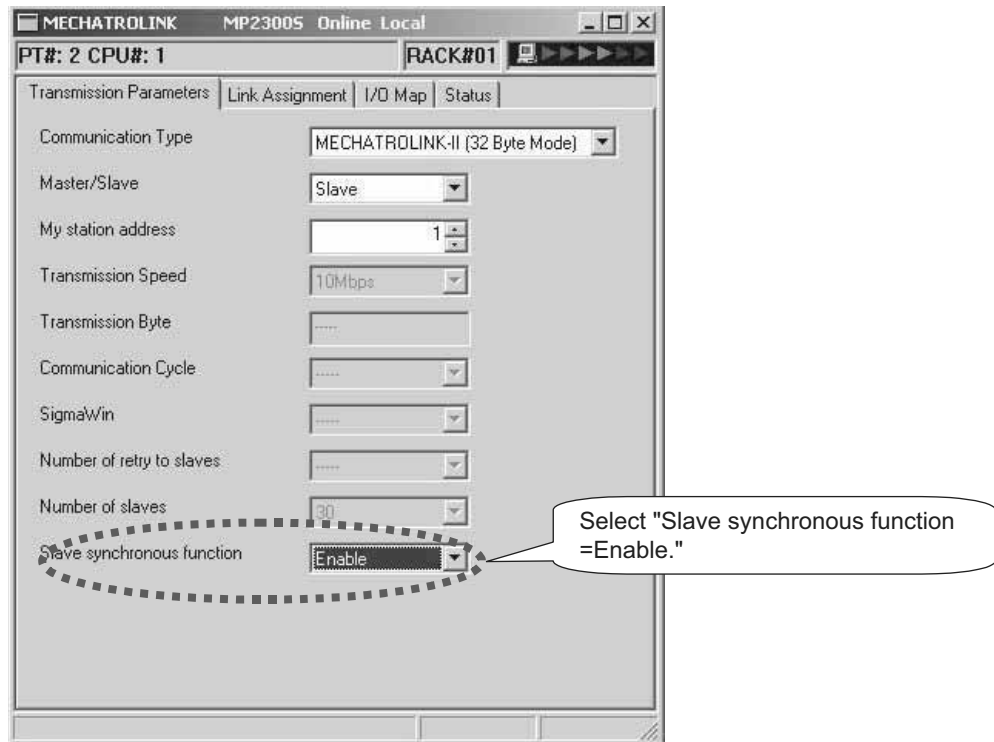
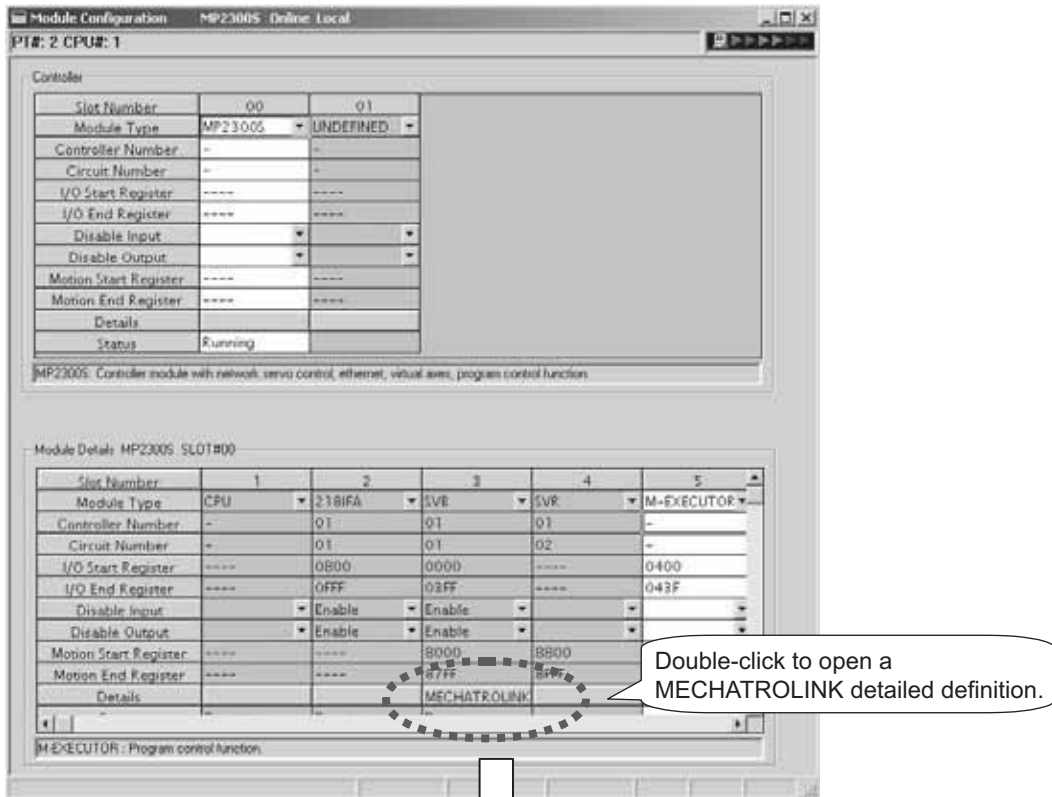

2. Set the synchronous scan to **High** as a MECHATROLINK link assignment.

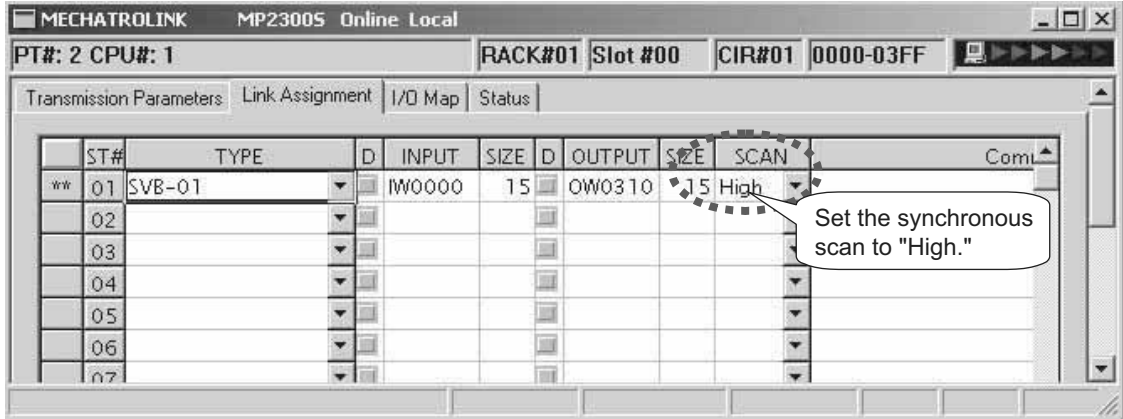

7.2.4 How to Execute Slave CPU Synchronous Function

When the execution requirements described in *7.2.2 Requirements to Execute Slave CPU Synchronous Function* are met, slave CPU synchronization will be automatically executed after the communication between the master and the MP2300S is established, so you do not need to explicitly command the start. Of course, you can explicitly control the start, if you wish, by using a slave side control bit SLVSC.

A precaution for the slave CPU synchronous process is given when powering the equipment.

As described in *7.4.1 Precautions on Usage*, when transforming from the asynchronous to synchronous state using the slave CPU synchronous function, a slave side scan cycle (high/low speed) may delay up to one scan cycle, affecting the slave side application.

To avoid this impact, the procedures of “Turning on the Master Side Power First” and “Turning on the Slave Side Power First,” are suggested.

In general, we recommend that you execute the simple procedure for “Turning on the Master Side Power First.”

(1) Turning ON the Master Side Power First

After confirming that the master side startup is complete, turn ON the slave side power.

To determine the startup completion within the application, use system register SB000401 “RUN”.

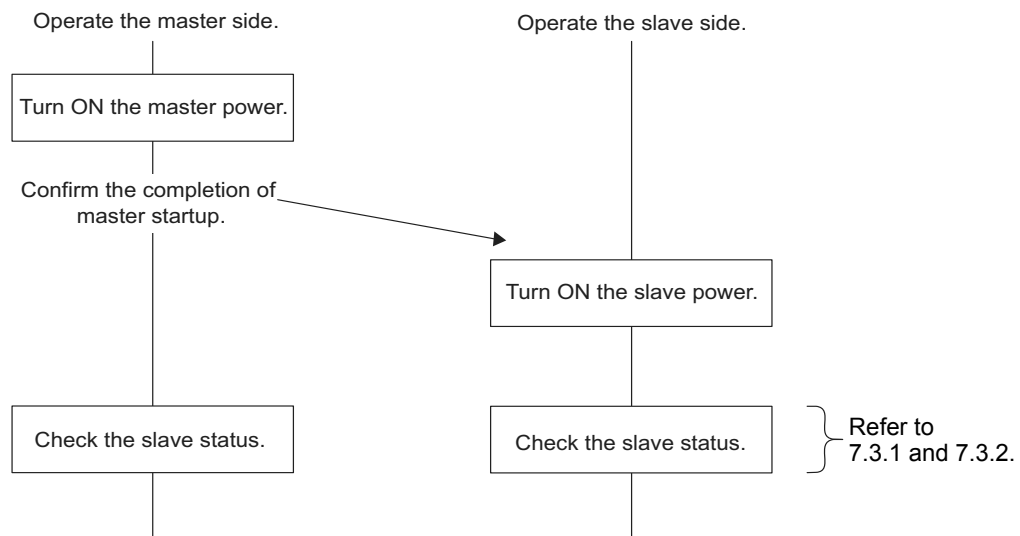

(2) Turning ON the Slave Side Power First

After confirming that the slave side startup is complete, use an application program to set control bit SLVSC = ON*. Then, turn ON the master side power.

After confirming that no axis connected to the motion module installed in a slave side optional slot is moving, the slave CPU synchronization can be executed by setting control bit SLVSC = OFF (*).

* For more information, refer to 7.3.6 *Management to Resume Slave CPU Synchronization*.

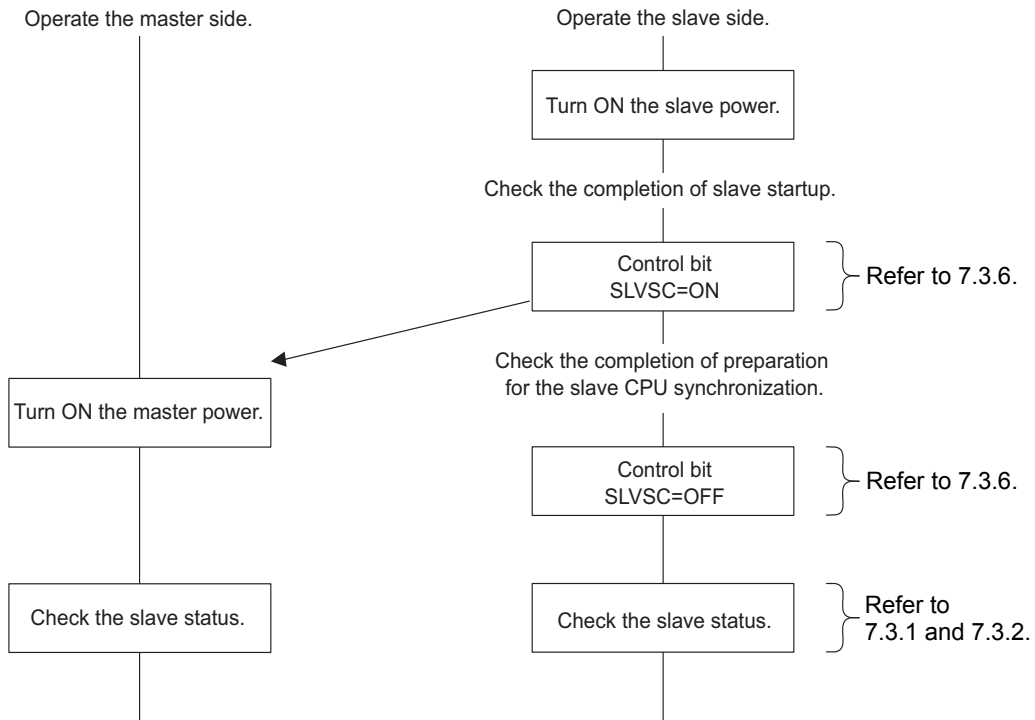

7.3 Operation

7.3.1 Input/Output Register

This section describes the details of the input/output register configured in the link assignment.

(1) Master Side Input/Output Data

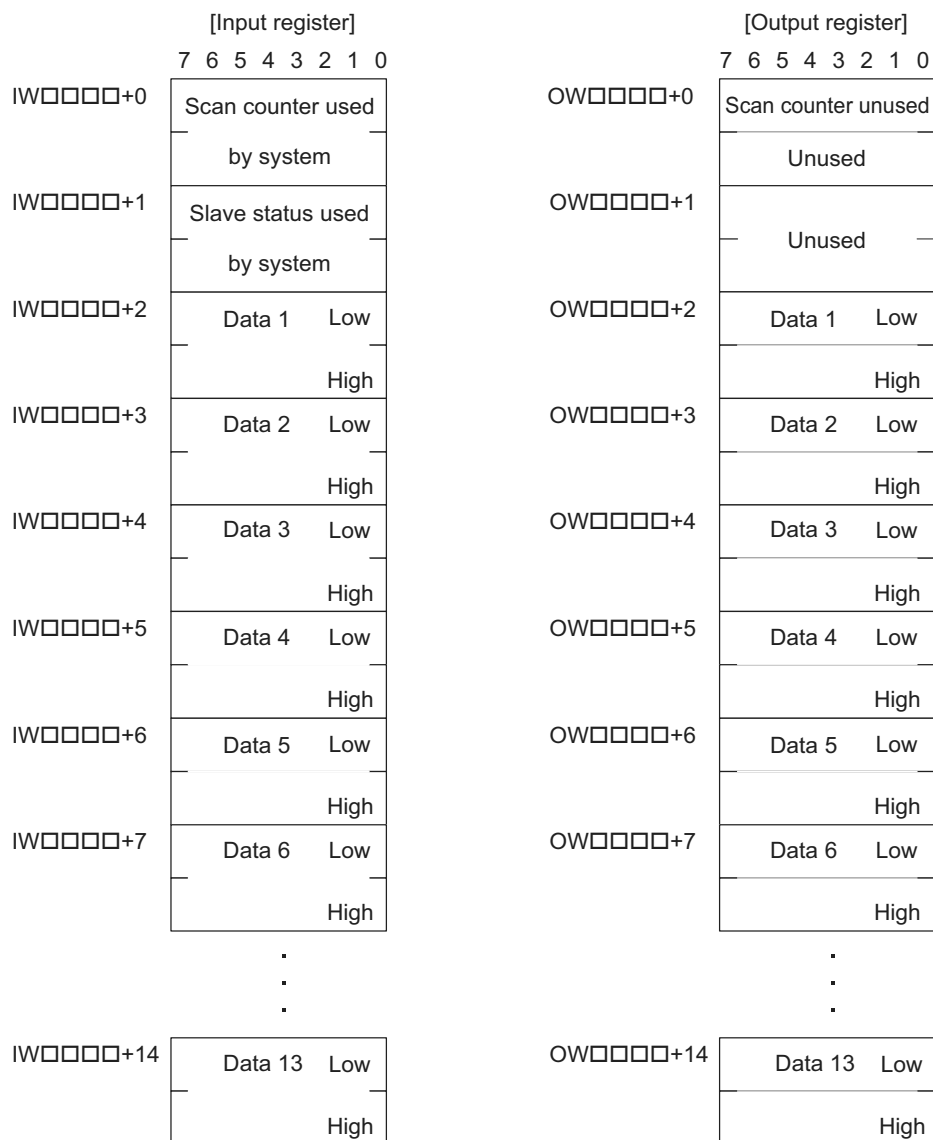

■ Input data details

Item	Description
Scan Counter	One byte of area which allows a master side application to check a value configured and updated by a slave side application. It is used for the following purposes: <ul style="list-style-type: none"> • Checks the update of input data from MP2300S. • Determines the MP2300S behavior (in operation/in pause). Note that the use of this area is optional.
Slave Status	Status of MECHATROLINK transmission unit of MP2300S. The configuration is shown on the subsequent page:
Data	Up to 6 words of data area for MECHATROLINK-II (17Byte) and up to 13 words of data area for MECHATROLINK-II (32Byte) are available.

■ Slave status details

bit7	bit6	bit5	bit4	bit3	bit2	bit1	bit0
SYNC	SYNCRDY	SBUSY	0		CMDRDY	WARNG	0

Name	Definition		Description
WARNG	0	Normal	When a slave detects one of the following errors, this bit is turned ON. When the cause is corrected, it is turned OFF. <ul style="list-style-type: none"> • Receive error • Unsupported command reception • Transmission cycle is out of the specification range • Data error in the receive command • Command execution requirement is not met
	1	Warning	
CMDRDY	0	Command Unreceivable (busy)	Turned ON when a process for the MECHATROLINK command transmitted from a master is completed and the slave is ready to receive the next command.
	1	Command receivable (ready)	
SBUSY	0	Steady state	This bit is turned ON while the slave CPU synchronization is in process.
	1	Transient state	
SYNCRDY	0	Preparation for slave synchronization not completed	This bit is turned ON when an execution requirement of the slave CPU synchronization is met. It is turned OFF in the following conditions: <ul style="list-style-type: none"> • An execution requirement of the slave CPU synchronization has not been met. • A control bit "SLVSC" is turned ON by MP2300S side
	1	Preparation for slave synchronization completed	
SYNC	0	Slave asynchronous state	This bit is turned ON when entering the slave CPU synchronous state.
	1	Slave synchronous state	

Note: When a receive error occurs, both system registers "I/O Error Count" (SW00200) and "Input Error Count" (SW00201) increase.

■ Output data details

Item	Description
Scan Counter	One byte of area which allows a master side application to check a value configured and updated by a slave side application. It is used for the following purposes: <ul style="list-style-type: none"> • Checks the update of output data from the master • Determines the master behavior (in operation/in pause) Note that the use of this area is optional and the data input/output process is carried out without updating the scan counter value.
Data	Up to 6 words of data area for MECHATROLINK-II (17Byte) and up to 13 words of data area for MECHATROLINK-II (32Byte) are available.

(2) Slave Side Input/Output Data

	[Input register]		[Output register]
	7 6 5 4 3 2 1 0		7 6 5 4 3 2 1 0
IW□□□□+0	Scan counter unused		OW□□□□+0 Scan counter unused
IW□□□□+1	Slave status unused		OW□□□□+1 Control bit
IW□□□□+2	Data 1 Low High		OW□□□□+2 Data 1 Low High
IW□□□□+3	Data 2 Low High		OW□□□□+3 Data 2 Low High
IW□□□□+4	Data 3 Low High		OW□□□□+4 Data 3 Low High
IW□□□□+5	Data 4 Low High		OW□□□□+5 Data 4 Low High
IW□□□□+6	Data 5 Low High		OW□□□□+6 Data 5 Low High
IW□□□□+7	Data 6 Low High		OW□□□□+7 Data 6 Low High
	⋮		⋮
IW□□□□+14	Data 13 Low High		OW□□□□+14 Data 13 Low High

■ Input data details

Item	Description
Scan Counter	One byte of area which allows a slave side application to check a value configured and updated by a master side application. It is used for the following purposes: <ul style="list-style-type: none"> • Checks the update of output data from the master. • Determines the master behavior (in operation/in pause). Note that the use of this area is optional.
Slave Status	Status of MECHATROLINK transmission unit of a slave-status MP2300S. It is the same content as reported to the master.
Data	Up to 6 words of data area for MECHATROLINK-II (17Byte) and up to 13 words of data area for MECHATROLINK-II (32Byte) are available.

■ Output data details

Item	Description
Scan Counter	One byte of area which allows a master side application to check a value configured and updated by a slave side application. It is used for the following purposes: <ul style="list-style-type: none"> • Checks the update of input data from MP2300S • Determines the MP2300S behavior (in operation/in pause) Note that the use of this area is optional and the data input/output process is carried out without updating the scan counter value.
Control Bit	Sets the behavior of the MECHATROLINK transmission unit of the control bit MP2300S. The configuration is shown as follows:
Data	Up to 6 words of data area for MECHATROLINK-II (17Byte) and up to 13 words of data area for MECHATROLINK-II (32Byte) are available.

■ Control bit details

bit7	bit6	bit5	bit4	bit3	bit2	bit1	bit0
Unused							SLVSC
bit15	bit14	bit13	bit12	bit11	bit10	bit9	bit8
Unused							

Name	Definition		Description
SLVSC	0	Resume enable	Even when the slave CPU synchronization is not carried out, the slave CPU synchronization is automatically resumed.
	1	Resume disable	Even when the slave CPU synchronization is not carried out, it continues to work in an asynchronous state.

Note: For information on SLVSC usage, refer to *7.3.6 Management to Resume Slave CPU Synchronization*.

(3) Input/Output Data Flow between Master and Slave

■ From MP2000 (master) to MP2300S (slave)

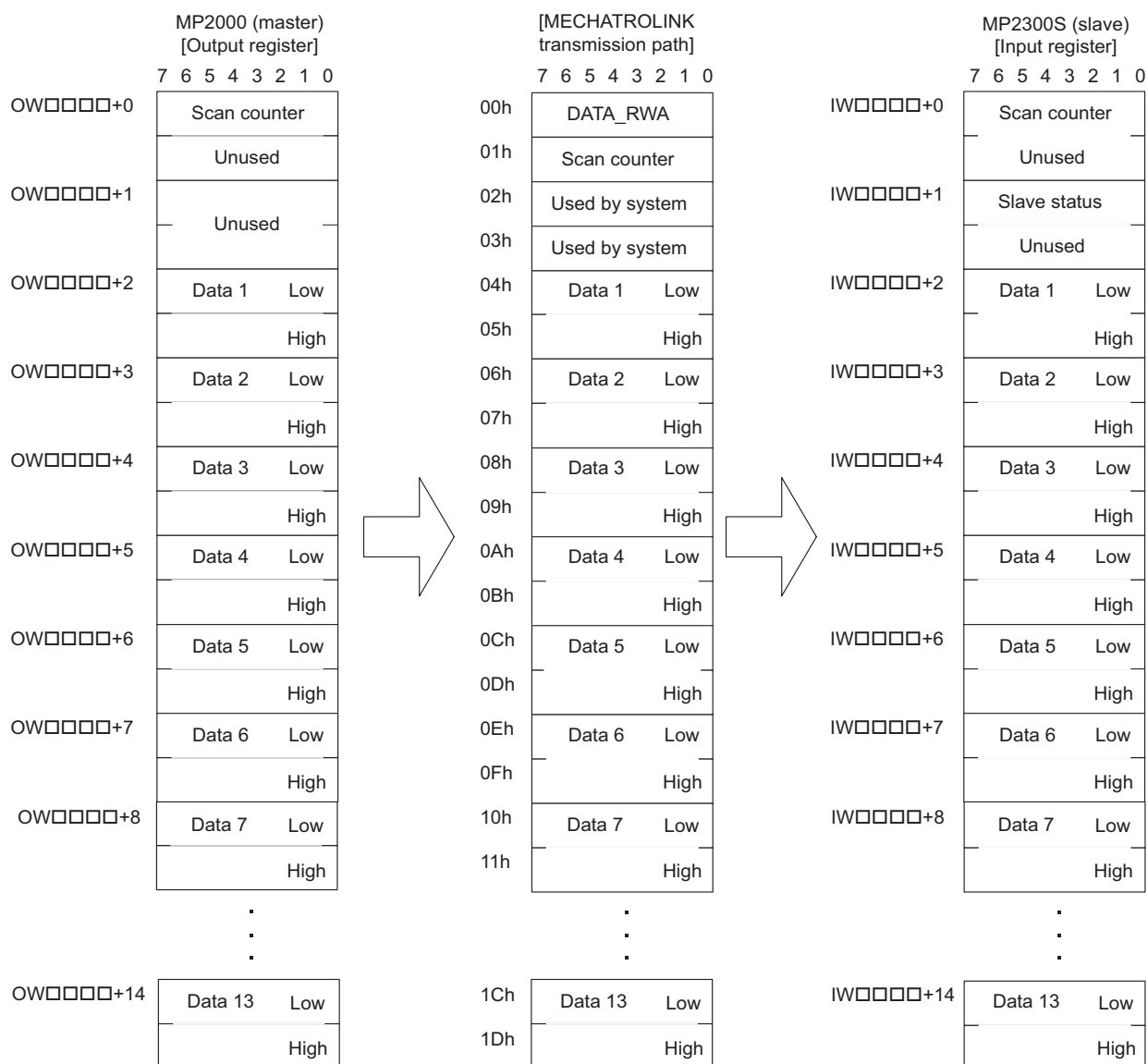

■ From MP2300S (slave) to MP2000 (master)

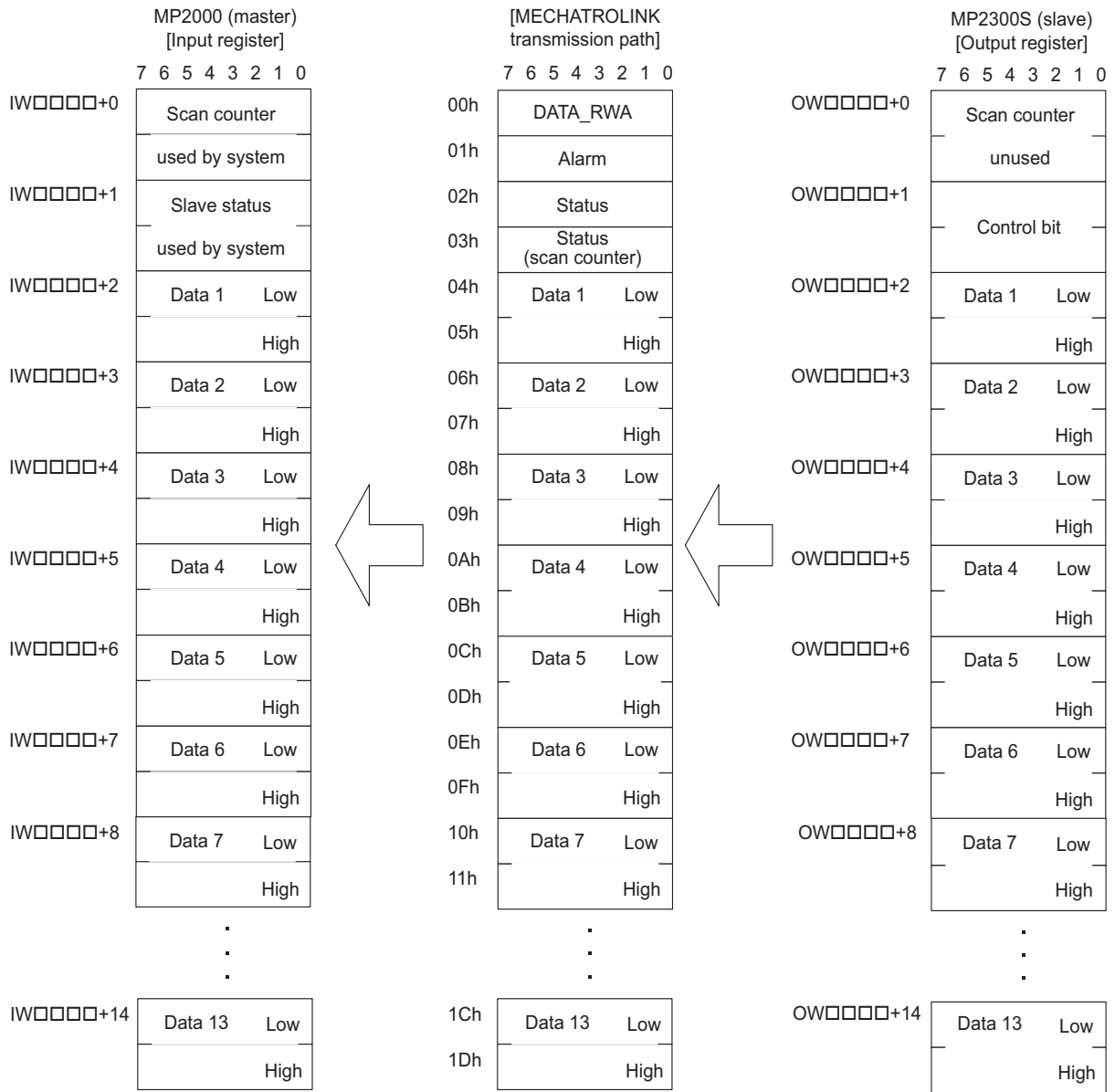

7.3.2 How to Determine Slave CPU Synchronous State

The way to determine the slave CPU synchronous state from an application program is as follows:

(1) How to Check with a Master Side Application

Use bit 7 “SYNC” of the second word “Slave Status” ($IW□□□□ + 1$) of an input register assigned to MP2300S.

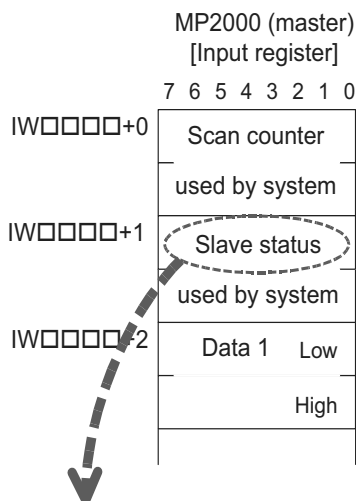

bit7	Bit6	bit5	bit4	bit3	bit2	bit1	bit0
SYNC	SYNCRDY	SBUSY	0		CMDRDY	WARNG	0

If SYNC = ON, it is in a slave CPU synchronous state.

(2) How to Check with a Slave Side Application

Use bit7 “SYNC” of the second word “Slave Status” ($IW□□□□ + 1$) of an input register assigned to a local station.

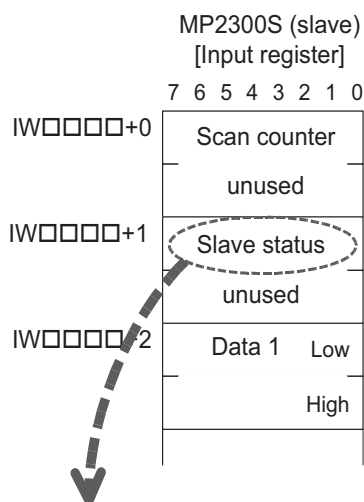

bit7	bit6	bit5	bit4	bit3	bit2	bit1	bit0
SYNC	SYNCRDY	SBUSY	0		CMDRDY	WARNG	0

If SYNC = ON, it is in a slave CPU synchronous state.

7.3.3 Calculation of Slave CPU Synchronous Delay Time

In a slave CPU synchronous arrangement, a command from the master is processed as in the following flow, and transmitted to the slave side.

Here, the time between ① and ④ is constant.

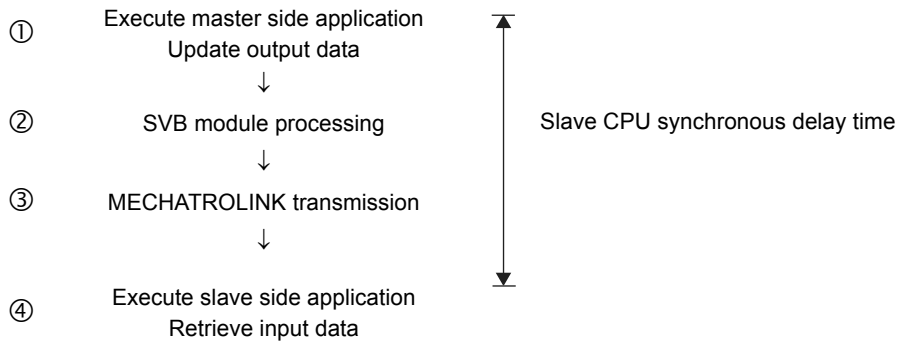

This delay time is referred to as “Slave CPU Synchronous Delay Time” and is calculated as follows:

$$\text{Slave CPU synchronous delay time} = \text{Master H scan cycle} \times 2 + \text{MECHATROLINK cycle}$$

[Setting Example]

$$\begin{aligned}
 &\text{Master side H scan setting: 4 ms} \\
 &\text{MECHATROLINK communication cycle setting: 1 ms} \\
 &\quad \downarrow \\
 &\text{Slave CPU synchronous delay time} = 4 \text{ ms} \times 2 + 1 \text{ ms} \\
 &\quad \quad \quad \quad \quad \quad \quad \quad = 9 \text{ ms}
 \end{aligned}$$

7.3.4 How to Use Scan Counter

A scan counter enables the reception device to check that data is updated by the transmission device.

It also allows the master and slave to confirm each other's proper working order.

Use of the scan counter is optional, and there is no problem if you choose not to use it.

An example follows. In this example, H scan cycles of both master and slave sides are assumed to have the same setting.

(1) Checking the Master Status Using a Slave Side Application

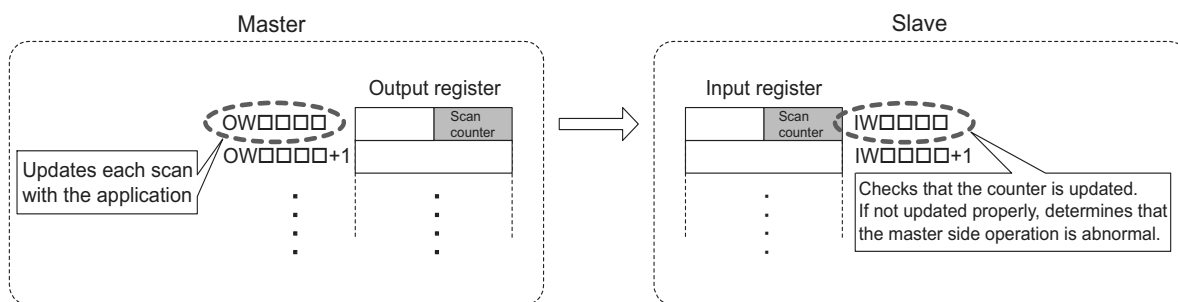

■ Master processing

A master side application is increased the setting value by one for the start word of an output register assigned to the MP2300S/SVB.

■ Slave processing

A slave side application checks that the scan counter value is increased by one from the previous value +1. As the scan counter is one byte of data, it only checks the lower byte.

If not updated normally, it determines that a problem has occurred with the master.

(2) Checking a Slave Status Using a Master Side Application

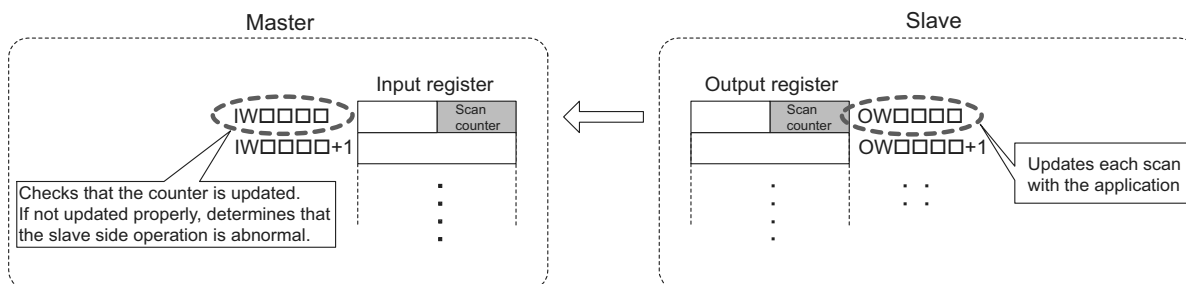

■ Master processing

A master side application checks that a scan counter value is increased by one from the previous value. As the scan counter is one byte of data, it only checks the lower byte.

If not updated normally, it determines that a problem has occurred with the slave.

■ Slave processing

A slave side application is increased the setting value by one for the start word of an output register mapped to SVB.

Note: In this example, H scan cycles of both master and slave sides have the same setting.

When they have a different scan cycle setting, they must be updated and checked accordingly.

7.3.5 How to Determine Input Error

(1) How to Determine an Input Error Using an Application Program

If it is determined that an input error has occurred, error processing, such as discarding the input data, must be implemented.

[a] Master Side

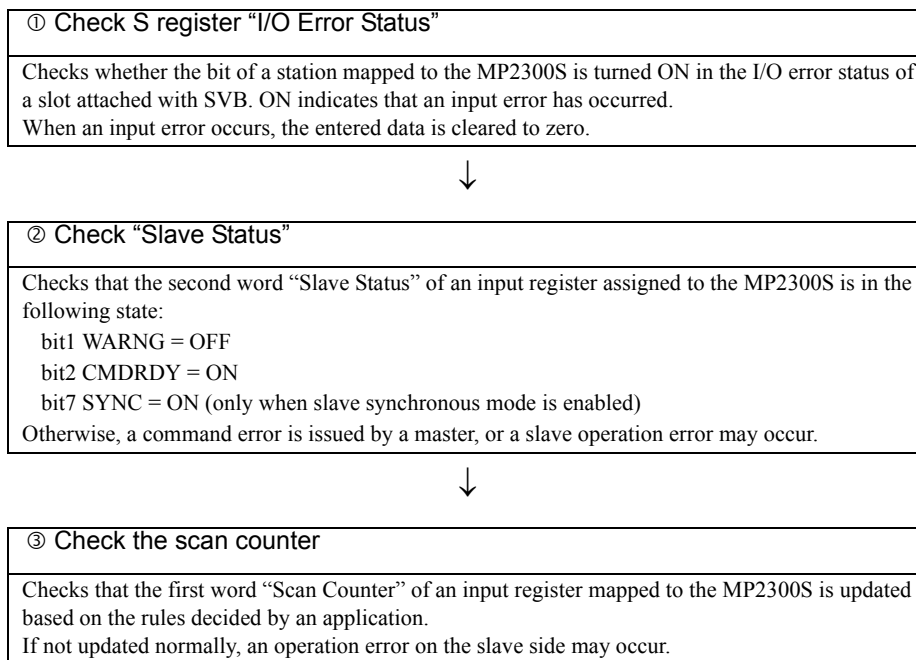

An example of an application which checks an input error is shown in the next page.

[Conditions] Use MP2200/CPU-02. SVB-01 is attached to the slot 1 of rack 1.

MP2300S is assigned to st#1

INPUT: IW0000 SIZE: 15W

OUTPUT: OW0010 SIZE: 15W

Register	Meaning	Remarks
DW00001	Copy of slave status	
DW00002	Condition check result	
DW00003	Copy of current value of scan counter	
DW00004	Previous value of scan counter	
DW00005	Data for checking scan counter	
DW00007	Input error counter value	Increased by one when an input error is detected.
DW00008	Error counter value of slave status	Increased by one when an error of the slave status is detected.
DW00009	Error counter value of a scan counter	Increased by one when an error of the scan counter is detected.
DW000010	Copy of input data (data 1)	
⋮	⋮	
DW000022	Copy of input data (data 13)	

■ Application Example

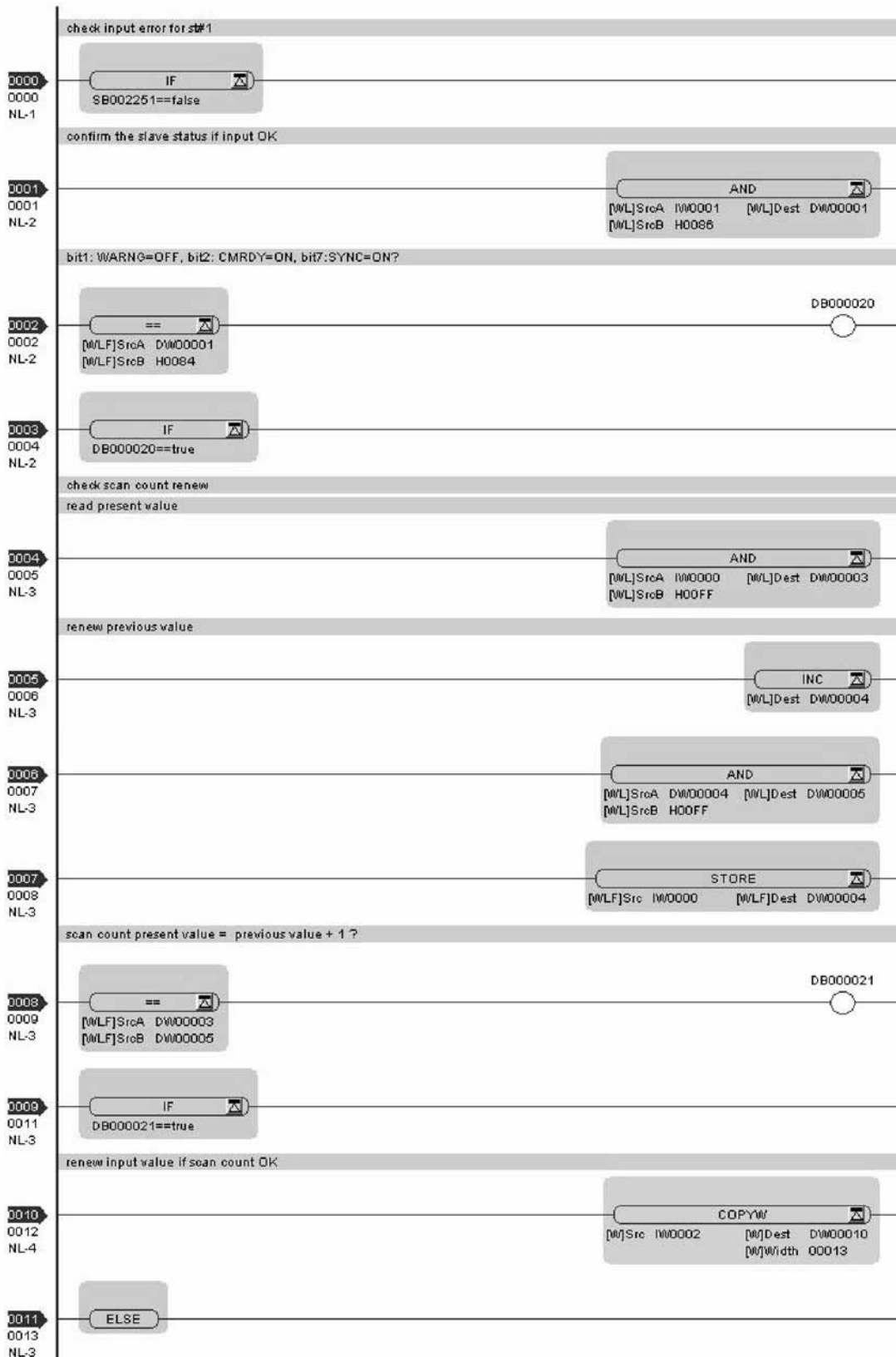

Continued on the next page

Continued from the previous page

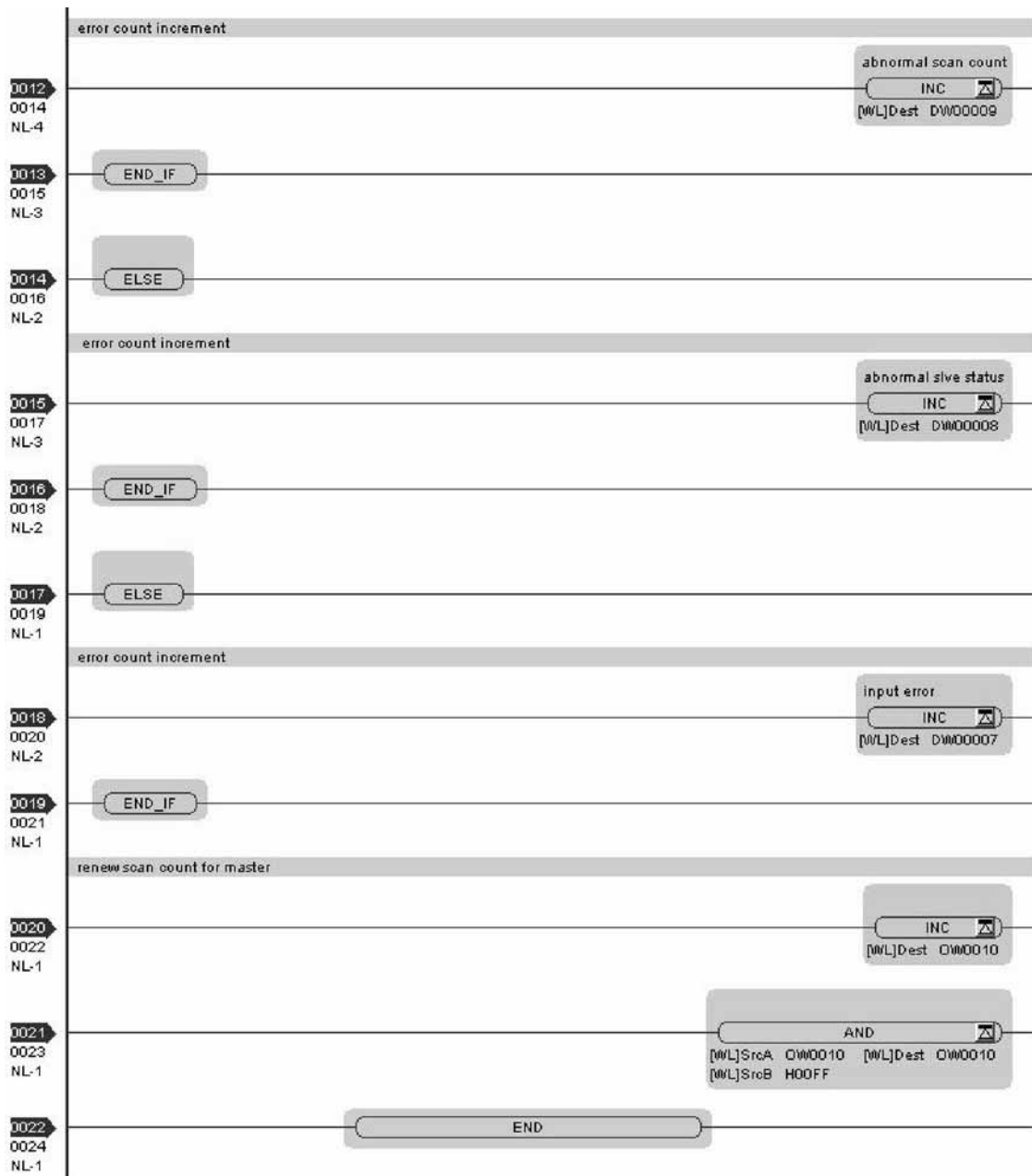

[b] Slave Side

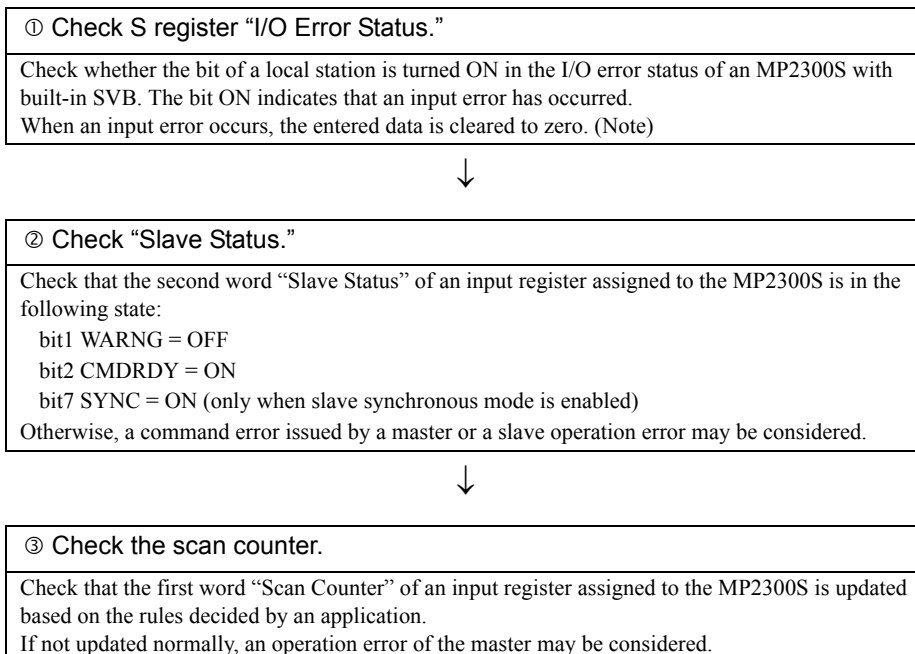

Note: For an error to be reported to an I/O Error Status, at least one normal input must be executed. For example, when the power is turned ON while unconnected to a master, the local bit of the I/O error status remains OFF.

An example of an application which checks input error is shown on the next page.

[Conditions] Local station (MP2300S) is assigned to st#1.

INPUT: IW0800, SIZE: 15W

OUTPUT: OW0810, SIZE: 15W

Register	Meaning	Remarks
DW00001	Copy of a slave status	
DW00002	Inspection result of conditions	
DW00003	Copy of current value of a scan counter	
DW00004	Previous value of a scan counter	
DW00005	Data for checking a scan counter	
DW00007	Input error counter value	Increased by one when an input error is detected.
DW00008	Error counter value of slave status	Increased by one when an error of the slave status is detected.
DW00009	Error counter value of scan counter	Increased by one when an error of the scan counter is detected.
DW000010	Copy of input data (data 1)	
⋮	⋮	
DW000022	Copy of input data (data 13)	

Application Example

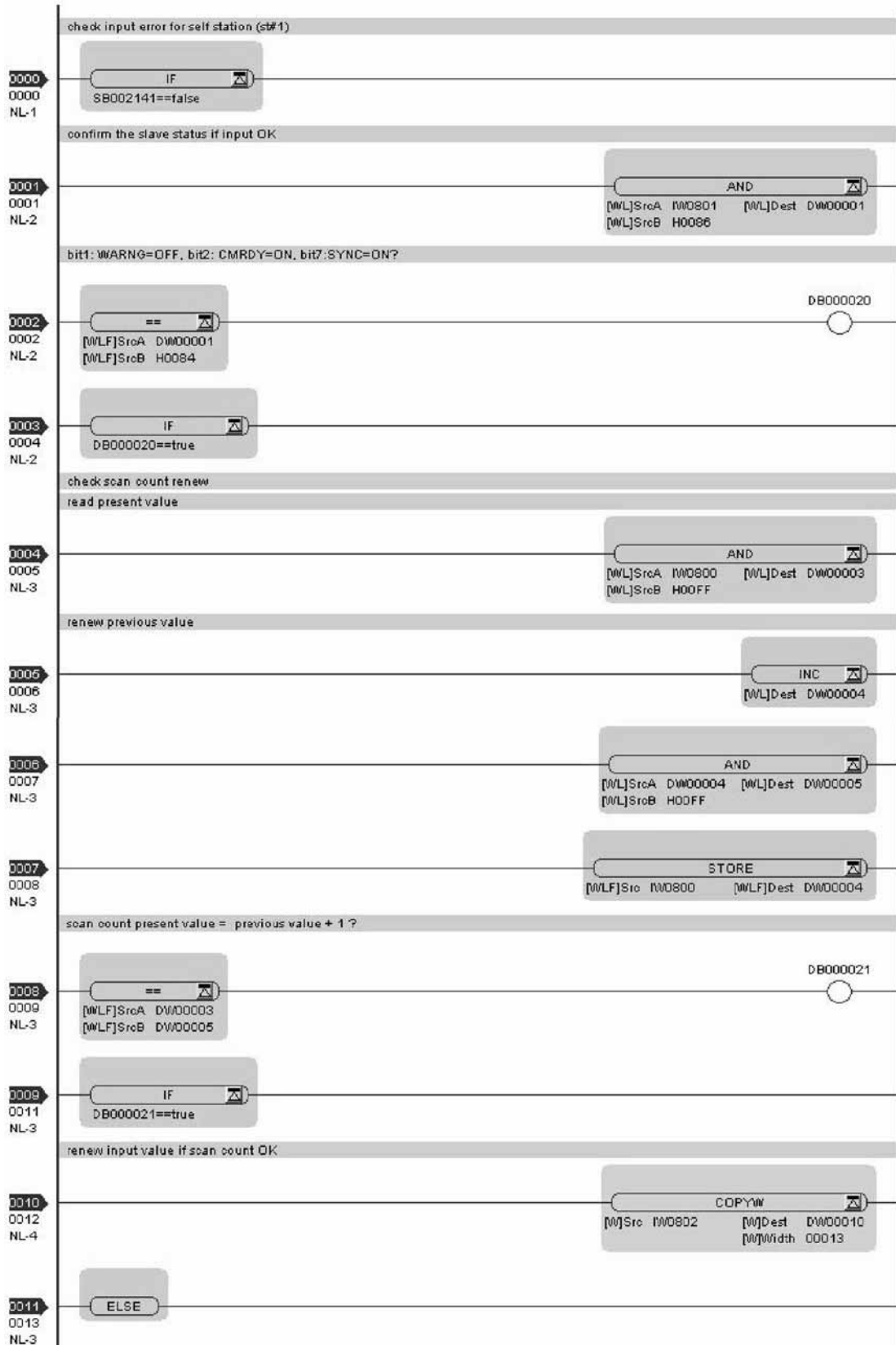

Continued on the next page

Continued from the previous page

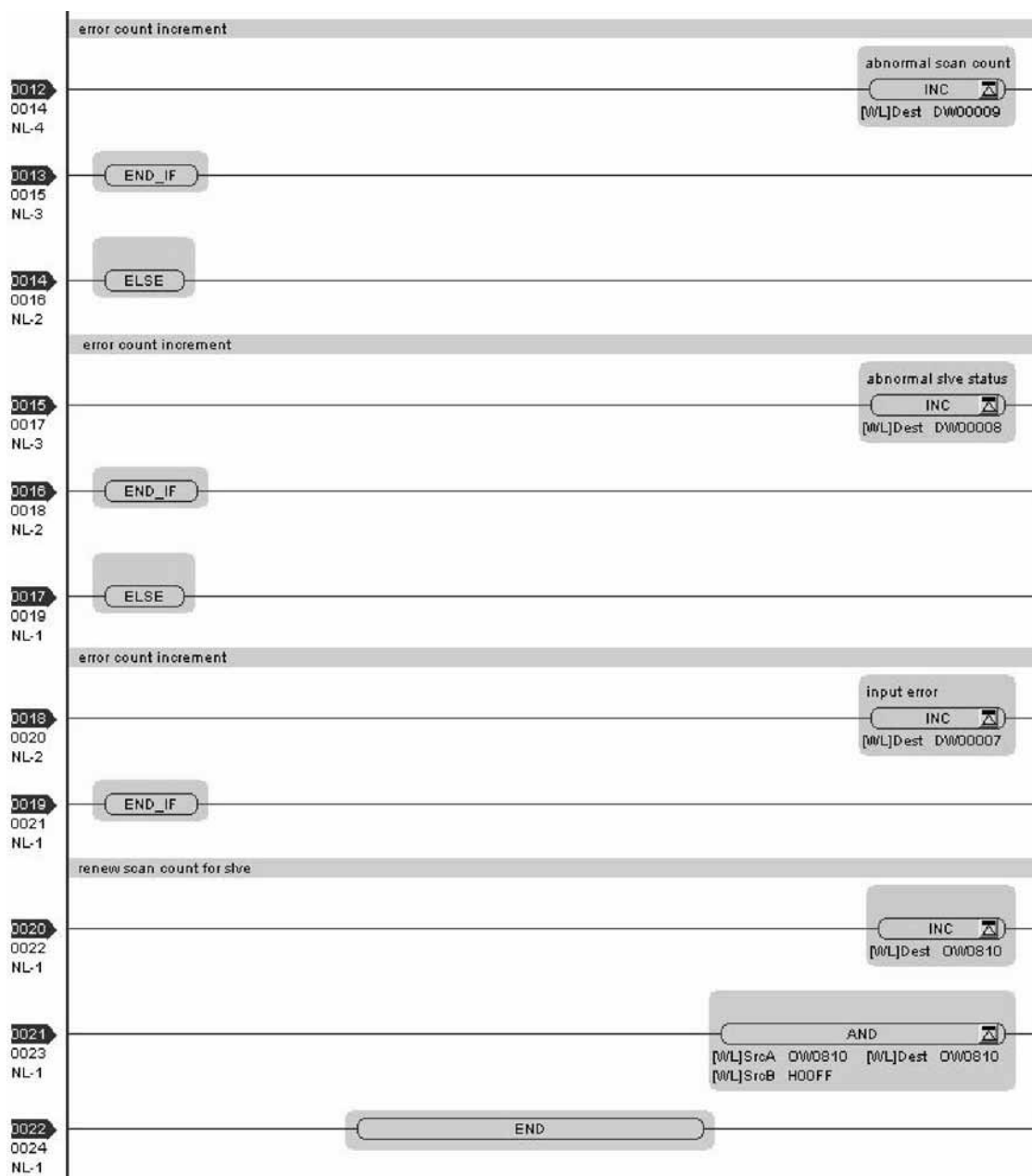

(2) How to Recover from Input Error

Recovery is automatic, and no particular operation is needed. However, if input errors occur frequently, check the following:

- Are local station addresses duplicated?
- Do scan time-overs occur?
- Is a MECHATROLINK terminating resistor attached?
- Is there a problem with MECHATROLINK wiring?

7.3.6 Management to Resume Slave CPU Synchronization

The slave CPU synchronous process is automatically carried out when its execution requirements are met. Here, in a transient state from slave CPU asynchronous to slave CPU synchronous state, the following operations are carried out by the system:

- Start of timing adjustment of the slave scan cycle
- When SVB-01 is attached to an optional slave slot, the MECHATROLINK communication is reset

As a result operation of the slave side application is affected as follows:

- One scan with a longer cycle than the setup time occurs
- When a servo connected to the SVB-01 is running, its axis stops and an alarm occurs

To avoid these impacts (to avoid automatic recovery to the slave CPU synchronous state), use the slave side application to operate a control bit “SLVSC (slave CPU synchronous resume control)”.

Operating this bit allows you to control the synchronous process.

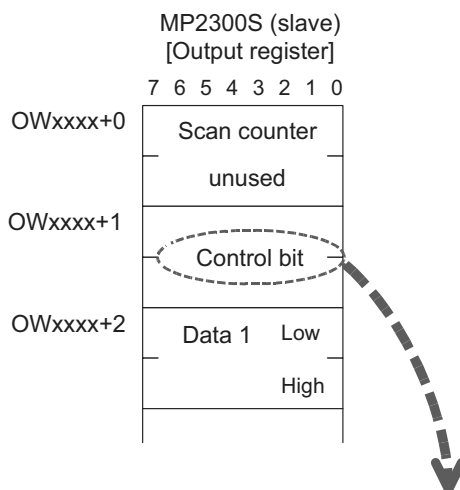

bit7	bit6	bit5	bit4	bit3	bit2	bit1	bit0
Unused							SLVSC
bit15	bit14	bit13	bit12	bit11	bit10	bit9	bit8
Unused							

Name	Definition	Description
SLVSC	0	Resume enable
	1	Resume disable

The example below shows how the slave side application controls the slave CPU synchronous resumption. In this example, the status is divided into three parts, and resumption is considered in a state transition diagram.

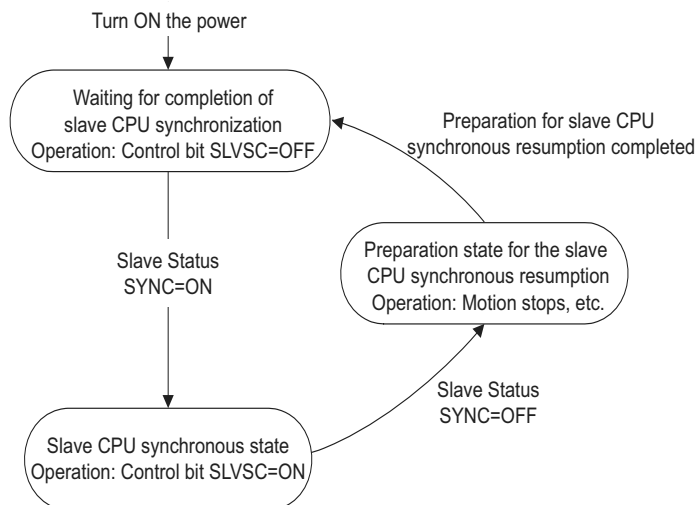

In each state, the following processes are carried out:

State	Process Description
Waiting state for the completion of slave CPU synchronization	Where the power was turned ON. Sets a control bit SLVSC=OFF, allowing you to execute the slave CPU synchronous process. If SYNC is turned ON while monitoring slave status "SYNC", changes the state to "slave CPU synchronous state".
Slave CPU synchronous state	When entering slave CPU synchronous state, turns ON the control bit SLVSC, and prohibits the slave CPU synchronous resumption. Thus, even when entering slave CPU asynchronous state, automatic recovery is not carried out. If SYNC is turned OFF while monitoring slave status "SYNC," changes the state to "Preparation for slave CPU synchronous resumption."
Preparation state for slave CPU synchronous resumption	Prepares for the resumption of slave CPU synchronization. In particular, stops an axis connected to the motion module attached to an optional slot. If ready, changes the state to "Waiting state for the completion of the slave CPU synchronization."

An example in which this process is executed using a ladder application is shown in the next page.

[Conditions] Local station (MP2300S) is assigned to st#1.

INPUT: IW0800, SIZE: 15W

OUTPUT: OW0810, SIZE: 15W

Register	Meaning	Remarks
MW00200	State	0: Waiting for the completion of slave CPU synchronization 1: Slave CPU synchronous state 2: Preparation state for slave CPU synchronous resumption Note: Initialized at figure A or the first scan.
MW00201	Check flag of preparation for a synchronous resumption	When resumption preparation is completed, set to 1.
DW00000	Temporary for updating condition	-

■ Application Example

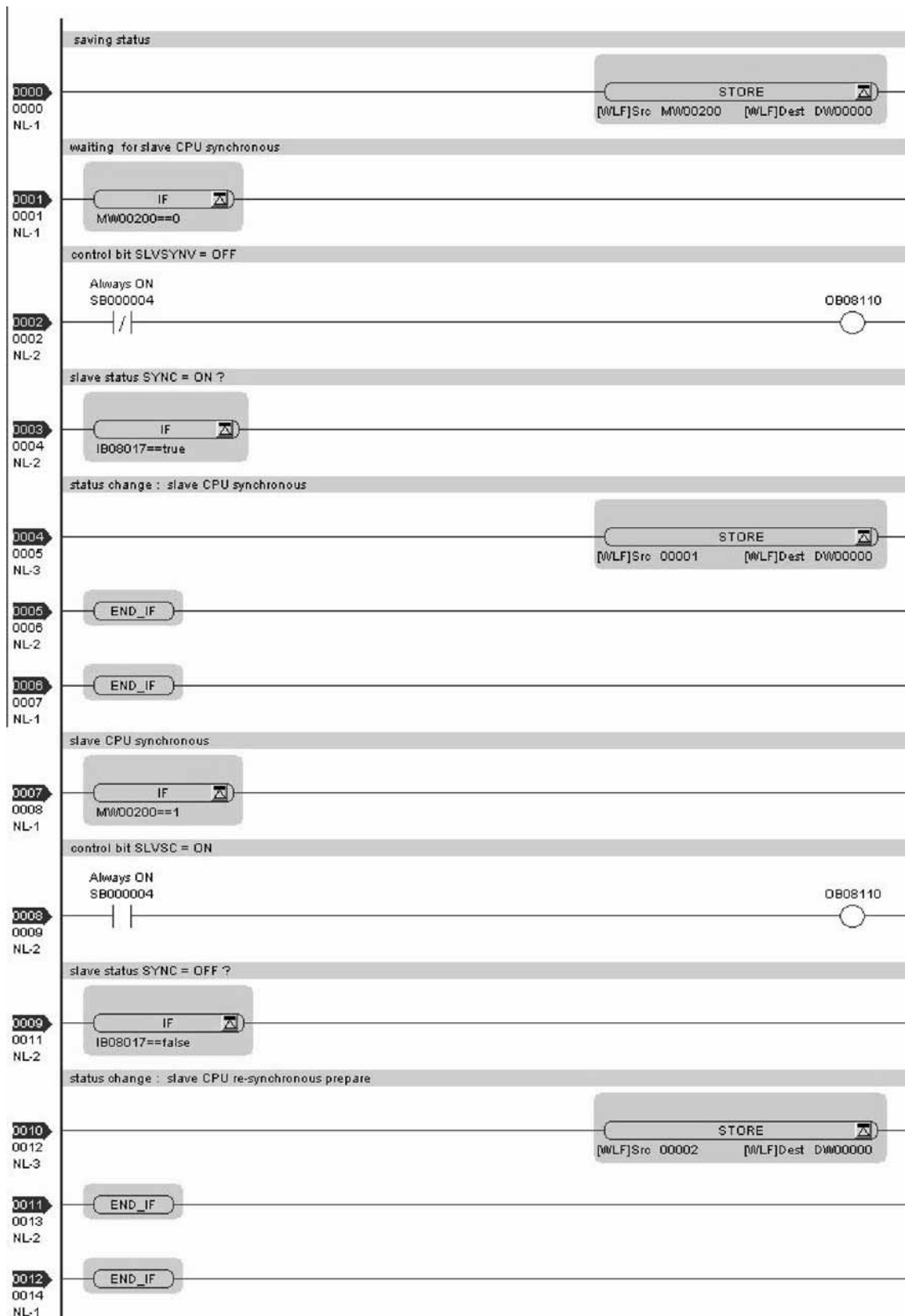

Continued on the next page

Continued from the previous page

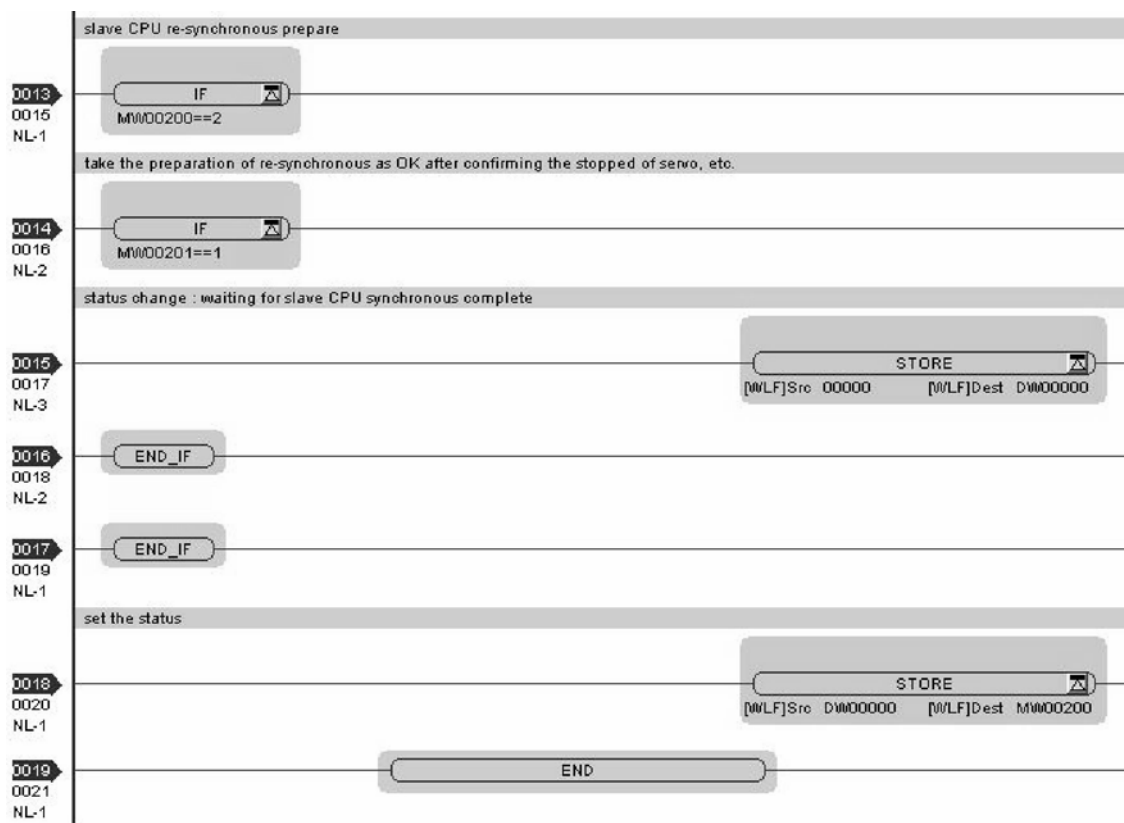

7.4 Precautions

7.4.1 Precautions on Usage

- When using the slave CPU synchronous function, the slave side cannot use option module PO-01. To use PO-01, disable the slave CPU synchronous function.
- In the transient condition from asynchronous to synchronous state using the slave CPU synchronous function, a slave-side scan cycle (high/low speed) may be delayed by up to one scan cycle. For an application which requires fixed timing and fixed cycles, take preventative measures if using any data that would affect the timing of such an application.
- When an SVA-01 is attached to a slave side optional slot, and the slave CPU synchronous state is entered, the operation may suffer such an impact that an axis is shocked. Stop the SVA-01 operation in advance.
- When an SVB-01 is attached to a slave side optional slot, during transition to the slave CPU synchronous state, disconnect and later reconnect the communication between a slave and its connected SVB-01. When a slave device such as a servo or inverter is connected, stop their operation in advance. Due to the disconnection of communications, the device may suffer shock when an axis is suddenly stopped.

- The operations below change the slave CPU synchronous state to the asynchronous state:

[Master side operation]

- Change of an H scan setting
- Saving of a MECHATROLINK communications definition
- Self-configuration

[Slave side operation]

- Change of an H scan setting
- Self-configuration

While recovering to the slave CPU synchronous state, a scan cycle disturbance may occur.

- When a communication error occurs, the condition changes from slave CPU synchronous to asynchronous state.
- When the MP2300S with a built-in SVB is changed from slave to master, flash save the change and turn ON the power again.
- The slave CPU synchronous function is available only when the MP2000 series SVB is used as a master. When connected to another master controller, it works in asynchronous mode.

- When the MP2300S with a built-in SVB works as a slave and the SVB-01 in an optional slot works as a master, never connect them so that they form a loop, as shown in the following figure.

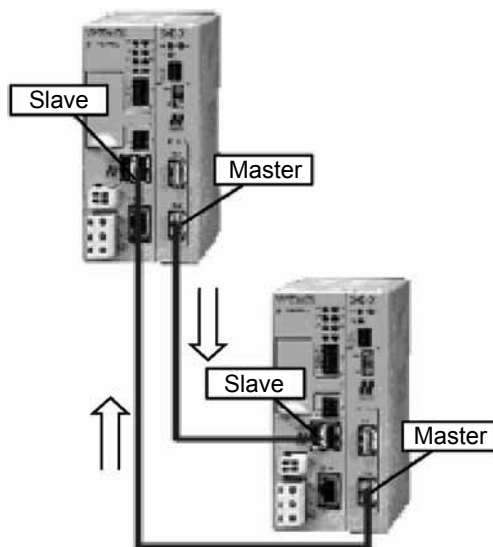

7.4.2 Effect of Error on Slave CPU Synchronous Operation

When an error occurs in a slave CPU synchronization, the slave side behavior reacts as follows:

Action	State
The master side power is turned OFF	Continues to work in slave CPU asynchronous state. An input error may occur, but other scan operations are not affected.
MECHATROLINK communication cable is disconnected	Continues to work in slave CPU asynchronous state. An input error may occur, but other scan operations are not affected.
MP2300S assignment is deleted in the master assignment	Continues to work in slave CPU asynchronous state. An input error may occur, but other scan operations are not affected.
MECHATROLINK definition is saved in the master side	Enters slave CPU asynchronous state once. When a control bit SLVSC=OFF, the master side will recover and communication will be resumed, and then enters slave CPU synchronous state again.
A transmission error occurs	If only a received data error occurs, it may not affect slave CPU synchronization. However, as the input data is not updated, when you are checking the state using a user application, a scan counter error may be detected according to the scan cycle and communication cycle settings. When an error (transmission cycle disturbance) of the MECHATROLINK communication itself occurs, it may affect slave CPU synchronization. In some cases, the MP2300S H-scan process may be disturbed.
RUN/STOP of the master side CPU	CPU RUN/STOP does not affect slave CPU synchronization.
RUN/STOP of the slave side CPU	CPU RUN/STOP does not affect slave CPU synchronization.
Master side H scan setting is changed	Enters into slave CPU asynchronous state once. When the changed H scan setting meets the execution requirement of slave CPU synchronization and control bit SLVSC=OFF, enters slave CPU synchronous state again.
Slave side H scan setting is changed	Enters slave CPU asynchronous state once. When the changed H scan setting meets the execution requirement of slave CPU synchronization and control bit SLVSC=OFF, enters slave CPU synchronous state again.

MEMO

Maintenance, Inspection, and Troubleshooting

This chapter explains daily and regular inspection items to ensure that the MP2300S can always be used at its best conditions.

8.1 Inspection Items	8-2
8.1.1 Daily Inspections	8-2
8.1.2 Regular Inspections	8-3
8.1.3 Replacing the Basic Module Battery	8-4
8.2 Troubleshooting	8-5
8.2.1 Basic Flow of Troubleshooting	8-5
8.2.2 MP2300S Error Check Flowchart	8-6
8.2.3 LED Indicators	8-6
8.2.4 Troubleshooting System Errors	8-8
8.2.5 Motion Program Alarms	8-25
8.2.6 List of Causes for Command Error Completed Status	8-30
8.2.7 Troubleshooting Motion Errors	8-33

8.1 Inspection Items

This section summarizes daily and regular inspection items that must be performed by the customer.

8.1.1 Daily Inspections

The following table lists the daily inspection items.

No.	Inspection Item	Inspection Details	Criteria	Action	
1	Installation conditions of Module, etc.	Check the mounting screws for looseness. Check whether the covers are all in place.	The screws and covers must be secured correctly.	Retighten the screws.	
2	Connection conditions	Check the terminal screws for looseness.	The screws must be tight.	Retighten the screws.	
		Check the connectors for looseness.	The connectors must be tight.	Retighten the connector set screws.	
		Check the gap between crimp terminals.	There must be an appropriate gap between the terminals.	Correct as necessary.	
3	LED Indicators	RDY	Check whether the indicator is lit.	The indicator must be lit. (It is abnormal if the indicator is not lit.)	Refer to <i>8.2 Troubleshooting</i> on page 8-5.
		RUN	Check whether the indicator is lit while the system is in RUN state.	The indicator must be lit. (It is abnormal if the indicator is not lit.)	
		ERR	Check whether the indicator is not lit.	The indicator must be not lit. (It is abnormal if the indicator is lit.)	
		ALM	Check whether the indicator is not lit.	The indicator must be not lit. (It is abnormal if the indicator is lit.)	
		MTX	Check whether the indicator lights during communication.	The indicator must be lit. (It is abnormal if the indicator is not lit.)	
		BAT	Check whether the indicator is not lit.	The indicator must not be lit. (The battery voltage is too low if the indicator is lit.)	Replace the battery.

8.1.2 Regular Inspections

This section explains inspection items that must be performed once or twice every six months to one year.

Inspections must also be performed when the equipment is relocated or modified or when the wiring is changed.

 PROHIBITED
<ul style="list-style-type: none"> Do not replace the built-in fuse. If the customer replaces the built-in fuse, the MP2300S may malfunction or break down. Contact your Yaskawa representative.

No.	Inspection Item	Inspection Details	Criteria	Action	
1	Operating Environment	Ambient Temperature	Check the temperature and humidity with a thermometer and hygrometer, respectively. Check for corrosive gases.	0°C to 55°C	If the MP2300S is used inside a panel, treat the temperature inside the panel as the ambient temperature.
		Ambient Humidity		30% to 95% RH	
		Atmosphere		There must be no corrosive gases.	
2	Power Supply Voltage Check	PS Module	Measure the voltage between 24-VDC terminals.	19.2 to 28.8 VDC	Change the power supply as necessary.
3	Installation Conditions	Looseness and Excess Play	Attempt to move the Module.	The Module must be secured properly.	Tighten the screws.
		Dust and Other Foreign Matter	Visually check.	The Module must be free from dust and other foreign matter.	Clean.
4	Connection Conditions	Check the Terminal Screws for Looseness.	Check by retightening the screws.	The screws must be tight.	Retighten.
		Gap between Crimp Terminals	Visually check.	There must be an appropriate gap between the terminals	Correct.
		Looseness of Connectors	Visually check.	The screws must be tight.	Retighten the connector set screws.
5	Battery	Check the BAT indicator on the front panel of the Basic Module.	The BAT indicator must be not lit.		If the BAT indicator is lit, replace the battery.

8.1.3 Replacing the Basic Module Battery

The Basic Module has one replaceable built-in battery. This battery is used to back up data to prevent the data stored in the memory from being lost when power is interrupted (e.g., when the power supply to the Basic Module is turned OFF).

The built-in battery can retain the contents of the memory until the total time of power interruptions reaches one year. The warranty period of the battery is five years from the date of purchase. These values, however, differ according to the operating conditions, including the ambient temperature.

If the BAT indicator on the Basic Module lights, replace the battery with a replacement battery (JZSP-BA01) within two weeks. Any delay in battery replacement will result in the data stored in the memory being lost.

The appearance of the battery is illustrated below.

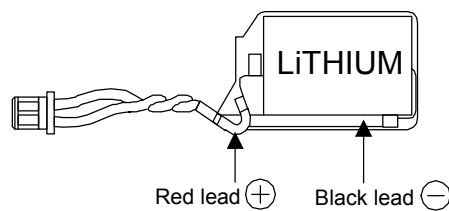

Fig. 8.1 JZSP-BA01 (Battery with Cable)

- This battery is not commercially available. Contact your Yaskawa representative.

(1) Procedure

⚠ CAUTION

- There is danger of electric shock if the battery is not replaced correctly. Furthermore, machine malfunction may occur, the operator may be injured, or the machine may be damaged. Allow only a qualified technician trained in safety procedures to replace the battery.
- When replacing the battery, always do so with power supplied to the Basic Module. If power to the Basic Module is turned OFF when the battery is replaced, data stored in the memory in the Module may be lost.
- Do not touch the battery electrodes. The battery may be destroyed by the static electricity.

1. Save the data stored in the Motion Board to a compact flash memory, hard disk on an external computer, or other media.
This data is used to restore any data accidentally lost during battery replacement.
 - For information on saving methods, refer to the *MPE720 Programming Device Software for MP900/MP2000 Machine Controllers User's Manual (Manual No. SIEPC88070005)*.
2. Check that the RDY indicator on the MP2300S Basic Module is lit.
3. Open the battery cover on the unit front surface.
4. Remove the connector on the end of lead of the built-in battery from the connector on the MP2300S Basic Module. Then, remove the built-in battery from the battery holder.
5. Insert securely the connector on the end of the lead of the replacement battery into the connector on the MP2300S. Then, insert the replacement battery into the battery holder.
6. Check if the BAT indicator on the MP2300S is unlit.
7. Close the battery cover. This completes replacing the battery.

8.2 Troubleshooting

This section describes the basic troubleshooting methods and provides a list of errors.

8.2.1 Basic Flow of Troubleshooting

When problems occur, it is important to quickly find the cause of the problems and get the system running again as soon as possible. The basic flow of troubleshooting is illustrated below.

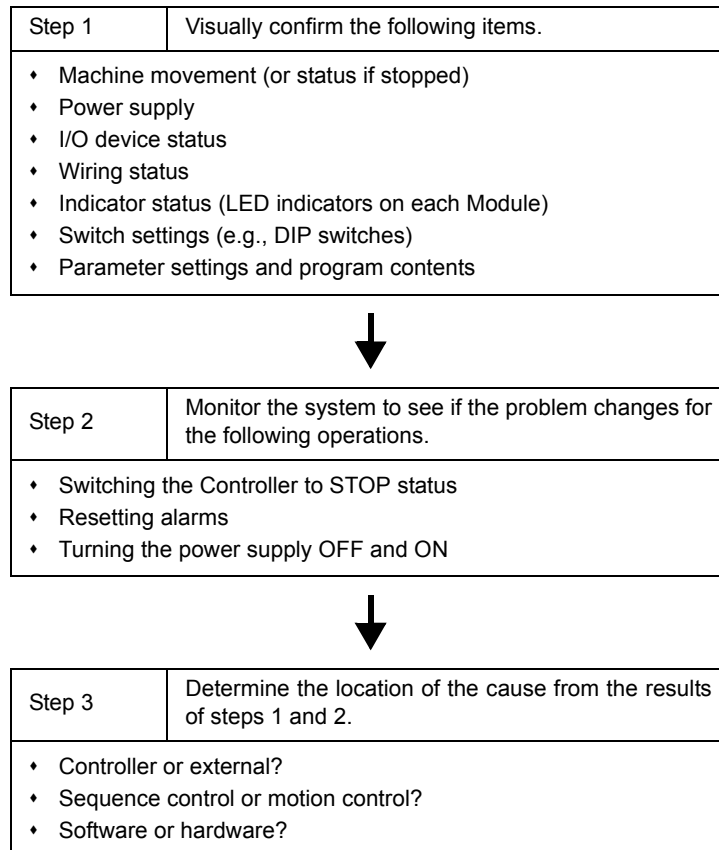

8.2.2 MP2300S Error Check Flowchart

Find corrective actions for the problem using the following flowchart, if the cause of the problem is thought to be the MP2300S or SERVOPACK.

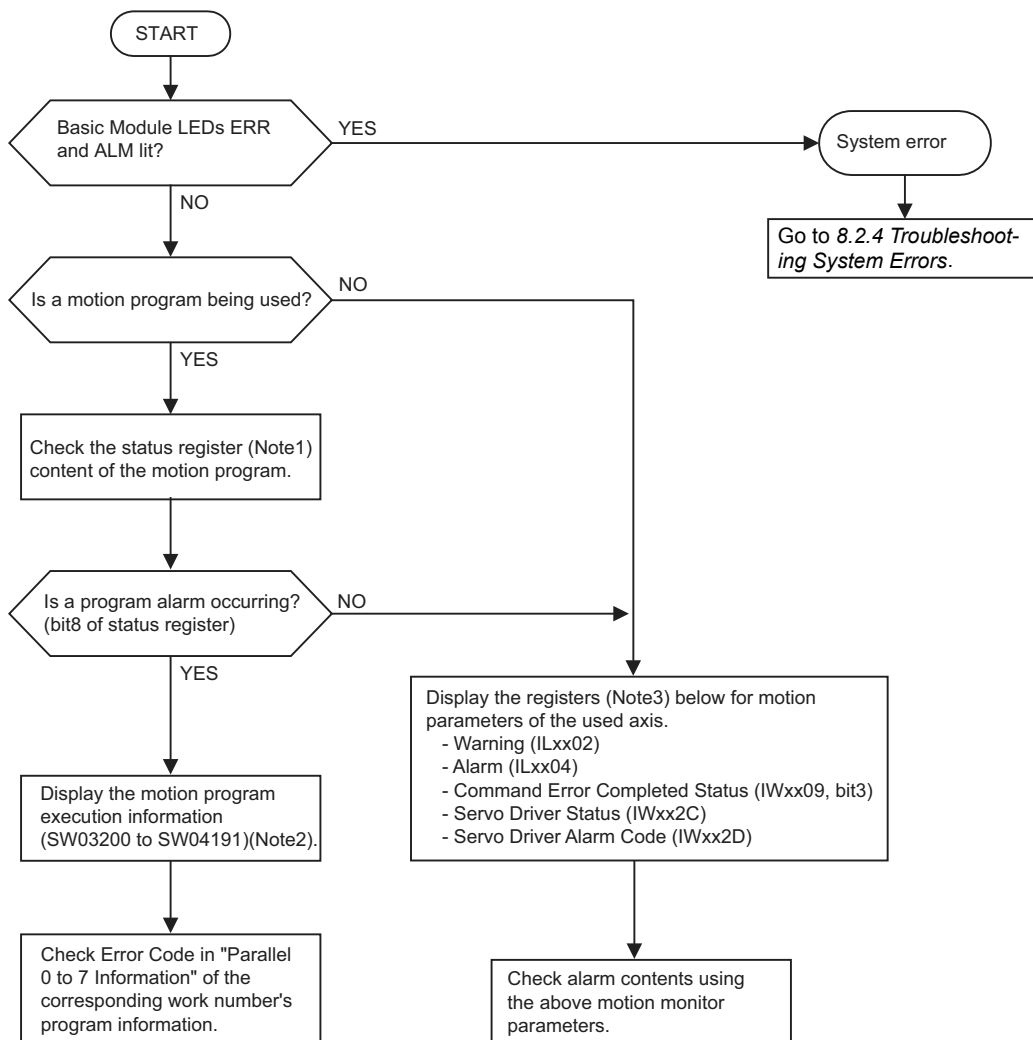

Note: 1. Refer to 5.2.2 (4) *Work Register* .

2. Refer to 5.2.2 (6) *Monitor the motion program execution information using S register*.

3. Refer to 8.2.6 *List of Causes for Command Error Completed Status* and 8.2.7 *Troubleshooting Motion Errors*.

8.2.3 LED Indicators

(1) LED Indicators

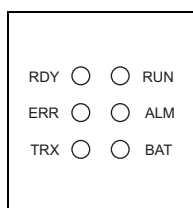

The status of the LED indicators on the front of the MP2300S can be used to determine the error status and meaning.

The locations in the program that need to be corrected can be determined by using the LED indicator status to determine the general nature of the error, using the contents of system (S) registers to check drawings and function numbers causing the error, and knowing the meaning of operation errors.

(2) LED Indicator Meanings

The following table shows how to use the LED indicators to determine the operating status of the MP2300S, as well as relevant error information when the LED indicator status indicates an error.

Classification	LED Indicator					Indicator Details	Countermeasures
	RDY	RUN	ALM	ERR	BAT		
Normal operation	Not lit	Not lit	Lit	Lit	Not lit	Hardware reset status	Usually the CPU will start within 10 seconds. If this status continues for more than 10 seconds, either a program error or hardware failure has occurred. Refer to <i>8.2.4 Troubleshooting System Errors</i> on page 8-8 and correct any system errors.
	Not lit	Not lit	Not lit	Not lit	Not lit	Initialization	
	Not lit	Lit	Not lit	Not lit	Not lit	Drawing A (DWG.A) being executed.	
	Lit	Not lit	Not lit	Not lit	Not lit	User program stopped. (Offline Stop Mode)	This status occurs <ul style="list-style-type: none"> When the stop operation is executed from the MPE720 When the STOP switch is turned ON This status does not indicate an error.
	Lit	Lit	Not lit	Not lit	Not lit	User program being executed normally.	This is the normal status.
Errors	Not lit	Not lit	Not lit	Lit	Not lit	A serious error has occurred.	Refer to <i>8.2.4 (4) Correcting User Program Errors</i> on page 8-12.
	No lit	Not lit	Lit	Not lit	Not lit		
	Not lit	Not lit	Not lit	Blinking	Not lit	Software Error Number of LED blinks indicates error type. 3: Address error (read) exception 4: Address error (write) exception 5: FPU exception 6: Illegal general command exception 7: Illegal slot command exception 8: General FPU inhibited exception 9: Slot FPU inhibited exception 10: TLB multibit exception 11: LTB error (read) exception 12: LTB error (write) exception 13: LTB protection violation (read) exception 14: LTB protection violation (write) exception 15: Initial page write exception	A hardware error has occurred. Replace the Module.
	Not lit	Not lit	Blinking	Blinking	Not lit	Hardware Error Number of LED blinks indicates error type. 2: RAM diagnostic error 3: ROM diagnostic error 4: CPU function diagnostic error 5: FPU function diagnostic error	
Warnings	–	–	–	–	Lit	Battery alarm	Refer to <i>8.1.3 Replacing the Basic Module Battery</i> on page 8-4 and replace the Battery.
	Lit	Lit	Lit	Not lit	Not lit	Operation error I/O error	Refer to <i>8.2.4 [c] System Register Configuration and Error Status</i> on page 8-19 and <i>8.2.4 [e] System Register Configuration and Error Status</i> on page 8-21.

8.2.4 Troubleshooting System Errors

The LED indicators on the front of the Basic Module can be used to determine MP2300S operating status and error status. To obtain more detailed information on errors, the system (S) registers can be used. A detailed check of the contents of system registers can be used to determine the location of the error and take the corrective measures.

Details on system registers are provided below.

(1) System Register Allocations

The following table shows the overall structure of the system registers.

SW00000	System Service Register	
SW00030	System Status	→ 8.2.4 [a] <i>System Register Allocations</i> on page 8-9
SW00050	System Error Status	→ 8.2.4 [b] <i>Accessing System Registers</i> on page 8-10
SW00080	User Operation Error Status	→ 8.2.4 [c] <i>Correcting User Program Errors</i> on page 8-15
SW00090	System Service Execution Status	→ 8.2.4 [d] <i>Correcting User Program Errors</i> on page 8-16
SW00110	User Operation Error Status Details	→ 8.2.4 [c] <i>Correcting User Program Errors</i> on page 8-15
SW00190	Alarm Counter and Alarm Clear	→ 8.2.4 [e] <i>System Register Configuration and Error Status</i> on page 8-21
SW00200	System I/O Error Status	
SW00500	Reserved by the system.	
SW00698	Interrupt Status	
SW00800	Module Information	→ 8.2.4 [g] <i>System Register Configuration and Error Status</i> on page 8-24
SW01312	Reserved by the system.	
SW02048	Reserved by the system.	
SW03200	Motion Program Information	→ 8.2.5 <i>Motion Program Alarms</i> on page 8-25
SW05200 to SW08191	Reserved by the system.	

(2) Accessing System Registers

To access the contents of system registers, start the MPE720 Programming Tool and use the **Register List** or **Quick Reference** function.

[a] Register List Display Procedure

Use the following procedure to display the register list.

1. Select **File - Open - Tool - Register List** from the MPE720 Engineering Manager Window to open the **Register List** Window.

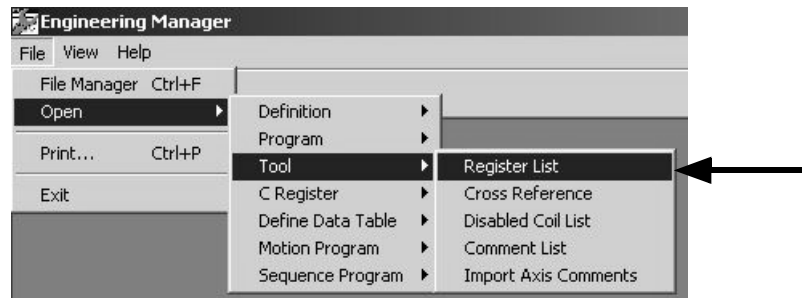

2. Select **ViewMode - HEX** to change the view mode to hexadecimal.

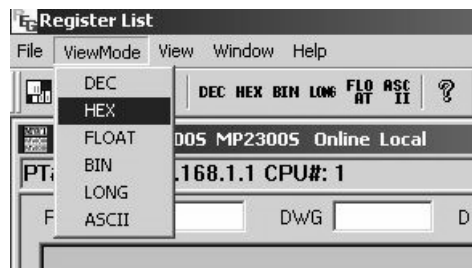

3. Input the register number of the first system register to be accessed for *Register*, input the register number of the last system register to be accessed for */D*, and click anywhere in the list. The contents of the specified range of register numbers will be displayed.

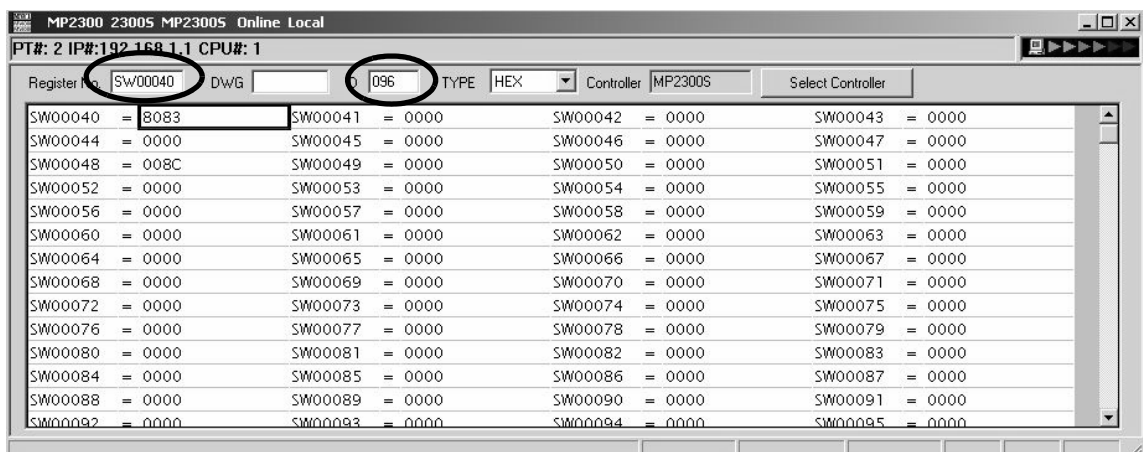

[b] Displaying a Register List with the Quick Reference

Register lists can also be accessed with the Quick Reference.

1. Select **View - Quick Reference** from the MPE720 Engineering Manager Window.

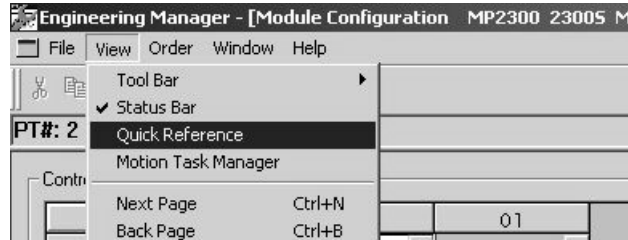

2. Click the **Register List** Tab to switch to the register list.
3. Input the register number of the first system register to be accessed for *Register*, input the register number of the last system register to be accessed for */D*, and click anywhere in the list. The contents of the specified range of register numbers will be displayed.

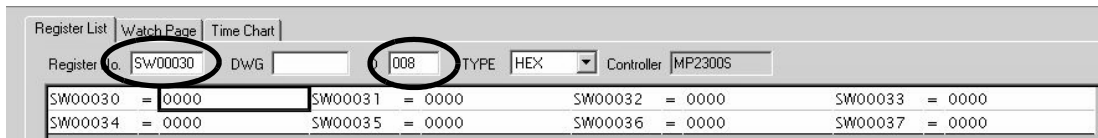

(3) Troubleshooting Flowchart for System Errors

A troubleshooting flowchart for system errors is provided below.

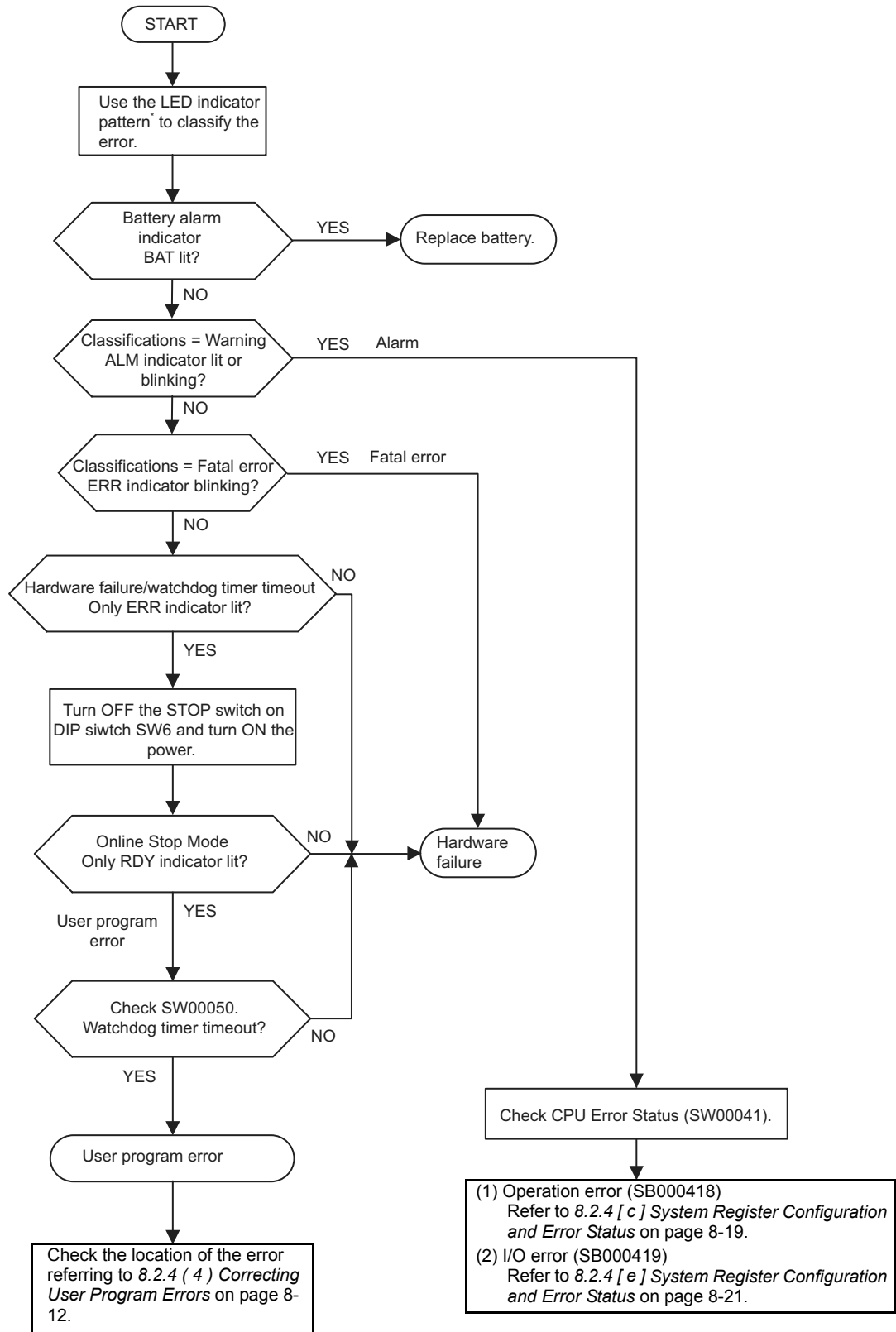

* For LED indicator pattern, refer to 8.2.3 (2) LED Indicator Meanings on page 8-7.

(4) Correcting User Program Errors

A serious error may have occurred if the ALM and ERR indicators on the front of the MP2300S Basic Module are lit red. Set the MP2300S in stop status (STOP switch on DIP switch 1-6: ON) and investigate the error.

Use the following procedure to investigate ladder program errors.

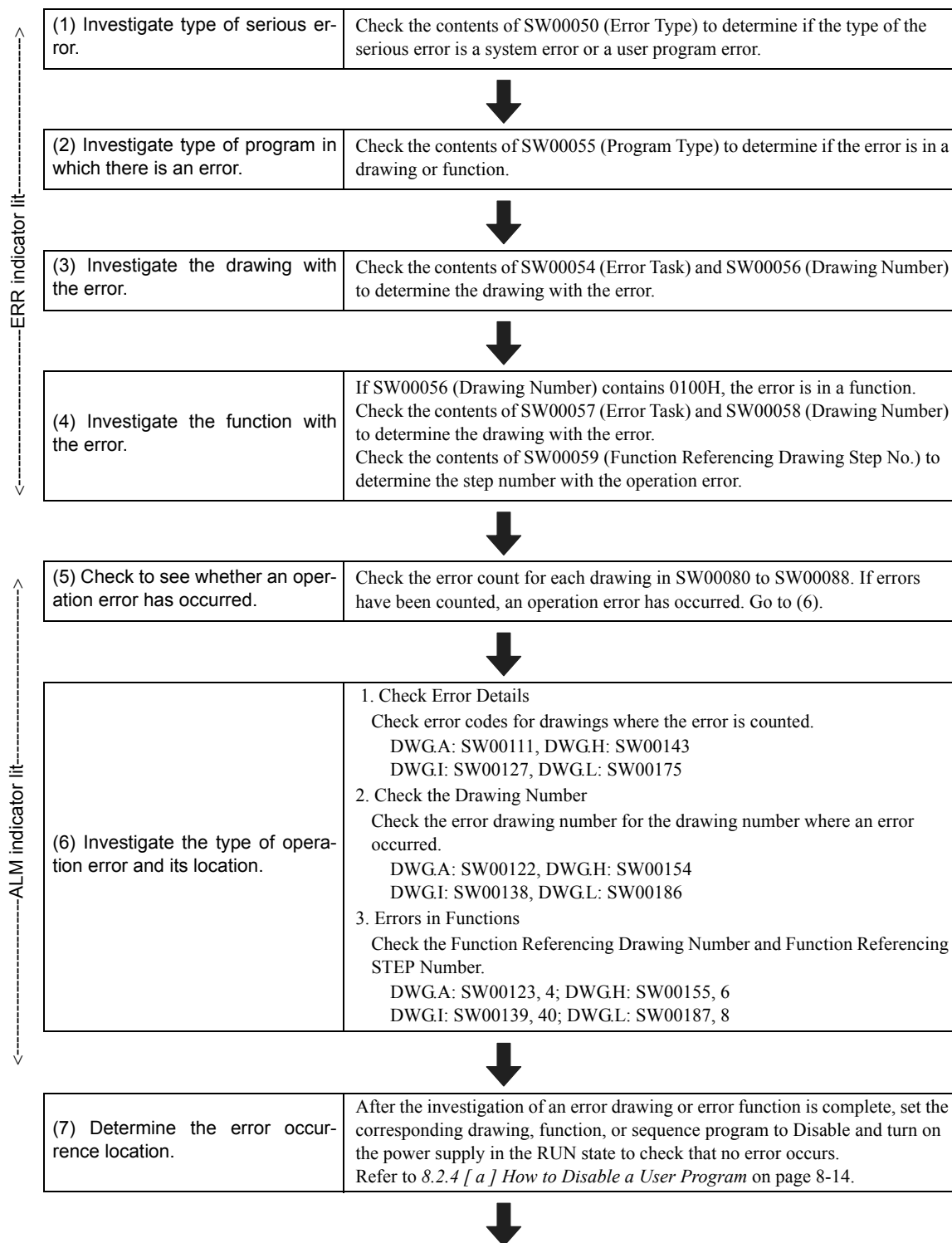

Go on to the next page.

Continued on from the previous page.

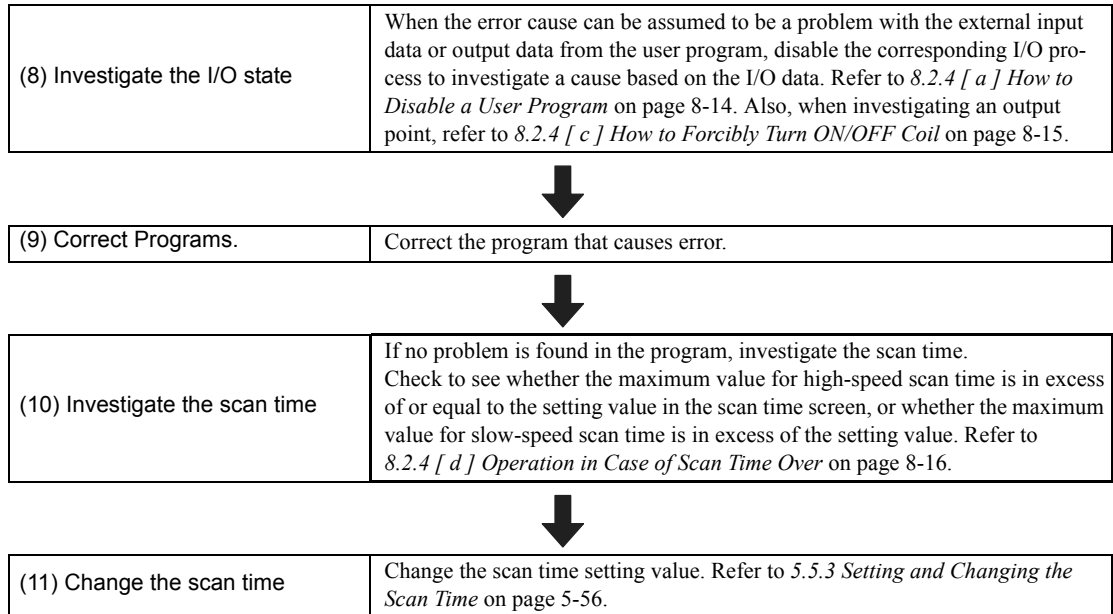

[a] How to Disable a User Program

- Drawing or Function

In the ladder subwindow of the MPE720 online mode, right-click the corresponding drawing and function and select Enable/Disable in the popup menu.



- Sequence Program

In the module configuration definition screen of the MPE720 online mode, open the M-EXECUTOR module definition and check D of the sequence program definition to save the definition.

No.	D	Execution type	Setting	Program
-	<input checked="" type="checkbox"/>	Sequence program(Start)	Direct	SPM001
1	<input checked="" type="checkbox"/>	Sequence program(L-scan)	Direct	SPM002
2	<input checked="" type="checkbox"/>	Sequence program(H-scan)	Direct	SPM003
3	<input type="checkbox"/>	-----		
4	<input type="checkbox"/>	-----		

■ Caution

When a drawing, function, or sequence program is disabled, the equipment may become unstable, causing personal injury or damage to the equipment. If carrying out an investigation, be aware of the behavior of the equipment when it is disabled. After the investigation, make sure to enable the drawing, function, or sequence program again.

(b) How to Disable the I/O Process

In the module configuration definition screen of the MPE720 online mode, open the detailed definition of the module for which you want to disable the I/O process. Click “D” and save it, to disable the I/O process for the clicked item. You can change the disabled input register to any value.

No.	Item	D	REG	Word	SCAN	Current Value	HEX
1	Local Input 1	<input checked="" type="checkbox"/>	IWOC40	1	HIGH		
2	Local Input 2	<input checked="" type="checkbox"/>	IWOC41	1	HIGH		
3	Local Output 1	<input checked="" type="checkbox"/>	OWOC40	1	HIGH		
4	Local Output 2	<input checked="" type="checkbox"/>	OWOC41	1	HIGH		
5	IRQ Input 1	<input type="checkbox"/>	IBOC400	-----	-		
6	IRQ Input 2	<input type="checkbox"/>	IBOC401	-----	-		
7	IRQ Input 3	<input type="checkbox"/>	IBOC410	-----	-		
8	IRQ Input 4	<input type="checkbox"/>	IBOC411	-----	-		

■ Caution

When an I/O process is disabled, the equipment may become unstable, causing personal injury or damage to the equipment. If carrying out an investigation, be aware of the behavior of the equipment when it is disabled. After the investigation, make sure you enable the I/O service again.

[c] How to Forcibly Turn ON/OFF Coil

In the main menu of the MPE720 online mode, select **Debug - Force ON** or **Force OFF** menus, in that order.

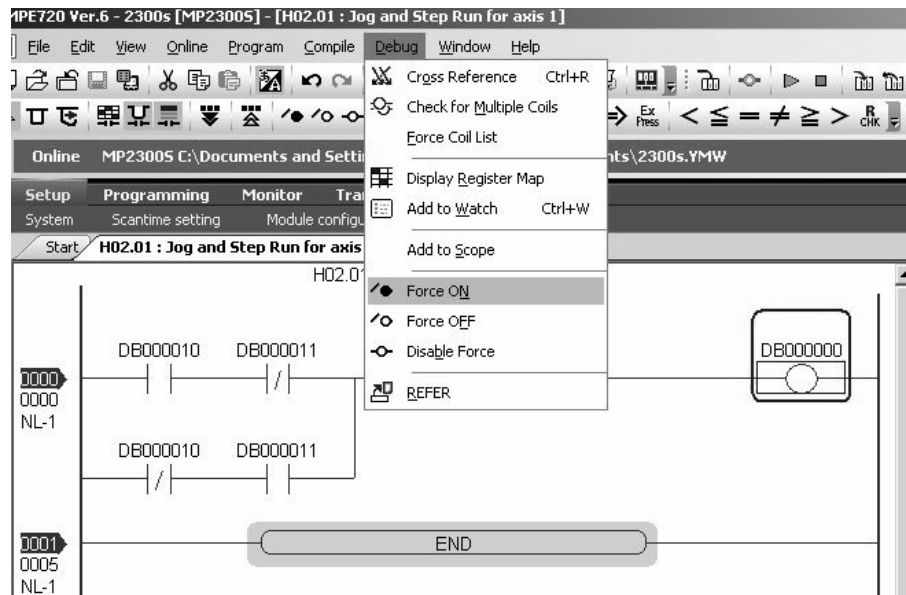

■ Caution

When a coil is set to forced ON or OFF, the equipment may become unstable, causing personal injury or damage to the equipment. If carrying out an investigation, be aware of the behavior of the equipment when it is forcibly turned ON/OFF. After the investigation, make sure to forcibly cancel the setting.

[d] Operation in Case of Scan Time Over

When the maximum value for high-speed scan time is equal to a setting value, a watchdog timeout error will occur because the time for performing a low-speed scan cannot be ensured.

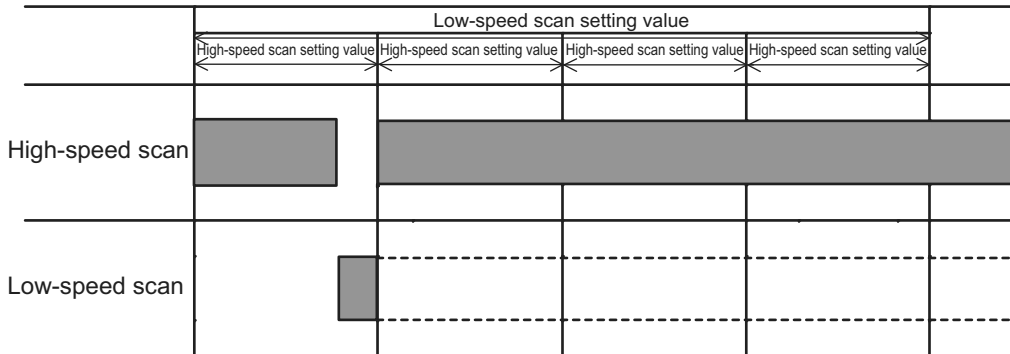

When the maximum value for a scan time is in excess of a setting value, the scan cannot be performed at every setting value. SW00044 is added due to a high-speed scan over, SW00046 is added due to a low-speed scan over.

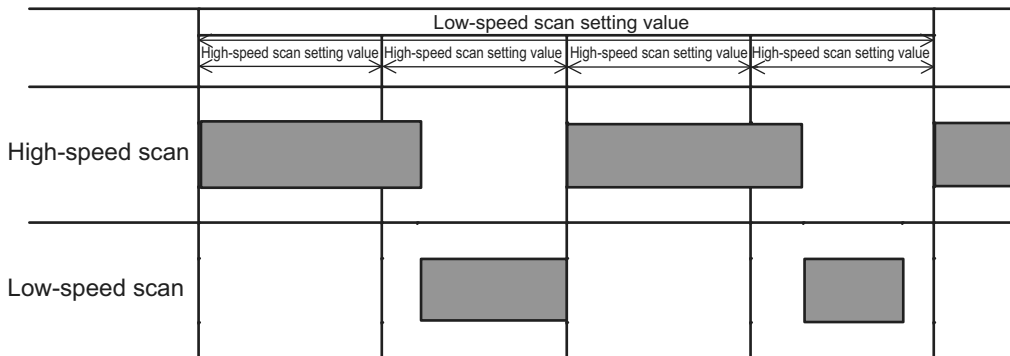

(5) System Register Configuration and Error Status

[a] System Status

System operating status and error status is stored in registers SW00040 to SW00048. Checking of system status details are used to determine whether hardware or software is the cause of an error.

Name	Register No.	Description		
Reserved by the system.	SW00030 to SW00039			
CPU Status	SW00040	SB000400	READY	0: Failure 1: Normal
		SB000401	RUN	0: Stopped, 1: Running
		SB000402	ALARM	0: Normal, 1: Alarm
		SB000403	ERROR	0: Normal, 1: Error
		SB000404	Reserved by the system.	
		SB000405	Reserved by the system.	
		SB000406	FLASH	1: Flash operation
		SB000407	WEN	0: Write-disabled, 1: Write-enabled
		SB000408 to SB00040D	Reserved by the system.	
		SB00040E	Operation Stop Request	0: RUN selection, 1: STOP selection
		SB00040F	Run Switch Status at Power ON	0: STOP 1: RUN
CPU Error Status	SW00041	SB000410	Serious Failure	1: WDGE, undefined command See SW00050 for details.
		SB000411	Reserved by the system.	
		SB000412	Reserved by the system.	
		SB000413	Exception Error	
		SB000414 to SB000417	Reserved by the system.	
		SB000418	User operation error	1: User operation error
		SB000419	I/O Error	1: I/O error
		SB00041A to SB00041F	Reserved by the system.	
H Scan Over Counter	SW00044			
L Scan Over Counter	SW00046			
Reserved	SW00047			
Hardware Configuration Status	SW00048	SB000480	TEST	DIP switch alarms 0: ON, 1: OFF
		SB000481	MON	
		SB000482	CNFG	
		SB000483	INIT	
		SB000484	SUP	
		SB000485	STOP	
		SB000486	–	
		SB000487	Battery Alarm	
		SB000488 to SB00048F	Reserved by the system.	
Reserved by the system.	SW00049 to SW00049F	Reserved by the system.		

[b] System Error Status

System error status is stored in registers SW00050 to SW00060.

Name	Register No.	Description		
32-bit Error Code	SW00050	0001H	Watchdog timer over error	
		0041H	ROM diagnosis error	
		0042H	RAM diagnosis error	
		0043H	CPU diagnosis error	
		0044H	FPU diagnosis error	
		00E0H	Address read execution error	
		0100H	Address write execution error	
		0120H	FPU exception error	
		0180H	Illegal general command error	
		01A0H	Illegal slot command error	
		01E0H	User break after command execution	
		0800H	General FPU prohibition exception error	
		0820H	Slot FPU prohibition exception error	
	SW00051	For system error analysis		
32-bit Addresses Generating Error	SW00052	For system error analysis		
	SW00053			
Program Error Task	SW00054	0000H: System 0001H: DWGA	0002H: DWGI 0003H: DWGH	0005H: DWGL
Program Type	SW00055	0000H: System 0001H: DWGA	0002H: DWGI 0003H: DWGH	0005H: DWGL 0008H: Function 000FH: Motion program/ sequence program
Program Error Drawing Number	SW00056	Ladder program parent drawing: FFFFH Ladder program function: 8000H Ladder program child drawing: □□00H (H□□: Child drawing number) Ladder program grandchild drawing: □□yyH (Hyy: Grandchild drawing number) Motion program/sequence program: F0xxH (Hxx: program number)		
Calling Drawing Type	SW00057	Type of drawing that calls the ladder program function in which an error occurred.		
		0001H: DWGA 0002H: DWGI 0003H: DWGH	0005H: DWGL 0008H: Ladder program function 000FH: Motion program/ sequence program	0010H: Reserved by system. 0011H: Reserved by system.
Ladder Program Function Calling Drawing Number	SW00058	Number of drawing that calls the ladder program function in which an error occurred. Parent drawing: FFFFH Function: 0100H Child drawing: □□00H (H□□: Child drawing number) Grandchild drawing: □□yyH (Hyy: Grandchild drawing number)		
Ladder Program Function Calling Drawing Number	SW00059	STEP number of the drawing that calls the ladder program function in which an error occurred. 0 when there is an error in the drawing.		
Error Data	SW00060 and SW00061	Reserved by the system.		
	SW00062 to SW00065	Name of Task Generating Error		
	SW00066 and SW00067	Reserved by the system.		
	SW00068	Year Generated		
	SW00069	Month Generated		
	SW00070	Day of Week Generated		
	SW00071	Day of Month Generated		
	SW00072	Hour Generated		
	SW00073	Minutes Generated		
	SW00074	Seconds Generated		
	SW00075	Milliseconds Generated (Not used.)		
SW00076 to SW00079	Reserved by the system.			

[c] Ladder Program User Operation Error Status

Error information for user operation errors in ladder programs is stored in registers SW00080 to SW00089 (Error Status 1) and SW00110 to SW00189 (Error Status 2).

Table 8.1 Ladder Program User Operation Error Status 1

Name	Register No.	Description
DWG.A Error Count Error Code	SW00080	Operation error code: See <i>Ladder Program User Operation Error Codes 1</i> . Error code when an index error occurs: See <i>Ladder Program User Operation Error Codes 2</i> .
	SW00081	
DWG.I Error Count Error Code	SW00082	
	SW00083	
DWG.H Error Count Error Code	SW00084	
	SW00085	
Reserved by the system.	SW00086	
	SW00087	
DWG.L Error Count Error Code	SW00088	
	SW00089	

Table 8.2 Ladder Program User Operation Error Status 2

Name	Register No.				Remarks
	DWG.A	DWG.I	DWG.H	DWGL	
Error Count	SW00110	SW00126	SW00142	SW00174	Error Drawing Number Parent drawing: FFFFH Child drawing: □□00H (H□□: Child drawing number) Grandchild drawing: □□yyH (Hyy: Grandchild drawing number) Function: 8000H Motion program/sequence program: F0xxH (Hxx: program number) Function Calling Drawing Number Number of the drawing that calls the function in which an error occurred. Function Calling DWG Step Number Step number of the drawing that calls the function in which an error occurred. 0 when there is an error in the drawing.
Error Code	SW00111	SW00127	SW00143	SW00175	
Error A Register	SW00112	SW00128	SW00144	SW00176	
	SW00113	SW00129	SW00145	SW00177	
Modification A Register	SW00114	SW00130	SW00146	SW00178	
	SW00115	SW00131	SW00147	SW00179	
Error F Register	SW00116	SW00132	SW00148	SW00180	
	SW00117	SW00133	SW00149	SW00181	
Modification F Register	SW00118	SW00134	SW00150	SW00182	
	SW00119	SW00135	SW00151	SW00183	
Address Generating Error	SW00120	SW00136	SW00152	SW00184	
	SW00121	SW00137	SW00153	SW00185	
Error Drawing Number	SW00122	SW00138	SW00154	SW00186	
Function Calling Drawing Number	SW00123	SW00139	SW00155	SW00187	
Function Calling DWG Step Number	SW00124	SW00140	SW00156	SW00188	
Reserved by the system.	SW00125	SW00141	SW00157	SW00189	

Table 8.3 Ladder Program User Operation Error Codes 1

	Error Code	Error Contents	User*	System Default Value	
Integer Operations	0001H	Integer operation - underflow	Yes	-32768 [-32768]	
	0002H	Integer operation - overflow	Yes	32767 [32767]	
	0003H	Integer operation - division error	Yes	The A register remains the same.	
	0009H	Double-length integer operation - underflow	Yes	-2147483648 [-2147483648]	
	000AH	Double-length integer operation - overflow	Yes	2147483647 [2147483647]	
	000BH	Double-length integer operation - division error	Yes	The A register remains the same.	
	010□H	Operation error drawing - integer operation error (□ = 1 to B)	No	Default indicated above.	
Real Number Operation	0010H	Integer storage - non-numeric error	Yes	Store not executed. [00000]	
	0011H	Integer storage - underflow	Yes	Store not executed. [-32768]	
	0012H	Integer storage - overflow	Yes	Store not executed. [+32767]	
	0021H	Real number storage - underflow	Yes	Store not executed. [-1.0E+38]	
	0022H	Real number storage - overflow	Yes	Store not executed. [1.0E+38]	
	0023H	Real number operation - division-by-zero error	Yes	Operation not executed. The F register remains the same.	
	0030H	Real number operation - invalid operation (non-numeric)	No	Operation not executed.	
	0031H	Real number operation - exponent underflow	No	0.0	
	0032H	Real number operation - exponent overflow	No	Maximum value	
	0033H	Real number operation - division error (non-numeric 0/0)	No	Operation not executed.	
	0034H	Real number storage - exponent underflow	No	Stores 0.0.	
	0035H	Real number operation - stack error			
	0040H to 0059H	Standard System Functions Real number operation errors		No	Interrupt operation and output = 0.0
		0040H: SQRT	0041H: SIN	0042H: COS	0043H: TAN
		0044H: ASIN	0045H: ACOS	0046H: ATAN	0047H: EXP
		0048H: LN	0049H: LOG	004AH: DZA	004BH: DZB
		004CH: LIM	004DH: PI	004EH: PD	004FH: PID
		0050H: LAG	0051H: LLAG	0052H: FGN	0053H: IFGN
		0054H: LAU	0055H: SLAU	0056H: REM	0057H: RCHK
0058H: BSRCH		0059H: SQRT			
1000H or 2000H is added for an index error.					

* Yes: Can be set to value other than system default from the user program.

No: The system default cannot be changed from the user program.

Table 8.4 Ladder Program User Operation Error Codes 2

	Error Code	Error Contents	User	System Default			
Integer - Real Number Operations	1000H	Index error within drawing	×	Execute again with i, j = 0.			
	2000H	Index error within function	×	Execute again with i, j = 0.			
Integer Operation	□060H to □077H (□ = 1, 2)	Integer system functions	×	Operation stopped and output = input. The A register remains the same.			
		Index error					
		□06DH: PI			□06DH: PD	□06FH: PID	□070H: LAG
		□071H: LLAG			□072H: FGN	□073H: IFGN	□074H: LAU
	□075H: SLAU	□076H: FGN	□077H: IFGN				

[d] System Service Execution Status

Table 8.5 Data Trace Execution Status

Name	Register No.	Remarks
Reserved by the system.	SW00090 to SW00097	
Existence Of Data Trace Definition	SW00098	Bit 0 to 3 = Group 1 to 4 Definition exists = 1, No definition = 0
Data Trace Execution Status	SW00099	Bit 0 to 3 = Group 1 to 4 Trace stopped = 1, Trace executing = 0

Table 8.6 Latest Data Trace Record Numbers

Name	Register No.	Remarks
Data Trace Group 1	SW00100	Latest record number
Data Trace Group 2	SW00101	Latest record number
Data Trace Group 3	SW00102	Latest record number
Data Trace Group 4	SW00103	Latest record number

[e] System I/O Error Status

Name	Register No.	Remarks
Current Alarm	SW00190	Cleared when power is turned ON.
Number of Alarm History Records	SW00191	The number of alarms in the alarm history.
Clear Alarms	SW00192	1: Alarm cleared 2: Current alarm and alarm history cleared
I/O Error Count	SW00200	Number of I/O errors
Input Error Count	SW00201	Number of input errors
Input Error Address	SW00202	Latest input error address (IW□□□□ register number)
Output Error Count	SW00203	Number of output errors
Output Error Address	SW00204	Latest output error address (OW□□□□ register number)
Reserved by the system.	SW00205	(Not used.)
	SW00206	
	SW00207	
I/O Error Status	SW00208 to SW00215	Slot 0 error status
	SW00216 to SW00223	Reserved by the system.
	SW00224 to SW00231	Slot 1 error status
	SW00232 to SW00239	Reserved by the system. (Slot 2 error status)
	SW00240 to SW00247	Reserved by the system. (Slot 3 error status)
	SW00248 to SW00255	Reserved by the system. (Slot 4 error status)
	...	
	SW00456 to SW00463	Reserved by the system. (Slot 30 error status)

[f] Actions to be Taken when a Transmission Error Occurs

When a transmission error occurs during system I/O, the error status is reported in the system registers as shown below.

Name	Register No.	Remarks
Slot 0 Error Status	SW00208 to SW00215	Refer to <i>Basic Module Error Status</i> .
Reserved by the system.	SW00216 to SW00223	(Depends on the mounted module and error code.)
Slot 1 Error Status	SW00224 to SW00231	(Depends on the mounted module and error code.)
Reserved by the system. (Slot 2 Error Status)	SW00232 to SW00239	(Depends on the mounted module and error code.)
Reserved by the system. (Slot 3 Error Status)	SW00240 to SW00247	(Depends on the mounted module and error code.)
Reserved by the system (Slot 4 Error Status)	SW00248 to SW00255	(Depends on the mounted module and error code.)
	...	
Reserved by the system (Slot 30 Error Status)	SW00456 to SW00463	(Depends on the mounted module and error code.)

The following [a] to [c] show the allocations of the registers when the Basic Module is allocated to the slot 0, the LIO-01/LIO-02 Module to the slot 1, and the 260IF-01 Module to the slot 3.

■ Basic Module Error Status (Slot 0)

(Bit number)	F-----8	7-----0			
SW00208	Error code (station error=1)	Subslot number (= 2)			
(Bit number)	F-----8	7-----0			
SW00213	Error code (station error=1)	Subslot number (= 3)			
(Bit number)	F	3	2	1	0
SW00214	ST #15	ST #3	ST #2	ST #1	Unused
SW00215	Unused	ST #30		ST #17	ST #16
SW00216	Unused				Unused
SW00217	Unused				Unused

■ LIO-01/LIO-02 Module Error Status (Example: Slot 1)

(Bit No.)	F-----8	7-----0
SW00224	Error Code (I/O error = 2)	Sub-slot No. (= 1)
SW00225	Error Code (I/O error = 2)	Sub-slot No. (= 2)
SW00226	Not used	Not used
SW00227	Not used	Not used
SW00228	Not used	Not used
SW00229	Not used	Not used
SW00230	Not used	Not used
SW00231	Not used	Not used

■ 260IF-01 Module Error Status (Example: Slot 1)

(Bit No.)	F-----8	7-----0
SW00224	Error Code (Station error = 1)	Sub-slot No. (= 2)
SW00225	ST15	ST#0
SW00226	ST31	ST#16
SW00227	ST47	ST#22
SW00228	ST63	ST#48

[Error status details]

Item	Code	Remarks
ST#n	0	Normal communication
	1	Communication error at station n (when slave, n becomes a local station number)

[g] Module Information

Name	Register No.	Contents
Module Information	SW00800	Basic Module (C380H)
	SW00801	Reserved by the system.
	SW00802	CPU Software version (BCD)
	SW00803	Number of sub-slots (0004H)
	SW00804	CPU Function ID (C310H)
	SW00805	CPU Function Module Status
	SW00806	I/O Function Module ID (8070H)
	SW00807	I/O Function Module Status
	SW00808	SVB Function Module ID (9113H)
	SW00809	SVB Function Module Status
	SW00810	SVR Function Module ID (9210H)
	SW00811	SVR Function Module Status
	SW00812	M-EXECUTOR function module ID (8430H)
	SW00813	M-EXECUTOR function module status
	SW00814 to SW00815	Reserved by the system.
	SW00816 to SW00823	Slot 1
	SW00824 to SW00831	Reserved by the system. (Slot 2)
	SW00832 to SW00839	Reserved by the system. (Slot 3)
	...	
	SW01008 to SW01015	Reserved by the system (Slot 26)

8.2.5 Motion Program Alarms

If a motion program alarm occurs, find the cause of alarm indicated by the alarm code.

The alarm code, alarm name, and its corrective actions in a motion program can be checked on the error information screen.

This section explains the error information screen and motion alarm codes:

(1) Error Information Screen

The following two options are available for displaying the error information screen.

[a] Open from Operation Control Panel

Click the **Display** Button on the **Drive Control Panel** Window to display error information.

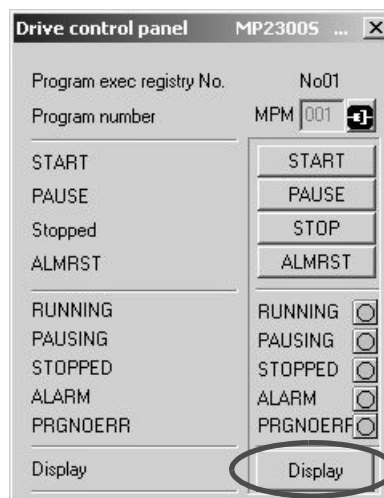

[b] Open from Right-click Menu on the Motion Editor

Select **Motion alarm analyzer** from the menu displayed by right-clicking on the motion editor.

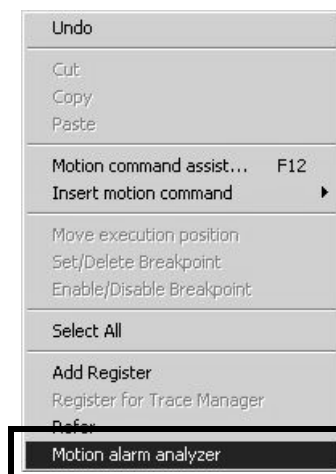

This section explains the error information screen.

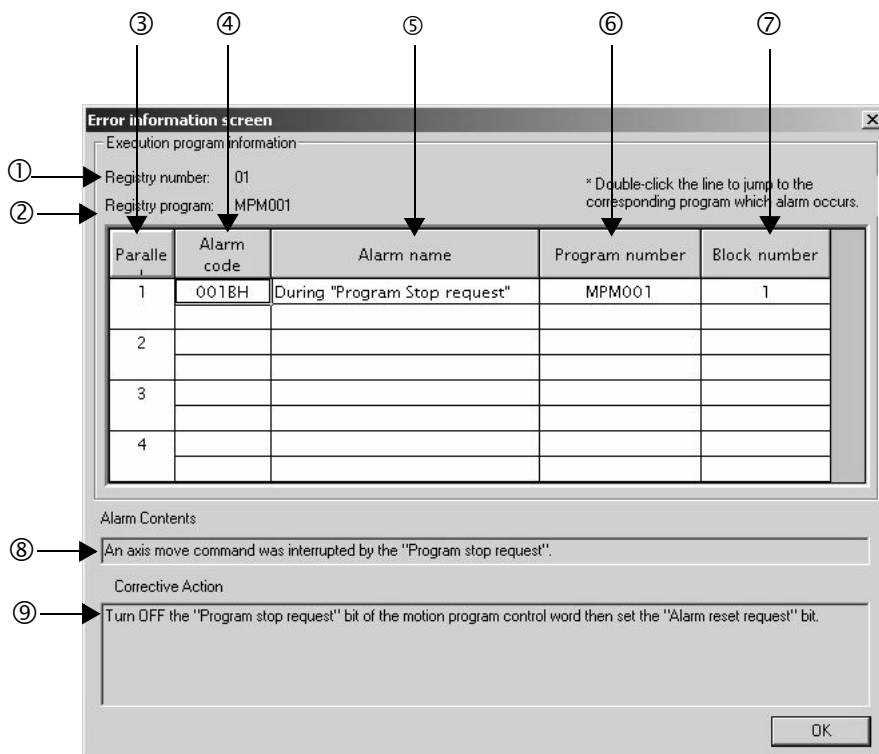

① Registry number

When an alarm occurs in a motion program registered in the M-EXECUTOR program execution definition, the M-EXECUTOR registry number is shown.

When an alarm occurs in a motion program referenced by an MSEE command from the ladder program, "---" is shown.

② Registry program

When an alarm occurs in a motion program registered in the M-EXECUTOR program execution definition, the program name registered in M-EXECUTOR is shown.

When an alarm occurs in a motion program referenced by an MSEE command from the ladder program, "---" is shown.

③ Parallel

When a parallel execution command (PFORK) is used in the motion program, multiple alarms may occur at the same time. For more information, refer to 3.1.11 *Parallel Execution Command (PFORK, JOINTO, PJOINT)* of *Machine Controller MP900/MP2000 Series Users Manual, Motion Program Section* (manual number: SIE-C887-1.3).

④ Alarm code

The alarm code is shown.

⑤ Alarm name

The alarm name is shown.

⑥ Program number

The name of the program where an error occurred is shown.

⑦ Block number

The number of the block where an error occurred is shown.

Double-clicking the number will bring you to the corresponding program where the error occurred.

The block number is shown in the motion editor.

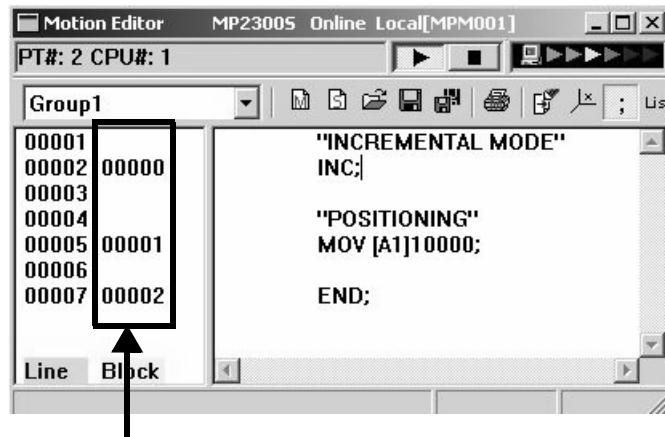

Block number

⑧ Alarm Contents

The alarm content are shown.

⑨ Corrective Action

Corrective actions for the alarm are shown.

(2) Motion Program Alarm Codes

(a) Configuration of Motion Program Alarms

The following diagram shows the configuration of alarms.

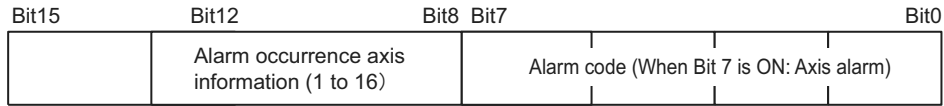

(b) Alarm Code List for Motion Program

The following table shows the alarm codes of motion programs.

Alarm Code	Name	Description	Corrective Actions
02h	Division error	Data divided by 0	Review the motion program.
10h	A circle instead of radius was specified	Turn number was specified instead of radius in the circular arc or helical interpolation command.	<ul style="list-style-type: none"> • Designate a center coordinate instead of a radius to perform the circular arc or helical interpolation command. • Never specify the turn number.
11h	Interpolation feeding speed over limit	Interpolation feeding speed exceeded the valid range of the FMX command.	Modify the interpolation feeding speed of the interpolation command
12h	No interpolation feeding speed specified	No interpolation feeding speed was specified. (once specified, this can be omitted as in the motion program)	Specify the interpolation feeding speed in the interpolation command.
13h	Range exceeded after converting acceleration parameter	Indirect acceleration parameter exceeded the valid range.	Change the indirect register value.
14h	Circular arc length exceeded LONG_MAX	Circular arc length exceeded the valid range in the circular arc or helical interpolation command.	Review the circular arc length in the circular arc or helical interpolation command.
15h	Vertical axis not specified for circular arc plane	Vertical axis was not specified in the circular arc or helical interpolation command.	Use PLN command to specify the axis.
16h	Horizontal axis not specified for circular arc plane	Horizontal axis was not specified in the circular arc or helical interpolation command.	Use PLN command to specify the axis.
17h	Specified axis over limit	Too many axes were configured in the circular arc (two axes) or helical (three axes) interpolation command.	Modify the axis in the circular arc or helical interpolation command.
18h	Turn number over limit	Turn number exceeded the valid range in the circular arc or helical interpolation command.	Modify the turn number in the circular arc or helical interpolation command.
19h	Radius exceeded LONG_MAX	Radius exceeded the valid range in the circular arc or helical interpolation command.	Review the radius in the circular arc or helical interpolation command.
1Ah	Center point error	Improper center point was specified in the circular arc or helical interpolation command.	Specify the center point properly in the circular arc or helical interpolation command.
1Bh	Running emergency stop command	Axis move command stopped due to a program stop request.	Turn OFF the program stop request for the motion program control signal, and turn ON the alarm reset request.
1Ch	Linear interpolation moving amount exceeded LONG_MAX	Moving amount exceeded the valid range in the linear interpolation command.	Review the moving amount in the linear interpolation command.
1Dh	FMX undefined	FMX command not executed in the motion program containing an interpolation command.	Perform an FMX command. The FMX command is required in each program containing an interpolation command.
1Eh	Address T out of range	Designation exceeded the valid range in the IAC/IDC/FMX commands.	Review the setting in the IAC/IDC/FMX command.
1Fh	Address P out of range	Designation exceeded the valid range in the IFP command.	Review the setting in the IFP command.

Alarm Code	Name	Description	Corrective Actions
21h	PFORK execution error	A motion command was instructed simultaneously at the second line in the PFORK of both a source motion program and a subprogram.	Review the source motion program or subprogram.
22h	Indirect register range error	Specified register address exceeds the register size range.	Review the motion program.
23h	Moving amount out of range	Axis moving amount with decimal point for an axis move command exceeded the possible range.	Review the axis moving amount.
80h	Use of logical axis prohibited	Multiple motion commands instructed against the same axis at the same time.	Review the motion program.
81h	Designation exceeded POSMAX in the infinite length axis	Moving distance designation exceeded POSMAX in the infinite length axis.	<ul style="list-style-type: none"> • Modify a fixed parameter “Maximum infinite length axis counter” • Review the motion program.
82h	Axis moving distance exceeded LONG_MAX	Axis moving distance designation exceeded the valid range.	Review the motion program.
84h	Duplicated motion command	Multiple commands were executed against a single axis.	Check whether another program gave a command to the same axis at the same time. If so, review the program.
85h	Motion command response error	A motion command response different from that instructed by the motion command is reported from a motion module.	<ul style="list-style-type: none"> • Remove the alarm cause from the destination axis. • If the servo is not turned ON, turn ON the servo. • Check whether another program gave a command to the same axis at the same time. If so, review the program.
87h	VEL setting data out of range	An instruction in the VEL command exceeded the valid range.	Review the VEL command.
88h	INP setting data out of range	An instruction in the INP command exceeded the valid range.	Review the INP command.
89h	ACC/SCC/DCC setting data out of range	An instruction in the ACC/SCC/DCC command exceeded the valid range.	Review the ACC/SCC/DCC command.
8Ah	No time specified in the MVT command	T designation in the MVT command was zero.	Review the MVT command.
8Bh	Command execution disabled	A motion command which cannot be executed by the destination motion module was instructed.	Review the motion program.
8Ch	Distribution incomplete	A motion command was executed when a motion module was not in the Distribution Completed state.	Review the motion program so that a motion command is executed in the Distribution Completed state.
8Dh	Motion command abnormally aborted	Motion module fell into the “Motion command abnormally aborted” state.	<ul style="list-style-type: none"> • Release the destination axis error. • Review the motion program.

8.2.6 List of Causes for Command Error Completed Status

The Command Error Completed Status (IW□□09, bit 3) turns ON when the set motion command cannot be executed for some reasons or the execution of motion command ended with error. The cause for which this bit turns ON differ depending on motion command.

The following table shows the causes of Command Error Completed Status by motion command.

Motion Command Code		Cause of Command Error Occurrence	Warning (W:) and Alarm (A:) That Occur at Command Error Occurrence
1	Positioning (POSING)	The positioning moving amount exceeds the allowable range.	A: Excessive Positioning Moving Amount
		The axis is a ABS infinite-length, and the zero point return setting is not completed	A: Zero Point Not Set
		In servo OFF status	A: Servo OFF
		Alarm is occurring.	–
		Asynchronous communication status	A: Servo Driver Synchronization Communication Error
2	External Positioning (EX_POSING)	The positioning moving amount exceeds the allowable range.	A: Excessive Positioning Moving Amount
		The axis is a ABS infinite-length, and the zero point return setting is not completed	A: Zero Point Not Set
		In servo OFF status	A: Servo OFF
		Alarm is occurring.	–
		Asynchronous communication status	A: Servo Driver Synchronization Communication Error
		SERVOPACK parameter writing was not completed within the specified time.	A: Servo Driver Command Timeout Error
		Warning A.94 or A.95 occurred in the SERVOPACK.	W: Servo Driver Error
		The selected external signal is out of the setting range.	W: Setting Parameter Error
3	Zero Point Return (ZRET)	In machine lock status	–
		In servo OFF status	1: Servo OFF
		An alarm is occurring.	–
		Asynchronous communication status	A: Servo Driver Synchronization Communication Error
		SERVOPACK parameter reading or writing was not completed within the specified time.	A: Servo Driver Command Timeout Error
		Warning A.94 or A.95 is occurring in the SERVOPACK.	W: Servo Driver Error
		The selected zero point return method is out of the setting range.	W: Setting Parameter Error
		POT method is selected for zero point return, but the approach speed is a negative value.	W: Setting Parameter Error
		NOT method is selected for zero point return, but the approach speed is a positive value.	W: Setting Parameter Error
		During zero point return using DEC1 + Phase-C, ZERO signal, or Phase-C method, the OT signal in zero point return direction was ON.	OT Alarm or OT Warning in Zero Point Return Direction
		4 · 5	Interpolation (INTERPOLATE) Interpolation last segment (ENDOF_INTERPOLATE)
The axis is ABS infinite length, and the zero point return (setting) is not completed.	A: Zero Point Not Set		
In servo OFF status	A: Servo OFF		
An alarm is occurring.	–		
Asynchronous communication status	A: Servo Driver Synchronization Communication Error		

Motion Command Code		Cause of Command Error Occurrence	Warning (W:) and Alarm (A:) That Occur at Command Error Occurrence
6	Latch (LATCH)	The commanded moving amount for one scan exceeds the segment that can be commanded to the MECHATROLINK SERVOPACK, or the speed feed forward value exceeds the allowable maximum speed.	A: Excessive Speed
		The axis is ABS infinite length, and the zero point return (setting) is not completed.	A: Zero Point Not Set
		In servo OFF status	A: Servo OFF
		An alarm is occurring.	–
		The selected latch signal is out of the setting range.	W: Setting Parameter Error
7	JOG Operation (FEED)	In machine lock status	–
		In servo OFF status	A: Servo OFF
		An alarm is occurring.	–
		Asynchronous communication status	A: Servo Driver Synchronization Communication Error
8	STEP operation (STEP)	Positioning moving amount exceeds the allowable value.	A: Excessive Positioning Moving Amount
		In servo OFF status	A: Servo OFF
		An alarm is occurring.	–
		Asynchronous communication status	A: Servo Driver Synchronization Communication Error
9	Zero Point setting (ZSET)	An alarm is occurring.	–
		Asynchronized communication status	A: Servo Driver Synchronization Communication Error
10 · 11	Change Acceleration Time (ACC) Change Deceleration Time (DCC)	An alarm is occurring.	–
		Asynchronous communication status	A: Servo Driver Synchronization Communication Error
		Executed while the distribution has not been completed (DEN = OFF)	–
		SERVOPACK parameter writing was not completed within the specified time.	A: Servo Command Timeout Error
		Warning A.94 or A.95 occurred in the SERVOPACK.	W: Servo Driver Error
12	Change Filter Time Constant (SCC)	An alarm is occurring.	–
		Asynchronous communication status	A: Servo Driver Synchronization Communication Error
		Executed while the distribution has not been completed (DEN = OFF)	A: Filter Time Constant Change Error
		SERVOPACK parameter writing was not completed within the specified time.	A: Servo Driver Command Timeout Error
		Warning A.94 or A.95 occurred in the SERVOPACK.	W: Servo Driver Error
13	Change Filter Type (CHG_FILTER)	An alarm is occurring.	–
		Asynchronous communication status	A: Servo Driver Synchronization Communication Error
		Executed while the distribution has not been completed (DEN = OFF).	A: Filter Time Constant Change Error
		The selected filter type is out of the setting range.	W: Setting Parameter Error
14 • 15 • 16	Change Speed Loop Gain (KVS) • Change Position Loop Gain (KPS) • Change Speed Feed Forward (KFS)	An alarm is occurring.	–
		Asynchronous communication status	A: Servo Driver Synchronization Communication Error
		SERVOPACK parameter writing was not completed within the specified time.	A: Servo Driver Command Timeout Error
		Warning A.94 or A.95 occurred in the SERVOPACK.	W: Servo Driver Error

Motion Command Code		Cause of Command Error Occurrence	Warning (W:) and Alarm (A:) That Occur at Command Error Occurrence
17 • 18	Read SERVOPACK Parameter (PRM_RD) Write SERVOPACK Parameter (PRM_WR)	An alarm is occurring.	–
		Asynchronous communication status	A: Servo Driver Synchronization Communication Error
		SERVOPACK parameter reading was not completed within the specified time.	A: Servo Driver Command Timeout Error
		Warning A.94 or A.95 occurred in the SERVOPACK.	W: Servo Driver Error
		SERVOPACK parameter number or size is out of the setting range.	W: Setting Parameter Error
19 • 20	Monitor SERVOPACK Alarms (ALM_MON) Monitor SERVOPACK Alarm History (ALM_HIST)	The command to the SERVOPACK was not completed within the specified time.	A: Servo Driver Command Timeout Error
		Servo driver alarm monitor number is out of setting range.	W: Setting Parameter Error
21	Clear SERVOPACK Alarm History (ALMHIST_CLR)	The command to the SERVOPACK was not completed within the specified time.	A: Servo Driver Command Timeout Error
22	Reset Absolute Encoder (ABS_RST)	This command was used for Σ -I SERVOPACK.	–
		Executed while servo is ON.	–
		Asynchronous communication status	A: Servo Driver Synchronization Communication Error
		The command to the SERVOPACK was not completed within the specified time.	A: Servo Driver Command Timeout Error
23	Speed Reference (VELO)	Commanded when having been connected to MECHATROLINK-I	–
		An alarm is occurring.	–
		Asynchronous communication status	A: Servo Driver Synchronization Communication Error
24	Torque Reference (TRQ)	Commanded when having been connected to MECHATROLINK-I	–
		An alarm is occurring	–
		Asynchronous communication status	A: Servo Driver Synchronization Communication Error
25	Phase Reference (PHASE)	The axis is ABS infinite length, and the zero point return (setting) is not completed.	A: Zero Point Not Set
		In servo OFF status	A: Servo OFF
		An alarm is occurring.	–
		Asynchronous communication status	A: Servo Driver Synchronization Communication Error
26	Change Position Loop Integration Time Constant (KIS)	An alarm is occurring.	–
		Asynchronous communication status	A: Servo Driver Synchronization Communication Error
		SERVOPACK parameter writing was not completed within the specified time.	A: Servo Driver Command Timeout Error
		Warning A.94 or A.95 occurred in the SERVOPACK.	W: Servo Driver Error
Others	Parameter Automatic Updating when Execution of Move Command Starts *	An alarm is occurring.	–
		Asynchronous communication status	A: Servo Driver Synchronization Communication Error
		SERVOPACK parameter writing was not completed within the specified time.	A: Servo Driver Command Timeout Error
		Warning A.94 or A.95 occurred in the SERVOPACK.	W: Servo Driver Error
		The distribution was not completed (DEN = OFF).	–

* When the fixed parameter Automatic Updating of Parameter was enabled, and the setting of Filter Time Constant, Acceleration Rate/Time, or Deceleration Rate/Time was changed at the time a move command was set

8.2.7 Troubleshooting Motion Errors

This section explains the details and remedies for errors that occur in motion control functions.

(1) Overview of Motion Errors

Motion errors in the MP2000-series Machine Controller include axis alarms detected for individual SERVOPACKs. The failure location can be determined and appropriate corrections can be taken simply by checking the contents of the Warning (IL□□02) and Alarm (IL□□04) monitoring parameters.

The motion alarms for the Machine Controller Basic Module's MECHATROLINK-I or MECHATROLINK-II functionality are shown below.

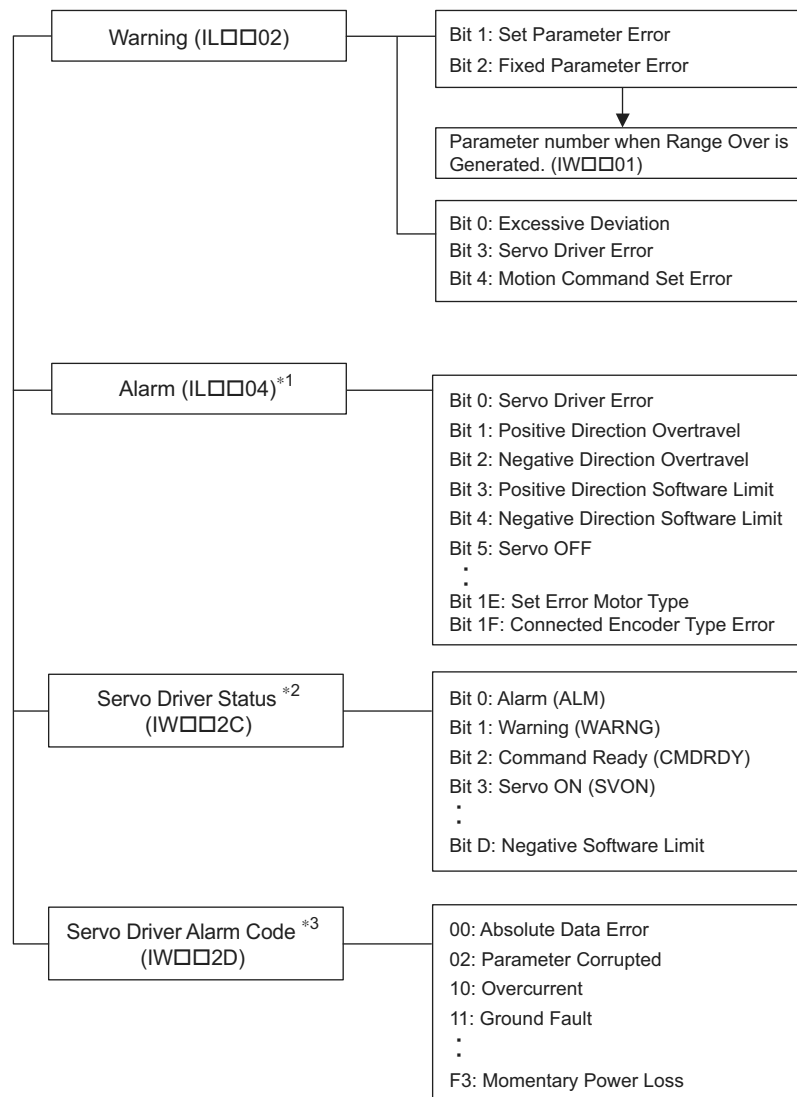

* 1. Refer to "[a] Alarm (IL□□04) List".

* 2. Refer to "[a] Servo Driver Status (IW□□2C) List".

* 3. Refer to "[b] Servo Driver Status (IW□□2C) List".

(2) Motion Error Details and Corrections

The following tables show the contents of the axis alarms (IL□□04) (subsection a) and axis alarm details (subsection b).

[a] Alarm (IL□□04) List

IL□□04	Alarm Contents	IL□□04	Alarm Contents
Bit 0	Servo Driver Error	Bit 10	Servo Driver Synchronization Communications Error
Bit 1	Positive Direction Overtravel	Bit 11	Servo Driver Communication Error
Bit 2	Negative Direction Overtravel	Bit 12	Servo Driver Command Time-out Error
Bit 3	Positive Direction Software Limit	Bit 13	Excessive ABS Encoder Rotations
Bit 4	Negative Direction Software Limit	Bit 14	Reserved
Bit 5	Servo OFF	Bit 15	Reserved
Bit 6	Positioning Time Over	Bit 16	Not used
Bit 7	Excessive Positioning Moving Amount	Bit 17	Not used
Bit 8	Excessive Speed	Bit 18	Not used
Bit 9	Excessive Deviation	Bit 19	Not used
Bit A	Filter Type Change Error	Bit 1A	Not used
Bit B	Filter Time Constant Change Error	Bit 1B	Not used
Bit C	Not used	Bit 1C	Not used
Bit D	Zero Point Unsetting	Bit 1D	Not used
Bit E	Not used	Bit 1E	Motor Type Set Error
Bit F	Not used	Bit 1F	Connected Encoder Type Error

[b] Bit 0: Servo Driver Error

Detection Timing	<ul style="list-style-type: none"> SERVOPACK alarms are continuously monitored by the alarm management section.
Processing when Alarm Occurs	<ul style="list-style-type: none"> The current command will be aborted. If a SERVOPACK error is detected during execution of a POSING command, the positioning will be aborted and the axis will decelerate to a stop. The Command Error Completed Status in the Motion Command Status (IW□□09, bit 3) will turn ON.
Error and Cause	<ul style="list-style-type: none"> The cause of the error depends on the type of alarm. The contents of an alarm is monitored in IW□□2D. Refer to the list of SERVOPACK alarms in 8.2.7 [b] <i>Servo Driver Status and Servo Driver Error Codes</i> on page 8-40 for details.
Correction	<ul style="list-style-type: none"> Confirm the SERVOPACK alarm and remove the cause. Reset the alarm.

- The above status bit will turn ON for any of the SERVOPACK alarm codes for alarms classified as SERVOPACK alarms.

[c] Bit 1: Positive Direction Overtravel and Bit 2: Negative Direction Overtravel

Detection Timing	<ul style="list-style-type: none"> Overtravel is continuously monitored by the position management section during execution of a motion command. Overtravel is detected when the overtravel signal in the direction of movement turns OFF.
Processing when Alarm Occurs	<ul style="list-style-type: none"> The SERVOPACK performs stop processing. The stop method and processing after stopping depends on the SERVOPACK parameter settings. The Command Error Completed Status in the Motion Command Status (IW□□09, bit 3) will turn ON. Machine Controller Processing The command is canceled and the axis decelerates to a stop. Follow-up processing (each scan the current position of the machine is adjusted to the reference position) is executed.
Error and Cause	<p>One of the following is possible.</p> <ul style="list-style-type: none"> A move command that exceeded the travel limit of the machine was executed as follows: A user program command exceeded the travel limit. The software limit was exceeded in manual operation. Overtravel signal malfunction.
Correction	<ul style="list-style-type: none"> Check the following. Check the overtravel signal. Check the program or manual operation. Then, after clearing the motion command code and resetting the alarm, use a return operation to eliminate the overtravel status. (Commands in the overtravel direction will be disabled and an alarm will occur again if one is executed.)

■ Precautions

- For a vertical axis, the following should be set at the SERVOPACK to avoid dropping and vibration at the overtravel limit.
 - An emergency deceleration stop
 - Zero clamp status after the deceleration stop

[d] Bit 3: Positive Direction Software Limit and Bit 4: Negative Direction Software Limit

Detection Timing	<ul style="list-style-type: none"> Enabled when using a motion command and detected by the position management section. The software limits are valid after a ZRET or ZSET command has been completed.
Processing when Alarm Occurs	<ul style="list-style-type: none"> The axis decelerates to a stop at the software limit. The Command Error Completed Status in the Motion Command Status (IW□□09, bit 3) will turn ON.
Error and Cause	<ul style="list-style-type: none"> A move command that exceeded a software limit of the machine was executed as follows: A user program command exceeded the software limit. The software limit was exceeded in manual operation.
Correction	<ul style="list-style-type: none"> Check the program or manual operation. Then, after clearing the motion command code and resetting the alarm, use a return operation to eliminate the software limit status. (Commands in the direction of the software limit will be disabled and an alarm will occur again if one is executed.)

[e] Bit 5: Servo OFF

Detection Timing	<ul style="list-style-type: none"> Servo OFF status is detected when a move command is executed.
Processing when Alarm Occurs	<ul style="list-style-type: none"> The specified movement command will not be executed. The Command Error Completed Status in the Motion Command Status (IW□□09, bit 3) will turn ON.
Error and Cause	<ul style="list-style-type: none"> A move command (commands for positioning, external positioning, STEP operation, JOG operation, etc.) was executed when the SERVOPACK was Servo OFF status.
Correction	<ul style="list-style-type: none"> After clearing the motion command and resetting the alarm, turn the SERVOPACK to the Servo ON status.

[f] Bit 6: Positioning Time Over

Detection Timing	<ul style="list-style-type: none"> Positioning was not completed within Positioning Completion Check Time (OW□□26) after completing pulse distribution.
Processing when Alarm Occurs	<ul style="list-style-type: none"> The current command was ended forcibly. The Command Error Completed Status in the Motion Command Status (IW□□09, bit 3) will turn ON.
Error and Cause	<p>One of the following is possible.</p> <ul style="list-style-type: none"> The position loop gain and speed loop gain are not set correctly, creating poor response. Or, there is oscillation. The Positioning Completion Check Time (OW□□26) is too short. The capacity of the motor is insufficient for the machine load. Connections are not correct between the SERVOPACK and the motor.
Correction	<p>Check the following.</p> <ul style="list-style-type: none"> Check the SERVOPACK gain parameters. Check connections between the SERVOPACK and the motor. Check the motor capacity. Check the Positioning Completion Check Time (OW□□26).

- The above check is not performed if the Positioning Completion Check Time (OW□□26) is set to 0.

[g] Bit 7: Excessive Positioning Moving Amount

Detection Timing	<ul style="list-style-type: none"> Positioning command is executed.
Processing when Alarm Occurs	<ul style="list-style-type: none"> The move command is not executed. The Command Error Completed Status in the Motion Command Status (IW□□09, bit 3) will turn ON.
Error and Cause	<ul style="list-style-type: none"> A move command (commands for positioning, external positioning, or STEP operation) was executed that exceeded the limit of the positioning moving amount.
Correction	<ul style="list-style-type: none"> Check the moving amount for the axis being positioned.

[h] Bit 8: Excessive Speed

Detection Timing	<ul style="list-style-type: none"> A move command is executed.
Processing when Alarm Occurs	<ul style="list-style-type: none"> The move command is not executed. The Command Error Completed Status in the Motion Command Status (IW□□09, bit 3) will turn ON.
Error and Cause	<ul style="list-style-type: none"> The speed (moving amount output for one scan in case of interpolation) commanded to MECHATROLINK servo exceeds the upper limit.
Correction	<ul style="list-style-type: none"> Check the settings for speed reference, interpolation command moving amount per scan, and speed compensation.

[i] Bit 9: Excessive Deviation

Detection Timing	<ul style="list-style-type: none"> Always except during speed control and torque control
Processing when Alarm Occurs	<ul style="list-style-type: none"> The move command is not executed. The Command Error Completed Status in the Motion Command Status (IW□□09, bit 3) will turn ON.
Error and Cause	<p>One of the following is possible.</p> <ul style="list-style-type: none"> The position loop gain and speed loop gain are not set correctly, creating poor response. The Error Count Alarm Detection (OL□□22) is too small. The capacity of the motor is insufficient for the machine load. SERVOPACK failure
Correction	<p>Check the following and correct the problem. If the problem persists, contact the maintenance department.</p> <ul style="list-style-type: none"> Check the position loop gain and speed loop gain. Check the Error Count Alarm Detection (OL□□22). Check the motor capacity.

- The above check is not performed if the Error Count Alarm Detection (OL□□22) is set to 0.

[j] Bit A: Filter Type Change Error

Detection Timing	<ul style="list-style-type: none"> Continuously monitored by the motion command processing section.
Processing when Alarm Occurs	<ul style="list-style-type: none"> The Change Filter Type command will not be executed. The Command Error Completed Status in the Motion Command Status (IW□□09, bit 3) will turn ON.
Error and Cause	<ul style="list-style-type: none"> An error occurs if the Change Filter Type command is executed before the specified pulse distribution has not been completed (i.e., when IW□□0C, bit 0 was OFF).
Correction	<ul style="list-style-type: none"> Correct the program to execute the Change Filter Type command after Discharging Completed status (i.e., that IW□□0C, bit 0 is ON) is checked.

- The command running will not stop even if the above error occurs. The stop processing from the user program is needed to stop running commands when necessary.

[k] Bit B: Filter Time Constant Change Error

Detection Timing	<ul style="list-style-type: none"> Continuously monitored by the motion command processing section.
Processing when Alarm Occurs	<ul style="list-style-type: none"> The SCC (Change Filter Time Constant) command will not be executed. The Command Error Completed Status in the Motion Command Status (IW□□09, bit 3) will turn ON.
Error and Cause	<ul style="list-style-type: none"> An error occurs if the SCC command is executed before the specified pulse distribution has not been completed (i.e., when IW□□0C0, bit 0 was OFF).
Correction	<ul style="list-style-type: none"> Correct the program to execute the SCC command after Discharging Completed status (i.e., that IB□□0C0 is ON) is checked.

- The command running will not stop even if the above error occurs. The stop processing from the user program is needed to stop running commands when necessary.

[l] Bit D: Zero Point Unsetting

Detection Timing	<ul style="list-style-type: none"> Enabled only when an absolute encoder is used for an infinite length axis and detected when the next command is set in the Motion Command Response Code (OW□□08). Commands: Positioning, External Positioning, Interpolation, Interpolation with position detection function, phase reference
Processing when Alarm Occurs	<ul style="list-style-type: none"> The set command will not be executed. The Command Error Completed Status in the Motion Command Status (IW□□09, bit 3) will turn ON.
Error and Cause	<ul style="list-style-type: none"> A move command was set without executing the ZSET command (IW□□0C, bit 5 is OFF).
Correction	<ul style="list-style-type: none"> After clearing the motion command and resetting the alarm, execute a Zero Point Setting operation.

[m] Bit 10: Servo Driver Synchronization Communications Error

Detection Timing	<ul style="list-style-type: none"> Detected by the communication control section when communication are synchronized between the Machine Controller and SERVOPACK.
Processing when Alarm Occurs	<ul style="list-style-type: none"> The current command will be aborted.
Error and Cause	<ul style="list-style-type: none"> Data of either Machine Controller or servo was not correctly updated.
Correction	<ul style="list-style-type: none"> Check the MECHATROLINK cable and reset the alarm.

[n] Bit 11: Servo Driver Communication Error

Detection Timing	<ul style="list-style-type: none"> Detected by the communication control section when communication is not synchronized between the Machine Controller and SERVOPACK.
Processing when Alarm Occurs	<ul style="list-style-type: none"> The current command will be aborted. The SERVOPACK will be Servo OFF status.
Error and Cause	<ul style="list-style-type: none"> MECHATROLINK communication stopped because the cable was disconnected, there is noise interference to the communication line or the power supply to the SERVOPACK was turned OFF.
Correction	<ul style="list-style-type: none"> Check the MECHATROLINK cable and reset the alarm. If this error frequently occurs, refer to <i>MECHATROLINK-II Installation Manual</i> (manual number: SIEPS 80000030) to correct wiring and eliminate noise interference.

[o] Bit 12: Servo Driver Command Time-out Error

Detection Timing	<ul style="list-style-type: none"> • Detected during execution of each motion commands. • Detected by the MECHATROLINK communication control section when the Servo command responses are checked for each process.
Processing when Alarm Occurs	<ul style="list-style-type: none"> • The current command will be aborted.
Error and Cause	<ul style="list-style-type: none"> • The MECHATROLINK Servo command did not complete within the specified time (5 s).
Correction	<ul style="list-style-type: none"> • Check for alarms in the SERVOPACK for MECHATROLINK communication.

- ♦ The above error occurs when Module allocations of SERVOPACK for MECHATROLINK communication have been completed and the power is not being supplied to the SERVOPACK.

[p] Bit 13: Excessive ABS Encoder Rotations

Detection Timing	<ul style="list-style-type: none"> • Enabled only when an absolute encoder is used for a finite length axis, and the electronic gear used. Detected by the position management section when power is turned ON.
Processing when Alarm Occurs	<ul style="list-style-type: none"> • The absolute position information read from the absolute encoder when the SEN signal turned ON is ignored.
Error and Cause	<ul style="list-style-type: none"> • An operation error occurred when the absolute position information read from the absolute encoder is converted from pulses to reference units at power ON.
Correction	<ul style="list-style-type: none"> • Check the gear ratio, number of encoder pulses for other motion fixed parameters.

[q] Bit 1E: Set Error Motor Type

Detection Timing	<ul style="list-style-type: none"> • Detected when the communication with the SERVOPACK is established.
Processing when Alarm Occurs	<ul style="list-style-type: none"> • None
Error and Cause	<ul style="list-style-type: none"> • The motor type setting (rotary/linear) of the Machine Controller fixed parameter does not agree with that of SERVOPACK parameter (Start Selection Pn000.3 for SGDH, Rotary/Linear for SGDS).
Correction	<ul style="list-style-type: none"> • Check the setting and model of the SERVOPACK.

[r] Bit 1F: Connected Encoder Type Error

Detection Timing	<ul style="list-style-type: none"> • Detected when the communication with the SERVOPACK is established.
Processing when Alarm Occurs	<ul style="list-style-type: none"> • None
Error and Cause	<ul style="list-style-type: none"> • The motor type setting (rotary/linear) of the Machine Controller fixed parameter does not agree with the motor type connected to the SERVOPACK.
Correction	<ul style="list-style-type: none"> • Check the motor.

(3) Servo Driver Status and Servo Driver Error Codes

[a] Servo Driver Status (IW□□2C) List

The status of a SERVOPACK for MECHATROLINK communication can be monitored in Monitor Parameter (IW□□2C).

The list of Monitor Parameter (IW□□2C) is provided in the following table.

Bit No.	Status	Description
Bit 0	Alarm (ALM)	OFF: No alarm occurred. ON: Alarm occurred.
Bit 1	Warning (WARNG)	OFF: No warning occurred. ON: Warning occurred.
Bit 2	Command Ready (CMDRDY)	OFF: Command reception not possible (busy). ON: Command reception possible (ready).
Bit 3	Servo ON (SVON)	OFF: Servo OFF (baseblock) ON: Servo ON (baseblock cleared)
Bit 4	Main Power Supply ON (PON)	OFF: Main power OFF ON: Main power ON
Bit 5	Machine Lock (MLOCK)	OFF: Machine lock released ON: Machine locked
Bit 6	Zero Position (ZPOINT)	OFF: The APOS (absolute position) is not in the zero point. ON: The APOS (absolute position) is in the zero point range.
Bit 7	Locating Complete (PSET)	OFF: Pulse distribution is not completed or the APOS is not in the positioning completed width. ON: Pulse distribution is completed and the APOS is within the positioning completed width.
Bit 8	Command Profile Complete (DEN)	OFF: Pulse distribution is being performed for positioning command. ON: Pulse distribution for positioning commands has been completed
Bit 9	Torque Restriction (T_LIM)	OFF: A torque limit is not being applied. ON: A torque limit is being applied.
Bit A	Latch Complete (L_CMP)	OFF: Latch not completed. ON: Latch completed.
Bit B	Locating neighborhood (NEAR)	OFF: The APOS is outside the position proximity range. ON: The APOS is inside the position proximity range.
Bit C	Positive Software Limit (P-SOT)	OFF: The positive software limit has not been exceeded. ON: The positive software limit has been exceeded.
Bit D	Negative Software Limit (N-SOT)	OFF: The negative software limit has not been exceeded. ON: The negative software limit has been exceeded.
Bit E	Reserved	–
Bit F	Reserved	–

[b] Servo Driver Alarm Code (IW□□2D)

When the Servo Driver Error (IL□□04, bit 0) turns ON, a SERVOPACK alarm will exist. The content of the alarm can be confirmed using the Servo Driver Alarm Code (monitoring parameter IW□□2D).

The Servo alarm codes are listed in the following tables.

■ Σ -I Series

Name	Register Number	Code	Meaning
Servo Driver Alarm Code	IW□□2D	99	Normal
		94	Parameter Setting Warning
		95	MECHATROLINK Command Warning
		96	MECHATROLINK Communication Error Warning
		00	Absolute Value Data Error
		02	Parameter Corrupted
		10	Overcurrent
		11	Ground Fault
		40	Overvoltage
		41	Undervoltage
		51	Overspeed
		71	Overload (Instantaneous)
		72	Overload (Continuous)
		7A	Heat Sink Heating
		80	Absolute Encoder Error
		81	Absolute Encoder Backup Error
		82	Absolute Encoder Checksum Error
		83	Absolute Encoder Battery Error
		84	Absolute Encoder Data Error
		85	Absolute Encoder Overspeed
		B1	Gate Array 1 Error
		B2	Gate Array 2 Error
		B3	Current Feedback Phase-U Error
		B4	Current Feedback Phase-V Error
		B5	Watchdog Detector Error
		C1	Servo Run-away
		C2	Encoder Phase Error Detected
		C3	Encoder Phase-A or -B Broken
		C4	Encoder Phase-C Broken
		C5	Incremental Encoder Initial Pulses Error
		D0	Position Error Exceeded
		E5	MECHATROLINK Sync Error
		E6	MECHATROLINK Communication Error
F1	Broken Phase in Power Line		
F3	Momentary Power Loss		

■ Σ -II Series

Name	Register Number	Code	Meaning
Servo Driver Alarm Code	IW□□2D	99	Normal
		90	Excessive Position Deviation Warning
		91	Overload Warning
		92	Regeneration Overload Warning
		93	Absolute Encoder Battery Error
		94	Data Setting Warning
		95	Command Warning
		96	Communication Warning
		02	Parameter Corrupted
		03	Main Circuit Detector Error
		04	Parameter Setting Error
		05	Combination Error
		09	Divider Setting Error
		0A	Encoder Type Mismatch
		10	Overcurrent or Heat Sink Overheat
		30	Regeneration Error
		32	Regeneration Overload
		33	Main Circuit Wiring Error
		40	Overvoltage
		41	Undervoltage
		51	Overspeed
		71	Overload (Instantaneous Maximum Load)
		72	Overload (Continuous Maximum Load)
		73	DB Overload
		74	Inrush Resistance Overload
		7A	Heat Sink Overheat
		81	Encoder Backup Alarm
		82	Encoder Checksum Alarm
		83	Encoder Battery Alarm
		84	Encoder Data Alarm
		85	Encoder Overspeed
		86	Encoder Overheat
		B1	Speed Reference A/D Error
		B2	Torque Reference A/D Error
		B3	Current Sensor Error
		B6	Gate Array Error
		BF	System Alarm
		C1	Servo Run-away
		C6	Fully-closed Loop Phase-A or -B Broken
		C7	Fully-closed Loop Phase-C Broken
		C8	Encoder Clear Error Multiturn Limit Setting Error
C9	Encoder Communication Error		
CA	Encoder Parameter Error		
CB	Encoder Echoback Error		
CC	Multiturn Limit Mismatch		
D0	Excessive Position Error		
D1	Excessive Error between Motor Load and Position		
E0	No Option		
E1	Option Timeout		

Name	Register Number	Code	Meaning
Servo Driver Alarm Code (cont'd)	IW□□2D (cont'd)	E2	Option WDC Error
		E5	WDT Error
		E6	Communication Error
		E7	Application Module Detection Failure
		E9	Bus OFF Error
		EA	SERVOPACK Failure
		EB	SERVOPACK Initial Access Error
		EC	SERVOPACK WDC Error
		ED	Command Execution Not Completed
		EF	Application Module Alarm
		F1	Broken Phase in Power Line
		F5	Motor Wire Disconnection (when control power supply is turned ON)
		F6	Motor Wire Disconnection (when Servo is ON)

■ Σ -III Series

Name	Register Number	Code	Meaning
Servo Driver Alarm Code	IW□□2D	000	Normal
		900	Excessive Position Error
		901	Excessive Position Error at Servo ON
		910	Overload
		911	Vibration
		920	Regeneration Overload
		930	Absolute Encoder Battery Error
		941	Parameter Change Requiring Power Recycling
		94A	Data Setting Warning 1 (Parameter Number)
		94B	Data Setting Warning 2 (Outside Data Range)
		94C	Data Setting Warning 3 (Calculation Error)
		94D	Data Setting Warning 4 (Parameter Size)
		95A	Command Warning 1 (Command Conditions Not Met)
		95B	Command Warning 2 (Unsupported Command)
		95C	Command Warning 3
		95D	Command Warning 4
		95E	Command Warning 5
		960	MECHATROLINK Communication Warning
		020	Parameter Checksum Error 1
		021	Parameter Format Error 1
		022	System Constant Checksum Error 1
		023	Parameter Password Error 1
		02A	Parameter Checksum Error 2
		02B	System Constant Checksum Error 2
		030	Main Circuit Detector Error
		040	Parameter Setting Error 1
		04A	Parameter Setting Error 2
		041	Divided Pulse Output Setting Error
		042	Parameter Combination Error
		050	Combination Error
		051	Unsupported Product Alarm

Name	Register Number	Code	Meaning
Servo Driver Alarm Code (cont'd)	IW□□2D (cont'd)	0B0	Servo ON Reference Invalid Alarm
		100	Overcurrent or Heat Sink Overheat
		300	Regeneration Error
		320	Regeneration Overload
		330	Main Circuit Wiring Error
		400	Overvoltage
		410	Undervoltage
		510	Overspeed
		511	Divided Pulse Output Overspeed
		520	Vibration Alarm
		710	Overload (Instantaneous Maximum Load)
		720	Overload (Continuous Maximum Load)
		730, 731	DB Overload
		740	Inrush Resistance Overload
		7A0	Heat Sink Overheat
		810	Encoder Backup Alarm
		820	Encoder Checksum Alarm
		830	Encoder Battery Alarm
		840	Encoder Data Alarm
		850	Encoder Over Speed
		860	Encoder Overheat
		870	Fully-closed Serial Encoder Checksum Alarm
		880	Fully-closed Serial Encoder Data Alarm
		8A0	Fully-closed Serial Encoder Scale Error
		8A1	Fully-closed Serial Encoder Module Error
		8A2	Fully-closed Serial Encoder Sensor Error (Incremental Value)
		8A3	Fully-closed Serial Encoder Position Error (Absolute Value)
		B31	Current Detection Error 1
		B32	Current Detection Error 2
		B33	Current Detection Error 3
		B6A	MECHATROLINK Communication ASIC Error 1
		B6B	MECHATROLINK Communication ASIC Error 2
		BF0	System Alarm 0
		BF1	System Alarm 1
		BF2	System Alarm 2
		BF3	System Alarm 3
		BF4	System Alarm 4
		C10	Servo Run-away
		C80	Encoder Clear Error Multiturn Limit Setting Error
		C90	Encoder Communication Error
		C91	Encoder Communication Position Data Acceleration Error
		C92	Encoder Communication Timer Error
		CA0	Encoder Parameter Error
CB0	Encoder Echoback Error		
CC0	Multiturn Limit Mismatch		
CF1	Fully-closed Serial Conversion Unit Communication Error (Reception Failure)		

Name	Register Number	Code	Meaning
Servo Driver Alarm Code (cont'd)	IW□□2D (cont'd)	CF2	Fully-closed Serial Conversion Unit Communication Error (Timer Stopped)
		D00	Excessive Position Error
		D01	Excessive Position Error Alarm at Servo ON
		D02	Excessive Position Error Alarm for Speed Limit at Servo ON
		D10	Excessive Error between Motor Load and Position
		E00	COM Alarm 0
		E01	COM Alarm 1
		E02	COM Alarm 2
		E07	COM Alarm 7
		E08	COM Alarm 8
		E09	COM Alarm 9
		E40	MECHATROLINK-II Transmission Cycle Setting Error
		E50	MECHATROLINK-II Sync Error
		E51	MECHATROLINK-II Sync Failure
		E60	MECHATROLINK-II Communication Error
		E61	MECHATROLINK-II Transmission Cycle Error
		EA0	DRV Alarm 0
		EA1	DRV Alarm 1
EA2	DRV Alarm 2		

- Alarm codes are normally two digits, but three-digit codes are stored in the Alarm Monitor for motion commands.

Appendices

A	System Registers Lists	A-2
A.1	System Service Registers	A-2
A.2	Scan Execution Status and Calendar	A-4
A.3	Program Software Numbers and Remaining Program Memory Capacity	A-4
B	SERVOPACK Parameter Data Flow	A-5
B.1	Operations and Parameter Data Flow	A-5
C	Initializing SERVOPACKs	A-14
D	Initializing the Absolute Encoder	A-15
D.1	S-III SERVOPACK	A-15
D.2	S-II SERVOPACK	A-16
D.3	S-I SERVOPACK	A-18
E	Motion Parameter Details	A-20
E.1	Fixed Parameter List	A-20
E.2	Setting Parameter List	A-22
E.3	Monitoring Parameter List	A-27
F	How to Set up Communication Process	A-31
F.1	Preparation	A-31
F.2	Procedure	A-31
G	MSG-SND/ MSG-RCV Functions	A-35
G.1	Message Transmit Function (MSG-SND)	A-35
G.2	Message Receive Function (MSG-RCV)	A-70
G.3	Communication Buffer Channel	A-102

Appendix A System Registers Lists

A.1 System Service Registers

(1) Shared by All Drawings

Name	Register No.	Remarks
Reserved (Reserved for the system)	SB000000	(Not used)
High-speed Scan	SB000001	ON for only the first scan after high-speed scan is started.
Low-speed Scan	SB000003	ON for only the first scan after low-speed scan is started.
Always ON	SB000004	Always ON (= 1)
Reserved (Reserved for the system)	SB000005 to SB00000F	(Not used)

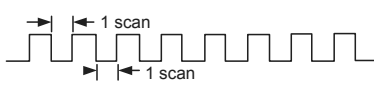
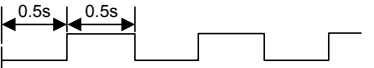
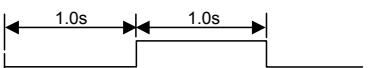
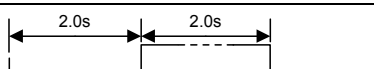
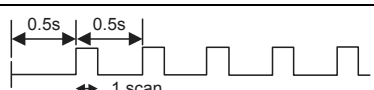
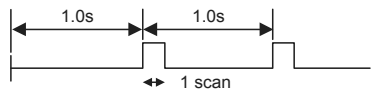
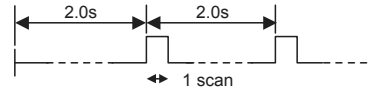
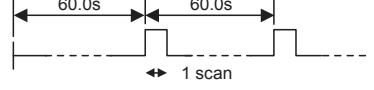
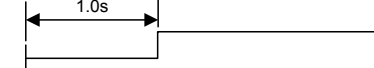
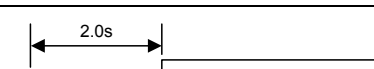
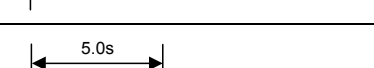

(2) DWG.H Only

The following relays are reset at the start of the high-speed scan.

Name	Register No.	Remarks
1-scan Flicker Relay	SB000010	
0.5-s Flicker Relay	SB000011	
1.0-s Flicker Relay	SB000012	
2.0-s Flicker Relay	SB000013	
0.5-s Sampling Relay	SB000014	
1.0-s Sampling Relay	SB000015	
2.0-s Sampling Relay	SB000016	
60.0-s Sampling Relay	SB000017	
1.0 s After Start of Scan Relay	SB000018	
2.0 s After Start of Scan Relay	SB000019	
5.0 s After Start of Scan Relay	SB00001A	

■ DWG.L Only

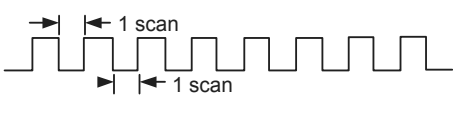
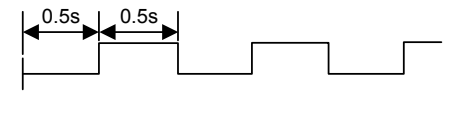
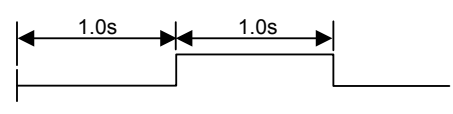
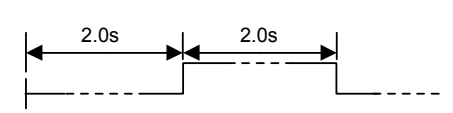
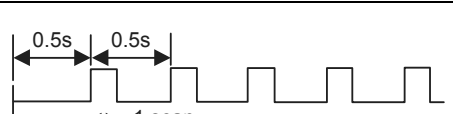
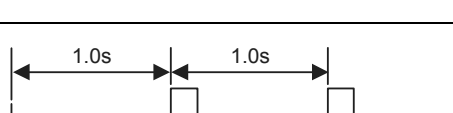
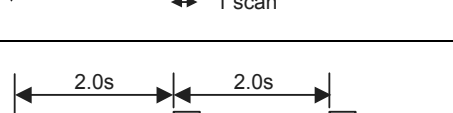
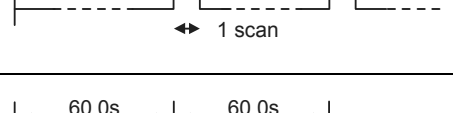
The following relays are reset at the start of the low-speed scan.

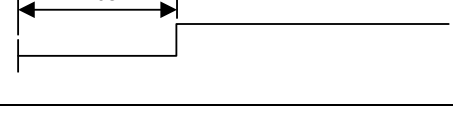
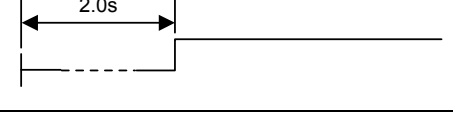
Name	Register No.	Remarks
One-scan Flicker Relay	SB000030	
0.5-s Flicker Relay	SB000031	
1.0-s Flicker Relay	SB000032	
2.0-s Flicker Relay	SB000033	
0.5-s Sampling Relay	SB000034	
1.0-s Sampling Relay	SB000035	
2.0-s Sampling Relay	SB000036	
60.0-s Sampling Relay	SB000037	
1.0 s After Start of Scan Relay	SB000038	
2.0 s After Start of Scan Relay	SB000039	
5.0 s After Start of Scan Relay	SB00003A	

A.2 Scan Execution Status and Calendar

Name	Register No.	Remarks
High-speed Scan Set Value	SW00004	High-speed Scan Set Value (0.1 ms)
High-speed Scan Current Value	SW00005	High-speed Scan Current Value (0.1 ms)
High-speed Scan Maximum Value	SW00006	High-speed Scan Maximum Value (0.1 ms)
Reserved by the system.	SW00007 to SW00009	(Not used)
Low-speed Scan Set Value	SW00010	Low-speed Scan Set Value (0.1 ms)
Low-speed Scan Current Value	SW00011	Low-speed Scan Current Value (0.1 ms)
Low-speed Scan Maximum Value	SW00012	Low-speed Scan Maximum Value (0.1 ms)
Reserved by the system.	SW00013	(Not used)
Executing Scan Current Value	SW00014	Executing Scan Current Value (0.1 ms)
Calendar: Year	SW00015	1999: 0099 (BCD) (Last two digits only)
Calendar: Month Day	SW00016	December 31: 1231 (BCD)
Calendar: Hours Minutes	SW00017	23 hours 59 minutes: 2359 (BCD)
Calendar: Seconds	SW00018	59 s: 59 (BCD)
Calendar: Day of Week	SW00019	0 to 6: Sun., Mon. to Sat.

A.3 Program Software Numbers and Remaining Program Memory Capacity

Name	Register No.	Remarks
System Program Software Number	SW00020	S□□□□ (□□□□ is stored as BCD)
System Number	SW00021 to SW00025	(Not used)
Remaining Program Memory Capacity	SL00026	Bytes
Total Memory Capacity	SL00028	Bytes

Appendix B SERVOPACK Parameter Data Flow

In systems connected to MECHATROLINK, SERVOPACK parameters can be read directly from the MP2300S. (Refer to *11.1 Parameters That Are Automatically Updated* in the Machine Controller MP2000-series SVB/SVB-01 Motion Module User's Manual (manual no.: SIEPC88070033). This means that parameters are saved in the memory area of both the MP2300S and the SERVOPACK. It is thus necessary to consider the relationship between the settings in both memory areas.

B.1 Operations and Parameter Data Flow

(1) Power ON

1. Parameter data saved in the SERVOPACK's EEPROM^{*1} is copied to SERVOPACK's RAM^{*2}.
2. Parameter data saved in the MP2300S's flash memory^{*1} for all axes is copied to SDRAM^{*2}. Some gain-related settings are sent from the MP2300S to SERVOPACK RAM.

* 1. EEPROM, flash memory, and SRAM: Store data even when the power is turned OFF.

* 2. RAM (SRAM, SDRAM): Lose data when the power is turned OFF.

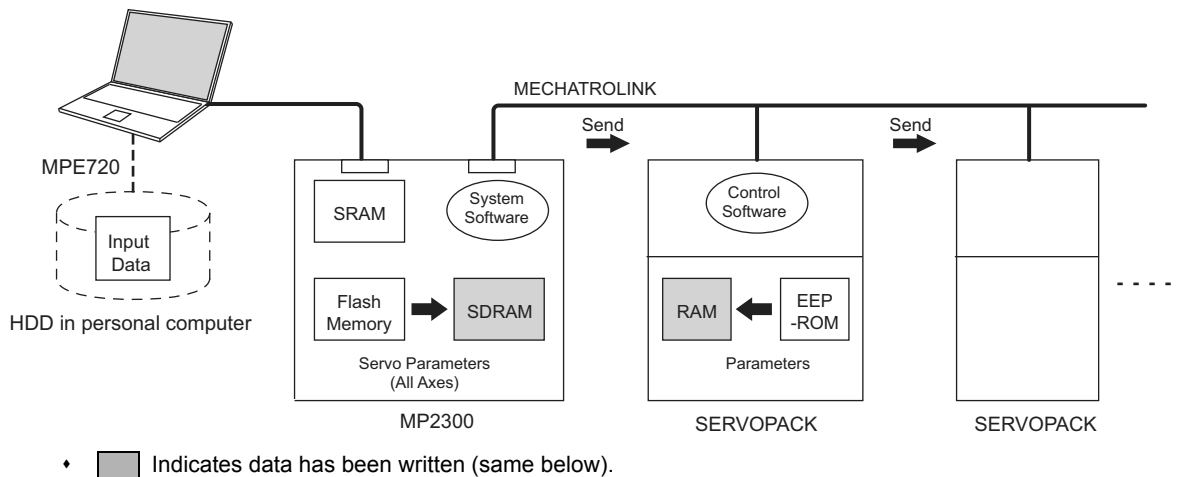

(2) Normal Operation

1. Control software of the SERVOPACK operates based on the parameter data held in SERVOPACK's RAM.
2. Some of MP2300S setting parameters and commands temporarily change SERVOPACK parameters. Refer to *Chapter 4* in the Machine Controller MP2000-series SVB/SVB-01 Motion Module User's Manual (manual no. SIEPC88070033) for details. RAM in the SERVOPACK are written.

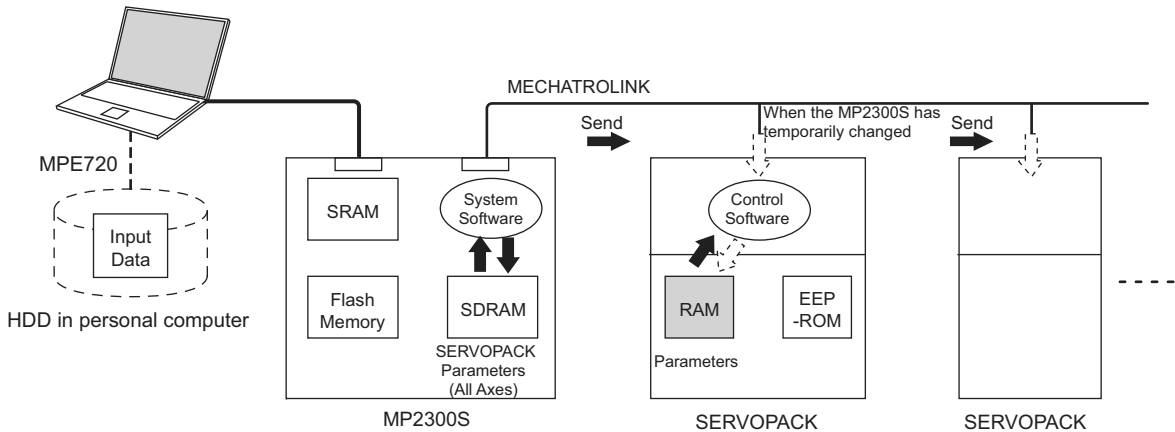

- Parameters held in the SERVOPACK's RAM are displayed on a Digital Operator connected to the SERVOPACK. They are also written to EEPROM when the DATA/ENTER Key is pressed.

(3) When the SERVOPACK Tab Page Is Open

The data flow for SERVOPACK parameters is as follows when the SERVOPACK Tab Page is open in the SVB Definitions Window on the MPE720 (refer to 2.2.5 (5) SVB Definition on page 2-45 for details on how to open the SERVOPACK Tab Page.)

1. The MPE720 writes and displays the parameters that are held in the SERVOPACK's RAM for the relevant axis to the **Current Value** in the **SERVOPACK** Tab Page. It also reads and displays the values that are held in the MP2300S's SDRAM values to the **Input Data** in the **SERVOPACK** Tab Page.

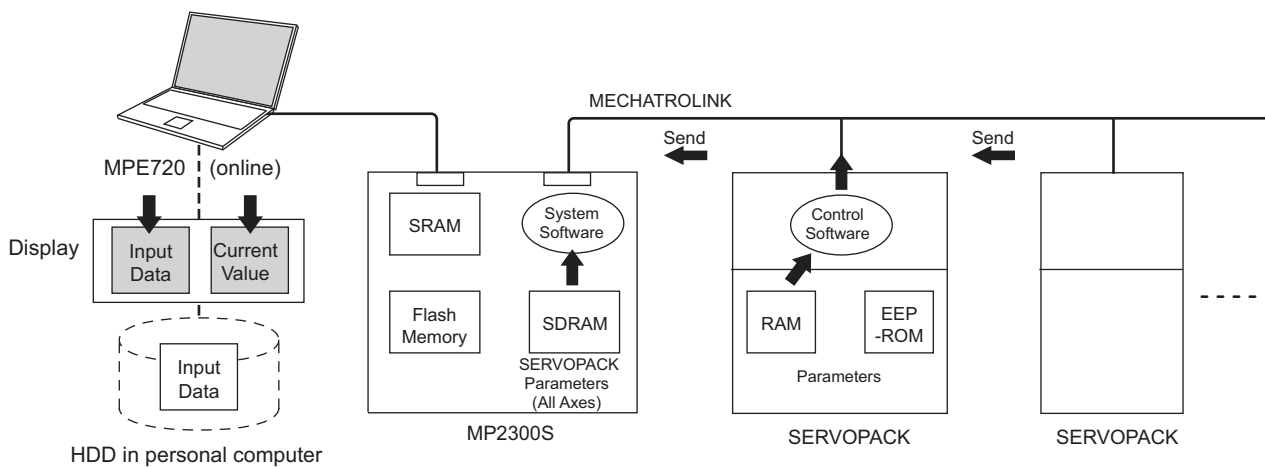

- The following figure shows an example of the SERVOPACK Tab in the **SVB Definition Window**. The values in **Current Value** are different from the values in **Input Data**.

No.	Name	Input Data	Unit	Current Value
0000	Function Selection Basic Switch 0	0000 H	-	0000 H
0001	Function Selection Application Switch 1	0000 H	-	0000 H
0002	Function Selection Application Switch 2	0011 H	-	0011 H
0004	Function Selection Application Switch 4	0110 H	-	0110 H
0006	Function Selection Application Switch 6	0002 H	-	0002 H
0007	Function Selection Application Switch 7	0000 H	-	0000 H
0008	Function Selection Application Switch 8	4000 H	-	4000 H
0100	Speed Loop Gain	40.0	Hz	100.0
0101	Speed Loop Integral Time Constant	20.00	ms	40.00
0102	Position Loop Gain	40.0	/s	100.0
0103	Moment of Inertia Ratio/Mass ratio.	0	%	0
0104	2nd Speed Loop Gain	40.0	Hz	40.0
0105	2nd Speed Loop Integral Time Constant	20.00	ms	20.00
0106	2nd Position Loop Gain	40.0	/s	40.0
0107	Bias	0	min-1	0

(4) SERVOPACK Parameters Saved in the MPE720

The data flow for SERVOPACK parameters is as follows when **File - Save** is selected from the **SERVOPACK Tab Page**:

- The MPE720 writes all the parameters in **Input Data** currently displayed on **SERVOPACK Tab Page** of the relevant axis to the followings.
 - HDD (hard disk) of the personal computer
 - SDRAM of MP2300S
 - RAM and EEPROM of the SERVOPACK
- After having completed writing the parameters, the MPE720 updates the values in **Current Value** on the **SERVOPACK Tab Page** with the SERVOPACK parameter values stored in the RAM.

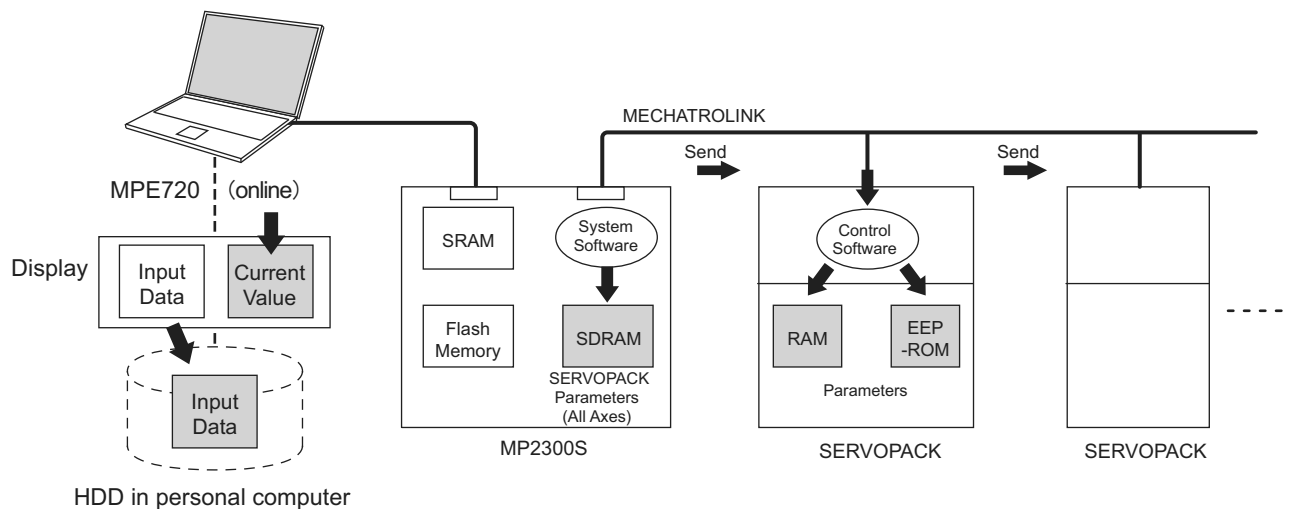

- The following figure shows a display example after having executed save operation on the **SERVOPACK** Tab in the **SVB Definition** Window. After having saved the data, the values in **Input Data** of all the parameters become the same as the values in **Current Value** on the **SERVOPACK** Tab.

Before saving

No.	Name	Input Data	Unit	Current Value
0000	Function Selection Basic Switch 0	0000 H	-	0000 H
0001	Function Selection Application Switch 1	0000 H	-	0000 H
0002	Function Selection Application Switch 2	0011 H	-	0011 H
0004	Function Selection Application Switch 4	0110 H	-	0110 H
0006	Function Selection Application Switch 6	0002 H	-	0002 H
0007	Function Selection Application Switch 7	0000 H	-	0000 H
0008	Function Selection Application Switch 8	4000 H	-	4000 H
0100	Speed Loop Gain	40.0 Hz		100.0
0101	Speed Loop Integral Time Constant	20.00 ms		40.00
0102	Position Loop Gain	40.0 /s		100.0
0103	Moment of Inertia Ratio/Mass ratio.	0%		0
0104	2nd Speed Loop Gain	40.0 Hz		40.0
0105	2nd Speed Loop Integral Time Constant	20.00 ms		20.00

After saving

No.	Name	Input Data	Unit	Current Value
0000	Function Selection Basic Switch 0	0000 H	-	0000 H
0001	Function Selection Application Switch 1	0000 H	-	0000 H
0002	Function Selection Application Switch 2	0011 H	-	0011 H
0004	Function Selection Application Switch 4	0110 H	-	0110 H
0006	Function Selection Application Switch 6	0002 H	-	0002 H
0007	Function Selection Application Switch 7	0000 H	-	0000 H
0008	Function Selection Application Switch 8	4000 H	-	4000 H
0100	Speed Loop Gain	40.0 Hz		40.0
0101	Speed Loop Integral Time Constant	20.00 ms		20.00
0102	Position Loop Gain	40.0 /s		40.0
0103	Moment of Inertia Ratio/Mass ratio.	0%		0
0104	2nd Speed Loop Gain	40.0 Hz		40.0
0105	2nd Speed Loop Integral Time Constant	20.00 ms		20.00

- The saving operation of **SERVOPACK** parameters can be used for writing data after **SERVOPACK** replacement because it writes all the parameters of the relevant axis.

(5) Copying Current Values to Set Values (Input Data) in the SERVOPACK Tab

The data flow for SERVOPACK parameters is as follows when selecting *Edit - Copy Current Value* from the **SERVO-
PACK** Tab in the SVB Definition Window on the MPE720:

1. The MPE720 copies the values currently displayed in **Current Value** to **Input Data** on the **SERVO-
PACK** Tab and displays.

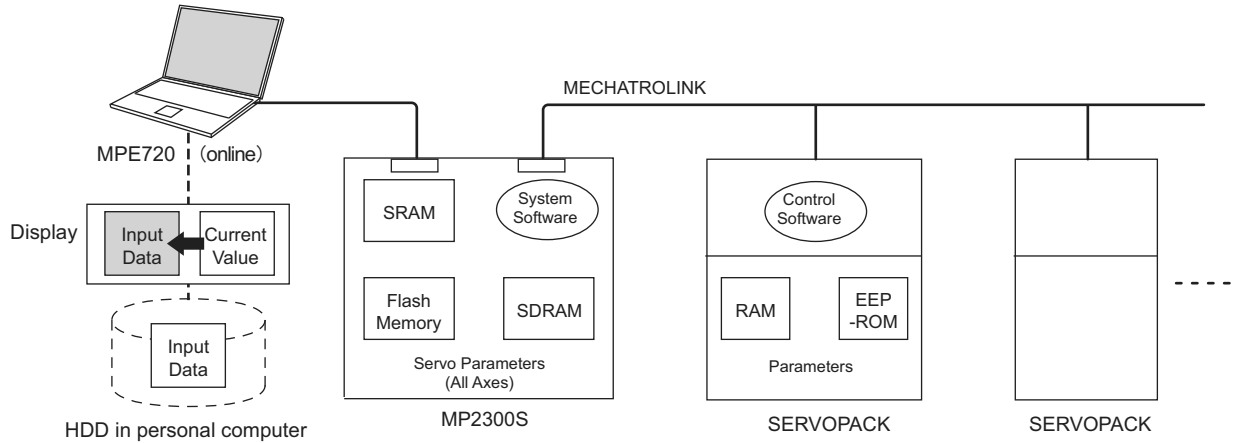

- The following figure shows a display example after having selected **Edit - Copy Current Value** on the **SERVOPACK** Tab in the **SVB Definition** Window. The values in **Current Value** are copied to **Input Data**.

Before copying

No.	Name	Input Data	Unit	Current Value
0000	Function Selection Basic Switch 0	0000 H	-	0000 H
0001	Function Selection Application Switch 1	0000 H	-	0000 H
0002	Function Selection Application Switch 2	0011 H	-	0011 H
0004	Function Selection Application Switch 4	0110 H	-	0110 H
0006	Function Selection Application Switch 6	0002 H	-	0002 H
0007	Function Selection Application Switch 7	0000 H	-	0000 H
0008	Function Selection Application Switch 8	4000 H	-	4000 H
0100	Speed Loop Gain	40.0 Hz		100.0
0101	Speed Loop Integral Time Constant	20.00 ms		40.00
0102	Position Loop Gain	40.0 /s		100.0
0103	Moment of Inertia Ratio/Mass ratio.	0 %		0
0104	2nd Speed Loop Gain	40.0 Hz		40.0
0105	2nd Speed Loop Integral Time Constant	20.00 ms		20.00

After copying

No.	Name	Input Data	Unit	Current Value
0000	Function Selection Basic Switch 0	0000 H	-	0000 H
0001	Function Selection Application Switch 1	0000 H	-	0000 H
0002	Function Selection Application Switch 2	0011 H	-	0011 H
0004	Function Selection Application Switch 4	0110 H	-	0110 H
0006	Function Selection Application Switch 6	0002 H	-	0002 H
0007	Function Selection Application Switch 7	0000 H	-	0000 H
0008	Function Selection Application Switch 8	4000 H	-	4000 H
0100	Speed Loop Gain	100.0 Hz		
0101	Speed Loop Integral Time Constant	40.00 ms		
0102	Position Loop Gain	100.0 /s		
0103	Moment of Inertia Ratio/Mass ratio.	0 %		0
0104	2nd Speed Loop Gain	40.0 Hz		40.0
0105	2nd Speed Loop Integral Time Constant	20.00 ms		20.00

(6) Changing Parameters in the SERVOPACK Tab Page

The data flow for SERVOPACK parameters is as follows when parameters for the cursor position are changed from the **SERVOPACK** Tab Page in the SVB Definition Window for MPE720:

1. The MPE720 writes parameters of the relevant axis to the followings when the **Enter** Key is pressed on the computer. (The parameters other than those of the relevant axis will not be written.)
 - **Input Data** (set data) on the **SERVOPACK** Tab Page
 - SDRAM of the MP2300S
 - RAM of the SERVOPACK
2. After having completed writing, the MPE720 updates the values in **Input Data** on the **SERVOPACK** Tab Page with the parameter values stored in the RAM of the SERVOPACK.

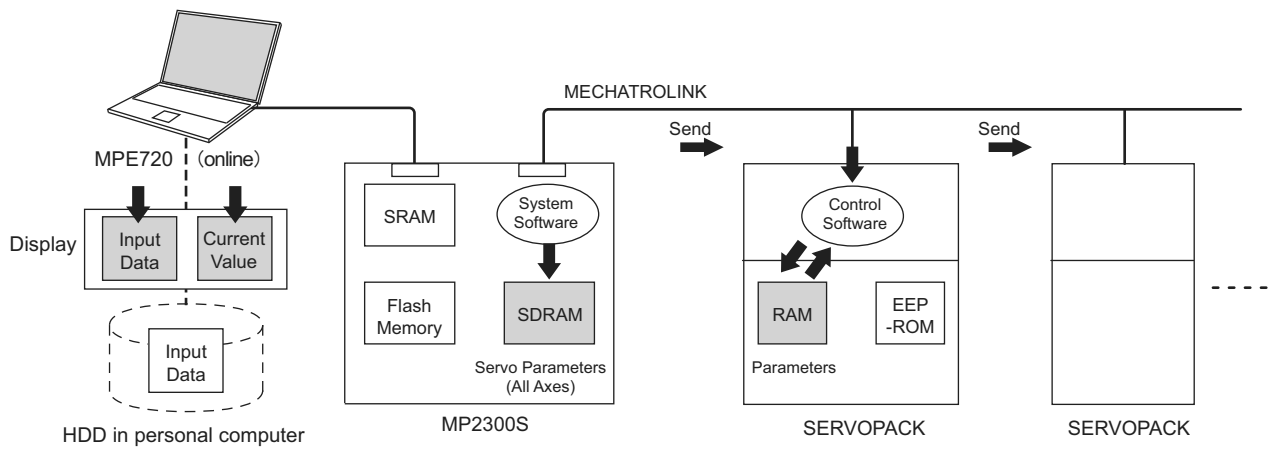

- The following figure shows a display example after having changed the value (*2nd Speed Loop Gain*) in **Input Data** on the **SERVOPACK** Tab. After having pressed the **Enter** Key, the values of **Speed Loop Gain**, **Speed Loop Integral Time Constant**, and **Position Loop Gain** (boxed in dotted line) in **Input Data** remain different from the values in **Current Value** since the parameters other than the one that has been changed are not written.

Before pressing
ENTER Key

No.	Name	Input Data	Unit	Current Value
0000	Function Selection Basic Switch 0	0000 H -		0000 H
0001	Function Selection Application Switch 1	0000 H -		0000 H
0002	Function Selection Application Switch 2	0011 H -		0011 H
0004	Function Selection Application Switch 4	0110 H -		0110 H
0006	Function Selection Application Switch 6	0002 H -		0002 H
0007	Function Selection Application Switch 7	0000 H -		0000 H
0008	Function Selection Application Switch 8	4000 H -		4000 H
0100	Speed Loop Gain	40.0 Hz		100.0
0101	Speed Loop Integral Time Constant	20.00 ms		40.00
0102	Position Loop Gain	40.0 /s		100.0
0103	Moment of Inertia Ratio/Mass ratio.	0 %		0
0104	2nd Speed Loop Gain	100.0 Hz		40.0
0105	2nd Speed Loop Integral Time Constant	20.00 ms		20.00
0106	2nd Position Loop Gain	40.0 /s		40.0
0107	Bias	0 min-1		0

After having
pressed ENTER
Key

No.	Name	Input Data	Unit	Current Value
0000	Function Selection Basic Switch 0	0000 H -		0000 H
0001	Function Selection Application Switch 1	0000 H -		0000 H
0002	Function Selection Application Switch 2	0011 H -		0011 H
0004	Function Selection Application Switch 4	0110 H -		0110 H
0006	Function Selection Application Switch 6	0002 H -		0002 H
0007	Function Selection Application Switch 7	0000 H -		0000 H
0008	Function Selection Application Switch 8	4000 H -		4000 H
0100	Speed Loop Gain	40.0 Hz		100.0
0101	Speed Loop Integral Time Constant	20.00 ms		40.00
0102	Position Loop Gain	40.0 /s		100.0
0103	Moment of Inertia Ratio/Mass ratio.	0 %		0
0104	2nd Speed Loop Gain	100.0 Hz		100.0
0105	2nd Speed Loop Integral Time Constant	20.00 ms		20.00
0106	2nd Position Loop Gain	40.0 /s		40.0
0107	Bias	0 min-1		0

(7) Saving Data to Flash Memory

The data flow for SERVOPACK parameters is as follows when saving the parameters to flash memory on the MPE720.

1. The MP2300S writes the parameters data (**Input Data**) held in SDRAM to flash memory.

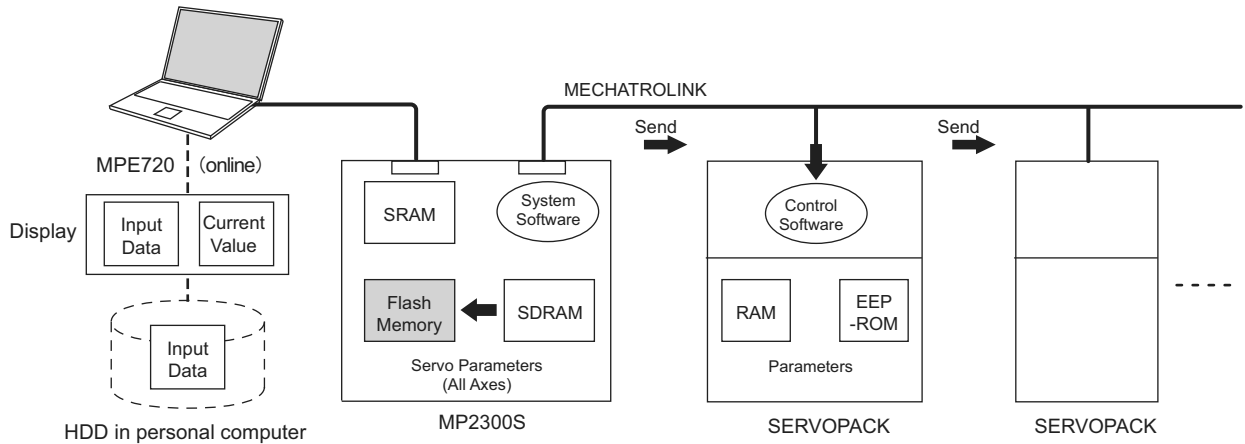

- Save to flash memory also after having changed set data of SERVOPACK parameter.



■ Precautions When Saving SERVOPACK Parameters

Before executing a saving operation in the **SERVOPACK** Tab Page, except during SERVOPACK replacement, always select **Edit - Current Value - Setting Value** to copy the values in **Current Value** to **Input Data**.

Appendix C Initializing SERVOPACKs

This section describes the procedure for initializing Σ -III SERVOPACKs using the Digital Operator. Always initialize SERVOPACKs that have been transferred from other systems.

- SERVOPACKs that are being used for the first time do not need to be initialized.

1. Check that the SERVOPACK power is OFF and then insert the Digital Operation connection plug into the CN3 connector on the SERVOPACK.
2. Turn ON the SERVOPACK control power and main power.
3. Turn ON the Digital Operator power.
4. Press the  Key on the Digital Operator to display the Auxiliary Function Mode main menu, and use the  or  Keys to select Fn005.

```
BB          - F U N C T I O N -  
Fn 0 0 4  
Fn 0 0 5  
Fn 0 0 6  
Fn 0 0 7
```

5. Press the  Key to switch to the Fn005 parameter initialization execution display.



- * If the display does not change and “NO-OP” is displayed on the status display, a Write Prohibited password has been set using Fn010 and the user settings cannot be initialized. Clear the write protection and execute the operation again.

6. Press the  Key again and execute Fn005.

“Parameter Init” will flash during initialization.

```
BB  
P a r a m e t e r   I n i t  
S t a r t   : [ D A T A ]  
R e t u r n : [ S E T ]
```

The flashing will stop when initialization has been completed and the status display will change from BB to Done to A.941.

- To cancel initialization, press the  Key before pressing the  Key. The display returns to the Auxiliary Function Mode main menu.

7. Turn the SERVOPACK control and main power supplies from OFF to ON to enable the initialization.

Appendix D Initializing the Absolute Encoder



The procedure for initializing an absolute encoder for a Σ -I, Σ -II, or Σ -III SERVOPACK is given below.

- Refer to 9.2.1 *System Startup Flowchart* in the *Machine Controller MP2000-series SVB/SVB-01 Motion Module User's Manual* (manual no. SIEPC88070033) for the procedure for absolute-position detection.

D.1 Σ -III SERVOPACK

- Refer to the following manuals for information on Σ -III series SERVOPACKS:
 Σ -III Series SGM \square S/SGDS User's Manual (Manual No. SIEP S80000000),
 Σ -III Series SGM \square S/SGDS User's Manual for MECHATROLINK-II Communications (Manual No. SIEP S80000011),
and *Σ -III Series SGM \square S/SGDS Digital Operator Instructions Manual (Manual No. TOBP S80000001)*

Follow the setup procedure below using a Digital Operator.

1. Press the  Key to display the Utility Function Mode main menu. Use the  Key or  Key to select Fn008.

```
BB      -FUNCTION-  
Fn007  
Fn008  
Fn009  
Fn00A
```

2. Press the  Key.

The display is switched to the execution display of Fn008 (Absolute encoder multi-turn reset and encoder alarm reset).

```
BB  
  
Multiturn Clear  
  
PGCL1
```

- If the display is not switched and "NO_OP" is displayed in the status display, the Write Prohibited setting (Fn010 = 0001) is set. Check the status and reset. Then clear the Write Prohibited setting.

3. Keep pressing the  Key until "PGCL1" is changed to "PGCL5."

```
BB  
  
Multiturn Clear  
  
PGCL5
```

4. Press the  Key.

"BB" in the status display changes to "Done."

```
Done  
  
Multiturn Clear  
  
PGCL5
```

5. Press the  Key. The display returns to the Utility Function Mode main menu.

This completes setting up the absolute encoder. Turn the power supply OFF and then back ON to reset the SERVOPACK.

D.2 Σ-II SERVOPACK

- Refer to the following manuals for information on Σ-II SERVOPACKS.
Σ-II Series SGM□H/SGDH User's Manual (SIEP S8000 000 05)
Σ-II Series SGM□/SGDB/SGM□H/SGDM User's Manual (SIEP S800000 15)

(1) Initialization Using a Hand-held Digital Operator

1. Press the DSPL/SET Key to select the Auxiliary Function Mode.



2. Select parameter Fn008 by pressing the LEFT (<) and RIGHT (>) Keys to select the digit to be changed and then using the UP (^) and DOWN (v) Keys to change the value of the digit.



3. Press the DATA/ENTER Key.

The following display will appear.

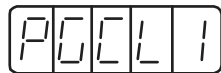

4. The rightmost digit will be incremented each time the UP (^) Key is pressed. Press the UP (^) Key several times until "PGCL5" is displayed.

If a mistake is made in the key operation, "nO_OP" will blink on the display for 1 second and then the display will return to the Auxiliary Function Mode. If this happens, return to step 3, above, and repeat the operation.

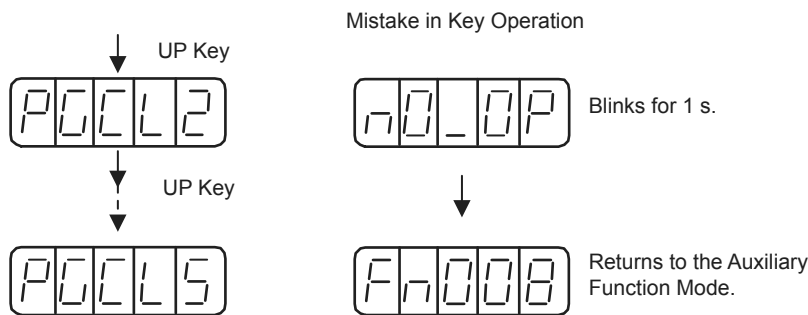

5. Press the DSPL/SET Key.

The display will change as shown below and the clear operation will be performed for multiturn data for the absolute encoder.

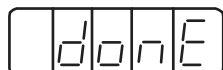
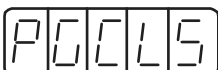
 Blinks for 1 s. → 

This completes initializing the absolute encoder. Reset the SERVOPACK to turn the power supply OFF and then back ON.

(2) Initialization Using the Built-in Panel Operator

1. Press the MODE/SET Key to select the Auxiliary Function Mode.

Fn000

2. Press the UP (▲) and DOWN (▼) Keys to select parameter Fn008.

Fn008

3. Press the DATA/ENTER Key for more than one second.

The following display will appear.

PGCL1

4. The rightmost digit will be incremented each time the UP (▲) Key is pressed. Press the UP (▲) Key several time until "PGCL5" is displayed.

If a mistake is made in the key operation, "nO_OP" will blink on the display for 1 second and then the display will return to the Auxiliary Function Mode. If this happens, return to step 3, above, and repeat the operation.

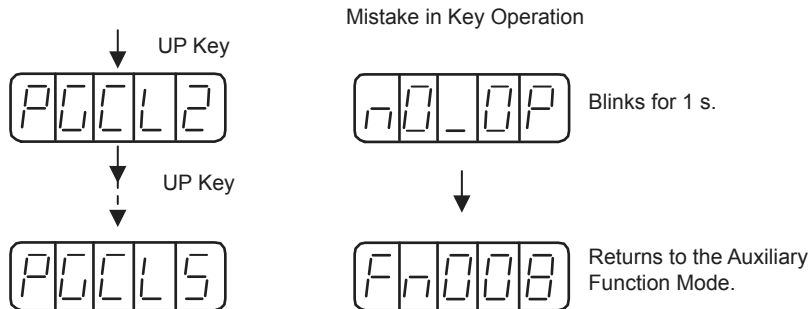

5. Press the MODE/SET Key.

The display will change as shown below and the clear operation will be performed for multiturn data for the absolute encoder.

done

Blinks for 1 s. → PGCL5

This completes initializing the absolute encoder. Reset the SERVOPACK to turn the power supply OFF and then back ON.

D.3 Σ -I SERVOPACK

- Refer to the following manuals for information on Σ -I SERVOPACKS.
 Σ Series SGM \square /SGD User's Manual (Manual No. SIE-S800-26.3)
 Σ Series SGM \square /SGDB High-speed Field Network MECHATROLINK-compatible AC Servo Driver User's Manual (Manual No. SIE-S800-26.4)

(1) Initializing a 12-bit Absolute Encoder

Use the following procedure to initialize a 12-bit absolute encoder.

1. Properly connect the SERVOPACK, Servomotor, and MP2300S.
2. Disconnect the connector on the encoder end and short-circuit pins 13 and 14 on the encoder end connector for 2 seconds or more.

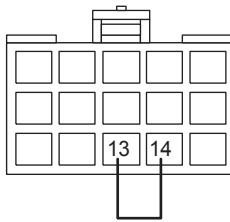

3. Remove the short piece and insert the connector securely in its original position.
4. Connect the cables using normal wiring and make sure the encoder battery is connected.
5. Turn ON the system.

Repeat the procedure starting from step 1 if an Absolute Encoder Alarm occurs, so the system has been successfully initialized.

(2) Initializing a 15-bit Absolute Encoder

Use the following procedure to initialize a 15-bit absolute encoder.

1. Turn OFF the SERVOPACK and MP2300S.
2. Discharge the large-capacity capacitor in the encoder using one of the following methods.
 - At the SERVOPACK End Connector
 - 1) Disconnect the connector on the SERVOPACK end.
 - 2) Use a short piece to short-circuit together connector pins 10 and 13 on the encoder end and leave the pins short-circuited for at least 2 minutes.
 - 3) Remove the short piece and insert the connector securely in its original position.
 - At the Encoder End Connector
 - 1) Disconnect the connector on the encoder end.
 - 2) Use a short piece to short-circuit together connector pins R and S on the encoder end and leave the pins short-circuited for at least 2 minutes.
 - 3) Remove the short piece and insert the connector securely in its original position.

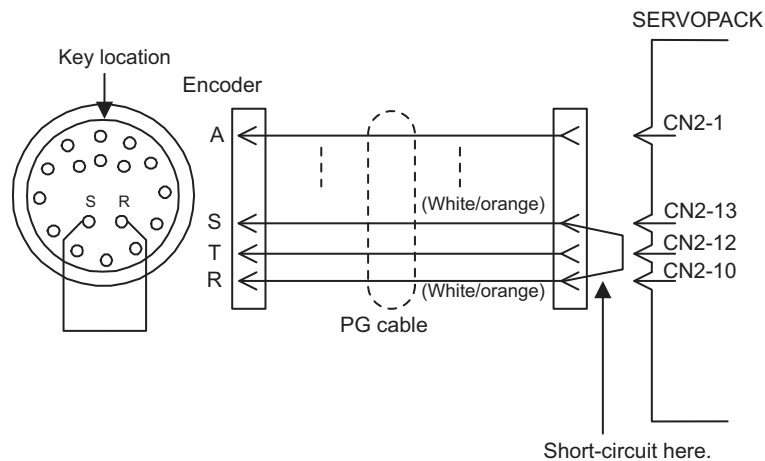

3. Connect the cables using normal wiring and make sure the encoder battery is connected.
4. Turn ON the system.

Repeat the procedure starting from step 1 if an Absolute Encoder Alarm occurs, so the system has been successfully initialized.

Appendix E Motion Parameter Details

E.1 Fixed Parameter List

The following table provides a list of SVB and SVR motion fixed parameters.

Slot Number	Name	Contents	SVB	SVR
0	Selection of Operation Modes	0: Normal Operation Mode	Yes	Yes
		1: Axis Unused	Yes	Yes
		2: Simulation Mode	Yes	
		3: Servo Driver Transmission Reference Mode	Yes	
		4 and 5: Reserved	–	–
1	Function Selection Flag 1	Bit 0: Axis Selection (0: Finite length axis/1: Infinite length axis) • Set to 0 for linear type.	Yes	Yes
		Bit 1: Soft Limit (Positive Direction) Enable/Disable	Yes	
		Bit 2: Soft Limit (Negative Direction) Enable/Disable	Yes	
		Bit 3: Overtravel Positive Direction Enable/Disable	Yes	
		Bit 4: Overtravel Negative Direction Enable/Disable	Yes	
		Bits 5 to 7: Reserved	–	–
		Bit 8: Interpolation Segment Distribution Processing	Yes	
		Bit 9: Simple ABS Rotary Pos. Mode (Simple Absolute Infinite Axis Position Control) (0: Disabled/1: Enabled) • Set to 0 for linear type.	Yes	
		Bit A: User Constants Self-writing Function	Yes	
		Bits B to F: Reserved		
2	Function Selection Flag 2	Bit 0: Communication Abnormality Detection Mask	Yes	
		Bit 1: WDT Abnormality Detection Mask	Yes	
		Bits 2 to F: Reserved for system use.	–	–
3	–	Reserved	–	–
4	Reference Unit Selection	0: pulse, 1: mm, 2: deg, 3: inch, 4: μm • For linear type, only valid for 0: pulse, 1: mm, 4: μm . When 2: deg, 3: inch is set, converted into 1: mm.	Yes	Yes
5	Number of Digits below Decimal Places	1 = 1 digit	Yes	Yes
6	Travel Distance per Machine Rotation (Rotary Motor)	1 = 1 reference unit	Yes	Yes
	Linear Scale Pitch (Linear Type)	1 = 1 reference unit	Yes	Yes
8	Servo Motor Gear Ratio	1 = 1 rotation (This setting is ignored if a linear motor is selected.)	Yes	Yes
9	Machine Gear Ratio	1 = 1 rotation (This setting is ignored if a linear motor is selected.)	Yes	Yes
10	Infinite Length Axis Reset Position (POSMAX)	1 = 1 reference units • Invalid for linear type.	Yes	Yes
12	Positive Software Limit Value	1 = 1 reference unit	Yes	
14	Negative Software Limit Value	1 = 1 reference unit	Yes	
16	Backlash Compensation Amount	1 = 1 reference unit	Yes	
18 to 29	–	Reserved	–	–
30	Encoder Selection	0: Incremental Encoder 1: Absolute Encoder 2: Absolute Encoder (Incremental encoder is used.) 3: Reserved	Yes	
31 to 33	–	Reserved	–	–

(cont'd)

Slot Number	Name	Contents	SVB	SVR
34	Rated Motor Speed (Rotary Motor)	1 = 1 rpm	Yes	Yes
	Rated Speed (Linear Type)	1 = 0.1 m/s, 0.1 mm/s	Yes	Yes
36	Number of Pulses per Motor Rotation (Rotary Motor)	1 = 1 pulse/rev Set the value after multiplication.	Yes	Yes
	Number of Pulses per Linear Scale Pitch (Linear Type)	1 = 1 pulse/scale pitch	Yes	Yes
38	Maximum Number of Absolute Encoder Turns Rotation	1 = 1 rotation • Set to 0 when a direct drive motor is being used.	Yes	
40 to 41	–	Reserved	–	–
42	Feedback Speed Movement Averaging Time Constant	1 = 1 ms	Yes	Yes

E.2 Setting Parameter List

The following table provides a list of SVB and SVR motion setting parameters.

- Refer to the pages listed in the *Details* column for details of each setting parameter.
- Refer to 2.2.6 *SVR Virtual Motion Module* on page 2-47 for information on SVR.

Register No.	Name	Contents	SVB	SVR
OW□□00	RUN Command Setting	Bit 0: Servo ON (0: OFF/1: ON)	Yes	Yes
		Bit 1: Machine Lock (0: Normal operation/1: Machine locked)	Yes	
		Bits 2 to 3: Reserved		
		Bit 4: Latch Detection Demand (0: OFF/1: ON)	Yes	
		Bit 5: Reserved for system use.		
		Bit 6: POSMAX Turn Number Presetting Demand (0: OFF/1: ON) • Set to 0 for linear type.	Yes	Yes
		Bit 7: Request ABS Rotary Pos. Load (Absolute System Infinite Length Position Information LOAD) (0: OFF/1: ON) • Set to 0 for linear type.	Yes	
		Bit 8: Forward Outside Limiting Torque/Thrust Input (Forward External Limiting Torque/Thrust Input) (0: OFF/1: ON)	Yes	
		Bit 9: Reverse Outside Limiting Torque/Thrust Input (Reverse External Limiting Torque/Thrust Input) (0: OFF/1: ON)	Yes	
		Bit A: Reserved		
		Bit B: Integration Reset (0: OFF/1: ON)	Yes	
		Bits C to D: Reserved		
		Bit E: Communication Reset (0: OFF/1: ON)	Yes	
		Bit F: Alarm Clear (0: OFF/1: ON)	Yes	Yes
OW□□01	Mode Setting 1	Bit 0: Excessive Deviation Error Level Setting (0: Alarm/1: Warning)	Yes	
		Bits 1 to 2: Reserved		
		Bit 3: Speed Loop P/PI Switch	Yes	
		Bit 4: Gain Switch	Yes	
		Bit 5: Gain Switch 2	Yes	
		Bits 6 to F: Reserved		
OW□□02	Mode Setting 2	Bit 0: Monitor 2 Enabled	Yes	
		Bits 1 to 3: Reserved		
		Bits 4: Reserved		
		Bits 5 to 7: Reserved		
		Bits 8 to 15: Stop Mode Selection	Yes	
OW□□03	Function Setting 1	Bits 0 to 3: Speed Unit Selection 0: Reference unit/s 1: 10 ⁿ reference unit/min 2: Percentage of rated speed (1 = 0.01%) 3: Percentage of rated speed (1 = 0.0001%)	Yes	Yes
		Bits 4 to 7: Acceleration/Deceleration Degree Unit Selection 0: Reference units/s ² 1: ms	Yes	Yes
		Bits 8 to B: Filter Type Selection 0: No filter 1: Exponential acceleration/deceleration filter 2: Moving average filter	Yes	Yes
		Bits C to F: Torque Unit Selection 0: Percentage of rated torque (1 = 0.01%) 1: Percentage of rated torque (1 = 0.0001%)	Yes	Yes

(cont'd)

Register No.	Name	Contents	SVB	SVR
OW□□04	Function Setting 2	Bits 0 to 3: Latch Detection Signal Selection		
		0: -		
		1: -		
		2: Phase-C Pulse Input Signal	Yes	
		3: /EXT1	Yes	
		4: /EXT2	Yes	
		5: /EXT3	Yes	
		Bits 4 to 7: External Positioning Signal Setting		
		0: -		
		1: -		
		2: Phase-C Pulse Input Signal	Yes	
		3: /EXT1	Yes	
		4: /EXT2	Yes	
		5: /EXT3	Yes	
		Bits 8 to B: Reserved		
		Bits C to F: Bank Selector	Yes	
OW□□05	Function Setting 3	Bit 1: Phase Reference Creation Calculation Disable (0: Enabled/1: Disabled)	Yes	
		Bits 2 to A: Reserved		
		Bit B: Zero Point Return Input Signal (0: OFF/1: ON)	Yes	
		Bits C to F: Reserved		
OW□□06 to OW□□07	-	Reserved	-	-
OW□□08	Motion Command	0: NOP (No Command) 1: POSING (Position Mode)(Positioning) 2: EX_POSING (Latch Target Positioning)(External Positioning) 3: ZRET (Zero Point Return) 4: INTERPOLATE (Interpolation) 5: ENDOF_INTERPOLATE (Last Interpolation Segment) 6: LATCH (Interpolation Mode with Latch Input) 7: FEED (Jog Mode) 8: STEP (Relative Position Mode)(Step Mode) 9: ZSET (Set Zero Point) 10: ACC (Change Acceleration Time) 11: DCC (Change Deceleration Time) 12: SCC (Change Filter Time Constant) 13: CHG FILTER (Change Filter Type) 14 : KVS (Change Speed Loop Gain) 15 : KPS (Change Position Loop Gain) 16: KFS (Change Feed-Forward) 17: PRM_RD (Read User Constant)(Read SERVOPACK Parameter) 18: PRM_WR (Write User Constant)(Write SERVOPACK Parameter) 19: ALM_MON (Alarm Monitor) 20: ALM_HIST (Alarm History Monitor) 21: ALMHIST_CLR (Clear Alarm History) 22: ABS_RST (Absolute Encoder Reset) 23: VELO (Speed Reference) 24: TRQ (Torque/Thrust Reference) 25: PHASE (Phase Reference) 26: KIS (Change Position Loop Integral Time Constant) 27: PPRM_WR (Stored Parameter Write)	Yes	Yes

(cont'd)

Register No.	Name	Contents	SVB	SVR
OW□□09	Motion Command Control Flag	Bit 0: Holds a Command. (0: OFF/1: ON)	Yes	Yes
		Bit 1: Interrupt a Command. (0: OFF/1: ON)	Yes	Yes
		Bit 2: Moving Direction (JOG/ STEP) (0: Forward rotation/1: Reverse rotation)	Yes	Yes
		Bit 3: Zero Point Return Direction Selection (0: Reverse rotation/1: Forward rotation)	Yes	
		Bit 4: Latch Zone Effective Selection (0: Disabled/1: Enabled)	Yes	
		Bit 5: Position Reference Type (0: Incremental Addition Mode/1: Absolute Mode)	Yes	Yes
		Bit 6: Phase Compensation Type (0: Incremental Addition Mode/1: Absolute Mode)	Yes	
		Bits 7 to F: Reserved		
OW□□0A	Motion Subcommand	0: NOP (No Command)	Yes	Yes
		1: PRM_RD (Read User Constant)(Read SERVOPACK Parameter) 2: PRM_WR (Write User Constant)(Write SERVOPACK Parameter) 3: Reserved 4: SMON (Status Monitor)	Yes	
		5: FIXPRM_RD (Read Fixed Parameters)	Yes	Yes
OW□□0B	–	Reserved		
OL□□0C	Torque/Thrust Reference Setting	Unit is according to OW□□03, bits 12 to 15 (Torque Unit).	Yes	Yes
OW□□0E	Speed Limit Setting at the Torque/Thrust Reference	1 = 0.01% (percentage of rated speed)	Yes	
OW□□0F	–	Reserved		
OL□□10	Speed Reference Setting	Unit is according to OW□□03, bits 0 to 3 (Speed Unit).	Yes	Yes
OW□□12 to OW□□13	–	Reserved	–	–
OL□□14	Positive Side Limiting Torque/Thrust Setting at the Speed Reference	Unit is according to OW□□03, bits C to F (Torque Unit).	Yes	
OL□□16	Secondly Speed Compensation	Unit is according to OW□□03, bits 0 to 3 (Speed Unit).	Yes	Yes
OW□□18	Override	1 = 0.01%	Yes	
OW□□19 to OW□□1B	–	Reserved	–	–
OL□□1C	Position Reference Setting	1 = 1 reference unit	Yes	Yes
OL□□1E	Width of Positioning Completion	1 = 1 reference unit	Yes	
OL□□20	NEAR Signal Output Width	1 = 1 reference unit	Yes	
OL□□22	Error Count Alarm Detection	1 = 1 reference unit	Yes	
OL□□24	–	Reserved for system use.	–	–
OW□□26	Position Complete Cheek Time	1 = 1 ms	Yes	
OW□□27	–	Reserved for system use.		
OL□□28	Phase Correction Setting	1 = 1 reference unit	Yes	
OL□□2A	Latch Zone Lower Limit Setting	1 = 1 reference unit	Yes	

(cont'd)

Register No.	Name	Contents	SVB	SVR
OL□□2C	Latch Zone Upper Limit Setting	1 = 1 reference unit	Yes	
OW□□2E	Position Loop Gain	1 = 0.1/s	Yes	
OW□□2F	Speed Loop Gain	1 = 1 Hz	Yes	
OW□□30	Speed Feedforward Amends	1 = 0.01% (percentage of distribution segment)	Yes	
OW□□31	Speed Compensation	1 = 0.01% (percentage of rated speed)	Yes	Yes
OW□□32	Position Integration Time Constant	1 = 1 ms	Yes	
OW□□33	–	Reserved	–	–
OW□□34	Speed Integration Time Constant	1 = 0.01 ms	Yes	
OW□□35	–	Reserved	–	–
OL□□36	Straight Line Acceleration/ Acceleration Time Constant	Unit is according to OW□□03, bits 4 to 7 (Speed Unit).	Yes	Yes
OL□□38	Straight Line Deceleration/ Deceleration Time Constant	Unit is according to OW□□03, bits 4 to 7 (Speed Unit).	Yes	Yes
OW□□3A	Filter Time Constant	1 = 0.1 ms	Yes	Yes
OW□□3B	Bias Speed for Index Deceleration/Acceleration Filter	Unit is according to OW□□03, bits 0 to 3 (Speed Unit).		Yes
OW□□3C	Zero Point Return Method	0: DEC1 + C (DEC 1 and C-Phase) 1: ZERO (Zero signal) 2: DEC1 + ZERO (DEC 1 and zero signal) 3: C (C-pulse)	Yes	
		4 to 10: Reserved	–	–
		11: C Pulse 12: POT & C Pulse 13: POT Only 14: HOME LS & C Pulse 15: HOME Only	Yes	
		16: NOT & C Pulse 17: NOT Only 18: INPUT & C Pulse 19: INPUT Only	Yes	
OW□□3D	Width of Starting Point Position Output	1 = 1 reference unit	Yes	Yes
OL□□3E	Approach Speed	Unit is according to OW□□03, bits 0 to 3 (Speed Unit).	Yes	
OL□□40	Creep Rate	Unit is according to OW□□03, bits 0 to 3 (Speed Unit).	Yes	
OL□□42	Zero Point Return Travel Distance	1 = 1 reference unit	Yes	
OL□□44	STEP Travel Distance	1 = 1 reference unit	Yes	Yes
OL□□46	External Positioning Final Travel Distance	1 = 1 reference unit	Yes	
OL□□48	Zero Point Position in Machine Coordinate System Offset	1 = 1 reference unit	Yes	Yes
OL□□4A	Work Coordinate System Offset	1 = 1 reference unit	Yes	Yes
OL□□4C	Number of POSMAX Turns Presetting Data	1 = 1 reference unit • Invalid for linear type.	Yes	Yes

(cont'd)

Register No.	Name	Contents	SVB	SVR
OW□□4E	Servo User Monitor Setting	Bits 0 to 3: Monitor 1 (Setting impossible) Bits 4 to 7: Monitor 2 Bits 8 to B: Monitor 3 (Setting impossible) Bits C to F: Monitor 4	Yes	
OW□□4F	Servo Driver Alarm Monitor No.	Set the number of the alarm to monitor.	Yes	
OW□□50	Servo Driver User Constant No.	Set the number of the SERVOPACK parameter.	Yes	
OW□□51	Servo Driver User Constant Number Size	Set the number of words in the SERVOPACK parameter.	Yes	
OL□□52	Servo Driver User Constant Set Point	Set the setting for the SERVOPACK parameter.	Yes	
OW□□54	Servo Driver for Assistance User Constant No.	Set the number of the SERVOPACK parameter number.	Yes	
OW□□55	Servo Driver for Assistance User Constant Size	Set the number of words in the SERVOPACK parameter.	Yes	
OL□□56	Servo Driver for Assistance User Constant Set Point	Set the setting for the SERVOPACK parameter.	Yes	
OW□□58 to OW□□5B	–	Reserved	–	–
OW□□5C	Fixed Parameter Number	Set the number of the fixed parameter to read with the FIXPRM_RD motion subcommand.	Yes	Yes
OW□□5D	–	Reserved	–	–
OL□□5E	Encoder Position When Power is OFF (Lower 2 Words)	1 = 1 pulse • Do not set in the linear type.	Yes	
OL□□60	Encoder Position When Power is OFF (Upper 2 Words)	1 = 1 pulse • Do not set in the linear type.	Yes	
OL□□62	Pulse Position When Power is OFF (Lower 2 Words)	1 = 1 pulse • Do not set in the linear type.	Yes	
OL□□64	Pulse Position When Power is OFF (Upper 2 Words)	1 = 1 pulse • Do not set in the linear type.	Yes	
OL□□66 to OL□□6E	–	Reserved	–	–
OW□□70 to OW□□7F	Command Buffer for Transparent Command Mode	This area is used for command data when MECHATROLINK servo commands are specified directly.	Yes	

E.3 Monitoring Parameter List

The following table provides a list of SVB and SVR motion monitoring parameters.

Register No.	Name	Contents	SVB	SVR
IW□□00	RUN Status	Bit 0 Motion Controller Operation Ready	Yes	Yes
		Bit 1: Running (At Servo ON)	Yes	Yes
		Bit 2: System Busy	Yes	
		Bit 3: Servo Ready	Yes	
		Bit 4: Latch Mode	Yes	
		Bits 5 to F: Reserved	–	–
IW□□01	Parameter Number When Range Over is Generated	Setting parameters: 0 or higher Fixed Parameters: 1000 or higher	Yes	Yes
IL□□02	Warning	Bit 0: Excessive Deviation	Yes	
		Bit 1: Set Parameter Error (Setting Parameter Error)	Yes	Yes
		Bit 2: Fixed Parameter Error	Yes	Yes
		Bit 3: Servo Driver Error	Yes	
		Bit 4: Motion Command Set Error	Yes	Yes
		Bit 5: Reserved (AD Conversion Error)	–	–
		Bit 6: Positive Direction Overtravel	Yes	
		Bit 7: Negative Direction Overtravel	Yes	
		Bit 8: Servo ON Incomplete	Yes	
		Bit 9: Servo Driver Communication Warning	Yes	
		Bits A to 1F: Reserved		
IL□□04	Alarm	Bit 0: Servo Driver Error	Yes	
		Bit 1: Positive Direction Overtravel	Yes	
		Bit 2: Negative Direction Overtravel	Yes	
		Bit 3: Positive Direction Software Limit	Yes	
		Bit 4: Negative Direction Software Limit	Yes	
		Bit 5: Servo OFF	Yes	Yes
		Bit 6: Positioning Time Over	Yes	
		Bit 7: Excessive Positioning Moving Amount	Yes	
		Bit 8: Excessive Speed	Yes	
		Bit 9: Excessive Deviation	Yes	
		Bit A: Filter Type Change Error	Yes	
		Bit B: Filter Time Constant Change Error	Yes	
		Bit C: Reserved	–	–
		Bit D: Zero Point Unsetting • Invalid for linear type.	Yes	
		Bit E: Reserved	Yes	
		Bit F: Reserved	Yes	
		Bit 10: Servo Driver Synchronization Communications Error	Yes	
		Bit 11: Servo Driver Communication Error	Yes	
		Bit 12: Servo Driver Command Time-out Error	Yes	
Bit 13: Excessive ABS Encoder Rotations • Invalid for linear type.	Yes			
Bits 14 to 1D: Reserved	–	–		
Bit1E: Motor Type Set Error				
Bit1F: Connected Encoder Type Error				
IL□□06	–	Reserved	–	–
IW□□08	Motion Command Response Code	Same as OW□□08 (Motion Command).	Yes	Yes

(cont'd)

Register No.	Name	Contents	SVB	SVR
IW□□09	Motion Command Status	Bit 0: Command Execution Flag	Yes	Yes
		Bit 1: Command Hold Completed	Yes	Yes
		Bit 2: Reserved	–	–
		Bit 3: Command Error Completed Status (Command Error Occurrence)	Yes	Yes
		Bits 4 to 6: Reserved	–	–
		Bit 7: Reset Absolute Encoder Completed	Yes	
		Bit 8: Command Execution Completed	Yes	Yes
		Bits 9 to F: Reserved	–	–
IW□□0A	Subcommand Response Code	Same as OW□□0A (Motion Subcommand).	Yes	Yes
IW□□0B	Subcommand Status	Bit 0: Command Execution Flag	Yes	Yes
		Bits 1 to 2: Reserved	–	–
		Bit 3: Command Error Completed Status (Command Error Occurrence)	Yes	Yes
		Bits 4 to 7: Reserved	–	–
		Bit 8: Command Execution Completed	Yes	Yes
		Bits 9 to F: Reserved	–	–
IW□□0C	Position Management Status	Bit 0: Distribution Completed	Yes	Yes
		Bit 1: Positioning Completed	Yes	Yes
		Bit 2: Latch Completed	Yes	
		Bit 3: NEAR Position	Yes	Yes
		Bit 4: Zero Point Position	Yes	Yes
		Bit 5: Zero Point Return (Setting) Completed	Yes	Yes
		Bit 6: During Machine Lock	Yes	
		Bit 7: Reserved	–	–
		Bit 8: ABS Rotary Pos. Load Complete (ABS System Infinite Length Position Control Information Load Completed) Invalid for linear type.	Yes	
		Bit 9: POSMAX Turn Preset Complete (TPRSE) • Invalid for linear type.	Yes	Yes
		Bits A to F: Reserved		
IW□□0D	–	Reserved	–	–
IL□□0E	Target Position in Machine Coordinate System (TPOS)	1 = 1 reference unit	Yes	Yes
IL□□10	Calculated Position in Machine Coordinate system (CPOS)	1 = 1 reference unit	Yes	Yes
IL□□12	Machine Coordinate System Reference Position (MPOS)	1 = 1 reference unit	Yes	Yes
IL□□14	CPOS for 32 bit	1 = 1 reference unit	Yes	Yes
IL□□16	Machine Coordinate System Feedback Position (APOS)	1 = 1 reference unit	Yes	Yes
IL□□18	Machine Coordinate System Latch Position (LPOS)	1 = 1 reference unit	Yes	
IL□□1A	Position Error (PERR)	1 = 1 reference unit	Yes	
IL□□1C	Target Position Difference Monitor	1 = 1 reference unit		Yes
IL□□1E	Number of POSMAX Turns	1 = 1 turn • Invalid for linear type.	Yes	Yes

(cont'd)

Register No.	Name	Contents	SVB	SVR
IL□□20	Speed Reference Output Monitor	pulse/s	Yes	
IL□□22 to IL□□2A	–	Reserved	–	–
IW□□2C	Servo Driver Status	Bit 0: Alarm (ALM) Bit 1: Warning (WRNG) Bit 2: Command Ready (CMDRDY) Bit 3: Servo ON (SVON) Bit 4: Main Power Supply ON (PON) Bit 5: Machine Lock (MLOCK) Bit 6: Zero Position (ZPOINT) Bit 7: Locating Completed (Positioning Completed)(PSET) Bit 8: Command Profile Complete (Distribution Completed) (DEN) Bit 9: Torque Restriction (T_LIM) Bit A: Latch Complete (L_CMP) Bit B: Locating Neighborhood (NEAR Position) (NEAR) Bit C: Positive Software Limit (P_SOT) Bit D: Negative Software Limit (N_SOT)	Yes	
		Bits E to F: Reserved	–	–
IW□□2D	Servo Driver Alarm Code	Stores the alarm code from the SERVOPACK.	Yes	
IW□□2E	Servo Driver I/O Monitor	Bit 0: Forward Side Limit Switch Input Bit 1: Reverse Side Limit Switch Input Bit 2: Deceleration Dog Switch Input Bit 3: Encoder Phase-A Signal Input Bit 4: Encoder Phase-B Signal Input Bit 5: Encoder Phase-C Signal Input Bit 6: EXT1 Signal Input Bit 7: EXT2 Signal Input Bit 8: EXT3 Signal Input Bit 9: Brake State Output Bit A: Reserved Bit B: Reserved Bit C: CN1 Input Signal (IO12) Bit D: CN1 Input Signal (IO13) Bit E: CN1 Input Signal (IO14) Bit F: CN1 Input Signal (IO15)	Yes	
IW□□2F	Servo Driver User Monitor Information	Bits 0 to 3: Monitor 1 Bits 4 to 7: Monitor 2 Bits 8 to B: Monitor 3 Bits C to F: Monitor 4	Yes	
IL□□30	Servo Driver User Monitor 2	Stores the result of the selected monitor.	Yes	
IL□□32	Servo Driver User Monitor 3	Reserved		
IL□□34	Servo Driver User Monitor 4	Stores the result of the selected monitor.	Yes	
IW□□36	Servo Driver User Constant No. (SERVOPACK Parameter No. for MECHATROLINK Command Area)	Stores the number of the parameter being processed.	Yes	
IW□□37	Supplementary Servo Driver User Constant No. (SERVOPACK Parameter No. for MECHATROLINK Subcommand Area)	Stores the number of the parameter being processed.	Yes	

(cont'd)

Register No.	Name	Contents	SVB	SVR
IL□□38	Servo Driver User Constant Reading Data (SERVOPACK Parameter Reading Data for MECHATROLINK Command Area)	Stores the data of the parameter being read.	Yes	
IL□□3A	Supplementary Servo Driver User Constant Reading Data (SERVOPCK Parameter Reading Data for MECHATROLINK Subcommand Area)	Stores the data of the parameter being read.	Yes	
IW□□3F	Motor Type	Stores the type of motor actually connected. 0: Rotation type motor 1: Linear motor	Yes	
IL□□40	Feedback Speed	Unit is according to OW□□03, bits 0 to 3 (Speed Unit).	Yes	Yes
IL□□42	Feedback torque/thrust	Unit is according to OW□□03, bits 12 to 15 (Torque Unit).	Yes	Yes
IW□□44 to IW□□55	–	Reserved	–	–
IL□□56	Fixed Parameter Monitor	Stores the data of the fixed parameter when FIXPRM-RD has been specified in the Motion Subcommand.	Yes	Yes
IW□□58 to IW□□5C	–	Reserved	–	–
IL□□5E	Encoder Position When the Power is OFF (Lower 2 Words)	1 = 1 pulse	Yes	
IL□□60	Encoder Position When the Power is OFF (Upper 2 Words)	1 = 1 pulse	Yes	
IL□□62	Pulse Position When the Power is OFF (Lower 2 Words)	1 = 1 pulse	Yes	
IL□□64	Pulse Position when the Power is OFF (Upper 2 Words)	1 = 1 pulse	Yes	
IW□□66 to IW□□6F	–	Reserved	–	–
IW□□70 to IW□□7F	Response Buffer for Transparent Command Mode	Stores the response data when MECHATROLINK Servo commands are specified directly.	Yes	

Appendix F How to Set up Communication Process

This section explains how to set up a communication process connecting the MPE720 and MP2300S.
 In MPE720 Ver6, set the communication process on the MPE720 screen.
 Prepare the following equipment to carry out this procedure:

F.1 Preparation

(1) Controller

Product Name	Model	Q'ty
MP2300S	JEPMC-MP2300S-E	1

(2) Personal Computer

Product Name	Model	Q'ty
MPE720	CPMC-MPE770 (Ver.6.04 or later)	1
Ethernet Communication Cable	Any Commercial product Ethernet cross cable (category 5 or more)	1
Personal Computer Main Unit	Any Commercial product	1

(3) Necessary Others

Name	Specification	Q'ty
24-VDC Power Supply	Current capacity 2A or more	1

F.2 Procedure

1. Turn OFF the MP2300S 24-VDC power supply.
2. Wire MPE720 and MP2300S.

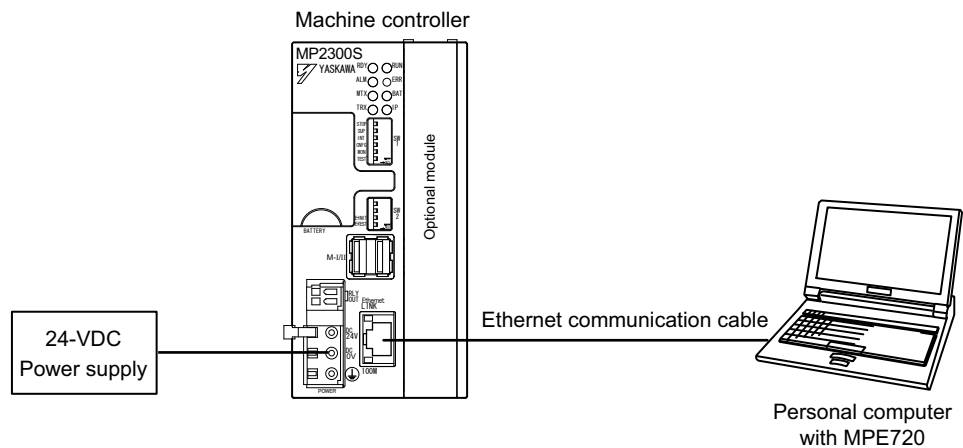

- Turn ON E-INIT of DIP switch (SW2) in the MP2300S main unit.

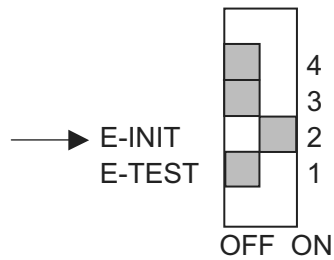

- Turn ON the 24-VDC power supply of the MP2300S, and confirm that the RDY, RUN, and IP LEDs are lit on the MP2300S main unit.
When the IP LED is lit, you can confirm that the MP2300S side has successfully retrieved an IP address.

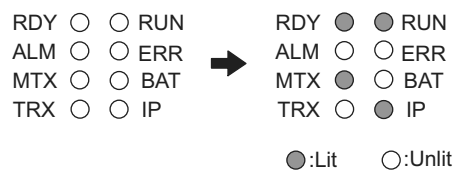

- Double-click the icon on the personal computer desktop to start up MPE720 Ver6.



- Create a new PLC folder.

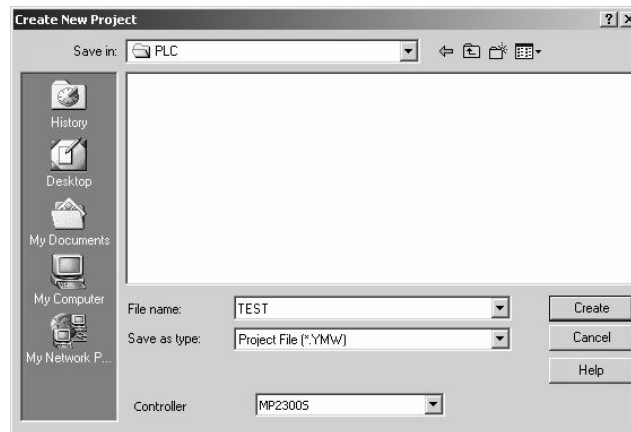

- Click **Communications Setting**.

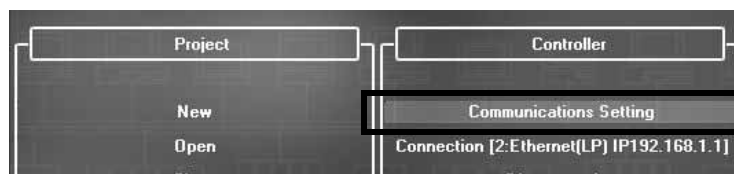

8. Select **Ethernet (LP) (IP:192.168.1.2)** as the communication port.



Personal computer IP address

Note: You can check the personal computer IP address in the control panel.

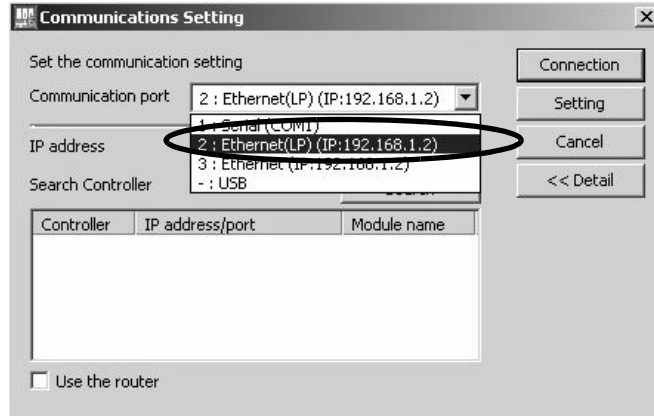

■ Difference between Ethernet (LP) and Ethernet

The LP of Ethernet (LP) is short for “Long packet.” Compared with Ethernet, Ethernet (LP) transmits and receives larger packets at one time, resulting in high-speed data transfer. Available communication ports may differ depending on the module of the connected controller. Select the communication port according to the table below.

Module of the Connected Controller Side	Name	Communication Port to Be Selected in MPE720
218IF-01	218IF	Ethernet
218IF-02	218IFB	Ethernet (LP)
MP2300S Built-in Ethernet	218IFA	

■ When there are multiple LAN ports on the personal computer

If there are multiple LAN ports on the personal computer, multiple IP addresses will be shown in the communication port. Select the IP address of the LAN port to which the cable is connected.

■ Controller search function

When Ethernet is selected in the communication port, the controller search function will be unavailable.

9. Click the **Search** Button.

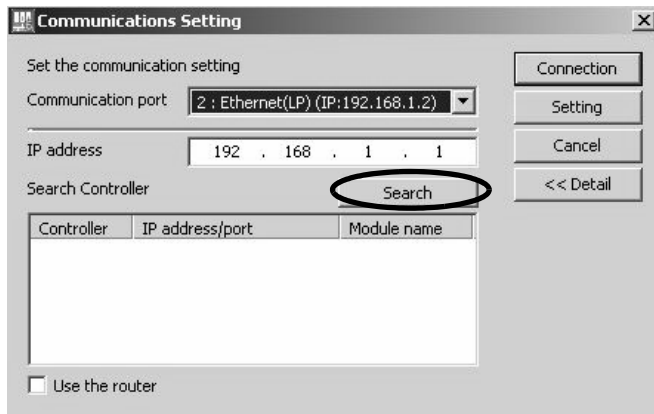

10. A controller search list will appear. Select the found controller and click the **Connection** Button.

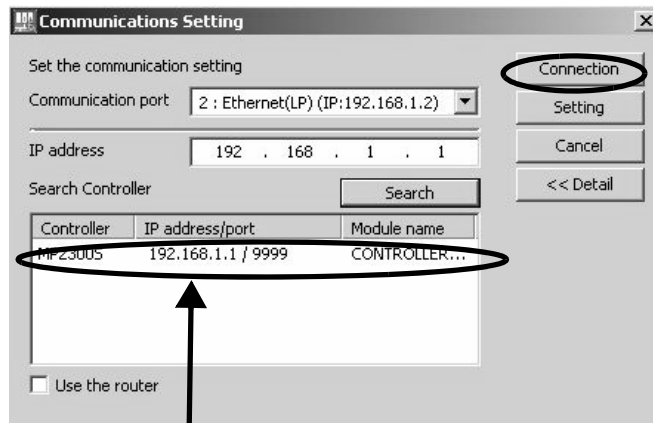

Personal computer IP address

11. MPE720 connects to the controller.

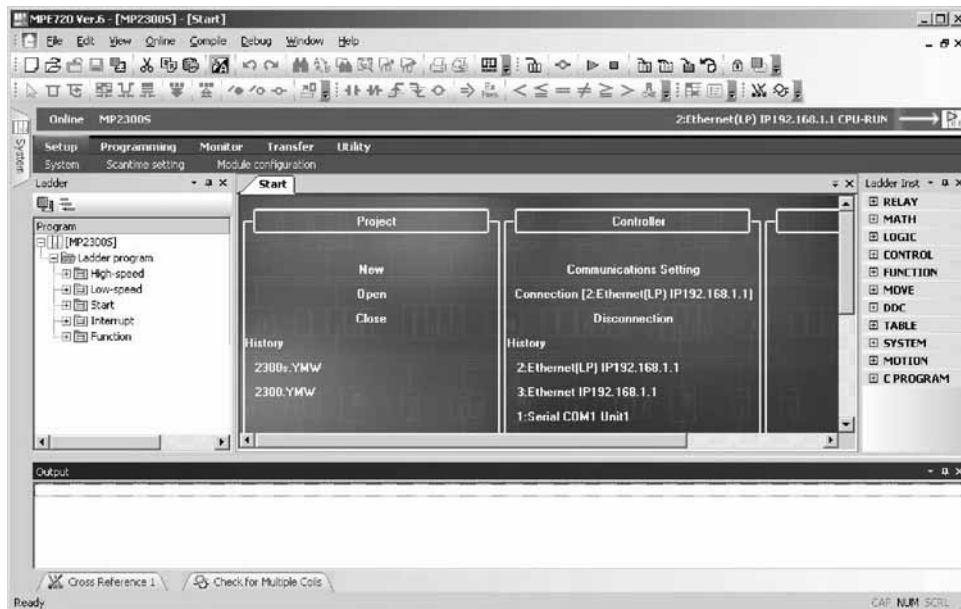

Appendix G MSG-SND/ MSG-RCV Functions

G.1 Message Transmit Function (MSG-SND)

This section explains the message transmit function (MSG-SND) used in a ladder program when transmitting messages.

G.1.1 Specification Overview of the Message Transmit Function

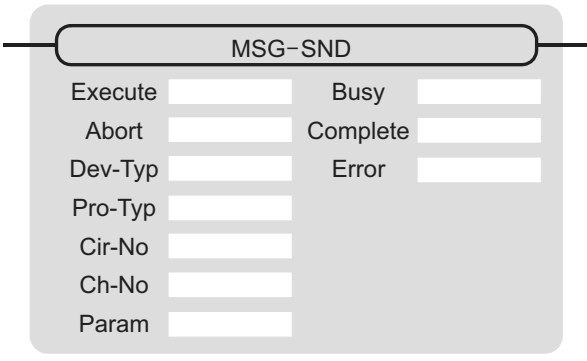
Function Name	MSG-SND			
Function	Transmits messages to a remote station on the circuit specified by the communication device type. Supports multiple protocols. Keep the execution command (Execute) until Complete or Error turns ON.			
Function Definition				
I/O Definition	No.	Name	I/O Option ^{(*)1}	Contents
Input Item	1	Execute	B-VAL	Executes a transmission
	2	Abort	B-VAL	Forcibly ends a transmission
	3	Dev-Typ	I-REG	Communication device type Ethernet (218IF) = 6, Ethernet (218IFA) = 16
	4	Pro-Typ	I-REG	Communication protocol MEMOBUS ^{(*)2} = 1, non-procedure 1 ^{(*)3} = 2, non-procedure 2 ^{(*)3} = 3
	5	Cir-No	I-REG	Circuit number Ethernet (218IF) = 1 to 8, Ethernet (218IFA) = 1 to 8
	6	Ch-No	I-REG	Communication buffer channel number Ethernet (218IF) = 1 to 10, Ethernet (218IFA) = 1 to 4
	7	Param	Address input	Parameter list start address (MA, DA)
Output Item	1	Busy	B-VAL	In process
	2	Complete	B-VAL	Process completed
	3	Error	B-VAL	Error has occurred

* 1. The meanings of I/O options are as follows:

B-VAL: Specify I/O by bit type data.

I-REG: Specify I/O by integer type data. When specifying, set an integer type register number.

As for the input only, it can be a constant (literal).

Address input: The address of the specified register (any integer register) is passed to the function.

* 2. When transmitting in MEMOBUS, Extended MEMOBUS, MELSEC, OMRON, or MODBUS/TCP protocol, set the communication protocol (Pro-Typ) to MEMOBUS(=1). The communication device automatically converts the protocol.

* 3. Non-procedure 1: In non-procedural communication, data is transmitted on a per-word basis.

Non-procedure 2: In non-procedural communication, data is transmitted on a per-byte basis.

G.1.2 I/O Item Details of the Message Transmit Function

(1) Input Item

The following table shows registers available for each input item.

Input Item	I/O Option	Available Register
Execute Abort	B-VAL	Every bit type register (except #, C registers), Same as above with subscript
Dev-typ Pro-Typ Cir-No Ch-No	I-REG	Every integer type register, Same as above with subscript, Constant
Param	Address input	Register address (except #, C registers), Same as above with subscript

1. Execute (executes a transmission)

Specifies a bit to command execution of a message transmission.

When the Execute bit turns ON, message transmission is implemented. To execute the process, a ladder program or the like needs to be used to switch it ON/OFF.

Note: Keep Execute (executes a transmission) ON until Complete (process completed) or Error (error occurred) is turned ON. When the command turns ON, the message transmission is implemented. To continuously command the transmit execution, make sure to turn Execute (executes a transmission) OFF for one scan or more.

2. Abort (forcibly ends a transmission)

Specify a bit to command a forced terminated of a message transmission.

When the Abort bit turns ON, the message transmission is forcibly terminated. Abort takes precedence over Execute.

In order to execute the forced abort, a ladder program or the like needs to be used to switch it ON/OFF.

3. Dev-Typ (communication device type)

Specify the type code of the communication device (refer to the table below).

Communication Device	Type Code
Ethernet (218IF)	6
Ethernet (218IFA)	16

4. Pro-Typ (communication protocol)

Specify the type code of the communication device (refer to the table below).

Type Code	Communication Protocol	Remarks
1	MEMOBUS	Set the type code to "1" when also transmitting using Extended MEMOBUS, MELSEC, or MODBUS/TCP protocol. The communication device automatically converts the protocol.
2	Non-procedure 1 (per word)	Data is transmitted on a per-word basis in non-procedural communication. No response is received from the remote.
3	Non-procedure 2 (per byte)	Data is transmitted on a per-byte basis in the non-procedural communication. No response is received from the remote.

5. Cir-No (line number)

Specify a circuit number for the communication device.

Specify it in accordance with the circuit number displayed in the MPE720 Module Configuration Definition Window.

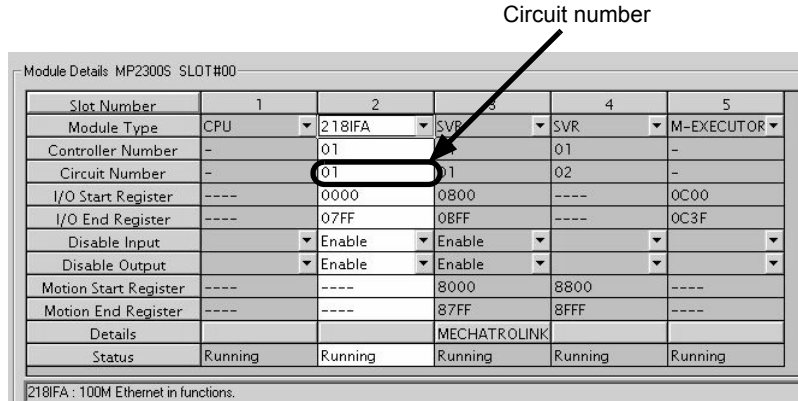

Fig. G.1 MPE720 Module Configuration Definition Window

The following table shows the scope of circuit numbers.

Communication Device	Valid Circuit Number
Ethernet (218IF or 218IFA)	1 to 8

6. Ch-No (communication buffer channel number)

Specify the channel of the communication buffer.

It can be any channel in the scope. However, when starting up multiple functions at the same time, set a unique channel for each function. If you do not start up multiple functions at the same time, the channel numbers can duplicate each other.

The following table shows the scope of channel numbers.

Communication Device	Valid Channel Number
Ethernet (218IF)	1 to 10
Ethernet (218IFA)	1 to 4

When the communication device is Ethernet (218IFA), because the communication buffer common to the transmission and reception has four channels, four transmissions (or receptions) are available at the same time by using channels 1 to 4.

- Note: 1. As many MSG-SND (or MSG-RCV) functions as lines used at the same time are required.
 2. For information on communication buffer channels, refer to G.3 *Communication Buffer Channel* on page A-102.

7. Param (parameter list start address)

Specify the start address of the parameter list. For the “parameter list,” 17 words are automatically assigned from the configured address. In the parameter list, enter the function code and its relevant parameter data. Also, process result and status are output.

Note: For more information about the parameter list, refer to the parameter details for each protocol from *G.1.4 Function Setting and Parameter Details for MEMOBUS and Extended MEMOBUS Protocols* on page A-41 to *G.1.7 Function Setting and Parameter Details for Non-procedural Protocol* on page A-61.

Example: When “DA00000” is specified as a parameter list start address.

Register	Parameter list			
	F	0
DW00000	PRAM00			
DW00001	PRAM01			
DW00002	PRAM02			
DW00003	PRAM03			
DW00004	PRAM04			
DW00005	PRAM05			
DW00006	PRAM06			
DW00007	PRAM07			
DW00008	PRAM08			
DW00009	PRAM09			
DW00010	PRAM10			
DW00011	PRAM11			
DW00012	PRAM12			
DW00013	PRAM13			
DW00014	PRAM14			
DW00015	PRAM15			
DW00016	PRAM16			

(2) Output Item

The following table shows the registers available for each output item.

Input Item	I/O Option	Available Register
Busy Complete Error	B-VAL	Every bit type register (except #, C registers), Same as above with subscript

1. Busy (in process)

Specify a bit that reports a message is transmitting.

The Busy bit is ON while executing a message transmission or forced abort process.

Keep Execute or Abort ON while Busy is ON.

2. Complete (process completed)

Specify a bit that reports that message transmission has ended.

When a message transmission or forced abort process is completed properly, the Complete bit will turn ON only for one scan.

3. Error (error occurred)

Specify a bit that reports that an error has occurred in the message transmission.

When an error occurs, the Error bit will turn ON only for one scan.

Note: For more information about the error cause, refer to *G.1.4 (2) Process Result (PARAM00)* on page A-42 and *G.1.4 (3) Status (PARAM00)* on page A-43.

A timing chart of bit type I/O items in the MSG-SND function is as follows:

[In Normal Condition]

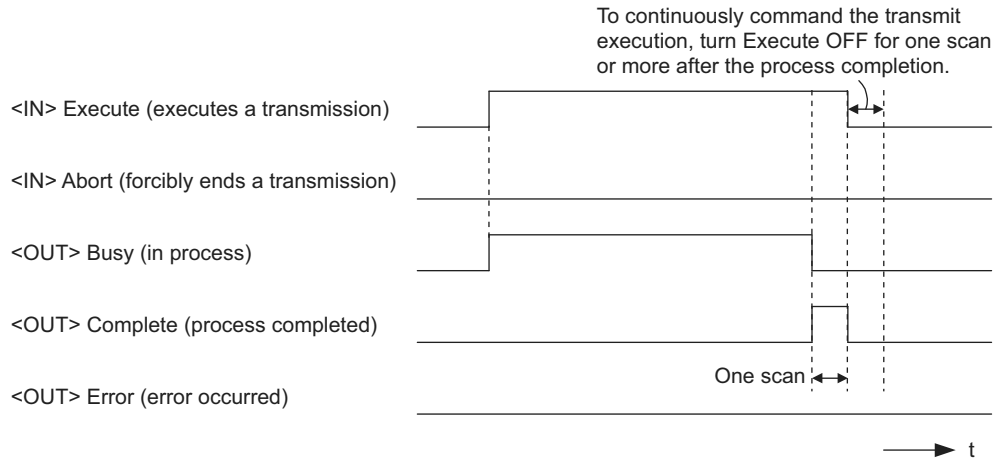

[When Forcibly Aborted]

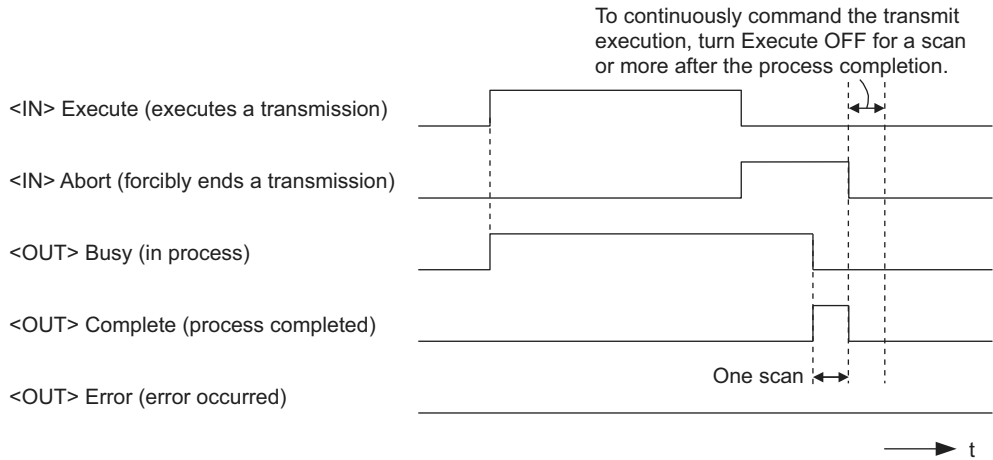

[When Error Occurs]

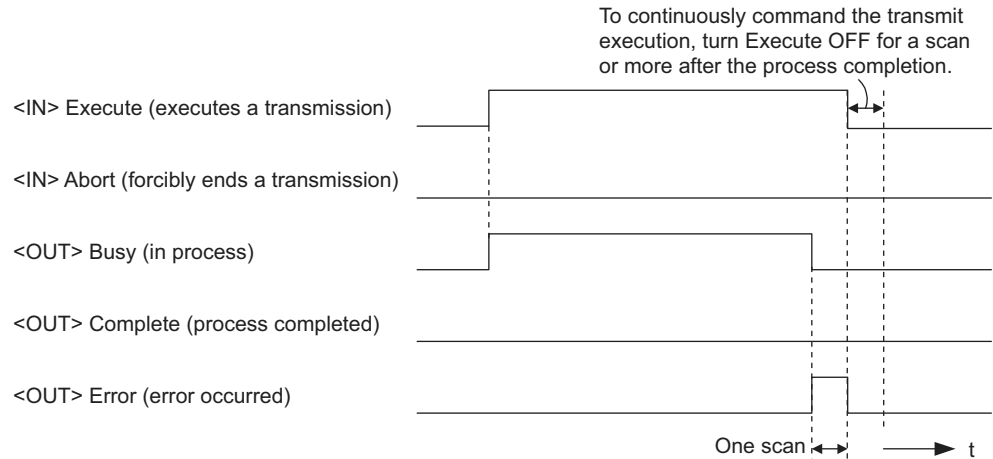

G.1.3 Message Transmit Function Parameter List (Param) Overview

The param of the MSG-SND function has a parameter list structure composed of 17 words. (The value of the Param itself is the start address (MA, DA) of the parameter list.)

In the parameter list, enter a connection number, function code and its relevant parameter data. Process results and status are also output.

When MEMOBUS or non-procedure is used as a communication protocol, the parameter list is as follows:

Note: Parameter details are explained in the parameter details for each protocol type. Refer to the following items:

- *G.1.4 Function Setting and Parameter Details for MEMOBUS and Extended MEMOBUS Protocols* on page A-41
- *G.1.5 Function Setting and Parameter Details for MELSEC Protocol* on page A-51
- *G.1.6 Function Setting and Parameter Details for MODBUS/TCP Protocol* on page A-56
- *G.1.7 Function Setting and Parameter Details for Non-procedural Protocol* on page A-61

(1) MEMOBUS Parameter List

Param No.	IN/OUT	Contents	Description
00	OUT	Process result	Process result is output.
01	OUT	Status	The status of the communication device is output.
02	IN	Connection number	Specifies the remote destination.
03	IN	Option	Sets a unique setting for each communication device.
04	IN	Function code	Sets a function code to transmit.
05	IN	Data address	Specifies the start address of the data.
06	IN	Data size	Sets the data size for a read/write request.
07	IN	Remote CPU number	Sets a remote CPU number.
08	IN	Coil offset	Sets the coil's offset word address.
09	IN	Input relay offset	Sets the offset word address of an input relay.
10	IN	Input register offset	Sets the offset word address of an input register.
11	IN	Holding register offset	Sets the offset word address of a holding register.
12	SYS	Reserved 1	
13 to 16	SYS	Reserved 2	

Note: IN: Input, OUT: Output, SYS: For system use

(2) Non-procedural Parameter List

Param No.	IN/OUT	Contents	Description
00	OUT	Process result	Process result is output.
01	OUT	Status	The status of the communication device is output.
02	IN	Connection number	Specifies the remote destination.
03	IN	(unused)	
04	IN	(unused)	
05	IN	Data address	Specifies the start address of the data.
06	IN	Data size	Sets the data size for a write request.
07	IN	(unused)	
08	IN	(unused)	
09	IN	(unused)	
10	IN	(unused)	
11	IN	Register offset	Sets the offset word address of the register.
12	SYS	Reserved 1	
13 to 16	SYS	Reserved 2	

Note: IN: Input, OUT: Output, SYS: For system use

G.1.4 Function Setting and Parameter Details for MEMOBUS and Extended MEMOBUS Protocols

This section explains the MSG-SND function setting and its parameter list details when MEMOBUS or Extended MEMOBUS is used as a protocol type.

(1) Message Transmit Function Setting

(a) 218IFA Setting Example

An example of a function setting when 218IFA is used as a communication device follows:

Set the protocol type to MEMOBUS even when used in Extended MEMOBUS protocol.

Set the circuit number in accordance with the line number allocated to the target 218IFA.

Set a unique communication buffer channel for the same circuit.

For information on the register number, refer to *G.1.2 (1) Input Item* on page A-36 and *G.1.2 (2) Output Item* on page A-38.

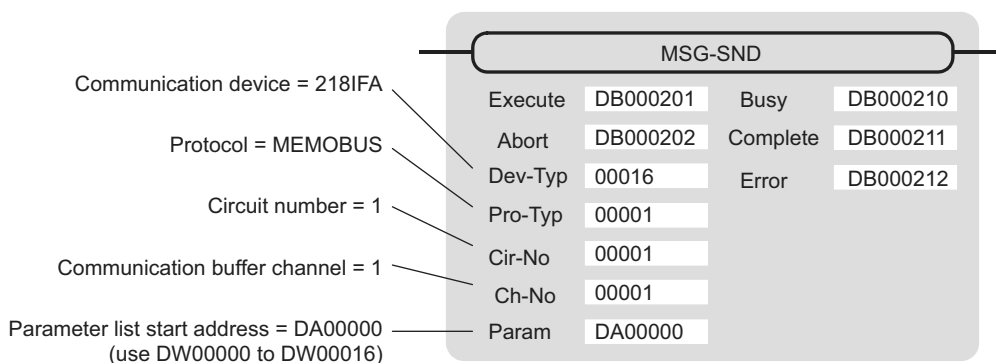

(b) 218IF Setting Example

An example of a function setting when 218IF is used as a communication device follows:

Set the protocol type to MEMOBUS even when used in Extended MEMOBUS protocol.

Set the circuit number in accordance with the line number allocated to the target 218IF.

Set a unique communication buffer channel for the same circuit.

For information on the register number, refer to *G.1.2 (1) Input Item* on page A-36 and *G.1.2 (2) Output Item* on page A-38.

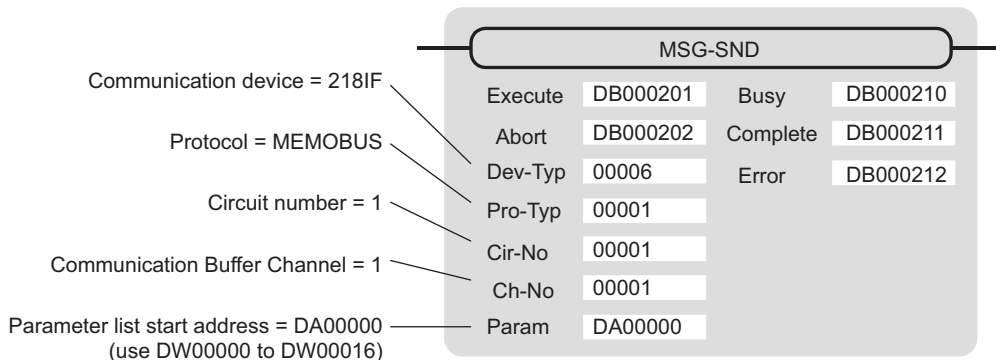

(2) Process Result (PARAM00)

Process result is output to the upper byte. Lower byte is used for system analysis.

Value of Process Result	Meaning
00□□H	In process (Busy)
10□□H	Process completed (Complete)
8y□□H	Error occurred (Error)

When an error occurs, take corrective action by referring to the following error contents:

Value of Process Result	Error Contents	Description
80□□H	–	Reserved
81□□H	Function code error	Unused function code was transmitted or received. Check PARAM04 (function code).
82□□H	Error in setting address	The following setting is out of the setting range. Check the setting. PARAM05 (data address) PARAM08 (coil offset) PARAM09 (input relay offset) PARAM10 (input register offset) PARAM11 (holding register offset)
83□□H	Data size error	The transmit or receive data size is out of the setting range. Check PARAM04 (data size).
84□□H	Error in setting circuit number	The circuit number is out of the setting range. Check Cir-No (circuit number) of the MSG-SND function.
85□□H	Error in setting channel number	The communication buffer channel number is out of the setting range. Check Ch-No (communication buffer channel number) of the MSG-SND function.
86□□H	Connection number error	The connection number is out of the setting range. Check PARAM02 (connection number).
87□□H	–	Reserved
88□□H	Communication section error	An error response was returned from the communication section (communication device). Check the equipment connection. In addition, confirm communication with the remote device.
89□□H	Device select error	Unavailable device is set. Check Dev-Typ (communication device type) of the MSG-SND function.

(3) Status (PARAM00)

Outputs status of the communication section (communication device).

The following figure shows the bit assignment and the bit assignment details is listed in the table (a) and after.

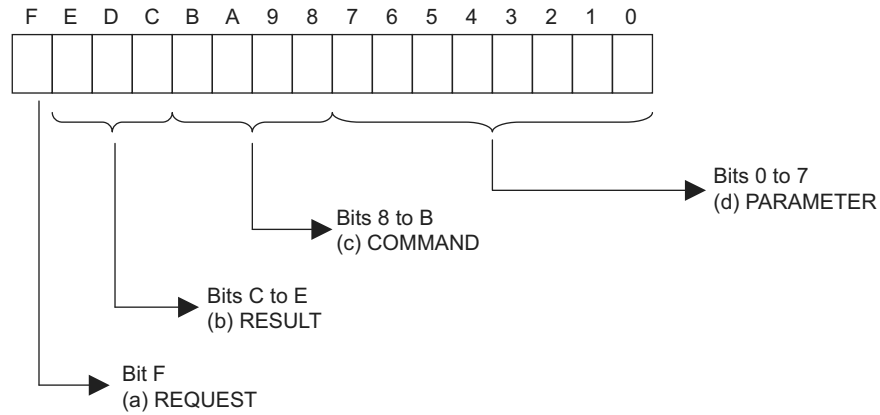

(a) REQUEST (request)

Outputs whether the MSG-SND function is requesting processing.

Bit State	Description
1	Requesting processing.
0	The acceptance of the process request is complete.

(b) RESULT (result)

Outputs the execution result of the MSG-SND function

Code	Abbreviation	Meaning
0	CONN_NG	In Ethernet communication, transmit error or connection error is complete
1	SEND_OK	Normal transmission complete
2	REC_OK	Normal reception complete
3	ABORT_OK	Forced abort complete
4	FMT_NG	Parameter format error
5	SEQ_NG	Command sequence error
6	RESET_NG	Reset state
7	REC_NG	Data reception error (error detected in the lower layer program)

(c) COMMAND (command)

Outputs a process command for the MSG-SND function. The executed process contents may differ depending on the command.

Code	Abbreviation	Meaning
1	U_SEND	General-purpose message transmission (for non-procedural protocol)
2	U_REC	General-purpose message reception (for non-procedural protocol)
3	ABORT	Forced termination
8	M_SEND	MEMOBUS command transmission: Completed when response is received
9	M_REC	MEMOBUS command reception: Accompanies a response transmission
C	MR_SEND	MEMOBUS response transmission

(d) PARAMETER (parameter)

When RESULT(process result) = 4 (FMT_NG: parameter format error), an error code in the table below is output. Otherwise, the connection number is output.

RESULT (process result)	Code (Hex)	Meaning
When RESULT (process result) = 4 (FMT_NG: parameter format error)	00	No error
	01	Connection number is out of range
	02	Time error for monitoring to receive MEMOBUS response
	03	Error in setting retransmit count
	04	Error in setting cyclic area
	05	CPU number error
	06	Data address error
	07	Data size error
	08	Function code error
Others	xx	Connection number

(4) Connection Number (PARAM02)

Specify the remote destination.

When the communication device is Ethernet (218IF/218IFA), set the connection number.

The following table shows the range of settings.

Communication Device	Connection Number	Remarks
Ethernet (218IF)	1 to 20	Transmits to the remote station set for the specified connection number.
Ethernet (218IFA)	1 to 4	Same as above

Note: When the communication device is Ethernet (218IF/218IFA), set the connection number in accordance with the connection number in the 218IF/218IFA Parameter Setting Window for the MPE720 module configuration definition.

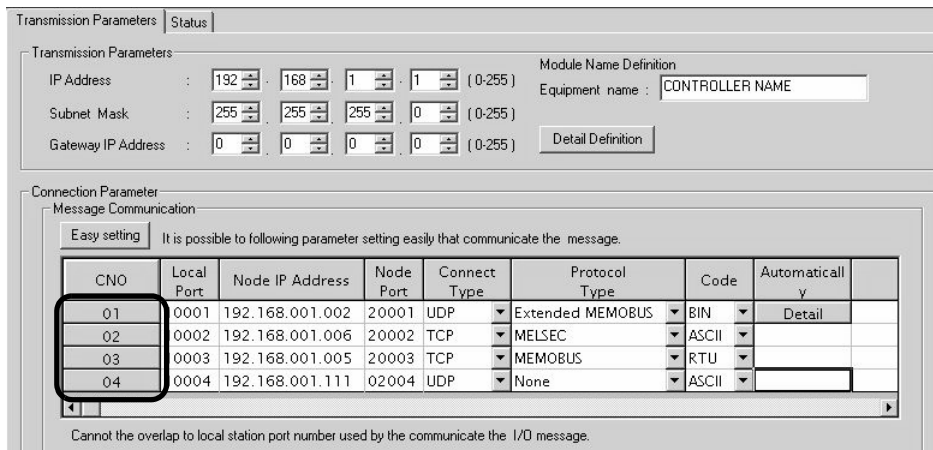

Fig. G.2 218IFA Parameter Setting Screen for the MPE720 Module Configuration Definition

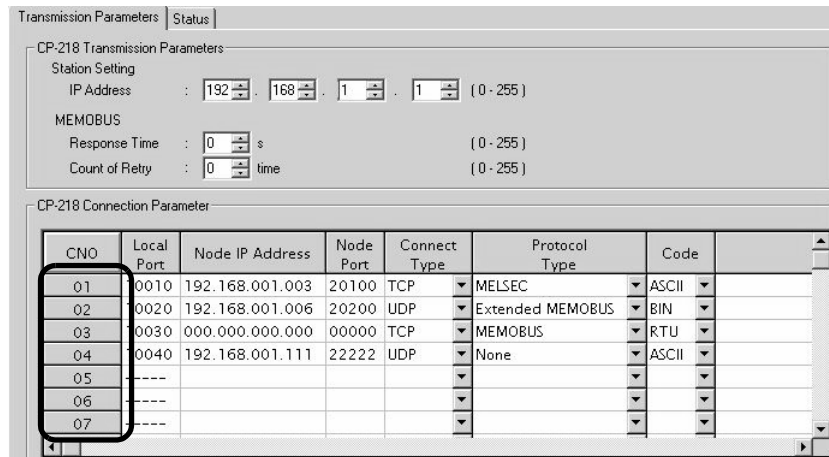

Fig. G.3 218IF Parameter Setting Screen for the MPE720 Module Configuration Definition

(5) Option (PARAM03)

Choose a unique setting for each communication device.

When the protocol is MEMOBUS or Extended MEMOBUS, this is not used, and no setting is necessary.

(6) Function Code (PARAM04)

Set a function code to transmit.

The functions (read coil or input relay state, write to holding register, etc.) registered in the function codes are made available by specifying the code.

The following table shows the function codes available when using a MEMOBUS or Extended MEMOBUS protocol.

Table G.1 Function Code List (MEMOBUS, Extended MEMOBUS)

Function Code	Target Data Type	Function	Protocol Type	
			Extended MEMOBUS	MEMOBUS
00H	—	Unused	—	—
01H	B	Reads coil state	√	√
02H	B	Reads input relay state	√	√
03H	W	Reads holding register content	√	√
04H	W	Reads input register content	√	√
05H	B	Changes single coil state	√	√
06H	W	Writes to single holding register	√	√
07H	—	Unused	—	—
08H	—	Loopback test	√	√
09H	W	Reads holding register content (extended)	√	—
0AH	W	Reads input register content (extended)	√	—
0BH	W	Writes to holding register (extended)	√	—
0CH	—	Unused	—	—
0DH	W	Discontinuously reads holding register (extended)	√	—
0EH	W	Discontinuously writes to holding register (extended)	√	—
0FH	B	Changes multiple coil states	√	√
10H	W	Writes to multiple holding registers	√	√

Note: 1. B: Bit type, W: Integer type

2. √: Available, -: Not available

3. Transmit and receive registers in the master operation mode are MW (MB) only.

4. In slave operation mode, the coil, holding register, input relay, and input register are MB, MW, IB, IW respectively.

(7) Data Address (PARAM05)

Specify the start address of the data.

The address must be input in decimal or hexadecimal numbers.

Example: When the start address is MW01000, specify “1000 (decimal)” or “3E8H (hexadecimal).”

The range of data addresses may differ, depending on the function code.

The following table shows the valid ranges of data addresses when using a MEMOBUS or Extended MEMOBUS protocol.

Table G.2 Valid Range of Data Addresses (MEMOBUS, Extended MEMOBUS)

Function Code	Target Data Type	Function	Valid Range of Data Addresses	
			Ethernet (2181F)	Ethernet (2181FA)
00H	—	Unused	Disable	
01H	B	Reads coil state*1	0 to 65535 (0 to FFFFH)	
02H	B	Reads input relay state*1	0 to 65535 (0 to FFFFH)	
03H	W	Reads holding register content*2	0 to 65534 (0 to FFFE H)	
04H	W	Reads input register content*2	0 to 32767 (0 to 7FFFH)	0 to 65535 (0 to FFFFH)
05H	B	Changes single coil state*1	0 to 65535 (0 to FFFFH)	
06H	W	Writes to single holding register*2	0 to 65534 (0 to FFFE H)	
07H	—	Unused	Disable	
08H	—	Loopback test	Disable	
09H	W	Reads holding register content (extended)*2	0 to 65534 (0 to FFFE H)	
0AH	W	Reads input register content (extended)*2	0 to 32767 (0 to 7FFFH)	0 to 65535 (0 to FFFFH)
0BH	W	Writes to holding register (extended)*2	0 to 65534 (0 to FFFE H)	
0CH	—	Unused	Disable	
0DH	W	Discontinuously reads holding register (extended)*3	0 to 65534 (0 to FFFE H)	
0EH	W	Discontinuously writes to holding register (extended)*3	0 to 65534 (0 to FFFE H)	
0FH	B	Changes multiple coil states*1	0 to 65535 (0 to FFFFH)	
10H	W	Writes to multiple holding registers*2	0 to 65534 (0 to FFFE H)	

* 1. Request for reading/writing coil or input relay: Specifies the start bit address of data

* 2. Request for continuously reading/writing register: Specifies the start word address of data

* 3. Request for discontinuously reading/writing register: Specifies the start M register number of the address table

Note: Address Table

An address table is used for specifying addresses indirectly in order to indicate discontinuous data. The PARAM06 (data size) sizes of addresses at the beginning of the M register set by PARAM05 (data address) are used as an address table.

When reading, specify the remote station's address to read for the data addresses 1-n. Read values are stored locally according to the data addresses 1-n.

When writing, data stored in the local data addresses 1-n is picked up and written into the remote station's data addresses 1-n.

The address table used when discontinuously reading/writing registers is as follows:

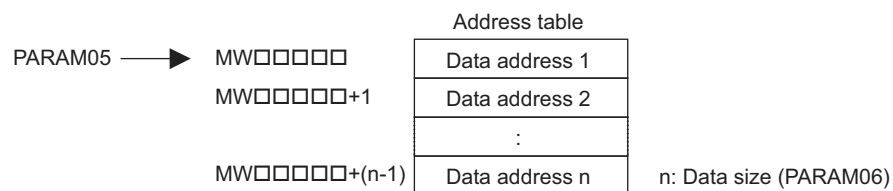

(8) Data Size (PARAM06)

Set the data size (number of bits or words) for the read/write request.

Be sure that the last data address determined based on the offset, data address, and data size does not go beyond the scope of the data addresses.

The range of data addresses may differ, depending on the function code and communication device.

The following table shows the valid ranges of data sizes when using a MEMOBUS or Extended MEMOBUS protocol.

Table G.3 Valid Range of Data Sizes (MEMOBUS, Extended MEMOBUS)

Function Code	Target Data Type	Function	Valid Range of Data Sizes	
			Ethernet(2181F)	Ethernet(2181FA)
00H	–	Unused	Disable	
01H	B	Reads coil state*1	1 to 2000	
02H	B	Reads input relay state*1	1 to 2000	
03H	W	Reads holding register content*2	1 to 125	
04H	W	Reads input register content*2	1 to 125	
05H	B	Changes single coil state	Disable	
06H	W	Writes to single holding register	Disable	
07H	–	Unused	Disable	
08H	–	Loopback test	Disable	
09H	W	Reads holding register content (extended)*2	1 to 508	1 to 2044 (BIN) 1 to 1020 (ASCII)
0AH	W	Reads input register content (extended)*2	1 to 508	1 to 2044 (BIN) 1 to 1020 (ASCII)
0BH	W	Writes to holding register (extended)*2	1 to 507	1 to 2043 (BIN) 1 to 1019 (ASCII)
0CH	–	Unused	Disable	
0DH	W	Discontinuously reads holding register (extended)*2	1 to 508	1 to 2044 (BIN) 1 to 1020 (ASCII)
0EH	W	Discontinuously writes to holding register (extended)*2	1 to 254	1 to 1022 (BIN) 1 to 510 (ASCII)
0FH	B	Changes multiple coil states*1	1 to 800	
10H	W	Writes to multiple holding registers*2	1 to 100	

* 1. Specifies the number of bits

* 2. Specifies the number of words

Note: Data size in the table is represented as a decimal number.

(9) Remote CPU Number (PARAM07)

Set a remote CPU number.

When the remote device is MP2□00 series, specify “1”.

When the remote device is a controller manufactured by YASKAWA Electric Corporation, but other than the MP2□00 series, and comprises multiple CPU modules, specify the destination CPU number.

Otherwise, specify “0”.

(10) Offset (PARAM08, PARAM09, PARAM10, PARAM11)

Specify the offset addresses of read data storage areas and write data source of the transmission side.

The address for the transmission side will be displaced by the number of words designated by the offset.

Note: 1. For more information, refer to *G.1.8 Relationship between Data Address, Data Size, and Offset for MSG-SND Function* on page A-66.

2. The offset cannot be a negative value.

The offset parameter is prepared for each target data type.

The following table lists the offset parameters.

Table G.4 Offset Parameter List

Parameter	Content	Description
PARAM08	Coil offset	Sets the coil's offset word address.
PARAM09	Input relay offset	Sets the offset word address of an input relay.
PARAM10	Input register offset	Sets the offset word address of an input register.
PARAM11	Holding register offset	Sets the offset word address of a holding register.

The valid offset parameter may differ, depending on the function code.

The following table provides the valid parameters for each function code.

Table G.5 Valid Parameter List for Offset of Each Function Code

Function Code	Function	Valid Offset Parameter	Protocol Type	
			Extended MEMOBUS	MEMOBUS
01H	Reads coil state	PARAM08	√	√
02H	Reads input relay state	PARAM09	√	√
03H	Reads holding register content	PARAM11	√	√
04H	Reads input register content	PARAM10	√	√
05H	Changes single coil state	PARAM08	√	√
06H	Writes to single holding register	PARAM11	√	√
09H	Reads holding register content (extended)	PARAM11	√	–
0AH	Reads input register content (extended)	PARAM10	√	–
0BH	Writes to holding register (extended)	PARAM11	√	–
0DH	Discontinuously reads holding register (extended)	PARAM11	√	–
0EH	Discontinuously writes to holding register (extended)	PARAM11	√	–
0FH	Changes multiple coil states	PARAM08	√	√
10H	Writes to multiple holding registers	PARAM11	√	√

Note: √: Available, -: Not available

(11) Reserved by System 1 (PARAM12)

Used by system (the channel number of the communication buffer in use is stored).

Note: Before the first scan during power up, make sure to set it to "0" by using a user program.

After that, the register is used by the system, so never change the value with the user program.

(12) Reserved by System 2 (PARAM13 to PARAM16)

Used by the system. Never change the value with the user program, etc.

G.1.5 Function Setting and Parameter Details for MELSEC Protocol

This section explains MSG-SND function setting and its parameter list details when MELSEC is used as a protocol.

(1) Message Transmit Function Setting

(a) 218IFA Setting Example

An example of a function setting when 218IFA is used as a communication device follows:

Set the protocol type to MEMOBUS when used in MELSEC protocol.

Set the circuit number in accordance with the circuit number allocated to the target 218IFA.

Set a unique communication buffer channel for the same circuit.

For information on the register number, refer to *G.1.2 (1) Input Item* on page A-36 and *G.1.2 (2) Output Item* on page A-38.

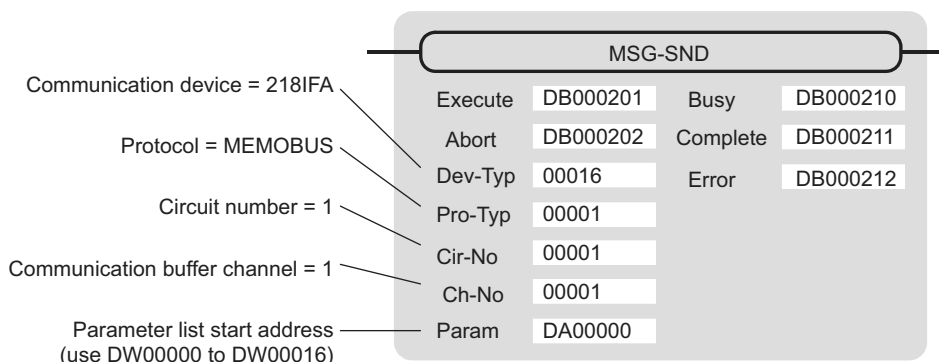

(b) 218IF Setting Example

An example of a function setting when 218IF is used as a communication device follows:

Set the protocol type to MEMOBUS when used in MELSEC protocol.

Set the circuit number in accordance with the circuit number allocated to the target 218IF.

Set a unique communication buffer channel for the same circuit.

For information on the register number, refer to *G.1.2 (1) Input Item* on page A-36 and *G.1.2 (2) Output Item* on page A-38.

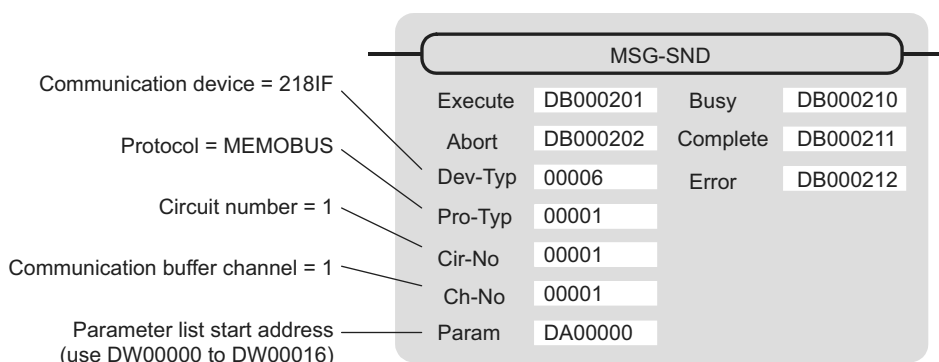

(2) Process Result (PARAM00)

Refer to *G.1.4 (2) Process Result (PARAM00)* on page A-42.

(3) Status (PARAM01)

Refer to *G.1.4 (3) Status (PARAM00)* on page A-43.

(4) Connection Number (PARAM02)

Refer to *G.1.4 (4) Connection Number (PARAM02)* on page A-45.

(5) Option (PARAM03)

Choose a unique setting for each communication device.

This is not used by the MELSEC protocol, and does not require setting when MELSEC is used.

(6) Function Code (PARAM04)

Set a function code to transmit.

The functions (read bit/word device, write to word device, etc.) registered in the function codes are made available by specifying the code.

The following table lists function codes used with the MELSEC protocol.

Table G.6 Function Code List

Function Code	MELSEC ACPU Common Command	Target Data Type	Function
01H/02H	00H	B	Reads bit device in units
03H/04H/09H/0AH	01H	W	Reads word device in units
05H/0FH	02H	B	Writes to bit device in units
06H/0BH/10H	03H	W	Writes to word device in units
08H	16H	–	Loopback test
0EH	05H	B	Specifies a device number for each word device at random and sets/resets each device
31H	60H	W	Writes to the fixed buffer in words
32H	61H	W	Reads from the random access buffer in words
33H	62H	W	Writes to the random access buffer in words

Note: 1. B: Bit type, W: Integer type

2. AnCPU dedicated commands are not supported. When accessing AnCPU, also use the ACPU common commands. You cannot access the AnCPU extended file register.

(7) Data Address (PARAM05)

Specify the start address of the data.

The address must be input in decimal or hexadecimal numbers.

Example: When the start address is MW01000, specify “1000 (decimal)” or “3E8H (hexadecimal).”

The valid range of usable function codes and data addresses may differ, depending on the device type and device range of the MELSEC side.

The following table gives the valid ranges of data addresses when using MELSEC as a protocol.

Table G.7 Valid Range of Data Addresses (MELSEC bit device)

Device	Device Range of ACPU Common Commands	Decimal/Hexadecimal	Function Code	Valid Range of Data Addresses	Corresponding Register Number
X	X0000 to X07FF	Hexadecimal	02H: Input relay	0 to 2047	MB000000 to MB00127F
Y	Y0000 to Y07FF	Hexadecimal	01H/0FH: Coil	0 to 2047	MB000000 to MB00127F
M	M0000 to M2047	Decimal	01H/05H/0FH: Coil	2048 to 4095	MB001280 to MB00255F
M	M9000 to M9255	Decimal	01H/05H/0FH: Coil	4096 to 4351	MB002560 to MB00271F
B	B0000 to B03FF	Hexadecimal	01H/05H/0FH: Coil	4352 to 5375	MB002720 to MB00335F
F	F0000 to F0255	Decimal	01H/05H/0FH: Coil	5376 to 631	MB003360 to MB00351F
TS	TS000 to TS255	Decimal	02H: Input relay	2048 to 2303	MB001280 to MB00143F
TC	TC000 to TC255	Decimal	02H: Input relay	2304 to 2559	MB001440 to MB00159F
CS	CS000 to CS255	Decimal	02H: Input relay	2560 to 2815	MB001660 to MB00175F
CC	CC000 to CC255	Decimal	02H: Input relay	2816 to 3071	MB001760 to MB00191F
M	M2048 to M8191	Decimal	01H/05H/0FH: Coil	8192 to 14335	MB005120 to MB00895F

Table G.8 Valid Range of Data Addresses (MELSEC word device)

Device	Device Range of ACPU Common Commands	Decimal/Hexadecimal	Function Code	Valid Range of Data Addresses	Corresponding Register Number
TN	TN000 to TN255	Decimal	04H/0AH: Input register	0 to 255	MW00000 to MW0255
CN	CN000 to CN255	Decimal	04H/0AH: Input register	256 to 511	MW00256 to MW00511
D	D0000 to D1023	Decimal	03H/06H/09H/0BH/0EH/10H: Holding register	0 to 1023	MW00000 to MW01023
D (special)	D9000 to D9255	Decimal	03H/06H/09H/0BH/0EH/10H: Holding register	1024 to 1279	MW01024 to MW01279
W	W0000 to W03FF	Hexadecimal	03H/06H/09H/0BH/0EH/10H: Holding register	1280 to 2303	MW01280 to MW02303
R	R0000 to R8191	Decimal	03H/06H/09H/0BH/0EH/10H: Holding register	2304 to 10495	MW02304 to MW10495
D	D1024 to D6143	Decimal	03H/06H/09H/0BH/0EH/10H: Holding register	10496 to 15615	MW10496 to MW15615

Note: 1. The device range may differ according to the MELSEC sequencer even within the device range. For more information, refer to the MELSEC manual.

2. The register number corresponding to MP2□00 can be adjusted by the offset setting of the MSG-SND function.

(8) Data Size (PARAM06)

Set the data size (number of bits or words) for the read/write request.

Be sure that the last data address determined based on the offset, data address, and data size does not go beyond the scope of the data addresses.

The range of data addresses may differ, depending on the function code and communication device.

The following table gives the valid ranges of data sizes when using MELSEC as a protocol.

Table G.9 Valid Range of Data Sizes

Function Code	MELSEC ACPU Common Command	Function	Valid Range of Data Sizes	
			Ethernet(2181F)	Ethernet(2181FA)
01H/02H	00H	Reads bit device in units	1 to 256 units	
03H/04H/ 09H/0AH	01H	Reads word device in units	1 to 256 units	
05H/0FH	02H	Writes to bit device in units	1 to 256 units	
06H/0BH/ 10H	03H	Writes to word device in units	1 to 256 units	
08H	16H	Loopback test	-	
0EH	05H	Specifies a device number for each word device at random and sets/resets each word device	1 to 40 units	
31H	60H	Writes to the fixed buffer in words	See the table below.	
32H	61H	Reads from the random access buffer in words		
33H	62H	Writes to the random access buffer in words		

Function	Connection Type	Code	Valid Range of Data Sizes	
			Ethernet(2181F)	Ethernet(2181FA)
Writes to the fixed buffer in words	TCP	BIN	1 to 507 words	1 to 727 words
		ASCII	1 to 362 words	1 to 362 words
	UDP	BIN	1 to 507 words	1 to 1017 words
		ASCII	1 to 507 words	1 to 508 words
Reads from the random access buffer in words	TCP	BIN	1 to 508 words	1 to 728 words
		ASCII	1 to 363 words	1 to 363 words
	UDP	BIN	1 to 508 words	1 to 1017 words
		ASCII	1 to 508 words	1 to 508 words
Writes to the random access buffer in words	TCP	BIN	1 to 507 words	1 to 726 words
		ASCII	1 to 361 words	1 to 361 words
	UDP	BIN	1 to 508 words	1 to 1017 words
		ASCII	1 to 508 words	1 to 508 words

Note: The restricted data size when using TCP is the maximum size transmitted using one segment. The segment size is determined by MTU (maximum transfer unit) as a TCP data transfer unit. The valid range of data sizes mentioned above is for MTU = 1500 bytes.

(9) Remote CPU Number (PARAM07)

Refer to *G.1.4 (9) Remote CPU Number (PARAM07)* on page A-49.

(10) Offset (PARAM08, PARAM09, PARAM10, PARAM11)

Specify the offset addresses of the read data storage area and the write data source of the transmission side. The address for the transmission side will be displaced by the number of words designated by the offset.

Note: 1. For more information, refer to *G.1.8 Relationship between Data Address, Data Size, and Offset for MSG-SND Function* on page A-66.

2. The offset cannot be a negative value.

The offset parameter is prepared for each target data type.

The following table provides the offset parameters.

Table G.10 Offset Parameter List

Parameter	Contents	Description
PARAM08	Coil offset	Sets the coil's offset word address.
PARAM09	Input relay offset	Sets the offset word address of an input relay.
PARAM10	Input register offset	Sets the offset word address of an input register.
PARAM11	Holding register offset	Sets the offset word address of a holding register.

The valid offset parameter may differ according to function code.

The following table provides the valid parameters for each function code.

Table G.11 Valid Parameter List for Offset of Each Function Code

Function Code	Function	Valid Offset Parameter
01H	Reads coil state	PARAM08
02H	Reads input relay state	PARAM09
03H	Reads holding register content	PARAM11
04H	Reads input register content	PARAM10
05H	Changes single coil state	PARAM08
06H	Writes to single holding register	PARAM11
09H	Reads holding register content (extended)	PARAM11
0AH	Reads input register content (extended)	PARAM10
0BH	Writes to holding register (extended)	PARAM11
0EH	Discontinuously writes to holding register (extended)	PARAM11
0FH	Changes multiple coil states	PARAM08
10H	Writes to multiple holding registers	PARAM11
31H	Write to fixed buffer	PARAM11
32H	Reads the random access buffer	PARAM11
33H	Writes to the random access buffer	PARAM11

(11) Reserved by System 1 (PARAM12)

Used by system (the channel number of the communication buffer in use is stored).

Note: At the first scan during power up, make sure to set it to "0" by using the user program. After that, the register is used by system. Do not change the value thereafter with the user program.

(12) Reserved by System 2 (PARAM13-PARAM16)

Used by system. Never change this value with the user program, etc.

G.1.6 Function Setting and Parameter Details for MODBUS/TCP Protocol

This section explains the MSG-SND function setting and its parameter list details when MODBUS/TCP is used as a protocol type.

(1) Message Transmit Function Setting

(a) 218IFA Setting Example

An example of a function setting when 218IFA is used as a communication device follows:

Set the protocol type to MEMOBUS when used in MODBUS/TCP protocol.

Set the circuit number in accordance with the circuit number allocated to the target 218IFA.

Set a unique communication buffer channel number for the same circuit.

For information on the register number, refer to *G.1.2 (1) Input Item* on page A-36 and *G.1.2 (2) Output Item* on page A-38.

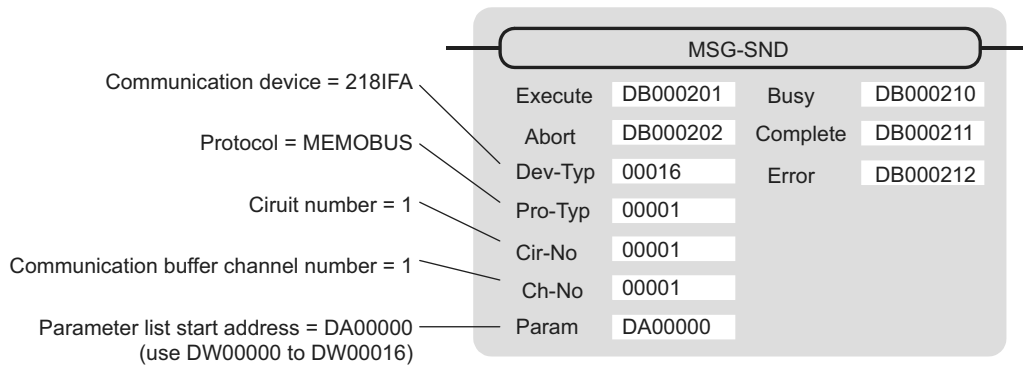

(b) 218IF Setting Example

An example of a function setting when 218IF is used as a communication device follows:

Set the protocol type to MEMOBUS when used in MODBUS/TCP protocol.

Set the circuit number in accordance with the circuit number allocated to the target 218IF.

Set a unique communication buffer channel number for the same circuit.

For information on the register number, refer to *G.1.2 (1) Input Item* on page A-36 and *G.1.2 (2) Output Item* on page A-38.

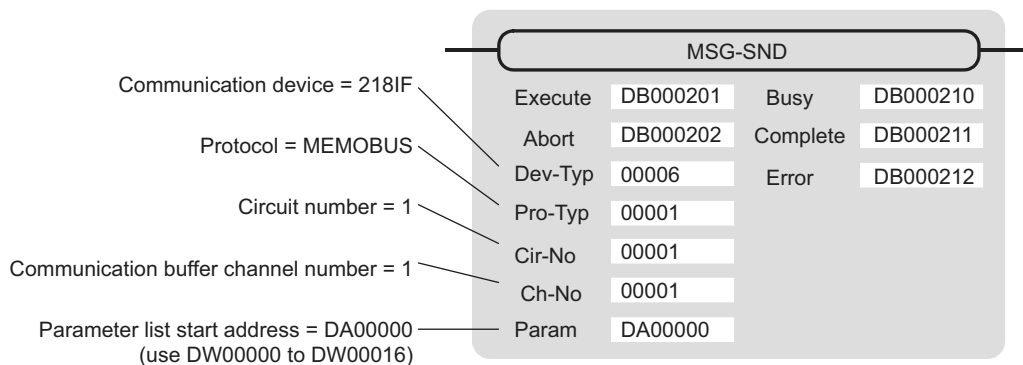

(2) Process Result (PARAM00)

Refer to *G.1.4 (2) Process Result (PARAM00)* on page A-42.

(3) Status (PARAM01)

Refer to *G.1.4 (3) Status (PARAM00)* on page A-43.

(4) Connection Number (PARAM02)

Refer to *G.1.4 (4) Connection Number (PARAM02)* on page A-45.

(5) Option (PARAM03)

Choose a unique setting for each communication device.

The following table provides the scope of the setting.

Communication Device	Valid Range	Remarks
Ethernet(218IF or 218IFA)	0 to 247, 255	Set a remote unit ID when MODBUS/TCP protocol is used. When the transmission target is MP2□00 series, specify "0."

(6) Function Code (PARAM04)

Set a function code to transmit.

The functions (read coil and input relay state, write to holding register, etc.) registered in the function codes are made available by specifying the code.

The following table shows the available function codes when using MODBUS/TCP as a protocol.

Table G.12 Function Code List (MODBUS/TCP)

Function Code	Target Data Type	Function	Communication device	
			Ethernet(218IF)	Ethernet(218IFA)
00H	–	Unused	–	–
01H	B	Reads coil state	√	√
02H	B	Reads input relay state	√	√
03H	W	Reads holding register content	√	√
04H	W	Reads input register content	√	√
05H	B	Changes single coil state	√	√
06H	W	Writes to single holding register	√	√
07H	–	Unused	–	–
:				
0EH				
0FH	B	Changes multiple coil states	√	√
10H	W	Writes to multiple holding registers	√	√
11H	–	Unused	–	–
:				
15H				
16H	W	Mask writes to holding register	–	√
17H	W	Reads/Writes multiple holding registers	–	√

Note: 1. B: Bit type, W: Integer type

2. √: Available, -: Not available

3. Transmit and receive registers in the master operation mode are MW (MB) only.

4. In the slave operation mode, coil, holding register, input relay, and input register are MB, MW, IB, IW respectively.

(7) Data Address (PARAM05)

Specify the start address of the data.

The address must be a decimal or hexadecimal number.

Example: When the start address is MW01000, specify “1000 (decimal)” or “3E8H (hexadecimal).”

The range of data addresses may differ according to the function code.

The following table gives the valid ranges of data addresses when using MODBUS/TCP as a protocol.

Table G.13 Valid Range of Data Addresses (MODBUS/TCP)

Function Code	Target Data Type	Function	Valid Range of Data Addresses
00H	–	Unused	Disable
01H	B	Reads coil state	0 to 65535 (0 to FFFFH)
02H	B	Reads input relay state	0 to 65535 (0 to FFFFH)
03H	W	Reads holding register content	0 to 65534 (0 to FFFE H)
04H	W	Reads input register content	0 to 32767 (0 to 7FFFH)
05H	B	Changes single coil state	0 to 65535 (0 to FFFFH)
06H	W	Writes to single holding register	0 to 65534 (0 to FFFE H)
07H	–	Unused	Disable
:			
0EH			
0FH	B	Changes multiple coil states	0 to 65535 (0 to FFFFH)
10H	W	Writes to multiple holding registers	0 to 65534 (0 to FFFE H)
11H	–	Unused	Disable
:			
15H			
16H	W	Mask writes to holding register ^{*1, *2}	0 to 65534 (0 to FFFE H)
17H	W	Reads/Writes multiple holding register ^{*1, *3}	0 to 65534 (0 to FFFE H)

* 1. Invalid when Ethernet (218IF) is used.

* 2. Mask write request to holding register: Specify the start M register number of the remote address-cum-local data table

* 3. Request for reading/writing multiple holding registers: Specify the start M register number of an address table

Note: 1. Data table

A data table used for a mask write request to the holding register is used for storing mask data. The two words of addresses at the beginning of the M register specified by PARAM05 (data address) are used as an address table.

Specify AND and OR mask data for the data table.

Note that PARAM05 (data address) used for the mask write request to the holding register doubles as the start M register number in the local station, which is also used for specifying the start data address and as the data table in the remote station for mask writing.

The contents of the data table used when mask writing to the holding register is as follows:

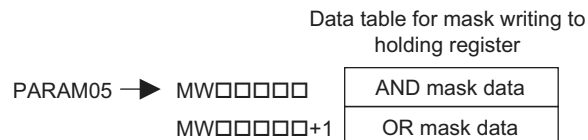

2. Address table

An address table used for the read/write request to the multiple holding registers is used for specifying addresses indirectly in order to indicate read/write data. The four words of addresses at the beginning of the M register set by PARAM05 (data address) are used as an address table.

For the address table, specify a data address and data size for reading and a data address and data size for writing.

Read behaves same as “Reads holding register content (function code: 03H)”. Write behaves same as “Writes to multiple holding registers (function code: 10H)”.

The address table used when reading/writing multiple holding registers is as follows:

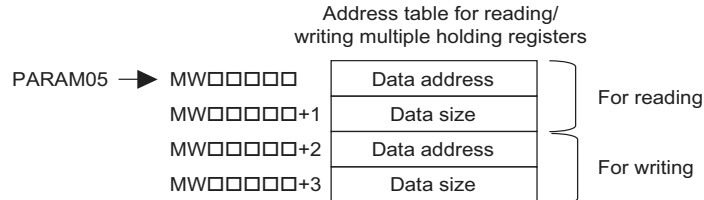

(8) Data Size (PARAM06)

Set the data size (number of bits or words) for the read/write request.

Be sure that the last data address determined based on the offset, data address, and data size does not go beyond the scope of the data addresses.

The range of data sizes may differ, depending on the function code.

The following table gives the valid ranges of data sizes when using MODBUS/TCP as a protocol.

Table G.14 Valid Range of Data Sizes (MODBUS/TCP)

Function Code	Target Data Type	Function	Valid Range of Data Addresses
00H	—	Unused	Disable
01H	B	Reads coil state ^{*1}	1 to 2000
02H	B	Reads input relay state ^{*1}	1 to 2000
03H	W	Reads holding register content ^{*2}	1 to 125
04H	W	Reads input register content ^{*2}	1 to 125
05H	B	Changes single coil state ^{*1}	Disable
06H	W	Writes to single holding register ^{*2}	Disable
07H	—	Unused	Disable
:			
0EH			
0FH	B	Changes multiple coil states ^{*1}	1 to 00
10H	W	Writes to multiple holding registers ^{*2}	1 to 100
11H	—	Unused	Disable
:			
15H			
16H	W	Mask writes to holding register ^{*2, *3}	Disable
17H	W	Reads/Writes multiple holding registers ^{*2, *3}	Read: 1 to 125 Write: 1 to 100

* 1. Specify the number of bits

* 2. Specify the number of words

* 3. Invalid when Ethernet (218IF) is used.

Note: The data size in the table is represented in decimal number.

(9) Remote CPU Number (PARAM07)

Refer to *G.1.4 (9) Remote CPU Number (PARAM07)* on page A-49.

(10) Offset (PARAM08, PARAM09, PARAM10, PARAM11)

Specify the offset addresses of the read data storage area and the write data source of the transmission side. The address for the transmission side will be displaced by the number of words designated by the offset.

Note: 1. For more information, refer to *G.1.8 Relationship between Data Address, Data Size, and Offset for MSG-SND Function* on page A-66.

2. The offset cannot be a negative value.

The offset parameter is prepared for each target data type.

The following table lists the offset parameters.

Table G.15 Offset Parameter List

Parameter	Contents	Description
PARAM08	Coil offset	Sets the coil's offset word address.
PARAM09	Input relay offset	Sets the offset word address of an input relay.
PARAM10	Input register offset	Sets the offset word address of an input register.
PARAM11	Holding register offset	Sets the offset word address of a holding register.

The valid offset parameter may differ, depending on the function code.

The following table lists the valid parameters for each function code.

Table G.16 Valid Parameter List for Offset of Each Function Code

Function Code	Function	Valid Offset Parameter
01H	Reads coil state	PARAM08
02H	Reads input relay state	PARAM09
03H	Reads holding register content	PARAM11
04H	Reads input register content	PARAM10
05H	Changes single coil state	PARAM08
06H	Writes to single holding register	PARAM11
0FH	Changes multiple coil states	PARAM08
10H	Writes to multiple holding registers	PARAM11
16H	Mask writes to holding register	PARAM11
17H	Reads/Writes multiple holding registers	PARAM11

(11) Reserved by System 1 (PARAM12)

Used by system (the channel number of communication buffer in use is stored).

Note: At the first scan during power up, make sure to set it to "0" by using the user program. After that, the register is used by system. Do not change the value thereafter with the user program.

(12) Reserved by System 2 (PARAM13 to PARAM16)

Used by system. Never change the value with the user program, etc.

G.1.7 Function Setting and Parameter Details for Non-procedural Protocol

This section explains the MSG-SND function setting and its parameter list details when non-procedure is used as a protocol.

Note: Non-procedure communication protocol transmits the M register content intact without a protocol conversion. You can create any protocol in accordance with the remote equipment.

(1) Message Transmit Function Setting

(a) 218IFA Setting Example

An example of a function setting when 218IFA is used as a communication device is as follows:

When non-procedure 2 (per byte) is used, set the Pro-Typ field to “00003” (non-procedure 1 (per word)).

Set the circuit number in accordance with the circuit number allocated to the target 218IFA.

Set a unique communication buffer channel number for the same circuit.

For information on the register number, refer to *G.1.2 (1) Input Item* on page A-36 and *G.1.2 (2) Output Item* on page A-38.

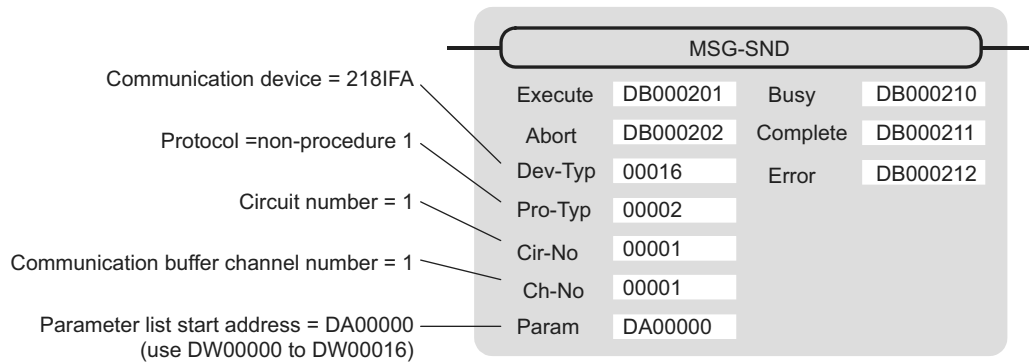

(b) 218IF Setting Example

An example of a function setting when 218IF is used as a communication device follows:

When non-procedure 2 (per byte) is used, set the Pro-Typ field to “00003” (non-procedure 1 (per word)).

Set the circuit number in accordance with the circuit number allocated to the target 218IF.

Set a unique communication buffer channel number for the same circuit.

For information on the register number, refer to *G.1.2 (1) Input Item* on page A-36 and *G.1.2 (2) Output Item* on page A-38.

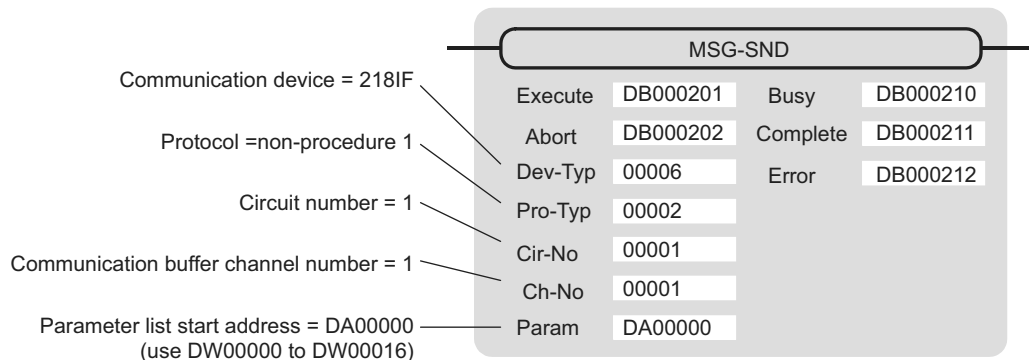

(2) Process Result (PARAM00)

The process result is output to the upper byte. The lower byte is used for system analysis.

Value of Process Result	Meaning
00□□H	In process (Busy)
10□□H	Process completed (Complete)
8y□□H	Error occurred (Error)

When an error occurs, take corrective action by referring to the following error contents:

Value of Process Result	Error Contents	Description
80□□H	—	Reserved
81□□H	—	—
82□□H	Error in setting address	The following setting is out of range. Check the setting. PARAM05 (data address) PARAM11 (register offset)
83□□H	Data size error	The transmit or receive data amount is out of range. Check PARAM06 (data size).
84□□H	Error in setting circuit number	The circuit number is out of range. Check Cir-No (circuit number) of the MSG-SND function.
85□□H	Error in setting channel number	The communication buffer channel number is out of range. Check Ch-No (communication buffer channel number) of the MSG-SND function.
86□□H	Connection number error	The connection number is out of range. Check PARAM02 (connection number).
87□□H	—	Reserved
88□□H	Communication section error	An error response was returned from the communication section (communication device). Check the equipment connection. In addition, confirm that the remote device is open to communication.
89□□H	Device select error	Unavailable device is set. Check Dev-Typ (communication device type) of the MSG-SND function.

(3) Status (PARAM01)

Outputs status of the communication section (communication device).

The following figure illustrates bit assignment. Bit assignment details are listed in the table below.

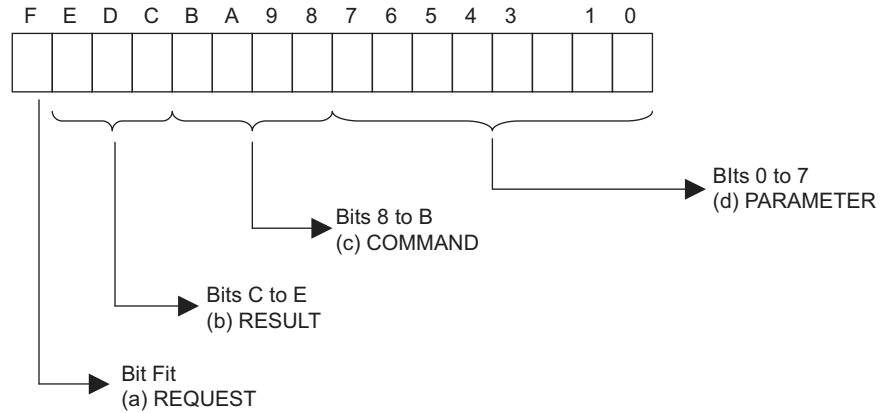

(a) REQUEST (request)

Outputs whether MSG-SND function is requesting a process.

Bit State	Contents
1	Requesting processing
0	The acceptance of process request is completed

(b) RESULT (result)

Outputs an execution result of the MSG-SND function

Code	Abbreviation	Meaning
0	CONN_NG	In Ethernet communications, transmit error or connection error is complete
1	SEND_OK	Normal transmission complete
2	REC_OK	Normal reception complete
3	ABORT_OK	Forced abort complete
4	FMT_NG	Parameter format error
5	SEQ_NG	Command sequence error
6	RESET_NG	Reset state
7	REC_NG	Data reception error (error detected in the lower layer program)

(c) COMMAND (command)

Outputs a process command for the MSG-SND function. The executed process contents can be found according to the command.

Code (Hex)	Abbreviation	Meaning
1	U_SEND	General-purpose message transmission
2	U_REC	General-purpose message reception
3	ABORT	Forced abort
8	M_SEND	MEMOBUS command transmission: Complete when response is received (for MEMOBUS protocol)
9	M_REC	MEMOBUS command reception: Accompanies a response transmission (for MEMOBUS protocol)
C	MR_SEND	MEMOBUS response transmission (for MEMOBUS protocol)

(d) PARAMETER (parameter)

When RESULT (process result) = 4 (FMT_NG: parameter format error), an error code in the table below is output. Otherwise, the connection number is output.

RESULT (process result)	Code (Hex)	Meaning
When RESULT (process result) = 4 (FMT_NG: parameter format error)	00	No error
	01	Connection number is out of range
	02	Time error while monitoring to receive MEMOBUS response (for MEMOBUS protocol)
	03	Error in setting retransmit count
	04	Error in setting cyclic area
	05	CPU number error
	06	Data address error
	07	Data size error
	08	Function code error (for MEMOBUS protocol)
Others	xx	Connection number

(4) Connection Number (PARAM02)

Refer to *G.1.4 (4) Connection Number (PARAM02)* on page A-45.

(5) Data Address (PARAM05)

Specify the start address of the data.

The address must be input in a decimal or hexadecimal number.

Example: When the start address is MW01000, specify “1000 (decimal)” or “3E8H (hexadecimal).”

The following table provides the valid ranges of the data addresses.

Table G.17 Valid Range of Data Addresses (non-procedure)

Non-procedural Type	Target Data Type	Function	Valid Range of Data Addresses	
			Ethernet(2181F)	Ethernet(2181FA)
Non-procedure 1	W	Transmits data in words	0 to 65534 (0 to FFFE _H)	
Non-procedure 2	B	Transmits data in bytes ^{*1}	0 to 65534 (0 to FFFE _H)	

* 1. The unit for address setting is word address.

(6) Data Size (PARAM06)

Set the data size (number of bits or words) for the write request.

Be sure that the last data address determined based on the offset, data address, and data size does not go beyond the scope of the data addresses.

The valid range of data sizes may differ according to the communication device.

Table G.18 Valid Range of Data Sizes (non-procedure)

Non-procedural Type	Target Data Type	Function	Valid Range of Data Sizes	
			Ethernet (2181F)	Ethernet (2181FA)
Non-procedure 1	W	Transmits data in words* ¹	1 to 510	1 to 2046 (BIN) 1 to 1023 (ASCII)
Non-procedure 2	B	Transmits data in bytes* ²	1 to 1020	1 to 4092 (BIN) 1 to 2046 (ASCII)

* 1. Specify the number of words

* 2. Specify the number of bytes

Note: The data size in the table is represented in decimal numbers.

(7) Register Offset (PARAM11)

Specify the offset address of write data source in the transmission side.

The address for the transmission side will be displaced by the number of words designated by the offset.

Note: 1. For more information, refer to *G.1.8 Relationship between Data Address, Data Size, and Offset for MSG-SND Function* on page A-66.

2. The offset cannot be a negative value.

Example: When specifying 1000 words of offset for the register address:

PARAM11=1000

(8) Reserved by System 1 (PARAM12)

Used by system (the channel number of the communication buffer in use is stored).

Note: At the first scan during power up, make sure to set this to "0" by the user program. After that, the register is used by system, so do not change the value with the user program.

(9) Reserved by System 2 (PARAM13-PARAM16)

Used by system. Do not change the value with the user program, etc.

G.1.8 Relationship between Data Address, Data Size, and Offset for MSG-SND Function

The relationship between data address, data size, and offset is as follows, when transmitted with offset:

(1) When Reading

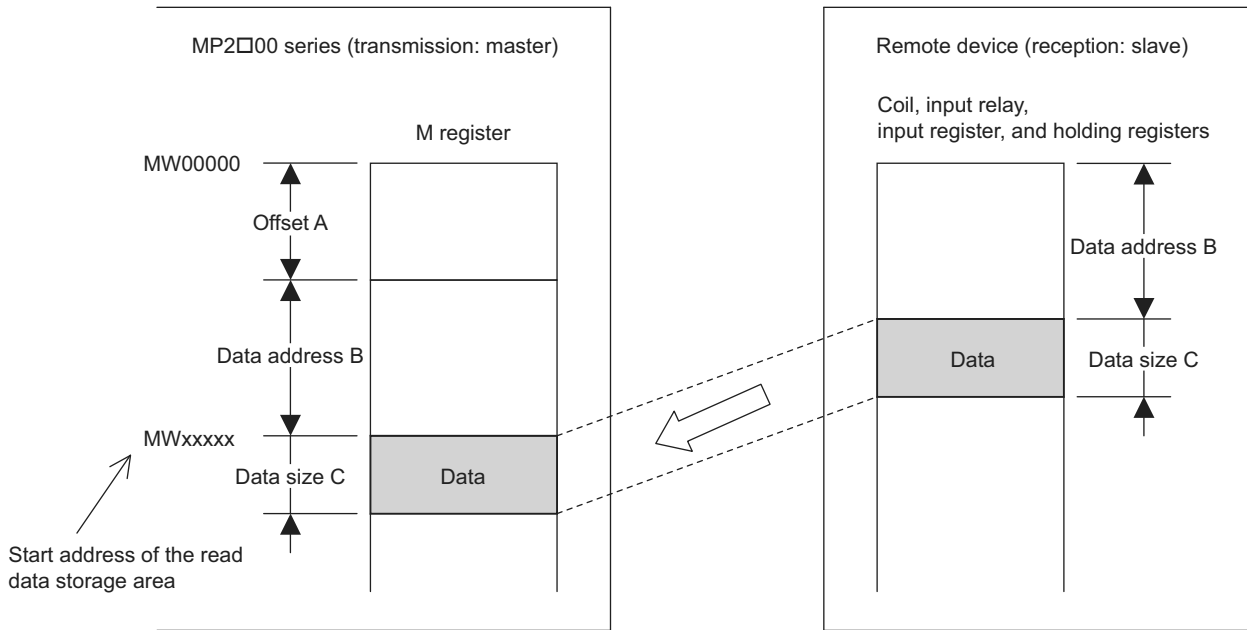

Fig. G.4 Data Flow when Reading

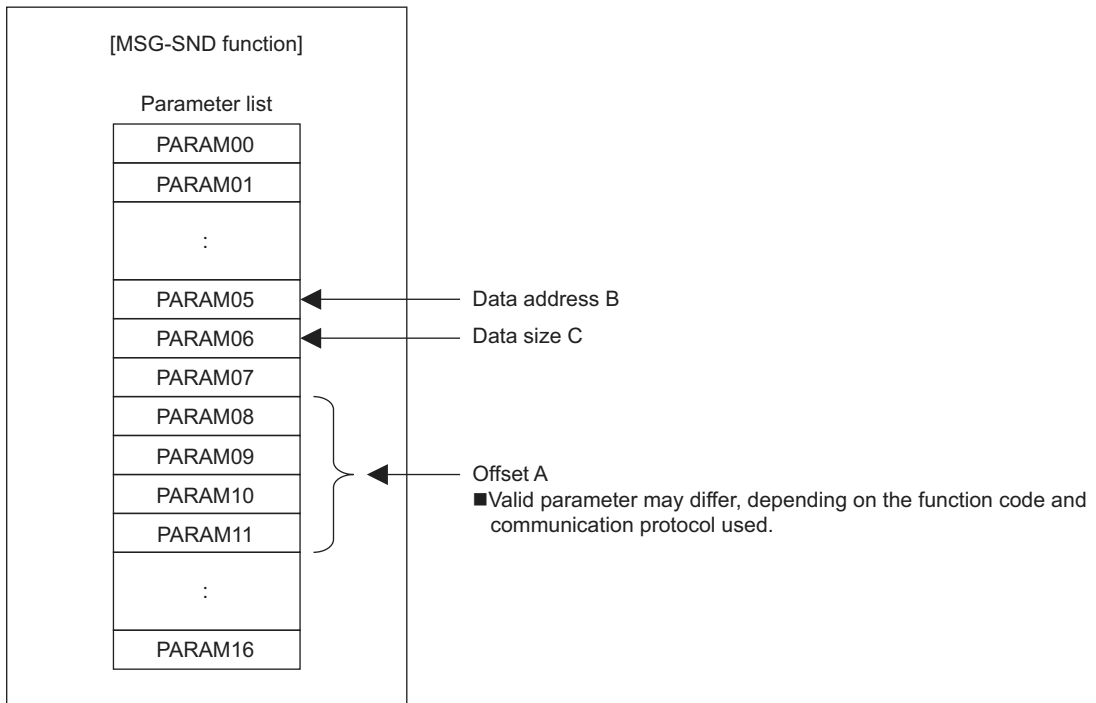

Fig. G.5 Parameter Setting

(2) When Writing

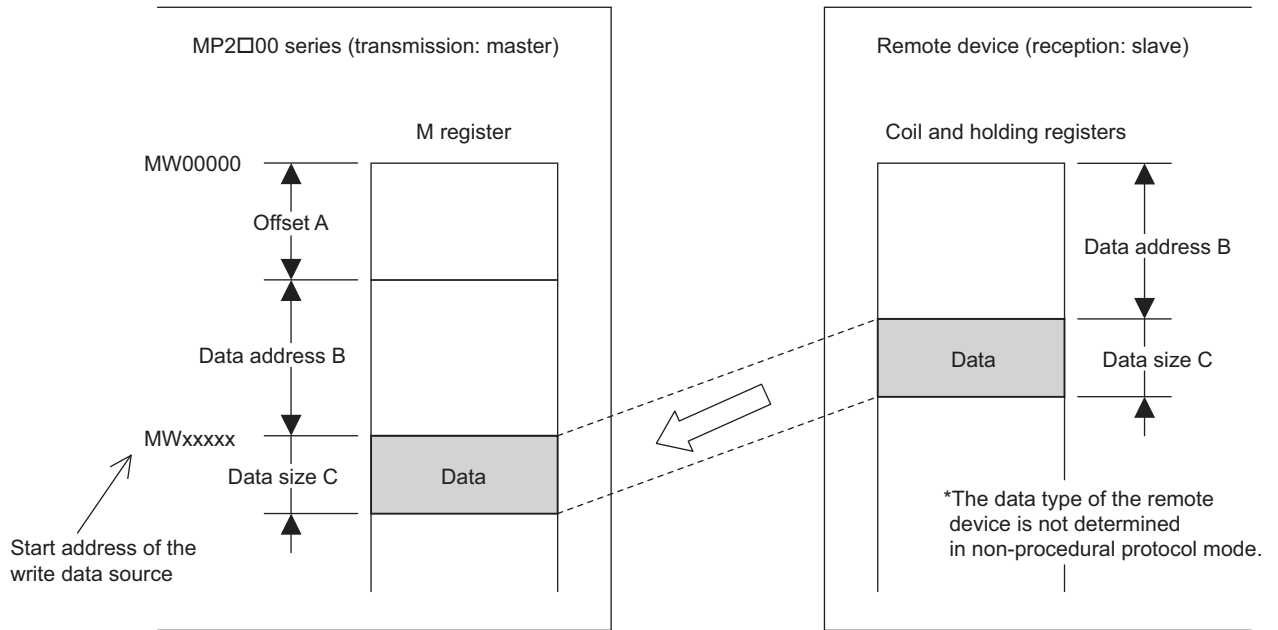

Fig. G.6 Data Flow when Writing

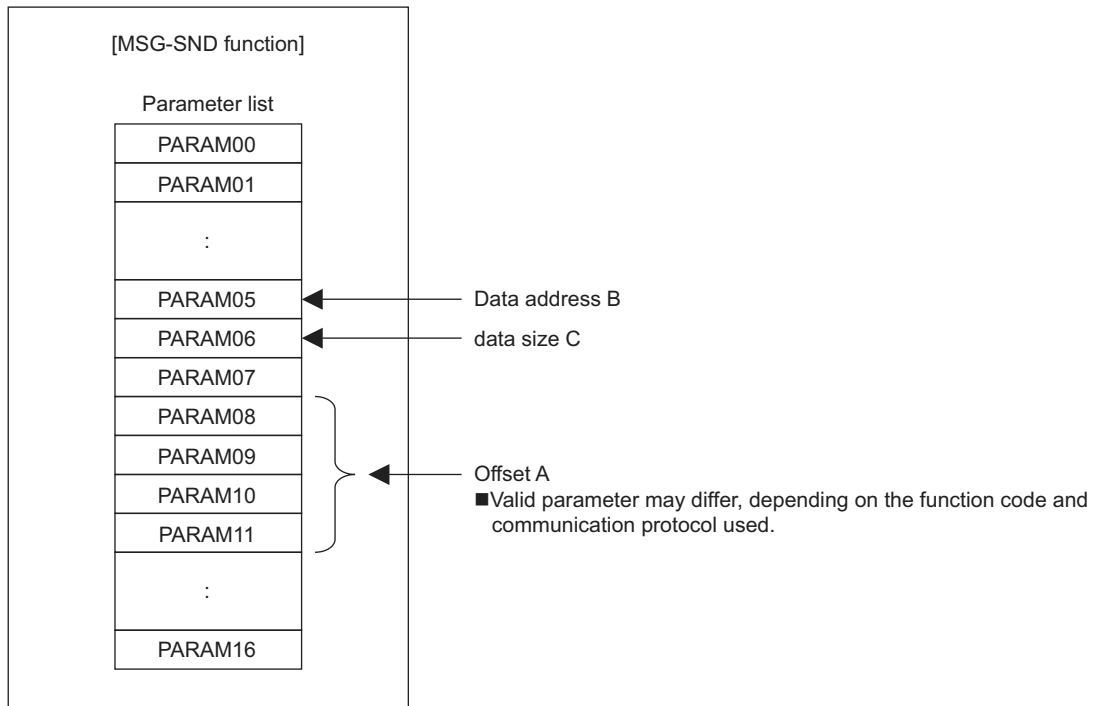
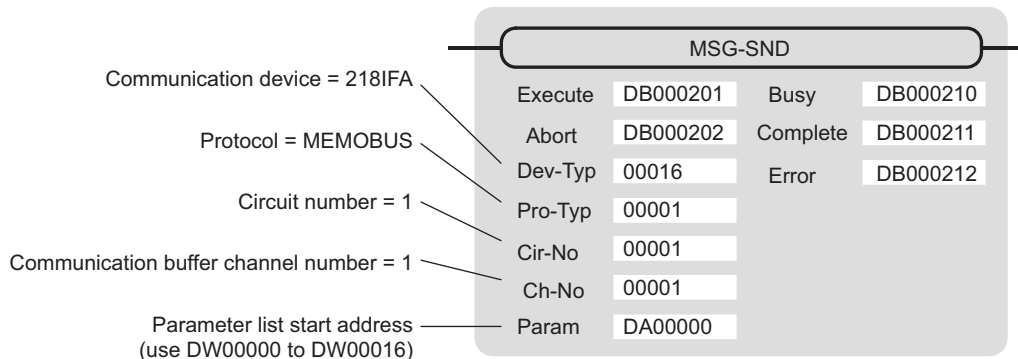

Fig. G.7 Parameter Setting

Example: When reading coil state with offset:

The various setting values and their relationships with the data of the remote device are as follows, when transmitting "reading coil state" with offset in MEMOBUS protocol:

- Description of the MSG-SND function in ladder program



- Parameter list setting of the MSG-SND function

Table G.19 Parameter List Setting

Register Number	Setting Value	Parameter Number	IN/OUT	Remarks
DW00000	–	PARAM00	OUT	Process result
DW00001	–	PARAM01	OUT	Status
DW00002	00001	PARAM02	IN	Connection number=1
DW00003	–	PARAM03	IN	Option (setting unnecessary)
DW00004	00001	PARAM04	IN	Function code=1 (reads coil state)
DW00005	08192	PARAM05	IN	Data address=8192 bits (512 words)
DW00006	00100	PARAM06	IN	Data size=100
DW00007	00001	PARAM07	IN	Remote CPU number=1
DW00008	01000	PARAM08	IN	Coil offset=1000 words
DW00009	00000	PARAM09	IN	Input relay offset=0 word
DW00010	00000	PARAM10	IN	Input register offset=0 word
DW00011	00000	PARAM11	IN	Holding register offset=0 word
DW00012	–	PARAM12	SYS	Reserved (zero clear at startup)
DW00013	–	PARAM13	SYS	Reserved
DW00014	–	PARAM14	SYS	Reserved
DW00015	–	PARAM15	SYS	Reserved
DW00016	–	PARAM16	SYS	Reserved

Note: IN: Input, OUT: Output, SYS: For system use

- Relationship with the Data of the Remote Device

The following figure shows the data flow when transmitting “reads coil state” with offset:

When transmission and reception are carried out normally in the figure below, the coil state in the device is stored in MW01512 and after of MP2300S.

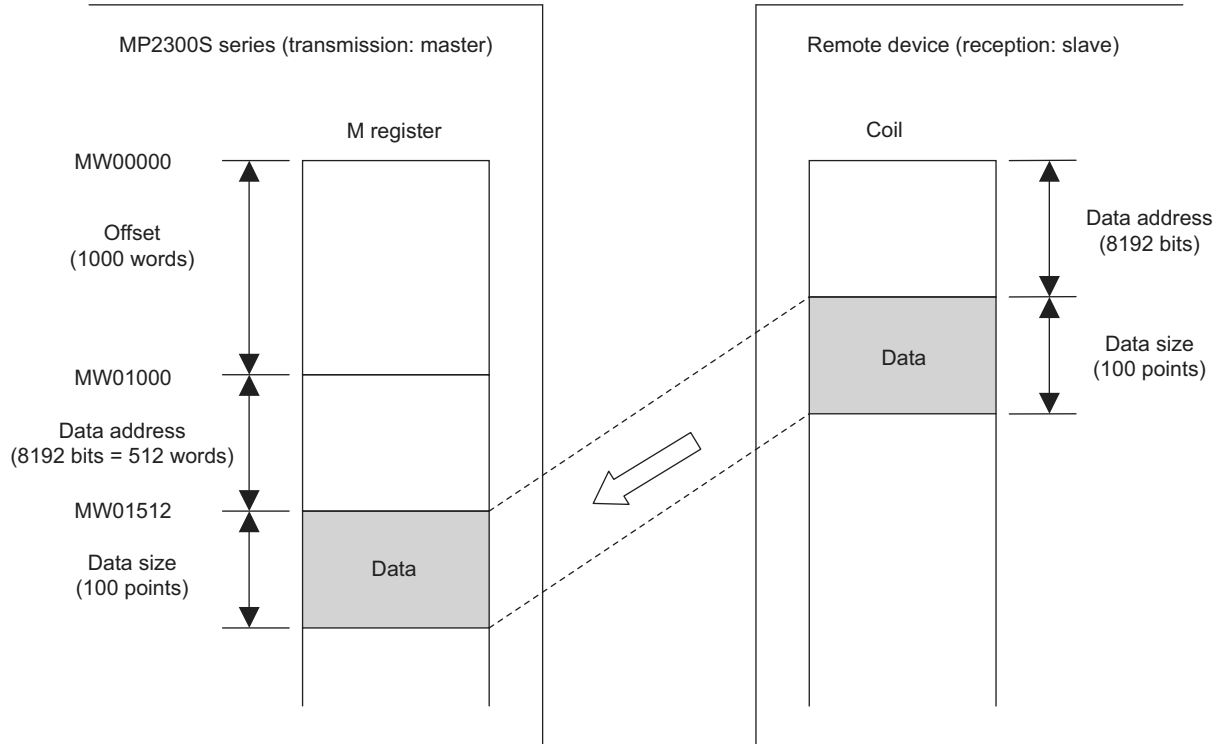
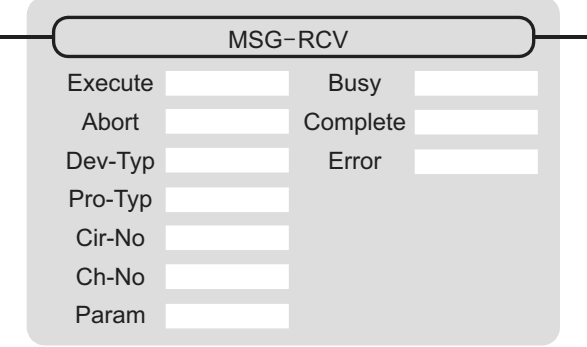

Fig. G.8 Reading Example of Coil State

G.2 Message Receive Function (MSG-RCV)

This section explains how the message receive function (MSG-RCV) is used in a ladder program when receiving messages.

G.2.1 Specification Overview of the Message Receive Function

Function Name	MSG-RCV			
Function	Receives messages from the remote station on the circuit specified by the communication device type. Supports multiple protocol types. Keep the execution command (Execute) until Complete or Error turns ON.			
Function Definition				
I/O Definition	No.	Name	I/O Option ^(*1)	Contents
Input Item	1	Execute	B-VAL	Executes a reception
	2	Abort	B-VAL	Forcibly ends a reception
	3	Dev-Typ	I-REG	Communication device type Ethernet (218IF) = 6, Ethernet (218IFA) = 16
	4	Pro-Typ	I-REG	Communication protocol MEMOBUS ^{*2} = 1, non-procedure 1 ^{*3} = 2, non-procedure 2 ^{*3} = 3
	5	Cir-No	I-REG	Line number Ethernet (218IF) = 1-8, Ethernet (218IFA) = 1 to 8
	6	Ch-No	I-REG	Communication buffer channel number Ethernet (218IF) = 1-10, Ethernet (218IFA) = 1 to 4
	7	Param	Address input	Parameter list start address (MA, DA)
Output Item	1	Busy	B-VAL	In process
	2	Complete	B-VAL	Process completed
	3	Error	B-VAL	Error occurred

* 1. The meanings of I/O options are as follows:

B-VAL: Specify I/O by bit type data.

I-REG: Specify I/O by integer type data. When specifying, set an integer type register number.

As for the input only, it can be a constant (literal).

Address input: The address of the specified register (any integer register) is passed to the function.

* 2. When transmitting in MEMOBUS, Extended MEMOBUS, MELSEC, OMRON, or MODBUS/TCP protocol, set the communication protocol (Pro-Typ) to MEMOBUS(=1). The communication device automatically converts the protocol.

* 3. Non-procedure 1: In non-procedural communication, data is received on a per-word basis.

Non-procedure 2: In non-procedural communication, data is received on a per-byte basis.

G.2.2 I/O Item Details of the Message Receive Function

(1) Input Item

The following table indicates the registers available for each input item.

Input Item	I/O Option	Available Register
Execute Abort	B-VAL	Every bit type register (except #, C registers), Same as above with subscript
Dev-typ Pro-Typ Cir-No Ch-No	I-REG	Every integer type register, Same as above with subscript, Constant
Param	Address input	Register address (except #, C registers), Same as above with subscript

1. Execute (executes a reception)

Specify a bit to command execution of a message reception.

When Execute turns ON, the message reception is carried out. In order to execute the process, a ladder program or the like needs to be used to switch the bit ON/OFF.

Note: Keep Execute (executes a reception) until Complete (process completed) or Error (error occurred) is turned ON. When the command turns ON, the message reception is carried out.

To continuously command the receive execution, make sure to turn Execute (executes a reception) OFF for one scan or more.

2. Abort (forcibly ends a reception)

Specify a bit to command a forced abort of a message reception.

When Abort turns ON, the message reception is forcibly terminated. Abort takes precedence over Execute.

In order to execute the forced abort, a ladder program or the like needs to be used to switch the bit ON/OFF.

3. Dev-Typ (communication device type)

Specify the type of communication device (refer to the table below).

Device	Type Code
Ethernet (218IF)	6
Ethernet (218IFA)	16

4. Pro-Typ (communication protocol)

Specify the communication protocol (refer to the table below).

Type Code	Communication Protocol	Remarks
1	MEMOBUS	Set the type code to "1" when also transmitting using Extended MEMOBUS, MELSEC, or MODBUS/TCP protocol. The communication device will automatically convert the protocol.
2	Non-procedure 1 (per word)	Data is received on a per-word basis in non-procedural communication. No response is transmitted to the remote.
3	Non-procedure 2 (per byte)	Data is received on a per-byte basis in non-procedural communication. No response is transmitted to the remote.

5. Cir-No (circuit number)

Specify a circuit number for the communication device.

Specify it in accordance with the circuit number displayed in the **MPE720 Module Configuration Definition Window**.

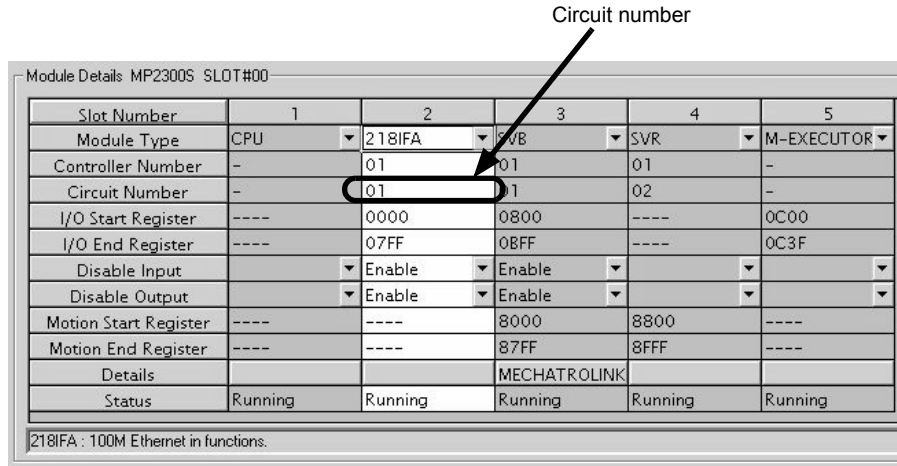

Fig. G.9 MPE720 Module Configuration Definition Window

The following table indicates the range of valid circuit numbers.

Communication device	Valid Circuit Number
Ethernet (218IF·218IFA)	1 to 8

6. Ch-No (communication buffer channel number)

Specify the channel number of a communication buffer.

It can be any channel number in the range. However, when starting multiple functions at the same time, set a unique channel for each function. (If you do not start up multiple functions at the same time, the channel numbers can duplicate each other.)

The following table indicates the range of valid channel numbers.

Communication device	Valid Channel Number
Ethernet (218IF)	1 to 10
Ethernet (218IFA)	1 to 4

When the communication device is Ethernet (218IFA), because the communication buffer common to the transmission and reception have four channels, four receptions (or transmissions) are available at the same time by using channel numbers 1 to 4.

- Note: 1. As many MSG-RCV (or MSG-SND) functions as lines used at the same time are required.
 2. For information on communication buffer channel, refer to G.3 *Communication Buffer Channel* on page A-102.

7. Param (parameter list start address)

Specify the start address of the parameter list. For the “parameter list,” 17 words are automatically assigned from the configured address. In the parameter list, enter the function code and its relevant parameter data. Additionally, process result and status are output.

Note: For more information about the parameter list, refer to the parameter details for each protocol from G.2.4 *Function Setting and Parameter Details for MEMOBUS and Extended MEMOBUS Protocols* on page A-77 to G.2.7 *Function Setting and Parameter Details for Non-procedural Protocol* on page A-93.

Example: When “DA00000” is specified as a parameter list start address:

Register	Parameter list
	F 0
DW00000	PRAM00
DW00001	PRAM01
DW00002	PRAM02
DW00003	PRAM03
DW00004	PRAM04
DW00005	PRAM05
DW00006	PRAM06
DW00007	PRAM07
DW00008	PRAM08
DW00009	PRAM09
DW00010	PRAM10
DW00011	PRAM11
DW00012	PRAM12
DW00013	PRAM13
DW00014	PRAM14
DW00015	PRAM15
DW00016	PRAM16

(2) Output Item

The following table lists the registers available for each output item.

Input Item	I/O Option	Available Register
Busy Complete Error	B-VAL	Every bit type register (except #, C registers), Same as above for subscript

1. Busy (in process)

Specify a bit to report message reception.

The Busy bit is turned ON while executing message reception or a forced abort process.

Keep Execute or Abort ON while Busy is ON.

2. Complete (process completed)

Specify a bit to report message reception ended.

When message reception or a forced abort process is completed properly, the Complete bit will turn ON only for one scan.

3. Error (error occurred)

Specify a bit to report when an error occurs in the message reception.

When an error occurs, the Error bit will turn ON only for one scan.

Note: For more information about the error cause, refer to G.2.4 (2) *Process Result (PARAM00)* on page A-78 and G.2.4 (3) *Status (PARAM01)* on page A-79.

A timing chart of bit type I/O items in the MSG-RCV function follows:

[In Normal Condition]

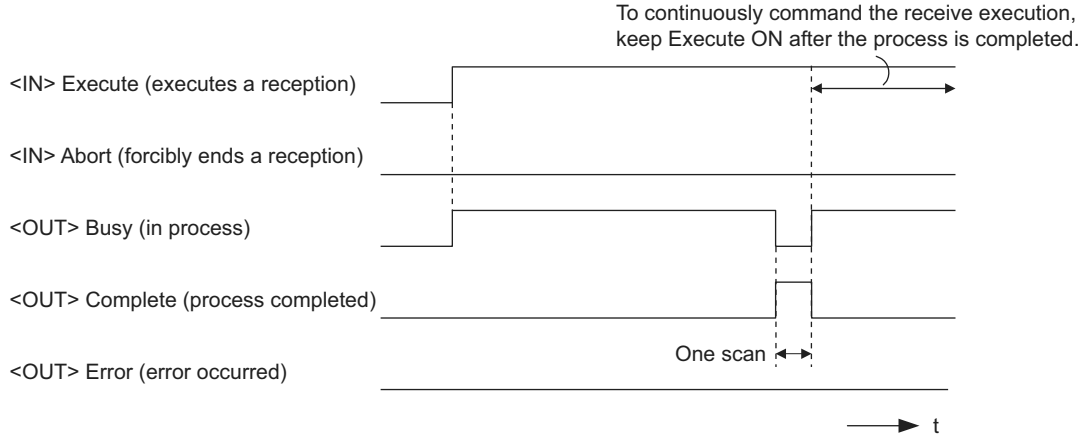

[When Forcibly Aborted]

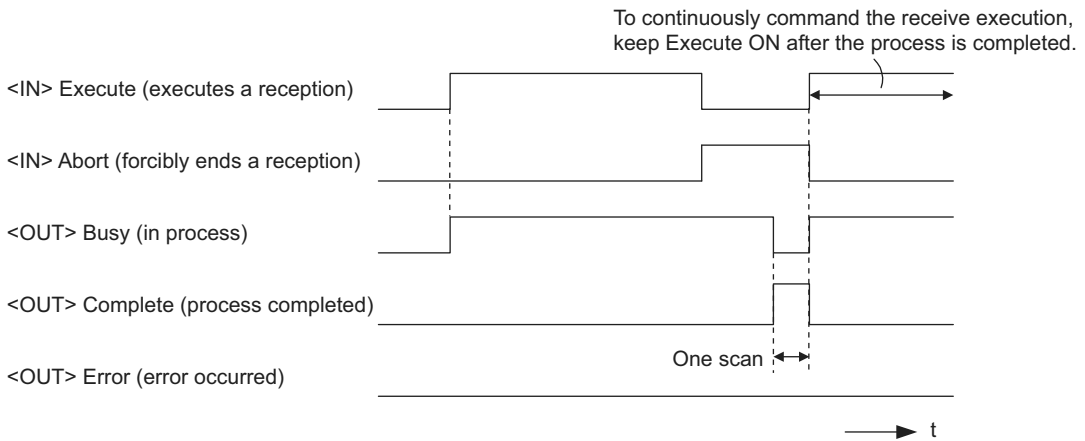

[When Error Occurred]

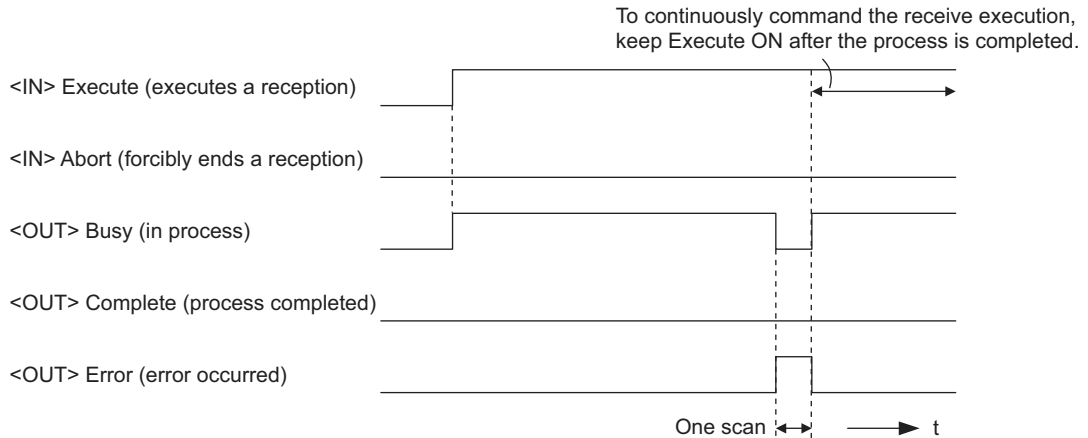

G.2.3 Message Receive Function Parameter List (Param) Overview

Param of the MSG-RCV function has a parameter list structure composed of 17 words. (The value of Param itself is the start address (MA, DA) of the parameter list.)

In the parameter list, enter the function code and its relevant parameter data. Process result and status are also output.

When MEMOBUS and non-procedure are used as a transmission protocol, the parameter list is as follows:

Note: Parameter details are explained in the parameter details for each protocol type. Refer to the following items:

- *G.2.4 Function Setting and Parameter Details for MEMOBUS and Extended MEMOBUS Protocols* on page A-77
- *G.2.5 Function Setting and Parameter Details for MELSEC Protocol* on page A-85
- *G.2.6 Function Setting and Parameter Details for MODBUS/TCP Protocol* on page A-89
- *G.2.7 Function Setting and Parameter Details for Non-procedural Protocol* on page A-93

(1) MEMOBUS Parameter List

Param No.	IN/OUT	Contents	Description
00	OUT	Process result	Outputs process results.
01	OUT	Status	Outputs the status of the communication device.
02	IN	Connection number	Specifies the remote source.
03	OUT	Option	Outputs a unique value for each communication device.
04	OUT	Function code	Outputs a function code requested from the transmission side.
05	OUT*	Data address	Outputs the start address of data requested from the transmission side.
06	OUT	Data size	Outputs the read/write data size requested from the transmission side.
07	OUT	Remote CPU number	Outputs the remote CPU number.
08	IN	Coil offset	Sets the coil's offset word address.
09	IN	Input relay offset	Sets the offset word address of an input relay.
10	IN	Input register offset	Sets the offset word address of an input register.
11	IN	Holding register offset	Sets the offset word address of a holding register.
12	IN	Write range LO	Sets the start address for a write range.
13	IN	Write range HI	Sets the last address for a write range.
14	SYS	Reserved 1	
05 to 16	SYS	Reserved 2	

* It is IN/OUT for MODBUS/TCP.

Note: IN: Input, OUT: Output, SYS: For system use

(2) Non-procedural Parameter List

Param No.	IN/OUT	Contents	Description
00	OUT	Process result	Outputs the process results.
01	OUT	Status	Outputs the status of the communication device.
02	IN	Connection number	Specifies the remote source.
03	OUT	Not used	
04	OUT	Not used	
05	OUT	Not used	
06	OUT	Data size	Outputs the write data size requested from the transmission side.
07	OUT	Not used	
08 to 11	IN	Not used	
12	IN	Register offset	Sets the register's offset word address.
13	IN	Write range HI	Sets the last address for a write range.
14	SYS	Reserved 1	
15 to 16	SYS	Reserved 2	

Note: IN: Input, OUT: Output, SYS: For system use

G.2.4 Function Setting and Parameter Details for MEMOBUS and Extended MEMOBUS Protocols

This section explains the MSG-RCV function setting and its parameter list details when MEMOBUS or Extended MEMOBUS is used as a protocol.

(1) Message Receive Function Setting

[a] 218IFA Setting Example

An example of a function setting when 218IFA is used as a communication device follows:

Set the protocol type to MEMOBUS even when used in Extended MEMOBUS protocol.

Set the circuit number in accordance with the circuit number allocated to the target 218IFA.

Set a unique communication buffer channel number for the same circuit.

For information on the register number, refer to *G.2.2 (1) Input Item* on page A-71 and *G.2.2 (2) Output Item* on page A-73.

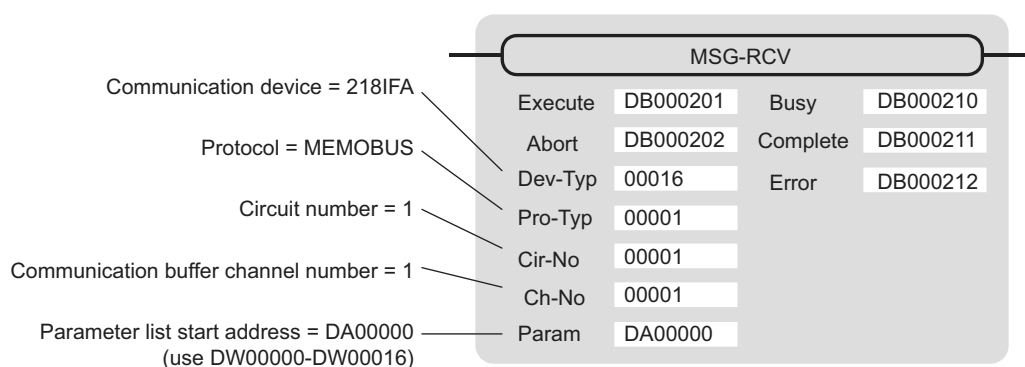

[b] 218IF Setting Example

An example of a function setting when 218IF is used as a communication device follows:

Set the protocol type to MEMOBUS even when used in Extended MEMOBUS protocol.

Set the circuit number in accordance with the circuit number allocated to the target 218IF.

Set a unique communication buffer channel number for the same circuit.

For information on the register number, refer to *G.2.2 (1) Input Item* on page A-71 and *G.2.2 (2) Output Item* on page A-73.

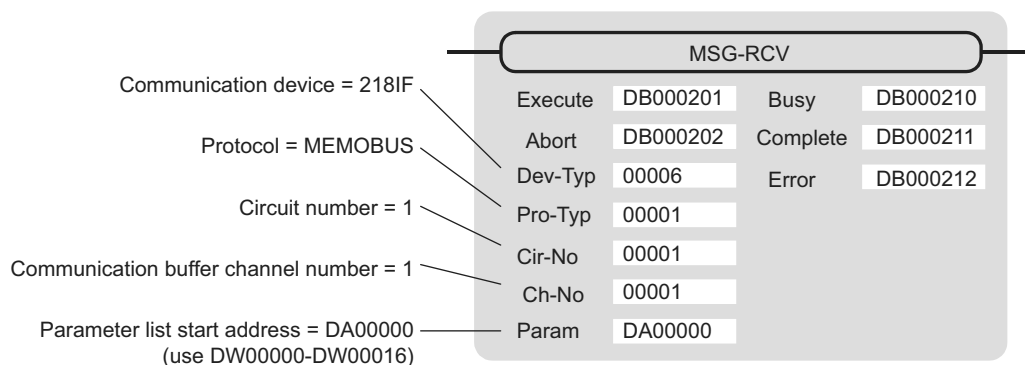

(2) Process Result (PARAM00)

The process result is output to the upper byte. The lower byte is used for system analysis.

Value of Process Result	Meaning
00□□H	In process (Busy)
10□□H	Process completed (Complete)
8y□□H	Error occurred (Error)

When an error occurs, take corrective action by referring to the following error contents:

Value of Process Result	Error Contents	Description
80□□H	–	Reserved
81□□H	Function code error	Unused function code was received. Check the source function code. The following setting is out of range. Check the setting.
82□□H	Error in setting address	Data address (request from transmission side) PARAM08 (coil offset) PARAM09 (input relay offset) PARAM10 (input register offset) PARAM11 (holding register offset)
83□□H	Data size error	The received data size is out of range. Check the source data size.
84□□H	Error in setting circuit number	The circuit number is out of range. Check Cir-No (circuit number) of the MSG-RCV function.
85□□H	Error in setting channel number	The communication buffer channel number is out of range. Check Ch-No (communication buffer channel number) of the MSG-RCV function.
86□□H	Connection number error	The connection number is out of range. Check PARAM02 (connection number).
87□□H	–	Reserved
88□□H	Communication section error	An error response was returned from the communication section (communication device). Check the equipment connection. In addition, check that the remote device is open to communication.
89□□H	Device select error	Unavailable device is set. Check Dev-Typ (communication device type) of the MSG-RCV function.

(3) Status (PARAM01)

Outputs status of the communication section (communication device).

The following figure shows the bit assignment. Bit assignment details are listed in the tables following.

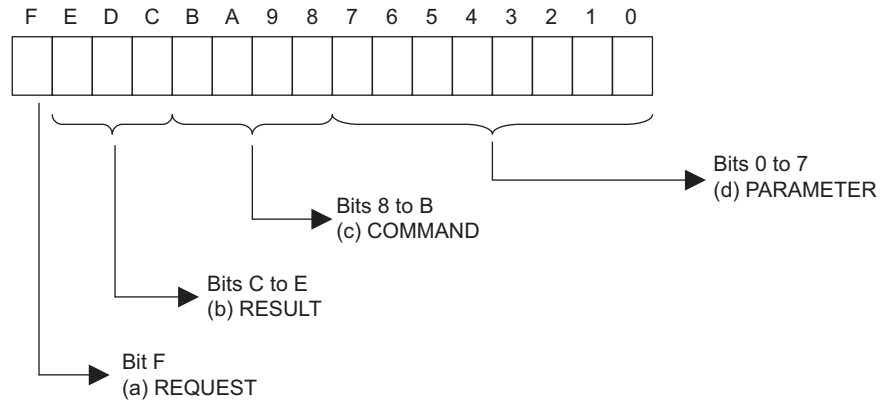

[a] REQUEST (request)

Outputs whether MSG-RCV function is requesting a process.

Bit State	Contents
1	Requesting processing
0	The acceptance of process request is completed

[b] RESULT (result)

Outputs the execution result of the MSG-RCV function.

Code	Abbreviation	Meaning
0	CONN_NG	In Ethernet communication, transmission or connection error is completed
1	SEND_OK	Normal transmission complete
2	REC_OK	Normal reception complete
3	ABORT_OK	Forced abort complete
4	FMT_NG	Parameter format error
5	SEQ_NG	Command sequence error
6	RESET_NG	Reset state
7	REC_NG	Data reception error (error detected in the lower layer program)

[c] COMMAND (command)

Outputs a process command for the MSG-RCV function. The executed process contents can be found according to the command.

Code (Hex)	Abbreviation	Meaning
1	U_SEND	General-purpose message transmission (for non-procedural protocol)
2	U_REC	General-purpose message reception (for non-procedural protocol)
3	ABORT	Forced abort
8	M_SEND	MEMOBUS command transmission: Completed when response is received
9	M_REC	MEMOBUS command reception: Accompanies a response transmission
C	MR_SEND	MEMOBUS response transmission

[d] PARAMETER (parameter)

When RESULT(process result) = 4 (FMT_NG: parameter format error), an error code in the table below is output. Otherwise, the connection number is output.

RESULT (process result)	Code (Hex)	Meaning
When RESULT (process result) =4 (FMT_NG: parameter format error)	00	No error
	01	Connection number is out of range
	02	Time error for monitoring to receive MEMOBUS response
	03	Error in setting retransmit count
	04	Error in setting cyclic area
	05	CPU number error
	06	Data address error
	07	Data size error
	08	Function code error
Others	xx	Connection number

(4) Connection Number (PARAM02)

Specify the remote source.

When the communication device is Ethernet (218IF or 218IFA), set the connection number.

The following table shows the setting range.

Communication Device	Connection Number	Remarks
Ethernet (218IF)	1 to 20	Receives from the remote station set for the specified connection number.
Ethernet (218IFA)	1 to 4	Same as above

Note: When the communication device is Ethernet (218IF/218IFA), set the connection number in accordance with the connection number in the 218IF/218IFA Parameter Setting Window for the MPE720 module configuration definition.

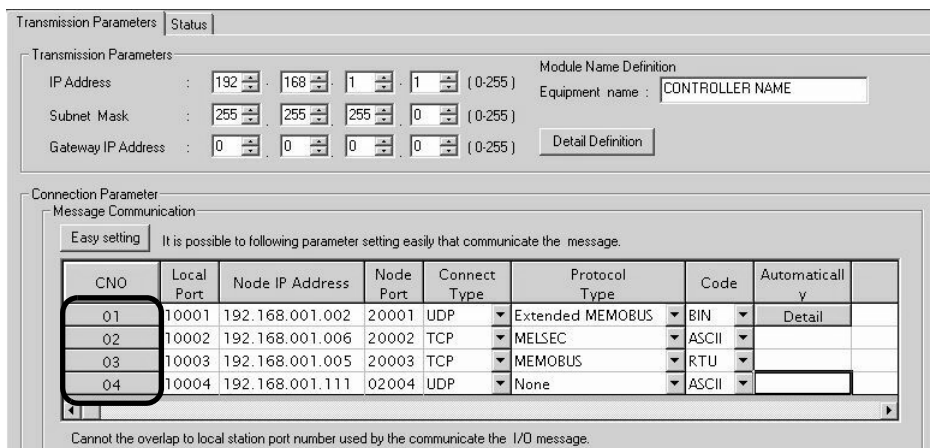

Fig. G.10 218IFA Parameter Setting Screen for the MPE720 Module Configuration Definition Window

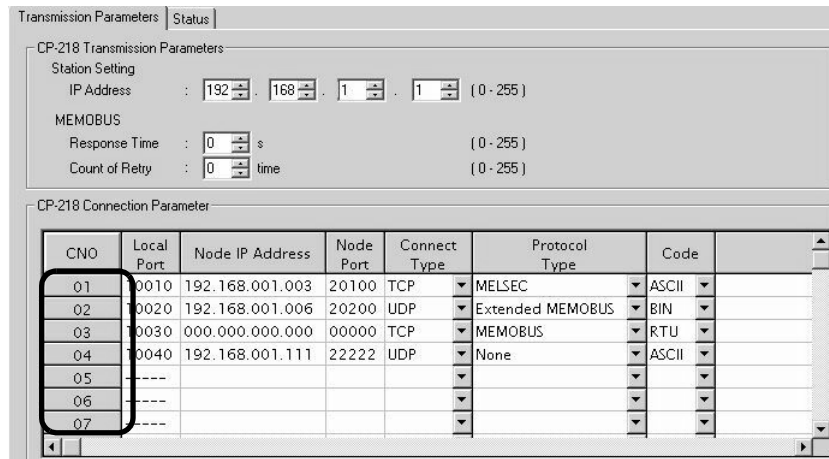

Fig. G.11 218IF Parameter Setting Screen for the MPE720 Module Configuration Definition Window

(5) Option (PARAM03)

A unique value is output for each communication device.

Not used for the MEMOBUS or Extended MEMOBUS protocols.

(6) Function Code (PARAM04)

Received function code is output.

The following table lists function codes available when using MEMOBUS or Extended MEMOBUS as a protocol.

Table G.20 Function Code List (MEMOBUS, Extended MEMOBUS)

Function Code	Target Data Type	Function	Protocol	
			Extended MEMO-BUS	MEMOBUS
00H	–	Unused	–	–
01H	B	Reads coil state	√	√
02H	B	Reads input relay state	√	√
03H	W	Reads holding register content	√	√
04H	W	Reads input register content	√	√
05H	B	Changes single coil state	√	√
06H	W	Writes to single holding register	√	√
07H	–	Unused	–	–
08H	–	Loopback test	√	√
09H	W	Reads holding register content (extended)	√	–
0AH	W	Reads input register content (extended)	√	–
0BH	W	Writes to holding register (extended)	√	–
0CH	–	Unused	–	–
0DH	w	Discontinuously reads holding register (extended)	√	–
0EH	w	Discontinuously writes to holding register (extended)	√	–
0FH	B	Changes multiple coil states	√	√
10H	W	Writes to multiple holding registers	√	√

Note: 1. B: Bit type, W: Integer type

2. √: Available, -: Not available

3. Transmit and receive registers in the master operation mode are MW (MB) only.

4. In the slave operation mode, coil, holding register, input relay, and input register are MB, MW, IB, IW respectively.

(7) Data Address (PARAM05)

A data address requested from the transmission side is output.

(8) Data Size (PARAM06)

The read/write data size (number of bits or words) requested from the transmission side is output.

(9) Remote CPU Number (PARAM07)

When the remote equipment is MP2□00 series, “1” is output.

When the remote equipment is a controller manufactured by YASKAWA Electric Corporation other than MP2□00 series and is comprised of multiple CPU modules, the remote CPU number is output.

Otherwise, “0” is output.

(10) Offset (PARAM08, PARAM09, PARAM10, PARAM11)

Specify an offset address for the reception side data address.

The address for the reception side will be displaced by the number of words designated by the offset.

Note: 1. For more information, refer to *G.2.8 Relationship between Data Address, Data Size, and Offset for MSG-RCV Function* on page A-98.

2. The offset cannot be a negative value.

The offset parameter is prepared for each target data type.

The following table lists the offset parameters.

Table G.21 Offset Parameter List

Parameter	Contents	Description
PARAM08	Coil offset	Sets the coil's offset word address.
PARAM09	Input relay offset	Sets the offset word address of an input relay.
PARAM10	Input register offset	Sets the offset word address of an input register.
PARAM11	Holding register offset	Sets the offset word address of a holding register.

The valid offset parameter may differ according to the function code.

The following table lists the valid parameters for each function code.

Table G.22 Valid Parameter List for Offset of Each Function Code

Function Code	Function	Valid Offset Parameter	Protocol Type	
			Extended MEMOBUS	MEMOBUS
01H	Reads coil state	PARAM08	√	√
02H	Reads input relay state	PARAM09	√	√
03H	Reads holding register content	PARAM11	√	√
04H	Reads input register content	PARAM10	√	√
05H	Changes single coil state	PARAM08	√	√
06H	Writes to single holding register	PARAM11	√	√
09H	Reads holding register content (extended)	PARAM11	√	—
0AH	Reads input register content (extended)	PARAM10	√	—
0BH	Writes to holding register (extended)	PARAM11	√	—
0DH	Discontinuously reads holding register (extended)	PARAM11	√	—
0EH	Discontinuously writes to holding register (extended)	PARAM11	√	—
0FH	Changes multiple coil states	PARAM08	√	√
10H	Writes to multiple holding registers	PARAM11	√	√

Note: √: Available, -: Not available

(11) Write Range (PARAM12, PARAM13)

Sets an available address range for the write request from the transmission side. A write request which is out of this available address range will cause an error.

Specify the address range (PARAM12, PARAM13) as a word address.

- Note: 1. In MP9□0/MP2□00 series, the data storage area for the write request from the transmission side is M register.
2. The write range parameter enables you to specify the range of M register which permits writing messages.

The following table indicates the write range parameters.

Table G.23 Write Range Parameter List

Parameter	Contents	Description
PARAM12	Write range LO	Start address of the write range
PARAM13	Write range HI	Last address of the write range

Specify the write range so that the expression below is met:

$$0 \leq \text{Write range LO} \leq \text{Write range HI} \leq \text{Maximum address of M register}$$

This write range is effective for the following function codes:

- 05H (changes single coil state)
- 06H (writes to single holding register)
- 0BH (writes to holding register (write))
- 0EH (discontinuously writes to holding register (extended))
- 0FH (changes multiple coil states)
- 10H (writes to multiple holding registers)

Example: When setting the address of M register which permits writing to 1000 to 1999:

PARAM12=1000

PARAM13=1999

The reception side will return an error against a write request to an address other than MW01000 to MW01999, and will not write it.

(12) Reserved by System 1 (PARAM14)

Used by system (the channel number of the communication buffer in use is stored).

Note: At the first scan during power up, make sure to set this to "0" with the user program. After that, the register is used by system, so do not change the value with the user program.

(13) Reserved by System 2 (PARAM15, PARAM16)

Used by system. Do not change the value with the user program, etc.

G.2.5 Function Setting and Parameter Details for MELSEC Protocol

This section explains the MSG-RCV function setting and its parameter list details when MELSEC is used as a protocol.

(1) Message Receive Function Setting

[a] 218IFA Setting Example

An example of a function setting when 218IFA is used as a transmission device follows:

Set the protocol type to MEMOBUS when used in MELSEC protocol.

Set the circuit number in accordance with the circuit number allocated to the target 218IFA.

Set a unique communication buffer channel number for the same circuit.

For information on the register number, refer to *G.2.2 (1) Input Item* on page A-71 and *G.2.2 (2) Output Item* on page A-73.

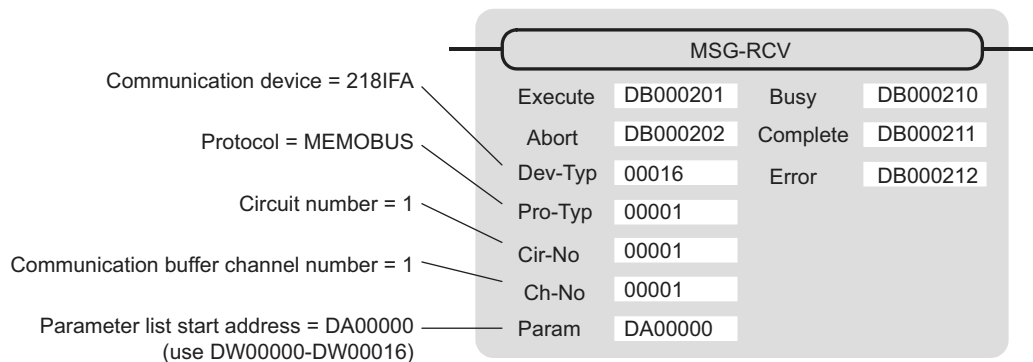

[b] 218IF Setting Example

An example of a function setting when 218IF is used as a communication device follows:

Set the protocol type to MEMOBUS when used in MELSEC protocol.

Set the circuit number in accordance with the circuit number allocated to the target 218IF.

Set a unique communication buffer channel number for the same circuit.

For information on the register number, refer to *G.2.2 (1) Input Item* on page A-71 and *G.2.2 (2) Output Item* on page A-73.

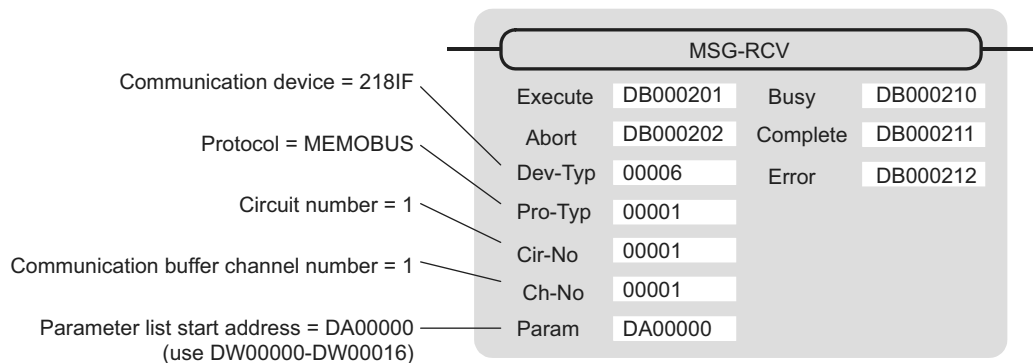

(2) Process Result (PARAM00)

Refer to *G.2.4 (2) Process Result (PARAM00)* on page A-78.

(3) Status (PARAM01)

Refer to *G.2.4 (3) Status (PARAM01)* on page A-79.

(4) Connection Number (PARAM02)

Refer to *G.2.4 (4) Connection Number (PARAM02)* on page A-80.

(5) Option (PARAM03)

A unique value is output for each communication device.
Not used for the MELSEC protocol.

(6) Function Code (PARAM04)

Received function code is output.
The following table lists the function codes available when using the MELSEC protocol.

Table G.24 Function Code List (MELSEC)

Function Code	MELSEC ACPU Common Command	Target Data Type	Function
01H/02H	00H	B	Reads bit device in units
03H/04H/09H/0AH	01H	W	Reads word device in units
05H/0FH	02H	B	Writes to bit device in units
06H/0BH/10H	03H	W	Writes to word device in units
08H	16H	—	Loopback test
0EH	05H	B	Specifies a device number for each word device at random and sets/resets each word device
31H	60H	W	Writes to the fixed buffer in words
32H	61H	W	Reads from the random access buffer in words (unable to receive for MP2□00 series)
33H	62H	W	Writes to the random access buffer in words

Note: 1. B: Bit type, W: Integer type

2. AnCPU dedicated commands are not supported. Commands for extended file register are not supported.

(7) Data Address (PARAM05)

A data address requested from the transmission side is output.

(8) Data Size (PARAM06)

The read/write data size (number of bits or words) requested from the transmission side is output.

(9) Remote CPU Number (PARAM07)

Refer to G.2.4 (9) Remote CPU Number (PARAM07) on page A-82.

(10) Offset (PARAM08, PARAM09, PARAM10, PARAM11)

Specify an offset address for the reception side data address.

The address for the reception side will be displaced by the number of words designated by the offset.

Note: 1. For more information, refer to *G.2.8 Relationship between Data Address, Data Size, and Offset for MSG-RCV Function* on page A-98.

2. The offset cannot be a negative value.

The offset parameter is prepared for each target data type.

The following table lists the offset parameters.

Table G.25 Offset Parameter List

Parameter	Contents	Description
PARAM08	Coil offset	Sets the coil's offset word address.
PARAM09	Input relay offset	Sets the offset word address of an input relay.
PARAM10	Input register offset	Sets the offset word address of an input register.
PARAM11	Holding register offset	Sets the offset word address of a holding register.

The valid offset parameter may differ according to the function code.

The following table lists the valid parameters for the function codes.

Table G.26 Valid Parameter List for Offset of Each Function Code

Function Code	Function	Valid Offset Parameter
01H	Reads coil state	PARAM08
02H	Reads input relay state	PARAM09
03H	Reads holding register content	PARAM11
04H	Reads input register content	PARAM10
05H	Changes single coil state	PARAM08
06H	Writes to single holding register	PARAM11
09H	Reads holding register content (extended)	PARAM11
0AH	Reads input register content (extended)	PARAM10
0BH	Writes to holding register (extended)	PARAM11
0EH	Discontinuously writes to holding register (extended)	PARAM11
0FH	Changes multiple coil states	PARAM08
10H	Writes to multiple holding registers	PARAM11
31H	Writes to fixed buffer	PARAM11
32H	Reads the random access buffer	Invalid
33H	Writes to the random access buffer	PARAM11

(11) Write Range (PARAM12, PARAM13)

Sets an available address range for a write request from the transmission side. A write request which is out of this available address range will cause an error.

Specify the address range (PARAM12, PARAM13) as a word address.

- Note: 1. In MP9□0/MP2□00 series, the data storage area for the write request from the transmission side is the M register.
2. The write range parameter enables you to specify the range of M register which permits writing messages.

The following table shows the write range parameters.

Table G.27 Write Range Parameter List

Parameter	Contents	Description
PARAM12	Write range LO	Start address of the write range
PARAM13	Write range HI	Last address of the write range

Specify the write range so that the expression below is met:

$$0 \leq \text{Write range LO} \leq \text{Write range HI} \leq \text{Maximum address of M register}$$

This write range is effective for the following function codes:

- 05H (changes single coil state)
- 06H (writes to single holding register)
- 0BH (writes to holding register (write))
- 0EH (discontinuously writes to holding register (extended))
- 0FH (changes multiple coil states)
- 10H (writes to multiple holding registers)
- 31H (writes to fixed buffer)
- 33H (writes to the random access buffer)

Example: When setting the address of the M register which permits writing to 1000 to 1999:

PARAM12=1000

PARAM13=1999

The reception side will return an error against a write request to an address other than MW01000 to MW01999, and will not write it.

(12) Reserved by System 1 (PARAM14)

Used by system (the channel number of the communication buffer in use is stored).

Note: At the first scan during power up, make sure to set this to "0" by user program. After that, the register is used by system, so do not change the value with the user program.

(13) Reserved by System 2 (PARAM15, PARAM16)

Used by system. Do not change the value with the user program, etc.

G.2.6 Function Setting and Parameter Details for MODBUS/TCP Protocol

This section explains the MSG-RCV function setting and its parameter list details when MODBUS/TCP is used as a protocol.

(1) Message Receive Function Setting

[a] 218IFA Setting Example

An example of a function setting when 218IFA is used as a transmission device follows:

Set the protocol type to MEMOBUS when used in MODBUS/TCP protocol.

Set the circuit number in accordance with the circuit number allocated to the target 218IFA.

Set a unique communication buffer channel number for the same circuit.

For information on the register number, refer to in *G.2.2 (1) Input Item* on page A-71 and *G.2.2 (2) Output Item* on page A-73.

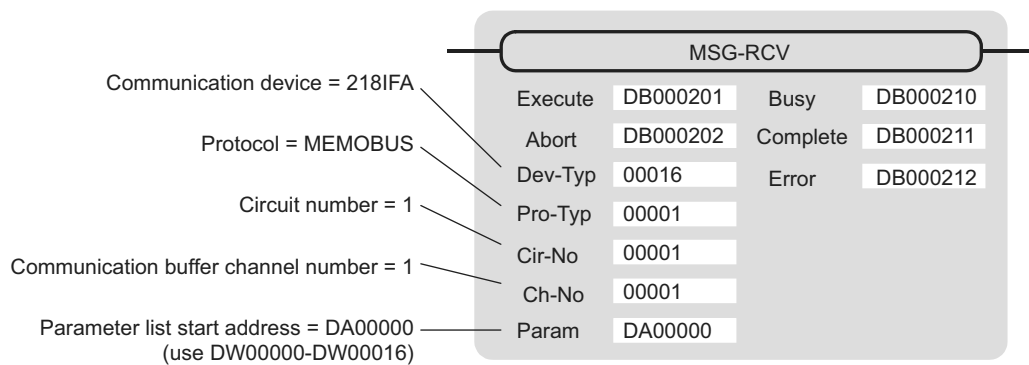

[b] 218IF Setting Example

An example of a function setting when 218IF is used as a communication device follows:

Set the protocol type to MEMOBUS when used in MODBUS/TCP protocol.

Set the circuit number in accordance with the circuit number allocated to the target 218IF.

Set a unique communication buffer channel number for the same circuit.

For information on the register number, refer to *G.2.2 (1) Input Item* on page A-71 and *G.2.2 (2) Output Item* on page A-73.

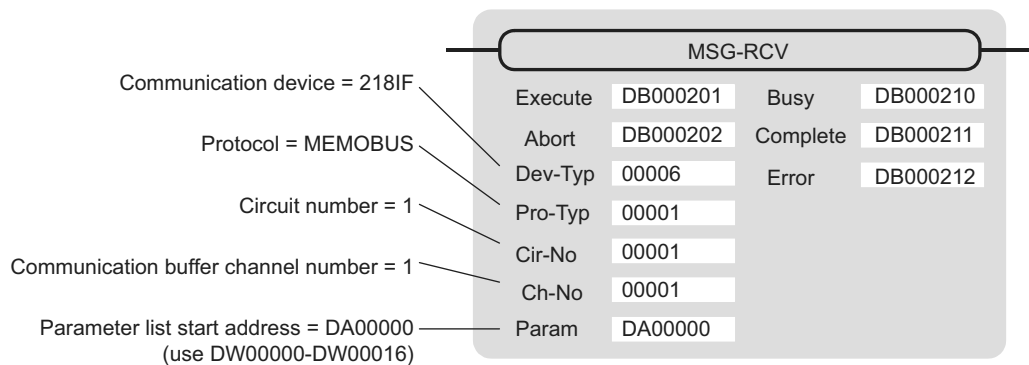

(2) Process Result (PARAM00)

Refer to *G.2.4 (2) Process Result (PARAM00)* on page A-78.

(3) Status (PARAM01)

Refer to G.2.4 (3) Status (PARAM01) on page A-79.

(4) Connection Number (PARAM02)

Refer to G.2.4 (4) Connection Number (PARAM02) on page A-80.

(5) Option (PARAM03)

A unique value is output for each communication device. The output details are as follows:

Communication device	Output Details
Ethernet (218IF·218IFA)	A remote unit ID is output when MODBUS/TCP protocol is used.

(6) Function Code (PARAM04)

Received function code is output.

The following table lists the function codes available when using the MODBUS/TCP protocol.

Table G.28 Function Code List (MODBUS/TCP)

Function Code	Target Data Type	Function	Protocol Type	
			Ethernet (218IF)	Ethernet (218IFA)
00H	—	Not used	—	—
01H	B	Reads coil state	√	√
02H	B	Reads input relay state	√	√
03H	W	Reads holding register content	√	√
04H	W	Reads input register content	√	√
05H	B	Changes single coil state	√	√
06H	W	Writes to single holding register	√	√
07H	—	Not used	—	—
:				
0EH				
0FH	B	Changes multiple coil states	√	√
10H	W	Writes to multiple holding registers	√	√
11H	—	Not used	—	—
:				
15H				
16H	W	Mask writes to holding register	—	√
17H	W	Reads/Writes multiple holding registers	—	√

Note: 1. B: Bit type, W: Integer type

2. √: Available, -: Not available

3. Transmit and receive registers in the master operation mode are MW (MB) only.

4. In the slave operation mode, coil, holding register, input relay, and input register are MB, MW, IB, IW respectively.

(7) Data Address (PARAM05)

A data address requested from the transmission side is output.

However, when reading/writing multiple holding registers (function code: 17H), enter a start M register number for the address table. The four words of addresses at the beginning of the M register set by PARAM05 (data address) are used as an address table. In this address table, read address, read size, write address, and write size requested from the transmission side are output.

For more information about the address table, refer to *G.1.6 (7) Data Address (PARAM05)* on page A-58.

(8) Data Size (PARAM06)

The read/write data size (number of bits or words) requested from the transmission side is output.

(9) Remote CPU Number (PARAM07)

Refer to *G.2.8 Relationship between Data Address, Data Size, and Offset for MSG-RCV Function* on page A-98.

(10) Offset (PARAM08, PARAM09, PARAM10, PARAM11)

Specify an offset address for the reception side data address.

The address for the reception side will be displaced by the number of words designated by the offset.

Note: 1. For more information, refer to *G.2.8 Relationship between Data Address, Data Size, and Offset for MSG-RCV Function* on page A-98.
2. The offset cannot be a negative value.

The offset parameter is prepared for each target data type.

The following table lists the offset parameters.

Table G.29 Offset Parameter List

Parameter	Contents	Description
PARAM08	Coil offset	Sets the coil's offset word address.
PARAM09	Input relay offset	Sets the offset word address of an input relay.
PARAM10	Input register offset	Sets the offset word address of an input register.
PARAM11	Holding register offset	Sets the offset word address of a holding register.

The valid offset parameter may differ according to the function code.

The following table lists the valid parameters for each function code.

Table G.30 Valid Parameter List for Offset of Each Function Code

Function Code	Function	Valid Offset Parameter
01H	Reads coil state	PARAM08
02H	Reads input relay state	PARAM09
03H	Reads holding register content	PARAM11
04H	Reads input register content	PARAM10
05H	Changes single coil state	PARAM08
06H	Writes to single holding register	PARAM11
0FH	Changes multiple coil states	PARAM08
10H	Writes to multiple holding registers	PARAM11
16H	Mask writes to holding register	PARAM11
17H	Reads/Writes multiple holding registers	PARAM11

(11) Write Range (PARAM12, PARAM13)

Sets an available address range for the write request from the transmission side. A write request which is out of this available address range will cause an error.

Specify the address range (PARAM12, PARAM13) as a word address.

- Note: 1. In MP9□0/MP2□00 series, the data storage area for the write request from the transmission side is the M register.
 2. The write range parameter enables you to specify the range of the M register which permits writing messages.

The following table indicates the write range parameters.

Table G.31 Write Range Parameter List

Parameter	Contents	Description
PARAM12	Write range LO	Start address of the write range
PARAM13	Write range HI	Last address of the write range

Specify the write range so that the expression below is met:

$$0 \leq \text{Write range LO} \leq \text{Write range HI} \leq \text{Maximum address of M register}$$

This write range is effective for the following function codes:

- 05H (changes single coil state)
- 06H (writes to single holding register)
- 0BH (writes to holding register (write))
- 0FH (changes multiple coil states)
- 10H (writes to multiple holding registers)
- 16H (mask writes to holding register)
- 17H (reads/writes multiple holding registers)

Example: When setting the address of the M register which permits writing to 1000 to 1999:

PARAM12=1000
 PARAM12=1000
 PARAM13=1999

The reception side will return an error against a write request to an address other than MW01000 to MW01999, and will not write it.

(12) Reserved by System 1 (PARAM14)

Used by system (the channel number of the communication buffer in use is stored).

Note: At the first scan during power up, make sure to set this to "0" by user program. After that, the register is used by system, so do not change the value with the user program.

(13) Reserved by System 2 (PARAM15, PARAM16)

Used by system. Do not change the value with the user program, etc.

G.2.7 Function Setting and Parameter Details for Non-procedural Protocol

This section explains the MSG-RCV function setting and its parameter list details when non-procedure is used as a protocol.

Note: Non-procedure communication protocol stores the received data in the M register intact without a protocol conversion.

You can receive any protocol in accordance with the remote device.

(1) Message Receive Function Setting

[a] 218IFA Setting Example

An example of a function setting when 218IFA is used as a transmission device follows:

When non-procedure 2 (per byte) is used, set the Pro-Typ field to "00003". (non-procedure 1 (per word))

Set the circuit number in accordance with the circuit number allocated to the target 218IFA.

Set a unique communication buffer channel number for the same circuit.

For information on the register number, refer to *G.2.2 (1) Input Item* on page A-71 and *G.2.2 (2) Output Item* on page A-73.

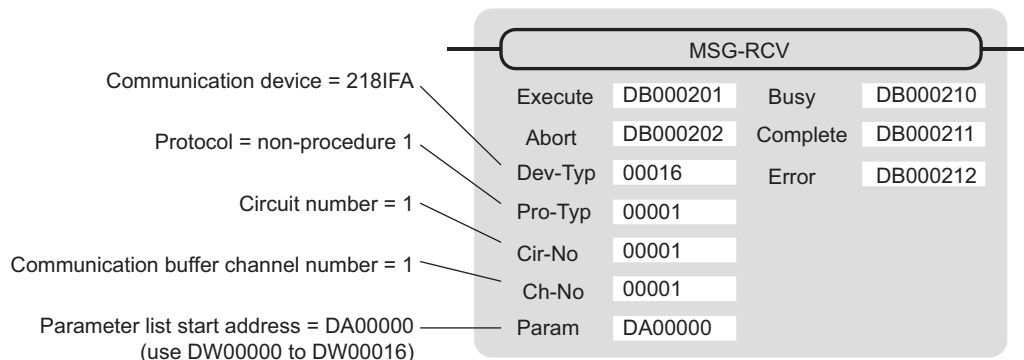

[b] 218IF Setting Example

An example of a function setting when 218IF is used as a communication device follows:

When non-procedure 2 (per byte) is used, set the Pro-Typ field to "00003". (non-procedure 1 (per word))

Set the circuit number in accordance with the circuit number allocated to the target 218IF.

Set a unique communication buffer channel number for the same circuit.

For information on the register number, refer to *G.2.2 (1) Input Item* on page A-71 and *G.2.2 (2) Output Item* on page A-73.

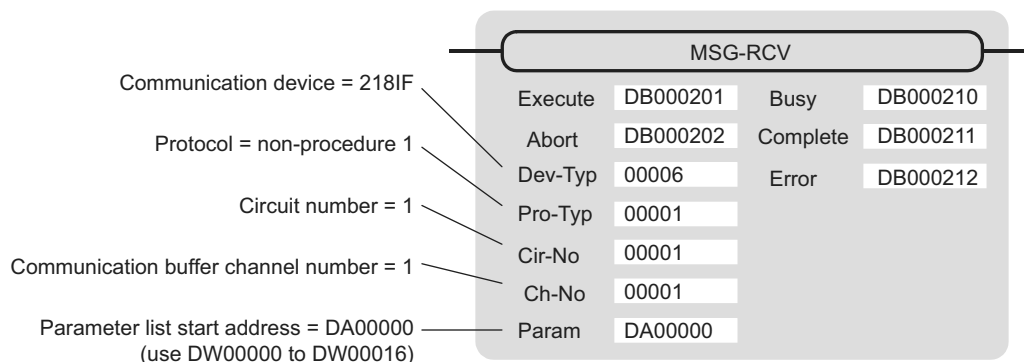

(2) Process Result (PARAM00)

The process result is output to the upper byte. The lower byte is used for system analysis.

Value of Process Result	Meaning
00□□H	In process (Busy)
10□□H	Process completed (Complete)
8y□□H	Error occurred (Error)

When an error occurs, investigate it by referring to the following error contents:

Value of Process Result	Error Contents	Description
80□□H	—	Reserved
81□□H	—	—
82□□H	Error in setting address	The following setting is out of range. Check the setting. PARAM11 (holding register offset)
83□□H	Data size error	The received data size is out of range. Check the source data size.
84□□H	Error in setting circuit number	The circuit number is out of range. Check Cir-No (circuit number) of the MSG-RCV function.
85□□H	Error in setting channel number	The communication buffer channel number is out of range. Check Ch-No (communication buffer channel number) for the MSG-RCV function.
86□□H	Connection number error	The connection number is out of range. Check PARAM02 (connection number).
87□□H	—	Reserved
88□□H	Communication section error	An error response was returned from the communication section (communication device). Check the equipment connection. In addition, check that the remote device is open to communication.
89□□H	Device select error	Unavailable device is set. Check Dev-Typ (communication device type) of the MSG-RCV function.

(3) Status (PARAM01)

Outputs status of the communication section (communication device). The following figure shows the bit assignment. The bit assignment details are listed in the following tables.

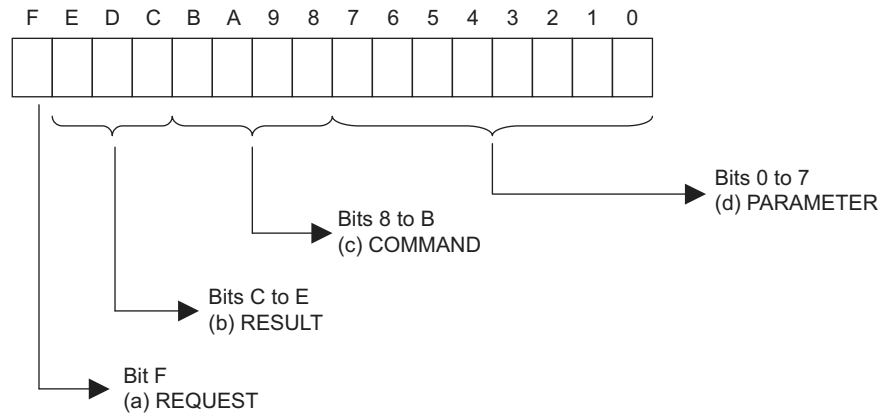

[a] REQUEST (request)

Outputs whether MSG-RCV function is requesting a process.

Bit State	Contents
1	Requesting to process
0	The acceptance of process request is completed

[b] RESULT (result)

Outputs the execution result of the MSG-RCV function

Code	Abbreviation	Meaning
0	CONN_NG	In Ethernet communications, transmit error or connection error is completed
1	SEND_OK	Normal transmission completed
2	REC_OK	Normal reception completed
3	ABORT_OK	Forced abort completed
4	FMT_NG	Parameter format error
5	SEQ_NG	Command sequence error
6	RESET_NG	Reset state
7	REC_NG	Data reception error (error detected in the lower layer program)

[c] COMMAND (command)

Outputs a process command for the MSG-RCV function The executed process content can be found according to the command.

Code (Hex)	Abbreviation	Meaning
1	U_SEND	General-purpose message transmission
2	U_REC	General-purpose message reception
3	ABORT	Forced abort
8	M_SEND	Command transmission: Completed when response is received (for MEMOBUS protocol)
9	M_REC	Command reception: Accompanies a response transmission (for MEMOBUS protocol)
C	MR_SEND	Response transmission (for MEMOBUS protocol)

[d] PARAMETER (parameter)

When RESULT (process result) = 4 (FMT_NG: parameter format error), an error code in the following table is output. Otherwise, the connection number is output.

RESULT (process result)	Code (Hex)	Meaning
When RESULT (process result) = 4 (FMT_NG: parameter format error)	00	No error
	01	Connection number is out of range
	02	Time error while monitoring to receive MEMOBUS response (for MEMOBUS protocol)
	03	Error in setting retransmit count
	04	Error in setting cyclic area
	05	CPU number error
	06	Data address error
	07	Data size error
	08	Function code error (for MEMOBUS protocol)
Others	xx	Connection number

(4) Connection Number (PARAM02)

Refer to *G.2.4 (4) Connection Number (PARAM02)* on page A-80.

(5) Data Size (PARAM06)

A data size requested from the transmission side is output.
In case of non-procedure 1, the number of words is output.
In case of non-procedure 2, the number of bytes is output.

(6) Register Offset (PARAM12)

Specify an offset address for the reception side data address.

The address for the reception side will be displaced by the number of words designated by the offset.

Note: 1. For more information, refer to *G.2.8 Relationship between Data Address, Data Size, and Offset for MSG-RCV Function* on page A-98.

2. The offset cannot be a negative value.

In case of non-procedure, received continuous data is stored in the M register. Setting the register offset enables you to specify a start address of the M register as a storage area.

Example: When specifying MW01000 for the start address of the M register for storing received data:
PARAM12=1000

(7) Write Range HI (PARAM13)

Sets an available address range for the write request from the transmission side. A write request which is out of this available address range will cause an error.

Specify the write range (PARAM13) as a word address.

Note: The write range parameter enables you to specify the range of the M register which permits writing messages.

Specify the write range so that the expression below is met:

$$0 \leq \text{Write range HI} \leq \text{Maximum address of M register}$$

Example: When setting the last address of the M register which permits writing to 1999:

PARAM13=1999

The reception side will return an error against a write request to an address other than MW00000 to MW01999, and will not write it.

(8) Reserved by System 1 (PARAM14)

Used by system (the channel number of the communication buffer in use is stored).

Note: At the first scan during power up, make sure to set this to "0" by user program.

After that, the register is used by system, so do not change the value with the user program.

(9) Reserved by System 2 (PARAM15, PARAM16)

Used by system. Do not change the value with the user program, etc.

G.2.8 Relationship between Data Address, Data Size, and Offset for MSG-RCV Function

The relationships between data address, data size, and offset when received with offset are as follows:

(1) When Reading

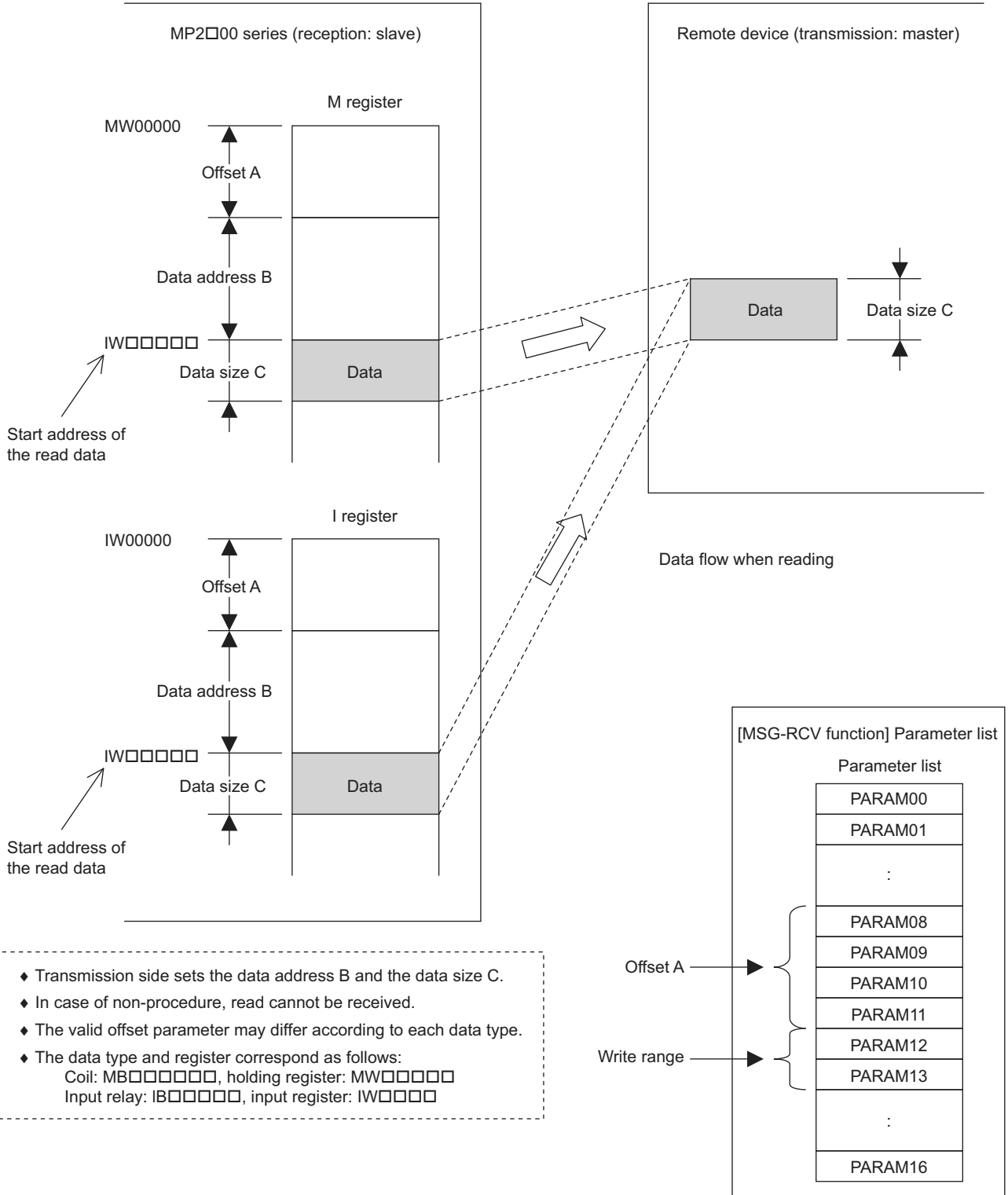

- ◆ Transmission side sets the data address B and the data size C.
- ◆ In case of non-procedure, read cannot be received.
- ◆ The valid offset parameter may differ according to each data type.
- ◆ The data type and register correspond as follows:
Coil: MB□□□□□□, holding register: MW□□□□□□
Input relay: IB□□□□□□, input register: IW□□□□□□

(2) When Writing

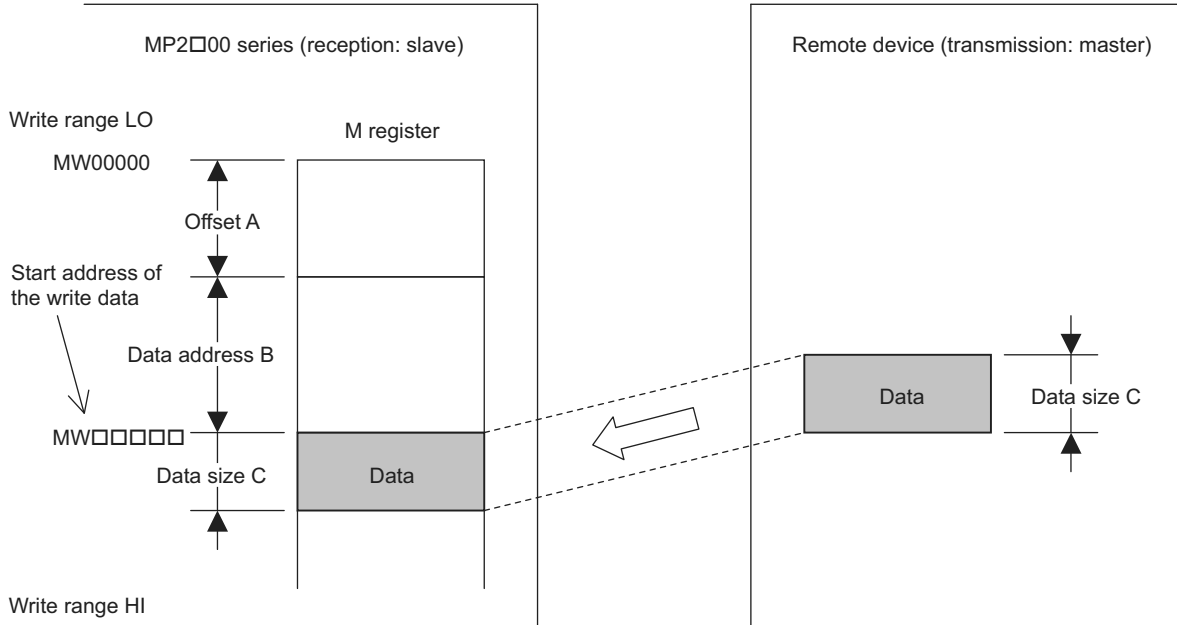

Data flow when writing

- ◆ Transmission side sets the data address B and the data size C.
- ◆ In case of non-procedure, write cannot be received.
- ◆ The valid offset parameter may differ according to each data type.
- ◆ The data type and register correspond as follows:
Coil: MB000000, holding register: MW00000

Communication protocol = MEMOBUS

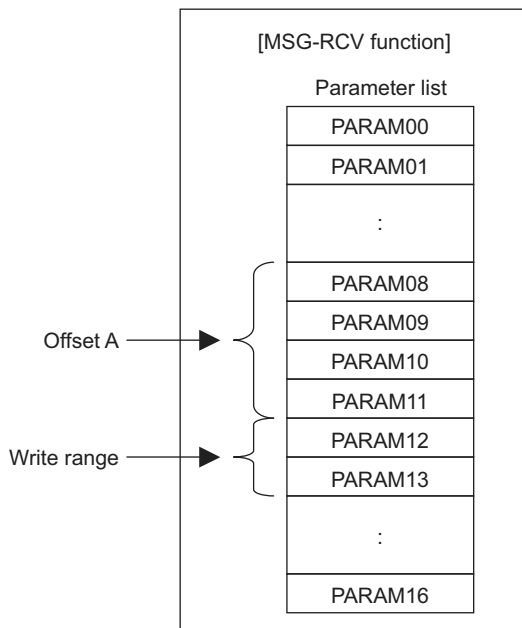

Communication protocol = non-procedure

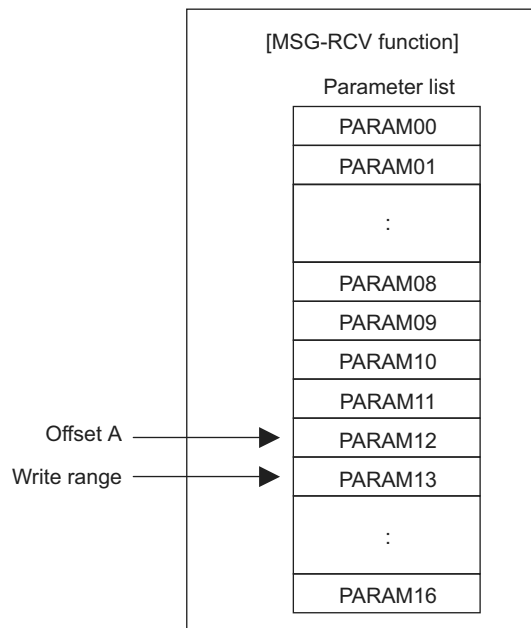

Example: "Writes to multiple holding registers" with offset is received:

When "writes to multiple holding registers" with offset is received in MEMOBUS protocol, various setting values and the relationship with the data of remote equipment are as follows:

- Description of the MSG-RCV function in ladder program

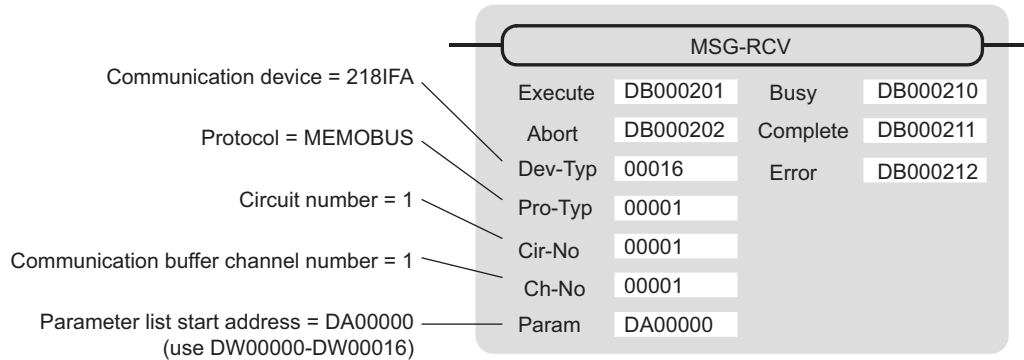

- Parameter list setting of the MSG-RCV function

Table G.32 Parameter List Setting

Register Number	Setting Value	Parameter Number	IN/OUT	Remarks
DW00000	-	PARAM00	OUT	Process result
DW00001	-	PARAM01	OUT	Status
DW00002	00001	PARAM02	IN	Connection number = 1
DW00003	-	PARAM03	OUT	Option (setting unnecessary)
DW00004	-	PARAM04	OUT	Function Code
DW00005	-	PARAM05	OUT	Data address
DW00006	-	PARAM06	OUT	Data size
DW00007	-	PARAM07	OUT	Remote CPU number
DW00008	00000	PARAM08	IN	Coil offset = 0 word
DW00009	00000	PARAM09	IN	Input relay offset = 0 word
DW00010	00000	PARAM10	IN	Input register offset = 0 word
DW00011	01000	PARAM11	IN	Holding register offset = 1000 words
DW00012	00000	PARAM12	IN	Write range LO = 0
DW00013	65534	PARAM13	IN	Write range HI = 65534
DW00014	-	PARAM14	SYS	Reserved (zero clear at startup)
DW00015	-	PARAM15	SYS	Reserved
DW00016	-	PARAM16	SYS	Reserved

Note: IN: Input, OUT: Output, SYS: For system use

- Relationship with the Remote Device Data

The following figure shows the data flow when receiving “writes to multiple holding registers” with offset:
 When transmission and reception are carried out normally in the figure below, the data in the remote device is stored in MW03000 and after of MP2300S.

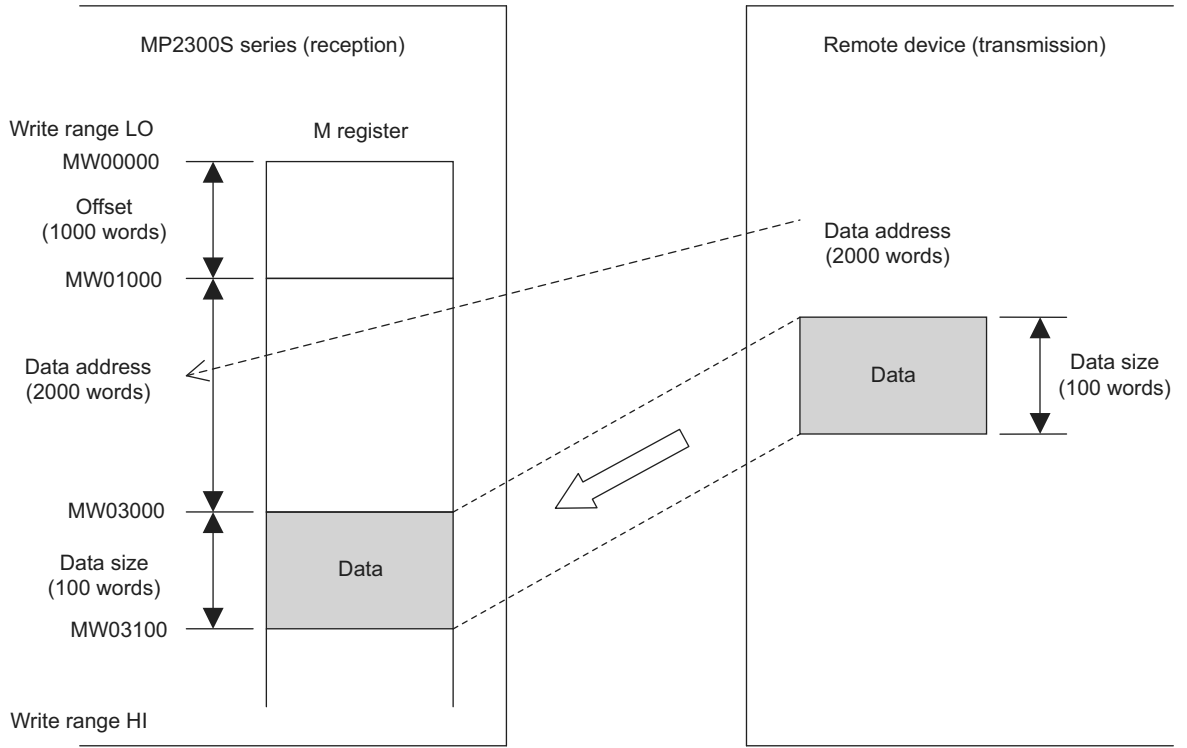

Fig. G.12 Writing Example to Multiple Holding Registers

G.3 Communication Buffer Channel

A communication buffer channel is used for giving and receiving data between the MSG-SND/ MSG-RCV function and communication device. This data buffer is composed of single or multiple channels, and each channel is distinguished by a communication buffer channel number.

The communication buffer channel is associated with a connection by setting the input item **Ch-No** (communication buffer channel number) of the MSG-SND/ MSG-RCV function and PARAM02 (connection number) in Param (parameter list).

A connection is configuration information for communication between local and remote stations, and is set in the **218IF/218IFA Parameter Setting** Window of the MPE720 module configuration definition.

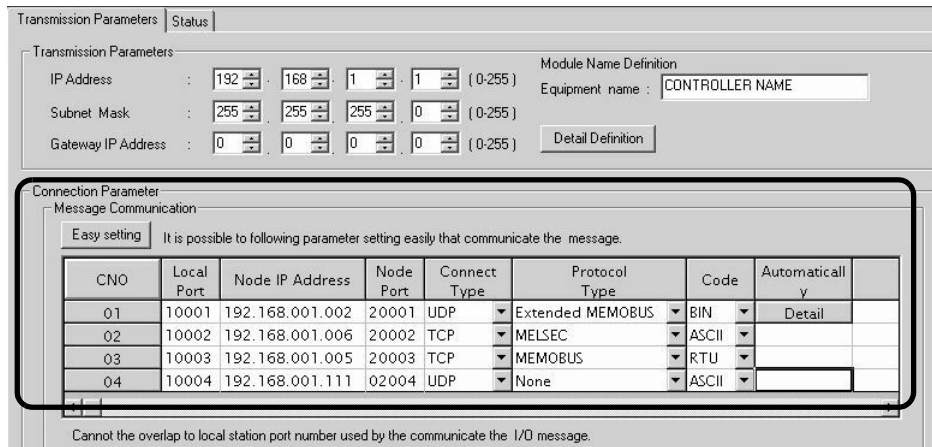

Fig. G.13 218IFA Parameter Setting Window for the MPE720 Module Configuration Definition

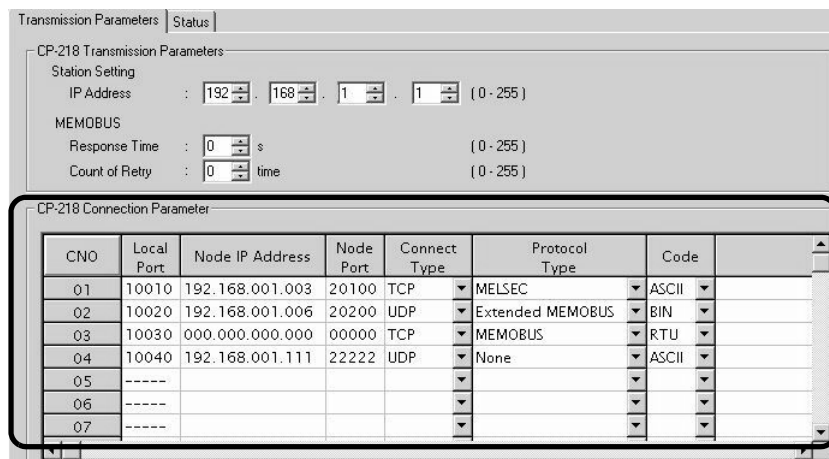
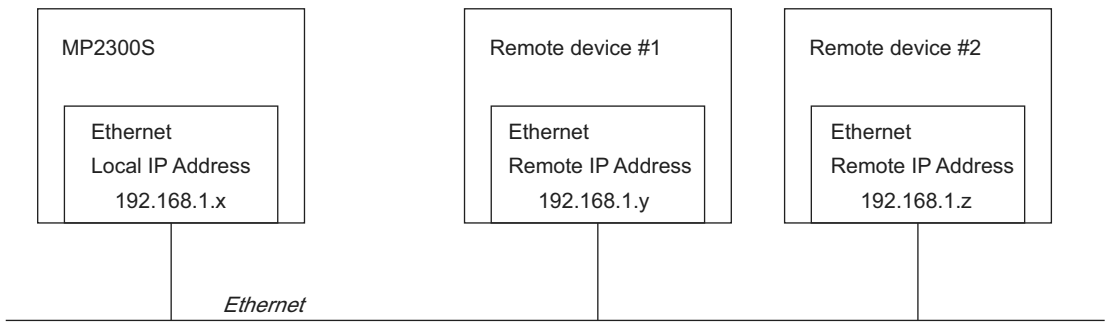

Fig. G.14 218IF Parameter Setting Window for the MPE720 Module Configuration Definition

A schematic diagram of the communication buffer channel is shown in the next page.



Network block diagram

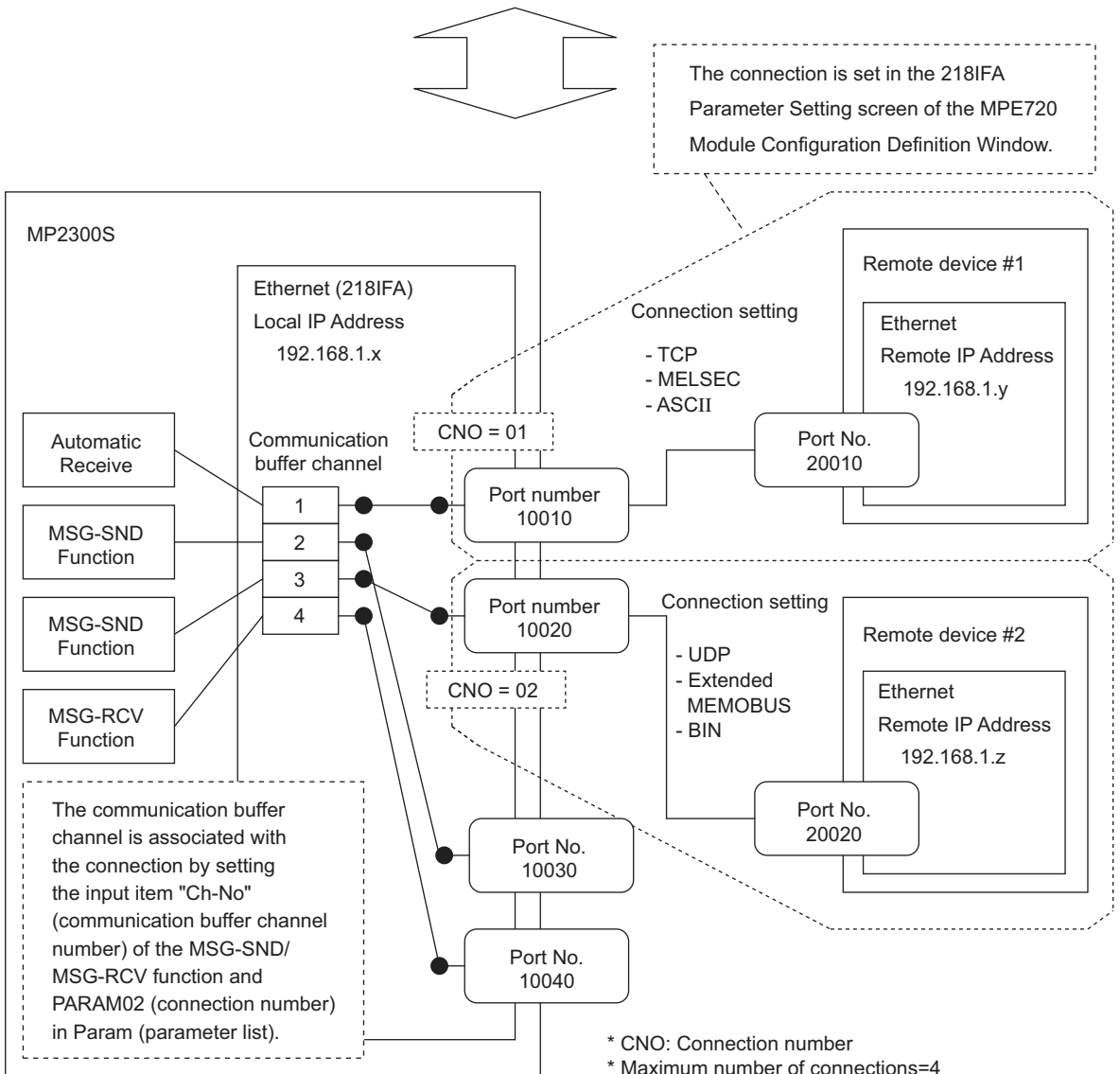

Fig. G.15 Schematic Diagram for Communication Buffer Channel

INDEX

Symbols

# registers	5-36
****I/O	2-43
****SERVO	2-43

Numerics

100Base-TX	3-19
10Base-T	3-19
17-byte mode	2-41
218IFA module	2-12
configuration definition	2-14
detailed screen	2-15
functions	2-12
Specification	2-13
32-byte mode	2-41

A

a way to immediately control a motion program	
from external equipment	5-20
ABS encoder count exceeded	8-38
accessories	1-9
actions to be taken when a transmission error occurs	8-22
address	5-39
alarm IL□□04 list	8-34
allocation contact interlock	5-20
ARP	2-13
automatic negotiation	2-13
automatic receive setting screen	2-22
axis alarms	8-34

B

basic module	2-7
appearance	1-3
connections	3-12
indicators	2-8
specifications	2-11
switch settings	2-9
battery	1-9
bit	5-39
built-in SVB module	2-30

C

cables	1-8, 3-15
calling a motion program	5-12
calling a sequence program	5-29
child drawings	5-31
communication buffer channel	A-102
communication cycle	2-41
communication interface	2-13
communication protocols	2-12
communication with other MP series	6-3
communication with PLC manufactured by Mitsubishi Electric Corporation	6-75
communication with touch panel	6-65
connection parameter	2-19, 2-24
connection procedure	3-14
constants registers	5-36
control signal	5-16

D

D registers	5-36
-------------	------

daily inspections	8-2
data registers	5-36
data types	5-39
definition information updated with self-configuration	5-51
details of program information used by work n	5-27
difference between Ethernet (LP) and Ethernet	A-33
differences from SVB simulation mode	2-49
digital operator	A-14
DIN rail mounting	3-2
DIN rail mounting clips	3-3
DIN Rail Mounting Parts	1-9
DIP switch settings	5-2
direct designation	5-12
distributed synchronizing system	1-6
double-length integer	5-39
drawing A	5-31
drawing execution control	5-32
drawing H	5-31
drawing I	5-31
drawing L	5-31
drawing types	5-31
DWG	5-31
DWG registers	5-36
DWGA	5-31
DWGH	5-31
DWGI	5-31
DWGL	5-31

E

EEPROM	A-5
encoder cable	4-4
Ethernet	2-12
communication methods	6-2
Ethernet cable	3-19
Ethernet connection example	3-20
Ethernet connector details	3-19
excessive positioning moving amount	8-36
excessive speed	8-36
excessively following error	8-36
executing motion	4-11
external function registers	5-37

F

filter time constant change error	8-37
filter type change error	8-37
fixed parameter list	A-20
flash memory	A-5
function input registers	5-37
function output registers	5-37
function registers	5-37
functions	5-31, 5-35

G

grandchild drawings	5-31
groups	5-7

H

hierarchical structure of drawings	5-33
how to determine input error	7-18
how to determine slave CPU synchronous state	7-15
how to disable a user program	8-14
how to disable the I/O process	8-15
how to forcibly turn ON/OFF coil	8-15
how to operate work register	5-19
how to set up communication process	A-31
how to use scan counter	7-17

I	
I/O map tab-----	2-44
I/O message-----	2-24, 2-26
ICMP-----	2-13
indirect designation-----	5-13
INIT-----	5-44
INIT switch and RAM data-----	5-44
initializing the absolute encoder-----	A-15
input registers-----	5-36
inspection items-----	8-2
integer-----	5-39
internal function registers-----	5-37
interpolation override-----	5-17
IP-----	2-13
J	
JZSP-BA01-----	8-4
L	
ladder drawings (DWG)-----	5-31
LAN cable-----	4-4
LED indicator details-----	5-5
LED indicators-----	8-6
link assignment tab page-----	2-43
list of causes for command error occurrence-----	8-30
M	
main program-----	5-7, 5-28
management to resume slave CPU synchronization-----	7-24
maximum number of slave stations-----	2-36
MECHATROLINK	
cable-----	3-15
communication specifications-----	2-36
connector-----	3-14
modules-----	1-7
SERVOPACKs-----	1-7
MECHATROLINK transmission definition-----	2-39
MECHATROLINK-compatible devices-----	1-7
MELSEC protocol-----	6-75
message communication-----	2-18, 2-19, 2-21
message receive function (MSG-RCV)-----	A-70
message transmit function (MSG-SND)-----	A-35
metal fittings-----	2-64
metal fittings for attachment-----	1-9
M-EXECUTOR module-----	2-50
configuration definition-----	2-52
control register mapping window-----	2-56
execution scheduling-----	2-59
function overview-----	2-50
program definition screen-----	2-54
program execution registration screen-----	2-58
specification-----	2-51
module information-----	8-24
monitor the motion program execution information-----	5-25
monitoring parameter list-----	A-27
motion control function specifications-----	2-5
motion control functions-----	2-34
motion error details-----	8-34
motion parameter details-----	A-20
motion program-----	5-7
motion program alarm codes-----	8-28
motion program alarms-----	8-25
motion program executor-----	2-50
mounting clamp-----	3-5
mounting to DIN rail-----	3-3
MP2300S	
appearance-----	2-63
error check flow-----	8-6
Features-----	1-2
general specifications-----	2-2
method-----	3-2
mount direction-----	3-7
product specifications-----	2-3
space required for mounting-----	3-8
MP2300S Modules-----	1-4
MPE720-----	1-9
MSG-RCV-----	A-70
MSG-SND-----	A-35
MSG-SND/MSG-RCV functions-----	A-35
multiple group operation-----	5-7
N	
negative overtravel-----	8-35
negative software limit-----	8-35
network servo status-----	8-39
O	
online self-diagnosis-----	5-4
operation error processing drawings-----	5-31
operation in case of scan time over-----	8-16
operation start-----	5-4
operation stop-----	5-4
option module-----	2-61
option module overview list-----	2-61
optional cover-----	3-11
optional modules-----	1-4
installing-----	3-11
removing-----	3-9
optional SVB-----	2-30
options-----	1-9
output registers-----	5-36
overview of motion errors-----	8-33
P	
parent drawings-----	5-31
PLC function specifications-----	2-4
positioning time over-----	8-36
positive overtravel-----	8-35
positive software limit-----	8-35
power supply connector-----	1-9, 3-13
precaution on using MP2300S-----	5-54
precautions when setting or changing the scan time-----	5-56
precautions when user definition file is configured/changed-----	5-54
processing time-----	2-49
program control method-----	2-51
program numbers-----	5-7, 5-28
programming-----	4-9
programming tool-----	1-9
R	
RAM-----	A-5
real number-----	5-39
recommended ferritic core-----	3-22
register designation-----	5-41
register number direct designation-----	5-41
registers-----	5-36
regular inspections-----	8-3
repeater-----	2-36
repeater HUB-----	3-20
replacing the battery-----	8-4
RLY OUT Connector-----	1-9

RLY OUT connector	
connection cable	3-23
details	3-23

S

S register	5-25
scan processing drawing	5-32
scan time set value examples	5-57
screwed method	3-5
SDRAM	A-5
self configuration of each module	5-48
self-configuration	5-4, 5-42
procedure using MPE720	5-45
procedure using the DIP switch	5-43
self-configuration for all the modules	5-45
self-diagnosis at startup	5-4
sequence program	2-50, 5-28
sequence program alarm	5-30
servo driver command timeout error	8-38
servo driver communication error	8-37
servo driver error	8-34
servo driver error codes	8-39
servo driver synchronization communication error	8-37
servo OFF	8-35
SERVOPACK initialization	A-14
SERVOPACK unmatched encoder type	8-38
SERVOPACK unmatched motor type	8-38
setting and changing scan time	5-56
setting or changing module configuration definition files	5-55
setting parameter list	A-22
simple setting screen	2-21, 2-26
single group operation	5-7
slave CPU synchronous delay time	7-16
slave CPU synchronous function	7-2
how to execute	7-7
how to set up	7-4
operation	7-9
requirements to execute	7-3
SRAM	A-5
standard system functions	5-35
starting motion program from an external signal	4-13
startup sequence	5-2
status flag of a motion program	5-15
status flag of sequence program	5-30
status tab page	2-44
sub program	5-7, 5-28
subscripts i, j	5-40
SVB	
features	2-30
specifications	2-34
SVB definition window	2-45
SVR	2-47
SVR execution timing	2-49
symbol designation	5-41
synchronization between modules	2-32
system configuration example	1-5, 2-31
system connection example	3-25
system error status	8-18
system errors	8-8
system I/O error status	8-21
system register	
accessing	8-9
allocations	8-8
system register configuration	8-17
system registers	5-36

system registers lists	A-2
system service execution status	8-21
system service registers	A-2
system startup	4-2
executing motion	4-11
programming	4-9
self configuration	4-5
test run	4-6
wiring	4-3
system status	8-17
system work number	5-18

T

TCP	2-13
terminating resistor	1-9
terminator	1-9, 3-15
terminator connections	3-17
total number of system works	5-18
transmission bytes	2-41
transmission distance	2-37
transmission parameter tab	2-40
troubleshooting	8-5
troubleshooting flowchart for system errors	8-11

U

UDP	2-13
user functions	5-35
user operation	
error status	8-19
user programs	5-6

V

virtual motion module	
SVR	2-47

W

when MP2300S acts as master	
(I/O message communication function is used)	6-36
when the MP2300S acts as a slave	
(ladder program which uses a MSG-RCV function)	6-17
When the MP2300S acts as master	
(ladder program which uses MSG-SND function)	6-49
when the MP2300S acts as slave	
(automatic receive function is used)	6-3
wild card I/O	2-43
wild card servo	2-43
without using a ladder program	2-50
work register	5-14, 5-30

Z

zero point not set	8-37
--------------------	------

Machine Controller MP2300S

Basic Module

USER'S MANUAL

IRUMA BUSINESS CENTER (SOLUTION CENTER)

480, Kamifujisawa, Iruma, Saitama 358-8555, Japan
Phone 81-4-2962-5696 Fax 81-4-2962-6138

YASKAWA ELECTRIC AMERICA, INC.

2121 Norman Drive South, Waukegan, IL 60085, U.S.A.
Phone 1-847-887-7000 Fax 1-847-887-7370

YASKAWA ELÉTRICO DO BRASIL LTDA.

Avenida Fagundes Filho, 620 São Paulo-SP CEP 04304-000, Brazil
Phone 55-11-3585-1100 Fax 55-11-5581-8795

YASKAWA ELECTRIC EUROPE GmbH

Am Kronberger Hang 2, 65824 Schwalbach, Germany
Phone 49-6196-569-300 Fax 49-6196-569-312

YASKAWA ELECTRIC UK LTD.

1 Hunt Hill Orchardton Woods Cumbernauld, G68 9LF, United Kingdom
Phone 44-1236-735000 Fax 44-1236-458182

YASKAWA ELECTRIC KOREA CORPORATION

7F, Doore Bldg. 24, Yeoido-dong, Youngdungpo-Ku, Seoul 150-877, Korea
Phone 82-2-784-7844 Fax 82-2-784-8495

YASKAWA ELECTRIC (SINGAPORE) PTE. LTD.

151 Lorong Chuan, #04-01, New Tech Park 556741, Singapore
Phone 65-6282-3003 Fax 65-6289-3003

YASKAWA ELECTRIC (SHANGHAI) CO., LTD.

No.18 Xizang Zhong Road, Room 1702-1707, Harbour Ring Plaza Shanghai 200001, China
Phone 86-21-5385-2200 Fax 86-21-5385-3299

YASKAWA ELECTRIC (SHANGHAI) CO., LTD. BEIJING OFFICE

Room 1011A, Tower W3 Oriental Plaza, No.1 East Chang An Ave.,
Dong Cheng District, Beijing 100738, China
Phone 86-10-8518-4086 Fax 86-10-8518-4082

YASKAWA ELECTRIC TAIWAN CORPORATION

9F, 16, Nanking E. Rd., Sec. 3, Taipei, Taiwan
Phone 886-2-2502-5003 Fax 886-2-2505-1280



YASKAWA

YASKAWA ELECTRIC CORPORATION

In the event that the end user of this product is to be the military and said product is to be employed in any weapons systems or the manufacture thereof, the export will fall under the relevant regulations as stipulated in the Foreign Exchange and Foreign Trade Regulations. Therefore, be sure to follow all procedures and submit all relevant documentation according to any and all rules, regulations and laws that may apply.

Specifications are subject to change without notice for ongoing product modifications and improvements.

© 2007 YASKAWA ELECTRIC CORPORATION. All rights reserved.

MANUAL NO. SIEP C880732 00A

Published in Japan November 2007 07-11
07-11-2