

Low voltage

Masterpact NT and NW

LV power circuit breakers
and switch-disconnectors

Catalogue
2009

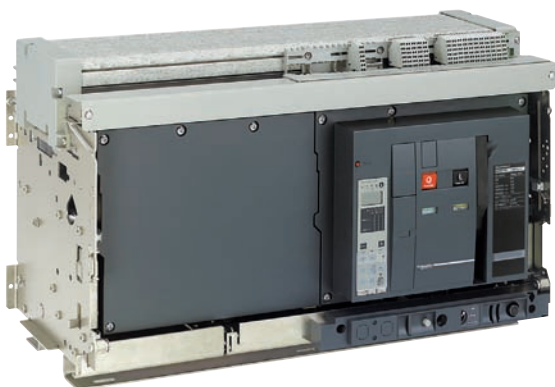

Masterpact NT and NW

The standard for power circuit breakers around the world.

Over the years, other major manufacturers have tried to keep up by developing products incorporating Masterpact's most innovative features, including the breaking principle, modular design and the use of composite materials.

In addition to the traditional features of power circuit breakers (withdrawability, discrimination and low maintenance), Masterpact NT and NW ranges offer built-in communications and metering functions, all in optimised frame sizes.

Masterpact NT and NW incorporate the latest technology to enhance both performance and safety. Easy to install, with user-friendly, intuitive operation and environment-friendly design, Masterpact NT and NW are, quite simply, circuit breakers of their time.



Covering all your applications

Masterpact meets the needs of all types of LV electrical distribution networks.



Building

- > Hotels
- > Hospitals
- > Offices
- > Retail



Data Centres and Networks

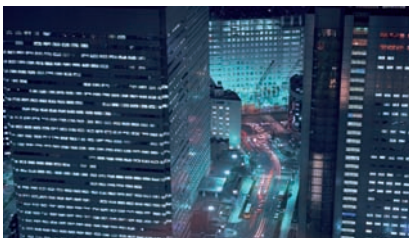

Industry

- > Mining and minerals
- > Automotive
- > Food and beverage
- > Chemical industry



Energy and Infrastructures

- > Airports
- > Oil and gas
- > Water
- > Electrical energy
- > Navy

An answer to specific applications

- > 1000 V for mining applications
- > Direct current networks
- > Corrosion protection
- > Switch-disconnectors and earthing switches
- > Automatic transfer switching equipment (ATSE) for emergency power systems
- > High electrical endurance applications: Masterpact NT H2 is a high performance device offering high breaking capacity (Icu: 50 kA/480 V) and a high level of discrimination, all in a small volume.

Whenever high short circuit is involved

Masterpact UR is a low voltage ultra rapid opening circuit breaker. Its fault detection rate and its reaction speed mean that it will stop a short circuit from developing. As a result, this is the key component in very high power installations equipped with a number of power sources connected in parallel.

Masterpact UR truly comes into its own when short circuit currents can reach very high levels and when continuity of service is a must: **offshore installations, cement plants, petrochemical industry**. It is also especially suited to electrical installations on board merchant.



All standards

Masterpact is compliant with international standards IEC 60947-1 and 2, IEC 68230 for type 2 tropicalisation, UL489, ANSI, UL1066, CCC and GOST.

Two families and three frame sizes

The range of power circuit breakers includes two families:

- > Masterpact NT, the world's smallest true power circuit breaker, with ratings from 630 to 1600 A
- > Masterpact NW, in two frame sizes, one from 800 to 4000 A and the other from 4000 A to 6300 A.

5 performance levels

- > N1 - for standard applications with low short-circuit levels.
- > H1 - for industrial sites with high short-circuit levels or installations with two parallel-connected transformers.
- > H2 - high-performance for heavy industry where very high short-circuits can occur.
- > H3 - for incoming devices supplying critical applications requiring both high performance and a high level of discrimination.
- > L1 - for high current-limiting capability and a discrimination level (37 kA) as yet unequalled by any other circuit breaker of its type; intended for the protection of cable-type feeders or to raise the performance level of a switchboard when the transformer power rating is increased.

Masterpact NT

630 to 1600 A



L1	150 kA	■	■	■		
H2	50 kA	■	■	■	■	■
H1	42 kA	■	■	■	■	■
		NT06	NT08	NT10	NT12	NT16

Masterpact NW

800 to 4000 A



L1	150 kA	■	■	■	■	■			
H3	150 kA					■	■	■	
H2	100 kA	■	■	■	■	■	■	■	
H1	65 kA	■	■	■	■	■	■	■	
N1	42 kA	■	■	■	■				
		NW08	NW10	NW12	NW16	NW20	NW25	NW32	NW40

4000 to 6300 A

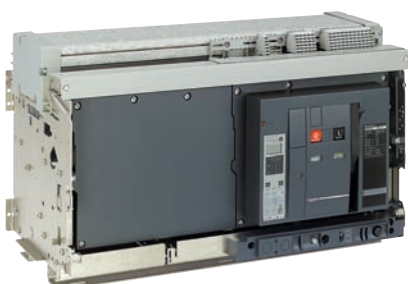

H2	150 kA	■	■	■
H1	100 kA	■	■	■
		NW40b	NW50	NW63

Optimised volumes and ease of installation

Aiming at standardising electrical switchboards at a time when installations are increasingly complex, Masterpact provides an unequalled simplicity, both concerning choice and installation.

The smallest circuit breaker in the world

Masterpact NT innovates by offering all the performance of a power circuit breaker in an extremely small volume. The 70 mm pole pitch means a three-pole draw out circuit breaker can be installed in a switchboard section 400 mm wide and 400 mm deep.

Maximum security

The arc chutes absorb the energy released during breaking, thus limiting the stresses exerted on the installation. They filter and cool the gases produced, reducing effects perceptible from the outside.

Optimised volumes

Up to 4000 A, Masterpact NW circuit breakers are all the same size, the same as the old M08 to 32 range. From 4000 A to 6300 A, there is just one size.

More than

60

patents are used to design Masterpact

Retrofit solutions

- > Special connections terminals are available to replace a fixed or a drawout Masterpact M08 to 32 with a Masterpact NW, without modifying the busbars or the door cut-out.
- > "Plug and Play" retrofit solution : this solution enables retrofitting of Masterpact M units with considerably reducing on-site intervention time and getting the performance of last generation device.



Standardisation of the switchboard

With optimised sizes, the Masterpact NT and NW ranges simplify the design of switchboards and standardise the installation of devices:

- > a single connection layout for Masterpact NT
- > three connection layouts for Masterpact NW:
 - one from 800 to 3200 A
 - one for 4000 A
 - one up to 6300 A
- > horizontal or vertical rear connections can be modified on-site by turning the connectors 90° or they can even be replaced by front connection terminals
- > identical connection terminals for the fixed or draw-out version for each rating (Masterpact NW)
- > front connection requires little space because the connectors not increase the depth of the device.



Practical installation solutions

The Masterpact NW range further improves the installation solutions that have built the success of its predecessors:

- > incoming connection to top or bottom terminals
- > no safety clearance required
- > connection:
 - horizontal or vertical rear connection
 - front connection with minimum extra space
 - mixed front and rear connections
- > 115 mm pole pitch on all versions
- > no derating up to 55 °C and 4000 A.

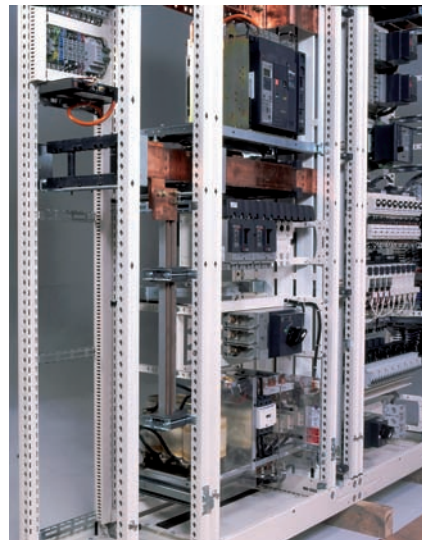
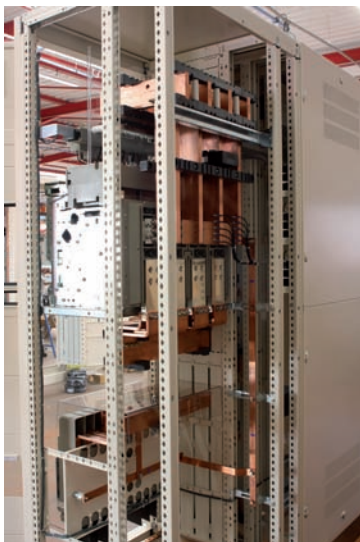

Compliance with environmental requirements

The materials used for Masterpact are not potentially dangerous to the environment and are marked to facilitate sorting for recycling.

Production facilities are non-polluting in compliance with the ISO 14001 standard.

Monitoring and protecting your low voltage network

Masterpact can be integrated in a general supervision system to optimise your electrical installation.

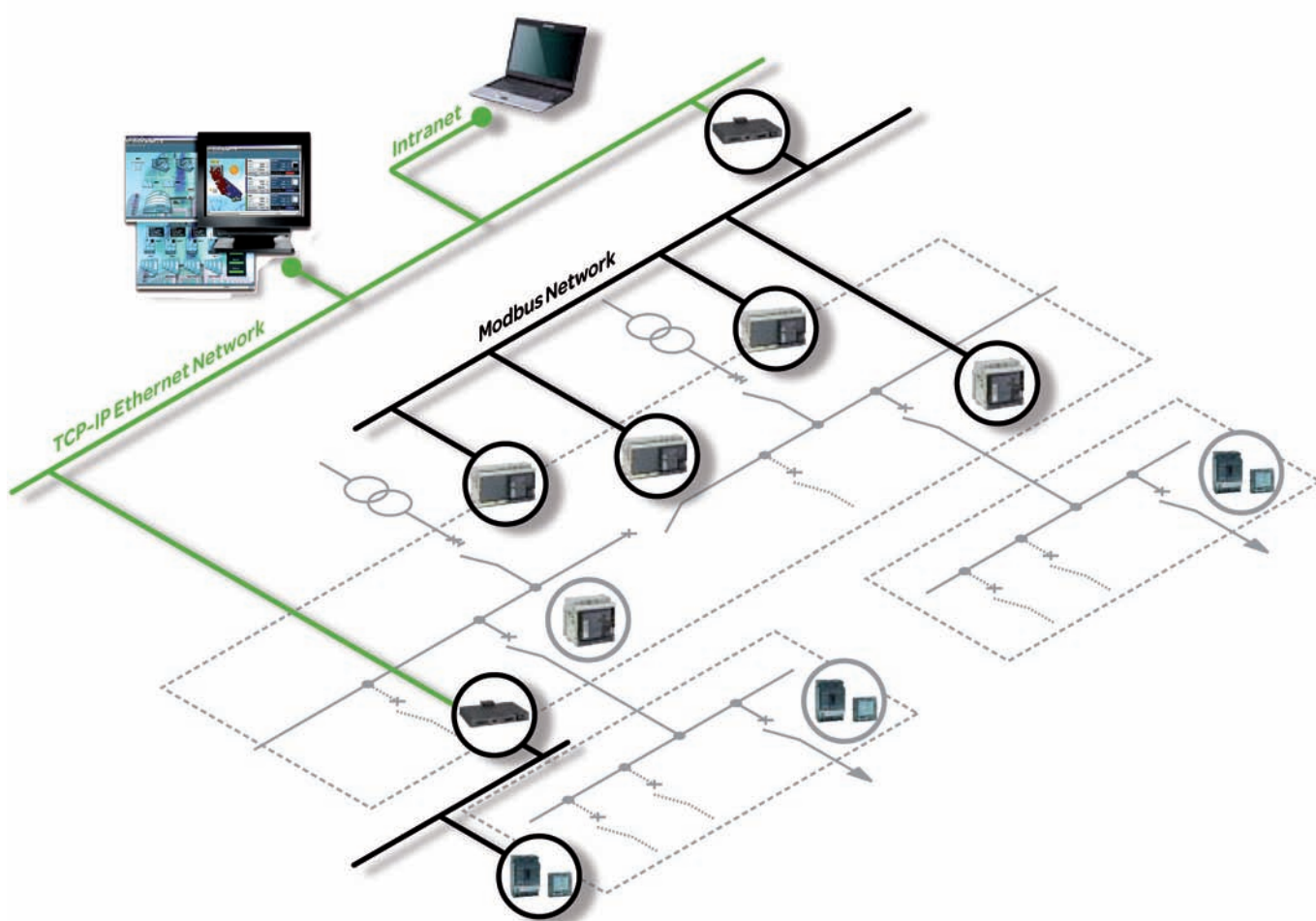

Intuitive use

Micrologic control units are equipped with a digital LCD display used in conjunction with simple navigation buttons. Users can directly access parameters and settings. Navigation between screens is intuitive and the immediate display of values greatly simplifies settings. Text is displayed in the desired language.

Ensuring safety at any time

All Masterpact circuit breakers are equipped with a Micrologic electronic control unit that offers all types of current and advanced protection, measurement and communication. Protection functions are separated from the measurement functions and are managed by an ASIC electronic component. This independence guarantees immunity from conducted or radiated disturbances and ensures the highest degree of reliability.

Maximising continuity of service

Because a LV power supply interruption is unacceptable especially in critical power applications, an automatic system is required for LV transfer switching. For your peace of mind, Masterpact enables automatic control and management of power sources in your low voltage distribution network guaranteeing the hi-reliability of your installation.

Optimising the management of your electrical installation

When equipped with a Micrologic type P, Masterpact can be integrated in a general supervision system to optimise installation operation and maintenance. Alarms may be programmed for remote indications. Used with PowerLogic ION Enterprise software, you can exploit the electrical data (current, voltage, frequency, power, and power quality) to optimise continuity of service and energy management:

- > reduce energy and operations costs
- > improve power quality, reliability and uptime
- > optimise equipment use.

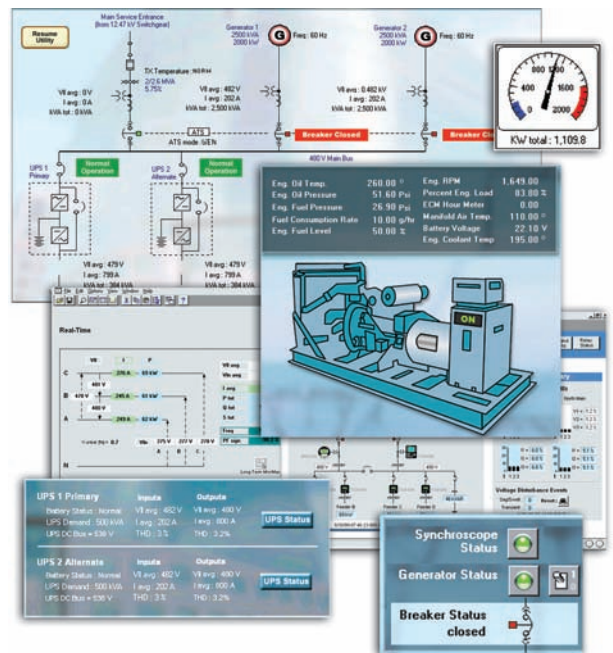

Real-time display of the data.

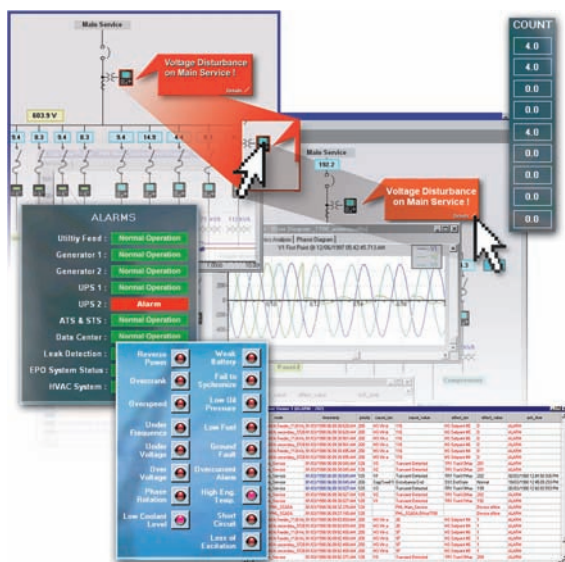

Alarms and control functions.



Presentation	1
--------------	---

Functions and characteristics	A-1
----------------------------------	-----

Installation recommendations	B-1
---------------------------------	-----

Dimensions and connection	C-1
------------------------------	-----

Electrical diagrams	D-1
---------------------	-----

Additional characteristics	E-1
-------------------------------	-----

Catalogue numbers and order form	F-1
-------------------------------------	-----

schneider-electric.com

This international site allows you to access all the Schneider Electric products in just 2 clicks via comprehensive range data-sheets, with direct links to:

- complete library: technical documents, catalogs, FAQs, brochures...

- selection guides from the e-catalog.

- product discovery sites and their Flash animations.

You will also find illustrated overviews, news to which you can subscribe, the list of country contacts...



The technical guide

These technical guides help you comply with installation standards and rules i.e.: the electrical installation guide, the protection guide, the switchboard implementation guide, the technical booklets and the co-ordination tables all form genuine reference tools for the design of high performance electrical installations. For example, the LV protection co-ordination guide - discrimination and cascading - optimises choice of protection and connection devices while also increasing markedly continuity of supply in the installations.



<i>Presentation</i>	1
General overview	
Detailed contents	A-2
Circuit breakers and switch-disconnectors	
NT06 to NT16 and NW08 to NW63	A-4
NT06 to NT16	A-6
NW08 to NW63	A-8
Micrologic control units	
Overview of functions	A-10
Micrologic A “ammeter”	A-12
Micrologic P “power”	A-14
Micrologic H “harmonics”	A-18
Accessories and test equipment	A-20
Portable data acquisition	
Masterpact and GetnSet	A-22
Communication	
COM option in Masterpact	A-24
Overview of functions	A-25
Masterpact in a communication network	A-26
Masterpact and the MPS100 Micro Power Server	A-28
Communication wiring system	A-30
Connections	
Overview of solutions	A-31
Accessories	A-32
Locking	
On the device	A-35
On the chassis	A-36
Indication contacts	A-37
Remote operation	
Remote ON / OFF	A-39
Remote tripping	A-42
Accessories	A-43
Source-changeover systems	
Presentation	A-44
Mechanical interlocking	A-45
Electrical interlocking	A-47
Associated automatic controllers	A-49
Masterpact NW with corrosion protection 800-4000 A	A-50
Earthing switch Masterpact	A-52
<i>Installation recommendations</i>	B-1
<i>Dimensions and connection</i>	C-1
<i>Electrical diagrams</i>	D-1
<i>Additional characteristics</i>	E-1
<i>Catalogue numbers and order form</i>	F-1

This chapter describes all the functions offered by Masterpact NT and NW devices. The two product families have identical functions implemented using the same or different components depending on the case.

PB100762-60A



Circuit breakers and switch-disconnectors page A-4

- ratings:
 - Masterpact NT 630 to 1600 A
 - Masterpact NW 800 to 6300 A
- circuit breakers type N1, H1, H2, H3, L1
- switch-disconnectors type NA, HA, HF
- 3 or 4 poles
- fixed or drawout versions
- option with neutral on the right
- protection derating.

Micrologic control units page A-10

Ammeter A

- 2.0 basic protection
- 5.0 selective protection
- 6.0 selective + earth-fault protection
- 7.0 selective + earth-leakage protection

Power meter P

- 5.0 selective protection
- 6.0 selective + earth-fault protection
- 7.0 selective + earth-leakage protection

Harmonic meter H

- 5.0 selective protection
- 6.0 selective + earth-fault protection
- 7.0 selective + earth-leakage protection
- external sensor for earth-fault protection
- rectangular sensor for earth-leakage protection
- setting options (long-time rating plug):
 - low setting 0.4 to 0.8 x I_r
 - high setting 0.8 to 1 x I_r
 - without long-time protection
- external power-supply module
- battery module.

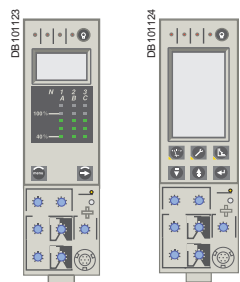

Portable data acquisition page A-22

- Masterpact and GetnSet

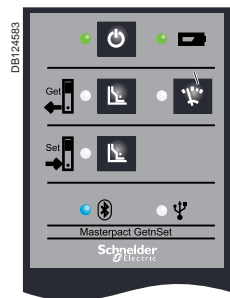

Communication page A-24

- COM option in Masterpact
- Masterpact in a communication network
- Masterpact and the Micro Power Server MPS100.

PB104347A55



Connections page A-31

- rear connection (horizontal or vertical)
- front connection
- mixed connections
- optional accessories
 - bare-cable connectors and connector shields
 - terminal shields
 - vertical-connection adapters
 - cable-lug adapters
 - interphase barriers
 - spreaders
 - disconnectable front-connection adapter
 - safety shutters, shutter locking blocks, shutter position indication and locking.

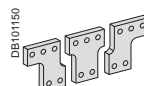
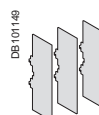
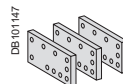
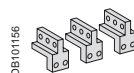

PB104348A55

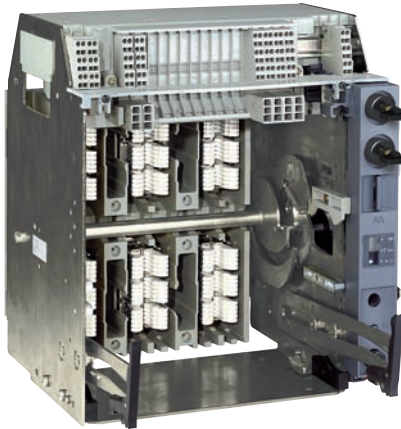

Locking

page A-35

- pushbutton locking by padlockable transparent cover
- OFF-position locking by padlock or keylock
- chassis locking in disconnected position by keylock
- chassis locking in connected, disconnected and test positions
- door interlock (inhibits door opening with breaker in connected position)
- racking interlock (inhibits racking with door open)
- racking interlock between crank and OFF pushbutton
- automatic spring discharge before breaker removal
- mismatch protection.

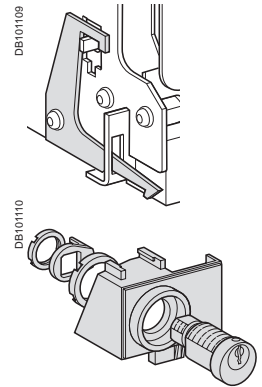

PB104353A55

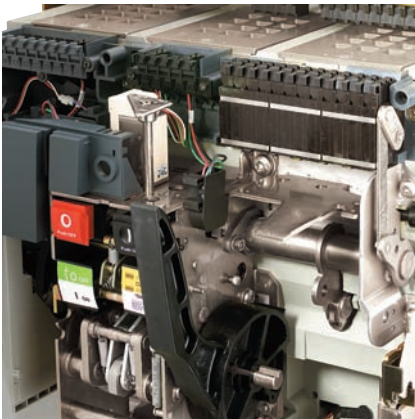

Indication contacts

page A-37

- standard or low-level contacts:
 - ON/OFF indication (OF)
 - "fault trip" indication (SDE)
 - carriage switches for connected (CE) disconnected (CD) and test (CT) positions
- programmable contacts:
 - 2 contacts (M2C)
 - 6 contacts (M6C).

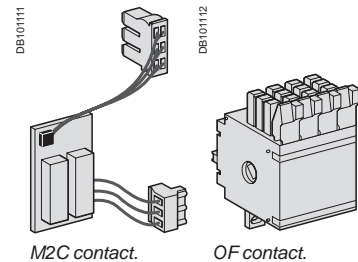

M2C contact.

OF contact.

PB104349A55

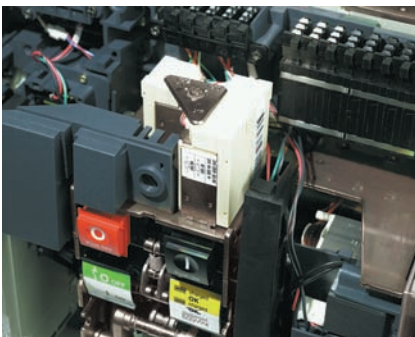

Remote operation

page A-39

- remote ON/OFF:
 - gear motor
 - XF closing or MX opening voltage releases
 - PF ready-to-close contact
- options: RAR automatic or RES electrical remote reset
 - BPFE electrical closing pushbutton
- remote tripping function:
 - MN voltage release
 - standard
 - adjustable or non-adjustable delay
 - or second MX voltage release.

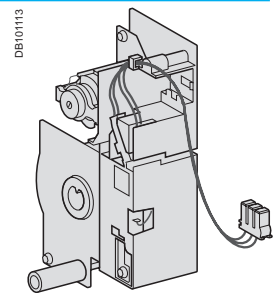

Gear motor.

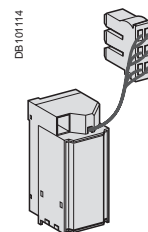

MX, XF and MN voltage releases.

Accessories

page A-43

- auxiliary terminal shield
- operation counter
- escutcheon
- transparent cover for escutcheon
- escutcheon blanking plate.

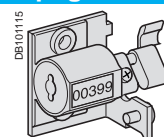

Circuit breakers and switch-disconnectors

NT06 to NT16 and NW08 to NW63

NT and NW selection criteria

	Masterpact NT			Masterpact NW	
	Standard applications			Standard applications	
	NT06, NT08, NT10, NT12, NT16 H1	H2	NT06, NT08, NT10 L1	NW08...NW16 N1	NW08...NW40 H1
Type of application	Standard applications with low short-circuit currents	Applications with medium-level short-circuit currents	Limiting circuit breaker for protection of cable-type feeders or upgraded transformer ratings	Standard applications with low short-circuit currents	Circuit breaker for industrial sites with high short-circuit currents
Icu/Ics at 440 V	42 kA	50 kA	130 kA	42 kA	65 kA
Icu/Ics at 1000 V	-	-	-	-	-
Icu/Ics at 500 V DC L/R < 15 ms	-	-	-	-	-
Position of neutral	Left	Left	Left	Left	Left or right
Fixed	F	F	F	F	F
Drawout	D	D	D	D	D
Switch-disconnector version	Yes	No	No	Yes	Yes
Front connection	Yes	Yes	Yes	Yes	Yes up to 3200 A
Rear connection	Yes	Yes	Yes	Yes	Yes
Type of Micrologic control unit	A, P, H	A, P, H	A, P, H	A, P, H	A, P, H

Masterpact NT06 to NT16 installation characteristics

Circuit breaker		NT06, NT08, NT10			NT12, NT16	
Type		H1	H2	L1	H1	H2
Connection						
Drawout	FC	■	■	■	■	■
	RC	■	■	■	■	■
Fixed	FC	■	■	■	■	■
	RC	■	■	■	■	■
Dimensions (mm) H x W x D						
Drawout	3P	322 x 288 x 277				
	4P	322 x 358 x 277				
Fixed	3P	301 x 276 x 196				
	4P	301 x 346 x 196				
Weight (kg) (approximate)						
Drawout	3P/4P	30/39				
	Fixed	3P/4P	14/18			

Masterpact NW08 to NW63 installation characteristics

Circuit breaker		NW08, NW10, NW12, NW16					NW20				
Type		N1	H1	H2	L1	H10	H1	H2	H3	L1	H10
Connection											
Drawout	FC	■	■	■	■	-	■	■	■	■	-
	RC	■	■	■	■	■	■	■	■	■	■
Fixed	FC	■	■	■	-	-	■	■	-	-	-
	RC	■	■	■	-	-	■	■	-	-	-
Dimensions (mm) H x W x D											
Drawout	3P	439 x 441 x 395									
	4P	439 x 556 x 395									
Fixed	3P	352 x 442 x 297									
	4P	352 x 537 x 297									
Weight (kg) (approximate)											
Drawout	3P/4P	90/120									
	Fixed	3P/4P	60/80								

(1) Except 4000

			Special applications				
H2	H3	L1	NW H10	NW H2 with corrosion protection	NW10...NW40 N DC	H DC	NW earthing switch
High-performance circuit breaker for heavy industry with high short-circuit currents	Incoming device with very high performance for critical applications	Limiting circuit breaker for protection of cable-type feeders or upgraded transformer ratings	1000 V systems, e.g. mines and wind power	Environments with high sulphur contents	DC system	DC system	Installation earthing
100 kA	150 kA	150 kA	-	100 kA	-	-	-
-	-	-	50 kA	-	-	-	-
-	-	-	-	-	35 kA	85 kA	-
Left or right	Left	Left	Left	Left or right	-	-	-
F	-	-	-	-	F	F	-
D	D	D	D	D	D	D	D
Yes	Yes	No	Yes	Yes	Yes	Yes	Yes
Yes up to 3200 A	Yes up to 3200 A	Yes up to 3200 A	No	Yes up to 3200 A	No	No	Yes up to 3200 A
Yes	Yes	Yes	Yes	Yes	Yes	Yes	Yes
A, P, H	A, P, H	A, P, H	A, consult us for P and H	A, P, H	DC Micrologic	DC Micrologic	-

NW25, NW32, NW40				NW40b, NW50, NW63	
H1	H2	H3	H10	H1	H2
■ ⁽¹⁾	■ ⁽¹⁾	■ ⁽¹⁾	-	-	-
■	■	■	■	■	■
■ ⁽¹⁾	■ ⁽¹⁾	-	-	-	-
■	■	-	-	■	■
				479 x 786 x 395	
				479 x 1016 x 395	
				352 x 767 x 297	
				352 x 997 x 297	
				225/300	
				120/160	

Circuit breakers and switch-disconnectors

NT06 to NT16

PE104378A48



Common characteristics

Number of poles		3/4
Rated insulation voltage (V)	Ui	1000
Impulse withstand voltage (kV)	Uimp	12
Rated operational voltage (V AC 50/60 Hz)	Ue	690
Suitability for isolation	IEC 60947-2	
Degree of pollution	IEC 60664-1	3

Basic switchgear

Circuit-breaker as per IEC 60947-2

Rated current (A)	In	at 40 °C/50 °C ⁽¹⁾
Rating of 4th pole (A)		
Sensor ratings (A)		
Type of circuit breaker		
Ultimate breaking capacity (kA rms) V AC 50/60 Hz	Icu	220/415 V 440 V 525 V 690 V
Rated service breaking capacity (kA rms)	Ics	% Icu
Utilisation category		
Rated short-time withstand current (kA rms) V AC 50/60 Hz	Icw	0.5 s 1 s 3 s
Integrated instantaneous protection (kA peak ±10 %)		
Rated making capacity (kA peak) V AC 50/60 Hz	Icm	220/415 V 440 V 525 V 690 V
Break time (ms) between tripping order and arc extinction		
Closing time (ms)		

Circuit-breaker as per NEMA AB1

Breaking capacity (kA) V AC 50/60 Hz		240 V 480 V 600 V
---	--	-------------------------

Switch-disconnector as per IEC 60947-3 and Annex A

Type of switch-disconnector

Rated making capacity (kA peak) AC23A/AC3 category V AC 50/60 Hz	Icm	220 V 440 V 525/690 V
Rated short-time withstand current (kA rms) AC23A/AC3 category V AC 50/60 Hz	Icw	0.5 s 1 s 3 s
Ultimate breaking capacity Icu (kA rms) with an external protection relay Maximum time delay: 350 ms		690 V

Mechanical and electrical durability as per IEC 60947-2/3 at In/Ie

Service life	Mechanical	without maintenance	
C/O cycles x 1000			
Type of circuit breaker			
Rated current			In (A)
C/O cycles x 1000	Electrical	without maintenance	440 V ⁽⁴⁾
IEC 60947-2			690 V
Type of circuit breaker or switch-disconnector			
Rated operational current			Ie (A) AC23A
C/O cycles x 1000	Electrical	without maintenance	440 V ⁽⁴⁾
IEC 60947-3			690V
Type of circuit breaker or switch-disconnector			
Rated operational current			Ie (A) AC3 ⁽⁵⁾
Motor power			380/415 V (kW) 440 V (kW)
C/O cycles x 1000	Electrical	without maintenance	440 V ⁽⁴⁾
IEC 60947-3 Annex M/IEC 60947-4-1			690 V

(1) 50 °C: rear vertical connected. Refer to temperature derating tables for other connection types.

(2) See the current-limiting curves in the "additional characteristics" section.

(3) SELLIM system.

(4) Available for 480 V NEMA.

(5) Suitable for motor control (direct-on-line starting).

Sensor selection

Sensor rating (A)	250 ⁽¹⁾	400	630	800	1000	1250	1600
I _r threshold setting(A)	100 to 250	160 to 400	250 to 630	320 to 800	400 to 1000	500 to 1250	640 to 1600

(1) For circuit-breaker NT02, please consult us.

NT06			NT08			NT10			NT12		NT16	
630			800			1000			1250		1600	
630			800			1000			1250		1600	
400 to 630			400 to 800			400 to 1000			630 to 1250		800 to 1600	
H1	H2	L1 ⁽²⁾							H1	H2		
42	50	150							42	50		
42	50	130							42	50		
42	42	100							42	42		
42	42	25							42	42		
100 %									100 %			
B	B	A							B	B		
42	36	10							42	36		
42	36	-							42	36		
24	20	-							24	20		
-	90	10 x I _n ⁽³⁾							-	90		
88	105	330							88	105		
88	105	286							88	105		
88	88	220							88	88		
88	88	52							88	88		
25	25	9							25	25		
< 50									< 50			
42 50 150									42 50			
42 50 100									42 50			
42 42 25									42 42			
HA									HA			
75									75			
75									75			
75									75			
36									36			
36									36			
20									20			
36									36			
12.5												
H1	H2	L1	H1	H2	L1	H1	H2	L1	H1	H2	H1	H2
630			800			1000			1250			
6	6	3	6	6	3	6	6	3	6	6	3	3
3	3	2	3	3	2	3	3	2	3	3	1	1
H1/H2/HA												
630			800			1000			1250			1600
6			6			6			6			3
3			3			3			3			1
H1/H2/HA												
500			630			800			1000			1000
≤ 250			250 to 335			335 to 450			450 to 560			450 to 560
≤ 300			300 to 400			400 to 500			500 to 630			500 to 630
6												
-												

Circuit breakers and switch-disconnectors

NW08 to NW63



Common characteristics

Number of poles		3/4
Rated insulation voltage (V)	Ui	1000/1250
Impulse withstand voltage (kV)	Uimp	12
Rated operational voltage (V AC 50/60 Hz)	Ue	690/1150
Suitability for isolation	IEC 60947-2	
Degree of pollution	IEC 60664-1	4 (1000 V) / 3 (1250 V)

Basic circuit-breaker

Circuit-breaker as per IEC 60947-2

Rated current (A)		at 40 °C / 50 °C ⁽¹⁾
Rating of 4th pole (A)		
Sensor ratings (A)		

Type of circuit breaker

Ultimate breaking capacity (kA rms) V AC 50/60 Hz	Icu	220/415/440 V 525 V 690 V 1150 V
--	------------	---

Rated service breaking capacity (kA rms)	Ics	% Icu
--	------------	-------

Utilisation category		
Rated short-time withstand current (kA rms) V AC 50/60 Hz	Icw	1 s 3 s

Integrated instantaneous protection (kA peak ±10 %)		
Rated making capacity (kA peak) V AC 50/60 Hz	Icm	220/415/440 V 525 V 690 V 1150 V

Break time (ms) between tripping order and arc extinction

Closing time (ms)

Circuit-breaker as per NEMA AB1

Breaking capacity (kA) V AC 50/60 Hz		240/480 V 600 V
---	--	--------------------

Unprotected circuit-breaker

Tripping by shunt trip as per IEC 60947-2

Type of circuit breaker

Ultimate breaking capacity (kA rms) V AC 50/60 Hz	Icu	220...690 V
Rated service breaking capacity (kA rms)	Ics	% Icu
Rated short-time withstand current (kA rms)	Icw	1 s 3 s

Overload and short-circuit protection

External protection relay: short-circuit protection, maximum delay: 350 ms ⁽⁴⁾

Rated making capacity (kA peak) V AC 50/60 Hz	Icm	220...690 V
---	------------	-------------

Switch-disconnector as per IEC 60947-3 and Annex A

Type of switch-disconnector

Rated making capacity (kA peak) AC23A/AC3 category V AC 50/60 Hz	Icm	220...690 V 1150 V
Rated short-time withstand current (kA rms) AC23A/AC3 category V AC 50/60 Hz	Icw	1 s 3 s

Earthing switch

Latching capacity (kA peak)		135
Rating short time withstand (kA rms)	Icw	1 s 60 Hz 3 s 50 Hz

Mechanical and electrical durability as per IEC 60947-2/3 at In/Ie

Service life	Mechanical	with maintenance	
C/O cycles x 1000		without maintenance	

Type of circuit breaker

Rated current		In (A)	
C/O cycles x 1000	Electrical	without maintenance	440 V ⁽⁵⁾
IEC 60947-2			690 V 1150 V

Type of circuit breaker or switch-disconnector

Rated operational current		Ie (A)	AC23A
C/O cycles x 1000	Electrical	without maintenance	440 V ⁽⁵⁾
IEC 60947-3			690 V

Type of circuit breaker or switch-disconnector

Rated operational current		Ie (A)	AC3 ⁽⁶⁾
Motor power			380/415 V (kW) 440 V ⁽⁵⁾ (kW) 690 V (kW)
C/O cycles x 1000	Electrical	without maintenance	440/690 V ⁽⁵⁾
IEC 60947-3 Annex M/IEC 60947-4-1			

⁽¹⁾ 50 °C: rear vertical connected. Refer to temperature derating tables for other connection types.

⁽²⁾ See the current-limiting curves in the "additional characteristics" section.

⁽³⁾ Equipped with a trip unit with a making current of 90 kA peak.

⁽⁴⁾ External protection must comply with permissible thermal constraints of the circuit breaker (please consult us).

No fault-trip indication by the SDE or the reset button.

⁽⁵⁾ Available for 480 V NEMA.

⁽⁶⁾ Suitable for motor control (direct-on-line starting).

Sensor selection

Sensor rating (A)	250 ⁽¹⁾	400	630	800	1000	1250	1600	2000	2500	3200	4000	5000	6300
Ir threshold setting(A)	100 to 250	160 to 400	250 to 630	320 to 800	400 to 1000	500 to 1250	630 to 1600	800 to 2000	1000 to 2500	1250 to 3200	1600 to 4000	2000 to 5000	2500 to 6300

(1) For circuit-breaker NW02, please consult us.

NW08	NW10	NW12	NW16		NW20					NW25	NW32	NW40		NW40b	NW50	NW63
800	1000	1250	1600		2000					2500	3200	4000		4000	5000	6300
800	1000	1250	1600		2000					2500	3200	4000		4000	5000	6300
400 to 800	400 to 1000	630 to 1250	800 to 1600		1000 to 2000					1250 to 2500	1600 to 3200	2000 to 4000		2000 to 4000	2500 to 5000	3200 to 6300
N1	H1	H2	L1 ⁽²⁾	H10	H1	H2	H3	L1 ⁽²⁾	H10	H1	H2	H3	H10	H1	H2	
42	65	100	150	-	65	100	150	150	-	65	100	150	-	100	150	
42	65	85	130	-	65	85	130	130	-	65	85	130	-	100	130	
42	65	85	100	-	65	85	100	100	-	65	85	100	-	100	100	
-	-	-	-	50	-	-	-	-	50	-	-	-	50	-	-	
100 %					100 %					100 %				100 %		
B					B					B				B		
42	65	85	30	50	65	85	65	30	50	65	85	65	50	100	100	
22	36	50	30	50	36	75	65	30	50	65	75	65	50	100	100	
-	-	190	80	-	-	190	150	80	-	-	190	150	-	-	270	
88	143	220	330	-	143	220	330	330	-	143	220	330	-	220	330	
88	143	187	286	-	143	187	286	286	-	143	187	286	-	220	286	
88	143	187	220	-	143	187	220	220	-	143	187	220	-	220	220	
-	-	-	-	105	-	-	-	-	105	-	-	-	105	-	-	
25	25	25	10	25	25	25	25	10	25	25	25	25	25	25	25	
< 70					< 70					< 70				< 80		
42	65	100	150	-	65	100	150	150	-	65	100	150	-	100	150	
42	65	85	100	-	65	85	100	100	-	65	85	100	-	100	100	

	HA	HF ⁽³⁾		HA	HF ⁽³⁾		HA	HF ⁽³⁾		HA	
	50	85		50	85		55	85		85	
	100 %			100 %			100 %			100 %	
	50	85		50	85		55	85		85	
	36	50		36	75		55	75		85	
	-	-		-	-		-	-		-	
	105	187		105	187		121	187		187	
NW08/NW10/NW12	NW16			NW20			NW25/NW32/NW40			NW40b/NW50/NW63	
NA	HA	HF	HA10	HA	HF	HA10	HA	HF	HA10	HA	
88	105	187	-	105	187	-	105	187	-	121	187
-	-	-	105	-	-	105	-	-	105	-	
42	50	85	50	50	85	50	50	85	50	55	85
-	36	50	50	36	50	50	36	75	50	55	75

25				20				10					
12.5				10				5					
N1/H1/H2	L1	H10		H1/H2	H3	L1	H10	H1/H2	H3	H10	H1	H2	
800/1000/1250/1600				2000				2500/3200/4000				4000b/5000/6300	
10	3	-		8	2	3	-	5	1.25	-	1.5	1.5	
10	3	-		6	2	3	-	2.5	1.25	-	1.5	1.5	
-	-	0.5		-	-	-	0.5	-	-	0.5	-	-	
H1/H2/HA/HF				H1/H2/H3/HA/HF				H1/H2/H3/HA/HF				H1/H2/HA	
800/1000/1250/1600				2000				2500/3200/4000				4000b/5000/6300	
10				8				5				1.5	
10				6				2.5				1.5	
H1/H2/HA/HF				H1/H2/H3/HA/HF									
800	1000	1250		1600				2000					
335 to 450	450 to 560	560 to 670		670 to 900				900 to 1150					
400 to 500	500 to 630	500 to 800		800 to 1000				1000 to 1300					
≤ 800	800 to 1000	1000 to 1250		1250 to 1600				1600 to 2000					

6

All Masterpact circuit breakers are equipped with a Micrologic control unit that can be changed on site. Control units are designed to protect Power circuits and loads. Alarms may be programmed for remote indications. Measurements of current, voltage, frequency, power and power quality optimise continuity of service and energy management.

Dependability

Integration of protection functions in an ASIC electronic component used in all Micrologic control units guarantees a high degree of reliability and immunity to conducted or radiated disturbances. On Micrologic A, P and H control units, advanced functions are managed by an independent microprocessor.

Accessories

Certain functions require the addition of Micrologic control unit accessories, described on [page A-20](#). The rules governing the various possible combinations can be found in the documentation accessible via the Products and services menu of the www.schneider-electric.com web site.

Micrologic name codes

2.0 A
X Y Z

X: type of protection

- 2 for basic protection
- 5 for selective protection
- 6 for selective + earth-fault protection
- 7 for selective + earth-leakage protection.

Y: control-unit generation

Identification of the control-unit generation. "0" signifies the first generation.

Z: type of measurement

- A for "ammeter"
- P for "power meter"
- H for "harmonic meter".



Current protection

Micrologic 2: basic protection

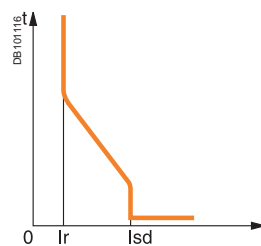

Protection:
long time
+ instantaneous

Micrologic 5: basic protection

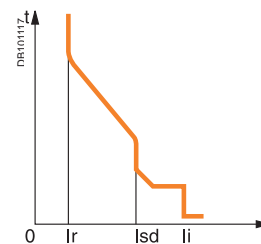

Protection:
long time
+ short time
+ instantaneous

Micrologic 6: selective + earth-fault protection

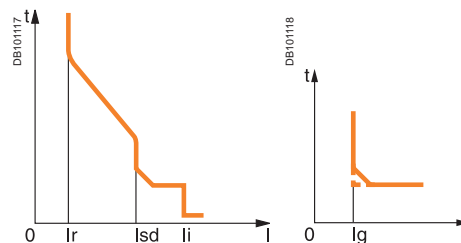

Protection:
long time
+ short time
+ instantaneous
+ earth fault

Micrologic 7: selective + earth-leakage protection

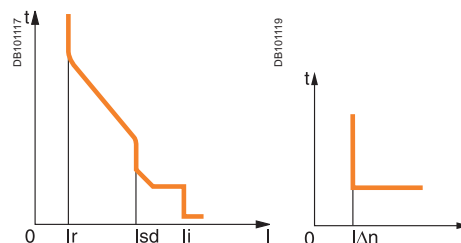

Protection:
long time
+ short time
+ instantaneous
+ earth leakage up to 3200A

Measurements and programmable protection

A: ammeter

- $I_1, I_2, I_3, I_N, I_{\text{earth-fault}}, I_{\text{earth-leakage}}$ and maximeter for these measurements
- fault indications
- settings in amperes and in seconds.

P: A + power meter + programmable protection

- measurements of V, A, W, VAR, VA, Wh, VARh, VAh, Hz, $V_{\text{peak}}, A_{\text{peak}}$, power factor and maximeters and minimeters
- IDMTL long-time protection, minimum and maximum voltage and frequency, voltage and current imbalance, phase sequence, reverse power
- load shedding and reconnection depending on power or current
- measurements of interrupted currents, differentiated fault indications, maintenance indications, event histories and time-stamping, etc.

H: P + harmonics

- power quality: fundamentals, distortion, amplitude and phase of harmonics up to the 31st order
- waveform capture after fault, alarm or on request
- enhanced alarm programming: thresholds and actions.

2.0 A



5.0 A



5.0 P



5.0 H



6.0 A



6.0 P



6.0 H



7.0 A



7.0 P



7.0 H



Micrologic A control units protect power circuits. They also offer measurements, display, communication and current maximeters. Version 6 provides earth-fault protection, version 7 provides earth-leakage protection.

"Ammeter" measurements

Micrologic A control units measure the true (rms) value of currents. They provide continuous current measurements from 0.2 to 20 I_n and are accurate to within 1.5 % (including the sensors).

A digital LCD screen continuously displays the most heavily loaded phase (I_{max}) or displays the $I_1, I_2, I_3, I_N, I_g, I_{\Delta n}$, stored-current (maximeter) and setting values by successively pressing the navigation button.

The optional external power supply makes it possible to display currents < 20 % I_n . Below 0.05 I_n , measurements are not significant. Between 0.05 and 0.2 I_n , accuracy is to within 0.5 % I_n + 1.5 % of the reading.

Communication option

In conjunction with the COM communication option, the control unit transmits the following:

- settings
- all “ammeter” measurements
- tripping causes
- maximeter readings.

Protection

Protection thresholds and delays are set using the adjustment dials.

Overload protection

True rms long-time protection.

Thermal memory: thermal image before and after tripping.

Setting accuracy may be enhanced by limiting the setting range using a different long-time rating plug.

Overload protection can be cancelled using a specific LT rating plug "Off".

Short-circuit protection

Short-time (rms) and instantaneous protection.

Selection of I^2t type (ON or OFF) for short-time delay.

Earth-fault protection

Residual or source ground return earth fault protection.

Selection of I^2t type (ON or OFF) for delay.

Residual earth-leakage protection (Vigi).

Operation without an external power supply.

⌚ Protected against nuisance tripping.

⚡ DC-component withstand class A up to 10 A.

Neutral protection

On three-pole circuit breakers, neutral protection is not possible.

On four-pole circuit breakers, neutral protection may be set using a three-position switch: neutral unprotected (4P 3d), neutral protection at 0.5 I_r (4P 3d + N/2), neutral protection at I_r (4P 4d).

Zone selective interlocking (ZSI)

A ZSI terminal block may be used to interconnect a number of control units to provide total discrimination for short-time and earth-fault protection, without a delay before tripping.

Overload alarm

A yellow alarm LED goes on when the current exceeds the long-time trip threshold.

Fault indications

LEDs indicate the type of fault:

- overload (long-time protection I_r)
- short-circuit (short-time I_{sd} or instantaneous I_i protection)
- earth fault or earth leakage (I_g or $I_{\Delta n}$)
- internal fault (A_p).

Battery power

The fault indication LEDs remain on until the test/reset button is pressed. Under normal operating conditions, the battery supplying the LEDs has a service life of approximately 10 years.

Test

A mini test kit or a portable test kit may be connected to the test connector on the front to check circuit-breaker operation. For Micrologic 6.0 A and 7.0 A control units, the operation of earth-fault or earth-leakage protection can be checked by pressing the test button located above the test connector.

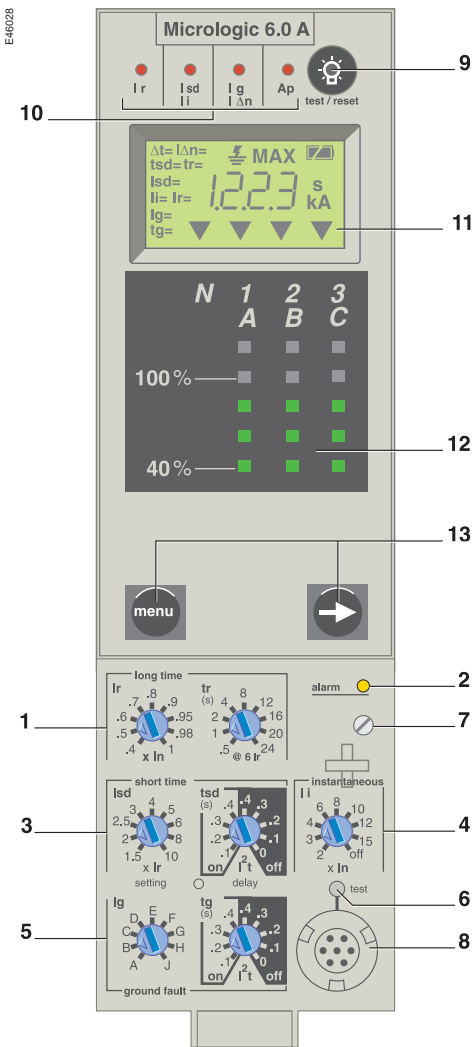

- 1 long-time threshold and tripping delay
- 2 overload alarm (LED) at 1,125 I_r
- 3 short-time pick-up and tripping delay
- 4 instantaneous pick-up
- 5 earth-leakage or earth-fault pick-up and tripping delay
- 6 earth-leakage or earth-fault test button
- 7 long-time rating plug screw
- 8 test connector
- 9 lamp test, reset and battery test
- 10 indication of tripping cause
- 11 digital display
- 12 three-phase bargraph and ammeter
- 13 navigation buttons

Note: Micrologic A control units come with a transparent lead-seal cover as standard.



Protection Micrologic 2.0 A

Long time		Micrologic 2.0 A											
Current setting (A)		0.4	0.5	0.6	0.7	0.8	0.9	0.95	0.98	1			
Tripping between 1.05 and 1.20 x Ir		Other ranges or disable by changing long-time rating plug											
Time setting	tr (s)	0.5	1	2	4	8	12	16	20	24			
Time delay (s)	Accuracy: 0 to -30 %	1.5 x Ir	12.5	25	50	100	200	300	400	500	600		
	Accuracy: 0 to -20 %	6 x Ir	0.7 ⁽¹⁾	1	2	4	8	12	16	20	24		
	Accuracy: 0 to -20 %	7.2 x Ir	0.7 ⁽²⁾	0.69	1.38	2.7	5.5	8.3	11	13.8	16.6		
Thermal memory		20 minutes before and after tripping											
(1) 0 to -40 % - (2) 0 to -60 %													
Instantaneous													
Pick-up (A)	I _{sd} = I _r x ...	1.5	2	2.5	3	4	5	6	8	10			
Accuracy: ±10 %													
Time delay		Max resettable time: 20 ms Max break time: 80 ms											

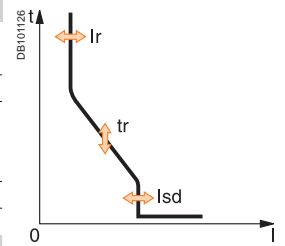

Ammeter Micrologic 2.0 A

Continuous current measurements		Micrologic 2.0 A			
Display from 20 to 200 % of I _n		I ₁	I ₂	I ₃	I _N
Accuracy: 1.5 % (including sensors)		No auxiliary source (where I > 20 % I _n)			
Maximeters		I ₁ max	I ₂ max	I ₃ max	I _N max



Protection Micrologic 5.0 / 6.0 / 7.0 A

Long time		Micrologic 5.0 / 6.0 / 7.0 A											
Current setting (A)	I _r = I _n x ...	0.4	0.5	0.6	0.7	0.8	0.9	0.95	0.98	1			
Tripping between 1.05 and 1.20 x Ir		Other ranges or disable by changing long-time rating plug											
Time setting	tr (s)	0.5	1	2	4	8	12	16	20	24			
Time delay (s)	Accuracy: 0 to -30 %	1.5 x Ir	12.5	25	50	100	200	300	400	500	600		
	Accuracy: 0 to -20 %	6 x Ir	0.7 ⁽¹⁾	1	2	4	8	12	16	20	24		
	Accuracy: 0 to -20 %	7.2 x Ir	0.7 ⁽²⁾	0.69	1.38	2.7	5.5	8.3	11	13.8	16.6		
Thermal memory		20 minutes before and after tripping											
(1) 0 to -40 % - (2) 0 to -60 %													
Short time													
Pick-up (A)	I _{sd} = I _r x ...	1.5	2	2.5	3	4	5	6	8	10			
Accuracy: ±10 %													
Time setting tsd (s)	Settings	I ² t Off	0	0.1	0.2	0.3	0.4						
		I ² t On	-	0.1	0.2	0.3	0.4						
Time delay (ms) at 10 x Ir (I ² t Off or I ² t On)	tsd (max resettable time)	20	80	140	230	350							
	tsd (max break time)	80	140	200	320	500							
Instantaneous													
Pick-up (A)	I _{li} = I _n x ...	2	3	4	6	8	10	12	15	off			
Accuracy: ±10 %													
Time delay		Max resettable time: 20 ms Max break time: 50 ms											
Earth fault		Micrologic 6.0 A											
Pick-up (A)	I _g = I _n x ...	A	B	C	D	E	F	G	H	J			
Accuracy: ±10 %	I _n ≤ 400 A	0.3	0.3	0.4	0.5	0.6	0.7	0.8	0.9	1			
	400 A < I _n < 1250 A	0.2	0.3	0.4	0.5	0.6	0.7	0.8	0.9	1			
	I _n ≥ 1250 A	500	640	720	800	880	960	1040	1120	1200			
Time setting tg (s)	Settings	I ² t Off	0	0.1	0.2	0.3	0.4						
		I ² t On	-	0.1	0.2	0.3	0.4						
Time delay (ms)	tg (max resettable time)	20	80	140	230	350							
at I _n or 1200 A (I ² t Off or I ² t On)	tg (max break time)	80	140	200	320	500							
Residual earth leakage (Vigi)		Micrologic 7.0 A											
Sensitivity (A)	I _{Δn}	0.5	1	2	3	5	7	10	20	30			
Accuracy: 0 to -20 %	Time delay Δt (ms)	Settings	60	140	230	350	800						
		Δt (max resettable time)	60	140	230	350	800						
		Δt (max break time)	140	200	320	500	1000						

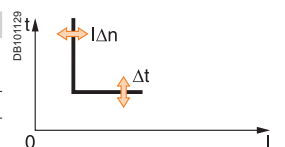
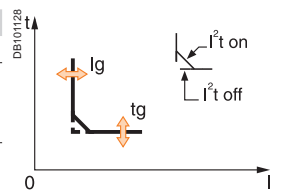
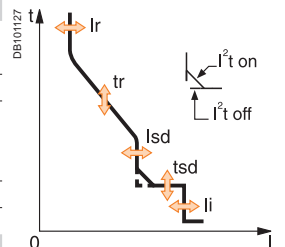

Ammeter Micrologic 5.0 / 6.0 / 7.0 A

Continuous current measurements		Micrologic 5.0 / 6.0 / 7.0 A					
Display from 20 to 200 % of I _n		I ₁	I ₂	I ₃	I _N	I _g	I _{Δn}
Accuracy: 1.5 % (including sensors)		No auxiliary source (where I > 20 % I _n)					
Maximeters		I ₁ max	I ₂ max	I ₃ max	I _N max	I _g max	I _{Δn} max

Note: All current-based protection functions require no auxiliary source.

The test / reset button resets maximeters, clears the tripping indication and tests the battery.

Micrologic P control units include all the functions offered by Micrologic A.
 In addition, they measure voltages and calculate power and energy values.
 They also offer new protection functions based on currents, voltages, frequency and power reinforce load protection in real time.

Protection.....



Protection settings

The adjustable protection functions are identical to those of Micrologic A (overloads, short-circuits, earth-fault and earth-leakage protection).

Fine adjustment

Within the range determined by the adjustment dial, fine adjustment of thresholds (to within one ampere) and time delays (to within one second) is possible on the keypad or remotely using the COM option.

IDMTL (Inverse Definite Minimum Time lag) setting

Coordination with fuse-type or medium-voltage protection systems is optimised by adjusting the slope of the overload-protection curve. This setting also ensures better operation of this protection function with certain loads.

Neutral protection

On three-pole circuit breakers, neutral protection may be set using the keypad or remotely using the COM option, to one of four positions: neutral unprotected (4P 3d), neutral protection at 0.5 Ir (4P 3d + N/2), neutral protection at Ir (4P 4d) and neutral protection at 1,6 Ir (4P 3d + 1,6N). Neutral protection at 1,6 Ir is used when the neutral conductor is twice the size of the phase conductors (major load imbalance, high level of third order harmonics).

On four-pole circuit breakers, neutral protection may be set using a three-position switch or the keypad: neutral unprotected (4P 3d), neutral protection at 0.5 Ir (4P 3d + N/2), neutral protection at Ir (4P 4d). Neutral protection produces no effect if the long-time curve is set to one of the IDMTL protection settings.

Programmable alarms and other protection

Depending on the thresholds and time delays set using the keypad or remotely using the COM option, the Micrologic P control unit monitors currents and voltage, power, frequency and the phase sequence. Each threshold overrun is signalled remotely via the COM option. Each threshold overrun may be combined with tripping (protection) or an indication carried out by an optional M2C or M6C programmable contact (alarm), or both (protection and alarm).

Load shedding and reconnection

Load shedding and reconnection parameters may be set according to the power or the current flowing through the circuit breaker. Load shedding is carried out by a supervisor via the COM option or by an M2C or M6C programmable contact.

Indication option via programmable contacts

The M2C (two contacts) and M6C (six contacts) auxiliary contacts may be used to signal threshold overruns or status changes. They can be programmed using the keypad on the Micrologic P control unit or remotely using the COM option.

Communication option (COM)

The communication option may be used to:

- remotely read and set parameters for the protection functions
- transmit all the calculated indicators and measurements
- signal the causes of tripping and alarms
- consult the history files and the maintenance-indicator register.
- maximeter reset.

An event log and a maintenance register, stored in control-unit memory but not available locally, may be accessed in addition via the COM option.

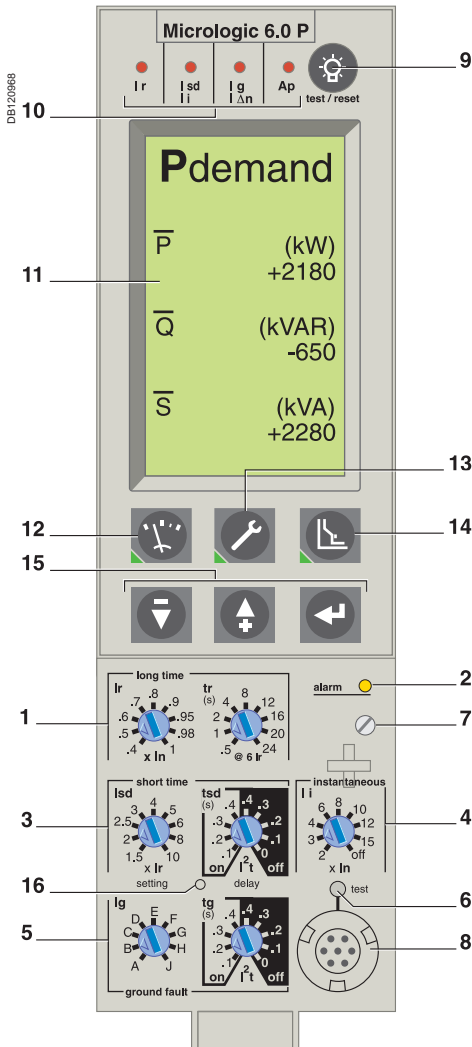

- 1 Long-time current setting and tripping delay.
- 2 Overload signal (LED).
- 3 Short-time pick-up and tripping delay.
- 4 Instantaneous pick-up.
- 5 Earth-leakage or earth-fault pick-up and tripping delay.
- 6 Earth-leakage or earth-fault test button.
- 7 Long-time rating plug screw.
- 8 Test connector.
- 9 Lamp + battery test and indications reset.
- 10 Indication of tripping cause.
- 11 High-resolution screen.
- 12 Measurement display.
- 13 Maintenance indicators.
- 14 Protection settings.
- 15 Navigation buttons.
- 16 Hole for settings lockout pin on cover.

Note: Micrologic P control units come with a non-transparent lead-seal cover as standard.



Protection Micrologic 5.0 / 6.0 / 7.0 P

Long time (rms)		Micrologic 5.0 / 6.0 / 7.0 P										
Current setting (A)	$I_r = I_n \times \dots$	0.4	0.5	0.6	0.7	0.8	0.9	0.95	0.98	1		
Tripping between 1.05 and 1.20 x I_r		Other ranges or disable by changing long-time rating plug										
Time setting	t_r (s)	0.5	1	2	4	8	12	16	20	24		
Time delay (s)	Accuracy: 0 to -30 %	1.5 x I_r	12.5	25	50	100	200	300	400	500	600	
	Accuracy: 0 to -20 %	6 x I_r	0.7 ⁽¹⁾	1	2	4	8	12	16	20	24	
	Accuracy: 0 to -20 %	7.2 x I_r	0.7 ⁽²⁾	0.69	1.38	2.7	5.5	8.3	11	13.8	16.6	
IDMTL setting	Curve slope	SIT	VIT	EIT	HVFuse	DT						
Thermal memory		20 minutes before and after tripping										
(1) 0 to -40 % - (2) 0 to -60 %												
Short time (rms)		Micrologic 6.0 P										
Pick-up (A)	$I_{sd} = I_r \times \dots$	1.5	2	2.5	3	4	5	6	8	10		
Accuracy: ±10 %												
Time setting t_{sd} (s)	Settings	I^2t Off	0	0.1	0.2	0.3	0.4					
		I^2t On	-	0.1	0.2	0.3	0.4					
Time delay (ms) at 10 I_r (I^2t Off or I^2t On)	t_{sd} (max resettable time)		20	80	140	230	350					
	t_{sd} (max break time)		80	140	200	320	500					
Instantaneous		Micrologic 7.0 P										
Pick-up (A)	$I_i = I_n \times \dots$	2	3	4	6	8	10	12	15	off		
Accuracy: ±10 %												
Time delay		Max resettable time: 20 ms Max break time: 50 ms										
Earth fault		Micrologic 6.0 P										
Pick-up (A)	$I_g = I_n \times \dots$	A	B	C	D	E	F	G	H	J		
Accuracy: ±10 %	$I_n \leq 400$ A	0.3	0.3	0.4	0.5	0.6	0.7	0.8	0.9	1		
	400 A < I_n < 1250 A	0.2	0.3	0.4	0.5	0.6	0.7	0.8	0.9	1		
	$I_n \geq 1250$ A	500	640	720	800	880	960	1040	1120	1200		
Time setting t_g (s)	Settings	I^2t Off	0	0.1	0.2	0.3	0.4					
		I^2t On	-	0.1	0.2	0.3	0.4					
Time delay (ms) at I_n or 1200 A (I^2t Off or I^2t On)	t_g (max resettable time)		20	80	140	230	350					
	t_g (max break time)		80	140	200	320	500					
Residual earth leakage (Vigi)		Micrologic 7.0 P										
Sensitivity (A)	$I_{\Delta n}$	0.5	1	2	3	5	7	10	20	30		
Accuracy: 0 to -20 %												
Time delay Δt (ms)	Settings	60	140	230	350	800						
	Δt (max resettable time)	60	140	230	350	800						
	Δt (max break time)	140	200	320	500	1000						

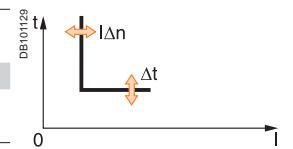
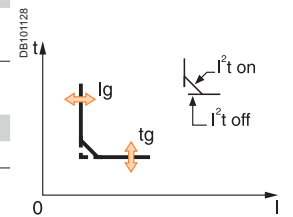
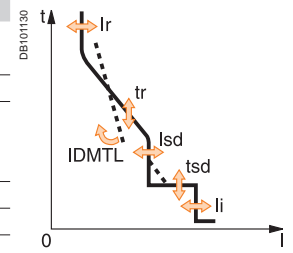

Alarms and other protection Micrologic 5.0 / 6.0 / 7.0 P

Current		Threshold		Delay	
Current unbalance	$I_{unbalance}$	0.05 to 0.6 I _{average}		1 to 40 s	
Max. demand current	$I_{max\ demand}$: I ₁ , I ₂ , I ₃ , I _N	0.2 I _n to I _n		15 to 1500 s	
Earth fault alarm		10 to 100 % I _n ⁽³⁾		1 to 10 s	
Voltage		2 to 30 % x U _{average}		1 to 40 s	
Voltage unbalance	$U_{unbalance}$	100 to U _{max} between phases		1.2 to 10 s	
Minimum voltage	U_{min}	U _{min} to 1200 between phases		1.2 to 10 s	
Maximum voltage ⁽⁴⁾	U_{max}				
Power		5 to 500 kW		0.2 to 20 s	
Reverse power	rP				
Frequency		45 to F _{max}		1.2 to 5 s	
Minimum frequency	F_{min}	F _{min} to 440 Hz		1.2 to 5 s	
Maximum frequency	F_{max}				
Phase sequence		Ø1/2/3 or Ø1/3/2		0.3 s	
Sequence (alarm)	$\Delta\emptyset$				

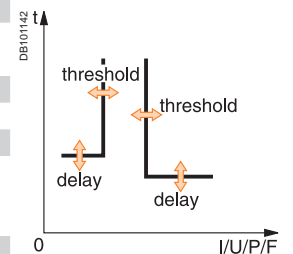

Load shedding and reconnection Micrologic 5.0 / 6.0 / 7.0 P

Measured value		Threshold		Delay	
Current	I	0.5 to 1 I_r per phases		20 % t_r to 80 % t_r	
Power	P	200 kW to 10 MW		10 to 3600 s	

(3) $I_n \leq 400$ A 30 %
 400 A < I_n < 1250 A 20 %
 $I_n \geq 1250$ A 10 %
 (4) For 690 V applications, a step-down transformer must be used if the voltage exceeds the nominal value of 690 V by more than 10 %.

Note: all current-based protection functions require no auxiliary source.
 Voltage-based protection functions are connected to AC power via a voltage measurement input built into the circuit breaker.

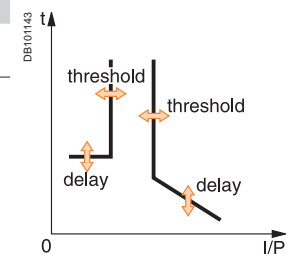

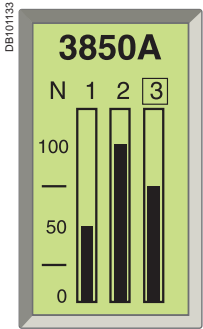

Default display.

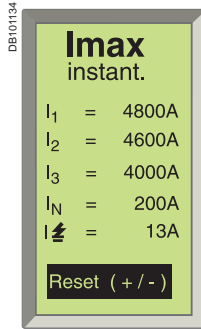

Display of a maximum current

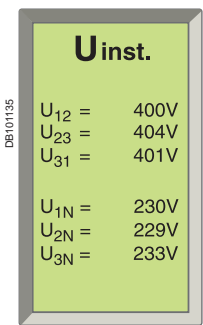

Display of a voltage.

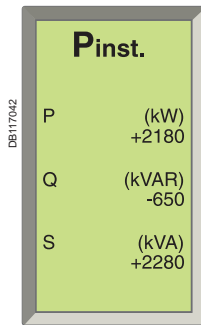

Display of a power.

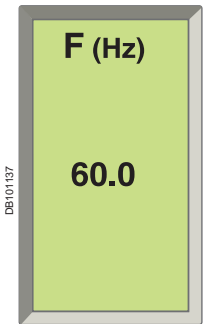

Display of a frequency.

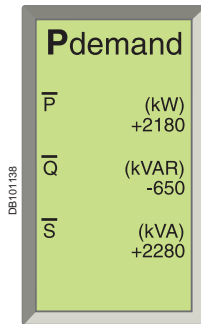

Display of a demand power.



Power View software.

Measurements

The Micrologic P control unit calculates in real time all the electrical values (V, A, W, VAR, VA, Wh, VARh, VAh, Hz), power factors and $\cos\phi$ factors.

The Micrologic P control unit also calculates demand current and demand power over an adjustable time period. Each measurement is associated with a minimeter and a maximeter.

In the event of tripping on a fault, the interrupted current is stored. The optional external power supply makes it possible to display the value with the circuit breaker open or not supplied.

Instantaneous values

The value displayed on the screen is refreshed every second.

Minimum and maximum values of measurements are stored in memory (minimeters and maximeters).

Currents

I rms	A	1	2	3	N
	A	E-fault		E-leakage	
I max rms	A	1	2	3	N
	A	E-fault		E-leakage	

Voltages

U rms	V	12	23	31
V rms	V	1N	2N	3N
U average rms	V	(U12 + U23 + U31) / 3		
U unbalance	%			

Power, energy

P active, Q reactive, S apparent	W, Var, VA	Totals
E active, E reactive, E apparent	Wh, VARh, VAh	Totals consumed - supplied
		Totals consumed
		Totals supplied
Power factor	PF	Total

Frequencies

F	Hz
---	----

Demand metering

The demand is calculated over a fixed or sliding time window that may be programmed from 5 to 60 minutes. According to the contract signed with the power supplier, an indicator associated with a load shedding function makes it possible to avoid or minimise the costs of overrunning the subscribed power. Maximum demand values are systematically stored and time stamped (maximeter).

Currents

I demand	A	1	2	3	N
	A	E-fault		E-leakage	
I max demand	A	1	2	3	N
	A	E-fault		E-leakage	

Power

P, Q, S demand	W, Var, VA	Totals
P, Q, S max demand	W, Var, VA	Totals

Minimeters and maximeters

Only the current and power maximeters may be displayed on the screen.

Time-stamping

Time-stamping is activated as soon as time is set manually or by a supervisor. No external power supply module is required (max. drift of 1 hour per year).

Reset

An individual reset, via the keypad or remotely, acts on alarms, minimum and maximum data, peak values, the counters and the indicators.

Additional measurements accessible with the COM option

Some measured or calculated values are only accessible with the COM communication option:

- $I_{peak} / \sqrt{2}$, $(I_1 + I_2 + I_3) / 3$, I unbalance
- load level in % I_r
- total power factor.

The maximeters and minimeters are available only via the COM option for use with a supervisor.

Additional info

Accuracy of measurements (including sensors):

- voltage (V) 0.5 %
- current (A) 1.5 %
- frequency (Hz) 0.1 %
- power (W) and energy (Wh) 2 %.

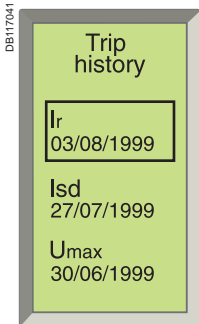

Display of a tripping history.

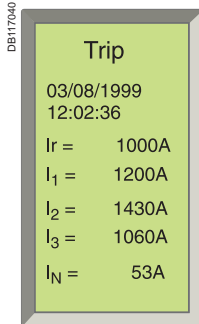

Display after tripping.

Histories and maintenance indicators

The last ten trips and alarms are recorded in two separate history files that may be displayed on the screen:

- tripping history:
 - type of fault
 - date and time
 - values measured at the time of tripping (interrupted current, etc.)
- alarm history:
 - type of alarm
 - date and time
 - values measured at the time of the alarm.

All the other events are recorded in a third history file which is only accessible through the communication network.

- Event log history (only accessible through the communication network)
 - modifications to settings and parameters
 - counter resets
 - system faults:
 - fallback position
 - thermal self-protection
 - loss of time
 - overrun of wear indicators
 - test-kit connections
 - etc.

Note:

All the events are time stamped: time-stamping is activated as soon as time is set manually or by a supervisor. No external power supply module is required (max. drift of 1 hour per year).

Maintenance indicators (with COM option)

A number of maintenance indicators may be called up on the screen to better plan for device maintenance:

- contact wear
- operation counter:
 - cumulative total
 - total since last reset.

Additional maintenance indicators are also available through the COM network, and can be used as an aid in troubleshooting:

- highest current measured
- number of test-kit connections
- number of trips in operating mode and in test mode.

Additional technical characteristics

Safety

Measurement functions are independent of the protection functions.

The high-accuracy measurement module operates independently of the protection module.

Simplicity and multi-language

Navigation from one display to another is intuitive. The six buttons on the keypad provide access to the menus and easy selection of values. When the setting cover is closed, the keypad may no longer be used to access the protection settings, but still provides access to the displays for measurements, histories, indicators, etc.

Micrologic is also multi-language, including the following languages: English, Spanish, Portuguese, Russian, Chinese, French, German...

Intelligent measurement

Measurement-calculation mode:

- energies are calculated on the basis of the instantaneous power values, in two manners:
 - the traditional mode where only positive (consumed) energies are considered
 - the signed mode where the positive (consumed) and negative (supplied) energies are considered separately
- measurement functions implement the new "zero blind time" concept which consists in continuously measuring signals at a high sampling rate. The traditional "blind window" used to process samples no longer exists. This method ensures accurate energy calculations even for highly variable loads (welding machines, robots, etc.).

Always powered

All current-based protection functions require no auxiliary source. Voltage-based protection functions are connected to AC power via a voltage measurement input built into the circuit breaker.

Stored information

The fine setting adjustments, the last 100 events and the maintenance register remain in the control-unit memory even when power is lost.

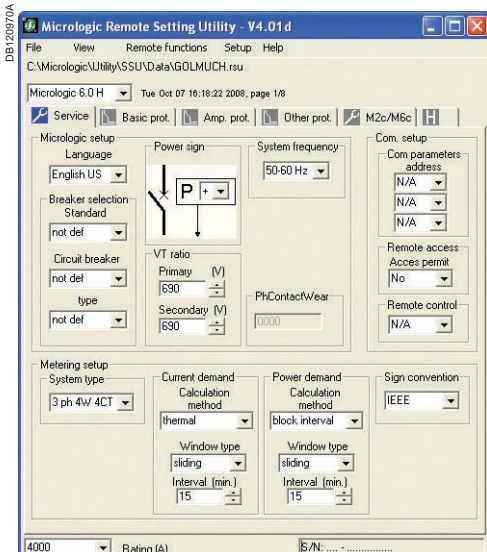

RSU configuration screen for a Micrologic.

Micrologic H control units include all the functions offered by Micrologic P. Integrating significantly enhanced calculation and memory functions, the Micrologic H control unit offers in-depth analysis of power quality and detailed event diagnostics. It is intended for operation with a supervisor.

In addition to the Micrologic P functions, the Micrologic H control unit offers:

- in-depth analysis of power quality including calculation of harmonics and the fundamentals
- diagnostics aid and event analysis through waveform capture
- enhanced alarm programming to analyse and track down a disturbance on the AC power system.

Measurements

The Micrologic H control unit offers all the measurements carried out by Micrologic P, with in addition:

- phase by phase measurements of:
 - power, energy
 - power factors
- calculation of:
 - current and voltage total harmonic distortion (THD)
 - current, voltage and power fundamentals
 - current and voltage harmonics up to the 31st order.

Instantaneous values displayed on the screen

Currents					
I rms	A	1	2	3	N
	A	E-fault		E-leakage	
I max rms	A	1	2	3	N
	A	E-fault		E-leakage	

Voltages					
U rms	V	12	23	31	
V rms	V	1N	2N	3N	
U average rms	V	(U12 + U23 + U31) / 3			
U unbalance	%				

Power, energy					
P active, Q reactive, S apparent	W, Var, VA	Totals	1	2	3
E active, E reactive, E apparent	Wh, VARh, VAh	Totals consumed - supplied			
		Totals consumed			
		Totals supplied			
Power factor	PF	Total	1	2	3

Frequencies					
F	Hz				

Power-quality indicators							
Total fundamentals		U	I	P	Q	S	
THD	%	U I					
U and I harmonics	Amplitude	3	5	7	9	11	13

Harmonics 3, 5, 7, 9, 11 and 13, monitored by electrical utilities, are displayed on the screen.

Demand measurements

Similar to the Micrologic P control unit, the demand values are calculated over a fixed or sliding time window that may be set from 5 to 60 minutes.

Currents					
I demand	A	1	2	3	N
	A	E-fault		E-leakage	
I max demand	A	1	2	3	N
	A	E-fault		E-leakage	

Power					
P, Q, S demand	W, Var, VA	Totals			
P, Q, S max demand	W, Var, VA	Totals			

Maximeters

Only the current maximeters may be displayed on the screen.

Histories and maintenance indicators

These functions are identical to those of the Micrologic P.

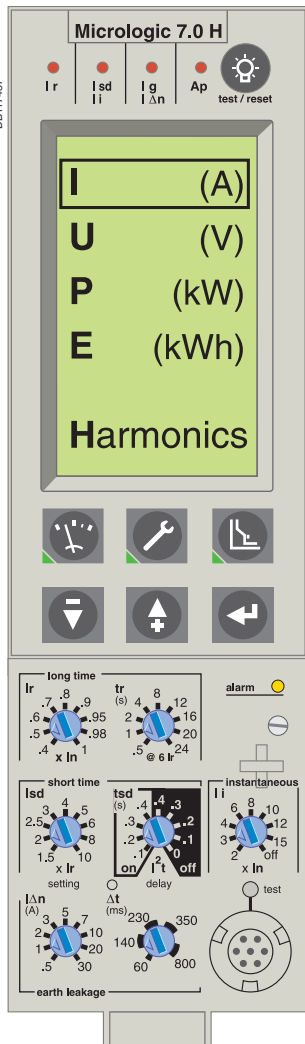

Note: Micrologic H control units come with a non-transparent lead-seal cover as standard.

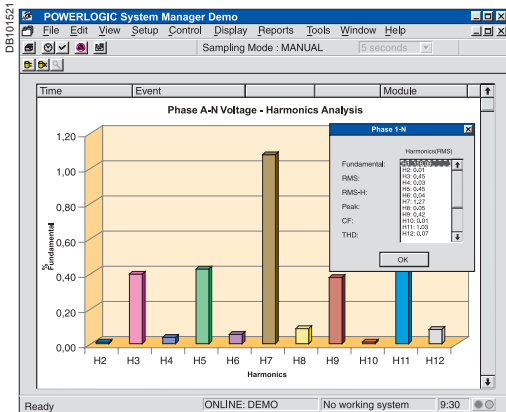

Display of harmonics up to 21th order.

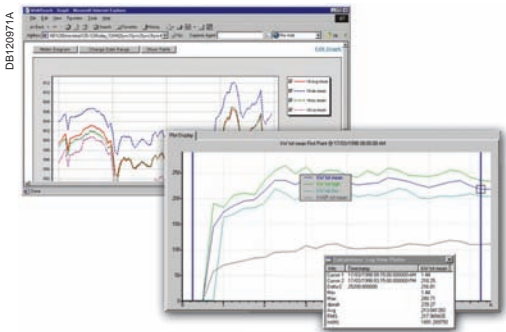

Label	N°	Stat	Pu. val	Unit	Pu. div	Do. val	Unit	Do. div	Log
Over Current Phase A	1	Off	N/A	A	N/A	N/A	A	N/A	Off
Over Current Phase B	2	Off	N/A	A	N/A	N/A	A	N/A	Off
Over Current Phase C	3	Off	N/A	A	N/A	N/A	A	N/A	Off
Over Neutral Current	4	Off	N/A	A	N/A	N/A	A	N/A	Off
Over Ground Current	5	Off	N/A	A	N/A	N/A	A	N/A	Off
Under Current Phase A	6	Off	N/A	A	N/A	N/A	A	N/A	Off
Under Current Phase B	7	Off	N/A	A	N/A	N/A	A	N/A	Off
Under Current Phase C	8	Off	N/A	A	N/A	N/A	A	N/A	Off
Over Current Unbalan...	9	Off	N/A	A	N/A	N/A	A	N/A	Off
Over Current Unbalan...	10	Off	N/A	A	N/A	N/A	A	N/A	Off
Over Current Unbalan...	11	Off	N/A	A	N/A	N/A	A	N/A	Off
Over Voltage Phase A	12	Off	N/A	V	N/A	N/A	V	N/A	Off
Over Voltage Phase B	13	Off	N/A	V	N/A	N/A	V	N/A	Off
Over Voltage Phase C	14	Off	N/A	V	N/A	N/A	V	N/A	Off
Under Voltage Phase A	15	Off	N/A	V	N/A	N/A	V	N/A	Off
Under Voltage Phase B	16	Off	N/A	V	N/A	N/A	V	N/A	Off
Under Voltage Phase C	17	Off	N/A	V	N/A	N/A	V	N/A	Off
Over Voltage Unbalan...	18	Off	N/A	%	N/A	N/A	%	N/A	Off
Over Voltage Unbalan...	19	Off	N/A	%	N/A	N/A	%	N/A	Off
Over Voltage Unbalan...	20	Off	N/A	%	N/A	N/A	%	N/A	Off
Over kVA 3-ph Total	21	Off	N/A	kVA	N/A	N/A	kVA	N/A	Off
Over kW Into the Loa...	22	Off	N/A	kW	N/A	N/A	kW	N/A	Off
Over kW (Out of the l...	23	Off	N/A	kW	N/A	N/A	kW	N/A	Off

Log.

With the communication option

Additional measurements, maximeters and minimeters

Certain measured or calculated values are only accessible with the COM communication option:

- $I_{peak} / \sqrt{2} (I_1 + I_2 + I_3) / 3, I_{unbalance}$
- load level in % Ir
- power factor (total and per phase)
- voltage and current THD
- K factors of currents and average K factor
- crest factors of currents and voltages
- all the fundamentals per phase
- fundamental current and voltage phase displacement
- distortion power and distortion factor phase by phase
- amplitude and displacement of current and voltage harmonics 3 to 31.

The maximeters and minimeters are available only via the COM option for use with a supervisor.

Waveform capture

The Micrologic H control unit stores the last 4 cycles of each instantaneous current or voltage measurement. On request or automatically on programmed events, the control unit stores the waveforms. The waveforms may be displayed in the form of oscillograms by a supervisor via the COM option. Definition is 64 points per cycle.

Pre-defined analogue alarms (1 to 53)

Each alarm can be compared to user-set high and low thresholds. Overrun of a threshold generates an alarm. An alarm or combinations of alarms can be linked to programmable action such as selective recording of measurements in a log, waveform capture, etc.

Event log and maintenance registers

The Micrologic H offers the same event log and maintenance register functions as the Micrologic P. In addition, it produces a log of the minimums and maximums for each "real-time" value.

Additional technical characteristics

Safety

Measurement functions are independent of the protection functions.

The high-accuracy measurement module operates independently of the protection module.

Simplicity and multi-language

Navigation from one display to another is intuitive. The six buttons on the keypad provide access to the menus and easy selection of values. When the setting cover is closed, the keypad may no longer be used to access the protection settings, but still provides access to the displays for measurements, histories, indicators, etc.

Micrologic is also multi-language, including the following languages: English, Spanish, Portuguese, Russian, Chinese, French, German;;

Intelligent measurement

Measurement-calculation mode:

- energies are calculated on the basis of the instantaneous power values, in two manners:
 - the traditional mode where only positive (consumed) energies are considered
 - the signed mode where the positive (consumed) and negative (supplied) energies are considered separately
- measurement functions implement the new "zero blind time" concept which consists in continuously measuring signals at a high sampling rate. The traditional "blind window" used to process samples no longer exists. This method ensures accurate energy calculations even for highly variable loads (welding machines, robots, etc.).

Always powered

All current-based protection functions require no auxiliary source. Voltage-based protection functions are connected to AC power via a voltage measurement input built into the circuit breaker.

Stored information

The fine setting adjustments, the last 100 events and the maintenance register remain in the control-unit memory even when power is lost.

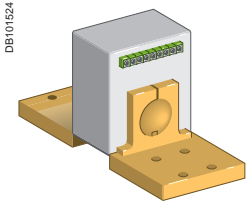

External sensor (CT).

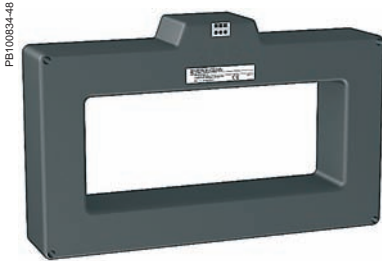

Rectangular sensor.



External sensor for source ground return protection.



External sensors

External sensor for earth-fault and neutral protection

The sensors, used with the 3P circuit breakers, are installed on the neutral conductor for:

- neutral protection (with Micrologic P and H)
- residual type earth-fault protection (with Micrologic A, P and H)..

The rating of the sensor (CT) must be compatible with the rating of the circuit breaker:

- NT06 to NT16: TC 400/1600
- NW08 to NW20: TC 400/2000
- NW25 to NW40: TC 1000/4000
- NW40b to NW63: TC 4000/6300.

For oversized neutral protection the sensor rating must be compatible with the measurement range: 1.6 x I_N (available up to NW 40 and NT 16).

Rectangular sensor for earth-leakage protection

The sensor is installed around the busbars (phases + neutral) to detect the zero-phase sequence current required for the earth-leakage protection. Rectangular sensors are available in two sizes.

Inside dimensions (mm)

- 280 x 115 up to 1600 A for Masterpact NT and NW
- 470 x 160 up to 3200 A for Masterpact NW.

External sensor for source ground return protection

The sensor is installed around the connection of the transformer neutral point to earth and connects to the Micrologic 6.0 control unit via an MDGF module to provide the source ground return (SGR) protection.

Voltage measurement inputs

Voltage measurement inputs are required for power measurements (Micrologic P or H) and for earth-leakage protection (Micrologic 7...).

As standard, the control unit is supplied by internal voltage measurement inputs placed downstream of the pole for voltages between 220 and 690 V AC. On request, it is possible to replace the internal voltage measurement inputs by an external voltage input (PTE option) which enables the control unit to draw power directly from the distribution system upstream of the circuit breaker. An 3 m cable with ferrite comes with this PTE option.

Long-time rating plug

Four interchangeable plugs may be used to limit the long-time threshold setting range for higher accuracy.

The time delay settings indicated on the plugs are for an overload of 6 I_r (for further details, see the characteristics on [page A-13](#) and [page A-15](#)).

As standard, control units are equipped with the 0.4 to 1 plug.

Setting ranges

Standard	I _r = I _n x...	0.4	0.5	0.6	0.7	0.8	0.9	0.95	0.98	1
Low-setting option	I _r = I _n x...	0.4	0.45	0.50	0.55	0.60	0.65	0.70	0.75	0.8
High-setting option	I _r = I _n x...	0.80	0.82	0.85	0.88	0.90	0.92	0.95	0.98	1
Off plug		No long-time protection (I _r = I _n for I _{sd} setting)								

Important: long-time rating plugs must always be removed before carrying out insulation or dielectric withstand tests.

External 24 V DC power-supply module

The external power-supply module makes it possible to use the display even if the circuit breaker is open or not supplied (for the exact conditions of use, see the "electrical diagrams" part of this catalogue).

This module powers both the control unit (100 mA) and the M2C and M6C programmable contacts (100 mA).

If the COM communication option is used, the communication bus requires its own 24 V DC power supply, independent with respect to that of the Micrologic control unit. With the Micrologic A control unit, this module makes it possible to display currents of less than 20 % of I_n.

With the Micrologic P and H, it can be used to display fault currents after tripping.

Characteristics

- power supply:
 - 110/130, 200/240, 380/415 V AC (+10 % -15 %)
 - 24/30, 48/60, 100/125 V DC (+20 % -20 %)
- output voltage: 24 V DC ±5 %, 200 mA.
- ripple < 1 %
- dielectric withstand : 3.5 kV rms between input/output, for 1 minute
- overvoltage category: as per IEC 60947-1 cat. 4.

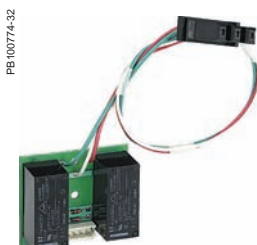

M2C.



M6C.

Battery module

The battery module maintains display operation and communication with the supervisor if the power supply to the Micrologic control unit is interrupted. It is installed in series between the Micrologic control unit and the AD module.

Characteristics

- battery run-time: 4 hours (approximately)
- mounted on vertical backplate or symmetrical rail.

M2C, M6C programmable contacts

These contacts are optional equipment for the Micrologic P and H control units. They are described with the indication contacts for the circuit breakers.

Characteristics		M2C/M6C	
Minimum load		100 mA/24 V	
Breaking capacity (A) p.f.: 0.7	V AC	240	5
		380	3
	V DC	24	1.8
		48	1.5
		125	0.4
		250	0.15

M2C: 24 V DC power supplied by control unit (consumption 100 mA).

M6C: external 24 V DC power supply required (consumption 100 mA).



Lead-seal cover.

Spare parts

Lead-seal covers

A lead-seal cover controls access to the adjustment dials.

When the cover is closed:

- it is impossible to modify settings using the keypad unless the settings lockout pin on the cover is removed
- the test connector remains accessible
- the test button for the earth-fault and earth-leakage protection function remains accessible.

Characteristics

- transparent cover for basic Micrologic and Micrologic A control units
- non-transparent cover for Micrologic P and H control units.

Spare battery

A battery supplies power to the LEDs identifying the tripping causes. Battery service life is approximately ten years.

A test button on the front of the control unit is used to check the battery condition.

The battery may be replaced on site when discharged.

Test equipment

Hand-held test kit

The hand-held mini test kit may be used to:

- check operation of the control unit and the tripping and pole-opening system by sending a signal simulating a short-circuit
- supply power to the control units for settings via the keypad when the circuit-breaker is open (Micrologic P and H control units).

Power source: standard LR6-AA battery.

Full function test kit

The test kit can be used alone or with a supporting personal computer.

The test kit without PC may be used to check:

- the mechanical operation of the circuit breaker
- the electrical continuity of the connection between the circuit breaker and the control unit
- operation of the control unit:
 - display of settings
 - automatic and manual tests on protection functions
 - test on the zone-selective interlocking (ZSI) function
 - inhibition of the earth-fault protection
 - inhibition of the thermal memory.

The test kit with PC offers in addition:

- the test report (software available on request).



Portable test kit.

GetnSet is a portable data acquisition and storage accessory that connects directly to the Micrologic control units of Masterpact circuit breakers to read important electrical installation operating data and Masterpact protection settings. This information is stored in the GetnSet internal memory and can be transferred to a PC via USB or Bluetooth for monitoring and analysis.

Overview of Masterpact GetnSet functions

GetnSet⁽¹⁾ is a portable data acquisition and storage device that works like a USB drive, letting users manually transfer data to and from a Masterpact circuit breaker or PC.

GetnSet can download operating data from Masterpact and download or upload settings.

Downloadable operating data include measurements, the last 3 trip history records and contact wear status.

Accessible settings include protection thresholds, external relay assignment modes and pre-defined alarm configurations if applicable.

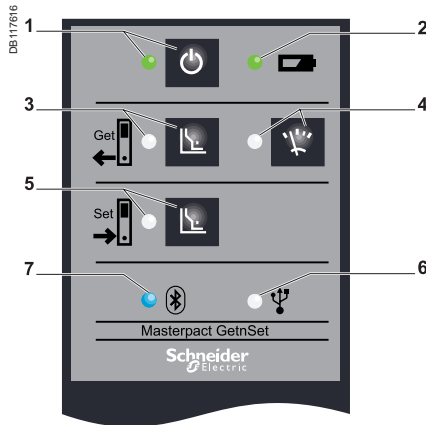

- 1 On/Off
- 2 batterie indicator
- 3 Download settings
- 4 Download operating parameters
- 5 Upload settings
- 6 USB indicator
- 7 Bluetooth indicator

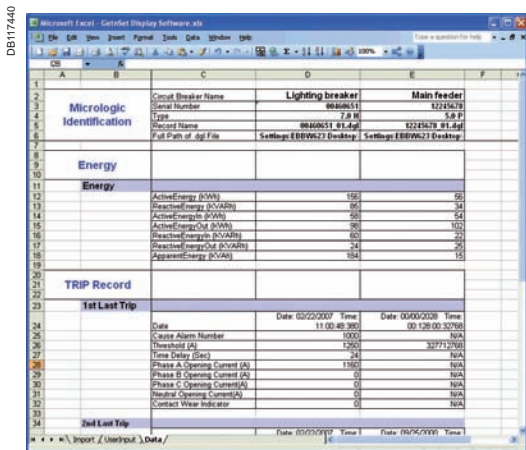

Operating data functions

Electrical installation information such as energy measurements and contact wear status is increasingly important to help reduce operating expenses and increase the availability of electrical power. Such data is often available from devices within the installation, but needs to be gathered and aggregated to allow analysis and determine effective improvement actions.

With GetnSet, this operating data can be easily read and stored as .dgl files in the internal memory. It can then be transferred to a PC via a USB or Bluetooth link and imported in an Excel spreadsheet.

The provided Excel spreadsheet can be used to display the operating data from several breakers in order to:

- analyse changes in parameters such as energy, power factor and contact wear
- compare the values of parameters between circuit breakers
- create graphics and reports using standard Excel tools

GetnSet data accessible in the Excel spreadsheet

Type of data	Micrologic		
Current	A	P	H
Energy, voltages, frequency, power, power factor		P	H
Power quality: fundamental, harmonics			H
Trip history		P	H
Contact wear		P	H

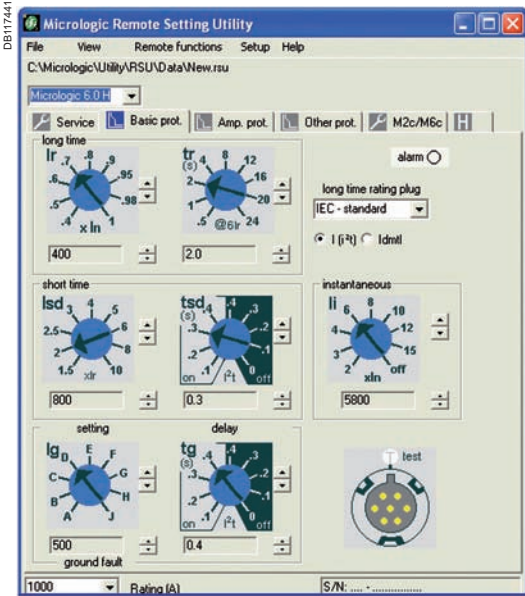

Protection setting functions

GetnSet can also be used to back up circuit breaker settings and restore them on the same device or, under certain conditions, copy them to any Masterpact circuit breaker equipped with the same type of Micrologic control unit. This concerns only advanced settings, as other parameters must be set manually using the dials on the Micrologic control unit.

- When commissioning the installation, safeguard the configuration parameters of your electrical distribution system by creating a back-up of circuit breaker settings so that they can be restored at any time.

- The settings read by GetnSet can be transferred to a PC and are compatible with RSU software (Remote Setting Utility). Protection configurations can also be created on a PC using this software, copied to GetnSet's internal memory and uploaded to a Masterpact circuit breaker with a compatible Micrologic trip unit and dial settings.

Operating procedure

The procedure includes several steps.

- Plug GetnSet into the receptacle on the front of the Micrologic control unit of a Masterpact circuit breaker.
- On the keypad, select the type of data (operating data or settings) and the transfer direction (download or upload). This operation can be done as many times as required for the entire set of Masterpact circuit breakers.
- Downloaded data is transferred to the GetnSet internal memory and a file is created for each Masterpact device (either an .rsu file for settings or a .dgl file for operating data).
- Data can be transferred between GetnSet and a PC via a USB or Bluetooth connection.
- Operating data can be imported in an Excel spreadsheet and protection settings can be read with RSU (remote setting utility) software.

Features

- Battery-powered to power a Micrologic control unit even if the breaker has been opened or tripped. This battery provides power for an average of 1 hour of use, enough for more than 100 download operations.
- Can be used on Masterpact circuit breakers equipped or not equipped with a Modbus "device" communication module.
- Portable, standalone accessory eliminating the need for a PC to connect to a Masterpact circuit breaker.
- No driver or software required for GetnSet connection to a PC.
- Can be used with many circuit breakers, one after the other.
- Embedded memory sized to hold data from more than 5000 circuit breakers.
- Supplied with its battery, a cable for connection to Micrologic trip units, a USB cable for connection to a PC and a battery charger.

Compatibility

- Micrologic control units A, P, H
- PC with USB port or Bluetooth link and Excel software

Technical characteristics

Charger power supply	100 – 240 V; ~1A; 50 – 60 Hz
Charger power consumption	Max 100 W
Battery	3.3 V DC; 9mAh; Li-Ion
Operating temperature	-20 to +60 °C
GetnSet dimensions	95 x 60 x 35 mm

The COM option is required for integration of the circuit breaker or switch-disconnector in a supervision system.

Masterpact uses the Modbus communications protocol for full compatibility with the supervision management systems. An external gateway is available for communication on other networks:

- Ion Enterprise (power management system)
- Ethernet gateway (MPS100/EGX)
- Ethernet...
- Profibus.

Eco COM is limited to the transmission of metering data and does not allow the control of the circuit breaker.

For fixed devices, the COM option is made up of:

- a "device" communication module, installed behind the Micrologic control unit and supplied with its set of sensors (OF, SDE, PF and CH micro-contacts) and its kit for connection to XF and MX1 communicating voltage releases.

For drawout devices, the COM option is made up of:

- a "device" communication module, installed behind the Micrologic control unit and supplied with its set of sensors (OF, SDE, PF and CH micro-contacts) and its kit for connection to XF and MX1 communicating voltage releases
- a "chassis" communication module supplied separately with its set of sensors (CE, CD and CT contacts).

Status indication by the COM option is independent of the device indication contacts. These contacts remain available for conventional uses.

Digipact or Modbus "Device" communication module

This module is independent of the control unit. It receives and transmits information on the communication network. An infra-red link transmits data between the control unit and the communication module.

Consumption: 30 mA, 24 V.

Digipact or Modbus "chassis" communication module

This module is independent of the control unit. With Modbus "chassis" communication module, this module makes it possible to address the chassis and to maintain the address when the circuit breaker is in the disconnected position.

Consumption: 30 mA, 24 V.

XF and MX1 communicating voltage releases

The XF and MX1 communicating voltage releases are equipped for connection to the "device" communication module.

The remote-tripping function (MX2 or MN) are independent of the communication option. They are not equipped for connection to the "device" communication module.



Modbus "device" communication module.

Modbus "chassis" communication module.

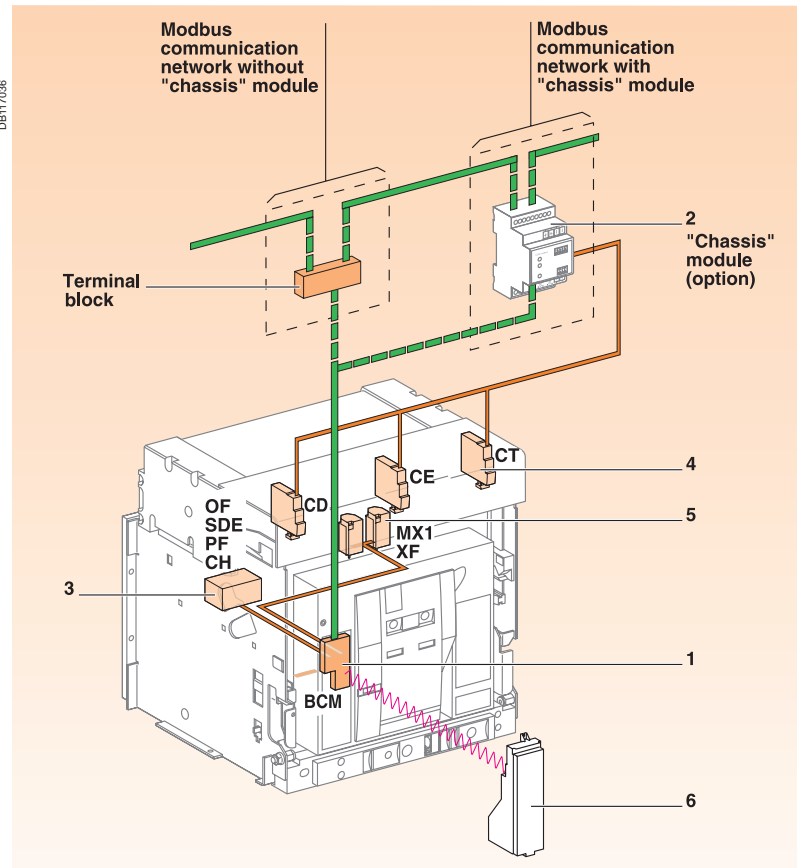

- 1 "Device" communication module.
- 2 "Chassis" communication module (option).
- 3 OF, SDE, PF and CH communicating "device" sensors.
- 4 CE, CD and CT communicating "chassis" sensors.
- 5 MX1 and XF communicating release.
- 6 Control unit.

— : Hard wire.
 — : Communication bus.

Overview of functions

056484N-60



The Masterpact circuit breakers and switch-disconnectors are compatible with the Digipact or Modbus COM option.

The COM option may be used to:

- identify the device
- indicate status conditions
- control the device.

Depending on the different types of Micrologic (A, P, H) control units, the COM option also offers:

- setting of the protection and alarms functions
- analysis of the AC-power parameters for operating-assistance and maintenance purposes.

	Switch-disconnector with communication bus	Circuit breaker with communication bus		
	Modbus	Modbus		
Device identification				
Address	■	A	P	H
Rating	-	A	P	H
Type of device	-		P	H
Type of control unit	-	A	P	H
Type of long-time rating plug	-	A	P	H
Status indications				
ON/OFF OF	■	A	P	H
Spring charged CH	■	A	P	H
Ready to close PF	(1)	A	P	H
Fault-trip SDE	■	A	P	H
Connected/disconnected/test position CE/CD/CT	■	A	P	H
Controls				
ON/OFF MX/XF	■	A	P	H
Spring charging	-			
Reset of the mechanical indicator	-			
Protections and alarms settings				
Reading of protections settings		A	P	H
Writing of fine settings in the range imposed by the adjustment dials			P	H
Reading/writing of alarms (load shedding and reconnect, M2C, etc.)			P	H
Reading/writing of custom alarms				H
Operating and maintenance aids				
Measurement				
Current		A	P	H
Voltages, frequency, power, etc.			P	H
Power quality: fundamental, harmonics				H
Programming of demand metering			P	H
Fault readings				
Type of fault		A	P	H
Interrupted current			P	H
Waveform capture				
On faults				H
On demand or programmed				H
Histories and logs				
Trip history			P	H
Alarm history			P	H
Event logs			P	H
Indicators				
Counter operation		A	P	H
Contact wear			P	H
Maintenance register			P	H

Note: see the description of the Micrologic control units for further details on protection and alarms, measurements, waveform capture, histories, logs and maintenance indicators.

(1) With modbus it is possible to monitor the PF status please see the instruction bulletin COMBT32AK at page 51/Register 661 documentation.

A: Micrologic with ammeter

P: Micrologic "Power"

H: Micrologic "Harmonics"

Modbus

- Modbus is the most widely used communication protocol in industrial networks.
- Masterpact, Compact NSX, PowerLogic and Sepam products all operate with this protocol. A Modbus network is generally implemented on an LV or MV switchboard scale.

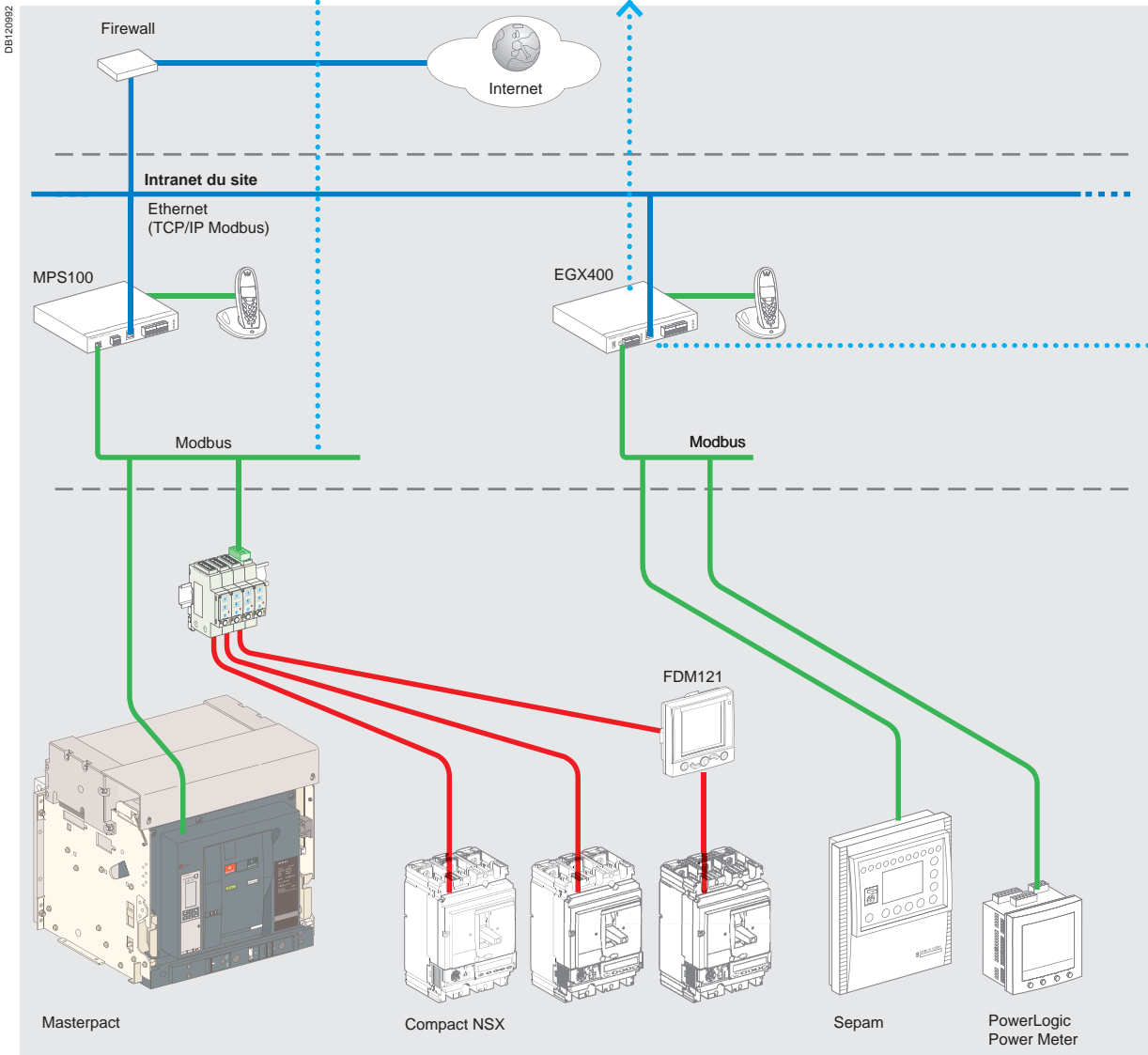

Gateway

A Modbus TCP gateway can be used to connect the Modbus network to ethernet. The gateway has the two main functions:

- access to the company intranet (Ethernet) by converting Modbus frames to the TCP/IP Modbus protocol,
 - optional web-page server for the information from the devices.
- Examples include MPS100, EGX400 and EGX100.

MPS100

■ Plug and play device. It comes loaded with a web-page application for graphic display of currents and voltages and viewing of circuit-breaker status and power and energy values.

To use the application, simply declare the Modbus addresses of the connected slaves. Automatically recognised devices include all Masterpact and Compact NSX Micrologic trip units and the PM500/700/800 and PM9c power monitoring units.

- Can be used for automatic alarm notification via a messaging server available on the site intranet or via mobile phones (e-mail converted into SMS).
- Can be used for logging of data that can be automatically sent as e-mail attachments, e.g. a weekly consumption report.

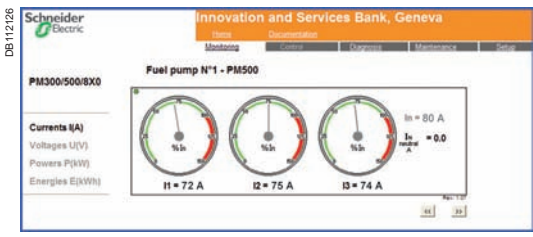

Web page.

Communication bus

Modbus bus

The Modbus RS485 system is an open bus on which communicating Modbus devices (Masterpact with Modbus COM, Power Meter, Sepam, VigiloHM, etc.) are installed. All types of PLCs and microcomputers may be connected to the bus.

Addresses

The Modbus parameters (address, baud rate, parity) are entered using the keypad on the Micrologic A, P or H. For a switch-disconnector, it is necessary to use the RSU (Remote Setting Utility) Micrologic utility.

The software layer of the Modbus protocol can manage up to 255 addresses (1 to 255).

The "device" communication module comprises three addresses linked to:

- circuit-breaker manager
- measurement manager
- protection manager.

The "chassis" communication module comprises one address linked to the chassis manager.

The division of the system into four managers secures data exchange with the supervision system and the circuit-breaker actuators.

The manager addresses are automatically derived from the circuit-breaker address @xx entered via the Micrologic control unit (the default address is 47).

Logic addresses

@xx	Circuit-breaker manager	(1 to 47)
@xx + 50	Chassis manager	(51 to 97)
@xx + 200	Measurement managers	(201 to 247)
@xx + 100	Protection manager	(101 to 147)

Number of devices

The maximum number of devices that may be connected to the Modbus bus depends on the type of device (Masterpact with Modbus COM, Power Meter, Sepam, VigiloHM, etc.), the baud rate (19200 is recommended), the volume of data exchanged and the desired response time. The RS485 physical layer offers up to 32 connection points on the bus (1 master, 31 slaves).

A fixed device requires only one connection point (communication module on the device).

A drawout device uses two connection points (communication modules on the device and on the chassis).

The number must never exceed 31 fixed devices or 15 drawout devices.

Length of bus

The maximum recommended length for the Modbus bus is 1200 meters.

Bus power source

A 24 V DC power supply is required (less than 20 % ripple, insulation class II).

Communication interface

The Modbus bus may be connected to the central processing device in any of three manners:

- direct link to a PLC. The communication interface is not required if the PLC is equipped with a Modbus port
- direct link to a computer. The Modbus (RS485) / Serial port (RS232) communication interface is required
- connection to a TCP/IP (Ethernet) network. The Modbus (RS485) / TCP/IP (Ethernet) communication interface is required.

Devices

Circuit breakers equipped with Micrologic control units may be connected to either a Modbus communication bus. The information made available depends on the type of Micrologic control unit (A, P or H) and on the type of communication bus (Modbus).

Switch-disconnectors can be connected to the Modbus communication bus. The information made available is the status of the switch-disconnector.

Software

To make use of the information provided by the communicating devices, software with a Modbus driver must be used.

Micrologic utilities

This is a set of software that may be used with a PC to:

- display the variables (I, U, P, E, etc.) with the RDU (Remote Display Utility)
- read/write the settings with the RSU (Remote Setting Utility)
- remotely control (ON / OFF) the device with the RCU (Remote Control Utility).

Micrologic utilities are available upon request

SMS (System Manager Software)

SMS is a software to monitor LV and/or MV electrical energy.

The SMS family includes a software range depending on the application and function, from single product monitoring to the management of a multiple building:

- Power Meter and Circuit Monitor units
- LV devices
- Sepam units.

The MPS100 Micro Power Server:

- notifies maintenance staff when any preset alarm or trip is activated by the Micrologic trip unit, automatically sending an e-mail and/or SMS
- data logs are periodically forwarded by e-mail
- the e-mails are sent via an Ethernet local area network (LAN) or remotely via modem.

PB100823-42



PB100804-60



MPS100 Micro Power Server.

PB100799-68



Main LV switchboard.

PB100877A-67

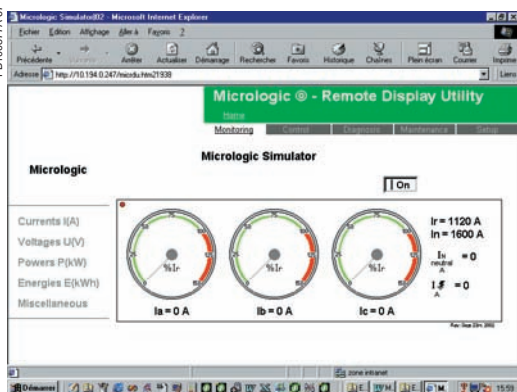

Monitoring of your main LV switchboard via embedded web pages in the MPS100 accessible with a standard web browser.

Micro Power Server makes data collection easy for monitoring Masterpact/Compact circuit breakers

Now, more than ever, there is a need to monitor electrical distribution systems in industrial and large commercial applications. The key to managing all equipment, maximising efficiencies, reducing costs and increasing up time is having the right tools.

Micro Power Server MPS100 is designed to withstand harsh electrical environments and provide a consistent flow of easy to interpret information.

Micro Power Server is designed for unattended operation within the main LV switchboard

The MPS100 is a self-contained facility information server that serves as a stand-alone device for power system monitoring.

It is used to transfer power system information via a standard web browser over an Ethernet local area network (LAN) or via modem, making it possible to view power system information on a PC with an Ethernet connection.

In either capacity, the Micro Power Server functions as a web server for Micrologic trip unit and Power Meter supervision, automatically notifying (e-mail and/or SMS) maintenance staff when any preset alarm or trip is activated in the Micrologic trip unit.

Benefits

- view your main LV switchboard without installing software on your local PC, eliminating the need for a dedicated PC with specific software
- Micro Power Server allows centralised monitoring, so you no longer waste precious time walking around the facility to collect data
- view your main LV switchboard via a modem connection (GSM or switched network), avoiding the need for a LAN
- maintenance people are automatically notified at any time, wherever they are, so you do not have to stay in front of a monitor all day long
- data logs can be periodically forwarded by sending e-mails to the relevant people (maintenance, accounting, application service provider) automatically
- possibility to monitor/notify six external events (limit switches, auxiliary switches...)
- back-up of Micrologic trip unit settings in the memory of the MPS100, so you know where to retrieve it when necessary.

Typical architecture

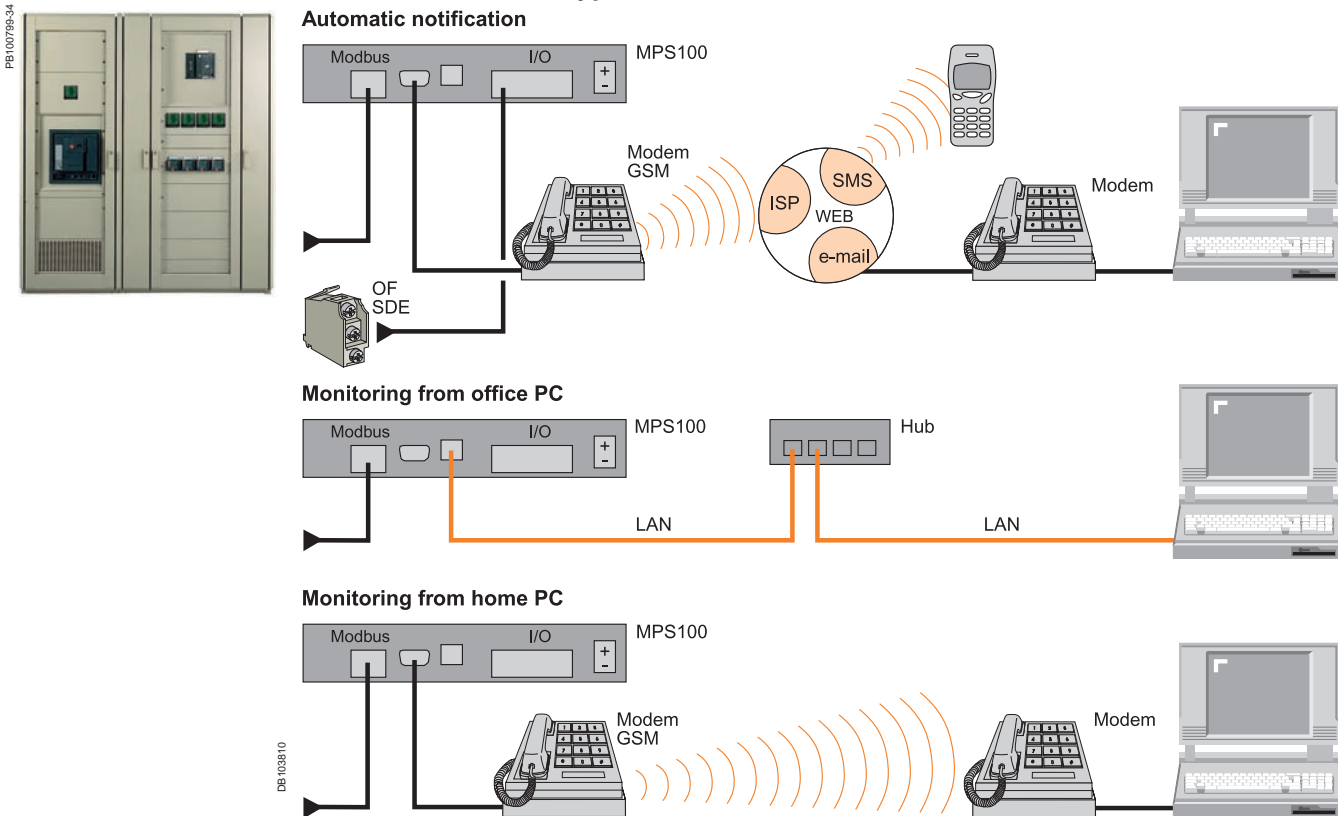

It is possible to combine the different types of architecture.

Supported Modbus devices

- Micrologic trip units
- Power Meters (PM700, PM800...).

Maximum recommended connected devices is 10.

Features

- access to the power system via a standard PC web browser
- real-time data displayed with an intuitive and user friendly interface (dashboard)
- Ethernet Modbus TCP/IP connectivity directly to the LAN or via modem (Point to Point Protocol services)
- SMTP (Simple Mail Transfer Protocol) client (capacity to send e-mail)
- local logging of data such as energy, power, current...
- set-up and system configuration through MPS100 embedded HTML pages
- user interface translatable in any language, factory settings in English and French
- 6 inputs/2 outputs (no-volt contact)
- DHCP (Dynamic Host Configuration Protocol) client.

Technical characteristics

Power supply	24 V DC \pm 15 %, consumption = 250 mA
Operating temperature	0 to +50 °C
Rugged compact metal housing	35 x 218 x 115 mm (H x W x D)
Additional information available at: http://194.2.245.4/mkt/microser.nsf	
User name: MPS, Password: MPS100	

PB100799-34

PB100803-14

Micrologic trip unit.

PB100708-15-SE

Power Meter.

PB104732



Short Message Service (SMS).

Wiring system

The wiring system is designed for low-voltage power switchboards. Installation requires no tools or special skills.

The prefabricated wiring ensures both data transmission (ModBus protocol) and 24 V DC power distribution for the communications modules on the Micrologic control units.

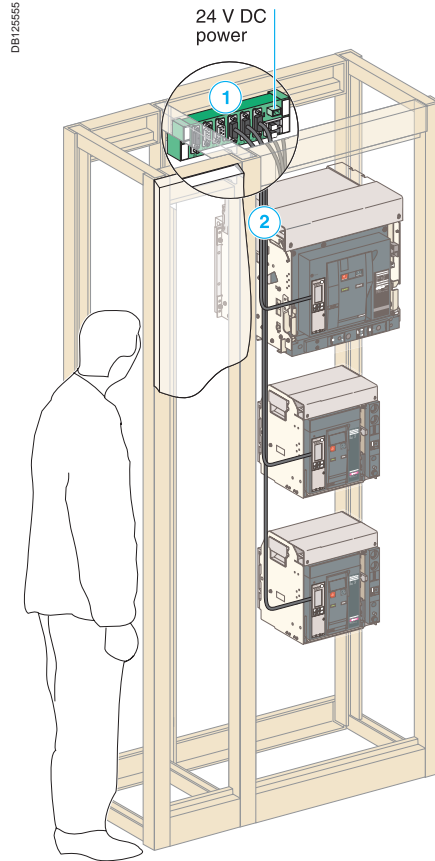

Masterpact circuit breakers equipped with Micrologic control units and the ModBus COM option.

Maximum distance between module and circuit breaker: 1200 m.

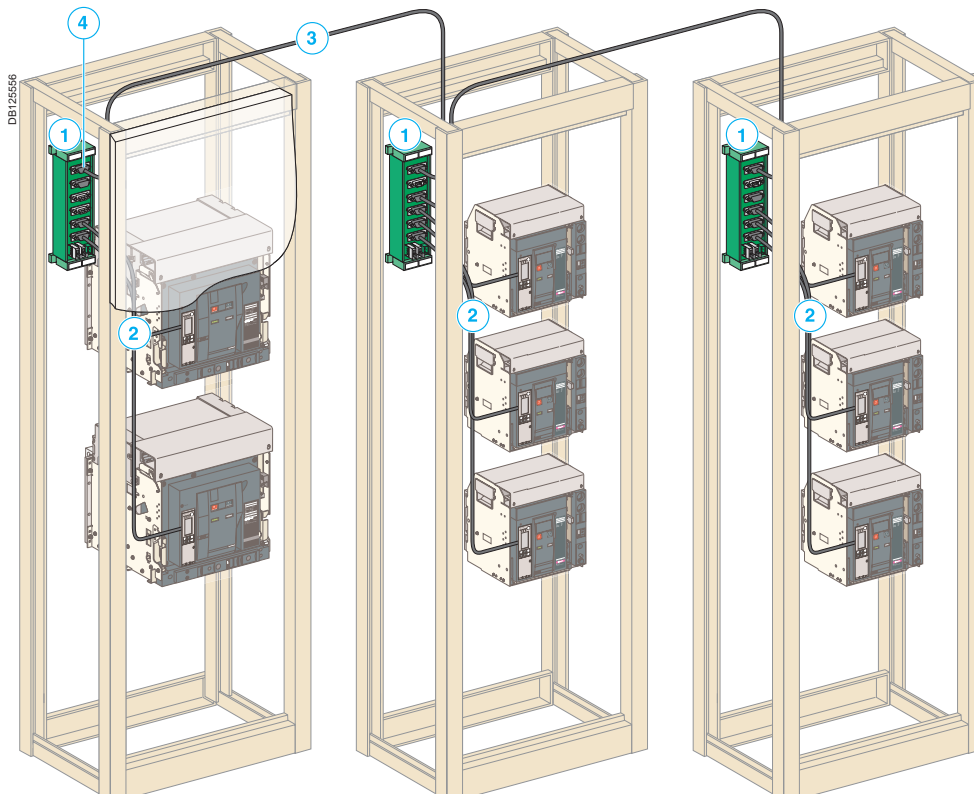

Masterpact circuit breakers equipped with Micrologic control units and the ModBus eco COM option.

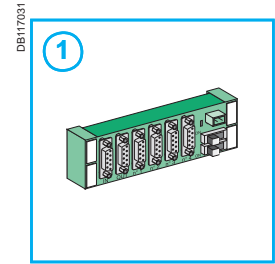

CJB 306 junction block.

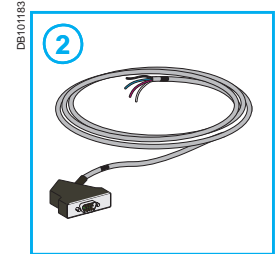

CCP 303: Connection cable between Masterpact or Compact and junction block.

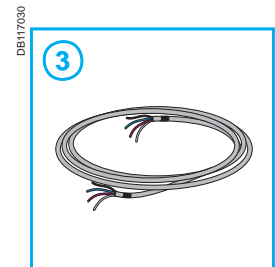

CCR 301: Roll of RS 485 cable (2 RS 485 wires + 2 power supply wires).

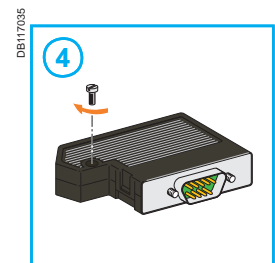

CSD 309: SubD 9-pin connector for colour-coded connection of wires to screw terminals.

Connections

Overview of solutions

Three types of connection are available:

- vertical or horizontal rear connection
- front connection
- mixed connection.

The solutions presented are similar in principle for all Masterpact NT and NW fixed and drawout devices.

Rear connection

Horizontal



Vertical

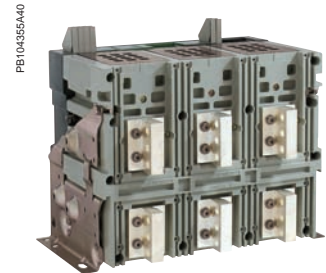

Simply turn a horizontal rear connector 90° to make it a vertical connector. For the 6300 A circuit breaker, only vertical connection is available.

Front connection

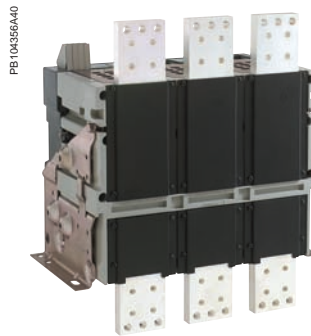

Front connection is available for NW fixed and drawout versions up to 3200 A.

Mixed connection

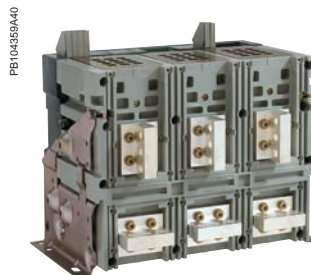
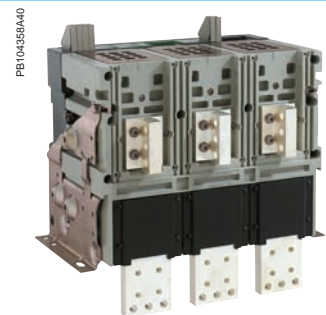
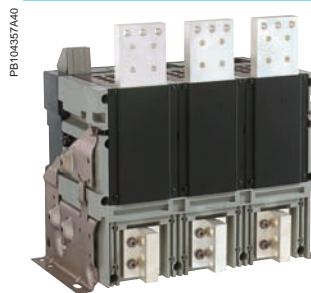

Note: Masterpact circuit breakers can be connected indifferently with bare-copper, tinned-copper and tinned-aluminium conductors, requiring no particular treatment.

Type of accessory	Masterpact NT06 to NT16				Masterpact NW08 to NW63			
	Fixed Front connection	Rear connection	Drawout Front connection	Rear connection	Fixed Front connection	Rear connection	Drawout Front connection	Rear connection
Vertical connection adapters								
Cable lug adapters								
Interphase barriers								
Spreaders								
Disconnectable front-connection adapter								
Safety shutters with padlocking				<i>standard</i>				<i>standard</i>
Shutter position indication and locking								
Arc chute screen								

- (1) Mandatory for voltages > 500 V.
- (2) Except for an NW40 equipped for horizontal rear connection, and for fixed NW40b-NW63.
- (3) Mandatory for 1000 V and for fixed NT front-connection versions with vertical-connection adapters oriented towards the front.
- (4) Mandatory for 1000 V.

Masterpact M replacement kit

A set of connection parts is available to allow replacement of a Masterpact M08 to M32 circuit breaker by a Masterpact NW without modifying the busbars (please consult us).

Mounting on a switchboard backplate using special brackets

Masterpact NT and NW fixed front-connected circuit breakers can be installed on a backplate without any additional accessories. Masterpact NW circuit breakers require a set of special brackets.

PB104360A30

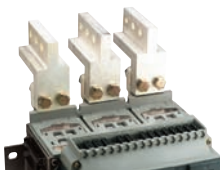

Vertical-connection adapters (option)

Mounted on front-connected devices or chassis, the adapters facilitate connection to a set of vertical busbars.

PB104361A30



Cable-lug adapters (option)

Cable-lug adapters are used in conjunction with vertical-connection adapters. They can be used to connect a number of cables fitted with lugs. To ensure adequate mechanical strength, the connectors must be secured together via spacers (**catalogue number 07251**).

PB104350A30

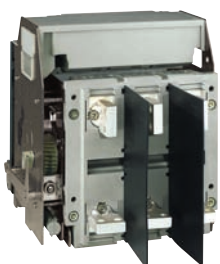

Interphase barriers (option)

These barriers are flexible insulated partitions used to reinforce isolation of connection points in installations with busbars, whether insulated or not. For Masterpact NT/NW devices, they are installed vertically between rear connection terminals. They are mandatory for NT devices at voltages > 500 V.

PB104362A30



Spreaders (option)

Mounted on the front or rear connectors, spreaders are used to increase the distance between bars in certain installation configurations.

DB117039

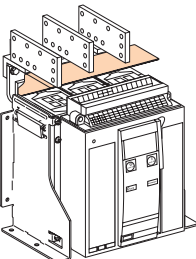

Arc chute screen (option)

For fixed Masterpact NT front-connection versions and with vertical-connection adapters oriented towards the front, an arc chute screen must be installed to respect safety clearances.

For Masterpact NT 1000 V, an arc chute screen must be installed to respect safety clearances.

PB104383A350



Disconnectable front-connection adapter (option)

Mounted on a fixed front-connected device, the adapter simplifies replacement of a fixed device by enabling fast disconnection from the front.

PB104384A50



Safety shutters (VO standard)

Mounted on the chassis, the safety shutters automatically block access to the disconnecting contact cluster when the device is in the disconnected or test positions (degree of protection IP 20). When the device is removed from its chassis, no live parts are accessible.

The shutter-locking system is made up of a moving block that can be padlocked (padlock not supplied). The block:

- prevents connection of the device
- locks the shutters in the closed position.

For Masterpact NW08 to NW63

A support at the back of the chassis is used to store the blocks when they are not used:

- 2 blocks for NW08 to NW40
- 4 blocks for NW40b to NW63.

DB101158

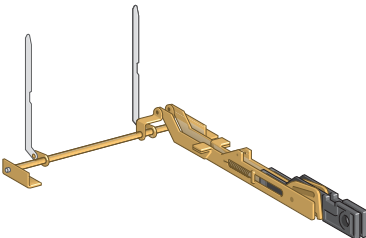

Shutter position indication and locking on front face (VIVC, NW only)

This option located on the chassis front plate indicates that the shutters are closed. It is possible to independently or separately padlock the two shutters using one to three padlocks (not supplied).

Locking On the device

DB101159

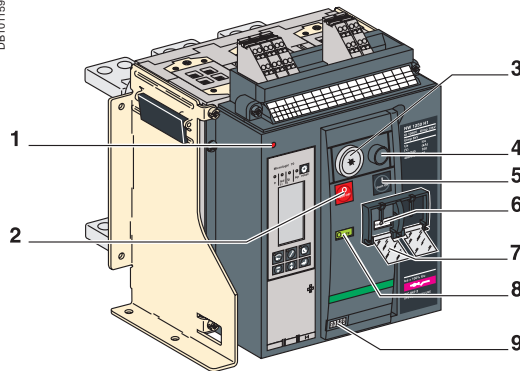

- 1 Reset button for mechanical trip indication.
- 2 OFF pushbutton.
- 3 OFF position lock.
- 4 Electrical closing pushbutton.
- 5 ON pushbutton.
- 6 Springs charged indication.
- 7 Pushbutton locking.
- 8 Contact position indication.
- 9 Operation counter.

PB100811-32



Access to pushbuttons protected by transparent cover.

Pushbutton locking VBP

The transparent cover blocks access to the pushbuttons used to open and close the device.

It is possible to independently lock the opening button and the closing button. The locking device is often combined with a remote operating mechanism.

The pushbuttons may be locked using either:

- three padlocks (not supplied)
- lead seal
- two screws.

PB100810-32



Pushbutton locking using a padlock.

Device locking in the OFF position VCPO by padlocks, VSPO by keylocks

The circuit breaker is locked in the OFF position by physically maintaining the opening pushbutton pressed down:

- using padlocks (one to three padlocks, not supplied)
- using keylocks (one or two different keylocks, supplied).

Keys may be removed only when locking is effective (Profalux or Ronis type locks). The keylocks are available in any of the following configurations:

- one keylock
- one keylock mounted on the device + one identical keylock supplied separately for interlocking with another device
- two different key locks for double locking.

Profalux and Ronis keylocks are compatible with each other.

A locking kit (without locks) is available for installation of one or two keylocks (Ronis, Profalux, Kirk or Castell).

PB100812-32



OFF position locking using a padlock.

Accessory-compatibility

For Masterpact NT: 3 padlocks or 1 keylock

For Masterpact NW: 3 padlocks and/or 2 keylocks

Cable-type door interlock IPA

This option prevents door opening when the circuit breaker is closed and prevents circuit breaker closing when the door is open.

For this, a special plate associated with a lock and a cable is mounted on the right side of the circuit breaker.

With this interlock installed, the source changeover function cannot be implemented.

PB104365A40



OFF position locking using a keylock.

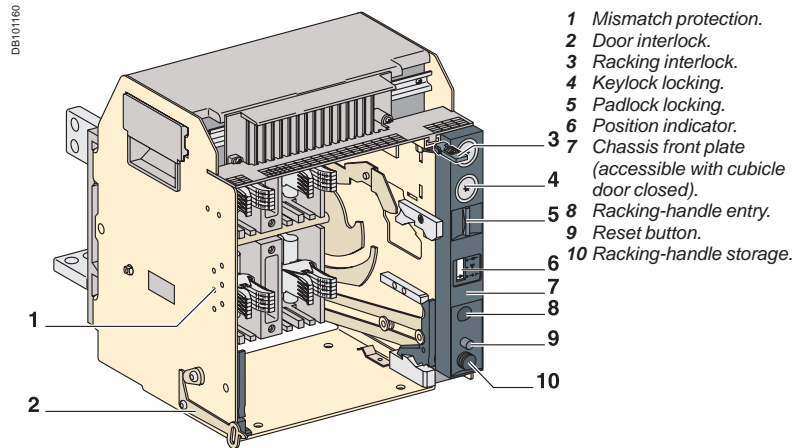

- 1 Mismatch protection.
- 2 Door interlock.
- 3 Racking interlock.
- 4 Keylock locking.
- 5 Padlock locking.
- 6 Position indicator.
- 7 Chassis front plate (accessible with cubicle door closed).
- 8 Racking-handle entry.
- 9 Reset button.
- 10 Racking-handle storage.



PB104366A32

"Disconnected" position locking by padlocks.



PB104367A34

"Disconnected" position locking by keylocks.

"Disconnected" position locking by padlocks (standard) or keylocks (VSPD option)

Mounted on the chassis and accessible with the door closed, these devices lock the circuit breaker in the "disconnected" position in two manners:

- using padlocks (standard), up to three padlocks (not supplied)
- using keylocks (optional), one or two different keylocks are available.

Profalux and Ronis keylocks are available in different options:

- one keylock
- two different keylocks for double locking
- one (or two) keylocks mounted on the device + one (or two) identical keylocks supplied separately for interlocking with another device.

A locking kit (without locks) is available for installation of one or two keylocks (Ronis, Profalux, Kirk or Castell).

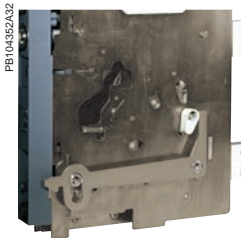

PB104352A32

Door interlock.

"Connected", "disconnected" and "test" position locking

The "connected", "disconnected" and "test" positions are shown by an indicator and are mechanically indexed. The exact position is obtained when the racking handle blocks. A release button is used to free it.

As standard, the circuit breaker can be locked only in "disconnected position". On request, the locking system may be modified to lock the circuit breaker in any of the three positions: "connected", "disconnected" or "test".

Door interlock catch VPEC

Mounted on the right or left-hand side of the chassis, this device inhibits opening of the cubicle door when the circuit breaker is in "connected" or "test" position. If the breaker is put in the "connected" position with the door open, the door may be closed without having to disconnect the circuit breaker.

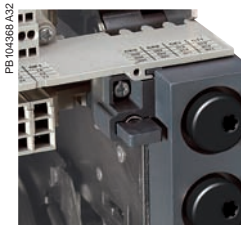

PB104368A32

Racking interlock.

Racking interlock VPOC

This device prevents insertion of the racking handle when the cubicle door is open.

Cable-type door interlock IPA

This option is identical for fixed and drawout versions.

Racking interlock between crank and OFF pushbutton IBPO (for NW only)

This option makes it necessary to press the OFF pushbutton in order to insert the racking handle and holds the device open until the handle is removed.

Automatic spring discharge before breaker removal DAE (for NW only)

This option discharges the springs before the breaker is removed from the chassis.

Mismatch protection VDC

Mismatch protection ensures that a circuit breaker is installed only in a chassis with compatible characteristics. It is made up of two parts (one on the chassis and one on the circuit breaker) offering twenty different combinations that the user may select.



PB100815-3DR_SE

Mismatch protection.

Indication contacts

Indication contacts are available:

- in the standard version for relay applications
- in a low-level version for control of PLCs and electronic circuits.

M2C and M6C contacts may be programmed via the Micrologic P and H control units.

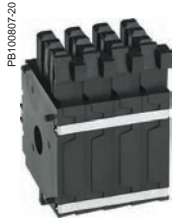
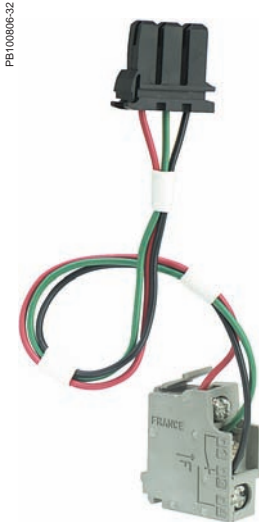

ON/OFF indication contacts (OF) (rotary type).

ON/OFF indication contacts (OF) (microswitch type).

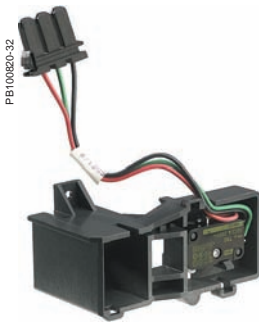

Additional "fault-trip" indication contacts (SDE).



Combined contacts.

ON/OFF indication contacts OF

Two types of contacts indicate the ON or OFF position of the circuit breaker:

- microswitch type changeover contacts for Masterpact NT
- rotary type changeover contacts directly driven by the mechanism for Masterpact NW. These contacts trip when the minimum isolation distance between the main circuit-breaker contacts is reached.

OF		NT	NW
Supplied as standard		4	4
Maximum number		4	12
Breaking capacity (A)	Standard	Minimum load: 100 mA/24 V	
p.f.: 0.3	V AC	240/380	6
AC12/DC12		480	6
		690	6
	V DC	24/48	2.5
		125	0.5
		250	0.3
	Low-level	Minimum load: 2 mA/15 V	
	V AC	24/48	5
		240	5
		380	5
	V DC	24/48	5/2.5
		125	0.5
		250	0.3

(1) Standard contacts: 10 A; optional contacts: 6 A.

"Fault-trip" indication contacts SDE

Circuit-breaker tripping due to a fault is signalled by:

- a red mechanical fault indicator (reset)
- one changeover contact SDE.

Following tripping, the mechanical indicator must be reset before the circuit breaker may be closed. One SDE is supplied as standard. An optimal SDE may be added. This latter is incompatible with the electrical reset after fault-trip option (RES).

SDE		NT/NW
Supplied as standard		1
Maximum number		2
Breaking capacity (A)	Standard	Minimum load: 100 mA/24 V
p.f.: 0.3	V AC	240/380
AC12/DC12		480
		690
	V DC	24/48
		125
		250
	Low-level	Minimum load: 2 mA/15 V
	V AC	24/48
		240
		380
	V DC	24/48
		125
		250

Combined "connected/closed" contacts EF

The contact combines the "device connected" and the "device closed" information to produce the "circuit closed" information. Supplied as an option for Masterpact NW, it is mounted in place of the connector of an additional OF contact.

EF		NW
Maximum number		8
Breaking capacity (A)	Standard	Minimum load: 100 mA/24 V
p.f.: 0.3	V AC	240/380
AC12/DC12		480
		690
	V DC	24/48
		125
		250
	Low-level	Minimum load: 2 mA/15 V
	V AC	24/48
		240
		380
	V DC	24/48
		125
		250



CE, CD and CT "connected/disconnected/test" position carriage switches.



M2C programmable contacts: circuit-breaker internal relay with two contacts.



M6C programmable contacts: circuit-breaker external relay with six independent changeover contacts controlled from the circuit breaker via a three-wire connection. (maximum length is 10 meters).

"Connected", "disconnected" and "test" position carriage switches

Three series of optional auxiliary contacts are available for the chassis:

- changeover contacts to indicate the "connected" position CE
- changeover contacts to indicate the "disconnected" position CD. This position is indicated when the required clearance for isolation of the power and auxiliary circuits is reached
- changeover contacts to indicate the "test" position CT. In this position, the power circuits are disconnected and the auxiliary circuits are connected.

Additional actuators

A set of additional actuators may be installed on the chassis to change the functions of the carriage switches.

		NT			NW		
Contacts		CE/CD/CT			CE/CD/CT		
Maximum number	Standard	3	2	1	3	3	3
	with additional actuators				9	0	0
					6	3	0
					6	0	3
Breaking capacity (A)		Standard			Minimum load: 100 mA/24 V		
p.f.: 0.3	V AC	240	8		8		
AC12/DC12		380	8		8		
		480	8		8		
		690	6		6		
	V DC	24/48	2.5		2.5		
		125	0.8		0.8		
		250	0.3		0.3		
	Low-level				Minimum load: 2 mA/15 V		
	V AC	24/48	5		5		
		240	5		5		
		380	5		5		
	V DC	24/48	2.5		2.5		
		125	0.8		0.8		
		250	0.3		0.3		

M2C / M6C programmable contacts

These contacts, used with the Micrologic P and H control units, may be programmed via the control unit keypad or via a supervisory station with the COM communication option. They require an external power supply module.

They indicate:

- the type of fault
- instantaneous or delayed threshold overruns.
- They may be programmed:
 - with instantaneous return to the initial state
 - without return to the initial state
 - with return to the initial state following a delay.

Characteristics		M2C/M6C	
Minimum load		100 mA/24 V	
Breaking capacity (A)	V AC	240	5
		380	3
p.f.: 0.7	V DC	24	1.8
		48	1.5
		125	0.4
			0.4
		250	0.15

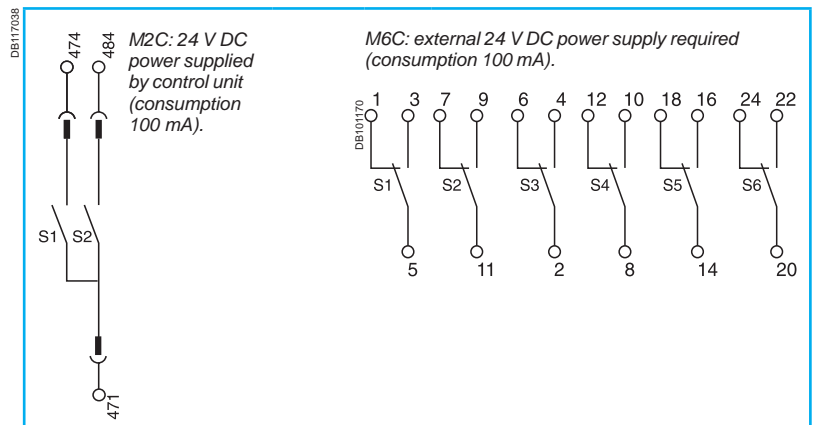

Remote operation

Remote ON/OFF

Two solutions are available for remote operation of Masterpact devices:

- a point-to-point solution
- a bus solution with the COM communication option.



Note: an opening order always takes priority over a closing order.

If opening and closing orders occur simultaneously, the mechanism discharges without any movement of the main contacts. The circuit breaker remains in the open position (OFF).

In the event of maintained opening and closing orders, the standard mechanism provides an anti-pumping function by blocking the main contacts in open position.

Anti-pumping function. After fault tripping or intentional opening using the manual or electrical controls, the closing order must first be discontinued, then reactivated to close the circuit breaker.

When the automatic reset after fault trip (RAR) option is installed, to avoid pumping following a fault trip, the automatic control system must take into account the information supplied by the circuit breaker before issuing a new closing order or blocking the circuit breaker in the open position (information on the type of fault, e.g. overload, short-time fault, earth fault, earth leakage, short-circuit, etc.).

Note: MX communicating releases are of the impulse type only and cannot be used to lock a circuit breaker in OFF position. For locking in OFF position, use the remote tripping function (2nd MX or MN).

When MX or XF communicating releases are used, the third wire (C3, A3) must be connected even if the communication module is not installed. When the control voltage (C3-C1 or A3-A1) is applied to the MX or XF releases, it is necessary to wait 1.5 seconds before issuing an order. Consequently, it is advised to use standard MX or XF releases for applications such as source-changeover systems.

The remote ON / OFF function is used to remotely open and close the circuit breaker. It is made up of:

- an electric motor MCH equipped with a "springs charged" limit switch contact CH
- two voltage releases:
 - a closing release XF
 - an opening release MX.

Optionally, other functions may be added:

- a "ready to close" contact PF
- an electrical closing pushbutton BPFE
- remote RES following a fault.

A remote-operation function is generally combined with:

- device ON / OFF indication OF
- "fault-trip" indication SDE.

Wiring diagram of a point-to-point remote ON / OFF function

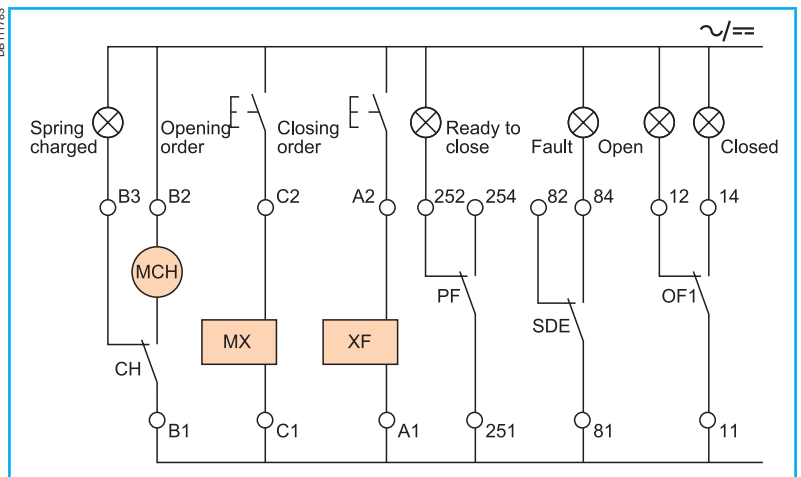

Wiring diagram of a bus-type remote ON / OFF function

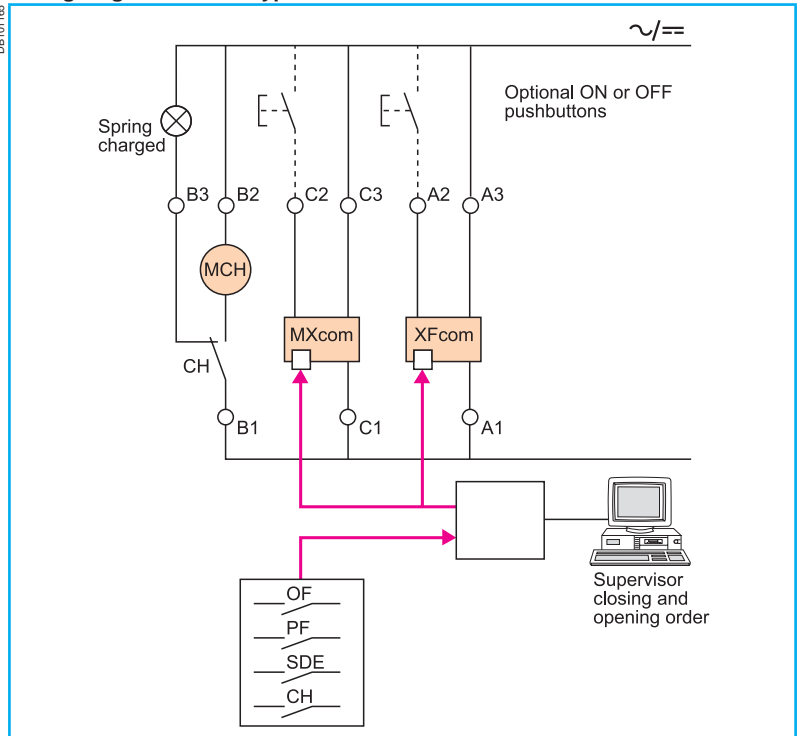

PB100707-23



Electric motor MCH for Masterpact NT.

PB100808-32



Electric motor MCH for Masterpact NW.

Electric motor MCH

The electric motor automatically charges and recharges the spring mechanism when the circuit breaker is closed. Instantaneous reclosing of the breaker is thus possible following opening. The spring-mechanism charging handle is used only as a backup if auxiliary power is absent.

The electric motor MCH is equipped as standard with a limit switch contact CH that signals the “charged” position of the mechanism (springs charged).

Characteristics

Power supply	V AC 50/60 Hz	48/60 - 100/130 - 200/240 - 277 - 380/415 - 400/440 - 480
	V DC	24/30 - 48/60 - 100/125 - 200/250
Operating threshold	0.85 to 1.1 Un	
Consumption (VA or W)	180	
Motor overcurrent	2 to 3 In for 0.1 s	
Charging time	maximum 3 s for Masterpact NT	
	maximum 4 s for Masterpact NW	
Operating frequency	maximum 3 cycles per minute	
CH contact	10 A at 240 V	

Voltage releases XF and MX

Their supply can be maintained or automatically disconnected.

Closing release XF

The XF release remotely closes the circuit breaker if the spring mechanism is charged.

Opening release MX

The MX release instantaneously opens the circuit breaker when energised. It locks the circuit breaker in OFF position if the order is maintained (except for MX “communicating” releases).

Note: whether the operating order is maintained or automatically disconnected (pulse-type), XF or MX “communicating” releases (“bus” solution with “COM” communication option) always have an impulse-type action (see diagram).

Characteristics

Characteristics	XF	MX
Power supply	V AC 50/60 Hz	24 - 48 - 100/130 - 200/250 - 277 - 380/480
	V DC	12 - 24/30 - 48/60 - 100/130 - 200/250
Operating threshold	0.85 to 1.1 Un	0.7 to 1.1 Un
Consumption (VA or W)	Hold: 4.5	Hold: 4.5
	Pick-up: 200 (200 ms)	Pick-up: 200 (200 ms)
Circuit-breaker response time at Un	55 ms ±10 (Masterpact NT)	50 ms ±10
	70 ms ±10 (NW ≤ 4000 A)	
	80 ms ±10 (NW > 4000 A)	

DB117037

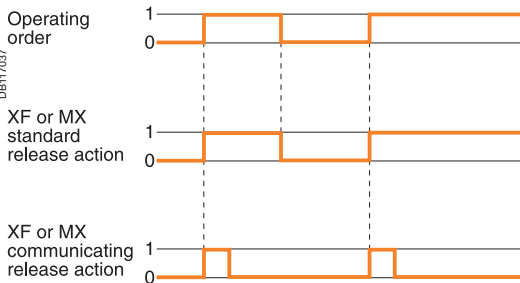

PE100809-16



XF and MX voltage releases.

PB100818-16



“Ready to close” contacts PF.

“Ready to close” contact PF

The “ready to close” position of the circuit breaker is indicated by a mechanical indicator and a PF changeover contact. This signal indicates that all the following are valid:

- the circuit breaker is in the OFF position
- the spring mechanism is charged
- a maintained opening order is not present:
- MX energised
- fault trip
- remote tripping second MX or MN
- device not completely racked in
- device locked in OFF position
- device interlocked with a second device.

Characteristics

Characteristics	NT/NW		
Maximum number	1		
Breaking capacity (A) p.f.: 0.3 AC12/DC12	Standard	V AC 240/380	5
		480	5
		690	3
	Low-level	V DC 24/48	3
		125	0.3
		250	0.15
Minimum load: 100 mA/24 V	Standard	V AC 24/48	3
		240	3
		380	3
	Low-level	V DC 24/48	3
		125	0.3
		250	0.15

PB100798-56

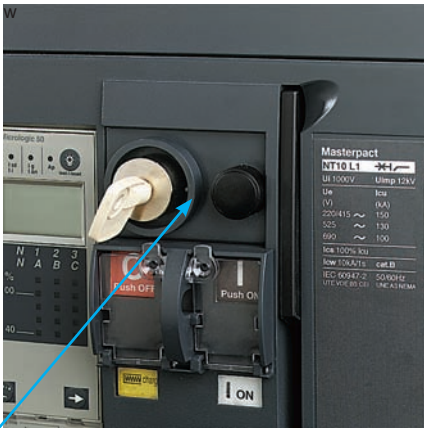

Electrical closing pushbutton BPFE.

Electrical closing pushbutton BPFE

Located on the front panel, this pushbutton carries out electrical closing of the circuit breaker. It is generally associated with the transparent cover that protects access to the closing pushbutton.

Electrical closing via the BPFE pushbutton takes into account all the safety functions that are part of the control/monitoring system of the installation.

The BPFE connects to the closing release (XF com) in place of the COM module.

The COM module is incompatible with this option.

Different types of voltage exist and the XF electromagnet is compulsory if the BPFE option is selected.

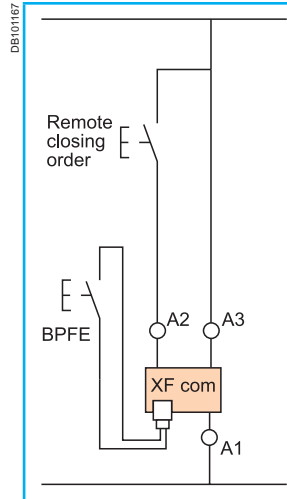

Remote reset after fault trip

Electrical reset after fault trip RES

Following tripping, this function resets the "fault trip" indication contacts SDE and the mechanical indicator and enables circuit breaker closing.

Power supply: 110 / 130 V AC and 200 / 240 V AC.

The use of XF closing release is compulsory with this option.

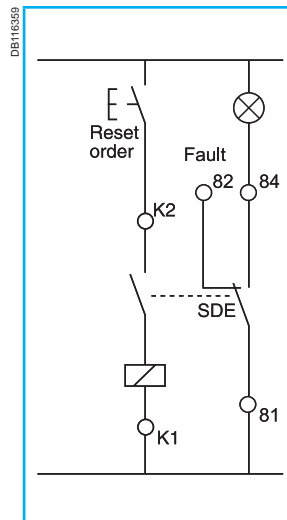

Automatic reset after fault trip RAR

Following tripping, a reset of the mechanical indicator (reset button) is no longer required to enable circuit-breaker closing. The mechanical (reset button) and electrical SDE indications remain in fault position until the reset button is pressed.

The use of XF closing release is compulsory with this option.

Remote operation

Remote tripping

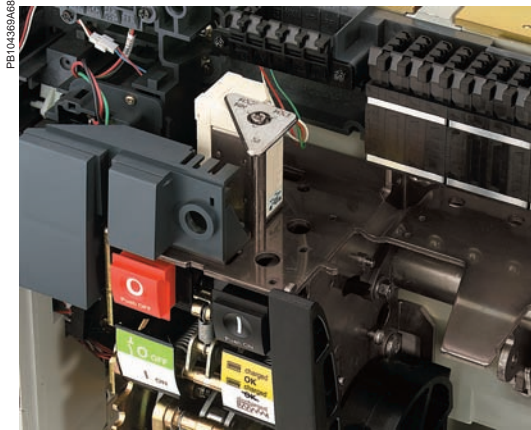

MX or MN voltage release.

This function opens the circuit breaker via an electrical order. It is made up of:

- a shunt release second MX
- or an undervoltage release MN
- or a delayed undervoltage release MNR: MN + delay unit.

These releases (2nd MX or MN) cannot be operated by the communication bus. The delay unit, installed outside the circuit breaker, may be disabled by an emergency OFF button to obtain instantaneous opening of the circuit breaker.

Wiring diagram for the remote-tripping function

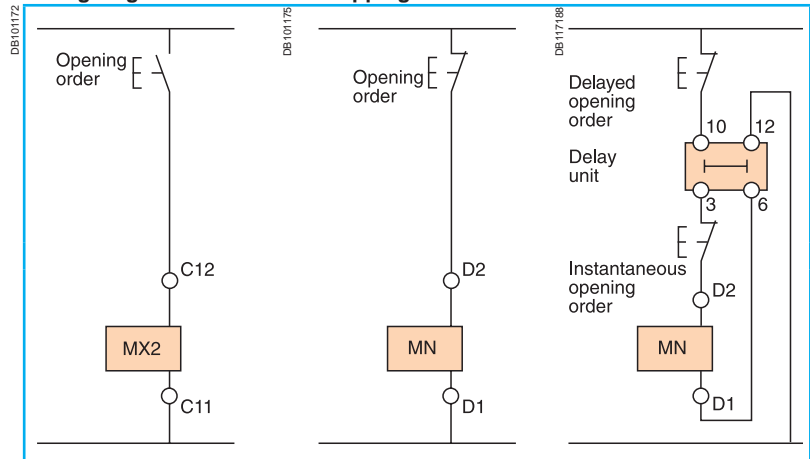

Voltage releases second MX

When energised, the MX voltage release instantaneously opens the circuit breaker. A continuous supply of power to the second MX locks the circuit breaker in the OFF position.

Characteristics		
Power supply	V AC 50/60Hz	24 - 48 - 100/130 - 200/250 - 277 - 380/480
	V DC	12 - 24/30 - 48/60 - 100/130 - 200/250
Operating threshold	0.7 to 1.1 Un	
Permanent locking function	0.85 to 1.1 Un	
Consumption (VA or W)	Pick-up: 200 (80 ms)	Hold: 4.5
Circuit-breaker response time at Un	50 ms ±10	

Instantaneous voltage releases MN

The MN release instantaneously opens the circuit breaker when its supply voltage drops to a value between 35 % and 70 % of its rated voltage. If there is no supply on the release, it is impossible to close the circuit breaker, either manually or electrically. Any attempt to close the circuit breaker has no effect on the main contacts. Circuit-breaker closing is enabled again when the supply voltage of the release returns to 85 % of its rated value.

Characteristics		
Power supply	V AC 50/60 Hz	24 - 48 - 100/130 - 200/250 - 380/480
	V DC	24/30 - 48/60 - 100/130 - 200/250
Operating threshold	Opening	0.35 to 0.7 Un
	Closing	0.85 Un
Consumption (VA or W)	Pick-up: 200 (200 ms)	Hold: 4.5
MN consumption with delay unit (VA or W)	Pick-up: 200 (200 ms)	Hold: 4.5
Circuit-breaker response time at Un	40 ms ±5 for NT	
	90 ms ±5 for NW	

MN delay units

To eliminate circuit-breaker nuisance tripping during short voltage dips, operation of the MN release can be delayed. This function is achieved by adding an external delay unit in the MN voltage-release circuit. Two versions are available, adjustable and non-adjustable.

Characteristics		
Power supply	Non-adjustable	100/130 - 200/250
	Adjustable	48/60 - 100/130 - 200/250 - 380/480
Operating threshold	Opening	0.35 to 0.7 Un
	Closing	0.85 Un
Delay unit consumption	Pick-up: 200 (200 ms)	Hold: 4.5
Circuit-breaker response time at Un	Non-adjustable	0.25 s
	Adjustable	0.5 s - 0.9 s - 1.5 s - 3 s

Accessories

PB104740

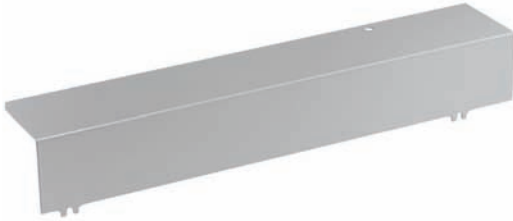

Auxiliary terminal shield CB

Optional equipment mounted on the chassis, the shield prevents access to the terminal block of the electrical auxiliaries.

PB104382A32



Operation counter CDM

The operation counter sums the number of operating cycles and is visible on the front panel. It is compatible with manual and electrical control functions. This option is compulsory for all the source-changeover systems.

DB101173

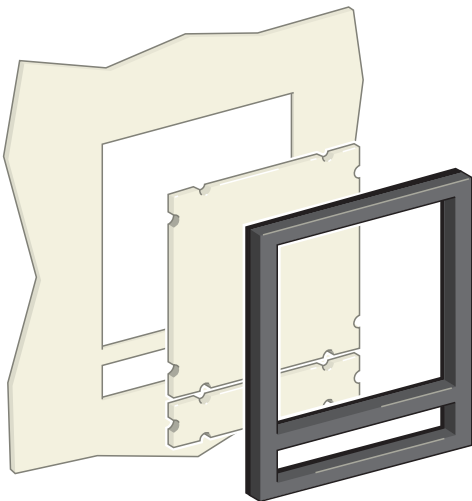

Escutcheon CDP

Optional equipment mounted on the door of the cubicle, the escutcheon increases the degree of protection to IP 40 (circuit breaker installed free standing: IP30) . It is available in fixed and drawout versions.

Blanking plate OP for escutcheon

Used with the escutcheon, this option closes off the door cut-out of a cubicle not yet equipped with a device. It may be used with the escutcheon for both fixed and drawout devices.

Transparent cover CCP for escutcheon

Optional equipment mounted on the escutcheon, the cover is hinged and secured by a screw. It increases the degree of protection to IP54, IK10. It adapts to drawout devices.

Escutcheon CDP with blanking plate.

PB100776-42



Transparent cover CCP for escutcheon.

PB100844A



Manual source-changeover system

This is the most simple type. It is controlled manually by an operator and consequently the time required to switch from the normal to the replacement source can vary.

A manual source-changeover system is made up of two or three mechanically interlocked manually-operated circuit breakers or switch-disconnectors.

Remote-operated source-changeover system

This is the most commonly employed system for devices with high ratings (above 400 A). No human intervention is required. Transfer from the normal to the replacement source is controlled electrically.

A remote-controlled source-changeover system is made up of two or three circuit breakers or switch-disconnectors linked by an electrical interlocking system that may have different configurations. In addition, a mechanical interlocking system protects against electrical malfunctions or incorrect manual operations.

Automatic source-changeover systems

An automatic controller may be added to a remote-operated source-changeover system for automatic source control according to programmable operating modes. This solution ensures optimum energy management:

- transfer to a replacement source according to external requirements
- management of power sources
- regulation
- emergency source replacement, etc.

The automatic controller may be fitted with an option for communication with a supervisor.

Communication option

The communication option must not be used to control the opening or closing of source-changeover system circuit breakers. It should be used only to transmit measurement data or circuit-breaker status.

The eco COM option is perfectly suited to these equipments.

PB100844A



Tertiaire :

- salles d'opérations des hôpitaux
- dispositifs de sécurité d'immeubles de grande hauteur
- salles d'ordinateurs (banques, assurances...)
- systèmes d'éclairage de centres commerciaux...

PB100845A



Industry:

- assembly lines
- engine rooms on ships
- critical auxiliaries in thermal power stations...

PB100846A



PB100847A



Infrastructures:

- port and railway installations
- runway lighting systems
- control systems on military sites...

Mechanical interlocking

DB101572

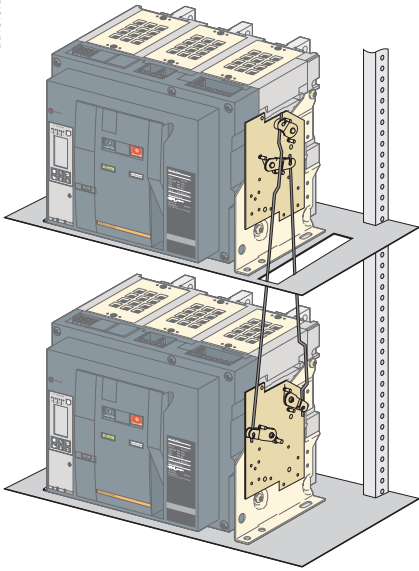

Interlocking of two Masterpact NT or NW circuit breakers using connecting rods.

Interlocking of two Compact NS630b to 1600 or two Masterpact NT and NW devices using connecting rods

The two devices must be mounted one above the other (either 2 fixed or 2 withdrawable/drawout devices).

Combinations are possible between Compact NS630b to NS1600 devices and between Masterpact NT and Masterpact NW devices.

Installation

This function requires:

- an adaptation fixture on the right side of each circuit breaker or switch-disconnector
- a set of connecting rods with no-slip adjustments.

The adaptation fixtures, connecting rods and circuit breakers or switch-disconnectors are supplied separately, ready for assembly by the customer.

The maximum vertical distance between the fixing planes is 900 mm.

Possible combinations of "Normal" and "Replacement" source circuit breakers

"Normal" N	"Replacement" R			
	NS630b to NS1600	NT06 to NT16	NW08 to NW40	NW40b to NW63
NS630b to NS1600				
Ratings 250... 1600 A	■			
NT06 to NT16				
Ratings 250... 1600 A		■	■	■
NW08 to NW40				
Ratings 320... 4000 A		■	■	■
NW40b to NW63				
Ratings 4000... 6300 A		■	■	■

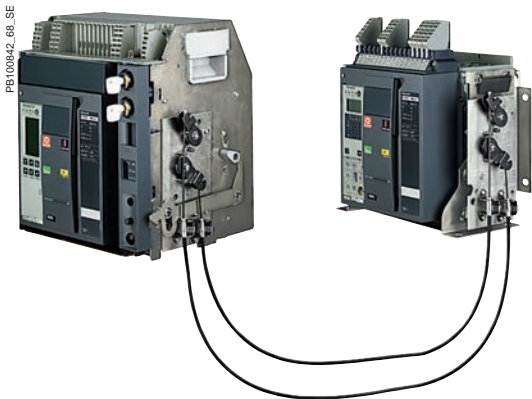

Interlocking of two Masterpact circuit breakers using cable.

Interlocking of two Masterpact NT/NW or up to three Masterpact NW devices using cables

For cable interlocking, the circuit breakers may be mounted one above the other or side-by-side.

The interlocked devices may be fixed or drawout, three-pole or four-pole, and have different ratings and sizes.

Interlocking between two devices (Masterpact NT and NW)

This function requires:

- an adaptation fixture on the right side of each device
- a set of cables with no-slip adjustments
- the use of a mechanical operation counter CDM is compulsory.

The maximum distance between the fixing planes (vertical or horizontal) is 2000 mm.

Interlocking between three devices (Masterpact NW only)

This function requires:

- a specific adaptation fixture for each type of interlocking, installed on the right side of each device
- two or three sets of cables with no-slip adjustments
- the use of a mechanical operation counter CDM is compulsory.

The maximum distance between the fixing planes (vertical or horizontal) is 1000 mm.

Installation

The adaptation fixtures, sets of cables and circuit breakers or switch-disconnectors are supplied separately, ready for assembly by the customer.

Installation conditions for cable interlocking systems:

- cable length: 2.5 m
- radius of curvature: 100 mm
- maximum number of curves: 3.

Possible combinations of “Normal” and “Replacement” source circuit breakers

“Normal N”	“Replacement” R		
	NT06 to NT16	NW08 to NW40	NW40b to NW63
NT06 to NT16			
Ratings 250... 1600 A	■	■	■
NW08 to NW40			
Ratings 320... 4000 A	■	■	■
NW40b to NW63			
Ratings 4000... 6300 A	■	■	■

All combinations of two Masterpact NT and Masterpact NW devices are possible, whatever the rating or size of the devices.

Possible combinations of three device

	NT06 to NT16	NW08 to NW40	NW40b to NW63
NT06 to NT16			
Ratings 250... 1600 A			
NW08 to NW40			
Ratings 320... 4000 A		■	■
NW40b to NW63			
Ratings 4000... 6300 A		■	■

Only Masterpact NW may be used for three-device combinations.

Types of mechanical interlocking and combinations

See catalogue “Source changeover systems”, réf. LVPED208007EN.

Electrical interlocking

Electrical interlocking is used with the mechanical interlocking system. It electrically interlocks the two circuit breakers and implements the time delays required for proper operation of the system.

An automatic controller may be added to take into account information from the distribution system.

Electrical interlocking is carried out by an electrical control device.

For Masterpact, this function can be implemented in one of two ways:

- using the IVE unit
- by an electrician based on the diagrams presented in the “Electrical diagrams” part of this catalogue.

Characteristics of the IVE unit

- external connection terminal block:
- inputs: circuit breaker control signals
- outputs: status of the SDE contacts on the “Normal” and “Replacement” source circuit breakers
- 2 connectors for the two “Normal” and “Replacement” source circuit breakers:
- inputs:
 - status of the OF contacts on each circuit breaker (ON or OFF)
 - status of the SDE contacts on the “Normal” and “Replacement” source circuit breakers
- outputs: power supply for operating mechanisms
- control voltage:
- 24 to 250 V DC
- 48 to 415 V 50/60 Hz - 440 V 60 Hz.

The IVE unit control voltage must be same as that of the circuit breaker operating mechanisms.

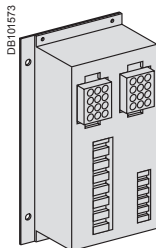

IVE unit.

Necessary equipment

For Masterpact NT and NW, each circuit breaker must be equipped with:

- a remote-operation system made up of:
 - MCH gear motor
 - MX or MN opening release
 - XF closing release
 - PF “ready to close” contact
 - CDM mechanical operation counter
- an available OF contact
- one to three CE connected-position contacts (carriage switches) on drawout circuit

Compact NS, Masterpact NT and NW

Types of mechanical interlocking	Possible combinations	Typical electrical diagrams	Diagram no.																					
2 devices																								
	<table border="1"> <thead> <tr> <th>QN</th> <th>QR</th> </tr> </thead> <tbody> <tr> <td>0</td> <td>0</td> </tr> <tr> <td>1</td> <td>0</td> </tr> <tr> <td>0</td> <td>1</td> </tr> </tbody> </table>	QN	QR	0	0	1	0	0	1	Masterpact NT and NW: <ul style="list-style-type: none"> ■ electrical interlocking with lockout after fault: <ul style="list-style-type: none"> <input type="checkbox"/> permanent replacement source (without IVE) 51201139 <input type="checkbox"/> with EPO by MX (without IVE) 51201140 <input type="checkbox"/> with EPO by MN (without IVE) 51201141 <input type="checkbox"/> permanent replacement source (with IVE) 51201142 <input type="checkbox"/> with EPO by MX (with IVE) 51201143 <input type="checkbox"/> with EPO by MN (with IVE) 51201144 ■ automatic control without lockout after fault: <ul style="list-style-type: none"> <input type="checkbox"/> permanent replacement source (without IVE) 51156226 <input type="checkbox"/> engine generator set (without IVE) 51156227 ■ automatic control with lockout after fault: <ul style="list-style-type: none"> <input type="checkbox"/> permanent replacement source (with IVE) 51156904 <input type="checkbox"/> engine generator set (with IVE) 51156905 ■ BA/UA controller (with IVE) 51156903 														
QN	QR																							
0	0																							
1	0																							
0	1																							
Masterpact NW only																								
3 devices: 2 "Normal" sources and 1 "Replacement" source																								
	<table border="1"> <thead> <tr> <th>QN1</th> <th>QN2</th> <th>QR</th> </tr> </thead> <tbody> <tr> <td>0</td> <td>0</td> <td>0</td> </tr> <tr> <td>1</td> <td>1</td> <td>0</td> </tr> <tr> <td>0</td> <td>0</td> <td>1</td> </tr> </tbody> </table>	QN1	QN2	QR	0	0	0	1	1	0	0	0	1	<ul style="list-style-type: none"> ■ electrical interlocking: <ul style="list-style-type: none"> <input type="checkbox"/> without lockout after fault 51156906 <input type="checkbox"/> with lockout after fault 51156907 										
QN1	QN2	QR																						
0	0	0																						
1	1	0																						
0	0	1																						
3 devices: 2 "Normal" sources and 1 "Replacement" source with source selection																								
	<table border="1"> <thead> <tr> <th>QN1</th> <th>QN2</th> <th>QR</th> </tr> </thead> <tbody> <tr> <td>0</td> <td>0</td> <td>0</td> </tr> <tr> <td>1</td> <td>0</td> <td>0</td> </tr> <tr> <td>0</td> <td>0</td> <td>1</td> </tr> <tr> <td>1</td> <td>1</td> <td>0</td> </tr> <tr> <td>0</td> <td>1</td> <td>0</td> </tr> </tbody> </table>	QN1	QN2	QR	0	0	0	1	0	0	0	0	1	1	1	0	0	1	0	<ul style="list-style-type: none"> ■ automatic control with engine generator set: <ul style="list-style-type: none"> <input type="checkbox"/> without lockout after fault (with MN) 51156908 <input type="checkbox"/> with lockout after fault (with MN) 51156909 				
QN1	QN2	QR																						
0	0	0																						
1	0	0																						
0	0	1																						
1	1	0																						
0	1	0																						
3 devices: 3 sources, only one device																								
	<table border="1"> <thead> <tr> <th>QS1</th> <th>QS2</th> <th>QS3</th> </tr> </thead> <tbody> <tr> <td>0</td> <td>0</td> <td>0</td> </tr> <tr> <td>1</td> <td>0</td> <td>0</td> </tr> <tr> <td>0</td> <td>1</td> <td>0</td> </tr> <tr> <td>0</td> <td>0</td> <td>1</td> </tr> </tbody> </table>	QS1	QS2	QS3	0	0	0	1	0	0	0	1	0	0	0	1	<ul style="list-style-type: none"> ■ electrical interlocking: <ul style="list-style-type: none"> <input type="checkbox"/> without lockout after fault 51156910 <input type="checkbox"/> with lockout after fault 51156911 							
QS1	QS2	QS3																						
0	0	0																						
1	0	0																						
0	1	0																						
0	0	1																						
3 devices: 2 sources + 1 coupling																								
	<table border="1"> <thead> <tr> <th>QS1</th> <th>QC</th> <th>QS2</th> </tr> </thead> <tbody> <tr> <td>0</td> <td>0</td> <td>0</td> </tr> <tr> <td>1</td> <td>0</td> <td>1</td> </tr> <tr> <td>1</td> <td>1</td> <td>0</td> </tr> <tr> <td>0</td> <td>1</td> <td>1</td> </tr> <tr> <td>1</td> <td>0</td> <td>0</td> </tr> <tr> <td>0</td> <td>0</td> <td>1</td> </tr> </tbody> </table> <p>(1) possible by forcing operation</p>	QS1	QC	QS2	0	0	0	1	0	1	1	1	0	0	1	1	1	0	0	0	0	1	<ul style="list-style-type: none"> ■ electrical interlocking: <ul style="list-style-type: none"> <input type="checkbox"/> without lockout after fault 51156912 <input type="checkbox"/> with lockout after fault 51156913 ■ automatic control with lockout after fault 51156914 	
QS1	QC	QS2																						
0	0	0																						
1	0	1																						
1	1	0																						
0	1	1																						
1	0	0																						
0	0	1																						

"Lockout after fault" option. This option makes it necessary to manually reset the device following fault tripping.

Associated automatic controllers

By combining a remote-operated source-changeover system with an integrated BA or UA automatic controller, it is possible to automatically control source transfer according to user-selected sequences.

These controllers can be used on source-changeover systems comprising 2 circuit breakers.

For source-changeover systems comprising 3 circuit breakers, the automatic control diagram must be prepared by the installer as a complement to diagrams provided in the "electrical diagrams" section of this catalogue.



BA controller.



UA controller.

Controller		BA	UA					
Compatible circuit breakers		All Masterpact circuit breakers						
4-position switch								
Automatic operation		■	■					
Forced operation on "Normal" source		■	■					
Forced operation on "Replacement" source		■	■					
Stop (both "Normal" and "Replacement" sources off)		■	■					
Automatic operation								
Monitoring of the "Normal" source and automatic transfer		■	■					
Generator set startup control			■					
Delayed shutdown (adjustable) of generator set			■					
Load shedding and reconnection of non-priority circuits			■					
Transfer to the "Replacement" source if one of the phases of the "Normal" phase is absent			■					
Test								
By opening the P25M circuit breaker supplying the controller		■						
By pressing the test button on the front of the controller			■					
Indications								
Circuit breaker status indication on the front of the controller: on, off, fault trip		■	■					
Automatic mode indicating contact		■	■					
Other functions								
Selection of type of "Normal" source (single-phase or three-phase) ⁽¹⁾			■					
Voluntary transfer to "Replacement" source (e.g. energy management commands)		■	■					
During peak-tariff periods (energy management commands) forced operation on "Normal" source if "Replacement" source not operational			■					
Additional contact (not part of controller). Transfer to "Replacement" source only if contact is closed. (e.g. used to test the frequency of UR).		■	■					
Setting of maximum startup time for the replacement source			■					
Options								
Communication option								
Power supply								
Control voltages ⁽²⁾		110 V	■	■				
		220 to 240 V 50/60 Hz	■	■				
		380 to 415 V 50/60 Hz and 440 V 60 Hz	■	■				
Operating thresholds								
Undervoltage		0.35 Un ≤ voltage ≤ 0.7 Un	■	■				
Phase failure		0.5 Un ≤ voltage ≤ 0.7 Un		■				
Voltage presence		voltage ≥ 0.85 Un	■	■				
IP degree of protection (EN 60529) and IK degree of protection against external mechanical impacts (EN 50102)								
Front		IP40	■	■				
Side		IP30	■	■				
Connectors		IP20	■	■				
Front		IK07	■	■				
Characteristics of output contacts (dry, volt-free contacts)								
Rated thermal current (A)		8						
Minimum load		10 mA at 12 V						
Output contacts:								
Position of the Auto/Stop switch			■	■				
Load shedding and reconnection order				■				
Generator set start order.				■				
Utilisation category (IEC 947-5-1)		AC		DC				
		AC12	AC13	AC14	AC15	DC12	DC13	
Operational current (A)		24 V	8	7	5	5	8	2
		48 V	8	7	5	5	2	-
		110 V	8	6	4	4	0.6	-
		220/240 V	8	6	4	3	-	-
		250 V	-	-	-	-	0.4	-
		380/415 V	5	-	-	-	-	-
		440 V	4	-	-	-	-	-
		660/690 V	-	-	-	-	-	-

(1) For example, 220 V single-phase or 220 V three-phase.

(2) The controller is powered by the ACP auxiliaries control plate. The same voltage must be used for the ACP plate, the IVE unit and the circuit-breaker operating mechanisms. If this voltage is the same as the source voltage, then the "Normal" and "Replacement" sources can be used directly for the power supply. If not, an isolation transformer must be used.

Masterpact NW with corrosion protection 800-4000 A

PB104383A50



Masterpact NW circuit breakers with corrosion protection are designed for use in industrial environments with high concentrations of sulphur compounds. Examples include paper mills, oil refineries, steel works and water treatment plants, all of which produce large quantities of sulphur dioxide (SO₂) or hydrogen sulphate (H₂S). Under such conditions, silver-plated parts rapidly turn black due to the formation of silver sulphate (Ag₂S) on the surface, an insulating material that can lead to abnormal temperature rise in electrical contacts. This phenomenon can have serious consequences on all equipment installed inside a switchboard.

Circuit breakers used in such environments generally require frequent maintenance and therefore a large number of replacement devices on the site. Furthermore, problems are often encountered even with intensive maintenance.

Masterpact NW circuit breakers with corrosion protection receive special surface treatment on all parts exposed to corrosion and critical with respect to electrical continuity. In this way, the availability of electrical power and operating safety are ensured without special maintenance for the following environmental condition classes as defined by standard IEC 721-3-3:

- 3C3 for H₂S (concentrations from 2.1 to 7.1 x 10⁻⁶)
- 3C4 for SO₂ (concentrations from 4.8 to 14.8 x 10⁻⁶).

The Masterpact NW range of power circuit breakers with corrosion protection offers the following features:

- rated current from 800 A to 4000 A
- 3 and 4-pole models
- drawout circuit breaker
- operational voltage up to 690 V AC
- Ics breaking capacity of 100 kA at 220/415 V AC
- reverse feed possible
- stored-energy mechanism for instantaneous closing (source coupling).
- 3 types of RMS electronic protection
- adjustable long-time settings from 0.4 to 1 In, with fine adjustment via local keypad or remote supervisor
- electronic functions dedicated to energy management and power-quality analysis.

The Masterpact NW range complies with the main standards and certifications:

- IEC 60947-1 and 60947-2
- IEC 68230 (damp heat) and IEC 68252 severity level 2 (salt mist)
- IEC 60068-2-42 and IEC 60068-2-43 for corrosive environments:
 - SO₂ : tested to IEC 60068-2-42 in a 3C4 environment as defined by IEC 60721-3-3
 - H₂S: tested to IEC 60068-2-43 in a 3C3 environment as defined IEC 60721-3-3.

A complete range of electrical accessories and auxiliaries:

- motor mechanism (MCH)
- undervoltage release (MN, MNR)
- shunt trip unit (MX)
- closing release (XF)
- auxiliary contacts (OF)
- low-level indication contacts (SDE, PF, CD, CT, CE and EF)
- electrical closing button (BPFE)
- locking by padlocks and/or keylocks.
- source-changeover systems for 2 or 3 devices

Maximum safety

The Masterpact NW range with corrosion protection offers the same safety features as the standard version:

- positive contact indication
- high impulse withstand voltage (12 kV)
- suitable for isolation in compliance with IEC 60947-2, as indicated by the disconnector symbol on the front face: 
- Front face insulation class 2, allowing class 2 installations with breaker control from outside.

Characteristics according to IEC 60 947-2

				NW08H2	NW10H2	NW12H2	NW16H2	NW20H2	NW25H2	NW32H2	NW40bH2
Number of poles				3, 4							
Rated insulation voltage		Ui (V)		1000							
Rated operational voltage		Ue (V)		690							
Closing time (ms)				< 50							
Rated current	In (A)	Vertical connection	40 °C	800	1000	1250	1600	2000	2500	3200	4000
			45 °C	800	1000	1250	1600	2000	2500	3200	4000
			50 °C	800	1000	1250	1600	2000	2500	3200	4000
			55 °C	800	1000	1250	1550	1900	2500	3150	4000
			60 °C	800	1000	1250	1500	1800	2500	3000	4000
		Horizontal connection	40 °C	800	1000	1250	1600	2000	2500	-	4000
			45 °C	800	1000	1250	1550	1900	2500	-	4000
			50 °C	800	1000	1250	1500	1800	2500	-	4000
			55 °C	800	1000	1250	1450	1700	2400	-	4000
			60 °C	800	1000	1250	1400	1600	2300	-	3900
4 th pole rating				800	1000	1250	1600	2000	2500	3200	4000
Rated ultimate breaking capacity	Icu (kA rms) CA 50/60 Hz	220/440 V	100	100	100	100	100	100	100	100	100
		690 V	85	85	85	85	85	85	85	85	85
Rated service breaking capacity		Ics = Icu x...		100 %	100 %	100 %	100 %	100 %	100 %	100 %	100 %
Break time (ms)				Total maxi	25 to 30 with no intentional delay						

Dimensions and connection

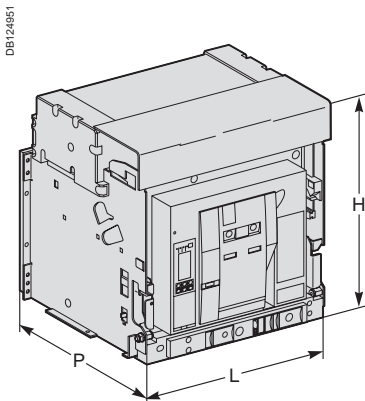

Masterpact NW08 to NW32 with corrosion protection.

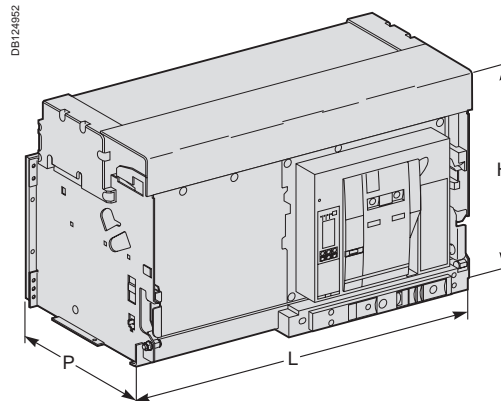

Masterpact NW40b with corrosion protection.

Drawout device	L (mm)		H (mm)	P (mm)
	3P	4P		
800 to 3200 A	441	556	439	395
4000 A	786	1016	479	395

Connection

- Power circuits:
 - vertical rear connection
 - horizontal rear connection (except for 3200 A)
- Auxiliaries connected to terminal block on circuit breaker front face.

The Masterpact Earthing Switch can be racked into any compatible Masterpact NW chassis in place of a Masterpact circuit breaker. It is used to interconnect and earth the phase and neutral conductors of an electrical installation to ensure the safety of personnel during servicing. It can be locked in earthed position.

Main characteristics

Rated insulation voltage	1000 V
Rated operational voltage	690 V
Rated current	800 to 4000 A
Latching capacity	135 kA peak
Rated short-time withstand current	60 kA/1s 50 kA/3s
Compatibility	Compatible with drawout NW08 to NW40 circuit breakers, types N1/H1/NA/HA, 3-pole and 4-pole rear connected versions
Remote indication	12 ON/OFF indication contacts that can be used according to the chassis auxiliary wiring

The Earthing Switch is compatible with Masterpact NW08 to NW40 type N1, H1, NA and HA circuit breakers in both 3-pole and 4-pole versions. It has two parts:

- a chassis earthing kit for installation on the Masterpact NW chassis. Two different versions are available for 3-pole and 4-pole chassis.
- the Earthing Switch itself, which is a specific Masterpact NW device that can be racked into any chassis equipped with an earthing kit, in place of the circuit breaker. Two versions are available (3-pole and 4-pole).

An earthing kit must be installed on the chassis of each circuit breaker protecting a circuit that may require earthing while work is being carried out. However, a single earthing switch is often sufficient for an entire installation if only one circuit is to be serviced at any given time.

The standard Earthing Switch comes with the short-circuit bar installed across the bottom (downstream) connections for earthing of the upstream portion of the circuit. The user can easily move the short-circuit bar to the top connections upstream if the downstream portion of the circuit needs to be earthed.

Earthing kit
(for chassis)

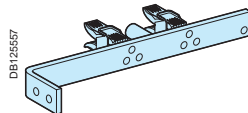

Earthing switch
(front view)

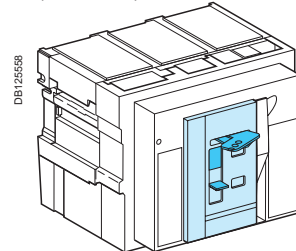

Earthing switch (rear view)

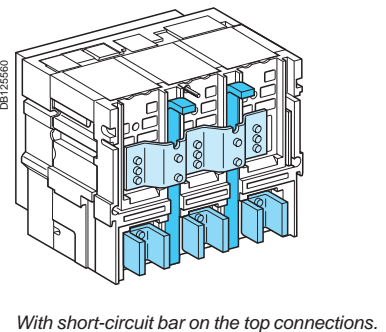
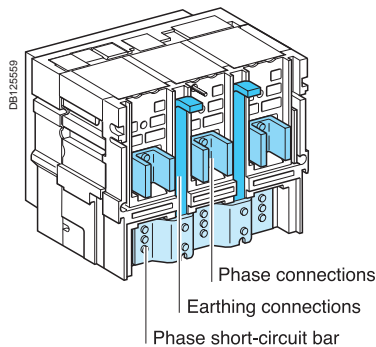

With short-circuit bar on the bottom connections.

With short-circuit bar on the top connections.

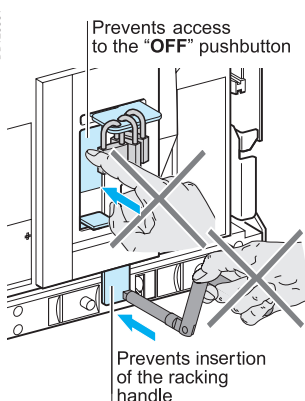

Locking in earthed position by 3 padlocks

The standard Earthing Switch can be locked in earthed position by one to three padlocks as long as the following conditions are satisfied:

- the Earthing Switch must be in "connected" position in a chassis equipped with an earthing kit
 - the Earthing Switch must be in "ON" position.
- Under these conditions, the installation is earthed.

When the Earthing Switch is locked in earthed position:

- it cannot be moved to "disconnected" position (a shutter prevents insertion of the racking handle)
- it cannot be turned "OFF" (a shutter prevents access to the "OFF" pushbutton).

Typical applications

The earthing switch is used to protect maintenance personnel working on an installation against the risk of accidental connection of a parallel source or energisation by reverse power. Protection is provided by earthing the part of the installation that is to be worked on.

Application n°1

Earthing of one section of a coupled busbar arrangement

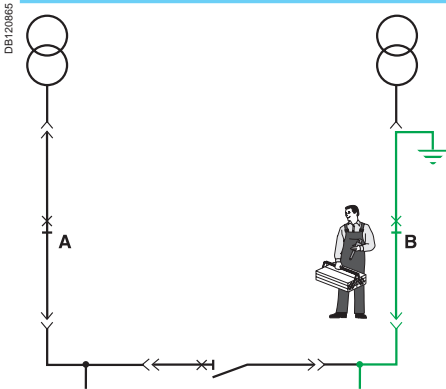

When working on section **B**, the bus coupler is normally open. To protect personnel in the event of accidental closing of this device, an earthing switch with the upstream terminals earthed is installed in place of the circuit breaker at **B**. In this way section **B** will remain at earth potential under all circumstances and the personnel can work in complete safety.

Application n°2

Earthing an outgoer

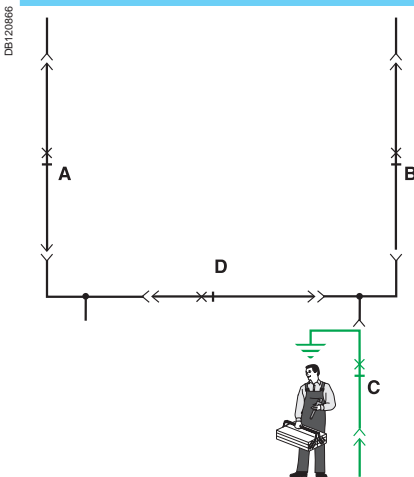

When working on outgoer **C**, installation of an earthing switch with the upstream terminals earthed (in place of the circuit breaker at **C**) ensures complete safety even if all the other devices on the installation are closed.

Application n°3

Earthing of an MV/LV transformer

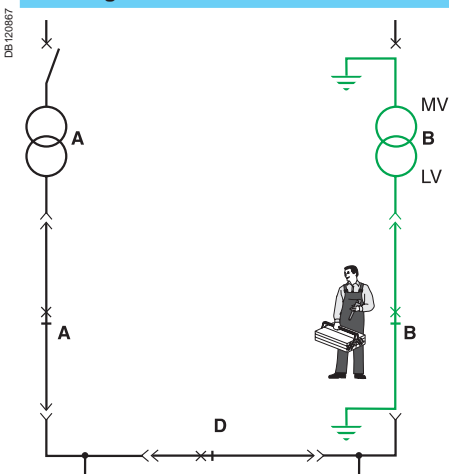

When working on an MV/LV transformer, upstream earthing is carried out by means of the usual medium voltage and high voltage procedures. Installation of an earthing switch with the downstream terminals earthed (in place of the circuit breaker at **B**) maintains the part of the installation between the upstream MV circuit breaker and the downstream LV circuit breaker at earth potential. In this way, the personnel can work in complete safety even if the rest of the installation is energised.

Dimensions and connection

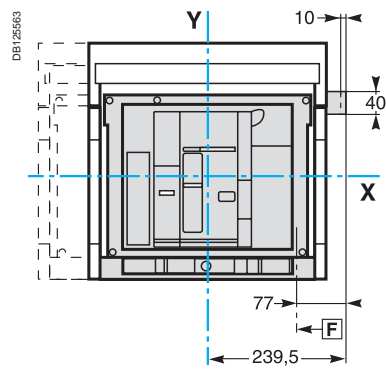
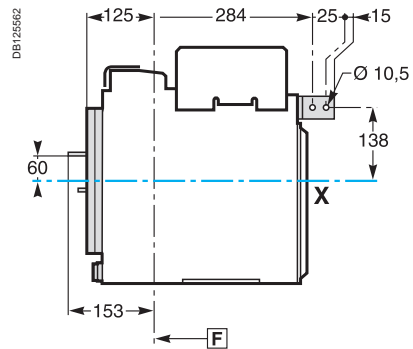



schneider-electric.com

This international site allows you to access all the Schneider Electric products in just 2 clicks via comprehensive range data-sheets, with direct links to:

- complete library: technical documents, catalogs, FAQs, brochures...
- selection guides from the e-catalog.
- product discovery sites and their Flash animations.

You will also find illustrated overviews, news to which you can subscribe, the list of country contacts...

CAD software and tools

The CAD software and tools enhance productivity and safety. They help you create your installations by simplifying product choice through easy browsing in the Schneider Electric offers.

Last but not least, they optimise use of our products while also complying with standards and proper procedures.



<i>Presentation</i>	1
<i>Functions and characteristics</i>	A-1
Operating conditions	B-2
Installation in switchboard	B-4
Door interlock catch	B-6
Control wiring	B-7
Power connection	B-8
Recommended busbars drilling	
Masterpact NT06 to NT16	B-10
Masterpact NW08 to NW63	B-11
Busbar sizing	B-12
Temperature derating	
Power dissipation and input / output resistance	B-14
Derating in switchboards	B-15
Substitution kit	
Fixed / drawout devices 800 to 3200 A	B-22
<i>Dimensions and connection</i>	C-1
<i>Electrical diagrams</i>	D-1
<i>Additional characteristics</i>	E-1
<i>Catalogue numbers and order form</i>	F-1

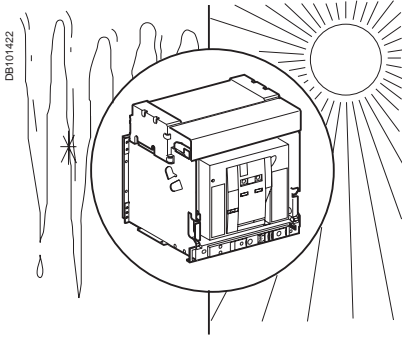

Ambient temperature

Masterpact devices can operate under the following temperature conditions:

- the electrical and mechanical characteristics are stipulated for an ambient temperature of -5 °C to $+70\text{ °C}$
- circuit-breaker closing is guaranteed down to -35 °C .

Storage conditions are as follows:

- -40 to $+85\text{ °C}$ for a Masterpact device without its control unit
- -25 °C to $+85\text{ °C}$ for the control unit.

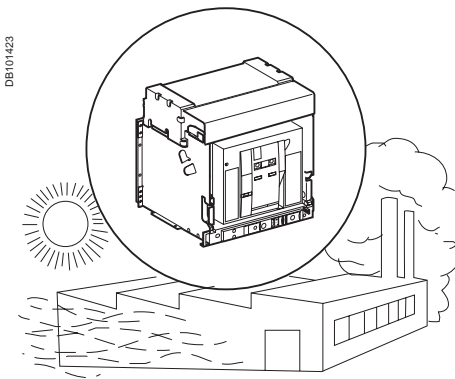

Extreme atmospheric conditions

Masterpact devices have successfully passed the tests defined by the following standards for extreme atmospheric conditions:

- IEC 60068-2-1: dry cold at -55 °C
- IEC 60068-2-2: dry heat at $+85\text{ °C}$
- IEC 60068-2-30: damp heat (temperature $+55\text{ °C}$, relative humidity 95 %)
- IEC 60068-2-52 level 2: salt mist.

Masterpact devices can operate in the industrial environments defined by standard IEC 60947 (pollution degree up to 4).

It is nonetheless advised to check that the devices are installed in suitably cooled switchboards without excessive dust.

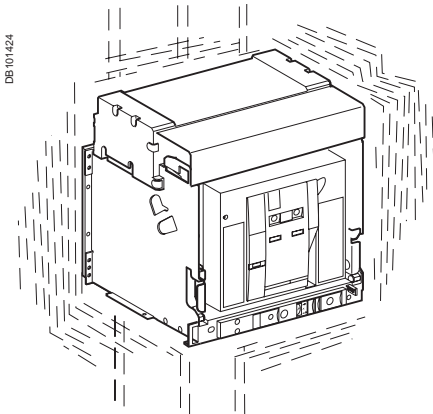

Vibrations

Masterpact devices are guaranteed against electromagnetic or mechanical vibrations.

Tests are carried out in compliance with standard IEC 60068-2-6 for the levels required by merchant-marine inspection organisations (Veritas, Lloyd's, etc.):

- 2 to 13.2 Hz: amplitude $\pm 1\text{ mm}$
- 13.2 to 100 Hz: constant acceleration 0.7 g .

Excessive vibration may cause tripping, breaks in connections or damage to mechanical parts.

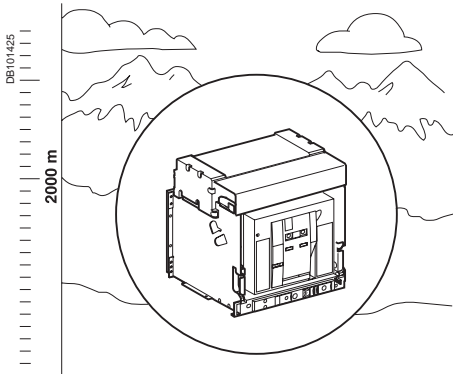

Altitude

At altitudes higher than 2000 metres, the modifications in the ambient air (electrical resistance, cooling capacity) lower the following characteristics as follows:

Altitude (m)	2000	3000	4000	5000
Dielectric resistance voltage (V)	3500	3150	2500	2100
Average insulation level (V)	1000	900	700	600
Maximum utilisation voltage (V)	690	590	520	460
Average thermal current (A) at 40 °C	1 x I _n	0.99 x I _n	0.96 x I _n	0.94 x I _n

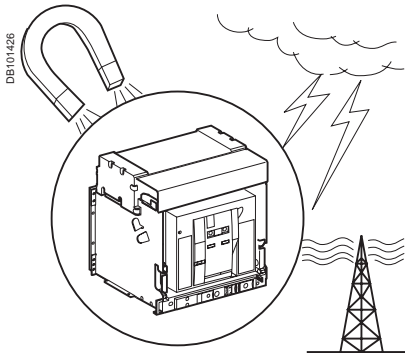

Electromagnetic disturbances

Masterpact devices are protected against:

- overvoltages caused by devices that generate electromagnetic disturbances
- overvoltages caused by atmospheric disturbances or by a distribution-system outage (e.g. failure of a lighting system)
- devices emitting radio waves (radios, walkie-talkies, radar, etc.)
- electrostatic discharges produced by users.

Masterpact devices have successfully passed the electromagnetic-compatibility tests (EMC) defined by the following international standards:

- IEC 60947-2, appendix F
- IEC 60947-2, appendix B (trip units with earth-leakage function).

The above tests guarantee that:

- no nuisance tripping occurs
- tripping times are respected.

Possible positions

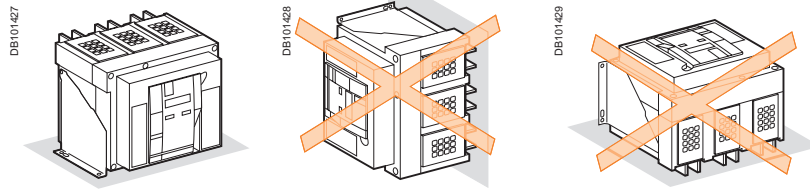

Power supply

Masterpact devices can be supplied either from the top or from the bottom without reduction in performance, in order to facilitate connection when installed in a switchboard.

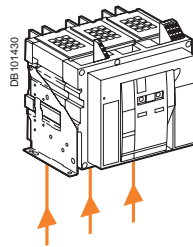

Mounting the circuit-breaker

It is important to distribute the weight of the device uniformly over a rigid mounting surface such as rails or a base plate.

This mounting plane should be perfectly flat (tolerance on support flatness: 2 mm). This eliminates any risk of deformation which could interfere with correct operation of the circuit breaker.

Masterpact devices can also be mounted on a vertical plane using the special brackets.

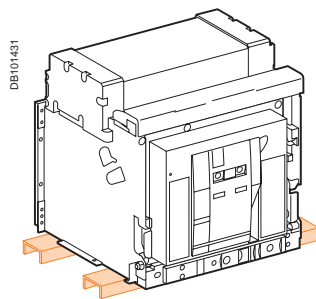

Mounting on rails.

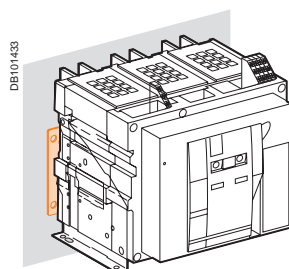
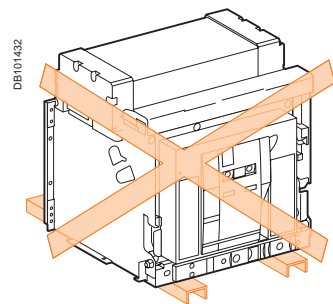

Mounting with vertical brackets.

Partitions

Sufficient openings must be provided in partitions to ensure good air circulation around the circuit breaker; Any partition between upstream and downstream connections of the device must be made of non-magnetic material.

For high currents, of 2500 A and upwards, the metal supports or barriers in the immediate vicinity of a conductor must be made of non-magnetic material **A**. Metal barriers through which a conductor passes must not form a magnetic loop.

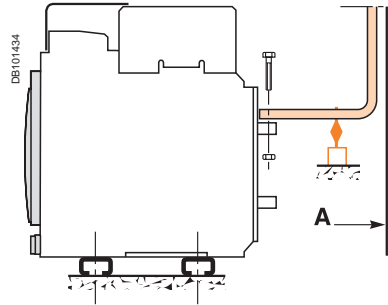

A : non magnetic material.



Busbars (NT, NW)

The mechanical connection must exclude the possibility of formation of a magnetic loop around a conductor.

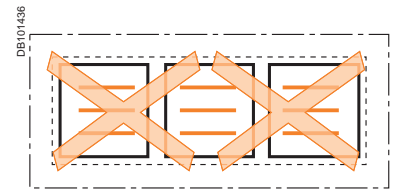
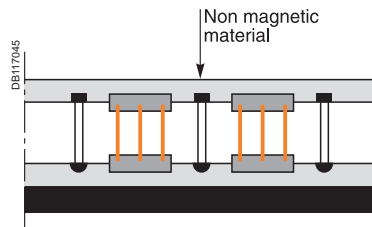

Busbars (NT)

For live busbars installed immediately above the circuit breaker (respecting the 100 mm safety clearance), the distance between bars must be 65 mm minimum. In a 1000 V system, the bars must be insulated.

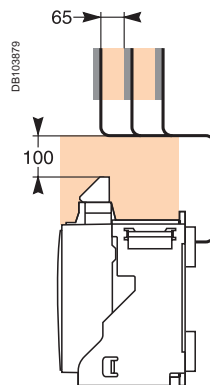

Interphase barrier

If the insulation distance between phases is not sufficient (≤ 14 mm), it is advised to install phase barriers (taking into account the safety clearances). Mandatory for a Masterpact NT > 500 V.

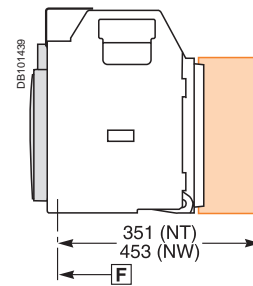
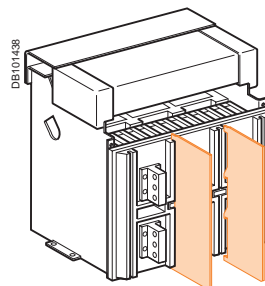

Door interlock VPEC

Mounted on the right or left-hand side of the chassis, this device inhibits opening of the cubicle door when the circuit breaker is in “connected” or “test” position. If the breaker is put in the “connected” position with the door open, the door may be closed without having to disconnect the circuit breaker.

Dimensions (mm)

Type	(1)	(2)
NT08-16 (3P)	135	168
NT08-16 (4P)	205	168
NW08-40 (3P)	215	215
NW08-40 (4P)	330	215
NW40b-63 (3P)	660	215
NW40b-63 (4P)	775	215

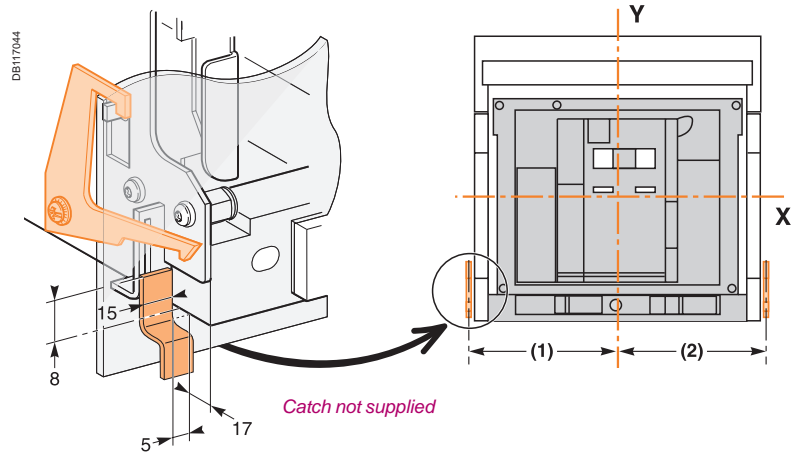

Breaker in “connected” or “test” position

Door cannot be opened

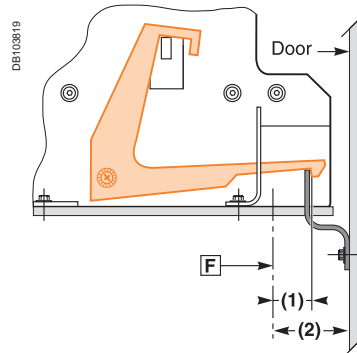

Breaker in “disconnected” position

Door can be opened

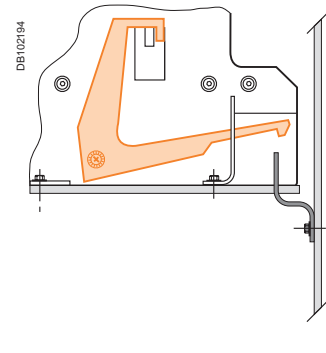

Dimensions (mm)

Type	(1)	(2)
NT	5	23
NW	83	103

Cable-type door interlock IPA

This option prevents door opening when the circuit breaker is closed and prevents circuit breaker closing when the door is open.

For this, a special plate associated with a lock and a cable is mounted on the right side of the circuit breaker. With this interlock installed, the source changeover function cannot be implemented.

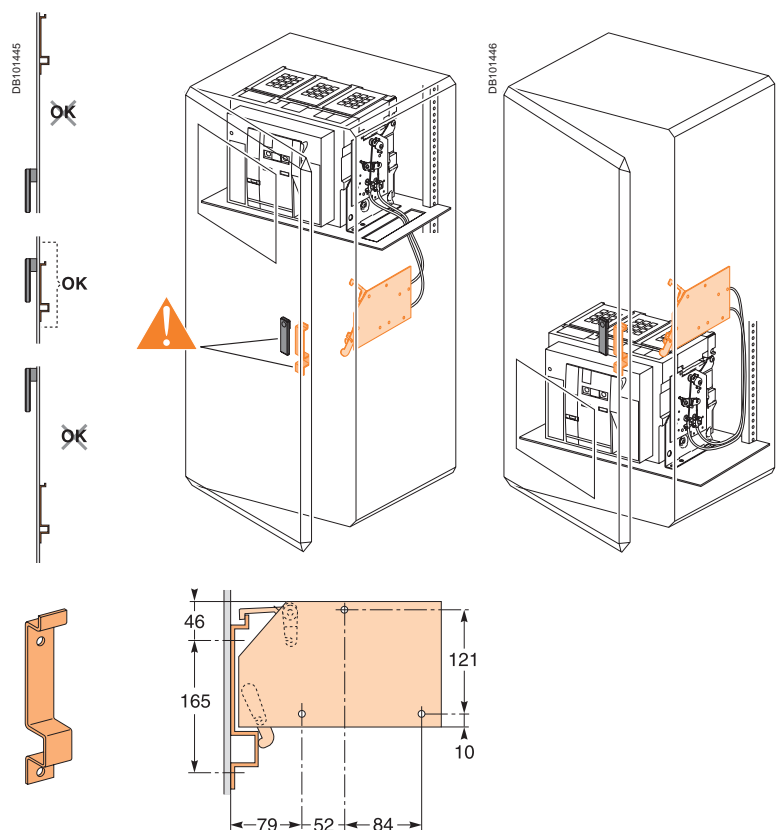

Note: the door interlock can either be mounted on the right side or the left side of the breaker.
F : datum.

Control wiring

Wiring of voltage releases

During pick-up, the power consumed is approximately 150 to 200 VA. For low control voltages (12, 24, 48 V), maximum cable lengths are imposed by the voltage and the cross-sectional area of cables.

Recommended maximum cable lengths (meter).

		12 V		24 V		48 V	
		2,5 mm ²	1,5 mm ²	2,5 mm ²	1,5 mm ²	2,5 mm ²	1,5 mm ²
MN	U source 100 %	–	–	58	35	280	165
	U source 85 %	–	–	16	10	75	45
MX-XF	U source 100 %	21	12	115	70	550	330
	U source 85 %	10	6	75	44	350	210

Note: the indicated length is that of each of the two wires.

24 V DC power-supply module

External 24 V DC power-supply module for Micrologic (F1-, F2+)

- do not connect the positive terminal (F2+) to earth
- the negative terminal (F1-) can be connected to earth, except in IT systems
- a number of Micrologic control units and M6C modules can be connected to the same 24 V DC power supply (the consumption of a Micrologic control unit or an M6C module is approximately 100 mA)
- do not connect any devices other than a Micrologic control unit or an M6C module
- the maximum length for each conductor is ten metres. For greater distances, it is advised to twist the supply wires together
- the 24 V DC supply wires must cross the power cables perpendicularly. If this is difficult, it is advised to twist the supply wires together
- the technical characteristics of the external 24 V DC power-supply module for Micrologic control units are indicated on [page A-20](#)

Communication bus

- do not connect the positive terminal (E1) to earth
- the negative terminal (E2) can be connected to earth
- a number of "device" or "chassis" communication modules can be connected to the same 24 V DC power supply (the consumption of each module is approximately 30 mA)
- the 24 V DC (E1, E2) power supply for the communication bus must be separate from the external 24 V DC power-supply module for Micrologic control units (F1-, F2+).

E1	E2	E3	E4	E5	E6
+	-	A/Tx ⁻	B/Tx ⁺	A'/Rx ⁻	B'/Rx ⁺

To create a two-wire Modbus communication bus, simply connect Tx⁻ with Rx⁻ and Tx⁺ with Rx⁺.

To connect a Modbus slave (Micrologic) to a Modbus master (PLC), connect:
 the slave Tx⁻ to the master Rx⁻ the slave Rx⁻ to the master Tx⁻
 the slave Tx⁺ to the master Rx⁺ the slave Rx⁺ to the master Tx⁺.

RS485 Modbus Junction Block

The diagram shows the RS485 Modbus Junction Block (DB117046) with four terminal blocks labeled 1, 2, 3, and 4. Each block has two terminals for 4-wire and 2-wire connections. A termination switch is located at the bottom, with 'ON' and 'OFF' positions. A ground symbol is also present. To the right, a 9-pin connector is shown with pins 1 through 9. A table below provides the pin-to-signal mapping and color coding.

Pins	Signal	Color
1	0 V	Black
2	24 V	Red
3	NC	
4	B' / Rx ⁺	Blue
5	B / Tx ⁺	Yellow
6	0 V	Black
7	24 V	Red
8	A' / Rx ⁻	White
9	A / Tx ⁻	Brown

Wiring of ZSI: it is recommended to use twisted shielded cable. The shield must be connected to earth at both ends.

Cables connections

If cables are used for the power connections, make sure that they do not apply excessive mechanical forces to the circuit breaker terminals.

For this, make the connections as follows:

- extend the circuit breaker terminals using short bars designed and installed according to the recommendations for bar-type power connections:
- for a single cable, use solution **B** opposite
- for multiple cables, use solution **C** opposite
- in all cases, follow the general rules for connections to busbars:
- position the cable lugs before inserting the bolts
- the cables should firmly secured to the framework **E**.

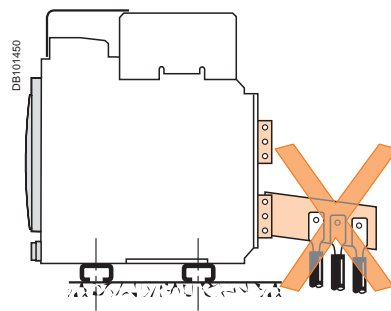
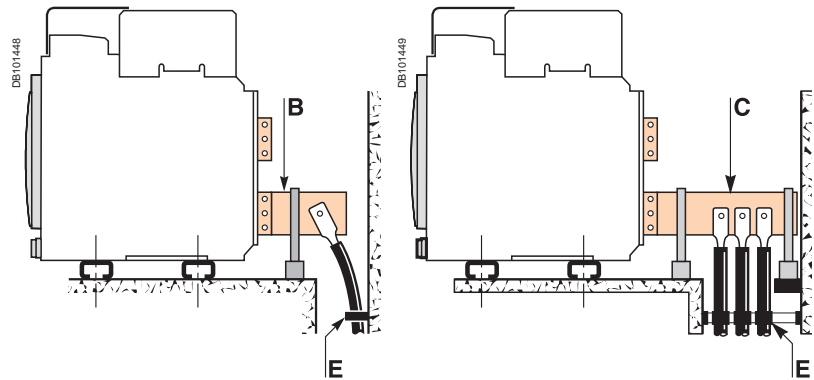

Busbars connections

The busbars should be suitably adjusted to ensure that the connection points are positioned on the terminals before the bolts are inserted **B**

The connections are held by the support which is solidly fixed to the framework of the switchboard, such that the circuit breaker terminals do not have to support its weight **C**. (This support should be placed close to the terminals).

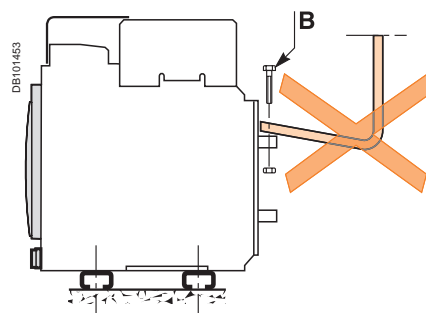
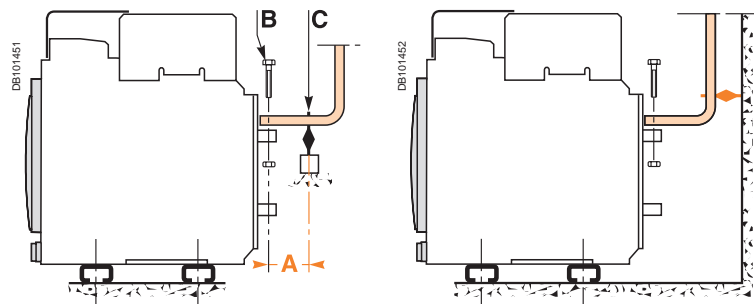

Electrodynamic stresses

The first busbar support or spacer shall be situated within a maximum distance from the connection point of the breaker (see table below). This distance must be respected so that the connection can withstand the electrodynamic stresses between phases in the event of a short circuit.

Maximum distance A between busbar to circuit breaker connection and the first busbar support or spacer with respect to the value of the prospective short-circuit current.

Isc (kA)	30	50	65	80	100	150
Distance A (mm)	350	300	250	150	150	150

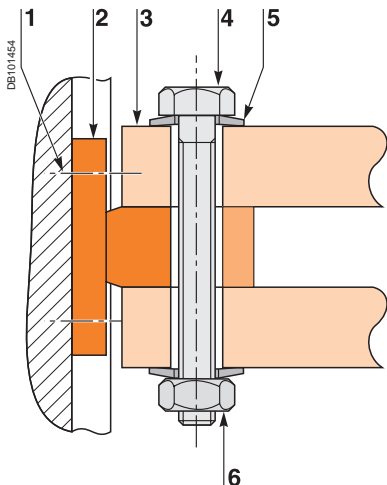

- 1 Terminal screw factory-tightened to 16 Nm (NW), 13 Nm (NT).
- 2 Breaker terminal.
- 3 Busbar.
- 4 Bolt.
- 5 Washer.
- 6 Nut.

Clamping

Correct clamping of busbars depends amongst other things, on the tightening torques used for the nuts and bolts. Over-tightening may have the same consequences as under-tightening.

For connecting busbars (Cu ETP-NFA51-100) to the circuit breaker, the tightening torques to be used are shown in the table below.

These values are for use with copper busbars and steel nuts and bolts, class 8.8. The same torques can be used with AGS-T52 quality aluminium bars (French standard NFA 02-104 or American National Standard H-35-1).

Examples

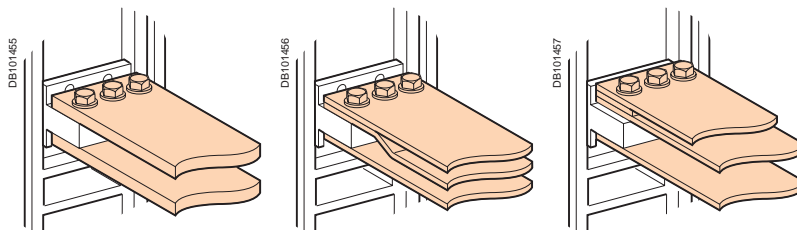

Tightening torques			
Ø (mm) Nominal	Ø (mm) Drilling	Tightening torques (Nm) with grower or flat washers	Tightening torques (Nm) with contact or corrugatec washers
10	11	37.5	50

Busbar drilling

Examples

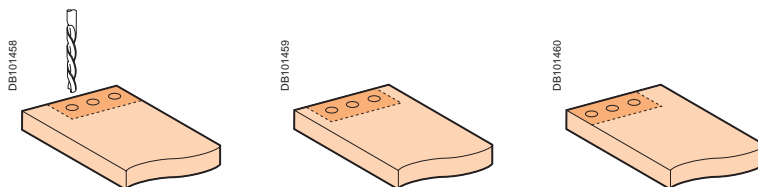

Isolation distance

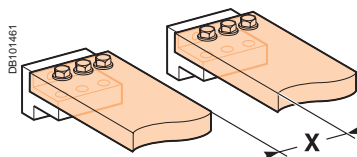

Dimensions (mm)

Ui	X min
600 V	8 mm
1000 V	14 mm

Busbar bending

When bending busbars maintain the radius indicated below (a smaller radius would cause cracks).

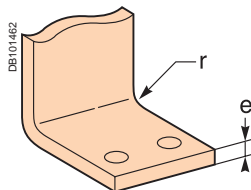

Dimensions (mm)

e	Radius of curvature r	
	Min	Recommended
5	5	7.5
10	15	18 to 20

Rear connection

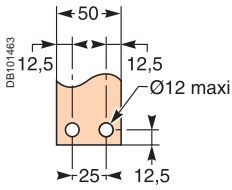

Rear connection with spreaders

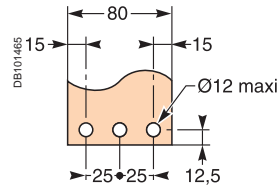
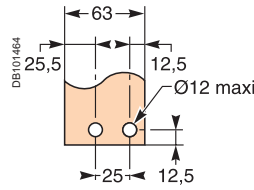
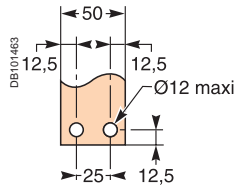

Middle left or middle right spreader for 4P

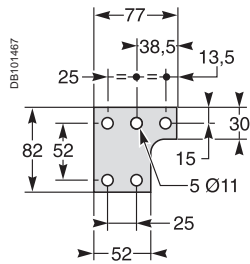
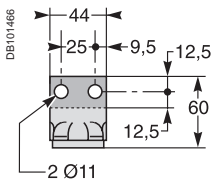

Middle spreader for 3P

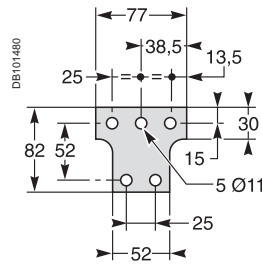

Left or right spreader for 4P

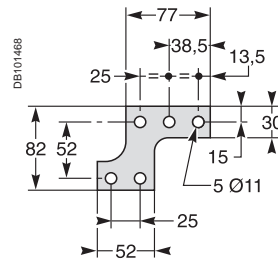

Left or right spreader for 3P

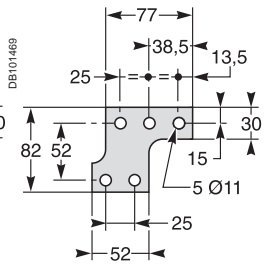

Vertical rear connection

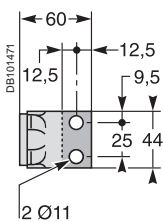
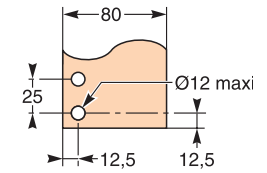
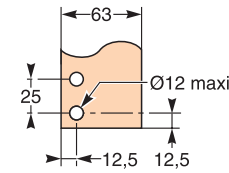
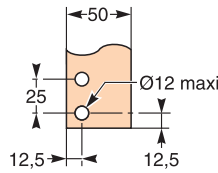
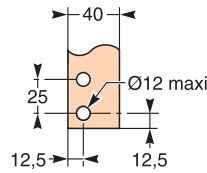
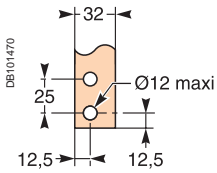

Front connection

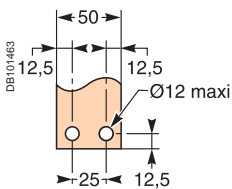

Front connection via vertical connection adapters

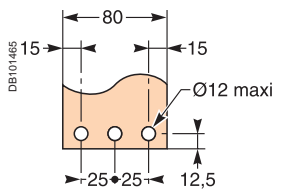
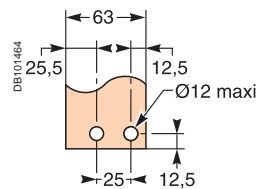
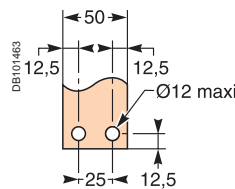

Top connection

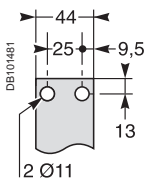

Bottom connection

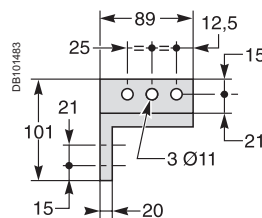
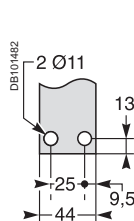

Mastercompact NW08 to NW63

Horizontal rear connection NW08 to NW32

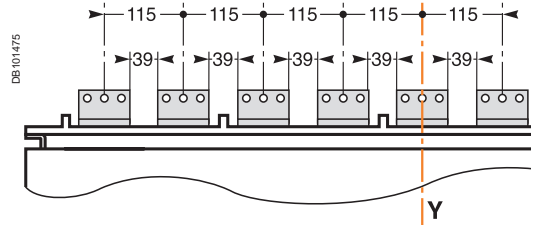
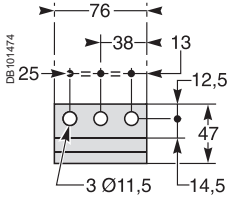
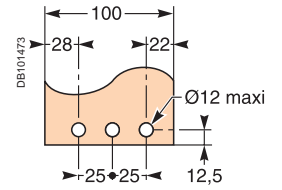
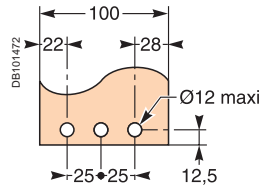
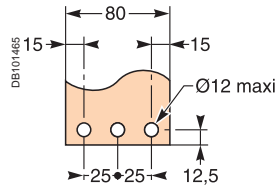
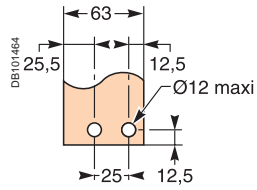
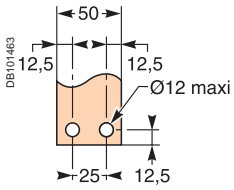

Vertical rear connection NW08 to NW32, NW40b to NW50

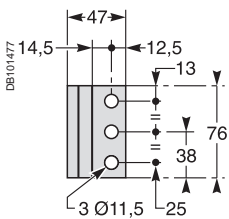
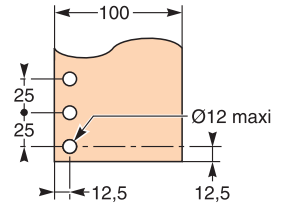
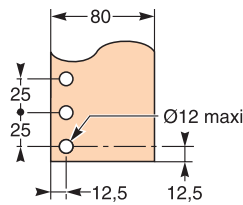
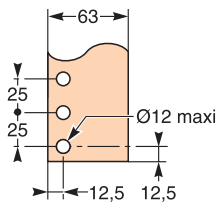
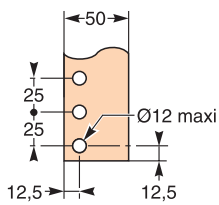
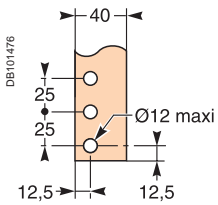

Front connection NW08 to NW32

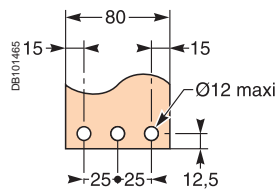
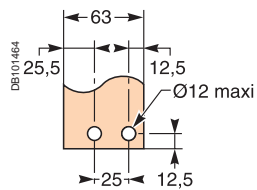
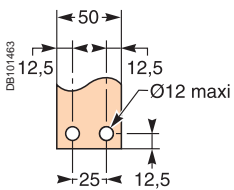

Top connection

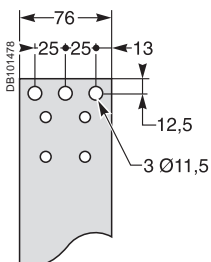

Bottom connection

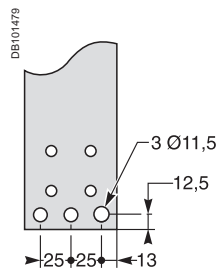

Basis of tables:

- maximum permissible busbars temperature: 100 °C
- T_i : temperature around the circuit breaker and its connection
- busbar material is unpainted copper.

Front or rear horizontal connection

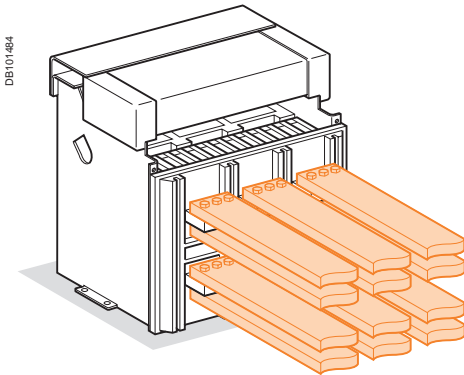

Masterpact	Maximum service current	$T_i : 40\text{ °C}$		$T_i : 50\text{ °C}$		$T_i : 60\text{ °C}$	
		No. of 5 mm thick bars	No. of 10 mm thick bars	No. of 5 mm thick bars	No. of 10 mm thick bars	No. of 5 mm thick bars	No. of 10 mm thick bars
NT06	400	2b.30 x 5	1b.30 x 10	2b.30 x 5	1b.30 x 10	2b.30 x 5	1b.30 x 10
NT06	630	2b.40 x 5	1b.40 x 10	2b.40 x 5	1b.40 x 10	2b.40 x 5	1b.40 x 10
NT08 ou NW08	800	2b.50 x 5	1b.50 x 10	2b.50 x 5	1b.50 x 10	2b.50 x 5	1b.63 x 10
NT10 ou NW10	1000	3b.50 x 5	1b.63 x 10	3b.50 x 5	2b.50 x 10	3b.63 x 5	2b.50 x 10
NT12 ou NW12	1250	3b.50 x 5	2b.40 x 10	3b.50 x 5	2b.50 x 10	3b.63 x 5	2b.50 x 10
		2b.80 x 5	2b.40 x 10	2b.80 x 5			
NT16 ou NW16	1400	3b.63 x 5	2b.40 x 10	3b.63 x 5	2b.50 x 10	3b.80 x 5	2b.63 x 10
NT16 ou NW16	1600	3b.80 x 5	2b.63 x 10	3b.80 x 5	2b.63 x 10	3b.80 x 5	3b.50 x 10
		NW20	1800	3b.80 x 5	2b.63 x 10	3b.80 x 5	2b.63 x 10
NW20	2000	3b.100 x 5	2b.80 x 10	3b.100 x 5	2b.80 x 10	3b.100 x 5	3b.63 x 10
NW25	2200	4b.100 x 5	2b.80 x 10	4b.100 x 5	2b.80 x 10	4b.100 x 5	2b.100 x 10
NW25	2500	4b.100 x 5	2b.100 x 10	4b.100 x 5	2b.100 x 10	4b.100 x 5	3b.80 x 10
NW32	2800	4b.100 x 5	3b.80 x 10	4b.100 x 5	3b.80 x 10	5b.100 x 5	3b.100 x 10
		3000	5b.100 x 5	3b.80 x 10	6b.100 x 5	3b.100 x 10	8b.100 x 5
NW32	3200	6b.100 x 5	3b.100 x 10	8b.100 x 5	3b.100 x 10		4b.100 x 10
		NW40	3800		4b.100 x 10		5b.100 x 10
NW40	4000		5b.100 x 10		5b.100 x 10		6b.100 x 10
NW50	4500		6b.100 x 10		6b.100 x 10		7b.100 x 10
		NW50	5000		7b.100 x 10		7b.100 x 10

With Masterpact NT, it is recommended to use 50 mm wideness bars (see "Recommended busbars drilling").

Example

Conditions:

- drawout version
- horizontal busbars
- T_i : 50 °C
- service current: 1800 A.

Solution:

For $T_i = 50\text{ °C}$, use an NW20 which can be connected with three 80 x 5 mm bars or two 63 x 10 mm bars.

Note: the values indicated in these tables have been extrapolated from test data and theoretical calculations. These tables are only intended as a guide and cannot replace industrial experience or a temperature rise test.

Basis of tables:

- maximum permissible busbars temperature: 100 °C
- T_i : temperature around the circuit breaker and its connection
- busbar material is unpainted copper.

Rear vertical connection

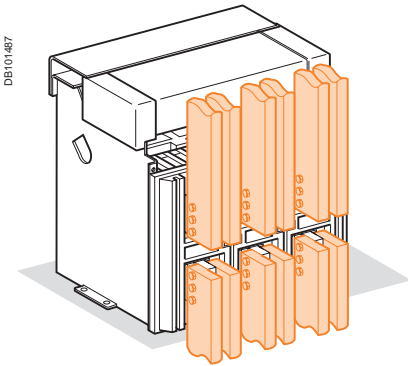

Masterpact	Maximum service current	$T_i : 40\text{ °C}$		$T_i : 50\text{ °C}$		$T_i : 60\text{ °C}$	
		No. of 5 mm thick bars	No. of 10 mm thick bars	No. of 5 mm thick bars	No. of 10 mm thick bars	No. of 5 mm thick bars	No. of 10 mm thick bars
NT06	400	2b.30 x 5	1b.30 x 10	2b.30 x 5	1b.30 x 10	2b.30 x 5	1b.30 x 10
NT06	630	2b.40 x 5	1b.40 x 10	2b.40 x 5	1b.40 x 10	2b.40 x 5	1b.40 x 10
NT08 ou NW08	800	2b.50 x 5	1b.50 x 10	2b.50 x 5	1b.50 x 10	2b.50 x 5	1b.50 x 10
NT10 ou NW10	1000	2b.50 x 5	1b.50 x 10	2b.50 x 5	1b.50 x 10	2b.63 x 5	1b.63 x 10
NT12 ou NW12	1250	2b.63 x 5	1b.63 x 10	3b.50 x 5	2b.40 x 10	3b.50 x 5	2b.40 x 10
NT16 ou NW16	1400	2b.80 x 5	1b.80 x 10	2b.80 x 5	2b.50 x 10	3b.63 x 5	2b.50 x 10
NT16 ou NW16	1600	3b.63 x 5	2b.50 x 10	3b.63 x 5	2b.50 x 10	3b.80 x 5	2b.63 x 10
NW20	1800	2b.100 x 5	1b.80 x 10	2b.100 x 5	2b.50 x 10	3b.80 x 5	2b.63 x 10
NW20	2000	3b.100 x 5	2b.63 x 10	3b.100 x 5	2b.63 x 10	3b.100 x 5	2b.80 x 10
NW25	2200	3b.100 x 5	2b.63 x 10	3b.100 x 5	2b.63 x 10	3b.100 x 5	2b.80 x 10
NW25	2500	4b.100 x 5	2b.80 x 10	4b.100 x 5	2b.80 x 10	4b.100 x 5	3b.80 x 10
NW32	2800	4b.100 x 5	2b.100 x 10	4b.100 x 5	2b.100 x 10	4b.100 x 5	3b.80 x 10
NW32	3000	5b.100 x 5	3b.80 x 10	6b.100 x 5	3b.100 x 10	5b.100 x 5	4b.80 x 10
NW32	3200	6b.100 x 5	3b.100 x 10	6b.100 x 5	3b.100 x 10		4b.100 x 10
NW40	3800		4b.100 x 10		4b.100 x 10		4b.100 x 10
NW40	4000		4b.100 x 10		4b.100 x 10		4b.100 x 10
NW50	4500		5b.100 x 10		5b.100 x 10		6b.100 x 10
NW50	5000		5b.100 x 10		6b.100 x 10		7b.100 x 10
NW63	5700		7b.100 x 10		7b.100 x 10		8b.100 x 10
NW63	6300		8b.100 x 10		8b.100 x 10		

Example

Conditions:

- drawout version
- vertical connections
- T_i : 40 °C
- service current: 1100 A.

Solution :

For $T_i = 40\text{ °C}$ use an NT12 or NW12 which can be connected with two 63 x 5 mm bars or with one 63 x 10 mm bar.

Note: the values indicated in these tables have been extrapolated from test data and theoretical calculations. These tables are only intended as a guide and cannot replace industrial experience or a temperature rise test.

Temperature derating Power dissipation and input / output resistance

Temperature derating

The table below indicates the maximum current rating, for each connection type, as a function of T_i around the circuit breaker and the busbars.

Circuit breakers with mixed connections have the same derating as horizontally connected breakers.

For T_i greater than 60 °C, consult us.

T_i : temperature around the circuit breaker and its connection.

Version	Drawout										Fixed									
	Front or rear horizontal					Rear vertical					Front or rear horizontal					Rear vertical				
Temp. T_i	40	45	50	55	60	40	45	50	55	60	40	45	50	55	60	40	45	50	55	60
NT06 H1/H2/L1	630					630					630					630				
NT08 H1/H2/L1	800					800					800					800				
NT10 H1/H2/L1	1000					1000					1000					1000				
NT12 H1/H2	1250					1250					1250					1250				
NT16 H1/H2	1600	1520	1480	1430		1600		1560	1510		1600				1550	1600				
NW08 N/H/L	800					800					800					800				
NW10 N/H/L	1000					1000					1000					1000				
NW12 N/H/L	1250					1250					1250					1250				
NW16 N/H/L	1600					1600					1600					1600				
NW20 H1/H2/H3	2000			1980	1890	2000					2000				1920	2000				
NW20 L1	2000	1900	1850	1800		2000					-	-	-	-	-	-	-	-	-	-
NW25 H1/H2/H3	2500					2500					2500					2500				
NW32 H1/H2/H3	3200	3100	3000	2900		3200					3200					3200				
NW40 H1/H2/H3	4000	3900	3750	3650		4000				3850	4000			3900	3800	4000				
NW40b H1/H2	4000					4000					4000					4000				
NW50 H1/H2	5000					5000					5000					5000				
NW63 H1/H2	-	-	-	-	-	6300				6200	-	-	-	-	-	6300				

Power dissipation and input / output resistance

Total power dissipation is the value measured at I_N , 50/60 Hz, for a 3 pole or 4 pole breaker (values above the power $P = 3RI^2$).

The resistance between input / output is the value measured per pole (cold state).

Version	Drawout		Fixed	
	Power dissipation (Watts)	Input/output resistance (μohm)	Power dissipation (Watts)	Input/output resistance (μohm)
NT06 H1/H2/L1	55/115 (H1/L1)	38/72	30/45	26/39
NT08 H1/H2/L1	90/140 (H1/L1)	38/72	50/80	26/39
NT10 H1/H2/L1	150/230 (H1/L1)	38/72	80/110	26/39
NT12 H1/H2	250	36	130	26
NT16 H1/H2	460	36	220	26
NW08 N1	137	42	62	19
NW08 H/L	100	30	42	13
NW10 N1	220	42	100	19
NW10 H/L	150	30	70	13
NW12 N1	330	42	150	19
NW12 H/L	230	27	100	13
NW16 N1	480	37	220	19
NW16 H/L	390	27	170	13
NW20 H/L	470	27	250	13
NW25 H1/H2/H3	600	19	260	8
NW32 H1/H2/H3	670	13	420	8
NW40 H1/H2/H3	900	11	650	8
NW40b H1/H2	550	7	390	5
NW50 H1/H2	950	7	660	5
NW63 H1/H2	1200	7	1050	5

Derating in switchboards

Factors affecting switchboard design

The temperature around the circuit breaker and its connections:

This is used to define the type of circuit breaker to be used and its connection arrangement.

Vents at the top and bottom of the cubicles:

Vents considerably reduce the temperature inside the switchboard, but must be designed so as to respect the degree of protection provided by the enclosure. For weatherproof heavy-duty cubicles, a forced ventilation system may be required.

The heat dissipated by the devices installed in the switchboard:

This is the heat dissipated by the circuit breakers under normal conditions (service current).

The size of the enclosure:

This determines the volume for cooling calculations.

Switchboard installation mode:

Free-standing, against a wall, etc.

Horizontal partitions:

Partitions can obstruct air circulation within the enclosure.

Basis of tables

- switchboard dimensions
- number of circuit-breakers installed
- type of breaker connections
- drawout versions
- ambient temperature outside of the switchboard: T_a (IEC 60439-1).

Masterpact NT06-16 H1/H2/L1 (switchboard 2000 x 400 x 400) - area of outlet vents: 150 cm²

Type	NT06 H1/H2/L1		NT08 H1/H2/L1		NT10 H1/H2/L1		NT12 H1/H2		NT16 H1/H2			
Switchboard composition												
Connection type	≡ ≡		≡ ≡		≡ ≡		≡ ≡		≡ ≡			
Busbar dimensions (mm)	2b. 40 x 5		2b. 50 x 5		3b. 63 x 5		3b. 63 x 5		3b. 80 x 5			
Ventilated switchboard (⇒ IP31)					H1/L1		H1/L1					
 (1) Area of outlet vents: 150 cm ² . (2) Area of inlet vents: 150 cm ² .	$T_a = 35\text{ °C}$		4		4		4		4			
	3		630	630	800	800	1000/1000	1000/1000	1250	1250	1400	1520
	2											
$T_a = 45\text{ °C}$		4		4		4		4		4		
3		630	630	800	800	1000/950	1000/1000	1250	1250	1330	1440	
2												
$T_a = 55\text{ °C}$		4		4		4		4		4		
3		630	630	800	800	1000/890	1000/960	1200	1250	1250	1340	
2												
1												
Non ventilated switchboard (⇒ IP54)	$T_a = 35\text{ °C}$		4		4		4		4			
3		630	630	800	800	1000/960	1000/1000	1250	1250	1330	1400	
2												
$T_a = 45\text{ °C}$		4		4		4		4		4		
3		630	630	800	800	1000/910	1000/980	1220	1250	1260	1330	
2												
$T_a = 55\text{ °C}$		4		4		4		4		4		
3		630	630	800	800	1000/860	1000/930	1150	1230	1200	1260	
2												
1												

Note: the values indicated in these tables have been extrapolated from test data and theoretical calculations. These tables are only intended as a guide and cannot replace industrial experience or a temperature rise test.

The values indicated for the cross-sectional area of the vents should be considered as general indications only given that the thermal performance of a switchboard with natural ventilation depends on many parameters, e.g. shape, porosity and location of vents and air flow within the switchboard.

Masterpact NT06-08 H1/H2/L1 (switchboard 2300 x 1100 x 500) - area of outlet vents: 300 cm²

Type	NT06 H1/H2/L1						NT08 H1/H2/L1				
Switchboard composition											
Connection type											
Busbar dimensions (mm)	2b. 40 x 5						2b. 50 x 5				

Ventilated switchboard (⇒ IP31)		NT06 H1/H2/L1						NT08 H1/H2/L1						
$T_a = 35\text{ °C}$	5				630	630						800		
	4				630	630	630					800	800	
	3				630	630	630	630				800	800	800
	2	630	630	630	630	630	630	800	800	800	800	800	800	
	1						630						800	
$T_a = 45\text{ °C}$	5				630	630						800		
	4				630	630	630					800	800	
	3				630	630	630	630				800	800	800
	2	630	630	630	630	630	630	800	800	800	800	800	800	
	1						630						800	
$T_a = 55\text{ °C}$	5				630	630						800		
	4				630	630	630					800	800	
	3				630	630	630	630				800	800	800
	2	630	630	630	630	630	630	800	800	800	800	800	800	
	1						630						800	

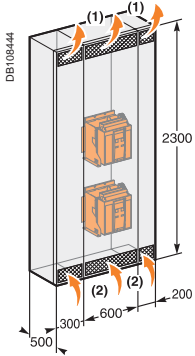

(1) Area of outlet vents: 300 cm².
(2) Area of inlet vents: 300 cm².

Non ventilated switchboard (⇒ IP54)		NT06 H1/H2/L1						NT08 H1/H2/L1						
$T_a = 35\text{ °C}$	5				630	630						800		
	4				630	630	630					800	800	
	3				630	630	630	630				800	800	800
	2	630	630	630	630	630	630	800	800	800	800	800	800	
	1						630						800	
$T_a = 45\text{ °C}$	5				630	630						800		
	4				630	630	630					800	800	
	3				630	630	630	630				800	800	800
	2	630	630	630	630	630	630	800	800	800	800	800	800	
	1						630						800	
$T_a = 55\text{ °C}$	5				630	630						800		
	4				630	630	630					800	800	
	3				630	630	630	630				800	800	800
	2	630	630	630	630	630	630	800	800	800	800	800	800	
	1						630						800	

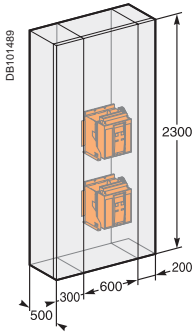

Note: the values indicated in these tables have been extrapolated from test data and theoretical calculations. These tables are only intended as a guide and cannot replace industrial experience or a temperature rise test.
The values indicated for the cross-sectional area of the vents should be considered as general indications only given that the thermal performance of a switchboard with natural ventilation depends on many parameters, e.g. shape, porosity and location of vents and air flow within the switchboard.

Masterpact NT10-16 H1/H2/L1 (switchboard 2300 x 1100 x 500) - area of outlet vents: 300 cm²

Type	NT10 H1/H2/L1				NT12 H1/H2				NT16 H1/H2		
Switchboard composition											
Connection type											
Busbar dimensions (mm)	3b. 63 x 5				3b. 63 x 5				3b. 80 x 5		

Ventilated switchboard (⇒ IP31)	2b. 63 x 5				3b. 50 x 5				3b. 63 x 5			
	5 H1/L1	H1/L1	H1/L1	H1/L1	5 H1/L1	H1/L1	H1/L1	H1/L1	5 H1/L1	H1/L1	H1/L1	
$T_a = 35\text{ °C}$	4			1000/1000				1250				
	3			1000/1000	1000/1000			1250	1250		1500	
	2	1000/1000	1000/1000	1000/1000	1000/1000	1250	1250	1250	1250	1460	1600	1550
	1											
$T_a = 45\text{ °C}$	4			1000/1000				1250				
	3			1000/1000	1000/1000			1250	1250		1420	
	2	1000/960	1000/1000	1000/1000	1000/1000	1250	1250	1250	1250	1400	1500	1480
	1											
$T_a = 55\text{ °C}$	4			1000/920				1250				
	3			1000/950	1000/930			1250	1250		1330	
	2	1000/900	1000/1000	1000/970	1000/950	1250	1250	1250	1250	1300	1400	1370
	1											

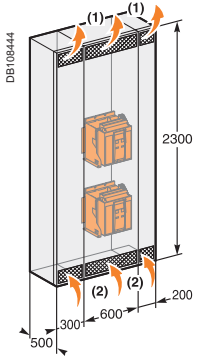

(1) Area of outlet vents: 300 cm²
 (2) Area of inlet vents: 300 cm².

Non ventilated switchboard (⇒ IP54)	2b. 63 x 5				3b. 50 x 5				3b. 63 x 5		
	5 H1/L1	H1/L1	H1/L1	H1/L1	5 H1/L1	H1/L1	H1/L1	H1/L1	5 H1/L1	H1/L1	H1/L1
$T_a = 35\text{ °C}$	4			1000/950				1250			
	3			1000/1000	1000/960			1250	1250		1370
	2	1000/1000	1000/1000	1000/1000	1000/970	1250	1250	1250	1250	1400	1500
$T_a = 45\text{ °C}$	4			1000/900				1180			
	3			1000/950	1000/910			1250	1190		1300
	2	1000/950	1000/1000	1000/960	1000/930	1250	1250	1250	1220	1350	1430
$T_a = 55\text{ °C}$	4			1000/850				1120			
	3			1000/900	1000/860			1200	1130		1210
	2	1000/880	1000/970	1000/910	1000/870	1210	1250	1210	1150	1250	1350

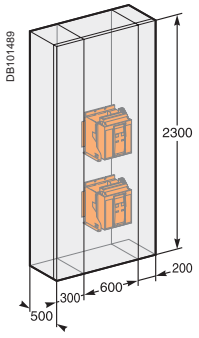

Note: the values indicated in these tables have been extrapolated from test data and theoretical calculations. These tables are only intended as a guide and cannot replace industrial experience or a temperature rise test.
 The values indicated for the cross-sectional area of the vents should be considered as general indications only given that the thermal performance of a switchboard with natural ventilation depends on many parameters, e.g. shape, porosity and location of vents and air flow within the switchboard.

Masterpact NW08-10 N/H/L (switchboard 2300 x 800 x 900) - area of outlet vents: 350 cm²

Type	NW08 N/H/L					NW10 N/H/L			
Switchboard composition									
Connection type									
Busbar dimensions (mm)	2b. 50 x 5					3b. 63 x 5			

Ventilated switchboard (⇒ IP31)		NW08 N/H/L					NW10 N/H/L			
$T_a = 35\text{ °C}$	4	800								
	3	800				800	1000			
	2	800			800	800	1000			1000
	1	800	800	800	800	800	1000	1000	1000	1000
$T_a = 45\text{ °C}$	4	800								
	3	800				800	1000			
	2	800			800	800	1000			1000
	1	800	800	800	800	800	1000	1000	1000	1000
$T_a = 55\text{ °C}$	4	800								
	3	800				800	1000			
	2	800			800	800	1000			1000
	1	800	800	800	800	800	1000	1000	1000	1000

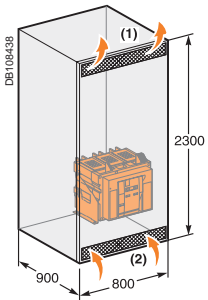

(1) Area of outlet vents: 350 cm².
(2) Area of inlet vents: 350 cm².

Non ventilated switchboard (⇒ IP54)		NW08 N/H/L					NW10 N/H/L			
$T_a = 35\text{ °C}$	4	800								
	3	800				800	1000			
	2	800			800	800	1000			1000
	1	800	800	800	800	800	1000	1000	1000	1000
$T_a = 45\text{ °C}$	4	800								
	3	800				800	1000			
	2	800			800	800	1000			1000
	1	800	800	800	800	800	1000	1000	1000	1000
$T_a = 55\text{ °C}$	4	800								
	3	800				800	1000			
	2	800			800	800	1000			1000
	1	800	800	800	800	800	1000	1000	1000	1000

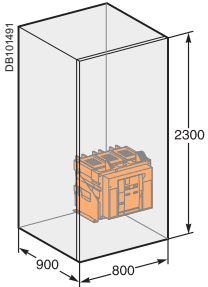

Note: the values indicated in these tables have been extrapolated from test data and theoretical calculations. These tables are only intended as a guide and cannot replace industrial experience or a temperature rise test.

The values indicated for the cross-sectional area of the vents should be considered as general indications only given that the thermal performance of a switchboard with natural ventilation depends on many parameters, e.g. shape, porosity and location of vents and air flow within the switchboard.

Masterpact NW12-16 N/H/L (switchboard 2300 x 800 x 900) - area of outlet vents: 350 cm²

Type	NW12 N1	NW12 H/L	NW16 N1	NW16 H/L
Switchboard composition				
Connection type				
Busbar dimensions (mm)	3b. 63 x 5 3b. 50 x 5	3b. 63 x 5 3b. 50 x 5	3b. 80 x 5 3b. 63 x 5	3b. 80 x 5 3b. 63 x 5

Ventilated switchboard (⇒ IP31)

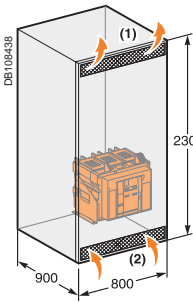

Temperature (T _a)	4	3	2	1	4	3	2	1	4	3	2	1
T _a = 35 °C		1250	1250	1250	1250	1250	1250	1250	1250	1250	1250	1250
T _a = 45 °C		1250	1250	1250	1250	1250	1250	1250	1250	1250	1250	1250
T _a = 55 °C		1250	1250	1250	1250	1250	1250	1250	1250	1250	1250	1250

- (1) Area of outlet vents: 350 cm².
- (2) Area of inlet vents: 350 cm².

Non ventilated switchboard (⇒ IP54)

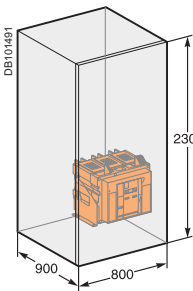

Temperature (T _a)	4	3	2	1	4	3	2	1	4	3	2	1
T _a = 35 °C		1240	1250	1250	1250	1250	1250	1250	1250	1250	1250	1250
T _a = 45 °C		1170	1210	1210	1250	1250	1250	1250	1250	1250	1250	1250
T _a = 55 °C		1100	1140	1170	1250	1250	1250	1250	1250	1250	1250	1250

Note: the values indicated in these tables have been extrapolated from test data and theoretical calculations. These tables are only intended as a guide and cannot replace industrial experience or a temperature rise test.
The values indicated for the cross-sectional area of the vents should be considered as general indications only given that the thermal performance of a switchboard with natural ventilation depends on many parameters, e.g. shape, porosity and location of vents and air flow within the switchboard.

Masterpact NW20-40 N/H/L (switchboard 2300 x 800 x 900) - area of outlet vents: 350 cm²

Type	NW20 H1/H2/H3	NW20 L1	NW25 H1/2/3	NW32 H1/2/3	NW40 H1/2/3
Switchboard composition					
Connection type					
Busbar dimensions (mm)	3b. 100 x 5	3b. 100 x 5	4b. 100 x 5	3b. 100 x 10	4b. 100 x 10

Ventilated switchboard (⇒ IP31)

Temperature (T _a)	Cross-sectional area of vents (cm ²)												
	4	3	2	1	4	3	2	1	4	3	2	1	
T _a = 35 °C		2000	2000	2000	2000	2000	2000	2375	2500	3040	3200	3320	3700
T _a = 45 °C		2000	2000	2000	1810	1960	1920	2250	2380	2880	3100	3160	3500
T _a = 55 °C		2000	2000	2000	1700	1850	1800	2100	2250	2690	2900	2960	3280

(1) Area of outlet vents: 350 cm².
(2) Area of inlet vents: 350 cm².

Non ventilated switchboard (⇒ IP54)

Temperature (T _a)	Cross-sectional area of vents (cm ²)											
	4	3	2	1	4	3	2	1	4	3	2	1
T _a = 35 °C		2000	1800	1900	1890	2125	2275	2650	2850	3040	3320	
T _a = 45 °C		1900	1680	1810	1800	2000	2150	2550	2700	2880	3120	
T _a = 55 °C		1780	1590	1700	1700	1900	2020	2370	2530	2720	2960	

Note: the values indicated in these tables have been extrapolated from test data and theoretical calculations. These tables are only intended as a guide and cannot replace industrial experience or a temperature rise test.

The values indicated for the cross-sectional area of the vents should be considered as general indications only given that the thermal performance of a switchboard with natural ventilation depends on many parameters, e.g. shape, porosity and location of vents and air flow within the switchboard.

Masterpact NW40b-63 H1/H2 (switchboard 2300 x 1400 x 1500) - area of outlet vents: 500 cm²

Type	NW40b H1/H2	NW50 H1/H2	NW63 H1/H2
Switchboard composition			
Connection type			
Busbar dimensions (mm)	5b. 100 x 10	7b. 100 x 10	8b. 100 x 10
Ventilated switchboard (⇒ IP31)			
$T_a = 35\text{ °C}$	4 3 2 4000 4000 1	4 3 2 4700 5000 1	4 3 2 5850 1
$T_a = 45\text{ °C}$	4 3 2 4000 4000 1	4 3 2 4450 4850 1	4 3 2 5670 1
$T_a = 55\text{ °C}$	4 3 2 4000 4000 1	4 3 2 4200 4600 1	4 3 2 5350 1
Non ventilated switchboard (⇒ IP54)			
$T_a = 35\text{ °C}$	4 3 2 4000 4000 1	4 3 2 4350 4650 1	4 3 2 5290 1
$T_a = 45\text{ °C}$	4 3 2 4000 4000 1	4 3 2 4100 4400 1	4 3 2 5040 1
$T_a = 55\text{ °C}$	4 3 2 3840 3840 1	4 3 2 3850 4150 1	4 3 2 4730 1

(1) Area of outlet vents: 500 cm².

(2) Area of inlet vents: 500 cm².

Note: the values indicated in these tables have been extrapolated from test data and theoretical calculations. These tables are only intended as a guide and cannot replace industrial experience or a temperature rise test.

The values indicated for the cross-sectional area of the vents should be considered as general indications only given that the thermal performance of a switchboard with natural ventilation depends on many parameters, e.g. shape, porosity and location of vents and air flow within the switchboard.

It is possible to replace a **Masterpact (M08 to M32)** with a new **Masterpact (NW08 to NW32)** with the same power rating.

Substitution is possible for the following types of circuit breakers:

- N1, H1, H2 for both fixed and drawout versions
- L1 for drawout versions up to 2000 A.

Mounting diagram

Fixed version

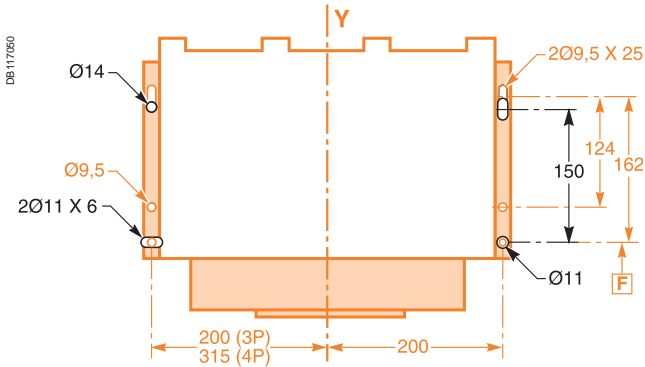

Drawout version

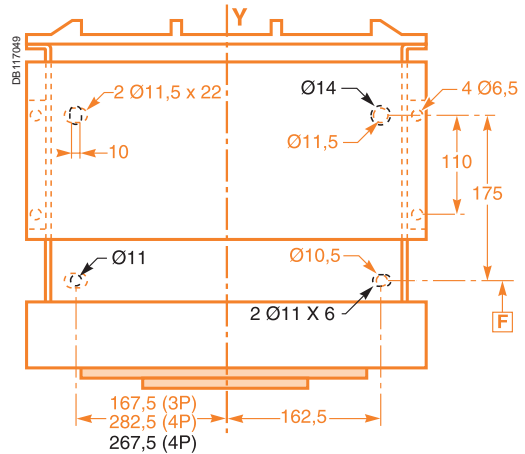

— : Masterpact NW
— : Masterpact M

Fixing points are identical for Masterpact (M08 to M32) and Masterpact (NW08 to NW32), except for the four-pole chassis.

Door cut-out

- without an escutcheon, the cut-out is identical (270 x 325 mm)
- with the former escutcheon, the cut-out is identical (270 x 325 mm)
- with the new escutcheon, the cut-out is different.

Fixed version

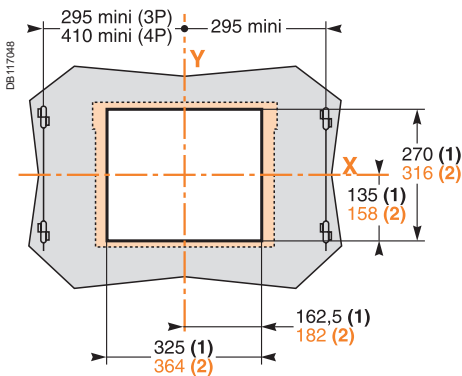

Drawout version

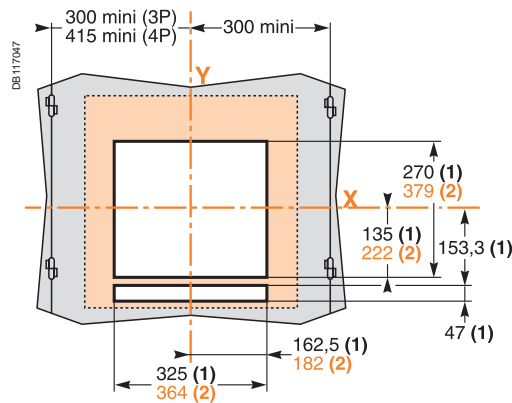

Power connection

Select a set of retrofit connectors to replace the standard connectors and avoid any modifications to the busbars (see the retrofit section in "orders and quotations").

Note:
(1) Without escutcheon.
(2) With escutcheon.

References **X** and **Y** represent the symmetry planes for three-pole devices.

Electrical diagrams

Correspondences between Masterpact NW and Masterpact M terminal blocks.

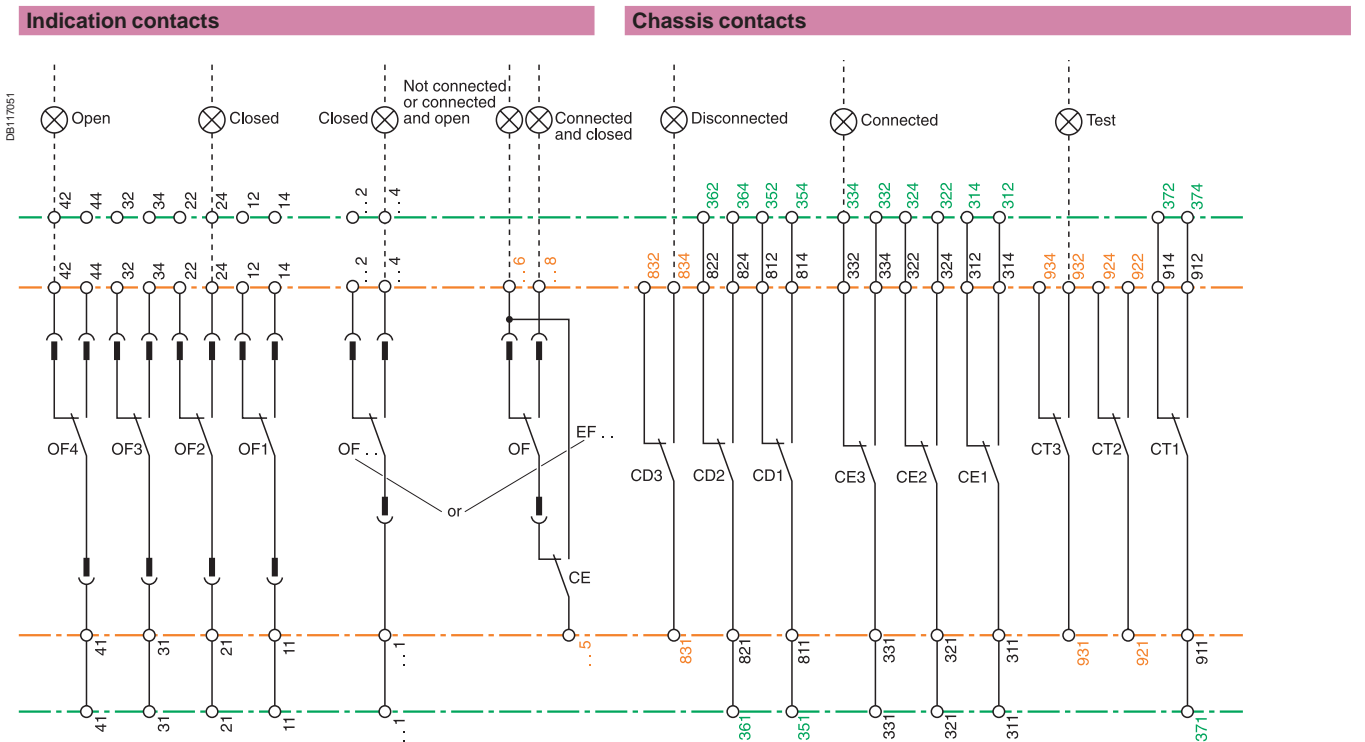
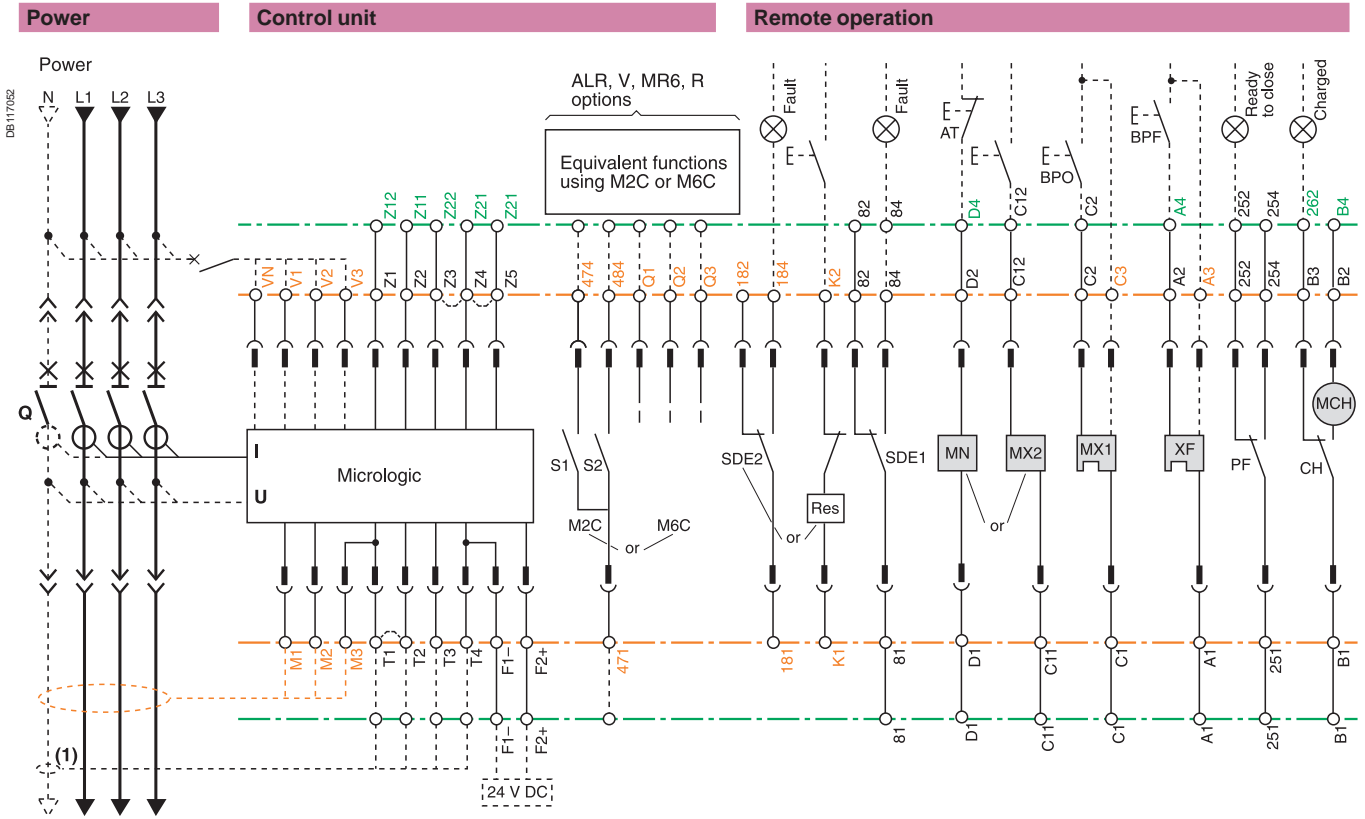

Identical to Masterpact M.

New or additional functions.

Different than Masterpact M.

(1) The current transformer for the external neutral must be replaced.

schneider-electric.com

This international site allows you to access all the Schneider Electric products in just 2 clicks via comprehensive range data-sheets, with direct links to:

- complete library: technical documents, catalogs, FAQs, brochures...

- selection guides from the e-catalog.

- product discovery sites and their Flash animations.

You will also find illustrated overviews, news to which you can subscribe, the list of country contacts...

Training

Training allows you to acquire the Schneider Electric expertise (installation design, work with power on, etc.) for increased efficiency and a guarantee of improved customer service.

The training catalogue includes beginner's courses in electrical distribution, knowledge of MV and LV switchgear, operation and maintenance of installations, design of LV installations to give but a few examples.



<i>Presentation</i>	1
<i>Functions and characteristics</i>	A-1
<i>Installation recommendations</i>	B-1
NT06 to NT16 circuit breakers	
Fixed 3/4-poles device	C-2
Drawout 3/4-poles device	C-6
NW08 to NW32 circuit breakers	
Fixed 3/4-poles device	C-10
Drawout 3/4-poles device	C-12
NW40 circuit breakers	
Fixed 3/4-poles device	C-14
Drawout 3/4-poles device	C-16
NW40b to NW63 circuit breakers	
Fixed 3/4-poles device	C-18
Drawout 3/4-poles device	C-20
NT/NW accessories	C-22
NT/NW external modules	C-24
<i>Electrical diagrams</i>	D-1
<i>Additional characteristics</i>	E-1
<i>Catalogue numbers and order form</i>	F-1

Dimensions

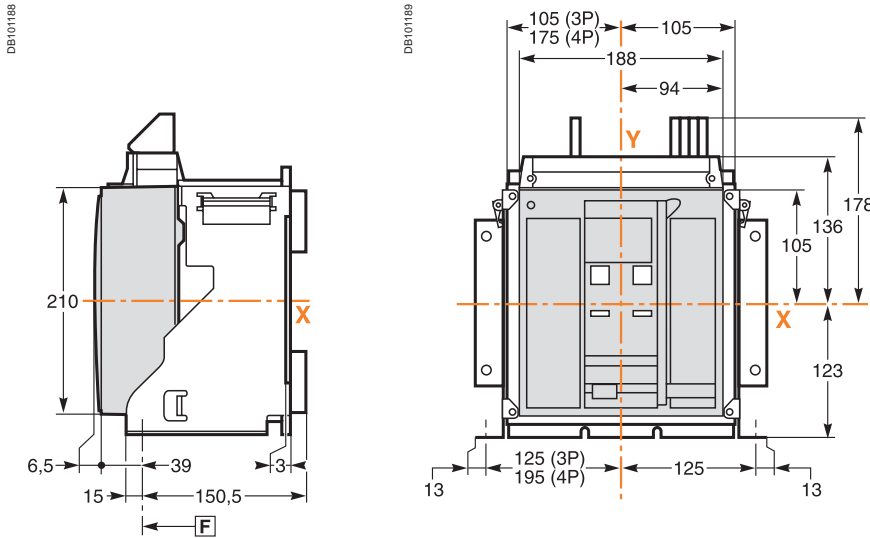

Bottom mounting (on base plate or rails)

Rear mounting detail (on upright or backplate)

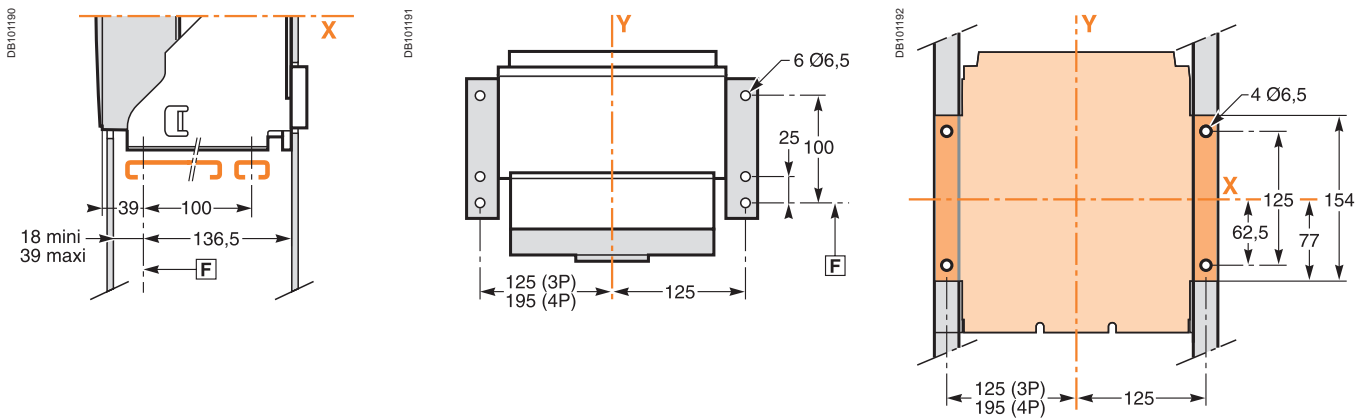

Safety clearances

Door cutout

Rear panel cutout

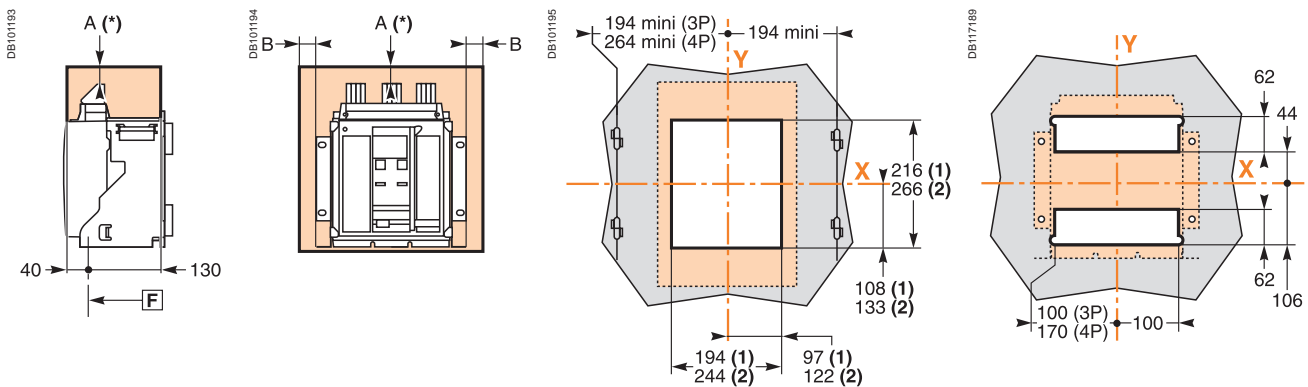

For voltages < 690 V

	Parts		
	Insulated	Metal	Energised
A	0	0	100
B	0	0	60

For 1000 V

	Parts		
	Insulated	Metal	Energised
A	0	100	500 ⁽³⁾
B	0	50	100 ⁽³⁾

F: datum.

(1) Without escutcheon.
(2) With escutcheon.

(3) With a minimum distance between bars of 65 mm (A and B) if the bars are not insulated.

Note: X and Y are the symmetry planes for a 3-pole device.

A(*) An overhead clearance of 50 mm is required to remove the arc chutes. An overhead clearance of 20 mm is required to remove the terminal block.

Connections

Horizontal rear connection

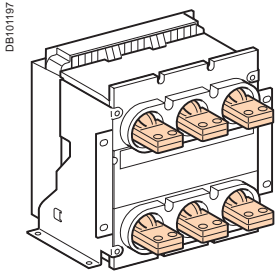

DB101197

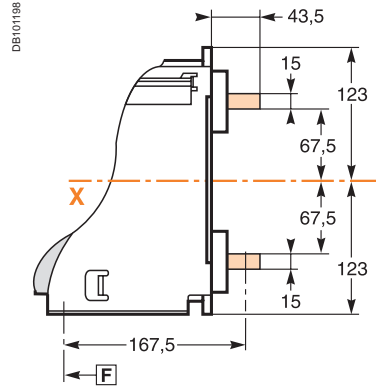

DB101198

Detail

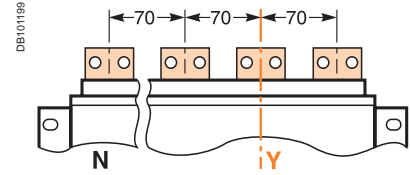

DB101199

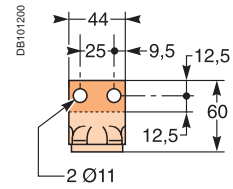

DB101200

Vertical rear connection

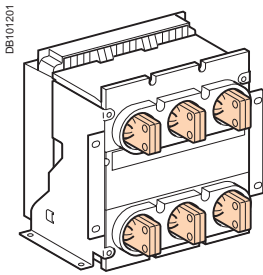

DB101201

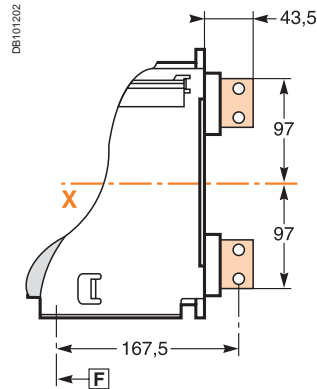

DB101202

Detail

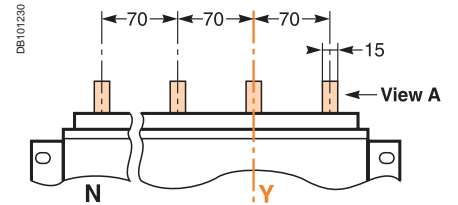

DB101230

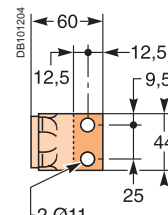

DB101204

View A detail.

Front connection

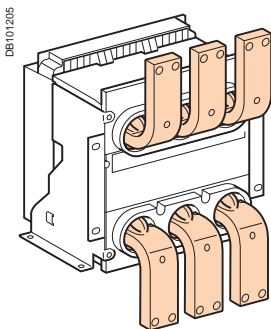

DB101205

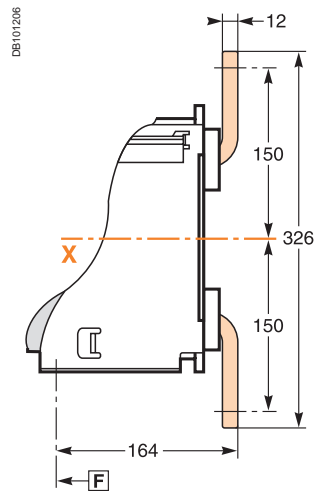

DB101206

Detail

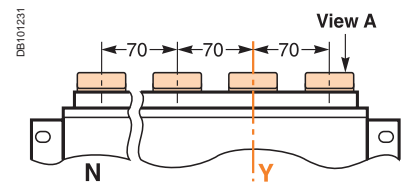

DB101231

Top connection

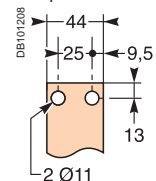

DB101208

View A detail.

Bottom connection

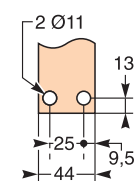

Note: recommended connection screws: **M10** class 8.8.
Tightening torque: **50 Nm** with contact washer.

Connections

Front connection with spreaders

Detail

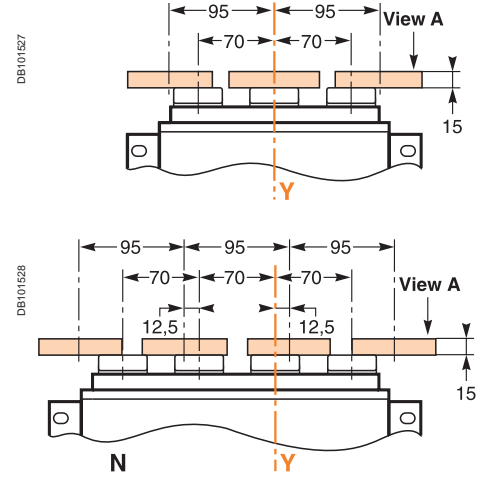
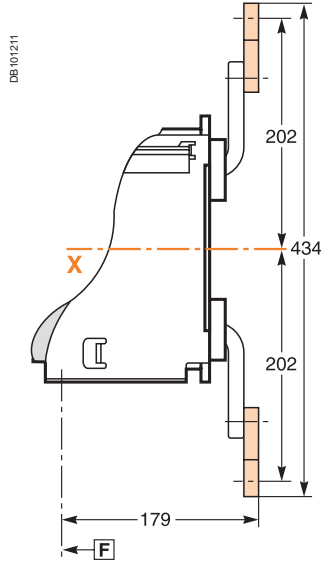
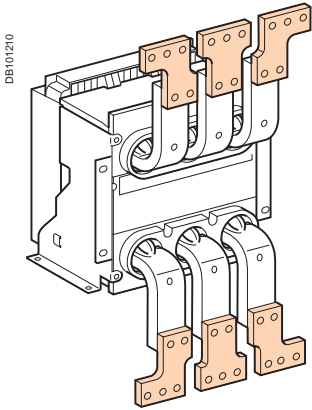

Rear connection with spreaders

Detail

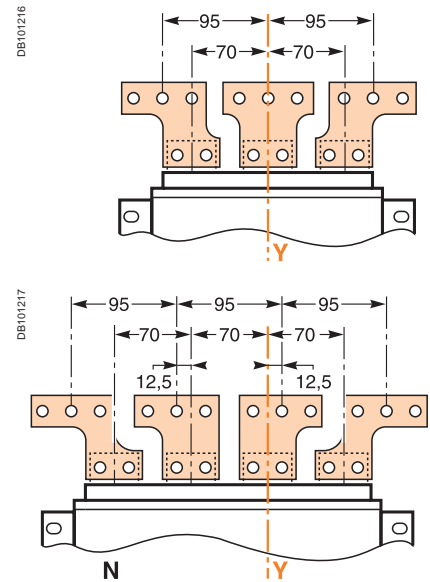
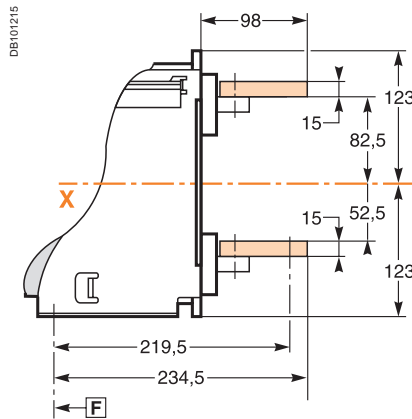
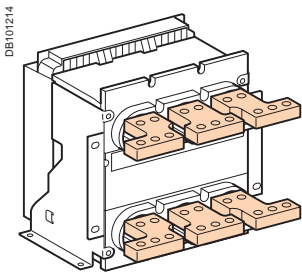

Spreader detail

Middle left or middle right spreader for 4P.

Middle spreader for 3P.

Left or right spreader for 4P.

Left or right spreader for 3P.

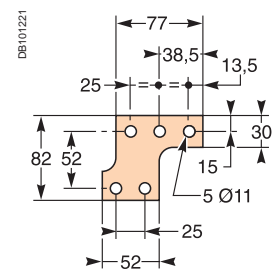
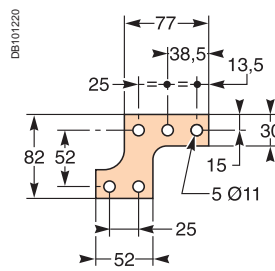
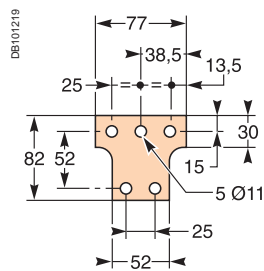
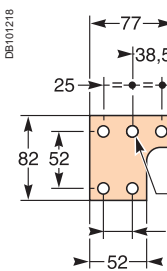

View A detail.

F : datum.

Note: X and Y are the symmetry planes for a 3-pole device.

Connections

Front connection via vertical connection adapters

Detail

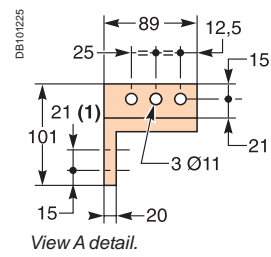
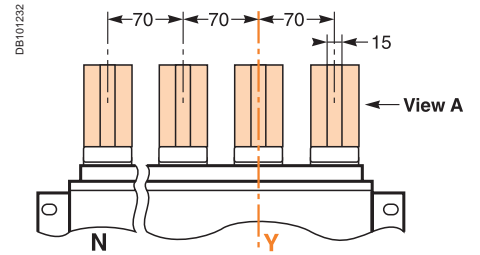
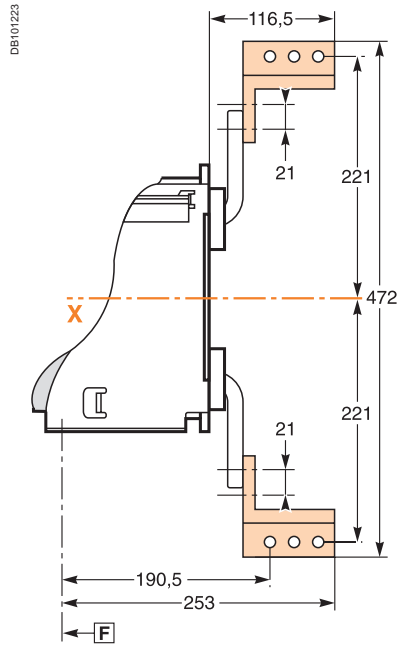
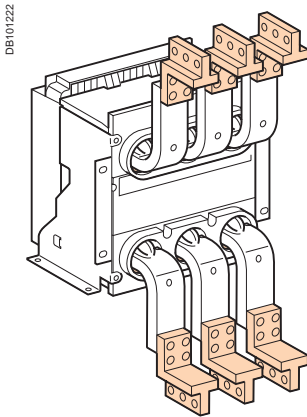

Front connection via vertical connection adapters fitted with cable-lug adapters

Detail

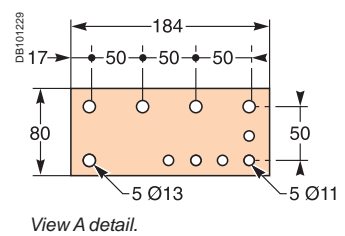
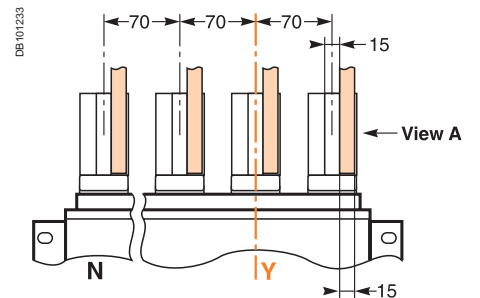
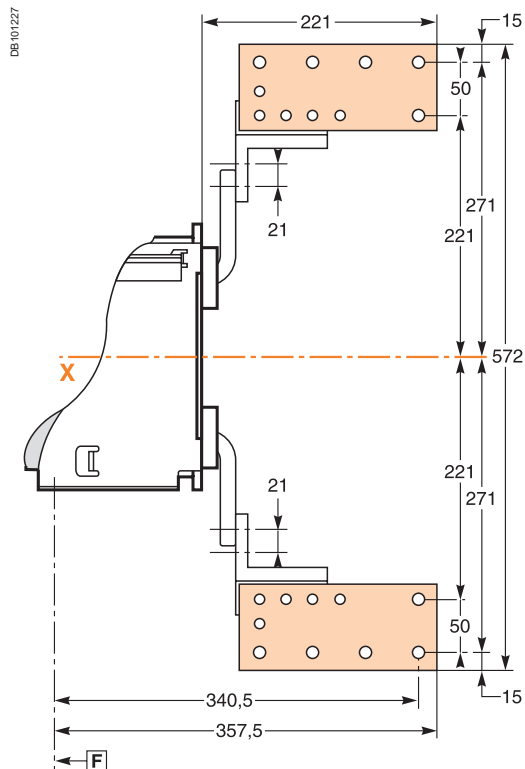
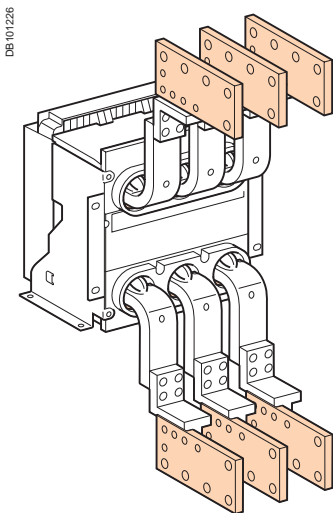

Note: recommended connection screws: **M10** class 8.8.
Tightening torque: **50 Nm** with contact washer.

(1) 2 connection possibilities on vertical connection adapters (21 mm between centres).

Dimensions

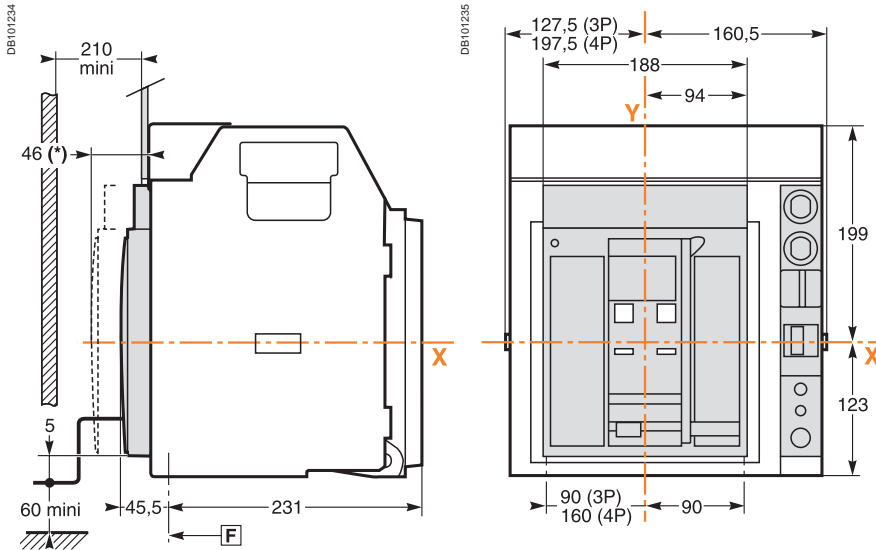

(*) Disconnected position.

Bottom mounting (on base plate or rails)

Rear mounting detail (on upright or backplate)

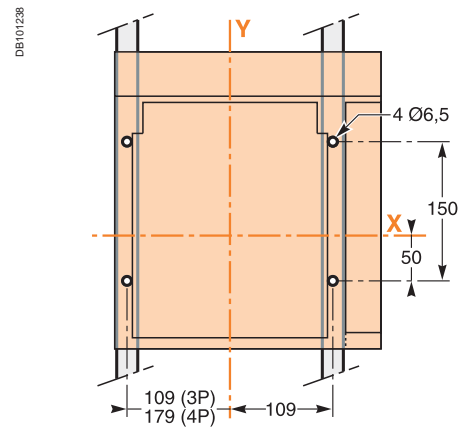
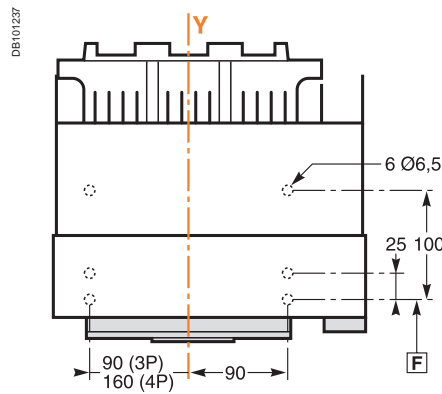
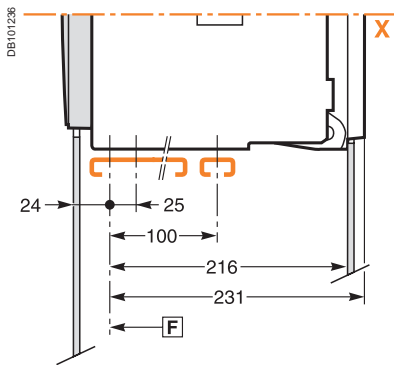

Safety clearances

Door cutout

Rear panel cutout

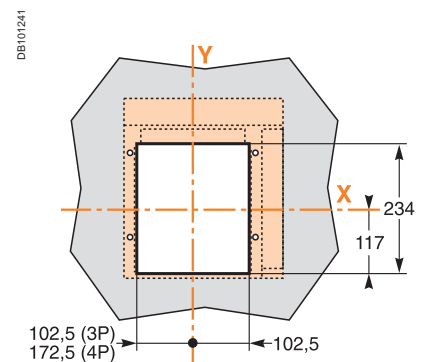
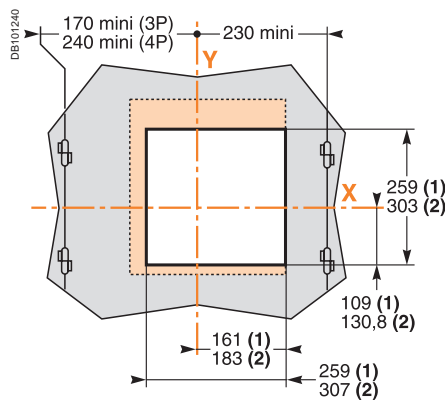
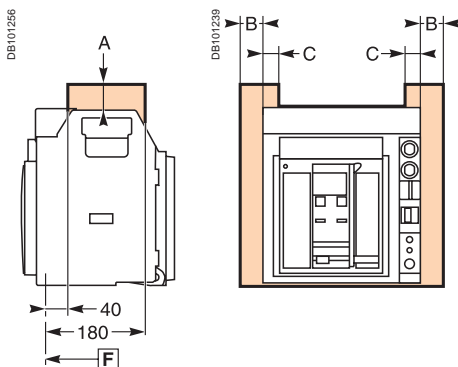

For voltages < 690 V or equal to 1000 V.

	Parts		
	Insulated	Metal	Energised
A	0	0	30
B	10	10	60
C	0	0	30

F : datum.

(1) Without escutcheon.

(2) With escutcheon.

Note: X and Y are the symmetry planes for a 3-pole device.

Connections

Horizontal rear connection

Detail

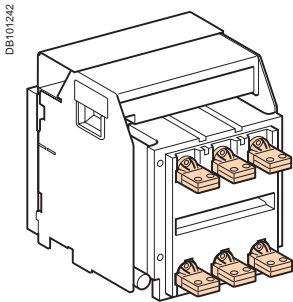

DB101242

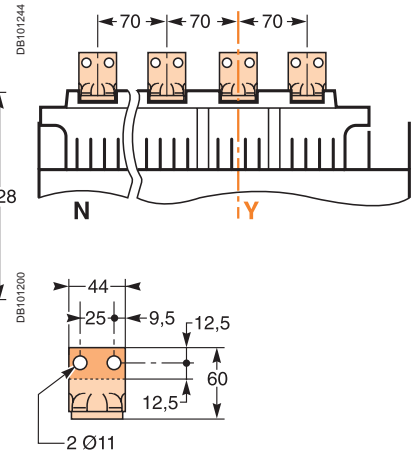
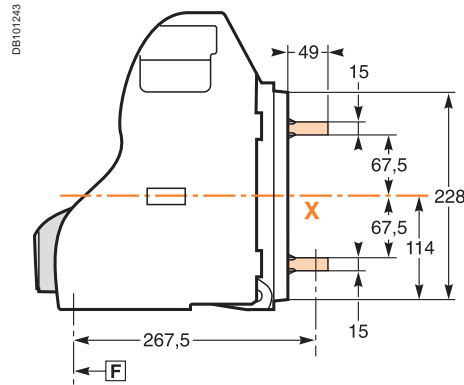

Vertical rear connection

Detail

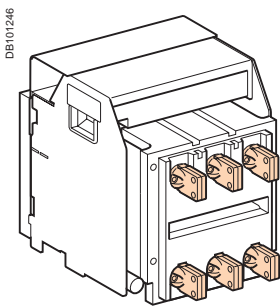

DB101246

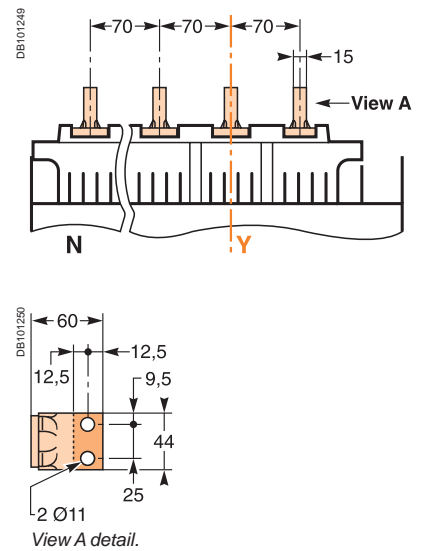
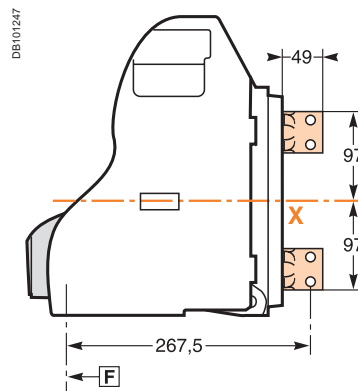

Front connection

Detail

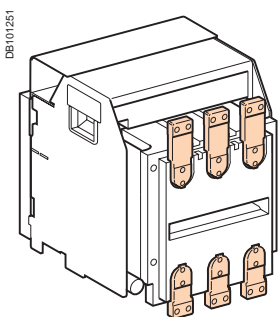

DB101251

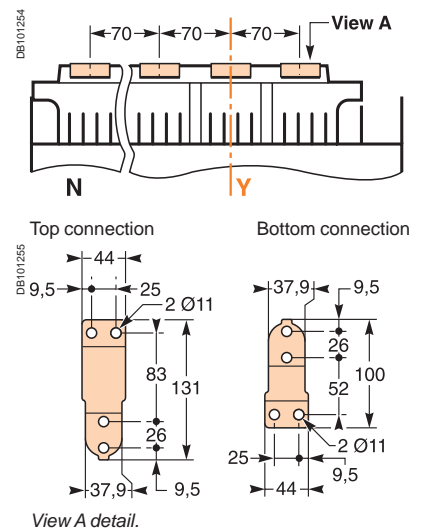
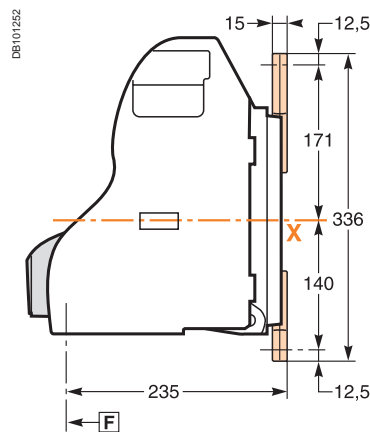

Note: recommended connection screws: **M10** class 8.8.
Tightening torque: **50 Nm** with contact washer.

Connections

Front connection with spreaders

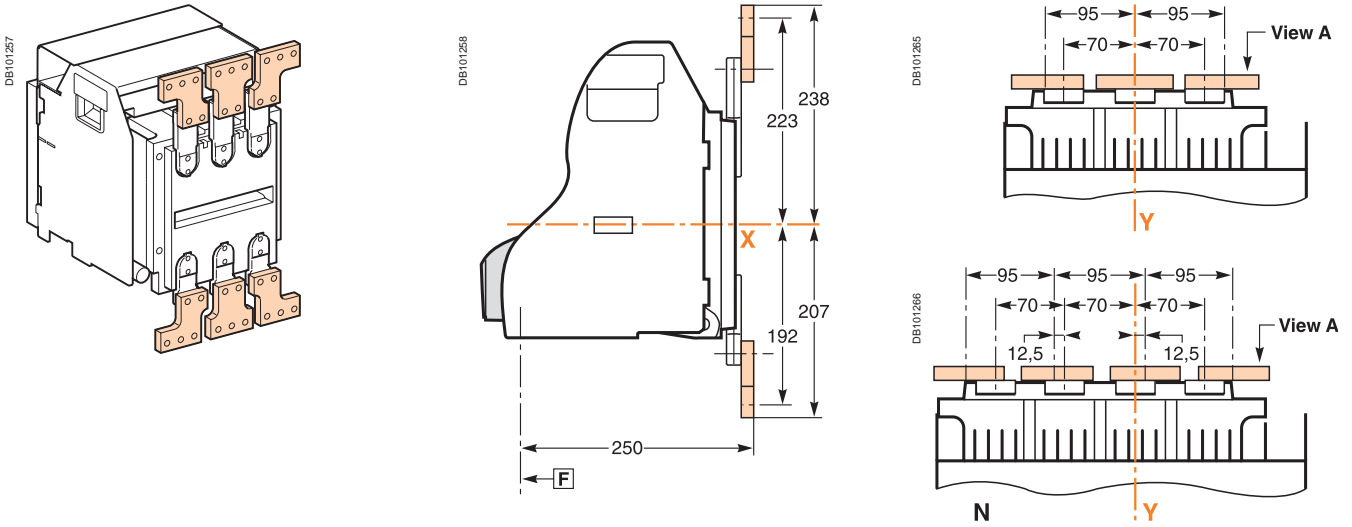

Spreader detail

Middle left or middle right spreader for 4P.

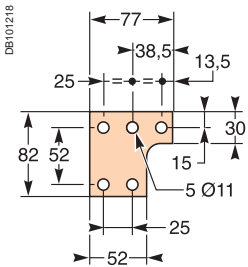

View A detail.

Middle spreader for 3P.

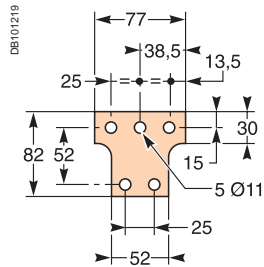

Left or right spreader for 4P.

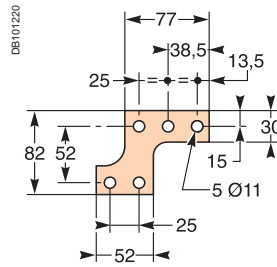

Left or right spreader for 3P.

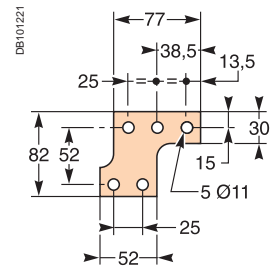

Connections

Front connection via vertical connection adapters fitted with cable-lug adapters

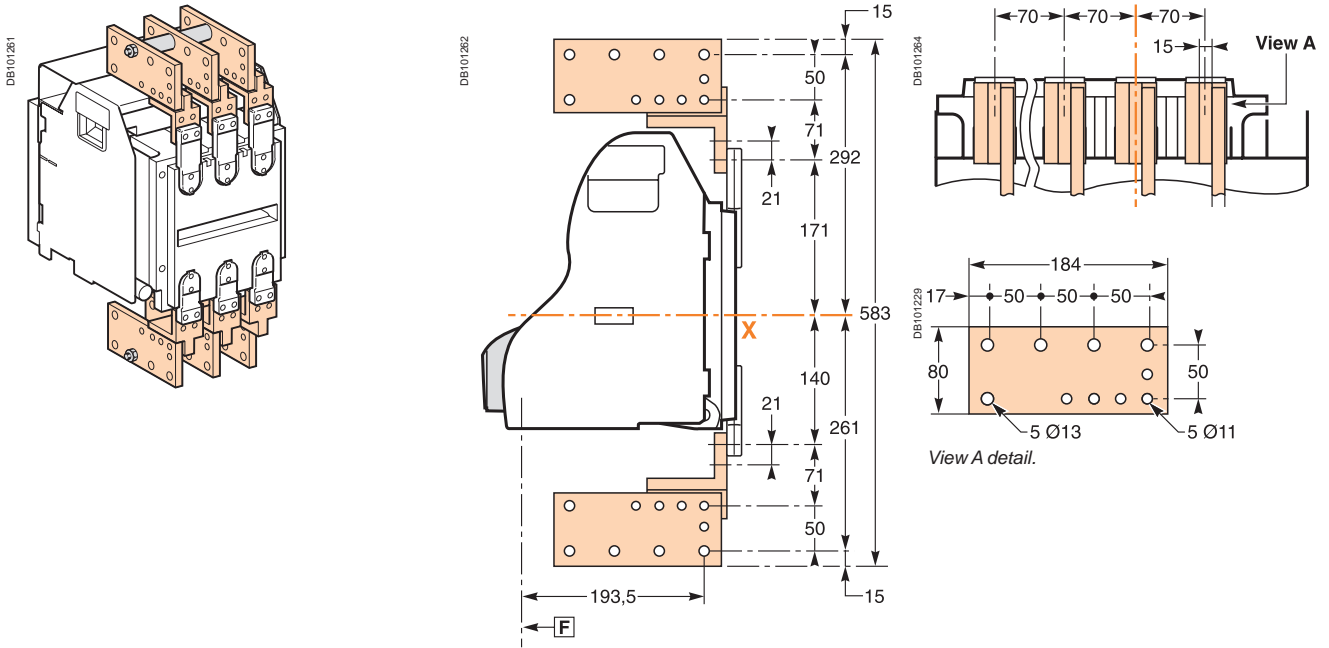

Note: recommended connection screws: **M10** class 8.8.
Tightening torque: **50 Nm** with contact washer.

Dimensions

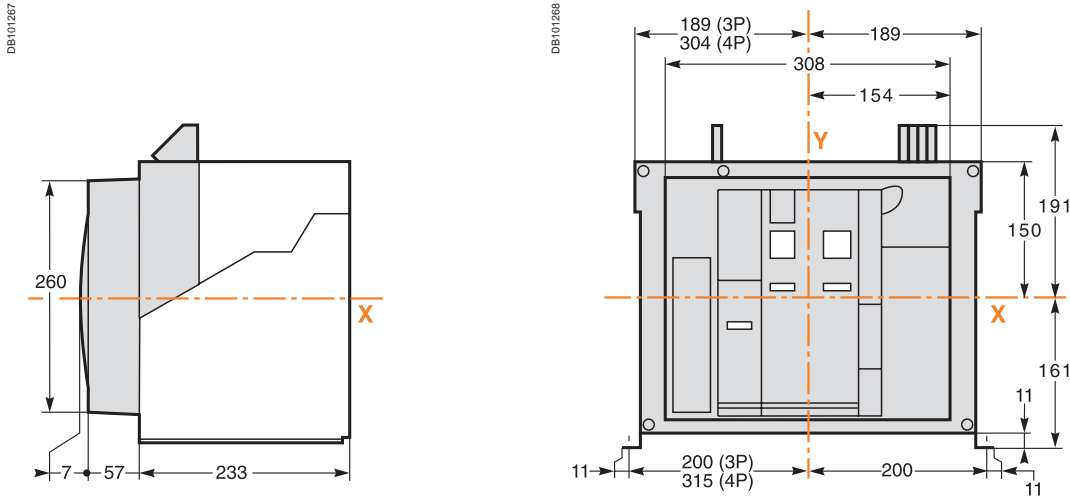

Mounting on base plate or rails

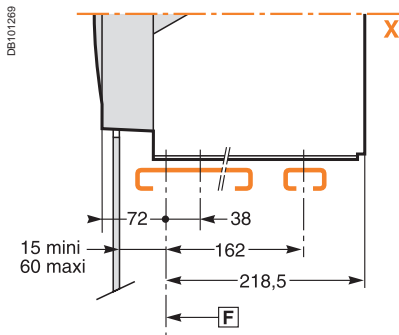

Mounting detail

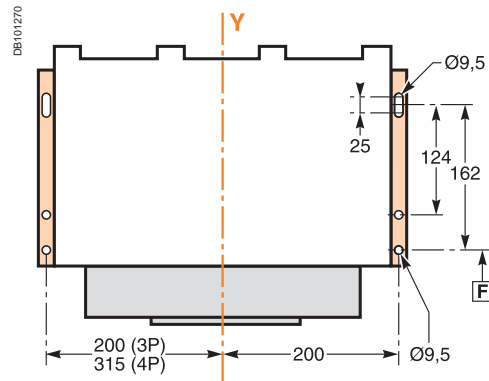

Safety clearances

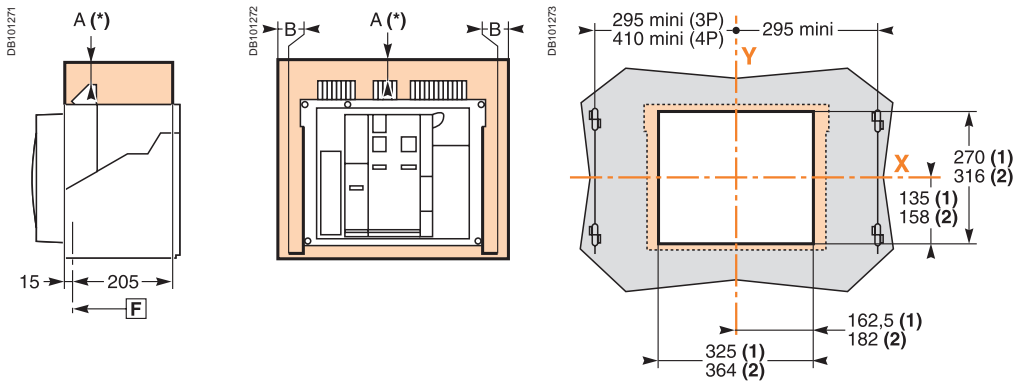

	Insulated parts	Metal parts	Energised parts
A	0	0	100
B	0	0	60

F : datum.

(1) Without escutcheon.

(2) With escutcheon.

Note: X and Y are the symmetry planes for a 3-pole device.

A(*) An overhead clearance of 50 mm is required to remove the arc chutes.

An overhead clearance of 20 mm is required to remove the terminal block.

Connections

Horizontal rear connection

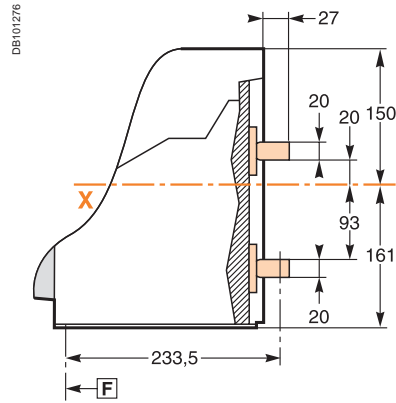
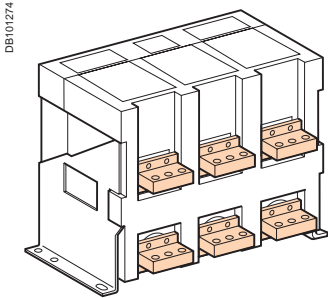

Detail

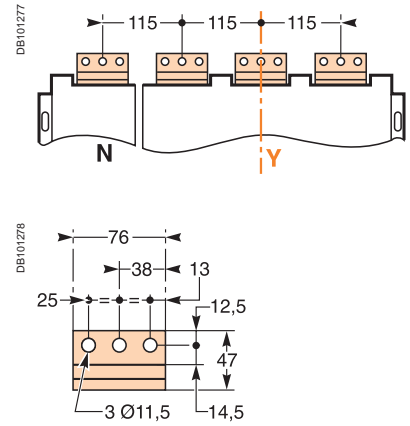

Vertical rear connection

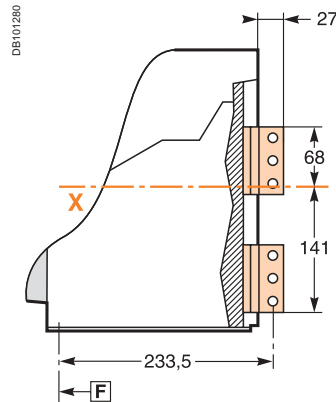
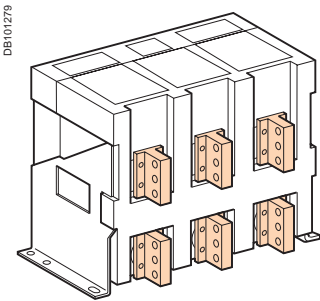

Detail

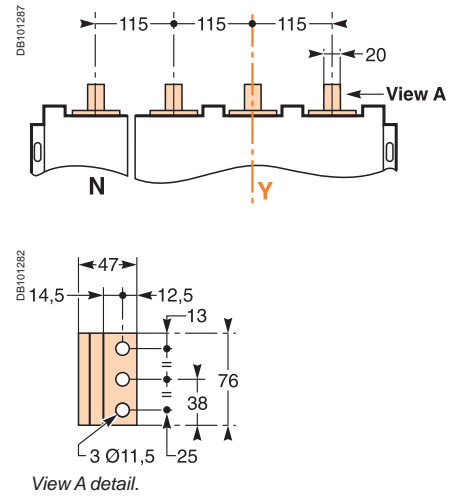

Front connection

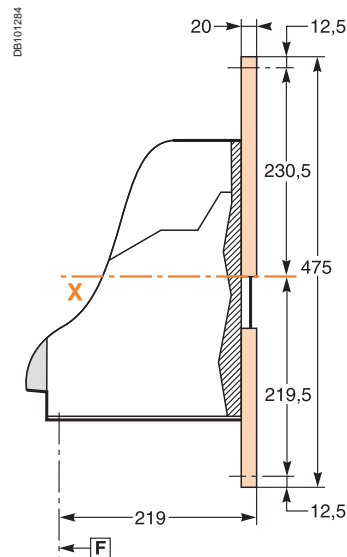
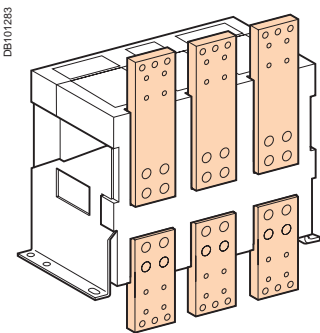

Detail

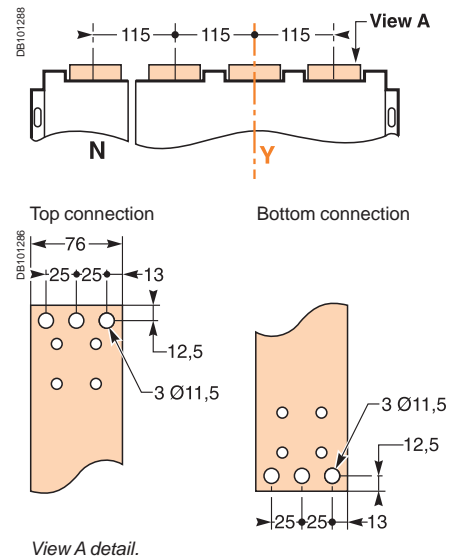

Note: recommended connection screws: **M10** class 8.8.
Tightening torque: **50 Nm** with contact washer.

Dimensions

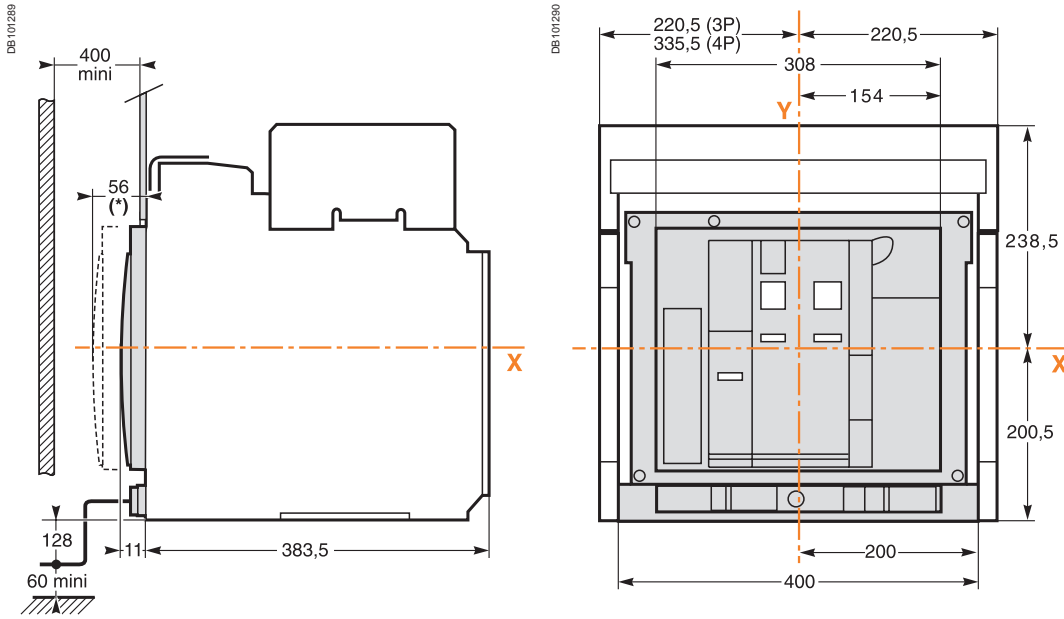

(*) Disconnected position.

Mounting on base plate or rails

Mounting detail

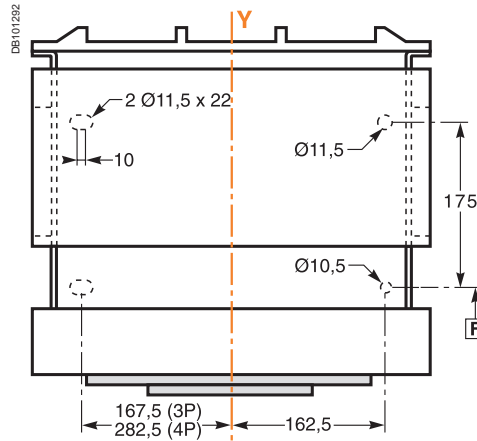
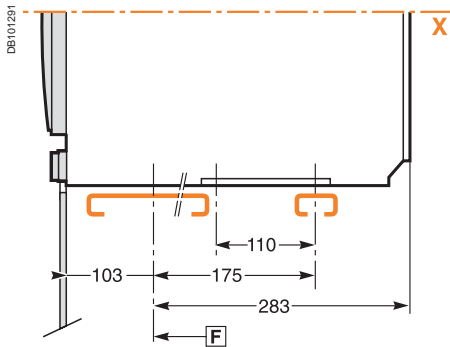

Safety clearances

Door cutout

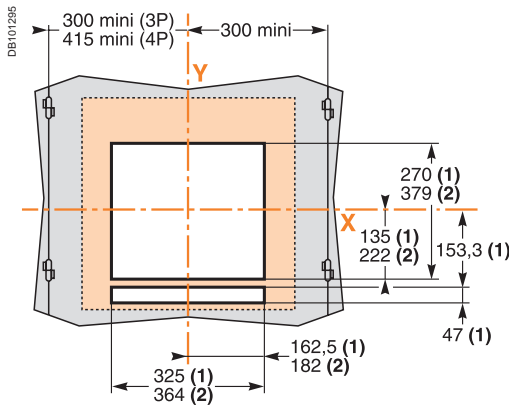
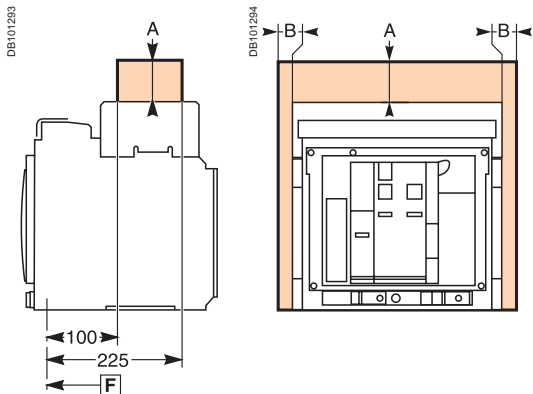

	Insulated parts	Metal parts	Energised parts
A	0	0	0
B	0	0	60

F : datum.

(1) Without escutcheon.

(2) With escutcheon.

Note: X and Y are the symmetry planes for a 3-pole device.

Connections

Horizontal rear connection

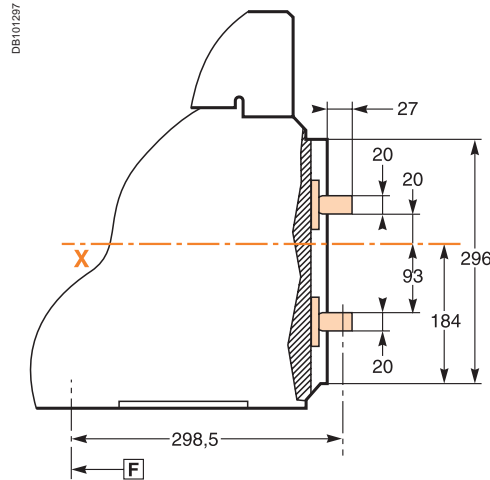
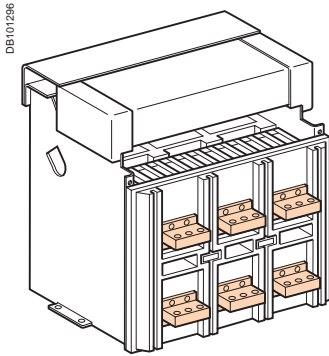

Detail

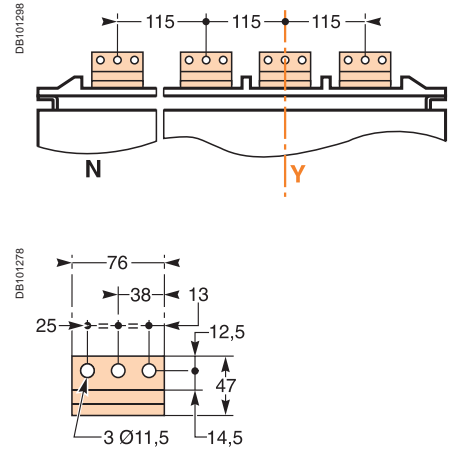

Vertical rear connection

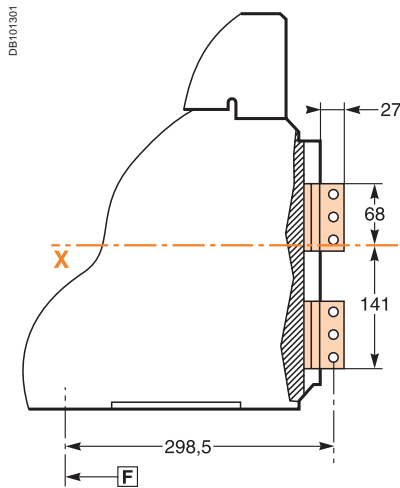
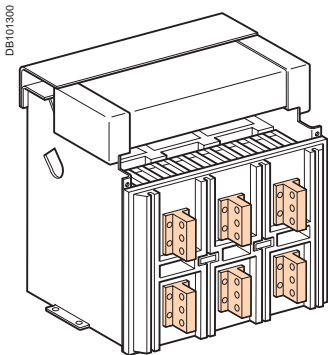

Detail

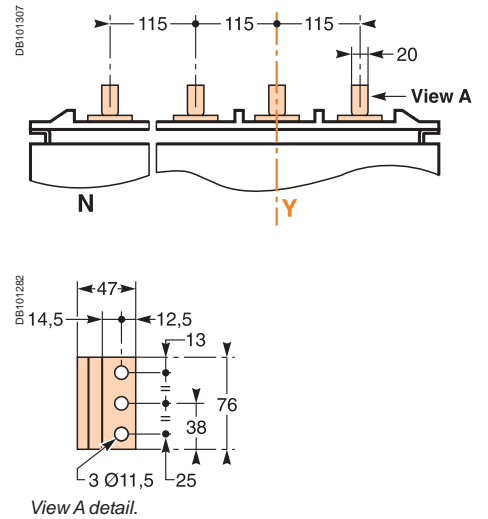

Front connection

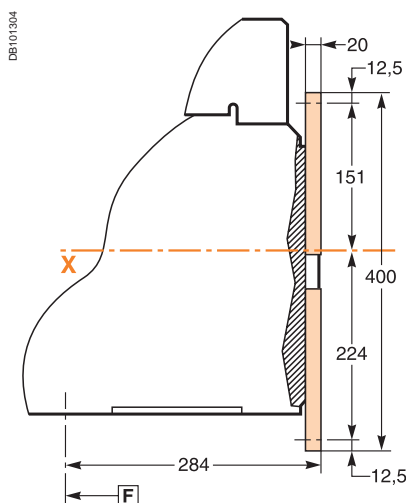
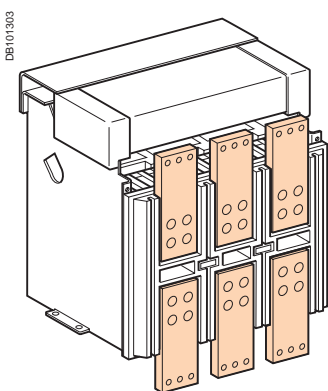

Detail

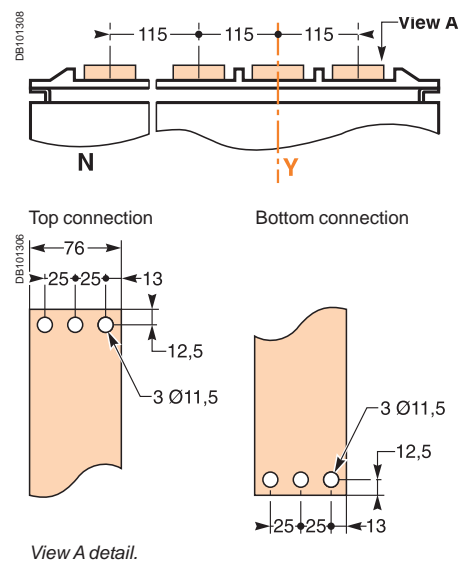

Note: recommended connection screws: **M10** class 8.8.
Tightening torque: **50 Nm** with contact washer.

Dimensions

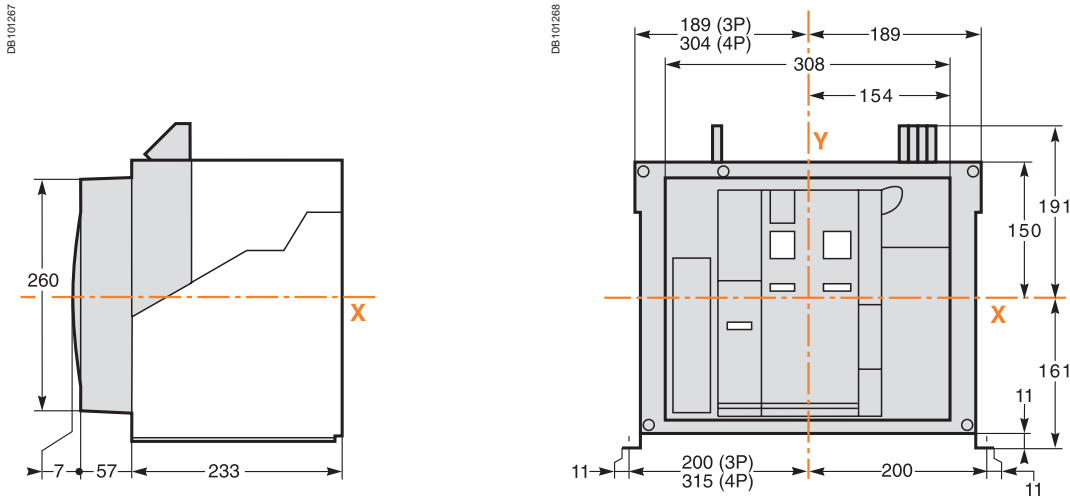

Mounting on base plate or rails

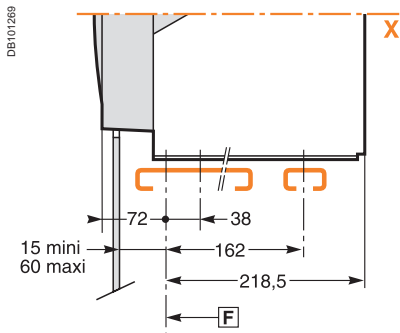

Mounting detail

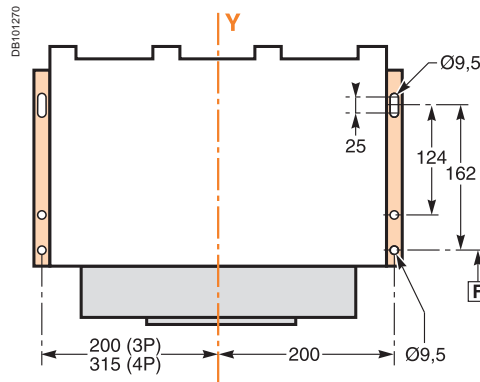

Safety clearances

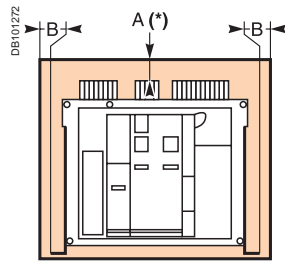
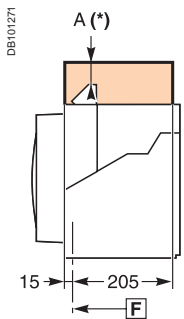

Door cutout

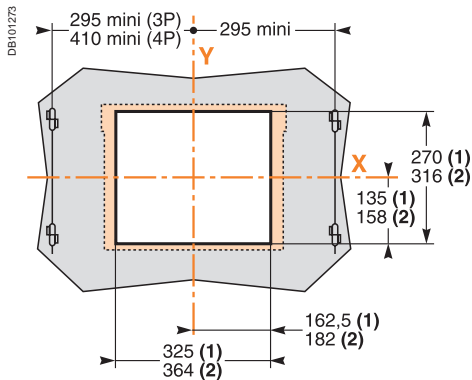

	Insulated parts	Metal parts	Energised parts
A	0	0	100
B	0	0	60

F : datum.

(1) Without escutcheon.

(2) With escutcheon.

Note: X and Y are the symmetry planes for a 3-pole device.

A(*) An overhead clearance of 110 mm is required to remove the arc chutes.

An overhead clearance of 20 mm is required to remove the terminal block.

Connections

Horizontal rear connection

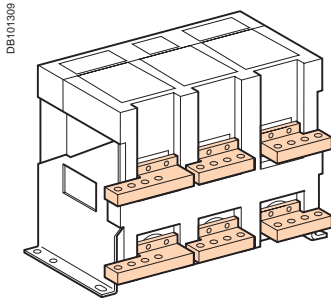

DB101309

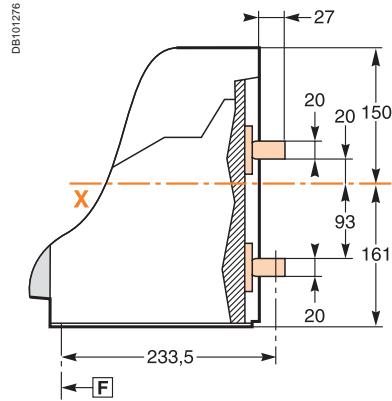

Detail

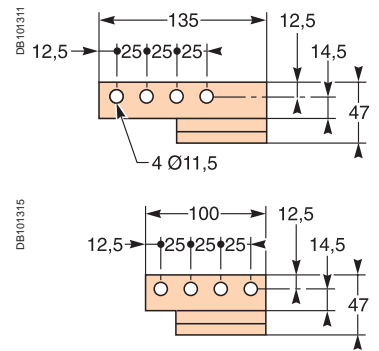
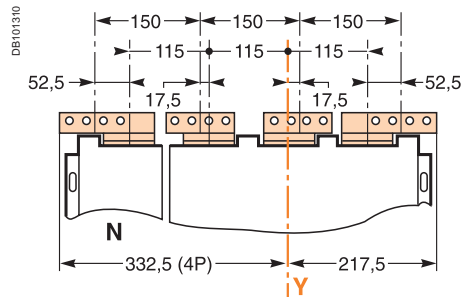

Vertical rear connection

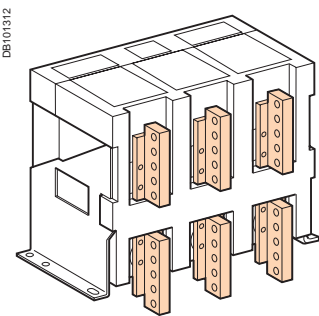

DB101312

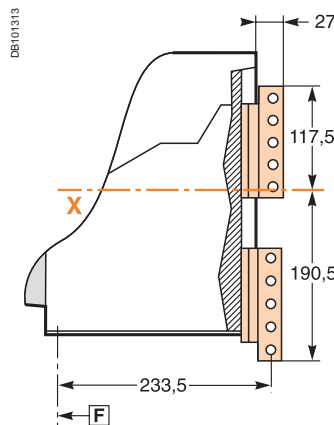

Detail

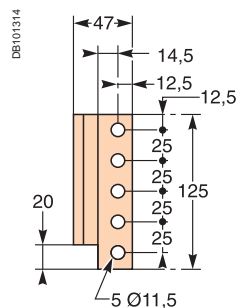
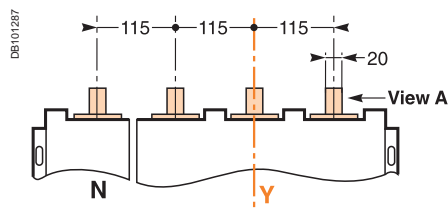

Note: recommended connection screws: **M10** class 8.8.
Tightening torque: **50 Nm** with contact washer.

Dimensions

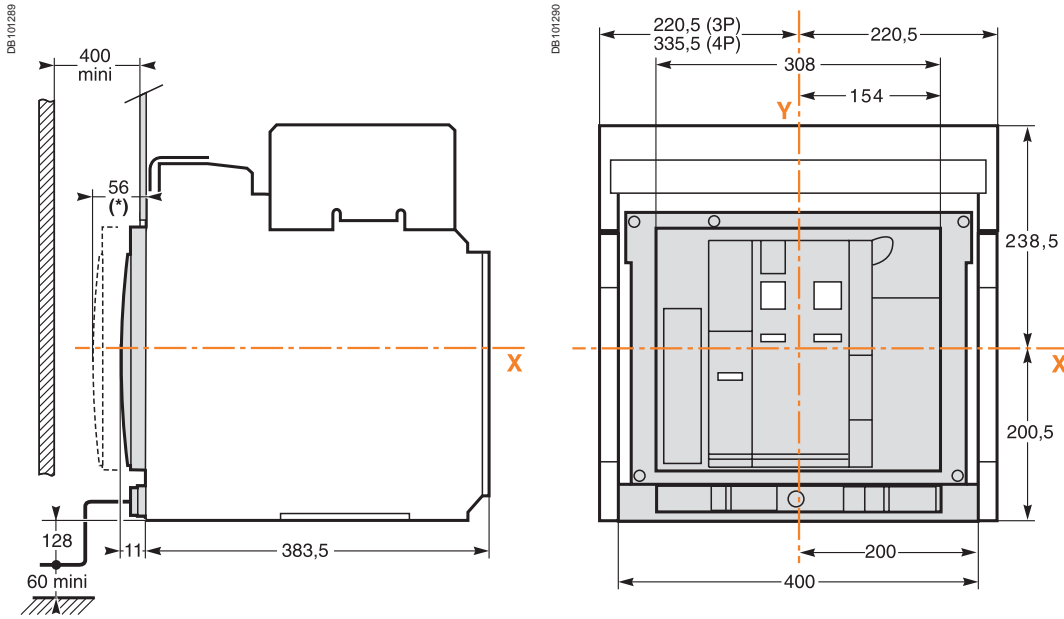

(*) Disconnected position.

Mounting on base plate or rails

Mounting detail

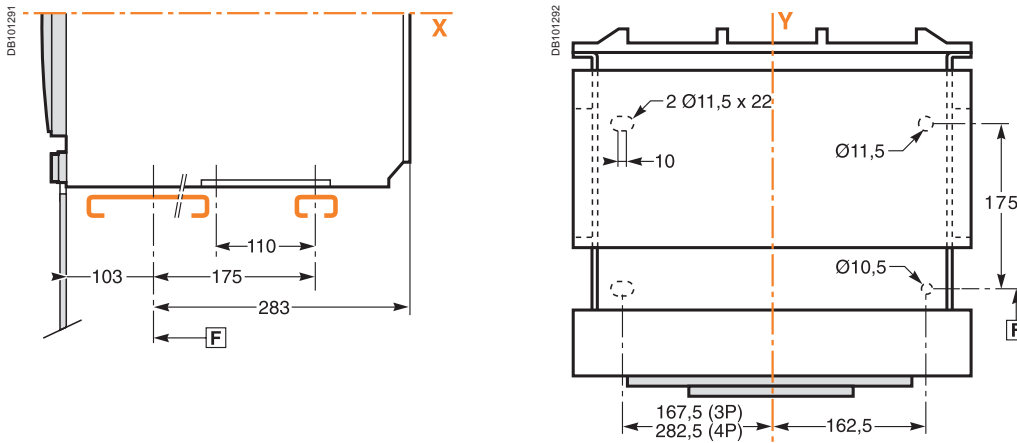

Safety clearances

Door cutout

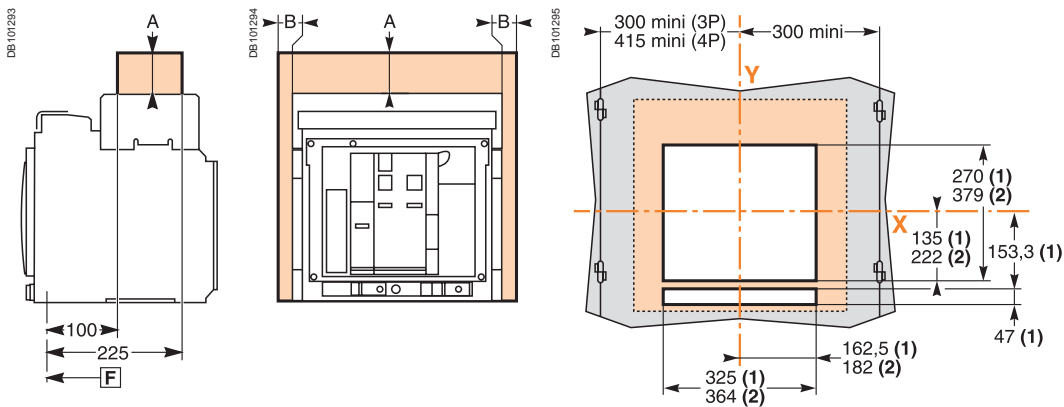

	Insulated parts	Metal parts	Energised parts
A	0	0	0
B	0	0	60

(1) Without escutcheon.

(2) With escutcheon.

Note: X and Y are the symmetry planes for a 3-pole device.

The safety clearances take into account the space required to remove the arc chutes.

F : datum.

Connections

Horizontal rear connection

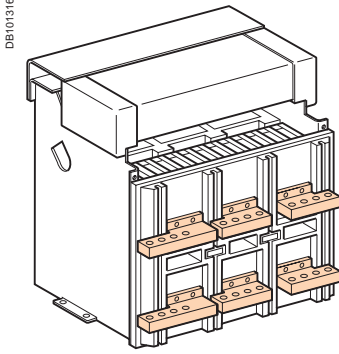

DB101316

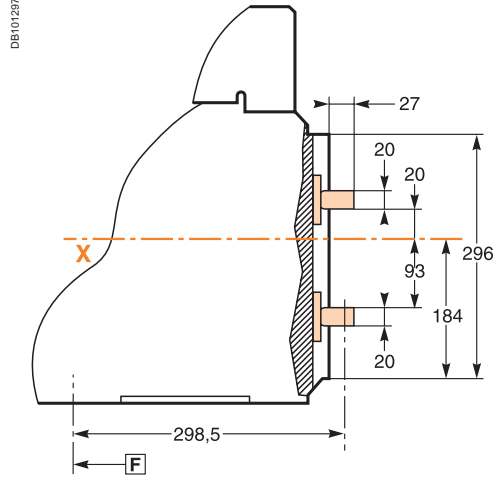

Detail

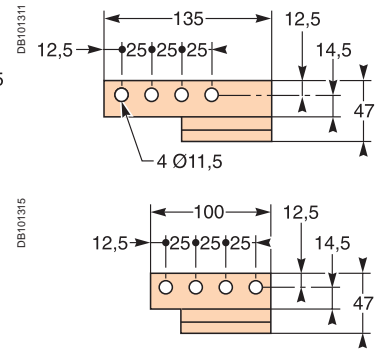
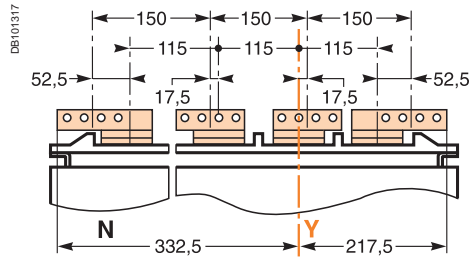

Vertical rear connection

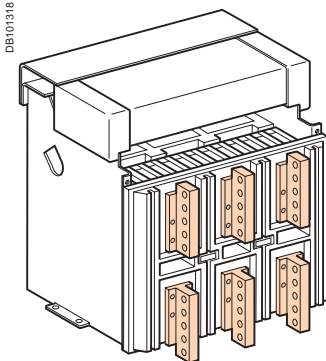

DB101318

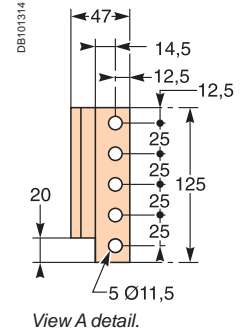
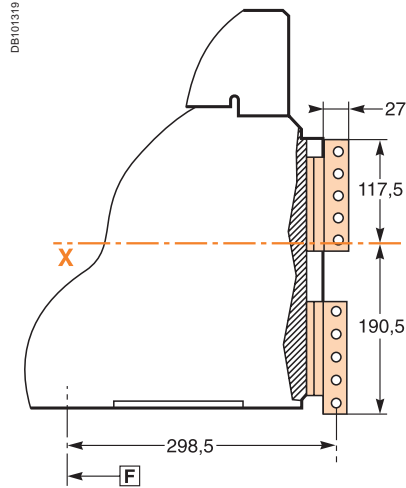

Detail

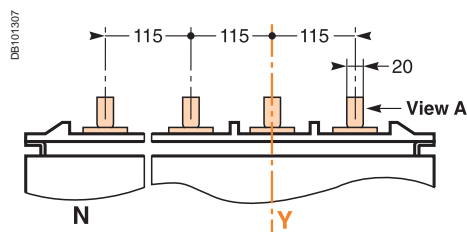

Note: recommended connection screws: **M10** class 8.8.
Tightening torque: **50 Nm** with contact washer.

NW40b to NW63 circuit breakers

Fixed 3/4-poles device

Dimensions

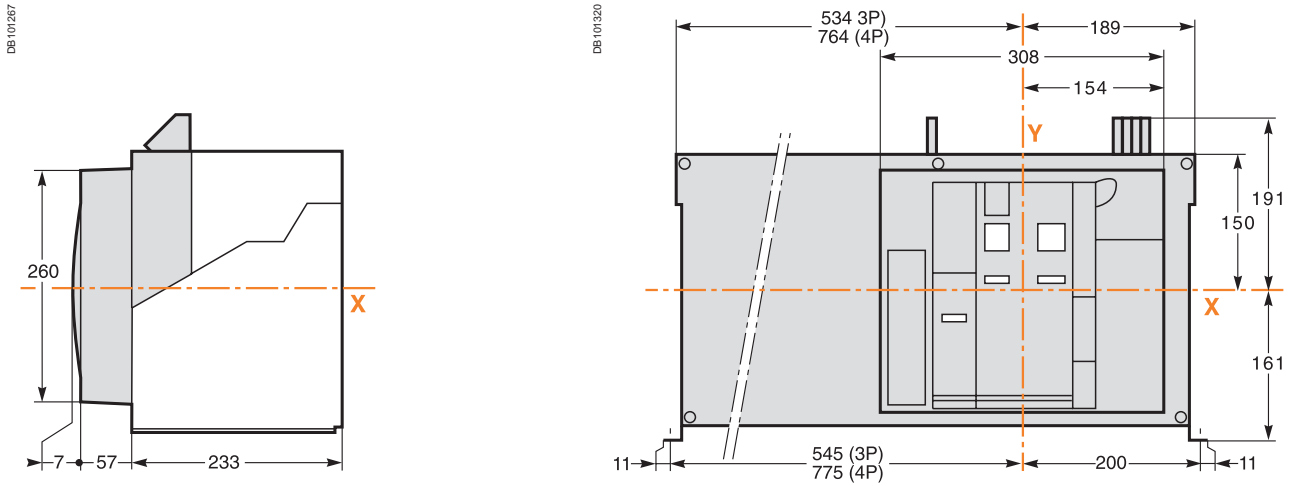

Mounting on base plate or rails

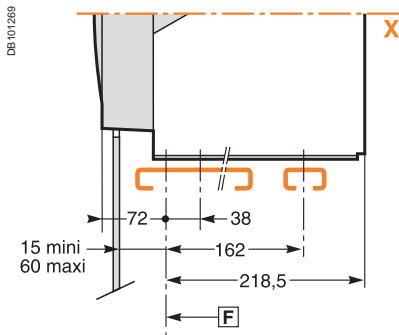

Mounting detail

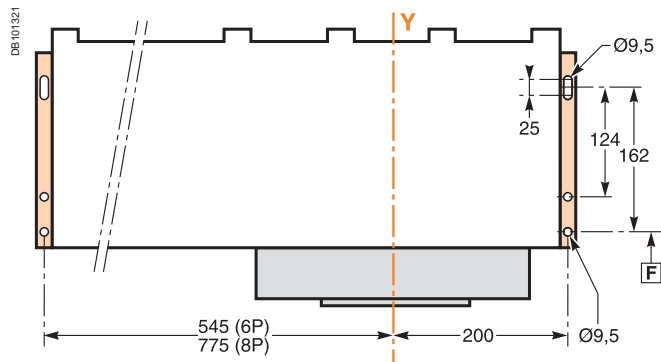

Safety clearances

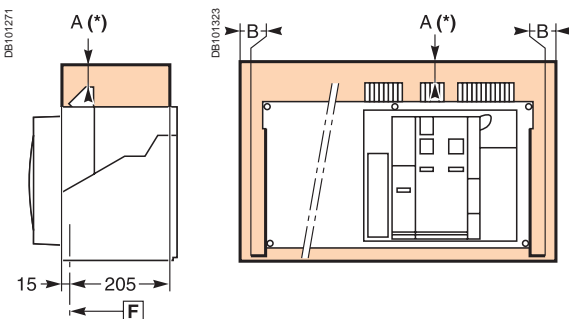

Door cutout

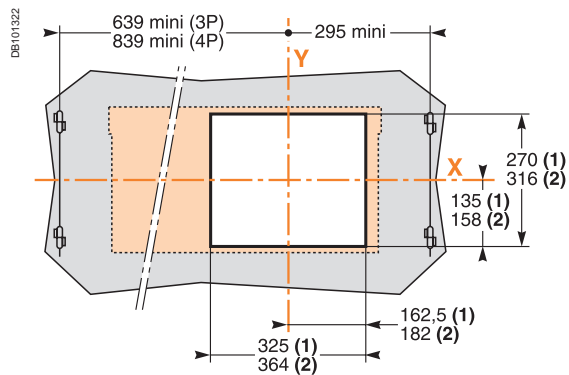

	Insulated parts	Metal parts	Energised parts
A	0	0	100
B	0	0	60

(1) Without escutcheon.

(2) With escutcheon.

Note: X and Y are the symmetry planes for a 3-pole device.

A(*) An overhead clearance of 110 mm is required to remove the arc chutes. An overhead clearance of 20 mm is required to remove the terminal block.

F : datum.

Connections

Horizontal rear connection (NW40b - NW50)

Detail

DB101332

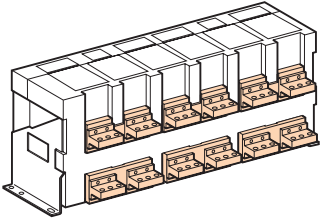

DB101324

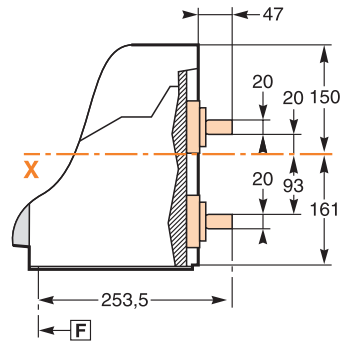

DB101325

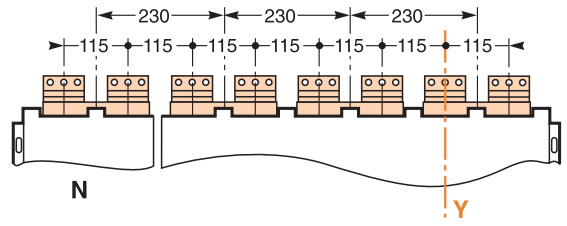

DB101278

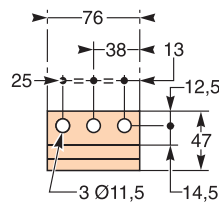

Vertical rear connection (NW40b - NW50)

Detail

DB101327

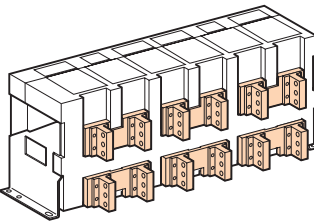

DB101328

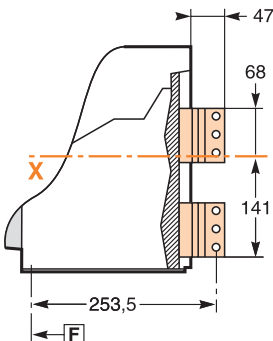

DB101333

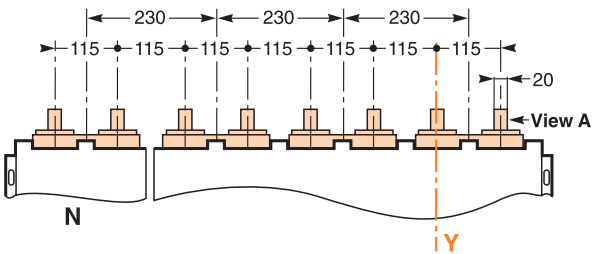

DB101282

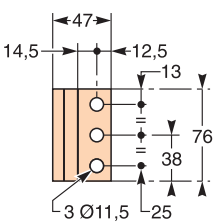

View A detail.

Vertical rear connection (NW63)

Detail

DB101330

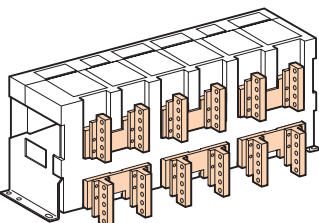

DB101331

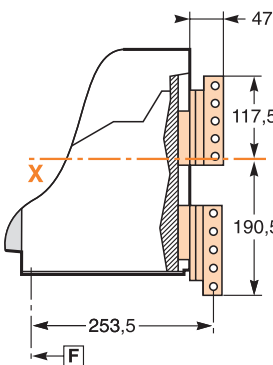

DB101333

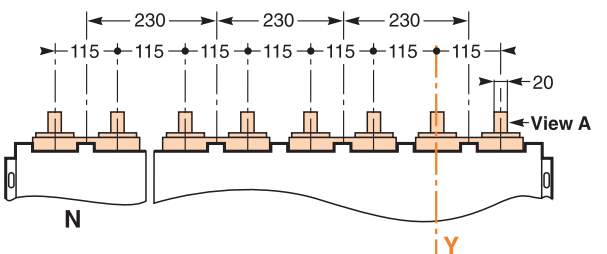

DB101314

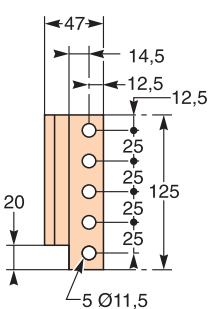

View A detail.

Note: recommended connection screws: **M10** s/s class A4 80.
Tightening torque: **50 Nm** with contact washer.

NW40b to NW63 circuit breakers

Drawout 3/4-poles device

Dimensions

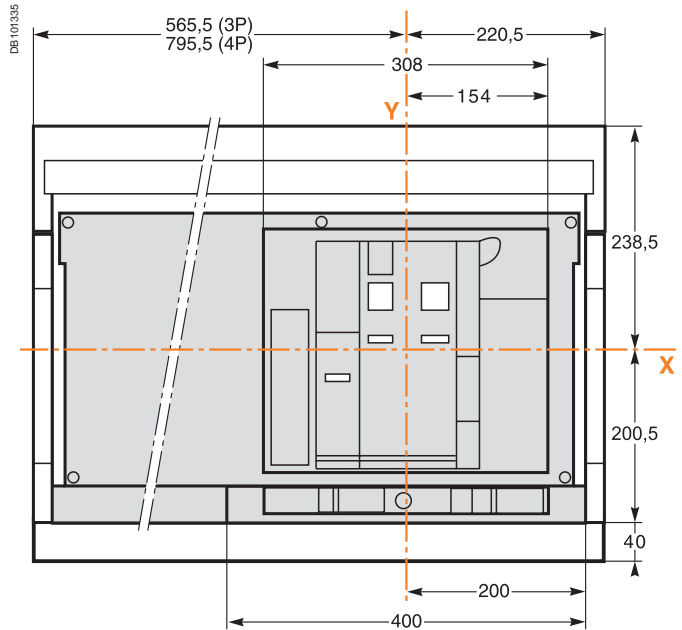
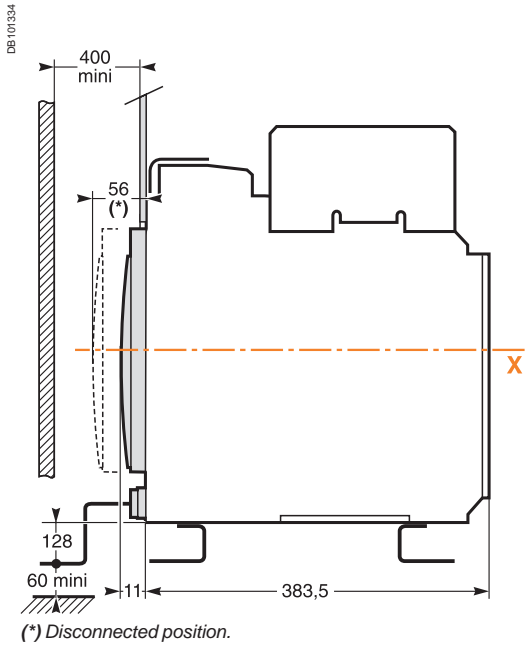

Mounting on base plate or rails

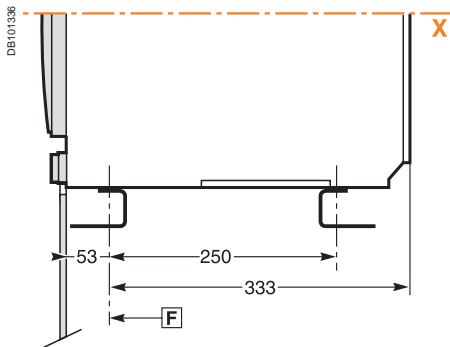

Mounting detail

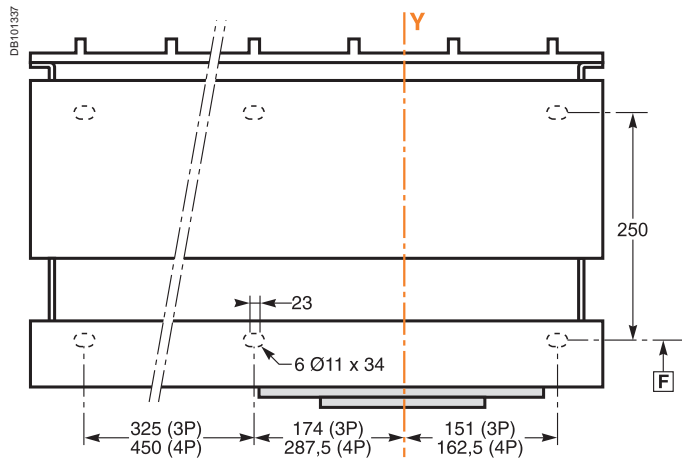

Safety clearances

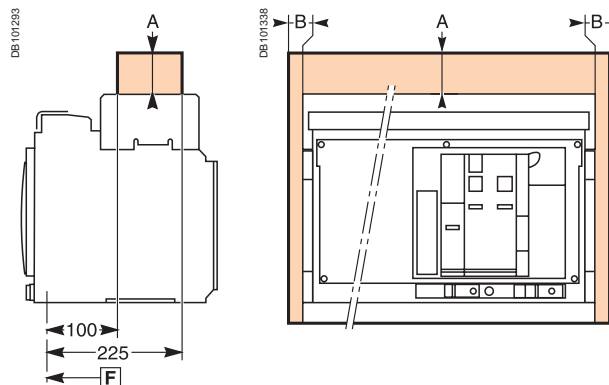

Door cutout

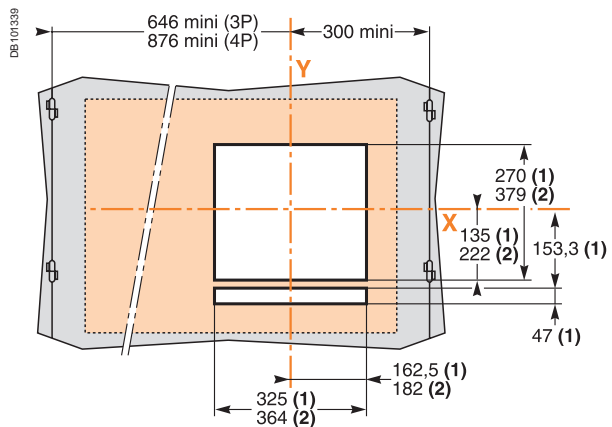

	Insulated parts	Metal parts	Energised parts
A	0	0	0
B	0	0	60

(1) Without escutcheon.

(2) With escutcheon.

Note: X and Y are the symmetry planes for a 3-pole device.

F : datum.

Connections

Horizontal rear connection (NW40b - NW50)

Detail

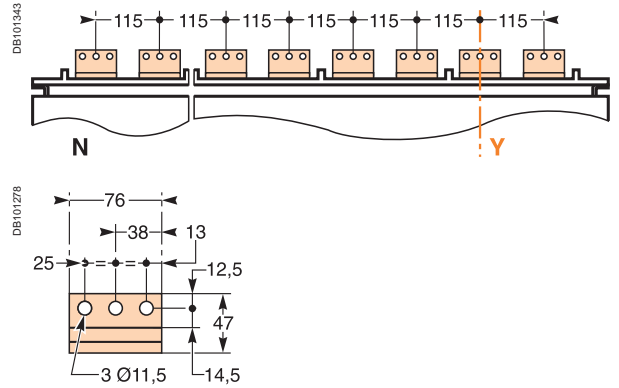
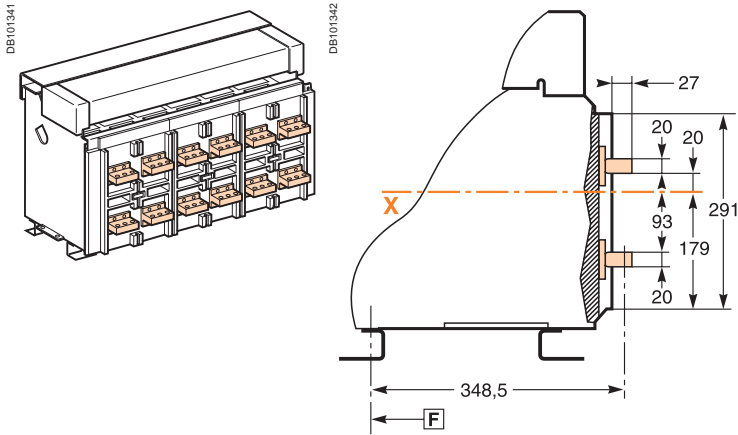

Vertical rear connection (NW40b - NW50)

Detail

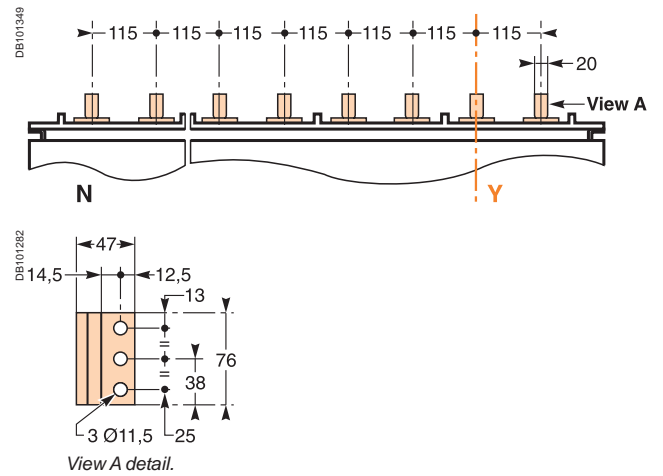
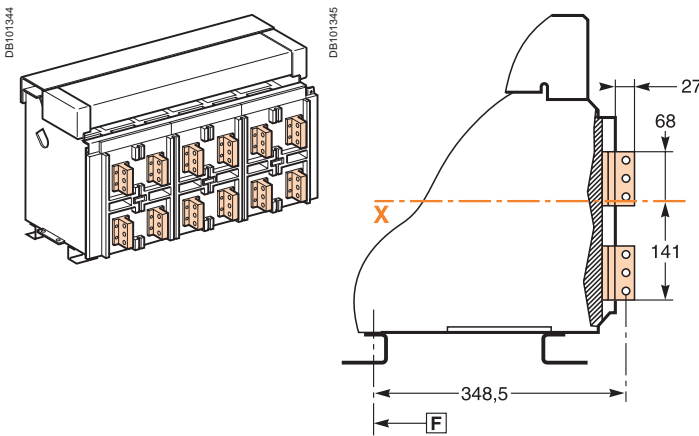

Vertical rear connection (NW63)

Detail

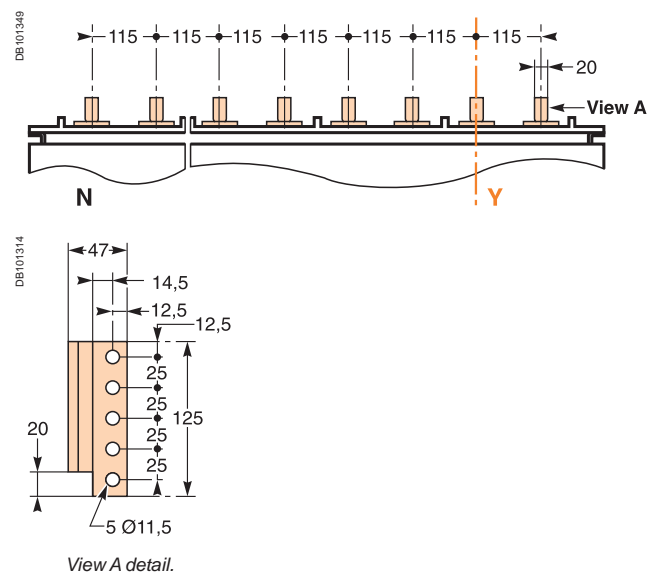
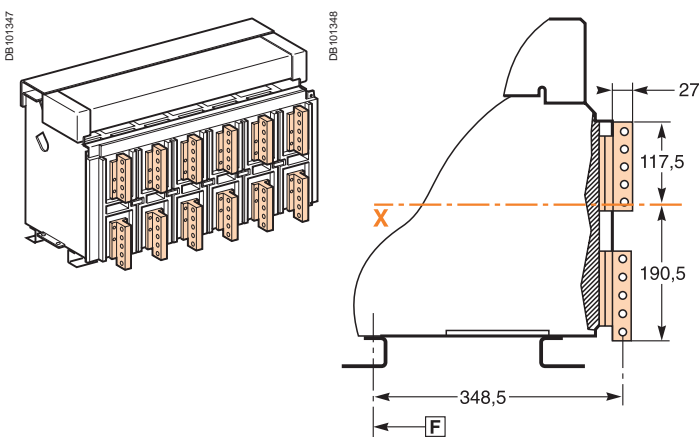

Note: recommended connection screws: **M10** s/s class A4 80.
Tightening torque: **50 Nm** with contact washer.

Mounting on backplate with special brackets (Masterpact NW08 to 32 fixed)

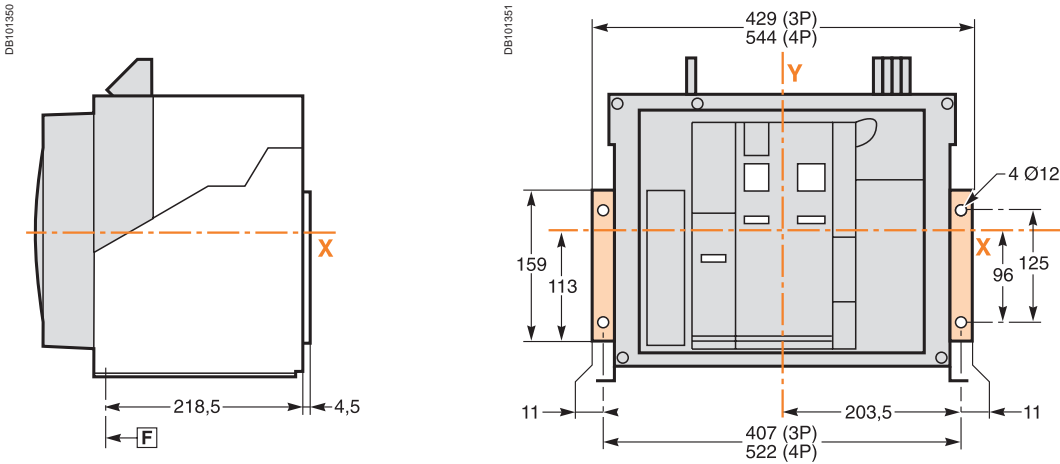

Disconnectable front-connection adapter (Masterpact NW08 to 32 fixed)

Horizontal rear connection

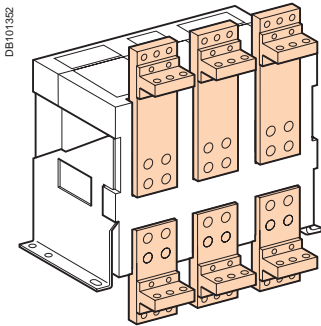

DB101352

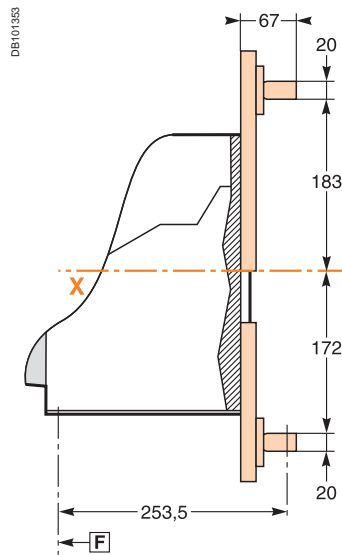

Detail

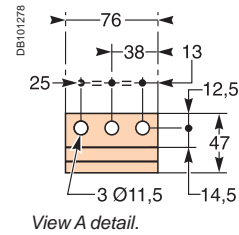
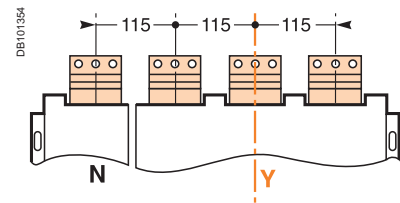

Vertical rear connection

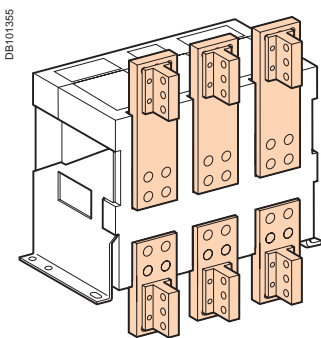

DB101355

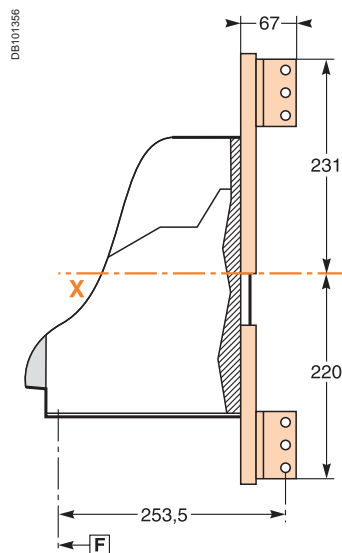

Detail

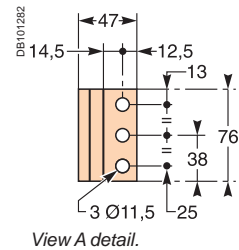
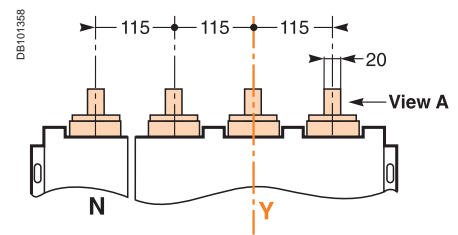

Note: recommended connection screws: **M10** class 8.8.
Tightening torque: **50 Nm** with contact washer.

F : datum.

Rear panel cutout (drawout devices)

NW08 to NW40

Rear view

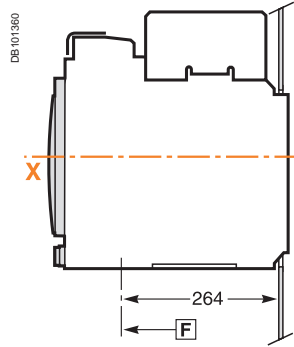
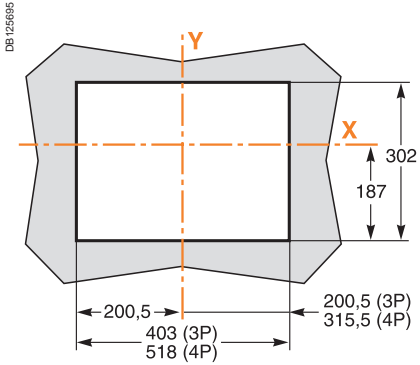

NW40b to NW63

Rear view

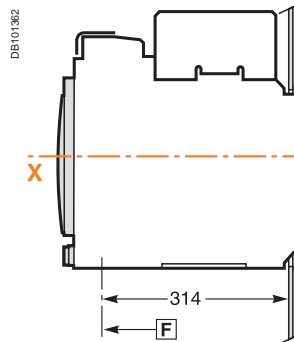
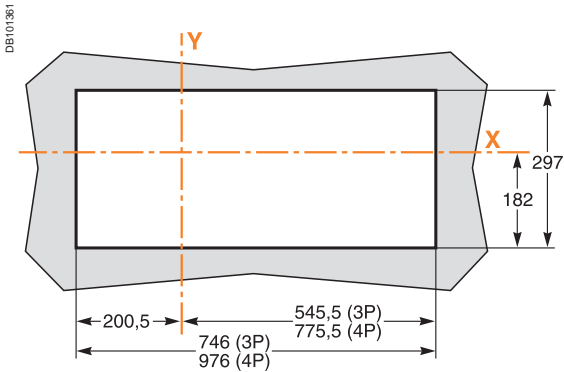

Escutcheon

Masterpact NT

Fixed device

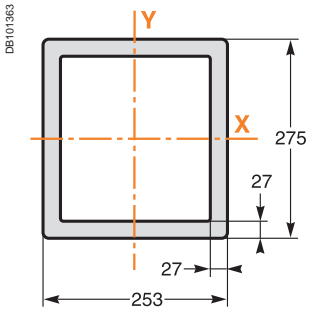

Drawout device

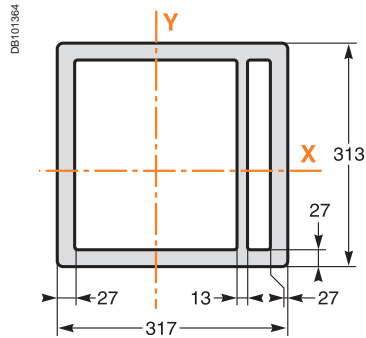

Masterpact NW

Fixed device

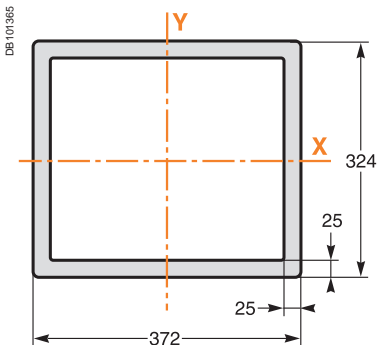

Drawout device

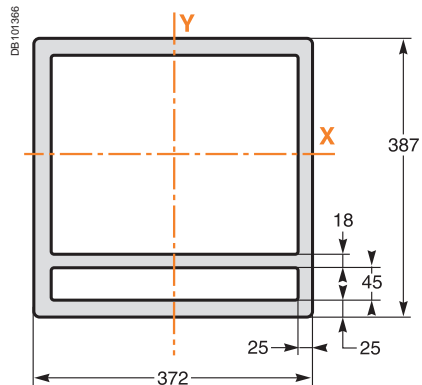

F : datum.

Connection of auxiliary wiring to terminal block

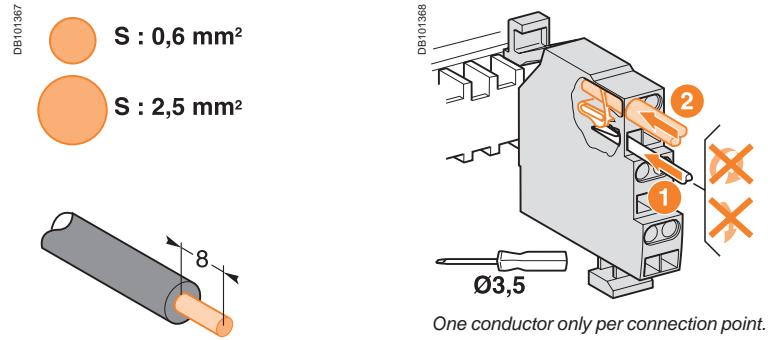

M6C relay module

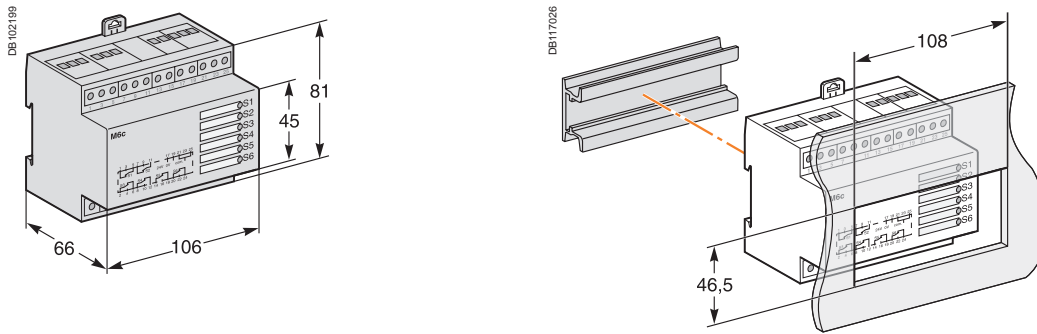

External power supply module (AD)

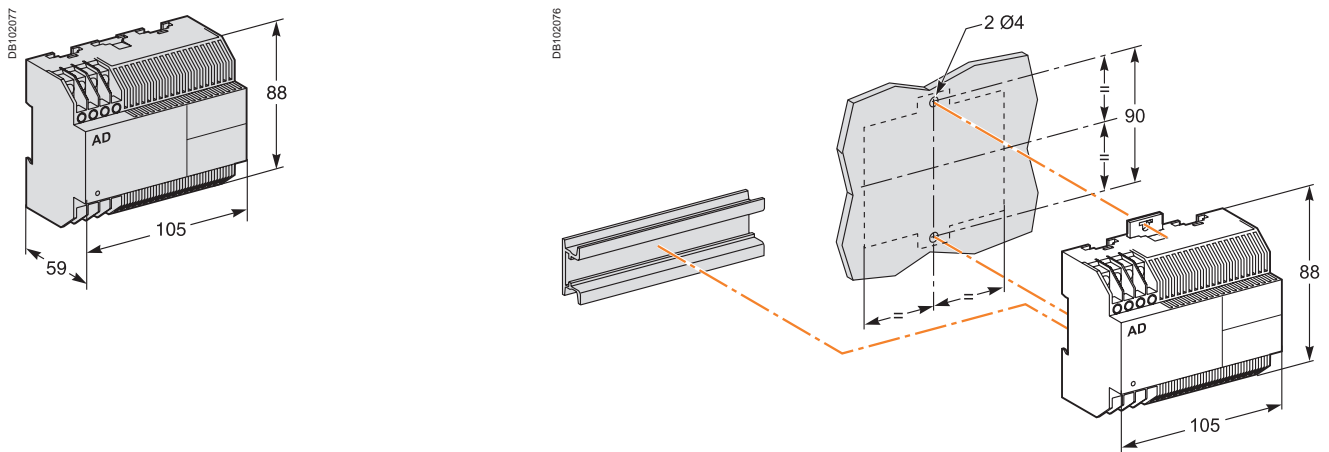

Battery module (BAT)

Mounting

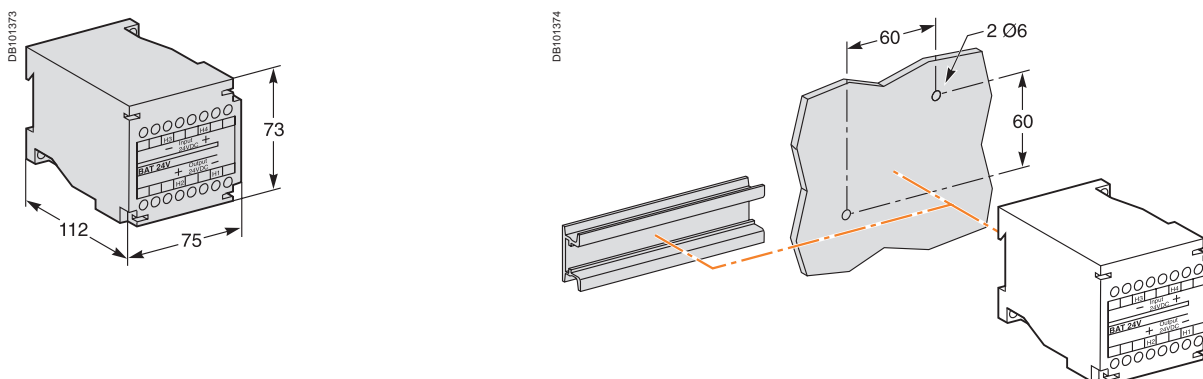

Delay unit for MN release

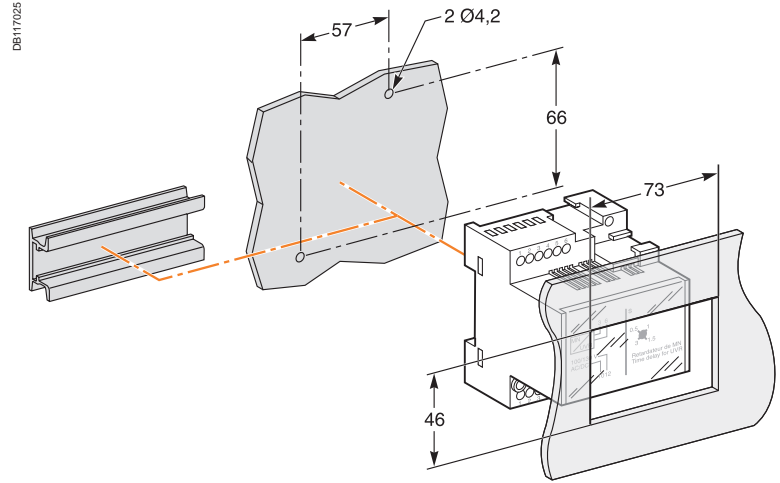
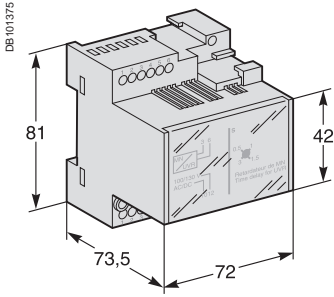

“Chassis” communication module

ModBUS

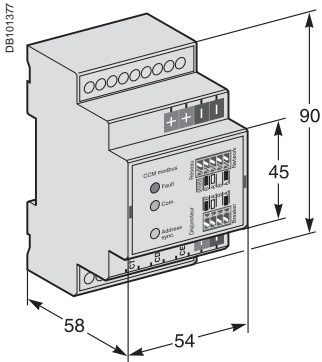

BatiBUS

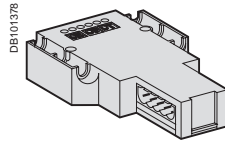

External sensor for source ground return (SGR) protection

Sensor

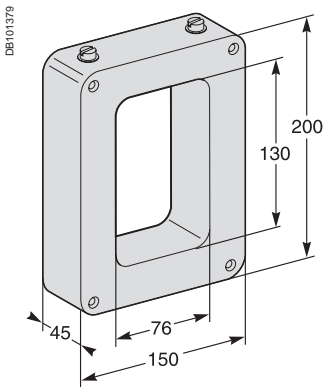

“MGDF summer” module

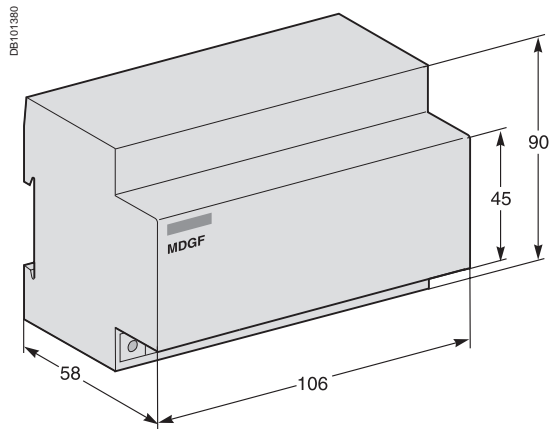

External sensor for external neutral

Dimensions

400/1600 A (NT06 to NT16)

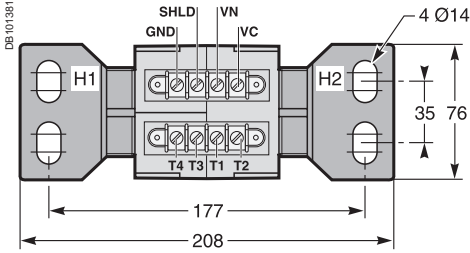

High: 137 mm.

400/2000 A (NW08 to NW20)

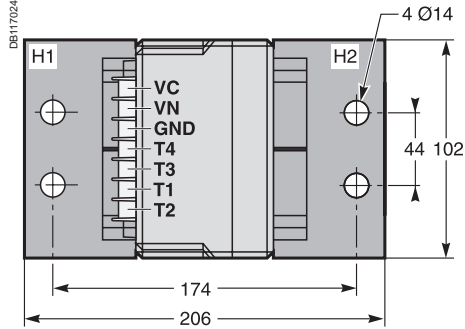

High: 162 mm.

1000/4000 A (NW025 to NW40)

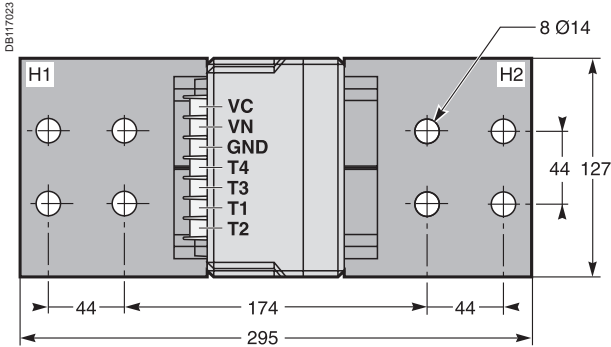

High: 162 mm.

4000/6300 A (NW40b to NW63)

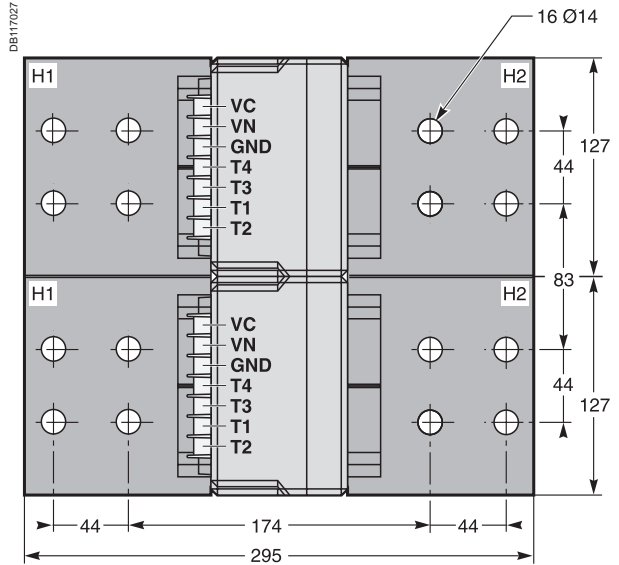

High: 168 mm.

Installation

400/1600 A (NT06 to NT16)

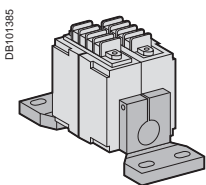

400/2000 A (NW08 to NW20)

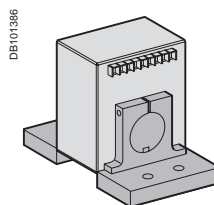

1000/4000 A (NW025 to NW40)

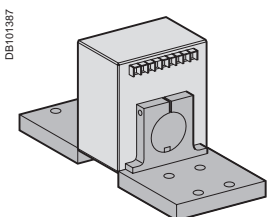

4000/6300 A (NW40b to NW63)

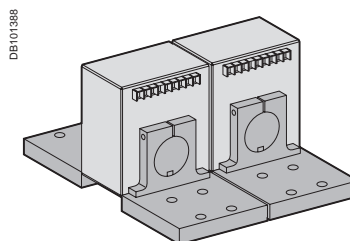

Rectangular sensor for earth leakage protection (Vigi)

280 x 115 mm window

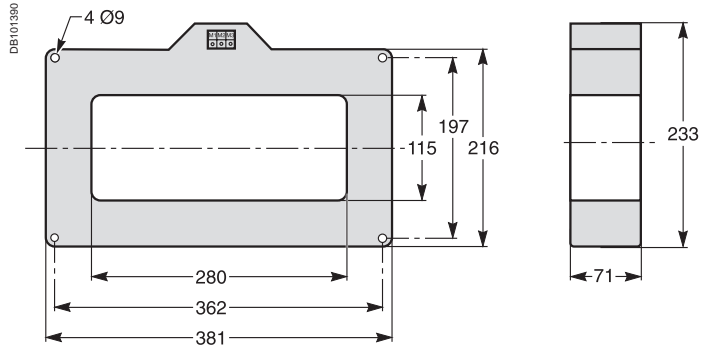
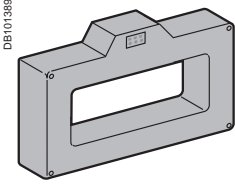

470 x 160 mm window

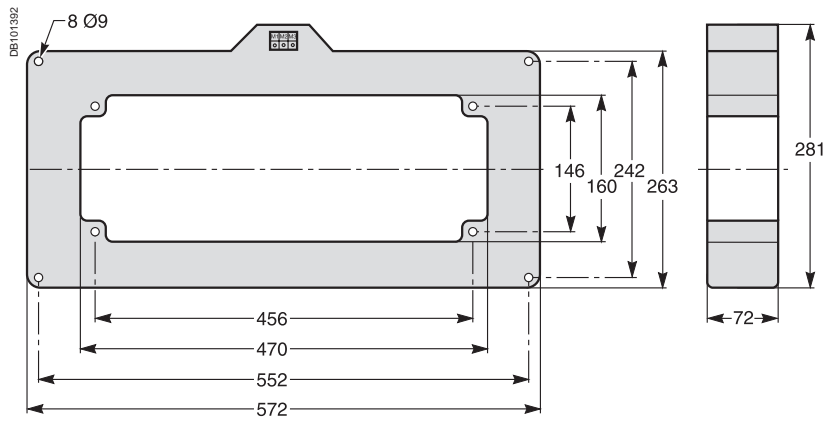
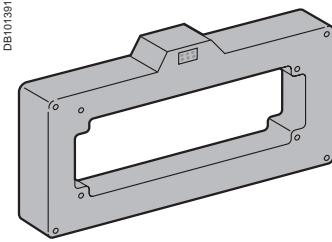

Busbars	I ≤ 1600 A	I ≤ 3200
Window (mm)	280 x 115	470 x 160
Weight (kg)	14	18

Busbars path

280 x 115 window

Busbars spaced 70 mm centre-to-centre

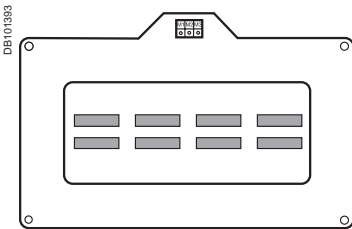

2 bars 50 x 10.

470 x 160 window

Busbars spaced 115 mm centre-to-centre

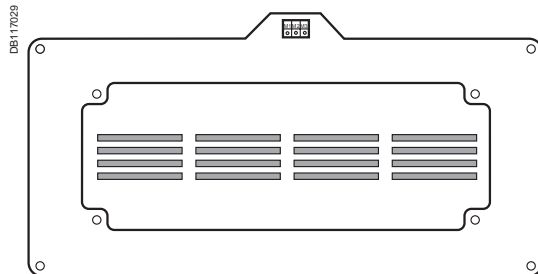

4 bars 100 x 5.

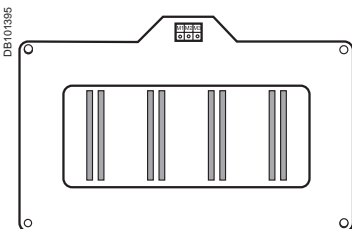

2 bars 100 x 5.

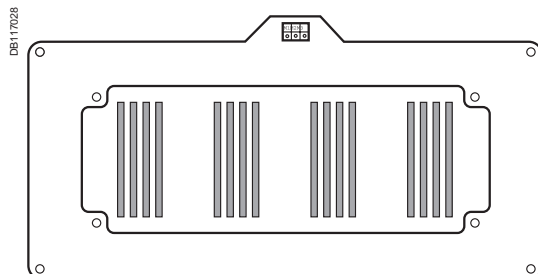

4 bars 125 x 5.

schneider-electric.com

This international site allows you to access all the Schneider Electric products in just 2 clicks via comprehensive range data-sheets, with direct links to:

- complete library: technical documents, catalogs, FAQs, brochures...

- selection guides from the e-catalog.

- product discovery sites and their Flash animations.

You will also find illustrated overviews, news to which you can subscribe, the list of country contacts...



The electrical installation guide

According to IEC 60364

This guide, part of the Schneider Electric offer, is the essential tool to "guide" you any time in your business:

- design office, consultant
- contractor, panelbuilder
- teacher, trainer.

Comprehensive and concrete information on:

- all the new technical solutions
- all the components
- of an installation from a global point of view
- all the IEC standards modifications
- all the fundamental electrotechnical knowledge
- all the design stages, from medium to low voltage.



<i>Presentation</i>	1
<i>Functions and characteristics</i>	A-1
<i>Installation recommendations</i>	B-1
<i>Dimensions and connection</i>	C-1
Masterpact NT06 to NT16	
Fixed and drawout devices	D-2
Masterpact NW08 to NW63	
Fixed and drawout devices	D-4
Masterpact NT and NW	
Communications of the 24 V DC	D-6
External power supply AD module	D-6
Communications option 24 V DC external power supply	D-8
Earth-fault and earth-leakage protection - Neutral protection	
Zone selective interlocking	D-10
<i>Additional characteristics</i>	E-1
<i>Catalogue numbers and order form</i>	F-1

The diagram is shown with circuits de-energised, all devices open, connected and charged and relays in normal position.

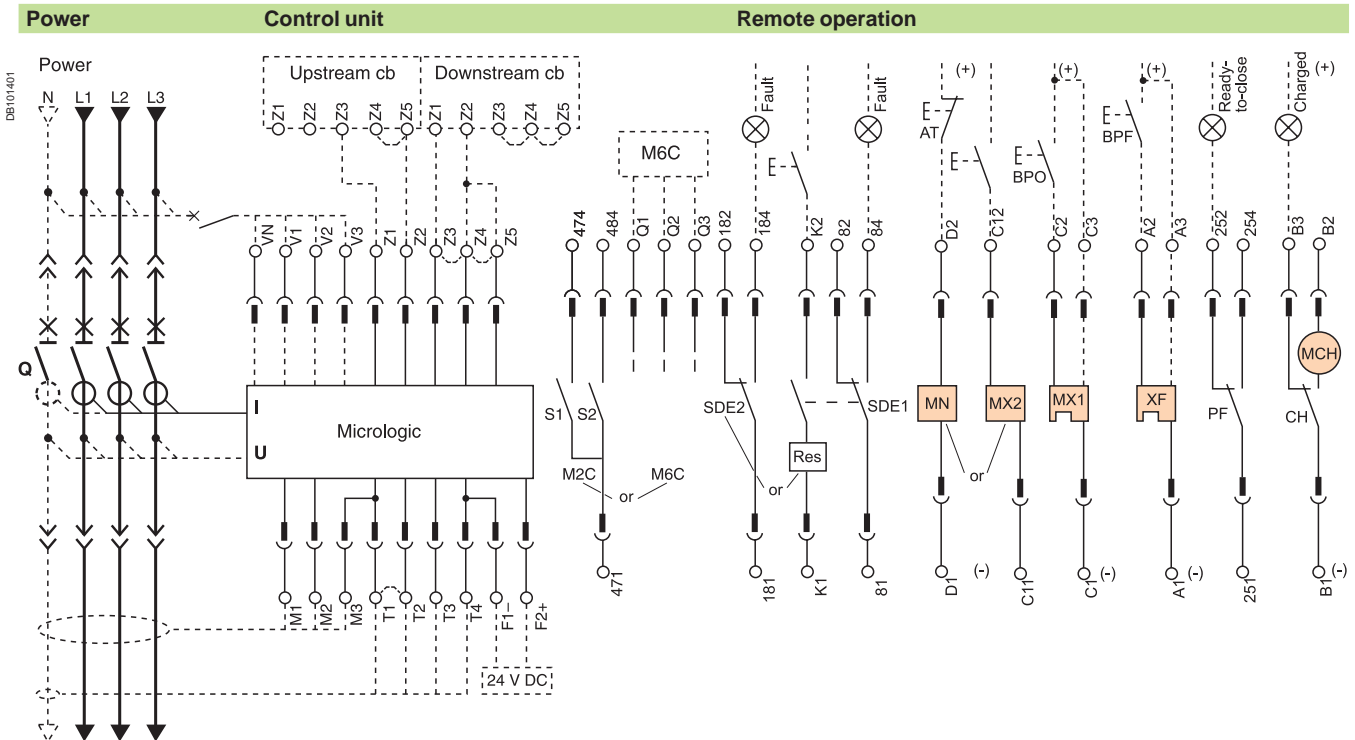

Terminal block marking	Control unit					
	Com	UC1	UC2	UC3	UC4 / M2C / M6C	
	○ E5	○ E6	○ Z5	○ M1	○ M2	○ M3
	○ E3	○ E4	○ Z3	○ Z4	○ T3	○ T4
	○ E1	○ E2	○ Z1	○ Z2	○ T1	○ T2
				○ F1-	○ F2+	
				○ VN	○ V1	○ V2
				○ V3	○ V4	○ V5
				○ M2C	○ M6C	
				○ Q1	○ Q2	○ Q3

Remote operation						
SDE2 / Res	SDE1	MN / MX2	MX1	XF	PF	MCH
○ 184 / K2	○ 84	○ D2 / C12	○ C2	○ A2	○ 254	○ B2
○ 182	○ 82		○ C3	○ A3	○ 252	○ B3
○ 181 / K1	○ 81	○ D1 / C11	○ C1	○ A1	○ 251	○ B1

A	P	H	Control unit
■	■	■	Com : E1-E6 communication
■	■	■	UC1 : Z1-Z5 zone selective interlocking Z1 = ZSI OUT SOURCE Z2 = ZSI OUT ; Z3 = ZSI IN SOURCE Z4 = ZSI IN ST (short time) Z5 = ZSI IN GF (earth fault) M1 = Vigi module input (Micrologic 7)
■	■	■	UC2 : T1, T2, T3, T4 = external neutral M2, M3 = Vigi module input (Micrologic 7)
■	■	■	UC3 : F2+, F1- external 24 V DC power supply VN external voltage connector (must be connected to the neutral with a 3P circuit breaker)
		■	UC4 : External Voltage Connector (PTE option) or M2C : 2 programmable contacts (external relay) ext. 24 V DC power supply required. or M6C : 6 programmable contacts to be connected to the external module M6C ext. 24 V DC power supply required.

Remote operation	
SDE2 : fault-trip indication contact or Res : remote reset	SDE1 : fault-trip indication contact (supplied as standard)
MN : undervoltage release or MX2 : shunt release	MX1 : shunt release (standard or communicating)
XF : closing release (standard or communicating)	PF : ready-to-close contact
MCH : electric motor	

Note: when communicating MX or XF releases are used, the third wire (C3,A3) must be connected even if the communication module is not installed.

A : digital ammeter.
P : A + power meter + additional protection.
H : P + harmonics.

Indication contacts

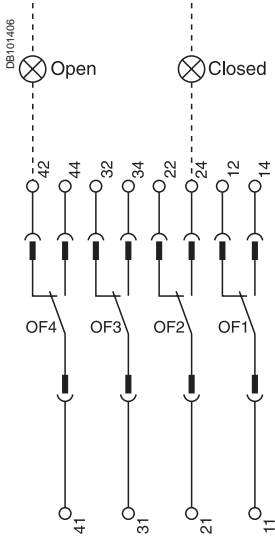

Chassis contacts

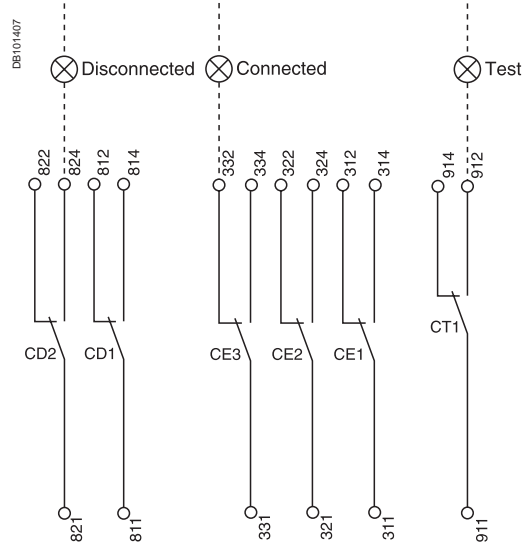

Indication contacts

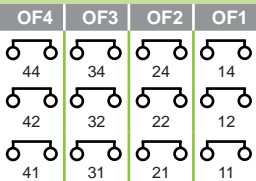

Chassis contacts

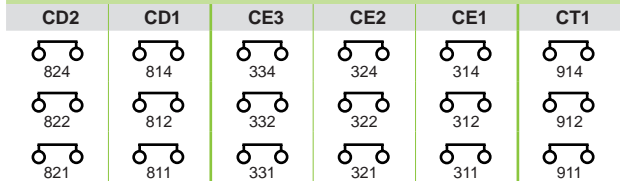

Indication contacts

OF4 / OF3 / OF2 / OF1 : ON/OFF indication contacts.

(*) Spring charging motor 440/480 V AC
(380 V motor + additional resistor).

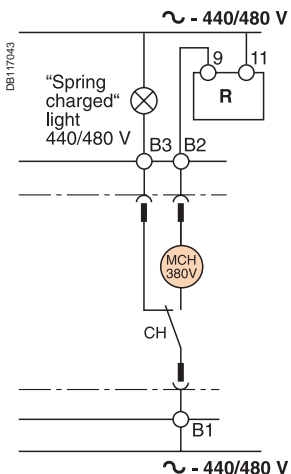

Chassis contacts

CD2 : disconnected position contacts
 CD1 : position contacts
 CE3 : connected position contacts
 CE2 : position contacts
 CE1 : contacts
 CT1 : test position contacts

Key:

- XXX drawout device only.
- XXX SDE1, OF1, OF2, OF3, OF4 supplied as standard.
- interconnected connections (only one wire per connection point).

The diagram is shown with circuits de-energised, all devices open, connected and charged and relays in normal position.

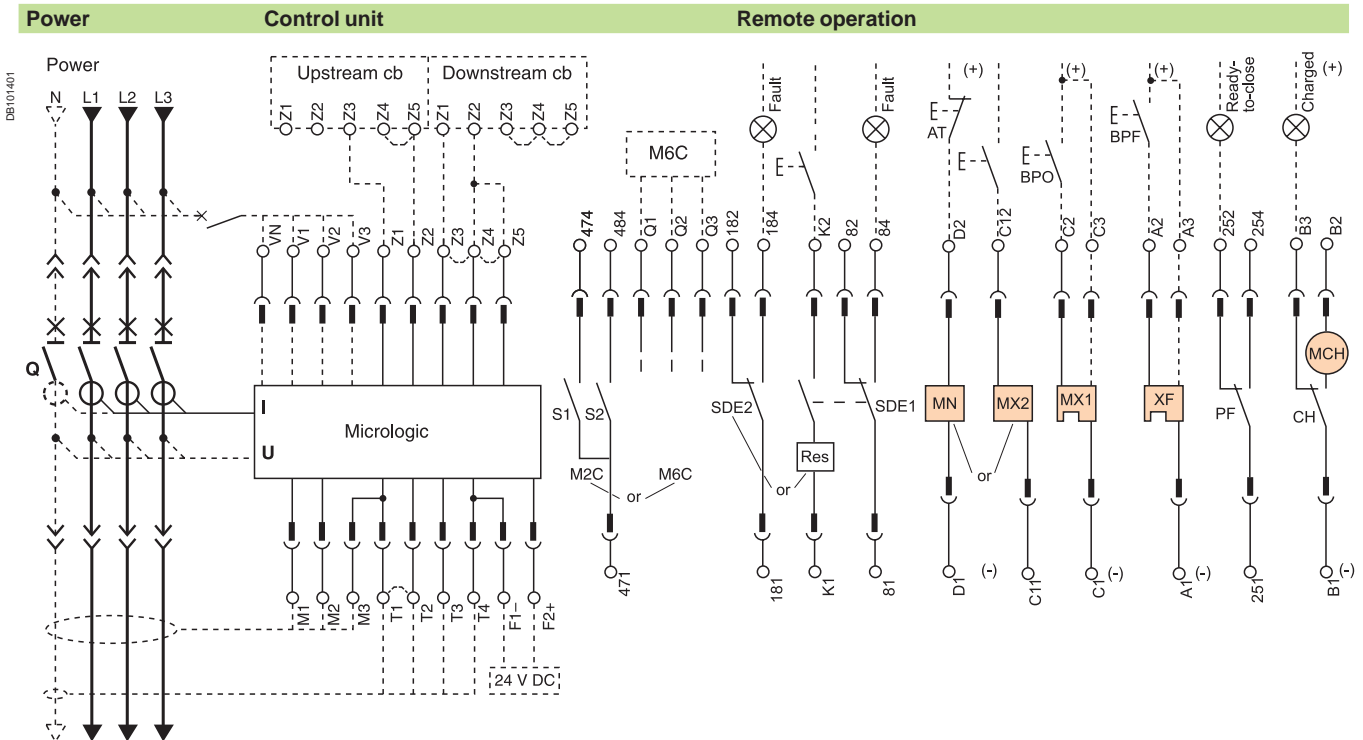

Terminal block marking	Control unit									
	Com	UC1	UC2	UC3	UC4	M2C / M6C				
	E5 E6	Z5 M1	M2 M3	F2+	V3	484	Q3			
	E3 E4	Z3 Z4	T3 T4	VN	V2	474	Q2			
	E1 E2	Z1 Z2	T1 T2	F1-	V1	471	Q1			

Remote operation											
SDE2 / Res	SDE1	MN / MX2	MX1	XF	PF	MCH					
184 / K2	84	D2 / C12	C2	A2	254	B2					
182	82		C3	A3	252	B3					
181 / K1	81	D1 / C11	C1	A1	251	B1					

A	P	H	Control unit
■	■	■	Com : E1-E6 communication
■	■	■	UC1 : Z1-Z5 zone selective interlocking Z1 = ZSI OUT SOURCE Z2 = ZSI OUT ; Z3 = ZSI IN SOURCE Z4 = ZSI IN ST (short time) Z5 = ZSI IN GF (earth fault)
■	■	■	M1 = Vigi module input (Micrologic 7)
■	■	■	UC2 : T1, T2, T3, T4 = external neutral M2, M3 = Vigi module input (Micrologic 7)
■	■	■	UC3 : F2+, F1- external 24 V DC power supply VN external voltage connector (must be connected to the neutral with a 3P circuit breaker)
■	■	■	UC4 : External Voltage Connector (PTE option)
■	■	■	M2C : 2 programmable contacts (internal relay) ext. 24 V DC power supply required
■	■	■	or M6C : 6 programmable contacts (to be connected to the external module M6C) ext. 24 V DC power supply required

Remote operation
SDE2 : fault-trip indication contact or Res : remote reset
SDE1 : fault-trip indication contact (supplied as standard)
MN : undervoltage release or MX2 : shunt release
MX1 : shunt release (standard or communicating)
XF : closing release (standard or communicating)
PF : ready-to-close contact
MCH : electric motor

Note: when communicating MX or XF releases are used, the third wire (C3, A3) must be connected even if the communication module is not installed.

A : digital ammeter.
P : A + power meter + additional protection.
H : P + harmonics.

Indication contacts

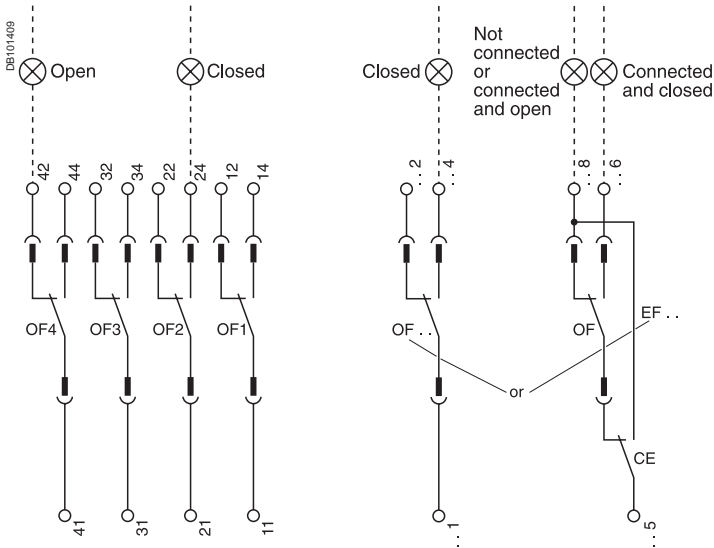

Chassis contacts

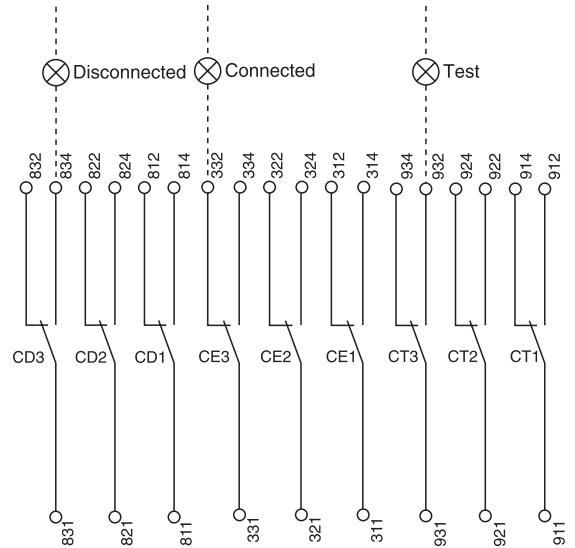

Indication contacts

OF4	OF3	OF2	OF1										
44	34	24	14	244	234	224	214	144	134	124	114		
42	32	22	12	242	232	222	212	142	132	122	112		
41	31	21	11	241	231	221	211	141	131	121	111		
				or	or	or	or	or	or	or	or	or	or
248	238	228	218	148	138	128	118						
246	236	226	216	146	136	126	116						
245	235	225	215	145	135	125	115						

Chassis contacts

CD3	CD2	CD1	CE3	CE2	CE1	CT3	CT2	CT1				
834	824	814	334	324	314	934	924	914				
832	822	812	332	322	312	932	922	912				
831	821	811	331	321	311	931	921	911				
						or						
364	354	344				394	384	374				
362	352	342				392	382	372				
361	351	341				391	381	371				

Indication contacts

OF4 :	ON/OFF indication contacts	OF24 or EF24	Combined "connected-deconnected" indication contacts
OF3		OF23 or EF23	
OF2		OF22 or EF22	
OF1		OF21 or EF21	
		OF14 or EF14	
		OF13 or EF13	
		OF12 or EF12	
		OF11 or EF11	

Chassis contacts

CD3	disconnected position contacts	CE3	connected position contacts	CT3	test position contacts
CD2		CE2		CT2	
CD1		CE1		CT1	
or			or		
CE6	connected position contacts	CE9	connected position contacts	CE8	position contacts
CE5		CE7		CE7	
CE4		CD6	disconnected position contacts	CD5	position contacts
		CD4		CD4	

Key:

drawout device only.

SDE1, OF1, OF2, OF3, OF4 supplied as standard.

interconnected connections (only one wire per connection point).

Masterpact NT and NW

Communications of the 24 V DC External power supply AD module

None of the control-unit protection functions require an auxiliary source. However, the 24 V DC external power-supply (AD module) is required for certain operating configurations as indicated in the table below.

Circuit breaker	Closed		Open
	Powered	Not powered	
Voltage measurement inputs			
M2C, M6C programmable contacts option	Yes	Yes	Yes
Protection function	No	No	No
Display function	No ⁽¹⁾	No ⁽²⁾	Yes
Time-stamping function	No	No	Yes ⁽³⁾
Circuit-breaker status indications and control via communications bus	No	No	No
Identification, settings, operation and maintenance aids via communications bus	No ⁽¹⁾	No ⁽²⁾	Yes

⁽¹⁾ Except for Micrologic A control units (if current < 20 % I_n).

⁽²⁾ Except for Micrologic A control units.

⁽³⁾ Time setting is manual and can be carried out automatically by the supervisor via the communications bus.

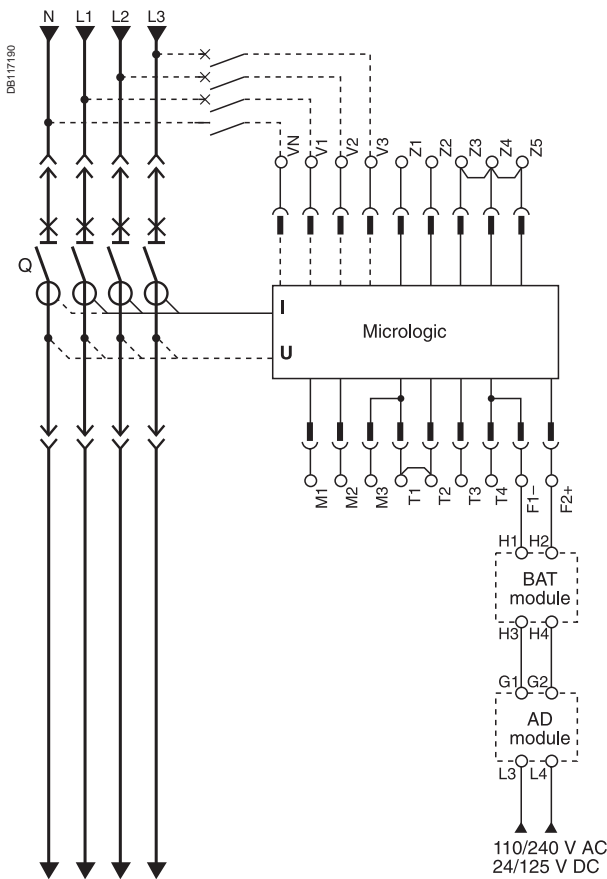

Note: In case of using the 24 V DC external power supply (AD module), maximum cable length between 24 V DC (G1, G2) and the control unit (F1-, F2+) must not exceed 10 meters.

The BAT battery module, mounted in series upstream of the AD module, ensures an uninterrupted supply of power if the AD module power supply fails.

The voltage measurement inputs are standard equipment on the downstream connectors of the circuit breaker.

External connections are possible using the PTE external voltage measurement input option. With this option, the internal voltage measurement inputs are disconnected and terminals VN, V1, V2, V3 are connected only to the control unit (Micrologic P and H only).

The PTE option is required for voltages less than 220 V and greater than 690 V (in which case a voltage transformer is compulsory). For three-pole devices, the system is supplied with terminal VN connected only to the control unit (Micrologic P and H).

When the PTE option is implemented, the voltage measurement input must be protected against short-circuits. Installed as close as possible to the busbars, this protection function is ensured by a P25M circuit breaker (1 A rating) with an auxiliary contact (cat. no. 21104 and 21117). This voltage measurement input is reserved exclusively for the control unit and must not ever be used to supply other circuits outside the switchboard.

Masterpact NT and NW

Communications of the 24 V DC

External power supply AD module

Wiring diagrams

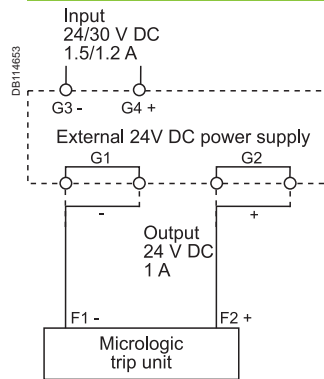

Power supply wiring for Micrologic trip unit only.

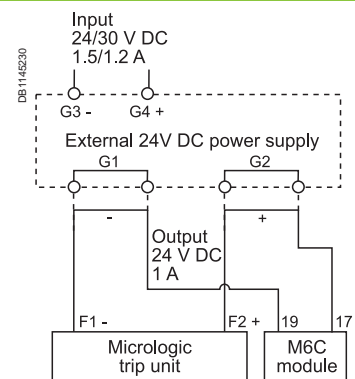

Power supply wiring for Micrologic trip unit and M6C module.

Connection

The maximum length for each conductor supplying power to the trip unit or M6C module is 10 m.

Do not ground F2+, F1-, or power supply output:

- the positive terminal (F2+) on the trip unit must not be connected to earth ground
- the negative terminal (F1-) on the trip unit must not be connected to earth ground
- the output terminals (- and +) of the 24 V DC power supply must not be grounded.

Reduce electromagnetic interference:

- the input and output wires of the 24 V DC power supply must be physically separated as much as possible
- if the 24 V DC power supply wires cross power cables, they must cross perpendicularly. If this is not physically possible, the power supply conductors must be twisted together
- Power supply conductors must be cut to length. Do not loop excess conductor.

Use only one 24 V DC power supply for each Micrologic trip unit.

Connect external 24 V DC power supply only per the following wiring diagrams.

Masterpact NT and NW

Communications option 24 V DC external power supply

Example of connection of the communications option

The communications bus requires its own 24 V DC power source (E1, E2).
This source is not the same as the 24 V DC external power-supply module (F1-, F2+).

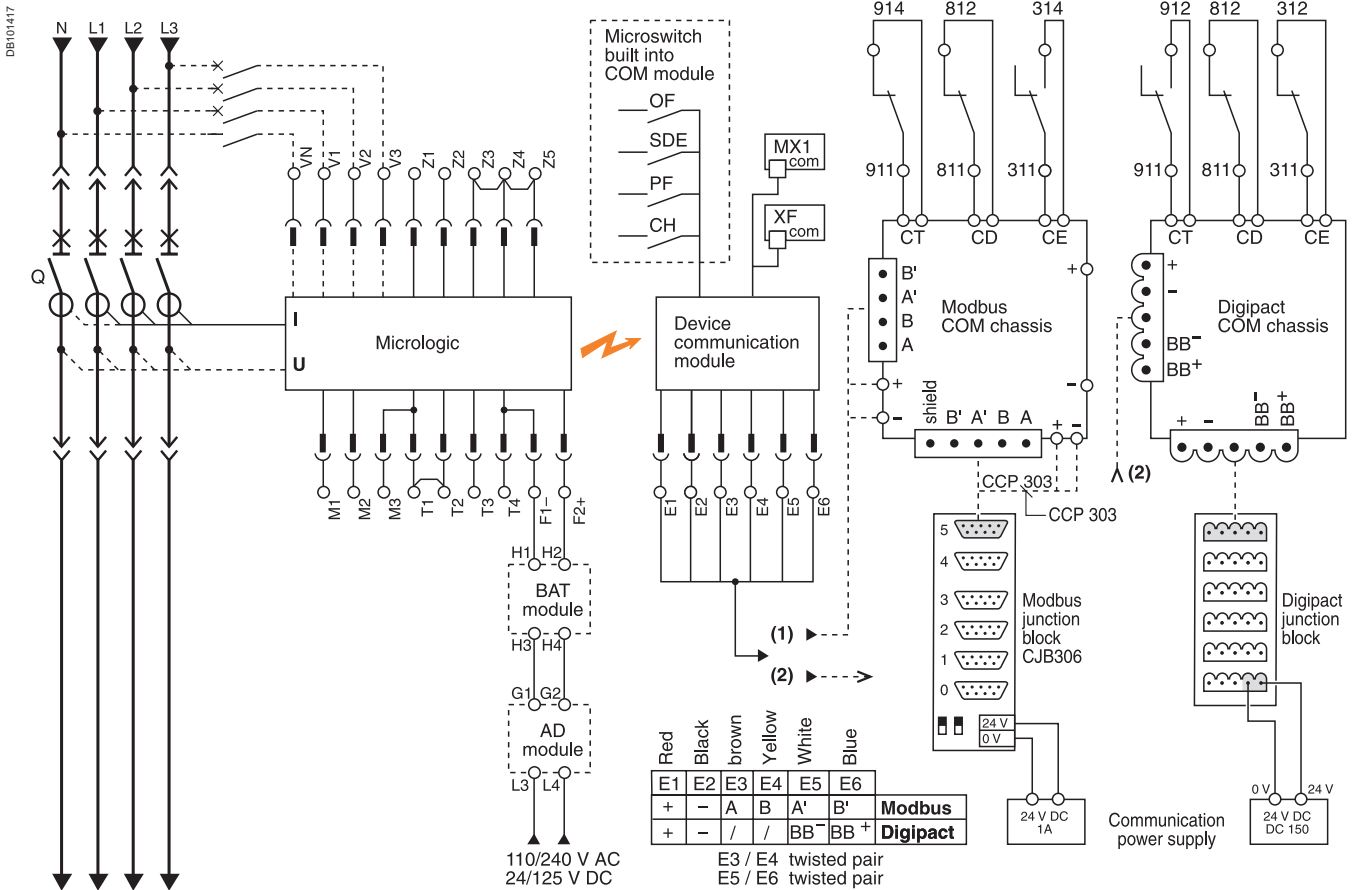

- (1) Drawout device equipped with Modbus chassis COM.
- (2) Drawout device equipped with Digipact chassis COM.

Masterpact NT and NW

Communications option 24 V DC external power supply

Examples using the COM communications option

Switchboard display unit

This architecture provides remote display of the variables managed by Micrologic control units equipped with the COM Modbus module.

- I (Micrologic A)
 - I, U, P, E (Micrologic P)
 - I, U, P, E, THD (Micrologic H)
- No programming is required.

For Micrologic A control unit (if current < 20 % I_n), it is recommended to use the 24 V DC external power supply (AD module).

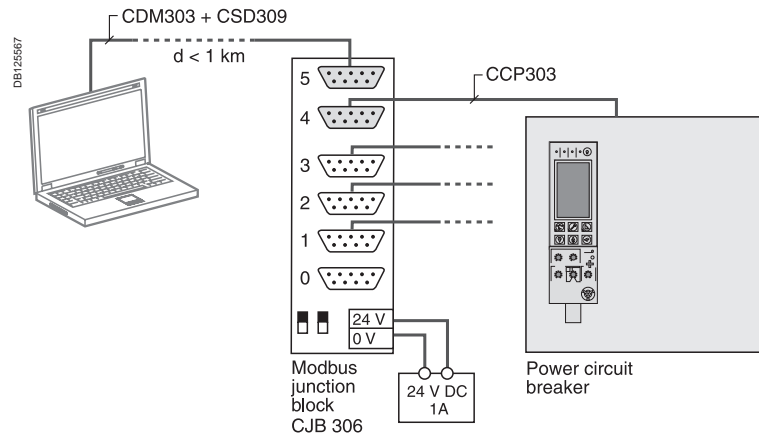

Communicating switchboard

This configuration provides remote display and control of Masterpact equipped with the Modbus module.

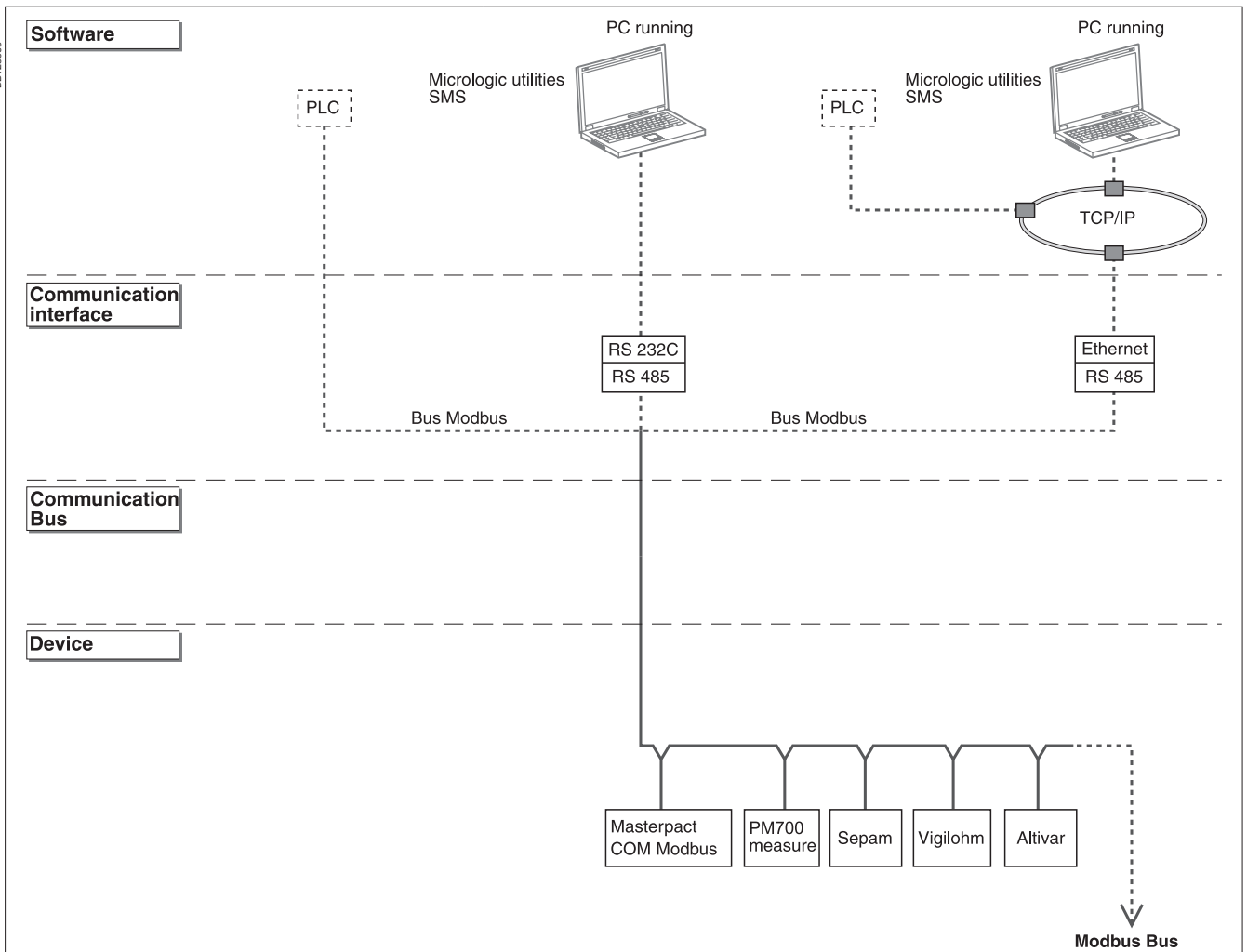

Masterpact NT and NW

Earth-fault and earth-leakage protection
Neutral protection
Zone selective interlocking

External sensor (CT) for residual earth-fault protection

Connection of current-transformer secondary circuit for external neutral

Masterpact equipped with a Micrologic 6 A/P/H:

- shielded cable with 2 twisted pairs
 - T1 twisted with T2
 - maximum length 10 meters
 - cable cross-sectional area 0.4 to 1.5 mm²
 - recommended cable: Belden 9552 or equivalent.
- For proper wiring of neutral CT, refer to instruction Bulletin 48041-082-01 shipped with it.

Do not remove factory-installed jumper between T1 and T2 unless neutral CT is connected.
Do not install jumper between T3 and T4.

If supply is via the top, follow the schematics.

If supply is via the bottom, control wiring is identical; for the power wiring, H1 is connected to the source side, H2 to the load side.

For four-pole versions, for residual earth-fault protection, the current transformer for the external neutral is not necessary.

Connection for signal VN is required only for power measurements (3 Ø, 4 wires, 4CTs).

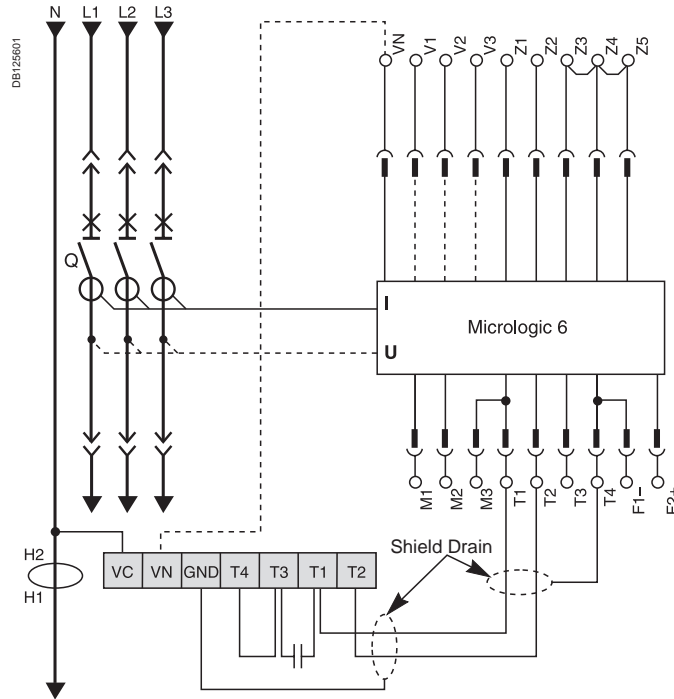

External transformer for source ground return (SGR) earth-fault protection

Connection of the secondary circuit

Masterpact equipped with a Micrologic 6 A/P/H:

- unshielded cable with 1 twisted pair
- maximum length 150 meters
- cable cross-sectional area 0.4 to 1.5 mm²
- terminals 5 and 6 may not be used at the same time
- use terminal 5 for NW08 to 40
- use terminal 6 for NW40b to 63
- recommended cable: Belden 9409 or equivalent.

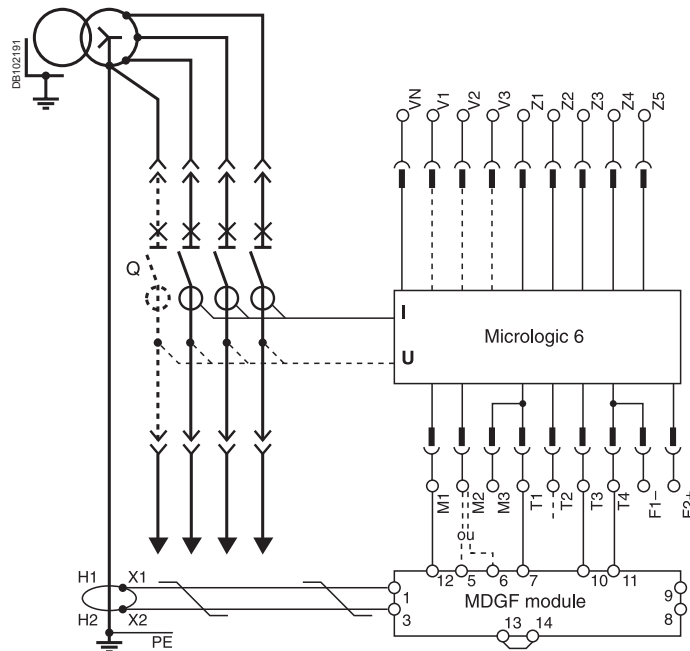

Earth-leakage protection

Connection of the rectangular-sensor secondary circuit

Use the cable shipped with the rectangular sensor.

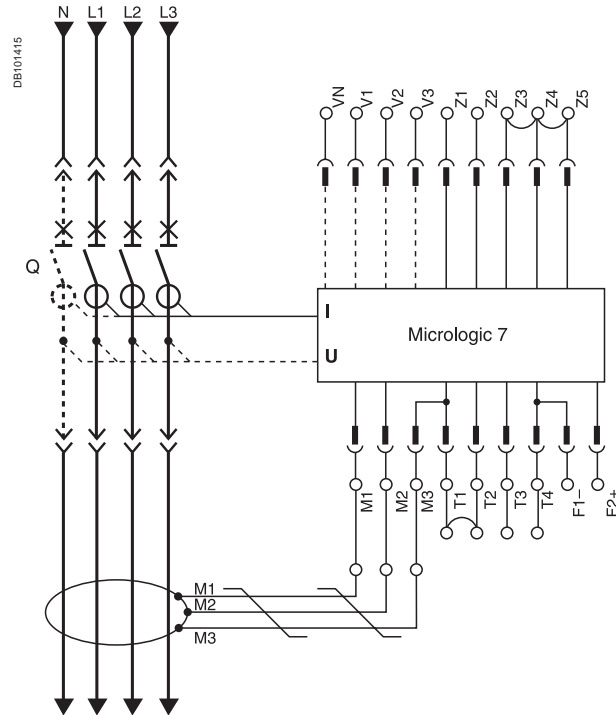

Neutral protection

- three pole circuit breaker:
 - neutral protection is impossible with Micrologic A
 - Masterpact equipped with Micrologic P or H
 - the current transformer for external neutral is necessary (the wiring diagram is identical to the one used for the residual earth-fault protection)
- four pole circuit breaker:
 - Masterpact equipped with Micrologic A, P or H
 - the current transformer for external neutral is not necessary.

Zone selective interlocking

Zone-selective interlocking is used to reduce the electrodynamic forces exerted on the installation by shortening the time required to clear faults, while maintaining time discrimination between the various devices.

A pilot wire interconnects a number of circuit breakers equipped with Micrologic A/P/H control units, as illustrated in the diagram above.

The control unit detecting a fault sends a signal upstream and checks for a signal arriving from downstream. If there is a signal from downstream, the circuit breaker remains closed for the full duration of its tripping delay. If there is no signal from downstream, the circuit breaker opens immediately, regardless of the tripping-delay setting.

Fault 1.

Only circuit breaker A detects the fault. Because it receives no signal from downstream, it opens immediately, regardless of its tripping delay set to 0.3.

Fault 2.

Circuit breakers A and B detect the fault. Circuit breaker A receives a signal from B and remains closed for the full duration of its tripping delay set to 0.3. Circuit breaker B does not receive a signal from downstream and opens immediately, in spite of its tripping delay set to 0.2.

Note: the maximum permissible distance between two devices is 3000 m. A downstream circuit breaker can "control" up to ten upstream circuit breakers.

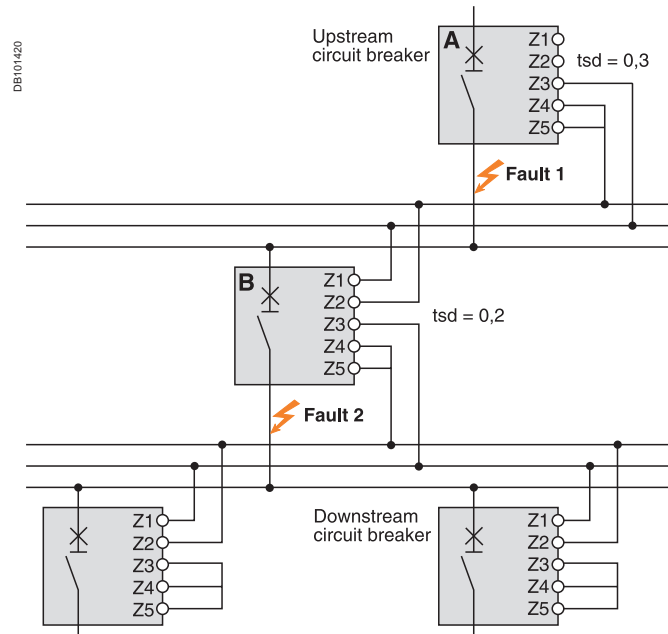

schneider-electric.com

This international site allows you to access all the Schneider Electric products in just 2 clicks via comprehensive range data-sheets, with direct links to:

- complete library: technical documents, catalogs, FAQs, brochures...

- selection guides from the e-catalog.

- product discovery sites and their Flash animations.

You will also find illustrated overviews, news to which you can subscribe, the list of country contacts...



The technical guide

These technical guides help you comply with installation standards and rules i.e.: the electrical installation guide, the protection guide, the switchboard implementation guide, the technical booklets and the co-ordination tables all form genuine reference tools for the design of high performance electrical installations. For example, the LV protection co-ordination guide - discrimination and cascading - optimises choice of protection and connection devices while also increasing markedly continuity of supply in the installations.



<i>Presentation</i>	1
<i>Functions and characteristics</i>	A-1
<i>Installation recommendations</i>	B-1
<i>Dimensions and connection</i>	C-1
<i>Electrical diagrams</i>	D-1
Tripping curves	E-2
Limitation curves	
Current limiting	E-4
Energy limiting	E-5
<i>Catalogue numbers and order form</i>	F-1

Tripping curves

Micrologic 2.0

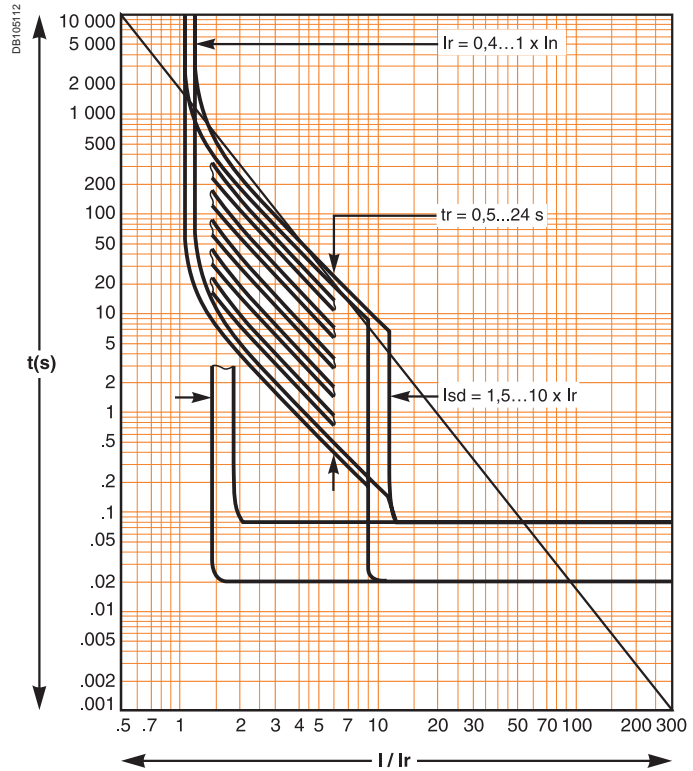

Micrologic 5.0, 6.0, 7.0

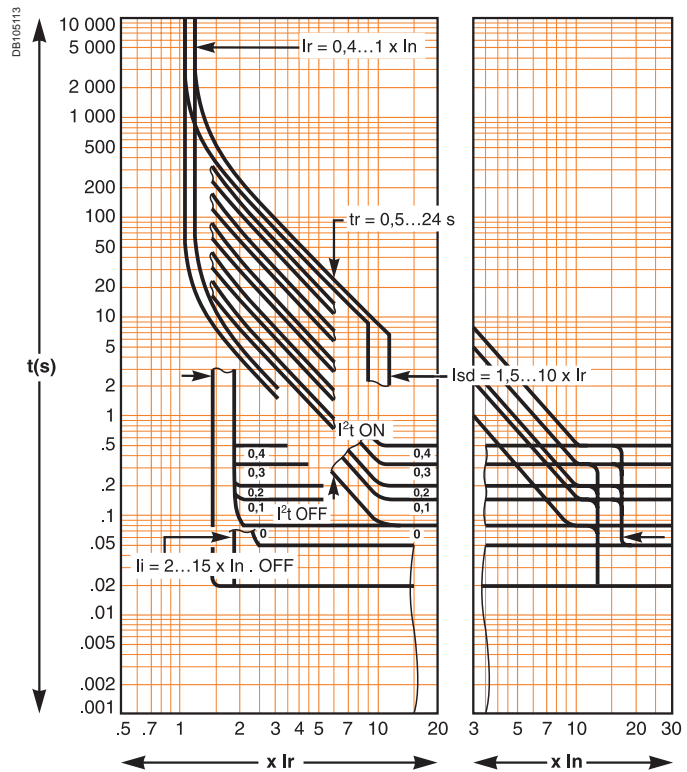

Earth fault protection (Micrologic 6.0)

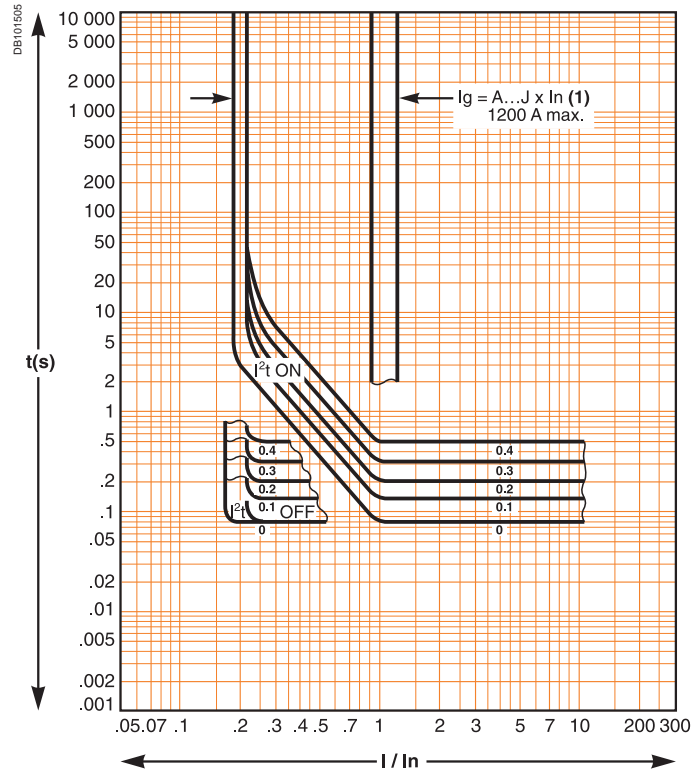

(1)

$I_g = I_n \times \dots$	A	B	C	D	E	F	G	H	I
$I_g < 400 \text{ A}$	0.3	0.3	0.4	0.5	0.6	0.7	0.8	0.9	1
$400 \text{ A} \leq I_g \leq 1200 \text{ A}$	0.2	0.3	0.4	0.5	0.6	0.7	0.8	0.9	1
$I_g > 1200 \text{ A}$	500	640	720	800	880	960	1040	1120	1200

IDMTL curve (Micrologic P and H)

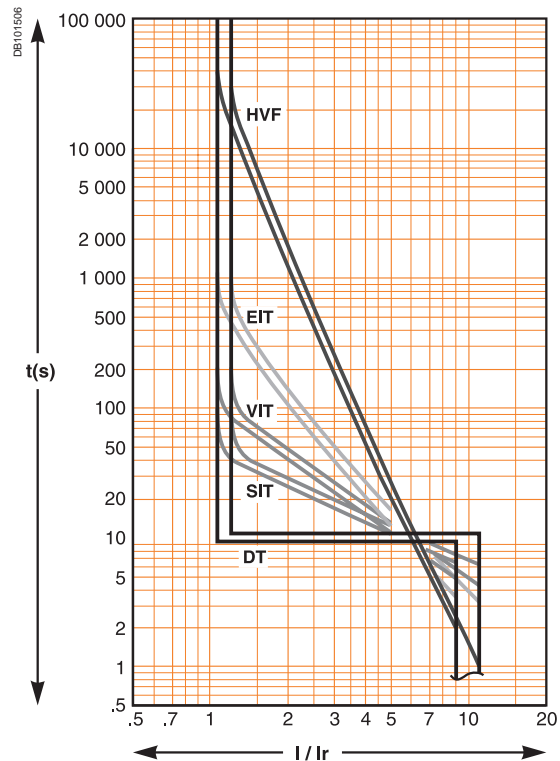

Limitation curves

Current limiting

Voltage 380/415/440 V AC

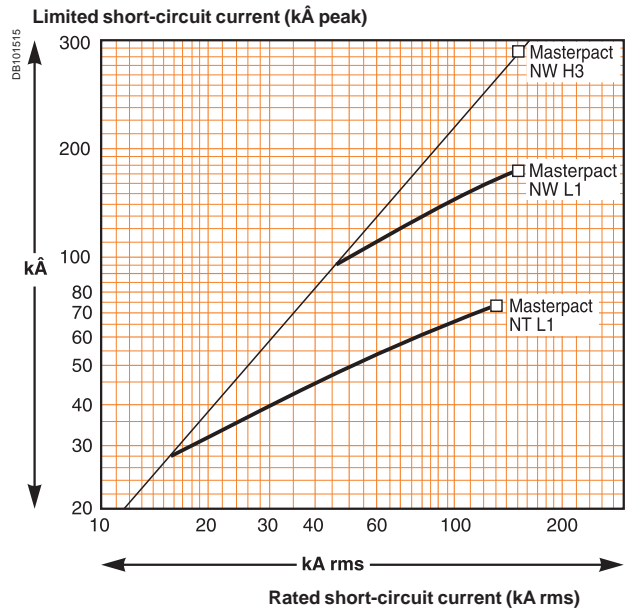

Voltage 660/690 V AC

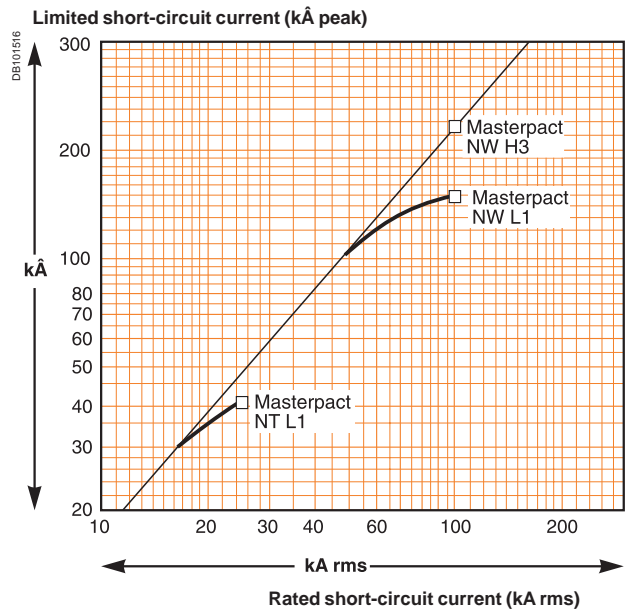

Energy limiting

Voltage 380/415/440 V AC

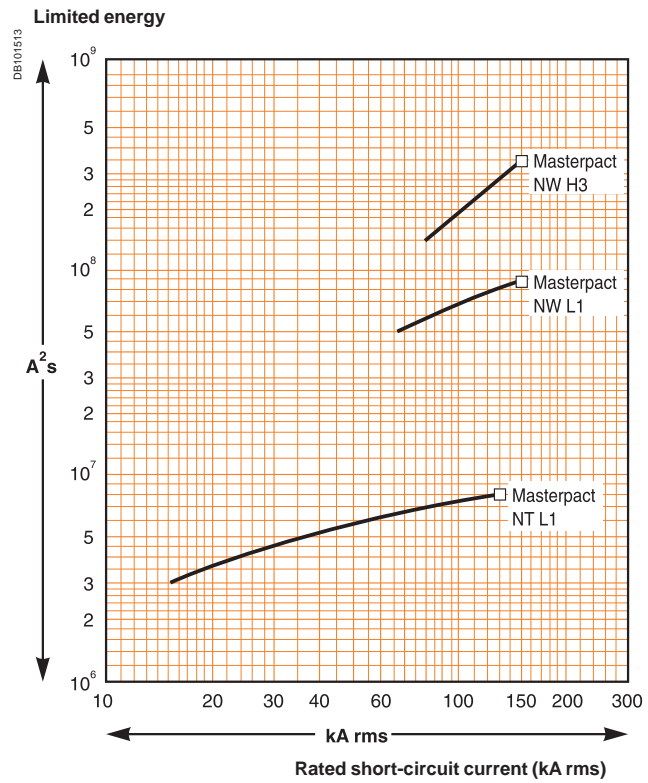

Voltage 660/690 V AC

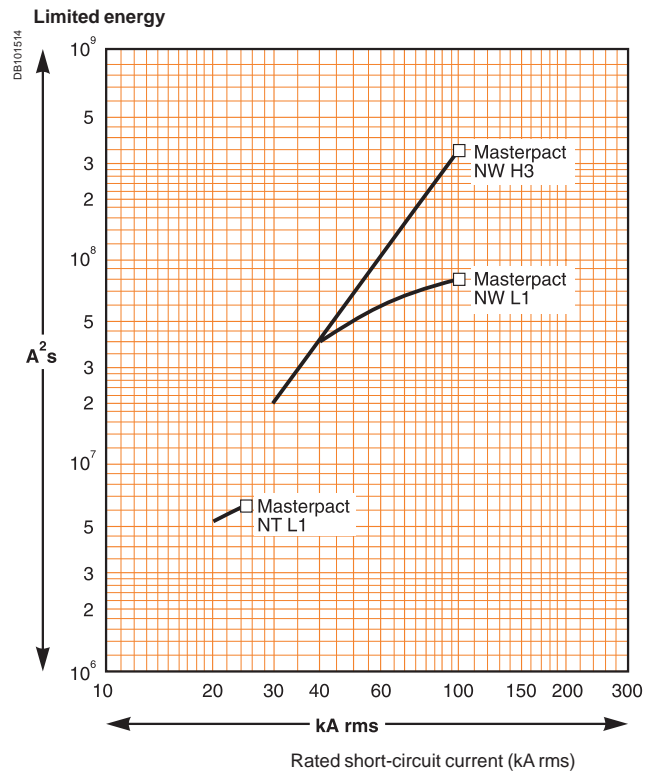

schneider-electric.com

This international site allows you to access all the Schneider Electric products in just 2 clicks via comprehensive range data-sheets, with direct links to:

- complete library: technical documents, catalogs, FAQs, brochures...
- selection guides from the e-catalog.
- product discovery sites and their Flash animations.

You will also find illustrated overviews, news to which you can subscribe, the list of country contacts...

CAD software and tools

The CAD software and tools enhance productivity and safety. They help you create your installations by simplifying product choice through easy browsing in the Schneider Electric offers.

Last but not least, they optimise use of our products while also complying with standards and proper procedures.

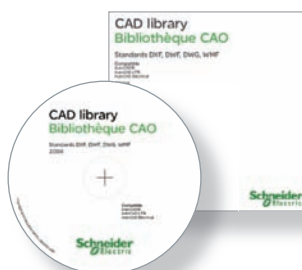

<i>Presentation</i>	3
<i>Functions and characteristics</i>	A-1
<i>Installation recommendations</i>	B-1
<i>Dimensions and connection</i>	C-1
<i>Electrical diagrams</i>	D-1
<i>Additional characteristics</i>	E-1
Retrofit solutions (*)	F-2
Connections for fixed devices	F-2
Connections for drawout devices	F-3
Masterpact NT	F-4
Connection	F-4
Micrologic control unit, communication option	F-5
Remote operation	F-6
Chassis locking and accessories	F-7
Clusters	F-8
Circuit breaker locking and accessories	F-9
Mechanical interlocking for source changeover	F-10
Indication contacts	F-11
Instructions	F-12
Portable data acquisition Communication bus accessories and Modbus	F-13
Masterpact NW	F-14
Connection	F-14
Micrologic control unit, communication option	F-15
Remote operation	F-16
Chassis locking and accessories	F-17
Clusters	F-18
Circuit breaker locking and accessories	F-19
Mechanical interlocking for source changeover	F-20
Indication contacts	F-21
Instructions	F-22
Portable data acquisition Communication bus accessories and Modbus	F-23
Masterpact NT and NW order form	F-24

To replace a Masterpact M with a Masterpact NW, order a retrofit device (without connections) and select a set of connectors corresponding to the replaced device.

The Masterpact NW is installed in exactly the same place as the old Masterpact M device, without any modifications required on the switchboard.

Horizontal rear connection				
Device to be replaced		Connection to be ordered		
Masterpact M08 to M12				
Type N1/NI				
		3P		4P
Top	3 x	48951	4 x	48951
Bottom	3 x	48964	4 x	48964
Type H1/H2/HI/HF				
Top	3 x	48954	4 x	48954
Bottom	3 x	48965	4 x	48965
Masterpact M16				
Type N1/NI/H1/H2/HI/HF				
Top	3 x	48954	4 x	48954
Bottom	3 x	48965	4 x	48965
Masterpact M20 and M25				
Type N1/NI/H1/H2/HI/HF				
Top	3 x	48957	4 x	48957
Bottom	3 x	48958	4 x	48958
Masterpact M32				
Type H1/H2/HI/HF				
Top	1 x	48962	1 x	48960
Bottom	1 x	48961	1 x	48960

^(*) Please contact U2R (Retrofit Replacement Unit).

Connections for drawout devices





To replace a Masterpact M with a Masterpact NW, order a retrofit device (without connections) and select a set of connectors corresponding to the replaced device.

The Masterpact NW is installed in exactly the same place as the old Masterpact M device, without any modifications required on the switchboard.

Vertical rear connection				
Device to be replaced		Connection to be ordered		
Masterpact M08 to M12				
Type N1/NI				
		3P		4P
Top	3 x	48966	4 x	48966
Bottom	3 x	48966	4 x	48966
Type H1/H2/HI/HF/L1				
Top	3 x	48969	4 x	48969
Bottom	3 x	48969	4 x	48969
Masterpact M16				
Type N1/NI/H1/H2/HI/HF/L1				
Top	3 x	48969	4 x	48969
Bottom	3 x	48969	4 x	48969
Masterpact M20 and M25				
Type N1/NI/H1/H2/HI/HF				
Top	3 x	48970	4 x	48970
Bottom	3 x	48970	4 x	48970
Masterpact M32				
Type H1/H2/HI/HF/M20/L1				
Top	1 x	48974	1 x	48978
Bottom	1 x	48974	1 x	48978

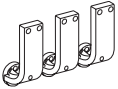
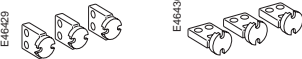
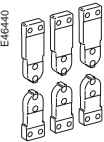
Horizontal rear connection				
Device to be replaced		Connection to be ordered		
Masterpact M08 to M12				
Type N1/NI				
		3P		4P
Top	3 x	48951	4 x	48951
Bottom	3 x	48964	4 x	48964
Type H1/H2/HI/HF/L1				
Top	3 x	48954	4 x	48954
Bottom	3 x	48965	4 x	48965
Masterpact M16				
Type N1/NI/H1/H2/HI/HF/L1				
Top	3 x	48954	4 x	48954
Bottom	3 x	48965	4 x	48965
Masterpact M20 and M25				
Type N1/NI/H1/H2/HI/HF				
Top	3 x	48957	4 x	48957
Bottom	3 x	48958	4 x	48958
Masterpact M32 neutral on left-hand side				
Type H1/H2/HI/HF/M20/L1				
Top	1 x	48973	1 x	48976
Bottom	1 x	48973	1 x	48977
Masterpact M32 neutral on right-hand side				
Type H1/H2/HI/HF/M20/L1				
Top	1 x	48973	1 x	48977
Bottom	1 x	48973	1 x	48976

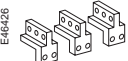
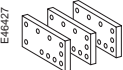
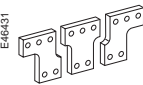
(*) Please contact U2R (Retrofit Replacement Unit).

Connection		3P	4P	
Fixed circuit breakers				
Front connection / Replacement kit (3 or 4 parts)				
 E46534	Top or bottom	250/630-1600 A	47069	47070
	Installation manual		47102	
Rear connection (vertical or horizontal mounting) / Replacement kit (3 or 4 parts)				
 E46429 E46430		250/630-1600 A	33584	33585
	Vert. mounting. Horiz. mounting.	Installation manual		47102
Drawout circuit breakers				
Front connection / Replacement kit (6 or 8 parts)				
 E46440	Top and bottom	250/630-1600 A	33588	33589
	Installation manual		47102	
Rear connection (vertical or horizontal mounting) / Replacement kit (3 or 4 parts)				
 E46429 E46430		250/630-1600 A	33586	33587
	Vert. mounting. Horiz. mounting.	Installation manual		47102
Connection accessories		3P	4P	
Vertical connection adapters 250/630-1600 A / Replacement kit (3 or 4 parts)				
 E46426	For fixed and drawout front-connected circuit breakers		33642	33643
	Installation manual		47102	
Cable lug adapters 250/630-1600 A / Replacement kit (3 or 4 parts)				
 E46427	For fixed and drawout front-connected circuit breakers		33644	33645
	Installation manual		47102	
Spreaders / Replacement kit 250/630-1600 A (3 or 4 parts)				
 E46431	For fixed and drawout front and rear-connected circuit breakers		33622	33623
	Installation manual		47102	
Interphase barriers / Replacement kit (3 or 4 parts)				
 E79151	For fixed and drawout front and rear-connected circuit breakers		33648	33648
	For drawout rear-connected circuit breakers		33768	33768
	Installation manual		47102	
Arc chute screen (1 part)				
 E74437	For fixed front-connected circuit breakers		47335	47336
	Installation manual		47102	

Micrologic control unit, communication option

Replacement parts for Micrologic control units

Long-time rating plug (limits setting range for higher accuracy) / 1 part

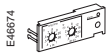

Standard	0.4 at 1 x Ir	33542
Low-setting option	0.4 at 0.8 x Ir	33543
High-setting option	0.8 at 1 x Ir	33544
Without long-time protection	off	33545

Battery + cover

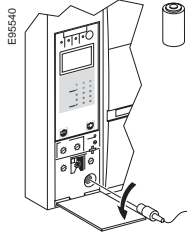

Battery (1 part)		33593
Cover (1 part)	For Micrologic A	33592
	For Micrologic P and H	47067

Communication option

Chassis

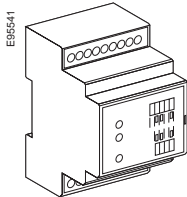

Modbus COM		64915
6 wires terminal drawout (1 part)		33099
6 wires terminal fixed (1 part)		47075

Installation manual		33088
---------------------	--	-------

External sensors

External sensor for earth-fault protection (TCE) / 1 part

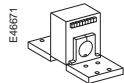

Sensor rating	400/1600 A	33576
---------------	------------	-------

Source ground return (SGR) earth-fault protection / 1 part



External sensor (SGR)		33579
MDGF summing module		48891

Rectangular sensor for earth-leakage protection + Vigi cable / 1 part



280 mm x 115 mm		33573
-----------------	--	-------

Vigi cable or external voltage cable / 1 part

Vigi cable or external voltage cable (1 part)		47090
---	--	-------

External power supply module (AD) / 1 part

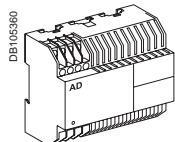

24-30 V DC	54440
48-60 V DC	54441
100-125 V DC	54442
110-130 V AC	54443
200-240 V AC	54444
380-415 V AC	54445

Battery module (BAT) / 1 part

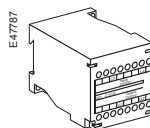

1 battery	24 V DC	54446
-----------	---------	-------

Test equipments / 1 part

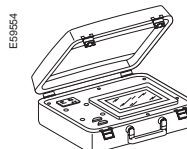

Hand held test kit (HHTK)		33594
Full function test kit (FFTK)		33595
Test report edition come from FFTK		34559
FFTK test cable 2 pin for STR trip unit		34560
FFTK test cable 7 pin for Micrologic trip unit		33590

Remote operation

Gear motor

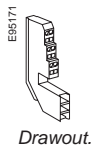
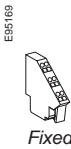
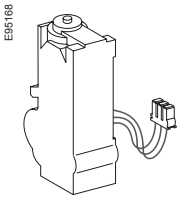

MCH (1 part)

AC 50/60 Hz	48 V	33186
	100/130 V	33176
	200/240 V	33177
	277/415 V	33179
	440/480 V	33179
	+ resistor	33193
DC	24/30 V	33185
	48/60 V	33186
	100/125 V	33187
	200/250 V	33188
Terminal block (1 part)	For fixed circuit breaker	47074
	For drawout circuit breaker	33098

Installation manual	47103
---------------------	-------

Closing and opening release (XF or MX)

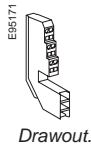
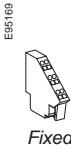
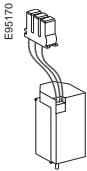

Standard coil (1 part)

AC 50/60 Hz	12 V DC	33658
	24/30 V DC, 24 V AC	33659
DC	48/60 V DC, 48 V AC	33660
	100/130 V AC/DC	33661
	200/250 V AC/DC	33662
	277 V AC	33663
	380/480 V AC	33664

Communicating coil (1 part)

AC 50/60 Hz	12 V DC	33032
	24/30 V DC, 24 V AC	33033
DC	48/60 V DC, 48 V AC	33034
	100/130 V AC/DC	33035
	200/250 V AC/DC	33036
	277 V AC	33037
	380/480 V AC	33038
	Terminal block (1 part)	For fixed circuit breaker
	For drawout circuit breaker	33098

Installation manual	47103
---------------------	-------

Undervoltage release MN

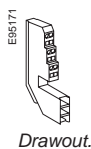
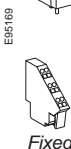
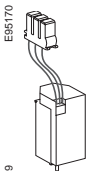

Undervoltage release (1 part)

AC 50/60 Hz	24/30 V DC, 24 V AC	33668
	48/60 V DC, 48 V AC	33669
DC	100/130 V AC/DC	33670
	200/250 V AC/DC	33671
	380/480 V AC	33673
	Terminal block (1 part)	For fixed circuit breaker
	For drawout circuit breaker	33098

Installation manual	47103
---------------------	-------

MN delay unit

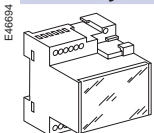

MN delay unit (1 part)

		R (non-adjustable)	Rr (adjustable)
AC 50/60 Hz	48/60 V AC/DC		33680
	100/130 V AC/DC	33684	33681
DC	200/250 V AC/DC	33685	33682
	380/480 V AC/DC		33683

Installation manual	47103
---------------------	-------

Chassis locking and accessories

Chassis locking

"Disconnected" position locking / 1 part

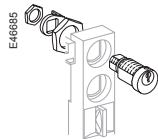

By padlocks		
	VCPO	Standard
By Profalux keylocks		
Profalux	1 lock with 1 key + adaptation kit	64909
	2 locks 1 keys + adaptation kit	64910
	2 locks 2 different keys + adaptation kit	64911
1 keylock Profalux (without adaptation kit):		
	identical key not identified combination	33173
	identical key identified 215470 combination	33174
	identical key identified 215471 combination	33175
By Ronis keylocks		
Ronis	1 lock with 1 key + adaptation kit	64912
	2 locks 1 keys + adaptation kit	64913
	2 locks 2 different keys + adaptation kit	64914
1 keylock Ronis (without adaptation kit):		
	identical key not identified combination	33189
	identical key identified EL24135 combination	33190
	identical key identified EL24153 combination	33191
	identical key identified EL24315 combination	33192
Adaptation kit (without keylock):	adaptation kit Profalux	33769
	adaptation kit Ronis	33770
	adaptation kit Castell	33771
	adaptation kit Kirk	33772
Installation manual		47104

Door interlock / 1 part

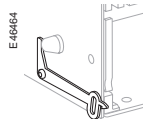

	Right and left-hand side of chassis (VPECD or VPECG)	33172
Installation manual		47104

Racking interlock / 1 part

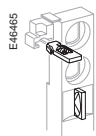

	Racking interlock (VPOC)	33788
Installation manual		47104

Breaker mismatch protection / 1 part

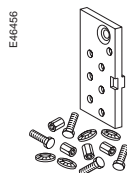

	Breaker mismatch protection (VDC)	33767
Installation manual		47104

Chassis accessories

Auxiliary terminal shield (CB) / 1 part

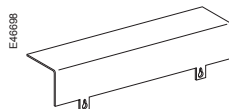

Terminal shield	3P	33763
	4P	33764
Installation manual		47104

Safety shutters + locking / 1 part

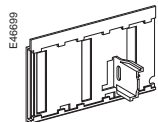

Safety shutters (VO)	3P	33765
	4P	33766
Installation manual		47104
<i>Note: the locking of safety shutters is integrated.</i>		

Clusters

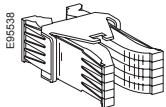

1 disconnecting contact cluster for chassis (see table below) 1 part

64906

Table : number of clusters required for the different chassis models

Chassis rating (A)	Masterpact NT	
	3P	4P
250	12	18
630	12	18
800	12	18
1000	12	18
1250	12	18
1600	18	24

Note: the minimum order is 6 parts.

Racking handle / 1 part

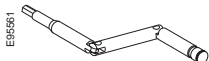

Racking handle

47098

Circuit breaker locking and accessories

Circuit breaker locking

Pushbutton locking device / 1 part

E-46686

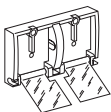

By padlocks 33897

Installation manual 47103

OFF position locking / 1 part

E-46701

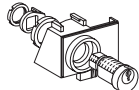

By padlocks + BPFE support 47514

By Profalux keylocks + BPFE support

Profalux 1 lock with 1 key + adaptation kit 64918

2 locks 1 keys + adaptation kit 64919

1 keylock Profalux (without adaptation kit):

identical key not identified combination 33173

identical key identified 215470 combination 33174

identical key identified 215471 combination 33175

By Ronis keylocks + BPFE support

Ronis 1 lock with 1 key + adaptation kit 64920

2 locks 1 keys + adaptation kit 64921

1 keylock Ronis (without adaptation kit):

identical key not identified combination 33189

identical key identified EL24135 combination 33190

identical key identified EL24153 combination 33191

identical key identified EL24315 combination 33192

Adaptation kit (without keylock): adaptation kit Profalux 47515

adaptation kit Ronis 47516

adaptation kit Kirk 47517

adaptation kit Castell 47518

Installation manual 47103

Other circuit breaker accessories

Mechanical operation counter / 1 part

DB125617



Operation counter CDM 33895

Installation manual 47103

Escutcheon and accessories / 1 part

E-46886

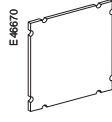
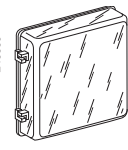
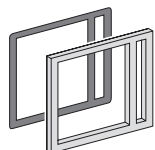

	Fixed	Drawout
Escutcheon	33718	33857
Transparent cover (IP54)		33859
Escutcheon blanking plate		33858

Escutcheon Cover Blanking plate Installation manual 47103

Front cover (3P / 4P) / 1 part

E-95558

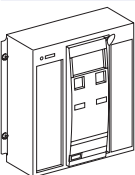

Front cover 47094

Installation manual 47103

Spring charging handle / 1 part

E-95559



Spring charging handle 47092

Installation manual 47103

Arc chute for Masterpact NT / 1 part

E-95560

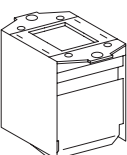

	3P	4P
Type H1/H2	3 x 47095	4 x 47095
Type L1	3 x 47096	4 x 47096

Installation manual 47103

Mechanical interlocking for source changeover

Interlocking using connecting rods

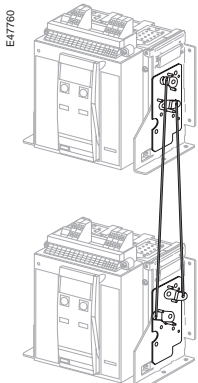

Complete assembly with 2 adaptation fixtures + rods

2 Masterpact NT fixed devices

33912

2 Masterpact NT drawout devices

33913

Note: the installation manual is enclosed.

Interlocking using cables⁽¹⁾

Choose 2 adaptation fixtures (1 for each breaker) + 1 set of cables

1 adaptation fixture for Masterpact NT fixed devices

33200

1 adaptation fixture for Masterpact NT drawout devices

33201

1 set of 2 cables

33209

(1) Can be used with any combination of NT or NW, fixed or drawout devices.

Cable-type door interlock

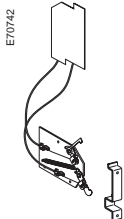

1 complete assembly for Masterpact NT fixed devices

33920

1 complete assembly for Masterpact NT drawout devices

33921

Note: the installation manual is enclosed.

Indication contacts

Indication contacts

ON/OFF indication contacts (OF) / 1 part

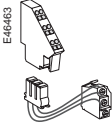
	Changeover contacts (6 A - 240 V)	47076	
	1 low-level OF to replace 1 standard OF (4 max.)	47077	
	Wiring	For fixed circuit breaker For drawout circuit breaker	47074 33098
	Installation manual	47103	

"Fault trip" indication contacts (SDE) / 1 part

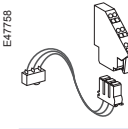
	1 additional SDE (5 A - 240 V)	47078	
	1 additional low-level SDE	47079	
	Wiring	For fixed circuit breaker For drawout circuit breaker	47074 33098
	Installation manual	47103	

"Ready to close" contact (1 max.) / 1 part

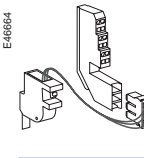
		PF	
	1 changeover contact (5 A - 240 V)	47080	
	1 low-level changeover contact	47081	
	Wiring	For fixed circuit breaker For drawout circuit breaker	47074 33098
	Installation manual	47103	

Electrical closing pushbutton / 1 part

		BPFE
	1 pushbutton	64917
	Installation manual	47103

Carriage switches (connected / disconnected / test position) / 1 part

	Changeover contacts (6 A - 240 V)	
	1 connected position contact (3 max.)	33170
	1 test position contact (1 max.)	33170
	1 disconnected position contact (2 max.)	33170
	And/or low-level changeover contacts	
	1 connected position contact (3 max.)	33171
	1 test position contact (1 max.)	33171
	1 disconnected position contact (2 max.)	33171

Auxiliary terminals for chassis alone

	3 wire terminal (1 part), terminal block (1 part)	33098
	Jumpers (10 parts)	47900
	Installation manual	47104

Instructions		
Chassis accessories		47104
Circuit breaker accessories		47103
Fixed and drawout circuit breaker		47102
Micrologic user manual	20/50 (French)	33076
	20/50 (English)	33077
	2A/7A (French)	33079
	2A/7A (English)	33080
	5P/7P (French)	33082
	5P/7P (English)	33083
	5H/7H (French)	33085
	5H/7H (English)	33086
NT user manual	French	47106
	English	47107
Modbus communication notice for manual		33088

Portable data acquisition Communication bus accessories and Modbus

Portable data acquisition

Masterpact GetnSet (*)

Masterpact GetnSet product with battery and accessories	48789
Spare battery for Masterpact GetnSet product	48790
Spare cable for Masterpact GetnSet product	48791

RS 485 Modbus pre-wired system

RS 485 Modbus junction block

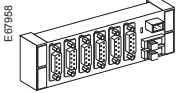

CJB306: 6 SubD 9 pins connectors junction block	50963
---	-------

RS 485 Modbus connector

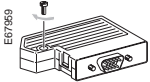

CSD309: 9 pins SubD with screw terminals	50964
--	-------

RS 485 Modbus cables



CDM303: display module pre-wired cable, 3 m length	50960
--	-------



CCP303: Masterpact or Compact pre-wired cable (4 RS 485 wires + 2 power wires) 3 m length	50961
---	-------



CCR301: RS 485 roll cable (2 RS 485 wires + 2 power wires) 60 m length	50965
--	-------

Micro Power Server MPS100

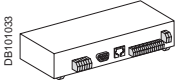

MPS100	33507
--------	-------

Converter



RS 485/RS 232 (ACE909) 12 V DC power supply included	59648	(2)
RS 485/RS 232	TSX SCA72	(1)
RS 485/Ethernet	174 CEV 300-10	
RS 485/Ethernet (SMS compatible)	EGX 100/400	(2)

(1) See catalogue Telemecanique.

(2) Consult PMC Department.

(*) Consult us.

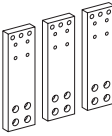
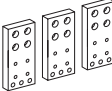
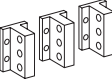
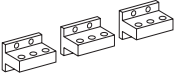
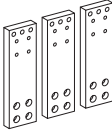
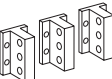
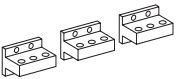
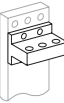
Connection

			3P	4P	
Fixed circuit breakers					
Front connection / Replacement kit (3 or 4 parts)					
 EB6557	800-1600 A	Top	47990	47991	
	2000/3200 A	Top	47992	47993	
 EB6533	800-1600 A	Bottom	47932	47933	
	2000/3200 A	Bottom	47942	47943	
Installation manual			47950		
Rear connection (vertical or horizontal mounting) / Replacement kit (3 or 4 parts)					
 E46445	800-2000 A	Vertical	47964	47965	
		Horizontal	47964	47965	
 E46446	2500/3200 A	Vertical	47966	47967	
		Horizontal	47966	47967	
Vertical mounting		4000 A	Vertical	47968	47969
Horizontal mounting		4000b/5000 A	Horizontal	47970	47971
		4000b/5000 A	Vertical	2x 47966	2x 47967
		4000b/5000 A	Horizontal	2x 47966	2x 47967
		6300 A	Vertical	2x 47968	2x 47969
Installation manual			47950		
Drawout circuit breakers					
Front connection / Replacement kit (3 or 4 parts)					
 E46450	800-1600 A	Top or bottom	47960	47961	
	2000/3200 A	Top or bottom	47962	47963	
Installation manual			47950		
Rear connection (vertical or horizontal mounting) / Replacement kit (3 or 4 parts)					
 E46445	800-2000 A types N1/H1/H2	Vertical	47964	47965	
	800-1600 A types H3/L1	Horizontal	47964	47965	
 E46446	2500/3200 A types H1/H2	Vertical	47966	47967	
	2000/3200 A types H3/L1	Horizontal	47966	47967	
Vertical mounting		4000 A	Vertical	47968	47969
Horizontal mounting		4000 A	Horizontal	47970	47971
		4000b/5000 A	Vertical	2x 47966	2x 47967
		4000b/5000 A	Horizontal	2x 47966	2x 47967
		6300 A	Vertical	2x 47968	2x 47969
Installation manual			47950		
Connection accessories					
Disconnectable front-connection adapter for fixed circuit breaker (3 or 4 parts)					
 E46889	1600 A		48464	48466	
	2000/3200 A		48465	48467	
Installation manual			47950		
Interphase barriers / Replacement kit (3 parts)					
 E46428	For fixed rear-connected circuit breaker		48599	48599	
	For drawout rear-connected circuit breaker		48600	48600	
Installation manual			47950		
Additional support brackets for mounting on a backplate					
 E47788	For fixed rear-connected circuit breaker (2 parts)			47829	

Micrologic control unit, communication option

Replacement parts for Micrologic control units

Long-time rating plug (limits setting range for higher accuracy) / 1 part

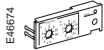

Standard	0.4 at 1 x Ir	33542
Low-setting option	0.4 at 0.8 x Ir	33543
High-setting option	0.8 at 1 x Ir	33544
Without long-time protection	off	33545

Battery + cover

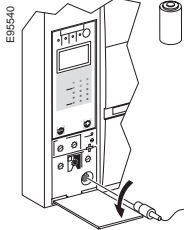

Battery (1 part)		33593
Cover (1 part)	For Micrologic A	33592
	For Micrologic P and H	47067

Communication option

Chassis

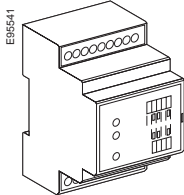

Modbus COM		64915
6 wires terminal drawout (1 part)		47850
6 wires terminal fixed (1 part)		47075

Installation manual		33088
---------------------	--	-------

External sensors

External sensor for earth-fault protection (TCE) / 1 part

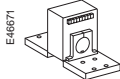

Sensor rating	400/2000 A	34035
	1000/4000 A	34036
	4000/6300 A	48182

Source ground return (SGR) earth-fault protection / 1 part



External sensor (SGR)		33579
MDGF summing module		48891

Rectangular sensor for earth-leakage protection + Vigi cable / 1 part (up to 3200 A)

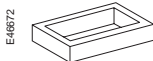

280 mm x 115 mm		33573
470 mm x 160 mm		33574

Vigi cable or external voltage cable / 1 part

Vigi cable or external voltage cable		47090
--------------------------------------	--	-------

External power supply module (AD) / 1 part

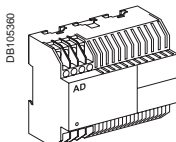

24-30 V DC	54440
48-60 V DC	54441
100-125 V DC	54442
110-130 V AC	54443
200-240 V AC	54444
380-415 V AC	54445

Battery module (BAT) / 1 part

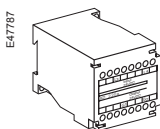

1 battery	24 V DC	54446
-----------	---------	-------

Test equipments / 1 part

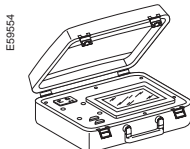

Hand held test kit (HHTK)		33594
Full function test kit (FFTK)		33595
Test report edition come from FFTK		34559
FFTK test cable 2 pin for STR trip unit		34560
FFTK test cable 7 pin for Micrologic trip unit		33590

Remote operation

Gear motor

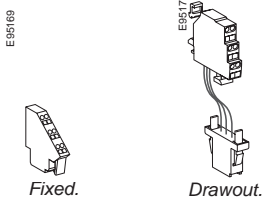
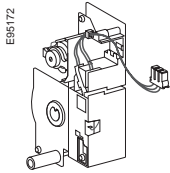

MCH (1 part)		
AC 50/60 Hz	48 V	47889
	100/130 V	47893
	200/240 V	47894
	250/277 V	47895
	380/415 V	47896
	440/480 V	47897
DC	24/30 V	47888
	48/60 V	47889
	100/125 V	47890
	200/250 V	47891
Terminal block (1 part)	For fixed circuit breaker	47074
	For drawout circuit breaker	47849

Installation manual	47951
---------------------	-------

Closing and opening release (XF or MX)

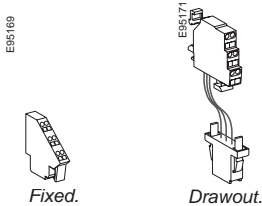
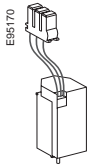

Standard coil (1 part)		
AC 50/60 Hz	12 V DC	33658
	24/30 V DC, 24 V AC	33659
	48/60 V DC, 48 V AC	33660
	100/130 V AC/DC	33661
	200/250 V AC/DC	33662
	277 V AC	33663
DC	380/480 V AC	33664

Communicating coil (1 part)		
AC 50/60 Hz	12 V DC	33032
	24/30 V DC, 24 V AC	33033
	48/60 V DC, 48 V AC	33034
	100/130 V AC/DC	33035
	200/250 V AC/DC	33036
	277 V AC	33037
DC	380/480 V AC	33038
	Terminal block (1 part)	
	For fixed circuit breaker	47074
	For drawout circuit breaker	47849

Installation manual	47951
---------------------	-------

Undervoltage release MN

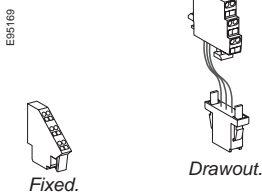
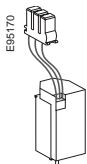

Undervoltage release (1 part)		
AC 50/60 Hz	24/30 V DC, 24 V AC	33668
	48/60 V DC, 48 V AC	33669
	100/130 V AC/DC	33670
	200/250 V AC/DC	33671
	380/480 V AC	33673
DC	Terminal block (1 part)	
	For fixed circuit breaker	47074
	For drawout circuit breaker	47849

Installation manual	47951
---------------------	-------

MN delay unit

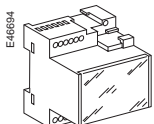

MN delay unit (1 part)			
		R (non-adjustable)	Rr (adjustable)
AC 50/60 Hz	48/60 V AC/DC		33680
	100/130 V AC/DC	33684	33681
	200/250 V AC/DC	33685	33682
DC	380/480 V AC/DC		33683
	Installation manual		47951

Chassis locking and accessories

Chassis locking

"Disconnected" position locking / 1 part

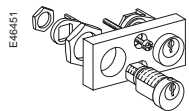

By padlocks		
	VCPO	Standard
By Profalux keylocks		
Profalux	1 lock with 1 key + adaptation kit	64934
	2 locks 1 keys + adaptation kit	64935
	2 locks 2 different keys + adaptation kit	64936
1 keylock Profalux (without adaptation kit):		
	identical key not identified combination	33173
	identical key identified 215470 combination	33174
	identical key identified 215471 combination	33175
By Ronis keylocks		
Ronis	1 lock with 1 key + adaptation kit	64937
	2 locks 1 keys + adaptation kit	64938
	2 locks 2 different keys + adaptation kit	64939
1 keylock Ronis (without adaptation kit):		
	identical key not identified combination	33189
	identical key identified EL24135 combination	33190
	identical key identified EL24153 combination	33191
	identical key identified EL24315 combination	33192
Adaptation kit (without keylock):		
	adaptation kit Profalux / Ronis	48564
	adaptation kit Kirk	48565
	adaptation kit Castell	48566
	Installation manual	47952

Door interlock / 1 part

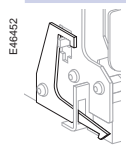

	Right and left-hand side of chassis (VPECD or VPECG)	47914
	Installation manual	47952

Racking interlock



	5 parts	64940
	Installation manual	47952

Breaker mismatch protection / 1 part

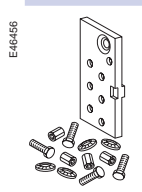

	Breaker mismatch protection (VDC)	33767
	Installation manual	47952

Chassis accessories

Auxiliary terminal shield (CB) / 1 part

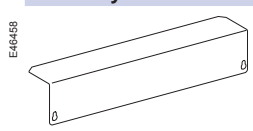

800/4000 A	3P	64942
	4P	48596
4000b/6300 A	3P	48597
	4P	48598
	Installation manual	47952

Safety shutters + locking block / 1 part

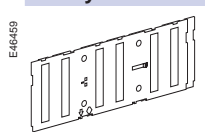

800/4000 A	3P	48721
	4P	48723
4000b/6300 A	3P	48722
	4P	48724
	Installation manual	47952

Shutter locking block (for replacement) / 1 part



	2 parts for 800/4000 A	48591
	Installation manual	47952

Earthing kit for chassis

	3P	4P
Types for N1/H1/NA/HA	48433	48434

Note: the installation manual is enclosed.

Clusters

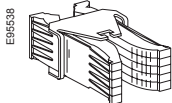

1 disconnecting contact cluster for chassis (see table below) (part 1)

64906

Table : number of clusters required for the different chassis models

Chassis rating (A)	Masterpact NW 3P				Masterpact NW 4P			
	N1	H1/H2	H3	L1	N1	H1/H2	H3	L1
250		12 (H1)						
630	6	12		24	8	16		32
800	6	12		24	8	16		32
1000	6	12		24	8	16		32
1250	6	12		24	8	16		32
1600	12	12		24	16	16		32
2000		24	24	42		32	32	56
2500		24	24			32	32	
3200		36	36			48	48	
4000		42	42			56	56	
4000b		72				96		
5000		72				96		
6300		72				96		

Note: the minimum order is 6 parts.

Racking handle

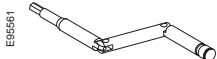

Racking handle

47944

DC rear connection

Serial connection kit

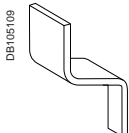

For NW10/20 DC

48642

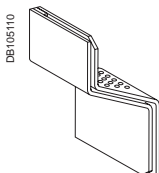

For NW40 DC

48643

Circuit breaker locking and accessories

Circuit breaker locking

Pushbutton locking device / 1 part

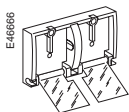

By padlocks 48536

Installation manual 47951

OFF position locking / 1 part

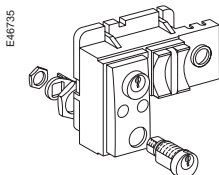

By padlocks 48539

By Profalux keylocks

Profalux	1 lock with 1 key + adaptation kit	64928
	2 locks 1 keys + adaptation kit	64929
	2 locks 2 different keys + adaptation kit	64930

1 keylock Profalux (without adaptation kit):

	identical key not identified combination	33173
	identical key identified 215470 combination	33174
	identical key identified 215471 combination	33175

By Ronis keylocks

Ronis	1 lock with 1 key + adaptation kit	64931
	2 locks 1 keys + adaptation kit	64932
	2 locks 2 different keys + adaptation kit	64933

1 keylock Ronis (without adaptation kit):

	identical key not identified combination	33189
	identical key identified EL24135 combination	33190
	identical key identified EL24153 combination	33191
	identical key identified EL24315 combination	33192

Adaptation kit (without keylock):

	adaptation kit Profalux / Ronis	64925
	adaptation kit Kirk	64927
	adaptation kit Castell	64926

Installation manual 47951

Other circuit breaker accessories

Mechanical operation counter / 1 part

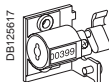

Operation counter CDM 48535

Installation manual 47951

Escutcheon and accessories / 1 part

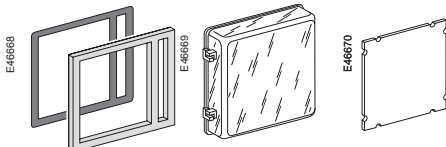

		Fixed	Drawout
Escutcheon		48601	48603
Transparent cover (IP 54)			48604
Escutcheon blanking plate		48605	48605

Installation manual 47951

Front cover (3P / 4P) / 1 part

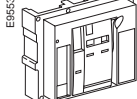

Front cover 47939

Installation manual 47951

Spring charging handle / 1 part



Spring charging handle 47940

Installation manual 47951

Arc chute for Masterpact NW / 1 part

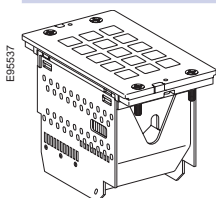

		3P	4P
Type N1	3 x	47935	4 x 47935
Type H1/H2 (NW08 to NW40)	3 x	47935	4 x 47935
Type H1/H2 (NW40b to NW63)	6 x	47936	8 x 47936
Type H3	3 x	47936	4 x 47936
Type L1	3 x	47937	4 x 47937
Type NW DC	3 x	47934	4 x 47934
Installation manual			47951

Mechanical interlocking for source changeover

Interlocking of 2 devices using connecting rods

E47762

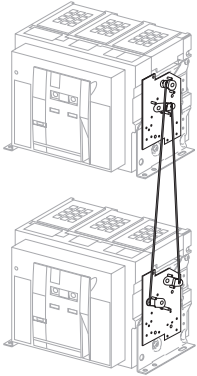

Complete assembly with 2 adaptation fixtures + rods

2 Masterpact NW fixed devices

48612

2 Masterpact NW drawout devices

48612

Can be used with 1 NW fixed + 1 NW drawout.

Note: the installation manual is enclosed.

Interlocking of 2 devices using cables⁽¹⁾

Choose 2 adaptation sets (1 for each device + 1 set of cables)

1 adaptation fixture for Masterpact NW fixed devices

47926

1 adaptation fixture for Masterpact NW drawout devices

47926

1 set of 2 cables

33209

⁽¹⁾ Can be used with any combination of NT or NW, fixed or drawout devices.

Interlocking of 3 devices using cables

Choose 3 adaptation (including 3 adaptation fixtures + cables)

3 sources, only 1 device closed, fixed or drawout devices

48610

2 sources + 1 coupling, fixed or drawout devices

48609

2 normal + 1 replacement source, fixed or drawout devices

48608

Cable-type door interlock

1 complete assembly for Masterpact NW fixed or drawout device

48614

Note: the installation manual is enclosed.

Indication contacts

Indication contacts

ON/OFF indication contacts (OF) / 12 parts

E46689

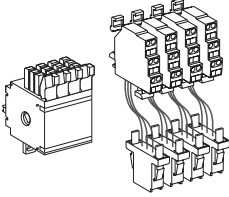

1 additional block of 4 contacts		64922
Wiring	For fixed circuit breaker	47074
	For drawout circuit breaker	47849

Installation manual		47951
---------------------	--	-------

"Fault trip" indication contacts (SDE) / 1 part

E46691

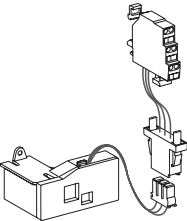

Changeover contact (SDE)	6 A - 240 V	47915
	Low-level	47916
Wiring	For fixed circuit breaker	47074
	For drawout circuit breaker	47849

Installation manual		47951
---------------------	--	-------

"Ready to close" contact (1 max.) / 1 part

E46638

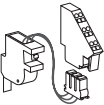

1 changeover contact (5 A - 240 V)		PF
1 low-level changeover contact		47081
Wiring	For fixed circuit breaker	47074
	For drawout circuit breaker	47849

Installation manual		47951
---------------------	--	-------

"Connected, disconnected, test position" indication contact (carriage switches) / 1 part

E46661

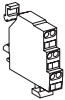

Changeover contacts	6 A - 240 V	33170
CE, CD, CT	Low-level	33171

Installation manual		47952
---------------------	--	-------

Set of additional actuators for carriage switches / 1 set

1 set		48560
-------	--	-------

Combined closed / connected contacts for use with 1 auxiliary contact / 1 part

E46690

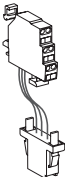

1 contact (5 A - 240 V)		48477
or 1 low-level contact		48478

Installation manual		47952
---------------------	--	-------

Electrical closing pushbutton / 1 part

E46677

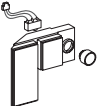

1 pushbutton		BPFE
		48534

Installation manual		47951
---------------------	--	-------

Auxiliary terminals for chassis alone

3 wire terminal (1 part)		47849
6 wire terminal (1 part)		47850
Jumpers (10 parts)		47900

Instructions		
Chassis accessories		47952
Circuit breaker accessories		47951
Fixed and drawout circuit breaker		47950
User manual	NW AC (French)	47954
	NW AC (English)	47955
	NW DC (French)	64923
	NW DC (English)	64924
Micrologic user manual	20/50 (French)	33076
	20/50 (English)	33077
	2A/7A (French)	33079
	2A/7A (English)	33080
	5P/7P (French)	33082
	5P/7P (English)	33083
	5H/7H (French)	33085
	5H/7H (English)	33086
Modbus communication notice for manual		33088

Portable data acquisition Communication bus accessories and Modbus

Portable data acquisition

Masterpact GetnSet (*)

Masterpact GetnSet product with battery and accessories	48789
Spare battery for Masterpact GetnSet product	48790
Spare cable for Masterpact GetnSet product	48791

RS 485 Modbus pre-wired system

RS 485 Modbus junction block

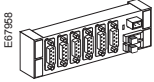

CJB306: 6 SubD 9 pins connectors junction block	50963
---	-------

RS 485 Modbus connector

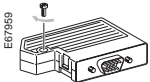

CSD309: 9 pins SubD with screw terminals	50964
--	-------

RS 485 Modbus cables



CDM303: display module pre-wired cable, 3 m length	50960
--	-------



CCP303: Masterpact or Compact pre-wired cable (4 RS 485 wires + 2 power wires) 3 m length	50961
---	-------



CCR301: RS 485 roll cable (2 RS 485 wires + 2 power wires) 60 m length	50965
--	-------

Micro Power Server MPS100

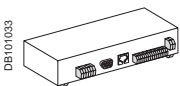

MPS100	33507
--------	-------

Converter

RS 485/RS 232 (ACE909) 12 V DC power supply included	59648	(2)
RS 485/RS 232	TSX SCA72	(1)
RS 485/Ethernet	174 CEV 300-10	
RS 485/Ethernet (SMS compatible)	EGX 100/400	(2)

(1) See catalogue Telemecanique.

(2) Consult PMC Department.

(*) Consult us.

To indicate your choice, check the applicable square boxes and enter the appropriate information in the rectangles

Circuit breaker or switch-disconnector		Quantity	
Masterpact type	NT <input type="checkbox"/> NW <input type="checkbox"/>		
Rating	A <input type="checkbox"/>		
Sensor rating	A <input type="checkbox"/>		
Circuit breaker	N1, H1, H2, H3, L1 <input type="checkbox"/>		
Special circuit breaker	H2 anticorrosion, H10 (NW) <input type="checkbox"/>		
Switch-disconnector	NA, HA, HF, ES, HA10 (NW) <input type="checkbox"/>		
Number of poles	3 or 4 <input type="checkbox"/>		
Brand	Schneider Electric <input type="checkbox"/> Square D <input type="checkbox"/>		
Option: neutral on right side (NW)	<input type="checkbox"/>		
Type of equipment	Fixed <input type="checkbox"/>		
	Drawout with chassis <input type="checkbox"/>		
	Drawout without chassis (moving part only) <input type="checkbox"/>		
	Chassis alone <input type="checkbox"/>		

Micrologic control unit			
A - ammeter	2.0 <input type="checkbox"/>	5.0 <input type="checkbox"/>	6.0 <input type="checkbox"/> 7.0 <input type="checkbox"/>
P - power meter	5.0 <input type="checkbox"/>	6.0 <input type="checkbox"/>	7.0 <input type="checkbox"/>
H - harmonic meter	5.0 <input type="checkbox"/>	6.0 <input type="checkbox"/>	7.0 <input type="checkbox"/>
LR - long-time rating plug	Standard 0.4 to 1 Ir <input type="checkbox"/>		
	Low setting 0.4 to 0.8 Ir <input type="checkbox"/>		
	High setting 0.8 to 1 Ir <input type="checkbox"/>		
	LR OFF <input type="checkbox"/>		

AD - external power-supply module	V <input type="checkbox"/>		
BAT - battery module	<input type="checkbox"/>		
TCE - external sensor (CT) for neutral and residual earth-fault protection	<input type="checkbox"/>		
TCE - external sensor (CT) for over sized neutral (3P - Micrologic P / H) and residual earth-fault protection	<input type="checkbox"/>		
TCW - external sensor for SGR protection	<input type="checkbox"/>		
Rectangular sensor for earth-leakage protection	NT (280 x 115 mm) <input type="checkbox"/>		
	NW (470 x 160 mm) <input type="checkbox"/>		
PTE - external voltage connector	<input type="checkbox"/>		

Communication			
COM module	JBus/ModBus Device <input type="checkbox"/>	Chassis <input type="checkbox"/>	
Eco COM module	JBus/ModBus Device <input type="checkbox"/>	Chassis (*) <input type="checkbox"/>	
	(*) for drawout devices, please order 1 JBus/Modbus chassis COM module		

Connection			
Horizontal	Top <input type="checkbox"/>	Bottom <input type="checkbox"/>	
Vertical	Top <input type="checkbox"/>	Bottom <input type="checkbox"/>	
Front	Top <input type="checkbox"/>	Bottom <input type="checkbox"/>	
Vertical-connection adapters	NT - FC fixed, draw. <input type="checkbox"/>		
Cable-lug adapters	NT - FC fixed, draw. <input type="checkbox"/>		
Arc chute screen	NT - FC fixed <input type="checkbox"/>		
Interphase barriers	NT, NW fixed, drawout <input type="checkbox"/>		
Spreaders	NT fixed, drawout <input type="checkbox"/>		
Disconnectable front connection adapter	NW fixed <input type="checkbox"/>		
Lugs for 240 ² or 300 ² cables	NT fixed, drawout <input type="checkbox"/>		

Micrologic control unit functions:
 2.0 : basic protection (long time + inst.)
 5.0 : selective protection (long time + short time + inst.)
 6.0 : selective + earth-fault protection (long time + short time + inst. + earth-fault)
 7.0 : selective + earth-leakage protection (long time + short time + inst. + earth-leakage)

Indication contacts

OF - ON/OFF indication contacts			
Standard	4 OF 6 A-240 V AC (10 A-240 V AC and low-level for NW)		
Alternate	1 OF low-level for NT	Max. 4	qty <input type="checkbox"/>
Additional	1 block of 4 OF for NW	Max. 2	qty <input type="checkbox"/>

EF - combined "connected/closed" contacts			
	1 EF 6 A-240 V AC for NW	Max. 8	qty <input type="checkbox"/>
	1 EF low-level for NW	Max. 8	qty <input type="checkbox"/>

SDE - "fault-trip" indication contact			
Standard	1 SDE 6 A-240 V AC		
Additional	1 SDE 6 A-240 V AC <input type="checkbox"/>	1 SDE low level <input type="checkbox"/>	

Programmable contacts			
	2 M2C contacts <input type="checkbox"/>	6 M6C contacts <input type="checkbox"/>	
Carriage switches	Low level <input type="checkbox"/>	6 A-240 V AC <input type="checkbox"/>	

CE - "connected" position	Max. 3 for NW/NT		qty <input type="checkbox"/>
CD - "disconnected" position	Max. 3 for NW - 2 for NT		qty <input type="checkbox"/>
CT - "test" position	Max. 3 for NW - 1 for NT		qty <input type="checkbox"/>

AC - NW actuator for 6 CE - 3 CD - 0 CT additional carriage switches

qty

Remote operation

Remote ON/OFF			
MCH - gear motor		V	<input type="checkbox"/>
XF - closing voltage release		V	<input type="checkbox"/>
MX - opening voltage release		V	<input type="checkbox"/>
PF - "ready to close" contact	Low level <input type="checkbox"/>	6 A-240 V AC <input type="checkbox"/>	

BPFE - electrical closing pushbutton	V	<input type="checkbox"/>
RES - electrical reset option	V	<input type="checkbox"/>
RAR - automatic reset option	<input type="checkbox"/>	

Remote tripping			
MN - undervoltage release	V	<input type="checkbox"/>	
R - delay unit (non-adjustable)	<input type="checkbox"/>		
Rr - adjustable delay unit	<input type="checkbox"/>		
2 nd MX - shunt release	V	<input type="checkbox"/>	

Locking

VBP - ON/OFF pushbutton locking (by transparent cover + padlocks)

OFF position locking:

VCPO - by padlocks			
VSPO - by keylocks	Keylock kit (w/o keylock)	Profalux <input type="checkbox"/>	Ronis <input type="checkbox"/>
	1 keylock	Profalux <input type="checkbox"/>	Ronis <input type="checkbox"/>
	2 identical keylocks, 1 key	Profalux <input type="checkbox"/>	Ronis <input type="checkbox"/>
	2 keylocks, different keys (NW)	Profalux <input type="checkbox"/>	Ronis <input type="checkbox"/>

Chassis locking in "disconnected" position:

VSPP - by keylocks	Keylock kit (w/o keylock)	Profalux <input type="checkbox"/>	Ronis <input type="checkbox"/>
		Kirk <input type="checkbox"/>	Castell <input type="checkbox"/>
	1 keylock	Profalux <input type="checkbox"/>	Ronis <input type="checkbox"/>
	2 identical keylocks, 1 key	Profalux <input type="checkbox"/>	Ronis <input type="checkbox"/>
	2 keylocks, different keys	Profalux <input type="checkbox"/>	Ronis <input type="checkbox"/>
	Optional connected/disconnected/test position lock <input type="checkbox"/>		

VPEC - door interlock	On right-hand side chassis <input type="checkbox"/>
	On left-hand side chassis <input type="checkbox"/>

VPOC - racking interlock

IPA - cable-type door interlock

VDC - mismatch protection

VIVC - shutter position indication and locking for NW

IBPO - racking interlock between crank and OFF pushbutton for NW

DAE - automatic spring discharge before breaker removal for NW

Accessories

VO - safety shutters on chassis for NT and NW		<input checked="" type="checkbox"/>
CDM - mechanical operation counter NT, NW		<input type="checkbox"/>
CB - auxiliary terminal shield for chassis NT, NW		<input type="checkbox"/>
CC - arc chute cover for fixed NT		<input type="checkbox"/>
CDP - escutcheon NT, NW		<input type="checkbox"/>
CP - transparent cover for escutcheon NT, NW		<input type="checkbox"/>
OP - blanking plate for escutcheon NT, NW		<input type="checkbox"/>
Brackets for mounting	NW fixed <input type="checkbox"/>	On backplates <input type="checkbox"/>
Test kits	Mini test kit <input type="checkbox"/>	Portable test kit <input type="checkbox"/>

Schneider Electric Industries SAS

35, rue Joseph Monier
CS 30323
F- 92506 Rueil Malmaison Cedex

RCS Nanterre 954 503 439
Capital social 896 313 776 €
www.schneider-electric.com

As standards, specifications and designs change from time to time, please ask for confirmation of the information given in this publication.



This document has been printed on ecological paper

Design: Schneider Electric
Photos: Schneider Electric
Printed: Imprimerie du Pont-de-Claix/JPF - made in France