

# HOFMANN



## Tire Changer

EEWH747A / EEW748A

All information contained or disclosed in this document is considered confidential and proprietary by Snap-on Tools Company. All manufacturing, use, reproduction, and sales rights are reserved by Snap-on Tools Company and the information contained herein shall not be used in whole or in part without the express written consent of Snap-on Tools Company.

# Table of Contents

CABINET.....	1
TOWER.....	2
TURNTABLE.....	3
TRANSMISSION.....	4
MOTOR & PULLEY.....	5
MOTOR & PULLEY 2 SPEED.....	6
SURGE TANK.....	7
AIR GUAGE.....	8
BEAD BLAST PEDAL & VALVE.....	9
PEDAL VALVE.....	10
LUBRICATOR.....	11
BEAD BREAKER CYLINDER.....	12
PEDAL VALVE ASSEMBLY.....	13
PEDAL VALVE.....	15
BEAD BREAKER FOOT PEDAL ASSEMBLY.....	17
INVERTER ASSEMBLY.....	18

*Blank Page*



# TOWER

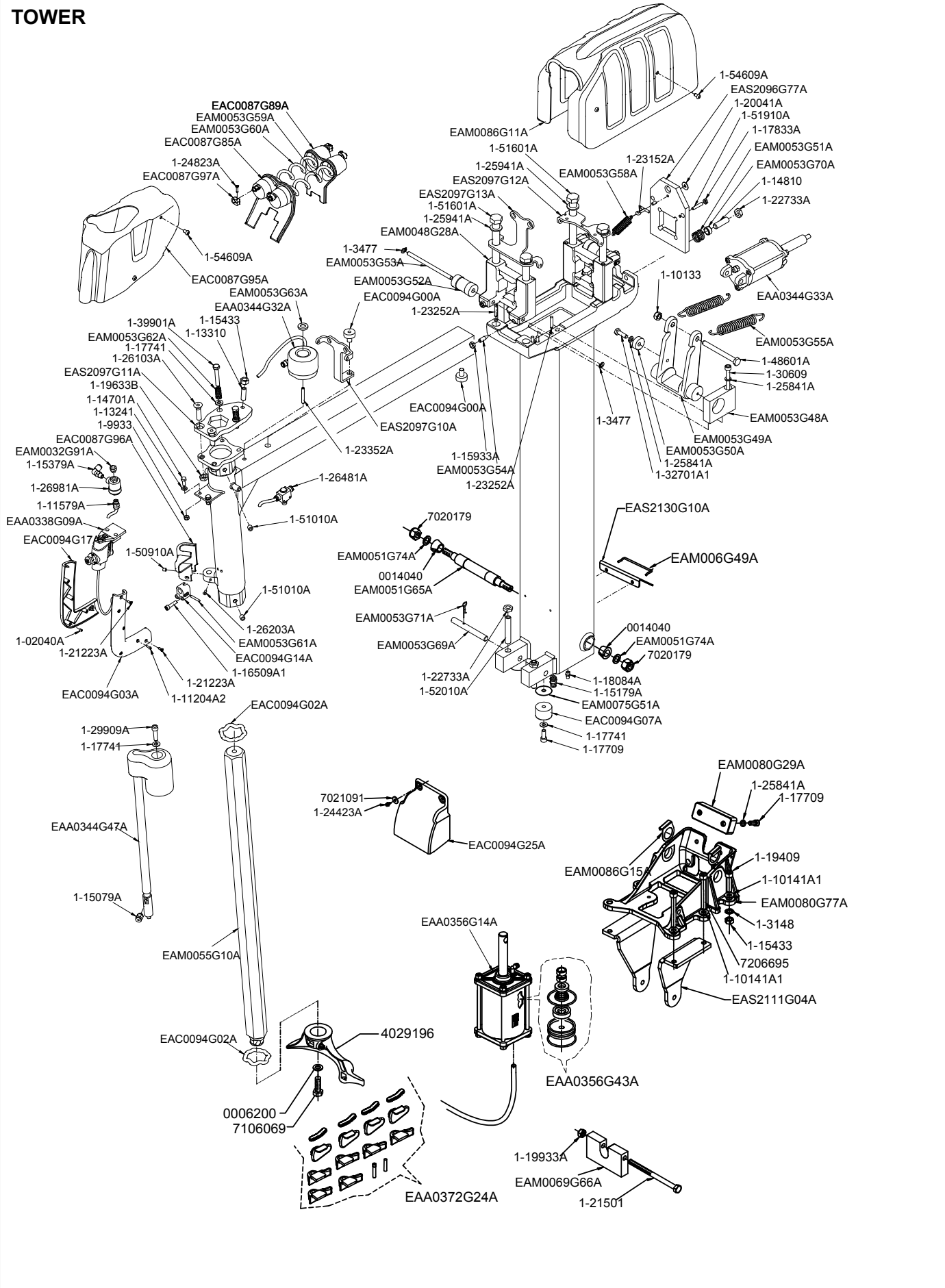



# TRANSMISSION

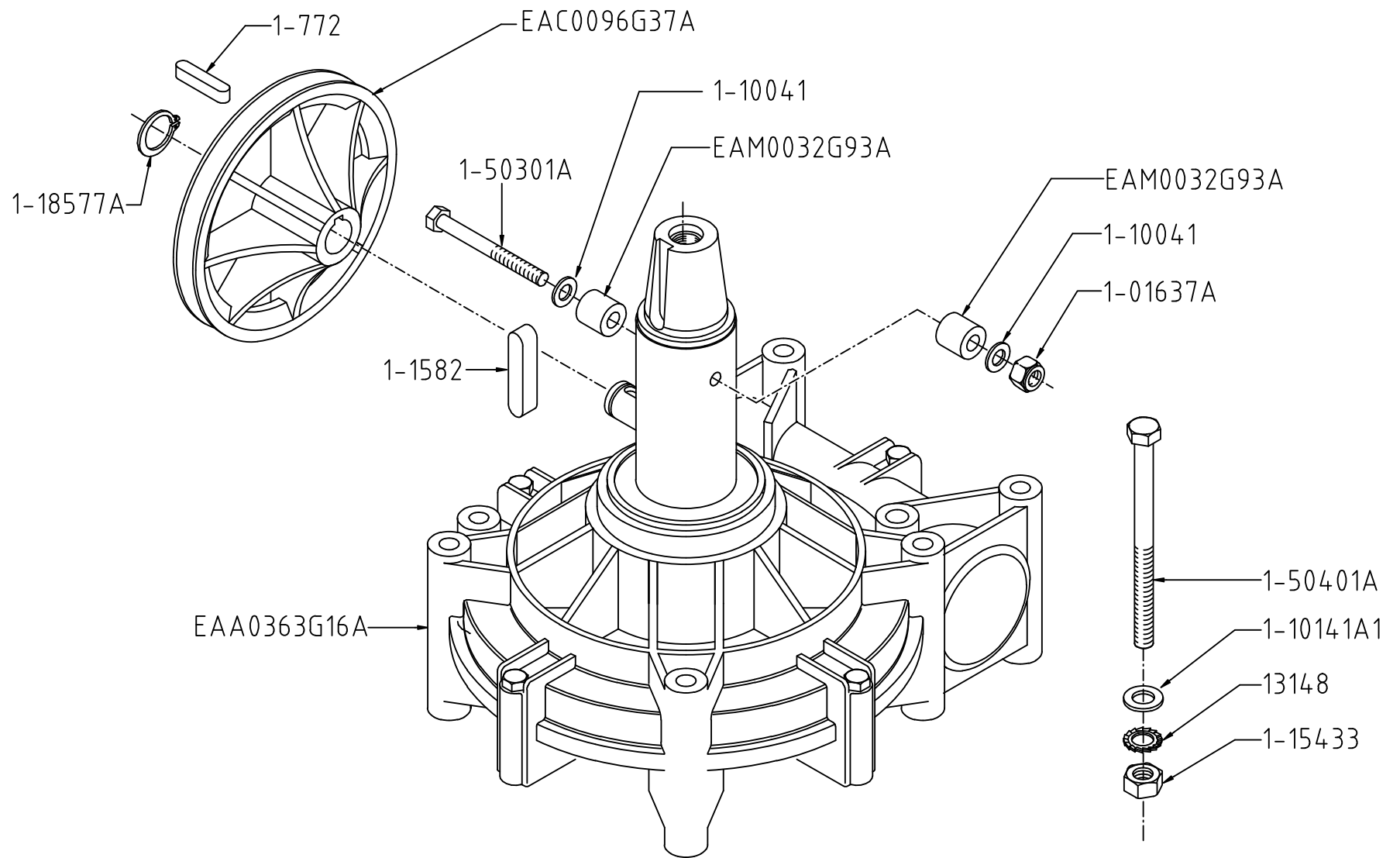



**MOTOR & PULLEY**

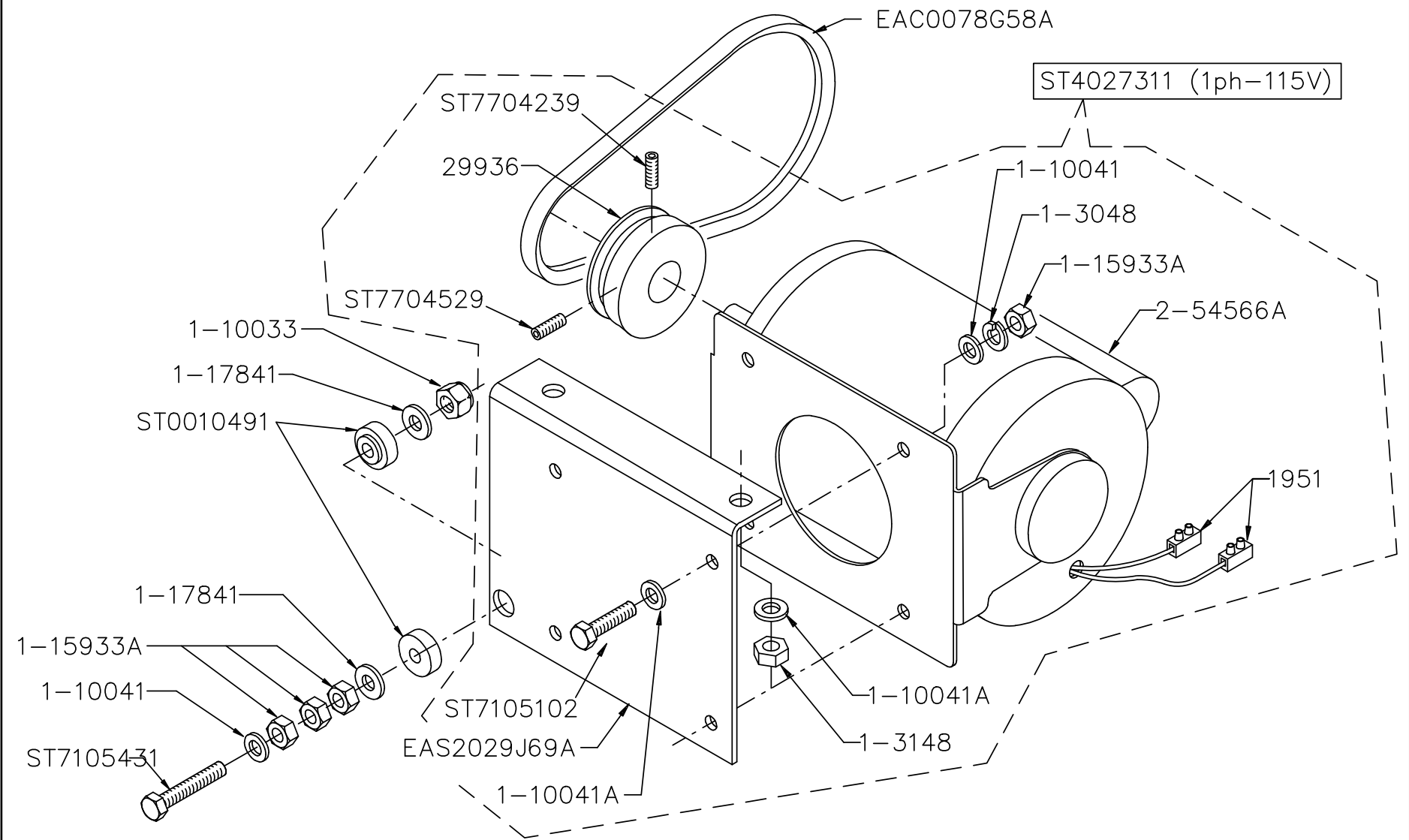

# MOTOR & PULLEY 2 SPEED

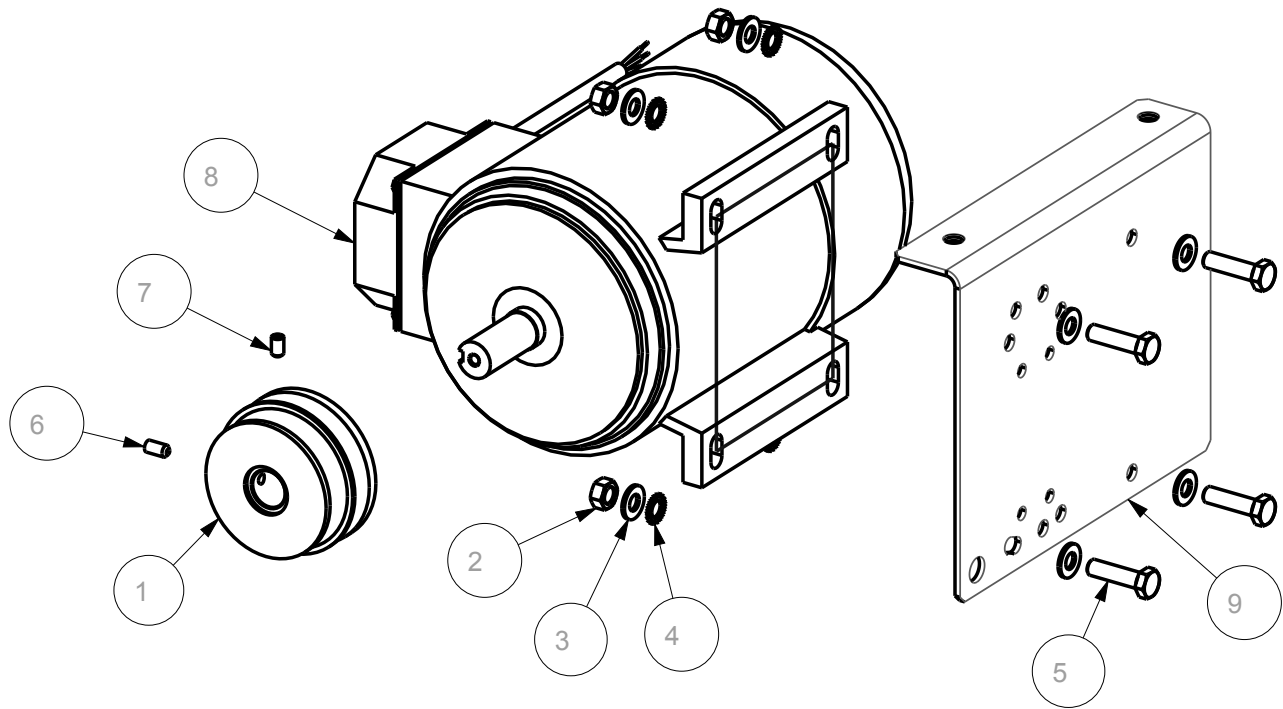

SYM	REQ	PART NO	DESCRIPTION
1	1	EAM0043G99A	PULLEY, DOUBLE
2	4	1-15933A	NUT M8 6S STAND WHITE ZINC
3	8	1-10041	WASHER D.8 UNI6592-69/DIN125
4	4	1-3048	WASHER SHAKEPROOF D8 *
5	4	1-32601	SCREW HEX HEAD MACHINE 8x30
6	1	1-50410A	SET SCREW HEX SOCKET M6X12
7	1	1-48910A	SCREW SET HEX SOC FLT PT, 6 X 10
8	1	2-49166A	MOTOR WITH CABLE FOR INVERTER
		EAW0282G24A	INVERTER - MOTOR CABLE CSA
9	1	EAS2029J69A	MOTOR SUPPORT

**SURGE TANK**

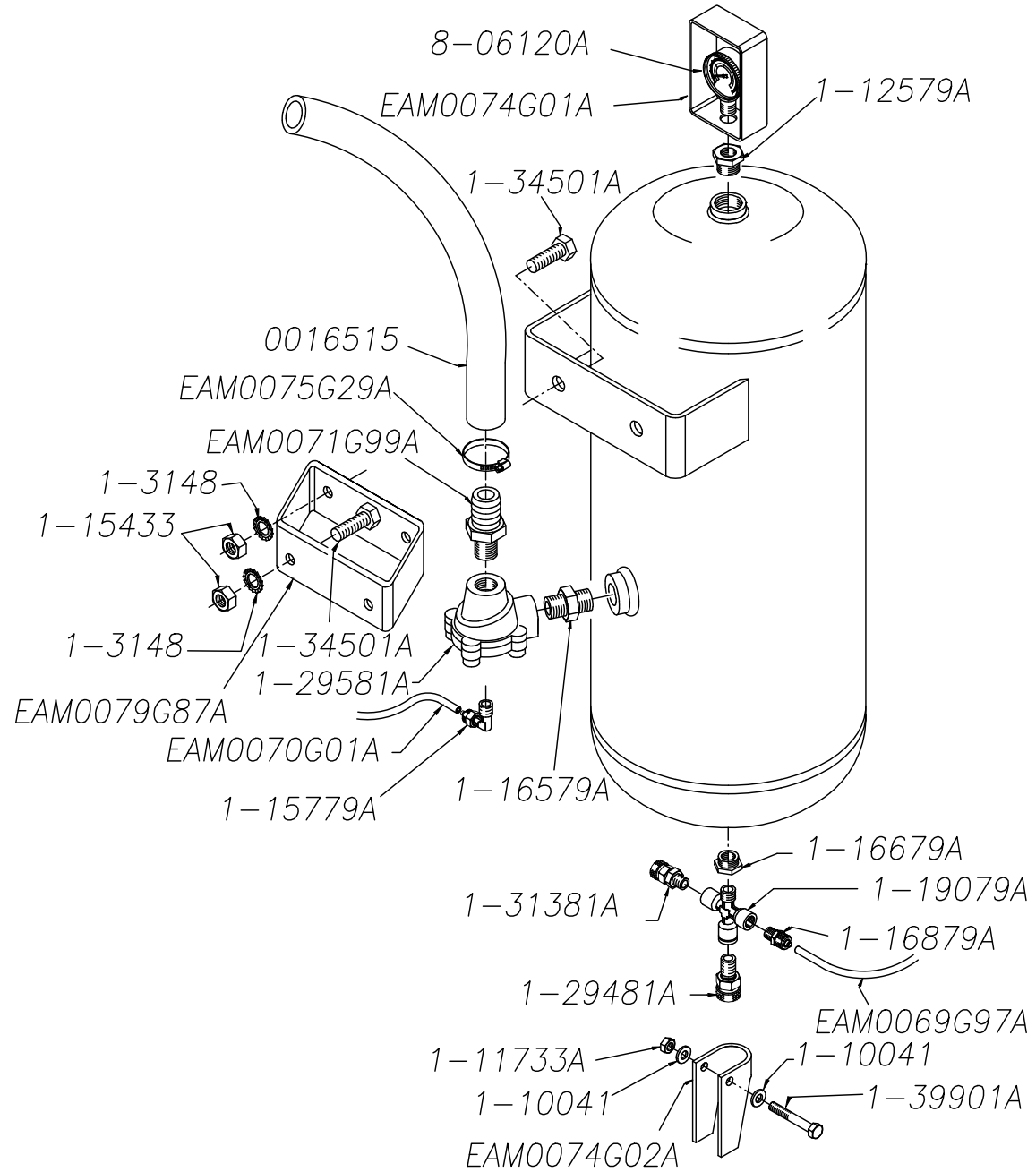

**AIR GUAGE**

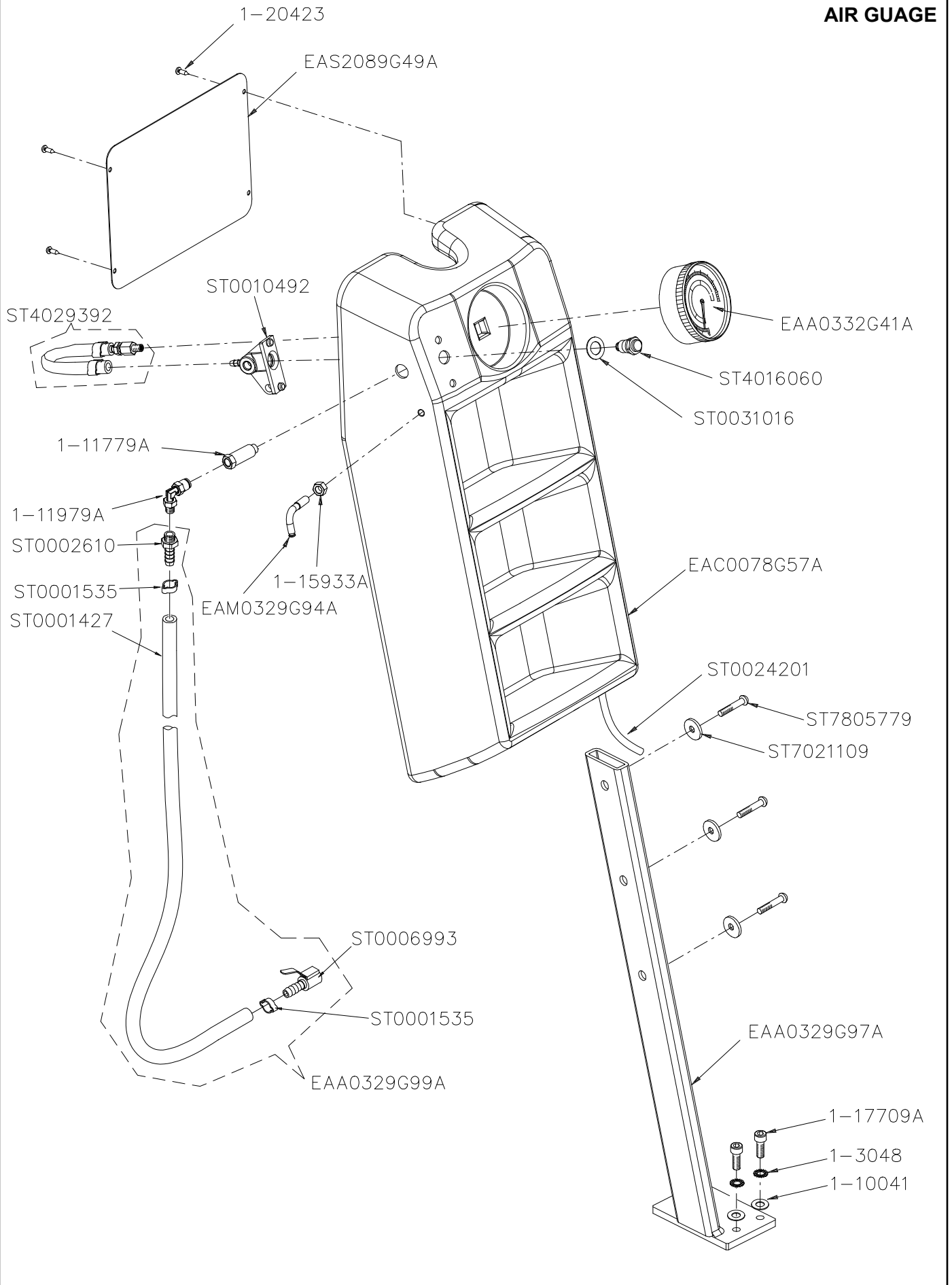

**BEAD BLAST PEDAL & VALVE**  
EAA0329G76A

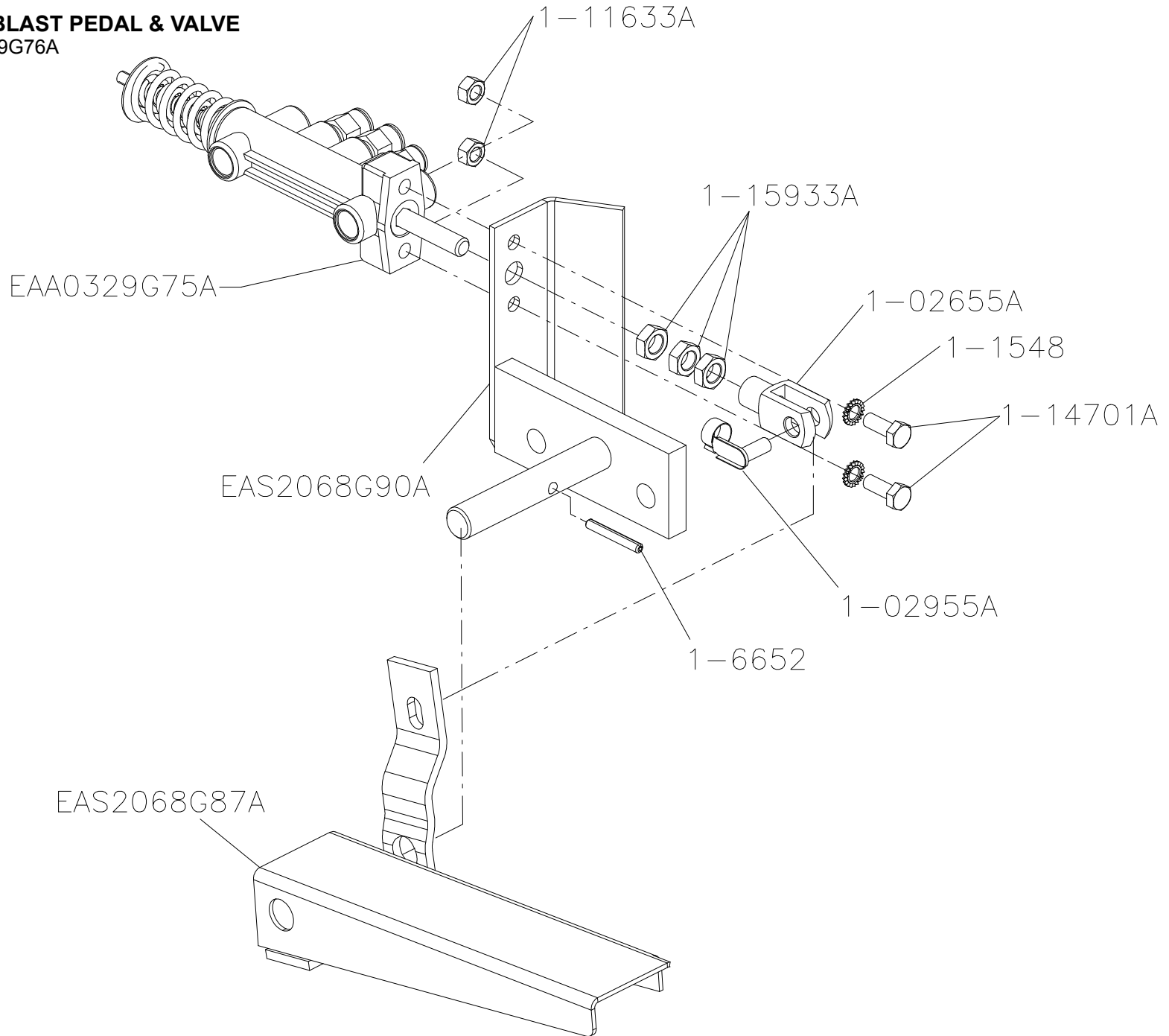

**PEDAL VALVE**

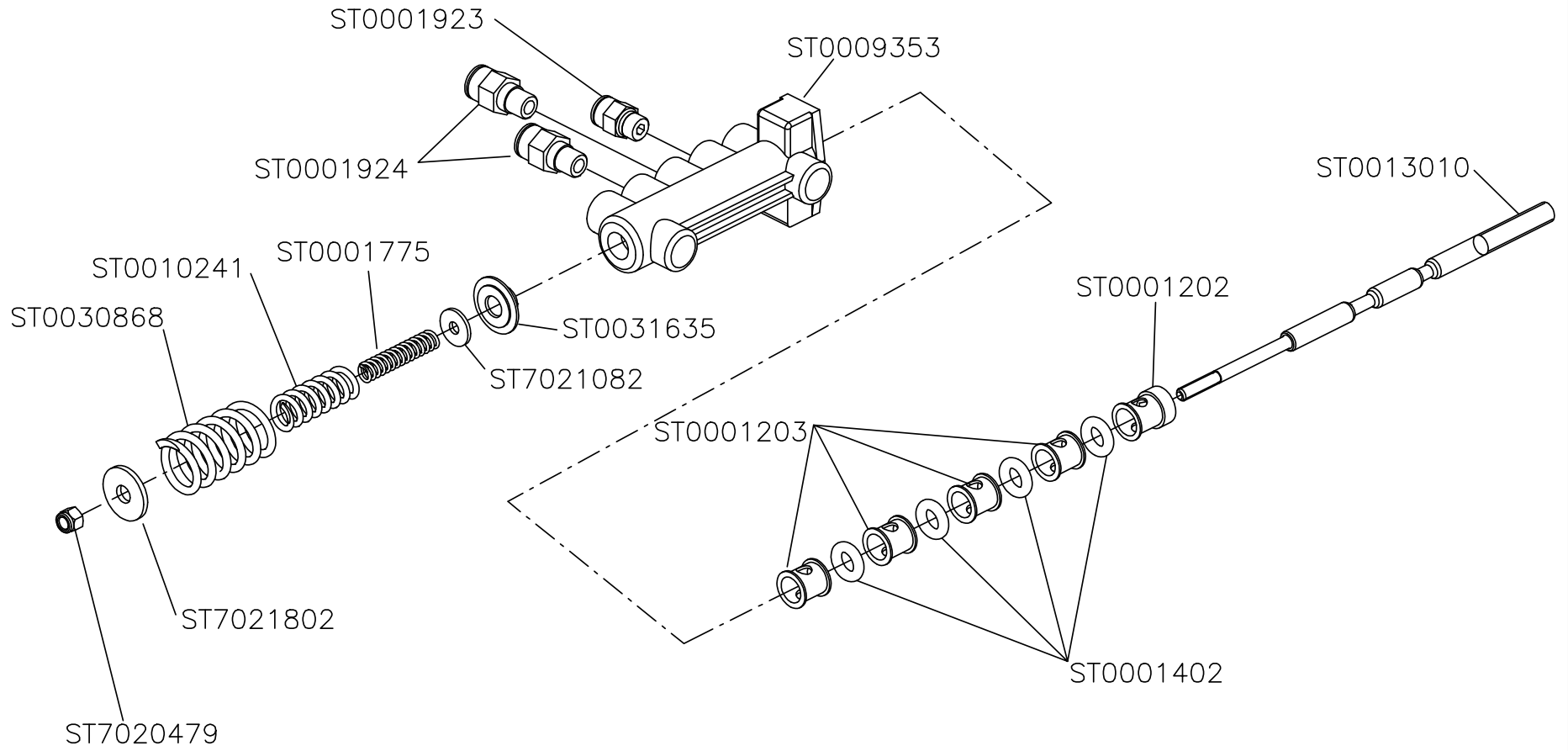

# LUBRICATOR

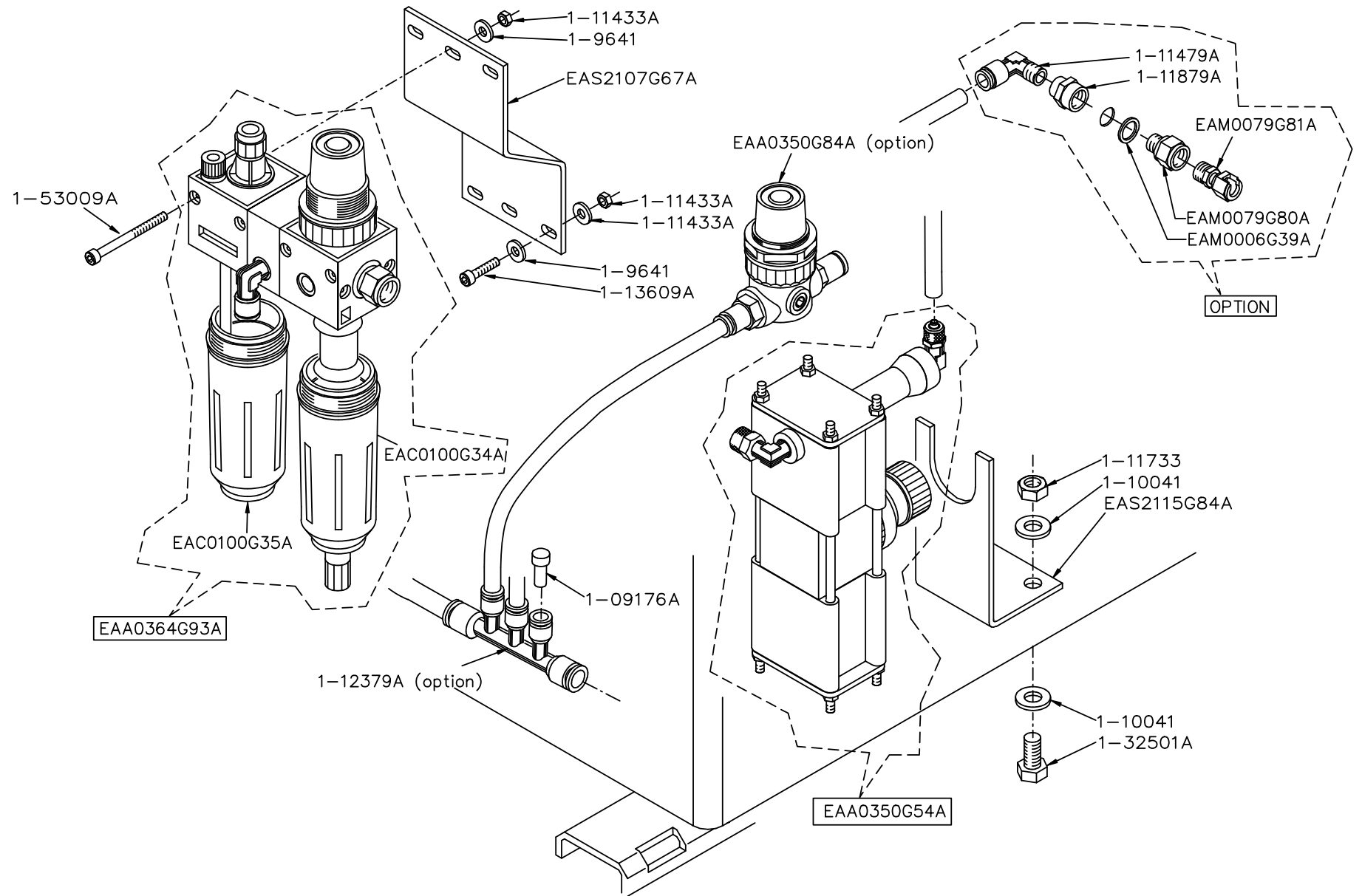

# BEAD BREAKER CYLINDER

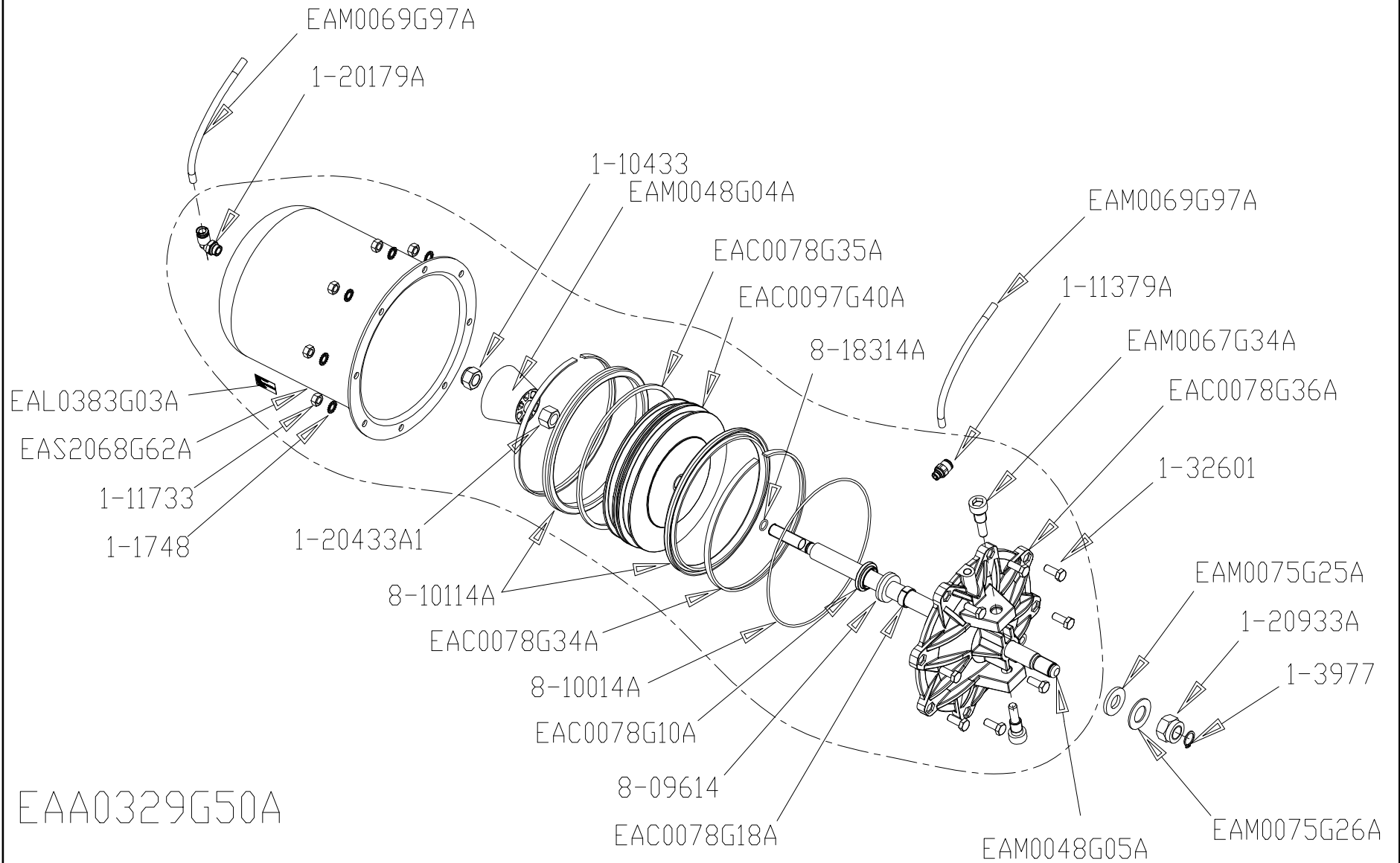



PEDAL VALVE ASSEMBLY

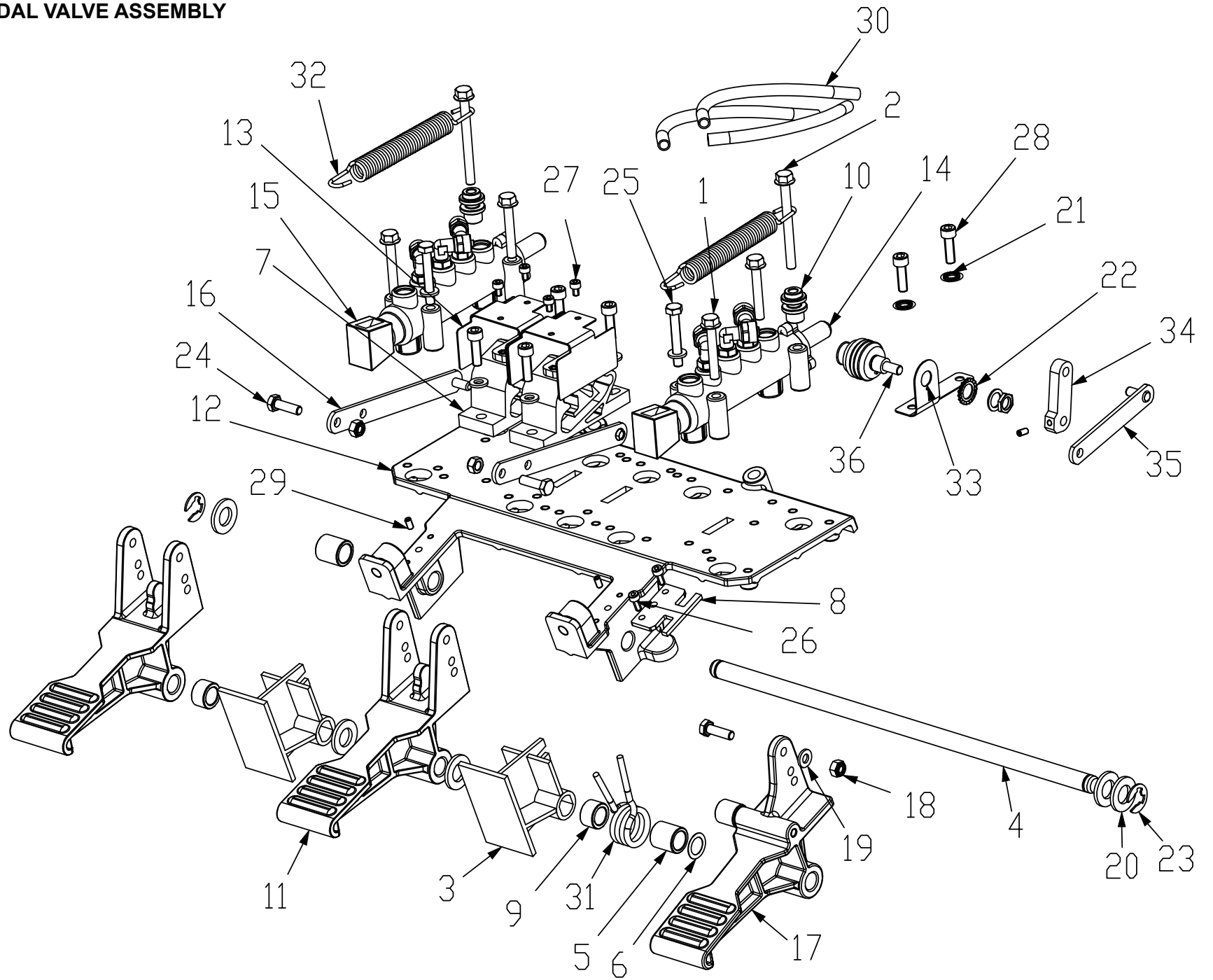

SYM	REQ	PART NO	DESCRIPTION
1	4	1-12626A	SCREW HEX FLANGE HEAD M6 x 40mm
2	2	1-12726A	SCREW HEX FLANGE HEAD M6 x 65mm
3	2	EAC0096G11A	SPACER-PEDAL
4	1	EAM0068G10A	SHAFT-HINGE PEDAL
5	2	EAM0048G79A	BUSHING CENTERING SPRING
6	1	1-25241A	SHIM RING D.12.2X18X0.3 MM DIN988
7	2	EAC0099G29A	CAM PEDAL
8	1	EAM0070G32A	COMMUTATOR SPRING GUIDE
9	2	EAM0070G46A	SPACER L=11 mm CENTERING SPRING
10	2	EAC0099G82A	SPRING FIXING PAWL
11	2	EAM0068G95A	STANDARD PEDAL MACHINED
12	1	EAM0068G80A	PEDAL ASSEMBLY SUPPORT - MACHINED
13	2	EAS2115G09A	PROTECTION SHEET FOR CAM
14	1	EAA0356G94A	VALVE 6x8 HOSES
15	1	EAA0356G96A	4x6 HOSES VALVE
16	2	EAS2111G73A	ROD POSITIONER PEDAL
17	1	EAA0356G92A	RIGHT SWITCH FOOT PEDAL
18	3	1-9933	NUT, PREVAILING TORQUE M6
19	7	1-9841	WASHER, PLAIN d6 ZINC.UNI6592-69
20	5	1-10241A	WASHER, ISO 7089 (DIN 125A)
21	2	1-1548	WASHER, EXT. SHAKEPROOF D6
22	1	1-3148	EXT. SHAKEPROOF D.10 DIN6798/A
23	2	1-18477A	RETAINING RING 10X1,2mm THK (A2R) BLK
24	3	1-14801A	SCREW, HEX HEAD MACHINE M6x20
25	2	1-31301A	SCREW TE 6X40 8G
26	2	1-13409	SCREW, HEX SOCKET CAP HEAD, M4X10 A2J
27	4	1-46809	Screw-HSHC M4x6 8.8 -A2J
28	6	1-16409	SCREW - HEX SOCKET HEAD CAP DIN 912
29	3	1-38910	SCREW M4X8SET CUP ZP
30	1	EAA0364G11A	HOSES KIT FOR FOOT PEDAL ASM 3P RACING
31	1	EAM0075G56A	SPRING, PEDAL SWITCH 2 SPEED
32	2	EAM0075G91A	SPRING RECALL PEDALS
33	1	EAS2132G60A	POTENTIOMETER SUPPORT
34	1	EAS2132G65A	POTENTIOMETER ROD
35	1	EAS2132G66A	ROD POTENTIOMETER PEDAL
36	1	EAW0282G16A	PEDAL CABLE WITH POTENTIOMETER

# PEDAL VALVE

EAA0356G94A

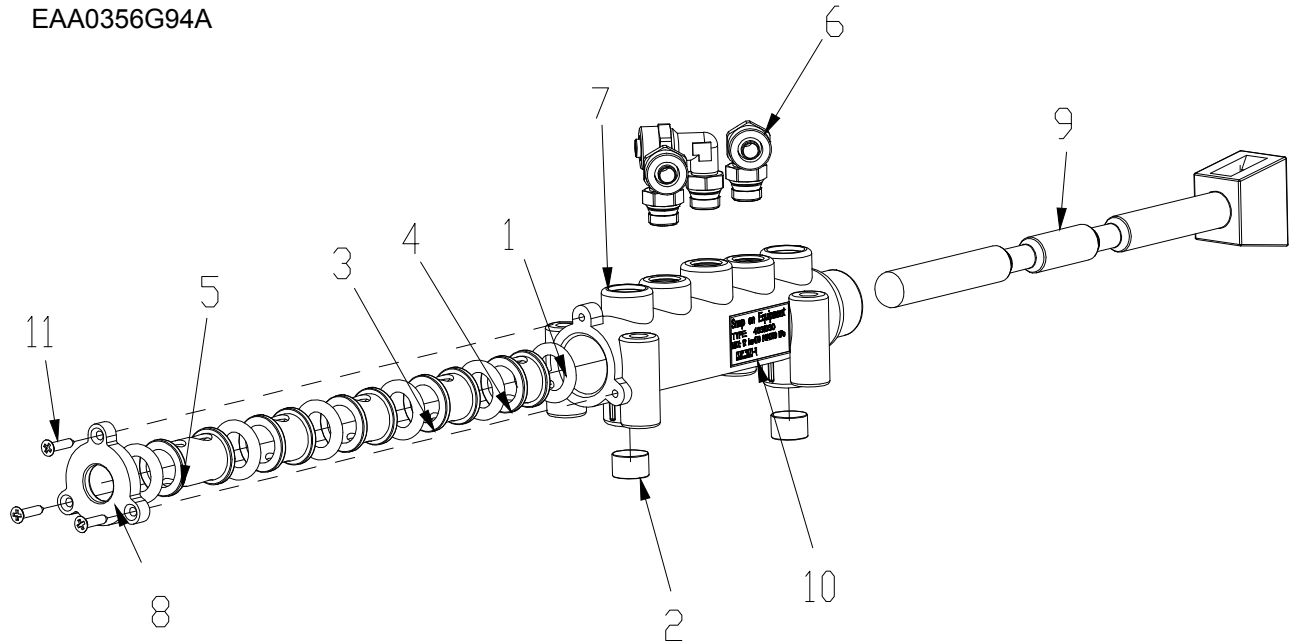

SYM	REQ	PART NO	DESCRIPTION
1	6	8-11014A	SEAL - OR
2	4	EAC0097G82A	WASHER MUFFLER D.12
3	3	EAC0097G78A	SPACER OR
4	1	EAC0097G77A	SPACER OR
5	1	EAC0097G79A	SPACER OR
6	3	1-17279A	FITTING "L" 6X8 1/8
7	1	EAC0099G30A	HOUSING BEAD BREAKER VALVE
8	1	EAC0099G31A	VALVES COVER
9	1	EAM0071G96A	VALVES ROD MACHINED
10	1	EAL0412G82A	4031030 VALVE LABEL
11	3	1-25123A	SELF-TAPPING SCREW 2,9x13

EAA0356G96A

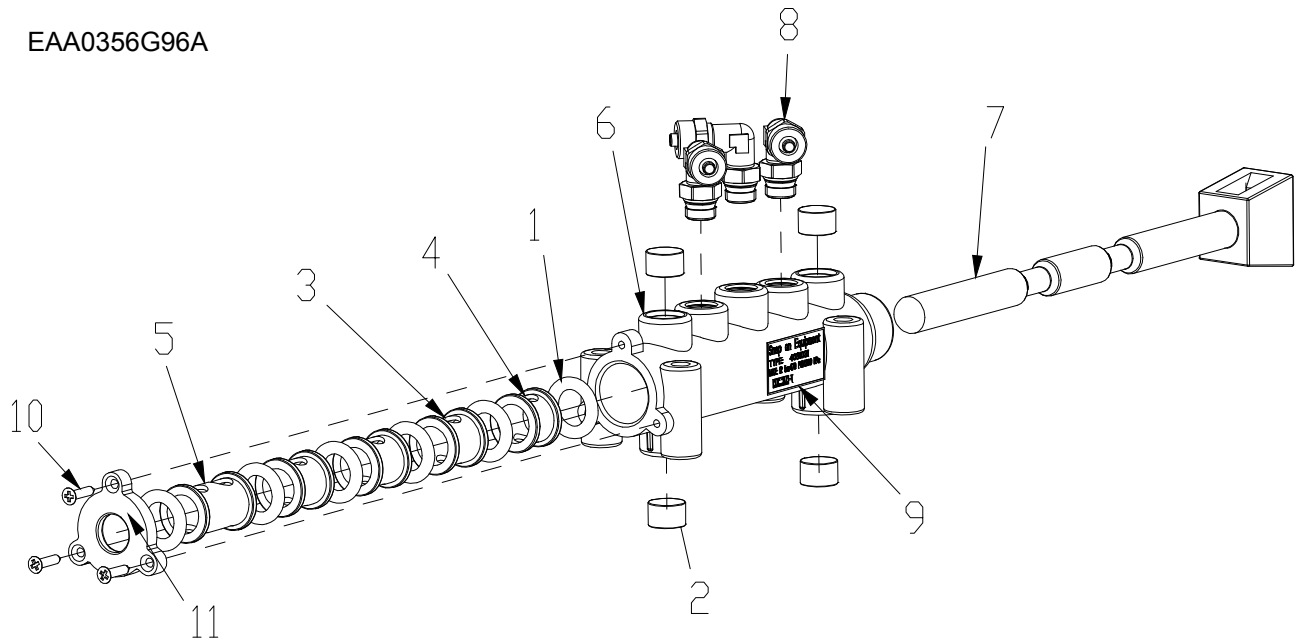

SYM	REQ	PART NO	DESCRIPTION
1	6	8-11014A	SEAL - OR
2	4	EAC0097G82A	WASHER MUFFLER D.12
3	3	EAC0097G78A	SPACER OR
4	1	EAC0097G77A	SPACER OR
5	1	EAC0097G79A	SPACER OR
6	1	EAC0099G33A	HOUSING TURNTABLE/TILTING VALVE
7	1	EAM0071G96A	VALVES ROD MACHINED
8	3	1-18879A	FITTING - L 4x6 1/8"
9	1	EAL0412G83A	4031031 VALVE LABEL
10	3	1-25123A	SELF-TAPPING SCREW 2,9x13
11	1	EAC0102G08A	YELLOW VALVES COVER

# BEAD BREAKER FOOT PEDAL

EAA0362G31A

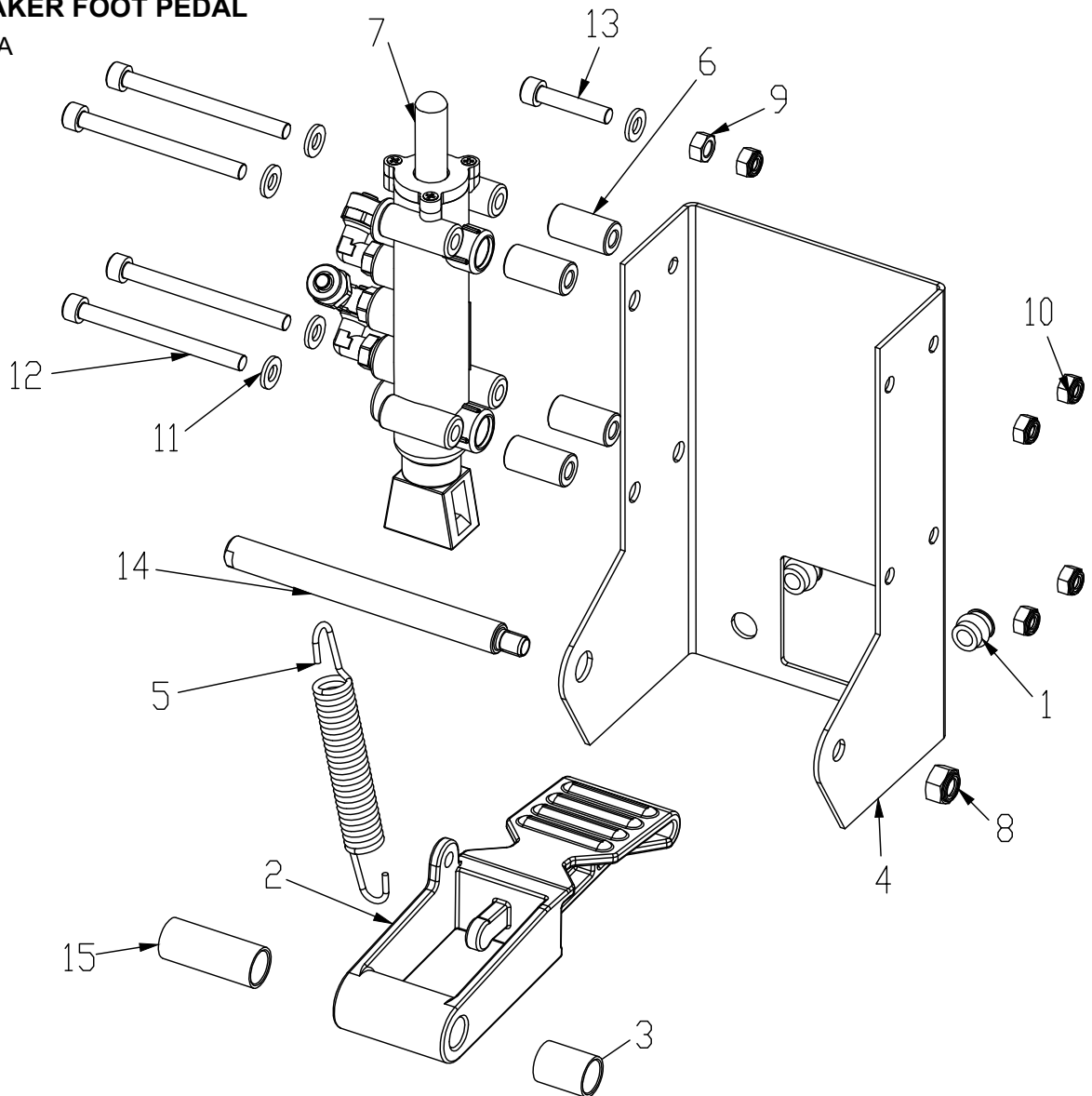

SYM	REQ	PART NO	DESCRIPTION
1	2	1-18359A_SQUEEZED_25	SELF CLINCHING NUT (M 8)
2	1	EAM0068G96A	BEAD BREAKER PEDAL - MACHINED
3	1	EAM0074G76A	SPACER Ø13 L=21
4	1	EAS2115G46A	BEAD BREAKER SUPPORT SHEET
5	1	EAM0074G78A	SPRING WIRE Ø2,2 L=115 mm
6	4	EAM0074G79A	SPACER Ø6.1 L=25
7	1	EAA0356G94A	VALVE 6x8 HOSES
8	1	1-10033	HEX NUT PREVAILING TORQUE M8
9	1	1-11633A	NUT-HEX. M6 6S
10	5	1-9933	NUT, PREVAILING TORQUE M6
11	5	1-9841	WASHER, PLAIN d6 ZINC.UNI6592-69
12	4	1-17409A	SCREW TCEI 6X70 8G
13	1	1-16609A	SCREW TCEI 6X30 8G
14	1	EAM0075G89A	BEAD BREAKER PEDAL SHAFT
15	1	EAM0075G90A	FOOT PEDAL SPACER

# INVERTER ASSEMBLY

EAA0383G04A

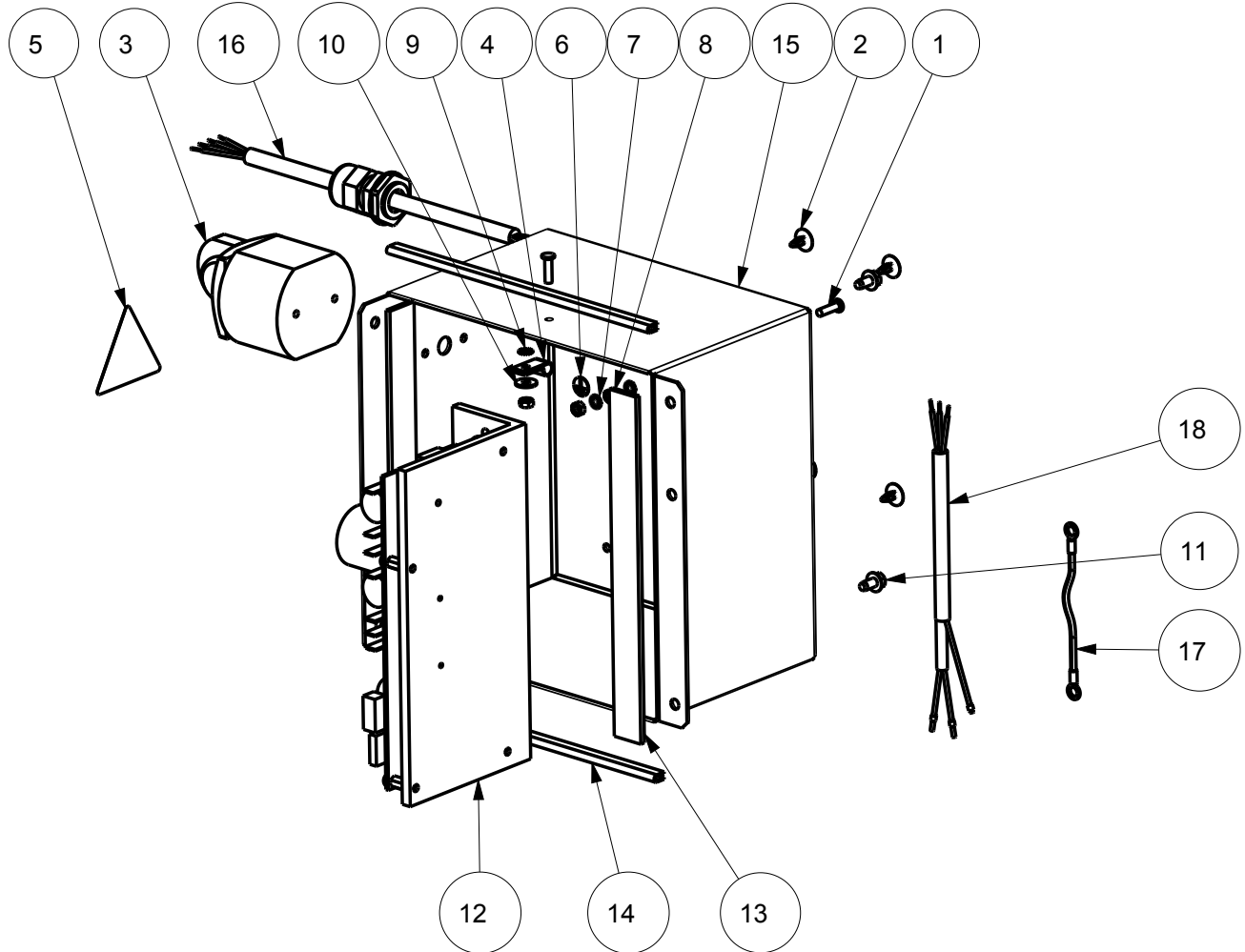

SYM	REQ	PART NO	DESCRIPTION
1	2	1-54801A	SELF-CLINCHING STUD M4X16
2	4	1-12176A	PLUG, Ø4.6mm BLACK NYLON
3	1	2-14861A	BIPOLAR POWER SWITCH
4	1	5-08745A	ALLUMINIUM CABLE CLAMP
5	1	8-23562A	STICKER, DANGER VDE
6	1	8-23762A	LABLE, GROUND(B)
7	2	1332041	BEVELED SERRATED WASHER
8	3	1-15833A	HEX NUT M4, BRASS
9	1	1-1348	LOCKWASHER D4
10	1	1-16441	WASHER 4X12X1
11	2	666204	Cutting Screw Hexagon M6SF-TT M5x10 FZB
12	1	EAA0378G69A	INVERTER AND HEATSINK
13	2	EAM0087G08A	SELF-ADHESIVE SEALING 3x20
14	2	EAM0087G09A	U PROFILE 2 mm GASKET RUBBER
15	1	EAS2132G53A	INVERTER BOX
16	1	EAW0282G20A	MAIN CABLE CSA
17	1	EAW0282G22A	CABLE, EARTH FOR CABINET
18	1	EAW0282G23A	MAIN SWITCH-INVERTER CABLE







# HOFMANN



309 Exchange Avenue  
Conway, AR 72032