



Video 2.5 HDD

Product Manual

Standard models

ST500VT000

ST500VT001

ST320VT000

ST250VT000

100713733, Rev. G
Gen 2.1 - October 2016

Document Revision History

Revision	Date	Pages affected and Description of Change
Rev. A	07/24/2013	Initial release.
Rev. B	05/02/2014	16.
Rev. C	11/07/2014	4 & 11.
Rev. D	09/24/2015	FC: New logo & cover design 4: Updated 1st & last support URLs 7 & 14: Revised Rated Workload statement All: New page numbering convention applied. BC: New logo
Rev. E	04/28/2016	7 & 14: Updated Warranty link text to "Is my Drive under Warranty" 15: Updated Section 2.12 Agency Certification
Rev. F	06/22/2016	18: Added temp checkpoint to mechanical drawing
Rev. G	10/14/2016	15: Updated to Electromagnetic Compatibility Directive 2014/30/EU 15: Added MSIP Korean text for Class B device warning 16: Updated to China RoHS 2

© 2016 Seagate Technology LLC. All rights reserved.

Publication number: 100713733, Rev. G October 2016

Seagate, Seagate Technology and the Spiral logo are registered trademarks of Seagate Technology LLC in the United States and/or other countries. 3D Defense System and SeaTools are either trademarks or registered trademarks of Seagate Technology LLC or one of its affiliated companies in the United States and/or other countries. The FIPS logo is a certification mark of NIST, which does not imply product endorsement by NIST, the U.S., or Canadian governments. All other trademarks or registered trademarks are the property of their respective owners.

No part of this publication may be reproduced in any form without written permission of Seagate Technology LLC.
Call 877-PUB-TEK1(877-782-8351) to request permission.

When referring to drive capacity, one gigabyte, or GB, equals one billion bytes and one terabyte, or TB, equals one trillion bytes. Your computer's operating system may use a different standard of measurement and report a lower capacity. In addition, some of the listed capacity is used for formatting and other functions, and thus will not be available for data storage. Actual quantities will vary based on various factors, including file size, file format, features and application software. Actual data rates may vary depending on operating environment and other factors. The export or re-export of hardware or software containing encryption may be regulated by the U.S. Department of Commerce, Bureau of Industry and Security (for more information, visit www.bis.doc.gov), and controlled for import and use outside of the U.S. Seagate reserves the right to change, without notice, product offerings or specifications.

Seagate® Technology Support Services	4
---	----------

1.0 Introduction	5
1.1 About the Serial ATA Interface	5

2.0 Drive Specifications	6
2.1 Formatted Capacity	7
2.1.1 LBA mode	7
2.2 Physical organization	8
2.3 Recording and Interface Technology	8
2.4 Physical Characteristics	8
2.5 Seek time	8
2.6 Start/stop times	9
2.7 Power Specifications	9
2.7.1 Power consumption	9
2.7.2 Conducted noise	11
2.7.3 Voltage tolerance	11
2.7.4 Power management modes	11
2.8 Environmental Specifications	12
2.8.1 Shock	12
2.8.2 Vibration	12
2.9 Acoustics	13
2.9.1 Test for prominent discrete tones (PDTs)	13
2.10 Electromagnetic Immunity	13
2.11 Reliability	14
2.11.1 Annualized Failure Rate (AFR)	14
2.12 Agency Certification	15
2.12.1 Safety certification	15
2.12.2 Electromagnetic Compatibility (EMC)	15
2.12.3 FCC verification	15
2.13 Environmental Protection	16
2.13.1 European Union Restriction of Hazardous Substances (RoHS) Directive	16
2.13.2 China Requirements — China RoHS 2	16
2.14 Corrosive Environment	16

3.0 Configuring and Mounting the Drive	17
3.1 Handling and Static-Discharge Precautions	17
3.2 Configuring the Drive	17
3.2.1 Serial ATA Cables and Connectors	17
3.3 Drive Mounting	18

4.0 Serial ATA (SATA) Interface	19
4.1 Hot-Plug Compatibility	19
4.2 Serial ATA Device Plug Connector Pin Definitions	19
4.3 Supported ATA Commands	20
4.3.1 Identify Device command	22
4.3.2 Set Features command	26
4.3.3 S.M.A.R.T. commands	27

Figure 1	Typical 5V Startup and Operation Current Profile	10
Figure 2	Attaching SATA Cabling	17
Figure 3	Mounting Dimensions (for standard models)	18

Seagate® Technology Support Services

For information regarding online support and services, visit: <http://www.seagate.com/contacts/>

For information regarding Warranty Support, visit: <http://www.seagate.com/support/warranty-and-replacements/>

For information regarding data recovery services, visit: <http://www.seagate.com/services-software/data-recovery-services/>

For Seagate OEM, Distribution partner and reseller portals, visit: <http://www.seagate.com/partners/>

1.0 Introduction

This manual describes the functional, mechanical and interface specifications for the following: Seagate® Video 2.5 HDD model drives:

Standard models
ST500VT000 - 1DK142
ST500VT001 - 1K6142
ST320VT000 - 1DK14C
ST250VT000 - 1DK141

These drives provide the following key features:

- 1000 Gs nonoperating shock and 400 Gs of operating shock.
- 16MB buffer. (ST500VT000, ST320VT000 and ST250VT000 models)
- 32MB buffer. (ST500VT001 model)
- 5400-RPM spindle speed.
- Full-track multiple-sector transfer capability without local processor intervention.
- High instantaneous (burst) data-transfer rates (up to 6Gb/s).
- Native Command Queuing (NCQ) with command ordering.
- Perpendicular recording technology.
- Quiet operation. Fluid Dynamic Bearing (FDB) motor.
- Reliability for 24x7 video applications.
- SeaTools™ diagnostic software performs a drive self-test that eliminates unnecessary drive returns.
- State-of-the-art cache and on-the-fly error-correction algorithms.
- Support for Read Multiple and Write Multiple commands.
- Support for S.M.A.R.T. drive monitoring and reporting.
- The 3D Defense System™, which includes Drive Defense, Data Defense and Diagnostic Defense, offers the industry's most comprehensive protection for disk drives.
- Worldwide Name (WWN) capability uniquely identifies the drive.

1.1 About the Serial ATA Interface

The Serial ATA interface provides several advantages over the traditional (parallel) ATA interface. The primary advantages include:

- Easy installation and configuration with true plug-and-play connectivity. It is not necessary to set any jumpers or other configuration options.
- Thinner and more flexible cabling for improved enclosure airflow and ease of installation.
- Scalability to higher performance levels.

In addition, Serial ATA makes the transition from parallel ATA easy by providing legacy software support. Serial ATA was designed to allow you to install a Serial ATA host adapter and Serial ATA disk drive in your current system and expect all of your existing applications to work as normal.

The Serial ATA interface connects each disk drive in a point-to-point configuration with the Serial ATA host adapter. There is no master/slave relationship with Serial ATA devices like there is with parallel ATA. If two drives are attached on one Serial ATA host adapter, the host operating system views the two devices as if they were both "masters" on two separate ports. This essentially means both drives behave as if they are Device 0 (master) devices.

Note	The host adapter may, optionally, emulate a master/slave environment to host software where two devices on separate Serial ATA ports are represented to host software as a Device 0 (master) and Device 1 (slave) accessed at the same set of host bus addresses. A host adapter that emulates a master/slave environment manages two sets of shadow registers. This is not a typical Serial ATA environment.
-------------	---

The Serial ATA host adapter and drive share the function of emulating parallel ATA device behavior to provide backward compatibility with existing host systems and software. The Command and Control Block registers, PIO and DMA data transfers, resets, and interrupts are all emulated.

The Serial ATA host adapter contains a set of registers that shadow the contents of the traditional device registers, referred to as the Shadow Register Block. All Serial ATA devices behave like Device 0 devices. For additional information about how Serial ATA emulates parallel ATA, refer to the *Serial ATA International Organization: Serial ATA* (Revision 2.6). The specification can be downloaded from www.serialata.org.

2.0 Drive Specifications

Unless otherwise noted, all specifications are measured under ambient conditions, at 25°C, and nominal power. For convenience, the phrases *the drive* and *this drive* are used throughout this manual to indicate the following drive models:

The specification summaries listed in the following tables are for quick reference. For details on specification measurement or definition, refer to the appropriate section of this manual.

Table 1 Drive Specifications Summary

Drive Specification	ST500VT001	ST500VT000	ST320VT000	ST250VT000
Formatted capacity ⁽¹⁾	500 GB		320 GB	250 GB
Guaranteed sectors	976,773,168		625,142,448	488,397,168
Heads	2			
Disks	1			
Bytes per sector	512 (logical) / 4096 (physical)			
Recording density	1875 Kb/in			
Track density	375 Ktracks/in avg			
Areal density	670 Gb/in ² avg			
Spindle speed	5400 RPM			
Sustained data transfer rate OD	100 MB/s max			
I/O data-transfer rate	600 MB/s max			
ATA data-transfer modes supported	PIO modes 0–4 Multiword DMA modes 0–2 Ultra DMA modes 0–6			
Cache buffer	32MB	16MB		
Height	6.8 +/- 0.2 mm (0.268 +/- .008 in)			
Width	69.85 +/- 0.25 mm (2.750 +/- 0.010 in)			
Length	100.35 +0.20 / -0.25 mm (3.951 +0.008 / -0.010 in)			
Weight (typical)	<95 g (0.209 lb)			
Average latency	5.6 ms			
Startup current (typical) 5V (peak)	1.0 A			
Voltage tolerance (including noise)	5V ± 5%			
Operating temperature	0° to 60°C			
Nonoperating temperature (Ambient)	–40° to 70°C			
Temperature gradient (max)	20°C per hour max (operating) 35°C per hour max (nonoperating)			
Relative humidity	5% to 95% (operating) 5% to 95% (nonoperating)			
Relative humidity gradient	30% per hour max			
Wet bulb temperature (max)	37.7°C max (operating) 40.0°C max (nonoperating)			
Altitude, operating	–304.8 m to 3048 m (–1000 ft to 10,000+ ft)			
Altitude, nonoperating (below mean sea level, max)	–304.8 m to 12,192 m (–1000 ft to 40,000+ ft)			
Operational Shock	400 Gs at 2 ms max			

Table 1 Drive Specifications Summary (continued)

Drive Specification	ST500VT001	ST500VT000	ST320VT000	ST250VT000
Non-Operational Shock	1000 Gs at 1 ms max			
Vibration, operating	5–200 Hz: 2.0 Gs 201–500 Hz: 1.0 Gs			
Vibration, nonoperating	5–500 Hz: 5.0 Gs			
Nonrecoverable read errors	1 per 10 ¹⁴ bits read			
Annualized Failure Rate (AFR)	0.55%			
Rated workload	Average annualized workload rating: <55 TB/year. The AFR specification for the product assumes the I/O workload does not exceed the average annualized workload rate limit of 55 TB/year. Workloads exceeding the annualized rate may degrade the product AFR and impact reliability as experienced by the particular application. The average annualized workload rate limit is in units of TB per calendar year.			
Warranty	To determine the warranty for a specific drive, use a web browser to access the following web page: http://www.seagate.com/support/warranty-and-replacements/ From this page, click on the “Is my Drive under Warranty” link. The following are required to be provided: the drive serial number, model number (or part number) and country of purchase. The system will display the warranty information for the drive.			
Load-unload cycles	600,000 at 25°C, 50% rel. humidity			
Supports Hotplug operation per the Serial ATA Revision 3.2 specification	Yes			

1. One GB equals one billion bytes when referring to hard drive capacity. Accessible capacity may vary depending on operating environment and formatting.

2.1 Formatted Capacity

Model	Formatted Capacity ⁽¹⁾	Guaranteed Sectors	Bytes per Sector
500GB model	500 GB	976,773,168	512 (logical) / 4096 (physical)
320GB model	320 GB	625,142,448	
250GB model	250 GB	488,397,168	

1. One GB equals one billion bytes when referring to hard drive capacity. Accessible capacity may vary depending on operating environment and formatting.

2.1.1 LBA mode

When addressing these drives in LBA mode, all blocks (sectors) are consecutively numbered from 0 to $n-1$, where n is the number of guaranteed sectors as defined above.

Refer to [Configuring and Mounting the Drive](#) on page 17 (words 60-61 and 100-103) for additional information about 48-bit addressing support of drives with capacities over 137 GB.

2.2 Physical organization

Drive model	Read/write heads	Number of disks
ST500VT000 and ST500VT001	2	1
ST320VT000		
ST250VT000		

2.3 Recording and Interface Technology

Interface	Serial ATA (SATA)
Recording method	Perpendicular
Recording density	1875 Kb/in
Track density	375 ktracks/in avg
Areal density	670 Gb/in ² avg
Spindle speed	5400 RPM +/- 0.2%
Sustained data transfer rate	100 MB/s max
I/O data-transfer rate	600 MB/s max

2.4 Physical Characteristics

All models	Height	6.8 +/- 0.2 mm (0.268 +/- .008 in)
	Width	69.85 +/- 0.25 mm (2.750 +/- 0.010 in)
	Length	100.35 +0.20 / -0.25 mm (3.951 +0.008 / -0.010 in)
	Typical weight	<95 g (0.209 lb)
ST500VT000, ST320VT000 and ST250VT000	Cache buffer	16 MB (16,192 KB)
ST500VT001		32MB (32,384 KB)

2.5 Seek time

Seek measurements are taken with nominal power at 25°C ambient temperature. All times are measured using drive diagnostics. The specifications in the table below are defined as follows:

- Track-to-track seek time is an average of all possible single-track seeks in both directions.
- Average seek time is a true statistical random average of at least 5000 measurements of seeks between random tracks, less overhead.

Table 2 Typical seek times

Typical seek times (ms)	Read
Track-to-track	1.5
Average	12.0
Average latency	5.6

Note	These drives are designed to consistently meet the seek times represented in this manual. Physical seeks, regardless of mode (such as track-to-track and average), are expected to meet the noted values. However, due to the manner in which these drives are formatted, benchmark tests that include command overhead or measure logical seeks may produce results that vary from these specifications.
-------------	---

2.6 Start/stop times

Table 3 Start/stop times

Typical seek times (ms)	Typical	Max @ 25°C
Power-on to ready	3.0	4.0
Standby to ready	2.5	3.0

2.7 Power Specifications

The drive receives DC power (+5V) through a native SATA power connector (refer to [Figure 2](#)).

2.7.1 Power consumption

Power requirements for the drives are listed in the table in [Table 4](#). Typical power measurements are based on an average of drives tested, under nominal conditions, at 25°C ambient temperature. These power measurements are done with Interface Power Management modes like HIPM and DIPM enabled.

■ Spinup power

Spinup power is measured from the time of power-on to the time that the drive spindle reaches operating speed.

■ Seek mode

During seek mode, the read/write actuator arm moves toward a specific position on the disk surface and does not execute a read or write operation. Servo electronics are active. Seek mode power is measured based on three random seek operations every 100 ms. This mode is not typical.

■ Read/write power and current

Read/write power is measured with the heads on track, based on three 63 sector read or write operations every 100 ms.

■ Idle mode power

Idle mode power is measured with the drive up to speed, with servo electronics active and with the heads in a random track location.

■ Standby mode

During standby mode, the drive accepts commands, but the drive is not spinning, and the servo and read/write electronics are in power-down mode.

Table 4 DC Power Requirements

Power Dissipation	+5V input average (25° C)
Spinup (max)	1.00A
Seek average	1.40W
Write average	1.70W
Read average	1.30W
Idle, performance ⁽¹⁾	1.20W
Idle, active	0.70W
Idle, low power mode	0.45W
Standby ⁽²⁾	0.18W
Sleep	0.18W

1. During periods of drive idle, some offline activity may occur according to the S.M.A.R.T. specification, which may increase acoustic and power to operational levels.

2. Standby power is measured at steady state (after 200ms from transition)

2.7.1.1 Typical current profiles

The typical 5V startup and operation current profile is shown in **Figure 1**.

Figure 1 Typical 5V Startup and Operation Current Profile

30-Nov-12
18:19:08

1
5 s
200mV

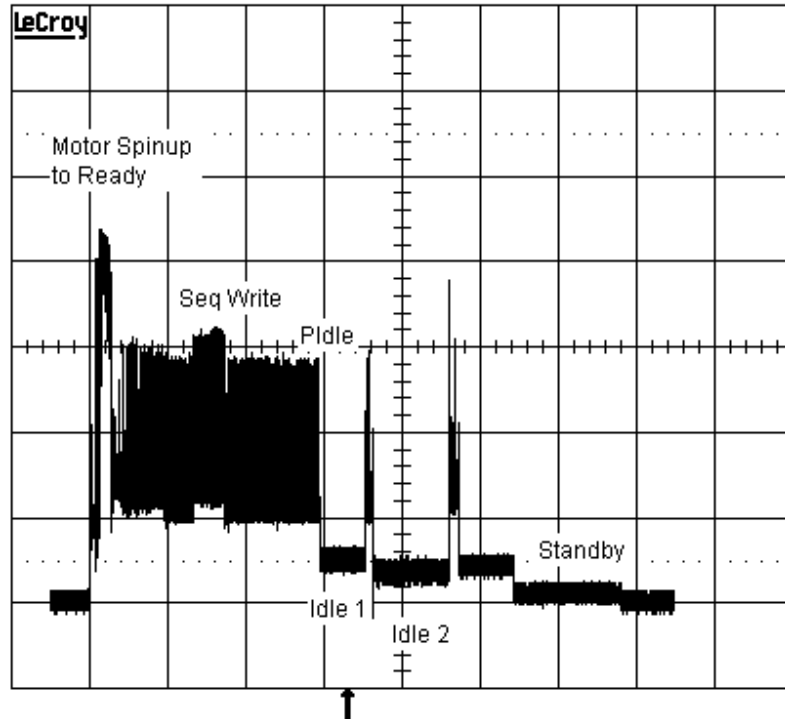

+5V Input
Supply Current

5 s

- 1 .2 V DC
- 2 1 V DC
- 3 .1 V DC $\times 10$
- 4 1 V DC



1 DC 0.532 V

100 kS/s

STOPPED

2.7.2 Conducted noise

Input noise ripple is measured at the host system power supply across an equivalent 15-ohm resistive load on the +5 volt line.

- Using 5-volt power, the drive is expected to operate with a maximum of 100 mV peak-to-peak square-wave injected noise at up to 20 MHz.

Note

Equivalent resistance is calculated by dividing the nominal voltage by the typical RMS read/write current.

2.7.3 Voltage tolerance

Voltage tolerance (including noise):

- +5V \pm 5%

2.7.4 Power management modes

The drive provides programmable power management to provide greater energy efficiency. In most systems, power management is controlled through the system setup program. The drive features the following power-management modes:

Power modes	Heads	Spindle	Buffer
Active (operating)	Tracking	Rotating	Full power
Idle, performance	Tracking	Rotating	Self refresh—low power
Idle, active	Floating	Rotating	Self refresh—low power
Idle, low power	Parked	Rotating	Self refresh—low power
Standby	Parked	Stopped	Self refresh—low power
Sleep	Parked	Stopped	Self refresh—low power

- **Active mode**

The drive is in active mode during the read/write and seek operations.

- **Idle mode**

The buffer remains enabled, and the drive accepts all commands and returns to active mode any time disk access is necessary.

- **Standby mode**

The drive enters standby mode when the host sends a standby Immediate command. If the host has set the standby timer, the drive can also enter standby mode automatically after the drive has been inactive for a specifiable length of time. The standby timer delay is established using a standby or idle command. In standby mode, the drive buffer is enabled, the heads are parked and the spindle is at rest. The drive accepts all commands and returns to active mode any time disk access is necessary.

- **Sleep mode**

The drive enters sleep mode after receiving a sleep command from the host. In sleep mode, the drive buffer is disabled, the heads are parked and the spindle is at rest. The drive leaves sleep mode after it receives a hard reset or soft reset from the host. After receiving a reset, the drive exits sleep mode and enters standby mode with all current translation parameters intact.

- **Idle and standby timers**

Each time the drive performs an active function (read, write or seek), the standby timer is reinitialized and begins counting down from its specified delay times to zero. If the standby timer reaches zero before any drive activity is required, the drive makes a transition to standby mode. In both Idle and standby mode, the drive accepts all commands and returns to active mode when disk access is necessary.

2.8 Environmental Specifications

This section provides the temperature, humidity, shock, and vibration specifications for Momentus drives.

Ambient temperature is defined as the temperature of the environment immediately surrounding the drive.

Above 1000 feet (305 meters), the maximum temperature is derated linearly by 1°C every 1000 feet.

The maximum allowable drive case temperature is 65°C (149°F)

Table 5: Environmental specifications

Parameters	Operating	Non-Operating
Ambient temperature	0° to 60°C (32° to 140°F)	-40° to 70°C (-40° to 158°F)
Temperature gradient	20°C per hour (68°F per hour) max, without condensation	35°C per hour (95°F per hour) max, without condensation
Humidity	5% to 95% non-condensing (30% per hour)	5% to 95% non-condensing (30% per hour)
Wet bulb	37.7°C (99.8°F) max	40°C (104°F) max
Altitude	-304.8m to 3048m (-1000ft to 10,000ft)	-304.8m to 12,192m (-1000ft to 40,000ft)

Note	<p>The recommended storage period:</p> <ul style="list-style-type: none"> • 1 year under controlled conditions of 34°C 90%RH or less • 90 days in uncontrolled storage conditions
-------------	---

2.8.1 Shock

All shock specifications assume that the drive is mounted securely with the input shock applied at the drive mounting screws. Shock may be applied in the X, Y, or Z axis.

2.8.1.1 Operating shock

These drives comply with the performance levels specified in this document when subjected to a maximum operating shock of 400 Gs based on half-sine shock pulses of 2ms. Shocks should not be repeated more than one time per axis

2.8.1.2 Nonoperating shock

The nonoperating shock level that the drive can experience without incurring physical damage or degradation in performance when subsequently put into operation is 800 Gs based on a nonrepetitive half-sine shock pulse of 2 ms duration.

The nonoperating shock level that the drive can experience without incurring physical damage or degradation in performance when subsequently put into operation is 1000 Gs based on a nonrepetitive half-sine shock pulse of 1 ms duration.

2.8.2 Vibration

All vibration specifications assume that the drive is mounted securely with the input vibration applied at the drive mounting screws. Vibration may be applied in the X, Y, or Z axis.

2.8.2.1 Operating vibration

The maximum vibration levels that the drive may experience while meeting the performance standards specified in this document are specified below.

5–200 Hz	2.0 Gs (0 to peak). Max displacement may apply below 10 Hz.
201–500 Hz	1.0 Gs (0 to peak).

2.8.2.2 Nonoperating vibration

The maximum nonoperating vibration levels that the drive may experience without incurring physical damage or degradation in performance when subsequently put into operation are specified below.

5–500 Hz	5.0 Gs (0 to peak). Max displacement may apply below 22 Hz.
----------	---

2.9 Acoustics

Drive emission of sound is measured consistent with the ECMA-74 and its referenced standards. Testing is conducted at room temperature (approximately 25°C). Emission levels are reported as the total A-weighted sound power levels for steady state, idle, and active seeks modes of operation.

Table 6 Drive A-weighted Sound Power Levels (SWL, BA)

Idle ⁽¹⁾	Performance Seek
2.0 bels (typ) 2.2 bels (max)	2.2 bels (typ) 2.4 bels (max)

1. During periods of drive idle, some offline activity may occur according to the S.M.A.R.T. specification, which may increase acoustic and power to operational levels.

2.9.1 Test for prominent discrete tones (PDTs)

Seagate follows the ECMA-74 standards for measurement and identification of PDTs. An exception to this process is the use of the absolute threshold of hearing. Seagate uses the lower limit for the threshold curve* to discern tone audibility and to compensate for the inaudible components of sound prior to computation of tone ratios according to Annex D of the ECMA-74 standards.

*Defined as the median curve given by ISO 389-7 (Tf curve) minus 10dB at all frequencies.

2.10 Electromagnetic Immunity

When properly installed in a representative host system, the drive operates without errors or degradation in performance when subjected to the radio frequency (RF) environment as defined in [Table 7](#).

Table 7 Radio Frequency Environments

Test	Description	Performance Level	Reference Standard
Electrostatic discharge	Contact, HCP, VCP: ± 4 kV; Air: ± 8 kV	B	EN 61000-4-2: 95
Radiated RF immunity	80 to 1GHz, 3 V/m, 80% AM with 1 kHz sine 900 MHz, 3 V/m, 50% pulse modulation @ 200 Hz	A	EN 61000-4-3: 96 ENV 50204: 95
Electrical fast transient	± 1 kV on AC mains, ± 0.5 kV on external I/O	B	EN 61000-4-4: 95
Surge immunity	± 1 kV differential, ± 2 kV common, AC mains	B	EN 61000-4-5: 95
Conducted RF immunity	150 kHz to 80 MHz, 3 Vrms, 80% AM with 1 kHz sine	A	EN 61000-4-6: 97
Power Frequency H-field immunity	1 A/m, 50Hz/60Hz, 3 axes	A	EN 61000-4-8: 97
Voltage dips, interrupts	30% Reduction for 25 cycles >95% Reduction for 250 cycles >95%, 0.5 cycles	C C B	EN 61000-4-11: 94

2.11 Reliability

2.11.1 Annualized Failure Rate (AFR)

The product will achieve an Annualized Failure Rate (AFR) of 0.55% when operated in an environment of ambient air temperatures of 25°C. Operation at temperatures outside the specifications in [Section 2.8, Environmental Specifications](#) may increase the product AFR. AFR is a population statistics that is not relevant to individual units.

AFR specifications are based on the following assumptions for consumer electronics environments:

- 8760 power-on-hours per year
- 10,000 average motor start/stop cycles per year
- Operations at nominal voltages
- Temperatures outside the specifications in [Section 2.8, Environmental Specifications](#) may reduce the product reliability.
- Normal I/O duty cycle for consumer electronics environments. Operation at excessive I/O duty cycle may degrade product reliability.

The consumer electronics environment of power-on-hours, temperature, and I/O duty cycle affect the product AFR. The AFR will be degraded if used in an enterprise application

Nonrecoverable read errors	1 per 10 ¹⁴ bits read, max
Load/Unload (U/UL) 25°C, 50% relative humidity	600,000 software-controlled power on/off cycles 20,000 hard power on/off cycles
Rated workload	Average annualized workload rating: <55 TB/year. The AFR specification for the product assumes the I/O workload does not exceed the average annualized workload rate limit of 55 TB/year. Workloads exceeding the annualized rate may degrade the product AFR and impact reliability as experienced by the particular application. The average annualized workload rate limit is in units of TB per calendar year.
Warranty	To determine the warranty for a specific drive, use a web browser to access the following web page: http://www.seagate.com/support/warranty-and-replacements/ From this page, click on the "Is my Drive under Warranty" link. The following are required to be provided: the drive serial number, model number (or part number) and country of purchase. The system will display the warranty information for the drive.

2.12 Agency Certification

2.12.1 Safety certification

These products are certified to meet the requirements of UL60950-1, CSA60950-1 and EN60950 and so marked as to the certify agency.

2.12.2 Electromagnetic Compatibility (EMC)

Hard drives that display the CE mark comply with the European Union (EU) requirements specified in the Electromagnetic Compatibility Directive [2014/30/EU](#). Testing is performed to the levels specified by the product standards for Information Technology Equipment (ITE). Emission levels are defined by EN 55022, Class B and the immunity levels are defined by EN 55024.

Drives are tested in representative end-user systems. Although CE-marked Seagate drives comply with the directives when used in the test systems, we cannot guarantee that all systems will comply with the directives. The drive is designed for operation inside a properly designed enclosure, with properly shielded I/O cable (if necessary) and terminators on all unused I/O ports. Computer manufacturers and system integrators should confirm EMC compliance and provide CE marking for their products.

Korean RRA

If these drives have the Korean Communications Commission (KCC) logo, they comply with paragraph 1 of Article 11 of the Electromagnetic Compatibility control Regulation and meet the Electromagnetic Compatibility (EMC) Framework requirements of the Radio Research Agency (RRA) Communications Commission, Republic of Korea.

These drives have been tested and comply with the Electromagnetic Interference/Electromagnetic Susceptibility (EMI/EMS) for Class B products. Drives are tested in a representative, end-user system by a Korean-recognized lab.

기종별	사용자안내문
B급 기기 (가정용 방송통신기자재)	이 기기는 가정용(B급) 전자파적합기기로서 주로 가정에서 사용하는 것을 목적으로 하며, 모든 지역에서 사용할 수 있습니다.

Australian RCM

If these models have the RCM marking, they comply with the Australia/New Zealand Standard AS/NZS CISPR22: 2009, and meet the Electromagnetic Compatibility (EMC) Framework requirements of the Australian Communication and Media Authority (ACMA).

2.12.3 FCC verification

These drives are intended to be contained solely within a personal computer or similar enclosure (not attached as an external device). As such, each drive is considered to be a subassembly even when it is individually marketed to the customer. As a subassembly, no Federal Communications Commission verification or certification of the device is required.

Seagate has tested this device in enclosures as described above to ensure that the total assembly (enclosure, disk drive, motherboard, power supply, etc.) does comply with the limits for a Class B computing device, pursuant to Subpart J, Part 15 of the FCC rules. Operation with noncertified assemblies is likely to result in interference to radio and television reception.

Radio and television interference This equipment generates and uses radio frequency energy and if not installed and used in strict accordance with the manufacturer's instructions, may cause interference to radio and television reception.

This equipment is designed to provide reasonable protection against such interference in a residential installation. However, there is no guarantee that interference will not occur in a particular installation. If this equipment does cause interference to radio or television, which can be determined by turning the equipment on and off, you are encouraged to try one or more of the following corrective measures:

- Reorient the receiving antenna.
- Move the device to one side or the other of the radio or TV.
- Move the device farther away from the radio or TV.
- Plug the computer into a different outlet so that the receiver and computer are on different branch outlets.

If necessary, you should consult your dealer or an experienced radio/television technician for additional suggestions. You may find helpful the following booklet prepared by the Federal Communications Commission: *How to Identify and Resolve Radio-Television Interference Problems*. This booklet is available from the Superintendent of Documents, U.S. Government Printing Office, Washington, DC 20402. Refer to publication number 004-000-00345-4.

2.13 Environmental Protection

Seagate designs its products to meet environmental protection requirements worldwide, including regulations restricting certain chemical substances.

2.13.1 European Union Restriction of Hazardous Substances (RoHS) Directive

The European Union Restriction of Hazardous Substances (RoHS) Directive, restricts the presence of chemical substances, including Lead, Cadmium, Mercury, Hexavalent Chromium, PBB and PBDE, in electronic products, effective July 2006. This drive is manufactured with components and materials that comply with the RoHS Directive.

2.13.2 China Requirements — China RoHS 2

China RoHS 2 refers to the Ministry of Industry and Information Technology Order No. 32, effective July 1, 2016, titled Management Methods for the Restriction of the Use of Hazardous Substances in Electrical and Electronic Products. To comply with China RoHS 2, we determined this product's Environmental Protection Use Period (EPUP) to be 20 years in accordance with the *Marking for the Restricted Use of Hazardous Substances in Electronic and Electrical Products*, SJ/T 11364-2014.

中国电器电子产品有害物质限制使用管理办法

(Management Methods for the Restriction of the Use of Hazardous Substances in Electrical and Electronic Products _ China RoHS)

产品中有害物质的名称及含量

(Name and Content of the Hazardous Substances in Product)



Table 8 Hazardous Substances

部件名称 Part Name	有害物质 Hazardous Substances					
	铅 Lead (Pb)	汞 Mercury (Hg)	镉 Cadmium (Cd)	六价铬 Hexavalent Chromium (CF (VI))	多溴联苯 Polybrominated biphenyls (PBB)	多溴二苯醚 Polybrominated diphenyl ethers (PBDE)
印刷电路板组装 PCBA	X	O	O	O	O	O
机壳 Chassis	X	O	O	O	O	O
本表格依据 SJ/T 11364 的规定编制。 This table is prepared in accordance with the provisions of SJ/T 11364-2014 O: 表示该有害物质在该部件所有均质材料中的含量均在 GB/T 26572 规定的限量要求以下。 O: Indicates that the hazardous substance contained in all of the homogeneous materials for this part is below the limit requirement of GB/T26572. X: 表示该有害物质至少在该部件的某一均质材料中的含量超出 GB/T 26572 规定的限量要求。 X: Indicates that the hazardous substance contained in at least one of the homogeneous materials used for this part is above the limit requirement of GB/T26572.						

2.14 Corrosive Environment

Seagate electronic drive components pass accelerated corrosion testing equivalent to 10 years exposure to light industrial environments containing sulfurous gases, chlorine and nitric oxide, classes G and H per ASTM B845. However, this accelerated testing cannot duplicate every potential application environment.

Users should use caution exposing any electronic components to uncontrolled chemical pollutants and corrosive chemicals as electronic drive component reliability can be affected by the installation environment. The silver, copper, nickel and gold films used in Seagate products are especially sensitive to the presence of sulfide, chloride, and nitrate contaminants. Sulfur is found to be the most damaging. In addition, electronic components should never be exposed to condensing water on the surface of the printed circuit board assembly (PCBA) or exposed to an ambient relative humidity greater than 95%. Materials used in cabinet fabrication, such as vulcanized rubber, that can outgas corrosive compounds should be minimized or eliminated. The useful life of any electronic equipment may be extended by replacing materials near circuitry with sulfide-free alternatives.

3.0 Configuring and Mounting the Drive

This section contains the specifications and instructions for configuring and mounting the drive.

3.1 Handling and Static-Discharge Precautions

After unpacking, and before installation, the drive may be exposed to potential handling and electrostatic discharge (ESD) hazards. Observe the following standard handling and static-discharge precautions.

CAUTION	<ul style="list-style-type: none"> • Keep the drive in the electrostatic discharge (ESD) bag until you are ready for installation to limit the drive's exposure to ESD. • Before handling the drive, put on a grounded wrist strap, or ground yourself frequently by touching the metal chassis of a computer that is plugged into a grounded outlet. Wear a grounded wrist strap throughout the entire installation procedure. • Handle the drive by its edges or frame <i>only</i>. • The drive is extremely fragile—handle it with care. Do not press down on the drive top cover. • Always rest the drive on a padded, antistatic surface until you mount it in the computer. • Do not touch the connector pins or the printed circuit board. • Do not remove the factory-installed labels from the drive or cover them with additional labels. Removal voids the warranty. Some factory-installed labels contain information needed to service the drive. Other labels are used to seal out dirt and contamination.
----------------	---

3.2 Configuring the Drive

Each drive on the Serial ATA interface connects in a point-to-point configuration with the Serial ATA host adapter. There is no master/slave relationship because each drive is considered a master in a point-to-point relationships. If two drives are attached on one Serial ATA host adapter, the host operating system views the two devices as if they were both “masters” on two separate ports. Both drives behave as if they are Device 0 (master) devices.

3.2.1 Serial ATA Cables and Connectors

The Serial ATA interface cable consists of four conductors in two differential pairs, plus three ground connections. The cable size may be 30 to 26 AWG with a maximum length of one meter (39.37 in). Refer to [Table 9](#) for connector pin definitions. Either end of the SATA signal cable can be attached to the drive or host.

For direct backplane connection, the drive connectors are inserted directly into the host receptacle. The drive and the host receptacle incorporate features that enable the direct connection to be hot pluggable and blind mateable. For installations which require cables, you can connect the drive as shown in [Figure 2](#).

Figure 2 Attaching SATA Cabling

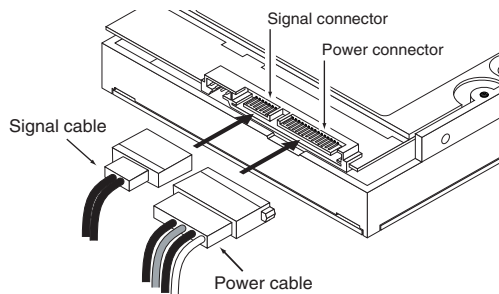

Each cable is keyed to ensure correct orientation. Seagate Video 2.5 HDD drives support latching SATA connectors.

3.3 Drive Mounting

You can mount the drive in any orientation using four screws in the side-mounting holes or four screws in the bottom-mounting holes. Refer to [Figure 3](#) for drive mounting dimensions. Follow these important mounting precautions when mounting the drive:

- Allow a minimum clearance of 0.030 in (0.76 mm) around the entire perimeter of the drive for cooling.
- Use only M3 x 0.5 mounting screws.
- Do not overtighten the mounting screws. Maximum torque: 4.0 in-lb (0.4519 N-m).
- Four (4) threads (0.080 in, 2.032 mm) minimum screw engagement recommended.
- Avoid excessive drive distortion when mounting. Refer to the following specifications for stiffness/deflection information:

Top cover stiffness/deflection	
Operating: no performance degradation, emitted noise, mechanical damage, or hard errors	10 mm probe: 1.02kgf or 5 mm probe: 0.92kgf
Non-operating: no hard errors	20 mm probe: 2.0kgf at any point of top cover 20 mm probe: 15.0kgf at top cover edges only

Figure 3 Mounting Dimensions (for standard models)

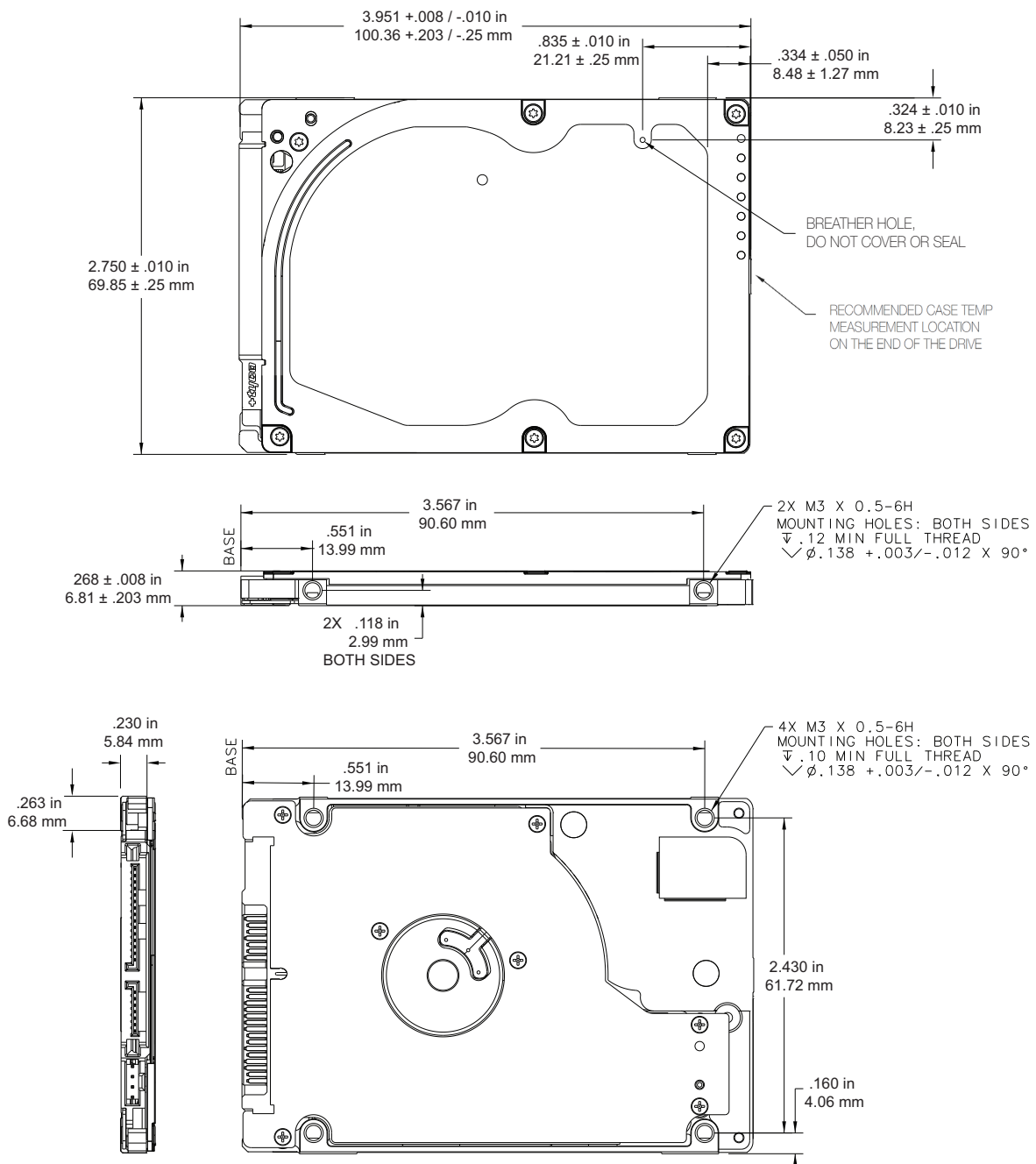

4.0 Serial ATA (SATA) Interface

These drives use the industry-standard Serial ATA interface that supports FIS data transfers. It supports ATA programmed input/output (PIO) modes 0–4; multiword DMA modes 0–2, and Ultra DMA modes 0–6. The drive also supports the use of the IORDY signal to provide reliable high-speed data transfers.

For detailed information about the Serial ATA interface, refer to the *Serial ATA: High Speed Serialized AT Attachment* specification.

4.1 Hot-Plug Compatibility

Seagate Video 2.5 HDD drives incorporate connectors which enable you to hot plug these drives in accordance with the Serial ATA: High Speed Serialized AT Attachment specification revision 2.0. This specification can be downloaded from www.serialata.org. This device requires a COMRESET from the host after a hotplug event.

4.2 Serial ATA Device Plug Connector Pin Definitions

Table 9 summarizes the signals on the Serial ATA interface and power connectors. Refer to the **Notes** below.

Table 9 Serial ATA Connector Pin Definitions

Segment	Pin	Function	Definition
Signal	S1	Ground	2nd mate
	S2	A+	Differential signal pair A from Phy
	S3	A-	
	S4	Ground	2nd mate
	S5	B-	Differential signal pair B from Phy
	S6	B+	
	S7	Ground	2nd mate
Key and spacing separate signal and power segments			
Power	P1	V33	3.3V power
	P2	V33	3.3V power
	P3	V33	3.3V power, pre-charge, 2nd mate
	P4	Ground	1st mate
	P5	Ground	2nd mate
	P6	Ground	2nd mate
	P7	V5	5V power, pre-charge, 2nd mate
	P8	V5	5V power
	P9	V5	5V power
	P10	Ground	2nd mate
	P11	Ground or LED signal	If grounded, drive does not use deferred spin
	P12	Ground	1st mate
	P13	V12	12V power, pre-charge, 2nd mate
	P14	V12	12V power
	P15	V12	12V power

Notes

- All pins are in a single row, with a 1.27 mm (0.050 in) pitch.
- The comments on the mating sequence apply to the case of backplane blindmate connector only. In this case, the mating sequences are:
 - the ground pins P4 and P12.
 - the pre-charge power pins and the other ground pins.
 - the signal pins and the rest of the power pins.
- There are three power pins for each voltage. One pin from each voltage is used for pre-charge when installed in a blind-mate backplane configuration.
- All used voltage pins (V_x) must be terminated.

4.3 Supported ATA Commands

Table 10 lists Serial ATA standard commands that the drive supports. For a detailed description of the ATA commands, refer to the *Serial ATA International Organization: Serial ATA (Revision 2.6)*. Refer to www.sata-io.org.

Refer to **S.M.A.R.T. commands** on page 27 for details and subcommands used in the S.M.A.R.T. implementation.

Table 10 Supported ATA commands

ATA-standard commands names	Command code (in hex)	
Device Configuration Restore	B1h/C0h	
Device Configuration Freeze Lock	B1h/C1h	
Device Configuration Identify	B1h/C2h	
Device Configuration Set	B1h/C3h	
Download Microcode	92h	
Execute Device Diagnostics	90h	
Flush Cache	E7h	
Flush Cache Extended	EAh	
Identify Device	ECh	
Initialize Device Parameters	91h	
Read Buffer	E4h	
Read DMA	C8h	
Read DMA Extended	25h	
Read DMA without Retries	C9h	
Read Long with Retries	22h	
Read Long without Retries	23h	
Read Multiple	C4h	
Read Multiple Extended	29h	
Read Native Max Address	F8h	
Read Native Max Address Extended	27h	
Read Sectors	20h	
Read Sectors Extended	24h	
Read Sectors without Retries	21h	
Read Verify Sectors	40h	
Read Verify Sectors Extended	42h	
Read Verify Sectors without Retries	41h	
Seek	70h	
Set Features	EFh	
Set Max Address	F9h	
Note: Individual Set Max commands are identified by the value placed in the Set Max Features register as defined to the right.	Address: Password: Lock: Unlock: Freeze Lock:	00 _H 01 _H 02 _H 03 _H 04 _H
Set Max Address Ext	37h	
Set Multiple Mode	C6h	
S.M.A.R.T. Disable Operations	B0h/D9h	
S.M.A.R.T. Enable/Disable Autosave	B0h/D2h	

Table 10 Supported ATA commands

ATA-standard commands names	Command code (in hex)
S.M.A.R.T. Enable Operations	B0h/D8h
S.M.A.R.T. Enable/Disable Auto Offline	B0h/DBh
S.M.A.R.T. Enable One Attribute Modification	B0h/E0h
S.M.A.R.T. Execute Offline	B0h/D4h
S.M.A.R.T. Free Fall Protection Host Interface	FEh
S.M.A.R.T. Read Attribute Thresholds	B0h/D1h
S.M.A.R.T. Read Data	B0h/D0h
S.M.A.R.T. Read Log Sector	B0h/D5h
S.M.A.R.T. Return Status	B0h/DAh
S.M.A.R.T. Save Attribute Values	B0h/D3h
S.M.A.R.T. Write Attribute Thresholds	B0h/D7h
S.M.A.R.T. Write Attribute Values	B0h/E1h
S.M.A.R.T. Write Log Sector	B0h/D6h
Write Buffer	E8h
Write DMA	CAh
Write DMA Extended	35h
Write DMA without Retries	CBh
Write Long with Retries	32h
Write Long without Retries	33h
Write Multiple	C5h
Write Multiple Extended	39h
Write Sectors	30h, 31h
Write Sectors Extended	34h
ATA-standard power-management commands	
Check Power Mode	E5h
Idle	E3h
Idle Immediate	E1h
Sleep	E6h
Standby	E2h
Standby Immediate	E0h
ATA-standard security commands	
Security Set Password	F1h
Security Unlock	F2h
Security Erase Prepare	F3h
Security Erase Unit	F4h
Security Freeze Lock	F5h
Security Disable Password	F6h

4.3.1 Identify Device command

The Identify Device command (command code EC_H) transfers information about the drive to the host following power up. The data is organized as a single 512-byte block of data, whose contents are shown in [Table 11](#). All reserved bits or words should be set to zero. Parameters listed with an “x” are drive-specific or vary with the state of the drive. Refer to [Drive Specifications](#) on page 6 for default parameter settings.

The following commands contain drive-specific features that may not be included in the Serial ATA specification.

Table 11 Identify Device command

Word	Description	Value
0	Configuration information: • Bit 15: 0 = ATA; 1 = ATAPI • Bit 7: removable media • Bit 6: removable controller • Bit 0: reserved	0C5A _H
1	Number of logical cylinders	16,383
2	Specific configuration	C837H
3	Number of logical heads	16
4	Retired	0000 _H
5	Retired	0000 _H
6	Number of logical sectors per logical track: 63	003F _H
7–9	Retired	0000 _H
10–19	Serial number: (20 ASCII characters, 0000 _H = none)	ASCII
20	Retired	0000 _H
21	Retired	8000 _H
22	Obsolete	0004 _H
23–26	Firmware revision: (8 ASCII character string, padded with blanks to end of string)	x.xx
27–46	Drive model number: (40 ASCII characters, padded with blanks to end of string)	ST500VT000 ST500VT001 ST320VT000 ST250VT000
47	(Bits 7–0) Maximum sectors per interrupt on Read multiple and Write multiple (16)	8010 _H
48	Trusted Computing Feature set options	0000 _H
49	Standard Standby timer, IORDY supported and may be disabled	2F00 _H
50	Capabilities	4000 _H
51	PIO data-transfer cycle timing mode	0200 _H
52	Retired	0200 _H
53	Words 54–58, 64–70 and 88 are valid	0007 _H
54	Number of current logical cylinders	xxxx _H
55	Number of current logical heads	xxxx _H
56	Number of current logical sectors per logical track	xxxx _H
57–58	Current capacity in sectors	xxxx _H
59	Number of sectors transferred during a Read Multiple or Write Multiple command	xxxx _H

Table 11 Identify Device command

Word	Description	Value
60–61	Total number of user-addressable sectors This field contains a value that is one greater than the total number of user-addressable sectors. The maximum value that shall be placed in this field is 0FFFFFFFh. The 0FFFFFFFh value applies to all capacities over 137GB (see Section 2.1 for related information).	ST500VT000 = 0FFFFFFFh ST500VT001 = 0FFFFFFFh ST320VT000 = 0FFFFFFFh ST250VT000 = 0FFFFFFFh
62	Retired	0000 _H
63	Multiword DMA active and modes supported (see note following this table)	xx07 _H
64	Advanced PIO modes supported (modes 3 and 4 supported)	0003 _H
65	Minimum multiword DMA transfer cycle time per word (120 ns)	0078 _H
66	Recommended multiword DMA transfer cycle time per word (120 ns)	0078 _H
67	Minimum PIO cycle time without IORDY flow control (240 ns)	0078 _H
68	Minimum PIO cycle time with IORDY flow control (120 ns)	0078 _H
69–74	ATA-reserved	0000 _H
75	Queue depth	001F _H
76	Serial ATA capabilities	0D06 _H
77	ATA-reserved	0000 _H
78	Serial ATA features supported	0048 _H
79	Serial ATA features enabled	0048 _H
80	Major version number	01F0 _H
81	Minor version number	0029 _H
82	Command sets supported	746B _H
83	Command sets supported	7D69 _H
84	Command sets support extension	61E3 _H
85	Command sets enabled	7469
86	Command sets enabled	BC49 _H
87	Command sets enable extension	61E3 _H
88	Ultra DMA support and current mode (see note following this table)	xx7F _H
89	Security erase time	xxxx _H
90	Enhanced security erase time	xxxx _H
91	Current APM values	8080 _H
92	Master password revision code	FFFE _H
93	Hardware reset value (see description following this table)	xxxx _H
94	Auto acoustic management setting	xxxx _H
95	Stream Min. Request Size	0000 _H
96	Streaming Transfer Time - DMA	0000 _H
97	Streaming Access Latency - DMA and PIO	0000 _H
98-99	Streaming Performance Granularity	0000 _H

Table 11 Identify Device command

Word	Description	Value
100–103	Total number of user-addressable LBA sectors available (see Section 3.2 for related information) These words are required for drives that support the 48-bit addressing feature. Maximum value: 0000FFFFFFFFH.	ST500VT000 = 976,773,168 ST500VT001 = 976,773,168 ST320VT000 = 625,142,448 ST250VT000 = 488,397,168
104	Streaming Transfer Time - PIO	0000 _H
105	Reserved	0000 _H
106	Physical sector size / Logical sector size	6003 _H
107	Seagate reserved	0000 _H
108-111	The mandatory value of the world wide name (WWN) for the drive. NOTE: This field is valid if word 84, bit 8 is set to 1 indicating 64-bit WWN support.	Each drive will have a unique value.
112-118	ATA-reserved	0000 _H
119	Free Fall Protection support (bit 5)	1 = Free Fall Protection supported 0 = Free Fall Protection not supported
120	Free Fall Protection enable/disable (bit 5)	1 = Free Fall Protection feature is enabled 0 = Free Fall Protection feature is disabled
121–127	ATA-reserved	0000 _H
128	Security status	0021 _H
129–159	Seagate-reserved	xxxx _H
160–221	ATA-reserved	0000 _H
222	Transport major version number	101F _H
223–254	ATA-reserved	0000 _H
255	Integrity word	xxA5 _H

Note	See the bit descriptions below for words 63, 88 and 93 of the Identify Drive data. (on next page)
-------------	---

Table 12 Bit Descriptions

Description (if bit is set to 1)	
Bit	Word 63
0	Multiword DMA mode 0 is supported.
1	Multiword DMA mode 1 is supported.
2	Multiword DMA mode 2 is supported.
8	Multiword DMA mode 0 is currently active.
9	Multiword DMA mode 1 is currently active.
10	Multiword DMA mode 2 is currently active.
Bit	Word 88
0	Ultra DMA mode 0 is supported.
1	Ultra DMA mode 1 is supported.
2	Ultra DMA mode 2 is supported.
3	Ultra DMA mode 3 is supported.
4	Ultra DMA mode 4 is supported.
5	Ultra DMA mode 5 is supported.
6	Ultra DMA mode 6 is supported.
8	Ultra DMA mode 0 is currently active.
9	Ultra DMA mode 1 is currently active.
10	Ultra DMA mode 2 is currently active.
11	Ultra DMA mode 3 is currently active.
12	Ultra DMA mode 4 is currently active.
13	Ultra DMA mode 5 is currently active.
14	Ultra DMA mode 6 is currently active.
Bit	Word 93
13	1 = 80-conductor cable detected, CBLID above VIH 0 = 40-conductor cable detected, CBLID below VIL

4.3.2 Set Features command

This command controls the implementation of various features that the drive supports. When the drive receives this command, it sets BSY, checks the contents of the Features register, clears BSY and generates an interrupt. If the value in the register does not represent a feature that the drive supports, the command is aborted. Power-on default has the read look-ahead and write caching features enabled.

The acceptable values for the Features register are defined as follows:

Table 13 Set Features command values

02 _H	Enable write cache (<i>default</i>).
03 _H	Set transfer mode (based on value in Sector Count register). Sector Count register values: 00 _H Set PIO mode to default (PIO mode 2). 01 _H Set PIO mode to default and disable IORDY (PIO mode 2). 08 _H PIO mode 0 09 _H PIO mode 1 0A _H PIO mode 2 0B _H PIO mode 3 0C _H PIO mode 4 (<i>default</i>) 20 _H Multiword DMA mode 0 21 _H Multiword DMA mode 1 22 _H Multiword DMA mode 2 40 _H Ultra DMA mode 0 41 _H Ultra DMA mode 1 42 _H Ultra DMA mode 2 43 _H Ultra DMA mode 3 44 _H Ultra DMA mode 4 45 _H Ultra DMA mode 5 46 _H Ultra DMA mode 6
55 _H	Disable read look-ahead (read cache) feature.
82 _H	Disable write cache
AA _H	Enable read look-ahead (read cache) feature (<i>default</i>).
C1 _H	Disable the Free Fall Protection feature (41 _H above enables the Free Fall Protection feature)
F1 _H	Report full capacity available

Note

At power-on, or after a hardware or software reset, the default values of the features are as indicated above

4.3.3 S.M.A.R.T. commands

S.M.A.R.T. provides near-term failure prediction for disk drives. When S.M.A.R.T. is enabled, the drive monitors predetermined drive attributes that are susceptible to degradation over time. If self-monitoring determines that a failure is likely, S.M.A.R.T. makes a status report available to the host. Not all failures are predictable. S.M.A.R.T. predictability is limited to the attributes the drive can monitor. For more information on S.M.A.R.T. commands and implementation, see the *Draft ATA-5 Standard*.

SeaTools diagnostic software activates a built-in drive self-test (DST S.M.A.R.T. command for D4_H) that eliminates unnecessary drive returns. The diagnostic software ships with all new drives and is also available at: <http://www.seagate.com/support/downloads/seatools/>.

This drive is shipped with S.M.A.R.T. features disabled. You must have a recent BIOS or software package that supports S.M.A.R.T. to enable this feature. The table below shows the S.M.A.R.T. command codes that the drive uses.

Table 14 S.M.A.R.T. Commands

Code in features register	S.M.A.R.T. command
D0 _H	S.M.A.R.T. Read Data
D2 _H	S.M.A.R.T. Enable/Disable Attribute Autosave
D3 _H	S.M.A.R.T. Save Attribute Values
D4 _H	S.M.A.R.T. Execute Off-line Immediate (runs DST)
D5 _H	S.M.A.R.T. Read Log Sector
D6 _H	S.M.A.R.T. Write Log Sector
D8 _H	S.M.A.R.T. Enable Operations
D9 _H	S.M.A.R.T. Disable Operations
DA _H	S.M.A.R.T. Return Status

Note

If an appropriate code is not written to the Features Register, the command is aborted and 0x04 (abort) is written to the Error register.



Seagate Technology LLC

AMERICAS Seagate Technology LLC 10200 South De Anza Boulevard, Cupertino, California 95014, United States, 408-658-1000

ASIA/PACIFIC Seagate Singapore International Headquarters Pte. Ltd. 7000 Ang Mo Kio Avenue 5, Singapore 569877, 65-6485-3888

EUROPE, MIDDLE EAST AND AFRICA Seagate Technology SAS 16-18 rue du Dôme, 92100 Boulogne-Billancourt, France, 33 1-4186 10 00

*Publication Number: 100713733, Rev. G
October 2016*