

PROLOGIC

Modular PLC CPU & I/O Modules



Catalog and Design Guide



P.O.Box 24
Stanfield 3613
SOUTH AFRICA

Tel: +27 (031) 7028033
Fax: +27 (031) 7028041
Email: proconel@proconel.com
Web: www.proconel.com

23/03/2007 V0.1 Preliminary

Disclaimer

Procon Electronics makes no representations or warranties with respect to the contents hereof. In addition, information contained herein are subject to change without notice. Every precaution has been taken in the preparation of this manual. Nevertheless, Procon Electronics assumes no responsibility, express or implied, for errors or omissions or any damages resulting from the use of the information contained in this publication.

All trademarks belong to their respective owners.

TABLE OF CONTENTS

1.	AN OVERVIEW OF THE PROLOGIC SYSTEM.....	6
1.1	INTRODUCTION	6
1.2	MODULE SELECTION TABLE	6
2.	PROLOGIC GENERAL INFORMATION	8
2.1	PHYSICAL DIMENSIONS	8
2.2	GROUNDING/SHIELDING	8
2.3	NETWORK TERMINATION	9
2.4	SETTING THE MODBUS NODE ID.....	9
2.4.1	Node ID Table.....	9
2.4.2	DIP Switch Status Register.....	9
2.5	COMMUNICATIONS SETTINGS	10
2.5.1	Communications Settings with DIP Switch 10 On.....	10
2.5.2	Modbus Register Types.....	10
3.	PROLOGIC MODULES	11
3.1	PL100 – ETHERNET INTERFACE MODULE.....	11
3.1.1	Description	11
3.1.2	Technical Specification of PL100.....	11
3.1.3	Status Indicators	12
3.1.4	Wiring.....	12
3.1.5	Configuration.....	13
3.1.6	Viewing Web Pages.....	16
3.1.7	Troubleshooting Guide.	17
3.1.8	Parameter Configuration.....	18
3.2	PL101 – PLC MODULE WITH ETHERNET AND SERIAL PORTS	20
3.2.1	Description	20
3.2.2	Technical Specification of PL101.....	21
3.2.3	Status Indicators	22
3.2.4	Wiring.....	22
3.2.5	Configuration.....	23
3.2.6	PL101 CPU Details.	23
3.2.7	Program Memory.	23
3.2.8	Data Memory.	23
3.2.9	Data Memory Map.	24
3.2.10	Digital Input Map.	24
3.2.11	Digital Output Map.	25
3.2.12	Timer Map.	25
3.2.13	Counter Map.	25
3.2.14	Control Relay Map.	25
3.2.15	System Relay Map.....	26
3.2.16	IO Table	26
3.2.17	RS485 Modbus Communications	32
3.2.18	Modbus Memory Map (MODULE TYPE = 121)	33
3.2.19	Ladder Logic Function Blocks.....	36
3.3	PL16DI - DIGITAL INPUTS WITH COUNTERS.....	40
3.3.1	Description	40
3.3.2	Technical Specification of PL16DI.....	40
3.3.3	Status Indicators	41
3.3.4	Wiring.....	41
3.3.5	Switch Settings	42
3.3.6	PL16DI Data Registers (MODULE TYPE = 100)	43
3.4	PL16DO - DIGITAL OUTPUTS.....	47

3.4.1	Description	47
3.4.2	Technical Specification of PL16DO	47
3.4.3	Status Indicators	48
3.4.4	Wiring	48
3.4.5	Switch Setting	49
3.4.6	PL16DO Data Registers (MODULE TYPE = 101).....	50
3.5	PL4RO - RELAY OUTPUTS	51
3.5.1	Description	51
3.5.2	Technical Specification of PL4RO	51
3.5.3	Status Indicators	52
3.5.4	Wiring	52
3.5.5	Switch Setting	53
3.5.6	PL4RO Data Registers (MODULE TYPE = 113).....	54
3.6	PL8DIO - DIGITAL INPUTS / OUTPUTS.....	55
3.6.1	Description	55
3.6.2	Technical Specification of PL8DIO	56
3.6.3	Status Indicators	56
3.6.4	Wiring.....	57
3.6.5	Switch Settings	57
3.6.6	PL8DIO Data Registers (MODULE TYPE = 102).....	58
3.7	PL8AI/I AND PL8AI/V - ANALOG INPUTS.....	60
3.7.1	Description	60
3.7.2	Technical Specification of PL8AI	60
3.7.3	Status Indicators	61
3.7.4	Wiring.....	61
3.7.5	Switch Settings	62
3.7.6	PL8AI Data Registers (PL8AI/I TYPE = 103 / PL8AI/V TYPE = 104)	63
3.8	PL8AI/I ISO AND PL8AI/V ISO - ISOLATED ANALOG INPUTS	65
3.8.1	Description	65
3.8.2	Technical Specification of PL8AI/I ISO and PL8AI/V ISO	66
3.8.3	Status Indicators	66
3.8.4	Wiring.....	67
3.8.5	Switch Settings	68
3.8.6	PL8AI ISO Data Registers (8AI/I TYPE = 107/8AI/V TYPE = 108).....	69
3.9	PL8TC - THERMOCOUPLE INPUTS	71
3.9.1	Description	71
3.9.2	Technical Specification of PL8TC.....	72
3.9.3	Status Indicators	72
3.9.4	Wiring.....	73
3.9.5	Switch Settings	73
3.9.6	PL8TC Data Registers (MODULE TYPE = 105)	74
3.10	PL8TCISO - ISOLATED THERMOCOUPLE INPUTS	75
3.10.1	Description	75
3.10.2	Technical Specification of PL8TC.....	76
3.10.3	Status Indicators	76
3.10.4	Wiring.....	77
3.10.5	Switch Settings	77
3.10.6	PL8TCISO Data Registers (MODULE TYPE = 106)	79
3.11	PL6RTD - RTD INPUTS	80
3.11.1	Description	80
3.11.2	Technical Specification of PL6RTD	80
3.11.3	Status Indicators	81
3.11.4	Wiring.....	81
3.11.5	Switch Settings	82
3.11.6	PL6RTD Data Registers (MODULE TYPE = 109).....	83
3.12	PLDAIO – DIGITAL + ANALOG INPUTS AND OUTPUTS.....	84
3.12.1	Description	84
3.12.2	Technical Specification of PLDAIO.....	86
3.12.3	Status Indicators	87
3.12.4	Wiring.....	88

3.12.5	Switch Settings	88
3.12.6	PLDAIO Data Registers (MODULE TYPE = 112)	89
3.13	PL8AO - ANALOG OUTPUTS	90
3.13.1	Description	90
3.13.2	Technical Specification of PL8AO	90
3.13.3	Status Indicators	91
3.13.4	Wiring	91
3.13.5	Switch Settings	92
3.13.6	PL8AO Data Registers (MODULE TYPE = 110)	92
3.14	PL8VO - ANALOG OUTPUTS	93
3.14.1	Description	93
3.14.2	Technical Specification of PL8VO	93
3.14.3	Status Indicators	94
3.14.4	Wiring	94
3.14.5	Switch Settings	95
3.14.6	PL8VO Data Registers (MODULE TYPE = 111)	95
4.	USING HTML WEB PAGES ON THE PL101	96
4.1	INTRODUCTION	96
4.2	USING FTP	96
4.3	CREATING AND USING WEB PAGES.	98
4.3.1	Writing HTML	98
4.3.2	HTML tags	98
4.3.3	Creating a new web page	98
4.4	ADDING A DATA TAG.....	100
4.5	AUTOMATICALLY UPDATING WEB PAGE DATA.	102
4.6	USING RADIO BUTTONS TO SWITCH A DIGITAL ON AND OFF.	105
4.7	USING A TEXT BOX TO ENTER A NEW ANALOG VALUE.	107
5.	SPECIFICATIONS.....	108
5.1	ENVIRONMENTAL	108
5.2	EMC INSTALLATION INSTRUCTIONS	108
5.3	CONFORMITY CERTIFICATE	109
5.4	EMC TEST RESULTS.....	110

1. AN OVERVIEW OF THE PROLOGIC SYSTEM

1.1 Introduction

PROLOGIC is an innovative modular PLC system which provides a simple low cost solution for distributed I/O requirements where control is required.

The PROLOGIC system consists of Digital and Analog Input and Output modules which are plugged together on a DIN rail .

The first module is the CPU or interface module. This module connects the Ethernet network to the internal bus which communicates with the I/O modules. This module also provides power to the I/O modules.

The modules communicate using the high speed built in communications bus. A 32bit ARM CPU is used in the modules to provide high speed data processing and fast communication turn around times.

All PROLOGIC modules plug directly onto an industry standard DIN rail. All modules have a minimum isolation of 1000VAC rms between the field and logic.

The modules have been equipped with status led's which are used to indicate the status of the Inputs or outputs. This visual indication assists with fault finding and diagnostics.

1.2 Module Selection Table

MODEL	MODULE TYPE
I/O MODULES	
PL16DI	16 DIGITAL INPUT MODULE INCLUDING COUNTERS
PL16DO	16 DIGITAL OUTPUT MODULE
PL4RO	4 RELAY OUTPUT MODULE
PL8DIO	8 DIGITAL INPUT / 8 DIGITAL OUTPUT MODULE
PL8AI/I	8 ANALOG INPUT 0 - 20mA / 4 - 20mA
PL8AI/V	8 ANALOG INPUT 0 - 5V / 1 - 5V / 0 - 10V / 2 - 10V
PL8AI/I ISO	8 ANALOG INPUT 0 - 20mA / 4 - 20mA / ± 20 mA FULLY ISOLATED
PL8AI/V ISO	8 ANALOG INPUT 0 - 1V / 0 - 10V / ± 1 V / ± 10 V FULLY ISOLATED
PL8TC	8 THERMOCOUPLE INPUT MODULE INCL. 0 - 50mV & ± 100 mV I/P
PL8TCISO	8 TC INPUT MODULE INCL. 0 - 50mV & ± 100 mV I/P FULLY ISOLATED
PL6RTD	6 RTD INPUT MODULE - PT100, Ni120, PT1000, Ni1000, Ni1000LG & Ohms
PLDAIO	2 RTD I/P, 2 ANALOG INPUT 0(4) - 20mA / 0(2) - 10V, 1 ANALOG OUTPUT 0(4) - 20mA / 0(2) - 10V, 4 DIGITAL INPUTS, 2 DIGITAL OUTPUTS
PL8AO	8 ANALOG OUTPUT MODULE 0(4) - 20mA
PL8VO	8 ANALOG OUTPUT MODULE 0(2) - 10V
CONVERTER	
PL100	Ethernet Interface
PLC CPU	
PL101	PLC CPU Module with Ethernet, RS232 and RS485

2. PROLOGIC GENERAL INFORMATION

2.1 Physical Dimensions

The PROLOGIC enclosure is shown below. The module clips directly onto an industry standard DIN rail. Field wiring is on the front of the module via a separate plug in connector. The module power and RS485 communications wiring is on a separate plug in connector on the underside of the housing.

Allow at least 25mm on front and below the module to accommodate the wiring. Ensure that enough space to kept above and below the module for good ventilation.

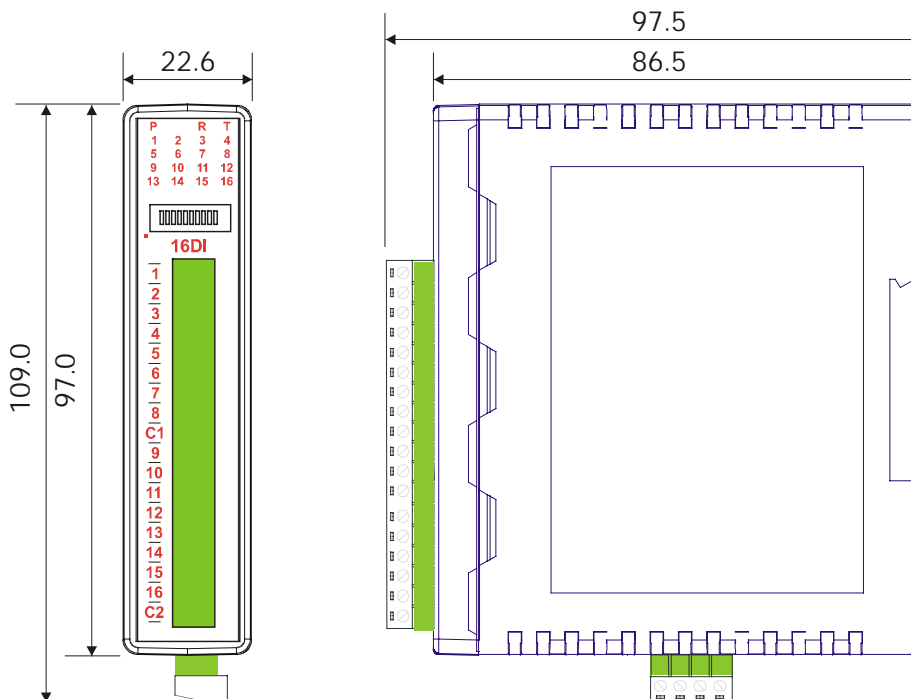

2.2 Grounding/Shielding

In most cases, PROLOGIC modules will be installed in an enclosure along with other devices which generate electromagnetic radiation. Examples of these devices are relays and contactors, transformers, motor controllers etc. This electromagnetic radiation can induce electrical noise into both power and signal lines, as well as direct radiation into the module causing negative effects on the system. Appropriate grounding, shielding and other protective steps should be taken at the installation stage to prevent these effects. These protective steps include control cabinet grounding, module grounding, cable shield grounding, protective elements for electromagnetic switching devices, correct wiring as well as consideration of cable types and their cross sections.

2.3 Network Termination

Transmission line effects often present a problem on data communication networks. These problems include reflections and signal attenuation.

To eliminate the presence of reflections from the end of the cable, the cable must be terminated at both ends with a resistor across the line equal to its characteristic impedance. Both ends must be terminated since the direction of propagation is bi-directional. In the case of an RS485 twisted pair cable this termination is typically 120 ohms.

2.4 Setting the Modbus Node ID

2.4.1 Node ID Table

The following table assists with the setting up of DIP switches for the required NODE ID.

NODE ID	DIP SWITCH SETTINGS						
	SW1	SW2	SW3	SW4	SW5	SW6	SW7
1	ON	OFF	OFF	OFF	OFF	OFF	OFF
2	OFF	ON	OFF	OFF	OFF	OFF	OFF
3	ON	ON	OFF	OFF	OFF	OFF	OFF
4	OFF	OFF	ON	OFF	OFF	OFF	OFF
5	ON	OFF	ON	OFF	OFF	OFF	OFF
6	OFF	ON	ON	OFF	OFF	OFF	OFF
7	ON	ON	ON	OFF	OFF	OFF	OFF
8	OFF	OFF	OFF	ON	OFF	OFF	OFF

2.4.2 DIP Switch Status Register.

Each module uses register 30100 to store the status of the DIP switches.

MSB														DIP SWITCH REGISTER														ADDRESS				
														LSB																		
15	14	13	12	11	10	9	8	7	6	5	4	3	2	1	0	15	14	13	12	11	10	9	8	7	6	5	4	3	2	1	0	30100
32768	16384	8192	4096	2048	1024	512	256	128	64	32	16	8	4	2	1	32768	16384	8192	4096	2048	1024	512	256	128	64	32	16	8	4	2	1	30100

0 0 0 0 0 0

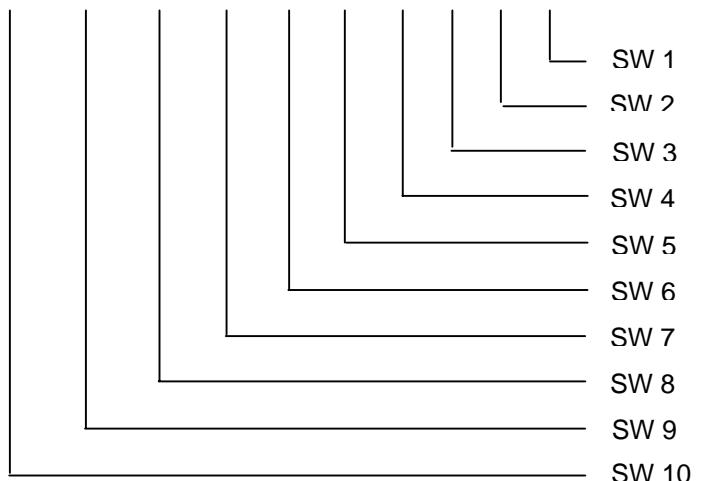

2.5 Communications Settings

The data in the modules is stored in 16 bit registers. These registers are accessed over the network using the MODBUS RTU communication protocol.

2.5.1 Communications Settings with DIP Switch 10 On

This setting enables the high speed data communications bus and must be in the ON position.

2.5.2 Modbus Register Types

There are 4 types of variables which can be accessed from the module. Each module has one or more of these data variables.

<u>Type</u>	<u>Start Address</u>	<u>Variable</u>	<u>Access</u>
1	00001	Digital Outputs	Read & Write
2	10001	Digital Inputs	Read Only
3	30001	Input registers (Analog)	Read Only
4	40001	Output registers (Analog)	Read & Write

Note: The Modbus message length must be limited to 100 consecutive read or write registers. If more registers are required then a new poll group must be added for the next xxx registers.

3. PROLOGIC MODULES

3.1 PL100 – Ethernet Interface Module

3.1.1 Description

The PL100 is an Ethernet to serial converter and connects the PROLOGIC modules to a 10/100 Base-TX Ethernet network.

The PL100 includes a web server which enables access to internal parameters for configuration. This allows configuration of IP address, default gateway IP address and subnet mask. The web server can be accessed by most web browsers.

The PL100 is factory programmed with a default IP address of 169.254.111.111. This address must be changed before the converter is added to an existing network.

The web page address for viewing the setup parameters is <http://169.254.111.111/index.htm> The web page address for configuring the converter is <http://169.254.111.111/ip.htm>

The master device which is polling the modules must be configured with the IP address of the PL100 and with the modbus ID of the PROLOGIC modules. As each PROLOGIC communications bus is separate, it is possible to have repeated Modbus ID's on the PROLOGIC modules provided they are attached to a different PL100. The IP address differentiates between the different PROLOGIC systems. Consequently, many hundreds of PROLOGIC modules may be added to a Ethernet network.

The PL100 is a Modbus gateway and the client must be configured to use **Port 502**. This is a reserved port number for Modbus TCP applications and informs the PL100 that it must implement the protocol conversion from Modbus TCP on the Ethernet network to Modbus RTU on the PROLOGIC serial communications bus.



3.1.2 Technical Specification of PL100

Power Supply	Logic Supply Voltage	12 -24 Vdc
	Logic Supply Power	0.8VA
Ethernet	10/100 Mbits/s	10/100Base-TX
	Connector	RJ45
Temperature	Operating Temperature.	-40°C to + 80°C
	Storage Temperature	-40°C to + 85°C
Connectors	Power.	4 way screw connector
Humidity		Up to 95% non condensing.

3.1.3 Status Indicators

- Power:** Flashes to indicate the CPU is running.
- Serial Bus Rx:** Flashes to indicate the unit has received a valid Modbus message from a PROLOGIC module.
- Serial Bus Tx:** Flashes to indicate the unit has sent a Modbus message to a PROLOGIC module.
- Modbus TCP Rx:** Flashes to indicate the unit has received a valid Modbus message on the Ethernet network.
- Modbus TCP Tx:** Flashes to indicate the unit has transmitted a Modbus message on the Ethernet network.
- Web Server:** Flashes to indicate the HTTP web server is being accessed.

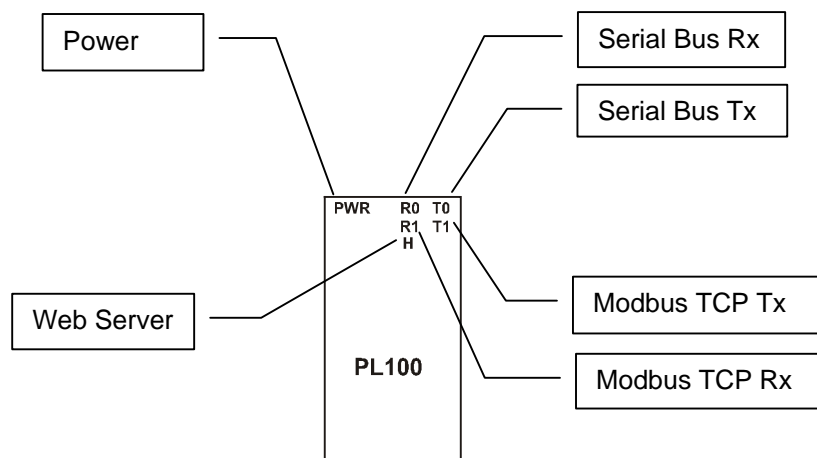

3.1.4 Wiring

The following diagram shows the wiring for the power.

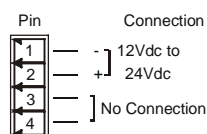

3.1.5 Configuration

3.1.5.1 Power Connections.

The PL100 Module must be clipped onto a DIN rail. Power for the PL100 must be applied to terminal 2 (+12/24VDC) and terminal 1 (0V). The power LED will flash and all LED's will be off.

3.1.5.2 Ethernet Connection.

Next the Ethernet connection is required, either through a network or directly to a PC. The Ethernet interface uses a standard RJ45 connector.

3.1.5.3 Connecting To a PC which is not Connected to a Network.

If the PC is equipped with an Ethernet card but not connected to a network, a local network address should be used for communication between the PL100 and the PC. The PL100 is shipped with a default IP address 169.254.111.111. This address is in the address area reserved for local networks not connected to the Internet. For direct connection between the PC and the PL100, a crossover Ethernet cable is required.

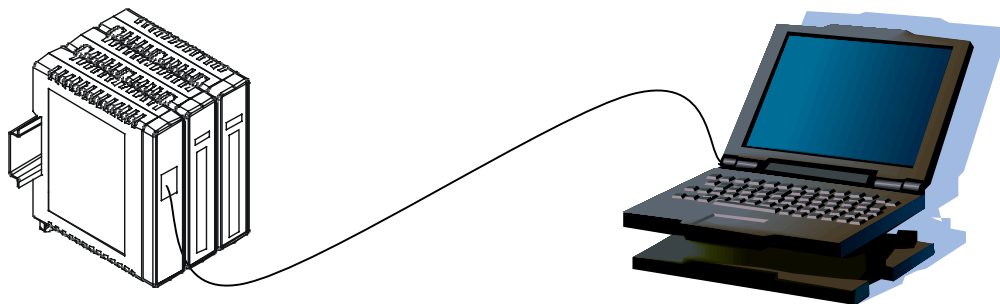

To setup your PC to connect directly to the PL100, an IP address in the same range as the PL100 must be assigned to the PC. In Windows environments, this should be done as follows:

- Connect the PC and the PL100 together using a crossover cable
- Open the Windows Control Panel
- Select Network
- Select TCP/IP -> the PC's Ethernet adaptor from the Configuration tab as shown below

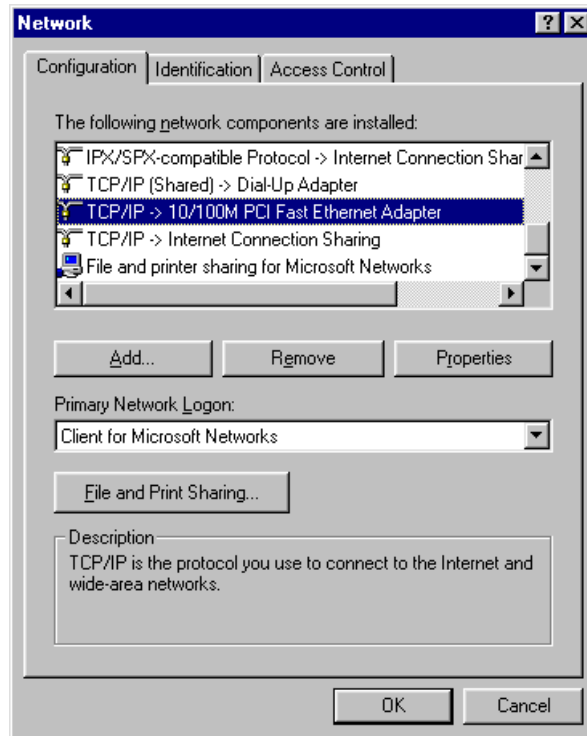

- Click the properties button. A TCP/IP Properties box similar to the one below should appear

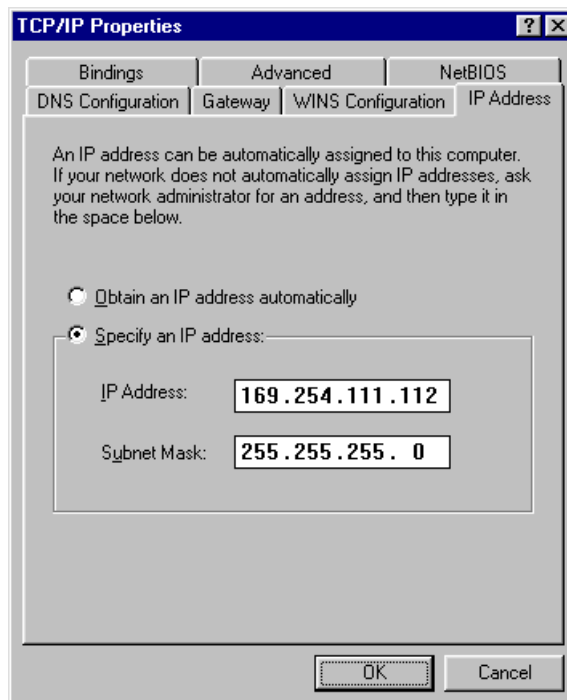

- Select the IP Address tab
- Choose to Specify an IP address as shown in the figure
- Insert the IP address 169.254.111.112 and the corresponding subnet mask as shown
- Save your settings by pressing OK in both TCP/IP properties and Network properties
- Reboot your PC

3.1.5.4 Connecting to a PC which is Connected to a Network.

If there is an Ethernet network available, the PL100 can be connected to any Ethernet connection or hub belonging to the network. If the PC is connected to a network, there is a strong possibility that the default IP address of the PL100 is outside the range of the network (the address doesn't belong to the IP subset of the network). If the Ethernet network is connected to the Internet, this is certain. In this case a new IP address for the PL100 is required. Contact the local network administrator to be assigned a free IP address for the PL100. The new IP address is programmed into the PL100 using a Web browser software such as Internet explorer. In this case the PL100 must first be connected directly to a PC as described above.

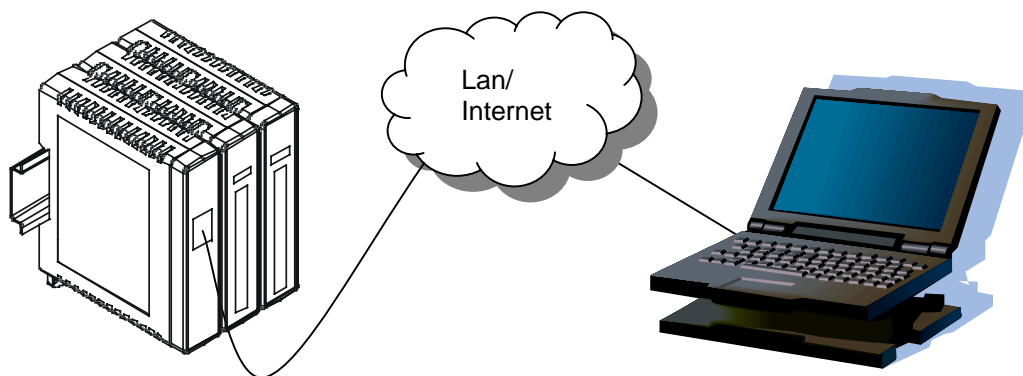

In the remainder of this chapter, the IP address 169.254.111.111 is used as an example. Exchange this IP address with the IP address you have set up in all the occurrences.

3.1.5.5 Testing the Connection

To test the connection between the PC and the PL100, a simple program called *ping* can be used. *Ping* sends a number of messages to the specified IP address and displays the response. The ping program can be run from the command line or from a DOS window on the PC, as follows:

- Open the Windows Start Menu
- Click Run
- In the Open box, type: "ping 169.254.111.111"

If the network connection is OK, the program will respond with:
"Reply from 169.254.111.111" and information about the response time.

If there is a problem with the network setup the program will respond:
"**Destination host unreachable**". There may be two solutions to this problem:

- If the PC is connected in a network, change the IP address to an address accessible from the local network.
- If the PL100 is connected directly to the PC(or through a hub), change the PC's IP address to one in the same address range as the PL100.

If there is a problem with the PL100 the program will respond:
"**Request timed out**", this means that the PL100 can not respond to messages. Check the power connection. Check that the Link LED is illuminated when the cable is plugged into the RJ45 connector.

3.1.6 Viewing Web Pages

The PL100 has built in web pages. These are used for checking the configuration and dynamic data, and for altering the configuration. To view these Web pages, a Web browser such as Internet Explorer or Netscape is needed.

To view the default Web page in PL100, start the Web browser and type "169.254.111.111" into the address line of the browser window. The main page of the PL100 will now be displayed in the browser window.

If no Web page is displayed, go back to testing the network connection to the PL100 by using the ping command. If the PL100 replies to the ping messages, check the setup of the Web browser. If the PL100 is directly connected to the same network as the PC, "direct connection to the network" or "bypass proxy server for local addresses" should be selected in the Web browser configuration menu. If the PL100 is connected to the PC through a firewall, a proxy server should be selected in the configuration menu. Contact the local network administrator for information about the network configuration.

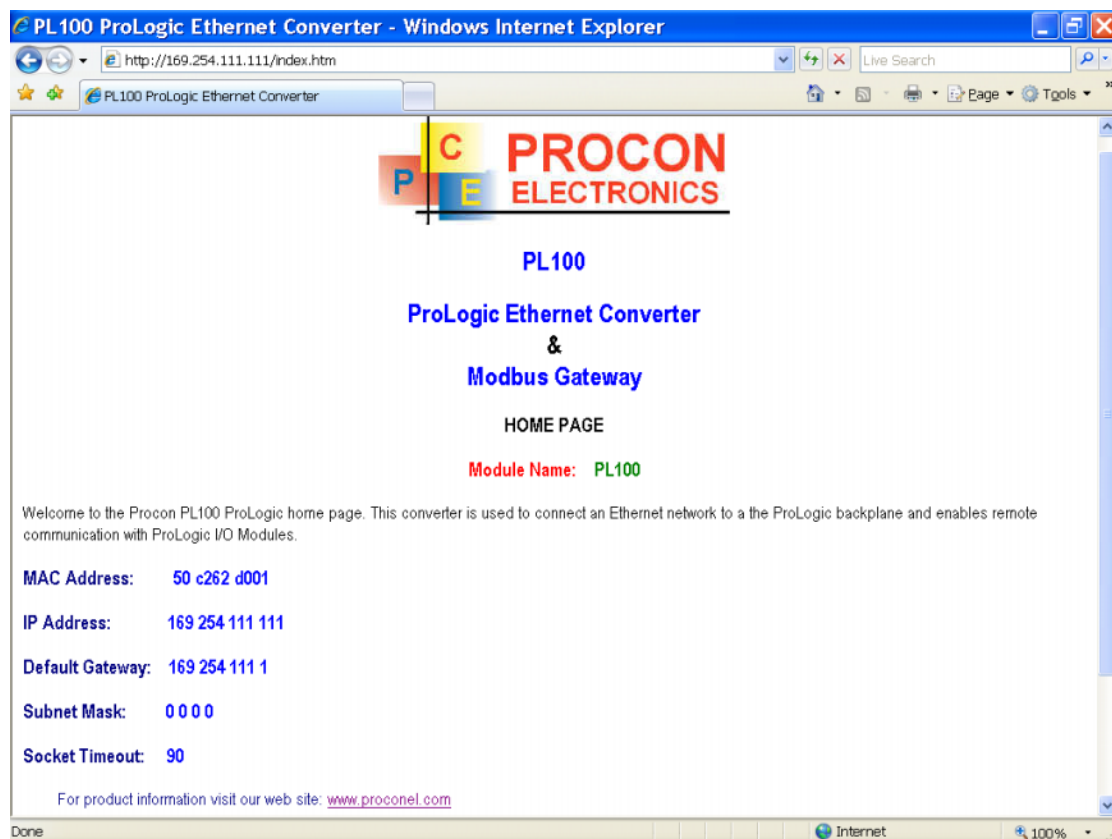

3.1.7 Troubleshooting Guide.

No	Checkpoint		Solution
1	Is the LINK LED on and is the ACTIVITY LED flashing with short pulses?	No	No network connection is detected. The Ethernet cable is either not plugged in or wrong type of cable is used. For connection to a network with a hub or switch, a normal network cable can be used. For direct connection to a PC network card, a twisted cable must be used.
		Yes	A network connection is detected, the PL100 is connected to the network.
2	Does the PL100 respond to PING requests?	No	Either the PC or the PL100 is setup with wrong IP address. To change the IP address of the PL100 back to the default address, remove the power, open the PL100 housing and remove the jumper labeled DEFAULT IP. Apply power to the PL100 for a short while. Now replace the jumper and close the enclosure. To change the IP address of a PC, use the Windows "control panel -> network -> TCP/IP properties" and setup an IP address close to the PL100 address. The PL100 is shipped with a default IP address of 169.254.111.111, the PC can be setup with an IP address of 169.254.111.112
		Yes	The PC and PL100 are setup with a correct IP address and they are able to communicate with each other.
3	Can the default Web page be accessed in a Web browser?	No	This is normally caused by the setup of the Web browser. In the "options" or "preferences" menu, check that the Web browser is configured for direct network connection or local area network and NOT using a proxy server.
		Yes	No problems.

3.1.8 Parameter Configuration

The Web page address "169.254.111.111/ip.htm" is entered into the address line of the browser window to access the configuration page. This page allows you to change the IP address of the PL100, Default Gateway, Subnet Mask, and to enter a Module Description Name for identification/maintenance purposes.

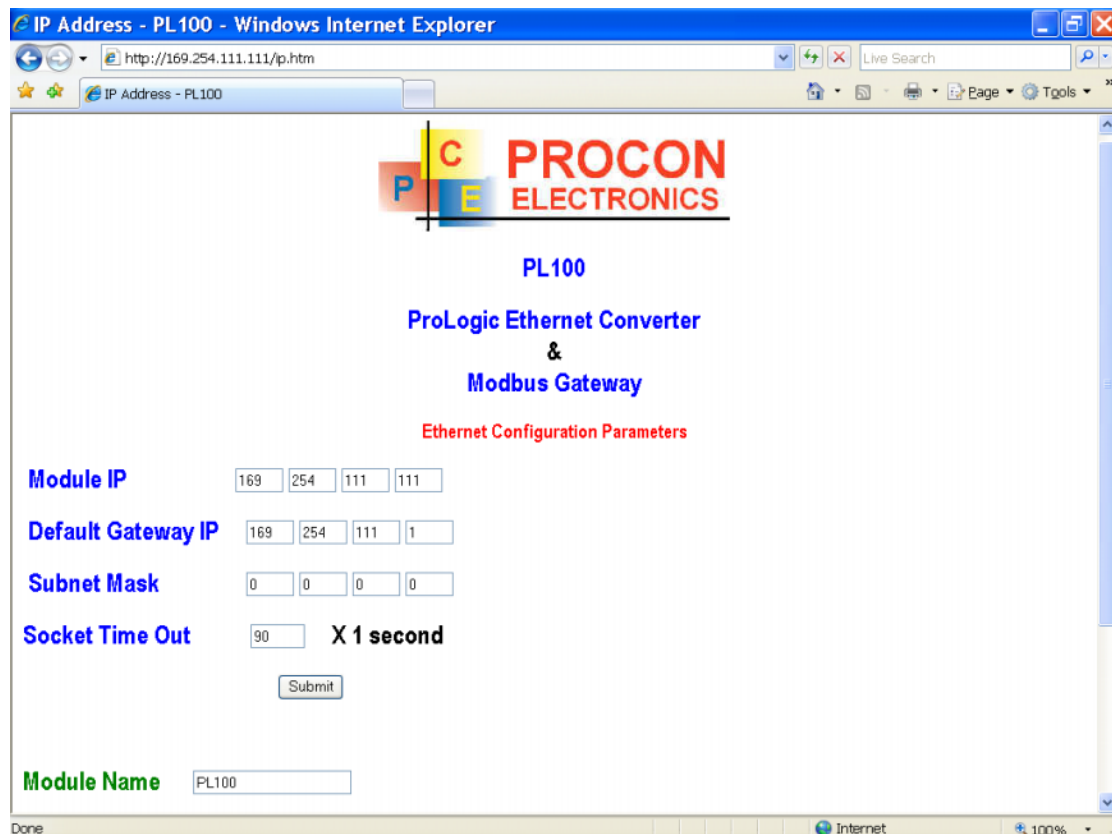

- **IP Address:** The new IP address can be entered into the web page as shown above. After this has been done, you must click the Submit button to send the values to the PL100. The screen will now be updated and if successful will continue to display the new IP address. The new IP address will only be effective after the PL100 power has been switched off and on again. This feature allows you to check that the correct IP address has been entered before being activated. If the IP address has been entered incorrectly and the power has not been switched off, it is possible to re-enter the correct IP address. If the power has been switched off and back on again, the PL100 will not communicate until you enter the new IP address into the address line of the browser window.
- **Default Gateway IP Address:** A **default gateway** is a node (a router) on a computer network that serves as an access point to another network. In enterprises, however, the gateway is the computer that routes the traffic from a PC to the outside network that is serving the Web pages. It is only necessary to configure the default gateway IP address if the PC that is accessing the PL100 is on a different network.
- **Subnet Mask:** In computer networks, a **subnetwork** or **subnet** is a range of logical addresses within the address space that is assigned to an organization. The subnet mask is used to inform the PL100 that it must send its replies to the gateway if the IP address of the PC is on a different network. When the subnet mask is set to "0.0.0.0" then it is effectively disabled and the default gateway is not used. A typical subnet mask would be "255.255.255.0".

- **Socket Timeout:** If a socket connection is broken, say due to a network fault, it must timeout to free it up so that it can be used again. This timer is triggered by activity on the converter, so if there is no communications activity for longer than the timeout period, the socket will close.
- **Module Name:** This field allows you to enter a module description name into the PL100. This is an identifier for diagnostic/maintenance purposes and is chosen to best describe the PL100 in the system by name or number.

3.2 PL101 – PLC Module with Ethernet and Serial Ports

3.2.1 Description

The PL101 PLC has been developed as a compact controller with a versatile combination of communication ports. The fact that the controller is programmable enables the user to program their own unique logic requirements and not be restricted by a pre-programmed unit or hardwired relays and timers.

The PROLOGIC modules plug into each other and the module on the left plugs into the PL101. Up to eight modules can be plugged together.

The PL101 PLC is programmed in ladder logic. Procon's ProSoft windows-based PC software is used to generate the ladder diagram, compile the program, and then download the program to the PL101 via the Ethernet port on the front of the unit.

The PL101 includes a web server which enables access to internal parameters for configuration. This allows configuration of IP address, default gateway IP address and subnet mask. The web server can be accessed by most web browsers. The PL101 supports the FTP protocol which enables the web pages to be customized if required.

The PL101 is factory programmed with a default IP address of 169.254.111.111. This address must be changed before the converter is added to an existing network.

The web page address for viewing the setup parameters is <http://169.254.111.111/index.htm>
The web page address for configuring the converter is <http://169.254.111.111/ip.htm>

The master device which is polling the PL101 must be configured with the IP address of the PL101 and with the Modbus ID of the PROLOGIC modules. The Modbus ID of the PL101 is 0 (zero).

The PL101 communicates using the Modbus TCP protocol and the client must be configured to use **Port 502**. This is a reserved port number for Modbus TCP applications.



3.2.2 Technical Specification of PL101

Power Supply	Logic Supply Voltage	12 -24 Vdc
	Logic Supply Power	0.8VA
Ethernet	10/100 Mbits/s	10/100Base-TX
	Connector	RJ45
Serial	RS232	3 Wire , TX,RX,GND
	RS485	2 Wire Multidrop twisted pair
	Baud Rate	2400, 4800, 9600, 19200, 38400, 57600, 115200
	Data Bits	5, 6, 7, 8 .
	Parity	none, even, odd.
	Stop Bits	1, 2.
Temperature	Operating Temperature.	-30°C to + 60°C
	Storage Temperature	-40°C to + 85°C
Connectors	Power.	4 way screw connector
Humidity		Up to 95% non condensing.

3.2.3 Status Indicators

- Power:** Flashes to indicate the CPU is running.
- Serial Bus Rx (0):** Flashes to indicate the unit has received a valid Modbus message from a PROLOGIC module.
- Serial Bus Tx (0):** Flashes to indicate the unit has sent a Modbus message to a PROLOGIC module.
- RS485 Rx (1):** Flashes to indicate the unit has received a valid Modbus message on the RS485 port.
- RS485 Tx (1):** Flashes to indicate the unit has sent a Modbus message on the RS485 port.
- RS232 Rx (2):** Flashes to indicate the unit has received a valid Modbus message on the RS232 port.
- RS232 Tx (2):** Flashes to indicate the unit has sent a Modbus message on the RS485 port.
- Modbus TCP Rx(3):** Flashes to indicate the unit has received a valid Modbus message on the Ethernet network.
- Modbus TCP Tx (3):** Flashes to indicate the unit has transmitted a Modbus message on the Ethernet network.
- Web Server:** Flashes to indicate the HTTP web server is being accessed.

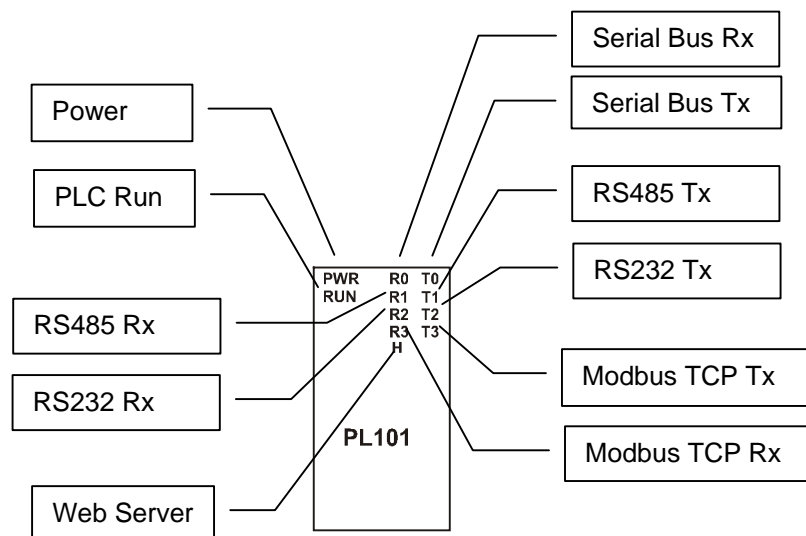

3.2.4 Wiring

The following diagram shows the wiring for the power and RS485 communications.

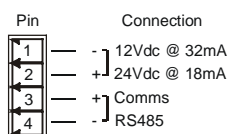

3.2.5 Configuration

The configuration of the IP Address is done using the web browser. Refer to the section in the PL100 chapter for setting up the TCP communications.

3.2.6 PL101 CPU Details.

The CPU (central Processing Unit) performs all of the tasks that are required to make the PLC function and run your ladder program. Some of the tasks include:

1. Reading the status of the inputs from the PROLOGIC modules.
2. Executing the program.
3. Updating the outputs on the PROLOGIC modules.
4. Doing diagnostics.
5. Servicing the communications ports.
6. Running the timers.

3.2.7 Program Memory.

The Ethernet port or RS232 port (11520 kbaud) are used to program the PLC. The program which is sent from the PC using the ProSoft ladder editor, is stored in FLASH memory. This memory does not get lost when the power fails and so will remain permanently in the PLC until it is reprogrammed.

3.2.8 Data Memory.

All the variables used in the program are stored in Data memory. Both the Digital and Analog values are stored in this memory along with the timers, counters, and user memory.

The memory is divided up into 3 sections.

1. RAM – Random Access Memory. This memory is the most widely used memory and is where most of the data is stored. All timers, counters, I/O statuses and system information use this memory. If the power fails then all the information in this memory is lost and is re-initialized to zero when the PLC starts again.
2. EEPROM – This memory is used to store parameters such as set-points and configuration data as it retains its memory when the power is turned off. The one point to remember is that this memory can only be written to 10 000 times before it wears out so you must not write to this memory all the time as you can with RAM.
3. BBRAM – This is battery backed RAM and also retains its memory when the power is switched off. This memory is slow compared to RAM and should not be used where normal RAM can be used. This memory is ideal for storing values such as used in counting applications. The Real time clock is also stored in this memory.

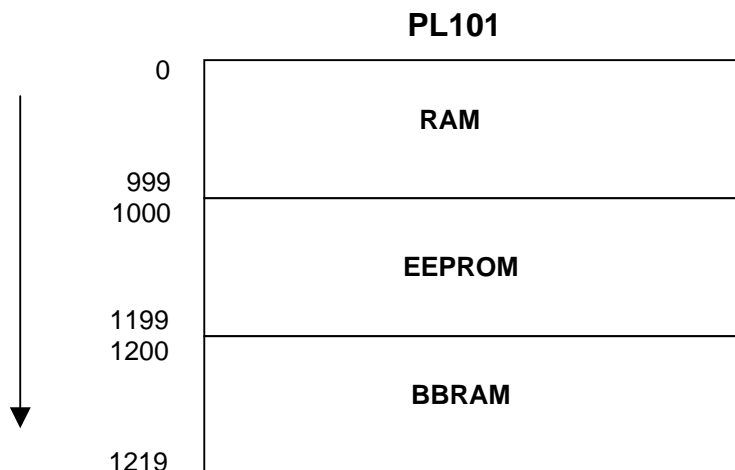

3.2.9 Data Memory Map.

All of the variables used in the PLC are stored in data memory. In order for your program to get access to these variables you need to know the memory address. The memory address starts at zero and the size depends on the PLC being used. Each memory location consists of 16 bits. Thus one memory location can be used to store the status of 16 digital I/O points or an analog value from 0 to 65535. Some of the ladder functions use two consecutive memory locations to store larger values. Refer to the ProSoft user manual to find out about the ladder functions.

PL101 MEMORY MAP			
Memory Type	Digital Reference	Memory Address	Quantity
Module Type = 121	-	M0	1
Digital Inputs	I1 to I64	M1 – M8	128
Digital Outputs	O1 to O4	M9 – M16	128
Timer Status	T1 to T64	M17 – M20	64
Counter Status	C1 to C64	M21 – M24	64
Control Relays	R1 to R64	M25 – M28	64
System Relays	S1 to S32	M29 – M30	32
Timer Memory	-	M33 – M96	64
Counter Memory	-	M97 – M160	64
User RAM Memory	-	M161 – M199	39
IO Table	-	M200 – M399	200
IO Status	-	M400	1
User RAM Memory	-	M401 – M999	599
User EEPROM	-	M1000 – M1199	200
User BBRAM	-	M1200 – M1219	20

3.2.10 Digital Input Map.

The digital input memory addresses correspond to the eight PROLOGIC modules, with the module ID1-8 being read into M1-M8. If the module is not an input module then the corresponding memory location will be unused.

PL101 Digital Inputs																Address
MSB															LSB	
15	14	13	12	11	10	9	8	7	6	5	4	3	2	1	0	
I16	I15	I14	I13	I12	I11	I10	I9	I8	I7	I6	I5	I4	I3	I2	I1	M1
I32	I31	I30	I29	I28	I27	I26	I25	I24	I23	I22	I21	I20	I19	I18	I17	M2
I48	I47	I46	I45	I44	I43	I42	I41	I40	I39	I38	I37	I36	I35	I34	I33	M3
I64	I63	I62	I61	I60	I59	I58	I57	I56	I55	I54	I53	I52	I51	I50	I49	M4
I80	I79	I78	I77	I76	I75	I74	I73	I72	I71	I70	I69	I68	I67	I66	I65	M5
I96	I95	I94	I93	I92	I91	I90	I89	I88	I87	I86	I85	I84	I83	I82	I81	M6
I112	I111	I110	I109	I108	I107	I106	I105	I104	I103	I102	I101	I100	I99	I98	I97	M7
I128	I127	I126	I125	I124	I123	I122	I121	I120	I119	I118	I117	I116	I115	I114	I113	M8

3.2.11 Digital Output Map.

The digital output memory addresses correspond to the eight PROLOGIC modules, with the module ID1-8 being written from M9-M16. If the module is not an output module then the corresponding memory location will be unused.

PL101 Digital Outputs																Addresses
MSB															LSB	
15	14	13	12	11	10	9	8	7	6	5	4	3	2	1	0	
O16	O15	O14	O13	O12	O11	O10	O9	O8	O7	O6	O5	O4	O3	O2	O1	M9
O32	O31	O30	O29	O28	O27	O26	O25	O24	O23	O22	O21	O20	O19	O18	O17	M10
O48	O47	O46	O45	O44	O43	O42	O41	O40	O39	O38	O37	O36	O35	O34	O33	M11
O64	O63	O62	O61	O60	O59	O58	O57	O56	O55	O54	O53	O52	O51	O50	O49	M12
O80	O79	O78	O77	O76	O75	O74	O73	O72	O71	O70	O69	O68	O67	O66	O65	M13
O96	O95	O94	O93	O92	O91	O90	O89	O88	O87	O86	O85	O84	O83	O82	O81	M14
O112	O111	O110	O109	O108	O107	O106	O105	O104	O103	O102	O101	O100	O99	O98	O97	M15
O128	O127	O126	O125	O124	O123	O122	O121	O120	O119	O118	O117	O116	O115	O114	O113	M16

3.2.12 Timer Map.

PL101 Timer status																Address
MSB															LSB	
15	14	13	12	11	10	9	8	7	6	5	4	3	2	1	0	
T16	T15	T14	T13	T12	T11	T10	T9	T8	T7	T6	T5	T4	T3	T2	T1	M17
T32	T31	T30	T29	T28	T27	T26	T25	T24	T23	T22	T21	T20	T19	T18	T17	M18
T48	T47	T46	T45	T44	T43	T42	T41	T40	T39	T38	T37	T36	T35	T34	T33	M19
T64	T63	T62	T61	T60	T59	T58	T57	T56	T55	T54	T53	T52	T51	T50	T49	M20

3.2.13 Counter Map.

PL101 Counter status																Address
MSB															LSB	
15	14	13	12	11	10	9	8	7	6	5	4	3	2	1	0	
C16	C15	C14	C13	C12	C11	C10	C9	C8	C7	C6	C5	C4	C3	C2	C1	M21
C32	C31	C30	C29	C28	C27	C26	C25	C24	C23	C22	C21	C20	C19	C18	C17	M22
C48	C47	C46	C45	C44	C43	C42	C41	C40	C39	C38	C37	C36	C35	C34	C33	M23
C64	C63	C62	C61	C60	C59	C58	C57	C56	C55	C54	C53	C52	C51	C50	C49	M24

3.2.14 Control Relay Map.

PL101 Control Relays																Address
MSB															LSB	
15	14	13	12	11	10	9	8	7	6	5	4	3	2	1	0	
R16	R15	R14	R13	R12	R11	R10	R9	R8	R7	R6	R5	R4	R3	R2	R1	M25
R32	R31	R30	R29	R28	R27	R26	R25	R24	R23	R22	R21	R20	R19	R18	R17	M26
R48	R47	R46	R45	R44	R43	R42	R41	R40	R39	R38	R37	R36	R35	R34	R33	M27
R64	R63	R62	R61	R60	R59	R58	R57	R56	R55	R54	R53	R52	R51	R50	R49	M28

3.2.15 System Relay Map.

MSB																PL101 System Relays																LSB		Addresses
15	14	13	12	11	10	9	8	7	6	5	4	3	2	1	0	S16	S15	S14	S13	S12	S11	S10	S9	S8	S7	S6	S5	S4	S3	S2	S1	M29		
S32	S31	S30	S29	S28	S27	S26	S25	S24	S23	S22	S21	S20	S19	S18	S17	M30																		

Bit Number	Digital Input Number	Description
0	S1	ON
1	S2	1st Scan
2	S3	0.1 Second Clock Period
3	S4	1 Second Clock Period
4	S5	1 Minute Clock Period
5	S6	CMP < MEM/K
6	S7	CMP = MEM/K
7	S8	CMP > MEM/K
8	S9	PLC Running
9	S10	PLC Re-Program Request
10	S11	PLC Re-Program Acknowledge
11	S12	-
12	S13	-
13	S14	Comm 1 Ready
14	S15	Comm 1 Error
15	S16	TCP Comm Ready
16	S17	TCP Comm Error

3.2.16 IO Table

If you click the mouse pointer on the **EDIT->I/O Module Addresses** menu item in the ProSoft program, a box will open which shows a list of the 8 I/O modules. By clicking on the pull down tab, you can select the module type that is assigned to the module ID 1 to 8.

The modules that can be selected are as follows:

1. PL16DI
2. PL16DO
3. PL8DIO
4. PL4RO
5. PL8AI/I
6. PL8AI/V
7. PL8TC
8. PL8TC ISO
9. PL8AI/I ISO
10. PL8AI/V ISO
11. PL6RTD
12. PL8AO
13. PL8VO
14. PLDAIO

Once you have selected the modules to be used in your application, ensure that the DIP switch is setup on each module with the correct Modbus address. It is good practice to start numbering from left to right.

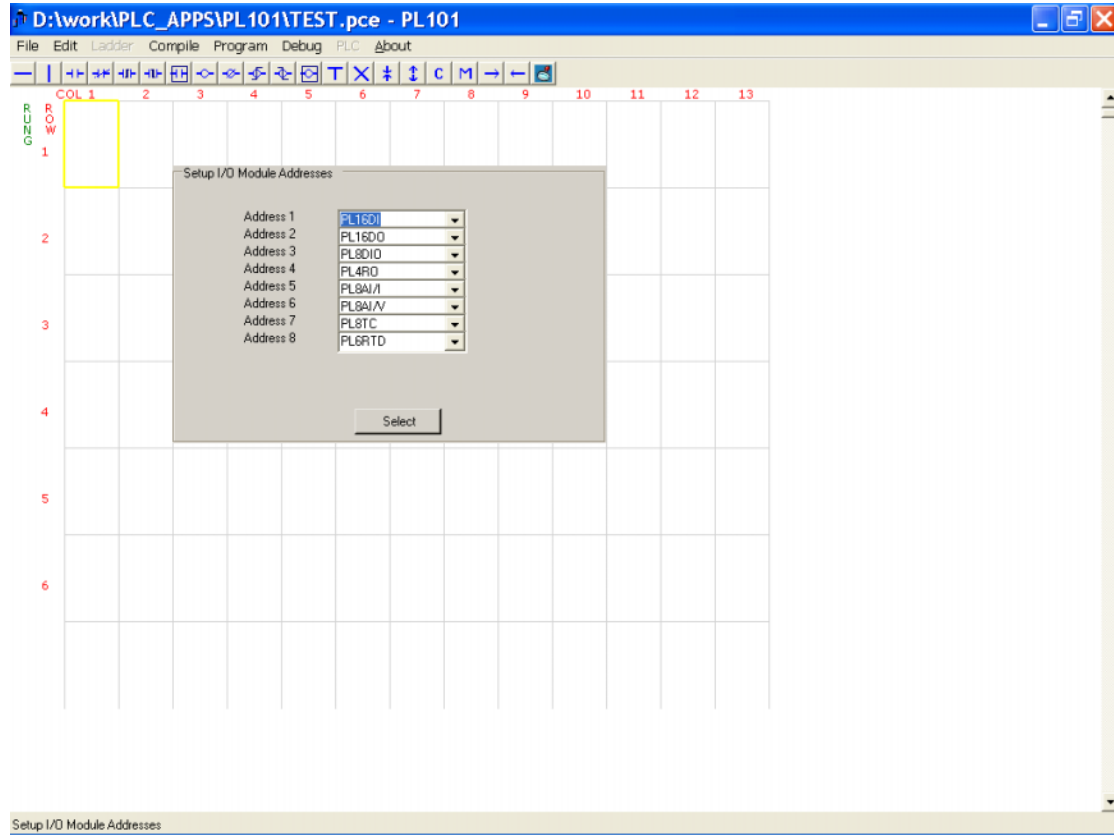

Once the ladder program is compiled and downloaded to the PL101, the PLC program will automatically start reading the modules and will check the module type against the configuration table. If the type does not match the table then a status error will be indicated in the I/O Status memory register **M400**. The bit in the register is set if the type check is OK, otherwise the bit is cleared. The format of the I/O Status register is as follows:

I/O Module Status Register															Address	
MSB								LSB								
15	14	13	12	11	10	9	8	7	6	5	4	3	2	1	0	M400
32768	16384	8192	4096	2048	1024	512	256	128	64	32	16	8	4	2	1	

0 0 0 0 0 0 0 0

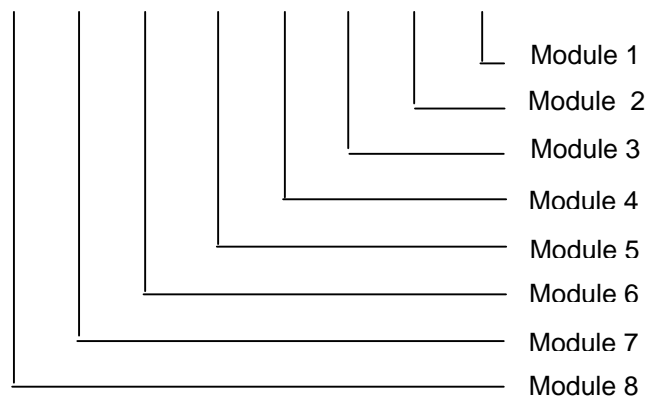

If the module type does not match the configuration table or the module is not present, the PLC software continues to scan the module every 2 seconds and updates the I/O table status register.

If the module type matches the configuration table, the PLC starts reading or writing the module either on every PLC ladder scan, on a change of state or on a timer, depending on the module type.

The following table describes the reading/writing of the modules:

Module Type	Read/Write Mode
PL16DI	Inputs read at the beginning of every PLC ladder cycle.
PL16DO	Outputs written every second or at the end of the PLC ladder cycle if there was a change of state.
PL8DIO	Inputs read at the beginning of every PLC ladder cycle. Outputs written at the end of the PLC ladder cycle if there was a change of state.
PL4RO	Outputs written every second or at the end of the PLC ladder cycle if there was a change of state.
PL8AI/I	Inputs read every 0.5 second at the beginning of PLC ladder cycle.
PL8AI/V	Inputs read every 0.5 second at the beginning of PLC ladder cycle.
PL8TC	Inputs read every 1.0 second at the beginning of PLC ladder cycle.
PL8TC ISO	Inputs read every 1.0 second at the beginning of PLC ladder cycle.
PL8AI/I ISO	Inputs read every 1.0 second at the beginning of PLC ladder cycle.
PL8AI/V ISO	Inputs read every 1.0 second at the beginning of PLC ladder cycle.
PL6RTD	Inputs read every 1.0 second at the beginning of PLC ladder cycle.
PL8AO	Outputs written every 0.5 second at the end of PLC ladder cycle.
PL8VO	Outputs written every 0.5 second at the end of PLC ladder cycle.
PLDAIO	Digital Inputs read at the beginning of every PLC ladder cycle. Analog Inputs read every 0.1 second. Outputs written at the end of the PLC ladder cycle if there was a change of state.

3.2.16.1 The format of the I/O Table

- The memory address of the I/O Table is fixed starting at M200.
- The table is divided into eight blocks, one for each module.
- Each block consists of 25 registers.
- The first register in each block contains the software version and module type identifier for that module.
- The remaining 24 registers contain the data that is read from the module. The modules do not use all of the registers. The number of registers used depends on the specific module.

Memory Address s	Module Number
M200	Start of module 1.
-	
M224	End of module 1.
M225	Start of module 2.
-	
M249	End of module 2.
M250	Start of module 3.
-	
M274	End of module 3.
M275	Start of module 4.
-	
M299	End of module 4.
M300	Start of module 5.
-	
M324	End of module 5.
M325	Start of module 6.
-	
M349	End of module 6.
M350	Start of module 7.
-	
M374	End of module 7.
M375	Start of module 8.
-	
M399	End of module 8.
M400	Module status register.

3.2.16.2 I/O table register layout

Memory Offset	PL16DI	PL16DO	PL8DIO	PL4RO
0	S/W Ver / Module Type	S/W Ver / Module Type	S/W Ver / Module Type	S/W Ver / Module Type
1	Digital Inputs	Digital Outputs	Digital Inputs	Relay Outputs
2			Digital Outputs	
3				
4				
5				
6				
7				
8				
9				
10				
11				
12				
13				
14				
15				
16				
17				
18				
19				
20				
21				
22				
23				
24				

Memory Offset	PL8AI/I, PL8AI/V, PL8AI/IISO, PL8AI/VISO	PL8TC & PL8TC ISO	PL6RTD	PL8AO & PL8VO
0	S/W Ver / Module Type	S/W Ver / Module Type	S/W Ver / Module Type	S/W Ver / Module Type
1	Analog Input 1	Thermocouple Input 1	RTD Input 1	Analog Output 1
2	Analog Input 2	Thermocouple Input 2	RTD Input 2	Analog Output 2
3	Analog Input 3	Thermocouple Input 3	RTD Input 3	Analog Output 3
4	Analog Input 4	Thermocouple Input 4	RTD Input 4	Analog Output 4
5	Analog Input 5	Thermocouple Input 5	RTD Input 5	Analog Output 5
6	Analog Input 6	Thermocouple Input 6	RTD Input 6	Analog Output 6
7	Analog Input 7	Thermocouple Input 7	RTD Input Status	Analog Output 7
8	Analog Input 8	Thermocouple Input 8		Analog Output 8
9	Analog Input Status	CJC Temperature		Analog Output Status
10		TC Input Status		
11				
12				
13				
14				
15				
16				
17				
18				
19				
20				
21				
22				
23				
24				

Memory Offset	PLDAIO			
0	S/W Ver / Module Type			
1	Digital Inputs			
2	Digital Outputs			
3	RTD Input 1			
4	RTD Input 2			
5	Analog Input 1			
6	Analog Input 2			
7	Analog Output 1			
8				
9				
10				
11				
12				
13				
14				
15				
16				
17				
18				
19				
20				
21				
22				
23				
24				

3.2.17 RS485 Modbus Communications

3.2.17.1 Modbus Master.

The RS485 communications port can be configured to function as a Modbus master device. To enable this mode you must make sure that the Modbus Master tick box is selected in Procon's ProSoft PLC programming software.

In this mode, you can configure the PL101 to read a range of registers from a remote Modbus slave or you can write a range of registers to a remote slave. You can configure up to 20 of these communications blocks.

The setup parameters are as follows:

- **Remote ID.** This is the network ID of the Modbus slave device.
- **Function.** You must enter a value of 3 to read a range of registers and a value of 16 to write to a range of registers. Function 3 reads registers in the slave and stores them in memory in the PL101. Function 16 reads memory in the PL101 and writes them to registers in the slave device.
- **Local Address.** This is the memory location in the PL101 where the data will be read from or written to. For example, if you want to access memory M1 then you must put a 1 into the local address field. (Do not put the Modbus address 30002).
- **Range.** This is the number of consecutive memory locations that will be transmitted.
- **Remote Address.** This is the register location in the slave device where data will be written to or read from. If you want to access a modbus register for example 40010 in the remote slave device, then you must put a value of 9 into this field.

3.2.17.2 Modbus Slave.

The RS485 communications port can be configured to function as a Modbus slave device.

When configured as a modbus slave, the PL101 will respond to network requests from a modbus master on the network. This could be another PL101.

The modbus functions supported are as follows:

PL101 Modbus Slave Commands				
Modbus Function	Description	Memory start	Memory end	Max. Range
1or2	Reads a range of bits from any part of RAM	M0	M999	1600
3or4	Reads a range of registers from RAM, EEPROM and BBRAM.	M0	M1219	100
5	Reads a single Bit from any part of RAM	M0	M999	1
6	Reads a single register from RAM, EEPROM and BBRAM.	M0	M1219	1
15	Writes a range of bits to RAM.	M9	M999	1600
16	Writes a range of registers from RAM, EEPROM and BBRAM.	M9	M1219	100

3.2.18 Modbus Memory Map (MODULE TYPE = 121)

Modbus Address	Mem Addr	Register Name	Low Limit	High Limit	Access	Comments
10017	1.1	Digital Input 1	0	1	R	Status of Digital Inputs 1.
“	“	“	“	“	“	“
10144	8.16	Digital Input 128	0	1	R	Status of Digital Inputs 128.
00145	9.1	Digital Output 1	0	1	R/W	Status of Digital Outputs 1.
“	“	“	“	“	“	“
00272	16.16	Digital Output 128	0	1	R/W	Status of Digital Outputs 128.
00273	17.1	Timer 1	0	1	R/W	Status of Timer 1.
“	“	“	“	“	“	“
00336	20.16	Timer 64	0	1	R/W	Status of Timer 64.
00337	21.1	Counter 1	0	1	R/W	Status of Counter 1.
“	“	“	“	“	“	“
00400	24.16	Counter 64	0	1	R/W	Status of Counter 64.
00401	25.1	Control Relay 1	0	1	R/W	Status of Control relay 1.
“	“	“	“	“	“	“
00464	28.16	Control Relay 64	0	1	R/W	Status of Control relay 64.
00465	29.1	System Relay 1	0	1	R/W	Status of System relay 1.
“	“	“	“	“	“	“
00496	30.16	System Relay 32	0	1	R	Status of System relay 32.
30001	0	S/W Version / Module Type	N/A	N/A	R	High Byte = Software Version Low Byte = 121
30002	1	Digital Inputs	N/A	N/A	R	Digital Inputs in 16 bits – Module 1.
30003	2	Digital Inputs	N/A	N/A	R	Digital Inputs in 16 bits – Module 2.
30004	3	Digital Inputs	N/A	N/A	R	Digital Inputs in 16 bits – Module 3.
30005	4	Digital Inputs	N/A	N/A	R	Digital Inputs in 16 bits – Module 4.
30006	5	Digital Inputs	N/A	N/A	R	Digital Inputs in 16 bits – Module 5.
30007	6	Digital Inputs	N/A	N/A	R	Digital Inputs in 16 bits – Module 6.
30008	7	Digital Inputs	N/A	N/A	R	Digital Inputs in 16 bits – Module 7.
30009	8	Digital Inputs	N/A	N/A	R	Digital Inputs in 16 bits – Module 8.
40010	9	Digital Outputs	N/A	N/A	R/W	Digital Outputs in 16bits– Module1.
40011	10	Digital Outputs	N/A	N/A	R/W	Digital Outputs in 16bits– Module2.
40012	11	Digital Outputs	N/A	N/A	R/W	Digital Outputs in 16bits–

						Module3.
40013	12	Digital Outputs	N/A	N/A	R/W	Digital Outputs in 16bits– Module4.
40014	13	Digital Outputs	N/A	N/A	R/W	Digital Outputs in 16bits– Module5.
40015	14	Digital Outputs	N/A	N/A	R/W	Digital Outputs in 16bits– Module6.
40016	15	Digital Outputs	N/A	N/A	R/W	Digital Outputs in 16bits– Module7.
40017	16	Digital Outputs	N/A	N/A	R/W	Digital Outputs in 16bits– Module8.
40018	17	Timer Status	N/A	N/A	R/W	Timer Status 16 – 1
40019	18	Timer Status	N/A	N/A	R/W	Timer Status 32 – 17
40020	19	Timer Status	N/A	N/A	R/W	Timer Status 48 – 33
40021	20	Timer Status	N/A	N/A	R/W	Timer Status 64 – 49
40022	21	Counter Status	N/A	N/A	R/W	Counter Status 16 – 1
40023	22	Counter Status	N/A	N/A	R/W	Counter Status 32 – 17
40024	23	Counter Status	N/A	N/A	R/W	Counter Status 48 – 33
40025	24	Counter Status	N/A	N/A	R/W	Counter Status 64 – 49
40026	25	Control Relay	N/A	N/A	R/W	Control Relay 16 – 1
40027	26	Control Relay	N/A	N/A	R/W	Control Relay 32 – 17
40028	27	Control Relay	N/A	N/A	R/W	Control Relay 48 – 33
40029	28	Control Relay	N/A	N/A	R/W	Control Relay 64 - 49
40030	29	System Relay	N/A	N/A	R/W	System Relay 16 – 1
40031	30	System Relay	N/A	N/A	R/W	System Relay 32 – 17
-	31	-	N/A	N/A	-	Do not use – System only
-	32	-	N/A	N/A	-	Do not use – System only
40034	33	Timer 1 Value	0	65535	R/W	Timer range 0 to 65535.
“	“	“	“	“	“	“
40097	96	Timer 64 Value	0	65535	R/W	Timer range 0 to 65535.
40098	97	Counter 1 Value	0	65535	R/W	Counter range 0 to 65535.
“	“	“	“	“	“	“
40161	160	Counter 64 Value	0	65535	R/W	Counter range 0 to 65535.
40162	161	User Memory	0	65535	R/W	0 to 65535.
“	“	“	“	“	“	“
40200	199	User Memory	0	65535	R/W	0 to 65535.
40201	200	IO Table	0	65535	R/W	0 to 65535.
“	“	“	“	“	“	“
40400	399	IO Table	0	65535	R/W	0 to 65535.
40401	400	IO Module Status	0	65535	R/W	0 to 65535.
40402	401	User Memory	0	65535	R/W	0 to 65535.
“	“	“	“	“	“	“
41000	999	User Memory	0	65535	R/W	0 to 65535.
41001	1000	User EEPROM	0	65535	R/W	User EEPROM
“	“	“	“	“	“	“
41170	1169	User EEPROM	0	65535	R/W	User EEPROM
41171	1170	Comms Settings	-	-	-	Do Not Use

“	“	“	“	“	“	“
41200	1199	Comms Settings	-	-	-	Do Not Use
41201	1200	Seconds	0	59	R/W	RTC Seconds
41202	1201	Minutes	0	59	R/W	RTC Minutes
41203	1202	Hours	0	23	R/W	RTC Hours
41204	1203	Day	1	7	R/W	RTC Day
41205	1204	Date	1	31	R/W	RTC Date
41206	1205	Month	1	12	R/W	RTC Month
41207	1206	Year	0	100	R/W	RTC Year
41208	1207	User BBRAM	0	65535	R/W	User BBRAM
“	“	“	“	“	“	“
41220	1219	User BBRAM	0	65535	R/W	User BBRAM

3.2.19 Ladder Logic Function Blocks

The function blocks supported by the PL101 are listed below:

PL101 Function Blocks	
Function	Function Block Description
Timer 0.1Sec	Single input timer with 0.1 Second time base. The timer will run as long as the input is on. The timer will be reset to zero when the input is off.
Timer 0.01Sec	Single input timer with 0.01 Second time base. The timer will run as long as the input is on. The timer will be reset to zero when the input is off.
TimerA 0.1Sec	Accumulating timer with 0.1 Second time base. The timer will run as long as the input is on and stops when the input is removed. The timer will continue when the input is on again. The timer will be reset to zero when the reset input is on.
TimerA 0.01Sec	Accumulating timer with 0.01 Second time base. The timer will run as long as the input is on and stops when the input is removed. The timer will continue when the input is on again. The timer will be reset to zero when the reset input is on.
Counter	Up counter with reset input. The counter will count up when the count input goes from off to on. The counter will be reset to zero when the reset input is on. The counter output will go on when the count value is greater or equal to the preset value. The counter memory is addressed as the counter number + an offset
Counter Up/Dn	Up/Down counter with reset input. The counter will count up when the Up count input goes from off to on. The counter will count down when the Down count input goes from off to on. The counter will be reset to zero when the reset input is on. The counter output will go on when the count value is greater or equal to the preset value. The counter memory is addressed as the counter number + an offset of 16, so for example the value for counter 1 is in memory 17
NOP	This is a no operation function.
END	Placing this output function in the ladder program will indicate the end of the program. Any ladder after this function will not be run.
LD	Load the accumulator from memory(M) or with a constant(K).
LDD	The Load Double loads the accumulator with a 32 bit value from memory(M) or with a constant(K). The memory used is the two consecutive 16 bit memory locations, M & M+1.
LDF	The Load Float loads the accumulator with a float value from memory(M) or with a constant(F). The memory used is the two consecutive 16 bit memory locations, M & M+1.
OUT	Outputs the accumulator to memory(M).
OUTD	Outputs the 32 bit accumulator to two consecutive memory locations, M & M+1.
OUTF	Outputs the float accumulator to two consecutive memory locations, M & M+1.
AND	AND the accumulator with memory(M) or with a constant(K).
ANDD	AND the 32 bit accumulator with memory(M) or with a constant(K). The memory used is the two consecutive 16 bit memory locations, M & M+1.
OR	OR the accumulator with memory(M) or with a constant(K).
ORD	OR the 32 bit accumulator with memory(M) or with a constant(K). The memory used is the two consecutive 16 bit memory locations, M & M+1.
XOR	Exclusive OR the accumulator with memory(M) or with a constant(K).
XORD	Exclusive OR the 32 bit accumulator with memory(M) or with a

PL101 Function Blocks	
Function	Function Block Description
	constant(K). The memory used is the two consecutive 16 bit memory locations, M & M+1.
CMP	Compare the accumulator lower 16 bits with memory(M) or with a constant(K). If the value in the accumulator is less than the value in memory/constant then system bit S6 is turned on. If the value in the accumulator is equal to the value in memory/constant then system bit S7 is turned on. If the value in the accumulator is greater than the value in memory/constant then system bit S8 is turned on.
CMPD	Compare the 32 bit accumulator with memory(M) or with a constant(K). If the value in the accumulator is less than the value in memory/constant then system bit S6 is turned on. If the value in the accumulator is equal to the value in memory/constant then system bit S7 is turned on. If the value in the accumulator is greater than the value in memory/constant then system bit S8 is turned on.
CMPF	Compare the 32 bit accumulator with memory(M) or with a constant(F). If the value in the accumulator is less than the value in memory/constant then system bit S6 is turned on. If the value in the accumulator is equal to the value in memory/constant then system bit S7 is turned on. If the value in the accumulator is greater than the value in memory/constant then system bit S8 is turned on.
ADD	Add the memory(M) or constant(K) to the accumulator. The result is stored in the accumulator.
ADDD	Add the memory(M) or constant(K) to the 32 bit accumulator. The result is stored in the accumulator. The memory used is the two consecutive 16 bit memory locations, M & M+1.
ADDF	Add the memory(M) or constant(F) to the float accumulator. The result is stored in the float accumulator. The memory used is the two consecutive 16 bit memory locations, M & M+1.
SUB	Sub the memory(M) or constant(K) from the accumulator. The result is stored in the accumulator
SUBD	Sub the memory(M) or constant(K) from the 32 bit accumulator. The result is stored in the accumulator. The memory used is the two consecutive 16 bit memory locations, M & M+1.
SUBF	Sub the memory(M) or constant(F) from the float accumulator. The result is stored in the float accumulator. The memory used is the two consecutive 16 bit memory locations, M & M+1.
MUL	Multiply the accumulator with the memory(M) or constant(K). The result is stored in the accumulator
MULD	Multiply the 32 bit accumulator with the memory(M) or constant(K). The result is stored in the accumulator. The memory used is the two consecutive 16 bit memory locations, M & M+1.
MULF	Multiply the float accumulator with the memory(M) or constant(F). The result is stored in the float accumulator. The memory used is the two consecutive 16 bit memory locations, M & M+1.
DIV	Divide the accumulator by the memory(M) or constant(K). The result is stored in the accumulator.
DIVD	Divide the 32 bit accumulator by the memory(M) or constant(K). The result is stored in the accumulator. The memory used is the two consecutive 16 bit memory locations, M & M+1.
DIVF	Divide the float accumulator by the memory(M) or constant(F). The result is stored in the float accumulator. The memory used is the two consecutive 16 bit memory locations, M & M+1.
INC	Increment the memory(M). The result is stored in the memory(M)
INCD	Increment two consecutive memory(M) locations. The result is stored in

PL101 Function Blocks	
Function	Function Block Description
	the memory M & M+1.
DEC	Decrement the memory(M). The result is stored in the memory (M).
DECD	Decrement two consecutive memory(M) locations. The result is stored in the memory M & M+1.
INV	Invert the bits in the accumulator
MOV	Moves a variable in a memory location to a new location. The accumulator must already contain the address of the memory location to be moved.
SHL	The bits in the accumulator are shifted left by the memory(M) or constant(K). The lower bits are filled with zeros.
SHR	The bits in the accumulator are shifted right by the memory(M) or constant(K). The upper bits are filled with zeros.
CALL	This function is used to call a subroutine. The constant(k) is the label of the subroutine.
SUBR	This function is the start of a subroutine. The constant(k) is the label of the subroutine which is called by the call function.
RET	This function must be placed at the last line of a subroutine. The function can also be used in the subroutine for a conditional return.
RAND	A random number from 0 to 100 is placed in the accumulator
ACOSF	Arc Cosine of float accumulator
ASINF	Arc Sine of float accumulator
ATANF	Arc Tangent of float accumulator
COSF	Cosine of float accumulator
SINF	Sine of float accumulator
TANF	Tangent of float accumulator
SQRTF	Square Root of float accumulator
BTOF	The value in the 32 bit accumulator is converted to a float value and stored in the float accumulator.
FTOB	The value in the float accumulator is converted to a binary number and stored in the 32 bit accumulator.
RADF	The Radian of the float accumulator.
DEGF	The degrees of the float accumulator.
LOGF	The log of the float accumulator.
EXPF	The exponential of the float accumulator
PWRF	The power of the float accumulator.
COMM	Communications function. Enter a parameter number to select the data to be saved. 0 = Port Number (default = 1) 1 = Protocol (default = 0) 2 = Slave network ID 3 = PLC Memory Address 4 = Range 5 = Slave Address 6 = Timeout 7 = Function
TCOM	MODBUS TCP/IP Communications.
REGR	Read a register from a module.
REGRD	Read a Double register from a module. (eg. PL16DI 32 bit Counters)
REGW	Write a register from PLC memory to a module.
REGWD	Write a Double register from PLC memory to a module.

3.3 PL16DI - DIGITAL INPUTS WITH COUNTERS

3.3.1 Description

The PL16DI module is a 16 channel digital input module. The inputs are isolated from the logic by bi-directional opto-couplers. The inputs are divided into 2 isolated groups of 8 inputs each. This allows for many configurations in which the input module may be used. One such configuration could be where one group is connected as common positive and the second group connected as common negative.

The counters operate in three modes.

In **mode 0**: All the counters are disabled.

In **mode 1**: The counters are 32 bit counters allowing a count value from 0 to 4294967295. The count value can be cleared by writing a zero to the associated registers or preset to any other value using the same method.

In **mode 2**: The inputs are connected as up/down counters. Input 1 will increment counter 1 whilst input 2 decrements counter1. In the same way, inputs 3&4 operate counter 2, inputs 5&6 operate counter 3 and inputs 7&8 operate counter 4, etc.

Note: The count values are not battery backed-up and will be lost if power is turned off.

The format of the registers allows the status of the inputs to be read as either single bits or all at once as a single register on the Modbus network.



3.3.2 Technical Specification of PL16DI

Power Supply	Logic Supply Voltage	Supplied from Power Bus
	Logic Supply Power	0.3VA
Digital Inputs	Input Points	16
	Input Voltage Range	12 - 24 Vdc
	Input Current per input	5mA @ 12Vdc / 11mA @ 24Vdc
	Isolation	1500Vrms between field and logic
Counters	Inputs	1 to 16
	Resolution	32 Bits
	Frequency	1KHz (max)
	Pulse Width	500us (min)
Temperature	Operating Temperature.	-40°C to + 80°C
	Storage Temperature	-40°C to + 85°C
Connectors	Logic Power and Comms.	32 PIN Double Sided DIN Connector
	Inputs	18 Way screw connector on front

Note: Inputs 1 to 16 are used as both digital inputs and counter inputs.

3.3.3 Status Indicators

- Power:** Flashes to indicate the CPU is running.
- RS485 Rx:** Flashes to indicate the unit has received a valid Modbus message.
- RS485 Tx:** Flashes to indicate the unit has sent a Modbus message.
- Input Status:** "OFF" when the input is off.
"ON" when the input is on.

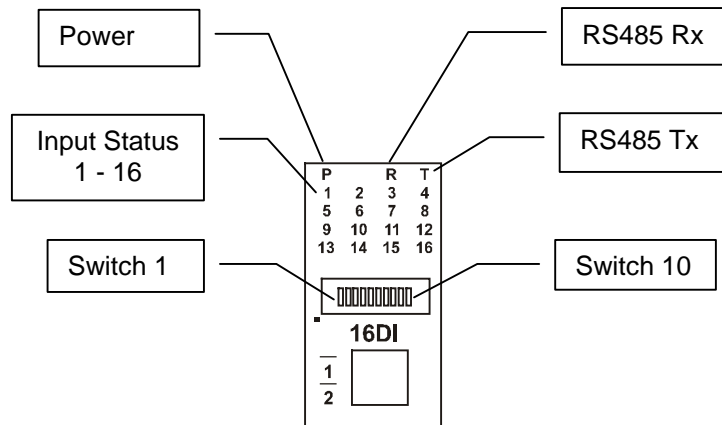

3.3.4 Wiring

The following diagram shows how the digital inputs are connected to potential free switches. The common can be connected to positive or negative as indicated.

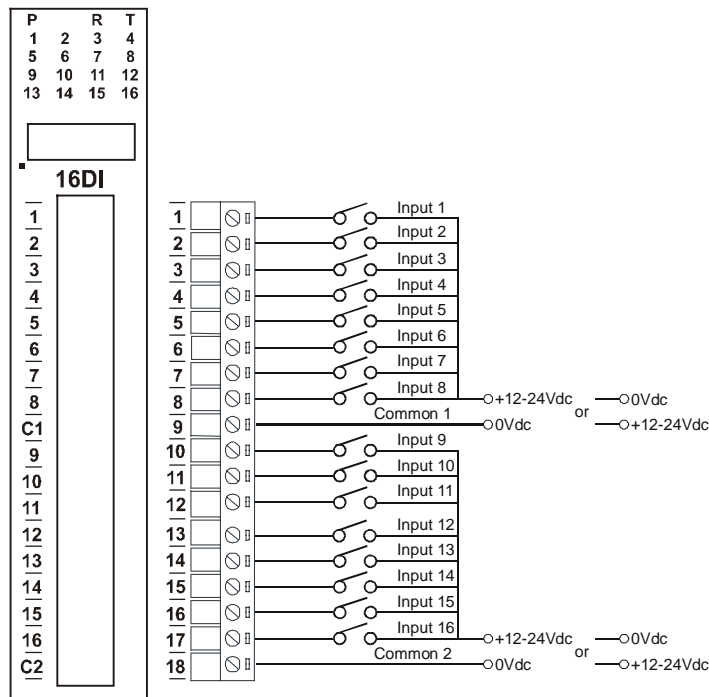

The following diagram shows how the digital inputs are connected a NPN transistor or a PNP transistor.

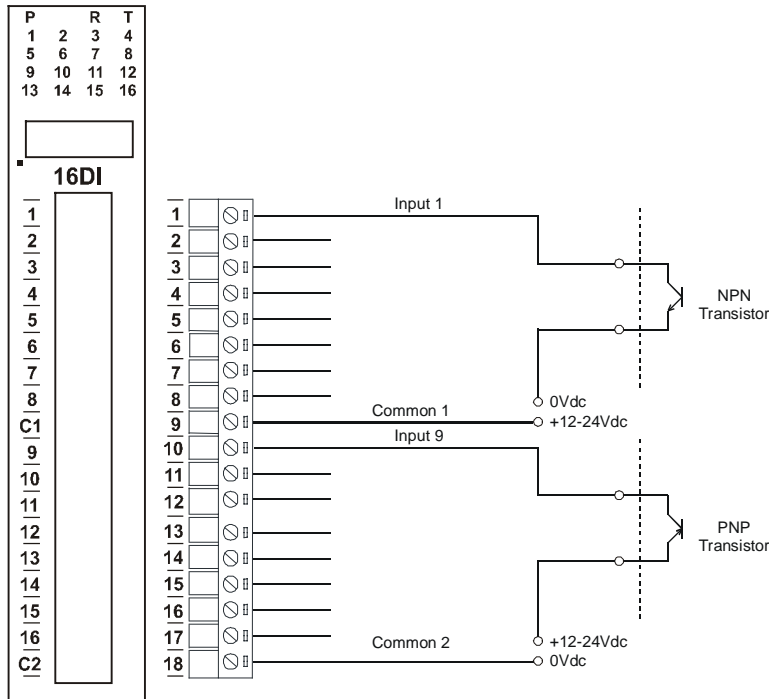

3.3.5 Switch Settings

SWITCH	FUNCTION	DESCRIPTION
1	NODE ID +1	Node ID's from 0 to 127 are set up using switches 1 to 7
2	NODE ID +2	"
3	NODE ID +4	"
4	NODE ID +8	"
5	NODE ID +16	"
6	NODE ID +32	"
7	NODE ID +64	"
8	INVERT	When switched ON the status of the inputs is inverted in the Modbus status register (30002).
9	-	Not Used.
10	BAUD RATE	Must be ON.

3.3.6 PL16DI Data Registers (MODULE TYPE = 100)

Modbus Address	Register Name	Low Limit	High Limit	Access	Description
10001	Digital Input 1	0	1	R	Status of Digital Inputs.
10002	Digital Input 2	0	1	R	
10003	Digital Input 3	0	1	R	
10004	Digital Input 4	0	1	R	
10005	Digital Input 5	0	1	R	
10006	Digital Input 6	0	1	R	
10007	Digital Input 7	0	1	R	
10008	Digital Input 8	0	1	R	
10009	Digital Input 9	0	1	R	
10010	Digital Input 10	0	1	R	
10011	Digital Input 11	0	1	R	
10012	Digital Input 12	0	1	R	
10013	Digital Input 13	0	1	R	
10014	Digital Input 14	0	1	R	
10015	Digital Input 15	0	1	R	
10016	Digital Input 16	0	1	R	
30001	S/W Version / Module Type	N/A	N/A	R	High Byte = Software Version Low Byte = 100
30002	Digital Inputs	N/A	N/A	R	Digital Inputs in 16 bits. 16 - 1.
40003	Counter 1 MSB	0	65535	R/W	Counter MSB and LSB combine to give a 32 bit Counter with range 0 to 4294967295.
40004	Counter 1 LSB	0	65535	R/W	
40005	Counter 2 MSB	0	65535	R/W	"
40006	Counter 2 LSB	0	65535	R/W	"
40007	Counter 3 MSB	0	65535	R/W	"
40008	Counter 3 LSB	0	65535	R/W	"
40009	Counter 4 MSB	0	65535	R/W	"
40010	Counter 4 LSB	0	65535	R/W	"
40011	Counter 5 MSB	0	65535	R/W	"
40012	Counter 5 LSB	0	65535	R/W	"
40013	Counter 6 MSB	0	65535	R/W	"
40014	Counter 6 LSB	0	65535	R/W	"
40015	Counter 7 MSB	0	65535	R/W	"
40016	Counter 7 LSB	0	65535	R/W	"
40017	Counter 8 MSB	0	65535	R/W	"
40018	Counter 8 LSB	0	65535	R/W	"
40019	Counter 9 MSB	0	65535	R/W	"
40020	Counter 9 LSB	0	65535	R/W	"
40021	Counter 10MSB	0	65535	R/W	"
40022	Counter 10LSB	0	65535	R/W	"
40023	Counter 11MSB	0	65535	R/W	"

Modbus Address	Register Name	Low Limit	High Limit	Access	Description
40024	Counter 11LSB	0	65535	R/W	Counter MSB and LSB combine to give a 32 bit
40025	Counter 12MSB	0	65535	R/W	Counter with range 0 to 4294967295.
40026	Counter 12LSB	0	65535	R/W	"
40027	Counter 13MSB	0	65535	R/W	"
40028	Counter 13LSB	0	65535	R/W	"
40029	Counter 14MSB	0	65535	R/W	"
40030	Counter 14LSB	0	65535	R/W	"
40031	Counter 15MSB	0	65535	R/W	"
40032	Counter 15LSB	0	65535	R/W	"
40033	Counter 16MSB	0	65535	R/W	"
40034	Counter 16LSB	0	65535	R/W	"
40035	Counter Capture	0	65535	R/W	Bit1 = 1 to Capture Counter1, Bit2 = 1 to Capture Counter2, etc.
40036	CCounter 1 MSB	0	65535	R/W	Capture Counter Registers. MSB and LSB
40037	CCounter 1 LSB	0	65535	R/W	combine to give a 32 bit Value.
40038	CCounter 2 MSB	0	65535	R/W	Counter with range 0 to 4294967295.
40039	CCounter 2 LSB	0	65535	R/W	"
40040	CCounter 3 MSB	0	65535	R/W	"
40041	CCounter 3 LSB	0	65535	R/W	"
40042	CCounter 4 LSB	0	65535	R/W	"
40043	CCounter 4 LSB	0	65535	R/W	"
40044	CCounter 5 MSB	0	65535	R/W	"
40045	CCounter 5 LSB	0	65535	R/W	"
40046	CCounter 6 MSB	0	65535	R/W	"
40047	CCounter 6 LSB	0	65535	R/W	"
40048	CCounter 7 MSB	0	65535	R/W	"
40049	CCounter 7 LSB	0	65535	R/W	"
40050	CCounter 8 MSB	0	65535	R/W	"
40051	CCounter 8 LSB	0	65535	R/W	"
40052	CCounter 9 MSB	0	65535	R/W	"
40053	CCounter 9 LSB	0	65535	R/W	"
40054	CCounter 10MSB	0	65535	R/W	"
40055	CCounter 10LSB	0	65535	R/W	"
40056	CCounter 11MSB	0	65535	R/W	"
40057	CCounter 11LSB	0	65535	R/W	"
40058	CCounter 12MSB	0	65535	R/W	"
40059	CCounter 12LSB	0	65535	R/W	"
40060	CCounter 13MSB	0	65535	R/W	"
40061	CCounter 13LSB	0	65535	R/W	"
40062	CCounter 14MSB	0	65535	R/W	"
40063	CCounter 14LSB	0	65535	R/W	"
40064	CCounter 15MSB	0	65535	R/W	"
40065	CCounter 15LSB	0	65535	R/W	"
40066	CCounter 16MSB	0	65535	R/W	"

Modbus Address	Register Name	Low Limit	High Limit	Access	Description
40067	CCounter 16LSB	0	65535	R/W	"
30100	DIP Switch	0	65535	R	Status of DIP Switch on Front Panel
40101	Counter Mode	0	2	R/W	0=Disable, 1=Up Counting, 2=Up/Down Count
40102	Input Filter	0	65535	R/W	0 = Disable, >0 = Enable. (x10ms)
40103	Capture Zero	0	65535	R/W	0 = Disabled, bit1 = auto zero counter 1.

3.3.6.1 Digital Input Register.

The digital inputs can be read in a single register as follows:

PL16DI DIGITAL INPUTS															ADDRESS	
MSB															LSB	
15	14	13	12	11	10	9	8	7	6	5	4	3	2	1	0	
32768	16384	8192	4096	2048	1024	512	256	128	64	32	16	8	4	2	1	30002
16	15	14	13	12	11	10	9	8	7	6	5	4	3	2	1	

Digital Input Number

3.3.6.2 Counter Registers.

The counters are stored a two 16 bit registers. The first register is the High Register and the second register is the Low Register. To get the actual 32 bit count value the registers must be combined as follows:

Counter High Value = Register 40003.

Counter Low Value = Register 40004.

Counter Value = (Counter High Value X 65535) + Counter Low Value.

3.3.6.3 Counter Capture.

To capture a counter a 1 must be written to the corresponding bit position in the Counter Capture Register 40035. For example:

1. Writing 1 to Register 40035 results in Counter 1 value being captured to Counter Capture 1.
2. Writing 2 to Register 40035 results in Counter 2 value being captured to Counter Capture 2.
3. Writing 3 to Register 40035 results in Counter 1 value being captured to Counter Capture 1 and Counter 2 value being captured to Counter Capture 2.

Once the module has Captured the counters the Counter Capture Register 40035 is cleared to zero. It is possible to read this register to get confirmation that the capture is complete before reading the captured counter values.

3.3.6.4 Counter Auto Zero.

The counter being captured can be auto zeroed. The purpose of this function is to let the module zero the counter so that no counts get lost due to delays from communication latency, etc.

To ensure that a counter is auto zeroed, a 1 must be written to the corresponding bit position in the Capture Zero Register 40103. For example:

Writing 1 to Register 40103 results in Counter 1 value being zeroed when the Counter Capture bit is 1.

The value in the Capture Zero Register 40103 is permanently stored in memory and only has to be configured once.

3.4 PL16DO - DIGITAL OUTPUTS

3.4.1 Description

This module has 16 open collector (NPN) digital outputs. The outputs may be used to drive lamps or external relays when more drive capability is required. The outputs are isolated from the logic and they share a common negative terminal.

Each output can be individually switched on or off, or all outputs can be set up at the same time by writing a single number to the output register which represents the status of all outputs.

An output watchdog timer can be configured to switch off all the outputs if there has been no communications with the module for up to 255 seconds. A value of 0 seconds will disable this timer and the outputs will remain in the last programmed state.



3.4.2 Technical Specification of PL16DO

Power Supply	Logic Supply Voltage	Supplied from Power Bus
	Logic Supply Power	0.3VA
	Field Supply Voltage	12 -24 Vdc
	Field Supply Current	6mA @ 12V / 6mA @ 24V
Digital Outputs	Output Points	16
	Maximum Voltage	36 Vdc
	Maximum Current	100 mA per output
	Vceon	1.1V Max.
	Isolation	1500Vrms between field and logic
Temperature	Operating Temperature.	-40°C to + 80°C
	Storage Temperature	-40°C to + 85°C
Connectors	Logic Power and Comms.	32 PIN Double Sided DIN Connector
	Outputs	18 Way screw connector on front

3.4.3 Status Indicators

- Power:** Flashes to indicate the CPU is running.
- RS485 Rx:** Flashes to indicate the unit has received a valid Modbus message.
- RS485 Tx:** Flashes to indicate the unit has sent a Modbus message.
- Output Status:** "OFF" when the output is off.
"ON" when the output is on.

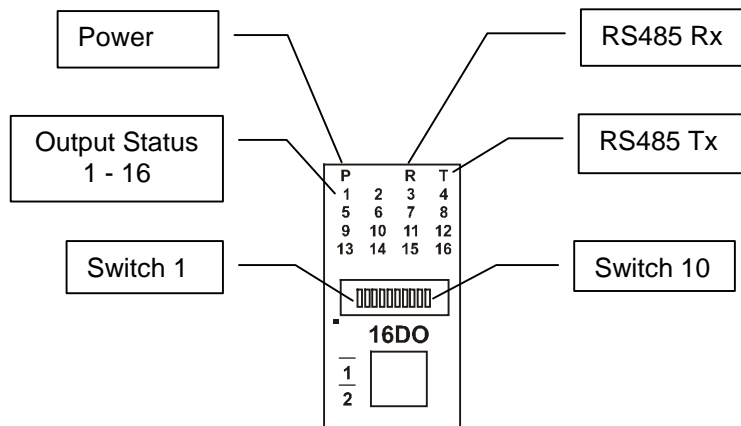

3.4.4 Wiring

The following diagram shows how the digital outputs are connected to the coil of a relay. The coil is connected to positive and switched to negative.

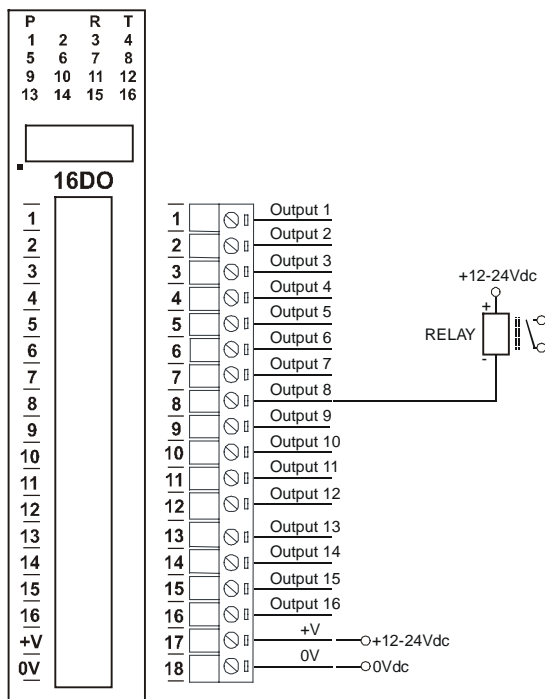

3.4.5 Switch Setting

<u>SWITCH</u>	<u>FUNCTION</u>	<u>DESCRIPTION</u>
1	NODE ID +1	Node ID's from 0 to 127 are set up using switches 1 to 7
2	NODE ID +2	“
3	NODE ID +4	“
4	NODE ID +8	“
5	NODE ID +16	“
6	NODE ID +32	“
7	NODE ID +64	“
8	-	Not Used.
9	-	Not Used.
10	BAUD RATE	Must be ON.

3.4.6 PL16DO Data Registers (MODULE TYPE = 101)

Modbus Address	Register Name	Low Limit	High Limit	Access	Comments
00001	Digital Output 1	0	1	R/W	Status of Digital Outputs.
00002	Digital Output 2	0	1	R/W	"
00003	Digital Output 3	0	1	R/W	"
00004	Digital Output 4	0	1	R/W	"
00005	Digital Output 5	0	1	R/W	"
00006	Digital Output 6	0	1	R/W	"
00007	Digital Output 7	0	1	R/W	"
00008	Digital Output 8	0	1	R/W	"
00009	Digital Output 9	0	1	R/W	"
00010	Digital Output 10	0	1	R/W	"
00011	Digital Output 11	0	1	R/W	"
00012	Digital Output 12	0	1	R/W	"
00013	Digital Output 13	0	1	R/W	"
00014	Digital Output 14	0	1	R/W	"
00015	Digital Output 15	0	1	R/W	"
00016	Digital Output 16	0	1	R/W	"
30001	S/W Version / Module Type	N/A	N/A	R	High Byte = Software Version Low Byte = 101
40002	Digital Outputs	N/A	N/A	R/W	Digital Outputs in bits. 16(msb) – 1(lsb).
30100	DIP Switch	0	65535	R	Status of DIP Switch on Front Panel
40101	Watchdog Timer	0	255	R/W	Timer in seconds. 0 = disabled. 1 - 255 = enabled.

3.4.6.1 Digital Output Register.

The digital outputs can be read/written in a single register as follows:

MSB		PL16DO DIGITAL OUTPUTS													LSB		ADDRESS
15	14	13	12	11	10	9	8	7	6	5	4	3	2	1	0		
32768	16384	8192	4096	2048	1024	512	256	128	64	32	16	8	4	2	1	40002	
16	15	14	13	12	11	10	9	8	7	6	5	4	3	2	1		

Digital Output

3.4.6.2 Output Watchdog Timer.

The watchdog timer is used to switch off all of the outputs in the event of a communications failure. When set to zero (register 40101) the watchdog timer is disabled.

3.5 PL4RO - RELAY OUTPUTS

3.5.1 Description

The MM4RO module has 4 normally open/ normally closed relay outputs. These modules may be used when a higher drive capability is required, or when isolation between outputs are required.

Each output can be individually switched on or off, or all outputs can be set up at the same time by writing a single number to the output register which represents the status of all outputs.

An output watchdog timer can be configured to switch off all the outputs if there has been no communications with the module for up to 255 seconds. A value of 0 seconds will disable this timer and the outputs will remain in the last programmed state.



3.5.2 Technical Specification of PL4RO

Power Supply	Logic Supply Voltage	Supplied from Power Bus
	Logic Supply Power	1.0VA
Relay Outputs	Output Points	4
	Maximum Current	0.5A @ 220VAC / 1A @ 28VDC
	Isolation	1000Vrms between field and logic 1000Vrms between outputs
Temperature	Operating Temperature.	-40°C to + 80°C
	Storage Temperature	-40°C to + 85°C
Connectors	Logic Power and Comms.	32 PIN Double Sided DIN Connector
	Outputs	18 Way screw connector on front

3.5.3 Status Indicators

- Power:** Flashes to indicate the CPU is running.
- RS485 Rx:** Flashes to indicate the unit has received a valid Modbus message.
- RS485 Tx:** Flashes to indicate the unit has sent a Modbus message.
- Output Status:** "OFF" when the output is off
"ON" when the output is on.

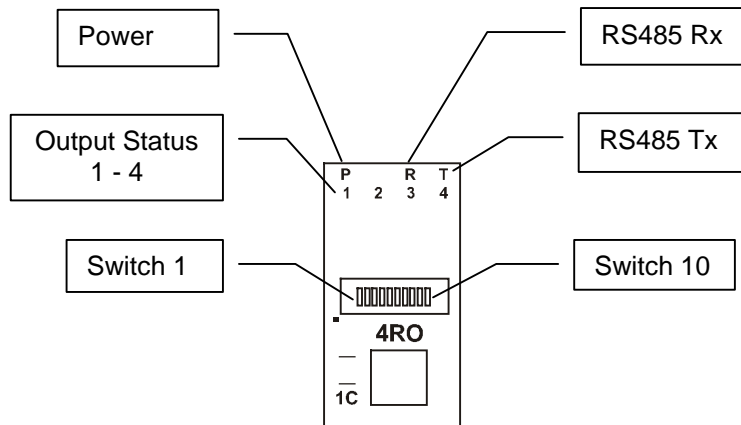

3.5.4 Wiring

The following diagram shows how the digital outputs are connected to the coil of a relay. The coil is connected to positive and switched to negative.

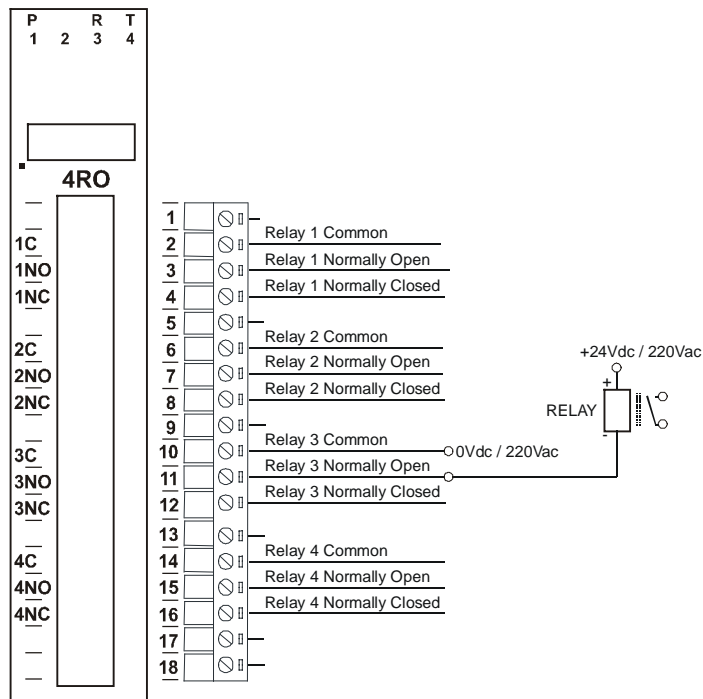

3.5.5 Switch Setting

<u>SWITCH</u>	<u>FUNCTION</u>	<u>DESCRIPTION</u>
1	NODE ID +1	Node ID's from 0 to 127 are set up using switches 1 to 7
2	NODE ID +2	"
3	NODE ID +4	"
4	NODE ID +8	"
5	NODE ID +16	"
6	NODE ID +32	"
7	NODE ID +64	"
8	-	Not Used.
9	-	Not Used.
10	BAUD RATE	Must be ON.

3.5.6 PL4RO Data Registers (MODULE TYPE = 113)

Modbus Address	Register Name	Low Limit	High Limit	Access	Comments
00001	Relay Output 1	0	1	R/W	Status of Digital Outputs.
00002	Relay Output 2	0	1	R/W	"
00003	Relay Output 3	0	1	R/W	"
00004	Relay Output 4	0	1	R/W	"
30001	S/W Version / Module Type	N/A	N/A	R	High Byte = Software Version Low Byte = 113
40002	Digital Outputs	N/A	N/A	R/W	Digital Outputs in bits. 4(msb) – 1(lsb).
30100	DIP Switch	0	65535	R	Status of DIP Switch on Front Panel
40101	Watchdog Timer	0	255	R/W	Timer in seconds. 0 = disabled. 1 - 255 = enabled.

3.5.6.1 Relay Output Register.

The relay outputs can be read/written in a single register as follows:

MSB		PL4RO DIGITAL OUTPUTS												LSB		ADDRESS
15	14	13	12	11	10	9	8	7	6	5	4	3	2	1	0	
32768	16384	8192	4096	2048	1024	512	256	128	64	32	16	8	4	2	1	40002
-	-	-	-	-	-	-	-	-	-	-	-	-	4	3	2	1

Relay Output

3.5.6.2 Output Watchdog Timer.

The watchdog timer is used to switch off all of the outputs in the event of a communications failure. When set to zero (register 40101) the watchdog timer is disabled.

3.6 PL8DIO - DIGITAL INPUTS / OUTPUTS

3.6.1 Description

The PL8DIO module is an 8 channel digital input and 8 channel digital output module.

The inputs are isolated from the logic by bi-directional opto-couplers. The common is connected internally to either the - volts or +volts field power supply terminals using a jumper link which is situated inside the housing.

The inputs have internal counters associated with them. These counters are 32 bit counters allowing a count value from 0 to 4294967295. The count value can be cleared by writing a zero to the associated registers or preset to any other value using the same method. The counters can also be reset automatically when read. This is done by setting on DIP switch 9 on the front panel.

Note: The count values are not battery backed-up and will be lost if power is turned off.

The format of the registers allows the status of the inputs to be read as either single bits or all at once as a single register on the Modbus network.

The 8 digital outputs are open collector (NPN). The outputs may be used to drive lamps or external relays when more drive capability is required. The outputs are isolated from the logic and they share a common negative terminal.

Each output can be individually switched on or off, or all outputs can be set up at the same time by writing a single number to the output register which represents the status of all outputs.



3.6.2 Technical Specification of PL8DIO

Power Supply	Logic Supply Voltage	Supplied from Power Bus
	Logic Supply Power	0.3VA
	Field Supply Voltage	12 -24 Vdc
	Field Supply Current	6mA @ 12V / 6mA @ 24V
Digital Inputs	Input Points	8
	Input Voltage Range	12 -24 Vdc
	Input Current per input	5mA@12Vdc / 11mA @24Vdc
	Isolation	1500Vrms between field and logic
Digital Outputs	Output Points	8
	Maximum Voltage	36 Vdc
	Maximum Current	100 mA per output
	Vceon	1.1V Max.
	Isolation	1500Vrms between field and logic
Counters	Inputs	1 to 16
	Resolution	32 Bits
	Frequency	1KHz (max)
	Pulse Width	500us (min)
Temperature	Operating Temperature.	-40°C to + 80°C
	Storage Temperature	-40°C to + 85°C
Connectors	Logic Power and Comms.	32 PIN Double Sided DIN Connector
	Outputs	18 Way screw connector on front

Note: Inputs 1 to 8 are used as both digital inputs and counter inputs.

3.6.3 Status Indicators

- Power:** Flashes to indicate the CPU is running.
- RS485 Rx:** Flashes to indicate the unit has received a valid Modbus message.
- RS485 Tx:** Flashes to indicate the unit has sent a Modbus message.
- Input Status:** "OFF" when the input is off
"ON" when the input is on.
- Output Status:** "OFF" when the output is off
"ON" when the output is on.

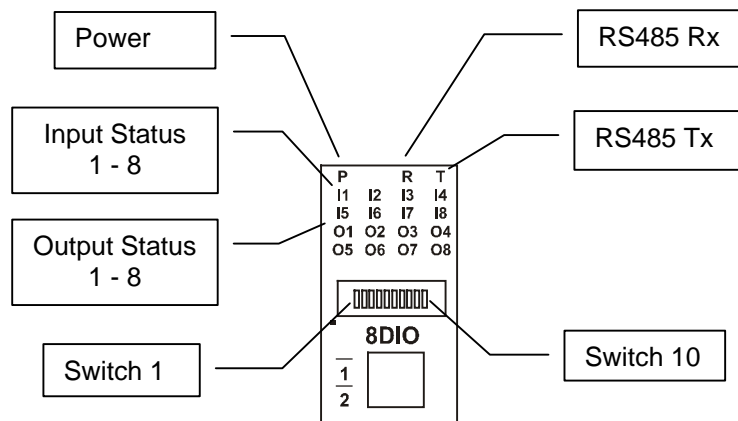

3.6.4 Wiring

The following diagram shows how the digital inputs and outputs are connected.

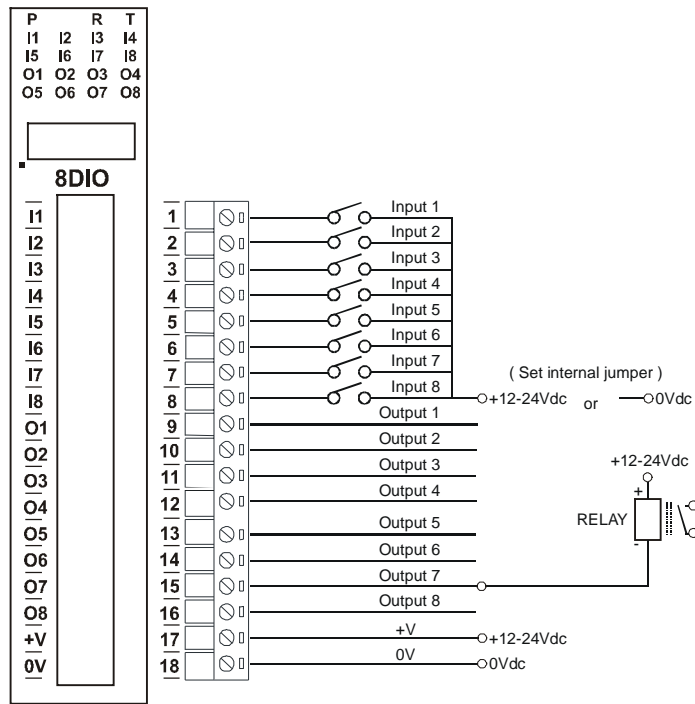

3.6.5 Switch Settings

SWITCH	FUNCTION	DESCRIPTION
1	NODE ID +1	Node ID's from 0 to 127 are set up using switches 1 to 7
2	NODE ID +2	"
3	NODE ID +4	"
4	NODE ID +8	"
5	NODE ID +16	"
6	NODE ID +32	"
7	NODE ID +64	"
8	INVERT	When switched ON the status of the inputs is inverted in the Modbus status register (30002).
9	-	Not Used.
10	BAUD RATE	Must be ON.

3.6.6 PL8DIO Data Registers (MODULE TYPE = 102)

Modbus Address	Register Name	Low Limit	High Limit	Access	Comments
10001	Digital Input 1	0	1	R	Status of Digital Inputs.
10002	Digital Input 2	0	1	R	"
10003	Digital Input 3	0	1	R	"
10004	Digital Input 4	0	1	R	"
10005	Digital Input 5	0	1	R	"
10006	Digital Input 6	0	1	R	"
10007	Digital Input 7	0	1	R	"
10008	Digital Input 8	0	1	R	"
00017	Digital Output 1	0	1	R/W	Status of Digital Outputs.
00018	Digital Output 2	0	1	R/W	"
00019	Digital Output 3	0	1	R/W	"
00020	Digital Output 4	0	1	R/W	"
00021	Digital Output 5	0	1	R/W	"
00022	Digital Output 6	0	1	R/W	"
00023	Digital Output 7	0	1	R/W	"
00024	Digital Output 8	0	1	R/W	"
30001	S/W Version / Module Type	N/A	N/A	R	High Byte = Software Version Low Byte = 102
30002	Digital Inputs	N/A	N/A	R	Digital Inputs in lower 8 bits. 8 - 1.
40003	Digital Outputs	N/A	N/A	R/W	Digital Outputs in lower 8 bits. 8 - 1.
40004	Counter 1 MSB	0	65535	R/W	Counter MSB and LSB combine to give a 32 bit
40005	Counter 1 LSB	0	65535	R/W	Counter with range 0 to 4294967295.
40006	Counter 2 MSB	0	65535	R/W	"
40007	Counter 2 LSB	0	65535	R/W	"
40008	Counter 3 MSB	0	65535	R/W	"
40009	Counter 3 LSB	0	65535	R/W	"
40010	Counter 4 MSB	0	65535	R/W	"
40011	Counter 4 LSB	0	65535	R/W	"
40012	Counter 5 MSB	0	65535	R/W	"
40013	Counter 5 LSB	0	65535	R/W	"
40014	Counter 6 MSB	0	65535	R/W	"
40015	Counter 6 LSB	0	65535	R/W	"
40016	Counter 7 MSB	0	65535	R/W	"
40017	Counter 7 LSB	0	65535	R/W	"
40018	Counter 8 MSB	0	65535	R/W	"
40019	Counter 8 LSB	0	65535	R/W	"
30100	DIP Switch	0	65535	R	Status of DIP Switch on Front Panel
40101	Watchdog Timer	0	255	R/W	Timer in seconds. 0 = disabled. 1 - 255 = enabled.
40105	Counter Mode	0	2	R/W	0=Disable, 1=Up Counting, 2=Up/Down Count
40106	Input Filter	0	65535	R/W	0 = Disable, >0 = Enable. (x10ms)

3.6.6.1 Digital Input Register.

The digital inputs can be read in a single register as follows:

MSB		PL8DIO DIGITAL INPUTS												LSB		ADDRESS	
15	14	13	12	11	10	9	8	7	6	5	4	3	2	1	0		
32768	1638	819	409	204	102	51	25	12	64	32	16	8	4	2	1	0	30002
	4	2	6	8	4	2	6	8									
0	0	0	0	0	0	0	0	8	7	6	5	4	3	2	1		

Digital Input Number

3.6.6.2 Digital Output Register.

The digital outputs can be read/written in a single register as follows:

MSB		PL8DIO DIGITAL OUTPUTS												LSB		ADDRESS	
15	14	13	12	11	10	9	8	7	6	5	4	3	2	1	0		
32768	1638	819	409	204	102	51	25	12	64	32	16	8	4	2	1	0	40003
	4	2	6	8	4	2	6	8									
0	0	0	0	0	0	0	0	8	7	6	5	4	3	2	1		

Digital Output Number

3.6.6.3 Counter Registers.

The counters are stored a two 16 bit registers. The first register is the High Register and the second register is the Low Register. To get the actual 32 bit count value the registers must be combined as follows:

Counter High Value = Register 40003.

Counter Low Value = Register 40004.

Counter Value = (Counter High Value X 65535) + Counter Low Value.

3.6.6.4 Output Watchdog Timer.

The watchdog timer is used to switch off all of the outputs in the event of a communications failure. When set to zero (register 40101) the watchdog timer is disabled.

3.7 PL8AI/I and PL8AI/V - ANALOG INPUTS

3.7.1 Description

The Analog Input modules are supplied as either a current input module (PL8AI/I) or a voltage input module (PL8AI/V). The inputs are isolated from the logic and share a common negative terminal.

The standard setting for the PL8AI/I module is 0 - 20mA input current which represents an output value of 0 - 4095 (12 bits) in the corresponding Modbus register. To obtain an output value of 0 to 4095 for an input signal of 4 to 20mA the offset switch is switched on.

The same applies to the PL8AI/V module. An input voltage of 0 - 10Volts represents an output of 0 - 4095 and 2 volts would give a reading of $819 \pm 1\text{LSB}$. To obtain an output value of 0 to 4095 for an input signal of 2 to 10V the offset switch is switched on. An input range of 0(1) to 5Vdc is available by removing the jumper link located on the analogue board inside the enclosure.



3.7.2 Technical Specification of PL8AI

Power Supply	Logic Supply Voltage	Supplied from Power Bus
	Logic Supply Current	0.3VA
	Field Supply Voltage	12 -24 Vdc
	Field Supply Current	8mA @ 12V / 15mA @ 24V
Voltage Inputs – PL8AI/V	Input Points	8
	Input Voltage	0(2) - 10 Vdc or 0(1) - 5 Vdc
	Input Resistance	20kohms
	Resolution	12 bits
	Drift	50ppm/°C
	Accuracy	0.2% of span
	Isolation	1500Vrms between field and logic
Current Inputs – PL8AI/I	Input Points	8
	Input Current	0(4) - 20 mA
	Input Resistance	250ohms
	Resolution	12 bits
	Drift	50ppm/°C
	Accuracy	0.2% of span
	Isolation	1500Vrms between field and logic
Temperature	Operating Temperature.	-40°C to + 80°C
	Storage Temperature	-40°C to + 85°C
Connectors	Logic Power and Comms.	32 PIN Double Sided DIN Connector
	Inputs	18 Way screw connector on front

3.7.3 Status Indicators

- Power:** Flashes to indicate the CPU is running.
- RS485 Rx:** Flashes to indicate the unit has received a valid Modbus message.
- RS485 Tx:** Flashes to indicate the unit has sent a Modbus message.
- Input Status:** "ON" when the input is zero.
 "OFF" when the input is greater than zero and less than 4095.
 "Flashing" when the input is over range, greater or equal to 4095.

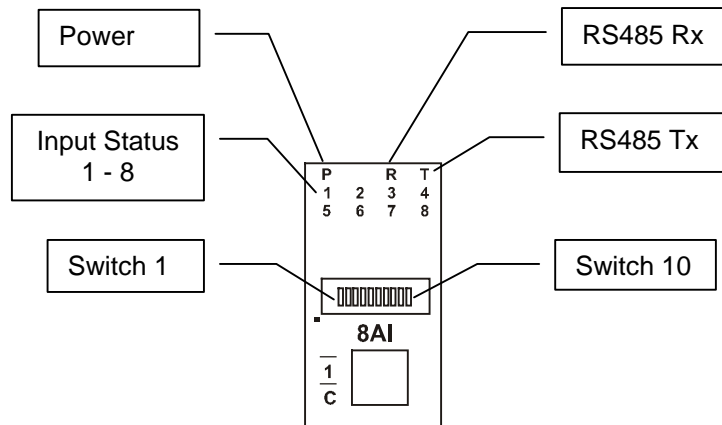

3.7.4 Wiring

The following diagram shows how the analog inputs are connected to a 0(4)-20mA source. All of the common terminals are connected together, and are connected to 0V internally.

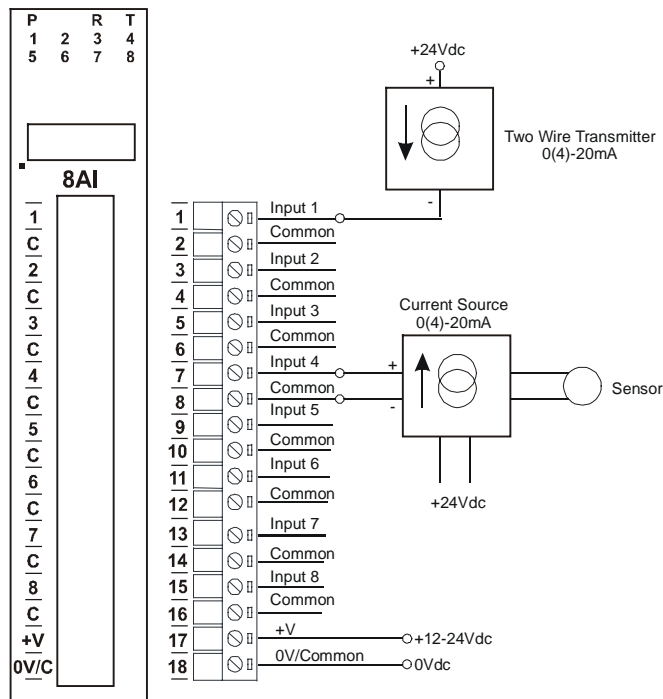

The following diagram shows how the analog inputs are connected to a 0(2)-10Vdc source. All of the common terminals are connected together, and are connected to 0V internally.

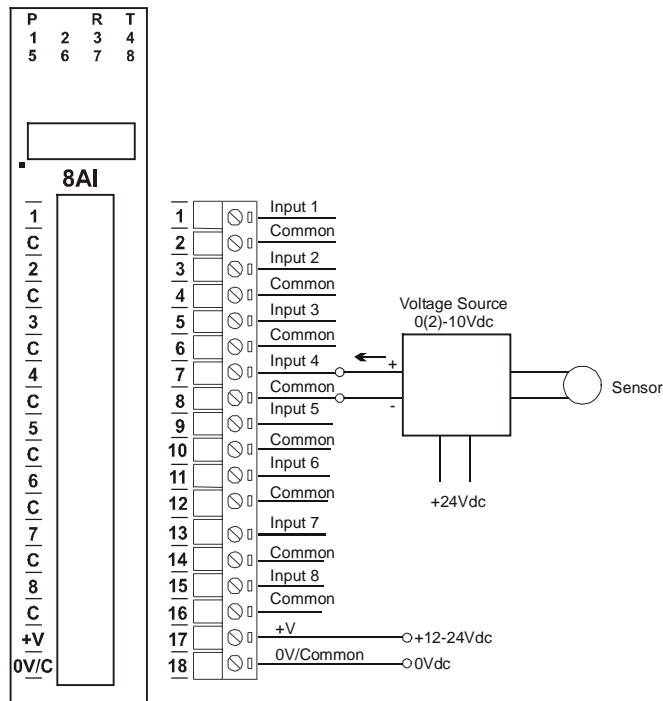

3.7.5 Switch Settings

SWITCH	FUNCTION	DESCRIPTION
1	NODE ID +1	Node ID's from 0 to 127 are set up using switches 1 to 7
2	NODE ID +2	"
3	NODE ID +4	"
4	NODE ID +8	"
5	NODE ID +16	"
6	NODE ID +32	"
7	NODE ID +64	"
8	-	Not used.
9	OFFSET	When switched ON the inputs scaled to accept a 2V or 4mA offset .
10	BAUD RATE	Must be ON.

3.7.6 PL8AI Data Registers (PL8AI/I TYPE = 103 / PL8AI/V TYPE = 104)

Modbus Address	Register Name	Low Limit	High Limit	Access	Description
30001	S/W Version / Module Type	N/A	N/A	R	High Byte = Software Version Low Byte = 103(PL8AI/I) or 104(PL8AI/V)
30002	Analog Input 1	0	4095	R	Analog Input lower 12 Bits
30003	Analog Input 2	0	4095	R	"
30004	Analog Input 3	0	4095	R	"
30005	Analog Input 4	0	4095	R	"
30006	Analog Input 5	0	4095	R	"
30007	Analog Input 6	0	4095	R	"
30008	Analog Input 7	0	4095	R	"
30009	Analog Input 8	0	4095	R	"
30010	Input Status	0	65535	R	bit2 = 0(open circuit or < 2), bit2 = 1(over range) bit1 = 0(OK),bit1 = 1(error)
30100	DIP Switch	0	65535	R	Status of DIP Switch on Front Panel

3.7.6.1 Analog Input Registers.

The analog inputs are read as a 12 bit value in the registers as follows:

MSB		PL8AI ANALOG INPUTS												LSB		ADDRESS
15	14	13	12	11	10	9	8	7	6	5	4	3	2	1	0	
32768	16384	8192	4096	2048	1024	512	256	128	64	32	16	8	4	2	1	300XX
0	0	0	0	x	x	x	x	x	x	x	x	x	x	x	x	

Analog Input: 12 Bit Value (0 - 4095)

3.7.6.2 Analog Input Status.

There are two status bits associated with each analog input. These bits are used to indicate if the input is zero or open circuit, in the working range 0-4095, or over range. If the input is open circuit or over range, then the error bit will be set. When the error bit is set, the range bit is zero if the input is open circuit and set if the input is over range, ie:

<u>Bit 1- Error</u>	<u>Bit 2-Range</u>	<u>Condition</u>	<u>Status LED</u>
0	don't care	Input working OK.	(LED OFF)
1	0	Input Open circuit or zero.	(LED ON)
1	1	Input Over range.	(LED FLASH)

The analog input status can be read in a single register as follows:

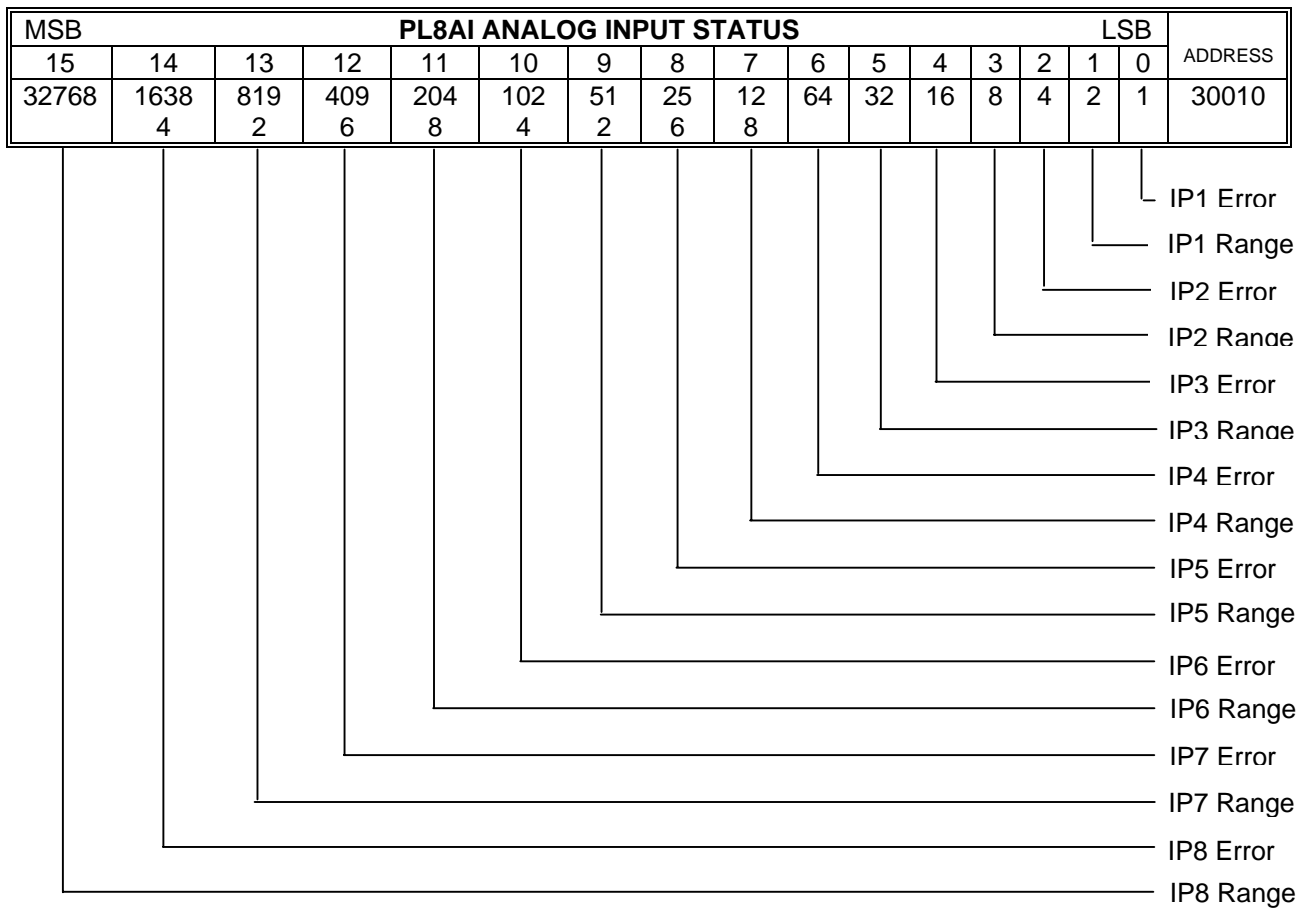

3.8 PL8AI/I ISO and PL8AI/V ISO - ISOLATED ANALOG INPUTS

3.8.1 Description

The Analog Input modules are supplied as either a current input module (PL8AI/I) or a voltage input module (PL8AI/V). The inputs are fully isolated from input to logic and between inputs. This module is ideal for monitoring existing 4-20mA current loops which are isolated from each other and cannot be connected to a common point of reference.

The standard setting for the PL8AI/I module is 0 - 20mA input current which represents an output value of 0 - 4095 (12 bits) in the corresponding Modbus register. To obtain an output value of 0 to 4095 for an input signal of 4 to 20mA the offset switch is switched on. This module can also be configured for a 0 – 20.000mA input range or +/- 20.000mA input.

The same applies to the PL8AI/V module. An input voltage of 0 - 10Volts represents an output of 0 - 4095 and 2 volts would give a reading of $819 \pm 1\text{LSB}$. To obtain an output value of 0 to 4095 for an input signal of 2 to 10V the offset switch is switched on. This module can also be configured for a 0 – 10.000V input range or +/- 10.000V input.



3.8.2 Technical Specification of PL8AI/I ISO and PL8AI/V ISO

Power Supply	Logic Supply Voltage	Supplied from Power Bus	
	Logic Supply Power	0.6VA	
Voltage Inputs – PL8AI/V	Input Points	8	
	Input Voltage	0(2) - 10 Vdc	
	InputType	Range	Resolution
	1	0 – 4095	12 bits
	2	0 – 10.000 V	1mV
	3	+/- 10.000 V	1mV
	4	0 – 1.0000 V	0.1mV
	5	+/- 1.0000 V	0.1mV
Drift	100ppm/°C		
Isolation	1500Vrms between field and logic 350Vpeak between each input		
Current Inputs – PL8AI/I	Input Points	8	
	Input Current	0(4) - 20 mA	
	InputType	Range	Resolution
	1	0 – 4095	12 bits
	2	0–20.000mA	1uA
	3	+/-20.000mA	1uA
Drift	100ppm/°C		
Isolation	1000Vrms between field and logic 350Vpeak between each input		
Temperature	Operating Temperature.	-40°C to + 80°C	
	Storage Temperature	-40°C to + 85°C	
Connectors	Logic Power and Comms.	32 PIN Double Sided DIN Connector	
	Inputs	18 Way screw connector on front	

3.8.3 Status Indicators

- Power:** Flashes to indicate the CPU is running.
- RS485 Rx:** Flashes to indicate the unit has received a valid Modbus message.
- RS485 Tx:** Flashes to indicate the unit has sent a Modbus message.
- Input Status:** “ON” when the input is zero.
“OFF” when the input is greater than zero and less than 4095.
“Flashing” when the input is over range, greater or equal to 4095.

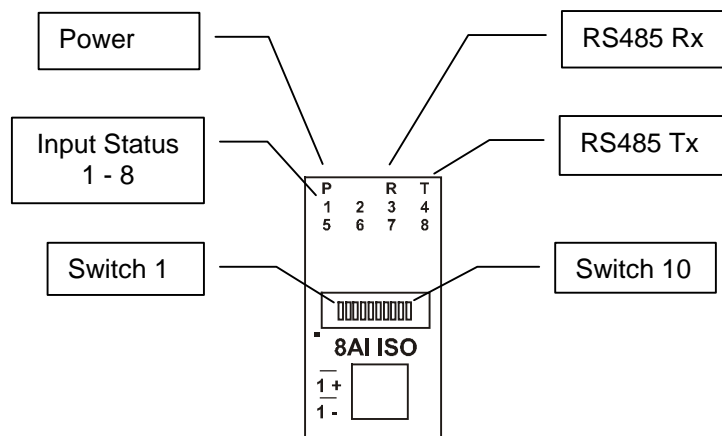

3.8.4 Wiring

The following diagram shows how the analog inputs are connected to a 0(4)-20mA source. All of the common terminals are isolated from each other.

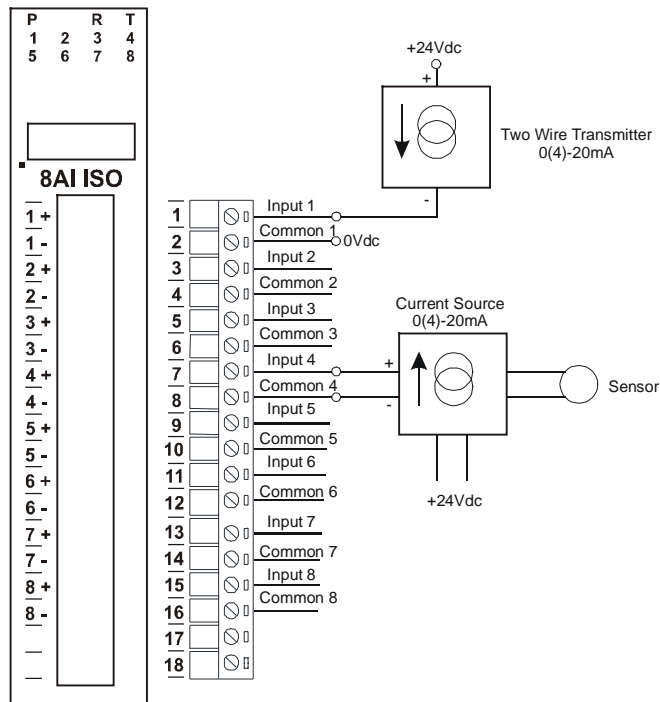

The following diagram shows how the analog inputs are connected to a 0(2)-10Vdc source. All of the common terminals are isolated from each other.

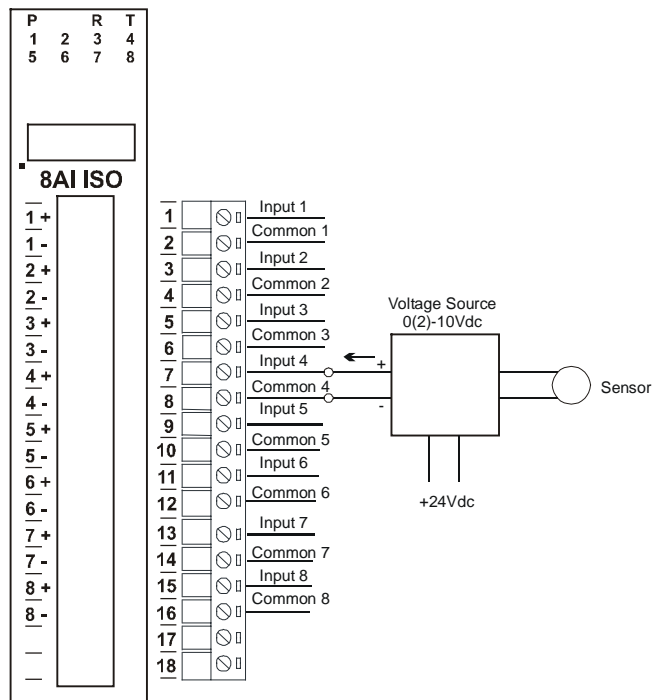

3.8.5 Switch Settings

<u>SWITCH</u>	<u>FUNCTION</u>	<u>DESCRIPTION</u>
1	NODE ID +1	Node ID's from 0 to 127 are set up using switches 1 to 7
2	NODE ID +2	"
3	NODE ID +4	"
4	NODE ID +8	"
5	NODE ID +16	"
6	NODE ID +32	"
7	NODE ID +64	"
8	-	Not used.
9	OFFSET	When switched ON the inputs scaled to accept a 2V or 4mA offset .
10	BAUD RATE	Must be ON.

3.8.6 PL8AI ISO Data Registers (8AI/I TYPE = 107/8AI/V TYPE = 108)

Modbus Address	Register Name	Low Limit	High Limit	Access	Description
30001	S/W Version / Module Type	N/A	N/A	R	High Byte = Software Version Low Byte = 107(PL8AI/I) or 108(PL8AI/V)
30002	Analog Input 1	0	4095	R	Analog Input lower 12 Bits
30003	Analog Input 2	0	4095	R	"
30004	Analog Input 3	0	4095	R	"
30005	Analog Input 4	0	4095	R	"
30006	Analog Input 5	0	4095	R	"
30007	Analog Input 6	0	4095	R	"
30008	Analog Input 7	0	4095	R	"
30009	Analog Input 8	0	4095	R	"
30010	Input Status	0	65535	R	bit2 = 0(open circuit or < 2), bit2 = 1(over range) bit1 = 0(OK),bit1 = 1(error)
30100	DIP Switch	0	65535	R	Status of DIP Switch on Front Panel

3.8.6.1 Analog Input Registers.

The analog inputs are read as a 12 bit value in the registers as follows:

MSB		PL8AI ANALOG INPUTS												LSB		ADDRESS
15	14	13	12	11	10	9	8	7	6	5	4	3	2	1	0	
32768	16384	8192	4096	2048	1024	512	256	128	64	32	16	8	4	2	1	300XX
0	0	0	0	x	x	x	x	x	x	x	x	x	x	x	x	

Analog Input: 12 Bit Value (0 - 4095)

3.8.6.2 Analog Input Status.

There are two status bits associated with each analog input. These bits are used to indicate if the input is zero or open circuit, in the working range 0-4095, or over range. If the input is open circuit or over range, then the error bit will be set. When the error bit is set, the range bit is zero if the input is open circuit and set if the input is over range, ie:

<u>Bit 1- Error</u>	<u>Bit 2-Range</u>	<u>Condition</u>	<u>Status LED</u>
0	don't care	Input working OK.	(LED OFF)
1	0	Input Open circuit or zero.	(LED ON)
1	1	Input Over range.	(LED FLASH)

The analog input status can be read in a single register as follows:

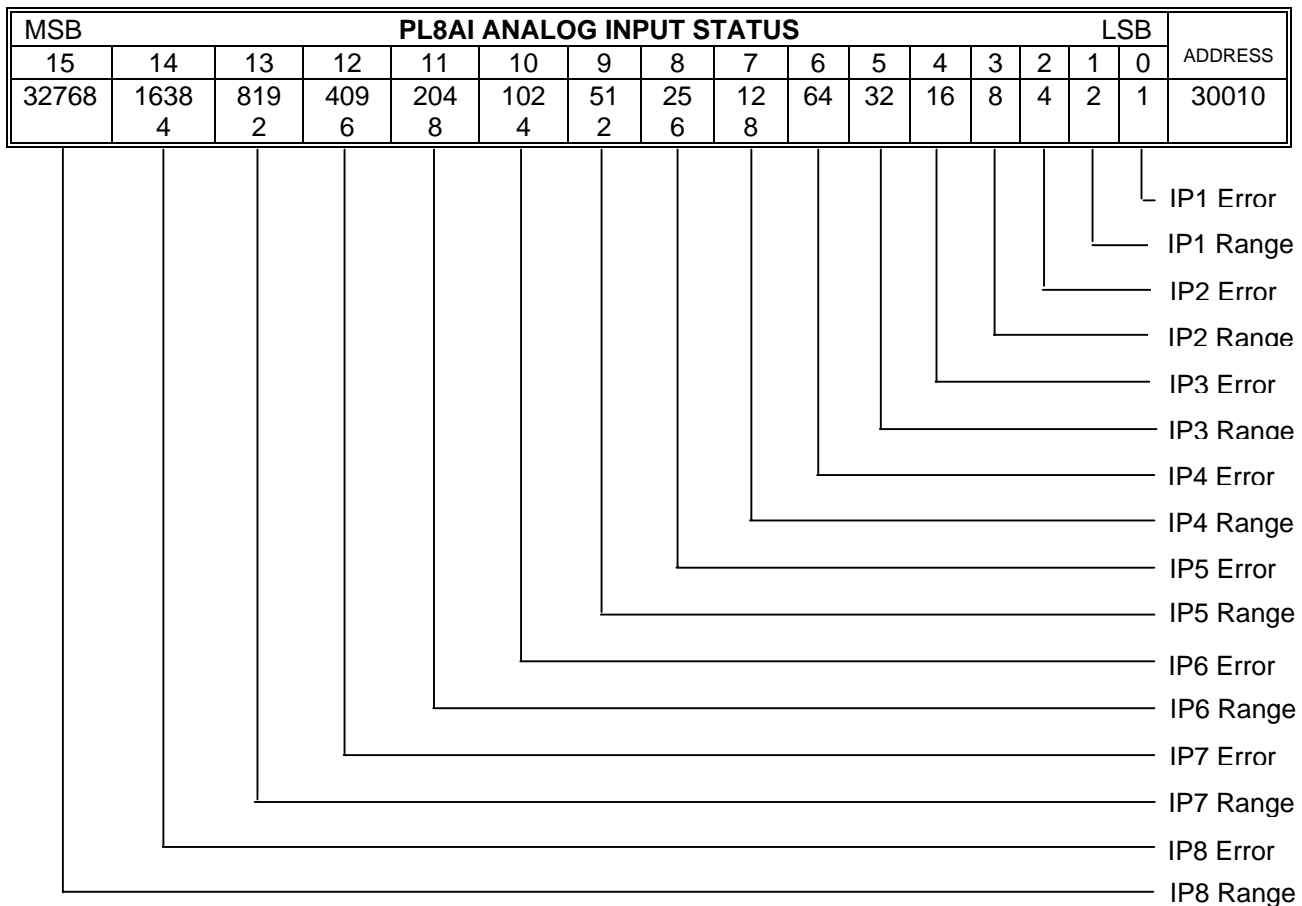

3.9 PL8TC - THERMOCOUPLE INPUTS

3.9.1 Description

The PL8TC module is a 8 thermocouple input module. The module uses differential inputs to reduce effects of electrical noise and mains pickup. The thermocouple inputs are isolated from the logic. If inter channel isolation is required then the PL8TCISO should be used.

The thermocouple voltage is read by the module circuitry, linearised and converted to degrees Centigrade. No ranging is required as the module covers the full range as indicated in the table of TC types. The value that is read from the Modbus register is the actual temperature in degrees centigrade to 0.1°C resolution. ie: a value of 3451 corresponds to a temperature of 345.1°C.

The thermocouple type is setup by writing a value to the TC Type register . The value is obtained from the table below. For example to select type K thermocouples, the value "2" must be written to the TC Type register. All 8 thermocouple inputs adopt the same TC type.

The DIP switch 9 is used to select upscale or downscale burnout. A value of 32768 is used to indicate upscale burnout and a value of -32767 is used to indicate downscale burnout.

The module has built in Cold Junction Compensation. Use must be made of the correct thermocouple extension wire to avoid reading errors.

The thermocouple module can also be configured for a 0 - 50mV input range. The TC Type register must be set to 9 for this option. The value in the register which is read back over the network is 0 - 50,000.

Note: As there is no inter-channel isolation, isolated thermocouples must be used in order to prevent ground loops and reading errors.



3.9.2 Technical Specification of PL8TC

Power Supply	Logic Supply Voltage	Supplied from Power Bus		
	Logic Supply Power	0.6VA		
TC Inputs	Input Points	8		
	Resolution	0.1°C		
	Drift	100ppm/°C Typ.		
	Isolation	1500Vrms between field and logic		
TC Type	Number	Type	Range	Accuracy
	1	J	-150 to 760 °C	0.2°C
	2	K	-200 to 1370 °C	0.3°C
	3	E	0 to 600 °C	0.1°C
	4	T	-200 to 400 °C	0.3°C
	5	N	0 to 1300 °C	0.3°C
	6	B	400 to 1820 °C	0.5°C
	7	S	-50 to 1767 °C	0.6°C
	8	R	-50 to 1767 °C	0.7°C
	9	mV	0 to 50mV	0.1%
	10	C	0 to 2315.5 °C	0.7°C
	11	D	0 to 2315.5 °C	0.7°C
	12	G	0 to 2315.5 °C	0.9°C
13	m V	+/- 100mV	0.1%	
Cold Junction	CJC Error	±0.5°C Typ. After 30 Minutes warm up time.		
Temperature	Operating Temperature.	-30°C to + 80°C		
	Storage Temperature	-40°C to + 85°C		
Connectors	Logic Power and Comms.	32 PIN Double Sided DIN Connector		
	Inputs	18 Way screw connector on front		

3.9.3 Status Indicators

- Power:** Flashes to indicate the CPU is running.
- RS485 Rx:** Flashes to indicate the unit has received a valid Modbus message.
- RS485 Tx:** Flashes to indicate the unit has sent a Modbus message.
- Input Status:** "ON" when the thermocouple is open circuit.
"OFF" when the thermocouple is connected.

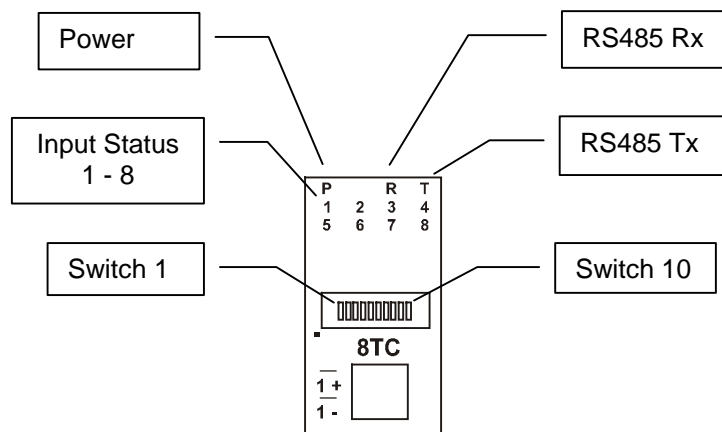

3.9.4 Wiring

The following diagram shows how the inputs are connected to a thermocouple.

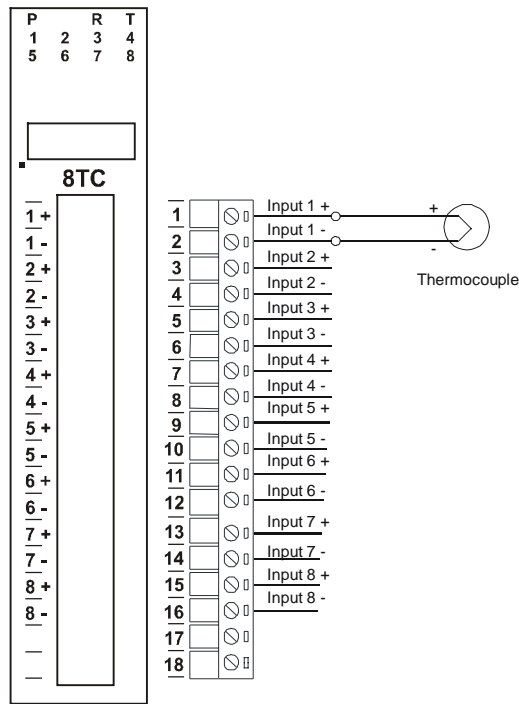

3.9.5 Switch Settings

SWITCH	FUNCTION	DESCRIPTION
1	NODE ID +1	Node ID's from 0 to 127 are set up using switches 1 to 7
2	NODE ID +2	"
3	NODE ID +4	"
4	NODE ID +8	"
5	NODE ID +16	"
6	NODE ID +32	"
7	NODE ID +64	"
8	-	Not used.
9	BREAK	TC break. When switched off the TC value will be loaded with -32767 when the TC is faulty. When switched on the TC value will be loaded with 32768.
10	BAUD RATE	Must be ON.

3.9.6 PL8TC Data Registers (MODULE TYPE = 105)

Modbus Address	Register Name	Low Limit	High Limit	Access	Description
30001	S/W Version / Module Type	N/A	N/A	R	High Byte = Software Version Low Byte = 105
30002	TC Input 1	-xxx.x	yyyy.y	R	Thermocouple Inputs. See table for range.
30003	TC Input 2	-xxx.x	yyyy.y	R	Resolution in 0.1°C.
30004	TC Input 3	-xxx.x	yyyy.y	R	"
30005	TC Input 4	-xxx.x	yyyy.y	R	"
30006	TC Input 5	-xxx.x	yyyy.y	R	"
30007	TC Input 6	-xxx.x	yyyy.y	R	"
30008	TC Input 7	-xxx.x	yyyy.y	R	"
30009	TC Input 8	-xxx.x	yyyy.y	R	"
30010	CJC Temp.	-xxx.x	yyyy.y	R	CJC Temperature in 0.1°C resolution.
30011	Input Status	0	65535	R	bit1 = 0(OK),bit1 = 1(error or open circuit)
30100	DIP Switch	0	65535	R	Status of DIP Switch on Front Panel
40101	TC Type	1	13	R/W	See TC Tables.
40102	Line Frequency	50	60	R/W	Line Frequency
40103	CJC Offset	1	199	R/W	100 = zero offset (0.0)
40104	Units Type	1	2	R/W	1=°C, 2=°F

3.10 PL8TCISO - ISOLATED THERMOCOUPLE INPUTS

3.10.1 Description

The PL8TCISO module is a 8 isolated thermocouple input module. The module uses differential inputs to reduce effects of electrical noise and mains pickup. The thermocouple inputs are isolated from the logic and from each other. This module is operated in an identical way to the PL8TC module and is fully interchangeable.

The thermocouple voltage is read by the module circuitry, linearised and converted to degrees Centigrade. No ranging is required as the module covers the full range as indicated in the TC table. The value that is read from the Modbus register is the actual temperature in degrees centigrade to 0.1°C resolution. ie: a value of 3451 corresponds to a temperature of 345.1°C.

The thermocouple type is setup by writing a value to the TC Type register. The value is obtained from the table below. For example to select type K thermocouples, the value "2" must be written to the TC Type register. All 8 thermocouple inputs adopt the same TC type.

The DIP switch 9 is used to select upscale or downscale burnout. A value of 32768 is used to indicate upscale burnout and a value of -32767 is used to indicate downscale burnout.

The module has built in Cold Junction Compensation. Use must be made of the correct thermocouple extension wire to avoid reading errors.

The thermocouple module can also be configured for a 0 - 50mV input range. The TC Type register must be set to 9 for this option. The value in the register which is read back over the network is 0 - 50,000.



3.10.2 Technical Specification of PL8TC

Power Supply	Logic Supply Voltage		Supplied from Power Bus	
	Logic Supply Power		0.6VA	
TC Inputs	Input Points		8	
	Resolution		0.1°C	
	Drift		100ppm/°C Typ.	
	Isolation		1500Vrms between field and logic 350Vpeak between each TC input	
TC Type	Number	Type	Range	Accuracy
	1	J	-150 to 760 °C	0.2°C
	2	K	-200 to 1370 °C	0.3°C
	3	E	0 to 600 °C	0.1°C
	4	T	-200 to 400 °C	0.3°C
	5	N	0 to 1300 °C	0.3°C
	6	B	400 to 1820 °C	0.5°C
	7	S	-50 to 1767 °C	0.6°C
	8	R	-50 to 1767 °C	0.7°C
	9	mV	0 to 50mV	0.1%
	10	C	0 to 2315.5 °C	0.7°C
	11	D	0 to 2315.5 °C	0.7°C
	12	G	0 to 2315.5 °C	0.9°C
13	m V	+/- 100mV	0.1%	
Cold Junction	CJC Error		±0.5°C Typ. After 30 Minutes warm up time.	
Temperature	Operating Temperature.		-30°C to + 80°C	
	Storage Temperature		-40°C to + 85°C	
Connectors	Logic Power and Comms.		32 PIN Double Sided DIN Connector	
	Inputs		18 Way screw connector on front	

3.10.3 Status Indicators

- Power:** Flashes to indicate the CPU is running.
- RS485 Rx:** Flashes to indicate the unit has received a valid Modbus message.
- RS485 Tx:** Flashes to indicate the unit has sent a Modbus message.
- Input Status:** "ON" when the thermocouple is open circuit.
"OFF" when the thermocouple is connected.

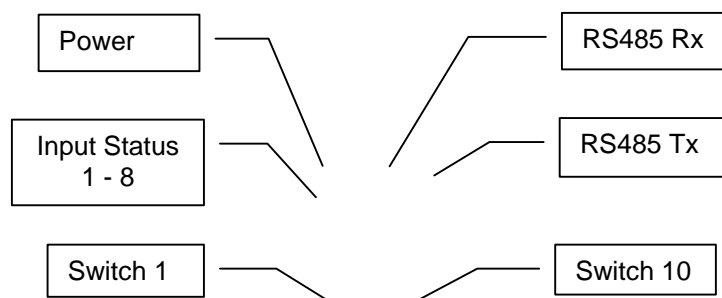

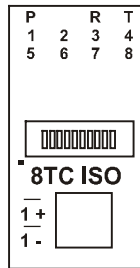

3.10.4 Wiring

The following diagram shows how the inputs are connected to a thermocouple.

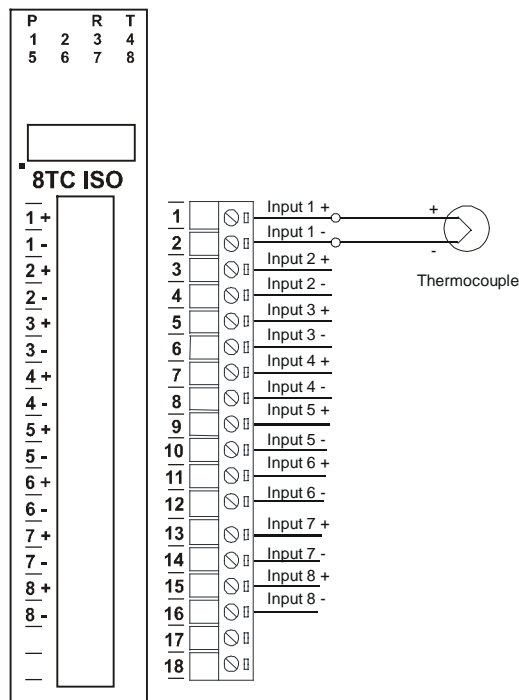

3.10.5 Switch Settings

SWITCH	FUNCTION	DESCRIPTION
1	NODE ID +1	Node ID's from 0 to 127 are set up using switches 1 to 7
2	NODE ID +2	"
3	NODE ID +4	"
4	NODE ID +8	"
5	NODE ID +16	"
6	NODE ID +32	"
7	NODE ID +64	"
8	-	Not used.
9	BREAK	TC break. When switched off the TC value will be loaded with -32767 when the TC is faulty. When switched on the TC value will be loaded with 32768.
10	BAUD RATE	Must be ON.

3.10.6 PL8TCISO Data Registers (MODULE TYPE = 106)

Modbus Address	Register Name	Low Limit	High Limit	Access	Description
30001	S/W Version / Module Type	N/A	N/A	R	High Byte = Software Version Low Byte = 106
30002	TC Input 1	-xxx.x	yyyy.y	R	Thermocouple Inputs. See table for range.
30003	TC Input 2	-xxx.x	yyyy.y	R	Resolution in 0.1°C.
30004	TC Input 3	-xxx.x	yyyy.y	R	"
30005	TC Input 4	-xxx.x	yyyy.y	R	"
30006	TC Input 5	-xxx.x	yyyy.y	R	"
30007	TC Input 6	-xxx.x	yyyy.y	R	"
30008	TC Input 7	-xxx.x	yyyy.y	R	"
30009	TC Input 8	-xxx.x	yyyy.y	R	"
30010	CJC Temp.	-xxx.x	yyyy.y	R	CJC Temperature in 0.1°C resolution.
30011	Input Status	0	65535	R	bit1 = 0(OK),bit1 = 1(error or open circuit)
30100	DIP Switch	0	65535	R	Status of DIP Switch on Front Panel
40101	TC Type	1	13	R/W	See TC Tables.
40102	Line Frequency	50	60	R/W	Line Frequency
40103	CJC Offset	1	199	R/W	100 = zero offset (0.0)
40104	Units Type	1	2	R/W	1=°C, 2=°F

3.11 PL6RTD - RTD INPUTS

3.11.1 Description

The PL6RTD module is a 6 RTD input module. The module can accommodate either 2 or 3 wire RTD sensors. The RTD inputs are isolated from the logic.

The RTD resistance is read by the module circuitry, linearised and converted to degrees Centigrade. No ranging is required as the module covers the full range of the RTD as indicated in the RTD table. The value that is read from the Modbus register is the actual temperature in degrees centigrade to 0.1°C resolution. ie: a value of 3451 corresponds to a temperature of 345.1°C.

The RTD type is setup by writing a value to the RTD Type register. The value is obtained from the table below. For example to select a PT100 RTD, the value "1" must be written to the RTD Type register. All 6 RTD inputs adopt the same RTD type.

The DIP switch 9 is used to select upscale or downscale burnout for break detection. A value of 32768 is used to indicate upscale burnout and a value of -32767 is used to indicate downscale burnout.

Note: As there is no inter-channel isolation, isolated RTD's must be used in order to prevent ground loops and reading errors.



3.11.2 Technical Specification of PL6RTD

Power Supply	Logic Supply Voltage	Supplied from Power Bus		
	Logic Supply Power	0.8VA		
RTD Inputs	Input Points	6		
	RTD Configuration	2 or 3 Wire		
	Resolution	0.1°C		
	Drift	100ppm/°C Typ.		
	Line resistance effect	< 0.1°C balanced		
	Max. line resistance	100ohms		
	Isolation	1500Vrms between field and logic		
RTD Type	Number	Type	Range	Accuracy
	1	PT100	-200 to 850°C	0.3°C IEC 751:1983
	2	Ni120	-80 to 320°C	0.3°C
	3	PT1000	-200 to 850°C	0.3°C
	4	Ni1000-DIN	-200 to 850°C	0.3°C
	5	Ni1000-Landys&Gyr	-200 to 850°C	0.3°C
	6	Ohms	10 - 400 ohms	
7	Ohms	100-4000ohms		
Temperature	Operating Temperature.	-40°C to + 80°C		
	Storage Temperature	-40°C to + 85°C		
	Logic Power and Comms.	32 PIN Double Sided DIN Connector		

Connectors	Logic Power and Comms.	32 PIN Double Sided DIN Connector
	Inputs	18 Way screw connector on front

3.11.3 Status Indicators

- Power:** Flashes to indicate the CPU is running.
- RS485 Rx:** Flashes to indicate the unit has received a valid Modbus message.
- RS485 Tx:** Flashes to indicate the unit has sent a Modbus message.
- Input Status:** "ON" when the RTD is open circuit.
"OFF" when the RTD is connected.

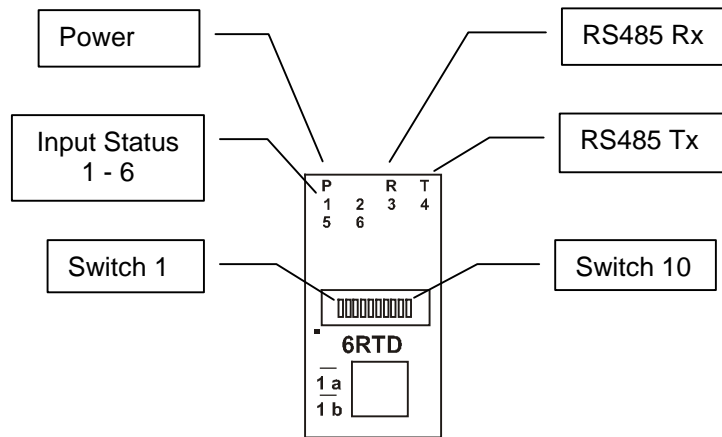

3.11.4 Wiring

The following diagram shows how the inputs are connected to a 2 and 3 wire RTD.

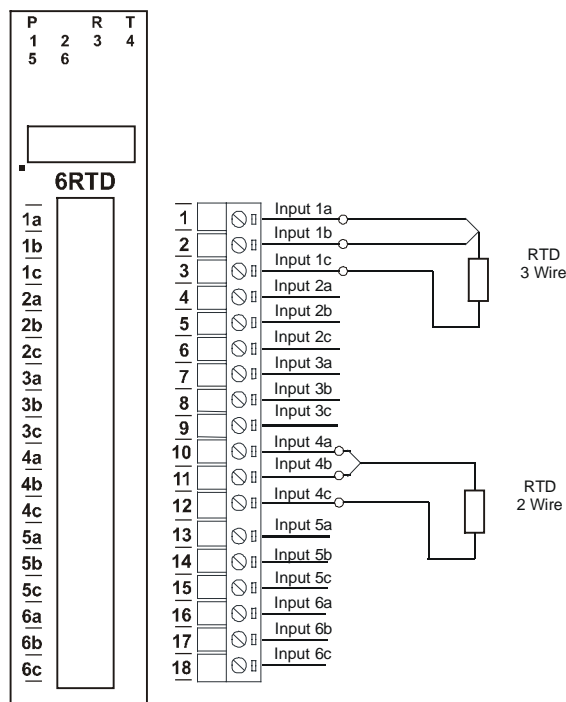

3.11.5 Switch Settings

<u>SWITCH</u>	<u>FUNCTION</u>	<u>DESCRIPTION</u>
1	NODE ID +1	Node ID's from 0 to 127 are set up using switches 1 to 7
2	NODE ID +2	"
3	NODE ID +4	"
4	NODE ID +8	"
5	NODE ID +16	"
6	NODE ID +32	"
7	NODE ID +64	"
8	-	Not used.
9	BREAK	RTD break. When switched off the RTD value will loaded with -32767 when the RTD is faulty. When switched on the RTD value will be loaded with 32768.
10	BAUD RATE	Must be ON.

3.11.6 PL6RTD Data Registers (MODULE TYPE = 109)

Modbus Address	Register Name	Low Limit	High Limit	Access	Description
30001	S/W Version / Module Type	N/A	N/A	R	High Byte = Software Version Low Byte = 109
30002	RTD Input 1	-xxx.x	yyyy.y	R	Thermocouple Inputs. See table for range.
30003	RTD Input 2	-xxx.x	yyyy.y	R	Resolution in 0.1°C.
30004	RTD Input 3	-xxx.x	yyyy.y	R	"
30005	RTD Input 4	-xxx.x	yyyy.y	R	"
30006	RTD Input 5	-xxx.x	yyyy.y	R	"
30007	RTD Input 6	-xxx.x	yyyy.y	R	"
30008	Input Status	0	65535	R	bit1 = 0(OK),bit1 = 1(error or open circuit)
30100	DIP Switch	0	65535	R	Status of DIP Switch on Front Panel
40101	RTD Type	1	7	R/W	See RTD Tables.
40102	Line Frequency	50	60	R/W	Line Frequency
40103	Units Type	1	2	R/W	1=°C, 2=°F

3.11.6.1 RTD Input Status.

There is one status bits associated with each RTD input. These bits are used to indicate if the input is open circuit or over range. If the input is open circuit or over range, then the error bit will be set.

<u>Bit 1- Error</u>	<u>Bit 2-Not Used</u>	<u>Condition</u>	<u>Status LED</u>
0	0	Input working OK.	(LED OFF)
1	0	Open circuit / Over range.	(LED ON)

The analog input status can be read in a single register as follows:

MSB															PL6RTD ANALOG INPUT STATUS															LSB		ADDRESS
15	14	13	12	11	10	9	8	7	6	5	4	3	2	1	0	15	14	13	12	11	10	9	8	7	6	5	4	3	2	1	0	
32768	16384	8192	4096	2048	1024	512	256	128	64	32	16	8	4	2	1	32768	16384	8192	4096	2048	1024	512	256	128	64	32	16	8	4	2	1	30008

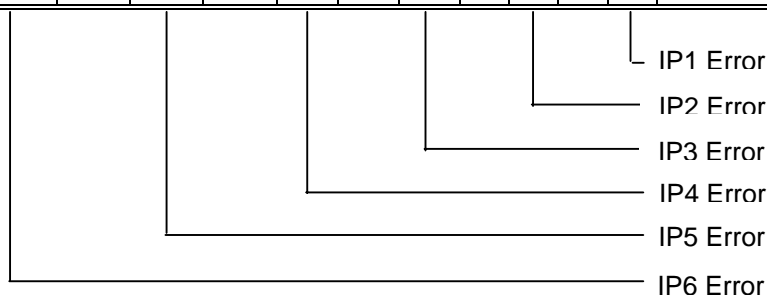

3.12 PLDAIO – DIGITAL + ANALOG INPUTS AND OUTPUTS

3.12.1 Description

The PLDAIO module is a multipurpose combination of inputs and outputs. The module can accommodate either 2 or 3 wire RTD sensors, current (0-20mA) and voltage (0-10V) inputs, current (0-20mA) or voltage (0-10V) output, and digital inputs and outputs.

RTD INPUTS:

There are 2 RTD inputs on the module. The RTD resistance is read by the module circuitry, linearised and converted to degrees Centigrade. No ranging is required as the module covers the full range of the RTD as indicated in the RTD table. The value that is read from the Modbus register is the actual temperature in degrees centigrade to 0.1°C resolution. ie: a value of 3451 corresponds to a temperature of 345.1°C.

The RTD type is setup by writing a value to the RTD Type register. The value is obtained from the table below. For example to select a PT100 RTD, the value "1" must be written to the RTD Type register.

A value of -32767 is used to indicate downscale burnout.

Note: As there is no inter-channel isolation, isolated RTD's must be used in order to prevent ground loops and reading errors.

ANALOG INPUTS:

The Analog Inputs (2) can be configured by internal jumpers as either a current input (0-20mA) or a voltage input (0-10V).

An input of 0 - 20mA input current or 0 – 10V input voltage represents an output value of 0 - 4095 (12 bits) in the corresponding Modbus register.

ANALOG OUTPUT:

There is a single analog output which can be configured with internal jumpers for a current output (0-20mA) or voltage output (0-10V).

The resolution is 12 bits, so writing a value to the Modbus register for each output of 0 - 4095 would give an output current of 0 - 20mA. A value of $819 \pm 1\text{LSB}$ will give a current output of 4mA.

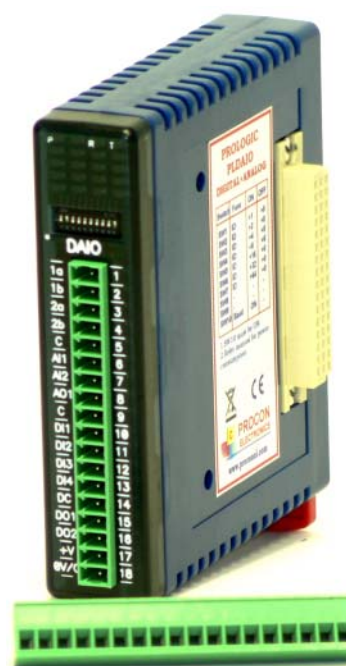

DIGITAL INPUTS:

There are 4 digital inputs on the module. The inputs share a common terminal and can be configured for common positive or common negative.

The inputs have got counters associated with them. The counters operate in three modes.

In **mode 0** all the counters are disabled.

In **mode 1** all counters are 32 bit counters allowing a count value from 0 to 4294967295. The count value can be cleared by writing a zero to the associated registers or preset to any other value using the same method.

In **mode 2** the inputs are connected as up/down counters. Input 1 will increment counter 1 whilst input 2 decrements counter1.

Note: The count values are not battery backed-up and will be lost if power is turned off.

The format of the registers allows the status of the inputs to be read as either single bits or all at once as a single register on the Modbus network.

DIGITAL OUTPUTS:

The module has 2 open collector (NPN) digital outputs. The outputs may be used to drive lamps or external relays when more drive capability is required.

The outputs are written to by the Modbus master device such as a PC or PLC. Each output can be individually switched on or off, or all outputs can be set up at the same time by writing a single number to the output register which represents the status of all outputs.

An output watchdog timer can be configured to switch off all the outputs if there has been no communications with the module for up to 255 seconds. A value of 0 seconds will disable this timer and the outputs will remain in the last programmed state.

3.12.2 Technical Specification of PLDAIO

Power Supply	Logic Supply Voltage		Supplied from Power Bus	
	Logic Supply Power		1.0VA	
	Field Supply Voltage		24 Vdc	
	Field Supply Current		25mA	
RTD Inputs	Input Points		2	
	RTD Configuration		2 or 3 Wire	
	Resolution		0.1°C	
	Drift		100ppm/°C Typ.	
	Line resistance effect		< 0.1°C balanced	
	Max. line resistance		100ohms	
	Isolation		1500Vrms between field and logic	
RTD Type	Number	Type	Range	Accuracy
	1	PT100	-200 to 850°C	0.3°CIEC 751:1983
	2	Ni120	-80 to 320°C	0.3°C
	3	PT1000	-200 to 850°C	0.3°C
	4	Ni1000-DIN	-200 to 850°C	0.3°C
	5	Ni1000- Landys&Gy r	-200 to 850°C	0.3°C
	6	Ohms	10 - 400 ohms	
	7	Ohms	100-4000ohms	
Current Inputs	Input Points		2	
	Input Current		0(4) - 20 mA	
	Input Resistance		250ohms	
	InputType	Range	Resolution	
	1	0 – 4095	12 bits	
	2	0–20.000mA	1uA	
	3	+/-20.000mA	1uA	
	Drift		100ppm/°C	
	Accuracy		0.2% of span	
	Isolation		1000Vrms between field and logic	
Voltage Inputs	Input Points		2	
	Input Voltage		0 - 1 Vdc or 0 – 10 Vdc	
	Input Resistance		190kohms	
	InputType	Range	Resolution	
	4	0 – 4095	12 bits	
	5	0 – 10.000 V	1mV	
	6	+/- 10.000 V	1mV	
	7	0 – 1.0000 V	0.1mV	
	8	+/- 1.0000 V	0.1mV	
	Drift		100ppm/°C	
	Accuracy		0.2% of span	
	Isolation		1000Vrms between field and logic	
	Current Output	Output Points		1
Output Current		0(4) - 20 mA		
OutputType		Range	Resolution	
1		0 – 4095	12 bits	
Drift		100ppm/°C		
Accuracy		0.05% of span		
Compliance		1000 ohms max. @ 24Vdc 500 ohms max. @ 12Vdc		

Voltage Output	Output Points	1
	Output Voltage	0(2) - 10 V
	OutputType	Range
	2	0 – 4095
	Resolution	12 bits
	Drift	100ppm/°C
	Accuracy	0.05% of span
Digital Inputs	Compliance	2000 ohms min. load
	Input Points	4
	Input Voltage Range	10 - 26 Vdc
Counters	Input Current per input	4mA@12Vdc / 8mA @24Vdc
	Inputs	1 to 4
	Resolution	32 Bits
	Frequency	50 Hz (max)
Digital Outputs	Pulse Width	20 ms (min)
	Output Points	2
	Maximum Voltage	36 Vdc
	Maximum Current	100 mA per output
Isolation	Vceon	1.1V Max.
Temperature	Between field and logic	1500Vrms between field and logic
	Operating Temperature.	-40°C to + 80°C
Connectors	Storage Temperature	-40°C to + 85°C
	Logic Power and Comms.	32 PIN Double Sided DIN Connector
	Inputs	18 Way screw connector on front

3.12.3 Status Indicators

- Power:** "ON" when module has power.
- RS485 Rx:** Flashes to indicate the unit has received a valid Modbus message.
- RS485 Tx:** Flashes to indicate the unit has sent a Modbus message.

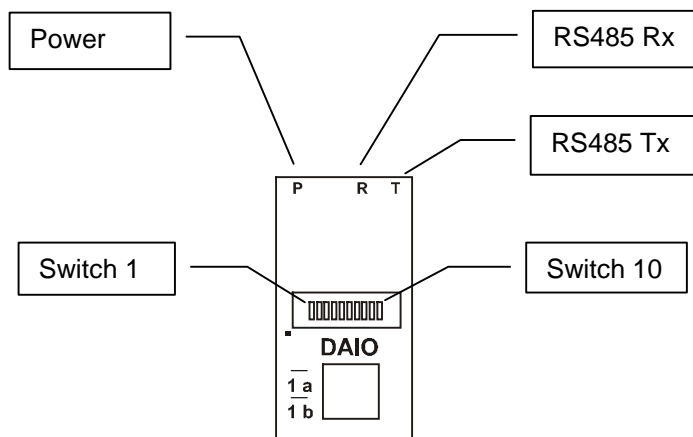

3.12.4 Wiring

The following diagram shows how the inputs and outputs are connected to the DAIO module.

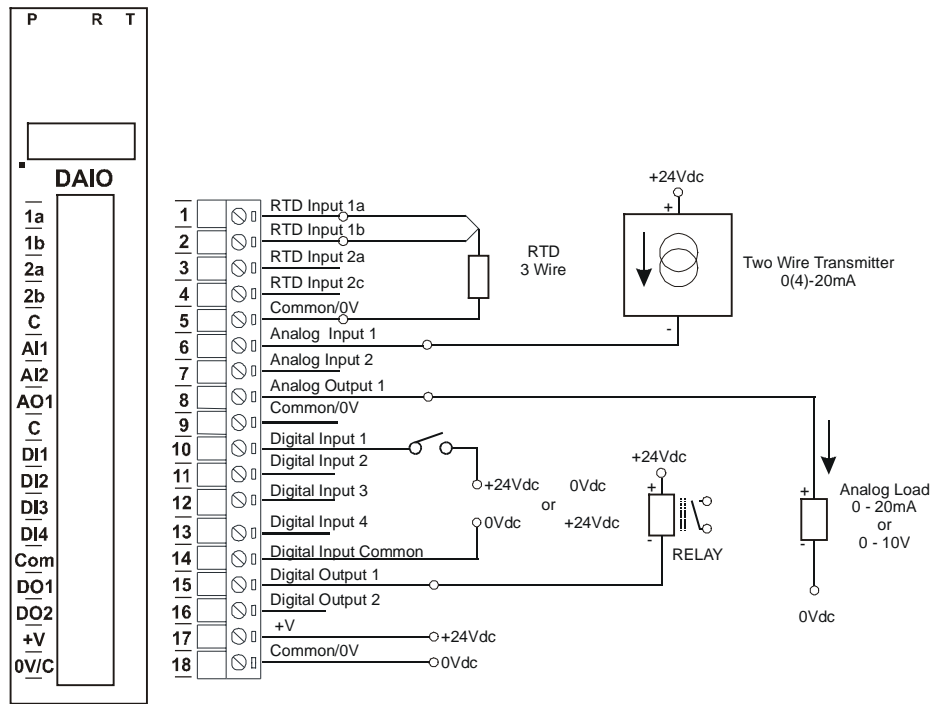

3.12.5 Switch Settings

SWITCH	FUNCTION	DESCRIPTION
1	NODE ID +1	Node ID's from 0 to 127 are set up using switches 1 to 7
2	NODE ID +2	"
3	NODE ID +4	"
4	NODE ID +8	"
5	NODE ID +16	"
6	NODE ID +32	"
7	NODE ID +64	"
8	-	Not used.
9	-	Not used.
10	BAUD RATE	Selects 9600 (off) or Programmed Baud Rate (on)

3.12.6 PLDAIO Data Registers (MODULE TYPE = 112)

Modbus Address	Register Name	Low Limit	High Limit	Access	Comments
10001	Digital Input 1	0	1	R	Status of Digital Inputs.
10002	Digital Input 2	0	1	R	"
10003	Digital Input 3	0	1	R	"
10004	Digital Input 4	0	1	R	"
00017	Digital Output 1	0	1	R/W	Status of Digital Outputs.
00018	Digital Output 2	0	1	R/W	"
30001	S/W Version / Module Type	N/A	N/A	R	High Byte = Software Version Low Byte = 112
30002	Digital Inputs	N/A	N/A	R	Digital Inputs in lower 8 bits. 8 - 1.
40003	Digital Outputs	N/A	N/A	R/W	Digital Outputs in lower 8 bits. 8 - 1.
40004	RTD Input 1	-xxx.x	yyyy.y	R	RTD Inputs. See table for range.
40005	RTD Input 2	-xxx.x	yyyy.y	R	Resolution in 0.1°C.
40006	Analog Input 1	0	4095	R	Analog Input lower 12 Bits
40007	Analog Input 2	0	4095	R	Analog Input lower 12 Bits
40008	Analog Output 1	0	4095	R/W	Analog Output lower 12 Bits
40009	Counter 1 MSB	0	65535	R/W	Counter MSB and LSB combine to give a 32 bit
40010	Counter 1 LSB	0	65535	R/W	Counter with range 0 to 4294967295.
40011	Counter 2 MSB	0	65535	R/W	"
40012	Counter 2 LSB	0	65535	R/W	"
40013	Counter 3 MSB	0	65535	R/W	"
40014	Counter 3 LSB	0	65535	R/W	"
40015	Counter 4 MSB	0	65535	R/W	"
40016	Counter 4 LSB	0	65535	R/W	"
30100	DIP Switch	0	65535	R	Status of DIP Switch on Front Panel
40101	Watchdog Timer	0	255	R/W	Timer in seconds. 0 = disabled. 1 - 255 = enabled.
40102	Counter Mode	0	2	R/W	0=Disable, 1=Up Counting, 2=Up/Down Count
40103	Input Filter	0	65535	R/W	0 = Disable, >0 = Enable. (x10ms)
40104	RTD 1 Type	1	7	R/W	See RTD Tables.
40105	RTD 2 Type	1	7	R/W	See RTD Tables.
40106	AI 1 Type	1	2	R/W	1 = 0-20mA, 2 = 0-10V
40107	AI 2 Type	1	2	R/W	"
40108	AO Type	1	2	R/W	"
40109	Line Frequency	50	60	R/W	Line Frequency
40110	Units Type	1	2	R/W	1=°C, 2=°F

3.13 PL8AO - ANALOG OUTPUTS

3.13.1 Description

The PL8AO is a 8 channel current output module. Each channel can be set to output a current in the range 0 - 20mA. The outputs are isolated from the logic and share a common negative terminal.

The resolution is 12 bits, so writing a value to the Modbus register for each output of 0 - 4095 would give an output current of 0 - 20mA. A value of $819 \pm 1\text{LSB}$ will give a current output of 4mA.



3.13.2 Technical Specification of PL8AO

Power Supply	Logic Supply Voltage	Supplied from Power Bus
	Logic Supply Power	0.3VA
	Field Supply Voltage	24 Vdc
	Field Supply Current	175mA
Current Output	Output Points	8
	Output Current	0(4) - 20 mA
	Resolution	12 bits
	Drift	100ppm/°C
	Accuracy	0.05% of span
	Compliance	1000 ohms max. @ 24Vdc 500 ohms max. @ 12Vdc
Isolation	Between field and logic	1500Vrms between field and logic
Temperature	Operating Temperature.	-40°C to + 80°C
	Storage Temperature	-40°C to + 85°C
Connectors	Logic Power and Comms.	32 PIN Double Sided DIN Connector
	Inputs	18 Way screw connector on front

3.13.3 Status Indicators

- Power:** Flashes to indicate the CPU is running.
- RS485 Rx:** Flashes to indicate the unit has received a valid Modbus message.
- RS485 Tx:** Flashes to indicate the unit has sent a Modbus message.
- Output Status:** "ON" when the output is zero.
"OFF" when the output is between zero and full scale.
"Flashing" when the output is at full scale.

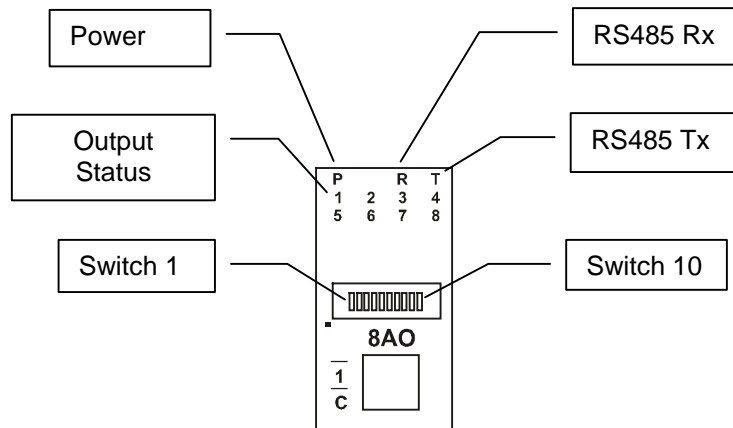

3.13.4 Wiring

The following diagram shows how the analog outputs are connected to a load.

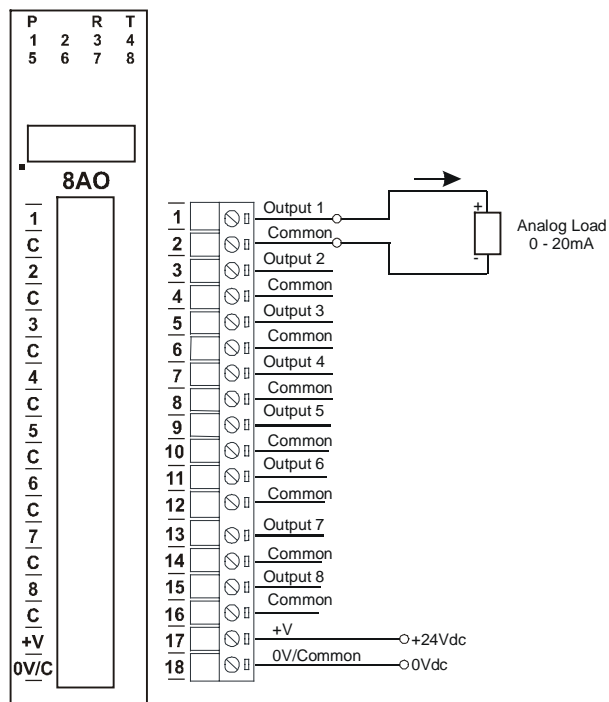

3.13.5 Switch Settings

SWITCH	FUNCTION	DESCRIPTION
1	NODE ID +1	Node ID's from 0 to 127 are set up using switches 1 to 7
2	NODE ID +2	
3	NODE ID +4	
4	NODE ID +8	
5	NODE ID +16	
6	NODE ID +32	
7	NODE ID +64	
8	-	Not used.
9	-	Not used.
10	BAUD RATE	Must be ON.

3.13.6 PL8AO Data Registers (MODULE TYPE = 110)

Modbus Address	Register Name	Low Limit	High Limit	Access	Comments
30001	S/W Version / Module Type	N/A	N/A	R	High Byte = Software Version Low Byte = 110
40002	Current Output 1	0	4095	R/W	Current Outputs. 0 - 4095 = 0(4) - 20mA.
40003	Current Output 2	0	4095	R/W	"
40004	Current Output 3	0	4095	R/W	"
40005	Current Output 4	0	4095	R/W	"
40006	Current Output 5	0	4095	R/W	"
40007	Current Output 6	0	4095	R/W	"
40008	Current Output 7	0	4095	R/W	"
40009	Current Output 8	0	4095	R/W	"
40010	Output Status	0	65535	R	bit2 = 0(0), bit2 = 1(4095) bit1 = 0(OK), bit1 = 1(error)
30100	DIP Switch	0	65535	R	Status of DIP Switch on Front Panel
40101	Watchdog Timer	0	255	R/W	Timer in seconds. 0 = disabled. 1 -255 = enabled.

3.14 PL8VO - ANALOG OUTPUTS

3.14.1 Description

The PL8VO is a 8 channel voltage output module. Each channel can be set to output a voltage in the range 0 – 10V. The outputs are isolated from the logic and share a common negative terminal.

The resolution is 12 bits, so writing a value to the Modbus register for each output of 0 - 4095 would give an output current of 0 – 10V. A value of $819 \pm 1\text{LSB}$ will give a current output of 2V.



3.14.2 Technical Specification of PL8VO

Power Supply	Logic Supply Voltage	Supplied from Power Bus
	Logic Supply Power	0.3VA
	Field Supply Voltage	24 Vdc
	Field Supply Current	85 mA max.
Voltage Output	Output Points	8
	Output Voltage	0(2) - 10 V
	Resolution	12 bits
	Drift	100ppm/°C
	Accuracy	0.05% of span
	Compliance	2000 ohms min. load
Isolation	Between field and logic	1500Vrms between field and logic
Temperature	Operating Temperature.	-40°C to + 80°C
	Storage Temperature	-40°C to + 85°C
Connectors	Logic Power and Comms.	32 PIN Double Sided DIN Connector
	Outputs	18 Way screw connector on front

3.14.3 Status Indicators

- Power:** Flashes to indicate the CPU is running.
- RS485 Rx:** Flashes to indicate the unit has received a valid Modbus message.
- RS485 Tx:** Flashes to indicate the unit has sent a Modbus message.
- Output Status:** "ON" when the output is zero.
"OFF" when the output is between zero and full scale.
"Flashing" when the output is at full scale.

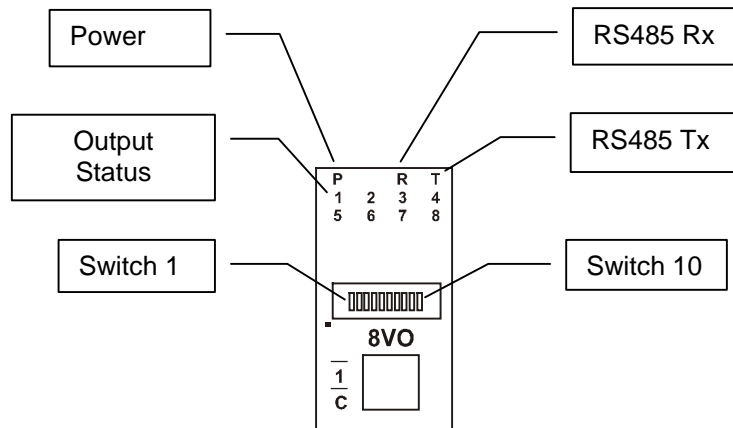

3.14.4 Wiring

The following diagram shows how the analog outputs are connected to a load.

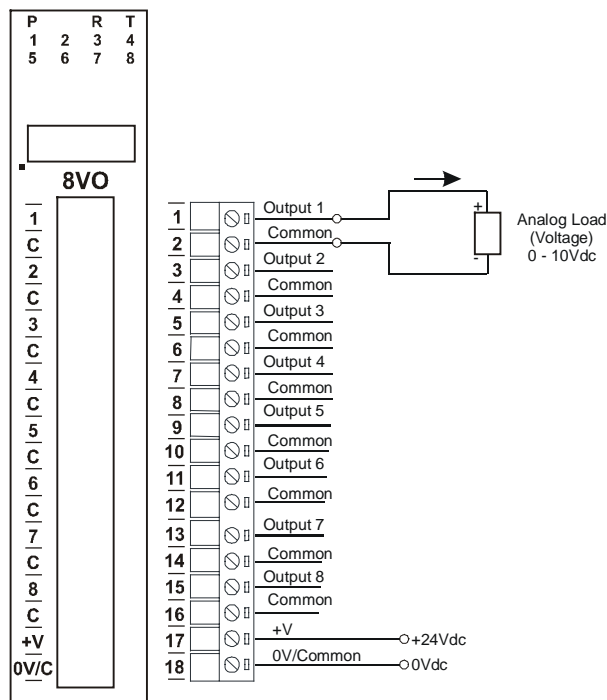

3.14.5 Switch Settings

SWITCH	FUNCTION	DESCRIPTION
1	NODE ID +1	Node ID's from 0 to 127 are set up using switches 1 to 7
2	NODE ID +2	"
3	NODE ID +4	"
4	NODE ID +8	"
5	NODE ID +16	"
6	NODE ID +32	"
7	NODE ID +64	"
8	-	Not used.
9	-	Not used.
10	BAUD RATE	Must be ON.

3.14.6 PL8VO Data Registers (MODULE TYPE = 111)

Modbus Address	Register Name	Low Limit	High Limit	Access	Comments
30001	S/W Version / Module Type	N/A	N/A	R	High Byte = Software Version Low Byte = 111
40002	Voltage Output 1	0	4095	R/W	Voltage Outputs. 0 - 4095 = 0 - 10V.
40003	Voltage Output 2	0	4095	R/W	"
40004	Voltage Output 3	0	4095	R/W	"
40005	Voltage Output 4	0	4095	R/W	"
40006	Voltage Output 5	0	4095	R/W	"
40007	Voltage Output 6	0	4095	R/W	"
40008	Voltage Output 7	0	4095	R/W	"
40009	Voltage Output 8	0	4095	R/W	"
40010	Output Status	0	65535	R	bit2 = 0(0), bit2 = 1(4095) bit1 = 0(OK), bit1 = 1(error)
30100	DIP Switch	0	65535	R	Status of DIP Switch on Front Panel
40101	Watchdog Timer	0	255	R/W	Timer in seconds. 0 = disabled. 1 -255 = enabled.

4. Using HTML web pages on the PL101

4.1 Introduction

The PL101 has a built in web server which enables configuration and dynamic data to be accessed using a web browser on a PC. The data registers in the PL101 can be accessed and displayed on web pages by using tags. This enables the user to create their own custom web pages relating to the application and display live data.

The web pages are stored on the PL101 as .htm files. It is also possible to store .jpg files for displaying pictures and other file types such as .js for JAVA script functions. The JAVA script functions enable variables on the web pages to be automatically updated without having to refresh the whole web page.

The PL101 has a built in flash drive for storing these files. The flash drive consists of a FAT (File allocation table) which stores all of the information used for saving and reading files. The flash drive is accessed (files read or written) by using FTP over the Ethernet network.

4.2 Using FTP

The first step is to learn how to access the flash drive. This can be done using the dos program "ftp" from a dos prompt, through explorer, or any other commercially available ftp program.

This example uses the ftp command from a dos prompt. Open a dos command box on your windows PC by clicking on:

- Start->All Programs->Accessories->Command Prompt.

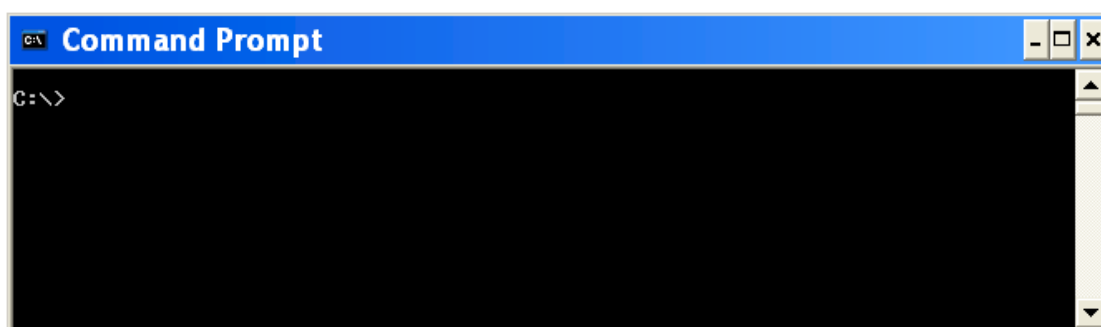

- To login to the PL101 you must first type in the ftp command and include the IP address of the PL101.
- The PL101 will respond with a request for the user name. The default user name is "q". Do not include the quotes.
- The PL101 will respond with a request for the password. The default password is "q"

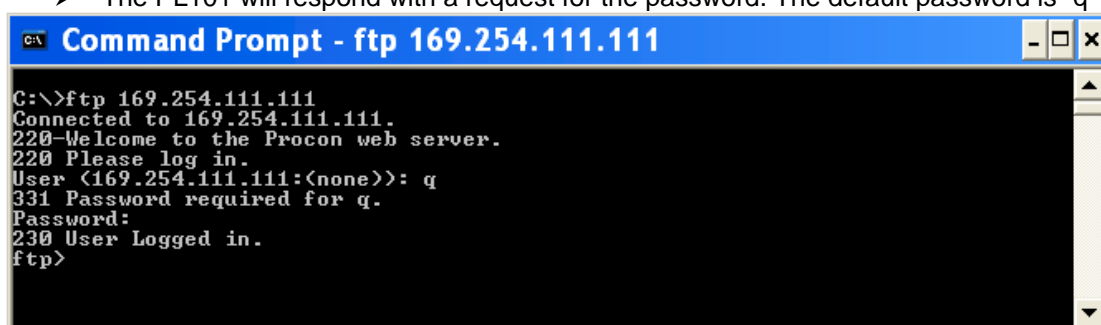

At this point you can now enter commands to access the flash drive on the PL101.

The commands supported are as follows:

dir – To display a list of files on the flash drive.

ls – To do a short directory list. This is useful as it also indicates the amount of free space on the flash drive.

put – This command is used to put or save a file onto the flash drive from the current directory of the command prompt. The format of the command is “put filename.htm”

get – This command is used to get or retrieve a file from the flash drive and save it on the current directory of the command prompt. The format of the command is “get filename.htm”

del – To delete a file from the flash drive. The format of the command is “del filename.htm”

bye – To log off use this command. The ftp program in the PL101 monitors activity and automatically logs off after one minute from the last command.

NOTE: The directory structure of the flash drive only allows for the 8.3 filename format. This means that the filename must be no more than 8 characters long and the file extension must be no more than 3 characters long.

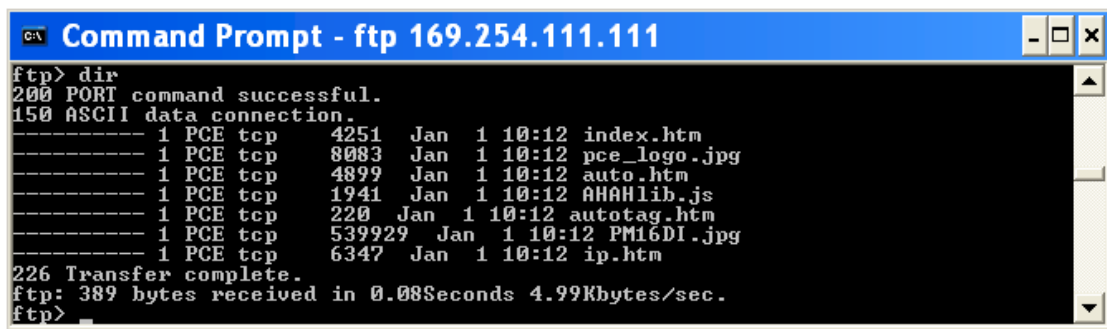

```
Command Prompt - ftp 169.254.111.111
ftp> dir
200 PORT command successful.
150 ASCII data connection.
----- 1 PCE tcp 4251 Jan 1 10:12 index.htm
----- 1 PCE tcp 8083 Jan 1 10:12 pce_logo.jpg
----- 1 PCE tcp 4899 Jan 1 10:12 auto.htm
----- 1 PCE tcp 1941 Jan 1 10:12 AHAHlib.js
----- 1 PCE tcp 220 Jan 1 10:12 autotag.htm
----- 1 PCE tcp 539929 Jan 1 10:12 PM16DI.jpg
----- 1 PCE tcp 6347 Jan 1 10:12 ip.htm
226 Transfer complete.
ftp: 389 bytes received in 0.08Seconds 4.99Kbytes/sec.
ftp> _
```

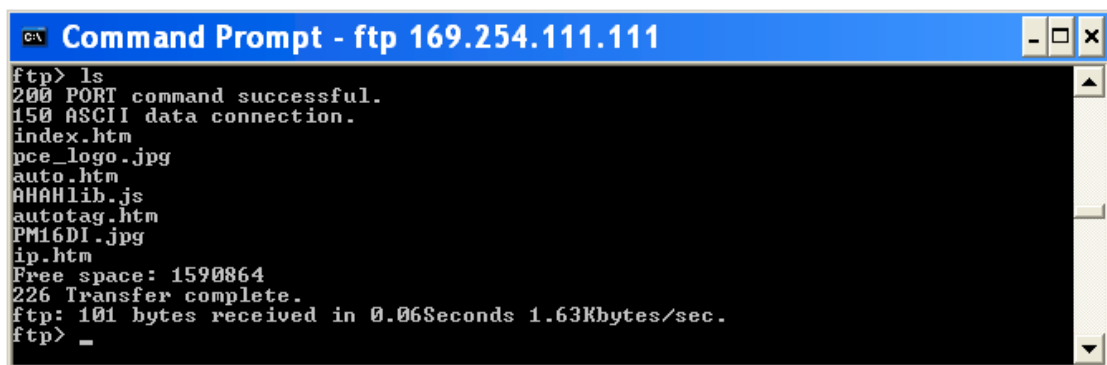

```
Command Prompt - ftp 169.254.111.111
ftp> ls
200 PORT command successful.
150 ASCII data connection.
index.htm
pce_logo.jpg
auto.htm
AHAHlib.js
autotag.htm
PM16DI.jpg
ip.htm
Free space: 1590864
226 Transfer complete.
ftp: 101 bytes received in 0.06Seconds 1.63Kbytes/sec.
ftp> _
```

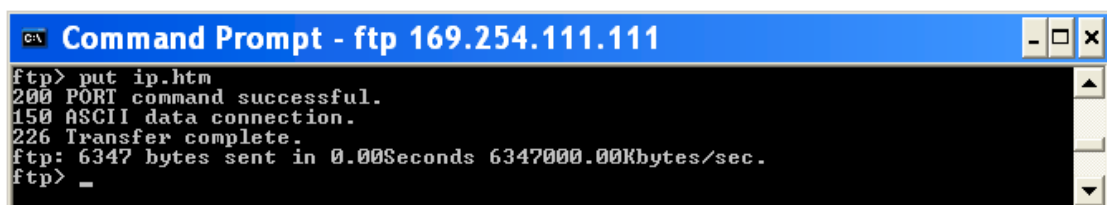

```
Command Prompt - ftp 169.254.111.111
ftp> put ip.htm
200 PORT command successful.
150 ASCII data connection.
226 Transfer complete.
ftp: 6347 bytes sent in 0.00Seconds 6347000.00Kbytes/sec.
ftp> _
```

4.3 Creating and using web pages.

An .htm file is used to store the information for a web page. The format of the information in the file or the programming language used is called HTML which *means HyperText Markup Language*.

If you are new to web page design then it is recommended that you first get a book to read up on HTML as it is beyond the scope of this manual to go into much detail.

4.3.1 Writing HTML

The contents of the file may be generated using a text editor such as “NOTEPAD” or a web page editor such as “FrontPage”. It is relatively easy to make a basic web page with a text editor, however adding tables and special effects gets a lot more complicated and a web page editor is recommended.

4.3.2 HTML tags

HTML tags are commands written between less than (<) and greater than (>) signs and are used to indicate how the browser should display the text. The closing tag must have the same name as the opening tag, however it must also have the (/) to indicate it is a closing tag.

 This will be in BOLD

4.3.3 Creating a new web page

Using a text editor such as NOTEPAD, open a new file and save it as test.htm.

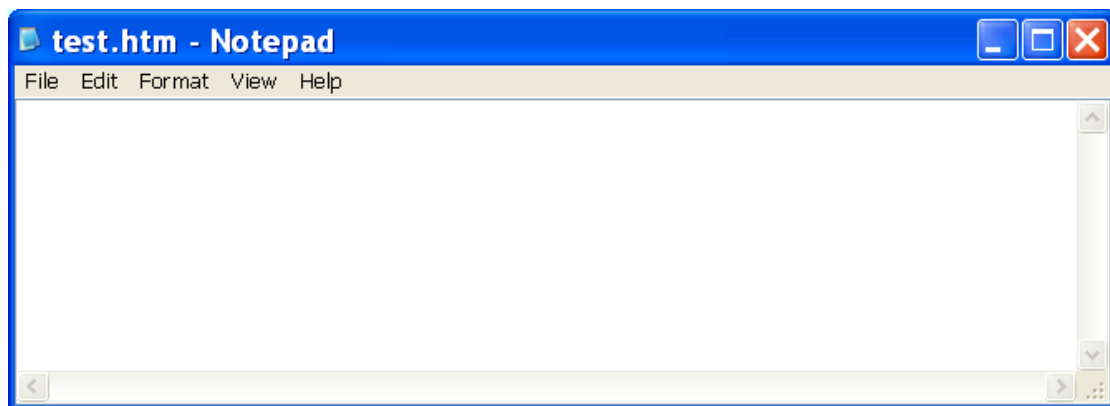

The first thing required on a web page is the HTML tag. It identifies the contents of your text document as HTML code.

Secondly divide the HTML page into two sections. The HEAD section and the BODY.

The HEAD section is where you define the title of the page and add advanced formatting information such as scripts.

The BODY encloses the content of the web page. The part you see on the screen in the browser.

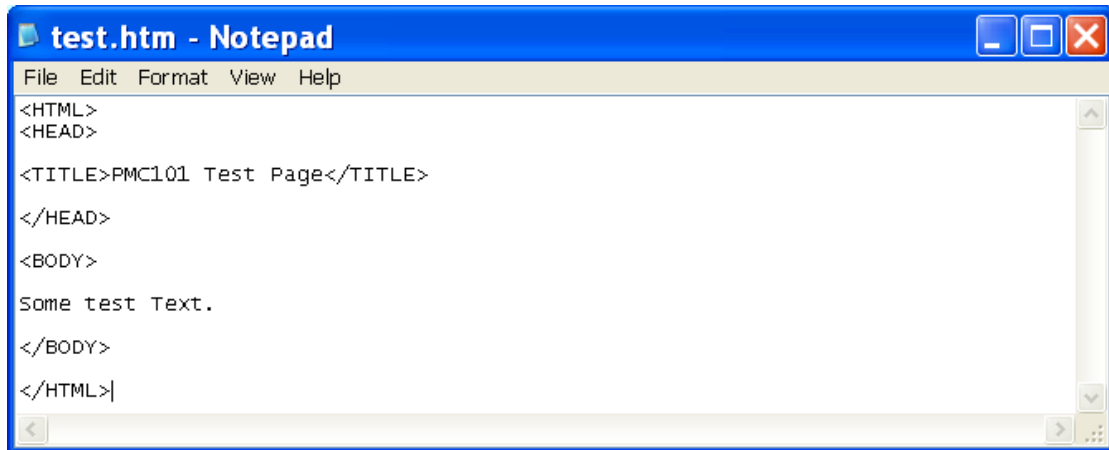

Save the file. Now open the file in your browser. You should see the following. Note the title at the top of the page and the content in the window.

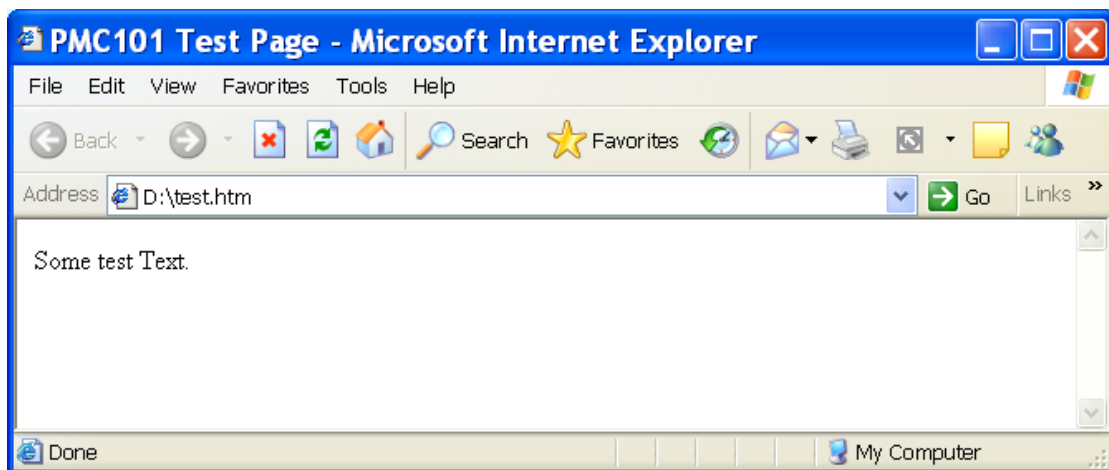

Now save the .htm file on the flash disk on the PL101 using the ftp commands.

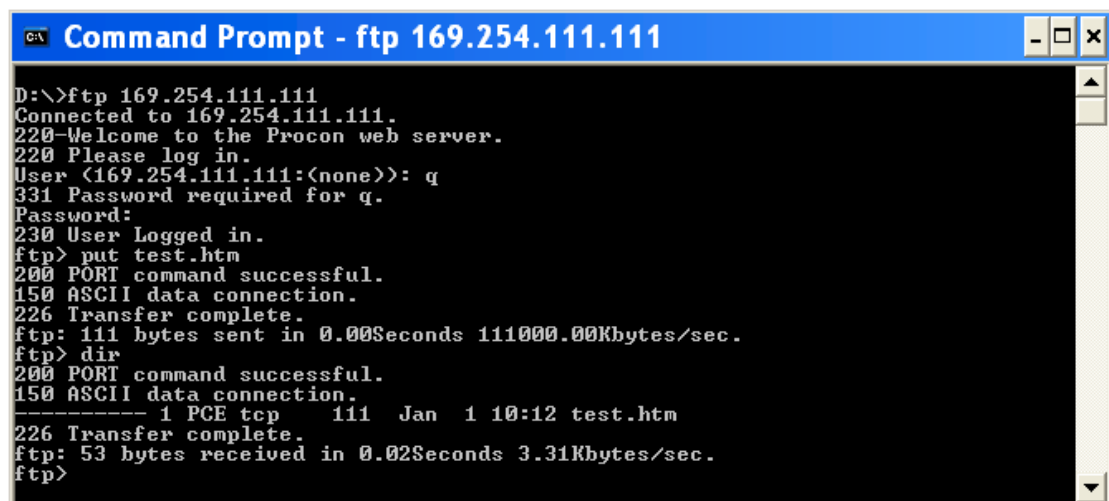

Go to your browser and open the file on the PL101.

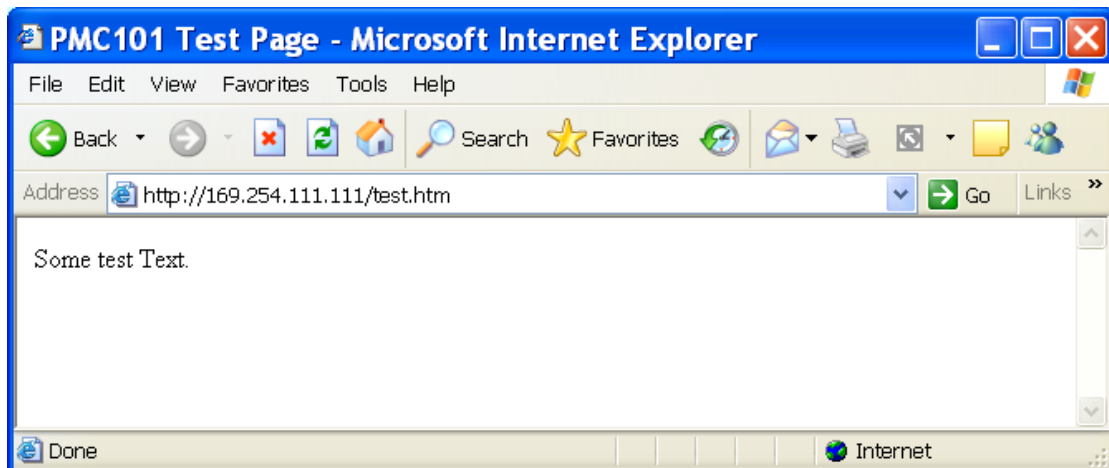

There are many tags you can use to format the text on the screen, such as changing the font, colour, new paragraph etc. You will see some in the following examples.

4.4 Adding a data tag.

When you open a web page with your browser the PL101 reads the file from the flash drive and sends it to the browser. It is possible for the PL101 to insert data from the ladder logic program or other memory locations so that you can view more useful information.

To display some data, you need to specify the data tag identifier, the memory type, and memory address. For example %B0017 will display digital input 1 and %M0000100 will display the contents of memory M100.

If you need to display a "%" then you must use %%%.

Edit the test file to include the following:

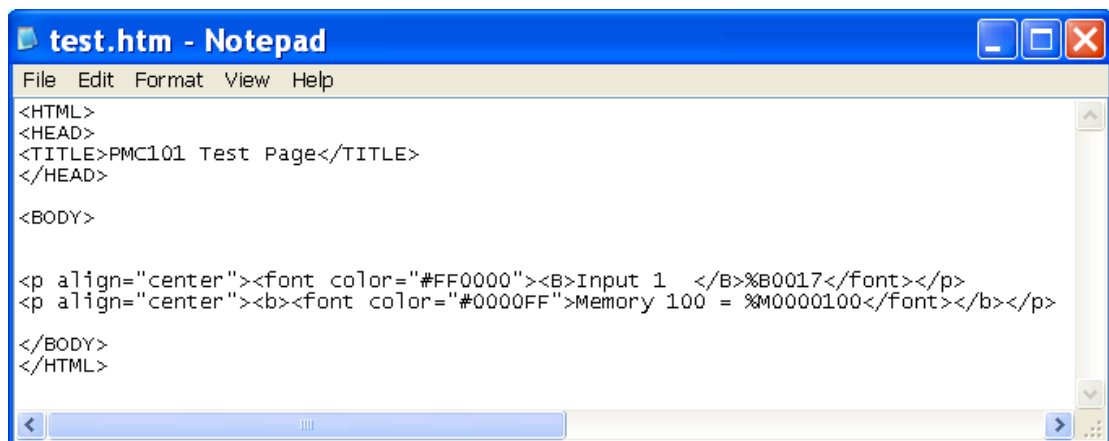

Put the test file into the PL101 and then open it with the browser. The values with the % sign are replaced with the actual data.

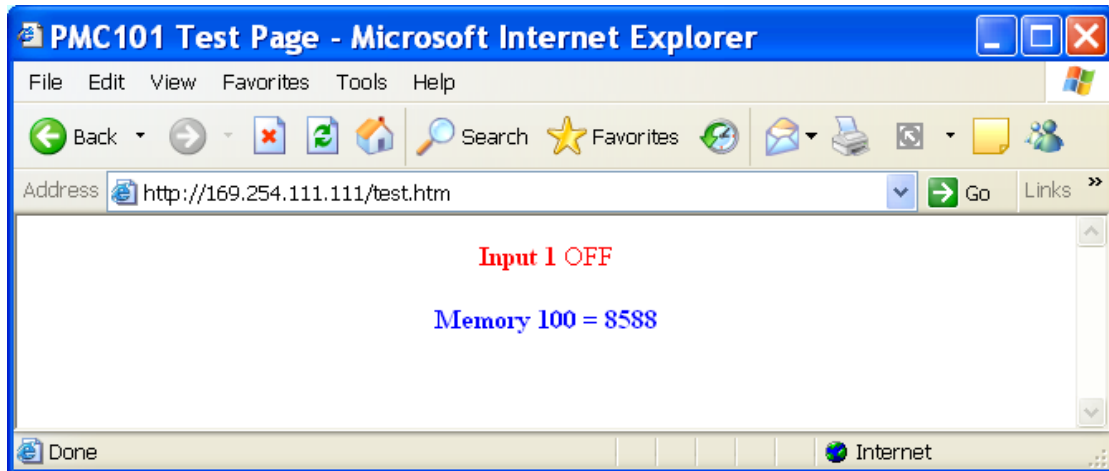

The different tags that can be used are shown:

- **%Bxxxx** This tag is used to access digital data or data bits. Bit 1 is the very first bit in memory M0 in the PL101. The digital inputs start at M1 and as each memory location has 16 bits you can work out that the address for input 1 is %B0017. The response will be "OFF" if the bit is zero and "ON" if the bit is one.
- **%Cxxxx and %Dxxxx** These are also digital bits and are used with check boxes to turn digital I/O on and off from the web page. This will be explained later. The response is "checked" or " ".
- **%Exxxx** This tag is used to access analog data or memory variables related to the HTTP and TCP/IP configuration. The table later in this manual shows the memory addresses for the %E registers. As an example, the IP address, subnet mask and default gateway addresses are saved here. If you edit the ip.htm page that comes with the PL101 you will see how these tags are used.
- **%Mfwdxxxx** This tag allows you to display the Memory M data from the ladder logic program. The %M tag includes three extra characters which are used to format the data being sent to the web browser.

f – Format Field This field is used to choose the format of the value being displayed.

%M Format	
Value	Format
0	Unsigned Single
1	Signed Single
2	Unsigned Double
3	Signed Double
4	Float

w – Width Field This field is used to specify the minimum number of characters to generate for the conversion. A value of zero (0) will let it the function generate an unrestricted number of characters.

d – Decimal Places Field This field is used to specify the number of fraction characters to generate for the conversion after the decimal point.

%M Decimal Places	
Value	Format
0	xxxxx
1	xxxx.x
2	xxx.xx
3	xx.xxx
4	x.xxxx

Using the %TAG method is the easiest way of inserting data onto your web page. The only problem with this technique is that if you want to get updated values then you need to do a refresh and load the whole web page again from the PL101.

4.5 Automatically updating web page data.

It is possible to update the data on the web page without actually reloading the complete page. This is a more complicated technique and may not be necessary if you just want to check some data values once in a while.

There are a number of ways of implementing this method, and the technique we will use makes use of a programming language called JavaScript.

JavaScript is not the same as JAVA in that it does not have to be compiled. You can insert JavaScript commands into the HTML code and they will be interpreted and executed as the web page is loaded into the browser.

When you want to automatically load data to a web page, a small program is required to request the data from the PL101. This program is written in JavaScript and is named "autoUpdate". The program is kept separate from the .htm web page as a library function so that it can be called by many different web pages. The file where the function is kept is called "AHAHlib.js" where the extension .js means JavaScript. This file must be put into the PL101 if you are going to use it from your web page.

The autoUpdate function is used to retrieve a file from the PL101 which includes a list of data tags that you want to update on the web page. The file is stored as a .htm file to inform the PL101 that the %tags must be replaced with the required data before it is sent to the browser. A typical file is shown:

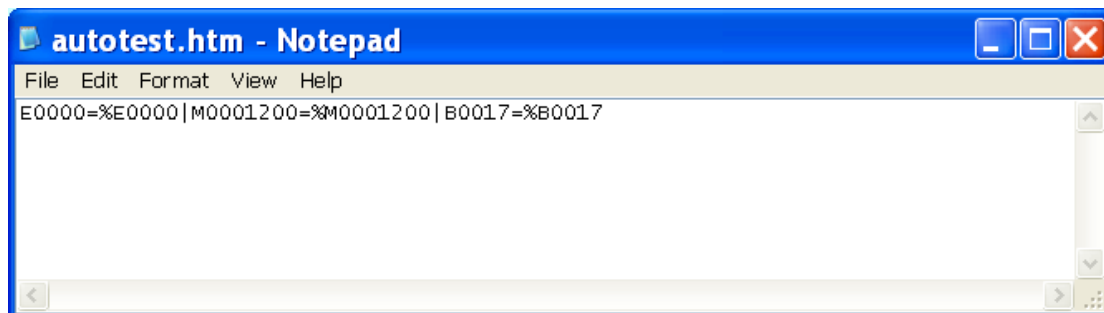

The first tag E0000 is a dummy tag at the beginning of the file for synchronization. The second tag is M0001200=%M0001200. We have chosen this memory as it is the seconds for the real time clock in the PL101 and will show changing data for our test. The PL101 will replace the %tag with a value, so the actual file that gets sent to the browser will be like this, M0001200=xxxx. You must also include the pipe character (|) between the fields as a separator.

We have made the file which determines what data will be sent to the web page. We now have to add the correct HTML and JavaScript code to our web page to make use of the file.

The `<script>` tag is used to tell the browser that the following information is to be used by the JavaScript interpreter.

The first line sets the language, JavaScript, and tells the interpreter where to find the library file "AHAHlib.js" which has the autoUpdate function.

The second line tells the interpreter to run the autoUpdate function every 1000 milliseconds and to use the autotest.htm file to send back the tags data.

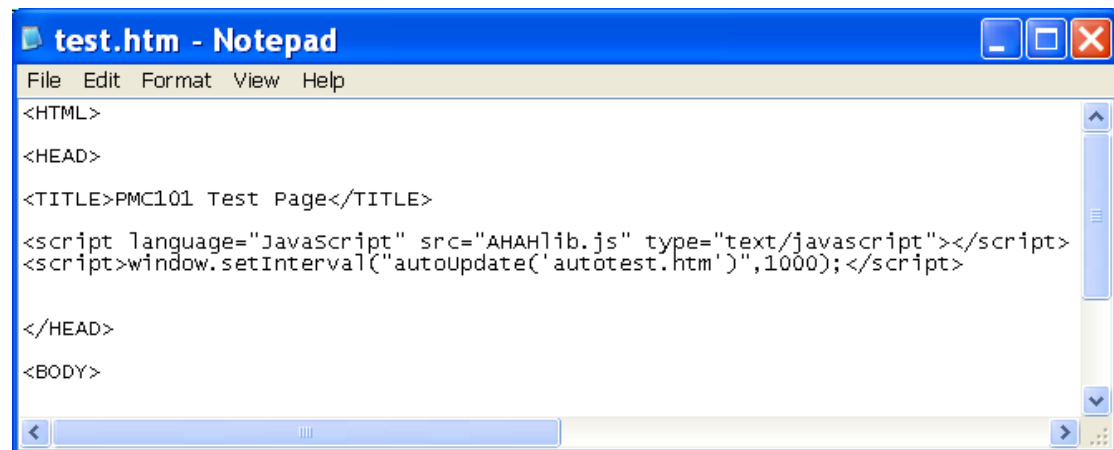

```
test.htm - Notepad
File Edit Format View Help
<HTML>
<HEAD>
<TITLE>PMC101 Test Page</TITLE>
<script language="JavaScript" src="AHAHlib.js" type="text/javascript"></script>
<script>>window.setInterval("autoUpdate('autotest.htm')",1000);</script>
</HEAD>
<BODY>
```

We now have to get the autoUpdate function to insert the data into the web page. The autoUpdate function looks through the web page for tags with ID's (Identification numbers).

When the browser gets the autotest.htm file from the PL101 it will read out M0001200=xxxx. The M0001200 is the tag ID, so the browser will look for a tag on the web page (id = "M0001200") and insert the data xxxx. The same applies to the tag %B0017.

In order to use the ID property, we need a tag that includes an ID property. For this we can use the built in `` tag. Add the span tags to the test.htm file as shown.

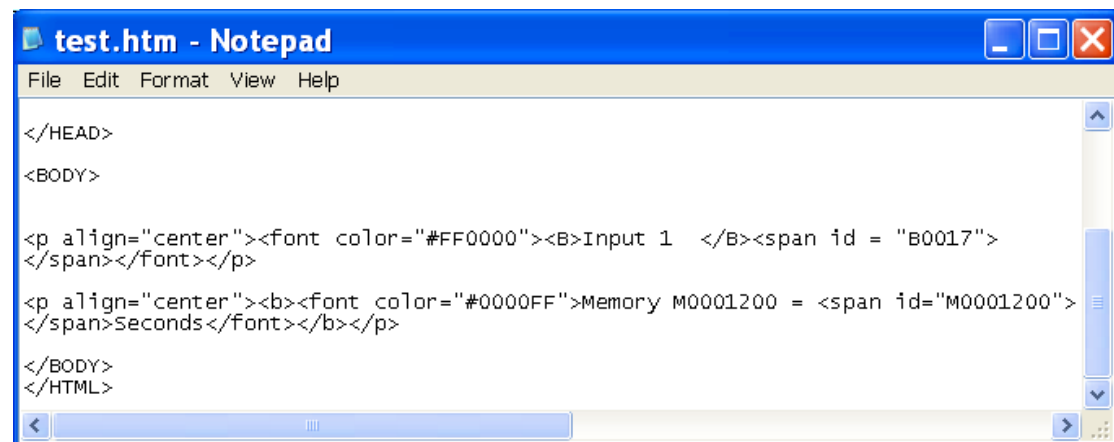

```
test.htm - Notepad
File Edit Format View Help
</HEAD>
<BODY>
<p align="center"><font color="#FF0000"><B>Input 1 </B><span id = "B0017">
</span></font></p>
<p align="center"><b><font color="#0000FF">Memory M0001200 = <span id="M0001200">
</span>Seconds</font></b></p>
</BODY>
</HTML>
```

Now put the three files into the PL101 as follows:

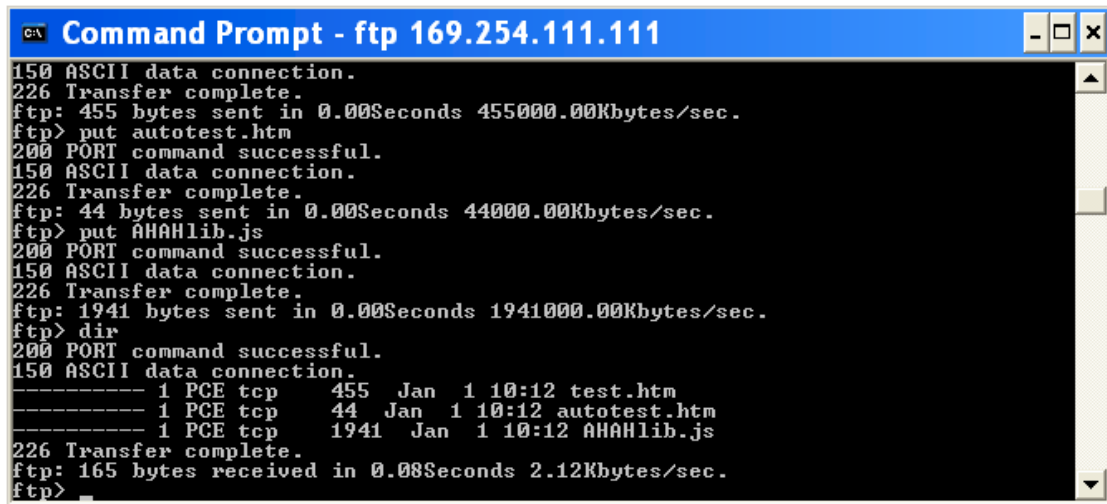

```
CA Command Prompt - ftp 169.254.111.111
150 ASCII data connection.
226 Transfer complete.
ftp: 455 bytes sent in 0.00Seconds 455000.00Kbytes/sec.
ftp> put autotest.htm
200 PORT command successful.
150 ASCII data connection.
226 Transfer complete.
ftp: 44 bytes sent in 0.00Seconds 44000.00Kbytes/sec.
ftp> put AHAHlib.js
200 PORT command successful.
150 ASCII data connection.
226 Transfer complete.
ftp: 1941 bytes sent in 0.00Seconds 1941000.00Kbytes/sec.
ftp> dir
200 PORT command successful.
150 ASCII data connection.
----- 1 PCE tcp 455 Jan 1 10:12 test.htm
----- 1 PCE tcp 44 Jan 1 10:12 autotest.htm
----- 1 PCE tcp 1941 Jan 1 10:12 AHAHlib.js
226 Transfer complete.
ftp: 165 bytes received in 0.00Seconds 2.12Kbytes/sec.
ftp>
```

Next open the browser and load the file test.htm from the PL101. You will see the seconds changing on the screen.

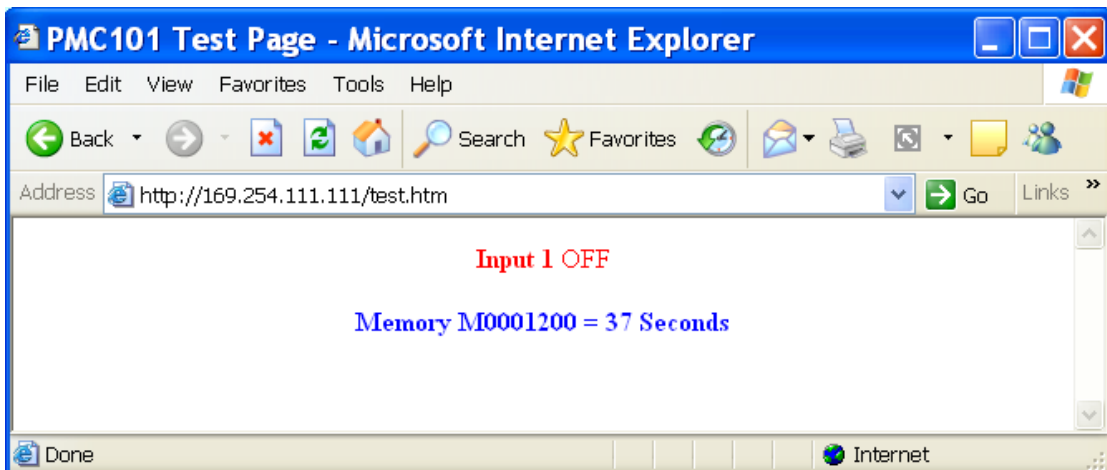

4.6 Using Radio Buttons to switch a Digital On and OFF.

Sometimes you may want to do more than just open a web page and view the contents. You may want to interact with the PL101 so that you can switch digitals on and off from the web page. One way of doing this is by using Radio Buttons.

Radio Buttons work in sets, where you can never push two buttons at once, and only one button can be **checked** at a time. Once you have checked the On or Off button, you need to send the information to the PL101 by clicking on a **Submit button**.

To use Radio Buttons you initially need to create a **Form** tag. The Radio Buttons and Submit button are placed within the Form tags.

The first line of the Form code is as follows:

```
<FORM METHOD=POST>
```

This line tells the browser that a form is being initiated and the POST command must be used to submit the information on the form.

Next we use the hidden input field:

```
<INPUT TYPE="hidden" NAME="form" VALUE="test">
```

This line informs the PL101 that name of the web page (**form**) that is sent back after the submit button is pressed is **test**. You could send back some other web page but you would normally want to just get an update of the current web page test.htm.

Now we do the Radio Button code:

```
<INPUT TYPE="RADIO" NAME="B0145" VALUE="ON" %C0145><font color="#008080">On</font>  
<INPUT TYPE="RADIO" NAME="B0145" VALUE="OFF" %D0145><font color="#FF0000">Off</font>
```

- INPUT TYPE="RADIO" tells the browser to put a Radio button on the web page. We use this twice to add two radio buttons.
- The Name is used to inform the PL101 which digital must be updated. Both radio buttons must have the same name so that they work together.
- The VALUE="ON" is sent to the PL101 when the first radio button is checked. The VALUE="OFF" is sent to the PL101 when the second radio button is checked.
- The %C0145 tag is used with the ON button and the %D0145 tag is used with the OFF button. If the digital is ON then the %C0145 tag will return *checked* to the browser and the %D0145 tag will return nothing to the browser. If the digital is OFF then the %C0145 tag will return nothing to the browser and the %D0145 tag will return *checked* to the browser.
- Finally we label the Radio Buttons with the text On and Off.

To send the information on the form to the PL101 we use the following code:

```
<INPUT TYPE="submit" VALUE="Update">
```

This code puts a Submit button on the web page with the label "Update".

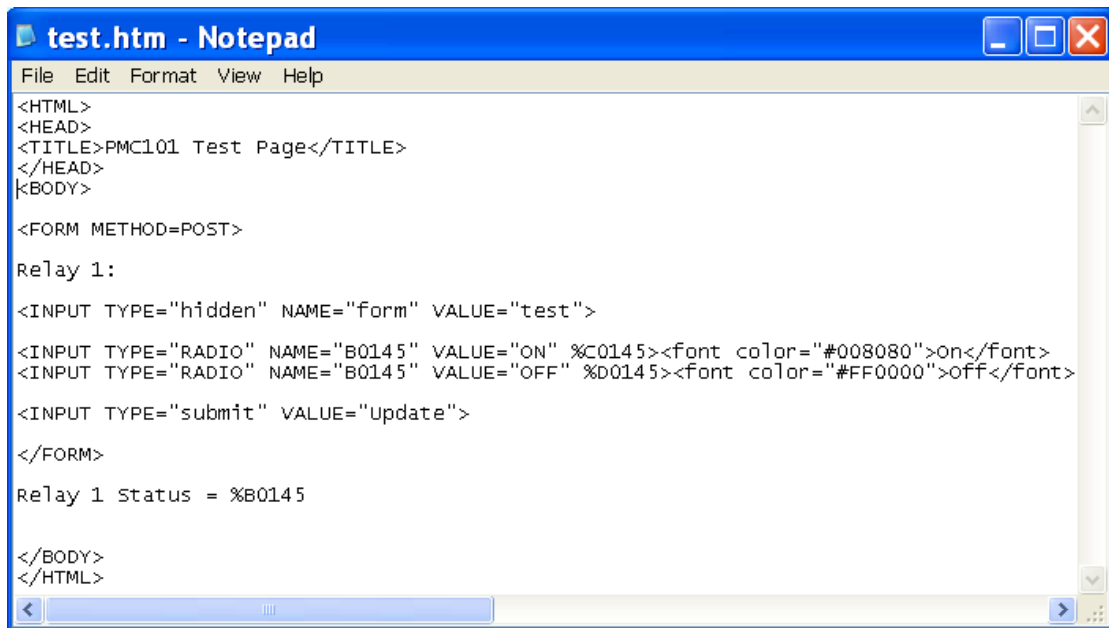

```
<HTML>
<HEAD>
<TITLE>PMC101 Test Page</TITLE>
</HEAD>
<BODY>

<FORM METHOD=POST>
Relay 1:
<INPUT TYPE="hidden" NAME="form" VALUE="test">
<INPUT TYPE="RADIO" NAME="B0145" VALUE="ON" %C0145><font color="#008080">on</font>
<INPUT TYPE="RADIO" NAME="B0145" VALUE="OFF" %D0145><font color="#FF0000">off</font>
<INPUT TYPE="submit" VALUE="update">
</FORM>
Relay 1 status = %B0145

</BODY>
</HTML>
```

Now ftp the file test.htm to the PL101 and open it with your browser.

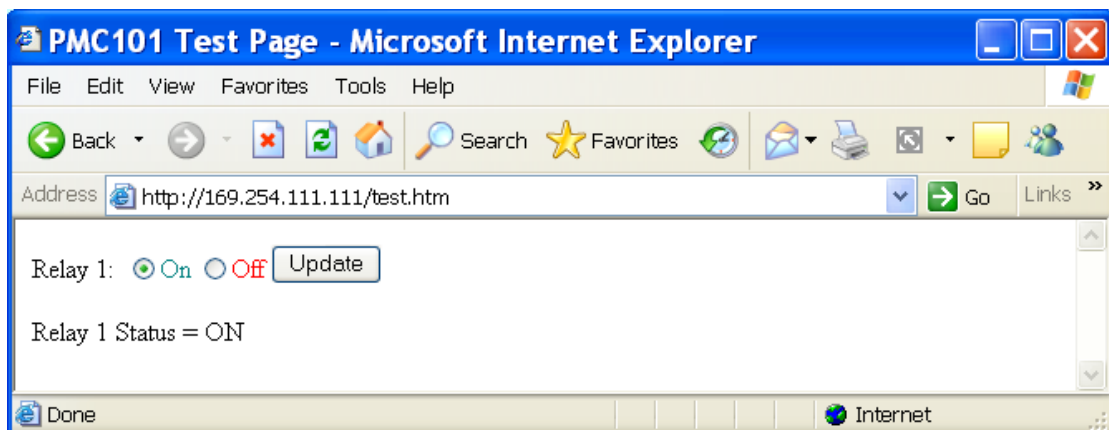

To test the web page, click on the On radio button and then Update. The Relay 1 Status should change to ON.

4.7 Using a Text Box to enter a new Analog Value.

This example shows how to write a new analog value to a memory location in the PL101.

A form is also required as with the Radio Button example.

The new value is entered into the text box as follows:

```
<input type="text" name="M0000100" size="5" maxlength="5" value="%M0000100">
```

- First a text box is added to the web page.
- The name="M0000100" tag informs the PL101 which memory is to be updated.
- The size determines the size of the text box on the web page.
- The maxlength determines how many numbers you can type into the text box.
- The " value="%M0000100" is used fill in the analog contents of the memory M100 when the web page is being sent to the browser so that you see it in the text box when the web page is displayed.

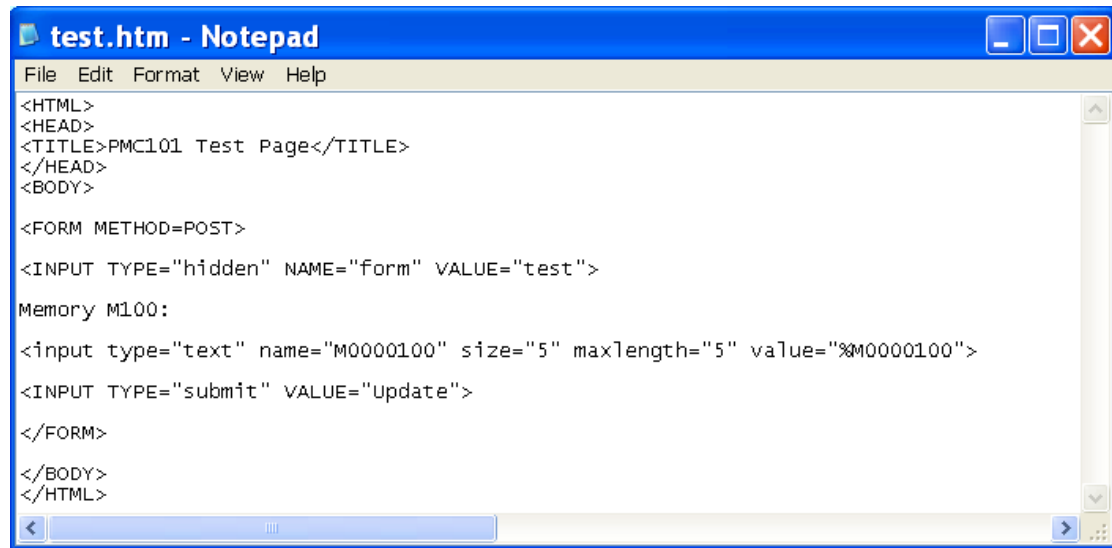

```
test.htm - Notepad
File Edit Format View Help
<HTML>
<HEAD>
<TITLE>PMC101 Test Page</TITLE>
</HEAD>
<BODY>

<FORM METHOD=POST>
<INPUT TYPE="hidden" NAME="form" VALUE="test">
Memory M100:
<input type="text" name="M0000100" size="5" maxlength="5" value="%M0000100">
<INPUT TYPE="submit" VALUE="Update">
</FORM>
</BODY>
</HTML>
```

Now ftp the file test.htm to the PL101 and open it with your browser.

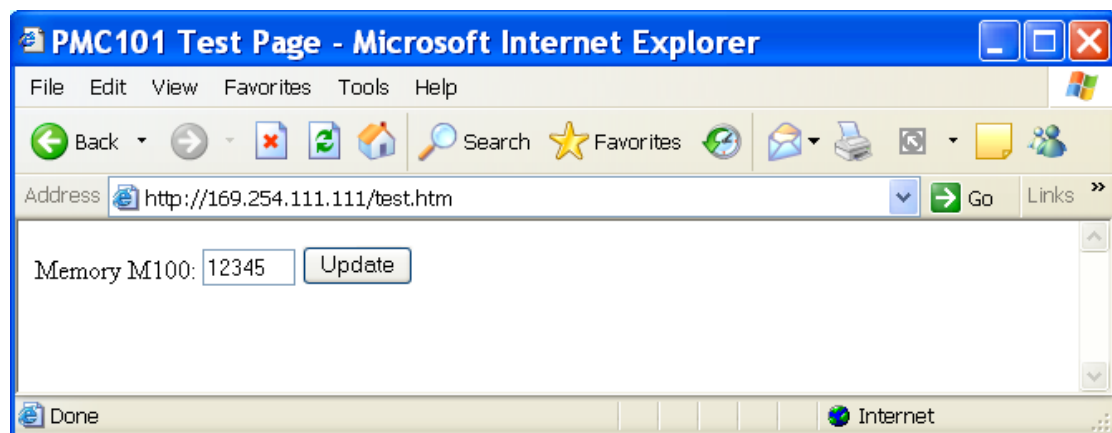

Type a new value into the text box and click on Update. The new value will now be in the PL101.

5. SPECIFICATIONS

5.1 Environmental

Operating Temperature	-30°C to +80°C
Storage Temperature	-40°C to +85°C
Humidity	Up to 95% non condensing.

5.2 EMC Installation Instructions

1. Screened twisted pair RS485 cable must be used with the screen grounded at one point only.
2. The RS485 cable must be terminated at both ends using a 120 ohm resistor.
3. Use should be made of screened I/O, T/C, RTD cable with the screens grounded at one point as close to the PROLOGIC module as possible.
4. The PROLOGIC modules must be installed in an appropriate enclosure inaccessible to the operator during normal use.

5.3 Conformity Certificate

DECLARATION OF CONFORMITY according to EN 45014		
Manufacturer's Name:	Procon Electronics CC	
Manufacturer's Address:	26 Wareing Park 2 Wareing Road Pinetown 3610 South Africa	
declares that the product		
Product Name:	PROLOGIC	
Model Number(s):	PL16DI, PL16DO, PL8DIO, PL4RO, PL8AI/I, PL8AI/V, PL8AI/IISO, PL8AI/VISO, PL8AO, PL8VO, PL8TC, PL8TCISO, PL6RTD, PLDAIO, PL100, PL101.	
complies with EMC Directive 89/336/EEC and Low Voltage Equipment Directive 73/23/EEC and conforms to the following Product specifications:		
Safety:	IEC 950	
EMC:	EN 61326-1 Electrical Equipment for measurement, control and laboratory use.	
<u>Pinetown, SA</u> Location	<u>August 2006</u> Date	D.Ruddock

5.4 EMC Test Results

PROLOGIC EMC Test Results									
Test	Standard	Test Value	PROLOGIC Product Compliance (PL)						
Immunity Test Results EN 61326-1			16DI	16DO	4RO	8DIO	8AII	8AII ISO	8AIV
Electrostatic Discharge	IEC 61000-4-2	8KV Air	A	A	A	A	A	B	A
		4KV Contact	A	A	A	A	A	A	A
Radiated Field	IEC 61000-4-3	10V/m	A	A	A	A	A	A	A
Fast Transients	IEC 61000-4-4	Power 2KV	A	A	A	A	A	B	A
		I/O 1KV	A	A	A	A	A	B	A
Surge	IEC 61000-4-5	Power 1KV/2KV	A	A	A	A	A	A	A
RF Conducted	IEC 61000-4-6	Power 3 Vrms	A	A	A	A	A	A	A
Voltage Interrupt	IEC 61000-4- 11	0.5cycle 100%	A	A	A	A	A	A	A
Emissions Test Results EN 61326-1 Class A									
Radiated Emissions	CISPR 22	Class A	✓	✓	✓	✓	✓	✓	✓
Conducted Emissions	CISPR 22	Class B	✓	✓	✓	✓	✓	✓	✓

Test	Standard	Test Value	PROLOGIC Product Compliance (PL)						
Immunity Test Results EN 61326-1			8AIV ISO	8TC	8TC ISO	6RTD	DAIO	8AO	8VO
Electrostatic Discharge	IEC 61000-4-2	8KV Air	B	A	B	A	A	A	B
		4KV Contact	A	A	A	A	A	A	A
Radiated Field	IEC 61000-4-3	10V/m	A	A	A	A	A	A	A
Fast Transients	IEC 61000-4-4	Power 2KV	B	A	B	A	A	A	A
		I/O 1KV	B	A	B	A	A	A	A
Surge	IEC 61000-4-5	Power 1KV/2KV	A	A	A	A	A	A	A
RF Conducted	IEC 61000-4-6	Power 3 Vrms	A	A	A	A	A	A	A
Voltage Interrupt	IEC 61000-4- 11	0.5cycle 100%	A	A	A	A	A	A	A
Emissions Test Results EN 61326-1 Class A									
Radiated Emissions	CISPR 22	Class A	✓	✓	✓	✓	✓	✓	✓
Conducted Emissions	CISPR 22	Class B	✓	✓	✓	✓	✓	✓	✓