



www.eurocarb2011.org  
info@eurocarb2011.org

# 16<sup>th</sup> European Carbohydrate Symposium

July 3<sup>rd</sup> - 7<sup>th</sup>, 2011  
Sorrento - Naples, Italy

## EUROCARB

■ eBook

## ABSTRACT



### Organizing Committee

University  
of Naples Federico II



Antonio Molinaro (Chair)  
Rosa Lanzetta (co-Chair)  
Michelangelo Parrilli  
Giovanni Palumbo  
Maria Michela Corsaro  
Cristina De Castro

In collaboration with

University  
of Milan-Bicocca



Francesco Nicotra (co-Chair)

University  
of Salerno



Raffaele Riccio

## **EDITORS**

Prof. Antonio Molinaro  
Prof.ssa Rosa Lanzetta  
Prof. ssa Maria Michela Corsaro  
Prof. Giovanni Palumbo

## **ADDRESS**

Università di Napoli Federico II  
Complesso Universitario Monte Sant'Angelo  
Dipartimento di Chimica Organica e Biochimica  
Via Cintia 4,  
80126 Napoli, Italy

## **PRODUCED BY**

YES Meet  
Via S. Nicola, 4  
80067 Sorrento (NA), Italy  
Tel. +39 0818770604  
Fax. +39 0818770258  
*info@eurocarb2011.org*  
*info@yesmeet.it*

## **PUBLISHER**

EDIZIONI ZIINO – Italy  
*www.edizioniziino.com*  
*www.comunicazionecongressuale.com*

## **NOTE**

Abstracts are published as submitted. Organizers do not accept any responsibility regarding the accuracy of the submission.

## WELCOME ADDRESS

Dear friends and colleagues,

The European Carbohydrate Organization (ECO) and the Local Organizing Committee cordially welcome you at the 16<sup>th</sup> European Carbohydrate Symposium (Eurocarb16), in Sorrento (Napoli) in July 3<sup>rd</sup> -7<sup>th</sup>, 2011, during the International Year of Chemistry.

At the moment I am writing this message, more than 650 participants representing 46 different countries have registered; the scientific program will deal with all the chemical, biological, biophysical and biotechnological aspects of carbohydrates, and will cover more than 150 Oral communications, 28 Invited lectures, 10 Plenary lectures, two Awarded plenary lectures as well as 400 Poster contributions. The Organisers would like to thank the members of the Scientific Advisory Board for the help and scientific guidance in planning and compiling the final program which foresees the presence of state-of-art Glycomics delivered by internationally recognized colleagues.

The meeting will take place in Sorrento at Hilton Sorrento Palace and it is organised by University of Napoli Federico II. It is indeed a very special occasion because it is the first time that such an important meeting is organised in Italy and in particular in Naples. Following the tradition of the previous meetings, the Emil-Fischer Carbohydrate Award and the Carbohydrate Research Award will be presented during the opening ceremony.

There will be two poster sessions and the organizers thank the European Journal of Organic Chemistry (Wiley WCH) and the European Polysaccharide Network Of Excellence (EPNOE) for donation of poster prizes. In addition, one plenary lecture is kindly sponsored by Starch (Wiley WCH).

The financial support by many organizations and companies is gratefully acknowledged and has been pivotal to keep the fees for students at a very competitive level and to include for all kind of registrations the Symposium Banquet within the registration fee. The symposium will be opened by a Welcome Reception after the two Award lectures, and from Monday on it will develop in four parallel sessions; the Wednesday afternoon is left for excursions and for the first time, the Symposium will be closed on Thursday evening by Symposium Banquet.

On behalf of the organizing committee I wish you a scientifically productive Eurocarb 16!  
Sincerely,

*Antonio Molinaro*  
*Symposium Chair*

## EUROPEAN CARBOHYDRATE ORGANIZATION (ECO)

President	Paul Kosma, Austria
Past President	Otto Holst, Germany
Secretary	Benjamin Davis, United Kingdom
Symposium	Chairman Antonio Molinaro, Italy

## NATIONAL REPRESENTATIVES

Austria	P. Kosma
Belgium	L. Wyns
Croatia	S. Tomic-Pisarovic
Czech Republic	V. Kren
Denmark	M. Bols
France	D. Bonnaffé
Germany	J. Thiem
Hungary	L. Somsák
Ireland	A. Savage
Israel	T. Baasov
Italy	F. Nicotra
Norway	B. Christensen
Poland	M. Chmielewski
Portugal	A. Rauter
Russia	Y. A. Knirel
Slovak Republic	J. Hirsch
Spain	M. Martin-Lomas
Sweden	S. Oscarson
Switzerland	B. Ernst
The Netherlands	J. P. Kamerling
United Kingdom	B. Davis



## PAST EUROCARB SYMPOSIA

<b>Year</b>	<b>Location</b>	<b>Chairperson</b>
1981	Vienna, Austria	Frank M. Unger
1983	Budapest, Hungary	Rezsoe Bognar
1985	Grenoble, France	Jacques Defaye
1987	Darmstadt, Germany	Frieder Lichtenthaler
1989	Prague, Czech Republic	Miloslav Czerny
1991	Edinburgh, UK	Grant Buchanan
1993	Cracow, Poland	Alexander Zamojski
1995	Seville, Spain	Manuel Martin-Lomas
1997	Utrecht, The Netherlands	Hans Vliegenthart
1999	Galway, Ireland	Angela Savage
2001	Lisbon, Portugal	Amélia Rauter
2003	Grenoble, France	Serge Perez
2005	Bratislava, Slovak Republic	Ján Hirsch
2007	Lübeck, Germany	Otto Holst
2009	Wien, Austria	Paul Kosma

## LOCAL ORGANIZING COMMITTEE

Chair Antonio Molinaro (Università di Napoli Federico II)

Co-Chairs Rosa Lanzetta (Università di Napoli Federico II)  
Francesco Nicotra (Università di Milano Bicocca)

Maria Michela Corsaro (Università di Napoli Federico II)  
Cristina De Castro (Università di Napoli Federico II)  
Giovanni Palumbo (Università di Napoli Federico II)  
Michelangelo Parrilli (Università di Napoli Federico II)  
Raffaele Riccio (Università degli Studi di Salerno)

**EUROPEAN ADVISORY BOARD**

- |     |                                       |     |                              |
|-----|---------------------------------------|-----|------------------------------|
| 1.  | G. Catelani, Italy                    | 23. | R. R. Schmidt, Germany       |
| 2.  | M. Chmielewski, Poland                | 24. | J. Thiem, Germany            |
| 3.  | B. Christensen, Norway                | 25. | T. Baasov, Israel            |
| 4.  | J. Defaye, France                     | 26. | Ben Davis, UK                |
| 5.  | D. Garozzo, Italy                     | 27. | B. Ernst, Switzerland        |
| 6.  | T. Feizi, United Kingdom              | 28. | L. Somsak, Hungary           |
| 7.  | I. Tvaroska, Slovak Republic          | 29. | D. Bonnaffé, France          |
| 8.  | O. Holst, Germany                     | 30. | L. Wyns, Belgium             |
| 9.  | E. Hounsell, United Kingdom           | 31. | S. Tomic-Pisarovic, Slovenia |
| 10. | O. Hindsgaul, Denmark                 |     |                              |
| 11. | J. Jimenez-Barbero, Spain             |     |                              |
| 12. | J. P. Kamerling, The Netherlands      |     |                              |
| 13. | Y. A. Knirel, Russia                  |     |                              |
| 14. | P. Kosma, Austria                     |     |                              |
| 15. | V. Kren, Czech Republic               |     |                              |
| 16. | M. Martin-Lomas, Spain                |     |                              |
| 17. | S. Oscarson, Sweden                   |     |                              |
| 18. | Anthony Moran, Ireland<br>Passed away |     |                              |
| 19. | U. Lindahl, Sweden                    |     |                              |
| 20. | G. Widmalm, Sweden                    |     |                              |
| 21. | S. Perez, France                      |     |                              |
| 22. | A. Rauter, Portugal                   |     |                              |

### THE EMIL FISCHER CARBOHYDRATE AWARD

The Emil Fischer Carbohydrate Award has been established by the European Carbohydrate Organization in order to honor active carbohydrate scientists distinguished with contributions of excellence. Following Richard R. Schmidt as the first awarded in 2009, the Emil Fischer Award 2011 will be presented to David Crich in recognition of his outstanding accomplishments in vital areas of glycochemistry.

Prof. Crich will present a plenary lecture on his work at the Eurocarb conference.



## CARBOHYDRATE RESEARCH AWARD

The *Carbohydrate Research* Award for Creativity in Carbohydrate Chemistry is given every two years to a carbohydrate scientist, no older than 15 years past the PhD, who has made significant original contributions to the field, in its broadest sense. The Award consists of a cheque for \$1000, a certificate and a complimentary subscription to the journal for two years. The 2011 Award is presented to Professor Matthieu Sollogoub, Professor of Molecular Chemistry at the Université Pierre et Marie Curie-Paris 6, Sorbonne Universités, Paris, France.



The research in Professor Sollogoub's group focuses on carbohydrates in the broadest sense ranging from monosaccharides, carbasugars, iminosugars, nucleotides to cyclodextrins and polysaccharides. It includes organic synthesis and methodology, inhibitor design, molecular probing of enzyme mechanism, supramolecular chemistry and catalysis. Notable recent achievements have included the development of novel methods for the site-selective functionalisation of cyclodextrins, the development of novel methodology for iminosugar and carbasugar synthesis, with the introduction of fluoro-carbasugars, the identification of cyclodextrin-based catalysts for asymmetric synthesis, with the new concept of pseudo-enantiomery and the development of supramolecular cross-linking agents for carbohydrate-based biopolymers. Professor Sollogoub has recently been appointed to the Institut Universitaire de France (IUF), an elite French institution, in recognition of his contributions to teaching and research in chemistry in general and in carbohydrate science in particular.

Previous winners of the *Carbohydrate Research* Award for Creativity in Carbohydrate Chemistry:

2001 Laura L. Kiesling, University of Wisconsin-Madison, USA

2003 Geert-Jan Boons, University of Georgia, USA

2005 Peter H. Seeberger, Eidgenössische Technische Hochschule Zürich, Switzerland

2007 Todd L. Lowary, University of Alberta, Canada

2009 Benjamin G. Davis, Oxford University, United Kingdom

## ACKNOWLEDGEMENTS



*Con il Patrocinio della Provincia di Napoli  
Questa iniziativa è contro il "Sistema" della camorra*



[www.neb.com](http://www.neb.com)



[www.edises.it](http://www.edises.it)



**Agilent Technologies**

[www.agilent.it](http://www.agilent.it)



[www.discoverysciences.com](http://www.discoverysciences.com)



[www.premierbiosoft.com](http://www.premierbiosoft.com)



[www.thieme-chemistry.com](http://www.thieme-chemistry.com)



**Taylor & Francis**  
Taylor & Francis Group

[www.taylorandfrancisgroup.com](http://www.taylorandfrancisgroup.com)



[www.epnoe.eu](http://www.epnoe.eu)



[www.eurjoc.com](http://www.eurjoc.com)



[www.piccin.it](http://www.piccin.it)



University of Natural Resources  
and Applied Life Sciences, Vienna  
Department of Chemistry

[www.boku.ac.at](http://www.boku.ac.at)



<http://www.mizutanifdn.or.jp>



## ACKNOWLEDGEMENTS



[www.cargill.com](http://www.cargill.com)



[www.omicronbio.com](http://www.omicronbio.com)



[www.absciex.com](http://www.absciex.com)



[www.dionex.com](http://www.dionex.com)



[www.bcp.it](http://www.bcp.it)



[www.carbosynth.com](http://www.carbosynth.com)



[www.novartis.com](http://www.novartis.com)



[http://onlinelibrary.wiley.com/journal/10.1002/\(ISSN\)1521-379X](http://onlinelibrary.wiley.com/journal/10.1002/(ISSN)1521-379X)



[www.lcsci.com](http://www.lcsci.com)



[www.bruker.com](http://www.bruker.com)



<http://www.cost.esf.org>

# TABLE OF CONTENTS

AWARD LECTURES	PAG. 12
PLENARY LECTURES	PAG. 15
INVITED LECTURES	PAG. 26
SPONSOR LECTURES	PAG. 55
ORAL PRESENTATIONS	PAG. 59
POSTER	PAG. 214
LIST OF PARTICIPANTS	PAG. 593

**AWARD  
LECTURES**

## AL 01

**METHODOLOGY DEVELOPMENT AND PHYSICAL ORGANIC CHEMISTRY;  
A POWERFUL COMBINATION FOR THE ADVANCEMENT  
OF GLYCOCHEMISTRY**

David Crich

*Centre de Recherche de Gif, Institut de Chimie des Substances Naturelles,  
CNRS, 91190 Gif-sur-Yvette, France  
dcrich@icsn.cnrs-gif.fr*

The lecture will consist of a personal overview of the current challenges faced by organic chemists working in the area of glycochemistry and glycoscience,<sup>1</sup> and a presentation of recent work in our laboratories directed at their solution.

**References**

1. (a) Bohé, L.; Crich, D. *Trends. Glycosci. Glycotech.* **2010**, *22*, 1-15. (b) Bohé, L.; Crich, D. *Comptes Rendus* **2011**, *14*, 3-16. (c) Crich, D. *Acc. Chem. Res.* **2010**, *43*, 1144-1153. (d) Aubry, S.; Sasaki, K.; Sharma, I.; Crich, D. *Topics in Current Chemistry* **2011**, DOI: 10.1007/128\_2010\_102. (e) Guinchard, X.; Picard, S.; Crich, D. In *Modern Tools for the Synthesis of Complex Bioactive Molecules*; Arseniyadis, S., Cossy, J., Eds.; Wiley: Hoboken, 2011, p in press.

## AL 02

## NEW OPPORTUNITIES FOR CYCLODEXTRINS

Matthieu Sollogoub

UPMC Univ Paris 06, Sorbonne Universités, IUF, IPCM, C181, 4 place Jussieu,  
75005 Paris, France  
matthieu.sollogoub@upmc.fr

Concave molecules such as cyclodextrins desperately need efficient poly hetero-functionalization methods to fulfil their promises. Based on the discovery of a regioselective debenzoylation reaction of sugars, and the understanding of its mechanism,<sup>1</sup> we delineated several strategies to access such cyclodextrins. Bascule-bridging and deoxygenation of sugars are two complementary ways to reach an unprecedented degree of complexity of functionalization of the primary rim of cyclodextrins allowing the access to a library of diversely functionalised cyclodextrins.<sup>2</sup>

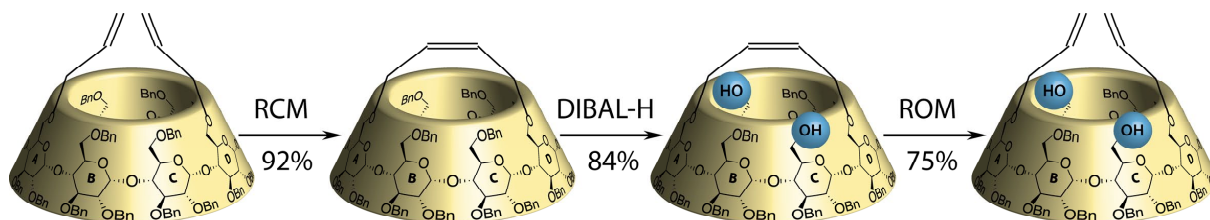

The access to such complex structures allows applications in a wide range of areas. We explored some, such as asymmetric catalysis using regioisomers<sup>3</sup> or the elaboration new biomaterial through supramolecular assemblies of physically cross-linked biopolymers.<sup>4</sup> It is our strong belief that many other possibilities are offered by this methodology.

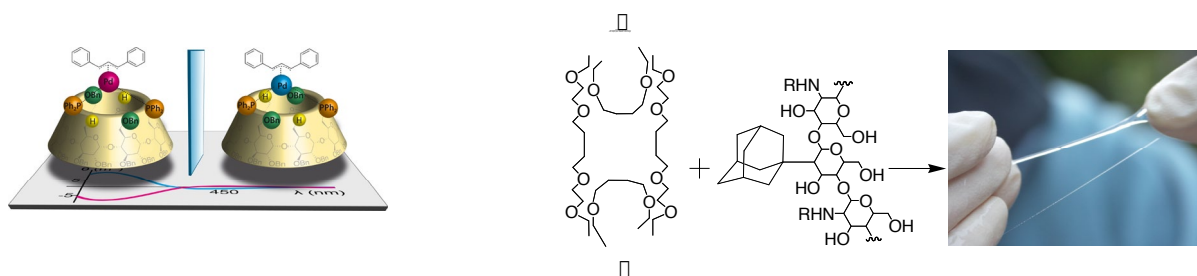
**References**

1. T. Lecourt, A. Hérault, A. J. Pearce, M. Sollogoub, P. Sinaÿ, *Chem. Eur. J.* **2004**, *10*, 2960-2971.
2. O. Bistri, P. Sinaÿ, M. Sollogoub, *Chem. Commun.* **2006**, 1112-1114; O. Bistri, P. Sinaÿ, J. Jimenez-Barbero, M. Sollogoub, *Chem. Eur. J.* **2007**, *13*, 9757-9774; S. Guieu, M. Sollogoub, *J. Org. Chem.* **2008**, *73*, 2819-2828; S. Guieu, M. Sollogoub *Angew. Chem., Int. Ed.* **2008**, *47*, 7060-7063.
3. S. Guieu, E. Zaborova, Y. Blériot, G. Poli, A. Jutand, D. Madec, G. Prestat, M. Sollogoub, *Angew. Chem. Int. Ed.* **2010**, *49*, 2314-2318
4. O. Bistri, K. Mazeau, R. Auzély-Velty, M. Sollogoub, *Chem. Eur. J.* **2007**, *13*, 8847-8857; T. Lecourt, Y. Blériot, R. Auzely-Velty, M. Sollogoub *Chem. Commun.*, **2010**, *46*, 2238-2240.



**PLENARY  
LECTURES**

## PL 01

## STRUCTURE AND FUNCTION OF CERTAIN BACTERIAL GLYCOLIPIDS

Otto Holst

*Division of Structural Biochemistry, Research Center Borstel, Leibniz-Center for Medicine and Biosciences, Parkallee 4a/c, D-23845 Borstel, Germany*  
*oholst@fz-borstel.de*

Glycolipids are amphiphilic membrane components that occur in all kingdoms of organisms, i.e., bacteria, plants, and animals including man. Glycolipids represent a very heterogeneous group of molecules which possess one or more monosaccharide units linked by a glycosyl linkage to a hydrophobic moiety like acylglycerol, ceramide, or prenyl phosphate. These glycoconjugates are not only important factors of membrane and cell surface stabilization but also play an important role in a broad variety of biological processes, e.g., in cell-cell communication, in receptor modulation, or in signal transduction.

This presentation deals with three particular examples of bacterial glycolipids, namely the phosphoinositolmannosides from pathogenic *Mycobacterium tuberculosis* comprising a heterogeneous mixture of molecules which could be separated into single species, glucosyldiacylglycerols from *Enterococcus faecalis* and their impact on biofilm production, and glucosylated sphingo- and glyceroletherlipids from *Sorangium cellulosum*, a Gram-negative bacterium that lacks lipopolysaccharide.

## PL 02

## AUTOMATED SYNTHESIS OF GLYCOSAMINOGLYCANS

Peter H. Seeberger<sup>1,2,3</sup> Steffen Eller,<sup>1,2</sup> Jian Yin,<sup>1,2</sup> Heung Sik Hahm,<sup>1,2</sup> Mayeul Collot,<sup>1,2</sup>  
J. Cullen Klein<sup>1,2</sup>

<sup>1</sup>*Max-Planck Institute of Colloids and Interfaces, Potsdam, Germany,*

<sup>2</sup>*Free University of Berlin, Germany and*

<sup>3</sup>*The Burnham Institute, La Jolla, CA USA, Arnimallee 22 14195 Berlin (Germany)*

*peter.seeberger@mpikg.mpg.de*

While heparin, a glycosaminoglycan (GAG) has served as an anticoagulant in heart disease for more than 60 years, the structure-activity relationship of heparin and chondroitin sulfate for specific interactions with proteins are still poorly understood. It has become evident that defined lengths and sequences or patterns are responsible for binding to a particular protein and modulating its biological activity. Determination of the structure-activity relationships of heparins and chondroitins creates an opportunity for the discovery of novel therapeutic interventions for a variety of disease states.

Defined heparin and chondroitin oligosaccharides are valuable molecular tools that have significantly contributed to gaining some understanding of specific sequences that are bound by particular proteins. Currently available synthetic methods for the preparation of heparins and chondroitins are time consuming and lack generality.

This plenary lecture will disclose for the first time a fully automated approach to GAG synthesis to produce defined heparin and chondroitin oligosaccharides with a linker on the reducing end to allow for ready attachment to surfaces and particles. These molecular tools have been employed to study the interaction of GAGs with growth factors, chemokines and other proteins.

**References**

1. Eller, S.; Yin, Y.; Hahm, H.S.; Collot, M.; Klein, J.C.; manuscript in preparation.

## PL 03

## THE UNIQUE SYSTEM OF N-LINKED PROTEIN GLYCOSYLATION

Markus Aebi

*ETH Zurich, Department of Biology, 8093 Zurich, Switzerland  
aebi@micro.biol.ethz.ch*

N-linked protein glycosylation is the most frequent post-translation modification in eukaryotic cells. The essential process initiates in the Endoplasmic Reticulum, where an oligosaccharide is assembled on the lipid carrier, dolichylpyrophosphate. In most of the eukaryotes, the oligosaccharide transferred is Glc<sub>3</sub>Man<sub>9</sub>GlcNAc<sub>2</sub>, however, in protozoa, simpler structures are also found. The covalent linkage of the oligosaccharide to selected asparagines residues of polypeptide chains, characterized by the sequon AsN-X-Ser/Thr (X = any amino acid residue except proline), is performed by the oligosaccharyltransferase (OST), a complex enzyme that is composed of eight different subunits, all of them membrane embedded proteins.

Interestingly, *Campylobacter jejuni*, a Gram-negative bacterium, is able to N-glycosylate proteins as well. A detailed analysis of this prokaryotic post-translational modification became possible due to the functional transfer of the pathway into the model system *Escherichia coli*. This analysis revealed that the bacterial and the eukaryotic process are homologous pathways that are based on the same principles: both pathways utilise isoprenoid lipids as carriers for the assembly of the oligosaccharide in the cytoplasm (requiring a translocation of the oligosaccharide across the membrane) and the AsN-X-Ser/Thr is the protein acceptor sequence in both cases. Importantly, the bacterial oligosaccharyltransferase consists of one single protein that is very similar in sequence to one of the essential subunits of the eukaryotic OST complex. Based on the structure of the bacterial enzyme, a catalytic mechanism for N-linked protein glycosylation is discussed.

## PL 04

**THE SPECIFIC INTERACTION OF CARBOHYDRATES WITH PROTEINS.  
A 3D VIEW BY USING NMR**

Jesús Jiménez-Barbero

*Centro de Investigaciones Biológicas-CSIC, Ramiro de Maeztu 9, 28040 Madrid  
jjbarbero@cib.csic.es*

Molecular recognition by specific targets is at the heart of the life processes. In recent years, it has been shown that the interactions between proteins (lectins, enzymes, antibodies) and carbohydrates mediate a broad range of biological activities, from fertilization, embryogenesis, and tissue maturation, to pathological processes. The elucidation of the mechanisms that govern how sugars are accommodated in the binding sites of these receptors is currently a topic of interest. Thus, the determination of the structural and conformational factors and the physicochemical features which govern the molecular recognition of these molecules is of paramount importance. This presentation is focused on the application of NMR methods to the study of molecular recognition processes between a variety of polypeptides and carbohydrate molecules and analogues as well as sugar-sugar interactions. Special attention will be paid to the conformational and structural details of the interaction process, with particular emphasis in the origin and strength of CH- $\pi$  interactions. The use of isotope-labeled receptors and ligands (with <sup>13</sup>C, <sup>15</sup>N, or <sup>19</sup>F stable isotopes) highly facilitates the analysis of the interactions between carbohydrates and glycomimetics with the corresponding receptors.



## PL 05

## RECENT ADVANCES IN OLIGOSACCHARIDE MIMICS

Anna Bernardi

*Universita' degli Studi di Milano , Dipartimento di Chimica Organica e Industriale,  
via Venezian 21, 20133 Milano, Italy  
anna.bernardi@unimi.it*

Interference with oligosaccharide-mediated recognition events can be achieved using functional mimics of carbohydrates, that could thus be used to modulate / alter signal transmission, or to prevent the onset of diseases. In recent years our laboratory has designed and prepared glycomimetic inhibitors of well-known target lectins (cholera toxin, DC-SIGN) using conformationally stable cyclohexane diols to replace structural units of galactose or mannose in the context of oligosaccharide sequences.<sup>1,2</sup> More recently, we have concentrated our attention on  $\alpha$ -glycosyl amides as mimics of  $\alpha$ -glycosides potentially endowed with metabolic stability properties.<sup>3,4</sup> The presentation will discuss the synthetic methodology developed to synthesize  $\alpha$ -glycosyl amides<sup>5</sup> and to incorporate them in (unnatural) glycopeptides sequences, as well as some of the applications we are exploring for this type of carbohydrate mimics.

**References**

1. A. Bernardi, P. Cheshev *Chemistry Eur. J.* **2008**, *14*, 7434-7441
2. S. Sattin, A. Daghetti, M. Thépaut, A. Berzi, M. Sánchez -Navarro, G. Tabarani, J. Rojo, F. Fieschi, M. Clerici, A. Bernardi *ACS Chem. Biol.* **2010**, *5*, 301-312
3. M. Andreini, M. Anderluh, A. Audfray, A. Bernardi, A. Imberty, *Carbohydrate Research* **2010**, *345*, 1400-1407
4. G. Timpano, G. Tabarani, M. Anderluh, D. Invernizzi, F. Vasile, D. Potenza, P. M. Nieto, J. Rojo, F. Fieschi, A. Bernardi *ChemBioChem* **2008**, *9*, 1921-1930
5. A. Bianchi, A. Bernardi *J. Org. Chem.* *71*, 4565-4577, **2006**; F. Nisic, A. Bernardi *Carb Res.* **2008**, *343*, 1636-1643

## PL 06

## GLYCOSIDASES: CONFORMATIONS AND INHIBITOR DESIGN/APPLICATION TO MODIFY GLYCOSYLATIONS

Gideon J Davies*Department of Chemistry, University of York, York YO10 5DD, U.K.**davies@ysbl.york.ac.uk*

Work in the Davies group has, over many years, focussed on the conformational changes that sugars undergo along their reaction coordinate in the active centre of glycosidase enzymes<sup>1</sup>. These include distortion from the stable chair forms that dominate in solution to a variety of boat & skew boat forms that allow in-line nucleophilic attack and also relieve some of the steric hindrances to substitution reactions at the anomeric centre. Recent work has probed the O-GlcNAc hydrolase conformational pathways<sup>2</sup>, the itinerary of  $\alpha$ -L fucosidases where structural insight dovetails with computational approaches<sup>3</sup> as well as novel  $\alpha$ -mannosidases<sup>4</sup> found in the human microbiota. Work on the O-GlcNAc hydrolase (OGA) that is responsible for removing the dynamic O-GlcNAc modification in man has allowed our collaborators to develop specific enzyme inhibitors to allow perturbation of O-GlcNAc levels in cells. Such inhibitors have been inspired by classical physical organic chemistry approaches and through 3-D structures of enzyme-inhibitor complexes. Recently such mechanism-inspired compounds have been used to probe the neurodegenerative diseases termed “tauopathies”<sup>5</sup>.

**References**

1. Vocadlo, D.J & Davies, G. J. *Curr Opin Chem Biol* **2008**, *12*, 539.
2. He, Y., Macauley, M. S., Stubbs, K. A., Vocadlo, D. J., Davies, G. J. *J Am Chem Soc* **2010**, *132*, 1807.
3. Lammerts van Bueren, A., Ardevol, A., Fayers-Kerr, J., Luo, B., Zhang, Y. M., Sollogoub, M., Bleriot, Y., Rovira, C., & Davies, G. J. *J Am Chem Soc* **2010**, *132*, 1804.
4. Zhu, Y. P., Suits, M. D. L., Thompson, A. J., Chavan, S., Dinev, Z., Dumon, C., Smith, N., Moremen, K. W., Xiang, Y., Siriwardena, A., Williams, S. J., Gilbert, H. J. & Davies, G. J. *Nature Chemical Biology* **2010**, *6*, 125.
5. Yuzwa, S. A., Macauley, M. S., Heinonen, J. E., Shan, X., Dennis, R. J., He, Y., Whitworth, G. E., Stubbs, K. A., McEachern, E. J., Davies, G. J. & Vocadlo, D. J. *Nature Chemical Biology* **2008**, *4*, 483.

## PL 07

**THE SWEET TOOTH OF PATHOGENS:  
STRUCTURE AND FUNCTION OF LECTINS FROM  
OPPORTUNISTIC BACTERIA**

Anne Imberty

CERMAV-CNRS, 601 rue de la chimie, BP 53, 38041 Grenoble cedex 09, France  
imberty@cermav.cnrs.fr

Recent interest in bacterial lectins demonstrated their role in host recognition, biofilm formation, tissue adhesion and virulence. *Pseudomonas aeruginosa* and *Burkholderia cenocepacia* are opportunistic pathogens responsible for lung infections that are life-threatening for cystic fibrosis patients and immuno-compromised individuals. Both bacteria contain several calcium-dependant lectins that demonstrate high affinity for diverse oligosaccharides that are present on human tissues. We used combined titration microcalorimetry, x-ray crystallography and molecular modeling approaches to decipher the thermodynamical and structural basis for high affinity binding of bacterial lectins to host carbohydrates [1].

Antibacterial tests in animal models infected with *P. aeruginosa* have been successfully conducted with the use of different classes of glycomimetics [2]. The complete characterization of carbohydrate specificity, affinity and atomic details of interaction between bacterial lectins and their ligands allowed for the design and synthesis of high affinity glycomimetics and glycodendrimers that can act as antiadhesive compounds [3]. The affinity of bacterial lectins for carbohydrate derivatives can also be used for diagnostic approaches by nanoelectronic detection of lectin-carbohydrate interactions using carbon nanotubes [4].

**References**

1. A. Imberty, A. Varrot, *Curr. Opin. Struct. Biol.*, **2008**, *18*, 567-576
2. C. Chemani, A. Imberty, S. de Bentzmann, M. Pierre, M. Wimmerová, B. P. Guery, K. Faure, *Infect. Immun.*, **2009**, *48*, 2684-2698.
3. S. Cecioni, R. Lalor, B. Blanchard, J.P. Praly, A. Imberty, S. E. Matthews, S. Vidal, *Chemistry*, **2009**, *15*, 13232-13240
4. H. Vedala, Y. Chen, S. Cecioni, A. Imberty, S. Vidal, A. Star, *Nano Lett.*, **2011**, *11*, 170-175

## PL 08

**GLYCOSAMINOGLYCAN SULFATION PATTERNS  
AND INTERACTIONS WITH PROTEINS**Sannaulah Khan,<sup>1</sup> Stephen J. Perkins,<sup>1</sup> and Barbara Mulloy<sup>2</sup><sup>1</sup>*Department of Structural and Molecular Biology, University College London, Gower Street,  
London WC1E 6BT, UK,*<sup>2</sup>*Laboratory for Molecular Structure, National Institute for Biological Standards and Control,  
Blanche Lane, South Mimms, Potters Bar, Herts. EN6 3QG, UK.  
barbara.mulloy@nibsc.hpa.org.uk*

The search for unique high-affinity sequences within glycosaminoglycans (and other sulfated polysaccharides) which interact specifically with a given protein has revealed only a very few positive results over the past several decades. This may be explained in a number of ways; perhaps for many GAG-protein interactions there is in fact no specificity. However, intermediate situations, in which a protein has affinity for a GAG ‘epitope’ made up of a three-dimensional pattern common to several different sequences may also be found. In addition, the size and spacing of sulfated sequences, particularly in heparan sulfate (HS), is another factor that needs to be taken into consideration<sup>1</sup>. The sulfated ‘S’ domains of HS are separated by longer unsulfated domains (‘NA’ domains), the properties of which have been relatively little explored. We have used analytical ultracentrifugation and X-ray scattering to compare the solution structure and flexibility of highly sulfated heparin fragments (a model of HS S-domains) with HS fragments prepared by removal of the S-domains by exhaustive digestion with heparinase I, leaving the NA-domains intact. The results indicate that HS consists of relatively stiff S-domains<sup>2</sup> separated by more flexible unsulfated domains, so that two or more protein-binding S-domains can be presented by the same HS chain in a variety of geometries.

**References**

1. Kreuger, J., Spillmann, D., Li, J.-P. and Lindahl, U., *J. Cell Biol.*, **2006**, 174, 323-327.
2. Khan, S., Gor, J., Mulloy, B., and Perkins, S. J. *J. Mol. Biol.* **2010**, 395, 504-521.

## PL 09

## SUGARS &amp; PROTEINS: SOME BIOPHYSICAL ORGANIC CHEMISTRY OF SUGARS

Benjamin G. Davis

*Department of Chemistry, University of Oxford, Mansfield Road, Oxford OX1 3TA, UK  
Ben.Davis@chem.ox.ac.uk*

Sugars and Post-Translational Modifications are critical biological markers that modulate the properties of Proteins. Our work studies the interplay of proteins, sugars and modifications.[1,2,3]

This lecture will cover recent examples from our group where the use of fundamental, quantitative Organic Chemistry/Physical-Organic Chemistry have allowed us to understand the underlying mechanisms and behaviours of sugars and their implications in Biology.

(i) Unpicking the Conformational Bias of Sugars: Although the shapes and interactions of sugars have long been studied in condensed phases, their 'naked' shapes free from confounding influences have been less well understood. Through a combination of synthesis, spectroscopy and computational analysis we have recently begun to explore these structures. Examples have shed light on: •reproducible 'secondary structure' associated with given carbohydrate building blocks[4] •N-linked glycoprotein motif conformational bias[5][6] •the presence of conserved 'pockets' for water-binding[7] •the contribution & relative value of CH- $\pi$  interaction in carbohydrate recognition[8][9] •the modes of microsolvation of key motifs critical to life, such as those found in cellulose[10] and glycoproteins[7] •the origin and role of the anomeric effect (absent of all solvent effects)[11][12] •the existence of the 'reverse' anomeric effect (ii) Unpicking the Mechanisms of Carbohydrate-Processing Enzymes and Pathways: In studies aimed at elucidating the biosynthetic pathways of natural product glycomimetics[13], glycosides[14] & glycolipidconjugates[15] we have begun to understand deeper aspects of the mechanisms of some intriguing enzymes. Examples have shed light on: •retaining glycosyltransfer •regioselectivity of reducing enzymes •natural strategies for C-C formation in sugars •pathogen biosynthesis.

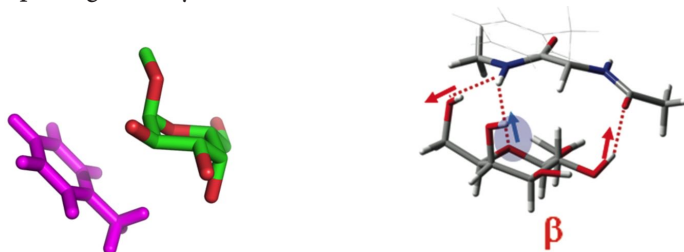
**References**

1. B.G. Davis, *Chem. Rev.* **2002**, *102*, 579-601; D.P. Gamblin et al. *Chem. Rev.* **2009**, *109*, 131-163
2. B.G. Davis, *Science* **2004**, *303*, 480-482
3. S.I. van Kasteren et al. *Nature* **2007**, *446*, 1105-1109.
4. P. Çarçabal et al., *J. Am. Chem. Soc.* **2005**, *127*, 11414-11425
5. P. Çarçabal et al., *J. Am. Chem. Soc.* **2006**, *128*, 1976-1981
6. E.J. Cocinero et al., *J. Am. Chem. Soc.* **2009**, *131*, 1282-1287
7. E.C. Stanca-Kaposta et al, *J. Am. Chem. Soc.* **2008**, *130*, 10691-10696
8. J. Screen et al., *Angew. Chem. Int. Ed.* **2007**, *46*, 3644-3648
9. E.J. Cocinero et al., *J. Am. Chem. Soc.* **2011**, *in press*
10. E.J. Cocinero et al., *J. Am. Chem. Soc.* **2009**, *131*, 11117-11123
11. E.J. Cocinero et al., *Nature* **2011**, *469*, 76-79.
12. N. Mayorkas et al., *Chem. Sci.* **2011**, *in press*
13. F.J. Wyszynski et al., *Chem. Sci.* **2010**, *1*, 581-589
14. J.C. Errey et al., *Angew. Chem. Intl Ed.* **2010**, *49*, 1234-1237
15. K.M. Backus et al. *Nature Chem. Biol.* **2011**, *in press*

## PL 10

## RECOGNITION OF LPS PATTERN BY TLR4-MD-2 COMPLEX

Jie-Oh Lee

*Department of Chemistry, KAIST, Korea*  
*jieoh@kaist.ac.kr*

TLR4 and MD-2 form a heterodimer that recognizes lipopolysaccharide (LPS) from Gram negative bacteria. LPS induced the formation of an m-shaped receptor multimer composed of two copies of the TLR4-MD-2-LPS complex arranged in a symmetrical fashion<sup>1</sup>. LPS interacts with a large hydrophobic pocket in MD-2 and directly bridges the two components of the multimer. Five of the six lipid chains of LPS are buried deep inside the pocket and the remaining chain is exposed to the surface of MD-2, forming a hydrophobic interaction with the conserved phenylalanines of TLR4. Eritoran is a candidate anti-sepsis drug that antagonizes LPS activity by binding to the TLR4-MD-2 complex. Eritoran binds to the LPS pocket in MD-2 and blocks LPS binding and TLR4-MD-2 heterotetramerization<sup>2</sup>. Structural comparison of the TLR4-MD-2-LPS complex with the TLR4-MD-2-Eritoran complex indicates that two additional lipid chains in LPS displace the phosphorylated glucosamine backbone towards the solvent area by ~5 angstrom. The crystal structures of TLR4 complexes together with structures of other TLR-ligand complexes illustrate the remarkable versatility of the ligand recognition mechanisms employed by the TLR family, which is essential for defense against diverse microbial infection<sup>3-5</sup>.

**References**

1. Park BS, Song DH, Kim HM, Choi B-S, Lee H, Lee J-O. *Nature*, **2009**, 458 (7242), 1191-1195.
2. Kim HM, Park BS, Kim JI, Kim SE, Lee J, Oh SC, Enkhbayar P, Matsushima N, Lee H, Yoo OJ, Lee J-O, *Cell*, **2007**, 130 (5), 906-17
3. Jin MS, Kim SE, Heo JY, Lee ME, Kim HM, Paik SG, Lee H, Lee J-O, *Cell*, **2007**, 130 (6), 1071-82
4. Kang JY, Nan X, Jin MS, Youn S-J, Ryu YH, Mah S, Han SH, Lee H, Paik S-G, Lee J-O, *Immunity*, **2009**, 31(6), 873-881
5. Kang JY, Lee J-O, *Ann. Rev. Biochem.*, **2011**, in press.

**INVITED  
LECTURES**

## IL 01

## SYNTHESIS OF EUKARYOTIC AND BACTERIAL GLYCANS

Yukishige Ito<sup>1,2</sup>

<sup>1</sup>RIKEN Advanced Science Institute and  
<sup>2</sup>ERATO JST, Wako, Saitama, 351-0198 Japan  
yukito@riken.jp

Glycoprotein structures are characterized by their complexity and diversity. Development of synthetic methodologies useful for efficient and facile preparation of oligosaccharides is a focal issue in carbohydrate chemistry. In light of their structural diversity, practical strategy to facilitate the synthesis of oligosaccharide is expected to be highly valuable. Recent studies have clarified that protein glycosylation is not limited to eukaryotes, suggesting its widespread occurrence. In fact, various bacteria carry glycoproteins which are known to play crucial roles in the establishment of infection.

This talk will provide summary of our studies on 1) organic synthesis based analysis of glycan-protein interactions which play key roles in glycoprotein folding [1,2] and 2) development of synthetic methods for glycans derived from pathogenic bacteria [3-6].

**References**

1. Y. Takeda, K. Totani, I. Matsuo, Y. Ito, *Curr. Opin. Chem. Biol.*, **2009**, *13*, 582-591.
2. A. Miyagawa, K. Totani, I. Matsuo, Y. Ito, *Biochem. Biophys. Res. Commun.*, **2010**, *430*, 322-328.
3. Y. J. Lee, A. Ishiwata, Y. Ito, *Org. Biomol. Chem.*, **2010**, *8*, 3596-3608.
4. Y. J. Lee, A. Ishiwata, Y. Ito, *J. Am. Chem. Soc.*, **2008**, *130*, 6330-6331.
5. A. Ishiwata, Y. Ito, *J. Am. Chem. Soc.*, in press.
6. Y. J. Lee, A. Kubota, A. Ishiwata, Y. Ito, *Tetrahedron Lett.*, **2011**, *52*, 418-421.



## IL 02

**STRUCTURE OF HEPARIN OLIGOSACCHARIDES. RECONCILIATION  
OF THEORETICAL AND EXPERIMENTAL NMR DATA**Miloš Hricovíni*Institute of Chemistry, Slovak Academy of Sciences, 845 38 Bratislava, Slovakia  
hricovini@savba.sk*

Theoretical density functional theory (DFT) calculations have been used to analyse the effect of both counter-ions and solvent upon the structure heparin oligosaccharides. NMR chemical shifts and scalar spin-spin coupling constants were computed from the optimized structures of heparin disaccharides and tetrasaccharides. The data analysis showed the influence of counter-ions ( $\text{Na}^+$ ,  $\text{Ca}^{2+}$ ) upon conformations of iduronic acid (IdoA) residues and the glycosidic linkages. Electrostatic interactions among  $\text{Na}^+$  ions and the negatively charged sulfates and carboxylates were found different in  ${}^1\text{C}_4$  and  ${}^2\text{S}_0$  forms of the IdoA residues. Such differences in positions of counter-ions and the differences in electrostatic interactions could explain stabilizations of various IdoA conformers. Three-bond proton-proton and one-bond proton-carbon spin-spin coupling constants were also calculated from the optimized molecular geometries.

## IL 03

PROMISCUITY OF FUNGAL  $\beta$ -N-ACETYLHEXOSAMINIDASES

Vladimír Křen, Kristýna Slámová, Pavla Bojarová, Karel Křenek, Radek Gažák,  
and Karel Bezouška<sup>1</sup>

*Institute of Microbiology, Centre of Biocatalysis and Biotransformation, Academy of Sciences of  
the Czech Republic, Vídeňská 1083, CZ-142 20 Prague, Czech Republic*  
kren@biomed.cas.cz

<sup>1</sup>*Department of Biochemistry, Faculty of Science, Charles University in Prague, Hlavova 8,  
CZ-12840 Prague, Czech Republic*

$\beta$ -N-Acetylhexosaminidases (EC 3.2.1.52, CAZy GH 20) are important not only due to their implication in human physiology and disease, but also due to their great potential in the enzymatic synthesis of carbohydrates and glycomimetics.  $\beta$ -N-Acetylhexosaminidases are not strictly specific to the configuration of the substrate C-4 hydroxyl moiety: we demonstrated that a number of fungal  $\beta$ -N-acetylhexosaminidases willingly cleave a substrate that lacked the C-4 hydroxyl completely. Using substrate **1** as glycosyl donor, three novel 4-deoxy disaccharides were obtained in the reaction catalyzed by  $\beta$ -N-acetylhexosaminidase from *Talaromyces flavus* in the total yield reaching 80 % [1].

Moreover,  $\beta$ -N-acetylhexosaminidase isolated from *Talaromyces flavus* (and some others) exhibited extraordinary tolerance to  $\beta$ -N-acetylglucosaminides modified at C-6, e.g. aldehyde (in the hydrated form, **2**) and negatively charged groups, such as carboxylate, sulphate, phosphate (**3**) both in hydrolytic and transglycosylation reaction modes. Oligosaccharides carrying a negatively charged moiety are strong ligands of the activation receptors of natural killer cells, particularly of CD69 protein, which results in immunostimulation *in vivo* [2]. Large series of C-6 modified disaccharides in transglycosylation reactions catalyzed by  $\beta$ -N-acetylhexosaminidase from *T. flavus* were prepared and some of them shown extraordinary high immunoactivation effects.  $\beta$ -N-Acetylhexosaminidases were shown to cleave C-N glycosidic bond in glycosyl azides (**4**) acting as very efficient glycosyl donors in synthetic reactions having superb properties. Additionally, the promiscuous  $\beta$ -N-acetylhexosaminidase from *T. flavus* was the only enzyme able to hydrolyze the C-N glycosidic bond in GlcNAc-1H-1,2,3-triazole **4**, which is a very rare example of such a cleavage by an O-glycosidase [3]. Fungal  $\beta$ -N-acetylhexosaminidases are highly versatile biosynthetic tools for the preparation of both natural and modified hexosaminides or glycomimetics under mild conditions with good yields.

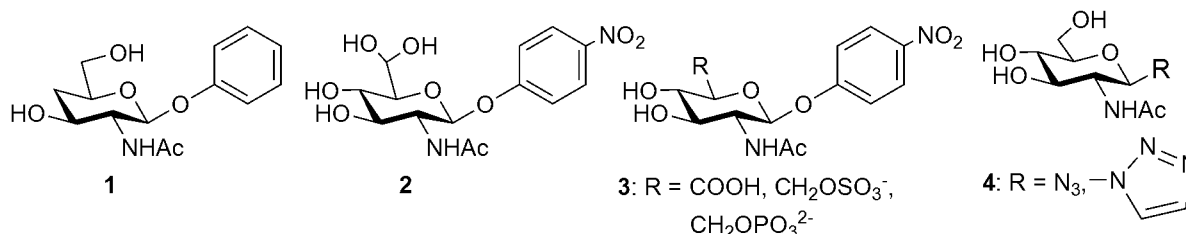

**Acknowledgement:** Support from EU FP7 project NOVOSIDES KBBE-4-265854, Czech Science Foundation P207/11/0629 and Ministry of Education of the Czech Republic (grants LC06010 and AV0Z50200510) is acknowledged.

### References

1. Slámová K, Křen V et al., *Biotech. Adv.* **2010**, 28, 682-693.
2. Slámová K, Křen V et al., *Glycobiology* **2010**, 20, 1002-1009.
3. Slámová K, Křen V et al., *Bioorg. Med. Chem. Lett.* **2010**, 20, 4263-4265.

## IL 04

## PROTEIN-CARBOHYDRATE INTERACTIONS AT HOST PATHOGEN INTERFACE

Alba Silipo

*Dipartimento di Chimica Organica e Biochimica, Università di Napoli Federico II,  
Complesso Universitario Monte Santangelo  
Via Cintia 4, I-80126 Napoli, Italy  
silipo@unina.it*

The interactions between proteins and carbohydrates are involved in important biological processes such as recognition of antigenic carbohydrates on the bacterial cell surface by antibodies or initiation of inflammatory response. Understanding of molecular recognition events in protein-carbohydrate systems is pivotal for the elucidation, at molecular level, of the events involved at the heart of biological phenomena and drug discovery process. Nuclear Magnetic Resonance (NMR) spectroscopy is a powerful method for studying protein-ligand interactions in solution. Two techniques, Saturation Transfer Difference (STD) NMR and transferred NOE, together provide a picture of ligand binding to a receptor. In this communication, preliminary studies on different systems of protein-carbohydrate interactions at host-pathogen interface will be reported.

## IL 05

**CYCLOSAL-NUCLEOTIDES AS PRECURSORS  
OF NUCLEOSIDEMONO- AND -DIPHOSPHATE-SUGARS**

Chris Meier\*, Nathalie Lunau, Saskia Wolf, Johanna Huchting, Niels Pohle

*Organic Chemistry, Department of Chemistry, Faculty of Sciences, University of Hamburg,  
Martin-Luther-King-Platz 6, D-20146 Hamburg, Germany  
chris.meier@chemie.uni-hamburg.de*

Nucleotide glycopyranoses as **1** (e.g. NDP- and NMP-sugars, sugar nucleotides) are of enormous importance in biology due to their key role as glycosyl donors in the biosynthesis of oligosaccharides. Moreover, glycosyltransferases that incorporate non-natural monosaccharides or accept non-natural substrates for glycosylation may become a powerful tool for the synthesis of non-naturally occurring bioconjugates. Thus, an efficient chemical access to these classes of compounds is of high importance. A number of methods have been developed for the synthesis of NM(D)P-sugars **1** but often these protocols involve long reaction times and gave low yields after tedious purifications. Recently we developed a high yielding method of the synthesis using strong-acceptor substituted *cycloSal*-nucleotides **2**.<sup>1,2</sup> *CycloSal*-triesters **2** were reacted with deprotonated, protected monosaccharides **3** or anomerically pure (un)protected glycosylphosphates **4** to give anomerically pure NM(D)P-sugars **1a,b** in (very) good chemical yields (up to 88%) after short reaction times. A great variety of NDP-sugars bearing naturally occurring nucleoside and sugar as well as analogues of both were prepared proving the general applicability of the procedure.<sup>3-5</sup> This procedure was used for the synthesis of fluorescently labelled NDP-sugars, functionalized NDP-sugar, the preparation of nucleotide sugars (NMP-sugars) as well as NDP-disaccharides.

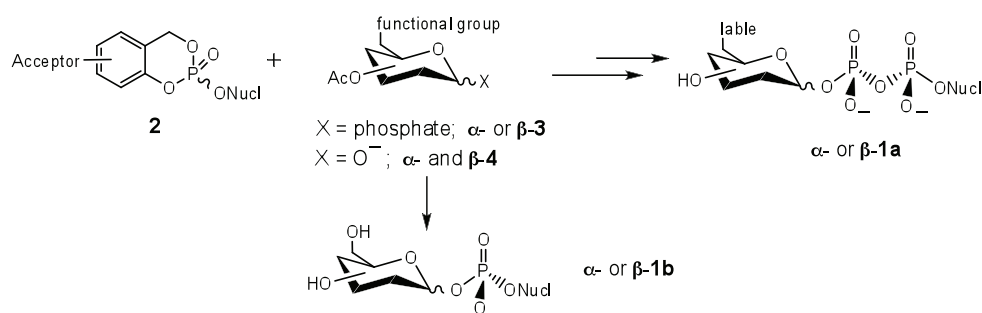

**Scheme 1:** Synthesis pathway to NMP-sugars, NDP-sugars and NDP-oligosaccharides starting from the same *cycloSal*-nucleotide precursor

### References

1. C. Meier, *Angew. Chem. Int. Ed.*, **1996**, 35, 70-72.
2. C. Meier, *Eur. J. Org. Chem.*, **2006**, 1081-1102.
3. S. Wendicke, S. Warnecke, C. Meier, *Angew. Chem. Int. Ed.*, **2008**, 47, 1500-1502.
4. S. Wolf, T. Zismann, N. Lunau, C. Meier, *Chem. – Eur. J.*, **2009**, 15, 7656-7664.
5. S. Wolf, T. Zismann, N. Lunau, S. Warnecke, S. Wendicke, C. Meier, *Eur. J. Cell Biol.*, **2010**, 89, 63-75.

## IL 06

## TARGETING DC-SIGN BY CARBOHYDRATE MULTIVALENT SYSTEMS

Javier Rojo

*Glycosystems Laboratory, Instituto de Investigaciones Químicas,  
CSIC – Universidad de Sevilla, Américo Vespucio 49, 41092 Seville, Spain.  
javier.rojo@iiq.csic.es*

DC-SIGN (Dendritic Cell-Specific ICAM-3 Grabbing Non-integrin) is a C-type lectin expressed mainly at the surface of immature dendritic cells. (right side of the Figure) This lectin presents at the C-terminus a Carbohydrate Recognition Domain (CRD) able to recognize highly glycosylated proteins such as gp120 (HIV), GP (Ebola virus), ICAM-2, ICAM-3, etc.<sup>1</sup> The role that DC-SIGN plays during the infection processes and its implication in the immune response has attracted the interest of many research groups. During last years, we have been involved in the design and preparation of carbohydrate dendritic multivalent systems (left side of the Figure) to study and interfere into those processes where DC-SIGN is involved with the aim to develop new antiviral drugs and immune modulators.<sup>2-5</sup> These multivalent systems were built up based on different scaffolds and then, functionalized with a variety of carbohydrates. This approach has allowed the development of multivalent systems showing different presentation and multivalency of carbohydrates for applications in nanomedicine.

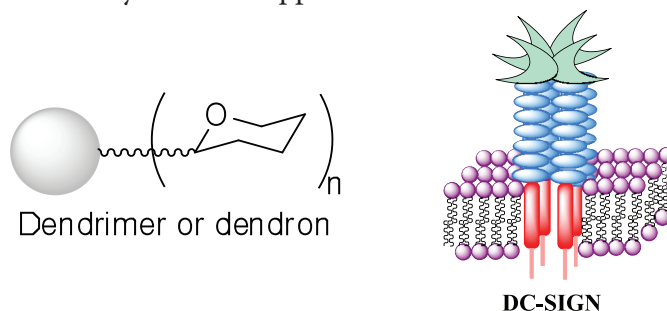

**Acknowledgements:** This work was funded by Ministry of Science and Innovation (MICINN, CTQ2008-01694) and the Marie Curie ITN FP7 project CARMUSYS (PITN-GA-2008-213592).

**References**

1. a) Geijtenbeek, T.B. *et al. Cell* **2000**, *100*, 587-597. b) van Kooyk, Y.; Geijtenbeek, T.B. *Nat. Rev. Immunol.* **2003**, *3*, 697-709.
2. Arce, E.; Nieto, P.M.; Díaz, V.; García-Castro, R.; Bernad, A.; Rojo, J. *Bioconjugate Chem.* **2003**, *14*, 817-823.
3. a) Lasala, F.; Arce, E.; Otero, J.R.; Rojo, J.; Delgado, R. *Antimicrob. Agents Chemother.* **2003**, *47*, 3970-3972; b) Rojo, J.; Delgado, R. *J. Antimicrob. Chemother.* **2004**, *54*, 579. d) Tabarani, G.; Reina, J.J.; Ebel, C.; Vivés, C.; Lortat-Jacob, H.; Rojo, J.; Fieschi, F. *FEBS Lett.* **2006**, *580*, 2402-2408.
4. Reina, J.J.; Sattin, S.; Invernizzi, D.; Mari, S.; Martínez-Prats, L.; Tabarani, G.; Fieschi, F.; Delgado, R.; Nieto, P.M.; Rojo, J.; Bernardi, A. *ChemMedChem* **2007**, *2*, 1030-1036.
5. Sattin, S.; Daggetti, A.; Thépaut, M.; Berzi, A.; Sánchez-Navarro, M.; Tabarani, G.; Rojo, J.; Fieschi, F.; Clerici, M.; Bernardi, A. *ACS Chem. Biol.* **2010**, *5*, 301-312.

## IL 07

**THE ROLE OF (POLY)SIALO GLYCOTOPES IN BRAIN DEVELOPMENT  
AND FUNCTION**

Herbert Hildebrandt, Iris Röckle, Tim Kröcher, Miriam Schiff, and Rita Gerardy-Schahn

*Hannover Medical School, Institute for Cellular Chemistry, Hannover, Germany  
Gerardy-Schahn.Rita@mh-hannover.de*

The neural cell adhesion molecule NCAM is modified with the unique carbohydrate polysialic acid (polySia), which is added to NCAM by the two polysialyltransferases ST8SiaII and ST8SiaIV. PolySia and NCAM are major determinants of cellular interactions during brain development. In humans, abnormal levels of NCAM or polySia as well as polymorphisms in the genes for NCAM and ST8SiaII have been linked to schizophrenia. In mice, the combined ablation of ST8SiaII and ST8SiaIV leads not only to a complete loss of polysialylation but also to a gain of polySia-free NCAM. The postnatally lethal phenotype of the polySia-negative NCAM-positive mice reveals the vital role of the polySia modification. In the brain, these mice are characterized by severe defects of major axon tracts and altered densities of defined GABAergic neuron populations. In this presentation, the neurodevelopmental mechanisms leading to these defects as well as the striking parallels to structural brain pathology in schizophrenia will be discussed.

## IL 08

EXPLORING GLYCOCHEMISTRY FOR MOLECULAR DIVERSITY  
AND BIOACTIVITY

Amélia P. Rauter

*Universidade de Lisboa, Faculdade de Ciências,  
Centro de Química e Bioquímica/Departamento de Química e Bioquímica, Campo Grande,  
Ed. C8, Piso 5, 1749-016 Lisboa, PORTUGAL  
aprauter@fc.ul.pt*

Glycochemistry continues to be a primary tool for the discovery of new drugs. In this lecture we demonstrate the use of glycosyl acetates, imidates and glycals for the construction of novel sugar-based compounds with potent antidiabetic, anticholinesterase or antimicrobial activity. Preliminary studies on the antidiabetic plant *Genista tenera* have shown that the plant extract major compound is 8-C-glucosylgenistein,<sup>1</sup> which is not commercially available. Bioactivity, and synthesis of this polyphenol derivative starting from glucosyl acetate, will be discussed. In addition, environmentally friendly methods for direct C-glycosylation of phenolic compounds, either in water with unprotected sugars or under zeolite catalysis with glycosyl imidates, will be disclosed.

The ongoing search for potent cholinesterase inhibitors to treat the late symptoms of Alzheimer's disease, which represents a growing public health threat, is mobilizing many organic chemists. This challenge inspired us towards the investigation of 2-acetamidopurine nucleosides, synthesised from sugar bicyclic glycosyl acetates,<sup>2</sup> some of which showed nanomolar inhibition of butyrylcholinesterase and low values for acute cytotoxicity, competing well with rivastigmine, a drug currently in use for the treatment of Alzheimer's disease.

With the steady emergence and spread of antibiotic resistant Gram-positive pathogens, the development of antimicrobial agents with novel mechanisms of action becomes a priority. We disclose herein a novel family of sugar-based antimicrobial agents easily obtained from glycals and exhibiting a potent activity against *Bacillus* species, particularly against *B. cereus*. This pathogenic bacteria is responsible for severe food-borne diseases, among others, and its eradication is of great importance for health purposes and also for the food industry.

**Acknowledgment:** Fundação para a Ciência e a Tecnologia (FCT) is gratefully acknowledged for the support of the projects PTDC/QUI/67165/2006 and POCI/QUI//59672/2004.

**References**

1. A. P. Rauter, A. Martins, C. Borges, J. Ferreira, J. Justino, M.-R. Bronze, A. V. Coelho, Y. H. Choi, R. Verpoorte, *J. Chromatogr. A*, **2005**, *1089*, 59-64.
2. F. Marcelo, F. V. M. Silva, M. Goulart, J. Justino, P. Sinaÿ, Y. Blériot, A. P. Rauter, *Bioorg. Med. Chem.* **2009**, *17*, 5106-5116.



## IL 09

## SYNTHESIS OF NOVEL CARBOHYDRATE MIMETICS

Hans-Ulrich Reissig<sup>1</sup>

<sup>1</sup>Institut für Chemie und Biochemie, Freie Universität Berlin, Takustr. 3,  
D-14195 Berlin, Germany  
hans.reissig@chemie.fu-berlin.de

Amino sugars as well as C-branched sugars have been identified as structural subunits of many antibiotics and other biologically active natural products. Based on our results on the Lewis-acid induced rearrangement of 1,2-oxazines<sup>1</sup> we discovered a short and stereoselective synthesis of C2-branched 4-amino sugars.<sup>2</sup> Thereby a thiophenyl-substituted 1,2-oxazine is transformed under Lewis-acidic conditions into a bicyclic 1,2-oxazinone that can be used as a glycosyl donor equivalent. Glycosidation reactions and subsequent reduction of the products stereoselectively deliver mono-, di- and trisaccharides with branched amino sugar units. The biological activity of these and related carbohydrate mimetics will be discussed.<sup>3</sup>

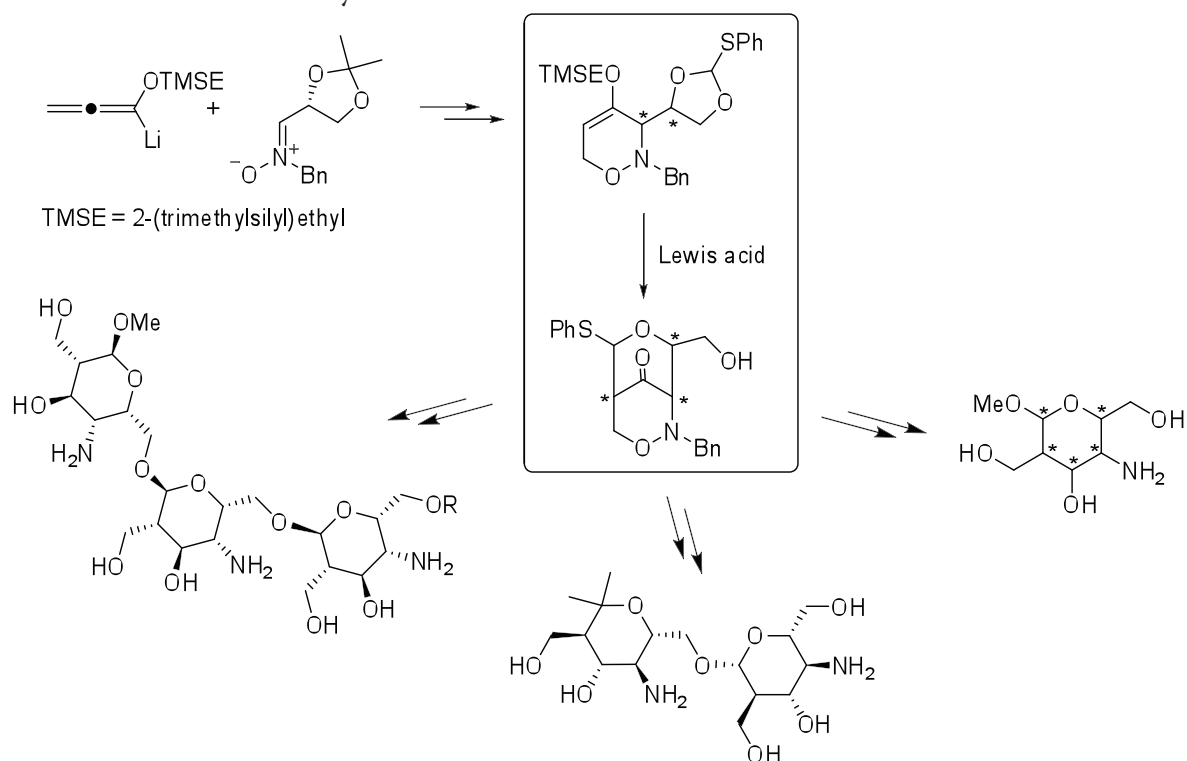

## References

1. A. Al-Harrasi, H.-U. Reissig, *Angew. Chem.* **2005**, *117*, 6383-6387; *Angew. Chem. Int. Ed.* **2005**, *44*, 6227-6231. A. Al-Harrasi, F. Pfrengle, V. Prisyazhnyuk, S. Yekta, P. Koós, H.-U. Reissig, *Chem. Eur. J.* **2009**, *15*, 11632-11642.
2. F. Pfrengle, D. Lentz, H.-U. Reissig, *Angew. Chem.* **2009**, *121*, 3211-3215; *Angew. Chem. Int. Ed.* **2009**, *48*, 3165-3169. F. Pfrengle, H.-U. Reissig *Chem. Eur. J.* **2010**, *16*, 11915-11925.
3. J. Dervedde, S. Enders, H.-U. Reissig, M. Roskamp, S. Schlecht, S. Yekta, *Chem. Commun.* **2009**, 932-934. M. Roskamp, S. Enders, F. Pfrengle, S. Yekta, V. Dekaris, J. Dervedde, H.-U. Reissig, S. Schlecht, *Chem. Eur. J.* **2011**, *17*, submitted.



## IL 10

**SYNTHETIC GLYCOLIPIDS TARGETING THE LPS-TLR4 SIGNALLING:  
A NEW GENERATION OF IMMUNOTHERAPEUTICS**

Francesco Peri, Matteo Piazza, Valentina Calabrese

*Dipartimento di Biotecnologie e Bioscienze; Università di Milano Bicocca  
Piazza della Scienza 2, 20126 Milano, Italy*

New synthetic glycolipids have been developed by our group that are active in modulating in animals the TLR4-mediated inflammatory and innate immunity responses to bacterial endotoxins (lipopolysaccharides, LPS).<sup>1</sup> Lipo-monosaccharides derived from D-glucose inhibit LPS- and lipid A-induced cytokine production in innate immunity cells.<sup>2-3</sup> These molecules are active *in vivo* in contrasting septic shock and other syndromes, such as neuropathic pain, caused by microglial TLR4 activation.<sup>4</sup> In collaboration with T. Gioannini and J. Weiss (University of Iowa, USA) we characterized the mechanism of action of these compounds. The strong antagonistic effect on LPS-dependent TLR4 activation of these molecules can be explained by their capacity to compete with endotoxin for binding to the CD14 receptor, that is an essential co-receptor for endotoxin presentation to TLR4.<sup>5</sup> To inhibit TLR4 signalling by selectively targeting the CD14 co-receptor is an innovative approach to sepsis therapy, that we are developing in collaboration with several industrial and academic groups. Disaccharide-derived molecules<sup>6</sup> and nanoparticles<sup>7</sup> able to selectively stimulate TLR4 will be also presented, in particular symmetric lipo-disaccharides and LPS-coated magnetic nanoparticles (LMNPs) formed by LPS adsorbed onto oleylamine-coated iron oxide nanoparticles. LMNPs induce mild CD14-dependent TLR4 activation in innate immunity cells, and are good candidates for the development of innovative vaccine adjuvants and immunotherapeutics.

**References**

1. F. Peri, F. Granucci, B. Costa, I. Zanoni, C. Marinzi and F. Nicotra, *Angew Chem Int Ed Engl*, 2007, **46**, 3308-3312.
2. M. Piazza, C. Rossini, S. Della Fiorentina, C. Pozzi, F. Comelli, I. Bettoni, P. Fusi, B. Costa and F. Peri, *J Med Chem*, 2009, **52**, 1209-1213.
3. M. Piazza, V. Calabrese, C. Baruffa, T. Gioannini, J. Weiss and F. Peri, *Biochem Pharmacol*, 2010, **80**, 2050-2056.
4. I. Bettoni, F. Comelli, C. Rossini, F. Granucci, G. Giagnoni, F. Peri and B. Costa, *Glia*, 2008, **56**, 1312-1319.
5. M. Piazza, L. Yu, A. Teghanemt, T. Gioannini, J. Weiss and F. Peri, *Biochemistry*, 2009, **48**, 12337-12344.
6. M. Piazza, G. Damore, B. Costa, T. L. Gioannini, J. P. Weiss and F. Peri, *Innate Immun*, 2010.
7. M. Piazza, M. Colombo, I. Zanoni, F. Granucci, P. Tortora, J. Weiss, T. Gioannini, D. Prospero and F. Peri, *Angew Chem Int Ed Engl*, 2011, **50**, 622-626.

## IL 11

**COMPUTATIONAL CARBOHYDRATE SCREENING IDENTIFIES  
NOVEL LIGAND BINDING SPECIFICITIES FOR A DIAGNOSTIC PROTEIN**

Matthew B. Tessier<sup>1</sup>, Jamie Heimburg-Molinaro<sup>2</sup>, Snehal Jadey<sup>2</sup>, Andrew Gulick<sup>3</sup>,  
Kate Rittenhouse-Olson<sup>2\*</sup> and Robert J. Woods<sup>1,4,\*</sup>

<sup>1</sup>*Complex Carbohydrate Research Center, University of Georgia, Athens, GA, 30602, USA,*

<sup>2</sup>*Department of Biotechnical and Clinical Laboratory Sciences,  
State University of New York, Buffalo, NY, 14203, USA,*

<sup>3</sup>*Hauptman-Woodward Institute, Department of Structural Biology,  
State University of New York, Buffalo, NY, 14203, USA,*

<sup>4</sup>*School of Chemistry, National University of Ireland,  
Galway, University Road, Galway, Ireland  
rob.woods@nuigalway.ie*

Experimental methods such as X-ray crystallography and NMR spectroscopy face enormous challenges when applied to the characterization of oligosaccharide-protein complexes. Biologically relevant glycans are often refractory to crystallization and difficult to obtain in large quantities. Conversely, theoretical methods are capable of generating 3D structures of protein-ligand complexes, and there is considerable interest in employing virtual ligand docking studies to predict the structures of carbohydrate-antibody complexes, due to the diagnostic and therapeutic relevance of antibodies. However, such predictions are difficult to validate, due to a paucity of experimental constraints. Glycan array screening provides rapid insight into binding specificities, limited only by the number of elements in the array, the largest of which currently contain on the order of 500 members. Although such data provide no direct insight into the nature of the 3D structure of the complex responsible for the observed specificities, they may be employed as constraints against which to validate theoretical 3D models for the complexes.

Here we employ a new technology, Computational Carbohydrate Grafting (CCG), to generate 3D models of glycan-antibody complexes that are consistent with the data from glycan array screening. Given any structure for the protein in complex with a carbohydrate ligand, CCG can be employed to generate a 3D model of an intact glycan in the complex by splicing the additional branches of the glycan into the bound fragment. Here we demonstrate that the initial structure for the carbohydrate-protein complex can itself be generated using virtual ligand docking. The theoretical poses of bound glycans are then validated by comparison with specificities predicted by experimental glycan array data. This virtual approach overcomes the experimental challenges of generating structures for antibody-carbohydrate complexes. In addition, by grafting novel glycan structures through a validated model for a known binding epitope it is possible to expand the CCG approach to glycans that are not currently present on experimental microarrays, and to predict previously unexpected ligand specificities.

## IL 12

**D-ARABINOSYLATION OF THE SURFACE LIPOPHOSPHOGLYCAN  
OF *LEISHMANIA MAJOR***

Natalia M. Novozhilova<sup>1,2</sup>, Timothy Notton<sup>3</sup>, Hongjie Guo<sup>3</sup>, Stephen M. Beverley<sup>3</sup>,  
and Salvatore J. Turco<sup>1</sup>

<sup>1</sup>*Dept. of Biochemistry, Univ Kentucky Med. Ctr., Lexington, KY 40536 USA;*

<sup>2</sup>*Shemyakin-Ovchinnikov Inst. Bioorganic Chem., 117997 Moscow, Russia,*

<sup>3</sup>*Dept. of Molecular Microbiology, Washington Univ. Sch. Med., St. Louis, MO 63110 USA*  
*turco@uky.edu*

Polysaccharides composed of arabinose residues are important constituents of glycoconjugates from many bacteria, protozoa and plants. Unlike the more common L-arabinofuranose, D-arabinopyranose is not widespread in organisms. Rare examples are protozoan parasites of the genus *Leishmania* (causative agents of the human disease leishmaniasis), which in part of their life cycle, use D-arabinopyranose as a critical component of glycoconjugates implicated in virulence. As a specific example, D-arabinosylation of the surface lipophosphoglycan (LPG) plays a key role in transmission of *L. major* via its phlebotomine sand fly vector. Previously, it has been shown that the donor for the incorporation of D-arabinopyranose into *Leishmania* surface glycans is GDP-D-arabinopyranose. In this work we identified and enzymatically characterized two closely related *L. major* genes (*FKP40* and *AFKP80*) encoding bifunctional proteins with kinase/pyrophosphorylase activities. Both were able to salvage the structurally-related L-fucose to GDP-L-fucose, but only *AFKP80* yielded GDP-D-Arap from exogenous D-arabinose. Correspondingly, *afkp80*<sup>-</sup> mutants lack D-Arap modifications while *fkp40*<sup>-</sup> mutants resembled WT. Detailed information of the LPG arabinosylation pathway and its regulation are keys to our understanding of transmission of the parasite and potentially could be exploited in chemo- or immunotherapeutic intervention.

## IL 13

## ACTIVITY-BASED GLYCOSIDASE PROFILING

Herman Overkleeft*Leiden Institute of Chemistry, Leiden University, Leiden, The Netherlands*

Aberrations in glucosylceramide metabolism are at the basis of several human disorders, including the lysosomal storage disorder, Gaucher disease, and type 2 diabetes. Factors involved in glucosylceramide metabolism are therefore valid targets for drug development [1]. In this lecture I will report on the progress we made in the development of activity-based probes for the profiling of retaining beta-glucosidases, including those involved in glucosylceramide metabolism. In our studies we compared 2-deoxy-2-fluoroglycosides and cyclitol epoxides and we evaluated the merits of direct and two-set bioorthogonal labeling strategies [2] to arrive at a highly sensitive acid glucosylceramidase probe with which this activity can be monitored in living cells. I will present our results in the use of this probe in monitoring enzyme activity in the context of Gaucher disease and in the presence of enzyme inhibitors/activity-based probes. I will conclude with discussing our current (unpublished) progress in the development of activity-based probes targeting a broader range of retaining glycosidases.

**References**

1. T. Wennekes, R. J. B. H. N. van den Berg, R. G. Boot, G. A. van der Marel, H. S. Overkleeft and J. M. F. G. Aerts, Glycosphingolipids – nature, function and pharmacological modulation, *Angew. Chem. Int. Ed.* **2009**, *48*, 8848 (review).
2. M. D. Witte, M. T. C. Walvoort, K.-Y. Li, W. W. Kallemeijn, W. E. Donker-Koopman, R. G. Boot, J. M. F. G. Aerts, J. D. C. Codée, G. A. van der Marel and H. S. Overkleeft, Activity-based profiling of retaining beta- glycosidases: a comparative study, *ChemBioChem* **2011** in press.
3. M. D. Witte, W. W. Kallemeijn, J. Aten, K.-Y. Li, A. Strijland, W. E. Donker-Koopman, B. Blijlevens, G. Kramer, A. M. C. H. van den Nieuwendijk, B. I. Florea, B. Hooibrink, C. E. M. Hollak, R. Ottenhoff, R. G. Boot, G. A. van der Marel, H. S. Overkleeft and J. M. F. G. Aerts, Ultrasensitive *in situ* visualization of active glucocerebrosidase molecules, *Nat. Chem. Biol.* **2010**, *6*, 907.

## IL 14

**PROTEIN-CARBOHYDRATE AND CARBOHYDRATE-CARBOHYDRATE INTERACTIONS.  
SOME EXAMPLES FROM THE MOLECULAR MODELLING PERSPECTIVE**

Sonsoles Martín-Santamaría

*Department of Chemistry, Faculty of Pharmacy, Univeridad San Pablo CEU,  
Urb. Monteprincipe, 28668 (Madrid, Spain)  
smsantamaria@ceu.es*

In the last decades, molecular modelling has been widely used for the understanding of relevant molecular recognition events. The knowledge of target-ligand interactions at atomic level has proven to have many beneficial applications for human health, as drug design, among others. We report here some examples that account for the application of molecular modelling tools to the study of a) protein-carbohydrate, and b) carbohydrate-carbohydrate interactions.

a) Docking and MD simulation techniques have been applied to the study of specific interactions of human galectin-1 and lactose mimetics.<sup>1</sup> Human galectin-1 is involved in cell recognition and adhesion processes, and has proven to play a pivotal role in metastasis. Insights into galectin binding can be very valuable for the understanding of the interaction mechanism of these compounds, and for further design of selective binders able to modulate galectins functions. It has been shown that intermolecular hydrogen bonds as well as van der Waals and CH- $\pi$  interactions are the key forces involved in the process. The role of water has also been evaluated.

b) Weak  $\text{Ca}^{2+}$ -mediated carbohydrate-carbohydrate interactions have been studied for sugar-decorated gold nanoparticles as the “macromolecule” and the same carbohydrate as the ligand. 3D models of trisaccharide- $\text{Ca}^{2+}$ -trisaccharide complexes based on results from MD simulations are presented, in agreement with experimental observations. The obtained complexes provide a working model on the cell-cell recognition process that mediates interactions in certain types of marine sponges.<sup>2</sup>

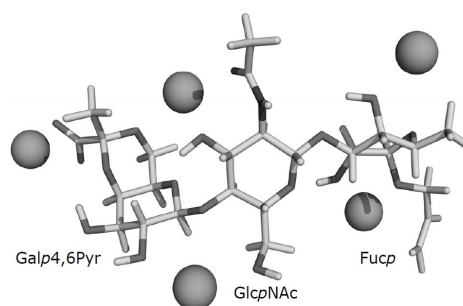
**References**

1. I. Camby, M. Le Mercier, F. Lefranc, R. Kiss, *Glycobiology*, **2006**, *16*, 137R-157R.
2. a) A. Carvalho de Souza, J. F. G. Vliegthart, J. P. Kamerling, *Org. Biomol. Chem.* **2008**, *6*, 2095-2102. b) J. I. Santos, A. Carvalho de Souza, J. Cañada, S. Martín-Santamaría, J. P. Kamerling, J. Jiménez-Barbero, *ChemBioChem*, **2009**, *10*, 511-519.

## IL 15

## PERIODATE OXIDISED POLYSACCHARIDES: BASIS FOR NOVEL BIOMATERIALS?

Bjørn E. Christensen

*NOBIPOL, Department of Biotechnology, Norwegian University of Science and Technology (NTNU).*

*Sem Saelands veg 6/8, NO-7491 Trondheim, Norway  
bjorn.christensen@ntnu.no*

A wide range of polysaccharides (alginates, chitosans, hyaluronan etc.) are well established as components of a wide range of biomaterials thanks to their biocompatibilities, degradabilities, gelling properties, and rather well-understood structure-function relationships.

A limited degree of periodate oxidation of such polysaccharides may give rise to derivatives (dialdehydes) with entirely altered chemical and physical properties which may be useful in the biomaterials area. The oxidative ring-opening of 1,4-linked sugars leads to the formation of highly flexible 'hinges' in otherwise rather semiflexible or rigid structures. This effect subsequently permits macromolecular compaction, allowing long-range intermolecular associations to take place if otherwise favoured thermodynamically. The compaction has been clearly demonstrated for both alginates and chitosans by a progressive decrease in persistence length with increasing degree of oxidation. Also, the gelling properties of alginates with calcium ions are strongly influenced, both because of the shortening of gelling G-blocks, but also to a large extent due to the flexibility introduced between the junction zones.

The dialdehydes are generally more labile under physiological conditions due to their susceptibility towards  $\beta$ -elimination. Likewise, the susceptibility towards acid hydrolysis increases following carbonyl reduction. Both cases allow for additional possibilities for design of biodegradable materials. The degradability of partly periodate oxidised polysaccharides (+/- subsequent reduction) was studied for a wide range of temperatures and pH values, and some novel results will be presented. The kinetics of degradation revealed in some cases a more complex behaviour than what could be expected on basis of randomly distributed dialdehydes.

The reaction with periodate suffers sometimes from side reactions, and precise detection and quantification of dialdehydes may be challenging. With alginates as example, carbonyl detection using either tritiated NaBH<sub>4</sub>, reaction with CCOA, or 2-AB, are reported and compared. The reaction with CCOA and 2-AB demonstrates that dialdehydes may serve as attachment points for substituents, for example through reductive amination. In the case of chitosans, detection of released ammonia seems to offer a route to determine the degree of oxidation in a system severely influenced by overoxidation and depolymerisation.

### References

1. Inger Mari N. Vold, Kåre A. Kristiansen and Bjørn E. Christensen, *Biomacromolecules*, **2006**, 7, 2136-2146.
2. Kåre A. Kristiansen, Antje Potthast, Bjørn E. Christensen, *Carbohydr. Res.*, **2010**, 345, 1264-1271.
3. Kåre A. Kristiansen, Bjørn C. Schirmer, Finn Aachmann, Gudmund Skjåk-Bræk, Kurt I. Draget and Bjørn E. Christensen, *Carbohydr. Polym.*, **2009**, 77, 725-735
4. Kåre A. Kristiansen, Simon Ballance, Antje Potthast and Bjørn E. Christensen, **2009**, *Carbohydr. Polym.*, 76, 196-205.
5. Christensen, B.E., Vold, I.M.N., Vårum, K.M. **2008**, *Carbohydr. Polym.* 74, 559-565.



## IL 16

SYNTHESIS OF CYCLIC TRITERPENE SAPONINS  
WITH POTENT ANTITUMOR ACTIVITIESXiaoyu Yang, Pingping Tang, Cunsheng Zhu, and Biao Yu\*

State Key Laboratory of Bioorganic and Natural Products Chemistry,  
Shanghai Institute of Organic Chemistry, Chinese Academy of Sciences, 345 Lingling Lu,  
Shanghai 200032, China.  
byu@mail.sioc.ac.cn

Lobatoside E is a member of the triterpene saponins named cyclic bisdesmosides, which have two oligosaccharides flanked on a pentacyclic triterpene and bridged with 3-hydroxy-3-methyl glutarate. Thus far, ten such compounds have been disclosed from two Chinese medicinal plants, that is *Bolbostemma paniculatum* and *Actinostemma lobatum* (Cucurbitaceae). Cyclic bisdesmosides are cytotoxic and might induce apoptosis of tumor cells. Removal of the glutarate bridge kills the activity, thus the novel cyclic structure of these saponins is crucial to their antitumor activity. Lobatoside E shows the highest potency among its congeners against the growth of tumor cells, and is especially sensitive toward the lung cancer cell A549, colon cancer cell SW-620, and melanoma SK-MEL-5, with  $GI_{50}$  values at 0.14-0.36 mM. We have accomplished the first total synthesis of Lobatoside E employing conventional glycosylation methods, wherein a total of 73 steps were required, with the longest linear sequence of 31 steps and an overall yield of 1.2%, starting from oleanolic acid, D-glucose, D-galactose, L-arabinose, and L-rhamnose.<sup>1</sup> Recently, we developed a highly efficacious glycosylation protocol with glycosyl ortho-alkynylbenzoates as donors and gold(I) complex as a catalyst.<sup>2,3</sup> This new method was successfully applied to the 2<sup>nd</sup> generation synthesis of Lobatoside E. In a modular manner, several of its congeners were also assembled. Interestingly, a simple congener showed more potent antitumor activity than the natural product.

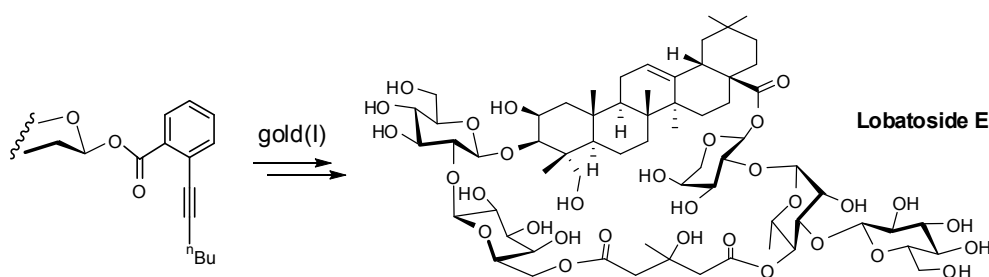

## References

1. C. Zhu, P. Tang, B. Yu, *J. Am. Chem. Soc.* **2008**, *130*, 5872.
2. Y. Li, X. Yang, Y. Liu, C. Zhu, Y. Yang, B. Yu, *Chem. Eur. J.* **2010**, *16*, 1871.
3. Y. Li, Y. Yang, B. Yu, *Tetrahedron Lett.* **2008**, *49*, 3604.

## IL 17

NEW CHEMICAL TOOLS TO STUDY THE GLYCOBIOLOGY  
OF PLANT-MICROBE INTERACTIONSKnud J. Jensen*Centre for Carbohydrate Recognition and Signalling  
University of Copenhagen, Faculty of Life Sciences*

The structural requirements for recognition of complex polysaccharides and the role of ligand-receptor interactions in the interaction between different cells and organisms remain unsolved for many systems. We are focusing on the 'communication' between rhizobium and leguminous plants, which leads to symbiosis and nitrogen fixation. A key goal is understanding at the molecular and atomic level the interaction between lipochitin oligosaccharide (Nod factor) signal molecules and their putative plant receptors.

We have developed a series of reagents and methods that use highly chemoselective chemistry at the anomeric center to enable the study of carbohydrate-protein interactions. They include new bifunctional linkers for the construction of glycan microarrays, glyconanoparticles and fluorescent glycoconjugates, as well as aniline catalysis for the formation of glycosyl oximes.

Utilizing these new reagents and methods, we here present a comprehensive approach, which includes (i) isolation and identification of lipochitin oligosaccharides from different microbial strains, (ii) construction of glycan microarrays with lipochitin oligosaccharides, (iii) chemical protein synthesis of partial structures of the putative plant receptors in order to study their interaction with the lipochitin oligosaccharides signal molecules, and (iv) synthesis of fluorescent labeling of lipochitin oligosaccharides and bioimaging studies to locate the receptors.

**References**

*Aniline catalysis*: M. B. Thygesen, H. Munch, J. Sauer, E. Clo, M. R. Jørgensen, O. Hindsgaul, K. J. Jensen, *J. Org. Chem.*, 2010, **75**, 1752-1755.

*Chemoselective formation of glyconanoparticles*: Mikkel B. Thygesen, Kasper K. Sørensen, Emiliano Cló, Knud J. Jensen, *Chem. Comm.*, 2009, 6367-6369

*Revision of Nod factor structure*: A. S. Albrektsen, J. Sauer, M. B. Thygesen, J. Duus, B. Pedersen, S. Thirup, E. James, K. J. Jensen, J. Stougaard, S. Radutoiu, *MPMI*, 2010, 58-66.

*Reagents for covalent glycan microarrays*: E. Cló, O. Blixt, K. J. Jensen, *Eur. J. Org. Chem.*, 2010, 540

*Review on solid-phase methods in glycobiology*: K. Larsen, M. B. Thygesen, F. Guillaumie, W. G. T. Willats, K. J. Jensen, *Carbohydr. Res.*, 2006, **341**, 1209-1234.



## IL 18

**THE ROLE OF ABC TRANSPORTERS IN THE BIOSYNTHESIS AND EXPORT OF BACTERIAL GLYCANS**

Chris Whitfield, Bradley R. Clarke, Laura Greenfield, and Jerry D. King.

*Department of Molecular & Cellular Biology, University of Guelph, Guelph, Ontario N1G2W1  
Canada  
cwhitfie@uoguelph.ca*

Complex glycoconjugates play critical roles in the biology of microorganisms. Despite the remarkable diversity in glycan structures, and the bacteria that produce them, conserved themes are evident in the biosynthesis/export pathways. One of the primary assembly pathways is characterized by the involvement of representatives of the ATP-binding cassette (ABC) transporter superfamily. These proteins are responsible for the export of a wide variety of cell-surface oligo- and polysaccharides in both Gram-positive and Gram-negative bacteria<sup>1</sup>. Recent investigations of ABC transporter-dependent pathways involved in the export of prototype lipopolysaccharide O antigens have revealed two fundamentally different strategies for coupling glycan polymerization (and chain-length regulation) to export. In one model, the glycan export substrate is capped by a non-reducing terminal modification, which serves as a chain-termination and export signal. The signal is recognized by a discrete substrate-binding domain in the nucleotide-binding domain polypeptide of the ABC transporter to engage the export process. In the other model, polymerization and export are obligatorily coupled and their relative activities dictate glycan chain length. A bioinformatic survey examining ABC exporters from known oligo- and polysaccharide biosynthesis loci identifies conserved nucleotide-binding domain protein families that correlate well with themes in the structures and assembly of diverse glycans<sup>1</sup>. I will discuss our progress in unravelling the details of the ABC transporter-dependent glycan biosynthesis and export pathways in prototype systems.

**References**

Cuthbertson, L, V. Kos and C. Whitfield, *Microbiology & Molecular Biology Reviews* **2010**, *74*, 341-362.

## IL 19

**THE MALDI TOF/TOF MASS SPECTROMETER AS A CHEMICAL LAB FOR THE STRUCTURAL CHARACTERIZATION OF LIPOOLIGOSACCHARIDES**

Luisa Sturiale<sup>1</sup>, Angelo Palmigiano<sup>1</sup>, Alba Silipo<sup>2</sup>, Rosa Lanzetta<sup>2</sup>, Michelangelo Parrilli<sup>2</sup>, Antonio Molinaro<sup>2</sup> and Domenico Garozzo<sup>1</sup>

<sup>1</sup>*CNR ICTP Catania Via P. Gaifami 18 95126 Catania Italy,*

<sup>2</sup>*Dipartimento di Chimica Organica e Biochimica,*

*Università degli Studi di Napoli Federico II, Via Cinthia 4, I-80126 Napoli, Italy*

*domenico.garozzo@cnr.it*

Lipooligosaccharide (LOS) is a powerful Gram negative glycolipid involved in immune system elusion and invasion of host animal and vegetal cells. Its structural elucidation is pivotal to understand at molecular levels mechanisms of infections. Due to its amphiphilic nature, it has resisted structural matrix assisted laser desorption/ionization (MALDI) analysis. Our approach has now resolved this important issue, permitting us to obtain high resolution MALDI mass spectra that are rich of information. In fact, they show both LOS quasi-molecular ions, and also well defined fragments due to a in-source decay which yields B-type ions corresponding to core oligosaccharide(s), and Y-type ions relating to lipid A unit(s). Moreover, MALDI tandem Time of Flight (TOF/TOF) mass spectrometry (MS) of lipid A allows its complete structural elucidation straight from the purified intact LOS, without any chemical manipulation. These findings constitute a significant improvement in the analysis of such important biomolecule by MS.

## IL 20

## MOLECULAR BASIS ON THE PREDOMINANT INTESTINAL GROWTH OF BIFIDOBACTERIA IN BREAST-FED INFANT

Motomitsu Kitaoka

National Food Research Institute, NARO, 2-1-12 Kannondai, Tsukuba,  
Ibaraki 305-8642, Japan  
mkitaoka@affrc.go.jp

Intestinal colonization by bifidobacteria is important for health of infants. Though It has been revealed that bifidobacteria utilize human milk oligosaccharides (HMOs) as carbon source to obtain their intestinal growth in infants since 1950s, complicated composition of HMOs with more than 130 different molecules had made the molecular mechanism on the growth promotion unrevealed for long time. Each component of HMOs can be described as one of the 12 core structures or those modified with  $\alpha$ -fucosyl and/or  $\alpha$ -sialyl residues.

We found that *Bifidobacterium longum* possessed the intracellular pathway specific to galacto-N-biose (Gal $\beta$ 1,3GalNAc, GNB) and lacto-N-biose I (Gal $\beta$ 1,3GlcNAc, LNB), the GNB/LNB pathway<sup>1</sup>. Since oligosaccharides containing LNB in their structure (Type I) are predominant in HMOs, the possession of the enzymes that liberate LNB from HMOs by bifidobacteria explains how HMOs promote the bifidobacterial growth. Such extracellular enzymatic system from *Bifidobacterium bifidum* including  $\alpha$ 1,2-fucosidase<sup>2</sup>,  $\alpha$ 1,3/4-fucosidase<sup>3</sup>, sialidase<sup>4</sup>, and lacto-N-biosidase<sup>5</sup> has been isolated (Figure). Bifidobacterial enzymes related to their metabolism of HMOs are useful tool for preparing compounds related to HMOs. For instance LNB<sup>6</sup> and GNB<sup>7</sup> were produced from sucrose and GlcNAc/GalNAc in one-pot using four such enzymes.

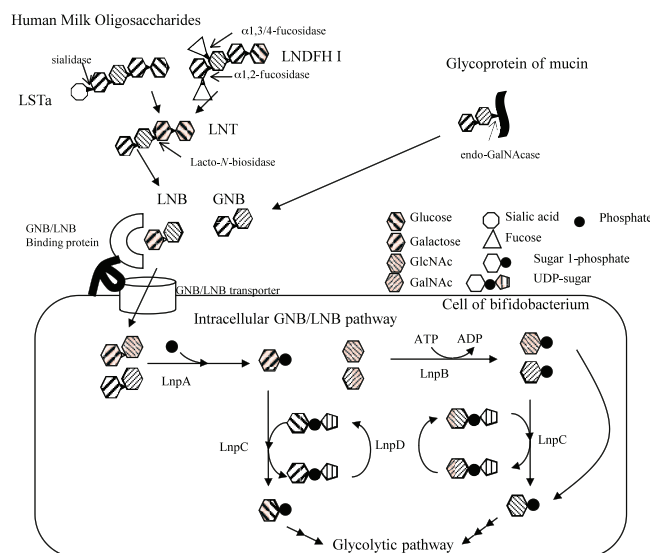

**Fig.** HMO-metabolizing pathway of *Bifidobacterium bifidum*

## References

1. Nishimoto, M., Kitaoka, M., *Appl. Environ. Microbiol.*, **2007**, 73, 6444-6449.
2. Katayama, T., *et al.*, *J. Bacteriol.*, **2004**, 186, 4885-4893.
3. Ashida, H., *et al.*, *Glycobiology*, **2009**, 19, 1010-1017.
4. Kiyohara, M., *et al.*, **2011**, *Glycobiology*, in press.
5. Wada, J., *et al.*, *Appl. Environ. Microbiol.*, **2008**, 74, 3996-4004.
6. Nishimoto, M., Kitaoka, M., *Biosci. Biotechnol. Biochem.*, **2007**, 71, 2101-2104.
7. Nishimoto, M., Kitaoka, M., *Carbohydr. Res.*, **2009**, 344, 2573-2576.

## IL 21

## GLYCOSAMINOGLYCANS : SYNTHETIC TRICKS, MIMETICS AND CHIMERAS TO UNRAVEL NEW THERAPEUTIC TARGETS

David Bonnaffé<sup>1</sup>

<sup>1</sup>Université Paris-Sud 11, ICMMO UMR CNRS-UPS 8182, Equipe Glycochimie Moléculaire et Macromoléculaire, Laboratoire de Chimie Organique Multifonctionnelle. Bat. 420 UPS, 91405 Orsay Cedex France; david.bonnaffe@u-psud.fr

Glycosaminoglycans, especially heparan sulfate (HS), are amongst the most heterogeneous and negatively charged biopolymers. Their expression is dynamically regulated at the cell surface where they display various epimerization and sulfation patterns that allow establishing selective interactions with numerous proteins and tuning of their bioactivities. Within the exception of the fully characterized heparin/AT-III interaction, involving a specific pentasaccharide sequence, there is much debate on the mechanisms allowing specific HS/protein interactions. HS displays two levels of molecular diversity: sulfation and epimerization hypervariability, in tetra to octasaccharide domains of the polymer, along with topological diversity due to the alternation of various lengths highly charged domains (S) and less charged ones (A). In tight collaboration with glycobiologists, chemists have thus a large playground to conceive tools to challenge hypotheses on HS-protein interactions. However, HS fragment syntheses is not trivial and many pitfall lies on the road to libraries of hypervariable fragments,<sup>1</sup> libraries of glycoconjugates mimetic of SAS domains<sup>2</sup> or other tools.<sup>3</sup> This prompts us to find “synthetic tricks” to reach our synthetic targets in order to establish new HS-protein interaction as relevant therapeutic targets.<sup>3</sup> Gratifyingly, we were able to identify an efficient inhibitor of IFN $\gamma$  proinflammatory activity<sup>4</sup> or to “lock the door” against HIV, by preventing it to bind its target with a peptide HS-chimera,<sup>5</sup> both active in the low nanomolar range.

Diversity due to micro-heterogeneities

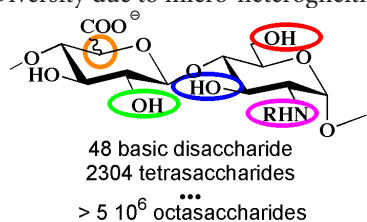

Diversity due to charge topologies

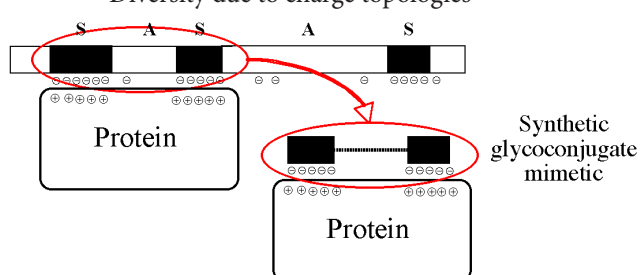

### References:

1. A. Dilhas, R. Lucas, L. Loureiro-Morais, Y. Hersant, D. Bonnaffé. *J. Comb. Chem.* **2008**, *10*, 166–169.
2. A. Lubineau, H. Lortat-Jacob, O. Gavard, S. Sarrazin, D. Bonnaffé, *Chem. Eur.J.* **2004**, *10*, 4265-4282.
3. D. Bonnaffé. *C. R. Chimie* **2011**, *14*, 29-73.
4. S. Sarrazin, D. Bonnaffé, A. Lubineau, H. Lortat-Jacob, *J. Biol. Chem.* **2005**, *280*, 37558-64.
5. F. Baleux, L. Loureiro-Morais, Y. Hersant, P. Clayette, F. Arenzana-Seisdedos, D. Bonnaffé, H. Lortat-Jacob. *Nature Chemical Biology* **2009**, *5* (10), 743-748.

## IL 22

## ABO BLOOD GROUP SYSTEM: CHEMICAL SYNTHESIS MEETS IMMUNOLOGY

Nicolai Bovin, Ivan Ryzhov, Elena Korchagina, Polina Obukhova

*Shemyakin Institute of Bioorganic Chemistry, Moscow, 117997 Russia*  
bovin@carb.ibch.ru

In spite of the long history of synthetic blood group glycans, there is plenty of room for further insights into the secrets of ABO system. Here, we give several examples of how chemical synthesis allows us to solve immunological “theorems”. Complex A and B antigens possess common fragments, terminal trisaccharides (3S) GalNAc $\alpha$ 1-3(Fuc $\alpha$ 1-2)Gal or Gal $\alpha$ 1-3(Fuc $\alpha$ 1-2)Gal respectively. The 3S, connected  $\beta$ 1-3 or  $\beta$ 1-4 with GlcNAc $\beta$  determine type 1 and type 2 of antigens, whereas connected  $\beta$ 1-3 with GalNAc $\alpha$  or  $\beta$  determine type 3 and type 4. This gives us an opportunity to use block approach as the most effective pathway to have *series* of glycans, including types 1, 2, 3, 4 tetrasaccharides (4S). We have developed “tri<sub>(donor)</sub>+mono<sub>(acceptor)</sub>” strategy, where “tri” is **1** or **2**), and “mono” is protected derivative of GlcN or GalN (**3** – **7**).

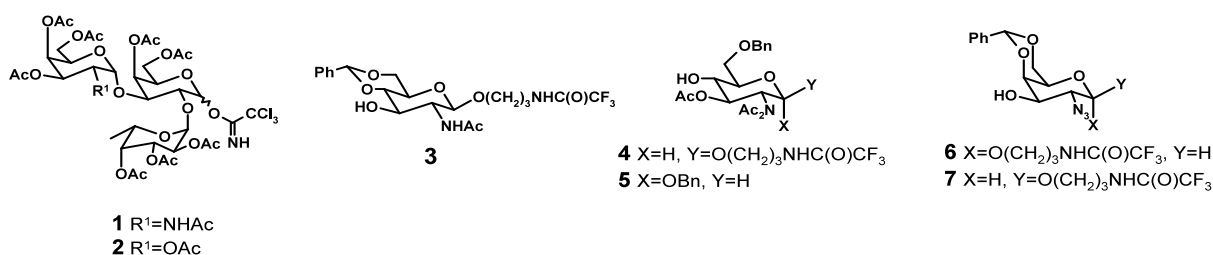

TMSOTf-promoted glycosylation of **3** led to A or B 4S (type 1), only aimed  $\beta$ -anomers. Acceptors **4** and **5** were used to get A and B (type 2) 3S, as  $\alpha/\beta$  (1:1). Glycosylation of **6** gave A and B (type 3) 3S ( $\alpha/\beta$  1:2). A and B (type 4) 3S were obtained using acceptor **7** ( $\alpha/\beta$  1:2). Thus, in spite of absence of assistant group,  $\beta$ -anomers were the major products in most cases.

Glycans printed on a chip allowed us to get new knowledge about human serum ABO-antibodies (Abs). Blood group A glycans (both 3S and 4S) in composition of printed glycan array bind donor's Abs weaker than the corresponding B analogs, whereas variability between donors is considerably higher in case of anti-A. Using affinity columns with the glycans we isolated human anti-A Abs. Interestingly, from A donor's serum we isolated auto-Abs, differing from allo-Abs by specificity. It was still unclear also to what exactly is the epitope that is recognized by Abs having AB specificity; we hypothesized that the AB-epitope should be situated oppositely to the NHAc group of GalNAc. We synthesized a conjugate in such a way that the A 3S is attached to a polymer via C-2 of GalNAc $\alpha$ ; the supposed AB-epitope should be maximally accessible for Abs, whereas the discrimination site should be maximally hidden due to the close proximity of the polymer. Interaction with human sera confirmed our hypothesis.

## IL 23

INTERACTIONS OF COMPLEMENT FACTOR H WITH  
GLYCOSAMINOGLYCANSDušan Uhrín

*University of Edinburgh, EaStCHEM, School of Chemistry, King's Buildings, West Mains Road,  
Edinburgh, EH9 3JJ, UK.  
dusan.uhrin@ed.ac.uk*

Complement factor H, CFH, the main fluid-phase regulator of the alternative pathway of the complement, is a 155 kDa heparin-binding protein consisting of twenty ~7 kDa complement control protein modules (CCPs) connected by linkers of 3-8 residues. CFH has the appearance of 20 beads on a string. By binding heparin sulfate or other cell-surface polyanions, CFH protects host cells from complement attack. Using two polyanion binding sites in CFH modules 6-8 (CFH6-8)<sup>1,2</sup> and CFH19,20<sup>3,4</sup> we discuss the strength and limitations of NMR spectroscopy in the study of protein-GAG interactions.

To complement the backbone NH chemical shift perturbation data obtained by acquiring <sup>1</sup>H, <sup>15</sup>N HSQC spectra we also monitored lysine N<sup>ε</sup>H<sub>3</sub><sup>+</sup> and arginine N<sup>ε</sup>H<sup>ε</sup> resonances by acquiring H<sup>1</sup>SQC and H<sup>2</sup>CN spectra while titrating the heparin oligosaccharides into CFH<sup>7</sup>. In addition, we used chemical cross-linking as a means to probe the roles of individual lysine side chains in the formation of protein-GAG complexes<sup>2</sup>.

We also investigated heparin-binding properties of CFH19,20 mutants using heparin-chromatography<sup>3</sup> and showed a lack of a straightforward correlation between their heparin binding properties and complement regulation in a biological assay. We used NMR and X-ray crystallography to study the C3d-CFH19-20 complex in atomic detail and identified glycosaminoglycan-binding residues in factor CFH20 of the C3d-CFH19-20 complex.

**References**

1. Prosser, B.E., Johnson, S., Roversi, P., Herbert, A.P., Blaum, B.S., Tyrrell, J., Jowitt, T.A., Clark, S.S., Tarelli, E. Uhrín, D., Barlow, P.N., Sim, R.B., Day, A.J., Lea, S.M. *J. Exp. Med.* 204, 2277 - 2283 (2007).
2. Blaum, B.S., Deakin, J.A., Johansson, C.M., Herbert, A.P., Barlow, P.N., Lyon, M., Uhrín, D., *J. Am. Chem. Soc.* 132, 6374-6381 (2010).
3. Ferreira, V. P., Herbert, A. P., Cortes, C., Mckee K. A., Blaum, B. S., Esswein, S. T., Uhrín, D., Barlow, P. N., Pangburn, M. K., Kavanagh, D., *J. Immunol.* 182, 7009-7018 (2009).
4. Morgan, H.P., Schmidt, C.Q., Guariento, M., Blaum, B.S., Gillespie, D., Herbert, A.P., Kavanagh, D., Mertens, H.D.T., Svergun, D.I., Johansson, C.M., Uhrín, D., Barlow, P.N., Hannan, J.P., *Nature Structural & Molecular Biology*, published online 13 February 2011; doi:10.1038/nsmb.2018



## IL 24

## CARBOHYDRATE STRUCTURE: AN NMR AND COMPUTATIONAL APPROACH

Göran Widmalm

*Department of Organic Chemistry, Arrhenius Laboratory, Stockholm University, S-106 91  
Stockholm, Sweden  
gw@organ.su.se*

The structural determination of carbohydrates is posed by the specific problem of limited spectral dispersion both for <sup>1</sup>H and <sup>13</sup>C nuclei. The use of <sup>15</sup>N and <sup>31</sup>P nuclei is also of importance in carbohydrate NMR spectral analysis. Employing one-, two-, as well as multidimensional NMR spectroscopy the process of assignment of a certain resonance to a specific nucleus is still tedious and the most time consuming part of the process. We developed a computerized method to determine carbohydrate structure from NMR spectra, termed CASPER, an acronym for Computer Assisted SPectrum Evaluation of Regular polysaccharides, but can it be used for oligosaccharides as well. Its advantage is that it uses *unassigned* NMR spectra. Recent developments include utilization of experiments based on through-bond connectivities over several bonds, i.e., <sup>1</sup>H,<sup>1</sup>H-homonuclear and <sup>1</sup>H,<sup>13</sup>C-heteronuclear spin-spin coupling constants [1]. In NMR terminology <sup>1</sup>H,<sup>1</sup>H-TOCSY, <sup>1</sup>H,<sup>13</sup>C-H2BC and <sup>1</sup>H,<sup>13</sup>C-HMBC experiments. A new function, employing knowledge about classes of glycans to generate only structures containing the structural elements of a specific kind of carbohydrates, is biological rules for N-linked and O-linked glycans, Wzx/Wzy dependent WecA assembled *E. coli* O-antigen repeating units, *S. flexneri* O-antigen repeating units and *H. influenzae* lipopolysaccharides.

For the analysis of the three-dimensional structure of glycans a number of experimental biophysical techniques are available, in particular NMR spectroscopy, X-ray diffraction on crystals, optical rotation, ultrasonic relaxation and Raman optical activity. The experimental techniques may be complemented by molecular dynamics simulations that give a detailed description of the dynamics of the systems [2]. The use of <sup>13</sup>C site-specifically synthesized oligosaccharides [3], for obtaining conformationally dependent trans-glycosidic homo- and heteronuclear coupling constants and interpretation of conformational equilibria from these based on recently developed Karplus-type relationships for *J* coupling constants over three bonds [4], will be presented in search for a description of the population distribution of the torsion angles at the glycosidic linkage.

**References**

1. M. Lundborg, G. Widmalm, *Anal. Chem.*, **2011**, 83, ASAP.
2. E. Hatcher, E. Säwén, G. Widmalm, A. D. MacKerell, Jr., *J. Phys. Chem. B*, **2011**, 115, 597-608.
3. K. H. M. Jonsson, R. Pendrill, G. Widmalm, *Magn. Reson. Chem.*, **2011**, 49, 117-124.
4. E. Säwén, T. Massad, C. Landersjö, P. Damberg, G. Widmalm, *Org. Biomol. Chem.*, **2010**, 8, 3684-3695.

## IL 25

## 1,2-DICARBONYL SUGARS IN BIOLOGY: PHOSPHATE-CATALYZED SKELETAL REARRANGEMENT INVOLVING C1-C2 TRANSPOSITION

Wenhui Zhang and Anthony S. Serianni

*Department of Chemistry and Biochemistry, University of Notre Dame, Notre Dame, IN 46556-5670 USA*  
*aseriann@nd.edu*

1,2-Dicarbonyl sugars such as 3-deoxy-D-erythro-hexos-2-ulose (3-deoxy-D-glucosone) (**1**) and D-arabino-hexos-2-ulose (D-glucosone) (**2**) have been implicated in the degradation of D-glucose *in vivo*, with **1** commonly detected as a metabolite in diabetic patients.<sup>1</sup> The contiguous electrophilic carbonyls in **1** and **2** make them susceptible to nucleophilic attack by protein side-chains (e.g., arginine), leading to structural modification and in some cases loss of protein function.<sup>2,3</sup> Degradation of **1** and **2** can generate reactive carbonyl species (RCS), such as glyoxal and methyl glyoxal, which can inflict more functional damage than **1** and **2** alone.<sup>4</sup> Recent studies of the solution behavior of **1** using

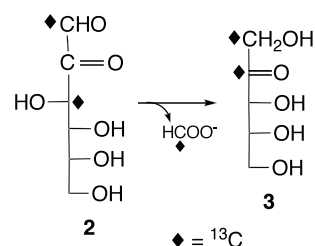
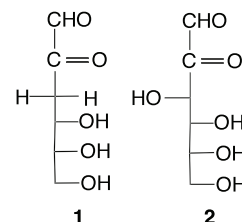

<sup>13</sup>C NMR and <sup>13</sup>C/<sup>1</sup>H-labeled compounds showed that **1** rearranges in solution under physiological conditions to give metasaccharinic acids exclusively via a 1,2-hydrogen transfer mechanism. Under the same solution conditions, **2** experiences C1-C2 bond cleavage to give D-ribulose **3** and other by-products.<sup>5</sup> <sup>13</sup>C NMR studies of <sup>13</sup>C isotopomers of **2** revealed an unexpected C1-C2 transposition in the conversion of **2** to **3** (e.g., D-[1,3-<sup>13</sup>C<sub>2</sub>]glucosone gives D-[1,2-<sup>13</sup>C<sub>2</sub>]ribulose). This transformation is phosphate- and arsenate-catalyzed

at pH 7.4, and may involve an osone-phosphate (or osone-arsenate) adduct as an intermediate. These findings suggest a new role for phosphate in the degradation of 1,2-dicarbonyl compounds *in vivo*. This work was supported by the National Institute of Diabetes and Digestive and Kidney Disease, research grant No. DK065138.

**References**

1. Wells-Knecht, K.J.; Lyons, T.J.; McCance, D.R.; Thorpe, S.R.; Feather, M.S.; Baynes, J.W. *Diabetes* **1994**, *43*, 1152-1156.
2. Biemel, K.M.; Friedl, D.A.; Lederer, M.O. *J. Biol. Chem.* **2002**, *277*, 24907-24915.
3. Chetyrkin, S.V.; Zhang, W.; Hudson, B.G.; Serianni, A.S.; Voziyan, P.A. *Biochemistry* **2008**, *47*, 997-1006.
4. Wolff, S.P.; Dean, R.T. *Biochem. J.* **1987**, *245*, 243-250.
5. Wells-Knecht, K.J.; Zyzak, D.V.; Litchfield, J.E.; Thorpe, S.R.; Baynes, J.W. *Biochemistry* **1995**, *34*, 3702-3709.



## IL 26

**RED MICROALGAL POLYSACCHARIDES FROM THE TEST TUBE  
TO THE FINAL PRODUCT**

Shoshana (Malis) Arad

*Ben-Gurion University of the Negev, Beer Sheva, Israel*

The cells of the red microalgae are encapsulated with sulfated polysaccharide. In recent years, our lab has developed the biotechnology for the production of valuable products from the red microalgae with the emphasis on cell-wall sulfated polysaccharides. The combination of the unique characteristics of these novel molecules (their composition, structure, rheology, and extreme stability) and their biological activities, has opened a vast range of potential applications. The bioactivities – including anti-inflammatory and soothing actions and antioxidant properties – have made the sulfated polysaccharides suitable for application in a wide range of dermal cosmetic preparations that are already on the market. Additional applications, e.g., pharmaceutical and nutritional applications, are currently under development.

The multidisciplinary R&D effort of our lab – integrating biological, chemical, molecular and engineering studies – has already yielded various commercial products. In the future, however, red microalgae will be exploited in a more sophisticated manner for additional applications—based on unraveling the enormous potential that lies in the algal genome concerning sugars and their biosynthesis.

## IL 27

SEVEN-MEMBERED IMINOSUGARS:  
FROM GLYCOSIDASE INHIBITION TO SKELETAL REARRANGEMENTY. Blériot

*Laboratoire de Synthèse et Réactivité des Substances Naturelles, UMR 6514,  
Université de Poitiers, 4, avenue Michel Brunet 86022 Poitiers, France  
yves.bleriot@univ-poitiers.fr*

Iminosugars, in which the ring oxygen has been replaced by nitrogen, constitute the most promising class of sugar analogues because their glycosidase and/or glycosyltransferase inhibition profile make them promising therapeutics.[1] As a consequence, some iminosugar derivatives are already on the market to treat diabetes or Gaucher disease while others are currently involved in clinical trials to treat cancer, viral infections or genetic diseases such as cystic fibrosis. While five- and six-membered iminosugars have been largely investigated, the unusual seven-membered analogues have been rather unexplored [2] despite an expected potential related to their conformational flexibility.

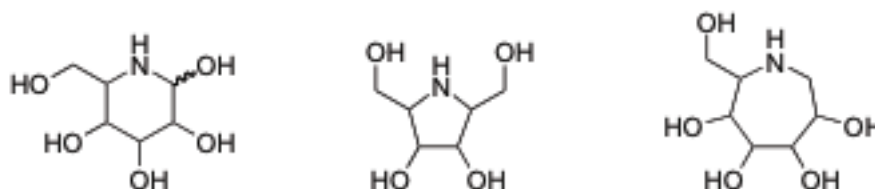

Structure of five-, six- and seven-membered iminosugars

We have launched a program to explore the synthetic access, the biological and the synthetic potential of these polyhydroxylated azepanes.[3] Recent results obtained with these odd iminosugars will be presented.

**References**

1. Iminosugars: From Synthesis to Therapeutic Applications; Compain, P., Martin, O.R., Eds.; Wiley-VCH: Weinheim, 2007.
2. F. Moris-Varas, X.-H. Qian, C.-H. Wong, *J. Am. Chem. Soc.* **1996**, *118*, 7647.
3. H. Li, Y. Blériot, C. Chantereau, J.-M. Mallet, M. Sollogoub, Y. Zhang, E. Rodriguez-Garcia, P. Vogel, J. Jimenez-Barbero, P. Sinaÿ, *Org. Biomol. Chem.* **2004**, *2*, 1492-1499.

## IL 28

## HIGHER-CARBON SUGARS OF BACTERIAL LIPOPOLYSACCHARIDES: SYNTHESIS AND BINDING INTERACTIONS WITH ANTIBODIES AND LECTINS

Paul Kosma

*Department of Chemistry, University of Natural Resources and Life Sciences,  
A-1190 Vienna Austria  
Paul.kosma@boku.ac.at*

Cell-wall anchored microbial sugars constitute an important class of ligands being exposed to the continuous interaction with the components of the adaptive and innate immune system. Extending common pyranose-ring chemical entities, higher carbon sugars such L-glycero- and D-glycero-D-manno-heptose (L,D-Hepp, D,D-Hepp), 3-deoxy-D-manno-oct-2-ulosonic acid (Kdo) and D-glycero-D-talo-oct-2-ulosonic acid (Ko) comprise structural and functional motifs for multiple binding interactions. In particular, side chain diol groups and ionic species present as carboxylate, phosphate or amino groups, respectively, provide significant binding contributions. Synthetic approaches to generate defined ligands for binding and crystallographic studies will be illustrated for biomedically important antigenic epitopes residing in the inner core of *Chlamydia*, *Burkholderia* and *Proteus* lipopolysaccharides to allow for in-depth molecular analysis of binding modes and definition of major factors in immune recognition of LPS inner core epitopes.<sup>1-4</sup>

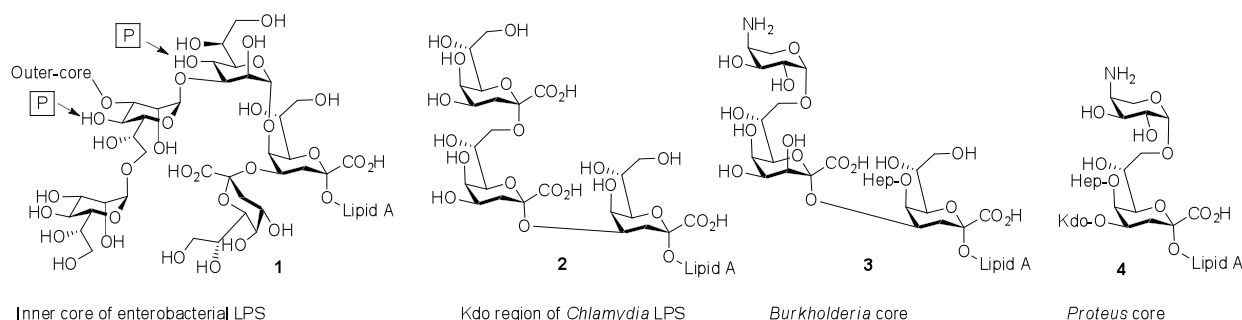

**Acknowledgments:** Financial support by Austrian Science Fund (FWF grants P19295 and P 22909)

### References

1. Evans, D.W., Müller-Loennies, S., Brooks, C.L., Brade, L., Kosma, P., Brade, H., Evans, S.V., *Glycobiol.*, **2011**, *in press*.
2. Gerstenbruch, S., Brooks, C.L., Kosma, P., Brade, L., MacKenzie, R., Evans, S.V., Brade, H., Müller-Loennies, S., *Glycobiol.*, **2010**, *20*, 461-472.
3. Kosma, P., *Curr. Org. Chem.*, **2008**, *12*, 1021-1039.
4. Wang, H., Head, J., Kosma, P., Brade, H., Müller-Loennies, S., Sheikh, S., McDonald, B., Smith, K., Cafarella, T., Seaton, B., Crouch, E., *Biochemistry*, **2008**, *47*, 710-720.

**SPONSOR  
LECTURES**

## SP 01

**DETECTION AND PURIFICATION OF CARBOHYDRATES AND CONJUGATED CARBOHYDRATES**Virginio Lonati

*Grace Davison Discovery Sciences  
Via Trento 7 - 20017 Passirana di Rho (MI)  
virginio.lonati@grace.com*

Separation and identification of carbohydrate-based compounds is complicated due to their structure and poor detection. Lack of chromophores, high sensitivity, and the compound's instability require a chromatographic system that is productive and efficient. The Reveleris® iES allows the detection and purification of carbohydrates and conjugated carbohydrates using multiple signal processing from UV and ELSD (Evaporative Light Scattering Detection). Using this RevealX™ detection technology in the Reveleris® iES flash chromatography system chemists can isolate both chromophoric compounds and non-chromophoric sugars present in the sample matrix during a single run.

## SP 02

## CAPILLARY ION CHROMATOGRAPHY IN CARBOHYDRATE ANALYSIS

Franco Abballe<sup>1</sup>

<sup>1</sup>Dionex SpA 20097 San Donato Milanese (Mi)  
franco.abballe@dionex.com

The Carbohydrate separation by HPAE PAD was largely used in last 20 years. The resolution power the sensitivity and the broad range of application capability has made very popular this technique in last twenty years. The development of detectors and chromatographic phases was improved by the time and the analytical technique is today robust, reliable and reproducible. Nevertheless the last innovation in Ion Chromatography, the capillary technology can still give improvement in such technique.

The new high efficient, carbonate free capillary electrochemical eluent generation offers high automation and robustness. Thanks to the capillary flow rate is possible to generate hydroxide up to 200 mM/l without Carbonate and with low content of hydrogen. Sample volume as little as 0,4  $\mu$ l is enough for an injection and the low consumption of eluent makes possible a no stop operation for several weeks.

The presentation describes the innovative IC instrument technology, the pump capillary the new electrochemical eluent generator for capillary and the original idea of the Dionex Cube. Several practical example will be discussed.

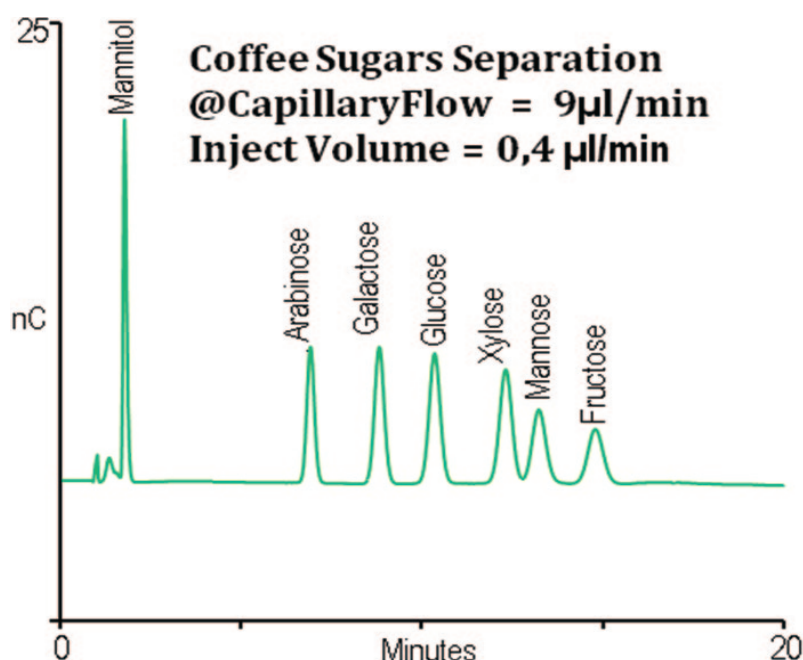

## SP 03

**SIMGLYCAN SOFTWARE  
A PREDICTIVE CARBOHYDRATE AND GLYCOPEPTIDE ANALYSIS TOOL  
FOR MS/MS DATA**

Matthias Glueckmann,<sup>1</sup> Jenny Albanese,<sup>1</sup> Volker Kruft,<sup>1</sup> Lydia Nuwaysir<sup>1</sup>  
Arun Apte,<sup>2</sup> Ningombam Sanjib Meitei<sup>2</sup>, Satya Kumar A.<sup>2</sup>

<sup>1</sup>AB SCIEX

<sup>2</sup>PREMIER Biosoft International

The analysis of glycans in MSMS mode is challenging due to the high complexity of fragment ion spectra. We present novel software for the interpretation of MSMS spectra which lead to the glycan structure, providing the glycan fragments, its structure, sequence, composition, the theoretical glycan mass and other information.

The analysis of carbohydrates is of high importance in modern biochemistry. Structure determination requires the knowledge of various sugar sequences, anomeric linkages between the monosaccharides and their fragmentation patterns under different experimental conditions such as permethylation, reducing end modifications, adducts used and the ion mode. The SimGlycan software ([www.premierbiosoft.com](http://www.premierbiosoft.com)) predicts the structure of a glycan based on MS/MS data acquired by mass spectrometry, facilitating the study of glycosylation and posttranslational modifications studies. SimGlycan software accepts the experimental MSMS data generated by a mass spectrometer and matches it with its own database of theoretical fragmentation of over 8,000 glycans and generates a list of probable glycan structures. Each structure is scored to reflect how closely it matches the experimental data. Other biological information for the probable glycan structures such as the glycan class, reaction, pathway and enzyme are also made available for easy reference.

SimGlycan software accepts experimental m/z and intensity values (MSMS data) of a glycan. Samples are analyzed using a quadrupole linear ion trap hybrid instrument, quadrupole-TOF instrument or TOF/TOF™ System. SimGlycan software verifies the monosaccharides composition of the experimental glycan using diagnostic ions calculated for the glycans in the database. The composition score is calculated for every probable. Further, the branching score is calculated for identification of the linkages and branching pattern of the unknown sugar by using the internal and cross ring cleavages of theoretical glycans. The glycan with highest composition and branching score is the predicted structure.

MSMS spectra allow differentiation of isomeric structures and the determination of oligosaccharide sequences and the linkage position of the reducing residue. In the MALDI CID MS/MS spectra a considerably greater number of fragments are found in comparison to other mass spectrometry fragmentation techniques. Although this may complicate their interpretation, it permits acquisition of more information on linkage position and points of branching.

For every probable glycan structure, SimGlycan software provides glycan fragments, structure, sequence, composition, glycan mass, class, reaction, pathway, enzyme and other database links. All the possible glycan structures are ranked based on proprietary search and scoring algorithm. The ranking algorithm is based on calculating the glycan score, which is a numerical representation of how close the experimental glycan is to theoretical glycans in terms of composition and branching pattern.

In summary mass spectrometry in combination with SimGlycan software demonstrated a powerful combination for the analysis of carbohydrates.

**ORAL  
PRESENTATIONS**



## OL 01

## THE IODINE/TRIETHYLSILANE SYSTEM: A VERSATILE COMBINATION WITH MULTIPLE APPLICATIONS IN SYNTHETIC CARBOHYDRATE CHEMISTRY

Matteo Adinolfi, Alfonso Iadonisi, Antonello Pastore, Silvia Valerio

*Dipartimento di Chimica Organica e Biochimica,  
Università degli Studi di Napoli "Federico II"  
iadonisi@unina.it*

Combination of I<sub>2</sub> and Et<sub>3</sub>SiH allows a rapid generation of HI under anhydrous conditions, and over the last years we have shown that an appropriate stoichiometric tuning of these reagents can lead to several useful synthetic routes in carbohydrate chemistry. The first reported application concerns the use of stoichiometric I<sub>2</sub> and catalytic Et<sub>3</sub>SiH as an activation system of trihaloacetimidate glycosyl donors<sup>1</sup> which was subsequently shown by Takahashi and co-workers to be especially effective for the stereocontrolled synthesis of β-glycosides of 2,6-dideoxy sugars.<sup>2</sup> In an alternative application, use of a slight equimolar excess of both reagents allows a very quick anomeric iodination of 1-O-acetylated precursors; incorporation of this transformation into several sequential procedures has led to the streamlined synthesis of a wide range of useful saccharidic derivatives such as 1,2-orthoesters, ethylidenes, glycals,<sup>3</sup> thio- and selenoglycosides,<sup>4,5</sup> estradiol glycosides.<sup>6</sup> Very recently the reagent system was disclosed to promote the fast regioselective deprotection of poly-O-benzylated substrates and in many cases an unprecedented regioselectivity control, with preferential deprotection of the most sterically encumbered carbinol positions (see representative examples in the following Scheme), was observed.<sup>7</sup>

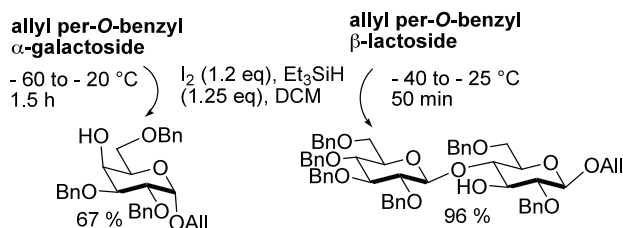

## References

- Adinolfi M., Barone G., Iadonisi A., Schiattarella M., *Synlett* **2002**, 269-270.
- Tanaka H., Yoshizawa A., Takahashi T., *Angew. Chem. Int. Ed.* **2007**, 46, 2505-2507.
- Adinolfi M., Iadonisi A., Ravidà A., Schiattarella M., *Tetrahedron Lett.* **2003**, 44, 7863- 7866.
- Valerio S., Iadonisi A., Adinolfi M., Ravidà A. *J. Org. Chem.* **2007**, 72, 6097- 6106.
- Pezzella A., Iadonisi A., Valerio S., Panzella L., Napolitano A., Adinolfi M., d'Ischia M. *J. Am. Chem. Soc.* **2009**, 131, 15270-15275.
- Adinolfi M., Iadonisi A., Pezzella A., Ravidà A., *Synlett* **2005**, 1848-1852.
- Pastore A., Valerio S., Adinolfi M., Iadonisi A., *Chem. Eur. J.* **2011**, in press.

## OL 02

TOWARDS SYNTHETIC GLYCONJUGATES BASED ON THE STRUCTURES OF *NEISSERIA MENINGITIDIS* A CAPSULAR POLYSACCHARIDEA. Black, D.V. Yashunsky, O.V. Sizova and A.V. Nikolaev

*Division of Biological Chemistry & Drug Discovery, College of Life Sciences,  
University of Dundee, Dundee DD1 5EH, UK  
a.v.nikolaev@dundee.ac.uk*

A Gram-negative bacterium *N. meningitidis* serogroup A causes endemic and epidemic meningitis in Sub-Saharan Afrika and sporadically throughout the world. The 1996 epidemic in the region known as African meningitis belt led to 250,000 cases and 25,000 deaths. Thus, a well-working vaccine to control the disease is greatly needed. Protection against the meningococcal infection is directly related to the presence of humoral IgG antibodies against the bacteria capsular polysaccharide (CPS), consisting of 3-O-Ac- $\alpha$ -D-ManNAc 1-phosphate repeat units (structure **1**). An effective and proved [V. Verez-Bencomo et al., *Science* **2004**, 305, 522] approach to a vaccine is to synthetically produce fragments of the CPS, followed by their conjugation to an immunogenic protein carrier, which induces a T-cell dependent immune response with immunological memory and gives protection to young children.

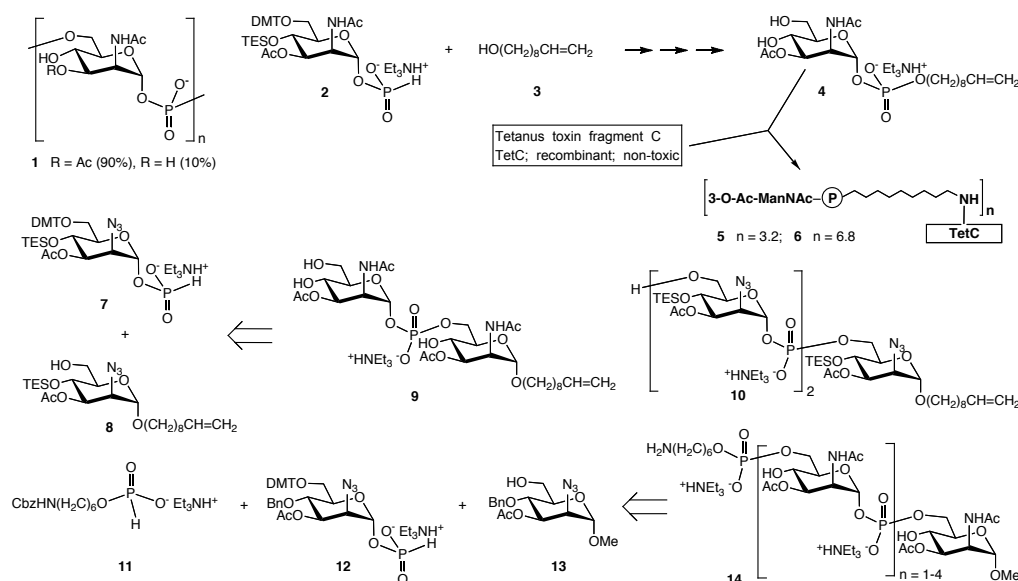

Here, we report the synthesis of some CPS structures and the preparation of neoglyconjugates therefrom. The H-phosphonate derivative **2** was coupled to dec-9-enol **3** to produce (after oxidation and deprotection) a monomer of the CPS repeat **4**. It was converted to the neoglyconjugates **5** and **6** via ozonolysis and coupling to TetC protein by reductive amination. The phosphosaccharides **9** and **10** containing two and three ManNAc units were prepared by stepwise chain elongation using the 6-O-DMT protected H-phosphonate **7** and the glycoside **8** as the first alcohol acceptor. A set of oligomers **14** containing from 2 to 5 phosphosaccharide repeats and a 6-aminohexyl spacer were made effectively from the H-phosphonate synthon **12** (for chain elongation), the 6-OH glycoside **13** and the N-Cbz-6-aminohexyl H-phosphonate **11** (for chain termination). The oligomers **14** will be further coupled to an aminoxylylated protein using V. Pozsgay technique [*J. Org. Chem.* **2005**, 70, 6987].

## OL 03

NEW APPROACHES TO STEREOCHEMICAL CONTROL; APPLICATIONS  
OF ASYMMETRIC CATALYSIS AND NEW TYPES OF NEIGHBOURING  
GROUP PARTICIPATION

Antony Fairbanks

Department of Chemistry, University of Canterbury, Private Bag 4800,  
Christchurch 8140, New Zealand  
antony.fairbanks@canterbury.ac.nz

The recent rapid development of asymmetric organocatalysis has opened up new avenues for the control of stereochemistry in a wide variety of synthetic arenas. However, as yet, organocatalysis has found scant application in the carbohydrate field. One intriguing possibility is that asymmetric catalysis could also be applied to achieve control of the diastereoselectivity of glycosylation; this<sup>1</sup> and other potential applications of chiral Brønsted acid catalysts in the carbohydrate field will be discussed.

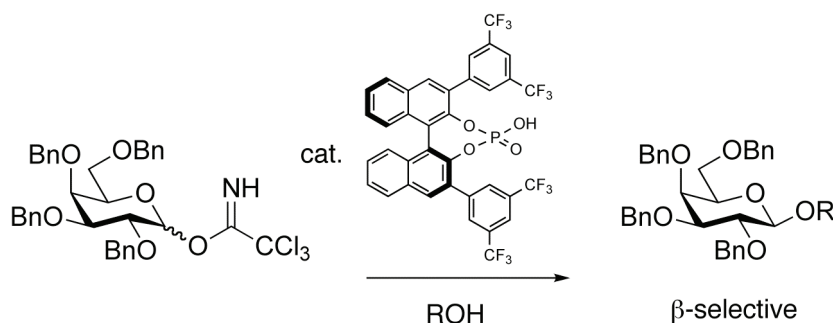

The development of stereoselective glycosylation mediated by chiral protecting groups, invented by Boon's in 2005,<sup>2</sup> has opened up new possibilities for the stereochemical control of glycosylation by different types of neighbouring group participation. Novel types of participating protecting groups that can be installed at the 2-hydroxyl of a glycosyl donor, and their influence on the stereochemical outcome of glycosylation, will also be discussed.<sup>3</sup>

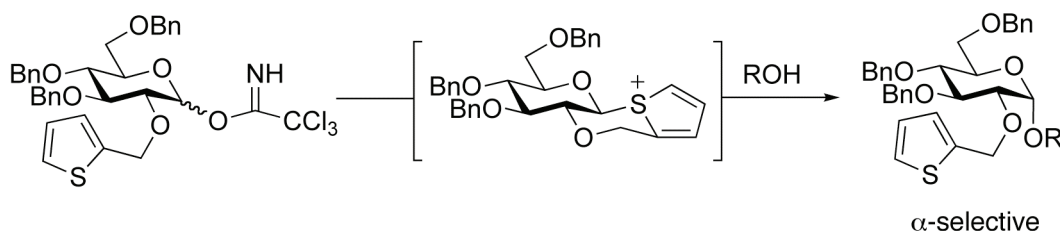

### References

1. D. J. Cox, M. D. Smith, A. J. Fairbanks, *Org. Lett.*, **2010**, *12*, 1452-1455.
2. a) J.-H. Kim, H. Yang, G.-J. Boons, *Angew. Chem., Int. Ed.* **2005**, *44*, 947-949. (b) J. H. Kim, H. Yang, J. Park, G.-J. Boons, *J. Am. Chem. Soc.* **2005**, *127*, 12090-12097. c) T. J. Boltje, J.-H. Kim, J. Park, G.-J. Boons, *Org. Lett.*, **2011**, *13*, 284-287.
3. D. J. Cox, A. J. Fairbanks, *Tetrahedron: Asymmetry*, **2009**, *20*, 773-780.

## OL 04

## SEMISYNTHESIS OF GLYCOFORMS OF HUMAN INTERLEUKIN 6

Sebastian Siebenhaar, Andrea Tröster, Andreas Reif, Phanindra Velisetty and Carlo Unverzagt

*Bioorganische Chemie, Universität Bayreuth, Gebäude NW I, 95440 Bayreuth, Germany  
carlo.unverzagt@uni-bayreuth.de*

Since the interest in well-defined glycoproteins is steadily increasing, various methods for the synthesis of homogeneously glycosylated proteins were developed [1]. A very versatile basis is the sequential or one-pot native chemical ligation (NCL) developed by Kent et al [2].

As a model glycoprotein we chose the human interleukin 6 (IL-6), a cytokine with pleiotropic functions [3]. Non-glycosylated IL-6 shows only a short half-life in vivo, thus native IL-6 glycoforms are of therapeutic interest.

For the semisynthesis of glycosylated IL-6 the protein was divided into three fragments. The N-terminal thioester fragment 1-42 and the C-terminal cysteine-fragment 49-183 were produced via expression of intein fusion proteins in *E. coli*. The released IL-6 49-183 containing an N-terminal cysteine was isolated after protection of the three thiols as mixed disulfides [4]. The glycosylated central IL-6 fragment 43-48 thioester was synthesized via different linkers on a solid phase and contained an N-terminal thiazolidine [2] and a GlcNAc moiety or a complex type nona-saccharide.

With this set of suitable protected building blocks in hand sequential ligations were carried out leading to different full length IL-6 glycoproteins. The IL-6 glycoproteins were refolded and assayed for activity.

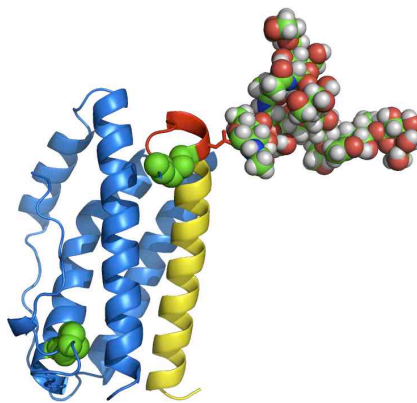

### References

1. D. P. Gamblin, E. M. Scanlan, B. G. Davis, *Chem. Rev.* **2009**, *109*, 131-163.
2. D. Bang, S. B. H. Kent, *Angew. Chem. Int. Ed.* **2004**, *43*, 2534-2538.
3. J. Simpson, *Protein Science* **1997**, *6*, 929-955.
4. C. Piontek, P. Ring, O. Harjes, C. Heinlein, S. Mezzato, N. Lombana, C. Pöhner, M. Püttner, D. Varòn Silva, A. Martin, F. X. Schmid, C. Unverzagt, *Angew. Chem. Int. Ed.* **2009**, *48*, 1936-1940.

## OL 05

## FLEXIBLE C-GLYCOSIDE SYNTHESIS

Daniel B. Werz

*Institute of Organic and Biomolecular Chemistry, Georg August University of Göttingen,  
Tammannstr. 2, 37077 Göttingen, Germany.  
dwerz@gwdg.de*

The development of novel strategies for the synthesis of carbohydrate mimetics is a major task in modern bioorganic and medicinal chemistry.<sup>[1, 2]</sup> During the last decades scientists succeeded in the modular synthesis of highly complex *O*-glycosides.<sup>[3]</sup> The most difficult synthetic modification with respect to the linkage is the construction of *C*-glycosides. Several elegant methods have been reported in literature, but most of them use highly elaborated systems<sup>[4]</sup> or can only be applied for very special cases. A general approach to form *C*-glycosidic bonds between monosaccharide units has still been lacking.

Our approach for the construction of *C*-glycosidic bonds between two monosaccharide units employs Pd-mediated coupling reactions. Monosaccharide building blocks are modified in such a way that sp<sup>2</sup>- or sp-hybridized carbons are available. Such a design enables us to use cross-coupling reactions to create the carbon-carbon bond. The pseudodisaccharides obtained by these reactions allow an access to either 2-deoxy-*C*-glycosides or to *C*-glycosides with the native hydroxyl pattern, either as  $\alpha$ - or as  $\beta$ -anomer. Using this methodology (1 $\rightarrow$ 2)-, (1 $\rightarrow$ 3)-, (1 $\rightarrow$ 4)- and (1 $\rightarrow$ 6)-linked *C*-glycosides can be created in a highly modular fashion.

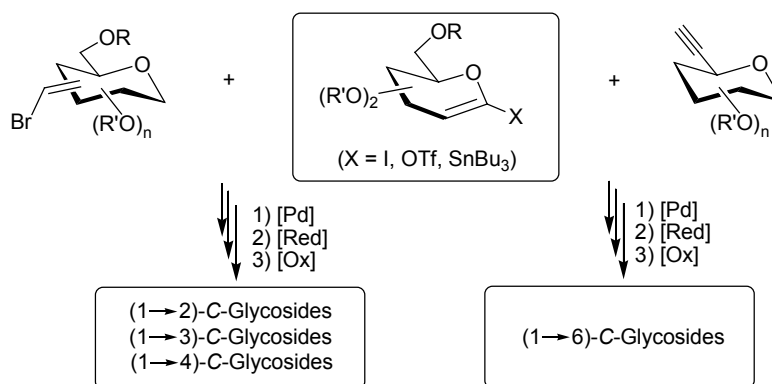
**References**

1. Review on carbohydrate mimetics: D. C. Koester, A. Holkenbrink, D. B. Werz, *Synthesis* **2010**, 3217-3242.
2. P. H. Seeberger, D. B. Werz, *Nature* **2007**, 446, 1046-1051.
3. X. Zhu, R. R. Schmidt, *Angew. Chem. Int. Ed.* **2009**, 48, 1900-1934.
4. M. H. D. Postema, J. L. Piper, V. Komanduri, *Angew. Chem. Int. Ed.* **2004**, 43, 2915-2918.
5. D. C. Koester, M. Leibeling, R. Neufeld, D. B. Werz, *Org. Lett.* **2010**, 12, 3934-3937.
6. D. C. Koester, E. Kriemen, D. B. Werz, *manuscript in preparation*.

## OL 06

## INNATE IMMUNITY: PLANT RECOGNITION OF BACTERIAL MAMPS

G. Erbs<sup>1</sup>, A. Silipo<sup>2</sup>, M. Parrilli<sup>2</sup>, A. Molinaro<sup>2</sup> and M.-A. Newman<sup>1</sup>

<sup>1</sup>*Faculty of Life Sciences, University of Copenhagen, Frederiksberg C, Denmark.*

<sup>2</sup>*Dipartimento di Chimica Organica e Biochimica, Università di Napoli Federico II,  
Complesso Universitario Monte Sant' Angelo, Napoli, Italy  
mari@life.ku.dk*

In an environment that is rich in potentially pathogenic microorganisms, the survival of higher eukaryotic organisms depends on efficient pathogen sensing and rapidly mounted defence responses. Such protective mechanisms are found in all multicellular organisms and are collectively referred to as innate immunity. Innate immunity is the first line of defence against invading microorganisms in vertebrates and the only line of defence in invertebrates and plants. Plants interact with a variety of microorganisms, and like insects and mammals, they respond to a range of microbial molecules from both host and non-host pathogens. The elicitors are essential structures for pathogen survival and are for that reason conserved among pathogens. These conserved microbe-specific molecules, also referred to as Microbe Associated Molecular Patterns (MAMPs), are recognised by the plant innate immune systems Pattern Recognition Receptors (PRRs). We have chemically and biologically examined lipopolysaccharides (LPS) and peptidoglycan (PGN) from two Gram-negative plant pathogens, *Xanthomonas campestris* pv. *campestris* (*Xcc*) and *Agrobacterium tumefaciens* (*At*). In the case of PGN we show that PGN functions as a MAMP in plants by triggering diverse innate immune responses, and that its perception is dose dependent. Clear differences in the structures of *Xcc* and *At* PGNs and their constituent muropeptides were found and may explain why *Xcc* PGN was a better elicitor of plant immune responses than *At* PGN; the lower efficacy of *At* PGN might relate with its subtle, biotrophic mode of invasion. However, for both bacteria the muropeptides were more effective in triggering immune responses in *Arabidopsis* than the native PGN. These findings demonstrate that PGN from true plant pathogenic bacteria functions as a MAMP.

The role of LPS in plant innate immunity has been investigated for a number of years in our group. I will present new data to show that *Arabidopsis* PEN1, a SNARE protein believed to be required for docking and fusion of intracellular transport vesicles, is involved in signal transduction leading to the induction of the innate immune responses by particular bacterial MAMPs. Specifically we show that PEN1 is required for *PR1* gene induction, callose deposition and generation of reactive oxygen species by LPS but not by Flg. These findings, which suggest multiple roles for PEN1 in determining plant resistance to pathogens, will be discussed in the light of previously published work that shows internalisation of LPS on application to suspension cultured cells and the recent work implicating PEN1 in resistance to fungal pathogens. Finally the effects of MAMP combinations and their interactions with the host cell wall were investigated. Early responses in *Arabidopsis*, elicited by non-saturating concentrations of Flg peptide (flg22), EF-Tu peptide (elf18), PGN, its constituent muropeptides, LPS and its core oligosaccharide derivative, revealed that some MAMPs have additive and even synergistic effects, while some mutually interfere. The peptide elicitors are potent at sub-nm levels, whereas PGN and LPS only at high  $\mu$ m levels induce low and late responses. This contrast may result from restricted access to receptors through the host wall of these macro-molecular MAMPs. Thus flg22 rapidly permeates a cell wall matrix, whereas LPS, which forms micelles, is severely constrained. Clearly, induction and suppression of innate immunity involves complex interactions between host and pathogen polymers.



## OL 07

LIPOCHITOOLIGOSACCHARIDIC SYMBIOTIC SIGNALS  
OF MYCORRHIZATION

V. Poinso<sup>1</sup>, V. Puech-Pagès<sup>2</sup>, MA. Carpéné<sup>1</sup> and F. Couderc<sup>1</sup>

<sup>1</sup> IMRCP, UMR 5623 CNRS-Université Paul Sabatier, 31062 Toulouse cedex, France,

<sup>2</sup> SCSV, UMR 5546, Université Paul Sabatier-CNRS; 31326 Castanet-Tolosan, France.  
poinso<sup>1</sup>@chimie.ups-tlse.fr

Arbuscular mycorrhizal (AM) fungi establish symbiotic associations with a majority of the vegetal kingdom of critical importance when soil fertility and water availability are low. AM is a difficult system to study, since the fungi can't be cultivated without vegetable host. Recent publications demonstrated the existence of a diffusible fungal signal, active on the plant and borrowing partly the transduction way of the Nod factors (signals for establishing the nitrogen fixing symbiosis) [1-2]. Our work reports the structural elucidation of this signal.

Very complex mycorrhized root exudates were extracted, prepurified on SPE and finally separated on semi-preparative or analytical reversed phase HPLC. Activity of the so obtained fractions was biologically tested. Due to the very low concentration of these signals ( $10^{-12}$ M), the scarcity and complexity of the biological material, different mass spectrometer and mass analyses were necessary. MRM experiments using a LC-Q-Trap were advantageously used for screening the presence of several expected Nod-factor-like structures at very low concentration levels. UPLC-Q-Tof MS/MS and exact masses determination were used for unambiguous structural identification of the major compounds. The characterization was performed after a cleaning up and a preconcentration of  $10^6$  times.

The fungal signal exhibiting the expected biological activity are lipo-oligomers belonging to the chitin series (LCO). The first elucidated compounds are similar to the well known Nod factors, but they exhibit a very simple structure and are synthesized as a mixture. These compounds of major ecological interest were investigated since years allowing their publication in Nature [3]. Our know-how allowed us to find very recently a new extremely active fungal LCO family.

**References**

1. Oláh B, Brière C, Bécard G, Dénarié J, Gough C., *Plant J.*, **2005**, *44*, 195-207.
2. Gutjahr C, Casieri L, Paszkowski U., *New Phytol.*, **2009**, *183*, 53-.
3. Poinso V, Maillet F, André O, Puech-Pagès V, Haouy A, Gueunier M, Cromer L, Giraudet D, Formey D, Niebel A, Martinez EA, Driguez H, Bécard G, Dénarié J. *Nature*, **2011**, *469*, 58-63.

## OL 08

**POLYSACCHARIDES OF BIOFILMS PRODUCED BY BURKHOLDERIA CEPACIA  
COMPLEX BACTERIA**

Bruno Cuzzi, Paola Cescutti, and Roberto Rizzo

*Department of Life Science, University of Trieste, via L. Giorgieri 1, 34127 Trieste, Italy  
pcescutti@units.it*

Biofilms are communities of bacteria that live in a polymeric matrix associated with a surface. This matrix grants the embedded bacteria a protective environment and helps pathogens to escape antibacterial agents. The composition of the matrix is quite complex containing polysaccharides, proteins and nucleic acids. Moreover, the polysaccharides produced in biofilm are not always identical to the ones produced in planktonic conditions. In fact, for *P. aeruginosa* biofilm, Byrd *et al.*<sup>1</sup> characterised a neutral polysaccharide constituted of mannose, rhamnose and glucose, and therefore deeply different from alginate.

The purpose of our investigation is to define the polysaccharides present in the biofilms matrix produced by *Burkholderia cepacia* complex (BCC) bacteria, which are important opportunistic pathogens for cystic fibrosis (CF) patients. CF is a common autosomal recessive genetic disease caused by a mutation in the gene for the protein cystic fibrosis transmembrane conductance regulator (CFTR). Lungs are affected by clogging of the airways due to mucus build-up, decreased mucociliary clearance which leads to bacterial infection, inflammation and often early death. The strain *B. cenocepacia* BTS2b was isolated from a CF patient and it was cultured in polystyrene plates in the biofilm mode of growth, using different media. The biofilm matrix was scraped off the plates, and the polysaccharidic component was purified. The <sup>1</sup>H-NMR spectra recorded were typical of polysaccharides, and all identical, regardless of the growth medium used. They were also very different from those of polysaccharides obtained using the same type of media, but growing the cells in planktonic mode. Methylation analysis suggested a backbone of (1-4)- $\beta$ -linked Gal with Ara side chains. It is remarkable that Ara has never been found before in polysaccharides from BCC bacteria. These results indicated that the major polysaccharide component produced by BTS2b in the biofilm matrix is neither cepacian nor any other known polysaccharides produced by BCC bacteria grown in liquid or solid media, but a completely novel polymer.

**References**

1. M. S. Byrd, I. Sadvokaya, E. Vinogradov, H. Lu, A. B. Sprinkle, S. H. Richardson, L. Ma, B. Ralston, M. R. Parsek, E. M. Anderson, J. S. Lam, D. J. Wozniak, *Mol. Microbiol.*, **2009**, 73(4), 622–638.



## OL 09

STRUCTURES OF THE O-ANTIGENS OF *CRONOBACTER SAKAZAKII*

Nikolai P. Arbatsky,<sup>1</sup> Yuriy A. Knirel,<sup>1</sup> Alexander S. Shashkov,<sup>1</sup> Min Wang,<sup>2,3</sup> Lu Feng,<sup>2,3</sup>  
and Lei Wang<sup>2,3</sup>

<sup>1</sup>*N.D. Zelinsky Institute of Organic Chemistry,  
Russian Academy of Sciences, 119991 Moscow, Russia;*

<sup>2</sup>*TEDA School of Biological Sciences and Biotechnology;*

<sup>3</sup>*Tianjin Key Laboratory for Microbial Functional Genomics, TEDA College, Nankai University,  
TEDA, Tianjin 300457, PR China  
yknirel@gmail.com*

*Cronobacter sakazakii* is an important food-borne pathogen, which can cause severe invasive infections in all age groups, especially, in immunocompromised infants and elders. Recently, based on the O-antigens, *C. sakazakii* strains have been classified into seven O-serotypes.<sup>1</sup> Structures of the O-antigens (O-polysaccharides) of serotypes O1 and O2 have been established.<sup>2,3</sup> In this work, the following O-polysaccharide structures of the reference strains of the remaining serotypes O3-O7 were elucidated using chemical analyses, selective degradations, and <sup>1</sup>H and <sup>13</sup>C NMR spectroscopy (all sugars are pyranosidic; non-stoichiometric O-acetylation is indicated in italics):

ATCC 29544 (O1) <sup>2</sup>	2)DQui3N(LA1aAc)(β1-6)DGlc(β1-3)DGalNAc(α1- DGlc(α1-4)DGlcA(α1-4)) <sup>↓</sup>
ATCC 12868 (O2) <sup>3</sup>	3)LRha(α1-4)DGlc(α1-2)LRha(α1-3)DGlcNAc(β1- L(2-1α)DGalA(4-1α)LRha <sub>2,3,4Ac</sub> )
G2726 (O3)	4)DQui3NAc(α1-3)LRha(α1-6)DGlcNAc(α1-4)DGlcA(β1-3)DGalNAc(α1- DGlc(β1-4)) <sup>↓</sup>
G2594 (O4)	2)DGlc(β1-2)DFuc3N(β1-6)DGlcNAc(α1-4)DGalNAc(α1-3)DGlcNAc(β1- L(4-1α)DGlc L C(O)CH <sub>2</sub> CH(OH)CH <sub>3</sub> DGlc(α1-6)) <sup>↓</sup>
G2706 (O5)	2)DQui3NAc(β1-3)LRha(α1-5)Kdo(α2-3)LRha <sub>2Ac</sub> (β1-4)DGlcNAc(β1- 3)DGlcNAc(β1-2)) <sup>↓</sup>
G2704 (O6)	4)Kdo(β2-6)DGlc(β1-6)DGal <sub>3,4Ac</sub> (β1-3)DGalNAc(β1- DGlcNAc(β1-2)) <sup>↓</sup>
G2592 (O7)	3)LFucNAc(α1-4)DGalA(α1-3)LFucNAc(α1-3)DGlcNAc(β1- DGlcNAc(β1-2)) <sup>↓</sup>

The observed two-way serological cross-reactivity of O1, O3, and O5 strains<sup>1</sup> could be accounted for by the presence of D-Qui3N derivatives at the non-reducing end of the O-units. The chromosomal O-antigen gene clusters of strains from all O-serotypes were sequenced, and the gene functions were tentatively assigned and found to correspond to the O-antigen structures established.

## References

1. Sun Y., Wang M., Liu H., He X., Zeng J., Guo X., Li K., et al. *Appl. Environ. Microbiol.* doi:10.1128/AEM.02229-10.
2. Arbatsky N.P., Wang M., Shashkov A.S., Feng L., Knirel Y.A., Wang L. *Carbohydr. Res.* **2010**, *345*, 2095-2098.
3. Arbatsky N.P., Wang M., Shashkov A.S., Feng L., Knirel Y.A., Wang L. *Carbohydr. Res.* **2010**, *345*, 2090-2094.

## OL 10

**STRUCTURAL AND FUNCTIONAL ANALYSIS OF THE CELL WALL LIPOOLIGOSACCHARIDES (LOSs) OF *MYCOBACTERIUM MARINUM***

Rombouts Yoann<sup>1</sup>, Ellass Elisabeth<sup>1</sup>, Maes Emmanuel<sup>1</sup>, Coddeville Bernadette<sup>1</sup>, Biot Christophe<sup>1</sup>, Trivelli Xavier<sup>1</sup>, Colucci-Guyon Emma<sup>3</sup>, Kremer Laurent<sup>2</sup> and Guérardel Yann<sup>1</sup>

<sup>1</sup>Unité de Glycobiologie Structurale et Fonctionnelle,  
UMR CNRS 8576, bâtiment C9, Université Lille 1, France.

<sup>2</sup>Laboratoire de Dynamique des Interactions Membranaires Normales et Pathologiques,  
UMR CNRS 5235, Université de Montpellier II, France.

<sup>3</sup>Unité Macrophages et Développement de l'Immunité, URA 2578 Institut Pasteur, Paris, France  
yoann.rombouts@gmail.com

*Mycobacterium marinum* (M.ma) is a natural pathogen of ectotherms genetically close to *M. tuberculosis*. This pathogen model is useful for deciphering the role of mycobacterial cell wall glycolipids in granulomatous infection <sup>1</sup>. In this context, we compared the glycolipids profiles of seven *M. marinum* natural strains inducing acute or chronic infection in zebrafish by TLC and showed that an avirulent strain (M.ma 7) was unable to synthesize one of the four lipooligosaccharides (LOSs) previously identified, the LOS IV <sup>2</sup>. In agreement, a previous study has shown that a LOS IV deficient mutant of M.ma was less phagocytosed by macrophages than WT strain <sup>3</sup>. LOSs are antigenic glycolipids present in numerous pathogenic mycobacteria including *M. canettii* <sup>4</sup>. However, their precise role in virulence of mycobacteria remains unclear. Structural analysis of the LOSs family from M.ma (including LOS-I to LOS-IV) by NMR, MS and GC demonstrated the presence of several rare or even unique monosaccharides including caryophyllose, derivatives and a *N*-acylated monosaccharide specific of LOS-IV <sup>2,5</sup>. Biological activity assays showed that LOSs exert an important pro-inflammatory effect by decreasing the TNF- $\alpha$  secretion from macrophages <sup>2</sup>. Moreover, LOS-IV was found to stimulate the expression of the chemokine IL-8 and cell surface antigens (CD40 and ICAM-1) on macrophages <sup>5</sup>. This specific immunostimulatory property was related to the presence of the terminal *N*-acylated monosaccharide in LOS-IV. Finally, preliminary *in vivo* tests with purified LOSs demonstrated that this family of glycolipid alone can induce granulomas formation in zebrafish. This work established for the first time the involvement of LOSs in mycobacterial virulence.

**References**

1. Pozos T. C., Ramakrishnan L., *Curr. Opin. Immunol.*, **2004**, 16 (4), 499-505.
2. Rombouts Y., Burguiere A., Maes E., Coddeville B., Ellass E., Guérardel Y., Kremer L., *J. Biol. Chem.*, **2009**, 284 (31), 20975-88.
3. Burguiere A., Hitchen P. G., Dover L. G., Kremer L., Ridell M., Alexander D. C., Liu J., Morris H. R., Minnikin D. E., Dell A., Besra G. S., *J. Biol. Chem.*, **2005**, 280 (51), 42124-33.
4. Daffe M., McNeil M., Brennan P. J., *Biochemistry*, **1991**, 30 (2), 378-88.
5. Rombouts Y., Ellass E., Biot C., Maes E., Coddeville B., Burguiere A., Tokarski C., Buisine E., Trivelli X., Kremer L., Guérardel Y., *J. Am. Chem. Soc.* **2010**, 132 (45), 16073-84.

## OL 11

**ON THE CONFORMATION OF THE L-IDURONATE RING IN SYNTHETIC  
HEPARIN LIKE TRISACCHARIDE MODELS:  
INFLUENCE OF ADJACENT RESIDUES**

Juan C. Muñoz-García,<sup>1</sup> Jesús Angulo<sup>1</sup>, Francisco Corzana<sup>3</sup>, Irene Díaz<sup>1</sup>, Javier López-Prados<sup>1</sup>, José L. de Paz<sup>1</sup>, Niels Reichardt<sup>2</sup>, Manuel Martín-Lomas<sup>2</sup>, Pedro M. Nieto<sup>1</sup>

<sup>1</sup>*Instituto de Investigaciones Químicas, Glycosystems Laboratory, CSIC-US,  
Américo Vespucio 49, 41092, Sevilla, Spain*

<sup>2</sup>*CIC-BiomaGUNE, CIBER-BBN Paseo Miramón 182, Parque Tecnológico, 20009,  
San Sebastián, Spain*

<sup>3</sup>*Universidad de la Rioja, Avd. de la Paz 93, 26006, Logroño, Spain.  
juan.munioz@iiq.csic.es*

Glycosaminoglycans (GAGs) heparin, heparan sulphate, and dermatan sulphate show particular conformational plasticities of their L-iduronic acid constituents, which affords them with remarkable protein adaptability.<sup>1</sup> They show equilibria between different conformations (<sup>1</sup>C<sub>4</sub>, <sup>2</sup>S<sub>O</sub>, and <sup>4</sup>C<sub>1</sub>), and their relative proportion of conformers is a function of sulphation pattern and sequence.<sup>2</sup> In the framework of a project aimed to explore the molecular bases of the selectivity in their interactions with heparin binding proteins,<sup>3</sup> we have synthesized a library of heparin like trisaccharide models, highly pure and structurally perfectly defined.

In addition to their suitability for the interaction studies, this library represents the minimum structural features around iduronate residues within GAG chains, in which the different possible substitution patterns are systematically varied. On the other hand, their small sizes allow to determine distances from NOEs with high accuracy as well as to measure very precise <sup>3</sup>J<sub>H-H</sub> values. Together with NMR experiments at variable temperature, these trisaccharides have been studied by MD simulations<sup>4</sup>, in explicit water, using Particle Mesh Ewald conditions to handle long-range electrostatic interactions, and by MD-tar simulations (time averaged restraints molecular dynamics) with vicinal coupling constants (<sup>3</sup>J<sub>H-H</sub>) or interproton distances as experimental restraints.

**Acknowledgements.** We thank the Spanish Ministry of Science and Innovation (grant CTQ2006-01123) and Junta de Andalucía (grant P07-FQM-02969) for financial support. J.A. acknowledges support from a M.E.C “Ramón y Cajal” fellowship. J.C.M.-G. is supported by a CSIC PhD fellowship.

**References.**

1. Mulloy, B.; Forster, M. J., *Glycobiology*, **2000**, *10*, 1147-1156.
2. Ferro, D. R.; Provasoli, A.; Ragazzi, M.; Casu, B.; Torri, G.; Bossennec, V.; Perly, B.; Sinay, P.; Petitou, M.; Choay, J. *Carbohydrate Research*, **1990**, *195*, 157-167.
3. Angulo, J.; Ojeda, R.; de Paz, J. L.; Lucas, R.; Nieto, P. M.; Lozano, R. M.; Redondo-Horcajo, M.; Gimenez-Gallego, G.; Martín-Lomas, M., *Chembiochem*, **2004**, *5*, 55-61.
4. Angulo, J.; Nieto, P. M.; Martín-Lomas, M. *Chem. Commun.*, **2003**, 1512-1513.

## OL 12

**LOW SULFOTRANSFERASES ACTIVITIES IS LINKED TO MUCIN  
HYPOSULFATION IN SALIVARY GLANDS FROM  
SJÖGREN'S SYNDROME PATIENTS**

Isabel Castro,<sup>1</sup> Inka Brockhausen,<sup>2</sup> Sergio Aguilera,<sup>3</sup> Cecilia Alliende,<sup>1</sup> Andrew F.G. Quest,<sup>1</sup>  
Ulla Mandel,<sup>4</sup> Claudio Molina,<sup>1</sup> Cecilia Leyton<sup>1</sup> and María-Julieta González<sup>1</sup>

<sup>1</sup>University of Chile, Santiago, Chile,

<sup>2</sup>Queen's University, Kingston, Ontario Canadá,

<sup>3</sup>INDISA-clinic, Santiago, Chile and

<sup>4</sup>University of Copenhagen, Copenhagen N, Denmark

jgonzale@med.uchile.cl

Sjögren's syndrome (SS) is a chronic autoimmune disease of the exocrine glands. Altered secretory function leads to the symptoms of dry mouth and eyes<sup>1</sup>. Salivary mucins are essential for lubrication of the oral epithelium. MUC5B, the predominant mucin in saliva contains neutral, sulfated and sialylated oligosaccharides<sup>2</sup>. Sulfated and sialylated glycans add negative charges to mucins conferring them the ability to retain water. MUC5B is hyposulfated in salivary glands (SG) from SS-patients<sup>3</sup> and decreased sulfation is observed in patients with either normal or decreased unstimulated salivary flow<sup>3</sup>. Therefore, in contrast to standard thinking, reduced water content of saliva may not be the only factor responsible for the dry mouth symptom in SS-patients. We postulated that reduced expression and/or activity levels of sulfotransferases may account for MUC5B hyposulfation in SG from SS patients. In this study SG from 31 SS-patients and 31 control subjects were analyzed. Relative mRNA levels of Gal3ST-2, 3, 4 and  $\beta$ 3GalT-5 were determined by real-time RT-PCR. Relative protein levels of Gal3ST-2, 4 and  $\beta$ 3GalT-5 were evaluated by Western blotting. Enzymatic activities were quantified using *in vitro* assays with radioactively labelled donor substrates and specific acceptor substrates. Enzyme products were purified by a two-step chromatographic procedure. Our results show that the activities of polypeptide GalNAc-transferase, core 1  $\beta$ 3- and  $\beta$ 4-Gal-transferases and core 2  $\beta$ 6-GlcNAc-transferase are similar in SG from controls and SS-patients. The same trend was observed for  $\alpha$ 3-sialyltransferase activity in both groups. However, levels of Gal-3-O-sulfotransferase activity were significantly decreased in SS patients ( $p = 0.0004$ ). These findings are not correlated with relative mRNA and protein levels for these enzymes. We conclude that the decrease in sulfotransferase activity may explain mucin hyposulfation observed in the SG and contribute to the dry mouth sensation in SS-patients. **Funded:** Fondecyt 1080006 (MJG, SA, CM).

**References**

1. Anaya JM, Talal N. *Semin Arthritis Rheum.* **1999**, 28(6),355-359.
2. Thomsson K.A., Prakobphol A., Leffler H., Reddy M.S., Levine M.J., Fisher S.J., Hansson G.C. *Glycobiology*, **2002**, 12(1), 1-14.
3. Alliende C., Kwon Y-J., Brito M., Molina C., Aguilera S., Pérez P., Leyton L., Quest A., Mandel U., Veerman E., Espinosa M., Clausen H., Leyton C., Romo R. and González M.J. *Ann Rheum Dis*, **2008**, 67(10), 1480-1487.

## OL 13

**<sup>13</sup>C-LABELED HEPARAN SULFATE ANALOGUE AS A TOOL TO STUDY  
PROTEIN/HEPARAN SULFATE INTERACTION.  
APPLICATION TO THE CXCL12A CHEMOKINE**

Cédric Laguri<sup>1</sup>, Nicolas Sapay<sup>2</sup>, Jean-Pierre Simorre<sup>1</sup>, Bernhard Brutscher<sup>1</sup>, Anne Imberty<sup>2</sup>,  
Pierre Gans<sup>1</sup>, Hugues. Lortat-Jacob<sup>1</sup>

<sup>1</sup>*Institut de Biologie Structurale Jean-Pierre Ebel, Grenoble (CNRS,CEA,UJF – Grenoble 1),*

<sup>2</sup>*Centre de recherche sur les Macromolécules Végétales - CNRS, 601 rue de la chimie, BP 53,  
38041 Grenoble cedex 9, France  
cedric.laguri@ibs.fr*

Heparan sulfate (HS), a polysaccharide of the glycosaminoglycan family characterized by a unique level of complexity, has emerged as a key regulator of many fundamental biological processes. Although it has become clear that this class of molecules exerts its function by interacting with proteins, the exact modes of interaction still remains largely unknown. Using the Heparosan producing *E. coli* K5 strain and chemical sulfation, we prepared <sup>13</sup>C labeled HS-like molecules and selected an octasaccharide which glucosamines were homogeneously *N*- and *6O*-sulfated for further studies. The availability of such a compound, together with a <sup>15</sup>N labeled chemokine (CXCL12 $\alpha$ ) allowed us to investigate the structural determinants of the protein-HS recognition by multidimensional Nuclear Magnetic Resonance spectroscopy. Chemical shift data and saturation transfer difference experiments provided site-specific information on both the oligosaccharide and the chemokine during the binding reaction, and NMR data have been used as restraints to derive a model of the CXCL12 $\alpha$ /octasaccharide complex. Altogether, this work demonstrates that isotopically labeled HS provides great opportunities for the study of protein-HS interaction and dynamics by NMR.

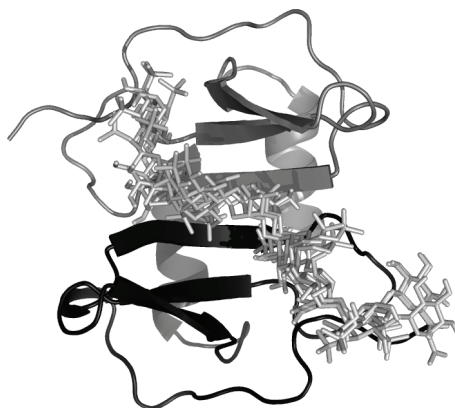



## OL 14

FLUORINATED MUC1 GLYCOPEPTIDE ANALOGS AS TOOLS  
FOR CANCER IMMUNOTHERAPY

Hoffmann-Röder Anja<sup>\*1</sup>, Wagner Sarah<sup>1</sup>, Mersch Christian<sup>1</sup>, Johannes Manuel<sup>1</sup>,  
Oberbillig Thomas<sup>2</sup>

<sup>1</sup>*Institute of Organic Chemistry, Johannes Gutenberg-University Mainz, Duesbergweg 10-14,  
D-55128 Mainz, Germany;*

<sup>2</sup>*Institut für Mikrotechnik Mainz GmbH, Carl-Zeiss-Strasse 18-20, D-55129 Mainz, Germany  
hroeder@uni-mainz.de*

Malignancies are frequently associated with the over-expression of various cell-surface glycoproteins and glycosphingolipids. In many carcinomas, the transmembrane glycoprotein mucin-1 (MUC1) is strongly over-expressed and characterized by the exposure of immunogenic peptide epitopes and truncated glycans, as a result of the down-regulation of certain glycosyltransferases.<sup>1</sup> Expression of various tumor-associated carbohydrate antigens (TACA) has been found to correlate with cancer progression and metastasis, and so these antigens are of particular interest for the development of cancer diagnostics and immunotherapy.<sup>2</sup>

Recently, we became interested in the use of fluorinated mucin-type glycopeptides as hydrolysis-resistant antigen mimics for cancer immunotherapy. Deoxyfluoro sugars have proven to be efficient mechanism-based inhibitors for glycosyl transferases,<sup>3</sup> but have not been used before as antigenic building blocks for carbohydrate-based vaccines. Here, we present our approaches and results concerning the preparation of various selectively fluorinated carbohydrate antigens (TN, TF and sTF antigen).<sup>4</sup> These TACA-threonine analogs were further subjected to solid-phase glycopeptide synthesis to allow the construction of first examples of fluorinated MUC1-BSA and MUC1-TTox vaccines for immunological studies.<sup>5</sup>

### References

1. a) G. F. Springer, *Science*, **1984**, 224, 1198-1206; b) J. Taylor-Papadimitriou, J. Burchell, D. W. Miles, M. Daziel, *Biochim. Biophys. Acta, Mol. Bas. Dis.* **1999**, 1455, 301-313.
2. T. Buskas, P. Thomson, G.-J. Boons, *Chem. Commun.* 2009, 5335-5349 and cited references.
3. a) S. G. Withers, I. P. Street, P. Bird, D. H. Dolphin, *J. Am. Chem. Soc.* **1987**, 109, 7530-7531; b) S. G. Withers, K. Rupitz, I. P. Street, *J. Biol. Chem.* **1988**, 263, 7929-7932.
4. a) C. Mersch, S. Wagner, A. Hoffmann-Röder, *Synlett* **2009**, 2167-2171; b) S. Wagner, C. Mersch, A. Hoffmann-Röder, *Chem. Eur. J.* **2010**, 16, 7319-7330.
5. A. Hoffmann-Röder, A. Kaiser, S. Wagner, N. Gaidzik, D. Kowalczyk, U. Westerlind, B. Gerlitzki, E. Schmitt, H. Kunz, *Angew. Chem. Int. Ed.* **2010**, 49, 8498-8503.

## OL 15

SYNTHESIS AND CONFORMATION EVALUATION  
OF  $\alpha$ -N-LINKED GLYCOPEPTIDESCinzia Colombo,<sup>1</sup> Fabio Doro,<sup>1</sup> Filipa Marcelo,<sup>2</sup> Jesús Jiménez-Barbero<sup>2</sup> Anna Bernardi,<sup>1</sup><sup>1</sup> *Universita' degli Studi di Milano, Dipartimento di Chimica Organica e Industriale,  
via Venezian 21, I-20133 Milano, Italy,*<sup>2</sup> *Centro de Investigaciones Biológicas (CSIC), Madrid 28040, Spain  
cinzia.colombo@unimi.it*

The synthesis of neo-glycoconjugates has been gaining much attention in recent years, due to the relevance of natural glycopeptides and glycoproteins in human health and disease.<sup>1</sup> Our group has been actively investigating the synthesis of  $\alpha$ -N-linked glycosyl amides and glycopeptides.<sup>2</sup> These compounds are practically unknown in nature and may lead to molecules tolerated by biological systems and yet less susceptible to chemical or enzyme-mediated hydrolysis. The synthesis of these unnatural compounds is not trivial because only few methods are available for  $\alpha$ -N glycosylation.<sup>2,3</sup> Recently, a route to obtain  $\alpha$ -N-linked glucosyl asparagine was introduced by DeShong and co-workers.<sup>3</sup> Starting from this strategy we were able to optimize and scale up the stereoselective synthesis of  $\alpha$ -N-glycosylated building blocks of glucosyl and galactosyl asparagine with suitable protecting groups for solid phase peptide synthesis. The resulting  $\alpha$ -N-linked glycosylaminoacids were initially employed in solution to determine activation conditions for both C-terminus and N-terminus elongation. After identification of appropriate condensing agents and deprotection conditions, solid phase synthesis (Fmoc protocol) was explored for the synthesis of more complex  $\alpha$ -N-linked glycopeptides (Scheme 1). The preparation of short model  $\alpha$ -N-linked glycopeptides has allowed to initiate the study of conformation and properties of these neo-glycoconjugates.

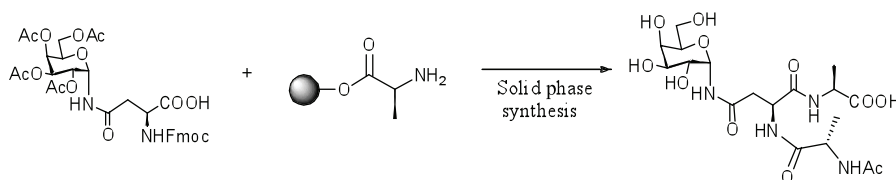

**Scheme 1.** Solid phase synthesis of  $\alpha$ -N-linked galactosyl tripeptide.

## References

1. a) O. Seitz, *ChemBiochem* **2000**, *1*, 214-246; b) D. P. Gamblin, E. M. Scanlan, B. G. Davis, *Chem. Rev.* **2009**, *109*, 131-163.
2. a) A. Bianchi, A. Bernardi, *J. Org. Chem.* **2006**, *71*, 4565-4577. b) F. Nisic, M. Andreini, A. Bernardi, *Eur. J. Org. Chem.* **2009**, 5744-5751. c) F. Nisic, A. Bernardi, *Carbohydr. Res.* **2011**, Article in press, doi:10.1016/j.carres.2010.12.020.
3. F. Damkaci, P. DeShong, *J. Am. Chem. Soc.* **2003**, *125*, 4408-4409.

## OL 16

**TARGETING GLYCOSAMINOGLYCANS BY A DECOY CXCL8 PROTEIN LEADS TO POTENT ANTI-INFLAMMATORY ACTIVITY IN MURINE LUNG INFLAMMATION MODELS OF COPD**

Andreas J Kungl, CSO

*ProtAffin Biotechnologie AG, Reinghausstrasse 13a, A-8020 Graz, Austria*

**Rationale:** Glycosaminoglycans (GAGs) can be found on the surface of almost all human cells. They mediate, or are directly responsible for, a wealth of (patho-)physiological processes. The question whether GAGs are amenable drug targets for therapeutic intervention is ultimately connected to the concept of ligand specificity, i.e. the existence of well-defined disease-specific GAG structure. The chemokine CXCL8 exerts its chemotactic activity by binding to its GPCR receptors located on the neutrophils, as well as through interactions with co-receptors located on the inflamed endothelium, the so-called glycosaminoglycans (GAGs). Binding to GAGs is required to create a solid-phase haptotactic gradient as well as to present CXCL8 in the proper conformation to its GPC receptors on circulating neutrophils. Neutrophils are playing a fundamental role in acute lung injury (ALI)/ARDS and in several chronic lung diseases including bronchiectasis, bronchiolitis, COPD and cystic fibrosis. Neutrophil infiltration of the airway-walls has been correlated to disease severity and progression in these pathologies. Among the mediators of neutrophil recruitment into the lung, CXCL8 is considered to be the major player. Increased CXCL8 levels have been reported in bronchoalveolar lavage (BAL) fluid as well as in sputum of patients and have been correlated to neutrophil presence and thus to lung disease.

**Methods:** We have engineered higher affinity for GAG binding into human CXCL8 thereby obtaining a protein-based inhibitor for the CXCL8/GAG interaction. By additionally knocking-out the GPCR domain of the chemokine, we obtained a decoy protein (termed PA401) with potent anti-inflammatory characteristics which inherently is able to recognise its cognate GAG ligand sequence on target cells.

**Results:** *In vitro* tests showed a >20-fold increased affinity of PA401 for its natural glycan ligand heparan sulfate and chemotactic activity reduced by 96% compared to wild type CXCL8, resulting in a dominant negative mutant of CXCL8. PA401 has been tested in murine models of lung inflammation induced by aerosolised lipopolysaccharide (LPS-*salmonella enterica*), showing strong dose-dependent BAL neutrophil reduction after intravenous and subcutaneous administration at doses of 40 and 400µg/kg. Activity upon subcutaneous administration was confirmed in a second model induced by intranasal administration of another LPS strain (*pseudomonas aeruginosa*), as well as in acute and sub-chronic models of tobacco-smoke (TS) induced lung inflammation. In the TS models, PA401 not only significantly reduced BAL neutrophils by 70%, but also prevented infiltration of macrophages, lymphocyte and epithelial cells. This refers to a broader range of action than a CXCL8-directed compounds.

**Conclusions:** The data obtained in the LPS models demonstrate strong activity of PA401 in acute lung neutrophilic inflammatory animal models resembling human ALI/ARDS and COPD exacerbations. The effects in the TS model corroborate the anti-inflammatory activity of PA401 on mixed cell infiltration in a model considered highly predictive for testing anti-inflammatory therapeutics for human COPD. PA401 is a new promising biologic therapeutic with a novel mechanism of action for interfering with lung inflammation by targeting glycosaminoglycans.



## OL 17

NMR STUDIES OF THE INTERACTIONS OF LANGERIN  
WITH SULFATED GLYCANS

Jesús Angulo,<sup>1</sup> Juan C. Muñoz-García,<sup>1</sup> Eric Chabrol,<sup>2</sup> José L. De Paz,<sup>1</sup> Javier Rojo,<sup>1</sup>  
Franck Fieschi,<sup>2</sup> Pedro M. Nieto<sup>1</sup>

<sup>1</sup>*Glycosystems Laboratory, Instituto de Investigaciones Químicas (CSIC-US),  
Américo Vespucio 49, 41092, Sevilla, Spain*

<sup>2</sup>*Membranes & Pathogens Group, Université Joseph Fourier, CEA, CNRS, Institut de Biologie  
Structurale Jean-Pierre Ebel, 41 rue Jules Horowitz, 38027 Grenoble, France  
jesus@iiq.csic.es*

Epidermal Langerhans cells (LCs) constitute a subset of dendritic cells (a sentinel immunity cell lineage) that express langerin, a C-type lectin which is a crucial component of Birbeck granules (BGs), subdomains of the endosomal compartment specific to LCs.<sup>1</sup> Langerin acts as a pathogen receptor by binding to surface glycoconjugates of a number of microorganisms (fungi, mycobacteria, viruses). Notably, langerin can prevent transmission of HIV from LCs to T cells by mediating internalization into BGs and degradation of the virus.<sup>2</sup> Within the C-type family of lectins, langerin seems to be a unique receptor as it has shown to have dual specificity, being able to recognize both, mannosylated and sulfated glycans, via a single C-type carbohydrate recognition domain (CRD).<sup>3-4</sup>

In this work we are interested in the characterization in structural terms of the second specificity of langerin; that for sulfated glycans. We have applied NMR spectroscopic techniques to study the interactions of sulfated ligands to the extracellular domain (ECD) of langerin in solution. We have paid particular attention to the effect of the different sulfation patterns of the ligands, as well to the role of the divalent cation, on the interactions. We demonstrate that STD NMR and transferred-NOE experiments can be optimized and successfully carried out on these highly charged systems, from which the binding epitopes and the bioactive conformations can be obtained.

**References**

1. M. Thépaut, J. Valladeau, A. Nurisso, R. Kahn, B. Arnou, C. Vivès, S. Saeland, C. Ebel, C. Monnier, C. Dezutter-Dambuyant, A. Imberty and F. Fieschi, *Biochemistry* **2009**, *48*, 2684-2698.
2. L. de Witte, A. Nabatov, M. Pion, D. Fluitsma, M. A. W. P. de Jong, T. de Gruijl, V. Piguet, Y. van Kooyk and T. B. H. Geijtenbeek, *Nat Med* **2007**, *13*, 367-371.
3. H. Tateno, K. Ohnishi, R. Yabe, N. Hayatsu, T. Sato, M. Takeya, H. Narimatsu and J. Hirabayashi, *Journal of Biological Chemistry* **2010**, *285*, 6390-6400.
4. H. Feinberg, M. E. Taylor, N. Razi, R. McBride, Y. A. Knirel, S. A. Graham, K. Drickamer and W. I. Weis, *Journal of Molecular Biology* **2011**, *405*, 1027-1039.

## OL 18

**ENHANCEMENT OF CHONDROITIN-LIKE *ESCHERICHIA COLI* K4  
CAPSULAR POLYSACCHARIDE PRODUCTION BY MONOSACCHARIDE  
SUPPLEMENTATION**

Odile Francesca Restaino, Irene di Lauro, Elisabetta Carlino, Donatella Cimini,  
Roberta De Mattia, Mario De Rosa and Chiara Schiraldi

*Department of Experimental Medicine, Second University of Naples, Via De Crecchio 7,  
80138, Naples, Italy.  
odile.francesca@libero.it*

*Escherichia coli* O5:K4:H4 produces a capsular polysaccharide (K4 CPS) whose repeating unit is constituted by glucuronic acid (GlcA), N-acetylgalactosamine (GalNAc) and a terminal residue of fructose (Fruct) and whose backbone resembles the structure of the mammal chondroitin sulfate (CS) chain [1]. CS is a very well noted bio active molecule and a widely used anti-osteo-arthritis drug, but it is nowadays mainly produced by animal tissue sources with unsafe extraction procedures. For these reasons recent studies explored the possibility to biotechnologically produce a CS precursor from the *E. coli* K4 capsular polysaccharide by using fermentation technologies [2]. Environmental and growth conditions like temperature, pH, carbon and nitrogen sources influence the K4 CPS production. In this research work we investigated the possibility to enhance the K4 CPS synthesis by supplementing the growth medium with the monosaccharides (GlcA, GalNAc, Fruct) that constitute the polysaccharide chain. Shake flasks experiments were performed by adding the monosaccharides singularly or together, testing also possible additive effects. An increase of 66% of K4 CPS titre, compare to the control, was observed in case of contemporary addition of 75 mM of GlcA and GalNAc while a maximum increase of 57% was noted when a 75 mM concentration of fructose was singularly supplemented. Similar results were obtained also in batch fermentation, performed on lab scale. The kinetic of sugar uptake as well as the organic acid metabolism were investigated to test the influence of monosaccharide additions too. The expression levels of the gene *kfoC*, coding for K4 polymerase, and of the gene of *galU*, coding for glucose-1-phosphate uridylyltransferase, were investigated by Real-Time PCR in different growth conditions.

**References**

1. Rodriguez M-L., Jann B. and Jann K., *Eur. J. Biochem.* **1988**, 177: 117-124.
2. Cimini D., Restaino O. F., Catapano A., De Rosa M., Schiraldi C. *Appl Microbiol Biotechnol.* **2010**, 85(6): 1779-87.

## OL 19

**COMPUTATIONAL ANALYSIS OF INTERLEUKIN-8 INTERACTIONS WITH HYALURONAN AND CHONDROITIN-SULFATE DERIVATIVES**

Sergey Samsonov<sup>1</sup>, Pichert Annelie<sup>2</sup>, Stephan Theisgen<sup>2</sup>, Jürgen Schiller<sup>2</sup>, Daniel Huster<sup>2</sup>, M. Teresa Pisabarro<sup>1</sup>

<sup>1</sup>BIOTEC TUD, Tatzberg 47-51, D-01307 Dresden, Germany;

<sup>2</sup>Institute of Medical Physics and Biophysics, University of Leipzig, Härtelstr 16-18, D-04107 Leipzig, Germany  
sergeys@biotec.tu-dresden.de

Glycosaminoglycans (GAGs) represent a class of linear negatively charged polysaccharides, which participate in many key events in the extracellular matrix by interactions with their protein targets<sup>1</sup>. Interleukin-8 (IL-8) is a chemotactic cytokine involved in inflammation processes by recruiting and activating neutrophil granulocytes via binding a G protein-coupled receptor. This activation is strongly influenced by the interaction of IL-8 with GAGs, which makes these molecular interactions of a great of interest for rational engineering. There are no experimental structures of IL-8-GAGs complexes available. However, several IL-8 residues were found to be responsible for heparin binding according in mutagenesis studies<sup>2</sup>. In this work, we use docking and molecular dynamics (MD) approaches to study molecular recognition of modified GAGs on monomeric and dimeric IL-8. For the analyzed GAGs, we find a common representative and high scoring docking binding pose similar to the previously described for heparin<sup>3</sup>. We analyze energetics of this pose using MM-PBSA free energy calculations and per residue energy decomposition. Our results are in agreement with binding data obtained by NMR and show: *i*) an electrostatics-driven general improvement of binding with the increase of GAGs sulfation; *ii*) GAGs sulfation position specific but not purely electrostatics dependent binding patterns. In addition, we investigate the influence of GAGs binding on the conformational space of their glycosidic linkages, the effect of GAGs elongation on binding to IL-8, the role of solvent in the GAG binding interface and the impact of GAGs binding on the thermodynamics of IL-8 dimerization.

**References**

1. Jackson R., Busch S., Cardin A., *Physiol Rev*, **1991**, 71, 481-539.
2. Kuschert G. et al., *Biochem*, **1998**, 37, 11193-11201.
3. Krieger E. et al., *Proteins*, **2004**, 54, 768-775.

## OL 20

**A HIGHLY SULFATED PYRANOSIC (1→3)- $\beta$ -L-ARABINAN WITH ANTICOAGULANT ACTIVITY. MECHANISM OF ACTION**

Marina Ciancia<sup>1,2</sup>, Paula Virginia Fernández<sup>1</sup>, Irene Quintana<sup>3</sup>, Alberto Saúl Cerezo<sup>2</sup>, José Manuel Estevez<sup>4</sup>

<sup>1</sup>*Cátedra de Química de Biomoléculas, Departamento de Biología Aplicada y Alimentos, Facultad de Agronomía, Universidad de Buenos Aires, Av. San Martín 4453, 1417 Buenos Aires, Argentina.*

<sup>2</sup>*CIHIDECAR-CONICET, Departamento de Química Orgánica, Facultad de Ciencias Exactas y Naturales, Universidad de Buenos Aires, Ciudad Universitaria, Pabellón 2, 1428 Buenos Aires, Argentina*

<sup>3</sup>*Laboratorio de Hemostasia y Trombosis, Departamento de Química Biológica, Facultad de Ciencias Exactas y Naturales, Universidad de Buenos Aires, Ciudad Universitaria - Pabellón 2, C1428EHA Buenos Aires, Argentina*

<sup>4</sup>*Departamento de Fisiología, Biología Molecular y Celular (IFIByNE-CONICET), Facultad de Ciencias Exactas y Naturales, Universidad de Buenos Aires, Ciudad Universitaria - Pabellón 2, 1428 Buenos Aires, Argentina.*  
*ciancia@agro.uba.ar*

The room temperature water extract obtained from green seaweed *Codium vermilara*<sup>1</sup> was fractionated by addition of KCl to give solutions of increasing concentrations of this salt. Only one insoluble product was obtained at 0.115 M (Ab) in 31% yield, which contained 97% of L-arabinose, a sulfate/arabinose molar ratio of 1.8/1, an  $[\alpha]_D = + 167.5^\circ$ , and a number average molecular weight of 180 KDa. Methylation analysis of Ab and its desulfated derivative (DAb) showed that this polysaccharide is mainly constituted by 3-linked 2,4-disulfated arabinopyranosyl residues, although some mono- and non-sulfated units are also present. Analysis of the corresponding NMR spectra confirmed this structure and showed that these units are in the  $\beta$ -configuration. This product showed a high anticoagulant activity, but lower than that of heparin, as 5 and 0.65 mg/ml, respectively were necessary to increase the clotting time in APTT assay in 2.5 times. The coagulation mechanism is in part through the direct inhibition of thrombin, although inhibition of thrombin by potentiation of antithrombin and heparin cofactor II was also found by amydotitic methods.

In conclusion, a highly sulfated pyranosic  $\beta$ -L-arabinan was isolated from the cell walls of a green seaweed. It showed anticoagulant behaviour by a mechanism different to that of heparin. To the best of our knowledge, this is the first report in nature of a polysaccharide constituted only by arabinose residues in the pyranosic form.

**Reference**

1. Marina Ciancia, Irene Quintana, María I. Vizcargüénaga, Luciana Kasulin, Agustina de Dios, José Manuel Estevez, Alberto S. Cerezo, *Int. J. Biol. Macromol.*, **2007**, *41*, 641-649.

## OL 21

**CHARACTERIZATION OF GLFT2, A BIFUNCTIONAL GALACTOFURANOSYLTRANSFERASE INVOLVED IN THE BIOSYTHESIS OF THE MYCOBACTERIAL CELL WALL**

Myles B. Poulin,<sup>1,2</sup> Robert W. Wheatley,<sup>1,3</sup> Kenneth K.-S. Ng,<sup>1,3</sup> Todd L. Lowary<sup>1,2</sup>

<sup>1</sup>Department of Chemistry and Alberta Ingenuity Centre for Carbohydrate Science,

<sup>2</sup>Department of Chemistry, University of Alberta, Edmonton, AB, Canada T6G 2G2,

<sup>3</sup>Department of Biological Sciences, University of Calgary, Calgary AB, T2N 1N4, Canada  
tlowary@ualberta.ca

Mycobacterial diseases, such as tuberculosis and AIDS-associated *Mycobacterium avium* infections, are re-emerging as worldwide health concerns, and their resurgence is providing significant motivation for the development of new anti-mycobacterial agents. A key structural component of the mycobacterial cell wall is arabinogalactan (AG), a polysaccharide composed almost exclusively of galactofuranose and arabinofuranose moieties. The galactan portion of the AG is assembled by two galactofuranosyltransferases, GlfT1 and GlfT2, which use the sugar nucleotide UDP-Galf as the donor species.<sup>1</sup> As galactan biosynthesis is essential for mycobacterial viability, these enzymes are ideal targets for drug action. We have expressed and purified recombinant mycobacterial GlfT2<sup>2</sup> and shown that the enzyme uses a single active site to carry out two distinct transferase reactions: the formation of  $\beta$ -Galf-(1 $\rightarrow$ 5)- $\beta$ -Galf- and  $\beta$ -Galf-(1 $\rightarrow$ 6)- $\beta$ -Galf linkages.<sup>3</sup> Recently, we have obtained structure of GlfT2 using X-ray crystallography and have further probed the specificity of the enzyme through the synthesis of a range of substrate analogs. Progress in these areas will be presented.

**References**

1. M. Beláňová, P. Dianišková, P. J. Brennan, G. C. Completo, N. L. Rose, T. L. Lowary, K. Mikušová, *J. Bacteriol.* **2008**, *190*, 1141–1145.
2. N. L. Rose, G. C. Completo, S.-J. Lin, M. R. McNeil, M. M. Palcic, T. L. Lowary *J. Am. Chem. Soc.* **2006**, *128*, 6721–6729.
3. M. G. Szczepina, R. B. Zheng, G. C. Completo, T. L. Lowary, B. M. Pinto *ChemBioChem* **2009**, *10*, 2052–2059.

## OL 22

**METABOLIC OLIGOSACCHARIDE ENGINEERING  
WITH A DIELS-ALDER REACTION WITH INVERSE ELECTRON DEMAND**

Valentin Wittmann, Andrea Niederwieser

*Fachbereich Chemie and Konstanz Research School Chemical Biology, Universität Konstanz,  
78457 Konstanz, Germany  
Valentin.Wittmann@uni-konstanz.de*

Glycosylation is the most complex form of posttranslational protein modification and is known to regulate many aspects of protein function. Whereas proteins can be labeled in a routine manner by genetic methods such as expression as GFP fusion proteins, comparable methods are not available for secondary gene products such as the glycans of glycoproteins. Metabolic oligosaccharide engineering offers a possibility to introduce carbohydrate residues with non-natural structural elements in the glycan chains without genetic manipulation.<sup>1</sup> In this way, functional groups with a unique chemical reactivity can be incorporated into the glycan chains and subsequently ligated to an exogenously delivered detectable probe by a bioorthogonal ligation reaction. Successfully applied bioorthogonal ligation reactions are mainly Staudinger ligation and azide-alkyne [3+2] cycloaddition.<sup>2</sup>

To increase the repertoire of existing methods, we developed a new ligation method based on a Diels-Alder reaction with inverse electron demand of electron deficient 1,2,4,5-tetrazines and terminal alkenes. Synthetic modified *N*-acetylmannosamine derivatives with a dienophile moiety in the *N*-acyl side chain were added to the culture medium of cells and metabolically introduced into cellular glycoconjugates. The modified cell-surface glycoconjugates were subsequently labeled on living cells with appropriately functionalized tetrazines.

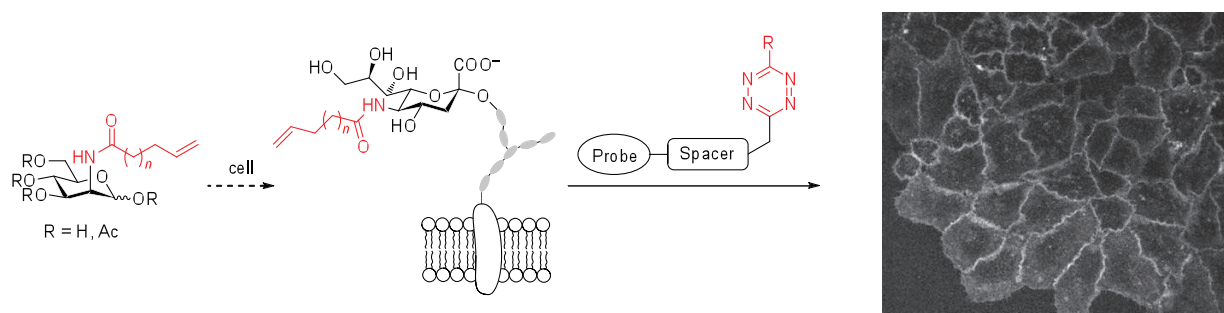

### References

1. O. T. Keppler, R. Horstkorte, M. Pawlita, C. Schmidt, W. Reutter, *Glycobiology* **2001**, *11*, 11R-18R.
2. J. A. Prescher, C. R. Bertozzi, *Nat. Chem. Biol.* **2005**, *1*, 13-21.



## OL 23

## NEW ASPECTS OF GLYCOSIDE BOND FORMATION

Amit Kumar, Vipin Kumar, Ravindra T. Dere, Richard R. Schmidt

*Fachbereich Chemie, Universität Konstanz, Fach 725, D-78457 Konstanz, Germany  
richard.schmidt@uni-konstanz.de*

The advances in glycoside synthesis have addressed major problems associated with glycoside-bond formation and provided efficient strategies and powerful tools for accessing complex oligosaccharides and glycoconjugates of biological significance. However, their synthesis is still by no means routine and not comparable to peptide and nucleotide synthesis. Often careful optimisation of all parameters including the leaving group, promoter/catalyst, protecting groups and glycosidation conditions is crucial for high yield and high stereoselectivity. Hence, new conceptual approaches to glycosylation are still welcome to meet the intrinsic structural diversity of carbohydrates.

In order to overcome some difficulties of intermolecular glycosidations, intramolecular glycosidation has attracted quite some interest.<sup>1</sup> In this context three different methods have been employed:

- (1) Glycosyl donor transfer to the acceptor linked via a spacer to a donor functional group.
- (2) (Rigid) Spacer mediated standard glycosidation.
- (3) Glycosyl donor transfer to the acceptor linked via a spacer to the donor leaving group.

Excellent results have been reported for the first two methods.<sup>1</sup> Their major drawback is the preparation of the starting material demanding a quite complex protecting group strategy. Hence, linkage of the donor and acceptor via the leaving group (method 3) seems to be an ideal alternative as it could be based on the same or even a simpler protecting group strategy as applied for intermolecular glycosidations. Results exhibiting the ease and general applicability of this intramolecular glycosidation method will be reported.

### References

1. K.-H. Jung, M. Müller, R. R. Schmidt, *Chem. Rev.* **2000**, *100*, 4423-4442.

## OL 24

## SYNTHESIS AND EVALUATION OF NOVEL PHOSPHA SUGAR ANTI-CANCER AGENTS

Mayumi Yamaoka,<sup>1</sup> Mitsuji Yamashita,<sup>\*2</sup> Manabu Yamada,<sup>2</sup> Michio Fujie,<sup>2,3</sup> Keita Kiyofuji,<sup>2</sup> Nobuhisa Ozaki,<sup>2</sup> Kazuhide Asai,<sup>1</sup> Taishi Niimi,<sup>1</sup> Takuya Suyama,<sup>1</sup> Junko Yamashita,<sup>2</sup> Akiho Sawada,<sup>4</sup> Reiko Makita,<sup>2</sup> Masaki Sugiyama,<sup>2</sup> Satoki Nakamura,<sup>3</sup> and Kazunori Ohnishi<sup>3</sup>

<sup>1</sup>Graduate School of Engineering, Shizuoka University, Hamamatsu 432-8561, Japan,

<sup>2</sup>Graduate School of Science and Technology, Shizuoka University, Hamamatsu 432-8561, Japan;

<sup>3</sup>Hamamatsu University School of Medicine, Hamamatsu 431-3192, Japan, and

<sup>4</sup>Faculty of Engineering, Shizuoka University, Hamamatsu 432-8561, Japan  
tcmyama@ipc.shizuoka.ac.jp

Sugar derivatives, whose oxygen atom in the hemiacetal ring is replaced by a carbon, nitrogen, or sulphur atom, are called as *carba*, *aza*, or *thia* sugars, respectively, which are categorized as pseudo sugars. The characterization of pseudo sugars of naturally occurring products and chemically synthesized derivatives are well investigated and many of them are known to be biologically active pseudo sugars. On the other hand, phospho sugars which are not yet found in the nature and the synthesis and the characterization of them are not yet so well studied in spite of being expected to exert biological activities. Apart from the previous methodologies for pseudo sugar chemistry, we were challenging to develop the novel synthetic routes starting from phosphorus heterocyclic compounds, mainly 2-phospholene derivatives. Mono-, di-, and tri-bromodeoxyphospho sugar analogues (Scheme 1) as well as some substituted phospho sugar analogues such as anhydrophospho sugar derivatives were prepared and their structures and bio-activities were studied.<sup>1</sup> The studies on the characterization of phospho sugars for the anti-cancer agents were carried out by MTT *in vitro* evaluation, cell cycle analysis, etc., to prove that they are potential anti-cancer agents<sup>2</sup> which possess (i) high anti-cancer activities, (ii) wide spectra, and (iii) selectivity and specificity against leukemia cell lines and solid tumor cells as well. The cell cycle analysis indicates that phospho sugars induce apoptosis just like Gleevec, a well known molecular targeting anti-cancer agent, does (Figure 1).

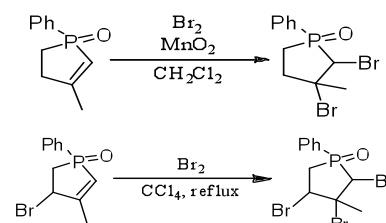

Scheme 1. Preparation of di- (top) and tri-bromo (bottom) deoxyphospho sugar analogues.

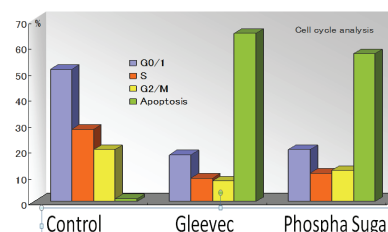

Figure 1. Cell cycle analysis of dibromo phospho sugar.

**Acknowledgement:** Financial supports by MEXT, JSPS, and JST of Japanese Government are greatly acknowledged.

## References

1. J. Yamashita, T. Suyama, K. Asai, M. Yamada, T. Niimi, M. Yamashita, et.al., *Heterocyclic Commun.*, **2010**, *16*, 89-97.
2. S. Nakamura, M. Yamashita, D. Yokota, I. Hirano, T. Ono, M. Fujie, K. Shibata, et.al., *Invest. New Drugs*, **2010**, *28*, 381-391.



## OL 25

## SYNTHESIS OF DISACCHARIDES WITH EXTENDED BIS-AZOLE LINKERS

Māris Turks,<sup>1</sup> Jevgeņija Mackeviča,<sup>1</sup> Jevgeņija Lugiņina,<sup>1</sup> Vitālijs Rjabovs,<sup>1</sup> Sergey Belyakov,<sup>2</sup> Antonio J. Moreno Vargas,<sup>3</sup> Inmaculada Robina<sup>3</sup>

<sup>1</sup>Faculty of Material Science and Applied Chemistry, Riga Technical University,  
14/24 Āzenes Str., Riga, LV-1048, Latvia,

<sup>2</sup>Latvian Institute of Organic Synthesis, 21 Aizkraukles Str, Riga, LV-1006, Latvia,

<sup>3</sup>Department of Organic Chemistry, Faculty of Chemistry, University of Seville Prof. García González 1, 41012 Seville, Spain.  
maris\_turks@ktf.rtu.lv

Triazole-carbohydrate conjugates exhibit a broad spectrum of biological properties such as inhibitory effects on the proliferation of leukemia cells<sup>1</sup> and glycosidases.<sup>2</sup> On the other hand, isoxazoles have been successfully used to link sugars with other molecules of medicinal interest.<sup>3</sup> Hence, we proceeded to the synthesis of novel type of disaccharides that are connected by an extended linker containing bis-triazole or bis-isoxazole units. Our synthetic approach is based on Cu(I)-catalyzed click-dimerization and nitrile oxide 1,3-dipolar cycloaddition reaction, respectively.

Diacetone-D-glucose, diacetone-D-allose, and diacetone-D-galactose derived azides, as well as diacetone-D-glucose derived nitromethyl derivatives were dimerized either with commercially available 1,n-diynes or 2,2-dipropargyl dimedone and 5,5-dipropargyl Meldrum's acid. Dimers were obtained within good to excellent isolated yields and further deprotected in order to obtain products of type **1**. The biological activities of the latter will be discussed.

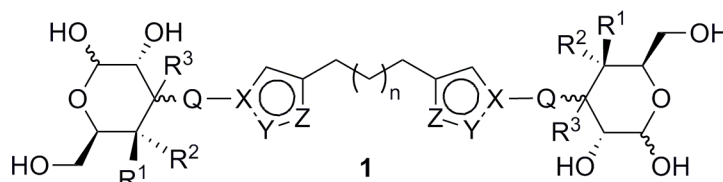

R<sup>1</sup>, R<sup>2</sup> = H, OH; R<sup>3</sup> = H, OH, SMe

Q = (CH<sub>2</sub>)<sub>0...1</sub>

for triazoles: X = Y = Z = N; for isoxazoles: X = C; Y = N; Z = O

## References

1. El Akri, K.; Bougrin, K.; Balzarini, J.; Faraj, A.; Benhida, R. *Biorg. Med. Chem. Lett.* **2007**, *17*, 6656-6659.
2. Ferreira, S. B.; Soderro, A. C. R.; Cardoso, M. F. C.; Lima, E. S.; Kaiser, C. R.; Silva Jr., F. P.; Ferreira, V. F. *J. Med. Chem.* **2010**, *53*, 2364-2375.
3. Wankhede, K. S.; Vaidya, V. V.; Sarang, P. S.; Salunkhe, M. M.; Trivedi, G. K. *Tetrahedron Lett.* **2008**, *49*, 2069-2073.

## OL 26

FORMATION AND REACTIVITY OF NOVEL NICHOLAS-FERRIER  
PYRANOSIDIC CATIONSAna M. Gómez,<sup>1</sup> Fernando Lobo,<sup>1</sup> Silvia Miranda,<sup>1</sup> J. Cristóbal López,<sup>1</sup><sup>1</sup>Instituto de Química Orgánica General, CSIC, Juan de la Cierva 3, 28006 Madrid, Spain  
clopez@iqog.csic.es

The Nicholas reaction<sup>1</sup> and the Ferrier (I) rearrangement<sup>2</sup> are two well-known, useful, synthetic transformations, which have in common the intermediacy of cationic species such as **1** and **3**, respectively. The reaction of these cations with nucleophiles (NuH) leads to propargylated derivatives (e.g. **2**) or allylic glycosides (e.g. **4**), respectively. In this context, we became interested in the study of Nicholas-Ferrier cations, e.g. **5**, since they might display new reactivity regarding unsaturated carbohydrate derivatives and/or Nicholas cations.

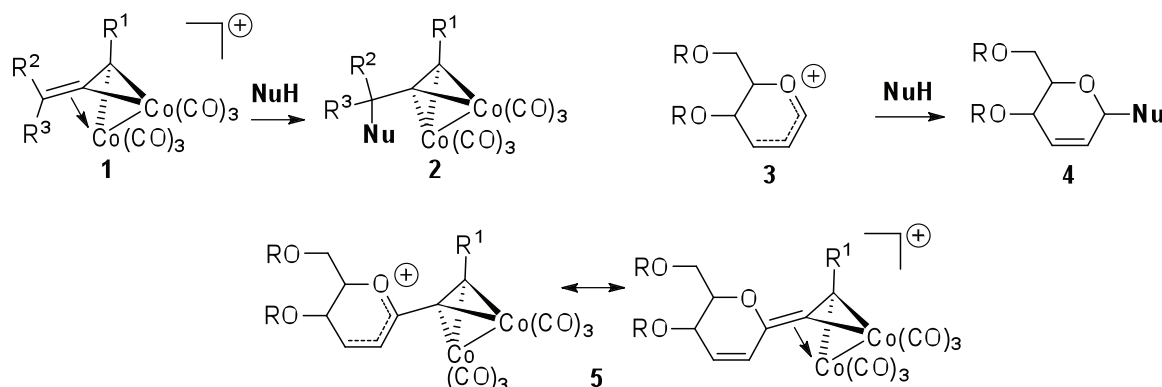

We have observed<sup>3</sup> that cations type **5**, which benefit from Nicholas stabilization at C-1, display a remarkable reactivity leading to a range of products (**7-11**), that depends on the substituent at O-6.

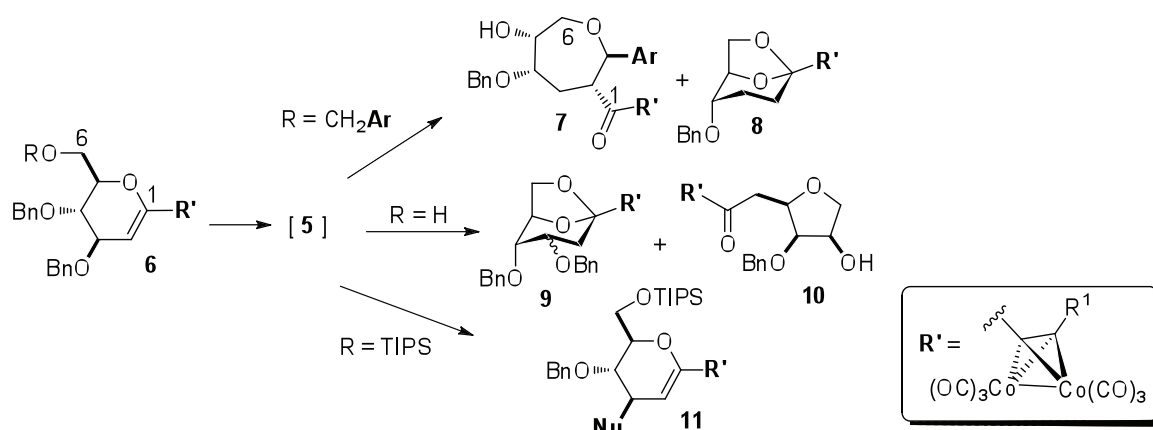

## References

1. a) Diaz, D.; Betancort, J. M.; Martín, V. S. *Synlett* **2007**, 343-359; b) Theobald, B. J.; *Tetrahedron*, **2002**, 58, 4133-4170; c) Green, J. R.; *Curr. Org. Chem.* **2001**, 5, 809-826; K. M. Nicholas, *Acc. Chem. Res.*, **1987**, 20, 207-214.
2. a) Ferrier, R. J.; Hoberg, H. O.; *Adv. Carbohydr. Chem. Biochem.* **2003**, 58, 55-119; b) Ferrier, R. J.; Zubkov, O. A. *Org. React.* **2003**, 62, 569-763; c) Ferrier, R. J. *Top. Curr. Chem.* **2001**, 215, 153-175; d) Ferrier, R. J. *Adv. Carbohydr. Chem. Biochem.* **1969**, 58, 199-266.
3. For a preliminary communication, see: Gómez, A. M.; Lobo, F.; Pérez de las Vacas, D.; Valverde, S.; López, J. C. *Chem. Commun.* **2010**, 46, 6159-6161.

## OL 27

SYNTHESIS AND NMR-SPECTROSCOPIC CHARACTERIZATION  
OF A WIDE RANGE OF GLYCOCONJUGATES

Filip S. Ekholm and Reko Leino

Laboratory of Organic Chemistry, Åbo Akademi University, FI-20500 Åbo, Finland.  
reko.leino@abo.fi

Glycoconjugates, molecules consisting of a glycone moiety attached to an aglycone backbone, are widely distributed in nature and are often strongly associated with interesting and important biological properties. Due to their wide presence in nature the glycosylation of different aglycones is an important topic in modern carbohydrate chemistry. Some of the challenges with glycosylation of various aglycones include control of stereo- and regioselectivity, low reactivity of secondary alcohols and steric hindrance from other functionalities attached to the aglycones. Recently, we have investigated methods for the glycosylation of several different aglycones, including steroids, lignans and anthracyclines. Herein, we present our results from these studies along with the complete NMR-spectroscopic characterization of some of the prepared structures.<sup>1</sup>

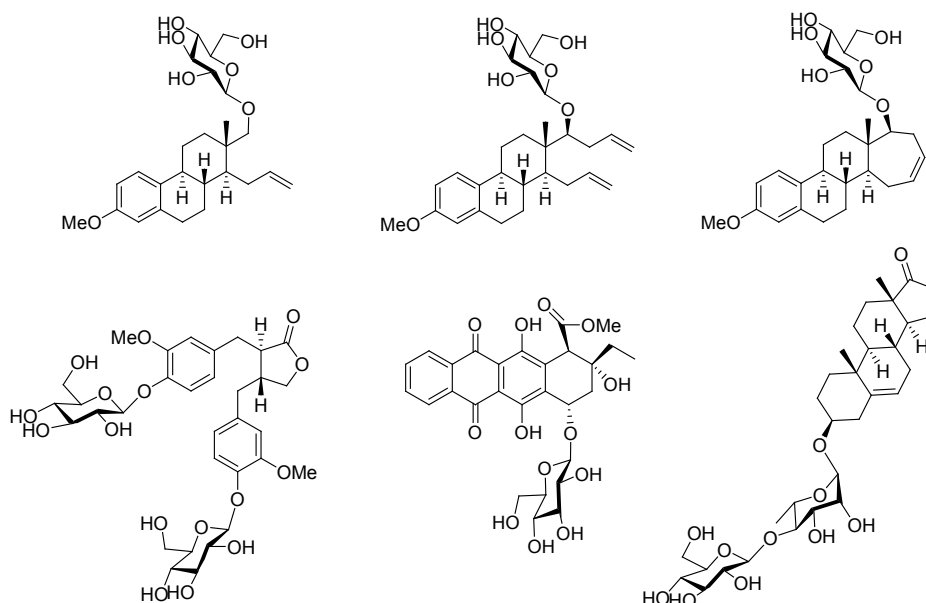
**References**

1. a) F. S. Ekholm, P. Eklund, R. Leino, *Carbohydr. Res.*, **2010**, 345, 1963–1967; b) F. S. Ekholm, G. Schneider, J. Wölfling, R. Leino, *Eur. J. Org. Chem.*, **2011**, 1064–1077; c) F. S. Ekholm, L. Lagerquist, R. Leino, *Carbohydr. Res.*, **2011**, DOI: 10.1016/j.carres.2011.01.028; d) F. S. Ekholm, G. Schneider, J. Wölfling, R. Leino, *manuscript* submitted to *Steroids*.

## OL 28

## CYPLOS, NOVEL CARBOHYDRATE-BASED SYNTHETIC ION TRANSPORTERS

Daniela Montesarchio,<sup>1</sup> Luca Simeone,<sup>1</sup> Lorenzo De Napoli,<sup>1</sup> Giuseppe Vitello,<sup>2</sup>  
Gerardino D'Errico,<sup>2</sup> Mariangela Boccalon<sup>3</sup> and Paolo Tecilla<sup>3</sup>

<sup>1</sup>Department of Organic Chemistry and Biochemistry, and  
<sup>2</sup>Dept. of Chemistry "P. Corradini", University "Federico II"  
of Napoli, Via Cintia, 4, I-80126 Napoli, Italy

<sup>3</sup>Department of Chemical Sciences, University of Trieste, Via L. Giorgieri, I-34127 Trieste, Italy  
daniela.montesarchio@unina.it

Artificial ion transporters are synthetic molecules mimicking at a functional level the activity of naturally occurring ion channels or carriers. In the frame of cyclodextrin mimicry, we recently described the synthesis and conformational properties of new carbohydrate-based macrocycles having the glucoside units connected through phosphodiester linkages, named CyPLOS (*Cyclic Phosphate-Linked Oligosaccharides*).<sup>1</sup> The cyclic disaccharide was adopted as a suitable synthetic platform to obtain a variety of analogs, carrying long alkyl or polyether chains, so to result into diverse jellyfish-shaped amphiphilic CyPLOS,<sup>2</sup> with some compounds acting as good ion transporters through lipid bilayers.<sup>3</sup> For a fine tuning of their properties and complexation abilities, a special reporter group is desirable at the extremities of the tentacles, so to insert *ad hoc* selected appendages. Through the design of a versatile key intermediate, bearing terminal azido groups, a fluorescently-labelled CyPLOS analog was synthesized, found to be a very active ionophore, also allowing detailed investigation on its mechanism of action and localization within the phospholipid bilayers.<sup>4</sup> Incorporation of a spin label at the CyPLOS tentacles provided further insight into the study of their interactions with phospholipid membranes by means of ESR spectroscopy.<sup>5,6</sup>

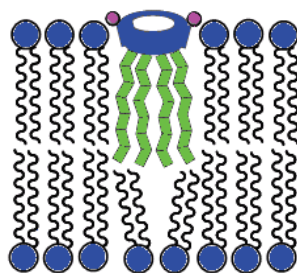

General structure of CyPLOS (right), and pictorial representation of the insertion of a CyPLOS derivative within phospholipids.

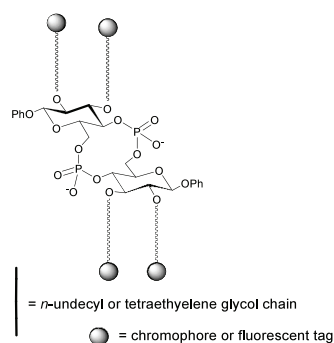

## References

1. G. Di Fabio, A. Randazzo, J. D'Onofrio, L. De Napoli, D. Montesarchio, *J. Org. Chem.* **2006**, *71*, 3395-3408.
2. C. Coppola, V. Saggiomo, G. Di Fabio, L. De Napoli, D. Montesarchio, *J. Org. Chem.* **2007**, *72*, 9679-9689.
3. S. Licen, C. Coppola, J. D'Onofrio, D. Montesarchio, P. Tecilla, *Org. Biomol. Chem.* **2009**, *7*, 1060-1063.
4. C. Coppola, A. Paciello, L. De Napoli, L. Paduano, P. Tecilla, D. Montesarchio, *Chem. Eur. J.* **2010**, *16*, 13757.
5. C. Coppola, L. Simeone, L. De Napoli, D. Montesarchio, *Eur. J. Org. Chem.*, **2011**, *6*, 1155-1165.
6. G. Vitiello, E. Busi, C. Coppola, D. Montesarchio, R. Basosi, L. Paduano, G. D'Errico, *ms. in preparation*.

## OL 29

## NANOVECTORS BASED ON CYCLODEXTRINS

Cédric Gervaise, Véronique Bonnet and Florence Djedaini-Pilard

*Laboratoire des Glucides, UMR-CNRS 6219 UPJV Amiens, France  
florence.pilard@u-picardie.fr*

It has been shown that a high diversity of structure such as vesicles, micelles or even mixed phospholipides/cyclodextrin derivatives films can be obtained depending on the structure of the cyclodextrins (CDs). For this purpose, novel classes of amphiphilic derivatives based on CDs were considered. Moreover, many researchs are realized to improve the efficiency of therapeutic treatments and to increase drug release through biological membranes and, particularly, the Blood Brain Barrier (BBB). The aim of our work is to synthesize new nanovectors, based on amphiphilic cyclodextrins, able to cross the BBB. First, the mono-amino permethylated  $\beta$ -cyclodextrin derivatives are obtained with a classical synthesis scheme. Then, Todd-Atherton reactions are carried out to have the expected products. The influence of the nature of the cyclodextrins (methylated or not, bearing a spacer ...) will be discussed.

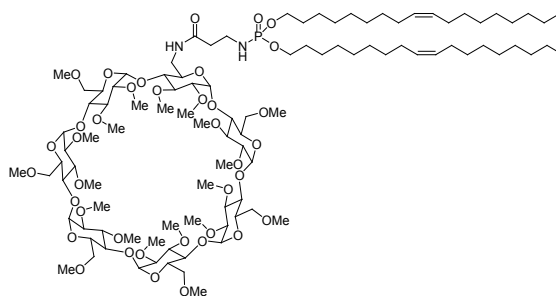

Studies of critical micelle concentration of auto-assembled objects in water and in buffer solutions will be presented. DLS measurements have been done to obtain the polydispersity and the average diameter of supramolecular objects. Moreover, the stability of these objects in several aqueous media has been studied. Then, interest molecules have been encapsulated in these nanoparticles, these phenomenons will be discussed.

**References**

- B. Perly, S. Moutard, F. Djedaini-Pilard, *Pharmachem*, **2005**, 1-2, 4-9;  
M. Roux, S. Moutard, B. Perly, F. Djedaini-Pilard, *Biophysical J.*, **2007**, 93, 1620-1629;  
F. Djedaini-Pilard, B. Perly, M. Roux, *European Biophysic Journal*, **2007**, 36:861-867;  
A. Angelova, C. Fajolles, C. Hocquelet, F. Djedaini-Pilard, S. Lesieur, V. Bonnet, B. Perly, G. Lebas, **2008**, *Journal of Colloid and Interface Science*, 2008, 322, 304-314  
V. Bonnet, C. Gervaise, A. Favrelle, C. Sarazin, F. Djedaini-Pilard., *Current Organic Chemistry*, **2010**, 14,1323-1236  
A. Favrelle, V. Bonnet, C. Avondo, F. Aubry, F. Djedaini-Pilard and C. Sarazzin., *J. Mol. Catal. B: Enzym* **2010**, 66, 224-227

## OL 30

**EXTRACELLULAR PRODUCTION OF CYCLOISOMALTOOLIGOSACCHARIDE  
GLUCANOTRANSFERASE AND CYCLODEXTRAN BY THE *BACILLUS SUBTILIS*  
HOST-VECTOR SYSTEM**

Kazumi Funane,<sup>1</sup> Yasuyuki Kawabata,<sup>2</sup> Ryuichiro Suzuki<sup>1</sup> and Keitarou Kimura<sup>1</sup>

<sup>1</sup> National Food Research Institute, NARO, 2-1-12 Kannondai, Tsukuba 305-8642, Japan,

<sup>2</sup> Osaka Shoin Women's University, 4-2-26 Hishiyaniishi, Higashi-Osaka 577-8550, Japan  
funane@affrc.go.jp

Cyclodextrans (CIs) are cyclic isomaltooligosaccharides that consist of 7 to 17 molecules of  $\alpha$ -1,6-linked glucoses in cyclic forms and are represented as CI-7 to CI-17 (Fig. 1) [1]. CIs prevent forming dental plaque by inhibiting glucansucrase activity of mutans streptococci [2]. CI-10 was reported to show an inclusion ability as good as cyclodextrins [3]. *Bacillus circulans* T-3040 was reported to simultaneously produce CIs along with the CI-producing enzyme, cycloisomaltooligosaccharide glucanotransferase (CITase; EC 2.4.1.248) in its culture supernatant when grown with the substrate dextran [4]. However, the CITase productivity of this strain is very low (0.001 U/mL) and thus not sufficient for commercial production of CIs. To improve the productivity, *B. circulans* T-3040 was mutagenized. The mutant strain *B. circulans* G22-10 produced approximately 110 times higher CITase than the parental strain. However, even *B. circulans* G22-10 requires a long culture period of at least 4 days to produce sufficiently large amounts of CIs for practical use. CITase gene of *B. circulans* T-3040, along with the  $\alpha$ -amylase promoter (*PamyQ*) and *amyQ* signal sequence of *B. amyloliquefaciens*, was cloned into the *Bacillus* expression vector pUB110 and subsequently expressed in *B. subtilis* strain 168 and its alkaline (*aprE*)- and neutral protease (*nprE*)-disrupted strains. This system using the *aprE* and *nprE* double-deficient strain successfully produced 8 times higher extracellular CITase than *B. circulans* G22-10. Moreover, CIs were simultaneously produced at a yield of 17% by direct fermentation of dextran using this *B. subtilis* host-vector system. This study was supported partially by a Program for Promotion of Basic and Applied Researches for Innovations in Bio-oriented Industry (BRAIN, Japan).

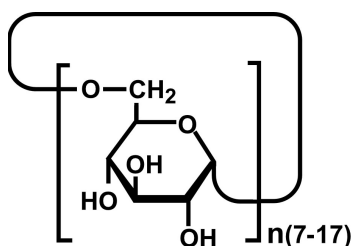

Fig. 1. Structure of cyclodextran.

### References

1. Funane, K. et al., *Biosci. Biotechnol. Biochem.*, **2008**, 72, 3277-3280.
2. Kobayashi, M. et al., *Biosci. Biotechnol. Biochem.*, **1995**, 59, 1861-1865
3. Funane, K., et al., *J. Biotechnol.*, **2007**, 130, 103-107.
4. Oguma, T. et al., *FEBS Lett.*, **1994**, 345, 135-138.



## OL 31

PNA-SUGAR CONJUGATES AS TOOLS FOR THE SPATIAL SCREENING  
OF CARBOHYDRATE-LECTIN INTERACTIONS

Christian Scheibe,<sup>1</sup> Alexander Bujotzek,<sup>2</sup> Jens Dervedde,<sup>3</sup> Marcus Weber,<sup>2</sup> and Oliver Seitz<sup>1</sup>

<sup>1</sup>Humboldt-Universität zu Berlin, Department of Chemistry,  
Brook-Taylor-Str. 2, 12489 Berlin, Germany,

<sup>2</sup>Zuse Institute Berlin, Takustr. 7, 14195 Berlin, Germany,

<sup>3</sup>Charité-Universitätsmedizin, Central Department of Laboratory Medicine  
and Pathobiochemistry, Hindenburgdamm 30, 12200 Berlin, Germany  
oliver.seitz@chemie.hu-berlin.de

Carbohydrate-lectin interactions are often characterized by low binding affinities. Stronger binding interactions occur in multivalent recognition events. However, number, orientation and distance between the presented carbohydrate ligands are crucial for enhanced potency.<sup>1</sup> PNA/DNA hybrids present a powerful scaffold for the multivalent presentation of carbohydrates. The defined structure and periodicity of the PNA/DNA duplex<sup>2</sup> enables Ångström-scale positioning and allows the precise control of number and distance between the presented carbohydrate ligands.

A wide range of multivalent complexes was assembled in a modular approach by hybridizing up to 4 PNA strands, some of which modified with *N*-acetylglucosamine (LacNAc), to a complementary DNA strand. Nick sites and partially unpaired regions were introduced into the duplex to increase the flexibility of the scaffold. The self-organized LacNAc assemblies were used for the spatial screening of accessible carbohydrate binding sites in the *Erythrina cristagalli* lectin sites in the *Erythrina cristagalli* lectin (ECL) by means of surface plasmon resonance (SPR). This systematic investigation revealed a distance dependence which is in agreement with the crystal structure analysis.<sup>3</sup>

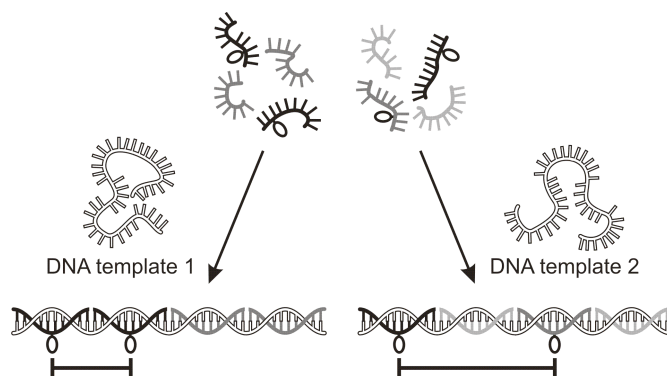

## References

1. R. J. Pieters, *Org. Biomol. Chem.*, **2009**, 7, 2013-2025.
2. M. Eriksson, P. E. Nielsen, *Nat. Struct. Biol.*, **1996**, 3, 410-413.
3. C. Scheibe, A. Bujotzek, J. Dervedde, M. Weber, O. Seitz, *Chem. Sci.*, **2011**, DOI: 10.1039/c0sc00565g.

## OL 32

**GLYCOCOATED CYCLODEXTRIN (CD):  
PDNA NANOPARTICLES (GLYCOCDPLEXES)  
FOR SITE- SPECIFIC GENE DELIVERY**

Alejandro Díaz-Moscoso,<sup>1</sup> Alejandro Méndez-Ardoy,<sup>2</sup> Nicolas Guilloteau,<sup>3</sup> Céline Bienvenu,<sup>3</sup>  
José L. Jiménez Blanco,<sup>2</sup> Christophe Di Giorgio,<sup>3</sup> Pierre Vierling,<sup>3</sup> Jacques Defaye,<sup>4</sup>  
Carmen Ortiz Mellet,<sup>2</sup> José M. García Fernández<sup>1</sup> and Juan M. Benito<sup>1</sup>

<sup>1</sup>*Instituto de Investigaciones Químicas, CSIC – Universidad de Sevilla, Spain,*

<sup>2</sup>*Dpto. Química Orgánica, Facultad de Química, Universidad de Sevilla, Spain,*

<sup>3</sup>*LCMBA UMR 6001CNRS – Université de Nice Sophia Antipolis, Nice, France,*

<sup>4</sup>*Dépt. de Pharmacochimie Moléculaire, Institut de Chimie Moléculaire de Grenoble*

(CNRS – Univ. de Grenoble), Grenoble, France

juanmab@iiq.csic.es

Multifunctional macrocyclic platforms<sup>1</sup> have emerged as suitable tools to build up monodisperse macromolecular constructs with the potential to condense DNA into transfectious nanoparticles. *Polycationic amphiphilic CDs* (paCDs) have shown significant promise towards this goal.<sup>2</sup> These jelly-fish-like molecules self-organize in the presence of pDNA to form small (40-70 nm) complexes (CDplexes) that mediate transfection with remarkable efficiency.<sup>3,4</sup> In principle, biorecognizable epitopes installed onto the hydrophilic rim in paCDs would be exposed at the surface of the corresponding CDplexes, accessible to molecular recognition events. After binding to the putative receptors, selective internalization mechanisms can be elicited (see Figure). To explore the potential of this strategy to manipulate DNA delivery efficiency towards specific cell targets, the construction of carbohydrate-coated paCD:pDNA mixed nanoparticles (*glycoCDplexes*), the evaluation of their ability to bind to specific lectins and the implications of glycoCDplex-lectin recognition phenomena in transfection efficiency has now been investigated.

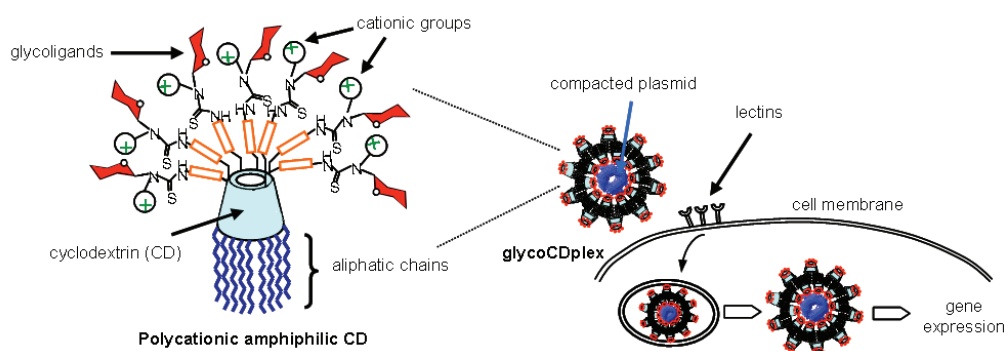

## References

1. C. Ortiz Mellet, J. M. Benito, J. M. García Fernández, *Chem. Eur. J.* **2010**, *16*, 6728.
2. C. Ortiz Mellet, J. M. García Fernández, J. M. Benito, *Chem. Soc. Rev.* **2011**, *40*, doi: 10.1039/c0cs00019a.
3. A. Díaz-Moscoso, L. Le Gourriérec, P. Balbuena, M. Gómez-García, J. M. Benito, N. Guilloteau, C. Di Giorgio, P. Vierling, J. Defaye, C. Ortiz Mellet, J. M. García Fernández, *Chem. Eur. J.* **2009**, *15*, 12871.
4. A. Díaz-Moscoso, D. Vercauteren, J. Rejman, J. M. Benito, C. Ortiz Mellet, S. C De Smedt, J. M. García Fernández, *J. Controlled Rel.* **2010**, *146*, 318.



## OL 33

SYNTHESIS & BIOLOGICAL ACTIVITY OF A LIBRARY  
OF FUNCTIONAL “GLYCO”- FOLDAMERS

Tushar Chakraborty,<sup>1</sup> Kirin Kumar,<sup>1</sup> Saumya Roy,<sup>2</sup> Omprakash Bande,<sup>2</sup> Subhash Ghosh,<sup>5</sup>  
José M. García Fernández,<sup>4</sup> Johannes W. Vad Pedersen,<sup>3</sup> Henrik Clausen,<sup>3</sup>  
Ravi S. Ampapathi,<sup>1</sup> Aloysius Siriwardena.<sup>2</sup>

<sup>1</sup>Central Drug Research Institute (CSIR), Chattar Manzil Palace,  
Lucknow - 226 001, UP, India,

<sup>2</sup>Laboratoire des Glucides, UMR 6912-CNRS, 33 Rue St Leu, 80039, Amiens, France,

<sup>3</sup>Instituto de Investigaciones Químicas, CSIC, Américo Vespucio 49,  
Isla de la Cartuja, E-41092 Sevilla, Spain,

<sup>4</sup>Københavns Universitet, Det Sundhedsvidenskabelige Fakultet, Institut for Cellulær  
og Molekylær Medicin Blegdamsvej 3B, 2200 København, Denmark,

<sup>5</sup>Indian Institute of Chemical Technology, Hyderabad – 500 007, India  
aloyus.siriwardena@u-picardie.fr

Research into foldamers - synthetic oligomers akin to natural polymers such as peptides, proteins and oligonucleotides - has given valuable insights into how non-covalent interactions can regulate the folding, assembly and catalysis of their natural counterparts. A limited number of “designer” foldamers have also been demonstrated to be functional.<sup>1</sup>

We describe here the study of a family of foldamers comprising pseudopeptide backbones derived from sugar amino acids (SAAs)<sup>1</sup> onto which glycans are grafted. These can be thought of as glycopeptide mimics or “glyco”-foldamers and are relevant in that the majority of proteins are glycosylated. Consequently, there is much interest in designing mimetics that are functional as they could provide an understanding of how glycopeptides themselves might exert their biological activity.<sup>3</sup> We demonstrate that various members of this new family of mimetics do adopt well-defined secondary structures that depend both on the nature of the SAA backbone and the structure of grafted glycan. In several cases the secondary structures of the glycofoldamers are maintained (after deprotection). The unique structural and physical features of our glycofoldamer family has given us a rare opportunity to investigate their activity against a variety of biological targets and has demonstrated certain of them indeed to be functional.

Data on the synthesis, conformational preferences and biological activity of examples of these novel glyco-foldamers will be presented.

### References

1. Goodman, C. A.; Choi, S.; Shandler, S.; DeGrado, W. F., , *Nature Chemical Biology* **2007**, *3*, 252 and references cited therein.
2. Chakraborty, T. K.; Srinivasu, P.; Tapadar, S.; Mohan, B. K., *Glycoconjug. J.*, **2005**, *22*, 83.
3. Wennemers, H.; Erdman, R. S., *J. Am. Chem. Soc.*, **2010**, *132*, 13957

## OL 34

**MULTIVALENT CARBOHYDRATE-BASED SYSTEMS OF A SYNTHETIC  
ANALOGUE OF A MELANOMA ASSOCIATED ANTIGEN:  
IMMUNOLOGICAL AND ANTIADHESIVE EVALUATION**

B. Richichi<sup>1</sup>, C. Nativi<sup>1</sup>, V. Kren<sup>2</sup>, A. Marra<sup>3</sup>, P. Chiarugi<sup>4</sup>

<sup>1</sup>Department of Chemistry "Ugo Schiff", University of Florence, Via della Lastruccia 13,  
50019 Sesto F.no (FI), Italy

<sup>2</sup>Laboratory of Biotransformation, Institute of Microbiology, Academy of Sciences  
of Czech Republic, Videňská 1083 - Praha 4, 142 20 Czech Republic

<sup>3</sup>Department of Chemistry, University of Ferrara, Via Borsari 46, 44100 Ferrara, Italy

<sup>4</sup> Department of Biochemical Sciences, University of Florence, Viale Morgagni 50,  
50134 Firenze, Italy.  
barbara.richichi@unifi.it

Nature frequently uses multivalency in several biological processes to overcome the limited affinities of ligands and to achieve tight binding<sup>1</sup>. The unique collective characteristics of multivalent interactions compared to monovalent constituents suggest new strategies for the design of bioactive molecules. Actually synthetic polyvalent ligands may be designed for several areas of application in particular multivalent interactions are valuable tools in the field of immunotherapy of tumours. As a matter of fact the multivalent presentation of an antigen overcomes the issues connected with the low immunogenicity of the monovalent hapten.

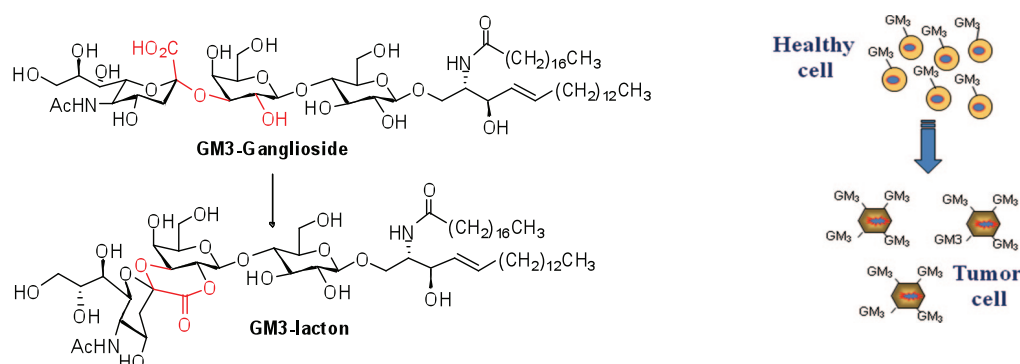

**Figure 1**

This communication will concern the synthesis within the immunological and antiadhesive assessments of multivalent carbohydrate-based systems obtained by functionalizing various branched scaffolds with a synthetic analogue of a carbohydrate melanoma-associated antigen<sup>2</sup>. Preliminary immunological and antiadhesive tests showed that our multivalent systems are attractive candidate for the development of new agent in melanoma treatment.

### References

1. Kiessling L.L., Gestwicki J. E., Strong L.E., *Angew. Chem. Int. Ed.*, **2006**, 45, 2348-2368; Mammen M., Choi S.K., Whitesides G.M., *Angew. Chem. Int. Ed.*, **1998**, 37, 2754-2794.
2. Toma L., Di Cola E., Ienco A., Legnani L., Lunghi C., Moneti G., Richichi B., Ristori S., Dell'Atti D., Nativi C., *Chem. Bio. Chem.*, **2007**, 8(14), 1646-1649; Arcangeli A., Toma L.; Contiero L.; Crociani C.; Legnani L.; Lunghi C.; Nesti E.; Moneti G.; Richichi B.; Nativi C.; *Bioconjugate Chem.*, **2010**, 21, 1432-1438.

## OL 35

**LECTIN-ARRAY BLOTS:  
ANALYSIS OF PROTEIN GLYCOSYLATION IN COMPLEX MIXTURES**

Juan Echevarria<sup>1</sup>, Javier Calvo<sup>2</sup>, Manuel Martin-Lomas<sup>1,3</sup> and Niels-Christian Reichardt<sup>1,3</sup>

<sup>1</sup>*Biofunctional Nanomaterials Unit, CICbiomaGUNE, Paseo Miramon 182,  
22000 San Sebastian, Spain*

<sup>2</sup>*Mass Spectrometry Platform, CICbiomaGUNE*

<sup>3</sup>*CIBER-BBN*

*nreichardt@cicbiomagune.es*

Glycan biomarker discovery programs require analytical techniques that allow the highthroughput analysis of protein glycosylation in clinical samples. Existing analytical technologies rely on the cumbersome separation of glycoproteins and the individual analysis of protein and glycans by established chromatographic and mass spectrometric methods or measure changes in bulk glycosylation with the help of lectin and antibody arrays.

Changes in the glycosylation often affect only a small proportion of the glycoproteome, of often special diagnostic value, and which can go unrecognized as they will be covered up by the glycosylation of highly abundant proteins.

By combining electrophoretic protein separation with lectin array based glycan analysis we have developed a hyphenated method that allows the simultaneous analysis of individual glycoproteins in serum and other complex matrices. Fluorescently tagged proteins are separated by gel electrophoresis and then diffusion-blotted onto a glass slide covered with multiple copies of micrometer size lectin arrays. Glycoproteins are sorted and retained by the printed panel of lectins according to their glycan decoration. We have applied this novel technique for the analysis of serum glycoprotein of various individuals and evaluated its utility for the detection and glycoanalysis of prostate specific antigen (PSA), a FDA approved biomarker of prostate cancer in serum .

## OL 36

**NEW METHODS FOR STUDYING THE ROLE OF IMMUNE LECTINS  
IN ANTIGEN CROSS-PRESENTATION**

Sander I. van Kasteren<sup>1/2</sup>, Huib Ovaa,<sup>2</sup> Colin Watts<sup>1</sup>

<sup>1</sup>*Department of Biological Sciences, University of Dundee, Dundee, Scotland,*

<sup>2</sup>*Netherlands Cancer Institute, Amsterdam, The Netherlands*

*s.v.kasteren@nki.nl*

Antigen cross-presentation is an important process in immunology. It is the process whereby antigenic material is taken up by endocytosis, and rather than being presented as 'normal' exogenous antigen on MHC-II complexes, it escapes from the endosomes and enters the antigen presentation pathway usually reserved for intracellular antigen presentation: the MHC-I pathway.

The mechanisms by which this occurs are poorly understood and hotly debated. One aspect that seems to control the routing is the engagement of specific immune lectins, such as DC-SIGN and the Mannose Receptor (MR). The engagement of these receptors appears to route antigenic materials to cross-presenting endosomes, but the exact mechanism of this is not yet known.

Here we present a new screening method based on the ubiquitously used *LacZ*-protein that allows us to very precisely study the first steps in antigen cross-presentation, namely the escape from endosomes. The combination of this high-throughput screening tool with the synthesis of ligands for specific immune lectins will allow us to elucidate the roles these receptors play in the early stages of antigen cross-presentation.

By using this new toolkit we hope to shed some light on a important, yet controversial, process.

## OL 37

**A MODEL OF ACTION FOR PERIPHERAL MEMBRANE-ASSOCIATED GT-B  
GLYCOSYLTRANSFERASES**

David Giganti,<sup>1,2,3</sup> Saioa Urresti,<sup>2,3</sup> Marco Bellinzoni<sup>1</sup>, Mary Jackson<sup>5</sup>, Pedro M. Alzari<sup>1</sup>  
and Marcelo E. Guerin<sup>2,3,4</sup>

<sup>1</sup>*Unite de Biochimie Structurale (CNRS URA 2185), Institut Pasteur, 25  
rue du Dr. Roux, 75724, Paris Cedex 15, France,*

<sup>2</sup>*Unidad de Biofisica, Centro Mixto Consejo Superior  
de Investigaciones Cientificas - Universidad del País Vasco/Euskal Herriko Unibertsitatea  
(CSIC-UPV/EHU), Barrio Sarriena s/n, Leioa, Bizkaia, 48940, Spain,*

<sup>3</sup>*Departamento de Bioquímica, Universidad del País Vasco, Spain*

<sup>4</sup>*IKERBASQUE, Basque Foundation for Science, 48011, Bilbao, Spain and*

<sup>5</sup>*Department of Microbiology, Immunology, and Pathology, Colorado State University,  
Fort Collins, Colorado 80523-1682  
mrcguerin@gmail.com*

Peripheral membrane-associated GT-B glycosyltransferases (GTs) are a ubiquitous family of enzymes that play essential roles in a variety of important biological processes in all living organisms. They transfer a sugar moiety from nucleotide- or lipid-phospho-sugar donors to a wide range of membrane-associated acceptors. Here we focus in PimA, an essential enzyme involved in the biosynthesis of phosphatidyl-myoinositol mannosides (PIMs), which are key glycolipids of the mycobacterial cell envelope<sup>1</sup>. PimA is a paradigm of this family of GTs, which the molecular mechanism of substrate/membrane recognition and catalysis is still unknown. We have solved the crystal structure of PimA from *M. smegmatis* in complex with its donor substrate GDP-Man. The notion of a membrane-associated protein via electrostatic interactions is consistent with the finding of an amphipathic  $\alpha$ -helix in the N-terminal domain of PimA. Based on structural, biophysics and biochemical studies, we proposed a model of interfacial catalysis in which PimA recognizes the fully acylated acceptor substrate, phosphatidyl-myoinositol (PI), with its polar head within the catalytic cleft and the fatty acid moieties only partially sequestered from the bulk solvent. In addition, we provided strong evidence showing that PimA undergoes significant conformational changes upon substrate binding. Altogether, our experimental data support a model wherein the flexibility and conformational transitions confer adaptability of PimA to the substrates, which seems to be of importance during catalysis. The proposed mechanism has fundamental implications for the comprehension of the peripheral membrane-associated GTs at the molecular level.

**References**

1. Guerin *et al.*, *J. Biol. Chem.* **2010**, 285, 33577-33583.
2. Guerin *et al.*, *J. Biol. Chem.* **2009**, 284, 21613-21625.
3. Guerin *et al.*, *J. Biol. Chem.* **2007**, 282, 20705-20714.

## OL 38

SUGAR-DECORATED HYDROXYAPATITE: AN INORGANIC MATERIAL  
BIOACTIVATED WITH MONOSACCHARIDESLaura Cipolla

*Dept. of Biotechnology and Biosciences, University of Milano-Bicocca, P.za della Scienza 2, 20126  
Milano-Italy  
laura.cipolla@unimb.it*

The promising trends in biotechnology and tissue engineering are based on development of advanced materials with biomimetic features created by designing and tailoring of specific surface properties such as the enhancement of the surface affinity to selective adhesion and proliferation of different cell strains, improvement of biological response and tissue compatibility.<sup>1</sup>

It has been widely described the ability of bioceramics such as hydroxyapatite (HA) to form a bonding with the surrounding bone tissue.<sup>2</sup> Since inorganic materials such as hydroxyapatite possess a paucity of reactive functional groups, biomolecular modification of these materials is still challenging.

An efficient method for the direct and covalent decoration of granules of nanostructured apatite with a sample monosaccharide is presented (Scheme); the hydroxyapatite material was directly functionalised with a short azido-containing spacer arm, to which  $\alpha$ -propargyl glucopyranoside has been chemoselectively ligated by Huisgen-type cycloaddition. The “glycosylated” hydroxyapatite was characterised by its ability to interact with glucose recognising lectins.

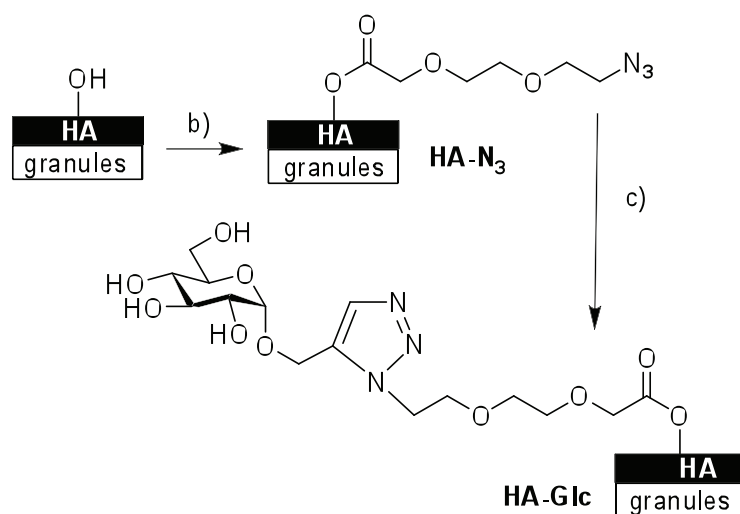

**Aknowledgments** We gratefully acknowledge MIUR, under project FIRB RBPO68JL9 and FONDAZIONE CARIPLO, project 2008/3175 for financial support.

**References**

1. Jones, J.R.; *Mat Today* **2006**; 9, 34-23.
2. Hench, L.L.; Wilson, J.; **1993**. An Introduction to Bioceramics, vol. 1.



## OL 39

## SYNAPTIC FUNCTIONS OF GLYCANS

Alexander Dityatev<sup>1,2</sup>

<sup>1</sup>*Department of Neuroscience and Brain Technologies, Italian Institute of Technology,  
via Morego 30, 16163 Genova, Italy;*

<sup>2</sup>*Laboratory for Brain ECM Research, University of Nizhny Novgorod, 23 Gagarin ave., 603950  
Nizhny Novgorod, Russia  
alexander.dityatev@iit.it*

The structural diversity of glycan chains allows for immense combinatorial possibilities that might underlie the fine-tuning of cell-cell and cell-matrix interactions. Recent studies uncovered the roles of multiple glycans in formation and function of synapses. The polysialylated form of the neural cell adhesion molecule NCAM in association with heparan sulfate proteoglycans regulates formation of synapses in an NMDA and FGF receptor-dependent manner <sup>1</sup>. Polysialic acid (PSA) is a necessary and sufficient part of NCAM for normal induction of long-term potentiation (LTP) in the CA1 region of the hippocampus <sup>2,3</sup>. PSA potentiates AMPA receptor-mediated currents in immature neurons and astrocytes and inhibits GluN2B-containing NMDA receptors <sup>4,5</sup>. In neurons deficient in PSA/NCAM, hyperactivity of extrasynaptic GluN2B impairs LTP and contextual fear conditioning by activation of p38 MAPK signalling pathway <sup>6</sup>. On the other hand, the effects of the extracellular matrix glycoprotein tenascin-R on GABAergic perisomatic inhibition are mediated by the associated HNK-1 carbohydrate, whose binding to GABA<sub>B</sub> receptors may regulate K<sup>+</sup> homeostasis in perisomatic inhibitory synapses <sup>7</sup>. HNK-1 and other carbohydrates, hyaluronic acid and chondroitin sulfates, are enriched in the extracellular matrix of perineuronal nets surrounding fast-spiking perisomatic inhibitory interneurons. Recordings from these interneurons after enzymatic removal of chondroitin sulfates revealed that these beautiful structures regulate excitability of interneurons and thus may shape LTP in the hippocampus <sup>8</sup>. Removal of hyaluronic acid by hyaluronidase treatment reduces activity of postsynaptic L-type Ca<sup>2+</sup> channels, which results in impairment of LTP and contextual fear memory<sup>9</sup>. These studies put forward the view that neural glycans mediate interplay between recognition molecules and ion channels/neurotransmitter receptors and affect multiple aspects of synaptic activity and plasticity.

**References**

1. Dityatev A, Dityateva G, Sytnyk V, Delling M, et al., *J. Neurosci.*, **2004**, *24*, 9372-9382.
2. Eckhardt M., Bukalo O., Chazal G., Wang L., et al., *J. Neurosci.*, **2000**, *20*, 5234-5244.
3. Senkov O, Sun M, Weinhold B, Gerardy-Schahn R, et al., *J. Neurosci.*, **2006**, *26*, 10888-10898.
4. Vaithianathan T, Matthias K, Mu S, Bahr B, et al., *J. Biol. Chem.*, **2004**, *279*, 47975-47984.
5. Hammond MSL, Sims C, Parameshwaran K, Suppiramaniam V, et al., *J. Biol. Chem.*, **2006**, *281*, 34859-34869.
6. Kochlamazashvili G, Senkov O, Grebenyuk S, Sims C, et al, *J. Neurosci.*, **2010**, *30*, 4171-4183.
7. Saghatelian AK, Snappyan M, Gorissen S, Meigel I, et al., *Mol. Cell. Neurosci.*, **2003**, *24*, 271-282.
8. Dityatev A, Brückner G, Dityateva G, Grosche J, et al., *Dev. Neurobiol.*, **2007**, *67*, 570-588.
9. Kochlamazashvili G, Bukalo O, Henneberger C, Dvoretzkova E, et al., *Neuron*, **2010**, *67*, 116-128.



## OL 40

**DEVELOPMENTAL MECHANISMS REGULATING NEURAL-SPECIFIC  
GLYCAN EXPRESSION**

Michael Tiemeyer, Sarah Baas, Varshika Kotu, Marion Marshall, Nickita Mehta,  
Toshihiko Katoh, Mary Sharrow, Mindy Porterfield, Kazuhiro Aoki

*Complex Carbohydrate Research Center and the Department of Biochemistry and Molecular  
Biology, University of Georgia, Athens, GA 30602 USA*

Multiple environmental, signaling, and metabolic processes shape the profile of glycans expressed by cells, whether in culture, in developing tissues, or in mature organs. In some contexts, specific signaling cascades have been shown to trigger the expression of glycan processing enzymes so that glycosylation is modified to meet a particular cellular function. In most cases, especially in developing tissues, the mechanisms that control cell-specific glycan expression are unknown. Unbiased genetic approaches are revealing new mechanisms for regulating glycan processing. In the *Drosophila* embryo, signaling through a Toll-like receptor expressed in non-neural cells influences neural-specific glycosylation. This non-cell autonomous pathway alters neural glycosylation by modulating the expression of a neuronal protein kinase that in turn influences Golgi dynamics. Thus, transcellular signals impinge on the organization of the secretory pathway to modulate glycan presentation. Genetic and biochemical approaches in sensitized backgrounds are identifying interacting pathways and relevant substrates, indicating that additional signals converge on differentiating neurons in order to tune cellular glycosylation to environmental conditions or developmental requirements.

## OL 41

## A NOVEL SITE OF ACTION FOR POLYSIALIC ACID IN THE BRAIN

Manuela Rollenhagen,<sup>1</sup> Sebastian P. Galuska,<sup>2</sup> Sarah Kuckuck,<sup>1</sup> Herbert Hildebrandt<sup>1</sup>,  
Rudolf Geyer,<sup>2</sup> Hildegard Geyer,<sup>2</sup> and Martina Mühlenhoff<sup>1</sup>

<sup>1</sup>*Institute of Cellular Chemistry, Hannover Medical School, D-30625 Hannover, Germany*

<sup>2</sup>*Institute of Biochemistry, Faculty of Medicine, University of Giessen,*

*D-35392 Giessen, Germany*

*muehlenhoff.martina@mh-hannover.de*

Polysialic acid (polySia) is a vertebrate-specific carbohydrate comprising  $\alpha$ 2,8-linked sialic acids that plays a crucial role in postnatal survival, brain wiring and maintaining synaptic plasticity. For decades, the function of polySia in the nervous system was studied in the context of the neural cell adhesion molecule NCAM, which represents the main carrier of polySia. However, brain of *Ncam*<sup>-/-</sup> mice still contains residual amounts of polySia and a glycoproteomics approach led to the identification of the synaptic cell adhesion molecule SynCAM 1 as a novel polysialylated glycoprotein in the developing mouse brain<sup>1</sup>. SynCAM 1 belongs to the immunoglobulin superfamily and acts as a powerful inducer of synapse formation. The extracellular part of SynCAM 1 consists of three immunoglobulin-like domains and mediates homo- and heterophilic interactions. Both polysialyltransferases, ST8SiaII and ST8SiaIV, were able to polysialylate SynCAM 1 *in vitro* and polysialylation of SynCAM 1 completely abolished homophilic binding. Analysis of serial sections of perinatal *Ncam*<sup>-/-</sup> brain revealed that polySia-SynCAM 1 positive cells were scattered throughout the grey matter but scarcely found in white matter such as corpus callosum. PolySia-SynCAM 1 was particularly abundant in the pontomedullary hindbrain and completely absent in brain sections of *Ncam*<sup>-/-</sup>*St8sia2*<sup>-/-</sup>*St8sia4*<sup>-/-</sup> triple knock-out mice. PolySia-SynCAM 1 was expressed exclusively by NG2 cells, an enigmatic multifunctional glia cell population that can receive glutamatergic input via unique neuron-NG2 cell synapses. By attenuating SynCAM 1-mediated functions, polysialylation of SynCAM 1 may have an important regulatory role during integration of NG2 cells into neural networks.

**References**

1. Galuska, S.P., Rollenhagen, M., Kaup, M., Eggers, K., Oltmann-Norden, I., Schiff, M., Hartmann, M., Weinhold, B., Hildebrandt, H., Geyer, R., Mühlenhoff, M., and Geyer H. *Proc. Natl. Acad. Sci. USA*, **2010**, 107, 10250-10255.

## OL 42

**DEVELOPMENT OF A NOVEL QUADRIVALENT MENINGOCOCCAL CRM<sub>197</sub>  
CONJUGATE VACCINE AGAINST SEROGROUPS A, C, W135, Y**

Francesco Berti

*Novartis Vaccines and Diagnostics - Research, Via Fiorentina 1 - 53100 Siena - Italy  
francesco.berti@novartis.com*

Meningococcal disease is a serious medical condition that can prove fatal within hours in otherwise healthy individuals. Epidemic and endemic disease are caused primarily by five different serogroups - A, B, C, W135 and Y. More than 500,000 cases of meningococcal disease are reported annually, with a high death toll. Approximately 10-15% of survivors experience morbidity in the form of neurological sequelae, loss of limbs, mental retardation, hearing loss and paralysis.

Primary prevention through universal implementation of effective vaccination programs offers the best prospect of reducing this burden of disease.

In order to address this unmet medical need, a new quadrivalent conjugate vaccine against *Neisseria meningitidis* serogroups A, C, W135 and Y has been developed and recently licensed. The specific technological approach, including the conjugation of oligosaccharides of defined length to the carrier protein CRM<sub>197</sub> and their physico-chemical characterization, is described herein.

In clinical trials, this vaccine has proven to be immunogenic in infants and other age groups, and it has therefore the potential to provide broad protection against meningococcal serogroups A, C, W135 and Y in all ages.

**References**

1. Bröker M, Dull PM, Rappuoli R, Costantino P, *Vaccine*, **2009**, 27(41), 5574-5580.
2. Cooper B, DeTora L, Stoddard J, *Expert Rev. Vaccines*, **2011**, 10(1), 21-33.
3. Snape MD, Perrett KP, Ford KJ, John TM, Pace D, Yu LM, Langley JM, McNeil S, Dull PM, Ceddia F, Anemona A, Halperin SA, Dobson S, Pollard AJ, *JAMA*, **2008**, 299(2), 173-184.
4. Perrett KP, Snape MD, Ford KJ, John TM, Yu LM, Langley JM, McNeil S, Dull PM, Ceddia F, Anemona A, Halperin SA, Dobson S, Pollard AJ, *Pediatr. Infect. Dis. J.*, **2009**, 28(3), 186-193.
5. Gill CJ, Baxter R, Anemona A, Ciavarro G, Dull P, *Hum. Vaccines*, **2010**, 6(11), 881-887.

## OL 43

**MECHANISMS OF BASEMENT MEMBRANE DISRUPTIONS IN CONGENITAL MUSCULAR DYSTROPHIES**Peng Zhang and Huaiyu Hu*Department of Neuroscience and Physiology, SUNY Upstate Medical University, NY, 13210  
huh@upstate.edu*

Brain malformations and retinal dysplasia in a subset of congenital muscular dystrophies (CMDs), dystroglycanopathies, are caused by disruptions of the basement membranes. Reduced extracellular matrix binding by the hypoglycosylated  $\alpha$ -dystroglycan because of mutations in several glycosyltransferases is the underlying molecular defects. It is not known how the basement membrane becomes disrupted. We hypothesized that assembly of the basement membrane is reduced in rate thus causing a physically compromised basement membrane. To test this hypothesis, we analyzed assembly of extracellular matrix on cultured neural stem cells and physical properties of the mutant basement membrane by atomic force microscopy. Laminin assembly on the protein O-mannose  $\beta$ 1,2-N-acetylglucosaminyltransferase 1 (POMGnT1) knockout neural spheres was reduced when compared to the wildtype. When incubated with Matrigel, extracellular matrix (ECM) molecules including all four major components of the basement membrane, laminin, collagen IV, perlecan, and nidogen co-aggregated. Rate of ECM aggregation was reduced on POMGnT1 knockout neural sphere as revealed by slower growth in aggregate size when compared to the wildtype. Immunofluorescence staining and proteomic comparison revealed that the mutant basement membrane exhibited compositional changes from the wildtype. Atomic force microscopic analysis revealed that the mutant basement membrane had reduced elastic modulus with surface topography showing bigger valleys than the controls. Thus, disruptions of the basement membrane in dystroglycanopathies may be caused by its weakened strength resulted from biochemical changes in composition and physical changes in structure and reduced assembly rate.

## OL 44

## DEVELOPMENT OF NOVEL FLUORESCENT GANGLIOSIDE ANALOGS AS RAFT MARKERS

Naoko Komura,<sup>1,2</sup> Hiromune Ando,<sup>1,2</sup> Izumi Matsui,<sup>1</sup> Kenji Tanaka,<sup>2</sup> Kenichi Suzuki,<sup>2,3</sup>  
Akihiro Kusumi,<sup>2</sup> Hideharu Ishida,<sup>1</sup> Makoto Kiso<sup>1,2</sup>

<sup>1</sup>*Department of Applied Bioorganic Chemistry, Gifu University, 1-1 Yanagido,  
Gifu 501-1193, Japan,*

<sup>2</sup>*iCeMS, Kyoto University, Yoshida Ushinomiya-cho, Sakyo-ku,  
Kyoto 606-8501, Japan,*

<sup>3</sup>*Precursory Research for Embryonic Science and Technology (PRESTO),  
Japan Science & Technology Agency (JST)  
hando@gifu-u.ac.jp*

Gangliosides are considered to have significant roles in the process of cell-cell signalling mediated by lipid rafts. In order to understand formations and functions of raft domains, we have developed the single molecule tracking techniques<sup>1</sup> using synthesized fluorescent probes. In this study, we have accomplished the synthesis of fluorescent GM3 and GM1 analogs in which glycan parts were labelled with various fluorescent dyes and evaluated the functionality of the GM1 and GM3 analogs as raft markers.

To introduce fluorescent labels into C9 position of Neu of GM1, we designed replacement of the C9 hydroxyl group with an amino group. The synthesis of GM1 tetrasaccharide was successfully achieved by the coupling of Gal-GalNTroc donor and Neu-Gal acceptor having a trifluoroacetamide at the C9 position. Then, the tetrasaccharide was transformed into imidate donor. The donor was glycosidated with the Glc-Cer acceptor<sup>2</sup> to yield the corresponding GM1 skeleton, which was further converted into an amino-GM1 ganglioside. Finally, fluorescent group was attached to GM1 through an amide linkage, producing the targeted GM1 analog. By exploiting similar synthetic process, GM3 analogs were successfully synthesized. The synthesized ganglioside analogs were subjected to biophysical evaluation; DRM analysis, Lo/Ld partition test, and simultaneous single molecule tracking of the analogs and CD59 clusters. Results obtained in the evaluation demonstrated that polarity and the loaded position of fluorescent molecule greatly influenced on the raftphilicity of ganglioside analogs.

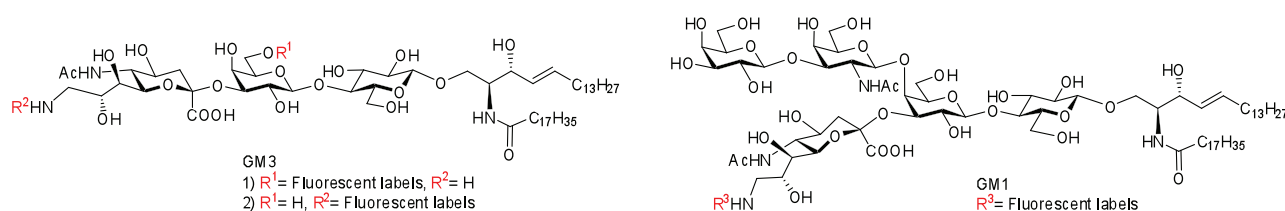

## References

1. K. G. N. Suzuki, T. K. Fujiwara, F. Sanematsu, R. Iino, M. Edidin, A. Kusumi, *J. Cell Biol.* **2007**, *177*, 717-730.
2. K. Fujikawa, T. Nohara, A. Imamura, H. Ando, H. Ishida, M. Kiso, *Tetrahedron Lett.* **2010**, *51*, 1126-1130.

## OL 45

## NEW STRATEGIES FOR THE SYNTHESIS OF THERAPEUTIC GLYCOPEPTIDES

Brendan L. Wilkinson,<sup>1</sup> Lara R. Malins,<sup>1</sup> Trent Conroy,<sup>1</sup> and Richard J. Payne<sup>1</sup><sup>1</sup>*School of Chemistry, The University of Sydney, New South Wales 2006, AUSTRALIA  
richard.payne@sydney.edu.au*

Glycosylation is the most complex post-translational modification of proteins. Over 50% of human proteins are thought to display covalently bound glycans which are required to mediate an array of biological recognition events, including cell adhesion, cell differentiation and cell growth. In addition, aberrant glycosylation is associated with a number of disease states including autoimmune diseases and cancer. Unfortunately, the detailed study of glycopeptide and glycoprotein structure and function at the molecular level has been hampered by the heterogeneous display of glycans on the protein backbone, resulting in glycoforms which are inseparable by current chromatographic techniques. This has led to the demand for new tools to facilitate the chemical synthesis of homogeneous glycopeptides and glycoproteins for biological study.<sup>1,2</sup> This talk will outline the development of new methods for the construction of glycopeptides. These include the solid-phase synthesis of *N*-linked glycopeptides<sup>3,4</sup> and the synthesis of large glycopeptides using new peptide ligation strategies.<sup>5,6</sup> The scope of these methods for the efficient chemical synthesis of complex glycopeptides will be discussed along with their potential applications in the construction of glycopeptide-based therapeutics.<sup>6</sup>

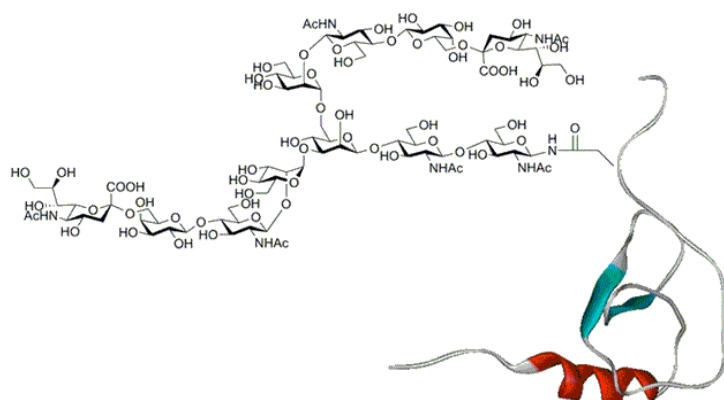
**References**

1. Gamblin, D. P.; Scanlan, E. M.; Davis B. G. *Chem. Rev.* **2009**, *109*, 131-163.
2. Payne, R. J.; Wong, C.-H. *Chem. Commun.* **2010**, *26*, 41-43.
3. Conroy, T.; Jolliffe, K. A.; Payne, R. J. *Org. Biomol. Chem.* **2009**, *7*, 2255-2258.
4. Conroy, T.; Jolliffe, K. A.; Payne R. J. *Org. Biomol. Chem.* **2010**, *8*, 3723-3733.
5. Wilkinson, B. L.; Malins, L. R.; Chun, C. K. Y.; Payne, R. J. *Chem. Commun.*, **2010**, *46*, 6249-6251.
6. Wilkinson, B. L.; Day, S.; Malins, L. R.; Apostolopoulos, V.; Payne, R. J. *Angew. Chem. Int. Ed.* **2011**, *50*, 1635-1639.

## OL 46

## AUTOMATED SOLID-PHASE SYNTHESIS OF GLYCEROL TEICHOIC ACIDS (GTAS)

Wouter F.J. Hogendorf,<sup>1</sup> Nico Meeuwenoord,<sup>1</sup> Dmitri V. Filippov,<sup>1</sup> Christian Theilacker,<sup>2</sup> Herman S. Overkleeft,<sup>1</sup> Johannes Huebner,<sup>2</sup> Jeroen D.C. Codée,<sup>1</sup> and Gijsbert A. Van der Marel<sup>1</sup>

<sup>1</sup>Department of Bioorganic Synthesis, Leiden Institute of Chemistry, Leiden University, The Netherlands,

<sup>2</sup>Division of Infectious Diseases, Department of Medicine, University Hospital Freiburg, Germany  
hogendorf@chem.leidenuniv.nl

Glycerol teichoic acids (GTAs) are prominent constituents of the cell walls of most gram-positive bacteria. GTAs provide elasticity and porosity to the cell wall and play an important role in the regulation of cell wall autolysis as well as the uptake of nutrients and metal ions. GTAs are structurally diverse and are often decorated with carbohydrate and D-alanine substituents. It recently became evident that GTAs are antigenic and can possess immunostimulatory properties.<sup>1</sup> To study the activity of GTAs, we set out to synthesize a row of molecules of well-defined length and composition. In this context, we explored a solution-phase approach to an  $\alpha$ -kojibiosyl substituted GTA, a structure that occurs in the cell wall of *Enterococcus Faecalis*.<sup>2,3</sup> Our next goal was to apply the same chemistry in an automated solid-phase protocol to access a number of GTAs from various gram-positive species, including *Staphylococcus Aureus*, varying in length ( $n = 6-20$ ) and structure ( $R = H$  or  $\alpha$ -glucosyl). The developed automated solid-phase methodology proved to be a fast and efficient means to obtain a variety of GTAs in good yields and purity.<sup>4</sup>

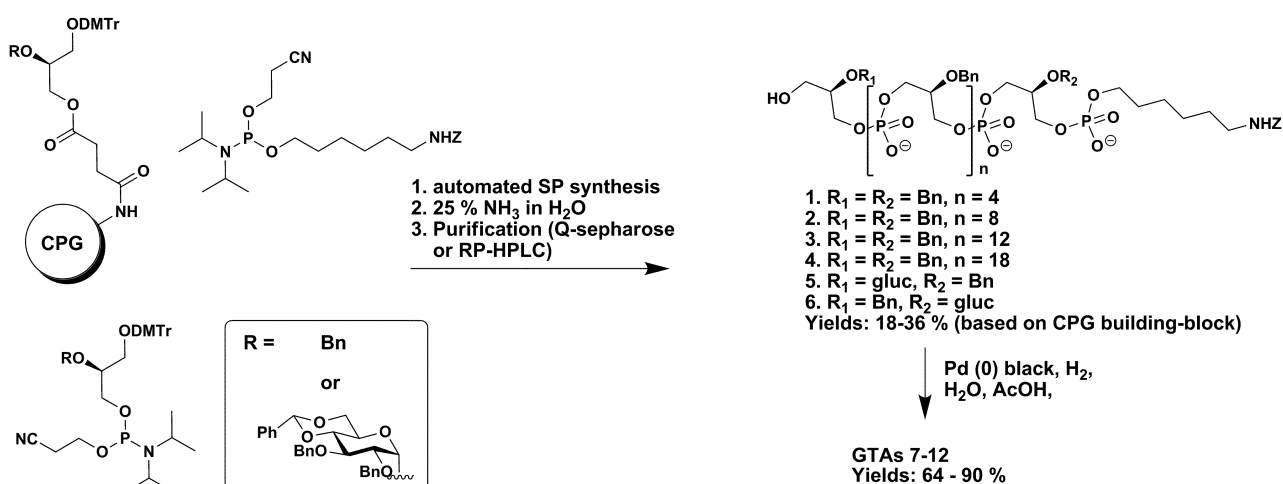

## References

1. Weidenmaier, Peschel, *Nat. Rev. Microbiol.*, **2008**, 6, 276-287.
2. Theilacker, Kaczynski, Kropec, Fabretti, Sange, Holst, Huebner, *Infect. Immun.*, **2006**, 74, 5703-5712.
3. Hogendorf, Van den Bos, Overkleeft, Codée, Van der Marel, *Bioorg. Med. Chem.*, **2010**, 18, 3668-3678.
4. Hogendorf *et al.*, manuscript in preparation.



## OL 47

CONCENTRATION DEPENDENCE OF GLYCOSYLATION OUTCOME:  
A CLUE FOR REPRODUCIBILITY

Leonid O. Kononov,<sup>1</sup> Nelly N. Malysheva,<sup>1</sup> Anna V. Orlova,<sup>1</sup>  
Alexander I. Zinin,<sup>1</sup> Tatiana V. Laptinskaya,<sup>2</sup> Natalya G. Kolotyrykina<sup>1</sup>

<sup>1</sup>N. D. Zelinsky Institute of Organic Chemistry, Leninsky prospect, 47, 11991 Moscow,  
Russian Federation;

<sup>2</sup>Faculty of Physics, M. V. Lomonosov Moscow State University, Moscow, Russian Federation  
kononov@ioc.ac.ru, leonid.kononov@gmail.com

During the development of preparative synthesis of Neu5TFA-( $\alpha$ -2 $\rightarrow$ 3)-Gal building block, useful for the preparation of sialooligosaccharides with various *N*-substituents, we faced a serious problem of reproducibility of yield and especially stereoselectivity of sialylation (Fig. A). In order to tackle this issue, we used a recently introduced supramer approach,<sup>1</sup> and studied the solutions of **1**, **2** and **1+2** in MeCN by polarimetry and laser light scattering. Several critical points on the plots of  $\alpha_D$ ,  $[\alpha]_D$  and hydrodynamic radius vs. concentration (*C*) were detected (marked with the arrows in Fig. B), and formation of mixed supramers {**1+2**} at *C* > 0.07 M was revealed. Using these critical concentrations as the guidelines, we performed a series of glycosylation experiments and found that changes in concentration of reagents dramatically modulate stereoselectivity (Fig. B, solid line, 2), the ratio of anomers being very high ( $\alpha : \beta \sim 20:1$ ) at *C* = 0.05 and 0.2 M, while the yield of disaccharide **3** levels off ( $\sim 72\%$ ) at *C* > 0.07 M (Fig. B, dashed line, 1). Correlation between stereoselectivity and optical rotation of **1** suggests it is the conformational changes<sup>2</sup> upon increase in concentration that determine stereoselectivity. This work was supported by RFBR (projects No. 08-03-00839, 11-03-00918) and the Council on Grants at the President of the Russian Federation (project MK-2533.2011.3).

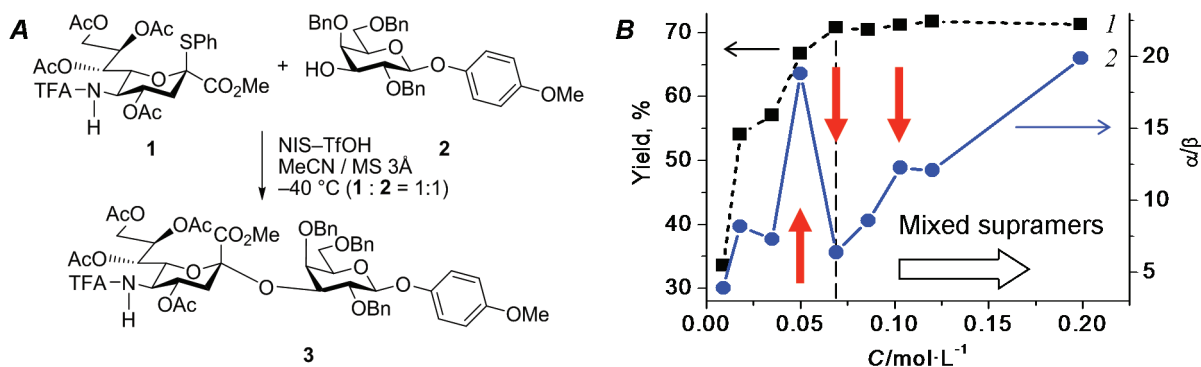

## References

1. L. O. Kononov, N. N. Malysheva, A. V. Orlova, *Eur. J. Org. Chem.* **2009**, 611–616, and references cited.
2. H. Satoh, H. S. Hansen, S. Manabe, W. F. van Gunsteren, P. H. Hünenberger, *J. Chem. Theory Comput.* **2010**, 6, 1783–1797, and references cited.

## OL 48

## GLYCURONIC ACIDS: REACTIVITY AND SELECTIVITY

Jeroen D. C. Codée, Marthe T. C. Walvoort, Na-Rae de Jong, Alpert E. Christina,  
Herman S. Overkleeft, Gijsbert A. van der Marel

*Bio-Organic Synthesis, Leiden Institute of Chemistry, Leiden University, PO Box 9205,  
2300 RA Leiden, The Netherlands  
jcodee@chem.leidenuniv.nl*

Glycuronic acids are prominent constituents of many naturally occurring oligo- and polysaccharides. For the assembly of uronic acid containing oligosaccharides two strategies exist, differing in the timing of the oxidation step which introduces the carboxylic acid function on the carbohydrate backbone or building block.<sup>1</sup> Because it is often assumed that the presence of a C5-carboxylic acid ester in a carbohydrate building block has a negative effect on its reactivity, the most commonly pursued approach involves assembly of the oligosaccharide chain prior to introduction of the uronic acid function(s). Over the last decade we have assembled various uronic acid containing oligosaccharides following the alternative approach using glycuronic acid building blocks.<sup>2,3</sup> In many cases good to excellent yields were obtained with these building blocks indicating that the reactivity of these species might not be as low as often surmised. In addition, it has been discovered that the presence of a C5-carboxylic acid ester in a glycosyl donor can have a profound effect on the stereochemical outcome of a glycosylation reaction, as highlighted by the excellent 1,2-*cis* selectivity displayed by various mannuronic acid donors.<sup>3</sup> To get a better understanding of glycuronic acid reactivity and selectivity we started a thorough investigation of the glycosylation properties of a broad palet of glycuronic acid donors, the results of which will be presented here. In contrast to common perception, several glycuronic acids turned out to be rather potent donor glycosides. The bearing of these results on the reaction mechanism and selectivity of glycosylation reactions involving uronic acid donors will be discussed.

**References**

1. L. J. van den Bos, J. D. C. Codée, R. E. J. N. Litjens, J. [Dinkelaar](#), H. S. Overkleeft, G. A. van der Marel, *Eur. J. Org. Chem.* **2007**, 24, 3963-3976.
2. a) J. D. C. Codée, B. Stubba, M. Schiattarella, H. S. Overkleeft, C. A. A. van Boeckel, J. H. van Boom, G. A. van der Marel, *J. Am. Chem. Soc.* **2005**, 127, 3767-3773. b) J. Dinkelaar, A. R. de Jong, R. van Meer, M. Somers, G. Lodder, H. S. Overkleeft, J. D. C. Codée, Gijsbert A. van der Marel, *J. Org. Chem.* **2009**, 74, 4982-4991. c) J. Dinkelaar, H. Gold, H. S. Overkleeft, J. D. C. Codée, G. A. van der Marel, *J. Org. Chem.* **2009**, 74, 4208-4216.
3. a) J.D.C. Codée, L.J. van den Bos, N. de Jong, J. Dinkelaar, G. Lodder, H.S. Overkleeft, G.A. van der Marel, *J. Org. Chem.* **2009**, 74, 37-47. b) M. T. C. Walvoort, G. Lodder, J. Mazurek, H. S. Overkleeft, J. D. C. Codée, G. A. van der Marel, *J. Am. Chem. Soc.* **2009**, 131, 12080-12081. c) M. T. C. Walvoort, G. Lodder, H. S. Overkleeft, J. D. C. Codée, G. A. van der Marel, *J. Org. Chem.* **2010**, 75, 7990-8002.

## OL 49

**SYNTHETIC STRATEGIES TO PRODUCE CHONDROITIN SULFATE  
POLYSACCHARIDES FROM *Escherichia coli* DERIVED CHONDROITIN**

Emiliano Bedini,<sup>1</sup> Cristina De Castro,<sup>1</sup> Mario De Rosa,<sup>2</sup> Annalida Di Nola,<sup>1</sup> Alfonso Iadonisi,<sup>1</sup>  
Odile Francesca Restaino,<sup>2</sup> Chiara Schiraldi,<sup>2</sup> Michelangelo Parrilli<sup>1</sup>

<sup>1</sup>Department of Organic Chemistry and Biochemistry, University of Naples "Federico II",  
Complesso Universitario Monte S. Angelo, via Cintia 4, I-80126 Naples, Italy,

<sup>2</sup>Department of Experimental Medicine, Second University of Naples,  
via De Crecchio 7, I-80138 Naples, Italy  
ebedini@unina.it

Chondroitin sulfate (CS) is a glycosaminoglycan found in both vertebrates and invertebrates. It is ubiquitously distributed in connective tissue extracellular matrices and on cell surfaces. CS is constituted of a 4)-β-GlcA-(1→3)-β-GalNAc-(1→ disaccharide repeating unit with a variable sulfation pattern, that is tissue/age specific, tightly regulated *in vivo* and considered to be able to encode functional information in a sequence-specific manner. CS predominantly

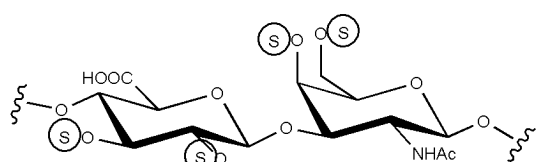

- |                        |                          |
|------------------------|--------------------------|
| O: GlcA-GalNAc         | E: GlcA-GalNAc(4,6S)     |
| A: GlcA-GalNAc(4S)     | K: GlcA(3S)-GalNAc(4S)   |
| C: GlcA-GalNAc(6S)     | L: GlcA(3S)-GalNAc(6S)   |
| D: GlcA(2S)-GalNAc(6S) | M: GlcA(3S)-GalNAc(4,6S) |

composed of A and C disaccharide subunits (CS-A,C) has been recently introduced as drug for the therapy of tibiofemoral osteoarthritis of the knee and in the articular cartilage osteoarthritis.<sup>1</sup> For these pharmacological applications, CS-A,C is obtained by extraction from bovine, porcine and shark cartilages. Nonetheless, the low abundance of the raw material and the laborious downstream purification limit CS availability in spite of the growing interest in expanding its application to

pharmacological fields other than osteoarthritis treatment. Furthermore, the ever more strict regulations for animal-derived drugs has led to a renewed search for synthetic replacements. In this communication it is reported a microbiological-chemical approach opening for the first time a preparative synthetic access to several CSs polysaccharides with a well-defined sulfation pattern. This approach relies upon a regioselective sulfation of *Escherichia coli* O5:K4:H4 derived chondroitin<sup>2</sup> through multistep protection/deprotection strategies, to afford CS-A,C, CS-L,M and some non-natural CSs. A detailed characterization by NMR, enzymatic digestion and high performance size exclusion chromatography combined with a triple detector array (HP-SEC-TDA) demonstrated a very close resemblance between synthesized CS-A,C and pharmacological CS standards.

### References

1. Reginster, J.-Y.; Heraud, F.; Zegels, B.; Bruyere, O. *Mini-Rev. Med. Chem.* **2007**, *7*, 1051-1061.
2. Cimini, D.; Restaino, O.F.; Catapano, A.; De Rosa, M.; Schiraldi, C. *Appl. Microbiol. Biotechnol.* **2010**, *85*, 1779-1787.

## OL 50

## PREPARATION OF THE ENES OF BACTERIAL NONULOSONATES

D.M. Whitfield I.C. Schoenhofen Evgeny Vinogradov and Susan M Logan

*National Research Council, Institute for Biological Sciences  
100 Sussex Drive, Ottawa, ON K1A 0R6 CANADA  
dennis.whitfield@nrc-cnrc.gc.ca*

Some bacterial species decorate their cell surfaces with nine carbon sugar analogues of sialic acids. Presumably these sugars interact with the bacterial host to provide some evolutionary advantage such as immune system evasion. One of the best known neuraminidase inhibitors is the 2-ene of sialic acid, DANA (2-deoxy-2,3-didehydro-N-acetylneuraminic acid). DANA inhibits most neuraminidases of viral, bacterial or mammalian origin to some extent. The well known anti-viral drugs Relenza and Oseltamivir are designed analogues of DANA. Our Institute has developed chemoenzymatic synthesis of both Legionaminic acid (5,7-diacetamido-3,5,7,9-tetra-deoxy-D-glycero-D-galacto-nonulosonic acid) and Pseudaminic acid (5,7-diacetamido-3,5,7,9-tetra-deoxy-L-glycero-L-manno-nonulosonic acid) as their activated CMP-derivatives.<sup>1</sup> Thus, it was of some interest to us to develop a method to convert these CMP-compounds to their corresponding 2-enes. We present a simple procedure featuring a one step thermal preparation method followed by purification and characterization by NMR and MS of such enes in mg quantities. To date the parent Leg5NHAc7NHAc 2-ene, Pse5NHAc7NHAc 2-ene as well as the Leg5NHAm7NHAc-2-ene and Pse5NHAc7NHAm 2-enes have been prepared. The last two are analogues where the acetamide group (NHAc) has been enzymatically converted to the amidine group (NHAm) using bacterial enzymes. Some preliminary data on their neuraminidase inhibitory potential will be reported.

**References**

1. Ian C Schoenhofen, Evgeny Vinogradov, Dennis M Whitfield, Jean-Robert Brisson, and Susan M Logan "The CMP-legionaminic acid pathway in *Campylobacter*: biosynthesis involving novel GDP-linked precursors" *Glycobiology* (2009) **19**, 715-725. and Ian C Schoenhofen, David J. McNally, Jean-Robert Brisson, and Susan M Logan "Elucidation of the CMP-pseudaminic acid pathway in *Helicobacter pylori*: synthesis from UDP-N-acetylglucosamine by a single enzymatic reaction" *Glycobiology* (2006) **16**, 8C-14C.

## OL 51

## SYNTHESIS AND EVALUATION OF HEPARIN SULFATE OLIGOSACCHARIDES

Steen U. Hansen,<sup>1</sup> Gavin J. Miller,<sup>1</sup> Marek Barath,<sup>1</sup> Karl Broberg,<sup>1</sup> Egle Avizienyte,<sup>2</sup> Claire Cole,<sup>2</sup> Graham Rushton,<sup>2</sup> Gordon C. Jayson,<sup>2</sup> John M. Gardiner<sup>\*1</sup>

<sup>1</sup>*School of Chemistry and Manchester Interdisciplinary Biocentre,  
University of Manchester, Manchester, UK,*

<sup>2</sup>*School of Cancer and Enabling Sciences, University of Manchester, Manchester, UK.  
gardiner@manchester.ac.uk*

Heparin/heparan sulphates (HS) are linear glycosaminoglycan (GAG) polysaccharides which play critical roles through binding to a wide range growth factors with biological evidence implicating L-iduronic containing domains and number/location of sulfation as key to effects on a number of FGFs.<sup>1</sup> The complex heterogeneity of natural HS oligosaccharides means defining roles of specific HS sequences - essential for providing designed sequences for potential therapeutic applications - is best addressed by specific synthesis of a diversity of structurally-defined HS sequences. We have developed a new, large scale synthetic entry to suitable iduronic acid derivatives and an improved access to scalable glucoazide intermediates. A range of oligosaccharides with differing sulfation patterns have thence been prepared, covering sequences up to 14 saccharides in length. The synthesis provides an iterative and modular approach to different heparin-related targets, which has enabled biological evaluations of a range of these synthetic oligosaccharides in binding, cell proliferation and migration, and cell signalling experiments, providing important structure-effect information. We have also adapted this synthesis to provide a versatile new end-labellable oligosaccharide entry, applicable to a range of conjugation and labelling strategies.

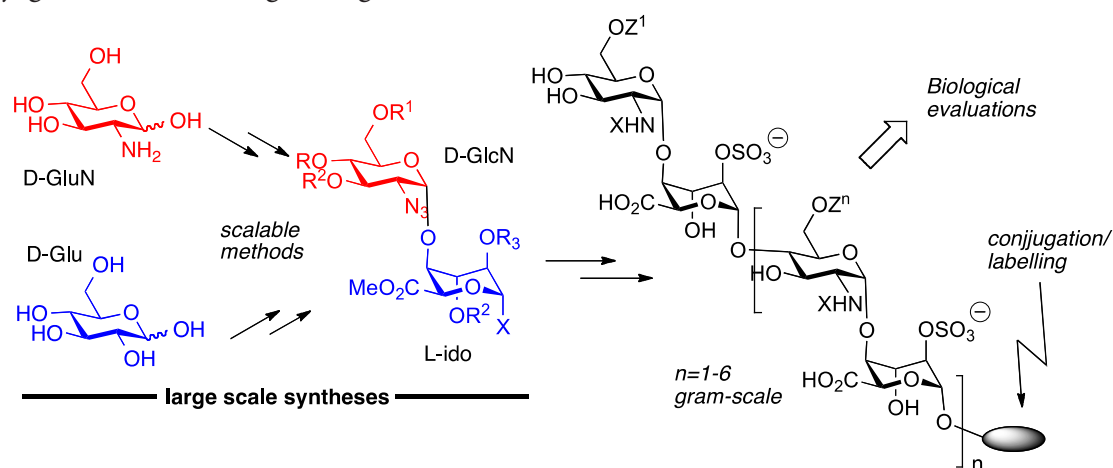

## References

1. (a) Casu, B.; Naggi, A.; Torri, G. *Matrix Biology* **2010**, *29*, 442-452. (b) Bishop, J.; Schuksz, M.; Esko, J. D. *Nature* **2007**, *446*, 1030-1037. (c) Sasisekharan, R.; Shriver, Z.; Venkataraman, G.; Narayanasami, U. *Nat. Rev. Cancer* **2002**, *2*, 521-528. (d) Hung, K. W.; Kurnar, T. K. S.; Kathir, K. M.; Xu, P.; Ni, F.; Ji, H. H. *Biochem.* **2005**, *44*, 15787-15798. (e) Olsen, S. K.; Ibrahim, O. A.; Raucci, A.; Zhang, F. *PNAS* **2004**, *101*, 935-941.
2. (a) Seeberger, P. H.; Werz, B. *Nature* **2007**, *446*, 1046-1051. (b) Cole, C.; Jayson, G. C. *Expert Opin. Biol. Ther.* **2008**, *8*, 351-362.

## OL 52

**TARGETING ANTHRACYCLINE-RESISTANT TUMOR CELLS  
WITH ALOE-EMODIN GLYCOSIDES**

Elinor Breiner-Goldstein,<sup>1</sup> Zoharia Evron,<sup>2</sup> Michael Frenkel,<sup>2</sup> Eliezer Flescher,<sup>2</sup>  
Micha Fridman,\*<sup>1</sup>

<sup>1</sup> School of Chemistry, Tel Aviv University, Tel Aviv, Israel. <sup>2</sup> School of Medicine, Department of  
Clinical Microbiology and Immunology, Tel Aviv University, Tel Aviv, Israel.  
mfridman@post.tau.ac.il

Anthracyclines such as doxorubicin (DOX, Figure 1) are antineoplastic agents commonly used for the treatment of hematopoietic and solid tumors. One of the major limitations on the clinical use of anthracyclines results from the emergence of tumor cells with resistance to these chemotherapeutic agents. In search for novel directions to develop anthracyclines with activity against resistant tumors, our attention was drawn to the unique properties of the natural anthranoid aloe-emodin (AE, Figure 1) which has antiproliferative activity against several tumor cell lines. Interestingly, although its activity was usually modest, AE demonstrated similar levels of cytotoxicity against several tumor cell lines and their corresponding anthracycline-resistant lines. Based on these observations, we reasoned that it should be possible to design AE analogs with potent antitumor activity against anthracycline-resistant tumor cell lines.

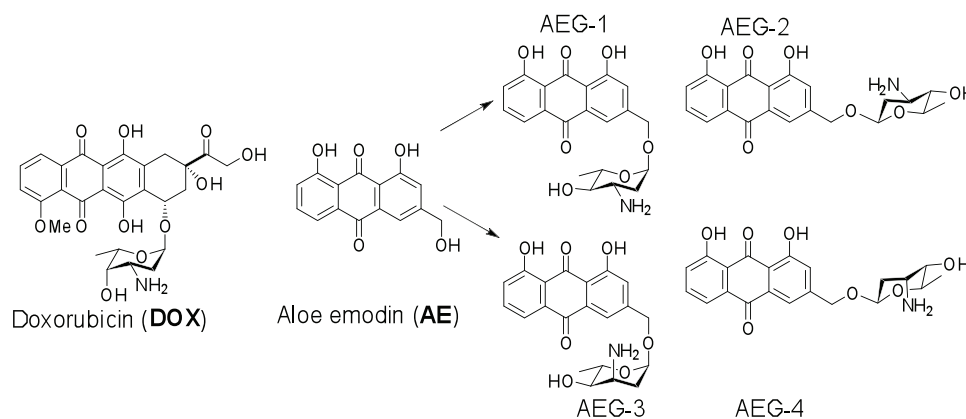

**Figure 1.** Anthracyclines, Aloe-Emodin and Synthetic AEGs

Hence, we designed and synthesized a small collection of AE glycosides (AEGs 1-4, Figure 1) by attaching a 2,3,6-trideoxy-3-amino-L-sugar to the anthranoid core of AE in order to improve the DNA minor groove binding properties and as such, the antitumor activity of these analogs. Some of the AEGs exhibited improved cytotoxic activity of more than two orders of magnitude relative to that of DOX in tumor cell lines with high levels of efflux pumps mediated anthracycline resistance. The synthetic AEGs were shown to readily permeate anthracycline-resistant tumor cells while DOX accumulates in these cells membranes. The results of this study demonstrate that AEGs may be used as a promising scaffold for the development of antineoplastic agents that will overcome the widespread problem of efflux pumps mediated anthracycline resistant tumors.



## OL 53

TOWARDS THE SYNTHESIS OF 4-AMINO-4-DEOXY-L-AMINOARABINOSE  
MODIFIED LIPID ARalph Hollaus<sup>1</sup>, Paul Kosma<sup>1</sup>, Alla Zamyatina<sup>1</sup><sup>1</sup>Department of Chemistry, University of Natural Resources and Life Sciences, Muthgasse 18,  
A-1190 Vienna  
alla.zamyatina@boku.ac.at

Covalent modification of lipid A by cationic  $\beta$ -L-Ara4N on either both phosphates or solely on the reducing phosphate, which is characteristic for several *Burkholderia*<sup>[1]</sup> and CF (cystic fibrosis) adapted *Pseudomonas aeruginosa*<sup>[2]</sup> strains, is deemed critical for bacterial survival in pulmonary airways and associated with increased virulence, resistance to antibiotics and modulation of TLR4-MD-2 regulated innate immune response. To better comprehend the biological consequences of this modification and to gain a detailed insight into the interaction of Ara4N-modified lipid A with TLR4-MD-2 complex, we embarked on the synthesis of L-Ara4N substituted lipid A structures, corresponding to native lipid A of *B. cepacia* complex and CF adapted *P. aeruginosa*.

H-phosphonate approach was found to be the method of choice for the stereocontrolled instalment of “double anomeric” phosphodiester linkage connecting glycosidic centres of reducing Glc2N of the lipid A carbohydrate backbone and divergently protected  $\beta$ -L-Ara4N hemiacetals. The options to access anomerically pure  $\beta$ -configured H-phosphonate of L-Ara4N starting from allyl glycosides were explored. The influence of the nature of protecting groups on the anomeric configuration of L-Ara4N hemiacetals and the corresponding H-phosphonates was assessed.

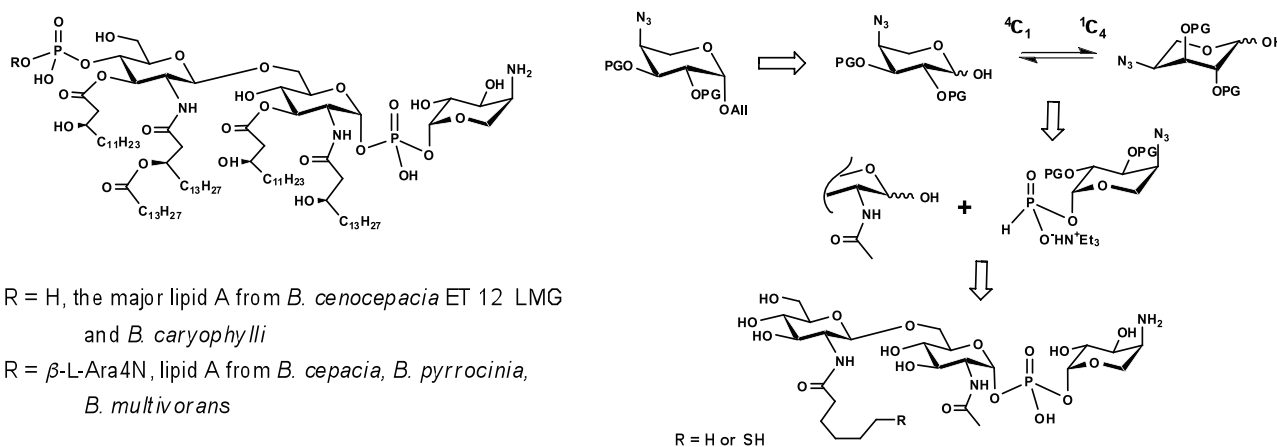

**Acknowledgments:** Financial support from FWF (grant P 21276) is gratefully acknowledged.

## References

1. a) Silipo, A.; Molinaro, A.; Cescutti, P.; Bedini, E.; Rizzo, R.; Parrilli, M.; Lanzetta, R. *Glyco-biol.* **2005**, *15*, 561-570. b) Silipo, A.; Molinaro, A.; Comegna, D.; Anthony; Sturiale, L.; Cescutti, P.; Garozzo, D.; Lanzetta, R.; Parrilli, M. *Eur. J. Org.Chem.* **2006**, *2006*, 4874-4883. c) Silipo, A.; Molinaro, A.; Ieranò, T.; De Soyza, A.; Sturiale, L.; Garozzo, D.; Aldridge, C.; Corris, P. A.; Khan, C. M. A.; Lanzetta, R. *Chem. Eur. J.* **2007**, *13*, 3501-3511. d) Ierano, T., Cescutti, P., Leone, M. R., Luciani, A., Rizzo, R., Raia, V., Lanzetta, R., Parrilli, M., Maiuri, L., Silipo, A. and Molinaro, A. *Innate Immunity*, **2010**, *16*, 354-365.
2. Ernst, R.; Moskowitz, S.; Emerson, J.; Kraig, G.; Adams, K.; Harvey, M.; Ramsey, B.; Speert, D.; Burns, J.; Miller, S. *J. Infect. Dis.* **2007**, *196*, 1088-1092.



## OL 54

**XYLOSE AND GALACTOSE METABOLISM IN THE PARASITE  
*TRICHOMONAS VAGINALIS***

Katharina Paschinger,<sup>1</sup> Andrea Rosenberger,<sup>1</sup> Lydia Hangelmann,<sup>1</sup> David Leitsch,<sup>2</sup>  
Julia Walochnik,<sup>2</sup> Ebrahim Razzazi-Fazeli,<sup>3</sup> Pamela Greenwell,<sup>4</sup> and Iain B. H. Wilson<sup>1</sup>

<sup>1</sup>*Department für Chemie, Universität für Bodenkultur Wien, 1190 Wien, Austria,*

<sup>2</sup>*Institut für spezifische Prophylaxe und Tropenmedizin,  
Medizinische Universität Wien, A-1090 Wien*

<sup>3</sup>*Vetomics Core Facility for Research, Veterinärmedizinische Universität,  
A-1210 Wien, Austria*

<sup>4</sup>*School of Biosciences, University of Westminster, London, W1W 6UW, UK  
iain.wilson@boku.ac.at*

Previous studies on the structure of the trichomonad lipophosphoglycan, a major cell surface component, have indicated the presence of xylose and galactose residues; this may indicate that the occurrence of these sugars in the N-glycans of this species is also very likely. However, neither the molecular mechanisms for xylose and galactose synthesis and transfer nor any details of the N-glycan structures of *Trichomonas vaginalis* have been published. We have now examined these questions and detect pentose residues on the N-glycans of both *Trichomonas vaginalis* and *Tritrichomonas foetus*; the reactivity of anti-horseradish peroxidase to trichomonad proteins suggests that these pentose residues are indeed xylose. In addition, various HPLC and MS experiments have been performed to analyse the N-glycans and also indicated the modification with galactose residues. Furthermore, based on homology to enzymes from other organisms, we have cloned *Trichomonas vaginalis* cDNAs encoding enzymes required for the generation of the nucleotide sugar donors involved in transfer of xylose and galactose residues to target glycoconjugates. Thereafter, the UDP-xylose synthase (also known as UDP-glucuronic acid decarboxylase) and one isoform of UDP-galactose epimerase were expressed in *Escherichia coli* and, as judged by HPLC assays, found to indeed possess the expected enzymatic activities. In conclusion, this study offers new evidence that there are indeed xylose and galactose metabolic pathways in the parasite *Trichomonas vaginalis*.

## OL 55

**CARBOHYDRATE RECOGNITION BY APICOMPLEXAN PARASITES – NEW INSIGHTS TO TROPISM FROM CARBOHYDRATE MICROARRAYS**

Yan Liu<sup>1</sup>, Robert A. Childs<sup>1</sup>, Maria A. Campanero-Rhodes<sup>1†</sup>, Angelina S. Palma<sup>1‡</sup>,  
Wengang Chai<sup>1</sup>, Livia Lai<sup>2</sup>, Ben Cowper<sup>2</sup>, Stephen Matthews<sup>2</sup>, Ten Feizi<sup>1</sup>

<sup>1</sup>The Glycosciences Laboratory, Department of Medicine, Imperial College London, UK

<sup>2</sup>Division of Molecular Biosciences, Imperial College London, UK

<sup>†</sup>Present address: Instituto de Química-Física “Rocasolano”,  
CSIC, and CIBERES, Madrid, Spain

<sup>‡</sup>Present address: REQUIMTE, CQFB, Faculty of Science and Technology /UNL,  
Caparica, Portugal  
yan.liu2@imperial.ac.uk

The Apicomplexa are a large group of parasites that contain some of the most widespread protozoan parasites of humans and animals. Among these are the *Plasmodium spp.* causing malaria, *Eimeria spp.*, *Neospora spp.*, and *Toxoplasma*, the causative agent of toxoplasmosis in warm blooded animals and humans. Unlike bacteria and viruses that often exploit host endocytic pathways for invasion, apicomplexan parasites use their own machinery for active penetration into host cells and this process critically depends on micronemal proteins<sup>1</sup>. By neoglycolipid-based microarray analyses, in conjunction with protein structural studies, we discovered that the cell-binding domain [called microneme adhesive repeat (MAR)] of a key micronemal protein of *Toxoplasma gondii*, TgMIC1, recognizes a wide range of sialyl oligosaccharides<sup>1,2</sup> of the types found on the surface of vertebrate cells, thus providing an explanation for the ability of *T. gondii* to infect all warm-blooded animals. Microarray analyses of a second micronemal protein of *T. gondii*, TgMIC13 and of MIC1 of *Neospora caninum*, NcMIC1, have shown different binding preferences to sialyl sequences<sup>3</sup>. We have now extended our studies to microarray analyses of a MAR-containing protein, EtMIC3, of *Eimeria tenella* which is one of the most economically significant species of *Eimeria* that causes coccidiosis in modern poultry farming. Compared to TgMIC1, a more restricted set of sialyl oligosaccharides are bound by EtMIC3; notably EtMIC3 does not recognize the *N*-glycolyl form of sialic acid (NeuGc). This could be an adaptation to the chicken host that lacks NeuGc. Also, in a follow-on study of *T. gondii* micronemal proteins, we are investigating an ‘apple’-domain-containing protein, TgMIC4, which is closely associated with TgMIC1. Microarray analyses reveal that TgMIC4 has a binding specificity distinct from that of TgMIC1, namely binding to a broad spectrum of galactose-terminating oligosaccharides. Thus microarray analyses are providing crucial information on the way that the apicomplexan parasites use their micronemal proteins to decipher and select carbohydrates of the host cells that they invade, with obvious implications for host/tissue tropisms and pathobiology of infections, and designs of therapeutic substances.

**References**

1. Blumenschein, T.M.A., Friedrich, N., Childs, et al. *EMBO Journal* **2007**, 26, 2808-2820.
2. Garnett, J.A., Liu, Y., et al. *Protein Science* **2009**, 18, 1935-1947.
3. Friedrich, N., Liu, Y., et al. *J Biol Chem* **2010**, 285, 2064-2076.

## OL 56

**EVALUATING THE ROLE OF UDP-GLUCOSE/ UDP-GALACTOSE METABOLISM IN THE PROTOZOAN PARASITE *LEISHMANIA MAJOR***

Sebastian Damerow<sup>1</sup>, Patricia Zarnovican<sup>1</sup> and Françoise H. Routier<sup>1</sup>

<sup>1</sup>Hannover Medical School, Institute of Cellular Chemistry, 30625 Hannover, Germany  
damerow.sebastian@mh-hannover.de

About 350 million people in tropical and subtropical regions face the risk of Leishmaniasis, a sandfly-transmitted parasitic infection of considerable health impact. The causative agent of this neglected disease is a protozoan parasite of the genus *Leishmania* with the ability to evade the human immune response and multiply within macrophages. One major virulence factor which is indispensable for survival of *Leishmania* within the insect vector and for establishment of infection in mammals is its thick glycocalyx, consisting of galactose rich glycans like the lipophosphoglycan (LPG). In order to cover the high demand on UDP-galactose for glycan biosynthesis *Leishmania* requires a specialized enzymatic machinery. The UDP-glucose pyrophosphorylase (UGP) activates glucose-1-phosphate with UTP, fueling this pathway with high amounts of UDP-glucose which in turn is converted into UDP-galactose by epimerization. However, the synthesis of LPG and parasite virulence was only partially affected after UGP gene deletion ( $\Delta ugp$ ) by homologous recombination<sup>1</sup>. This effect could be traced back to a homologue of the plant UDP-sugar pyrophosphorylase (USP) found in *Leishmania* parasites and several other protists, displaying specificity for galactose- and glucose-1-phosphate activation consistent with a role in monosaccharide salvage<sup>2</sup>.

We have now studied the *in vivo* role of USP by targeted gene deletion in *L. major* ( $\Delta usp$ ). Similar to the deletion of UGP the absence of USP had only mild effect on growth and glycoconjugate biosynthesis. In contrast, a conditional mutant deficient in both UGP and USP is unviable under repressive conditions. The subcellular localization of the enzymes involved in UDP-glucose/-galactose metabolism was further elucidated using immunofluorescence, successive permeabilization and isopycnic centrifugation experiments. Interestingly, despite putative targeting motifs USP and UGP are not situated within the peroxisome-like glycosomes but in the cytosol. These findings delineate the UDP-Gal and UDP-Glc biosynthetic pathway in *Leishmania* and demonstrate the importance of these nucleotide sugars for parasite survival.

**References**

1. Lamerz AC, Damerow S, Kleczka B, Wiese M, van Zandbergen G, Lamerz J, Wenzel A, Hsu FF, Turk J, Beverley SM, Routier FH; *Glycobiology*; **2010 Jul**;20(7):872-82.
2. Damerow S, Lamerz AC, Haselhorst T, Führung J, Zarnovican P, von Itzstein M, Routier FH; *J Biol Chem*. **2010 Jan 8**;285(2):878-87.

## OL 57

**COLLECTIN KIDNEY 1 (CL-K1) IN BLOOD IS DETECTED  
BY A NOVEL ELISA SYSTEM**

Takayuki Yoshizaki, Katsuki Ohtani, Wataru Motomura, Seong-Jae Jang, Ken-ichiro Mori,  
Itsuro Yoshida, Yasuhiko Suzuki, Nobutaka Wakamiya

*Department of Microbiology and Immunochemistry, Asahikawa Medical University, 2-1-1-1  
Midorigaoka-Higashi, Asahikawa 078-8510, Japan*

We have identified the human collectin kidney 1 (CL-K1, *COLEC11*) from human kidney cDNA library (Keshi, H., et al., *Microbiol. Immunol.* 50, 1001-1013, 2006). The high homology between human and mice CL-K1 among 6 collectin members suggests it might be a prototype of collectin. To quantitate the blood CL-K1 concentration, we have developed polyclonal and monoclonal antibodies for human CL-K1 and have set the best matching sandwich enzyme-linked immunosorbent assay (ELISA) system. Mannan-binding lectin (MBL) is the first discovered and famous collectin in which the plasma concentration is almost similar to the serum one. Although the low blood concentration of MBL is often found due to its single nucleotide polymorphisms (SNPs) which is seemed to be related in opsonic defect, the low blood case of CL-K1 in about fifty samples was not found shown in MBL. The real time PCR study to quantitate the CL-K1 mRNA in human and mice tissues demonstrated the similar expression profiles to each other and liver was its major expression organ like MBL. The ELISA system developed in this study will be useful for elucidating the physiological and pathophysiological role of CL-K1 in humans.

## OL 58

**COMPARISON OF THE CHARACTERIZATION AND FUNCTION OF PROTEIN O-MANNOSYLTRANSFERASES BETWEEN ZEBRAFISH AND HUMAN**

Yutaka Tamaru,<sup>1</sup> Eriko Eriko Avşar-Ban,<sup>1</sup> Hiroshi Many,<sup>2</sup> and Tamao Endo<sup>2</sup>

<sup>1</sup>*Department of Life Science, Mie University Graduate School of Bioresources,  
1577 Kurimamachiya, Tsu, Mie 514-8507, Japan,*

<sup>2</sup>*Glycobiology Research Group, Tokyo Metropolitan Institute of Gerontology,  
35-2 Sakaecho, Itabashi, Tokyo 173-0015, Japan.  
ytamaru@bio.mie-u.ac.jp*

$\alpha$ -Dystroglycan ( $\alpha$ -DG) is a highly glycosylated surface membrane protein. The main glycan of  $\alpha$ -DG was found to be O-mannosylglycan. Protein O-mannosylation is important in muscle and brain development. Glycosyltransferases such as protein O-mannosyltransferase 1 (POMT1) and POMT2 were identified and characterized in O-mannosylglycan synthesis. Since POMT1/2 were found to be responsible for Walker-Warburg syndrome (WWS), WWS is now congenital muscular dystrophies with brain malformation and structural eye abnormalities together with selectively deficiency of glycosylated  $\alpha$ -DG. Therefore, we focused on protein O-mannosylation in zebrafish that is catalyzed by POMT1/2. In particular, to elucidate how different it is between human and zebrafish, we have recently cloned two zebrafish protein O-mannosyltransferase genes encoding zPOMT1 and zPOMT2. Injection of antisense morpholino oligonucleotides of zPOMT1 and zPOMT2 resulted in several severe phenotypes - including bended body, edematous pericardium, and abnormal eye pigmentation. We also found that co-expression of both genes is necessary to show protein O-mannosyltransferase activity similar to human enzymes. These results indicated that the protein O-mannosyltransferase machinery between zebrafish and human is highly conserved and suggested that zebrafish is useful for functional studies of protein O-mannosylation. In this presentation, possible regulatory mechanism of protein O-mannosylation will be discussed.

**References**

1. E. Avşar-Ban, H. Ishikawa, H. Many, M. Watanabe, S. Akiyama, H. Miyake, T. Endo, Y. Tamaru, *Glycobiology*, **2010**, *20*, 1089-1102.

## OL 59

**HIGH-THROUGHPUT GLYCOSYLATION PATTERN ANALYSIS  
OF GLYCOPROTEINS UTILIZING A  
MULTIPLEXING CAPILLARY-DNA-SEQUENCER**

Erdmann Rapp<sup>1</sup>, René Hennig<sup>1</sup>, Matthias Borowiak<sup>1</sup> and Udo Reichl<sup>1,2</sup>

<sup>1</sup>Max Planck Institute for Dynamics of Complex Technical Systems, Magdeburg/Germany,

<sup>2</sup>Chair of Bioprocess Engineering, Otto-von-Guericke University, Magdeburg/Germany  
rapp@mpi-magdeburg.mpg.de

Glycomics is a rapidly emerging field that can be viewed as a complement to other „omics“ approaches including proteomics and genomics. Hence, there is a dramatic dynamic increase in the demand for sophisticated databases and analytical tools in glycobiology respectively glycobotechnology. In order to enhance and improve the comparatively small existing glycoanalytical toolbox, fully automated high-throughput (HTP) and high-resolution (HR) analysis methods including automated data evaluation are required.

Besides several mass spectrometry and liquid chromatography based analysis techniques, electromigrative separation techniques for the analysis of oligosaccharides have been developed over the last years. Especially, capillary gel electrophoresis with laser induced fluorescence detection (CGE-LIF) shows high potential for HTP glycoprofiling of fluorescently labeled glycans<sup>1,2</sup>. This glycoanalysis approach based on multiplexed CGE-LIF is utilizing a DNA-sequencer, and the instruments - based electromigrative separation - in principle (with some minor modifications) are well suited for glyco-profiling of glycoconjugates.

The aim of the project presented was to further investigate and to improve this innovative approach with respect to sample preparation and data analysis. First, sample preparation method and workflow were further optimized with respect to performance and feasibility regarding HTP. Second, data analysis was computerized developing a novel modular software-tool for automated data-processing and structural elucidation by interfacing a corresponding oligosaccharide-database. Using this software-tool, the generated “normalized” electropherograms of the glyco-moieties (“fingerprints”) can be evaluated on two stages: “simple” qualitative and quantitative fingerprint comparison and structural elucidation of each single glyco-component. The application of this technique with up to 96 capillaries in parallel, results in massive reduction of the effective separation time per sample combined with an impressive sensitivity achieved due to LIF detection<sup>3</sup>.

This novel modular glycoanalysis system and method allows fully automated, highly sensitive instrument-, lab- and operator-independent high-throughput HTP-glycoanalysis, even when operated by non-experts. This is in contrast to the currently prevailing methods, where multiplexing with respect to high-throughput is highly cost and lab-space intensive and ties up a lot of manpower and experts hands-on-time.

**References**

1. Schwarzer J, Rapp E, Reichl U, *Electrophoresis*, **2008**, 29, 4203-4214.
2. Laroy W, Contreras R, Callewaert N, *Nature Protocols*, **2006**, 1, 397-405.
3. Ruhaak LR, Hennig R, Huhn C, Borowiak M, Dolhain RJEM, Deelder AM, Rapp E, Wührer M, *Journal of Proteome Research*, **2010**, 9, 6655-6664.



## OL 60

## SYNTHESIS AND BIOLOGICAL EVALUATION OF BIVALENT 1,2,3-TRIAZOLE LINKED GALACTOPYRANOSIDE INHIBITORS OF CHOLERA TOXIN

David Leaver,<sup>1</sup> Andrew Hughes,<sup>1</sup> Anastasios Polyzos,<sup>2,3</sup> and Raymond Dawson<sup>4</sup>

<sup>1</sup>La Trobe University, Bundoora, VIC, 3086 Australia,

<sup>2</sup>Commonwealth Scientific and Industrial Research Organisation Materials Science and Engineering, Clayton, VIC, 3168 Australia,

<sup>3</sup>University of Cambridge, Lensfield Road, Cambridge CB2 1EW, United Kingdom,

<sup>4</sup>The Defence Science and Technology Organisation, Fishermans Bend, VIC, 3207 Australia  
d.leaver@latrobe.edu.au

Cholera toxin (CT) is the enterotoxin produced by *Vibrio cholerae* (causal agent of cholera). It is estimated that 120,000 deaths worldwide are caused by cholera each year.<sup>1</sup> Antibiotic treatment can shorten the course of the disease by limiting *V. cholerae* growth. However, there are no effective small molecule prophylactics or therapeutic drugs available that block the action of CT, which means that the development of such drugs would be of great worldwide benefit.<sup>2</sup>

Proposed structures of multivalent inhibitors will be discussed that will enable the development of cholera prophylactics and therapeutics. It is important that the CT receptor-binding antagonists mimic the terminal galactose and sialic acid groups on the G<sub>M1</sub> oligosaccharide (cell surface receptor of CT).

These multivalent inhibitors need a precise geometry that matches the binding epitopes on the CT surface. Huisgen 1,3-dipolar cycloaddition of azides to alkynes ('Click' chemistry) will be discussed in the proposed synthesis.

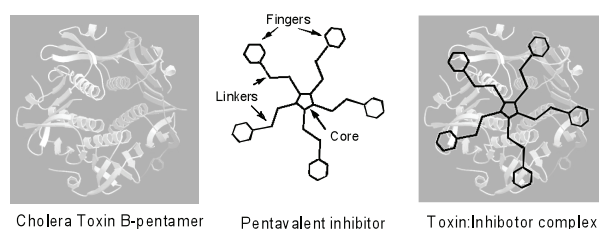

**Figure 1:** A conceptual diagram illustrating how proposed cholera toxin inhibitors were designed.

### References

1. World Health Organization, *Weekly Epidemiological Record*, **2001**, 76, 117-124.
2. Mitchell, D. D., Pickens, J. C., Korotkov, K., Fan, E., Hol, W. G. J., *Bioorganic & Medicinal Chemistry*, **2004**, 12, 907-920.



## OL 61

**PUCKER-FUNCTION RELATIONSHIPS: NEW INSIGHTS  
FROM EQUILIBRIUM SIMULATIONS**

Ben Sattelle and Andrew Almond

*Manchester Interdisciplinary Biocentre, University of Manchester, 131 Princess Street, Manchester  
M1 7DN, UK  
Ben.Sattelle@Manchester.ac.uk*

The vast biotechnological potential of sulfated carbohydrates could be harnessed if only the relationship between molecular structure and function could be understood. One route to this goal is via 3D-structure, which depends on two key determinants: glycosidic linkage and monosaccharide pucker. Linkage geometry equilibrates on ns-timescales, allowing even short simulations to be tested with experiments, and hence it is understood microscopically to some extent. Ring puckering, however, occurs on ms-timescales and remains enigmatic, since it has been difficult to study experimentally and inaccessible to simulations. To overcome this, we employed massively-parallel graphics processing units (GPUs) to perform ms-simulations in explicit water and calculate free energy landscapes (Figure 1) for three monosaccharide constituents of heparin (one of the oldest and most widely used drugs).<sup>1</sup> In doing so, the first complete exploration of room temperature conformational phase-space was achieved for these

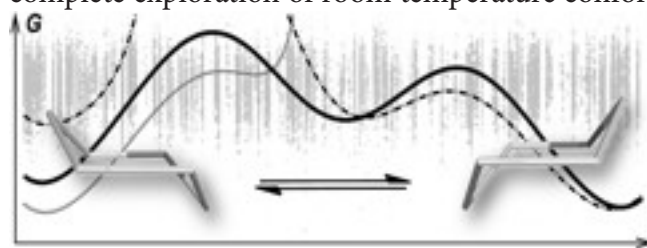

**Figure 1:** Computed equilibrium free energies (G) (IdoA2S) was predicted to destabilize the <sup>4</sup>C<sub>1</sub>-chair conformer by 2.6 kcal mol<sup>-1</sup>

<sup>1</sup> and the computed IdO2S and IdO2S <sup>1</sup>C<sub>4</sub>-chair energies were identical. Synthesis and ultra-high-field NMR validated these observations. Subsequent equilibrium simulations (including oligosaccharides) showed that sulfation does not significantly perturb linkage geometry, in agreement with previous data.<sup>2,3</sup> Interestingly, this chemical modification was predicted to fine-tune pucker, which lead to the novel hypothesis that puckering is a key determinant of carbohydrate structure-activity relationships. The GPU-accelerated calculations have provided a step-change in our understanding of this biological phenomenon by exposing biologically-relevant spatiotemporal dynamic equilibrium properties that are inaccessible to experiment and conventional modeling. This approach promises to pave the way to unlocking structural glycobiology and rational design of carbohydrate-based biotechnologies.

### References

1. Sattelle, B. M.; Hansen, S. U.; Gardiner, J.; Almond, A. *J Am Chem Soc* **2010**, *132*, 13132-4.
2. Mulloy, B.; Forster, M. J. *Glycobiology* **2000**, *10*, 1147-56.
3. Sattelle, B. M.; Shakeri, J.; Roberts, I. S.; Almond, A. *Carbohydr Res* **2010**, *345*, 291-302.

## OL 62

**REPAIRING FAULTY GENES BY SMALL MOLECULES: DEVELOPMENT OF NEW DERIVATIVES OF AMINOGLYCOSIDES FOR TREATMENT OF HUMAN GENETIC DISEASES**

Jeyakumar Kandasamy, Dana Atia-Glikin, Valery Belakhov and Timor Baasov

*The Edith and Joseph Fisher Enzyme Inhibitors Laboratory, Schulich Faculty of Chemistry,  
Technion – Israel Institute of Technology, Haifa 32000, Israel  
jkumar@tx.technion.ac.il*

A large number of human genetic disorders including cystic fibrosis, Duchenne muscular dystrophy and several types of cancer are resulted from nonsense mutations. Aminoglycoside antibiotics were the first small molecule drugs that gave promising results as a potential therapy of such genetic disorders. However, high human toxicity and reduced readthrough efficiency at safe doses, largely limits their use for suppression therapy. To date, no systematic studies have been performed to optimize aminoglycosides activity for readthrough activity and reduced toxicity.

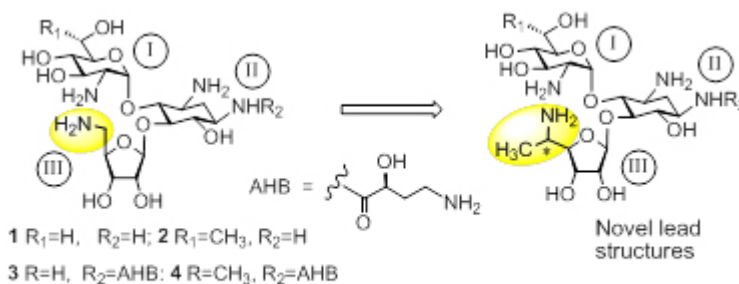

**Figure 1.** Novel aminoglycosides as potent readthrough inducers

Towards these ends we reported on the development of novel pseudo-trisaccharide derivatives of paromomycin (Figure 1, 1-4) with significantly improved readthrough activity and reduced toxicity in comparison to those of parent paromomycin and gentamicin.<sup>1-3</sup> In attempts to further improve the readthrough efficiency we discovered that the introduction of a chiral C5''-methyl group on the ribosamine ring (ring III) of these lead structures (1-4) significantly improves the suppression activity of the observed derivatives while the toxicity was retained unchanged and similarly low as that of the parent leads.<sup>4</sup> By separately synthesizing each C5''-diastereomers of the ribosamine ring and solving their absolute configuration, we also discovered significant preference of the (S)-C5''-methyl group over that of (R)-C5''-methyl group in the resulted pseudo-trisaccharides, both in cell-free and cell-based readthrough activity tests. The new developed pharmacophore, (S)-C5''-methyl group, was further introduced in combination with other structural elements and created most powerful pseudo-trisaccharide derivatives exhibiting the highest readthrough efficacy and reduced toxicity ever reported. These new biochemical data, mostly unpublished together with very recently communicated data<sup>4</sup> will be presented.

### References

1. Nudelman *et al.*, *Bioorg. Med. Chem. Lett.*, **2006**, 16, 6310.
2. Nudelman *et al.*, *J. Med. Chem.*, **2009**, 52, 2836.
3. Nudelman *et al.*, *Bioorg. Med. Chem.*, **2010**, 18, 3735.
4. Jeyakumar *et al.*, *Med. Chem. Commun.*, **2011**, DOI: 10.1039/c0md00195c.

## OL 63

**TOWARDS THE DEVELOPMENT OF GLYCOCONJUGATE VACCINES:  
SYNTHESIS OF CAPSULAR POLYSACCHARIDE STRUCTURES  
OF *CRYPTOCOCCUS NEOFORMANS***Stefan Oscarson,<sup>1</sup> Rebecca Ulc,<sup>1</sup> Lina Rydner<sup>2</sup><sup>1</sup>Centre for Synthesis and Chemical Biology, School of Chemistry and Chemical Biology,  
University College Dublin, Belfield, Dublin 4, Ireland,<sup>2</sup>Department of Organic Chemistry, Arrhenius Laboratory, Stockholm University, S-10691  
Stockholm, Sweden

stefan.oscarson@ucd.ie, rebecca.ulc@ucd.ie

*Cryptococcus neoformans* is an opportunistic fungal pathogen that causes severe diseases primarily in immunocompromised individuals (e.g. HIV positive patients).<sup>[1]</sup> *C. neoformans* is surrounded by a thick layer of capsular polysaccharides (CPS), which is an important virulence factor. In order to investigate the immunobiological properties of the fungal CPS and to develop glycoconjugate vaccines, chemically synthesised part structures of the fungal CPS are required. Currently, we are focusing on the synthesis of a thioglycoside hexasaccharide building block containing  $\alpha$ -Manp,  $\beta$ -Xylp,  $\beta$ -Glc pA and 6-O-acetyl motifs. The hexasaccharide corresponds to serotype A structures of *C. neoformans*. Our aim is to use the hexasaccharide as a building block in the construction of large oligosaccharide structures in order to determine structure and size of protective epitopes.<sup>[2]</sup>

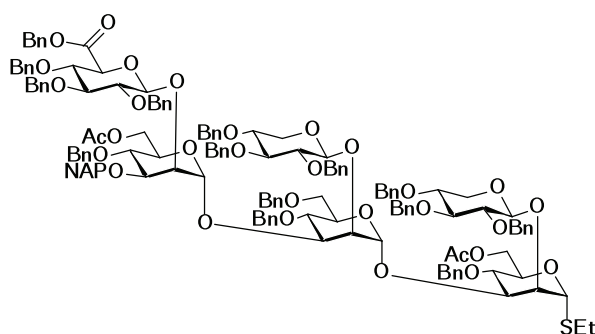

We present an improved synthetic pathway to the various Xylp-Manp and Glc pA-Manp disaccharides and their assembly to the hexasaccharide. A reliable methodology to access structurally related thioglycoside building blocks has been developed previously in our group.<sup>[3,4,5]</sup>

**References**

1. E. Brummer, *Mycopathologia*, **1999**, *143*, 121-125.
2. S. Oscarson, M. Alpe, P. Svahnberg, A. Nakouzi, A. Casadevall, *Vaccine*, **2005**, *23*, 3961-3972.
3. M. Alpe, P. Svahnberg, S. Oscarson, *J. Carbohydr. Chem*, **2003**, *22*, 565-577.
4. M. Alpe, P. Svahnberg, S. Oscarson, *J. Carbohydr. Chem*, **2004**, *23*, 403-416.
5. J. Vésely, L. Rydner, S. Oscarson, *Carbohydr. Res.*, **2008**, *343*, 2200-2208.

## OL 64

**CRAZY POLYSACCHARIDES:  
SCREENING OF ACTIVE ENZYMES ON A COLLECTION  
OF POLYSACCHARIDES HAVING KNOWN AND UNKNOWN STRUCTURE**

William Helbert &amp; Maude Fer

*CNRS-University Pierre and Marie Curie, UMR 7139 Marine Plants and Biomolecules,  
Station Biologique de Roscoff, F-29682 Roscoff, France*

Polysaccharides are the most abundant and the most diverse renewable polymers found on earth. Except polysaccharides used traditionally in food and non-food industries, the structure and the functionality of most of them are unknown and unexplored. Structural analyses of complex polysaccharides benefit strongly from the use of polysaccharides depolymerising enzymes: glycoside hydrolases (GH) and polysaccharide lyases (PL).

Aiming at crossing the chemical diversity of terrestrial and marine polysaccharides with the biological diversity of bacteria as source of new GH and PL, we have designed and implemented a medium throughput screening strategy polysaccharides having known and unknown structure. The detection of active enzymes is achieved by colorimetric method and by mass spectrometry using protocol allowing detection of anionic and neutral oligosaccharides. In parallel, a collection of more than 150 polysaccharides substrates was collected. This includes polysaccharides extracted from land plants, marine macroalgae (red, brown and green) and, land and marine bacteria.

The screening was successfully applied to complex bacterial extracts allowing highlighting different profiles of GH or PL production according to culture conditions (i.e. induction by polysaccharides). As an example, the comparison of predicted enzyme activities from the sequenced genome of *Pseudalteromonas atlantica* with the experimentally detected activities allows us evidencing new polysaccharides degrading enzymes.

The screening program involved a consortium of French laboratories interested in understanding polysaccharides/protein interaction, resolving the structure of complex polysaccharides as well as ascribing function of putative GH and PL (INRA: M. Lahaye, D. Ropartz; IFREMER: C. Boisset, CNRS: R. Daniel; CEVA: J.-F. Sassi, CNRS: B. Henrissat, G. Michel)

## OL 65

NEW CHROMOGENIC SUBSTRATES FOR THE SCREENING OF ACTIVE ENZYMES  
IN THE CONTROLLED BIOCHEMICAL CONVERSION  
OF ARABINOXYLANS

Vinciane Borsenberger<sup>1,2,3</sup>, Fernando Ferreira<sup>1,2,3</sup>, Mélanie Ragon<sup>1,2,3</sup>, Cédric Montanier<sup>1,2,3</sup>,  
Claire Dumon<sup>1,2,3</sup>, Sophie Bozonnet<sup>1,2,3</sup>, Régis Fauré<sup>1,2,3</sup>, Michael O'Donohue<sup>1,2,3</sup>

<sup>1</sup>Université de Toulouse; INSA, UPS, INP; LISBP, 135 Avenue de Rangueil,  
F-31077 Toulouse, France

<sup>2</sup>INRA, UMR792 Ingénierie des Systèmes Biologiques et des Procédés,  
F-31400 Toulouse, France

<sup>3</sup>CNRS, UMR5504, F-31400 Toulouse, France  
vinciane.borsenberger@insa-toulouse.fr

The increasing use of enzymes in industrial processes has led to an increase in research aimed at enzyme discovery and engineering. In turn, high throughput discovery methods, such as functional metagenomics, are underlining the need for more efficient and reliable screening assays. Chromogenic substrates are useful, because they provide quick and easy detection of activity in enzymes libraries and are compatible with automated strategies involving image capture and analysis.<sup>1,2</sup> One group of enzymes that is receiving considerable attention are biomass-degrading enzymes, which are useful tools for biorefinery processes. Cellulases are the main targets, but hemicellulases that breakdown complex arabinoxylans, which account for up to 35% of the dry weight of higher plants, are also very important and highly diverse in terms of their specificities. In this work, new carbohydrate substrates that release a chromophore upon hydrolysis have been synthesized. Specifically, a series of catechol and indolyl glycosides that can be used for the detection and study of different hemicellulases.

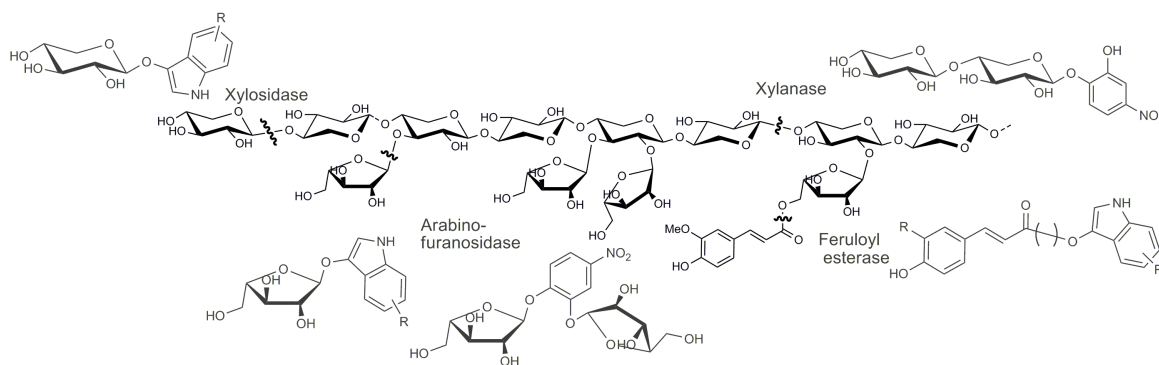

These molecules have been tested in different assay conditions. In addition to their good stability to spontaneous hydrolysis, our results reveal that these chromogenic glycosides allow the reliable and specific detection of their target enzymes in different screening modes.

### References

- Marmuse L., Asther M., Fabre E., Navarro D., Lesage-Meessen L., Asther M., O'Donohue M., Fort S., Driguez H., *Org. Biomol. Chem.*, **2008**, *6*, 1208-1214.
- Reymond J.-L., Fluxà V.S., Maillard N., *Chem. Comm.*, **2009**, *1*, 34-46.
- Ferreira F., Ragon M., Bozonnet S., Record E., Fauré R., O'Donohue M., *In preparation*.

## OL 66

**FAMILY GH19 CHITINASE FROM MOSS: NEW INSIGHTS  
FROM NMR SPECTROSCOPY, ITC EXPERIMENTS, AND ENGINEERING  
INTO A GLYCOSYNTASE**

Tamo Fukamizo<sup>1</sup>Takayuki Ohnuma,<sup>1</sup> Shoko Shinya,<sup>1</sup> Takuya Nagata,<sup>1</sup> Tatsuya Fukuda,<sup>1</sup>  
Morten Sørli,<sup>2</sup> Yuji Honda,<sup>3</sup> Toki Taira,<sup>4</sup>

<sup>1</sup>*Department of Advanced Bioscience, Kinki University, Nara, 631-8505 Japan;*

<sup>2</sup>*Norwegian University of Life Sciences, Ås, Norway;* <sup>3</sup>

*Ishikawa Prefectural University, Ishikawa, Japan,*

<sup>4</sup>*University of Ryukyus, Okinawa, Japan*

*fukamizo@nara.kindai.ac.jp*

Chitin, a β-1,4-linked polysaccharide of *N*-acetylglucosamine (GlcNAc), is hydrolyzed by chitinases (EC 3.2.1.14), which are divided into two families, family GH18 and family GH19 (<http://www.cazy.org>). Although the family GH18 enzymes have been intensively studied with respect to their structure and function, the family GH19 enzymes have been poorly characterized. In this study, oligosaccharide binding study was conducted by NMR spectroscopy and isothermal titration calorimetry (ITC) using family GH19 chitinase from moss, *Bryum coronatum* (BcChi-A)<sup>1</sup>. We also tried to produce a glycosynthase from the moss chitinase.

**NMR spectroscopy.** <sup>15</sup>N/<sup>13</sup>C-labeled BcChi-A was produced by *E. coli* expression system, and the backbone resonances in the <sup>1</sup>H-<sup>15</sup>N HSQC spectrum were assigned by three-dimensional NMR measurements. NMR titration experiments were conducted with (GlcNAc)<sub>n</sub> (n=2, 4, and 6) to identify the substrate binding site of the enzyme. The oligosaccharides were found to bind preferentially to the aglycon binding site. **ITC analysis.** (GlcNAc)<sub>n</sub> (n=2, 3, 4, 5, and 6) binding to the inactive BcChi-A mutant (BcChi-A-E61A) was analyzed by ITC. The binding was found to be enthalpically driven. The longer the chain-length of (GlcNAc)<sub>n</sub> added, the larger the negative values of binding free energy changes. The binding cleft of BcChi-A is likely more extended than that expected from the modeled structure. **Engineering into a glycosynthase.** To convert BcChi-A to a glycosynthase, mutations of Ser102 residue orienting the water molecule, which attacks the C1 carbon of the -1 sugar in the hydrolytic reaction, were conducted to produce the three mutant enzymes (S102A, S102G, or S102C). Each mutant exhibited a glycosynthase activity forming (GlcNAc)<sub>4</sub> from α-(GlcNAc)<sub>2</sub> fluoride. The glycosynthase activity of S102C was the highest among these mutants. This is the first case of a glycosynthase derived from an inverting endo-chitinase.

### References

1. Taira, Ohnuma, Fukamizo, *Glycobiology*, **2011**, in press.



## OL 67

AN ENDO- $\beta$ -1, 6-GLUCANASE INVOLVED IN FUNGAL AUTOLYSIS

Naotake Konno and Yuichi Sakamoto

*Iwate Biotechnology Research Center, 22-174-4 Narita, Kitakami-shi, Iwate, 024-0003, Japan  
naotake-k@ibrc.or.jp*

The cell wall structure of fungi is constantly changing, and morphological changes involving synthesis, reorienting and lysis of the cell wall structure are an essential process in fungi. Fungi are known to produce glycoside hydrolases (GH) associated with the cell wall polysaccharides. Some of these fungal GH act on cell wall components and are responsible for morphological changes. We reported two types of  $\beta$ -1,3-glucanases involved in cell wall autolysis, EXG2 [1] and TLG1 [2], from harvested *Lentinula edodes* fruiting bodies. In the present study, a novel  $\beta$ -1,6-glucanase involved in autolysis of *L. edodes* fruiting body (mushroom), termed LePus30A, was purified, cloned and characterized.

LePus30A with a molecular mass of 49 kDa was purified from extracts prepared from gills of *L. edodes* fruiting bodies on day 4 after harvest. The cDNA of LePus30A includes an open reading frame of 1,575 bp encoding an 18-amino-acid signal peptide and the 506-amino-acid mature protein. Sequence analysis indicated that LePus30A is a member of GH family 30. The transcriptional level of LePus30A was significantly increased in fruiting bodies preserved postharvest, suggesting that LePus30A is responsible for the degradation of the cell wall components during fruiting body autolysis after harvest.

$\beta$ -1,6-glucanases degrade  $\beta$ -1,6-glucan polysaccharides which is a unique and essential component of fungal cell walls. The purified LePus30A catalyzed depolymerization of  $\beta$ -1,6-glucan endolytically, and was highly specific toward  $\beta$ -1,6-glucan polysaccharide. Since mainly glucose was liberated when a  $\beta$ -1,3/1,6-glucan (laminarin) was treated with LePus30A, the enzyme presumably cut the  $\beta$ -1,6-linked side chains in laminarin. Some mushroom  $\beta$ -glucans are known as antitumor polysaccharides, and  $\beta$ -1,6-linked glycosyl structures are believed to be important components for this function. We suppose that the  $\beta$ -1,6-glucanase activity of LePus30A is effective for development of studies and applications of functional  $\beta$ -glucans.

### References

1. Sakamoto Y, Minato K, Nagai M, Kawakami S, Mizuno M, Sato T, *Curr Genet*, **2005**, *48*, 195–203
2. Sakamoto Y, Watanabe H, Nagai M, Nakade K, Takahashi M, Sato T, *Plant Physiol*, **2006**, *141*, 793–801



## OL 68

**INTERACTIONS OF  $\alpha$ -AMYLASE WITH THE SURFACE OF STARCH GRANULES: THE ROLE OF SUPRAMOLECULAR STARCH STRUCTURE**

Frederick J. Warren<sup>1</sup>, Paul G. Royall<sup>2</sup>, Simon Gaisford<sup>3</sup>, Peter J. Butterworth<sup>1</sup>  
and Peter R. Ellis<sup>1</sup>

<sup>1</sup>King's College London, School of Medicine, Diabetes and Nutritional Sciences Division, Biopolymers Group, Franklin-Wilkins Building, 150 Stamford Street, London, SE1 9NH, U.K.,

<sup>2</sup>King's College London, School of Biomedical and Health Sciences, Pharmaceutical Sciences Division, Drug Delivery Group, King's College London, Franklin-Wilkins Building, 150 Stamford Street, London SE1 9NH, U.K.,

<sup>3</sup>School of Pharmacy, University of London, 29-39 Brunswick Square, London, WC1N 1AX, U.K

*frederick.warren@kcl.ac.uk*

Starch, which is composed of two  $\alpha$ -glucan polymers, the essentially linear amylose and the highly-branched amylopectin, is a main source of carbohydrate in the diet of humans and some farm animals. It is well known that large variations exist in the rate that different starchy foods are digested<sup>1-4</sup>. The rate of starch digestion in the gut is believed to explain much of the variation seen in the glycaemic index (GI) of starchy foods<sup>1-3</sup>. There is a lack of mechanistic understanding, however, of how the structure of starch itself, and other components in the diet, create variations in the rate that  $\alpha$ -amylase degrades starch<sup>3,4</sup>. The hydrolysis of starch granules is also an important step in a range of industrial processes (e.g. bioethanol production).

This project was a study of the equilibrium binding and binding rate of amylase to starches from a variety of botanical origins. The aim was to characterise the binding properties of the enzyme to solvent-exposed  $\alpha$ -glucan chains on the granule surfaces and seek information about the significance of physico-chemical properties of the starch granules for binding. The enzyme was either (a) equilibrated at 0<sup>o</sup> C with starch at different concentrations for 30 min and the mixture then centrifuged to separate the polysaccharide, or (b) mixed with a constant starch concentration and the polysaccharide separated from the supernatant by filtration at defined time points. The quantity of bound amylase was determined by a sensitive fluorometric method. The morphology and physico-chemical properties of the starches used in the study were characterised using FTIR, particle sizing methods, scanning electron microscopy and calorimetric methods.

It was found that the main variable affecting the equilibrium dissociation constant is starch granule surface area. However, the main factor determining enzyme binding rate is the structural organisation of the starch at the granule surface. We believe that amylase binding is a key step in starch hydrolysis and that our results will aid understanding of this important process.

**References**

1. Roder N, Gerard C, Verel A, Bogracheva TY, Hedley CL, Ellis PR, Butterworth PJ, *Food Chemistry*, **2009**, 113, 471-478.
2. Tahir R, Ellis PR, Butterworth PJ, *Carbohydrate Polymers*, **2010**, 81, 57-62.
3. Tahir R, Ellis PR, Bogracheva TY, Meares-Taylor C, Butterworth PJ, *Biomacromolecules*, **2011**, 12, 123-133.
4. Butterworth PJ, Warren FJ, Ellis PR, *Starch/Stärke*, **2011**, In Press.

## OL 69

## TARGETING 5'-METHYLTHIOADENOSINE PATHWAYS IN CANCER AND QUORUM SENSING WITH SULFUR-FREE TRANSITION STATE ANALOGUES

Indranil Basu,<sup>1</sup>Gary B. Evans,<sup>2</sup> Jemy A. Gutierrez,<sup>1</sup> Alistair Longshaw,<sup>2</sup> Vern L. Schramm,<sup>1</sup> and Peter C. Tyler<sup>2</sup>

<sup>1</sup> Department of Biochemistry, Albert Einstein College of Medicine of Yeshiva University, 1300 Morris Park Avenue, Bronx, New York 10461,

<sup>2</sup>Carbohydrate Chemistry Group, Industrial Research Limited, P.O. Box 31310, Lower Hutt, New Zealand  
g.evans@irl.cri.nz

Enzymatic transition state structure provides information on both the geometric and electronic features of a transition state.<sup>1</sup> Inhibitor design based on transition state theory has been successfully applied to a number of *N*-ribosyl transferases including 5'-methylthioadenosine phosphorylase (MTAP)<sup>2</sup> and 5'-methylthioadenosine nucleosidase (MTAN).<sup>3</sup> MT-DADMe-ImmA (**1**) is an iminosugar based nucleoside analogue with low pM dissociation constants for both MTAP and MTAN and whose design incorporated several transition state features.<sup>4,5</sup> MT-DADMe-ImmA has proven effective in treating a variety of human cancers, such as head and neck and lung cancers, using mouse xenograph models.<sup>6,7</sup> However, thiols are susceptible to metabolic oxidation. In order to probe the necessity of the sulfur atom present in **1** we have synthesised a variety of sulfur free analogues and assayed these against both human MTAP and *E. coli* MTAN and these results are reported. Also described is the multi-gram synthesis of the lead compound, Bu-DADMe-ImmA (**2**), which was required for in vivo screens. The synthesis of **2**, in particular, and the other inhibitors described required the development of a scalable process for the synthesis of 9-deazaadenine (**3**) and this work is also presented.

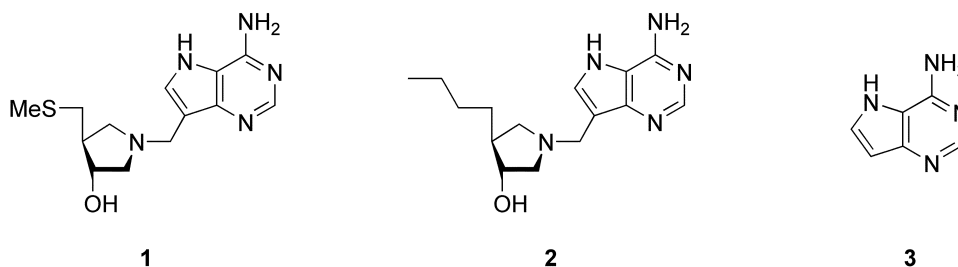

### References

1. Schramm, V. L. *J. Biol. Chem.* **2007**, *282*, 28297 – 28300.
2. Singh, V.; Schramm, V. L. *J. Am. Chem. Soc.* **2006**, *128*, 14691-14696.
3. Singh, V.; Schramm, V. L. *J. Am. Chem. Soc.* **2007**, *129*, 2783-2795.
4. Evans, G. B.; Furneaux, R. H.; Lenz, D. H.; Painter, G. F.; Schramm, V. L.; Singh, V.; Tyler, P. C. *J. Med. Chem.* **2005**, *48*, 4679-4689.
5. Gutierrez, J. A.; Luo, M.; Singh, V.; Li, L.; Brown, R. L.; Norris, G. E.; Evans, G. B.; Furneaux, R. H.; Tyler, P.C.; Painter, G. F.; Lenz, D. H.; Schramm, V. L. *ACS Chem. Biol.*, **2007**, *2*, 725-734.
6. Basu, I.; Cordovano, G.; Das, I.; Belbin T. J.; Guha C.; Schramm, V. L. *J. Biol. Chem.*, **2007**, *282*, 21477-21486.
7. Basu, I.; Locker, J.; Cassera, M.B.; Belbin, T.J.; Merino, E.F.; Dong, X.; Hemeon, I; Evans, G.B.; Guha, C.; Schramm, V.L. *J. Biol. Chem.* **2011**, *286*,4902-11.

## OL 70

## NONCOVALENT INTERACTIONS BETWEEN SUGARS AND AROMATIC AMINO ACID ANALOGS

Manju Kumari,<sup>1</sup> Petety V. Balaji<sup>1</sup> and Raghavan B. Sunoj<sup>2</sup>

<sup>1</sup>*Department of Biosciences and Bioengineering,*

<sup>2</sup>*Department of Chemistry*

*Indian Institute of Technology Bombay, Mumbai 400 076, India*

*manjusah@iitb.ac.in*

The importance of noncovalent interactions in chemical and biological systems has long been recognized in a plethora of situations.<sup>1</sup> In biological systems, the interactions between saccharide and aromatic amino acids have been shown to be critical for a large number of recognition processes, and are suggested to involve vital C–H $\cdots$  $\pi$  interactions. These are non-conventional hydrogen bonds, largely governed by dispersive contributions. To develop a molecular understanding of noncovalent interactions in the recognition process, we have examined a series of binary complexes between aromatic amino acid analogs of tryptophan, tyrosine, and phenylalanine with saccharide. Conformational sampling has been performed to obtain the initial geometry. The interaction energies ( $E_{\text{INT}}$ ) of optimized binary complexes are obtained at the MP2(full)/6-31G(d,p) and the M06/TZV2D//MP2/6-31G(d,p) level of theories. The conventional hydrogen bonding such as N–H $\cdots$ O, O–H $\cdots$ O and C–H $\cdots$ O as well as nonconventional O–H $\cdots$  $\pi$  and C–H $\cdots$  $\pi$  type of interactions are identified in such binary complexes. More number of prominent conventional hydrogen bonding contacts remain as a characteristic feature of the strongly bound complexes and the lower end of the  $E_{\text{INT}}$  spectrum is dominated by multiple C–H $\cdots$  $\pi$  interactions. The complexes exhibiting as many as four C–H $\cdots$  $\pi$  contacts are identified in the case of  $\alpha/\beta$ -D-glucose, b-D-galactose, and  $\alpha/\beta$ -L-fucose with an  $E_{\text{INT}}$  hovering around -8.00 kcal/mol with tryptophan analogue. The presence of effective C–H $\cdots$  $\pi$  interactions is found to be dependent on saccharide configuration and the type of aromatic amino acids analog.<sup>2</sup> The study illustrates the significance and ubiquitous nature of C–H $\cdots$  $\pi$  interactions in carbohydrate–protein complexes.

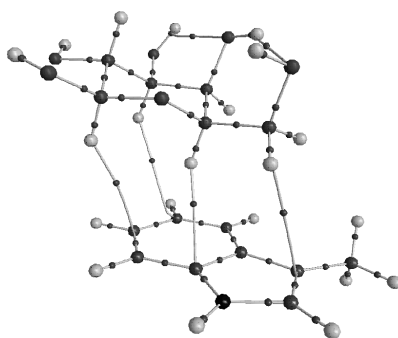

**Figure:** Important bond critical points in  $\beta$ -D-Galactose:Trp complex exhibiting four C–H $\cdots$  $\pi$  interactions.

### References

1. M. Nishio, *Cryst. Eng. Comm.* **2004**, 6, 130–158.
2. M. Kumari, P. V. Balaji, R. B. Sunoj, *Phys. Chem. Chem. Phys.* **2011** (Accepted for publication).

## OL 71

## CARBOHYDRATE-BASED POLYOLS OF POTENTIAL INDUSTRIAL USE

Maïke Tober,<sup>1</sup> Toine Biemans,<sup>2</sup> Marc-Henri Deransart<sup>2</sup> and Joachim Thiem<sup>1</sup>

<sup>1</sup> *University of Hamburg, Department of Chemistry, Faculty of Sciences,  
Martin-Luther-King-Platz 6, 20146 Hamburg, Germany*

<sup>2</sup> *Worlée-Chemie GmbH, Söllerstr. 12-16, 21481 Lauenburg/Elbe, Germany  
tober@chemie.uni-hamburg.de*

Owing to prospective shortage of crude oil and rising costs of oil production access to petrochemically based raw materials for industrial purposes may be restricted or become unattainable due to price increases.<sup>1</sup> Therefore, next to alternative, renewable feedstock based pathways to these chemicals, also the formation of alternative raw materials needs to be investigated. Carbohydrates as a renewable feedstock are mostly confined to textile, paper and coating industries, other applications are alkyl polyglycosides (APGs), polylactic acid (PLA) and furfural.<sup>2</sup> Further development of carbohydrate based monomers as replacement of established raw materials is a challenging task. For example: Polyols should be substituted by novel carbohydrate based monomers.

The systematic development of carbohydrate-based monomers with defined properties and the analysis of their thermostability aims at the transformation of renewables into polyols for industrial use. Based on D-glucose (**1**), the alditol derivatives **2-4** could be synthesized and their suitability tested for polymer synthesis.

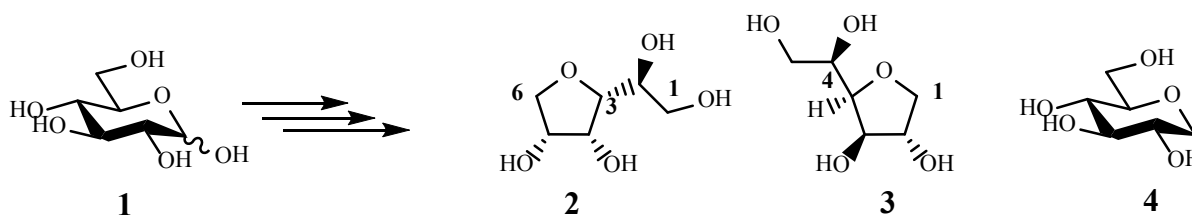

**Acknowledgements:** This work was supported by the FNR, Gülzow, Germany.

### References

1. H. Rempel, H.-G. Babies, *Energierohstoffe 2009*, BGR, Hannover, **2009**, 46-70.
2. F. W. Lichtenhaler, S. Peters, *C. R. Chimie*, **2004**, 7, 65-90.

## OL 72

**PROTEIN O-MANNOSYLATION DISRUPTION DOES NOT ALTER MYCOBACTERIAL GROWTH IN VITRO**

M. Beau, C-F. Liu, D. Bouyssié, A. Stella, W. Malaga, C. Guilhot, G. Puzo, O. Schiltz, M. Riviere

*CNRS; IPBS; Université de Toulouse; UPS;205 route de Narbonne, F-31077 Toulouse, France.*

Protein glycosylation is currently acknowledged as of the most abundant and biologically significant post translational modifications with considerable effects on protein biological activities. Several glycosylation patterns have been identified including the *O*-mannosylation of secretory proteins, which has emerged as an essential modification thought to be restricted to eukaryotes (except plantae). However, *O*-mannosylation has been demonstrated also in prokaryota including in the major human pathogen *Mycobacterium tuberculosis* (Mtb) [1]. Recent works from us and others, suggest that protein *O*-mannosylation is essential for Mtb infectiousness [2-3] and Mtb manno-proteins are emerging as a new class of secreted bacterial molecules thought to contribute to Mtb survival through interaction with host innate immune system C-Type lectins (SP-A, SP-D, DC-SIGN, MMR). However, to date only four such glycoproteins have been formally described in Mtb but which are totally dispensable for Mtb survival. Our objective is then to better define the outcome of protein *O*-mannosylation in Mtb virulence by identifying those still unknown glycoproteins potentially involved in Mtb survival in vivo. In this aim we recently produce a mutant of mycobacteria invalidated for a putative protein mannosyl transferase (PMT) gene. Unlike expectations, phenotypic analysis of this mutant did not revealed any obvious growth alteration in vitro[2]. However, interruption of protein *O*-glycosylation could be confirmed by LC-LTQ MS-MS proteomic analysis using a home developed specific glycopeptide MS-MS peak pattern signature search algorithm. Interestingly, this “molecular phenotype” defined through MS analysis by the absence of secreted glycoproteins is readily reversed by complementation confirming the involvement of the PMT gene in the initiation of the protein *O*-mannosylation process. In addition, several still unreported mycobacterial secreted glycoproteins could be identified through this original approach combining genetic invalidation and exhaustive glycopeptide MS specific signature search. Finally this work reveals that *O*-mannosylation which is likely to constitute the unique protein post-translational glycosyl modification in mycobacteria seems to represent a fairly restricted event restrained to a few secreted proteins totally dispensable for bacterial growth in vitro.

**References**

1. Lommel, M. and Strahl, S., Protein *O*-mannosylation: conserved from bacteria to humans. *Glycobiology* 2009. 19: 816-828.
2. Sassetti, C. M., Boyd, D. H. and Rubin, E. J., Genes required for mycobacterial growth defined by high density mutagenesis. *Mol Microbiol* 2003. 48: 77-84.
3. Ragas, A., Roussel, L., Puzo, G. and Riviere, M., The *Mycobacterium tuberculosis* cell-surface glycoprotein apa as a potential adhesin to colonize target cells via the innate immune system pulmonary C-type lectin surfactant protein A. *J Biol Chem* 2007. 282: 5133-5142.

## OL 73

## DEVELOPMENT OF A NEW AND SENSITIVE DETECTION TECHNOLOGY FOR GALECTIN CANCER PROTEINS

Van Hattum, Hilde<sup>1</sup>, Ruijtenbeek, Rob<sup>2</sup> and Pieters, Roland J.<sup>1</sup>

<sup>1</sup>Medicinal Chemistry and Chemical Biology, Utrecht University, Universiteitsweg 99, 3585 CG UTRECHT, The Netherlands,

<sup>2</sup>PamGene International B.V., Nieuwstraat 30, 5211 NL 's-Hertogenbosch, The Netherlands  
R.J.Pieters@uu.nl

The galectin protein family consists of fifteen galactoside-binding proteins that are present in all classes of life where they function as cell-cell and cell-matrix interaction mediators. Galectins are however also highly overexpressed in various processes related to cancer, including apoptosis, angiogenesis and metastasis<sup>1</sup>. Galectins are therefore excellent targets for tumor diagnostics and medical prognostic purposes.

Current proteomic tools, e.g. Polymerase Chain Reaction (PCR) and Enzyme-linked Immunosorbent Assay (ELISA), are based on protein abundance rather than protein activity. In contrast, we have developed a galectin detection assay that visualizes galactoside-binding, i.e. functional, galectins using PamChip<sup>®</sup> microarray technology (Fig 1). Firstly, antibodies directed against different galectins are efficiently immobilized on the microarray surface by the Fc-binding protein A/G. Then galectin-1 and -3 are captured from a spiked cell lysate that is added to the microarray and the unbound proteins are washed away. The galectin presence is subsequently quantified with a general fluorescent ligand that is only bound by active galectins. Several ligands based on lactose and lactosamine were designed and tested. With the best ligands it was possible to detect galectin quantities in the low nanogram range using only 1 µg or less of precious anti-galectin antibodies per measurement (Fig 2). These results are truly promising for the use of the newly developed galectin detection technology in a clinical setting.

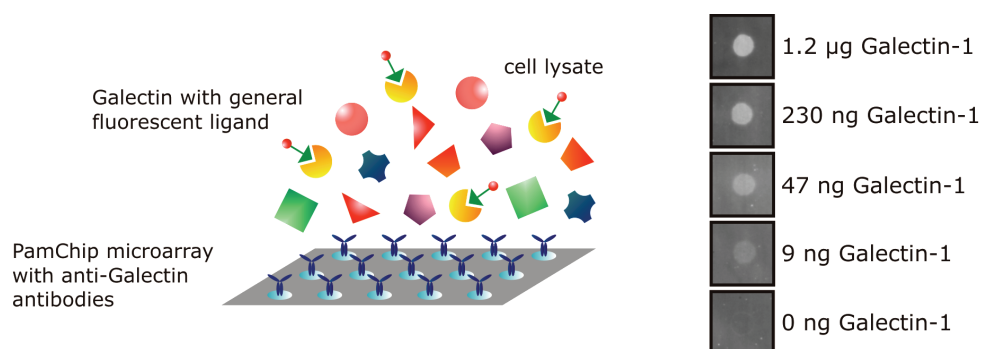

**Figure 1** Schematic representation of the newly developed Galectin detection technology

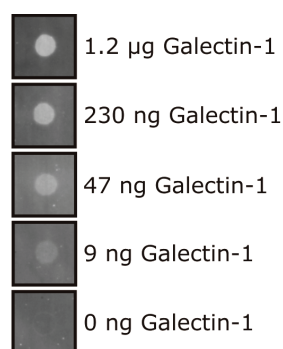

**Figure 2** Fluorescent detection of Galectin-1 in 8 µg *E. coli* cell lysate

## References

1. Liu, F., Rabinovich G., *Nature rev Cancer*, 2005, 5, 29-41.



## OL 74

**A RAPID SCREENING METHOD FOR IDENTIFICATION OF  
OSELTAMIVIR-RESISTANT INFLUENZA VIRUS BY COMBINING  
CARBOHYDRATE MICROARRAY ANALYSIS AND  
NANOPARTICLE-BASED DETECTION**

Chi-Hui Liang,<sup>1</sup> Nung-Sen Wang,<sup>1</sup> Chien-Tai Ren,<sup>1</sup> Yih-Shyun E. Cheng,<sup>1</sup> Jim-Min Fang,<sup>1,2</sup>  
Chi-Huey Wong,<sup>1</sup> and Chung-Yi Wu<sup>1</sup>

<sup>1</sup>*The Genomics Research Center, Academia Sinica, 128  
Academia Road, Section 2, Taipei, 115, Taiwan*

<sup>2</sup>*Department of Chemistry, National Taiwan University,  
1 Roosevelt Road, Section 4, Taipei, 106, Taiwan  
JamesL@gate.sinica.edu.tw*

**Influenza antiviral resistance is a growing clinical problem.** The threat of drug resistance poses major challenges in diagnosis and clinical management of seasonal and pandemic influenza. When drug resistance is not noticed, use of ineffective therapy may cause selection of highly resistant viral populations and other mutations. Therefore, monitoring of viral clearance during treatment of influenza in patients is essential. Unfortunately, options for rapid detection of drug resistance are currently limited. So far, the most available detection system is the neuraminidase inhibition assay followed by RT-PCR to detect mutations associated with the resistance. However, RT-PCR sometimes may not detect oseltamivir resistance, because it is sequence specific, and any genetic shift can alter the assay performance. In this study, a novel carbohydrate microarray assay was developed to detect the oseltamivir resistant influenza virus. Drug-resistant and -sensitive viruses could be differentiated using the nanoparticle-based imaging patterns. This carbohydrate microarray assay may be performed directly on patient specimens, can detect resistant virus at low levels, and therefore may provide early warning of developing resistance within patients or the population, and can be used in resource-limited settings.



## OL 75

MALDI-TOF ANALYSIS OF ENZYMATIC ACTIVITY ON  
AN ARRAY OF N-GLYCANS

Antonio Sánchez-Ruiz,<sup>1</sup> Manuel Martin-Lomas<sup>1,2</sup> and Niels C. Reichardt<sup>1,2</sup>

<sup>1</sup> *Biofunctional Nanomaterials Unit, CICbiomaGUNE. Paseo Miramon 182,  
20009 San Sebastian (Spain) Fax: (+) 34 943 005 314.*

<sup>2</sup> *CIBER-BBN*

*asanchez@cicbiomagune.es*

A simple and sensitive platform for the immobilization and analysis of surface bound complex oligosaccharides has been developed. Complex oligosaccharides tagged with a lipid can be efficiently immobilized via hydrophobic interactions on self assembling monolayers of alkanethiols and resist washings with aqueous solutions. Through this setup it is possible to follow the action of glycosyltransferases and hydrolases on surface bound large oligosaccharides. Additionally, the utility of the system for the selective trapping and identification of a lectin from a complex mixture was demonstrated.

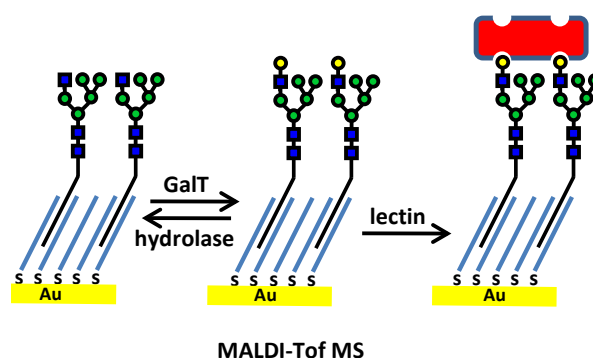

### References

1. Sánchez-Ruiz, A.; Serna, S.; Ruiz N.; Martin-Lomas, M.; Reichardt, N. C. *Angew. Chem. Int. Ed.* **2011**, DOI: 10.1002/anie.201006304

## OL 76

MASS SPECTROMETRY CHARACTERIZATION OF NEW GLYCOCLUSTERS  
DESIGNED FOR LECTIN RECOGNITION

Cendret Virginie,<sup>1</sup> Moreau Vincent,<sup>1</sup> Djedaini-Pilard Florence,<sup>1</sup> Vidal Sébastien,<sup>2</sup>  
and Pilard Serge<sup>3</sup>

<sup>1</sup>UPJV, Laboratoire des Glucides UMR CNRS 6219, 33 rue Saint-Leu,  
80039 Amiens Cedex, France

<sup>2</sup>UCBL, ICBMS UMR CNRS 5246, 43 boulevard du 11 novembre 1918,  
69622 Villeurbanne Cedex, France

<sup>3</sup>UPJV, Plateforme Analytique, 33 rue Saint-Leu, 80039 Amiens Cedex, France  
serge.pilard@u-picardie.fr

Monitoring carbohydrate-lectin interactions using new multivalent structures is a continuous challenge. For this purpose the coupling between monosaccharides and platform molecules such as porphyrines or calixarenes has been developed using click chemistry.<sup>1</sup> Somewhere else the efficiency of a  $\alpha(1,3)\text{-}\alpha(1,6)$  trimannoside moiety for lectin recognition was demonstrated using cyclodextrins bearing oligomannosides.<sup>2</sup> It was thus intended to investigate new glycoclusters based on this natural trisaccharide.

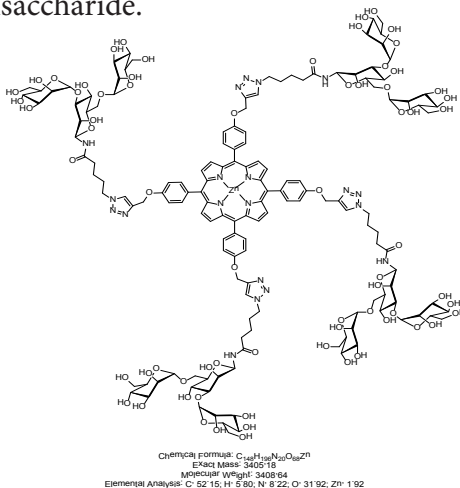

This communication describes the electrospray ionization mass spectrometry (ESI-MS) investigations on a new glycoporphyrin, including positive and negative ion modes, accurate mass measurements and MS/MS experiments (CID, HCD) using the respective capabilities of Q-TOF<sup>3</sup> (Waters) and LTQ-Orbitrap<sup>4</sup> (Thermo Fisher) mass spectrometers. The preliminary results obtained for calixarenes<sup>5</sup> derivatives will also be presented.

### References

- (a) Hao, E., Jensen, T. J., Vicente, M. G. H., *J. Porphyrins Phthalocyanines*, **2009**, *13*, 51-59.  
(b) Cecioni, S., Lalor, R., Blanchard, B., Praly, J. P., Imberty, A., Matthews, S. E., Vidal, S. *Chem. Eur. J.*, **2009**, *15*, 13232-13240.
- Smiljanic, N., Moreau, V., Yockot, D., Garcia Fernandez, J. M., Djedaini-Pilard, F., *J. Incl. Phenom. Macrocycl. Chem.*, **2007**, *57*, 9-14.
- Morris, H. R., Paxton, T., Dell, A., Langhorne, J., Berg, M., Bordoli, R. S., Hoyes, J., Bateman R. H., *Rapid Commun. Mass Spectrom.*, **1996**, *10*, 889-896.
- Hu, Q., Noll, R. J., Li, H., Makarov A., Hardman, M., Cooks, R. G., *J. Mass Spectrom.*, **2005**, *40*, 430-443.
- Precursors of calix[4]arenes glycoconjugates are a generous gift of Dr. S. E. Matthews, University of East Anglia, Norwich, (UK).

## OL 77

**STRUCTURAL AND IMMUNOLOGICAL CHARACTERIZATION OF  
POLYSACCHARIDIC COMPONENTS OF *ENTEROCOCCUS FAECALIS*  
CELL WALL**

Zbigniew Kaczyński<sup>1</sup>, Christian Theilacker<sup>2</sup>, Anna Bychowska<sup>1</sup>, Małgorzata Czerwicka<sup>1</sup>,  
Kinga Marszewska<sup>1</sup>, Piotr Stepnowski<sup>1</sup>, Johannes Huebner<sup>2</sup>, Otto Holst<sup>3</sup>

<sup>1</sup> Faculty of Chemistry, University of Gdańsk, Sobieskiego 18, 80-952 Gdańsk, Poland,

<sup>2</sup> Division of Infectious Diseases, Dept. of Medicine II, University Hospital,  
Hugstetter Str. 55, D-79106 Freiburg, Germany,

<sup>3</sup> Division of Structural Biochemistry, Research Center Borstel,  
Leibniz-Center for Medicine and Biosciences, Parkallee 4a, D-23845 Borstel, Germany.  
zbyszek@chem.univ.gda.pl

The Gram-positive bacterium *Enterococcus faecalis* represents a natural inhabitant of the mammalian gastrointestinal tract and is also commonly found in soil, sewage, water, and food, frequently through fecal contamination<sup>1</sup>.

Infections commonly caused by enterococci include urinary tract infections, endocarditis, bacteremia, catheter-related infections, wound infections, intra-abdominal and pelvic infections. The increasing occurrence of enterococcal strains resistant to multiple antibiotics underscores the necessity to improve our understanding of the pathogenesis of enterococcal infection.

We have structurally characterized capsular polysaccharides, teichoic acids, lipoteichoic acids, and wall teichoic acids isolated from enterococci as in search for carbohydrate virulence factors and for the development of glycoconjugate vaccines to combat enterococcal infections<sup>2</sup>.

The carbohydrates were isolated and purified by gel-permeation, **hydrophobic interaction chromatography**, and anion exchange chromatography compounds and subsequently studied by compositional analyses, one-dimensional (<sup>1</sup>H, <sup>13</sup>C and <sup>31</sup>P), two-dimensional homonuclear (<sup>1</sup>H,<sup>1</sup>H COSY, TOCSY, and ROESY), as well as two-dimensional heteronuclear (<sup>1</sup>H,<sup>13</sup>C HMQC, HMQC-TOCSY, HMBC and <sup>1</sup>H,<sup>31</sup>P HMQC) NMR spectroscopy.

Moreover, we have revisited the cell wall carbohydrates of *E. faecalis* and investigated their role as antigens in a CPS-serotyping system<sup>3</sup>. Using highly purified polysaccharides, we were able to show that opsonic antibodies are directed against only two of these antigens: in acapsular strains, LTA is the major opsonic epitope and in encapsulated strains opsonic antibodies bind to a novel diheteroglycan, the putative capsular polysaccharide of *E. faecalis* in CPS-C and CPS-D strains. These cell-wall associated polymers are promising candidates for vaccination and add to our armamentarium to fight this important nosocomial pathogen.

**References**

1. Klare, I., Werner, G. and Witte, W. *Contrib. Microbiol.* **2001**, *8*, 108-22.
2. Theilacker, C., Krueger, W. A., Kropec, A. and Huebner, J. *Vaccine* **2004**, *22* Suppl 1, S31-8.
3. Hufnagel M., Hancock L.E., Koch S., Theilacker C., Gilmore M.S., Huebner J. *J. Clin. Microbiol.* **2004**, *42*, 2548-2557.

## OL 78

**A HERBAL OIL COMPOSITION IN CONTROLLING BLOOD SUGAR WITHOUT  
ANY RISK OF HYPOGLYCEMIA**

Anil Kumar Gupta

*Associate Professor, Department of Chemistry, D.A.V., College.  
C.S.J.M., University, Kanpur – 208 001 (U.P.) India  
ak\_gupta56@yahoo.co.in*

Diabetes has now become a global disease. Type – 2 diabetes form 90% of the estimated 40 million diabetic cases in India. Due to diabetes some time post meal blood sugars rises high and remain uncontrolled even on taking oral medicines, which can lead to a series of complications in brain, kidneys, heart or eyes. In type I diabetes, insulin is injected but this carries the risk of causing hypoglycemia. The newly invented herbal oil composition can be prescribed to both type of diabetics (Type- I and type – II), is more cost effective and potent with negligible side effects in comparison to sulphonamides (Oral drugs) and insulin, both of which contain amino group as pharmacophoric moiety. While using the herbal oil, the excess of glucose present in blood is converted into more glucuronic acid which then form uridine di phosphate glucuronic acid (UDPAG). Mean while free hydroxyl group of pharmacophore present in herbal oil conjugates with UDPAG and form glucuronide in presence of enzyme glucuronyl transferase to reduce glucose level in the blood.

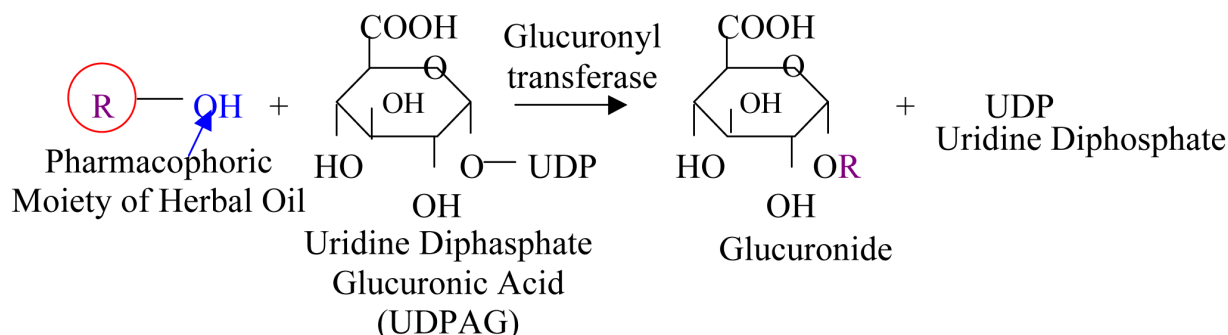

## OL 79

NEW FEATURES AND IMPROVEMENTS IN CARBOHYDRATE 3D STRUCTURE  
VALIDATION

Denis Mokros,<sup>1</sup> Robbie P. Joosten,<sup>2</sup> Miguel A. Rojas-Macias,<sup>3</sup> Andreas Dominik,<sup>1</sup>  
and Gert Vriend,<sup>4</sup> Thomas Lütke<sup>3</sup>

<sup>1</sup>University of Applied Sciences, Giessen-Friedberg, Department MNI,  
35390 Giessen, Germany,

<sup>2</sup>Department of Biochemistry, NKI, 1066 CX Amsterdam, The Netherlands,

<sup>3</sup>Justus-Liebig-University Gießen, Institute of Veterinary Physiology and Biochemistry,  
35392 Gießen, Germany,

<sup>4</sup>CMBI, NCMLS, Radboud-University Nijmegen Medical Centre, 6525  
GA Nijmegen, The Netherlands  
[miguel.rojas@vetmed.uni-giessen.de](mailto:miguel.rojas@vetmed.uni-giessen.de)

More than 5000 entries in the Protein Data Bank (PDB, [www.pdb.org](http://www.pdb.org), the largest collection of biomolecular 3D-structures) contain carbohydrates. This makes the PDB a valuable resource not only for proteomics but also for glycoscience. Unfortunately, the quality of the carbohydrate moieties is significantly lower than that of the protein parts of glycoproteins or protein-carbohydrate complexes in the PDB; many entries contain errors. There are several reasons for this, one of them being the lack of validation software. Only recently crystallographers became aware of this problem and started to use tools such as *PDB Carbohydrate Residue check* (*pdb-care*) to examine the carbohydrate parts. Here we present an updated version of *pdb-care*, which in addition to the residue notation checks already performed by the former version also detects other problems such as invalid residues within the N-glycan core structure (e.g.  $\alpha$ -D-GlcpNAc instead of  $\beta$ -D-GlcpNAc), missing LINK records, which often result in “1-deoxy” sugars, or superfluous atoms within glycosidic linkages.

The results are presented via a new, clearly arranged web interface for human readability, or as a computer-readable xml file to aid automatic validation routines. Suggestions how to correct errors are also included in many instances. These are used e.g. within the PDB\_REDO project ([www.cmbi.ru.nl/pdb\\_redo/](http://www.cmbi.ru.nl/pdb_redo/)) to enable an automatic correction of some of the problems.

The interface to *pdb-care* is available at [www.glycosciences.de/tools/pdb-care/](http://www.glycosciences.de/tools/pdb-care/).

## OL 80

**DC-SIGN BINDING MODE OF DI- AND TRI-MANNOSE MIMICS REVEALED BY NMR AND X-RAY CRYSTALLOGRAPHY**

Ieva Sutkeviciute,<sup>3</sup> Michel Thépaut,<sup>3</sup> Cinzia Guzzi,<sup>1</sup> Norbert Varga,<sup>2</sup> Sara Sattin,<sup>2</sup> Javier Rojo,<sup>1</sup> Pedro M. Nieto,<sup>1</sup> Jesús Angulo,<sup>1</sup> Anna Bernardi,<sup>2</sup> Franck Fieschi.<sup>3</sup>

<sup>1</sup>*Grupo Carbohidratos, Instituto de Investigaciones Químicas, CSIC – Universidad de Sevilla, Américo Vespucio 49, 41092 Sevilla;*

<sup>2</sup>*Università degli Studi Milano, Dipartimento di Chimica Organica e Industriale, via Venezian 21, 20133 Milano, Italia;*

<sup>3</sup>*Institut de Biologie structurale, Université Grenoble I, 41 rue Jules Horowitz. 38027 Grenoble*

Dendritic cells (DCs) are “gate keepers” of the body, being at the first place of contacts with pathogens within epithelia and mucosa. They are key players in the immune system by their ability to recognise and process pathogens for further T cells activation. Indeed, DCs possess multiple receptors on their surface able to recognise specific pathogenic patterns. Amongst them DC-SIGN (dendritic cell-specific ICAM-3 grabbing nonintegrin) is a C-type lectin involved in the recognition of mannose and fucose based glycosylation motifs. Several pathogens are able to hijack DC-SIGN to circumvent the immune system. Indeed, DC-SIGN is able to bind HIV through the high mannose glycans exposed on the envelope gp120. This is used by HIV to be captured at the level of mucosal tissue and finally to be presented to its target, T lymphocytes, in lymphoid organs. For these reasons, DC-SIGN has become an interesting target for therapeutic intervention.

Glycomimetics are good drug candidates for DC-SIGN inhibition due to their high solubility, resistance to glycosidases and non-toxicity. Recently, we described 2 molecules of this type, mannose-based glycomimetics, able to inhibit DC-SIGN-mediated HIV infection. In order to improve their efficiency, we co-crystallized these compounds in complex with the carbohydrate binding domain of DC-SIGN. Surprisingly, despite a similar binding affinity of natural and mimetic compounds, these X-ray structures reveal different binding modes. In addition, we performed NMR STD experiments that gave us a full picture of the binding properties in solution. On the basis of these structural and dynamic informations, new improvement of the molecules have been designed and approached.

The global strategy of DC-SIGN inhibition will be presented, X-ray structures and binding mode of these glycomimetic compounds with DC-SIGN will be analysed and preliminary results on second generation glycomimetics will be disclosed.

## OL 81

MOLECULAR RECOGNITION AND CONFORMATION ANALYSIS  
OF O- AND N-LINKED GLYCOPEPTIDES

Filipa Marcelo,<sup>1</sup> Francisco Corzana,<sup>2</sup> Jesús M. Peregrina,<sup>2</sup> Anna Bernardi,<sup>3</sup> Cinzia Colombo,<sup>3</sup>  
F. Javier Cañada,<sup>1</sup> Jesús Jiménez-Barbero<sup>1</sup>

<sup>1</sup> *Centro de Investigaciones Biológicas (CSIC), Ramiro de Maeztu 9, Madrid 28040, Spain*

<sup>2</sup> *Departamento de Química, Universidad de La Rioja, Madre de Dios 51),  
Logroño 26006, Spain*

<sup>3</sup> *Universita' degli Studi di Milano, Dipartimento di Chimica Organica e Industriale,  
via Venezian 21, I-20133 Milano, Italy  
fmmarcelo@cib.csic.es*

Molecular recognition events are at the heart of live processes.<sup>1</sup> The understanding of these events is of paramount importance to achieve a better knowledge of the living systems. In addition, it has been recognised that glycans on cell surface (attached to membrane proteins or lipids) and those bound to proteins ([glycoproteins](#)) play a critical role in biology.<sup>2</sup> Therefore, study of the structure and dynamics of this interacting glycoconjugates are crucial for recognition. NMR has become a major tool to disclose the conformational behaviour and the interaction properties of either O- and N-linked glycopeptides.<sup>3</sup> In this context, we are interested to investigate the molecular recognition events of natural and unnatural glycopeptides in both free and bound state to protein receptors. For that purpose new synthetic glycopeptides containing either unnatural aminoacids (e.g. methyl serine) or uncommon glycosidic bonds ( $\alpha$ -N-linked glycopeptides) were prepared.

In this communication the implications on the molecular recognition of short tumor-associated glycopeptides **1** and **2** studied by STD-NMR and molecular modelling will be reported.<sup>4</sup>

Afterwards conformation analysis and interaction studies of uncommon  $\alpha$ -N-linked glycopeptides using STD-NMR and TR-NOESY techniques will be also presented.

**References**

1. J. Rebek, *Proc. Natl. Acad. Sci. USA*, **2009**, *106*, 10423-10424.
2. A. Varki, R. Cummings, J. Esko, H. Freeze, G. Hart, J. Marth, *Essentials of Glycobiology*. New York: Cold Spring Harbor Laboratory Press; **1999**.
3. H. Kogelberg, D. Solís, J. Jiménez-Barbero, *Curr. Opin. Struct. Biol.* **2003**, *13*, 646-653.
4. F. Corzana, J. H. Busto, F. Marcelo, M. G. Luis, J. L. Asensio, S. Martín-Santamaría, J. Jiménez-Barbero, A. Avenoza, J. M. Peregrina, *Chem. Eur. J.* **2011**, DOI: 10.1002/chem.201003124.



## OL 82

**VISUALIZATION OF CONTAMINANTS IN HEPARIN SAMPLES BY TWO-DIMENSIONAL CORRELATION SPECTROSCOPY FILTERING OF <sup>1</sup>H NMR SPECTRA**

Timothy R. Rudd<sup>1,2</sup>, Davide Gaudesi<sup>1</sup>, Marcelo A. Lima<sup>3</sup>, Mark A. Skidmore<sup>4</sup>, Barbara Mulloy<sup>5</sup>, Giangiacomo Torri<sup>1</sup>, Helena B. Nader<sup>3</sup>, Marco Guerrini<sup>1</sup> and Edwin A. Yates<sup>2</sup>.

<sup>1</sup> *Istituto di Ricerche Chimiche e Biochimiche "G. Ronzoni",  
Via Giuseppe Colombo, 81 Milano 20133 ITALY.*

<sup>2</sup> *School of Biological Sciences, University of Liverpool, P.O. Box 147,  
Liverpool, L69 3BX UK.*

<sup>3</sup> *UNIFESP - Universidade Federal de São Paulo, Departamento de Bioquímica,  
Disciplina de Biologia Molecular, Rua Três de Maio 100,  
4 andar - Vila Clementino, 04044-020 BRAZIL.*

<sup>4</sup> *Institute for Science and Technology in Medicine, Keele University Keele,  
Staffordshire ST5 5BG UK.*

<sup>5</sup> *National Institute for Biological Standards and Control, South Mimms, Potters Bar,  
Hertfordshire EN6 3QG UK.*

*timrudd@gmail.com*

A novel application of two-dimensional correlation analysis has been employed to filter <sup>1</sup>H NMR heparin spectra to distinguish acceptable natural variation and foreign species. Analysis of contaminated heparin samples, compared to a dataset of accepted heparin samples using two-dimensional correlation spectroscopic analysis of their 1-dimensional <sup>1</sup>H NMR spectra allowed the spectral features of contaminants to be recovered with high sensitivity, without having to resort to more complicated NMR experiments. Contaminants which exhibited features distinct from those of heparin and those with features normally hidden within the spectral mass of heparin could be distinguished readily. When a heparin sample which had been pre-mixed with a known contaminant, oversulfated chondroitin sulfate (OSCS), was tested against the heparin reference library, it was possible to recover the <sup>1</sup>H NMR spectrum of the OSCS component through difference 2D-COS power spectrum analysis of as little as 0.25 % (w/w) with ease and of 2 % (w/w) for more challenging contaminants, whose NMR signals fell under those of heparin. The approach shows great promise for both the quality control and regulatory analysis of heparin, as well as other intrinsically heterogeneous and varied products<sup>1</sup>.

**References**

1. Rudd T.R., Gaudesi D., Lima M.A., Skidmore M.A., Mulloy B., Torri G., Nader H.B., Guerrini M., and Yates E.A. *Analyst* (2011) DOI: 10.1039/c0an00835d.

## OL 83

SYSTEMS BIOLOGY APPROACH FOR LEVAN PRODUCTION  
BY *HALOMONAS SP*

Özlem Ateş, Kazım Yalçın Arga and Ebru Toksoy Öner

Department of Bioengineering, Marmara University, Goztepe 34722, Istanbul, Turkey

ozlem.ates@marmara.edu.tr

ebru.toksoy@marmara.edu.tr

kazim.arga@marmara.edu.tr

Levan which is a linear  $\beta(2-6)$ -linked fructose polymer (fructan) has valuable properties like low viscosity, high solubility in oil, stability to heat, acid and alkali, and good biocompatibility and many potential use as emulsifier, stabilizer and thickener, an encapsulating agent, osmoregulator and cryoprotector in foods, feeds, cosmetics, and the pharmaceutical and chemical industries. Halophilic bacteria *Halomonas sp.* has been reported as a high level levan-producer for the first time by our research group (Poli *et al.*, 2009). Besides sucrose-based chemical media, high production yields were achieved when agroindustrial wastes were used as fermentation substrate (Kucukasik *et al.*, 2010). Considering the significance of biopolymers, elucidating the metabolic reactions and pathways for the production of this novel biopolymer is very important for controlling and hence improving its biosynthesis. However, there is very limited information about the mechanisms involved in the biosynthesis of exopolysaccharides (EPS) from extremophiles and no report about a systematic approach to EPS production by *Halomonas sp.* To investigate biosynthesis mechanism by a systems-based approach, a genome-scale metabolic model of a halophilic bacterium, *Chromohalobacter salexigens* DSM 3043 (formerly *Halomonas elongata* DSM 3043) was reconstructed based on genomic, biochemical and physiological information (Ates *et al.* 2011). This model was adopted for *Halomonas sp.* via integration of the physiological and phenotypic data. *In silico* model was verified with dynamic experimental data on different medium compositions and used to elucidate the metabolism of levan synthesis in *Halomonas sp.* The results of the work will serve as a framework to design metabolic engineering strategies for overproduction of levan.

**References**

1. Poli, A., Kazak, H., Gürleyendağ, B., Tommonaro, G., Pieretti, G., Toksoy Öner, E. & Nicolaus, B. *Carbohydr Polym*, **2009**, 78, 651-657.
2. Küçükaşık, F., Kazak, H., Güney, D., Finore, I., Poli, A., Yenigün, O., Nicolaus, B., Toksoy Öner, E., *Applied Microbiology and Biotechnology*, **2010**.
3. Ates, O., Toksoy Oner, E., Arga K.Y., *BMC Systems Biology*, **2011**, 5, 2.

## OL 84

NOVEL ENGINEERED GLYCOSIDASES FOR THE SYNTHESIS  
OF ALPHA-GLYCANS

Beatrice Cobucci-Ponzano<sup>1</sup>, Carmela Zorzetti<sup>1</sup>, Andrea Strazzulli<sup>1</sup>, Emiliano Bedini<sup>2</sup>,  
Maria Michela Corsaro<sup>2</sup>, Gerlind Sulzenbacher<sup>3</sup>, Mosè Rossi<sup>1</sup> and Marco Moracci<sup>1</sup>

<sup>1</sup>*Institute of Protein Biochemistry – Consiglio Nazionale delle Ricerche,  
Via P. Castellino 111, 80131, Naples, Italy.*

<sup>2</sup>*Dipartimento di Chimica Organica e Biochimica, Università di Napoli Federico II,  
Complesso Universitario di Monte S. Angelo, via Cinthia 4, 80126 Naples, Italy.*

<sup>3</sup>*Architecture et Fonction des Macromolécules Biologiques, UMR6098 CNRS,  
Université de Provence, Université de la Méditerranée, Case 932, 163 Avenue de Luminy, 13288  
Marseille cedex 9, France.  
b.cobucciponzano@ibp.cnr.it*

Glycosynthases, a class of mutant glycosidases obtained by replacing the active site nucleophile with a non-nucleophilic residue, represent an interesting tool for the chemo-enzymatic synthesis of carbohydrates. These enzymes are completely inactive, but, in the presence of a substrate with good leaving group ability, their activity can be restored. In fact, the small cavity created upon mutation can accommodate a substrate with inverted anomeric configuration when compared with the original substrate (*inverting glycosynthases*)<sup>1,2</sup>, or a small anion (*retaining glycosynthases*)<sup>3</sup>. In both cases, the mutant enzyme promotes the transglycosylation to an acceptor with almost quantitative yields. However, several glycosidases are not prone to function as glycosynthases, the most noticeable examples are retaining alpha-glycosidases. We report here on a new glycosynthetic methodology for the production of alpha-glycosynthases exploiting beta-glycosyl azide derivatives. This approach allowed the production of two inverting alpha-fucosynthases and an alpha-galactosynthase with transglycosylation yields up to 91%<sup>4,5</sup>. The use of azide derivatives opens new perspectives that may be of general application for the production of engineered alpha-glycosidases for the synthesis of oligosaccharides of biotechnological interest.

**References**

1. Mackenzie LF, Wang Q, Warren RAJ, Withers SG, *J. Am. Chem. Soc.*, **1998**, *120*, 5883-5884.
2. Malet C and Planas A, *FEBS Lett.*, **1998**, *440*, 208-212.
3. Moracci M, Trincone A, Perugino G, Ciaramella M, Rossi M, *Biochemistry*, **1998**, *37*, 17262-17270.
4. Cobucci-Ponzano B, Conte F, Bedini E, Corsaro M.M, Parrilli M, Sulzenbacher G, Lipski A, Dal Piaz F, Lepore L, Rossi M, Moracci M, *Chem Biol*, **2009**, *16*, 1097-1108.
5. Cobucci-Ponzano B, Zorzetti C, Strazzulli A, Carillo S, Bedini E, Corsaro MM, Comfort DA, Kelly RM, Rossi M, Moracci M, *Glycobiology*, **2010**, doi:10.1093/glycob/cwq177.

## OL 85

**STRUCTURE AND MECHANISM OF OXIDOREDUCTASES PROVIDING SUGAR PRECURSORS FOR GLYCOSAMINOGLYCAN BIOSYNTHESIS: UDP-GLUCOSE DEHYDROGENASE AND UDP-XYLOSE SYNTHASE**

Nidetzky Bernd<sup>1</sup>, Egger Sigrid<sup>1</sup>, Sykora Sabine<sup>1</sup>, Brecker Lothar<sup>2</sup>, Chaikuad Apirat<sup>3</sup>,  
Kavanagh Kathryn<sup>3</sup>, Oppermann Udo<sup>3</sup>

<sup>1</sup>*Institute of Biotechnology and Biochemical Engineering, Graz University of Technology,  
Petersgasse 12, A-8010 Graz, Austria;*

<sup>2</sup>*Institute of Organic Chemistry, University of Vienna, Währingerstraße 38,  
A-1090 Vienna, Austria;*

<sup>3</sup>*Structural Genomics Consortium, University of Oxford, Oxford OX3 7DQ, UK  
bernd.nidetzky@tugraz.at*

Human extracellular matrix glycosaminoglycans play significant roles in many cellular processes like signaling, morphogenesis and matrix organization. Their biosynthesis requires UDP-glucuronic acid (UDP-GlcA) as precursor. UDP-GlcA is obtained by two-fold NAD<sup>+</sup>-dependent oxidation of UDP-glucose catalyzed by UDP-glucose 6-dehydrogenase (UGDH). UDP-xylose is utilized to initiate glycosaminoglycan attachment to a protein core during proteoglycan formation. UDP-xylose synthase (UXS) is responsible for its production from UDP-GlcA through an oxidoreductive decarboxylation reaction. Crystal structures of the human forms of UGDH and UXS have been determined, and catalytic mechanisms for the two enzymes are proposed using combined evidence from structures, site-directed mutagenesis, and kinetic studies.

Four-electron oxidation of UDP-glucose requires the consecutive activities of alcohol dehydrogenase and aldehyde dehydrogenase, both recruited from a single UGDH catalytic center. Cooperation of active-site residues in UGDH to achieve this complex catalytic task is described. The different chemical steps of the reaction of UGDH must be precisely timed with intermediate physical steps of coenzyme binding and release. Conformational changes at different levels of the enzyme structure have key roles in promoting the overall enzymatic reaction and are directly conducive to catalysis. UXS is a member of the short-chain dehydrogenase/reductase superfamily. Its catalytic mechanism occurs through a three-step cascade whereby NAD<sup>+</sup>-dependent oxidation of the C4 alcohol of UDP-GlcA precedes decarboxylation at C5. The resulting keto-intermediate is reduced stereospecifically to UDP-xylose by the enzyme-bound NADH that was produced in the initial oxidation step. Results of in-situ NMR studies for wild-type and mutated enzymes portray the course of the enzymatic reaction and allow assignment of catalytic function to individual groups in the active site.

## OL 86

FROM ENZYMES TO ARTIFICIAL CATALYSTS:  
ORGANOCATALYTIC SYNTHESIS OF CARBOHYDRATES

Jacek Mlynarski

*Faculty of Chemistry Jagiellonian University, Ingardena 3, Krakow, Poland, and Institute of Organic Chemistry, Polish Academy of Sciences, Kasprzaka 44/52, Warsaw, Poland*  
jacek.mlynarski@gmail.com www.jacekmlynarski.pl

Stereoselective formation of the carbon-carbon bond in nature is assisted by enzymes named lyases, which catalyze the usually reversible addition of carbon nucleophiles to carbonyl groups. Aldolases belong to the group of lyases and have evolved to catalyze the anabolism and catabolism of highly oxygenated metabolites. They are essential for many biosynthetic pathways of carbohydrates, keto acids and some amino acids. It is highly desirable to develop chemical systems that can mimic the action of enzymes and perform organic reaction, particularly aldol addition, with perfect efficiency and stereoselectivity. Following nature's lead, the area of direct asymmetric aldol reaction (also in water) has received much attention in light of perception both of its green chemistry advantages and its analogy to eon-perfected enzyme catalysis.<sup>1,2</sup> Now, when the development of practical and efficient synthetic methodologies reached reasonable level of sophistication the time is ripe for its application to the synthesis of carbohydrate targets.<sup>3</sup>

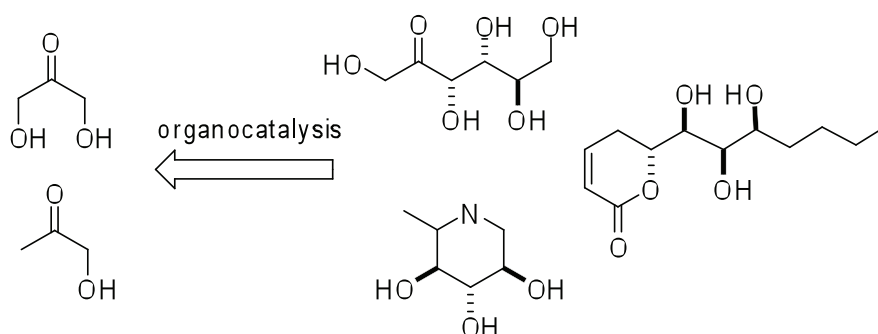

Attempt to the synthesis of polyhydroxylated natural products as well as few ketoaldoses, and iminosugars will be presented by using direct activation of hydroxyacetone and dihydroxyacetone donors.

### References

1. J. Mlynarski, J. Paradowska, *Chem. Soc. Rev.*, **2008**, 37, 1502.
2. J. Paradowska, M. Stodulski, J. Mlynarski, *Angew. Chem. Int. Ed.*, **2009**, 48, 4288.
3. U. Kazmaier, *Angew. Chem. Int. Ed.*, **2005**, 44, 2186.

## OL 87

ENZYMES AS A TOOL FOR THE SYNTHESIS OF  
CARBOHYDRATE DERIVATIVES

Lambertus A.M. van den Broek,<sup>1</sup> Marinella B. van Leeuwen,<sup>1</sup> Ramona Croitoru,<sup>2</sup>  
Carmen G. Boeriu,<sup>1</sup>

<sup>1</sup>Wageningen UR Food & Biobased Research, P.O. Box 17,  
6700 AA Wageningen, The Netherlands,

<sup>2</sup>University "Politehnica" Timisoara, Telbisz Str. 2, Timisoara, Romania  
Ben.vandenbroek@wur.nl

Proteins and polysaccharides have multiple applications in both the food and non-food industries, as thickening, gelling, foaming, and suspending agents, as stabilizer in foams and emulsions and as texturizer. However, limitations exist for both polymers. Cross linking of proteins with carbohydrates will result in a new class of block polymers and may surpass these limitations. The first step in the cross linking procedure is the synthesis of carbohydrate derivatives containing reactive groups. Enzymes can be used in these synthesis reactions because they are in particular highly selective and have a high activity under mild reaction conditions. Another advantage is that they often can be applied in food processes.

In this study a whole range of enzymes, such as lipases, glycoside hydrolases and sucrose phosphorylases, were tested if it was possible to synthesize carbohydrates with phenolic or amino side groups.  $\beta$ -Galactosidase and  $\beta$ -glucosidases, both glycoside hydrolases, were able to add phenolic side groups to glycosides, although the conversion rate was low. *Candida antarctica* lipase B proved to be the most efficient catalyst in transesterification reactions of the primary alcohol with an aliphatic fatty acid ester but also allowed the formation of products with an aromatic ester. For the synthesis of carbohydrate phenyl esters the lipase from *Thermomyces lanuginosus* seems to be the best option due to a broad specificity for the carbohydrate residues and due to a good activity with phenolic esters as acyl reagents. Sucrose phosphorylase from *Leuconostoc mesenteroides* and *Bifidobacterium adolescentis* were able to add a glucose unit at catechin. Different isomers of glucosylated catechin were identified.

In conclusions positive results were obtained using enzymatic synthesis of reactive carbohydrate derivatives bearing either a phenolic or amino side groups.



## OL 88

## ENGINEERING THE THERMOSTABILITY OF SUCROSE PHOSPHORYLASE

Tom Desmet, An Cerdobbel, Karel De Winter and Wim Soetaert

*Centre for Industrial Biotechnology and Biocatalysis, Ghent University, Coupure Links 653,  
B-9000 Ghent, Belgium  
t.desmet@ugent.be*

Sucrose phosphorylase (SP) catalyzes the reversible phosphorolysis of sucrose into  $\alpha$ -D-glucose-1-phosphate and fructose. Thanks to its broad acceptor specificity, however, SP can also be employed for the transfer of glucose to a wide variety of carbohydrates as well as non-carbohydrate molecules.<sup>1</sup> Unfortunately, the commercial exploitation of these glycosylation reactions has been hampered by the low thermostability of the enzyme. We have, therefore, evaluated several engineering strategies to improve the stability of the SP from *Bifidobacterium adolescentis* at the process temperature of 60°C.

By substituting the most flexible residues in SP with amino acids that occur more frequently at the corresponding positions in related sequences, we were able to increase the enzyme's melting temperature by several degrees. A similar result was also obtained after introducing substitutions that promote electrostatic interactions at the protein surface. Combining all of the beneficial mutations in a single enzyme generated a biocatalyst whose half-life at 60°C has doubled compared to the wild-type SP. Furthermore, the enzyme's stability against the presence of organic co-solvents was also markedly enhanced, which should allow the use of SP for the glycosylation of hydrophobic acceptors.

In parallel, immobilization of SP has been performed to improve the enzyme's operational stability. Covalent coupling to a Sepabeads carrier was found to increase the optimal temperature for activity with 7°C,<sup>2</sup> while preparation of a cross-linked enzyme aggregate (CLEA) increases the optimum with an impressive 17°C.<sup>3</sup> More importantly, the CLEA preparation remained fully active for more than one week at 60°C, during which it could be recycled at least ten times for use in repetitive batch conversions. This easy and cheap procedure should allow the cost-efficient application of SP for glycosylation reactions performed at the industrial scale.

### References

1. Goedl C, Sawangwan T, Wildberger P, Nidetzky B, *Biocat Biotransform*, **2010**, 28, 10-21.
2. Cerdobbel A, Desmet T, De Winter K, Maertens J, Soetaert W, *J Biotechnol*, **2010**, 150, 125-130.
3. Cerdobbel A, De Winter K, Desmet T, Soetaert W, *Biotechnol J*, **2010**, 5, 1192-1197.



## OL 89

UNDERSTANDING THE ROLE OF LPTA AND LPTC TWO PROTEINS OF THE LIPOPOLYSACCHARIDE TRANSPORT SYSTEM IN *ESCHERICHIA COLI*

Paola Sperandeo, Riccardo Villa, Alessandra Martorana, Elisa Maccagni  
and Alessandra Polissi

*Dipartimento di Biotecnologie e Bioscienze, Università di Milano-Bicocca,  
Piazza della Scienza 2, 20126, Milano  
alessandra.polissi@unimib.it*

Lipopolysaccharide (LPS) is a major glycolipid present in the outer membrane (OM) of Gram-negative bacteria<sup>1</sup>. The peculiar permeability barrier of the OM is due to the presence of LPS at the outer leaflet of this membrane that prevents many toxic compounds from entering the cell. LPS is essential for growth in most Gram-negative bacteria. In *Escherichia coli* LPS synthesized inside the cell is translocated over the inner membrane (IM) by the essential MsbA flippase, then seven essential Lpt proteins located in the IM (LptBCDF), in the periplasm (LptA) and in the OM (LptDE) are responsible for LPS transport across the periplasm and its assembly at the cell surface<sup>2</sup>. The Lpt proteins form a transenvelope complex spanning IM and OM and genetic data suggest that they operate as a single device. LptA and LptC have been shown to bind LPS *in vitro* with LptA capable to displace LPS from LptC consistent with their proposed placement in a unidirectional export pathway<sup>2,3</sup>.

We demonstrated that LptA and LptC physically interact and form a stable complex. Failure of LptC to interact with LptA results in LptA degradation. By the analysis of loss of function mutations in LptC we predict that the C-terminal region of LptC is implicated in LptA binding. LptA level is also decreased in cells lacking LptDE thus removing the OM LptA docking site. Finally our recent data suggest that LptA form oligomers *in vivo* and that oligomerization protects the protein from degradation. Based on these data, we suggest that the steady-state level of LptA is controlled at the protein stability level by the assembly of the Lpt complex and that the inability of the protein to properly interact with IM and OM docking sites results in its degradation. Therefore, the LptA level could be used as a marker of properly bridged IM and OM components.

Overall, our data strongly support the transenvelope complex model for LPS transport.

**References**

1. Raetz C. R., and C. Whitfield, *Annu.Rev.Biochem.*, **2002**, 71:635-700.
2. Sperandeo P., G. Dehò, and A. Polissi, *Biochim.Biophys.Acta*, **2009**, 1791:594-602.
3. Tran A. X., C. Dong, and C. Whitfield, *J.Biol.Chem.*, **2010**, 285:33529-33539.

## OL 90

**CELL SURFACE GLYCANS ARE INVOLVED IN PROTEIN CARGO SELECTION INTO BACTERIAL VESICLES**

M. Florencia Haurat<sup>a</sup>, Joseph Aduse-Opoku<sup>b</sup>, Kenneth McMahon<sup>a</sup>, Wael Elhenawy<sup>a</sup>,  
Michael A. Curtis<sup>b</sup>, and Mario F. Feldman<sup>a</sup>

<sup>a</sup> *Alberta Ingenuity Centre of Carbohydrate Science, Edmonton, Canada.  
Department of Biological Sciences, University of Alberta, Edmonton, Canada.*

<sup>b</sup> *MRC Molecular Pathogenesis Group, Centre for Infectious Disease,  
Institute of Cell and Molecular Science,*

*Barts & The London Queen Mary's school of Medicine and Dentistry, London, UK.*

<sup>c</sup> *Department of Chemical and Materials Engineering,  
University of Alberta, Edmonton, Canada*

The formation and trafficking of membrane vesicles is an essential process in eukaryotes. These structures are formed to store, traffic, or digest cellular components and virtually all the organelles of the eukaryotic cell, including mitochondria and chloroplasts, are able to form vesicles<sup>1</sup>. In prokaryotes, vesicle formation was reported several decades ago; first in Gram-negative bacteria and recently in Gram-positive bacteria and in archaea. In contrast to the well established multiple cellular roles of membrane vesicles in eukaryotic cell biology, outer membrane vesicles (OMV) produced via blebbing of Gram-negative outer membranes (OM) have frequently been regarded as cell debris or microscopy artifacts. It has only relatively recently been acknowledged that OMV possess multiple functional roles, including response to diverse forms of stress, intra-species communication, long distance virulence factor delivery and contribution to immune system evasion. Although the importance of OMV is now established, it remains to be determined whether OMV result from a directed process or by passive disintegration of the OM as well as the mechanism(s) involved in their biogenesis and secretion.

In our work we have analyzed the OMV produced by the human oral pathogen *Porphyromonas gingivalis*. The most abundant proteins from purified OM and OMV were identified by tandem mass spectrometry. Our results have shown that *P. gingivalis* has a mechanism to selectively sort OM proteins into OMV. This process results in the preferential packaging of gingipains, a group of proteases that constitute a major virulence factor of *P. gingivalis*, and in the exclusion of abundant OM proteins from the protein cargo. OM and OMV were not only differing in the protein composition but also in distribution of the LPS. The OMV were enriched in LPS molecules containing long O antigen chains and deacylated lipid A structures. Furthermore, we have shown that mutations affecting the synthesis of LPS result in aberrant protein sorting into the OMV. These results assigned a critical role for the LPS in directing the protein sorting mechanism, reminiscent to the role of galectin in eukaryotes endosomal vesicles formation. We have explored if this process also takes place in other bacteria like *Salmonella typhimurium* and *Serratia marcescens* and the results of these experiments will be discussed. The existence of a process to package specific virulence factors into OMV may significantly alter our current understanding of host-pathogen interactions.

## OL 91

**CHARACTERIZATION OF BACTERIAL UDP-GLUCOSE:  
UNDECAPRENYL-PHOSPHATE GLUCOSE-1-PHOSPHATE TRANSFERASES  
INVOLVED IN EXOPOLYSACCHARIDE BIOSYNTHESIS**Kinnari B. Patel<sup>1</sup>, and Miguel A. Valvano<sup>1,2\*</sup>

<sup>1</sup>Departments of Microbiology and Immunology, and <sup>2</sup>Medicine, University of Western Ontario,  
London, Ontario, Canada N6A 5C1

*Escherichia coli* K-12 WcaJ and *Caulobacter crescentus* HfsE, PssY and PssZ proteins are predicted to initiate the synthesis of colanic acid (CA) and holdfast polysaccharide, respectively. These proteins belong to a large prokaryotic family of membrane enzymes that catalyze the formation of a phosphoanhydride bond joining a hexose-1-phosphate with undecaprenyl phosphate (Und-P). Previous work on the structure of CA suggested that WcaJ transfers glucose-1-phosphate to Und-P, while microscopy and polystyrene adherence assays in *C. crescentus* demonstrated that HfsE, PssY and PssZ are required for holdfast production. However, the sugar specificity of the *C. crescentus* proteins was not established, as a complete structural characterization of the holdfast polysaccharide is not available. Here we investigated the enzymatic function of these proteins and demonstrate the requirement of WcaJ for CA production in *E. coli* K12. Through *in vivo* complementation assays, we also demonstrate that overexpression of WcaJ, PssY or RcsA, a positive transcriptional regulator of CA, in an O antigen deficient strain of *S. enterica* Typhimurium results in the attachment of CA to lipid A-core. *In vitro* transferase assays conclusively demonstrate that both WcaJ and PssY utilize UDP-glucose, while the function of HfsE and PssZ remains to be elucidated.

## OL 92

## SYNTHESIS OF GLYCOCONJUGATES FROM BACTERIA FOR REGULATION OF IMMUNE SYSTEM

Yukari Fujimoto, Atsushi Shimoyama, Akinori Saeki, Yasunori Kajiki, Koichi Fukase

*Department of Chemistry, Graduate School of Science, Osaka University, Machikaneyama, Toyonaka, Osaka, 560-0043, Japan*  
*yukarif@chem.sci.osaka-u.ac.jp*

Innate immune system is essential for the host defense, and is activated with microbial components such as bacterial cell wall peptidoglycan (PGN; Nod1, and Nod2 ligands), lipopolysaccharide (LPS; TLR4/MD-2 ligand), lipoprotein/peptide (LP; TLR2 ligand), and etc. Recent results suggested that the regulation of these receptors do not only stimulate/regulate the host's protecting system, but also affect on the developing of immune system in early childhood, or inducing chronic inflammation.

We have developed synthetic methods to obtain these bacterial immunostimulatory glycoconjugates, and also analyzed the biological functions.<sup>1</sup> One of these glycoconjugates is lipophilic terminal structure of LPS (incl. lipid A) of Gram-negative bacteria. In the case of lipid A from *Helicobacter pylori*, we synthesized various kinds of lipid A structures, i.e., tri-acylated lipid A and Kdo-lipid A, with or without the ethanolamine group at the 1-phosphate via a new divergent synthetic route.<sup>2</sup> Stereoselective  $\alpha$ -glycosylation of Kdo *N*-phenyltrifluoroacetimidate was effected by using microfluidic methods. None of the lipid A and Kdo-lipid A structures were not strong inducers of IL-1b, IL-6, and IL-8 in human peripheral blood cells (HPBC), suggesting that *H. pylori* LPS is unable to induce acute inflammation. On the other hand, these *H. pylori* LPS partial structures showed potent IL-18 and IL-12 inducing activity. Since IL-18 has been shown to correlate with chronic inflammation, *H. pylori* LPS may be implicated in the chronic inflammatory responses induced by *H. pylori*. We also developed other immune regulatory compounds from our library of synthesized bacterial glycoconjugates.

**References**

1. a) PGN: Y. Fujimoto, K. Fukase, *J. Nat. Prod.* **2011**, *in press*. b) LP: Y. Fujimoto, M. Hashimoto, M. Furuyashiki, M. Katsumoto, T. Seya, Y. Suda, K. Fukase, *ChemBioChem*, **2009**, *10*, 2311-2315.
2. A. Shimoyama, A. Saeki, N. Tanimura, H. Tsutsui, K. Miyake, Y. Suda, Y. Fujimoto, K. Fukase, **2011**, *submitted*.

## OL 93

STRUCTURAL STUDIES ON THE LIPOPOLYSACCHARIDES OF TWO SPECIES OF  
*PSYCHROBACTER*

Anna N. Kondakova,<sup>1</sup> Kseniya A. Novototskaya-Vlasova,<sup>2</sup> Sof'ya N. Senchenkova,<sup>1</sup>  
Alexander S. Shashkov,<sup>1</sup> Marina S. Drutskaya,<sup>3,4</sup> David A. Gilichinsky,<sup>2</sup>  
Sergei A. Nedospasov<sup>3,4</sup>, and Yuriy A. Knirel<sup>1</sup>

<sup>1</sup>N.D. Zelinsky Institute of Organic Chemistry RAS, 119991 Moscow, Russian Federation,

<sup>2</sup>Institute for Physicochemical and Biological Problems in Soil Science RAS,  
142290 Pushchino, Russian Federation,

<sup>3</sup>Engelhardt Institute of Molecular Biology RAS, 119991 Moscow, Russian Federation;

<sup>4</sup>Moscow State University, 119991 Moscow, Russian Federation;

annakond@gmail.com

The genus *Psychrobacter* belongs to the family Moraxellaceae of the order Pseudomonadales of gammaproteobacteria. The bacteria live in extremely cold habitats, such as Antarctic ice, soil, and sediments, as well as in deep sea environments. No data on lipopolysaccharide (LPS) of this genus are available. In this work, we analyzed the LPSs of two *Psychrobacter* species: *P. muriicolla* (strain 2pS) and *P. maritimus* (strain 3pS) isolated from a ~110 thousand-year-old lenses of overcooled (-10 °C) water brines within Siberian permafrost sediments.

Each LPS was cleaved by mild acid hydrolysis to yield an O-polysaccharide (O-antigen) and lipid A. The following structures of the O-polysaccharides were established by chemical methods and one- and two-dimensional <sup>1</sup>H and <sup>13</sup>C NMR spectroscopy:

*P. muriicolla* 2pS

→4)-α-L-GulpNAcA6Gly-(1→3)-β-D-GlcpNAc-(1→

*P. maritimus* 3pS

→2)-α-Rhap-(1→4)-α-GalpNAcA-(1→3)-α-QuipNAc4NHb-(1→3)-β-QuipNAc4NHb-(1→  
where L-GulNAcA6Gly stands for N-(2-acetamido-2-deoxy-L-guluronoyl)glycine and QuipNAc4NHb for 2-acetamido-4-(3-hydroxybutanoylamino)-2,4,6-trideoxyglucose. To the best of our knowledge, L-GulNAcA6Gly has not been hitherto found in nature.

Mass-spectrometric analysis showed that lipid A from both strains possesses a bisphosphorylated diglucosamine backbone, which is acylated with shorter-chain fatty acids as compared to lipid A of enterobacteria. The predominant structural variant is a hexaacyl lipid A with four primary 3-hydroxy-lauroyl groups and two secondary decanoyl groups.

## OL 94

 **$\beta$ -(1,3)-(THIO)GLUCANS AND THEIR INTERACTIONS WITH RECOMBINANT HUMAN RECEPTORS USING HIGH-RESOLUTION NMR STUDIES**

Vincent Ferrières,<sup>1,2</sup> Balla Sylla, Richard Daniellou,<sup>1,2</sup> Laurent Legentil,<sup>1,2</sup>  
Caroline Nugier-Chauvin,<sup>1,2</sup> Vaclav Vetvicka<sup>3</sup>

<sup>1,2</sup>*Ecole Nationale Supérieure de Chimie de Rennes, CNRS, UMR 6226, Avenue du Général  
Leclerc, CS 50837, 35708 Rennes Cedex 7, France, Université européenne de Bretagne,*

<sup>3</sup>*Department of Pathology, University of Louisville, 511 S. Floyd Street, MDR Building, Louisville,  
KY 40202, USA*

*vincent.ferrieres@ensc-rennes.fr*

$\beta$ -(1 $\rightarrow$ 3)-Glucans<sup>1,2</sup> are probably amongst the most fascinating biomolecules in the world of glycosciences, as evidenced by the tremendous number of publications since the discovery of their biological properties in the sixteens. All the potential applications relate with the fact that  $\beta$ -(1 $\rightarrow$ 3)-glucans are likely to enhance the immune system of mammals, which are not able to biosynthesize nor metabolize these polymers, for instance against some bacteria, yeast, fungi, and viral pathogens.<sup>3-6</sup> Despite these apparent advances,  $\beta$ -(1 $\rightarrow$ 3)-glucans unfortunately suffer from inherent drawbacks: a small chemical purity (great polydispersity), a variability of the production sets, many branching differences. Reading data from literature, it is however very difficult to ascertain the biological pathways that are used by very small oligosaccharides and the receptors with whom they interact.

To increase our understandings in that tremendous field, we first designed new well-defined small oligo-thioglucons to increase stability and substrate/receptors interactions, and have demonstrated that a very short trisaccharide is able to stimulate the immune system in murin model. In a second part, a full characterization of the high-resolution NMR spectrum of the laminarihexaose was performed and used for the determination of the binding epitope of the more complex but structurally related laminarin. These biophysical data extend the current knowledge of  $\beta$ -glucans / Dectin-1<sup>7,8</sup> interactions and suggest different biological mechanisms in close relation with the size of the saccharidic chain.

**References**

1. Barsanti, Passarelli, Evangelista, Frassanito, Gualtieri, *Nat. Prod. Rep.* **2011**, DOI: 10.1039/c0np00018c.
2. Descroix, Ferrières, Jamois, Yvin, Plusquellec, *Mini-Rev. Med. Chem.* **2006**, 6, 1341-1349.
3. Vetvicka, Vetvickova, *JANA* **2007**, 10, 25-31.
4. Weitberg, *J. Exp. Clin. Cancer Res.* **2008**, 27, 40.
5. Cheung, Modak, Vickers, Knuckles, *Cancer Immunol. Immunother.* **2002**, 51, 557-564.
6. Allendorf, Jun, Ross, Hansen, Baran, Subbarao, Wang, Haribabu, *J. Immunol.* **2005**, 174, 7050-7056.
7. Brown, Gordon, *Nature* **2001**, 413, 36-37.
8. Mukhopadhyay, Gordon, *Immunobiol.* **2004**, 209, 39-49.



## OL 95

AROMATIC INTERACTIONS AT THE CATALYTIC SUBSITE  
OF SUCROSE PHOSPHORYLASE: ANALYSIS OF THEIR ROLE IN  
ENZYMATIC GLUCOSYL TRANSFER

Wildberger Patricia<sup>1</sup>, Luley-Goedl Christiane<sup>1</sup>, Nidetzky Bernd<sup>1</sup>

<sup>1</sup> *Institute of Biotechnology and Biochemical Engineering, Graz University of Technology,  
Petersgasse 12/1, A-8010 Graz  
patricia.wildberger@tugraz.at*

Recognition of carbohydrates by proteins often involves  $\pi$ -interactions from aromatic side chains of Phe, Tyr and Trp, whereby the  $\pi$ -electron cloud of the aromatic ring interacts with the aliphatic protons of the sugar ring. These carbohydrate- $\pi$  interactions are widely utilized by sugar processing enzymes, such as glycoside hydrolases and glycosyltransferases. Members from the glycoside hydrolase family 13 contain a special aromatic motif where a highly conserved Phe/Tyr is positioned at the B-face of the glucopyranosyl ring bound in the catalytic subsite. Sucrose phosphorylase (SPase; EC 2.4.1.7) is a bacterial transglucosidase from the GH 13 family that catalyzes the reversible conversion of sucrose ( $\alpha$ -D-glucopyranosyl-1,2- $\beta$ -D-fructofuranoside) and phosphate into D-fructose and  $\alpha$ -D-glucose-1-phosphate. Using site-directed mutagenesis Phe<sup>52</sup> of SPase was replaced by alanine (F52A) and asparagine (F52N) to probe the role of aromatic stacking in the catalytic reaction. The resulting mutants were characterized by free energy profile analysis for catalytic glucosyl transfer from sucrose to phosphate that occurs in two steps via a  $\beta$ -glucosyl enzyme intermediate. Despite large destabilization ( $\geq 3.5$  kcal/mol) of the transition states for enzyme glucosylation and deglucosylation in both mutants as compared to wild-type, the relative stability of the covalent intermediate was not (F52A) or only weakly ( $\approx 1.6$  kcal/mol; F52N) affected by substitution of Phe<sup>52</sup>. In reverse reaction where fructose becomes glucosylated from  $\beta$ -D-glucopyranosyl phosphate, “error hydrolysis” was the preponderant path of breakdown of the covalent intermediate of F52A and F52N. Thus, aromatic interactions from Phe<sup>52</sup> facilitate enzymatic catalysis of reversible phosphorolysis of sucrose in two different ways. Firstly, Phe<sup>52</sup> is selective for transition state stabilization via cation- $\pi$  interactions and secondly, Phe<sup>52</sup> is required for precise positioning of the transferred glucosyl moiety at the catalytic subsite.

**References**

1. Wildberger, Luley-Goedl, Nidetzky, *FEBS Letters*, **2011**, 585, 499-504.



## OL 96

MULTIVALENT GLYCODERIVATIVES AS POTENTIAL INHIBITORS  
FOR INFLUENZA LECTIN HAEMAGGLUTININ H5

Moritz Waldmann<sup>1</sup> and Bernd Meyer<sup>1</sup>

<sup>1</sup>*University of Hamburg, 20146 Hamburg, Germany*  
*moritz.waldmann@chemie.uni-hamburg.de*

Carbohydrate recognizing proteins play a key role in many biological processes. Multivalent effects are ubiquitous in nature and are employed to overcome the generally weak carbohydrate-protein interactions<sup>[1]</sup>. Therefore well defined multivalent glycoconjugates represent a valuable tool for the investigation of carbohydrate-lectin interactions.

Here we want to report the structure based design, synthesis and analysis of a polyvalent ligand for the haemagglutinin of the avian influenza H5 as a novel potential lead structure for an effective and highly specific entry inhibitor.

Based on the H5 crystal structures published 2001 by Wiley et al.<sup>[2]</sup> (PDB: 1J5O) and 2006 by Kawaoka et al.<sup>[3]</sup> (PDB: 2IBX) molecular modeling studies were performed. Different structures were modeled and analyzed by *in silico* binding studies. The ligand with the highest *in silico* affinity for the HA was a trimeric molecule with a rigid anchor and a peptidic linker terminated by the sialic acid derivative for the attachment. The synthesis was performed by a convergent strategy and the building blocks were coupled by active ester strategy with HATU to give a trimeric ligand. The *in vitro* potency of the ligand will be tested by STD-NMR-spectroscopy<sup>[4]</sup> and SPR-spectrometry. Synthesis and analysis of a small library of derivatives with variable chain length will provide precious information about the nature and the grade of the polyvalent interaction.

### References

1. P. I. Kitov, D. R. Bundle, *J. Am. Chem. Soc.*, 2003, 125, 16271-16284.
2. Y. Ha, D. J. Stevens, J. J. Skehel, D. C. Wiley, *Proc. Natl. Acad. Sci.*, 2001, 98, 11181-11186.
3. S. Yamada, Y. Suzuki, T. Suzuki, M. Q. Le, C. A. Nidom et al., *Nature*, 2006, 444, 378-382.
4. M. Mayer, B. Meyer, *Angew. Chem. Int. Ed.*, 1999, 38, 1784-1788.

## OL 97

**HYBRID GANGLIOSIDES FOR THE DETECTION OF ANTI-GANGLIOSIDE COMPLEX ANTIBODIES**

Laura Mauri,<sup>1</sup> Riccardo Casellato,<sup>1</sup> Maria G. Ciampa,<sup>1</sup> Ken-ichi Kaida,<sup>2</sup> Mayumi Motoyama,<sup>3</sup> Susumu Kusunoki,<sup>3</sup> and Sandro Sonnino<sup>1</sup>

<sup>1</sup> *Department of Medical Chemistry, Biochemistry and Biotechnology, University of Milan, Via F.lli Cervi 93, 20090 Segrate, Italy,*

<sup>2</sup> *Division of Neurology, Internal medicine 3 National Defense Medical College, Saitama 359-8513, Japan,*

<sup>3</sup> *Department of Neurology, Kinki University School of Medicine 377-2 Ohno-Higashi, Osaka-Sayama, Osaka 589-8511, Japan*  
*laura.mauri@unimi.it*

Gangliosides are glycosphingolipids that are concentrated in the outer leaflet of neuronal membranes with exposure of their oligosaccharides on the cell surface<sup>1</sup>. Guillain-Barre' syndrome (GBS) is acute autoimmune neuropathy, often subsequent to an infection. Antiganglioside antibodies are often closely associated with clinical phenotype and specific symptoms of GBS. Recent studies demonstrated that some GBS patients had serum antibodies that specifically recognize the novel glycoepitopes formed by two individual ganglioside molecules and named such antibodies as 'anti-ganglioside complex (GSC) antibodies'. Those antibodies can be used as diagnostic markers of GBS. Conventional measurement of antiganglioside antibodies has been done for purified single ganglioside antigens using enzyme-linked immunosorbent assays (ELISAs) or thin-layer chromatogram (TLC)-immunostaining.<sup>2-4</sup>

The availability of several hybrid gangliosides, containing two or more oligosaccharide chains and the availability of simple analytical approaches opens new perspectives for the understanding and therapy of several neuropathies. For this purpose we prepared the dimeric hybrid GM1-GD1a ganglioside derivative that contains two structural different oligosaccharide chains. A mixture of the two natural gangliosides was described to be recognized by the sera from patients with specific and clinical characterized GBS. We prepared the GM1-GM1 and GD1a-GD1a dimers to be used as controls. After removal of the acyls and reconstitution of the original acetylated sugars, the lyso-gangliosides, were connected with adipic acid to form the hybrid compound, a same-how mimic of the heterogeneous plasma membrane cluster of gangliosides. The dimeric hybrid GM1-GD1a was very well recognized by the GBS serum. However no reactivity was observed with the patient serum and the dimeric GM1 and dimeric GD1a. This suggests that both the GM1 and GD1a chain are necessary for a strong interaction and to maintain stable the antibody-antigen complex.

**References**

1. S. Hakomori, *Glycoconj. J.*, **2000**, *17*, 143–151
2. K. Kaida, S. Kusunoki, *J. Neuroim.*, **2010**, *223*, 5–12
3. S. Kusunoki, K. Kaida, *J. Neurochem.*, **2011**, 10.1111/j.1471-4159.2010.07029
4. H. J. Willison, N. Yuki, *Brain*, **2002**, *125*, 2591-2625

## OL 98

## SIALIC ACID DERIVATIVES TARGETTING THE OPEN '150-LOOP' FORM OF GROUP-1 INFLUENZA A VIRUS SIALIDASES

Santosh Rudrawar,<sup>1</sup> Jeffrey C. Dyason,<sup>1</sup> Marie-Anne Rameix-Welti,<sup>2</sup> Faith J. Rose,<sup>1</sup> Philip S. Kerry,<sup>3</sup> Rupert J.M. Russell,<sup>3</sup> Sylvie van der Werf,<sup>2</sup> Robin J. Thomson,<sup>1</sup> Nadia Naffakh<sup>2</sup> and Mark von Itzstein<sup>1</sup>

<sup>1</sup>*Institute for Glycomics, Gold Coast Campus, Griffith University, Queensland 4222, Australia.*

<sup>2</sup>*Institut Pasteur, Unité de Génétique Moléculaire des Virus à ARN, Département de Virologie, Paris F-75015, France.*

<sup>3</sup>*Interdisciplinary Centre for Human and Avian Influenza Research, University of St Andrews, North Haugh, St Andrews, Fife KY16 9ST, UK.  
m.vonitzstein@griffith.edu.au; s.rudrawar@griffith.edu.au*

The sialidase (neuraminidase, NA) of influenza virus plays a major role in the virus' life cycle by facilitating release of virus progeny from the infected host cell.<sup>1</sup> The enzyme has been successfully targetted in the development of anti-influenza therapeutics,<sup>2</sup> with the potent and selective influenza NA inhibitors zanamivir **1** (Relenza™) and oseltamivir carboxylate **2** (Tamiflu™) currently on the market for treatment of influenza virus infection. However, the emergence of seasonal and pandemic influenza A H1N1 and avian H5N1 ('bird flu') viruses resistant to the most widely used drug Tamiflu,<sup>3</sup> underscores the need for the development of next-generation anti-influenza drugs.

Influenza A virus NAs can be divided phylogenetically into two groups, with recent structural studies<sup>4</sup> showing that the two groups differ in the flexibility of the so-called '150-loop'. As a result of apparently greater flexibility in the 150-loop, group-1 NAs (including N1) present a more open active site architecture in the *apo* form compared to group-2 enzymes (including N2). This newly observed structural feature provides opportunities for new directions in anti-influenza drug design. Using a multidisciplinary approach, we have developed novel sialic acid derivatives of type **3**, which bind the open 150-loop form of group-1 NAs, and show selectivity in inhibition of N1 compared to N2 NA.<sup>5</sup> This presentation will describe the design and development of this new class of influenza virus NA inhibitor.

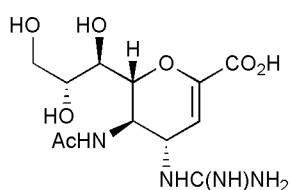
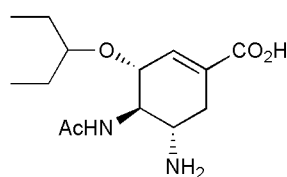
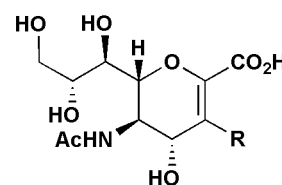
zanamivir **1**oseltamivir carboxylate **2**C3-substituted Neu5Ac2en **3**

## References

1. Wagner, R.; Matrosovich, M.; Klenk, H.-D. *Rev. Med. Virol.* **2002**, *12*, 159-166.
2. von Itzstein, M. *Nat. Rev. Drug Discov.* **2007**, *6*, 967-974.
3. Okomo-Adhiambo, M.; Nguyen, H.T.; Sleeman, K.; *et al.* *Antiviral Res.* **2010**, *85*, 381-388.
4. Russell, R.J.; Haire, L.F.; Stevens, D.J.; Collins, P.J.; *et al.* *Nature* **2006**, *443*, 45-49.
5. Rudrawar, S.; Dyason, J.C.; Rameix-Welti, M.-A.; *et al.* *Nat. Commun.* **2010**, *1*:113 doi: 10.1038/ncomms1114.

## OL 99

**THIOL-CLICK CHEMISTRY APPROACH (TEMA) TO GLYCOMIMETICS.  
SYNTHESIS OF NEW INHIBITORS OF GALECTIN-3**

Zbigniew J. Witczak, Arthur Jankowski, Nguyen Nguyen

*Department of Pharmaceutical Sciences, Nesbitt School of Pharmacy, Wilkes University,  
Wilkes-Barre, PA 18766, USA  
zbignew.witczak@wilkes.edu*

During the last decade, Sharpless concept of click chemistry was transplanted to carbohydrate chemistry<sup>1-3</sup>. While, the original alkyne-azide concept of click-chemistry is well known, the alternative thiol-click is relatively unexplored. Recently, we have developed one-pot, **Thiol Enone Michael Addition (TEMA)** click procedure for the synthesis of new family of (1-5)-C-thiodisaccharides<sup>4</sup>. Starting templates for the specifically developed TEMO thiol-click approach were new reactive enones **3** and **4** conveniently prepared in our laboratory.

Enones **3** & **4** undergoes base catalyzed Michael additions with D-galactose 1-thiol **5** via one step thiol-click approach. The exclusive regio- and stereochemistry of the Michael addition reaction proceeds with the formation of 1, 4-adducts **6-7** in high yields. These adducts upon the conventional borohydride reductions, affords free amines in good yields. The conventional functionalization of amines with protected amino acids produced the first representatives of new family of non-hydrolysable glycosyl thiocarbamino peptides **8-9** and **10-11**. They will be used as new tools for glycobiology and specifically as new inhibitors of **galectin-3**.<sup>5</sup> The inhibition data of these thiosugars will be discussed in details.

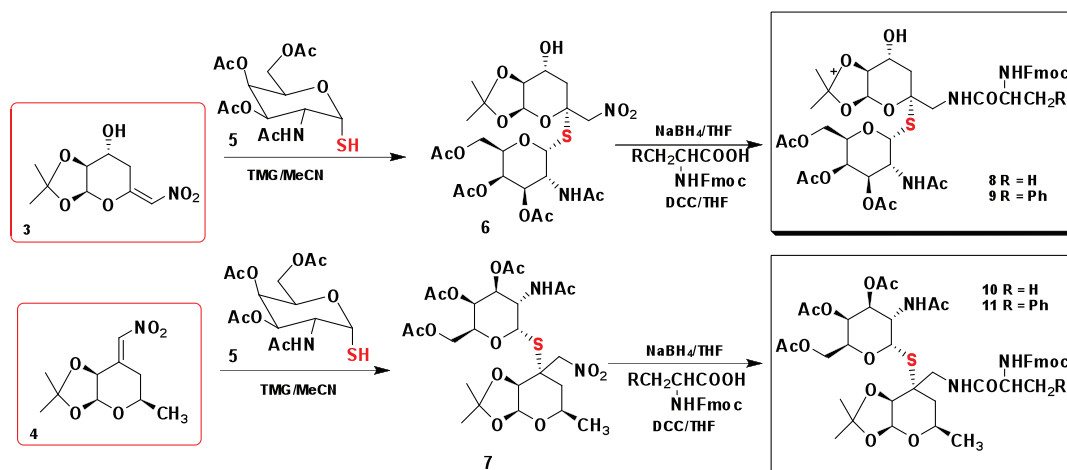

## References

1. Click Chemistry Approaches in Carbohydrate Chemistry ACS Symposium, Anaheim CA, March 28, 2011
2. M. Fiore, A. Mara, and A. Dondoni, *J. Org.Chem.*, **2009**, 74, 4422-4425.
3. S. G. Gouin, L. Bultel, C. Falentin and J. Kovensky, *Eur. J. Org. Chem.* **2007**, 1160-1162.
4. Z. J. Witczak, D. Lorchak and N. Nguyen, *Carbohydr. Res.*, **2007**, **342**, 1929-1931.
5. Galectins, J. Wiley & Sons, NY, **2008**. A. Klyosov, Z. J. Witczak, D. Platt, Editors.

## OL 100

**THEORETICAL INVESTIGATION OF THE CARBOHYDRATE  
CH/ $\pi$  INTERACTIONS FAVOURABLE REGIONS IN THE CARBOHYDRATE  
SURROUNDINGS**

Stanislav Kozmon,<sup>1,2</sup> Radek Matuška,<sup>2</sup> Vojtěch Spiwok,<sup>3</sup> Jaroslav Koča<sup>1,2</sup>

<sup>1</sup> *Central European Institute of Technology (CEITEC),*

<sup>2</sup> *Faculty of Science - National Centre for Biomolecular Research, Masaryk University,  
Kamenice 5, 625 00 Brno, Czech Republic,*

<sup>3</sup> *Institute of Chemical Technology, Department of Biochemistry & Microbiology, Technická 5  
Prague 166 28, Czech Republic  
stano@chemi.muni.cz*

Molecular recognition of carbohydrates by proteins plays a key role in many biological processes including immune response, pathogen entry into a cell, cell-cell adhesion and so forth<sup>1-5</sup>. Recent studies show that key role in protein - saccharide recognition may play dispersive interactions, such as CH/ $\pi$  interactions of aromatic amino acids with non polar faces of carbohydrates.

In this study we present the first systematic computational three-dimensional scan of carbohydrate hydrophobic patches for the ability to interact via CH/ $\pi$  dispersion interactions. The carbohydrates  $\beta$ -D-glucopyranose,  $\beta$ -D-mannopyranose and  $\alpha$ -L-fucopyranose were studied in a complex with a benzene molecule, which served as a model of the CH/ $\pi$  interaction in carbohydrate/protein complexes. The 3D relaxed scans were performed at the SCC-DFTB-D level with 3 757 grid points for both carbohydrate hydrophobic sides. The interaction energy of all grid points was recalculated at the DFT-D BP/def2-TZVPP level. The results obtained clearly show highly delimited and separated areas around each CH group, with interaction energy up to the -5.40 kcal/mol. Identified most stable complexes were optimized at the DFT-D BP/def2-TZVPP level and the interaction energies of these complexes were refined by use of the high level *ab initio* computation at the CCSD(T)/CBS level.<sup>6</sup>

**Acknowledgment** This work was funded by the European Community's Seventh Framework Programme under grant agreement n° 205872, the Ministry of Education of the Czech Republic (MSM0021622413, LC06030, MSM6046137305), Czech Science Foundation (GD301/09/H004). The authors would like thank the Czech National Supercomputer Centre, METACENTRUM, for the support of computational power. Access to the MetaCentrum computing facilities provided under the research intent MSM6383917201 is acknowledged.

**References**

1. Ambrosi, M.; Cameron, N. R.; Davis, B. G. *Organic & Biomolecular Chemistry* **2005**, *3*, 1593-1608.
2. Gabius, H. J.; Siebert, H. C.; Andre, S.; Jimenez-Barbero, J.; Rudiger, H. *ChemBioChem* **2004**, *5*, 741-764.
3. Holgersson, J.; Gustafsson, A.; Breimer, M. E. *Immunol. Cell Biol.* **2005**, *83*, 694-708.
4. Lis, H.; Sharon, N. *Chem. Rev.* **1998**, *98*, 637-674.
5. Sharon, N.; Lis, H. *Glycobiology* **2004**, *14*, 53r-62r.
6. Kozmon, S.; Matuska, R.; Spiwok, V.; Koca, J. *Chemistry-a European Journal* **2011**, *in press*.



## OL 101

ATOMIC FORCE MICROSCOPIC VIEW  
INTO THE BINDING OF BACTERIA TO THE HUMAN GLYCOCALYX

Mirja Hartmann,<sup>1</sup> Thomas Gutschmann,<sup>2</sup> and Thisbe K. Lindhorst<sup>1</sup>

<sup>1</sup>*Otto Diels Institute of Organic Chemistry, Christiana Albertina University of Kiel,  
Otto-Hahn-Platz 4, D-24098 Kiel*

<sup>2</sup>*Research Center Borstel, Division of Biophysics, Parkallee 10, D-23845 Borstel  
mhartmann@oc.uni-kiel.de*

Bacterial colonization of human tissue is an important public health issue. Uropathogenic strains of *Escherichia coli* (*E. coli*) bacteria cause the greatest part of all urinary tract infections.

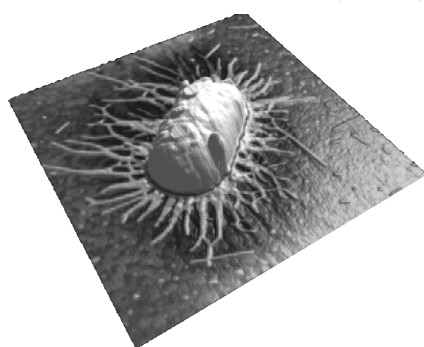

AFM image of a live  
5  $\mu\text{m}$  long *E. coli* cell, immobilized  
on polystyrene.

Initiating the contact to their host, *E. coli* bind to carbohydrate residues of the glycocalyx on the mammalian cell surface. This adhesion is mediated by FimH, a lectin on the distal tip of bacterial type 1 fimbriae. This binding event has been studied recently in adhesion inhibition experiments<sup>1</sup> and with isolated parts of the fimbriae<sup>2</sup> and the isolated lectin FimH.<sup>3</sup> We now performed AFM measurements with covalently carbohydrate-functionalized cantilever tips and live *E. coli* bacteria in buffer solution. With this set-up it was possible to investigate the influence of the sugar specificity, the glycosidic linkage, and the rupture force on glycoside-FimH interactions in the native protein environment.

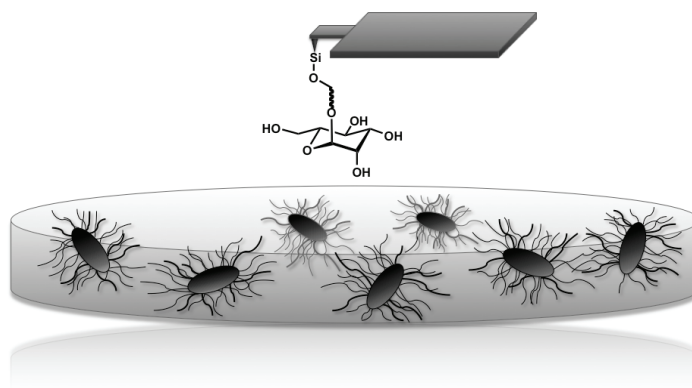

### References

1. M. Hartmann, A. K. Horst, P. Klemm, T. K. Lindhorst, *Chem. Commun.* **2010**, 46, 330–332.
2. I. Le Trong, P. Aprikian, B. A. Kidd, M. Forero-Shelton, V. Tchesnokova, P. Rajagopal, V. Rodriguez, G. Interlandi, R. Klevit, V. Vogel, R. E. Stenkamp, E. V. Sokurenko, W. E. Thomas, *Cell* **2010**, 141, 645–655.
3. Z. Han, J. S. Pinkner, B. Ford, R. Obermann, W. Nolan, S. A. Wildman, D. Hobbs, T. Ellenberger, C. K. Cusumano, S. J. Hultgren, J. W. Janetka, *J. Med. Chem.* **2010**, 53, 4779–4792.

## OL 102

COMPREHENSIVE STUDY TOWARDS THE SYNTHESIS OF  
AZIDE-CONTAINING MANNURONATES

Marthe T. C. Walvoort, Gert-Jan Moggré, Herman S. Overkleeft, Jeroen D. C. Codée,  
Gijsbert A. van der Marel

*Department of Bio-Organic Synthesis, Leiden Institute of Chemistry, Leiden University  
Einsteinweg 55, 2333 CC Leiden, The Netherlands  
m.t.c.walvoort@chem.leidenuniv.nl*

*N*-Acetyl mannuronic acid (ManNAcA) and 2,3-di-*N*-acetyl mannuronic acid (Man2,3diNAcA) are constituents of acidic polysaccharides found on the cell wall of various bacteria. In these polymers the mannuronic acids are primarily  $\beta$ -1,3 and  $\beta$ -1,4 linked. To construct such complex oligosaccharides efficiently, a comprehensive survey of the possible donor building blocks is essential.<sup>1</sup>

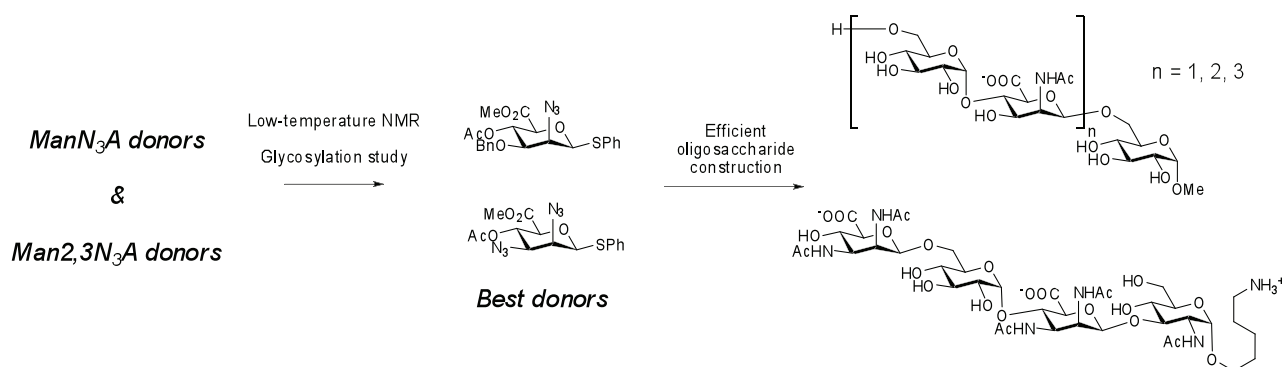

A variety of donors equipped with different anomeric leaving groups are pre-activated and the resulting intermediates are detected by low-temperature NMR spectroscopy.<sup>2</sup> Large differences were observed between  $\alpha$ - and  $\beta$ -fused donors and between anomeric moieties. A selection of suitable donors was explored for their  $\beta$ -stereoselective properties with different acceptors. The most suited donors were used in the efficient construction of natural anionic oligosaccharides. This communication will clarify the need for a thorough study of the glycosylating properties of the donor glycosides when challenging carbohydrate moieties like ManNAcA and Man2,3diNAcA are the building blocks of interest.

## References

- Walvoort, M. T. C.; Lodder, G.; Overkleeft, H. S.; Codée, J. D. C.; van der Marel, G. A. *J. Org. Chem.* **2010**, *75*, 7990-8002.
- Low-temperature NMR spectroscopy of activated intermediates has been described before, see for example: a) Crich, D.; Sun, S. X. *J. Am. Chem. Soc.* **1997**, *119*, 11217-11223; b) Garcia, B. A.; Gin, D. Y. *J. Am. Chem. Soc.* **2000**, *122*, 4269-4279; c) Walvoort, M. T. C.; Lodder, G.; Mazurek, J.; Overkleeft, H. S.; Codée, J. D. C.; van der Marel, G. A. *J. Am. Chem. Soc.* **2009**, *131*, 12080-12081.



## OL 103

## AN EXAMINATION OF IMMOBILIZATION OF REDUCING SUGARS USED IN SPR DETECTORS

Thygesen, M. B.; Sauer, J.; Abou-Hachem, M.; Svensson, B.; Jensen, K. J.

<sup>1</sup>*IGM-Nanobioscience, Faculty of Life Sciences, University of Copenhagen, Denmark;*

<sup>2</sup>*Department of Systems Biology, Enzyme and Protein Chemistry,  
Technical University of Denmark*

Solid-phase chemical tools for studying carbohydrate-protein interactions are in increasingly high demand and Surface Plasmon Resonance (SPR) based detectors show great potential for label-free analysis within the fields of glycobiology and glycomics. We have previously developed a general and flexible method for bio-compatible functionalization of gold nanoparticles based on bifunctional PEG linkers. Using this system we were able to study protein binding, carbohydrate processing and self-assembly of carbohydrate-encapsulated nanoparticles.<sup>[1]</sup>

Here we demonstrate how this chemistry can be applied to a BiaCore™ type instrument as a general method for functionalization of chips with carbohydrates. The method relies on a bifunctional PEG-linker containing a mercapto group in one end and a free aminoxy group at the other. The resulting linker layer potentially allows on-line immobilization of any reducing sugar that is passed over the chip. Aniline catalysis of carbohydrate oxime formation, which we recently reported,<sup>[2]</sup> proved advantageous also here. The feasibility of the method is demonstrated using the inhibitor Acarbose and variants of the enzyme glucoamylase from *Aspergillus niger* that are modified in the binding properties by mutations in those sub-sites that are known to be in contact with this pseudo-tetrasaccharide. We examine the efficiency of chemoselective anchoring of the glycan to the sensor surface and the importance of chemical display of the glycan in different sensor surface architectures.

### References

1. Thygesen, M. B.; Sauer, J.; Jensen, K. J. *Chem. Eur. J.* **2009**, 15, 1649-1660; Thygesen, M. B.; Sørensen, K. K.; Cló, E.; Jensen, K. J. *Chem. Commun.* **2009**, 6367-6369.
2. Thygesen, M. B.; Munch, H.; Sauer, J.; Cló, E.; Jørgensen, M.; Hindsgaul, O.; Jensen, K. J. *J. Org. Chem.* **2010**, 75, 1752-1755.

## OL 104

D-GLUCOSAMINE IN A CHIMERIC PROLINAMIDE ORGANOCATALYST  
FOR DIRECT ASYMMETRIC ALDOL ADDITIONMauro De Nisco,<sup>1</sup> Silvana Pedatella,<sup>1</sup> Semiha Bektaş,<sup>1</sup> Ada Nucci,<sup>2</sup> and Romualdo Caputo<sup>1</sup><sup>1</sup>*Dipartimento di Chimica Organica e Biochimica, Università di Napoli Federico II  
Via Cynthia 4, 80126 Napoli, Italy;*<sup>2</sup>*Istituto di Scienze degli Alimenti e della Nutrizione, Università Cattolica del S. C.,  
Piacenza, Italy  
pedatell@unina.it*

Organocatalysts are metal-free organic compounds characterized by large-scale bioavailability (chiral pool of nature) and low toxicity, capable of promoting reactions in substoichiometric amounts. Indeed, the great attention they have received in the last decade, was probably due to their efficacy in carrying out reactions in aqueous medium, hence under environmentally friendly conditions that either reduce or even avoid the use of organic solvents.<sup>1</sup>

Under these circumstances, a recent trend is toward the use of organocatalysts which can catalyze efficiently a number of related C-C bond formation processes such as the enantioselective aldol addition and Mannich, Michael and Diels–Alder transformations in aqueous medium since water is a safe, economical, and environmentally benign solvent.

Simple D-glucosamine was already demonstrated<sup>2</sup> to exert a catalytic role on direct aldol reaction (DAA) of ketones and aromatic aldehydes, although affording moderate yields and rather poor enantiomeric excess of the aldol product.<sup>3</sup> On the other hand, small proline-based molecules bearing hydrophobic groups were reported to act as good organocatalysts for aldol reactions. Therefore, we have combined all this information in the same molecule, actually the chimeric carbohydrate-amino acid catalyst containing L-proline, **1**. Synthesis and successful applications of catalyst **1** in the DAA of cyclohexanone and acetone to variously substituted benzaldehydes will be presented.

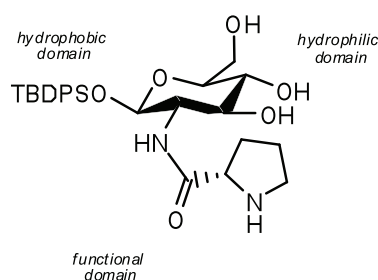
**References**

1. a) Gruttadauria, M.; Giacolone, F.; Noto, R. *Chem. Soc. Rev.* **2008**, *37*, 1666-1688; b) Melchiorre, P.; Marigo, M.; Carlone, A.; Bartoli, G. *Angew. Chem., Int. Ed.* **2008**, *47*, 6138-6171.
2. N. Singh, J. Pandey, R. P. Tripathi, *Cat. Comm.* **2008**, *9*, 743-746.
3. Y. Hayashi, T. Sumiya, J. Takahashi, H. Gotoh, T. Urushima, M. Shoji, *Angew. Chem. Int. Ed.* **2006**, *45*, 958-961.

## OL 105

## C-GLYCOSYL AMINO ACIDS VIA HYDROBORATION-CROSS COUPLING OF EXO-GLYCAL

Stefan Koch<sup>1</sup>, Holger Löwe<sup>1,2</sup> and Horst Kunz<sup>1</sup><sup>1</sup>Institute of Organic Chemistry, Johannes Gutenberg-University Mainz, Duesbergweg 10-14, D-55128 Mainz, Germany<sup>2</sup>IMM Institut fuer Mikrotechnik Mainz, Carl-Zeiss-Straße 18-20, D-55129 Mainz, Germany  
kochst@uni-mainz.de

Glycosylation is one of the most common post-translational modifications of proteins. As in natural glycosyl amino acids the glycosidic bond represents the weakest connection within the building block, the schematical substitution of the exocyclic heteroatom by a methylene-bridge leads to C-glycosides, which show high long term stability in alkaline and acidic media as well as against enzymatic degradation<sup>1</sup>.

For the synthesis of the biologically interesting C-glycosyl amino acids we chose a modular approach offering access to a large number of combinations of different amino acid moieties with different carbohydrates *via* hydroboration of the fully protected *exo*-glycals followed by Suzuki-Miyaura cross coupling<sup>2</sup> with the corresponding halides of the protected amino acids.

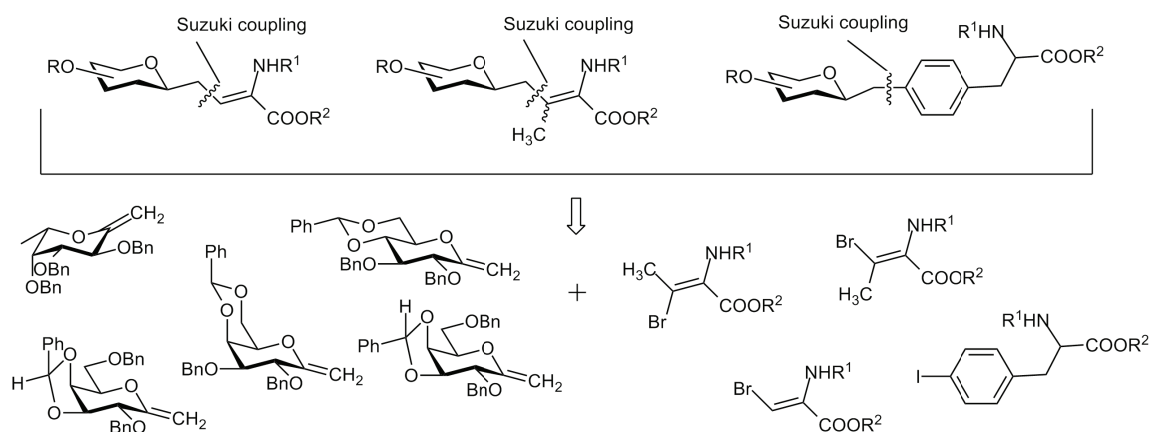

The choice of a suitable protecting group pattern at the sugar moiety allows further functionalization of the resulting C-glycosyl amino acids, as for example, the attachment of the Lewis<sup>x</sup>-trisaccharide.

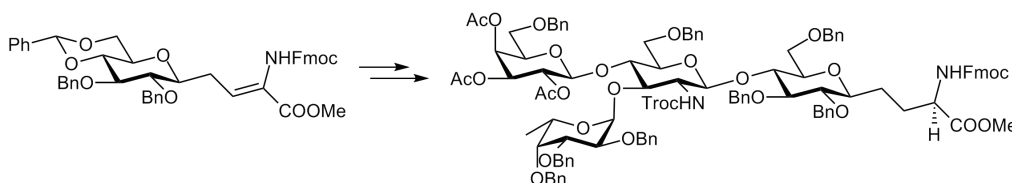

## References

1. D.E. Levy, C. Tang, *Tetrahedron Organic Chemistry Series Volume 13. The Chemistry of C-Glycosides*, Pergamon, Oxford, **1995**.
2. N. Miyaura, T. Ishiyama, M. Ishikawa, A. Suzuki, *Tetrahedron Lett.* **1986**, 27, 6369-6367.

## OL 106

**GLYCOSYL ALKOXYTHIOIMIDATES AS COMPLEMENTARY BUILDING BLOCKS  
FOR CHEMICAL GLYCOSYLATION AND EXPEDITIOUS  
OLIGOSACCHARIDE SYNTHESIS**

Sneha C. Ranade, Sophon Kaeothip and Alexei V. Demchenko\*

*Department of Chemistry and Biochemistry, University of Missouri – St. Louis,  
One University Blvd., St. Louis, MO 63121, USA  
sneha.ranade@umsl.edu*

Challenges faced in the synthesis of oligosaccharides can be addressed by developing efficient strategies in which the stability and reactivity of glycosyl donors plays an important role.<sup>1</sup> Amongst the myriad of glycosyl donors introduced during the last two decades, glycosyl thiocyanates stand out due to their ability to provide unusually high diastereoselectivity in glycosylation.<sup>2,3</sup> However, high lability and incompatibility with most protecting group manipulations make this class of compounds unsuitable for building block-based expeditious oligosaccharide synthesis. Our laboratory has been investigating glycosyl thioimidates, and the synthesis of the S-benzoxazolyl (SBox)<sup>4</sup> and S-thiazolynyl (STaz)<sup>5</sup> derivatives and their application as glycosyl donors has been reported. Undoubtedly, thioimidates have some structural similarity with thiocyanates; our comparative studies, however, indicated potential orthogonality of these two classes of glycosyl donors.<sup>6</sup>

Herein we report the development of a series of novel glycosyl alkoxythioimide derivatives, which have been specifically designed to represent a hybrid structure bridging between simple acyclic thiocyanates and cyclic SBox glycosides. During the course of comparative reactivity study of a variety of alkoxythioimidates we observed that S-glycosyl O-methyl phenylcarbamothioates (SNea) are significantly more stable than both the SBox glycosides and thiocyanates and tolerate selected protecting group manipulations. We also demonstrated that SNea have a fully orthogonal character in comparison to SBox glycosides.<sup>6</sup> These features make glycosyl alkoxythioimidates new promising building blocks for further utilization in oligosaccharide synthesis. This work was supported by Awards from the NSF and NIGMS supported this work.

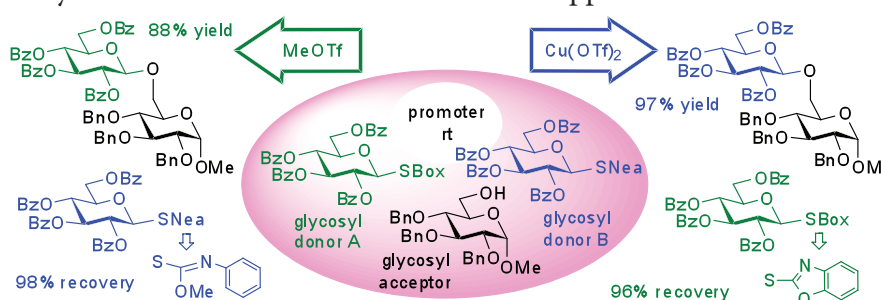

## References

- Smoot, J. T.; Demchenko, A. V. *Adv. Carbohydr. Chem. Biochem.* **2009**, *62*, 161-250.
- Kochetkov, N. K.; Klimov, E. M.; Malysheva, N. N.; Demchenko, A. V. *Carbohydr. Res.* **1991**, *212*, 77-91.
- Kaeothip, S.; Akins, S. J.; Demchenko, A. V. *Carbohydr. Res.* **2010**, *345*, 2146-2150.
- Demchenko, A. V.; Malysheva, N. N.; De Meo, C. *Org. Lett.* **2003**, *5*, 455-458.
- Demchenko, A. V.; Pornsuriyasak, P.; De Meo, C.; Malysheva, N. N. *Angew. Chem. Int. Ed.* **2004**, *43*, 3069-3072.
- Ranade, S. C.; Kaeothip, S.; Demchenko, A. V. *Org. Lett.* **2010**, *12*, 5628-5631.

## OL 107

SYNTHESIS OF HIGH-MANNOSE TYPE OLIGOSACCHARIDE MIMETICS  
BASED ON HUISGEN'S COPPER-CATALYSED [3+2] CYCLOADDITIONMoreau Vincent,<sup>1</sup> Cendret Virginie,<sup>1</sup> François-Heudes Marc,<sup>1</sup> Djedaini-Pilard Florence.<sup>1</sup><sup>1</sup>Laboratoire des Glucides, UMR 6219, Université de Picardie Jules Verne,  
80039 Amiens, France  
vincent.moreau@u-picardie.fr

It is now well known that *N*-glycans, the oligosaccharidic counterparts of many glycoproteins, are involved in several biological events, such cell-cell interactions or bacteria and virus adhesion to host-cell.<sup>1,2</sup> Among them, "High-Mannose" type *N*-glycans contain two to six mannose residues linked to a common pentasaccharidic core. For the past three decades, several groups<sup>3</sup> have reported the synthesis of such oligosaccharides with the aim to study their implication in different biological processes. But even if significant progresses have been made and many different approaches have been developed in oligosaccharide synthesis field,<sup>4</sup> reach such complex structures remains a challenge.

Cu<sup>I</sup>-catalysed azide-alkyne cycloaddition has been widely used in carbohydrates chemistry, mainly to the preparation of triazole-linked glycoclusters but also to the synthesis of oligosaccharide mimetics.<sup>5</sup> The use of click azide-alkyne cycloaddition for the quick preparation of pseudo "High-Mannose" type oligosaccharides, in which some carbohydrate units were replaced by a triazole ring will be presented and discussed.

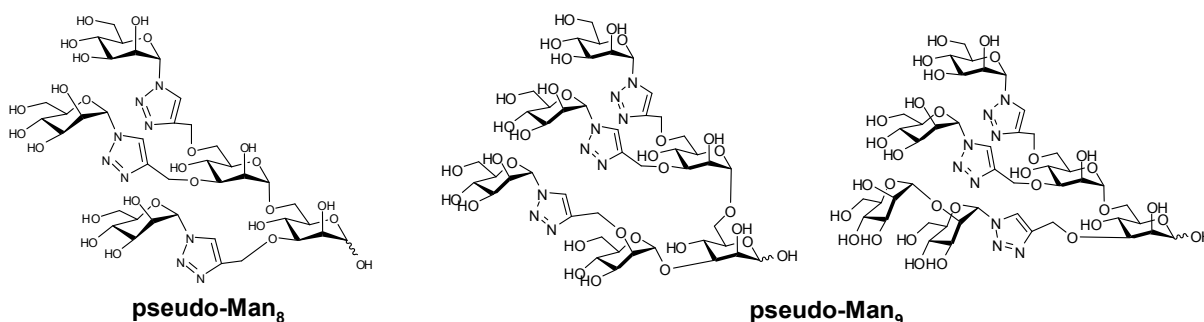

## References

1. *Essentials of Glycobiology*, Varki, A., Cummings, R., Esko, J., Freeze, H., Hart, G., Marth, J., Eds.; Cold Spring Harbor Laboratory Press: Cold spring Harbor, New York, 1999.
2. Wittman V., in *Glycoscience*, Fraser-Reid, B., Tatsuta, K., Thiem, J., Eds.; Springer-Verlag Berlin Heidelberg, **2008**, pp 1735-1793.
3. (a) Merritt, J. R., Naisang, E., Fraser-Reid, B. *J. Org. Chem.* **1994**, 59, 4443-4449. (b) Grice, P., Ley, S. V., Pietruszka, J., Osborn, H. M. I., Priepeke, H. W. M., Warriner, S. L., *Chem. Eur. J.* **1997**, 3, 431-440. (c) Ratner, D. M., Plante, O. J., Seeberger, P. H., *Eur. J. Org. Chem.* **2002**, 826-833.
4. Smoot, J. T., Demchenko, A. V., *Adv. Carbohydr. Chem. Biochem.*, **2009**, 62, 161-250.
5. Dedola, S., Nepogodiev, S. A., Field, R. A., *Org. Biomol. Chem.*, **2007**, 5, 1006-1017.

## OL 108

## GLYCOSYL SULFOIUM IONS AS STORABLE GLYCOSYLATION INTERMEDIATES

Toshiki Nokami,<sup>1</sup> Yuki Nozaki,<sup>1</sup> Yoshihiro Saigusa,<sup>1</sup> Shino Manabe, Yukishige Ito,<sup>2,3</sup>  
and Jun-ichi Yoshida

<sup>1</sup>Department of Synthetic Chemistry and Biological Chemistry, Kyoto University,  
Nishikyo-ku, Kyoto 615-8510, Japan

<sup>2</sup>RIKEN Advanced Science Institute, Hirosawa, Wako, Saitama 351-0198, Japan

<sup>3</sup>ERATO JST, Hirosawa, Wako, Saitama 351-0198, Japan  
tnokami@sbchem.kyoto-u.ac.jp

Much attention has been paid to glycosyl sulfonium ions as useful glycosylation intermediates because of their application to  $\alpha$ -selective glycosylations which make 1,2-*cis* glycosidic linkages.<sup>1</sup> We reported a novel method for preparing glycosyl sulfonium ions using electrochemical oxidation and investigated the stability and reactivity of glycosyl sulfonium ions.<sup>2</sup> On the basis of these results, it is reasonable to assume that stability and reactivity of glycosyl sulfonium ions can be tuned by changing substituents on the sulfur atom. In this study, we demonstrate that glycosyl sulfonium ions bearing appropriate substituents on the sulfur atom can serve as storable intermediates for glycosylations.

We have developed the electrochemical method to generate and accumulate highly reactive glycosyl triflates at low temperatures.<sup>3,4</sup> Glycosyl sulfonium ions, which serve as persistent glycosyl cation equivalents were prepared by the addition of diorganosulfides to the electrochemically generated glycosyl triflate. Low-temperature and variable-temperature NMR studies were performed to reveal the structure, stability, and reactivity of glycosyl sulfonium ions. The glycosyl sulfonium ion which was prepared from methyl phenyl sulfide could be used as a storable intermediate for reactions with various glycosyl acceptors including thioglycosides to give the corresponding disaccharides.<sup>5</sup>

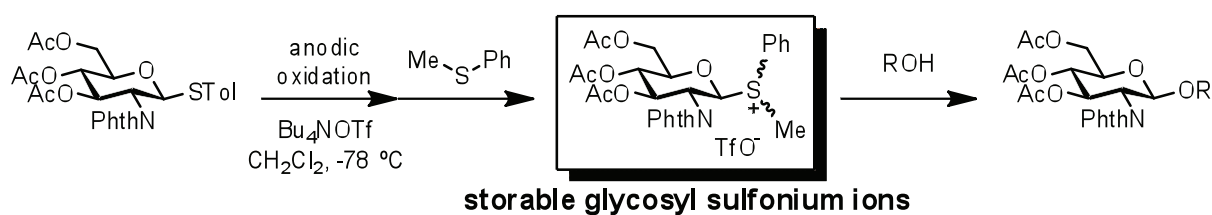

### References

1. T. J. Boltje, J.-H. Kim, J. Park, G. J. Boons, *Nat. Chem.*, **2010**, *2*, 552-557. and references therein.
2. T. Nokami, A. Shibuya, S. Manabe, Y. Ito, J. Yoshida, *Chem. Eur. J.*, **2009**, *15*, 2252-2255.
3. T. Nokami, A. Shibuya, H. Tsuyama, A. A. Bowers, D. Crich, S. Suga, J. Yoshida, *J. Am. Chem. Soc.*, **2007**, *128*, 10922-10928.
4. T. Nokami, A. Shibuya, J. Yoshida, *Trends Glycosci. Glycotechnol.*, **2008**, *20*, 175-185.
5. T. Nokami, Y. Nozaki, Y. Saigusa, A. Shibuya, S. Manabe, Y. Ito, J. Yoshida, *Org. Lett.*, in press.



## OL 109

## SYNTHESIS OF TAILOR-MADE OLIGOSACCHARIDES AS SPACER MOLECULES FOR BIOPHYSICAL APPLICATIONS

Timmy Fyrner, Peter Konradsson

*Department of Physics, Chemistry and Biology, Linköping University,  
SE-581 83 Linköping, Sweden.  
timfy@ifm.liu.se*

The use of an appropriate spacer molecule is of great importance in many systems, ranging from biosensor applications<sup>1</sup> to membrane-anchoring<sup>2</sup> or as a crosslinker between biomolecules. Studies have shown that variations in the spacer length influence the mobility of the attached moieties (i.e. proteins, carbohydrates)<sup>3</sup>. To avoid a complicated synthesis of natural occurring carbohydrate containing linkers such as GPI anchors<sup>4</sup> we turned our attention to the synthesis of various oligosaccharide units with variable length.

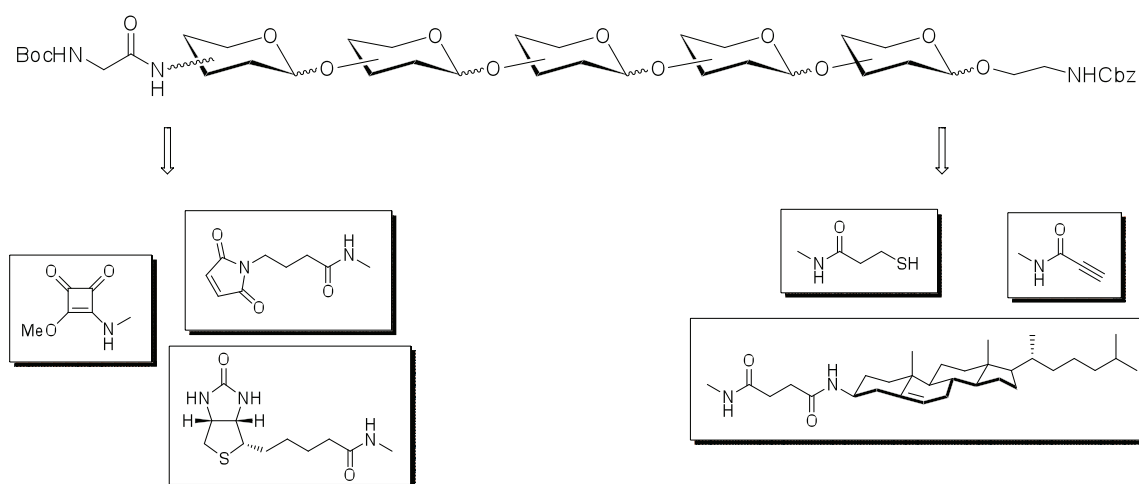

In our study, we present the synthesis and characterization of orthogonally protected tri-, penta- and heptasaccharides. These oligosaccharides could further be functionalized using different chemical handles (e.g. biotin, maleimide or alkyne), thereby enable the incorporation of biomolecules in biophysical systems (e.g. nanoparticles, SAMs, or vesicles).

### References

1. Larsson, A.; Angbrant, J.; Ekeröth, J.; Månsson, P.; Liedberg, B.; *Sensors and Actuators B*, **2006**, *113*, s 730-748.
2. Paulick, M. G.; Bertozzi, C. R.; *Biochemistry*, **2008**, *47*, s 6991-7000.
3. Gege, C.; Geyer, A.; R. R. Schmidt.; *Chem. Eur. J.*; **2002**, *8*, No.11, s 2454-2463.
4. a) Ruda, K.; Lindberg, J.; Garegg, P. J.; Oscarson, S.; Konradsson, P.; *J. Am. Chem. Soc.*, **2000**, *122*, s 11067-11072. b) Hederö, M.; Konradsson, P.; *J. Am. Chem. Soc.*, **2006**, *128*, s 3414-3419.



## OL 110

**SYNTHESIS OF HOMOGENEOUS GLYCOPROTEINS BEARING  
HIGH-MANNOSE OR COMPLEX TYPE BIAN TENNARY  
ASIALOOLIGOSACCHARIDE**

Simone Dedola,<sup>1,2</sup> Yutaka Makimura,<sup>1,2</sup> Masayuki Izumi,<sup>1,2</sup> Yukishige Ito,<sup>1,3</sup>  
Yasuhiro Kajihara.<sup>1,2</sup>

<sup>1</sup>*Japan Science and Technology Agency, ERATO, Ito Glycotriology Project*

<sup>2</sup>*Osaka University, Department of Chemistry, Graduate School of Science,  
1-1 Machikaneyama, Toyonaka, Osaka 560-0043, Japan*

<sup>3</sup>*RIKEN Advanced Science Institute, 2-1 Hirosawa, Wako, Saitama 351-0198, Japan  
s\_dedola@chem.sci.osaka-u.ac.jp*

Protein glycosylation is one of the most important post-translational modification on protein surface and the presence of carbohydrates on proteins is associated with a number of biological events.<sup>1</sup> In nature glycoproteins are found in complex heterogeneous mixture which complicates their characterisation and function. To understand the role of each carbohydrate substituent on the glycoprotein is therefore essential to have access to homogeneous glycoproteins.<sup>2</sup> Using crambin as a model protein we synthesized homogeneous “glycocrambin” bearing high-mannose or asialo complex type oligosaccharide in order to investigate the different impact of the two N-glycans on the protein structure. Wild type crambin consists of 46 aminoacids and this is to be a non-glycosylated protein involving three disulfide bonds and one salt bridge.<sup>3</sup> The full length sequence (1-46) was divided into two segments of which the N-terminal peptide thioester (1-15) was synthesized by Boc chemistry and the glycosylated C-terminal peptide segment (16-46) was synthesized by Fmoc chemistry. The Fmoc-Asn-oligosaccharide was introduced at the position 17. After obtaining the full length amino acid sequence of crambin by native chemical ligation,<sup>4</sup> the 46 residues-glycopeptide was folded to afford the three disulfide bonds. Further detail will be discussed in this presentation.

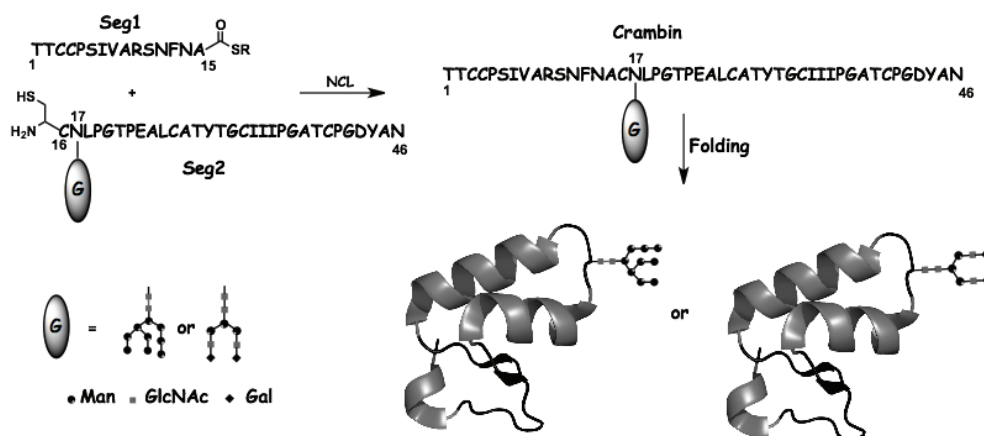

### References

1. Dwek R.A., *Chem. Rev.*, **1996**, 96, 683-720.
2. Kajihara Y., Yamamoto N., Okamoto R., Hirano K., Murase T., *Chem. Rec.*, **2010**, 10, 89-100.
3. Bang D., Kent S.B.H., *Angew. Chem. Int. Ed.*, **2004**, 43, 2534-2538.
4. Dawson P.E., Muir T.W., Clarklewis I., Kent S.B.H., *Science*, **1994**, 266, 776-779.

## OL 111

## SUCROSE BASED MACROCYCLES. SYNTHESIS AND COMPLEXATION ABILITY TOWARDS CHIRAL CATIONS

Bartosz Lewandowski,<sup>1</sup> Slawomir Jarosz\*,<sup>1</sup>

<sup>1</sup>*Institute of Organic Chemistry, Polish Academy of Sciences, Kasprzaka 44/52,  
01-224 Warsaw, Poland  
sljar@icho.edu.pl*

Recently we have proposed a convenient route to sucrose-based macrocycles of the general formula **1**.<sup>1</sup> These compounds have very interesting complexing properties; for example the ability constant of the complex of compound **1a** ( $n = 1$ ;  $X = \text{NBn}$ ) with S-phenylethylamine is 1.5 times higher than with the R-enantiomer the ( $K_a = 1200$  vs. 800). Even more enantioselective was receptor **1b** ( $X = \text{O}$ ,  $Y = \text{NBn}$ ,  $n = 2$ ) which complexed only the S-isomer of the amine.<sup>2</sup> We have prepared also more complex sucrose based receptors with the  $C_2$ -symmetry such as **4**, which were obtained from the linear precursors **3**. The cyclization was possible only in the presence of optically pure template: L-phenylalanine.<sup>3</sup>

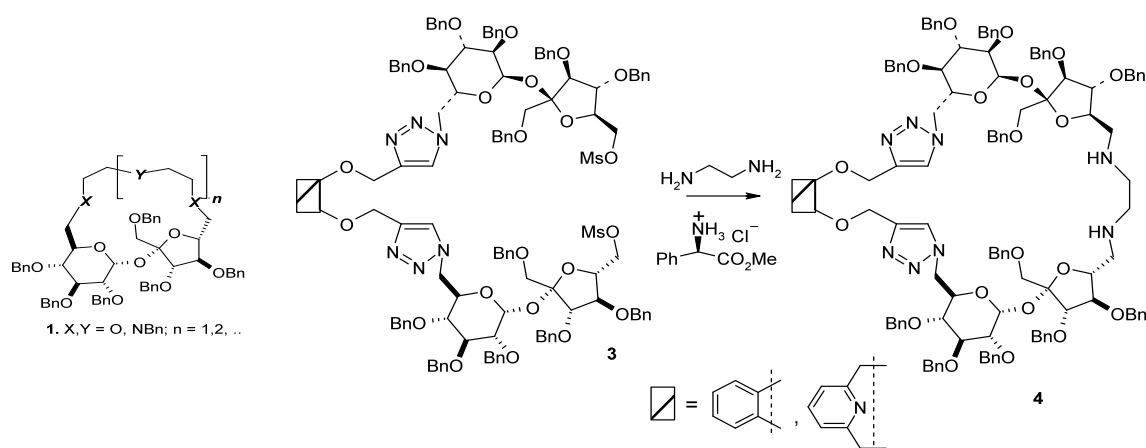

Stereochemical aspects of these processes will be discussed.

## References

1. S. Jarosz, B. Lewandowski, *Carbohydr. Res.*, **2008**, 343, 965-969 and references therein.
2. B. Lewandowski, S. Jarosz, *ChemCommun.*, **2008**, 6399-6401.
3. B. Lewandowski, S. Jarosz, *Org. Letters*, **2010**, 12, 2532-2535.

## OL 112

## DESIGN, PREPARATION AND PRELIMINARY EVALUATION OF GLYCOCONJUGATE VACCINES ACTIVE AGAINST ANTHRAX

Ophélie Milhomme, Florence Djédaini-Pilard and Cyrille Grandjean

Laboratoire des Glucides, 10 rue Baudelocque 80080 Amiens Cedex  
*ophelie.milhomme@u-picardie.fr*

*Bacillus anthracis*, the causative agent of anthrax, is currently one of the main bioterrorist threats. Thus, the development of a potent effective vaccine against anthrax has become a pressing target worldwide. In particular, the development of a glycoconjugate vaccine, known to be safe and well tolerated in humans, has been stimulated by the recent discovery of the structure of a tetrasaccharide<sup>[1]</sup> expressed on the surface glycoprotein of the spores of the bacteria (Fig 1).

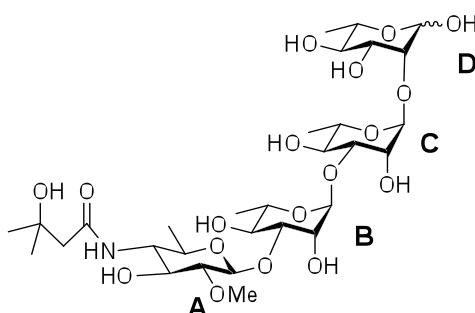

**Fig 1:** Structure of the native tetrasaccharide of the exosporium glycoprotein of *B. anthracis*

The preparation of the different anthrose-containing carbohydrate moieties of the glycoconjugates relies on a new synthetic route. This strategy takes advantages of cyclic sulfite/sulfate intermediates which serve successively as protecting and as leaving groups.

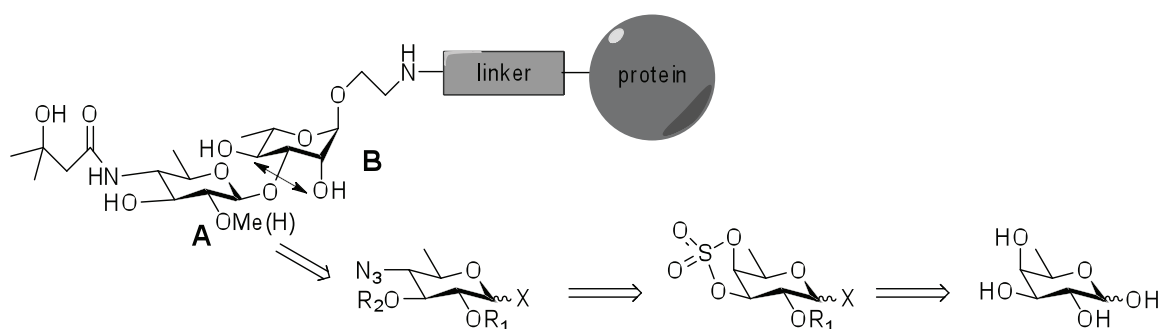

**Scheme 1:** Retrosynthetic strategy of anthrose-containing derivatives

The conjugation of these disaccharides to a carrier protein as well as to T-helper epitopes and the preliminary evaluation of the vaccine potency of these glycoconjugates will be presented as well.

## References

1. Daubenspeck, J. M. Z.; Chen, H. P.; Dong, S.; Steichen, C. T.; Krishna, N. R.; Pritchard, D. G.; Turnbough, C. L.; *J. Biol. Chem.*, **2004**, 279, 30945-30953
2. Dong, S.; McPherson, S. A.; Tan, L.; Chesnokova, O. N.; Turnbough, Jr., C.L.; Pritchard, D. G.; *J. Bacteriol.*, **2008**, 190, 2350-2359

## OL 113

## SELECTIVE FUNCTIONALIZATION OF ENZYMATICALLY OXIDIZED POLYSACCHARIDES

Kirsti Parikka,<sup>1</sup> Ann-Sofie Leppänen,<sup>2</sup> Stefan Willför,<sup>2</sup> Maija Tenkanen<sup>1</sup><sup>1</sup> Department of Food and Environmental Sciences, University of Helsinki, P.O. Box 27, FIN-00014 Helsinki, Finland,<sup>2</sup> Laboratory of Wood and Paper Chemistry, Åbo Akademi University, Turku, Finland  
Kirsti.Parikka@helsinki.fi

Galactose-containing polysaccharides, spruce galactoglucomannan, guar galactomannan (guar gum), and tamarind galactoxyloglucan, were selectively modified in aqueous media, aiming to obtain materials with improved physicochemical properties and new functionalities. The polysaccharides were first oxidized with galactose oxidase (GO) [1] to introduce reactive carbonyl groups, which enabled the selective further modifications.

GO (EC 1.1.3.9) oxidizes primary alcohols to corresponding aldehydes with high regioselectivity [2]. The C-6 hydroxyl groups of the galactosyl units of the polysaccharides were oxidized in good yield, and further reacted by techniques suitable for one-pot procedures, performed directly after the enzymatic oxidation in aqueous media. Selective carboxylation, reductive amination and metal-mediated allylation were studied (Scheme 1).

Combination of the enzymatic oxidation with the chemical reactions was found a good method for the production of polysaccharides with new properties and several potential applications. The polysaccharides carrying the anionic carboxyl groups are interesting novel polyelectrolytes, for example, for the paper industry due to the specific binding of these polysaccharides to cellulose. The derivatives with non-polar carbon chains may find uses as emulsifiers in e.g. cosmetic and pharmaceutical products, and the reactive double bond of the allylated products gives way to new additional modifications. In this paper, this feasible and sustainable chemo-enzymatic functionalization of natural polysaccharides will be discussed in more detail.

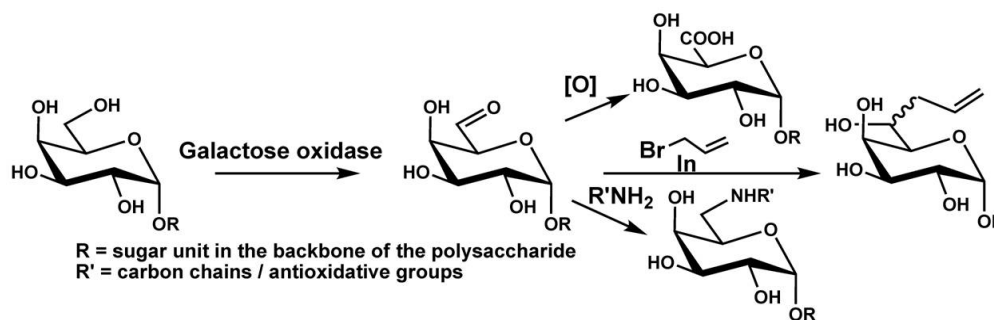

Scheme 1. Galactose oxidase -catalyzed oxidation and further modifications of polysaccharides

## References

1. Parikka K., Leppänen A.-S., Pitkänen L., Reunanen M., Willför S., Tenkanen M. *J. Agric. Food Chem.* **2010**, 58 262-271.
2. Whittaker J. W. *Chem. Rev.* **2003**, 103, 2347-2363.

## OL 114

**SUGAR-DERIVED NITRONES AND ALDEHYDES: KEY BUILDING BLOCKS  
FOR THE SYNTHESIS OF GLYCOSYL HYDROLASES INHIBITORS**

Francesca Cardona,<sup>1</sup> Giampiero D'Adamio,<sup>1</sup> Camilla Parmeggiani,<sup>1,2</sup> Camilla Matassini,<sup>1</sup>  
Daniele Martella<sup>1</sup> and Andrea Goti<sup>1</sup>

<sup>1</sup>Dipartimento di Chimica "Ugo Schiff", Via della Lastruccia 13,  
Polo Scientifico e Tecnologico, 50019 Sesto Fiorentino, Firenze, Italy,

<sup>2</sup>CNR-INO and European Laboratory for Non-linear Spectroscopy (LENS), via N. Carrara 1,  
Polo Scientifico e Tecnologico, 50019 Sesto Fiorentino, Firenze, Italy  
francesca.cardona@unifi.it

Iminosugars are very attractive carbohydrate mimics in which the endocyclic oxygen atom is replaced by the more basic, trivalent nitrogen atom.<sup>1</sup> In their protonated form, iminosugars resemble the transition state or intermediate generated during the hydrolysis reaction catalysed by glycosidases, key hydrolytic enzymes involved in many physiological functions. Given the important role of glycosidases in controlling the structures and functions of carbohydrates in cell surfaces, inhibitors of these classes of enzymes are potential antidiabetes, agrochemicals, anti-viral and anti-cancer agents, and also potential drugs for the treatment of lysosomal storage disorders.<sup>1</sup>

We have developed several straightforward synthetic strategies for the syntheses of pyrrolidine, piperidine, pyrrolizidine and indolizidine iminosugars that employ pyrrolidine nitrones readily derived from carbohydrates, such as arabinose, ribose, and xylose as the key building blocks. The nitrones are then reacted in highly stereoselective reactions such as cycloadditions with suitable dipolarophiles<sup>2</sup> or addition reactions with organometallic derivatives. We will also present our recent approach to lipophilic 3,4,5-trihydropiperidine derivatives through a double reductive amination strategy on a mannose-derived dialdehyde with primary amines.

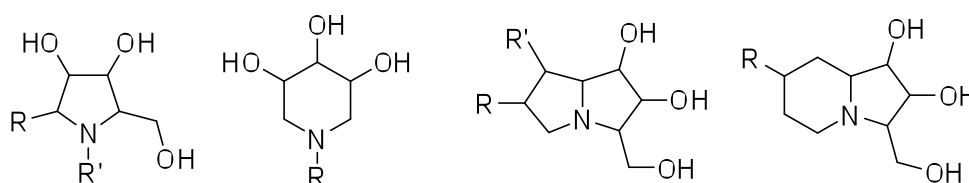

### References

1. P. Compain, O. R. Martin (Eds.), *Iminosugars: from synthesis to therapeutic applications*, Wiley-VCH Weinheim, **2007**.
2. a) F. Cardona, C. Parmeggiani, E. Faggi, C. Bonaccini, P. Gratteri, L. Sim, T. M. Gloster, S. Roberts, G. J. Davies, D. R. Rose, A. Goti, *Chem. Eur. J.* **2009**, *15*, 1627-1636; b) C. Parmeggiani, D. Martella, F. Cardona, A. Goti, *J. Nat. Prod.* **2009**, *72*, 2058-2060; c) F. Cardona, A. Goti, C. Parmeggiani, P. Parenti, M. Forcella, P. Fusi, L. Cipolla, S. M. Roberts, G. J. Davies, T. M. Gloster, *Chem. Commun.* **2010**, *46*, 2629-2631; d) C. Bonaccini, M. Chioccioli, C. Parmeggiani, F. Cardona, D. Lo Re, G. Soldaini, P. Vogel, C. Bello, A. Goti, P. Gratteri, *Eur. J. Org. Chem.* **2010**, 5574-5585.

## OL 115

ACCESS TO GLUCOSE-BASED 1,4,5-TRISUBSTITUTED TRIAZOLES  
BY 1,3-DIPOLAR CYCLOADDITION AND SUZUKI COUPLING,  
AND EVALUATION AS GLYCOGEN PHOSPHORYLASE INHIBITORS

David Goyard,<sup>1</sup> Sébastien Vidal,<sup>1</sup> Jean-Pierre Praly,<sup>1</sup> Aikaterini S. Chajistamatiou<sup>2</sup>  
and Evangelia D. Chrysina<sup>2</sup>

<sup>1</sup>Université Claude Bernard Lyon 1, ICBMS UMR 5246,  
Laboratoire de Chimie Organique 2 – Glycochimie  
43 Boulevard du 11 Novembre 1918, 69622 Villeurbanne Cedex, France

<sup>2</sup>The National Hellenic Research Foundation (NHRF),  
Institute of Organic & Pharmaceutical Chemistry  
48, Vassileos Constantinou Avenue 116 35 Athens, Greece  
david.goyard@etu.univ-lyon1.fr

Type 2 diabetes mellitus (T2DM) is a chronic metabolic disease that affects almost 5% of the adult population in western countries.<sup>1</sup> A dramatic rise of the number of patients suffering from T2DM is forecast in the coming years, and the world health organization estimates that this number will reach 250 millions in 2030.<sup>2</sup> Various antihyperglycaemic agents have been developed for several years. However they suffer from limitations (side effects, loss of efficiency) and polytherapies are often required.<sup>2</sup> Glycogen phosphorylase (GP) plays an important role in the regulation of blood glucose level, and its inhibition could open new pathways for the treatment of hyperglycaemia in T2DM affected patients.<sup>3</sup> Glucose-based glycomimetics have been developed in our group, thanks to several collaborations, and have demonstrated promising activities.<sup>4</sup> Enzymatic and crystallographic studies have shown that glucose-based molecules with a  $\beta$ -oriented aromatic moiety at the anomeric center, are capable of strong binding at the catalytic site and nearby  $\beta$ -pocket of GP.<sup>3</sup> We have developed a new family of potential inhibitors using Huisgen 1,3-dipolar cycloaddition. Use of stoichiometric amounts of Cu(I)-halide afforded 5-halogenated triazoles. Subsequent Suzuki cross coupling yielded 1,4,5 trisubstituted triazoles with two aromatic moieties. Kinetic and crystallographic data will be presented.<sup>5</sup>

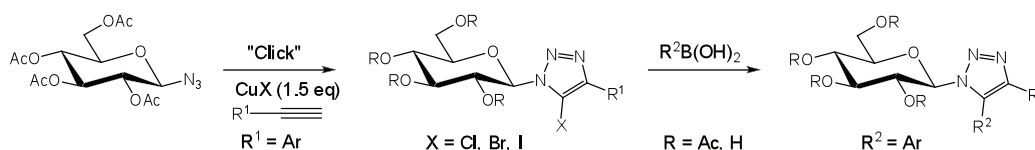

## References

1. Zimmet, P.; Alberti, K. G.; Shaw, J. *Nature* **2001**, *414*, 782-787.
2. Ross, S. A.; Gulve, E. A.; Wang, M. *Chem. Rev.* **2004**, *104*, 1255-1282.
3. a) Chrysina, E. D. *Mini-Rev. Med. Chem.* **2010**, *10*, 1093-1101; b) Praly, J.-P.; Vidal, S. *Mini-Rev. Med. Chem.* **2010**, *10*, 1102-1126.
4. a) Tóth, M.; Kun, S.; Bokor, E.; Benlifa, M.; Tallec, G.; Vidal, S.; Docsa, T.; Gergely, P.; Somsák, L.; Praly, J.-P. *Bioorg. Med. Chem.* **2009**, *17*, 4773-4785; b) Benlifa, M.; Hayes, J. M.; Vidal, S.; Gueyrard, D.; Goekjian, P. G.; Praly, J.-P.; Kizilis, G.; Tiraidis, C.; Alexacou, K.-M.; Chrysina, E. D.; Zographos, S. E.; Leonidas, D. D.; Archontis, G.; Oikonomakos, N. G. *Bioorg. Med. Chem.* **2009**, *17*, 7368-7380; c) Nagy, V.; Benlifa, M.; Vidal, S.; Berzsényi, E.; Teilhet, C.; Czifrák, K.; Batta, G.; Docsa, T.; Gergely, P.; Somsák, L.; Praly, J.-P. *Bioorg. Med. Chem.* **2009**, *17*, 5696-5707.
5. Project GPDia ANR-08-BLAN-0305-01.



## OL 116

GENERAL STRATEGY FOR THE SYNTHESIS OF GPI-ANCHORS  
AND GPI-ANCHORED PROTEINSTsai Yu-Hsuan,<sup>1,2</sup> Götze Sebastian,<sup>1</sup> Seeberger Peter<sup>1,2</sup> and Varón-Silva Daniel<sup>1</sup><sup>1</sup>Max Planck Institute of Colloids and Interfaces, Am Mühlenberg 1, 14476 Potsdam,<sup>2</sup>Free University of Berlin, Arnimallee 22, 14195 Berlin, Germany

daniel.varon@mpikg.mpg.de

Many proteins and glycoproteins are attached to the cell membrane by a glycosylphosphatidylinositol (GPI) anchor. Although the structure of this GPI is diverse and cell type depending, a conserved core pseudo-pentasaccharide containing a Man3-GlcNH<sub>2</sub>-Inositol is observed. Additional modifications like lipidation, phosphorylation and additional glycosylation are the major modifications found on this core.<sup>1</sup> GPI molecules from mammalian cells have been described to contain additional branched carbohydrate structures. This modification extends the diversity of the GPI and has been reported as a critical moiety for the function and recognition of the GPI anchored protein.<sup>2</sup>

In order to understand the role of the branching glycosylations and other modifications like phosphorylations in the function of GPIs and GPI anchored proteins, the chemical synthesis of these structures and successive ligation to proteins offer a good alternative for understanding the biological processes associated with these molecules.

Here we reported a new general strategy for the total synthesis of different branched GPI anchors and GPI-anchored proteins. The strategy is based on the chemical synthesis of lipidated and phosphorylated GPIs and the subsequent ligation to recombinantly expressed proteins.<sup>3</sup> The syntheses of the GPI-glycan moieties have been performed using pre-synthesized building blocks by [2+n+2] and [3+n+2] glycosylation strategies. The branching glycosylation has been introduced through an orthogonal protected mannose building block elongated at 4-O with a mono-, di- and trisaccharide. Finally, phosphorylations and incorporation of a cysteine residue on a phosphate-ethanolamine enables the ligation of the GPI anchors to proteins via native chemical ligation resulting in homogenous GPI-anchored proteins.

**References**

1. Ferguson, M. A. J.; Williams, A. F. *Annual Review of Biochemistry* **1988**, *57*, 285.
2. Debierre-Grockiego, F.; Schwarz, R. T. *Glycobiology* **2010**, *20*, 801.
3. Becker, C. F. W.; Liu, X. Y.; Olschewski, D.; Castelli, R.; Seidel, R.; Seeberger, P. H. *Angew. Chem.-Int. Edit.* **2008**, *47*, 8215.



## OL 117

**IODOSULFONAMIDATION OF PERACETYLATED GLYCALLS; APPLICATION  
TO THE PREPARATION OF GALECTIN'S LIGANDS**

François-Moana Gautier, Florence Djedaïni-Pilard and Cyrille Grandjean

*Laboratoire des Glucides, UMR CNRS 6219, Université de Picardie Jules Verne,  
10 rue Baudelocque, F-80000 Amiens  
cyrille.grandjean@u-picardie.fr*

1,2-Di-nitrogenated sugars are important motifs, featuring in all *N*-glycoproteins and in many glycoconjugates.

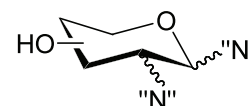

Simple access to these derivatives from readily accessible peracetylated glycols using Danishefsky's iodosulfonamidation followed by azidation,<sup>1</sup> is hampered by the rapid isomerisation of the *trans* 1,2-iodosulfonamide intermediates, initially formed, into their corresponding, unreactive *cis* isomers (Scheme).<sup>2</sup>

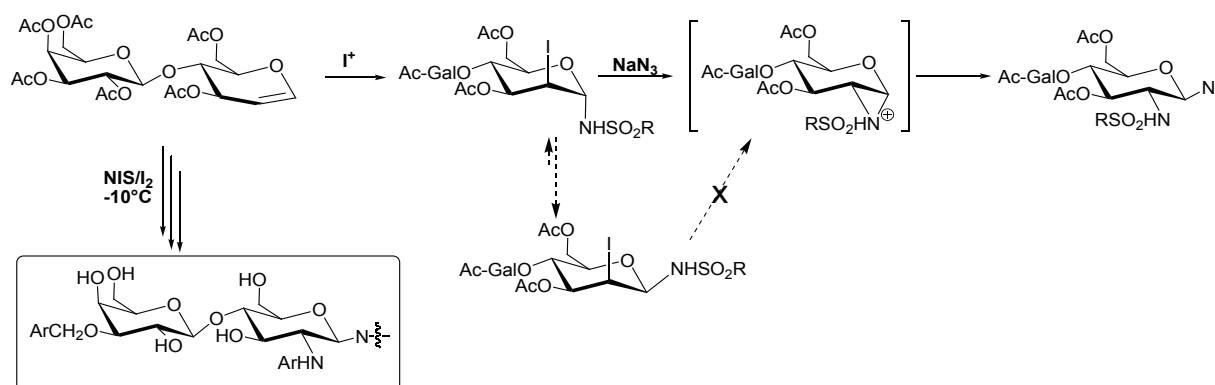

**Scheme.** Modified Danishefsky's azido-sulfonamidation procedure

By using a combination of NIS/I<sub>2</sub> as a source of iodonium ion, we have been able to circumvent this limitation,<sup>3</sup> thereby restoring its full utility to this procedure.

Application of this methodology to the straightforward synthesis of novel, potent mono- and multivalent ligands of the human galectins will also be presented.

### References

1. McDonald, F. E.; Danishefsky, S. J. *J. Am. Chem. Soc.*, **1992**, *114*, 7001-7002.
2. Owens, J. M.; Yeung, B. K. S.; Hill, D. C.; Petillo, P. A. *J. Org. Chem.*, **2001**, *66*, 1484-1486.
3. Gautier, F. -M., Djedaïni-Pilard, F., Grandjean, C. *Carbohydr. Res.*, **2011**, in the press.

## OL 118

## DESIGN AND SYNTHESIS OF NEW AMINO IMINO HEXITOLS VIA NOVEL ASYMMETRIC STRECKER + CARBAMATE ANNULATION METHODOLOGY

Anna L. Win-Mason,<sup>1</sup> Emma M. Dangerfield,<sup>1,2</sup> Peter C. Tyler,<sup>3</sup> Bridget L. Stocker,<sup>2</sup> Mattie S. M. Timmer.<sup>1</sup>

<sup>1</sup> School of Chemical and Physical Sciences, Victoria University of Wellington,  
PO Box 600, Wellington, New Zealand.

<sup>2</sup> Malaghan Institute of Medical Research, PO Box 7060, Wellington, New Zealand.

<sup>3</sup> Industrial Research Ltd., PO Box 31-310, Lower Hutt, New Zealand  
anna.win@vuw.ac.nz

As noted inhibitors of carbohydrate processing enzymes,<sup>1</sup> iminosugars, including amino imino hexitols, hold much promise as therapeutics for the treatment of a variety of diseases including diabetes, cancer and lysosomal storage disorders.<sup>2</sup> The biological activity of iminosugars has been largely attributed to their ability to mimic oxocarbenium ion intermediates formed during glycosidase reactions, and for this reason, functional and stereochemical modifications of the iminosugar scaffold have proven important in developing specific and potent inhibitors.<sup>3</sup> New methodology for the preparation of a number of known and novel amino imino hexitols will be presented, starting from readily available methyl iodoglycosides (Scheme 1). Key steps in each synthesis include an asymmetric Strecker reaction, without the need for a chiral Lewis acid or catalyst, and a novel carbamate annulation.<sup>4</sup> The effects that the substitution patterns of the  $\alpha$ -amino nitrile precursors have on the diastereoselectivity of the annulations will be highlighted.

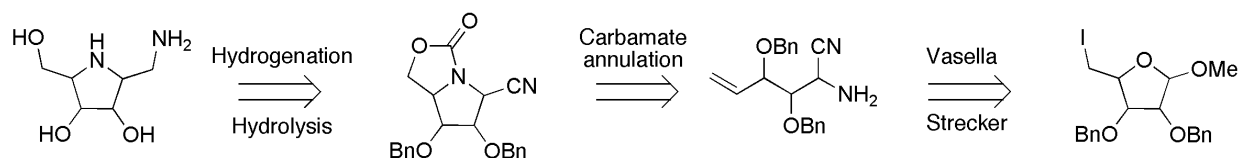

**Scheme 1.** Retrosynthesis towards amino imino hexitols.

## References

1. Winchester, B., Fleet, G. W. J., *Glycobiol.*, **1992**, *2*, 199-210.
2. Pearson, M. S. M., Mathe-Allainmat, M., Fargeas, V., Lebreton, J., *Eur. J. Org. Chem.*, **2005**, 2159-2191.
3. Stocker, B. L., Dangerfield, E. M., Win-Mason, A. L., Haslett, G. W., Timmer, M. S. M., *Eur. J. Org. Chem.*, **2010**, 1615-1637.
4. Dangerfield, E. M., Timmer, M. S. M., Stocker, B. L., *Org. Lett.*, **2009**, *11*, 535-538.

## OL 119

**SYNTHESIS OF  $\beta$ -D-GLUCOPYRANOSYLAMINE URONIC ACID  
IN AQUEOUS SOLUTION: KINETIC STUDY AND SYNTHETIC POTENTIAL**

Luca Albertin, Ali Ghadban, Alain Heyraud

*Centre de Recherches sur les Macromolécules Végétales (CERMAV-CNRS)<sup>1</sup>,  
BP53, 38041 Grenoble cedex 9, France  
luca.albertin@cermav.cnrs.fr*

The products of the reaction of sodium D-glucuronate with various combinations of ammonia and volatile ammonium salts in water were studied by NMR. For long reaction times (~24 hrs), the expected products  $\beta$ -D-glucopyranosylamine uronic acid and *N*-( $\beta$ -D-glucopyranosyl) carbamate were obtained in good to high yield, whereas 7 intermediate species were identified in samples taken at earlier reaction times. We established that two of them are actually anomer of the main products, whereas the others are precursors to their formation. In general, higher ammonia and/or ammonium salt concentrations lead to a faster conversion of the starting sugar into the intermediate species and of the latter into the final products. Yet, some interesting trends and exceptions were observed: The use of saturated ammonium carbamate leads to the fastest rates and the highest final yields of  $\beta$ -glycosylamine/carbamate. With the exception of 1 M ammonia plus 0.6 M ammonium salt, all tested protocols lead to higher yields of  $\beta$ -glycosylamine/carbamate than concentrated ammonia alone. The mole fraction of  $\alpha$ -glycosylamine/carbamate at equilibrium is around 7-8 % in water at 30 °C. Concerning di-( $\beta$ -D-glucopyranosyl)amine uronic acid, less than 3 % of it is formed in all cases, with a minimum value of 0.5 % in the case of saturated ammonium carbamate. Surprisingly, the formation of  $\beta$ -glycopyranosylamine / *N*-( $\beta$ -glycopyranosyl)carbamate is 4 to 8 times faster in the case of D-glucuronic acid than in the case of D-glucose, possibly due to a higher proportion of acyclic aldehyde form in aqueous solution. Finally, the synthetic usefulness of our approach was demonstrated by the synthesis of three  $\beta$ -D-glucopyranosylamide uronic acids and one *N*-( $\beta$ -D-glucopyranosyluronic acid)-*N'*-(alkyl) urea directly in aqueous/organic solution without resorting to protective groups' chemistry.

**References**

1. Ghadban, A.; Condamine, E.; Moussavou MOUNGUENGUI, R. W.; Heyraud, A.; Albertin, L. **2011**, Submitted.
2. Ghadban, A.; Albertin, L.; Moussavou MOUNGUENGUI, R. W.; Peruchon, A.; Heyraud, A. **2011**, Submitted.

---

<sup>1</sup> Affiliated with *Université Joseph Fourier*, and member of the *Institut de Chimie Moléculaire de Grenoble*.

## OL 120

**IONIC-LIQUID-BASED CATCH AND RELEASE OLIGOSACCHARIDE SYNTHESIS (ICROS).  
CHEMICAL AND ENZYMATIC APPLICATIONS**

M. Carmen Galan, A. T. Tran, C. Bernard

School of Chemistry, University of Bristol, Cantock's Close, BS8 1TS, Bristol/United Kingdom  
m.c.galan@bristol.ac.uk

The development of general and efficient methodologies for the preparation of complex oligosaccharides has been the subject of research for many years. Herein, we describe an ionic based “catch-and-release” oligosaccharide strategy for the chemical<sup>1</sup> and enzymatic<sup>2</sup> synthesis and fast purification of oligosaccharides.

We demonstrate that the methodology is compatible with thioglycoside and trichloroacetimidate glycosylation strategies and amenable to protecting group manipulations. Furthermore, we have also shown that the ICROS methodology is compatible with glycosyltransferase enzymatic transformations.

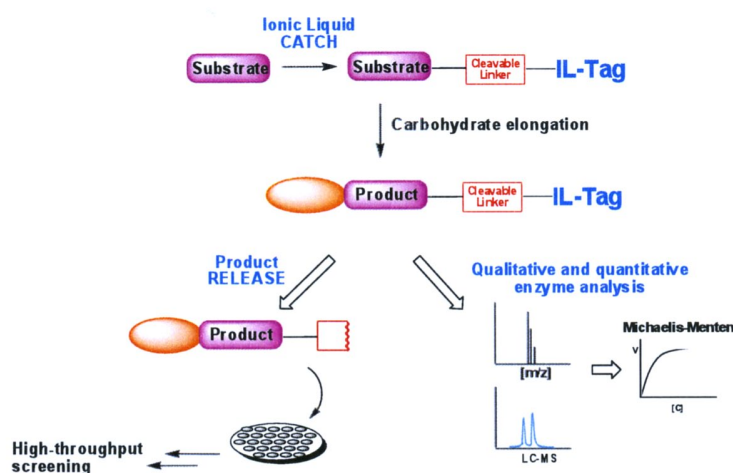

**Scheme 1:** General Scheme for ICROS

The ionic-liquid-based tags (ITags) developed are designed for easy attachment to substrates and simple product release that is amenable to conjugation to array platforms for further high-throughput biological screening. In addition, the ITags can be used as fast, robust and sensitive tools for reaction monitoring and quantitative kinetic analysis.

**References**

1. A. T. Tran, R. A. Burden, D. Racys and M. C. Galan, *Chem. Commun.* DOI:10.1039/C0CC05580H.
2. M. C. Galan, A. T. Tran and C. Bernard, *Chemical Communications*, 2010, 46, 8968-8970.

## OL 121

## MANNOSE-GLYCODENDRIMERS AS ELECTROCHEMICAL SENSORS

Manuel C. Martos-Maldonado, Juan M. Casas-Solvas, Indalecio Quesada-Soriano,  
Luis García-Fuentes and Antonio Vargas-Berenguel

*Carbohydrates and Proteins Group, University of Almería, 04120 Almería, Spain  
avargas@ual.es*

Important biological events such as viral and bacterial infections, cell-cell adhesion, inflammatory and immune response, fertilization, and cancer metastasis are governed by multivalent interactions between carbohydrates and cell-surface proteins.<sup>1</sup> Inherent in the advance of glycomics, is the challenge to develop synthetic tools that can be used to inhibit, modulate, detect and probe those interactions.<sup>2</sup> In this respect, ferrocene-containing carbohydrates could be of particular interest as the reversible and tunable redox properties of the ferrocene moiety could be applied in the development of molecular devices for the detection of carbohydrate-protein interactions, as well as in a redox switchable control of such interactions.

Considering the above, we have synthesized electroactive PAMAM-based glycodendrimers which include 4 (**P0FcM4**), 8 (**P0FcM8**) or 16 (**P0FcM16**) ferrocene-mannose units. The capabilities of these compounds to recognize Concanavalin A (Con A) and to act as electrochemical sensors for such lectin has been studied using calorimetric and electrochemical methods and compared with results obtained for ferrocene-mannose conjugates synthesized previously that contain one (**FcM**) or two (**FcM2**) mannose units.<sup>3</sup>

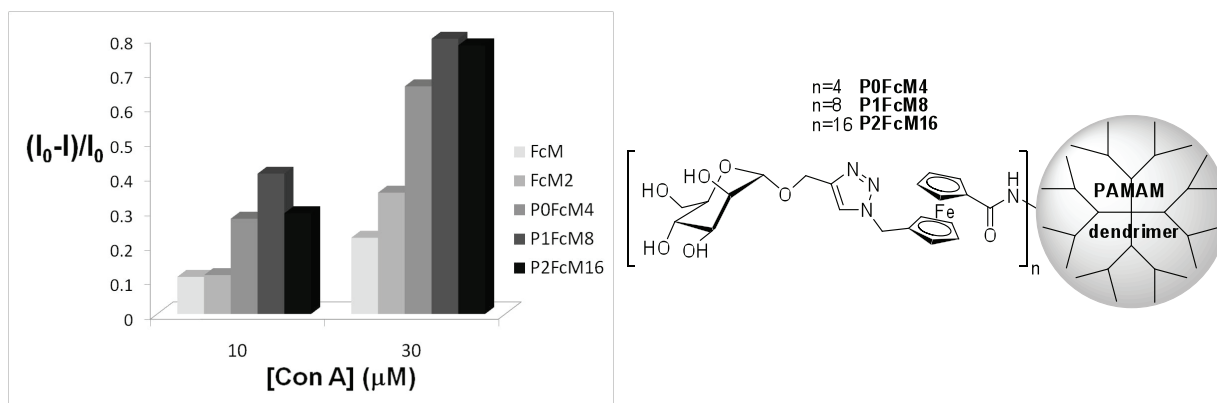

## References

1. (a) Dwek, R. A. *Chem Rev.* **1996**, 96, 683-720. (b) Lis, H.; Sharon, N. *Chem. Rev.* **1998**, 98, 637-674.
2. Timmer, M. S.; Stocker, B. L.; Seeberger, P. H. *Curr. Opin. Chem. Biol.*, **2007**, 11, 59-65.
3. Casas-Solvas, J. M.; Ortiz-Salmeron, E.; Garcia-Fuentes, L.; Vargas-Berenguel, A. *Org. Biom. Chem.* **2008**, 6, 4230-4235.

## OL 122

**THEORETICAL INVESTIGATIONS OF SOLVENT EFFECTS  
ON GLYCOSYLATION REACTIONS:  
THE CONFORMER AND COUNTERION DISTRIBUTION HYPOTHESIS**

Hiroko Satoh,<sup>1</sup> Halvor S. Hansen,<sup>2</sup> Shino Manabe,<sup>3</sup> Wilfred F. van Gunsteren,<sup>2</sup>  
and Philippe H. Hünenberger<sup>2</sup>

<sup>1</sup>National Institute of Informatics, Tokyo 101-8430, Japan,

<sup>2</sup>Laboratory of Physical Chemistry, Swiss Federal Institute of Technology (ETH),  
CH-8093 Zurich, Switzerland,

<sup>3</sup>RIKEN Advanced Science Institute, Saitama 351-0198, Japan  
hsatoh@nii.ac.jp

The mechanism of solvent effects on the stereoselectivity of glycosylation reactions is investigated using density functional theory (DFT) calculations and molecular dynamics (MD) simulations.<sup>1</sup> The DFT calculations on oxacarbenium-solvent complexes do not provide support to the usual solvent-coordination hypothesis, suggesting that an experimentally observed  $\beta$ -selectivity ( $\alpha$ -selectivity) is caused by the preferential coordination of a solvent molecule to the reactive cation on the  $\alpha$ -side ( $\beta$ -side) of the anomeric carbon. Instead, explicit-solvent MD simulations of the oxacarbenium-counterion complex are compatible with an alternative mechanism, termed here the conformer and counterion distribution hypothesis. This new hypothesis suggests that the stereoselectivity is dictated by two interrelated conformational properties of the reactive complex. For example, in acetonitrile, the calculations suggest a dominant  $B_{2,5}$  ring conformation of the cation with preferential coordination of the counterion on the  $\alpha$  side, both factors leading to the experimentally observed  $\beta$  selectivity. Conversely, in dioxane, they suggest a dominant  ${}^4H_3$  ring conformation with preferential counterion coordination on the  $\beta$  side, both factors leading to the experimentally observed  $\alpha$  selectivity.

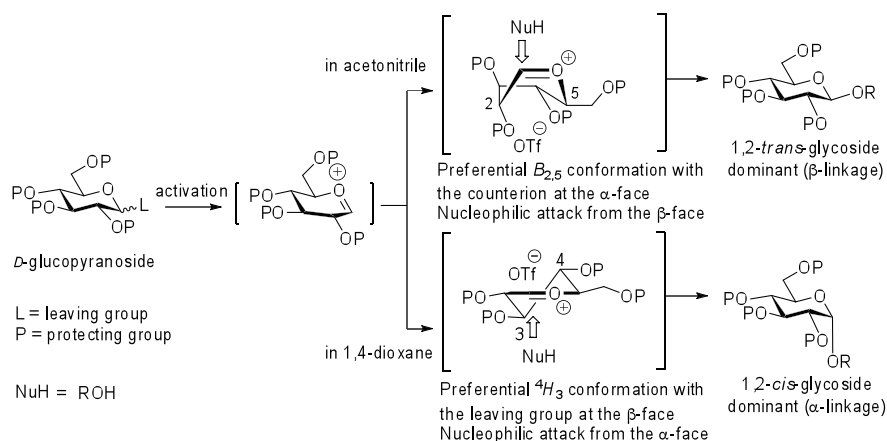

### Reference

1. H. Satoh, H. S. Hansen, S. Manabe, W. F. van Gunsteren, P. H. Hünenberger, *J. Chem. Theory Comput.*, **2010**, *6*, 1783-1797.

## OL 123

**2-ALLYLPHENYL GLYCOSIDES AS VERSATILE GLYCOSYL DONORS  
FOR CHEMICAL GLYCOSYLATION AND ORTHOGONAL  
OLIGOSACCHARIDE SYNTHESIS**

Hemali D. Premathilake and Alexei V. Demchenko

*Department of Chemistry & Biochemistry, University of Missouri – St. Louis  
One University Boulevard, St. Louis, Missouri 63121, USA.  
hdp9tb@umsl.edu*

Only recently has the tremendous biological significance and therapeutic potential of carbohydrates and conjugates thereof (glycoproteins, glycolipids, proteoglycans, etc.) begun to emerge.<sup>1</sup> The ongoing search for new and efficient methods for chemical glycosylation has remained a topic of high significance.<sup>2</sup> Therefore, the development of highly reactive and stereoselective glycosyl donors that would also be compatible with common protecting group manipulations is of high importance in the field.

Developed in our laboratory, allylphenyl glycosides offer a new robust method for chemical glycosylation and excellent flexibility in multi-step oligosaccharide synthesis. These novel glycosyl donors were synthesized using inexpensive 2-allylphenol as the aglycone. Noteworthy, being structural analogs of 4-pentenyl and aryl glycosides, 2-allylphenyl glycosides show high reactivity in glycosylation and have dual activation properties. This new leaving group can be activated remotely, via the allyl group, like in conventional 4-pentenyl glycosides. Conversely, this can be activated directly via the anomeric oxygen, similarly to that of aryl glycosides. Having explored these mechanistic pathways for their glycosidation, we determined that the 2-allylphenyl glycosides also fit into existing progressive concepts for oligosaccharide synthesis.<sup>3</sup> Thus, 2-allylphenyl glycosides can be chemoselectively activated in the armed-disarmed fashion and show complete orthogonality with thioglycosides. This work has been generously supported by awards from the NSF and NIGMS. The presenting author is indebted to UM – St. Louis Graduate School for awarding her with the Dissertation Fellowship.

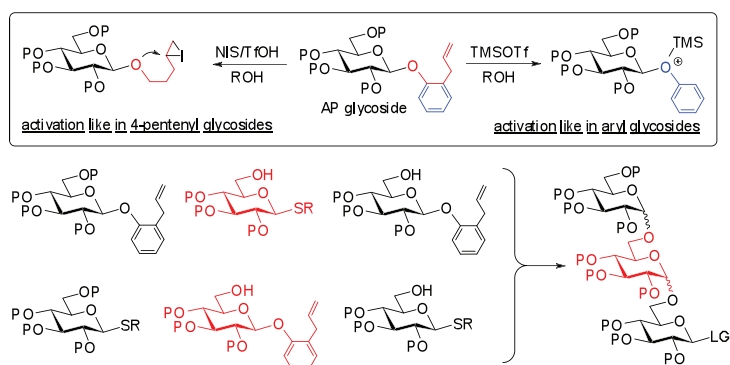

### References

1. *Essentials of Glycobiology*; Second ed.; Varki, A.; Cummings, R. D.; Esko, J. D.; Freeze, H. H.; Bertozzi, C. R.; Stanley, P.; Hart, G. W.; Etzler, M. E., Eds.; CSH Laboratory Press: New York, **2009**.
2. *Handbook of Chemical Glycosylation: Advances in Stereoselectivity and Therapeutic Relevance*; Demchenko, A. V., Ed.; Wiley-VCH: Weinheim, Germany, **2008**.
3. Smoot, J. T.; Demchenko, A. V. *Adv. Carbohydr. Chem. Biochem.* **2009**, 62, 161-250.



## OL 124

## PREPARATION OF MUCIN TYPE O-GLYCANS BY IONIC CATCH AND RELEASE OLIGOSACCHARIDE SYNTHESIS (ICROS)

Rachel A. Jones,<sup>a</sup> Anh Tuan Tran,<sup>a</sup> Nichola Smith<sup>b</sup> and M. Carmen Galan.<sup>a\*</sup>

<sup>a</sup>*School of Chemistry, University of Bristol, Bristol, BS8 1TS, U.K.*

<sup>b</sup>*Novartis Institute for Biomedical Research, Horsham, West Sussex, RH12 5AB, U.K.*  
*rachel.a.jones@bristol.ac.uk*

Mucins are high molecular weight glycoproteins in which the oligosaccharide motif is α-O-linked to the peptide backbone via a serine or threonine residue. These glycoproteins form an integral part of mucosal barriers and offer protection against pathogenic infection.<sup>1</sup>

To date, eight core oligosaccharides have been identified as being present on the mucins. However, there have been few syntheses of these carbohydrate cores due to the lack of available methods for the preparation of complex carbohydrates.<sup>2-6</sup>

We recently developed the ionic catch and release oligosaccharide synthesis (ICROS) as a general and efficient method for the preparation of complex oligosaccharides that requires no lengthy chromatography after each reaction step. It has been shown that this methodology is compatible with current glycosylation strategies and amenable to protecting group manipulations.<sup>7</sup>

Exploiting this recently developed ICROS; we herein present the application of ICROS to the rapid and efficient synthesis of core 1, 3 and 4 oligosaccharides.

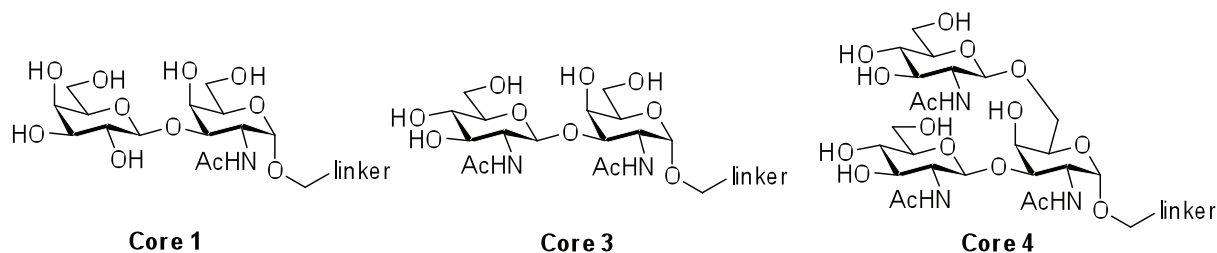

**Figure One:** Core 1, 3 and 4 structures of mucin-type O-linked glycans

### References

1. Varki, A., Lowe, J. B., *Essentials of glycobiology*, Varki, A., Ed., Cold Spring Harbor Laboratory Press, 2009., Cold Spring Harbor (NY), 2009.
2. Mathieux, N., Paulsen, H., Meldal, M., Bock, K., *J. Chem. Soc., Perkin Trans. 1*, **1997**, 2359-2368.
3. Geiger, J., Reddy, B. G., Winterfeld, G. A., Weber, R., Przybylski, M., Schmidt, R. R. *J. Org. Chem.* **2007**, *72*, 4367-4377.
4. Smoot, J. T.; Demchenko, A. V. *Adv. Carbohydr. Chem. Biochem.*, **2009**, *62*, 161-250.
5. Galan, M. C., Benito-Alifonso, D., Watt, G. M., *Org. Biomol. Chem.*, DOI:10.1039/C0OB01017K.
6. Galan, M. C., Corfield, A. P., *Biochem. Soc. Trans.*, **2010**, *38*, 1368-1373.
7. Tran, A. T., Burden, R., Racys, T. D., Galan, M. C., *Chem Commun*, DOI:10.1039/C0CC05580H

## OL 125

**IMMOBILIZATION OF CELLS OF LEUCONOSTOC MESENTEROIDES  
KIBGE HA1 ON CALCIUM ALGINATE BEADS FOR THE CONTINUOUS  
PRODUCTION OF LOW MOLECULAR WEIGHT DEXTRAN**

Shah Ali Ul Qader, Aman A, Azhar A

*The Karachi Institute of Biotechnology and Genetic Engineering (KIBGE),  
University of Karachi – Pakistan  
madar\_chem@yahoo.com*

Dextran is an extracellular long chain polymer of D-glucopyranose with predominantly  $\alpha$ -(1 $\rightarrow$ 6) linkage in the main chain. Bacterial strains of *Leuconostoc*, *Streptococcus* and *Acetobacter* produce dextran under certain conditions. The advantages of immobilizing the cell rather than a purified enzyme are numerous. These includes; the expense of separation, isolation and purification of enzymes is minimized, a wider scope of reactions is possible including multi-step reactions utilizing several enzymes and enhanced stability of enzymes achieved since the enzyme is maintained in its native site. The cells of *Leuconostoc mesenteroides* KIBGE HA1 were immobilized on calcium alginate for the continuous production of dextran. Concentration of sodium alginate and calcium chloride was optimized for maximum entrapment of cells. From immobilized cells of *Leuconostoc mesenteroides* KIBGE HA1 the dextran production was effected by the temperature. Dextran production increases as the temperature increases and after reaching maximum at 30°C the production suddenly decreases. It was also observed that at 50°C the dextran production decreases upto 25% as compared to 100% production at 30°C. Dextran production from immobilized cells was also compared from free cells at various temperature and found that there was no shift in temperature optimum of the dextran produced by immobilized and free cells. Sucrose at substrate concentration of 10% produced high yield of dextran at 30°C with a percent conversion of 5.82 while at 35°C it was 3.5. However, increasing levels of sucrose concentration as a substrate diminished dextran yields. The free cells stopped producing dextran after 144 hours, while immobilized cells continued to produce dextran even after 480 hours. Molecular mass distribution of dextran from free cells indicated that it is identical to that of blue dextran while the molecular mass of dextran from immobilized cells is lower than that of free cells. The production of different molecular mass dextran can easily be controlled by varying different incubation time of immobilized cells and substrate.

## OL 126

ANOMERIZATION REACTION OF PYRANOSIDES  
WITH 2,3-*trans* CARBAMTE GROUPShino Manabe,<sup>1</sup> Yukishige Ito<sup>1,2</sup><sup>1</sup>RIKEN Advanced Science Institute,<sup>2</sup>ERATO, JST

smanabe@riken.jp

Since pyranosides are asymmetrical acetal, two cleavage patterns are possible: endocyclic cleavage vs. exocyclic cleavage. In an endocleavage mode, the bond between anomeric carbon and ring oxygen is cleaved. The 2,3-*trans* carbamate and carbonate carrying pyranosides are easily anomerized from the  $\beta$ - to the  $\alpha$ -direction via endocyclic cleavage-recyclization process. The acyclic cation generated via endocyclic cleavage was captured by reduction, intra- and intermolecular Friedel-Crafts reaction.<sup>1</sup> Significant solvent effect was found in the anomerization reaction<sup>2</sup>. The anomerization reaction was accelerated in CH<sub>3</sub>CN, on the other hand no anomerization was observed in Et<sub>2</sub>O. The substitution effect was also observed in the anomerization reaction<sup>3</sup>. The acyl group on the nitrogen enhances the anomerization reaction. The utility of this anomerization in the oligosaccharide preparation will be reported.

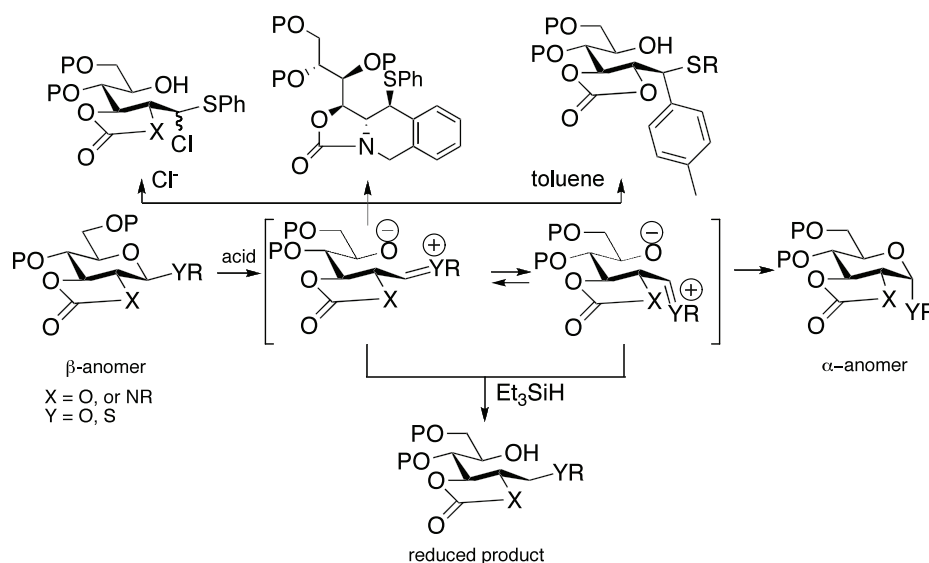

## References

1. S. Manabe, K. Ishii, D. Hashizume, H. Koshino, Y. Ito, **2009**, *15*, 6894-6901.
2. S. Manabe, Y. Ito, *Tetrahedron Lett.*, **2009**, *50*, 4827-4829.
3. H. Satoh, S. Manabe, Y. Ito, H. P. Luthi, T. Laino, J. Hutter, *submitted*.

## OL 127

## SYNTHESIS OF CALIXARENE-BASED GLYCOCLUSTERS: INFLUENCE OF THE SPACER ARM ON THE AFFINITY FOR LECTINS

Samy Cecioni,<sup>1,2</sup> Susan E. Matthews,<sup>3</sup> Jean-Pierre Praly,<sup>1</sup> Anne Imberty<sup>2</sup>  
and Sébastien Vidal<sup>1,\*</sup>

<sup>1</sup> Institut de Chimie et Biochimie Moléculaires et Supramoléculaires,  
Laboratoire de Chimie Organique 2 - Glycochimie, UMR5246, Université Claude Bernard Lyon 1  
and CNRS, 43 Boulevard du 11 Novembre 1918, F-69622, Villeurbanne, France

<sup>2</sup> CERMAV – CNRS, affiliated with Université Joseph Fourier and ICMG, BP 53, F-38041,  
Grenoble Cedex 9, France

<sup>3</sup> School of Pharmacy, University of East Anglia, Norwich, NR4 7TJ, United Kingdom  
sebastien.vidal@univ-lyon1.fr

Lectin-carbohydrate interactions are playing a major role in several pathologies such as viral or bacterial infection, cancer metastasis, cell-cell communication of even fecundation. Although this interaction is highly specific, the affinity is usually weak ( $K_d \sim \text{mM}$ ) for monovalent interactions. Therefore, Nature uses the so-called “glycoside cluster effect”<sup>1</sup> to overcome this weak interaction by presenting several saccharides ligands interacting with one or more of their receptor(s) at once. Several approaches have been designed to take advantage of multivalency<sup>2</sup> including glycoclusters, glycodendrimers, and glycopolymers.<sup>3</sup>

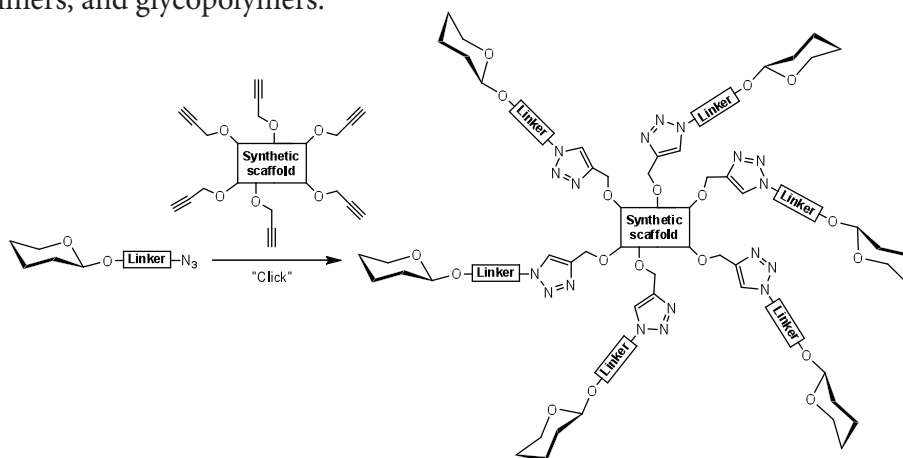

We have designed a general and flexible synthesis of glycoclusters using microwaves assisted “click chemistry” methodology for the conjugation of carbohydrate residues to multivalent scaffolds.<sup>4</sup> The binding studies (hemagglutination, ELLA, SPR and ITC) displayed preferences based on the nature of the spacer arm.

*In vivo* studies in mice models demonstrated the potential applications of such glycoclusters as **anti-adhesive agents for the treatment of bacterial infection.**<sup>5</sup>

### References

1. J.J. Lundquist, E.J. Toone, *Chem. Rev.* **2002**, 102, 555-578.
2. M. Mammen, S.-K. Choi, G.M. Whitesides, *Angew. Chem. Int. Ed.* **1998**, 37, 2754-2794.
3. R. Roy. Chabre *Adv Carb Chem Biochem*
4. (a) H. Vedala *et al. Nano Lett.* **2011**, 1, 170-175. (b) S. Cecioni *et al. Chem. Eur. J.* **2011**, in press. (c) S. Cecioni *et al. Chem. Eur. J.* **2011**, <http://dx.doi.org/10.1002/chem.201002635>. (d) J.-F. Nierengarten *et al. Chem. Commun.* **2010**, 46, 3860-3862. (e) S. Cecioni *et al. Chem. Eur. J.* **2009**, 15, 13232-13240. (f) F. Morvan *et al. Bioconjugate Chem.* **2007**, 18, 1637-1643.
5. Patent application PCT/IB2010/055741 “Glycomimetic Compounds as Anti-Infectious against Pathogens Lectins”.

## OL 128

THE INFLUENCE OF SOLVENTS ON THE STEREOSELECTIVITY  
OF GLYCOSYLATIONS

Péter Fügedi

*Department of Carbohydrate Chemistry, Chemical Research Center,  
Hungarian Academy of Sciences,  
Pusztaszeri út 59-67, H-1025 Budapest, Hungary  
pfugedi@chemres.hu*

Solvents are long known to affect the yields, rates, and stereoselectivities of glycosylation reactions. The origin of these effects, however, is somewhat obscure, and there are no clear guidelines either, how to alter stereoselectivity by the choice of solvents.

In a systematic study on factors affecting the results of glycosylations we have studied the effect of solvents on the stereoselectivity in detail.

Previously, we have found that electron withdrawing substituents remote from the anomeric position exert a strong shift on the stereoselectivity. We now present that the extent of these effects varies with the solvent and strongly correlates with the polarity of the reaction media.

The remote substituent effects in glycosylations are best explained by the conformational equilibrium of an oxocarbenium ion intermediate and stereoselective reactions of the individual oxocarbenium ion conformers. As charge neutralization is the major driving force of the conformational preference of an oxocarbenium ion, it is readily understandable that the polarity of the solvent exerts a major influence on its conformational equilibrium. The observed solvent effects clearly support this explanation, and, in the cases studied, they refute the widely used interpretation that remote substituent effects in glycosylations are caused by the formation of cyclic acyloxonium ion intermediates.

From the preparative aspect, it is important that synthetically useful stereoselectivities can frequently be achieved by the appropriate choice of a remote substituent and solvent. It should also be noted that, depending on the substrate, the same solvent is capable to increase both a and b stereoselectivities.

## OL 129

## ACCESS TO UNNATURAL OLIGOSACCHARIDES UNDER MILD GLYCOSIDATION CONDITIONS

Daniele D'Alonzo, Annalisa Guaragna, Antonio Dell'Isola and Giovanni Palumbo

*Dipartimento di Chimica Organica e Biochimica, Università "Federico II" di Napoli, Via Cinthia, 4 I-80126 Napoli (ITALY)  
dandalonzo@unina.it*

As a consequence of the progresses in glycobiology and the development of carbohydrate-based pharmaceuticals,<sup>1</sup> innovative procedures for the synthesis of natural and unnatural oligosaccharides and glycoconjugates have been explored over the last years.<sup>2</sup> Particularly, synthetic studies enabling assembly of oligosaccharides containing L-sugars have drawn attention,<sup>3</sup> given the occurrence of L-sugars in bioactive natural products and the emergence of synthetic drug candidates based on L-carbohydrates and their analogues.<sup>4</sup> However, access to such oligosaccharides is still complicated by the limited availability of the corresponding L-monomers, for which preparation simple synthetic procedures are highly demanding. Herein, we report a new strategy for the synthesis of oligosaccharides containing enantiopure L-hexoses. Key for the success of this approach is the use of  $\alpha$ -L- and  $\beta$ -L-sugar derivatives **2** and **3**, whose preparation through a "domino" reaction starting from heterocycle **1** has already been at the core of previous studies on the synthesis of the whole series of L-hexoses.<sup>5</sup> Based on the unique properties of our sulfur-containing cyclic scaffolds, unprecedented orthogonal activation of **2** and **3** respectively at C1 and C4 positions under extremely mild acidic conditions has been exploited for their conjugation to various sugar units, enabling straightforward access to L-hexoses-containing di- and trisaccharides.

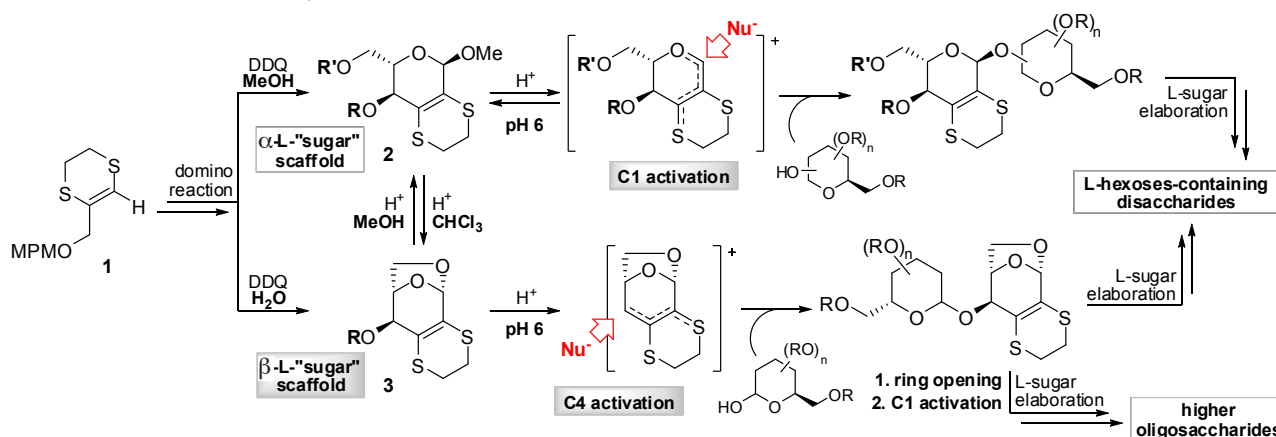

## References

1. B. Ernst, J. L. Magnani, *Nat. Rev. Drug Discovery*, **2009**, *8*, 661–677.
2. T. J. Boltje, T. Buskas, G.-J. Boons, *Nature Chem.*, **2009**, *1*, 611–622.
3. D. D'Alonzo, A. Guaragna, G. Palumbo, *Curr. Org. Chem.*, **2009**, *13*, 71–98.
4. J. J. Forsman, R. Leino, *Chem. Rev.*, **2011**, *in press*. DOI: 10.1021/cr1002563.
5. A. Guaragna, D. D'Alonzo, C. Paolella, C. Napolitano, G. Palumbo, *J. Org. Chem.*, **2010**, *75*, 3558–3568.



## OL 130

## CARBOHYDRATES IN CATALYSIS

Holger Grugel, Gülsüm Özüdüdu, Tobias Minuth, Mike M. K. Boysen

Institute of Organic Chemistry, Gottfried Wilhelm Leibniz University of Hannover, Schneiderberg 1B, 30167 Hannover, Germany  
 mike.boysen@oci.uni-hannover.de

The demand for enantiomerically pure compounds in medicinal chemistry and natural product synthesis has spurred a tremendous interest in stereoselective transformations. As asymmetric catalysis using metal complexes with chiral ligands offers efficient access to chiral building blocks, the design of new ligands is an active field of research. Carbohydrates, which have long been regarded as ill suited for ligand design, are nowadays becoming more and more popular scaffolds for new chiral complex ligands.<sup>1</sup>

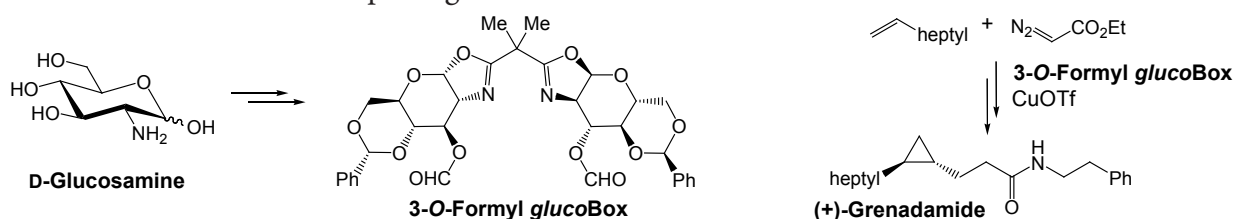

We have introduced new bis(oxazoline) ligands based on D-glucosamine (*glucoBox*),<sup>2</sup> which were successfully applied to the synthesis of the natural product grenamide<sup>3</sup> via an asymmetric cyclopropanation.<sup>4</sup> With ligands *gluco-enoPhos* and *galacto-enoPhos* we have designed novel olefin-phosphinite ligands easily accessible from D-glucose and D-galactose.<sup>5</sup> These act as a set of highly efficient *pseudo* enantiomers in asymmetric rhodium-catalysed 1,4-addition reactions.<sup>6</sup>

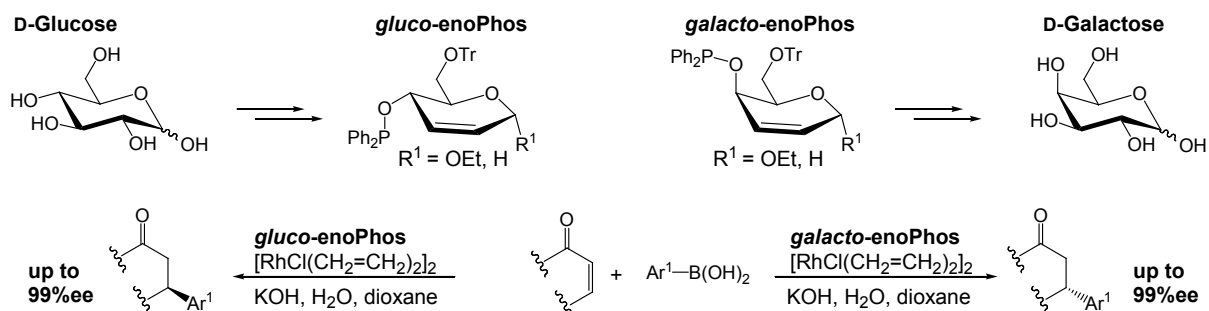

## References

- Reviews: (a) M. Diéguez, O. Pamies, C. Claver, *Chem. Rev.* **2004**, *104*, 3189-3215; (b) M. Diéguez, C. Claver, O. Pamies, *Eur. J. Org. Chem.* **2007**, 4621-4634; (c) M. M. K. Boysen, *Chem. Eur. J.* **2007**, *13*, 8648-8659; (d) V. Benessere, A. De Roma, R. Del Litto, F. Ruffo, *Coord. Chem. Rev.* **2010**, *254*, 390-401; (e) S. Woodward, M. Dieguez, O. Pamies, *Coord. Chem. Rev.* **2010**, *254*, 2007-2030.
- a) T. Minuth, M. Irmak, A. Groschner, T. Lehnert, M. M. K. Boysen, *Eur. J. Org. Chem.* **2009**, *7*, 997-1008; b) T. Minuth, M. M. K. Boysen, *Beilstein J. Org. Chem.* **2010**, *6*.
- T. Minuth, M. M. K. Boysen, *Synthesis* **2010**, 2799-2803.
- D. A. Evans, K. A. Woerpel, M. M. Hinman, M. M. Faul, *J. Am. Chem. Soc.* **1991**, *113*, 726-729.
- a) T. Minuth, M. M. K. Boysen, *Org. Lett.* **2009**, *11*, 4212-4215; b) H. Grugel, T. Minuth, M. M. K. Boysen, *Synthesis* **2010**, 3248-3258; c) H. Grugel, M. M. K. Boysen, manuscript in preparation.
- T. Hayashi, K. Yamasaki, *Chem. Rev.* **2003**, *103*, 2829-2844.



## OL 131

## SYNTHESIS OF OLIGOETHYLENEGLYCOL-LINKED CARBOHYDRATE EPITOPES AS ARTIFICIAL LIGANDS FOR THE CARBOHYDRATE-BINDING PROTEIN MALECTIN

Lisa N. Müller<sup>1</sup>, Claudia Muhle-Goll<sup>2</sup> and Moritz B. Biskup<sup>1</sup><sup>1</sup>Karlsruher Institut für Technologie - KIT, Institut für Organische Chemie (IOC), Fritz-Haber-Weg 6, D-76131 Karlsruhe<sup>2</sup>Karlsruher Institut für Technologie - KIT, Institut für Biologische Grenzflächen (IBG-II), D-76344 Eggenstein-Leopoldshafen  
moritz.biskup@kit.edu

The carbohydrate-binding protein *malectin*, an ER-resident protein, is currently being discussed as a possible player in *N*-glycoprotein quality control in higher eukarya.<sup>1</sup> Its binding affinity to disaccharides and to defined fragments of the Glc<sub>3</sub>Man<sub>9</sub>GlcNAc<sub>2</sub>-*N*-glycan precursor **1**, e.g. fragments as the Glc<sub>2</sub>Man<sub>7</sub>GlcNAc<sub>2</sub>-*N*-glycan, has been demonstrated.<sup>2,3</sup> As the exact binding epitopes of such carbohydrate structures remained unknown, we commenced a synthetic program aimed at the preparation of defined *N*-glycan precursor fragments as possible *malectin* ligands. Recently, we reported on the synthesis of a Glc<sub>2</sub>Man<sub>2</sub>-fragment **2** (highlighted region in **1**) and its binding properties with regard to *malectin*.<sup>4</sup>

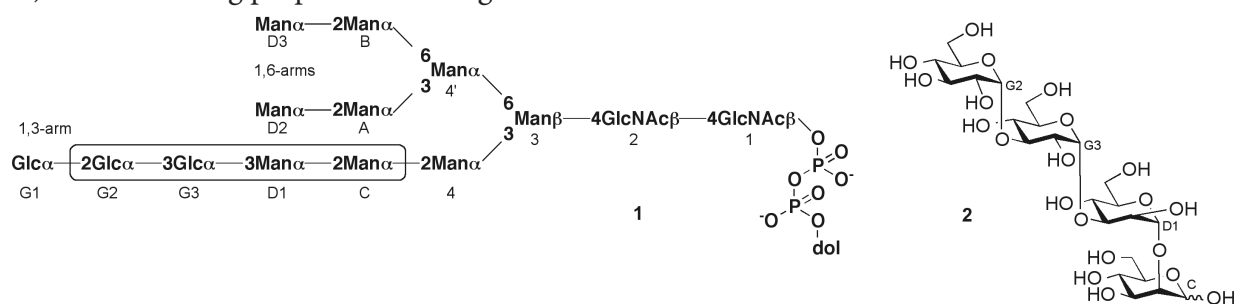

Based on these results we envisioned a second generation of potential *malectin* ligands, incorporating not only carbohydrate residues from the *N*-glycan precursor's 1,3-arm (highlighted in blue), but from the 1,6-arms (highlighted in green) as well.

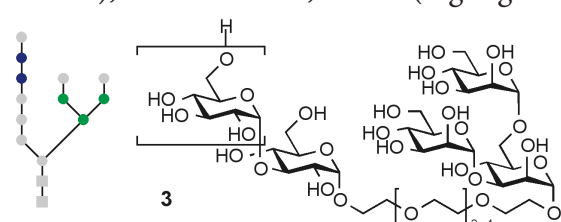

Here, we present the synthesis of compounds presenting two distinct, oligoethyleneglycol-linked carbohydrate epitopes (**3**); as well as our results regarding their binding properties with respect to *malectin* (determined from NMR-experiments).

## References

1. M. Aebi, R. Bernasconi, S. Clerc, M. Molinari, *Trends Biochem. Sci.* **2010**, *35*, 74-82.
2. T. Schallus, C. Jaekch, K. Feher, A. S. Palma, Y. Liu, J. C. Simpson, M. Mackeen, G. Stier, T. J. Gibson, T. Feizi, T. Pieler, C. Muhle-Goll, *Mol. Cell. Biochem.* **2008**, *19*, 3404-3414.
3. T. Schallus, K. Feher, U. Sternberg, V. Rybin, C. Muhle-Goll, *Glycobiology* **2010**, *20*, 1010-1020.
4. L. N. Müller, C. Muhle-Goll, M. B. Biskup, *Org. Biomol. Chem.* **2010**, *8*, 3294-3299.

## OL 132

## SYNTHESIS OF BIOACTIVE SUGARS WITH CONJUGATED CARBONYL FUNCTIONS AND RELATED TRIAZOLES FROM BICYCLIC LACTONES

Nuno M. Xavier,<sup>1,3</sup> Margarida Goulart,<sup>2</sup> Ana Neves,<sup>2</sup> Jorge Justino,<sup>2</sup> Amélia P. Rauter,<sup>1</sup> and Yves Queneau<sup>3</sup>

<sup>1</sup>Universidade de Lisboa, Faculdade de Ciências, Centro de Química e Bioquímica/Departamento de Química e Bioquímica, Campo Grande, Ed. C8, Piso 5, 1749-016 Lisboa, PORTUGAL,

<sup>2</sup>Escola Superior Agrária, Instituto Politécnico de Santarém, Complexo Andaluz, 2001-904 Santarém, PORTUGAL,

<sup>3</sup>ICBMS, Université Lyon-CNRS, UMR 5246, INSA Lyon, Bât J. Verne, 20 Av. A. Einstein, F-69621 Villeurbanne, FRANCE  
nmxavier@fc.ul.pt

Sugar enones are versatile building blocks for a variety of natural products and relevant bioactive chiral molecules [1]. The fungal metabolite Microthecin [2] is an example of a bioactive pyranoid enone, presenting a 3-enopyran-2-ulose skeleton. Enones of this type possess stereogenic centers next to the conjugated system, which may induce stereoselectivity in addition reactions, turning them useful chiral precursors for derivatization. Among the methods known for the synthesis of such enones, those employing  $\beta$ -acylated pyran-2-uloses are preferred since these compounds are prone to  $\beta$ -elimination. In this context we used triacetylated carboxymethyl glycoside lactones (CMGL, **1**) as synthons [3]. The opening of their lactone moiety, especially by amines, provides adducts containing a free and unique OH group at C-2. Further oxidation is shown to occur with concomitant 3,4-elimination [4]. In the present work, different oxidation methods were used and the influence of configuration at C-1 and C-4 on the oxidation-elimination process towards the target enones (**2**) was investigated. Branching at C-2 by Wittig olefination was subsequently explored leading to conjugated dienepyransides **3**. (*N*-Propargylcarbamoyl)methyl glycosides were used for the incorporation of an additional triazole motif, leading to **4–5**. The results of the antimicrobial evaluation performed on these series of compounds against clinically significant pathogens and those of acute toxicity will also be disclosed in this communication.

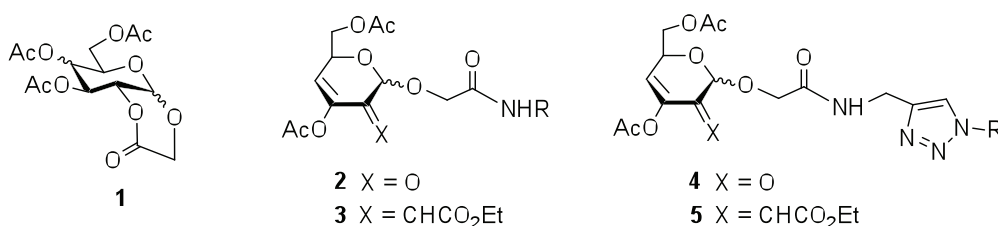

## References

- Xavier, N. M.; Rauter, A. P. *Carbohydr. Res.*, **2008**, *343*, 1523–1539.
- Fiskesund, R.; Thomas, L. V.; Schobert, M.; Ernberg, I.; Lundt, I.; Yu, S. *J. Appl. Microbiol.*, **2009**, *106*, 624–633.
- Cheab, R.; Listkowski, A.; Chambert, S.; Queneau, Y. *Tetrahedron: Asymmetry*, **2008**, *19*, 1919–1933.
- Xavier, N. M.; Goulart, M.; Neves, A.; Justino, J.; Chambert, S.; Rauter, A. P.; Queneau, Y. *Bioorg. Med. Chem.*, **2011**, *19*, 926–938

## OL 133

INFLUENCE OF IONIC LIQUIDS ON ENZYMATIC SYNTHESIS  
OF  $\beta$ -GALACTOSIDASE FROM *Thermus Thermophilus*:  
A SURFACE PLASMON RESONANCE AND MOLECULAR MODELING ANALYSIS

M. Sandoval,<sup>1</sup> Álvaro Cortés,<sup>2</sup> Eloy Ferreras,<sup>2</sup> Juan Treviño,<sup>3</sup> José Berenguer,<sup>2</sup> Pedro Lozano,<sup>4</sup>  
José V. Sinisterra,<sup>1,3</sup> María J. Hernaiz,<sup>1,3\*</sup>

<sup>1</sup>Department of Pharmaceutical and Organic Chemistry, Complutense University of Madrid,  
Campus de Moncloa, 28040, Madrid, Spain,

<sup>2</sup>Center of Molecular Biology Severo Ochoa. Faculty of Biology.  
CSIC-Autónoma University, Madrid. Spain,

<sup>3</sup>Molecular Interactions Unit and Biotransformations Unit, Science Park of Madrid.  
Campus de Moncloa, 28040, Madrid. Spain,

<sup>4</sup>Department of Biochemistry and Molecular Biology. Faculty of Chemistry.  
University of Murcia. Campus de Espinardo. E-30.100. Murcia. Spain  
mjhernai@farm.ucm.es

The use of enzymes and whole cells for catalysis in the chemical industry is of great interest, as environmentally friendly alternative (1,2). The combination of biocatalysts with the appropriate solvents is key to the successful construction of a bioprocess. As many enzymes can catalyze reactions in organic solvents, there is much interest in the use of ionic liquids (ILs) as (co) solvents to create novel reaction media for such biocatalytic processes. ILs have emerged as a potentially attractive “green” recyclable alternative to environmentally harmful organic solvents (1,2).

The use of enzymes in ILs has proven to have many advantages, such as, high conversion rates, high enantioselectivity, and better enzyme stability (3). Several authors have explained this behaviour in terms of enzyme-ILs molecular interactions but to our knowledge nobody has tried to quantify them until now. So far, ILs have been used in various enzymatic reactions, but studies of the use of ILs in transglycosylation catalyzed by glycosidases are scarce (4).

In this communication we have studied for the first time the influence of ILs as co-solvents in the enzymatic synthesis of a  $\beta$ -galactosidase from *Thermus thermophilus* (cell extracts and purified recombinant enzyme TTP0042 his<sub>6</sub>tag). TTP0042 his<sub>6</sub>tag exhibit important yields of *N*-Acetyllactosamine (Gal- $\beta$ [1 $\rightarrow$ 4]GlcNac) in one pot process, reducing classic self-condensation of glycosyl donor and improving yields. Some ILs employed are insoluble in water and could be re-use in many reactions, reducing economical costs., The increased activity found is believed to be caused by the interactions between the enzyme and ILs that were studied by molecular modelling and measured using surface plasmon resonance (SPR).

### References

1. M.J. Hernaiz, A.R. Alcántara, J.I. García, J.V. Sinisterra, *Chem. Eur. J.*, **2010**, 16, 9422 – 9437.
2. M. Pérez, J.V. Sinisterra, M.J. Hernaiz, *Curr. Org. Chem.*, **2011**, in press.
3. P. Lozano, *Green Chem.*, **2010**, 12, 555–569
4. (a) M. Lang, T. Kamrat, B. Nidetzky, *Biotech. Bioeng.* **2006**, 95, 1093 (b) N. Kaftzik, P. Wasserscheid, U. Kragl, *Org. Process Res. Dev.*, **2002**, 6, 553.

## OL 134

## EFFICIENT SYNTHESIS OF BUILDING BLOCKS AND BLOCKWISE BUILD-UP OF RHAMNOGALACTURONAN FRAGMENTS BY MODULAR DESIGN

Amayak Pogosyan, Vogel Christian

Universität Rostock, Institut für Chemie Albert-Einstein-Straße 3a 18059 Rostock  
 amayak.pogosyan@uni-rostock.de ; christian.vogel@uni-rostock.de

Blockwise build-up of homogalacturonan and rhamnogalacturonan fragments by modular design principle is based on an orthogonal protecting group strategy<sup>1</sup>. In first part this work are introduced context of methods and concrete algorithms for efficient synthesis L-rhamnose and D-galacturonoacide derivatives as a building blocks<sup>2</sup> (Schema 1).

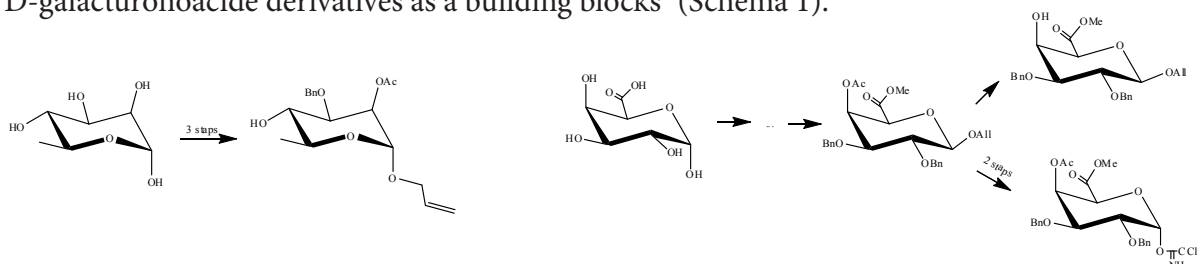

Schema 1

Second part of our investigation refers to a plan of action designed to achieve a particular goal-build up of rhamnogalacturonan fragments (Schema 2).

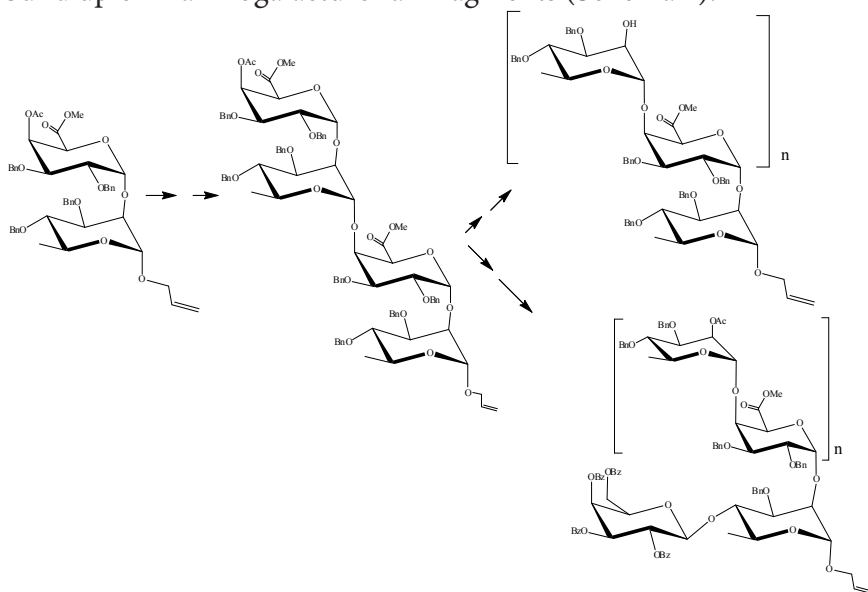

Schema 2

## References

1. Vogel, C.; Nolting, B.; Kramer, S.; Steffan, W.; Ott, A.–J. Synthesis of pectin fragments by modular design principle. In *Advances in Pectin and Pectinase Research*; Voragen, F., Schols, H., Visser, R., Eds.; Kluwer Academic Publishers: Dordrecht, Boston, London, 2003; pp 209–220.
2. Voss, A.; Nemati, N.; Poghosyan, H.; Endress, H.-U.; Krause, A. and Vogel, C; *Carbohydrate Chemistry: Proven Synthetic Methods* vol. 1 (in press)

## OL 135

## STRUCTURAL ANALYSIS OF CARBOHYDRATES AND GLYCOPROTEINS USING RAMAN OPTICAL ACTIVITY

Christian Johannessen<sup>1</sup> and Ewan W. Blanch<sup>1</sup>

<sup>1</sup>*Manchester Interdisciplinary Biocentre, University of Manchester, 131 Princess St., Manchester M1 7DN, United Kingdom.  
Christian.Johannessen@manchester.ac.uk*

Raman optical activity (ROA) has over the last few decades emerged as a powerful tool in the structural analysis of biomolecules.<sup>[1,2]</sup> This chiroptical technique, measuring a small intensity difference in the circularly polarised components of the Raman scattered light from chiral molecules, combines the conformational sensitivity of circular dichroism with the structural information available from conventional vibrational spectroscopy. ROA is highly sensitive to local chirality, making the technique ideally suited for the study of chiral biomolecules in solution, from simple amino acids and monosaccharides,<sup>[3]</sup> through peptides, proteins and oligosaccharides<sup>[4]</sup> and even complex samples such as intact viruses and glycoproteins.<sup>[5]</sup> Here, we present ROA as a novel tool in the detailed structural analysis of carbohydrates and the glycan moieties of glycoproteins in solution. Comparison of experimental ROA spectra of glycoproteins with spectra obtained from smaller saccharides found as components in the glycan coats indicate that the over-all conformation of the component saccharides in the glycan coat are preserved in solution.<sup>[6]</sup> Therefore, it is possible to study the three dimensional structure of complex saccharides by zooming in on specific component parts, reducing the computational costs of the conformational analysis. By combining experimental ROA studies with molecular dynamics simulations and quantum mechanical calculations on density functional theory level, we have studied the conformational states of monosaccharides and smaller oligosaccharides in detail and show that the structural results can be transferred onto polysaccharides or even whole glycan coats. The data presented in this talk will focus on recent structural studies performed on high mannose type glycoproteins and mannose saccharides,<sup>[6]</sup> as well as on results obtained on the linear glycosaminoglycan hyaluronan.<sup>[7]</sup>

### References

1. L.D. Barron, *Curr. Opin. Struc. Biol.* **2006**, *16*, 638-643.
2. L.D. Barron, F. Zhu, L. Hecht, G.E. Tranter and N.W. Isaacs, *J. Mol. Struc.*, **2007**, *834-836*, 7-16.
3. Z.Q. Wen, L. Hecht and L.D. Barron, *J. Am. Chem. Soc.*, **1993**, *115*, 285-292.
4. A.F. Bell, L. Hecht, L.D. Barron, *Jour. Ram. Spec.*, **1995**, *26*, 1071-1074.
5. F. Zhu, N.W. Isaacs, L. Hecht, G.E. Tranter and L.D. Barron, *Chirality*, **2006**, *18*, 103-115.
6. C. Johannessen, R. Pendrill, G. Widmalm, L. Hecht and L.D. Barron, *submitted to Angew. Chem.*
7. N. Yaffe, A. Almond and E.W. Blanch, *J. Am. Chem. Soc.*, **2010**, *132*, 10654-10655.

## OL 136

**ENHANCED HETEROTETRAMERIC FORMATION OF POTATO ADP-GLUCOSE  
PYROPHOSPHORYLASE THROUGH REVERSE GENETICS**

A. Bengisu Seferoglu, Ibrahim Baris and I. Halil Kavakli

*Department of Chemical and Biological Engineering, Collage of Engineering,  
Koc University, Rumeli Feneri Yolu Istanbul, Turkey  
aseferoglu@ku.edu.tr*

ADP glucose pyrophosphorylase (AGPase) is a key regulatory enzyme of bacterial glycogen and plant starch synthesis as it controls carbon flux via its allosteric regulatory behavior. Whereas the bacterial enzyme is composed of a single subunit type, the plant AGPase is a heterotetrameric enzyme ( $\alpha 2\beta 2$ ) with distinct roles for each of the two subunit types. The large subunit (LS) is involved mainly in allosteric regulation through its interaction with the catalytic small subunit (SS). Previously, critical amino acids of potato (*Solanum tuberosum* L.) LS that interact with SS in the native heterotetramer structure were identified by both computationally and experimentally<sup>1</sup>. In this study, we aim to improve heterotetrameric assembly of potato AGPase with a reverse genetics approach. A mutant,  $\alpha 2\beta 2$  formation deficient, large subunit of potato (*Solanum tuberosum* L.) AGPase named LS<sub>R88A</sub> was subjected to random mutagenesis using error prone PCR and screened for the capacity to form an enzyme restoring glycogen production in *glgC*<sup>-</sup> *Escherichia coli*, AGPase activity deficient, containing wild type SS by assessing iodine staining. Many suppressor mutants were identified and sequence analysis of these mutants revealed that mutations are mainly clustered at regions that would be significant for subunit association. Subsequently, R88A mutation was reversed with site directed mutagenesis to see the effect of these mutations in the absence of R88A mutation. We are currently characterizing the effects of these mutants on heterotetrameric formation of AGPase. Obtaining stable AGPase variants will enable us to use these mutants to increase the yield in crop plants and so to increase the use of starch for industrial purposes.

**References**

1. Baris I, Tuncel A, Ozber N, Keskin O, Kavakli IH, *PLoS Comput Biol.*, **2009**, 5(10):e1000546.



## OL 137

**IMPROVED PROCESS FOR ENHANCED PRODUCTION  
OF SUGARS FROM SUGAR BEET**

Ahmad Adnan, Saleem Ahmad Bokhari and Fahim Ashraf Qureshi

Sugar production from sugar beet has been known for many years. The current processes for sugar production from Sugar beet is energy intensive, involving high pressure steam, and involves wastage of approximately 25 – 30 percent of cellulosic waste. We have developed a process for extraction of sugar from Sugar beet crop that utilizes various enzymes and also converts the cellulosic material (waste) into sugars. The overall recovery of sucrose has been raised to 11% as compared to 8% by conventional diffusion techniques for sugar extraction from Sugar beet. The process also envisages 13% recovery of reducing sugars from this new process. Residual biomass is mainly composed of lignin which may be utilized for other industrial application thus making the process nearly with zero waste. Since this new process does not require any additional water, the overall process will need relatively less energy for crystallization of sugars from the resulting solution.



## OL 138

## STARCH-CELLULOSE RETICULATION – TOWARDS A NEW MATERIAL

Pierre-Henri Elchinger,<sup>1,2</sup> Daniel Montplaisir,<sup>2</sup> Rachida Zerrouki<sup>1</sup>

<sup>1</sup>Laboratoire de chimie des substances naturelles, Université de Limoges,  
123 avenue Albert Thomas 87060 Limoges, FRANCE,

<sup>2</sup>Centre de recherche en pâtes et papiers, Université du Québec à Trois-Rivières, 3351  
boul. des Forges, C.P. 500, Trois-Rivières (QC) G9A 5H7,  
elchinger@live.fr

Starch application in papermaking dates back to the invention of paper itself 2000 years ago, when starch was applied to the paper for a stronger, smoother writing surface. One of the many possible applications of starch in paper manufacturing is its use as a binding agent which can enhance paper's mechanical properties, and also improve paper manufacturing by increasing paper pulp retention the paper machine. Here, we take the advantage of the CuAAC reaction<sup>1</sup> to fix starch on cellulose in order to create a three-dimensional network. This crosslinked network can be used in new biocomposite materials.

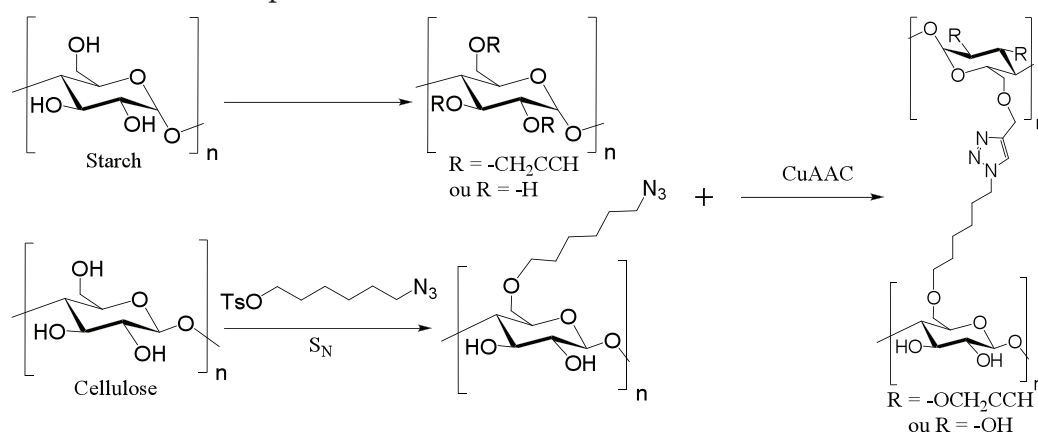

This research describes a click reticulation through a spacer molecule, for modified polysaccharides crosslinking. Doing so, the reactive functions become more accessible, returning any ulterior reaction easier. Alkyne starch was synthesized using the classical method.<sup>2</sup> Azide spacer molecule was obtained in two steps, first by di-tosylation in solvent free condition, then by a mono-azidation. The spacer molecule was then fixed on cellulose by nucleophilic substitution. The two modified polysaccharides were crosslinked in the presence of Cu(I) catalyst, a type of Huisgen's 1,3-dipolar azide-alkyne cycloaddition which is also defined as "click chemistry". Modified polysaccharides substrates were characterized by NMR, FTIR and XPS spectroscopies and the resulting material was characterised by means of scanning electron microscopy (SEM).

### References

- (a) R. Huisgen, R. Knorr, L. Mobius, G. Szeimmies, *Chem. Ber.*, **1965**, 98, 4014-4021. (b) H. C. Kolb, M. G. Finn, K. B. Sharpless, *Angew. Chem. Int. Ed.*, **2001**, 40, 2004-2021. (c) R. Lucas, R. Zerrouki, R. Granet, P. Krausz, Y. Champavier, *Tetrahedron*, **2008**, 64, 5467-5471.
- P. F. Tankam, R. Müller, P. Mischnicka, H. Hopf, *Carbohydrate Research*, **2007**, 342, 2049-2060.

## OL 139

## SYNTHESIS OF MULTIVALENT OLIGOSACCHARIDES AS ANTIMICROBIAL AGENTS FOR TREAT GUT INFECTION

Guan-Nan Wang,<sup>1</sup> Paul V Murphy<sup>1</sup>

<sup>1</sup> *School of Chemistry, National University of Ireland, Galway, University Rd, Galway*  
*guan-nan.wang@nuigalway.ie*

*Helicobacter pylori* infects over half of the world's population and is thought to be a leading cause of chronic gastritis, peptic ulcer, and gastric cancer. *Campylobacter jejuni* is another enteric and gastric bacteria which is the most common cause of bacterial diarrhea. Both of these microbes adhere to mucosa by binding blood group antigen-related carbohydrates expressed on epithelial cells.<sup>1</sup> Breast feeding protects infants against these bacterial infections, which was proven to be a consequence of the presence of large quantities of antigen oligosaccharides in human milk. Multivalent human milk oligosaccharides were synthesized with rigid and flexible scaffolds<sup>2</sup> designed to present the carbohydrates diversely. These multivalent compounds were evaluated on purified chicken large intestine mucin. Some of the compounds inhibit the binding of bacteria to the mucin. These multivalent oligosaccharides are promising prophylactic and therapeutic antimicrobials for gastric and intestinal diseases.

**References**

1. Ruiz-Palacios, G. M.; Cervantes, L. E.; Ramos, P.; Chavez-Munguia, B.; Newburg, D. S. *J. Biol. Chem.* **2003**, *278*, 14112-14120.
2. Leyden, R.; Velasco-Torrijos, T.; Andre, S.; Gouin, S.; Gabius, H. J.; Murphy, P. V. *J. Org. Chem.* **2009**, *74*, 9010-9026.

## OL 140

SYNTHETIC HIGH GLYCOSYLATED MUC1 GLYCOPEPTIDE ANTIGENS  
BOUNDED TO SYNTHETIC ADJUVANS AS POTENTIAL CANCER VACCINES

Simone Di Pietro and Horst Kunz

Department of Organic Chemistry, Johannes Gutenberg-University Mainz,  
Duesbergweg 10-14, D-55128 Mainz, Germany  
dipietro@uni-mainz.de

The mucin MUC1 is a high molecular weight membrane glycoprotein found on the surface of many epithelial cell types such as those from the breast, prostate, intestinal tract, liver, pancreas and kidney.<sup>1,2</sup> It consists of a hydrophobic transmembrane domain, a short cytoplasmic tail and a relatively large, heavily O-glycosylated extracellular domain rich in serine, threonine and proline amino acid residues. Most O-glycosylations occur at the serine and threonine residues within the 20 amino acid tandem repeat domain of MUC1 (GSTAPPAHGVTSAPDTRPAP). This number can vary from 20 to 120. The primary function of MUC1 is protection of the epithelial cells from insult, from chemical or microbial sources, resulting in the induction of inflammatory and repair or healing processes,<sup>3</sup> and has also been implicated in important cell-cell adhesion events. The MUC1 glycoprotein is an important biological target for the immunotherapy of cancer due to its altered level of expression on the surface of tumour cells. These changes manifest in an over-expression of the glycoprotein, altered levels of glycosylation and a loss of polarisation at the cell surface.<sup>4</sup> Significantly, the changes in the glycosylation profile result in the presentation of specific tumour-associated carbohydrate antigens, as well as exposure of important peptide epitopes. In its tumour-associated form, the mucin exhibits altered levels of glycosylation resulting in short, prematurely sialylated glycan chains including the T<sub>N</sub>, sialyl-T<sub>N</sub> (ST<sub>N</sub>),  $\alpha$ -2,6-sialyl-T ( $\alpha$ -2,6-ST) and  $\alpha$ -2,3-sialyl-T antigens and exposure of the immunodominant PDTRP epitope.<sup>5</sup> Although the type, number and glycosylation position of the tumour-associated carbohydrate antigens is tissue-dependent, there has been some conjecture as to whether glycosylation within the immunodominant motif increases the binding affinity of the peptide. The aim of the cancer immunotherapy is to override the multiple suppressive mechanisms and to potentiate existing immune responses against cancer cells. Therefore, we synthesized **1** in which the built-in immunoadjuvant (VQGEESNDK) corresponds to a peptide sequence derived from the interleukin 1 (IL-1) cytokine.<sup>6</sup> In addition, we conjugate different core MUC1 structures to synthetic adjuvans like Pam3Cys and Lipid A as an immunostimulant to get glycopeptide vaccine **2**.

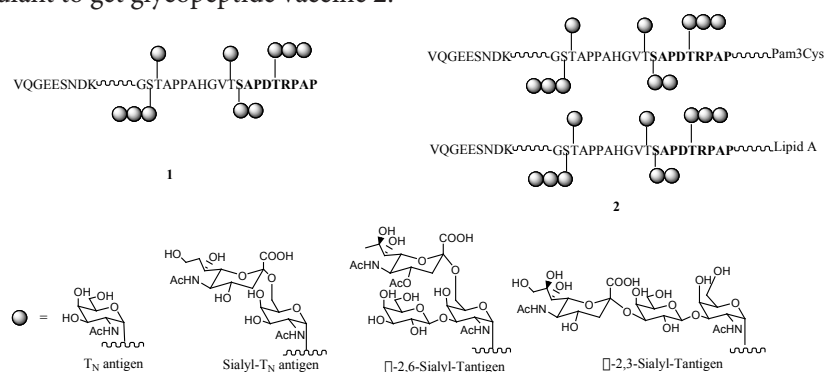

## References

- Gum, J. R. *Biochem. Soc. Trans.* **1995**, *23*, 795.
- Carlstedt, I.; Davies, J. R. *Biochem. Soc. Trans.* **1997**, *25*, 214.
- Tran, C. P.; Cook, G. A.; Yeomans, N. D.; Thim, L.; Giraud, A.; Trefoil, S. *Gut* **1999**, *44*, 636.
- Taylor-Papadimitriou, J.; Burchell, J.; Miles, D. W.; Dalziel, M. *Biochim. Biophys. Acta.* **1999**, 301.
- Burchell, J.; Taylor-Papadimitriou, J.; Boshell, M.; Gendler, S. J.; Dulig, T. *Int. J. Cancer* **1989**, *44*, 691.
- Liakatos, Angela; Kunz, H. *Current Opinion in Molecular Therapeutics* **2007**, *9*, 35
- A. Kaiser, H. Kunz, *Angew. Chem. Int. Ed.* **2010**, *49*, 3688-3692

## OL 141

**SYNTHESIS, CONJUGATION, AND IMMUNOLOGICAL EVALUATION  
OF PHOSPHONOESTER ANALOGUES OF SEROGROUP A  
NEISSERIA MENINGITIDIS CAPSULAR POLYSACCHARIDE**

Silvia Fallarini,<sup>1</sup> Fabrizio Mancin,<sup>2</sup> and Luigi Lay<sup>3</sup>

<sup>1</sup>DISCAFF, University of "Piemonte Orientale Amedeo Avogadro",  
Via Bovio 6, 28100 Novara, Italy

<sup>2</sup>Department of Chemical Sciences and ITM-CNR, University of Padova,  
Via Marzolo 1, 35131 Padova, Italy

<sup>3</sup>Department of Organic and Industrial Chemistry and CISI, University of Milano,  
Via Venezian 21, 20133 Milano, Italy  
luigi.lay@unimi.it

Serogroup A *Neisseria meningitidis* (MenA) is a Gram-negative, encapsulated bacterium, which can cause explosive epidemics of meningitis, especially in the sub-saharian region of Africa. The defence against MenA infection is mediated by the production of antibodies directed against its capsular polysaccharide (CPS), composed of (→6)-N-acetylmannosamine α-1-O-phosphate repeating units. The development of an efficient vaccine against MenA is greatly hampered by the inherent instability of the anomeric phosphodiester bridges and by the poor immunogenicity of unconjugated natural saccharides. To enhance chemical stability, fragments 1-3 of MenA CPS,

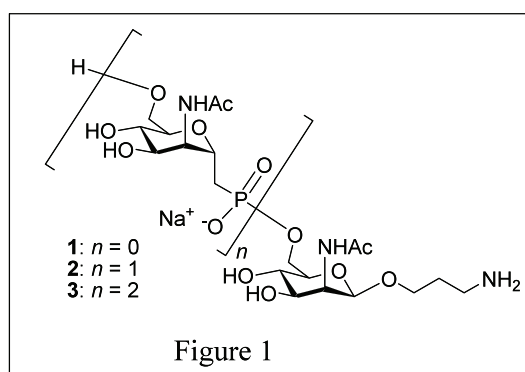

containing interglycosidic phosphonoester linkages, in place of the naturally occurring phosphodiester bridges, have been synthesised (Figure 1), showing that the synthetic fragments 2 and 3 containing the unnatural phosphonoester linkage are recognized by a human polyclonal anti-MenA serum (ELISA).<sup>1</sup> The synthetic oligomers were conjugated to passivating thiols and employed for the fabrication of multivalent gold glyconanoparticles, that bind to specific antibodies with affinities far higher than the analogous monovalent systems.<sup>2</sup> In addition, we

found that synthetic saccharide-functionalized nanoparticles are able to induce immune cell responses,<sup>3</sup> opening the access to fully synthetic leads for new vaccine development.

**Acknowledgments:** This work has been supported by MIUR-Italy (PRIN 2008).

### References

1. M. I. Torres-Sanchez, C. Zaccaria, B. Buzzi, G. Miglio, G. Lombardi, L. Polito, G. Russo, L. Lay, *Chem. Eur. J.*, **2007**, *13*, 6623-6635.
2. F. Manea, C. Bindoli, S. Fallarini, G. Lombardi, L. Polito, L. Lay, R. Bonomi, F. Mancin, P. Scrimin, *Adv. Mater.*, **2008**, *20*, 4348-4352.
3. S. Fallarini, T. Paoletti, P. Ronchi, L. Lay, R. Bonomi, S. Jha, F. Mancin, P. Scrimin, G. Lombardi, manuscript submitted

## OL 142

**INPUT OF NON STOECHIOMETRIC O-ACETYLATION ON ANTIGENICITY:  
SHIGELLA FLEXNERI 2A LPS AS AN EXAMPLE**

Charles Gauthier,<sup>1</sup> Pierre Chassagne,<sup>1</sup> Françoise Thouron,<sup>2</sup> Catherine Guerreiro,<sup>1</sup>  
François-Xavier Theillet,<sup>3</sup> Muriel Delepierre,<sup>3</sup> Armelle Phalipon,<sup>3</sup> Laurence A. Mulard<sup>1</sup>

<sup>1</sup>Institut Pasteur, Chimie des Biomolécules (URA CNRS 2128),

<sup>2</sup>Pathogénie Microbienne Moléculaire (INSERM U786),

<sup>3</sup>RMN des Biomolécules (URA CNRS 2185), 25-28 rue du Dr Roux, 75015 Paris, France  
laurence.mulard@pasteur.fr

*Shigella flexneri* are Gram-negative enterobacteria responsible for bacillary dysentery. As an alternative to *Shigella* detoxified lipopolysaccharide-protein conjugate vaccines under development, we have investigated the use of synthetic oligosaccharide-based conjugates as immunogens. We have identified the synthetic pentadecasaccharide [AB(E)CD]<sub>3</sub>, a trimer of the basic repeating unit of the *S. flexneri* 2a (SF2a) O-antigen (O-Ag), as a promising functional mimic of the native polysaccharide, and a conjugate thereof, as the first synthetic oligosaccharide-based vaccine candidate against SF2a infection.<sup>1</sup> The recent disclosure of the non stoichiometric O-acetylation of the SF2a O-Ag at both hydroxyls OH-6<sub>D</sub> and OH-3<sub>A</sub>,<sup>2,3</sup> suggested further improvements.

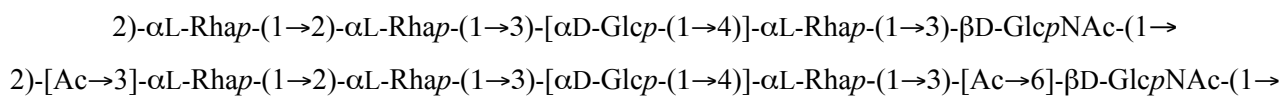

Basic repeating unit of SF2a O-Ag: AB(E)CD and its O-acetylated counterpart <sub>Ac</sub>AB(E)C<sub>Ac</sub>D

Positioned in the context of future developments in the field of *S. flexneri* carbohydrate-based vaccines, this communication reports on our present understanding of the influence of O-acetylation on SF2a O-Ag:antibody recognition. First, we will expose the convergent synthesis of three [AB(E)CD]<sub>2</sub> deca-saccharides, mono- and/or di-O-acetylated at positions 3<sub>A</sub> and 6<sub>D</sub>, by use of a common fully protected deca-saccharide intermediate. Next, we will discuss the binding of the synthetic deca-saccharides, O-acetylated or not, to five protective monoclonal IgG antibodies.

### References

1. Phalipon A, Tanguy M, Grandjean C, Guerreiro C, Belot F, Cohen D, Sansonetti PJ, Mulard LA, *J Immunol*, **2009**, 182, 2241-2247.
2. Kubler-Kielb J, Vinogradov E, Chu C, Schneerson R, *Carbohydr Res*, **2007**, 342, 643-647.
3. Perepelov AV, Lvov VL, Liu B, Senchenkova SN, Shekht ME, Shashkov AS, Feng L, Aparin PG, Wang L, Knirel YA, *Carbohydr. Res.* **2009**, 344, 687-692.

## OL 143

## TOWARDS LIPOPOLYSACCHARIDE CONJUGATE VACCINES BASED ON SYNTHETIC OLIGOSACCHARIDES

H. Horan, K. Daragics, J.-L. Bouissiere, J. D. M. Olsson, and S. Oscarson

Centre for Synthesis and Chemical Biology,  
University College Dublin, Belfield, Dublin 4, Ireland  
stefan.oscarson@ucd.ie

The lipopolysaccharides of *Neisseria meningitidis*, *Haemophilus influenzae* and *Moraxella catarrhalis* are all of the rough type, i.e., they lack the polysaccharidic O-antigen component and contains only the core and the Lipid A part. The outer core part of these bacteria show a lot of heterogeneity both within and between species, but the inner core parts are quite conserved and have common motifs (Figure 1).

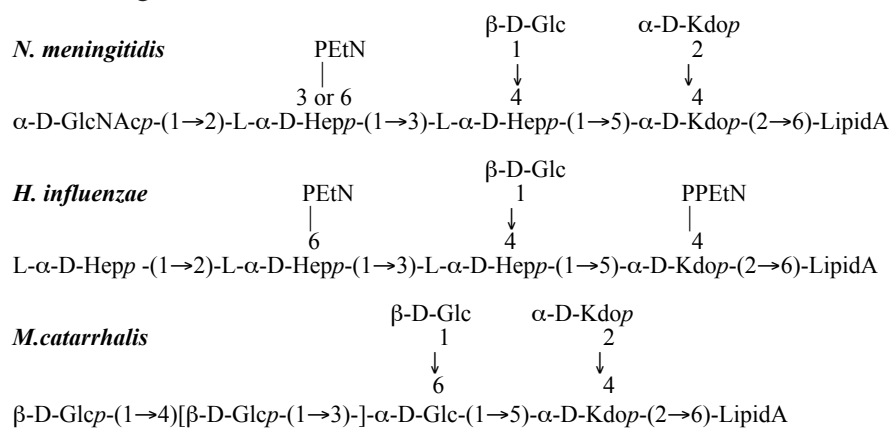

**Figure 1.**  $\beta\text{-D-Glcp-(1}\rightarrow\text{4)[}\beta\text{-D-Glcp-(1}\rightarrow\text{3)-]}\alpha\text{-D-Glc-(1}\rightarrow\text{5)-}\alpha\text{-D-Kdop-(2}\rightarrow\text{6)-LipidA}$

As part of a programme aiming at developing glycoconjugate vaccines against these bacteria based on LPS motifs, we are synthesising oligosaccharides related to these structures. Syntheses of core structures from *N. meningitidis*, *H. influenzae* and *M. catarrhalis* have been published.<sup>1-3</sup> We now present efforts towards synthesis of structures also containing the Kdo and lipid A part. A block synthesis is attempted using various core thioglycoside donors in couplings with Kdo acceptors including a lipid A analogue part (Scheme 1). Global deprotection affords target structures ready for conjugation to a carrier protein through the spacer moiety to produce vaccine candidates.

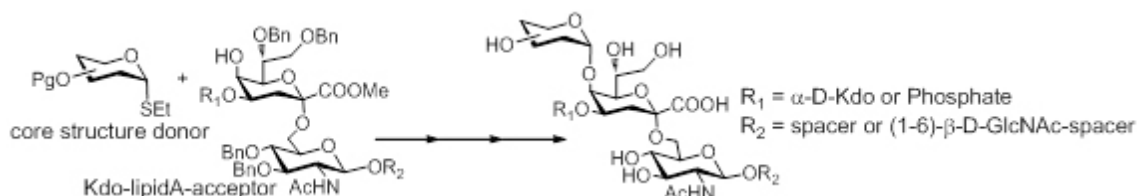

**Scheme 1.** General block synthetic strategy for synthesis of target structures.

## References

1. K. Ekelöf, S. Oscarson *J. Org. Chem.* **1996**, 61, 7711-7718.
2. K. Mannerstedt, E. Segerstedt, J. D. M. Olsson, S. Oscarson, *Org. Biomol. Chem.*, **2008**, 6, 1087-1091.
3. J. D. M. Olsson, S. Oscarson, *Tetrahedron Asymm.*, **2009**, 20, 879-886.



## OL 144

**A FULLY SYNTHETIC CARBOHYDRATE VACCINE  
CANDIDATE BASED ON GOLD NANOPARTICLES**

Fabrizio Chiodo,<sup>1</sup> Dodi Safari,<sup>2</sup> Marco Marradi,<sup>1</sup> Huberta A. Th. Dekker,<sup>2</sup> Yulong Shan,<sup>3</sup>  
Roberto Adamo,<sup>4</sup> Stefan Oscarson,<sup>5</sup> Ger T. Rijkers,<sup>6</sup> Martina Lahmann,<sup>3</sup>  
Johannis P. Kamerling,<sup>4</sup> Harm Snippe,<sup>2</sup> and Soledad Penadés<sup>1</sup>

<sup>1</sup>Lab. of GlycoNanotechnology, Biofunctional Nanomaterials,  
CIC biomaGUNE / CIBER-BBN, San Sebastián, Spain

<sup>2</sup>Department of Medical Microbiology, University Medical Center Utrecht,  
Utrecht, The Netherlands.

<sup>3</sup>School of Chemistry, Bangor University, Bangor, UK.

<sup>4</sup>Bijvoet Center, Department of Bio-Organic Chemistry,  
Utrecht University, Utrecht, The Netherlands.

<sup>5</sup>Center for Synthesis and Chemical Biology,  
University College Dublin, Belfield, Dublin 4, Ireland;

<sup>6</sup>Department of Medical Microbiology and Immunology,  
St. Antonius Hospital, Nieuwegein, The Netherlands

fchiodo@cicbiomagune.es

Synthetic carbohydrate vaccines have been developed to overcome the poor immunogenicity of natural carbohydrates.[1] In search for effective vaccines against *Streptococcus pneumoniae*, the major cause of acute respiratory bacterial infection, we developed a new strategy for the presentation of carbohydrate antigens to the immune system. According to a single-step protocol,[2] we prepared 2nm gold nanoparticles coated with three different conjugates: the synthetic branched tetrasaccharide  $\beta$ -D-Galp-(1 $\rightarrow$ 4)- $\beta$ -D-Glcp-(1 $\rightarrow$ 6)-[ $\beta$ -D-Galp-(1 $\rightarrow$ 4)-] $\beta$ -D-GlcpNAc-(1 $\rightarrow$ ) related to the *S. pneumoniae* type 14 capsular polysaccharide, the OVA<sub>323-339</sub> peptide of ovalbumin, and D-glucose. These nanoparticles were able to induce an immune response in mice demonstrating their usefulness as a versatile platform for the development of synthetic carbohydrate-based vaccines.

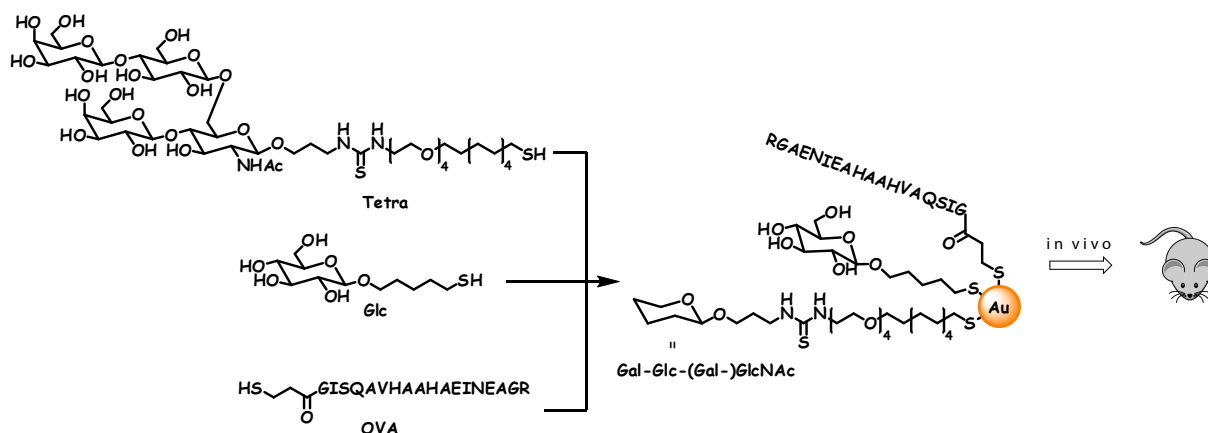

### References

1. R. D. Astronomo, D. R. Burton, *Nat. Rev. Drug Discov.*, **2010**, 9, 308-324
2. R. Ojeda, J. L. de Paz, A. G. Barrientos, M. Martín-Lomas, S. Penadés, *Carbohydr. Res.*, **2007**, 342, 448-459



## OL 145

## SPECIFIC INTERACTION OF THE SERUM MANNAN-BINDING PROTEIN WITH TUMOR-ASSOCIATED OLIGOSACCHARIDES AND TUMOR TISSUES

Toshisuke Kawasaki<sup>1</sup>, Motohiro Nonaka<sup>1,4</sup>, Nobuko Kawasaki<sup>1</sup>,  
Keiko Kawabe<sup>1</sup>, Hiromi Nakao<sup>1</sup>,  
Bruce Yong Ma<sup>1</sup>, Hirotsugu Imaeda<sup>2</sup>, Yoshihide Fujiyama<sup>2</sup>, Akira Andoh<sup>3</sup>

<sup>1</sup>Research Center for Glycobiotechnology, Ritsumeikan University,

<sup>2</sup>Department of Internal Medicine, Shiga University of Medical Science.

<sup>3</sup>Graduate School of Medicine, Shiga University of Medical Science.

<sup>4</sup>Research Fellow of the Japan Society for the Promotion of Science, Japan  
tkawasak@fc.ritsumei.ac.jp

Studies on endogenous lectins have contributed greatly to our understanding of the physiological significance of glycans in humans and animals. The serum mannan-binding protein MBP binds to mannose, *N*-acetylglucosamine and L-fucose via the carbohydrate binding sites in its carbohydrate recognition domain (CRD). In pathogenic microorganisms, manno-oligosaccharides on the cell surface appear to be the major glycans involved in the interaction with MBP, whereas in human colorectal carcinoma SW1116 cells, which could be endogenous target cells of MBP, Lewis (Le)-type oligosaccharides with the type I structure appear to play a major role in the interaction with the lectin. In fact, MBP ligand oligosaccharides (MLO), which have complex type *N*-glycans with at least four Fuc(Hex-HexNAc) units, have been isolated with an MBP affinity column, whereas complex type *N*-glycans having three or less Fuc(Hex-HexNAc) units as well as high-mannose type structures (Man5 to Man8) did not bind to the MBP affinity column. The structure of MLO is very unique and distinct from those of other previously reported tumor-specific carbohydrate antigens, and thus this should be considered as a representative of a new family of tumor-associated carbohydrate antigens. In order to study the potential clinical use of MBP as novel cancer diagnostic and therapeutic agents, we have carried out histochemical studies on various human colorectal cancer cell lines and also human colorectal cancer tissues using serum MBP as a probe. Interestingly, the results obtained indicated that MBP recognizes certain types of human colorectal cancer cells. It may be reasonable to assume that this lectin or modifications of it may have potential clinical use as novel cancer diagnostic agents for cancer patients.

**References**

1. Terada, M., Khoo, K.H., Inoue, R., Chen, C.I., Yamada, K., Sakaguchi, H., Kadowaki, N., Ma, B. Y., Oka, S., Kawasaki, T., & Kawasaki, N., *J. Biol. Chem.*, **2005**, 280, 10897-10913.
2. Kawasaki, N., Lin, C.W., Inoue, R., Khoo, K.H., Kawasaki, N., Ma, B.Y., Oka, S., Ishiguro, M., Sawada, T., Isida, H., Hashimoto, T., & Kawasaki, T., *Glycobiology*, **2009**, 19, 437-450.

## OL 146

## PRE-ACTIVATED DMF-MODULATING GLYCOSYLATION STRATEGY

Shao-Ru Lu, Yen-Hsun Lai, Jiun-Han Chen, Kwok-Kong Tony Mong\*

National Chiao-Tung University, Ta Hsueh Rd, Hsinchu City, 30010, Taiwan, R.O.C.  
 tmong@mail.nctu.edu.tw

In previous study of mild chlorination of glycosyl hemiacetals, it was found that residual DMF in glycosylation mixture promoted 1,2-cis alpha-glycosidic bond formation.<sup>[1]</sup> A search in literature also revealed that Koto et al reported the use of DMF as a glycosylation additive; however, their protocol was plagued by formation of undesired glycosyl formate and only moderate selectivity of glycosylation was achieved.<sup>[2]</sup> We hypothesized that the activation of thioglycoside generates an oxocarbenium ion pair during glycosylation, which would be trapped by nucleophilic DMF to form an alpha-glycosyl imidate. Subsequent reaction of the imidate with an acceptor furnishes the alpha-anomer as the major product (see Figure 1). Since DMF acts a modulator during glycosylations, this method is coined as the DMF-modulating glycosylation strategy. This new DMF-modulating glycosylation strategy achieves excellent 1,2-cis alpha-selectivity in glycosylations of a wide range acceptors with thioglycosyl donors bearing benzylidene protected D-galacto scaffold. Based on this method, a new iterative pre-activated glycosylation procedure was established for thioglycoside substrates. Herein, we also reported the results of an unprecedented real-time NMR study for this modulating glycosylation method as a support for the proposed mechanism.

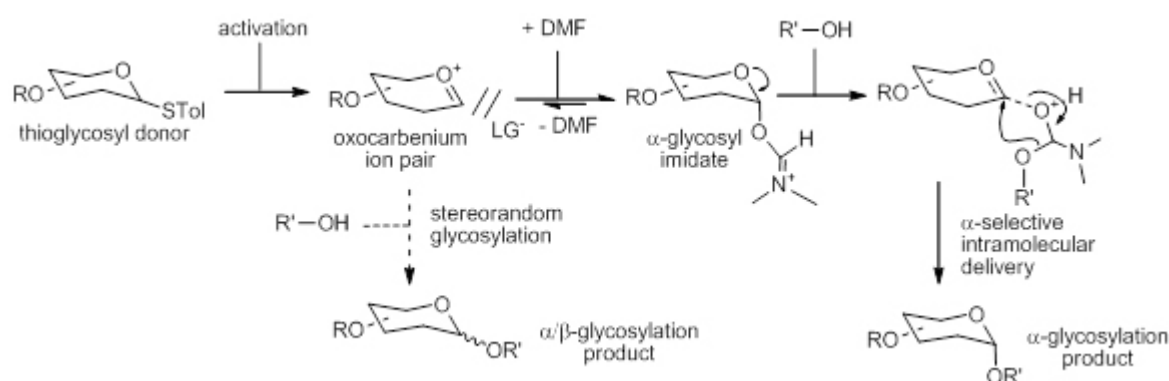

## References

1. C.-W. Chang, S.-S. Chang, C.-S. Chao, K. K. T. Mong, *Tetrahedron Lett.* **2009**, 50, 4536-4540.
2. S. Koto, N. Morishima, M. Owa, S. Zen, *Carbohydr. Res.* **1984**, 130, 73-83.

## OL 147

SYNTHESIS OF *C. DIFFICILE* PS-II CELL WALL POLYSACCHARIDE REPEATING UNIT

Elisa Danieli<sup>1</sup>, Luigi Lay<sup>2</sup>, Daniela Proietti<sup>1</sup>, Francesco Berti<sup>1</sup>, Paolo Costantino<sup>1</sup>,  
Roberto Adamo<sup>1</sup>

<sup>1</sup>Novartis Vaccines & Diagnostics, Vaccine Chemistry Department,  
Via Fiorentina 1, 51300 Siena, Italy.

<sup>2</sup>University of Milan, Department of Organic and Industrial Chemistry,  
CISI and ISTM-CNR, Via G. Venezian 21, 20133 Milan, Italy  
roberto.adamo@novartis.com

*Clostridium difficile* is a Gram positive spore-forming anaerobic bacterium, which is considered the most important definable cause of nosocomial diarrhea.<sup>1</sup> Since its description in 1978 as a cause of antimicrobial-associated diarrhea, colitis and pseudomembranous colitis (PMC) the interest in this pathogen is growing due to its impact on morbidity and mortality in the elderly and among hospitalized patients.<sup>2</sup> Treatment failures and recurrences with antibiotics are emphasizing the need for the discovery of a vaccine.

Monteiro's group recently analyzed the cell wall polysaccharide of *C. difficile* rybotype 027, considered the most virulent strain, and two additional strains, MOH900 (classified as NAP2) and MOH718.<sup>3</sup> Two different structures were identified, named PS-I and PS-II. However PS-II, whose repeating unit is [→6)-β-D-Glcp-(1→3)-β-D-GalpNAc-(1→4)-α-D-Glcp-(1→4)-[β-D-Glcp-(1→)-β-D-GalpNAc-(1→3)-α-D-Manp-(1→P)], resulted the only structure occurring in all strains. This finding strongly suggests that PS-II is a conserved surface antigen, which may be advantageous in the development of a carbohydrate-based anti *C. difficile* vaccine.

With the aim of studying the role of the phosphate group in the carbohydrate structure, we synthesized the natural phosphate-containing hexasaccharide repeating unit and its non-phosphorylated counterpart via a (4+2) convergent approach from a common tetrasaccharide intermediate AB(D)C.<sup>4</sup> These compounds bear an α-O-linked aminopropyl spacer at the anomeric position of

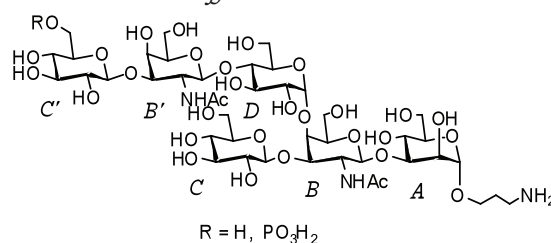

the reducing end to allow their conjugation to a carrier protein. Ongoing immunological studies on the glycoconjugates prepared from the synthesized molecules and the native polysaccharide will provide information about the feasibility of a carbohydrate-based vaccine against *C. difficile*.

## References

1. H. L. Koo, K. W. G., H. L. DuPont *Expert Opin. Invest. Drugs* **2010**, 825; F. C. Knoop, M. O., I. C. Crocker *Clin. Microbiol. Rev.* **1993**, 6, 251.
2. J. Freeman, M. P. B., S. D. Baines, J. Corver, W. N. Fawley, B. Goorhuis, E. J. Kuijper, M. H. Wilcox *Cl. Microbiol. Rev.* **2010**, 23, 529.
3. J. Ganeshapillai, E. V., J. Rousseau, J. Scott Weesec, M. A. Monteiro *Carbohydr. Res.* **2008**, 343, 703.
4. E. Danieli, L. Lay, D. Proietti, F. Berti, P. Costantino, R. Adamo *Org. Lett.* **2010**, DOI: 10.1021/ol1026188

## OL 148

SYNTHESIS OF *N*-( $\beta$ -D-GLYCOSYL) GUANIDINOACETAMIDES  
AND GUANIDINE LINKED *N*-GLYCOSYL AMINO ACIDS

Amrita Srivastava and Duraikkannu Loganathan\*

Department of Chemistry, Indian Institute of Technology Madras, Chennai, 600036, India  
loganath@iitm.ac.in

Formation of sugar-amino acid linkage is a crucial event in the biosynthesis of the carbohydrate units of glycoproteins. Glycosylation is the most complicated co- or posttranslational modification that proteins undergo in nature. The  $\beta$ -glycosyl linkage of GlcNAc to asparagine (Asn) represents the most widely distributed carbohydrate-peptide bond and is the site of attachment for a large variety of complex and high mannose oligosaccharides in proteins with well-known biological functions. The  $\beta$ -glucosyl linkage to the guanidine group of arginine (Arg) is found in amylogenin, a glycoprotein from sweet corn. Such a linkage, a rare example of *N*-glycosyl bond,<sup>1,2</sup> is often labile under physiological conditions.

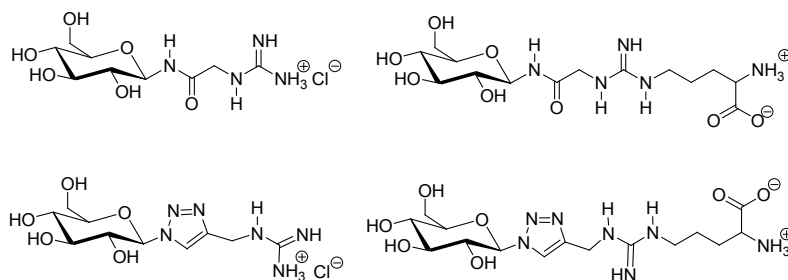

The present work is aimed at the design and synthesis of relatively stable Glc $\beta$ -Arg conjugates, potentially useful for enhancing the half-life of drugs such as erythropoietin. Our novel design, which is biomimetic in nature, is based on the conserved GlcNAc $\beta$ -Asn linkage of eukaryotic glycoproteins with a spacer between the glycosyl residue and the guanidine moiety. Two types of spacers, acetamido and triazole moieties, were chosen. The synthetic methodology involves, as a key step, the reaction of appropriately protected sugar unit containing a free amino group with suitably functionalized bis-Boc-thiourea<sup>3</sup> or the reverse combination. Details of the synthesis of title conjugates and their structural characterization will be presented.

**References**

1. Singh, David G.; Lomako, J.; Lomako, W. M.; Whelan, W. J.; Meyer, H. E.; Serwe, M.; Metzger, J. W. *FEBS Letters* **1995**, 376, 61-64.
2. Spiro, R. G. *Glycobiology* **2002**, 12, 43R-46R.
3. C. LevaUet, J. Lerpiniere, S. Y. Ko, *Tetrahedron*, **1997**, 53, 5291-5304.

## OL 149

**GALACTURONIC ACID LACTONES IN THE SYNTHESIS  
OF ALL TRISACCHARIDE REPEATING UNITS OF THE ZWITTERIONIC  
POLYSACCHARIDE SP1**

Alphert E. Christina, Leendert J. van den Bos, Herman S. Overkleeft, Gijsbert A. van der Marel  
and Jeroen D. C. Codée

*Bio-Organic Synthesis, Leiden Institute of Chemistry, Leiden University,  
PO Box 9205, 2300 RA Leiden, The Netherlands  
christinaae@chem.leidenuniv.nl*

Zwitterionic polysaccharides (ZPs) are the only class of bacterial polysaccharides that is capable of eliciting a T-cell dependent immune response, brought about in a MHC-II dependent manner.<sup>1</sup> In addition, ZPs have been shown to stimulate the innate immune system through interaction with the Toll-like receptor 2 (TLR2).<sup>2</sup> To elucidate the mode of action of ZPs at the molecular level, well-defined ZPs fragments can serve as valuable tools. We therefore synthesized all possible trimer repeating units of the type 1 capsular polysaccharide of *Streptococcus pneumoniae*, Sp1. A key feature of our synthesis is the use of 1-thio galacturonic acid lactones<sup>3</sup> as  $\alpha$ -selective donor and suitable nucleophilic acceptor building blocks.<sup>4</sup>

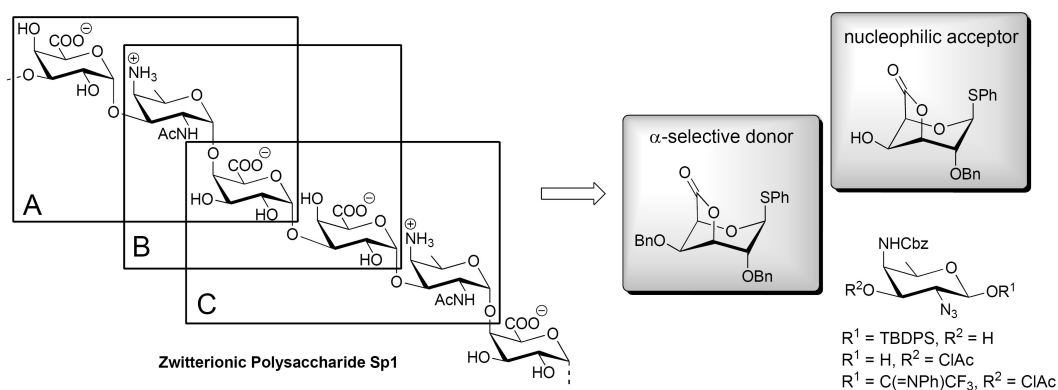

### References

- (a) Tzianabos, A. O.; Onderdonk, A. B.; Rosner, B.; Cisneros, R. L.; Kasper, D. L. *Science* **1993**, *262*, 416-419. (b) Cobb, B. A.; Kasper, D. L. *Cell. Microbiol.* **2005**, *7*, 1398-1403. (c) Cobb, B. A.; Wang, Q.; Tzianabos, A. O.; Kasper, D. L. *Cell* **2004**, *117*, 677-687.
- (a) Wack, A.; Gallorini, S. *Immunopharm, Immunot.* **2008**, *30*, 761-770. (b) Wang, Q.; McLoughlin, R. M.; Cobb, B. A.; Charrel-Dennis, M.; Zaleski, K. J.; Golenbock, D.; Tzianabos, A. O.; Kasper, D. L. *J. Exp. Med.* **2006**, *203*, 2853-2863.
- van den Bos, L. J.; Litjens, R.; van den Berg, R. J. B. H. N.; Overkleeft, H. S.; van der Marel, G. A. *Org. Lett.* **2005**, *7*, 2007-2010.
- Christina, A. E.; van den Bos, L. J.; Overkleeft, H. S.; van der Marel, G. A.; Codée, J. D. C. *J. Org. Chem. Manuscript accepted for publication.*

## OL 150

DISPROPORTIONATION OF ALPHA-GLUCANS BY GLYCOSIDE HYDROLASE  
FAMILY 70 ENZYMES

Justyna M. Dobruchowska, Hans Leemhuis, Johannes P. Kamerling and Lubbert Dijkhuizen

*Microbial Physiology, Groningen Biomolecular Sciences and Biotechnology Institute (GBB),  
University of Groningen, Nijenborgh 7, 9747 AG Groningen, The Netherlands  
j.dobruchowska@rug.nl*

The glycoside hydrolase family 70 (GH70) (1) is a group of bacterial enzymes that synthesize  $\alpha$ -glucan polymers such as dextran and mutan. These enzymes are called glucansucrases as they use sucrose as glucose donor. Until recently it was believed that sucrose was the only glucose donor used by GH70 enzymes, till it was reported that the *Lactobacillus reuteri* 121 GH70 enzyme GTFB uses  $\alpha$ -(1 $\rightarrow$ 4)-oligosaccharides, but not sucrose, as glucose donor to synthesize oligosaccharides high in  $\alpha$ -(1 $\rightarrow$ 6)-glycosidic bonds even though the primary sequence of this enzyme is highly similar to sucrose utilizing GH70 enzymes (2).

Here we report that several lactic acid bacteria encode a GH70 enzyme that disproportionates  $\alpha$ -(1 $\rightarrow$ 4)-oligosaccharides and also starches, thus demonstrating that this reaction specificity is a common activity within the GH70 family and was not simply an abnormality found once only. The important feature of these enzymes is that they can generate  $\alpha$ -glucan products with a high degree of  $\alpha$ -(1 $\rightarrow$ 6)-glycosidic linkages starting with starches and as such hold great potential in the production of prebiotics. The  $\alpha$ -glucan products made by these enzymes are studied in detail using analytical methods such as MALDI-TOF mass spectrometry and 1D/2D <sup>1</sup>H/<sup>13</sup>C NMR spectroscopy. This revealed that the disproportionating GH70 enzymes form linear  $\alpha$ -glucans, whereas the sucrose utilizing GH70 enzymes produce branched  $\alpha$ -glucan polymers. These data are used to discuss the structure/function relationships of the GH70 family, which became possible with the recent publication of the first GH70 crystal structure (3).

**References**

1. Cantarel BL, Coutinho PM, Rancurel C, Bernard T, Lombard V, Henrissat B, *Nucl. Acid. Res.*, **2009**, 37, D233-D238.
2. Dijkhuizen L, van der Maarel MJEC, Kamerling JP, Leemhuis RJ, Kralj S, Dobruchowska JM, *Patent*, **2010**, WO/128859.
3. Vujcic-Zagar A, Pijning T, Kralj S, Lopez CA, Eeuwema W, Dijkhuizen L, Dijkstra BW, *PNAS USA*, **2010**, 107 (50), 21406-21411.



## OL 151

## AMINOGLYCOSIDE BASED MIMICRY OF ANTIMICROBIAL PEPTIDES

Smritilkeha Bera,<sup>1</sup> Ramesh Dhondi,<sup>1</sup> George, G. Zhanel,<sup>2</sup> Frank Schweizer<sup>1,2</sup>

<sup>1</sup>*Department of Chemistry, University of Manitoba, Winnipeg, MB, R3T 2N2, Canada,*

<sup>2</sup>*Department of Medical Microbiology, University of Manitoba, Winnipeg, MB, R3A 1R9  
schweize@cc.umanitoba.ca*

The explosive growth of multidrug-resistant bacteria and the declining rate of antibacterial drug discovery have led to an emerging crisis where an increasing number of antibiotics cease to be of clinical usefulness. As a result, there is an urgent need for novel classes of antibacterial agents with new or combined mechanisms of action and reduced likelihood to lead to the development of resistance. Both, cationic amphiphilic peptides and aminoglycoside antibiotics contain multiple charges that ensure accumulation at polyanionic microbial surfaces. However, while cationic amphiphilic peptides enhance the permeability of the cytoplasmic bacterial membrane and/or translocate across the membrane and act on internal targets, aminoglycoside antibiotics interact predominantly with RNA after self-promoted uptake. Recent work has shown that amphiphilic aminoglycosides<sup>1-4</sup> and amphiphilic aminoglycoside platforms<sup>5,6</sup> (AAPs) restore antibacterial efficacy against aminoglycoside resistant strains. Preliminary mode of action studies indicate that AAPs display a different mode of action when compared to aminoglycoside analogs.<sup>7</sup> The presence of a common cationic amphiphilic pharmacophore in both cationic antimicrobial peptides and amphiphilic aminoglycoside antibiotics suggests that AAPs can serve as functional mimics of AAPs. This talk will provide an update on our efforts to develop potent and nontoxic AAP-based antimicrobial peptidomimetics.

### References

1. Hanessian, S, Szychowski, J.; Adhikari, S.S., et al. *J. Med. Chem.* **2007**, *50*, 2352-2369.
2. Bera, S., Schweizer. *J. Med. Chem.* **2008**, *51*, 6160-6164.
3. Bera, S., Zhanel, G.G., Schweizer, F. *Bioorg. Med. Chem. Lett.* **2010**, *20*, 3031-3035 (2010).
4. Hanessian, S., Pachamuthu, K.; Szychowski, J., et al. *Bioorg. Med. Chem. Lett.* **2010**, *20*, 7097-7101.
5. Bausanne, I., Bussière, A.; Halder, S. et al. *J. Med. Chem.* **2010**, *53*, 119-127.
6. Bera, S, Zhanel, G.G., Schweizer, F. *J. Med. Chem.* **2010**, *53*, 3626-3631.

## OL 152

**INDUSTRIAL DEVELOPMENT  
OF COMPLEX, FULLY SYNTHETIC OLIGOSACCHARIDES**P. Potier

*Sanofi Aventis, Route de Gap, 04200 Sisteron, France  
pierre.potier@sanofi-aventis.com*

For more than twenty years, Sanofi-Aventis has been involved in industrial oligosaccharide chemistry throughout hemi-synthetic or fully synthetic heparinoïds exhibiting anti-thrombotic activities and leading to very active compounds, some of them being on the market.

Around ten fully synthetic oligosaccharides, dealing with up to 80 chemical steps, have been discovered by our researchers and then worked by our development teams in the aim of being able to produce hundreds of kilograms of active ingredients. These developments were done taking into account all important aspects of industrialization (safety, environment, regulatory aspects, GMP productions ...) and managing the industrial risk (long cycle time synthesis, cost of goods...).

The presentation will be focused on representative steps and will deal with original synthesis, process improvement, batch productions results, carryover/mapping of impurities, robustness studies (DOE...), analytical developments and main issues.

This work has never been either published or presented.

## OL 153

**FLUORESCENT CYCLODEXTRIN DERIVATIVES:  
AID IN THE DEVELOPMENT OF NOVEL ANTICANCER STRATEGIES  
AND IN VISUALIZING BIOLOGICAL BARRIERS CROSSING**

Milo Malanga, László Jicsinszky, Kata Tuza and Éva Fenyvesi

*CycloLab Ltd., H-1097 Budapest, Illatos út 7, Hungary  
milomalanga@gmail.com*

In the recent past, nanostructures gained considerable attention in the field of medicine due to their ability to cross biological barriers (including the blood brain barrier, BBB) and to behave as effective drug delivery systems. These properties have made them promising tools to overcome some of the current therapeutic drawbacks related to the major diseases in our society, particularly cancer.

Cyclodextrins (CDs) are widely used by the pharmaceutical industry as drug carriers. The  $\beta$ -CD derivatives (those consisting of seven glucopyranose units) have special selectivity for complexing cholesterol therefore they have a potential for regulating the cholesterol trafficking as an active pharmaceutical ingredient. It is still, however, not understood how CDs work, if they can cross the biological barriers such as BBB.

In order to provide useful tools for studying the behaviour of promising nanostructures in antitumor therapy and for following the transmembrane processes in a sensitive and non-destructive way we prepared several fluorescent CD derivatives.

The introduction of a chromophore to cyclodextrins is not always a simple task. One difficulty is often originated from the reactivity of the hydroxyl group which is usually accompanied by poor regioselectivity and poor control of the degree of substitution. Additionally, the complexation of the chromophore causes further complications and the purification of the products is laborious. The first task of the synthetic work consisted in the introduction of the azide/amino function in the selected CDs (such as  $\beta$ CD, (2-hydroxy)propyl- $\beta$ CD, carboxymethyl- $\beta$ CD, randomly methylated- $\beta$ CD) to create the key intermediates for the following fluorescent modifications. Among the tested methods, click chemistry and the Edman coupling approach were proven to be the most effective in the synthesis of fluorescent CDs. We have developed new rhodaminyl-, fluoresceinyl- and nitro-benzofurazanil CD derivatives. The structures were confirmed by spectroscopic methods and capillary electrophoresis.

**Acknowledgement:** The support of Marie Curie Programme Initial Training Network - Project N° 237962 (CYCLON) is greatly acknowledged.

## OL 154

**PROTECTED SULFATE GROUPS – AN APPLICATION TO THE SYNTHESIS OF SULFATED SACCHARIDES–**

Kenya Matsushita, Shinji Funamoto, Jun-ichi Tamura

*Tottori University, Tottori, 680-8551 Japan*

Naturally occurring saccharides often have *O*- and *N*-sulfates which deeply relate to various biological activities depending on the sulfation patterns. However, sulfated poly- and oligosaccharides, such as bioactive chondroitin sulfates and heparan sulfates, consist of different repeating units with various sulfation patterns. Although precisely sulfated oligosaccharides at the specific positions are useful tools for medical purposes, it is difficult to prepare the substrates for probes having homogeneous sulfation patterns from nature.

On the other hand, chemical synthesis is a powerful method to get the substrates having sulfate groups at the specific positions. Generally, chemical sulfation at the liberated hydroxyl and amino groups are executed in the final stage of the total syntheses. In spite of the worked out planning, we still have some difficulties to get the sulfated products. Some hydroxyl groups resist the sulfation. In addition, acetamides of the substrates are occasionally sulfated and prevent the following *O*-sulfation<sup>1</sup>.

Recently, 2,2,2-trichloroethoxy sulfate ester was reported as a protected sulfate<sup>2</sup>. The trichloroethoxysulfonated sugars have high solubility in nonpolar aprotic solvents such as dichloromethane, and are useful for many reactions including glycosylation. The appropriate saccharide moieties having protected sulfates strongly contribute to the modular synthesis of larger glycans. Nevertheless, the protected sulfates are still ambiguous to be used in many organic reaction conditions. These facts prompted us to apply the protected sulfate groups to our on-going project, synthesis of the sulfated carbohydrates. We executed the protected sulfation to the multifunctional alcohols. In addition, we examined the influence and tolerance of the protected sulfates against the various kinds of reactions.

**References**

1. J. Tamura, K. W. Neumann, S. Kurono, T. Ogawa, *Carbohydr. Res.*, **1998**, 305, 43-63.
2. L. J. Ingram, S. D. Taylor, *Angew. Chem. Int. Ed.*, **2006**, 45, 3503-3506.

**POSTER**

## PO 01

## A NOVEL STEREOSELECTIVE SYNTHESIS OF CHIRAL CYCLOPENTANE

Raid Abdel-Jalil,<sup>1</sup> Wolfgang Voelter,<sup>2</sup> and Thomas Steinbrecher<sup>3</sup><sup>1</sup>Chemistry Department, College of Science, Sultan Qaboos University, Muscat-Oman,<sup>2</sup>Interfakultäres Institut für Biochemie, Universität Tübingen,  
Hoppe-Seyler Straße 4, 72076 Tübingen, Germany,<sup>3</sup>Inst. f. phys. Chemie Abt. Theor. Chem. Biol. Kaiserstr. 12, Universität Karlsruhe,  
76131 Karlsruhe, Germany.

jalil@squ.edu.om

The development of new routes for the stereospecific synthesis of cyclopentane rings continues to attract attention due largely to the wide variety of natural products containing this structural unit which exhibit a broad spectrum of biological activities. Herein, we<sup>1</sup> report a regio- and stereoselective annellation of cyclopentane on pyranoside ring in one step and high yield protocol. The reaction of the intermediary reagent 3-lithio-2-[lithiomethyl]-propene with the  $\beta$ -L sugar triflate **1** leads to the formation of 1-methylene-(benzyl3,4-dideoxy- $\alpha$ -D-arabinopyranoso)-[3,4-c]-cyclopentane (**3**). Applying the same reaction conditions on the  $\alpha$ -D isomer **2** leads to the formation of benzyl 2,3-anhydro-4-deoxy-4-C-(2-methylpropen-3-yl)- $\beta$ -L-lyxopyranoside (**4**). A theoretical investigation was also carried out to calculate the heat of formation and most stable structure of the intermediates in an attempt to justify these data.

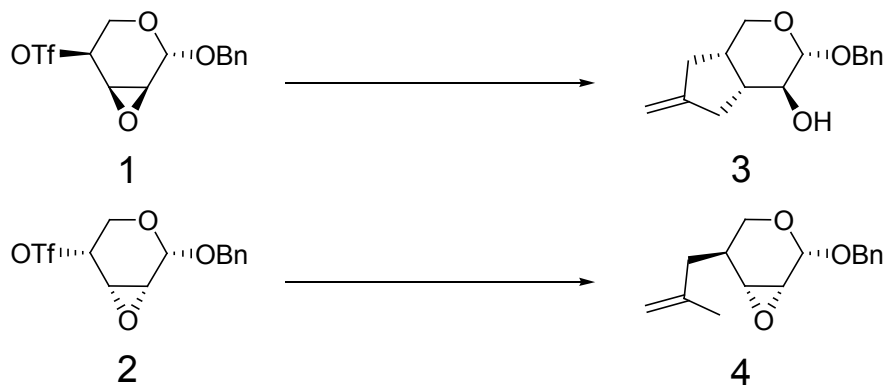

## References

1. P. Dolashka-Angelova, R. J. Abdel-Jalil, R. A. Al-Qawasme, N. Stambolieva, Wolfgang Voelter, Carbohydrate Res., **2010**, 345, 2343-2347.



## PO 02

## SYNTHESIS OF MUCIN O-GLYCAN CORE STRUCTURES FOR THE INVESTIGATION OF BINDING TO GUT BACTERIA

Stefan Oscarson\*, [Fana Abraha](mailto:Fana.Abraha@ucdconnect.ie) and Martin Hollinger*Centre for Synthesis and Chemical Biology, University College Dublin, Belfield, Dublin 4, Ireland**Fana.Abraha@ucdconnect.ie, Stefan.Oscarson@ucd.ie*

Mucosa is the innermost layer of the gastrointestinal tract (GI) that is surrounding the lumen and forms a major barrier between the internal and external environment which are constantly exposed to microorganisms.<sup>1,2</sup> *Helicobacter pylori* and *Campylobacter jejuni* are pathogenic species responsible for acute and chronic infections of the human gut.<sup>2,4</sup> We want to investigate the interaction between these bacteria and mucin glycoproteins.

A number of mucin O-glycan core structures (1-7) with different aglycons have been synthesized (Figure 1). These structures will be used for identifying binding structure hits and preparation of microarrays. Different methodologies will be investigated to generate the target core structures.

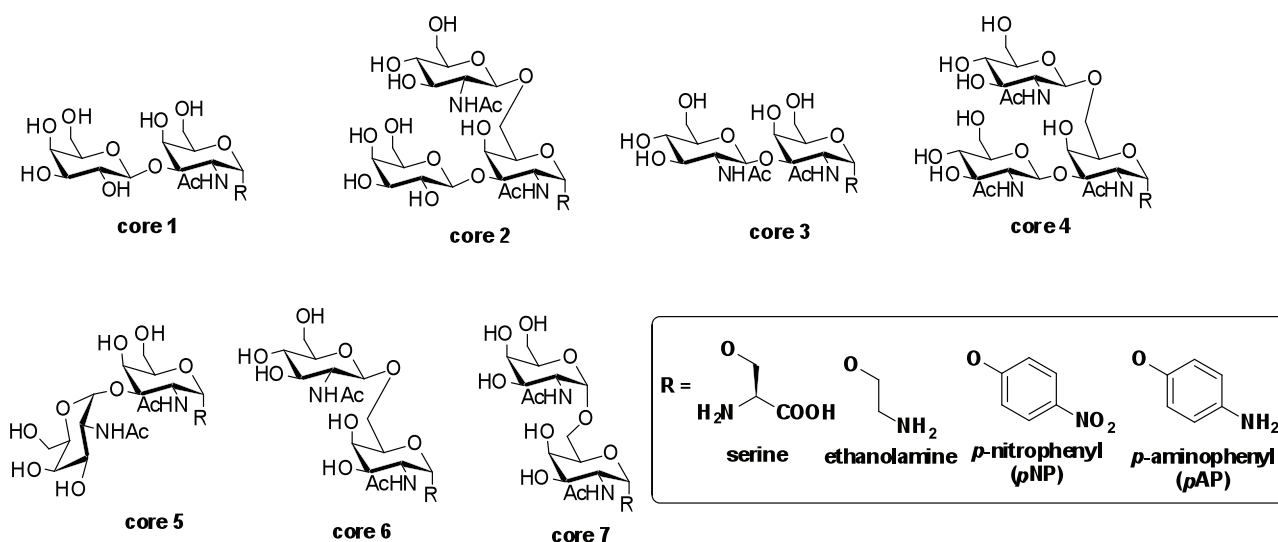

**Figure 1.** Mucin type O-glycan core structures with different  $\alpha$ -glycosidic linkers.

## References

1. V. Lievin-Le Moal, A. L. Servin, *Clin. Microbiol. Rev.*, **2006**, *19* (2), 315.
2. R. D. Berg, *Trends Microbiol.*, **1996**, *11*, 430.
3. T. L. Cover, D. E. Berg, M. J. Blaser, H. L. T. Mobley, *Principles of bacterial pathogenesis*, **2001**, 510-558.
4. K. T. Young, L. M. Davis, and V. J. Dirita, *Nat. Rev. Microbiol.*, **2007**, *5*, 665.

## PO 03

UNUSUAL STEREOSELECTIVITY OF GLYCOSYLATION OF  
NOVEL 4-(2-CHLOROETHOXY)PHENYL ARABINOFURANOSIDE

Polina I. Abronina, Nikita I. Podvalnyy, Alexander I. Zinin, Vladimir I. Torgov,  
Leonid O. Kononov

*N. D. Zelinsky Institute of Organic Chemistry, Leninsky prospect, 47,  
11991 Moscow, Russian Federation  
kononov@ioc.ac.ru*

Development of novel approaches to stereoselective synthesis of 1,2-*cis*-arabinofuranosides related to mycobacterial arabinans remains an important task, and a variety of approaches have been proposed for this purpose.<sup>1,2</sup> Thioglycosides **1** with conformationally-restricting 3,5-*O*-(*tert*-butylsilylene) group (DTBS) and non-participating (usually benzyl) group at O-2 have been successfully used by others<sup>1</sup> and us<sup>3</sup> for straightforward introduction of 1,2-*cis*-linked arabinofuranose residues into oligosaccharides by low-temperature glycosylation in CH<sub>2</sub>Cl<sub>2</sub> promoted by NIS–AgOTf. Here, we report that glycosylation of monosaccharide acceptor **2** with thioglycoside **1a** (Ar = Ph, R = Bn) unexpectedly resulted in selective formation of 1,2-*trans*-linked disaccharide ( $\alpha:\beta = 5:1$ ) while thioglycoside **1b** (R = TIPS) performed as expected according to 1,2-*cis*-selective glycosylation pattern ( $\alpha:\beta = 1:4.5$ ). This prompted us to vary protecting groups at O-2 (R = Bn, MPM, TIPS, Ms, TCA, TFA, *etc.*) and O-3/O-5. In particular, we found that the use of glycosyl donor **1c** (R = TFA) with acyl (trifluoroacetyl) group at O-2 slightly improved stereoselectivity towards  $\beta$ -anomer ( $\alpha:\beta = 3:1$ ) when compared with **1a** possessing alkyl (benzyl) group. Even more unusual was the observation that glycosyl donor **3** containing only acyl protecting groups gave the corresponding disaccharide with essentially the same stereoselectivity ( $\alpha:\beta = 3.8:1$ ). These results indicate that (1) 3,5-DTBS protection does not always lead to enhanced 1,2-*cis*-selectivity (and hence the current theoretical background may need revision) and (2) TFA group might be regarded as a non-participating protecting group. This work was supported by RFBR (projects No. 10-03-01019, 11-03-00918, 11-03-00925).

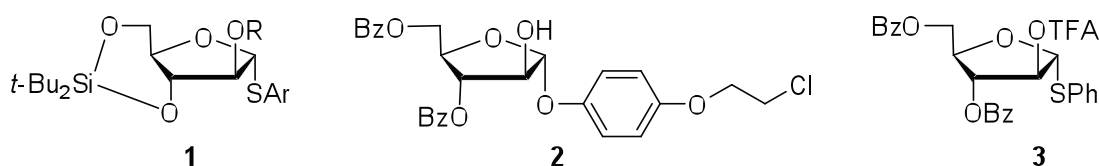
**References**

1. P.-H. Tam, T. L. Lowary, *Carbohydr. Chem.* **2010**, 36, 38–63; and references cited therein.
2. C. Liu, M. R. Richards, T. L. Lowary, *J. Org. Chem.* **2010**, 75, 4992–5007; and references cited therein.
3. P. I. Abronina, N. M. Podvalnyy, T. M. Melnikova, A. I. Zinin, K. G. Fedina, V. I. Kachala, V. I. Torgov, L. O. Kononov, E. A. Panferzev, E. V. Baranova, V. V. Mochalov, V. I. Dyatlova, S. F. Biketov, *Izv. AN, Ser. Khim.* **2010**, 2276–2280 [*Russ. Chem. Bull.* **2010**, 59, No.12].

## PO 04

STEREOCONTROLLED SYNTHESIS OF POTENTIAL ACCEPTORS  
OF GLYCOSYLTRANSFERASES IMPLICATED  
IN PROTEOGLYCAN'S BIOSYNTHESIS

K. Ait-Mohand,<sup>1</sup> C. Lopin-Bon,<sup>1</sup> J.-C. Jacquinet<sup>1</sup>

<sup>1</sup>Institut de Chimie Organique et Analytique (ICOA)-UMR CNRS 6005,  
Université d'Orléans-BP6759, 45067 Orléans (France)  
katia.ait-mohand@univ-orleans.fr

The proteoglycans (PGs) are macromolecules which are composed by glycosaminoglycans (GAGs) covalently linked to a core protein by the intermediary of a common tetrasaccharidic linkage structure. The key step in the assembly of PGs is a sequential stepwise addition of each saccharidic unit by respective O-glycosyltransferases<sup>1,2</sup> (Fig. 1).

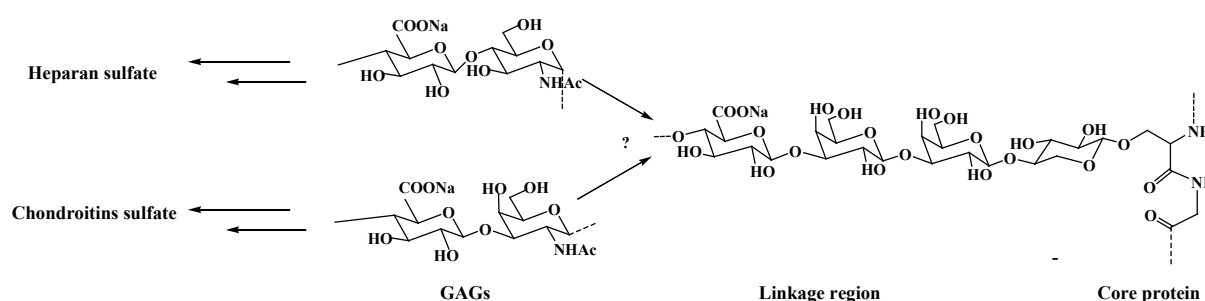

Fig. 1 The linkage region of proteoglycans.<sup>3</sup>

The aim of this work is to better understand the GAG's assemblage process and in particular, the influence of the sulfation of the linkage sequence on the orientation to CS or HS chains. In this aim, a library of biotinylated acceptors of the linkage region without sulfate or monosulfated in positions 4 or 6 of the two galactose unities, alternatively (1), have been synthesized from commercial D-galactose (2) and D-glucurono-6,3-lactone (3) (Fig. 2).

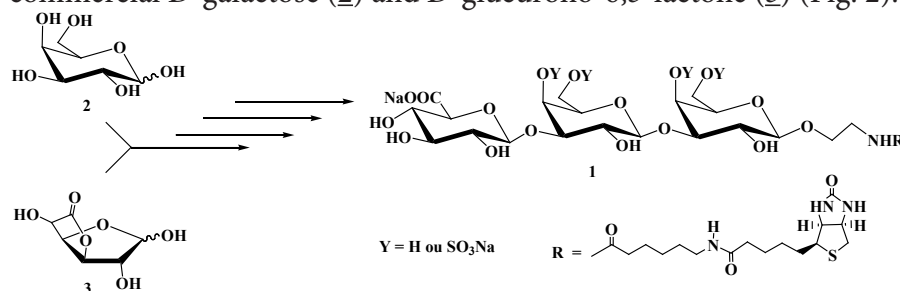

Fig. 2 Synthesis strategy

All these compounds will be tested as potential substrates of the CS GalNAcT and the HS GlcNAcT, which initiate biosynthesis of CS and HS chains.

### References

1. M. Ouzzine and coll. *New Developments in Therapeutic Glycomics*, 2006: 351-376
2. J.-C. Jacquinet, *Carbohydr. Res.*, 2006, 341, 1630-1644
3. B. Thollas and J.-C. Jacquinet, *Org. Biomol. Chem.*, 2004, 2, 434-442

## PO 05

SYNTHESIS OF SILYL PROTECTED *GLUCO*-PYBOX LIGANDSFabian Albrecht<sup>1</sup>, Jacek Mlynarski<sup>2</sup>, Mike M. K. Boysen<sup>1</sup><sup>1</sup>*Institute of Organic Chemistry, Gottfried Wilhelm Leibniz University Hannover, Schneiderberg 1B, D-30167 Hannover, Germany*<sup>2</sup>*Institute of Organic Chemistry, Polish Academy of Sciences, Kasprzaka 44/52, 01-224 Warsaw, Poland  
fabian.albrecht@oci.uni-hannover.de*

Processes using water as a reaction medium have recently attracted a great deal of attention, partly because of the unique properties of this solvent but chiefly due to its *green chemistry* aspect.<sup>1</sup> Running Lewis acid catalysed reactions in aqueous media is especially challenging as many Lewis acids are destroyed by water. Jacek Mlynarski and co-workers achieved excellent results for asymmetric Mukaiyama-aldol reactions<sup>2</sup> in water, using zinc triflate in combination with a sterically demanding and hydrophobic pyridylbis(oxazoline) ligand (*he-pybox*).<sup>3,4</sup>

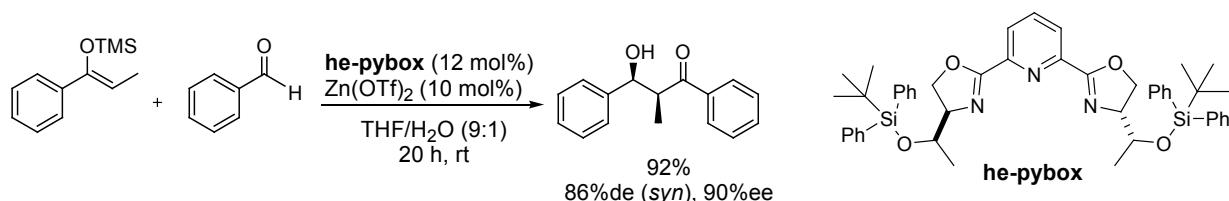

Our group has recently introduced a series carbohydrate-derived bis(oxazoline) ligands based on D-glucosamine.<sup>5,6</sup> In a collaboration project with the Mlynarski group, we are working towards the application of these ligands in aqueous asymmetric Mukaiyama aldol reactions. In initial experiments, our ligand 3-OH-*gluco*Box achieved only moderate stereoselectivities, therefore we are currently testing persilylated and selectively 3-O-silyl protected *gluco*Pybox ligands in combination with various metals salts for asymmetric Mukaiyama-aldol reactions in aqueous media.

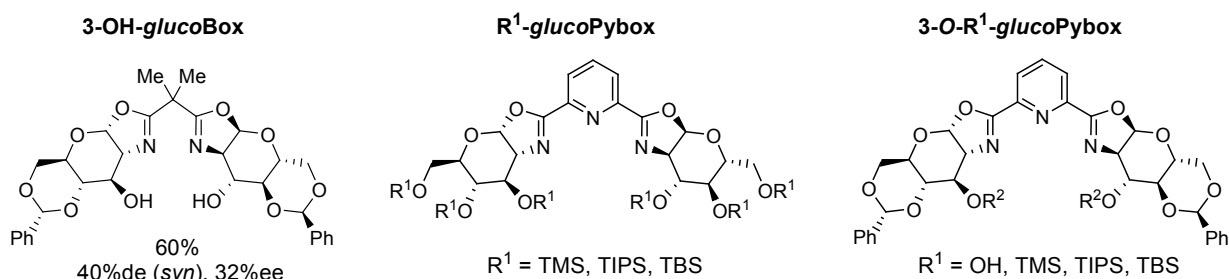

## References

1. a) C.-J. Li, *Chem. Rev.* **2005**, *105*, 3095-3166; b) Lindström, U. M., Andersson, F., *Angew. Chem. Int. Ed.* **2006**, *45*, 548-551.
2. S. Kobayashi, Y. Fujishita, T. Mukaiyama, *Chem. Lett.* **1990**, *8*, 1455-1458.
3. J. Jankowska, J. Paradowska, B., Rakiel, J. Mlynarski, *J. Org. Chem.* **2007**, *72*, 2228-2231.
4. J. Mlynarski, J. Paradowska, *Chem. Soc. Rev.* **2008**, *37*, 1502-1511.
5. M. Irmak, M. M. K. Boysen, *Adv. Synth. Catal.* **2008**, *350*, 403-405.
6. T. Minuth, M. Irmak, A. Groschner, T. Lehnert, M. M. K. Boysen, *Eur. J. Org. Chem.* **2009**, 997-1008.

## PO 06

**MALTOSE DERIVATIVES AS POTENTIAL PRECURSORS  
FOR MALTOOLIGOSACCHARIDES AND CYCLODEXTRINS**

Maryam Amiri,<sup>1</sup> Mozhgan Torabi,<sup>1</sup> Wolfgang Holzer,<sup>2</sup> Helmut Viernstein,<sup>1</sup> Frank M. Unger<sup>1</sup>

<sup>1</sup> *Department of Pharmaceutical Technology and Biopharmaceutics and*

<sup>2</sup> *Department of Pharmaceutical Chemistry,*

*Faculty of Life Sciences, University of Vienna, Althanstrasse 14, A-1090 Vienna, Austria*

*maryam.amiri@univie.ac.at*

Maltose phosphorylase from *Enterococcus* sp. catalyses the reversible phosphorolysis of maltose to form glucose and  $\beta$ -D-glucose-1-phosphate. In the reverse reaction mode, its capability to catalyse the formation of disaccharides from  $\beta$ -D-glucose-1-phosphate and various glucose analogues such as D-xylose, 2-deoxyglucose or 6-deoxy-glucose can be utilized to synthesize maltose analogues.<sup>1</sup>

Maltose analogues are of interest as precursors for nutritional supplements, biomimetic polymers and as building blocks for innovative pharmaceutical excipients such as novel cyclodextrins. Enzyme reaction systems based on maltose phosphorylase are under development which permit large-scale enzyme catalysis, cycling of intermediates and regeneration of substrates.<sup>2</sup> Glycomimetics of maltose are being tested as substrates of cyclodextrin-glycosyltransferase<sup>3</sup> with the aim of discovering new, useful analogues of maltooligosaccharides or cyclodextrins. Over-all, syntheses are being designed to maximize enzyme-catalysed steps and minimize environmentally less benign organic-chemical reaction sequences.

**References**

1. E.W. Putman, C.F. Litt, W.Z. Hassid, *J. Am. Chem. Soc.*, **1955**, *77*, 4351-4353.
2. K. Aisaka, T. Masuda-Kato, T. Chikamune, K. Kamilori, Y. Uosaki, Y.J. Saito, *J. Biosci. Bioeng.*, **2000**, *90*, 208-213.
3. H. Leemhuis, J.C.M. Uitdehaag, H.J. Rozeboom, B.W. Dijkstra, L. Dijkhuizen, *J. Biol. Chem.*, **2002**, *277*, 1113-1119.

## PO 07

## SYNTHESIS OF PECTIC OLIGOSACCHARIDES

Mathias C. F. Andersen<sup>1</sup>, Mads H. Clausen,<sup>1</sup><sup>1</sup>DTU Chemistry, Kemitorvet 201, 2800 Kgs. Lyngby, Denmark  
fraa@kemi.dtu.dk

The consumption of fruits and vegetables with high levels of polysaccharide fibres is known to be an important aspect of a healthy diet but our present understanding of the precise *in vivo* effects of plant fibres is limited. We aim to elucidate the connection between dietary fibre and health specifically in relation to cancer treatment and prophylaxis. The key goals are to investigate the molecular basis of the interaction between specific glycan structures present in dietary fibre and a class of carbohydrate-binding proteins called galectins that are typically over-expressed on the surface of multiple myeloma and other cancer cells. This interaction is known to trigger apoptosis of cancer cells *in vitro* and is thought to be the basis of the anti-cancer activities of certain pectic polysaccharides *in vivo*.

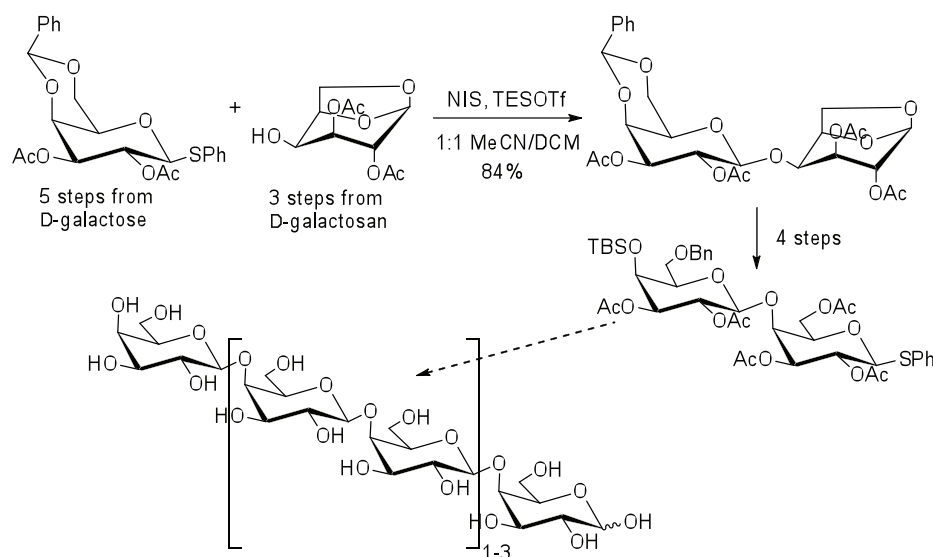

Since galectins are known to bind galactose-containing moieties, such as pectic galactan, the preliminary focus has been on oligogalactosides. The first oligosaccharides to be investigated were linear  $\beta$ -(1 $\rightarrow$ 4)-linked oligogalactosides of four to eight residues.

The problem of the inherently low reactivity of the axial 4-hydroxyl of D-galactose has been addressed through the use of a 1,6-anhydro sugar in the first glycosylation. The disaccharide was subsequently converted to the corresponding thioglycoside which served as building block for the synthesis of the target molecules. These were conjugated to bovine serum albumin, immobilized on microarrays and screened against recombinant galectin and antibodies.

## PO 08

## SYNTHESIS AND ENZYMATIC STUDY OF NOVEL SELENOGLYCOSIDE

Takayuki Ando,<sup>1,2</sup> Hiromune Ando,<sup>1,2</sup> Yumiko Kawai,<sup>1</sup> Rie Tamai,<sup>1</sup>  
Hideharu Ishida<sup>1</sup> and Makoto Kiso<sup>1,2</sup>

<sup>1</sup>*Department of Applied Bioorganic Chemistry,  
Gifu University, 1-1 Yanagido, Gifu 501-1193, Japan,*

<sup>2</sup>*CeMS, Kyoto University, Yoshida Ushinomiya-cho, Sakyo-ku, Kyoto 606-8501, Japan  
an429@gifu-u.ac.jp*

Glycoside analogues, in which oxygen atom was replaced by other atoms, such as carbon, nitrogen and sulfur, enhanced binding properties or increased stability toward enzymatic degradation, compared with the natural glycosides.<sup>1</sup> It has great interest to investigate the biological properties of these pseudo glycosides containing selenoglycosidic linkage.

Recently, we have reported a facile synthetic method for  $\beta$ -selenoglycoside and succeeded in various selenoglycosides.<sup>2</sup> The reactions between *p*-methylbenzoyl selenoglycoside and bromides (alkyl, aryl and glycosyl) in the presence of secondary amine and Cs<sub>2</sub>CO<sub>3</sub> gave the corresponding  $\beta$ -selenoglycosides in high yields, respectively.

In this study, the typical selenohexopyranosides,  $\beta$ -selenogalactoside and  $\beta$ -*N*-acetyl-selenoglucosaminide (Fig. 1) were systematically synthesized to examine their susceptibilities (Fig. 2) and inhibitory activities against the corresponding glycosidases,  $\beta$ -galactosidase and  $\beta$ -hexosaminidase. Furthermore, the kinetic constants (*K<sub>m</sub>*, *V<sub>max</sub>* and *K<sub>cat</sub>*) were measured to compare with the corresponding *O*-glycosides.

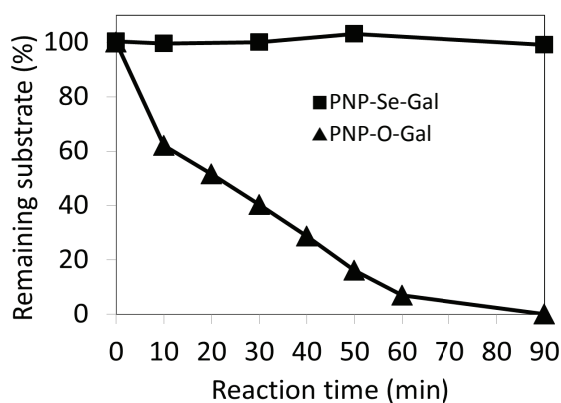
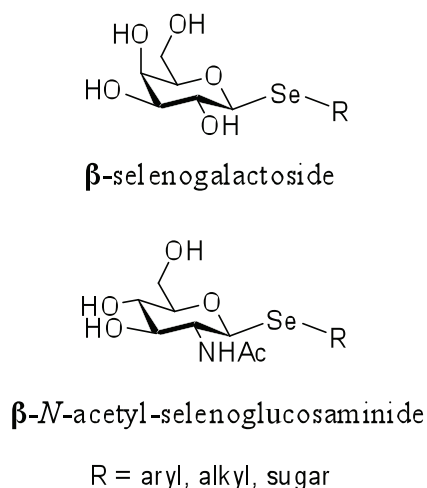

**Fig.1** Synthesized selenoglycosides in this study    **Fig. 2** Time course of hydrolysis of PNP-Se-Gal by  $\beta$ -galactosidase from *E. coli*

## References

1. W. J. Zbigniew, *Curr. Med. Chem.* **1999**, 6, 165-178.
2. Y. Kawai, H. Ando, H. Ozeki, M. Koketsu, H. Ishihara, *Org. Lett.* **2005**, 7, 4653-4656



## PO 09

SYNTHESIS OF ANHYDROSUGAR DERIVATIVES FROM  
6-DEOXYHEX-5-ENOPYRANOSIDEValquiria Aragão-Leoneti,<sup>1,2</sup> Ivone Carvalho,<sup>1</sup> and Stuart J. Conway<sup>2</sup><sup>1</sup> Faculdade de Ciências Farmacêuticas de Ribeirão Preto- USP. Av. Café S/N, CEP 14040-903, Ribeirão Preto-SP, Brazil,<sup>2</sup> Department of Chemistry, Chemistry Research Laboratory, University of Oxford, Mansfield Road, Oxford OX1 3TA, UK  
varagao@usp.br

D-*myo*-Inositol 1,4,5-trisphosphate (InsP<sub>3</sub>) is a ubiquitous Ca<sup>2+</sup>-releasing second messenger involved in a wide range of cellular functions.<sup>1</sup> Consequently, many syntheses of both the natural InsP<sub>3</sub> and numerous unnatural derivatives have been completed.<sup>1</sup> We have previously reported the synthesis of InsP<sub>3</sub> and derivatives from a 6-deoxyhex-5-enopyranoside *via* a Ferrier rearrangement.<sup>2,3</sup> However, this process involved use of super stoichiometric mercuric acetate and proceeded in moderate yield. Consequently, we are interested in evaluating the efficiency of other metals in mediating the Ferrier rearrangement. During our studies toward a gold-mediated Ferrier rearrangement, we observed the surprising formation of the anhydrosugar derivatives **3** and **4** from 6-deoxyhex-5-enopyranosides **2**.

The precursor **2** was synthesised in five steps from methyl α-D-glucopyranose **1** (Scheme 1).<sup>2</sup> A range of reaction conditions, employing gold catalysts, was investigated in order to obtain inositol derivatives. However, the treatment of compound **2** with AuCl<sub>3</sub> and AgBF<sub>4</sub> unexpectedly resulted in the formation of **3** and **4** in 9 and 27% yield, respectively (Scheme 1). Compound **3** is potentially an intermediate in the synthesis of the glycosidase inhibitor, 1-deoxynojirimycin, *via* 5-ketoglucose.<sup>4</sup> To the best of our knowledge compound **4** has not been previously reported.

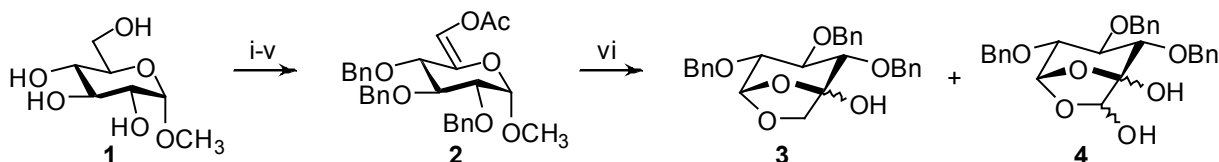

**Scheme 1.** Synthesis of compounds **3** and **4**. Reagents and conditions: (i) PhCH(OMe)<sub>2</sub>, THF, rt, 50%; (ii) NaH, BnBr, DMF, rt, 84%; (iii) DIBAL-H, CH<sub>2</sub>Cl<sub>2</sub>, rt, 81%; (iv) DMP, CH<sub>2</sub>Cl<sub>2</sub>, rt, 67%; (v) K<sub>2</sub>CO<sub>3</sub>, Ac<sub>2</sub>O, DMAP, MeCN, reflux, 61%; (vi) AuCl<sub>3</sub>, AgBF<sub>4</sub>, dioxane/water (4:1), reflux, 9% of **3** and 27% of **4**.

In conclusion, progress has been achieved in the synthesis of anhydrosugars **3** and **4**, which are useful precursors to a range of biologically important compounds.

**Acknowledgements:** FAPESP

### References

- Conway, S. J.; Miller, G. J. *Nat. Prod. Rep.* **2007**, *24*, 687-707.
- Keddie, N. S.; Bultynck, G.; Luyten, T.; Slawin, A. M. Z.; Conway, S. J. *Tetrahedron: Asymmetry* **2009**, *20*, 857-866.
- Keddie, N. S.; Ye, Y.; Aslam, T.; Luyten, T.; Bello, D.; Garnham, C.; Bultynck, G.; Galione, A.; Conway, S. J. *Chem. Commun.* **2011**, *47*, 242-244.
- Enright, P. M.; O'Boyle, K. M.; Murphy, P. V. *Org. Lett.* **2000**, *2*, 3929-3932.

## PO 10

**A LACTOSE DERIVATIVE AS DOUBLE LIGAND FOR GALECTIN3 AND MMP12.  
STUDY OF THE INTERACTION BY NMR AND MODELING**

Ana Ardá-Freire,<sup>1</sup> Blanca Eda Domínguez,<sup>1,4</sup> Marco Bartolini,<sup>2</sup> F. Javier Cañada,<sup>1</sup>  
Sabine André<sup>3</sup>, Hans-Joachim Gabius,<sup>3</sup> Cristina Nativi<sup>2</sup> and Jesús Jiménez-Barbero<sup>1</sup>

<sup>1</sup>Department of Chemical and Physical Biology, CIB-CSIC, Ramiro de Maeztu 9,  
28040, Madrid, Spain

<sup>2</sup>Department of Organic Chemistry, Università di Firenze, Sesto Fiorentino,  
Firenze, I-50019, Italy

<sup>3</sup>Institut für Physiologische Chemie, Ludwig Maximilians-Universität, V  
eterinaärstr. 13, D-80539 München, Germany

<sup>4</sup>Centro de Investigaciones Químicas, Universidad Autónoma de Morelos,  
Av. Universidad 1001, 62210, Cuernavaca, México  
aarda@cib.csic.es

Galectins are a family of animal proteins characterised by their affinity for  $\beta$ -galactoside containing glycans, and sharing consensus amino acid sequences. They play important roles in cancer, contributing to tumor cell survival, angiogenesis and tumor metastasis.<sup>1</sup> Anti-galectin compounds have been proposed as potential anti-cancer drugs, in that they can restrict the levels of migration of several types of cancer cell.<sup>2</sup> Matrix Metalloproteinases (MMPs) are a family of mammalian endopeptidases involved in the degradation of extracellular matrix components, thus playing a key role in different tissue remodelling processes. Their overexpression or wrong modulation are also related to cancer.<sup>3</sup> The development of MMP inhibitors has gathered much efforts in the drug discovery field in the last few years.<sup>4</sup>

We present here a new ligand designed for targeting both class of proteins. The interaction of compound **1** with Galectin 3 and Matrix Metalloproteinase 12 have been studied by NMR from both the perspective of the ligand (STD and trNOE)<sup>5</sup> and the proteins (<sup>1</sup>H-<sup>15</sup>N HSQC chemical shift mapping).<sup>6</sup> These experimental results together with molecular modeling allow us to picturise a 3D model of the interaction.

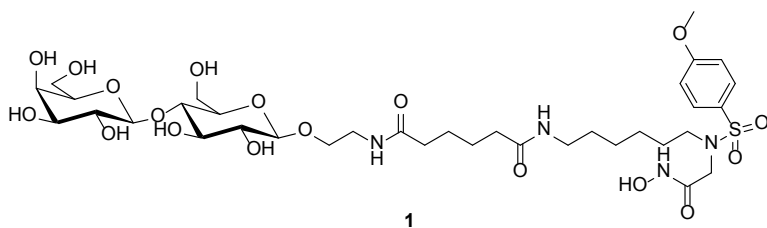

### References

1. H. Lahm, S. André, A. Hoefflich, H. Kaltner, H. C. Siebert, B. Sordat, C.W. von der Lieth, E. Wolf, H. J. Gabius, *Glucocconj. J.* **2004**, *20*, 227.
2. L. Ingrassia, I. Camby, F. Lefranc, V. Mathieu, P. Nshimyumukiza, F. Darro, R. Kiss, *Curr. Med. Chem.*, **2006**, *13*, 3513-3527.
3. D. Bourboulia, W. G. Stetler-Stevenson *Seminars in CancerBiology*, **2010**, *20*, 161-168.
4. M. Whittaker, C. D. Floyd, P. Brown, A. J. Gearing, *Chem Rev.*, **1999**, *99*, 2735-2776.
5. M. Mayer, B. Meyer, *Angew. Chem. Int. Ed.*, **1999**, *38*, 1784.
6. S. B.Shuker, P. J.Hajduk, R. P.Meadows, S. W.Fesik, *Science*, **1996**, *274*, 1531.

## PO 11

**FURTHER SAR STUDIES ON A VERY POTENT OPIOID NEOGLYCOPEPTIDE  
RELATED TO ENKEPHALINS**

Gemma Arsequell<sup>1</sup>, Mònica Rosa<sup>1</sup>, Verónica Gonzalez-Nunez<sup>2</sup>, Katherine Barreto-Valer<sup>2</sup>,  
Filipa Marcelo<sup>3</sup>, Luis P. Calle<sup>3</sup>, Raquel E. Rodríguez<sup>3</sup>, Jesús Jiménez-Barbero<sup>3</sup>, Gregorio Valencia<sup>1</sup>

<sup>1</sup>*Instituto de Química Avanzada de Cataluña (IQAC-CSIC), Barcelona (Spain);*

<sup>2</sup>*Department of Biochemistry and Molecular Biology, Faculty of Medicine,  
Instituto de Neurociencias de Castilla y León (INCyL), University of Salamanca (Spain);*

<sup>3</sup>*Chemical and Physical Biology, Centro de Investigaciones Biológicas, (CIB-CSIC),  
Madrid (Spain)*

*gregorio.valencia@iqac.csic.es*

One of the already known strategies to obtain potent and systemically active antinociceptive enkephalin analogues is to make use of glycosylation technologies. Early studies in our group have revealed that the introduction of glucose and galactose via *O*- linkage to Hyp<sup>5</sup> of the Tyr-D-Met-Gly-Phe-Pro-NH<sub>2</sub> enkephalin sequence<sup>1</sup> greatly improved its antinociceptive activity, but there was a clear cut difference in that the galactosyl analogue was always more potent than the glucosyl<sup>2</sup>. These differences were temptatively explained by the different conformations of the analogues<sup>3</sup>. Recently, we have prepared a mannosyl derivative of morphine which has shown remarkable antinociceptive properties that may be attributed to a particular dynamic behaviour of the molecule<sup>4</sup>. To explore if an opioid peptide ligand may also show similar biological and conformational effects than those induced on morphine by the mannosyl residue, we have further expanded our SAR studies on the neoglycopeptide structure shown below.

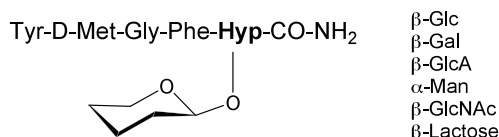

The synthesis of the six neoglycopeptides and of their parent compound have been performed by solid-phase peptide synthesis. Their binding affinity for the δ- and μ- zebrafish cloned opioid receptors have been assessed. NMR conformational studies in aqueous and membrane model media have also been conducted to explain the different affinities of these compounds.

### References

1. Bajusz S., Ronai A.Z., Szdkely J.I., Graf L., Dunnai-Kovacs Z., Berzétei I. *FEBS Lett.*, **1977**, 76, 91-93.
2. Rodríguez R.E., Rodríguez F.D., Sacristán M.P., Torres J.L., Valencia G., García Antón J.M. *Neuroscience Lett.*, **1989**, 101, 89-94.
3. Torres J.L., Pepermans H., Valencia G., Reig F., Garcia-Antón J.M., Van Binst G. *EMBO J.*, **1989**, 8, 2923-2932.
4. Arsequell G.; Salvatella M., Valencia G., Fernández-Mayoralas A., Fontanella M., Venturi Ch., Jiménez-Barbero J., Marrón E., Rodríguez R.E. *J. Med. Chem.* **2009**, 52, 2656-2666.

## PO 12

**BAML - A NEWLY IDENTIFIED LECTIN FROM *BURKHOLDERIA AMBIFARIA* WITH SPECIFICITY TOWARDS HUMAN BLOOD GROUP EPITOPES**Aymeric Audfray<sup>1</sup>, Saïda Abounit<sup>2</sup>, Winfried Römer<sup>2</sup>, Annabelle Varrot<sup>1</sup> and Anne Imberty<sup>1</sup><sup>1</sup>CERMAV-CNRS, BP 53, 38041 Grenoble cedex 09, France;<sup>2</sup>Institut Curie, 26 Rue d'Ulm, 75248 Paris cedex 05, France

aymeric.audfray@cermav.cnrs.fr

The *Burkholderia cepacia* complex (Bcc) is a group of genetically distinct but phenotypically similar bacteria with interesting environmental and biotechnological potential [1]. Bcc cause a variety of infections in immunocompromised patients, in patients with cystic fibrosis (CF) and granulomatous disease and is responsible for the “cepacia syndrome” that leads to rapid lung deterioration. Within the Bcc, *B. ambifaria* is one of the species that has been isolated from CF patients [2]. As observed for other opportunistic bacteria [3], species from the Bcc have been reported to produce soluble lectins able to bind to glycoconjugates present in human tissues [4]. This work describes the production and characterization of BamL, a new lectin from *B. ambifaria*. BamL, that presents similarity with a lectin from the plant pathogen *Rasltonia solanacearum* and binds with micromolar affinity to fucosylated ligands with a preference for blood group epitopes. Crystal structures of BamL in complex with  $\alpha$ -methyl-fucoside, blood group B, blood group H and lewis X oligosaccharides have been solved at high resolution. BamL is a homotrimeric  $\beta$ -propeller with two binding sites per monomer. We have used giant unilamellar vesicles with incorporated glycosphingolipids that represent a minimal cellular plasma membrane to define BamL cellular receptors. We show that, in this context, the binding of BamL was optimal with blood group A glycolipids. In conclusion, these results underline a new type of lectin from a member of Bcc with binding preferences for blood group epitopes. These epitopes might be used by the bacterium to bind and invade human cells. Consequently, BamL constitute a potential target for anti-adhesive treatments.

**References**

1. Schmidt, S., J. F. Blom, J. Pernthaler, G. Berg, A. Baldwin, E. Mahenthiralingam, L. Eberl (2009). *Environmental Microbiology* **11**(6): 1422-37
2. Coenye, T., E. Mahenthiralingam, D. Henry, J. J. LiPuma, S. Laevens, M. Gillis, D. P. Speert, P. Vandamme (2001). *Int J Syst Evol Microbiol* **51**(4): 1481-90.
3. Imberty, A. Varrot A. *Curr. Opin. Struct. Biol.*, **2008**, *18*, 567-576
4. E. Lameignere, L. Malinová, M. Slavikova, E. Duchaud, E.P. Mitchell, A. Varrot, O. Šedo, A. Imberty & M. Wimmerová. *Biochem. J.*, **2008**, *41*, 12846-12858.

## PO 13

STUDIES DIRECTED TOWARDS THE SYNTHESIS OF A HEPTASACCHARIDE  
REPEATING UNIT OF THE LIPOPOLYSACCHARIDE  
OF *PROVIDENCIA RUSTIGIANII*

Shahid I. Awan, Daniel B. Werz

Institute of Organic and Biomolecular Chemistry, Georg August University of Goettingen,  
Tammannstr. 2, D-37077 Goettingen, Germany.  
sawan@gwdg.de

Oligosaccharides have immense biological impact as secondary metabolites. The biological importance of oligosaccharides has rendered them targets of intense examination and syntheses. Since the microheterogeneity of carbohydrates limits the amount of pure oligosaccharides that may be isolated from natural sources, chemical synthesis is essential to procure appreciable quantities of material for biological studies.<sup>[1]</sup>

Lipopolysaccharides (LPS) are a major component of the outer membrane of the cell wall and are considered as a virulence factor of Gram-negative bacteria, including *Providencia*.<sup>[2]</sup> In order to facilitate detection of *Providencia* bacteria the heptasaccharidic repeating unit of the LPS (Fig. 1) will be synthesized by a (4+2+1) strategy. At first, all appropriate building blocks for the required branching and respective selectivities at the anomeric centres have to be created. Immunization studies using this target molecule will be performed to get access to corresponding antibodies.

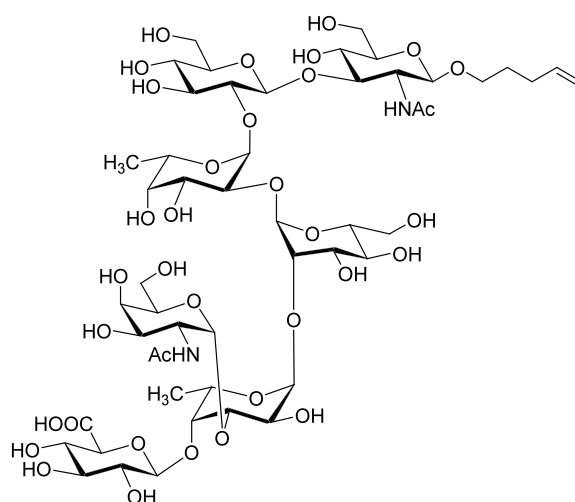

**Figure 1.** A heptasaccharidic repeating unit of LPS from *Providencia rustigianii*.

**References**

1. P. H. Seeberger, D. B. Werz, *Nature*, **2007**, *446*, 1046–1051.
2. N. A. Kocharova, A. N. Kondakova, E. Vinogradov, O. G. Ovchinnikova, B. Linder, A. S. Shashkov, A. Rozalski, Y. A. Knirel, *Chem. Eur. J.*, **2008**, *14*, 6184–6191.

## PO 14

## PROPERTIES OF ACIDIC XYLAN PRESENT IN BASIL SEED MUCILAGES

Jun-ichi AZUMA<sup>1</sup>, Taitso IKAWA<sup>1</sup>, Yayoi MAITANI<sup>1</sup>, Masahiro SAKAMOTO<sup>1</sup>,  
Rike YUDIANTI<sup>2</sup> and Lucia INDRARTI<sup>2</sup>

<sup>1</sup>Laboratory of Forest Biochemistry, Division of Environmental Science and Technology,  
Graduate School of Agriculture, Kyoto University, Kyoto, Japan,

<sup>2</sup>Research Centre for Physics, Indonesian Institute of Sciences, Bandung, Indonesia  
azumaji@kais.kyoto-u.ac.jp

Basils belong to Genus *Ocimum* in Lamiaceae and distribute worldwide as a king of herbs. In Southeastern Asia three different species, *Ocimum basilicum* L., *O. x citriodorum* L. and *O. americanum* L., are commonly cultivated and their nutlets were used in cold drinks as a kind of dietary fibers after swelling in water with addition of sweeteners and an antipyretic pharmaceutical agent. Hydrogels produced from the epicarp of their edible nutlets are present as a composite of cellulose and hemicellulosic polysaccharides differing in proportion among species. In this study, precise chemical structures of the hemicellulosic polysaccharides present in the hydrogels exuded out from three species of basils were comparatively characterized by methylation, NMR spectroscopic and MALDI-TOF and MALDI-TOF/TOF mass spectroscopic analyses in relation to their rheological properties. The neutral fraction is commonly composed of a mixture of at least three types of polysaccharides consisting of arabinan, arabino-(1,3;1,6)-galactan and a small amount of glucomannan the amount of which differed among species. The acidic fraction is, however, exclusively composed of a  $\beta$ -(1,4)-linked xylan substituted highly with 4-O-methylglucuronic acid with a molar ratio of 1.6-1.8:1.0. By the MALDI-TOF and MALDI-TOF/TOF mass analysis of the partially hydrolyzed materials from the reduced acidic xylan, a series of 37 ions as  $[M+Na]^+$  from  $m/z$  349 ( $X_1MG_1$ ; X = Xyl, MG = 4-O-methylglucose) to  $m/z$  4046 ( $X_{17}MG_{10}$ ) were identified. Furthermore, a similar experiment by using the partially hydrolyzed native acidic xylan gave 13 ions with the parental ion as  $[M+Na]^+$  at  $m/z$  2633 ( $X_{11}MGA_6$ ; MGA = 4-O-methylglucuronic acid). Presence of contiguous substitution with 4-O-methylglucuronic acids in an irregular fashion was also indicated by the MALDI-TOF and MALDI-TOF/TOF methods. Viscoelastic properties are largely depending upon the cellulose content. The results of analysis of interaction between cellulose and hemicellulosic polysaccharides by graded alkaline solutions and microwave heating indicate that the acidic xylans were weakly associated with cellulose, although they are the major contributor for maintaining hydrogel structure<sup>1</sup>.

### References

1. Yudianti, R., Karina, M., Sakamoto, M. and Azuma, J., *Macromol. Res.*, 2009, 17, 332-338.



## PO 15

## FORMAL SYNTHESIS OF NECTRISINE

Mariam Azzouz, Josep Llaveria, Patricia Marcé, M. Isabel Matheu, Yolanda Díaz\*  
and Sergio Castellón\*

*Departament de Química Analítica i Química Orgànica, Facultat de Química,  
Universitat Rovira I Virgili,  
C/Marcel·lí Domingo s/n,43007, Tarragona, Spain. Fax:977558446; Tel: 977558293.  
mariam.azzouz@estudiants.urv.cat*

Nectrisine (**1**) (Scheme 1), isolated from the fungus *Nectricine lucida* as immunomodulator FR-900483,<sup>1</sup> had been found to exhibit inhibitory activity on  $\alpha$ -glycosidases.<sup>2</sup> Furthermore, nectrisine is involved in the prevention of different diseases such as immunosuppressed mice<sup>1a</sup> and Newcastle disease virus.<sup>1b</sup>

Due to its important biological activity, organic chemists have been interested on the development of new methods for the synthesis of this compound from the chiral pool compounds such as diethyl tartrate,<sup>3,4</sup> aminoacids,<sup>5,6</sup> and carbohydrates.<sup>7,8</sup>

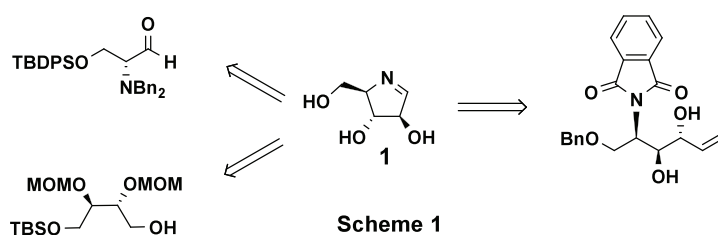

Scheme 1

We present a formal synthesis of the target compound. The synthetic route starts with racemic butadiene monoepoxide **6**, which is transformed into the chiral allylic amine **5** via a Pd-catalyzed Dynamic Kinetic Asymmetric Transformation.<sup>9</sup> Ru-cross-metathesis reaction of **5** with different  $\alpha,\beta$ -unsaturated carbonyl compounds, followed by Os-catalyzed dihydroxylation affords the useful intermediate **3**. Deprotection of the benzoate group, deprotection of *N*-Boc group and *in situ* cyclization renders lactame **2** from which synthesis of Nectrisine has been already reported.<sup>5</sup>

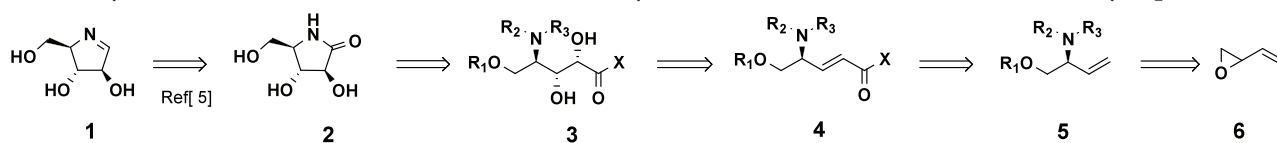

Scheme 2

## References

- (a) T. Shibata, O. Nakayama, Y. Tsurumi, M. Okuhara, H. Terano, M. Kohsaka, *J. Antibiot.* **1988**, *41*, 296-301; (b) E. Tsujii, M. Muroi, N. Shiragami, A. Takatsuki, *Biochem. Biophys. Res. Commun.* **1996**, *220*, 459-466.
- (a) B. Ganem, *Acc. Chem. Res.* **1996**, *29*, 340-347. (b) P. Compain, O.R. Martin, *Bioorg. Med. Chem.* **2001**, *9*, 3077-3092. (c) N. Asano, *Glycobiology.* **2003**, *13*, 93R-104R.
- Y. J. Kim, A. Takatsuki, N. Kogoshi, T. Kitahara, *Tetrahedron.* **1999**, *55*, 8353-8364.
- Y. J. Kim, T. Kitaraha, *Tetrahedron Lett.* **1997**, *38*, 3423-3426.
- A. N. Hulme, C.H. Montgomery, *Tetrahedron Lett.*, **2003**, *44*, 7649-7653.
- C. Ribes, E. Falomir, M. Carada, J. A. Marco, *J. Org. Chem.* **2008**, *73*, 7779-7782.
- M. Bosco, P. Bissere, C. Bouix-Peter, J. Eustache, *Tetrahedron Lett.* **2001**, *42*, 7949-7952.
- P. Merino, A. Goti et al, *Eur. Org. Chem.* **2008**, 2929-2947.
- (a) B. M. Trost, D.R. Fandrick, T. Brodmann, D.T. Stiles, *Angew. Chem. Int. Ed.* **2007**, *119*, 6235-6237; (b) B. M. Trost, R. C. Bunt, R. C. Lemoine, T. L. Calkins, *J. Am. Chem. Soc.* **2008**, *122*, 5968-5976.



## PO 16

**IN VITRO AND IN VIVO MECHANISMS OF THE YEAST  
OLIGOSACCHARYLTRANSFERASE ACCESSORY PROTEINS OST3 AND OST6  
AND THE HUMAN HOMOLOGS N33 AND IAP**

Bailey U.-M., Jamaluddin M.F., Bailey P.J. and Schulz B.L.

*School of Chemistry and Molecular Biosciences (SCMB), University of Queensland,  
Brisbane St Lucia, QLD 4072, Australia  
u.bailey@uq.edu.au*

Protein N-glycosylation is a common and essential co- and post-translational modification of membrane and secreted proteins that in eukaryotes is catalysed by the multicomplex enzyme Oligosaccharyltransferase (OTase) (1). A number of the genes that encode for subunits within the OTase complex have been implicated in human health and disease such as prostate cancer, ovarian cancer and mental retardation. The specific glycan structures modulate protein function in developmental programs, during immune responses, in cell-cell interaction and in many other cellular processes. With over half of all proteins predicted to be glycosylated, the sequence and structural diversity of protein acceptor sites is extraordinarily large (2). Incorporation of either of the homologous proteins Ost3p or Ost6p in OTase results in two isoforms of the yeast enzyme, which have different protein substrate specificities at the level of individual glycosylation sites (3).

Here we present in vitro and in vivo analyses that map specific interactions that can occur between substrate proteins and yeast Ost3/6p. We also present the expression profile of the human Ost3 and Ost6 homologs, N33 and IAP, in a panel of breast cancer cell lines.

**References**

1. Kelleher DJ & Gilmore R., *Glycobiology*, **2006**, *16*, 47R-62R.
2. Apweiler, R., Hermjakob, H., and Sharon, N., *Biochim Biophys Acta*, **1999**, *1473*, 4-8.
3. Schulz BL, Stirnimann C, Grimshaw JPA, BrozzoMS, Fritsch F, Mohorko E, Capitani G, Glockshuber R, Grütter MG and Aebi, M., *PNAS*, **2009**, *106*,11061-6.

## PO 17

**TOLL-LIKE RECEPTOR 4 (TLR4) RECOGNIZES RHAMNOMANNANS OF *PSEUDALLESCHERIA BOYDII* CELL WALL**

Rodrigo T. Figueiredo<sup>1,2</sup>, Vera Carolina B. Bittencourt<sup>3</sup>, Livia Cristina L. Lopes<sup>4</sup>,  
Guilherme L. Sasaki<sup>5</sup>, Marcelo T. Bozza<sup>1</sup> and Eliana Barreto-Bergter<sup>4</sup>

<sup>1</sup>*Departamento de Imunologia, Instituto de Microbiologia, Universidade Federal do Rio de Janeiro (UFRJ), Rio de Janeiro, 21941-902, Brasil,*

<sup>2</sup>*Polo de Xerém, Instituto de Ciências Biomédicas, Universidade Federal do Rio de Janeiro (UFRJ), Rio de Janeiro, 21941-902, Brasil,*

<sup>3</sup>*Instituto Biomédico, UNIRIO, Rio de Janeiro, RJ, Brasil,*

<sup>4</sup>*Departamento de Microbiologia Geral, Instituto de Microbiologia, Universidade Federal do Rio de Janeiro (UFRJ), Rio de Janeiro, 21941-902, Brasil*

*Pseudallescheria boydii* is a saprophytic fungus widespread in the environment, and has recently emerged as an agent of localized as well as disseminated infections in both immunocompromised and immunocompetent hosts [1]. The host response to fungi is in part dependent on activation of evolutionary conserved receptors including toll-like receptors and phagocytic receptors. However, the molecular nature of fungal ligands responsible for this activation is largely unknown. In this work, we describe the isolation and structural characterization of a rhamnomannan from *P.boydii* cell wall and evaluate its role in the induction of innate immune response. We have previously shown that an  $\alpha$ -glucan stimulates the secretion of inflammatory cytokines by macrophages and dendritic cells and induces cytokine secretion by cells of the innate immune system through TLR2, CD14 and MyD88 [2]. A fraction highly enriched in rhamnomannans characterized by NMR, high performance TLC and GC-MS, triggered cytokine release by macrophages, as well as MAPKs phosphorylation and I $\kappa$ Ba degradation. Cytokine release induced by *P.boydii*-derived rhamnomannans was dependent on TLR4 recognition and required the presence of rhamnose non-reducing end units, but not of O-linked oligosaccharides from peptidorhamnomannan. These results indicate that *P.boydii*-derived rhamnomannans are molecular patterns recognized by TLR4. These results add new information on the role of mannan-containing polymers in the recognition of fungal pathogens.

**References**

1. Cortez *et al.*, 2008. Clin. Microbiol. Rev., 21: 157-197
2. Bittencourt *et al.*, 2006. J. Biol. Chem., 281: 22614-22623

Supported by: CNPq, FAPERJ, PRONEX

## PO 18

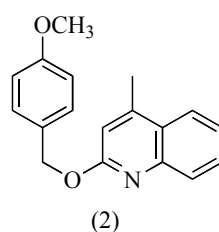
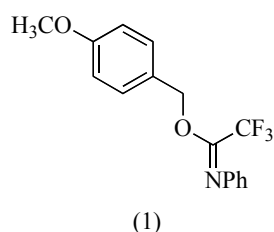
ACID-CATALYSED INTRODUCTION OF *p*-METHOXYBENZYL ETHER:  
A NOVEL ALTERNATIVEMohamed Benchekroun<sup>1</sup>, Filipe Gomez da Cruz, Nadine Barroca-Aubry<sup>1</sup>  
and David Bonnaffé<sup>1</sup><sup>1</sup>G2M-LCOM, ICMMO, UMR CNRS-UPS 8182, Bât. 420,  
Université Paris Sud 11, 91405 Orsay cedex, France  
nadine.aubry-barroca@u-psud.fr

Benzyl type protecting group such as benzyl (Bn) or *p*-methoxybenzyl (PMB) ethers always play a central role in strategies for oligosaccharide synthesis. Usually, they are introduced by in strong basic media. Such conditions are not eligible for alkali-labile protecting groups nor for compounds, which could be sensitive to racemisation or  $\beta$ -elimination.

Methods for acid-catalysed introduction of *p*-methoxybenzyl (PMB) ethers have already been developed. Some are not so convenient: the low stability of the reagent leads to low yields and messy reactions (*p*-methoxybenzyl trichloroacetimidate).<sup>1</sup> Others are not so easy to prepare: obtained *via* nitrile from the corresponding amides at  $-78^\circ\text{C}$  (*p*-methoxybenzyl perfluoroacetimidates).<sup>2</sup>

First of all, we want to report here the successful preparation and application of a novel benzyl type reagent: the *p*-methoxybenzyl *N*-phenyl-2,2,2-trifluoroacetimidate (1). The synthesis of this imidate is very efficient (starting from commercially available reagents) and it has been obtained as very stable crystals (stable for one year at room temperature). We want to exemplify here the application of this reagent to introduce very cleanly and with very mild activation *p*-methoxybenzyl ethers.

In a second time, we want to outline the utilisation of the known *p*-methoxybenzyl lepidine (2)<sup>3</sup>: we mention a new type of activation for this lepidine with trimethylsilyl triflate or lanthanide triflates. These new activations afford slowly but cleanly the *p*-methoxybenzylated compound without troublesomes.

### References

1. Iversen T., Bundle D. R., *J. Chem. Soc. Chem Commun.* **1981**, 1240-1241 ; Wessel H.-P., Iversen T., Bundle D. R., *J. Chem. Soc. Perkin Trans 1.* **1985**, 2247-2250.
2. Nakajima N., Sato M., Ubukata M., *Tetrahedron lett.* **1998**, 39, 5565-5568 ; Nakajima N., Sato M., Ubukata M., *Tetrahedron* **2002**, 58, 3561-3577.
3. Nwoye E. O., Duddley G. B., *Chem Commun.* **2007**, 1436-1437 ; Stewart C. A., Peng X., Paquette L. A., *Synthesis* **2008**, 3, 0433-0437 ; Albiniak P. A., Duddley G. B., *Synlett.* **2010**, 6, 0841-0851.

## PO 19

«ONE POT» REGIOSELECTIVE PROTECTION: AN EFFICIENT PREPARATION  
OF KEY SYNTHONS INVOLVED IN HEPARAN SULFATE FRAGMENTS  
SYNTHESIS

Dayana Jonathan,<sup>1</sup> Amar Sahoul,<sup>1</sup> Nadine Barroca-Aubry,<sup>1</sup> David Bonnaffé,<sup>1</sup>

<sup>1</sup>G2M-LCOM, ICMMO, UMR CNRS-UPS 8182, Bât. 420, Université Paris Sud 11,  
91405 Orsay cedex, France  
Nadine.aubry-barroca@u-psud.fr

Heparan sulfate (HS) is a sulfated glycosaminoglycan formed by repetition of a basic disaccharide: an uronic acid (L-iduronic or D-glucuronic) linked to a D-glucosamine by  $\beta(1-4)$  ligation. HS is one of the most heterogeneous biopolymers by both existence along the chain of large range of sulfation and epimerisation pattern.<sup>1</sup> In order to access to this molecular diversity, we develop combinatorial methods syntheses of HS fragments by oligomerisation of suitably functionalised disaccharide building blocks.<sup>2</sup>

We will present our results on a highly convergent synthesis, based on extremely regioselective reactions. We particularly pointed out the regioselective introduction of

- benzylidene/*p*-methoxybenzylidene,
- benzyl ether by reductive etherification
- selective 6-acetylation by temporary *in situ* protection.

This methodology afforded in particular disaccharide **2a** and **2d** from the sole precursor **1**

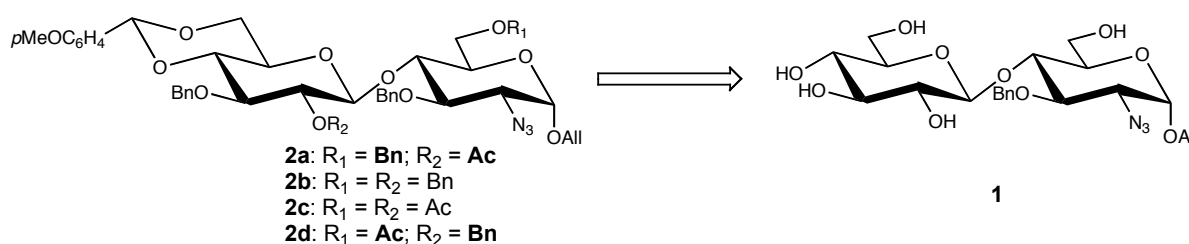

Access to this molecular diversity will allow us to prepare libraries of HS octasaccharides fragments in order to achieve the molecular optimization of 2O10, a dimeric octasaccharide, which has shown an ability to inhibit both interaction between interferon- $\gamma$  (IFN- $\gamma$ ) / IFN- $\gamma$  receptor and IFN- $\gamma$  / HS. The decrease in pro-inflammatory action of IFN by such glycoconjugates is an innovative therapeutic lead for treatment of many disabling inflammatory pathologies.

### References

1. Esko, J.D. ; Lindhal, U. *J. Clin. Invest.* **2001**, *108*, 169-173.
2. Dhilas, A.; Lucas, R.; Loureiro-Morais L.; Hersant Y.; Bonnaffe D. *J. Comb. Chem.* **2008**, *10*, 166-169.
3. Sarrazin S.; Bonnaffé D.; Lubineau A.; Lortat-Jacob H. *J. Biol. Chem.* **2005**, *280*, 37558-37564.

## PO 20

SYNTHESIS OF LIPID A – DERIVED NEOGLYCOCONJUGATES BASED ON GALACTOSAMINE – MODIFIED LIPID A OF *FRANCISELLA TULARENSIS*

David Baum, Paul Kosma, Alla Zamyatina

Department of Chemistry, University of Natural Resources and Life Sciences, Muthgasse 18,  
A-1190 Vienna, Austria  
alla.zamyatina@boku.ac.at

*F. tularensis* is a highly infectious human pathogen which causes tularaemia, an extremely contagious lethal pulmonary disease, which is of concern because of its potential for bioterrorism. An important role in the pathogenesis of *Francisella* infections plays its tetraacylated lipid A, which lacks 4'-phosphate and is covalently modified with  $\alpha$ -D-GalNH<sub>2</sub> at the reducing phosphate.<sup>[1,2]</sup> Since around 90% of *Francisella* Lipid A is present in a free form, i.e., not 6'-linked to Kdo, and, presumably, 6'-linked to a  $\alpha$ -D-glucose residue<sup>[3]</sup>, lipid A-based neoglycoconjugates containing the epitope GlcN( $\beta$ -1 $\rightarrow$ 6)GlcN( $\alpha$ -1 $\rightarrow$ P $\rightarrow$ 1- $\alpha$ )GalN, which is conserved in all virulent *Francisella* strains, will be of considerable use for the generation of specific antibodies in an attempt to elaborate effective sub-unit vaccines and might be utilized in diagnostic immunoassays as capture antigen.

An efficient approach based on the H-phosphonate methodology was elaborated for the construction of glycosyl phosphodiester in which the anomeric centres of  $\alpha$ -D-GalN and  $\alpha$ -D-GlcN are the parts of the phosphodiester bond. Conformation-constraining 4,6-DTBS protection of GalN was employed to ensure the  $\alpha$ -selective phosphorylation. Conditions for final deprotection which warrant the integrity of anomeric phosphodiester were optimized. The introduction of the thiol-terminated spacer allows either coupling to BSA or immobilization on gold nanoparticles.

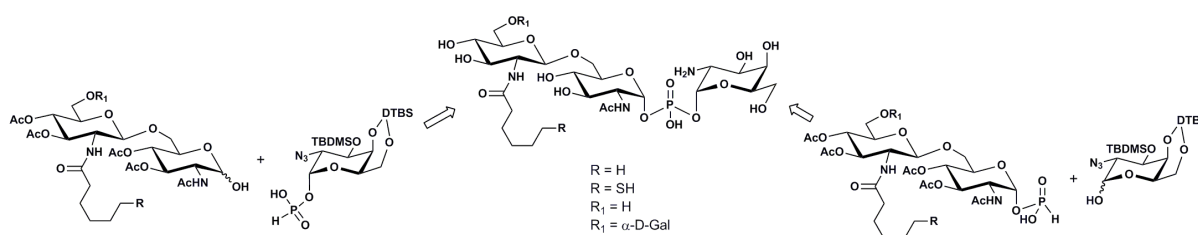

**Acknowledgments:** Financial support from FWF (grant P 21276) is gratefully acknowledged.

### References

1. Phillips, N. J.; Schilling, B.; McLendon, M. K.; Apicella, M. A.; Gibson, B. W. *Infect. Immun.* **2004**, *72*, 5340-5348.
2. Gunn, J. S.; Ernst, R. K. *The Ann. NY Acad. Sci.* **2007**, *1105*, 202-218.
3. Wang, X.; Ribeiro, A. A.; Guan, Z.; McGrath, S. C.; Cotter, R. J.; Raetz, C. R. H. *Biochemistry* **2006**, *45*, 14427-14440.

## PO 21

## ENTEROCOCCAL CELL WALL POLYSACCHARIDE – A PUTATIVE MECHANISM TO MISLEAD THE IMMUNE SYSTEM

Agnieszka Beczala<sup>1,2</sup>, Stefan Geiss<sup>1</sup>, Christian Theilacker<sup>1</sup>, Otto Holst<sup>2</sup>, Johannes Huebner<sup>1</sup>

<sup>1</sup>University Medical Center Freiburg, Department of Medicine, Division of Infectious Diseases,  
Hugstetter Str. 49 Freiburg, 79095 Germany;

<sup>2</sup>Research Center Borstel, Leibniz-Center for Medicine and Biosciences,  
Division of Structural Biochemistry, Parkallee 4a,  
28345 Borstel, Germany.  
johannes.huebner@uniklinik-freiburg.de

*Enterococcus faecalis* is a commensal Gram-positive bacterium commonly found in the human gastrointestinal tract. It is also a causative agent of urinary tract infections, endocarditis and bacteraemia<sup>1</sup>. One of the keys to understanding the mechanism of enterococcal pathogenesis is to identify virulence factors expressed by the bacterium such as proteins and capsular polysaccharides. Cell-wall-associated polysaccharides (CWP) are a major structural component of the enterococcal cell wall influencing not only biofilm formation and adherence to host tissues, but also resistance to host defence mechanisms such as phagocytosis and induction of host inflammatory responses<sup>2,3,4</sup>.

Complement induced opsonophagocytic killing seems to be more efficient in *E. faecalis* V583Δ1172 insertion mutant (mutation of *tagB* gene) than in *E. faecalis* wild type strain. Preliminary analysis of CWP after cleaving the phosphodiester bonds and size exclusion chromatography revealed the presence of a polysaccharide lacking in the mutant strain. Therefore we hypothesise that the polysaccharide fraction absent in the mutant strain may contribute to resistance of complement induced opsonophagocytosis in *E. faecalis* V583. Compositional and methylation analysis of this polysaccharide revealed the presence of terminal glucose, 1,2- and 1,2,3-linked hexosamines and ribitol as main constituents. HPLC analysis allowed obtaining two subfractions, which indicated the high heterogeneity of the material and complicated the structure elucidation. Further investigations are on the way.

### References

1. Richards, M. J., Edwards J. R., Culver D. H., Gaynes R. P. Nosocomial infections in combined medical-surgical intensive care units in the United States. *Infect. Control Hosp. Epidemiol.* **2000.** 21,510-515.
2. Sava I. G., Heikens E., Huebner J. Pathogenesis and immunity in enterococcal infections. *Clin Microbiol Infect.* **2010.** 16, 533-40.
3. Teng F., Singh K. V., Bourgogne A., Zeng J., Murray B. E. Further characterization of the epa gene cluster and Epa polysaccharides of *Enterococcus faecalis*. *Infect Immun.* **2009.** 77, :3759-67.
4. Hancock L. E., Gilmore M. S. The capsular polysaccharide of *Enterococcus faecalis* and its relationship to other polysaccharides in the cell wall. *Proc Natl Acad Sci USA.* **2002.** 99, 1574-1579.



## PO 22

SYNTHESIS OF *N*-DEACYLATED PEPTIDOGLYCAN FRAGMENTS

Emiliano Bedini,<sup>1</sup> Luigi Cirillo,<sup>1</sup> Antonio Molinaro,<sup>1</sup> Michelangelo Parrilli<sup>1</sup>

<sup>1</sup>*Department of Organic Chemistry and Biochemistry, University of Naples "Federico II",  
Complesso Universitario Monte S. Angelo, via Cintia 4, I-80126 Naples, Italy,*

Peptidoglycan is an essential and unique structural part of the bacterial cell wall. It has a polymeric structure with alternating *N*-acetyl-glucosamine (GlcNAc) and *N*-acetyl-3-*O*-(*R*)-lactyl-glucosamine (muramic acid, MurNAc) linked through  $\beta$ -1 $\rightarrow$ 4-bonds. The lactyl moiety of MurNAc is covalently attached to a pentapeptide chain, that is employed in polymer cross-linking. Structural modifications in the glycan strand often affect bacterial recognition by hosts. One of the most common modifications is *N*-deacetylation. It has been recently demonstrated that the absence of *N*-acetyl substituent in the glucosamine residue of peptidoglycans from *Listeria monocytogenes* – a Gram positive human intracellular pathogen – is critical for the bacterium to evade or at least mitigate the host innate immune system, survive in gastrointestinal environment and disseminate to various organs by surviving in human macrophages.<sup>1</sup> Similar results were found in other Gram positive bacteria and, very recently, in *Helicobacter pylori*, a Gram negative pathogenic bacterium infecting over 50% of humans.<sup>2</sup> On the contrary, in the case of the Gram negative phytopathogenic bacterium *Xanthomas campestris* pv. *campestris* the effect of *N*-deacetylation at glucosamine site seems to hyper-elicite a plant immune response.<sup>3</sup> In the last decade there was a great deal of activity directed toward the chemical synthesis of several peptidoglycan fragments,<sup>4</sup> because of the lack of pure and discrete species for precise structural and biochemical studies. Nonetheless, to the best of our knowledge, no synthesis of *N*-deacetylated-GlcN-containing structures has been reported yet. For this reason and in light of our interest in the chemical synthesis and phytopathological study of microbe-associated molecular patterns (MAMP)-related compounds,<sup>5</sup> we embarked in the synthesis of peptidoglycan fragments containing *N*-deacetylated glucosamine units.<sup>6</sup>

**References**

1. Boneca, I.G.; Dussurget, O.; Cabanas, D.; Nahori, M.-A.; Sousa, S.; Lecuit, M.; Psylinakis, E.; Bouriotis, V.; Hugot, J.-P.; Giovannini, M.; Coyle, A.; Bertin, J.; Namane, A.; Rousselle, J.-C.; Cayet, N.; Prévost, M.-C.; Balloy, V.; Chignard, M.; Philpott, D.J.; Cossart, P.; Girardin, S.E. *Proc. Natl. Acad. Sci. U.S.A.* **2007**, *104*, 997-1002.
2. Ge, W.; Olczak, A.; Forsberg, L.S.; Maier, R.J. *J. Biol. Chem.* **2009**, *284*, 6790-6800.
3. Erbs, G.; Silipo, A.; Aslam, S.; De Castro, C.; Liparoti, V.; Flagiello, A.; Pucci, P.; Lanzetta, R.; Parrilli, M.; Molinaro, A.; Newman, M.-A.; Cooper, R.M. *Chem. Biol.* **2008**, *15*, 438-448.
4. Lee, M.; Heseck, D.; Shah, I.M.; Oliver, A.G.; Dworkin, J.; Mobashery, S. *ChemBioChem* **2010**, *11*, 2525-2529 and references cited therein.
5. Bedini, E.; De Castro, C.; Erbs, G.; Mangoni, L.; Dow, J.M.; Newman, M.-A.; Parrilli, M.; Unverzagt, C. *J. Am. Chem. Soc.* **2005**, *127*, 2414-2416.
6. Cirillo, L.; Bedini, E.; Molinaro, A.; Parrilli, M. *Tetrahedron Lett.* **2010**, *51*, 1117-1120.



## PO 23

THE CONFORMATION OF CELLOBIOSE INVESTIGATED BY RESIDUAL  
DIPOLAR COUPLING CONSTANTS

Nicholle G. A. Bell, Graeme Rigg and Dušan Uhrín

*University of Edinburgh, EaStCHEM, School of Chemistry, King's Buildings, West Mains Road,  
Edinburgh, EH9 3JJ, UK  
dusan.uhrin@ed.ac.uk*

The conformation of the basic structural unit of cellulose, cellobiose, was investigated by residual dipolar coupling constants (RDCs) using NMR spectroscopy. Our data is compatible with the existence of syn-conformations for both  $\phi$  and  $\psi$  dihedral angles. We were not able to ascertain the existence of minor anti-conformers predicted theoretically<sup>1</sup>. During this work we have developed new <sup>13</sup>C-detected NMR methods for the measurement of proton-carbon RDCs. These were essential for the structural investigation of cellobiose - a disaccharide that shows considerable overlap of <sup>1</sup>H resonances even at 800 MHz.

One-bond proton-carbon RDCs (<sup>1</sup>D<sub>CH</sub>) are the most readily accessible coupling constants that are often measured in structure elucidation studies of small molecules with natural abundance of <sup>13</sup>C. Traditionally, and certainly for more weakly aligned samples, this type of measurement is performed using <sup>1</sup>H-detection and frequency-based methods. However, a recent introduction of cryogenically cooled probes with a cooled <sup>13</sup>C preamplifier or even direct <sup>13</sup>C-detection has boosted the sensitivity of <sup>13</sup>C-detection significantly. Capitalizing on this development and the unique high-resolution of 1D <sup>1</sup>H-decoupled <sup>13</sup>C NMR spectra, the measurement of <sup>1</sup>D<sub>CH</sub> coupling constants now looks very promising. We present here one-dimensional, intensity-based <sup>13</sup>C-detected methods that provide these coupling constants with high-accuracy.

In some structural motives the orientation of CH vectors is highly degenerate, meaning that <sup>1</sup>D<sub>CH</sub> coupling constants alone are not sufficient for the calculation of the alignment tensors. The long-range proton-carbon RDCs (<sup>n</sup>D<sub>CH</sub>) sample many more internuclear orientations therefore allowing the alignment tensors to be properly characterized. We have, therefore, also developed intensity-based <sup>13</sup>C-detected methods that provide small <sup>n</sup>D<sub>CH</sub> coupling constants with high-accuracy.

**References**

1. Larsson, EA, Staaf, M, Soderman, P, Hoog, C, Widmalm, G *J Phys. Chem. A*, **2004**, *108*, 3932-3937.

## PO 24

## NOVEL C-GLYCOSIDE LIGANDS FOR DC-SIGN

Benedetta Bertolotti,<sup>1</sup> Petra Hlavatá,<sup>1</sup> Ieva Sutkeviciute,<sup>2</sup> Ladislav Kniežo,<sup>1</sup>  
 Franck Fieschi,<sup>2</sup> Jitka Moravcová<sup>1</sup>

<sup>1</sup>Department of Chemistry of Natural Compounds, Institute of Chemical Technology, Prague,  
 Technická 5, 166 28 Prague, Czech Republic;

<sup>2</sup>Laboratory of Membrane Proteins,  
 University Joseph Fourier/CEA, 41, rue Jules Horowitz, 38027 Grenoble Cedex 1, France  
 benedetta.bertolotti@vscht.cz

DC-SIGN (Dendritic Cell-Specific Intercellular adhesion molecule-3-Grabbing Non-integrin) is a C-type receptor present on both dendrimeric cells and macrophages. Lectin DC-SIGN has a high affinity for D-mannose and a moderate affinity for L-fucose, for this reason it is able to recognize pathogens that express mannosylated and fucosylated glycoproteins at their surface including HIV-1, hepatitis C virus, Ebola virus, Dengue virus, cytomegalovirus, *Mycobacterium tuberculosis*, *Helicobacter pylori* and others. Many viruses use DC-SIGN as vector to get to the target cells.<sup>1,2</sup>

Knowing this we proposed a series of stable mimics based on D-mannose or L-fucose scaffold containing non-hydrolysable C-C bond instead of glycosidic C-O bond. Two starting model C-glycosides **1** and **2** were prepared by procedure exemplified in the scheme and their ability to interact with DC-SIGN was assessed by SPR. The terminal azide function allows click reaction with Boltorn dendrimer to create carbohydrate multivalent tools.

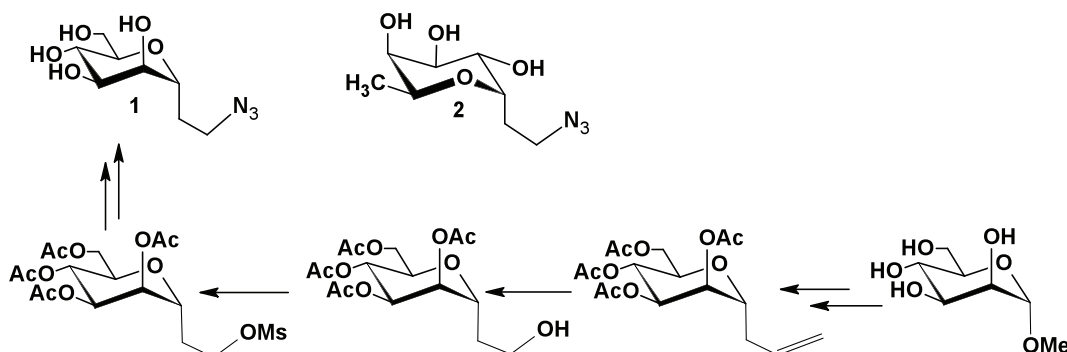

**Acknowledgment:** This work was supported by the Ministry of Education, Youth and Sports of the Czech Republic under the project MSM 6046137305 and by 7FP under project Carmusys.

### References

1. S. J. van Vliet *et al.*, *Curr. Opin. Immunol.*, **2007**, *19*, 435-440.
2. Y. Guo, H.R. Feinberg, E. Conroy, D. A. Mitchell, R. Alvarez, O. Blixt, M. E. Taylor, W. I. Weis, K. Drickamer, *Nat. Struct. Mol. Biol.*, **2004**, *11*, 591-598

## PO 25

**ACCELERATING THE INTRODUCTION OF *H. INFLUENZAE* TYPE B  
CONJUGATE VACCINES IN DEVELOPING COUNTRIES**

Hans Kreeftenberg, Ahd Hamidi, Michel Beurret

*Centre for Infectious Disease Control (CIb), National Institute for Public Health  
and the Environment (RIVM)  
Postbus 1, 3720 BA Bilthoven, The Netherlands  
Michel.Beurret@rivm.nl*

Important lessons were learned during the development of a *Haemophilus influenzae* type b (Hib) conjugate vaccine, and transfer of the technology to vaccine manufacturers in developing countries. At the start of the project, only about 25% of children worldwide had access to Hib conjugate vaccines, partly because of high prices, and because local vaccine manufacturers did not master Hib vaccine technology. To address this problem, the RIVM has developed a production process based on public knowledge<sup>1</sup>, and has transferred this technology to several public and private industrial partners. The simplicity and robustness of this process have facilitated its adoption. Eight to ten years after inception of the project, licenses have been granted for both lyophilized and liquid presentations, either with Hib alone or as part of combination vaccines. Overall, the vaccine has proven to be consistent, stable and immunogenic in humans.

Transfer of the Hib process has resulted in access to the technology for emerging manufacturers in developing countries<sup>2</sup>, and in an increased and sustainable supply of affordable Hib vaccines, through the establishment of a level playing field and the stimulation of competition. These manufacturers began to use up-to-date technologies that they did not master before. Moreover, this paved the way for them to build a new capacity to experiment and innovate, and motivated them to invest in their research and development infrastructure. The threshold to start working on other conjugate vaccines was hereby reduced.

Lastly, it has been clearly proven that manufacturers in developing countries are capable of producing high quality new-generation vaccines that do meet stringent World Health Organization (WHO)<sup>3</sup> requirements. The RIVM Hib conjugate vaccine project therefore provides a valid model for successful transfer of modern vaccine technology to developing countries.

**References**

1. Chu, Schneerson, Robbins, Rastogi, *Infect. Immun.*, **1983**, *40*, 245-256.
2. Milstien, Kaddar, *Vaccine*, **2010**, *28*, 2115-2121.
3. WHO Expert Committee on Biological Standardization, *WHO Technical Report Series*, **2000**, *897*, 27-60.

## PO 26

## SYNTHESIS OF NUCLEOSIDE-LINKED AMINOCYCLITOLS AS POTENTIAL ANTITUMOR AGENTS

Pedro A. B. Morais, Ivone Carvalho\*

Faculty of Pharmaceutical Sciences, University of São Paulo, Av. do Café (no number),  
14040903 Ribeirão Preto, São Paulo, Brazil.  
carronal@usp.br\*

Over the past decade, aminoglycosides were established as universal RNA binders, being able to link to TAR<sup>1</sup> and RRE sites, in HIV-1 RNA, replacing two essential viral regulatory proteins, Tat and Rev, respectively. Transcription and translation of the viral RNA is dependent upon this sequence-specific interaction. The literature reports several aminoglycosides that bind to TAR and inhibit Tat-TAR interaction, as well as, competitively inhibit the bind between Rev protein and RRE, for example, neomycin and tobramycin<sup>2</sup>.

Considering the importance for searching novel and efficient drugs for the treatment of the HIV/AIDS, the synthesis of potential inhibitors related to neamine, subunit of aminoglycoside antibiotic neomycin, conjugated to commercial nucleosides, such as, adenosine was performed by 1,3-dipolar cycloaddition (click chemistry) (Scheme 1)<sup>3</sup>.

The treatment of adenosine (1) with 5-chloro-1-pentyne (1.2 equiv.), sodium hydride (1.2 equiv.) and tetrabutylammonium iodide (1.2 equiv.), in anhydrous DMF, under microwave-assisted condition, gave intermediate 2 in 26% yield. Ongoing experiments are being performed by click chemistry to convert compound 2 into product 3, which will be submitted to antitumor biological assay.

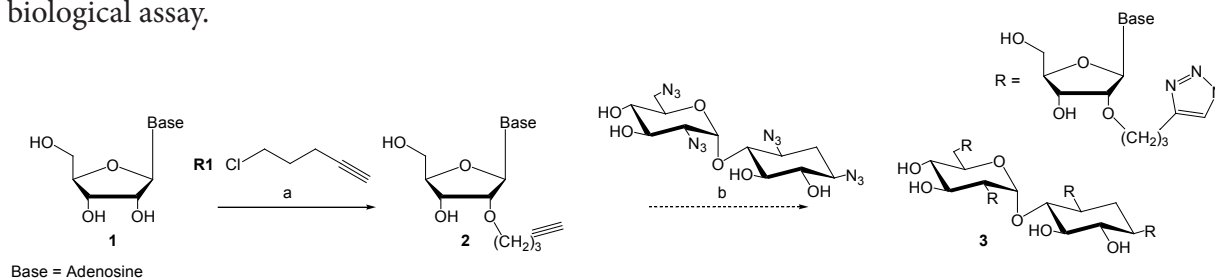

**Scheme 1.** Reagents and conditions: (a) NaH, TBAI, DMF, 110 °C, 100 W, 30 min; (b) CuSO<sub>4</sub>, sodium ascorbate, DMF, 150W, 70°C, 10 min.

## References

1. H. -Y. Mei, D. P. Mack, A. A. Galan, N. S. Halim, A. Heldsinger, J. A. Loo, D. W. Moreland, K. A. Sannes-Lowery, L. Sharmeen, H. N. Truong, A. W. Czarnik. *Bioorg. Med. Chem.* **1997**, 5, 1173-1184.
2. T. K. Stage, K. J. Hertel, O. C. Uhlenbeck, *RNA*. **1995**, 1, 95-101.
3. A. M. Jawalekar, N. Meeuwenoord, J. G. O. Cremers, H. S. Overkleeft, G. A. van der Marel, F. P. J. T. Rutjes, F. L. van DELFT. *Journal of Organic Chemistry*. **2008**, 73, 287.

## PO 27

IMINOSUGAR-BASED TREHALOSE MIMETICS  
AS TREHALASE INHIBITORS

Davide Bini,<sup>1</sup> Mauro Zappa,<sup>1</sup> Matilde Forcella,<sup>1</sup> Francesca Cardona,<sup>2</sup>  
Camilla Matassini,<sup>2</sup> Laura Cipolla,<sup>1</sup> Paola Fusi<sup>1</sup>

<sup>1</sup>Dept. of Biotechnology and Biosciences, University of Milano-Bicocca, P.za della Scienza 2,  
20126 Milano-Italy; <sup>2</sup>Dept. of Chemistry, University of Florence Via della Lastruccia 13,  
Sesto Fiorentino, Firenze-Italy  
davidebini@hotmail.com

Among glycosidases, trehalase (EC 3.2.1.28) is a very specific inverting glycosidase that hydrolyses trehalose (**1**, a non-reducing disaccharide formed by two molecules of  $\alpha,\alpha$ -1,1-linked D-glucose) [1] to two glucose units, a process which is essential to vital functions of several organisms, in particular fungi and insects. Trehalase inhibitors are valuable tools for studying the molecular physiology of trehalase function and sugar metabolism in insects and have the potential to produce novel insecticides. We recently synthesized some of the most powerful inhibitors of trehalase identified to date, with an imino sugar linked to the sugar moiety in a pseudo disaccharide structure (compounds **2**, Fig. 1) [2]. In the present work we wish to report the synthesis of new trehalose mimetics **3** based on the iminosugar nojirimycin, as potential trehalase inhibitors (Fig. 1).

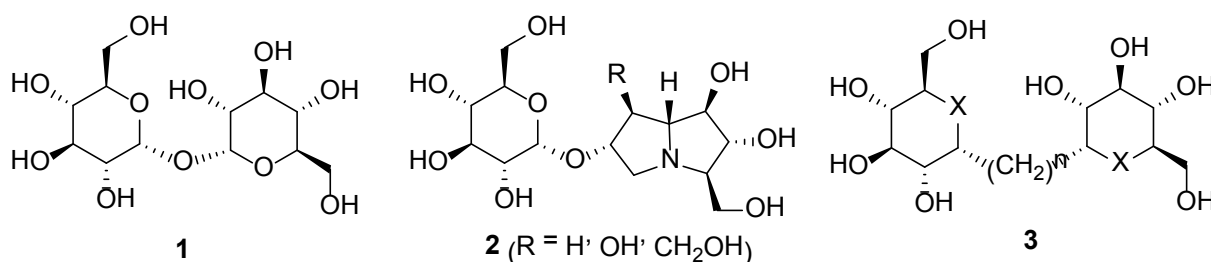

Fig. 1. General structure of trehalose mimetics (X = O, NH).

The disaccharide analogues were synthesised by CM reaction on C-allyl-nojirimycin and/or allyl-C-glucoside. Preliminary evaluation of the inhibitory activity against porcine trehalase was performed.

**Acknowledgments.** We gratefully acknowledge C.I.N.M.P.I.S for financial support.

### References

1. Elbein, A.D.; Pan, Y.T.; Pastuszak, I.; Carroll, D. *Glycobiology* **2003**, *13*, 17R-27R.
2. Cardona, F.; Goti, A.; Parmeggiani, C.; Parenti, P.; Forcella, M.; Fusi, P.; Cipolla, L.; Roberts, S.; Davies, G. J.; Gloster, T. M. *Chem. Commun.*, **2010**, *46*, 2629-2631 and refs cited therein.

## PO 28

## SYNTHESIS OF A SIALIC ACID PARAMAGNETIC CONJUGATE FOR MAGNETIC RESONANCE INVESTIGATIONS

Davide Bini, Luca Gabrielli, Francesco Nicotra, Laura Cipolla

Dept. Of Biotechnology and Biosciences, University of Milano-Bicocca, P.za della Scienza 2,  
20126 Milano-Italy.  
francesco.nicotra@unimib.it

N-Acetylneuraminic acid (NeuAc, **1** Fig. 1) represents the most ubiquitous member of the sialic acid family of derivatives present on cell surface glycoproteins and glycolipids.<sup>1</sup> Aberrant glycosylation is known to be a common feature of cancer cells and sialidases, which catalyzes the removal of sialic acid residues from glycoproteins and glycolipids, has also been suggested to play important roles in many biological processes through regulation of cellular sialic acid contents.

NMR of paramagnetic systems continues to be a highly active field, indicative of the richness of the physics of coupled electron-nuclear spin systems and the importance of paramagnetic metal ions in chemistry, biochemistry and diagnostics. Intensive work continues on the optimization of paramagnetic complexes as molecular imaging agents in Magnetic Resonance Imaging (MRI).<sup>2</sup>

Independently from the magnetic resonance technique of choice, the system necessitates the attachment of an extrinsic paramagnetic group to the (macro)molecule of interest through appropriate chemical modification.

Here we report the synthesis of a paramagnetic sialic acid conjugate (**3**, figure), for PRE and MRI applications.

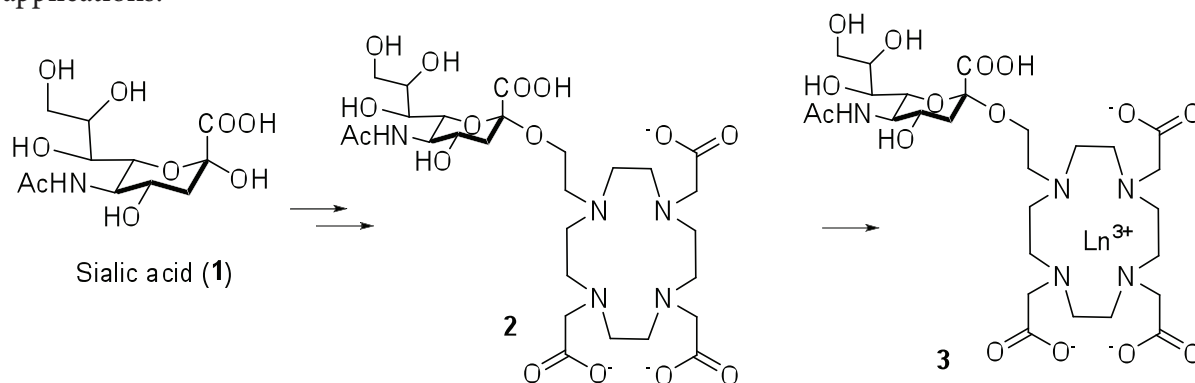

**Acknowledgments:** This work is supported by CINMPIS Consortium

### References

- Schauer, R. *Zoology* **2004**, *107*, 49.
- AA.VV. Chemistry of Molecular Imaging-Special Issue - *Acc. Chem. Res.* **2009**, *42*, issue 7.



## PO 29

## STRUCTURAL ANALYSIS OF HEPARAN SULFATE FROM RABBIT CARTILAGES BY NMR SPECTROSCOPY AND MASS SPECTROMETRY

Alessandro Parra<sup>1</sup>, Noemi Veraldi<sup>2</sup>, Manuela Locatelli<sup>1</sup>, Milena Fini<sup>3</sup>, Lucia Martini<sup>3</sup>,  
Giangiacomo Torri<sup>2</sup>, Luca Sangiorgi<sup>1</sup>, Antonella Bisio<sup>2</sup>.

<sup>1</sup>*Istituti Ortopedici Rizzoli, S.S.D. Genetica Medica e Malattie Rare Ortopediche,  
via di Barbiano 1/10 40136 Bologna,*

<sup>2</sup>*Istituto di Ricerche Chimiche e Biochimiche G. Ronzoni, V. G.Colombo 81, 20133 Milan,*

<sup>3</sup>*Laboratorio Studi Preclinici e Chirurgici, Istituto Ortopedico Rizzoli, via di Barbiano 1/10  
40136, Bologna, Italia.  
bisio@ronzoni.it*

Heparan sulfates (HSs) are linear polysaccharides belonging to the glycosaminoglycan (GAG) family. Their backbone consists in repeating dimers of D-glucosamine, and D-glucuronic acid or L-iduronic acid to form chains that usually range from 20 up to 80 units. A varied N-substitution pattern with appreciable proportions of both N-sulfation and N-acetylation, together with O-sulfation at various positions typically occurs. HS synthesis occurs in Golgi lumen by two type II transmembrane enzymes encoded by EXT1 /EXT2 genes whose mutations are thought to be responsible for the onset of Multiple Osteochondromas (MO) disease<sup>1,2</sup>. It is characterized by cartilage capped bony outgrowths arising from the metaphyseal zone of endochondral ossifying bones. Although the many studies performed, information about the correlation between MO and the quali-quantitative modifications of HSs chains is still lacking. Accordingly, the characterization of HS from pathological cartilages in comparison with healthy cartilage could lead to a better comprehension of the causes of MO disease.

In the framework of a study aimed at elucidating the structure of cartilaginous HSs from pathological specimens in comparison with healthy articular cartilage, a flexible method for GAGs isolation has been set up starting from rabbit cartilaginous tissues, allowing their subsequent fractionation and purification. This process was driven to the isolation of the pure native HS fractions for the NMR structural characterization. Such fractions were subsequently degraded by enzymatic treatment with specific lyases to di-oligosaccharide fragments that have been analysed by mass spectrometry to obtain a complete characterization of the HS structure. As a result, HS structure was isolated, for the first time, from rabbit growth plate cartilage as a minor but significantly represented GAG component and fully characterized for its mono and disaccharide composition<sup>3</sup>, sulfation degree and average chain length. In addition, also rabbit articular cartilage HS was analysed. It turned out to be significantly less abundant with respect to the previous one, however an appraisal of its structural features was achieved by mass spectrometry. The presented approach will be useful for the analysis and the determination of the molecular phenotype of GAGs, and in particular of HSs, in case of suspicion of HSs defects.

### References

1. McCormick C, Duncan G, Goutsos KT, Tufaro F. *Proc Natl Acad Sci*, **2000**, 97 (2): 668-673.
2. Jennes I, Entius MM, Van Hul E, Parra A, Sangiorgi L, Wuyts W. *J Mol Diag*, **2008**, 10(1):85-92.
3. Guerrini M, Naggi A, Guglieri S, Santarsiero R, Torri G. *Anal Biochem*, **2005**, 337, 35-47.



## PO 30

**CARBOHYDRATE-FUNCTIONALIZED CATIONIC VESICLES:  
STUDY OF THEIR INTERNALISATION MECHANISMS INTO CELLS**

Pauline Castagnos, Muriel Blanzat and Isabelle Rico-Lattes

*Laboratoire IMRCP, UMR CNRS 5623, Université Paul Sabatier, 118 route de Narbonne, 31062  
Toulouse, France  
blanzat@chimie.ups-tlse.fr*

Among drug delivery systems, cationic vesicles have appeared as powerful candidates for pharmaceutical applications because they are relatively cheap and easy to use, thus well corresponding to industrial requirements<sup>1</sup>. Using labelled vesicles made of a sugar-based cationic surfactant<sup>2</sup>, the work reported here aims at exploring the mechanisms of their internalisation into cells.

The study was performed on various cell types such as phagocytic as well as non-phagocytic cells using confocal laser scanning microscopy and flow cytometry. Using various inhibitors and various temperature of incubation, endocytosis and also membrane fusion were found to be the prominent mechanisms involved in cellular uptake of cationic vesicles.

Finally, to highlight the potential of cationic vesicles for future pharmaceutical applications as a drug delivery system, an example of application of this cationic system is presented. A photosensitizer used in photodynamic therapy was solubilised in cationic vesicles, incubated with cells and then irradiated with a laser. First results tend to confirm the gain in photocytotoxicity and then the efficiency of the drug delivery system.

**References**

1. E. Soussan, S. Cassel, M. Blanzat, I. Rico-Lattes, *Angew. Chem. Int. Ed.*, **2009**, 48, 274-288.
2. E. Soussan, C. Mille, M. Blanzat, P. Bordat, I. Rico-Lattes, *Langmuir*, **2008**, 24(6), 2326-2330.
3. A. Boudier, E. Soussan, P. Castagnos, G. Beaune, H. Belkhef, C. Menager, V. Cabuil, L. Haddioui, C. Roques, I. Rico-Lattes, M. Blanzat, *International Journal of Pharmaceutics*, **2011**, 403(1-2), 230-236.

## PO 31

SYNTHESIS OF ARA4N CONTAINING DI- AND TRISACCHARIDES OF THE INNER CORE LPS OF *BURKHOLDERIA CEPACIA* AND *PROTEUS MIRABILIS* R45Markus Blaukopf<sup>1</sup>, Bernhard Müller<sup>1</sup>, Paul Kosma<sup>1</sup><sup>1</sup>Department of Chemistry, University of Natural Resources and Life Sciences, Muthgasse 18, A-1190 Vienna  
markus.blaukopf@boku.ac.at

4-Amino-4-deoxy-arabinose (Ara4N) substitution of LPS is a frequently detected modification in bacterial strains that have developed resistance to cationic antimicrobial peptides. Substitution by Ara4N has been reported for the inner core region, where Ara4N either is linked to the 8-position of an inner 3-deoxy-D-manno-oct-2-ulosonic acid (Kdo) unit (as in *Proteus mirabilis* R45) or at O-8 of a distal 3-hydroxy-analogue of Kdo, termed Ko, in *B. cepacia*.<sup>[1,2]</sup> To further assess the antigenic properties of Ara4N epitopes, BSA conjugates containing inner core ligands of *Burkholderia cepacia* and *P. mirabilis* LPS (Figure 1a and 1b) were prepared.

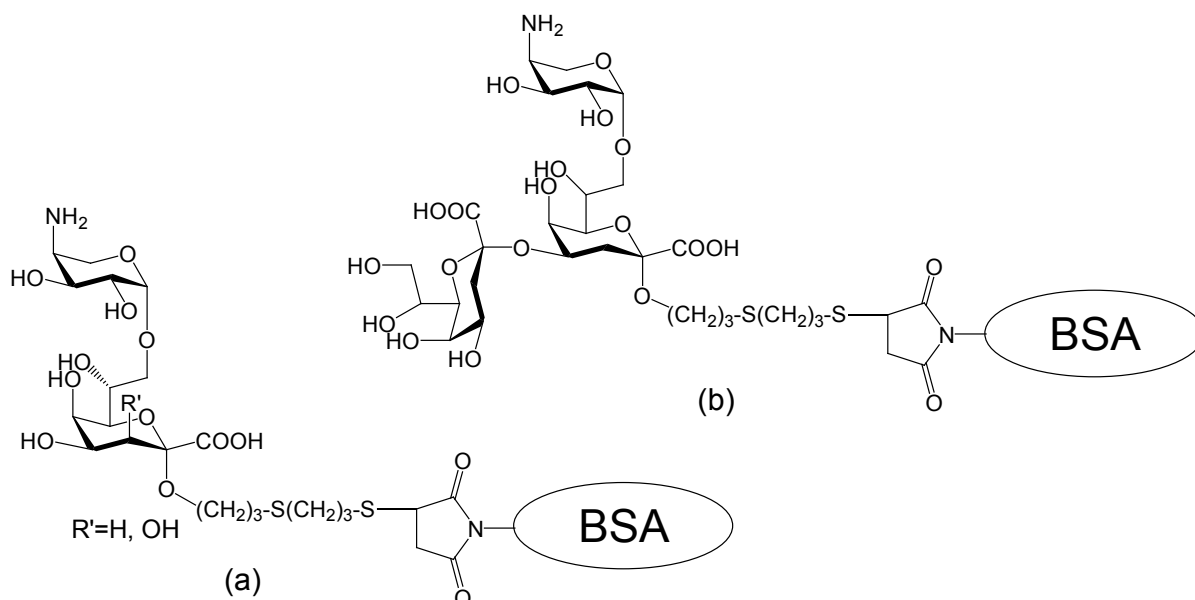

**Figure 1:** BSA conjugates corresponding to *Burkholderia cepacia* (a) and *Proteus mirabilis* (b)

Glycosylation using an 4-azido-2,3-di-O-benzyl-4-deoxy-arabinosyl *N*-phenyltrifluoroacetimidate donor with Kdo and Ko acceptors generated the corresponding disaccharides in good yields (70-80%) but moderate stereoselectivity (Fig. 1a). An Ara4N-Kdo disaccharide intermediate served as acceptor in a subsequent regioselective glycosylation step to give the corresponding trisaccharide in moderate yield. The O-debenzylation next to an allyl moiety and the introduction of a thio-linker was effectively achieved to provide the corresponding spacer glycosides which were coupled to maleimide-activated BSA.

**Acknowledgments:** Financial support from FWF (grants P 19295 and P22909).

### References

1. Z. Sidorczyk, W. Kaca, H. Brade, E.T. Rietschel, V. Sinnwell, U. Zähringer, *Eur. J. Biochem.*, 1987, 168, 269-273.
2. Y. Isshiki, K. Kawahara, U. Zähringer, *Carbohydr. Res.*, 1998, 313, 21-27.

## PO 32

## STUDIES ON THE RELATIVE STABILITY OF BENZYL-TYPE PROTECTING GROUPS

Magdolna Csávás,<sup>1</sup> Ádám Hadházi,<sup>1</sup> Anikó Borbás,<sup>1</sup> András Lipták<sup>1</sup> and Sándor Antus<sup>1,2</sup><sup>1</sup>Research Group for Carbohydrates of the Hungarian Academy of Sciences,  
University of Debrecen, H-4010, Debrecen, PO Box 94, Hungary,<sup>2</sup>Department of Organic Chemistry, University of Debrecen, H-4010, Debrecen,  
PO Box 20, Hungary,  
borbasa@puma.unideb.hu

Benzyl-type protecting groups are frequently applied in carbohydrate chemistry, especially in the synthesis of higher oligosaccharides to mask hydroxyl groups either permanently or temporarily. A systematic study has been undertaken to establish the relative stability of benzyl, *p*-methoxybenzyl, 1-(naphthyl)methyl,<sup>1</sup> 2-(naphthyl)methyl, diphenylmethyl, 9-fluorenyl, (9-anthracenyl)methyl and *p*-chlorobenzyl ethers under different cleavage conditions.

Here, we report our study on the removal of the different ethers of compounds **1a-h**, as well as compounds **2a-h** by catalytic hydrogenation to give **3** and **4**, respectively, in competitive reactions. Investigation of sequential deprotection by acidic hydrolysis, by oxidative conditions (DDQ or CAN)<sup>2</sup> or by treatment of *p*-toluenesulfonamide,<sup>3</sup> as well as possible application of the ethers as orthogonal protecting groups are also discussed.

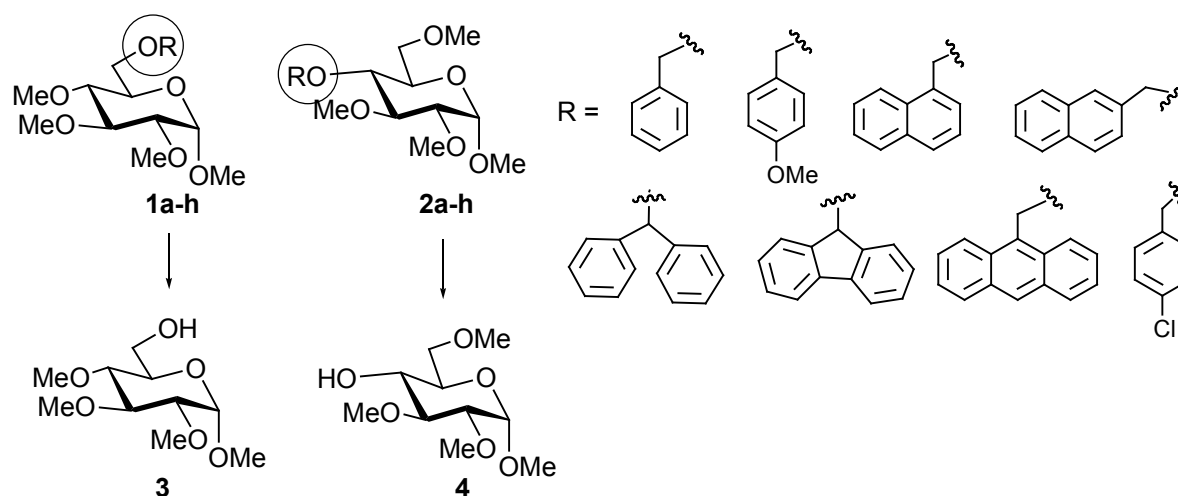

## References

1. K. Daragics, P. Fügedi *Tetrahedron Lett.* **2009**, 50, 2914–2916.
2. W. Liao, R. D. Locke, K. L. Matta *Chem. Comm.* **2000**, 369–370.
3. R. J. Hinklin, L. L. Kiessling *Org. Lett.* **2002**, 4, 1131–1133.

## PO 33

**2D SEPARATION AND PROFILING OF COMPLEX OLIGOSACCHARIDE MIXTURES**

Nathalie Bouly<sup>1,2</sup> Nico Callewaert,<sup>2</sup> Anita Van Landschoot,<sup>1,2</sup> Ingeborg Stals<sup>1,2</sup>

<sup>1</sup> *Faculty of Applied Engineering Sciences, University College Ghent, Schoonmeersstraat 52, 9000 Gent,*

<sup>2</sup> *Department of Biochemistry and Microbiology, Ghent University, K.L.-Ledeganckstraat 35, 9000 Gent  
nathalie.bouly@hogent.be*

Oligo- and polysaccharides are often comprised of many different building blocks that are branched, substituted and differently linked to each other. These saccharides constitute a structurally heterogeneous family of macromolecules, of importance in biology, medicine and industrial applications. Carbohydrate mixtures, generated from various natural sources (e.g. N-glycans, plant cell wall hydrolysates, saccharides in food and feed) can contain isomeric and isobaric structures that have the same molecular weight and behave very similarly. Because of their complexity, these mixtures are difficult to separate with conventional analytical methods. Over the past years, we developed an analytical fingerprinting method that is able to resolve many of these structures and provides adequate sensitivity and throughput. Using standard DNA sequencing equipment, fluorescently labeled carbohydrates are separated by carbohydrate electrophoresis (CE) and detected using laser-induced fluorescence.

We describe here the off-line coupling of this electrophoretic technique to analytical high-performance anion-exchange chromatography (HPAEC). In this first dimension, unlabeled poly- and oligosaccharides are separated based on their size and charge, and collected in fractions. In the second dimension, these fractions are analyzed by CE on a capillary DNA sequencer to obtain a higher resolution, thus yielding a 2D map. To demonstrate the technique, the profiles of xylan (hemicellulose) hydrolysates and Belgian beers were analyzed.

Results showed that several fractions collected from the first dimension contain different components while only displaying one peak in the HPAEC chromatogram, indicating the occurrence of isomeric structures that could not be fully separated during HPAEC analysis. Using CE in the second dimension, these components could be fully resolved.

Although this technique was developed as a profiling method for the analytical separation and detection of a mixture of saccharides, it is also possible to further analyze the fractions generated in the first dimension with MALDI-TOF-MS(MS). This step is useful to identify glycan structures which vary between samples under study.

## PO 34

## SYNTHESIS AND BIOLOGICAL INVESTIGATION OF PHENOLIC GLYCOLIPIDS ASSOCIATED WITH TUBERCULOSIS HYPERVIRULENCE

Jean Bourke,<sup>1</sup> Eoin M. Scanlan<sup>1</sup><sup>1</sup> School of Chemistry, Trinity College Dublin, Dublin 2, Ireland

bourkeje@tcd.ie, eoin.scanlan@tcd.ie

Tuberculosis (TB) is an infectious bacterial disease caused mainly by *Mycobacterium tuberculosis*. It is currently one of the leading causes of mortality in developing countries and is responsible for 2-3 million deaths per year. Hypervirulence in TB has been attributed to small glycolipid molecules expressed by the bacteria that are necessary for disease pathogenesis. Phenolic Glycolipids (PGLs), produced by a subset of *M. tuberculosis* isolates belonging to the W-Beijing family have been shown to induce 'hyperlethality' in murine disease models.<sup>1</sup> It is believed that these molecules promote an immune suppression effect that allows the disease to progress uninhibited in the host.

Phenolic glycolipids (PGLs) are complex carbohydrates, linked via a phenol ring to a lipid chain<sup>2</sup>. It is the aim of this research to synthesise and investigate a number of PGLs displaying natural and non-natural methylation patterns and to investigate the immune response to these compounds. A convergent strategy for PGL synthesis has been developed and a number of PGL molecules have been prepared. The synthetic route is flexible enough to allow variation of the carbohydrate methylation pattern and lipid group.

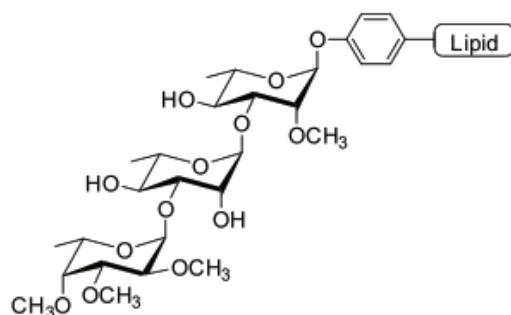
**Figure 1:** Phenolic Glycolipid<sup>3</sup>**References**

1. M. B. Reed, P. Domenech, C. Manca, H. Su, A. K. Barczak, B. N. Kreiswirth, G. Kaplan and C. E. Barry III, *Nature*, **2004**, *431*, 84-87.
2. K. Zegelaar-Jaarsveld, G. A. van der Marel and J. H. van Boom, *Tetrahedron*, **1992**, *48*, 10133-10148.
3. M. Daffe, C. Lacave, M. A. Laneelle and G. Laneelle, *Eur. J. Biochem.*, **1987**, *167*, 155-160.

## PO 35

## MANIPULATION OF SUGARS: STEREOCHEMICAL FIXATION OF THE 6-HYDROXYL GROUP BY SPIROANNELATED CYCLOPROPANES

Christian Brand, Daniel B. Werz

*Institute of Organic and Biomolecular Chemistry of the  
Georg-August-University of Göttingen,  
Tammannstr. 2, D-37077, Germany.  
bchrist@gwdg.de*

Carbohydrates have become a major focus in current biological and biochemical research.<sup>[1]</sup> The high density of functional groups and the immense variety of complex structures represent a great challenge for their synthesis, but also for the preparations of carbohydrate mimetics. Different classes of carbohydrate mimetics are known in literature.<sup>[2,3]</sup> One class of carbohydrate mimetics is the modification of linkages in oligosaccharides. A stereochemical fixation of the 6-hydroxyl group by a simple cyclopropane would lead to a reduced flexibility at this position (Figure 1). A Simmons-Smith-Furukawa cyclopropanation of the literature known enol acetate **1**<sup>[4]</sup> afforded the spiroannulated glucose **2**. Standard deprotection conditions led to glucose derivative **3**. The same synthetic route was applied to yield a small library of manipulated monosaccharides **4-6**. Investigations with respect to the incorporation into larger oligosaccharides are underway.

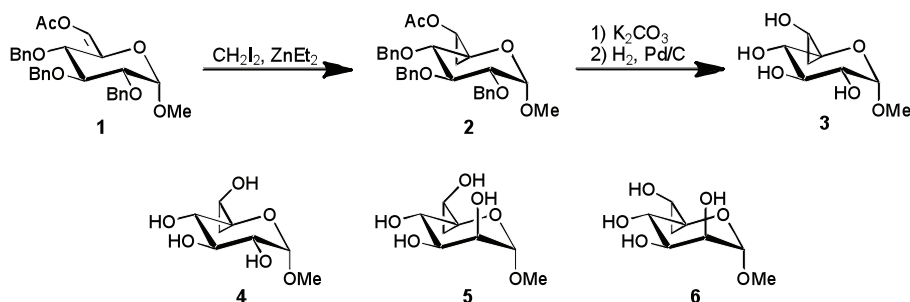

**Figure 1:** Synthesis of cyclopropanated monosaccharides.

**References**

1. A. Varki, *Glycobiology*, **1993**, 3, 97.
2. D. C. Koester, A. Holkenbrink, D. B. Werz, *Synthesis*, **2010**, 3217-3242.
3. C. Brand, G. Rauch, M. Zanoni, B. Dittrich, D. B. Werz, *J. Org. Chem.*, **2009**, 74, 8779-8786.
4. H. Takahashi, H. Kittaka, S. Ikegami, *J. Org. Chem.*, **2001**, 66, 2705-2716.

## PO 36

SYNTHESIS OF PHOTOACTIVABLE PROBES FOR THE STUDY OF  
GLYCOSPHINGOLIPID-PROTEIN INTERACTIONS

Giuseppina Brasile,<sup>1</sup> Federica Compostella,<sup>1</sup> Laura Mauri,<sup>2</sup>  
Sandro Sonnino<sup>2</sup> and Fiamma Ronchetti<sup>1</sup>

<sup>1</sup>*Dipartimento di Chimica, Biochimica e Biotecnologie per la Medicina,  
Università di Milano Via Saldini 50, 20133-Milano, Italy;*

<sup>2</sup>*Via Fratelli Cervi 93, 20190- Segrate (Milano), Italy  
giuseppina.brasile@unimi.it*

It is widely accepted that glycosphingolipids (GSLs) at the level of the plasma membrane can affect the biological functions of protein molecules, such as cell surface receptors or transporters. The interactions between GSLs and proteins belonging to specific membrane microdomains, called lipid rafts, could be responsible for the modulation of the functional properties of membrane proteins participating in signal transduction. GSL-protein interactions can be investigated by cell photolabelling experiments using radioactive photoactivable GSLs, which yield, when illuminated, a very reactive intermediate that covalently binds to the molecules in the environment, *i.e.* proteins.<sup>1,2</sup>

In this context, we have designed a fatty acid probe with two nitrophenylazide photoactivable groups, one at position 2 and the other at the end of the acyl chain. The conjugation of the fatty acid to a radioactive sphingoglycolipid generates a species to be used for photolabelling experiments. In this way, the simultaneous identification of the proteins belonging to both the leaflets of the plasma membrane, the cytoplasmatic and the extracellular one, will be realized. Herein we describe a general synthetic strategy to obtain not commercially available  $\alpha,\omega$ -diamino acids, the synthetic precursors of the labelled fatty acids, which we have applied to the synthesis of a C-18 derivative. Furthermore, it will be described the preparation of a photolabelled radioactive GSL as a case study.

**References**

1. Aureli M., Prioni S., Mauri L., Loberto N., Casellato R., Ciampa M.G., Chigorno V., Prinetti, A.; Sonnino S. *J. Lipid Res.* **2010**, *51*, 798-808
2. Mauri L., Prioni S., Loberto N., Chigorno V., Prinetti A., Sonnino S. *Glycoconj. J.* **2004**, *20*, 11-23.



## PO 37

**EXPLORING THE MULTIVALENCE EFFECT ON THE IMMUNOGENICITY OF A  $\beta$ -(1,3) GLUCAN GLYCOCONJUGATE CANDIDATE VACCINE AGAINST *CANDIDA ALBICANS***

G. Brogioni, M. R. Romano, R. Adamo, E. Danieli,  
G. Costantini, D. Proietti, M. Tontini, F. Berti, P. Costantino

*Novartis Vaccines & Diagnostics Research Center, Via Fiorentina 1, 53100 Siena, Italy*

Laminarin (Lam) conjugated to non toxic mutant of diphtheria toxin CRM<sub>197</sub> has been demonstrated to confer protection against *C. albicans* in mice.<sup>1</sup> Within a small set of glucans mimicking the branching point of Laminarin, the linear  $\beta$ -(1,3) glucan hexasaccharide was selected by ELISA assay as the best fragment able to inhibit the binding between laminarin and the specific antibodies induced by Laminarin- CRM<sub>197</sub> conjugate immunization.

Based on the concept that the hapten loading in addition to the saccharide chain length can influence the immune response, several bifunctional linkers were tested to identify the optimal conditions for a fully loading of PAMAM scaffold to be coupled to hexa  $\beta$ -(1,3) glucan. The PAMAM hexa  $\beta$ -(1,3) was consequently prepared, conjugated to the CRM<sub>197</sub> and compared in a mouse animal model against the glycoconjugate obtained by direct coupling of laminarin to the protein. This approach was useful to explore the concept of multivalence for conjugate vaccines.

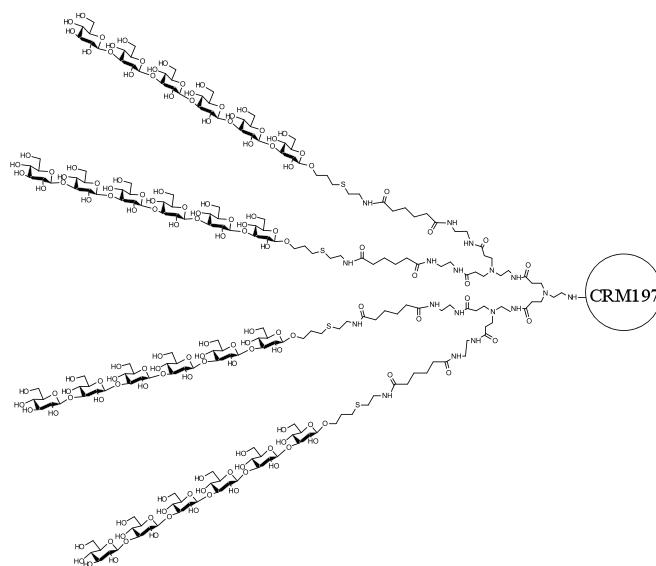
**References**

1. A. Torosantucci, C. Bromuro, P. Chiani, F. De Bernardis, F. Berti, C. Galli, F. Norelli, C. Bellucci, L. Polonelli, P. Costantino, R. Rappuoli, A. Cassone, *J. Exp. Med.* **2005**, 202 (5), 597–606;
2. C. Bromuro, M. R. Romano, P. Chiani, F. Berti, M. Tontini, D. Proietti, E. Mori, A. Torosantucci, P. Costantino, R. Rappuoli, A. Cassone, *Vaccine* **2010**, 28, 2615–2623.

## PO 38

STEREOCHEMISTRY CONTROL IN GLYCOSYLATION VIA MODIFIED  
O-2-BENZYL GROUPSzymon Buda,<sup>1</sup> Patrycja Gołębiowska,<sup>1</sup> Jacek Mlynarski<sup>1,2</sup><sup>1</sup>Faculty of Chemistry Jagiellonian University, Ingardena 3, Krakow, Poland<sup>2</sup>Institute of Organic Chemistry, Polish Academy of Sciences,  
Kasprzaka 44/52, Warsaw, Poland

buda@chemia.uj.edu.pl www.jacekmlynarski.pl

Stereocontrolled synthesis of a new glycosidic bond is one of the most interesting and most investigated issues in organic chemistry. This problem can be solved in many ways. One of the methods can be use of appropriate protecting groups which as a result of anticipated impact enforced proper conformation or allow to obtain the desired electronic structure.

One of the most versatile methodology is the use of adjunctive ester-type group at O-2 position of monosaccharide ring. Venturing into the synthesis of complex molecules we often do not have the possibility to introduce desired ester group in specified position. An interesting solution is the use of the 2'-pyridylmethyl group activating the anomeric center by forming six-membered ring.<sup>1,2</sup> The advantage of the application of 2-O-picoyl group beside of stabilization of the intermediate product leading to  $\beta$ -glycoside, is its stability comparable to the ether groups.

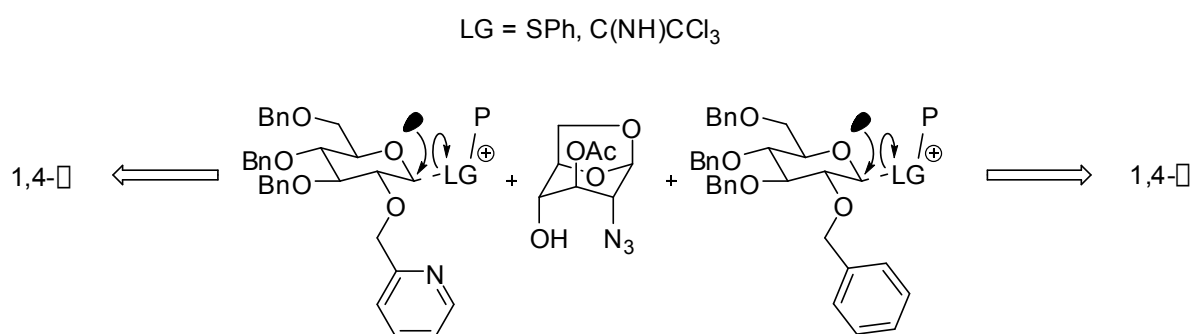

Presented strategy can be useful in glycosylation of monosaccharides as well as in the synthesis of complex polysaccharide motives.

**References**

1. J. T. Smoot, P. Pornsuriyasak, A. V. Demchenko, *Angew. Chem. Int. Ed.*, **2005**, *44*, 7123-7126.
2. J. T. Smoot, A. V. Demchenko, *J. Org. Chem.*, **2008**, *73*, 8838-8850.

## PO 39

## NMR STUDY OF RALSTONIA SOLANACEARUM LECTIN INTERACTIONS

Peter Bystrický,<sup>1</sup> Karel Kubíček,<sup>1</sup> Marie Pokorná,<sup>1</sup> Radek Fiala,<sup>1</sup> Michaela Wimmerová<sup>1,2</sup>

<sup>1</sup>CEITEC, NCBR, Masaryk University, Brno, Czech republic,

<sup>2</sup>Department of Biochemistry, Masaryk University, Brno, Czech republic

*peterbys@chemi.muni.cz*

Carbohydrates play an important role in many biological processes like cell recognition, signaling, differentiation, carcinogenesis and others. Carbohydrate interactions with proteins - lectins are also involved in the first step of pathogenic bacteria adhesion, invasion and infectivity. The structural details of such interactions between lectins and carbohydrates are best studied by various NMR techniques that are currently available. These results are then complementary to surface plasmon resonance and microcalorimetry methods. Such NMR study then gives details on the binding site, the identities of lectin's amino acids involved, functional groups of carbohydrate ligand involved in the interaction and others. In the current study a fucose binding lectin from pathogenic plant bacterium – *Ralstonia solanacearum* (RSL) was studied.<sup>1</sup> The interaction of RSL with its ligands as well as potential ligands was studied by saturation transfer difference NMR spectroscopy.<sup>2</sup> In order to have a complete picture of the interaction, the lectin's binding site was studied by titration of <sup>13</sup>C and <sup>15</sup>N doubly labelled RSL with Fuc while acquiring HSQC spectra between the titration steps. The assignment of key amino acids for the binding, tryptophans, was achieved by amino acid selective <sup>15</sup>N-Trp labelling and by use of single point Trp mutants.

**Acknowledgments:** This project is financed from SoMoPro programme. The research leading to these results has received funding from the European Community's Seventh Framework Programme (FP/2007-2013) under the grant agreement no. 229603. The research is further co-financed by South Moravian region.

**References**

1. Kostlanova N. et al., *J. Biol. Chem.*, **2005**, 280, 27839–27849.
2. Mayer M. and Meyer B., *Angew. Chem. Int. Ed.*, **1999**, 38, 1784-1788.

## PO 40

## A NOVEL FUNGAL XYLANASE ISOLATED FROM SOUTH AMERICAN BRAVE STRAW

Karen Cabero<sup>1</sup> Tania Pozzo<sup>2</sup>, Eva Nordberg Karlsson<sup>2</sup>, Gunnar Liden<sup>1</sup>

<sup>1</sup>Department of Chemical Engineering, Lund University Box 124 SE-221 00 Sweden,

<sup>2</sup>Department of Biotechnology, Lund University Box 124 SE-221 00 Sweden  
Gunnar.Liden@chemeng.lth.se

Cellulases are key components for second-generation biofuel production from lignocellulose. Substantial efforts are currently made to improve these enzymes by molecular biological techniques and by the use of biodiversity. The present investigation has been focused on isolation of cellulase producing fungi from the Bolivian Andean region, an ecosystem characterised as an extreme arid highland. Thirty-two fungi were isolated and screened for presence of cellulose activity using a plate assay with CMC as carbon source.

Strain BLT1C was selected from the screening and cultivated using brave straw, an abundant native grass from the area as carbon source<sup>1</sup>. Characterization of the extracellular enzyme activity induced in brave straw supplemented cultures showed high xylanase activity and moderate endoglucanase activity compared to *Trichoderma reesei* species previously used in enzymatic pretreatment for bioethanol production<sup>2</sup>. Zymograms and SDS-PAGE analysis revealed a 60-kDa xylanase. N-terminal sequencing, in-gel digestion, and mass spectrometry showed the enzyme to be novel and to consist of a glycoside hydrolase family 11 (GH11) a catalytic module putatively connected to a GH6 domain.

Three of the isolated strains including BLT1C were identified by sequence analysis of the internal transcribed spacer (ITS) regions to the genus *Trichoderma/Hypocrea* and were also containing the species specific regions identified for *Trichoderma harzianum/Hypocrea lixii*<sup>3</sup>.

### References

1. Carrasco C., Baudel H., Penarrieta M., Solano C., Tejada L., Roslander C., Galbe M., Lidén G, *J.Bioscience and Bioengineering*, **2010**, 111, 167-174
2. Abou Hachem, M, Olsson, F, Williamson, M.P., Linse S., Crennell, S.J., Hreggvidsson, G.O., Kristjansson J.K., Holst, O., and Nordberg Karlsson, E. *Biocat. Biotrans.*, **2003**, 21, 253-260
3. Druzhinina IS, Kopchiniskyi AG, Komon M, Bissett J, Szakacs G, Kubicek CP, *Fungal Gen. Biol.*, **2005**, 64, 813-828

## PO 41

## A GENERAL RING CONTRACTION REACTION FOR THE SYNTHESIS OF FUNCTIONALIZED TETRAHYDROFURANS

P. Borrachero-Moya, F. Cabrera-Escribano, A. Franconetti, M. Gómez-Guillén and S. Jatunov

*Departamento de Química Orgánica, Facultad de Química, Universidad de Sevilla, Apartado de Correos No. 1203, 41071 Sevilla, Spain. Fax: +34954624960; Tel: +34954556805; fcabrera@us.es*

Ring contraction reactions are an important method to increase molecular complexity in a single step, because, in several cases, bond reorganization occurs with a high level of selectivity, affording products not easily accessible by other approaches. Previous work of our group<sup>1</sup> led to the development of a simple and efficient methodology allowing easy access to 2,5-anhydro-*al*-dehydro-sugar derivatives (formyl *C*-glycofuranosides), starting from hexose-derived *equatorial*-2-OH-glycopyranosides through a ring contraction rearrangement promoted by diethylamino-sulphur trifluoride (DAST).<sup>2</sup>

Following this line, and considering the interest of functionalized *C*-glycofuranosides as key building blocks for biologically relevant more complex *C*-glycofuranoside-based molecules (*C*-oligosaccharides and *C*-glycoconjugates) we have now investigated: a) the adjustment/improvement of this methodology to accomplish our goal in a multigram scale, and b) the extension of the approach for synthesizing ring-contracted compounds involving nucleophiles different from fluorine. In particular, enantiomerically pure synthetic equivalents of formyl *C*-glycofuranosides, such as compounds **2-5** have been obtained in two steps from the corresponding 2-*equatorial*-OH-hexopyranoside **1** in very mild conditions, and high yield.

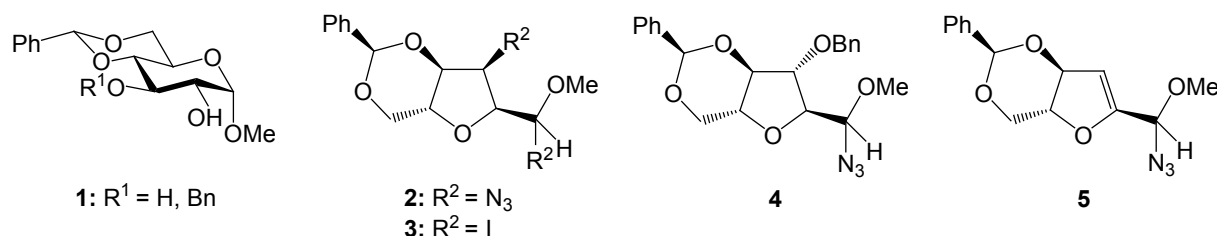

**Acknowledgments:** We thank the AECID (Projects A/023577/09 and A/04032/10) and the 'Junta de Andalucía' (FQM 142 and Project P09-AGR-4597) for financial support.

**References**

1. Y. Vera-Ayoso, P. Borrachero, F. Cabrera-Escribano, M. Gómez-Guillén, J. Caner, J. Farrás, *Synlett*, **2010**, 271-275, and references therein.
2. H. Ferret, I. Déchamps, D. Gómez Pardo, L. Van Hijfte, J. Cossy, *Arkivoc*, **2010**, 126-159.

## PO 42

SYNTHESIS OF CONFORMATIONALLY RESTRICTED  
SUGAR-PEPTIDE HYBRIDS

P. Borrachero-Moya, F. Cabrera-Escribano, A. Franconetti, M. Gómez-Guillén and S. Jatunov

*Departamento de Química Orgánica, Facultad de Química, Universidad de Sevilla,  
Apartado de Correos No. 1203, 41071 Sevilla, Spain. Fax: +34954624960; Tel: +34954556868;  
fcabrera@us.es*

The study of foldamers, non-natural oligomers with discrete folding propensities, has demonstrated that a variety of synthetic backbones can show biopolymer-like conformational behavior. Early work in this area focused on oligomers comprised of a single type of monomer subunit, but recent efforts have highlighted the potential of mixed or “heterogeneous” backbones to expand the structural and functional repertoire of foldamers.<sup>1</sup> Since carbohydrates are conformationally restricted structures with the added hydrogen capability, we pursued the goal of synthesizing sugar-peptide hybrids:  $\alpha/\beta$  and  $\alpha/\gamma$ -hybrid glycoamino acids, as possible monomeric structures for the future construction of foldamers. The use of heterogeneous backbone offers advantages over homogeneous backbone including access to many new molecular shapes, based on variations in the stoichiometries and patterns of subunit combination, and improved prospects for side chain diversification. We have previously described the synthesis of enantiopure C-glycofuranoside-based  $\alpha/\beta$ -amino acids.<sup>2</sup> Herein, we report the preparation of a variety of six membered ring  $\alpha/\gamma$  glycoamino acids, such as **2-4**, in a straightforward way starting from the sugar deoxy-3-azido-glucopyranoside **1**.

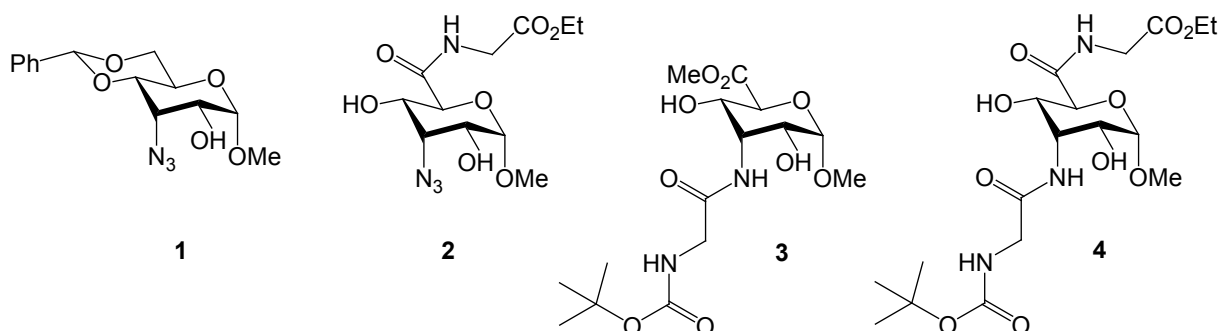

**Acknowledgments:** We thank the AECID (Projects A/023577/09 and A/04032/10) and the ‘Junta de Andalucía’ (FQM 142 and Project P09-AGR-4597) for financial support.

**References**

1. W. S. Horne, S. H. Gellman, *Acc Chem Res.* **2008**, *41*, 1399–1408.
2. Y. Vera-Ayoso, P. Borrachero, F. Cabrera-Escribano, M. Gómez-Guillén, J. Caner, J. Farrás, *Synlett*, **2010**, 271-275.

## PO 43

## ROLE OF FUNCTIONAL GROUPS AND BINDING GEOMETRY OF TRIPODAL RECEPTORS ON CARBOHYDRATE RECOGNITION

Martina Cacciarini,<sup>1</sup> Martina Norcini,<sup>1</sup> Samuele Staderini,<sup>1</sup> Oscar Francesconi,<sup>1</sup> Cristina Nativi,<sup>1,2</sup> Stefano Roelens<sup>1,3</sup>

<sup>1</sup>Department of Chemistry, University of Firenze, via della Lastruccia 3-13, I-50019, Sesto F.no (Firenze), Italy,

<sup>2</sup>Centro Risonanza Magnetice (CERM), Polo Scientifico e Tecnologico, 50019, Sesto F.no (Firenze), Italy,

<sup>3</sup>Istituto di Metodologie Chimiche (IMC), Consiglio Nazionale delle Ricerche (CNR), Polo Scientifico e Tecnologico, 50019, Sesto F.no (Firenze), Italy  
martina.cacciarini@unifi.it

Over the last two decades molecular recognition of carbohydrates has become a challenging topic of investigation due to the essential roles exhibited in biological processes, from carbohydrate metabolism and transport, to cell-cell adhesion, cell infection by pathogens, the immune response, and enzyme activity regulation.<sup>1</sup> Several synthetic receptors have been designed, synthesized and widely investigated to provide new insights on the key features of carbohydrate recognition.<sup>2</sup> In this context, we have developed a family of effective carbohydrate receptors,<sup>3</sup> based on a hexasubstituted benzene scaffold, bearing functional units able to interact with saccharides mainly through H-bonding interactions. In an effort to expand on recognition properties, we explored different type of binding groups introduced on the same scaffold. Herein the structural and functional variations investigated will be described and presented.

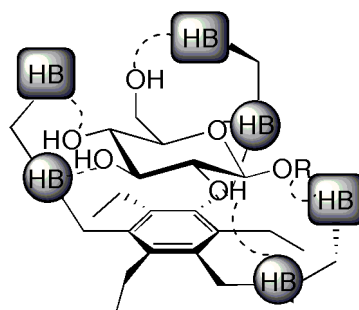

### References

1. (a) *The sugar code: Fundamentals of Glycosciences* ed. H.-J. Gabius, Wiley-VCH, Weinheim, **2009**; (b) B. Ernst, W. Hart and P. Sinay, *Carbohydrates in Chemistry and Biology*, Wiley-VCH, Weinheim, **2000**, Part I, Vol. 2 and Part II, Vol. 4; (c) T. K. Lindhorst, *Essential of Carbohydrate Chemistry and Biochemistry*, Wiley-VCH, Weinheim, **2000**.
2. A. P. Davis and T. D. James, in *Functional Synthetic Receptors*, T. Schrader and A. D. Hamilton, Eds.; Wiley-VCH; Weinheim, Germany, **2005**, 45-109.
3. (a) M. Cacciarini, C. Nativi, M. Norcini, S. Staderini, O. Francesconi, S. Roelens, *Org. Biomol. Chem.*, **2011**, 9, 1085-1091. (b) C. Nativi, M. Cacciarini, O. Francesconi, A. Vacca, G. Moneti, A. Ienco, S. Roelens, *J. Am. Chem. Soc.*, **2007**, 129, 4377-4385.



## PO 44

A GFP-CHROMOPHORE APPENDED  $\beta$ -CYCLODEXTRIN:  
SYNTHESIS AND PROPERTIES

Martina Cacciarini,<sup>1</sup> Lavinia G. Marinescu-Pedersen,<sup>2</sup> Mikael Bols<sup>2</sup> and Mogens B. Nielsen<sup>2</sup>

<sup>1</sup>Department of Chemistry, University of Firenze, via della Lastruccia 3-13,  
I-50019, Sesto F.no (Firenze), Italy,

<sup>2</sup> Department of Chemistry, University of København, Universitetsparken 5,  
2100 København Ø, Denmark  
martina.cacciarini@unifi.it

Macrocyclic hosts of different nature, shape and characteristics from crown ethers, to cryptands, from cyclophanes, to calixarenes and cucurbiturils have been synthesized and received much attention as new supramolecular systems and materials.<sup>1</sup> Among them, cyclodextrins (CDs) are the most important and promising macrocyclic hosts because of their water solubility, low cost, commercial availability and easy functionalization.<sup>2</sup> Besides chromophore-modified CDs have been studied for a long time by many researchers and several sensors bearing different type of chromophores have been reported.<sup>1</sup>

In the last decade, green fluorescent protein (GFP) has changed from a barely known protein to a commonly used tool as biological marker in molecular biology and medicine, due to the special features of its chromophore, which depend both on the environment and the hydrogen-bonding network around itself.<sup>3</sup> In this context we have focused on the design and synthesis of a GFP-like chromophore appended  $\beta$ -cyclodextrin, prepared *via* click chemistry from a  $\beta$ -cyclodextrin azide and an alkynyl-chromophore. The preparation, the inclusion ability and the properties of this new cyclodextrin derivative will be described and discussed in this communication.

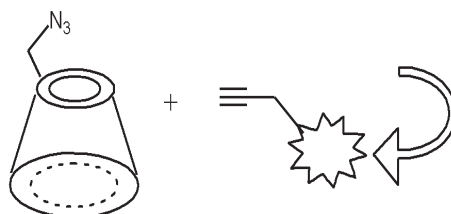
**References**

1. T. Ogoshi, A. Harada, *Sensors*, **2008**, 8, 4961-4982.
2. (a) J. Szejtli, T. Osa Eds *Comprehensive cyclodextrin chemistry*; Pergmon: Oxford, U.K. **1996**,  
3. (b) *Chem. Rev.* **1998**, 98 (5).
3. M. Zimmer, *Chem. Rev.* **2002**, 102, 759-781.

## PO 45

**DERMATAN SULFATE UPREGULATES NFκB SIGNALING PATHWAY DURING  
ENDOTHELIAL CELL PROLIFERATION**

Rita Rasente, Roxana Oberkersch, Paula Egitto and Graciela Calabrese

*Universidad de Buenos Aires, Facultad de Farmacia y Bioquímica,  
Cátedra de Biología Celular y Molecular.*

*Junín 954, Primer Piso (C1113AAD) Ciudad Autónoma de Buenos Aires. Argentina*

Temporal and spatial regulation of vascular extracellular matrix remodelling allows local changes in the net matrix deposition or its degradation, which in turn contributes to the control of angiogenesis by regulating cell growth, migration, and differentiation. Although it was shown that Decorin, a small dermatan sulfate (DS) proteoglycan, and the peptides derived from it have antiangiogenic properties<sup>1</sup>, little is known about DS biological activities. The aim of the present study was to evaluate the role of low molecular mass DS<sup>2</sup> (LMMDS) on angiogenesis, particularly on endothelial cell (EC) proliferation. DS (~60 kDa) peroxy-radical depolymerization produced a LMMDS of around 5 kDa (PAGE analysis), with a significant increase in sulfate content  $27.7 \pm 1.9 \mu\text{g}\%$  (n=6) (p<0.05 LMMDS vs DS). The cellular line H5V, derived from polyoma middle T-transformed murine heart endothelium, was grown in the presence or absence of increased concentrations of LMMDS (1-100  $\mu\text{g}/\text{ml}$ ). EC proliferation was evaluated by 1) the activity of mitochondrial respiratory chain with second-generation tetrazolium derivate MTS<sup>3</sup>; 2) hematoxylin/eosin stain in order to visualize mitotic figures; and 3) immunofluorescence studies of sub-cellular distribution of the Proliferating Cell Nuclear Antigen (PCNA, Mouse IgG 2ak, Pharmigen). Sub-cellular fractions from ECs, obtained by differential centrifugation, were analyzed by Western Blot to study Transforming necrosis factor (TNF $\alpha$ ) production and the distribution of its associated transcriptional factor: NFκB. A slight increase in ECs number was measured in the presence of LMMDS, without significant differences between 5 to 15  $\mu\text{g}/\text{ml}$ . On the other hand, a significant increase in the number of mitotic figures (p<0.01) and in the nuclear translocation of PCNA was detected when 25 and 10  $\mu\text{g}/\text{ml}$  of LMMDS were added to the cultures, respectively. The presence of 10  $\mu\text{g}/\text{ml}$  of LMMDS showed an increase of more than one time in TNF $\alpha$  production and in NFκB nuclear translocation compared with control conditions. In summary, the results suggest that the presence of 10  $\mu\text{g}/\text{ml}$  of LMMDS induced the proliferation of EC through NFκB signaling pathway. LMMDS provides new opportunities to understand the molecular mechanism involved in the early phases of angiogenesis and may also act as a prototype for further development of drugs potentially useful in tissue-repair therapy.

**References**

1. Fan H., Sulochana K, Chong Y-Seng, Ge R. *Int Journal of Biochemistry & Cell Biology*, **2008**, 40,2120-2128.
2. Calabrese G, Gazzaniga S, Oberkersch R, Wainstok R. *Histol and Histopathol*, **2011**, in press.
3. Galluzi L et al. *Cell Death Differ*, **2009**, 16 (8), 1093-1107.

## PO 46

SYNTHESIS AND BIOLOGICAL CHARACTERIZATION OF  
A NEW FLUORESCENT TLR4 ANTAGONIST

Valentina Calabrese,<sup>1</sup> Matteo Piazza,<sup>1</sup> Theresa Giannini,<sup>2,3</sup> Jerrold Weiss,<sup>2</sup> Francesco Peri.<sup>1</sup>

<sup>1</sup>Department of Biotechnology and Bioscience, University of Milano Bicocca,  
Piazza della Scienza, 2; Milano, Italy;  
<sup>2</sup>Department of Internal Medicine and The Inflammation Program,  
<sup>3</sup>Departments of Biochemistry and Microbiology, Roy J. and Lucille A. Carver  
College of Medicine, University of Iowa, Iowa City, Iowa 52246 USA  
valentina.calabrese@unimib.it

LPS, found at the surface of Gram-negative bacteria, is the primary exogenous ligand recognized by Toll-like receptor 4 (TLR4). LPS is the major structural component of the outer leaflet of the bacterial outer membrane, and from the three components of the LPS molecule, O antigen, core, and lipid A, the latter is responsible for TLR4-dependent proinflammatory activity, and it is also known as endotoxin. The induction of inflammatory responses by LPS is achieved by the coordinate and sequential action of four principal endotoxin-binding proteins: the LPS binding protein (LBP), the cluster differentiation antigen 14 (CD14), the myeloid differentiation protein (MD-2) and the Toll-like receptor 4 (TLR4).<sup>1</sup> We recently developed<sup>2</sup> D-glucose-derived glycolipids active in inhibiting the TLR4 signalling by antagonizing the endotoxin-CD14 interaction.<sup>3</sup> Those compounds were active *in vivo* in protecting mice from LPS-induced septic shock and were also active in contrasting other pathologies caused by TLR4 activation, such as inflammation and neuropathic pain.<sup>4</sup> In this communication we present the synthesis and the biological characterization of novel, fluorescent glycolipids structurally related to the previously developed CD14 ligands together with fluorescence microscopy studies investigating their cellular distribution and mode of action on mammalian cells.

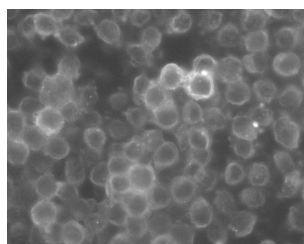

**Figure 1:** Fluorescence microscopy image of HEK cells treated with a fluorescent glycolipid.

### References

1. R. Jerala, *Int J Med Microbiol*, **2007**, 297, 353-363.
2. M. Piazza, C. Rossini, S. Della Fiorentina, C. Pozzi, F. Comelli, I. Bettoni, P. Fusi, B. Costa and F. Peri, *J Med Chem*, **2009**, 52, 1209-1213.
3. M. Piazza, L. Yu, A. Teghanemt, T. Giannini, J. Weiss and F. Peri, *Biochemistry*, **2009**, 48, 12337-12344.
4. I. Bettoni, F. Comelli, C. Rossini, F. Granucci, G. Giagnoni, F. Peri and B. Costa, *Glia*, **2008**, 56, 1312-1319.

## PO 47

STRUCTURAL INVESTIGATION OF THE LIPOOLIGOSACCHARIDE  
FROM THE PSYCHROPHILIC BACTERIUM  
*PSEUDOALTEROMONAS HALOPLANKTIS* TAB 23

Sara Carillo<sup>1</sup>, Giuseppina Pieretti<sup>1</sup>, Ermenegilda Parrilli<sup>1</sup>, Luisa Tutino<sup>1</sup>, Sabrina Gemma<sup>2</sup>, Monica Molteni<sup>2</sup>, Rosa Lanzetta<sup>1</sup>, Michelangelo Parrilli<sup>1</sup>, Maria Michela Corsaro<sup>1</sup>

<sup>1</sup>Dipartimento di Chimica Organica e Biochimica, Università di Napoli Federico II,  
Complesso Universitario di Monte S. Angelo, Via Cynthia 4, 80126 Napoli, Italy

<sup>2</sup>Bluegreen Biotech s.r.l., Via La Masa 19 Milano, Italy

sara.carillo2@unina.it

*Pseudoalteromonas haloplanktis* TAB 23 is a Gram-negative psychrophilic bacterium isolated from the Antarctic costal sea.<sup>1</sup> To survive in these conditions psychrophilic bacteria have evolved typical membrane lipids and 'antifreeze' proteins to protect the inner side of the microorganism.<sup>2</sup> As for Gram-negative bacteria, the outer membrane is mainly constituted by lipopolysaccharide (LPS). Although this portion of the membrane is the first to come in contact with the external environment very little is known about the peculiarity of LPS from Gram-negative psychrophilic bacteria and which is their role in the adaptation to cold temperature.<sup>3,4</sup>

We report the complete structure of the lipooligosaccharide from *P. haloplanktis* TAB 23. The dried cells were extracted obtaining the LOS fraction.

The oligosaccharide fraction was obtained after strong alkaline hydrolysis. The oligosaccharides mixture was purified with HPAEC-PAD giving three main fractions, characterized by means of 2D NMR spectroscopy. All the data collected showed a very short highly phosphorylated saccharidic chain which is in agreement with the feature of the core structures isolated up to now from *Pseudoalteromonas* genus.<sup>5</sup> As for *P. haloplanktis* TAB 23 the core has the following general structure

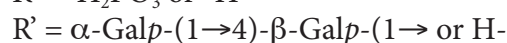
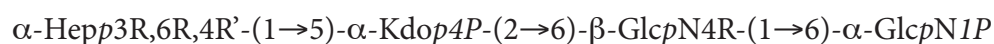

### References

1. G. Feller, T. Lonhienne, C. Deroanne, C. Libiouille, J. Van Beeumen, C. Gerday, *J. Biol. Chem.* **1992**, 267, 5217-5221.
2. N.J. Russell, *Adv. Biochem. Eng. Biotechnol.* **1998**, 61, 1-21.
3. M.M. Corsaro, R. Lanzetta, E. Parrilli, M. Parrilli, M.L. Tutino, *Eur. J. Biochem.* **2001**, 268, 5092-5097
4. M.M. Corsaro, G. Pieretti, B. Lindner, R. Lanzetta, E. Parrilli, M.L. Tutino, M. Parrilli, *Chemistry* **2008**, 14, 9368-76.
5. S. Leone, A. Silipo, E.L. Nazarenko, R. Lanzetta, M. Parrilli, A. Molinaro, *Mar. Drugs* **2007**, 5, 85-112.

## PO 48

**BIOLOGICAL ACTIVITIES OF THE LIPID A FROM THE PSYCHROPHILIC BACTERIUM *PSEUDOALTEROMONAS HALOPLANKTIS* TAB 23**

Sara Carillo<sup>1</sup>, Giuseppina Pieretti<sup>1</sup>, Ermenegilda Parrilli<sup>1</sup>, Luisa Tutino<sup>1</sup>, Sabrina Gemma<sup>2</sup>, Monica Molteni<sup>2</sup>, Rosa Lanzetta<sup>1</sup>, Michelangelo Parrilli<sup>1</sup>, Maria Michela Corsaro<sup>1</sup>

<sup>1</sup>*Dipartimento di Chimica Organica e Biochimica, Università di Napoli Federico II, Complesso Universitario di Monte S. Angelo, Via Cynthia 4, 80126 Napoli, Italy*

<sup>2</sup>*Bluegreen Biotech s.r.l., Via La Masa 19 Milano, Italy*  
sara.carillo2@unina.it

It is well known that the ability of bacterial LPS to stimulate the innate immune system depends on the lipid A moiety, which is recognized as a pathogen-associated molecule by TLR4 and induces the immune cells to activate the release of pro-inflammatory cytokines.

It has been demonstrated that lipid A from non-pathogenic microorganisms such as Gram-negative photosynthetic bacteria are relatively nontoxic and can antagonize many of the known effects of pathogenic LPS *in vitro* and *in vivo*.<sup>1,2</sup> Little information is available about the biological effects on innate immune system exerted by lipid A obtained from other Gram-negative microorganisms, such as extremophilic cold-adapted bacteria. In this context we isolated and fully characterized by MALDI-TOF MS the lipid A from *Pseudoalteromonas haloplanktis* TAB 23, a Gram-negative psychrophilic bacterium isolated from the Antarctic costal sea.<sup>3</sup>

Moreover the lipid A was tested *in vitro* in a human monocytic cell line, using the release of the pro-inflammatory mediators TNF $\alpha$  and IL-6, as markers of cell activation. As a result *P. haloplanktis* lipid A exerted a significant inhibitory effect on the LPS-induced pro-inflammatory cytokine production when added in culture with LPS from *Escherichia coli*, while alone it failed to activate the production of TNF $\alpha$ .

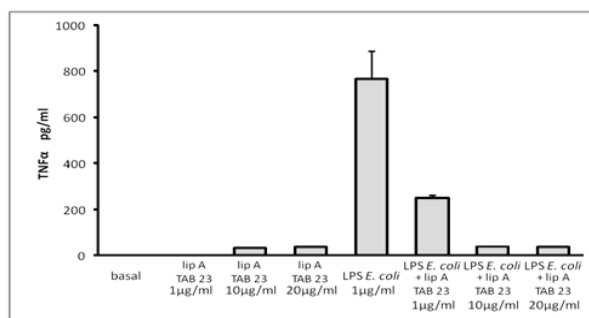

### References

1. J.R. Rose, W.J. Christ, J.R. Bristol, T. Kawata, D.P. Rossignol, *Infect. Immun.* **1995**, 63, 833-839.
2. H. Loppnow, P. Libby, M. Freudenberg, J.H. Krauss, J. Weckesser, H. Mayer, *Infect. Immun.* **1990**, 58, 3743-3750.
3. G. Feller, T. Lonhienne, C. Deroanne, C. Libiouille, J. Van Beeumen, C. Gerday, *J. Biol. Chem.* **1992**, 267, 5217-5221.

## PO 49

EXPLORING A MULTIVALENT APPROACH ON  $\alpha$ -L-FUCOSIDASE INHIBITION

Elena Moreno-Clavijo, Lidia Molina, Adil Sghiouri Idrissi, Ana T. Carmona,  
Antonio J. Moreno-Vargas and Inmaculada Robina

*Department of Organic Chemistry, Faculty of Chemistry, University of Seville.  
Prof. García González, 1, 41012-Seville, Spain  
anatare@us.es*

The recognition of clustered sugars by proteins has been broadly studied in the case of lectins, however the evaluation of multivalent inhibition of glycosidases, another protein recognition process, has been disregarded to only few examples.<sup>1</sup>  $\alpha$ -L-Fucosidases participate in many important biological processes<sup>2</sup> nevertheless the structural data existing in the literature on this enzyme is not yet complete in most cases with exception of  $\alpha$ -L-fucosidases from *Thermotoga maritima* (TmFuc).<sup>3</sup> Its crystal shows a compact hexameric arrangement to which several fucose or fucose mimic ligands can bind simultaneously. As far as we are aware there are not precedents of a multivalent approach regarding  $\alpha$ -L-fucosidases.

We now report the syntheses and of a series of short and long tethered di- and tri-valent iminosugars based on *fuco*-configured 1,4-imino- and 1,4-biimino-cyclitol epitopes. The new compounds were evaluated as glycosidase inhibitors with the aim of studying the multivalent effect on fucosidase inhibition and for obtaining structural information on  $\alpha$ -L-fucosidases. The design of these scaffolded iminosugars is based on the results obtained for 1,4-imino- and 1,4-biimino-cyclitols, previously prepared by us as  $\alpha$ -fucosidase inhibitors.<sup>4</sup>

**References**

1. (a) Diot, J.; García-Moreno, M. I.; Gouin, S. G.; Ortiz Mellet, C.; Haupt, K.; Kovensky, J. *Org. Biomol. Chem.* **2009**, *7*, 357; (b) Compain, P. *et al Angew. Chem. Int. Ed.* **2010**, *49*, 1.
2. (a) Hooper, L. V.; Gordon, J. I. *Glycobiology* **2001**, *11*, 1R; (b) Ayude, D. *et al Oncology* **2000**, *59*, 310; (c) Khunnsook, S.; Bean, B.; McGowan, S. R.; Alhadeff, J. A. *Biol. Reprod.* **2003**, *68*, 709.
3. Sulzenbacher, G., Bignon, C., Nishimura, T., Tarling, C. A., Withers, S. G., Henrissat, B.; Bourne, Y. *J. Biol. Chem.* **2004**, *279*, 13119.
4. (a) Robina, I.; Moreno-Vargas, A. J.; Fernández-Bolaños, J. G.; Fuentes, J.; Demange, R.; Vogel, P. *Bioorg. Med. Chem. Lett.* **2001**, *11*, 2555. (b) Moreno-Vargas, A. J.; Carmona, A. T.; Mora, F.; Vogel, P.; Robina, I. *Chem. Commun.* **2005**, 4949. (c) Moreno-Clavijo, E.; Carmona, A. T.; Vera-Ayoso, Y.; Moreno-Vargas, A. J.; Bello, C.; Vogel, P.; Robina, I. *Org. Biomol. Chem.* **2009**, *7*, 1192. (d) Moreno-Clavijo, E.; Carmona, A. T.; Moreno-Vargas, A. J.; Robina, I.; Rodríguez-Carvajal, M. A.; Robina, I. *Bioorg. Med. Chem.* **2010**, *18*, 4648.



## PO 50

STRUCTURE OF SINORHIZBIUM MELILOTI'S CAPSULAR  
POLYSACCHARIDES ANCHOR

MA. Carpéné, V. Poinsoot and F. Couderc

*IMRCP, UMR 5623 CNRS-Université Paul Sabatier, 31062 Toulouse cedex, France.**carpene@chimie.ups-tlse.fr*

In field, when the ground is nitrate and ammonium starved, a plant family is still thriving: the leguminous. For this performance, the plant enters in symbiosis with a bacteria family, the rhizobia, to establish the nitrogen fixing symbiosis. Indeed, the rhizobia are able to reduce atmospheric nitrogen into ammonia.

During the symbiosis installation, the plant allows a hazardous process: the infection of its roots. To avoid the pathogenic intrusion, both partners have molecular tools allowing a host/invited recognition [1]. One of these rhizobia tools is the external face of their external membrane, mainly made up of polysaccharides. Quantity of recent work showed that these surface compounds play a crucial role in the symbiosis establishment [2]. Among them, one can find exopolysaccharides, lipopolysaccharides, capsular polysaccharides and cyclic glucanes. The symbiotic role as well as the structure of the capsular polysaccharides (KPS) is still unclear [3]. Actually, rhizobia KPSs exhibit a consensus structure of the repeating unit : -[Kdx-Hex]-, where Kdx is a 2-keto,3-desoxysugar and Hex a neutral or acidic carbohydrate. Their size are commonly ranging 20-80 kDa.

We published recently, that the KPS of the european model for rhizobia -*Sinorhizobium meliloti* 1021 (Sm 1021)- exhibits a singular structure. Sm1021 synthesizes only a low molecular mass (~7kDa) homopolymer of  $\beta(2\rightarrow7)$  2-keto, 3-deoxyoctulosonic acid (Kdo). Moreover, this polysaccharide exhibits a lipid anchor allowing its stowing and/or its transport to the external membrane [4]. We also demonstrate that this compound is ubiquitous at least in the *Sinorhizobium* gender [5].

This time, we finalize the KPS structural elucidation by determining the structure of the lipid anchor, using a wide panel of methods (enzyme digestion, GC/MS, LC/MS/MS, NMR). This structure consist in a singular glycerophospholipid.

**References**

1. Kiers E.T., Rousseau R.A., West S.A. et Denison R.F., *Nature*, **2003**, 425, 78.
2. Fraysse N., Couderc F. , Poinsoot V., *European journal Biochem.*, **2003**, 270,1365.
3. Becker A., Fraysse N., Sharypova L., *Mol. Plant microbe Interact.*, **2005**, 18, 899.
4. Fraysse N., Lindner B., Kaczynski Z., Sharypova L., Holst O., Niehaus K., Poinsoot V., *Glycobiology*, **2005**, 15, 101
5. Chataigné G., Couderc F. et Poinsoot V., *J. Chromatogr. A*, **2008**, 1185, 241.



## PO 51

SYNTHESIS OF GLYCODIKETOPIPERAZINES DERIVED FROM  
ALPHA N-ACETYL-GALACTOSAMINE

Ivone Carvalho, Vanessa L. Campo and Maristela B. Martins-Teixeira

Faculty of Pharmaceutical Sciences of Ribeirão Preto-University of São Paulo,  
Av. do Café s/n, Monte Alegre, Ribeirão Preto, SP, Brazil, CEP: 14040-903  
carronal@usp.br

Mucins comprise a class of heavily O-glycosylated proteins coating mammalian cells, with a major structural feature: a moiety of N-acetyl- $\alpha$ -D-galactosamine ( $\alpha$ -GalNAc) bound to hydroxyl protein residues in the reducing end of oligosaccharide chains. In malignant cells, biosynthetic disruption leads to incomplete glycans, abnormally exposing the  $\alpha$ -GalNAc motif, so called Tn antigen, that plays active deleterious role in cancer cells. Such major tumor associated carbohydrate antigen is considered a promising selective target for cancer treatment.<sup>1</sup> Antitumoral activity is an inherent property of 2,5-diketopiperazines (DKPs), heterocyclic systems presenting spatially defined substituents around a proteolysis-resistant peptide-mimicking scaffold, derived from the cross-link between two amino acid residues via a pair of complementary amide bonds. This stable and rigid core is a privileged structure that can be conveniently functionalized at different positions and configurations to display pharmacophoric groups in a controlled fashion.<sup>2</sup>

Aiming to combine potential antitumoral properties from both Tn antigen and DKPs into an hybrid glycopeptidic molecule, O-glycosyl dipeptides of interest were prepared and subjected to head-to-tail cyclization, leading to glycosyl diketopiperazine (40%), as outlined in Scheme 1.

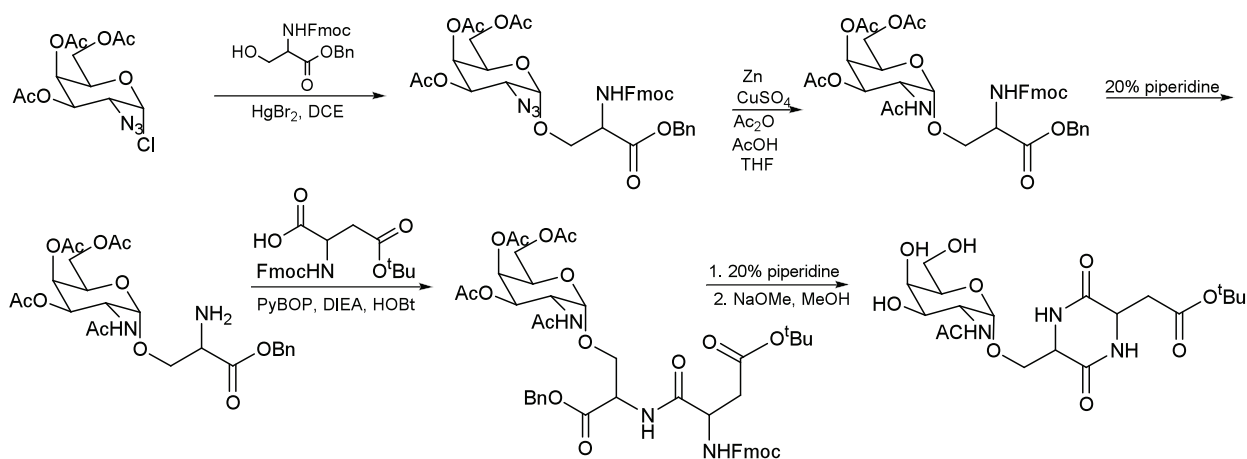

Scheme 1. Synthesis of glycosyl diketopiperazine

## References

1. Brocke, C.; Kunz, H. *Bioorg. Med. Chem.* **2002**, *10*, 3085.
2. V.L. Campo et al. / *Tetrahedron* **65** (2009) 5343–5349

PO 52

**CARBOHYDRATE-BASED SURFACTANTS:  
RATIONALISATION OF THEIR SELF-ASSEMBLY BEHAVIOUR  
IN NON-CONVENTIONAL MEDIA**

Stéphanie Cassel, Roland Ramsch, Isabelle Rico-Lattes

*Laboratoire des IMRCP, UMR CNRS 5623, Université Paul Sabatier, 118 route de Narbonne,  
31062 Toulouse Cedex 4, France  
cassel@chimie.ups-tlse.fr*

Catanionic surfactants are of special interest in supramolecular chemistry since they are able to spontaneously form aggregates such as vesicles in water. Carbohydrate-based ones, obtained from renewable resources and most of the time biocompatible and biodegradable are good candidates for applications in drug delivery.<sup>1</sup> Moreover, the sugar moiety can allow the targeting of the vector towards specific cells or tissues, or bring specific properties (anti-inflammatory).

According to the application, the formulation has to be adapted and therefore a potentially destabilizing effect of a co-solvent such as glycerol or ethanol can occur.

This is why we have initiated a study in which we rationalise the formation of aggregates (size, shape, stability) in different media according to the size/nature of the polar head group and the length of the hydrocarbon tail.

Glucose-based catanionic surfactants (*N*-alkylamino-1-deoxy-*D*-glucitol) were combined with fatty acids of different chain lengths to yield the catanionic surfactants. General behaviour of non-ionic and ionic surfactants in non-aqueous media already described in the literature could be confirmed and extended. The role of some physical parameters of the solvents in the aggregation process was investigated.<sup>2,3</sup> The formation of vesicles or micelles could be observed in the different solvents and solvent mixtures. The results allowed a better understanding of the aggregation mechanism of carbohydrate-based catanionic surfactants in non-aqueous solvents and of the key parameters required to obtain specific self-organised aggregates.

### References

1. Soussan, E. ; Cassel, S. ; Blanzat, M. ; Rico-Lattes, I., *Angew. Chemie Int. Ed.*, **2009**, 48, 274-288.
2. Ramsch, R. ; Cassel, S. ; Rico-Lattes, I., *Jorn. Com. Esp. Deterg., Commun.*, **2009**, 39, 83-92.
3. Ramsch, R. ; Cassel, S. ; Rico-Lattes, I., *Langmuir*, **2009**, 25, 6733-6738.

## PO 53

SYNTHESIS, DERIVATIZATION AND BIOLOGICAL EVALUATION OF  
1,3-OXATHIOLAN-2-IMINE-CARBOHYDRATE DERIVATIVES

Javier Castilla,<sup>1</sup> Deysi Cruz,<sup>1</sup> Rocío Risquez Cuadro,<sup>2</sup> Carmen Ortiz Mellet,<sup>2</sup>  
José Manuel García Fernández,<sup>3</sup> Yolanda Díaz,<sup>1</sup> Sergio Castellón<sup>1</sup>

<sup>1</sup>Departament de Química Analítica i Química Orgànica, Facultat de Química,  
Universitat Rovira i Virgili, Tarragona, Spain.

<sup>2</sup>Departamento de Química Orgánica, Facultat de Química, Universidad de Sevilla, Spain.

<sup>3</sup>Instituto de Investigaciones Químicas, CSIC – Universidad de Sevilla, Spain.  
javier.castilla@urv.cat

Carbohydrate-fused heterocycles form a diverse family of compounds that exhibit interesting biological effects, and particularly behave as glycosidase inhibitors.<sup>1</sup> It has been shown that the heterocyclic moiety is directly involved in the binding process in the enzyme pocket,<sup>2</sup> and much effort has focused in recent years on the synthesis of new and more potent analogous compounds bearing different heterocyclic moieties.

Herein, we show a general, short and efficient procedure for synthesizing a new family of carbohydrates with a 1,3-oxathiolan-2-imine moiety bearing different substituents at the exocyclic nitrogen. Interestingly, glycosidase inhibition tests showed highly specific inhibition of mammalian  $\beta$ -glycosidases with a marked dependence of the potency upon the nature of the substituent.

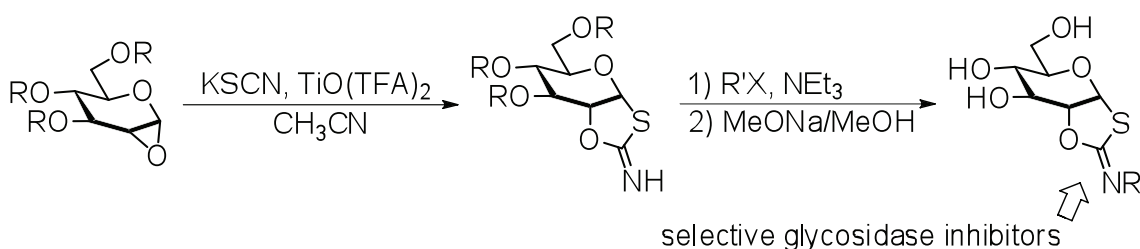

## References

1. a) Girniene, J.; Tatibouët, A.; Sackus, A.; Yang, J.; Holman, G. D.; Rollin, P. *Carbohydr. Res.* **2003**, 338, 711-719. b) Dallemagne, P.; Khanh L. P.; Alsaïdi, A.; Varlet, I.; Collot, V.; Paillet, M.; Bureau, R.; Rault, S. *Bioorg. Med. Chem.* **2003**, 11, 1161-1167. c) Lohray, B. B.; Lohray, V. B.; Srivastava, B. K.; Gupta, S.; Solanki, M.; Kapadnis, P.; Takale, V.; Pandya, P. *Bioorg. Med. Chem. Lett.* **2004**, 14, 3139-3142.
2. Bortone, K.; Monzigno, A. F.; Stephen, E.; Robertus, J. D. *J. Mol. Biol.* **2002**, 320, 293-302.
3. Castilla, J.; Marín, I.; Matheu, M. I.; Díaz, Y.; Castellón, S. *J. Org. Chem.*, **2010**, 75, 514-517.

## PO 54

## LARGE DISPERSE DYES TRANSFORMED INTO "NATURALIZED DYES" THROUGH GLYCOCONJUGATION WITH LACTOSE

Roberto Bianchini,<sup>2</sup> Marco Bonanni,<sup>2</sup> Giorgio Catelani,<sup>1</sup> and Massimo Corsi<sup>2</sup><sup>1</sup>Dipartimento di Chimica Farmaceutica, Università di Pisa, via Bonanno 56126 Pisa,<sup>2</sup>Dipartimento di Chimica, Università di Firenze, Via della Lastruccia 13,  
Sesto Fiorentino (FI), 50123 Italy

giorgio.catelani@farm.unipi.it; roberto.bianchini@unifi.it

The conjugation of a disperse dye with common mono- and disaccharides, preferably lactose, has been recently introduced into dye's chemistry, leading to the so called "naturalized dyes".<sup>1</sup> The transformation is effective, so that the dye becomes soluble in water and able to dye with success synthetic, artificial, and natural materials in a really environmentally sounding way, where surface agents are not anymore requested, and lower temperatures are working. This kind of derivation of dyes is therefore able to transform the dyes into multipurpose, and may be universal dyes, since they reveal the ability to dye with a relevant success even leather, or wood. The glycoconjugation process has so far mainly developed using lactose, since this disaccharide is really cheap, and can be easily and selectively protected, allowing first the formation of a covalent bond with a linker and therefore with the starting dye. In order to extend these characteristics to higher molecular weight dyes, a double glycoconjugation with lactose is requested, the single one being not sufficient to reach the result. Presented here is a simple and efficient procedure, where the glutamic acid is the linker, allowing the formation of a double glycoconjugated derivative through two amide bonds between the glutamic linker and two 6'-aminolactose units.

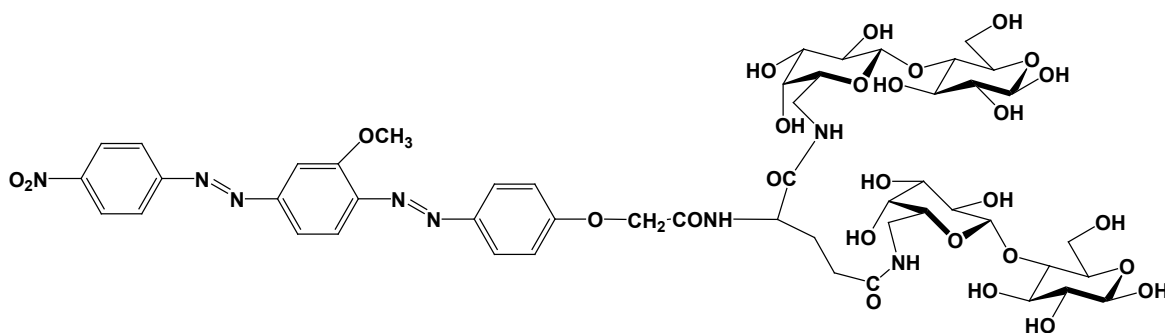

Through this process the saccharide moiety becomes as large as the dye plus the linker, and the final results is that dye turns to hydrosolubility and displays the above claimed multipurpose properties. Also, researches are running concerning the possibility of bio-degradation of these naturalized dyes with microorganisms, in order to develop an innovative "green" tinctorial process.

## References

1. a) G. Bartalucci, R. Bianchini, G. Catelani, F. D'Andrea, L. Guazzelli, *Eur. J. Org. Chem.* **2007**, 588-595; b) R. Bianchini, G. Catelani, J. Isaad, R. Cecconi, F. D'Andrea, L. Guazzelli, M. Rola. *Eur. J. Org. Chem.* **2008** (3) 444-454.

## PO 55

## A NEW INTERACTION MODE OF LANGERIN FOR GLYCOSAMINOGLYCANS

Eric Chabrol<sup>1</sup>, Michel Thépaut<sup>1</sup>, Jenny Valladeau<sup>2</sup>, Corinne Vivès<sup>1</sup>, Romain Vivès<sup>1</sup>,  
Colette Dezutter-Dambuyant<sup>2</sup>, Eric Girard<sup>1</sup>, Franck Fieschi<sup>1</sup>.

<sup>1</sup> *Institut de Biologie structurale, UMR 5075 CEA/CNRS/UJF 41 rue Jules Horowitz,  
38027 Grenoble.*

<sup>2</sup> *Centre Léon Bérard, Inserm 590, 28, rue Laënnec - 69373 Lyon.  
eric.chabrol@ibs.fr*

Dendritic cells (DCs) play a crucial role in the immune system by their localisation (in epithelia) and their ability to recognise and process pathogens for further T cell activation. To play this role, DCs possess multiple receptors on their surface. Among those receptors, C-type lectins are able to recognise oligosaccharide motifs present on the pathogen surface. In the case of HIV-1 infection, two different DC subsets, dermal DC and langerhans cells, interfere differently with the virus using two distinct C-type lectins. They either favour transmission of HIV-1 to T cells (DC-SIGN lectin), or prevent HIV-1 transmission (Langerin lectin) by internalisation and degradation of the virus into Birbeck granules (a specific organelle of Langerhans cells). These two C-type lectins recognise mannose, N-acetyl-glucosamine and fucose and in a calcium dependent manner. More specifically they recognize "High Mannose" patterns on the virus envelope glycoprotein 120 (gp120). Langerin, which can prevent HIV-1 transmission, has additional specificity towards sulfated sugars.

In this study, we show by Surface Plasmon Resonance two different modes of Langerin interaction with "High Mannose" patterns and a specific family of sulfated sugars, the Glycosaminoglycans (GAGs). We demonstrated that Langerin/GAG interaction is not dependent on the calcium-binding site, contrary to the interaction with "High Mannose" patterns. Furthermore, this interaction does not proceed through single carbohydrate domain but is absolutely dependent upon Langerin trimerisation. And Moreover, these two interaction modes are cumulated and Langerin/GAGs complexation does not inhibit gp120 interaction but stabilises it.

### References

1. Lot de Witte and al. *Nature Medicine* **13**, 367-371. 2007.
2. Thépaut and al. *Biochemistry* **48**, 2684-2698. 2009.
3. Valladeau and al. *Journal of Immunology* **168**(2), 782-92. 2002.

## PO 56

## CARBOHYDRATE-BASED PROBES FOR NONLINEAR MEMBRANE IMAGING

Redon Sébastien,<sup>1,2</sup> Massin Julien,<sup>1,3</sup> Cottet Davy,<sup>4</sup> Wage Hartmut,<sup>4</sup> Douady Julien,<sup>4</sup>  
 Pouvreau Sandrine,<sup>1,5</sup> Andraud Chantal,<sup>1,3</sup> Queneau Yves,<sup>1,2</sup> Girard-Egrot Agnès,<sup>1,6</sup>  
 Bretonnière Yann,<sup>1,3</sup> Chambert Stéphane<sup>1,2</sup>

<sup>1</sup> Université Lyon F-69622, Lyon, France,

<sup>2</sup> COB, ICBMS, UMR 5246, INSA-Lyon, France,

<sup>3</sup> Laboratoire de Chimie de l'ENS Lyon, CNRS, ENS Lyon, UCBL, UMR 5182, France,

<sup>4</sup> LSP, UMR 5588 CNRS-Université Grenoble 1, 38402 Saint Martin d'Hères, France.

<sup>5</sup> Physiologie Intégrative, Cellulaire et Moléculaire, UMR CNRS 5123,

Université Lyon 1, France,

<sup>6</sup> GEMBAS, ICBMS, UMR 5246, Université Lyon 1, France.

stephane.chambert@insa-lyon.fr

In this interdisciplinary project, by mimicking the overall structure of natural glycolipids we wish to benefit of their well known membrane specificity in order to produce new tools dedicated to two promising emerging nonlinear membrane imaging experiments (TPM: two-photon excited fluorescence microscopy and SHIM: second-harmonic imaging microscopy).<sup>1,2</sup> By taking advantage of straightforward methods for modifying and then grafting highly diverse carbohydrate backbones<sup>3,4</sup> onto especially designed push-pull chromophores, a first series of probes was obtained.<sup>5</sup> They were the first neutral synthetic dyes to show a long living SHG signal in cell culture and thus validated our initial postulate by showing the improved properties attained with the use of a carbohydrate hydrophilic moiety. In order to better fulfill the standard requirements of membrane imaging dyes, two new series of probes were designed. Their synthesis as well as their enhanced behavior will also be discussed (optical characterization, membrane insertion evaluation, biological and imaging properties).

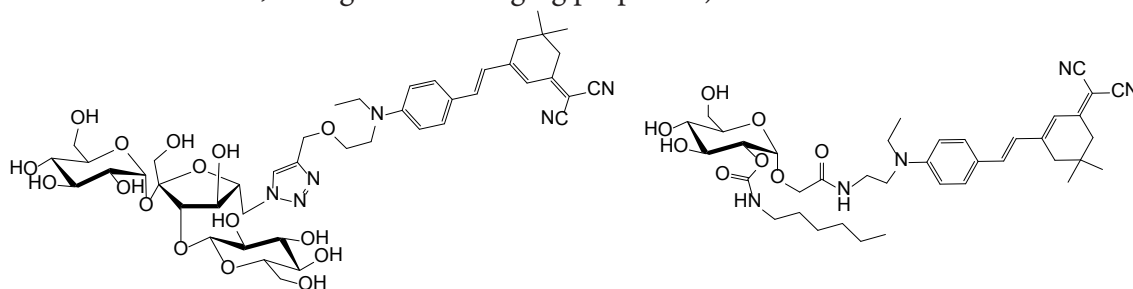

## References

1. Reeve J. E., Anderson H. L., Clays K., *Phys. Chem. Chem. Phys.*, **2010**, 12, 13484–13498.
2. Millard A. C., Jin L., Wei M.-D., Wuskell J. P., Lewis A., Loew L. M., *Biophys. J.*, **2004**, 86, 1169-1176.
3. Trombotto S., Danel M., Fitremann J., Bouchu A., Queneau Y., *J. Org. Chem.*, **2003**, 68, 6672-6678.
4. Besset C., Chambert S., Fenet B., Queneau Y., *Tetrahedron Lett.*, **2009**, 50(50), 7043-7047.
5. Barsu C., Cheaib R., Chambert S., Queneau Y., Maury O., Cottet D., Wege H., Douady J., Bretonnière Y., Andraud C., *Org. Biomol. Chem.*, **2010**, 8(1),142-150.

## PO 57

## PHOTOSWITCHABLE GLYCO-SAMS

Vijayanand Chandrasekaran, Thisbe K. Lindhorst

*Otto Diels Institute of Organic Chemistry, Christiana Albertina University of Kiel,  
Otto-Hahn-Platz-4, 24098, Kiel, Germany.  
vanand@oc.uni-kiel.de*

Eukaryotic cell surfaces are covered by a thick layer of complex carbohydrates called glycocalyx. This glycocalyx is very important in many biological processes such as cell-cell communication, cell signaling and cell adhesion.[1] Molecular recognition of glycocalyx saccharides, such as in carbohydrate-protein interactions is accompanied by conformational changes within the ligand and its receptor as well as within the supramolecular environment of the cell surfaces. Conformational changes of cell surface carbohydrates, however, have received only little attention until to date.[2] To address the issue of conformational control of carbohydrate recognition, we have designed photo-switchable glycosides that can form carbohydrate-decorated monolayers on gold surfaces in the form of self-assembled monolayers, so-called glyco-SAMs.[3] We report on the fabrication of glyco-SAMs from azobenzene glycosides, which can be “switched” between the *E*- and the *Z*-state of the azobenzene moiety (Fig. 1). The photostationary equilibria of the prepared azobenzene glycosides were determined by <sup>1</sup>H NMR and UV-Vis spectroscopy. The photochromic properties of the respective glycol-SAMs has been investigated by IRRAS (Infrared reflection-absorption spectroscopy) employing a series of systematically varied SAMs.

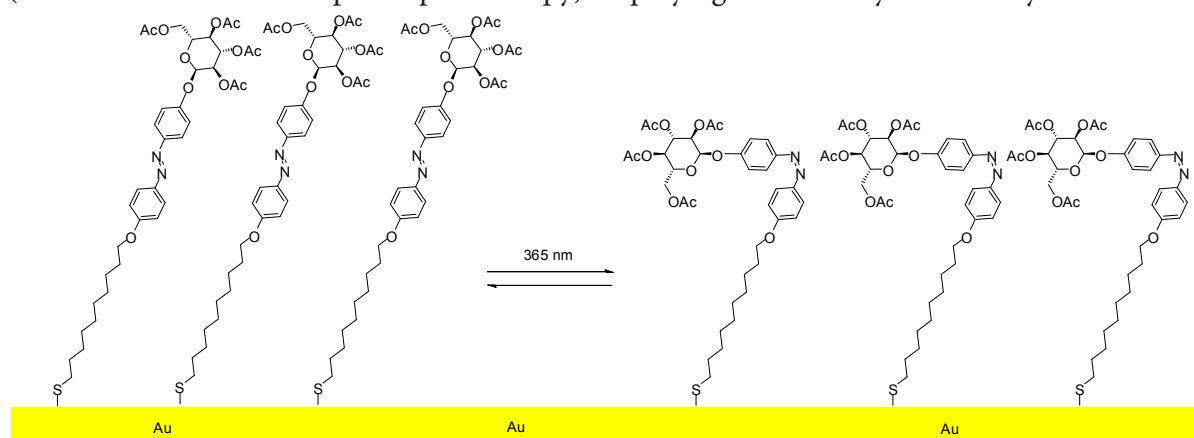

**Figure 1:** Schematic representation of photoswitchable glyco-SAMs on Au (111) surface.

### References

1. Crocker, P; Paulson, J. C; Varki, A. *Nat. Rev. Immunol.* **2007**, 7, 255-266.
2. Srinivas, O; Mitra, N; Surolia, A; Jayaraman, N. *Glycobiology*, **2005**, 15, 861-873.
3. Kleinert, M; Winkler, T; Terfort, A; Lindhorst, Th. K. *Org. Biomol. Chem.*, **2008**, 6, 2118-2132.



## PO 58

## SEPTANOSIDES FROM HEXOPYRANOSIDES VIA 5,6-EXO-GLYCAL

Jackowski O.<sup>1</sup>, Chrétien F.<sup>2</sup>, Didierjean C.<sup>2</sup>, and Chapleur Y.<sup>1</sup><sup>1</sup>Groupe SUCRES, UMR7565 SRS MC Nancy-Université – CNRS, BP 70239, F-54506, Nancy Vandoeuvre (France)<sup>2</sup>UMR CRM2, Nancy-Université – CNRS, BP 70239, F54506, Nancy Vandoeuvre (France)  
yves.chapleur@uhp-nancy.fr

Hexoses exist under two main different forms i.e. pyranose and furanose ring. In free sugars, these forms are in equilibrium with each other and with the linear form. In contrast with pentoses, the primary hydroxyl group is rarely involved in a cycle except in 1,6 anhydro derivatives. Due to their growing importance as carbohydrate mimics,<sup>1</sup> septanose and septanosides have attracted interest and have been introduced in biologically significant structures. Thus, new elegant routes to heptoses in their septanose form have been open by ring expansion of pyranoses<sup>2</sup> mainly using cyclopropanation of glycals<sup>3</sup> or furanolactone<sup>4</sup> or by *de novo* construction of the oxepane ring by ring closing metathesis.<sup>5</sup> Additional to their interest as carbohydrate mimics, septanoses offer the unique possibility of 5-OH group manipulation, a much difficult operation in pyranose ring systems. In this context, we have explored new accesses to septanose and septanoside derivatives of D-glucose starting from 5,6-exo-glycals.<sup>6</sup>

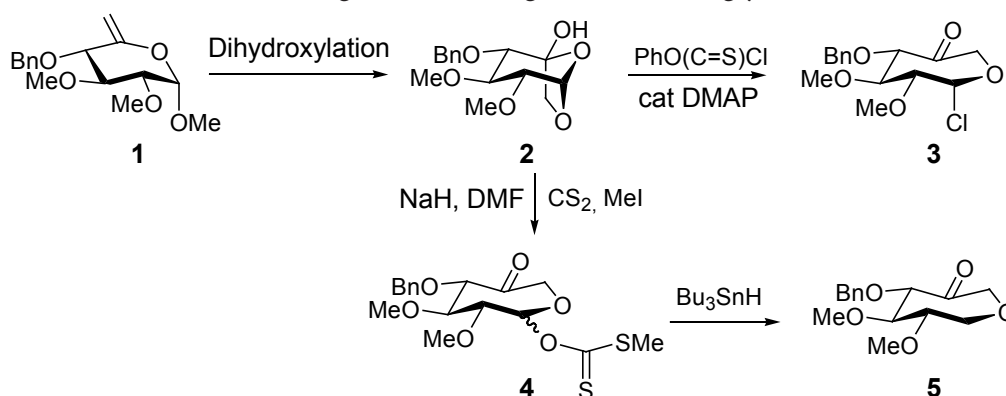

For example, dihydroxylation of exo-glycal **1** gave 1,6 anhydro derivative **2** which was elaborated to a stable 5-ulo septanosyl chloride **3** or to an anomeric septanoside xanthate **4** easily reduced under radical conditions to the 3-oxepanone **5**

## References

1. *Carbohydrate Mimics*; Chapleur Y. Ed.; Wiley-VCH: Weinheim, 1998.
2. Saha, J.; Peczu, M. W. *Org. Lett.* **2009**, *11*, 4482.
3. Hewitt, R. J.; Harvey, J. E. *J. Org. Chem.* **2010**, *75*, 955–958.
4. Castro, S.; Johnson, C. S.; Surana, B.; Peczu, M. W. *Tetrahedron* **2009**, *65*, 7921.
5. Jadhav, V. H.; Bande, O. P.; Pinjari, R. V.; Gejji, S. P.; Puranik, V. G.; Dhavale, D. D. *J. Org. Chem.* **2009**, *74*, 6486.
6. Taillefumier, C.; Chapleur, Y. *Chem. Rev.* **2004**, *104*, 263.

## PO 59

C-GLYCOSYL COMPOUNDS BY FUNCTIONNALISATION-REDUCTION  
OF EXO-GLYCALS

H.-T. Tran-Thien, A. Novoa, N. Pellegrini-Moïse and Y. Chapleur

Groupe SUCRES, UMR7565 SRSMC Nancy-Université – CNRS, BP 70239,  
F-54506, Nancy Vandoeuvre (France)  
yves.chapleur@uhp-nancy.fr

Formation of carbon-carbon bond at the anomeric centre is a long standing interest of carbohydrate chemists and many methods have been developed. Creating C-C double bonds at the anomeric centre should offer more possibilities for further manipulation of the anomeric carbon in particular for the synthesis of C-glycosyl compounds. Such olefin formation is also challenging and only a few solutions are available to date to prepare the so-called *exo*-glycals.<sup>1</sup> We have established some time ago, one of the first direct method of *exo*-glycal synthesis starting from lactones via Wittig reactions.<sup>2</sup> However, there are some limitations in the choice of the phosphorane reagents useful in this particular olefination reaction. To overcome this problem, it would be of interest to achieve further functionalization of easily accessible *exo*-glycals. Thus, starting from easily available *exo*-glycal esters **1**, we have explored their electrophilic halogenation<sup>3</sup> as a way to activate the double bond. Brominated compounds **2** were obtained in fair to good yields as variable *Z/E* mixtures by simple treatment with bromine and a base. From these vinylic bromides, palladium-catalyzed cross coupling reactions were investigated.

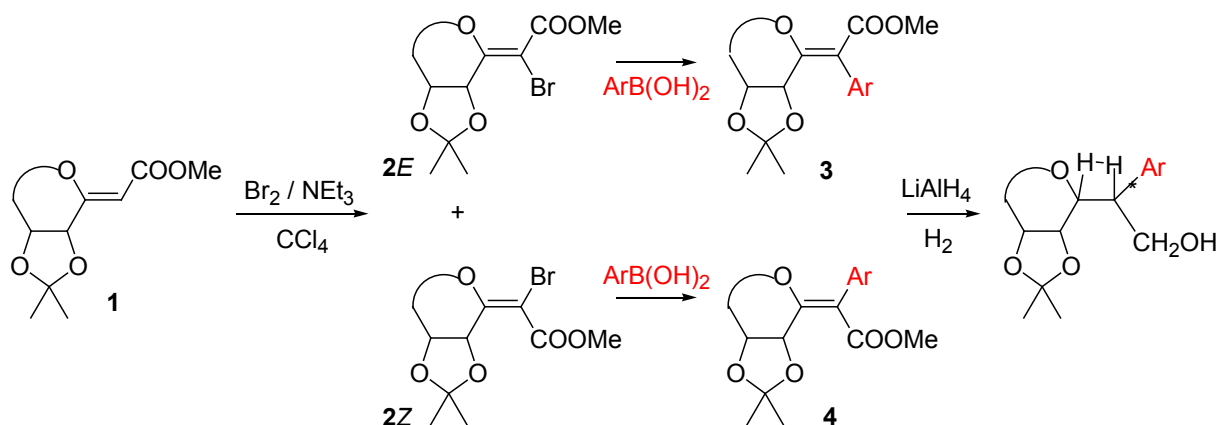

Compounds **3** or **5** were obtained stereoselectively. Ester reduction and catalytic hydrogenation of the double bond afforded the corresponding C-glycosyl derivatives with high stereoselectivity.

## References

1. Taillefumier, C.; Chapleur, Y. *Chem. Rev.* **2004**, *104*, 263-292.
2. Lakhrissi, M.; Chapleur, Y. *Angew. Chem. Int. Ed. Engl.* **1996**, *35*, 750-752
3. Lakhrissi, M.; Chapleur, Y. *Tetrahedron Lett.* **1998**, *39*, 4659-4662. See also for example : Gomez, A. M.; Pedregosa, A.; Uriel, C.; Valverde, S.; Lopez, J. C. *Eur. J. Org. Chem.* **2010**, 5619-5632 and references cited.

## PO 60

STRUCTURAL CHARACTERIZATION OF LIPID A FROM  
AZORHIZOBIUM CAULINODANS

Adam Choma,<sup>1</sup> Iwona Komaniecka,<sup>1</sup> Anna Turska-Szewczuk,<sup>1</sup> Witold Danikiewicz<sup>2</sup>

<sup>1</sup>*Department of Genetics and Microbiology, Maria Curie-Skłodowska University,  
Akademicka 19, 20-033 Lublin, Poland;*

<sup>2</sup>*Institute of Organic Chemistry, Polish Academy of Sciences, Kasprzaka 44/52,  
01-224 Warsaw, Poland  
adam.choma@poczta.umcs.lublin.pl*

*Azorhizobium caulinodans* is a microsymbiont of the tropical legume *Sesbania rostrata*. These bacteria can induce nitrogen-fixing nodules on both stems and roots of their host plants. The cell envelope of *Azorhizobium*, a Gram-negative bacterium, consists of two membranes: an inner (cytoplasmic) membrane (IM or CM) composed of phospholipids and an outer membrane (OM), which is asymmetrical and contains primarily phospholipids in the inner leaflet and lipopolysaccharide (LPS) in the outer leaflet. The LPS is anchored in the OM by its lipophilic part called lipid A. The chemical structure of lipid A, isolated by mild acid hydrolysis from lipopolysaccharide of *Azorhizobium caulinodans*, was investigated. To determine the structural details of the lipid A sugar backbone, chemical composition analyses and 1D and 2D NMR spectroscopy were applied. Data obtained from analyses performed on a matrix-assisted laser desorption/ionization time of flight mass spectrometer (MALDI-TOF, Voyager-Elite, PE Biosystems) as well as on an electrospray ionization (ESI) mass spectrometer (4000 QTrap triple quadrupole/linear ion trap mass spectrometer, Applied Biosystems) were used to determine fatty acid distribution. The location of amide-linked fatty acids in the lipid A backbone was established by identifying diagnostic ions derived from native and O-deacylated lipid A preparations. Additional diagnostic ions were derived during fragmentation of the selected precursor ions using MS/MS mode of the 4000 QTrap spectrometer.

The backbone structure of *A. caulinodans* lipid A was identified as a  $\beta$ -(1 $\rightarrow$ 6) linked 2,3-diamino-2,3-dideoxy-D-glucosamine (GlcN3N) disaccharide substituted with  $\alpha$ -D-glucurono-3,6-lactone at position C-1 of the reducing end of the disaccharide. The lipid A preparation contained mainly a heptaacyl component in which 3-hydroxytetradecanoyl [14:0-(3-OH)] was linked at C-3 and C-3' positions, whereas 3-hydroxyoctadecanoyl [18:0-(3-OH)] and 3-hydroxyeicosenoyl [20:1-(3-OH)] were linked at C-2 and C2' positions in the GlcN3N-disaccharide, respectively. The distribution of secondary fatty acid substituents [16:0, 18:0, and 18:0-(3-OH)] is still under investigation.

## PO 61

## SYNTHESIS OF C-9 FUNCTIONALISED N-ACETYLNEURAMINIC ACID DERIVATIVES AS BIOLOGICAL PROBES

Pradeep Chopra, Robin J. Thomson, Jeffery C. Dyason, I. Darren Grice and Mark von Itzstein

*Institute for Glycomics, Griffith University, Gold Coast campus, Queensland, 4222, Australia  
p.chopra@griffith.edu.au*

Sialic acids [e.g. *N*-acetylneuraminic acid (1)] are 9-carbon acidic sugars that constitute the terminal residue on many glycoproteins and glycolipids.<sup>1</sup> They are involved in various biologically important processes and human diseases.<sup>2</sup> As such, study of sialic acid metabolising and recognising proteins, as well as of modified sialic acids<sup>3</sup> is an area of great interest. As part of our ongoing interest in the development of novel sialic acids as biological probes,<sup>4</sup> we have developed an efficient synthesis of C-9 oxidised sialic acid derivatives (2).<sup>5</sup> The carboxylate group is useful for further elaboration, for example through amidation, to provide valuable probes for a range of sialic acid recognizing proteins.

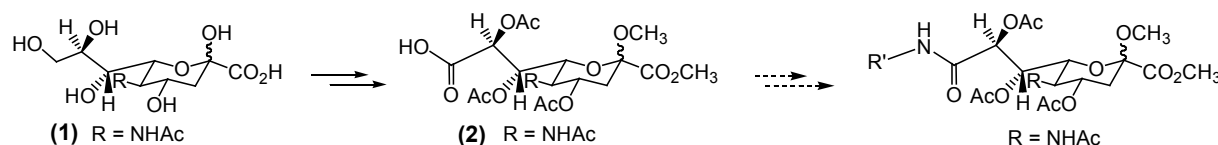

## References

- Schauer, R. *Angew. Chem. Intl. Ed.* **1973**, 12, 127-138.
- Schauer, R.; Kelm, S.; Reuter, G.; Roggentin, P.; Shaw, L. in *Biology of the sialic acids*, Rosenberg, A., Ed. Plenum press: New York, 1995.
- Zbiral, E. in *Carbohydrates- Synthetic methods and applications in medicinal chemistry*, Ogura, H.; Hasegawa, A.; Suami, T., Eds. VCH: Weinheim, 1992.
- (a) Kong, D. C. M.; von Itzstein, M. *Tetrahedron Lett.* **1995**, 36, 957-960. (b) Groves, D. R.; von Itzstein, M. *J. Chem. Soc. Perkin Trans. 1* **1996**, 2817-2821. (c) Kiefel, M. J.; Bennett, S.; von Itzstein, M. *J. Chem. Soc. Perkin Trans. 1* **1996**, 439-442. (d) Kiefel, M. J.; Wilson, J. C.; Bennett, S.; Gredley, M.; von Itzstein, M. *Bioorg. Med. Chem.* **2000**, 8, 657-664.
- Kiefel, M.J. ; Chopra, P.; Madge, P.D.; Szyzew, A.J.; Thomson, R.J.; Grice I.D.; von Itzstein, M. *Tetrahedron Lett.* **2011**, 52, 98-100.

## PO 62

SYNTHESIS OF DIMERIC GLYCOMIMETIC LIGANDS TO  
NK CELL ACTIVATION RECEPTORS

Helle Christensen,<sup>1</sup> Anna Drozdová,<sup>2,3</sup> Pavla Bojarová,<sup>2,3</sup> Lenka Weignerová,<sup>2</sup> Lothar Elling,<sup>4</sup>  
Karel Křenek,<sup>2,3</sup> Karel Bezouška,<sup>2,3</sup> Kristýna Slámová,<sup>2</sup> Vladimír Křen,<sup>2</sup>  
Henrik Helligsø Jensen.<sup>1</sup>

<sup>1</sup>Department of Chemistry, Aarhus University, Langelandsgade 140, DK-8000 Aarhus C, Denmark.

<sup>2</sup>Institute of Microbiology, Academy of Sciences of the Czech Republic,  
Videňská 1083, CZ-14220 Praha 4, Czech Republic.

<sup>3</sup>Department of Biochemistry, Faculty of Science, Charles University in Prague,  
Hlavova 8, CZ-12840 Praha 2, Czech Republic.

<sup>4</sup>Helmholtz Institute for Biomedical Engineering, RWTH Aachen University,  
Pauwelsstr. 20, D-52074 Aachen, Germany.  
hellec@chem.au.dk

This study is aimed at the preparation of divalent LacdiNAc ligands for the natural killer (NK) cell activation. The bivalent structures were subjected to binding and precipitation studies with two model activation receptors of NK cells, namely NKR-P1 (rat) and CD69 (human). The prepared compounds proved to be very good precipitation agents, especially for the CD69 receptor, where the additionally introduced GalNAc units greatly improved the precipitation effect. Since NK cells are a unique population of lymphocytes able to eliminate malignant, virally infected, or damaged cells,<sup>1</sup> this class of compounds could show a new way in experimental tumour therapy.<sup>2</sup>

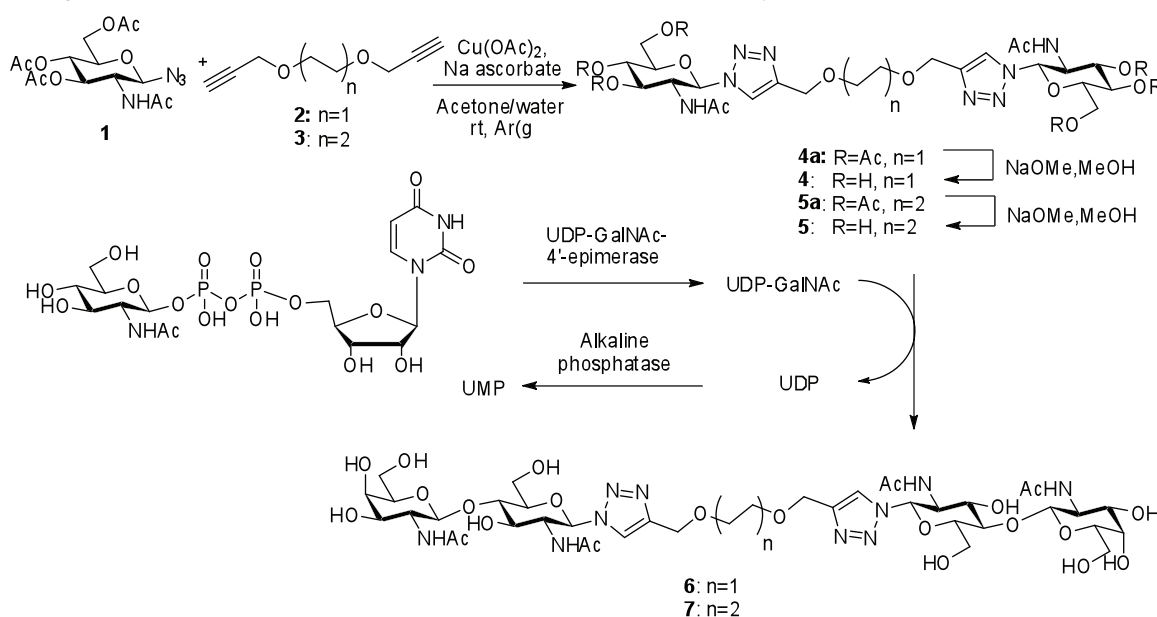

**Scheme 1:** Yield: **4a**: 51%, **4**: quantitative yield, **5a**: 56%, **5**: quantitative yield. **6**: 28%, **7**: 47%.

## References

- Vivier, E., Tomasello, E., Baratin, M., Walter, T., Ugolini, S. *Nat. Immunol.*, **2008**, 9, 503-551. Di Santo, J. P. *Nat. Immunol.*, **2008**, 9, 473-475.
- Bezouška, K., Sklenář, J., Dvořáková, J., Havlíček, V., Pospíšil, M., Thiem, J., Křen, V. *Biochem. Biophys. Res. Commun.*, **1997**, 238, 149-153. Pospíšil, M., Vannucci, L., Fišerová, A., Krausová, K., Horváth, O., Křen, V., Mosca, F., Sadalpure, K., Lindhorst, T.K., Bezouška, K. *Adv. Exp. Biol. Med.*, **2001**, 495, 343-348.

## PO 63

## STEREOSELECTIVE SYNTHESIS OF LONG-CHAIN CARBOHYDRATES

Maciej Cieplak, Sławomir Jarosz

*Institute of Organic Chemistry PAS, ul. M. Kasprzaka 44/52, 01-224 Warsaw, Poland,  
maciej.cieplak@icho.edu.pl*

Monosaccharides containing more than 10 carbon atoms in the chain, very rare in nature, have interesting properties. They can be used as non-metabolized analogues of di- and oligosaccharides, are interesting targets for developing new synthetic methodologies and studying conformational features. In the past several years we have elaborated a convenient methodology for the preparation of higher dialdoses by coupling of two suitably activated simple sugar subunits. Especially useful was the reaction of phosphonates with sugar aldehydes providing a higher enone, finally converted into the desired dialdose.<sup>[1]</sup> The route we propose now involves synthesis of compound **1** which can be selectively deprotected at either end.

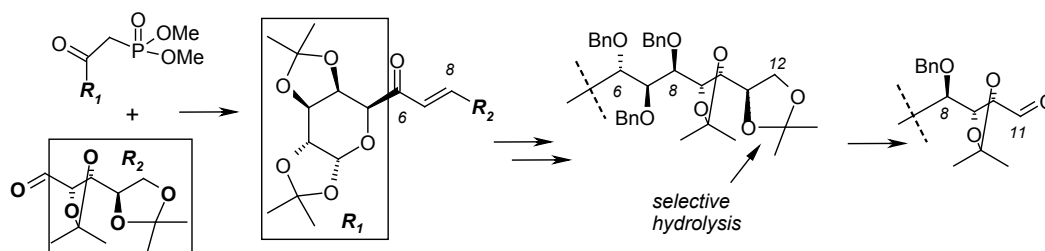

Alternatively, we have applied the methodology proposed by Enders and Barbas III for the preparation of other useful synthons.<sup>[2]</sup> The (S)-proline catalyzed reaction of various sugar aldehydes with protected dihydroxyacetone opens a convenient route to such complex molecules.

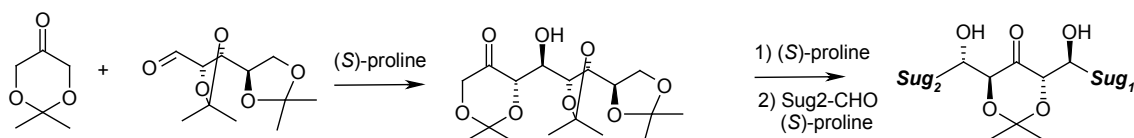

## References

1. S. Jarosz, *J. Carbohydr. Chem.*, **2001**, *20*, 93-107.
2. D. Enders, S.J. Ince, M. Bonnekesel, J. Runsik, G. Raabe, *Synlett.*, 2002, 962.
3. J.T. Suri, S. Mitsumori, F. Tanaka, C.F. Barbas III, *J. Org. Chem.*, **2006**, *71*, 3822-3828.

## PO 64

## DEPOLYMERISATION OF CELLULOSE IN IONIC LIQUID MEDIA

Claisse Nathalie<sup>1,2</sup>, Vidal Serge<sup>2</sup>, Fort Sébastien<sup>1</sup>

<sup>1</sup>CERMAV CNRS, 601 rue de la chimie BP53 38041 GRENOBLE cedex 9, FRANCE

<sup>2</sup>ERAS Labo, 222 D1090 38330 SAINT-NAZAIRE-LES-EYMES, FRANCE

Nathalie.Claisse@cermav.cnrs.fr

The valorisation of cellulose, which is a main component of plants and the most abundant polysaccharide, is a great concern nowadays since the interest in biomass-derived products is increasing. Intense research is being focused on total depolymerisation of cellulose into fermentable sugars for the production of bio-fuel. Controlled hydrolysis into cellodextrins is however little investigated although these oligosaccharides can meet diverse applications including as substrates in cellulase assays.<sup>1,2</sup> Thus there is an existing need to improve methods to produce cellodextrins. Cellulose has the particularity to be insoluble in most of the commonly used solvents, and this is challenging for its modification and its valorisation. Chemical hydrolysis by mineral acids has been already widely described but this method is characterised by harsh conditions, low yields and poor selectivity in the degree of polymerisation of the oligosaccharides produced.<sup>3</sup> Ionic liquids are capable of dissolving cellulose<sup>4</sup> and they represent the possibility to achieve its depolymerisation<sup>5</sup> as well as its functionalisation by other means than the already existing ones. In this communication, controlled chemo-enzymatic depolymerisation of cellulose in ionic liquid media to produce cellodextrins will be reported. Influence of the reaction conditions on the size of the resulting oligosaccharides will be discussed.

### References

1. Boyer V; Fort S, Frandsen T, Schülein M, Cottaz S, Driguez H, *Chemistry: A European Journal*, **2002**, 8, 1389-1394
2. Huang Y; Krauss G; Cottaz S; Driguez H; Lipps G; *Biochemical Journal*, **2005**, 385, 581-588
3. Zhang Y ; Lynd L ; *Analytical Biochemistry*, **2003**, 322, 225-232
4. Pinkert A; Marsh K; Pang S; Staiger M, *Chemical Reviews*, **2009**, 109, 6712-6728
5. Rinaldi R; Palkovits R; Schüth F, *Angewandte Chemie*, **2008**, 47, 8047-8050



## PO 65

**SYNTHESIS OF 6'-AZIDO LAMINARIBIOSYL BUILDING BLOCKS  
FOR GLYCOSYNTASE-CATALYZED BIOPOLYMERIZATION**

Victoria Codera, Eduardo Andrés, Magda Faijes, and Antoni Planas\*

*Laboratory of Biochemistry, Institut Químic de Sarrià, Universitat Ramon Llull,  
Via Augusta, 390, Barcelona, Spain  
antoni.planas@iqs.es*

Glycosynthases are mutated glycosidases devoid of hydrolase activity but able to catalyze efficiently the formation of glycosidic bonds when using activated glycosyl fluoride donors. Since the development of the glycosynthase methodology in 1998<sup>1,2</sup>, these engineered enzymes became an efficient tool for the synthesis of oligosaccharides. Recently, this technology opened a new window to the enzyme catalyzed preparation of artificial polysaccharides<sup>3</sup>.

Using this technology developed in our group<sup>2,3</sup>, we are currently exploring the introduction of functional groups in the building blocks acting as glycosyl donors for the glycosynthase-catalyzed polymerization. The functionalities introduced in the glycosyl donors will be inherited in the resulting polymer and should confer new properties while retaining the biodegradability given by its unaltered sugar backbone. We have developed two approaches for the synthesis of a disaccharide donor modified in the 6' position with an azido group whose polymerization will give an (A-B)<sub>n</sub> heteropolymer.

The first 'Polymer approach' takes advantage of a natural raw material to easily access to a disaccharide. The position C-6' of this disaccharide can be selectively modified. Alternatively, the 'Total synthesis' approach starts from individual monosaccharides where the different positions are easily differentiated before its chemical coupling to obtain an A-B building block. By properly choosing orthogonal protecting groups, the functionality is either introduced first in the donor before glycosylation (total synthesis II) or in the disaccharide product after glycosylation (total synthesis I).

**References**

1. Mackenzie, L.F., Wang, Q., Warren, R.A.J., Withers, S. G. *J. Am. Chem. Soc.*, **1998**, *120*, 5583 – 5584
2. Malet, C., Planas, A., *FEBS Letters.*, **1998**, *440*, 208 – 212
3. Faijes, M., Imai, T., Bulone, V., Planas, A., *Biochemical Journal*, **2004**, *380*, 635 – 641
4. Pérez, X., Faijes, M., Planas, A, *Biomacromolecules.*, **2011**, *12*, 494-501

## PO 66

**APPLICATION OF NITRILE OXIDE CYCLOADDITION “CLICK-CHEMISTRY”  
IN GLYCOCONJUGATE SYNTHESIS.  
SCOPE AND LIMITATIONS**

Oscar Mariano Rodríguez, Rodolfo Daniel Bravo, Pedro Alfonso Colinas

*LADECOR, Departamento de Química, Facultad de Ciencias Exactas,  
Universidad Nacional de La Plata, 47 y 115 (1900) La Plata, Argentina.  
pcolinas@quimica.unlp.edu.ar*

The Huisgen 1,3-dipolar cycloaddition reaction of organic azides and alkynes has gained considerable attention in recent years due to the introduction of Cu(I) catalysis, leading to a major improvement in both rate and regioselectivity of the reaction. The great success of the Cu(I) catalyzed reaction is rooted in the fact that it is a virtually quantitative, very robust, insensitive, general, and orthogonal ligation reaction, suitable for even biomolecular ligation and *in vivo* tagging.<sup>1</sup> Despite the successes of these reactions a number of concerns persist. Apprehension exists over the handling of potentially toxic and explosive organic azides and whilst *in situ* dipole generation begins to address this problem, the requirement for a Cu(I) catalyst brings its own technical difficulties. In the search for new strategies for the covalent assembly of the different components of such multivalent structures, we<sup>2</sup> and others<sup>3</sup> have recently introduced the 1,3-dipolar cycloadditions of alkene and alkyne carbohydrate with nitrile oxides as an efficient, metal-free tool that allows the preparation of a variety of carbohydrate derivatives. The aim of the present work is to examine the scope and limitations of nitrile oxide cycloadditions to alkene and alkyne O- and C-glycosides. Nitrile oxides were obtained from aldoximes in an one-step operation using sodium hypochlorite (in the presence of triethylamine) in a biphasic system, or employing chloramine-T as halogenating reagent and base. This methodology allowed us to obtain the new glycoconjugates in 78-86 % yields and with excellent regioselectivity. As expected, alkene carbohydrates led mostly to very low diastereoselectivity.<sup>4</sup> The influence of oxime substituent on the cycloadditions will also be discussed.

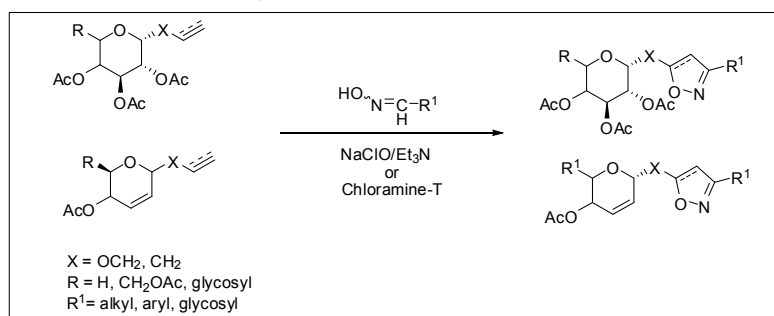

### References

1. D. Simone, S. A. Nepogodieva, R. A. Field, *Org. Biomol. Chem.*, **2007**, *5*, 1006–1017.
2. P. A. Colinas, V. Jäger, A. Lieberknecht, R. D. Bravo, *Tetrahedron Lett.*, **2003**, *44*, 1071–1074.
3. F. Pérez-Balderas, F. Hernández-Mateo, F. Santoyo-González, *Tetrahedron*, **2005**, *61*, 9338–9348.
4. V. Jäger, P. A. Colinas, *Nitrile Oxides en Synthetic Applications of 1,3-Dipolar Cycloaddition Chemistry Toward Heterocycles and Natural Products*, Padwa A.; Pearson, W. H., eds., Hoboken, New Jersey, USA. Wiley, 2003.

## PO 67

**IMMUNOLOGY OF CARBOHYDRATE ANTIGENS RELATED  
TO *STREPTOCOCCUS PNEUMONIAE* INFECTION:  
SYNTHESIS OF A GLYCOLIPID CONSTRUCT**

Federica Compostella,<sup>1</sup> Lucio Toma,<sup>2</sup> Laura Poletti,<sup>3</sup> Silvia Fallarini,<sup>4</sup> and Fiamma Ronchetti<sup>1</sup>

<sup>1</sup> *Dipartimento di Chimica, Biochimica e Biotecnologie per la Medicina,  
Università di Milano, Via Saldini 50, 20133-Milano, Italy;*

<sup>2</sup> *Dipartimento di Chimica Organica, Università di Pavia,  
Via Taramelli 10, 27100-Pavia, Italy;*

<sup>3</sup> *Dipartimento di Chimica Organica e Industriale, Università di Milano,  
Via Venezian 21, 20133-Milano, Italy;*

<sup>4</sup> *Dipartimento di Scienze Chimiche, Alimentari Farmaceutiche e Farmacologiche,  
Università del Piemonte Orientale, Via Bovio 6, 28100-Novara, Italy.  
federica.compostella@unimi.it*

Carbohydrates in the form of capsular polysaccharides are the major components on the surface of bacteria, and are important virulence factors of invading bacteria. Immunity against these components confers protection against the infectious disease. However, there are several problems associated to the development of vaccines based on saccharidic antigens. Bacterial polysaccharides are poorly immunogenic T-independent antigens, and they are able to induce only the release of low affinity antibody from B lymphocytes, but not their differentiation.<sup>1</sup> The T-lymphocyte independent nature of a polysaccharide may be overcome by conjugating the native or depolymerized polysaccharide to a carrier protein. In a similar way, the conjugation to an immunoadjuvant could lead to a construct able to stimulate a sustainable antibody response. Recently, lipoproteins, *i.e.* Pam<sub>3</sub>Cys, have been shown as potent activators of B-lymphocytes and macrophages,<sup>2</sup> and thus represent a promising tool for the development of conjugated vaccines. Herein, the synthesis of a glycoconjugate where the repeating unit of *Streptococcus pneumoniae* (SP) type 19F capsular polysaccharide is linked to a Pam<sub>3</sub>CysSer residue through an amino propyl linker will be presented as a case study. The final aim is to evaluate the influence of the lipopeptide on the immune response towards SP, and if antigen specific antibodies can be elicited with low molecular weight conjugates of Pam<sub>3</sub>CysSer with a saccharide-based hapten.

**References**

1. Pletz M. W., Maus U., Krug N., Welte T. Lode H. *Int. J. Antimicrob. Agents*, **2008**, 32, 199-206.
2. BenMohamed L., Wechsler S. L., Nesburn A. B., *Lancet Infect. Dis.*, **2002**, 2, 425-431.

## PO 68

**MARASMIUS OREADES AGGLUTININ (MOA) IS A CYTOTOXIC LECTIN WITH PROTEOLYTIC ACTIVITY**

Gabriele Cordara<sup>1,2</sup> Wolfgang Egge-Jacobsen<sup>3</sup> Elin Grahn<sup>1</sup> Harry C. Winter<sup>4</sup>  
Irwin J. Goldstein<sup>4</sup> Kirsten Sandvig<sup>2,3,5</sup> and Ute Krengel<sup>1</sup>

<sup>1</sup>Department of Chemistry, University of Oslo, Blindern, 0315 Oslo, Norway,

<sup>2</sup>Department of Biochemistry, Institute for Cancer Research,

The Norwegian Radium Hospital, Oslo University Hospital, Montebello, 0310 Oslo, Norway,

<sup>3</sup>Department of Molecular Biosciences, University of Oslo, Blindern, 0316 Oslo, Norway, <sup>4</sup>Department of Biological Chemistry, Medical School,

University of Michigan, MI 48109-0606 Ann Arbor, USA,

<sup>5</sup>Centre for Cancer Biomedicine, University of Oslo, Norway

*gabriele.cordara@kjemi.uio.no*

The *Marasmius oreades* mushroom lectin (MOA) is known since the 1950s for its blood group type B binding specificity.<sup>1,2</sup> The three-dimensional structure of the lectin, recently determined by X-ray crystallography,<sup>3,4</sup> elucidated the details of its carbohydrate binding characteristics, and in particular how this lectin discriminates between blood group A and B structures. MOA's C-terminal domain adopts an a/b fold. This domain primarily serves as the dimerization interface for MOA protomers, although its structural similarity to hydrolytic enzymes suggests that it may exhibit additional functions. Here, we show that MOA indeed has a previously unknown proteolytic activity linked to its C-terminal domain, involving Cys215 as the catalytically active residue and a strict dependence on the calcium ion fulfilling a fundamental structural role.

**References**

1. Elo, Estola, *Ann. Med. Exp. Biol. Fenn.*, **1952**, 30, 165-167.
2. Elo, Estola, Malmström, *Ann. Med. Exp. Biol. Fenn.*, **1953**, 31, 82-90.
3. Grahn, Askarieh, Holmner, Tateno, Winter, Goldstein, Krengel, *J. Mol. Biol.*, **2007**, 369, 710-721.
4. Grahn, Winter, Tateno, Goldstein, Krengel, *J. Mol. Biol.*, **2009**, 390, 457-466.

## PO 69

## DIVERSITY ORIENTED SYNTHESSES OF LENTIGINOSINE DERIVATIVES

Franca M. Cordero,<sup>1</sup> Paola Bonanno,<sup>1</sup> Bhushan Khairnar,<sup>1</sup> Matteo Chioccioli,<sup>2</sup> Paola Gratteri,<sup>2</sup> and Alberto Brandi<sup>1</sup>

<sup>1</sup>University of Firenze, Department of Chemistry "Ugo Schiff" and HeteroBioLab, via della Lastruccia 13, 50019 Sesto Fiorentino (FI), Italy,

<sup>2</sup>University of Firenze, Department of Pharmaceutical Sciences, Laboratory of Molecular Modeling Cheminformatics & QSAR and HeteroBioLab, via U. Schiff 6, 50019 Sesto Fiorentino (FI), Italy  
franca.cordero@unifi.it

(+)-Lentiginosine [(+)-**1**], an indolizidine alkaloid isolated for the first time by Elbein et al. from the leaves of *Astragalus lentiginosus* in 1990,<sup>1</sup> is the less oxygenated iminosugar able to mimic glucosidase natural substrates and it is a selective inhibitor of amyloglucosidases.<sup>2</sup> The non-natural enantiomer (–)-**1** is a weaker inhibitor than (+)-**1**, and was recently shown to be a caspase-dependent apoptosis inducer on tumor cells of different origin.<sup>3</sup> The important activity of these compounds suggested the collection of several differently functionalised derivatives to study their interaction with bioreceptors. Taking advantage of the highly reliable and selective nitrene 1,3-dipolar cycloaddition, various 7-substituted- and *e*-benzocondensed lentiginosine derivatives were synthesized starting from enantiopure pyrroline *N*-oxides derived from L- and D-tartaric acid (Scheme 1).<sup>4</sup> Moreover, a docking study into the active site of glucoamylase from *Aspergillus awamori* was carried out to set up the basis of a virtual screening of these lentiginosine derivatives as glucosidase inhibitors.

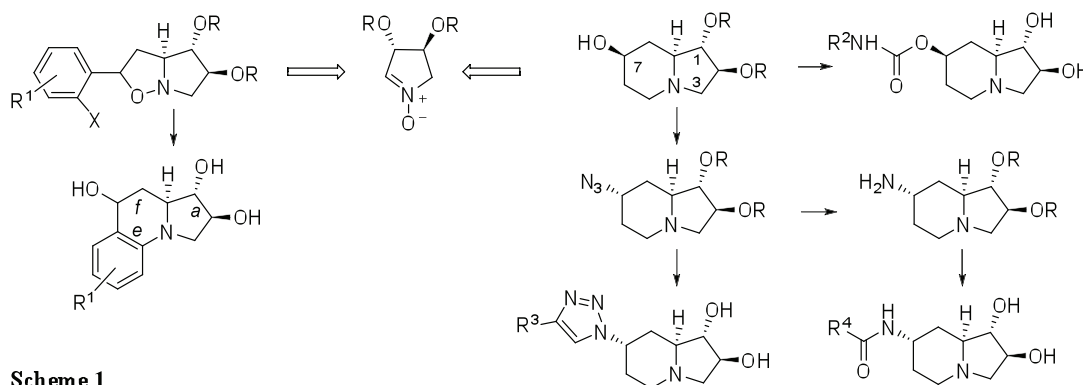

In this communication, some aspects of the stereoselective synthesis of lentiginosine derivatives and some results of the computational study will be presented.

## References

1. I. Pastuszak, R. J. Molyneux, L. F. James, A. D. Elbein, *Biochemistry* **1990**, *29*, 1886–1891.
2. A. Goti, F. Cardona, A. Brandi, S. Picasso, P. Vogel, *Tetrahedron: Asymmetry* **1996**, *7*, 1659–1674.
3. B. Macchi, A. Minutolo, S. Grelli, F. Cardona, F. M. Cordero, A. Mastino, A. Brandi *Glyco-biology* **2010**, *20*, 500–506.
4. F. M. Cordero, P. Bonanno, S. Neudeck, C. Vurchio, A. Brandi *Adv. Synth. Catal.* **2009**, *351*, 1155–1161.

## PO 70

## SYNTHESIS OF N-ACETYL-NEURAMINIC ACID-CONTAINING GALACTOSIDES BY THIO-CLICK REACTIONS

Magdolna Csávas<sup>1</sup>, Anikó Borbás<sup>1</sup>, András Lipták<sup>1</sup>, Sándor Antus<sup>1,2</sup><sup>1</sup>Research Group for Carbohydrates of the Hungarian Academy of Sciences, H-4010 Debrecen, Pf. 94.<sup>2</sup>Department of Organic Chemistry, University of Debrecen, H-4032 Debrecen, Egyetem tér 1. csavas@index.hu

N-Acetylneuraminic acid is bound to the exo-terminal  $\beta$ -galactosyl residues of cell-surface glycoproteins or glycolipids, and plays an important role in the carbohydrate–protein recognition events leading to cell adhesion, extravasation of leukocytes and bacterial or viral infections. Mimetics that are able to inhibit sialic acid binding proteins (such as sialoadhesins, selectins, and influenza hemagglutinins), may show potent anti-inflammatory, antiviral or antibacterial effects.

The thio-click reaction<sup>1,2</sup> proved to be an effective, successful, and simple method for the synthesis of totally new-type analogues of sialic acid-containing galactosides.

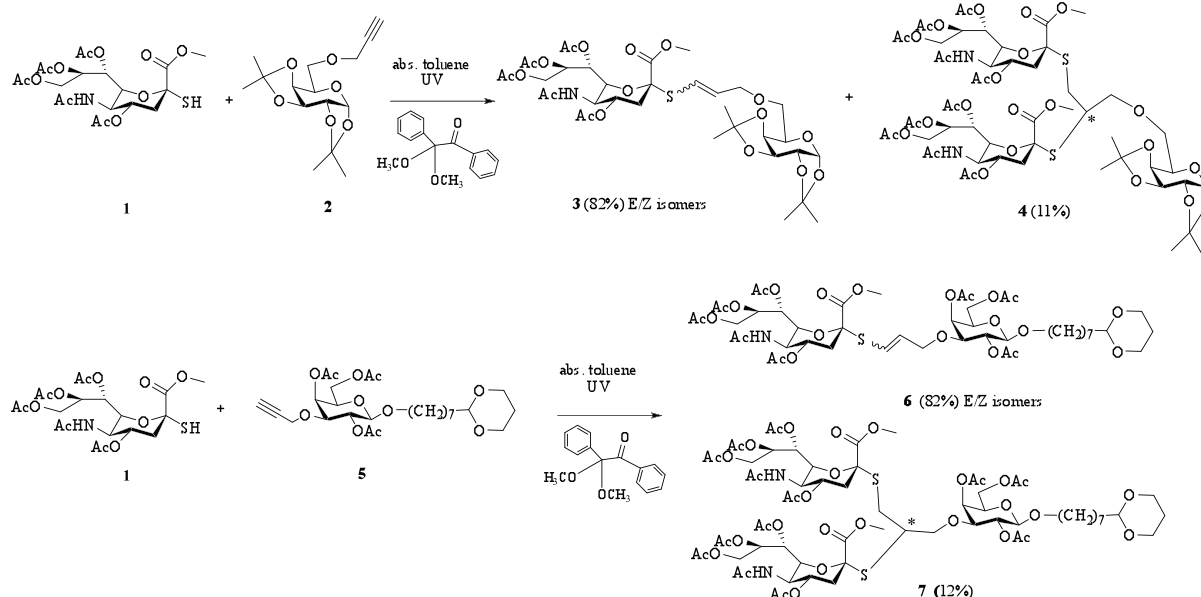

## References

1. H.B. Kolb, M.G. Finn, K.B. Sharpless, *Angew. Chem.*, **2001**, *40*, 2004-2021.
2. A. Dondoni, *Angew. Chem.*, **2008**, *47*, 8995-8997.



## PO 71

STRUCTURE INVESTIGATIONS OF LIPOTEICHOIC ACID ISOLATED  
FROM *STREPTOCOCCUS UBERIS* 233

Anna Czabańska<sup>1</sup>, Katarzyna Duda<sup>1</sup> and Otto Holst<sup>1</sup>

<sup>1</sup>*Division of Structural Biochemistry, Research Center Borstel,  
Leibniz-Center for Medicine and Biosciences, Borstel, Germany  
aczabanska@fz-borstel.de*

Mastitis, namely infection and inflammation of the udder in cattle, is of prime economic importance in dairy industry. About 200 different bacterial species belonging to different groups have been reported to cause mastitis. One of the most important pathogen is *Streptococcus uberis*. It is a Gram-positive, non haemolytic coccus which elicits 20-30% of all mastitis cases in UK [1]. A typical *S. uberis* infection is often sudden in onset and causes a hard swollen quarter of the udder with big, white clots in the milk along with elevated body temperature. In addition to the acute form of mastitis there are also *S. uberis* strains resulting in chronic, recurrent and subclinical mastitis with pathogens surviving inside the host cells [2,3]. A specific set of virulence factors of *S. uberis* isolated from cows suffering from mastitis have been proposed: capsule, neutrophil toxin, M-like protein, R-like protein, hyaluronidase and uberis factor [4]. Since many reports suggested lipoteichoic acid (LTA) to be protective for bacteria, it was interesting to examine the *S. uberis* LTA structure. LTA was isolated from disrupted *S. uberis* 233 cells using *n*-butanol extraction, and purified by hydrophobic-interaction chromatography (HIC) on octyl sepharose column. Compositional analysis of LTA identified glucose and rhamnose (in an approx. molecular ratio of 1:4), phosphate, alanine, and glycerol, and the fatty acids 16:0, 18:1, 18:0, 16:1, 18:2, 12:0, and 14:0 (in an approx. molecular ratio of 17,5:12,8:6,5:1:1). We began our work with the structural determination of the linker moiety which connects the polyalditol chain and the acylated glycerol. For this purpose, LTA was treated with 48% hydrofluoric acid, and the sample was neutralized and extracted with chloroform from which the linker was recovered. Fatty acids were removed by treatment with abs. hydrazine, and the structure of the backbone was determined by compositional analyses and 1D and 2D NMR spectroscopy as  $\alpha$ -D-Glcp-(1→2)- $\alpha$ -D-Glcp(1→1)-Gro.

**References**

1. Coffey T.J., Pullinger G.D., Urwin R., Jolley K.A., Wilson S.M, Maiden M.C., Leigh J.A., *Appl Environ Microbiol.*, **2006**, vol. 72, 1420-1428.
2. Hensen S.M., Pavicic M.J., Lohuis J.A., de Hoog J.A., Poutrel B. , *J Dairy Sci.*, **2000**, vol. 83, 1966-1975.
3. Bal E.B., Bayar S., Bal M.A., *J Microbiol.*, **2010**, vol. 48, 267-274.
4. Oliver S.P., Almeida R.A., Calvinho L.F., *J Vet Med.*, **1998**, vol. 45, 461-475.



PO 72

SYNTHETIC GLYCOPORPHYRINS FOR USE AS  
PHOTODYNAMIC THERAPY AGENTSRobin Daly<sup>1</sup>, Gisela Vaz<sup>2</sup>, Mathias O. Senge<sup>1,2</sup>, Anthony M. Davies<sup>2</sup> and Eoin M. Scanlan<sup>2</sup><sup>1</sup>*School of Chemistry, Trinity College Dublin, Dublin 2, Ireland*<sup>2</sup>*Institute of molecular medicine, St. James Hospital, Dublin  
dalyro@tcd.ie, eoin.scanlan@tcd.ie*

Photodynamic therapy (PDT) agents<sup>1</sup> are a class of molecules which induce light activated toxicity. These agents have significant potential for use in chemotherapy, anti-bacterial and anti-viral treatments. The benefits of these compounds include the selective activation through singlet oxygen formation of an otherwise non toxic drug. Singlet oxygen induces apoptosis in the cells where it is formed, thus providing it's therapeutic activity. Major drawbacks of these compounds have historically been poor site specificity, low solubility, post treatment photosensitization and low light absorption at activating wavelengths.

This project focuses on the conjugation of biologically relevant carbohydrates to a PDT scaffold<sup>2</sup>. Certain tumor<sup>3</sup> and bacterial<sup>4</sup> cell lines over express carbohydrate recognizing proteins called lectins. These lectins could be used as a method of selectively targeting glycoporphyrins to the relevant cells, thereby increasing site specificity. The carbohydrates being highly hydrophilic molecules result in vastly improved water solubility. The increased polarity of these compounds may allow faster clearance from the body hence lowering post treatment photosensitization. Presented is a summary of the work to date on the synthesis and biological evaluation of this novel class of compounds.

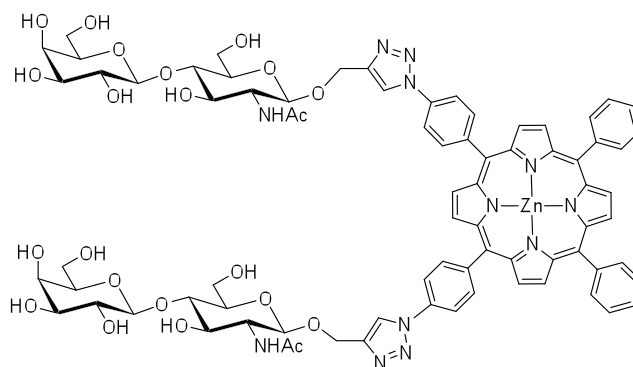
**References**

1. Q. Peng, *J. Natl. Cancer Inst.* **1998**, 90, 889-905.
2. E. M. Scanlan, *Eur. J. Org. Chem.* **2010**, 6, 1026-1028.
3. X. Zhu, *BMC Cancer.* **2010**, 10, 290-302.
4. R. Roy, *Chem. Med. Chem.* **2007**, 2, 119-1201.

## PO 73

## TOTAL SYNTHESIS OF AZASUGARS WITHOUT PROTECTING GROUPS

Emma M. Dangerfield,<sup>1,2</sup> Stefan Munneke,<sup>1,2</sup> Mattie S. M. Timmer,<sup>2</sup> Bridget L. Stocker<sup>1</sup>

<sup>1</sup>Malaghan Institute of Medical Research, P. O. Box 7060, Wellington, New Zealand,

<sup>2</sup>School of Chemical and Physical Sciences, Victoria University of Wellington,

P. O. Box 600, Wellington, New Zealand

edangerfield@malaghan.org.nz

Over the past 40 years interest in azasugars has increased as their potential in the treatment of disease is realised.<sup>1</sup> In particular, their ability to inhibit glycosidase enzymes makes them an interesting and valuable pharmacophore to study.<sup>2</sup> However, due to the limited number of azasugars isolated from nature, only a few have been widely investigated for their therapeutic potential. The ability to rapidly and efficiently synthesise azasugars represents enormous potential for full assessment of their biological profiles.<sup>3</sup>

In this work we report methodology for the protecting group free total synthesis of 3,4-*cis*-disubstituted azasugars, **1** to **4**,<sup>4-6</sup> and 4,5-*cis*-azasugars **5** and **6**, from readily available carbohydrate precursors. In the course of this work two novel reaction methodologies were developed: one for the stereoselective formation of cyclic carbamates from olefinic amines<sup>4</sup> and the other for the formation of primary amines from aldehydes without the need for protecting groups.<sup>7</sup>

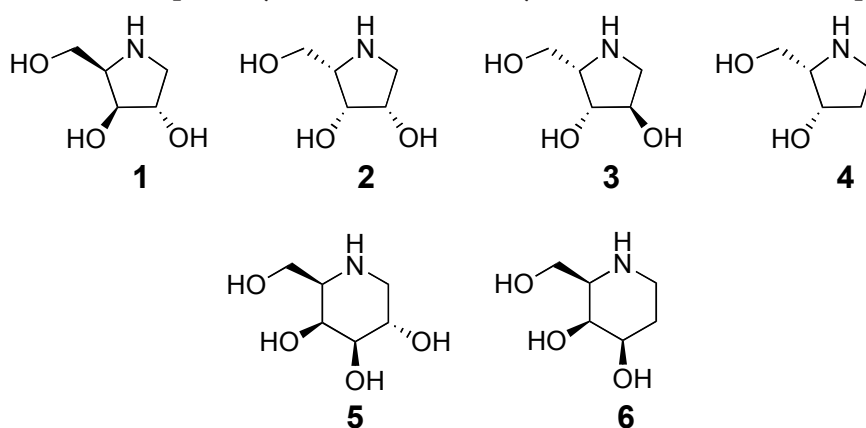

## References

1. Winchester, B. G. *Tetrahedron: Asymmetry* **2009**, *20*, 645-651.
2. Asano, N.; Kato, A.; Watson, A. A. *Mini. Rev. Med. Chem.* **2001**, *1*, 145-154.
3. Stocker, B. L.; Dangerfield, E. M.; Win-Mason, A. L.; Haslett, G. W.; Timmer, M. S. M. *Eur. J. Org. Chem.* **2010**, 1615-1637.
4. Dangerfield, E. M.; Timmer, M. S. M.; Stocker, B. L. *Org. Lett.* **2009**, *11*, 535-538.
5. Dangerfield, E. M.; Plunkett, C. H.; Stocker, B. L.; Timmer, M. S. M. *Molecules* **2009**, *14*, 5298-5307.
6. Dangerfield, E. M.; Gulab, S. A.; Plunkett, C. H.; Timmer, M. S. M.; Stocker, B. L. *Carbohydr. Res.* **2010**, *345*, 1360-1365.
7. Dangerfield, E. M.; Plunkett, C. H.; Win-Mason, A. L.; Stocker, B. L.; Timmer, M. S. M. *J. Org. Chem.* **2010**, *75*, 5470-5477.

PO 74

## FLUORESCENCE LABELING OF GLYCOSPHINGOLIPIDS IN LIVING CELLS

Martin Dauner<sup>1,2,3</sup>, Verena Bachmann<sup>4</sup>, Christof R. Hauck<sup>2,4</sup> and Valentin Wittmann<sup>1,2</sup>

<sup>1</sup>Fachbereich Chemie,

<sup>2</sup>Konstanz Research School Chemical Biology,

<sup>3</sup>Zukunftskolleg der Universität Konstanz,

<sup>4</sup>Fachbereich Biologie, Universität Konstanz, Universitätsstr. 10, 78457 Konstanz, Germany

Valentin.Wittmann@uni-konstanz.de

Lipid microdomains play important roles in many cellular processes, but fundamental issues of their nature remain poorly understood.<sup>1</sup> To gain more insight into their composition and behavior, novel tools are required that allow for authentic visualization of these entities in biological membranes. Glycosphingolipids as an integral component of lipid rafts play important roles in many cellular recognition processes and, therefore, were chosen as a tool to visualize membrane lipids in cells.

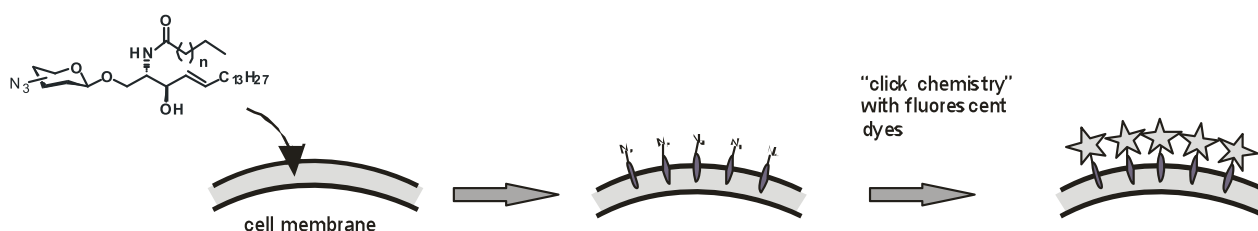

Our work concentrates on the synthesis of alkyne- or azide-labeled glycosphingolipids, which are applied to cells and subsequently can be labeled with fluorescent dyes in a Cu(I)-catalyzed or copper-free [3+2] azide-alkyne cycloaddition. The resulting fluorescent conjugates are studied by fluorescence microscopy.

In our work, we compare different glycolipids and fluorescence dyes. Our studies include analogues of glucosyl and lactosyl ceramide which result in selective labeling of the cell membrane. It is of particular interest whether differential lateral organization of these lipids can be observed by varying the length of the *N*-acyl chain, as long-chained asymmetric sphingolipids are supposed to play an essential role in lipid microdomains.<sup>2</sup>

### References

1. K. Simons, M. J. Gerl, *Nature Rev. Mol. Cell Biol.*, **2010**, *11*, 688-699.
2. P. J. Quinn, *Prog. Lipid Res.*, **2010**, *49*, 390-406.

## PO 75

SYNTHESIS AND EVALUATION OF SUCCINYL-D-GALACTOPYRANOSIDES  
TOWARDS *TRYPANOSOMA CRUZI* TRANS-SIALIDASE

Peterson de Andrade and Ivone Carvalho\*

Faculty of Pharmaceutical Sciences - University of São Paulo,  
Av. do Café (S/N) CEP 1404090 Ribeirão Preto, São Paulo, Brazil.  
carronal@usp.br

Chagas' disease, also known as American trypanosomiasis, is one of the most devastating tropical disease and it is caused by the protozoan *Trypanosoma cruzi*.<sup>1</sup> The parasite expresses a cell surface *trans*-sialidase enzyme (TcTS) responsible for the transference of sialic acids from host cells to terminal  $\beta$ -galactose molecules present on its glycoprotein surface. As a result, TcTS plays a key role in the recognition and invasion of host cells.<sup>2</sup> Moreover, the lack of *trans*-sialidase in humans makes TcTS a potential drug target to be explored, however no strong inhibitors (at nanomolar range) of this enzyme are known to date.<sup>3</sup>

Considering the importance of galactose unit and the carboxyl function in sialic acid for interactions in the active site of TcTS, we have envisaged the synthesis of galactose derivatives containing succinic acid in different positions of the sugar ring aiming inhibition of TcTS. Thus, the developed work allowed the synthesis of compounds **1**, **2**, **3** in few steps and good yields. Furthermore, these compounds are being tested towards TcTS by fluorimetric assay<sup>4</sup>.

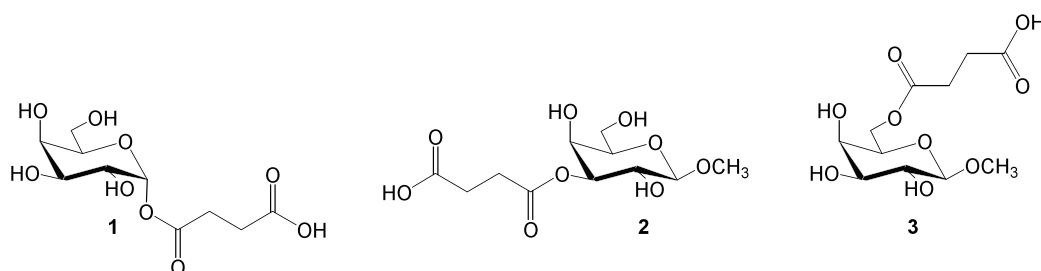

## References

1. M. Sanchez-Moreno, A. M Sanz, F. Gomez-Contreras, P. Navarro, C. Marin, I. Ramirez-Macias, M. J. Rosales, F. Olmo, I. Garcia-Aranda, L. Campayo, C. Cano, F. Arrebola, M. J. R Yunta, *Journal of Medicinal Chemistry*, **2011**, 54, 970-979.
2. I. Carvalho, P. Andrade, V. L. Campo, P. M. M. Guedes, R. Sesti-Costa, J. S. Silva, S. Schenkman, S. Dedola, L. Hill, M. Rejzek, S. A. Nepogodiev, R. A. Field, *Bioorganic Medicinal Chemistry*, **2010**, 18, 2412-2427.
3. J. Neres, R. A. Bryce, K. T. Douglas, *Drug Discovery Today*, **2008**, 3, 110-117.
4. J. Neres, A. Buschiazzo, P. M. Alzari, I. Walsh, K. T. Douglas, *Analytical Biochemistry*, **2006**, 357, 302-304.

## PO 76

## RELATIVE REACTIVITIES OF THIO-GLUCOSIDES AND THIO-GLUCURONIC ACID ESTERS

Ana-Rae de Jong, Bas Hagen, Herman S. Overkleeft, Jeroen D.C. Codée,  
and Gijsbert A. Van der Marel.

*Bio-Organic Synthesis, Leiden Institute of Chemistry, Leiden University,  
PO Box 9205, 2300 RA Leiden, The Netherlands  
n.dejong@chem.leidenuniv.nl*

Uronic acids are found in many polysaccharides and are involved in several biological processes.<sup>1</sup> Oligosaccharides containing uronic acids are mostly synthesized using a post-glycosylation oxidation approach, since uronic acids are assumed to be less reactive than the corresponding non-oxidized glycosides.<sup>2</sup> In this study, the relative reactivities of a series of thio-glucosides and thio-glucuronic acid esters have been explored (Scheme 1). We will demonstrate that glucuronic acid donors can be more reactive than often presumed.

## Thio-glucosides and thio-glucuronic acid esters

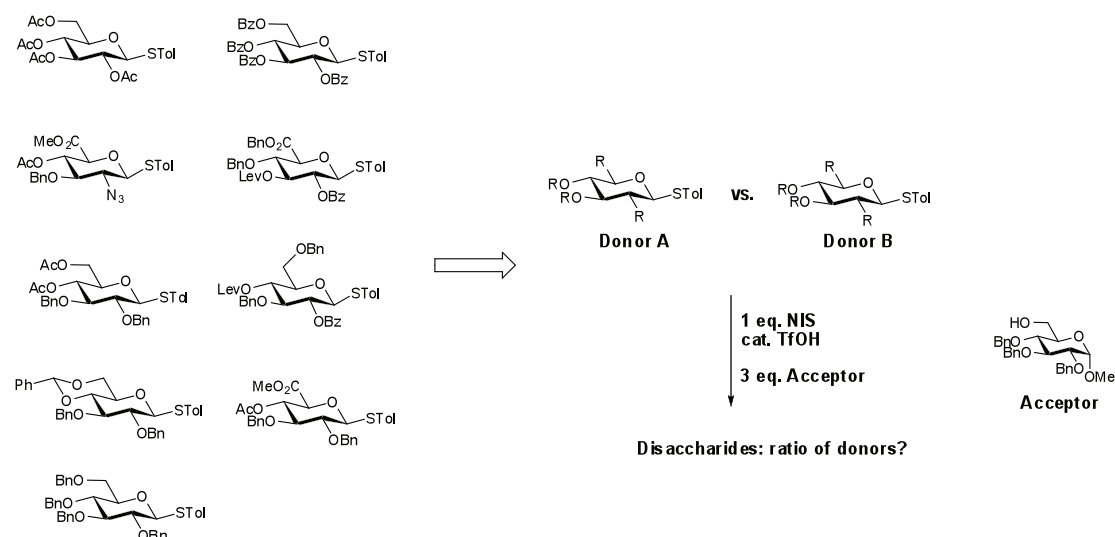

**Scheme 1.** The donor thio-glucosides and thio-glucuronic acid esters used in the competition experiments (left) and the design of the competition experiments (right).

The relative reactivities obtained have been used in the design of a convenient synthesis of bacterial capsular oligosaccharides containing glucuronic acid residues.

## References

1. Iwamoto, M., Kurachi, M., Nakashima, T., Kim, D., Yamaguchi, K., Oda, T., Iwamoto, Y., Muramatsu, T.I., *FEBS Letters*, **2005**, 579, 4423-4429.
2. Van den Bos, L.J., Codée, J.D.C., Litjens, R.E.J.N., Dinkelaar, J., Overkleeft, H.S., Van der Marel, G.A., *Eur. J. Org. Chem.*, **2007**, 24, 3963-3976.

PO 77

NOVEL SUPRAMOLECULAR EDIFICES  
FROM CYCLODEXTRIN-NUCLEOBASE CONJUGATESJérôme Désiré,<sup>1</sup> Vanessa Legros,<sup>1</sup> Florian Hamon,<sup>1</sup> Florence Djedaïni-Pilard<sup>2</sup>  
and Christophe Len<sup>1,3</sup><sup>1</sup>Université de Poitiers, UMR CNRS 6514, 86022 Poitiers, France,<sup>2</sup>Université de Picardie, UMR CNRS 6219, 80039 Amiens, France,<sup>3</sup>Université de Technologie de Compiègne, EA 4297 UTC/ESCOM,  
60200 Compiègne, France.

jerome.desire@univ-poitiers.fr

Recognition processes due to base pairing have been widely studied, especially in order to obtain well-defined assemblies by organization of small molecules.<sup>1-2</sup> Our group is interested in supramolecular chemistry, particularly in the synthesis of novel self-assembled systems involving cyclodextrins (CDs) and nucleobases. CDs, a family of cyclic oligosaccharides composed of  $\alpha$ -(1-4)-linked D-glucopyranose units, feature a conical cavity, and enable to form inclusion with a large variety of organic molecules. To enhance inclusion properties, various structural architectures of CD dimers<sup>3</sup> have been prepared, but one challenge is to obtain supramolecular CD dimers linked by non-covalent interactions. We reported the synthesis of CD monomers bearing a nucleobase and showed the formation of supramolecular CD dimers.<sup>4</sup> Unfortunately the association constant between the CD-Adenine and CD-Thymine derivatives determined by NMR in CDCl<sub>3</sub> is low.

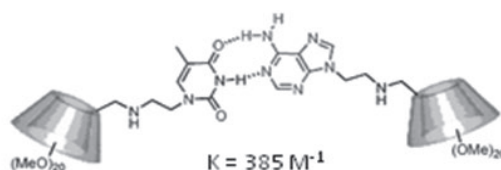

**Figure:** Supramolecular cyclodextrin-nucleobase dimer CD-A and CD-T

As guanine is well known to self-assemble into hydrogen-bonded cyclic tetramers, the so-called G-quartet,<sup>5</sup> and in order to improve the associations between CD-nucleobase conjugates, the synthesis of cyclodextrin derivatives functionalized with guanine was achieved.

The synthesis of nucleobases (A, T, G)-cyclodextrin conjugates,<sup>6</sup> and the NMR studies of the formation of new supramolecular assemblies will be described.

### References

1. S. Sivakova, S. J. Rowan, *Chem. Soc. Rev.*, **2005**, *34*, 9-21.
2. J. L. Sessler, C. M. Lawrence, J. Jayawickramarajah, *Chem. Soc. Rev.*, **2007**, *36*, 314-325.
3. Y. Liu, Y. Chen, *Acc. Chem. Res.*, **2006**, *39*, 681-691.
4. F. Hamon, B. Violeau, F. Turpin, L. Bouteiller, F. Djedaïni-Pilard, C. Len, *Synlett*, **2009**, *17*, 2875-2879.
5. M. Gellert, M. N. Lipsett, D. R. Davies, *Proc. Natl. Acad. Sci. USA*, **1962**, *48*, 2013-2018.
6. V. Legros, F. Hamon, B. Violeau, F. Turpin, F. Djedaïni-Pilard, J. Désiré, C. Len, *Synthesis*, **2011**, *2*, 235-242.

PO 78

**SEVEN-MEMBERED IMINOSUGARS:  
RING ISOMERISATION AND GLYCOSIDASE INHIBITION**Nathalie Fontelle, Jérôme Désiré, Martine Mondon, Nicolas Auberger, Yves Blériot\*

*Laboratoire de Synthèse et Réactivité des Substances Naturelles,  
UMR CNRS 6514-Université de Poitiers, 4 Rue Michel Brunet, 86022 POITIERS, FRANCE.  
yves.bleriot@univ-poitiers.fr and jerome.desire@univ-poitiers.fr*

Iminosugars, in which the ring oxygen has been replaced by nitrogen, constitute the most promising class of sugar analogues because their glycosidase and/or glycosyltransferase inhibition profile make them promising therapeutics.<sup>1</sup> As a consequence, some iminosugar derivatives are already on the market to treat diabetes or Gaucher disease while others are currently involved in clinical trials to treat cancer, viral infections or genetic diseases such as cystic fibrosis. While five- and six-membered iminosugars have been largely investigated, the unusual seven-membered analogues have been rather unexplored,<sup>2</sup> despite an expected potential related to their conformational flexibility.

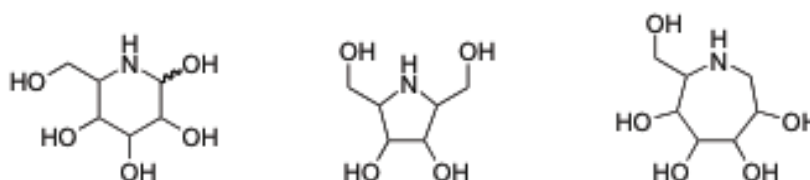

**Figure 1:** Structure of five-, six- and seven-membered iminosugars

We have launched a program to explore the synthetic access, the biological and the synthetic potential of these polyhydroxylated azepanes.<sup>3</sup>

We will present herein recent results regarding these flexible iminosugars.

**References**

1. Iminosugars: From Synthesis to Therapeutic Applications, P. Compain, O. R. Martin, Eds., Wiley-VCH: Weinheim, 2007.
2. F. Moris-Varas, X.-H. Qian, C.-H. Wong, *J. Am. Chem. Soc.* **1996**, *118*, 7647-7652.
3. H. Li, Y. Blériot, C. Chantereau, J.-M. Mallet, M. Sollogoub, Y. Zhang, E. Rodriguez-Garcia, P. Vogel, J. Jiménez-Barbero, P. Sinaÿ, *Org. Biomol. Chem.*, **2004**, *2*, 1492-1499.



PO 79

**ENANTIOSELECTIVE SYNTHESIS OF DIASTEREOISOMERIC  
CARBA ANALOGUES OF GLYCAL-DERIVED VINYL EPOXIDES:  
A NEW ACCESS TO CARBASUGARS**

Ileana Frau, Chiara Peccioli, Lucilla Favero, Valeria Di Bussolo and Paolo Crotti

*Dipartimento di Scienze Farmaceutiche, Università di Pisa,  
Via Bonanno, 33 56126 Pisa, Italy  
valeriadb@farm.unipi.it*

Carbasugars are carbocyclic analogues of carbohydrates that play a crucial role within the broad field of carbohydrate mimetics.<sup>1</sup> Within the synthetic strategies adopted to obtain carbapyransoses, the ones that use carbohydrates as starting materials<sup>2</sup> provide important advantages over other methods, mostly because the enantiomeric purity of the target carbasugars is guaranteed. Recently, in our group we developed a new uncatalyzed and substrate-dependent, stereospecific glycosylation process, using the diastereoisomeric D-allal and D-galactal-derived vinyl epoxides **1 $\alpha$**  and **1 $\beta$** , as unprecedented glycosyl donors.<sup>3</sup>

We herein report the enantioselective synthesis of carba analogues of glycosyl donors **1 $\alpha$**  and **1 $\beta$** , the diastereoisomeric chiral vinyl epoxides (-)-**2 $\alpha$**  and (-)-**2 $\beta$** , to check their suitability as glycosyl donors, with the aim to realize a new approach to the stereoselective synthesis of carbasugars.

The most significant features of our synthetic strategy are: *i*) construction of the carbocyclic system (-)-**4** by way of a new application of the Claisen rearrangement<sup>4</sup> to glycal substrate (+)-**3** *ii*) synthesis of an efficient carba type precursor, diol (+)-**5**, which can be easily transformed into the chiral diastereoisomeric vinyl epoxides (-)-**2 $\alpha$**  and (-)-**2 $\beta$**

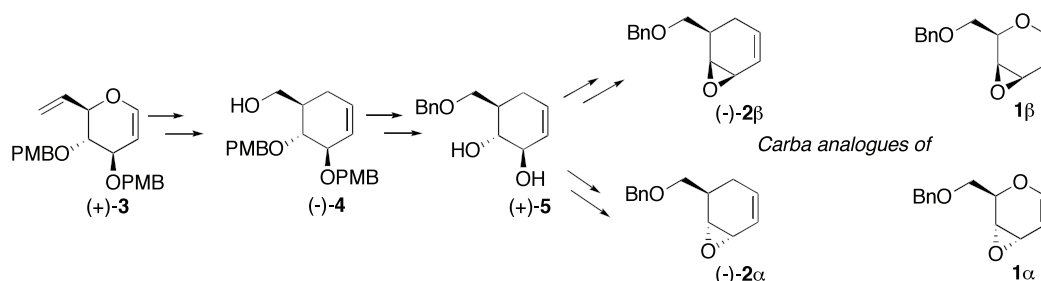

### References

1. Ogawa, S. *Trends Glycosci. Glycotechnol.* **2004**, *16*, 33- 42.
2. Arjona, O.; Gómez, A.M.; López, J. C.; Plumet, J. *Chem. Rev.* **2007**, *107*, 1919-2036.
3. a) Di Bussolo, V.; Romano, M.R.; Caselli, M.; Pineschi, M.; Crotti, P. *J. Org. Chem.* **2004**, *69*, 7383-7386. b)
4. *J. Org. Chem.* **2004**, *69*, 8702-8708.

## PO 80

**BIOSYNTHESIS OF THE *BURKHOLDERIA CENOCEPACIA* K56-2  
LIPOPOLYSACCHARIDE O-ANTIGEN**

Flaviana Di Lorenzo<sup>1</sup>, Alba Silipo<sup>1</sup>, Mohamad Hamad<sup>2</sup>, Antonio Molinaro<sup>1</sup>, M. A. Valvano<sup>2</sup>

<sup>1</sup>*Dipartimento di Chimica Organica e Biochimica,  
Università di Napoli Federico II, Napoli 80126*

<sup>2</sup>*Center for Human Immunology, Department of Microbiology and Immunology,  
and Department of Medicine, University of Western Ontario,  
London, Ontario N6A 5C1, Canada  
fladilorenzo@gmail.com*

*Burkholderia cenocepacia* is a Gram-negative opportunistic pathogen that affects immune-compromised patients such as those with cystic fibrosis and chronic granulomatous disease. Infected cystic fibrosis patients commonly develop chronic lung infections that are very difficult to treat because these bacteria are intrinsically resistant to virtually all clinically useful antibiotics including antimicrobial peptides. Lipopolysaccharide (LPS) is a key bacterial surface molecule that plays a critical role as a major determinant of intrinsic antibiotic and antimicrobial peptide resistance (1, 2). LPS consists of lipid A, core oligosaccharide (OS), and in some bacteria O-specific polysaccharide or O-chain. The O-chain acts as a protective barrier against desiccation, phagocytosis, and serum complement-mediated killing, particularly this polysaccharide portion elicits a robust immune response. We have previously characterized the structure of the lipid A-core OS of the model *B. cenocepacia* strain K56-2 (1). This work also helped elucidating the structure of the linkage between the core OS and the O antigen. Here, we combine mutagenesis experiments and phenotypic analyses of LPS electrophoretic profiles with structural elucidation of LPS glycans that allowed us to assign function to the genes involved in biosynthesis of *B. cenocepacia* O-antigen polysaccharide, which map into a complex gene cluster (3) encoding functions for the biosynthesis of nucleotide sugar precursors, glycosyltransferases, and an ABC transporter for the export of O antigen precursors across the bacterial inner membrane prior to their ligation to the lipid A core OS.

**References**

1. X. Ortega, A. Silipo, M.S. Saldías, C.C. Bates, A. Molinaro and M.A. Valvano, *J. Biol. Chem.*, **2009**, *284*, 21738–21751.
2. S.A. Loutet, L.E. Mussen, R.S. Flannagan, and M.A. Valvano. *Environ. Microbiol. Rep.*, **2011**, *3*, 278-285.
3. X. Ortega, T.A. Hunt, S. Loutet, A.D. Vinion-Dubiel, A. Datta, B. Choudhury, J.B. Goldberg, R. Carlson, and M.A. Valvano, *J. Bacteriol.*, **2005**, *187*, 1324-1333.

## PO 81

**STRUCTURAL DETERMINATION OF THE LPS ISOLATED FROM THE SLIGHTLY THERMOPHILIC  $\gamma$ -PROTEOBACTERIUM *THERMOMONAS HYDROTHERMALIS***

Flaviana Di Lorenzo<sup>1</sup>, Alba Silipo<sup>1</sup>, Rosa Lanzetta<sup>1</sup>, Michelangelo Parrilli<sup>1</sup>, Milton S. da Costa<sup>2</sup>, Antonio Molinaro<sup>1</sup>

<sup>1</sup>*Dipartimento di Chimica Organica e Biochimica,  
Università di Napoli Federico II, Napoli 80126.*

<sup>2</sup>*Departamento de Bioquímica, Universidade de Coimbra, Coimbra, Portugal  
fladilorenzo@gmail.com*

Lipopolysaccharide (LPS) is the major component of the outer membrane of Gram-negative bacteria, greatly contributing to the structural integrity and protection of the bacterial cell envelope. LPSs are amphiphilic macromolecules consisting of a hydrophilic hetero-polysaccharide (formed by the *Core oligosaccharide* and the *O*-specific polysaccharide or *O*-chain) covalently linked to a lipophilic domain called *Lipid A*. Besides their general architectural principle, a number of structural changes and chemical variations are at the basis of the dynamic environmental adaptation as in case of extremophilic bacteria. In this work we have elucidated the structure of the LPS isolated from *Thermomonas hydrothermalis*, a new slightly thermophilic  $\gamma$ -proteobacterium isolated from a Hot Spring at São Gemil in Central Portugal (1). It is accepted that this bacterium is closely related to *Thermomonas haemolytica*, but has a higher growth temperature range than this species (1). It is very interesting to determinate the complete structure of the LPS from this new isolated extremophile. LPS was extracted with phenol/chloroform/light petroleum, purified via gel permeation chromatography and underwent compositional analyses that showed the presence of hexoses, hexuronic acids, hexosamines and Kdo residues. The fatty acid component showed the presence of: C11:3OH, C15:0, C16:0, C17:0 and C18:0. The complete elucidation of LPS has been carried out by a combination of chemical analysis, NMR spectroscopy and Mass spectrometry (MALDI).

**References**

1. M. P. Alves, F. A. Rainey, M. F. Nobre, and M. S. da Costa, *System. Appl. Microbiol.*, **2003**, *26*, 70–75.

## PO 82

## SYNTHETIC HIGH GLYCOSYLATED MUC1 GLYCOPEPTIDE ANTIGENS BOUNDED TO SYNTHETIC ADJUVANTS AS POTENTIAL CANCER VACCINES

Simone Di Pietro and Horst Kunz

Department of Organic Chemistry, Johannes Gutenberg-University Mainz,  
 Duesbergweg 10-14, D-55128 Mainz, Germany  
 dipietro@uni-mainz.de

The mucin MUC1 is a high molecular weight membrane glycoprotein found on the surface of many epithelial cell types such as those from the breast, prostate, intestinal tract, liver, pancreas and kidney.<sup>1,2</sup> It consists of a hydrophobic transmembrane domain, a short cytoplasmic tail and a relatively large, heavily O-glycosylated extracellular domain rich in serine, threonine and proline amino acid residues. Most O-glycosylations occur at the serine and threonine residues within the 20 amino acid tandem repeat domain of MUC1 (GSTAPPAHGVTSAPDTRPAP). This number can vary from 20 to 120. The primary function of MUC1 is protection of the epithelial cells from insult, from chemical or microbial sources, resulting in the induction of inflammatory and repair or healing processes,<sup>3</sup> and has also been implicated in important cell-cell adhesion events. The MUC1 glycoprotein is an important biological target for the immunotherapy of cancer due to its altered level of expression on the surface of tumour cells. These changes manifest in an over-expression of the glycoprotein, altered levels of glycosylation and a loss of polarisation at the cell surface.<sup>4</sup> Significantly, the changes in the glycosylation profile result in the presentation of specific tumour-associated carbohydrate antigens, as well as exposure of important peptide epitopes. In its tumour-associated form, the mucin exhibits altered levels of glycosylation resulting in short, prematurely sialylated glycan chains including the T<sub>N</sub>, sialyl-T<sub>N</sub> (ST<sub>N</sub>),  $\alpha$ -2,6-sialyl-T ( $\alpha$ -2,6-ST) and  $\alpha$ -2,3-sialyl-T antigens and exposure of the immunodominant PDTRP epitope.<sup>5</sup> Although the type, number and glycosylation position of the tumour-associated carbohydrate antigens is tissue-dependent, there has been some conjecture as to whether glycosylation within the immunodominant motif increases the binding affinity of the peptide. The aim of the cancer immunotherapy is to override the multiple suppressive mechanisms and to potentiate existing immune responses against cancer cells. Therefore, we synthesized **1** in which the built-in immunoadjuvant (VQGEESNDK) corresponds to a peptide sequence derived from the interleukin 1 (IL-1) cytokine.<sup>6</sup> In addition, we conjugate different core MUC1 structures to synthetic adjuvants like Pam3Cys and Lipid A as an immunostimulant to get glycopeptide vaccine **2**.

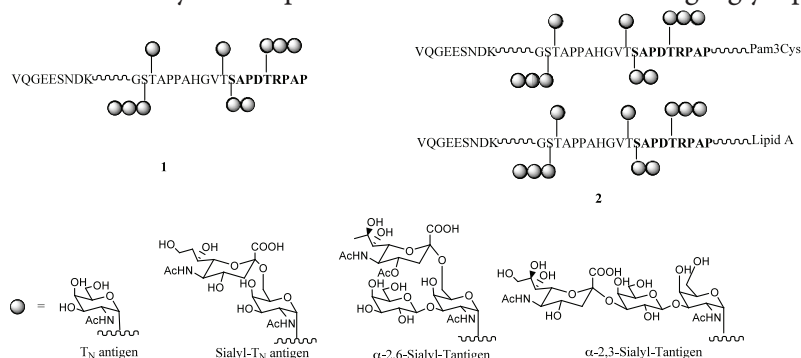

## References

- Gum, J. R. *Biochem. Soc. Trans.* **1995**, *23*, 795.
- Carlstedt, I.; Davies, J. R. *Biochem. Soc. Trans.* **1997**, *25*, 214.
- Tran, C. P.; Cook, G. A.; Yeomans, N. D.; Thim, L.; Giraud, A.; Trefoil, S. *Gut* **1999**, *44*, 636.
- Taylor-Papadimitriou, J.; Burchell, J.; Miles, D. W.; Dalziel, M. *Biochim. Biophys. Acta.* **1999**, 301.
- Burchell, J.; Taylor-Papadimitriou, J.; Boshell, M.; Gendler, S. J.; Dulig, T. *Int. J. Cancer* **1989**, *44*, 691.
- Liakatos, Angela; Kunz, H. *Current Opinion in Molecular Therapeutics* **2007**, *9*, 35
- A. Kaiser, H. Kunz, *Angew. Chem. Int. Ed.* **2010**, *49*, 3688-3692

PO 83

**PERFLUOROALKYLATED MUC1-GLYCOPEPTIDE ANTIGENS  
FOR CANCER IMMUNOTHERAPY**

Jérôme Schoenhentz and Anja Hoffmann-Röder\*

*Institute of Organic Chemistry, Johannes Gutenberg-University Mainz,  
Duesbergweg 10-14, D-55128 Mainz, Germany  
hroeder@uni-mainz.de*

The correct expression of glycoproteins is fundamental for a variety of important biological events. For instance, alterations in cell surface carbohydrate structures affect normal cellular interactions and contribute to pathogenesis and progression of neoplasia.<sup>1</sup> Most carcinoma express abnormal forms of the transmembrane glycoprotein mucin-1 (MUC1) characterized by the exposure of immunogenic peptide epitopes and truncated glycan chains. Several studies have shown that these tumor-associated MUC1-glycoforms are of particular interest for diagnostic tools and represent attractive targets for the development of anticancer vaccines.<sup>2</sup> In addition to conjugate vaccines using carrier proteins, antigenic glycopeptides have also been coupled to lipids.<sup>3</sup> To limit undesired biological side effects, self-assembled liposomal systems based on fluorinated surfactants were recently developed.<sup>4</sup> Besides, temporary attachment of fluorocarbon linkers and fluororous tags is an attractive strategy to specifically immobilize glycans within fluororous microarray formats.<sup>5</sup>

Herein, we describe modular syntheses of amphiphilic fluororous-tagged MUC1 glycopeptides with varied glycosylation patterns and their use as diagnostic tools in cancer immunotherapy.<sup>6</sup> The hydrophilic part of the amphiphiles consists of complete tandem repeat domains of MUC1 glycosylated at Thr6 and/or Thr18 with T<sub>N</sub> antigen residues, while the hydrophobic part is built of tris(hydroxymethyl)aminomethane (TRIS) onto which perfluoroundecyl chains were crafted.

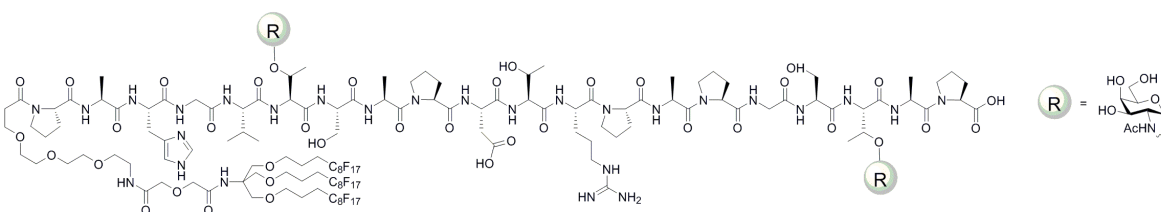

### References

1. T. Ninkovic, L. Kinarsky, K. Engelmann, V. Pisarev, S. Sherman, O. J. Finn, F. G. Hanisch, *Mol. Immunol.* **2009**, *47*, 131.
2. T. Buskas, P. Thomson, G.-J. Boons, *Chem. Commun.* **2009**, 5335-5349 and cited references.
3. a) S. Ingale, M. A. Wolfert, T. Buskas, G.-J. Boons, *ChemBioChem* **2009**, *10*, 455-463; b) B. L. Wilkinson, L. R. Malins, C. K. Y. Chun, R. J. Payne, *Chem. Commun.* 2010, *46*, 6249-6251.
4. J. G. Riess, *Curr. Opin. Colloid Interf. Sci.* **2009**, *14*, 294-304 and cited references.
5. N. L. Pohl, *Angew. Chem. Int. Ed.* **2008**, *47*, 3868-3870.
6. A. Hoffmann-Röder, J. Schoenhentz, S. Wagner, E. Schmitt, *Chem. Commun.* **2011**, *47*, 382-384.

## PO 84

## SYNTHESIS OF FUCOSE BASED LIGANDS FOR DC-SIGN

Daniela Doknić,<sup>1</sup> José Reina,<sup>1</sup> Manuel Andreini,<sup>1</sup> Anna Bernardi,<sup>1</sup> Ieva Sutkeviciute,<sup>2</sup>  
Michel Thepaut,<sup>2</sup> Franck Fieschi,<sup>2</sup> Javier Rojo<sup>3</sup>

<sup>1</sup> *Università degli Studi di Milano, Dipartimento di Chimica Organica e Industriale and CISI, via Venezian 21, 20133 Milano (Italy),*

<sup>2</sup> *Institut de Biologie Structurale Jean-Pierre Ebel, CEA/CNRS/Université Joseph Fourier, 41 rue Jules Horowitz, 38027 Grenoble (France),*

<sup>3</sup> *Departamento de Química Bioorgánica, Instituto de Investigaciones Químicas, CSIC, Américo Vespucio 49, 41092 Sevilla (Spain)  
daniela.doknic@unimi.it*

As a C-type lectin expressed in dendritic cells, DC-SIGN is known to be involved in many infection processes. Pathogens like HIV make use of DC-SIGN to invade the host immune system. DC-SIGN is a mannose- and fucose-specific lectin and selectively recognizes Lewis-type fucosylated oligosaccharides.<sup>1</sup> Our group has reported on the synthesis of a Lewis-x mimic, **2**, with inhibiting properties for this lectin.<sup>2</sup> The mimic is built on a  $\beta$ -aminoacid scaffold connecting via amide bonds an  $\alpha$ -fucosyl amide and a galactose mimic.

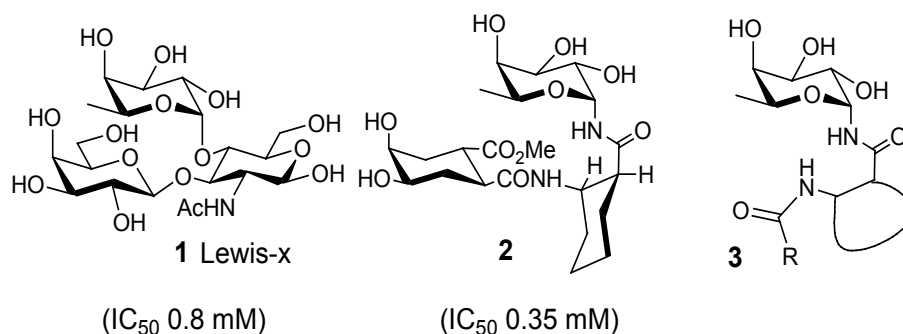

Influenced by suggestions from computational studies, we developed a library of general formula **3**, using different cyclic and acyclic  $\beta$ -aminoacid scaffolds as well as different R groups, in an effort to improve the affinity of these ligands for DC-SIGN. The activity of these products was tested by means of SPR-studies. Out of the tested compounds the most active and the most economic ones have been chosen for a further functionalisation with the goal of creating multivalent structures.

### References

1. Y. van Kooyk, T. H. B. Geijtenbeek, *Nat. Rev. Immunol.* **2003**, *3*, 697 – 709.
2. G. Timpano, G. Tabarani, M. Anderluh, D. Invernizzi, F. Vasile, D. Potenza, P. M. Nieto, J. Rojo, F. Fieschi, A. Bernardi, *ChemBioChem* **2008**, *9*, 1921-1930.



## PO 85

**CELL-WALL POLYSACCHARIDES OF BIOTECHNOLOGICALLY PROMISING BACTERIA FROM THE BELARUS COLLECTION OF MICROORGANISMS**

Galina Novik<sup>1</sup>, Evelina Zdorovenko<sup>3</sup>, Vyacheslav Melnikov<sup>2</sup>, Yuriy Knirel<sup>3</sup>

<sup>1</sup>*Institute of Microbiology, National Academy of Sciences of Belarus, 220141, Minsk, Belarus;*

<sup>2</sup>*International Science and Technology Center, 127473 Moscow, Russia;*

<sup>3</sup>*N.D. Zelinsky Institute of Organic Chemistry,*

*Russian Academy of Sciences, 119991 Moscow, Russia*

*zdorovenkoe@mail.ru*

Valuable industrial microbial strains deposited at the Belarus collection of microorganisms could be used in manufacturing enzyme preparations, ferments ensiling plant substrates; producing preventive-therapeutic compositions enhancing immune potential in humans and animals; development of biological agents to control plant pathogens; bacterial preparations for degradation of toxic organic substances and bioremediation of natural and industrial media. Currently, over 1200 microbial strains are maintained at the Belarus collection of non-pathogenic microorganisms. Basic guidelines for the activities of the collection are isolation of new microbial strains from natural sources which are potential objects for industrial, agricultural and environmental biotechnologies, compiling data bank characterizing properties of bacteria, filamentous fungi, yeasts and bacteriophages, elaboration of theoretical and practical recommendations for application of industrial strains from the collection stock. A promising trend in functioning of the collection is introduction of chemical and biochemical methods for detection of polysaccharides, phospholipids and glycolipids as chemotaxonomic markers of microorganisms. Composition and structure of cell-wall polysaccharides of biotechnologically promising probiotic bacteria *Bifidobacterium bifidum* BIM B-465D and *Bifidobacterium longum* BIM B-476D were characterized. The major polysaccharide specific for strain *B. bifidum* BIM B-465D was found to be a branched glucogalactan with a heptasaccharide repeating unit. The second, minor polysaccharide is a branched glucan having a main chain of 1,6-linked  $\alpha$ -glucopyranose residues and side chains of single  $\alpha$ -glucopyranose residues attached at position 2 of ~60% glucose residues in the main chain. A similar glucan has been reported as an exopolysaccharide of a ropy strain of *Lactobacillus* spp. G-77. *B. longum* BIM B-476D produced several polysaccharides, including a glucosylated ribitol teichoic acid and a polymer with a branched pentasaccharide 1-phosphate repeating unit. In prospect the probiotic glycoconjugates, including cell-wall polysaccharides, may be used in technologies aimed at manufacturing of highly effective therapeutic products.



## PO 86

**STRUCTURE OF THE O-ANTIGEN OF *PSEUDOMONAS FLUORESCENS* BIM B-582  
CONTAINING 4-DEOXY-D-XYLO-HEXOSE, A NOVEL COMPONENT  
OF BACTERIAL POLYSACCHARIDES**

Olga Valueva,<sup>1</sup> Evelina Zdorovenko,<sup>1</sup> Dzianis Rakhuba,<sup>2</sup> Galina Novik,<sup>2</sup> Elena Kiseleva,<sup>2</sup>  
Alexander Shashkov,<sup>1</sup> Yuriy Knirel<sup>1</sup>

<sup>1</sup>*N.D. Zelinsky Institute of Organic Chemistry, Russian Academy of Sciences,  
Leninsky Prospekt 47, 119991 Moscow, Russia;*

<sup>2</sup>*Institute of Microbiology, National Academy of Sciences of Belarus, ul. Kuprevicha 2, 220141,  
Minsk, Belarus  
zdorovenkoe@mail.ru*

Gram-negative bacteria *Pseudomonas fluorescens* are typical representatives of fluorescent bacteria from the genus *Pseudomonas*. Strains of *P. fluorescens* are divided into five biovars having undefined taxonomical rank. They are heterogenous in terms of genotypic and phenotypic characters, including the lipopolysaccharide structure. In this work, the structure of the O-specific polysaccharide chain (O-antigen) of the lipopolysaccharide of *P. fluorescens* BIM B-582 was studied by sugar analysis, Smith degradation, and two-dimensional <sup>1</sup>H and <sup>13</sup>C NMR spectroscopy. The polysaccharide was found to contain L-rhamnose, 2-acetamido-2-deoxy-D-glucose, and 4-deoxy-D-xylo-hexose (D-4dxy/Hex). The last monosaccharide was isolated by paper chromatography after mild acid hydrolysis of the polysaccharide and characterized by NMR spectroscopy and specific optical rotation. To our knowledge, D-4dxy/Hex is found for the first time in bacterial polysaccharides. The O-antigen of *P. fluorescens* BIM B-582 is composed of D-GlcNAc→L-Rha disaccharide repeating units, ~40% of which are substituted with a branching D-4dxy/Hex<sub>p</sub> residue.

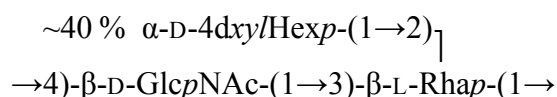
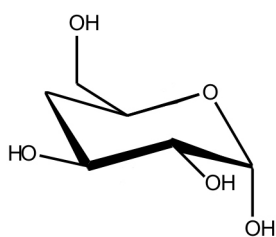

Structures of 4-deoxy-α-D-xylo-hexopyranose and the O-antigen of *P. fluorescens* BIM B-582

This work was supported by the Russian Foundation for Basic Research (Project No. 10-04-90047-Bel\_a) and Belarusian Foundation for Basic Research (Project No. X10P-130).

## PO 87

**RECENT ADVANCES IN GAGs CHEMISTRY: DESIGN AND SYNTHESIS  
OF NEW FGF-R AGONISTS**

Pierre-Alexandre Driguez, Pierre Fons, Corentin Herbert, Geneviève Gueguen,  
Gilbert Lassalle, Jean-Marc Herbert, and Françoise Bono

<sup>1</sup>*Sanofi-Aventis R&D  
Early to Candidate Unit  
195, Route d'Espagne  
31036 Toulouse Cedex 1 (France)  
alexandre.driguez@sanofi-aventis.com*

Heparin (HP) is a complex sulfated Glycosaminoglycan (GAG) involved in various essential biological processes from blood coagulation to cell-cell communication, growth and differentiation. It also plays a critical role in several pathological conditions such as cancer, angiogenesis, some neurodegenerative diseases like Alzheimer's, atherosclerosis and microorganisms infectivity [1]. HP, as well as its structurally related Heparan sulfate (HS), contains highly negative charges coming from sulfate and carboxylate groups that greatly impact its abilities to interact with biological factors, therefore resulting in specific properties. For example, the sulfation pattern of HS has an impact on the complex formation efficiency with Fibroblast Growth Factors (FGFs) and their receptors. The result of this interaction leads to intracellular signal transduction and may improve recovery through angiogenesis and arteriogenesis after heart ischemia as well as in treatment of peripheral nerve injury or peripheral arteries occlusion disease. The communication will focus on the recent advances of our group in finding potent and selective compounds that may promote this process.

**References**

1. For a Review Article, see N. S. Gandhi and R. L. Mancera, *Chem Biol Drug Des*, **2008**, 72, 455-482
2. L. D. Thompson, M. W. Pantoliano, B. A. Springer, *Biochemistry*, **1994**, 33, 3831-3840

## PO 88

**CHARACTERIZATION OF N-LINKED GLYCANS FROM  
THE ENVELOPE PROTEINS  
OF SANOFI PASTEUR DENGUE VACCINE**

Jean Dubayle, Sandrine Vialle, Diane Schneider, Nathalie Mantel, Bruno Guy  
and Philippe Talaga

*Sanofi Pasteur, Campus Mérieux, 1541 avenue Marcel Mérieux, 69280  
Marcy L'etoile, FRANCE  
jean.dubayle@sanofipasteur.com*

Dengue disease affects more than 230 millions people every year in inter-tropical areas, causing approximately 25 000 deaths, mostly children. Dengue viruses (DENV) are enveloped *Flavivirus* that are transmitted *via* the bite of *Aedes* mosquitoes. The DENV particle is made up of three structural proteins; among these, the envelope protein (E) is the major surface glycoprotein, responsible for virus attachment and fusion<sup>1</sup>. Human dendritic cells (DCs) are targets of DENV, and infection is mediated in part by the binding of DENV to DC-specific ICAM3-grabbing non integrin. Recent work has shown that N-glycosylation can influence the virus growth cycle, and terminal mannosylation of E protein is essential for infecting DCs<sup>2</sup>. In addition, these membrane protein N-linked oligosaccharides are differentially processed by enzymes in insect and mammalian cells. The sanofi pasteur tetravalent dengue vaccine is composed of four chimeric viruses based on the backbone of the attenuated yellow fever 17D vaccine (YFV 17D), and expressing structural antigens of each of the four dengue virus serotypes (E and prM). In this study we characterized the N-linked glycans from the envelope protein of chimeric vaccine serotype 2 produced in Vero cells. Due to the low level of N-glycosylation (~5%) and the difficulty to purify large amounts of E protein, we used mass spectrometry approaches: MALDI-TOF and nanoLC-ESI-MS/MS. Evidence for mannosylation of E protein were obtained for serotype 2, see table below.

<i>N-glycans composition deduced from mass measurements</i>	<i>N-glycans type</i>	<i>Chimerivax Serotype CYD2</i>
N2H6	Oligomannose 6	+
N2H7	Oligomannose 7	+
N2H8	Oligomannose 8	+
N4H5	Complex/hybride	+
N5H4	Complex/hybride	+
N4H5F	Complex/hybride	+
N5H5	Complex/hybride	+
N5H5F	Complex/hybride	+

N corresponds to N-Acetyl Glucosamine, H to Hexose and F to Fucose  
CYD2 serotype derived from DENV2

### References

1. Bärbel Kaufmann and Michael G. Rossmann, *Microbes and Infection*, **2011**, *13*, 1-9.
2. Kari Hacker, Laura White, and Aravinda M. de Silva, *Journal of General Virology*, **2009**, *90*, 2097-2106.

## PO 89

THE STRUCTURAL CHARACTERIZATION OF THE  
O-POLYSACCHARIDE ANTIGEN OF THE LIPOPOLYSACCHARIDE  
OF MAMMOPATHOGENIC STRAIN *ESCHERICHIA COLI* P4Katarzyna Duda<sup>1</sup>, Ulrich Dobrindt<sup>2</sup> and Otto Holst<sup>1</sup><sup>1</sup>*Division of Structural Biochemistry, Research Center Borstel, Leibniz-Center  
for Medicine and Biosciences, D-23845 Borstel, Germany,*<sup>2</sup>*Institute for Hygiene, University of Münster, D-48149 Münster, Germany  
kduda@fz-borstel.de*

Mastitis, the inflammation of the mammary gland, affects humans and dairy cattle. In case of the latter, this often leads to culling of the infected animals, thus provoking high economic importance of mastitis<sup>1</sup>. Gram-negative coliform bacteria cause mainly the acute form of the disease. Nevertheless, no set of specific virulence factors was found in mastitis-inducing *Escherichia coli* strains, suggesting that severity of *E. coli* mastitis is determined by cow factors<sup>2</sup>. The O-polysaccharide (OPS) is a highly variable part of the lipopolysaccharide (LPS), the major constituent of the outer membrane of Gram-negative bacteria, which is used as the basis for bacterial serotyping and is essential for the full function and virulence of bacteria<sup>3</sup>.

Mammopathogenic *E. coli* P4 strain was cultivated in Luria Bertani medium, and LPS was isolated utilizing hot phenol/water extraction<sup>4</sup>. The OPS fraction was obtained after LPS hydrolysis with 1% acetic acid for 2 h at 100°C following by the removal of precipitated lipid A, and fractionation of the polysaccharide by Sephadex G-50 size exclusion chromatography. Compositional analysis of OPS revealed the presence of 2-acetamido-2,6-dideoxy-galactose (FucNAc), 2-acetamido-2-deoxy-glucose (GlcNAc) and galactose. The structure of the OPS was analyzed by 1D and 2D spectroscopical methods and was determined to be unbranched polymer of a repeating trisaccharide unit having the following structure:  $\rightarrow 2)\text{-}\beta\text{-Galp}(1\rightarrow 3)\text{-}\alpha\text{-FucpNAc}(1\rightarrow 3)\text{-}\beta\text{-GlcNAc}(1\rightarrow$ .

**References**

1. Mitterhuemer S., Petzl W., Krebs S. *et al.*, *BMC Genomics*, **2010**, *11*, 138-154.
2. Burvenich C, Van Merris V, Mehrzad J, Diez-Fraile A, Duchateau L., *Vet Res*, **2003**, *34*, 521-64.
3. Knirel Y. In: *Microbial Glycobiology* (ed. Moran A., Holst O., Brennan P. J., von Itzstein M.), **2009**, 57-73.
4. Westphal O., Jann K. *Met Carbohydr Chem*, **1965**, 83-91.

## PO 90

SYNTHESIS AND EVALUATION OF NEW SULFATED DISACCHARIDES  
DISPLAYING STRONG APHICIDAL EFFECTS

Christophe Dussouy,<sup>1</sup> Laurent Bultel,<sup>1</sup> Eric Grand,<sup>1</sup>  
Philippe Giordanengo,<sup>2</sup> and José Kovensky<sup>1</sup>

<sup>1</sup>Laboratoire des Glucides CNRS UMR 6219,

<sup>2</sup>Laboratoire de Biologie des Plantes et Contrôle des Insectes Ravageurs EA 3900

Université de Picardie Jules Verne, 33 rue Saint Leu 80039 Amiens, France.

christophe.dussouy@u-picardie.fr, jose.kovensky@u-picardie.fr

The homopteran *M. persicae* is one of the most polyphagous insects worldwide, as it successfully develops on hundreds of plant species. We have shown that a sulfated disaccharide (**1**) induced differential aphicidal effects on *M. persicae*.<sup>1</sup> In our first synthetic strategy, compound **1** was isolated from a mixture of  $\alpha/\beta$  disaccharides. In order to develop a stereoselective approach to **1** and its non-sulfated and/or deacetylated analogues **2**, **3**, and **4**, different glycosylation donors **6** to **13** were prepared and reacted with acceptor **5**. The influence of different experimental conditions and protecting groups on donor reactivity and stereoselectivity will be discussed. 2-Azido compounds led to  $\alpha/\beta$  mixtures. Oxazolidinone **11** gave exclusively the  $\beta$ -(1 $\rightarrow$ 4) disaccharide in 30% yield. 2-Trichloroacetyl trichloroacetimidates **12** and **13** afforded stereoselectively the target compounds **14** and **15** in high yields.

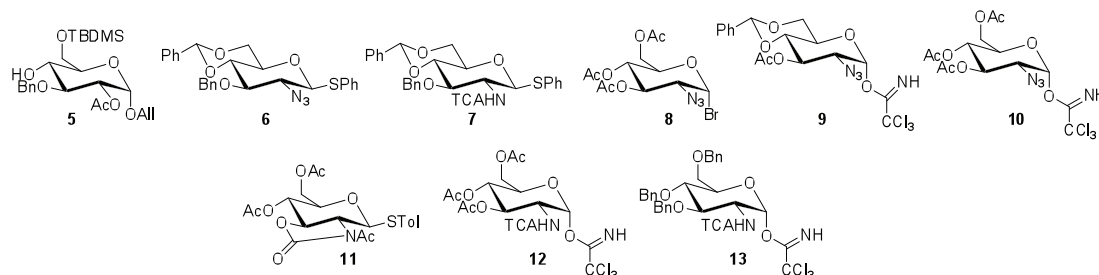

Specific deprotection sequences (desilylation, TCA reduction, deacetylation and hydrogenation) allowed to obtain the final compounds **1** to **4**, which were used for biological tests.

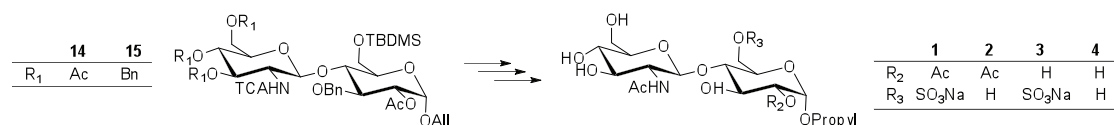

Aphids fed with different concentrations of sulfated disaccharides showed an increase of larval mortality and a reduction of fecundity. Inhibition tests on bacterial, fungal and *M. persicae* endo- and exochitinases showed selectivity towards insect's chitinases.

## References

1. L. Bultel, J. Saguez, P. Giordanengo, J. Kovensky, WO20090984000.

## PO 91

## EFFICIENT SYNTHESIS OF A DIMERIC BUILDING BLOCK FOR HYALURONAN FRAGMENTS

Markus S. Ehret<sup>1</sup> and Moritz B. Biskup<sup>1</sup>

<sup>1</sup>Karlsruhe Institute of Technology, Institute of Organic Chemistry,  
Fritz-Haber-Weg 6, 76131 Karlsruhe  
moritz.biskup@kit.edu

The various biological roles of small hyaluronan fragments are highly dependent on their size.<sup>1</sup> For detailed studies organic synthesis can provide hyaluronan fragments of defined length and constitution and easily allows specific functionalisation or derivatisation. Different routes for the synthesis of hyaluronan fragments have been reported.<sup>2-6</sup> Besides requiring stereoselective and high-yielding coupling reactions in chain elongation, easy and efficient access to large quantities of building blocks is essential. Therefore we envisioned a strategy with a dimeric donor containing the glucuronic acid at the reducing end and activated as a trichloroacetimidate as previously reported by *Blatter and Jacquinet*.<sup>2</sup>

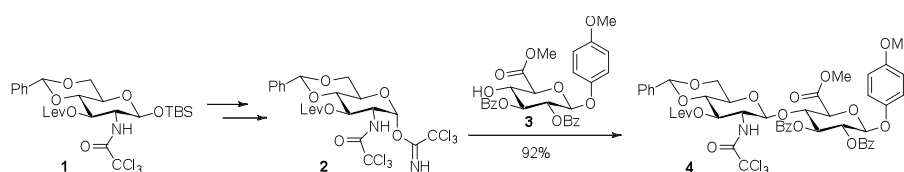

Known<sup>6</sup> compound 1 was synthesised on 50 g scale, further activated as the trichloroacetimidate on 10 g scale and coupled with known<sup>2</sup> acceptor 3. Resulting compound 4 was elaborated to key donor 5 on multigram scale and acceptor 6 was easily prepared, too. The efficient glycosylation of 5 and 6 demonstrates the usefulness of our approach. Dry column vacuum chromatography allowed for rapid purification of intermediates on multigram scale.<sup>7</sup>

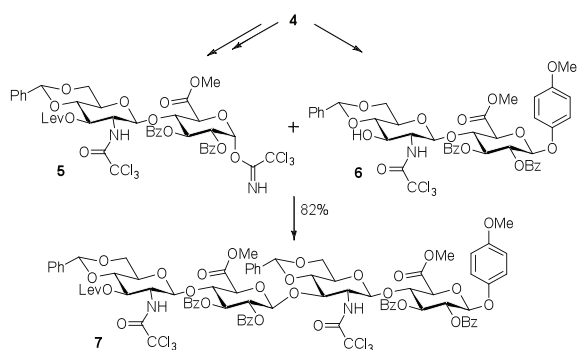

We believe that these results will allow for the synthesis of longer hyaluronan fragments and an easy access to specifically functionalised fragments for in-depth studies of their biological properties.

## References

1. R. Stern, A. A. Asari, K. N. Sugahara, *Eur. J. Cell Biol.* **2006**, *85*, 699–715 and references cited therein.
2. G. Blatter, J.-C. Jacquinet, *Carbohydrate Res.* **1996**, *288*, 109–125.
3. J. Dinkelaar, H. Gold, H. S. Overkleeft, J. D. C. Codée, G. A. van der Marel, *J. Org. Chem.* **2009**, *74*, 4208–4216 and references cited therein.
4. X. Lu, M. N. Kamat, L. Huang, X. Huang, *J. Org. Chem.* **2009**, *74*, 7608–7617 and references cited therein.
5. M. Virlouvet, M. Gartner, K. Koroniak, J. P. Sleeman, S. Bräse, *Adv. Synth. Catal.* **2010**, *352*, 2657–2662.
6. E. R. Palmacci, P. H. Seeberger, *Tetrahedron* **2004**, *60*, 7755–7766.
7. D. S. Pedersen, C. Rosenbohm, *Synthesis* **2001**, 2431–2434 and references cited therein.

## PO 92

**STRUCTURAL INVESTIGATION OF THE LIPOPOLYSACCHARIDE ISOLATED FROM A CLINICAL ISOLATE OF *PREVOTELLA INTERMEDIA*, AN ANAEROBE OBLIGATE CF PATHOGEN**

Concetta Elefante, Alba Silipo, Rosa Lanzetta, Michelangelo Parrilli, Antonio Molinaro.

*Dipartimento di Chimica Organica e Biochimica, Università di Napoli "Federico II",  
Complesso Universitario Monte S. Angelo  
concettaelefante@hotmail.it*

Cystic fibrosis is an autosomal recessive disorder, characterized by chronic bacterial airway infection, which leads to progressive lung deterioration, with fatal outcome. Pulmonary infection in CF is polymicrobial and it is possible that anaerobic bacteria reside within infected anaerobic airway mucus.<sup>1</sup> Patients affected by Cystic Fibrosis (CF) with *Pseudomonas aeruginosa* lung infections produce endobronchial mucus plugs, giving rise to the growth of obligate anaerobes including *Prevotella intermedia*.

*Prevotella intermedia* is an anaerobic, rod-shaped, black-pigmented, Gram negative bacterium. The major components of its outer membrane are lipopolysaccharides, which exhibit powerful immunostimulatory and inflammatory activities.<sup>2</sup> Bacterial Lipopolysaccharides (LPS) typically consists of a hydrophobic domain known as lipid A (or endotoxin), a core oligosaccharide, and an O-specific polysaccharide region (O-chain).

The structure characterisation of the LPS endotoxins isolated from CF opportunistic pathogens is of pivotal importance, therefore in this work the LPS from a clinical isolate of *Prevotella intermedia* has been extracted and characterized by using biochemical approaches and state-of-art techniques such as Nuclear Magnetic Resonance Spectroscopy (NMR) and Mass Spectrometry (MALDI).

**References**

1. T. R. Field a, C. Sibley a, M.D. Parkin, "The genus *Prevotella* in cystic fibrosis airways", *Elsevier*, **2010**, *16*, 337-344.
2. M. Hashimoto, Y. Asai, R. Tamai, T. Jinno, *FEBS Letters*, **2003**, *543*, 98-102.



## PO 93

**GRAM-NEGATIVE PEPTIDOGLYCAN MODIFICATIONS  
AS A STRATEGY TO LOWER INNATE IMMUNITY DURING  
CHRONIC LUNG INFECTION IN CYSTIC FIBROSIS**

Concetta Elefante<sup>1</sup>, Alba Silipo<sup>1</sup>, Rosa Lanzetta<sup>1</sup>, Laura Curcuru<sup>2</sup>, Maria Lina Bernardini<sup>2</sup>,  
Michelangelo Parrilli<sup>1</sup>, Antonio Molinaro<sup>1</sup>

<sup>1</sup>*Dipartimento di Chimica Organica e Biochimica, Università di Napoli "Federico II;*

<sup>2</sup>*Dipartimento di Biologia e Biotecnologie "Charles Darwin", Università di Roma La Sapienza  
concettaelefante@hotmail.it*

Peptidoglycan, also known as murein, is a polymer consisting of sugars and amino acids that forms a mesh-like layer outside the plasma membrane of bacteria, shaping the cell wall. The sugar component consists of linear chains of two alternating amino sugars, namely *N*-acetylglucosamine (GlcNAc or NAG) and *N*-acetylmuramic acid (MurNAc or NAM), connected by a  $\beta$ -(1,4)-glycosidic bond. A peptide chain of three to five amino acids is linked to the *N*-acetylmuramic acid to complete the structure.

The importance of studying the structure of Peptidoglycan is due to the fact that it belongs to the family of PAMPs (Pathogen-Associated Molecular Patterns), a set of molecular structures, highly conserved, essential for life and survival of the bacterium. These molecules are recognized by the host through specific receptors known as PRRs (Patterns Recognition Receptors) that are able to activate an inflammatory response by the immune system. The receptors responsible for recognition of PGN are known as Nod1 and Nod2.<sup>1</sup> Cystic fibrosis lung disease is characterized by transient airway infections and excessive neutrophil-dominated inflammation early in life, followed by permanent chronic infection that causes persistent respiratory symptoms and decline in lung functions.<sup>2</sup>

In this work, in order to check possible changes in the immune response, PGN has been extracted and purified from three clonal strains of *Pseudomonas aeruginosa*, isolated from CF patients at different times of colonization and the proinflammatory activity analyzed *in vivo* and *in vitro*:

AA / 2, isolated after 6 months of colonization;

AA / 43, isolated after 7.5 years of colonization (mucoid strain);

AA / 44, isolated after 7.5 years of colonization (non-mucoid strain).

**References**

1. Akira S, Uematsu S, Takeuchi, *Cell*, **2006**, *124*, 783–801.
2. Gibson RL, Burns JL, Ramsey BW, *Am J Respir Crit Care Med*, **2003**, *168*, 918–951.

## PO 94

SYNTHESIS OF TETHERED METHYL  $\alpha$ -CELLOBIOSIDESOlof Engström,<sup>1</sup> and Göran Widmalm<sup>1</sup>

<sup>1</sup>Department of Organic Chemistry, Arrhenius Laboratory, Stockholm University, 106 91  
Stockholm, Sweden  
olof@organ.su.se

To investigate flexibility and dynamics of oligosaccharides in solution description of the preferred conformations at the glycosidic torsion angles is essential. Several NMR observables are usually measured, in particular, <sup>1</sup>H,<sup>1</sup>H cross-relaxation rates from which effective interproton distances can be obtained and transglycosidic <sup>3</sup>J<sub>C,H</sub> and <sup>3</sup>J<sub>C,C</sub> that can be interpreted via Karplus-type relationships.<sup>1-3</sup> If homo- and heteronuclear coupling constants can be determined for oligosaccharides for which the conformation or conformational distribution at the glycosidic torsion angles is known, further refinement of Karplus-type relationships can be obtained. We have therefore initiated the synthesis of tethered model compounds to this end. The disaccharides are related to methyl  $\alpha$ -cellobioside (**1**) in which the length of the tether is varied (**2** – **4**). In addition, two monosaccharides related to  $\alpha$ -D-Glcp (**5**) and  $\beta$ -D-Glcp (**6**) will also be synthesized. The <sup>3</sup>J<sub>C,H</sub> and <sup>3</sup>J<sub>C,C</sub> coupling constants will be compared to existing Karplus-type relationships.

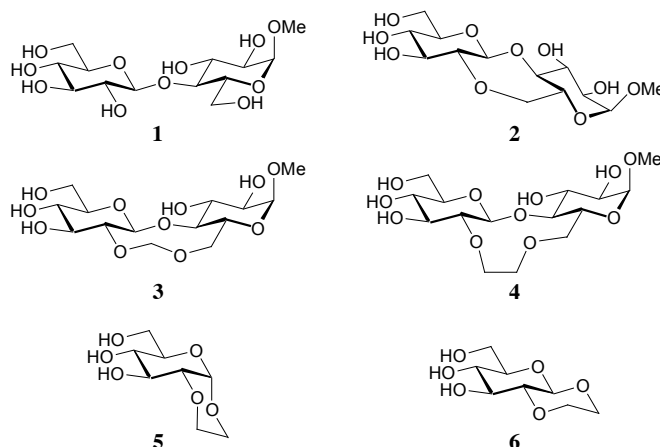

**Figure 1.** Methyl  $\alpha$ -cellobioside (**1**), tethered methyl  $\alpha$ -cellobiosides (**2** - **4**), tethered  $\alpha$ -D-Glcp (**5**) and  $\beta$ -D-Glcp (**6**).

**References**

1. Karplus, M., *J. Am. Chem. Soc.*, **1963**, 85, 2870-2871.
2. Coxon, B., *Adv. Carbohydr. Chem. Biochem.*, **2009**, 62, 17-82.
3. Säwén, E., Massad, T., Landersjö, Damberg, P., Widmalm, G., *Org. biomol. chem.*, **2010**, 8, 3684-3695

## PO 95

**ON THE LPS FROM *PSEUDOMONAS CHLORORAPHIS* SUBSP. *AUREOFACIENS* STRAIN M71, A BIOLOGICAL CONTROL AGENT OF CYPRESS BARK CANCKER DISEASE CAUSED BY *SEIRIDIUM CARDINALE***

Giuseppina Pieretti,<sup>1</sup> Gerardo Puopolo,<sup>2</sup> Sara Carillo,<sup>1</sup> Astolfo Zoina,<sup>2</sup> Rosa Lanzetta,<sup>1</sup>  
Antonio Evidente<sup>3</sup>, Maria Michela Corsaro<sup>1</sup>

<sup>1</sup>*Dipartimento di Chimica Organica e Biochimica,  
Complesso Universitario di Monte S. Angelo, 80126 Napoli, Italy*

<sup>2</sup>*Dipartimento di Arboricoltura, Botanica e Patologia Vegetale  
and* <sup>3</sup>*Dipartimento di Scienze del Suolo, della Pianta,  
dell'Ambiente e delle Produzioni Animali, 80055 Portici, Italy  
evidente@unina.it*

Members of the subspecies *Pseudomonas chlororaphis aureofaciens* can be employed as biological control agents against several important phytopathogenic fungi. Recently, *P. chlororaphis* subsp. *aureofaciens* strain M71<sup>1</sup> has shown interesting properties exploitable for the control of *Seiridium cardinale*, the causative agent of cypress (*Cupressus sempervirens* L.) bark canker disease.<sup>2</sup> Production of the antibiotic compound (phenazine-1-carboxylic acid) by strain M71 is involved in the control of this plant pathogen fungus.<sup>1</sup>

At the moment, application of strain M71 and its antibiotic compound represents the first biological control method for the prevention of bark canker disease incited by *S. cardinale*; therefore a full characterization of this biocontrol agent needs to be accomplished.

Although LPS from several *Pseudomonas* have been described so far, little is known about the structure of LPS in members of the subspecies *P. chlororaphis aureofaciens*. The structure of LPS from strain M71 and their antimicrobial activity as a whole and as single components (Lipid A, Core and/or O-chain) will be described. The LPS was extracted from dried cells<sup>3</sup> and preliminary analysis (SDS-PAGE) showed its smooth nature. In addition the sugar analysis showed the presence of rhamnose (Rha), 2,6-dideoxy-2-amino-glucose (QuiN), 2,6-dideoxy-2-amino-galactose (FucN), 2-deoxy-2-amino-glucose (GlcN), glucose (Glc), heptose (Hep) and Kdo.

**References**

1. Raio A., Puopolo G., Cimmino A., Danti, R., Della Rocca G., Evidente A. *Biological Control*, **2011**, accepted
2. Graniti, A., 1998. *Annual Review of Phytopathology*, **1998**, 36, 91-114.
3. Westphal, O.; Jann, K. *Methods Carbohydr. Chem.* **1965**, 5, 83-91.

## PO 96

## METABOLIC ENGINEERING FOR GLYCOGLYCEROLIPIDS PRODUCTION

Neus Mora-Buyé, Magda Faijes and Antoni Planas*Institut Químic de Sarrià, Universitat Ramon Llull, Barcelona  
magda.faijes@iqs.url.edu*

Metabolic engineering is a useful strategy to achieve target molecules using microorganisms. Different glycoconjugates have been successfully obtained by this methodology (1,2). Our group studies the *Mycoplasma genitalium* glycosyltransferase responsible of glycolipid synthesis as novel therapeutic target against mycoplasma infections (3). The enzyme encoded by the *mg517* gene catalyzes the condensation between a glycosyl donor (Glc-UDP) and diacylglycerol (DAG) to form two glycolipids: the monoglucosyldiacylglycerol (MGDAG) and the diglucosyldiacylglycerol (DGDAG) with  $\beta$ -1,6 linkage. Due to the amphiphilic structure of these compounds they are of interest as biosurfactants and also as drug delivery systems. Enzymatic synthesis of glyco glycerolipids offers a significant advantage over chemical synthesis in their ability to form specific glycosidic linkages with high regio- and stereoselectivity. But the use of glycosyltransferases are still limited due to the cost of the sugar nucleotide donor and the difficulty of enzyme purification. Metabolic engineering is an alternative that overcomes these limitations.

For this purpose, *mg517* gene is overexpressed in *E. coli* strain together with *galU* and *plsC* genes involved in the biosynthesis of the precursors Glc-UDP and DAG. Co-expression of *galU*, *plsC* and *mg517* genes are analyzed in terms of metabolic effects and glycolipids production.

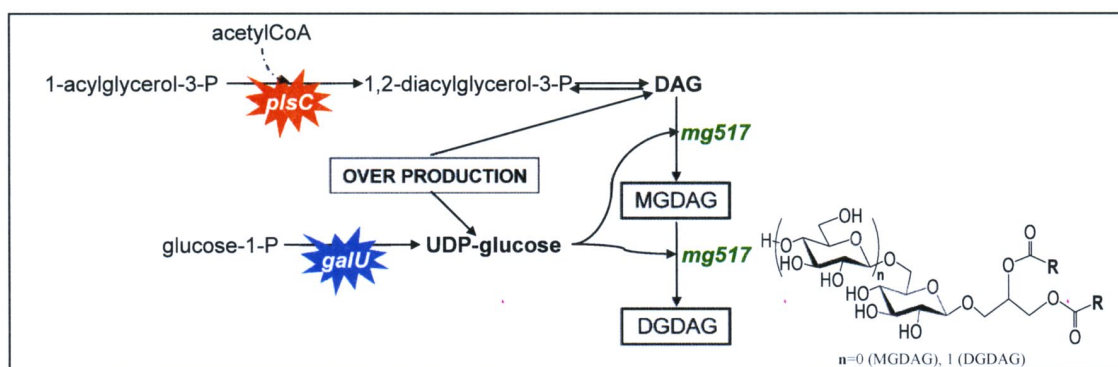

## References

1. A.M, Ruffing, R.R. Chen, *Microb. Cell. Fact.*, **2010**, 12, 9:1.
2. E. Yavuz, S. Drouillard, E. Samain, I. Roberts, B. Priem, *Glycobiology*, **2008**, 18(2),152-7.
3. N. Martínez, E. Andrés, A. Planas, *paper submitted*.

PO 97

## CROSSLINKED CELLULOSE, A NEW MATERIAL DEVELOPED BY CLICK CHEMISTRY

Faugeras Pierre-Antoine,<sup>1,2</sup> Brouillette François,<sup>2</sup> and Zerrouki Rachida<sup>1</sup>

<sup>1</sup> Laboratoire de chimie des substances naturelles, Université de Limoges, 123 avenue Albert Thomas 87060 Limoges, FRANCE.,

<sup>2</sup> Centre de recherche en pâtes et papiers, Université du Québec à Trois-Rivières, 3351 boul. des Forges, C.P. 500, Trois-Rivières (QC) G9A 5H7.

pierre-antoine.faugeras@etu.unilim.fr, pierre-antoine.faugeras@uqtr.ca

This work deals with a novel approach of cellulose reticulation using the Huisgen 1,3-dipolar cycloaddition, also known as “click chemistry”, catalyzed by copper and developed by Sharpless.<sup>1</sup> This reaction is carried out by the condensation of a true alkyne and an azide to form a triazole ring connecting the two polysaccharide chains. The condensation of two different functions will allow us to control the crosslinking reaction, to avoid intra-chain reactions and thus to promote the creation of an enhanced three-dimensional network.

We initially used microcrystalline cellulose as a model substrate for reactions development before proceeding on with wood pulp fibres. Azidodeoxycellulose<sup>2</sup> was obtained with a DS of 1.3 from tosylcellulose<sup>3</sup>. The propargylation reaction was conducted with cellulose dissolved in a 5 % sodium hydroxide aqueous solution<sup>4</sup> with propargyl bromide leading to propargylcellulose with a DS of 1.3. CuAAC reaction was performed between azidodeoxycellulose and propargylcellulose in a DMSO/H<sub>2</sub>O system using CuSO<sub>4</sub>, 5 H<sub>2</sub>O/sodium ascorbate as catalytic system. SEM pictures of the product show a morphological modification, compared to reactants. We are now working to adapt these reactions to wood pulp fibres (Kraft pulp and thermomechanical pulp). Preliminary trials led to encouraging results.

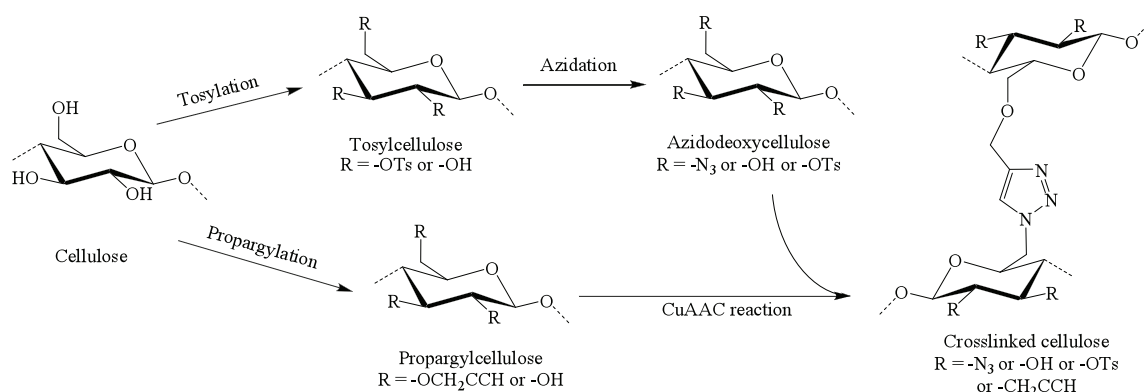

### References

1. Kolb, H. C. ; Finn, M. G. ; Sharpless, K. B. *Angew. Chem. Int. Ed.*, **2001**, 40, 2004-2021.
2. Liebert, T. ; Hänsch, C. ; Heinze, T. *Macromol. Rapid Commun.*, **2006**, 27, 208-213.
3. Heinze, T. ; Rahn, K. ; Jaspers, M. ; Berghmans, H. *Macromol. Chem. Phys.*, **1996**, 197, 4207-4224.
4. Isogai, A. ; Atalla, R.H. *Cellulose*, **1998**, 5, 309-319.

## PO 98

KINETIC STUDIES OF SWEET POTATO BETA-AMYLASE  
ON CNP- $\beta$ -MALTOOLIGOSIDES

Erika Fazekas, Lili Kandra, Gyöngyi Gyémánt

<sup>1</sup>University of Debrecen, Department of Inorganic and Analytical Chemistry  
fazekas.erika@science.unideb.hu

$\beta$ -Amylase catalyzes the liberation of maltose from the nonreducing ends of starch having a strict specificity to produce beta-anomeric maltose. It has been classified as a typical inverting enzyme. The enzyme is distributed in higher plants such as soybean, sweet potato and barley, and in some microorganisms. On the basis of sequence alignment  $\beta$ -amylase has been classified as belonging to the glycoside hydrolase family 14. Subsite maps of alpha-amylases from different origin were calculated earlier,<sup>1-3</sup> but detailed knowledge about subsite architecture of beta-amylases is scarce.  $\beta$ -Amylase from sweet potato was chosen as model enzyme for subsite mapping of  $\beta$ -amylases. Hydrolysis of chromophore-substituted maltooligosaccharides<sup>4,5</sup> of degree of polymerization 3-8 was studied.

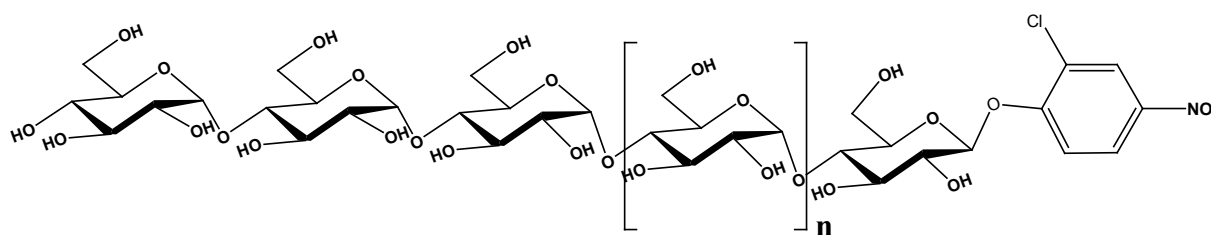

Sweet potato  $\beta$ -amylase cleaves maltose unit from the non-reducing end of oligomer substrates and the concentration of CNP-glycoside reducing end products was measured by HPLC as a function of time. Initial reaction rates and kinetic constants were calculated for substrates with different chain length. Hydrolysis of long substrates containing even and odd number glucose units (DP 7 and 8) were followed until formation of CNP-maltotriose and CNP-maltose as final products, respectively. The concentration-time relationships were evaluated numerically using a “single chain mechanism” reaction model. Reaction scheme was suggested to describe the total hydrolysis of the oligomer substrate catalysed by sweet potato beta-amylase.

**References**

1. Kandra, L., Gyémánt, G., Remenyik, J., Hovánszki, G., Lipták, A., FEBS Lett 518 (2002) 79-82.
2. Kandra, L., Gyémánt, G., Remenyik, J., Ragunath, C., Ramasubbu, N., FEBS Lett., 544 (2003) 194-198.
3. Kandra, L., Abou Hachem, M., Gyémánt, G., Kramhoft, B., Svensson, B., FEBS Lett. 580 (2006) 5049-5053.
4. Kandra, L., Gyémánt, Gy., Lipták, A., Carbohydrate Research, **1999**, Vol 315, 180-186
5. Kandra, L., Gyémánt, Gy., Pál, M., Petró, M., Remenyik, J. Lipták, A. Carbohydrate Research, **2001**, Vol 333, 129-136



## PO 99

DETECTION OF CARBOHYDRATE-CARBOHYDRATE INTERACTIONS USING A PEPTIDE SCAFFOLD: STUDY OF THE LEWIS<sup>X</sup> SYSTEM

Christian Fernández-García,<sup>1</sup> Timothy Altamore,<sup>1</sup> Derek N. Woolfson<sup>1,2</sup>  
and Timothy Gallagher<sup>2</sup>

<sup>1</sup>School of Chemistry, University of Bristol, Bristol, BS8 1TS, U.K.

<sup>2</sup>School of Biochemistry, University of Bristol, Bristol, BS8 1TD, U.K.

Since the discovery of carbohydrate-carbohydrate interactions (CCIs),<sup>1</sup> several studies examining this phenomenon have been reported. CCIs are intrinsically weak, which makes their study, detection and quantification at a monovalent level highly challenging. Previous work has generally relied on macroscopic and multivalent systems focusing on the biologically important Lewis<sup>X</sup>-Lewis<sup>X</sup> (Le<sup>X</sup>-Le<sup>X</sup>) interaction.<sup>2</sup>

We have explored a conformationally dynamic system to report on a weak, attractive CCI. A peptide random-coil:α-helix equilibria, designed to be more helical in the presence of favourable side chain interaction, has been used in the current study to qualitatively detect a weak CCI (Figure 1). The peptide scaffold used has been designed to be approximately 50 % helical. Deviation from this value by incorporating modifications at specific sites has been measured using circular dichroism (CD) spectroscopy.

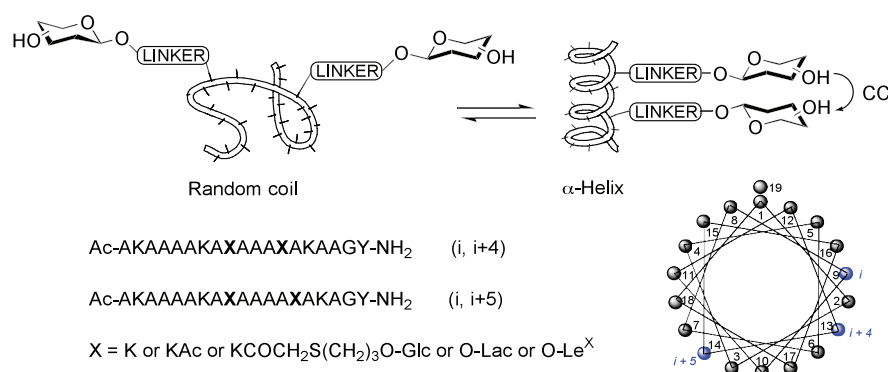

**Figure 1** Schematic of random-coil:α-helix for detection of CCI.

The glycopeptide with Le<sup>X</sup> in an *i, i+4* relationships shows the highest helical content compared to the other peptides. This suggests that the Le<sup>X</sup>-Le<sup>X</sup> interaction has a helix stabilising effect within these peptides and implies detection of a monovalent CCI is possible within this system.

### References

- (a) Hakomori, S. *Glycoconjugate J.* **2004**, *21*, 125137. (b) Bucior, I.; Burger, M. M. *Glycoconjugate J.* **2004**, *21*, 111-123.
- (a) Chen, Q.; Cui, Y.; Zhang, T. L.; Cao, J.; Han, B. H. *Biomacromolecules* **2010**, *11*, 13-19. (b) Tromas, C.; Rojo, J.; de la Fuente, J. M.; Barrientos, A. G.; García, R.; Penadés, S. *Angew. Chem. Int. Ed.* **2001**, *40*, 3052-3055.



## PO 100

N-ALKOXYAMINE-MEDIATED GLYCODIVERSIFICATION  
OF DOPAMINE AND TAURINE

M. Ángeles López-García, José M. Márquez, Óscar López, Inés Maya and  
José G. Fernández-Bolaños

*Departamento de Química Orgánica, Universidad de Sevilla, Apto. 1203,  
E-41071 Seville, SPAIN  
bolanos@us.es*

Glycodiversification allows the development of carbohydrate libraries that can provide a molecular picture of biological processes involving carbohydrates. A recent and powerful approach to afford neoglycoconjugates is glycorandomization, an approach based on a one-step sugar ligation reaction that does not require any prior sugar protection or activation.<sup>1,2</sup> Dopamine is a neurotransmitter involved in numerous functions in the brain, including roles in mood, attention, working memory, and learning.<sup>3</sup> Taurine is an inhibitory **neurotransmitter**, neuromodulator, and neuroprotector,<sup>4</sup> it can be used in the treatment of cardiovascular diseases,<sup>5</sup> and hypertension.<sup>6</sup> It has also been described that taurine delays diabetic complications.<sup>7</sup> Herein, we describe the synthesis of *N*-methoxydopamine **2** and *N*-benzyloxytaurine **5** from dopamine **1** and taurine **4**, respectively, and the coupling with reducing sugars to give stable *N*-glycosyl dopamine and *N*-glycosyl taurine derivatives such as **3** and **6**, using a chemoselective neoglycosidation methodology.<sup>2</sup>

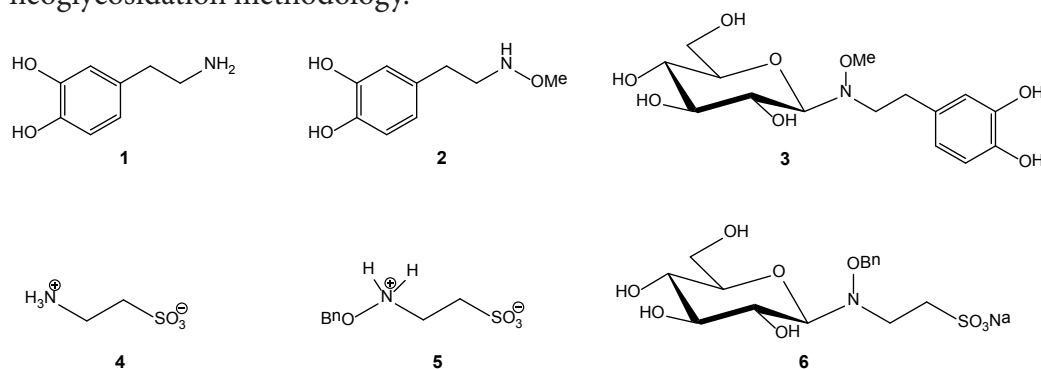

**Acknowledgements** to the Junta de Andalucía (FQM 134) and Dirección General de Investigación of Spain (CTQ2008-02813) for financial support. M.A.L.G. and J.M.M. thank Ministerio de Educación for FPU grants.

### References

1. J. M. Langenhan, B. R. Griffith, J. S. Thorson, *J. Nat. Prod.*, **2005**, 68, 1696-1711.
2. F. Nicotra, L. Cipolla, F. Peri, B. La Ferla, C. Redaelli, *Adv. Carbohydr. Chem. Biochem.*, **2008**, 61, 353-398.
3. S. Chen, F. Liu, *J. Neurosci. Res.* **2010**, 88, 2504-2512.
4. D. B. Rosemberg, L. W. Kist, R. J. Etchart, E. P. Rico, A. S. Langoni, *et al.*, *Neurosci. Lett.* **2010**, 481, 105-109.
5. A. Zulli, *Curr. Opin. Clin. Nutr. Metab. Care*, **2011**, 14, 57-60.
6. J. Hu, X. Xu, J. Yang, G. Wu, C. Sun, Q. Lv, *Adv. Exp. Med. Biol.* **2009**, 643, 75-84.
7. D. Gossai, C. A. Lau-Cam, *Adv. Exp. Med. Biol.* 2009, 643, 369-379.

## PO 101

STRUCTURAL ELUCIDATION OF *LACTOCOCCUS LACTIS*  
G121 LIPOTEICHOIC ACIDSKathleen Fischer<sup>1</sup>, Buko Lindner<sup>2</sup> and Otto Holst<sup>1</sup>

Divisions of <sup>1</sup>Structural Biochemistry and <sup>2</sup>Immunochemistry, Research Center Borstel,  
Leibniz-Center for Medicine and Biosciences, D-23845 Borstel, Germany  
kfischer@fz-borstel.de; oholst@fz-borstel.de

Growing up on a traditional farm and exposure to components derived from microbes, fungi and plants minimizes the risk to come down with allergic asthma later in life.<sup>[1]</sup> Gram-positive *L. lactis* G121 was isolated from Bavarian cowshed dust. It was found out to impair allergic responses in the lung of mice. Ovalbumin-sensitized mice showed a decrease in eosinophils and goblet cells after treatment with *L. lactis* G121 *per inhalation*.<sup>[2]</sup> Lipoteichoic acid (LTA), as one main cell wall constituent, was prepared to elucidate its structure and role in immuno-modulation. Extraction with *n*-butanol at 20-22°C provided crude LTA, which was purified by hydrophobic interaction chromatography on a HiPrep octyl-sepharose column performing a gradient of 15% -60% *n*-propanol in 0.1 M ammonium acetate. Analytical chemistry, ESI FT-ICR-mass spectrometry as well as NMR spectroscopy were applied. Glycerol, phosphate, D-galactose (Gal), D-glucose (Glc), and D-alanine (Ala) were identified. Also fatty acids 14:0, 16:1, 16:0, 18:1, and Δ-19:0 were detected. Based on this and the masses found in the ESI-MS spectrum, 5 LTA species varying in the fatty acid composition are proposed. Two dimensional homonuclear as well as heteronuclear NMR experiments identified a 1,3-poly(glycerol phosphate) backbone with D-Ala and α-D-Galp substituents at C-2 of glycerol. Mass spectrometry indicated a linking moiety comprising the fatty acids, glycerol and two hexoses. After HF cleavage (48%, 4°C, 48h) and hydrazinolysis (37°C, 1h), assignment of NMR spectra revealed the linker to be α-D-Glcp-(1→2)-α-D-Glcp-(1→3)-Gro. The entire LTA structure can be summarized as

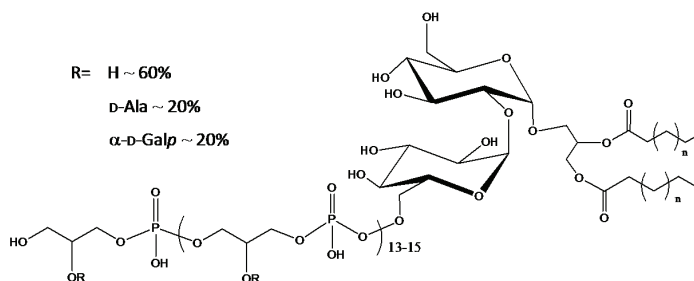

## References

1. Kabesch M., and Lauener R. P. *J. Leukoc. Biol.* (2004) 75, 383-387
2. Debarry J., Garn H., Hanuszkiewicz A., Dickgreber N., Blümer N., von Mutius E., Bufe A., Gattermann S., Renz H., Holst O. and Heine H. *J. Allergy Clin. Immunol.* (2007) 119, 1514-1521

## PO 102

OCCURRENCE OF CYCLIC FORMS OF THE ENTEROBACTERIAL COMMON ANTIGEN IN THE PATHOGENIC STRAIN *ESCHERICHIA COLI* O157:H-

Eleonora Fregolino,<sup>1</sup> Radka Ivanova,<sup>2</sup> Rosa Lanzetta,<sup>1</sup> Michelangelo Parrilli,<sup>1</sup>  
Tsvetelina Paunova,<sup>2</sup> Stoyanka Stoitsova,<sup>2</sup> and Cristina De Castro<sup>1</sup>

<sup>1</sup>Università degli Studi di Napoli Federico II, Complesso Universitario Monte Sant' Angelo,  
Via Cintia 4, 80126 Napoli, Italy

<sup>2</sup>Institute of Microbiology, Bulgarian Academy of Sciences, Acad. G. Bonchev Str., Bl. 26,  
Sofia 1113, Bulgaria  
eleonora.fregolino@unina.it

All gram-negative enteric bacteria express on their cell surface an antigenic polysaccharide known as the *Enterobacterial Common Antigen* (ECA).<sup>1,2</sup> It is a heteropolysaccharide made up of a trisaccharide repeating unit: 3)- $\alpha$ -D-FucNAc-(1 $\rightarrow$ 4)- $\beta$ -D-ManNAcA-(1 $\rightarrow$ 4)- $\alpha$ -D-GlcNAc-(1 $\rightarrow$ ). The major and ubiquitous form is the glycolipid ECA<sub>PG</sub> where the ECA polysaccharide chains are anchored to the outer membrane through a diacylglycerolphosphate aglycon. Two related forms are the ECA<sub>LPS</sub><sup>3</sup> and the cyclic soluble ECA<sub>CYC</sub> that contains only the trisaccharide repeating units with different O-acetylation degree.<sup>4</sup> Their occurrence is quite restricted and in particular ECA<sub>CYC</sub> was characterized in *Yersinia pestis* (from 3 to 5 repeating units),<sup>5</sup> *Shigella sonnei* (from 4 to 6 repeating units),<sup>6,7</sup> and *Plesiomonas shigelloides* (4 repeating units).<sup>6</sup> To date ECA<sub>CYC</sub> is considered a molecular determinant associated to pathogenic enterobacterial species, with *Escherichia coli* K12 as the only exception known, where it is present in its tetrameric form.<sup>8,9</sup> Investigations on the pathogenic *Escherichia coli* O157: H- led to the identification and characterization of two cyclic forms (tetrameric and pentameric) of the ECA. Polysaccharide material was extensively purified by gel permeation chromatography and the identification of the two forms of the cyclic ECA was performed through the use of NMR spectroscopy and MALDI spectrometry. Further studies will be focused on the study of biological functions of these molecules and eventually on their role in the virulence of the bacterium.

### References

1. Mäkelä P.H., Mayer H., *Bacteriol. Rev.*, **1976**, *40*, 591-632.
2. Kuhn H. M., Meier-Dieter U., Mayer H., *FEMS Microbiol. Rev.*, **1988**, *4*, 195-222.
3. Kiss P., Rinno J., Schmidt G., Mayer H., *Eur. J. Biochem.*, **1978**, *88*, 211-218.
4. Dell A., Oates J., Lugowski C., Romanowska E., Kenne L., Lindberg B., *Carbohydr. Res.*, **1984**, *133*, 95-104.
5. Vinogradov E.V., Knirel Y.A., Thomas-Oates J.E., Shashkov A.S., Lvov L. *Carbohydr. Res.*, **1994**, *258*, 223-232.
6. Staaf M., Hoog C., Stevansson B., Maliniak A., Widmalm, G., *Biochemistry*, **2001**, *40*, 3623-3628.
7. Lugowski C., Romanowska E., *Eur. J. Biochem.*, **1978**, *91*, 89-97.
8. Erbel P.J., Barr K., Gao N., Gerwig G.J., Rick P.D., Gardner, K.H. *J. Bacteriol.*, **2003**, *185*, 1995-2004.
9. Kajimura J., Rahman A., Rick, P.D., *J. Bacteriol.* **2005**, *187*, 6917-6927.

PO 103

ELECTRONIC- OR CONFORMATIONAL EFFECT IN GLYCOSYLATION OF  
B-MANNOSIDES?Tobias G. Frihed, Christian M. Pedersen and Mikael Bols*Department of Chemistry, University of Copenhagen, Denmark  
tobias\_frihed@jubii.dk*

$\beta$ -mannosides are a class of carbohydrates found e.g. in *N*-bound glycoproteins. The chemical synthesis of  $\beta$ -mannosides has until recently been giving poor yields (mainly the  $\alpha$ -anomer is formed) or required methods. The discovery by Crich that benzylidene protected mannosides favored the desired  $\beta$ -mannosides have greatly improved  $\beta$ -mannoside synthesis.<sup>1</sup> According to Crich the benzylidene locks the molecule in a less reactive conformation leading to increased stereoselectivity. Subsequently Bols and coworkers have found that the diminished reactivity of the benzylidene is due to an electronic effect.<sup>2</sup>

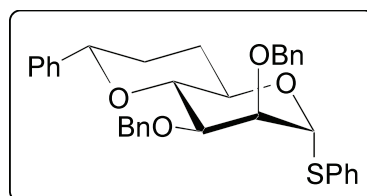

To address this problem and expand the explanation a derivative of the benzylidene protected mannoside containing a methylene group at the 6-position was synthesized. Herein the synthesis over 14 steps will be presented. Afterwards the compound was subjected to glycosylation with different acceptors to determine the  $\alpha/\beta$ -ratio. The results were compared with the benzylidene protected mannoside.

**References**

1. Crich, D.; Sun, S. *Tetrahedron* **1998**, *54*, 8321-8348.
2. Jensen, H. H.; Nordstrøm, L. U.; Bols, M. *J. Am. Chem. Soc.* **2004**, *126*, 9205-9213.

## PO 104

SYNTHESIS OF POTENTIAL INHIBITORS OF KEY ENZYMES  
FOR LIPOPOLYSACCHARIDE BIOSYNTHESIS

Luca Gabrielli,<sup>1</sup> Silvia Fusari,<sup>1</sup> Alice Capitoli,<sup>1</sup> Marco Alati,<sup>1</sup> Xiang Ruan,<sup>2</sup> Laura Cipolla,<sup>1</sup>  
Miguel A. Valvano,<sup>2</sup> Francesco Nicotra<sup>1</sup>

<sup>1</sup>Dept. Of Biotechnology and Biosciences, University of Milano-Bicocca,  
P.za della Scienza 2, 20126 Milano-Italy.

<sup>2</sup>Dept. of Microbiology and Immunology University of Western Ontario, London, Ontario, N6A 5C1, Canada  
l.gabrielli2@campus.unimib.it

The lipopolysaccharide (LPS), a major component of the outer membrane of Gram-negative bacteria, plays critical roles in bacterial cell physiology and in disease. The structure of LPS is complex and consists of a minimum of lipid A and core oligosaccharide (OS). Many Gram-negative bacteria also have an O-specific antigen polysaccharide (or O antigen) attached to one of the terminal residues of the core OS. The O antigen is the most variable portion of the LPS molecule and arises from the polymerization of discrete oligosaccharide units<sup>1</sup>. LPS contributes to the formidable permeability barrier of the outer membrane to antibiotics and it is also a potent stimulant of innate immune responses that can lead to septic shock. The O antigen confers resistance to lysis by serum complement<sup>2</sup> and can also influence entry to host cells<sup>3</sup>, as well as intracellular survival<sup>4</sup>. The core OS contains a highly conserved 3-deoxy-D-manno-oct-2-ulosonic acid (Kdo)<sup>1</sup>. Targeting the biosynthesis of this monosaccharide allows the development of new potential antibacterials. In particular we have targeted the Kdo biosynthetic enzyme KsD, which is an arabinose phosphate isomerase (API)<sup>5</sup>. Preventing the biosynthesis of O antigen will facilitate bacterial clearance from infected organs and tissues. Therefore, we also have targeted in our studies the O antigen ligase WaaL, which despite different specificities has a common mechanism of recognition of the lipid-PP-linked O antigen precursors.

Two different classes of analogues were been designed and synthesized: linear and cyclic arabinose 5-phosphate analogues, modifying mainly positions 3, 4, 5 (Fig.A) and potential inhibitors for WaaL, modifying mainly the anomeric position of galacto-diphospho-undecaprenil (Fig.B).

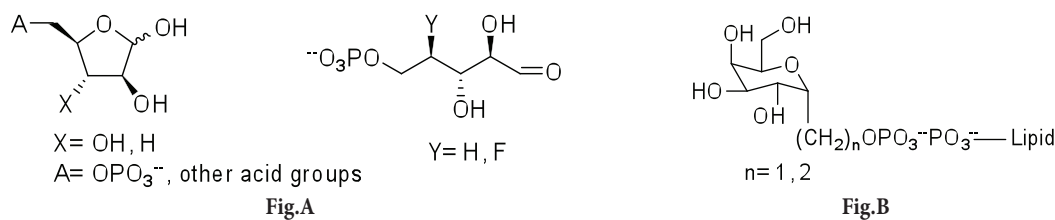

**Acknowledgments.** We gratefully acknowledge MIUR, under project PRIN2008/24M2HX, \* \*FINLOM-BARDA-Regione Lombardia Fondo per la promozione di Accordi Istituzionali- 2009 under project “Rational Drug Design to target outer membrane biogenesis of Gram-negative pathogenic bacteria”

## References

1. a) Nikaido H., *Microbiol. Mol. Rev.*, **2003**, 67, 593-656. b) Ulevitch RJ, Mathison JC, da Silva Correia J., *Vaccine*, **2004**, 22, 25-30. c) Raetz CR, Whitfield C., *Annu Rev Biochem.*, **2002**, 71, 635-700. d) Valvano MA., *Front. Biosci.*, **2003**, 8, 452-71
2. Ilg K, Endt K, Misselwitz B, Stecher B, Aebi M, Hardt WD., *Infect Immun.*, **2009**, 6, 2568-75. b) Schreiber J, Jenner RG, Murray HL, Gerber GK, Gifford DK, Young RA., *Proc. Natl. Acad Sci USA* **2006**, 15, 5899-904. c) Clay CD, Soni S, Gunn JS, Schlesinger LS., *J. Immunol.*, **2008**, 8, 5568-78
3. Saldías MS, Ortega X, Valvano MA., *J Med Microbiol.* **2009**, 58, 1542-8. B) Duerr CU, Zenk SF, Chassin C, Pott J, Gütle D, Hensel M, Hornef MW., *PLoS Pathog.*, **2009**, 9. C) West NP, et al., *Science*, **2005**, 307, 1313-7
4. Paixão TA, et al., *Infect Immun.* **2009**, 10, 4197-208.
5. C. Airoidi, et al., *Chemistry, Eur. J.* **2010**, 161897-1902.

## PO 105

**ULTRASONIC DEGRADATION OF WATER-SOLUBLE GLYCOCONJUGATES  
WITH ANTICOAGULANT ACTIVITY ISOLATED  
FROM *AGRIMONIA EUPATORIA* L.**

Dagmara Borucka<sup>1</sup>, Marta Lewik-Tsirigotis<sup>1</sup>, Izabela Pawlaczyk<sup>1,2</sup>,  
Irena Gancarz<sup>3</sup>, Roman Gancarz<sup>1,2</sup>

<sup>1</sup>*Division of Medicinal Chemistry and Microbiology, Wrocław University of Technology, ul.  
Łukasiewicza 2, 50-371 Wrocław, Poland*

<sup>2</sup>*Regional Specialist Hospital in Wrocław, Research and Development Centre, ul. Kamińskiego  
73a, 51-124 Wrocław, Poland*

<sup>3</sup>*Division of Polymer and Carbon Materials, Wrocław University of Technology, Wyb.  
Wyspiańskiego 41, 50-370 Wrocław, Poland*  
*roman.gancarz@pwr.wroc.pl*

*Agrimonia eupatoria* L. is a very popular in Europe, minor Asia and North Africa medicinal plant<sup>1</sup>. The macromolecular water-soluble polyphenolic-polysaccharide conjugates isolated from flowering parts of *A. eupatoria* with multi-step process<sup>2</sup> have anticoagulant activity, *in vitro* on human blood plasma as well as *in vivo* on Wistar rats. Ultrasonic degradation of such kinds of water-soluble polymers, especially polysaccharides from different sources, has been extensively investigated by many workers and reviewed<sup>3,4,5</sup>. Their results indicate that degradation or scission of polymers in organic solvents is mainly caused by shear force generated by the relative motion between solvent and polymer chains during bubble collapse, i.e. mechanical or physical effects<sup>3</sup>. The preparation of *A. eupatoria*, containing the mixture of the polyphenolic glycoconjugates was depolymerized by ultrasonication. Sonolysis was carried out using a 20 kHz ultrasound generator, on 1.0% glycoconjugate solution, at a few irradiation times: 15, 30, 60, 90 120 and 240 min by varying ultrasonic power from 20 to 70 W at 25 °C. Changes in molecular weight and molecular weight distribution were observed by size exclusion chromatography. The effects of time and ultrasonic power on fragmentation process were followed by viscometry and size exclusion chromatography. The experimental results showed that the rate of fragmentation increased with an increase in power of ultrasound and time. It was concluded that ultrasonic irradiation is a suitable method to perform partial depolymerization and to obtain moderate macromolecules from large ones and it may give structures with better anticoagulant activity.

**Acknowledgments:** Studies are a part of the project supported by European Regional Development Fund and the Polish Government (Operational Programme - Innovative Economy) Grant WROVASC (Integrated Cardiovascular Centre, 2007-2013).

**References**

1. Clapham A R et al., Flora of the British Isles, 1952, University Press, Cambridge
2. Pawlaczyk, I. et al., Carbohydr. Polymers, 2009, 77, 568-575
3. Price G.J. et al., in: T.J. Mason, A. Tiehm (Eds.), Advances in Sonochemistry, Vol. 1, Jai Press Ltd., 1999
4. Koda S. et al., Polymer, 1994, 3, 30-33
5. Grönroos A. et al., Ultrason. Sonochem., 2008, 15, 644-648



PO 106

**SYNTHESIS OF CARBA-ANALOGUES OF  
CAPSULAR POLYSACCHARIDE FRAGMENTS  
FROM *NEISSERIA MENINGITIDIS* SEROTYPE A**

Qi Gao<sup>1</sup>, Laura Poletti<sup>1</sup>, Marta Tontini<sup>2</sup> and Luigi Lay<sup>1</sup>

<sup>1</sup> *Universita degli studi di Milano, Dipartimento di Chimica Organica ed Industriale,  
Via Venezian 21, 20133, Milano, Italy*

<sup>2</sup> *Novartis Vaccines and Diagnostics, Via Fiorentina 1, 53100, Siena, Italy  
qi.gao@unimi.it*

*Neisseria meningitidis* type A (MenA) is a Gram-negative encapsulated bacterium that cause recurrent epidemics of meningitis in the sub-Saharan region of Africa.<sup>1</sup> The development and manufacture of an efficient glycoconjugate vaccine against MenA has to consider the poor hydrolytic stability of its capsular polysaccharide (CPS), which is made up of (1→6)-linked 2-acetamido-2-deoxy- $\alpha$ -D-mannopyranosyl phosphate repeating units.<sup>2</sup>

Since the chemical lability of MenA CPS is a product of the inherent instability of the phosphodiester bridge, a possible solution could be the replacement of the pyranose oxygen atom with a methylene group to give carbocyclic analogues. In this way, the acetal character of the phosphodiester is lost, and the new molecules are expected to be of comparable stability to

that of oligonucleotides. Previous conformational studies indicated that the carba analogues of MenA CPS could be effective structural mimics of MenA CPS fragments.<sup>3</sup>

We describe herein the design, synthesis and preliminary immunochemical evaluation of carba-oligomers of MenA CPS (monomer, dimer and trimer, **Figure 1**). All the synthetic molecules are equipped with a phosphodiester-linked aminopropyl spacer at the reducing end to facilitate the conjugation to a carrier protein or to a multivalent support.

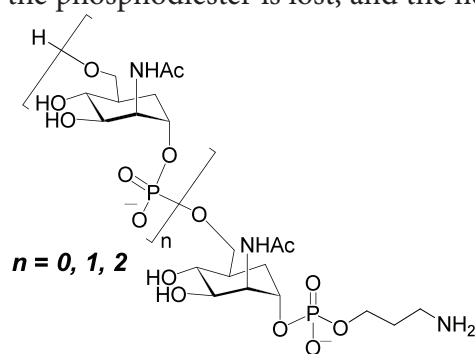

**Acknowledgments:** This work has been supported by MIUR-Italy (PRIN 2008).

### References

1. a) C. Jones, *Carbohydrates in Europe* **1998**, *21*, 10-16; b) S. Segal, A. J. Pollard, *Br. Med. Bull.* **2004**, *72*, 65-81.
2. D.R. Bundle, I.P.C. Smith, *J. Biol. Chem.* **1974**, *249*, 83-96
3. L. Toma, L. Legnani, A. Rencurosi, L. Poletti, L. Lay, G. Russo, *Org. Biomol. Chem.*, **2009**, *7*, 3734-3740.



PO 107

**POLYCATIONIC AMPHIPHILIC CYCLODEXTRINS AS THERAPEUTIC GENE VECTORS**

Alejandro Méndez-Ardoy,<sup>1</sup> Koldo Urbiola,<sup>2</sup> Cristina Aranda,<sup>2</sup> Carmen Ortiz Mellet,<sup>1</sup>  
Conchita Tros de Ilarduya<sup>2</sup> and José M. García Fernández<sup>3</sup>

<sup>1</sup>Dpto. Química Orgánica, Facultad de Química, Universidad de Sevilla, Spain,

<sup>2</sup>Department of Pharmaceutical Technology, University of Navarra, Pamplona, Spain,

<sup>3</sup>Instituto de Investigaciones Químicas, CSIC – Universidad de Sevilla, Spain,  
jogarcia@iiq.csic.es

A set of polycationic amphiphilic cyclodextrins (paCDs)<sup>1,2</sup> has been evaluated as therapeutic gene vectors for *in vivo* purposes. The paCDs efficiently complexed and protected pDNA by spontaneously forming monodisperse (<100 nm) and stable nanoparticles (CDplexes), which exhibited positive z-potential. A tetradecacationic structure incorporating 14 primary amino groups and 7 thioureido groups in the primary face of the cyclooligosaccharide core and 14 hexanoyl chains in the secondary face was judged to be optimal. This compound efficiently mediated serum-resistant transfection in human cancer HeLa and HepG2 cell lines, comparing favorably with branched poly(ethyleneimine) (bPEI) and exhibiting a low associated toxicity. Further transfection experiments using an encoding therapeutic gene plasmid (pCMVIL-12) were effected to report expression levels of interleukin-12. *In vivo* gene delivery experiments by systemic injection in mice indicated relatively high transfection levels in the liver, overcoming trapping of the nanoparticles in lung cells (see Figure). The measured levels of luciferase in the liver are comparable to those reported for receptor-targeted liposomes,<sup>3</sup> thus suggesting that paCDs may be well oriented to cytokine-based hepatocellular carcinoma treatment as indicated by the significant transfection levels of IL-12 in HepG2.

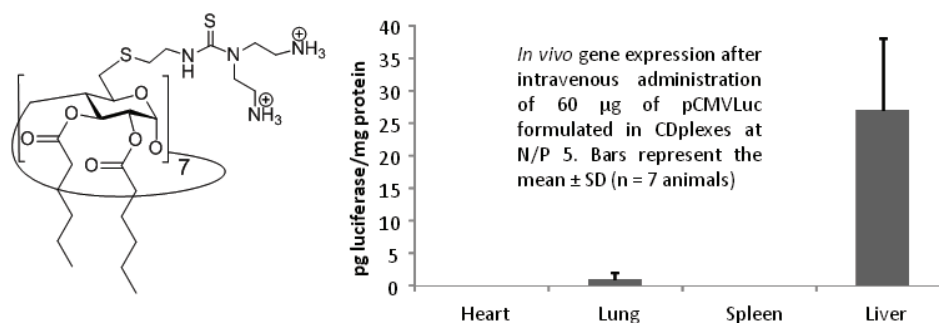

### References

1. A. Díaz-Moscoso, L. Le Gourriérec, P. Balbuena, M. Gómez-García, J. M. Benito, N. Guilleloteau, C. Di Giorgio, P. Vierling, J. Defaye, C. Ortiz Mellet, J. M. García Fernández, *Chem. Eur. J.* **2009**, *15*, 12871-12888.
2. A. Méndez-Ardoy, M. Gómez-García, C. Ortiz Mellet, N. Sevillano, M. Dolores Girón, R. Salto, F. Santoyo-González, J.M. García Fernández, *Org. Biomol. Chem.* **2009**, *7*, 2681-2684.
3. S. Diez, G. Navarro, C. Tros de Ilarduya, *J. Gene Med.* **2009**, *11*, 38-45.

## PO 108

SYNTHESIS OF A CHEMICAL LIBRARY BASED ON MUCIN-1  
FOR RAPID EPITOPE DISCOVERYFayna Garcia-Martin,<sup>1</sup> Takahiko Matsushita,<sup>1</sup> Hiroshi Hinou,<sup>1</sup> Shin-Ichiro Nishimura<sup>1</sup><sup>1</sup> Graduate School of Life Science, Hokkaido University, Sapporo, 001-0021, Japan  
faynagarciam@glyco.sci.hokudai.ac.jp

Certain interested cancer antigens are mucin derived glycopeptides, being mucin-1 (MUC-1) the most known and characterized mucin. Tumoral cells present different glycosylation and expose novel tumor specific peptide epitopes compared to normal cells. Therefore, it is of great interest to get specific cancer-related MUC-1 glycopeptides and anti MUC-1 antibodies for the application on immunotherapy and diagnosis.

Our interest is exploring a high number of different possible combinations in order to develop high specific and strong MUC-1 epitopes. Thus, one bead one compound (OBOC) method was chosen as it is a potent way to accelerate drug discovery by getting high number of compounds on bead in a shorter time. Further, screening analysis can be performed on bead.

In the first library, the glycan structure attached to the MUC-1 peptide sequence was varied in order to explore the specificity and strength of the binding with anti-MUC-1 antibody. During the glycopeptides elongation, a tag corresponding to the glycosyl moieties and position is also achieved to recognize the glycan groups on positive beads. The synthetic strategy to construct the family of analogues was based on using PEG-based resins topologically segregated. The library of glycopeptides was synthesized on the exterior of the resin by using Fmoc chemistry, while the tag was elongated on the interior of the bead by Alloc chemistry.

After synthesis of the MUC-1 glycopeptides and corresponded tags, the beads were screening by two different techniques based on fluorescence and magnetic beads. This method permits to create a high number of glycopeptides and elucidate the specific and high affinity MUC-1 epitopes.

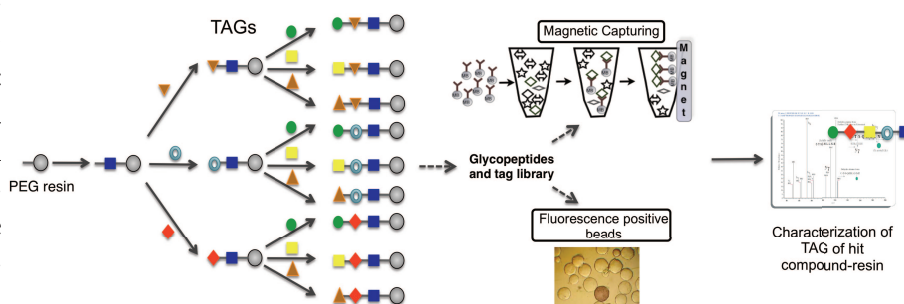

## References

1. Ruiwu Liu, Jan Marik, Kit S Lam, *J Am Chem Soc*, **2002**, 124, 7678-7680.
2. Takahiko Matsushita, Hiroshi Hinou, Shin-Ichiro Nishimura, et al. *J Org Chem*, **2005**, 71, 3051-3063.

## PO 109

**sp<sup>2</sup> –IMINOSUGAR-TYPE (GALACTO)NOJIRIMYCIN ANALOGUES  
WITH PHARMACOLOGICAL CHAPERONE ACTIVITY FOR  
G<sub>M1</sub>-GANGLIOSIDOSIS AND FABRY DISEASE**

T. Mena-Barragán,<sup>1</sup> L. Li,<sup>2</sup> M. Aguilar-Moncayo,<sup>1</sup> M. I. García-Moreno,<sup>1</sup> Z. Luan,<sup>3</sup>  
E. Namba,<sup>2</sup> K. Ohno,<sup>3</sup> C. Ortiz Mellet,<sup>1</sup> K. Higaki,<sup>2</sup> Y. Suzuki,<sup>4</sup> and J. M. García Fernández<sup>5</sup>

<sup>1</sup>Dpto. Química Orgánica, Facultad de Química, Universidad de Sevilla, Spain,

<sup>2</sup>Research Center for Bioscience and Technology, Tottori University, Japan

<sup>3</sup>Institute of Neurological Sciences, Faculty of Medicine, Tottori University, Japan,

<sup>4</sup>International University of Health and Welfare, Graduate School, Otawara, Japan,

<sup>5</sup>Instituto de Investigaciones Químicas, CSIC – Universidad de Sevilla, Spain

isagar@us.es

Lysosomal storage disorders (LSDs) are a clinically heterogeneous group of genetically inherited disorders caused by the deficiency in the activity of a particular lysosomal enzyme. In several LSDs, the mutant enzyme is a glycosidase that retain catalytic activity but has folding defects and undergo endoplasmic reticulum-associated degradation. Some iminosugars with glycosidase inhibitory activity are able to promote the correct folding in mutant forms of the enzymes and their subsequent trafficking to the lysosome, being currently under study as pharmacological chaperones (PCs) for the treatment of some of these pathologies.<sup>1</sup> However, most of the iminosugar-type glycomimetics can inhibit simultaneously various glycosidases, which represents a serious limitation for clinical applications. In order to tackle this problem, we developed a new family of glycomimetics in which the amine-type N-atom typical of iminosugars has been transformed into a pseudoamide-type nitrogen, namely sp<sup>2</sup>-iminosugars. The concept was first demonstrated for Gaucher disease, a LSD associated to mutant b-glucocerebrosidase.<sup>2</sup> Molecular diversity-oriented strategies have now led to promising and very selective PCs candidates for LSDs associated to b-galactosidase (G<sub>M1</sub>-gangliosidosis) and a-galactosidase (Fabry disease).

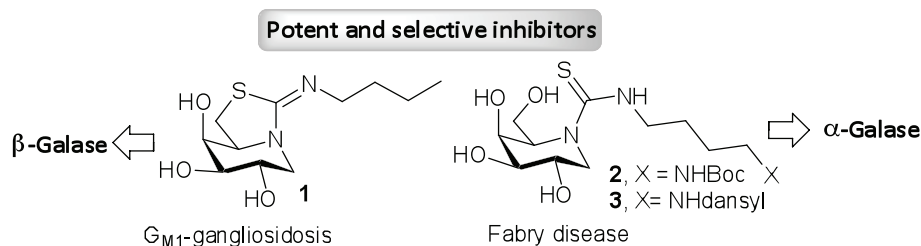

## References

1. T. Wennekes, R. J. B. H. N. van den Berg, R. G. Boot, G. A. van der Marel, H. S. Overkleeft, J. M. G. F. Aerts *Angew. Chem. Int. Ed.* **2009**, *48*, 8848-8869.
2. Z. Luan, K. Higaki, M. Aguilar-Moncayo, H. Ninomiya, K. Ohno, M. I. García-Moreno, C. Ortiz Mellet, J. M. García Fernández, Y. Suzuki, *ChemBioChem*, **2009**, *10*, 2780-2792.

PO 110

## NEW D-ARABINO-CONFIGURED CARBOHYDRATE-BASED HETEROCYCLES AS POTENTIAL GLYCOSIDASE INHIBITORS

Penélope Merino-Montiel, Consolación Gasch, Óscar López, and José G. Fernández-Bolaños*Departamento de Química Orgánica. Universidad de Sevilla. Apto. 1203.**E-41071 Seville. SPAIN.**cgasch@us.es*

The preparation of carbohydrate-based heterocycles is a challenging task in Organic and Medicinal Chemistry, due to the important biological activities exhibited by many of such derivatives, considered to be potential therapeutic agents mainly as antiviral and anticancer drugs.<sup>1</sup> Among the plethora of derivatives reported in the literature, spironucleosides<sup>2</sup> constituted a relatively novel family of this type of compounds. Glycopyranosylidene-spiro derivatives bearing hydantoin, thiohydantoin or oxathiazole scaffolds were found to be among the most potent inhibitors of glycogen phosphorylase<sup>3</sup>, and some other spiranic derivatives of sugars turned out to be potent salivary  $\alpha$ -amylase,<sup>4</sup> or adenylosuccinate synthetase inhibitors.<sup>5</sup> In this context, we have recently reported a series of spiranic pseudonucleosides bearing oxazolidine-, imidazolidine-2-thione (selone), thiohydantoin-, perhydrooxazine- and azetidine heterocycles.<sup>6</sup> On the other hand, interest of triazolic compounds in Medicinal Chemistry has increased due to their capacity to form hydrogen bonds and their high stability to hydrolysis and oxidative/reductive conditions. Recently the synthesis of novel 1*H*-1,2,3-triazoles attached to carbohydrates and their evaluation as  $\alpha$ -glucosidases inhibitors has been reported.<sup>7</sup> In this communication we describe the synthesis of new carbohydrate-based heterocycles *via* the  $\alpha$ -azido ester **1**:  $\alpha$ -triazolyl lactones (**2**) and spiroselehydrodantoin (**3**) and spirothiohydantoin (**4**).

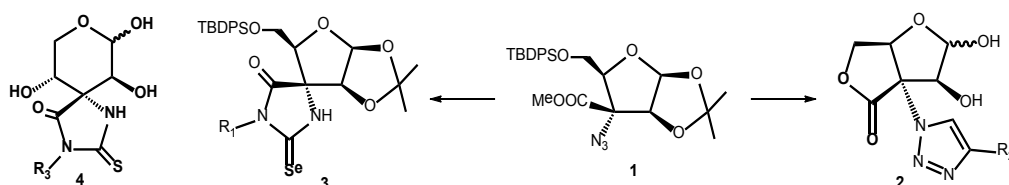

## References

- Romeo, G., Chiacchio, U., Corsaro, A., Merino, P., *Chem. Rev.* **2010**, *110*, 3337-3370.
- Pradhan, R., Patra, M., Behera, A. K., Mishra, B. K., Behera, R. K. *Tetrahedron* **2006**, *62*, 779-828.
- Nagy, V., Benlifa, M., Vidal, S., Berzsényi, E., Teilhet, C., Czifrák, K., Batta, G., Docsa, T., Gergely, P., Somsák, L., Praly, J.-P. *Bioorg. Med. Chem.*, **2009**, *17*, 5696-5707.
- (a) Gyémánt, G., Kandra, L., Nagy, V., Somsák, L. *Biochem. Biophys. Res. Commun.* **2003**, *312*, 334-339. (b) Kandra, L., Zajác, A., Remenyik, J., Gyémánt, G. *Biochem. Biophys. Res. Commun.* **2005**, *334*, 824-828.
- Hanessian, S., Lu, P.-P., Sancéau, J.-Y., Chemla, P., Gohda, K., Fonne-Pfister, R., Prade, L., Cowan-Jacob, S. W. *Angew. Chem., Int. Ed.* **1999**, *38*, 3159-3162.
- Gasch, C., Merino-Montiel, P., López, O., Fernández-Bolaños, J. G., Fuentes, J. *Tetrahedron* **2010**, *66*, 9964-9973 and references of the same authors therein contained.
- Ferreira, S. B., Sodero, A. C. R., Cardoso, M. F. C., Lima, E. S., Kaiser, C. R., Silva, F. P., Jr., Ferreira, V. F. *J. Med. Chem.*, **2010**, *53*, 2364-2375.

PO 111

**HIGHLY CONVERGENT SYNTHESIS OF THREE MONO- AND DI-O-ACETYLATED DECASACCHARIDES AS MIMICS OF THE *SHIGELLA FLEXNERI* SEROTYPE 2A O-ANTIGEN**

Charles Gauthier, Pierre Chassagne, Catherine Guerreiro, Laurence A. Mulard\*

*Institut Pasteur, Chimie des Biomolécules (URA CNRS 2128), 28 rue du Dr Roux,  
75015 Paris, France  
laurence.mulard@pasteur.fr*

*Shigella flexneri* serotype 2a (SF2a) is an enteroinvasive bacteria causing bacillary dysentery in developing countries.<sup>1</sup> The O-antigen (O-Ag) part of the SF2a lipopolysaccharide represents an important target for the development of carbohydrate-based vaccines.<sup>2</sup> The SF2a Ag-O consists of a repeating pentasaccharide unit [AB(E)CD], which is non-stoichiometrically acetylated at both the 6<sub>D</sub> and 3<sub>A</sub> positions.<sup>3</sup> This contribution describes the highly convergent synthesis of three mono- and di-O-acetylated deca-saccharides (**1-3**) corresponding to two repeating units of SF2a O-Ag, by use of a common deca-saccharide scaffold. The synthesis of novel rhamnose and glucosamine donors (**4-7**) featuring different neighboring participating groups, and that of a new glucosamine acceptor (**8**) will be presented. Next, the various routes, which were evaluated for elaboration of key tetra- and pentasaccharide building blocks, and their combination into a fully protected deca-saccharide intermediate, will be discussed. Last, the optimization of the regioselective deprotection and O-acetylation steps leading to the targets (**1-3**) will be described.

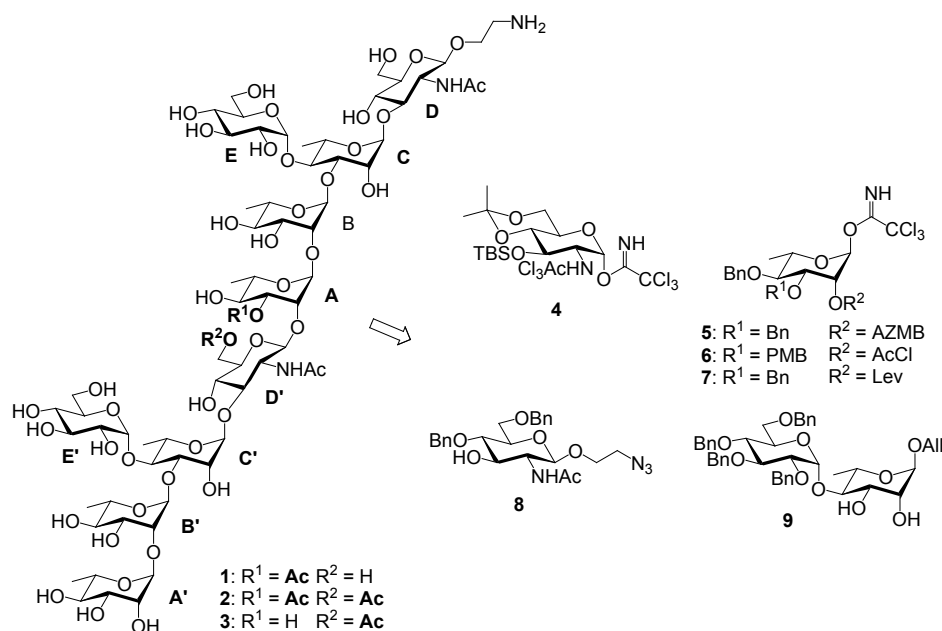

### References

- Phalipon A, Mulard LA, Sansonetti PJ, *Microbes Infect*, **2008**, *10*, 1057-1062.
- Phalipon A, Tanguy M, Grandjean C, Guerreiro C, Belot F, Cohen D, Sansonetti PJ, Mulard LA, *J Immunol*, **2009**, *182*, 2241-2247.
- Kubler-Kielb J, Vinogradov E, Chu C, Schneerson R, *Carbohydr Res*, **2007**, *342*, 643-647.

## PO 112

**OPTIMIZED LINKAGE ANALYSIS OF OLIGO- AND POLYSIALIC ACIDS  
BY FLUORESCENCE LABELING AND PERMETHYLATION**

Sebastian P. Galuska<sup>1</sup>, Hildegard Geyer<sup>1</sup>, Werner Mink<sup>1</sup>, Peter Kaese<sup>1</sup>, Rita Gerardy-Schahn<sup>2</sup>,  
and Rudolf Geyer<sup>1\*</sup>

<sup>1</sup>*Institute of Biochemistry, Faculty of Medicine, University of Giessen, Friedrichstrasse 24,  
D35392 Giessen, Germany*

<sup>2</sup>*Institute of Cellular Chemistry, Hannover Medical School, Carl-Neuberg-Str. 1,  
D30625 Hannover, Germany  
hildegard.geyer@biochemie.med.uni-giessen.de*

Oligo- and polysialic acid (oligo- and polySia) chains can be synthesized by many prokaryotic as well as eukaryotic organisms and are involved in a number of distinct biological processes depending on their chain lengths, the type of sialic acids present and their glycosidic linkages. For the determination of the length of the oligomer/polymer chains and the sialic acid constituents a wide panel of highly sensitive techniques is available, but no microscale method exists for linkage analysis. Here, we describe a highly sensitive procedure for the analysis of the glycosidic linkages present within oligo- and polySia chains by permethylation after preceding fluorescence labeling of the reducing end. Using  $\alpha$ 2,8- and  $\alpha$ 2,9-linked sialic acid polymers the type of linkage could be determined employing less than 10 ng of each polymer. Moreover, a mixture of different oligo- and polySia species can be separated by anion-exchange chromatography after fluorescence labeling and peaks of interest can be collected individually for methylation analysis. The described strategy offers a very sensitive and efficient detection of internal sialic acid residues and their glycosidic linkages.



PO 113

REDUCING-END FUNCTIONALISATION OF (1→4)-β-D-MANNURONAN  
AND (1→4)-α-L-GULURONAN OLIGOMERS IN AQUEOUS SOLUTION:  
TOO BIG A CHALLENGE?

Ali Ghadban, Luca Albertin, Alain Heyraud

Centre de Recherches sur les Macromolécules Végétales (CERMAV-CNRS),  
Affiliated with Université Joseph Fourier, and member of the Institut de Chimie Moléculaire  
de Grenoble BP53, 38041 Grenoble cedex 9, France  
ali.ghadban@cermav.cnrs.fr

Oligomers of (1→4)-β-D-mannuronan and (1→4)-α-L-guluronan can be prepared on a multi-gram scale by acid hydrolysis of alginate samples followed by selective precipitation.<sup>1,2</sup> Besides possessing interesting physical properties, this type of oligosaccharides are potent immune-stimulating agents and induce cytokine production by monocytes.<sup>3,4</sup> Also, they appear to elicit the growth of plants<sup>5,6</sup> and Bifidobacteria.<sup>7</sup> In order to incorporate oligo(uronic acid)s into glycoconjugates, it would be advantageous to selectively functionalise their reducing end without resorting to protective groups' chemistry. In our group, we have explored two strategies for introducing a primary amino group at the hemiacetal end of oligo(alginate)s directly in aqueous solution: reductive amination and transformation into the corresponding glycosylamine. Both strategies proved to be a challenge, and the respective advantages and disadvantages will be discussed in this communication.

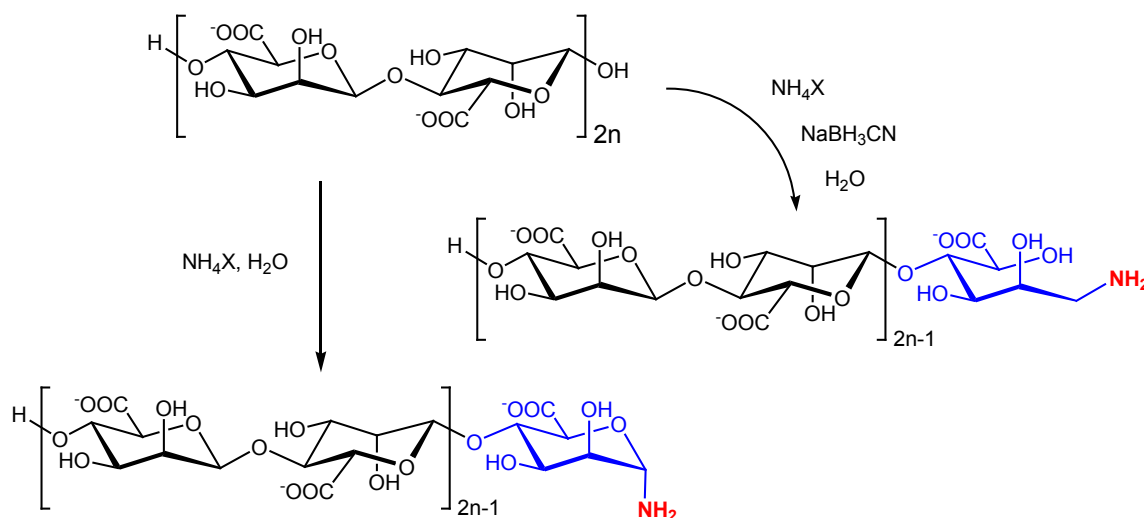

### References

- Haug, A.; Larsen, B.; Smidsroed, O. *Acta Chem Scand* **1963**, 17, (5), 1466-1468.
- Haug, A.; Larsen, B.; Smidsroed, O. *Acta Chem Scand* **1966**, 20, (1), 183-190.
- Otterlei, M. et al. *J. Immunother.* **1991**, 10, (4), 286-291.
- Otterlei, M. et al. *Infect. Imm.* **1993**, 61, (5), 1917-1925.
- Natsume, M.; Kamo, Y.; Hirayama, M.; Adachi, T. *Carbohydrate Research* **1994**, 258, 187-197.
- Yonemoto, Y. et al. *Journal of Fermentation and Bioengineering* **1993**, 75, (1), 68-70.
- Akiyama, H. et al. *Bioscience, Biotechnology, and Biochemistry* **1992**, 56, (2), 355-356.

PO 114

## SYNTHESIS OF HYDROPHOBIC *N*-ALKYLATED IMINOSUGARS AS POTENT AND SELECTIVE INHIBITORS OF GLUCOSYLCERAMIDE METABOLISM

Amar B.T Ghisaidoobe,<sup>1</sup> Bart van Ommen,<sup>1</sup> Nuria R. Monsalves,<sup>1</sup>  
Richard J.B.H.N van den Berg,<sup>1</sup> Johannes M.F.G Aerts,<sup>2</sup> Gijs A. van der Marel<sup>1</sup>  
and Herman S. Overkleeft<sup>1</sup>

<sup>1</sup>Leiden Institute of Chemistry, P.O Box 9502, 2300 RA Leiden, The Netherlands.

<sup>2</sup>Department of Medical Biochemistry, Academic Medical Center, Amsterdam, The Netherlands  
A.ghisaidoobe@chem.leidenuniv.nl

Lipophilic iminosugars are widely employed to inhibit different carbohydrate processing enzymes.<sup>1</sup> It is believed that iminosugars act as mimic of the oxacarbenium-ion transition state, resulting in potent inhibition of these enzymes.

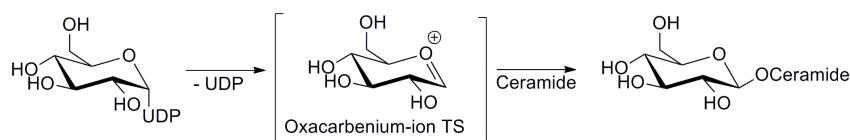

**Scheme 1:** Biosynthesis of glucosylceramide mediated by glucosylceramide synthase.

Several classes of *N*-alkylated iminosugars were synthesized to evaluate their effects on the enzymes involved in the glucosylceramide metabolism. These iminosugars were designed to incorporate several features of the oxacarbenium-ion TS as well as the product.

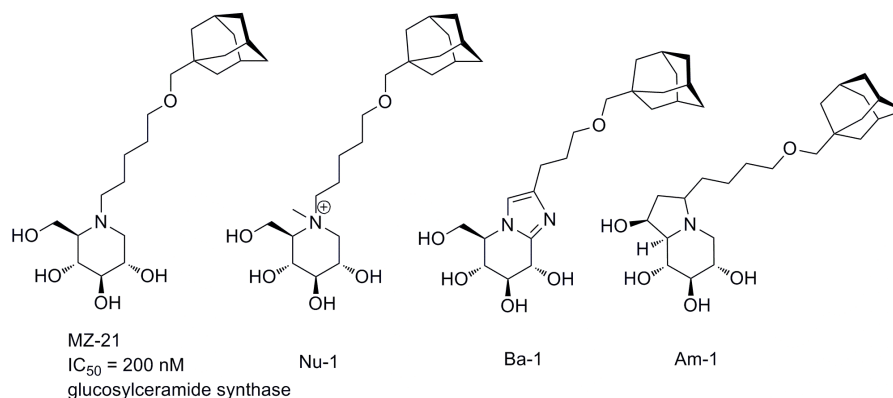

**Figure 1:** Lead structure MZ-21<sup>2</sup> and four different classes of hydrophobic iminosugars.

### References

1. Phelippe Compain and Oliver R. Martin; Iminosugars: From synthesis to therapeutic applications, France, Wiley 2007.
2. Overkleeft, H.S. et al. *J. Biol Chem.* **1998**, 273, 26522-26527.

PO 115

**STRUCTURES OF THE O-SPECIFIC POLYSACCHARIDE CHAIN OF THE LIPOPOLYSACCHARIDE AND CAPSULAR POLYSACCHARIDE ISOLATED FROM *A. PUNCTATA* AMG272**

Rocío Contreras,<sup>1</sup> Miguel Ángel Rodríguez-Carvajal,<sup>1</sup> M<sup>a</sup> del Rosario Espuny,<sup>2</sup>  
F. Javier Ollero- Márquez,<sup>2</sup> and Antonio M. Gil-Serrano<sup>1</sup>

<sup>1</sup> Department of Organic Chemistry, Faculty of Chemistry, University of Seville

<sup>2</sup> Department of Microbiology, Faculty of Biology, University of Seville

Agil@us.es

*A. punctata* AMG272 is a Gram-negative bacterium that has been isolated from agricultural soil and studied for their plant growth-promoting activities such as production of indole acetic acid and siderophores.<sup>1-2</sup> The outer membrane of almost Gram-negative bacteria is composed of phospholipids, lipopolysaccharide (LPS), proteins and capsular (CPS) or loosely adherent polysaccharides that mediate cellular interactions with diverse environments. Lipopolysaccharide is composed of three distinct regions: lipid A, core oligosaccharide and O-antigen polysaccharide which can be separated by mild acid hydrolysis. The aim of this work is to isolate and elucidate the structure of the O-specific polysaccharide chain of *A. punctata* AMG272 lipopolysaccharide and its capsular polysaccharide. LPS and CPS were separated by size exclusion chromatography on Sephacryl S-500 from aqueous-phenolic extract<sup>3</sup> of freeze-dried bacterial *A. punctata* AMG272 cells. Their structures were elucidated using NMR spectroscopy and GC-MS (Figure 1 y 2). Remarkable is the presence of a peculiar aminosugar rarely occurring component of bacterial polysaccharide, Fucp3NAc that is almost exclusively found in phytopathogenic O-antigens.

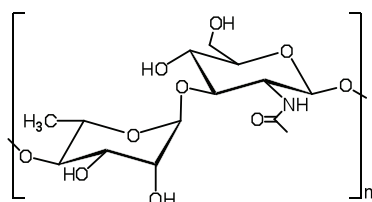

→4)-α-L-Rhap-(1→3)-β-D-GlcpNAc-(1→

**Figure 1.** Structures of the repeating unit of the O-antigen isolated from *A. Punctata* AMG272.

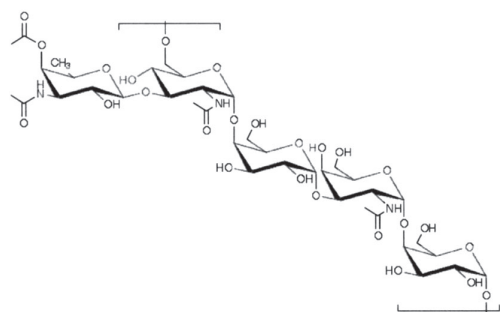

→6)[β-D-Fucp3NAc4Ac-(1→3)]-α-D-GlcpNAc-(1→  
→4)-α-D-Galp-(1→3)-α-D-GalpNAc-(1→4)-α-D-Galp-(1→

**Figure 2.** Structure of the repeating unit of the capsular polysaccharide isolated from *A. Punctata* AMG272.

### References

1. Lambrecht, M., Okon, Y., Vande, B. A., *Trends Microbiol.*, **2000**, 8, 298-300.
2. Scher, F. M., Baker, R., *Phytopathology*, **1982**, 72, 1567-73.
3. Westphal, O., Jann, K., *Methods Carbohydr. Chem.*, **1965**, 5, 83-91.

PO 116

**SYNTHESIS AND CHARACTERIZATION  
OF CARBOHYDRATE-FUNCTIONALIZED GRAPHITE NANOFIBERS**John A. Hull, Hye Jin Yoo, and Robert Giuliano*Department of Chemistry, Villanova University, Villanova, PA, 19085**robert.giuliano@villanova.edu*

Graphite nanofibers (GNFs) are novel nanoscale materials that can be prepared inexpensively, in gram quantities, via the catalytic decomposition of carbon monoxide or hydrocarbons over mono- or bi-metallic catalysts. GNFs have potential for applications across a diverse spectrum of research areas in chemistry, biology, medicine, and energy storage. Surface functionalization and characterization are both critical to the further development of GNFs. Recently, we were able to identify and quantify surface aldehyde/ketone, carboxyl, and hydroxyl groups on oxidized herringbone GNFs using a technique known as FLOSS (Fluorescent Labeling of Surface Species).<sup>1</sup> Information that was obtained about the surface chemistry of GNFs is now being used to guide the covalent functionalization of the fiber surface with amino sugars, aminoglycoside antibiotics, and other carbohydrates.

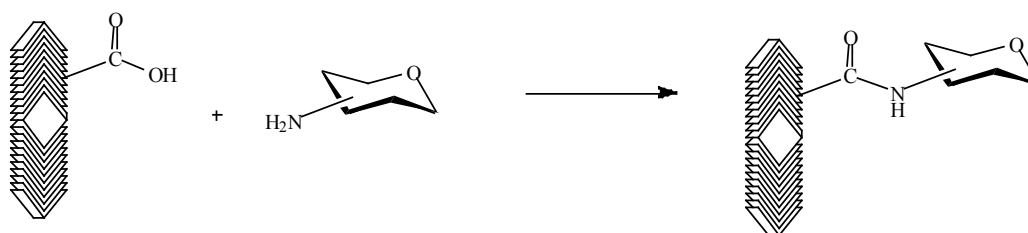

Herringbone GNF

**Reference**

1. T. Pellenbarg, N. Dimentev, R. Jean-Gilles, C. Bessel, E. Borguet, N. Dollahon, and R. Giuliano, "Detecting and Quantifying Oxygen Functional Groups on Graphite Nanofibers by Fluorescence Labeling of Surface Species," *Carbon* **2010**, 48, 4256-4267.

## PO 117

## SYNTHESIS AND COUPLING REACTIONS OF CYCLOPROPYL GLYCOSIDES

Clark Scholl and Robert Giuliano

*Department of Chemistry, Villanova University, Villanova, PA, 19085*  
*robert.giuliano@villanova.edu*

Our laboratory has been investigating the synthesis of cyclopropyl glycosides and their use as glycosyl donors. Cyclopropyl glycosides containing different substituents were prepared by cyclopropanation of the corresponding vinyl glycosides,<sup>1</sup> or by glycosidation of cyclopropyl alcohols, which are synthesized by the Kulinkovich reaction.

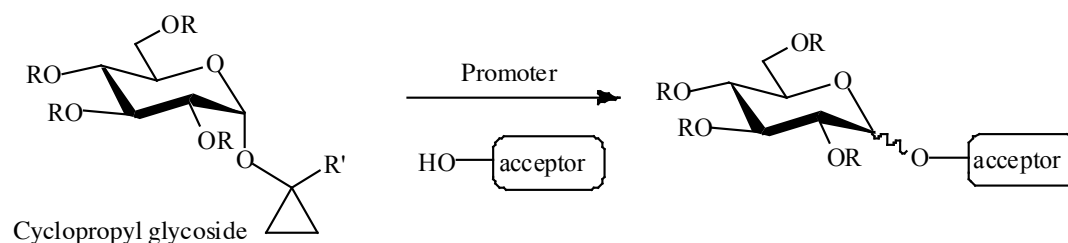

Methyl-substituted cyclopropyl glycosides ( $R=CH_3$ ) undergo coupling to Fmoc-protected serine and threonine in the presence of TMS triflate to give glycosidated amino acids. Cyclopropyl-based glycosidations of other acceptors were carried out to determine the scope and limitations of this reaction in glycoside synthesis.

**References**

1. K. D. Hughes, T.-L. Nguyen, D. Dyckman, D. Dulay, W. J. Boyko, and R. M. Giuliano, "Synthesis of Vinyl Glycosides and Carbohydrate Vinyl Ethers by the Gassman Reaction. A Hetero-Diels-Alder Approach to Deoxygenated Disaccharides," *Tetrahedron: Asymmetry*, **2005**, *16*, 273-282.

PO 118

**CHEMICAL STRUCTURE OF THE POLYSACCHARIDES FROM ENDEMIC MONGOLIAN DESERT PLANTS AND THEIR EFFECT ON THE INTESTINAL PERMEABILITY**

Victoria Golovchenko<sup>1</sup>, Daria Khramova<sup>1</sup>, Alexandre Shashkov<sup>2</sup>, Dorjgoo Otgonbayar<sup>3</sup>,  
Aria Chimidsogzol<sup>3</sup>

<sup>1</sup>*Institute of Physiology, Komi Science Centre, The Urals Branch of the Russian Academy of Sciences, 50, Pervomaiskaya str., Syktyvkar, 167982, Russia*

<sup>2</sup>*N.D.Zelinsky Institute of Organic Chemistry, Russian Academy of Sciences, 47, Leninsky prospect, Moscow, 119991, Russia*

<sup>3</sup>*Institute of Chemistry and Chemical Technology, the Mongolian  
gol@physiol.komisc.ru*

Using successive extraction with water, aqueous hydrochloric acid (pH 4.0), and 0.5 % aqueous ammonium oxalate, pectic polysaccharides were isolated from the plants growing in the arid climate of Mongolia (Gobi) as follows: *Dontostemon dentatus* (Bunge) Ledeb., *Halogeton glomeratus* (M. Bieb.) C.A. Mey., *Nitraria sibirica* Pall., *Peganum garmala* L., *Rheum nanum* Sievers, *Haloxylon ammodendron* Maxim, *Zygophyllum gobicum* Maxim., *Amygdalus mongolica* Maxim. The data obtained demonstrate that the cell wall pectic polysaccharides appeared to be synthesized mainly by plants growing in the dry climatic zone. Yield of the pectins was shown to reach 4%. Water soluble pectins were identified only in *Rheum* and *Haloxylon*, their contents were shown to be 2.6% and 0.4% of dried raw materials. Structural carbohydrate chemistry in combination with NMR spectroscopy demonstrated that that pectic polysaccharides were composed of the backbone comprised regions of linear 1,4- $\alpha$ -D-galacturonan and ramified regions RG-I. Galacturonan was determined to be a substantial part of the macromolecule of pectins from *Dontostemon*, *Halogeton*, *Rheum*, *Haloxylon*, *Zygophyllum*. A higher degree of methyl esterification was observed in the pectic polysaccharides of *Bassia* (51%), *Rheum* (in fraction extracted with water – 33%, with ammonium oxalate – 48%), *Haloxylon* (in fraction extracted with water – 30%, with ammonium oxalate – 31%), *Amygdalus* (25%), *Zygophyllum* and *Nitraria* (18%). The pectic polysaccharides from *Peganum*, *Nitraria* and *Amygdalus* included the regions of RG-I, that contained the rhamnose residues substituted in 4-position with the terminal residues of L-arabinose and the residues of this sugar substituted in 5-, and 3,5-positions as well as the galactose residues substituted in 4-, 4,6-, and 3,4-positions. The pectic polysaccharides from endemic Mongolian desert plants were shown to decrease the intestinal permeability to ovalbumin. The decrease in the penetration of immunogenic OVA into the serum was shown to accompany with the protein sorption by the pectic macromolecule.



## PO 119

## HYDROGELS BASED ON CHITOSAN FOR BIOMEDICAL APPLICATIONS

G. Gomez d'Ayala<sup>1</sup>, P. Laurienzo<sup>1</sup>, G. Maglio<sup>2</sup>, M. Malinconico<sup>1</sup>, P. Tirino<sup>2</sup>, R. Palumbo<sup>2</sup>

<sup>1</sup>*Institute of Polymer Chemistry and Technology, CNR, via Campi Flegrei 34,  
Pozzuoli (Naples), Italy*

<sup>2</sup>*Chemistry Department "Paolo Corradini", University of Naples Federico II,  
via Cinthia, Naples, Italy  
giovanna.gomez@ictp.cnr.it*

Hydrogels, due to their biocompatibility, flexible methods of synthesis, range of constituents, and desirable physical characteristics, have been the material of choice for many applications in regenerative medicine.<sup>1</sup> Polysaccharide-based hydrogels are very close to natural ECM, which contains HA as a component and, in particular, chitosan-based hydrogels are widely used in tissue engineering for its high biocompatibility and antimicrobial properties. Nevertheless, their hydrophilic nature is able to discourage protein absorption and, in turn, cell anchorage. As a consequence, chemical modification by insertion of hydrophobic segments, as synthetic biocompatible polymers, is usually performed for such applications.<sup>2</sup> Traditional hydrogel synthesis relies upon uncontrolled crosslinking methods, such as radical chemistry. This results in poorly defined materials and increases the difficulty in relating the network structure to the final physical properties of the gel. In the present work, we will report on new hydrogels based on chitosan characterized by controlled crosslinking segment length and three-dimensional structure. A well-defined hydrogel network structure is highly desirable for tissue constructs as well as for drug delivery. The synthesis is based on new methods of crosslinking that utilize "click" reactions, recently proposed in the case of polyethylenglycole (PEG) hydrogels.<sup>3</sup> "Click" chemistry provides mild reaction conditions with high chemical selectivity. Chitosan has been first functionalized by insertion of azido groups, which are able to react with alkyne groups via the "click"-Cu(I) catalyzed cycloaddition. Mono-alkyl or di-alkyl terminated polymers, as PEG or polycaprolactone (PCL), will be used either to reduce hydrophylicity or to form crosslinks between chitosan chains. The amino groups on chitosan have been previously protected by a selective reaction with isophthaloyl anhydride, in order to increase its solubility in organic solvents, then deprotected in the final copolymer. The intermediates and the products of synthesis have been chemically characterized through elemental analysis, NMR and FTIR spectroscopies, while the structure of hydrogels (homogeneity and dimension of pores) will be evaluated by Environmental Scanning Electron Microscopy (ESEM).

### References

1. V. B. Slaughter, S. S. Khurshid, O. Z. Fisher, . Khademhosseini, N. A. Peppas. *Adv. Mater.*, **2009**, *21*, 3307-3329
2. P. Laurienzo, M. Malinconico, A. Motta, A. Vicinanza, *Carbohydr Polym*, **2005**, *62*, 274-282.
3. M. Malkoch, R. Vestberg, N. Gupta, L. Mespouille, P. Dubois, A. F. Mason, J. L. Hedrick, Q. Liao, C.W. Frank, K. Kingsbury , C. J. Hawker. *Chem. Commun.*, **2006**, 2774-2776

PO 120

**BIOPOLYMER PRODUCTION BY AN EXTREMOPHILIC BACTERIA,  
*Halomonas* STRAIN CRSS DSM 15686 : INSIGHTS FROM GENOME  
SCALE METABOLIC MODEL**

Gonca Özdemir, Özlem Ateş, Ebru Toksoy Öner, Kazim Yalcin Arga

*Department of Bioengineering, Marmara University, Goztepe 34722, Istanbul, Turkey*

Exopolysaccharides (EPSs) make up a substantial component of the extracellular polymers surrounding most microbial cells in extreme environments like Antarctic ecosystems, saline lakes, geothermal springs or deep sea hydrothermal vents. The extremophiles have developed various adaptation mechanisms, enabling them to compensate for the deleterious effects of extreme conditions, e.g. high temperatures, salt, low pH or temperature, high radiation. Among these adaptation strategies, EPS biosynthesis is one of the most common protective mechanisms. The unusual metabolic pathways revealed in some extremophiles raised interest in extremophilic microorganisms as potential producers of EPSs with novel and unusual characteristics and functional activities under extreme conditions.

A haloalkalophilic strain CRSS, isolated from salt sediments in Antarctica, produces exocellular polysaccharides. The composition of media strongly affects the nature of the polymers. Acetate was the most efficient carbon source for EPS production and in presence of this substrate; a novel fructo-glucan polysaccharide is produced, which is composed of glucose, fructose, and glucosamine in relative proportions of 1:0.7:0.3. Glucosamine, a molecule derived from the sugar glucose by the addition of an amino (NH<sub>2</sub>) group, is a component of a number of structures including the blood group substances and cartilage and glucosamine has been marketed as a “cartilage rebuilders” in rebuilding cartilage that is damaged by osteoarthritis. Therefore, the glucosamine content of the EPS has gained industrial importance.

Besides production, systemic *in silico* analyses of metabolic and biotechnological capacities of the haloalkalophilic strain CRSS should be researched under systems biology perspective. The metabolic and regulatory mechanisms should be represented by informative mathematical models in genome-scale. These models should be able not only to represent the potential of the network in terms of phenotypic characterization but also to predict metabolic fluxes and active regulation mechanisms during osmoadaptation, both of which were consistent with the experimental data from phenome, fluxome, metabolome and transcriptome levels. The reconstructed model will accelerate the research on extremophilic bacteria towards application of systems biology approaches and design of metabolic engineering strategies for EPS production.

## PO 121

PRELIMINARY STUDIES OF MYCOLIC ACID STRUCTURE DIVERSITY  
IN NOCARDIA SPECIES

Sabina Górska-Frączek<sup>1,2</sup>, Mariola Paściak<sup>1,2</sup>, Paulina Gąsecka<sup>1</sup> and Andrzej Gamian<sup>1,2</sup>

<sup>1</sup>L. Hirszfeld Institute of Immunology and Experimental Therapy,  
Polish Academy of Sciences, Weigla 12, 53-114 Wrocław, Poland

<sup>2</sup> Wrocławskie Centrum Badań EIT+ Sp. z o.o., Stabłowicka 147/149, 54-066 Wrocław, Poland  
pasciak@iitd.pan.wroc.pl

Mycolic acids are complex hydroxylated branched-chain fatty acids with increased carbon numbers (20-90). They may also contain diverse functional groups such as methoxy, keto, epoxy ester group and cyclopropane ring<sup>1</sup> or form complexes with glycolipids.<sup>2</sup> They are localized in the inner leaflet of the bacterial cell wall either covalently bound or loosely associated with arabinogalactan polymers. Mycolic acids are found in the mycolata taxon, a group of bacteria that included *Mycobacterium*, *Rhodococcus*, *Nocardia*, *Corynebacterium*. They are involved in maintaining a rigid cell shape but also they contribute to resistance to chemical injury and to protection of cells against hydrophobic antibiotics e.g. the presence of mycolic acids gives *M. tuberculosis* many characteristics that defy medical treatment.

In our studies we focused on nocardiomycolic acids characteristics which could be useful in chemiotaxonomic purposes. Nocardiosis, an opportunistic infection mostly of lungs is caused by bacteria belonging to *Nocardia asteroides* complex that includes three actinobacterial species: *N. asteroides*, *N. farcinica*, *N. nova*. Clinical evidences indicate that *N. cyriacigeorgica* is also isolated with increasing frequency from clinical specimens, and especially from immunocompromised patients.<sup>3</sup> Proper identification and classification of these bacteria is still not very well elaborated.

Mycolic esters were prepared by alkaline and acid methanolysis of bacterial cells after removal of free lipids by extraction with chloroform:methanol. The mycolate methyl esters of the four strains (*N. asteroides*, *N. farcinica*, *N. nova*, *N. cyriacigeorgica*) were determined by analytical thin layer chromatography. We developed new method of mycolic acid esters separation by column chromatography. Pure mycolic acids were analyzed by MALDI-ToF mass spectrometry. Results indicate that carbon chain lengths of mycolic acid are specific for particular *Nocardia* species.

### References

1. Barry CE, *Prog Lipid Res*, **1998**, 37, 143-79.
2. Han Y, He H, Oka S, Yano I. *Acta Leprol.* **1989**,7, 130-2.
3. Schlager R, Huard RC, Della-Latta P. *J Clin Micro.* **2008**, 46, 265-273.

PO 122

### SQUARIC ACID MONOAMIDE MANNOSIDES AS LIGANDS FOR THE BACTERIAL LECTIN FimH: COVALENT INHIBITION OR NOT?

Carsten Grabosch, Mirja Hartmann, Jörn Schmidt-Lassen, Thisbe K. Lindhorst

Christiana Albertina University of Kiel, Otto-Hahn-Platz 4, D-24098 Kiel  
cgrabosch@oc.uni-kiel.de

Bacterial infections are a global health problem is effected by bacterial infections, especially threatening the health of young children.<sup>1</sup> The most common serious neonatal infections involve bacteraemia, meningitis, and respiratory tract infections.<sup>2</sup> Key pathogens in these infections are *Escherichia coli*, *Klebsiella spp.*, *Staphylococcus aureus* and *Streptococcus pyogenes*. For the colonization of cell surfaces they express adhesive organells, so-called fimbriae or pilli on their surface. Type 1 fimbriae possess a mannose-specific lectin at their tips, called FimH. The FimH structure has been elucidated in X-ray studies, however, the *in vivo*-process of bacterial adhesion is not fully understood as yet.<sup>3</sup>

Therefore, carbohydrate recognition by FimH is still under investigation in *in vivo* as well as *in vitro* studies. Previous work from our laboratory has revealed that mannosidic squaric acid

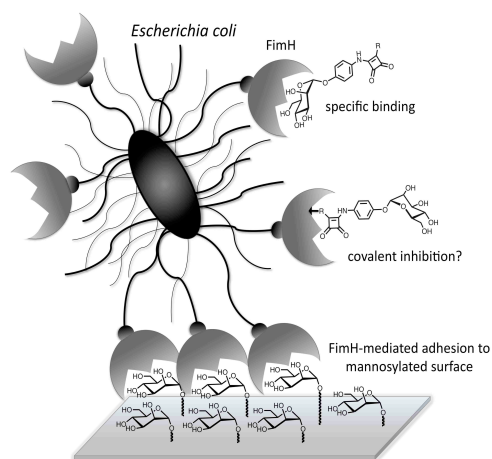

monoamides serve especially well as inhibitors of type 1 fimbriae-mediated bacterial adhesion.<sup>4</sup> This effect is either due to specific inhibition of the bacterial lectin FimH or owed to unspecific bioconjugation between the lectin's carbohydrate binding site and a squaric acid monoamide (Figure 1). The possibility of covalent cross-linking of squaric acid monoamides with the lectin to form the respective squaric acid diamide, was investigated by two different adhesion assays<sup>5,6</sup> in a systematic study employing tailor-made mannosides and other control compounds and has been supplemented by molecular docking.

**Figure 1:** Cartoon of the adhesion of *E. coli* to glycosylated surfaces and its inhibition by addition of appropriate mannosides. [5,6] Copyright: Mirja Hartmann.

#### References

1. E. K. Mulholland, R. A. Adegbola, *N. Engl. J. Med.*, **2005**, 352, 75-77.
2. D. Osrin, S. Vergnano, A. Costello, *Curr. Opin. Infect. Dis.*, **2004**, 17, 217-224.
3. S. D. Knight, J. Buckaert, *Topics Curr. Chem.*, **2009**, 288, 67-107.
4. O. Sperling, A. Fuchs, Th. K. Lindhorst, *Org. Biomol. Chem.*, **1996**, 4, 3913-3922.
5. M. Hartmann, A. K. Horst, P. Klemm, Th. K. Lindhorst, *Chem. Commun.*, **2010**, 46, 330-332.
6. C. Grabosch, M. Hartmann, J. Schmidt-Lassen, Th. K. Lindhorst, *ChemBioChem*, **2011**, in press.

PO 123

## SYNTHESIS OF NEW AMINOSUGARS AS POTENTIAL ACTIVATORS OF NATURAL KILLER CELLS

Giorgio Catelani,<sup>1</sup> Felicia D'Andrea,<sup>1</sup> Tiziana Gragnani,<sup>1</sup> Alessio Griselli,<sup>1</sup> Karel Křenek,<sup>2</sup>  
Karel Bezouška,<sup>2,3</sup> Vladimír Křen<sup>2</sup>

<sup>1</sup>*Dipartimento di Scienze Farmaceutiche, Università di Pisa, Via Bonanno 33, 56126 Pisa (I);*

<sup>2</sup>*Institute of Microbiology, Czech Academy of Sciences, Videnska 1083, 14220 Praha 4 (CZ);*

<sup>3</sup>*Faculty of Sciences, Department of Biochemistry, Charles University, Praha (CZ)*

*tiziana.gragnani@for.unipi.it*

Natural Killer (NK) cells are key component of innate immunity playing an early protection against viruses, parasites and microbial pathogens. Interestingly, D-deoxynojirimycin (DNJ) and its glycosylated derivatives **1a** and **1b** have been recognized as agonists of the NK cell receptors NKR-P1 and CD69.<sup>1a</sup> On the basis of these results, we have planned the synthesis of two new azadisaccharides **1c** and **1d** and of PAMAM-based glycodendrimers loaded with DNJ,  $\beta$ -D-ManpNAc-(1 $\rightarrow$ 4)-D-DNJ (**1b**) and the control disaccharide  $\beta$ -D-ManpNAc-(1 $\rightarrow$ 4)-D-Glc.

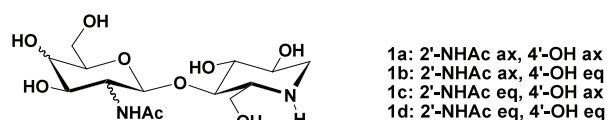

The preparation of building blocks **4** and **6** to be loaded on dendritic matrices was achieved starting from the known derivative **2**.<sup>1b</sup> Key intermediate for the synthesis of azadisaccharide **4** was the 1,5-dicarbonyl disaccharide **3**, that was submitted to a double reductive aminocyclization with mono-*N*-Boc protected ethanolamine hydrochloride and sodium cyanoborohydride. Disaccharide **6**, oxygenated analogue of **4**, was in turn obtained by glycosidation of *N*-Boc-propanolamine with disaccharide glycosyl donors **5**.

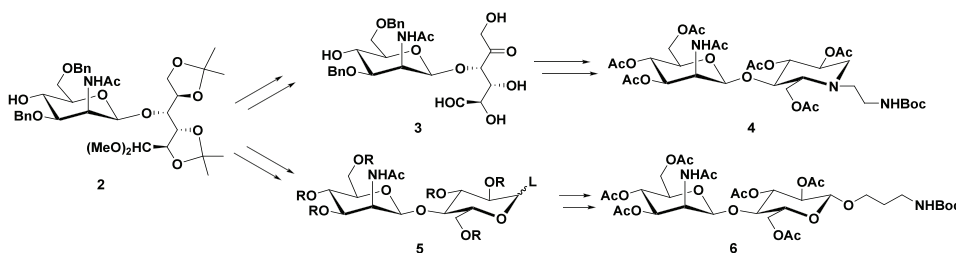

The loading of **4** and **6** on PAMAM dendrons following the thioureidic bridge approach, was finally performed in satisfactory yield.

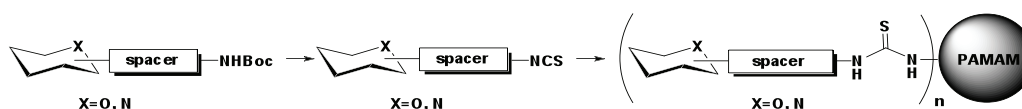

### References

- a) Catelani, G.; D'Andrea, F.; Griselli, A.; Guazzelli, L.; Nemcova, P.; Bezouška, K.; Křenek, K.; Křen, V. *Bioorg. Med. Chem. Letters*, **2010**, *20*, 4645-4648; b) Attolino, E.; Bonaccorsi, F.; Catelani, G.; D'Andrea, F.; Křenek, K.; Bezouška, K.; Křen, V. *J. Carbohydr. Chem.* **2008**, *27*, 156-171.

PO 124

## GLYCOSYL-DISULFIDE-BASED OLIGOSACCHARIDE SYNTHESIS

Elizabeth. J. Grayson<sup>1</sup>, and Benjamin. G. Davis<sup>2</sup><sup>1</sup>Department of Chemistry, Durham University, Durham DH1 3LE, UK<sup>2</sup>Chemistry Research Laboratory, University of Oxford, Oxford OX1 3TA, UK

e.j.grayson@durham.ac.uk

Thioglycosides are widely used as glycosyl donors in oligosaccharide synthesis<sup>1</sup>. We have found that glycosyl disulfides exhibit reactivity similar to that of thioglycosides in glycosylation reactions<sup>2</sup>. However, they have the advantage that the disulfide linkage can be readily cleaved to allow the aglycon to be adjusted for reactivity tuning. We have exploited this in the synthesis of a glucose-based trisaccharide and a rhamnose-based pentasaccharide<sup>3</sup>. We are now extending the methodology by testing the viability of using a galactosyl disulfide **2a** and a glucosyl methanethiosulfonate **2b** as glycosyl acceptors to give disaccharides **3a** and **3b**. Aglycon alteration gives the active donors **4a** and **4b**, which can then undergo glycosylations with diacetone galactose **5** to give model trisaccharides **6a** and **6b**.

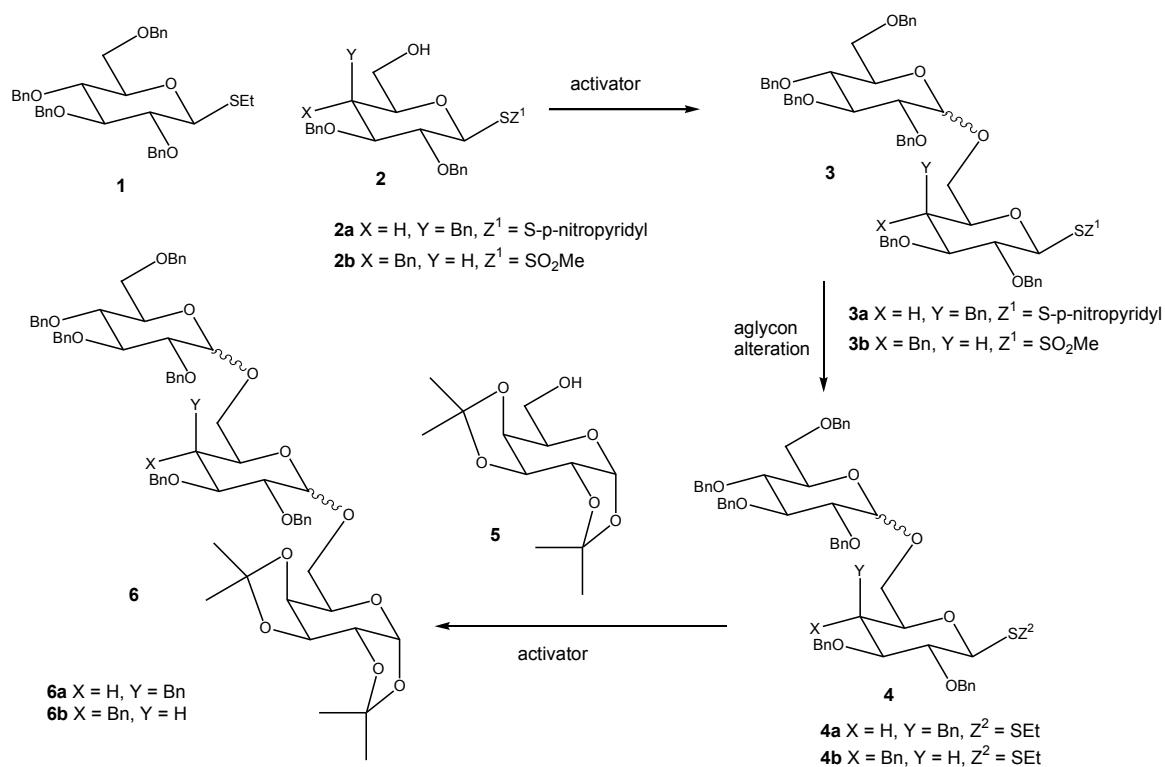

## References

1. P. J. Garegg, *Adv. in Carbohydrate Chem. and Biochem.*, **1997**, 52,179-205.
2. E.J. Grayson, S.J. Ward, A.L. Hall, P.M. Rendle, D.P. Gamblin, A.S. Batsanov and B.G. Davis, *J. Org. Chem.*, **2005**, 70, 9740-9754.
3. E. J. Grayson, G. J. L. Bernades, J. M. Chalker, O. Boutureira, J. R. Koeppe and B. G. Davis, *Angew. Chem. Int. Ed.*, in press.



PO 125

**DOMINO APPROACH TO A NOVEL CLASS OF  
N-RIBOSYLTRANSFERASE TRANSITION STATE ANALOGUES**

Antonio Dell'Isola, Annalisa Guaragna, Daniele D'Alonzo, Concetta Paoletta,  
Giovanni Palumbo

*Dipartimento di Chimica Organica e Biochimica, Università "Federico II" di Napoli,  
Via Cinthia, 4 I-80126 Napoli (ITALY)  
annalisa.guaragna@unina.it*

*N*-Ribosyltransferase inhibition represents a target of broad pharmacological relevance, given the crucial role of such enzymes in a number of disease-related events.<sup>1</sup> This is exemplified by the case of Immucillin-H (**1**, Forodesine<sup>TM</sup>), which picomolar activity has been exploited for diverse therapeutic purposes, e.g. treatment of leukemia, parasite-mediated diseases and autoimmune disorders.<sup>1b</sup> In all cases, enzymatic inhibition is due to the resemblance of pyrrolidine moiety (in its protonated form) with the upcoming oxocarbenium ion **2** in the transition state of enzymatic ribonucleoside phosphorolysis.<sup>1a</sup> Over the years, interest in the excellent activity of **1** has been witnessed by the development of several derivatives/analogues, some of them endowed with even more intriguing properties.<sup>1b</sup> Our approach at the synthesis of novel analogues of **1** is based on the finding that structurally preorganized nucleosides, owing to the reduction of all conformational states to those required for binding, usually show dramatic improvement of enzymatic recognition.<sup>2</sup> Accordingly, we have devised preparation of iminosugar nucleosides **3**, which piperidine scaffold, restricted in a <sup>4</sup>C<sub>1</sub> conformation, closely mimics the bioactive C3'-*endo* sugar pucker adopted by natural ribonucleosides. Our strategy relies on the use of the synthetically available heterocycle **4** as starting material, while a multistep "domino" reaction<sup>3</sup> enables expeditious assembly of piperidine ring. Nucleobases insertion at C2' position by ring opening of oxirane **6** will provide desired nucleosides to be preliminarily tested as anti-leukemic agents.

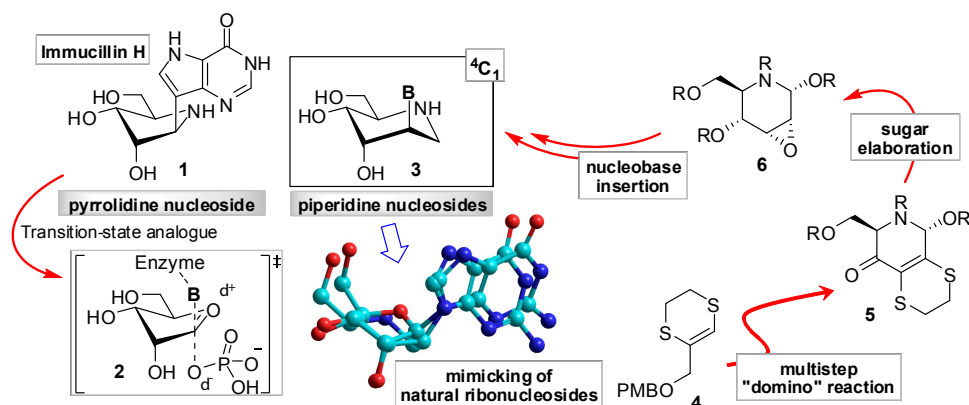

### References

- (a) S. D. Schwartz, V. L. Schramm, *Nat. Chem. Biol.*, **2009**, *5*, 551–558; (b) M.-C. Ho, W. Shi, A. Rinaldo-Matthis, P. C. Tyler, G. B. Evans, K. Clinch, S. C. Almo, V. L. Schramm, *PNAS*, **2010**, *107*, 4805–4812.
- P. Herdewijn, *Chem. Biodivers.*, **2010**, *7*, 1–59.
- A. Guaragna, D. D'Alonzo, C. Paoletta, C. Napolitano, G. Palumbo, *J. Org. Chem.*, **2010**, *75*, 3558–3568.

PO 126

**SYNTHESIS OF CAPSULAR POLYSACCHARIDE STRUCTURES  
OF *CRYPTOCOCCUS NEOFORMANS* SEROTYPE D**

Lorenzo Guazzelli, Rebecca Ulc, Lina Rydner, Stefan Oscarson

*Centre for Synthesis and Chemical Biology, School of Chemistry and Chemical Biology,  
University College Dublin, Belfield, Dublin 4, Ireland  
lorenzo.guazzelli@ucd.ie*

*Cryptococcus neoformans* is a fungal pathogen which causes meningitis and death especially in immuno-compromised persons, e.g. AIDS-patients and in patients going through organ transplantation, and recognized as an emerging health risk.<sup>1</sup> There are also reports that cryptococci infections during childhood might be a cause of later development of asthma.<sup>2</sup> *C. neoformans* is surrounded by capsular polysaccharides (CPS), of which the major one is the GXM-polysaccharide containing glucuronic acid, xylose and mannose residues and acetyl substituents.

The development of a glycoconjugate vaccine against this pathogen based on synthetic oligosaccharide structures is an open challenge and is under investigation in our laboratory.<sup>3,4,5</sup> Owing to the suggested repetitiveness of the structure of the *Cryptococcus* CPS both in mono-trisaccharide blocks as well as triads of these, a block synthesis approach seems the most advantageous one and we here report our efforts toward the synthesis of structures related to Serotype D which is one of the most prevalent in human infections.

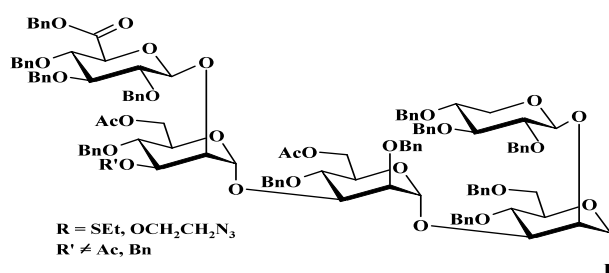

*Pentasaccharide corresponding to serotype D*

### References

1. Park, B.J., Wannemuehler, K.A., Marston, B.J., Govender, N., Pappas, P.G., Chiller, T. M., *AIDS*, **2009**, *23*, 525-530.
2. Goldman, D.L., Davis, J., Bommarito, F., Shao, X., Casadevall, A., *J. Infect. Diseases*, **2006**, *193*, 1178-1186.
3. Alpe, M., Svahnberg, P., Oscarson, S., *J. Carbohydr. Chem.*, **2004**, *23*, 403-416.
4. Vésely, J., Rydner, L., Oscarson, S., *Carbohydr. Res.*, **2008**, *343*, 2200-2208.
5. Nakouzi, A., Zhang, T., Oscarson, S., Casadevall, A., *Vaccine*, **2009**, *27*, 3513-3518.

## PO 127

**RECOGNITION MECHANISMS OF *AERUGINOSA*-II LECTIN (PA-III)  
– GLYCAN INTERACTIONS<sup>+</sup>**

Albert M. Wu<sup>1</sup>, Yu-Ping Gong<sup>1</sup>, Chia-Chen Li<sup>1</sup> and Nechama Gilboa-Garber<sup>2</sup>

<sup>1</sup>*Glyco-Immunochemistry Research Laboratory, Institute of Molecular and Cellular Biology, College of Medicine, Chang-Gung University, Kwei-san, Tao-yuan, 333, Taiwan*

<sup>2</sup>*The Mina and Everard Faculty of Life Sciences, Bar-Ilan University, Ramat Gan 52900, Israel*

Study of *Pseudomonas aeruginosa*-II lectin (PA-III) complexes with Man derivatives as a recognition factor has been neglected since its monomer is a very weak ligand. In this study, the roles of Man oligomers and complexes in PA-III carbohydrate-recognition were studied by both enzyme-linked lectinosorbent and inhibition assays. From the results obtained, it is proposed that high density weak -OH conformation as seen in yeast mannan is also an important PA-III recognition factor. This finding provides a peculiar concept of the duality of PA-III recognition system for LFuca1→ and related complexes and for high density Mana1→ complexes present in polymannosylated target macromolecules.

**References**

1. Mitchell, E., Houles, C., Sudakevitz, D., Wimmerova, M., Gautier, C., Pérez, S., Wu, A.M., Gilboa-Garber, N. and Imberty, A. (2002) Structural basis for oligosaccharide-mediated adhesion of *Pseudomonas aeruginosa* in the lungs of cystic fibrosis patients. *Nat. Struct. Biol.* 9, 918-921.
2. Wu, A.M., Wu, J.H., Singh, T., Liu, J.H., Tsai, M.S. and Gilboa-Garber, N. (2006) Interactions of the fucose-specific *Pseudomonas aeruginosa* lectin, PA-III, with mammalian glycoconjugates bearing polyvalent Lewis(a) and ABH blood group glycotopes. *Biochimie.* 88, 1479-1492.
3. Wu, A.M., Gong, Y.P., Li C.C., Gilboa-Garber, N. (2010) Duality of the carbohydrate-recognition system of *Pseudomonas aeruginosa*-II lectin *FEBS Lett.*, 584: 2371-2375

PO 128

**A NOVEL EXOPOLYSACCHARIDE PRODUCED  
BY *STENOTROPHOMONAS MALTOPHILIA*, AN OPPORTUNISTIC PATHOGEN  
FOR CYSTIC FIBROSIS PATIENTS**

Paola Cescutti, Bruno Cuzzi, Gianfranco Liut and Roberto Rizzo

*Department of Life Science, University of Trieste, via L. Giorgieri 1, 34127 Trieste, Italy*  
*pcescutti@units.it*

Cystic Fibrosis (CF) is a genetic disease caused by mutations of the gene coding for the Cystic Fibrosis Transmembrane Regulator, the protein involved in the chloride ion transport across cell membranes. The disease causes alterations in the functions of exocrine glands and in the composition of the fluid present on the lung epithelium. Most of these alterations may be effectively controlled by specific therapies, but the clogging of the airways due to mucus build-up and the decreased mucociliary clearance lead to bacterial infection. Recently, *Stenotrophomonas maltophilia* has emerged as an opportunistic pathogen for CF and immuno-compromised patients causing lung infection associated with function deterioration. *S. maltophilia* was grown on solid medium, cells were collected, and the exopolysaccharide (EPS) was isolated and purified. The EPS showed to be very resistant to acid hydrolysis and in general to chemical modifications, therefore determination of the primary structure was achieved mainly resorting to 1D and 2D NMR spectroscopy and ESI-MS. All the data collected are in agreement with the following oligosaccharide repeating unit:

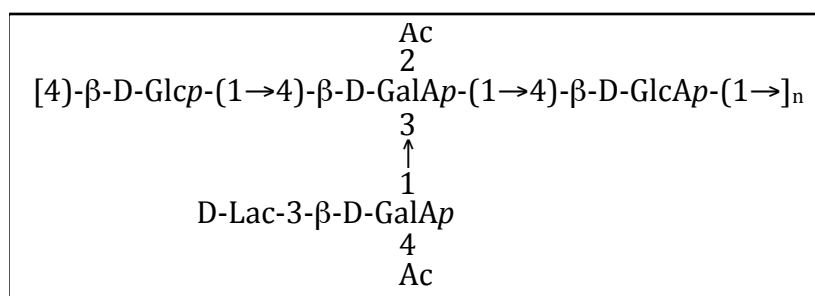

This primary structure is uncommon, being constituted of 3 uronic acid residues, one substituted with a lactate group, thus generating a polysaccharide with a charge density similar to alginate. Lactate itself is also a rare component of bacterial polysaccharides. Two acetyl groups are present per repeating unit. Two different isolates of *S. maltophilia*, one from a CF patient in France and the other from a CF patient in Rome, were used for EPS production. Both of them synthesised the polymer depicted above, thus suggesting that this EPS may be typical of this species, as alginate is for *P. aeruginosa*.

## PO 129

**STRUCTURAL AND DYNAMIC PROPERTIES OF HUMAN-LIKE ( $\alpha$ 2-6 SIALYLATED) AND AVIAN-LIKE ( $\alpha$ 2-3 SIALYLATED) GLYCAN RECEPTORS GOVERNING THEIR BINDING TO HEMAGGLUTININ FROM INFLUENZA A VIRUSES**

Marco Guerrini,<sup>1</sup> Guilherme L. Sassaki,<sup>1</sup> Stefano Elli,<sup>1</sup> Timothy R. Rudd,<sup>1</sup> Rahul Raman,<sup>3</sup> Zachary Shriver,<sup>3</sup> Ram Sasisekharan<sup>3</sup>, Giangiacomo Torri,<sup>1</sup>

<sup>1</sup>Ronzoni” Institute for Chemical and Biochemical Research, via G. Colombo 81, 20133 Milan, Italy.

<sup>2</sup>Harvard-MIT Division of Health Sciences and Technology, Koch Institute for Integrative Cancer Research, Department of Biological Engineering, Massachusetts Institute of Technology, Cambridge, MA 02139 USA.

One of the key steps in the infection and human host adaptation of influenza A viruses is the interaction between the viral surface protein, hemagglutinin (HA), and sialylated glycans on the epithelial cell surface of the human upper respiratory tract<sup>1</sup>. The cross-over of influenza A viruses from birds to humans is believed to be associated with the ability of an avian-adapted HA to acquire mutations that change its binding preference from  $\alpha$ 2 $\rightarrow$ 3 to  $\alpha$ 2 $\rightarrow$ 6 sialylated glycans, the latter structures being predominantly expressed in human upper respiratory epithelia<sup>2,3</sup>. The conformational properties of the sialylated glycan receptors have been investigated previously using X-ray crystal structures of HA-glycan complexes<sup>3</sup> and *ab-initio* MD simulations<sup>4</sup>. Building on these studies, it was apparent that a complete study of the conformational properties in solution of model glycans is essential to improve our understanding of HA-glycan interactions. In the work presented here, the structural properties of both  $\alpha$ 2 $\rightarrow$ 3 (Neu5Ac- $\alpha$ 2 $\rightarrow$ 3-Gal- $\beta$ 1 $\rightarrow$ 3-GlcNAc- $\beta$ 1 $\rightarrow$ 3-Gal- $\beta$ 1 $\rightarrow$ 4-Glc) and  $\alpha$ 2 $\rightarrow$ 6 (Neu5Ac- $\alpha$ 2 $\rightarrow$ 6-Gal- $\beta$ 1 $\rightarrow$ 4-GlcNAc- $\beta$ 1 $\rightarrow$ 3-Gal- $\beta$ 1 $\rightarrow$ 4-Glc) sialylated glycans were studied by solution NMR and molecular modelling. Through NOE measurements and molecular dynamic calculations it is possible to elucidate different glycosidic torsion angles for the trisaccharide motifs Neu5Ac- $\alpha$ 2 $\rightarrow$ 3-Gal- $\beta$ 1 $\rightarrow$ 3-GlcNAc and Neu5Ac- $\alpha$ 2 $\rightarrow$ 6-Gal- $\beta$ 1 $\rightarrow$ 4-GlcNAc. Moreover, T1 and T2 <sup>13</sup>C-NMR relaxation measurements indicated different dynamic properties for the two pentasaccharides.

**References**

1. Shinya K, Ebina M, Yamada S, Ono M, Kasai N, Kawaoka Y. *Nature* **2006**, 435–436.
2. Shriver Z, Raman R, Viswanathan K, Sasisekharan R. *Chem. Biol* **2010**, 16, 803-814
3. Chandrasekaran A, Srinivasan A, Raman R, Viswanathan K, Raguram S, Tumpey TM, Sasisekharan V, Sasisekharan R. *Nat. Biotech.* **2008**, 26, 107-113.
4. Xu D, Newhouse EI, Amaro RE, Pao HC, Cheng LS, Markwick PRL, McCammon JA. *J. Mol. Biol.* **2009**, 387, 465-491

## PO 130

## MANNOSE-BINDING LECTIN ACTIVITY OF LACTOBACILLI

Shweta Malik<sup>1</sup>, Sarah Lebeer<sup>1</sup>, Mariya Petrova<sup>1</sup>, Jan Balzarini<sup>2</sup>, Jos Vanderleyden<sup>1</sup>

<sup>1</sup> Centre of Microbial and Plant Genetics, K.U.Leuven, Kasteelpark Arenberg 20, 3001 Leuven, Belgium, <sup>2</sup> Rega Institute for Medical Research, K.U.Leuven, Minderbroedersstraat 10, B-3000 Leuven, Belgium  
*shweta.malik@biw.kuleuven.be*

Probiotics are live micro-organisms, which upon administration in adequate amounts can confer a health benefit to the host. An important mechanism of probiotic action is the exclusion or inhibition of pathogens by the production of antimicrobial compounds and/or competition for adhesion sites. Various pathogens (bacteria and viruses) infect host cells via binding to specific glycans at the host surface through carbohydrate-binding proteins on their cell surface which are named lectins. Probiotic bacteria also have lectins at their cell surface that could play a role in pathogen exclusion by (1) competitively binding to the same glycans on the host surface, thereby blocking pathogen adhesion or (2) by binding glycans on the pathogenic surfaces, thereby blocking virulence mechanisms such as invasion. In this project, the mannose-binding lectin (MBL) activity of lactobacilli is explored for its potential to exclude mannose-binding or mannose-containing gastro-intestinal and vaginal pathogens such as various pathogenic *Escherichia coli* strains, *Candida albicans* and viruses such as HIV. Hereto, a total of 70 selected *Lactobacillus* strains isolated from various sources were screened for the presence of MBLs based on the yeast agglutination assay. Seven *Lactobacillus* strains were found to coaggregate with *Saccharomyces cerevisiae* in a calcium-independent manner that could be inhibited by methyl-alpha-D-mannopyranoside. The strain with the highest activity for yeast agglutination exhibited also a strong auto-aggregating phenotype. Its aggregation is inhibited upon treatment with mannose-specific inhibitors and is abolished by proteinase K treatment. The strain is capable of forming biofilms on abiotic surfaces and adheres well to human intestinal and vaginal epithelial cell lines. Coaggregation studies of the MBL positive strains with pathogens are the next step to further evaluate the potential of these *Lactobacillus* strains. Ultimately we aim to biochemically characterize the putative lectins involved in pathogen exclusion.



## PO 131

**STUDIES OF MULTIVALENT INTERACTIONS BETWEEN DC-SIGN AND GLYCOMIMETIC LIGANDS BY NMR AND COMPUTATIONAL TECHNIQUES**

Cinzia Guzzi<sup>1</sup>, Jesus Angulo<sup>1</sup>, Juan J. Reina<sup>3</sup>, Michel Thepaut<sup>2</sup>, Frank Fieschi<sup>2</sup>, Anna Bernardi<sup>3</sup>, Javier Rojo<sup>1</sup> and Pedro M. Nieto<sup>1</sup>

<sup>1</sup>*Glycosystems Laboratory, Instituto de Investigaciones Químicas – CSIC – US, C/Américo Vespucio 49, 41092, Sevilla, Spain*

<sup>2</sup>*Laboratoire des Protéines Membranaires, Université Joseph Fourier, CEA, DSV, Institut de Biologie Structurale Jean-Pierre Ebel, 41 rue Jules Horowitz, 38027 Grenoble, France*

<sup>3</sup>*Dipartimento di Chimica Organica e Industriale, Università di Milano, via Venezian 21, 20133 Milano, Italy  
cinzia.guzzi@iiq.csic.es*

DC-SIGN (Dendritic Cell-Specific ICAM-3 Grabbing Non-integrin) is a C-type lectin presenting a Carbohydrate Recognition Domain (CRD) at the C-terminus that specifically recognizes highly glycosylated structures present at the surface of several pathogens such as viruses (HIV, SIV, Hepatitis C), bacteria, yeasts, and parasites. This lectin plays a key role in the infection processes of some of these pathogens, which are recognized by interactions of the lectin with carbohydrate structures from pathogens glycoproteins (gp120, GP1, etc.).

We have performed a structural study of the interaction between DC-SIGN (extracellular domain) and glycomimetic ligands by NMR and computational techniques. Ligand binding was analyzed mainly by Saturation Transfer Difference (STD) NMR spectroscopy, one of the most widespread NMR methods to characterize weak binding interactions between small ligands and macromolecular receptors<sup>1</sup>. Using the CORCEMA-ST protocol, based on the general Complete Relaxation and Conformational Exchange Matrix (CORCEMA) theory<sup>2</sup>, we have investigated the existence of multiple modes of binding<sup>3</sup>, and the effects of multivalent interactions.

**Acknowledgments:** We would like to thank the EU for funding (PITN-GA-2008-213592, CARMUSYS)

**References**

1. Meyer B. and Peters T., *Angew. Chem. Int. Ed. Engl.*, **2003**, 42, 864-890.
2. Jayalakshmi V. and Krishna N. R., *J. Magn. Reson.*, **2004**, 168, 36-45.
3. Feinberg H., Castelli R., Drickamer K., Seeberger P.H., Weis W. I., *J. Biol. Chem.*, **2007**, 282, 4202-4209.

## PO 132

## SUBSITE STRUCTURE OF DISPERSIN B; A BIOFILM DEGRADING ENZYME

Gyöngyi Gyémánt, Erika Fazekas, Lili Kandra

<sup>1</sup>University of Debrecen, Department of Inorganic and Analytical Chemistry  
gyemant@science.unideb.hu

Biofilms formed on different medical devices are one of the most serious problems of present day clinical practice. A major component of the biofilm matrix is a poly- $\beta$ -D-(1-6)-*N*-acetylglucosamine (PNAG) that mediates intercellular adhesion. Dispersin B (DspB, EC 3.2.1.52) a soluble  $\beta$ -*N*-acetylglucosaminidase originated from periodontal pathogen *Aggregatibacter actinomycetemcomitans*<sup>1</sup> is able to disperse and detach biofilms produced by *S. epidermidis*. On the basis of biofilm-releasing activity of DspB this enzyme can be used as an antibiofilm agent to remove *S. epidermidis* biofilms from medical devices. DspB, according to our earlier ligand docking and hydrolysis experiments, appears to be specific to a linear polymer of  $\beta$ -(1-6)-linked *N*-acetyl-D-glucosamine (GlcNAc) and removes the terminal GlcNAc moiety from the non-reducing end<sup>2</sup>. A series of  $\beta$ -(1-6)-linked *N*-acetyl-D-glucosamine thiophenyl glycosides with degree of polymerisation (DP) of 2, 3, 4 and 5 were synthesized<sup>3</sup>, and substrate specificity of DspB was studied on these oligosaccharides. Concentration of substrate and reducing end hydrolysis products was determined by HPLC using reverse phase separation and detection at 254 nm. The concentration-time relationships were evaluated numerically using a consecutive reaction model. On the basis of kinetic rate constants substrate binding site of DspB consists of at least four subsites. The following scheme was suggested to describe the total hydrolysis of the pentamer substrate catalysed by DspB.

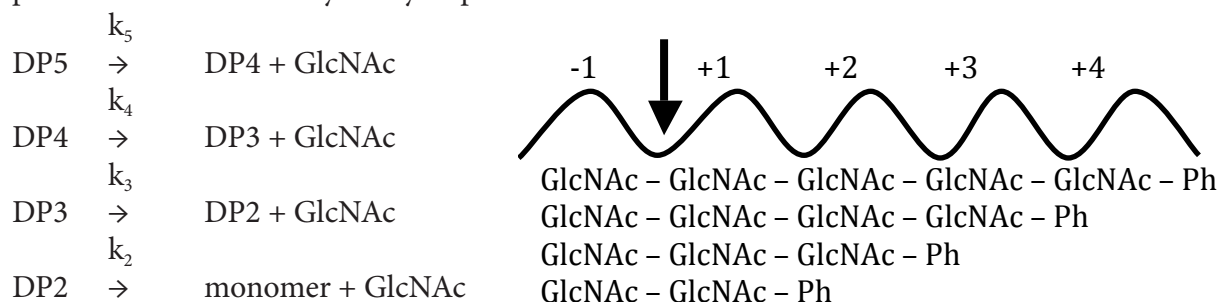
**References**

1. Kaplan, J. B.; Ragunath, C.; Ramasubbu, N.; Fine, D. H. J., *Bacteriol.*, **2003**, *185*, 4693-4698.
2. Kerrigan, J. E.; Ragunath, C.; Kandra, L.; Gyémánt, G.; Lipták, A.; Jánossy, L.; Kaplan, J. B.; Ramasubbu, N., *Acta Biol. Hung.*, **2008**, *59*, 439-451
3. Fekete, A., Borbás, A., Gyémánt, G., Kandra, L., Fazekas, E., Ramasubbu N., Antus, S., *Carbohydr. Res.*, **2011**, submitted

PO 133

NEW SYNTHETIC TOOLS FOR THE STUDY  
OF PROTEIN-GLYCOSAMINOGLYCAN COMPLEXES BY NMREmiliano Gemma, Alison N. Hulme, Odile Meyer, and Sarah J. Thomas

*University of Edinburgh, School of Chemistry, King's Buildings,  
West Mains Road, Edinburgh, EH9 3JJ, UK.  
Alison.Hulme@ed.ac.uk*

Glycosaminoglycans (GAGs) are linear polysaccharides found on most animal cell surfaces and in extracellular matrices. Their key biological roles include cell signalling and cell-to-cell recognition, bacterial and viral adhesion, and antibody production.<sup>1</sup> They are composed of a disaccharide repeating unit, containing uronic acid and amino sugar residues, and are highly heterogeneously sulfated. Protein-GAG complexes are thought to play an important role in a number of aspects of cancer development, but are an under-studied area due to a lack of chemical tools to facilitate their analysis.<sup>2</sup>

Structure analysis of protein-GAG complexes is hampered by the heterogeneous character of GAGs and the nature of their interactions. To allow for high resolution NMR studies of protein-GAG complexes to be carried out, the aim of this work is to develop synthetic procedures for the incorporation of paramagnetic centres into GAG oligosaccharides.

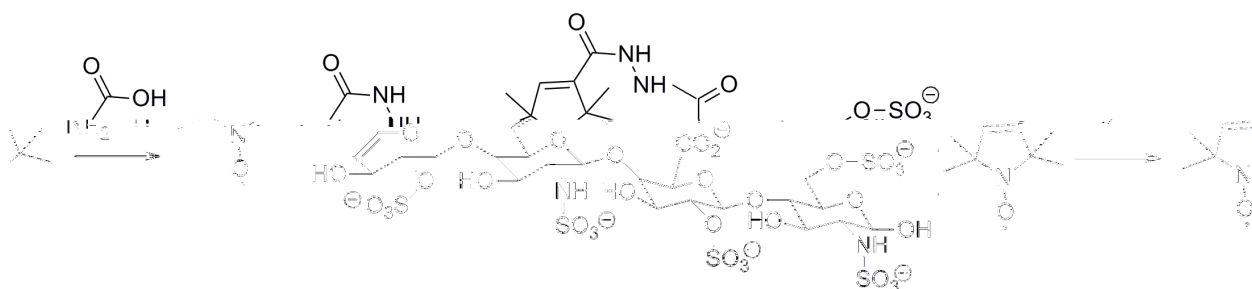

**Scheme 1:** Synthesis of a Spin Label and Incorporation into GAG Oligosaccharides

A procedure for the synthesis of the spin label 2,2,5,5-tetramethylpyrrolinoxyl hydrazide has been developed and optimised (Scheme 1) and future plans include the optimisation of a site-specific coupling procedure to incorporate this spin label into selected GAG oligosaccharides.

**References**

1. R. J. Lindhardt, T. Toida, *Acc. Chem. Res.* **2004**, 37, 431-438.
2. E. Gemma, O. Meyer, D. Uhrin, A. N. Hulme, *Mol. Biosyst.* **2008**, 4, 481-495.

## PO 134

**A SOLUTION NMR STUDY OF THE CARBOHYDRATE BINDING PROTEIN CEL7A AND ITS ENANTIOSELECTIVE BINDING TO PROPRANOLOL ANALOGUES**

Christoffer Hamark<sup>1</sup>, Robert Pendrill<sup>1</sup>, Jens Landström<sup>2</sup>, Alexandra Fagerström<sup>3</sup>, Jerry Ståhlberg<sup>4</sup> and Göran Widmalm<sup>1</sup>

<sup>1</sup> Dept. of Organic Chemistry, Arrhenius Laboratory, Stockholm University, Sweden.

<sup>2</sup> York Structural Biology Laboratory, Dept. of Chemistry, University of York, UK.

<sup>3</sup> Plant glycobiology, Dept. of Plant Biology and Biotechnology, LIFE, University of Copenhagen, Denmark.

<sup>4</sup> Dept. of Structural Biology, Biomedical Centre, Swedish University of Agricultural Sciences, Uppsala, Sweden.  
christoffer@organ.su.se

Cel7A is a cellobiohydrolase produced by the cellulose degrading fungus *Trichoderma Reesei*. The enzyme releases cellobiose from crystalline cellulose chain ends as well as from cello-oligosaccharides. It also binds enantioselectively to the chiral  $\beta$ -blocker propranolol and analogues thereof<sup>1</sup>. Prior to this study, such analogues have been synthesized<sup>1</sup> and their interactions with Cel7A have been analyzed with a number of techniques including X-ray crystallography<sup>2</sup> and affinity capillary electrophoresis (CE)<sup>1</sup>.

Ligand-based NMR techniques have been carried out on Cel7A in complex with propranolol and its dihydroxy analogue in solution; specifically saturation transfer difference (STD) NMR spectroscopy,  $T_{1\rho}$  spin-lock filtered experiments and transferred NOE experiments. Group epitope mapping from STD NMR indicates differential binding modes of the enantiomers. These epitope models were validated with relaxation matrix calculations. Further knowledge was obtained through molecular docking simulations. NMR titration experiments revealed binding affinities for the propranolol enantiomers similar to those previously deduced by affinity CE. This study shows that NMR together with computer simulations deliver structural and affinity information of propranolol-Cel7A binding in solution as a complement and as an extended view to that of X-ray crystallography.

**References**

1. Fagerström, A. *et al.*, *Organic & Biomolecular Chemistry*, **2006**, 4, 3067-3076.
2. Ståhlberg, J. *et al.*, *J. Mol. Biol.*, **2001**, 305, 79-93.

## PO 135

## SYNTHESIS AND MULTIVALENT PRESENTATION OF TUMOR-ASSOCIATED GLYCOPEPTIDE MUC1 ON GOLD NANOPARTICLES

Hartmann Sebastian,<sup>1</sup> Tavernaro Isabella,<sup>2</sup> Schlecht Sabine<sup>2</sup> and Hoffmann-Röder Anja<sup>1\*</sup>

<sup>1</sup>Johannes Gutenberg-Universität, Institut für Organische Chemie, Duesbergweg 10-14, 55128 Mainz, Germany

<sup>2</sup>Justus Liebig-Universität, Institut für Anorganische und Analytische Chemie, Heinrich-Buff-Ring 58, 35392 Giessen, Germany  
hroeder@uni-mainz.de

Alterations of the glycoprotein profile differentiate cancer from normal cells.<sup>1</sup> The extracellular part of the epithelial transmembrane protein mucin MUC1 has been found to be overexpressed on tumor cells. The MUC1 tandem repeat sequenz consists 20 aminoacids with five potential O-glycosylation sites.<sup>2</sup> The saccharide side chains of tumor associated MUC1 are much shorter and less complex. As a consequence, a number of possible tumor selective antigen epitopes within the peptide backbone become accessible to the immune system. Past studies showed that the tumor associated MUC1 antigenes are auspicious targets for the development of new anticancer vaccines.<sup>3</sup> However, single haptenes are not sufficiently immunogenic and a multivalent presentation is usually necessary to induce strong humoral immune responses. Beside the possibility to couple the glycoproteins to suitable carrier proteins such as BSA or TTOX, alternative conjugation strategies to dendrimers and nanoparticles have been reported.<sup>4</sup> Herein we describe the modular synthesis of functionalized gold nanoparticles carrying complete tandem repeat units of the MUC1 including T<sub>N</sub> antigen units. These tumor-associated glycopeptide antigens were coupled to nanoparticles of different sizes, by two different strategies.

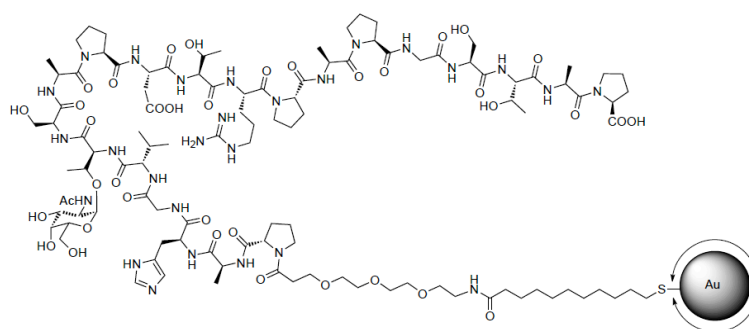

### References

1. a) G. F. Springer, *Science (Washington, DC, United States)*, **1984**, 224, 1198. b) I. Brockhausen, *Biochim. Biophys. Acta*, **1999**, 1473, 67.
2. a) J. Taylor-Papadimitriou, J. Burchell, D. W. Miles, M. Dalziel, *Biochim. Biophys. Acta*, **1999**, 301. b) F. G. Hanisch, S. Muller, *Glycobiology*, **2000**, 10, 349.
3. T. Ninkovic, L. Kinarsky, K. Engelmann, V. Pisarev, S. Sherman, O. J. Finn, F. G. Hanisch, *Mol. Immunol.*, **2009**, 47, 131.
4. a) S. Keil, A. Kaiser, F. Syed, H. Kunz, *Synthesis*, **2009**, 8, 1355. b) A. Sundgren, J. J. Barchi Jr., *Carbohydr. Res.*, **2008**, 343, 1594.

## PO 136

## SYNTHETIC STUDY ON SIALYL SELENOGLYCOSIDES AS HYDROLYTICALLY STABLE PSEUDOGLYCOSIDES

Chieka Hayashi,<sup>1</sup> Masanori Menjo,<sup>3</sup> Takayuki Ando,<sup>1,2</sup> Hiromune Ando,<sup>1,2</sup> Hideharu Ishida<sup>1</sup> and Makoto Kiso<sup>1,2</sup>

<sup>1</sup>Department of Applied Bioorganic Chemistry, Gifu University, 1-1 Yanagido, Gifu 501-1193, Japan,

<sup>2</sup>iCeMS, Kyoto University, Yoshida Ushinomiya-cho, Sakyo-ku, Kyoto 606-8501, Japan,

<sup>3</sup>Department of Chemistry, Faculty of Engineering, Gifu University, 1-1 Yanagido, Gifu 501-1193, Japan

p8101043@edu.gifu-u.ac.jp

Substitution of interglycosidic or intraring oxygen in carbohydrates with other elements such as carbon, nitrogen, and sulfur has been addressed to establish glycosidase-resistant biosimilars to their equivalent O-glycosides with the aim of developing carbohydrate-based therapeutics and vaccines. Over the last two decades, thioglycosides in particular become popular as such biosimilars. On the contrary, the potentials of other chalcogeno-glycosides, such as seleno- and telluro-glycosides, have not intensively been explored. Recently, we have developed a facile synthetic method for  $\alpha$  and  $\beta$ -selenoglycosides of normal hexoses, in which glycosyl selenolate anion generated in situ swiftly reacted with various electrophiles while retaining its anomeric configuration.<sup>1,2</sup> Herein, we report the synthesis of  $\alpha$ -selenoglycoside of sialic acid and the susceptibility to hydrolysis by sialidases.

$\alpha$ -Toluoyl selenoglycoside **1** as a sialyl selenolate anion equivalent was synthesized by the reaction of  $\beta$ -sialyl chloride and bis-toluoylselenide in the presence of piperidine and Cs<sub>2</sub>CO<sub>3</sub>. Upon action of piperazine and Cs<sub>2</sub>CO<sub>3</sub> in DMF, the acyl selenoside was converted into  $\alpha$ -sialyl selenolate anion **2** in situ, which was subsequently reacted with various electrophiles to yield the corresponding selenoglycosides **3** in high yields. Similarly, the alkylation of the sialyl selenolate with 6-iodo galactoside successfully afforded *Se*- $\alpha$ (2,6)sialyl galactoside in good yield (83%). Finally, subsequent cleavage of acyl groups and saponification of methyl ester group provided unprotected  $\alpha$ -selenosialosides. We have obtained preliminary results that benzyl selenosialoside showed potent resistance to hydrolysis by sialidase from *Clostridium perfringens*.

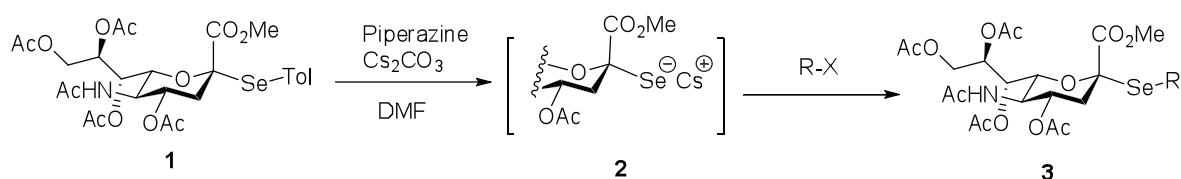

## References

1. Y. Kawai, H. Ando, H. Ozeki, M. Koketsu, H. Ishihara, *Org. Lett.* **2005**, *7*, 4653-4656.
2. M. Nanami, H. Ando, Y. Kawai, M. Koketsu, H. Ishihara, *Tetrahedron Lett.*, **2007**, *48*, 1113-1116.



PO 137

## IMMUNOLOGICALLY-ACTIVE LEADS FROM MYCOBACTERIAL EXTRACTS

Gary Ainge,<sup>1</sup> Benjamin Compton,<sup>1</sup> Jacquie Harper,<sup>2</sup> Colin Hayman,<sup>1</sup> David Larsen,<sup>3</sup> William John Martin,<sup>2</sup> Gavin Painter,<sup>1</sup> Gurmit Singh-Gill,<sup>3</sup> Steven Toms,<sup>1</sup> Thomas J Wilson,<sup>1</sup>

<sup>1</sup> Industrial Research Limited, Carbohydrate Chemistry group, Lower Hutt, New Zealand.

<sup>2</sup> Malaghan Institute of Medical Research, Wellington, New Zealand

<sup>3</sup> Department of Chemistry, University of Otago, Dunedin, New Zealand  
c.hayman@irl.cri.nz

Phosphatidylinositol Mannosides (PIMs) are immunomodulatory entities unique to mycobacterial cell walls. Exposure to mycobacteria has been shown to correlate with reduced susceptibility to atopic disorders later in life.<sup>1</sup> Also the observed biological activity of PIMs including their ability to upregulate IL-6 production, negatively regulate TLR-4 and suppress LPS-induced cytokine production in primary macrophages<sup>2,3</sup> have elevated these phosphoglycolipids to serve as leads in a drug discovery programme focussing on discrete synthetic materials.

Improvements to synthetic approaches has allowed ready access to useful amounts of high-purity PIMs, including the more highly glycosylated variants such as PIM<sub>6</sub>, and a variety of analogues. An overview of synthetic efforts and key biological data will be presented.<sup>3</sup>

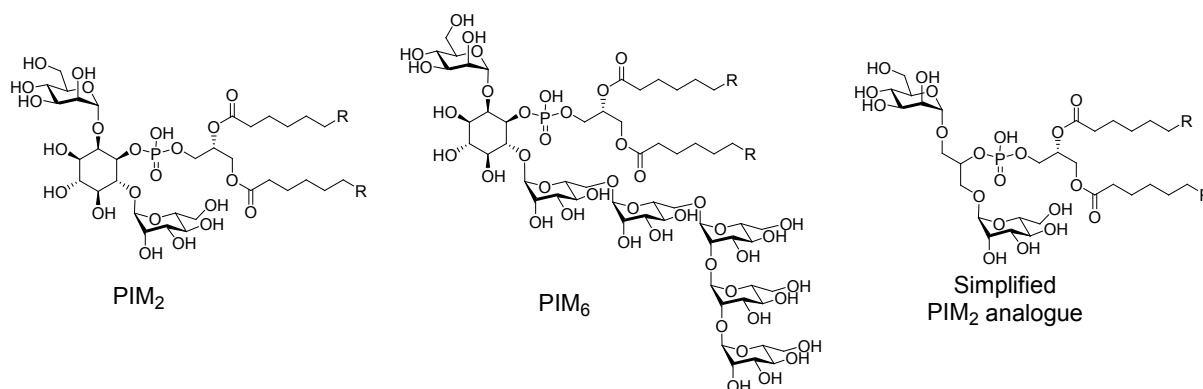

## References

1. Shirakawa, T., Enomoto, T., Shimazu, S., Hopkin, J. M., Science, 1997, 275, 77–9.
2. I. Sayers, W. Severn, C. Scanga, J. Hudson, G. LeGros and J.L. Harper, J., Allergy Clin. Immunol., 2004, 114, 302–309. Doz E, Rose, S., Court, N., Front, S., Vasseur, V., Charron, S., Gilleron, M., Puzo, G., Fremaux, I., Delneste, Y., Erard, F., Ryffel, B., Martin, O. R., Quenieux, V. F. J., J Biol Chem. 2009, 284, 23187–96.
3. Harper, J.L., Hayman, C. M., Larsen, D. S., Painter, G. F., Singh-Gill, G., Bioorg. Med. Chem. 2011, 917-925; Dyer, B. S., Jones, J. D, Ainge, G. D., Denis, M., Larsen, D. S., Painter, G. F., J. Org. Chem., 2007, 72, 3282–3288; Ainge, G. D.; Hudson, J.; Larsen, D. S.; Painter, G. F.; Singh Gill, G.; Harper, J. L. Bioorg. Med. Chem., 2006, 14, 5632.

## PO 138

**TOWARD THE MONITORING OF PHYSICO-CHEMICAL PROPERTIES  
OF CARRAGEENAN USING NEW SULFATASES**

Sabine Genicot, Aurélie Préchoux and William Helbert

*CNRS-University Pierre and Marie Curie, UMR 7139 Marine Plants and Biomolecules,  
Station Biologique de Roscoff, F-29682 Roscoff, France*

Carrageenan is the generic name for a family of natural, water-soluble sulfated galactans extracted from numerous species of red seaweeds. They are composed of alternating 3-linked  $\beta$ -D-galactopyranose (G-units) and 4-linked  $\alpha$ -D-galactopyranose (D-units) or 4-linked 3,6-anhydrogalactose (DA-units) disaccharide repetition units—called carrabiose units—that form the neutral backbone of carrageenans. Carrageenans are classified according to the occurrence of the 3,6-anhydrogalactose on the 4-linked residue and the position and number of sulfate (S) groups. The variability of carrageenan composition, which depends on algal source, life stage and extraction procedure, offers a wide range of physico-chemical properties for various food industry applications. The properties of carrageenans are directly correlated to their degree of sulphation. In fact, higher levels of ester sulphate produce lower strength gels. Sulfatases, enzymes that catalyse the hydrolysis of sulphate esters bonds, have been detected ubiquitously, from mammals to bacteria (such as *Klebsiella*, *Enterobacter*, *Pseudomonas* and *Salmonella*). They are involved in various metabolism processes. Studies on carbohydrate sulfatases have been focussed mainly on enzymes involved in several inherited human diseases (i.e. glycosaminoglycan sulphatase, cerebroside sulphatase). In contrast, there are very few data on carbohydrate sulphatases from other origins.

Aiming at controlling the rheological properties of carrageenans, we focused our research on sulfatases that act specifically on carrageenans. For the first time, we have isolated and purified sulfatases from marine bacteria *Pseudoalteromonas atlantica* and *Pseudoalteromonas carrageenovora*. Although they have the same specificity, both enzymes are biochemically and structurally different. *P. atlantica* sulphatase belongs to the well known formyl glycine dependent sulphatase family whereas *P. carrageenovora* sulphatase does not share any sequence homology with any known enzymes and belongs therefore to a new class of sulfatases. These results allow envisioning introducing biotechnology in carrageenan industry and highlight the unexplored diversity of carbohydrate sulfatase.

PO 139

**SYNTHESIS OF SULFONIC ACID ANALOGUES  
OF THE ANTITHROMBIN-BINDING DOMAIN OF HEPARIN**

Mihály Herczeg<sup>1</sup>, László Lázár<sup>1</sup>, Zsuzsanna Bereczky<sup>2</sup>, Anikó Borbás<sup>1</sup>, András Lipták<sup>1</sup>,  
Sándor Antus<sup>1,3</sup>

<sup>1</sup>Research Group for Carbohydrates of the Hungarian Academy of Sciences,  
University of Debrecen, H-4010 Debrecen, P.O. Box 94, Hungary,

<sup>2</sup>Clinical Research Center, Medical and Health Science Center, University of Debrecen,  
Debrecen, Hungary,

<sup>3</sup>Department of Organic Chemistry, University of Debrecen, H-4010 Debrecen,  
P.O. Box 20, Hungary  
mihaly.herczeg@freemail.hu

Heparin is a well-known member of the glycosaminoglycans and plays a crucial role in maintaining the haemostatic state of blood through interaction with antithrombin III (AT-III), a serine protease inhibitor that blocks thrombin and factor Xa in the coagulation cascade. After isolation and structural elucidation of the antithrombin-binding pentasaccharide domain of heparin a concerted drug development program to the development of Arixtra® (1), which became the first synthetic antithrombotic drug.<sup>1</sup>

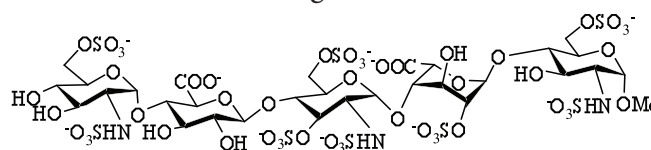

1 (Arixtra)

We envisaged that isosteric sulfonate analogues of the AT-III binding pentasaccharide of heparin may afford bioactive derivatives. Therefore, we decided to prepare sulfonatomethyl-containing analogues of the heparin pentasaccharide by systematic replacement of the sulfate esters with a sodium sulfonatomethyl moiety.<sup>2,3</sup> The non-glycosaminoglycan-type synthetic pentasaccharide idraparinux (2) was chosen as a reference compound, since it has increased anticoagulant activity and it is much easier to synthesize compared to Arixtra.

Here, synthesis and anticoagulant activity of pentasaccharide sulfonic acids (3 and 4) will be presented.

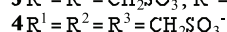
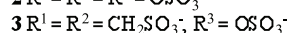
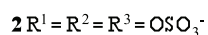
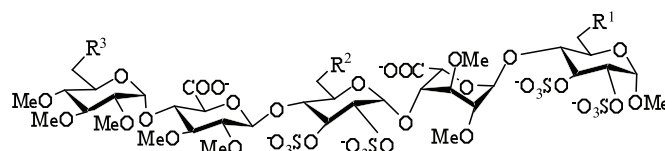

## References

1. M. Petitue, C. A. A. van Boeckel, *Angewandte Chemie Int. Ed.* **2004**, *43*, 3118-3133.
2. M. Herczeg, L. Lázár, A. Borbás, A. Lipták, S. Antus, *Org. Lett.* **2009**, *11*, 2619-2622.
3. L. Lázár, M. Herczeg, A. Borbás, A. Lipták, S. Antus, *Tetrahedron. Lett.* **2010**, *11*, 2619-2622.

## PO 140

## SYNTHESIS OF PHOSPHONATE ANALOGUES OF LIPID II

Anikó Borbás<sup>1</sup> and Pál Herczegh<sup>2</sup><sup>1</sup>Research Group for Carbohydrates of the Hungarian Academy of Sciences,  
University of Debrecen, H-4010, Debrecen, PO Box 94, Hungary,<sup>2</sup>Department of Pharmaceutical Chemistry, Center of Medical and Health Sciences,  
University of Debrecen, Debrecen, H-4010, PO Box 70, Hungary  
herczegh.pal@pharm.unideb.hu

The bacterial cell wall is a resistant exoskeleton based on a polymeric network of a peptidoglycan consisting of *N*-acetyl-D-glucosaminyl-*N*-acetylmuramyl peptide as the repeating unit. This building block is synthesized within the bacterial cell in activated form as an undecaprenyl diphosphate derivative, which is known as lipid II. It is anchored through the lipophilic side chain in the membrane. Lipid II, once synthesized within the cell, is transported to the external surface of the cell membrane where it reacts with the reducing end of the growing peptidoglycan chain. This reaction is catalyzed by transglycosylase enzymes. Since these molecules are building up outside of the bacterial membrane, possible inhibitors, antibiotics, targeting this process do not have to cross the membrane to reach their target, therefore, such inhibitors can be of therapeutic importance. Inhibitors of bacterial transglycosylases can be classified in two types: the substrate binders and the enzyme binders.<sup>1</sup> Glycopeptide-type antibiotics, such as vancomycin and teicoplanin belong to the first class,<sup>2</sup> and the only known natural product that binds to transglycosylases is moenomycin A. The latter antibiotic contains a characteristic side chain attached to an oligosaccharide through a phosphate ester, mimicking the substrate of a transglycosylase.

Here, we report the synthesis of simple, glycosylthio analogues of lipid II carrying a lipophilic chain and a phosphonate moiety. The synthesis involved conjugate addition of a 1-thio-*N*-acetyl-D-glucosamine derivative onto ethylidene bisphosphonate and subsequent Wadsworth-Horner-Emmons reaction with long chain aliphatic aldehydes.

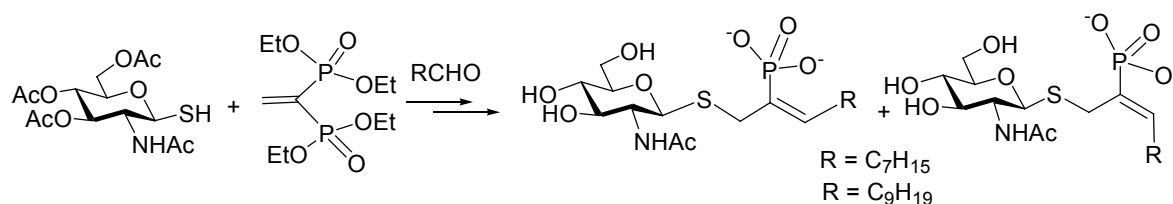

## References

- Ostash, B.; Walker, S. *Curr. Opin. Chem. Biol.* **2005**, *9*, 459–466.
- Chen, L.; Walker, D.; Sun, B.; Hu, Y.; Walker, S.; Kahne, D. *Proc. Natl. Acad. Sci. USA* **2003**, *100*, 5658–5663.

## PO 141

## CONVERSION OF CARBOHYDRATES INTO FLUORINATED ANALOGUES USING PERFLUOROALKANESULFONYL FLUORIDES

Jennifer Hesse, Loana Arns, Elisabeth Mischler, Alexandra Hölemann

Department of Chemistry, Organic Chemistry, Technische Universität Dortmund, 44221  
Dortmund, Germany  
jennifer.hesse@tu-dortmund.de

Because of their interesting properties and their special chemical reactivity fluorinated carbohydrates have attracted considerable attention in biochemical investigations, e.g. in the study of enzyme-carbohydrate interactions and of antibody-carbohydrate binding.<sup>1</sup> Moreover, fluorinated carbohydrates are useful compounds for medical applications, in particular for metabolic studies and disease diagnosis. A prominent example is 2-deoxy-2-[<sup>18</sup>F]-fluoro-D-glucose, which is used as a radiopharmaceutical in oncology and cardiology.<sup>2</sup> Fluorinated carbohydrates are often synthesized by nucleophilic substitution of hydroxyl groups.<sup>3</sup> Different fluorination reagents are commercially available; however, these reagents are often toxic, expensive, difficult to handle, not stable or need harsh reaction conditions. In the past decades, it has been demonstrated that perfluoroalkanesulfonyl fluorides are attractive fluorinating agents that can be employed under mild reaction conditions.<sup>4</sup> They have already been applied to the fluorination of different alcohols in good yields, but until now they have rarely been used to convert carbohydrates into their corresponding fluorinated analogues.<sup>4a-d</sup> In this project a protocol for the fluorination of different orthogonally protected carbohydrates using these reagents is established. The scope and limitations of this method are discussed.

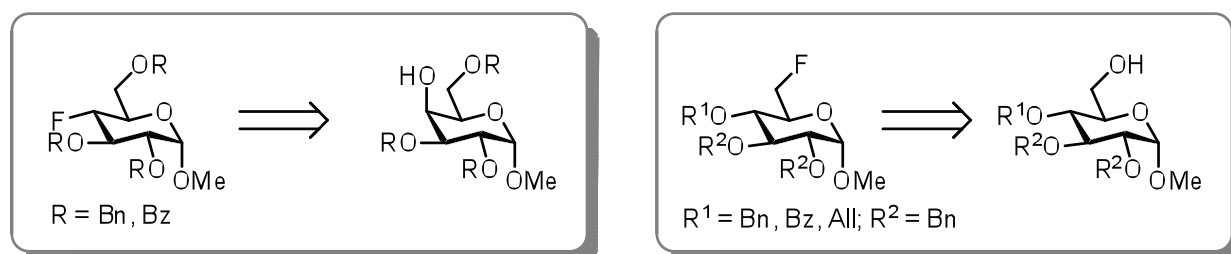

## References

1. *Fluorinated Carbohydrates, Chemical and Biochemical Aspects*, Ed. N. F. Taylor, ACS Symposium Series, **1988**.
2. B. Beuthien-Baumann, K. Hamacher, F. Oberdorfer, J. Steinbach, *Carbohydr. Res.*, **2000**, 327, 107-118.
3. K. Dax, M. Albert, J. Ortner, B. J. Paul, *Carbohydr. Res.* **2000**, 327, 47-86.
4. a) J. Yin, D. S. Zarkowsky, D. W. Thomas, M. M. Zhao, M. A. Huffman, *Org. Lett.* **2004**, 6, 1465-1468; b) B. Benua-Skalmowski, H. Vorbrüggen, *Tetrahedron Lett.*, **1995**, 36, 2611-2614; c) B. Benua-Skalmowski, H. Vorbrüggen, *Nucleosides Nucleotides*, **1996**, 15, 739-742; d) X. Zhao, W. Zhuang, D. Fang, X. Xue, J. Zhou, *Synlett*, **2009**, 5, 779-782; e) R. Zimmer, M. Webel, H.-U. Reißig, *J. prakt. Chem.* **1998**, 340, 274-277.

## PO 142

**A NOVEL ROUTE TO IDOPYRANOSIDES AND ITS APPLICATION IN THE  
SYNTHESIS OF 6-DEOXY- $\beta$ -D-HEPTOPYRANOSIDES FROM *CAMPYLOBACTER  
JEJUNI* CAPSULAR POLYSACCHARIDE**

Rachel Hevey, Chang-Chun Ling

*Alberta Ingenuity Centre for Carbohydrate Science, Department of Chemistry,  
University of Calgary, Canada, T2N 1N4  
rhevey@ucalgary.ca*

*C. jejuni* infection is the leading cause of gastroenteritis in developed countries which places a large financial burden on health systems.<sup>1</sup> These bacteria express both capsular polysaccharides (CPs) and lipopolysaccharides (LPs) on their cell membrane, the latter of which has been associated with the development of Guillain-Barré Syndrome (GBS). GBS results from an immune response to *C. jejuni* LPs which have structural elements resembling human gangliosides expressed on nervous tissue; the host produces antibodies that can cross-react with human gangliosides, resulting in a self-destructive auto-immune response.<sup>2</sup> It has been hypothesized that re-directing the immune response towards CPs could decrease the risk of generating this disease.

In an effort to study this hypothesis, a disaccharide repeating unit identified as a CP component of *C. jejuni* strain CG8486 was selected as a synthetic target for a glycoconjugate vaccine design. The disaccharide contains an unusual 6-deoxy-D-*ido*-heptopyranose unit that is  $\beta$ -linked to the O-4 position of *N*-acetyl-D-glucosamine (1).<sup>3</sup> We designed an efficient route to obtain  $\beta$ -idopyranosides from D-galactose, which relies on a key double inversion of the C-2 and C-3 positions of  $\beta$ -galactopyranoside (2) to give (3) with the desired *ido*-configuration. This approach affords orthogonally protected intermediates thus allowing a selective deprotection at O-3 for future development of glycosylations. This orthogonal protection strategy could also be applied in the synthesis of heparin, heparan, and dermatan glycosaminoglycans.

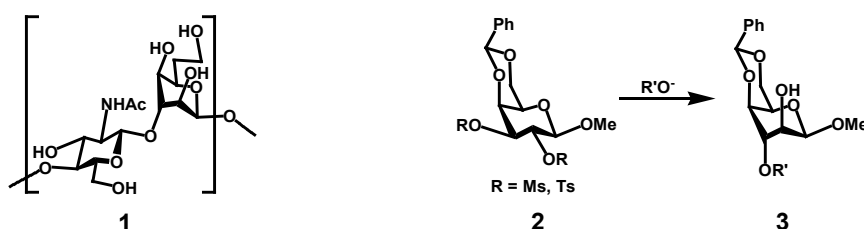

### References

1. E. Galanis, *CMAJ*, **2007**, *177*, 570-571.
2. R. K. Yu, S. Usuki, T. Ariga, *Infect. Immun.*, 2006, *74*, 6517-6527.
3. Y. H. Chen, F. Poly, Z. Pakulski, P. Guerry, M. A. Monteiro, *Carbohydr. Res.*, **2008**, *343*, 1034-1040.



PO 143

**TOWARDS THE DEVELOPMENT OF ANTITUBERCULAR DRUGS:  
SYNTHESIS OF ANALOGUES OF MYCOTHIOL**Brian Higgins, Stefan Oscarson

School of Chemistry and Chemical Biology, University College Dublin,  
Belfield, Dublin 4, Ireland  
stefan.oscarson@ucd.ie, brian.higgins@ucd.ie

Mycothiol (**1**, Fig. 1) is a pseudodisaccharide which is the putative defence of the gram-positive *Actinomycetales* bacteria against xenobiotics and oxidative stress. This group of bacteria includes the pathogen, *Mycobacterium tuberculosis* which causes tuberculosis.<sup>1</sup> It has been suggested that due to the increased sensitivity of mycothiol-deficient mutants to electrophiles, free radicals and antibiotics, the enzymes involved in the biosynthesis of mycothiol are potential drug targets.<sup>2</sup> Mycothiol and analogues will shed light on the important interactions between the enzymes and their specific substrates thus aiding the development of anti-tubercular drugs.

The aim of this project is to synthesise stable carbohydrate based analogues of mycothiol as S- and C- glycosides that vary in the inositol moiety and at the thiol functional group. Synthesis of thio-analogue **2**<sup>3</sup> as well as methods for the regioselective protection of the *myo*-inositol moiety and its conversion to the thio-acceptor is described. Methodologies for the synthesis of C-glycoside analogues of mycothiol that are currently being pursued will be outlined in this presentation.

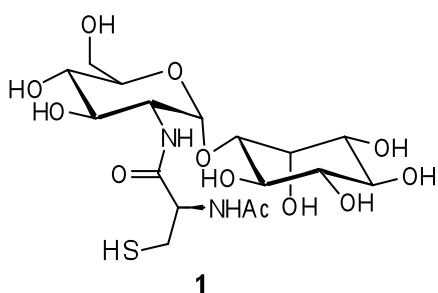
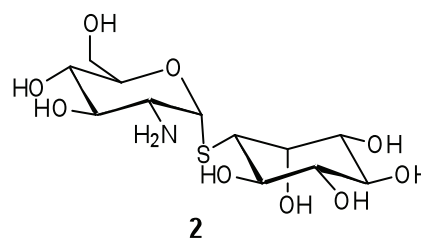
**Fig. 1:** Mycothiol**Fig. 2:** Thio-analogue**References**

1. Spies, H., Steenkamp, D., *Eur. J. Biochem/FEBS*, **1994**, 224 (1), 203-213.
2. Metaferia, B., Ray, S., Smith, J., Bewley, C., *Bioorg. Med. Chem. Lett*, **2007**, 17 (2), 444-447.
3. Slättegård, R., Oscarson, S., dissertation, Institutionen för organisk kemi, Stockholm **2007**.

PO 144

**GLYCOMIMETICS OF THE INHIBITORS  
OF GLYCOSYLTRANSFERASES – DESIGN AND SYNTHESIS**

Ján Hirsch, Marek Baráth, Miroslav Kooš and Igor Tvaroška

*Institute of Chemistry, Slovak Academy of Sciences,  
Dúbravská cesta 9, 845 38 Bratislava, Slovakia  
chemhirs@savba.sk*

Glycosyltransferases (GT's) represent an important group of enzymes involved in the biosynthesis of *N*- and *O*-linked complex oligosaccharides of glycoproteins providing the formation of a new glycosidic linkage. They cause significant structural variations in biological systems and thereby modulate intermolecular interactions by steric influence and lectin bindings. On the other hand, the part of these structural variations, raised by catalytic effect of GT's, contribute to various mammalian diseases that can span from early childhood to adult life [1,2].

This contribution based on the rational design of the transition state analog inhibitors of the GT's, representing donor UDP-GlcNAc [3], introduces the synthesis of four precursors, namely benzyl 2-thio- $\alpha$ -D-fructofuranoside 1-diethylphosphate (**1**), its  $\beta$ -anomer (**2**), and their ethyl 2-thio analogues ( $\alpha$ -anomer **3** and  $\beta$ -anomer **4**).

Starting from benzyl or ethyl 2-thio- $\alpha$ - or  $\beta$ -D-fructofuranosides, respectively [4], sequential protection at position C-6 with *tert*-butyldimethylsilyl group, at C-1 with dimethoxytrityl group, at C-3 and C-4 with acetyl groups, followed by detritylation afforded nucleophiles having a free OH-group at C-1 [5]. These were coupled with diethyl chlorophosphate to give blocked D-fructofuranoside 1-diethylphosphates. The desired precursors **1-4** were finally obtained by usual detritylation and deacetylation.

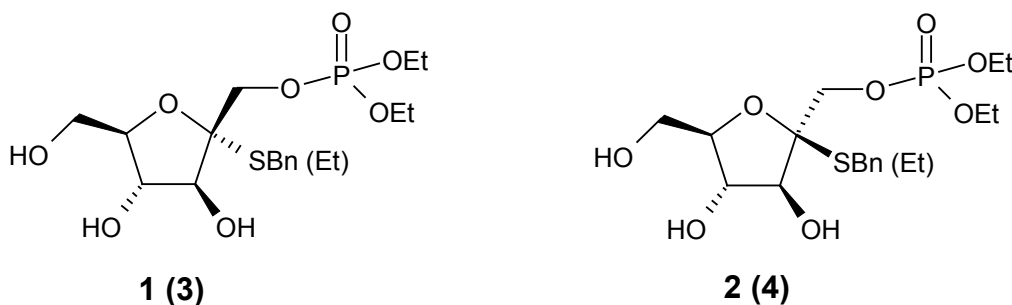

**Acknowledgements:** This work was partially supported by the grants VEGA 2/0199/09 and 2/0101/11

### References

1. Montreuil J., Vlieghehart J.F.G., Schachter H., *Glycoproteins I*, **1995**, Vol. 29A, Amsterdam: Elsevier
2. Montreuil J., Vlieghehart J.F.G., Schachter H., *Glycoproteins and Diseases*, **1996**, Vol 30, Amst.: Elsevier
3. Raab M., Kozmon S., Tvaroška I., *Carbohydr. Res.*, **2005**, 340, 1051
4. Krog-Jensen C., Oscarson S., *J. Org. Chem.*, **1996**, 61, 1234
5. Hirsch J., Kooš M., Tvaroška I., *Chem. Papers*, **2009**, 63, 329

## PO 145

## FTIR AND NMR SPECTROSCOPIC STUDY OF MODIFIED PECTINS

Anna Malovíková<sup>1</sup>, Vlasta Sasinková<sup>1</sup>, Iva Sroková<sup>2</sup>, Lydia Rychlá<sup>3</sup>, Ivica Janigová<sup>3</sup>,  
Katarína Csomorová<sup>3</sup>, Ján Hirsch<sup>1</sup>, Anna Ebringerová<sup>1</sup>

<sup>1</sup>*Institute of Chemistry, Center for Glycomics, Slovak Academy of Sciences,  
Dubravsku cesta 9, 845 38 Bratislava, Slovakia*

<sup>2</sup>*Faculty of Industrial Technologies, Trenčín University of A. Dubček, Trenčín, Slovakia*

<sup>3</sup>*Polymer Institute, Slovak Academy of Sciences, 845 41 Bratislava, Slovakia  
chemhirs@savba.sk*

Pectins are widely used as gelling and thickening agents in food industry and are known as valuable dietary fiber components [1]. Pectins can be structurally modified to alter their physicochemical properties so that their functional properties can be improved as well as novel ones achieved. In this way, they have gained a large impact in pharmacy and medicine [2,3]. Besides the types of substitution, the degree of substitution (DS) affects properties of the derivatives. DS is normally determined by wet chemistry methods which are destructive to the samples, time-consuming and may involve the use of harmful chemical reagents. As alternatives, vibrational and NMR spectroscopy are becoming more and more reliable and affordable candidates.

In this study, Fourier transform infrared (FTIR) and <sup>1</sup>H- and <sup>13</sup>C-NMR spectroscopy techniques were used to analyze a set of chemically modified derivatives prepared from citrus pectin by the controlled de-esterification of commercial methyl esterified pectin, acetylation, amidation and alkylamidation. Distinct vibrations and corresponding chemical shifts of functional groups in FTIR spectra and NMR spectra, respectively, were used to determine the structural changes introduced by the different modifications. For comparison, the DS of the derivatives was determined by chemical methods (alkalimetry, elemental analysis). The functional properties of the pectin derivatives were studied in view of the emulsifying capability and thermal and thermooxidative stability, which both are important for characterizing pectin additives in food, cosmetics and pharmacy. The results will also aid their future applications in the characterization of pectic polysaccharides from novel plant sources and/or identification of various pectin additives in food products.

**Acknowledgements:** This work was supported by the Slovak Grant Agency VEGA, grant No. 2/0062/09.

**References**

1. Willats, W. G. T., Knox, P., Mikkelsen, J. D. *Trends Food Sci. Technol.*, **2006**, 17, 97–104.
2. Yang, S., Cheng, K., Lin, Y., Liu, Y., Hou, W. *J. Agric. Food Chem.*, **2004**, 52, 4270–4273.
3. Sørensen, I., Pedersen, H. L., Willats, W. G. T. *Carbohydr. Res.*, **2009**, 344, 1872–1878.

## PO 146

FLUORESCENT AND  $\alpha$ -HYDROXYLATED GLYCOSPHINGOLIPIDS  
TO INVESTIGATE DOMAIN FORMATION

Annika Holkenbrink, Lukas J. Patalag, Dirk N. H. Meineke and Daniel B. Werz

*Institute of Organic and Biomolecular Chemistry, Georg August University of Göttingen,  
Tammannstr. 2, D-37077 Göttingen, Germany  
aholken@gwdg.de*

Glycosphingolipids can be found in all eucaryotic cell membranes, but mainly in the plasma membrane. They are known to form clusters, so called membrane domains, which can move within the fluid bilayer. Such lipid rafts seem to play an important role in the regulation of different cellular processes like signal transduction. From a retrosynthetic point of view, glycosphingolipids consist of three major building blocks; a carbohydrate component, a fatty acid and a sphingoid base.<sup>[1]</sup>

Due to great structural variety of glycosphingolipids it would be interesting to investigate the influence of different structural motifs on domain formation and in addition to find new fluorescent tags close to the native structure of glycosphingolipids. Till now fluorescence spectroscopy in order to study domain formation needs bulky fluorescent tags like NBD and BODIPY, which change the chemical and physical properties of glycosphingolipids dramatically and makes the observation of lipid rafts quite difficult. Conjugated polyene lipids show a strong similarity to natural lipids and were already used as tags by *Kuerschner et al.*<sup>[2]</sup> studying membrane phase partitioning. Such fatty acid precursors would be a good possibility to install a fluorophore in the glycosphingolipid backbone.

Our attempt is to build up different sets of glycosphingolipids, where either the carbohydrate part or the fatty acid part differs. Different chain lengths, the grade of saturation and  $\alpha$ -hydroxylation of the fatty acids are considered. As *D-erythro-(2S,3R)-sphingosine*<sup>[3]</sup> is the main sphingoid base in mammalian tissue, no structural change in this building block is envisaged.

**References**

1. A. Wedeking, G. van Echten-Deckert, *Curr. Org. Chem.*, **2007**, *11*, 579-589.
2. L. Kuerschner, C. S. Ejsing, K. Ekroos, A. Shevchenko, K. I. Anderson, C. Thiele, *Nat. Methods*, **2005**, *2*, 39-45.
3. P. M. Koskinen, A. M. P. Koskinen, *Synthesis*, **1998**, *8*, 1075-1091.

## PO 147

**THE GH9 PROTEIN FROM *PHOTOBACTERIUM PROFUNDUM* SS9  
IS AN EXO- $\beta$ -D-GLUCOSAMINIDASE (EC 3.2.1.165)**

Yuji Honda, Nozomi Shimaya, Kana Ishisaki, Mitsuru Ebihara and Hajime Taniguchi

*Ishikawa Prefectural University, Department of Food Science, 1-308 Suematsu,  
Nonoichi, Ishikawa 921-8836, Japan  
honda@ishikawa-pu.ac.jp*

Chitin catabolic systems of Vibrionaceae have been elucidated by microarray expression profiling studies [1]. The chitin catabolic operon is conserved in the genomic sequences of *Photobacterium profundum* SS9 [2]. In the chitin catabolic system, the gene cluster contains various glycoside hydrolases (GHs), such as a  $\beta$ -*N*-acetylglucosaminidase (GH20), a *N,N'*-diacetylchitobiose phosphorylase (GH94), a glucosamine kinase and an exo- $\beta$ -1,4-glucosidase (GH9), respectively.

Here, the enzymatic properties of the GH9 protein from *P. profundum* SS9 are discussed by comparison with the substrate specificities of other GHs belonging to GH9 family. The protein had no signal peptide sequence, indicating that it was intracellular protein. The enzyme hydrolyzed  $\beta$ -1,4 glycosidic bonds of cellooligosaccharides and chitooligosaccharides. The enzyme also released 4-nitro phenol from 4-nitrophenyl  $\beta$ -glucoside and 4-nitrophenyl  $\beta$ -glucosaminide, suggesting that the enzyme released sugar unit from non reducing end of oligosaccharides. Time-dependent <sup>1</sup>H-NMR analysis of the enzymatic reaction suggest that the hydrolytic reaction occurred by anomeric inversion. Kinetic analysis of the hydrolytic activities toward cellooligosaccharides and chitooligosaccharides indicated the enzyme is an exo- $\beta$ -D-glucosaminidase (EC 3.2.1.165) but not an exo- $\beta$ -1,4-glucosidase.

**References**

1. Meibom, K.L., Li, X.B., Nielsen, A.T., Wu, C.Y., Roseman, S. and Schoolnik, G.K. *Proc. Natl. Acad. Sci. USA*, **2004**, *101*, 2524-2529.
2. Vezzi, A., Campanaro, S., D'Angelo, M., Simonato, F., Vitulo, N., Lauro, F.M., Cestaro, A., Malacrida, G., Simionati, B., Cannata, N., et al. *Science*, **2005**, *307*, 1459-1461.

## PO 148

STRUCTURE AND SPECIFICITY OF A BLOOD GROUP OLIGOSACCHARIDE SPECIFIC LECTIN FROM *ASPERGILLUS FUMIGATUS*

Josef Houser<sup>1</sup>, Jan Komárek<sup>2</sup>, Nikola Kostlánová<sup>1</sup>, Gianluca Cioci<sup>3</sup>, Anne Imberty<sup>4</sup>,  
Michaela Wimmerová<sup>1,2</sup>

<sup>1</sup>National Centre for Biomolecular Research and

<sup>2</sup>Department of Biochemistry, Faculty of Science, Masaryk University,  
Kotlářská 2, 611 37 Brno,

<sup>3</sup>ESRF, 6 rue Jules Horowitz, 38043 Grenoble, France,

<sup>4</sup>CERMAV-CNRS, BP53, 38041 Grenoble Cedex 9, France  
houser@mail.muni.cz

*Aspergillus fumigatus* is well known allergen and opportunistic pathogen as well. The infection occurs seldom in immunocompetent person, but can be a life-threatening complication in people with altered immunity, such as the patients on immunosuppressive treatment after organ transplantations or the AIDS patients. Although the invasive aspergillosis can be caused by several *Aspergillus* species, *A. fumigatus* is the most frequently detected pathogen.

We have identified ten lectin-like proteins in the recently sequenced genome of *A. fumigatus*, including AFL1 that displays 32 % sequence identity with the fucose-binding lectin AAL from *Aleuria aurantia*<sup>1</sup>. Surface plasmon resonance (SPR) experiments and other functional studies of AFL revealed its high specificity for fucose and fucosylated derivatives, which are bound with micromolar affinity. The structure of AFL has been solved using X-ray diffraction in complex with histo-blood group A and Lewis X oligosaccharides and fucosylated disaccharides. The data revealed not only presence of sixth binding site that is missing in the AAL homologue, but proved also the specificity differences among the sites within one monomer. Although fucose is the recognized part of the ligand, individual sites prefer different linkages between fucose and an adjacent saccharide. The consequences and comparison to related lectins will be discussed. Thanks to the combination of protein X-ray crystallography and functional studies of lectin-ligand interactions we shed a light on lectin-carbohydrate binding and in the next step could contribute to new antiadhesive drugs development or mutant lectins design for specific use in biotechnology.

*The research has been supported by Ministry of Education of the Czech Republic (MSM0021622413, LC06030, ME08008), Grant Agency of the Czech Republic (303/09/1168) and the European Community's Seventh Framework Program under grant agreement n°205872.*

**References**

1. M. Wimmerova, E. Mitchell, J.-F. Sanchez, C. Gautier, A. Imberty, *J. Biol. Chem.*, **2003**, 278(29), 27059–27067



PO 149

**A NEW APPROACH TO AMADORI KETOSES VIA MO<sup>VI</sup> - CATALYZED STEREOSPECIFIC ISOMERIZATION OF 2-C-BRANCHED AZIDOSUGARS IN MICROWAVE FIELD**

Zuzana Hricovíniová

*Institute of Chemistry, Slovak Academy of Sciences, SK-845 38 Bratislava, Slovakia  
chemhric@savba.sk*

One of the useful applications of catalyzed chemical transformations is the synthesis of biologically active carbohydrates. This work gives an example of the use of transition metal-catalyzed transformation in the synthesis of saccharide derivatives bearing amino group. Amino sugars are an important class of compounds having broad spectrum of applications in biochemical, medicinal and pharmaceutical fields.<sup>1</sup> The substitution of a hydroxyl function by an amino group may alter properties of the sugar significantly, for example, its solubility, hydrogen bonding properties and charge. Consequently, amino sugars play important physiological roles in many glycoconjugates and are of interest for the development of new drugs.<sup>2</sup> The transformation studies involve formation of molybdate complexes of reducing saccharides bearing azido function.<sup>3</sup> Molybdate ions can form highly reactive, catalytically active complexes that promote the unique stereospecific rearrangement of the saccharide carbon skeleton.<sup>4-5</sup> The branched-chain aldose bearing azido group at position C-2 provides access to the corresponding 1-*deoxy*-1-azido- and 1-*deoxy*-1-amino ketoses in a single step through a stereospecific isomerisation. The isomerisation exploited the catalytic effect of molybdate ions and microwave irradiation.

**References**

1. Hanessian, S. *Total Synthesis of Natural Products: The "Chiron" Approach*, Pergamon, Oxford, **1983**.
2. *Carbohydrate Based Drug Discovery* Ed.: Wong C.-H.; Wiley-VCH, Weinheim, **2003**, chap.26.3
3. Hricovíniová, Z. *Tetrahedron: Asymmetry* **2010**, *21*, 2238-2243.
4. Bílik, V. *Chem. Zvesti* **1972**, *26*, 183-186, 187-189, 372-375.
5. Petruš, L.; Petrušová, M.; Hricovíniová, Z. *Topics in Current Chemistry. Glycoscience: Epimerisation*,
6. *Isomerisation and Rearrangement Reactions of Carbohydrates*, Springer-Verlag, **2001**, 215, 15-41.

## PO 150

SYNTHESIS OF GLYCOSYL PHOSPHATE CONJUGATES USING  
THE CYCLOSAL-METHOD

Johanna Huchting and Chris Meier

Organic Chemistry, Department of Chemistry, Faculty of Sciences, University of Hamburg,  
Martin-Luther-King-Platz 6, D-20146 Hamburg, Germany  
huchting@chemie.uni-hamburg.de

Glycosyl phosphate units are found in several bioconjugates serving different biological functions. Attached to nucleotides – so-called sugar nucleotides – they act as substrates for glycosyltransferases which catalyze the *in vivo* synthesis of oligo- and polysaccharides.<sup>1</sup> Repeating units of glycosyl phosphates are found in capsular polysaccharides of bacteria as well as in glycocalix lipophosphoglycans and secreted proteophosphoglycans of parasites.<sup>2,3</sup> With regard to their versatile biological functions glycosyl phosphate conjugates are important subjects of research. Our group developed a method for the efficient synthesis of phosphorylated bioconjugates such as NDP/ NMP pyranoses, nucleoside di- and triphosphates as well as dinucleoside oligophosphates.<sup>4,5</sup> Recently, we were able to apply this method to the synthesis of NDP disaccharides. As shown in scheme 1, the coupling of the sugar phosphate with the acceptor substituted *cycloSal*-nucleotide as activated phosphate yields the anomericly pure NDP disaccharide.

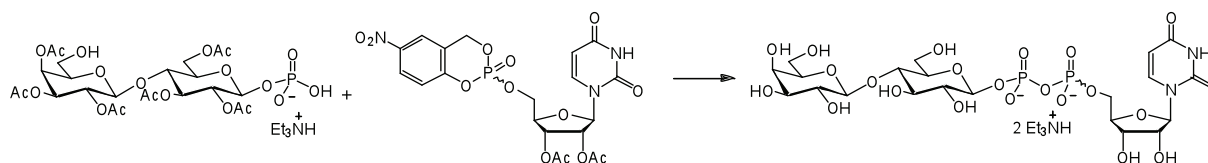
Scheme 1: synthesis of UDP- $\beta$ -Lactose

These very promising results open an access of chemically synthesizing not only more complicated NDP sugars than the well known NDP monosaccharides but also di-/ oligosaccharides bearing a phosphatediester linkage.

## References

1. Wong, C.-H.; Halcomb, R. L.; Ichikawa, Y.; Kajimoto, T. *Angew. Chem.* **1995**, *107*, 453-474; *Angew. Chem. Int. Ed.*, **1995**, *34*, 412-432 (Pt. 1), *Angew. Chem.* **1995**, *107*, 569-593; *Angew. Chem. Int. Ed.*, **1995**, *34*, 521-546 (Pt. 2).
2. Nikolaev, A. V.; Botvinko, I. V.; Ross, A. J. *Carbohydr. Res.*, **2007**, *342*, 297-344.
3. Sato, K.; Oka, N.; Fujita, S.; Matsumura, F.; Wada, T. *J. Org. Chem.*, **2010**, *75*, 2147-2156.
4. Wendicke, S., Warnecke, S., Meier, C. *Angew. Chem.* **2008**, *120*, 1523-1525; *Angew. Chem. Int. Ed.*, **2008**, *47*, 1500 – 1502.
5. Wolf, S.; Zismann, T.; Lunau, N.; Warnecke, S.; Wendicke, S.; Meier C. *Eur. J. Cell Biol.*, **2010**, *89*, 63-75.

## PO 151

## SYNTHESIS OF THIOLYCOGLYLATED INDOLES AS PRECURSORS OF SOLUBLE EUMELANIN POLYMERS

Matteo Adinolfi, Marco d'Ischia, Alfonso Iadonisi, Loredana Leone,  
Lucia Panzella, Alessandro Pezzella, Silvia Valerio

Department of Organic Chemistry and Biochemistry, University of Naples "Federico II"  
Via Cintia 4, I-80126, Naples, Italy  
iadonisi@unina.it

Eumelanins are the components of human skin and hair. These bio-polymers are mainly composed of 5,6-dihydroxy indole units interconnected via 2-4' and 2-7' C-C bonds. A long-standing issue related to eumelanins lies in their the poor solubility which renders very difficult their structural determination and consequently the clarification of the origin of their black colour, a rather unusual feature for an organic derivative. Very recently we have synthesized a new class of water-soluble eumelanins whose spectroscopic analysis provided some indications on the interactions likely involved in determining the peculiar absorption properties of eumelanins. These polymers were accessed through the overall sequence shown below entailing in the final stage the sequential de-O-acetylation and oxidative polymerization of a stable precursor as 3-thiogalactosylated 5,6-dihydroxy indole **1** (scheme).<sup>1</sup>

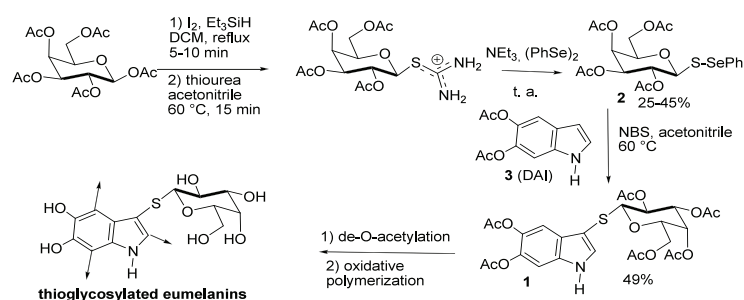

In view of the potential of glycosylated eumelanins either in glycobiology as a multivalent array of saccharidic units or in science of materials due to the interesting optical properties, we have been spurred to reconsider the overall synthetic procedure in order to get the thioglycosylated indole monomer **1** with improved yields. In this communication we

will report a new strategy in which both the synthesis of the thioglycosylation agent and the subsequent coupling with indole **3** (to yield **1**) are occurring at a sensibly higher yield than in the previous approach.

## References

1. A. Pezzella, A. Iadonisi, S. Valerio, L. Panzella, A. Napolitano, M. Adinolfi, M. d'Ischia *J. Am. Chem. Soc.* **2009**, *131*, 15270-15275.

PO 152

## SYNTHESIS OF FLUORINATED OLIGOSACCHARIDES FOR INTERACTION STUDIES WITH LECTINS

Stefan Oscarson and Angela Simona Infantino*Centre for Synthesis and Chemical Biology, UCD, Belfield, Dublin 4, Ireland**Angela.Infantino@ucdconnect.ie*

Lectins are carbohydrate-binding proteins without enzymatic activity and non immune origin. Although they were first discovered and characterized in plants, lectins are also expressed by animals and microorganisms. Apart from being popular analytical tool owing to their selective binding to glycans, lectins are also involved in a wide number of biological events: microbial adhesion, lymphocyte homing, intracellular protein trafficking, cell-cell recognition, cancer metastasis etc.<sup>1</sup> Understanding the biochemistry of lectins and the physical nature of the protein-carbohydrate interaction will provide important insights into biological information transfer. To investigate the scope of using <sup>19</sup>F-detected heteronuclear <sup>1</sup>H→<sup>19</sup>F-STD NMR spectroscopy<sup>2,3</sup> in lectin glycan interaction studies this project focus on synthesis of a library of 2-fluorinated mannose oligosaccharides (disaccharides and trisaccharides) and screening their binding activity to Concavalin A using the mentioned STD NMR method as well as other methods (e.g. ITC).

The synthesis is based on the combined use of common mannose building block derivatives as donors or acceptors.

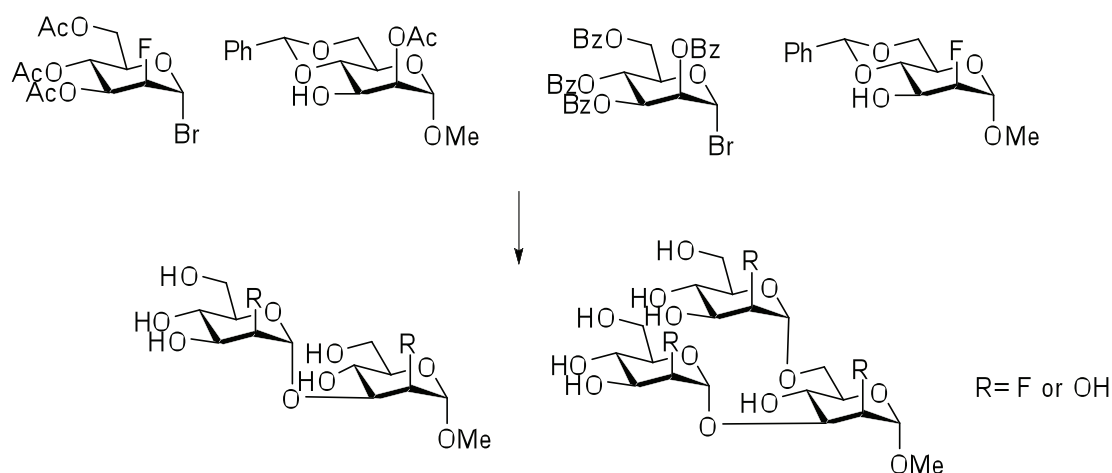
**References**

1. H.-J. Gabius, *The sugar code: Fundamentals of Glycosciences*, Wiley-VCH, Weinheim, **2009**, 261-347.
2. M. Mayer, B. Meyer *Angew. Chem. Int. Ed.*, **1999**, 38, 1784-1788.
3. T. Diercks, J. P. Ribeiro, F. J. Cañada, S. André, J. Jiménez-Barbero, H.-J. Gabius *Chem. Eur. J.*, **2009**, 15, 5666-5668.

PO 153

**SYNTHESIS OF NOVEL ISOSTERIC FLUOROPHOSPHONATE DERIVATIVES OF  
GLUCOSE 1-PHOSPHATE AND THEIR EVALUATION IN PHOSPHORYL TRANSFER  
REACTIONS**

David L. Jakeman,<sup>1,2</sup>

<sup>1</sup>College of Pharmacy, <sup>2</sup>Department of Chemistry, Dalhousie University, Halifax,  
Nova Scotia, B3H 3J5, Canada  
david.jakeman@dal.ca

Enzyme-catalysed phosphoryl transfer reactions play integral roles in metabolism, regulation and cell signaling and are associated with some of the largest enzymatic rate enhancements yet known.  $\beta$ -phosphoglucomutase ( $\beta$ PGM) catalyses the isomerisation of  $\beta$ -glucose 1-phosphate ( $\beta$ G1P) to  $\beta$ -glucose 6-phosphate ( $\beta$ G6P). Allen and Dunaway-Mariano claimed to observe a high energy pentacoordinate phosphorane intermediate in the enzyme active site by X-ray crystallography at low temperature,<sup>1</sup> a chemical entity previously postulated to exist only transiently. Trifluoromagnesate ( $\text{MgF}_3^-$ ) has recently been identified as a trigonal planar mimic for the phosphate ( $\text{PO}_3^{2-}$ ) group in transition states for  $\beta$ PGM.<sup>2</sup> In this work, we have prepared novel stable probes for the phosphoryl transfer process catalyzed by  $\beta$ PGM and examined them in complex with  $\beta$ PGM.

Synthetic routes to novel  $\beta$ -glucose 1-phosphate derivatives (**1**, **2**, and **3**) were devised and executed. The existence of complexes between **1**, **2**, **3** and  $\beta$ PGM- $\text{MgF}_3^-$  were investigated in the phosphoryl transfer reaction using a variety of techniques including <sup>19</sup>F NMR spectroscopy to gain insight into the phosphoryl transfer process and the ability to mimic the substrates with isosteric and isoelectronic analogues. The coordination of the  $\text{MgF}_3^-$  moiety clearly questions the previous observation of the elusive high energy pentacoordinate phosphorane.

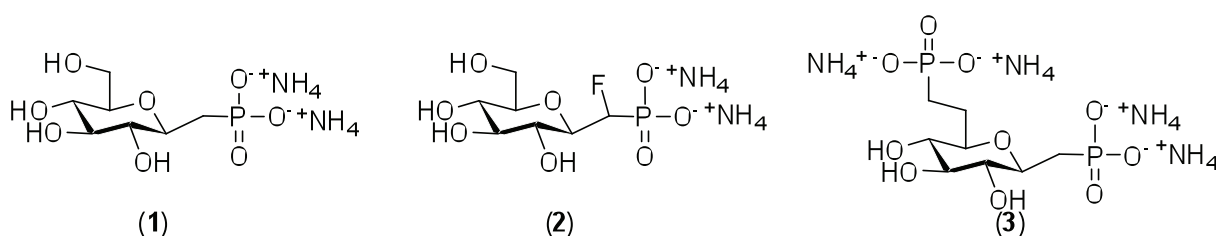

### References

1. Sushmita D. Lahiri, Guofeng Zhang, Debra Dunaway-Mariano, Karen N. Allen *Science* **2003**, 299, 2067-2071.
2. Nicola J. Baxter, Luis F. Olguin, Marko Golic̃nik, Guoqiang Feng, Andrea M. Hounslow, Wolfgang Bermel, G. Michael Blackburn, Florian Hollfelder, Jonathan P. Waltho, and Nicholas H. Williams *Proc. Nat. Acad. Sci. U.S.A.* **2006**, 103, 14732-14737.

## PO 154

## SYNTHESIS OF A STABLE HEMI-AMINAL GLUCURONIDASE INHIBITOR

Tina S. Rasmussen,<sup>1</sup> Henrik H. Jensen<sup>1</sup><sup>1</sup>*Department of Chemistry, Aarhus University, Langelandsgade 140, 8000 Aarhus C  
hhj@chem.au.dk*

We have recently shown<sup>1</sup> that a hybrid (Noeurostegine) of natural compound Calystegine B<sub>2</sub> and inherently unstable glucosidase inhibitor Noeuromycin<sup>2</sup> provides a potent and selective inhibitor of  $\beta$ -glucosidase. We here report on the synthesis and inhibitory data for an analogous compound (**1**) designed to inhibit glucuronidase.

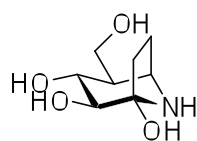

Noeurostegine

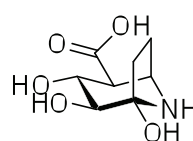
uronic-Noeurostegine  
(this study)**Reference**

1. Rasmussen, T. S., Jensen, H. H., *Org. Biomol. Chem.*, **2010**, 8, 433-441.
2. Liu, H., Liang, X., Søhoel, H., Bülow, A., Bols, M. *J. Am. Chem. Soc.*, **2001**, 123, 5116-5117.



PO 155

**SYNTHESIS OF A VERSATILE BUILDING BLOCK FOR THE  
PREPARATION OF 6-N-DERIVATIZED  $\alpha$ -GALACTOSYL  
CERAMIDES: RAPID ACCESS TO BIOLOGICALLY ACTIVE  
GLYCOLIPIDS**

Peter J. Jervis,<sup>1</sup> Liam R. Cox<sup>2</sup> and Gurdyaal S. Besra<sup>1</sup>

<sup>1</sup>*School of Biosciences, University of Birmingham, Edgbaston,  
Birmingham B15 2TT, United Kingdom,*

<sup>2</sup>*School of Chemistry, University of Birmingham, Edgbaston,  
Birmingham B15 2TT, United Kingdom*

*p.j.jervis@bham.ac.uk*

A concise route to the 6-azido-6-deoxy- $\alpha$ -galactosyl-phytosphingosine derivative **1** is reported. Orthogonal protection of the two amino groups allows elaboration of **1** into a range of 6-*N*-derivatized  $\alpha$ -galactosyl ceramides by late-stage introduction of the acyl chain of the ceramide and the 6-*N*-group in the sugar head-group. Some biologically active glycolipids have been synthesized to illustrate the applicability of the approach.

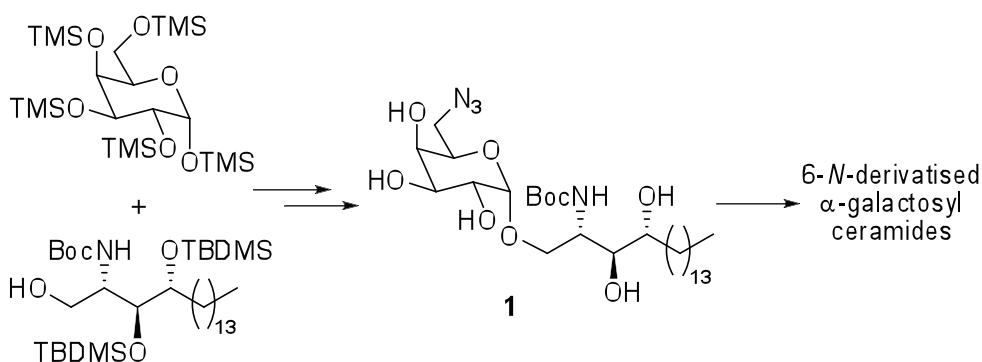

### References

1. Koch, M.; Stronge, V. S.; Shepherd, D.; Gadola, S. D.; Mathew, B.; Ritter, G.; Fersht, A. R.; Besra, G. S.; Schmidt, R. R.; Jones, E. Y.; Cerundolo, V. *Nat. Immunol.* **2005**, *6*, 819-826.
2. A Borg, N. A.; Wun, K. S.; Kjer-Nielson, L.; Wilce, M. C.; Pellicci, D. G.; Koh, R.; Besra, G. S.; Bharadwaj, M.; Godfrey, D. I.; McCluskey, J.; Rossjohn, J. *Nature* **2007**, *448*, 44-49.
3. Prigozy, T. I.; Naidenko, O.; Qazba, P.; Elewaut, D.; Brossay, L.; Khurana, A.; Natori, T.; Koezuka, Y.; Kulkarni, A.; Kronenberg, M. *Science* **2001**, *291*, 664-667.

## PO 156

EFFICIENT METHODOLOGIES TOWARDS THE SYNTHESIS OF  
C-GLYCOSYL ISOFLAVONES

Ana Rita Jesus, Amélia Pilar Rauter

Universidade de Lisboa, Faculdade de Ciências, Centro de Química  
e Bioquímica/Departamento de Química e Bioquímica, Edifício C8, 5o Piso, Campo Grande,  
1749-016 Lisboa, Portugal  
arxjesus@gmail.com

C-Glycosyl phenols and -polyphenols occur widely in nature and present a variety of biological properties, namely antitumor, antibacterial and antidiabetic activities. Synthetic access to such structures relies mainly on efficient methodologies for phenols C-glycosylation.<sup>1</sup> In the past few years major advances have been described addressing the use of Fries rearrangement to obtain a diversity of C-glycosyl compounds<sup>1</sup> such as orientin, parkinsonin A, isoswertiajaponin, parkinsonin B, orobol and genistein 8-C- $\beta$ -D-glucopyranosides.<sup>2,3</sup>

We present now an efficient method for the synthesis of the C-glycosyl isoflavone, 8-C- $\beta$ -D-glucosylgenistein using scandium(III) triflate as activator for the C-glycosylation of partially protected acetophloroglucinol with glycosyl acetate as donor. The construction of the flavonoid moiety was easily carried out using new conditions and leading to better yields.

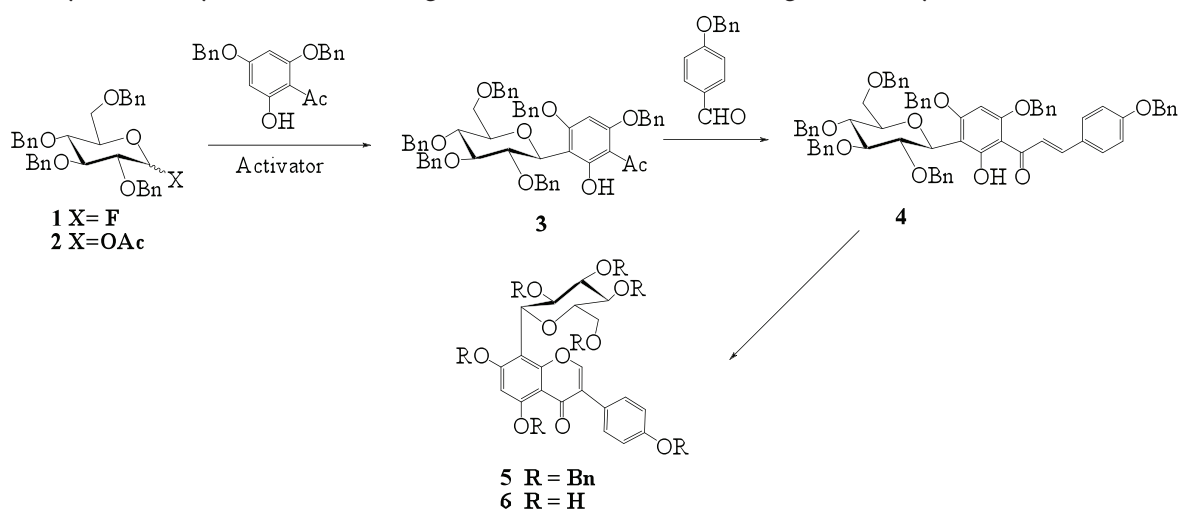

**Scheme 1.** Synthetic pathway for the synthesis of 8-C- $\beta$ -D-glucosylgenistein

**Acknowledgments** The authors acknowledge Fundação para a Ciência e Tecnologia for financial support (PTDC/QUI/67165/2006).

## References

1. Santos, R.; Jesus, A.R.; Caio, J.M.; Rauter, A.P., *Current Organic Chemistry*, **2011**, *15*, 128-148
2. Kumazawa, T.; Kimura, T.; Matsuba, S.; Sato, S.; Onodera, J., *Carbohydrate Research*, **2001**, *334*, 183-193
3. Sato, S.; Hiroe, K.; Kumazawa, T.; Jun-ichi, O., *Carbohydrate Research*, **2006**, *341*, 1091-1095

PO 157

## STRUCTURE-ACTIVITY RELATIONSHIP STUDIES ON POLYCATIONIC AMPHIPHILIC CYCLODEXTRINS AS GENE DELIVERY SYSTEMS

Alejandro Méndez-Ardoy,<sup>1</sup> Álvaro Martínez-Ceballos,<sup>2</sup> Nicolas Guilloteau,<sup>3</sup> Céline Bienvenu,<sup>3</sup> José L. Jiménez Blanco,<sup>2</sup> Christophe Di Giorgio,<sup>3</sup> Pierre Vierling,<sup>3</sup> Francisco-Santoyo-González,<sup>4</sup> Carmen Ortiz Mellet,<sup>2</sup> José M. García Fernández<sup>1</sup> and Juan M. Benito<sup>1</sup>

<sup>1</sup>Dpto. Química Orgánica, Facultad de Química, Universidad de Sevilla, Spain,

<sup>2</sup>Instituto de Investigaciones Químicas, CSIC – Universidad de Sevilla, Spain,

<sup>3</sup>LCMBA UMR 6001CNRS – Université de Nice Sophia Antipolis, Nice, France.

<sup>4</sup>Dpto. de Química Orgánica, Facultad de Ciencias, Instituto de Biotecnología, Univ. Granada, E-18071, Spain

jljb@us.es

Cationic polymers with cyclodextrin (CD) moieties in the backbone have shown significant promise towards the design of efficient nonviral gene carriers.<sup>1</sup> However, the intrinsic polydisperse nature of these materials represents a drawback for structure-activity relationship (SAR) studies. Recently, a new generation of well-defined polycationic CDs (paCDs) with gene delivery capabilities has been reported.<sup>2</sup> The existence of two well-differentiated faces in combination with selective functionalization methodologies allows endowing these systems with facial amphiphilicity properties, which results in improved plasmid DNA (pDNA) complexing and transfection abilities.<sup>3,4</sup> In order to evaluate the influence of structural features on transfection efficiency, a novel collection of paCDs having variable ring size, number of positive charges, lipophilic chains and anchoring segments have been prepared. Preliminary results on transfection efficiency and cell viability towards different cell lines will also be presented.

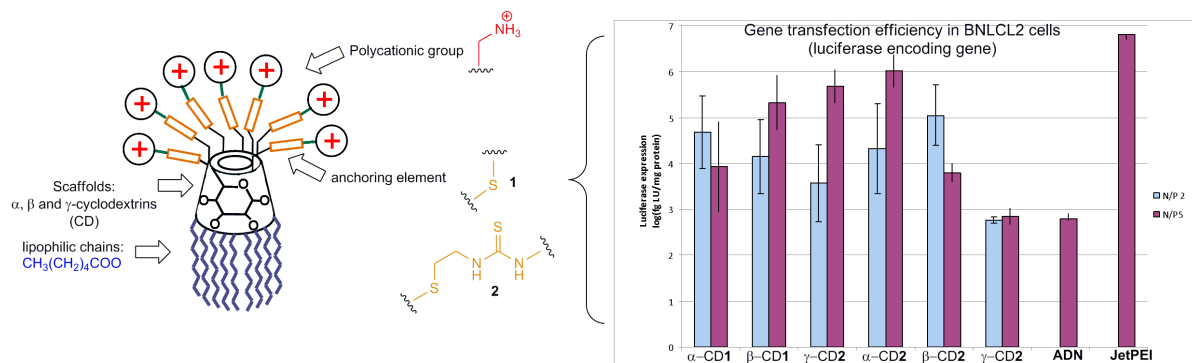

### References

1. M. E. Davis, M. E. Brewster, *Nature Rev. Drug. Discov.* 2004, **3**, 1023-1025. C. Ortiz Mellet, J. M. Benito, J. M. García Fernández, *Chem. Eur. J.* **2010**, *16*, 6728.
2. C. Ortiz Mellet, J. M. García Fernández, J. M. Benito, *Chem. Soc. Rev.* **2011**, *40*, doi: 10.1039/c0cs00019a.
3. A. Díaz-Moscoso, L. Le Gourriérec, P. Balbuena, M. Gómez-García, J. M. Benito, N. Guilloteau, C. Di Giorgio, P. Vierling, J. Defaye, C. Ortiz Mellet, J. M. García Fernández, *Chem. Eur. J.* **2009**, *15*, 12871.
4. A. Méndez-Ardoy, M. Gómez-García, C. Ortiz Mellet, N. Sevillano, M. D. Girón, R. Salto, F. Santoyo-González, J. M. García Fernández, *Org. Biomol. Chem.* **2009**, *7*, 2681.

## PO 158

## ONE-POT, REGIOSELECTIVE GLYCOSYLATION OF FREE SUGARS BY MEANS OF MASKING THROUGH BISBORONATE INTERMEDIATES

Kaji Eisuke, Yamamoto Daisuke, Shirai Yuko, Ishige Koji, Arai Yoshika, Shirahata Tatsuya, Makino Kazuishi, and Nishino Takashi

School of Pharmacy, Kitasato University,  
Shirokane 5-9-1, Minato-ku, Tokyo 108-8641, Japan  
kajie@pharm.kitasato-u.ac.jp

A facile, regioselective glycosylation has been developed for fully unprotected aldohexoses and ketohexoses through masking of hydroxy groups with double molar aryl boronic acids. In a general hexose unit, only one unmasked hydroxy group should be regioselectively glycosylated with various glycosyl donors as phenylthio glycosides to give disaccharides depending on the bisboronate structures of hexose acceptors.

Among aldohexoses employed as acceptors, D-glucose and D-galactose were glycosylated to 6-OH of the acceptors with phenyl tetra-*O*-benzoyl-1-thio- $\beta$ -D-glucopyranoside to afford  $\beta$ -D-Glcp-(1 $\rightarrow$ 6)-D-Glcp/D-Galp in good yields.

Glycosylation of D-mannose acceptor with various glycosyl donors resulted in unique products through a furanose-type bisboronate intermediate to give  $\beta$ -D-glycopyranosyl-(1 $\rightarrow$ 1)- $\alpha$ -D-mannofuranosides in good yields. Application of this method to other glycosyl acceptors is also discussed.

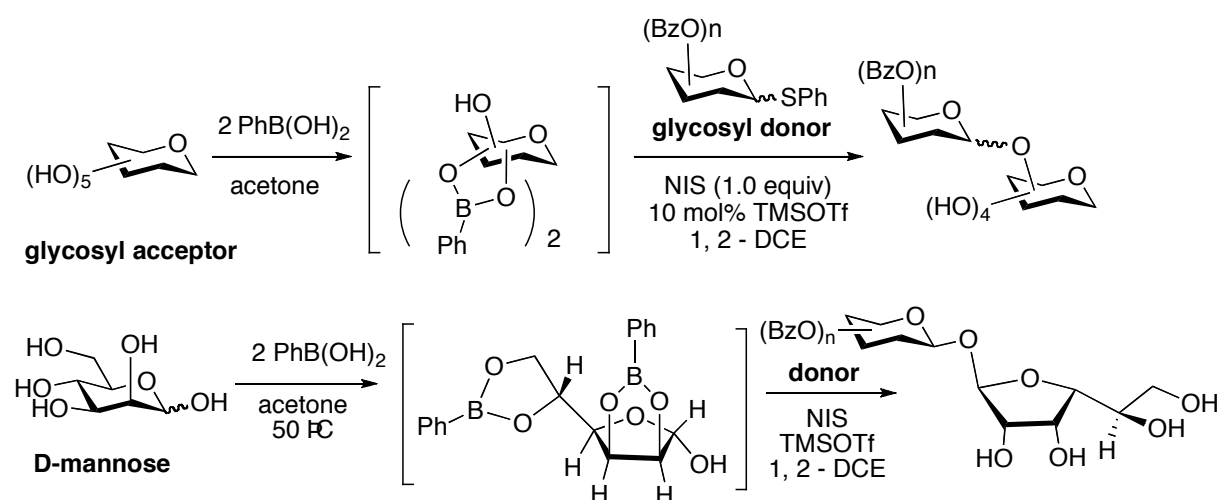

PO 159

EFFICIENT AND PRACTICAL SYNTHETIC METHODS  
OF GLYCOPEPTIDE- $\alpha$ THIOESTER

Yasuhiro Kajihara, Masumi Murakami, Keiko Morooka, Masayuki Izumi and Ryo Okamoto

*Department of Chemistry, Graduate School of Science,  
Osaka University, 1-1, Machikaneyama,  
Toyonaka, Osaka 560-0043, Japan  
kajihara@chem.sci.osaka-u.ac.jp*

Oligosaccharides linked to protein play important roles in several biological events such as protein folding, protein-lifetime in blood, transportation and immune response. In order to study the function of oligosaccharides, homogeneous glycoproteins are essential. Recently, chemical synthesis of glycoproteins as well as glycopeptides has developed. We have also demonstrated the syntheses of several bioactive glycoproteins, i.e. monocyte chemotactic protein-3, and erythropoietin analogues.<sup>[1-2]</sup> In order to synthesize glycoproteins by use of native chemical ligation, development of efficient synthetic methods of glycopeptides- $\alpha$ thioester is still essential<sup>[1-4]</sup> Therefore we have examined to establish efficient and practical synthetic method of glycopeptide- $\alpha$ thioester and recently we found two efficient methods.

Thioesterification toward unprotected glycopeptide was demonstrated by the activation of cysteine<sup>n</sup>-thiol at the C-terminal of glycopeptide. This condition affords xanthate derivative and then generates thioester of the terminal amino acid<sup>n-1</sup> cleaving the amide bond between amino acid<sup>n-1</sup> and terminal xanthate-cysteine<sup>n</sup>. This method successfully afforded peptide<sup>n</sup>-thioester as well as glycopeptide- $\alpha$ thioester in good yield.

In addition to this method, we successfully developed the synthesis of acid labile sialylglycopeptide- $\alpha$ thioesters under Boc-solid phase peptide synthesis (SPPS) conditions. It is known that Boc-SPPS is the best method for the synthesis of peptide- $\alpha$ thioester. However, strong acid condition under Boc-SPPS, especially final deprotection step, easily cleaves acid-labile sialyl linkages (sialoside). Therefore sialylglycopeptide could not be synthesized by Boc-SPPS using strong acid conditions. We thought that carboxylic acid of sialic acid work as intramolecular acid catalyst to accelerate acid hydrolysis of sialoside.<sup>[5]</sup> Recently we demonstrated that suitable protecting group of this carboxylic acid such as phenacyl group enabled us to perform synthesis of sialylglycopeptide- $\alpha$ thioester under Boc-SPPS. This method accelerates to obtain sialylglycopeptide- $\alpha$ thioester comparing conventional Fmoc methodology.

In this presentation, we would like to discuss new methodology combined with sialoside chemistry and peptide chemistry to develop the synthesis of sialylglycoproteins in detail.

**References**

1. K. Hirano, D. Macmillan, K. Tezuka, T. Tsuji, Y. Kajihara; *Angew. Chem. Int. Ed.* (2009), 48, 9557-9560.
2. N. Yamamoto, Y. Tanabe, R. Okamoto, P. E. Dawson, Y. Kajihara; *J. Am. Chem. Soc.* (2008), 130(2), 501-510.
3. R. Okamoto, Y. Kajihara; *Angew. Chem. Int. Ed.* (2008), 47(29), 5402-5406.
4. N. Yamamoto, A. Takayanagi, A. Yoshino, T. Sakakibara, Y. Kajihara; *Chem. Eur. J.* (2007), 13(2), 613-625.
5. N. Yamamoto, Y. Ohmori, T. Sakakibara, K. Sasaki, L. R. Juneja, Y. Kajihara; *Angew. Chem. Int. Ed.* (2003), 42(22), 2537-2540.

## PO 160

## ENZYMATIC SYNTHESIS OF GLYCOSIDES FROM GLYCALs

Anna Kasprzycka, Przemysław Hahn and Wiesław Szeja

*Silesian University of Technology, Department of Chemistry, Krzywoustego 4,  
44-100 Gliwice, Poland  
anna.kasprzycka@polsl.pl*

Glycosidases catalyse the synthesis of anomerically pure alkyl glycosides in one step. In contrast, chemical synthesis of anomerically pure glycosides is circuitous and expensive. Glycosidases exhibit absolute selectivity with regard to the stereochemistry at the anomeric centre and show a high degree of chemoselectivity for different hydroxyl groups of primary, secondary alcohols and phenols.<sup>1</sup>  $\beta$ -Glycosidase from different sources has been used for an efficient synthesis of 2-deoxy- $\beta$ -glycosides and for stereochemical studies of the reactions of glycal with acceptors which was alkyl alcohols and derivatives of carbohydrate.<sup>2,3</sup> The synthesis of 2-deoxyglycosides is very important niche in the field of carbohydrate chemistry. 2-Deoxy- $\beta$ -glycosyl moieties are present in biologically active natural products such as compactin, olivimycin, mithramycin, daunomycin, calicheamicin. The anomerically selective enzymatic synthesis of 2-deoxy- $\beta$ -glycosides is a very interesting approach in contrast to multi-stage chemical synthesis requiring the use of temporary groups equatorially disposed at C(2) which must be removed in later steps, often lowering reaction yields.<sup>4</sup>

In this communication we report the novel method of synthesis 2-deoxy- $\beta$ -D-galactosides using D-galactal with the  $\beta$ -galactosidase from *Aspergillus oryzae* with derivatives of benzyl alcohols as acceptors. These reactions, conducted with 5-9 molar excesses of acceptor, gave good yields ranged from 30 up to 50% after 24-48h of reaction.

**Acknowledgement** Research studies part-financed by the European Union within the European Regional Development Fund (POIG. 01.01.02-14-102/09).

**References**

1. van Rantwijk F., Woudenberg-van Oosterom M., Sheldon R.A., *Journal of Molecular Catalysis B: Enzymatic*, **1999**, 6, 511-532
2. Trincone A., Pagnotta E., Rossi M., Mazzone M., *Tetrahedron: Asymmetry*, **2001**, 12, 2783-2787
3. Petit J. M., Paquet F., Beau J. M., *Tetrahedron Letters*, **1991**, 32, 6125-6128
4. Marzabaldi C. H., Franck R. W., *Tetrahedron*, **2000**, 56, 8385-8417.





## PO 161

MODE OF ACTION OF A NOVEL FAMILY GH-23 CHITINASE  
FROM *Ralstonia* sp. A-471

Noriko Kawamoto,<sup>1</sup> Mitsuhiro Ueda,<sup>1</sup> Masami Nakazawa,<sup>1</sup> Kazutaka Miyatake,<sup>1</sup>  
Takayuki Onuma,<sup>2</sup> Tamo Fukamizo,<sup>2</sup>

<sup>1</sup> Graduate School of Life Science and Environment,  
Osaka Prefecture University, Sakai, Osaka 599-8531, Japan ,

<sup>2</sup> Department of Advanced Bioscience, Kinki University,  
3327204 Nakamachi, Nara 631-8505, Japan  
mu201017@edu.osakafu-u.ac.jp

Chitin, a  $\beta$ -1,4 linked polymer of *N*-acetyl-D-glucosamine (GlcNAc), is the second abundant biopolymer found in nature next to cellulose. For efficient utilization of chitin, the polysaccharides degradation by chitinases, has been regarded as one of the most useful and environment-friendly strategies. Recently, we have cloned a novel chitinase gene from thermophilic bacterium *Ralstonia* sp. A-471 (Ra-ChiC) and the recombinant enzyme was characterized<sup>1</sup>. Amino acid sequence of the catalytic domain of Ra-ChiC is homologous to those of goose-type lysozymes, that belong glycoside hydrolase family 23 (Family GH-23). However, Ra-ChiC has hydrolytic activities toward soluble chitin substrates, but not the activity toward the cell wall of *Micrococcus lysodeikiticus*. In this study, mutation study was conducted for this novel chitinase, Ra-ChiC, to understand the catalytic mechanism.

The Ra-ChiC expression plasmid constructed from pCold1 vector was transformed into *E. coli* JM109. The recombinant Ra-ChiC was expressed, and purified by a Ni affinity column, a hydrophobicity column, and a gel filtration column chromatographies. We analyzed the enzymatic products from the Ra-ChiC reaction toward chitin oligosaccharide [(GlcNAc)<sub>n</sub>] by HPLC. From the substrate (GlcNAc)<sub>6</sub>, the wild type enzyme produced predominantly (GlcNAc)<sub>2</sub> and (GlcNAc). The newly produced reducing end was largely  $\alpha$ -form, indicating that the enzyme is an inverting mechanism. Then, we mutated the putative catalytic residues, Glu141 and Glu162, to alanine (E141A and E162A) by site-direct mutagenesis to get insight into the catalytic mechanism. When the chitinase activity was determined using ethylene glycol chitin, the activity was almost completely eliminated in E141A and E162A, indicating that Glu141 and Glu162 are important for reaction. However, when Glu162 was mutated to glutamine (E162Q), the activity surprisingly increased two-fold when compared with that of the wild type. The binding mode of the oligosaccharide substrates was found to shift toward non-reducing end side in E162Q. Glu162 is likely involved in substrate binding as well as in catalytic reaction as a base.

### References

1. Mitsuhiro Ueda , Konomi Ohata , Toshiaki Konishi, Aji Sutrisno, Hitomi Okada, Masami Nakazawa, Kazutaka Miyatake, Appl Microbiol Biotechnol **2009**, 81, 1077–1085

## PO 162

**MUTAGENESIS OF SUBSTRATE INTERACTING RESIDUES IN THE ACTIVE SITE OF *TnBglA* FOR IMPROVED DEGLUCOSYLATION OF ANTIOXIDANTS**

Samiullah Khan<sup>1</sup>, Tahir Mahmood<sup>1</sup>, Sofia Lindahl<sup>2</sup>, Charlotta Turner<sup>2</sup>  
and Eva Nordberg Karlsson<sup>1</sup>

<sup>1</sup>Department of Biotechnology, P.O Box 124, Lund University, SE-22100 Lund, Sweden

<sup>2</sup>Department of organic chemistry, P.O Box 124, Lund University, SE-22100 Lund, Sweden  
sami.khan@biotek.lu.se

Waste from yellow onions is a good source of polyphenolic antioxidants from the flavonoid-group and the major forms are quercetin-glucosides, glucosylated at the 3 and 4'-position. Deglucosylation to the aglycone form (quercetin) creates a uniform product with stronger antioxidative power. In this project we aim to develop a thermostable b-glucosidase from *Thermotoga neapolitana* (*TnBglA* of Glycoside hydrolase family 1 [GH1]) for this purpose. *TnBglA* is a promising biocatalyst in deglucosylation of quercetin-glucosides using an environmental friendly process with subcritical water. The sub-critical water extraction procedure requires high temperatures, so use of a thermostable enzyme is necessary.

The selectivity of *TnBglA* was studied and the enzyme was shown to favour hydrolysis of glucosyl-groups attached to the 4'-position of the flavonoid (quercetin-4'-glucoside, Q-4) while the quercetin-3-glucoside (Q-3) was more difficult to hydrolyse. To improve the selectivity for the quercetin-3-glucoside and related substrates e.g. kaempferol-3 glucoside (K-3) and isorhamnetin-3-glucoside (Iso-3), different mutants of *TnBglA* were designed. Residues for mutation were selected based on alignment of enzymes within GH1, of different specificities, including the primary sequence of *TnBglA* and combined with inspection of a modelled 3D-structure of the enzyme. All mutants were expressed in *E. coli* and purified with immobilized metal ion affinity chromatography, utilizing the C-terminal His-tag included in the cloning design.

Kinetic parameters of all the mutants were determined using the model substrate para-nitrophenyl-b-D-glucopyranoside (pNPGlc). Based on these results the mutants were further screened on glucosylated flavonoid substrates to determine their potential in deglucosylation reactions. Enzymes mutated at position N221S or N220S showed increased catalytic efficiency towards Q-3, K-3, Iso-3, genestein-7-glucoside, daidzein-7-glucoside and Q-4' compared to the wild type.

## PO 163

TDM ANALOGUES AS MODULATORS OF THE IMMUNE SYSTEM  
AND IMPROVED FRATER'S ALKYLATION METHODOLOGY

Ashna A. Khan,<sup>1,2</sup> Stephanie H. Chee,<sup>2</sup> Jacque L. Harper,<sup>2</sup> Bridget L. Stocker<sup>2</sup>  
and Mattie S.M. Timmer.<sup>1</sup>

<sup>1</sup> School of Chemical and Physical Sciences, Victoria University of Wellington, P. O. Box 600,  
Wellington, New Zealand.

<sup>2</sup> Malaghan Institute of Medical Research, P. O. Box 7060, Wellington New Zealand.  
akhan@malaghan.org.nz

Trehalose dimycolates (TDMs) (Figure 1A) are glycolipids that are a major constituent of the cell wall of *Mycobacterium tuberculosis* (*M. tb*). TDMs have been shown to have important immunological properties such as anti-tumour activity, adjuvant activity in TB vaccines, and are also involved in angiogenesis and granuloma formation during challenge with *M. tb*.<sup>1</sup> The signalling pathway of TDMs was recently deduced and it was seen that TDMs and its more simple analogue trehalose dibehenate (TDB - Figure 1B) bind to the macrophage inducible C-type lectin (MINCLE).<sup>2</sup>

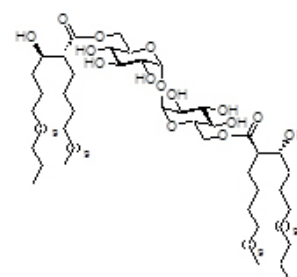
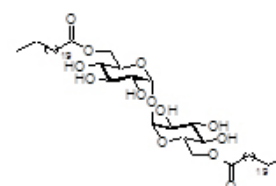
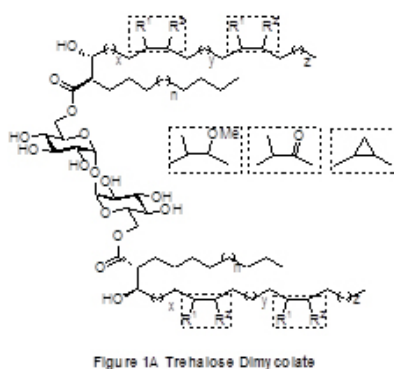

In this work, we present the synthesis of a variety of TDB analogues and the determination of their immunomodulatory profile. This will provide insight into the effects of lipid length on the activity of TDMs, which may lead to the generation of novel immunostimulatory agents with application in a variety of diseases.

Key step in the preparation of the more complex TDM (Figure 1A) and trehalose dicorynomycolate (TDCM) analogues (Figure 1C) is the efficient synthesis of  $\alpha$ -alkyl- $\beta$ -hydroxy fatty acids *via* a Frater's alkylation.<sup>3</sup> This methodology is commonly used for  $\alpha$ -alkylation of  $\beta$ -hydroxy esters using alkyl halides, although the yields from the reaction can vary dramatically (depending on the alkyl chain). We have found that the use of allylic halides significantly increases the yields of this reaction. The allylic halides in turn could be synthesised readily from commercially available aldehydes in two steps. The synthesis of TDM analogues using this methodology and their immunological properties will be presented.

### References

1. Ryll, R., Kumazawa, Y., Yano, I. *Microbiol. Immunol.* **2001**, *45*, 801-811.
2. Schoenen, H. *et. al. Immunol* **2010**, *184*, 2756-2760.
3. Frater, G., Müller, U., Günther, W. *Tetrahedron* **1984**, *40*, 1269-1277.

## PO 164

**THE EFFECT OF THE POLYSACCHARIDES FROM BULB ONION  
ON THE *IN VITRO* PEPTIC DIGESTION OF OVALBUMIN**

Daria Khramova<sup>1</sup>, Victoria Golovchenko<sup>1</sup>, Raisa Ovodova<sup>1</sup>

<sup>1</sup>*Institute of Physiology, Komi Science Centre, The Urals Branch of the Russian Academy of Sciences, 50, Pervomaiskaya str., Syktyvkar, 167982, Russia;*  
*dkhramova@yahoo.com*

Food allergens are mostly proteins that invoke IgE-mediated immune reactions. Egg represents, together with cow's milk, the most common cause of allergic reactions to food that affect approximately 6% of children and 3-4% of adults, and ovalbumin (OVA), the major protein in egg white (58% w/w), is considered as a dominant allergen [1]. Among the physicochemical properties usually examined for the food allergens the stability to digestion in the human gastrointestinal tract is common [2]. Low methylesterified pectin, gum arabic and xylan failed to affect the peptic digestibility of the proteins [3]. The objective of the present study was to assess the effect of the polysaccharides from bulb onion (*Allium cepa* L.) on the *in vitro* peptic digestibility of OVA. The pectic polysaccharide AC-1 was extracted with an aqueous ammonium oxalate at 70°C for 6 h and AC-2 - using a simulated gastric media (saline solution containing HCl (pH 1.5)) at 37°C for 4 h. Polysaccharides were shown to consist of D-galacturonic acid (55 and 40% for AC-1 and AC-2 respectively), galactose (30% for both AC-1 and AC-2) residues and protein (10 and 25% for AC-1 and AC-2 respectively). These polysaccharides were digestible with 1,4- $\alpha$ -D-galacturonase to yield D-galacturonic acid, thus confirming AC-1 and AC-2 as a pectic polysaccharides. Partial acid hydrolysis of pectins revealed galacturonan to be the core of the macromolecules. Pectin AC-2 was precipitated by trichloroacetic acid to yield two polysaccharide fractions five-fold differed in protein content. SDS-PAGE electrophoresis indicates that OVA was highly hydrolyzed by pepsin. Intact OVA was detectable even after 120 min of the incubation. The protein fragments with molecular weights of 22, 16, 18 and 10 kDa were determined in the digested OVA samples. The absence of the fragments with molecular weights of 18 and 10 kDa in the OVA samples digested in the polysaccharides presence indicates the inhibitory effect of pectins on the *in vitro* peptic digestibility of OVA. The inhibitory effect of pectins was detected for all examined polysaccharide fractions. The amount of protein in the polysaccharide fractions appeared not to affect the pectins activity.

**References**

1. Hong S. and Vogel N., *Clev. Clin. J. Med.*, **2010**, 77, 51-59.
2. Moreno J., *Biomedicine & Pharmacotherapy*, **2007**, 61, 50-60.
3. Mouecoucou J., Fremont S., Villaume C., Sanchez C., Mejean L., *Food Chemistry*, **2007**, 104, 1242-1249.

The work was supported by Russian Fund for Basic Research (09-04-00017- $\alpha$ ).

## PO 165

CHARACTERIZATION OF *THERMOPLASMA ACIDOPHILUM*  $\alpha$ -GLUCOSIDASE AND ENZYMATIC SYNTHESIS OF ARBUTIN DERIVATIVES

Jieun Kim, Seong-Hwa Seo, Kyoung-Hwa Choi, Hyun Su Park, Hyun Jin Jang, and Jaeho Cha\*

*Department of Microbiology, College of Natural Sciences,  
Pusan National University, Busan 609-735, Korea  
jhcha@pusan.ac.kr*

The gene (Ta0298) encoding a putative  $\alpha$ -glucosidase from hyperthermophilic archaeon *Thermoplasma acidophilum* (AglA) was cloned and expressed in *Escherichia coli*. The recombinant AglA was purified by heat treatment and Ni-affinity chromatography. Gel filtration chromatography of the purified enzyme indicated that the native form consists of four to five identical subunits with strong maltose ( $\alpha$ -1,4 linkage)-hydrolyzing activity. AglA was optimally active at pH 5-6 and 80°C and had a half-life of 8 h and 30 min at 85 and 90°C, respectively. The enzyme also hydrolyzes kojibiose ( $\alpha$ -1,2), nigerose ( $\alpha$ -1,3), and isomaltose ( $\alpha$ -1,6) to a lesser extent. Analyses of the reaction with maltooligosaccharides and panose as substrates show that AglA specifically liberates glucose from the non-reducing end indicating that it is typical of a GH31  $\alpha$ -glucosidase. Kinetic analyses revealed that the hydrolytic activity of AglA was greatly affected by the chain length of the substrate and the regiospecificity of the glucosidic linkages. The enzyme showed highest specificity for maltose and decreasing values ( $k_{cat}/K_m$ ) towards higher maltooligosaccharides, although these are still substrates. Inhibition profile of AglA revealed that aesculin was a mixed type of noncompetitive inhibition with  $K_i$  value of 4.30 mM and  $K_i'$  of 12.5 mM while acarbose showed competitive inhibition pattern with  $K_i$  of 2.99 mM. When the enzyme incubated with maltose and arbutin, two major arbutin derivatives were detected by thin-layer chromatography. Structural analyses using NMR indicated that glucose unit of maltose was transferred to the C-3 and C-6 position in the glucose moiety of arbutin, respectively.

**References**

1. Faijes, M and Planas, A. *Carbohydr. Res.* **2007**, 342, 1581-1594.
2. Bojarova, P and Kren, V. *Trends Biotechnol.* **2009**, 27, 199-209.



PO 166

### FLUOROUS-TAG ASSISTED SYNTHESIS OF PHENOLIC GLYCOLIPID DERIVATIVES

Daniel Kmoch, Valeska von Kiedrowski, Alexandra Hölemann

Department of Chemistry, Organic Chemistry, Technische Universität Dortmund,  
44221 Dortmund, Germany  
daniel.kmoch@tu-dortmund.de

In recent years, the fluorine-tag assisted assembly of carbohydrates has gained considerable attention as an interesting alternative to solid-phase oligosaccharide syntheses.<sup>1</sup> This approach offers several advantages over solid-phase approaches, e.g. favourable solution-phase kinetics, reaction monitoring by conventional analytical methods, and no need for a large excess of reagents. The products can be easily purified by fluorine solid-phase or fluorine liquid-liquid extraction, which increases the efficacy and practicability of oligosaccharide synthesis.

This work focuses on the application of this technique to the synthesis of fluorinated derivatives of phenolic glycolipid I (PGL-I), a specific glycolipid found on the cell surface of *Mycobacterium leprae*, the causative agent of leprosy.<sup>2</sup> Recent studies have revealed that PGL-I plays a crucial role in the pathogenesis of this disease, particularly in the damage of the peripheral nerves.<sup>3,4</sup> However, many details about the mechanism and the involved receptors on the Schwann cell still remain unknown.

Fluorinated analogues of PGL-I represent a possible approach to address these questions. Thus, the scope of this work is the development of a flexible, fluorine-tag assisted strategy to synthesize the trisaccharide moieties of naturally occurring PGL-I (**1**) and of mono-fluorinated derivatives such as **2**.

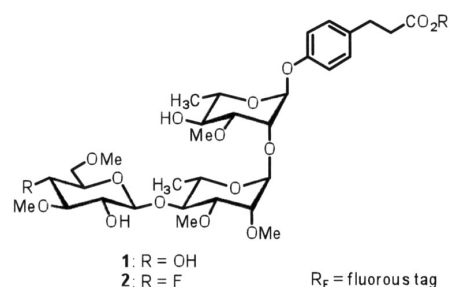

**Figure 1:** Structures of the characteristic trisaccharide moieties of PGL-I (**1**) and a fluorinated analogue (**2**).

#### References

- Selected references: a) F. A. Jaipuri, N. L. Pohl, *Org. Biomol. Chem.* **2008**, *6*, 2686-2691; b) K. Goto, M. Mizuno, *Tetrahedron Lett.* **2007**, *48*, 5605-5608; c) F. R. Carrel, P. H. Seeberger, *J. Org. Chem.* **2008**, *73*, 2058-2065; d) T. Miura, K. Goto, H. Waragai, H. Matsumoto, Y. Hirose, M. Ohmae, H. Ishida, T. Inazu, *J. Org. Chem.* **2004**, *69*, 5348.
- Y. Sugita, *Clin. Dermatol.* **1995**, *13*, 235-243.
- a) S. W. Hunter, T. Fujiwara, P. J. Brennan, *J. Biol. Chem.* **1982**, *257*, 15072-15078; b) S. W. Hunter, P. J. Brennan, *J. Biol. Chem.* **1983**, *258*, 7556-7562.
- a) A. Rambukkana, *Curr. Op. Microbiol.* **2001**, *4*, 21-27; b) D. B. Young, *Trends Microbiol.* **2001**, *9*, 52-54; c) V. Ng, G. Zanazzi, R. Timpl, J. F. Talts, J. L. Salzer, P. J. Brennan, A. Rambukkana, *Cell* **2000**, *103*, 511-524; d) A. Rambukkana, J. L. Salzer, P. D. Yurchenco, E. I. Tuomanen, *Cell* **1997**, *88*, 811-821; e) A. Rambukkana, H. Yamada, G. Zanazzi, T. Matus, J. L. Salzer, P. D. Yurchenco, K. P. Campbell, V. A. Fischetti, *Science* **1998**, *282*, 2076-2079.



PO 167

**PETASIS OLEFINATION IN A CONTINUOUS FLOW MICROWAVE REACTOR:  
EXO-GLYCALS FROM SUGAR-LACTONES**

Stefan Koch<sup>1</sup>, Holger Löwe<sup>1,2</sup> and Horst Kunz<sup>1</sup>

<sup>1</sup>Institute of Organic Chemistry, Johannes Gutenberg-University Mainz, Duesbergweg 10-14, D-55128 Mainz, Germany

<sup>2</sup>IMM Institut fuer Mikrotechnik Mainz, Carl-Zeiss-Straße 18-20, D-55129 Mainz, Germany  
kochst@uni-mainz.de

Owing to their distinct nucleophilic reactivity, enol ethers and, in particular, *exo*-glycals are considered interesting synthons for further conversion, as for example, to spiroketals<sup>1</sup> or C-glycosides<sup>2</sup>.

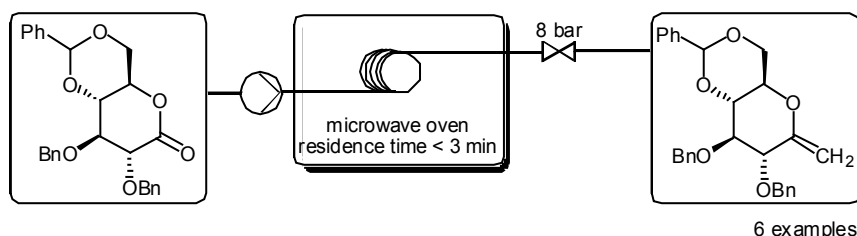

For the synthesis of these valuable compounds, an efficient Petasis olefination<sup>3</sup> of sugar lactones under continuous flow microwave conditions was developed. The conversion of these lactones to *exo*-glycals can be steered by adjusting the residence time and the concentration of the solution within the reactor as monitored by NMR-spectroscopy.

Applying this continuous flow procedure, the reaction time can be shortened to less than 3 minutes, several hundred times shorter compared to values given in the literature for batch procedures. This setup is utilizable for a gram-scale synthesis of enol ethers and *exo*-glycals, in particular, such containing sensitive structures and protecting groups.

### References

1. Brand C.; Rauch, G; Zanoni, M; Dittrich, B; Werz, D.B. *J. Org. Chem.*, **2009**, 74, 8779 and literature cited therein.
2. Woodward, H.; Smith, N.; Gallagher, T. *Synlett*, **2010**, 869.
3. Petasis, N. A.; Bzowej, E. I. *J. Am. Chem. Soc.* **1990**, 112, 6392; (b) Petasis, N. A.; Patane, M. A. *Tetrahedron Lett.* **1990**, 31, 6799; (c) Petasis, N. A.; Lu, S.-P. *Tetrahedron Lett.* **1996**, 37, 141; (d) Csuk, R.; Glänzer, B.I. *Tetrahedron* **1991**, 47, 1655. e) Hartley, R. C.; McKiernan, G. J. *J. Chem. Soc., Perkin Trans. 1*, **2002**, 2763–2793. (f) Hartley, R. C.; Ji, J. F.; Main, C. A.; McKiernan, G. J. *Tetrahedron*, **2007**, 63, 4825–4864.

## PO 168

COMPARATIVE ANALYSIS OF LIPIDS A OF *BRADYRHIZOBIUM* STRAINS

Iwona Komaniecka,<sup>1</sup> Adam Choma,<sup>1</sup> Katarzyna Zamlynska,<sup>1</sup> Malgorzata Pac,<sup>1</sup> Buko Lindner,<sup>3</sup> Otto Holst<sup>2</sup>

<sup>1</sup>Department of Genetics and Microbiology, Maria Curie-Skłodowska University, Akademicka 19, 20-033 Lublin, Poland;

Divisions of:

<sup>2</sup>Structural Biochemistry and

<sup>3</sup>Immunochemistry, Research Center Borstel, Leibniz-Center for Medicine and Biosciences, 23845 Borstel, Germany

ikoma@hektor.umcs.lublin.pl

Lipid A preparations were isolated by mild acid hydrolysis of LPS from seven strains of *Bradyrhizobium*: *B. elkanii* USDA 76, *B. yuanmingense* CCBAU 10071, *B. liaoningense* USDA 3622, *B. canariense* BC-P5 and BC-C2, *Bradyrhizobium* sp. (Lupinus) USDA 3045 and *Bradyrhizobium* sp. ORS 278. The chemical structures of these lipids A were determined using compositional analysis and mass spectrometry (MALDI-TOF, ESI-MS).

All examined lipids A contained a disaccharide backbone exclusively composed of 2,3-diamino-2,3-dideoxy-D-glucopyranose (Glc<sub>p</sub>N<sub>3</sub>N), the distal residue of which was decorated with a D-Man<sub>p</sub>-(1→6)-D-Man<sub>p</sub> disaccharide, whereas the reducing hydroxyl of the proximal Glc<sub>p</sub>N<sub>3</sub>N was replaced either by a D-Man<sub>p</sub> residue or D-GalA or/and galacturonolactone. It has been proved that lipids A from all *Bradyrhizobium* strains were a mixture of glycolipids bearing the same set of amide-linked 3-hydroxy fatty acids, i.e. two of 12:0(3-OH) and two of 14:0(3-OH). These primary fatty acids were esterified with secondary (ω-1)-fatty acid residues having very long acyl chains (VLCFA, containing from 26 to 34 carbon atoms in aliphatic chains), forming acyloxyacyl residues. *Bradyrhizobium* lipids A differed by the type of the predominant VLCFA, e.g. the shortest fatty acid (i.e.: 25OH-26:0) was the major one in *B. canariense* BC-C5 and *Bradyrhizobium* sp. ORS 278, whereas the *B. canariense* BC-C2 lipid A preparation contained the same amounts of two main fatty acids [26:0(25-OH) and 32:0(31-OH)]. The lipid A from *Bradyrhizobium* sp. (Lupinus) USDA 3045 was acylated mainly with 31:0(30-OH) and 33:0(32-OH). The 28:0(27-OH) was the most abundant acyl residue in the lipids A from *B. elkanii* USDA 76<sup>1</sup> and *B. liaoningense* USDA 3622. Some species of *Bradyrhizobium* contained lipids A with two acyloxyacyl residues (e.g. *B. elkanii* USDA 76)<sup>1</sup> whereas others (e.g. *B. yuanmingense*) synthesized lipids A containing three or even four acyloxyacyl residues. Usually, one of these long-chain fatty acids was further acylated by 3-hydroxybutyric linked to the (ω-1)-hydroxy group as tertiary residue.

## References

1. Komaniecka I., Choma A., Lindner B., Holst O., *Chem. Eur. J.* **2010**, *16*, 2922-2929.

This work was partly supported by the Polish Ministry of Science and Higher Education (grant no. 303 109 32/3593).

## PO 169

4-(2-CHLOROETHOXY)PHENYL GROUP –  
NOVEL ANOMERIC PROTECTION WITH DUAL FUNCTION

Nikolay N. Kondakov, Alexander I. Zinin, Anna M. Shpirt, Polina I. Abronina,  
Vladimir I. Torgov, Alexander O. Chizhov, Leonid O. Kononov

*N. D. Zelinsky Institute of Organic Chemistry, Leninsky prospect, 47, 11991 Moscow,  
Russian Federation  
kononov@ioc.ac.ru*

A choice of anomeric protective group (APG) is often of decisive importance for the successful assembly of an oligosaccharide and, more importantly, for its transformation to a derivative with a functional group in aglycon, and further to the corresponding neoglycoconjugates (NGCs).<sup>1</sup> Here, we introduce 4-(2-chloroethoxy)phenyl (CEP) aglycon as a novel APG with dual function. CEP group is useful both for block synthesis of complex oligosaccharides (CEP acts as an anomeric blocking group similar to the well-known 4-methoxyphenyl group) and for the preparation of NGCs of the target oligosaccharide and any intermediate CEP glycoside (after replacement of chlorine with azide, CEP acts as a pre-spacer obviating the need for an additional glycosylation). CEP glycosides of Glc, Gal, Man, Rha, Fuc, Ara, GlcN and Lac were synthesized and were demonstrated to readily cleave the aglycon off under the action of cerium-ammonium nitrate or to convert CEP group to the corresponding azido derivative by treatment with  $\text{NaN}_3$ . The results of the CEP-mediated synthesis of PGL-I trisaccharide<sup>2</sup> and the corresponding NGCs will be presented (see Scheme). This work was supported by RFBR (project No. 10-03-01019).

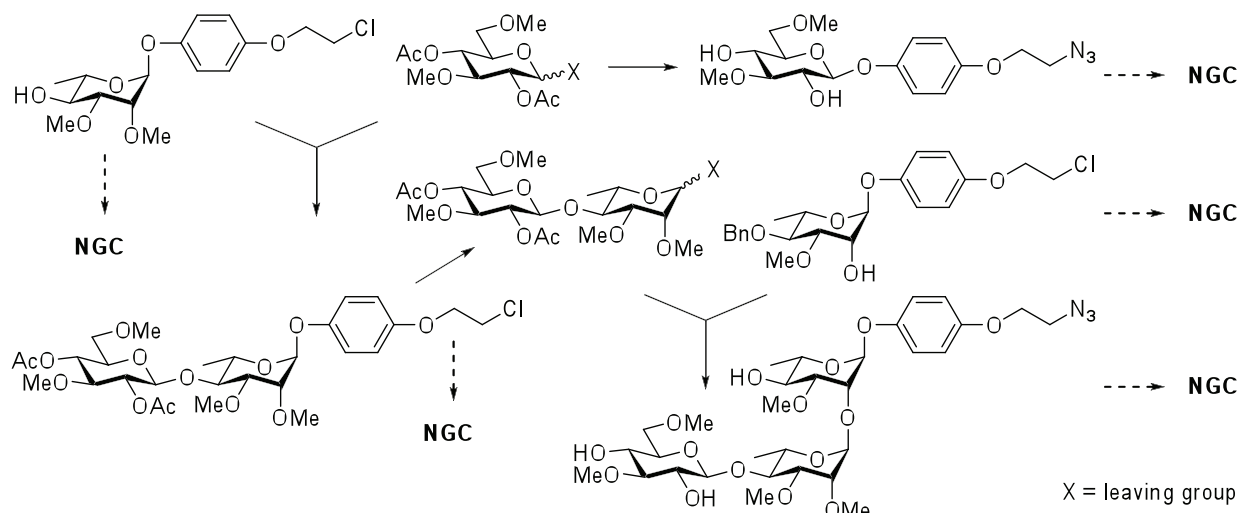

## References

1. G. Magnusson, A. Ya. Chernyak, J. Kihlberg, L. O. Kononov, in *Neoglycoconjugates: Preparation and Application*, Y. C. Lee and R. T. Lee (Eds.), Academic Press Inc: San Diego, California, **1994**, pp. 53–143.
2. X. Wu, J.-R. Mariño-Albernas, F.-I. Auzanneau, V. Verez-Bencomo, B. M. Pinto, *Carbohydr. Res.*, **1998**, 306, 493–503, and references cited.

PO 170

## THE FIRST TOTAL SYNTHESIS OF GANGLIOSIDE GALNAC-GM1B USING A NOVEL CYCLIC GLC-CER ACCEPTOR

Miku Konishi,<sup>1</sup> Kohki Fujikawa,<sup>2</sup> Hiromune Ando,<sup>1,2</sup> Hideharu Ishida,<sup>1</sup> Makoto Kiso<sup>1,2</sup><sup>1</sup>Department of Applied Bio-organic Chemistry, Faculty of Applied Biological Sciences, Gifu University, Gifu 501-1193, Japan,<sup>2</sup>Institute for Integrated Cell-Material Sciences (iCeMS), Kyoto University, Kyoto 606-8501, Japan  
p8101021@edu.gifu-u.ac.jp

Guillain-Barré Syndrome (GBS) is autoimmune peripheral neuropathy in which limb muscle weakness and absent deep tendon reflex develop as main symptom. Molecules mistargeted by the immune response are thought to be gangliosides such as GM1, GQ1b, and GalNAc-GD1a. Recently, it has been revealed that serum antibody in some GBS patients recognize ganglioside GalNAc-GM1b as well.<sup>1</sup> A homogeneous sugar antigen synthesized by chemical approach is useful to elucidate the pathogenic mechanism of GBS with GalNAc-GM1b. However, there has been no report on its synthesis. We here report the first total synthesis of GalNAc-GM1b, which was achieved efficiently by disconnecting the glucosyl ceramide part from the target molecule. Non-reducing end sugar part was efficiently synthesized by the coupling of GM2 core trisaccharide donor and GalNAc-Gal disaccharide acceptor. The obtained pentasaccharide was converted into the trichloroacetimidate donor, *via* reductive removal of benzyl groups, followed by *O*-benzoylation, then the removal of the 4-methoxyphenyl group and treatment with trichloroacetonitrile. The subsequent coupling with a cyclic Glc-Cer acceptor developed by our group,<sup>2</sup> which was obtained by intramolecular glycosylation, afforded the fully protected GalNAc-GM1b. Finally, the protected GalNAc-GM1b was transformed, *via* *O*-deacylation and followed by saponification, into ganglioside GalNAc-GM1b in good yield.

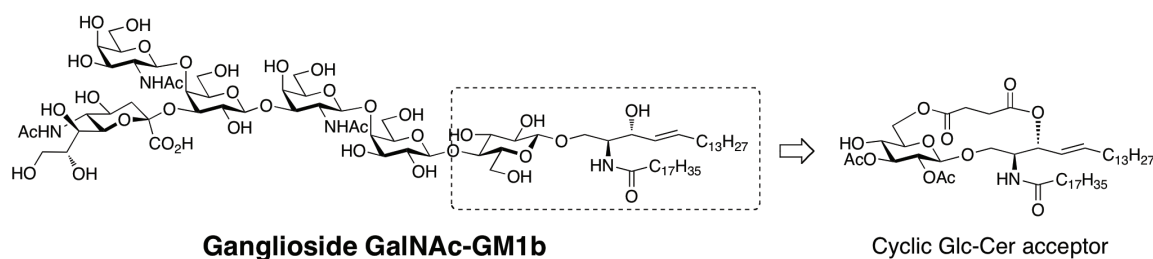
**References**

1. N. Yuki, T. Taki, S. Honda, *J. Neuroimmunology* **1999**, *71*, 155–161.
2. K. Fujikawa, S. Nakashima, M. Konishi, T. Fuse, N. Komura, H. Ando, N. Yuki, H. Ishida, M. Kiso, *Chem. Eur. J.* **2011**, *accepted*.

PO 171

## N- AND C-GLYCOPYRANOSYL-HETEROCYCLES AS GLYCOGEN PHOSPHORYLASE INHIBITORS

Bálint Kónya,<sup>1</sup> Marietta Tóth,<sup>1</sup> Laura Czecze,<sup>1</sup> László Juhász,<sup>1</sup> Sándor Kun,<sup>1</sup> Mária Polyák,<sup>1</sup>  
Tibor Docsa,<sup>2</sup> Pál Gergely,<sup>3</sup> László Somsák<sup>1</sup>

<sup>1</sup>Department of Organic Chemistry, University of Debrecen,  
POB 20, H-4010 Debrecen, Hungary

<sup>2</sup>Cell Biology and Signaling Research Group of the Hungarian Academy of Sciences  
at the Department of Medical Chemistry, Medical and Health Science Centre,  
University of Debrecen, Egyetem tér 1, H-4032 Debrecen, Hungary

<sup>3</sup>Department of Medical Chemistry, Medical and Health Science Centre,  
University of Debrecen, Egyetem tér 1, H-4032 Debrecen, Hungary  
somsak.laszlo@science.unideb.hu

Glycogen phosphorylase (GP), catalyzing the rate limiting step in the degradation of glycogen in animals, plays an important role in controlling blood glucose levels. Inhibitors of GP can be potential antihyperglycaemic drugs, and may lead to a new therapy for the treatment of type 2 diabetes. *N*-Acyl-*N'*-β-D-glucopyranosyl ureas **1** are effective glucose analogue inhibitors of GP.<sup>1</sup> The syntheses of sugar derivatives where the first (**2**) or both amide units (**3**, **4**) of compound **1** are replaced with heterocycles (e.g. 1,2,3-triazole, 1,3,4-oxadiazole, isoxazole) has now been carried out. Molecules with a methylene group between the two heterocycles were also synthesized. In the presentation details of the syntheses and preliminary enzyme kinetic results will be shown.

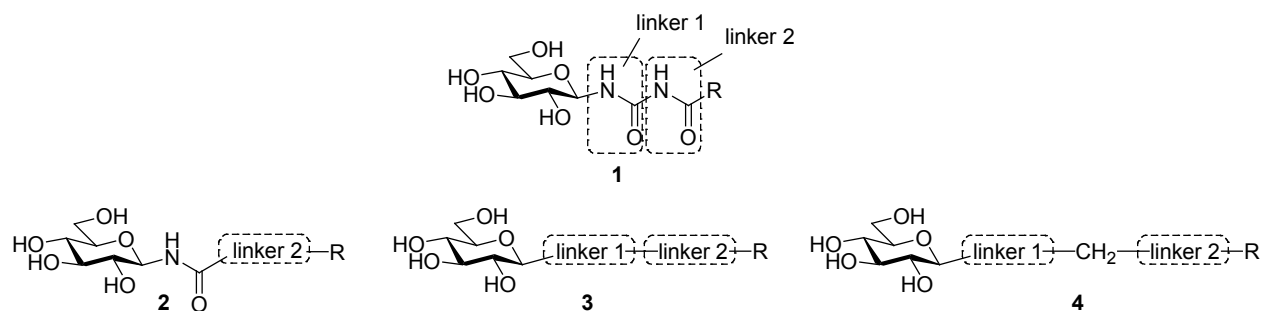

### References

1. L. Somsák, K. Czifrák, M. Tóth, É. Bokor, E. D. Chrysina, K.-M. Alexacou, J. M. Hales, E. Lazoura, D. D. Leonidas, E. S. Zographos, N. G. Oikonomakos, *Curr. Med. Chem.* **2008**, *15*, 2933-2983.

PO 172

**TOWARDS SOLID PHASE SYNTHESIS  
OF HEPARIN-LIKE OLIGOSACCHARIDES:  
DESIGN OF A NOVEL LINKER AND SYSTEMATIC STUDY  
OF COUPLING REACTIONS**

Sebastian Kopitzki,<sup>1</sup> Pawel Czechura,<sup>1</sup> Nerea Guedes,<sup>1</sup>  
Manuel Martin-Lomas<sup>1,2</sup> and Niels-Christian Reichardt<sup>1</sup>

<sup>1</sup> *Biofunctional Nanomaterials Unit, CICbiomaGUNE. Paseo Miramon 182,  
20009 San Sebastian (Spain)*

<sup>2</sup> *CIBER-BBN*

*skopitzki@cicbiomagune.es*

Glycan arrays of short Heparin/Heparin sulfate (HS) fragments with systematic variations of sequence and sulfation pattern have been proposed to accelerate the analysis of the functions and the molecular basis of protein–HS interactions.<sup>[1]</sup> Solid-phase synthesis of oligosaccharides is a promising approach for the preparation of ligand libraries needed for glycan arrays,<sup>[2]</sup> only a few examples, however, have been reported for glycosaminoglycans.<sup>[3]</sup> Here we present a new solid phase approach using a novel linker based on a 4-hydroxymethylbenzyl *N*-(5-hydroxypentyl)-*N*-benzyl carbamate moiety, which provides a stable handle under Lewis acidic,

mild basic and nucleophilic conditions. In addition, monosaccharide building blocks were applied in the stereospecific solid-phase supported construction of Heparin/HS precursors.<sup>[4]</sup> A diverse set of glycosyl donors with different properties regarding steric and electronic effects were tested, especially, idose derivatives which have advantage over iduronic acid and can be subsequently oxidized. The results lead to an optimized glycosylation protocol in solid-phase synthesis of Heparin/HS.

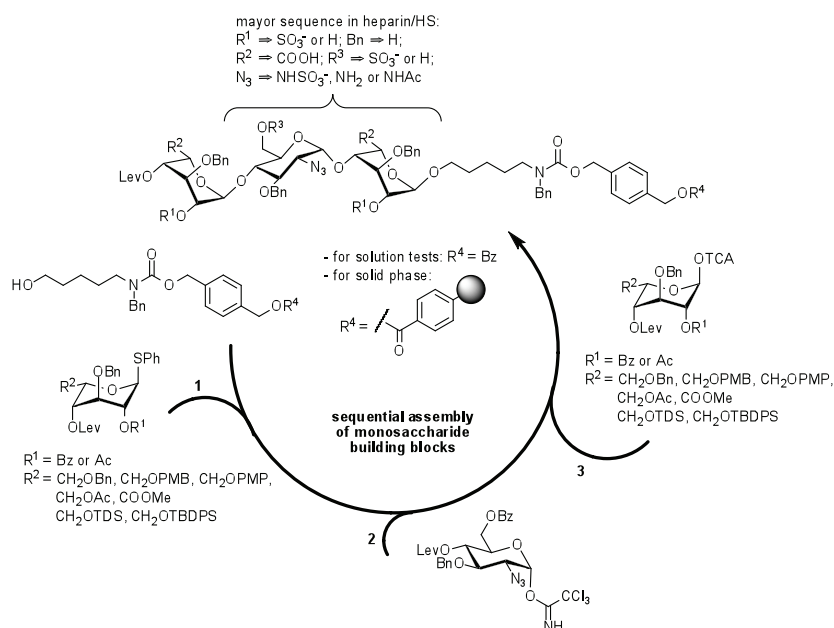

## References

1. J. L. de Paz, C. Noti, P. H. Seeberger, *J. Am. Chem. Soc.* **2006**, *128*, 2766-2767.
2. P. H. Seeberger, W. C. Haase, *Chem. Rev.* **2000**, *100*, 4349-4393.
3. R. Ojeda, J. L. de Paz, M. Martin-Lomas, *Chem. Comm.* **2003**, 2486-2487.
4. P. Czechura, N. Guedes, S. Kopitzki, N. Vazquez, M. Martin-Lomas, N.-C. Reichardt, *Chem. Comm.* **2011**, *47*, 2390-2392.



PO 173

SYNTHESIS OF MULTIVALENT  $\beta$ -1-THIOGALACTOSIDES THROUGH AZIDE-SYMMETRIC ALKYNE RU(II)-CATALYZED CYCLOADDITIONJosé Kovensky,<sup>1</sup> Alejandro J. Cagnoni,<sup>1,2</sup> Oscar Varela<sup>2</sup> and María Laura Uhrig<sup>2</sup><sup>1</sup>Laboratoire des Glucides, UMR 6219, Université de Picardie Jules Verne, 33 Rue Saint-Leu, 80039 Amiens, France,<sup>2</sup>CIHIDECAR-CONICET, Departamento de Química Orgánica, FCEN-UBA, Pabellón II, Ciudad Universitaria, 1428 Buenos Aires, Argentina  
jose.kovensky@u-picardie.fr

As part of our ongoing project on the synthesis of multivalent glycoclusters designed to be hydrolytically stable in biological media,<sup>1</sup> we describe here the synthesis of multi-thiogalactosides using as key step the Ruthenium(II)-catalysed cycloaddition of azidosugars and a disubstituted (internal) alkyne chain carrying two thiogalactoside residues.<sup>2</sup>

A symmetric divalent 1- $\beta$ -thiogalactoside precursor (**1**) has been synthesized from an diethyleneglycol-type linker functionalized with an internal triple bond. On the other hand, azide-containing scaffolds as 2,3,4,6-tetra-*O*-acetyl- $\beta$ -D-glucopyranosyl azide and the per-*O*-acetyl-6,6'-diazidotrehalose **2** were prepared by previously reported methods.<sup>1</sup> Coupling of **1** to the selected scaffolds was achieved by Ru(II) catalyzed cycloaddition, using chloro(pentamethylcyclopentadienyl) (cyclooctadiene)ruthenium(II) complex as catalyst, in dioxane as solvent. Glycoclusters containing two or four residues of 1- $\beta$ -thiogalactose have been obtained in good yields. Deacetylation with Et<sub>3</sub>N/MeOH/H<sub>2</sub>O led to the final products. After complete characterization by NMR spectroscopy and HR-MS techniques, these new multivalent ligands have been evaluated as inhibitors of *E. coli*  $\beta$ -galactosidase. These compounds are interesting as potential modulators of lectin-mediated processes.

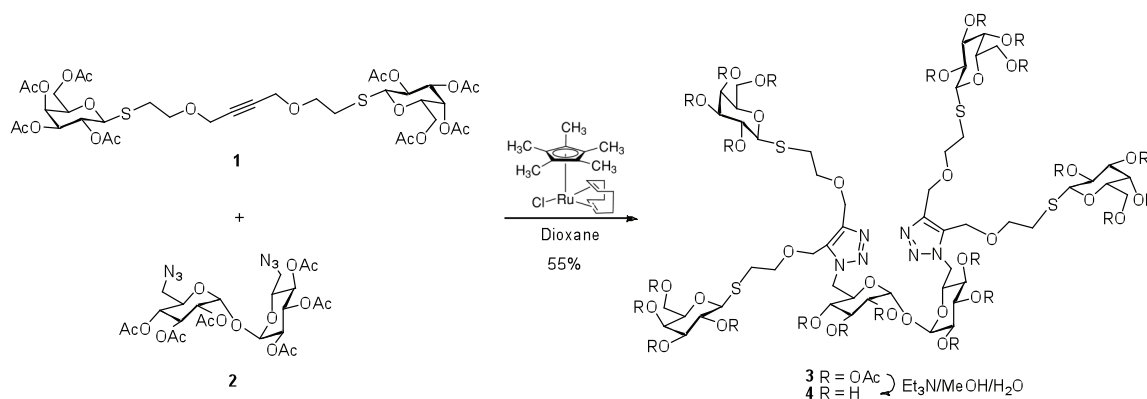

## References

- Uhrig, M.L, Cagnoni, A.J, Varela, O., Gouin, S.G, Kovensky, J. *25<sup>th</sup> International Carbohydrate Symposium*, Japan, **2010**, A-P5-068, p. 215.
- Boren, B. C., Narayan, S., Rasmussen, L.K., Zhang, L., Zhao, H., Lin, Z., Jia, G., Fokin, V., *J. Am. Chem. Soc.*, **2008**, *130*, 8923-8930.

PO 174

**CHEMICAL SYNTHESIS OF ARABINO GALACTAN-PROTEIN  
BACKBONE MOTIFS**

Jonas Krag<sup>1</sup>, Carl Erik Olsen<sup>2</sup>, Mohammed Saddik Motawia<sup>1</sup>

<sup>1</sup>*Department of Plant Biology and Biotechnology, University of Copenhagen,  
Faculty of Life Sciences, Thorvaldsensvej 40,  
DK-1871 Frederiksberg C, Copenhagen, Denmark,*

<sup>2</sup>*Department of Basic Sciences and Environment, University of Copenhagen, Faculty  
of Life Sciences Thorvaldsensvej 40, DK-1871 Frederiksberg C, Copenhagen, Denmark  
jonaskrag@life.ku.dk*

Gum Arabic is natural plant exudates in response to mechanical wounding of Acacia trees in Africa and is widely used as an emulsifier in the food industry. Gum Arabic is an arabinogalactan-protein (AGP) and is composed of a linear  $\beta$ -(1 $\rightarrow$ 3) galactan backbone carrying short  $\beta$ -(1 $\rightarrow$ 6) galactan side chains.<sup>1</sup> This backbone is considered to be essential to emulsifying effect of the AGPs. Motifs of this galactan backbone with side chains have been synthesised. Using a new strategy we have synthesised Methyl  $\beta$ -Gal-  $\beta$ -(1 $\rightarrow$ 3) Gal, Methyl  $\beta$ -Gal-  $\beta$ -(1 $\rightarrow$ 6) Gal, Methyl  $\beta$  - [Gal-  $\beta$ -(1 $\rightarrow$ 6)]- Gal - $\beta$ - (1 $\rightarrow$ 3)-Gal, Methyl  $\beta$  -Gal -  $\beta$ -(1 $\rightarrow$ 3)-[Gal-  $\beta$ -(1 $\rightarrow$ 6)]- Gal, Methyl  $\beta$  -Gal -  $\beta$ -(1 $\rightarrow$ 3)-[Gal-  $\beta$ -(1 $\rightarrow$ 3)]- Gal. These motifs can be used to study the biosynthetic pathway of Gum Arabic arabinogalactan-protein.

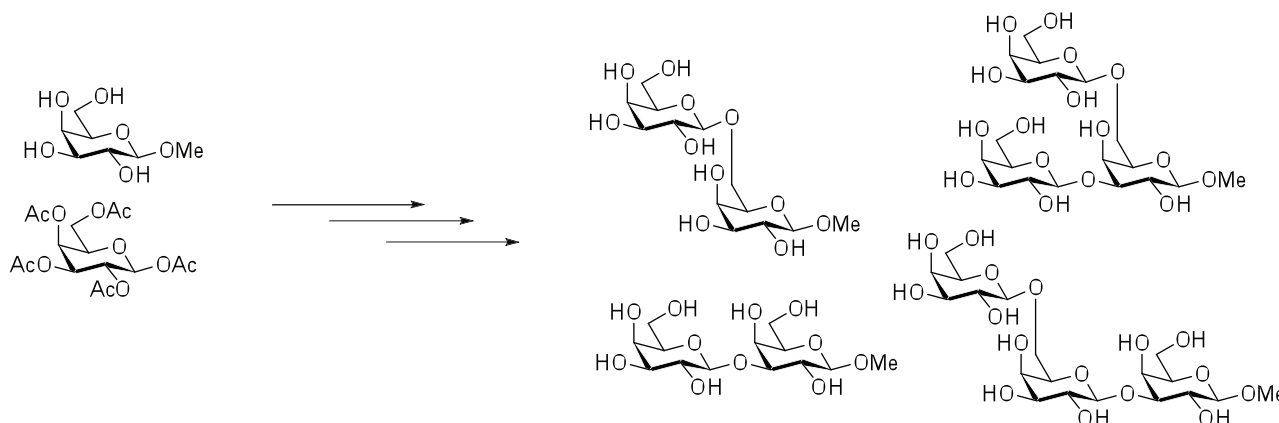

**Scheme 1.** Synthesis of AGP motifs

### References

1. Tan, L.; Qui, F.; Lamport, D. T. A.; Kieliszewski, M. J., *J. Biol. Chem.*, **2004**, 279, 13156-13165

PO 175

## CHEMICAL SYNTHESIS OF $\beta$ -GLUCANS FOR HYDRATION AND MOLECULAR MODELLING STUDIES

Jonas Krag<sup>1</sup>, Tore Folkerman<sup>1</sup>, Carl Erik Olsen<sup>2</sup>, Mohammed Saddik Motawia<sup>1</sup>

<sup>1</sup>Department of Plant Biology and Biotechnology, University of Copenhagen, Faculty of Life Sciences, Thorvaldsensvej 40, DK-1871 Frederiksberg C, Copenhagen, Denmark,

<sup>2</sup>Department of Basic Sciences and Environment, University of Copenhagen, Faculty of Life Sciences Thorvaldsensvej 40, DK-1871 Frederiksberg C, Copenhagen, Denmark  
jonaskrag@life.ku.dk

Glucose polymers linked  $\beta$ -(1 $\rightarrow$ 3) and  $\beta$ -(1 $\rightarrow$ 4) have different roles in biological systems. An example of this is cellulose, which gives the land plants their structural rigidity and the laminaran can be as energy reserves in certain brown algaeas.<sup>1</sup> These structures which polymers with  $\beta$ -(1 $\rightarrow$ 3) and  $\beta$ -(1 $\rightarrow$ 4) linkages gives rise to are respectively a triple helical structure,<sup>2</sup> and a flat fibrous structure.<sup>3</sup> These polymers are insoluble, but a mixed linkage of  $\beta$ -(1 $\rightarrow$ 3) and  $\beta$ -(1 $\rightarrow$ 4) in glucose polymers are excellent gelling agents. These mixed linked polymers are found in high concentrations in the cell wall of barley and oat. We want to elucidate the structural basis by focusing on motifs of the  $\beta$ -(1 $\rightarrow$ 3), $\beta$ -(1 $\rightarrow$ 4)- $\beta$ -D-glucans, which can be done by hydration and molecular modelling studies.<sup>4</sup> We have synthesised fragments which represent the fundamental structure of the  $\beta$ -(1 $\rightarrow$ 3), $\beta$ -(1 $\rightarrow$ 4)- $\beta$ -D-glucans, to investigate all the possibilities of which the  $\beta$ -(1 $\rightarrow$ 3), $\beta$ -(1 $\rightarrow$ 4)- $\beta$ -D-glucans are composed.

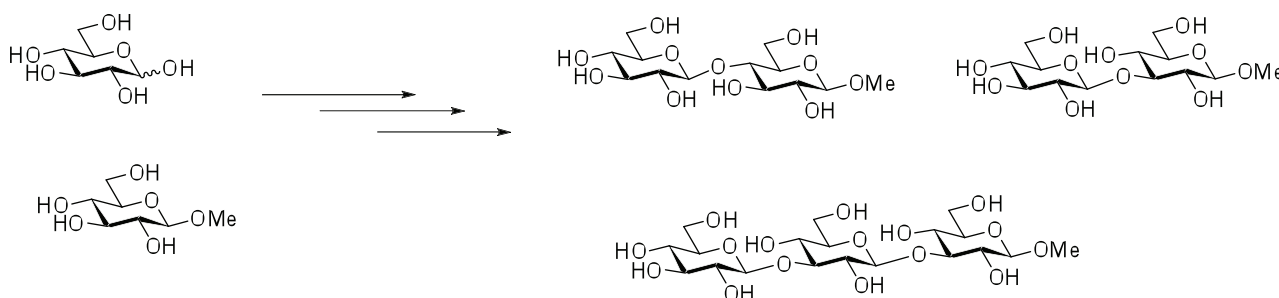

### References

1. Sathyanarayana, B. K.; Rao, V. R. S., *Biopolymers*, **1971**, *10*, 1605-1615
2. Deslandes, Y.; Marchessault, R. H.; Sarko, A., *Macromolecules*, **1980**, *13*, 1466-1471
3. Marchessault, R. H.; Sundararajan, P. R., *Cellulose, The Polysaccharides*; Aspinall, G. O., Ed.; Academic Press: New York, 1983; Vol, pp 11-95
4. Christensen, N. J.; Hansen, P. I.; Larsen, F. H.; Folkerman, T.; Motawia, M. S.; Engelsen, S. B., *Carbohydr. Res.*, **2010**, *345*, 474-486

PO 176

**COMPARATIVE GENOMICS ANALYSIS OF COMPLETELY SEQUENCED MICROBIAL GENOMES REVEALS THE UBIQUITY OF N-LINKED GLYCOSYLATION IN PROKARYOTES**Manjeet Kumar and Petety V. Balaji

*Department of Biosciences and Bioengineering, Indian Institute of Technology Bombay,  
Mumbai 400 076 India.  
mpawaria@iitb.ac.in*

Glycosylation of proteins in prokaryotes is known since the last few decades. Glycosylated proteins are diverse in their function which is evident by examples like chaperonin, some enzymes, pilin, flagellin, and the S-layer glycoprotein. Even in terms of localization diversity is reflected as these proteins are not confined at one place in cell rather they can be found inside the cell, on cell surface as well as in the periplasm. Glycosylation has been shown to be associated with a wide range of biological phenomena. Characterization of the various types of glycans and the glycosylation machinery are critical to understand such processes. However, glycan structures and/or the glycosylation pathways have been experimentally characterized in only a small number of prokaryotes. Even this has become possible only during the last decade or so, primarily due to technological and methodological developments. In view of this, the experimentally characterized pgl system of *Campylobacter jejuni*, responsible for N-linked glycosylation, has been used in this comparative genomics study to identify their homologs in 865 prokaryotes whose genomes have been completely sequenced. This study shows that only a small number of organisms have homologs for all the pgl enzymes, and a few others have homologs for none of the pgl enzymes. Most of the organisms have homologs for only a subset of the pgl enzymes. There is no specific pattern for the presence / absence of pgl homolog vis-à-vis 16S rRNA sequence-based phylogenetic tree. This may be due to differences in the glycan structures, high sequence divergence among the members of different pgl enzyme families, phenomena of horizontal gene transfer and non-orthologous gene displacement. Homologs of pgl enzymes are found in organisms belonging to all the groups considered in the study i.e., archaea, firmicutes, proteobacteria (alpha, beta, gamma, delta and epsilon), etc. The presence of homologs for pgl enzymes is not correlated with either their habitat, pathogenicity, energy generation mechanism, etc. This hints towards the ubiquity of N-linked glycosylation in prokaryotes. This study facilitates the experimental characterization of these genes and in the identification of novel targets for designing drugs, diagnostics, and engineering of therapeutic proteins.

**Reference**

1. Kumar, M. and Balaji, P.V., *Mol. Biosyst.*, **2011**, In press.

PO 177

## SYNTHESIS OF C-GLUCOPYRANOSYL PYRROLES FOR THE INHIBITION OF GLYCOGEN PHOSPHORYLASE

Sándor Kun, László Somsák

Department of Organic Chemistry, University of Debrecen, POB 20,  
H-4010 Debrecen, Hungary  
somsak.laszlo@science.unideb.hu

A widely investigated therapeutic possibility to regulate blood glucose levels in type 2 diabetes is the inhibition of glycogen phosphorylase (GP) which is the rate limiting enzyme of glycogen degradation.<sup>1</sup> C-β-D-glucopyranosyl heterocycles, like benzimidazole<sup>2</sup> **1** and 1,2,4-oxadiazoles<sup>3</sup> **2a,b** showed micromolar activity against GP. Strong binding at the active site is the result of direct and water mediated H-bonds between the protein and the heterocycle, and van der Waals interactions of the large aromatic group in the β-channel of the enzyme. Pursuing structure-activity relationships among C-glucosyl heterocycles, β-D-glucopyranosyl pyrrole derivatives were designed and synthesized for further studies. Details of the synthesis and inhibition properties of the new compounds will be shown in the presentation.

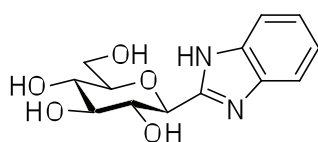
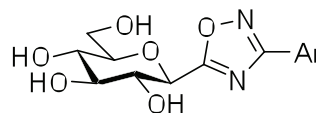
**1**  $K_i = 8.6 \mu\text{M}$ **2a** Ar = Ph ( $K_i = 64 \mu\text{M}$ )  
**2b** Ar = 2-Naphth ( $K_i = 11.6 \mu\text{M}$ )**References**

1. L. Somsák, K. Czifrák, M. Tóth, É. Bokor, E.D. Chrysina, K.-M. Alexacou, J.M. Hayes, C. Tiraidis, E. Lazoura, D.D. Leonidas, S.E. Zographos, N.G. Oikonomakos, *Curr. Med. Chem.*, **2008**, *15*, 2933-2983.
2. Zs. Hadady, M. Tóth, L. Somsák, *ARKIVOC*, **2004**, *7*, 140-149.
3. M. Tóth, S. Kun, É. Bokor, M. Benlifa, G. Tallec, S. Vidal, T. Docsa, P. Gergely, L. Somsák, J.-P. Praly, *Bioorg. Med. Chem.*, **2009**, *17*, 4773-4785.

## PO 178

## DEVELOPMENT OF HYALURONIC ACID SCAFFOLDS FOR TISSUE ENGINEERING APPLICATIONS

Annalisa La Gatta, Agata Papa and Chiara Schiraldi

*Department of Experimental Medicine, Faculty of Medicine, Second University of Naples,  
Via L. De Crecchio 7, 80138 Naples, Italy  
annalisa.lagatta@unina2.it*

Hyaluronic acid (HA) ([D-glucuronic acid (1- $\beta$ -3) N-acetyl-D-glucosamine (1- $\beta$ -4)]<sub>n</sub>) is widely distributed throughout the ECM of all mammalian connective tissues playing important roles in many fundamental biological processes such as cell migration, adhesion and proliferation. For these reasons, HA has been recognized as an ideal material for scaffolds in Tissue Engineering (TE) applications. When proposed for this purpose, linear, naturally occurring HA is submitted to crosslinking or derivatization processes in order to overcome the high rate of its *in vivo* turnover and contemporary improve its mechanical properties. A great part of the scientific research in polymeric biomaterials is currently focused on the development of novel scaffolds including HA as a key component [1-3].

In this work, the development of novel HA based scaffolds is presented. In particular, linear HA solutions were processed by lyophilization in order to obtain a micrometric porous structure. Such structure was submitted to a crosslinking process involving the formation of amide bonds using a biocompatible di-amine as the crosslinking agent. Different crosslinker amounts were tested. The 3D architecture during the crosslinking process was retained as proved by Scanning Electron Microscopic analyses. The resulting scaffolds were characterized *in vitro* for their swelling properties in water and in saline solutions; their stability in cells culture medium and biocompatibility were studied. They proved stable and biocompatible revealing the feasibility to propose them for biomedical applications.

**References**

1. Wang TW, Sun JS, Wu HC, Huang YC, Lin FH, 2007. Evaluation and biological characterization of bilayer gelatin/chondroitin-6-sulphate/hyaluronic acid membrane. *J Biomed Mater Res Part B: Appl Biomater* 82B: 390-399.
2. Xu S, Li J, He A, Liu W, Jiang X, Zheng J, Han CC, Hsiao BS, Chu B, Fang D, 2009. Chemical crosslinking and biophysical properties of electrospun hyaluronic acid based ultrathin fibrous membranes. *Polymer* 50: 3762-3769.
3. Nesti LJ, Li WJ, Shanti RM, Jiang YJ, Jackson W, Freedman BA, Kuklo TR, Giuliani JR, Tuan RS, 2008. Intervertebral disk tissue engineering using a novel hyaluronic acid-nanofibrous scaffold (HANFS) amalgam. *Tissue Engineering Part A* 14(9): 1527-1537



PO 179

**DESIGN OF BIS-TERMINAL TRI-GALACTOSYL AND TRI-CARBORANE  
COMPOUND FOR BORON NEUTRON CAPTURE THERAPY APPLICATION**

Chian-Hui Lai<sup>1</sup>, You-Juan Lin<sup>2</sup>, Feng-Ying Chou<sup>2</sup>, Yung-Jen Chuang<sup>3</sup> and Chun-Cheng Lin<sup>1\*</sup>

<sup>1</sup>Department of Chemistry, National Tsing Hua University, Hsinchu 300, Taiwan;

<sup>2</sup>Nuclear Science and Technology Development Center,  
National Tsing Hua University, Taiwan;

<sup>3</sup> Department of Medical Science and Institute of Bioinformatics and Structural Biology,  
National Tsing Hua University, Hsinchu, Taiwan  
cclin66@mx.nthu.edu.tw

Carbohydrates are one of the most reliable candidates as ligands modified on a drug for specific targeting. In particular, galactose or *N*-acetyl-galactosamines residues preferably interact with asialoglycoprotein receptors (ASGP-Rs), which are found on the hepatocyte cell surface with a large amount (about 1–5 × 10<sup>5</sup> ASGP-R/cell, as found for HepG2). Previously, we took advantage of the high affinity and specificity of typical trivalent ASGP-R ligands binding to HepG2, and incorporated it into a multifunctional nanoparticle.

Boron neutron capture therapy (BNCT) of cancer is a binary radiation therapy that involves the irradiation of non-radioactive <sup>10</sup>B-rich tumors with low energy thermal neutrons to yield high linear energy transfer (LET) particles. Our research in this field led to the design and synthesis of a potent Boron neutron capture therapy (BNCT) agent in the class of galactosyl derivatives with trivalent carboranes, which would contain 30 boron atoms in one molecular. The challenge of BNCT agent is the site-specific delivery of a sufficient boron load without peripheral toxicity. Because galactose is a natural ligand for ASGP-R, we speculate that our BNCT agent would attach to ASGP-R expressed on the HepG2 surface via tri-galactosyl moiety. Furthermore, owing to our BNCT agent being rich in boron atoms, our compound can achieve therapeutic activity in low concentrations, which also means low cytotoxicity. The novel our compound finally combined with neutron irradiation to prove its suitability for cancer therapy by neutron capture.

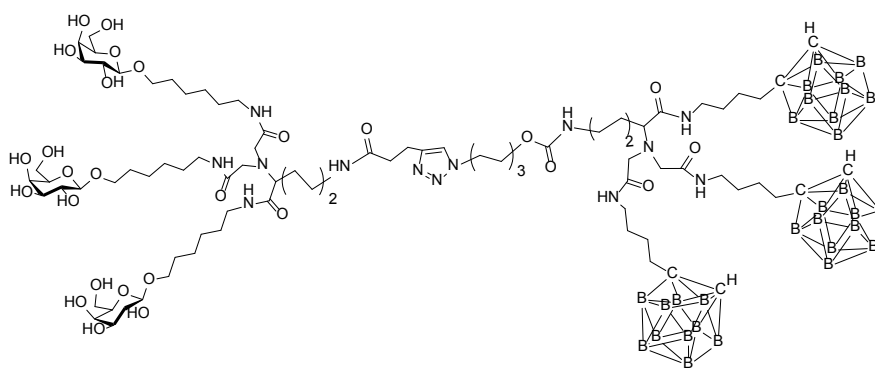

### References

1. Rolf F. Barth, Jeffrey A. Coderre, M. Gra\_a H.Vicente, Thomas E. Blue, *Clinical Cancer Research*, **2005**, *11*, 3987-4002e.
2. Chian-Hui Lai, Chia-Yi Lin, Huan-Ting Wu, Hau-Shien Chan, Yung-Jen Chuang, Chien-Tien Chen, and Chun-Cheng Lin, *Adv.Funct. Mater.*, **2010**, *20*, 3948-3958.

PO 180

**IMMUNOCHEMILUMINESCENT LIVE IMAGE DETECTION  
OF DESIALYLATED BLOOD SERUM PATIENT GLYCOCONJUGATES  
AS POTENTIAL DISEASE MARKERS**

Mikhail Lakhtin, Vladimir Lakhtin, Leonid Kozlov, Vladimir Alyoshkin

Gabrichevsky Research Institute, Medical Biotechnology, 125212 Moscow, Russia  
*lakhtinv@yandex.ru*

Introduction: Human complement components C4B and C4A are known as covalent acceptors of carbohydrates or proteins. They characterize some pathological states. In addition, they are used as reference desialylated glycoproteins in electrophoresis. The aim was to develop live image chemiluminescent IEF-PAG-blot-peroxidase method for serum C4 isotype glycoconjugate surrounding on the blot upon diseases. Reagents and methods: Sera of patients having autoimmune or other chronic diseases were desialylated with *Clostridium perfringens* sialidase (Grade V or VI, Sigma, USA) in optimal for human C4A and C4B conditions, separated by IEF(pH 3-5 and/or pH 4-6) in PAG(horizontal plate), electroblotted, identified with a panel of antibody-peroxidase in direct or sandwich type immunoassay. Additional acidic transfer of peroxidase conjugate from blot to blot was used to control results. Live image chemiluminescence was monitored using BioChemi System (UVP, Calif.). Results: C4A and C4B isotypes were varied among patients in expected manner. In cases of systemic lupus erythematosus earlier additional characteristic distribution of IgM-containing bands between C4A and anode were identified. C4B region was closed to the carbohydrate rich glycoconjugates (C1-inhibitor, IgM, IgA, protein-A-binding targets). IgG bands were preferentially located in positions which were closed to C4A region. Pictures were changed upon treatments and rehabilitation of patient. Conclusions: ImmunoChemiluminescent methodology developed can be used for any serum glycoconjugates as disease markers especially in the C4B surrounding regions. C4B can serve as additional sensitive indicator of semipreparative polyacrylamide miniblocks as sources of pathologically altered human glycome.

## PO 181

HUMAN PROBIOTIC BACTERIAL LECTINS IN STUDY  
OF CANDIDA-NON-ALBICANS CLINICAL STRAINS

M. Lakhtin, A. Bayrakova, V. Lakhtin, S. Afanasyev, V. Pospelova, V. Alyoshkin

*G.N.Gabrichesky Research Institute for Epidemiology and Microbiology, Moscow, Russia*  
*lakhtinv@yandex.ru*

Introduction: Anti-*C.albicans* actions of human probiotic bacterial lectins (PBL) were established [1]. The aim was to study anti-*C.non-albicans* action of PBL and antibiotics. Reagents and methods: Freshly isolated urogenital 71 *C.tropicalis*, 23 *C.krusei*, 4 *C.glabrata*, and 32 *C.albicans* clinical strains were studied. *Candida* growth in suspension cultures in microplate or on *Sabouraud* agar was monitored in the presence of free or disc-applied forms of PBL, respectively. Standardized preparations of L of lactobacilli (acidic and cationic L: aLL, cLL) - ingredients of the probiotic Acilact and L of bifidobacteria (aLB, cLB) - ingredients of the probiotic Bifidin and others were used in subhemagglutinating dilutions. The panel of PBL was used to discriminate alpha-(phospho)mannan and/or desialylated mucin surface alpha-GalNAc-containing antigen-like structures. Standard disc-antibiotics were amphotericin-B[A], fluconazol[F], itraconazol[I], ketoconazol[Ke], klotrimazol[Kl], nystatin[N]. Results: *Candida* growth inhibition depended on type of PBL, antibiotic, and/or nature of strain. The ranged sets of antibiotic relative effectiveness against *C.krusei* (Kl>I≥[Ke>F]>A≥N), *C.tropicalis* (Kl>[Ke>F]>I>A=N), and *C.albicans* ([Ke≥F]≥Kl>I>A≥N) were differed in position of azole block [Ke,F] (as indicator of *Candida species* relative antibiotic resistance). Among PBL tested, aPBL were usually more anti-*C.non-albicans* effective than cPBL. The growth of *C.albicans* or *C.tropicalis* was preferentially inhibited as aLB>aLL. In case of *C.krusei* aLL revealed higher inhibition effectiveness depending on time of (PBL plus strain suspension) incubation. There were other interspecies and strain differences revealed with a panel of PBL. PBL were able to inhibit antibiotic-resistant *C.non-albicans* strains. PBL in combinations with antibiotics revealed synergistic anti-*C.non-albicans* action. Clinical strains were typed with a PBL-panel as varying combinations LB(-,+2+,3+)LL(-,+2+). Conclusions: Results indicate potential usefulness of a panel of PBL in additional *C.non-albicans* clinical strain typing and early diagnostics using *Candida* surface screening (upon candidiasis, mixed fungal infection, immune compromise pathology, etc.). Synergistic anti-*C.non-albicans* combinations of PBL and azoles are perspective.

**References**

1. Lakhtin, M.; Alyoshkin, V.; Lakhtin, V.; Afanasyev, S.; Pozhalostina, L.; Pospelova, V. *Probiotics & Antimicro. Prot.* **2010**, 2, 186-196.

Keywords: probiotic lectins, antibiotics, *Candida species*, synergism.

## PO 182

**PROFILING OF GLYCANS AND POSTTRANSLATIONAL MODIFICATIONS  
IN HUMAN BREAST ADENOCARCINOMA MCF-7 AND T-LYMPHOBLASTOID  
CELLS AFTER DIFFERENT TREATMENTS**

Erika Lattová<sup>1</sup>, Boguslaw Tomanek<sup>2</sup>, Dorota Bartusik<sup>3</sup>, H  l  ne Perreault<sup>1</sup>

<sup>1</sup>Chemistry Department, University of Manitoba, Winnipeg, MB, Canada R3T 2N2;

<sup>2</sup>Institute for Biodiagnostics), 3330 Hospital Drive NW, Calgary, Alberta T2N 4N1, Canada;

<sup>3</sup>Cross Cancer Institute, Medical Physics Department, 11560  
University Ave, Edmonton T6G 1Z2, Canada

Glycosylation of proteins is a ubiquitous type of post-translational modification in living systems. Variations in oligosaccharide structures are associated with many normal and pathological events in cells and targeted glycosylation research has become important in the area of developing novel therapeutic approaches [1]. Current cancer therapy uses several approaches including drugs based on monoclonal antibodies. However, cancers very often develop resistance to drugs. The investigation on cellular and molecular level might provide more understanding in the mechanism of cancer cell resistance, so that therapies could be optimized more individually. In this regard, our work has been aimed at the investigation of posttranslational modifications in terms of glycosylation in cancer cells after treatment under different conditions.

Cancer cells were treated with colchicines, tocopherols, anti-Her-2 and Herceptine. Whole cell lysates after each treatment were digested with trypsin and oligosaccharides were released from total cell digests enzymatically (PNGaseF). After fractionation, each fraction was analyzed by MALDI-MS. Trypsin digests only were subsequently examined under LC-MS conditions.

The HPLC profiles of trypsin digested samples and examination of glycans pools indicated differences between original and treated cells. However these variations depended on the type of treatment. A major population of N-glycans detected in both types of cells before treatment corresponded to high-mannose structures accompanied by less abundant of fucosylated tri- and tetraantennary higher sialylated glycans [2]:

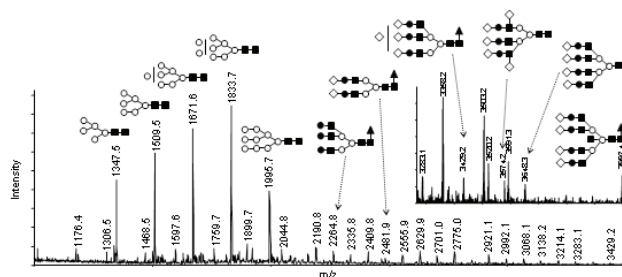

After treatment high-mannose structures as dominant oligosaccharides were detected only in cells treated with anti-Her-2 antibody, where as Herceptin treatment resulted in biantennary fucosylated glycans originated from antibody. The growth of additional new oligosaccharides depended on the absence/presence of lipofectamine. Colchicine derivatives were clearly associated with the eradication of glycoprotein bearing high-mannose glycans in original cancer cells. A fully sialylated triantennary glycan was the dominant oligosaccharide detected in the pool analyzed. The detailed examination of glycopeptides confirmed changes on the peptide level as well, suggesting that more multipart changes in glycoconjugates are associated with treatment.

### References

- Walsh G. and Jefferis R. *Nat. Biotechnol.* **2006**, 24, 1241-1252.
- Lattov   E., Tomanek B., Bartusik D., Perreault, H. *J. Proteome Res.* **2010**, 9, 1533-1540.

## PO 183

**CHARACTERIZATION OF FRUCTAN FROM CHIKUYO-SEKKO-To, A KAMPO PRESCRIPTION, AND ITS ANTIHERPETIC ACTIVITY *IN VITRO* AND *IN VIVO***

Jung-Bum Lee, Tomoko Fukai, Kyoko Hayashi, and Toshimitsu Hayashi

*Graduate School of Medicine and Pharmaceutical Sciences for Research,  
University of Toyama, 2630 Sugitani, Toyama, Toyama 930-0194, Japan  
lee@pha.u-toyama.ac.jp*

Herpes simplex virus type 2 (HSV-2) causes genital herpes, and its infection has also been linked to three times higher risk of sexually acquired human immunodeficiency virus (HIV). Therefore, treatment and prophylaxis of HSV-2 infection should reduce the likelihood of HIV infection. Chikuyo-Sekko-To (CST), which consists of Lophatheri Folium (*Lophatherum gracile*), Ginseng Radix (*Panax ginseng*), Glycyrrhizae Radix (*Glycyrrhiza glabra* or *G. uralensis*), Ophiopogonis Tuber (*Ophiopogon japonicus*), Pinelliae Tuber (*Pinellia ternata*), Oryzae Semen (*Oryza sativa*) and Gypsum Fibrosum (gypsum), is a traditional Japanese herbal (Kampo) medicine used for infectious diseases. Here, we characterized a fructan from CST and evaluated its biological activities including antiviral potencies against HSV-2 *in vitro* and *in vivo* and stimulatory effect on macrophages.

The fructan was isolated by combination of column chromatographies including anion-exchange and gel filtration from hot water extract of CST. Chemical and spectroscopic analyses revealed that the polysaccharide was a highly branched one consisted of terminal (19.0%), 2,1- (61.9%), 2,6- (4.9%) and 1,2,6-linked b-D-Fruf residues. The fructan showed anti-HSV-2 effect *in vitro*. In the animal model, topical application of the polysaccharide significantly reduced virus titers as compared with that of untreated mice. As predicted from viral shedding, the fructan could elongate the survival period at a dose of 1 mg/day when compared with that of control group. In addition, the fructan showed stimulatory effects against murine macrophage-like cell line, RAW264.7 cells.

From these results, the fructan from CST was suggested to be a candidate as an anti-HSV-2 agent.

## PO 184

**ENZYMATIC TOOLS FOR THE DEPOLYMERIZATION OF MARINE BACTERIAL EXOPOLYSACCHARIDES: INVESTIGATION OF GLYCOSYDE HYDROLASES OR LYASES**

Florian Lelchat\*<sup>1</sup>, Christophe Brandily<sup>1</sup>, Joëlle Cozien<sup>1</sup>, Andréa Leroy<sup>1</sup> and Claire Boisset<sup>1</sup>

*Biotechnology and Marine Molecules Laboratory, Ifremer, BP 70, 29280, FRANCE.  
florian.lelchat@ifremer.fr*

Some marine bacteria are able to synthesise and to excrete natural macromolecules such as Exopolysaccharides (EPS). These biopolymers having specific physico-chemical and biological properties, demonstrate potent biotechnological applications (food-processing industry, medical care, cosmetic, environmental engineering...). In return, their major ecological roles during the establishment of potentially pathogenic strains biofilms can make their eradication complicated.

The depolymerization of exopolysaccharides can occur using chemical or physical methods. The hydrolysis of the glycosidic linkage is made at random and finally a mixture of molecules is obtained. A more specific way is the use of enzymes for producing calibrated low molecular weight polysaccharides or oligosaccharides. There is a large number of polysaccharide-degrading enzymes: glycoside hydrolases cleave glycosidic bonds and generate reducing ends while polysaccharide lyases proceed by  $\beta$ -elimination by generating insaturated non reducing ends. The large diversity and the complex structures of EPS make it difficult to find the proper enzymes to cleave these polysaccharides.

Here we focus on the depolymerization of complex marine bacterial EPS by enzymes produced by marine bacteria as well as by marine virus (bacteriophages). Depolymerases have been already highlighted from an EPS-producing bacterial strain.

The development of enzymatic tools will have multiple applications such as the fine structural elucidation of complex EPS or the production of bioactive calibrated polysaccharidic fractions for example.



PO 185

**EFFICIENT SYNTHESIS OF MYCOBACTERIUM SULFOLIPIDS USING A ONE-POT  
REGIOSELECTIVE PROTECTION OF TREHALOSE BY AN IRON(III)  
CHLORIDE-TANDEM CATALYSIS**

Lemétais Aurélie,<sup>1</sup> Bourdreux Yann,<sup>1</sup> Beau Jean-Marie<sup>\*1</sup>

<sup>1</sup>Université Paris-Sud 11, Institut de Chimie Moléculaire et des Matériaux d'Orsay,  
Laboratoire de Synthèse de Biomolécules, UMR CNRS 8182  
Bât. 430, 91405 Orsay cedex, France  
aurelie.lemetais@u-psud.fr

Sulfolipids-I, -II and their analogues (acylated  $\alpha,\alpha$ -trehaloses containing a sulfate moiety) are abundant metabolites found in the cell wall of *Mycobacterium tuberculosis*.<sup>1</sup> They were identified as new mycobacterium antigens able to control mycobacterial infection.<sup>2</sup> Therefore, they appear to be promising candidates for the development of a new tuberculosis vaccine. In order to test their *in vivo* activity, we focused on the synthesis of sulfolipids-I and -II and their analogues starting from trehalose, which is a C<sub>2</sub>-symmetric disaccharide.

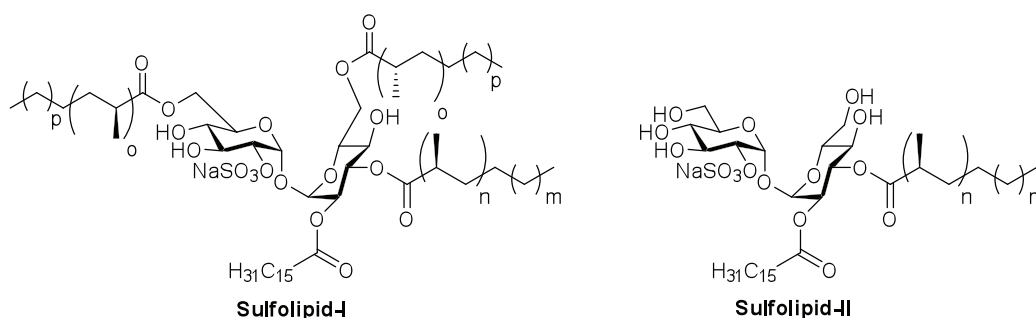

The syntheses of di- and tetra-acylated sulfolipids were achieved from a one-pot regioselective protection of trehalose by an iron(III) chloride hexahydrate tandem catalysis which is a convenient methodology for the construction of biologically active oligosaccharides.<sup>3</sup> Then, desymmetrization of the trehalose derivative and regioselective O-debenzylation led to an efficient synthesis of model sulfolipids. Our strategy will be presented.

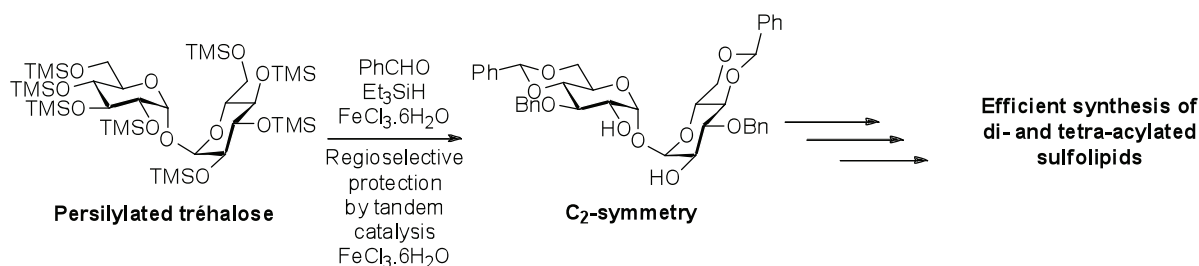

### References

- Gilleron, M.; Stenger, S.; Mazorra, Z.; Wittke, F.; Mariotti, S.; Böhmer, G.; Prandi, J.; Mori, L.; Puzo, G.; De Libero, G. *J. Exp. Med.* **2004**, *199*, 649-659.
- Guiard, J.; Collmann, A.; Gilleron, M.; Mori, L.; De Libero, G.; Prandi, J.; Puzo, G. *Angew. Chem. Int. Ed.* **2008**, *47*, 9734-9738.
- Bourdreux, Y.; Lemétais, A.; Urban, D.; Beau, J.-M. *Chem. Commun.* **2011**, *47*, 2146-2148.

PO 186

SYNTHESIS OF REGIOSPECIFIC FLUORINATED SEVEN CARBON SUGARS  
AS TUMORSPECIFIC CONTRAST AGENTSYevgeniy Leshch, Joachim Thiem*University of Hamburg, Faculty of Sciences, Department of Chemistry  
Martin-Luther-King-Platz 6, D-20146 Hamburg, Germany  
leshch@chemie.uni-hamburg.de*

To date cancer is one of most common and often fatal diseases which in 2004 caused 7.4 million death worldwide, and it is estimated that by 2030 this figure will rise to 12 million.<sup>[1]</sup>

Cancer is effectively found in every organ and tissue posing a complex diagnostic challenge for specific targeting. Non-invasive imaging techniques such as PET and MRI can be used. The structural resemblance of seven carbon sugars such as gluco- and manno-hept-2-uloses could allow for their application as organ or tissue specific contrast agents. Since FDG [<sup>18</sup>F]-2-deoxy-2-fluoro-D-glucose<sup>[2]</sup> is used as a common contrast agent for detection of higher glucose-levels in malignant tissues the formation of corresponding heptose derivatives was of interest.

To date only few syntheses of heptose derivatives were reported. A versatile route to a number of rare heptoses and their fluoro derivatives will be presented. Starting from monosaccharides **1**, a C-1 extension via heptenitols **2** as key intermediates allows for subsequent regiospecific transformations into the target compounds **3**.

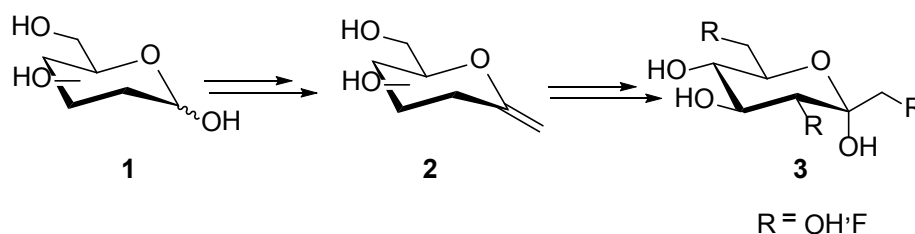

**Acknowledgements:** This work was supported by the European Community FP7-NMP, grant agreement n° 228933.

**References**

1. Cancer. World Health Organization, **2009**. p. Fact Sheet 297.
2. H. Fukuda *et al.*, *Eur. J. Nucl. Med.*, **1982**, 7, 294-297.

PO 187

GLC-MS ANALYSIS OF GLYCOCONJUGATES WITH ANTICOAGULANT  
ACTIVITY FROM *AGRIMONIA EUPATORIA* L. FRACTIONATED  
WITH ANION-EXCHANGE CHROMATOGRAPHY

Marta Lewik-Tsirigotis<sup>1</sup>, Izabela Pawlaczyk<sup>1,2</sup>, Roman Gancarz<sup>1,2</sup>

<sup>1</sup>Division of Medicinal Chemistry and Microbiology, Wrocław University of Technology,  
ul. Łukasiewicza 2, 50-371 Wrocław, Poland

<sup>2</sup> Regional Specialist Hospital in Wrocław, Research and Development Centre,  
ul. Kamieńskiego 73a, 51-124 Wrocław, Poland  
marta.tsirigotis@pwr.wroc.pl

*Agrimonia eupatoria* L. (*Rosaceae* family) is a medicinal plant, native to mainland Europe, and occurring across the North Africa and Minor Asia<sup>1</sup>. *A. eupatoria* is used in folk medicine as haemostatic, tonic for asthenia, astringent in diarrhoea, and diuretic agent. Besides, this plant has been used to treat blood, cardiovascular, gastrointestinal, genitourinary, inflammatory, liver, respiratory track, skin and some other<sup>2</sup>.

The macromolecular ( $M_w \geq 12.500$ ), pectin-like polyphenolic-polysaccharide conjugate preparation has been isolated from the flowering parts of *A. eupatoria* by multi-step process<sup>3</sup>, with 6.5 % (w/w) yield of the starting material. The plant preparation was analysed with ion-exchange chromatography, DEAE type, by step-wise elution, with NaCl solutions in different concentrations (0.05-1.2 M). The anticoagulant activity of separated fractions of *A. eupatoria* conjugate, were tested *in vitro* on human blood plasma with aPTT test, TT test and PT test. The neutral monosaccharides in separated fractions were estimated as borohydrate-reduced alditol acetates<sup>4</sup> by GLC-MS (Focus ITQ 700 chromatograph coupled with ion trap MS detector), using Rtx-225 column (0.25 mm × 30 m). Separation conditions: helium as carrier gas at flow rate of 3 ml min<sup>-1</sup>, oven temperature from 180°C after 1 min hold time was increased at a rate of 2°C min<sup>-1</sup> to 205°C and held for 30 min at final temperature. The results of analyses suggest the pectin-like and polyanionic heparin-like character of the separated fractions of polyphenolic-polysaccharide conjugate from *A. eupatoria*.

**Acknowledgments:** Studies are a part of the project **supported** by Narodowego Centrum Nauki (grant:

### References

1. Clapham A R et al, Flora of the British Isles, 1952, University Press, Cambridge
2. Bilia A R et al, *Phytochemistry*, 1993, 32, 1078-1079
3. Gancarz R, Pawlaczyk I., Kleszczyńska H., 2007, Patent Application No P 382973
4. Biermann C.J., McGinnis G.D., Analysis of Carbohydrates by GLC and MS, 1989, Boca Raton, FL: CRC Press

## PO 188

## AZIRIDINE-FUSED-CYCLITOL AS GLUCOSIDASE ACTIVITY-BASED PROBE

K.-Y. Li,<sup>1</sup> M.D. Witte,<sup>1</sup> W.W. Kallemeijn,<sup>2</sup> W. Donker-Koopman,<sup>2</sup> A. Strijland,<sup>2</sup>  
G.A. van der Marel,<sup>1</sup> J.M. Aerts<sup>2</sup> and H.S. Overkleeft<sup>1</sup>

<sup>1</sup>Dept. of Bio-organic Synthesis, Leiden Institute of Chemistry, Einsteinweg 55,  
2333 CC Leiden, The Netherlands

<sup>2</sup>Dept. of Medical Biochemistry, Academic Medical Center, Meibergdreef 15,  
1105 AZ Amsterdam, The Netherlands

E-mail: likj@chem.leidenuniv.nl or h.s.overkleeft@chem.leidenuniv.nl

Retaining glucosidases catalyze the hydrolytic cleavage of glucosidic bonds. This class of enzymes plays important roles in fundamental biochemical processes (e.g. lysosomal catabolism of glycoconjugates and control of protein folding).<sup>1</sup> To gain more insight into these biochemical processes activity-based protein profiling (ABPP) can be applied.

Recently, our group has published two potent, sensitive and cell permeable activity-based probes (ABPs) for glucocerebrosidase (GBA).<sup>2</sup> In addition, these cyclophellitol-based ABPs (MDW933 and MDW934) specifically label GBA. This can be explained by the constrained active sites of other *exo*-glucosidases excluding the incorporation of bulky (reporter) groups at the C6 position of inhibitors. Therefore, we envisioned that installation of bulky modifications (e.g. biotin or fluorophores) in a potential inhibitor at the aglycone site can result in a new class of broad-spectrum glucosidase ABPs. To this end, an aziridine-fused cyclitol functionalized with a fluorescent reporter group (MDW1044) was designed and synthesized by a novel straightforward method using iodolactonization as the key step. In a substrate-based assay, it was demonstrated that MDW1044 is a potent inhibitor of GBA and almond  $\beta$ -glucosidase. *In vitro* labeling by MDW1044 was superior to the cyclophellitol-based ABPs MDW933 and MDW934 for GBA as well as for  $\beta$ -almond glucosidases.

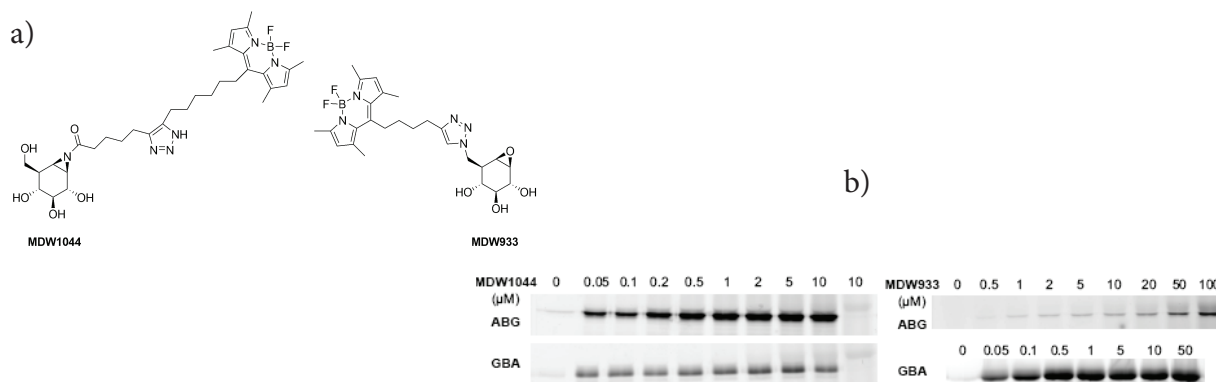

**Figure 1.** a) Cyclitol-based ABPs and b) *In vitro* labeling of recombinant GBA and  $\beta$ -almond glucosidase

### References

- Melo E.B., Carvalho A.D.S., *Tetrahedron*, **2006**, 62, 10277-10302.
- Witte M.D., Kallemeijn W.W. *et al*, *Nat. Chem. Biol.*, **2010**, 6, 907-913.

PO 189

SYNTHESIS OF S-LINKED  $\alpha(2\rightarrow8)$  AND  $\alpha(2\rightarrow8)/\alpha(2\rightarrow9)$  HEXASIALIC ACIDS VIA S-ALKYLATIONChien-Fu Liang,<sup>1</sup> Ting-Chun Kuan,<sup>1</sup> Tsung-Che Chang,<sup>1</sup> Chun-Cheng Lin<sup>1</sup><sup>1</sup> Department of Chemistry, National Tsing Hua University, Hsinchu, Taiwan  
liangchienfu@gmail.com

We developed a route for the synthesis of S-linked  $\alpha(2\rightarrow8)$  hexasialic acid and alternating S-linked  $\alpha(2\rightarrow8)$  and  $\alpha(2\rightarrow9)$  hexasialic acid. The method involves chemo- and stereo-selective alkylation of a C2-thiosialoside as the nucleophilic donor and a C8-iodosialoside as the electrophilic acceptor. For the synthesis of C8-iodosialoside, we developed an efficient method to intramolecularly transfer the C7-acetyl group of a sialoside to the C9 position under mildly basic conditions. The C9-acetylsialoside was then used for the synthesis of the C8-iodosialoside. Using these procedures, S-linked  $\alpha(2\rightarrow8)$  and  $\alpha(2\rightarrow8)/\alpha(2\rightarrow9)$  hexasialic acids were synthesized.

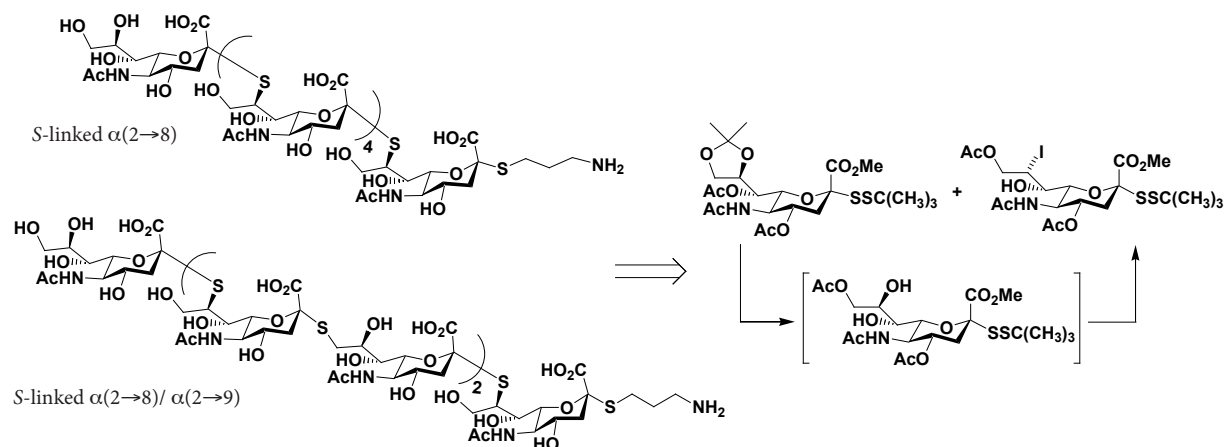

## References

1. C.-F. Liang, M.-C. Yan, T.-C. Chang, C.-C. Lin, *J. Am. Chem. Soc.* **2009**, *131*, 3138-3139.
2. G. Hummel, O. Hindsgaul, *Angew. Chem.* **1999**, *111*, 1900-1902; *Angew. Chem. Int. Ed.* **1999**, *38*, 1782-1784.
3. J. R. Rich, D. R. Bundle, *Org. Lett.* **2004**, *6*, 897-900.
4. D. R. Bundle, J. R. Rich, S. Jacques, H. N. Yu, M. Nitz, C. C. Ling, *Angew. Chem.* **2005**, *117*, 7903-7907; *Angew. Chem. Int. Ed.* **2005**, *44*, 7725-7729.
5. K. Pachamuthu, R. R. Schmidt, *Chem. Rev.* **2006**, *106*, 160-187.

## PO 190

SYNTHESIS OF ZANAMIVIR-BASED DERIVATIVES  
AS ANTI-INFLUENZA INHIBITORS

Chien-Hung Lin,<sup>1</sup> Tsung-Che Chang,<sup>1</sup> Jo-Chun Chen,<sup>1</sup> Chun-Cheng Lin<sup>1</sup>, Tsu-An Hsu,<sup>2</sup>

<sup>1</sup>Department of Chemistry, National Tsing Hua University, 101, Section 2, Kuang-Fu Road, Hsinchu 30013, Taiwan.

<sup>2</sup>National Institute of Cancer Research and Division of Biotechnology and Pharmaceutical Research, National Health Research Institutes, 35, Keyan Road, Zhunan 35053, Taiwan  
aganken@oz.nthu.edu.tw

Influenza is a serious world-wide health care problem. In this work, we describe the structure-based strategy for inhibition of neuraminidase (NA) for the discovery of novel anti-influenza agents. Novel inhibitors based on zanamivir were generated to target the 150-loop binding pocket that is in close proximity to the neuraminic acid binding site<sup>1,2</sup>. We synthesized a compound library consisting of ~ 50 analogues by linking various acidic moieties to the guanidine group of zanamivir through an amide bond. Through such a linkage, fifty different kinds of acids were incorporated into zanamivir ethyl ester. The results showed that thirty compounds present better activity than the parent compound. Compound 13r has the best inhibitory activity against H1N1 with an IC<sub>50</sub> of 0.53 nM. The inhibitory activity of compound 13r is slightly better than zanamivir against H1N1 virus. On the other hand, some synthesized inhibitors show better inhibition potency against H1N1 virus than H3N2 virus; indicating that all the substituent groups of the compounds are likely to be positioned in the 150-cavity. Overall, results from this study showed that both N1 and N2 subtypes of NA can be inhibited by zanamivir derivatives generated by modifications at the C-4 position.

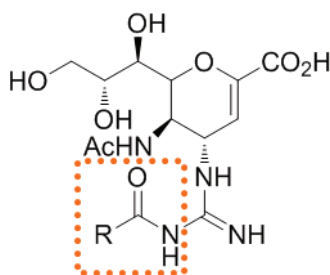

**Zanamivir Derivatives**

### References

1. Wen, W.-H.; Wang, S.-Y.; Tsai, K.-C.; Cheng, Y.-S. E.; Yang, A.-S.; Fang, J.-M.; Wong, C.-H., *Bioorganic Medicinal Chemistry*, **2010**, *18*(11), 4074-4084
2. Rudrawar, S.; Dyason, J. C.; Rameix-Welti, M.-A.; Rose, F. J.; Kerry, P. S.; Russell, R. J. M.; van der Werf, S.; Thomson, R. J.; Naffakh, N.; von Itzstein, M., *Nat Commun*, **2010**, *1*(8), 113-119



PO 191

**CARBOHYDRATE-MODIFIED NON-LIPID POLYDIACETYLENE-BASED  
BIOSENSOR FOR DETECTION OF LECTIN AND BACTERIA**

S.P Liu<sup>1</sup>, J.J. Koh<sup>2</sup>, W.N. Zeng<sup>3</sup>, S. Valiyaveetil<sup>2</sup>, D.R. Cao<sup>3</sup>, R.W. Beuerman<sup>1</sup>

<sup>1</sup> Singapore Eye Research Institute, 11 Third Hospital Avenue, #06-00  
SNEC Bulding. Singapore 168751.

<sup>2</sup> Department of Chemistry, National University of Singapore.

<sup>3</sup> School of Chemistry and Chemical engineering, South China University of Technology, China.  
liushouping@gmail.com

Bacterial identification is of interest due to the numerous species associated with infectious disease and of relevance in food, water control, environmental protection and biological warfare<sup>[1-3]</sup>. In this study, three non-lipid based diacetylene monomers which are functionalized by glucose (M1), galactose(M2) and mannose(M3) were designed and used to prepare their corresponding conjugated polydiacetylenes (Scheme 1) by UV light of 254nm. Polymer 1, 2 and 3 were obtained MW of 7402, 6264 and 6328, respectively, which correspond to 19-22 repeating units. Fluorescence spectroscopy has shown that the intensities of the polymer spectra are much higher than the intensities of monomer spectra due to the conjugation system. Binding tests were performed to evaluate the potential of polymers and monomers as a biosensor. Binding test with lectin (Concanavalin A) has shown that binding ability of the polymer 3 with quenching constant of 8092 is the best when compared with polymer 1 with quenching constant of 2314, and polymer 2 and mannose-containing monomer 3 without significant quenching effect. Detection linear range of polymer 3 was found to be 0-1X10<sup>-4</sup>M. Hysteresis studies were performed and the results have shown again the polymer 3 has the strongest binding ability with the lectin. Percentage of recovery of pure ConA, polymer 1, polymer 2, polymer 3 and monomer 3 are 51%, 44%, 53%, 33% and 59%, respectively. Similar results were obtained when binding tests were performed using *E.coli*. Polymer 3 has the strongest binding ability with *E. coli* with a slope of 5.38X10<sup>-8</sup> and linear range of 0-1X10<sup>7</sup> Ctu/m<sup>3</sup>. However, no colour change could be observed when binding tests were performed. Polymer 3 with mannose is the best among polymers and monomers systems. Lastly, specificity test was performed using human cell and the results have shown that the human cell has negligible effect compared to the binding using bacteria, with linear range of only 0-5X10<sup>4</sup> cells/mL (1000X lower than *E. coli*).

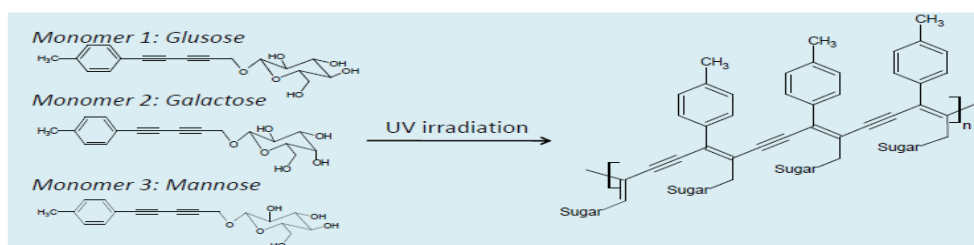

**Scheme 1:** The general structures of three novel carbohydrate-containing monomers and polymers

### Reference

1. M. D. Disney, J. Zheng, T. M. Swager, P. H. Seeberger, JACS, 2004, 126, 13343-13346
2. A. Duarte, A. Chworos, S. F. Flagan. G. Hanrahan and G. C. Bazan, JACS, 2010, 132, 12562--12564
3. H. Y. Liu, chapter 24, 659-688, M. Zourob et al (eds) Principles of Bacterial Detection: Biosensors, Recognition Receptors and Microsystems. Springer Science+Business Media, LLC 2008

## PO 192

## ISOFLAGOMIDINE: A GLYCOSIDASE INHIBITOR WITH AN AMIDINE GROUP AT THE PSEUDOANOMERIC POSITION

Emil Lindbäck,<sup>1</sup> Óscar López,<sup>2</sup> José G. Fernández-Bolaños,<sup>2</sup> Stephan P. A. Sauer,<sup>1</sup> and Mikael Bols<sup>1</sup>

<sup>1</sup>Department of Chemistry, University of Copenhagen. Universitetsparken 5, 2100 Kbh Ø, Denmark,

<sup>2</sup>Departamento de Química Orgánica, Universidad de Sevilla. Apto. 1203. E-41071 Seville, Spain  
osc-lopez@us.es

Glycosidases are enzymes that catalyze the hydrolysis and formation of exocyclic C-O bonds in glycosides, and therefore they undergo pivotal biological roles in living beings.<sup>1</sup> Moreover, they are related to a high number of diseases such as diabetes, lysosomal storage disorders, viral and bacterial infections or cancer, among others.<sup>2</sup> The design of potent and selective glycosidase inhibitors resembling the transition state of the hydrolytic reactions of glycosides in terms of geometry and charge<sup>3</sup> is an intense research area in the Bioorganic and Medicinal Chemistry fields, as this kind of compounds are postulated as potential therapeutical agents. Among the numerous compounds exhibiting inhibition properties, iminosugars, azasugars and related compounds comprise the more numerous families; azasugars such as noeuromycin **1**, isofagomine **2** and isofagomine lactam **3** are remarkable.<sup>4</sup> In this communication we report the preparation of isofagomidine **4**, an isofagomine analogue bearing an amidino moiety in the pseudoanomeric position. Inhibition studies and computational calculations on **4** are also covered.

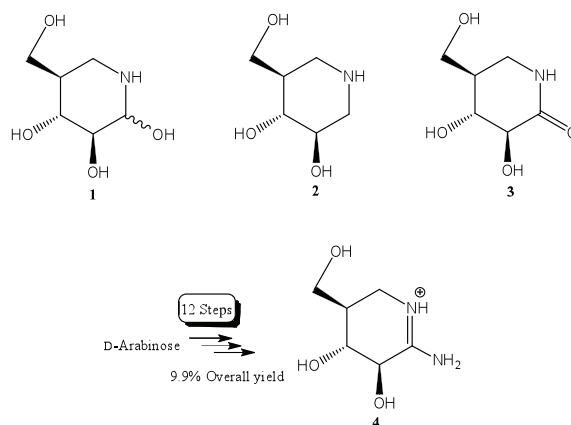

We acknowledge the Dirección General de Investigación of Spain (CTQ2008 02813), Junta de Andalucía (FQM 134), Lundbeck foundation, FNU and DCSC for financial support.

### References

1. Kato, A., Kato, N., Kano, E., Adachi, I., Ikeda, K., Yu, L., Okamoto, T., Banba, Y., Ouchi, H., Takahata, H., Asano, N., *J. Med. Chem.* 2005, 48, 2036-2044.
2. Bols, M., López, O. Ortega-Caballero, F in *Glycosidase inhibitors: Structure, activity, synthesis and medical relevance*. Comprehensive Glycoscience - From Chemistry to Systems Biology, Ed. Elsevier, 2007, 815-884.
3. Lillelund, V. H., Jensen, H. H., Liang, X., Bols, M., *Chem. Rev.* 2002, 102, 515-553.
4. a) Andersch, J., Bols, M., *Chem. Eur. J.* 2001, 7, 3744-3747. b) Ernholz, B. V., Thomsen, I. B., Lohse, A., Plesner, I. W., Jensen, K. B., Hazell, R. G., Liang, X., Jakobsen, A., Bols, M., *Chem. Eur. J.* 2000, 6, 278-287.

PO 193

**FROM POLYMER TO SIZE-DEFINED OLIGOMERS:  
AN EFFICIENT AND STEREOCONTROLLED CONSTRUCTION OF BIOTINYLATED  
CHONDROITIN OLIGOSACCHARIDES**

Chrystel Lopin-Bon,<sup>[1]</sup> Jean-Claude Jacquinet,<sup>[1]</sup> Aude Vibert<sup>[2]</sup>

<sup>[1]</sup> ICOA-CNRS UMR 6005, UFR Sciences, University of Orléans, BP 6759,  
45067 Orléans Cedex 2/France;

<sup>[2]</sup> Institute of Organic Chemistry and Biochemistry AS CRA, University of Praha,  
Flemingovo nám. 2., 166 10 Praha 6/Czech republic  
chrystel.lopin-bon@univ-orleans.fr

Chondroitin Sulfate (CS) belongs to the family of complex, polyanionic, linear polymer called glycosaminoglycans (GAGs). CS polymer is one of the major components of cartilage matrix and a defect in the biosynthesis of chondroitin sulfate has been observed in several diseases such as osteoarthritis. Within a program devoted to the study of the biosynthesis of CS chain, a collection of biotinylated oligosaccharide (sulfated (in position 4 or 6) or not) derivatives has been prepared in order to study the substrate specificity of chondroitin synthase, the glycosyl-transferase responsible for the polymerization of the chondroitin chain.

Controlled acid hydrolysis of heterogeneous polymeric chondroitin sulfate of bovine origin afforded a basic disaccharide **I** that was used as starting material for the preparation of tailor-made building block **II**. From this key intermediate, several imidates compounds (**III**) has been synthesised and allowed the stereocontrolled construction of a collection of size-defined biotinylated chondroitin oligosaccharides sulfated or not (**V**).<sup>2,3</sup>

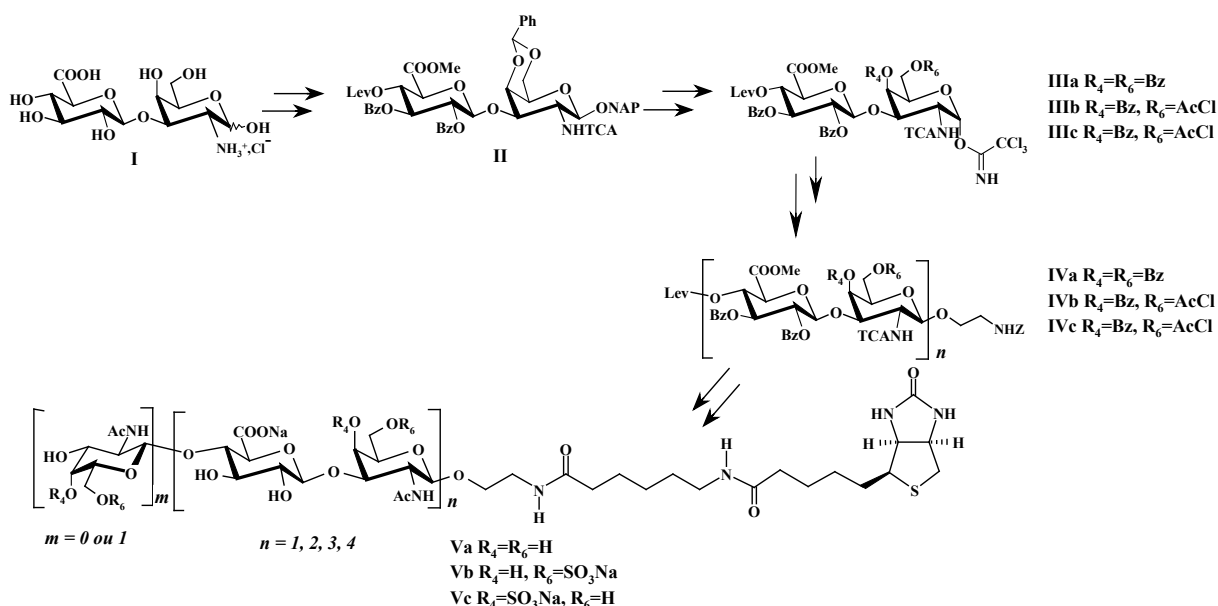

**Scheme 1.** Synthesis of biotinylated chondroitin oligosaccharides

## References

- Lopin, C., Jacquinet, J.-C., *Angew. Chem. Int. Ed.*, **2006**, *45*, 2574-2578.
- Vibert, A., Lopin-Bon, C., Jacquinet, J.-C., *Chem. Eur. J.*, **2009**, *15*, 9561-9578.
- Jacquinet, J.-C., Vibert, A., Lopin-Bon, C., *Chem. Eur. J.*, **2009**, *15*, 9579-9595.

## PO 194

## SYNTHESIS OF MEMBRANE-PERMEABLE RIBOSE-PRODRUGS

Nathalie Lunau, Katharina Klingeberg and Chris Meier

Organic Chemistry, Department of Chemistry, Faculty of Sciences, University of Hamburg,  
Martin-Luther-King-Platz 6, D-20146 Hamburg, Germany  
lunau@chemie.uni-hamburg.de

Thymidine phosphorylase (TP) is overexpressed in a variety of malignant solid tumors. It promotes tumor growth and metastasis progression by preventing apoptosis and inducing angiogenesis, the formation of new blood vessels.<sup>1</sup> Thus, TP turned out to be a promising target for an antiangiogenic treatment of cancer. The angiogenic effect of TP is related to its enzymatic activity: it catalyzes the reversible decomposition of thymidine to thymine and 2-deoxy-D-ribose-1-phosphate (dR-1-P), which can be further converted to deoxyribose (dR).<sup>2</sup>

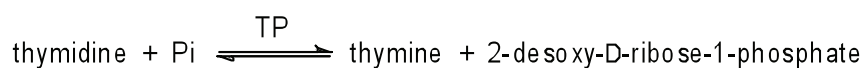

dR-1-P could serve as a mediator for the angiogenic activity of TP and would consequently be involved in the stimulation of tumor growth. In order to prove if dR-1-P is actually responsible for the angiogenic stimulation, it is necessary to deliver it into cells. Due to the high polarity of sugar-phosphates at physiological pH, these compounds are unable to penetrate the hydrophobic cell membrane. Different prodrug systems have been developed to achieve the intracellular release of such biologically active monophosphates. The *cycloSal*-concept is a well established system for the delivery of nucleoside monophosphates which was also successfully applied for mannose-1-monophosphates.<sup>3,4</sup>

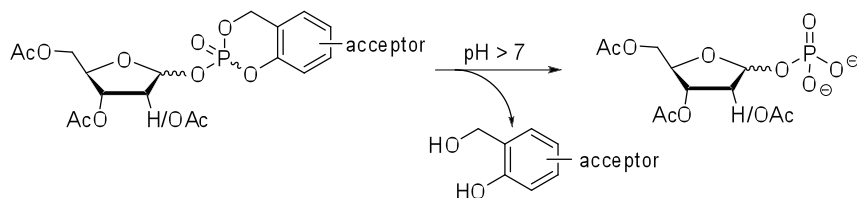

**Scheme 1:** *cycloSal*-(d)R-1-P and the chemical release of (d)R-1-P.

We have synthesized different lipophilic *cycloSal*-(d)R-1-Ps in order to study their potential for a selective delivery of the corresponding (d)R-1-P.

### References

1. A. Bronckaers, F. Gago, J. Balzarini, S. Liekens, *Med. Res. Rev.* **2009**, 29, 903-53.
2. S. Akiyama, T. Furukawa, T. Sumizawa, Y. Takebayashi, *Cancer Sci*, **2004**, 95, 851-857.
3. C. Meier, *Eur. J. Org. Chem.* **2006**, 1081-1102.
4. U. Muus, C. Kranz, T. Marquardt, C. Meier, *Eur. J. Org. Chem.* **2004**, 1228-1235.

## PO 195

## STUDY OF CARBOHYDRATE-PROTEIN INTERACTIONS USING AMINE-FUNCTIONALIZED HEPARIN OLIGOSACCHARIDES

Susana Maza, Giuseppe Macchione, Rafael Ojeda, Javier López Prados, José L. De Paz, Pedro M. Nieto

*Instituto de Investigaciones Químicas CSIC – US  
Avda. Américo Vespucio, 49. 41092 Sevilla (Spain)  
giuseppe.macchione@iiq.csic.es*

Heparin is a highly sulfated, linear polymer that participates in a plethora of biological processes by interaction with many proteins. The synthesis of pure heparin oligosaccharides is required in order to establish specific structure-activity relationships for heparin sequences and elucidate the role of these complex sugars in nature.

Here, we present the study of heparin-protein interactions on microtiter plates using synthetic amine-functionalized oligosaccharides. These compounds contain the GlcN-IdoA repeating unit of the major sequence of heparin and were obtained using a convergent  $n + 2$  modular strategy from key disaccharide structures.<sup>1</sup> The use of microwave irradiation was key for the efficient and fast O- and N-sulfation of the oligosaccharide intermediates.<sup>2</sup>

The amino group at the reducing end of the chain was employed for the covalent attachment of the oligosaccharides to appropriately functionalized microtiter plates. We demonstrated the utility of our approach by probing the carbohydrate affinity of a model heparin-binding protein, FGF2. Our results are in agreement with those obtained using microarrays.<sup>3</sup>

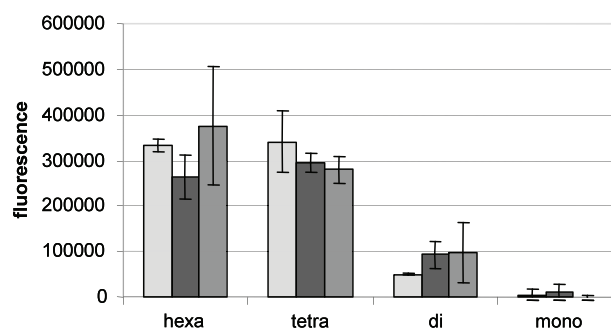
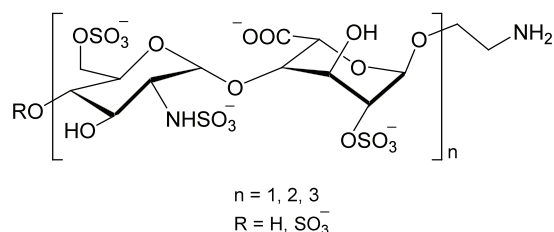

## References

1. J. L. De Paz, J. Angulo, J. M. Lassaletta, P. M. Nieto, M. Redondo-Horcajo, R. M. Lozano, G. Giménez-Gallego and M. Martín-Lomas. *ChemBioChem*. **2001**, 2, 673-685.
2. S. Maza, J. L. De Paz, P. M. Nieto. *Tetrahedron Lett*. **2011**, 52, 441-443.
3. C. Noti, J. L. De Paz, L. Polito, P. H. Seeberger. *Chem. Eur. J*. **2006**, 12, 8664-8686.

PO 196

**ASYMMETRIC SYNTHESIS OF 1,7-DIOXA SPIRO[5,5]UNDECANE  
("SPIRO SUGAR") VIA HIGHER-CARBON SUGAR FROM  
PROLINAMIDE-CATALYZED TANDEM ALDOL REACTION**Tomoya Machinami,\* [Daisuke Miura](#), Ryou Kano, Yousuke Usui, and Takashi Fujimoto*Department of Chemistry, Meisei University, 2-1-1 Hodokubo, Hino, Tokyo 191-8506, Japan  
machinam@chem.meisei-u.ac.jp*

During the search of an efficient organocatalyst for the asymmetric aldol reaction in aqueous media, methyl 2-deoxy-2-proliamido-D-glucopyranosides [1], prolinamido-glycosides, have been found to have substrate selectivity for water-soluble aldehyde acceptor, such as aldoses. For the reaction with aldoses as chiral aldehyde acceptor, the efficiency to lead to high stereoselectivity were depended on the co-relation between the both configuration of aldose and polylyl moiety of the prolinamido-glycoside catalyst. Thus, 1,3-dideoxy-D-erythro-hexulose was obtained by the reaction of acetone with D-glyceraldehyde using D-prolinamido-glycoside as a catalyst in 88 % yield with 93 % ee.

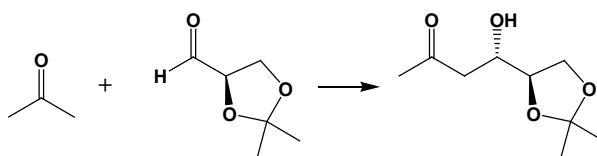

In the reaction, the prolinamido-glycoside catalyst was observed to promote the tandem aldol reaction and provided 5-nonulose when excess aldehyde acceptor was used. Removal of the protective group on 5-nonulose was followed by a simultaneous bis-acetalation and afforded 1,7-dioxaspiro[5,5]undecane as a sole product, whose absolute configuration was determined by X-ray crystallographic analysis.

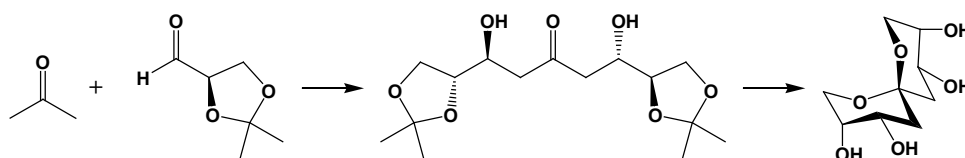

As a result, acetone with excess D-glyceraldehydes undergo a four-step cascade reaction to give 1,7-dioxaspiro[5,5]undecane.

**References**

1. A. Tsutsui, H. Takeda, M. Kimura, T. Fujimoto, and T. Machinami, *Tetrahedron Lett.*, 2007, **48**, 5213-5217.



PO 197

**STEREOSELECTIVE SYNTHESIS OF HIGHLY OXIGENATED  
BICYCLIC COMPOUND FROM SUGAR ALLYL TIN DERIVATIVES**

Marta Magdycz, Sławomir Jarosz

*Institute of Organic Chemistry, Polish Academy of Sciences, Kasprzaka 44/52,  
01-224 Warsaw, Poland  
marta.magdycz@icho.edu.pl*

Application of sugar as starting material for the preparation of complex optically pure products is a well established method in synthetic organic chemistry.<sup>1</sup> This method is successfully applied in the synthesis of polyhydroxylated carbocyclic compounds which are known to display potent biological activity.

Our methodology,<sup>2</sup> shown in *Figure 1*, allows us to obtain enantiomerically pure bicyclo[4.3.0]nonenes and bicyclo[4.4.0]decenes from sugar allyltins.

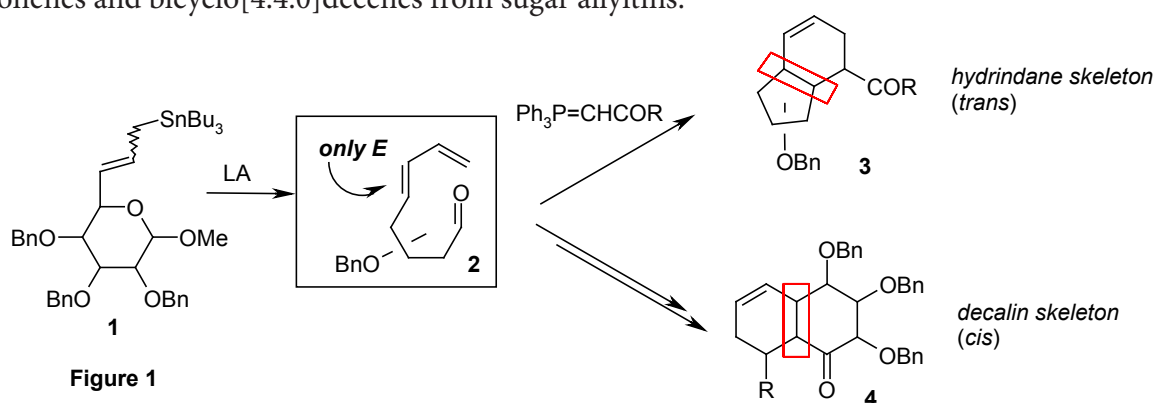

Functionalization of the ring **A** in compounds **3** provide highly oxygenated optically pure derivatives of bicyclo[4.3.0]nonanes (in *Figure 2* functionalization one of diastereoisomers is shown).

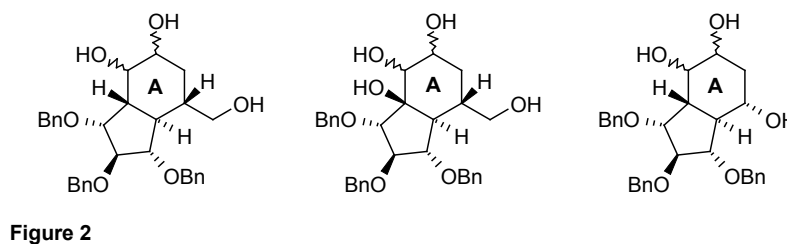

### References

1. Hanessian, S. *Total Synthesis of Natural Products: The Chiron Approach*, Pergamon Press, New York, 1983;
2. S. Jarosz, A. Gaweł, *Eur. J. Org. Chem.*, **2005**, 3415;

## PO 198

SYNTHETIC METHODOLOGIES TOWARDS THE SYNTHESIS  
OF GLUCOSIDASE INHIBITORS

Aoife Malone<sup>1</sup>, Eoin M. Scanlan<sup>1</sup>

<sup>1</sup>*School of Chemistry, Trinity College Dublin, Dublin 2, Ireland  
maloneao@tcd.ie, eoin.scanlan@tcd.ie*

Sugars with heteroatoms other than oxygen in the ring (e.g. azasugars, thiosugars) are known to exhibit interesting biological activities and possess considerable therapeutic potential. Their biological activity can be principally attributed to their inhibitory effect on glycosyltransferases and glucosidases. Inhibition of these enzymes render thiosugars and azasugars therapeutically useful against a range of diseases including diabetes, HIV, hepatitis and cancer<sup>1,2</sup>.

This work aims to access glucosidase inhibitors with therapeutic potential. Two distinct cyclisation routes to the sugar core have been investigated: route (A) using a free radical mediated ring closure process and route (B) via heterolytic cyclisation.

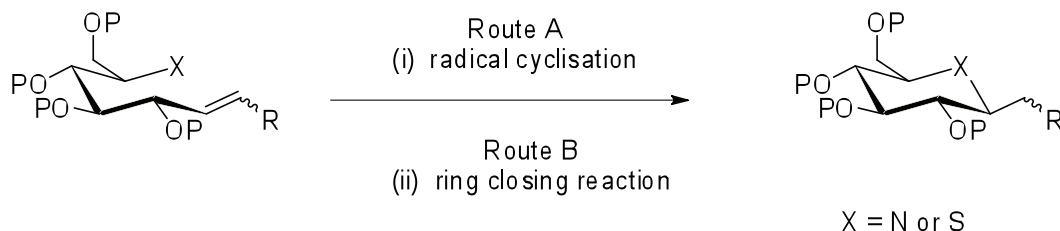

The use of a radical mediated cyclisation in carbohydrate synthesis offers several advantages over other methods. Cyclisation reactions can be carried out under mild reaction conditions and in the presence of a wide range of functional groups. Using this methodology a reliable, rapid synthetic route to highly functionalised glycoconjugates can be achieved. Several examples of glucosidase inhibitors have been synthesised and cyclisations have been observed with yields in excess of 90%. Biological evaluation of novel heterosugars is currently ongoing.

### References

1. Markad, S. D.; Karanjule, N. S.; Sharma, T.; Sabharwal, S. G.; Dhavale, D. D. *Bioorg. Med. Chem.* **2006**, *14*, 5535-5539.
2. Van Den Broek, L. A. G. M.; Van den Witzak, Z. J.; Nieforth, K. A. *Carbohydrates in Drug Design*. **1997**, 471-493, Marcel Dekker Inc.

PO 199

SYNTHETIC STRATEGIES FOR THE PREPARATION  
OF BIOACTIVE GLYCOGLYCEROLIPIDS

Emiliano Manzo,<sup>1</sup> Maria Letizia Ciavatta,<sup>1</sup> Annabella Tramice,<sup>1</sup> Genoveffa Nuzzo,<sup>2</sup>  
and Angelo Fontana.<sup>1</sup>

<sup>1</sup>*Institute of Biomolecular Chemistry (National Council of Research), via campi flegrei 3-80078,  
Pozzuoli (Naples-Italy)*

<sup>2</sup>*Universita' degli Studi di Salerno, via Ponte Don Melillo 84084, Fisciano (Salerno-Italy)  
emanzo@icb.cnr.it*

Glycolipids, carbohydrate-attached lipids, are membrane components and are present in all the living organisms kingdoms, i.e. bacteria, plants and animals. In all these organisms, they have important roles as energy source and markers for the cellular recognition and communication. Structurally they can be divided in different families like glycoacylglycerolipids, with acylated glycerol attached to the carbohydrate part, glycosphingolipids with an acylated sphingosine (ceramide) and isoprenoid glycosides, with a terpene alcohol as aglycon. All this kind of molecules are characterized by very important biological activities.<sup>1,2</sup> In particular there is a big interest in both intracellular and extracellular glycolipids, especially galactosyl glycolipids as antitumour promoters in cancer chemoprevention.<sup>3</sup> The possibility to get from nature these active molecules is limited by the difficulty of their isolation and purification and by their very small amounts. For this reason the chemical synthesis could represent a good choice to overcome their scarce natural availability. In this frame, the chemoenzymatic synthetic strategies could give an important help for this purpose, by glycosidases enzymes useful for the stereoselective synthesis of  $\alpha$  or  $\beta$  glycosidic linkages.

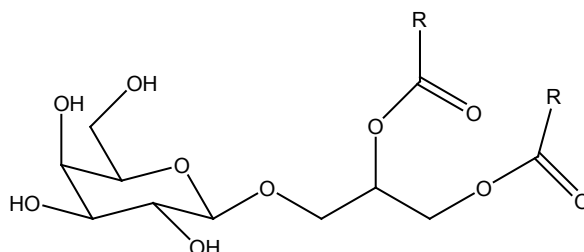
**References**

1. Oshida, Y., Yamada, S., Matsunaga, K., Moriya, T., Ohizumi, Y., *J. Nat. Prod.*, **1994**, 57(4), 534-536.
2. Nakato, K., Guo, C-T, Matsufuji, M., Yoshimoto, A., Inagaki, M., Higuchi, R., Suzuki, Y., *J. Biochem.*, **2000**, 127, 191-198.
3. Colombo, D., Scala, A., Taiano, I.M., Toma, L., Ronchetti, F., Tokuda, H., Nishino, H., Sakakibara, J., *Bioorg. Med. Chem. Lett.*, **1996**, 6, 1187-1190.

## PO 200

**ANALYSIS OF THE BINDING OF THE LPS-SPECIFIC MONOCLONAL ANTIBODY MAB 5D8 TO ISOLATED O-POLYSACCHARIDE FROM *BURKHOLDERIA ANTHINA***

R. Marchetti, R. Lanzetta, M. Parrilli, A. Molinaro, A. Silipo

*Dipartimento di Chimica Organica e Biochimica, Università di Napoli "Federico II",  
Complesso Universitario Monte S. Angelo, Via Cintia 4, 80126 Napoli.  
roberta.marchetti@unina.it*

The glycans have fundamental roles in the development and function of all living organism. In *in vivo*, glycoconjugates cover cell surfaces often providing the first point of contact for host pathogen interactions. Carbohydrate-binding proteins on the pathogen surface target specific host glycans facilitating infection by both viruses and bacteria. On another front, polysaccharide chains present on the surface of many bacteria are among the first antigens presented to the host immune system; therefore, glycans and carbohydrate-binding proteins present numerous opportunities for therapeutic development and bacterial surface polysaccharides can be employed in anti-bacterial vaccines.

Computational methods and, in particular, molecular dynamics simulation provide complementary tools to argument NMR (Nuclear Magnetic Resonance) data in order to characterize the structure and dynamics of glycans and protein-carbohydrate interactions<sup>[1]</sup>. By this approach, we analyzed the binding between a LPS-specific monoclonal antibody, designated 5D8, and the O-polysaccharide chain isolated from the LPS (lipopolysaccharide) of a Gram negative bacterium, *Burkholderia anthina*, that is an uncommon pathogen of cystic fibrosis patients<sup>[2]</sup>. It is known that the LPS are endotoxins intercalated into the outer membrane of Gram negative organisms, essential for bacterial survival and defined as one of the most important virulence factor of the infections affecting cystic fibrosis patients. In order to fully describe, at molecular level, this system of interaction, at first we extracted LPS from a clinical isolate strain of *Burkholderia anthina* and performed a structural and conformational analysis of its polysaccharide region. Then we performed specific NMR experiments; first of all the STD NMR (Saturation Transfer Difference<sup>3</sup>), to deeply characterize the binding and perform an epitope mapping defining which region of the ligand contributes more to the binding to the antibody.

**References**

1. Fadda, E.; Woods, R.J. *Drug Discovery Today*, 2010. **15**: 596-609.
2. AuCoin, D.P. et al. *Journal of Medical Microbiology*, 2010. **59**: 41-47.
3. Johnson, MA; Pinto, BM. *Bioorg Med Chem.*, 2004 **12**: 295-300.

## PO 201

**PROTEIN-PEPTIDOGLYCAN INTERACTIONS AS KEY PHENOMENON  
OF GERMINATION OF DORMANT BACTERIAL SPORES**

<sup>1</sup>Roberta Marchetti, <sup>2</sup>Flavia Squeglia, <sup>1</sup>Rosa Lanzetta, <sup>1</sup>Michelangelo Parrilli, <sup>2</sup>Rita Berisio,  
<sup>1</sup>Alba Silipo, <sup>1</sup>Antonio Molinaro.

<sup>1</sup>*Dipartimento di Chimica Organica e Biochimica, Università di Napoli "Federico II",  
Complesso Universitario Monte S. Angelo, Via Cintia 4, 80126 Napoli*

<sup>2</sup>*Institute of Biostructures and Bioimaging, CNR, Via Mezzocannone 16.  
I-80134 – Napoli, Italy,  
roberta.marchetti@unina.it*

The interactions between proteins and glycans (oligo- and polysaccharides) are involved in important biological processes such as recognition of antigenic carbohydrates on the bacterial cell surface by antibodies or initiation of inflammatory response. Understanding of molecular recognition events in protein-carbohydrate systems is pivotal for the elucidation, at molecular level, of the events involved at the heart of biological phenomena and drug discovery process.

Nuclear Magnetic Resonance (NMR) spectroscopy is a powerful method for studying protein-ligand interactions in solution. Two techniques<sup>[1]</sup>, Saturation Transfer Difference (STD) NMR and Transferred NOE, together provide a picture of ligand binding to a receptor.

By this approach we analyzed the interaction between peptidoglycan (PGN) fragments of bacterial cell wall, named muropeptides, and an eukaryotic-like Ser/Thr membrane kinase, characteristic of Gram positive bacteria. This protein contains an extracellular domain, named PASTA, capable of binding the muropeptides of PGN DAP(*meso*-diaminopimelic acid)-type released into extracellular milieu during bacterial growth <sup>[2]</sup>. The recognition PASTA-peptidoglycan is the trigger of the germination of dormant bacterial spores because it represents a signal of favorable environmental conditions.

In order to fully describe, at molecular level, this system of interaction we performed NMR experiments on the extracellular domain of kinases from two different Gram positive bacteria, *Bacillus subtilis* and *Staphylococcus aureus*, using as ligands monomeric and dimeric muropeptides deriving from the PGN DAP-type.

**References**

1. Vogtherr, M.; Peters, T. *Angew. Chem. Int. Ed.* **2003**, 42, 864.
2. Shah, I.M.; Laaberki, M.H.; Popham, D.L.; Dworkin, J. *Cell.* **2008**, 135, 486.

## PO 202

## STEREOSELECTIVE TANDEM EPOXIDATION-GLYCOSYLATION OF GLYCALs

Irene Marín, Javier Castilla, M. Isabel Matheu, Yolanda Díaz,\* Sergio Castellón\*

Departament de Química Analítica i Química Orgànica, Universitat Rovira i Virgili,  
C/ Marcel·lí Domingo s/n, 43007 Tarragona, Spain  
irene.marin@urv.cat

Carbohydrates continue to be a focus of research both in chemistry and biology because they play a critical role in a variety of biochemical processes [1]. Glycals are employed in the assembly of oligosaccharides and other glycoconjugates. By the pioneering research of Lemieux [2] and Thiem [3], glycals are known to act as glycosyl donors, being activated by a variety of electrophilic reagents (for instance through epoxidation, azidonitration, sulfonamidoglycosylation or Ferrier rearrangement) [4].

Epoxidation provides valuable capabilities for the conversion of glycals **1** to common glycosides **3** used in the synthesis of glycoconjugates (Scheme 1). Danishefsky [4a] developed a convenient method for the direct preparation of 1,2-anhydrosugars **2** from glycals using 3,3-dimethyldioxirane (DMDO) as an effective epoxidation reagent. Therefore, its replacement by safer and more stable oxidants, particularly for large-scale preparations, is a valuable task.

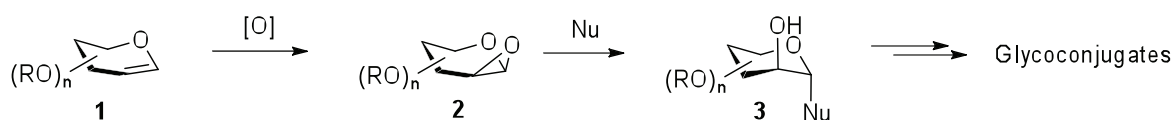

Scheme 1

In this context, we present the study of new epoxidation-alcoholysis methods for the synthesis of  $\alpha$ - and  $\beta$ - epoxides through catalytic molybdenum systems and/or stoichiometric oxidant reagents as *m*-chloroperbenzoic acid (MCPBA). Moreover we show the usefulness of the direct tandem epoxidation-glycosylation procedure developed by the straightforward synthesis of the orthogonally protected *manno* glycosyl donors (useful synthons in the synthesis of complex oligosaccharides).

## References

1. Varki, A. *Glycobiology* **1993**, 3, 97-130.
2. Lemieux, R. U.; Levine, S. *Can. J. Chem.* **1964**, 42, 1473-1480.
3. Thiem, J.; Karl, H.; Schwentner, J. *Synthesis* **1978**, 696-698.
4. a) Danishefsky, S. J.; Halcomb, R. L. *J. Am. Chem. Soc.* **1989**, 111, 6661-6666. b) Seeberger, P. H.; Bilodeau, M. T.; Danishefsky, S. J. *Aldrichimica Acta* **1997**, 30, 75-92. c) Ferrier, R. J.; Prasad, N. *J. Chem. Soc. C* **1969**, 570-575.



## PO 203

## SYNTHESIS AND INVESTIGATION OF GLYCOPEPTIDE COATED CARBON NANOTUBES FOR TUMOUR SPECIFIC DRUG DELIVERY

Lyn Markey<sup>1,2</sup>, Kevin Flavin<sup>1,2</sup>, Eoin M. Scanlan<sup>1</sup>, Silvia Giordani<sup>1,2</sup><sup>1</sup>School of Chemistry, Trinity College Dublin, Dublin 2, Ireland<sup>2</sup>CRANN, Trinity College Dublin, Dublin 2, Ireland

lmarkey@tcd.ie, eoin.scanlan@tcd.ie

It has been demonstrated that  $\alpha$ -helical peptides self assemble on the surface of carbon nanotubes to form a 'biolayer' that significantly alter the properties of the nanotubes<sup>1</sup>. Functionalised nanomaterials offer significant potential for the development of a wide range of biological applications including drug delivery and biosensors. A novel, convergent strategy for the synthesis of glycopeptides has been developed and a number of synthetic glycopeptides have been prepared. This strategy uses an iterative approach to functionalised peptides combining Native Chemical Ligation with Thiolene Click chemistry<sup>2</sup> (NCL-TEC). By carrying out a number of NCL-TEC cycles, glycopeptides of suitable length for self assembly on nanomaterials can be obtained. The functionalisation of nanomaterials with glycopeptides using both covalent and noncovalent interactions is currently under investigation.

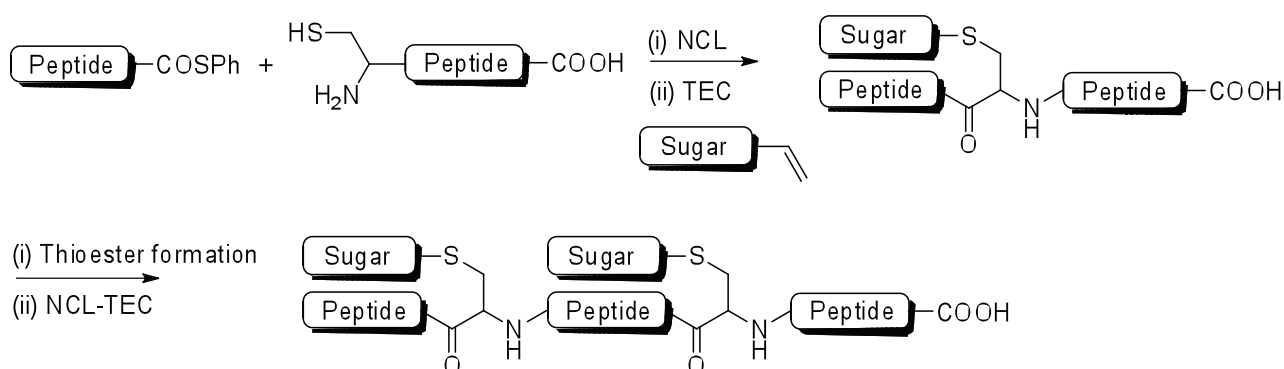

Glycopeptide synthesis for self assembly on nanomaterials

## References

1. G. R. Dieckmann, A. B. Dalton, P. A. Johnson, J. Razal, J. Chen, G. M. Giordano, E. Muñoz, I. H. Musselman, R. H. Baughman, R. K. Draper, *J. Am. Chem Soc.* **2003**, *125*, 1770-1777.
2. M. Lo Conte, S. Pacifico, A. Chambery, A. Marra and A. Dondoni, *J. Org. Chem.* **2010**, *75*, 4644-4647.

## PO 204

**GOLD NANOPARTICLES COATED WITH HIGH MANNOSE-TYPE OLIGOSACCHARIDES MIMIC THE GLYCOSYLATED OUTER DOMAIN OF HIV**

Marco Marradi,<sup>1,2</sup> Paolo Di Gianvincenzo,<sup>1</sup> Pedro M. Enríquez-Navas,<sup>1</sup> Olga M. Martínez-Ávila,<sup>1</sup> Fabrizio Chiodo,<sup>1</sup> Eloísa Yuste,<sup>3,4</sup> Jesús Angulo,<sup>5</sup> and Soledad Penadés<sup>1,2</sup>

<sup>1</sup>Laboratory of GlycoNanotechnology, Biofunctional Nanomaterials Unit, CIC biomaGUNE

<sup>2</sup>Biomedical Research Networking Center in Bioengineering, Biomaterials and Nanomedicine (CIBER-BBN), Paseo Miramón 182, E-20009 San Sebastián, Spain;

<sup>3</sup>Retrovirology and Viral Immunopathology Laboratory, IDIBAPS, Hospital Clínic, University of Barcelona,

<sup>4</sup>HIVACAT, Hospital Clínic, Faculty of Medicine, University of Barcelona, Barcelona, Spain;

<sup>5</sup>Department of Bioorganic Chemistry, Instituto de Investigaciones Químicas (CSIC – US), Américo Vespucio 49, E-41092, Sevilla, Spain  
mmarradi.ciber-bbn@cicbiomagune.es

Human antibody 2G12 neutralises a broad range of HIV-1 isolates and its epitope is a cluster of high mannose glycans on the viral envelope glycoprotein gp120. [1] These glycans have been thus envisaged as a target to develop an HIV vaccine capable to elicit 2G12-like antibodies. [2] Gold nanoparticles coated with self-assembled monolayers of synthetic oligomannosides which are present on gp120 (*manno*-GNPs) [3] are able to bind 2G12 with high affinity and to interfere with the 2G12/gp120 binding as determined by surface plasmon resonance (SPR) and saturation transfer difference NMR spectroscopy (STD-NMR). Cellular neutralization assays demonstrates that GNPs coated with a linear tetramannoside block the 2G12-mediated neutralization of HIV-1 infection of target cells. The opportunity of inserting onto the same nanoparticle more than one component makes *manno*-GNPs versatile, polyvalent and multifunctional chemical tools which may help to develop new strategies against HIV.

**References**

1. C. N. Scanlan et al., *J. Virol.*, **2002**, 76, 7306-7321.
2. A.Pashov, M. Perry, M. Dyar, M. Chow, T. Kieber-Emmons, *Curr. Pharm. Des.* **2007**, 13, 185-201.
3. O. Martínez-Ávila, K. Hijazi, M. Marradi, C. Clavel, C. Campion, C.Kelly, S. Penadés, *Chem. Eur. J.* **2009**, 15, 9874-9888.

PO 205

**COMPUTATIONAL STUDY OF THE ACTIVITY AND MECHANISM  
OF GLICOSYLTRANSFERASES**Hansel Gómez,<sup>1</sup> José M. Lluch<sup>1,2</sup> and Laura Masgrau<sup>\*1</sup><sup>1</sup> *Institut de Biotecnologia i de Biomedicina,*<sup>2</sup> *Departament de Química,**Universitat Autònoma de Barcelona, Spain**Laura.Masgrau@uab.cat*

Glycosyltransferases (GTs) are responsible for the biosynthesis of glycans, a large group of molecules involved in a variety of biological processes and functions. As a result, GTs are studied in many chemical, biomedical and biotechnological applications.

In the last years there has been an important increase in the knowledge of GTs, but the molecular basis of their specificity and their reaction mechanism are still not completely understood. All together make the study of GTs a very attractive (and challenging) research topic for a (“young”) computational scientist.

We are now starting a research line on the molecular modelling of GTs activity. The group has a good expertise in the computational study of chemical and biochemical reactions, and we are now combining a range of computational techniques (including hybrid quantum mechanical molecular mechanics methods, molecular dynamics simulations, and free energy calculations) to study GTs mechanism. The aim is to help defining their reaction mechanism, analyse the main factors contributing to catalysis and understand at the atomic level the basis of their specificity. The mid-term goal will be to provide valuable information for both, the design of inhibitors and protein/substrate engineering. In this poster we will present an overview of the work carried out so far.

## PO 206

SYNTHESIS OF 1,2-DIIMIDO-GLYCOSIDES AS VANADIUM(IV)LIGANDS  
AND THEIR APPLICATION AS CATALYSTS IN THE ENANTIOSELECTIVE  
SYNTHESIS OF CYANOHYDRINESThomas Mathieu<sup>1</sup>, Horst Kunz<sup>1</sup>

<sup>1</sup>Institute of Organic Chemistry, Johannes Gutenberg-University Mainz,  
Duesbergweg 10-14, 55128 Mainz, Germany  
mathth00@uni-mainz.de

Carbohydrates are very versatile chiral molecules that can be employed as auxiliaries such as glycosylamines in the stereoselective synthesis of organic compounds.<sup>1</sup> The only lack of this method is that equimolar amounts of the auxiliary are needed. For this reason it appears attractive to use carbohydrates with their well defined chiral surrounding as catalysts.

Inspired by the vanadium catalyst of *Belokon et al.*<sup>2</sup> which catalyzes the addition of trimethylsilyl cyanide to aldehydes the *trans*-1,2-diamino-cyclohexane structure of the catalyst has been replaced by carbohydrate derivatives (figure 1).

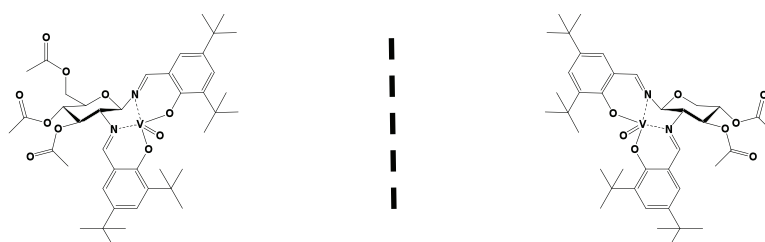

**Figure 1:** Pseudo-enantiomeric vanadium(IV)-complexes for enantioselective synthesis of cyanohydrines

As starting material for the synthesis of the 1,2-diimido-glycoside D-glucosamine was used and converted into the glycosyl azide. After a few conversions the vanadium complex can be achieved by refluxing the salen like diimine with vanadium oxysulfate in THF/EtOH.<sup>2</sup>

To ensure the synthesis of both cyanohydrine enantiomers the L-1,2-diimido-xylose derivative as the pseudoenantiomere of the D-1,2-diimido-glucose structure was also synthesized. Therefore, D-1-azido-arabinose was converted into the 2,3-epoxy derivative which gives the D-1,2-diazido-arabinose unit after an optimized ring opening.<sup>3</sup> After further steps the desired vanadium complex including the L-1,2-diimidoxylose unit was obtained.

Both vanadium complexes show high activity in the enantioselective addition of trimethylsilyl cyanide to aldehydes which will be presented besides the detailed synthesis of the carbohydrate catalysts.

### References

1. H. Kunz, W. Sager, *Angew. Chem.*, **1987**, 99, 595-597.
2. Y. N. Belokon, M. North, T. Parsons, *Org. Lett.*, **2000**, 2, 1617-1619.
3. V. Popsavin, G. Benedekovic, M. Popsavin, B. Sreco, D. Djokovic, *Carbohydr. Res.*, **2005**, 240, 1866-1871.

## PO 207

SYNTHESIS AND X-RAY CRYSTALLOGRAPHIC STUDY OF *N*-( $\beta$ -GLYOSYL)ALKANAMIDES: ANALOGS OF THE CONSERVED CHITOBIOSYLASPARAGINE LINKAGE IN *N*-GLYCOPROTEINS

Manoharan Mathiselvam and Duraikkannu Loganathan\*

Department of Chemistry, Indian Institute of Technology Madras, Chennai, 600036, India  
 loganath@iitm.ac.in

Glycoprotein glycans serve as key recognition determinants in many biological processes and are also known to influence protein folding.<sup>1</sup> The linkage region constituents, 2-acetamido-2-deoxy- $\beta$ -D-glucopyranose (GlcNAc) and L-asparagine (Asn), are conserved in all eukaryotic *N*-glycoproteins. Since dynamics of the GlcNAc-Asn linkage can often influence the presentation of the glycan chain on the membrane surface of cells, elucidation of the structure and conformation of glycoprotein linkage region is of fundamental importance.

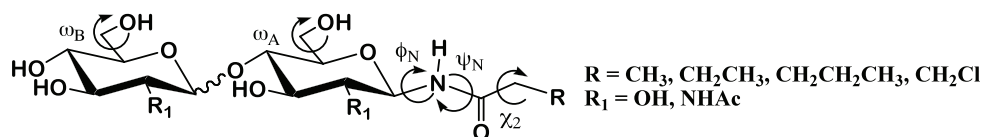

A major program of our laboratory is aimed at understanding the structural significance of the conserved *N*-glycoprotein linkage region. X-ray crystallographic study of several  $\beta$ -1-*N*-alkanamido derivatives of monosaccharides has shown that the *N*-glycosidic torsion,  $\phi_N$ , is influenced to a greater extent by the structural variation of the sugar part than that of the aglycon moiety.<sup>2</sup> The variation in  $\phi_N$  among these models and analogs is possibly due to the differences in the molecular assembly, influenced by intra- and intermolecular interactions involving regular hydrogen bonds and weak C-H...O contacts.<sup>2,3,4</sup>

In continuation of the above mentioned program, the present work was undertaken to explore the effect of distal sugar structure on  $\phi_N$ . To accomplish this objective, several disaccharide alkanamides, derived from chitobiose, cellobiose and maltose, have been synthesized by selective *N*-acylation of  $\beta$ -D-glycosylamine. Comparative analysis of their crystal structures with those reported for GlcNAc $\beta$ Asn has shed new light on the factors governing their conformation and molecular packing. Details of their synthesis and detailed structural investigation will be presented.

## References

1. Varki, A., *Glycobiology* **1993**, 3, 97-130.
2. Lakshmanan, T.; Sriram, D.; Priya, K.; Loganathan, D. *Biochem. Biophys. Res. Commun.* **2003**, 312, 405-13.
3. (a) Loganathan, D.; Aich, U. *Glycobiology* **2006**, 16, 343. (b) Mohamed Naseer Ali, M.; Aich, U.; Varghese, B.; Pérez, S.; Imberty, A.; Loganathan, D. *Carbohydr. Res.* **2009**, 344, 355-361.
4. Mohamed Naseer Ali, M.; Aich, U.; Varghese, B.; Pérez, S.; Imberty, A.; Loganathan, D. *J. Am. Chem. Soc.* **2008**, 130, 8317-8325.

## PO 208

## SYNTHESIS AND SELF-ASSEMBLED BEHAVIOR OF C-GLYCOSIDES

Sho Matsuda and Toshiyuki Inazu

Department of Applied Chemistry, School of Engineering, Tokai University;  
 Institute of Glycoscience, Tokai University,  
 4-1-1 Kitakaname, Hiratsuka, Kanagawa, 259-1292, Japan  
 inz@keyaki.cc.u-tokai.ac.jp

Amphiphilic molecule possesses antagonistic hydrophilic and hydrophobic moieties in the same molecule. These molecules are formed capsule-like aggregates, such as micell, vesicle, cylindrical micell, and so on. Recently, amphiphilic glycosides are often used glyco-cluster tool for carbohydrate-protein interaction analyses [1,2]. The synthesis of self-assembled mannoside derivatives and the interaction analysis of between these mannosides and Con A were reported. However, aglycon of these mannosides were composed of unusual functions such as, tetra(*p*-phenylene) and oligo(ethylene oxide) groups.

In this study, we designed and synthesized self-assembled artificial C-glycosides having simple structures, and evaluated their self-assembled behavior. C-Glycosides not only are of interest as stable mimics of natural O-glycosides, but also receive much attention from biological and synthetic standpoints.

We synthesized octyl, dodecyl, benzyl  $\beta$ -C-glucopyranosides, and benzyl  $\beta$ -C-mannopyranoside from glucono-1,5-lactone or manno-1,5-lactone derivatives. Next, we investigated self-assembled behaviors of alkyl  $\beta$ -C-glycopyranosides using dynamic light scattering (DLS) studies, atomic force spectroscopy (AFM) experiments, and transmission electron spectroscopy (TEM) experiments. The aggregate size of a solution of octyl  $\beta$ -C-glucopyranoside (**1**, 400 mM) was observed approximately 10-30 nm by the DLS in 2-propanol/H<sub>2</sub>O (1:3). A solution of **1** (400 mM) in 2-propanol/H<sub>2</sub>O (1:3) was deposited on a micro cover glass. The image by AFM tapping mode is shown in Fig. 1B. Some aggregates, which had diameter of 30-50 nm, were observed. The same C-glycoside solution described above was placed on carbon grids and stained with an aqueous solution of 1 wt % of RuO<sub>4</sub> at room temperature for 10 min. Fig. 1C shows the high resolution TEM image. We observed some circular aggregates, which had diameter of 30-50 nm, as similar to those seen in the AFM image. From these results, we speculated that the nanostructure of these glycosides might be vesicle as shown in Fig. 1A.

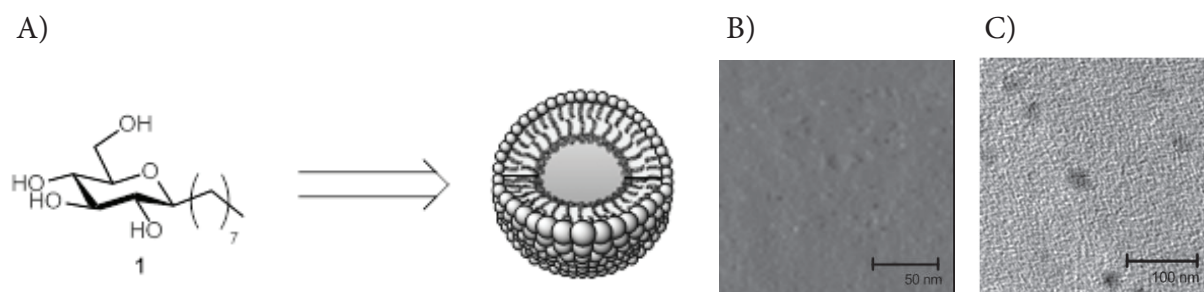

Fig. 1 AFM and TEM images of self-assembled formation of octyl  $\beta$ -C-glucopyranoside

## References

1. B. -S. Kim, D. -J. Hong, J. Bae, M. Lee, *J. Am. Chem. Soc.*, **2005**, *127*, 16333-16337.
2. B. -S. Kim, W. -Y. Yang, J. -H. Ryu, Y. -S. Yoo, M. Lee, *Chem. Commun.*, **2005**, 2035-2037.



## PO 209

**ORIENTED MUC1 GLYCOPEPTIDE MICROARRAY TOWARD EXPLORING DISEASE-SPECIFIC EPITOPES**

Takahiko Matsushita,<sup>1</sup> Wataru Takada,<sup>2</sup> Hiroshi Hinou,<sup>1</sup> and Shin-Ichiro Nishimura<sup>1</sup>

<sup>1</sup> Graduate School of Advanced Life Science, Hokkaido University, Sapporo, 001-0021, Japan,

<sup>2</sup>Sumitomo Bakelite Co. Ltd., Kobe 651-2241, Japan

*t-matsushita@glyco.sci.hokudai.ac.jp*

MUC1 is a highly glycosylated membrane-bound glycoprotein distributing on the apical surface of normal epithelial cells. In tumor cells, aberrantly *O*-glycosylated MUC1 is overexpressed on the whole-cell surface, which is due to MUC1 shedding or cell surface release to bloodstream. Therefore, MUC1 is considered an attractive target as serum tumor biomarker. Development of disease-specific biomarkers and monoclonal antibodies for early detection and diagnosis of cancers requires new strategies for characterization of epitopes based on carbohydrate moiety of glycoprotein. Recently, we have revealed the MUC1 heptapeptide PDTRPAP having  $\alpha$ 2,3-sialylated T antigen at Thr residue as an essential epitope of anti-KL-6 monoclonal antibody, which is a beneficial tool for diagnosis and monitoring patients with interstitial pneumonia, by focused MUC1 glycopeptide library and common ELISA protocol. [1]

Here we present a novel MUC1 glycopeptide microarray based on our polymer blotting method [2] for facile and oriented immobilization of MUC1 glycopeptides toward high-throughput exploring of disease-specific epitopes recognized by antibodies against abnormal glycoproteins. Our fabricated microarray plastic slides have the surface coated by aminoxy-functionalized polymer. Aminoxy groups allow glycopeptide library introduced 5-oxohexanoic acid at *N*-terminus in the end of solid-phase synthesis to display *via* oxime bond formation in mild acidic aqueous condition. In addition, the surface is effectively designed to limit non-specific binding for reduction of background noise in detection of antibody binding. The results of epitope identification by utilizing our developing microarray displayed overlapping MUC1 tandem repeat peptides and glycopeptide library focused on the site and structure in *O*-glycosylation will be discussed.

**References**

1. N. Ohyabu, H. Hinou, T. Matsushita, R. Izumi, H. Shimizu, K. Kawamoto, Y. Numata, H. To-game, H. Takemoto, H. Kondo, S.-I. Nishimura, *J. Am. Chem. Soc.*, **2009**, *131*, 17102–17109.
2. M. Fumoto, H. Hinou, T. Ohta, T. Ito, K. Yamada, A. Takimoto, H. Kondo, H. Shimizu, T. Inazu, Y. Nakahara, S.-I. Nishimura, *J. Am. Chem. Soc.*, **2005**, *127*, 11804–11818.

PO 210

MULTIVALENT NEOGLYCOCONJUGATES BASED ON ALKOXYAMINES  
AND *CLICK* CHEMISTRY

Elisa Martínez-Castro, Óscar López, Inés Maya and José G. Fernández-Bolaños

*Departamento de Química Orgánica, Universidad de Sevilla, Apto. 1203,  
E-41071 Seville, SPAIN  
imaya@us.es*

Carbohydrates are implicated in biological processes involving cell-cell recognition, cell-protein interactions, and are the targets of hormones, antibodies, and toxins.<sup>1</sup> In these processes, multivalent interactions are involved,<sup>2</sup> and a variety of neoglycoconjugates have been synthesized to understand the multivalent lectin-carbohydrate interactions.<sup>3</sup>

Multivalent neoglycoconjugates usually comprise a core molecule that serve as a scaffold for the linking of sugar molecules giving rise to chemically well-defined molecules such as glycoclusters,<sup>4</sup> glycodendrimers,<sup>5</sup> glycocyclodextrins,<sup>6</sup> glycolixarenes.<sup>7</sup>

We describe the synthesis of new neoglycoconjugated using glycosylated alkoxyamines<sup>8</sup> with mono and disaccharides linked to the sugar core through a 1,2,3-triazole moiety and different spacers.

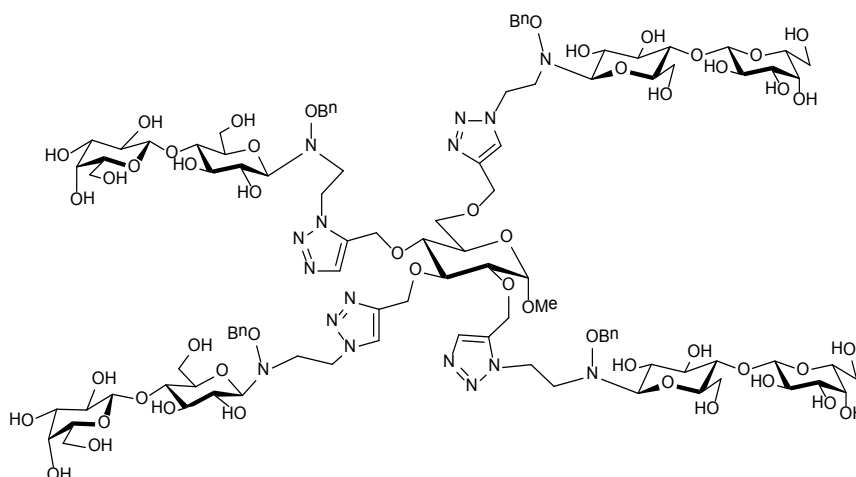

We acknowledge the Dirección General de Investigación of Spain (CTQ2008 02813) and Junta de Andalucía (FQM 134) for financial support.

### References

1. R. A. Dwek, *Chem. Rev.*, **1996**, 96, 683-720.
2. J. J. Lundquist, E. J. Toone, *Chem. Rev.*, **2002**, 102, 555-578.
3. S. K. Choi, in *Synthetic multivalent molecules: Concept and biomedical applications*, Wiley, USA, 2005.
4. M. Ortega-Muñoz, F. Pérez-Balderas, J. Morales-Sanfrutos, F. Hernandez-Mateo, J. Isac-García, F. Santoyo-González, *Eur. J. Org. Chem.*, **2009**, 2454-2473.
5. R. Roy, *Trends Glycosci. Glycotechnol.*, **2003**, 15, 291-310.
6. A. Vargas-Berenguel, F. Ortega-Caballero, J. M. Casas-Solvas, *Mini-Rev. Org. Chem.*, **2007**, 4, 1-14.
7. D. A. Fulton, J. F. Stoddart, *Bioconjugate Chem.*, **2001**, 12, 655-672.
8. F. Nicotra, L. Cipolla, F. Peri, B. La Ferla, C. Redaelli, *Adv. Carbohydr. Chem. Biochem.*, **2008**, 61, 353-398.

## PO 211

**PROTEIN DEGLYCOSYLATION MIX FOR REMOVING N-LINKED  
AND O-LINKED GLYCANS FROM GLYCOPROTEINS**

Alicia M. Bielick, Paula Magnelli, Beth McLeod and Ellen P. Guthrie

*New England Biolabs, Ipswich, MA 01938, USA*

Both chemical and enzymatic methods exist for removing oligosaccharides from glycoproteins. However, chemical methods such as  $\beta$ -elimination with mild alkali or mild hydrazinolysis can be harsh and may result in incomplete sugar removal and degradation of the protein, whereas enzymatic methods are much gentler and can provide complete sugar removal with no protein degradation.

PNGase F is the most effective enzymatic method for removing almost all *N*-linked oligosaccharides from glycoproteins. PNGase F digestion deaminates the asparagine residue to aspartic acid, and leaves the oligosaccharide intact and suitable for further analysis. Oligosaccharides containing a fucose  $\alpha(1-3)$ -linked to the glycan core, a modification found on plant and insect glycoproteins, are resistant to PNGase F. Steric hindrance can sometimes slow or inhibit the action of PNGase F on certain residues of glycoproteins, therefore denaturation by heating with SDS and DTT can greatly increase the rate of deglycosylation.

To remove *O*-linked glycans, monosaccharides must be removed by a series of exoglycosidases until only the Gal $\beta$ 1-3GalNAc (core 1) and/or the GlcNAc $\beta$ 1-3GalNAc (core 3) cores remain attached to the serine or threonine. The *Enterococcus faecalis* Endo- $\alpha$ -*N*-Acetylgalactosaminidase, also called *O*-Glycosidase, can then remove these core structures if there are no further modifications of the serine or threonine residues. Any modification of the core structures, including sialylation, will block the action of the *O*-Glycosidase. Sialic acid residues are easily removed by a general  $\alpha$ 2-3,6,8 Neuraminidase. In addition, exoglycosidases such as  $\beta(1-4)$ Galactosidase and  $\beta$ -*N*-Acetylglucosaminidase can be included in deglycosylation reactions to remove other complex modifications often known to be present on the core structures.

Here we describe a method that facilitates removal of *O* and *N*-linked glycans by combining PNGase F, *O*-Glycosidase, Neuraminidase,  $\beta$ -*N*-Acetylglucosaminidase and  $\beta(1-4)$ Galactosidase in a single mix. We have used this method to remove glycans from both bovine fetuin and human chorionic gonadotropin (hCG). The treatment of these particular glycoproteins affects their electrophoretic mobility allowing us to analyze the efficiency of the reactions by SDS-PAGE.

## PO 212

**IDENTIFICATION OF NOVEL ANTIGENIC CARBOHYDRATES FROM THE HUMAN BLOOD FLUKE, *SCHISTOSOMA JAPONICUM***

Hamish E.G. McWilliam<sup>1</sup>, David Piedrafita<sup>1</sup>, Patrick Driguez<sup>2</sup>, Brian B. Haab<sup>3</sup>, Kevin A. Maupin<sup>3</sup>, Donald P. McManus<sup>2</sup>, and Els N.T. Meeusen<sup>1</sup>

<sup>1</sup> School of Biological Sciences, Monash University, Melbourne, Australia;

<sup>2</sup> Queensland Institute of Medical Research, Brisbane, Australia.

<sup>3</sup> Van Andel Research Institute, Grand Rapids, Michigan, United States of America  
hamish.mcwilliam@monash.edu

Schistosomiasis, caused by the human blood flukes (schistosomes), has a serious health impact in the developing world, with over 200 million people infected. The only available treatment, praziquantel, has a short efficacy period and requires repeated treatment, making this control method impractical. An anti-schistosome vaccine would contribute significantly to the effective control of this parasite, however, despite numerous attempts no vaccine is currently available. During schistosomiasis, the majority of the antibody response is directed towards carbohydrate epitopes which decorate the surface and secreted components of the parasite; therefore these antigenic glycans are considered to be potential vaccine targets<sup>1</sup>, particularly in light of recent advances in carbohydrate vaccine development<sup>2</sup>. While significant steps have been taken to elucidate the structures of schistosome glycans, it is likely that novel and promising glycans remain undiscovered. Additionally, the larval stage which migrates through the lung is a prime target of immunity in schistosomiasis, and knowledge of antigenic carbohydrates specific to this developmental stage is scarce. To identify novel larval glycan epitopes, we have probed the glycan array from the Consortium for Functional Glycomics (CA, USA) using antibodies generated against migrating *S. japonicum* larvae. These antibodies were obtained using a method which isolates the local antibody response from different tissue compartments<sup>3</sup>. Antibodies obtained from the lung revealed several carbohydrate motifs which are recognised specifically, including a terminal O-glycan core 3 motif, among others. The specificity of multiple lung antibody samples against this structure was confirmed by ELISA. We plan to further characterise this motif to determine its expression in schistosome development, in order to assess its potential as a vaccine candidate.

**References**

1. Nyame, A.K., Kwar, Z.S. & Cummings, R.D., *Arch. Biochem. Biophys.*, **2004**, 426, 182-200.
2. Astronomo, R.D. & Burton, D.R., *Nat. Rev. Drug. Discov.*, **2010**, 9, 308-324.
3. Meeusen, E.N. & Brandon, M.R., *J. Immunol. Methods.*, **1994**, 172, 71-76.

PO 213

**SYNTHESIS AND NMR CHARACTERISATION OF METHYL  
(ETHYL 2,3,5-TRI-O-BENZOYL-1-THIO- $\alpha,\beta$ -D-GALACTOFURANOSID)URONATE**

Dirk Michalik,<sup>1,3</sup> Ambar K. Choudhury,<sup>2</sup> Andreas Gottwald,<sup>3</sup> Christian Vogel,<sup>3</sup>  
Nirmolendu Roy<sup>4</sup>

<sup>1</sup>Leibniz Institute for Catalysis, Albert-Einstein-Str. 29a, Rostock 18059, Germany

<sup>2</sup>Sami Laboratories Limited, Bangalore 560058, India

<sup>3</sup>University of Rostock, Department of Chemistry, Rostock 18059, Germany

<sup>4</sup>Department of Biological Chemistry, India Association  
for the Cultivation of Science, Kolkata 700 032, India

dirk.michalik@catalysis.de

Toluene-*p*-sulfonic acid-catalyzed methanolysis of *t*-butyl 1,2:3,4-di-*O*-isopropylidene- $\alpha$ -D-galactopyranuronate (**1**) prepared from 1,2:3,4-di-*O*-isopropylidene- $\alpha$ -D-galactopyranose was re-investigated. In contrast to previous results,<sup>1</sup> besides the  $\beta$ -form of methyl (methyl D-galactofuranosid)uronate (**2**) also the  $\alpha$ -anomer was formed in an anomeric ratio of  $\alpha:\beta = 28:72$ .

Further reactions including acetolysis followed by treatment with ethanethiol gave the thio furanoside (**3**) in an anomeric mixture of  $\alpha:\beta = 15:85$ , which is an important building block for oligosaccharide synthesis. Full structure elucidation was done using 1D and 2D NMR techniques.<sup>2</sup>

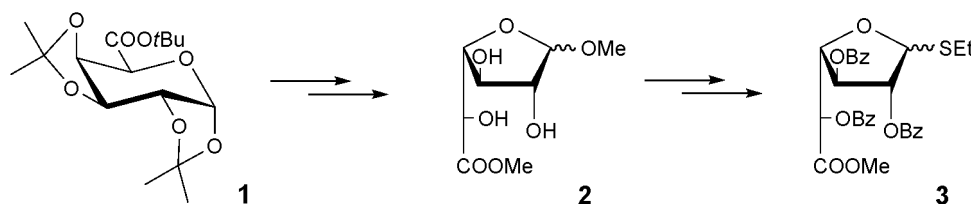
**References**

1. Choudhury A.K., Roy N., *Synlett*, **1997**, 105-106.
2. Choudhury A.K., Michalik D., Gottwald A., Roy N., *Proven Synthetic Methods, Volume 1*, Kovac P. (Ed.), CRC Press, **2011**, in press.

## PO 214

## SYNTHESES OF MALTOOLIGOSACCHARIDES AND MALTOSE-RELATED GLYCOMIMETICS

Supatta Midpanon,<sup>1</sup> Wolfgang Holzer,<sup>2</sup> Helmut Viernstein<sup>1</sup> and Frank M. Unger<sup>1</sup>

<sup>1</sup>Department of Pharmaceutical Technology and Biopharmaceutics and

<sup>2</sup>Department of Pharmaceutical Chemistry, Faculty of Life Sciences, University of Vienna,  
Althanstrasse 14, A-1090 Wien, Austria  
smidpanon@yahoo.com

Conventional protocols have been developed to synthesize maltooligosaccharides. Thus, disaccharide derivative **1** constitutes a flexible intermediate from which disaccharide acceptor **2** or disaccharide donor **3** can be prepared.

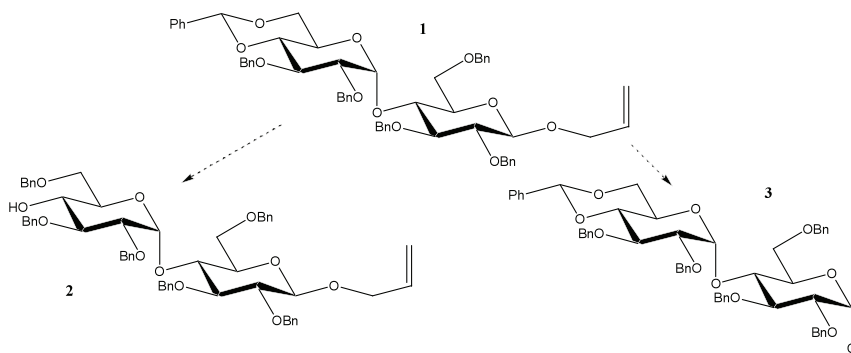

The 2+2 glycosylation of **2** with **3** affords a tetrasaccharide derivative which can in turn be converted into a glycosyl acceptor at the nonreducing and/or into a glycosyl donor at the reducing end. By introduction of modified glucose units into maltose, artificial substrates for enzyme-catalyzed oligomerizations are being produced with the goal of producing artificial maltodextrins and cyclodextrins.

### References

1. Michael P. DeNinno\*, John B. Etienne, and Kimberly C. Duplantier, *Tetrahedron Letters*, **1995**, 36(5), 669-672.
2. Mina Tsuzuki, Tsutomu Tsuchiya \*, *Carbohydrate Research*, **1998**, 311(1-2), 11-24.



PO 215

**SIPROPS – NEW PROTECTING GROUPS FOR CARBOHYDRATE SYNTHESIS**

Hannes Mikula, Christian Hametner, Johannes Fröhlich

*Institute of Applied Synthetic Chemistry, Vienna University of Technology,  
1060 Vienna, Austria  
hannes.mikula@ias.tuwien.ac.at*

A major challenge for the synthesis of natural products, especially oligosaccharides is the selection of a reliable protecting group strategy. Over the years a lot of different types of protecting groups were introduced and applied in syntheses of many complex compounds. Orthogonality and highly selective deprotection conditions are key issues in this field of research. Furthermore semiorthogonal sets of related protecting groups like *p*-halobenzyl ethers (Seeberger et al.<sup>1</sup>) were investigated. These substituted benzyl ethers can be converted to aryl amines via palladium catalyzed amination and finally deprotected under mild Lewis acid conditions. Different rates of reaction in the first step allow for iterative deprotection and make this method also interesting for automated oligosaccharide synthesis.

Inspired by this work we decided to develop a new set of semiorthogonal protecting groups based on an approach by Crich et al., who used propargyl and (1-naphthyl)propargyl ethers for diastereoselective  $\beta$ -mannosyl donors<sup>2,3</sup>.

Different silylated propargyl ethers were therefore prepared and converted to (1-naphthyl)propargyl ethers using optimized sila-Sonogashira conditions (1-naphthyl iodide, Pd(Ph<sub>3</sub>P)<sub>4</sub>, AgCl). By using different bases during this cross coupling reaction iterative deprotection depending on the silyl substituent (TMS, TBDMS, TIPS) was achieved after cleavage of the resulting (1-naphthyl)propargyl ether using DDQ. Combined with a classic Sonogashira coupling for the conversion of propargyl to (1-naphthyl)propargyl ethers, which is also an alternative to the known deprotection procedure for propargyl groups (treatment with base followed by catalytic osmylation), a set of four semiorthogonal protecting groups (silylated propargyl ethers, *SiProps*, fig. 1) was developed and already applied in an exemplary oligosaccharide synthesis.

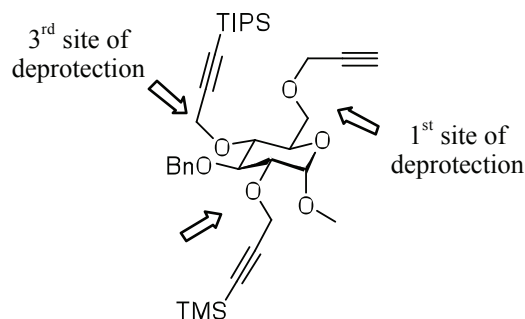

**Figure 1:**  
Semiorthogonal *SiProp*-protected D-glucose

**References**

1. Obadiah J. Plante, Stephen L. Buchwald, Peter H. Seeberger, *J. Am. Chem. Soc.*, **2000**, *122*, 7148-7149.
2. David Crich, Prasanna Jayalath, *Org. Lett.*, **2005**, *7* (11), 2277-2280.
3. David Crich, Baolin Wu, *Org. Lett.*, **2006**, *8* (21), 4879-4882

PO 216

## MODULAR SYNTHESIS OF MULTIVALENT C-GLYCOSIDES AND END-LABELLING

Gavin J. Miller,<sup>1</sup> John M. Gardiner<sup>1</sup>

<sup>1</sup>*School of Chemistry and Manchester Interdisciplinary Biocentre,  
University of Manchester, Manchester, UK  
gardiner@manchester.ac.uk*

A large number of essential biological processes rely on carbohydrate-mediated recognition events at the cell surface,<sup>1</sup> many of which involve multivalent carbohydrate species. Synthetic multivalent carbohydrate architectures thus provide useful tools for studying cluster-glycoside-mediated biological recognition processes.<sup>2</sup> There is particular importance in synthetic access to diverse multivalent carbohydrates with useful functional tethers, providing reagents for conjugation to labelling agents, immobilization and array applications.<sup>3</sup> C-Glycosidic multivalent saccharides provide the potential to generate libraries of stereochemically-defined multivalent mimetics which are hydrolytically and enzymatically stable.<sup>4</sup> A modular approach to the synthesis of a range of trivalent C-glycosidic carbohydrates is described. The multivalent core scaffold, and the C-glycoside subunits bear different length linker units to address a matrix of potential multivalent geometries (Figure 1). The core is functionalized via a succinamide-based, conjugatable linker unit employed for conjugation to different fluorophores and extended thiol-terminated inker units, illustrated by mannosyl examples of the types shown in Scheme 1.

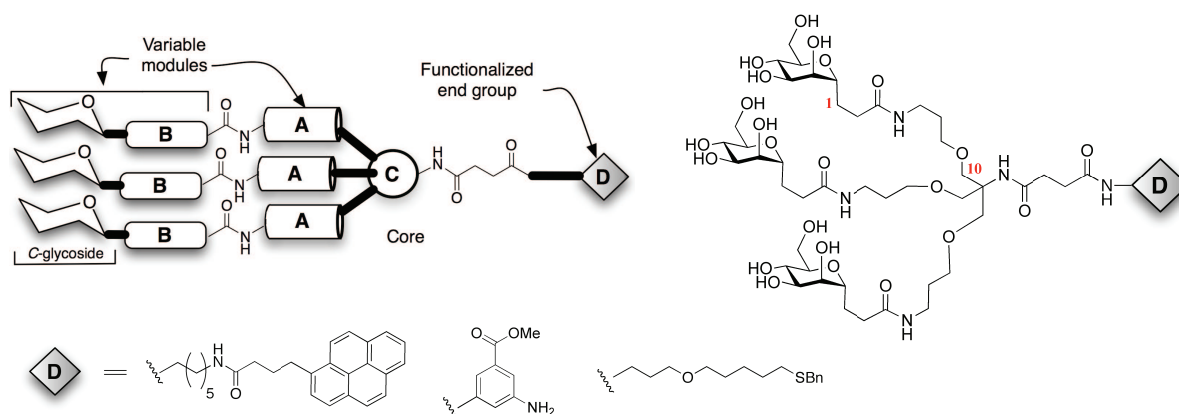

Figure 1

### References

- (a) Pieters, R. J. *Med. Res. Rev.* **2007**, *27*, 796–816. (b) Pieters, R. J. *Org. Biomol. Chem.* **2009**, *7*, 2013–2025.
- (a) Lindhorst, T. K.; Bruegge, K.; Fuchs, A.; Sperling, O. *Beilstein J. Org. Chem.* **2010**, *6*, 801–809. (b) Ortega-Muñoz, M.; Perez-Balderas, F.; Julia Morales-Sanfrutos, J.; Hernandez-Mateo, F.; Isac-Garcia, J.; Santoyo-Gonzalez, F. *Eur. J. Org. Chem.* **2009**, *15*, 2441–2453.
- (a) Pera, N. P.; Branderhorst, H. M.; Kooij, R.; Maierhofer, C.; van der Kaaden, M.; Liskamp, R. M. J.; Wittmann, V.; Ruijtenbeek, R.; Pieters, R. J. *ChemBioChem.* **2010**, *11*, 1896–1904. (b) Lindhorst, T. K.; Märten, M.; Fuchs, A.; Knight, S. D. *Beilstein J. Org. Chem.* **2010**, *6*, 810–822.
- (a) Perez-Balderas, F.; Hernandez-Mateo, F.; Francisco Santoyo-Gonzalez, F. *Tetrahedron* **2005**, *61*, 9338–9348. (b) Alessandro Dondoni, A.; Kleban, M.; Hu, X.; Marra, A.; Banks, H. D. *J. Org. Chem.* **2002**, *67*, 4722–4733.

## PO 217

**MARINE BACTERIAL SIALYLTRANSFERASE: A POWERFUL TOOL FOR ENZYMATIC SYNTHESIS OF VARIOUS SIALYL COMPOUNDS**

Toshiki Mine,<sup>1</sup> Tatsuo Miyazaki,<sup>2</sup> Hitomi Kajiwara,<sup>1\*</sup> Naoya Tateda,<sup>2</sup> Naofumi Kaneko,<sup>2</sup> Katsumi Ajisaka,<sup>2</sup> and Takeshi Yamamoto<sup>1\*\*</sup>

<sup>1</sup>*Glycotechnology Business Unit, Japan Tobacco Inc., 700 Higashibara, Iwata, Shizuoka 438-0802, Japan,*

<sup>2</sup>*Department of Applied Life Sciences, Niigata University of Pharmacy and Applied Life Sciences, 265-1 Higashijima, Akiha-ku, Niigata 956-8603, Japan.*

*Present address: \*Intellectual Property Center, Legal Division, Japan Tobacco Inc., 2-1, Toranomom 2-chome, Minato-ku, Tokyo 105-8422, Japan, \*\*Product Science Division, R&D Group, Tobacco Business Headquarters, Japan Tobacco Inc., 6-2 Umegaoka, Aoba-ku, Yokohama, Kanagawa 227-8512, Japan  
toshiki.mine@jt.com*

Sialyltransferases transfer *N*-acetylneuraminic acid (Neu5Ac) from the common donor substrate of these enzymes, cytidine 5'-monophospho-*N*-acetylneuraminic acid (CMP-Neu5Ac), to acceptor substrates. The enzymatic reaction products including sialyl-glycoproteins, sialyl-glycolipids and sialyl-oligosaccharides are important molecules in various biological and physiological processes. Thus, sialyltransferases are thought to be important enzymes in the field of glycobiology. To date, we have demonstrated that marine bacterial sialyltransferases show broad acceptor substrate specificities. Among them,  $\alpha$ 2,3-sialyltransferase from *Photobacterium* sp. JT-ISH-224 can produce quite unique reaction products from various acceptor substrates. We have demonstrated that this enzyme transferred Neu5Ac to both the O-3' and the O-2 hydroxyl groups of lactose simultaneously, and gave 2,3'-disialyllactose as the reaction product [1]. Furthermore, we have also demonstrated that the sialyltransferase transferred Neu5Ac to the  $\beta$ -anomeric position of mannose, and gave the corresponding reaction product [2]. In the former case, the stereochemistry of C-1 to C-3 of the  $\alpha$ -glucopyranoside moiety is identical to that of the C-4 to C-2 of  $\alpha$  galactopyranoside moiety, which is common acceptor toward the sialyltransferases. For the later, the stereochemistry of C-2 to C-1 of the  $\beta$ -mannopyranoside moiety is superimposable on that of the C-4 to C-3 of the galactopyranoside moiety. Recently, we have confirmed that the  $\alpha$ 2,3-sialyltransferase also recognized inositols, having a structure corresponding to the C-3 to C-4 of a galactopyranoside moiety, as acceptor substrates, and transferred Neu5Ac to them [3]. From these results, it was clearly shown that the  $\alpha$ 2,3-sialyltransferase from *Photobacterium* sp. JT-ISH-224 recognizes acceptor substrates through the *cis*-diol structure corresponding to the 3- and 4-positon of the galactopyranoside moiety.

**References**

1. Mine, T.; Kajiwara, H.; Murase, T.; Kajihara, Y.; Yamamoto, T. *J. Carbohydr. Chem.* **2010**, *29*, 51-60.
2. Mine, T.; Miyazaki, T.; Kajiwara, H.; Naito, K.; Ajisaka, K.; Yamamoto, T. *Carbohydr. Res.* **2010**, *345*, 1417-1421.
3. Mine, T.; Miyazaki, T.; Kajiwara, H.; Tateda, N.; Ajisaka, K.; Yamamoto, T. *Carbohydr. Res.* **2010**, *345*, 2485-2490.

PO 218

**HIGH-PERFORMANCE ANION EXCHANGE CHROMATOGRAPHY  
WITH PULSED AMPEROMETRIC DETECTION-BASED CARBOTYPING  
OF MENINGOCOCCAL LIPOOLIGOSACCHARIDES**

Noëlle Mistretta, Frédéric Blanc, Marina Brossaud, Sandrine Vialle,  
Geneviève Renault-Montgénie and Philippe Talaga

*Sanofi Pasteur, 69280 Marcy l'Etoile, France  
noelle.mistretta@sanofipasteur.com*

Meningococcal lipoolysaccharides (LOS) have been classified into 12 immunotypes based on monoclonal antibody recognition. Each LOS immunotype is related to a specific oligosaccharide structure which was established for most of them by a combination of analyses such as wet chemistry, immunoblots, 2D-NMR and mass spectrometry techniques. None of these techniques, which requires for some of them large amounts of purified starting material, can provide complete and unambiguous structural information for these molecules with very high heterogeneity.

High-performance anion-exchange chromatography with pulsed amperometric detection (HPAEC-PAD) has been proven to be a rapid and sensitive method for carbohydrates analysis. Position of glycosidic linkages and the overall conformational structures of oligosaccharides are important factors for their separation by HPAEC-PAD. Moreover, the nature, the number and the positions of charged chemical groups, such as phosphoethanolamine (PEtn) are critical (1). To obtain quick and efficient structural information of meningococcal LOS, we have developed an HPAEC-PAD method for structure characterization of oligosaccharides released from meningococcal LOS by mild acid hydrolysis. Identify of LOS immunotype by this method is also possible starting directly from inactivated meningococcal whole cells without any purification step.

This method can determine the number of PEtn residues and provide quantitative information and nearly complete structures rapidly.

**References**

1. Swanson, K.V. and Griffiss, J. McL. *Carbohydr. Res.* **2006**, *34*, 388-396.

PO 219

**GENERATION OF WELL-DEFINED CLICKABLE GLYCOPOLYMERS  
FROM AQUEOUS RAFT POLYMERIZATION OF ISOMALTULOSE-DERIVED  
ACRYLAMIDES**

*Sylvie Moebis-Sanchez,<sup>1,2</sup> Ouais Abdelkader,<sup>1,2,3</sup> Yves Queneau,<sup>1,2</sup>  
Julien Bernard,<sup>3</sup> Etienne Fleury<sup>3</sup>*

<sup>1</sup> INSA-Lyon, Institut de Chimie et de Biochimie Moléculaires et Supramoléculaires, F-69621, Villeurbanne Cedex (France)

<sup>2</sup> ICBMS, UMR 5246 ; CNRS ; Université de Lyon; Université Lyon 1; INSA-Lyon; CPE-Lyon; F-69621, Villeurbanne Cedex (France)

<sup>3</sup> Université de Lyon, INSA-Lyon, Université Claude Bernard Lyon 1, Ingénierie des Matériaux Polymères (UMR-CNRS 5223), F-69621, Villeurbanne Cedex (France)  
sylvie.moebis@insa-lyon.fr

Glycopolymers have received much attention as the biomimetic counterparts of natural polysaccharides notably to study enhanced carbohydrate-protein interactions benefitting from multivalency.<sup>1</sup> Original carbohydrate-based acrylamide monomers, 2-[( $\alpha$ -D-glucopyranosyloxy)-ethanamido]-ethyl acrylamide **I** and its analogs bearing one azide group in C-2 (**II**) or C-6 (**III**) have been synthesized. Whereas the reversible addition fragmentation chain transfer (RAFT) process ensured the preparation of well-defined glycopolymers from **I**, the polymerization of monomers **II** and **III** proved to be challenging at temperatures compatible with a thermally initiated radical process and the influence, on the controlled/"living" status of the process, of the azide group's position could be observed. In contrast to **III**, for which no polymer could be obtained under any conditions, performing the RAFT polymerization of **II** at 30°C clearly favoured the radical polymerization and conferred a controlled character to the process, affording well-defined azide-functionalized glycopolymers. Block copolymerization as well as incorporation of a carbohydrate-based alkyne on the "clickable" polymer backbone were also investigated.<sup>2</sup>

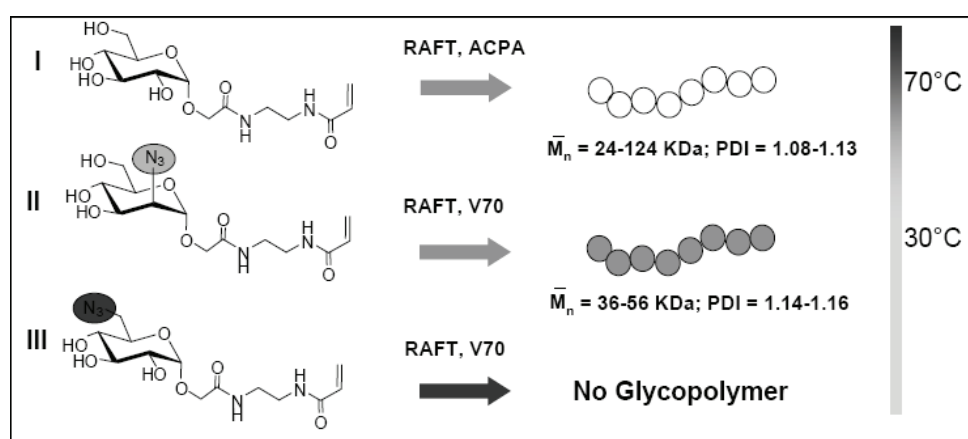

### References

1. S. R. S. Ting, G. J. Chen and M. H. Stenzel, *Polym. Chem.*, **2010**, *1*, 1392-1412.
2. O. Abdelkader, S. Moebis-Sanchez, Y. Queneau, J. Bernard and E. Fleury, *J. Polym. Sci., Part A: Polym. Chem.*, **2011**, *49*, 1309-1318.

PO 220

## SYNTHESIS OF SUGAR NUCLEOTIDES

Saskia Wolf and Chris Meier

Organic Chemistry, Department of Chemistry, Faculty of Science,  
University of Hamburg, Martin-Luther-King-Platz 6, D-20146 Hamburg, Germany  
saskia.wolf@chemie.uni-hamburg.de

Sugar nucleotides **1** (nucleoside *monophosphate* sugars or nucleoside *diphosphate* sugars) are an enormously important class in biological chemistry. NDP-sugars act as glycosyl donors in the biosynthesis of oligosaccharides. Moreover, glycosyltransferases that incorporate non-natural monosaccharides or accept non-natural substrates for glycosylation may become a powerful tool for the synthesis of non-naturally occurring bioconjugates.<sup>[1]</sup> As an example for NMP-sugars, the most interesting and highly important one is CMP-Neu5Ac as activated form of neuraminic acid. In general, sialic acids play an essential role in glycoproteins and glycolipids and are key factors in cell-cell recognition.<sup>[2]</sup>

For this reason an efficient and generally applicable synthesis of sugar nucleotides **1** is of great importance. A number of methods have been developed but often these protocols involve long reaction times and tedious purifications. Furthermore, the yields are low and sometimes the stereochemistry at the anomeric center can not be controlled.

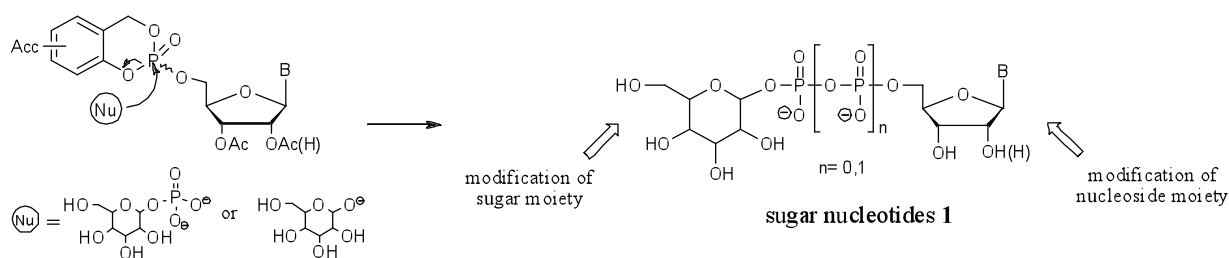

A new access for the synthesis of sugar nucleotides **1** -in solution and solid-support assisted- has been developed based on the *cycloSal*-concept.<sup>[3]</sup> Using this approach, excellent chemical yields were obtained within short reaction times. In comparison to other methods the *cycloSal*-concept allows a fast and efficient preparation of *monophosphate* and *diphosphate* linked sugar nucleotides **1**. On top of this, our method is applicable to a wide variety of nucleosides and pyranoses. Such a broadly applicable chemical synthesis offers an efficient access not only to the naturally occurring sugar nucleotides **1** but also to structural analogues of these compounds.<sup>[4,5]</sup>

## References

1. N.K. Kotchetkov, N.V. Shibaev, *Adv. Carbohydr. Chem.*, **1973**, 28, 307-399.
2. R. Schauer, *Adv. Carbohydr. Chem. Biochem.*, **1982**, 40, 1-31.
3. S. Wendicke, S. Warnecke, C. Meier, *Angew. Chem.*, **2008**, 120, 1523-1525; *Angew. Chem. Int. Ed.*, **2008**, 47, 1500-1502.
4. S. Wolf, T. Zismann, N. Lunau, C. Meier, *Chem. Eur. J.*, **2009**, 15, 7656-7664.
5. S. Wolf, T. Zismann, N. Lunau, S. Warnecke, S. Wendicke, C. Meier, *Eur. J. Cell Biol.*, **2010**, 89, 63-75.



## PO 221

ARCHAEAL GLYCOSYLATION: ANALYSIS OF THE GLYCOME  
AND IDENTIFICATION OF THE ENZYMES INVOLVED

Maria Carmina Ferrara<sup>1</sup>, Beatrice Cobucci-Ponzano<sup>1</sup>, Patrizia Contursi<sup>2</sup>, Gabriella Fiorentino<sup>2</sup>,  
Danila Limauro<sup>2</sup>, Andrea Carpentieri<sup>3</sup>, Angela Amoresano<sup>3</sup>, Mosè Rossi<sup>1</sup>,  
Simonetta Bartolucci<sup>2</sup> and Marco Moracci<sup>1</sup>

<sup>1</sup>*Institute of Protein Biochemistry, CNR, Via P. Castellino 111, 80131, Naples, Italy,*

<sup>2</sup>*Dipartimento di Biologia Strutturale e Funzionale, Università degli Studi di Napoli  
"Federico II", Complesso Universitario Monte S. Angelo, Via Cinthia, 80126 Naples, Italy,*

<sup>3</sup>*Department of Organic Chemistry and Biochemistry, School of Biotechnological Sciences,  
Federico II University of Naples, Naples, Italy  
m.moracci@ibp.cnr.it*

Glycosylation is one of the most prevalent post-translational modifications of proteins that expand the diversity of the proteome by the addition of different glycan moieties. Long believed a prerogative of eukaryotes, it is now clear that both N-glycosylation and O-glycosylation also transpire in Bacteria and Archaea. In recent years, substantial progresses are being made in understanding bacterial glycosylation while much less is known of this post-translational modification in Archaea, despite the fact that the first prokaryotic N-glycosylated protein was discovered over three decades ago in the haloarchaeon *Halobacterium salinarum*<sup>1</sup> and that N-glycosylated proteins are more prevalent in Archaea than in Bacteria. Archaeal glycosylation displays bacterial- and eukaryal-like traits, such as monomeric oligosyltransferases and dolichol phosphate carrier respectively, in addition to unique features<sup>2</sup>.

Insights into the biosynthesis and the nature of N-linked glycans decorating archaeal glycoproteins arise from euryarchaeal model species<sup>3</sup>. In Crenarchaea, a phylum evolutionarily distant from Euryarchaea, the study of the steps and the components of the machinery involved in glycosylation and of the nature of the glycosylated proteins is still in its infancy. However, preliminary results indicate that glycosylation in these organisms is indispensable for cell survival<sup>4</sup> and even more widespread than in Euryarchaea<sup>5</sup>. Here, we report our recent studies on the enzymes from the hyperthermophilic crenarchaeon *Sulfolobus solfataricus* involved in the synthesis and in the maturation of the glycan component of the glycoproteins<sup>6</sup>. Moreover, sugar composition and structure of the sulfolobales glycoproteins are explored by glycoproteomic analysis. A better understanding of crenarchaeal glycosylation will provide new insights into this post-translational modification across evolution as well as protein processing under extreme conditions.

### References

1. Mescher MF and Strominger JL, *Journal of Biological Chemistry*, **1976**, 251, 2005-14.
2. Calo D, Kaminski L and Eichler J, *Glycobiology*, **2010**, 20, 1065-76.
3. Abu-Qarn M and Eichler J, *Molecular Microbiology*, **2006**, 61, 511-25.
4. Lindås AC, Karlsson EA, Lindgren MT, Ettema TJ, Bernander R, *Proc Natl Acad Sci USA*, **2008**, 105, 18942-6.
5. Koerdt A, Gödeke J, Berger J, Thormann KM, Albers SV, *PLoS One*, **2010**, 5, e14104
6. Cobucci-Ponzano B, Conte F, Strazzulli A, Capasso C, Fiume I, Pocsfalvi G, Rossi M, Moracci M, *Biochimie*, **2010**, 92, 1895-907.

## PO 222

**A NOVEL APPROACH FOR THE CHEMO-ENZYMATIC SYNTHESIS OF GALACTO-OLIGOSACCHARIDES USING MUTANTS OF THE THERMOPHILIC  $\beta$ -GALACTOSIDASE FROM *ALICYCLOBACILLUS ACIDOCALDARIUS***

Andrea Strazzulli<sup>1</sup>, Beatrice Cobucci-Ponzano<sup>1</sup>, Giuseppe Perugino<sup>1</sup>, Maria Michela Corsaro<sup>2</sup>, Emiliano Bedini<sup>2</sup>, Gabriella Pocsfalvi<sup>1</sup>, Stephen G. Withers<sup>3</sup>, Mosè Rossi<sup>1</sup> and Marco Moracci<sup>1</sup>

<sup>1</sup>*Institute of Protein Biochemistry, CNR, Via P. Castellino 111, 80131, Naples, Italy.*

<sup>2</sup>*Dipartimento di Chimica Organica e Biochimica, Università di Napoli "Federico II", Complesso Universitario di Monte S. Angelo, Via Cinthia 4, 80126 Naples, Italy.*

<sup>3</sup>*Department of Chemistry, The University of British Columbia, 2036 Main Mall, Vancouver, British Columbia, Canada V6T 1Z1.  
m.moracci@ibp.cnr.it*

The galacto-oligosaccharides (GOSs) belong, for their indigestible nature, to the group of prebiotics, which beneficially affect the host by stimulating the growth and/or activity of colon bacteria, as resulted by several studies on both infants and adults showing that their consumption led to a significant increase in *Bifidobacteria*<sup>1</sup>. GOSs naturally occur in human milk, and commercially available products are broadly used in infant formula, biscuits, food for critical illnesses<sup>2</sup>. For these reasons, the large demand for these important nutraceuticals requires the development of new efficient and economically sustainable methods for their synthesis.

Synthesis of GOSs is commonly performed by  $\beta$ -galactosidases *via* transglycosylation reactions starting from lactose. The drawback of this approach is the limited final yield, because the products are still substrates of this enzyme. Moreover the subsequent formation of free glucose shows an inhibitory effect for the synthesis of products<sup>3</sup>. To expand the chemo-enzymatic tools for the GOSs synthesis we have characterized, in detail, two mutants of the GH42  $\beta$ -galactosidase (*Aa* $\beta$ -Gal) from the moderately thermophilic bacterium *A. acidocaldarius*, namely Glu313Gly (the mutant of the nucleophile residue<sup>4</sup>) and Glu361Gly. We show here that they are better than the wild type in the synthesis/hydrolysis activity ratio for the production of GOSs. In particular, the mutant *Aa* $\beta$ -Gal Glu361Gly catalyzes transgalactosylation reactions with high efficiency on different *acceptors*.

**References**

1. Piirainen, L., Kekkonen, R. A., Kajander, K., Ahlroos, T., Tynkkynen, S., Nevala, R., and Korpela, R. *Annals of Nutrition & Metabolism*, **2008**, 52, 204-8.
2. Coulier, L., Timmermans, J., Bas, R., Van Den Dool, R., Haaksman, I., Klarenbeek, B., Slaghek, T., and Van Dongen, W. *Journal of Agricultural and Food Chemistry*, **2009**, 57, 8488-95.
3. Park, A.R. and Oh, D.K. *Applied microbiology and biotechnology*, **2010**, 85, 1279-86.
4. Di Lauro, B., Strazzulli, A., Perugino, G., La Cara, F., Bedini, E., Corsaro, M. M., Rossi, M., and Moracci, M. *Biochimica et Biophysica Acta*, **2008**, 1784, 292-301.

PO 223

**SYNTHESIS OF *NEISSERIA MENINGITIDIS* X  
CAPSULAR POLYSACCHARIDE FRAGMENTS**

Laura Morelli and Luigi Lay

*Università degli Studi di Milano, Dipartimento di Chimica Organica e Industriale,  
via Venezian 21, 20133 Milano  
laura.morelli@unimi.it*

*N. meningitidis* type X (Men X), first described in the 1960s<sup>1</sup>, has been found to cause a few cases of invasive disease<sup>2,3</sup> and in 2006 WHO started to consider Men X as a substantial threat. Since capsular polysaccharides (CPSs) are the key virulence factors for encapsulated bacteria, the development of more comprehensive glycoconjugate vaccines including Men X CPS fragments become an urgent issue in the near future.<sup>4</sup> The CPS of *N. meningitidis* X is a linear homopolymer of (1→4)-linked 2-acetamido-2-deoxy- $\alpha$ -D-glucopyranosyl phosphate residues (*Figure 1*), with an average chain length of 50 units.<sup>5</sup> The present research project is focused on the synthesis of phosphodiester-linked oligomers of the native Men X CPS (*Scheme 1*). In order to improve the immune response of the synthesized oligomers they will be employed in the synthesis of neo-glycoconjugates by exploiting the amino group of the spacer arm at the reducing end of each fragment. The phosphodiester linkages will be installed via the well-established H-phosphonate strategy.

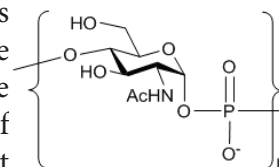

**Figure 1**

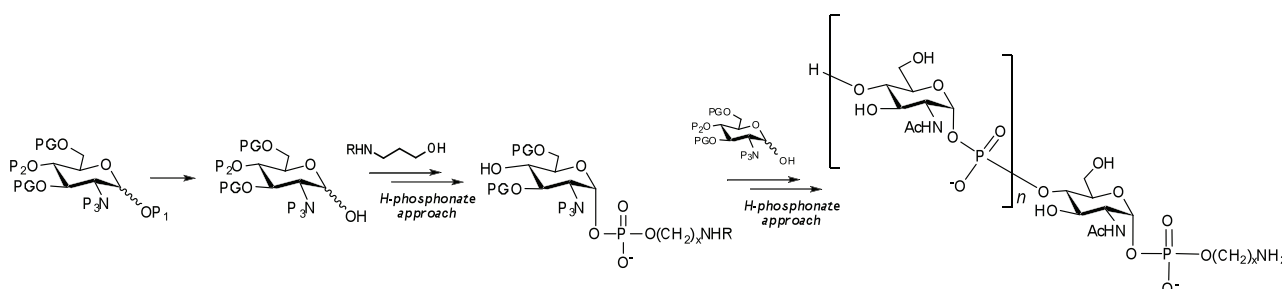

**Scheme 1**

### References

1. R. Evans, M. S. Artenstein, D. H. Hunter, *Am. J. Epidemiol.* **1968**, 87, 643-646.
2. S. Djibo, P. Nicolas, J. M. Alonso, A. Djibo, D. Couret, J. Y. Riou, J. P. Chippaux, *Trop. Med. Int. Health* **2003**, 8, 1118-112.
3. P. Boisier, P. Nicolas, S. Djibo, M. K. Taha, I. Jeanne, H. B. Mainassara, B. Tenebray, K. K. Kairo, D. Giorgini, S. Chanteau, *Clin. Infect. Dis.* **2007**, 44, 657-663.
4. S. P. Gagneux, A. Hodgson, T. A. Smith, T. Wirth, I. Ehrhard, G. Morelli, B. Genton, F. N. Binka, M. Achtman, G. Pluschke, *J. Infect. Dis.* **2002**, 185, 618-626.
5. D. R. Bundle, H. J. Jennings, C. P. Kenny, *J. Biol. Chem.* **1974**, 249, 4797-4801.
6. E. D. Goddard-Borger and R.V. Stick, *Org. Lett.*, **2007**, Vol. 9, No. 19, 3797-3800.

PO 224

## SYNTHESIS OF IMINOSUGARS AND ANALOGUES FROM PYRROLE

R. Kieffer, T. Sigstam, A. J. Moreno-Vargas, E. Moreno-Clavijo,  
A. T. Carmona and I. Robina

*Department of Organic Chemistry, Faculty of Chemistry, University of Seville.  
Prof. García González, 1, 41012-Seville, Spain  
ajmoreno@us.es*

The synthesis of carbohydrates and analogues from 7-oxabicyclo[2.2.1]hept-2-enes as starting materials (easily obtained from furan) was pioneered by Just<sup>1</sup> and developed extensively by Vogel's group (naked sugar methodology).<sup>2</sup> We now intend to extend this methodology to the synthesis of further products of interest such as proline analogues and dideoxyiminoalditols and derivatives starting from *N*-Boc protected 7-azabicyclo[2.2.1]heptane derivatives such as **1** (easily obtained from pyrrole). Part of this new methodology has been recently reported for the preparation of hydroxylated prolines,<sup>3</sup> rigid swainsonine analogues<sup>4</sup> and iminosugar derived hemiaminals.<sup>5</sup> In this communication we present the recent synthetic studies for the transformation of the azabicyclic derivative **1** into 2,5-disubstituted-3-pyrrolines, that could be used as versatile synthetic intermediates into the preparation of new iminosugars, hydroxylated indolizidines and pyrrolizidines, and hydroxylated prolines of biological interest.

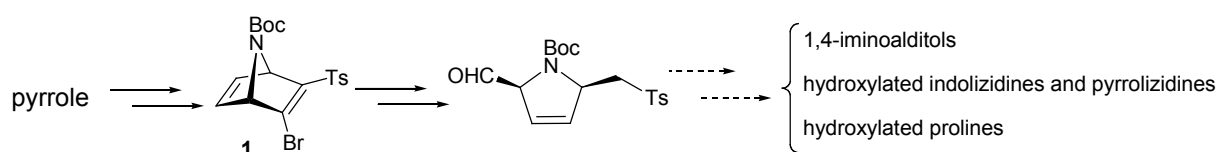

## References

1. Just, G.; Martel, A.; Grozinger, K.; Ramjeesingh, M. *Can. J. Chem.* **1975**, *53*, 131 and references therein.
2. (a) Vogel, P. *Curr. Org. Chem.* **2000**, *4*, 455. (b) Vogel, P. *Organic Chemistry of Sugars*, Levy, D. E.; Fügedi, P. Eds., CRC Press LLC, Boca Raton, FL **2006**, 629.
3. (a) Moreno-Vargas, A. J.; Petricci, E.; Robina, I.; Vogel, P. *J. Org. Chem.* **2004**, *69*, 4487. (b) Ruggiu, A. A.; Lysek, R.; Moreno-Clavijo, E.; Moreno-Vargas, A. J.; Robina, I.; Vogel, P. *Tetrahedron* **2010**, *66*, 7309.
4. Moreno-Vargas, A. J.; Schütz, C.; Scopelliti, R.; Vogel, P. *J. Org. Chem.* **2003**, *68*, 5632.
5. Moreno-Vargas, A. J.; Vogel, P. *Tetrahedron Lett.* **2003**, *44*, 5069.

PO 225

## DEHYDRATIVE GLYCOSYLATION WITH HENDRICKSON REAGENT

M. Mossotti, L. Panza*DiSCAFF, Università del Piemonte Orientale, Via Bovio 6, 28100-Novara, Italy  
mossotti@pharm.unipmn.it*

The key reaction for oligosaccharides synthesis is the formation of the glycosidic bond from monosaccharide precursors. Most carbohydrate coupling strategies have concentrated on the derivatization of the anomeric position as a latent leaving group, and the intermediate glycosyl donor is usually isolated. In a second step the leaving group is then activated in the presence of a nucleophilic glycosyl acceptor to form the glycosidic bond.

A far less developed strategy for glycosidic bond formation is a dehydrative coupling strategy, in which a 1-hydroxy carbohydrate can be employed directly as the glycosyl donor. Over the past years, many direct dehydrative glycosylation methods have been developed to address these difficulties via the *in situ* generation of a variety of reactive glycosyl donors. Interesting examples have been studied by Gin exploiting diphenylsulfonium reagents<sup>1</sup> and by Kobayashi, who developed the activation of 1-OH sugars by their conversion to bromides in dehydrative conditions using the Appel reagent.<sup>2</sup>

Among them, however only few attempts to activate the anomeric hydroxyl group by its conversion into an oxyphosphonium specie have been described using Mitsunobu conditions, but only with phenols or acids as nucleophiles. Glycosyl phosphonium salts, generated either by treatment of glycosyldiphenylphosphinites with electrophiles or glycosyl halides with phosphine oxides have been postulated as intermediates in glycosylation reactions developed by Mukaiyama.<sup>3</sup>

In light of previous observations, we planned to study the possibility to use the Hendrickson reagent (POP) **1**, obtained from triphenyl phosphine oxide and triflic anhydride, known for its strongly dehydrative properties.<sup>4</sup> The results obtained with this new approach and some insight into the reaction mechanism will be reported.

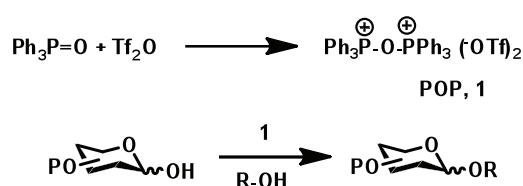

## References

1. Garcia, B. A., Gin, D.A. *J. Am. Chem. Soc.* **2000**, *122*, 4269-4279 and ref. cited therein.
2. Shingu, Y., Nishida, Y., Dohi, H., Kobayashi, K. *Org. Biomol. Chem.* **2003**, *1*, 2518-2521.
3. Mukaiyama, T., Kobashi, Y., Shintouy, T. *Chem. Lett.* **2003**, *32*, 900-901.
4. Hendrickson, J. B., Hussoin, S. *J. Org. Chem.* **1989**, *54*, 1144-1149

PO 226

**DESIGN, SYNTHESIS AND BIOLOGICAL EVALUATION OF GLYCOSYLATED LIPID PORPHYRIN DERIVATIVES AS ANTI-CANCER THERAPEUTICS**

Claire Moylan,<sup>1</sup> Robin Daly<sup>1</sup>, Gisela Vaz<sup>2</sup>, Carsten Ehrhardt<sup>3</sup>, Eoin M. Scanlan<sup>1</sup>  
and Mathias O. Senge.<sup>1,2</sup>

<sup>1</sup>*School of Chemistry, Trinity College Dublin, Dublin 2, Ireland*

<sup>2</sup>*Institute of molecular medicine, St. James Hospital, Dublin*

<sup>3</sup>*School of Pharmacy, Trinity College Dublin, Dublin 2, Ireland*  
*moylanc@tcd.ie, eoin.scanlan@tcd.ie*

Porphyrins have been investigated as highly effective therapeutics for the treatment of cancers by Photodynamic Therapy (PDT) leading to clinically approved treatments<sup>1</sup>. The cytotoxic activity of these compounds is induced by the photochemical production of highly reactive oxygen species. Amphiphilic porphyrins have been shown to have a high selectivity towards neoplastic tissue and there is strong biological evidence that amphiphilic porphyrins interact strongly with lipoproteins during cellular uptake<sup>2</sup>. Modification of the porphyrin scaffold with a combination of carbohydrates and lipids allows control over the amphiphilicity and subsequent biological activity of PDT therapeutics.

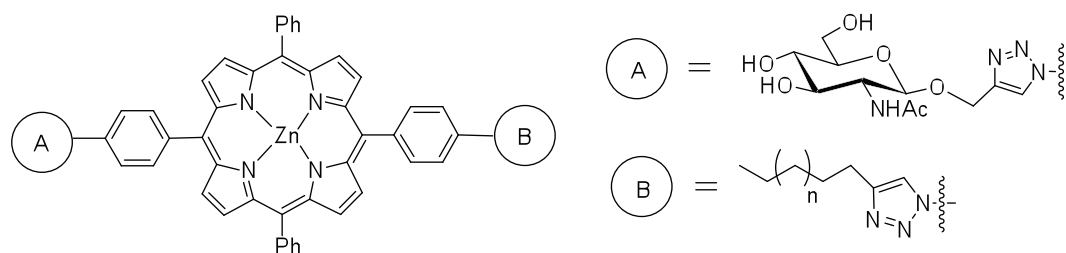

The aim of this project is the synthesis and biological evaluation of glycosylated lipid porphyrin derivatives with improved tumour selectivity and uptake for PDT. The carbohydrate modality is hydrophilic and increases solubility in aqueous media, complex carbohydrates may be used to target tumour specific lectins. The introduction of lipid functionalities to the molecule can cause aggregation of these molecules into vesicle structures. Careful selection of carbohydrates and lipids allows for fine tuning of the amphiphilicity of these important therapeutics and both solution phase and in vitro behaviour will be studied.

### References

1. Q. Peng, *J. Natl. Cancer Inst.* **1998**, 90, 889-905.
2. P. P. Mishra, S. Patel and A. Datta, *J. Phys. Chem. B.* **2006**, 110, 21238-44.



PO 227

**AZIDO DERIVATIVES OF CELLOBIOSE: SUBSTRATE STUDIES  
WITH CELLULASE AND CELLOBIOSE OXIDASE**

Dafina Mulla,<sup>1</sup> Borjana Lubura,<sup>2</sup> Nermeen Gabra,<sup>2</sup> Wolfgang Holzer,<sup>3</sup> Yasser Saber,<sup>2</sup>  
Renate Löppert,<sup>4</sup> Werner Praznik,<sup>4</sup> Roland Ludwig,<sup>5</sup> Helmut Viernstein<sup>2</sup>  
and Frank M. Unger<sup>2</sup>

<sup>1</sup>Department of Pharmacy, Faculty of Medicine, University of Prishtina, QKUK, Prishtina 10000,  
Republic of Kosova,

<sup>2</sup>Department of Pharmaceutical Technology and Biopharmaceutics,

<sup>3</sup>Department of Pharmaceutical Chemistry, Faculty of Life Sciences, University of Vienna,  
Althanstrasse 14, A-1090 Wien, Austria,

<sup>4</sup>Department of Chemistry,<sup>5</sup>Department of Food Sciences and Technology,  
University of Natural Resources and Applied Life Sciences, A-1190 Wien, Austria  
mulladafina@hotmail.com

The azido cellobiose analogs, 6-azido-6-deoxycellobiose, 6'-azido-6'deoxycellobiose, and 2-azido-2-deoxycellobiose have been studied as substrates of cellobiose oxidase. Azido cellobiose analogs have been synthesized from known, protected cellobiose precursors by conventional chemistry or by combined chemoenzymatic methods employing cellobiose phosphorylase from *Clostridium thermocellum*.<sup>1</sup> Under catalysis by cellobiose oxidase,<sup>2</sup> azido cellobiose analogs are converted into the corresponding azido lactones/azido cellobionic acids. Following reduction of the azido group, such lactones may be polymerized into perlon-type polymers. By analogy with cellobiose, azido cellobiose analogs may form azido cellooligomers<sup>3</sup> under catalysis by cellulase from *Trichoderma reesei*.

**References**

1. Y. Saber, B. Lubura, D. Mulla, *et al.*, manuscript in preparation.
2. R. Ludwig, W. Harreither, F. Tasca, L. Gorton, *Chem Phys Chem.* **2010**, *11*, 2674 –2697.
3. S. Kobayashi, S.-i. Shoda, M. J. Donnelly, and S. P. Church, *Enzymatic Synthesis of Cellulose*, in *Methods in Biotechnology, Vol. 10, Carbohydrate Biotechnology Protocols*, Ed. C. Bucke, Humana Press Inc., Totowa, NJ, 1999; pp. 57 – 69 and references therein.

PO 228

**A CIRCUITOUS BUT STEREOSPECIFIC SYNTHESIS OF  
2-AZIDO-2-DEOXY-D-GLUCOSE**

Nermeen Gabra,<sup>1</sup> Borjana Lubura,<sup>1</sup> Dafina Mulla,<sup>2</sup> Yasser Saber,<sup>1</sup> Wolfgang Holzer,<sup>3</sup>  
Helmut Viernstein<sup>1</sup> and Frank M. Unger<sup>1</sup>

<sup>1</sup>*Department of Pharmaceutical Technology and Biopharmaceutics, Faculty of Life Sciences,  
University of Vienna, Althanstrasse 14, A-1090 Wien, Austria,*

<sup>2</sup>*Department of Pharmacy, Faculty of Medicine, University of Prishtina,  
QKUK, Prishtina 10000, Republic of Kosova, and*

<sup>3</sup>*Department of Pharmaceutical Chemistry, Faculty of Life Sciences, University of Vienna,  
Althanstrasse 14, A-1090 Wien, Austria*

*borjana.lubura@univie.ac.at*

2-Azido-2-deoxyhexose derivatives have been prepared by azidonitration of glycols, as first described by Lemieux and Ratcliffe.<sup>1</sup> While azidonitration of peracetylated D-galactal proceeds with high *galacto* over *talo* stereoselectivity,<sup>1</sup> azidonitration of peracetylated D-glucal affords the *manno* and *gluco* products in ratios ranging from 3:1 to 1:5, as reviewed by Seeberger.<sup>2</sup> In our hands, azidonitration of the crystalline cellobial peracetate **1** affords mainly the *gluco* azidonitrate **2** which was converted into the crystalline 2-azido-2-deoxy-cellobiose derivative **3** in high yield. The 2-azido-2-deoxycellobiose **4** obtained by sodium methoxide catalyzed methanolysis is cleaved under catalysis by cellobiose phosphorylase from *Clostridium thermocellum* to afford  $\alpha$ -D-glucose 1-phosphate **5** and 2-azido-2-deoxy-D-glucose **6**.

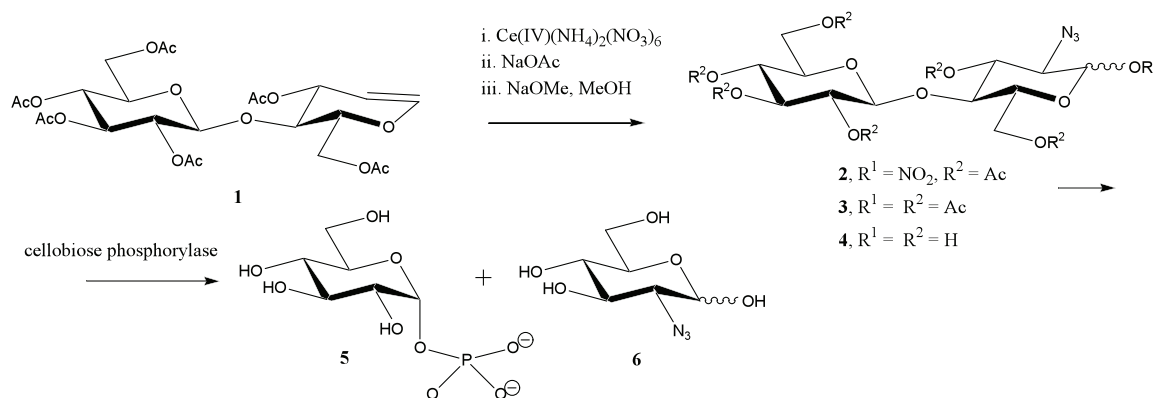

### References

1. R. U. Lemieux, R. M. Ratcliffe, *Can J Chem*, **1979**, *51*, 1244-1251.
2. P. H. Seeberger, S. Roehrig, P. Schell, Y. Wang, W. J. Christ, *Carbohydr Res*, **2000**, *328*, 61-69 and numerous references therein.

PO 229

SYNTHESIS OF  $\alpha$ -S-GALACTOSYLCERAMIDES AS POTENTIAL VACCINE ADJUVANTS

Niamh Murphy, Xiangming Zhu and Paul Evans

School of Chemistry and Chemical Biology, University College Dublin,  
 Belfield, Dublin 4, Ireland  
 niamhmurphy@ucd.ie

$\alpha$ -S-Galactosylceramide (**1**), a thioglycosidic analogue of the powerful immunostimulant  $\alpha$ -GalCer (**2**),<sup>[1]</sup> was recently first synthesised in our group.<sup>[2]</sup>  $\alpha$ -Galactosylceramides activate Natural Killer T cells to produce proinflammatory T helper 1 (Th1) cytokines and immunomodulatory T helper 2 (Th2) cytokines. Antitumour, antiviral and antibacterial effects of  $\alpha$ -GalCer are thought to correlate with Th1 production and therefore  $\alpha$ -GalCer analogues with Th1/Th2 biased response are of significant interest.

$\alpha$ -S-GalCer has shown promising biological results and we have synthesised compounds (**3**) and (**4**) with a view to improving the Th1 bias, based on results of similar  $\alpha$ -GalCer analogues.<sup>[3]</sup> It is thought that introduction of terminal aromatic groups on the fatty acyl chain can increase stability of the glycolipid/CD1d complex resulting from additional lipophilic interactions.<sup>[4]</sup> Currently we are developing a more convergent synthesis of  $\alpha$ -S-Galactosylceramide analogues.

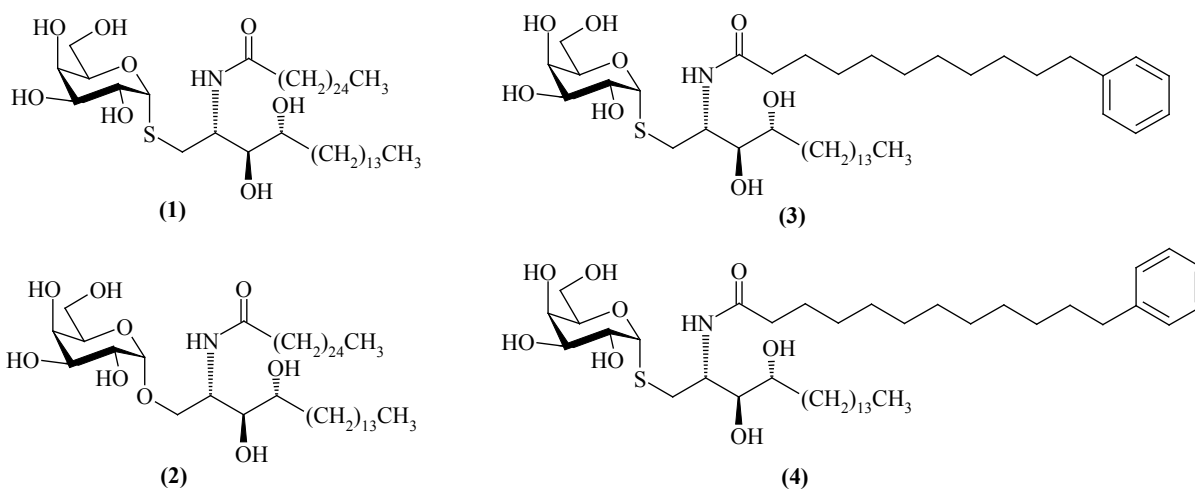

## References

1. M. Morita, K. Motoki, K. Akimoto, T. Natori, T. Sakai, E. Sawa, K. Yamaji, Y. Koezuka, E. Kobayashi and H. Fukushima, *J. Med. Chem.*, **1995**, 38, 2176 – 2187.
2. R. T. Dere and X. Zhu, *Org. Lett.*, **2008**, 10, 4641 – 4644.
3. D. Wu, M. Fujio and C. H. Wong, *Bioorg. Med. Chem.*, **2008**, 16, 1073 – 1083.
4. N. Murphy, X. Zhu and R. R. Schmidt, “ $\alpha$ -Galactosylceramides and Analogues – Important Immunomodulators for Use as Vaccine Adjuvants”, *Specialist Periodic Reports: Carbohydrate Chemistry*, **2010**, 36, 64 – 100 (RSC Publishing).

PO 230

**N-SUBSTITUTED ANALOGUES OF DIOSGENYL  
2-AMINO-2-DEOXY- $\beta$ -D-GLUCOPYRANOSIDE**

Henryk Myszka, Daria Plaskiewicz and Agata Walczewska

*Faculty of Chemistry, University of Gdańsk, Sobieskiego 18, 80-952 Gdańsk, Poland  
myszka@chem.univ.gda.pl*

Diosgenyl glycosides are steroid glycosides widely distributed in plants and in some marines organisms. The carbohydrate residue, usually mono-, di-, tri- or tetrasaccharide, is covalently attached to the diosgenin backbone. The carbohydrate chain constitutes a hydrophilic part while appropriate sapogenin is a hydrophobic fragment in this kind of glycosides. Usually, in natural diosgenyl glycosides  $\beta$ -D-glucopyranose is the first sugar attached to diosgenin. Some of the diosgenyl glycosides exhibit a wide spectrum of biological activities including antifungal, antibacterial and anticancer properties.

We have synthesized a diosgenyl glycosides containing D-glucosamine derivatives as a carbohydrate residue. This glycosides have not been found in natural sources so far.

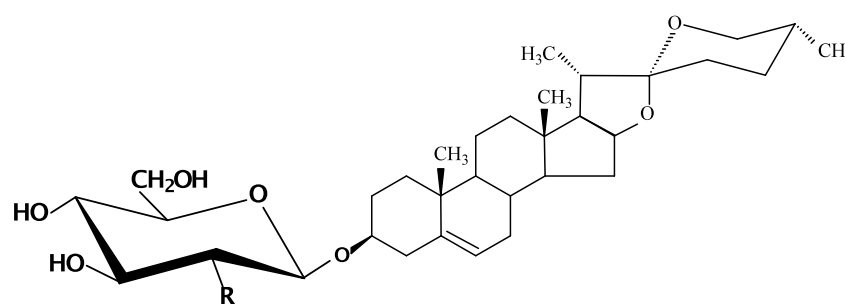

**R = NH<sub>2</sub>, HCl, NH-alkyl, N-dialkyl**

The synthetic strategy is based on the preparation of glycosyl donor (bromide with tetra-chlorophthalimido group at C-2) and coupling of these donor with diosgenin. The coupling reaction provided to the 1,2-*trans*-glycosidic bond in good yield. The protecting groups were easily and clearly cleaved leading to diosgenyl 2-amino-2-deoxy- $\beta$ -D-glucopyranoside. The structure of our products were confirmed by <sup>1</sup>H and <sup>13</sup>C NMR spectroscopy.

In biological set of experiments we have investigated the bactericidal and fungicidal effect some of this saponins.

This research was part-financed by the European Union within the European Regional Development Fund - grant UDA-POIG.01.01.02-14-102/09-01.

PO 231

## THE NMR INVESTIGATIONS OF D-GLUCOFURANOSIDURONO-6,3-LACTONES CONFORMATIONS

Dominik Walczak, Henryk Myszka and Beata Liberek

Faculty of Chemistry, University of Gdańsk, Sobieskiego 18, 80-952 Gdańsk, Poland  
myszka@chem.univ.gda.pl

Despite of their ubiquity in biological structures, furanosides have received much less attention than pyranosides as regards the conformational analysis. This is because different conformations of five-membered rings have quite similar energies, whereas six-membered rings are normally present in a single low-energy chair conformation. Therefore, conformations of pyranosides in solution are easily identified by NMR techniques, which is not the case with furanosides. These are equilibrating rapidly on the NMR scale and averaging of coupling constants occurs. However, when a tetrahydrofuran ring is conformationally restricted by a rigid second skeleton, it is possible to predict its conformation.<sup>1</sup>

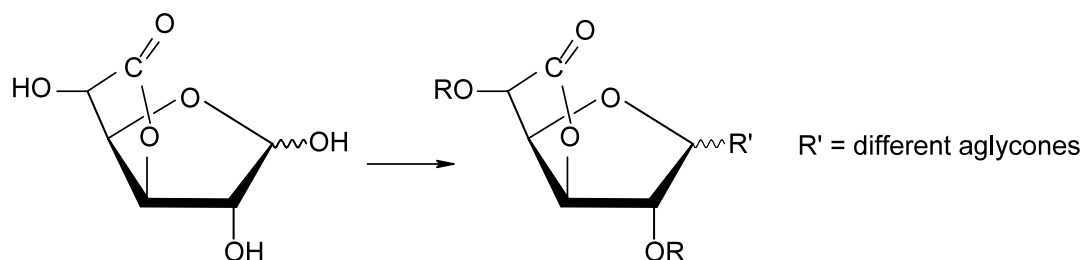

Previously, we found that methyl 2,5-di-*O*-acetyl- $\beta$ -D-glucofuranosidurono-6,3-lactone and 1,2,5-tri-*O*-acetyl- $\beta$ -D-glucofuranurono-6,3-lactone adopt a  ${}^1T_2$ -like conformation, both in the crystal structure and in solution.<sup>2</sup> It seems to us that the characteristic  ${}^1H$  NMR spectra of these  $\beta$ -D-glucofuranosidurono-6,3-lactones may be indicative of a  ${}^1T_2$ -like conformation. To verify this thesis we synthesized a series of D-glucofuranosidurono-6,3-lactones with different aglycones. The NMR studies of obtained  $\beta$ -D-glucofuranosidurono-6,3-lactones confirm our assumptions. Additionally, we obtained the NMR data, indicative for  $\alpha$ -D-glucofuranosidurono-6,3-lactones in a  ${}^1T_2$ -like conformation.

**References:**

1. Ellervik, U.; Magnusson, G. *J. Am. Chem. Soc.* **1994**, *116*, 2340-2347.
2. Liberek, B.; Tuwalska, D.; do Santos-Zounon, I.; Konitz, A.; Sikorski, A.; Smiatacz, Z. *Carbohydr. Res.* **2006**, *341*, 2275-2285.

PO 232

**MEMBRANE-BOUND STABLE GLYCOSYLTRANSFERASES:  
HIGHLY ORIENTED PROTEIN IMMOBILIZATION BY A C-TERMINAL CATIONIC  
AMPHIPATHIC PEPTIDE**Kentaro Naruchi, Shin-Ichiro Nishimura*Graduate School of Life Science, Hokkaido University, Sapporo 001-0021, Japan  
naruken@glyco.sci.hokudai.ac.jp*

Human gastric pathogenic bacteria *Helicobacter pylori* expresses Lewis blood group antigens of lipopolysaccharides to mask the pathogen from host immune surveillance by mimicking host cell surface carbohydrate structures. Fucosyltransferases (FucTs) of *H. pylori* are membrane-associated key enzymes responsible for the synthesis of Lewis antigens of *H. pylori* lipopolysaccharides. Although molecular cloning and expression of the *H. pylori*  $\alpha$ 1,3/ $\alpha$ 1,4-FucTs gene have been reported, production of full-length FucTs from *H. pylori* has not been achieved because of the insolubility caused by the C-terminal sequence that has heptad repeats followed by a highly conserved region rich in cationic and hydrophobic residues.

Here we present a novel method for the full-length expression of soluble and highly active *H. pylori*  $\alpha$ 1,3-FucT by regulating specific secondary structural basis of C-terminal cationic amphipathic domain. Chemical approach revealed that putative  $\alpha$ -helical conformation of C-terminus of this enzyme is induced only through the interaction with phospholipid micelles.<sup>1</sup> Unique mechanism in structural alteration of C-terminal amphipathic peptide during the formation of native quaternary structure of membrane-bound *H. pylori*  $\alpha$ 1,3-FucT encouraged us to expand this mechanism for creating high performance immobilized glycosyltransferases<sup>1-2</sup> that provide membrane-associated biocatalysts with widespread utility for the construction of a variety of cancer-related antigenic glycoconjugates *in vitro*.

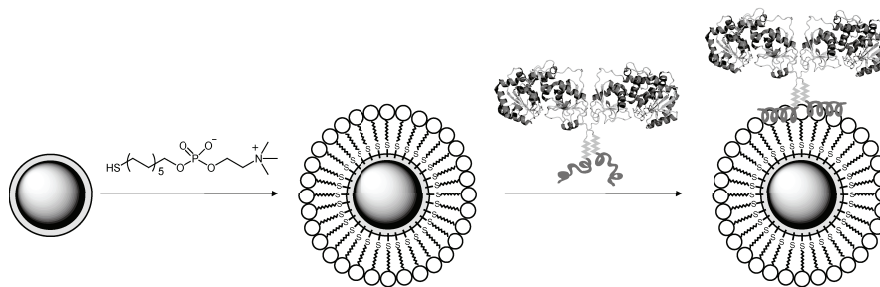
**References**

1. Kentaro Naruchi, Shin-Ichiro Nishimura, *Angew. Chem. Int. Ed.* **2011**, 50, 1328-1331.
2. Takaomi Ito, Reiko Sadamoto, Kentaro Naruchi, Hiroko Togame, Hiroshi Takemoto, Hirosato Kondo, Shin-Ichiro Nishimura, *Biochemistry*, **2010**, 49, 2604-2614.



## PO 233

## DESIGN AND SYNTHESIS OF GASTRIN-RELEASING PEPTIDE ANALOGS

A. Orsato, D. Aurilia, B. La Ferla, F. Nicotra

*Dipartimento di Biotecnologie e Bioscienze, Università degli Studi di Milano Bicocca,  
Piazza della Scienza, 2, 20126 Milano (Italy)  
alexandre.orsato@unimib.it*

Cancer is the second leading cause of death in developed countries. In order to face this disease several therapeutic strategies have been investigated, among them tumor drug targeting, the selective delivery of cytotoxic drugs to tumor cells. Its concept was popularized by Paul Ehrlich more than a hundred years ago, whom used the expression “magic bullets”. The gastrin-releasing peptide (GRP) receptor is clearly overexpressed in a wide range of tumors, thus successful targeting of the GRP receptor can enable the selective delivery of cytotoxic drugs to tumor cells. Designing GRP mimetics is a challenging task because of the absent information on the 3D structure of the GRP receptor. Therefore, our design of ligands for this receptor was based on the 3D structure of its natural ligand, GRP. In this work we report the design and synthesis of non-peptide GRP analogs with potential affinity for the GRP receptor. We studied the three dimensional structure of GRP and a peptide analog (agonist of GRP) by computational methods. Using a technique known as “scaffold hopping”, we designed potential GRP analogs by replacing the peptide backbone with a more rigid bicyclic scaffold, which maintained the same orientation of the most important side chains of both peptides (Fig. 1). The synthesis was carried out by first generating the galactose-based bicyclic scaffold and then by insertion of the desired pharmacophores. Preliminary biological evaluation of the compounds revealed that the presence of three pharmacophores results in an antagonist behavior in comparison with the natural ligand of the GRP receptor.

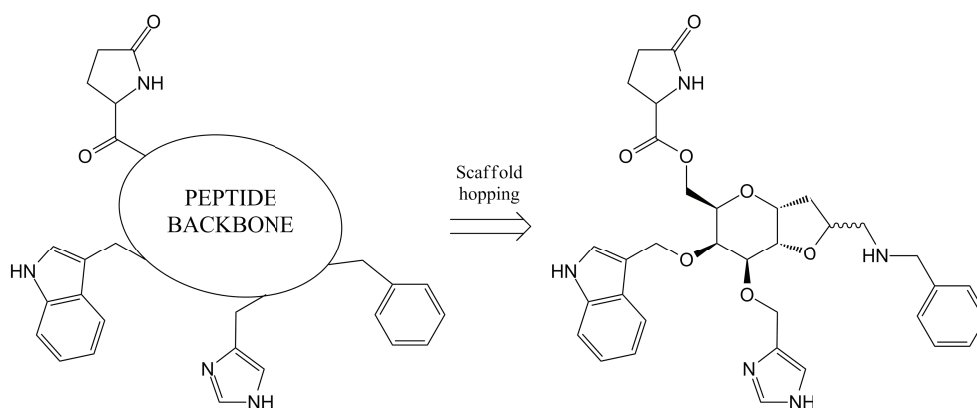

**Figure 1:** design of a galactose-based GRP mimetic by scaffold hopping

PO 234

**GLYCOFUSED TRICYCLIC BETA-AMYLOID LIGANDS FOR THE DIAGNOSIS AND THERAPY OF ALZHEIMER'S DISEASE**F. Nicotra<sup>1</sup>, F. Cardona<sup>1,2</sup>, B. La Ferla<sup>1</sup>, E. Sironi<sup>1</sup>, C. Airoidi<sup>1</sup>, A. Silva<sup>2</sup><sup>1</sup>*Department of Biotechnology and Biosciences, University of Milano-Bicocca, Piazza della Scienza 2, 20126-Milano, Italy*<sup>2</sup>*Department of Chemistry, University of Aveiro, Campus Universitário de Santiago, 3810-193 Aveiro, Portugal  
Francesco.Nicotra@unimib.it*

Alzheimer Disease (AD) is a neuropathology characterized by neurofibrillary tangles, an intracellular cytoskeletal alteration, and deposits of  $\beta$ -amyloid peptides ( $A\beta$ ) in the brain parenchyma and on the wall of cerebral blood vessels.

Compounds able to link  $A\beta$ -peptides can find application in AD diagnosis and therapy. Among them, tetracyclines display anti-amyloidogenic activity both *in vivo* and *in vitro*<sup>1</sup>, but suffers from chemical instability, low water solubility and posses, in this contest, undesired anti-bacterial activity.

We studied the topology of the tetracycline- $A\beta$  binding and generated a glycofused tricyclic scaffold<sup>2</sup> possessing the structural requirements essential the binding. This tricyclic compound has improved chemical stability and water solubility with respect to tetracycline, and the ductile structure allow easy lead optimisation.

The ability of these compounds to bind  $A\beta$  oligomers was verified by STD-NMR and trNOESY experiments. All these compounds were able to bind  $A\beta$  peptides but their affinities were modulated by the functional groups present at the aromatic ring. We demonstrated with molecular dynamic studies that all these molecules have the same 3D-structure and conformation, so the diverse affinity may be only due to the different polarity determined by the aromatic substituents. No influence on the binding was observed for the sugar moiety, which in fact displays only a minor involvement in the interaction with amyloid peptides.

**Acknowledgments:** This work was supported by the European Community's FP7 programme under contract CP-IP 212043-2 NAD, and by *Fundação para a Ciência e Tecnologia* (FCT, Portugal) for the PhD grant (SFRH/44888/2008), which we gratefully thank.

**References**

1. a) K. Ono, M. Yamada, *J. Neurochem.*, **2006**, 97, 105-115; b) I. Cardoso, G. Merlini, M. J. Saraiva, *FASEB J.*, **2003**, 17, 803-809; c) J.F. Aitken, K.M. Loomes, B. Konarkowska, G.J. Cooper G., *Biochem J.*, **2003**, 374, 779-84.
2. J.S. Yadav B.V.S Reddy, L. Chandraiah, B. Jagannadh, S. Kiran Kumar C. A. Kunwar *Tetrahedron Lett.* **2002**, 43, 4527

PO 235

**STRUCTURAL AND CONFORMATIONAL FEATURES  
OF THE FGF-HEPARIN-FGFR TERNARY COMPLEX IN SOLUTION  
FROM A NMR PERSPECTIVE**

Lidia Nieto,<sup>1</sup> Ángeles Canales,<sup>2</sup> Israel Sánchez,<sup>1</sup> Pilar López-Navajas,<sup>1</sup> Pedro M. Nieto,<sup>3</sup>  
Manuel Martín-Lomas,<sup>4</sup> Guillermo Giménez-Gallego<sup>1</sup> and Jesús Jiménez-Barbero<sup>1</sup>

<sup>1</sup>Centro de Investigaciones Biológicas (CIB), CSIC, Ramiro de Maeztu 9,  
Madrid, 28040 Spain

<sup>2</sup>Universidad Complutense de Madrid (UCM), Av. Complutense s/n, Madrid, 28040 Spain

<sup>3</sup>Instituto de Investigaciones Químicas, CSIC, Américo Vespucio 49, Sevilla, 41092 Spain

<sup>4</sup>CIC Biomagune, Paseo Miramón 182, San Sebastián, 20009 Spain  
linieto@cib.csic.es

Fibroblast growth factors (FGFs) are involved in a variety of key biological processes, including cell replication, angiogenesis, differentiation, cell adhesion, migration and wound healing. FGFs exert their diverse biological actions by binding to a series of membrane tyrosine kinase receptors (FGFRs), being the interaction of FGF with heparin or heparan sulfate proteoglycans (HSPGs) required for receptor activation and initiation of biological responses.

Based on crystal structures of the ternary complex FGF-heparin-FGFR complex, two competing models have been proposed, with symmetric<sup>1</sup> and an asymmetric<sup>2</sup> topologies, with different stoichiometries, and HSPG-receptor interactions. Since the contacts detected by X-ray crystallography may be due to crystal packing forces, it is important to validate the presence of these interactions in solution.

In this context, we have investigated the interaction of two biologically active heparin-like oligosaccharides, with the Ig2 domain of human FGFR2 and FGF1, by using multidimensional NMR spectroscopy and computational methods.

The present study aims to increase the understanding of the interactions between FGFR, FGF and heparin at the molecular level, and gain insight into the role of heparin oligosaccharides in the architecture of the ternary complex in solution.

### References

1. J. Schlessinger, A. N. Plotnikov, O. A. Ibrahimi, A. V. Eliseenkova, B. K. Yeh, A. Yayon, R. J. Linhardt and M. Mohammadi, *Mol Cell*, **2000**, 6, 743-750.
2. L. Pellegrini, D. F. Burke, F. von Delft, B. Mulloy, and T. L. Blundell, *Nature*, **2000**, 407, 1029-1034.

## PO 236

**GUT ANTI-INFLAMMATORY ACTIVITY OF LENTINAN: INFLUENCE ON IL-8 AND TNFR1 EXPRESSION IN INTESTINAL EPITHELIAL-LIKE CACO-2 CELLS**

Yosuke Nishitani<sup>1</sup>, Ling Zhang<sup>2</sup>, and Masashi Mizuno<sup>2</sup>

<sup>1</sup> *Organization of Advanced Science and Technology, Kobe University, Kobe, 657-8501, Japan,*

<sup>2</sup> *Department of Agrobioscience, Graduate School of Agricultural Science, Kobe University,*

*Kobe, 657-8501, Japan*

*nishitani@people.kobe-u.ac.jp*

Glucans have been known to exert immunomodulating activities. However, it is unknown whether glucans can modulate gut immune system. Here, we study the anti-inflammatory activity of lentinan (*Lentinula edodes*-derived  $\beta$ -1,3-1,6-glucan) by using an *in vivo* and an *in vitro* gut inflammation model. In dextran sulfate sodium (DSS)-induced colitis mouse model, administration of lentinan (100  $\mu$ g/mouse/day) significantly improved body weight loss ( $P < 0.05$ ), shortening of colon length ( $P < 0.05$ ), and histological score of the colon ( $P < 0.01$ ). In addition, the treatment of lentinan improved the aberrant mRNA expression of pro-inflammatory cytokines such as IFN- $\gamma$  ( $P < 0.01$ ) and IL-1 $\beta$  ( $P < 0.05$ ) in inflamed tissue. To investigate the mechanism of anti-inflammatory activity of lentinan *in vivo*, the co-culture system, consisting Caco-2 cells (apical side) and RAW264.7 cells stimulated by LPS (basolateral side), was used. Lentinan exerted an inhibitory effect on the IL-8 mRNA expression in Caco-2 cells ( $P < 0.01$ ) without reduction of the TNF- $\alpha$  production from RAW264.7 cells. In this system, no lentinan was detected in the basolateral supernatant. Lentinan also suppressed the translocation of NF- $\kappa$ B, which is known to be a transcription factor for the IL-8 gene expression, into the nucleus of Caco-2 cells ( $P < 0.05$ ). Immunofluorescent analysis showed that TNFR1 on the basolateral side of the cells was remarkably decreased by lentinan treatment while it was uniformly distributed from apical to basolateral side without lentinan. The alteration of TNFR1 distribution by lentinan treatment was inhibited by incubation on ice. In summary, these results suggest that lentinan exhibits gut anti-inflammatory activity through inhibition of IL-8 mRNA expression associated with the inhibition of NF- $\kappa$ B nuclear translocation which is triggered by TNFR1 internalization in intestinal epithelial cells.

PO 237

**THE ZEBRAFISH (*DANIO RERIO*) GALECTIN REPERTOIRE:  
MULTIPLE TANDEM-REPEAT TYPE GALECTINS WITH DISTINCT  
DOMAIN ORGANIZATION**

Hafiz Ahmed<sup>2</sup>, Mihai Nita-Lazar<sup>1</sup>, and Gerardo R. Vasta<sup>1</sup>

<sup>1</sup>*Department of Microbiology and Immunology, and*

<sup>2</sup>*Department of Biochemistry and Molecular Biology, University of Maryland School of Medicine,  
Program in the Biology of Model Systems, UMB, IMET, 701 East Pratt Street,*

*Baltimore, MD 21202, USA*

*GVasta@som.umaryland.edu*

Galectins, a family of  $\beta$ -galactoside-binding proteins, participate in a variety of biological processes, such as early development, immune regulation, and tumor evasion. However, the detailed mechanisms of their biological roles are not yet fully understood. In recent years, the use of zebrafish (*Danio rerio*) for the elucidation of biological roles of galectins in embryogenesis and innate immunity has expanded dramatically. All three major galectin types described in mammals, “proto”, “chimera”, and “tandem-repeat”, are present in zebrafish, and phylogenetic topologies confirm the expected clustering with their mammalian orthologues. In mammals, tandem-repeat galectins are defined as those in which two CRDs are joined by a functional linker peptide, and include galectin-4, -6, -8, -9, and -12. We previously characterized three prototype, one chimera, and one tandem-repeat (galectin-9-like; Drgal9-L1) galectins in zebrafish. In this study we identified additional galectin-9-like proteins of distinct domain organization. Interestingly, these newly identified zebrafish galectins and the previously described Drgal9-L1 are clustered in chromosome 15, which is syntenic with the human chromosome 17. The authenticity, chromosomal location, and expression of the galectin-9-like genes were verified by various molecular procedures [Supported by grants 1R01GM070589-01 and 5R01GM070589-06 from the National Institutes of Health to G.R.V.].

## PO 238

**C-TYPE LECTIN DC-SIGN INTERACTS WITH MAC-2 BINDING PROTEIN EXPRESSED ON COLORECTAL CARCINOMA THROUGH TUMOR-ASSOCIATED LEWIS GLYCANS**

Motohiro Nonaka<sup>1,2</sup>, Bruce Yong Ma<sup>1</sup>, Nobuko Kawasaki<sup>1</sup>, and Toshiyuki Kawasaki<sup>1</sup>

<sup>1</sup>Research Center for Glycobiotechnology, Ritsumeikan University, Shiga, 525-8577, Japan,

<sup>2</sup>Research Fellow of the Japan Society for the Promotion of Science, Japan

mnonaka@fc.ritsumei.ac.jp

Dendritic cell (DC)-specific intercellular adhesion molecule-3-grabbing nonintegrin (DC-SIGN) is one of the major C-type lectins expressed on myeloid DCs in lymphoid tissues, such as lymph nodes, tonsils and spleen, and IL-4/GM-CSF-treated monocyte-derived immature DCs (MoDCs). DC-SIGN functions as an adhesion receptor and mediates the binding and internalization of pathogens such as viruses (HIV and HCV), bacteria (*Mycobacterium*), fungi, and parasites. DC-SIGN specifically recognizes glycoconjugates containing mannose and fucose on many pathogens and shows high affinity with nonsialylated Lewis epitope (Le<sup>a</sup>/Le<sup>b</sup>/Le<sup>x</sup>/Le<sup>y</sup>) structures in a Ca<sup>2+</sup>-dependent manner.

Recently, we and the other group have reported that DC-SIGN recognizes human colorectal carcinoma cells through carcinoembryonic antigen (CEA). However, DC-SIGN ligands on colorectal carcinoma cells have not been fully characterized yet. In this study, we demonstrated that immature MoDCs adhere to COLO205 cells, a human colorectal carcinoma cells, although MoDCs and COLO205 cells did not agglutinate by themselves, respectively. These cell-cell adhesions between MoDCs and COLO205 were blocked by anti-DC-SIGN antibody, indicating that DC-SIGN is involved in the interactions. We then identified Mac-2 binding protein (Mac-2BP) expressed on COLO205 cells as a novel ligand for DC-SIGN. We showed that Lewis glycans were expressed on colon carcinoma-derived Mac-2BP and that  $\alpha$ 1-3, 4-fucose moieties of the Lewis glycans were important for the interaction with DC-SIGN.

Furthermore, we revealed that DC-SIGN-dependent cellular interactions between immature MoDCs and colorectal carcinoma cells significantly inhibited MoDC functional maturation. Our results suggest that Mac-2BP may provide a tolerogenic microenvironment for colorectal carcinoma cells through DC-SIGN-dependent recognition.

**References**

1. Nonaka, M., Ma, B. Y., Murai, R., Nakamura, N., Baba, M., Kawasaki, N., Hodohara, K., Asano, S., Kawasaki, T., *J Immunol*, **2008**, *180*, 3347-3356



PO 239

## STEREOSELECTIVE SYNTHESIS OF *P*-MODIFIED $\alpha$ -GLYCOSYL PHOSPHATES BY THE OXAZAPHOSPHOLIDINE APPROACH

Mihoko Noro, Shoichi Fujita, and Takeshi Wada

Department of Medical Genome Sciences, Graduate School of Frontier Sciences, The University of Tokyo, Bioscience Building 702, 5-1-5 Kashiwanoha, Kashiwa, Chiba 277-8562, Japan  
wada@k.u-tokyo.ac.jp

$\alpha$ -Glycosyl phosphate derivatives are widely known as constituents of biomolecules. They have repeating units of phosphoglycans, many of which are considered to be important factors in several biophenomena. Therefore, in order to clarify biomechanisms of them and apply to the drug development, an efficient method to obtain such biomolecules is required. In this study, we aim to a stereoselective synthesis of  $\alpha$ -glycosyl phosphate derivatives. Furthermore, we represent a new approach to the stereoselective modification of the intersugar phosphorus atom, intended the creation of new  $\alpha$ -glycosyl phosphate analogs with properties differing from natural biomolecules.

Oxazaphospholidine derivatives are known as an efficient chiral auxiliary to synthesize stereoregulated *P*-modified biomolecules.<sup>1</sup> We examined three strategies (Route A,<sup>2</sup> B,<sup>2</sup> and C<sup>1</sup> in Figure 1) to synthesize several  $\alpha$ -glycosyl 1-*O*-oxazaphospholidine derivatives as monomer units. Among them, the reaction of sugar derivatives bearing a free anomeric hydroxy group with 2-chloro-1,3,2-oxazaphospholidine derivatives gave the monomer units exclusively in high stereoselectivity. Using these oxazaphospholidine monomers, we achieved highly-stereoselective synthesis of  $\alpha$ -(*Rp*)- and  $\alpha$ -(*Sp*)-glycosyl phosphorothioate derivatives.

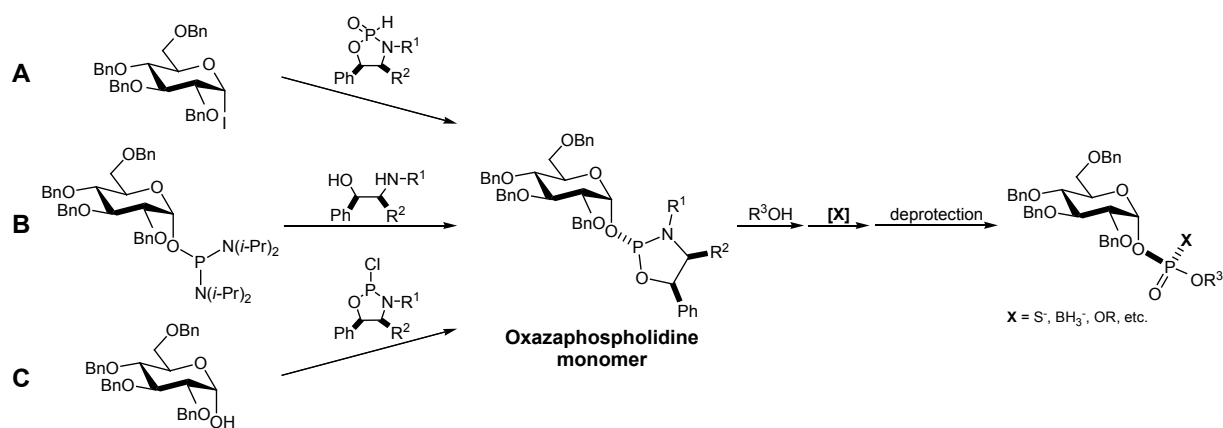

**Figure 1** Strategies of synthesis via the oxazaphospholidine approach.

### References

- Oka, N.; Yamamoto, M.; Sato, T.; Wada, T. *J. Ame. Chem. Soc.* **2008**, *130*, 16031-16037.
- Matsumura, F.; Oka, N.; Wada, T. *Org. Let.* **2008**, *10*, 5297-5300.

PO 240

SYNTHESIS OF FLUORINATED TUMOR-ASSOCIATED  
TF-ANTIGEN ANALOGSOberbillig Thomas<sup>1</sup>, Johannes Manuel<sup>2</sup>, Hoffmann-Röder Anja<sup>\*2</sup><sup>1</sup>Institut für Mikrotechnik Mainz GmbH, Carl-Zeiss-Strasse 18-20, D-55129 Mainz, Germany;<sup>2</sup>Institute of Organic Chemistry, Johannes-Gutenberg-University Mainz, Duesbergweg 10-14, D-55128 Mainz, Germany  
hroeder@uni-mainz.de

Due to their modified expression- and glycosylation profile, malignant cells show a characteristically altered glycosylation pattern. For example, the Thomsen-Friedenreich (TF) saccharide is a human tumor-associated carbohydrate antigen that is rarely found in normal tissue.<sup>1</sup> Over the years, many approaches to direct a specific and effective immune response towards this antigen by virtue of anticancer vaccines have been reported and the TF antigen has been used as a diagnostic marker for preclinical tumor detection.<sup>2</sup> A major obstacle associated with the development of carbohydrate-based cancer vaccines is the rapid *in vivo* degradation of the glycosidic bonds which will affect antigen presentation and specificity by loss of essential saccharide recognition elements. An interesting approach to circumvent hydrolytic degradation relies *inter alia* on the use of deoxyfluoro antigen mimetics.<sup>3</sup> Therefore, improved syntheses towards the preparation of fluorinated analogs of the TF antigen as well as its precursor TN antigen ( $\alpha$ GalNAc-O-Thr) will be presented. The corresponding fluorinated glycosyl amino acids are interesting building blocks for the solid phase peptide synthesis of structurally modified MUC1 glycopeptide vaccines.

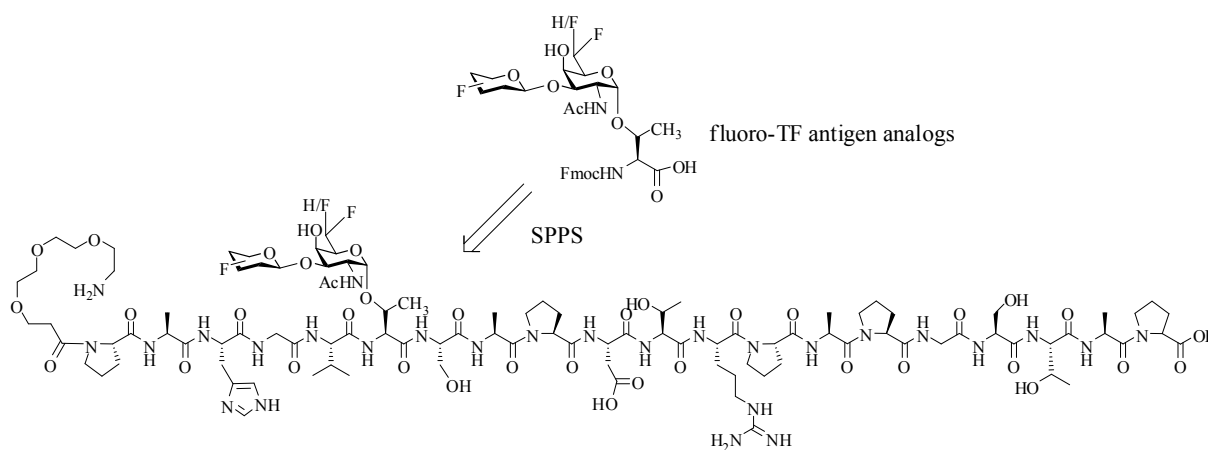

## References

1. S. I. Hakomori, *Adv. Cancer Res.* **1989**, 52, 257-331.
2. G. F. Springer, *J. Mol. Med.* **1997**, 75, 594-602.
3. S. Wagner, C. Mersch, A. Hoffmann-Röder, *Chem. Eur. J.*, **2010**, 16, 7319-7330.

PO 241

## CARBOHYDRATE BIS(OXAZOLINE) LIGANDS IN THE CYCLOPROPANATION OF INDOLES

Gülsüm Özüdüdu, Tobias Minuth, Mike M. K. Boysen

*Institute of Organic Chemistry, Gottfried Wilhelm Leibniz University Hannover,  
Schneiderberg 1B, D-30167 Hannover, Germany  
guelsuem.oezueduru@oci.uni-hannover.de*

Bis(oxazoline) ligands are one of the most successful classes of chiral inductors for metal-catalysed asymmetric reactions.<sup>1</sup> We have introduced carbohydrate-based bis(oxazolines) **1**<sup>2</sup> and found a strong impact of steric demand as well as electronic properties of the 3-O-substituents and the pyranose conformation on the enantioselectivity of asymmetric cyclopropanation reactions.<sup>3</sup> In addition, we have prepared 3-O-R *allo*Box derivatives **2** to investigate the influence of the configuration at pyranose position 3.<sup>4</sup> As a result of these studies we obtained optimised ligand 3-O-formyl *gluco*Box (**1**, R = formyl) leading to selectivities up to 95%ee.<sup>4</sup>

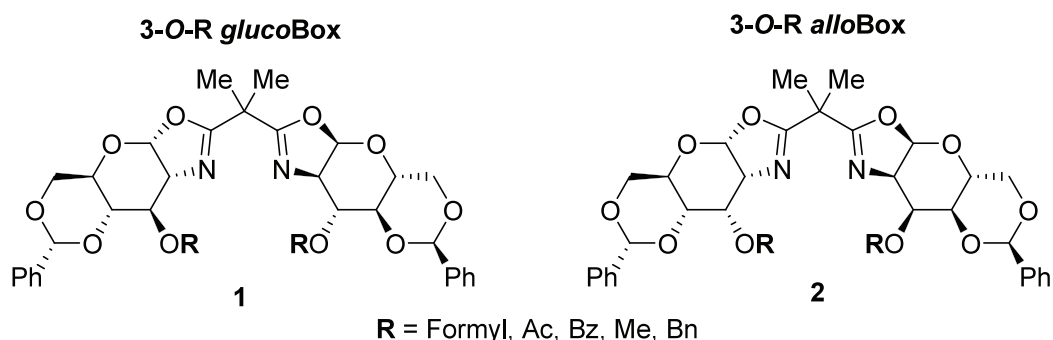

After the successful application of ligand 3-O-formyl *gluco*Box in the stereoselective synthesis of the natural product grenadamide,<sup>4b</sup> we are currently studying carbohydrate-based bis(oxazolines) **1** and **2** in the asymmetric cyclopropanation of *N*-protected indoles **3**, where we have achieved first promising results. Even though there is literature precedence for racemic cyclopropanations of these substrates<sup>5</sup> as yet there are surprisingly no reports on an asymmetric version of this reaction.

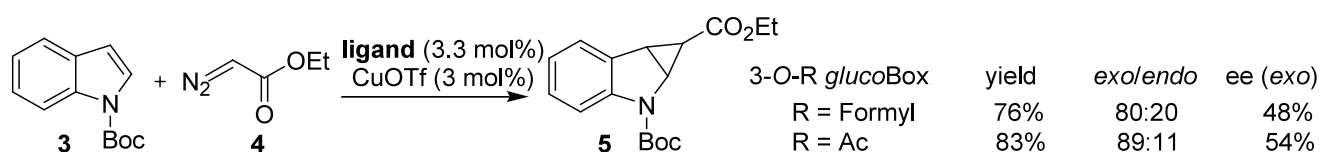

## References

- a) G. Desimoni, G. Faita, K. A. Jørgensen, *Chem. Rev.* **2006**, *106*, 3561-3651; b) H. A. McManus, P. J. Guiry, *Chem. Rev.* **2004**, *104*, 4151-4202.
- T. Minuth, M. Irmak, A. Groschner, T. Lehnert, M. M. K. Boysen, *Eur. J. Org. Chem.* **2009**, *7*, 997-1008.
- D. A. Evans, K. A. Woerpel, M. M. Hinman, M. M. Faul, *J. Am. Chem. Soc.* **1991**, *113*, 726-729.
- a) T. Minuth, M. M. K. Boysen, *Beilstein J. Org. Chem.* **2010**, *6*; b) T. Minuth, M. M. K. Boysen, *Synthesis* **2010**, 2799-2803.
- a) E. Wenkert, M. E. Alonso, H. E. Gottlieb, E. L. Sanchez, *J. Org. Chem.* **1977**, *42*, 3945-3949; b) F. Gnad, M. Poleschak, O. Reiser, *Tetrahedron Lett.* **2004**, *45*, 4277-4280; c) X. Zhang, S. Liu, M. Yan, *Chin. J. Chem.*, **2008**, *26*, 716-720.

PO 242

**sp<sup>2</sup>-IMINOSUGAR-TYPE O-, S- AND N-DISACCARIDE MIMICS:  
CONFORMATION-SENSITIVE GLYCOSIDASE INHIBITORS**

Elena M. Sánchez Fernández, Rocío Rísquez-Cuadro,<sup>1</sup> Carmen Ortiz Mellet,<sup>1</sup> Jesús Angulo,<sup>2</sup> Pedro Nieto,<sup>2</sup> and José. M. García Fernández<sup>2</sup>

<sup>1</sup>Dpto. Química Orgánica, Facultad de Química, Universidad de Sevilla, Spain,

<sup>2</sup>Instituto de Investigaciones Químicas, CSIC – Universidad de Sevilla, Spain  
mellet@us.es

The orbital (negative hyperconjugation) contribution to the generalized anomeric effect is highly increased in bicyclic glycomimetics with a pseudoamide-type endocyclic nitrogen atom (sp<sup>2</sup>-iminosugars),<sup>1</sup> which has been exploited for the stereoselective synthesis of configurationally stable  $\alpha$ -linked O, S- and N-glycoside mimics. Interestingly, these type of derivatives behave as aglycon-sensitive glycosidase inhibitors. The concept has been applied to the design of selective inhibitors of the neutral  $\alpha$ -glycosidases of the endoplasmic reticulum that exhibited remarkable antiproliferative activity in breast cancer MCF-7 cells.<sup>2</sup> We have now synthesized O, S- and N-disaccharide heteroanalogues of the natural disaccharides maltose and isomaltose and evaluated their glycosidase inhibitory activity against a series of glycosidases.<sup>3</sup> Striking differences were observed as a function of the nature of the glycosidic heteroatom. An NMR and computational analysis reveals significant differences in the conformational behaviour within each series that are probably at the origin of the observed results.

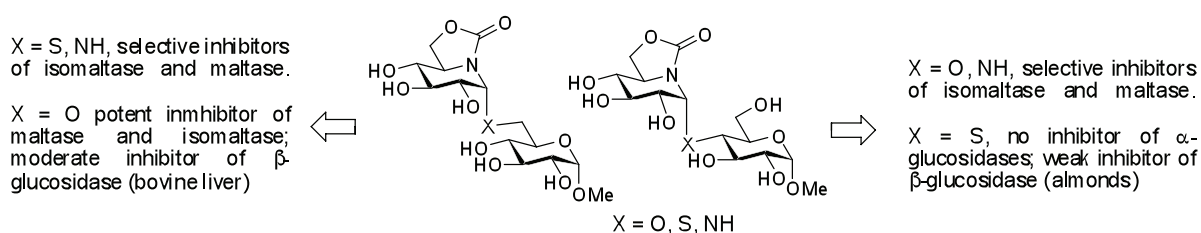

## References

- For recent publications on the synthesis and biological activity of sp<sup>2</sup>-iminosugars, see: (a) Z. Luan, K. Higaki, M. Aguilar-Moncayo, H. Ninomiya, K. Ohno, M. I. García-Moreno, C. Ortiz Mellet, J. M. García Fernández, Y. Suzuki, *ChemBioChem* **2009**, *10*, 2780. (b) B. Brumshtein, M. Aguilar-Moncayo, M. I. García-Moreno, C. Ortiz Mellet, J. M. García Fernández, I. Silman, Y. Shaaltiel, D. Aviezer, J. L. Sussman, A. H. Futerman, *ChemBioChem* **2009**, *10*, 1480. (c) M. Aguilar-Moncayo, C. Ortiz Mellet, J. M. García Fernández, M. I. García-Moreno, M. I. *J. Org. Chem.*, **2009**, *74*, 3585. (d) M. Aguilar-Moncayo, T. M. Gloster, J. P. Turkenburg, M. I. García-Moreno, C. Ortiz Mellet, G. J. Davies, J. M. García Fernández. *Org. Biomol. Chem.* **2009**, *7*, 2738. (e) Z. Luan, K. Higaki, M. Aguilar-Moncayo, L. Li, H. Ninomiya, E. Namba, K. Ohno, M. I. García-Moreno, C. Ortiz Mellet, J. M. García Fernández, Y. Suzuki, *ChemBioChem* **2010**, *11*, 2453. (f) M. Aguilar-Moncayo, M. I. García-Moreno, A. E. Stütz, J. M. García Fernández, T. M. Wroddnig, C. Ortiz Mellet, *Bioorg. Med. Chem.* **2010**, *18*, 7439.
- E. M. Sánchez-Fernández, R. Rísquez-Cuadro, M. Aguilar-Moncayo, M. I. García-Moreno, C. Ortiz Mellet, J. M. García Fernández. *Org. Lett.* **2009**, *11*, 3306.
- E. M. Sánchez-Fernández, R. Rísquez-Cuadro, M. Chasseraud, A. Ahidouch C. Ortiz Mellet, H. Ouadid-Ahidouch J. M. García Fernández, *Chem. Commun.* **2010**, 46, 5328.

PO 243

## CONCISE SYNTHESIS OF PROTECTED MONOSACCHARIDE UNITS USING FLUOROUS METHOD

Kenji Osumi, Kohtaro Goto, Hiroko Kawakami, Yuriko Hirose, Mamoru Mizuno

Laboratory of Glyco-organic Chemistry, The Noguchi Institute  
osumi@noguchi.or.jp

Since fluorous chemistry was first reported by Horváth and Rábai,<sup>1</sup> who used a fluorous biphasic system, it has been applied in various fields. For example, Curran and co-workers described a fluorous synthesis that is suitable as a strategic alternative to solid-phase synthesis.<sup>2</sup> This strategy is very efficient because, unlike the case for the solid-phase method, it does not inevitably resort to chromatography. Recently, we have also achieved the efficient synthesis of oligosaccharides through the use of various fluorous tags.<sup>3</sup> However, this improvement in efficiency is limited to the glycosylation steps. Monosaccharide units are still prepared by classical organic synthesis, requiring many steps and much labor. In this study, we describe the efficient synthesis of protected monosaccharide units by the use of fluorous methods.<sup>4</sup> Further, we describe the synthesis of a monosaccharide unit using the combination of fluorous chemistry and a microreactor as a single system.<sup>5</sup>

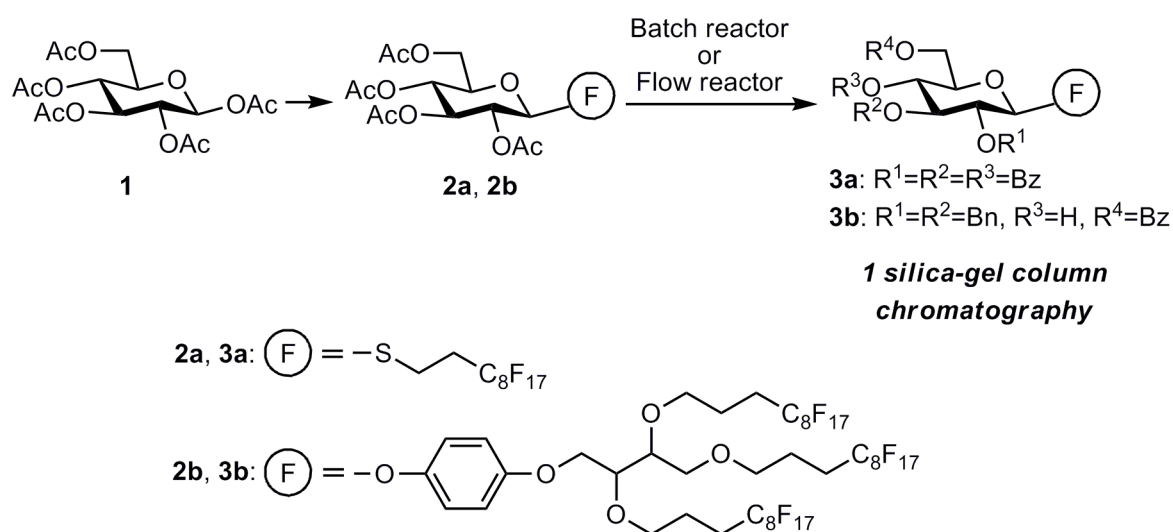

### References

1. I. T. Horváth, J. Rábai, *Science*, **1994**, 266, 72-75.
2. A. Studer, S. Hadida, R. Ferritto, S. -Y. Kim, P. Jeger, P. Wipf, D. P. Curran, *Science*, **1997**, 275, 823-826.
3. M. Mizuno, K. Goto, T. Miura, T. Inazu, *QSAR Comb. Sci.*, **2006**, 25, 742-752 and references cited therein.
4. K. Goto, M. Mizuno, *Tetrahedron Lett.*, **2007**, 48, 5605-5608.
5. H. Kawakami, K. Goto, M. Mizuno, *Chem. Lett.*, **2009**, 38, 906-907.

## PO 244

THE USE OF SIALYLGLYCOPEPTIDE FROM HEN'S EGG YOLK  
IN A LECTIN-BINDING ASSAYKenji Osumi,<sup>1</sup> Takashi Shirai,<sup>1</sup> Mamoru Mizuno,<sup>1</sup> Shu-ichi Sugahara,<sup>1,2</sup><sup>1</sup>The Noguchi Institute, <sup>2</sup>Asahi Kasei Corporation  
osumi@noguchi.or.jp

Sialylglycopeptide (SGP) is a naturally abundant *N*-glycan isolated from hen's egg yolk.<sup>1</sup> The Neu5Ac( $\alpha$ 2-6)Gal residue of SGP is known to bind with type-A human influenza virus hemagglutinin.<sup>2</sup> To develop a convenient tool for monitoring oligosaccharide-lectin interactions, we studied the use of SGP as a ligand in a lectin-binding assay. SGP was immobilized on microtiter plates (Immobilizer<sup>TM</sup> Amino, Nalge Nunc Int., NY) through lysine amino groups of SGP. The physical condition of SGP on the microtiter plates was estimated by performing binding studies both with *Sambucus sieboldiana* (SSA) and *Maackia amurensis* (MAM) lectins. The immobilized SGP was selectively recognized by SSA lectin with specificity for the Neu5Ac( $\alpha$ 2-6)Gal/GalNAc sequence, but not by MAM lectin with specificity for the Neu5Ac( $\alpha$ 2-3)Gal( $\beta$ 1-4)GlcNAc sequence. The association constant ( $K_a$ ) between SGP and SSA lectin of  $1.1 \times 10^6 \text{ M}^{-1}$  was obtained by using this binding assay. The value is similar to the  $K_a$  value of  $2.5 \pm 0.4 \times 10^7 \text{ M}^{-1}$  obtained for SSA lectin binding to the Neu5Ac( $\alpha$ 2-6)Gal sequence in an oligosaccharide derived from SGP by using a quartz-crystal microbalance assay.<sup>3</sup> The immobilized SGP also interacted with recombinant human influenza A virus hemagglutinin H1N5 protein. This interaction showed a significant difference compared with the results of control experiments performed using the same procedure but without the protein.

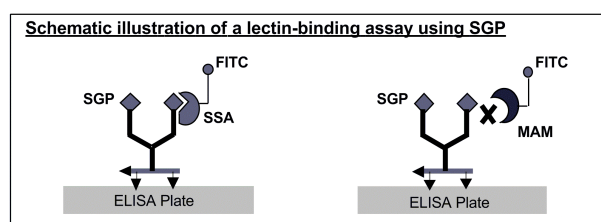
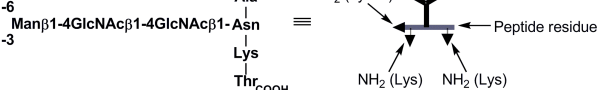
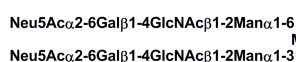
**Structure of SGP****References**

1. A. Seko, M. Koketsu, M. Nishizono, Y. Enoki, H. R. Ibrahim, L. R. Juneja, M. Kim, T. Yamamoto, *Biochim. Biophys. Acta*, **1997**, 1335, 23-32.
2. G. N. Rogers, J. C. Paulson, *Virology*, **1983**, 127, 361-373.
3. T. Mori, Y. Sekine, K. Yamamoto, Y. Okahata, *Chem. Commun.*, **2004**, 2692-2693.



## PO 245

## SYNTHESIS OF A TRISACCHARIDE PROBE AS A PUTATIVE VIRUS RECEPTOR

Gyorgyi Osztrovszky<sup>1,2</sup>, Mark von Itzstein<sup>2</sup><sup>1</sup>Department of Chemistry, Technical University of Denmark, Denmark<sup>2</sup>Institute for Glycomics, Griffith University, Australia

Dengue fever is caused by Dengue virus (DENV), an old mosquito-borne flavivirus. Mammalian host cell infection by DENV is mediated by the envelope glycoprotein (EGP) which covers all the exposed surface of the mature virus particle and is comprised of three exposed protein domains (DI, DII and DIII) as well as a transmembrane anchor. A previous study has reported that the tetrasaccharide Gal $\beta$ 1-4GlcNAc $\beta$ 1-3Gal $\beta$ 1-4Glc $\beta$  (Lacto-*N*-neotetraose, nLc<sub>4</sub>) shows effective inhibition of the mammalian cell infection of DENV.

We have had a growing interest in the identification of putative receptors for DENV and required the synthesis of a range of nLc<sub>4</sub>-related glycan structures that we felt would be of interest in further biological studies.

To this end we have investigated several approaches towards the synthesis of such trisaccharides that involved various protecting group manipulations. We found suitable conditions that led to the coupling of **1** glycosyl donor and **2** glycosyl acceptor affording the protected trisaccharide (**3**) efficiently, from which the desired final compound (**4**) can be synthesized. The prepared trisaccharide is now under biological investigation.

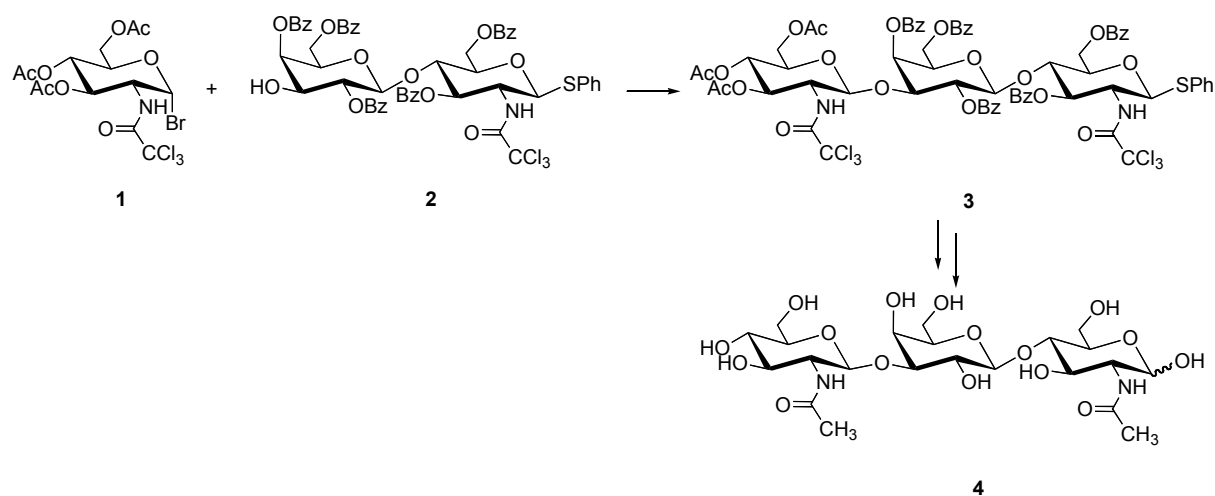

## PO 246

**MECHANISM OF MACROPHAGE STIMULATION BY FUCOIDAN  
FROM SPOROPHYLLS OF *UNDARIA PINNATIFIDA***

Yutaka Ozawa,<sup>1</sup> Jung-Bum Lee,<sup>1</sup> Kyoko Hayashi,<sup>1</sup> Keiko Yoshinaga,<sup>2</sup> Takahisa Nakano<sup>1</sup>  
and Toshimitsu Hayashi<sup>1</sup>

<sup>1</sup>Graduate School of Medicine and Pharmaceutical Sciences for Research, University of Toyama,  
2630 Sugitani, Toyama, Toyama 930-0194, Japan,

<sup>2</sup>Riken Vitamin Co., Ltd., 2-9-18 Misaki-Cho, Chiyoda-ku, Tokyo 101-8370, Japan  
lee@pha.u-toyama.ac.jp

Recently, virus infectious diseases have increasingly become serious problems. We have reported that fucoidan from sporophylls of *Undaria pinnatidida* possesses antiviral effects *in vitro* and *in vivo*.<sup>1,2)</sup> Those mechanisms were suggested to be direct antiviral effects and host-mediated mechanism such as stimulation of host immune function. In particular, macrophages are key participants of pathogen recognition and induction of innate immune responses. Thus, we examined the mechanisms of macrophage stimulation by the fucoidan.

The polysaccharides induced NO production by RAW264.7 cells in a dose-dependent manner. In addition, the fucoidan also induced the expression of cytokine mRNAs including TNF- $\alpha$ , IL-1 $\beta$ , IL-6, and INF-  $\alpha$ . The stimulatory effects of the fucoidan on NO production were inhibited in the presence of various signal transduction inhibitors including SP600125 (JNK/SAPK inhibitor), AG490 (JAK inhibitor), MG132 (inhibitor of I $\kappa$ B degradation), budenoside (NF- $\kappa$ B inhibitor) and geldanamycin (HSP90 inhibitor). Therefore, it was suggested that NF- $\kappa$ B was concerned with the activation of macrophages by fucoidan. On the other hands, scavenger receptor A was also suggested to involve the activation of the cells since the geldanamycin suppressed NO production.

**References**

1. Lee, J.-B., Hayashi, K., Hashimoto, M., Nakano, T., & Hayashi, T., *Chem. Pharm. Bull.*, **2004**, 52, 1091-1094.
2. Hayashi, K., Nakano, T., Hashimoto, M., Kan,ekiyo, K., & Hayashi, T. *Journal*, **2008**, 8, 109-116.

PO 247

## SYNTHESIS AND ANTICANCER ACTIVITY OF LUPANE-TYPE SAPONINS

Zbigniew Pakulski,<sup>a</sup> Piotr Cmoch,<sup>a</sup> Jana Okleštková,<sup>b</sup> and Miroslav Strnad<sup>b</sup><sup>a</sup>*Institute of Organic Chemistry, Polish Academy of Sciences,  
Kasprzaka 44/52, 01-224 Warszawa, Poland;*<sup>b</sup>*Laboratory of Growth Regulators, Palacky University & Institute of Experimental Botany ASCR,  
Slechtitelu 11, CZ-783 71 Olomouc, Czech Republic  
pakul@icho.edu.pl*

Saponins are a large family of steroid or triterpenoid glycosides, widely distributed in plants and in some marine organisms, in which hydrophilic mono- or oligosaccharides are attached to a hydrophobic sapogenin backbone.<sup>1</sup> They possess promising biological and pharmaceutical properties, including antitumor, antiviral, antifungal and antiinflammatory activities.<sup>2</sup> Lupeol (**1**), betulin (**2**) and betulinic acid (**3**) are found in many plant species, especially they are highly abundant components of outer birch bark. Some derivatives of compounds **1-3** showed high anti-HIV activity, as well as significant cytotoxicity and anti-tumor properties. Although betulin and lupeol themselves are usually inactive, betulinic acid was found to be selectively cytotoxic against several cancer cell lines.<sup>3</sup> In this communication, we will present our results on the synthesis and anticancer activity of mono- and trisaccharide derivatives of lupeol, betulin and betulinic acid.<sup>4</sup>

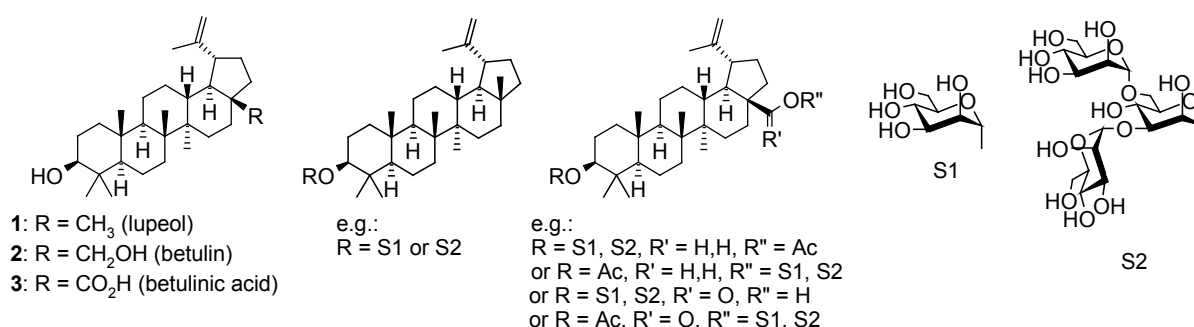

## References

- Hostettmann, K.; Marston, A., *Saponins*, Cambridge University Press: Cambridge, UK, **1995**.
- (a) Nakamura, T. et. al., *Biol. Pharm. Bull.* **1996**, *19*, 564; (b) Hu, K. et. al., *Planta Med.* **1996**, *62*, 573; (c) Ikeda, T. et. al., *Biol. Pharm. Bull.* **2000**, *23*, 363; (d) Takechi, M. et. al., *Phytochemistry* **1991**, *30*, 3943; (e) Mimaki, Y. et. al., *Phytochemistry* **1995**, *38*, 1279; (f) Yamashita, K. et. al., *Clin. Chim. Acta* **2002**, *325*, 91.
- (a) Sami, A. et. al., *Eur. J. Pharm. Sci.* **2006**, *29*, 1; (b) Sun, I.-C. et. al., *J. Med. Chem.* **1998**, *41*, 4648; (c) Wang, B. H. et. al., *Phytochemistry* **1996**, *41*, 55.
- (a) Pakulski, Z., *Polish J. Chem.* **2005**, *79*, 361; (b) Cmoch, P.; Pakulski, Z.; Swaczynová, J.; Strnad, M., *Carbohydr. Res.* **2008**, *343*, 995.

## PO 248

## STRUCTURAL CHARACTERISATION OF MARINE GLYCOSAMINOGLYCANS

Charalampos Panagos<sup>1</sup>, Derek Thomson<sup>2</sup>, Claire Moss<sup>2</sup>, Charlie Bavington<sup>2</sup>, Dušan Uhrín<sup>1</sup>

<sup>1</sup>University of Edinburgh, EaStCHEM, School of Chemistry, King's Buildings,  
West Mains Road, Edinburgh, EH9 3JJ, UK.

<sup>2</sup>Glycomar Ltd, European Centre for Marine Biotechnology, Dunstaffnage Marine Laboratory,  
Dunbeg, Oban, Argyll, PA37 1QA, Scotland  
dusan.uhrin@ed.ac.uk

Glycosaminoglycans (GAGs) are a group of structurally related polysaccharides found as the carbohydrate moieties of proteoglycans and sometimes as free polysaccharides. They are widely distributed throughout the animal kingdom<sup>1</sup>. GAGs are usually isolated from animal tissues, e.g. pharmaceutical grade heparin is derived from mucosal tissues of slaughtered meat animals, porcine intestines or bovine lungs<sup>2</sup>. During the past decade there has been an increased interest in analysing sulfated polysaccharides from marine organisms, such as fucosylated chondroitin sulphates from Echinoderms<sup>3</sup>, due to their unique structures and properties.

Here we report a structure of an oversulfated dermatan sulfate, **I**, isolated from a sea squirt, as determined by a combination of 2D HSQC, 2D HSQC-TOCSY, 2D HMBC and 2D HSQC-NOESY. This polysaccharide has significant anti-inflammatory, but not anticoagulant properties and is resistant to enzymatic depolymerisation. In order to prepare low molecular fragments of **I**, free radical depolymerisation was used. Such fragments are of interest as potential active compounds but can also help during the structure elucidation process. However, radical depolymerisation generates heterogeneous samples. In order to better understand this procedure we have analyzed, using NMR, the products of the free radical depolymerisation of porcine dermatan sulfate.

### References

1. Cássaro CM, Dietrich CP. Distribution of sulfated mucopolysaccharides in invertebrates. *J Biol Chem.* Apr 1977;252(7):2254-2261.
2. Linhardt RJ, Gunay NS. Production and chemical processing of low molecular weight heparins. *Semin Thromb Hemost.* 1999;25 Suppl 3:5-16.
3. Mourão PA, Pereira MS, Pavão MS, et al. Structure and anticoagulant activity of a fucosylated chondroitin sulfate from echinoderm. Sulfated fucose branches on the polysaccharide account for its high anticoagulant action. *J Biol Chem.* Sep 1996;271(39):23973-23984.

PO 249

**CONSTRUCTION OF GLYCAN MICROARRAYS, FACILE, SITE-SPECIFIC  
IMMOBILIZATIONS OF DIVERSE UNMODIFIED GLYCANS  
ON HYDRAZIDE-DERIVATIZED GLASS SLIDES**Sungjin, Park, Jaeyoung Pai, Injae Shin

*Center for Biofunctional Molecules, Department of Chemistry,  
Yonsei University, Seoul 120-749, Korea  
injae@yonsei.ac.kr*

Glycan microarrays have received great attention as high-throughput analytic tools in studies of carbohydrate-mediated biological processes. Most of the methods employed to fabricate glycan microarrays rely on the immobilization of modified glycans on the properly derivatized surfaces. This immobilization strategy requires the availability of modified glycans whose syntheses in many cases are time-consuming and difficult. We have developed a simple and direct immobilization technique that involves a one-step, site-specific attachment of diverse unmodified glycans to the hydrazide-derivatized glass surface. To demonstrate the generality of this direct immobilization method, we examined its use for the construction of carbohydrate microarrays containing a variety of glycans. The results of protein and cell-binding experiments indicate that the glycan microarrays, prepared by using this methodology, are applicable to the rapid evaluation of glycan-mediated biomolecular interactions and the determination of quantitative binding affinities between carbohydrates and proteins.

**References**

1. Sungjin Park, Injae Shin., *Bioconjugate Chem.*, **2009**, *20*, 155-162
2. Sungjin Park, Injae Shin., *Angew. Chem., Int. Ed.*, **2002**, *41*, 3180-3182.

## PO 250

ONE-STEP, ACID-MEDIATED METHOD FOR MODIFICATION  
OF GLASS SURFACES WITH N-HYDROXYSUCCINIMIDE ESTERS  
AND ITS APPLICATION TO THE CONSTRUCTION OF MICROARRAYS  
FOR STUDIES OF BIOMOLECULAR INTERACTIONS

Sungjin Park, Jaeyoung Pai, Injae Shin

*Center for Biofunctional Molecules, Department of Chemistry, Yonsei University,  
Seoul 120-749, Korea*

*injae@yonsei.ac.kr; junch@yonsei.ac.kr*

Microarray technologies have received considerable attention owing to the fact that they serve as powerful tools for the high-throughput analysis of biomolecular interactions and the identification of bioactive substances that bind to biomolecules. Most of the current methods used to construct microarrays rely on the immobilization of substances on properly derivatized surfaces. Among various functional groups used for this purpose, the *N*-hydroxysuccinimide (NHS) ester group has been largely employed because it can be readily reacted with amine or hydrazide functionalities in substances of interest. However, the NHS ester group is usually introduced onto the surface of a glass slide by employing inconvenient and time-consuming multistep processes. In recent studies, we have developed an efficient, single step method for derivatization of glass surfaces with NHS ester groups that takes advantage of an acid-mediated reaction of NHS ester functionalized dimethylsilylanes with silanols on the glass surface. Conditions for the surface modification procedure that utilize TfOH rather than Sc(OTf)<sub>3</sub> were found to be superior. Protein and RNA-binding experiments show that glass surfaces modified by employing this method are suitable for efficient immobilization of various substances that are appended by amine, hydrazide, and alcohol functionalities. The microarrays, generated in this way, are applicable to procedures for rapid analysis of protein–protein, protein–glycan, protein–small molecule, and peptide–RNA interactions, as well as for profiling enzyme activities. The newly developed acid-mediated, glass surface modification method should be generally applicable to the preparation of various functional group-modified surfaces.

### References

1. Sungjin Park, Jaeyoung Pai, Eun-Hee Han, Chul-Ho Jun and Injae Shin, *Bioconjugate Chem*, **2010**, *241*, 1246-1253
2. Yeon, Y.-R., Park, Y. J., Lee, J.-S., Park, J.-W., Kang, S.-G., and Jun, C.-H., *Angew. Chem., Int. Ed.*, **2008**, *47*, 109–112



## PO 251

SYNTHESIS OF A TRISACCHARIDE FRAGMENT OF THE  
OUTER CORE REGION OF THE  
*Burkholderia cepacia* pv. *vietnamiensis* LIPOOLIGOSACCHARIDEEmiliano Bedini,<sup>1</sup> Luigi Cirillo<sup>1</sup> Michelangelo Parrilli<sup>1</sup><sup>1</sup>Department of Organic Chemistry and Biochemistry, University of Naples "Federico II",  
Complesso Universitario Monte S. Angelo, via Cintia 4, I-80126 Naples, Italy

*Burkholderia cepacia* complex (*Bcc*) comprehends diverse *Burkholderia* species, each characterized from being an opportunistic pathogen in patients with cystic fibrosis. Since *Bcc* is inherently resistant to antibiotic treatment, the development of convenient vaccines represents a desirable resource for the therapeutic approach. The preparation of synthetic glycoconjugate vaccines, where an oligosaccharide hapten is linked to an immunogenic protein, attracts more and more efforts for the treatment of several human pathologies.<sup>1</sup> Due to the high number of pathogenic *Bcc* bacterial strains, usually exposing different saccharide structures on their cell surface, the choice of the oligosaccharide hapten is rather large. On the basis of recent literature data,<sup>2</sup> an epitope possessing the general structure Sug-(1→3)- $\alpha$ -D-GalNAc(1→3)- $\beta$ -D-GalNAc was identified to be exposed on the cell surface of several *Bcc* species, as outer core region of lipooligosaccharides (LOSs) or repeating unit of O-chain of lipopolysaccharides (LPSs). Therefore, this epitope could be identified as a good hapten candidate for the development of a glycoconjugate to be tested as a vaccine against a broad range of *Bcc* pathogens. In this communication the focus is on the first synthesis of the trisaccharide fragment of the outer core region of the *Burkholderia cepacia* pv. *vietnamiensis* LOS. The trisaccharide was designed with a  $\beta$ -allyl aglycone, that could be further manipulated for conjugation with an immunogenic protein. The optimization of the conditions for the key glycosylation steps in terms of yield and stereoselectivity will be discussed.

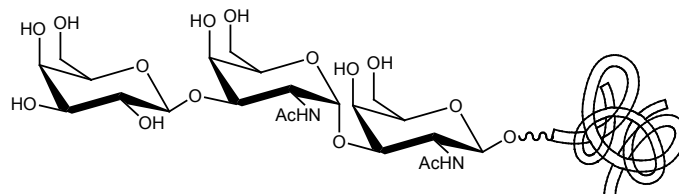
**References**

1. Astronomo, R.D.; Burton, D.R. *Nat. Rev. Drug Discov.* **2010**, *9*, 308-324.
2. (a) Ortega, X.; Hunt, T.A.; Loutet, S.; Vinion-Dubiel, A.D.; Datta, A.; Choudhury, B.; Golberg, J.B.; Carlson, R.; Valvano, M.A. *J. Bacteriol.* **2005**, *187*, 1324-1333; (b) Ieranò, T.; Silipo, A.; Sturiale, L.; Garozzo, D.; Brookes, H.; Khan, C.M.A.; Bryant, C.; Gould, F.F.; Corris, P.A.; Lanzetta, R.; Parrilli, M.; De Soya, A.; Molinaro, A. *Glycobiology* **2008**, *18*, 871-881; (c) Ieranò, T.; Silipo, A.; Sturiale, L.; Garozzo, D.; Bryant, C.; Lanzetta, R.; Parrilli, M.; Aldridge, C.; Gould, F.K.; Corris, P.A.; Khan, C.M.A.; De Soya, A.; Molinaro, A. *Glycobiology* **2009**, *19*, 1214-1223.

PO 252

## A NOVEL ACCESS TO VERSATILE UREA-LINKED AMINOSUGAR DIMERS

Emiliano Bedini,<sup>1</sup> Luigi Cirillo,<sup>1</sup> Michelangelo Parrilli<sup>1</sup><sup>1</sup>*Department of Organic Chemistry and Biochemistry, University of Naples "Federico II",  
Complesso Universitario Monte S. Angelo, via Cintia 4, I-80126 Naples, Italy*

A particular area of interest in glycomimetics is that of pseudosaccharides, which are oligosaccharides whose acid-labile glycosidic bonds have been substituted with non-acetal linkages. Among these, urea-linked oligomers emerged because of the high chemical and biological potential of urea moieties, as well as their capability to self-assemble into highly ordered supramolecular architectures. Several methods have been documented to obtain urea-linked pseudosaccharides.<sup>1</sup> In this communication, we report a novel procedure affording symmetrical urea-linked aminosugar 2,2'-dimers through a modification of the known<sup>2</sup> oxazolidinone ring closure reaction from a 2,3-aminoalcohol. A detailed study of the parameters influencing the dimerization process was conducted. The obtained dimers were demonstrated to be versatile building blocks for the synthesis of higher linear and cyclic pseudosaccharides<sup>3</sup> as well as to design a family of self-assembling derivatives with potential properties as low molecular weight organogelators.

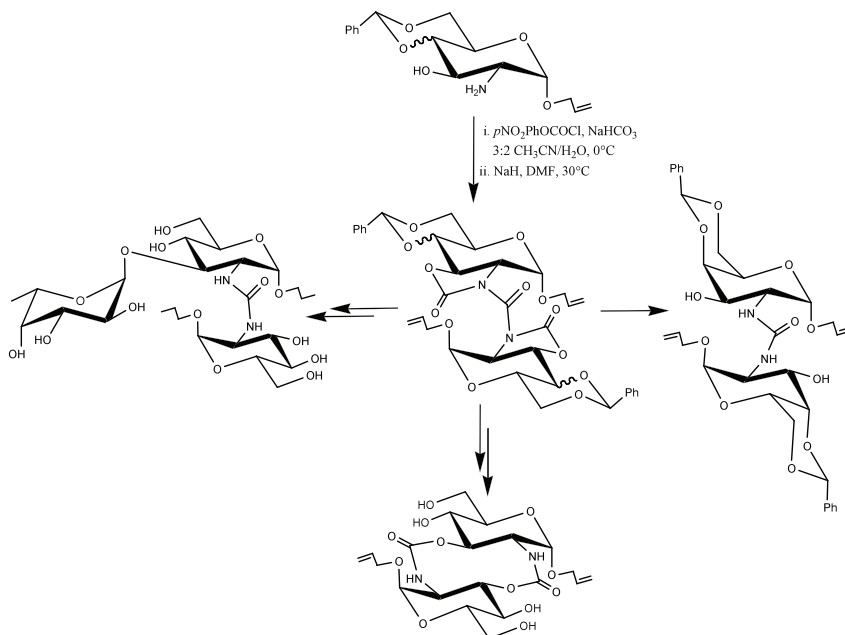
**References**

1. Jiménez Blanco, J.L.; Ortega-Caballero, F.; Ortiz Mellet, C.; García Fernández, J.M. *Beilstein J. Org. Chem.* **2010**, *6*, doi:10.3762/bjoc.6.20.
2. a) K. Benakli, C. Zha, R. J. Kerns, *J. Am. Chem. Soc.* **2001**, *123*, 9461–9462; b) D. Crich, A. U. Vinod, *Org. Lett.* **2003**, *5*, 1297–1300; c) S. Manabe, K. Ishii, Y. Ito, *J. Am. Chem. Soc.* **2006**, *128*, 10666–10667.
3. Cirillo, L.; Silipo, A.; Bedini, E.; Parrilli, M. *Eur. J. Org. Chem.* **2010**, 4062–4074.

PO 253

**EXPLOITATION OF PUBLIC PROTEIN DATA AND SUBCELLULAR FRACTIONATION TO IDENTIFY POST TRANSLATIONAL MODIFICATIONS IN THE MODEL PLANT *ARABIDOPSIS THALIANA***

Harriet T. Parsons, Hiren J. Joshi and Joshua L. Heazlewood

*Joint BioEnergy Institute and Physical Biosciences Division, Lawrence Berkeley National Laboratory, Berkeley, CA 94720, USA*  
*htparsons@lbl.gov, hjjoshi@lbl.gov*

Plants glycoproteins are essential components of growth, development, pathogen interactions, stress responses and cell wall integrity. However, the variety and importance of roles carried out by glycosylated proteins are relatively poorly understood compared to yeast and mammalian systems. Manipulation of biosynthetic pathways in plants is likely to be important in the development of future engineered crops, and will require detailed knowledge of processes such as feedback signalling and trafficking, in which glycosylation will no doubt prove to be essential. The plant Golgi apparatus is enriched in glycoproteins in transit to their final, functionally active destinations. Recently we have developed a method for the preparation of high-purity *Arabidopsis thaliana* Golgi vesicles and proteomic characterisation by mass spectrometry. However, peptides carrying large side chains are less easily detected by mass spectrometry than non-glycosylated peptides, so identification of glycosylation sites are excluded from these analyses. Consequently, we are developing a strategy by which we compare proteomic analysis of purified plant Golgi vesicles before and after chemical deglycosylation using TFMS, in an effort to identify modified peptides and sites of glycosylation.

Complementary to the mass spectrometric analysis, we are developing software tools (ModHunter) that allow the mapping of potential post-translational modifications in *Arabidopsis thaliana* proteins. Employing the array of existing mass spectrometric data, single nucleotide polymorphisms (SNPs) from natural variants of *Arabidopsis* in combination with other bioinformatics techniques we hope to predict protein regions that are likely sites of modification, and validate potential carbohydrate laden peptides from the experiments outlined above.

High-throughput, systems biology approaches to plant protein glycosylation such as this will play a vital role in expanding this area of knowledge.

## PO 254

ANALYSIS OF N-GLYCANS OF THE EASTERN OYSTER  
(*CRASSOSTREA VIRGINICA*)

Katharina Paschinger,<sup>1</sup> Simone Kurz,<sup>1</sup> Ebrahim Razzazi-Fazeli,<sup>2</sup>  
Gerardo Vasta<sup>3</sup> and Iain B. H. Wilson<sup>1</sup>

<sup>1</sup>*Department für Chemie, Universität für Bodenkultur Wien, 1190 Wien, Austria,*

<sup>2</sup>*Vetomics Core Facility for Research, Veterinärmedizinische Universität,  
A-1210 Wien, Austria*

<sup>3</sup>*Department of Microbiology and Immunology, University of Maryland School of Medicine,  
Baltimore, MD 21202, USA*

*katharina.paschinger@boku.ac.at*

The Eastern Oyster (*Crassostrea virginica*) is a resident mollusc off the shores of the eastern coast of the United States and was formerly of great commercial value – however, a number of factors such as over-harvesting, pollution and disease have devastated stocks. One of these diseases is Dermo disease caused by the protozoan *Perkinsus marinus*, which degrades a major plasma defence protein in the oyster (so-called dominin) and is taken up by the major immune cells (haemocytes) in the haemolymph via a galectin-dependent system. In order to examine the glycomic potential of the host organism, the N-glycans were released from glycopeptides prepared from both the plasma and haemocytes. Normal-phase HPLC analysis in combination with MALDI-TOF MS suggested the presence of two major subsets of glycans with those of earlier retention time showing mass differences, as compared to those of later retention time, of  $m/z$  80 or 102. Selected fractions were subject to exoglycosidase digestions and MS/MS – the data were compatible with ‘blocking’ of antennal galactose residues by sulphation of the earlier-eluting glycans. Furthermore, some of the galactose residues were modified by methylated and non-methylated  $\alpha$ -N-acetylgalactosamine. Some of core and peripheral N-acetylglucosamine residues were fucosylated; in the haemocytes, there is also evidence of core difucosylation of a subset of N-glycans as well as some oligomannosidic forms. In summary, the Eastern Oyster expresses a range of apparently novel N-glycans, with sulphate, GalNAc and fucose residues, on its plasma and haemocyte proteins.

PO 255

**MAJOR GLYCOLIPIDS OF NOCARDIA  
CYRIACIGEORGICA- IMMUNOCHEMICAL STUDIES**

Paściak Mariola,<sup>1,2</sup> Paulina Gąsecka<sup>1</sup>, Sabina Górską-Frączek<sup>1,2</sup> and Gamian Andrzej<sup>1,2</sup>

<sup>1</sup>*Institute of Immunology and Experimental Therapy Polish Academy of Sciences,  
Rudolfa Weigla 12, 53-114 Wrocław, Poland,*

<sup>2</sup>*Wrocław Research Centre EIT+, Stabłowska 147/149, 54-066 Wrocław, Poland  
pasciak@iitd.pan.wroc.pl*

Nocardiosis is a localized or disseminated infection caused by actinomycete *Nocardia* spp. that affects both normal and immunocompromised patients. Nocardiosis is considered as not frequent diseases in humans, where a classical pathology is sporadically described. The true incidence of *Nocardia* infections is always poorly documented because of difficulties in identifying the bacteria. It was estimated that 150 to 250 new cases of nocardiosis occur each year in France, and 90-140 cases in Italy every year <sup>1,2</sup>.

*Nocardia cyriacigeorgica* taxon was described in 2001<sup>3</sup> and up to now, the number of the case reports has been increasing <sup>4,5</sup>. These microorganisms cause opportunistic infections relatively often, but their proper classification is difficult and they may be mistaken with other similar taxa.

Lipid compounds of the nocardial cell envelope are useful taxonomic markers: mycolic acids and polar lipids, mainly glycolipids and phospholipids. This work is dedicated for structural investigation of glycolipids from *N. cyriacigeorgica*.

Polar lipids were isolated by chloroform-methanol extraction and subsequently purified using chromatographic methods. Structural studies were carried out utilizing chemical analysis, GLC-MS and MALDI-TOF.

In *N. cyriacigeorgica* cells two major glycolipids were found, these compounds are also present in other representatives of *Nocardia* genus studied. Major glycolipids were found to be a phosphatidylinositolmannosides, which differed in number of mannose residues. The distribution of the fatty acids was similar in both glycolipids, they contained hexadecanoic acids, octadecanoic acids and tuberculostearic acids.

In ELISA tests weak cross-reactivity of both glycolipids with rabbit sera against different *Nocardia* species was observed.

**References**

1. Farina C., Boiron P., Ferrari I., et al., *Eur. J. Epidemiol.*, **2001**, 17, 1019-1022.
2. Boiron P., Provost F., Chevrier G., et al., *Eur. J. Clin. Microbiol. Infect. Dis.*, **1992**, 1, 709-714.
3. Yassin A.F., Rainey F.A., Steiner U., *Int. J. Syst. Evol. Microbiol.*, **2001**, 51, 1419-1423.
4. Schlager R., Huard R. C., Della-Latta P., *J. Clin. Microbiol.* **2008**, 46, 265-273.
5. Akcaglar S., Yilmaz E., Heper Y., et al., *Int. J. Infect. Dis.*, **2008**, 12, 335-8.

PO 256

**5-AMINO-2-PYRIDYL 1-THIOGLYCOSIDES IN SYNTHESIS  
OF GLYCOCONJUGATES CONTAINING GLYCINE EPITOPE AS A  
POTENTIAL IMMUNOMODULATORY FACTOR**

Gabriela Pastuch-Gawołek,<sup>1</sup> Katarzyna Dzierzba,<sup>2</sup> Andrzej Gamian,<sup>2,3</sup> Wiesław Szeja<sup>1</sup>

<sup>1</sup>*Silesian University of Technology, Department of Organic Chemistry,  
Bioorganic Chemistry and Biotechnology, Krzywoustego 4, 44-100 Gliwice, Poland*

<sup>2</sup>*Wroclaw Medical University, Department of Medical Biochemistry,  
Chalubinskiego 10, 50-368 Wroclaw, Poland*

<sup>3</sup>*Polish Academy of Sciences, Institute of Immunology and Experimental Therapy,  
Weigla 12, 53-114 Wroclaw, Poland  
gabriela.pastuch@polsl.pl*

Non-sugar substituents are frequently localized in the natural bacterial structures e.g. in peptidoglycans, lipoteichoic acids and particularly in lipopolysaccharides (LPS).<sup>1-2</sup> Their biological importance has not been explained sufficiently. Structural and functional studies under them are complicated because of their lability. The glycine epitope presented in these structures could play an important role in the immunological response after bacterial infections occurred during sepsis or septic shock. Modified thioglycosides conjugated with glycine residue could be used for broadly reactive antibodies production which would be able to neutralize endotoxin biological activity. The biological properties of this antigen would be helpful in vaccines construction against bacterial sepsis induced by different bacterial strains which are the most frequently isolated organisms responsible for severe sepsis. Sepsis leads to multiple organs dysfunction syndrome (MODS), acute respiratory distress syndrome (ARDS) and mostly to death.

We prepared 5-amino-2-pyridyl 1-thioglycosides derivatives of monosugars such as D-glucose and D-galactose as well as disaccharides: melibiose, lactose and maltose according earlier published procedure.<sup>3-4</sup> These 1-thioglycosides were acylated with N-acetylglycine. Obtained compounds containing glycine epitope should be introduced to therapeutics as potential vaccines against pathological bacterial strains contributed to sepsis propagation.

**Acknowledgement** Research studies part-financed by the Polish State Committee for Scientific Research (Grant No. N N209 186338), the PhD thesis framework is supported by research fellowship within POKL.08.02.02-02-001/10.

### References

1. Gamian A., Mieszala M., Katzenellenbogen E., Czarny A., Zal T., Romanowska E., *FEMS Immunol Med Microbiol.*, **1996**, 13, 261-268.
2. Zielińska-Kuźniarz K., Mieszala M., Lipiński T., Gamian A., *Postępy Hig. Med. Dośw.*, **2003**, 57, 473-483.
3. Pastuch G., Szeja W., *Carbohydr. Lett.*, **1997**, 2, 281-286.
4. Pastuch G., Wandzik I., Szeja W., *Tetrahedron Lett.*, **2000**, 41,9923-9926.



PO 257

**CONJUGATES OF URIDINE AND 1-THIOSUGAR DERIVATIVES  
AND THEIR BIOLOGICAL ACTIVITY**Gabriela Pastuch-Gawolek,<sup>1</sup> Marta Grec,<sup>1</sup> Roman Komor,<sup>1</sup> Piotr Świerk,<sup>1</sup> Wiesław Szeja<sup>1</sup>

<sup>1</sup>*Silesian University of Technology, Department of Organic Chemistry, Bioorganic Chemistry and Biotechnology, Krzywoustego 4, 44-100 Gliwice, Poland*  
*gabriela.pastuch@polsl.pl*

Glycoconjugates play a fundamental role in many important biological processes.<sup>1</sup> Enzymes responsible for creating the glycosidic bonds in nature belong to the family of glycosyltransferases (GTs). Studies of control of glycosyltransferases activity are interesting and evolving course of action. Inhibition of these enzyme leads to the modulation of oligosaccharide biosynthesis and enables us to study their biological functions. Some of such inhibitors might be of therapeutic interest. Glycosyltransferases inhibitors designing is generally based on analogies between the three different moieties composing GTs natural substrates in which the diphosphate linkage plays a key role in most GTs activities.<sup>2</sup>

We prepared a wide range of GTs natural substrates analogues using aryl and heteroaryl 1-thioglycosides as glycosyl units connected to uridine by amide bond with or without a spacer. We also synthesized compounds in which various protected 5'-uridine derivatives were connected to 1-thiosugars with thiophosphoesters fragment. We believe that the presence of sulfur atom instead of glycosidic oxygen atom increases the stability of sugar-aglycon linkage against enzymatic cleavage.<sup>3</sup> In this way we obtained several uridine derivatives containing different types of diphosphate mimic linkers. Studies of biological properties of these compounds revealed that some of them exhibited antiviral activity against classical swine fever virus (CSFV).<sup>4</sup> We also tested biological activity of presented glycoconjugates paying special attention to possibility of 1,4- $\beta$ -galactosyltransferase inhibition.

**Acknowledgement** Research studies part-financed by the European Union within the European Regional Development Fund (POIG.01.01.02-14-102/09).

**References**

1. Weijers C.A.G.M., Franssen M.C.R., Visser G.M., *Biotechnol. Adv.*, **2008**, 26, 436-456.
2. Jung, K. H.; Schmidt, R. R., *Glycosyltransferase Inhibitors* in: „Carbohydrate-Based Drug Discovery”, C.-H. Wong (Ed.), Wiley-VCH, **2003**, 23, 609-659.
3. Zhu X., Stolz F., Schmidt R.R., *J. Org. Chem.*, **2004**, 69, 7367-7370.
4. Szewczyk B., Tyborowska J., Krol E., Szeja W.: *J. Biotechnol.*, **2005**, 118S1, S84-S85.

PO 258

## SYNTHESIS OF C-5 SUBSTITUTED URIDINE DERIVATIVES WITH POSSIBILITY OF DIVALENT METAL ION COORDINATION

Jadwiga Paszkowska,<sup>1</sup> Ilona Wandzik<sup>1</sup>, Tadeusz Bieg<sup>1</sup>

<sup>1</sup>Silesian University of Technology, Faculty of Chemistry, Department of Organic Chemistry, Bioorganic Chemistry and Biotechnology, Krzywoustego 4 Street, 44-100 Gliwice, Poland  
jadwiga.paszowska@polsl.pl

Glycosyltransferases are enzymes involved in the biosynthesis of glycoconjugates and modulation of their activity by efficient inhibitors is of great importance [1].

The majority of glycosyltransferases utilise donors containing uridine diphosphate leaving group (UDP). UDP-sugars are known to bind to the active site of the enzyme by coordination to divalent metal ion through pyrophosphate group. The aim of our study was the synthesis of C-5 substituted uridine derivatives with potential ability for coordination to  $M^{2+}$ . These compounds could be recognized by glycosyltransferases and act as inhibitors.

In order to construct target compounds: **1** and **2** selectively protected uridine derivatives were coupled with appropriate aromatic systems. Compounds in series **1** were synthesised using protected salicyl chlorides while compound **2** was synthesised from 2-bromo-2'-hydroxyacetophenone. Synthetic details will be presented.

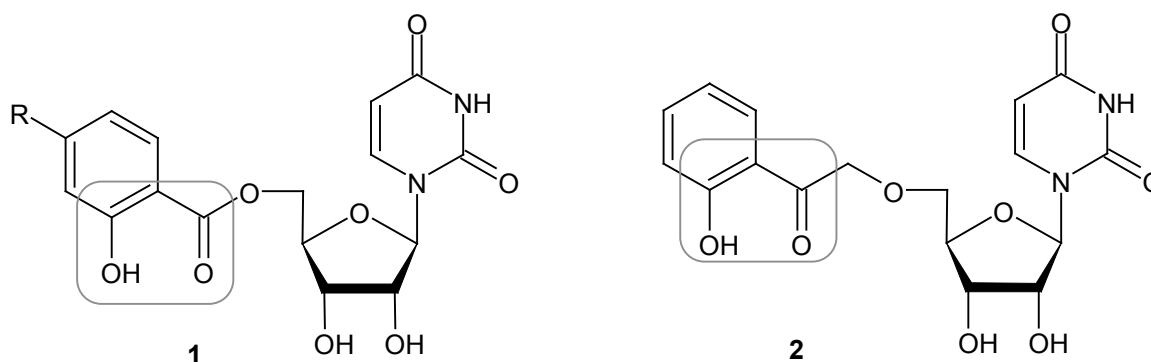

R=H; R=OH; R=NH<sub>2</sub>; R=NO<sub>2</sub>

**Acknowledgement** Research studies part-financed by European Union within the European Regional Development Fund (POIG 01.01.02-14-102/09).

**References**

1. K.-H. Jung, R.R. Schmidt, *Glycosyltransferase Inhibitors in Carbohydrate-Based Drug Discovery* (C.-H. Wong, Ed.), Wiley-VCH Verlag, Weinheim, **2003**, 2, 609-659

PO 259

ISOLATION PROCESS OF POLYPHENOLIC-POLYSACCHARIDE  
PREPARATION FROM  
*FRAGARIA VESCA* (L.) WITH THE ANTICOAGULANT ACTIVITY  
ON HUMAN BLOOD PLASMA

Izabela Pawlaczyk<sup>1,2</sup>, Olga Lisowska<sup>1</sup>, Peter Capek<sup>3</sup>, Roman Gancarz<sup>1,2</sup>

<sup>1</sup>Division of Medicinal Chemistry and Microbiology, Wrocław University of Technology,  
ul. Łukasiewicza 2, 50-371 Wrocław, Poland

<sup>2</sup> Regional Specialist Hospital in Wrocław, Research and Development Centre,  
ul. Kamińskiego 73a, 51-124 Wrocław, Poland

<sup>3</sup> Center for Glycomics, Institute of Chemistry, Slovak Academy of Sciences, Dubrávská cesta 9,  
845 38 Bratislava, Slovakia  
izabela.pawlaczyk@pwr.wroc.pl

Many biological effects of the wild strawberry (*Fragaria vesca* L., Rosaceae family) fruits consumption have been documented, mostly attributed to the phenolic compounds, such as an increase of the serum antioxidant capacity in humans<sup>1</sup>, anti-carcinogenic activity<sup>2,3</sup>, anti-thrombotic effects<sup>4</sup>, etc. However, strawberry leaves, as a source of bioactive compounds with potentially beneficial biological effects, have been largely overlooked by researchers. Apart from reports on the use of wild strawberry leaves in traditional medicine as an aqueous extract for the treatment of several diseases<sup>5</sup>, scientific reports of its effects on biological systems are lacking.

The aim of presented researches was to isolate polysaccharide-polyphenolic complexes from dried leaves of *Fragaria vesca*, suspected to have an anticoagulant activity on human blood plasma *in vitro*. The research was focused on modification of the method of isolation<sup>6</sup>, with a view to optimizing the process of obtaining the most optimal anticoagulant active compounds from the plant material. To determine in the polysaccharide part the carbohydrates, uronic acids also, and the amount of phenolic rests in the polyphenolic part of this conjugate, the colorimetric methods were used. The amounts of neutral monosaccharides as borohydrate-reduced alditol acetates were estimated by GLC-MS method. The anticoagulant activity of separated glucoconjugates, were tested *in vitro* on human blood plasma with aPTT test, PT test and TT test.

**Acknowledgments:** Studies are a part of the project supported by European Regional Development Fund and the Polish Government (Operational Programme - Innovative Economy) Grant WROVASC (Integrated Cardiovascular Centre, 2007-2013).

### References

1. Cao, G. et al., J. Nutr. 1998, 128, 2383–2390
2. Carlton, P.S. et al., Carcinogenesis, 2001, 22, 441–446
3. Wedge, D.E. et al., J. Med. Food, 2001, 4, 49–51
4. Naemura, A. et al., Blood Coagulation Fibrinolysis, 2005, 16, 501–509
5. Jaric, S. et al., J. Ethnopharmacol., 2007, 111, 160–175
6. Pawlaczyk I. et al., Patent Application PL 380 474, 21.08.2006

PO 260

QUANTIFYING ELECTRONIC EFFECTS OF COMMON CARBOHYDRATE  
ACCEPTORS  
USING AN AMINOSUGAR MODEL SYSTEM.

Christian M. Pedersen\*, Jacob I. Olsen, Azra Brka, Mikael Bols\*

<sup>1</sup>Department of Chemistry, University of Copenhagen, Universitetsparken 5,  
2100 Copenhagen O, Denmark  
cmp@chem.ku.dk

Glycosylation chemistry is dependent on the reactivity of the glycosyl donor, which has been well studied over the last decades.<sup>1</sup> The reactivity of the acceptor, however, has gained much less attention, but can be decisive for a successful glycosylation. In order to investigate this aminosugars containing the amino functionality in each of the four possible non-anomeric positions with  $\alpha$  and  $\beta$  gluco,  $\alpha$ -galacto or  $\alpha$ -manno stereo chemistry, were synthesized and their  $pK_a$  values determined by titration. The model compounds were chosen after being the amino-derivatives of the most common glycosyl acceptors. Through this systematic study it was possible to get a picture of the electron density at each of the given positions by comparing them in between by their  $pK_a$  values.

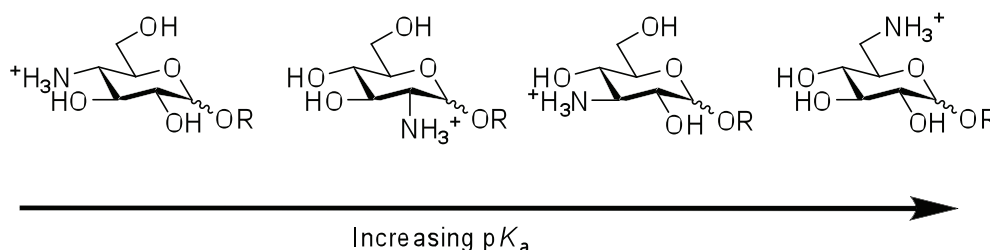

By looking at 32 different amino-sugars and sugars<sup>2</sup> some general statements arose: the order of basicity and hence nucleophilicity of the corresponding hydroxyl group is 6>3>2>4 (referring to the position). The basicity is general increasing when one or more substituents on the sugar ring are axial. The acidity is increasing when the amine is anti-periplanar to an oxygen. These findings are in agreement with the observations obtained from glycosylation chemistry and regioselective protection of sugars.

### References

1. a) N.L. Douglas, S.V. Ley, U. Lücking, S.L. Warriner *J. Chem. Soc. Perkin Trans. 1*, **1998**, 51-65; b) Z. Zhang, R.I. Ollmann, X.-S. Ye, R. Wischenat, C.-H. Wong *J. Am. Chem. Soc.* **1999**, 121, 734-753; c) X.-S. Ye, C.-H. Wong *J. Org. Chem.* **2000**, 65, 2410-2431; d) K.M. Koeller, C.-H. Wong *Chem. Rev.* **2000**, 100, 4465-4493; e) C.M. Pedersen, L.G. Marinescu, M. Bols *Chem. Commun.* **2008**, 2465-2467; f) M. Heuckendorff, C.M. Pedersen, M. Bols *Chem. Eur. J.* **2010**, 16, 13982-13994
2. C. M. Pedersen, J. I. Olsen, A. Brka, M. Bols *Chem. Eur. J.* **2011** (Accepted for publication)

## PO 261

**ELUCIDATION OF THE O-ANTIGEN STRUCTURES  
OF *Escherichia coli* O69, O158, AND O180**

Sofia N. Senchenkova,<sup>1</sup> Andrei V. Perepelov,<sup>1</sup> Alexander S. Shashkov,<sup>1</sup> Yuriy A. Knirel,<sup>1</sup>  
Quan Wang,<sup>2,3</sup> Lu Feng,<sup>2,3</sup> and Lei Wang<sup>2,3</sup>

<sup>1</sup>*N.D. Zelinsky Institute of Organic Chemistry, Russian Academy of Sciences,  
Leninsky prosp. 47, 119991 Moscow, Russia;*

<sup>2</sup>*TEDA School of Biological Sciences and Biotechnology, Nankai University,  
TEDA, Tianjin 300457, PR China;*

<sup>3</sup>*Tianjin Key Laboratory for Microbial Functional Genomics, TEDA College, Nankai University,  
TEDA, Tianjin 300457, PR China  
perepel@ioc.ac.ru*

*Escherichia coli* is the predominant species in the human intestinal microflora but can cause diarrhoeal diseases and includes several pathogenic forms. *E. coli* strains are classified by a combination of the O-, H-, and sometimes K-antigens. Currently, *E. coli* typing scheme contains 171 O-antigen forms, their differences being almost entirely due to variations in the O-antigen gene cluster. Expression of only one O-antigen form and the variation may offer to various clones a selective advantage in the niche occupied. Structures of about one third of the *E. coli* O-antigens remain unknown. In this work, we established the O-antigen structures of three *E. coli* O-serogroups:

→3)-β-D-GlcpNAc-(1→3)-β-D-GlcpNAc4lac-(1→2)-α-L-Rhap-(1→2)-α-L-Rhap-(1→2)-α-D-Galp-(1→  
**O69**

α-L-Rhap3,4Ac-(1→3)⌋  
→4)-β-D-ManpNAc-(1→4)-α-D-GalpA-(1→3)-β-D-GalpNAc-(1→  
β-D-Glcp-(1→6)⌋ **O158**

→4)-β-D-ManpNAc3NAcA-(1→2)-α-L-Rhap-(1→3)-β-L-Rhap-(1→4)-α-D-GlcpNAc-(1→  
**O180**

A new unique structure was established for the *E. coli* O180 antigen containing rarely occurring 2,3-diacetamido-2,3-dideoxy-D-mannuronic acid (D-ManNAc3NAcA). The O-antigen structures of *E. coli* O69 and O158 have been reported earlier (see <http://www.casper.org.su.se/ECODAB/>) but their O-antigen gene clusters sequenced by us did not correspond with the published structures. A reinvestigation revealed new structures of both O-antigens, which were in agreement with the gene clusters. They differed from the reported structures in the presence of an additional residue of 2-acetamido-4-O-[(R)-1-carboxyethyl]-2-deoxy-D-glucose (D-GlcNAc4lac) in the O69 repeating unit and in composition and structure of the O158 repeating unit.

This work was supported by the Russian Foundation for Basic Research (Projects No. 11-04-01020 and 11-04-91173-NNSF).

## PO 262

**STRUCTURES AND GENETICS OF THE O-ANTIGENS OF *Salmonella*  
AND THEIR RELATIONSHIPS TO THE O-ANTIGENS OF *Escherichia coli***

Andrei V. Perepelov,<sup>1</sup> Sofia N. Senchenkova,<sup>1</sup> Alexander S. Sashkov,<sup>1</sup> Yuriy A. Knirel,<sup>1</sup>  
Bin Liu,<sup>2,3</sup> Lu Feng,<sup>2,3</sup> and Lei Wang<sup>2,3</sup>

<sup>1</sup>*N.D. Zelinsky Institute of Organic Chemistry, Russian Academy of Sciences,  
Leninsky prosp. 47, 119991 Moscow, Russia;*

<sup>2</sup>*TEDA School of Biological Sciences and Biotechnology, Nankai University,  
TEDA, Tianjin 300457, PR China;*

<sup>3</sup>*Tianjin Key Laboratory for Microbial Functional Genomics, TEDA College, Nankai University,  
TEDA, Tianjin 300457, PR China  
perepel@ioc.ac.ru*

*Salmonella* serovars are one of the leading causes of food-borne illness outbreaks. Except for *S. bongori*, they are classified into a single species, *S. enterica*. The O-antigen (OAg) on the outer membrane of Gram-negative bacteria appears to be the major target of the host immune system and bacteriophages and is important for bacterial virulence and niche adaptation. The OAg diversity is mainly due to variations in the OAg gene cluster and is the basis for bacterial O-serotyping. Currently, *S. enterica* strains are classified into 46 O-serogroups.

From *S. enterica* OAg's whose structures have been elucidated earlier, five OAg's (serogroups O6,14, O30, O35, O48, and O50) are closely related to various *Escherichia coli* O-serogroups, whereas others possess unique structures. We established new unique OAg structures in seven *S. enterica* O-serogroups (O21, O41, O44, O53, O56, O59, and O60) and found that in 14 more O-serogroups (O13, O16, O17, O28, O38, O42, O47, O51, O52, O55, O57, O58, O65, and O66), the OAg's are identical or similar to those of *E. coli* O-serogroups. In addition to unusual OAg components already reported in *S. enterica*, we identified 3-formamido-3,6-dideoxy-D-galactose (serogroup O60), *N*-acetyl-L-seryl (O56) and *N*-[(*S*)-3-hydroxybutanoyl]-D-alanyl (O58) derivatives of 4-amino-4,6-dideoxy-D-glucose, and D-ribitol 5-phosphate (O47). Some OAg's are modified by non-stoichiometric O-acetylation (O16, O17, O53, and O66) and glucosylation (O16).

The OAg gene clusters of all *S. enterica* O-serogroups were sequenced, and functions of the genes were tentatively assigned by search in available gene databases and taking into account the OAg structures established. The structural relatedness in the newly discovered pairs of *S. enterica* and *E. coli* OAg's was found to be due to the identity or close similarity of their OAg gene clusters. These findings are useful for understanding serological relationships between the OAg's in the family Enterobacteriaceae and for elucidation of the evolution of their structural variations.

This work was supported by the Russian Foundation for Basic Research (Projects No. 11-04-01020 and 11-04-91173-NNSF).



PO 263

## 2-ALKOXY GLYCOOXAZOLINES: NEW MILD AND STEREOSELECTIVE GLYCOSYL DONORS FOR 1,2-TRANS GLYCOSAMINIDE SYNTHESIS

Sergey S. Pertel, Elena S. Kakayan, Vasily Ya. Chirva

National Taurida V. Vernadsky University, Vernadsky ave. 4, Simferopol,  
Crimea, 95007, Ukraine,  
sergepertel@yahoo.com

2-Alkyl glycooxazolines are widely known as highly stereoselective reagents for 1,2-trans glycosaminide bond formation. However, they are stable and weakly reactive and therefore are practically not utilized as glycosylating agents [1, 2]. Glycosyl donors with electronwithdrawing substituents in the second position of the pyranose cycle, e.g. with urethane ones are more reactive and are widely used in the present time [2]. It is likely that the intermediate, highly reactive 2-alkoxy glycooxazolines can form at activation of such glycosyl donors in the conditions of glycoside synthesis. We have synthesized some 2-alkoxy glycooxazolines by treatment of O-acetylated 2-(alkoxycarbonylamino)-2-deoxy-D-glucopyranosyl halides with silver perchlorate in the presence of a base. The <sup>1</sup>H-NMR spectra of these compounds are analogous to the spectra of 2-alkyl glycooxazolines. <sup>1</sup>H-NMR data corroborate of <sup>0</sup>S<sub>2</sub> conformation of pyranoid ring, which is also characteristic for 2-alkyl glycooxazolines [3]. As it turned out, the synthesized 2-alkoxy oxazolines 3 and 4 were reacting actively with alcohols in very mild conditions in the presence of catalytic quantities of *symm*-collidine perchlorate in DCM at r.t. But only 2-(trichloroethoxy) oxazoline 4 was able to react with weakly nucleophilic 2,2,2-trichloroethanol, suggesting that this oxazoline possesses higher reactivity. 2-(Trichloroethoxy) oxazoline 4 also reacts with low reactive 4-OH group of otherwise protected N-acetyl-D-glucosamine derivatives to form disaccharides 7 and 8 stereoselectively.

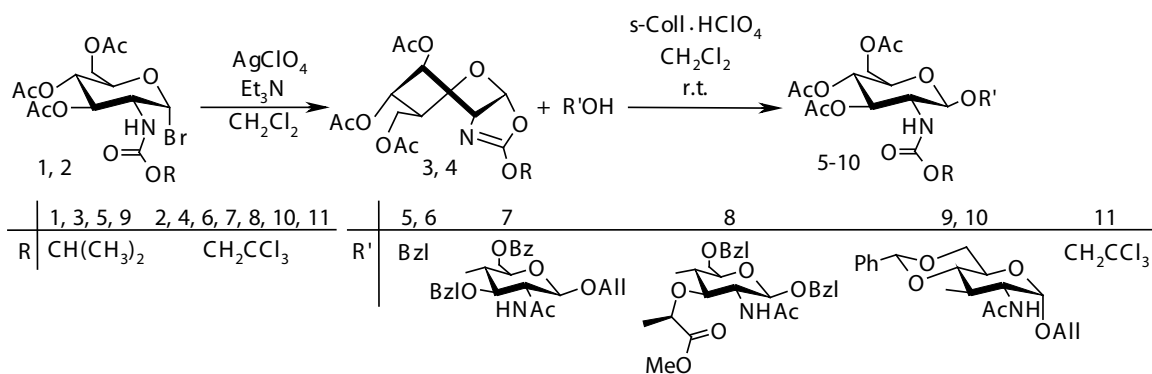

## References

- Banoub J., Boullanger P., Lafont D., *Chem. Rev.*, **1992**, 92, 1167-1195.
- Bongat A.F.G., Demchenko A.V., *Carbohydr. Res.*, **2007**, 342, 374-406.
- Foces-Foces C., Cano F.H., Bernabe M., Penades S., Martin-Lomas M., *Carbohydr. Res.*, **1984**, 135, 1-11.

## PO 264

## DESIGN, SYNTHESIS AND PRELIMINARY BIOLOGICAL EVALUATION OF IMINOSUGAR-BASED POTENTIAL Akt INHIBITORS

Alexandre Orsato<sup>1</sup>, Giuseppe D'Orazio<sup>1</sup>, Barbara La Ferla<sup>1</sup>, Francesco Nicotra<sup>1</sup><sup>1</sup>Dipartimento di Biotecnologie e Bioscienze, Università degli Studi di Milano Bicocca, Piazza della Scienza, 2, 20126 Milano (Italy)  
alexandre.orsato@unimib.it

Akt is a proto-oncogenic serine/threonine kinase that plays a critical role in the PI3k/Akt signaling pathway. The activation and overexpression of this kinase have been verified in many types of human cancers.<sup>1</sup> Many studies showed how Akt plays a critical role in the development, growth and in the therapeutic resistance of various forms of cancer.<sup>2</sup> The activation of Akt occurs after the binding between the PH domain (pleckstrin homology) and a molecule of phosphatidylinositol, phosphorylated at positions 3 and 4. Current studies on Akt have been limited by the absence of PH domain-specific inhibitors, therefore their development not only would facilitate biochemical studies but also allow the identification of lead compounds for the development of potential antitumor drugs. Recently many analogues of phosphatidylinositol with favorable inhibitory activity for Akt have been synthesized,<sup>2,3</sup> among them compound **2**<sup>4</sup> (fig.1), which has been currently used as the selective inhibitor of reference. Biological results suggest that the use of a carbonate group in C1 as a surrogate of the phosphate group does not compromise the activity and enhances the stability of the compound. In addition, modeling studies showed that the axial hydroxymethyl group at position 3 provides strong hydrogen bonding interaction with the Arg25 residue in the PH domain of Akt, resulting in enhanced selectivity. In this work we performed the design and synthesis of analogues of phosphatidylinositol ether lipid in which the inositol ring is substituted by an iminosugar ring, and the phosphate group at C1 is substituted by a carboxymethyl group (**3-13**).

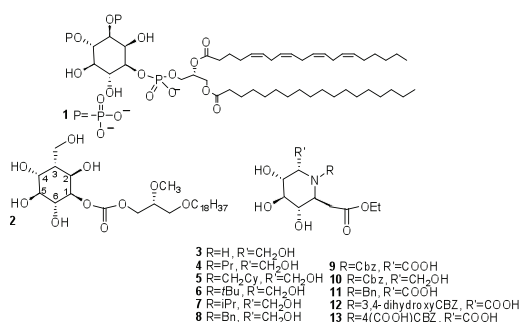

Based on this rationale, metabolic and chemical stability of the compounds can be enhanced by the presence of the carboxymethyl group at C1. Moreover, the nitrogen atom located in the iminosugar ring provided a convenient site for derivatization with hydrophobic substituents that could be responsible for new interactions between our compounds and the PH domain of Akt, increasing the inhibitory activity. The axial hydroxymethyl group was maintained, considered critical for selectivity. Interestingly, oxidation of this group provided compound **9** with an axial carboxyl group, that displayed the best inhibitory activity against Akt.

## References

1. a) Coffey, P.J.; Jin, J.; Woodgett, J.R. *Biochem. J.* 335, **1998**, 1-13; b) Staal, S.P. *Proc. Natl. Acad. Sci. U.S.A.* 84, **1987**, 5034-5037; c) Bellacosa, A.; Feo, D.D.; Godwin, A.K.; Bell, D.W.; Cheng, J.Q.; Altomare, D.A.; Wan, M.; Dubeau, L.; Scambia, G.; Masciullu, V.; Ferrandina, G.; Panici, P.B.; Mancuso, S.; Neri, G.; Testa, J.R. *Int. J. Cancer*, 64, **1995**, 280-285; d) Thompson, F.H.; Nelson, M.A.; Trent, J.M.; Guan, X.Y.; Liu, Y.; Yang, J.M.; Emerson, J.; Adair, L.; Wymer, J.; Balfour, C.; Massey, K.; Weinstein, R.; Alberts, D.S.; Taetle, R. *Cancer Genet. Cytogenet.* 87, **1996**, 55-62; e) Cheng, J.Q.; Ruggeri, B.; Klein, W.M.; Sonoda, G.; Altomare, D.A.; Watson, D.K.; Testa, J.R. *Proc. Natl. Acad. U.S.A.* 93, **1996**, 3636-3641.
2. Sianna Castillo S.; Brognard, J.; Petukhov, P.A.; Zhang, C.; Tsurutani, J.; Granville, C.A.; Li, M.; Jung, M.; West, K.A.; Gills, J.G.; Kozikowski, A.P.; Tennis, P.A. *Cancer Research* 64, **2004**, 2782-2792, e rif. ivi contenuti.
3. a) Sun, H.; Reddy, G.B.; Gorge, C.; Meuillet, E.J.; Berggren, M.; Powis, G.; Kozikowski, A.P. *Tetrahedron Lett.*, 43, **2002**, 2835-2838; b) Kozikowski, A.P.; Sun, H.; Brognard, J.; Dennis, P.A. *J. Am. Chem. Soc.* 125, **2003**, 1144-1145.
4. Hu, Y. Et al., *J. Med. Chem.* 43, **2000**, 3045-3051.

## PO 265

## DANSYLATED C-GLYCOSIDES: DRUG CANDIDATES AS ANTIINFLAMMATORY AGENTS AND MOLECULAR TOOLS FOR BIOLOGICAL STUDIES

Giuseppe D'Orazio<sup>1</sup>, Barbara La Ferla<sup>1</sup>, Marta Coppola<sup>1</sup>, Cristiano Rumio<sup>2</sup>, Francesco Nicotra<sup>1</sup><sup>1</sup>Department of Biotechnology and Bioscience, Università degli Studi di Milano Bicocca, P.zza della Scienza 2, 20126 Milano (Italy).<sup>2</sup>MIL- Mucosal Immunity Laboratory, Department of Human Morphology, Università degli Studi di Milano, Via Mangiagalli, 31, 20133 Milano (Italy).  
g.dorazio@campus.unimib.it

Sepsis describes a complex clinical syndrome, that results from a systemic inflammatory response, caused by a microbial infection<sup>[1]</sup>. In sepsis, Lipopolisaccharides (LPS) of Gram negative bacteria, play a central role triggering the inflammatory response, characterized by an overproduction of pro-inflammatory cytokines and chemokines by cells of the immune system. Bacterial LPS acts interacting with Toll-like receptors (TLRs), in particular with TLR4, located on the surface of immunity system cells, as dendritic cells, macrophages and monocytes, as well as on the membrane of enterocytes (intestinal epithelial cells). Indeed, the intestinal epithelium not only absorbs nutrients, but also plays a central role in host defence. Moreover, enterocytes are able to respond to LPS present in the intestinal lumen, producing pro-inflammatory chemokines. Recent works have demonstrated that hyperactivation of immunity system is inhibited by oral ingestion of high dose of glucose (2.5 g/kg)<sup>[2]</sup> and much lower dose of synthetic C-glycoside **1** (25 µg/kg)<sup>[3]</sup> (Fig. 1), protecting 100% of mice from lethal endotoxic shock induced by intraperitoneal LPS administration. This protection was found to be mediated by sodium-dependent glucose transporter 1 (SGLT-1). Despite its great activity, compound **1** suffers from a low solubility due to the formation of inactive aggregated species. In order to overcome this drawback our goal was to search for derivatives of compound **1** with reduced aggregation ability and improved water solubility. In this contest we designed compounds **2**, **3** and **4**. Compound **2**, a diastereoisomeric mixture of bicyclic derivatives of **1**, thanks to the increased rigidity of the saccharidic scaffold, showed an improved water solubility while maintaining an anti-inflammatory activity of compound **1**. In order to determine the activity of each diastereoisomer, the two compounds were also obtained as pure compounds. Compounds **3** and **4** have been designed as pro-drug analogues of compound **1**, in which the solubility is increased through the introduction of a polyethylene glycol chain. In compound **3** this chain is connected to the pyranose ring of the molecule through an acetal, while in compound **4** via an ester bond. Both the acetal and the ester are acid labile bonds, that should release compound **1** in vivo, in a non-aggregated form, due to the breaking of these bonds in the gastrointestinal tract.

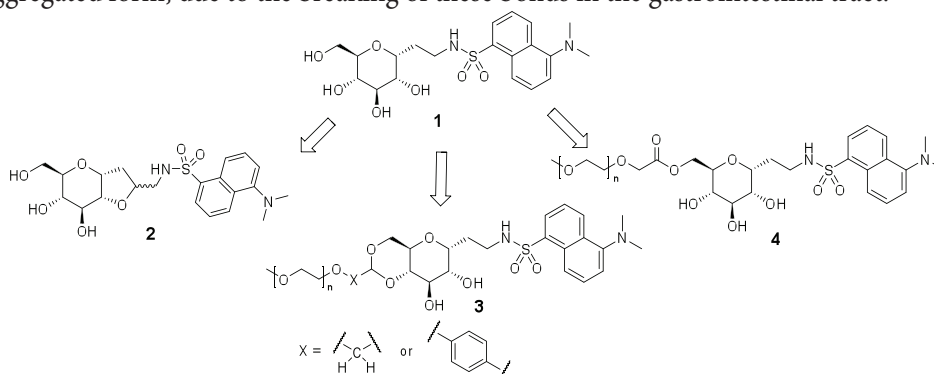

## References

1. J. Cohen, *Nature* **2002**, *420*, 885-891.
2. M. Palazzo, S. Gariboldi, L. Zanobbio, S. Selleri, G. F. Dusio, V. Mauro, A. Rossini, A. Balsari, C. Rumio, *Journal of Immunology* **2008**, *181*, 3126-3136.
3. B. La Ferla, V. Spinosa, G. D'Orazio, M. Palazzo, A. Balsari, A. A. Foppoli, C. Rumio, F. Nicotra, *ChemMedChem* **2010**, *5*, 1677-1680.

## PO 266

## GLYCOSYLATION AS A TOOL FOR EUMELANIN POLYMERS INVESTIGATION

Matteo Adinolfi, Marco d'Ischia, Alfonso Iadonisi, Loredana Leone,  
Lucia Panzella, Alessandro Pezzella, Silvia Valerio

*Department of Organic Chemistry and Biochemistry, University of Naples "Federico II"*  
*Via Cintia 4, I-80126, Naples, Italy*  
*alessandro.pezzella@unina.it*

Eumelanins<sup>1</sup> are a class of natural pigments composed mainly of 5,6-dihydroxyindole units linked through 2-4' and 2-7' C-C bonds and responsible for the dark colorations of human skin and hair. The unique status of eumelanins among natural pigments is due to their socio-economic and biomedical relevance, encompassing racial pigmentation, skin photoprotection, sun tanning and pigmentary disorders such as albinism, vitiligo, and melanoma.<sup>1</sup> Moreover, they display a quite unusual set of physicochemical properties such as broadband monotonic absorption in the UV-visible range and insolubility in all solvents. This latter issue has made their structural determination, and consequently the clarification of the origin of their black colour, a rather challenging task. Very recently we have synthesized a new class of water-soluble eumelanins<sup>2</sup> whose spectroscopic analysis provided some indications on the interactions purportedly involved in eumelanin buildup and peculiar absorption properties. These polymers were accessed through the overall sequence shown below involving in the final stage the sequential de-O-acetylation and oxidative polymerization of a stable precursor as 3-thiogalactosylated 5,6-dihydroxyindole **1** (scheme).<sup>2</sup>

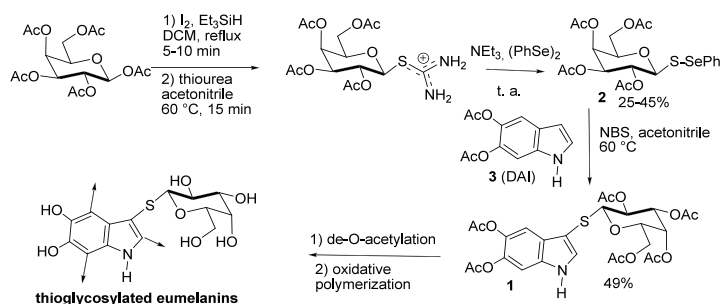

This eumelanin model proved to be a valuable tool for addressing the optical properties of natural eumelanins. Here we also extend the scope of this model to address pigment-metal ions interaction. Preliminary results would confirm the valuable use of the water-soluble pigment and its variants to as a tool to address the sites and mode of binding of metal ions of biological relevance.

## References

1. Prota, G. *Melanins and Melanogenesis*; Academic Press: San Diego, CA, 1992.
2. A. Pezzella, A. Iadonisi, S. Valerio, L. Panzella, A. Napolitano, M. Adinolfi, M. d'Ischia *J. Am. Chem. Soc.* **2009**, *131*, 15270-15275.

## PO 267

**STRUCTURAL INVESTIGATIONS OF THE INTERACTION OF INTERLEUKIN-8 WITH GLYCOSAMINOGLYCANS USING SOLUTION NMR SPECTROSCOPY**

Pichert Annelie<sup>1</sup>, Sergey Samsonov<sup>2</sup>, Stephan Theisgen<sup>1</sup>, Jürgen Schiller<sup>1</sup>,  
Annette G. Beck-Sickinger<sup>3</sup>, María Teresa Pisabarro<sup>2</sup>, Daniel Huster<sup>1</sup>

<sup>1</sup>*Institute of Medical Physics and Biophysics, University of Leipzig, Härtelstr 16-18,  
D-04107 Leipzig, Germany*

<sup>2</sup>*BIOTEC, Technical University Dresden, Tatzberg 47-51, D-01307 Dresden, Germany*

<sup>3</sup>*Institute of Biochemistry, University of Leipzig, Brüderstr. 34, D-04103 Leipzig, Germany  
Annelie.Pichert@medizin.uni-leipzig.de*

IL-8 is a chemotactic cytokine that is able to trigger inflammation by recruiting and activation of neutrophils [1]. Strong interactions of IL-8 with negatively charged glycosaminoglycans (GAGs) of the extracellular matrix have been reported before [2, 3]. Here, we have studied binding of IL-8 to GAGs that bind IL-8 less strongly. Such weak binding is required for the development of artificial matrices for regenerative medicine that increase the bioavailability of endogenous cytokines and growth factors. Structural studies and binding measurements between IL-8 and the respective GAGs were done by solution NMR experiments. To this end, large amounts of <sup>15</sup>N-labelled IL-8 (1-77) were produced in a prokaryotic expression system. After isolation and purification of the protein, a <sup>1</sup>H-<sup>15</sup>N HSQC spectrum of IL-8 was recorded, representing one signal for each amide in the peptide backbone. With the help of further two dimensional <sup>1</sup>H-<sup>1</sup>H TOCSY and NOESY NMR experiments, full resonance assignment was achieved. To analyse the binding between IL-8 and the GAGs hyaluronic acid (HA), chondroitin-4-sulphate (C4S) and chondroitin-6-sulphate (C6S) as hexasaccharides, titration studies were done by recording HSQC spectra in the presence of varying GAG concentrations. Changes in the chemical shifts induced by ligand binding could be used to identify the interacting amino acids. The NMR results as well as molecular modelling have shown that rather weak interactions are found between the HA hexasaccharide and IL-8. In contrast, in the presence of C4S and C6S clear shifts of certain peaks could be observed.

**References**

1. Mukaida N., *Am. J. Physiol. Lung Cell. Mol. Physiol.*, **2002**, 284(4), L566-L577.
2. Kuschert G., Hoogewerf A. J., Proudfoot A. E., Chung C. W., Cooke R. M., Hubbard R. E., Wells T. N., Sanderson P. N., *Biochem.*, **1998**, 37(32), 11193-11201.
3. Goger B., Halden Y., Rek A., Mösl R., Pye D., Gallagher J., Kungl A. J., *Biochem.*, **2002**, 41(5), 1640-1646.



## PO 268

**CORE STRUCTURE FROM THE LIPOPOLYSACCHARIDE  
OF THE HUMAN PATHOGEN *HALOMONAS STEVENSII* STRAIN S18214**

Giuseppina Pieretti<sup>1</sup>, Sara Carillo<sup>1</sup>, Keun Chul Lee<sup>2</sup>, Buko Lindner<sup>3</sup>, Kwang Kyu Kim<sup>2</sup>,  
Jung-Sook Lee<sup>2</sup>, Rosa Lanzetta<sup>1</sup>, Michelangelo Parrilli<sup>1</sup>, M. Michela Corsaro<sup>1</sup>

<sup>1</sup>*Dipartimento di Chimica Organica e Biochimica, Università di Napoli Federico II,  
Complesso Universitario Monte S. Angelo, Via Cinthia 4, 80126 Napoli, Italy*

<sup>2</sup>*Korea Research Institute of Bioscience and Biotechnology, 52 Eoeun-dong, Yuseong-gu,  
Daejeon 305-806, Republic of Korea*

<sup>3</sup>*Division of Immunochemistry, Research Center Borstel, Leibniz- Center for Medicine  
and Biosciences, Parkallee 10, 23845 Borstel, Germany*

*gpieretti@unina.it*

The genus *Halomonas* belongs to the family *Halomonadaceae* and accommodates moderately halophilic/halotolerant microorganisms that generally thrive in high salt environments.<sup>1</sup> These bacteria have not previously been reported to be a cause of human infections. Very recently, 14 bacterial strains have been isolated from the blood of two patients and from the dialysis machines in a Renal Care Center and classified as three novel *Halomonas* species.<sup>2,3</sup> Among these, two patient isolates, strains S18214 and T49407, belonged to *H. stevensii*.<sup>3</sup> The patients developed a bacteraemia, which, in addition to those developed in patients infected by *Halomonas venusta*<sup>4</sup> and *Halomonas phocaeensis*,<sup>5</sup> highlighted the pathogenic potential of the genus *Halomonas*. Since Gram-negative bacterial infections are closely associated with the presence of the lipopolysaccharides (LPSs) on their outer membrane,<sup>6</sup> we started to investigate the structure of the LPS from *H. stevensii*.<sup>7</sup> In this communication we report the structure of the core oligosaccharide. The products obtained by both mild acid and strong alkaline hydrolysis were purified and analysed by ESI FT-ICR MS and NMR spectroscopy.

**References**

1. Franzmann P.D., Wehmeyer U., Stackebrandt E., *Syst. Appl. Microbiol.* **1988**, *11*, 16-19.
2. Stevens D.A., Hamilton J.R., Johnson N., Kim K.K., Lee J.S., *Medicine* **2009**, *88*, 244-249.
3. Kim K.K., Lee K.C., Oh H.M., Lee J.S., *Int. J. Syst. Evol. Microbiol.* **2010**, *60*, 369-377.
4. Von Graevenitz A., Bowman J., Del Notaro C., Ritzler M., *J. Clin. Microbiol.* **2000**, *38*, 3123-3124.
5. Berger P., Barguelli F., Raoult D., Drancourt M., *J. Hosp. Infect.* **2007**, *67*, 79-85.
6. Rietschel E.T., Westphal O., 1999. Endotoxin: Historical Perspectives. p. 1-30. In D. C. Morrison, H. Brade, S. Opal, S. Vogel (ed.), *Endotoxin in Health and Disease*, M. Dekker. Inc., New-York.
7. Pieretti G., Carillo S., Kim K. K., Lee K. C., Lee J.-S., Lanzetta R., Parrilli M., Corsaro M. M., *Carbohydr. Res.* **2011**, *346*, 362-365.



## PO 269

IDENTIFICATION OF THE FLAGELLIN GLYCOSYLATION  
IN *AEROMONAS HYDROPHILA* AH1

Giuseppina Pieretti,<sup>1,4</sup> Maria Michela Corsaro,<sup>1</sup> Fabrizio Dal Piaz,<sup>2</sup> Rocìo Canals,<sup>3</sup>  
Juan M. Tomàs,<sup>3</sup> Laura Bindila,<sup>4</sup> Sergey Vakhrushev,<sup>4</sup> Jasna Peter-Katalinic<sup>4</sup>

<sup>1</sup>*Dipartimento di Chimica Organica e Biochimica, Università di Napoli Federico II,  
Complesso Universitario Monte S. Angelo, Via Cinthia 4, 80126 Napoli, Italy*

<sup>2</sup>*Dipartimento di Scienze Farmaceutiche, Università degli Studi di Salerno,  
via Ponte don Melillo, I-84084 Fisciano (Salerno), Italy*

<sup>3</sup>*Departamento de Microbiologia, Universidad de Barcelona, Diagonal 645,  
08071 Barcelona, Spain.*

<sup>4</sup>*Institute for Medical Physics and Biophysics, University of Münster, Robert-Koch Str. 31,  
48149 Münster, Germany.  
gpieretti@unina.it*

Mesophilic *Aeromonas* are ubiquitous water-borne bacteria and pathogen of reptiles, amphibians and fish.<sup>1</sup> In humans, *Aeromonas hydrophila* belonging to hybridization group 1 and 3 (HG1 and HG3) and others *Aeromonas* strains have been associated with gastrointestinal and extraintestinal infection and less commonly with septicaemia in immunocompromised patients.<sup>2</sup> The pathogenicity of mesophilic *Aeromonas* has been linked to different determinants, such as toxins, LPS, outer membrane proteins and flagella.<sup>3,4</sup> The flagella structure can be divided in three regions: the basal body, the hook and the filament. The latter is constituted by multiple copies of proteins, called flagellins, that are responsible for bacteria adherence and colonization of the host cells. Very little is known about *Aeromonas hydrophila* AH1 flagellins, but previous results indicated the presence of two types of flagellins (FlaA and FlaB) with post translational modifications.<sup>5</sup> In particular the presence of pseudaminic acid derivatives glycans O-linked to the flagellin of *Aeromonas caviae*, *Campilobacter jejuni* and *Helicobacter pylori* has been reported.<sup>5,6,7</sup>

The flagellins from *A. hydrophila* AH1 was digested with trypsin and successively with chymotrypsin and the mixture of peptides and glycopeptides obtained were analysed by nanoLC Q-TOF. The characterized peptides allowed the identification of both FlaA and FlaB. The putative glycopeptides were analysed by LC MS-MS. These experiments allowed the identification of a pseudaminic acid derivative on the *A. hydrophila* AH1 flagellins.

### References

1. Austin, B. and Adams, C. 1996 Fish pathogens, p.197-243. In B. Austin, M. Altwegg, P. J. Gosling and S.W. Joseph (ed.), The genus *Aeromonas*. John Wiley and Sons, New York, N.Y.
2. Janda, J.M. and Abbott, S.L. 1998. Evolving concepts regarding the genus *Aeromonas*: an expanding panorama of species, disease, presentation and unanswered questions. *Clin Infect Dis* 27, 332-344.
3. Merino, S., Rubirès, X., Aguilar, A., Tomàs, J.M., 1997. FEMS Microbiol. Lett. 151, 213-217.
4. Rabaan, A.A., Gryllos, I., Tomàs, J.M., Shaw, J.G. 2001. Infect Immun 69, 4257-4267.
5. Yu JB, Kaur R, Lim S, Wang XH, Leung KY 2007 *Proteomics*, 7 436-449
6. Thibault P, Logan S M, Kelly J F, Brisson J R, Ewing C P, Trust T J, Guerry P. *J. Biol. Chem.* 2001, 276, 34862-34870.
7. Schirm M, Soo E C, Aubry A J, Austin J, Thibault P, Logan SM *Mol. Microbiol.* 2003, 48, 1579-1592.

PO 270

PERFLUORINATED DOUBLE-TAILED GLYCOCONJUGATES  
OF TUMOR-ASSOCIATED MUC1 ANTIGENSTobias Platen, Anja Hoffmann-Röder\*

*Institute of Organic Chemistry, Johannes Gutenberg-University Mainz, Duesbergweg 10-14,  
D-55128 Mainz, Germany  
hroeder@uni-mainz.de*

To effectively activate the immune system with weak immunogens (e.g., tumor-associated carbohydrate antigens), a multivalent arrangement of binding epitopes is of fundamental importance.<sup>1</sup> A simple and robust strategy to obtain distinct functional microdomains within artificial membranes is fluorocarbon-directed self-assembly of lipid analogs.<sup>2</sup> Fluorocarbons show a high tendency to phase separation when mixing with alkyl lipids, and this allows compartmentalization within colloidal systems by changing the ratio between the alkylated and perfluoroalkylated lipids. Recently, we initiated a study in which novel neoglycoconjugates with perfluorinated and semifluorinated amphiphilic anchors based on lysine and glutamic acid cores were prepared. The double-tailed fluorinated amphiphiles were condensed with tumor-associated glycopeptide fragments ranging from glycosyl dipeptides to complete 20mer tandem repeat sequences of MUC1. With the resulting glyco(lipo)conjugates we hope to mimic the natural multimeric antigen presentation on the surface of stabilized F-liposomes that could be used as antigen-delivery systems. In this regard, the segregation behaviour of the fluororous amphiphiles was studied by Langmuir-Blodgett through and Atomic Force Microscopy (AFM).<sup>4</sup> Moreover, such hydrophobized antigen conjugates might prove to be valuable tools for diagnostic microarrays mapping the specificity of anti-MUC1 antibodies.<sup>5</sup>

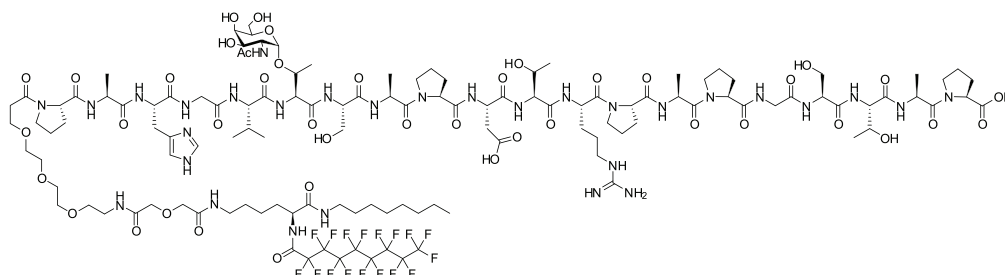
**References**

1. a) F. Reichel, P. R. Ashton, G. J. Boons, *Chem. Commun.* **1997**, 2087-2088; b) F. Reichel, A. M. Roelofson, H. P. M. Geurts, T. Hamalainen, M. C. Feiters, G. J. Boons, *J. Am. Chem. Soc.* **1999**, *121*, 7989-7997.
2. N. C. Yoder, D. Yüksel, L. Dafik, K. Kumar, *Curr. Opin. Chem. Biol.* **2006**, *10*, 576-583.
3. P. Scheibe, J. Schoenhentz, T. Platen, A. Hoffmann-Röder, R. Zentel, *Langmuir* **2010**, *26*, 18246-18255.
4. K.-S. Ko, F. A. Jaipuri, N. L. Pohl, *J. Am. Chem. Soc.* **2005**, *127*, 13162-13163.

PO 271

**PREPARATION AND CHARACTERIZATION OF  $\alpha$ -GAL FUNCTIONALIZED SILICA NANOPARTICLES**

Patrice G. J. Plaza-Alexander,<sup>1</sup> Peter J. Meloncelli,<sup>1</sup> Anne M. Slaney,<sup>2</sup>  
Mylvaganam Jeyakanthan,<sup>3</sup> Jillian M. Buriak,<sup>2</sup> Lori J. West,<sup>3</sup> and Todd L. Lowary.<sup>1</sup>

<sup>1</sup>Department of Chemistry and Alberta Ingenuity Centre for Carbohydrate Science,  
Gunning-Lemieux Chemistry Centre, University of Alberta, Edmonton, AB, Canada T6G 2G2,

<sup>2</sup>National Institute for Nanotechnology and Department of Chemistry,  
University of Alberta, Edmonton, AB, Canada T6G 2G2,

<sup>3</sup>Departments of Pediatrics, Surgery and Immunology, University of Alberta,  
Edmonton, AB, Canada T6G 2E1

tlowary@ualberta.ca

Glyconanoparticles have gained much interest in recent years due to their high potential for use in glycoscience and biomedical applications.<sup>1</sup> Herein we describe the chemical synthesis of  $\alpha$ -Gal epitopes **1** and **2** and the subsequent conjugation of these epitopes to silica microparticles. Compounds **1** and **2** were synthesized using trichloroacetimidate donors. A UV catalyzed thiolene reaction of the linker to cysteamine, followed by amide coupling to di-*p*-nitrophenyl adipate produced the desired  $\alpha$ -Gal ligands containing an activated *p*-nitrophenyl ester. Silica particles containing a fluorescent dye were first functionalized using 3-(aminopropyl) trimethoxysilane (APTMS) to introduce an amine residue. The particles were then treated with Fmoc-NH-PEG-NHS, deprotected and reacted with the activated ligand to give the  $\alpha$ -Gal glyconanoparticles. These particles will be used to study the ability of  $\alpha$ -Gal carrying particles to induce antigen specific B-cell tolerance during immunological immaturity in a mouse model of  $\alpha$ -Gal incompatible heart transplantation.

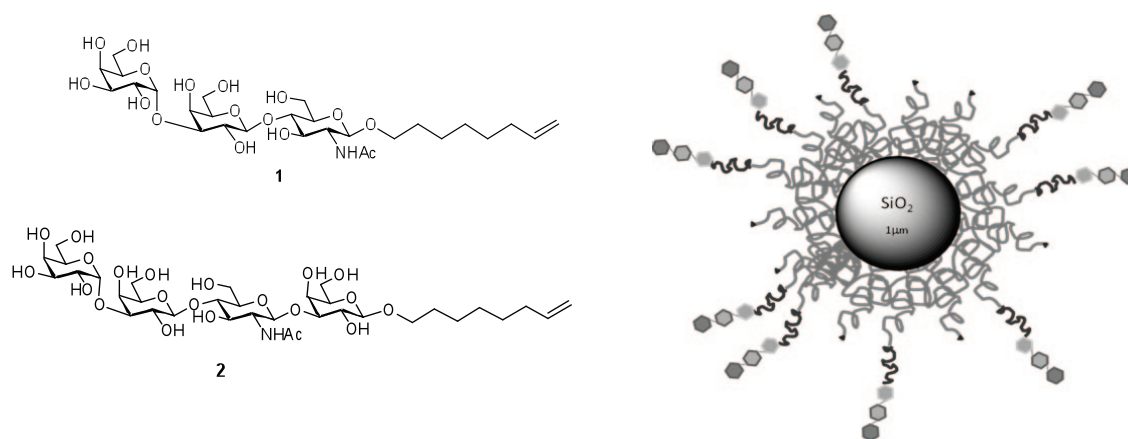
**References**

1. De la Fuente, J. M., Penades, S., *Biochimica et Biophysica Acta*, **2006**, 1760, 636-651.

PO 272

**SYNTHESIS OF FRAGMENT OF  $\beta$ -GLUCANS AS POTENTIAL LIGANDS FOR DECTIN-1**Laura Poletti, Laura Morelli and Luigi Lay

*Dipartimento di Chimica Organica e Industriale, Università di Milano, Via Venezian 21,  
20133-Milano, Italy  
laura.poletti@unimi.it*

$\beta$ -glucans are glucose polymers linked together by a 1,3 linear  $\beta$ -glycosidic chain core, differing from each other by their length and branching configuration. The branches derived from the glycosidic chain core are either 1,4 or 1,6 glycosidic chains and appear to be dependent on the source.

Dectin-1 [1] is a unique C-type lectin that recognizes  $\beta$ -glucan carbohydrates present on the surface of various fungi, including *C. albicans*. Its activation promotes microbial uptake and phagocytosis, but also mediates, in synergy with TLRs, the production of cytokines such as IL-12 and TNF alfa, leading ultimately to the initiation of the adaptive immune response. For this reason,  $\beta$ -glucans – or their fragments – can be referred to as a possible class of adjuvants to increase the immune response to pathogens. In addition, the administration of  $\beta$ -glucan-derived compounds can help in gaining new insights on the mechanism of action of dectin-1 receptor. Dectin-1 binds  $\beta$ -glucan polymers with affinities ranging from very low ( $3 \times 10^{-3}$  M) to very high ( $2 \times 10^{-12}$  M). The wide range of affinities appears to be due to the differing sizes and numbers of branches in  $\beta$ -glucans from various sources [2].

Although the interaction between Dectin-1 and  $\beta$ -glucans has been supposed to involve a conformational epitope as a high order local helix, little is known about the binding mode and the degree of (1-6)-branching of the glucan chain in the binding epitope. For this reason, a series of fragments of  $\beta$ -glucans, differing in the 6-*O* branching degree, has been synthesised. Their ability to bind to dectin-1 and of activating the inflammatory response will be subsequently tested.

**References**

1. Goodridge, H.; Wolf, A. J.; Underhill, D. M., *Immunol. Rev.* **2009**, 230(1), 38-50.
2. Adams, E. L., *J. Pharmacol. Exp. Ther.* **2008**, 325, 115–123.

## PO 273

**OVERPRODUCTION OF LEVAN BY HALOPHILIC HALOMONAS SP.:  
EFFECTS OF GROWTH CONDITIONS ON EXOPOLYSACCHARIDE YIELDS**

Annarita Poli,<sup>1</sup> Gianluca Anzelmo,<sup>1</sup> Giuseppina Pieretti,<sup>3</sup> Barbara Nicolaus,<sup>1</sup>  
Faruk Kucukasik<sup>2</sup>, Hande Kazak<sup>2</sup>, K. Yalcin Arga<sup>2</sup>, Ebru Toksoy Oner<sup>2</sup>

<sup>1</sup>*Council of National Research (C.N.R.), Institute of Biomolecular Chemistry,  
Via Campi Flegrei 34, 80078 Pozzuoli (NA), Italy,*

<sup>2</sup>*Department of Bioengineering, Marmara University, Goztepe 34722, Istanbul, Turkey*

<sup>3</sup>*Department of Organic Chemistry and Biochemistry, University Federico II, Via Cinthia 4,  
80126, Naples, Italy  
apoli@icb.cnr.it*

Exopolysaccharides (EPS) are high molecular weight polymers that make up a substantial component of the extracellular matrix surrounding most microbial cells in extreme environments. Due to their many interesting physicochemical and rheological properties with novel functionality, the microbial EPSs act as new biomaterials and find wide range of applications in many industrial sectors. Unlike mesophilic producers of EPSs, extremophilic microorganisms provide non-pathogenic products appropriate for environmental and human compatibility<sup>1</sup>. The Joint Project between C.N.R. and TUBITAK, "Extremophiles as Sources of Polysaccharides", has provided an EPS producer bacterium, a halophilic *Halomonas* sp. strain AAD6 able to produce high levels of levan at pre-stationary phase of growth, in the presence of sucrose in chemical medium with yield of 1.844 g L<sup>-1</sup> in bioreactor cultures<sup>2</sup>. Levan has many outstanding properties like high solubility in oil and water, good biocompatibility and film forming ability but its industrial use has long been hampered by costly production processes which usually rely on mesophilic bacteria and plants. Experiments conducted using pretreated sugar beet molasses and starch molasses have demonstrated that these inexpensive waste substrates are feasible substitutes for sucrose in media compositions. Using 30 g L<sup>-1</sup> of pretreated beet molasses, a levan concentration of 12.4 g L<sup>-1</sup> was reached<sup>3</sup>. In order to elucidate the potential market of this EPS, its physicochemical properties were explored: levan by *Halomonas* sp. presented a good flocculation activity comparable to commercial synthetic ones<sup>4</sup>. Moreover, its pseudoplastic behavior and high biocompatibility were also established.

**References**

1. Nicolaus B., Kambourova M., Toksoy Öner E., *Environmental Technology*, **2010**, 31 (10), 1145-1158.
2. Poli A., Kazak H., Gürleyendağ B., Tommonaro G., Pieretti G., Toksoy Öner E., Nicolaus B., *Carbohydrate Polymers*, **2009**, 78, 651-657.
3. Küçükaşık F., Kazak H., Güney D., Finore I., Poli A., Yenigün O., Nicolaus B., Toksoy Öner E., *Applied Microbiology and Biotechnology*, *in press*.
4. Sam S., Kucukasik F., Yenigun O., Nicolaus B., Toksoy Oner E., Yukselen M.A., *Biore-source Technology*, **2011**, 102 (2), 1788-1794.



## PO 274

POLYSACCHARIDES RECOVERY FROM INDUSTRIAL WASTE  
FOR METAL REMOVAL FROM WASTEWATERM. Fabbicino,<sup>1</sup> and L. Pontoni,<sup>1</sup><sup>1</sup>University of Naples Federico II, department of Hydraulics Geotechnics  
and Environmental Engineering, Via Claudio 21 80125 Naples, Italy  
ludovico.pontoni@gmail.com

Most of solid waste produced by agro-alimentary industries are rich in polysaccharides which can be easily recovered to produce a low-cost adsorbent useful for wastewater treatment. Use of residues as non conventional adsorbents is economically convenient as traditional adsorbents are characterized by high costs which tends to limit their applications despite good performances often related to adsorption processes. Many polysaccharide-rich residues have been tested as low-cost adsorbents. Among others cellulose waste, sugar waste and rice and wheat residues play primary roles for dyes and heavy metals removal, and have been proved efficient also for cyanide and ammonia nitrogen adsorption<sup>1,2,3,4,5,6</sup>. Starting from the encouraging results obtained in the past it has been carried out an experimental research aimed at investigating the possibility of re-using wastes coming from fishery industry in chromium removal from tannery wastewater<sup>7</sup>. Tanneries use large amount of chromium to stabilize animal hides, so it is not rare to find, in spent tanning baths, Cr(III) concentrations reaching several thousands milligrams per liter. It follows that chromium removal from tannery wastewater represents a big priority for environment conservation. For this purpose chitosan is already known to be useful due to his high natural abundance, low cost and high efficiency, as it can be obtained by de-acetylation of chitin which is the main component of seafood shells, and can be easily recovered from residues of fishery industry. Moreover fishery waste disposal represent a big deal for many countries in the world. The most important characteristic of the present study is the use of the residues simply washed and grinded without recourse to any other processing, and the comparison made with performances obtained using more traditional adsorbent materials or commercial polysaccharides. As an example of the performances obtained using simply grinded shrimp shell, in Figure 1 is indicated the amount of recovered chromium as function of time, using a dosage of 30 mg·L<sup>-1</sup>.

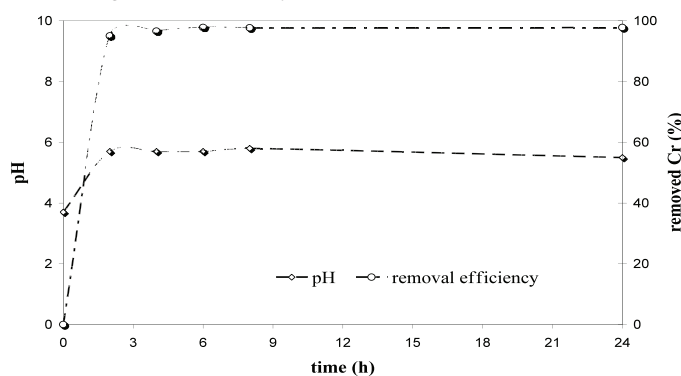

Figure 1: Chromium removal and pH variation as function of time

## References

1. Bhatnagar A., Sillanpaa M. *Chemical Engineering Journal*, **2010**, 157, 277-296.
2. Bhattacharya A.K., Naiya T.K., Mandal S.N., Das S.K., *Chemical Engineering Journal*, **2008**, 137, 529-541.
3. Demirbas A., *Journal of Hazardous Materials*, **2008**, 157, 220-229.
4. Fahim N.F., Barsoum B.N., Eid A.E., Khalil M.S., *Journal of Hazardous Materials*, **2006**, B136, 303-309.
5. Hansen H.K., Arancibia F., Gutierrez C., *Journal of Hazardous Materials*, **2010**, 180, 442-448.
6. Liu H., Dong Y., Liu Y., Wang H., *Journal of Hazardous Materials*, **2010**, 178, 1132-1136.
7. Cesaro R., Fabbicino M., Lanzetta R., Mancino A., Naviglio B., Parrilli M., Sartorio R., Tomaselli M., and Tortora G., *Water science & technology*, **2008**, 58.3, 735-738.



## PO 275

## ENZYMATIC GLYCOSYLATION OF FLAVONOIDS USING CARBOHYDRATE ACTIVE ENZYMES OF THERMOPHILIC ORIGIN

Tania Pozzo<sup>1</sup>, Zubaida Gulshan<sup>1</sup>, Nilgün Kayhan<sup>1</sup>, Eva Nordberg Karlsson<sup>1</sup>

<sup>1</sup>Department of Biotechnology, Lund University Box 124 SE-221 00 Sweden  
Eva.Nordberg\_Karlsson@biotek.lu.se

Flavonoids are secondary metabolites existing in plants, vegetables and fruits. They are molecules giving colour, having favourable health effects, and they are previously reported to have antioxidizing as well as antimicrobial properties. However, flavonoids have low stability and variable solubility in water, physico-chemistry properties that affect their use in different applications<sup>1</sup>.

Extreme environments are great sources for biocatalyst discovery with potential application in biotechnological processes and new sustainable technologies<sup>2</sup>. In this project, two recombinantly expressed thermostable  $\beta$ -glucosidases from *Thermotoga neapolitana*, TnBgl1A (GH1) and TnBgl3B (GH3) and one glycosyl transferase AFCGT (GH57) from *Archaeoglobus fulgidus* 7324 are used as biocatalysts in the biotransformation of flavonoids. These biocatalysts were produced and expressed in soluble form in *E. coli*. Protein purification was carried out using affinity chromatography. Based on structural studies and flavonoid docking, new rationally designed mutants were created.

A novel direct 96-well screening method was used to assess mutants with increased efficiency in enzymatic synthesis<sup>3</sup>. Enzymatic reactions were further optimized based on water activity and different acceptor and donor glycosides in the case of the best mutants. The results of these studies will be presented, along with data on glycosidic bond formation, antioxidant stability and capacity at different temperatures and pHs.

### References

1. Wang A., Zhang F., Huang L., Yin X., Li H., Wang Q., Zeng Z., Xie T., *Journal of Medicinal Plants Research*, **2010**, 4:10, 847-856
2. Turner. P, Mamo.G, Nordberg Karlsson. E., *Microbial Cell Factories*, **2007**, 6:9 1-23
3. Gräber.M, Andersson.M, Rundbäck. F, Pozzo.T, Nordberg Karlsson. E., *Journal of Biotechnology*, **2010**, 145: 2, 186-192

PO 276

**CHARACTERISATION OF POLYSACCHARIDES FROM GRAPE STALKS  
OF RED GRAPE POMACES**Sónia O. Prozil<sup>1</sup>, Dmitry V. Evtuguin<sup>1</sup>, Luísa P. Cruz Lopes<sup>2</sup><sup>1</sup>University of Aveiro, CICECO and Department of Chemistry, 3810-193 Aveiro, Portugal<sup>2</sup>Polytechnic Institute of Viseu- CI&DETS and Department of Environment,  
3504-510 Viseu, Portugal  
prozilsonia@gmail.com

The grape stalks is a massive by-product of the wine sector and composed essentially by cellulose (30.3%), hemicelluloses (21.0%), tannins (15.9%), proteins (6.1%) and lignin (17.4%). Among hemicelluloses xylan is the most abundant contributing to 12% wt., the second been  $\beta$ -glucan (6-7%) of unknown structure<sup>[1]</sup>. The grape stalks need to be utilized according to environmental regulations and the present study on polysaccharide structure was a part of strategy towards exploitation of this underused resource. Cellulose was isolated by Kürscher and Höffer method and characterized by wide angle X-ray scattering (WAXS). The xylan was isolated from corresponding peracetic holocellulose by DMSO extraction followed by precipitation in ethanol<sup>[2]</sup>. The molecular weight of xylan was assessed by SEC and the structure was inferred by wet chemistry (methanolysis and methylation analysis) and spectroscopic (<sup>1</sup>H NMR, <sup>1</sup>H-<sup>1</sup>H (TOCSY) and <sup>1</sup>H-<sup>13</sup>C (HSQC)) techniques. X-ray analysis revealed the parameters of cellulose unitary cell (8.0 x 7.9 x 10.3 Å), average diameter of nanofibrils (4.2 nm) and the degree of crystallinity (75.4%). The xylan was partially acetylated (DS=0.49) glucuronoxylan possessing of average molecular weight of ( $M_w$ ) of ca 20 kDa and which backbone composed by (1 $\rightarrow$ 4)-linked  $\beta$ -D-xylopyranosyl units ramified with (1 $\rightarrow$ 2)-linked 4-O-methyl- $\alpha$ -D-glucuronosyl residues (MeGlc<sub>p</sub>A) at a molar ratio 1:25. The ratio of O-3:O-2 linked acetyl groups was 0.29:0.20. The isolated heteroxylan contained concomitant  $\beta$ -glucan (ca 12%), which structure was elucidated by methylation linkage analysis and by ESI-MS<sup>n</sup> after enzymatic hydrolysis with xylanase. The results obtained revealed  $\beta$ -glucan from grape stalks as mixed (1,3;1,4)- $\beta$ -D-glucan with a molar ratio of (1 $\rightarrow$ 3)- and (1 $\rightarrow$ 4)-linked  $\beta$ -D-glucose building blocks 1:2.

**References**

1. Prozil, S.O., Evtuguin, D.V., Cruz Lopes, L.P. *Industrial Crops & Products*, **2011**, submitted.
2. Evtuguin, D., Tomás, J., Silva, A., Neto, C. P., *Carbohydrate Research*, **2003**, 338 (7), 597-604.

PO 277

**REGIOSELECTIVE AND STEREOSELECTIVE PROTECTION  
FUNCTIONAL GROUPS OF THE SUGARS**Agata Ptaszek, Anna Kasprzycka, Wiesław Szeja*Silesian University of Technology, Department of Chemistry, Krzywoustego 4,  
44-100 Gliwice, Poland  
agata.ptaszek@polsl.pl*

The selection of a protective group and protection strategy are important components of synthetic methodology always where the chemical reaction must be carried out selectively at one reaction side in a multifunctional compound, than other side requires to be temporarily blocked. In the case of natural compound like carbohydrates, nucleosides or steroids, functional groups are hydroxyls and amines, which necessities regioselective protection strategies. Etherification is one of the most fundamental and most frequently used important reaction in synthetic carbohydrates chemistry<sup>1</sup>. Protection of a hydroxyl functionality as the methoxybenzyl ethers is preferred as a temporary protective group when neutral condition of deprotection are required. Additionally this type of protective group in contrast to ester, acetal and silyl protective groups, do not undergo unwanted migration between neighboring functional groups. The methoxybenzyl protection of carbohydrates was already reported in literature with application of different strategies and conditions. Despite that, the search for new efficient etherification method is still a matter of general interest<sup>2,3</sup>.

In this communication we report the novel method protection of hydroxyl and amine functionality with *p*-methoxybenzyl, 2,4-dimethoxybenzyl and 3,4-dimethoxybenzyl groups using methoxybenzyl *N*-allyl thiocarbamates as donors protective groups. These compounds are readily obtained from methoxybenzyl alcohols by reaction with commercially available *N*-allyl isothiocyanate<sup>4</sup>.

**Acknowledgement** Research studies part-financed by the European Union within the European Regional Development Fund (POIG. 01.01.02-14-102/09).

**References**

1. Green T., Wuts P., *Protective Groups in Organic Synthesis*, 2<sup>nd</sup> ed.: John Wiley and Sons: New York, **1997**.
2. Levy D. E., Fügelli, P., *The Organic Chemistry of Sugars*, Taylor Francis Group LLC: New York, **2006**.
3. Hanessian, S., *Preparative carbohydrate chemistry*, Marcel DEKKER; New York, **1996**.



PO 278

**INVESTIGATION OF THE LOOP DYNAMICS IN THE SUBSTRATE BINDING OF THE H5N1 NEURAMINIDASE**

Michal Raab, Igor Tvaroška

*Institute of Chemistry, Centre for Glycomics, Slovak Academy of Sciences,  
Dúbravská cesta 9, 845 38 Bratislava, Slovakia  
chemmrsa@savba.sk*

The avian influenza H5N1 virus has emerged as an important pathogen, causing severe disease in humans and posing a pandemic threat. Substrate specificity is crucial for the virus to obtain the ability to spread from avian to human. Therefore, an investigation of the binding properties of ligands at the molecular level is important for understanding the catalytic mechanism of the avian influenza virus neuraminidase and for designing novel and specific inhibitors of H5N1 neuraminidase. We have performed extended molecular dynamics studies to clarify the role of the loops surrounding the active site of the H5N1 neuraminidase in the binding of the two natural substrates, namely the 3'sialyllactoside and 6'sialyllactoside. Our results suggest different binding of the two substrates to the adjacent loops. Furthermore, the MD simulations have revealed decreased mobility of the catalytic aspartate in the case of 6'sialyllactoside complex, which can explain the experimentally observed preference of the H5N1 neuraminidase for the 3'sialyllactoside.

**References**

1. M. Raab, I. Tvaroška, *J. Mol. Modeling* **2010**, DOI: 10.1007/s00894-010-0852-z

## PO 279

**PREDICTION OF SPECTRAL AND CHIROPTICAL PROPERTIES  
OF CARBOHYDRATES USING HYBRID QM/MM CALCULATIONS**

Ivan Raich, Vít Novák and Kateřina Tomčáková

*Institute of Chemical Technology, Department of Chemistry of Natural Compounds,  
Technická 5, 166 28 Prague 6, Czech Republic  
Ivan.Raich@vscht.cz*

It is known that solvation influences the spatial arrangement of dissolved compounds as well as the spectral properties themselves. In our previous computational studies<sup>1</sup> we confirmed that the quality of solvent representation has a substantial effect on the agreement between calculated and experimental data.

Our present computational study uses ONIOM hybrid QM/MM model, as implemented in Gaussian 09 software suite, to include explicit solvent molecules both into geometry optimization and NMR, IR or optical rotation calculations. Various combinations of ONIOM layers and theoretical levels were tested.

Initial number of solvent molecules and their exact positions were determined using molecular dynamics. A new technique was elaborated for the construction of primarily non-water solvent boxes filled with practically any solvent or their combination with a subsequent equilibration and soaking the solute molecule.

Calculated vibrational frequencies in IR spectra, chemical shifts and coupling constants in NMR spectra and optical rotations of various, usually bicyclic, conformationally rigid, monosaccharide molecules are both qualitatively and quantitatively compared with experimental data as well as with our previous calculated data using improved CPCM implicit solvation model in Gaussian 09.

**Acknowledgement** This work was supported by the Ministry of Education of the Czech Republic, project MSM6046137305.

**References**

1. Kaminský J., Raich I., Tomčáková K., Bouř P.: *J. Comput. Chem.*, **2010**, *31*, 2213-2224.

## PO 280

EFFICIENT SYNTHESIS OF AMINOPROPYL-BLOOD GROUP  
A TRIAOSE IN ENGINEERED *ESCHERICHIA COLI*

Mialy Randriantsoa\*\*, Sophie Drouillard\*, Sébastien Fort\*, Patricia Chaud\*,  
Stéphane Havet\*\*, Eric Samain\*

\*CERMAV-CNRS, BP 53, F-38041 Grenoble, France

\*\* ELICITYL, 746 avenue Ambroise Croizat, F-38920 Crolles, France  
mialy.randriantsoa@elicityl.fr

We have previously reported the large scale synthesis of human ABO(H) blood group antigens by growing metabolically engineered *Escherichia coli* strains (Randriantsoa. M, PhD thesis 2009). In the present study, we have extended the method to the biosynthesis of blood group A antigen triaose (GalNAc $\alpha$ -3(Fuc $\alpha$ -2)Gal) bearing an aminopropyl group at its reducing end (figure 1). The system is based on high cell density culture of a recombinant strain overexpressing two heterologous glycosyltransferase genes: the *Helicobacter pylori futC* gene which encodes an  $\alpha$ -2 fucosyltransferase and the human *gtA* gene which encodes an  $\alpha$ -3 *N*-acetylgalactosaminyltransferase. The culture was carried out in the presence of aminopropyl-galactoside which was actively internalized into the cytoplasm and converted into the target compound. This chemically activated oligosaccharide can be used as standard building block to design neoglycoconjugates and construct biotechnological tools such as affinity columns and glycan microarrays.

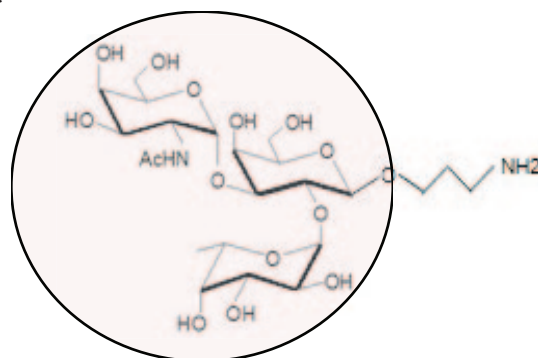

Blood group A determinant

**Figure 1:** Aminopropyl-blood group A triaose (GalNAc $\alpha$ -3(Fuc $\alpha$ -2)Gal-O-(CH<sub>2</sub>)<sub>3</sub>-NH<sub>2</sub>)



## PO 281

**NOVEL INSIGHTS IN THE GLYCOBIOLOGY OF DIABETIC NEPHROPATHY:  
A STUDY WITH DIAGNOSTIC POTENTIAL**

Alessandra Ravidá<sup>1</sup>, Marjut Kreivi<sup>1</sup>, Luca Musante<sup>1</sup>, Ilkka Miinalainen<sup>1</sup>, Paola Grassi<sup>2</sup>, Barry Byrne<sup>1</sup>, Mayank Saraswat<sup>1</sup>, Michael Henry<sup>3</sup>, Paula Meleady<sup>3</sup>, Finbarr O'Sullivan<sup>3</sup>, Martin Clynes<sup>3</sup>, Anne Dell<sup>2</sup>, and Harry Holthofer<sup>1</sup>

<sup>1</sup>*Centre for BioAnalytical Sciences, Dublin City University, Dublin, Republic of Ireland*

<sup>2</sup>*Division of Molecular Biosciences, Faculty of Natural Sciences,  
Imperial College London, London, UK*

<sup>3</sup>*National Institute for Cellular Biotechnology, Dublin City University, Dublin,  
Republic of Ireland  
Alessandra.ravida@dcu.ie*

In most Western countries, diabetic nephropathy (DN) and chronic hypertension account for 80% of the incidence of end-stage renal disease (ESRD) cases, with diabetes being the major single cause. The worsening epidemic of ESRD has been identified as a major health-care socio-economic challenge throughout the world, with an urgent need to transfer the results of basic research to produce effective early diagnostics and better therapeutic strategies.

In this study we aim to study whether the development of the diabetic nephropathy onset associates with changes in the glycosylation of kidney glycoproteins with a particular focus on the cortical region of the organ.

Detection of differential glycosylation patterns as associated with progression of the disease was first carried out by the means of lectin assays on kidney cortex specimens from the well established *in vivo* rat model of Streptozotocin-induced diabetes.

Selected lectins were further exploited in a set of affinity chromatography experiments for the isolation of candidate glycoproteins, whose identification was performed by LC-MS analysis. The data thus obtained were validated by western blot and Histochemistry and additional glycobiological techniques.

This study represents the first systematic approach towards a novel understanding of the glycobiology of diabetic nephropathy. We demonstrated the feasibility of detecting diabetes-induced changes in the glycosylation patterns of the kidney by lectin assays. Furthermore, it is expected that these promising protein candidates will pave the way for a novel approach to the early-stage diagnosis of diabetic nephropathy.

PO 282

**PHOTO-DISSOCIATION OF TAGGED CARBOHYDRATES:  
QUANTIFICATION AND ACCESS TO STRUCTURAL INFORMATIONS**

Redon Sébastien,<sup>1,2</sup> Racaud Amandine,<sup>1,3,4</sup> Enjalbert Quentin,<sup>1,3,4</sup> Antoine Rodolphe,<sup>1,3</sup>  
Loison Claire,<sup>1,3</sup> Ayhan Mehmet Menaf,<sup>1,5</sup> Queneau Yves,<sup>1,2</sup> Andraud Chantal,<sup>1,5</sup>  
Chambert Stéphane,<sup>1,2</sup> Bretonnière Yann,<sup>1,5</sup> Dugourd Philippe,<sup>1,3</sup> Lemoine Jérôme<sup>1,4</sup>

<sup>1</sup>Université Lyon F-69622, Lyon, France,

<sup>2</sup> COB, ICBMS, UMR 5246, INSA-Lyon, France,

<sup>3</sup>CNRS, UMR5579, LASIM, Villeurbanne, France,

<sup>4</sup>CNRS, UMR 5180, LSA, Villeurbanne, France,

<sup>5</sup> Laboratoire de Chimie de l'ENS Lyon, CNRS, ENS Lyon, UCBL, UMR 5182, France.

sebastien.redon@insa-lyon.fr

The present work focuses on mass spectrometry photo-dissociation experiments used towards both quantitative<sup>1</sup> and structural analysis of carbohydrates. The study relies on the straightforward access to carbohydrate azides directly obtained from the corresponding unprotected carbohydrates.<sup>2</sup> Azido-carbohydrates were then grafted to push-pull chromophores by “click chemistry” to give probes which were analyzed using two different methods. A new technique (photo-SRM) dedicated to quantification was developed. For this purpose non-discriminating collision-induced dissociation (CID) mode has been replaced by a more specific photo-dissociation process governed by the properties of a target molecule (using a judicious overlap between compound absorbing properties and the excitation wavelength of the laser beam). Proof of principle of photo-SRM was carried out with the tagged-sucrose molecule **1** and it was shown that the experiment could even be performed when diluted in whole plasma hydrolysate. Photo-dissociation produces complementary fragmentation to CID when implemented for activation of model labeled carbohydrates. Analogous to photo-dissociation performed using UV light,<sup>3</sup> experiments taking advantage of the efficient absorption of the visible laser beam of tagged-carbohydrates such as disaccharides **2** and **3** afforded structural informations on the glycosidic bond between the two hexoses by fragment analysis.

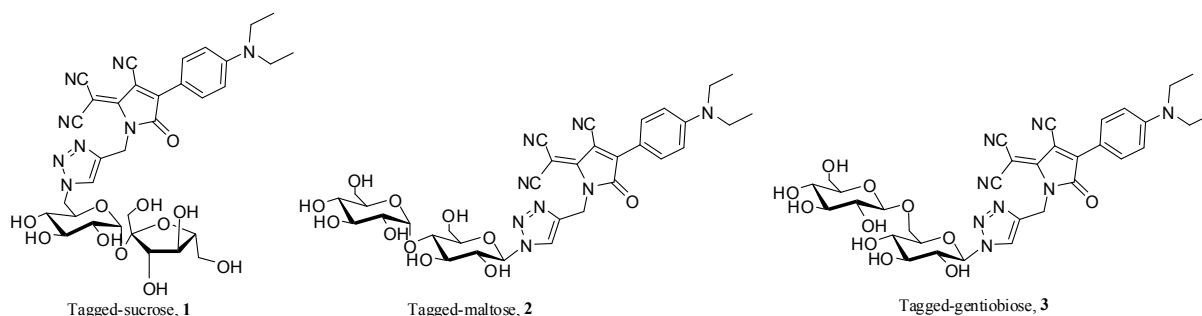

## References

1. Enjalbert Q., Simon R., Salvador A., Antoine R., Redon S., Ayhan M. M., Darbour F., Chambert S., Bretonnière Y., Dugourd P., Lemoine J., Submitted.
2. a) Besset C., Chambert S., Fenet B., Queneau Y., *Tetrahedron. Lett.*, **2009**, 50, 7043-7047. b) Tanaka T., Nagai H., Masato N., Kobayashi A., Shoda S.-I., *Chem. Comm.*, **2009**, 3378-3379.
3. Wilson J. J., Brodbelt J. S., *Anal. Chem.*, 2008, 80, 5186-5196.

## PO 283

**PSEUDOSACCHARIDES FUNCTIONALIZED DENDRONS INHIBITORS OF MBL ARE ABLE TO PREVENT ISCHEMIC INJURY IN MICE**

Roberta Ottria,<sup>1</sup> José J. Reina,<sup>1</sup> Franca Orsini,<sup>2</sup> Elisa R. Zanier,<sup>2</sup> Raffaella Gesuete,<sup>2</sup> Matteo Stravalaci,<sup>3</sup> Daiana de Blasio,<sup>2</sup> Marco Gobbi,<sup>3</sup> Maria Grazia di Simoni,<sup>2</sup> Javier Rojo<sup>4</sup> and Anna Bernardi<sup>1</sup>

<sup>1</sup>Dipartimento di Chimica Organica e Industriale, Università degli Studi di Milano, Milano, Italy;

<sup>2</sup>Department of Molecular Biochemistry and Pharmacology, Mario Negri Institute, Milan, Italy;

<sup>3</sup>Department of Molecular Biochemistry and Pharmacology, Mario Negri Institute, Milan, Italy;

<sup>4</sup>Glycosystems Laboratory, Instituto de Investigaciones Químicas, CSIC-Universidad de Sevilla  
jose.reina@unimi.it

Recently, it has been demonstrated that the powerful protective effect of recombinant human complement C1-inhibitor (rhC1-INH) in cerebral ischemia is due to its ability to inhibit the activation of complement lectin pathway by binding to mannose binding lectin (MBL),<sup>1</sup> likely through its mannose-enriched N-terminal domain. To explore the relevance of the lectin pathway in cerebral ischemia we have determined if newly synthesized mannosylated mimetic molecules, characterized and selected for their binding to MBL, are able to prevent ischemic injury in mice. Multivalent carbohydrate systems are required to interact in an efficient manner with this receptor and compete with the natural ligands. We have previously demonstrated that linear pseudodi- and pseudotriscaccharides are adequate ligands for lectins that recognize mannose, for example, DC-SIGN.<sup>2</sup> In this work, we show that multivalent presentations of these glycomimetics based on dendrons lead to very potent inhibitors of MBL and also we indicate that the inhibition of this protein leads to neuroprotection. The affinity of mannosylated molecules to MBL was measured by surface plasmon resonance (SPR). The molecule showing the highest affinity to MBL was administered intravenously to ischemic mice and neurological deficits and infarct volume were evaluated. Polyman002, a dendron exposing four copies of the pseudo-triscaccharide bind MBL with a  $K_D=2.3\pm 0.7\mu\text{M}$  and induced a significant reduction of neurological deficits and ischemic volume *in vivo*. Our findings, together with those recently published by Cervera et al.,<sup>3</sup> indicate that MBL inhibition may represent a novel therapeutic target for stroke.

**References**

1. Gesuete, R., Storini, C., Fantin, A., Stravalaci, M., Zanier, E.R., Orsini, F., Vietsch, H., Man-nessem M.L., Ziere, B., Gobbi, M., De Simoni, M.G., *Ann. Neurol.*, **2009**, 66, 332-342.
2. (a) Sattin, S., Daghetti, A., Thépaut, M., Berzi, A., Sánchez-Navarro, M., Tabarani, G., Rojo, J., Fieschi, F., Clerici, M., Bernardi, A., *ACS Chem. Biol.*, **2010**, 3, 301-312. (b) Luczkowiak, J., Sattin, S., Reina, J.J., Sánchez-Navarro, M., Sutkevičiūtė, I., Thépaut, M., Martínez-Prats, L., Daghetti, A., Fieschi, F., Delgado, R., Bernardi, A., Rojo, J., *unpublished results*.
3. Cervera, A., Planas, A.M., Justicia, C., Urra, X., Jensenius, J.C., Torres, F., Lozano, F., Chamorro, A., *PLoS One*, **2010**, 5, e8433.

PO 284

**COMPLETE SET OF MONOSUBSTITUTED  $\alpha$ -CYCLODEXTRINS AS PRECURSORS  
FOR FURTHER SYNTHESIS**

Michal Řezanka,<sup>1</sup> and Jindřich Jindřich<sup>1</sup>

<sup>1</sup> *Department of Organic and Nuclear Chemistry, Faculty of Science, Charles University in Prague, Hlavova 8, 128 43 Praha 2, Czech Republic*  
rezanka@natur.cuni.cz

Cyclodextrins<sup>1</sup> (CDs) and their derivatives have good complexation abilities due to the rigid, cone-shaped cavity formed by  $\alpha$ -1,4-linked D-glucopyranose units. Nowadays native cyclodextrins play hidden, but important role in our lives. They are used in many areas e. g. food industry (additive permitted in food within the European Union)<sup>2</sup> or pharmacy (drug additive to improve solubility, stability or masking bitter taste).<sup>3</sup>

In order to extend possibilities of utilization of cyclodextrins it is necessary to prepare their suitable derivatives. One way to extend this idea is to prepare monosubstituted derivatives of cyclodextrins. In this regard as ideal starting substrates can be considered selectively allylated, formylmethylated or carboxymethylated cyclodextrins in which the functional group could participate in further reactions. Formylmethyl or carboxymethyl derivatives could be prepared from allyl or cinnamyl derivatives by oxidative cleavage. Our research is focused on the preparation of a complete set of the above mentioned peracetylated 2<sup>1</sup>-O-, 3<sup>1</sup>-O- and 6<sup>1</sup>-O-derivatives of  $\alpha$ -CD (Scheme 1).

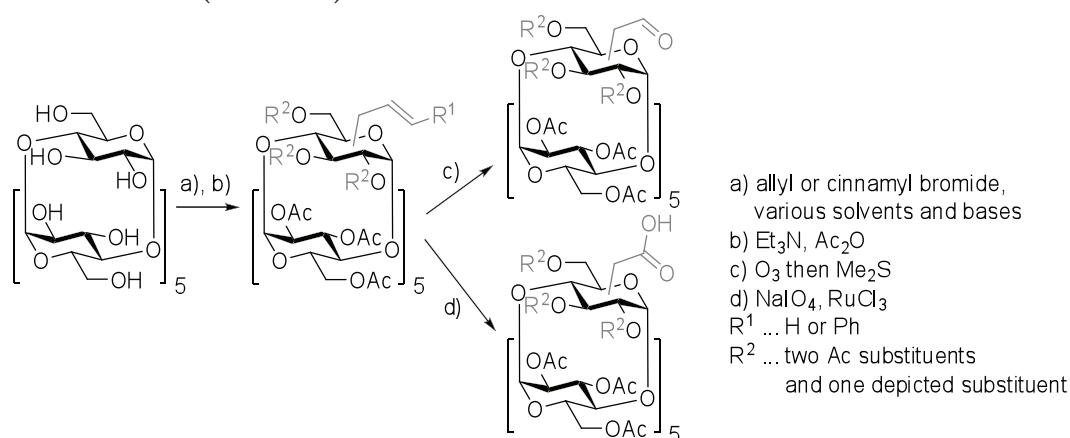

**Scheme 1.** Preparation of peracetylated 2<sup>1</sup>-O-, 3<sup>1</sup>-O- and 6<sup>1</sup>-O- monosubstituted derivatives of  $\alpha$ -CD.

This work was supported by grants No. MSM0021620857 and No. KAN 200200651.

### References

1. J. Szejtli, *Chem. Rev.*, **1998**, 98, 1743-1754.
2. *European Parliament and Council Directive No 95/2/EC*, **1995**.
3. A. Vyas, S. Saraf, S. Saraf, *J. Inclusion Phenom. Macrocyclic Chem.*, **2008**, 62, 23-42.

## PO 285

## SYNERGISTIC APPLICATION OF GLYCOSYLTRANSFERASES AND AN ENDOGLYCOCERAMIDASE GLYCOSYNTASE TO GLYCOSPHINGOLIPID SYNTHESIS

Jamie R. Rich,<sup>1</sup> Michel Gilbert,<sup>2</sup> and Stephen G. Withers<sup>1</sup><sup>1</sup>University of British Columbia Department of Chemistry, Vancouver, BC, Canada,<sup>2</sup>Institute for Biological Sciences, National Research Council Canada, Ottawa, ON, Canada  
jrich@chem.ubc.ca

Glycosphingolipids (GSLs) are acknowledged for their important functions in human health and disease, for instance through their roles in lipid raft organization and participation in signalling and pathogen engagement. As appreciation of their non-structural roles has grown rapidly, so too have demands for access to homogeneous GSLs. Enzymatic synthesis is a logical approach with obvious advantages over isolation and chemical synthesis. Unfortunately, practical considerations prevent their assembly via stepwise addition of monosaccharide units onto ceramide by glycosyltransferases (GTs). Here we present two methods for chemoenzymatic GSL synthesis. In the first, nucleophile mutants of endoglycoceramidase II from *Rhodococcus* strain M-777 (EGCase glycosynthase)<sup>1</sup> are used to catalyze formation of lactosyl sphingosine from lactosyl fluoride (LacF) and sphingosine. Subsequent elaboration with recombinant GTs provides access to more complex GSLs. In the second, LacF is elaborated to a more complex glycosyl fluoride via sequential GT-catalyzed monosaccharide couplings, and the oligosaccharyl fluoride is then transferred *en bloc* to sphingosine by an EGCase glycosynthase. Glycosyl sphingosines obtained by either method may be converted directly to glycosyl ceramides or to unnatural GSLs bearing, for example, fluorescent tags. Syntheses of ceramide pentahexoside (Gal $\alpha$ 1,3-Gal $\beta$ 1,4-GlcNAc $\beta$ 1,3-Gal $\beta$ 1,4-Glc $\beta$ -Cer) and 3-sialylparagloboside (Neu5Ac $\alpha$ 2,3-Gal $\beta$ 1,4-GlcNAc $\beta$ 1,3-Gal $\beta$ 1,4-Glc $\beta$ -Cer) highlight the promise of this strategy.

**References**

1. Vaughan, M.D, Johnson, K., Defrees, S., Tang, X., Warren, R.A.J., Withers, S.G., *J. Am. Chem. Soc.*, **2006**, *128*, 6300-6301.

PO 286

**SYNTHESIS AND BIOLOGICAL EVALUATION OF S-NEOGALACTOPEPTIDES  
WITH POTENTIAL AFFINITY TOWARDS ENTEROTOXINS**

Francisco J. Ramos Soriano, Inmaculada Robina\* Antonio J. Moreno-Vargas,  
Ana T. Carmona and Elena Moreno-Clavijo

*Department of Organic Chemistry, Faculty of Chemistry, University of Seville,  
St/ Professor García González 1, 41012 Seville, Spain. Fax: +34954624960; Tel: +34954556858.  
robina@us.es*

*Vibrio cholerae* (CT) toxins and the closely related heat-labile toxin of *Escherichia coli* (LT), which cause diarrheal diseases, are proteins that present heterophilic binding with their receptors.<sup>1</sup> They belong to the bacterial AB<sub>5</sub> holotoxin family where the B subunits are responsible for binding to GM1. Several glycomimetics have been described to have affinity towards CT and LT.<sup>2</sup> Based on our previous results on SLe<sup>x</sup> mimetics,<sup>3</sup> we now present the preparation and biological study of various S-neogalactopeptides as GM1 glycomimetics. The new compounds are within the structural models I and II. They are structurally simpler and more stable than the natural ganglioside GM1, contain the necessary pharmacophores for their interaction with the enterotoxins CT and LT and have appropriate groups to generate structural diversity and for their assembly into multivalent structures.

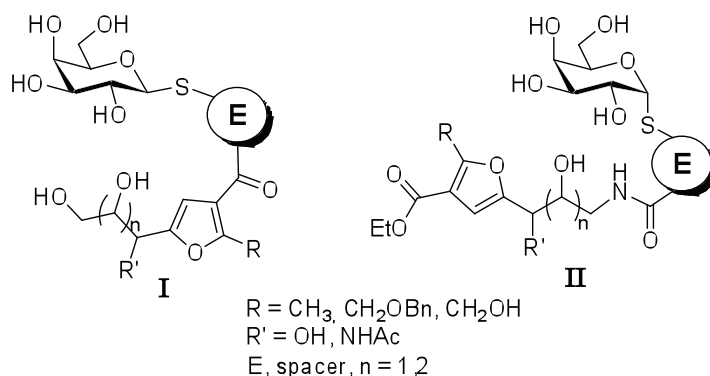

### References

1. a) Hindsgaul, O.; Cummings, R.D. *Essentials of Glycobiology (Chapter 4. Protein-Glycan Interactions)*, Eds. Cold Spring Harbor, 1999. b) Watt; S. M.; Teixeira, A. M.; Zhou, G.-Q.; Doyonnas, R.; Zhang, Y.; Grunert, F.; Blumberg, R. S.; Kuroki, M.; Skubitz, K. M.; Bates, P. A. *Blood*. **2001**, 98, 1469.
2. a) Ernst, B.; Magnani, J. *Nat. Rev. Drug. Discovery*. **2009**, 8, 661. b) Pickens, J. C.; Merritt, E. A.; Ahn, M.; Verlinde, C. L. M. J.; Hol, W. G. J.; Fan, E. K. *Chem. Biol.* **2002**, 9, 215. c) Bernardi, A.; Podlipnik, C.; Jiménez-Barbero, J. *Protein-Carbohydrate Interactions in Infectious Diseases*, **2006**, 73. d) Bernardi, A.; Cheshev, P. *Chem. Eur. J.* **2008**, 14, 7434. e) Bernardi, A. et al. *Carbohydr. Res.* **2007**, 342, 1651. f) Bernardi, A. et al. *Chem. Eur. J.* **2010**, 16, 1951.
3. a) Moreno-Vargas, A. J.; Molina, L.; Carmona, A. T.; Lambelet, M.; Spertini, O.; Robina, I. ES Patent, ES2325567B2, **2010**. b) Moreno-Vargas, A. J.; Molina, L.; Carmona, A. T.; Lambelet, M.; Spertini, O.; Robina, I. ES Patent, ES2324137B2, **2010**. c) Moreno-Vargas, A. J.; Molina, L.; Carmona, A. T.; Ferrali, A.; Lambelet, M.; Spertini, O.; Robina, I. *Eur. J. Org. Chem.* **2008**, 2973.



PO 287

**THE PROMINENT ROLE OF TRYPTOPHAN IN PROTEIN- CARBOHYDRATE INTERACTIONS DERIVED FROM THE PROTEIN DATA BANK (PDB)**Miguel Rojas-Macias<sup>1</sup> and Thomas Lütteke<sup>2</sup>

<sup>1</sup>*Institute of Veterinary Physiology and Biochemistry, Frankfurter Straße 100 35392 Gießen, Germany*  
*miguel-rojas@vetmed.uni-giessen.de*

Protein-carbohydrate interactions are the basis of numerous biological processes, such as the attachment of bacteria, viruses (e.g. influenza) and their toxins (e.g. cholera), as the first step in the initiation of infection. All these events require a precise recognition of the carbohydrates by the binding proteins. It's not yet fully understood how the proteins are able to distinguish even between very similar carbohydrates. 3D structural data are the key to this question. Such data can be found in the Protein Data Bank (PDB), the largest resource of freely available biomolecular 3D structures.

The GlyVicinity software of the GLYCOSCIENCES.de web portal is dedicated to statistically analyze the amino acids that are found in spacial vicinity of carbohydrate residues in the PDB. The amino acid patterns differ between different kinds of carbohydrate residues. Expectedly, polar residues are more frequently found than non polar ones. Aromatic amino acids, especially tryptophan, form a remarkable exception, as they are relatively non-polar but clearly over-represented around carbohydrate residues.

Applying the well known CD-HIT program to the data in order to remove redundancy, clusters of 70% up to 100% sequence similarity were obtained. The subsequent analysis of single representatives of each cluster are consistent and certainly confirm the results. This indicates that tryptophan residues play an important role in carbohydrate binding. Most of the interactions between tryptophan and carbohydrate residues can be identified as stacking interactions.

Glyvicinity is available online at [www.glycosciences.de/tools/glyvicinity/](http://www.glycosciences.de/tools/glyvicinity/). Access to the entire data available in the PDB is warranted by weekly automatic updates of the data sets with interaction data from new PDB entries.

PO 288

## DEVELOPMENT OF A NEW LIGATION METHOD FOR OLIGOSACCHARIDE ENGINEERING

Andrea Niederwieser, Valentin Wittmann

*Fachbereich Chemie and Konstanz Research School Chemical Biology, Universität Konstanz,  
Universitätstr. 10, 78457 Konstanz, Germany  
Valentin.Wittmann@uni-konstanz.de*

Glycoconjugates, such as glycoproteins, play an important role in numerous biological processes. Understanding their function requires the investigation of their biosynthesis and distribution in cells.

Here, we present the development and the application of a new metal-free ligation method for metabolic oligosaccharide engineering based on the Diels-Alder reaction with inverse electron demand (DARinv). Chemically modified *N*-acetylmannosamine derivatives with dienophile moieties in the *N*-acyl side chain were synthesized and metabolically introduced into cellular glycoconjugates. The modified glycoconjugates were subsequently labeled in living cells with appropriately functionalized tetrazines. We synthesized different functionalized electron-deficient 1,2,4,5-tetrazines and compared their suitability for cell-surface staining of glycoconjugates.

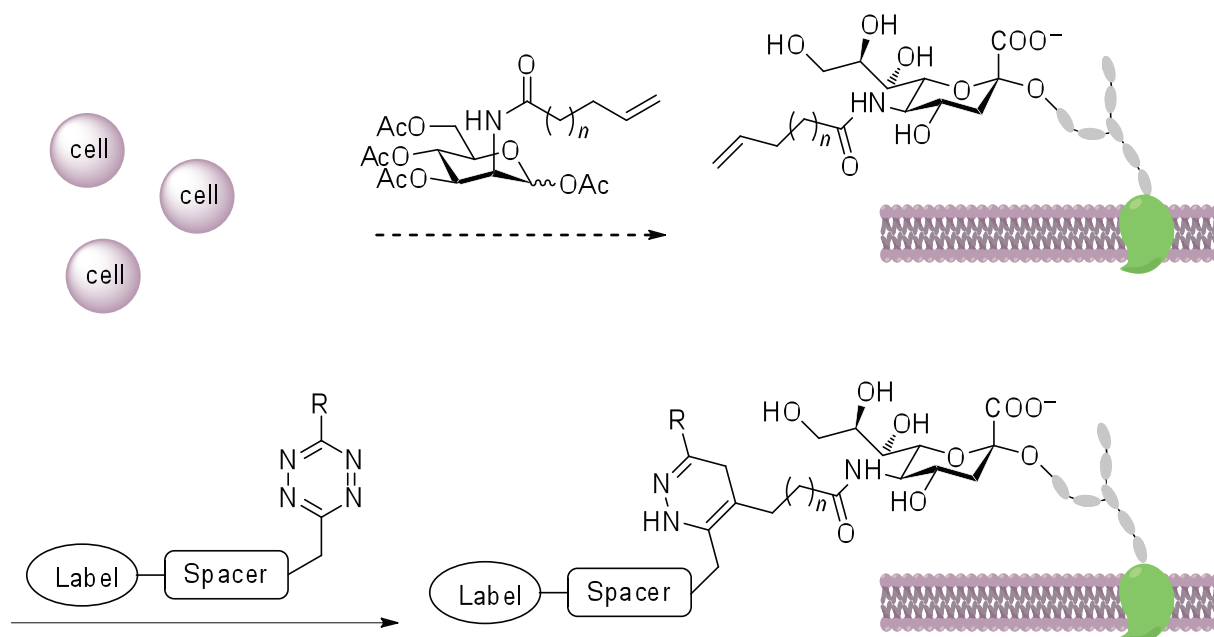

PO 289

### STUDY OF SOME PARAMETERS ON UNLOADED CHITOSAN-TPP NANOPARTICLES ELABORATION

Ruth Rojo<sup>1</sup>, Paloma Gatón<sup>1</sup>, M<sup>a</sup> Luisa Mussons<sup>1</sup>, Francisco Javier Gutiérrez<sup>1</sup>,  
Gregorio Antolín<sup>1,2</sup>

<sup>1</sup>CARTIF Centro Tecnológico. Div. Químico-Alimentaria. Parque Tecnológico de Boecillo,  
parcela 205. 47151 Boecillo (Valladolid) España,

<sup>2</sup>E.T.S.I. Industriales. Dpto. de Ingeniería Química y Tecn. del Medio Ambiente.  
Universidad de Valladolid. P<sup>a</sup> del Cauce s/n. 47011 Valladolid España  
fragut@cartif.es

This work is based on the systematic study of the physicochemical properties of nanoparticles formed by chitosan-tripolyphosphate (TPP) interactions amplifying former studied ranges and corroborating previous research on this field<sup>1,2</sup>. Different conditions on nanoparticles formation were analysed (reactants concentrations, mass ratio and stirring time).

The main advantages of chitosan nanoparticles are their capacity to cross biological barriers, to protect macromolecules (genes, proteins...) from degradation in biological media, to deliver drugs to a target site with following controlled release and the delivery efficacy of their active principles.

Particles were prepared as previously reported by <sup>3,4</sup>. Three different chitosan concentrations (1,4-5,6 mg/mL) and five TPP concentrations (from 0,2-2,7 mg/mL) were assayed. Particle size distribution and zeta potential (ZP) were determined using Zetasizer Nano-ZS after 24h and morphology study was carried out by FEI Quanta 200 Scanning Electronic Microscopy (SEM). Average particle diameter was around 300nm when the concentration of chitosan and TPP was set at 1,4 and 0,893mg/mL respectively, at pH 4.8. Both, particles size and zeta potential increase with raising chitosan concentrations, while decrease with raising TPP concentrations. (See Fig.1). Study shows that the higher mass ratio, the bigger particle size is reached; however, tendency is not lineal. Concerning zeta potential (ZP), 10 is a critical mass ratio value. Stirring times seems not to affect ZP and for size, stability was only found for the described optimal concentrations.

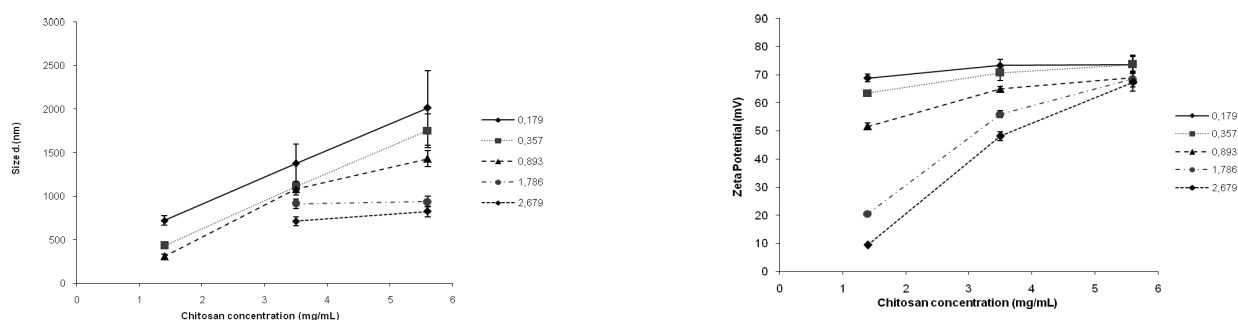

Fig.1. Size (left) and zeta potential (right) variation for different chitosan and TPP concentrations (mg/mL).

#### References

1. Liu H & Gao C., *Polymers Advanced Technologies*, **2009**, 20:613–619
2. Wang, C., Xiong, F., Yang, L., *Chinese Science Bulletin*, **2007**, 52, 883-889
3. Calvo, P, Remuñán-López, C., Vila-Jato, J.L., et al. *Journal of Applied Polymer Science*, **1997**, 63, 125–132
4. Qi L., Xu, Z., Jiang, X., et al. *Carbohydrate Research*, **2004**, 339, 2693–2700

## PO 290

**EVALUATION OF DIFFERENT CARRIER PROTEINS FOR MENINGOCOCCAL A, C, W-135, AND Y CONJUGATE VACCINES**

Marta Tontini, Maria Rosaria Romano, Daniela Proietti, Tommaso Niccolai, Francesco Berti, Cristiana Balocchi, Elena Mori, Paolo Costantino

*Novartis Vaccines and Diagnostics Research Center, Via Fiorentina 1, 53100 Siena, Italy*

Meningococcal disease is a sudden, severe, unpredictable and potentially fatal disease in otherwise healthy individuals. Five out of 13 known *Neisseria meningitidis* serogroups cause the majority of disease. The polysaccharide capsule is one of the major virulence factors of the meningococcus, and the bacterial-cell surface polysaccharides have long been key antigens for vaccines against major disease-causing meningococcal serogroups A, C, W-135 and Y (Men A, MenC, MenW-135, MenY). Conjugation of polysaccharides to a protein carrier has conferred important public health benefits; little research examines the differences between carriers [1, 2, 3, 4].

We prepared and characterized meningococcal serogroup A, C, W-135 and Y glycoconjugates with CRM<sub>197</sub>, Diphtheria Toxoid (DT), Tetanus Toxoid (TT) used in licensed vaccines.

The different conjugates were tested in a mouse animal model: Balb/C mice were each injected subcutaneously with 2µg of MenA, and 1µg of MenC, MenW-135, and MenY with AlumPhosphate as adjuvant. Control animals were injected with adjuvant only. Additional doses were administered after 14 and 28 days. Vaccinated and control animals were bled 27 and 42 days after the second and third conjugate injection.

Post immunization sera were analyzed by ELISA for specific anti-polysaccharide and anti-carrier IgG. Functionality of the antibodies elicited against the capsular polysaccharide was assessed in a serum bactericidal assay using rabbit complement (rSBA).

Preliminary data showed comparable results for CRM<sub>197</sub>, TT and DT conjugates.

**References**

1. Bardotti A., Averani G., Berti F., Berti S., Carinci V., D'Ascenzi S., Fabbri B., Giannini S., Giannozzi A., Magagnoli C., Proietti D., Norelli F., Rappuoli R., Ricci S., Costantino P. *Vaccine* 26(18), 2284-2296 (2008).
2. Bröker M., Dull P. M., Rappuoli R., Costantino P. *Vaccine* 27, 5574-5580 (2009).
3. Snape M.D., Perrett K.P., Ford K.J., John T.M., Pace D., Yu L.M., Langley J.M., McNeil S., Dull P.M., Ceddia F., Anemona A., Halperin S.A., Dobson S. and Pollard A.J. *JAMA* 299(2), 173-184 (2008).
4. Perrett K.P., Snape M.D., Ford K.J., John T.M., Yu L.M., Langley J.M., McNeil S., Dull P.M., Ceddia F., Anemona A., Halperin S.A., Dobson S., Pollard A.J. *Pediatr. Infect. Dis. J.* 28(3), 186-193 (2009).

PO 291

**CONFORMATIONAL STUDIES OF XYLOSIDIC ANTICANCER  
AGENTS BY NMR SPECTROSCOPY**

Jerk Rönnols,<sup>1</sup> Ulf Ellervik<sup>2</sup> and Göran Widmalm<sup>1</sup>

<sup>1</sup> Arrhenius laboratory, Stockholm University, S-106 91 Stockholm,  
Sweden

<sup>2</sup> Organic chemistry, Lund University, SE22100 Lund, Sweden  
jerk@organ.su.se

Some  $\beta$ -xylopyranoside derivatives with hydrophobic aglycons have been shown to initiate glycosaminoglycan (GAG) synthesis in eukaryotic cells. In cancer cells some of these compounds initiate formation of GAG chains with antiproliferative abilities, which render good anticancer properties.<sup>1</sup> It has been speculated that this potency is related to the conformational flexibility of the xyloside ring, which is known to appear in  ${}^4C_1$ ,  ${}^2S_0$  and  ${}^1C_4$ -conformations in different derivatives.

The conformational flexibility of a group of synthesized structures was analyzed by NMR-spectroscopic methods in solution, relying on  ${}^3J_{\text{HH}}$ -coupling constant analysis with aid from the PERCH software and calculations. The compounds contained different aglycons (see figure) and the hydroxyl groups were methylated, removed or left untouched.

The results show that the nature of the aglycon (of the ones studied) plays little or no role for the conformation in solution. Neither does methylation of the ring hydroxyls affect the conformational equilibrium. Deoxygenation, however, shifts the conformation away from the otherwise observed pattern.

The conformational behaviour in solvents of differing polarity as well as the link between conformation and biology will be presented.

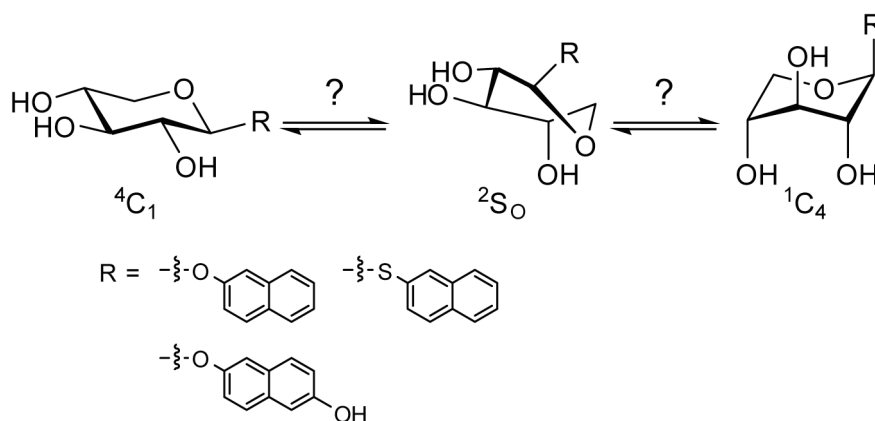

### References

1. Nilsson, U., Johnsson, R., Fransson, L.-Å., Ellervik, U., Mani, K., *Cancer research*, **2010**, *70*, 3771-3779.

## PO 292

**IMPLEMENTATION OF A HIGH THROUGHPUT MALDI MS PLATFORM FOR THE DISCOVERY OF CARBOHYDRATE DEPOLYMERISING ENZYMES**

Ropartz David<sup>1</sup>, Bodet Pierre-Edouard<sup>1,2</sup>, Przybylski Cédric<sup>2</sup>, Fer Maude<sup>3</sup>, Helbert William<sup>3</sup>,  
Gonnet Florence<sup>2</sup>, Daniel Régis<sup>2</sup>, Bertrand Dominique<sup>1</sup>, Rogniaux Hélène<sup>1</sup>

<sup>1</sup>INRA UR1268 *Biopolymères Interactions Assemblages*,  
*Plate-Forme BIBS, F-44316 Nantes, France*

<sup>2</sup>CNRS UMR 8587, *Laboratoire Analyse et Modélisation pour la Biologie et l'Environnement*,  
*Université d'Evry-Val-d'Essonne, F-91025 Evry, France*

<sup>3</sup>CNRS-UPMC UMR 7139 *Végétaux Marins et Biomolécules*,  
*Station Biologique, F-29680 Roscoff, France*  
*david.ropartz@nantes.inra.fr*

Depolymerising enzymes are helpful for industrial applications of polysaccharides and also bring a significant help in the structural elucidation of complex polysaccharides. However, very few of them have been described so far. A broad exploration of the natural biodiversity could help to the discovery of new enzymatic activities. Yet, this exploration requires new screening methods able to monitor enzymatic depolymerization on a wide range of polysaccharides. The method must obviously be adapted to the high throughput of large samples collection.

An experimental design based on MALDI mass spectrometry was settled for that aim. The major interest of this method is to evidence enzyme activity through the detection of degraded products. In addition, in the same step, accurate mass determination permits to address their fine molecular structure and deduce the enzymes specificities.

In MALDI mass spectrometry, the choice of the matrix is usually made according to the analyte chemical properties. In our project, many different kinds of polysaccharides were susceptible to be investigated and it was not conceivable to design one matrix preparation for each. Thus, we sought for the most generic candidate amongst more than forty matrices, based on several critical features for screening purpose: homogeneity of the signal distribution amongst the sample-matrix deposit, mass deviation, reliability of the mass spectral representation of the sample, and finally, required replicates to achieve a signal repeatability (variation of signal intensity).

Amongst all tested compounds, we propose a single matrix preparation that allow the rapid and automated detection of polysaccharides degradation in complex mixtures. Notably, this matrix proved to be adapted to many chemical natures of polysaccharides. MALDI analyses could be done without any sample preparation like desalting, and the same matrix could be used in both positive and negative ionization modes.



## PO 293

**ON THE USE OF TANDEM MASS SPECTROMETRY TO LOCALISE  
THE PHOSPHORYLATION SITE ON OLIGOSACCHARIDES**

Ropartz David<sup>1</sup>, Bruel Laetitia<sup>2</sup>, Giardina Thierry<sup>2</sup>, Rogniaux Hélène<sup>1</sup>

<sup>1</sup>*INRA UR1268 Biopolymères Interactions Assemblages,  
Plate-Forme BIBS, F-44316 Nantes, France*

<sup>2</sup>*Institut des Sciences Moléculaires de Marseille, UMR 6293  
F-13397 Université Paul Cézanne, Marseille, France  
david.ropartz@nantes.inra.fr*

In bacteria, phosphorylation of carbohydrates is a modification that plays an important role in the metabolism of polysaccharides. In order to better decipher the mode of action of phosphorylating enzymes, it is necessary to not only detect phosphorylated species, but also accurately localise the phosphate group on the glucidic compound and, mass spectrometry is well adapted to monitor modifications on such molecules. However, from an analytical point of view, phosphorylation is difficult to address due to the lability of this kind of modification.

An original enzyme from human microbiota with hydrolase and kinase activity was heterologously expressed and characterized. The present work illustrates the use of several techniques of mass spectrometry to finely characterize the phosphorylation status of degraded products originating from raffinose. Enzyme activities were first probed by monitoring all substrates with MALDI mass spectrometry. However, no information on the localisation of the phosphate could be obtained using MALDI MS/MS: the energetic fragmentation process produced the immediate loss of the phosphate. Phosphorylated products were thus further submitted to tandem mass spectrometry using electrospray, a “softer” ionization technique. Interestingly, some fragments were observed that could unambiguously position the phosphate group.

## PO 294

## RECENT ADVANCES IN THE SYNTHESIS OF SIALIC ACID DERIVATIVES WITH POSSIBLE SIALYLTRANSFERASE OR SIALIDASE INHIBITORY ACTIVITY

Paola Rota,<sup>1</sup> Pietro Allevi,<sup>1</sup> Irene S. Agnolin,<sup>1</sup> Antonio Gregorio,<sup>1</sup> Roberto Mattina,<sup>2</sup>  
and Mario Anastasia<sup>1</sup>

Department of Chemistry, Biochemistry and Biotechnology for Medicine, 20133 Milano Italy,<sup>1</sup>  
Department of Public Health, Microbiology, Virology, Via Pascal 36, University of Milan.<sup>2</sup>  
paola.rota@guestunimi.it

Sialic acids (**1**) are acidic natural sugars occurring as an  $\alpha$ -linked terminal sialosides cell surface where they are involved in a number of important physiological processes and diseased states, that include cell-biomolecule interactions, the masking of receptor by cell-surface glycans, markers in certain cancers and as ligands for proteins.<sup>1</sup>

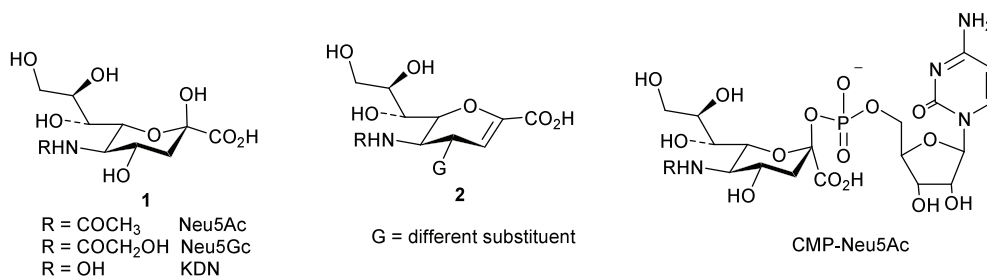

Examples of these interactions include the binding of influenza virus hemagglutinine to sialic acid prior to viral entry and the cleavage of the terminal sialic acid residue from infected cells.<sup>1</sup> In our laboratory we have developed some new reactions<sup>2-6</sup> which allow a simple preparation of Sialic acids 2-glycals having a substituent at position 4, taking (2) advantage from some new chemistry developed during a in a dept study involving inner 1,7-lactonization<sup>2</sup> of Sialic acid. Moreover, we have evidenced some general reactions of Sialic acid that allow to prepare in a simple way analogues mimicking the structure of donor substrate CMP-Neu5Ac (3).<sup>7</sup> Some new reactions of Sialic acids disclosed during the work will be discussed.

## References

- Varki, A., Cummings, R.D., Esko, J.D., Freeze, H.H., Stanley, P., Bertozzi, C.R., Hart, G.W., Etzler, M.E., *Essentials of Glycobiology, 2nd editino*, **2009**, Cold Spring Harbor (NY).
- Colombo, R., Anastasia, M., Rota, P., Allevi, P., *Chem. Commun.*, **2008**, 5517-5519.
- Rota, P., Allevi, P., Colombo, R., Costa, M.L., Anastasia, M., *Angew. Chem.*, **2010**, *49*, 1850.
- Rota, P., Allevi, P., Mattina, R., Anastasia, M. *Biomol. Org. Chem*, **2010** *8*, 3771-3776.
- Rota, P., Allevi, P., Costa, M.L., Anastasia, M., *Tetrahedron Asymmetry*. **2010**, *21*, 2681-2686.
- Allevi, P.; Rota, P.; Scaringi, R., Colombo, R.; Anastasia, M. *J. Org. Chem.* **2010**, *75*, 5542-5548.
- P., Allevi, P., Costa, M.L., Anastasia, M., submitted.

## PO 295

**ANALYSIS OF SEROGROUP C MENINGOCOCCAL AND GROUP B STREPTOCOCCUS GLYCOCONJUGATES BY CAPILLARY ELECTROPHORESIS**

Michele Rovini, Barbara Fabbri, Cristiana Campa, Stefano Ricci, Sandro D'Ascenzi

*Novartis Vaccines and Diagnostics, Technology Development- Analytical Development,  
via Fiorentina 1, 53100 Siena, Italy  
michele.rovini@novartis.com*

Glycoconjugate vaccines are prepared by linking a saccharidic antigen to a carrier protein. The saccharidic antigen can be polysaccharidic or oligosaccharidic. An example of the first category is the developmental Group B *Streptococcus* (GBS) vaccine, while the commercial *Neisseria meningitidis* serogroup C (MenC) vaccine is a typical oligosaccharide-glycoconjugate vaccine. They are both produced at Novartis V&D. The development of fast and reliable approaches for the analysis of glycoconjugate vaccines and relevant intermediates is of primary importance for conjugation process monitoring and stability evaluation. In this work, capillary electrophoresis is demonstrated to be a suitable tool for the baseline separation of glycoconjugates and of the corresponding relevant intermediates (free carrier protein and unconjugated saccharidic antigen) without sample pre-treatment. Interestingly, upon tuning the buffer composition, this result was achieved for both polysaccharide and oligosaccharide glycoconjugates. CRM-GBS glycoconjugates, unconjugated CRM and GBS polysaccharides were separated by Micellar Capillary Electrophoresis with UV detection (MEKC-UV), in conditions analogue to those reported in literature for other glycoconjugates<sup>1</sup>. The quantitative analysis of the intermediates could be achieved. CRM-MenC glycoconjugate, unconjugated CRM and MenC oligosaccharide (end- hydrolysis) could not be separated in the investigated MEKC-UV conditions, but good separation selectivity could be achieved upon applying Capillary Zone Electrophoresis with UV detection (CZE-UV). Investigations were performed on the electrophoretic behaviour of MenC oligosaccharide, upon analysis by CZE-ESI (Ion Trap) Mass Spectrometry. Due to the high sensitivity of MS, the lowest molecular weight components (i.e., DP<sub>≤</sub>5) could be detected and demonstrated to have an electrophoretic behaviour depending on the chain length. For higher oligomers, no influence of DP on the electrophoretic behaviour could be noticed, since they all co-migrated in one peak (also detected by UV). This observation allows supposing that the longer MenC oligosaccharides have a comparable charge density.

**References**

1. DH Lamb, L Summa, QP Lei, G Duval, O Adam, *Journal of Chromatography A*, **2000**, 894, 311-318.

## PO 296

**LEWIS BLOOD GROUP DETECTION FROM HUMAN MILK OLIGOSACCHARIDE MASS FINGER PRINTS**

Dennis Blank<sup>1</sup>, Kai Maass<sup>1</sup>, Viktoria Dotz<sup>2</sup>, Sabine Gebhardt<sup>2</sup>, Clemens Kunz<sup>2</sup>, Rudolf Geyer<sup>1</sup>

<sup>1</sup>*Institute of Biochemistry, Faculty of Medicine, Justus-Liebig-University of Giessen, Friedrichstrasse 24, 35392 Giessen, Germany,*

<sup>2</sup>*Institute of Nutritional Science, Justus-Liebig-University of Giessen, Wilhelmstrasse 20, 35392 Giessen, Germany*

*rudolf.geyer@biochemie.med.uni-giessen.de*

The structural diversity of human milk oligosaccharides (HMOs) strongly depends on the Lewis (Le) blood group status of the donor which allows a classification of these glycans into three different groups. Due to the divergent expression of the involved fucosyltransferases respective HMO classes differ, in particular, in the structural diversity of fucosylated glycan species displaying a large number of positional isomers. In this study we have developed a rapid mass spectrometric (MS) approach which can be used for correlation of HMO structures with the respective Lewis blood group of the donor. The relative abundance of diagnostically relevant compositional species, such as, Hex<sub>2</sub>Fuc<sub>2</sub>, Hex<sub>3</sub>HexNAc<sub>1</sub>Fuc<sub>2</sub> and Hex<sub>4</sub>HexNAc<sub>2</sub>Fuc<sub>3</sub> in profile mass spectra is used as a first step for Lewis blood group identification. In a second step MS/MS analysis of characteristic precursor ions is performed. For each Lewis blood group, i.e., Le(a-b+), Le(a+b-) and Le(a-b-), specific mass profile and fragmentation patterns could be identified allowing a rapid HMO classification without the need of a blood sample. The outlined protocol can be used for rapid screening of human milk in clinical studies providing detailed information about neutral as well as acidic oligosaccharide patterns of specific samples and allowing also a relative quantification of individual compositional glycan species. Moreover, the described analytical approach enables an easy quality control of milk samples acquired from milk banks.

## PO 297

**ANALYSIS OF N-ACETYLNEURAMINIC ACID CONTENT IN *SALMONELLA* STRAINS USING GAS CHROMATOGRAPHY CONNECTED WITH TANDEM MASS SPECTROMETRY (GC-MS/MS)**

Jacek Rybka<sup>1</sup>, Gabriela Bugła-Płoskońska<sup>2</sup>, Aleksandra Skwara<sup>2</sup>, Bartłomiej Dudek<sup>2</sup>,  
Wojciech Rybka<sup>1</sup>, Włodzimierz Doroszkiewicz<sup>2</sup>, Andrzej Gamian<sup>1,3</sup>

<sup>1</sup>Ludwik Hirszfeld Institute of Immunology and Experimental Therapy,  
Polish Academy of Sciences, 53-114 Wrocław, Weigla 12, Poland,

<sup>2</sup>Institute of Genetics and Microbiology, University of Wrocław, Przybyszewskiego 63/77,  
51-148 Wrocław, Poland,

<sup>3</sup>Department of Medical Biochemistry, Wrocław Medical University,  
Chalubińskiego 10, 50-368 Wrocław, Poland  
rybka@iitd.pan.wroc.pl

Several strains of Gram-negative bacteria from the family of *Enterobacteriaceae* contain N-acetylneuraminic acid (sialic acid, NeuAc) as a component of bacterial envelope (1). *Salmonella* from somatic antigen group O48 contains sialic acid in its LPS structure (2). The sialic acid on the surface of bacterial cell can influence the bactericidal activity of immune system of the host (3), therefore a method for quick and reliable evaluation of its content in the bacterial mass samples is needed. Classical colorimetric methods (resorcinol and TBA tests) do not allow for microanalysis of small amount of bacterial cells e.g. from simple colony, neither for the discrimination between NeuAc and 2-keto-3-deoxyoctulosonic acid (Kdo) – the component of bacterial lipopolysaccharide. The analysis of NeuAc and Kdo content in the cells of Gram-negative bacteria with sialic acid-containing lipopolysaccharide can be used for estimation of lipopolysaccharide length and its distribution analysis. Using the gas-liquid chromatography / tandem mass spectrometry analysis (GC-MS/MS) method on Thermo Scientific ITQ 700™ system instrument equipped with Thermo TR-5ms SQC column we have determined NeuAc/Kdo ratio for several tested strains of *Salmonella* from somatic antigen group O48. Considerable differences in that value between analysed strains have been found, which could reflect a difference in average lipopolysaccharide molecule length of particular strain and also the density of LPS molecules on the bacterial cell surface.

**References**

1. Traving C., Schauer R. *Cell Mol Life Sci.* **1998**, *54*, 1330-49
2. Gamian A., Kenne L. *J Bacteriol.* **1993**, *175*, 1508-13
3. Bugła-Płoskońska G., Rybka J., Futoma-Kołocho B., Cisowska A., Gamian A., Doroszkiewicz W. *Microbial Ecology*, **2010**, *59*, 601-13

## PO 298

THE CHEMICAL MARKER KDO FOR GC-MSMS ANALYSIS  
OF ENDOTOXIN CONTENT IN ANIMAL SERA

Jacek Rybka<sup>1</sup>, Magdalena Mierzchała<sup>2</sup>, Wojciech Rybka<sup>1</sup>, Tadeusz Stefaniak<sup>3</sup>, Andrzej Gamian<sup>1,2</sup>

<sup>1</sup>Ludwik Hirszfeld Institute of Immunology and Experimental Therapy,  
Polish Academy of Sciences, 53-114 Wrocław, Weigla 12, Poland,

<sup>3</sup>Department of Medical Biochemistry, Wrocław Medical University,  
Chalubińskiego 10, 50-368 Wrocław, Poland,

<sup>2</sup>Department of Immunology, Pathophysiology and Prevention Veterinary,  
Wrocław University of Environmental and Life Sciences, Norwida 31, 50-375 Wrocław, Poland,  
rybka@iitd.pan.wroc.pl

Lipopolysaccharides (LPS, endotoxins) are major components of the outer membrane of Gram-negative bacterial cell envelope. LPS possess immunostimulatory and toxic properties to mammalian organisms, therefore detection and quantitation of endotoxins is an important issue especially for medical and pharmacological industry. Nowadays the indirect and expensive endotoxin quantitation methods are used: biological rabbit pyrogen test and Limulus Amebocyte Lysate (LAL) test. There is no valid diagnostic method for the direct detection of endotoxin in body fluids for example in blood or blood serum so far. Development of bacterial infection in blood, sepsis and septic shock are ones of the most important medical problems leading frequently to the death of the patient. Despite of intensive investigations there is no reliable procedure for diagnosis and monitoring of septic shock. Elaboration of a simple and accurate method of chemical detection of endotoxin and its quantitation would be very helpful in sepsis and septic shock treatment.

One of the integral components of endotoxin molecule is 2-keto-3-deoxyoctulosonic acid (Kdo). In the present work we present a method of detection of Kdo as an endotoxin marker. Kdo, after chemical derivatization, is detected using gas-liquid chromatography / tandem mass spectrometry analysis (GLC/MSMS). The method has been used for the determination of natural endotoxin content in sera of various animals.

**References**

1. Rybka J., Gamian A. *J. Microbiol. Meth.*, **2006** 64, 171-84.



PO 299

## SELECTIVE MONO-ACETYLATION OF TRIOLS USING TRANSIENT PROTECTION

Sahloul Kamar, Hersant Yaël, Le Narvor Christine and Bonnaffé David

G2M-LCOM, ICMMO, UMR CNRS-UPS 8182, Bât 420, Université Paris-Sud 11,  
91405 Orsay Cedex, France  
kamar.sahloul@u-psud.fr

In our **strategy for the preparation of Heparan Sulfate libraries**,<sup>1</sup> the disaccharide building blocks **1** and **2** are protected precursors to obtain **A** and **B** motifs.

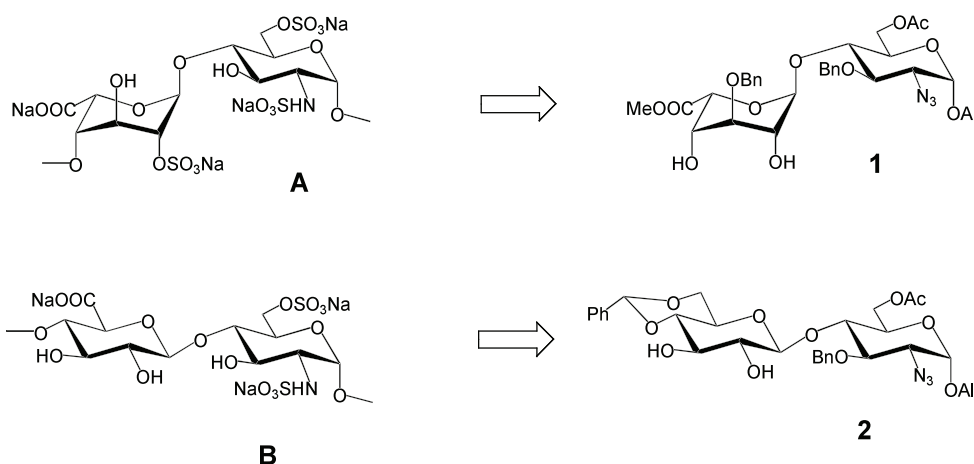

The selective introduction of an acetyl group on the 6 position of the 2-azido moiety represents a key step, less straightforward than it could be anticipated. We will show that the introduction of a transient protection of the secondary hydroxyls allows a highly selective acetylation of the primary hydroxyls on both derivatives.

**References**

1. Anna Dilhas, Ricardo Lucas, Latino Loureiro-Morais, Yaël Hersant, and David Bonnaffé, *J. Comb. Chem.* **2008**, *10*, 166–169.

PO 300

**NON-STRICT PROTECTING GROUP CONTROL IN A CHIMERA TYPE  
GLYCOSYL ACCEPTOR TOWARDS HIGHLY EFFICIENT SYNTHESIS OF  $\beta$ -(1 $\rightarrow$ 3)-  
BRANCHED OLIGOSACCHARIDES**

Sang-Hyun Son<sup>1</sup> and Nobuo Sakairi<sup>1</sup>

<sup>1</sup>*Division of Environmental Materials Science, Graduate School of Environmental Science,  
Hokkaido University, Kita-ku, Sapporo 60-0810, Japan  
nsaka@ees.hokudai.ac.jp*

Since the **three dimensional shape of oligosaccharides, including** branched-chain structures, is of paramount importance to understand their cellular function and signal transduction, their efficient preparation has been a major focus in carbohydrate chemistry. Although considerable progress has been made in recent years, unexpected difficulties ramps up in constructing some branched chain structures, which requires to change the synthetic strategy and/or to explore a new glycosylation reaction. Whereas facile introduction of  $\alpha$ -D-mannopyranose into 3-position of a 1 $\rightarrow$ 6 linked oligosaccharide was reported,<sup>1</sup> poor yield and stereoselectivity were shown in our previous investigation of similar  $\beta$ -glucosylation.<sup>2</sup> We deduced that a concept of double stereo differentiation between glycosyl donor and acceptor<sup>3</sup> was applied to the oligosaccharides, and that glycosylation would proceed smoothly if the steric congestion around the acceptor site would be reduced. Here, we report the effectiveness of chimera type acceptors having vicinal triol systems in practical synthesis of a 3,6-di-*O*-( $\beta$ -D-glucopyranosyl)- $\beta$ -D-glucopyranosyl structure.

We designed a chimera type acceptor **1**, which has two 2,3,4-triol domains and bulky pivaloyl protecting groups. NIS-TfOH promoted glycosylation of **1** with a pivaloylated donor **2** found to proceed predominantly at both 3-positions with high  $\beta$ -selectivity, giving the heptasaccharide in 76% isolated yield. Further investigations along this line will be discussed.

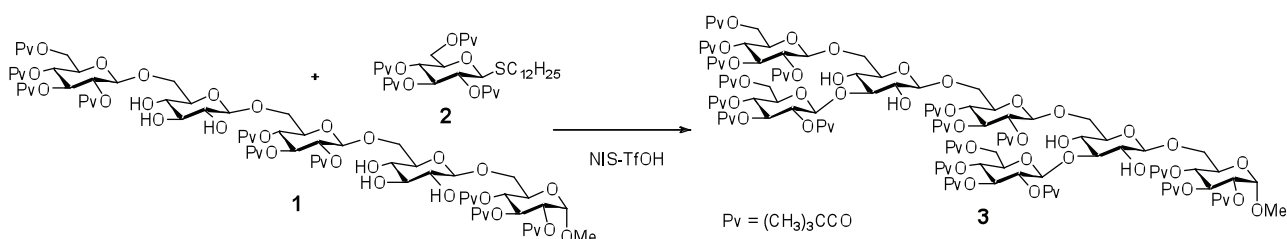

### References

1. F. A. Jaipuri and N. L. Pohl, *Org. Biom. Chem.*, **2008**, 2686-2691.
2. S.-H. Son and N. Sakairi, *Org. Biom. Chem.*, **2008**, 1441-1449.
3. N. M. Spijker and C. A. A. van Boeckel, *Angew. Chem. Int. Ed. Engl.*, **1991**, 30, 180-182.

PO 301

CHEMICAL SYNTHESIS OF PEPTIDOGLYCAN FRAGMENT  
OF *S. AUREUS* CELL WALL  
USING SPPS METHOD

J. Samaszko, M. Szulc, R. Ślusarz, A. Nowak, J. Madaj

Chair of Sugar Chemistry, Faculty of Chemistry, University of Gdańsk  
Sobieskiego 18/19, PL-80-952 Gdańsk, POLAND  
samaszko@chem.univ.gda.pl

*Staphylococcus aureus* is one of the most pathogenic of bacteria, about 40% of the human population regularly carry it. *S. aureus* is responsible for a variety of serious infections.<sup>1)</sup> Staph infections, including MRSA and VRSA, occur most often among persons in hospitals and healthcare facilities (such as nursing homes and dialysis centers) who have weakened immune systems.<sup>2)</sup>

The structure of *S. aureus* is quite simple: the most important components forming the bacterial cell wall and occupying most of the space are peptidoglycan (PGN) and lipoteichoic acid (LTA).<sup>3)</sup> PGN is a long polymer containing sugar chains linked to short peptide (usually pentapeptide) components. The sugar fragments are made up of repeating disaccharide units, *N*-acetyl-D-glucosamine (GlcNAc) and *N*-acetyl-D-muramic acid (MurNAc) - linked by  $\beta(1\rightarrow4)$  *O*-glycosidic bonds. The carboxyl group of MurNAc is the point of linkage to the peptide fragments, which contain both D- and L-amino acids. The peptide subunits are cross-linked to other peptides that are connected to a neighboring glycan strand, which produces a three-dimensional structure. In *S. aureus* the glycan strands are connected by a pentaglycine bridge.<sup>4)</sup>

Even though the Gram-positive bacteria structure is quite simple there no exist good method of treating against this bacteria and nowadays there are many new strains expressing increasing levels of resistance to the glycopeptide antibiotics. The most popular antibiotic used against *S. aureus* is vancomycin. Due to understand interactions between vancomycin and bacterial cell wall very important is chemical synthesis of native peptidoglycan fragments. This work present synthesis of peptidoglycan fragment of *S. aureus* cell wall using SPPS (solid phase peptide synthesis) method. Using this method we will be able to obtain more pure fragments than using traditional method synthesis. These compounds we are planning to use to further study on interactions with vancomycin.

**Acknowledgements:** This work was part-financed by the European Union within the European Regional Development Fund (POIG.01.01.02-14-102/09-01) and grant DS/8451-4-0134-11.

### References

1. Heyman, D. *Control of Communicable Diseases Manual* 18th Edition. Washington DC: American Public Health Association, 2004.
2. Labischinski, H.; Johannsen, L. *Drug Resistance Updates* 1999, 2, 319-325.
3. Steinberg, J.P.; Clark, C.C.; Hackman, B.O. *Clin Infect Dis.* 1996, 23(2), 255-259.
4. Cabeen, M.T.; Jacobs-Wagner, Ch. *Bacterial cell shape* *Nav. Rev. Micro.* 2005, 3, 601-610.

## PO 302

## SYNTHESIS AND BIOLOGICAL ACTIVITIES OF N-[n-(β-D-GLUCOPYRANOSYLOXY) ALKYL]AMINIUM SALTS

Barbara Dmochowska<sup>1</sup>, Karol Sikora<sup>1</sup>, Justyna Samaszko<sup>1</sup>, Anna Woziwodzka<sup>2</sup>, Jacek Piosik<sup>2</sup><sup>1</sup>University of Gdańsk, Faculty of Chemistry, Sugar Chemistry Group,  
J. Sobieskiego 18, 80-952, Gdańsk, Poland<sup>2</sup>Intercollegiate Faculty of Biotechnology, University of Gdańsk  
and Medical University of Gdańsk, Poland  
bdmochow@chem.univ.gda.pl

Quaternary ammonium salts (QACs) constitute a huge, very interesting and widely used group of organic compounds. Their antibacterial, antiviral and antifungal activities are known well. The activity of many biological agents depends on the quaternary ammonium group presence. Many of them demonstrate antistatic and anticorrosive activity. Numerous QACs exhibit also surface activity, good detergency and low toxicity.[1]

A new series of quaternary ammonium bromides have been synthesized in reaction of 2-bromoethyl 2',3',4',6'-tetra-O-acetyl-β-D-glucopyranoside, 6-bromohexyl 2',3',4',6'-tetra-O-acetyl-β-D-glucopyranoside and 11-bromoundecyl 2',3',4',6'-tetra-O-acetyl-β-D-glucopyranoside with tertiary amines: pyridine and trimethylamine (scheme 1).

The structures of isolates were determined by spectral analysis including extensive 2D NMR analyses and X-ray crystallography. QACs demonstrated mutagenic activity in bioluminescence mutagenicity assay based on *Vibrio harveyi* A16 strain.[2]

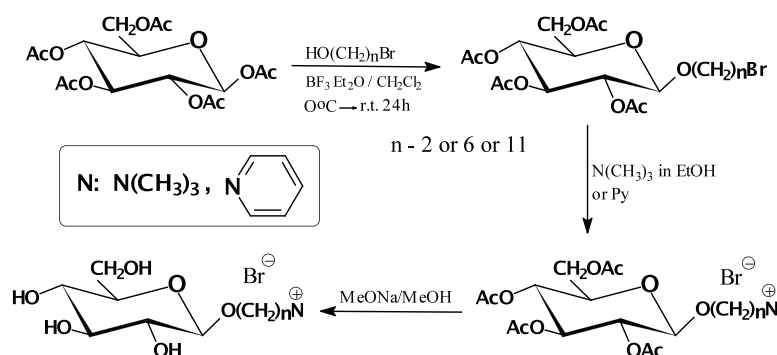

Scheme 1

**Acknowledgements:** This work was partially financed by grant DS/8451-4-0134-11

**References:**

1. E. Obłąk, A. Gamian, *Postepy Hig. Med. Dosw.*, **2010**, *64*, 201-211.
2. B.Podgorska, G.Wegrzyn, *Lett. Appl. Microbiol.*, **2006**, *42*, 578-582.

PO 303

**TARGETING MEDICALLY RELEVANT LECTINS WITH  
MULTIVALENT GLYCOCALIXARENES**

Silvia Bernardi, Francesco Sansone, Alessandro Casnati and Rocco Ungaro

*Dipartimento di Chimica Organica e Industriale, Università degli Studi,  
Parco Area delle Scienze 17/A, 43124 Parma, Italy  
francesco.sansone@unipr.it*

The involvement of carbohydrate-protein recognition processes in numerous pathological events make them an attractive target for the development of new therapeutic strategies. The efficiency of glycosides or mimics in the inhibition of lectin activity strongly depends not only on their proper structural features, but also on their exposition. A multivalent presentation can significantly improve their potency, as in fact often occurs at the biological level, and then help in obtaining new potential biologically active compounds. For these reasons, since some years we are developing clusters based on calixarenes functionalized with different carbohydrate units depending on the target lectin.<sup>1-3</sup> In particular we focused our attention and efforts towards medically relevant proteins such as plant toxins,<sup>3</sup> bacterial lectins,<sup>2</sup> human galectins.<sup>3</sup> Calixarenes of different sizes, conformational properties, valency and functionalized *via* chemical or chemo-enzymatic procedures with galactose, lactose, LacNAc units or oligosaccharides and mimics have shown their high efficiency and selectivity in the inhibition of different types of lectins.

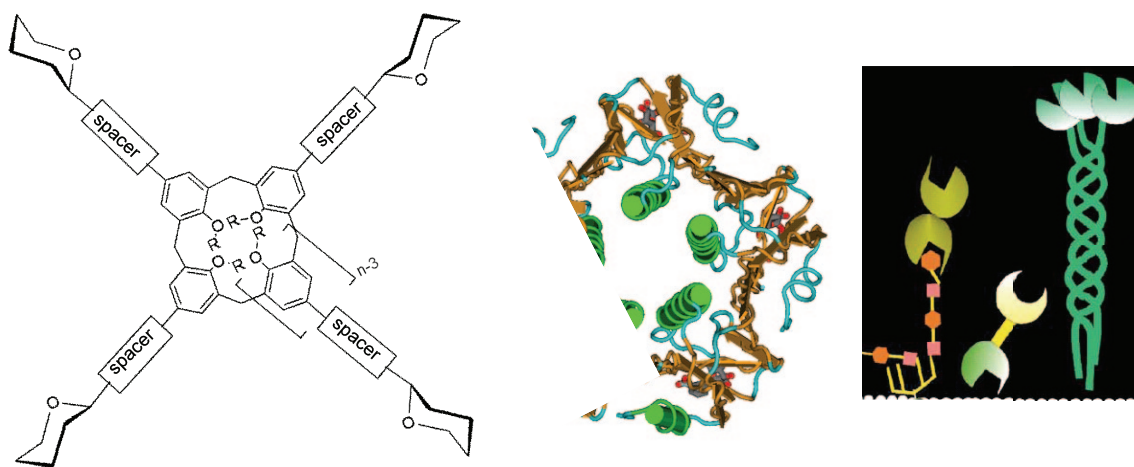

**Figure.** A general structure of glyco-calixarenes, a pentameric toxin and schematic representation of galectins

### References

1. Francesco Sansone, Laura Baldini, Alessandro Casnati, Rocco Ungaro, *Supramol. Chem.* **2008**, *20*, 161-168.
2. Daniela Arosio, Marco Fontanella, Laura Baldini, Laura Mauri, Anna Bernardi, Alessandro Casnati, Francesco Sansone, Rocco Ungaro, *J. Am. Chem. Soc.* **2005**, *127*, 3660-3661.
3. Sabine André, Francesco Sansone, Herbert Kaltner, Alessandro Casnati, Jürgen Kopitz, Hans-Joachim Gabius, Rocco Ungaro, *ChemBioChem* **2008**, *9*, 1649-1661.

## PO 304

**IN VIVO ANTIVIRAL ACTION OF FUCOIDAN FROM EDIBLE BROWN ALGA  
UNDARIA PINNATIFIDA IN INFLUENZA VIRUS-INFECTED ANIMALS**

Kohei Sasaki,<sup>1</sup> Kyoko Hayashi,<sup>1</sup> Hiroki Onoue,<sup>1</sup> Jung-Bum Lee,<sup>1</sup> Keiko Yoshinaga<sup>2</sup>  
and Toshimitsu Hayashi<sup>1</sup>

<sup>1</sup>Graduate School of Medicine and Pharmaceutical Sciences for Research,  
University of Toyama, Toyama 930-0194, Japan,

<sup>2</sup>Riken Vitamin Co., Ltd., 2-9-18 Misaki-cho, Chiyoda-ku, Tokyo 101-8370, Japan

Influenza viruses have been the pathogens of frequent morbidity and mortality, particularly in high risk immunocompromised populations. Recently, the emergence of pandemic 2009 H1N1 viruses and highly pathogenic avian influenza A virus has become of major concern.

We have previously reported that fucoidan (FU), a sulfated polysaccharide isolated from *U. pinnatifida*, inhibited the *in vitro* replication of influenza A virus (IFV), and stimulated the immune defense functions in virus-infected mice.<sup>1,2)</sup> In the present study, we evaluated the effect of oral administration of FU on IFV infection of immunocompetent and immunocompromised mice. In both animal groups, the efficacy of FU was demonstrated in reducing viral replication, decreasing weight loss and mortality, and prolonging survival. In immunocompromised mice, drug-resistant viruses were frequently recovered after treatment with oseltamivir, an anti-IFV agent; no resistant viruses were isolated from FU-treated mice. In contrast with oseltamivir, oral FU resulted in stimulating systemic and local immune systems. These immunostimulating effects of FU should be favorable in the control of IFV infections. We are now elucidating in detail the effects of FU on immune functions including the phagocytosis of peritoneal macrophages and the gene expression in the mucosal tissues using DNA microarray analyses. Since it is unclear whether and how FU could be incorporated into the body, we are also studying the incorporation of fluorescein-labeled FU into the Peyer's patches of mouse.

**References**

1. Hayashi, K., Nakano, T., Hashimoto, M., Kanekiyo, K., Hayashi, T, *Int. Immunopharmacol.* **2008**, 8, 109-116..
2. Hayashi, T., Hayashi, K., Kanekiyo, K., Ohta, Y., Hashimoto, M., Nakano, T. In *Combating the Threat of Pandemic Influenza: Drug Discovery Approaches* (Torrence,P.F,ed.), **2007**, 116-132.



## PO 305

**STRUCTURAL CHARACTERISTICS OF SOME BIOMOLECULES EXTRACTED FROM THE LAKE MAGGIORE FOAM COLLECTED IN RECENT YEARS**

Guilherme L. Sasaki,<sup>1,2</sup> Marcello Iacomini,<sup>2</sup> Cesare Cosentino,<sup>1</sup> Laura Muzi,<sup>1</sup> Marco Guerrini,<sup>1</sup> Luigi Guidetti,<sup>3</sup> Licia Guzzella,<sup>4</sup> Giangiacomo Torri<sup>1</sup>

<sup>1</sup>*"G. Ronzoni" Institute for Chemical and Biochemical Research,  
Via G. Colombo 81, 20133 Milano,*

<sup>2</sup>*Departamento de Bioquímica e Biologia Molecular, Universidade Federal do Paraná,  
Curitiba – PR CEP: 81531-980, Brazil,*

<sup>3</sup>*Arpa Piemonte Dipartimento del Verbano Cusio Ossola  
via IV novembre, 294 28887 - OMEGNA (VB),*

<sup>4</sup>*CNR-IRSA, Via del Mulino 19, 20047 Brugherio, Italy  
sasaki@ufpr.br*

The research was focused on the composition of the foam formed in 2007, 2008 and 2010 in the Lakes Maggiore and d'Orta, which are located on the Southern side of the Alps between Italy and Switzerland. The origin of the foam formation is unknown at this time, however in several occasions it was not related to human activities. It was supposed to be a polysaccharide produced by algae and/or cyanobacteria from their physiological activities or by decomposition biological process. In order to correlate the origin of the foam and its properties this work was focused on the characterisation of the biomolecules by NMR and mass spectrometry. Solid state NMR spectrum showed carbohydrate signals from 50 to 110 ppm, signals of aliphatic carbons belonging to protein and lipids were detected ranging from 10 to 40 ppm, the presence of protein material is also supported by the presence of signals at 110-150 ppm, the signal at 170 ppm was attributed to carboxyl groups belonging to amide, esters or acids. GC-MS analysis of the foam showed Ara:Xyl:Man:Gal:Glc at molar ratios of 20:1:1:10:1.6. Due to the complex NMR solid state spectrum, the foam was fractionated by extraction with organic solvents, followed by water extraction. The resulting material obtained after fractionation gave the following yields: CHCl<sub>3</sub>:MeOH 2:1 (27.6%), water (16.7%), hot water (11.3%), hot aqueous alkaline solution (10%), however, 26.0 % remained insoluble. Combining the <sup>1</sup>H and 2D-HSQC experiments we were able to observe differences between the fractions. The organic layer confirmed the presence of lipids, since <sup>1</sup>H lipid-aliphatic signals at 1.2-2.3 ppm as well as double bonds at 5.3-5.2 ppm were observed. NMR analysis from the water fractions showed the presence of proteins, O-linked carbohydrates, suggesting the presence of polysaccharides as well as free monosaccharides, and other low molecular weight compounds such as lactate, acetate, alanine, valine, leucine, N-acetyl aspartate and glutamate were detected. These preliminary results showed a complex biomolecular composition, which could be related by the presence of several microorganisms, creating a micro-environmental system to carry out many anabolic and catabolic processes.

PO 306

**SYNTHESIS OF A DONORSUBSTRATE INHIBITOR OF THE HUMAN BLOOD GROUP B GALACTOSYLTRANSFERASE**Katrin Schaefer,<sup>1</sup> Joachim Albers,<sup>1</sup> Thomas Peters<sup>2</sup> and Bernd Meyer<sup>1</sup><sup>1</sup>University of Hamburg, Hamburg, 20146 Germany, <sup>2</sup>University of Lubeck, Lubeck, 23538Germany  
katrin.schaefer@chemie.uni-hamburg.de

The human blood group B galactosyltransferase (GTB) transfers a galactose unit from UDP-galactose to the H-antigen. Due to transferred NOE experiments and the crystal structure of the protein the bioactive conformation of the donor and acceptor substrate as well as a mechanism of the binding event is proposed.<sup>[1],[2]</sup>

Here, we present the synthesis of an inhibiting analog of UDP-galactose. *In silico* docking experiments were used to identify suitable molecules exhibiting an uric acid fragment and an  $\alpha$ -D-galactoside moiety in a certain distance such that it can mimic the normal donorsubstrate. The molecule chosen for synthesis revealed an arabinityl linking moiety between those two fragments.

The synthesis of the analog of UDP-gal is started with D-melibiose to obtain 5-O- $\alpha$ -D-galactopyranosyl-D-arabinitylamine. The substitution of the amine with 5-nitro-6-chloro-2,4(1H,3H)-pyrimidinedione yielded in the corresponding nitroaminouracil derivative. In analogy to Cushman's protocol<sup>[3]</sup> 5-nitro-6-(5-O- $\alpha$ -D-galactopyranosyl)-D-arabinitylamino-2,4(1H,3H)-pyrimidinedione was reduced and consequently converted to the ethylcarbamoyl derivative. The target molecule was achieved by cyclization.

Binding affinity studies will be reported for the inhibiting uric acid derivative.

**References**

1. S.I. Patenaude, N. O. Seto, S. N. Borisova, A. Szpacenko, S. L. Marcus, M. M. Palcic, S. V. Evans, *Nat. Struct. Biol.*, **2002**, 9, 685-690.
2. J. Angulo, B. Langpap, A. Blume, T. Biet, B. Meyer, N. Rama Krishna, H. Peters, M. M. Palcic, T. Peters, *J. Am. Chem. Soc.*, **2006**, 128, 13529-13538.
3. M. Cushman, D. Yang, K. Kis, A. Bacher, *J. Org. Chem.*, **2001**, 66,8320-8327.

## PO 307

**TIME LAPSE VIDEOMICROSCOPY TO STUDY THE EFFECT OF HYALURONAN AT DIFFERENT MOLECULAR WEIGHT ON A WOUND HEALING MODEL *IN VITRO***Antonella D'Agostino<sup>1</sup>, Teresa Busico<sup>1</sup>, Mario De Rosa, Chiara Schiraldi<sup>1</sup>

*Department of Experimental Medicine, Faculty of Medicine, Second University of Naples,  
Via L. De Crecchio 7, 80138 Naples, Italy  
chiara.schiraldi@unina2.it*

Hyaluronic acid (HA) is a glycosaminoglycan that plays a role in tissue growth and development, wound healing and inflammation. In particular it is known that different molecular weights of HA promote *in vivo* healing of different tissue (1,2). Several studies of wound healing *in vitro* using appropriate cellular model like fibroblasts, keratinocytes and co-culture are in progress for understanding the complex mechanism of wound repair in terms of cell migration and proliferation (3). In the framework of this research we attempted the degradation of high molecular weight hyaluronic acid (HMW-HA) maintaining the fundamental structure of the polysaccharide, comparing diverse protocols. The HA derived chains were extensively characterized and the effect of high/low molecular weight HA on *in vitro* wound healing process was studied through time lapse videomicroscopy. Thermal degradation of HA powder at different temperatures and times in a conventional oven under rolling has been performed in order to obtain low molecular weight (LMW-HA). The fragments have been evaluated in term of molecular weight distribution and intrinsic viscosity through an innovative size exclusion chromatography coupled with triple detector SEC-TDA equipment by Viscotek (on line laser light scattering, refractometry and viscosimetry).

The results showed that, through this depolymerization strategy, we are able to produce LMW-HA with determined and reproducible molecular weight and a suitable polydispersity index ( $M_w/M_n \sim 2$ ). The wound repair *in vitro* in presence of hyaluronic acid has been evaluated on a confluent monolayer of keratinocytes, grown on collagen and successively opportunely scratched. This method represents a typical *in vitro* injury. In each well it is possible to add appropriate aliquots of hyaluronan and follow in the time the repair kinetics through videomicroscopy time lapse, and subsequent image analysis exploiting a specific software. The use of this innovative technology allows prolonged observations of cell events and behaviour, in particular in the case cell migration and proliferation. Finally the image analysis permitted the comparison of the differently treated samples vs the control and a qualitative-quantitative evaluation of the repair kinetic in presence of HMW-HA and LMW-HA was obtained.

**References**

1. Balazs EA. The viscoelastic intercellular matrix and control of cell function by hyaluronan. In: Laurent TC, editor. The chemistry, biology and medical applications of hyaluronan and its derivatives. London: Portland Press; 1998. p 185–204.
2. Laurent TC, editor. The chemistry, biology and medical applications of hyaluronan and its derivatives. London: Portland Press; 1998.
3. M. Oberringer<sup>1</sup>, C. Meins, Monika B. and T. Pohlemann. A new *in vitro* wound model based on the co-culture of human dermal microvascular endothelial cells and human dermal fibroblasts Biol. Cell (2007) 99, 197–207

PO 308

**C,N-DIGLYCOSYLATED HETEROCYCLIC CORES FOR THE CONSTRUCTION  
OF POTENTIAL SELECTIN LIGANDS**

C. Schlemmer, T. Opatz\*

*Johannes Gutenberg-Universität Mainz, Duesbergweg 10-14, D-55128 Mainz, Germany  
schlemme@uni-mainz.de*

The interaction of P- and E-selectin with their glycopeptidic ligands PSGL-1 and ESL-1, leading to the adhesion of leukocytes to the endothelial surface, represents the key-step in the inflammatory cascade.<sup>[1]</sup> Undesired cell-cell interactions do not only lead to a variety of chronically inflammatory diseases,<sup>[2]</sup> for example rheumatoid arthritis, but also play an important role in tumor metastasis.<sup>[3]</sup> The above-mentioned natural ligands contain the well-known tetrasaccharides sialyl-Lewis<sup>X</sup> and sialyl-Lewis<sup>a</sup>. Therefore, the suppression of unwanted cell-adhesion processes by the usage of soluble sialyl-Lewis<sup>X</sup>-mimetics acting as competitive inhibitors is of great interest. As shown before,<sup>[4]</sup> the N-acetylglucosamine residue in these saccharides can completely be substituted by carbo- or heterocycles. In the presented structures, an isoindolin-1-one system synthesized in a Pd-mediated sp-sp<sup>2</sup>-coupling<sup>[5]</sup> followed by a 5-*exo*-dig cyclization<sup>[6]</sup> is used to mimic the naturally occurring GlcNAc residue. Thus, two of the O-glycosidic bonds of the native structure are replaced by a C-C- and a C-N-bond. These trisaccharide mimetics may be elongated with either sialic acid or L-cyclohexyl lactic acid.<sup>[7]</sup>

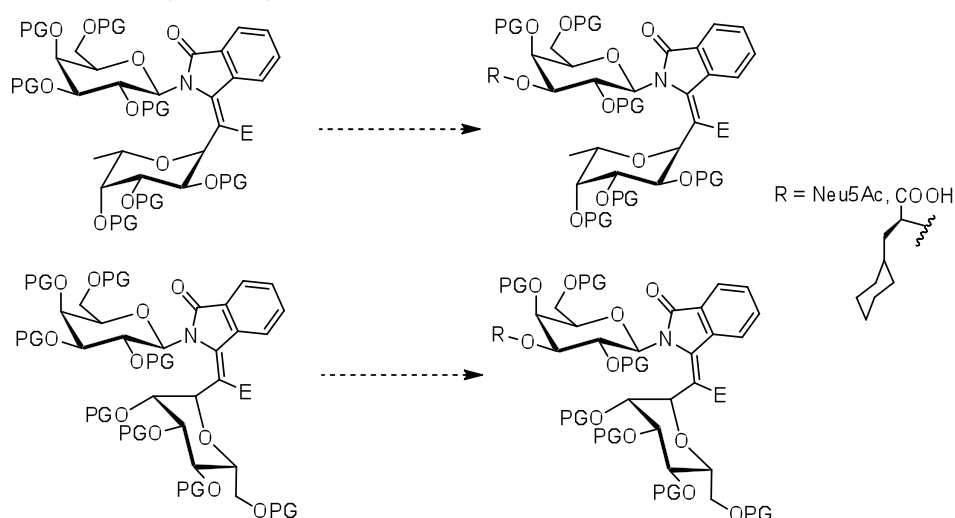

### References

1. D. Vestweber, J. E. Blanks, *Physiol. Rev.*, **1999**, 79, 181-213.
2. J. Mestas, K. Ley, *Trends Cardiovasc. Med.*, **2008**, 18, 228-232.
3. A. Takada, K. Ohmori, T. Yoneda, K. Tsuyuoka, A. Hasegawa, M. Kiso, R. Kannagi, *Cancer Res.*, **1993**, 53, 354-361.
4. C.-Y. Tsai, W. K. C. Park, G. Weitz-Schmidt, B. Ernst, C.-H. Wong, *Bioorg. Med. Chem. Lett.* **1998**, 8, 2333-2338.
5. N. G. Kundu, M. W. Khan, *Tetrahedron*, **2000**, 56, 4777-4792.
6. T. Yao, R. C. Larock, *J. Org. Chem.*, **2005**, 70, 1432-1437.
7. R. Banteli, B. Ernst, *Tetrahedron Lett.*, **1997**, 38, 4059-4062.

PO 309

**GRAM SCALE SYNTHESIS OF 3-FLUORO-1-HYDROXYACETONE PHOSPHATE  
(FHAP) AND ITS USE IN RABBIT MUSCLE ALDOLASE (RAMA)  
CATALYZED ALDOL REACTIONS**

Michael Fischer, Hanspeter Kählig and Walther Schmid

*Department of Organic Chemistry, University of Vienna, Währingerstraße 38, 1090 Vienna,  
AUSTRIA*

*walther.schmid@univie.ac.at*

Rabbit muscle aldolase (RAMA) has proven to be an exceptionally versatile biocatalyst for synthetic organic applications.<sup>1</sup> RAMA catalyzes the stereospecific aldol condensation of aldehydes with dihydroxyacetone phosphate (DHAP) generating a *D-threo* configuration at the newly formed stereocenters. While RAMA tolerates a broad variety of aldehydes as electrophilic components, it is very restrictive concerning the nucleophilic component DHAP.

The substitution of the free hydroxyl group in DHAP by fluorine represents the smallest possible bioisosteric change of the nucleophilic donor substrate and opens access towards RAMA catalyzed synthesis of biological important fluorinated carbohydrates. We developed a gram-scale synthesis of this interesting building block starting from easily accessible ethyl  $\alpha$ -fluoromethylacrylate **1**<sup>2</sup> to yield FHAP **2** in 42 % over 4 steps. In contrast to previous reports,<sup>3</sup> FHAP acts as a donor substrate for RAMA giving access towards 3-deoxy-3-fluoro-2-uloses **3**. Additionally, a fast proton-deuterium exchange and different binding preferences of the *gem*-diol and keto-form of FHAP **2** were investigated by <sup>19</sup>F-NMR.

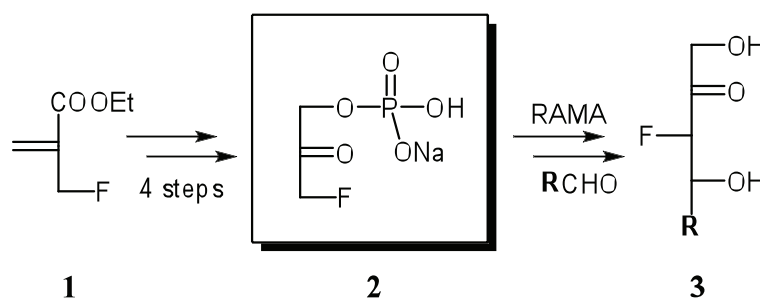

### References

1. Wong, C.-H. in "Enzyme Catalysis in Organic Synthesis"; Vol 2.; (Eds.: Drautz, K.; Waldmann, H.); VCH; New York; **1995**; p 931
2. Villieras, J.; Rambaud, M.; *Synthesis* **1982**, 924-926.
3. Wong, C.-H.; Drueckhammer, D.G.; Sweers, H.M. *ACS Symp. Ser.* **1988**, 374, 29-31.

## PO 310

REDUCTIVE SAMARIATION OF GLYCAL INCLUDING 2,3-UNSATURATED  
N-ACETYLNEURAMINIC ACID

Caroline Papin, Xuan Tien Le, Gilles Doisneau and Jean-Marie Beau

Université Paris-Sud 11, Laboratoire de Synthèse de Biomolécules,  
 Institut de Chimie Moléculaire et des Matériaux, F-91405 Orsay Cedex, France  
 gilles.doisneau@u-psud.fr

Following our interest on samarium mediated coupling reactions on carbohydrate templates<sup>1,2</sup>, we will present our last results focusing on the use of samarium diiodide in the preparation of modified sialic acid derivatives. We recently found that selective transformations at C-2 were available using reductive samariation of appropriate allylic esters of Neu5Ac2en derivatives. As exemplified in the following scheme, treatment of **1**, under classical reductive samariation conditions (2 equivalents of SmI<sub>2</sub>), in the presence of selected carbonyl electrophiles, leads to the C-2 modified products **2** with total a regio- and stereocontrol of the reaction. Yields of products highly depend however on the protecting group pattern at C-7, C-8 and C-9 positions of the Neu5Ac2en derivatives.

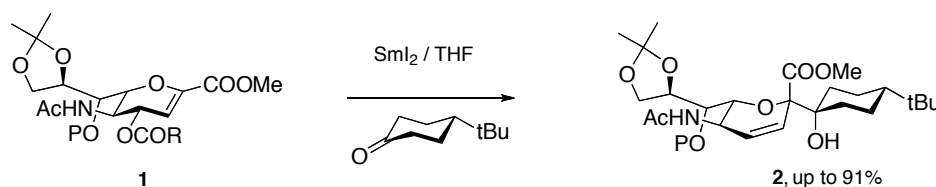

As these reactions are performed in *absence of any palladium catalyst*, the ester group at the allylic position should be easily be reduced by the Sm<sup>(III)</sup>-THF solution to provide a direct “umpolung” of the allylic esters to allyl-samarium derivatives which are trapped by the electrophile. In order to rationalize these results, we have extended these reductive samariation conditions to several glycal series to selectively obtain the C-3 modified products (scheme).

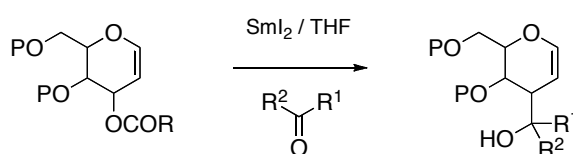

The poster will present these results and the scope of this samarium mediated transformation.

## References

1. Adeline Malapelle, Anna Coslovi, Gilles Doisneau and Jean-Marie Beau, *Eur. J. Org. Chem.* **2007**, 3145-3157.
2. Caroline Papin, Gilles Doisneau and Jean-Marie Beau, *Chem. Eur. J.* **2009**, *15*, 53-57



PO 311

ANTITUMOUR ACTIVITY  
OF SOME GLYCYRRHETINIC ACID GLYCOSIDES

Stefan Schwarz<sup>1</sup>; Bianka Siewert<sup>1</sup>; René Csuk<sup>1</sup>; Nuno Manuel Xavier<sup>2</sup>; Ana Rita Jesus<sup>2</sup>;  
Amelia Pilar Rauter<sup>2</sup>

<sup>1</sup>Martin-Luther-Universität Halle-Wittenberg, Naturwissenschaftliche Fakultät II, Bereich Organische Chemie, 06120 Halle/ Saale, Germany; E-Mail: rene.csuk@chemie.uni-halle.de

<sup>2</sup>Faculdade de Ciências da Universidade de Lisboa, Centro de Química e Bioquímica/Departamento de Química e Bioquímica, Campo Grande, Ed. C8, Piso 5, 1749-016 Lisboa, Portugal; aprauter@fc.ul.pt

Sugars do not only have their own potential in the field of medicinal chemistry but are also used in combination with other drugs, especially as glycosides, to increase drugs' hydrophilicity. Therefore, conditions of uptake and biological availability of lipophilic drugs can be ameliorated when they are linked to a sugar moiety.

Our target, glycyrrhetic acid (GA), belongs to the group of pentacyclic triterpene acids. Some of its members, e.g. betulinic acid or oleanolic acid, are well known for their activity against various tumour cell lines. Although GA is not as active as for instance betulinic acid, it triggers apoptosis in tumour cells<sup>1</sup> and can be converted into more active derivatives through the introduction of a hydrophilic moiety.<sup>2</sup> Thus, we have glycosylated the methyl ester of GA in position 3 (1) with trichloroacetimidate donors derived from various hexoses and pentoses belonging to series D and L.

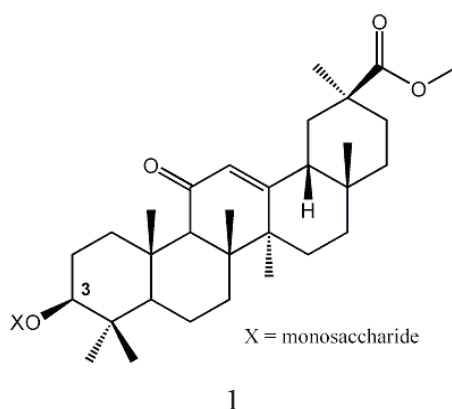

All glycosides were tested in a sulforhodamine B (SRB) assay as well as in a trypan blue test and acridine orange/ethidium bromide test for apoptosis. The synthesis of the compounds as well as their biological data will be presented and compared.

**References**

1. Liu, D.; Song, D.; Guo, G.; Wang, R.; Lu, J.; Jing, Y.; Zhao, L. *Bioorg. Med. Chem.*
2. Csuk, R.; Schwarz, S.; Kluge, R.; Ströhl, D. *Eur. J. Med. Chem.* **2010**, 45(12), 5718-5723.

PO 312

**STABILIZATION OF THE POLYPROLINE II HELIX BY HYDROXYPROLINE GLYCOSYLATION**Neil W Owens,<sup>1</sup> Sreenivas Bommagani,<sup>1</sup> Jörg Stetefeld,<sup>1</sup> Frank Schweizer<sup>1,2</sup><sup>1</sup>*Department of Chemistry, University of Manitoba, Winnipeg, MB, R3T 2N2, Canada,*<sup>2</sup>*Department of Medical Microbiology, University of Manitoba, Winnipeg, MB, R3A 1R9  
schweize@cc.umanitoba.ca*

The hydroxyproline-rich glycoproteins (HRGPs) are the major structural proteins of the extracellular matrix of algae and land plants. HRGPs are characterized by a rigid polyproline type II (PPII) conformation and extensive O-glycosylation of 4(*R*)-hydroxy-L-proline (Hyp) residues, which is a unique post-translational modification of proteins. The functional and structural consequences of HRGP glycosylation remain unclear, but has been implicated in contributing to their structural rigidity.<sup>1,2</sup> Here we have investigated the effects of naturally-occurring O-galactosylation of Hyp residues on the conformational stability of the PPII helix and other HRGP mimics.<sup>4</sup> In a series of well-defined model peptides we demonstrate that contiguous O-galactosylation of Hyp-residues causes a dramatic increase in conformational stability of the PPII helix according to thermal melting curves.<sup>3</sup> This represents the first quantitative data on the contributions of glycosylation to stabilizing the PPII conformation. Molecular modeling and computational studies indicate the increase in conformational stability may be due to regular network of interglycan and glycan-peptide hydrogen bonds, in which the carbohydrate residues form a hydrophilic “overcoat” of the PPII helix. This study gives further insight into the effects of naturally-occurring Hyp-O-linked glycans on the PPII conformation as found in HRGPs in plant cell walls, and also indicates that polyproline sequences may be suitable for the development of molecular scaffolds for the presentation of glycan structures.

**References**

1. Owens, N.W., Braun, C., O’Neil, J. D., Marat, K. and Schweizer, F. *J. Am. Chem. Soc.* **2007**, *129*, 11670-71.
2. Owens, N. W., Lee, A., Marat, K., Schweizer, F. *Chem. Eur. J.* **2009**, *15*, 10649-10657.
3. Owens, N.W., Stetefeld, J., Lattová, E., Schweizer, F. *J. Am. Chem. Soc.* **2010**, *132*, 5036-5042.
4. Bommagani, S., Schweizer, F (unpublished results).

PO 313

## QUALITY XYLOSE-RICH LIQUOR BY STATISTICALLY MODELED HYDROLYSIS OF ENERGY AGRO-CROPS

Anatoly A. Shatalov, Helena Pereira

Forest Research Center, Institute of Agronomy, Technical University of Lisbon  
Tapada da Ajuda, 1349-017 Lisbon, Portugal  
anatoly@isa.utl.pt

Efficient utilization of hemicelluloses is of vital importance for sustainable biorefinery of lignocellulosic biomass.<sup>1</sup> The low temperature dilute sulfuric acid hydrolysis of two potential energy crops giant reed and cardoon has been statistically modeled and optimized using Response Surface Methodology (RSM)<sup>2</sup> to produce a quality xylose-rich substrate for subsequent biochemical conversion to value-added products. The central composite rotatable design (CCRD) was employed to assess the effect of the principal independent process variables on efficiency and selectivity of xylan conversion to xylose. The second-order polynomial model was fitted to experimental data to find an optimal set of reaction conditions by multiple regression analysis.

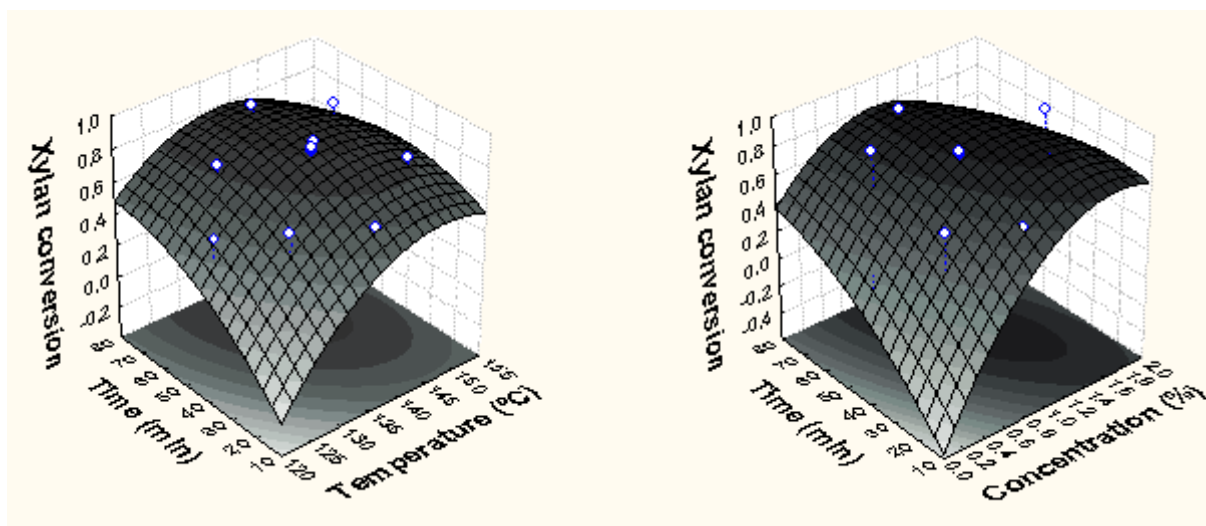

**Figure.** Response surfaces and contour plots of cardoon xylan conversion to xylose as a function of reaction time ( $t$ , min), temperature ( $T$ , °C) and acid concentration ( $C$ , %).

Under established optimum hydrolysis conditions the monomeric xylose recovery in solution (yield) of 94% and 86% was achieved respectively for giant reed and cardoon (vs. 93% and 87% predicted by model), with limited cellulose degradation and by-products (furans) formation.

**Acknowledgements:** Research contract PTDC/AGR-CFL/103840/2008 (FCT, Portugal).

**References**

1. B. Kamm, M. Kamm, *Adv. Biochem. Engin. Biotechnol.*, **2007**, *105*, 175–204.
2. D.C. Montgomery, *Design and analysis of experiments*, John Wiley & Sons, New York, **2001**.

## PO 314

## THE REGIOSELECTIVE PROTECTION OF DISACCHARIDES AND THEIR USE AS BUILDING BLOCKS IN THE SYNTHESIS OF HEPARIN OLIGOSACCHARIDES

Kevin Sheerin, Tamara Strebel and Stefan Oscarson

*University College Dublin, Belfield, Dublin 4, Ireland*  
*kevin.sheerin@ucd.ie*

Heparin, a major class of glycosaminoglycans, plays diverse roles in a number of physiological and pathological processes. These include cell adhesion, embryogenesis, viral invasion and most notably in the regulation of the blood coagulation cascade<sup>1-2</sup>. Heparin structures contain a high degree of complexity pertaining to the variation of sulfation pattern present throughout each structure. For this reason chemical synthesis of Heparin can be quite difficult. Presented here are techniques for the syntheses of disaccharide building blocks with varying protecting group patterns from a common disaccharide precursor. Using disaccharide over monosaccharide building blocks effectively reduces the number of glycosylation reactions by more than half and also overcomes the difficulty often encountered when using the relatively deactivated uronic acids as donors in glycosylation. This method is also extremely attractive for target structures which contain a 2'-nonparticipating protecting group.

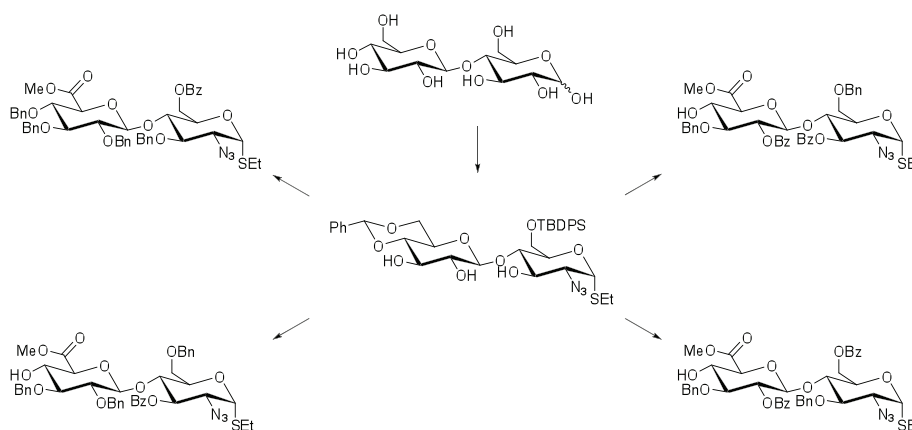

**Scheme 1**

### References

1. I. M. Bernfield, M. Grotte, P.W. Park, O. Reizes, M. L. Fitzgerlad, J. Lincecum, *Annu. Rev. Biochem.*, **1999**, *68*, 729-777.
2. Capila, R. J. Linhardt, *Angew. Chem. Int. Ed.*, **2002**, *41*, 390-412.

PO 315

**SUBSTRATE BINDING TO FAMILY GH-23 LYSOZYME AND  
FAMILY GH-19 CHITINASE AS DETERMINED BY NMR SPECTROSCOPY**

Shoko Shinya<sup>1</sup>, Takuya Nagata<sup>1</sup>, Takayuki Ohnuma<sup>1</sup>, Shunsuke Kawamura<sup>2</sup>, Takao Torikata<sup>2</sup>,  
Toki Taira<sup>3</sup>, Shigenori Nishimura<sup>4</sup>, Tamo Fukamizo<sup>1</sup>

<sup>1</sup>Department of Advanced Bioscience, Kinki University, 3327-204 Nakamachi Nara 631-8505, Japan,

<sup>2</sup>Department of Bioscience, School of Agriculture, Tokai University, Aso, Kumamoto, 869-1404 Japan,

<sup>3</sup>Department of Bioscience and Biotechnology, Ryukyu University, 1 Senbaru Nishihara  
Okinawa 903-0213 Japan, and

<sup>4</sup>Graduate School of Life and Environmental Sciences, Osaka Prefecture University, 1-1 Gakuen-cho,  
Nakaku, Sakai, Osaka 599-8531 Japan  
1033690015j@nara.kinadai.ac.jp

Glycoside hydrolases belonging to family GH-19 and family GH-23 are the defensive enzymes that hydrolyze polysaccharides forming the fungal or bacterial cell wall. The catalytic cleft of the two families of enzymes has been shown to consist of common structural elements<sup>1</sup>. In this study, to examine the substrate-binding mode in solution, NMR titrations of chitin oligosaccharides [(GlcNAc)<sub>n</sub>] were conducted using Family GH-23 lysozyme from ostrich egg white (OEL) and Family GH-19 chitinase from moss, *Bryum coronatum* (BcChi-A).

To obtain <sup>15</sup>N/<sup>13</sup>C-labeled proteins, OEL and BcChi-A were expressed in *Pichia pastoris*<sup>2</sup> and *Escherichia coli*<sup>3</sup>, respectively, in the presence of <sup>15</sup>NH<sub>4</sub>Cl and <sup>13</sup>C-glucose. Each enzyme was purified by ion exchange chromatography followed by gel filtration. The inactive mutants, E73A-OEL and E61A-BcChi-A, were also obtained similarly. NMR spectra were recorded at 300K with a Bruker AV-500 spectrometer. The backbone resonances observed in <sup>1</sup>H-<sup>15</sup>N HSQC spectra of both enzymes were assigned sequentially using three-dimensional HNCA, HNCOC, HNCO, HNCACO, CBCA(CO)NH and HNCACB spectra. (GlcNAc)<sub>6</sub> binding to E73A-OEL affected the backbone HSQC resonance of Gln95, Asp97, and Arg99, which are located in the β-sheet region forming the substrate-binding surface of the glycon binding site. On the other hand, for the E61A-BcChi-A, the resonance of Ser62, Glu70, and Ile99, which are located at the aglycon binding site, were strongly affected by the addition of (GlcNAc)<sub>6</sub>. The association constant of (GlcNAc)<sub>6</sub> binding to E73A-OEL was calculated to be 5.91 × 10<sup>3</sup> M<sup>-1</sup> and lower than that to E61A-BcChi-A (4.69 × 10<sup>4</sup> M<sup>-1</sup>).

**References**

1. Monzingo, Marcotte, Hart, Robertus, *Nat Struct Biol*, **1996**, 3(2), 133-40.
2. Kawamura, Fukamizo, Araki, Torikata, *J Biochem*, **2003**, 133(1), 122-31.
3. Taira et al., *Glycobiology*, **2011**, in press

PO 316

**STRUCTURAL ANALYSIS OF THE O-ANTIGEN OF THE LIPOPOLYSACCHARIDE FROM *AZOSPIRILLUM BRASILENSE* SP7.K2**

Elena N. Sigida<sup>a</sup>, Yuliya P. Fedonenko<sup>a</sup>, Evelina L. Zdorovenko<sup>b</sup>, Svetlana A. Konnova<sup>a</sup>, Aleksander S. Shashkov<sup>b</sup>, Vladimir V. Ignatov<sup>a</sup>

<sup>a</sup>*Institute of Biochemistry and Physiology of Plants and Microorganisms, Russian Academy of Sciences, Saratov, Russia*

<sup>b</sup>*N. D. Zelinsky Institute of Organic Chemistry, Russian Academy of Sciences, Moscow, Russia  
room308@ibppm.sgu.ru*

The gram-negative bacteria of the genus *Azospirillum* are an intensively studied associative partner of a wide range of plants growing in diverse climatic zones. Interest in the surface polysaccharides of azospirilla is due to the important role of these macromolecules in bacterial competition in soil and also to their involvement in the key stages of the plant-microbial associations.

O-specific polysaccharide (OPS, O-antigen) of the bacteria membrane lipopolysaccharide (LPS) carries the main antigen determinants and in this case it probably can be the microorganism recognition factor for the macropartner [1]. It is known that OPS is the most variable part of LPS molecule and bacteria can alter its structure for adaptation to changing living conditions. We established the repeating-unit structure for the OPS of a derivate strain *Azospirillum brasilense* Sp7.K2, obtained after long-term storage of a wild type strain *A. brasilense* Sp7 on a rich nutrient medium at room temperature. A mixture of two structurally distinct O-polysaccharides was obtained by mild acid degradation of the lipopolysaccharide isolated by the phenol/water extraction. Using gas-liquid chromatography, and one and two NMR methods (<sup>1</sup>H, <sup>13</sup>C, <sup>1</sup>H/<sup>1</sup>H COSY, TOCSY, ROESY and <sup>1</sup>H/<sup>13</sup>C HMBC, HSQC) the following structures were determined:

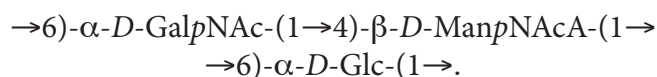

Earlier it was shown that O-antigen of another mutant strain *A. brasilense* 245.5 [2] has the same structure as the first polysaccharide of *A. brasilense*. Sp7.k2. This fact let us suppose that spontaneous mutation of two different azospirillum strains leads to activation of silent genes whose products are involved in the synthesis of the same OPS. Heterogeneity of the OPS may be the result of high-level adaptation properties of the bacteria.

**References**

1. Newman, M.A et al. *J. Endotoxin Res.* **2007**, 13(2); 69-82.
2. Fedonenko, Yu.P. et al *RJB.* **2010**, 36 (2); 236-240.



PO 317

**ELABORATION AND SELF-ASSEMBLY PROPERTIES  
OF BIOACTIVE LIPOSACCHARIDES**

Christelle Silioc, Catherine Ladavière, Stéphane Trombotto, Laurent David

*Ingénierie des Matériaux Polymères (IMP), UMR CNRS 5223,  
Université Claude Bernard Lyon 1, Université de Lyon, 69622 Villeurbanne Cedex, France  
csilioc@gmail.com*

This work is part of a research program on the elaboration, physicochemical and biological properties of innovative molecular systems and materials for life sciences.<sup>1</sup> Molecular systems based on amphiphilic molecules have received an increasing interest due to their self-assembly properties in aqueous media.<sup>2</sup> In this context, we develop a new generation of nano-organized amphiphilic molecular systems owning the dual property of bioactivity and self-assembly via the synthesis of specific bioactive glycolipids. Concerning the design of these glycolipids, the hydrophilic part would be composed of hydrosoluble, biocompatible, and bioactive oligosaccharides,<sup>3</sup> and the hydrophobic part of controlled length alkyl chains. The chosen synthesis strategy to functionalize saccharidic polar heads with alkyl chains requires the grafting of an alkylamine on the reducing end of the sugar thanks to a reductive amination reaction (figure 1). Here are described preliminary results using synthesized models composed of monosaccharidic polar heads, *i.e.* D-glucose, D-glucosamine and *N*-acetyl-D-glucosamine, and different alkyl chain lengths from C6 to C16. These amphiphilic structures were formulated with phospholipids, and the resulting self-assembly morphologies were examined as a function of the glycolipid/phospholipid molar ratio by QELS, TEM, and SAXS.

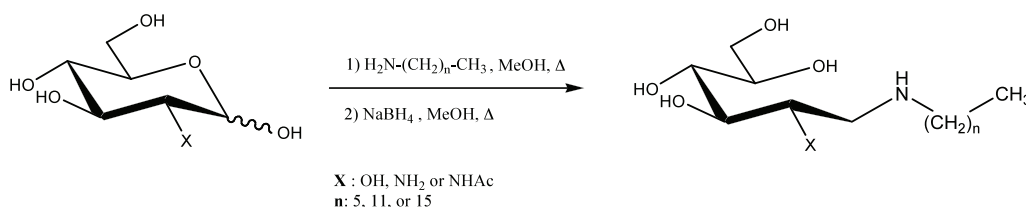

**Figure 1:** General structure of synthesized glycolipid models

### References

- (i) S. Ladet, L. David, A. Domard, *Nature*, **2008**, 452, 76-79; (ii) A. Montembault, K. Tahiri, C. Korwin-Zmijowska, X. Chevalier, M. T. Corvol, A. Domard, *Biochimie*, **2006**, 88, 551-564.
- I. Rico-Lattes, *Actualité Chimique*, **2007**, 305, I-XII.
- K.V. Harish Prashanth, R.N. Tharanathan, *Trends in Food Science & Technology*, **2007**, 18, 117-131.

## PO 318

VALIDATION OF MONOSACCHARIDES CONFORMATIONS  
USING OPTICAL ROTATIONRenato R. Andrade, Clarissa O. da Silva*Departamento de Química, UFRRJ, Rodovia BR465, km 47, Seropédica, RJ, Brazil, 23890-000  
clarissa-dq@ufrj.br*

Optical rotation (OR) is an extensive property that has been associated with carbohydrates for long time. Although the experimental measurement of its intensive form – the specific rotation ( $[\alpha]_D$ ) – is very simple, only recently its theoretical calculation using quantum mechanics was made possible for rigid isolated<sup>1</sup> or solvated<sup>2</sup> systems. Some studies have shown that it is extremely sensitive to the orientation of hydroxyl and hydroxymethyl groups in monosaccharides prototypes<sup>3</sup>. More recently,  $[\alpha]_D$  values were calculated for two conformers of the same anomer of both glucose (G)<sup>4</sup> and xylose (X)<sup>5</sup>. These conformers differ from each other by the position of only one hydrogen atom of a hydroxyl group (Figure). They have show an  $[\alpha]_D$  difference higher than  $60^\circ/(\text{dm}(\text{g}/\text{cm}^3))$ . Since such a difference is much higher than the error of the calculated property, it would be very difficult to find two distinct conformational sets of monosaccharides with similar  $[\alpha]_D$  final values. In fact, in these previous studies, conformational sets for glucose (8 conformations) and xylose (14 conformations) were validated by calculating the  $[\alpha]_D$  individual values and then averaging them by the relative abundance of each conformation and, finally, comparing with the experimental benchmark. The final values found were for G= $+58.75^\circ/(\text{dm}(\text{g}/\text{cm}^3))$  and X= $+20.36^\circ/(\text{dm}(\text{g}/\text{cm}^3))$ , in agreement respectively with the experimental values  $+52.7^\circ/(\text{dm}(\text{g}/\text{cm}^3))$  and  $+18.8^\circ/(\text{dm}(\text{g}/\text{cm}^3))$ .

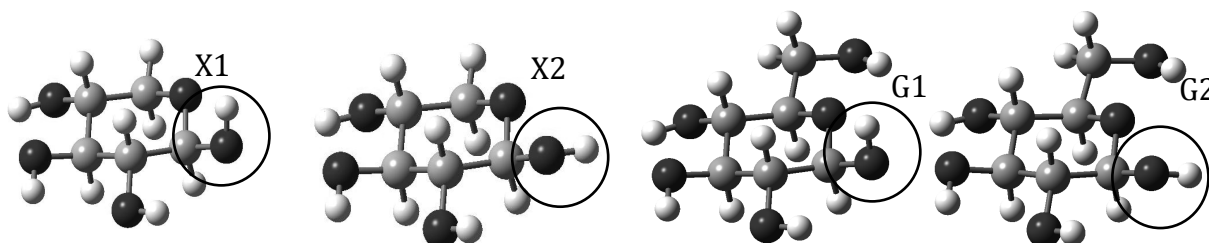

Conformer	xylose	glucose
1	+43.2	+79.4
2	-21.3	-4.03
Difference	64.5	83.4

Individual  $[\alpha]_D$  values in  $\text{deg}/(\text{dm}(\text{g}/\text{cm}^3))$ , calculated at B3LYP/6-311++G(2d,2p) level in aqueous solution described by a continuum dielectric approach, on geometries optimized at B3LYP/6-31+G(d,p) level.

**References**

- Stephens, P. J.; Devlin, F. J.; Cheeseman, J. R.; Frisch, M. J. *J. Phys. Chem. A* **2001**, *105*, 5356-5371.
- Mennucci, B.; Tomasi, J.; Cammi, R.; Cheeseman, J. R.; Frisch, M. J.; Devlin, F. J.; Gabriel, S.; Stephens, P. J. *J. Phys. Chem. A* **2002**, *106*, 6102-6113.
- Silva, C. O.; Mennucci, B. *J. Chem. Theory Comp.* **2007**, *3*, 62-70.
- Silva, C. O.; Mennucci, B.; Vreven, T. *J. Org. Chem.* **2004**, *69*, 8161-8164.
- Silva, C. O.; Andrade, R. R. *Mini-Rev. Org. Chem.* **2011**, in press.

## PO 319

## SYNTHESIS OF THIAZOLINE DERIVATIVES OF SUGARS

Petr Šimon, Lucie Petrásková, Kristýna Slámová, Helena Pelantová, and Vladimír Křen

*Institute of Microbiology, Academy of Sciences of the Czech Republic, Vídeňská 1083,  
CZ-142 20 Prague, Czech Republic  
petr.simon@biomed.cas.cz*

$\beta$ -*N*-Acetylhexosaminidases (EC 3.2.1.52.; CAZy GH20 and 84) are *exo*-glycosidases, catalyzing the cleavage of terminal  $\beta$ -D-GlcNAc and  $\beta$ -D-GalNAc residues.<sup>1</sup> Dysfunctions in human hexosaminidases (GH20) result in serious lysosomal storage disorders, while selective inhibition of *O*-GlcNAcase (GH84) can slow down progress of Alzheimer's disease.<sup>2</sup> Thus, small molecule inhibitors of family GH20 and 84 enzymes are very important both as tools for elucidating the role of these enzymes in biological processes as well as for developing therapeutics. One of the most effective  $\beta$ -Hex inhibitors, GlcNAc-thiazoline mimics the bicyclic oxazoline intermediate in the substrate-assisted mechanism of GH20 and 84 hexosaminidases. So far, all existing inhibitors are structurally based on GlcNAc, which is the basic substrate of  $\beta$ -Hex; GalNAc-thiazoline was prepared but it was studied only in a limited way.

We have demonstrated quite recently that  $\beta$ -Hex from filamentous fungi are well able to cleave and transfer also 4-deoxy substrates.<sup>3</sup> In this study, we present the synthesis of a set of C-4 modified HexNAc-thiazolines and their inhibition activity towards selected hexosaminidases from bacterial and fungal sources as model enzymes.

Synthesis of HexNAc-thiazolines is based on the reaction of acylated hexosamine derivative with Lawesson's reagent (LR),<sup>4</sup> followed by respective deprotection. LR converts amidic group into thioamide, which then cyclizes by displacement of anomeric  $\beta$ -acetate to provide respective thiazoline derivative.

**Acknowledgement** Support from EU project FP7 NOVOSIDES KBBE-4-265854 and Czech Science Foundation P207/11/0629 is acknowledged.

**References**

1. Slamova K, Bojarova P et al., *Biotech. Adv.*, **2010**, *28*, 682-693.
2. Yuzwa SA, Macauley MS et al., *Nature Chem. Biol.*, **2008**, *4*, 483-490.
3. Slamova K, Gazak R et al., *Glycobiology* **2010**, *20*, 1002-1009.
4. Knapp S, Vocadlo DJ et al., *J. Am. Chem. Soc.*, **1996**, *118*, 6804-6805.

PO 320

**AN ENTRY TO CARBAPENAMS VIA ASYMMETRIC KINUGASA REACTION  
INVOLVING CYCLIC NITRONES DERIVED  
FROM SUGARS AND TERMINAL ACETYLENES**

Magdalena Soluch, Sebastian Stecko, Adam Mames, Bartłomiej Furman, Marek Chmielewski

*Institute of Organic Chemistry, Polish Academy of Sciences, 01-224 Warsaw, POLAND  
chmiel@icho.edu.pl*

The copper(I) mediated reaction of nitrones and terminal acetylenes, which is known as Kinugasa reaction, represents an attractive method of direct formation of the  $\beta$ -lactam ring.<sup>1,2</sup> This reaction can be performed in many ways including diastereo- and enantioselective versions. In most cases, as 1,3-dipoles simple acyclic nitrones have been used.<sup>3</sup> Number of reactions involving cyclic ones is limited.

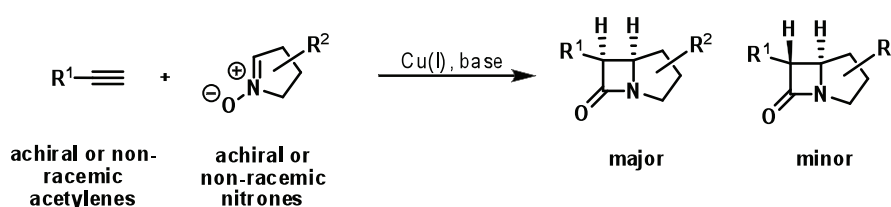

Herein, we present our recent studies on Kinugasa reaction involving cyclic nitrones readily available from hydroxy acids or pentoses and terminal acetylenes either achiral or bearing a stereogenic center.<sup>4</sup> All investigated reactions proceeded in good yield and with high diastereoselectivity providing an attractive entry to carbapenams of a potential biological activity.<sup>5</sup> The stereochemical pathway of the reaction and influence of geometry and substitutions in one or both reactants on direction and magnitude of asymmetric induction will be discussed.

### References

1. (a) Kinugasa, M.; Hashimoto, S. *J. Chem. Soc., Chem. Commun.* **1972**, 466–467, (b) Pal, R.; Ghosh, S.; Chandra, K.; Basak, A. *Synlett* **2007**, 2321–2330.
2. Brandi, A.; Cicchi, S.; Cordero, F. *Chem. Rev.* **2008**, *108*, 3988–4035.
3. (a) Miura, M.; Enna, M.; Okuro, K.; Nomura, M. *J. Org. Chem.* **1995**, *18*, 4999–5004; (b) Lo, M.; Fu, G. *J. Am. Chem. Soc.* **2002**, *124*, 4572–4573; (c) Ye, M.-C.; Zhou, J.; Tang, Y. *J. Org. Chem.* **2006**, *71*, 3576–3582.
4. (a) Stecko, S.; Mames, A.; Furman, B.; Chmielewski, M. *J. Org. Chem.* **2008**, *73*, 7402–7404; (b) Stecko, S.; Mames, A.; Furman, B.; Chmielewski, M. *J. Org. Chem.* **2009**, *74*, 3094–3098; (c) Soluch, M.; Mikołajczyk, P.; Stecko, S.; Mames, A.; Furman, B.; Chmielewski, M., *J. Org. Chem.* **2010**, *75*, 7580–7592.
5. *Chemistry and Biology of  $\beta$ -Lactam Antibiotics*, M. Morin, M. Gorman, Eds., Wiley-VCH, New York, 1982.

## PO 321

## SYNTHESIS OF (HEPT-2-ULOPYRANOSYLPHOSPHATE)ONIC ACID DERIVATIVES

Katalin Czifrák,<sup>1</sup> Péter Szilágyi,<sup>1</sup> Isabelle Bruyère,<sup>2</sup> Jean-Pierre Praly,<sup>2</sup> László Somsák<sup>1</sup><sup>1</sup>University of Debrecen, Department of Organic Chemistry,  
PO Box 20, H-4010 Debrecen, Hungary<sup>2</sup>Université Claude Bernard Lyon 1, ICBMS UMR 5246,  
Laboratoire de Chimie Organique 2 – Glycochimie  
43 Boulevard du 11 Novembre 1918, 69622 Villeurbanne Cedex, France  
somsak.laszlo@science.unideb.hu

Glycosyl transferases catalyse transfer of sugar residues from suitably activated derivatives e.g. UDP-sugars to saccharides, proteins or lipids. Their biochemical functions are extremely versatile since oligosaccharides, glycoproteins, and glycolipids play important roles in many vital recognition processes of living organisms.<sup>1</sup> Inhibitors of such enzymes have among others been designed by replacement (modifications) of the diphosphate unit in the UDP-sugars.<sup>2</sup> In our approach shown below, the diphosphate unit is maintained and an additional substituent at the anomeric carbon is introduced. Such compounds can be new substrate analogue inhibitors of sugar-processing enzymes.<sup>3</sup> The presentation will show details of our first results.

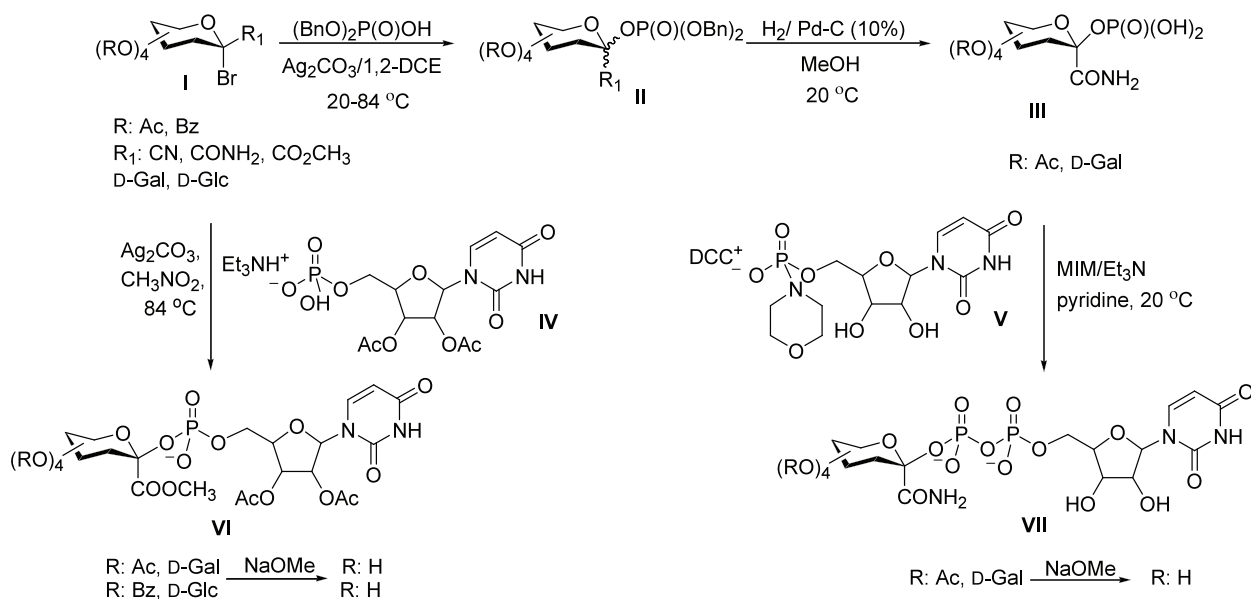
1,2-DCE=ClCH<sub>2</sub>CH<sub>2</sub>Cl; MIM=*N*-methylimidazole; DCC<sup>+</sup>=*N,N'*-dicyclohexylcarboxamidinium

## References

1. Wagner, K. G.; Pesnot, T. *ChemBioChem* **2010**, *11*, 1939-1949.
2. Kajimoto, T.; Node, M. *Synthesis* **2009**, *19*, 3179-3210.
3. Vidal, S.; Bruyère, I.; Malleron, A.; Augé, C.; Praly, J.-P. *Bioorg. Med. Chem.*, **2006**, *14*, 7293-7301.

PO 322

**CRYSTAL STRUCTURE OF METHYL L-glycero- $\alpha$ -D-manno-HEPTOPYRANOSIDE AND SYNTHESIS OF 1 $\rightarrow$ 7 LINKED L-glycero- $\alpha$ -D-manno-HEPTOBIOSIDES**

Christian Stanetty,<sup>1</sup> Kurt Mereiter,<sup>2</sup> Daniel Artner,<sup>1</sup> Alla Zamyatina,<sup>1</sup> Paul Kosma<sup>1</sup>

<sup>1</sup>Department of Chemistry, University of Natural Resources and Life Sciences, A-1190 Vienna Austria

<sup>2</sup>Institute of Chemical Technologies and Analytics, University of Technology, Getreidemarkt 9, A-1060 Vienna, Austria  
Christian.stanetty@boku.ac.at

Methyl L-glycero- $\alpha$ -D-manno-heptopyranoside **2** was synthesized in good yield by a Fischer-type glycosylation of the corresponding reducing heptopyranose with methanol in the presence of cation-exchange resin. The compound crystallized in an orthorhombic lattice of space group P2<sub>1</sub>2<sub>1</sub>2 (no. 18). As model compounds for the side chain domains of the inner core structure of bacterial lipopolysaccharide, the disaccharides L-glycero- $\alpha$ -D-manno-heptopyranosyl-(1 $\rightarrow$ 7)-L-glycero-D-manno-heptopyranose **5** and the corresponding methyl glycoside **6** were prepared. The former compound was generated via glycosylation of benzyl 5,6-dideoxyhept-5-enofuranoside **1** followed by catalytic osmylation and deprotection. The known<sup>1</sup> disaccharide **6** was efficiently synthesized in high yield by a straightforward coupling of the N-phenyltrifluoroacetimidate heptopyranosyl donor **4** to an acetylated 7-hydroxy heptoside acceptor derivative derived from **2**, followed by Zemplén deacetylation.

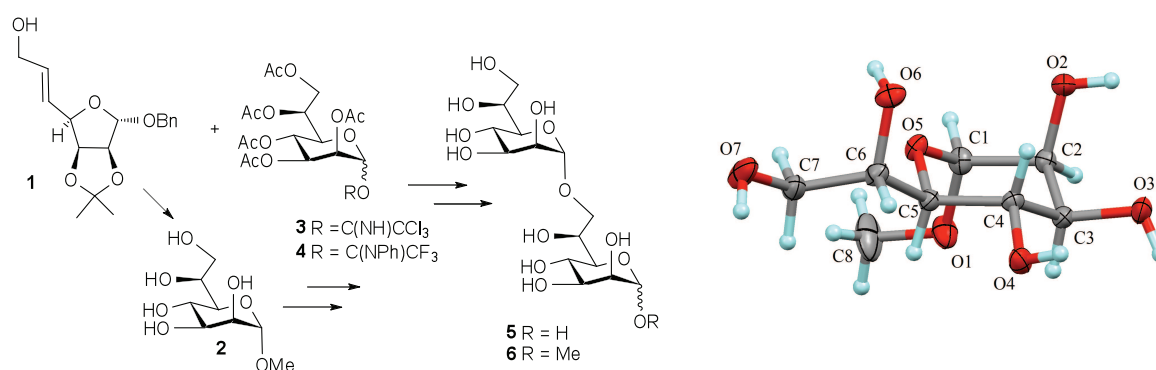

**Acknowledgments:** Financial support by Austrian Science Fund (FWF grant P 22909)

### References

1. a) Yamasaki, R.; Takajyo, A.; Kubo, H.; Matsui T.; Ishii, K.; Yoshida, M. *J. Carbohydr. Res.* **2001**, *20*, 171-180; b) Kim, M.; Grzeszczyk, B., Zamojski, A. *Tetrahedron* **2000**, *56*, 9319-9337; c) Stewart, A.; Bernlind, C.; Martin, A.; Oscarson, S.; Richards, J. C. Schweda, E. K. H. *Carbohydr. Res.* **1998**, *313*, 193-202; d) Boons, G. J. P. H.; van der Marel, G. A.; Poolman, J. T.; van Boom J. H. *Rec. Trav. Chim. Pays-Bas* **1989**, *108*, 339-343.



PO 323

## C-5 MODIFICATIONS IN THE HEXOSE SERIES

Martin Thonhofer, Patrick Kosmus, Tanja M. Wrodnigg, Arnold E. Stütz

*Glycogroup, Institut für Organische Chemie, Technical University Graz, Stremayrgasse 9,  
A-8010 Graz, Austria  
tm2204@sbox.tugraz.at*

In pyranoid iminosugars, the ring oxygen O-5 is usually replaced by a basic nitrogen. For the synthetic introduction of this hetero atom into a sugar, 1,2-*O*-protected derivatives of *D*-glucose, as are easily available from *D*-glucofuranurono-6,3-lactone, have been suitable intermediates. Other modifications at C-5 may take advantage of the same strategy providing new structures en route to biologically active compounds. In context with our interest in pharmacological chaperones for selected lysosomal storage disorders such as Gaucher's disease,  $G_{M1}$  gangliosidosis as well as Morquio B, we have successfully been relying on this approach which has provided highly active pyrrolidine and piperidine type iminoalditols.

A set of recent new synthetic applications and the resulting structures will be presented and their properties will be discussed.

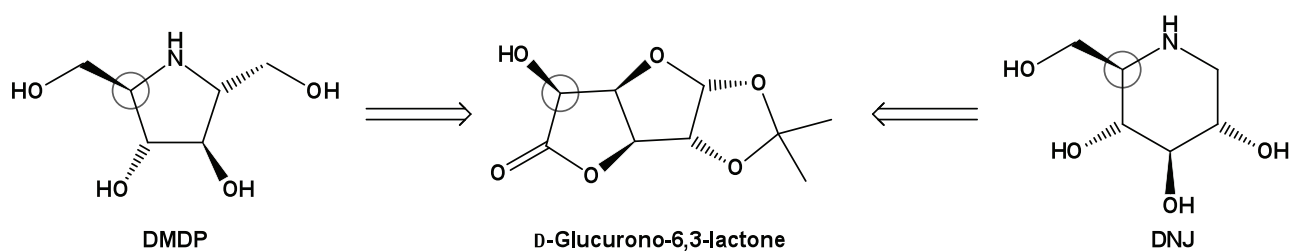

## PO 324

**MASS SPECTROMETRY CONTRIBUTION TO THE DIAGNOSIS  
AND CHARACTERIZATION OF CONGENITAL DISORDERS OF GLYCOSYLATION (CDG):  
OUR EXPERIENCE IN THE EUROGLYCANET EUROPEAN NETWORK**

Luisa Sturiale<sup>1</sup>, Rita Barone<sup>2</sup>, Agata Fiumara<sup>2</sup>, Giovanni Sorge<sup>2</sup>, Jaak Jaeken<sup>3</sup>,  
Domenico Garozzo<sup>1</sup>

<sup>1</sup>*Institute of Chemistry and Technology of Polymers – CNR- Catania, Italy.*

<sup>2</sup>*Centre for Inherited Metabolic Diseases - Department of Pediatrics – University of Catania, Catania, Italy*

<sup>3</sup>*Department of Pediatrics – University of Leuven, Leuven, Belgium.*

Congenital Disorders of Glycosylation (CDG) comprise an ever increasing group of inborn errors in the proteins glycosylation pathway, representing a paradigm as they disclose the direct connection between glycosylation changes and human diseases.

Since the first description in 1980 [1], about 40 CDG forms were discovered, each with a variable clinical spectrum, from multisystem diseases to single organ involvements, causing high morbidity and even mortality. Sharing information and competences is an essential step in order to identify new CDG types and to promote awareness and early diagnosis.

Mass spectrometry contributed significantly to this research field to identify possible underglycosylation profiles of intact individual glycoproteins and/or to map glycan population of the sample under study, typically serum or plasma. Here we report on serum glycosylation analyses by MALDI-MS in patients with CDG recruited in the context of Euroglycanet, an European network focused on diagnosis and understanding CDG [2]. During the last five years (2005-2010), almost 3000 samples of Italian patients with clinical suspicion of CDG were analyzed by serum Transferrin (Tf) isoelectric focusing (IEF) in a clinical setting at the University Paediatric Hospital in Catania. Patient with abnormal IEF pattern underwent MALDI MS glycosylation analyses at the ICTP-CNR in Catania, where a specific method for intact glycoprotein investigation and N-glycan analyses was set up [3]. Eighteen patients showed by MS the Tf abnormal glycosylation profile characteristic of type I CDG, encompassing defects in the assembly of dolichol-linked oligosaccharide in the Endoplasmic reticulum. Among these, PMM2-CDG (or CDG-Ia) was most frequently found (11 cases). Of particular importance, one patient affected with epileptic encephalopathy, had a newly identified CDG type due to DPM2 gene mutation [4].

Moreover, MS glycosylation analysis was performed on seventy-one serum samples with type II IEF pattern, collected from the Euroglycanet partners. Two of these samples showed recognizable glycan processing defects, respectively caused by gene mutations of subunit 5 and subunit 7 of the Conserved Oligomeric Golgi (COG) complex (COG5-CDG and COG7-CDG) [5-6]. Four more samples with combined Type I and Type II Tf MS profiles were also found; this significant information makes disease comprehension at molecular basis and diagnosis particularly challenging in these patients.

**References**

1. Jaeken J, Vanderschueren-Lodeweyckx M, Casaer P, Snoeck L, Corbeel L, Eggermont E, Eeckels R. *Pediatr Res* (1980) 14:179
2. Matthijs G. *Eur J Hum Genet.* (2005) 13:395
3. Sturiale L, Barone R, Palmigiano A, Ndosimao CN, Briones P, Adamowicz M, Jaeken J, Garozzo D. *Proteomics* (2008)18:3822
4. Barone R, Race V, Sturiale L, Bammens R, Vleugels W, Keldermans L, Garozzo D, Foulquier F, Jaeken J, Sorge G, Fiumara A, Matthijs G. *J Inherit Metab Dis* (2010) 33:S74.
5. Manuscript in preparation
6. Zeevaert R, Foulquier F, Cheillan D, Cloix I, Guffon N, Sturiale L, Garozzo D, Matthijs G, Jaeken J. *Eur J Med Genet.* (2009) 52:303

## PO 325

**THE MULTIVALENT MANNOSE-BASED GLYCOMIMETIC COMPOUNDS ARE PROMISING INHIBITORS OF DC-SIGN/PATHOGEN INTERACTIONS**

Ieva Sutkeviciute<sup>3</sup>, Norbert Varga<sup>2</sup>, Renato M. R. Viana<sup>1</sup>, Michel Thépaut<sup>3</sup>, Javier Rojo<sup>1</sup>, Anna Bernardi<sup>2</sup>, Franck Fieschi<sup>3</sup>

<sup>1</sup>*Grupo Carbohidratos, Instituto de Investigaciones Químicas, CSIC – Universidad de Sevilla, Américo Vespucio 49, 41092 Sevilla;*

<sup>2</sup>*Università degli Studi Milano, Dipartimento di Chimica Organica e Industriale, via Venezian 21, 20133 Milano, Italia;*

<sup>3</sup>*Institut de Biologie Structurale, Université Grenoble I, 41 rue Jules Horowitz, 38027 Grenoble.*

Dendritic cells (DCs) are the first immune barrier encountered by various pathogens after they invade peripheral tissues. A range of different receptors expressed on the surface of DCs serves to capture pathogens for further processing, antigen presentation and T cells activation. One of these receptors, a C-type lectin DC-SIGN (Dendritic Cell-Specific Intercellular adhesion molecule 3-Grabbing Non-integrin), has an important role in host immune functions regulation. However, it also binds to a number of lethal opportunistic pathogens, including HIV-1, and consequentially enhances their adhesion, infectivity and persistence in patients, which makes DC-SIGN an important pharmaceutical target (1). DC-SIGN binds pathogens through complex mannose and fucose based oligosaccharide structures on the glycoproteins. DC-SIGN has been shown to exist in the form of tetramers, which in turn are clustered in lipid rafts on DCs (2). Due to such clustered organization of DC-SIGN and high glycosylation of its ligands, the interactions with the pathogens are multivalent and have high avidity. Thus, these properties must be considered for development of DC-SIGN/pathogen interaction inhibitors.

Glycomimetic molecules are interesting drug candidates for DC-SIGN inhibition due to their high solubility, resistance to glycosidases and non-toxicity. Indeed, a first molecule has been shown as efficient to inhibit DC-SIGN-mediated HIV infection (3). In this study, we have designed mannose based glycomimetic compounds and tested their potencies to inhibit DC-SIGN interaction with a model glycoprotein in surface plasmon resonance (SPR) assay. In these series several glycomimetic compounds were identified as best inhibitors. Furthermore, we have developed several scaffolds for glycomimetic ligand presentation at various multivalency levels and different spacings. These scaffolds were conjugated with natural or selected glycomimetic ligands and their potencies to block DC-SIGN binding to glycoproteins were evaluated in SPR. The results revealed several scaffolds that possess significant avidity values.

**References**

1. Beat Ernst and John L. Magnani. *Nature Reviews Drug Discovery* **8**, 661-677 (2009)
2. A. Cambi et al. *J. Cell. Biol.* **164** (1), 145-155 (2004)
3. Sara Satin et al. *ACS Chemical Biology* **5**, 301-312 (2010)

PO 326

ALTERATION OF PRODUCT SPECIFICITY  
OF CYCLOISOMALTOOLIGOSACCHARIDE GLUCANOTRANSFERASE  
FROM *BACILLUS CIRCULANS* T-3040

Ryuichiro Suzuki,<sup>1</sup> Nobuhiro Suzuki,<sup>2</sup> Zui Fujimoto,<sup>2</sup> Mitsuru Momma,<sup>2</sup> Keitarou Kimura,<sup>1</sup>  
Atsuo Kimura,<sup>3</sup> and Kazumi Funane<sup>1</sup>

<sup>1</sup>National Food Research Institute, NARO, Tsukuba, Ibaraki 305-8642, Japan,

<sup>2</sup>National Institute of Agrobiological Sciences, Tsukuba, Ibaraki 305-8602, Japan,

<sup>3</sup>Research Faculty of Agriculture, Hokkaido University, Sapporo, Hokkaido 060-8589, Japan  
ryuichi@affrc.go.jp

Cycloisomaltooligosaccharide glucanotransferase (CITase; EC 2.4.1.248) catalyses the intramolecular transglycosylation of dextran to produce cyclic isomaltooligosaccharides (cyclodextrins; CIs) [1]. CITase is classified into glycoside hydrolase family 66 (<http://www.cazy.org/>). At present CI-7 to CI-17 which consisted of 7 to 17 glucose molecules, respectively, have been isolated [2-3]. CI-10 (Fig. 1) exhibited an ability to form inclusion complexes as well as cyclodextrins (CDs) did and is therefore of interest to industrial applications [3]. Since CIs (CI-7 to CI-12) strongly inhibit streptococcal glucansucrases, CIs are expected to be useful in preventing dental caries. CITase from *Bacillus circulans* T-3040 strain (T-3040 CITase) produces CI-8 predominantly (Fig. 1). In this study we report the construction and characterization of mutant CITase that efficiently produces useful CI-10 by means of site-directed mutagenesis. Recently, we showed that the T-3040 CITase is subdivided into five regions and demonstrated that conserved N-terminal region and CITase-specific insertion (R1) region affect the catalytic reaction of the enzyme [4]. We introduced mutations into these regions and analyzed reaction products of the resulting mutants by using HPLC. Mutations in conserved N-terminal region increased the amount of CI-8 production. On the other hand, mutations in R1 region lost the preference of CI-8 production. Consequently, R1 region mutants produced CI-10 and larger CIs efficiently. This study was supported partially by a Program for Promotion of Basic and Applied Researches for Innovations in Bio-oriented Industry (BRAIN, Japan).

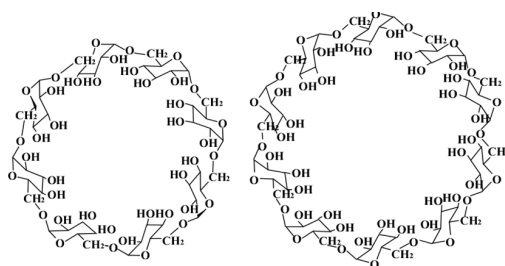

Structures of CI-8 (left) and CI-10 (right).

## References

1. Oguma, T., et al., *FEBS Lett.*, **1994**, 345, 135-138.
2. Funane, K., et al., *Biosci. Biotechnol. Biochem.*, **2008**, 72, 3277-3280.
3. Funane, K., et al., *J. Biotechnol.*, **2007**, 130, 188-192.
4. Funane, K., et al., *Biochim Biophys Acta. Proteins and Proteomics*, **2011**, 1814, 428-434.

PO 327

**C-( $\beta$ -D-GLUCOPYRANOSYL) HETEROCYCLES AND  
4-( $\beta$ -D-GLUCOPYRANOSYL) SEMICARBAZONES AS GLYCOGEN PHOSPHORYLASE  
INHIBITORS**

Béla Szócs,<sup>1</sup> Tímea Kaszás,<sup>1</sup> Marietta Tóth,<sup>1</sup> Tibor Docsa,<sup>2</sup> Pál Gergely,<sup>3</sup> László Somsák<sup>1</sup>

<sup>1</sup>Department of Organic Chemistry, University of Debrecen, POB 20, H-4010 Debrecen, Hungary

<sup>2</sup>Cell Biology and Signaling Research Group of the Hungarian Academy of Sciences  
at the Department of Medical Chemistry, Medical and Health Science Centre,  
University of Debrecen, Egyetem tér 1, H-4032 Debrecen, Hungary

<sup>3</sup>Department of Medical Chemistry, Medical and Health Science Centre, University of Debrecen,  
Egyetem tér 1, H-4032 Debrecen, Hungary  
somsak.laszlo@science.unideb.hu

At the end of the 20<sup>th</sup> century a dramatic increase in the number of patients diagnosed with type 2 diabetes has been observed worldwide. The search for potent and selective inhibitors of glycogen phosphorylase (the main regulatory enzyme of glycogen degradation) may lead to antihyperglycaemic drugs.  $\beta$ -D-Glucopyranosyl ureas (**1**, **2**), *N*-acyl-*N'*- $\beta$ -D-glucopyranosyl ureas (**3-5**), and aldehyde 4-( $\beta$ -D-glucopyranosyl) thiosemicarbazones (**6-8**) are effective inhibitors of glycogen phosphorylase (GP).<sup>1,2</sup> Based on these preliminaries the syntheses of C-glucopyranosyl-heterocycles were planned, by replacing the amide part of **1-5** with non classical bioisosters, such as 1,3,4-oxadiazoles and -thiadiazoles. 4-( $\beta$ -D-Glucopyranosyl) semicarbazones were also synthesized to compare the inhibitory effect to that of the S-analogues (**6-8**). Details of the syntheses and preliminary enzyme kinetic results will be shown in the presentation.

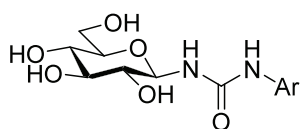

**1** Ar = 2-Naphth  $K_i = 5.2 \mu\text{M}$   
**2** Ar = Ph  $K_i = 18 \mu\text{M}$

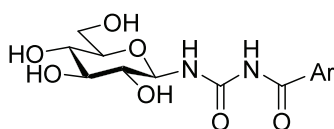

**3** Ar = 2-Naphth  $K_i = 0,4 \mu\text{M}$   
**4** Ar = Ph  $K_i = 4,6 \mu\text{M}$   
**5** Ar = 3-NO<sub>2</sub>-Ph  $K_i = 3,3 \mu\text{M}$

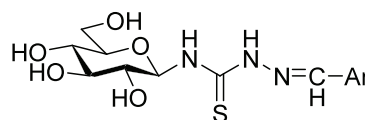

**6** Ar = 4-F-Ph  $IC_{50} = 5,7 \pm 0,4 \mu\text{M}$   
**7** Ar = 3-Cl-Ph  $IC_{50} = 23,2 \pm 0,5 \mu\text{M}$   
**8** Ar = 3-Br-Ph  $IC_{50} = 50,4 \pm 1,9 \mu\text{M}$

### References

1. L. Somsák, K. Czifrák, M. Tóth, É. Bokor, E. D. Chrysina, K.-M. Alexacou, J. M. Hales, E. Lazoura, D. D. Leonidas, E. S. Zographos, N. G. Oikonomakos, *Curr. Med. Chem.* **2008**, *15*, 2933-2983.
2. K.-M. Alexacou, A.-C. Tenchiu Deleanu, E. D. Chrysina, M.-D. Charavgi, I. D. Kostas, S. E. Zographos, N. G. Oikonomakos, *Bioorg. Med. Chem.* **2010**, *18*, 7911-7922.

PO 328

**SYNTHESIS AND ANTIBACTERIAL ACTIVITY  
OF NEW DERIVATIVES OF VANCOMYCIN**Monika Szulc, Justyna Samaszko, Janusz Madaj

*Chair of Sugar Chemistry, Faculty of Chemistry, University of Gdańsk  
Sobieskiego 18/19, PL- 80 – 952 Gdańsk, POLAND  
monikas@chem.univ.gda.pl*

Vancomycin is a glycopeptide antibiotic of the last resort for the treatment of infections caused by Gram-positive bacteria [1].

The antibacterial activity of this glycopeptide antibiotic arises from specific binding of this drug to bacterial cell wall precursor terminating in the sequence D-Ala-D-Ala [2].

Although vancomycin is immensely useful, the emergence of vancomycin clinical resistance underscored the importance of developing new drugs with improved antibacterial activity [3]. The most common forms of vancomycin resistance are found in enterococcal strains where the peptidoglycan precursor is induced to shift from a D-Ala-D-Ala to D-Ala-D-Lac peptide terminus to which vancomycin binds 1000-fold less effectively [4]. Accordingly, there is still an intensive search for novel antibacterial agents among semisynthetic derivatives of vancomycin that exhibit antibacterial activity and improved pharmacological properties against resistant bacterial strains [5].

As a part of our effort to discover new antibacterial agents to treat serious Gram-positive infections we synthesized a new derivatives of vancomycin.

In the search for synthetic analogs the carboxyl group of cyclic heptapeptide was modified with sugar moieties. Additionally we worked on modification of the aglycon which we obtained by hydrolysis of vancomycin.

These analogs will be examine for antibiotic activity against vancomycin-sensitive and vancomycin-resistant strains, as well as methicillin-resistant *Staphylococcus aureus* (MRSA).

**Acknowledgements:** This work was part-financed by the European Union within the European Regional Development Fund (POIG.01.01.02-14-102/09-01) and grant DS/8451-4-0134-11.

**References**

1. D. Kahne; C. Leimkuhler; W. Lu; C. Walsh; *Chem. Rev.* **2005**, *105*, 425 – 428.
2. D. H. Williams; B. Bardsley; *Angew. Chem. Int. Ed.* **1999**, *38*, 1172 – 1193.
3. J. Pootoolal; J. Neu; G. D. Wright; *Annu. Rev. Pharmacol. Toxicol.* **2002**, *42*, 381.
4. B. K. Hubbard; C. T. Walsh; *Angew. Chem. Int. Ed.* **2003**, *42*, 730.
5. M. N. Preobrazhenskaya; E. N. Olsufyeva; Patents on glycopeptides of the vancomycin family and their derivatives as antimicrobials. *Expert Opin. Ther. Pat.* **2004**, *14* (2), 141 – 173.



PO 329

**SYNTHESIS OF 1,4-ANHYDRO-2,5-DIDEOXY-D-ERYTHRO-  
-3-(HYDROGEN PHOSPHATE)-5-AMINIUM-PENTITOL**

Barbara Dmochowska, Karol Sikora, Monika Szulc, Andrzej Wiśniewski

*University of Gdańsk, Faculty of Chemistry, Sugar Chemistry Group  
J. Sobieskiego 18, 80-952 Gdańsk, Poland  
bdmochow@chem.univ.gda.pl*

Alditols and anhydroalditols are widespread in both the animal and plant kingdoms. They also occur in human blood and urine and in the amniotic and cerebrospinal fluids. These compounds and some of their derivatives have been used in medicine. For instance, 1,4:3,6-dianhydro-D-glucitol 2,5-dinitrate (Sorbonit) and 1,4:3,6-dianhydro-D-glucitol 5-nitrate (Mononit) are vasodilators used for the treatment of chronic circulatory insufficiency and stenocardia. Both chemists and biologist are currently interested in pseudo-nucleosides in which the sugar residue is substituted by 1,4-anhydropentitol or 1,5-anhydrohexitol derivatives. Some of these compounds are effective against viruses, for instance against the HIV virus. Intense chemical and biological investigations are also conducted on analogues of DNA containing substituted 1,5-anhydrohexitols in place of 2-deoxy-D-ribose.

In view of these developments, we decided to continue our synthetic and biological research on these compound types.

Actually we are working on the synthesis of 1,4-anhydro-2,5-dideoxy-D-erythro-3-(hydrogen phosphate)-5-aminium-pentitol in reaction of *N*-(1,4-anhydro-2,5-dideoxy-D-erythro-pentitol-5-yl)aminium tosylates (QACs) with phosphoryl chloride and trimethyl phosphate (Scheme 1). The structures of isolates were determined by spectral analysis including extensive 2D NMR analyses and X-ray crystallography. QACs demonstrated mutagenic activity in bioluminescence mutagenicity assay based on *Vibrio harveyi* A16 strain.

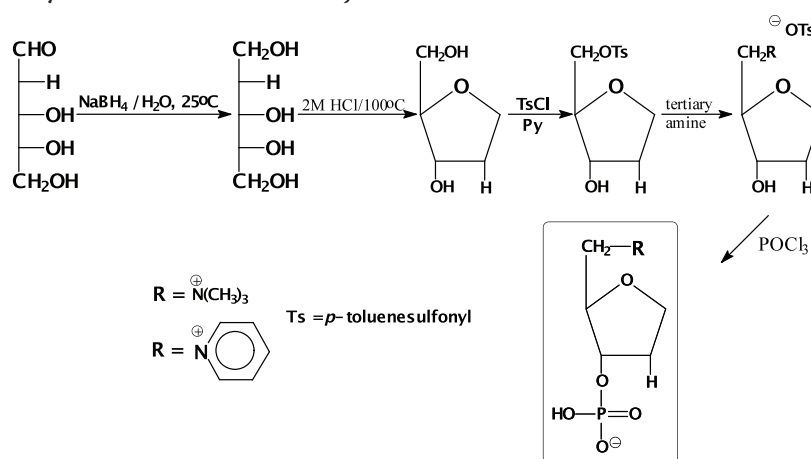

**Acknowledgements:** This work was partially financed by grant DS/8451-4-0134-11

## PO 330

SYNTHESIS OF 2,5-DIDEOXY-2,5-IMINO-D-HEXITOL DERIVATIVES: POTENTIAL INHIBITORS OF LYSOSOMAL  $\alpha$ -GALACTOSIDASE?Patrick Kosmus, Martin Thonhofer, Arnold E. Stütz, Tanja M. Wrodnigg

*Glycogroup, Institute of Organic Chemistry, Technical University Graz, Stremayrgasse 9,  
Graz, Austria  
pkosmus@sbox.tugraz.at*

Iminoalditols, which are sugar analogues with a basic trivalent nitrogen instead of the oxygen in the ring, are well known as powerful glycosidase inhibitors. This property sets the seal on their use as analytical tools for the investigation of carbohydrate processing enzymes as well as their application as pharmaceuticals against diseases involving this enzyme class.<sup>1</sup>

In line with our research towards applications of *N*-modified iminoalditols as pharmacological chaperones<sup>2</sup> we have become interested in the synthesis of  $\alpha$ -galactosidase inhibitors in context with Fabry's disease. To this end, 2,5-dideoxy-2,5-imino-D-altritol, originally isolated from *Adenophora triphylla*, is known to have respective biological properties for this application.<sup>3</sup> We will present the synthesis of C-1 amino modified 2,5-dideoxy-2,5-iminohexitols such as structure **6** starting from known Amadori rearrangement product **4**.

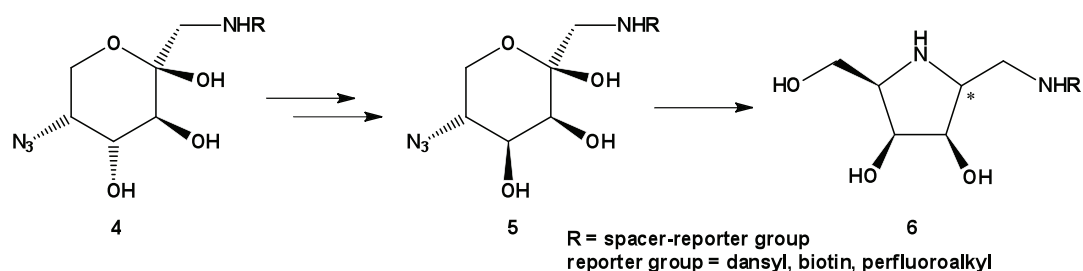

## References

1. *Iminosugars – From synthesis to therapeutic applications*, Compain, P.; Martin, O. R., Eds. Wiley: Chichester, 2007.
2. Fantur, K.; Hofer, D.; Schitter, G.; Steiner, A. J.; Pabst, B. M.; Wrodnigg, T. M.; Stütz, A. E.; Paschke, E. *Mol. Gen. Metabol.*, **2010**, 100 (3), 262 - 268. Fröhlich, R.; Furneaux, R. H.; Mahuran, D. J.; Rigat, B. A.; Stütz, A. E.; Tropak, M. B.; Wicki, J.; Withers, S. G.; Wrodnigg, T. M. *Carbohydr. Res.*, **2010**, 345(10), 1371 - 1376.
3. Kato, A.; Yamashita, Y.; Nakagawa, S.; Koike, Y.; Adachi, I.; Hollinshead, J.; Nash, R. J.; Ikeda, K.; Asano, N. *Bioorg. Med Chem.*, **2010**, 18, 3790 - 3794:

PO 331

**SURVEY THE INFLUENCE OF MICROBIAL TRANSGLUTAMINASE  
FOR FORMATION OF  
TRANSGLUTAMINASE-INDUCED GELS**

Mahsa Tabari<sup>1</sup>, Asghar Ebrahimi<sup>2</sup>

*<sup>1</sup>Assistance Professor of Food Science and Technology.*

*Department of Food Science and Technology, Faculty of Agriculture and Natural Resources,  
Lahijan Branch - Islamic Azad University, Lahijan, Iran.*

*<sup>2</sup>Msc of biotechnology and Bioscience, Department of biotechnology and Bioscience*

*University of Milano-Bicocca, Italy*

*ma.tabari@gmail.com*

Mechanical and structural properties of transglutaminase-induced casein gels are described here and compared with those of traditional acid casein gels. These gels were characterised by rheology and microscopy (confocal laser scanning microscopy and transmission electron microscopy). Unlike traditional casein gels produced by acidification and/or renneting which lead to gels cross-linked by weak physical interactions, gels formed using transglutaminase are covalently cross-linked. Gels with different characteristics can therefore be formed in this way and have some unusual and interesting features in terms of strength, kinetics of gelation, sensitivity to heat treatment and syneresis behaviour. The first steps of the transglutaminase-induced micellar aggregation were followed by turbidimetry and a mechanism for the aggregation process proposed. Unlike traditional casein gels produced by acidification and/or renneting, which lead to gels by weak physical interactions, gels by transglutaminase-treated casein micelles lead to covalently cross-linked gels. Gels with various characteristics can therefore be formed.

**Key words:** Gels; Transglutaminase; Cross-linking; Rheology; Microstructure.



## PO 333

**O-PENTYNYL DEXTRAN AS SUPPORT FOR THE IMMOBILIZATION OF LIPASE FROM *R. ARRHIZUS* – LONG-TERM ENZYME STABILITY, USAGE AS BIOCATALYST AND COMPARIOSN WITH COMMERCIAL ION EXCHANGE RESINS**

Muhammad Nazir Tahir<sup>1,2</sup>, Petra Mischnick<sup>2,3</sup>

<sup>1</sup>Lab. of Organic Chemistry, Wageningen University, Dreijenplein 8,  
6703 HB Wageningen, The Netherlands

<sup>2</sup>Technische Universität Braunschweig, Institute of Food Chemistry, Schleinitzstr. 20,  
D-38106 Braunschweig, Germany

<sup>3</sup>KTH Stockholm, Fibre and Polymer Technology, Teknikringen 58, SE-10044 Stockholm, Sweden  
m.nazirtahir@yahoo.com

Lipases are the most popular enzymes in biocatalysis, because they can be used in a variety of reactions due to their regio- and enantioselectivity and their reusability [1]. Polysaccharides, beside low cost in some cases, are non-toxic, biocompatible, inert in physiological conditions and can offer appropriate micro-environment to avoid severe conformational changes in the enzyme [2]. Alkynyl ethers of dextrans are very promising candidates for immobilization of lipase and its use as biocatalyst in organic synthesis [3]. O-Pentynyl dextran (PyD), an amphiphilic polysaccharide derivative with degree of substitution (DS) 0.43 was synthesized [4] and compared with ion exchange resins Lewatit VP OC 1600, Amberlite XAD 761 and Duolite A568 for immobilization of Lipase from *Rhizopus arrhizus* by adsorption method. Biocatalysts were used for the synthesis of the click beetle pheromone geranyl octanoate. PyD showed higher lipase adsorption and esterification activity than other supports. Lipase immobilized on all supports except PyD became completely inactive within 8 weeks while lipase immobilized on PyD retained its full esterification activity for at least 14 weeks. In repeated use, yield decreased rapidly after two cycles for all supports except for PyD. For this biopolymeric support, constantly 90% yield were achieved even after eight cycles.

**References**

1. Bhushan, I.; Parsad, R.; Qazi, GN.; Ingavle, G.; Rajan, CR.; Ponrathnam, S.; Gupta, VK.; *Process Biochem.*, 2008, 43, 321-330.
2. Kosaka, PM.; Kawano, Y.; Seoud, OAE.; Petri, DFS.; *Langmuir*, 2007, 23, 2167-2173.
3. Tahir, MN.; Adnan, A.; Mischnick, P.; *Process Biochem.*, 2009, 44, 1276-1283.
4. Tahir, MN.; Bork, C.; Risberg, A.; Horst, JC.; Komöß, C.; Vollmer, A.; Mischnick, P.; *Macromol. Chem. Phys.* **2010**, 211, 1648-1662.

PO 334

**MICROWAVE-ASSISTED FACILE SYNTHESIS OF POLYESTERS  
AND POLYCARBONATES DERIVED FROM GLUCOSE**

Kazuhiko Takeuchi\*, Ritsuko Nagahata\*, Hiroshi Iida, Yoshiko Doi, Yuko Saito,  
Yukie Mori, Takashi Nakamura

*National Institute of Advanced Industrial Science and Technology (AIST)*  
takeuchi-kazuhiko@aist.go.jp, nagahata-ritsuko@aist.go.jp

Isosorbide (IS) is a diol obtained by hydrogenation and dehydration of glucose via sorbitol. IS is used for the manufacture of specialty polymers in the polyester, polycarbonate, and polyurethane families. According to its rigid structure, IS is the only biobased diol that improves resistance to heat, UV rays and chemicals, and offers excellent optical and mechanical properties on the materials produced. Thus far, various polymers composed of IS were reported, however, the synthesis processes for these polymers are need very long reaction time for more than decades of hours to some days, and high reaction temperature of 200 to 300 °C<sup>1</sup>).

Microwave (MW) heating is well known to accelerate many organic reactions at the speed of light<sup>2</sup>). We have already exhibited that polycondensations of diols and dicarboxylic acids were drastically accelerated compared with conventional heating processes<sup>3</sup>). We have also demonstrated a commercial microwave-assisted polycondensation plant for lactic acid polymerization<sup>4</sup>).

Recently, we extended the MW-assisted polycondensation to synthesis of polyesters and polycarbonates by use of IS as one monomer component. The polycondensation of IS, diols, and dicarboxylic acids gave polyesters with Mw ~70,000 in quantity in 60 min. IS and diols produced polycarbonates (Mw ~42,000) by transesterification with diphenyl carbonate in 60min in a good yield as shown in Scheme 1.

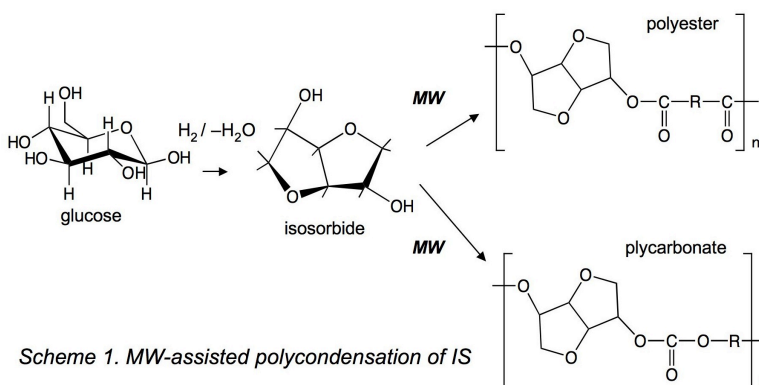

**Acknowledgments** A part of this work was financially supported by the Development of Fundamental Technologies for Green Sustainable Chemistry in 2009 from the New Energy and Industrial Technology Development Organization (NEDO) of Japan.

### References

1. F. Fenouillot, et al., *Progress in Polymer Science*, **2010**, 35 (2010) 578–622.
2. For example, A. Loupy (Ed.), “*Microwaves in Organic Synthesis*”, vols. 1&2, Wiley-VHC (2006); O. Kappe, et al., “*Practical Microwave Synthesis for Organic Chemists: Strategies, Instruments, and Protocols*”, Wiley-VHC (2009).
3. S. Velmathi, et al., *Polym. J.*, **2007**, 39, 841-844.
4. T. Nakamura, et al., *Org. Process Res. Dev.*, **2010**, 14, 781-786.



## PO 335

**CONTENTS AND COMPOSITIONAL ANALYSES OF GLYCOSAMINOGLYCANS FROM MARINE RESOURCE**

Jun-ichi Tamura<sup>1</sup>, Hiroyuki Fujita<sup>1</sup>, Shin Morimoto<sup>1</sup>, Manami Kawano<sup>1</sup>, Haruna Tanaka<sup>1</sup>, Kenya Matsushita<sup>1</sup>, Masahiro Kitagaki<sup>1</sup>, Ayumi Nakamura<sup>1</sup>, Yuka Hieda<sup>1</sup>, Shinya Masuda<sup>2</sup>, Yukio Ishihara<sup>2</sup>, Kazuhiko Yoshioka<sup>3</sup>, and Shinobu Yoshioka<sup>3</sup>

<sup>1</sup>Tottori University, Tottori, 6808551 Japan,

<sup>2</sup>Tottori Prefectural Fisheries Experimental Station, Sakaiminato, 6840046 Japan,

<sup>3</sup>OAK Co. Ltd., Sakaiminato, 6840046 Japan

*jtamura@rstu.jp*

The major source of chondroitin sulfate (CS) is shark and pig. However, indiscriminate fishing diminishes the number of sharks. In addition, the material tissues derived from the vertebrates are used in fear of the infectious diseases. Glycosaminoglycans (GAGs) including CS, dermatan sulfate (DS) and hyaluronic acid (HA) show various biological properties. We gave attention to the marine products as resources of GAG.

Horse mackerel is one of the major fishes of which uneatable parts are byproducts during the food processes. We clarified that the GAG derived from 1 kg of the defatted dry tissue of the horse mackerel predominantly contained 350 mg of CS-A ( $\beta$ GalNAc4S- $\beta$ GlcA) and 250 mg of DS ( $\beta$ GalNAc4S- $\alpha$ IdoA). Recently we reported the amount and the sulfation patterns of CS in the tissues of large squid, *Thysanoteuthis rhombus*<sup>1</sup> of which skin contained 3.8 g of E-type rich CS per kg of defatted dry tissue. We also investigated several fishes including unused snailfish and eelpouts living in the deep Japanese Sea. Skin of these fishes contained DS rather than CS. Some of their tissues contained about 2 and 8 g/(kg of defatted dry tissue) of unsulfated CS and HA, respectively. These results suggest that the uneatable parts of the marine products are able to be alternative resources of CS, DS and HA in place of the conventional resource animals.

**References**

1. J. Tamura et al., *Biosci. Biotech. Biochem.*, **2009**, 73, 1387-1391.

PO 336

## SYNTHESIS OF CATABOLIC-RESISTANT GLYCOLIPIDS

Hidenori Tanaka, Ole Hindsgaul

Carlsberg Laboratory, Gamle Carlsberg Vej 10, 1799 Copenhagen V, Denmark  
tanaka@crc.dk

Glycolipids, found on neural cell surfaces, can act as recognition molecules in biological events. It is also known that defects in glycolipid metabolism lead to devastating diseases. There has therefore been a long-standing interest in understanding the biosynthetic pathways for both glycolipid biosynthesis and catabolism.

We present here the synthesis of a lactosylsphingosine with a thioglycosidic linkage between the Gal and Glc residues,<sup>1</sup> which is resistant to glycosidases. This compound was coupled with the fluorescent tetramethylrhodamine (TMR) tag we reported previously.<sup>2</sup> Subsequent glycosylation using glycosyltransferase will give the compounds shown below which are used as probes in the study of metabolic pathways.

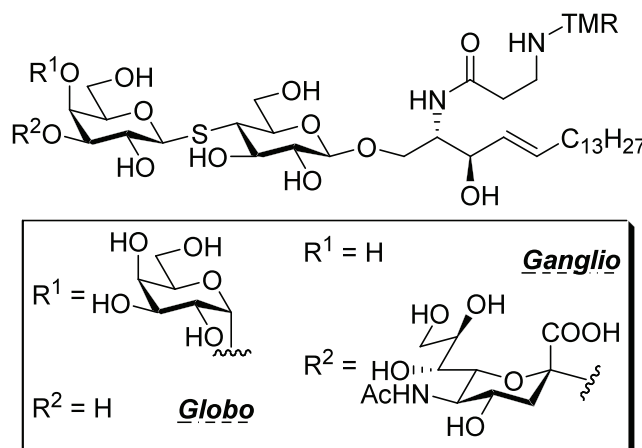
**References**

1. Bernd Albrecht, Ute Pütz, Günter Schwarzmann, *Carbohydr. Res.*, **1995**, 276, 289-308.
2. E. Andreas Larsson, Ulf Olsson, Colin D. Whitmore, Rita Martins, Guido Tettamanti, Ronald L. Schnaar, Norman J. Dovichi, Monica M. Palcic and Ole Hindsgaul, *Carbohydr. Res.*, **2007**, 342, 482-489.

PO 337

**A NEW INOSITOL-HOPANOID FROM AN INDONESIAN SPECIMEN  
OF THE SPONGE *PLAKORTIS SIMPLEX***

Valeria Costantino, Ernesto Fattorusso, Alfonso Mangoni, Cristina Perinu, Roberta Teta

*Dipartimento di Chimica delle Sostanze Naturali, Università degli Studi di Napoli Federico II,  
via Domenico Montesano 49, 80131 Napoli, Italy  
roberta.teta@unina.it*

The Caribbean sponge *Plakortis simplex* has been extensively studied by our group, and a large variety of unusual glycolipids and other amphiphilic compounds have been isolated, including simplexide (1), discoside (2), and 12-methylbacteriohopanetetrol (3).

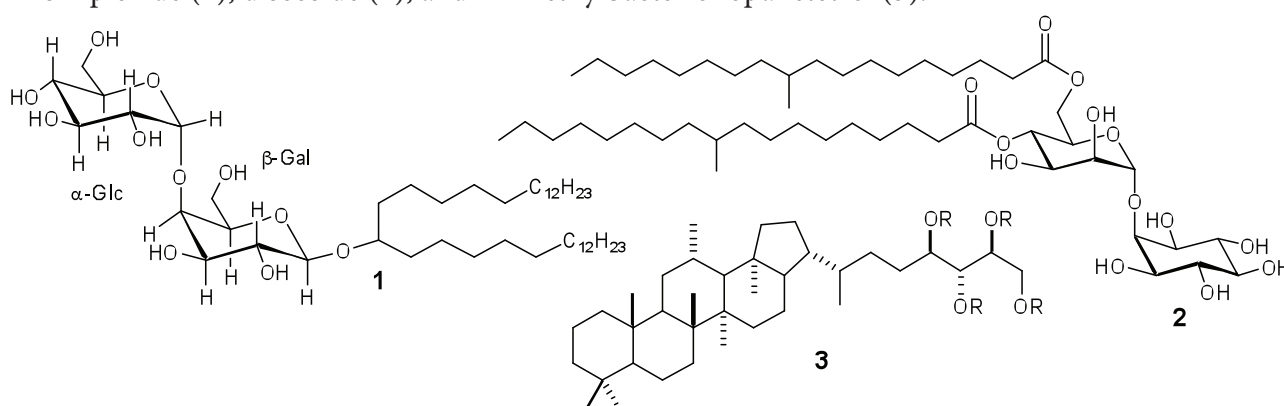

Recently, we had occasion to analyze for glycolipids an Indonesian specimen of *P. simplex*. In spite of the geographical distance, we found that the glycolipids composition of the Indonesian and Caribbean specimens were very similar. However, the Indonesian *P. simplex* also contained a new glycolipid, combining structural features of hopanoids and discoside, whose structure elucidation will be described.

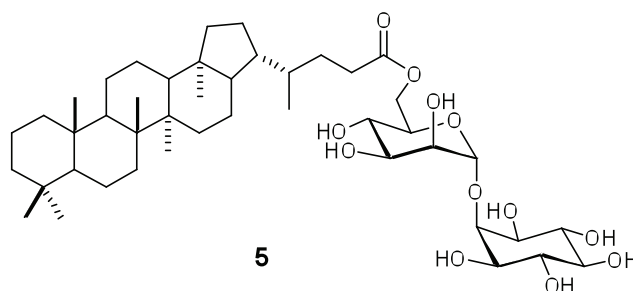

### References

1. Costantino V., Fattorusso E., Menna M., Tagliatela-Scafati O., "Chemical Diversity of Bio-active Marine Natural Products: An Illustrative Case Study", *Current Medicinal Chemistry*, **2004**, *11*, 1671-1692.

## PO 338

**OPTIMIZATION OF THE ENZYME-LINKED LECTIN ASSAY FOR ENHANCED GLYCOPROTEIN AND GLYCOCONJUGATE ANALYSIS**

Róisín Thompson<sup>1</sup>, Aileen Creavin<sup>2</sup>, Michael O'Connell<sup>2</sup>, Brendan O'Connor<sup>2</sup>, Paul Clarke<sup>1</sup>

<sup>1</sup> *National Centre for Sensor Research, Dublin City University, Glasnevin, Dublin 9, Ireland,*

<sup>2</sup> *School of Biotechnology, Dublin City University, Glasnevin, Dublin 9, Ireland*

*roisin.thompson@dcu.ie*

Lectins are proteins capable of recognising and binding to specific oligosaccharide structures found on glycoproteins and other biomolecules. As such they have found utility for glycoanalytical applications. One common difficulty encountered in the application of these proteins, particularly in multi-well plate assay formats known as Enzyme Linked Lectin Assays (ELLA's), is in finding appropriate blocking solutions to prevent non-specific binding with plate surfaces. Many commonly used blocking agents contain carbohydrates and generate significant background signals in ELLA's, limiting the utility of the assay.

In this study we examined the suitability of a range of blocking reagents, including protein based, synthetic and commercially available carbohydrate free blocking reagents, for ELLA applications. Each blocking reagent was assessed against a panel of 19 commercially available biotinylated lectins exhibiting diverse structures and carbohydrate specificities. We identified the synthetic polymer Polyvinyl Alcohol (PVA) as the best global blocking agent for performing ELLA's. We ultimately present an ELLA methodology facilitating broad spectrum lectin analysis of glycoconjugates and extending the utility of the ELLA.

PO 339

## SYNTHESIS OF RG-I OLIGOSACCHARIDES

Alexandra Zakharova, Robert Madsen and Mads H. Clausen*Department of Chemistry, Technical University of Denmark, DK-2800 Lyngby, Denmark  
mhc@kemi.dtu.dk*

Pectins are polysaccharides of plant origin. They are found in the primary cell walls and contribute to a number of cell functions. The chemical structure of pectin molecules is immensely complex. Their backbone consists of D-galacturonic acid and a number of neutral sugars. Three types of pectic polysaccharides have been identified: homogalacturonan (HG) and rhamnogalacturonan (RG) I and II. This work is focused on synthesis of RG-I oligosaccharides (repeating units of  $[\alpha\text{-L-Rhap-(1}\rightarrow\text{4)-}\alpha\text{-D-GalpA-(1}\rightarrow\text{2)}]$ ). The targeted molecules are highly relevant to the study of enzymes and antibodies acting on plant polysaccharides and are to be used within the LeanGreenFood network ([www.leangreenfood.eu](http://www.leangreenfood.eu)) that focuses on improving processes in the food industry. Initially, a hexasaccharide fragment of RG-I has been targeted (Scheme 1). The synthesis is planned to be carried out through a sequence of two glycosylation reactions using the disaccharide building block **A** followed by a late stage oxidation of the 6-position in galactose. In order to assemble **A**, suitably protected monosaccharide building blocks **B** and **C** have been designed and synthesized. Usage of phenyl thioglycosides and *n*-pentenyl glycosides as glycosyl donors has been explored. The key feature of the synthesis is a chemoselective activation of the glycosyl donor in the presence of the glycosyl acceptor. The reactivity of the donor and the acceptor is differentiated by the electronic effects of the protective groups through the so-called armed/disarmed effect.

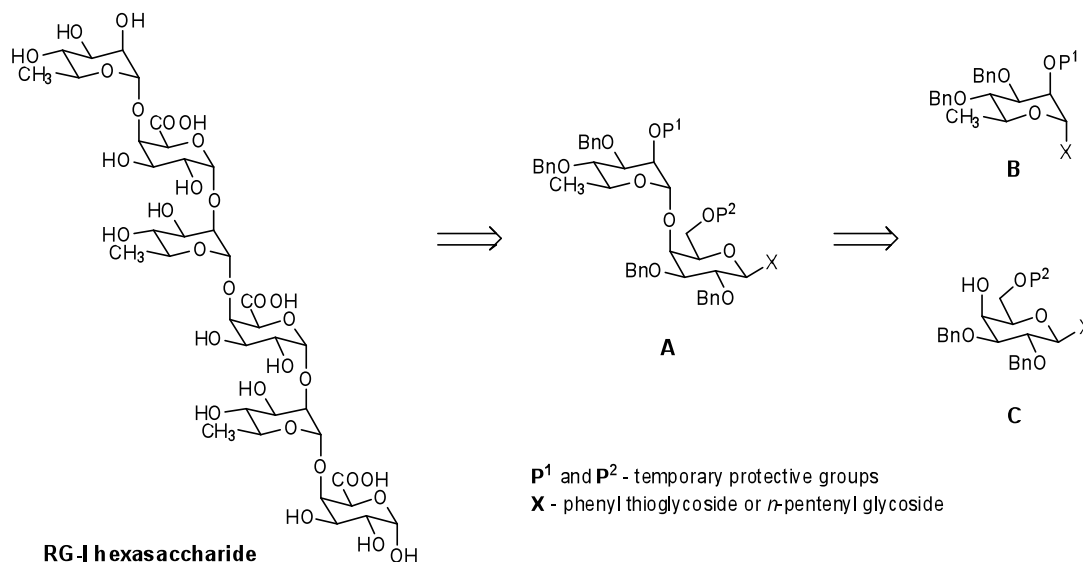
**Scheme 1.** Retrosynthesis of RG-I hexasaccharide.

PO 340

**SYNTHESIS OF A FLUORINATED ANALOGUE  
OF PHENOLIC GLYCOLIPID I**

Matthias Tokarski, Katrin Belger and Alexandra Hölemann

*Department of Chemistry, Organic Chemistry, Technische Universität Dortmund, 44221  
Dortmund, Germany  
matthias.tokarski@tu-dortmund.de*

Phenolic glycolipid I (PGL-I, Figure 1) is a specific glycolipid exclusively found on the cell surface of *Mycobacterium leprae*, the causative agent of leprosy.<sup>1</sup> Recently, it has been shown that PGL-I plays a crucial role in the pathogenesis of leprosy, in particular in the damage of peripheral nerves.<sup>2,3</sup> PGL-I is able to bind *via* its characteristic trisaccharide to laminin- $\alpha$ -2, a glycoprotein in the basal lamina surrounding the Schwann cell, thereby inducing demyelination, leading to inflammatory responses and nerve damage. However, the precise mechanism as well as the nature of the involved receptors on the Schwann cell surface are not fully known and are topic of current research.

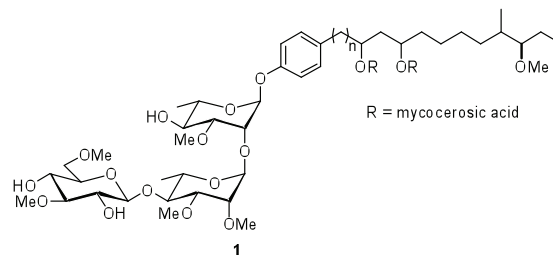

**Figure 1:** Phenolic glycolipid I.

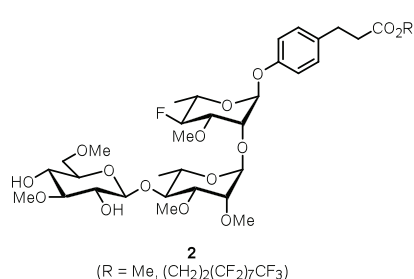

**Figure 2:** Fluorinated derivative of PGL-I.

Synthetic fluorinated derivatives of PGL-I, with one or more hydroxyl groups of the trisaccharide unit substituted by fluorine, may offer an interesting starting point to adjust these questions. These compounds may be used in structure-activity relationship studies to gain a better understanding of the biological role of PGL-I. The aim of this project is the synthesis of fluorinated PGL-I derivative 2 (Figure 2), in which the hydroxyl group in 4-position of the first rhamnose building block is selectively replaced by fluorine. An efficient strategy for the synthesis of the corresponding fluorinated building block and the assembly of the trisaccharide is presented.

### References

1. Y. Sugita, *Clin. Dermatol.* **1995**, *13*, 235-243.
2. a) S. W. Hunter, T. Fujiwara, P. J. Brennan, *J. Biol. Chem.* **1982**, *257*, 15072-15078; b) S. W. Hunter, P. J. Brennan, *J. Biol. Chem.* **1983**, *258*, 7556-7562.
3. a) A. Rambukkana, *Curr. Op. Microbiol.* **2001**, *4*, 2-271; b) D. B. Young, *Trends Microbiol.* **2001**, *9*, 52-54; c) V. Ng, G. Zanazzi, R. Timpl, J. F. Talts, J. L. Salzer, P. J. Brennan, A. Rambukkana, *Cell* **2000**, *103*, 511-524; d) A. Rambukkana, J. L. Salzer, P. D. Yurchenco, E. I. Tuomanen, *Cell* **1997**, *88*, 811-821.



## PO 341

**STRUCTURAL STUDIES ON ENDOTOXIN OF *RICKETTSIA TYPHI* -THE  
ETIOLOGICAL AGENT OF ENDEMIC TYPHUS**Pavol Vadovic, Marcela Fodorova and Rudolf Toman

*Laboratory for Diagnosis and Prevention of Rickettsial and Chlamydial Infections,  
Dept. of Rickettsiology, Institute of Virology, Slovak Academy of Sciences, Dubravska cesta 9, 8  
45 05 Bratislava, Slovakia  
Rudolf.Toman@savba.sk*

*Rickettsia typhi* causes endemic typhus. The disease is relatively mild, acute febrile illness characterized by headache and macular rash. It is maintained in rodents and transmitted to humans by the rat flea *Xenopsylla cheopsis*. It is known that *R. typhi* contains endotoxin which is thought to display a noticeable endotoxic activity but the structure/function relationship studies have not been performed thus far. Our studies have shown that the major *R. typhi* lipid A species consists of the  $\beta$ -(1 $\rightarrow$ 6)-linked D-GlcN disaccharide backbone carrying two phosphate groups. One of them is linked to the glycosidic hydroxyl group of GlcN I and the other one is ester-linked to the O-4' position of GlcN II. The primary fatty acids consist of two C14:0(3-OH) and two C16:0(3-OH). The former are ester- and the latter amide-linked to both GlcN. Two secondary fatty acids are represented by C18:0 and C16:0 that are ester-linked at the positions N-2' and O-3', respectively. Mass spectrometric analyses also revealed the presence of one minor molecular lipid A species in which ester-linked C18:0 is substituted by C16:0 at C16:0(3-OH) of GlcN II. The studies revealed a noticeable compositional and structural heterogeneity of lipid A of *R. typhi* with respect to the content of phosphate groups and the degree of acylation. The significance of the acyl pattern variation in the investigated lipid A is still unclear, but it may play a role in the biological activities. In addition, it is well known that enteric bacteria can synthesize different forms of lipid A in response to the host environment. We assume, however, that a part of the observed heterogeneity in the investigated lipid A could be generated by its incomplete biosynthesis in the living bacterium and by degradation processes during its isolation from the parent lipopolysaccharide. Thus, the presence of other lipid A isoforms in the *R. typhi* lipid A cannot be excluded. In conclusion, the structural features of lipid A of *R. typhi* resemble classical forms of enterobacterial lipids A and this fact may indicate a high endotoxic potency of the whole bacterium. However, more detailed structure/function relationship studies have to be performed in future to throw more light on this important problem.

## PO 342

**INVESTIGATIONS ON THE STRUCTURE-FUNCTION RELATIONSHIPS  
OF THE LIPOPOLYSACCHARIDES FROM *COXIELLA BURNETII*,  
THE ETIOLOGICAL AGENT OF Q FEVER**

Rudolf Toman<sup>1</sup>, Pavol Vadovic<sup>1</sup>, Martina Hamadova<sup>1</sup>, Kristina Bartova<sup>1</sup>, Eva Betinova<sup>1</sup>  
and Jean-Louis Mege<sup>2</sup>

<sup>1</sup>Laboratory for Diagnosis and Prevention of Rickettsial and Chlamydial Infections,  
Dept. of Rickettsiology, Institute of Virology, Slovak Academy of Sciences, Dubravska cesta 9,  
845 05 Bratislava, Slovakia,

<sup>2</sup>Unité de Recherche sur les Maladies Infectieuses Transmissibles et Emergentes, CNRS-IRD UMR  
6236, Institut Fédératif de Recherche 48, Université de la Méditerranée, Faculté de Médecine,  
13385 Marseille, France  
[Rudolf.Toman@savba.sk](mailto:Rudolf.Toman@savba.sk)

*Coxiella burnetii* is the etiological agent of Q fever. An easy aerosol dissemination, environmental persistence, and high infectivity make the bacterium a serious threat for humans and animals. A lipopolysaccharide (LPS) has been considered to be a major determinant of virulence expression and infection of *C. burnetii*. LPS I, isolated from virulent phase I bacterium, contains a noticeable amount of two sugars virenose (Vir) and dihydrohydroxystreptose (Strep), which have not been found in other LPSs and can be considered as unique biomarkers of the bacterium. Both sugars are located in the O-polysaccharide chain of LPS I, mostly in terminal positions. In the later stages of Q fever, a remarkable decrease in the serological activity of LPS I was observed when Vir and Strep were selectively released from its O-chain. This might indicate that most so-called phase I antibodies are directed against the epitopes containing Vir and Strep. The phagocytosis of virulent LPS I containing *C. burnetii* cells requires the engagement of  $\alpha\text{v}\beta 3$  integrin and leads to a low phagocytosis rate and intracellular survival. The phagocytosis of avirulent variants containing truncated (R) LPS II is mediated by  $\alpha\text{v}\beta 3$  integrin and CR3 ( $\alpha\text{M}\beta 2$  integrin, CD11b/CD18) and results in a high phagocytosis rate and bacterial elimination. The low efficiency of virulent bacteria uptake is probably critical for the persistence of *C. burnetii* in monocytes and macrophages. Inefficient uptake results from the uncoupling of the  $\alpha\text{v}\beta 3$  integrin from CR3, which is secondary to the inappropriate activation of macrophages and to actin cytoskeleton reorganization. It should be noted here that lipids A from LPS I and LPS II have the same structural features. In addition, the structure of *C. burnetii* lipid A differs considerably from those reported for strongly endotoxic enterobacterial lipids A.

PO 343

**TOTAL SYNTHESIS OF THE NATURALLY OCCURRING  
VACCINE ADJUVANT LABLABOSIDE F**Douglas R. Crump,<sup>a</sup> Sarah Hook,<sup>b</sup> Phillip Rendle,<sup>a</sup> Steven M. Toms<sup>a</sup>

<sup>a</sup> *Industrial Research Limited, Lower Hutt, New Zealand* <sup>b</sup> *School of Pharmacy,  
University of Otago, Dunedin, New Zealand*  
s.toms@irl.cri.nz

Lablaboside F was isolated from the seeds of *Dolichos lablab*.<sup>1</sup> and has been shown to have strong adjuvant activity but little haemolytic activity. Lablaboside F was shown to exhibit an almost ten fold increase in adjuvant activity in comparison to the purified plant extract QS-21<sup>2</sup> which has already entered numerous clinical trials based on its adjuvant activity. Lablaboside F comprises two trisaccharide units attached to the C3 hydroxyl and the C28 carboxylic acid of the oleanate triterpenoid backbone. The successful synthesis required the stepwise sequential attachment of protected glucose, galactose and rhamnose monosaccharide trichloroacetimidate donors to the C3 terminus of the triterpene before a selective oxidation/esterification procedure of the glucose residue to provide the glucuronic ester moiety. The C28 terminus trisaccharide was synthesised by glycosylation of a protected glucosyl acceptor with a rhamnose trichloroacetimidate followed by chain extension with a second rhamnose trichloroacetimidate. Allyl glycoside deprotection followed by glycosyl bromide formation provided the key donor for esterification to yield the protected lablaboside F. Global deprotection furnished synthetic lablaboside F which provided spectroscopic data in full agreement with that of the material derived from the natural source. Biological evaluation of synthetic lablaboside F is currently being undertaken and results will be presented.

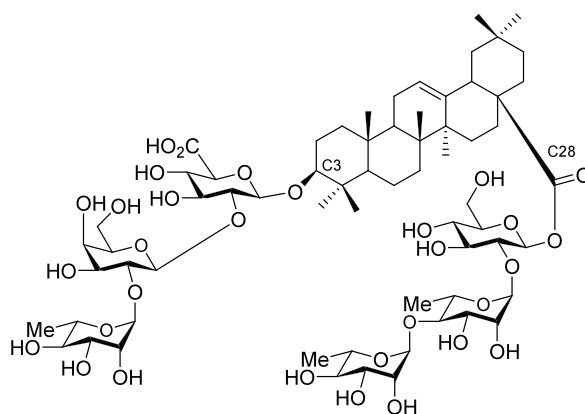
**Lablaboside F****References**

1. H. Komastu, T. Murakami, H. Matsuda and M. Yoshikawa; *Heterocycles*; **1998**, 48, 703.
2. K. Oda, H. Matsuda, T. Murakami, S. Katayama, T. Ohgigani and M. Yoshikawa; *Biol. Chem.*; **2000**, 381, 67.

PO 344

**ENZYME-CATALYZED HYDROLYSIS OF THE POLYSACCHARIDES  
FROM *STERCULIA URENS* AND *STERCULIA LYCHNOPHORA***

Mozhgan Torabi<sup>1</sup>, Maryam Amiri<sup>1</sup>, Renate Loeppert<sup>2</sup>, Werner. Praznik<sup>2</sup>, Helmut Viernstein<sup>1</sup>,  
Frank M. Unger<sup>1</sup>

<sup>1</sup>*Department of Pharmaceutical Technology and Biopharmaceutics, University of Vienna,  
Faculty of Life Sciences, Althanstrasse 14, A-1090 Vienna, Austria*

<sup>2</sup>*Department of Chemistry, University of Natural Resources and Applied Life Sciences, University  
of Vienna, Muthgasse 18, A-1190 Vienna, Austria  
mozhgan.torabi@univie.ac.at*

Polysaccharides from deacetylated *Sterculia urens* (karaya) gum and from *Sterculia lychnophora* seeds are similar, irregular polysaccharides. The *Sterculia urens* polysaccharide<sup>1</sup> contains residues of glucuronic acid, galacturonic acid, galactose and rhamnose, while the *Sterculia lychnophora* polysaccharide is composed of galacturonic acid, rhamnose, arabinose and galactose with minor amounts of glucose and xylose. Structure elucidation of such polysaccharides requires the hydrolytic generation of oligosaccharides for detailed methylation analysis, mass spectrometry and NMR spectroscopy. Studies of enzyme action (pectinases, cellulases, hemicellulases, etc.) have been performed on the two native (alkali – treated) polysaccharides and on the two carboxyl – reduced<sup>2</sup> polysaccharides. Enzyme-catalyzed hydrolysis of the carboxyl-reduced polysaccharides was found to result in a higher yield of oligosaccharides than the same treatment of the solely alkali treated ones. Discovery of suitable endoglycosidase enzymes is expected to provide an environment friendly approach to the production of oligosaccharides for nutritional and pharmaceutical use.

**References**

1. G. O. Aspinall, Nasir-ud-din, *J Chem Soc*, **1965**, 2710 - 2720.
2. G. O. Aspinall, G. R. Sanderson, *J Chem Soc*, **1970**, 2259 – 2264.

PO 345

**MACROMOLECULAR PROPERTY OF TAMARIND SEED POLYSACCHARIDE ASSOCIATED WITH HYALURONIC ACID**Giangiaco Torri,<sup>1</sup> Davide Paganini,<sup>1</sup> Marco Sansò,<sup>2</sup> Andrea Giori,<sup>3</sup> and Sabrina Bertini<sup>1</sup><sup>1</sup>Ronzoni Institute, via G. Colombo 81, Milan, Italy,<sup>2</sup>FARMIGEA S.p.A, via G.B.Oliva, 6, Pisa, Italy,<sup>3</sup> R&D Centre, Indena S.p.A., via D. Minzoni, 6, Settala (Milan), Italy

torri@ronzoni.it

Tamarind seed polysaccharide (TSP) xyloglucan is stored in the seed of *Tamarindus indica*. The primary structure of TSP consists of a (1→4)-β-D-glucan spine with (1→6)-α-branched xylose, which is partially substituted by (1→2)-β-galacto-xylose. It is characterized by high viscosity, broad pH tolerance and adhesivity. Such properties led to its application as stabilizer, thickener, gelling agent and binder in the food and pharmaceutical products. Other important properties of TSP have been recently identified. These include non-carcinogenicity, mucoadhesivity, biocompatibility and high drug holding capacity. Hyaluronic acid (HA), an anionic biodegradable glycosaminoglycan, is used for formulations of hydrogels in the biomedical field and the major disadvantages of the commercially available HA formulations are their low stability and fast degradability. In order to overcome this problem HA/TSP mixtures were prepared and the present study was undertaken to highlight the chemical-physical property of HA/TSP mixtures by Low Resolution NMR spectroscopy technique. In particular, the measurement of NMR proton relaxation parameters T1 and T2 showed that between HA and TSP there is a strong cooperative interaction that influenced the amount of water that interacted with polysaccharides. Moreover, to evaluate the stability of TSP and HA we performed selectivity enzymatic degradations of HA and TSP to compare the kinetics of hydrolyses of polysaccharides alone or in mixture. To evaluate the enzymatic activity we followed the decrease of molecular weight by high performance size exclusion chromatography and we demonstrated that the stability of TSP/HA mixtures was superior to those of pure polysaccharides.

PO 346

**GLYCOPYRANOSYLIDENE-SPIRO-ISOXAZOLINES AS  
GLYCOGEN PHOSPHORYLASE INHIBITORS**

Marietta Tóth,<sup>1</sup> Bálint Kónya,<sup>1</sup> David Goyard,<sup>2</sup> László Kulcsár,<sup>1</sup> Ravindra R. Kamble,<sup>1</sup>  
Sébastien Vidal,<sup>2</sup> Aikaterini S. Chajistamatiou,<sup>3</sup> Evangelia D. Chrysina,<sup>3</sup> Jean-Pierre Praly,<sup>2</sup>  
László Somsák<sup>1</sup>

<sup>1</sup>Department of Organic Chemistry, University of Debrecen, POB 20, H-4010 Debrecen, Hungary

<sup>2</sup>Laboratoire de Chimie Organique 2 - Glycochimie, Université de Lyon, Institut de Chimie et Biochimie Moléculaires et Supramoléculaires associé au CNRS, UMR 5246, Bâtiment Curien, 43 boulevard du 11 Novembre 1918, F-69622 Villeurbanne, France

<sup>3</sup>The National Hellenic Research Foundation, Institute of Organic & Pharmaceutical Chemistry, 48 Vassileos Constantinou Avenue 116 35 Athens, Greece  
somsak.laszlo@science.unideb.hu, jean-pierre.praly@univ-lyon1.fr, echrysina@eie.gr

In the search for new possibilities to treat type 2 diabetes, inhibition of glycogen phosphorylase (GP), the main regulatory enzyme of glycogen degradation, has become a validated approach. Glucopyranosylidene-spiro-isoxazolines<sup>1</sup> **1a-d** are among the most effective glucose analogue inhibitors of GP.<sup>2</sup> The good inhibition is mainly due to the presence of large aryl group which makes favourable contacts in the so called  $\beta$ -pocket of the enzyme. In order to further study the effect of the aryl moiety a series of hetaryl substituted spiro-isoxazolines were synthesized and the effect of changing the sugar configuration was also studied. In the presentation details of the syntheses and preliminary enzyme kinetic results will be shown.

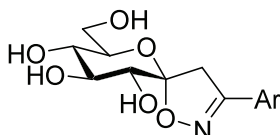

**1a** Ar = 4-OMe-Ph ( $K_i$  = 6.6  $\mu$ M)

**1b** Ar = 4-Me-Ph ( $K_i$  = 7.9  $\mu$ M)

**1c** Ar = Ph ( $K_i$  = 19.6  $\mu$ M)

**1d** Ar = 2-Naphth ( $K_i$  = 0.63  $\mu$ M)

### References

1. M. Benlifa, J. M. Hayes, S. Vidal, D. Gueyrard, P. G. Goekjian, J.-P. Praly, G. Kizilis, C. Tiraidis, K.-M. Alexacou, E. D. Chrysina, S. E. Zographos, D. D. Leonidas, G. Archontis, Nikos G. Oikonomakos, *Bioorg. Med. Chem.*, **2009**, *17*, 7368–7380.
2. L. Somsák, K. Czifrák, M. Tóth, É. Bokor, E. D. Chrysina, K.-M. Alexacou, J. M. Hales, E. Lazoura, D. D. Leonidas, E. S. Zographos, N. G. Oikonomakos, *Curr. Med. Chem.* **2008**, *15*, 2933–2983.

This research was carried out in the frame of collaborative programs supported by the French CNRS and Hungarian Academy of Sciences (PICS project n°4576) and ANR (GPdia project), Hungarian Scientific Research Fund (OTKA CK77712, CNK80709), TÁMOP-4.2.1./B-09/1/KONV-2010-0007, TÁMOP-4.2.2-08/1-2008-0014 projects implemented through the New Hungary Development Plan, co-financed by the European Social Fund, and by the FP7 Capacities coordination and support actions REGPOT-2008-1-No 230146 ‘EUROSTRUCT’ and REGPOT-2009-1-No 245866 ‘ARCADE’.



PO 347

**ENZYMATIC GLYCOSYLATION OF OLIVE OIL ANTIOXIDANT BIOPHENOLS BY MARINE  $\alpha$ -D-GLUCOSIDASE FROM *APLYSIA FASCIATA***Annabella Tramice<sup>1</sup>, Antonio Trincone<sup>1</sup> and Eduardo Pagnotta<sup>1</sup>

<sup>1</sup>*Biomolecular Chemistry Institute of National Research Council of Italy,  
Via Campi Flegrei 34, 80072 Pozzuoli, Naples, Italy  
atramice@icb.cnr.it*

There is growing interest in novel sources of natural antioxidants, due to the recognized involvement of reactive oxygen species in the onset of several human diseases<sup>1</sup> and in the oxidative degradation of food, animal feed, and other goods such as cosmetics<sup>2</sup>.

Olives and olive oil contain phenolic compounds that, *in vitro*, have been shown to exert potent biological activities including, but not limited to, antioxidant actions<sup>3</sup>.

The biophenolic fraction of olive oil comprises only 2% of the total phenolic content of the olive fruits, with the remaining 98% being lost in olive mill waste (OMW). Thus, OMW is also potentially a rich source of a diverse range of biophenols with a wide array of biological activities<sup>4</sup>.

Polyphenols in vegetable oils are a complex mixture of compounds, that include oleuropein, 4-hydroxyphenylethanol (tyrosol), 3,4-dihydroxy-phenylethanol (hydroxytyrosol), 4-hydroxyphenylacetic acid, protocatechuic acid, syringic acid, vanillic acid, caffeic acid, p-coumaric acid, and sinapic acid. Among them, we focused our attention on the most abundant tyrosol and hydroxytyrosol. If tyrosol shows mild antioxidant properties<sup>5</sup>, on the contrary, hydroxytyrosol, which is the most active component of OMW extract, is known to possess strong antioxidant scavenging abilities<sup>6</sup>, together with and antithrombotic activities such as inhibition of LDL oxidation, platelet aggregation and endothelial cell activation properties.

Here we present a new synthetic strategy for the production of mono- and oligosaccharidic derivatives of tyrosol and hydroxytyrosol, performed by the  $\alpha$ -D-glucosidase from the sea hare *Aplysia fasciata*<sup>7</sup>. A subsequent oxidation of glycosylated products, using commercial mushroom tyrosinase<sup>8</sup>, allowed us to produce the corresponding hydroxytyrosol saccharidic derivatives; their antioxidant activities were evaluated by DPPH test and compared with that of hydroxytyrosol.

**References**

1. Aruoma, O. I., *J. Am. Oil Chem. Soc.*, **1998**, 75, 199-212.
2. Aruoma, O. I., *Int. News Fats, Oils Relat. Mater.*, **1997**, 8, 1236-1242.
3. Visioli, F., Galli, C., *J. Agric. Food Chem.*, **1998**, 46, 4292-4296
4. Rodis, P. S., Karathanos, V. T., Mantzavinou, A., *J. Agric. Food Chem.*, **2002**, 50, 596-601.
5. Visioli, F., Bellomo, G., Montedoro, G., Galli, C., *Atherosclerosis*, **1995**, 117, 25-32.
6. O'Dowd, Y., Driss, F., My-Chan Dang, P., Elbim, C., Gougerot-Pocidallo, M. A., Pasquier, C., El-Benna J., *Biochemical Pharmacology*, **2004**, 68, 2003-2008.
7. Andreotti, G., Giordano, A., Tramice, A., Mollo, E., Trincone, A., *J Biotechnol*, **2006**, 122, 23, 274-284.
8. Espín, J. C., Soler-Rivas, C., Cantos, E., Tomás-Barbern F. A., Wichers, H. J., *J. Agric. Food Chem.*, **2001**, 49, 1187-1193.

PO 348

**MECHANISMS INVOLVED DURING THE ULTRASONICALLY INDUCED  
DEPOLYMERIZATION OF CHITOSAN AND HYALURONIC ACID  
IN AQUEOUS SOLUTIONS**Jorge A. de M. Delezuk<sup>1,2</sup>, Stéphane Trombotto<sup>2</sup>, Sérgio P. Campana-Filho<sup>1</sup>, Laurent David<sup>2</sup><sup>1</sup> *Laboratório de Físico-Química Orgânica, Instituto de Química de São Carlos,  
Universidade de São Paulo, São Carlos, Brasil.*<sup>2</sup> *Ingénierie des Matériaux Polymères (UMR 5223), Université de Lyon 1, Villeurbanne, France.  
stephane.trombotto@univ-lyon1.fr*

Polysaccharide-based multifunctional materials find a continuous and growing interest in food, cosmetics and biomaterial fields. Among polysaccharides, chitosan and hyaluronic acid show a remarkable potential for their physical and biological properties.<sup>1</sup> In order to control and identify their specific properties, a key strategy is to produce tailor-made polymer/oligomer series of varying degrees of polymerization (*DP*) with a low polydispersity index (*Ip*).<sup>2,3</sup>

Among the methods reported to produce chitosans and hyaluronic acids of adjusted molecular weight down to oligomers, chemical hydrolysis and enzymatic treatments are frequently proposed.<sup>3</sup> However, all these methods require a systematic purification of the resulting products due to the presence of additives used to initiate the reactions of depolymerization. Moreover, the obtained low molecular weight polymers or oligomers show a rather large polydispersity. As a result, the depolymerization induced by ultrasounds was considered as an interesting alternative.<sup>4,5</sup>

In the present work, we report on an experimental study of the ultrasound treatment of chitosan and hyaluronic acid in aqueous solutions, highlighting the main parameters influencing the depolymerization kinetics. First, the results enable the identification of two mechanisms involved during the reaction. Their modelling allows us to obtain chitosan and hyaluronic acid chains of precise degree of polymerization and low polydispersity or, alternately, a pure collection of corresponding oligosaccharides with a large polydispersity. Moreover, using a “master curve” approach, a general law of the evolution of the molecular weight during the depolymerization is proposed. This law can be used for the production of polymers with controlled degrees of polymerization in various experimental conditions, and is conjectured to be applicable to other polysaccharide polyelectrolyte solutions.

**References**

1. Suh, J.K.F. ; Matthew, H.W.T. *Biomaterials*, **2000**, *21*, 2589-2598.
2. Lamarque, G. ; Lucas, J.-M. ; Viton, C. ; Domard, A. *Biomacromolecules*, **2005**, *6*, 131-142.
3. Trombotto, S. ; Ladavière, C. ; Delolme, F. ; Domard, A. *Biomacromolecules*, **2008**, *9*, 1731-1738.
4. Barreto Cardoso, M. ; Signini, R. ; Campana-Filho, S.P. *Polymer Bulletin* **2001**, *47*, 183-190.
5. Popa-Nita, S. ; Lucas, J.-M. ; Ladavière, C. ; David, L. ; Domard, A. *Biomacromolecules* **2009**, *10*, 1203-1211.

PO 349

**DETERMINATION OF THE DEGREE OF N-ACETYLATION OF CHITOSAN  
BY <sup>1</sup>H NMR SPECTROSCOPY: A COMPARATIVE STUDY**

Stéphane Trombotto

*Ingénierie des Matériaux Polymères (UMR 5223), Université Lyon 1, Villeurbanne, France.  
stephane.trombotto@univ-lyon1.fr*

Chitosan is a linear copolymer of (1→4)-linked 2-acetamido-2-deoxy-β-D-glucopyranose (GlcNAc) and 2-amino-2-deoxy-β-D-glucopyranose (GlcN) units in varying proportions (Figure 1). This polysaccharide is produced industrially by chemical *N*-deacetylation of chitin, the most naturally occurring polymer, mainly present in the cuticles of arthropods. Recently, chitosan has received considerable attention as a functional biopolymer with a wide range of applications in food, agriculture, medicine, pharmaceuticals and cosmetics, taking advantage of its various interesting physicochemical and biological properties.<sup>1</sup>

The degree of *N*-acetylation (DA) of chitosan is an important characterization parameter since the charge density of the chitosan molecule is responsible for potential biological and functional effects. The DA is defined as the molar fraction of GlcNAc units in the polymer chain.

Liquid phase <sup>1</sup>H NMR spectroscopy is a very suitable method for the determination of the DA of chitosan. Several studies have reported on the NMR determination of chemical composition and sequential arrangement of monomer units in chitosan.<sup>2</sup> This technique is found to be fast, precise, reproducible, rugged, robust, stable and requires only a small amount of chitosan.

In this work, a comparative study of the determination of the DA of various chitosan samples is described involving a routine method developed in our lab and two main standard test methods published in the literature for the use of chitosan in biomedical and pharmaceutical applications.<sup>3</sup>

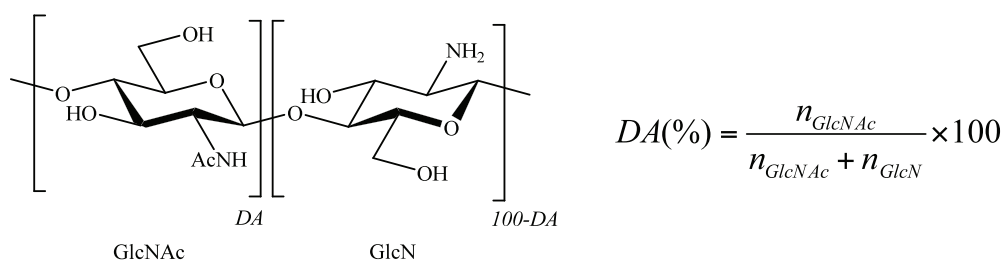

**Figure 1** : Chemical structure of chitosan

### References

1. Rinaudo, M. *Prog. Polym. Sci.* **2006**, *31*, 603-632.
2. Lavertu, M.; Xia, Z.; Serreqi, A.N.; Berrada, M.; Rodriguez, A.; Wang, D.; Buschmann, M.D.; Gupta, A. *J. Pharm. Biomed. Anal.* **2003**, *32*, 1149-1158.
3. (a) ASTM F2260 – 03 (2008) Standard Test Method for Determining Degree of Deacetylation in Chitosan Salts by Proton Nuclear Magnetic Resonance (<sup>1</sup>H NMR) Spectroscopy ; (b) *Pharmaceut. Forum* **2009**, *35(1)*, 115.

## PO 350

## SYNTHESIS OF MONOSACCHARIDE-AZOLE CONJUGATES

Māris Turks,<sup>1</sup> Vitālijs Rjabovs,<sup>1</sup> Jeļena Grigorjeva,<sup>1</sup> Jevgeņija Lugiņina,<sup>1</sup> Jevgeņija Mackeviča,<sup>1</sup>  
 Jekaterina Rjabova,<sup>1</sup> Pāvels Ostrovskis,<sup>1</sup> Sergey Belyakov,<sup>2</sup> Antonio J. Moreno Vargas,<sup>3</sup>  
 Inmaculada Robina<sup>3</sup>

<sup>1</sup> Faculty of Material Science and Applied Chemistry, Riga Technical University,  
 Āzenes str. 14/24, Riga, LV-1007, Latvia.

<sup>2</sup> Latvian Institute of Organic Synthesis, 21 Aizkraukles Str, Riga, LV-1006, Latvia,

<sup>3</sup>Department of Organic Chemistry, Faculty of Chemistry, University of Seville Prof. García  
 González 1, 41012 Seville, Spain.

maris\_turks@ktf.rtu.lv

Carbohydrates are recognized as a versatile structural platform for development of biologically active compounds. In recent years oligosaccharides and glycopeptides were described as anti-malarial<sup>1</sup> and anti-cancer vaccine candidates.<sup>2</sup> On the other hand, small molecule carbohydrate-heterocycle conjugates are widely used as enzyme inhibitors.<sup>3</sup>

Herein, we present a synthetic approach to a wide variety of carbohydrate-azole conjugates from common intermediate **1**. Different azole precursors **2**, **3** and **4** are synthesized and then converted to the 1,4-disubstituted 1,2,3-triazoles and 3,5-disubstituted isoxazoles via 1,3-dipolar cycloadditions of terminal alkynes to azides and nitrile oxides, respectively. Biological activities of selected compounds will be reported.

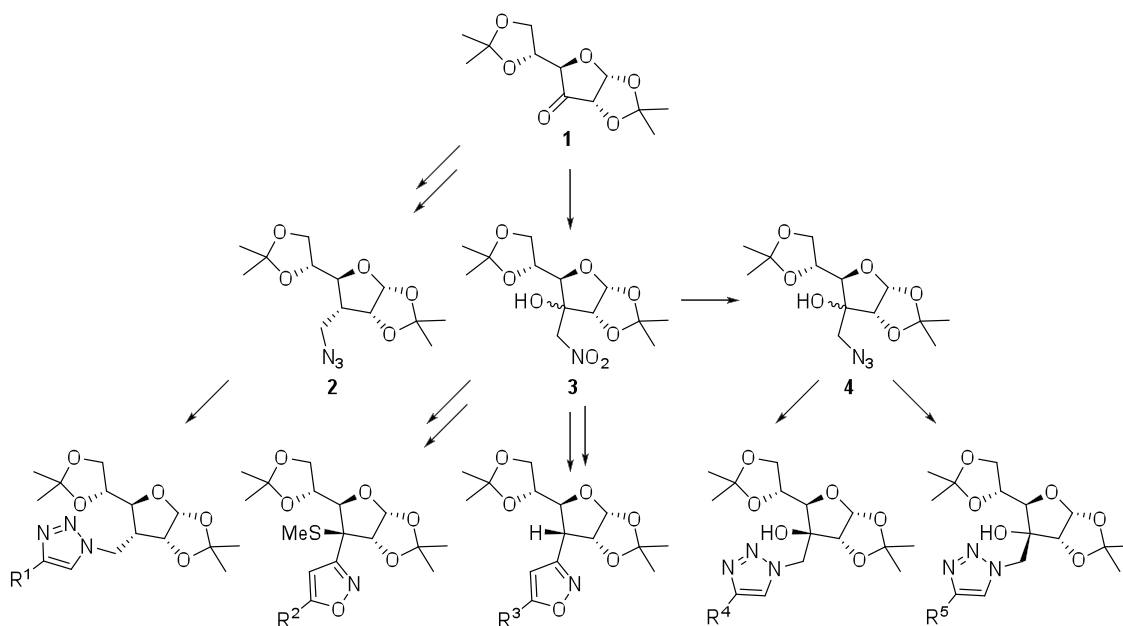

## References

1. Seeberger, P.H.; Werz, D.B. *Nature*, **2007**, *446*, 1046-1051.
2. Brendan L. Wilkinson, B. L.; Day, S.; Malins, L. R.; Apostolopoulos, V.; Payne, R. J. *Angew. Chem. Int. Ed.*, **2011**, *50*, 1635-1639.
3. Ferreira, S. B.; Sodero, A. C. R.; Cardoso, M. F. C.; Lima, E. S.; Kaiser, C. R.; Silva Jr., F. P.; Ferreira, V. F. *J. Med. Chem.* **2010**, *53*, 2364-2375.

PO 351

**STRUCTURAL STUDIES OF THE O-SPECIFIC POLYSACCHARIDE  
OF *AEROMONAS VERONII* BV. *SOBRIA* LIPOPOLYSACCHARIDE**

Anna Turska-Szewczuk,<sup>1</sup> Hubert Pietras,<sup>1</sup> Małgorzata Gęca,<sup>1</sup> Adam Choma<sup>1</sup> and Otto Holst<sup>2</sup>

<sup>1</sup>*Department of Genetics and Microbiology, M. Curie-Skłodowska University,  
Akademicka 19, 20-033 Lublin, Poland*

<sup>2</sup>*Division of Structural Biochemistry, Research Center Borstel,  
Leibniz-Center for Medicine and Biosciences, Parkallee 4a/c, 23845 Borstel, Germany,  
aturska@hektor.umcs.lublin.pl*

*Aeromonas* are ubiquitous water-borne bacteria especially known as important fish pathogens. They cause chronic disease with skin ulceration or acute systemic infection described as motile aeromonad septicemia. A number of potential virulence factors for *Aeromonas* pathogenesis have previously been identified, including polar flagella, pili, surface layer proteins, and lipopolysaccharide (LPS).<sup>1</sup> Taxonomic studies have revealed that diseases, and thus losses, in commercial polish aquacultures of carp and trout<sup>2</sup> have mostly been caused by strains within *A. veronii* bv. *sobria* genomospecies and thus have an important role in the pathology of farmed fish. Sugar analysis of the O-specific polysaccharide (OPS) isolated from LPS of *A. veronii* bv. *sobria* strain K49 showed the presence of L-rhamnose (L-Rha), 3-amino-3,6-dideoxy-D-glucose (D-Qui3N), and 2-amino-2,6-dideoxy-D-galactose (D-FucN) residues. GLC-MS analysis of the partially methylated monosaccharides resulted in the identification of 3-substituted Rha<sub>p</sub>, and 2-substituted Rha<sub>p</sub>, 2-substituted Qui3N, and 3-substituted Fuc<sub>p</sub>N. The spin systems for five monosaccharides, i.e. two α-Rha residues and one each of β-Rha, α-FucN, and β-Qui3N were identified on the basis of the <sup>1</sup>H and <sup>13</sup>C chemical shifts and the coupling constant values, and those of amino sugars were confirmed by correlations revealed by the <sup>1</sup>H,<sup>13</sup>C HSQC experiment. The <sup>13</sup>C NMR spectrum of the studied OPS contained signals for five anomeric carbons at δ 96.32, 103.07, 103.40, 105.23 and 103.67, two nitrogen-bearing carbons (FucN C-2, and Qui3N C-3) at δ 48.77 and 56.77, several methyl groups of 6-deoxysugars (Rha, FucN and Qui3N), and two N-acetyl groups (CH<sub>3</sub>, at δ 23.2 and CO group at δ 175.04). In the NOESY spectrum of the K49 OPS the following strong NOE contacts were observed: α-FucN H-1 (A), β-Qui3N H-2 (D) (δ 5.63/3.47); β-Qui3N H-1 (D), α-Rha H-3 (B) (δ 4.89/3.96); α-Rha H-1 (B), α-Rha H-3 (C), (δ 5.02/3.87); α-Rha H-1 (C), β-Rha H-2 (E), (δ 4.98/3.86), and β-Rha H-1 (E), α-FucN H-3 (A), (δ 4.78/3.67). These data enabled determination of the linkage position and the sequence of the sugar residues in the repeating unit

→3)-α-D-Fuc<sub>p</sub>Nac<sup>A</sup>-(1→2)-β-D-Quip<sub>3</sub>Nac<sup>D</sup>-(1→3)-α-L-Rhap<sup>B</sup>-(1→3)-α-L-Rhap<sup>C</sup>(1→2)-β-L-Rhap<sup>E</sup>-(1→

### References

1. Cipriano R. C. *Fish Disease Leaflet*, **2001**, 68, 1-25.
2. Kozińska A, Pękała A. *Bull Vet Inst Pulawy*, **2010**, 54, 315-320.

## PO 352

## NEW ANTI-MALARIAL DRUGS TARGETING PURINE SALVAGE PATHWAYS

Keith Clinch,<sup>1</sup> Douglas R Crump,<sup>1</sup> Gary B Evans,<sup>1</sup> Keith Hazleton,<sup>2</sup> Vern L Schramm,<sup>2</sup>  
and Peter C Tyler<sup>1</sup>

<sup>1</sup>*Industrial Research Ltd, P O Box 31310, Lower Hutt, New Zealand,*

<sup>2</sup>*Albert Einstein College of Medicine, Bronx, New York.*

*p.tyler@irl.cri.nz*

Malaria has probably infected humans for over 50,000 years.<sup>1</sup> The disease is caused by a mosquito-borne parasite and currently there are ~ 250 million cases per year with about 1 million deaths – mostly children. The development of resistance to anti-malarial drugs has increased the importance of the discovery of new drugs and new drug targets.<sup>2</sup>

The malaria parasite is unable to biosynthesize its own purines and relies on salvage enzymes to harvest purines from the host. We have validated the salvage enzyme purine nucleoside phosphorylase (PNP) as a malarial drug target and have shown that a PNP inhibitor will cure *Plasmodium falciparum* infections in monkeys.

Here we present results on the design and synthesis of transition state analogue inhibitors of another purine salvage enzyme, hypoxanthine-guanine-xanthine phosphoribosyltransferase (HGXPRTase) which is expected to be essential for parasite survival. We have discovered some simple phosphonic acid derivatives that are potent and selective inhibitors of the *Plasmodium falciparum* HGXPRTase. A novel pro-drug approach will also be presented which has allowed the development of compounds that kill the parasite in infected red blood cells.

### References

1. D.A. Joy, X. Feng, J. Mu, T. Furuya, K. Chotivanich, A.U. Krettli, M. Ho, A. Wang, N.J. White, E. Suh, P. Beerli and X-Z Su, *Science*, **2003**, *300*, 318-321.
2. H. Noedl, Y. Se, K. Schaecher, B.L. Smith, D. Socheat, and M.M. Fukuda, *N. Engl. J. Med.* **2008**, *359*, 2619-2620.



## PO 353

**A NOVEL-CLOD ADAPTED CELLULASE COMPLEX FROM *EISENIA FOETIDA*:  
CHARACTERIZATION OF A MULTIENZYME COMPLEX  
WITH CARBOXYMETHYLCELLULASE,  $\beta$ -GLUCOSIDASE,  $\beta$ -1, 3 GLUCANASE, AND  
 $\beta$ -XYLOSIDASE**

Mitsuhiro Ueda<sup>1</sup>, Takahiro Goto<sup>1</sup>, Masami Nakazawa<sup>1</sup>, Kazutaka Miyatake<sup>1</sup>,  
Minoru Sakaguchi<sup>2</sup>, Kuniyo Inouye<sup>3</sup>

<sup>1</sup>Graduate School of Life and Environmental Sciences, Osaka Prefecture University,  
Sakai, Osaka, 599-8531, Japan,

<sup>2</sup>Laboratory of Cell Biology, Osaka University of Pharmaceutical Sciences, 4-20-1  
Nasahara, Takatsuki, Osaka 569-1094, Japan,

<sup>3</sup>Division of Food Science and Biotechnology, Graduate School of Agriculture,  
Kyoto University, Sakyo-ku, Kyoto 606-8502, Japan.  
mueda@biochem.osakafu-u.ac.jp

In our screening program for glycoside hydrolases, we have found high cellulolytic activity in the body wall extract of the earthworm *Eisenia foetida*. Interestingly, the activity is active even at lower temperature as 15°C. Previously, we have studied cold-adapted raw starch-digesting amylases from the cell-free extract of *E. foetida*<sup>1</sup>. It is of interest that a protein with anti-plant viral activity has been found in the same crude extract that exhibits protease activity at lower temperatures<sup>2</sup>. *Clostridium* sp. and some bacterial cellulases exist as an enzyme complex with cellulolytic, and hemicellulolytic enzymes, so called “cellulosome”. In this article, we report that *E. foetida* carboxymethylcellulase (EF-CMCase25) occurs as a complex with  $\beta$ -glucosidase,  $\beta$ -1,3 glucanase, and  $\beta$ -xylosidase<sup>3</sup>. The multienzyme complex had a molecular mass 150 kDa on gel filtration under non-reducing condition. After the gel filtration, the enzyme complex was purified to homogeneous state on blue-native page. The SDS-PAGE demonstrated that the purified protein is a complex with at least one CMCase (25 kDa), one  $\beta$ -glucosidase (32 kDa), and one  $\beta$ -1,3 glucanase (40 kDa) components. The CMCase activity in the purified enzyme complex at 15°C was 44% of that obtained at the optimal temperature. The reaction products from degradation of carboxymethyl cellulose (CMC) by the purified enzyme complex were determined to be glucose, cellobiose, cellotriose, and cellooligosaccharides of higher degree of polymerization (DP) by thin-layer chromatography.

### References

1. Ueda M., Asano T., Nakazawa M., Miyatake K., Inouye K. Comp. Biochem. Physiol. Part B, **2008**, *150*, 125-130.
2. Ueda M., Noda K., Nakazawa M., Miyatake K., Sakaguchi M., Inouye K. Comp. Biochem. Physiol. Part B, **2008**, *151*, 381-385
3. Ueda M., Goto T., Nakazawa M., Miyatake K., Sakaguchi M., Inouye K. Comp. Biochem. Physiol. Part B, **2010**, *157*, 26-32.

PO 354

MILD AND REGIOSELECTIVE O-DEBENZYLATION OF SACCHARIDES  
VIA A RADICAL PROCESSAngie Attouche,<sup>1</sup> Dominique Urban,<sup>1</sup> and Jean-Marie Beau<sup>1</sup>

<sup>1</sup>*Institut de Chimie Moléculaire et Macromoléculaire d'Orsay, Université Paris Sud 11  
Laboratoire de Synthèse de Biomolécules, UMR CNRS 8182, F-91405 Orsay cedex  
dominique.urban@u-psud.fr*

The synthesis of biologically active molecules from carbohydrates derivatives requires the preparation of suitably protected monomers. The one-pot regioselective protection of hydroxyl groups represents an important strategy for the preparation of these molecules.<sup>1</sup> However, the selective deprotection of this function could represent an interesting alternative method.

The benzyl ether is one of the most widely used protecting group due to its easy formation, stability under various conditions and the numerous deprotection methods. Hence, several methods of *O*-debenzylation of perbenzylated saccharides<sup>2</sup> were reported in the literature. Most of these approaches are however incompatible with thioglycosides<sup>3</sup> which represent a major building block in oligosaccharides synthesis.

We report here a new radical reaction for an efficient selective *O*-debenzylation, which is based on an intramolecular hydrogen transfer.

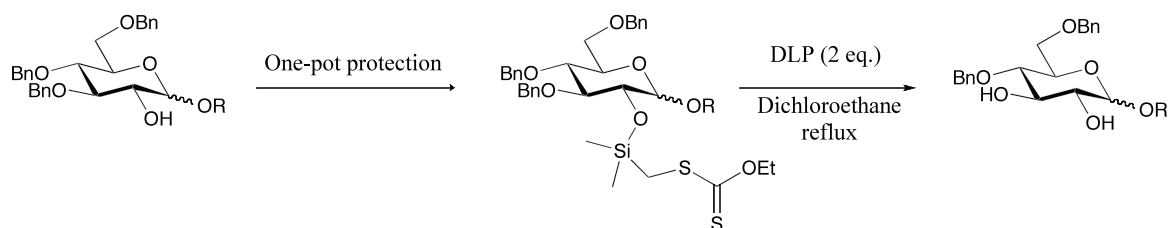

This methodology was successfully applied to a wide range of protected mono and disaccharides with various anomeric protecting groups.

**References**

1. (a) A. Français, D. Urban, J.-M. Beau, *Angew. Chem. Int. Ed.*, **2007**, *46*, 8662-8665; (b) Y. Bourdreux, A. Lemétais, D. Urban, J.-M. Beau, *Chem. Commun.*, **2011**, *47*, 2146-2148.
2. (a) Z.-J. Yin, B. Wang, Y.-B. Li, X.-B. Meng, Z.-J. Li, *Org. Lett.*, **2010**, *12*, 536-539; (b) T. Lecourt, A. Herault, A.J. Pearce, M. Sollogoub, P. Sinaÿ, *Chem. Eur. J.*, **2004**, *10*, 2960-2971.
3. A. Brar, Y. D. Vankar, *Tetrahedron Lett.*, **2006**, *47*, 5207-5210.

PO 355

**STRUCTURE DETERMINATION OF *STREPTOCOCCUS SUIIS*  
TYPE 14 CAPSULAR POLYSACCHARIDE**

Marie-Rose Van Calsteren,<sup>1,2</sup> Fleur Gagnon,<sup>1</sup> Cynthia Calzas,<sup>2,3</sup> Guillaume Goyette-Desjardins,<sup>2,3</sup>  
Masatoshi Okura,<sup>4</sup> Daisuke Takamatsu,<sup>4,5</sup> Marcelo Gottschalk,<sup>2,3</sup> and Mariela Segura<sup>2,3</sup>

<sup>1</sup>Centre de recherche et de développement sur les aliments, Agriculture et Agroalimentaire Canada,  
Saint-Hyacinthe, Québec J2S 8E3, Canada,

<sup>2</sup>Centre de recherche en infectiologie porcine (CRIP) and

<sup>3</sup>Groupe de recherche sur les maladies infectieuses du porc (GREMIP), Faculté de médecine  
vétérinaire, Université de Montréal, Saint-Hyacinthe, Québec J2S 7C6, Canada,

<sup>4</sup>Research Team for Bacterial/Parasitic Diseases, National Institute of Animal Health, National  
Agriculture and Food Research Organization, Tsukuba, Ibaraki 305-0856, Japan,

<sup>5</sup>United Graduate School of Veterinary Sciences, Gifu University, Gifu 501-1193, Japan  
Marie-Rose.VanCalsteren@AGR.GC.CA

*Streptococcus suis* is an important swine and emerging zoonotic pathogen. Of the 35 capsular types described, *S. suis* types 2 and 14 are both considered important human threats. So far, only type 2 capsular polysaccharide (CPS) has been structurally characterized by our team.<sup>1</sup>

To determine the structure of *S. suis* type 14 CPS, reference strain DAN 13730 was grown in Todd-Hewitt broth, cells were harvested, and the capsule was released by autoclaving. The purified CPS was obtained after extraction, precipitation, and gel filtration as described previously.<sup>1</sup>

The *Sambucus nigra* lectin, which recognizes the Neu5Ac(α2-6)Gal/GalNAc sequence, showed binding to the native CPS. Sugar and absolute configuration analyses gave 3:1:1:1 for D-Gal, D-Glc, D-GlcN, and Neu. After mild acid hydrolysis of the native CPS, <sup>1</sup>H NMR revealed that the resulting polysaccharide had only lost the sialic acid residue, confirming its terminal location. Methylation analysis of the desialylated polysaccharide indicated the presence of terminal Gal, 4-linked Glc, 3-linked Gal, 3,6-linked Gal, and 4-linked GlcN. <sup>1</sup>H and <sup>13</sup>C NMR data of the desialylated and native polysaccharides are consistent with the following hexasaccharide repeating unit for the CPS:

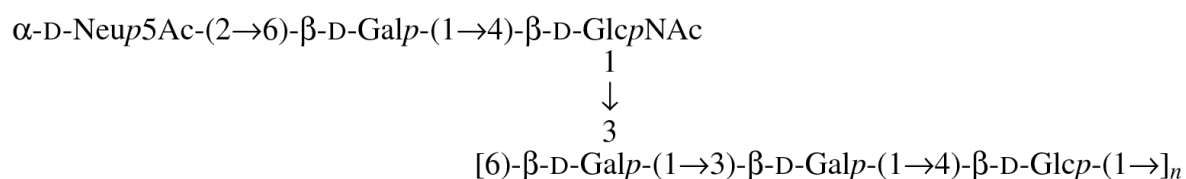

A correlation was tentatively established between this CPS structure and the genes encoding glycosyltransferases and polymerase responsible for its biosynthesis. Finally, the structure was compared with that of CPSs from *S. suis* type 2 and other pathogenic streptococcal antigens.

### References

1. Van Calsteren, M.-R., Gagnon, F., Lacouture, S., Fittipaldi, N., Gottschalk, M., *Biochemistry and Cell Biology*, **2010**, 88, 513–525.

PO 356

**PIPERIDINE AND PYRROLIDINE ALKALOIDS AS POTENTIAL AND SELECTIVE INHIBITORS FOR THE ENZYMES RESPONSIBLE FOR THE METABOLISM OF GLUCOCEREBROSIDE**

Richard JBHN van den Berg,<sup>1</sup> Amar Ghisaidoobe,<sup>1</sup> Adrianus MCH van den Nieuwendijk,<sup>1</sup>  
Tom Wennekes,<sup>1</sup> Wilma E. Donker,<sup>2</sup> Anneke Strijland,<sup>2</sup> Johannes MFG Aerts,<sup>2</sup>  
Gijs A van der Marel,<sup>1</sup> Herman S. Overkleeft<sup>1</sup>

<sup>1</sup>Leiden Institute of Chemistry, P.O Box 9502, 2300 RA Leiden, The Netherlands,  
<sup>2</sup>Department of Medical Biochemistry, Academic Medical Center, Amsterdam, The Netherlands  
r.j.vdberg@chem.leidenuniv.nl

Glycosphingolipids (GSLs) are essential constituents of cellular membranes of eukaryotic cells. The structure of almost all GSLs is based on the glucocerebroside core. Glucocerebroside is made by the glycosyl transferase glucosylceramide synthase (GCS).<sup>1</sup> GCS is an important target for clinical drug development for the treatment of lysosomal storage disorders such as Gaucher disease and a promising target for combating type 2 diabetes.<sup>2</sup> Small compounds such as Zavesca (**1**) and PDMP **2** which are, supposed partial ceramide mimics, potent and selective inhibitors of GCS<sup>3,4</sup> found their way into the clinics. In our groups *N*-alkylated DNM derivatives **3** and **4** were developed and proved to be highly potent and selective inhibitors for GCS.<sup>2,5</sup> Here we present our first results in the systematic study of combining chemical properties of the four lead compounds **1** - **4**. In library A (48 entries) lead-compounds **1**, **3** and **4** are stripped towards diol and triol derivatives to mimic as closely as possible ceramide. Subject of library B (24 compounds) is the head to head comparison of the aliphatic chain character of leads **1**, **2** and **4**.<sup>6</sup> In library C (39 compounds) from compounds **1**, **2** and **3** DMDP **4** analogues were constructed.

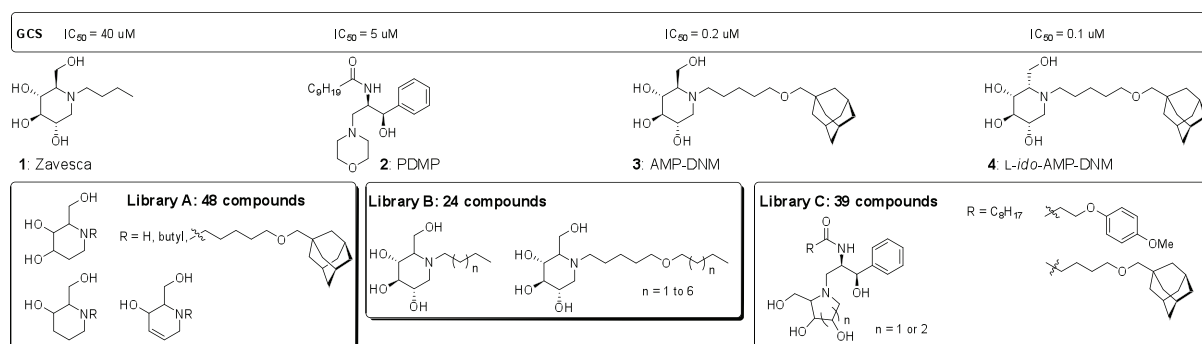

## References

1. Jeckel, D.; et al. *J. Cell. Biol.* **1992**, *117*, 259-267.
2. Aerts, JMFG.; et al. *Diabetes* **2007**, *56*, 1341-1349.
3. Platt, FM.; et al. *J. Biol. Chem.* **1994**, *269*, 8362-8365.
4. Vennum, RR.; et al. *Chem. Phys. Lipids* **1980**, *26*, 265-278.
5. Overkleeft, HS.; et al. *J. Biol. Chem.* **1998**, *273*, 26522-26527.
6. Ghisaidoobe, A.; et al. *ACSMed. Chem Lett.* **2011**, *2*, 119-123.

PO 357

**EXTRACELLULAR POLYSACCHARIDE PRODUCTION  
IN *BACILLUS LICHENIFORMIS* SVD1**J Susan van Dyk, Brett Ivan Pletschke

*Department of Biochemistry, Microbiology and Biotechnology, Rhodes University,  
PO Box 94, Grahamstown, 6140, South Africa.  
B.Pletschke@ru.ac.za*

Based on our previous research, we established that *B. licheniformis* SVD1 produces a multi-enzyme complex (MEC) with mainly hemicellulolytic activity<sup>1,2,3</sup>. This MEC co-purifies with an extracellular polysaccharide (EPS) of 2,000 kDa that is produced by this organism. We are investigating the relationship between EPS and the MEC and whether the MEC is formed by entrapment of enzymes within the polysaccharide matrix, as well as assisting the organism in binding to insoluble biomass, thus bringing the enzymes into close proximity to the substrate and facilitating degradation. Initial work has focused on characterisation of the EPS and it was found that the organism produces EPS with two different molecular weights - 2,000 kDa, as well as a smaller molecular weight ~100-500 kDa as measured using Sepharose 4B size exclusion chromatography. The highest levels of EPS were produced when the organism was cultured on sucrose, although EPS production was also observed on carbon sources such as mannose and glucose. Yeast extract was the best nitrogen source for EPS production. EPS production was observed over time and it was established that cell-associated polysaccharides were present at their highest levels during the log phase of growth, while the highest levels of polysaccharides in the supernatant were detected during stationary phase. Field emission electron microscopy (FESEM) and transmission electron microscopy (TEM) were carried out to observe the characteristics of the EPS in relation to the cells during log phase. Cells were stained with various stains such as 0.15% (w/v) alcian blue and 0.15% (w/v) ruthenium red. The EPS was observed as long fibrils forming a network between cells and attaching cells to one another while knoblike structures also appeared to be present on the cells. Initial structural analysis using TLC and GCMS indicate that the EPS is mainly composed of fructose. Further analysis is being performed using NMR, as well as linkage analysis using GCMS to determine the complete structure of the EPS. Many bacterial polysaccharides are known to have various medical applications, such as immunoregulatory effects, lowering of cholesterol levels and are used as vaccines. Thus, the effect of the purified EPS on immune response (TNF $\alpha$  and IL-6 levels) will be examined.

**References**

1. Van Dyk, JS, Sakka, M, Sakka, K and Pletschke, BI. *Enzyme and Microbial Technology* (2009) 45: 372-378
2. Van Dyk, JS, Sakka, M, Sakka, K and Pletschke, BI. *Enzyme and Microbial Technology* (2010) 47:112-118
3. Van Dyk, JS, Sakka, M, Sakka, K and Pletschke, BI. *Enzyme and Microbial Technology* (2010) 47:174-177

PO 358

## CHEMO-ENZYMATIC SYNTHESIS OF EIGHT 1-DEOXYNOJIRIMICIN ISOMERS FROM A SINGLE CHIRAL CYANOHYDRIN

Adrianus M.C.H. van den Nieuwendijk, Richard J.B.H.N. van den Berg, Martin D. Witte, Johannes Brussee, Gijbert A. van der Marel, Herman S. Overkleeft.

<sup>1</sup>Leiden Institute of Chemistry, Gorlaeus Laboratories, Leiden University,  
P. O. Box 9502, 2300 RA Leiden, The Netherlands.  
nieuwend@chem.leidenuniv.nl

Chiral cyanohydrins have proven their merits as building blocks in modern stereoselective synthesis.<sup>1</sup> In our laboratories cyanohydrin **1**, derived from crotonic aldehyde and HCN

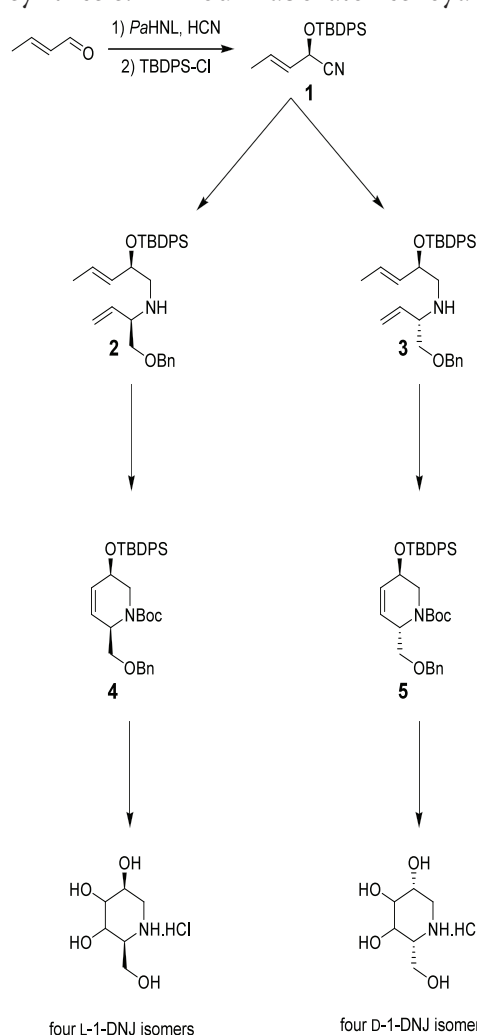

with the aid of a hydroxynitrile lyase from almonds (*PaHNL*),<sup>2</sup> has been applied as starting material on several occasions. Most recently, **1** was used in the enantioselective synthesis of three iminosugars of the 1-deoxynojirimicin (1-DNJ) type,<sup>3</sup> as a part of our ongoing research program regarding the synthesis of iminosugars (and derivatives thereof) in search of new glycosidase inhibitors.<sup>4</sup> We now report on the elaboration of this project to the synthesis of eight 1-deoxynojirimicin isomers from **1**.

The synthesis starts with the conversion of crotonic aldehyde into (*R*)-cyanohydrin **1** using *PaHNL* and HCN, followed by TBDPS-protection. Conversion of **1** via a one-pot *Dibal-H* reduction - *transimination* (employing (*R*)- or (*S*)-*O*-benzylvinylglycinol) - *NaBH<sub>4</sub>* reduction sequence<sup>5</sup> afforded the secondary amines **2** and **3**. Subsequent *N*-protection and Grubb's cyclization gave building blocks **4** and **5** in 72% overall yield from **1**. Dihydroxylation of the double bond in **4** and **5** followed by several manipulations, gave both enantiomers of four different 1-deoxynojirimicin isomers.

## References

1. a) J. Holt, U. Hanefeld, *Curr. Org. Synth.*, **2009**, 6, 15-37. b) M. North, *Tetrahedron: Asymmetry*, **2003**, 14, 147-176.
2. P. Zandbergen, J. van der Linden, J. Brussee, A. van der Gen, *Synth. Commun.*, **1991**, 21, 1387-1391.
3. A.M.C.H. van den Nieuwendijk *et al.*, *Org. Lett.*, **2010**, 12, 3957-3959.
4. T. Wennekes, H.S. Overkleeft, J.M.F.G. Aerts, *Eur. J. Org. Chem.*, **2010**, 1258-1283.
5. P. Zandbergen *et al.*, *Tetrahedron*, **1992**, 48, 3977-3982.



PO 359

**THE AMINOGLYCOSIDES: POTENTIAL ANTIVIRAL AGENTS  
TARGETING HIV RNA SEQUENCES**

Vanhaverbeke Cécile,<sup>1</sup> Baussanne Isabelle,<sup>1</sup> Ennifar Eric,<sup>2</sup>  
Dumas Philippe,<sup>2</sup> and Décout Jean-Luc<sup>1</sup>

<sup>1</sup>Université de Grenoble I/CNRS, UMR 5063, Département de Pharmacochimie Moléculaire,  
ICMG FR2607, France

<sup>2</sup>Architecture et Réactivité de l'ARN, Université de Strasbourg, IBMC CNRS, Strasbourg, France  
Jean-Luc.Decout@ujf-grenoble.fr

Since the discovery of streptomycin in the 1940s, aminoglycosides have enjoyed widespread applications as chemotherapeutic agents in the treatment of many types of bacterial infections, including both Gram-positive and Gram-negative pathogens.<sup>1</sup> Their antibacterial mechanism of action has been shown to be linked to the aminoglycoside molecular interaction with the 16S rRNA subunit of the 30S bacterial ribosome that disturbs protein synthesis.

In the family of the aminoglycosides, neomycin B has also appeared to be able to strongly inhibit the interaction between the HIV-1 TAR RNA and the transactivating protein Tat.<sup>2</sup> However, aminoglycosides have no real antiviral activity.

In the search for new antiviral agents, a small aminoglycoside, neamine, which corresponds in neomycin B to a crucial recognition element for TAR RNA interaction, has been modified selectively on different hydroxyl functions. Several derivatives able to strongly inhibit the TAR-Tat binding with submicromolar concentrations were identified using FRET experiments.<sup>3</sup> Affinity constants for TAR of the inhibiting derivatives also were measured by SPR and microcalorimetry (ITC).

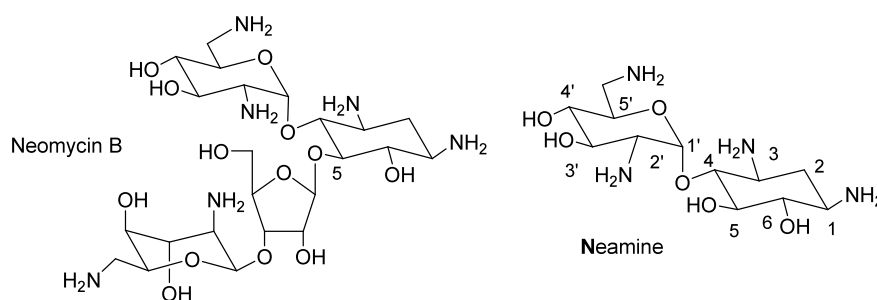
**References**

1. J. Zhou, G. Wang, L.-H. Zhang, X.-S Ye, *Med. Res. Reviews*, **2007**, 27, 279-316.
2. H.-Y. Mei, A. Galan, S. Halim, P. Mack, W. Moreland, B. Sanders, H. N. Truong, A. W. Czamik, *Bioorg. Med. Chem. Lett.*, **1995**, 5, 2755-2760.
3. E. Riguet, J. Désiré, O. Boden, V. Ludwig, M. Göbel, C. Bailly, J.-L. Décout, *Bioorg. Med. Chem. Lett.*, **2005**, 15, 4651-4655.

PO 360

SYNTHESIS AND ANTIMICROBIAL EVALUATION  
OF AMPHIPHILIC NEAMINE DERIVATIVESZimmermann Louis<sup>1</sup>, Baussanne Isabelle<sup>1</sup>, Vanhaverbeke Cécile<sup>1</sup>, Bussière Antoine<sup>1</sup>,  
Ouberai Myriam<sup>2</sup>, Mingeot-Leclercq Marie-Paule<sup>2</sup>, Décout Jean-Luc<sup>1</sup><sup>1</sup>Université de Grenoble I/CNRS, UMR 5063, Département de Pharmacochimie Moléculaire,  
ICMG FR2607, France<sup>2</sup>Université Catholique de Louvain, Louvain Drug Research Institute, LDRI,  
Unité de Pharmacochimie Cellulaire et Moléculaire, FACM, Brussel, Belgium  
Jean-Luc.Decout@ujf-grenoble.fr

Since the discovery of streptomycin in the 1940s, aminoglycosides have enjoyed widespread applications as chemotherapeutic agents in the treatment of many types of bacterial infections, including both Gram-positive and Gram-negative pathogens. Their antibacterial mechanism of action has been shown to be linked to the aminoglycoside molecular interaction with the 16S rRNA subunit of the 30S bacterial ribosome that disturbs protein synthesis. Due to the rapid emergence of resistant bacterial strains and the toxicity of certain antibiotics, it is imperative to discover and develop novel antimicrobial drugs.

In the search for new antibiotics agents, neamine derivatives were prepared through modification of the amino or the hydroxyl functions in order to increase the affinity for rRNA and prevent the activity of aminoglycoside-modifying enzymes. For this purpose, it is necessary to develop short and regioselective methodologies to introduce for example aromatic rings able to improve the affinity for the RNA target, through groove binding and/or stacking<sup>1</sup>.

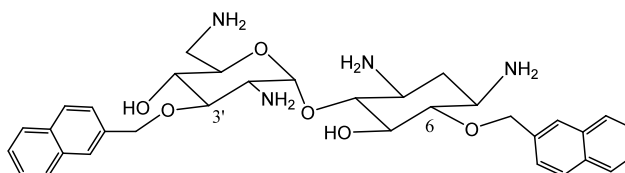

The antibiotic activities of different neamine derivatives were measured on a wild type and resistant cells. Neamine carrying two or three naphthylmethylene groups in position 3', 4' and/or 6 were found to be interesting antibiotic agents against a broad range of Gram (+) and (-) strains surexpressing resistance to aminoglycosides<sup>2</sup>. Mechanistic studies suggest a new mode of action for the aminoglycosides through a membrane destabilization<sup>3</sup>.

**References**

1. E. Riguet, J. Désiré, C. Bailly, J.-L. Decout, *Tetrahedron*, **2004**, 60, 8053-8064.
2. I. Baussanne, A. Bussière, S. Halder, C. Ganem-Elbaz, M. Ouberai, M. Riou, J.-M. Paris, E. Ennifar, M.-P. Mingeot-Leclercq, J.-L. Décout, *J. Med. Chem.*, **2010**, 59, 119-127.
3. M. Ouberai, F. El Garch, A. Bussière, M. Riou, D. Alsteens, L. Lins, I. Baussanne, Y. F. Dufrêne, R. Brasseur, J.-L. Décout, M.-P. Mingeot-Leclercq, *Biochim. Biophys. Acta*, **2011**, doi: 10.1016/j.bbamem.2011.01.014.

## PO 361

## SYNTHESIS OF INHIBITORS OF DC-SIGN MEDIATED INFECTIONS

Norbert Varga,<sup>a</sup> Renato Ribeiro,<sup>b</sup> Ieva Sutkeviciute,<sup>c</sup> Michel Thépaut,<sup>c</sup> Javier Rojo,<sup>b</sup>  
Franck Fieschi,<sup>c</sup> Anna Bernardi.<sup>a</sup>

*a. Università degli Studi di Milano, Dipartimento di Chimica Organica e Industriale,  
via Venezian 21, 20133 Milano, Italy b. Instituto de Investigaciones Químicas, CSIC. Seville c.  
Institut de Biologie Structurale, CNRS. Grenoble  
norbert.varga@unimi.it*

HIV infection is pandemic in humans and is responsible for millions of deaths every year. The discovery of new cellular targets that can be used to prevent the infection process represents a new opportunity for developing more effective antiviral drugs. In this work, dendritic cell-specific ICAM-3 grabbing non-integrin (DC-SIGN), a lectin expressed at the surface of immature dendritic cells and involved in the initial stages of HIV infection, is described as a promising therapeutic target. The project is being developed within the European research Network CARMUSYS (<http://www.carmusys.iiq.csic.es>). Herein we show the synthesis of a small library of derivatives of a dimannoside mimic recently reported by our laboratory.<sup>1</sup> The mimic was functionalized with two identical amide groups. Further, multivalent presentations of the prepared DC-SIGN ligands were obtained via click chemistry using dendrimeric scaffolds. The activities of the prepared molecules towards DC-SIGN were determined using surface plasmon resonance (SPR) technique. Multivalency showed significant improvement of the DC-SIGN inhibition in comparison with the corresponding monovalent ligands.

**References**

1. J.J.Reina, S. Sattin, D. Invernizzi, S. Mari, L. Martínez-Prats, G. Tabarani, F. Fieschi, R. Delgado, P. M. Nieto, J. Rojo, A. Bernardi *ChemMedChem* **2007**, 2, 1030 – 1036

PO 362

**EXOPOLYSACCHARIDE PRODUCTION BY THERMOPHILIC BACTERIA  
FROM TURKEY AND BULGARIA**Songul Yasar Yildiz,<sup>1</sup> Nadia Radchenkova,<sup>2</sup> Ebru Toksoy Oner,<sup>1</sup> Margarita Kambourova,<sup>2</sup><sup>1</sup>*Department of Bioengineering, Marmara University, Istanbul, Turkey,*<sup>2</sup>*Department of Extremophilic Bacteria, Institute of Microbiology, BAS, Sofia, Bulgaria*  
*songulyasar@marun.edu.tr*

The enthusiastic search for novel extremophiles has largely been stimulated by the uniqueness of their survival mechanisms which result into valuable commercial applications. One of the adaptation strategies to extreme environments conditions is the production of exopolysaccharides (EPSs) expressing unusual physicochemical and rheological properties, and correspondingly novel functionality. Thermophilic microorganisms are known to produce EPSs in short fermentation processes with better mass transfer and decreased viscosity. Hence studies were initiated to investigate the EPS production profile of thermophilic strains isolated from hot springs in Bulgaria and Turkey in aim to isolate and identify good EPS producers, to develop effective fermentation processes for polymer synthesis and to characterize the biopolymers properties. A total of 14 thermophilic bacterial strains were tested for their ability to produce EPSs. After quantitative analysis of the produced biopolymers, two strains were chosen for further work. Studies on optimization of culture media content revealed maltose (at optimum concentrations of 1.8% for the first strain and 1.2 % for the second strain) and pepton (at 0.1 % optimum concentration) were found to be the best carbon and nitrogen sources, correspondingly. Whereas optimal pHs for the strains were 6.5 and 7.0, highest amounts of EPS were recovered at 55°C for both strains. Biopolymers were synthesized at late exponential and early stationary phases. In the presence of trace elements (Fe<sup>2+</sup>, Co<sup>2+</sup>, Mn<sup>2+</sup>, Cu<sup>2+</sup>, Zn<sup>2+</sup>), cultures were found to reach lower optical densities, however improved detachment of the exopolysaccharides from the biomass was found to facilitate their further recovery from culture liquid. Studies on the optimization of air supply and mass transfer in bioreactor cultures as well as on monosaccharide composition of the biopolymers are in progress.

**References**

- KAMBOUROVA M., Mandeva R., Dimova D., Poli A., Nicolaus B. and Tommonaro, G. Production and characterization of a microbial glucan, synthesized by *Geobacillus tepidamans* V264 isolated from Bulgarian hot spring, *Carbohydr. Polym.*, (2009), 77, 338-343.
- RUFFING A. ve Chen R.R., Metabolic engineering of microbes for oligosaccharide and polysaccharide synthesis, *Microb. Cell Fact.*, (2006), 5, 25.
- NICOLAUS B., Kambourova M., ve Toksoy Oner E., "Exopolysaccharides from extremophiles: From fundamentals to biotechnology", *Environmental Tech.*, (2010), 31 (10), 1145-1158.

PO 363

**CLICK SYNTHESIS OF DNJ NEOGLYCOCONJUGATES:  
LENGTH OF THE SIDE CHAIN TUNES BIOLOGICAL ACTIVITY**

Nicolas Ardes-Guisot,<sup>1</sup> Dominic S. Alonzi,<sup>2</sup> Gabriele Reinkensmeier,<sup>2</sup> Terry D. Butters,<sup>2</sup>  
Caroline Norez,<sup>3</sup> Frédéric Becq,<sup>3</sup> Yves Blériot,<sup>4</sup> Matthieu Sollogoub,<sup>4</sup> and Boris Vauzeilles<sup>1</sup>

<sup>1</sup> CNRS and Univ Paris-Sud, Glycochimie Moléculaire et Macromoléculaire,  
ICMMO, UMR 8182, Orsay F-91405, France,

<sup>2</sup> Glycobiology Institute, Oxford University, South Parks Road, Oxford OX1 3QU, UK,

<sup>3</sup> Institut de Physiologie et Biologie Cellulaires, Université de Poitiers, CNRS, 1 rue Georges  
Bonnet, BP633, 86022 Poitiers cedex, France,

<sup>4</sup> UPMC, Univ Paris 06, Institut Parisien de Chimie Moléculaire, (UMR CNRS 7201),  
4 place Jussieu, C. 181, F-75005 Paris, France.  
boris.vauzeilles@u-psud.fr

Iminosugars, sugar mimics in which the endocyclic oxygen is formally replaced by nitrogen, represent a most promising class of sugar analogues for therapeutic applications.<sup>1</sup>

We have prepared a series of neoglycoconjugates derived from deoxynojirimycin by click connection<sup>2</sup> with functionalised adamantane derivatives.<sup>3</sup> These conjugates were assayed as inhibitors of the glycoenzymes relevant to the treatment of Gaucher disease, as well as correctors of the defective ion-transport protein involved in cystic fibrosis. We will show that according to the length of the chain linking DNJ and adamantane, we can selectively either strongly inhibit ER- $\alpha$ -glucosidases and ceramide glucosyltransferase or restore the activity of CFTR. This strategy proves therefore very attractive for the rapid synthesis of iminosugar-based libraries for biological applications.

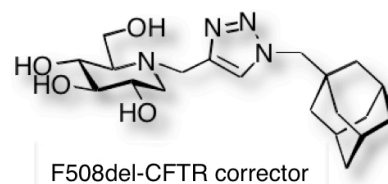
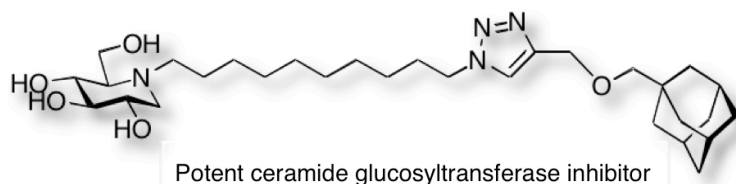

### References

1. See A.E. Stütz *Iminosugars as Glycosidase Inhibitors: Nojirimycin and Beyond*; Wiley-VCH : Weinheim, **1999** ; b) O.R. Martin, P. Compain, *Iminosugars: From synthesis to therapeutic applications*; Wiley-VCH : Weinheim **2007**.
2. C.W. Tornøe, C. Christensen, M. Meldal, *J. Org. Chem.* **2002**, 67, 3057-3064; V.V. Rostovtsev, L.G. Green, V.V. Fokin, K.B. Sharpless, *Angew. Chem. Int. Ed.* **2002**, 41, 2596-2599.
3. H.S. Overkleeft, G.H. Renkema, J. Neele, P. Vianello, I.O. Hung, A. Strijland, A.M. van der Burg, G.-J. Koomen, U.K. Pandit, J.M.F.G. Aerts, *J. Biol. Chem.* **1998**, 273, 26522-26527.
4. N. Ardes-Guisot, D. S. Alonzi, G. Reinkensmeier, T. D. Butters, C. Norez, F. Becq, Y. Blériot, M. Sollogoub, B. Vauzeilles, *submitted*.

PO 364

**PARALLEL ANALYSIS OF GLYCOPROTEINS USING LECTIN- FUNCTIONALISED  
MONOLITHIC COLUMNS INTEGRATED IN  
HYBRID SILICON/GLASS MICRO-FLUIDIC CHIPS**

Mercedes Vázquez, Ekaterina Nesterenko, Paul Clarke, Roisin Thompson, Brendan O'Connor,  
Dermot Brabazon, and Brett Paull

*Irish Separation Science Cluster (ISSC), National Centre for Sensor Research,  
Dublin City University, Glasnevin, Dublin 9, Dublin, Ireland  
mercedes.vazquez@dcu.ie*

The last decade has witnessed an increasing interest in the development of micro-fluidic devices integrating monolithic materials for chemical and (bio)analytical applications. These materials are very versatile as they can be prepared with different porosities, pore sizes, and a wide variety of functionalities using many different precursors and chemistries<sup>1</sup>. Furthermore, they can be prepared *in situ* in specific areas of micro-fluidic channels by photo-initiated (UV-initiated) polymerization employing customized photo-masks<sup>2</sup>. Advantages from the use of microchip platforms include very fast analysis times, the use of small sample volumes, minimal reagent consumption and waste generation, disposability, portability and ease of mass-production.

In this work we present the fabrication of monolithic columns in high-pressure glass/silicon microfluidic chips for the selective capture of glycoproteins, as well as their specific glycoforms, in parallel *via* immobilisation of different lectins in four separate micro-channels contained in a single chip. The monolith was prepared in-situ within the micro-channels by UV-polymerisation, which allowed control of its specific location in the channel. In order to increase the monolith surface area, immobilisation of gold nanoparticles on the monolith was carried out. Covalent immobilisation of commercial lectins was then achieved employing well-known gold chemistry protocols. The resulting monolithic beds were characterised using optical microscopy and scanning electron microscopy (SEM). Comparative performance evaluation of the resulting micro-fluidic platforms for selective recognition, capture and analysis of glycoproteins was performed using a High-Performance Liquid Chromatography (HPLC) pump with UV detection.

### References

1. F. Svec, T.B. Tennikova, Z. Deyl, Eds., *Monolithic materials: preparation, properties and applications*, **2003**, 1st ed., Elsevier, Amsterdam.
2. C. Yu, F. Svec, J. M. J. Frechet, *Electrophoresis*, **2000**, 21, 120-127.



PO 365

**SYNTHESIS AND BIOLOGICAL ACTIVITY OF  $\alpha$ -GALACTOSYL CERAMIDE  
AND GALACTOSYL ( $\alpha$ 1 $\rightarrow$ 2) GALACTOSYL CERAMIDE**

Natacha Veerapen,<sup>1</sup> Manfred Brigl,<sup>2</sup> Salil Garg,<sup>2</sup> Vincenzo Cerundolo,<sup>3</sup> Michael B. Brenner,<sup>2</sup>  
Gurdyal S. Besra<sup>1</sup>

<sup>1</sup> School of Biosciences, University of Birmingham, Edgbaston, Birmingham B15 2TT, UK #1,

<sup>2</sup> Division of Rheumatology, Immunology, and Allergy, Brigham and Women's Hospital,  
Harvard Medical School, 1 Jimmy Fund Way, Boston, MA 02115#2,

<sup>3</sup> Tumor Immunology Group, Weatherall Institute of Molecular Medicine,  
John Radcliffe Hospital, Headington, Oxford, OX1 3QT, UK#3

N.Veerapen@bham.ac.uk

When the synthetic glycolipid  $\alpha$ -galactosyl ceramide ( $\alpha$ -GalCer),<sup>1</sup> known as KRN7000 (**1**), is bound to CD1d and presented to the T cell receptors (TCRs) on the surface of invariant killer cells (*i*NKT) cells, the latter are activated to release diverse cytokines, including both Th1 and Th2 cytokines. It is believed that the release of Th1 cytokines may contribute to antitumour and antimicrobial functions while that of Th2 cytokines may help alleviate autoimmune diseases such as multiple sclerosis and arthritis.<sup>2-4</sup>  $\alpha$ -GalCer and its derivatives are invaluable tools in understanding the functioning of CD1d and NKT cells in a wide range of immune responses. We present a direct approach towards the synthesis of the biologically attractive,  $\alpha$ -galactosyl ceramide ( $\alpha$ -GalCer) and its analogues. More importantly, the use of a silicon tethered intramolecular glycosylation reaction gives easy access to the diglycosyl ceramide Gal( $\alpha$ 1 $\rightarrow$ 2GalCer) (**2**), which has been shown to require uptake and processing to the biologically active  $\alpha$ -GalCer derivative.<sup>5</sup>

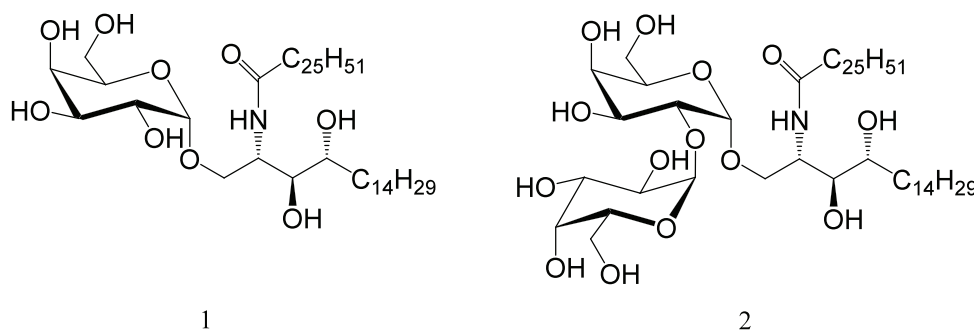

### References

1. Kronenberg, M. *Annu. Rev. Immunol.* **2005**, *23*, 877-900.
2. Miyamoto, K.; Miyake, S.; Yamamura, T. *Nature* **2001**, *413*, 531-534.
3. Chiba, A.; Oki, S.; Miyamoto, K.; Hashimoto, H.; Yamamura, T.; Miyake, S. *Arthritis Rheum.* **2004**, *50*, 305-313.
4. Romagnani, S. *Immunol Today.* **1997**, *18*, 263-266.
5. Veerapen, N.; Brigl, M.; Garg, S.; Cerundolo, V.; Cox, L.R.; Brenner, M.B.; Besra, G.S. *Bioorg. Med. Chem. Lett.* **2009**, *19*, 4288-4291

PO 366

**LIPOPOLYSACCHARIDE STRUCTURE OF *HELICOBACTER PYLORI*  
WILD-TYPE STRAIN 26695**

Eleonora Altman, Vandana Chandan, Jianjun Li and Evgeny Vinogradov

*Institute for Biological Sciences, National Research Council Canada, 100 Sussex Drive, Ottawa,  
ON, K1A 0R6, Canada*

*Helicobacter pylori* is an important human pathogen responsible for the stomach ulcer and its complications. Lipopolysaccharide (LPS) is a surface component of this microorganism, conferring protection against immune system and a potential vaccine candidate. The structure of *Helicobacter* LPS have been studied during the last 15 years and numerous structural variants were published. The repetitive elements of LPS such as glucan and heptan were usually shown in publications in an uncertain way or as intrinsically irregular structures. Reliable NMR studies on purified LPS components had never been performed. We undertook reinvestigation of the LPS from several strains of *H. pylori*. Our data show that *H. pylori* LPS has well defined structure, with the only variable element being the length of heptan and glucan (if present). The complete structure, including linkages between heptan, glucan, and the O-chain, was determined for several strains. It is significantly different from previously reported structures.

Here we describe the structure of the LPS from *H. pylori* genomic strain 26695 and its HP0826::Kan mutant lacking the O-chain component. Data are based on NMR analysis of the oligosaccharide products obtained by several degradation procedures performed on the LPS from both strains, supported by CE-MS and chemical data.

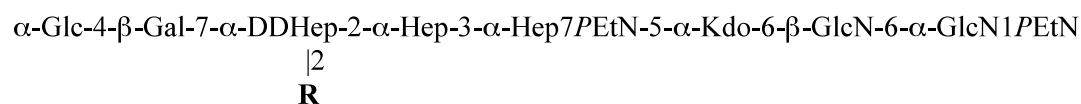

where **R** = H or  $\beta$ -GlcNAc- or  $\alpha$ -DDHep-3- $\alpha$ -L-Fuc-3- $\beta$ -GlcNAc- or

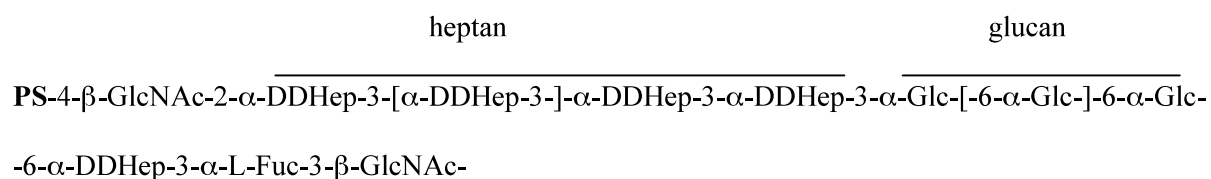

where **PS** is the O-chain polysaccharide.

## PO 367

**CHARACTERIZATION OF LIPOSOMES FORMED BY LIPOPOLYSACCHARIDES FROM *BURKHOLDERIA CENOCEPACIA*, *BURKHOLDERIA MULTIVORANS* AND *AGROBACTERIUM TUMEFACIENS*: FROM THE MOLECULAR STRUCTURE TO THE AGGREGATE ARCHITECTURE**

Giuseppe Vitiello,<sup>1,2</sup> Gerardino D'Errico,<sup>1,2</sup> Alba Silipo,<sup>3</sup> Gaetano Mangiapia,<sup>1,2</sup>  
Aurel Radulescu,<sup>4</sup> Antonio Molinaro,<sup>3</sup> Rosa Lanzetta<sup>3</sup> and Luigi Paduano<sup>1,2</sup>

<sup>1</sup> Department of Chemistry, University of Naples "Federico II", Naples, Italy

<sup>2</sup> CSGI (Consorzio per lo Sviluppo dei Sistemi a Grande Interfase), Florence, Italy

<sup>3</sup> Department of Organic Chemistry and Biochemistry, University of Naples "Federico II",  
Naples, Italy

<sup>4</sup> Institut für Festkörperforschung Forschungszentrum Jülich and Jülich Centre for Neutron  
Science, Garching bei München, Germany  
giuseppe.vitiello@unina.it

The microstructure of liposomes formed by the lipopolysaccharides (LPS) derived from *Burkholderia cenocepacia* ET-12 type strain LMG 16656, *Burkholderia multivorans* strain C1576 and *Agrobacterium tumefaciens* strain TT111 has been investigated by a combined experimental strategy, including dynamic light scattering (DLS), small-angle neutron scattering (SANS) and electron paramagnetic resonance (EPR). The results highlight that the LPS molecular structure determines, through a complex interplay of hydrophobic, steric and electrostatic interactions, the morphology of the aggregates formed in aqueous medium. All the considered LPS form liposomes that in most cases present a multilamellar arrangement. The thickness of the hydrophobic domain of each bilayer and the local ordering of the acyl chains are determined not only by the molecular structure of the LPS glycolipid portion (lipid A), but also, indirectly, by the bulkiness of the saccharidic portion. In the case of a long polysaccharidic chain, such as that of the LPS derived from *Burkholderia multivorans*, liposomes coexist with elongated micellar aggregates, whose population decreases if a typical phospholipid, such as dioleoyl phosphatidylethanolamine (DOPE) is introduced in the liposome formulation. The effect of temperature has also been considered: for all the considered LPS an extremely smooth transition of the acyl chain self-organization from a gel to a liquid crystalline phase is detected around 30–35 °C. In the biological context, our results suggest that the rich biodiversity of LPS molecular structure could be fundamental to finely tune the structure and functional properties of the outer membrane of Gram negative bacteria.<sup>1,2</sup>

**References**

1. D'Errico G, Silipo A, Mangiapia G, Molinaro A, Paduano L, Lanzetta R, *Phys. Chem. Chem. Phys.*, **2009**, *11*, 2314–2322.
2. D'Errico G, Silipo A, Mangiapia G, Vitiello G, Radulescu A, Molinaro A, Lanzetta R, Paduano L, *Phys Chem Chem Phys*, **2010**, *12*, 13574–13585.

## PO 368

## PECTINS SULFATES AND THEIR ANTICOAGULANT ACTIVITY

Fedor Vityazev<sup>1</sup>, Natalia Drozd<sup>2</sup>

<sup>1</sup>*Institute of Physiology, Komi Science Centre, The Urals Branch of the Russian Academy of Sciences, 50, Pervomaiskaya str., Syktyvkar, 167982, Russia;*

<sup>2</sup>*Haematological Scientific Centre Russian Academy of Medical Sciences, 4a Novy Zykovskii pr.; Moscow. 125167, Russia  
rodefex@mail.ru*

The search of the anticoagulant medicines devoid of side effect is of a great interest of present. The widely used heparin preparations represented an sulfated linear glycosaminoglycan of animal tissue have been found to possess a series of side effects as follows: hemorrhages, allergic reactions and thrombocytopenia [1, 2]. The present study reveled the results sulfation of the following physiologically active pectins: lemnan LM of duckweed *Lemna minor* L, and bergenan BC of *Bergenia crassifolia* L, followed by elucidation of anticoagulant activity of the corresponding sulfate derivatives. Synthesis of pectin sulfated was carried out using a treatment with pyridine monomethyl sulfate, pyridine sulfonamide, and chlorosulfonic acid [3-5]. The optimal conditions of sulfation were estimated using variations of reaction time, temperature and amounts of reagent. As a result the maximal degree of sulfation (1.5 mol SO<sub>3</sub> per 1 mol of the galacturonic acid residue) was found to achieve at threefold excess of chlorosulfonic acid per are hydroxyl group of the galacturonic acid residue. Using HPLC, an appearance of fragments with molecular weight below 50 kDa was observed as a rewet of a partial cleavage of pectin sugar chair.

The sulfated lemnan LM and bergenan BC were shown possess the anticoagulant activity namely the human blood coagulation time diminished twofold thus exceeding five-fold activity of heparin used as a positive control. The antithrombotic activity of the same sulfates was found to be 90.3±8.9 and 64.5±5.5 U/mg respectively, twofold lower as heparin level.

### References

1. Díaz-Nido J., Wandosell F., Avila J., *Peptides*, **2002**, 23, 1323–1332
2. Hirsh J., O'Donnell M., Weitz J.I. *Blood*, **2005**, 105, 453-463.
3. Takano R., Nagai, T., Wu X., Xu X., Tien Huy N., Kamei K., Hara S., *J. Carbohydr. Chem*, **2000**, 19, 1185-1190.
4. Mahner C., Lechner M. D., Nordmeier E., *Carbohydr. Res*, **2001**, 331, 203-208.
5. Vogt S., Heinze T., Röttig K., Klemm D., *Carbohydr. Res.*, **1995**, 266, 315-320.

This work was supported by the Integration Project of Basic Research of the Urals Branch and Siberian Division of the Russian Academy of Sciences, and the program of the Presidium of the Russian Academy of Sciences “Molecular and Cellular Biology”.

## PO 369

## RAPID ACCESS TO URONATES, URONAMIDES AND OTHER BUILDING BLOCKS FROM GLUCURONIC ACID

Anne Wadouachi, Stéphanie Rat, Michael Bosco, José Kovensky

Laboratoire des Glucides UMR CNRS 6219, Université de Picardie Jules Verne, 33 rue Saint Leu,  
80039 Amiens, France  
anne.wadouachi@u-picardie.fr

D-Glucuronic acid (GlcA) is an ubiquitous compound of oligo- and polysaccharides of biological importance. GlcA derivatives have been synthesized for several applications, as surface-active compounds<sup>[1,2]</sup> or as bioactive molecules.<sup>[3]</sup> We have been interested in developing a rapid access to modified uronate derivatives by regioselective opening of the 6,1-lactone intermediate **1** (obtained in a “one pot” reaction from D-glucuronic acid) with O- and N-nucleophiles. Reactions were performed under microwave irradiation when heating was necessary. An efficient and fast reaction allowed to prepare glucuronamides from this lactone **1** and different amines.<sup>[4]</sup> On the other hand, reaction of **1** with alcohols in the presence of common Lewis acidic catalysts gave glycosylated-esterified compounds or only esterified compounds.<sup>[5]</sup> The use of these products as key intermediates for the preparation of enzyme inhibitors will be presented. In order to develop a green methodology for the modification of this lactone, we combined microwave-assisted reactions with Lewis acidic polyoxometalates as recyclable catalysts.<sup>[6]</sup>

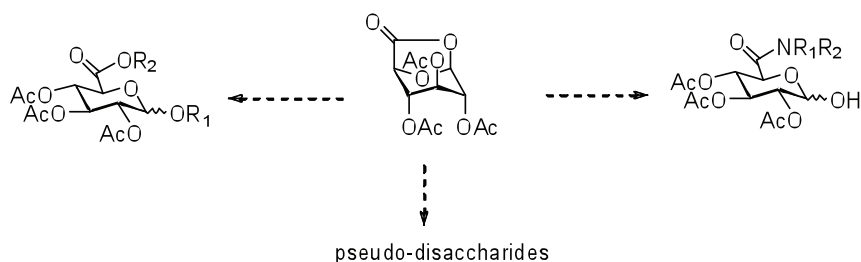

## References

1. H. Razafindralambo, C. Blecker, S. Mezdour, C. Deroanne, J. M. Crowet, R. Brasseur, L. Lins, M. Paquot, *J. Phys.Chem. B* **2009**, *113*, 8872-8877
2. (a) M. Berchel, L. Lemiègre, J. Jeftic, T. Benvegnu, *Tetrahedron Lett.* **2008**, *49*, 4690-4692; b) M. Berchel, L. Lemiègre, S. Trépout, O. Lambert, J. Jeftic, T. Benvegnu, *Tetrahedron Lett.* **2008**, *49*, 7419-7422.
3. (a) R. W. M. Aben, J.W. Scheeren, J. J. Cornelissen, M. Lamberuts, D. De Vos, H. J. Haisma, EP 2098533, **2009**; b) F. Scheinmann, S. Joel, A. V. Stachulski, US 5977326, **1999**.
4. M. Bosco, S. Rat, J. Kovensky, A. Wadouachi, *Tetrahedron Letters*, **2010**, *51*, 2553-2556.
5. S. Rat, D. Mathiron, P. Michaud, J. Kovensky, A. Wadouachi, *Tetrahedron* **2007**, *63*, 12424-12428.
6. M. Bosco S. Rat, N. Dupré, B. Hasenknopf, E. Lacôte, M. Malacria, P. Rémy, J. Kovensky, S. Thorimbert, A. Wadouachi, *ChemSusChem*, **2010**, *3*, 1249-12

## PO 370

## A FIRST FUNCTIONAL FLUORINATED MUC1-GLYCOPEPTIDE VACCINE

Sarah Wagner, Manuel Johannes and Anja Hoffmann-Röder\*

Institute of Organic Chemistry, Johannes Gutenberg-University Mainz, Duesbergweg 10-14,  
D-55128 Mainz, Germany  
hroeder@uni-mainz.de

The aberrant glycosylation profiles of mucin glycoproteins on epithelial tumor cells represent attractive target structures for the development of cancer diagnostics and immunotherapy.<sup>1,2</sup> Mucin-type glycopeptides have been successfully investigated as molecularly defined vaccine prototypes for triggering humoral immunity in animal models.<sup>3</sup> A severe drawback in the development of efficient carbohydrate-based vaccines is the low metabolic stabilities of their glycosidic bonds, which are easily cleaved by endogenous glycosidases. To enhance the bioavailability of the antigenic glycan structure, a hydrolysis-resistant tumor-associated TF antigen analog with fluorine substituents at positions C6 and C6' was synthesized and incorporated into the tandem repeat sequence of the mucin MUC1.<sup>4</sup> The resulting pseudo-glycopeptide was further conjugated to tetanus toxoid (TTox) as a carrier protein and subjected to immunization studies.<sup>5</sup> The difluoro-TF-antigen-MUC1-TTox vaccine induced very strong immune responses in mice with antibodies strongly binding to breast cancer MCF-7 cells.

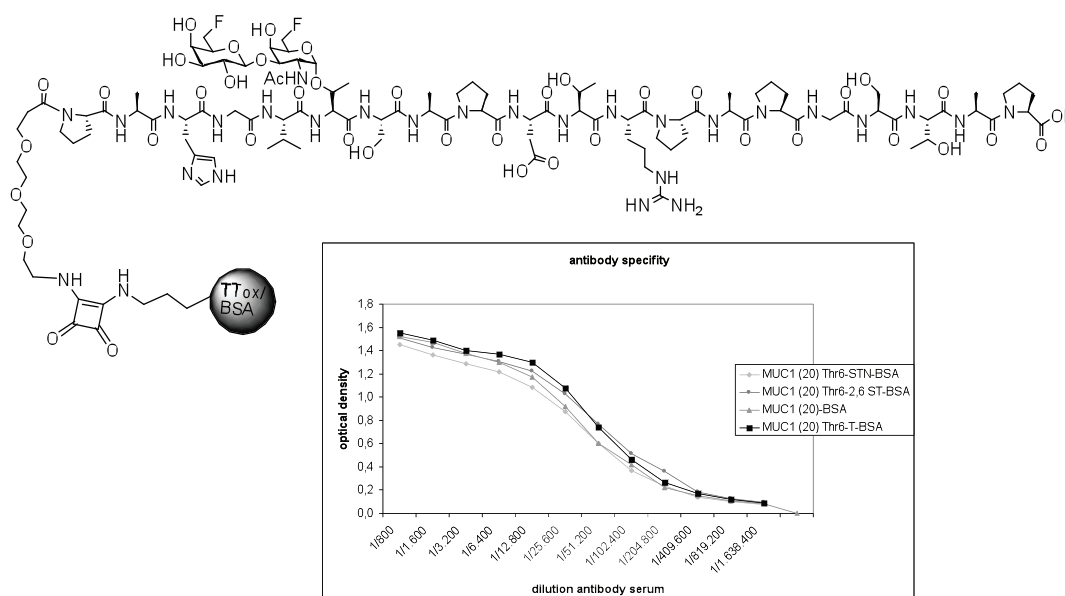

## References

1. G. F. Springer, *Science*, **1984**, 224, 1198-1206.
2. J. Taylor-Papadimitriou, J. Burchell, D. W. Miles, M. Daziel, *Biochim. Biophys. Acta, Mol. Bas. Dis.* **1999**, 1455, 301-313.
3. T. Buskas, P. Thomson, G.-J. Boons, *Chem. Commun.* **2009**, 5335-5349 and cited references.
4. S. Wagner, C. Mersch, A. Hoffmann-Röder, *Chem. Eur. J.* **2010**, 16, 7319-7330.
5. A. Hoffmann-Röder, A. Kaiser, S. Wagner, N. Gaidzik, D. Kowalczyk, U. Westerlind, B. Gerlitzki, E. Schmitt, H. Kunz, *Angew. Chem. Int. Ed.* **2010**, 49, 8498-8503.



## PO 371

## ARE MANNURONIC ESTER DONORS UNREACTIVE?

Marthe T. C. Walvoort, Jesse van Dijk, Wilbert de Witte, Herman S. Overkleeft,  
Jeroen D. C. Codée, Gijsbert A. van der Marel

*Department of Bio-Organic Synthesis, Leiden Institute of Chemistry, Leiden University  
Einsteinweg 55, 2333 CC Leiden, The Netherlands  
m.t.c.walvoort@chem.leidenuniv.nl*

For the construction of uronic acid-containing natural oligosaccharides two strategies are available: 1) glycosylation followed by oxidation in the oligosaccharide stage and 2) oxidation of the monosaccharides prior to glycosylation. Most often the first protocol is employed to avoid difficult glycosylations with donor glycosides bearing an electron-withdrawing carboxylic acid functionality. Recently we reported on the efficient construction of a pentasaccharide composed of  $\beta$ -1,4-mannuronic acid building blocks.<sup>1</sup> In this synthesis a mannuronic ester was iteratively glycosylated with high yield and excellent  $\beta$ -stereoselectivity. We have also described the synthesis of a heptasaccharide containing three  $\beta$ -linked 2-*N*-acetyl mannosaminuronic acids using 2-azido-2-deoxy mannuronic ester donors to construct the  $\beta$ -manno configured linkages.<sup>2</sup>

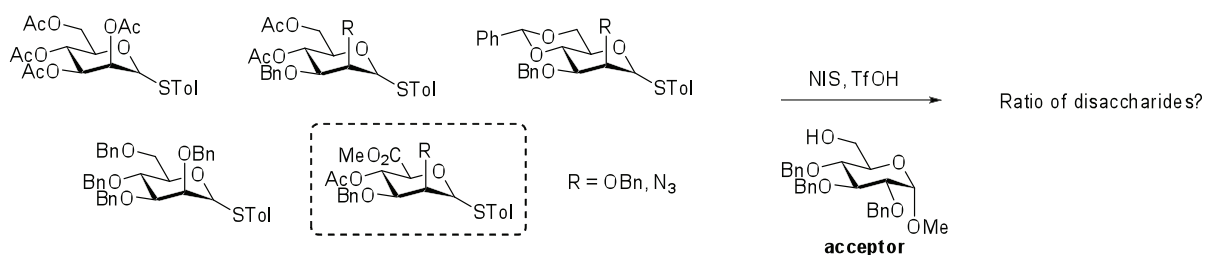

The excellent results observed with the  $\beta$ -fused mannuronate donors inspired us to investigate the reactivities of various mannose and mannuronate donors. A protocol was designed in which two thio-donors compete for the activator *N*-iodosuccinimide,<sup>3</sup> and subsequently the activated glycoside is trapped with a primary acceptor. Surprisingly, mannuronic acid donors can be more reactive than non-oxidized donors. Furthermore, striking differences between  $\alpha$ - and  $\beta$ -anomers are revealed. This communication will disclose the results of these competition experiments and provide possible explanations for some remarkable observations.

## References

1. Codée, J. D. C.; van den Bos, L. J.; de Jong, A.-R.; Dinkelaar, J.; Lodder, G.; Overkleeft, H. S.; van der Marel, G. A. *J. Org. Chem.* **2009**, *74*, 38-47
2. Walvoort, M. T. C.; Lodder, G.; Overkleeft, H. S.; Codée, J. D. C.; van der Marel, G. A. *J. Org. Chem.* **2010**, *75*, 7990-8002
3. Zhang, Z.; Ollmann, I. R.; Ye, X.-S.; Wischnat, R.; Baasov, T.; Wong, C.-H. *J. Am. Chem. Soc.* **1999**, *121*, 734-753

PO 372

## MICROWAVE ASSISTED REGIOSELECTIVE BENZYLATION OF GLYCAL

Tadeusz Bieg<sup>1</sup>, Katarzyna Kral<sup>1</sup>, Wiesław Szeja<sup>1</sup>, Ilona Wandzik<sup>1</sup>

<sup>1</sup>Silesian University of Technology, Faculty of Chemistry, Department of Organic Chemistry, Bioorganic Chemistry and Biotechnology, Krzywoustego 4 Street, 44-100 Gliwice, Poland  
ilona.wandzik@polsl.pl

Regioselective functionalization of hydroxyl groups in carbohydrate chemistry is a crucial task in a block synthesis of oligosaccharides. Glycals are versatile building blocks and a regioselective protection of hydroxyl groups is of great importance. It is possible to differentiate the reactivity of hydroxyl groups via organotin derivatives [1, 2]. Preparative utility of tributyltin ethers and dibutylstannylene acetals of D-glucal and their subsequent benzylation have been reported [3, 4]. Both steps: regioselective O-stannylation and benzylation take several hours of heating in reflux to afford disubstituted 3,6-di-O-benzyl-D-glucal as a major product. The purpose of our work is to compare the classical reaction conditions with microwave heating. Reactions were carried out with controlled microwave irradiation under sealed vessel conditions by using the CEM Discover microwave synthesizer. Derivatives of D-glucal and D-galactal were benzylated in a regioselective manner in yield comparable to the classical synthesis. In all cases C-3 hydroxyl group stayed unsubstituted. The reaction time depended on applied microwave power and can be shortened to 30 minutes in the O-stannylation step and up to 5 minutes in the benzylation step.

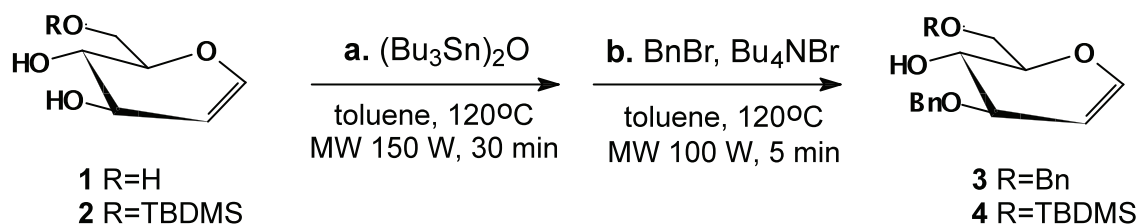

**Acknowledgement** Research studies part-financed by European Union within the European Regional Development Fund (POIG 01.01.02-14-102/09).

## References

1. S. David, S. Hanessian, *Tetrahedron* **1985**, 41, 643-663.
2. C. Cruzado, M. Barnabe, M. Martin-Lomas, *J. Org. Chem.*, **1989**, 54, 465-469.
3. M. Gallant, J. T. Link, S. J. Danishefsky, *J. Org. Chem.*, **1993**, 58, 343-349.
4. S. J. Danishefsky, V. Behar, J. T. Randolph, K. O. Lloyd, *J. Am. Chem. Soc.*, **1995**, 117, 5701-5711.

PO 373

**C-MANNOSYLATION OF PHENOLS AND O/C-DIGLYCOSIDE SYNTHESIS AS KEY STEPS FOR THE PREPARATION OF OLIGOSACCHARIDE MIMETICS**Stefan Weck<sup>1</sup> and Till Opatz<sup>1</sup>

<sup>1</sup> Johannes Gutenberg Universität Mainz, Institut für Organische Chemie, Duesbergweg 10-14, 55128 Mainz, Germany  
wecks@uni-mainz.de

C-glycosides with an aromatic or heteroaromatic aglycon have been isolated from natural sources and some of these compounds have been found to exhibit potent antibacterial and antiproliferative activity.<sup>[1]</sup> Furthermore, they are inherently inert against degradation by acid or hydrolytic enzymes making them interesting as metabolically stable mimetics for O-glycosides. A prominent and useful method for their preparation is the ortho-C-glycosylation of electron rich phenols which has been suggested to proceed in a stepwise fashion furnishing only a single regioisomer.<sup>[2]</sup>

Investigation of the C-mannosylation of electron rich phenols with a benzylated trichloroacetimidate<sup>[3]</sup> showed a high stereo selectivity at the anomeric center depending on the reaction conditions. Using the common TMSOTf as promoter surprisingly leads to the exclusive formation of aryl  $\beta$ -C-mannosides, probably due to steric effects of the aromatic substituent. As  $\beta$ -O-mannosides are usually hard to gain through a direct glycosylation this could be a good approach to corresponding mimetics. When changing the promoter to ZnCl<sub>2</sub>,  $\alpha$ -C-mannosides are formed from the same reactants. Due to unfavorable 1,3-diaxial interactions in the latter products, an inversion of the ring conformation occurs.<sup>[4]</sup>

Moreover, O/C-diglycosides could be prepared by sequential C- and O-glycosylation of naphthol derivatives. The products can serve as core structure for metabolically stable oligosaccharide mimetics. Further elongation should make them e.g. useful for the construction of selectin inhibitors.

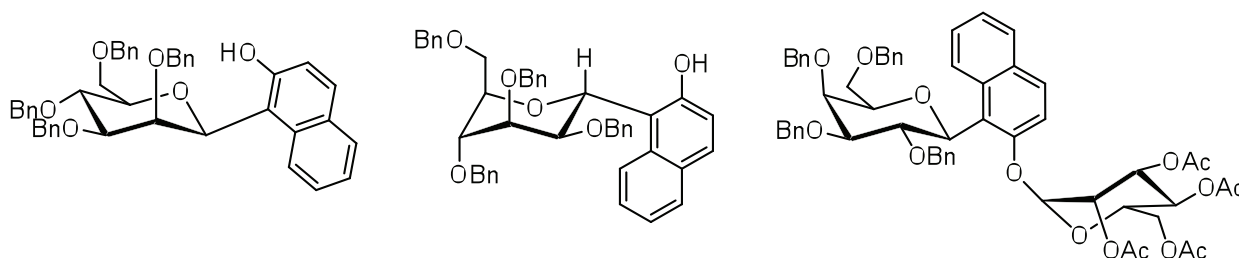
**References**

1. T. Bililign, B. R. Griffith, J. S. Thorson, *Natural Product Reports* **2005**, 22, 742-760.
2. T. Kometani, H. Kondo, Y. Fujimori, *Synthesis* **1988**, 1005-1007.
3. J. A. Mahling, R. R. Schmidt, *Synthesis* **1993**, 325-328.
4. S. Weck, T. Opatz, *Synthesis*, **2010**, 2393-2398.

PO 374

**CONFORMATIONALLY SWITCHABLE GLYCOARRAYS:  
APPLYING CYSTEINE-CONTAINING GLYCOPEPTIDES**

Johannes W. Wehner, Thisbe K. Lindhorst

Otto Diels Institute of Organic Chemistry, Christiana Albertina University of Kiel  
Otto-Hahn-Platz 3/4, D-24098 Kiel, Germany  
jwehner@oc.uni-kiel.de

Despite many efforts, processes like biochemical communication events are not well understood in the glycosciences. One relevant modern field of carbohydrate recognition emphasizes on carbohydrate-protein interactions on glycosylated surfaces. Here, conformational control of carbohydrate presentation within a supramolecular array of molecules has stimulated our interest. Structural changes induced by molecular interactions with a glycosylated cell surface could launch specific biochemical processes such as cell signalling.<sup>1</sup> Thus, it has become our aim to synthesise glycomimetics that allow to alter the conformational presentation of carbohydrate ligands by actuation of an embedded moiety, called a molecular relay or switch, respectively. We have chosen cysteine-containing glycomimetics, which can be reversibly altered in their conformational flexibility in an oxidation/reduction sequence (Fig. 1).<sup>2</sup> It is appealing that protecting group free native chemical ligation can be applied in this approach.<sup>3</sup> To investigate potential changes in carbohydrate-protein interactions upon thiol-disulfide switching, mannose-specific bacterial adhesion will serve as a first biological test system.<sup>4</sup>

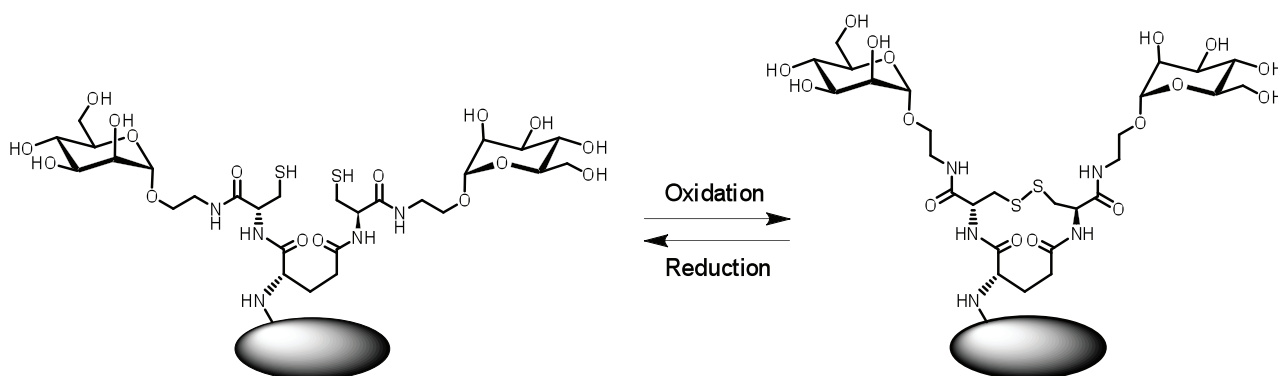

**Figure 1:** Cartoon of a glycomimetic switch on a surface that can be actuated by oxidation and reduction, respectively.

**References**

1. A.-J. Petrescu, M. R. Wormald, R. A. Dwek, *Curr. Opin. Struct. Biol.*, **2006**, *16*, 600-607.
2. J. M. Chalker, G. J. L. Bernardes, Y. A. Lin, B. G. Davis, *Chem. Asian J.*, **2009**, *4*, 630-640.
3. J. W. Wehner, T. K. Lindhorst, *Synthesis*, **2010**, *18*, 3070-3082.
4. M. Hartmann, A. K. Horst, P. Klemm, T. K. Lindhorst, *Chem. Commun.*, **2010**, *46*, 330-332.

PO 375

**DIGLYCOSYLATED HETEROCYCLES AS METABOLICALLY STABLE TRISACCHARIDE MIMETICS**

C. Wiebe, T.Opatz\*

Johannes Gutenberg-Universität Mainz, Duesbergweg 10-14, D-55128 Mainz, Germany  
christine.wiebe@t-online.de

Oligosaccharides containing 2,3- or 3,4-diglycosylated hexopyranose units play an important role in many biological processes. Replacement of the central hexose hinge by an, isomorphous substitute may lead to mimetics with increased stability against enzymatic degradation. A prototype example, in which the hinge carbohydrate is known to play a subordinate role in binding to the biological target, is the  $\beta$ -D-Gal-(1 $\rightarrow$ 3)]- $\beta$ -D-GlcNAc portion of the sialyl Lewis<sup>X</sup> tetrasaccharide (sLe<sup>X</sup>) which can function as a ligand for E- and P-selectin and mediates cell adhesion processes involved in the inflammatory cascade.<sup>[1,2]</sup>

Replacement of the *N*-acetylglucosamine by a suitable heterocycle should convey high stability against glycosidases while retaining the native spatial arrangement of the attached hexose units. This, however, requires suitable protocols for the vicinal attachment of two hexose residues to a given heterocyclic core structure. Here we wish to report on the preparation of 1,3- and 2,3-diglycosylated indoles by means of either cyclization-glycosylation or sequential diglycosylation. The products may be viewed as trisaccharide surrogates with a heterocyclic core.

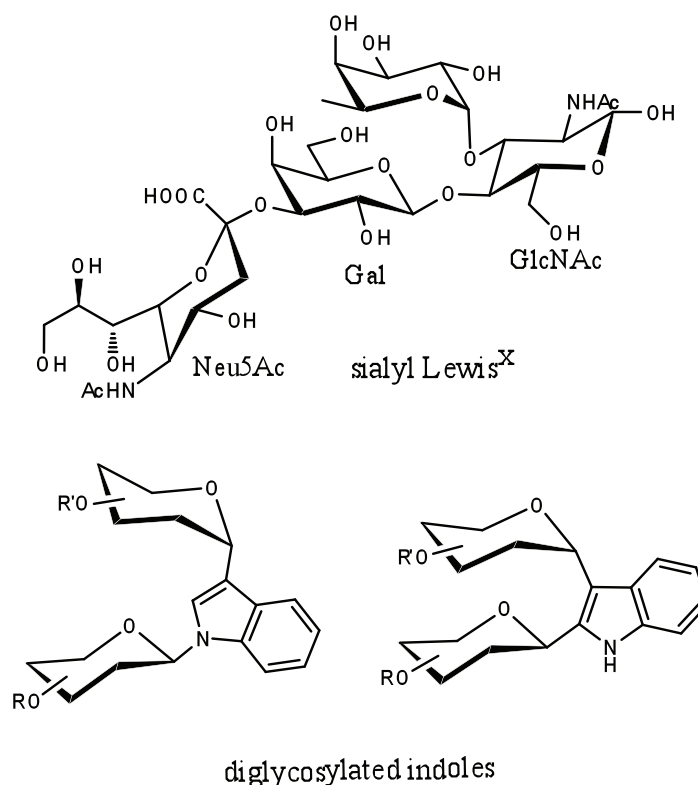
**References**

1. S. D. Rosen, C.R. Bertozzi, *Curr. Opin. Cell. Biol.*, **1994**, 6, 663-673.
2. W. S. Somers, J. Tang, G. D. Shaw, R. T. Camphausen, *Cell.*, **2000**, 103, 467-479.

PO 376

## SYNTHESIS AND EVALUATION OF MDP DERIVATIVES

Marian M.J.H.P. Willems, Selina Khan, Ferry Ossendorp, Hermen S. Overkleeft,  
Dimitri V. Filippov, Gijsbert A. Van der Marel and Jeroen D.C. Codée

*Bio-Organic Synthesis, Leiden Institute of Chemistry, Leiden University, PO Box 9205, 2300 RA  
Leiden, The Netherlands;  
m.willems@chem.leidenuniv.nl*

The first line of defense against microorganisms is represented by the pattern-recognition receptors (PRRs) of the innate immune system. These receptors, classified in Toll-like, NOD-like and RIG-like classes, detect pathogen-associated molecular patterns (PAMPs), molecules that specifically occur in microbes. Recognition of PAMPs by PRRs induces specific signaling pathways that trigger immune responses against microbes. Peptidoglycan (PG), found in bacterial cell walls of Gram-positive and Gram-negative bacteria, consists of polysaccharide chains of alternating  $\beta$ -(1-4)-linked *N*-acetylglucosamine (GlcNAc) and *N*-acetylmuramic acid (MurNAc) residues, which are interconnected via a peptide bridge attached to the carboxylic acid of the MurNAc (**1**).<sup>1</sup>

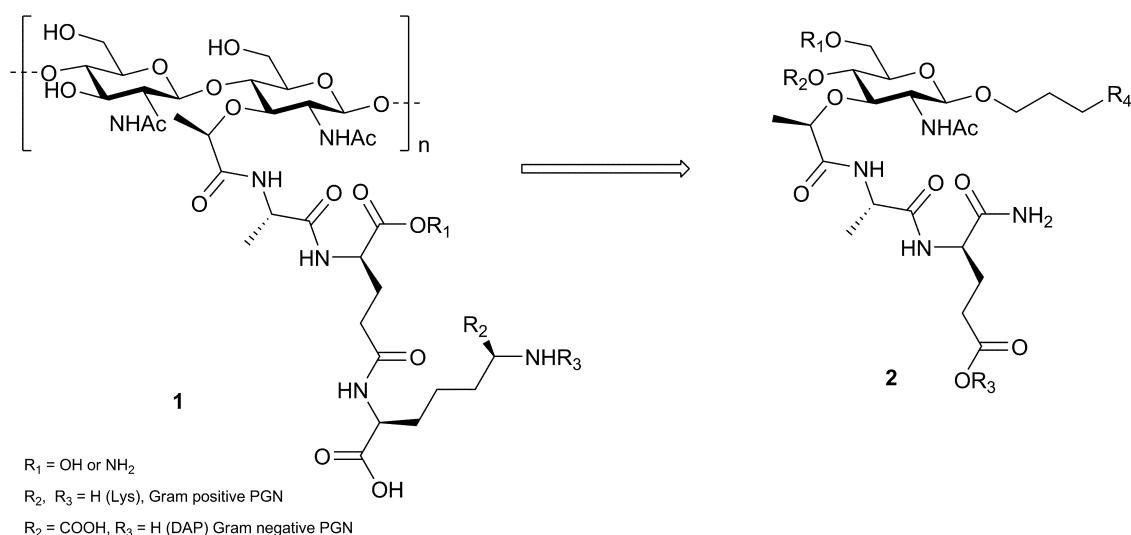

The minimal structure required for recognition by NOD2, an intracellular PRR, is *N*-acetylmuramyl-*L*-alanine-*D*-isoglutamine (MDP). With the objective to gain more insight in the structure-activity relationship of NOD2 ligands a row of MDP derivatives<sup>2</sup> with general structure **2** has been prepared using solid-phase and solution phase procedures and evaluated for their immunostimulatory activity.

## References

- Murray, P.J. *Nature immunology*, **2009**, *10*, 1053-1054; Kufer, T.A., Sansonetti, P.J., *Nature Immunology*, **2011**, *12*, 121-128.
- Uehori, J., Fukase, K., akazawa, T., Uematsu, S., Akira, S., Funami, K., Shingai, M., Matsumoto, M., Azuma, I., Toyoshima, K., Kusumoto, S., Seya, T., *The Journal of Immunology*, **2005**, *174*, 7096-7103.



PO 377

## THERMODYNAMICS BEHIND CV-IIL BINDING OF SACCHARIDES

Jan Alán<sup>1</sup>, Eva Dejmková<sup>1</sup>, Petr Kulháněk<sup>1</sup>, Jaroslav Koča<sup>1,2</sup>, Michaela Wimmerová<sup>1,2,3</sup><sup>1</sup>National Centre for Biomolecular Research and<sup>3</sup>Department of Biochemistry, Faculty of Science, Masaryk University, Kotlářská 2,  
611-37 Brno, Czech Republic,<sup>2</sup>Central European Institute of Technology, Masaryk University,  
Kamenice 5, 62500 Brno, Czech Republic  
michaw@chemi.muni.cz

Understanding of lectin-carbohydrate interaction is one of the most challenging topics in glycobiochemistry field. Knowledge of the role of each binding participant within the binding site is crucial for protein engineering of lectins.

This contribution is focused on engineering of the CV-IIL lectin from opportunistic human pathogen *Chromobacterium violaceum*, which shows ability to bind L-fucose and D-mannose with high affinity. Mutations of wild type lectin are designed to replace a conserved water molecule within the binding site, which plays a special role by bridging sugar with backbone nitrogen atom and with the side chain of the amino acid threonine in position 97. Several mutants of the CV-IIL lectin were designed with more hydrophobic or bulky side chain amino acids both *in vitro* and *in silico* approaches.

Molecular dynamics and free energy calculation methods were used to assess the most promising mutants. The binding free energies were calculated by MM/PBSA and thermodynamic integration approaches. The extensive thermodynamical analysis was performed using isothermal titration microcalorimetry, which allows for obtaining detailed thermodynamical profiles of the lectin-saccharide interaction from a single experiment.

The detailed thermodynamic profiles of protein/sugar interactions will be shown together with the results of the calculations.

**References**

1. Pokorná, M., Cioci, G., Perret, S., Rebuffet, E., Kostlánová, N., Adam, J., Gilboa-Garber, N., Mitchell, E.P., Imberty, A., Wimmerová, M., *Biochemistry*, **2006**, *45*, 7501-7510

The work is supported by the Ministry of Education (MSM0021622413, LC6030, ME08008) and the Czech Science Foundation (GA/303/09/1168, GD301/09/H004) of the Czech Republic.

PO 378

SYNTHESIS AND MOLECULAR DYNAMICS SIMULATIONS OF  
 $\beta$ -D-ManpNAc-(1 $\rightarrow$ 4)[ $\alpha$ -D-Glcp-(1 $\rightarrow$ 3)]- $\alpha$ -L-Rhap-OMeMona V. Zaccheus,<sup>1</sup> Jens Landström<sup>2</sup> and Göran Widmalm<sup>1</sup><sup>1</sup>Stockholms Universitet, Organisk kemi, Arrheniuslaboratoriet, 106 91 Stockholm, Sweden,<sup>2</sup>York Structural Biology Laboratory, Department of Chemistry, University of York,  
Heslington, York, UK, YO10 5DD

mona@organ.su.se

The trisaccharide  $\beta$ -D-ManpNAc-(1 $\rightarrow$ 4)[ $\alpha$ -D-Glcp-(1 $\rightarrow$ 3)]- $\alpha$ -L-Rhap-OMe represents the repeating unit of the O-antigen from an *Aeromonas salmonicida* strain, which is a fish pathogen that causes furunculosis – boils on the skin of the fish. When the trisaccharide was investigated by Peters et al. using NMR spectroscopy an interesting observation was made, where H2 in 2-acetamido-2-deoxy-mannose gave a negative NOE to H2 in rhamnose, and vice versa, in contrast to all other NOEs<sup>1</sup>. In a recent molecular dynamics (MD) simulation an explanation for this was found in the conformational changes of the (1 $\rightarrow$ 3) linkage of the trisaccharide<sup>2</sup>. The conformational exchange was shown to be fast on the NMR time scale, yielding a dynamic three-spin effect where the magnetization is transferred via H1 in glucose. In the  $\beta$ -D-ManpNAc-(1 $\rightarrow$ 4)- $\alpha$ -L-Rhap-OMe disaccharide, the NOE phenomenon is not present.

In order to study the dynamic three-spin effect in more detail, further conformational analysis of the target molecule using NMR techniques such as 1D NOESY is of interest. The existing synthetic pathway described by Paulsen et al is improved and a novel synthetic route towards the trisaccharide as well as the two corresponding disaccharides will be described<sup>3</sup>.

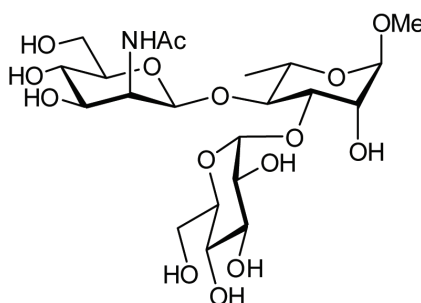
**References**

1. Peters, T., Weimar, T., *J. Biomol. NMR*, **1994**, 4, 97-116.
2. Landström, J., Widmalm, G., *Carbohydr. Res.*, **2010**, 345, 330-333
3. Paulsen, H., Lorentzen, J. P., *Carbohydr. Res.*, **1987**, 165, 207-227

**LIST  
OF PARTICIPANTS**

**A****ABBALLE FRANCO**

Dionex S.p.A.  
Via XXV Aprile, 6  
San Donato Milanese, Italy  
Tel: +39 0251621267  
*franco.abballe@thermofisher.com*

**ABDEL-JALIL RAID**

Sultan Qaboos University  
Department of Chemistry  
P.B. No. 36 , P.C 123 , Al-khod, Muscat, Oman  
Tel: +96824141483  
*jalil@squ.edu.om*

**ABRAHA FANA**

University College Dublin (UCD)  
Centre for Synthesis and Chemical Biology  
(CSCB)  
61 Cranford court, Dublin, Ireland  
Tel: +353874144557  
*fana.abraha@ucdconnect.ie*

**ABRONINA POLINA**

N.D. Zelinsky Institute of Organic Chemistry  
N.K. Kochetkov Laboratory of Carbohydrate  
Chemistry  
Leninsky prosp., 47, Moscow, Russia  
Tel: +7-495-943-2946  
Fax: +7-499-135-5328  
*polina-abronina@yandex.ru*

**ADAMO ROBERTO**

Novartis Vaccines - Research  
Via Fiorentina 1, Siena, Italy  
Tel: +39 0577 245301  
*roberto.adamo@novartis.com*

**ADANITSCH FLORIAN**

University of Natural Resources and  
Applied Life Sciences  
Department of Chemistry  
Muthgasse 18, 1190, Wien, Austria  
Tel: +43 1 47654 6531  
*florian.adanitsch@boku.ac.at*

**ADNAN AHMAD**

GC University Lahore  
Department of Chemistry  
GC University, 54000, Lahore, Pakistan  
Tel: +923234829242  
*adnan\_biochem@yahoo.com*

**AEBI MARKUS**

ETH Zürich - Department of Biology  
Wolfgang Pauli Str. 10, HCI f407 - CH-8093,  
Zürich, Switzerland  
Tel: +41-44-632 64 13  
*aebi@micro.biol.ethz.ch*

**ÁGOSTON ÁGNES**

Glycom  
Pusztaszeri ut 59-67, Budapest, Hungary  
Tel: +36 1 4381101/133  
*agnes.agoston@glycom.com*

**ÁGOSTON KÁROLY**

Glycom  
Pusztaszeri ut 59-67, Budapest, Hungary  
Tel: +36 1 4381101/156  
*karoly.agoston@glycom.com*

**AIT-MOHAND KATIA**

ICOA, UMR 6005, University of Orléans  
Department of Chemistry  
Université d'Orléans, BP 6759, rue de Chartres,  
45067 Orléans Cedex 2, France  
Tel: +33(2) 38 41 70 72  
Fax: +33(2) 38 41 72 81  
*katia.ait-mohand@univ-orleans.fr*

**ALBERTIN LUCA**

CNRS - CERMAV  
BP53 - 38041, Grenoble, France  
Tel: +33 4 76 03 76 25  
*luca.albertin@cermav.cnrs.fr*

**ALBRECHT FABIAN**

Leibniz University of Hannover  
Institute of Organic Chemistry  
Schneiderberg 1B, D-30167, Hannover, Germany  
Tel: +495117624631  
Fax: +495117623011  
*fabian.albrecht@oci.uni-hannover.de*

**ANDERSEN MATHIAS**

Technical University of Denmark  
Department of Chemistry  
Skindergade 20 2. th., Copenhagen K, Denmark  
Tel: 31612295  
*fraa@kemi.dtu.dk*

**ANDO HIROMUNE**

Gifu University  
Department of Applied Bioorganic Chemistry  
1-1 Yanagido, Gifu, Japan  
Tel: +81-58-293-3452  
*hando@gifu-u.ac.jp*

**ANDO TAKAYUKI**

Gifu University  
Department of Applied Bioorganic Chemistry  
1-1 Yanagido, Gifu, Japan  
Tel: +81-58-293-2918  
*an0429@gifu-u.ac.jp*

**ANGULO JESUS**

Instituto de Investigaciones Químicas (CSIC-US)  
Glycosystems Laboratory  
Americo Vespucio, 49, Sevilla, Spain  
Tel: +34954489568  
Fax: +34 95 446 0565  
*jesus@iiq.csic.es*

**ANZELMO GIANLUCA**

CNR - Institute of Biomolecular Chemistry  
Via Campi Flegrei, 34 - 80078,  
Pozzuoli (NA), Italy  
Tel: +393290610681  
*gianluca.anzelmo@uniparthenope.it*

**ARAD SHOSHANA**

Ben Gurion  
Biotechnology Engineering  
POB 653, Beer Sheva, Israel  
Tel: +972-8-9479069  
Fax: 972-8-6479067  
*arad@bgu.ac.il*

**ARAGÃO LEONETI VALQUIRIA**

University of São Paulo (USP)  
Pharmaceutical Sciences  
14040903, Ribeirão Preto, Brazil  
Tel: 16 3602-4715  
Fax: 16 3602-4879  
*varagao@usp.br*

**ARAUJO RDORIGUES  
MUCHIUTTI PÂMELA**

Natura - Researcher  
13207340, Jundiai, Brazil  
Tel: +551144462725  
*pamelaaraujo@natura.net*

**ARDÀ FREIRE ANA**

CIB-CSIC, Chemical and Physical Biology  
Ramiro De Maeztu 9, 28040  
Madrid, Spain  
Tel: +34 91 837 31 12  
Fax: +34 91 536 04 32  
*aarda@cib.csic.es*

**ARSEQUELL GEMMA**

IQAC-CSIC, Química-Biomèdica  
Jordi Girona 18-26, Barcelona, Spain  
Tel: +34934006113  
*gemma.arsequell@iqac.csic.es*

**ARTNER DANIEL**

University of Natural Resources and  
Applied Life Sciences  
Department of Chemistry  
Muthgasse 18, A-1190, Wien, Austria  
Tel: +43 1 / 47654-6083  
*daniel.artner@boku.ac.at*

**ATES OZLEM**

Marmara University Faculty of Engineering  
Department of Bioengineering  
Goztepe Campus 34722, Istanbul, Turkey  
Tel: +902163480292 ext 718  
*ozlem.ates@marmara.edu.tr*

**AUDFRAY AYMERIC**

CERMAV-CNRS  
BP53, 38041 cedex 9, Grenoble, France  
Tel: +33 4 76 03 76 63  
*aymeric.audfray@cermav.cnrs.fr*

**AUSTIN SEAN**

Nestle Research Centre  
Department of Quality & Safety  
Vers-Chez-Les-Blanc, PO Box 44  
Lausanne, Switzerland  
Tel: +41 21 7858050  
Fax: +41 21 7858553  
*sean.austin@rdls.nestle.com*

**AWAN SHAHID I.**

Georg August University  
Institute of Organic and Biomol. Chemistry  
Labor. 202 IOBC. Tammannstr., 2 - 37077,  
Goettingen, Germany  
Tel: +49551393230  
*shahid14m@yahoo.com*

**AYKAÇ AHMET**

University of Almeria  
Organic Chemistry Department  
Ctra Sacramento s/n La cañada de San Urbano  
04120, Almeria, Spain  
Tel: +34950015481  
*aykaca@ual.es*

**AZUMA JUN-ICHI**

Kyoto University - Graduate School of Agriculture  
Kitashirakawa Oiwake-cho, Kyoto, Japan  
Tel: +81-75-753-6463  
Fax: +81-75-753-6471  
*azumaji@kais.kyoto-u.ac.jp*

**AZZOUZ MARIAM**

University Rovira i Virgili  
Química Analítica i Química Orgànica  
43007, Tarragona, Spain  
Tel: +34977558293  
*mariam.azzouz@estudiants.urv.cat*

**B****BAASOV TIMOR**

Technion - Department of Chemistry  
Schulich Faculty of Chemistry  
Haifa, Israel  
Tel: +972 48292590  
Fax: +972 48295703  
*chtimor@technion.ac.il*

**BAILEY ULLA MAJA**

University of Queensland - SCMB  
Building 76-125, Qld 4072, St Lucia  
Brisbane, Australia  
Tel: +61733651892  
*u.bailey@uq.edu.au*

**BARDILI BURKHART**

EPO  
Allingerstr. 26a, Eichenau, Germany  
Tel: 8923992132  
*bbardili@epo.org*

**BARRETO-BERGTER ELIANA**

Universidade Federal do Rio de Janeiro  
Instituto de Microbiologia  
Departamento de Microbiologia Geral  
CCS-Bloco I -room 65-Ilha do Fundão- 21941-  
902, Rio de Janeiro, Brazil  
Tel: +552125626741  
Fax: +552125608344  
*eliana.bergter@micro.ufrj.br*

**BARROCA-AUBRY NADINE**

Université Paris sud 11  
ue Georges Clemenceau, 91405, Orsay, France  
Tel: +33169154719  
Fax: +331694715  
*nadine.aubry-barroca@u-psud.fr*

**BATTA GYULA**

University of Debrecen  
Department of Chemistry  
Egyetem tér 1, Debrecen, Hungary  
Tel: +36 512 900 22234  
*batta@tigris.unideb.hu*

**BAUM DAVID**

University of Natural Resources and  
Life Sciences Vienna  
Department of Chemistry  
Division of Organic Chemistry  
Muthgasse 18, Wien, Austria  
Tel: +43-1-36006-6531  
*david.baum@boku.ac.at*

**BECCATI DANIELA**

Momenta Pharmaceuticals - Research Analytics  
675 West Kendall Street, Cambridge, USA  
Tel: +1 617 395 2785  
Fax: +1 617 621 0431  
*dbeccati@momentapharma.com*

**BECZALA AGNIESZKA**

University of Freiburg  
23845, Borstel, Germany  
Tel: +494537188257  
*abeczala@fz-borstel.de*

**BEDINI EMILIANO**

Università di Napoli Federico II  
Dipartimento di Chimica Organica e Biochimica  
Via Cintia 4, 80126, Napoli, Italy  
Tel: +39 081 674 153  
*ebedini@unina.it*

**BEERENS KOEN**

Ghent University  
Biochemical and Microbial Technology (InBio.be)  
Coupure links 653, Gent, Belgium  
Tel: +32 9 264 60 33  
Fax: +32 9 264 62 31  
*koen.beerens@ugent.be*

**BELL NICHOLLE**

University of Edinburgh  
Department of Chemistry  
West Mains Rd, Edinburgh, UK  
Tel: +441316507061  
*N.G.A.Bell@sms.ed.ac.uk*



**BENITO JUAN M**

CSIC - University of Sevilla  
Institute of Chemical Research  
Americo Vespucio, 49, E-41092, Sevilla, Spain  
Tel: +34954489560  
*juanmab@iiq.csic.es*

**BERNARDI ANNA**

Università degli Studi di Milano  
Chimica Organica e Industriale  
via Venezian 21 - 20133, Milano, Italy  
Tel: +39-02-50314092  
*anna.bernardi@unimi.it*

**BERTAUD ELISABETH**

GSK - R&D  
1330, Rixensart, Belgium  
Tel: +3226565912  
*cecile.latteur@gskbio.com*

**BERTI FRANCESCO**

Novartis Vaccines - Research  
Via Fiorentina 1, Siena, Italy  
Tel: +39 0577 243895  
*francesco.berti@novartis.com*

**BERTOLOTTI BENEDETTA**

Institute of Chemical Technology Prague  
Department of Chemistry of Natural Compounds  
Technicka 5, Prague, Czech Republic  
Tel: +420 220444239  
*benedetta.bertolotti@vscht.cz*

**BEURRET MICHEL**

RIVM  
Postbus 1, 3720 BA Bilthoven, The Netherlands  
Tel: +31-30-274 39 86  
*Michel.Beurret@rivm.nl*

**BHOWRUTH VEEMAL**

University of Birmingham  
School of Biosciences  
B15 2TT, Birmingham, UK  
Tel: 0121 4158123  
*veemal\_bhowruth@hotmail.com*

**BINI DAVIDE**

Università di Milano Bicocca  
Dipartimento di Biotecnologie e Bioscienze  
20126, Milano, Italy  
Tel: +39264483427  
*davide.bini@unimib.it*

**BISIO ANTONELLA**

Istituto di Ricerche Chimiche e Biochimiche  
"G. Ronzoni"  
Carbohydrate Sciences  
20133, Milano, Italy  
Tel: +39 02 70641630  
Fax: +39 02 70641634  
*bisio@ronzoni.it*

**BISKUP MORITZ B.**

Karlsruher Institut für Technologie  
Institut für Organische Chemie  
Fritz-Haber-Weg 6, Karlsruhe, Germany  
Tel: +49 721 608-48795  
Fax: +49 721 608-45637  
*moritz.biskup@kit.edu*

**BLANZAT MURIEL**

Université Toulouse III  
IMRCP, UMR CNRS 5623  
118 route de Narbonne, Toulouse, France  
Tel: +33 5 61 55 73 75  
*blanzat@chimie.ups-tlse.fr*

**BLAUKOPF MARKUS**

University of Natural Resources and  
Life Sciences  
Department of Chemistry  
Muthgasse 18, Wien, Austria  
Tel: +431476546083  
*markus.blaukopf@boku.ac.at*

**BLERIOT YVES**

Poitiers University - Department of Chemistry  
Laboratoire SRSN UMR 6514, Poitiers University,  
4 avenue Michel Brunet, Poitiers, France  
Tel: +33549453966  
*yves.bleriot@univ-poitiers.fr*

**BOISSET CLAIRE**

IFREMER - RBE  
BP 70 Technopole Brest Iroise, Plouzané, France  
Tel: +33 2 98 22 46 10  
Fax: 33 2 98 22 47 57  
*claire.boisset@ifremer.fr*

**BØJSTRUP MARIE**

Carlsberg Laboratory  
Carbohydrate Chemistry Group  
Gamle Carlsbergvej 10 - DK-1799  
Copenhagen V, Denmark  
Tel: +45 25219494  
*marie.bojstrup@carlsberglab.dk*

**BONNAFFÉ DAVID**

Université Paris-Sud 11 - ICMMO  
Bat. 420 UPS - 91 405, Orsay Cedex, France  
Tel: +33 1 69 15 72 33  
Fax: 33 1 69 15 47 15  
*david.bonnaffe@u-psud.fr*

**BORBÁS ANIKÓ**

University of Debrecen  
Research Group for Carbohydrates  
PO Box 94, Debrecen, Hungary  
Tel: +3652512900  
*borbasa@puma.unideb.hu*

**BORSENBARGER VINCIANE**

INSA Toulouse  
135 avenue de Rangueil, Toulouse, France  
Tel: +33561559988  
*vinciane.borsenberger@insa-toulouse.fr*

**BOULY NATHALIE**

University College Ghent  
9000, Ghent, Belgium  
Tel: +32 09/2447937  
*nathalie.bouly@hogent.be*

**BOURDREUX YANN**

Université Paris Sud 11  
Département de Chimie  
11, rue Georges Clemenceau, Orsay, France  
Tel: +33169157135  
Fax: +33169853715  
*yann.bourdreux@u-psud.fr*

**BOURKE JEAN**

Trinity College Dublin - Department of  
Chemistry  
64 Windmill Lane Apts, Sir John Rogerson Quay,  
Dublin 2, Dublin, Ireland  
Tel: +353868732219  
*bourkeje@tcd.ie*

**BOVIN NICOLAI**

Shemyakin&Ovchinnikov Institute of  
Bioorganic Chemistry  
Laboratory of Carbohydrates  
Miklukho-Maklaya 16/10, Moscow, Russia  
Tel: +74953307138  
*bovin@carb.ibch.ru*

**BOYSEN MIKE**

Leibniz University of Hannover  
Institute of Organic Chemistry  
Schneiderberg 1B, D-30167, Hannover, Germany  
Tel: +495117624643  
Fax: +495117623011  
*mike.boysen@oci.uni-hannover.de*

**BRAND CHRISTIAN**

Goettingen  
Organic and Biomolecular Chemistry  
Tammannstr. 2, Goettingen, Germany  
Tel: +49551393229  
*bchrist@gwdg.de*

**BRASILE GIUSEPPINA**

Università di Milano  
Chimica, Biochimica, Biotecnologie  
per la Medicina  
Via del Franzone 43, Brescia, Italy  
Tel: +39 3286933843  
*giuseppina.brasile@unimi.it*

**BREGOLA MASSIMO**

Cargill - Sales  
Via Cerestar, 1, Castelmassa (RO), Italy  
Tel: +39 0425 848601  
*massimo\_bregola@cargill.com*

**BROGIONI GIULIA**

Novartis Vaccines - Research  
Via Fiorentina 1, Siena, Italy  
Tel: +39 0577 245303  
*giulia.brogioni@novartis.com*

**BROUILLETTE FRANÇOIS**

Université du Québec à Trois-Rivières  
Département de Chimie  
3351 boul. des Forges, Trois-Rivières, Canada  
Tel: +1-819-376-5011  
*brouillf@uqtr.ca*

**BUDA SZYMON**

Jagiellonian University  
Faculty of Chemistry  
30-060, Kraków, Poland  
Tel: +48-12-663-2035  
*szymek\_n@wp.pl*

**BUSICO TERESA**

II Università degli Studi di Napoli  
Medicina Sperimentale  
81055, S. Maria Capua Vetere, Italy  
Tel: +39 0823797204  
*teresa.busico@alice.it*

**BYSTRICKY PETER**

Masaryk University - CEITEC MU  
Kamenice 5, Brno, Czech Republic  
Tel: +420-549493253  
*peterbys@chemi.muni.cz*

**C****CABERO KAREN**

Lund University  
PO Box 124, Lund, Sweden  
Tel: +46462228269  
*karen.cabero@chemeng.lth.se*

**CABRERA-ESCRIBANO FRANCISCA**

University of Seville  
Department of Organic Chemistry  
Apartado de Correos, No. 1203, 41071  
Seville, Spain  
Tel: +34 954556868  
Fax: +34 954624960  
*fcabrera@us.es*

**CACCIARINI MARTINA**

Università di Firenze  
Dipartimento di Chimica "U. Schiff"  
50019, Sesto F.no (FI), Italy  
Tel: +390554573544  
*martina.cacciarini@unifi.it*

**CALABRESE GRACIELA**

Buenos Aires University  
Department of Biological Sciences  
Junin 956 First Floor, Buenos Aires, Argentina  
Tel: +54-011-49648238  
*gcalabe@ffyb.uba.ar*

**CALABRESE VALENTINA**

Università Milano-Bicocca  
Dipartimento di Biotecnologie e bioscienze  
Via Martiri di Cefalonia 5/f, Opera (MI), Italy  
Tel: +39 0257619165  
*valentina.calabrese@unimib.it*

**CANCOGNI DAMIANO**

Università degli Studi di Milano  
Dipartimento di Chimica Organica e Industriale  
Via Venezian 21, Milano, Italy  
Tel: +39 0250314063  
*damiano.cancogni@unimi.it*

**CANGIANO ADRIANO**

Instituto de Química Orgánica General  
Dipartimento di Química Biorganica  
Calle Juan de la Cierva 3, Madrid, Spain  
Tel: +34 915622900  
Fax: +34 915644853  
*a.cangiano@iqog.csic.es*

**CARDONA FRANCESCA**

University of Florence  
Department of Chemistry  
Via della Lastruccia 13, Sesto Fiorentino, Italy  
Tel: +39 055 4573504  
Fax: +39 055 4573531  
*francesca.cardona@unifi.it*

**CARILLO SARA**

Università di Napoli Federico II  
Dipartimento di Chimica Organica e Biochimica  
Via Cintia 4, 80126, Napoli, Italy  
Tel: +39 081 674 150  
*sara.carillo2@unina.it*

**CARMONA ASENJO ANA TERESA**

University of Seville  
Department of Organic Chemistry  
41012, Seville, Spain  
Tel: +34954559997  
Fax: +34954624960  
*anaterere@us.es*

**CARPENE MARIE-ANNE**

CNRS - UMR5623  
bat 2R1 118 route de Narbonne 31062  
Toulouse, France  
Tel: +33 56155-8333  
*carpene@chimie.ups-tlse.fr*

**CARVALHO IVONE**

University of São Paulo  
Department of Pharmaceutical Sciences  
Avenida do Café s/n, Monte Alegre  
CEP: 14040-903, Ribeirão Preto, Brazil  
Tel: +55 16 36024709  
Fax: +55 16 36024178  
*carronal@usp.br*

**CASADO BEGOÑA**

Nestlé Research Center  
Vers-chez-les-blanc, Lausanne, Switzerland  
Tel: +41217858668  
*begona.casado@rdls.nestle.com*

**CASSEL STEPHANIE**

University Toulouse III  
IMRCP, UMR CNRS 5623  
118 route de Narbonne, Toulouse, France  
Tel: +33 5 61 55 73 75  
*cassel@chimie.ups-tlse.fr*

**CASTILLA LÓPEZ JAVIER**

Universitat Rovira i Virgili  
Departament de Química Analítica i  
Química Orgànica  
C\ Mossen Salvador Babot nº21 (43480)  
Vilaseca (Tarragona), Spain  
Tel: +34676944273  
*javier.castilla@urv.cat*

**CASTRO ISABEL**

University of Chile  
Department of Cellular and Molecular Biology  
Independencia 1027, Independencia  
Santiago, Chile  
Tel: +56-02-9786581  
*iv\_castro@med.uchile.cl*

**CATELANI GIORGIO**

Università di Pisa  
Dipartimento di Scienze Farmaceutiche  
Via Bonanno 33, Pisa, Italy  
Tel: +39 050 2219678  
Fax: + 39 050 2219660  
*giorgio.catelani@farm.unipi.it*

**CATTANEO VITTORIO**

Università degli Studi di Milano  
Dipartimento di Chimica Organica e Industriale  
via Venezian 21, Milano, Italy  
Tel: +39 250314063  
*vittorio.cattaneo@unimi.it*

**CESCUTTI PAOLA**

University of Trieste  
Department of Life Sciences  
via L. Giorgieri 1, Trieste, Italy  
Tel: +39 040 5583685  
Fax: +39 040 5583691  
*pcescutti@units.it*

**CHA JAEHO**

Pusan National University  
Department of Microbiology  
609-735, Busan, Korea  
Tel: +82-51-510-2196  
*jhcha@pusan.ac.kr*

**CHABROL ERIC**

Univ Grenoble 1 - IBS  
41 RUE JULES HOROWITZ, Grenoble, France  
Tel: +33 4 38 78 56 09  
Fax: +33 4 38 78 54 94  
*eric.chabrol@ibs.fr*

**CHAMBERT STÉPHANE**

COB - INSA Lyon - ICBMS  
Bat J Verne, 20 Avenue A Einstein  
Villeurbanne, France  
Tel: +33 4 72.43.83.42  
Fax: +33 4 72.73.88.96  
*stephane.chambert@insa-lyon.fr*

**CHANDRASEKARAN VIJAYANAND**

Christiana Albertina University of Kiel  
Otto Diels Institute of Organic Chemistry  
Otto Hahn Platz 4 - 24098, Kiel, Germany  
Tel: +49 431 8801936  
Fax: +49 431 8807410  
*vanand@oc.uni-kiel.de*

**CHAPLEUR YVES**

Nancy - Groupe SUCRES  
BP 70239, Vandoeuvre, France  
Tel: +33383684773  
Fax: +33383684780  
*yves.chapleur@sucres.uhp-nancy.fr*

**CHASSAGNE PIERRE**

Institut Pasteur - Chimie des Biomolécules  
27 rue du Dr Roux, 75015 Paris, France  
Tel: +33140613677  
*pierre.chassagne@pasteur.fr*

**CHIEN-FU LIANG**

National Tsing Hua University  
Department of Chemistry  
101, Sec 2, Kuang-Fu Rd., 30013 Hsinchu, Taiwan  
Tel: +886-3-5731288  
*liangchienfu@gmail.com*

**CHIEN-HUNG LIN**

National Tsing Hua University  
Department of Chemistry  
101, Sec 2, Kuang-Fu Rd., 30013 Hsinchu, Taiwan  
Tel: +886-3-5731288  
*aganken@gmail.com*

**CHIODO FABRIZIO**

CIC biomaGUNE  
Biofunctional Nanomaterials  
Paseo de Miramón n° 182, San Sebastián, Spain  
Tel: +34943005324  
Fax: +34943005314  
*fchiodo@cicbiomagune.es*

**CHMIELEWSKI MAREK**

Institute of Organic Chemistry  
Polish Academy of Sciences  
ul. Kasprzaka 44/52, 01-224 Warsaw, Poland  
Tel: +48(22)3432320  
Fax: +48(22)6326681  
*marek.chmielewski@icho.edu.pl*

**CHOMA ADAM**

Maria Curie-Skłodowska University  
Department of Genetics and Microbiology  
Akademicka 19, 20-033, Lublin, Poland  
Tel: +48 81 537 5981  
Fax: +48 81 537 5959  
*adam.choma@poczta.umcs.lublin.pl*

**CHOPRA PRADEEP**

Griffith University - Institute of Glycomics  
9 LONGCOVE PLACE, Parkwood Qld 4214,  
Australia  
Tel: +61 425879765  
*p.chopra@griffith.edu.au*

**CHRISTENSEN BJØRN E.**

Norwegian Univ. of Science and Technology  
(NTNU) - Biotechnology  
Sem Saelands veg 6/8, Trondheim, Norway  
Tel: +4773593327  
*b.christensen@biotech.ntnu.no*

**CHRISTENSEN HELLE**

Aarhus University - Department of Chemistry  
8000, Århus C, Denmark  
Tel: +458942 1111  
Fax: +458619 6199  
*hellec@chem.au.dk*

**CHRISTINA ALPHERT**

Leiden University - Bio-organic Synthesis Group  
Einsteinweg 55, Leiden, The Netherlands  
Tel: +3171 527 44 77  
*christinaae@chem.leidenuniv.nl*

**CIANCIA MARINA**

Universidad de Buenos Aires  
Catedra de Quimica de Biomoleculas  
Av San Martin 4453, Buenos Aires, Argentina  
Tel: + 54 11-4524-8088  
Fax: + 54 11-4524-8088  
*ciancia@agro.uba.ar*

**CIEPLAK MACIEJ**

Institute of Organic Chemistry PAS  
ul. Kasprzaka 44/52, 01-224, Warsaw, Poland  
Tel: +48 22 343 20 00  
*maciej.cieplak@icho.edu.pl*

**CIPOLLA LAURA**

University of Milano-Bicocca  
Biotechnology and Biosciences  
P.za della Scienza 2, Milano, Italy  
Tel: +390264483427  
*laura.cipolla@unimib.it*

**CLAISSE NATHALIE**

Cermav  
601 rue de la chimie, BP53 cedex 9, 38041  
Grenoble, France  
Tel: 0476037665  
*Nathalie.Claisse@cermav.cnrs.fr*

**CLARKE PAUL**

Dublin City University - ISSC  
Collins Avenue, Dublin, Ireland  
Tel: +35317005961  
Fax: +35317008021  
*paul.clarke3@gmail.com*

**CLAUSEN MADS**

Technical University of Denmark  
Department of Chemistry  
Kemitorvet 201 - 2800 Kgs., Lyngby, Denmark  
Tel: +45 45252131  
*mhc@kemi.dtu.dk*

**COBUCCI-PONZANO BEATRICE**

CNR - Institute of Protein Biochemistry  
via P. Castellino 111, Naples, Italy  
Tel: +39 081 6132564  
*b.cobucciponzano@ibp.cnr.it*

**CODEE JEROEN**

Leiden University - Institute of Chemistry  
Einsteinweg 55, Leiden, The Netherlands  
Tel: +31-715274280  
*jcodee@chem.leidenuniv.nl*



**CODERA VICTORIA**

IQS-Universitat Ramon Llull  
Bioengineering Department  
Via Augusta 390, Barcelona, Spain  
Tel: +34-932672000  
*mcoderap@iqs.es*

**COLINAS PEDRO A.**

Universidad Nacional de La Plata  
LADECOR, Departamento de Química, Facultad  
de Ciencias Exactas  
47 y 115, La Plata, Argentina  
Tel: +54-221-4243104  
*pcolinas@quimica.unlp.edu.ar*

**COLOMBO CINZIA**

Università degli Studi di Milano  
Chimica Organica e Industriale  
Via Venezian 21, Milano, Italy  
Tel: +39 0250314088  
*cinzia.colombo@unimi.it*

**COMPOSTELLA FEDERICA**

University of Milan  
Dept. of Medical Chemistry, Biochemistry and  
Biotechnology  
Via Saldini, 50, Milano, Italy  
Tel: +39 0250316045  
Fax: +39 0250316036  
*federica.compostella@unimi.it*

**CORDARA GABRIELE**

University of Oslo  
Department of Chemistry  
Sem Saelandsvei 26, Oslo, Norway  
Tel: +4722857382  
*gabriele.cordara@kjemi.uio.no*

**CORDERO FRANCA M.**

Università di Firenze - Dipartimento di Chimica  
via della Lastruccia 13, Sesto Fiorentino (FI), Italy  
Tel: +39 055 4573498  
*franca.cordero@unifi.it*

**CORSARO MARIA MICHELA**

Università di Napoli Federico II  
Dipartimento di Chimica Organica e Biochimica  
Via Cintia 4, 80126, Napoli, Italy  
Tel: +39 081 674 149  
*corsaro@unina.it*

**COSTANTINO PAOLO**

Novartis Vaccines - Research  
Via Fiorentina, 1, Siena, Italy  
Tel: +39-0577-243324  
*paolo.costantino@novartis.com*

**CRICH DAVID**

CNRS - ICSN  
avenue de la Terrasse, Gif-sur-Yvette, France  
Tel: +33 1 69 82 30 89  
*dcrich@icsn.cnrs-gif.fr*

**CROTTI PAOLO**

Università di Pisa  
Dipartimento di Scienze Farmaceutiche  
Via Bonanno, 33 - 56126 Pisa, Italy  
Tel: +39 050 2219690  
Fax: +39 050 2219660  
*paolo.crotti@farm.unipi.it*

**CSÁVÁS MAGDOLNA**

University of Debrecen  
Research Group for Carbohydrates  
4032, Debrecen, Hungary  
Tel: +3652512900/22157  
*csavas@index.hu*

**CZABANSKA ANNA**

Research Center Borstel - Structural Biochemistry  
23845, Borstel, Germany  
Tel: +494537188320  
*aczabanska@fz-borstel.de*

**D****D'ALONZO DANIELE**

Università di Napoli Federico II  
Dipartimento di Chimica Organica e Biochimica  
Via Cintia 4, 80126, Napoli, Italy  
Tel: +39 081 674 119  
*dandalonzo@unina.it*

**DALY ROBIN**

Trinity College Dublin - Department  
of Chemistry  
19 Rosslee, Kilkenny Cross, Castlebar, Co. Mayo,  
Castlebar, Ireland  
Tel: 87764-6024  
*dalyro@tcd.ie*

**DAMEROW SEBASTIAN**

Hannover Medical School  
Institute of Cellular Chemistry  
Carl-Neuberg Strasse 1, Hannover, Germany  
Tel: +49511 5328303  
*damerow.sebastian@mh-hannover.de*



**D'ANDREA FELICIA**

University of Pisa - Scienze Farmaceutiche  
via Bonanno 33, Pisa, Italy  
Tel: +390502219679  
Fax: +390502219660  
*felicia.dandrea@farm.unipi.it*

**DANGERFIELD EMMA**

Malaghan Institute of Medical Research/VUW  
38 Rintoul St, Newtown, Wellington  
New Zealand  
Tel: +64 4 9703791  
*edangerfield@malaghan.org.nz*

**D'ASCENZI SANDRO**

Novartis Vaccines - Tech. Development  
Via Fiorentina 1, Siena, Italy  
Tel: +39 0577 243218  
*sandro.dascenzi@novartis.com*

**DAUNER MARTIN**

Universität Konstanz  
Universitätsstr. 10 - 78457, Konstanz, Germany  
Tel: +497531882821  
*martin.dauner@uni-konstanz.de*

**DAVIES GIDEON**

University of York - Department of Chemistry  
Structural Biology Laboratory  
University of York, York, UK  
Tel: +441904328260  
*davies@ysbl.york.ac.uk*

**DAVIS BENJAMIN**

University of Oxford  
Chemistry Research Laboratory  
12 Mansfield Road, Oxford, UK  
Tel: +441865275652  
*ben.davis@chem.ox.ac.uk*

**DE ANDRADE PETERSON**

Faculty of Pharmaceutical Sciences  
University of São Paulo  
Pharmaceutical Sciences  
1404090, Ribeirão Preto, Brazil  
Tel: +55(16) 36024709  
*peterson@fcfrp.usp.br*

**DE CASTRO CRISTINA**

Università di Napoli Federico II  
Dipartimento di Chimica Organica e Biochimica  
Via Cintia 4, 80126, Napoli, Italy  
Tel: +39 081 674 124  
Fax: +39 081 674 393  
*decastro@unina.it*

**DE JONG AR**

Leiden University - Bio-Organic Synthesis  
Vierlinghlaan 166, 2332CZ, Leiden, The  
Netherlands  
Tel: 61540-3534  
*naraedejong@gmail.com*

**DE NISCO MAURO**

Università di Napoli Federico II  
Dipartimento di Chimica Organica e Biochimica  
Via Cintia 4, 80126, Napoli, Italy  
Tel: +39 081 674 118  
*denisco@unina.it*

**DE WINTER KAREL**

Ghent University  
Biochemical and Microbial Technology (InBio.be)  
Coupure links 653, Gent, Belgium  
Tel: +32 9 264 60 33  
Fax: +32 9 264 62 31  
*karel.dewinter@ugent.be*

**DEDOLA SIMONE**

University of Osaka - Department of Chemistry  
560-0043, Osaka, Japan  
Tel: +81 6-6850-5381  
Fax: +81 6-6850-5382  
*s\_dedola@chem.sci.osaka-u.ac.jp*

**DESIRE JEROME**

Université de Poitiers - Umr Cnrs 6514  
40 Av. Recteur Pineau 86022, Poitiers, France  
Tel: +33 5 49 36 63 89  
*jerome.desire@univ-poitiers.fr*

**DESMET TOM**

Ghent University  
Biochemical and Microbial Technology (InBio.be)  
Coupure links 653, Gent, Belgium  
Tel: +32 9 264 60 33  
Fax: +32 9 264 62 31  
*t.desmet@ugent.be*

**DI BUSSOLO VALERIA**

Università di Pisa  
Dipartimento di Scienze Farmaceutiche  
Via Bonanno, 33, Pisa, Italy  
Tel: +39 0502219667  
Fax: +39 0502219660  
*valeriadb@farm.unipi.it*

**DI LORENZO FLAVIANA**

Università di Napoli Federico II  
Dipartimento di Chimica Organica e Biochimica  
Via Cintia 4, 80126, Napoli, Italy  
Tel: + 39 3206817311  
*flavianadilorenzo@gmail.com*

**DI PIETRO SIMONE**

Johannes Gutenberg Universität Mainz  
Department of Organic Chemistry  
Duesbergweg 10-14, Mainz, Germany  
Tel: +4961313922272  
Fax: +49061313922338  
*dipietro@uni-mainz.de*

**DIAZ YOLANDA**

University Rovira i Virgili  
Department of Organic Chemistry  
C(Marcel·lí Domingo s/n Campus Sescelades -  
43007, Tarragona, Spain  
Tel: +34 977 55 8151  
Fax: +34 977558446  
*yolanda.diaz@urv.cat*

**DITYATEV ALEXANDER**

Italian Institute of Technology  
Neuroscience and Brain Technologies  
via Morego 30, Genova, Italy  
Tel: +39 010 71781515  
*alexander.dityatev@iit.it*

**DIXON RACHEL**

Industrial Research Limited  
GlycoSyn  
69 Gracefield Road, PO Box 31-310  
Lower Hutt, New Zealand  
Tel: +64 4 9313106  
*r.dixon@irl.cri.nz*

**DJEDAINI-PILARD FLORENCE**

University of Picardy Jules Verne  
Laboratoire des Glucides  
F-80 039, Amiens, France  
Tel: +33 3 22 82 75 62  
Fax: 33 3 22 82 75 60  
*florence.pilard@u-picardie.fr*

**DOBRUCHOWSKA JUSTYNA**

University of Groningen  
Department of Microbial Physiology  
Nijenborgh 7, Groningen, The Netherlands  
Tel: +31503632166  
*j.dobrurowska@rug.nl*

**DOISNEAU GILLES**

University Paris-Sud - Department of Chemistry  
Faculté des sciences, LSB Bât 430, ICMMO  
Orsay, France  
Tel: +33 1 69 15 48 33  
Fax: +33 1 69 85 37 15  
*gilles.doisneau@u-psud.fr*

**DOKNIC DANIELA**

Università degli Studi di Milano  
Dipartimento di Chimica Organica e Industriale  
Via Venezian 21, Milano, Italy  
Tel: +39 0250314088  
*daniela.doknic@unimi.it*

**D'ORAZIO GIUSEPPE**

University of Milano - Bicocca  
Department of Biotechnology and Biosciences  
20126, Milano, Italy  
Tel: +39 0264483419  
*g.dorazio@campus.unimib.it*

**DRIGUEZ PIERRE-ALEXANDRE**

Sanofi-Aventis  
Early To Candidate  
1, Avenue Pierre Brossolette, 91385  
Chilly-Mazarin, France  
Tel: +33 01 60 49 68 99  
*alexandre.driguez@sanofi-aventis.com*

**DUBAYLE JEAN**

Sanofi Pasteur  
Analytical Research and Development  
1541 Avenue M.Mérieux, 69280  
Marcy L'Etoile, France  
Tel: +33 04 37 37 97 88  
Fax: + 33 04 37 37 31 80  
*jean.dubayle@sanofipasteur.com*

**DUDA KATARZYNA**

Research Center Borstel - Structural Biochemistry  
Parkallee 4a/4c, D-23845, Borstel, Germany  
Tel: +494537188249  
*kduda@fz-borstel.de*

**DURAIKKANNU LOGANATHAN**

Indian Institute of Technology Madras  
Department of Chemistry  
600036, Chennai, India  
Tel: +91-44-22574206  
Fax: +91-44-22570509  
*loganath@iitm.ac.in*

**DUSSOUY CHRISTOPHE**

Université de Picardie Jules Verne  
15 rue de Verdun - Résidence "Rives D'ambiani"  
Appartement 124, Amiens, France  
Tel: +33 322827560  
*christophe.dussouy@u-picardie.fr*

**DUVIVIER PIERRE**

GSK - R&D  
1330, Rixensart, Belgium  
Tel: +3226565912  
*pierre.duvivier@gskbio.com*

**E****EHRET MARKUS**

Karlsruhe Institute of Technology  
Institute of Organic Chemistry  
Fritz-Haber-Weg 6 - 76131, Karlsruhe, Germany  
Tel: +4972160845636  
Fax: +4972160845637  
*markus.ehret@kit.edu*

**EKHOLM FILIP**

Åbo Akademi University  
Laboratory of Organic Chemistry  
20100, Åbo, Finland  
Tel: +35840-7590853  
*filip.ekholm@abo.fi*

**ELCHINGER PIERRE-HENRI**

Université de Limoges - Sciences  
123 Avenue ALBERT THOMAS, Limoges, France  
Tel: +33627709517  
*elchinger@live.fr*

**ELEFANTE CONCETTA**

Università di Napoli Federico II  
Dipartimento di Chimica Organica e Biochimica  
Via Cintia 4, 80126, Napoli, Italy  
Tel: +39 3497467631  
*concettaelefante@hotmail.it*

**ELLI STEFANO**

Istituto di Ricerche Chimiche e Biochimiche  
"G. Ronzoni"  
NMR and Carbohydrates  
via Giuseppe Colombo 81, Milano, Italy  
Tel: +39 02 70641601  
Fax: +39 02 70641634  
*stefano.elli@gmail.com*

**ERBS GITTE**

LIFE, University of Copenhagen  
Dept. of Plantbiology and Biotechnology  
1871, Frederiksberg C., Denmark  
Tel: +45 35332581  
*ger@life.ku.dk*

**EVANS GARY**

Industrial Research  
Carbohydrate Chemistry Group  
69 Gracefield Rd, Lower Hutt, New Zealand  
Tel: +64-4-9313040  
*g.evans@irl.cri.nz*

**EVERSLEY DAVID**

Carbosynth Ltd  
8 & 9 Old Station Business Park, Compton,  
Berkshire, Newbury, UK  
Tel: +44 (0) 1635 578444  
Fax: +44 (0) 1635 579444  
*david.eversley@carbosynth.com*

**EVIDENTE ANTONIO**

Università di Napoli Federico II  
Scienze del Suolo, della Pianta, dell'Ambiente e  
delle Produzioni Animali  
Via Università 100 - 80055, Portici, Italy  
Tel: +390812539179  
Fax: +300812539186  
*evidente@unina.it*

**F****FAIJES MAGDA**

IQS-Universitat Ramon Llull  
Bioengineering Department  
Via Augusta 390, Barcelona, Spain  
Tel: +34 932672000  
*magda.faijes@iqs.es*

**FAIRBANKS ANTONY**

University of Canterbury  
Department of Chemistry  
Christchurch, New Zealand  
Tel: +6433643097  
Fax: +6433642110  
*antony.fairbanks@canterbury.ac.nz*

**FAUGERAS PIERRE-ANTOINE**

Université de Limoges - LCSN  
123 ave Albert Thomas, Limoges, France  
Tel: +33-5-55-45-72-02  
*pierre-antoine.faugeras@etu.unilim.fr*

**FAZEKAS ERIKA**

University of Debrecen  
Department of Inorganic and Analytical  
Chemistry  
4031, Debrecen, Hungary  
Tel: +3652/512900/22843  
*fazekas.erika@science.unideb.hu*

**FELDMAN MARIO**

University of Alberta - Biologicals Sciences  
T6G 2E9, Edmonton, Canada  
Tel: +1 780 4926105  
*mfeldman@ualberta.ca*

**FERNÁNDEZ-BOLAÑOS JOSÉ G.**

University of Seville  
Department of Organic Chemistry  
Prof García González 1, E-41012, Seville, Spain  
Tel: +34 954 550996  
Fax: +34 954 624960  
*bolanos@us.es*

**FERNANDEZ-GARCIA CHRISTIAN**

University of Bristol - School of Chemistry  
BS8 1TS, Bristol, UK  
Tel: +44 (0)117 954 6312  
*chycf@bristol.ac.uk*

**FERRIERES VINCENT**

ENSC Rennes - UMR CNRS 6226  
Avenue du Général Leclerc - CS 50837, 35708  
Rennes Cedex 7, France  
Tel: +33 223238058  
Fax: +33 223238046  
*vincent.ferrieres@ensc-rennes.fr*

**FIESCHI FRANCK**

Univ Grenoble 1 - IBS  
41 Rue Jules Horowitz, Grenoble, France  
Tel: +33 4 38 78 91 77  
Fax: +33 4 38 78 54 94  
*franck.fieschi@ibs.fr*

**FISCHER KATHLEEN**

Research Center Borstel - Structural Biochemistry  
Parkallee 4a - 23845, Borstel, Germany  
Tel: +49 4537 188320  
*kfisher@fz-borstel.de*

**FORINI ANDREA**

Cargill - Sales Dept.  
Via Cerestar, 1, Castelmassa (RO), Italy  
Tel: +39 0425 848714  
*andrea\_forini@cargill.com*

**FORT SÉBASTIEN**

CERMAV CNRS  
38041, Grenoble, France  
Tel: +33 476 03 76 64  
*Sebastien.fort@cermav.cnrs.fr*

**FRAU ILEANA**

Università di Pisa  
Dip. Scienze Farmaceutiche  
Via Bonanno, 33 - 56126, Pisa, Italy  
Tel: +39 0502219696  
Fax: +39 0502219660  
*ileana.frau@farm.unipi.it*

**FREGOLINO ELEONORA**

Università di Napoli Federico II  
Dipartimento di Chimica Organica e Biochimica  
Via Cintia 4, 80126, Napoli, Italy  
Tel: +39 081 674 152  
*eleonora.fregolino@unina.it*

**FRIDMAN MICHA**

Tel-Aviv University - Department of Chemistry  
School of Chemistry, Tel Aviv, Israel  
Tel: +972-3-640-8687  
Fax: +972-3-640-9293  
*mfridman@post.tau.ac.il*

**FRIHED TOBIAS**

University of Copenhagen  
Department of Chemistry  
Øster Voldgade 20, 401, København K, Denmark  
Tel: 2693-4585  
*tobias\_frihed@jubii.dk*

**FÜGEDI PÉTER**

Chemical Research Center  
Hungarian Academy of Sciences  
Pusztaszeri ut 59-67, Budapest, Hungary  
Tel: +36-1-4381100  
*pfugedi@chemres.hu*

**FUJIMOTO YUKARI**

Osaka University - Department of Chemistry  
Graduate School of Science  
560-0043, Toyonaka, Japan  
Tel: +81-6-6850-5391  
Fax: +81-6-6850-5419  
*yukarif@chem.sci.osaka-u.ac.jp*

**FUKAMIZO TAMO**

Kinki University  
Department of Advanced Bioscience  
3327-204 Nakamachi, Nara, Japan  
Tel: +81-742-43-8237  
Fax: +81-742-43-8976  
*fukamizo@nara.kindai.ac.jp*

**FUNANE KAZUMI**

National Food Research Institute  
Applied Microbiology Division  
2-1-12 Kannondai, Ibaraki 305-8642  
Tsukuba, Japan  
Tel: +81-29-838-8075  
Fax: +81-29-838-8122  
*funane@affrc.go.jp*

**FYRNER TIMMY**

Linköping University - IFM/Chemistry  
Linköpings Universitet, Linköping, Sweden  
Tel: +4613286603  
*timfy@ifm.liu.se*

**G****GABRIELLI LUCA**

University of Milano-Bicocca  
Biotechnology and Biosciences  
P.za della Scienza 2, Milano, Italy  
Tel: +390264483427  
*l.gabrielli2@campus.unimib.it*

**GALAN M. CARMEN**

University of Bristol - School of Chemistry  
Cantock's Close, Bristol, UK  
Tel: +44 1179287654  
*chmcgh@bris.ac.uk*

**GANCARZ ROMAN**

Wrocław University of Technology  
Chemistry Department  
50-371, Wrocław, Poland  
Tel: +48 71 320 39 72  
*roman.gancarz@pwr.wroc.pl*

**GAO QI**

Università degli Studi di Milano  
Chimica Organica e Industriale  
via Venezian 21, 20133, Milano, Italy  
Tel: +39 0250314063  
Fax: +39 0250314061  
*qi.gao@unimi.it*

**GARCIA-MORENO MARIA ISABEL**

University of Seville  
Department of Organic Chemistry  
Faculty of Chemistry, c/ Profesor Garcia  
Gonzalez, 1, E41012, Seville, Spain  
Tel: +34954559997  
Fax: +34954624960  
*isagar@us.es*

**GAROZZO DOMENICO**

CNR ICTP Catania  
Via P. Gaifami 18, Catania, Italy  
Tel: +39 0957338259  
*domenico.garozzo@cnr.it*

**GASCH ILLESCAS CONSOLACIÓN**

Universidad de Sevilla, Facultad de Química  
c/ Prof. García González, nº1  
Departamento de Química Orgánica  
41012, Seville, Spain  
Tel: +34954557150  
Fax: +34 954624960  
*cgasch@us.es*

**GAUTHIER CHARLES**

University of Oxford  
Chemistry Research Laboratory  
Flat 3, Staincross House, Albion Place, Oxford,  
UK  
Tel: +44 1865 726754  
*charlo.gauthier@gmail.com*

**GAVARD OLLIVIER**

GSK - R&D  
1330, Rixensart, Belgium  
Tel: +3226565912  
*ollivier.gavard@gskbio.com*

**GERARDY-SCHAHN RITA**

Medizinische Hochschule Hannover  
Abteilung Zelluläre Chemie, OE 4330  
Carl-Neuberg-Strasse 1 - 30625  
Hannover, Germany  
*Gerardy-Schahn.Rita@mh-hannover.de*

**GEYER HILDEGARD**

Justus-Liebig-University Giessen  
Institute of Biochemistry, FB 11  
Friedrichstrasse 24 - D35392, Giessen, Germany  
Tel: +49 641 9947412  
*hildegard.geyer@biochemie.med.uni-giessen.de*

**GEYER RUDOLF**

Justus-Liebig-University Giessen  
Institute of Biochemistry, FB 11  
Friedrichstrasse 24 - D35392, Giessen, Germany  
Tel: +49 641 9947400  
*rudolf.geyer@biochemie.med.uni-giessen.de*

**GHADBAN ALI**

CNRS - CERMAV  
BP53, 38041, Grenoble, France  
Tel: +33 4 76 03 76 25  
*ali.ghadban@cermav.cnrs.fr*



**GHISAIDOOBE AMAR**

University of Leiden - Biosyn  
Einstein weg 50, Leiden, The Netherlands  
Tel: 65164-4764  
*a.ghisaidoobe@chem.leidenuniv.nl*

**GIL-SERRANO ANTONIO M.**

University of Seville  
Department of Organic Chemistry  
Prof. García González nº1, Seville, Spain  
Tel: +34 954559563  
Fax: +34 954624960  
*agil@us.es*

**GIULIANO ROBERT**

Villanova University  
Department of Chemistry  
800 E Lancaster Ave, Villanova PA 19085, USA  
Tel: 610519-5433  
Fax: 610519-7167  
*robert.giuliano@villanova.edu*

**GOLOVCHENKO VICTORIA**

Institute of Physiology, Komi Science Centre,  
The Urals Branch of the Russian  
50, Pervomaiskaya str., Syktyvkar, 167982,  
Syktyvkar, Russia  
Tel: +7(8212)241001  
Fax: +7(8212)241101  
*lemnan@mail.ru*

**GOMEZ D'AYALA GIOVANNA**

CNR - Institute of Polymer Chemistry and  
Technology (ICTP)  
Via Campi Flegrei 34, Pozzuoli (NA), Italy  
Tel: +39 0818675214  
*giovanna.gomez@ictp.cnr.it*

**GÓRSKA-FRĄCZEK SABINA**

Institute of Immunology and  
Experimental Therapy  
Medical Microbiology  
Weigla 12, Wrocław, Poland  
Tel: +48 71 337-11-72  
*sabina.gorska@iitd.pan.wroc.pl*

**GOSS EVA**

LC Scientific Inc.  
5-150 Connie Crescent, Concord  
Ontario, Canada  
Tel: +1-905-669-0017  
Fax: +1-905-669-0193  
*evagoss@lcsci.com*

**GOSS BARBARA**

LC Scientific Inc.  
5-150 Connie Crescent, Concord  
Ontario, Canada  
Tel: +1 905 669 0017  
Fax: +1 905 669 0193  
*evagoss@lcsci.com*

**GOTI ANDREA**

University of Firenze - Department of Chemistry  
Via della Lastruccia 13, Sesto Fiorentino (FI), Italy  
Tel: +39 055 4573505  
Fax: +39 055 4573531  
*andrea.goti@unifi.it*

**GOYARD DAVID**

University of Lyon / CNRS  
Department of Chemistry and Biochemistry  
Universite Lyon 1 / ICBMS / Bat Curien CPE /  
43 Bd du 11 Novembre, F-69622 Villeurbanne,  
France  
Tel: +33 472 448 349  
*davidgoyard@gmail.com*

**GRABOSCH CARSTEN**

Christiana Albertina University of Kiel  
Otto Diels Institute of Organic Chemistry  
Otto Hahn Platz 4 - 24098, Kiel, Germany  
Tel: +49 431 8801937  
Fax: +49 431 8807410  
*cgrabosch@oc.uni-kiel.de*

**GRAGNANI TIZIANA**

University of Pisa  
Dipartimento di Scienze Farmaceutiche  
Via Bonanno 33, Pisa, Italy  
Tel: +39 0502219697  
Fax: +39 0502219660  
*tiziana.gragnani@for.unipi.it*

**GRANDJEAN CYRILLE**

Université de Picardie Jules Verne  
UMR CNRS 6219 - Laboratoire des Glucides  
10, rue Baudelocque - 80000, Amiens, France  
Tel: +33 322 828 812  
Fax: +33 322 827 560  
*cyrille.grandjean@u-picardie.fr*

**GRAYSON ELIZABETH**

Durham University - Department of Chemistry  
South Road, Durham DH1 3LE, UK  
Tel: +44 191 3342059  
*e.j.grayson@durham.ac.uk*



**GUARAGNA ANNALISA**

Università di Napoli Federico II  
Dipartimento di Chimica Organica e Biochimica  
Via Cintia 4, 80126, Napoli, Italy  
Tel: +39081674119  
*guaragna@unina.it*

**GUAZZELLI LORENZO**

University College Dublin  
Centre for Synthesis and Chemical Biology  
Belfield, Dublin 4, Ireland  
Tel: +393403737497  
*lorenzo.guazzelli@ucd.ie*

**GUERIN MARCELO**

Unidad de Biofisica - (CSIC-UPV/EHU)  
Barrio Sarriena s/n, Leioa, Spain  
Tel: +34946018052  
*mrcguerin@gmail.com*

**GUERRINI MARCO**

Istituto di Ricerche Chimiche e Biochimiche  
"G. Ronzoni" - NMR center  
Via G. Colombo 81, Milano, Italy  
Tel: +39 0270641628  
Fax: +39 0270641634  
*guerrini@ronzoni.it*

**GUILLO NATHALIE**

Sanofi-Aventis R&D - E2C DPU  
195 route d'Espagne, Toulouse, France  
Tel: +33 5 34 63 23 25  
Fax: +33 5 34 63 30 48  
*nathalie.guillo@sanofi-aventis.com*

**GUPTA ANIL**

DAV College - Department of Chemistry  
12/474, Navsheel Dwellings, Flat 106, Church  
Road, Gwaltoli, Kanpur, Uttar Pradesh, India  
Tel: +91-9935360458  
*ak\_gupta56@yahoo.co.in*

**GUZZI CINZIA**

Instituto de Investigaciones Químicas CSIC-US  
Glycosystems Laboratory  
C/ Américo Vespucio, 49, Seville, Spain  
Tel: +34 954489500 (9606)  
*cinzia.guzzi@iiq.csic.es*

**GYÉMÁNT GYÖNGYI**

University of Debrecen  
Department of Inorganic and  
Analytical Chemistry  
POBox 21, Debrecen, Hungary  
Tel: +3652512900  
Fax: +3652518660  
*gyemant@science.unideb.hu*

**H****HADJ BOUAZZA AMEL**

Université du Quebec a Trois-Rivieres  
Chimie-Biologie  
3351, Boul des Forges, Trois-Rivieres, Canada  
Tel: +1 8193803053  
Fax: +1 8193765148  
*Amel.Hadj-Bouazza@uqtr.ca*

**HAMARK CHRISTOFFER**

Stockholm University  
Department of Organic Chemistry  
Arrhenius Laboratory, Stockholm, Sweden  
Tel: +46 8162478  
*christoffer@organ.su.se*

**HARTMANN SEBASTIAN**

University of Mainz  
Department of Organic Chemistry  
An der Wanne 8 - 89441, Medlingen, Germany  
Tel: +49 17624342552  
*seb.hartmann@gmx.de*

**HARTMANN MIRJA**

Christiana Albertina University of Kiel  
Otto Diels Institute of Organic Chemistry  
Otto Hahn Platz 4 - 24098, Kiel, Germany  
Tel: +49 431 8804047  
Fax: +49 431 8807410  
*mhartmann@oc.uni-kiel.de*

**HAYASHI CHIEKA**

Gifu University - Applied Bioorganic Chemistry  
1-1 Yanagido, Gifu, Japan  
Tel: +81-58-293-2918  
*p8101043@edu.gifu-u.ac.jp*

**HAYMAN COLIN**

Industrial Research Limited  
69 Gracefield Road, Lower Hutt 5010  
New Zealand  
Tel: +64 4 9313301  
Fax: +6449313055  
*c.hayman@irl.cri.nz*

**HELBERT WILLIAM**

CNRS - Végétaux Marins et Biomolécules  
Station Biologique, Pl. Georges Teissier, F-29680,  
Roscoff, France  
Tel: + 33 298292332  
*helbert@sb-roscoff.fr*

**HERCZEG MIHÁLY**

University of Debrecen  
Research Group for Carbohydrates  
4032, Debrecen, Hungary  
Tel: +3652512900/22178  
Fax: +3652512900/22342  
*mihaly.herczeg@freemail.hu*

**HERCZEGH PAL**

University of Debrecen  
Department of Pharmaceutical Chemistry  
Egyetem ter 1, Debrecen, Hungary  
Tel: +36 52 316 666  
*herczeghp@gmail.com*

**HERNAIZ MARIA J.**

Complutense University  
Organic & Pharmaceutical Department  
Plz. Ramon y Cajal s/n, Madrid, Spain  
Tel: +34 913941821  
Fax: +34913941822  
*mjhernai@farm.ucm.es*

**HESSE JENNIFER**

TU Dortmund - Faculty of Chemistry  
Otto-Hahn-Straße 6 - 44227, Dortmund,  
Germany  
Tel: +492317553887  
*jennifer.hesse@tu-dortmund.de*

**HEVEY RACHEL**

University of Calgary - Department of Chemistry  
3712 14 St NW, Calgary, Canada  
Tel: 011 4038271355  
*rhevey@ucalgary.ca*

**HIGGINS BRIAN**

University College Dublin  
School of Chemistry & Chemical Biology  
Centre for Synthesis and Chemical Biology  
Belfield, Dublin 4, Ireland  
Tel: +353 1 716 2977  
*brian.higgins@ucd.ie*

**HINDSGAUL OLE**

Carlsberg Laboratory - Carbohydrate Chemistry  
Gamle Carlsberg Vej 10 - DK-1799  
Copenhagen-V, Denmark  
Tel: +45 3327 5382  
Fax: +45 3327 4708  
*hindsgaul@crc.dk*

**HIRSCH JAN**

Institute of Chemistry  
Slovak Academy of Sciences  
Dubravska cesta 9, Bratislava, Slovakia  
Tel: +421 2 59410333  
Fax: +421 2 59410222  
*chemhirs@savba.sk*

**HOFFMANN-RÖDER ANJA**

Johannes Gutenberg University Mainz  
Institute of Organic Chemistry  
Duesbergweg 10-14 - D-55128, Mainz, Germany  
Tel: +49 6131 39 22417  
Fax: +49 6131 39 26006  
*hroeder@uni-mainz.de*

**HOGENDORF WOUTER**

Leiden University - Bioorganic synthesis  
Einsteinweg 55, Leiden, The Netherlands  
Tel: +31715274642  
*hogendorfwfj@chem.leidenuniv.nl*

**HOLKENBRINK ANNIKA**

Georg-August University Göttingen  
Institute of Organic and Biomolecular Chemistry  
Tammannstr. 2 - 37077, Göttingen, Germany  
Tel: +49551393230  
*aholken@gwdg.de*

**HOLLAUS RALPH**

University of Natural Resources and Life Sciences  
Department of Chemistry  
St.Petergasse 22, A-1170, Wien, Austria  
Tel: +4316509152425  
*ralph.hollaus@boku.ac.at*

**HOLST OTTO**

Research Center Borstel - Molecular Infectiology  
Parkallee 4a/c, Borstel, Germany  
Tel: +49-4537-188472  
Fax: +49-4537-188745  
*oholst@fz-borstel.de*

**HONDA YUJI**

Ishikawa Prefectural University  
1-308 Suematsu, Nonoichi, Ishikawa, Japan  
Tel: +81-76-227-7453  
*honda@ishikawa-pu.ac.jp*

**HOUNSELL ELIZABETH**

Birkbeck, University of London  
Biological and Chemical Sciences  
Malet St., London, UK  
Tel: +44 (0) 1297680726  
*e.hounsell@bbk.ac.uk*

**HOUSER JOSEF**

Masaryk University  
National Centre for Biomolecular Research  
Kotlarska 2, Brno, Czech Republic  
Tel: +420549492527  
Fax: +420549492556  
*houser@mail.muni.cz*

**HRICOVÍNI MILOŠ**

Slovak Academy of Sciences  
Institute of Chemistry  
Dubravska cesta 9, 84538 Bratislava, Slovakia  
Tel: +4121 5941 0323  
*Milos.Hricovini@savba.sk*

**HRICOVÍNIOVÁ ZUZANA**

Slovak Academy of Sciences  
Institute of Chemistry  
Dubravska cesta 9, 84538 Bratislava, Slovakia  
Tel: +4212 5941 0282  
Fax: +4212 5941 0222  
*Zuzana.Hricoviniova@savba.sk*

**HU HUAIYU**

SUNY Upstate Medical University  
750 E. Adams Street, Syracuse, USA  
Tel: +1 315-464-8143  
*huh@upstate.edu*

**HUCHTING JOHANNA**

University of Hamburg - Department of  
Chemistry  
Martin Luther King Platz 6 – 20146  
Hamburg, Germany  
Tel: +49 40428384334  
*huchting@chemie.uni-hamburg.de*

**I****IADONISI ALFONSO**

Università di Napoli Federico II  
Dipartimento di Chimica Organica e Biochimica  
Via Cintia 4, 80126, Napoli, Italy  
Tel: +39 081 674 1654  
*iadonisi@unina.it*

**IMBERTY ANNE**

CERMAV-CNRS  
601 rue de la chimie, BP53, 38041 Grenoble  
Cedex 9, France  
Tel: +33 4 76 03 76 36  
*imberty@cermav.cnrs.fr*

**INFANTINO ANGELA SIMONA**

University College Dublin  
Centre for Synthesis and Chemical Biology  
Dublin 6, Dublin, Ireland  
Tel: +353 85 2116980  
*Angela.Infantino@ucdconnect.ie*

**ITO YUKISHIGE**

RIKEN Advanced Science Institute  
2-1 Hirosawa, Wako, Saitama, Japan  
Fax: +81-48-462-4680  
*yukito@riken.jp*

**J****JAKEMAN DAVID**

Dalhousie University - College of Pharmacy  
5968 College ST., Halifax, Canada  
Tel: +1 902 494 7159  
Fax: +1 902 494 1396  
*david.jakeman@dal.ca*

**JANSSON MATHIESEN ANITA**

Carlsberg Laboratory  
Gamle Carlsberg Vej 10 - DK-1799  
Copenhagen, Denmark  
Tel: +45 33275287  
Fax: +45 33274708  
*anita@crc.dk*

**JAROSZ SŁAWOMIR**

Institute of Organic Chemistry  
Polish Academy of Sciences  
ul. Kasprzaka 44/52, 01-224 Warsaw, Poland  
Tel: +48(22)3432320  
Fax: +48(22)6326681  
*slawomir.jarosz@icho.edu.pl*

**JENSEN HENRIK**

Aarhus University - Department of Chemistry  
Langelandsgade 140, Aarhus C, Denmark  
Tel: +45 89423963  
*hhj@chem.au.dk*

**JENSEN KNUD**

University of Copenhagen Faculty of Life  
Sciences  
Thorvaldsensvej 40 - 1871, 1871  
Frederiksberg, Denmark  
Tel: +45 3533 2430  
*kjj@life.ku.dk*

**JERVIS PETER**

University of Birmingham - Biosciences  
Edgbaston, Birmingham B15 2TT,  
Birmingham, UK  
Tel: +44 1214158123  
*p.j.jervis@bham.ac.uk*

**JESUS ANA RITA**

Faculty of Sciences - University of Lisbon  
Chemistry and Biochemistry  
Campo Grande 1749-016, Lisboa, Portugal  
Tel: +351 21 750 00 00  
*arxjesus@gmail.com*

**JIMENEZ BLANCO JOSE LUIS**

University of Seville  
Department of Organic Chemistry  
Prof. García González 1 E-41012, Seville, Spain  
Tel: +34 954555150  
Fax: +34 954624960  
*jljb@us.es*

**JIMENEZ-BARBERO JESUS**

CIB-CSIC - Chemical and Physical Biology  
Ramiro de Maeztu 9, Madrid, Spain  
Tel: +34918373112  
*jjbarbero@cib.csic.es*

**JOHANNESSEN CHRISTIAN**

University of Manchester  
Manchester Interdisciplinary Biocentre  
131 Princess Streed, M1 7DN, Manchester, UK  
Tel: +44 07914 011209  
*christian.johannessen@manchester.ac.uk*

**JONES RACHEL**

University of Bristol - Department of Chemistry  
School of Chemistry, Cantocks Close, BS8 1TS,  
Bristol, UK  
Tel: +44 1179287654  
*rachel.a.jones@bristol.ac.uk*

**JOSE M. GARCIA FERNANDEZ**

CSIC  
Instituto de Investigaciones Químicas  
Américo Vespucio 49, Isla de la Cartuja, E-41092,  
Sevilla, Spain  
Tel: +34 954489553  
Fax: +34 954460565  
*jogarcia@iiq.csic.es*

**JUSTINO JORGE**

Instituto Politecnico de Santarém  
Escola Superior Agraria  
2001-904, Santarém, Portugal  
Tel: +351 243 327542  
*jorge.justino@ipsantarém.pt*

**K****KACZYNSKI ZBIGNIEW**

University of Gdansk - Faculty of Chemistry  
80-952, Gdansk, Poland  
Tel: +48 58 5235397  
*zbyszek@chem.univ.gda.pl*

**KAJI EISUKE**

Kitasato University - School of Pharmacy  
Shirokane 5-9-1, Minato-ku, 108-8641  
Tokyo, Japan  
Tel: +81-3-3444-6161  
Fax: +81-3-3444-4741  
*kajie@pharm.kitasato-u.ac.jp*

**KAJIHARA YASUHIRO**

Osaka University - Department of Chemistry  
1-1, Machikaneyama, Toyonaka, Japan  
Tel: +81-6-6850-5380  
*kajihara@chem.sci.osaka-u.ac.jp*

**KAMERLING JOHANNIS**

Utrecht University - Bijvoet Center  
Padualaan 8, 3584 CH Utrecht, The Netherlands  
Tel: +31 348 415011  
*j.p.kamerling@uu.nl*

**KANDASAMY JEYAKUMAR**

Technion-Israel Institute of Technology  
Department of Chemistry  
Haifa, Haifa, Israel  
Tel: +972-4-8293730  
*jkumar@tx.technion.ac.il*

**KANDRA LILI**

University of Debrecen  
Department of Inorganic and Analytical  
Chemistry  
Egyetem tér 1, Debrecen, Hungary  
Tel: +3652512900  
*kandra@puma.unideb.hu*

**KASPRZYCKA ANNA**

Silesian University of Technology  
Department of Chemistry  
Krzywoustego 4, 44-100 Gliwice, Poland  
Tel: +48322371810  
*anna.kasprzycka@polsl.pl*

**KAWAMOTO NORIKO**

Osaka Prefecture University  
599-8531, Sakai, Japan  
Tel: +81-0722-54-9468  
*mu201017@edu.osakafu-u.ac.jp*

**KAWASAKI TOSHISUKE**

Ritsumeikan University  
Research Center for Glycobiotechnology  
Nojihigashi 1-1-1, Kusatsu, Japan  
Tel: +81-77-561-3444  
Fax: +81-77-561-3496  
*tkawasak@fc.ritsumei.ac.jp*

**KAWASAKI NOBUKO**

Ritsumeikan University  
Research Center for Glycobiotechnology  
1-1-1 Nojihigashi, Kusatsu, Shiga 525-8577, Japan  
Tel: +81-77-562-3452  
Fax: +81-77-561-3452  
*nobukokw@se.ritsumei.ac.jp*

**KHAN SAMIULLAH**

Lund University - Biotechnology  
Box 124, Lund, Sweden  
Tel: +46462228282  
Fax: +46462224713  
*sami.khan@biotek.lu.se*

**KHAN ASHNA**

Victoria University of Wellington  
SCPS  
4/129 The Parade, Island Bay  
Wellington, New Zealand  
Tel: +64 211558009  
*akhan@malaghan.org.nz*

**KHAN AGHA Z.**

Glycprobe AB  
Sölvegatan 41, 223 70 Lund, Sweden  
Tel: +46-46-2865784  
*aghazkhan@hotmail.com*

**KHRAMOVA DARYA**

Institute of Physiology Komi Science Centre the  
Urals Branch of the Russian  
50, Pervomaiskaya str., Syktyvkar, 167982, Russia,  
Syktyvkar, Russia  
Tel: +7(8212)241001  
Fax: +7(8212)241001  
*dkhramova@yahoo.com*

**KIM KWAN-SOO**

Yonsei University - Department of Chemistry  
Seodaemun-gu, Seoul, Korea  
Tel: +82-2-2123-2640  
*kwan@yonsei.ac.kr*

**KITAOKA MOTOMITSU**

National Food Research Institute  
2-1-12 Kannondai, Tsukuba, Japan  
Tel: +81-29-838-8071  
Fax: +81-29-838-7321  
*mkitaoka@affrc.go.jp*

**KMOCH DANIEL**

TU Dortmund - Faculty of Chemistry  
Otto-Hahn-Straße 6 - 44227, Dortmund,  
Germany  
Tel: +492317553887  
*daniel.kmoch@tu-dortmund.de*

**KNIREL YURIY**

Zelinsky Institute of Organic Chemistry  
Leninsky Prospekt 47, Moscow, Russia  
Tel: +7 499 1376148  
Fax: +7 499 1355328  
*yknirel@gmail.com*

**KOCA JAROSLAV**

Masaryk University  
Central European Inst. of Technology  
Kotlarska 2, Brno, Czech Republic  
Tel: +420-549494947  
*jkoca@chemi.muni.cz*

**KOCH STEFAN**

Johannes Gutenberg-University Mainz  
Institute of Organic Chemistry  
Duesbergweg 10-14 - 55128, Mainz, Germany  
Tel: +49061313925874  
*kochst@uni-mainz.de*

**KOMANIECKA IWONA**

Maria Curie-Skłodowska University  
Department of Genetics and Microbiology  
Akademicka 19, Lublin, Poland  
Tel: +48 81 537 5981  
Fax: +48 81 537 5959  
*ikoma@hektor.umcs.lublin.pl*

**KOMURA NAOKO**

Gifu University - Applied Bioorganic Chemistry  
1-1 Yanagido, Gifu, Japan  
Tel: +81-58-298-2913  
*komura@gifu-u.ac.jp*

**KONDAKOVA ANNA**

ND Zelinsky Institute of Organic Chemistry  
Leninsky prospekt 47, Moscow, Russia  
Tel: +74991376148  
*annakond@gmail.com*



**KONISHI MIKU**

Gifu University - Applied Bioorganic Chemistry  
1-1 Yanagido, Gifu, Japan  
Tel: +81-58-293-2918  
*p8101021@edu.gifu-u.ac.jp*

**KONNO NAOTAKE**

Iwate Biotechnology Research Center  
024-0003, Kitakami-shi, Japan  
Tel: +81-197-68-2911  
Fax: +81-197-68-3881  
*naotake-k@ibrc.or.jp*

**KONONOV LEONID**

N.D. Zelinsky Institute of Organic Chemistry  
N.K. Kochetkov Laboratory of Carbohydrate  
Chemistry  
Leninsky prosp., 47, Moscow, Russia  
Tel: +7-495-943-2946  
Fax: +7-499-135-5328  
*leonid.kononov@gmail.com*

**KONRADSSON PETER**

Linköping University - IFM/Chemistry  
Linköpings Universitet, Linköping, Sweden  
Tel: +4613281728  
*petko@ifm.liu.se*

**KONYA BALINT**

University of Debrecen  
Department of Organic Chemistry  
Egyetem ter 1., Debrecen, Hungary  
Tel: +3652/512-900/22453  
*konya.balint@gmail.com*

**KOPITZKI SEBASTIAN**

CICbiomagune  
Biofunctional Nanomaterials  
Paseo Miramon 182, 20009 San Sebastian, Spain  
Tel: +34943005300  
Fax: +34943005301  
*skopitzki@cicbiomagune.es*

**KOSMA PAUL**

University of Natural Resources and Life Sciences  
Department of Chemistry  
Muthgasse 18, A-1190, Wien, Austria  
Tel: +43-1-47654-6055  
Fax: +43-1-47654-6059  
*paul.kosma@boku.ac.at*

**KOVACS LAJOS**

University of Szeged  
Department of Medicinal Chemistry  
Dom ter 8, Szeged, Hungary  
Tel: +3662545145  
*kovacs@ovrisc.mdche.u-szeged.hu*

**KOVENSKY JOSE**

Université de Picardie Jules Verne  
Laboratoire Des Glucides CNRS UMR 6219  
33 Rue Saint Leu, Amiens, France  
Tel: +33322827567  
Fax: +33322827568  
*jose.kovensky@u-picardie.fr*

**KOZMON STANISLAV**

Masaryk University  
Central European Institute of Technology -  
CEITEC  
Kamenice 5, Brno, Czech Republic  
Tel: +420549495108  
*stano@chemi.muni.cz*

**KRAG JONAS**

University of Copenhagen  
Plant Biology and Biotechnology  
Thorvaldsensvej 40, Frederiksberg, Denmark  
Tel: +4535333308  
*jonaskrag@life.ku.dk*

**KREN VLADIMIR**

Institute of Microbiology  
Czech Academy of Sciences  
Center of Biocatalysis and Biotransformation  
Videnska 1083 - CZ 14220, Prague 4, Czech  
Republic  
Tel: +420296442510  
Fax: +420296442509  
*kren@biomed.cas.cz*

**KUMAR MANJEET**

Indian Institute of Technology Bombay  
Biosciences & Bioengineering  
Department of Biosciences and Bioengineering,  
IIT Bombay, Adi Sankaracharya Marg, Powai,  
Mumbai, India  
Tel: +91-22-25764757  
Fax: +91-22-25723480  
*mpawaria@iitb.ac.in*

**KUMARI MANJU**

Indian Institute of Technology Bombay  
Biosciences & Bioengineering  
400076, Mumbai, India  
Tel: +91 22 25764757  
Fax: +91 22 25723480  
*manjusah@iitb.ac.in*

**KUN SÁNDOR**

University of Debrecen  
Department of Organic Chemistry  
H-4032, Egyetem tér 1., Debrecen, Hungary  
Tel: +3652512900/22453  
*therealkuni@gmail.com*



**KUNGL ANDREAS**

ProtAffin Biotechnologie AG  
Reininghausstrasse 13a, Graz, Austria  
Tel: +43 (0)316 382541 13  
Fax: +43 (0)316 382541 4  
*akunagl@protaffin.com*

**L****LA GATTA ANNALISA**

Second University of Naples  
Experimental Medicine  
via De Crecchio, 7 80138, Naples, Italy  
Tel: +390815667673  
Fax: +390815667546  
*annalisa.lagatta@unina2.it*

**LAGURI CEDRIC**

CNRS - IBS  
41 Rue Jules Horowitz, Grenoble, France  
Tel: +33 43 87 89 577  
Fax: +33 43 87 85 494  
*cedric.laguri@ibs.fr*

**LAI CHIAN-HUI**

National Tsing Hua University  
Department of Chemistry  
101, Sec 2, Kuang-Fu Rd., 30013 Hsinchu, Taiwan  
Tel: +886-3-5731288  
*poohchilai@gmail.com*

**LAKHTIN VLADIMIR**

G.N. Gabrichevsky Research Institute for  
Epidemiology and Microbiology  
Medical Biotechnology  
125212, Moscow, Russia  
Tel: +7-495-452-18-16  
Fax: +7-495-452-18-30  
*lakhtinv@yandex.ru*

**LANZETTA ROSA**

Università di Napoli Federico II  
Dipartimento di Chimica Organica e Biochimica  
Via Cintia 4, 80126, Napoli, Italy  
Tel: +39 081 674 148  
*lanzetta@unina.it*

**LATTOVA ERIKA**

University of Manitoba  
Department of Chemistry  
R3T2N2, Winnipeg, Canada  
Tel: +1 204-4748392  
*lattovae@cc.umanitoba.ca*

**LAY LUIGI**

University of Milan  
Department of Organic and Industrial Chemistry  
Via venezian 21, Milano, Italy  
Tel: +39 0250314062  
*luigi.lay@unimi.it*

**LEAVER DAVID**

La Trobe University  
Department of Chemistry  
La Trobe University, Melbourne, Australia  
Tel: +61 (0)431 281 774  
*d.leaver@latrobe.edu.au*

**LEE SANG-KYU (Q)**

Genencor - Department of Biochemistry  
925 Page Mill Road, Palo Alto, USA  
Tel: +1 650-846-4082  
*sang-kyu.lee@danisco.com*

**LEE JIE-OH**

KAIST - Department of Chemistry  
335 Gwahak-ro Yusong-gu, Daejeon, Korea  
Tel: +82-42-350-2839  
*jieoh@kaist.ac.kr*

**LEE JUNG-BUM**

University of Toyama  
930-0194, Toyama, Japan  
Tel: +81-76-434-7580  
*lee@pha.u-toyama.ac.jp*

**LEINO REKO**

Åbo Akademi University  
Laboratory of Organic Chemistry  
Biskopsgatan 8, Åbo, Finland  
Tel: +358-2-2154132  
*reko.leino@abo.fi*

**LEMETAIS AURÉLIE**

Université Paris Sud 11  
Department of Chemistry  
Rue du Doyen Joseph Pérès, 91400 Orsay, France  
Tel: +33169154832  
*aurelie.lemetais@u-psud.fr*

**LESHCH YEVGENIY**

University of Hamburg  
Department of Organic Chemistry  
Martin-Luther-King Platz 6 - 20146, Hamburg,  
Germany  
Tel: +49 40 42838 -2810  
*leshch@chemie.uni-hamburg.de*

**LEWIK TSIRIGOTIS MARTA**

Wroclaw University of Technology  
Chemistry Department  
Wybrzeże Wyspiańskiego 27, Wrocław, Poland  
Tel: +48 71 320 38 90  
Fax: +48 71 328 40 64  
*marta.tsirigotis@pwr.wroc.pl*

**LI KAH-YEE**

Leiden University - Bio-Organic Synthesis  
Einsteinweg 55, Leiden, The Netherlands  
Tel: +31715274355  
*likj@chem.leidenuniv.nl*

**LIANG CHI-HUI**

Academia Sinica - Genomics Research Center  
128 Academia Road, Section 2, Nankang  
Taipei, Taiwan  
Tel: +886-2-2789-8786  
*JamesL@gate.sinica.edu.tw*

**LINDHORST THISBE**

Christiana Albertina Kiel  
Otto Diels-Institute of Organic Chemistry  
Otto-Hahn-Platz 3/4 - 24098, Kiel, Germany  
Tel: +49(0)431 880 7443  
Fax: +49(0)431 880-7410  
*tklind@oc.uni-kiel.de*

**LIU YAN**

Imperial College London  
Glycosciences Laboratory  
Department of Medicine  
Northwick Park and St Mark's Campus, Harrow,  
HA1 3UJ,, Harrow, UK  
Tel: +44(0)2088693463  
*yan.liu2@imperial.ac.uk*

**LIU SHOUPING**

Singapore Eye Research Institute  
168751, Singapore, Singapore  
Tel: +65-63275892  
Fax: +65-63224599  
*liushouping@gmail.com*

**LONATI VIRGINIO**

Alltech Italia SRL  
20017, Passirana di Rho, Italy  
Tel: +39 02 93537658  
Fax: +39 02 93537650  
*barbara.callini@grace.com*

**LOPEZ J CRISTOBAL**

Instituto Quimica Organica General  
Quimica Biorganica  
Juan De La Cierva 3, Madrid, Spain  
Tel: +34 912587476  
*jc.lopez@csic.es*

**LÓPEZ ÓSCAR**

University of Seville  
Department of Organic Chemistry  
Prof. García González 1 E-41012, Seville, Spain  
Tel: +34 954 559997  
*osc-lopez@us.es*

**LOPIN-BON CHRYSTEL**

ICOA, UMR 6005, University of Orléans  
Department of Chemistry  
Université d'Orléans, BP 6759, rue de chartres  
45067 Orléans Cedex 2, France  
Tel: +33 (0)2 38 41 70 77  
Fax: +33 (0)2 38 41 72 81  
*chrystel.lopin-bon@univ-orleans.fr*

**LORTAT JACOB HUGUES**

Institut de Biologie Structurale  
41 rue Jules Horowitz, 38027 Grenoble Cedex 1,  
France  
Tel: +33 438 784 485  
Fax: +33 438 785 494  
*hugues.lortat-jacob@ibs.fr*

**LOWARY TODD**

The University of Alberta  
Department of Chemistry  
Gunning-Lemieux Chemistry Centre E5-52,  
Edmonton, AB, Canada  
Tel: 0117804921861  
*tlowary@ualberta.ca*

**LU SHAO-RU**

National Chiao Tung University  
Department of Applied Chemistry  
No.11, Aly. 66, Ln.294, Sec.4, Chenggong Rd.,  
Neihu Dist.  
Taipei City 114, Taiwan (R.O.C.), Taipei, Taiwan  
Tel: +886 (0)22790-6312  
*blackrobinhood@hotmail.com*

**LUNAU NATHALIE**

University of Hamburg - Department of  
Chemistry  
Martin Luther King Platz 6 - 20146  
Hamburg, Germany  
Tel: +4940428384334  
*lunau@chemie.uni-hamburg.de*

**M****MA CHING YUNG**

University of Hong Kong  
School of Biological Sciences  
Pokfulam Road, Hong Kong, Hong Kong  
Tel: +852 28185877  
Fax: +852 22990318  
*macy@hkucc.hku.hk*

**MACCHIONE GIUSEPPE**

CSIC-US  
Instituto de Investigaciones Químicas  
41092, Seville, Spain  
Tel: +34954489500  
*giuseppe.macchione@iiq.csic.es*

**MACHINAMI TOMOYA**

Meisei University - Department of Chemistry  
191-8506, Hino, Japan  
Tel: +81 42 591 7485  
Fax: +81 42 591 7485  
*machinam@chem.meisei-u.ac.jp*

**MADAJ JANUSZ**

University of Gdansk - Sugar Chemistry Chair  
Bazynskiego 1A, 80-952 Gdansk, Gdansk, Poland  
Tel: +48 585235364  
*januszm@chem.univ.gda.pl*

**MAGDYCZ MARTA**

Institute of Organic Chemistry PAS  
Kasprzaka 44/52, Warsaw, Poland  
Tel: +48503631341  
*marta.magdycz@icho.edu.pl*

**MAHMOOD TAHIR**

Lund University – Dept. of Biotechnology  
Box 124, Lund, Sweden  
Tel: +46462228282  
Fax: +46462224713  
*tahir.mu@hotmail.com*

**MALANGA MILO**

CycloLab Ltd.  
Mester utca 48-52, Budapest, Hungary  
Tel: +393332085711  
*milomalanga@gmail.com*

**MALIK SHWETA**

Katholieke University Leuven  
140 Naamsesteenweg, Bus 21, Heverlee, Belgium  
Tel: +32 (0) 488076460  
*shweta.malik@biw.kuleuven.be*

**MALONE AOIFE**

Trinity College Dublin - Department of  
Chemistry  
Dublin 2, Dublin, Ireland  
Tel: +353877747004  
*maloneao@tcd.ie*

**MANGONI ALFONSO**

Università di Napoli Federico II  
Dipartimento di Chimica delle Sostanze Naturali  
via Domenico Montesano 49, Napoli, Italy  
Tel: +39 081678532  
Fax: +39 081678552  
*alfonso.mangoni@unina.it*

**MANOHARAN MATHISELVAM**

Indian Institute of Technology Madras  
Department of Chemistry  
TAMILNADU-PIN 600036, Chennai, India  
Tel: +91-44-22575221  
Fax: +91-44-22574202  
*mathi24@gmail.com*

**MANZO EMILIANO**

National Council of Research  
Institute of Biomolecular Chemistry  
Via cinthia Parco S. Paolo is. 3, Napoli, Italy  
Tel: +39 0818675310  
*emanzo@icb.cnr.it*

**MARCELO FILIPA**

Centro de Investigaciones Biológicas - CIB  
28040, Madrid, Spain  
Tel: +34918373112  
*fmmarcelo@cib.csic.es*

**MARCHETTI ROBERTA**

Università di Napoli Federico II  
Dipartimento di Chimica Organica e Biochimica  
Via Cintia 4, 80126, Napoli, Italy  
Tel: +39 3493191533  
*roberta.marchetti@unina.it*

**MARÍN IRENE**

University Rovira i Virgili  
Química Analítica i Química Orgànica  
43007, Tarragona, Spain  
Tel: +34977558292  
Fax: +34977558446  
*irene.marin@urv.cat*

**MARKEY LYN**

Trinity College Dublin -Department of Chemistry  
Dublin 2, Dublin, Ireland  
Tel: +353872611576  
*lmarkey@tcd.ie*

**MARRADI MARCO**

Cic Biomagune, Ciber -BBN  
Biofunctional Nanomaterials  
Paseo de Miramon N° 182, San Sebastian, Spain  
Tel: +34943005328  
*mmarradi.ciber-bbn@cicbiomagune.es*

**MARTIN-LOMAS MANUEL**

Cic Biomagune - Management  
20009, San Sebastian, Spain  
Tel: +34 943 00 53 00  
*nlaespada@cicbiomagune.es*

**MARTIN-SANTAMARIA SONSOLES**

Universidad San Pablo CEU  
Department of Chemistry  
Facultad de Farmacia  
Urb. Monteprincipe – 28668  
Boadilla del Monte, Spain  
Tel: +34 659670946  
*smsantamaria@ceu.es*

**MARTOS-MALDONADO MANUEL C.**

University of Almería  
Geometry, Topology and Organic Chemistry  
CITE-I, Universidad de Almería  
Ctra. Sacramento s/n  
La Cañada de San Urbano, 04120  
Almería, Spain  
Tel: +34 950 015619  
Fax: +34 950 015481  
*mmm588@alboran.ual.es*

**MASGRAU LAURA**

Universitat Autònoma de Barcelona  
Institut de Biotecnologia i de Biomedicina  
IBB, Edifici Mòdul de Recerca B, Campus UAB,  
Cerdanyola del Vallès, Spain  
Tel: +34935868937  
*laura.masgrau@uab.cat*

**MATHEU MARIBEL**

University Rovira i Virgili  
Analytical and Organic Chemistry  
Campus Sescelades. C/Marcel.li Domingo s/n  
43007, Tarragona, Spain  
Tel: +34977558289  
Fax: +34 977558446  
*maribel.matheu@urv.cat*

**MATHIEU THOMAS**

Johannes Gutenberg-University  
Institute of Organic Chemistry  
Duesbergweg 10-14 - 55128, Mainz, Germany  
Tel: +49061313925874  
*mathth00@uni-mainz.de*

**MATSUDA SHO**

Tokai University  
4-1-1 Kitakaname, Hiratsuka, Kanagawa, Japan  
Tel: +81-463-58-1211  
*s.matsuda@star.tokai-u.jp*

**MATSUI IZUMI**

Gifu University  
Applied Bioorganic Chemistry  
1-1 Yanagido, Gifu, Japan  
Tel: +81-58-293-2918  
*p8101046@edu.gifu-u.ac.jp*

**MATSUSHITA TAKAHIKO**

Hokkaido University  
Faculty of Advanced Life Science  
Nishi-11 Kita-21 Kita-ku, Sapporo, Japan  
Tel: +81-11-706-9059  
Fax: +81-11-706-9042  
*t-matsushita@glyco.sci.hokudai.ac.jp*

**MATSUSHITA KENYA**

Tottori University - Regional Environment  
Koyamacho-minami 4-101  
Tottori 680-8551, Japan  
Tel: +81-857-31-5108  
Fax: +81-857-31-5108  
*M10N1306B@edu.tottori-u.ac.jp*

**MAURI LAURA**

Università degli studi di Milano  
Dipartimento di Chimica, Biochimica e  
Biotecnologie per la Medicina  
via F.lli Cervi 93, Segrate, Italy  
Tel: +39 02 50330379  
*laura.mauri@unimi.it*

**MAYA INÉS**

University of Seville  
Department of Organic Chemistry  
41012, Seville, Spain  
Tel: +34 954 556549  
*imaya@us.es*

**MCLEOD ELIZABETH**

New England Biolabs  
4 Bancroft Way, Hamilton, USA  
Tel: +1 978-468-0230  
*mcleod@neb.com*

**MCWILLIAM HAMISH**

Monash University - Physiology  
Wellington Rd, Clayton, Australia  
Tel: +61399058003  
*hamish.mcwilliam@monash.edu*

**MEIER CHRIS**

University of Hamburg - Chemistry Department  
Faculty of Sciences, Martin Luther King Platz 6 -  
20146, Hamburg, Germany  
Tel: +4940428384324  
*chris.meier@chemie.uni-hamburg.de*

**MEZZATO STEFANO**

European Patent Office  
Department of Organic Chemistry  
80335, Munich, Germany  
Tel: +49 089 2399 7387  
*smezzato@epo.org*

**MICHALIK DIRK**

Leibniz Institute of Catalysis  
Albert-Einstein-Str. 29a - D 18059  
Rostock, Germany  
Tel: +49-381-4986353  
Fax: +49-381-4986352  
*dirk.michalik@catalysis.de*

**MIDPANON SUPATTA**

University of Vienna  
Department of Pharmaceutical Technology and  
Biopharmaceutics  
Althanstrasse 14, A-1090, Wien, Austria  
Tel: +43(0)-1-4277-55 415  
Fax: +43(0)-1-4277-95 54  
*smidpanon@hotmail.com*

**MIKULA HANNES**

Vienna University of Technology  
Institute of Applied Synthetic Chemistry  
1060, Wien, Austria  
Tel: +43158801163171  
*hannes.mikula@ias.tuwien.ac.at*

**MILHOMME OPHÉLIE**

Université Picardie Jules Verne  
10 rue Baudelocque, Amiens, France  
Tel: +33 322827560  
*ophelie.milhomme@u-picardie.fr*

**MILLER GAVIN**

University of Manchester  
Department of Chemistry  
Manchester Interdisciplinary Biocentre,  
Manchester, UK  
Tel: +44 7725622443  
*gavin.miller@manchester.ac.uk*

**MINE TOSHIKI**

Japan Tobacco Inc.  
Glycotechnology Business Unit  
4380077, Iwata, Japan  
Tel: +81-538-32-8073  
*toshiki.mine@jt.com*

**MISTRETTA NOELLE**

Sanofi Pasteur - Discovery  
1541 avenue Marcel Merieux  
Marcy l'Etoile, France  
Tel: +33 (0)4 37 37 38 68  
*noelle.mistretta@sanofipasteur.com*

**MIURA DAISUKE**

Meisei University  
Department of Chemistry  
191-8506, Hino, Japan  
Tel: +81 42 591 7485  
Fax: +81 42 591 7485  
*09m2004@stu.meisei-u.ac.jp*

**MIZUNO MASASHI**

Kobe University  
Department of Agricultural Science  
1-1, Rokkodai-cho, Nada-ku, Kobe 657-8501,  
Japan  
Tel: +81-78-803-5835  
Fax: +81-78-803-5835  
*mizuno@kobe-u.ac.jp*

**MŁYNNARSKI JACEK**

Jagiellonian University  
Faculty of Chemistry  
30-060, Kraków, Poland  
Tel: +48-12-663-2034  
*jacek.mlynarski@gmail.com*

**MOEBS SYLVIE**

INSA-Lyon  
ICBMS-COB  
20 Avenue Albert Einstein  
Villeurbanne, France  
Tel: +33 472438098  
*sylvie.moebis@insa-lyon.fr*

**MOLINARO ANTONIO**

Università di Napoli Federico II  
Dipartimento di Chimica Organica e Biochimica  
Via Cintia 4, 80126, Napoli, Italy  
Tel: +39 081 674 123  
*molinaro@unina.it*



**MONTESARCHIO DANIELA**

Università di Napoli Federico II  
Dipartimento di Chimica Organica e Biochimica  
Via Cintia 4, 80126, Napoli, Italy  
Tel: +39 081 674 126  
Fax: +39 081 674 393  
*daniela.montesarchio@unina.it*

**MONTPLAISIR DANIEL**

Universite du Quebec a Trois-Rivieres  
Chimie-Biologie  
3351. Boul des Forges, Trois-Rivieres, Canada  
Tel: +1 8193803053  
Fax: +1 8193765148  
*daniel.montplaisir@uqtr.ca*

**MORACCI MARCO**

CNR - Institute of Protein Biochemistry  
Via P. Castellino 111, Naples, Italy  
Tel: +39-081-6132271  
*m.moracci@ibp.cnr.it*

**MORAIS PEDRO**

University of Sao Paulo - Pharmaceutical Sciences  
14040903, Ribeirão Preto, Brazil  
Tel: +55(16)36024715  
*ceara\_es@fcfrp.usp.br*

**MORAVCOVA JITKA**

Institute of Chemical Technology, Prague  
Dept. of Chemistry of Natural Compounds  
Technicka 5, Prague, Czech Republic  
Tel: +420 220444283  
Fax: +420 220444422  
*Jitka.Moravcova@vscht.cz*

**MOREAU VINCENT**

Université de Picardie Jules Verne  
Laboratoire des Glucides  
33 rue St Leu, Amiens, France  
Tel: +33 (0)3 22 82 76 61  
*vincent.moreau@u-picardie.fr*

**MORELLI LAURA**

Università degli Studi di Milano  
Chimica Organica e Industriale  
via Venezian 21, Milano, Italy  
Tel: +39 0250314063  
*laura.morelli@unimi.it*

**MORENO VARGAS ANTONIO JOSE**

University of Seville  
Department of Organic Chemistry  
41012, Seville, Spain  
Tel: +34954559997  
Fax: +34954624960  
*ajmoreno@us.es*

**MOSSOTTI MATTEO**

Università del Piemonte orientale - DISCAFF  
Via Don A. Mella 27, Carpignano Sesia, Italy  
Tel: +39 0321825394  
*matteo.mossotti@pharm.unipmn.it*

**MOTAWIA MOHAMMED SADDIK**

Copenhagen University  
Dept. of Plant Biology and Biotechnology  
1871, Frederiksberg C., Denmark  
Tel: +45 35333305  
Fax: +45 35333333  
*mosm@life.ku.dk*

**MOYLAN CLAIRE**

Trinity College Dublin - Department of  
Chemistry  
48 The Grove, Kingswood Heights, Dublin 24,  
Dublin, Ireland  
Tel: +353861643216  
*moylanc@tcd.ie*

**MULARD LAURENCE**

Institut Pasteur - Chimie des Biomolécules  
28 rue du Dr Roux, Paris Cedex 15, France  
Tel: +33 1 40 61 38 20  
Fax: +33 1 45 68 84 04  
*lmulard@pasteur.fr*

**MULLA DAFINA**

University of Vienna  
Pharmaceutical Technology and  
Biopharmaceutics  
Neilreichgasse 70/18 - A-1100, Wien, Austria  
Tel: +43(0)-1- 4277 55415  
Fax: +43(0)-1-4277-9554  
*mulladafina@hotmail.com*

**MULLOY BARBARA**

NIBSC  
Laboratory for Molecular Structure  
Blanche Lane, South Mimms, Potters Bar, UK  
Tel: +44 1707 641208  
Fax: +44 1707 641050  
*Barbara.Mulloy@nibsc.hpa.org.uk*

**MUÑOZ GARCIA JUAN CARLOS**

Instituto de Investigaciones Químicas  
Química Bio-orgánica  
49 Americo Vespucio St, 41092, Seville, Spain  
Tel: +34 669092470  
*juan.munioz@iiq.csic.es*



**MURPHY NIAMH**

University College Dublin  
School of Chemistry and Chemical Biology  
58 Dargle Road, Blackrock, Ireland  
Tel: +353 1 7162448  
*niamh.murphy@ucd.ie*

**MYSZKA HENRYK**

University of Gdansk - Department of Chemistry  
Sobieskiego 18, Gdansk, Poland  
Tel: +48 58 523 53 44  
Fax: +48 58 523 54 72  
*myszka@chem.univ.gda.pl*

**N****NARUCHI KENTARO**

Hokkaido University  
Graduate School of Life Science  
001-0021, Sapporo, Japan  
Tel: +81-11-706-9059  
Fax: +81-11-706-9042  
*naru511129@yahoo.co.jp*

**NATIVI CRISTINA**

University of Florence - Department of Chemistry  
via della Lastruccia, 13, Florence, Italy  
Tel: +390554573540  
*cristina.nativi@unifi.it*

**NEWMAN MARI-ANNE**

LIFE, University of Copenhagen  
Dept. of Plant Biology and Biotechnology  
1871, Frederiksberg C., Denmark  
Tel: +45 35332581  
*mari@life.ku.dk*

**NÍCHEALLAIGH AISLING**

University College Dublin  
Department of Chemistry  
74 Thornhill Gardens, Celbridge, Kildare, Ireland  
Tel: +353877769758  
*Aisling.Ni-Cheallaigh@ucdconnect.ie*

**NICOTRA FRANCESCO**

University of Milano-Bicocca  
Dean of the Faculty of Sciences  
Piazza della Scienza 3, I-20126 Milano, Italy  
Tel: tel. +39.02.6448 2152  
Fax: fax. +39.02.6448 2169  
*francesco.nicotra@unimib.it*

**NIDETZKY BERND**

Graz University of Technology  
Institute of Biotechnology and Biochemical  
Engineering  
Petersgasse 12, Graz, Austria  
Tel: +43 316 873 8400  
*bernd.nidetzky@tugraz.at*

**NIEDERWIESER ANDREA**

Universität Konstanz  
Universitätsstr. 10, 78457, Konstanz, Germany  
Tel: +497531885190  
*andrea.niederwieser@uni-konstanz.de*

**NIETO LIDIA**

Centro de Investigaciones Biológicas CSIC  
Chemical and Physical Biology  
Ramiro de Maeztu 9, Madrid, Spain  
Tel: +34918373112  
*linieto@cib.csic.es*

**NIKOLAEV ANDREI**

University of Dundee - College of Life Sciences  
Dow Street, DD1 5EH, Dundee, UK  
Tel: +44(1382)384325  
*a.v.nikolaev@dundee.ac.uk*

**NISHITANI YOSUKE**

Kobe University  
Rokkodai-cho 1-1, Nada-ku  
Kobe, Japan  
Tel: +81-78-803-5907  
*nishitani@people.kobe-u.ac.jp*

**NOKAMI TOSHIKI**

Kyoto University  
Synthetic Chemistry and Biological Chemistry  
615-8510, Kyoto, Japan  
Tel: +81-75-383-2730  
Fax: +81-75-383-2725  
*tnokami@sbchem.kyoto-u.ac.jp*

**NONAKA MOTOHIRO**

Ritsumeikan University  
1Research Center for Glycobiotechnology  
525-0058, Kusatsu-City, Shiga, Japan  
Tel: +81-77-561-3450  
Fax: +81-77-561-3451  
*mnonaka@fc.ritsumei.ac.jp*

**NORDBERG KARLSSON EVA**

Lund University - Biotechnology  
SE-22100, Lund, Sweden  
Tel: +46462224626  
Fax: +46462224713  
*eva.nordberg\_karlsson@biotek.lu.se*

**NORO MIHOKO**

The University of Tokyo  
Medical Genome Sciences  
5-1-5 Kashiwanoha, Kashiwa, Chiba, Japan  
Tel: +81-4-7136-3613  
*kk096391@mgs.k.u-tokyo.ac.jp*

**O****O. DA SILVA CLARISSA**

UFRRJ - Chemistry Department  
DEQUIM-ICE/ UFRRJ, Rodovia BR465 Km 47,  
Seropédica, Brazil  
Tel: +55-21-2682-2807  
Fax: +55-21-2686-2807  
*clarissa-dq@ufrj.br*

**OBERBILLIG THOMAS**

University of Mainz  
Department of Organic Chemistry  
Duesbergweg 10-14, 55128, Mainz, Germany  
Tel: +4961313922364  
*oberthom@gmail.com*

**OELTMANN TOM**

Vanderbilt University Medical School  
Department of Biochemistry  
340 Light Hall, Nashville, TN 37232, USA  
Tel: + 615-322-7368  
*tom.oeltmann@Vanderbilt.Edu*

**OEZUEDURU GUELSUEM**

Leibniz University of Hannover  
Institute of Organic Chemistry  
Schneiderberg 1B, D-30167, Hannover, Germany  
Tel: +495117624631  
Fax: +495117623011  
*guelsuem.oezueduru@oci.uni-hannover.de*

**ONOUE HIROKI**

University of Toyama  
930-0194, Toyama, Japan  
Tel: +81-76-434-7561  
*s0660213@ems.u-toyama.ac.jp*

**ORTIZ MELLET CARMEN**

University of Seville  
Department of Organic Chemistry  
C/ Profesor Garcia Gonzalez 1, 41012  
Seville, Spain  
Tel: +34 954 559806  
Fax: +34 954 624960  
*mellet@us.es*

**OSCARSON STEFAN**

University College Dublin  
Centre for Synthesis and Chemical Biology  
Belfield, Dublin 4, Ireland  
Tel: +35317162318  
Fax: +35317162501  
*stefan.oscarson@ucd.ie*

**OSUMI KENJI**

The Noguchi Institute  
1-8-1, Kaga, Itabashi-Ku, 173-0003  
Tokyo, Japan  
Tel: +81-3-5944-3214  
Fax: +81-3-5944-3222  
*sugawara.sb@noguchi.or.jp*

**OSZTROVSZKY GYORGYI**

Technical University of Denmark  
Department of Chemistry  
Kemitorvet Building 201, Kgs. Lyngby, Denmark  
Tel: +45 45252382  
*gyosz@kemi.dtu.dk*

**OVERKLEEF HERMAN**

Universiteit Leiden - Department of Chemistry  
Einsteinweg 55, Leiden, The Netherlands  
Tel: +31 (0)71 5274342  
*h.s.overkleeft@chem.leidenuniv.nl*

**OZAWA YUTAKA**

University of Toyama  
930-0194, Toyama, Japan  
Tel: +81-76-434-7561  
*s0660212@ems.u-toyama.ac.jp*

**P****PAKULSKI ZBIGNIEW**

Institute of Organic Chemistry  
Polish Academy of Sciences  
Kasprzaka 44/52, 01-224 Warszawa, Poland  
Tel: +48223432005  
*pakul@icho.edu.pl*

**PALCIC MONICA**

Carlsberg Laboratory - Enzymology  
Gamle Carlsberg Vej 10, DK-1799  
Copenhagen-V, Denmark  
Tel: +45 3327 5345  
Fax: +45 3327 4708  
*monica@crc.dk*

**PALUMBO GIOVANNI**

Università di Napoli Federico II  
Dipartimento di Chimica Organica e Biochimica  
Via Cintia 4, 80126, Napoli, Italy  
Tel: +39 081 674 116  
*gipalumb@unina.it*

**PANAGOS CHARALAMPOS**

University of Edinburgh  
Department of Chemistry  
EH166TD, Edinburgh, UK  
Tel: +441312585269  
*C.Panagos@sms.ed.ac.uk*

**PARIKKA KIRSTI**

University of Helsinki  
Department of Food and Environmental Sciences  
P. O. Box 27, Latokartanonkaari 11  
Helsinki, Finland  
Tel: +358407365769  
*kirsti.parikka@helsinki.fi*

**PARK SUNGJIN**

Yonsei University  
Center for Biofunctional Molecules  
Department of Chemistry  
120-749, Seoul, Korea  
Tel: +8223125623  
*ystoftof@yonsei.ac.kr*

**PARRILLI MICHELANGELO**

Università di Napoli Federico II  
Dipartimento di Chimica Organica e Biochimica  
Via Cintia 4, 80126, Napoli, Italy  
Tel: +39 081 674 147  
*parrilli@unina.it*

**PARSONS HARRIET**

Lawrence Berkeley National Laboratories  
Joint BioEnergy Institute  
473 D Alcatraz Avenue, Oakland 94609,  
California, USA  
Tel: +19252627315  
*htparsons@lbl.gov*

**PASCHINGER KATHARINA**

Universität für Bodenkultur  
Department für Chemie  
Muthgasse 18, Wien, Austria  
Tel: +43-1-47654-6541  
*katharina.paschinger@boku.ac.at*

**PAŚCIAK MARIOLA**

Institute of Immunology and  
Experimental Therapy  
Medical Microbiology  
Weigla 12, Wrocław, Poland  
Tel: +71 337-11-72  
*pasciak@iitd.pan.wroc.pl*

**PASTUCH-GAWOLEK GABRIELA**

Silesian University of Technology  
Department of Chemistry  
ul. Krzywoustego 4, 44-100 Gliwice, Poland  
Tel: +48 32 2372138  
*gabriela.pastuch@polsl.pl*

**PASZKOWSKA JADWIGA**

Silesian University of Technology  
Department of Organic Chemistry,  
Bioorganic Chemistry and Biotechnology  
Krzywoustego 4 Street, 44-100  
Gliwice, Poland  
Tel: +48 32 237 20 28  
*jadwiga.paszowska@polsl.pl*

**PATERSON DUNCAN**

Corden Pharma Switzerland  
Eichenweg 1, Liestal, Switzerland  
Tel: +41 61 906 59 70  
Fax: +41 61 906 5958  
*duncan.paterson@genzyme.com*

**PAVLIAK VILIAM**

Pfizer Vaccine Research  
Early Development  
401 N. Middletown Rd  
Pearl River, New York, USA  
Tel: +1-845-602-2837  
*viliam.pavliak@pfizer.com*

**PAWLACZYK IZABELA**

Wrocław University of Technology  
Chemistry Department  
ul. Łukasiewicza 2, Wrocław, Poland  
Tel: +48 71 320 38 90  
*izabela.pawlaczyk@pwr.wroc.pl*

**PAYNE RICHARD**

The University of Sydney  
Department of Chemistry - School of Chemistry  
Sydney, Australia  
Tel: +61293515877  
Fax: +61293513329  
*richard.payne@sydney.edu.au*

**PEDATELLA SILVANA**

Università di Napoli Federico II  
Dipartimento di Chimica Organica e Biochimica  
Via Cintia 4, 80126, Napoli, Italy  
Tel: +39 081 674 118  
*pedatell@unina.it*

**PEDERSEN CHRISTIAN MARCUS**

University of Copenhagen  
Department of Chemistry  
Universitetsparken 5, Copenhagen O, Denmark  
Tel: +45 35320190  
*cmp@kemi.ku.dk*

**PEIRANO RETO**

Beiersdorf AG  
Unnastrasse 48, Hamburg, Germany  
Tel: +49-40-4909-3783  
Fax: +49-40-4909-183783  
*Reto.Peirano@Beiersdorf.com*

**PENADÉS SOLEDAD**

CIC biomaGUNE  
Laboratory of Glyconanotechnology  
Paseo de Miramón n° 182, San Sebastián, Spain  
Tel: +34943005307  
*spenades@icbiomagune.es*

**PEREPELOV ANDREY**

N.D. Zelinsky Institute of Organic Chemistry RAS  
Leninsky prosp. 47, 119991, Moscow, Russia  
Tel: +7 499 1376148  
Fax: +7 499 1376148  
*perepel@ioc.ac.ru*

**PERI FRANCESCO**

University of Milano-Bicocca  
Biotechnology and Biosciences  
Via Chopin, 99, 20141 Milano, Italy  
Tel: +39 0264483453  
*francesco.peri@unimib.it*

**PERTEL SERGEY**

V. I. Vernadsky Taurida National University  
Department of Organic and Biological Chemistry  
Vernadsky ave. 4, Simferopol, Ukraine  
Tel: +380 652 608 379  
Fax: +380 652 637 589  
*sergepertel@yahoo.com*

**PEZZELLA ALESSANDRO**

Università di Napoli Federico II  
Dipartimento di Chimica Organica e Biochimica  
Via Cintia 4, 80126, Napoli, Italy  
*alessandro.pezzella@unina.it*

**PICHERT ANNELIE**

University of Leipzig  
Institute of Medical Physics and Biophysics  
Lößniger Str. 52, 04275, Leipzig, Germany  
Tel: +49 3419715738  
*Annelie.Pichert@medizin.uni-leipzig.de*

**PIERETTI GIUSEPPINA**

Università di Napoli Federico II  
Dipartimento di Chimica Organica e Biochimica  
Via Cintia 4, 80126, Napoli, Italy  
Tel: +39 081 674 150  
*gpieretti@unina.it*

**PILARD SERGE**

UPJV - Analytical Platform  
UFR Sciences 33 rue Saint-Leu, 80039  
Amiens, France  
Tel: +33 3 22 82 88 54  
Fax: +33 3 22 82 88 57  
*serge.pilard@u-picardie.fr*

**PLANAS ANTONI**

IQS-Universitat Ramon Llull  
Bioengineering Department  
Via Augusta 390, Barcelona, Spain  
Tel: +34-932672000  
Fax: +34-932056266  
*antoni.planas@iqs.es*

**PLATEN TOBIAS**

Johannes Gutenberg Universtiy  
Institute of Organic Chemistry  
Duesbergweg 10-14, Mainz, Germany  
Tel: +49 (0)6131 3922364  
*platen@uni-mainz.de*

**PLAZA-ALEXANDER PATRICE**

The University of Alberta  
Department of Chemistry  
Gunning-Lemieux Chemistry Centre E5-52,  
Edmonton, AB, Canada  
Tel: 0117809158846  
Fax: 0117804927705  
*plazaale@ualberta.ca*

**POGOSYAN AMAYAK**

University Rostock  
Department of Organic Chemistry  
18059, Rostock, Germany  
Tel: +49 176 83137562  
*amayak.pogosyan@uni-rostock.de*

**POINSOT VERENA**

CNRS - UMR5623 IMRCP  
118 route de Narbonne, Toulouse, France  
Tel: +33 561558333  
Fax: +33 561558155  
*poinsot@chimie.ups-tlse.fr*

**POLETTI LAURA**

University of Milan  
Organic and Industrial Chemistry  
Via Venezian 21, Milano, Italy  
Tel: +39 02 50314063  
Fax: +39 02 50314061  
*laura.poletti@unimi.it*

**POLISSI ALESSANDRA**

Università degli Studi di Milano-Bicocca  
Dipartimento di Biotecnologie e Bioscienze  
20132, Milano, Italy  
Tel: +39-02-6448-3431  
*alessandra.polissi@unimib.it*

**PONTONI LUDOVICO**

Università degli Studi di Napoli Federico II  
Dip. di Ingegneria Idraulica, Geotecnica ed  
Ambientale  
Via Claudio 21, Napoli, Italy  
Tel: +39 0817683425  
*ludovico.pontoni@gmail.com*

**POTIER PIERRE**

Sanofi Aventis  
4200, Sisteron, France  
Tel: +33 (0)4 92 33 39 83  
*pierre.potier@sanofi-aventis.com*

**POZZO TANIA**

Lund University – Dept. Biotechnology  
Box 124, Lund, Sweden  
Tel: +46462227335  
Fax: +46462224713  
*tania.pozzo@biotek.lu.se*

**PRALY JEAN-PIERRE**

University of Lyon  
Institut de Chimie et Biochimie Moléculaires et  
Supramoléculaires  
CPE, 43 blvd du 11 Novembre 1918, F-69622,  
Villeurbanne, France  
Tel: +33 4 72 43 11 61  
Fax: +33 4 72 43 14 08  
*jean-pierre.praly@univ-lyon1.fr*

**PREMATHILAKE HEMALI**

University of Missouri - St. Louis  
Chemistry and Biochemistry  
2948 University Meadows drive, Apt. 913A  
Saint Louis, USA  
Tel: +1 314-591-5719  
*hdp9tb@umsl.edu*

**PROZIL SÓNIA**

University of Aveiro - Department of Chemistry  
3810-193, Aveiro, Portugal  
Tel: +35 258842471  
*prozilsonia@gmail.com*

**PTASZEK AGATA**

Silesian University of Technology  
Department of Chemistry  
Krzywoustego 4, 44-100 Gliwice, Poland  
Tel: +48322371810  
*agata.ptaszek@polsl.pl*

**PULEO LETIZIA**

Sanofi Aventis - Exploratory Unit  
VIA GAETANO SBODIO2, 20134 Milano, Italy  
Tel: +390221042346  
Fax: +390221049808  
*letizia.puleo@sanofi-aventis.com*

**Q****QURESHI FAHIM**

GC University - Dept. of Chemistry  
Katchery Road, Off Lower Mall, Lahore, Pakistan  
Tel: +92(0)42 38711654  
*qureshifa@gcu.edu.pk*

**R****RAAB MICHAL**

Institute of Chemistry, Centre for Glycomics  
Structure and Function of Saccharides  
Dubravska cesta 9, Bratislava, Slovakia  
Tel: +421259410203  
*chemmrsa@savba.sk*

**RAICH IVAN**

Institute of Chemical Technology  
Dept. of Chemistry of Natural Compounds  
Technicka 5, Prague 6, Czech Republic  
Tel: +420 220 443 240  
*Ivan.Raich@vscht.cz*



**RAMER SANDRA**

Genencor - Biochemistry  
925 Page Mill Road, Palo Alto, USA  
Tel: +1 650-846-5831  
*sandra.ramer@danisco.com*

**RANADE SNEHA**

University of Missouri- Saint Louis  
Chemistry and Biochemistry  
2948 University Meadows drive apt # 913D, Saint  
Louis, USA  
Tel: +1 3017045736  
*sneha.ranade@umsl.edu*

**RANDRIANTSOA MIALY**

ELICITYL  
746 avenue ambroise croizat, Crolles, France  
Tel: +33476407161  
*mialy.randriantsoa@elicityl.fr*

**RAPP ERDMANN**

Max Planck Institute for Dynamics of  
Complex Technical Systems  
Sandtorstrasse 1, Magdeburg, Germany  
Tel: +49 (0)391-6110-0  
*rapp@mpi-magdeburg.mpg.de*

**RAUTER AMELIA PILAR**

Universidade de Lisboa  
Departamento de Química e Bioquímica  
Campo Grande, Ed. C8, Piso 5, Lisboa, Portugal  
Tel: +351 217500952  
Fax: +351 217500088  
*aprauter@fc.ul.pt*

**RAVIDÀ ALESSANDRA**

Dublin City University  
Centre for Bioanalytical Sciences  
Collins Avenue, Glasnevin, Dublin, Ireland  
Tel: +353(0)1 7006364  
*alessandra.ravida@dcu.ie*

**REDON SÉBASTIEN**

COB, ICBMS, INSA-Lyon  
Bat J Verne, 20 avenue A Einstein 69621,  
Villeurbanne, France  
Tel: +33 4 72 43 83 42  
*seb.redon@laposte.net*

**REICHARDT NIELS-CHRISTIAN**

CICbiomaGUNE  
Biofunctional Nanomaterials  
Paseo Miramon 182, San Sebastian, Spain  
Tel: +34 943005309  
*nreichardt@cicbiomagune.es*

**REINA MARTÍN JOSÉ JUAN**

Università degli Studi di Milano  
Chimica Organica e Industriale  
Via Venezian, 21, CAP 20133, Milano, Italy  
Tel: +39-02-50314090  
Fax: +39-02-50314072  
*jose.reina@unimi.it*

**REISSIG HANS**

Freie Universitaet Berlin  
Institut fuer Chemie und Biochemie  
Takustr. 3 - 14195, Berlin, Germany  
Tel: +49(0)3083855366  
*hans.reissig@chemie.fu-berlin.de*

**RESTAINO ODILE FRANCESCA**

Second University of Naples  
Experimental Medicine  
Vle M C di Savoia 18, Naples, Italy  
Tel: 39081566-7661  
*odile.francesca@libero.it*

**REUTTER WERNER**

Charité  
Biochemistry, CBF  
Arnimallee 22 - 14195, Berlin, Germany  
Tel: +49-30-83871350  
Fax: +49-30-83871541  
*werner.reutter@charite.de*

**ŘEZANKA MICHAL**

Charles University in Prague - Faculty of Science  
Department of Organic and Nuclear Chemistry  
Hlavova 8, Prague, Czech Republic  
Tel: +420221951327  
*rezanka@natur.cuni.cz*

**RICCIO RAFFAELE**

Università di Salerno  
Scienze Farmaceutiche e Biomediche  
Via Ponte don Melillo, Fisciano (SA), Italy  
Tel: +39 089969300  
*riccio@unisa.it*

**RICHICHI BARBARA**

University of Florence  
Department of Organic Chemistry  
Via della Lastruccia 13, Sesto Fiorentino, Italy  
Tel: +39 0554573492  
*barbara.richichi@unifi.it*

**RIVIERE MICHEL**

CNRS/Toulouse University  
IPBS  
205 route de Narbonne, Toulouse, France  
Tel: +33 561 175 558  
*riviere@ipbs.fr*



**RIZZO ROBERTO**

University of Trieste - Life Sciences  
via L. Giorgieri 1, Trieste, Italy  
Tel: +39 040 5583695  
Fax: +39 040 5583691  
*rizzor@units.it*

**RJABOVŠ VITALIJS**

Riga Technical University  
Faculty of Material Science and  
Applied Chemistry  
Azenes 14/24, LV-1007, Riga, Latvia  
Tel: +37128353052  
*v.rjabovs@gmail.com*

**ROBINA INMACULADA**

University of Seville  
Department of Organic Chemistry  
C/ Milán 6, Seville, Spain  
Tel: 4954556858  
*robina@us.es*

**ROGNIAUX HÉLÈNE**

INRA - BIA  
rue de la Géraudière - BP 71627  
Nantes, France  
Tel: +33 (0)240675034  
*helene.rogniaux@nantes.inra.fr*

**ROJAS MACIAS MIGUEL**

University of Giessen  
Institute of Veterinary Physiology and  
Biochemistry  
Mittelweg 5, Giessen, Germany  
Tel: +49 17678749025  
*miguel.rojas@vetmed.uni-giessen.de*

**ROJO RUTH**

Centro Tecnológico CARTIF  
Food and Chemicals Division  
Parque Tecnológico de Boecillo, 205  
Boecillo, Spain  
Tel: +34 (0)983546504  
Fax: +34 (0)983546521  
*rutroj@cartif.es*

**ROJO F. JAVIER**

CSIC  
Instituto de Investigaciones Químicas  
Américo Vespucio, 49, Seville, Spain  
Tel: +34 954489568  
*javier.rojo@iiq.csic.es*

**ROLLENHAGEN MANUELA**

Hannover Medical School  
Institute of Cellular Chemistry  
Carl Neuberg Strasse 1 – 30625  
Hannover, Germany  
Tel: +49511 5325210  
*rollenhagen.manuela@mh-hannover.de*

**ROMANO MARIA**

Novartis Vaccines - Research  
Via Fiorentina 1, Siena, Italy  
Tel: +39 0577 245572  
*maria\_rosaria.romano@novartis.com*

**ROMBOUTS YOANN**

Université des Sciences et Technologies de Lille  
Laboratoire de Glycobiologie Structurale et  
Fonctionnelle - UMR 8576 - UFR de Biologie  
59655, Villeneuve d'Ascq Cedex, France  
Tel: +33 (0)32033 6347  
Fax: +33 (0)32043 6555  
*yoann.rombouts@gmail.com*

**RÖNNOLS JERK**

Stockholm University  
Department of Organic Chemistry  
Arrhenius laboratory, Stockholm, Sweden  
Tel: +46-8-162478  
*jerk@organ.su.se*

**ROPARTZ DAVID**

INRA - BIA  
Rue de la Géraudière - BP 71627  
Nantes, France  
Tel: +33 (0) 240675034  
*david.ropartz@nantes.inra.fr*

**ROSA MÒNICA**

IQAC-CSIC  
Química-Biomèdica  
Jordi Girona 18,24, Barcelona, Spain  
Tel: +34934006113  
*monica.rosa@iqac.csic.es*

**ROTA PAOLA**

University of Milan  
Department of Public Health, Microbiology,  
Virology  
Via Pascal 36, 20133, Milan, Italy  
Tel: +39 0250316047  
*paola.rota@guest.unimi.it*

**ROVINI MICHELE**

Novartis Vaccines - Tech. Development  
Via Fiorentina 1, Siena, Italy  
Tel: +39 0577243206  
*michele.rovini@novartis.com*

**RUDD TIMOTHY**

Istituto di Ricerche Chimiche e Biochimiche  
"G. Ronzoni" - NMR center  
Via Giuseppe Colombo, 81 - 20133, Milan, Italy  
Tel: +39 0270641627  
Fax: +39 0270641634  
*timrudd@gmail.com*

**RUDRAWAR SANTOSH**

Griffith University - Institute of Glycomics  
Griffith University Qld 4222  
Gold Coast, Australia  
Tel: +61 7 555 29351  
Fax: +61 7 555 28098  
*s.rudrawar@griffith.edu.au*

**RYBKA JACEK**

Institute of Immunology and  
Experimental Therapy  
Immunology of Infectious Diseases  
Weigla 12, Wroclaw, Poland  
Tel: +4871 3321924  
*rybka@iitd.pan.wroc.pl*

**S****SAHLOUL KAMAR**

Université Paris Sud 11  
rue Georges Clemenceau, 91405, Orsay, France  
Tel: +33169154719  
*kamar.sahloul@u-psud.fr*

**SAKAIRI NOBUO**

Hokkaido University  
Environmental Science  
N10 W5, Kita-ku, Sapporo 060-0810, Japan  
Tel: +81-11-706-2257  
Fax: +81-11-706-2257  
*nsaka@ees.hokudai.ac.jp*

**SAMASZKO JUSTYNA**

University of Gdansk - Chair of Sugar Chemistry  
Bazynskiego 1A, 80-952 Gdansk, Gdansk, Poland  
Tel: +48 58 523 53 77  
Fax: +48 58 523 54 72  
*samaszk@chem.univ.gda.pl*

**SAMSONOV SERGEY**

Biotec TUD - Structural Bioinformatics  
Tatzberg 47/49, 01307, Dresden, Germany  
Tel: +4935146380083  
Fax: +4935146380087  
*sergeys@biotec.tu-dresden.de*

**SANCHEZ RUIZ ANTONIO**

CICbiomaGUNE  
Biofunctional Nanomaterials Unit  
Paseo Miramon 182, San Sebastian, Spain  
Tel: +34 943005319  
*asanchez@cicbiomagune.es*

**SANSONE FRANCESCO**

Università di Parma  
Dipartimento di Chimica Organica e Industriale  
Parco Area delle Scienze 17/A, 43124 Parma, Italy  
Tel: +39 0521 905458  
*francesco.sansone@unipr.it*

**SASAKI KOHEI**

University of Toyama  
930-0194, Toyama, Japan  
Tel: +81 76 434 7561  
*m1061222@ems.u-toyama.ac.jp*

**SASSAKI GUILHERME**

Istituto di Chimica e Biochimica "G. Ronzoni"  
NMR Center  
Giuseppe Colombo 81, 20133, Milano, Italy  
Tel: +39 02 3894515147  
*guilherme.sasaki@gmail.com*

**SATOH HIROKO**

National Institute of Informatics  
101-8430, Tokyo, Japan  
Tel: +81 3 4212 2501  
*hsatoh@nii.ac.jp*

**SATTELLE BEN**

University of Manchester  
Faculty of Life Sciences  
Manchester Interdisciplinary Biocentre, 131  
Princess Street, M1 7DN, Manchester, UK  
Tel: +44 161 306 4182  
*ben.sattelle@manchester.ac.uk*

**SCANLAN EOIN**

Trinity College Dublin  
Department of Chemistry  
College Green, Dublin 2, Dublin, Ireland  
Tel: +353871253061  
*eoin.scanlan@tcd.ie*

**SCHAEFER KATRIN**

University of Hamburg  
Department of Organic Chemistry  
Martin Luther King Platz 6 - 20146, Hamburg,  
Germany  
Tel: +44 0-428382861  
*katrin.schaefer@chemie.uni-hamburg.de*

**SCHEIBE CHRISTIAN**

Humboldt-Universität zu Berlin  
Department of Chemistry  
Brook-Taylor-Str. 2, Berlin, Germany  
Tel: +493020937449  
Fax: +493020937266  
*christian.scheibe@chemie.hu-berlin.de*

**SCHLEMMER CLAUDINE**

Johannes Gutenberg-Universität Mainz  
Department of Organic Chemistry  
Duesbergweg 10-14, 55128, Mainz, Germany  
Tel: +49 6131-39 25356  
Fax: +49 6131-39 22338  
*schlemme@uni-mainz.de*

**SCHMID WALTHER**

University of Vienna  
Dept. of Organic Chemistry  
Währingerstrasse 38 - 1090, Wien, Austria  
Tel: +43-1-4277-52102  
Fax: +43-1-4277-9521  
*walther.schmid@univie.ac.at*

**SCHMIDT RICHARD R.**

Konstanz - Department of Chemistry  
D-78457, Konstanz, Germany  
Tel: +49 7531 882538  
Fax: +49 7531 883135  
*richard.schmidt@uni-konstanz.de*

**SCHWARZ STEFAN**

Martin Luther Universität Halle Wittenberg  
Hallbergsbreite 14 - 06120  
Halle/ Saale, Germany  
Tel: +49 345 5508001  
*stefan.schwarz.halle@freenet.de*

**SCHWEIZER FRANK**

University of Manitoba  
Department of Chemistry  
Department of Chemistry 144 Dysart Rd,  
Winnipeg, Canada  
Tel: +1 204-474-7012  
Fax: +1 204-474-7608  
*schweize@cc.umanitoba.ca*

**SEEBERGER PETER H.**

Max Planck Institute of Colloids and Interfaces  
Biomolecular Systems  
Am Mühlenberg 1, Potsdam-Golm, Germany  
Tel: +49 (0) 30-838-59300  
Fax: +49 (0) 30-838-59302  
*peter.seeberger@mpikg.mpg.de*

**SEFEROGLU AYSE BENGISU**

Koc University  
Chemical and Biological Engineering  
Koc Universitesi Rumeli feneri yolu  
Istanbul, Turkey  
Tel: +90 212 3381361  
*aseferoglu@ku.edu.tr*

**SEIFERT JOACHIM**

Alchemia LTD  
PO Box 4851, Eight Mile Plains, QLD - 4113,  
Australia  
Tel: +61733400261  
Fax: +61733400222  
*jseifert@alchemia.com.au*

**SERIANNI ANTHONY S.**

University of Notre Dame  
Department of Chemistry and Biochemistry  
251 Nieuwland Science Hall, Notre Dame, IN  
46556-5670, USA  
Tel: +1 574 631 7807  
*serianni.1@nd.edu*

**SHATALOV ANATOLY A.**

Technical University of Lisbon  
CEF-ISA  
Tapada da Ajuda, Lisboa, Portugal  
Tel: + 351 213653379  
Fax: + 351 213653338  
*anatoly@isa.utl.pt*

**SHIN INJAE**

Yonsei University  
Center for Biofunctional Molecules  
Department of Chemistry  
120-749, Seoul, Korea  
Tel: +82221232631  
*injae@yonsei.ac.kr*

**SHINO MANABE**

Riken - Advanced Science Institute  
351-0198, Wako, Japan  
Tel: +81-48-467-9432  
*smanabe@riken.jp*

**SHINYA SHOKO**

Kinki University  
3327-204, Nara, Japan  
Tel: +81-742-43-8237  
*1033690015j@nara.kindai.ac.jp*

**SIGIDA ELENA**

Institute of Biochemistry and Microbiology of  
Plants and Microorganisms  
Russian Academy of Sciences  
Laboratory of Biochemistry  
410049 Prospekt Entuziastov, 13, Saratov, Russia  
Tel: +78452970444  
*si\_elena@mail.ru*

**SILIOC CHRISTELLE**

Université Lyon 1  
IMP  
15 bd Latarjet, Université Lyon 1  
Villeurbanne, France  
Tel: +33472432713  
*csilioc@gmail.com*

**SILIPO ALBA**

Università di Napoli Federico II  
Dipartimento di Chimica Organica e Biochimica  
Via Cintia 4, 80126, Napoli, Italy  
Tel: +39 081 674 404  
*silipo@unina.it*

**SIMON PETR**

Institute of Microbiology  
Academy of Sciences of the Czech Republic  
Videnska 1083, Prague 4, Czech Republic  
Tel: +420 296 442 360  
*petr.simon@biomed.cas.cz*

**SINGH LATIKA**

Alchemia LTD  
PO Box 4851, Eight Mile Plains, QLD-4113,  
Australia  
Tel: +61733400220  
Fax: +61733400222  
*lsingh@alchemia.com.au*

**SIRIWARDENA ALOYSIUS**

Université de Picardie Jules Verne  
Laboratoire des Glucides, CNRS-UMR6912  
33 Rue St Leu, Amiens, France  
Tel: + 33 3 22 82 76 73  
Fax: +33 322827560  
*aloysius.siriwardena@u-picardie.fr*

**SOLLOGOUB MATTHIEU**

UPMC, Univ Paris 6  
Institut Parisien de Chimie Moléculaire  
C181, 4 place Jussieu, Paris, France  
Tel: +33 (0)1 44 27 61 63  
*matthieu.sollogoub@upmc.fr*

**SOLUCH MAGDALENA**

Institute of Organic Chemistry  
Polish Academy of Sciences  
ul. Kasprzaka 44/52, 01-224 Warsaw, Poland  
Tel: +48(22)3432320  
Fax: +48(22)6326681  
*magdalena.soluch@icho.edu.pl*

**SOMSÁK LÁSZLÓ**

University of Debrecen  
Department of Organic Chemistry  
Egyetem tér 1, Debrecen, Hungary  
Tel: +3652512900 ext 22348  
Fax: +3652512744  
*somsak@tigris.unideb.hu*

**SQUEGLIA FLAVIA**

Bioimaging and Biostructure Institute (IBB)  
CNR  
Via Mezzocannone 16, Naples, Italy  
Tel: +39 0771659705  
*alysia@hotmail.it*

**SRIVASTAVA AMRITA**

Indian Institute of Technology, Madras  
Department of Chemistry  
Tamilnadu, Chennai, India  
Tel: +91 4422575221  
Fax: +91 44-22574202  
*amritasrivastavaster@gmail.com*

**STANETTY CHRISTIAN**

University of Natural Resources and Life Sciences  
Department of Chemistry  
Muthgasse 18, A-1190, Wien, Austria  
Tel: +43-1-47654-6083  
Fax: +43-1-47654-6059  
*christian.stanetty@boku.ac.at*

**STREBEL TAMARA**

University College Dublin  
Center for Synthesis and Chemical Biology  
Flat 2, 40 Waterloo Road, Dublin, Ireland  
Tel: +353866656667  
*tamara.strebel@ucdconnect.ie*

**STÜTZ ARNOLD**

Technical University Graz  
Institute of Organic Chemistry  
Stremayrgasse 9, Graz, Austria  
Tel: +43 316 873 32430  
Fax: +43 316 873 32402  
*stuetz@tugraz.at*

**STURIALE LUISA**

ICTP - CNR  
95126, Catania, Italy  
Tel: +39 (0) 957338248  
*luisella.sturiale@cnr.it*

**SUE SHIH-CHE**

National Tsing-Hua University  
Department of Life Science  
30013, Hsin-Chu, Taiwan  
Tel: +886 3 5742025  
*scsue@life.nthu.edu.tw*

**SUTKEVICIUTE IEVA**

Univ Grenoble 1 - IBS  
41 Rue Jules Horowitz, Grenoble, France  
Tel: +33 4 38 78 56 09  
Fax: +33 4 38 78 54 94  
*ieva.sutkeviciute@ibs.fr*

**SUZUKI RYUICHIRO**

National Food Research Institute  
National Agriculture and Food Research  
Organization - Applied Microbiology Division  
2-1-12 Kannondai, Tsukuba, Ibaraki, Japan  
Tel: +81-29-838-8075  
Fax: +81-29-838-8122  
*ryuichi@affrc.go.jp*

**SVENSSON STEFAN**

Linköping University - IFM/Chemistry  
Linköpings Universitet, Linköping, Sweden  
Tel: +4613281366  
*sts@ifm.liu.se*

**SZŐCS BÉLA**

University of Debrecen  
Department of Organic Chemistry  
H-4032, Egyetem tér 1, Debrecen, Hungary  
Tel: +3652512900/22453  
*szbela9@gmail.com*

**SZULC MONIKA**

University of Gdansk - Chair of sugar Chemistry  
Bazynskiego 1A, 80-952 Gdansk, Gdansk, Poland  
Tel: +48 58 523 53 77  
Fax: +48 58 523 54 72  
*monikas@chem.univ.gda.pl*

**T****TABARI MAHSA**

Islamic Azad University of Iran, Lahijan Branch  
Department of Food Science  
Lahijan Branch, Iran  
Tel: +989126069959  
*ma.tabari@gmail.com*

**TAHIR MUHAMMAD NAZIR**

Wageningen University  
Lab. of Organic Chemistry  
Dreijenplein 8, Building 316, 6700 EG,  
Wageningen, The Netherlands  
Tel: +31317482360  
*m.nazirtahir@yahoo.com*

**TAKEUCHI KAZUHIKO**

National Institute of Advanced Industrial Science  
and Technology (AIST)  
Research Institute for Innovation in Sustainable  
Chemistry  
AIST Tsukuba Central 5, 1-1-1 Higashi, Tsukuba,  
Ibaraki, Japan  
Tel: +81-29-861-6325  
Fax: +81-29-861-6325  
*takeuchi-kazuhiko@aist.go.jp*

**TAMARU YUTAKA**

Mie University Graduate School of Bioresources  
Life Science  
1577 Kurimamachiya, Tsu, Mie 514-8507, Japan  
Tel: +81-59-231-9560  
Fax: +81-59-231-9560  
*ytamaru@bio.mie-u.ac.jp*

**TAMURA JUN-ICHI**

Tottori University  
Regional Environment  
Koyamacho-minami 4-101  
Tottori 6808551, Japan  
Tel: +81-857-31-5108  
Fax: +81-857-31-5108  
*jtamura@rstu.jp*

**TANAKA HIDENORI**

Carlsberg Laboratory  
1799, Copenhagen V, Denmark  
Tel: +4533275302  
*Hidenori.Tanaka@carlsberglab.dk*



**TETA ROBERTA**

Università degli Studi di Napoli Federico II  
Chimica delle Sostanze Naturali  
Via Domenico Montesano, 49, Napoli, Italy  
Tel: +39 081678517/531  
Fax: +39 081678552  
*roberta.teta@unina.it*

**THIMM JULIAN**

University of Hamburg  
Department of Chemistry  
Martin Luther King Platz 6, Hamburg, Germany  
Tel: +4940428382820  
*thimm@chemie.uni-hamburg.de*

**THOMAS SARAH**

University of Edinburgh - School of Chemistry  
Kings Buildings, West Mains Road, Edinburgh,  
UK  
Tel: +44 7751101364  
*S.J.Thomas-4@sms.ed.ac.uk*

**THOMPSON ROISIN**

Dublin City University - ISSC  
Collins Avenue, Dublin, Ireland  
Tel: +35317005971  
Fax: +35317008021  
*roisin.thompson@dcu.ie*

**THYGESEN MIKKEL B.**

University of Copenhagen  
Faculty of Life Sciences  
IGM-Nanobioscience  
Thorvaldsensvej 40, DK-1871 Frederiksberg C,  
Denmark  
Tel: +45 35332462  
Fax: +45 35332398  
*mbth@life.ku.dk*

**TIEMEYER MICHAEL**

University of Georgia  
Complex Carbohydrate Research Center  
315 Riverbend Rd., Athens, GA, USA  
Tel: +1 706 542-2740  
Fax: +1 706 542-2740  
*mtiemeyer@ccrc.uga.edu*

**TOBER MAIKE**

University of Hamburg  
Department of Organic Chemistry  
Martin Luther King Platz 6 -20146, Hamburg,  
Germany  
Tel: +4940428382827  
*tober@chemie.uni-hamburg.de*

**TOKARSKI MATTHIAS**

TU Dortmund - Faculty of Chemistry  
Otto-Hahn-Str. 6 - 44227, Dortmund, Germany  
Tel: +492317553887  
*matthias.tokarski@tu-dortmund.de*

**TOMAN RUDOLF**

Institute of Virology, Slovak Academy of Sciences  
Dubravska cesta 9, 845 05 Bratislava, Slovakia  
Tel: +421 2 59302418  
Fax: +421-2-54774284  
*virutoma@savba.sk*

**TOMIC-PISAROVIC SRDANKA**

University of Zagreb - Faculty of Science  
Dept of Chemistry  
Horvatovac 102a - HR-10000, Zagreb, Croatia  
Tel: +38514606411  
Fax: +385 1 4606401  
*stomic@chem.pmf.hr*

**TOMS STEVEN**

Industrial Research Ltd  
Carbohydrate Chemistry  
69 Gracefield Road, Lower Hutt, New Zealand  
Tel: +64-4-9313116  
*s.toms@irl.cri.nz*

**TORRI GIANGIACOMO**

Istituto di Ricerche Chimiche e Biochimiche  
Carbohydrate Science Group  
G. Colombo 81, Milano, Italy  
Tel: +39 027064161  
Fax: +39 02 70641634  
*torri@ronzoni.it*

**TRAMICE ANNABELLA**

National Research Council  
Biomolecular Chemistry Institute  
viale Campi Flegrei 34, comprensorio Olivetti,  
Pozzuoli, Italy  
Tel: +390818675070  
Fax: +390818041770  
*atramice@icb.cnr.it*

**TROMBOTTO STEPHANE**

University Lyon 1 - IMP  
69622, Villeurbanne, France  
Tel: +33472431210  
*stephane.trombotto@univ-lyon1.fr*



**TURCO SALVATORE**

University of Kentucky  
Department of Biochemistry  
741 South Limestone, BBSRB, Lexington,  
Kentucky, USA  
Tel: +1 859-323-6693  
*turco@uky.edu*

**TURKS MARIS**

Riga Technical University  
14/24 Azenes Str., Riga, Latvia  
Tel: +37167089251  
*maris\_turks@ktf.rtu.lv*

**TURSKA-SZEWCZUK ANNA**

Maria Curie-Skłodowska University  
Department of Genetics and Microbiology  
Akademicka 19, 20-033, Lublin, Poland  
Tel: +48 81 537 5981  
Fax: +48 81 537 5959  
*aturska@hektor.umcs.lublin.pl*

**TVAROSKA IGOR**

Institute of Chemistry  
Slovak Academy of Sciences  
Dubravska cesta 9, Bratislava, Slovakia  
Tel: +421254772080  
Fax: +421259410222  
*chemitsa@savba.sk*

**TYLER PETER**

Industrial Research Limited  
Carbohydrate Chemistry  
P O Box 31310, Lower Hutt, New Zealand  
Tel: +64-4-9313062  
*p.tyler@irl.cri.nz*

**U****UEDA MITSUHIRO**

Osaka Prefecture University  
Applied Biological Chemistry  
5998531, Osaka, Japan  
Tel: +81-72-254-9468  
Fax: +81-72-254-9468  
*mueda@biochem.osakafu-u.ac.jp*

**UHRIN DUSAN**

University of Edinburgh  
Department of Chemistry  
West Mains Rd, Edinburgh, UK  
Tel: +441316507061  
*dusan.uhrin@ed.ac.uk*

**UL QADER SHAH ALI**

University of Karachi  
The Karachi Institute of Biotechnology and  
Genetic Engineering (KIBGE)  
University Road, Karachi, Pakistan  
Tel: +92-21-36347780  
Fax: +92-21-32229310  
*madar\_chem@yahoo.com*

**ULC REBECCA**

University College Dublin  
School of Chemistry and Chemical Biology  
Belfield, Dublin 4, Dublin, Ireland  
Tel: +353-1-7162977  
*rebecca.ulc@ucd.ie*

**UNVERZAGT CARLO**

University of Bayreuth  
Gabaeude NWI, Universitaet Bayreuth - 95440,  
Bayreuth, Germany  
Tel: +49-921-552670  
*carlo.unverzagt@uni-bayreuth.de*

**URBAN DOMINIQUE**

University Paris Sud 11  
Department of Chemistry  
Rue Georges Clémenceau, Orsay, France  
Tel: +33 1 69 15 71 35  
Fax: +33 1 69 85 37 15  
*dominique.urban@u-psud.fr*

**V****VÁGVÖLGYINÉ TÓTH MARIETTA**

University of Debrecen  
Organic Chemistry Department  
4032 Debrecen Egyetem tér 1.  
Debrecen, Hungary  
Tel: +36 52 512-900/22474  
Fax: +36 512-744  
*toth.marietta@science.unideb.hu*

**VALENCIA GREGORIO**

IQAC-CSIC, Química-Biomèdica  
Jordi Girona 18,26, Barcelona, Spain  
Tel: +34934006113  
*gregorio.valencia@iqac.csic.es*

**VALVANO MIGUEL**

University of Western Ontario  
Microbiology and Immunology  
Dental Sciences Building 3014, London, Canada  
Tel: +1 519-661-3427  
Fax: +1 519-661-3499  
*mvalvano@uwo.ca*

**VAN CALSTEREN MARIE-ROSE**

Agriculture et Agroalimentaire Canada  
Centre de Recherche et de développement  
sur les aliments  
3600 Casavant Blvd. West, Saint-Hyacinthe,  
Quebec, Canada  
Tel: +1 450-768-3334  
Fax: +1 450-773-8641  
*Marie-Rose.VanCalsteren@AGR.GC.CA*

**VAN DEN BERG RICHARD**

Leiden University  
Bio-Organic Synthesis  
P.O. Box 9502, 2300 RA Leiden, The Netherlands  
Tel: +31-71-5274353  
*r.j.vdberg@chem.leidenuniv.nl*

**VAN DEN BROEK LAMBERTUS**

WUR - Food & Biobased Research  
P.O. Box 17, Wageningen, The Netherlands  
Tel: +31 317 480104  
*ben.vandenbroek@wur.nl*

**VAN DEN NIEUWENDIJK RIAN**

Leiden University - Bio-Organic Synthesis  
PO Box 9502, 2300 RA Leiden, The Netherlands  
Tel: +31-71-5274483  
*nieuwend@chem.leidenuniv.nl*

**VAN DER MAREL GIJS**

Universiteit Leiden  
Leiden Institute of Chemistry  
Einsteinweg 55, Leiden, The Netherlands  
Tel: +31715274280  
*marel\_g@chem.leidenuniv.nl*

**VAN DYK SUSAN**

Rhodes University - Biochemistry  
PO Box 94, Grahamstown, South Africa  
Tel: +27-46-6038441  
Fax: +27-46-6223984  
*s.vandyk@ru.ac.za*

**VAN HATTUM HILDE**

Utrecht University  
Medicinal Chemistry & Chemical Biology  
Hugo van der Goeslaan 10, 3723 WK  
Bilthoven, The Netherlands  
Tel: +31 6 17 380 930  
*H.vanHattum@uu.nl*

**VAN KASTEREN SANDER**

Netherlands Cancer Institute  
Cell Biology  
Plesmanlaan 121, 1066CX, Amsterdam  
The Netherlands  
Tel: +31205121972  
*s.v.kasteren@nki.nl*

**VANHAVERBEKE CÉCILE**

Grenoble - Département de Chimie Moléculaire  
Bât. E (André Rassat) Pôle chimie – BP53 38041  
Grenoble Cedex 9, Grenoble, France  
Tel: +33 4 76 63 53 19  
*Cecile.Vanhaverbeke@ujf-grenoble.fr*

**VARGA NORBERT**

University of Milano  
Organic and Industrial Chemistry  
via Venezian 21, 20133, Milano, Italy  
Tel: +39 3278474900  
*norbert.varga@unimi.it*

**VARGAS-BERENGUEL ANTONIO**

University of Almeria  
Department of Organic Chemistry  
Carretera de Sacramento, Almeria, Spain  
Tel: +34 950015315  
Fax: +34 950 015481  
*avargas@ual.es*

**VARON SILVA DANIEL**

Max Planck Institute of Colloids and Interfaces  
Biomolecular Systems  
Arnimallee 22, Berlin, Germany  
Tel: + 49 30 83852450  
Fax: + 49 30 838 59302  
*daniel.varon@mpikg.mpg.de*

**VAUZEILLES BORIS**

CNRS-Univ. Paris-Sud 11  
ICMMO-LG2M  
Bât 420 - Univ. Paris-Sud 11, Orsay, France  
Tel: +33 1 69 15 68 36  
*boris.vauzeilles@u-psud.fr*

**VAZQUEZ MERCEDES**

Dublin City University - ISSC  
Collins Avenue, Dublin, Ireland  
Tel: +35317007602  
Fax: +35317008021  
*mercedes.vazquez@dcu.ie*

**VEERAPEN NATACHA**

University of Birmingham  
BioSciences  
Edgbaston, B15 2TT, Birmingham, UK  
Tel: +441214158123  
*N.Veerapen@bham.ac.uk*

**VERCAUTEREN RONNY**

Cargill  
Havenstraat 84 - 1800, Vilvoorde, Belgium  
Tel: +32 02 2570695  
Fax: +32 02 2570675  
*Ronny\_Vercauteren@cargill.com*

**VIDAL SEBASTIEN**

University of Lyon / CNRS  
Department of Chemistry and Biochemistry  
Universite Lyon 1 / ICBMS / Bat Curien CPE / 43  
Bd du 11 Novembre - F-69622  
Villeurbanne, France  
Tel: +33 472 448 349  
Fax: +33 472 432 752  
*sebastien.vidal@univ-lyon1.fr*

**VINCENT STÉPHANE**

University of Namur - Department of Chemistry  
Rue de Bruxelles 61, Namur, Belgium  
Tel: +32 081724521  
*stephane.vincent@fundp.ac.be*

**VINOGRADOV EVGENY**

IBS NRC  
100 Sussex Dr, Ottawa ON, Canada  
Tel: +1 613 990 0832  
*evguenii.vinogradov@nrc.ca*

**VIRLOUVET MICKAEL**

Fresenius Kabi Austria  
Estermannstrasse 17 - 4020, Linz, Austria  
Tel: +4373276512454  
*mickael.virlouvet@fresenius-kabi.com*

**VITIELLO GIUSEPPE**

Università di Napoli Federico II  
Dipartimento di Chimica Organica e Biochimica  
Via Cintia 4, 80126, Napoli, Italy  
Tel: +39 081 674 249  
*giuseppe.vitiello@unina.it*

**VITYAZEV FEDOR**

Institute of Physiology, Komi Science Center, Ural  
Branch of the Russian Academy of Sciences  
st. Pervomaiskaya 50, 167982, Syktyvkar, Russia  
Tel: +7 8212 241001  
Fax: +7 8212 241001  
*RodefexVit@yandex.ru*

**VLIEGENTHART HANS**

Utrecht University - Bijvoet Center  
Padualaan 8, Utrecht, The Netherlands  
Tel: +31302532168  
*j.f.g.vliegenthart@uu.nl*

**W****WADA TAKESHI**

The University of Tokyo  
Medical Genome Sciences  
277-8562, Kashiwa, Japan  
Tel: +81-4-7136-3612  
Fax: +81-4-7136-3612  
*wada@k.u-tokyo.ac.jp*

**WADOUACHI ANNE**

Université de Picardie Jules Verne  
Laboratoire des Glucides UMR 6219  
33 rue Saint Leu, 80039 Amiens, France  
Tel: +33 322 827 527  
*anne.wadouachi@u-picardie.fr*

**WAGNER SARAH**

University Mainz  
Department of Organic Chemistry  
Duesbergweg 10-14, 55128, Mainz, Germany  
Tel: +496131 3922364  
*wagnersa@uni-mainz.de*

**WAKAMIYA NOBUTAKA**

Asahikawa Medical University  
Microbiology and Immunochemistry  
2-1-1-1 Midorigaoka Higashi, Asahikawa, Japan  
Tel: +81-166-68-2393  
*wakamiya@asahikawa-med.ac.jp*

**WALDMANN MORITZ**

University of Hamburg  
Department of Organic Chemistry  
Martin Luther King Platz 6 - 20146  
Hamburg, Germany  
Tel: +4940428385049  
*moritz.waldmann@chemie.uni-hamburg.de*

**WALVOORT MARTHE**

Leiden University - Bio-organic Synthesis  
Einsteinweg 55, 2333 CC  
Leiden, The Netherlands  
Tel: +31-715274508  
*m.t.c.walvoort@chem.leidenuniv.nl*

**WANDZIK ILONA**

Silesian University of Technology  
Department of Organic Chemistry, Bioorganic  
Chemistry and Biotechnology  
44-100, Gliwice, Poland  
Tel: +48 32 237 2028  
*ilona.wandzik@polsl.pl*

**WANG GUAN-NAN**

National University of Ireland-Galway  
Department of Chemistry  
School of Chemistry, National University of  
Ireland-Galway, University road, Galway, Ireland  
Tel: +353 91 495707  
*guan-nan.wang@nuigalway.ie*

**WARREN FREDERICK**

Kings College London  
Diabetes and Nutritional Sciences  
Franklin Wilkins Building, Stamford Street, SE1  
9NH, London, UK  
Tel: +442078484883  
*frederick.warren@kcl.ac.uk*

**WEBER CORINNA**

University of Graz - Pharmaceutical Chemistry  
8010, Graz, Austria  
Tel: +436766868729  
*corinna.weber@uni-graz.at*

**WECK STEFAN**

Johannes Gutenberg-University Mainz  
Department of Organic Chemistry  
Duesbergweg 10-14, 55128, Mainz, Germany  
Tel: +49-6131-39-25356  
*wecks@uni-mainz.de*

**WEHNER JOHANNES**

Christiana Albertina University of Kiel  
Otto Diels Institute of Organic Chemistry  
Otto Hahn Platz 4, 24098, Kiel, Germany  
Tel: +49 431 8801933  
Fax: +49 431 8807410  
*jwehner@oc.uni-kiel.de*

**WERZ DANIEL B**

University of Goettingen  
Tammannstr. 2, 37077  
Goettingen, Germany  
Tel: +49-551-393251  
*dwerz@gwdg.de*

**WHITFIELD DENNIS**

National Research Council  
Institute for Biological Sciences  
100 Sussex Drive, Ottawa, Canada  
Tel: +1 613-993-5265  
*dennis.whitfield@nrc-cnrc.gc.ca*

**WHITFIELD CHRIS**

University of Guelph  
Molecular & Cellular Biology  
50 Stone Road E, Guelph, Canada  
Tel: +1-519-824-4120 x53361  
Fax: +1-519-837-3273  
*cwhitfie@uoguelph.ca*

**WIDMALM GÖRAN**

Stockholm University  
Department of Organic Chemistry  
Stockholms universitet, Stockholm, Sweden  
Tel: +468163742  
Fax: +468154908  
*gw@organ.su.se*

**WIEBE CHRISTINE**

Johannes Gutenberg - Universität Mainz  
Organische Chemie  
Duesbergweg 10-14, 55128, Mainz, Germany  
Tel: +491715421578  
*christine.wiebe@t-online.de*

**WILDBERGER PATRICIA**

Graz University of Technology  
Institute of Biotechnology and  
Biochemical Engineering  
8010, Graz, Austria  
Tel: +43 (316) 873 - 8907  
*patricia.wildberger@tugraz.at*

**WILLEMS MARIAN**

Leiden University - Bio-organic Synthesis  
Einsteinweg 55, Leiden, The Netherlands  
Tel: +31 (0)71 527 4477  
*m.willems@chem.leidenuniv.nl*

**WILSON IAIN**

Universität für Bodenkultur  
Department für Chemie  
Muthgasse 18, Wien, Austria  
Tel: +43-1-47654-6541  
*iaain.wilson@boku.ac.at*

**WIMMEROVA MICHAELA**

Masaryk University  
Kamenice 5, Brno, Czech Republic  
Tel: +420549498166  
*michaw@chemi.muni.cz*

**WIN-MASON ANNA**

Victoria University of Wellington  
School of Chemical and Physical Sciences  
PO BOX 600, Wellington, 6140, New Zealand  
Tel: +642 1447836  
*anna.win@vuw.ac.nz*

**WITCZAK ZBIGNIEW**

Wilkes University  
Department of Pharmaceutical Sciences  
84 W. South Street, Wilkes-Barre, USA  
Tel: 1+ 570-408-4276  
Fax: 1+ 570-408-4299  
*zbigniew.witczak@wilkes.edu*

**WITTMANN VALENTIN**

University of Konstanz - Department of  
Chemistry  
Universitätsstr. 10, 78457, Konstanz, Germany  
Tel: +49 7531 884572  
Fax: +49 7531 884573  
*Valentin.Wittmann@uni-konstanz.de*

**WOLF SASKIA**

University of Hamburg - Department of  
Chemistry  
Martin Luther King Platz 6 – 20146  
Hamburg, Germany  
Tel: +4940428384250  
*wolf@chemie.uni-hamburg.de*

**WOODS ROBERT J.**

University of Georgia  
Complex Carbohydrate Research Center  
315 Riverbend Rd., Athens, USA  
Tel: +1-706-542-4454  
Fax: +1 706-542-4412  
*rwoods@ccrc.uga.edu*

**WRODNIGG TANJA**

Technical University Graz  
Institute of Organic Chemistry  
Stremayrgasse 9, Graz, Austria  
Tel: +43 316 873 32433  
Fax: +43 316 873 10 32433  
*t.wrodnigg@tugraz.at*

**WU ALBERT M.**

Chang-Gung University  
Glyco-Research Lab, College of Medicine  
333, Tao-Yuan, Taiwan  
Tel: +886-3-211-8800#5176  
Fax: +886-3-211-8456  
*amwu@mail.cgu.edu.tw*

**X****XAVIER NUNO MANUEL**

Universidade de Lisboa, Faculdade de Ciências  
Departamento de Química e Bioquímica, Centro  
de Química e Bioquímica  
Campo Grande, Ed. C8, Piso 5 - 1749-016  
Lisboa, Portugal  
Tel: +351 217500952  
*nmxavier@fc.ul.pt*

**Y****YAMASHITA MITSUJI**

Shizuoka University  
Graduate School of Science and Technology  
3-5-1 Johoku, Naka-ku, Hamamatsu, Japan  
Tel: +81 534781144  
Fax: +81 534781144  
*tcmiyama@ipc.shizuoka.ac.jp*

**YAN SHI**

Universität für Bodenkultur  
Department für Chemie  
Muthgasse 18, A-1190, Wien, Austria  
Tel: +43-1-360066422  
*shi.yan@boku.ac.at*

**YAŞAR YILDIZ SONGÜL**

Marmara University - Bioengineering  
Marmara University Göztepe Campus  
Istanbul, Turkey  
Tel: +902123475124  
*songulyasar@marun.edu.tr*

**YU TING-FONG**

University of Birmingham - Biosciences  
University of Birmingham, Edgbaston,  
Birmingham, B15 2TT, Birmingham, UK  
Tel: +44 (0)121 4158123  
*tfy583@bham.ac.uk*

**YU BIAO**

Shanghai Institute of Organic Chemistry  
Chinese Academy of Sciences  
200032, Shanghai, China  
Tel: + 86-21-54925131  
*byu@mail.sioc.ac.cn*

**Z****ZACCHEUS MONA**

Stockholm University  
Department of Organic Chemistry  
Arrheniuslaboratoriet 106 91  
Stockholm, Sweden  
Tel: +468162478  
*mona@organ.su.se*

**ZAKHAROVA ALEXANDRA**

DTU - Department of Chemistry  
Kemitorvet 201, Lyngby, Denmark  
Tel: +45 31441423  
*aleza@kemi.dtu.dk*

**ZAMYATINA ALLA**

University of Life Sciences and Natural Resources  
Department of Chemistry  
Muthgasse 18, 1190, Wien, Austria  
Tel: +43 1 47654 6084  
*alla.zamyatina@boku.ac.at*

**ZDOROVENKO EVELINA**

N.D. Zelinsky Institute of Organic Chemistry  
Lab 21  
Leninsky Prospekt 47, Moscow, Russia  
Tel: +7 499 1376148  
Fax: +7 499 1376148  
*zdorovenkoe@mail.ru*

**ZERROUKI RACHIDA**

Université de Limoges - Département de Chimie  
123 Avenue Albert Thomas, Limoges, France  
Tel: +33 555457224  
*rachida.zerrouki@unilim.fr*



The Organizing Committee would like to acknowledge the participation of a considerable number of Partners of the COST Action BM1003 “Microbial cell surface determinants of virulence as targets for new therapeutics in Cystic Fibrosis”. Glycoconjugates and/or glycan-binding proteins are known to be involved in disease processes due to opportunistic CF pathogens. Strengthening glycosciences through Eurocarb XVI conferences offers a wealth of opportunities for translational breakthroughs leading to improved diagnosis, treatment, and prevention of the disease.



**VISIT OUR WEBSITE:**  
**<http://www.cost-bm1003.info/>**

