

~~ALFA~~
~~LAL~~

197

Instruction Manual for Freshwater Generator Type JWSP-26-C100

Serial No.: N-010770

Shipname/
Hull No.: JLZ020504

Customer: Jin Ling Shipyard

Book Number O26WSE07.fm

37300-4

MF32-1



19761

IMO 9274654
JLZ-020504

Instruction Manual for Freshwater Generator Type JWSP-26-C100

Serial No.: N-010770

Shipname/
Hull No.: JLZ020504

Customer: Jin Ling Shipyard

Book Number O26WSE07.fm

Alfa Laval reserve the right to make changes at any time without prior notice.

Any comments regarding possible errors and omissions or suggestions for improvement of this publication would be gratefully appreciated.

Copies of this publication can be ordered from your local Alfa Laval company.

Published by: Alfa Laval Desalt A/S
Maskinvej 5
DK-2860 Søborg
(Copenhagen) Denmark

© **Copyright Alfa Laval Desalt.**

This document and its content must not be copied, reproduced, transmitted or disclosed to any third party without consent of Alfa Laval Desalt.

Table of Contents

Safety Instructions and Warnings

1.0.0 Safety Instructions and Warnings	page 5
--------------------------------------------------	--------

System Description

1.0.0 Working Principle	page 7
1.1.0 Freshwater Quality	page 7
1.2.0 Main Components.	page 7
1.3.0 Alternative Steam	page 8

Operating Instructions

1.0.0 Starting and Stopping Procedure	page 9
1.1.0 Starting-up the Plant with Jacket Cooling Water Heating	page 9
1.1.1 Evaporation	page 9
1.1.2 Condensation	page 10
1.2.0 Adjustment of Jacket Water Flow	page 10
1.3.0 Adjustment of Sea Cooling Water.	page 11
1.4.0 Stopping the Plant	page 11
2.0.0 Before Starting Up the Plant with Steam Injection Equipment	page 12
2.1.0 Starting Up the Plant with Steam Injection Equipment (AS).	page 13
2.1.1 Evaporation	page 13
2.1.2 Condensation	page 14
2.2.0 Adjustment of the Freshwater Production.	page 14
2.3.0 Stopping the Plant Working with Steam Injection Heating	page 14
2.4.0 Changing from Steam Injection Heating to Jacket Cooling Water	page 15
2.5.0 Long Term Standstill.	page 16

Maintenance

1.0.0 Why you need to perform regular maintenance duties	page 17
1.1.0 Overhaul Intervals.	page 17
1.2.0 Maintenance of Separator Vessel.	page 18
1.3.0 Maintenance of Evaporator Section	page 19
1.4.0 Maintenance of Condenser Section	page 20
1.5.0 Renewal of Plate Heat Exchanger Gaskets	page 22
1.5.1 Removal of Old Gaskets	page 22
1.5.2 Cleaning	page 22
1.5.3 Preparation of New Gaskets	page 23
1.5.4 Fitting New Gaskets	page 23

Table of Contents

Chemical Dosing of Scale Control Chemicals

1.0.0 Prevention of Scaling	page 25
1.1.0 Feed Water Ratio	page 25
1.2.0 Chemical Dosage	page 25
1.2.1 Scale Inhibitor Dosage Equipment for Feed Water	page 26
1.2.2 Safety Precautions with the use of Chemicals	page 27

Trouble-Shooting

1.0.0 Test Sheet	page 29
1.1.0 Trouble Shooting Table	page 29

Maintenance of Freshwater Pump

1.0.0 Maintenance of Freshwater Pump Types PVVF 1525-1532-2040	page 33
1.1.0 Overhaul of the Pump	page 33
1.1.1 Clearance	page 34
1.1.2 Dismantling Pump Shaft	page 34

Maintenance of Ejector Pump

1.0.0 Maintenance of Ejector Pump	page 37
1.1.0 Overhaul of the Pump	page 37
1.1.1 Clearance	page 38
1.1.2 Dismantling Pump Shaft	page 40

Salinometer

1.0.0 Salinometer Type DS-20	page 41
1.1.0 Technical Specification	page 41
1.2.0 Installation (for DS-20)	page 41
1.3.0 Instructions for use	page 42
1.3.1 Testing the Instrument	page 42
1.3.2 Adjustment of Alarm Level	page 42
1.3.3 Maintenance	page 43

Spare Parts

1.0.0 Ordering Spare Parts	page 45
1.1.0 Alfa Laval Service	page 45

Index

Safety Instructions and Warnings

Should you need further clarification regarding this manual, do not hesitate to contact your local Alfa Laval representative - or call Alfa Laval Desalt directly:

Telephone +45 (for Denmark) 39 53 60 00

Telefax +45 (for Denmark) 39 53 65 66

1.0.0 Safety Instructions and Warnings

The following symbols in this manual point out safety precautions. It means your attention is needed and your safety is involved.



WARNING

This symbol is used to indicate the presence of a hazard which can or will cause severe personal injury, if the warning is ignored.



CAUTION

Certain passages of the text will be marked with a caution mark. This mark indicates the presence of hazard which will or can cause property damage if the instructions are not observed.

NOTE

This type of instruction indicates a situation which, if not avoided, could result in damage to the equipment.

It is the owner's and operator's responsibility to see that any person involved with the use or operation of this equipment follow all safety instructions.

Read all safety instructions carefully and insist that they will be followed by those working with you and for you. Not following the instructions may cause severe personal injury or damage the equipment beyond repair.

Do not allow this equipment to be used if it is faulty or the operator does not understand the proper use.

Safety Instructions and Warnings



WARNING

The freshwater generator is not to be operated in polluted water or within 20 miles from the coast

Freshwater must not be produced from polluted water, as the produced water can be unsuitable for human consumption.

If manuals are translated to local language the unit comply with the EEC Machinery Directive and EN 292-1/2 standards. For EEC land installations manuals MUST be available in local language before installing and operating the unit.

The unit also comply with EN 50081-2 and EN 50082-2 "Industry" with regards to the EMC directive from EEC.



WARNING

Noise hazards

- Use ear protection in noisy environments.

Crush hazards

- Use correct lifting tools.
- Do not work under hanging load.

Burn hazard

- Wear gloves to avoid burns by hot surfaces.

Cut hazards

- Wear gloves to avoid cuts by sharp edges when handling machined parts.
- Wear helmet to avoid cuts by sharp edges during maintenance of the equipment.

NOTE

- Max. ambient temperature for the equipment is 50°C (122°F).
- Min. ambient temperature for the equipment is 0°C (32°F).

System Description

1.0.0 Working Principle

The combined brine/air ejector driven by the ejector pump creates a vacuum in the system in order to lower the evaporation temperature of the feedwater.

The feedwater is introduced into the evaporator section through an orifice, and is distributed into every second plate channel (evaporation channels).

The hot water is distributed into the remaining channels, thus transferring its heat to the feedwater in the evaporation channels.

Having reached boiling temperature - which is lower than at atmospheric pressure - the feed water undergoes a partial evaporation, and the mixture of generated vapour and brine enters the separator vessel, where the brine is separated from the vapour and extracted by the combined brine/air ejector.

Having passed a demister the vapour enters every second plate channel in the condenser section.

The sea water supplied by the combined cooling/ejector water pump distributes itself into the remaining channels, thus absorbing the heat being transferred from the condensing vapour.

The produced freshwater is extracted by the freshwater pump and led to the freshwater tank.

1.1.0 Freshwater Quality

To continuously check the quality of the produced freshwater, a salinometer is provided together with an electrode unit fitted on the freshwater pump delivery side.

If the salinity of the produced freshwater exceeds the chosen maximum value, the dump valve and alarm are activated to automatically dump the produced freshwater to the bilge.

If there are no special requirements from the authorities, the produced freshwater can be used directly as drinking water.

1.2.0 Main Components

The freshwater generator consists of the following components:

1. Evaporator section

The evaporator section consists of a plate heat exchanger and is enclosed in the separator vessel.

System Description

2. **Separator vessel**
The separator separates the brine from the vapour.
3. **Condenser section**
Just like the evaporator section the condenser section consists of a plate heat exchanger enclosed in the separator vessel.
4. **Combined brine/air ejector**
The ejector extracts brine and in condensable gases from the separator vessel.
5. **Ejector pump**
Normally, the ejector pump is delivered by Alfa Laval, and the ejector pump is a single-stage centrifugal pump. This pump supplies the condenser with sea water and the brine/air ejector with jet water as well as feed water for evaporation.
6. **Freshwater pump**
The freshwater pump is a single-stage centrifugal pump. The freshwater pump extracts the produced freshwater from the condenser, and pumps the water to the freshwater tank.
7. **Salinometer**
The salinometer continuously checks the salinity of the produced water. The alarm set point is adjustable.
8. **Control panel**
Normally, the control panel is delivered by Alfa Laval. It contains motor starters, running lights, salinometer, contacts for remote alarm and is prepared for start/stop.

1.3.0 Alternative Steam

1. **Steam injector**
Instead of jacket cooling water heating, saturated live steam can alternatively be used as heating medium for the freshwater generator. In the steam injector the steam transfers partly heat, partly kinetic energy to the circulating water.

The condensate produced in this circuit is transferred to the condensate well through G3.
2. **Safety valve**
If the pressure after the steam injector exceeds 1 bar g the safety valve will open to secure the vessel.
3. **Steam quality**
The steam supplied to the steam injector must be saturated steam.

Operating Instructions



WARNING

DO NOT operate the plant in polluted water.

Freshwater must not be produced from polluted water, as the produced water will be unsuitable for human consumption.

1.0.0 Starting and Stopping Procedure



CAUTION

Before starting up please observe instructions for feedwater treatment, see "Chemical dosing of scale control chemicals".

Please refer to PI-diagram (see "FWG Order Specification").

1.1.0 Starting-up the Plant with Jacket Cooling Water Heating

1. Open valves on the suction and discharge side of the ejector pump PU-SC-01.
2. Open overboard valve for combined brine/air ejector.
3. Close air screw VA-E1-01 on the separator.
4. Start ejector pump PU-SC-01 to create a vacuum of min. 90%.

Pressure at combined brine/air ejector inlet minimum 300 kPa
(3.0 kp/cm²).

Back pressure at combined brine/air ejector outlet maximum 60 kPa
(0.6 kp/cm²).

1.1.1 Evaporation

When there is a minimum of 90% vacuum (after maximum 10 minutes),

Operating Instructions



CAUTION

To secure that the boiler water and the jacket water do not mix the two butterfly **valves** in the steam injector circuit must be closed.

5. Close the two butterfly **valves** in the steam injector circuit.
6. Open valve for feedwater treatment, if any.
7. Open hot water inlet and outlet valves.
8. Start hot water supply to distiller by adjusting bypass valve step-wise 10°C, until the desired jacket water temperature is reached.

The boiling temperature now rises, while the obtained vacuum drops to approx. 85%.

This indicates that evaporation has started.

1.1.2 Condensation

After approx. 3 minutes the boiling temperature will drop again, and normal vacuum is reestablished.

9. Open valve to freshwater tank.
10. Switch on salinometer.
11. Start **freshwater pump PU-FR-01/PU-FR-02**.

NOTE

The freshwater pump pressure must be between 120 and 160 kPa (1.2 - 1.6 kp/cm²).

1.2.0 Adjustment of Jacket Water Flow

Please refer to "FWG Order Specification" for specified hot water flow.

In order to obtain the specified flow of hot water, it is necessary to adjust the bypass

valve until desired flow is achieved.

The flow can be calculated as follows:

$$M_{JW} = \frac{K_{JW} \times \text{cap.m}^3/24\text{h}}{\Delta t_{JW}} = \text{m}^3/\text{h}$$

Where:

M_{JW} = Flow of hot water in one hour.

K_{JW} = Constant=26.67 for 1-stage freshwater generator
 = Constant =15.52 for 2-stage freshwater generator

Δt = Difference in temperature of hot water in and out.

Cap.m³/24h = Freshwater production in 24 hours, i.e. production in 5 min.times 288.

Example: cap. m³/24h = 20m³
 T_{sw} = 32°C

Δt_{JW} = 6°C

1-stage freshwater generator

$$M_{JW} = \frac{26.67 \times 20}{6} = 89 \text{ m}^3/\text{h}$$

1.3.0 Adjustment of Sea Cooling Water

The sea cooling water flow is correct, when the pressure at the inlet of the combined brine/air ejector is between 300 and 400 kPa (3.0 - 4.0 kp/cm²).

1.4.0 Stopping the Plant

1. Stop hot water supply to distiller.
2. Close valve for feedwater treatment, if any.
3. Stop freshwater pump PU-FR-01/PU-FR-02.
4. Switch off salinometer.
5. Stop ejector pump PU-SC-01.

Operating Instructions

6. Open air screw VA-E1-01.
7. Close inlet and outlet valves for ejector pump.
8. Close overboard valve for combined brine/air ejector.
9. Close the valve to fresh water tank.

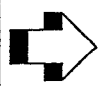

CAUTION

All valves must be shut, while the generator is out of operation. Except air screw.

2.0.0 Before Starting Up the Plant with Steam Injection Equipment



WARNING

The steam arrangement must be filled with fresh water from hydrophone system, before steam is supplied to the system.

When changing from jacket water heating to steam injection heating

1. Close in- and outlet valves for jacket cooling water system (yard supply)
2. Empty the jacket cooling water by G4 to the bilge
3. Open the plug at G2.
4. When empty: close the outlet G4

To fill up the steam injection system with clean fresh water or steam condensate.

5. Open the two butterfly valves in the steam injector circuit
6. Fit a water hose into G2.
7. Fill up the system, with boiler feed water or clean fresh water until water escape from ball valve at the steam condensate outlet G3.
8. Then close this valve.
9. Dismantle the water hose.

10. Close the G2 with a plug.



WARNING

No valve at all must be fitted on the pipe from the safety valve (G16) as this pipe must be open to the atmospheric pressure.

2.1.0 Starting Up the Plant with Steam Injection Equipment (AS)

1. Open valves on the suction and discharge side of the combined **ejector/cooling water pump PU-SC-01**.
2. Open overboard valve for **combined brine/air ejector EW-ES-01**.
3. Close **air screw VA-E1-01** on the separator.
4. Start **combined ejector/cooling water pump PU-SC-01** to create a vacuum of min. 90%.

Pressure at combined brine/air ejector inlet minimum 300 kPa (3.0 kp/cm²).

Back pressure at combined brine/air ejector outlet maximum 60 kPa (0.6 kp/cm²).

2.1.1 Evaporation

5. Open the two butterfly valves in the steam injector circuit.
6. Open valve for feedwater treatment, if any.
7. Open the steam inlet valve (yard supply) slowly.
8. Wait a few minutes until the equipment will be noiseless.
9. Continue the supply of steam until the desired inlet pressure is reached. Steam pressure must be in accordance with pressure stated in "Technical specification".



WARNING

Max. back pressure in condensate discharge line is 80 kPa (0.8 kp/cm²).

Operating Instructions

2.1.2 Condensation

10. Open valve to freshwater tank.
11. Switch on salinometer.
12. Start **freshwater extraction/transfer pump PU-FR-01/PU-FR-02.**
13. Readjust the steam supply to reach the freshwater production.

NOTE

The freshwater pump pressure must be between 120 and 160 kPa (1.2 - 1.6 kp/cm²).

2.2.0 Adjustment of the Freshwater Production

The freshwater production can be regulated by adjustment of the quantity of steam supplied to the steam injector.

The steam inlet pressure corresponding to the production of fresh water in question can be regulated either by means of a manually operated regulating valve (yard supply) or by an automatic reduction valve (yard supply).

Steam pressure must be in accordance with pressure stated in "FWG Order Specification".



WARNING

Do not open steam inlet valve for the steam injector before the ejector pump PU-SC-01 has been started and serves feed water to the evaporator.

2.3.0 Stopping the Plant Working with Steam Injection Heating

1. Close steam inlet valve (yard supply).
2. Close valve for feedwater treatment, if any

3. Stop freshwater pump PU-FR-01/PU-FR-02.
4. Switch off salinometer.
5. Stop ejector pump PU-SC-01.
6. Open air screw VA-E1-01.
7. Close inlet and outlet valves for ejector pump.
8. Close overboard valve for combined brine/air ejector.
9. Close the valve to fresh water tank.

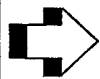

CAUTION

When stopping the plant always check that the steam inlet valve is completely closed.

This to avoid high temperature in the evaporator, as this might cause:

- Scale formation on the inside of the heat exchanger plates.
- Damage the gaskets in the heat exchanger.

2.4.0 Changing from Steam Injection Heating to Jacket Cooling Water

1. Close the valve for steam supply (yard supply).
2. Close the two butterfly valves for **steam injection equipment**.
3. Open the ball valve at the steam condensate outlet G3.
4. Empty the boiler water by G4 to the bilge.
5. When empty: Close the outlet G4.
6. Close the ball valve mentioned above.
7. Open the valves for in- and outlet jacket cooling water to the evaporator (yard supply).
8. Start hot water supply to distiller by adjusting bypass valve step-wise until the desired jacket water temperature is reached.

2.5.0 Long Term Standstill

If the distiller is out of operation for periods longer than 14 days, please observe "Maintenance of separator vessel".

Maintenance

1.0.0 Why you need to perform regular maintenance duties

Regular maintenance of the plant will improve performance and availability.

The maintenance schedule on the following pages will tell you how often service should be performed on the main components.

As the actual operating conditions of the plant are of major influence on the life time, the overhaul dates are not obligatory but only recommended intervals.

When the plant has been in operation for a longer period of time and experience has been established as to the actual performance, it will be possible to adapt the maintenance schedule.

For service on minor components please refer to component instructions.

1.1.0 Overhaul Intervals

Component	Operating Hours	Action
Evaporator section	As required	Clean in inhibited acid bath
Condenser action	As required	Clean with pure freshwater and brush
Separator vessel with anodes	2000 h	See separator instructions
Combined ejector/cooling water pump with motor	8000 h	Measure seal ring and impeller. Examine mechanical shaft seal, cooling water pipe passage. Megger-test electric motor. Clean pump thoroughly before reassembly.
Freshwater extraction pump with motor	8000 h	See above
Combined air/brine ejector	8000 h	Measure nozzles and diffuser and compare to measurements in technical specification. Max. wear 20% on diffuser cylindrical bore.

Maintenance

Component	Operating Hours	Action
MV-valves	4000 h	Disassembly and inspect for damage
Demister	8000 h	Clean in inhibited acid bath
Manometers	8000 h	Adjust with control manometer
Salinometer	See "Maintenance of salinometer type DS-20"	See "Maintenance of salinometer type DS-20"

1.2.0 Maintenance of Separator Vessel

The front cover and the pressure plates for the heat exchanger sections (evaporator and condenser) are made of stainless steel with a special chemical treatment. This treatment will reestablish normal surface oxidation after work-up at the factory. The preparation is a natural protection of the stainless steel.

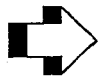

CAUTION

To preserve this natural protection DO NOT scrape or scratch the inside surface of the front cover.

Whenever the separator vessel is opened,

- check that the anodes are functioning.

If the anodes are not functioning and/or scarified, replace them.

NOTE

If the unit is stopped for a longer period than 14 days.

- Open front covers and clean unit inside with freshwater.
- Let the unit dry out completely, before closing covers.

1.3.0 Maintenance of Evaporator Section

Clean evaporator as follows:

1. Remove bolts in front cover, and open.
2. Loosen the
2 nuts for P-16 distiller
4 nuts for P-26 distiller
in plate stack gradually, so that no nut is carrying the entire load alone.
3. Remove plate stack.

NOTE

If some of the gaskets come loose on removing plate stack, please see section 1.5.2

4. Submerge plates completely in a hot, inhibited acid bath at maximum 50°C. For further instructions see "Chemical dosing of scale control chemicals".



WARNING

Always follow carefully the suppliers instructions when using inhibited acids.

Remember to neutralize according to suppliers instructions.

5. Examine plates and gaskets for possible damage, and remove damaged plates and/or replace damaged gaskets.
6. If a defective plate is found, remove the plate together with one of the adjacent plates.

NOTE

The assembly measurements must be reduced with

2.8 mm for P-16 distiller

3.5 mm for P-26 distiller

per plate, if plates are removed from plate stack.



CAUTION

The ES and EE plate cannot be removed but must always be replaced with a corresponding plate.

7. Reassemble evaporator section in accordance with assembly scheme.
8. Tighten plate stack to measurements stated in technical specification.
9. Pressure test evaporator section before closing front cover.

The evaporator section is pressure tested by letting hot water circulate through the section with bypass valve for hot water in normal running position.

10. When the evaporator section is found to be tight, close front cover and tighten bolts.
11. Retighten cover, when vacuum has been reestablished.

1.4.0 Maintenance of Condenser Section

Clean condenser as follows:

1. Remove bolts in front cover, and open.
2. Loosen the

2 nuts for P-16 distiller

6 nuts for P-26 distiller

in plate stack gradually, so that no nut is carrying the entire load alone.

3. Remove plate stack.

NOTE

If some of the gaskets come loose on removing plate stack, please see section 1.5.2

4. Scrub plates with a soft brush and plain hot water at maximum 50°C.
5. Examine plates and gaskets for possible damage, and remove damaged plates and/or replace damaged gaskets.
6. If a defective plate is found, remove the plate and one of the adjacent plates.

NOTE

The assembly measurements must be reduced with

2.8 mm for P-16 distiller

3.5 mm for P-26 distiller

per plate, if plates are removed from plate stack.



CAUTION

The KS and KE plate cannot be removed but must always be replaced with a corresponding plate.

7. Reassemble condenser section in accordance with assembly scheme.
8. Tighten plate stack to measurements stated in technical specification.
9. Pressure test condenser section before closing front cover.

The condenser section is pressure tested by letting sea water from the combined cooling water/ejector pump circulate through the section.



CAUTION

Before starting the combined ejector/cooling water pump, the feed water must be sealed off.

10. When the condenser section is found to be tight, close front cover and tighten bolts.
11. Retighten, when vacuum has been reestablished.
12. Do not forget to remove the feed water sealing as mentioned above.

1.5.0 Renewal of Plate Heat Exchanger Gaskets

1.5.1 Removal of Old Gaskets

Pull the old gaskets out of groove.

If the gasket cannot come off directly, heat the back of the gasket groove with a hot-air blower or butane gas burner.

Pay attention not to overheat the plates.

You will obtain a suitable temperature, if the flame is held 10 to 15 cm behind the plate.



WARNING

DO NOT use *acetylene gas*.

1.5.2 Cleaning

Charred or loose glue and rubber remains must be removed, e.g. using a rotating stainless steel brush. The width should be adapted (\varnothing 40-50 mm, width 8-10 mm). Thin layers of glue which are difficult to remove, may remain.

Clean the gasket groove with a clean cloth, dipped in a solvent (acetone, methyl ethyl ketone, trichlorethylene etc.).



WARNING

Be careful when handling these solvents, as they may be hazardous to your health.

Observe suppliers' instructions.

Gaskets, that have loosened, can be glued on. Clean gasket groove carefully with a sharp tool. Then clean the loose part of the gasket with emery cloth or sandpaper. Finally clean groove and gasket with a solvent, and glue.

1.5.3 Preparation of New Gaskets

Dry new gaskets with a clean cloth that has been slightly moistened with a solvent.

1.5.4 Fitting New Gaskets

1. Apply a thin layer of glue to both gasket and groove.
2. Let the glue dry for 10-15 minutes.
3. Fit new gasket into groove.

Gaskets may sometimes be slightly short or long.

Short gaskets should be stretched before being fitted into the groove.

Long gaskets should be fitted into the grooves at the plate ends first and then gradually be pushed into the groove towards the middle.

If necessary, tape gasket into groove.

Chemical Dosing of Scale Control Chemicals

1.0.0 Prevention of Scaling

During the evaporation of sea water there is always a risk of scaling on the heating surfaces. This will lead to a reduction of the K-values of the heating surface and decreasing freshwater production and reduction of plant efficiency.

In order to effectively prevent scaling the operators must be aware of the factors influencing the scale formation.

1.1.0 Feed Water Ratio

The feedwater ratio is an extremely important factor. It is defined by the relationship between the feedwater amount fed into the plant and the produced amount of freshwater.

If the feedwater ratio is reduced, the concentration will rise in the plant subsequently resulting in scale formations.

Two things may shift the feedwater ratio: first of all direct adjustment of the feedwater system, and secondly exceeding the maximum freshwater production laid out for the plant. The operators must observe the following rules at all times.



CAUTION

DO NOT adjust feedwater system. Feedwater pressure min. 3.0 max. 4.0 bar g.

1.2.0 Chemical Dosage

In order to control scale formations on the heating surfaces and continuously ensure long operation periods without acid cleaning the plant, it is absolutely necessary to dose scale control additives to the feedwater. The operators must follow the instructions for chemical dosing given by the chemical supplier carefully.



CAUTION

If the distiller is operated at boiling temperatures above 45°C without chemicals, frequent cleaning of the evaporator will be necessary.

We recommend that you do not operate the freshwater distiller without recommended chemical dosage at boiling temperatures above 45°C. Even at lower temperatures it can be recommended.

1.2.1 Scale Inhibitor Dosage Equipment for Feed Water

Please refer to drawing, see "FWG Order Specification".

- When adding chemicals mix thoroughly to ensure a homogenous blend of chemicals and water.

Use a fully soluble scale inhibitor, e.g. on polymer basis. The following products can be recommended:

NALFLEET Evaporator treatment 9-913

AMEROYAL EVAPORATOR TREATMENT

HEXAMETHAPHOSPHATE

1. Mix the required quantity for 24 hours operation in the tank according to maker's instructions.
2. Adjust flowmeter to cover the maximum freshwater output from the distiller.
3. Flush the dosage system regularly.

1.2.2 Safety Precautions with the use of Chemicals



WARNING

- 1 USE eye protection and gloves. Avoid direct skin contact, eye contact or contact with clothes.
- 2 CLEAN empty containers before disposal.
- 3 If chemicals are spilled on clothes, rinse with water and dispose off clothes.
- 4 If chemicals are spilled on the floor, rinse with water and suck remaining chemicals off with sand. Clean the spot immediately afterwards.
- 5 Scale inhibitor is hazardous, if consumed in a concentrated solution. If consumed by mistake.
IMMEDIATELY SEEK MEDICAL ATTENTION.
- 6 If eyes get in contact with the chemicals, rinse for at least 20 minutes.
IMMEDIATELY SEEK MEDICAL ATTENTION.

Chemical Dosing of Scale Control Chemicals

Trouble-Shooting

1.0.0 Test Sheet

Before taking any action, please fill in a test sheet to find possible causes of malfunctions.

Test sheets can be found in the back of this binder.

1.1.0 Trouble Shooting Table

Problem	Cause	Action
Drop in production.	Partially blocked feed water orifice and/or sludge deposits on hot water side.	Dismantle evaporator section, and clean evaporator and orifice.
	Sludge on the heat exchanger plates on the sea water side.	Dismantle condenser section, and clean.
	Inlet channel in evaporator/condenser plate stack blocked, e.g. with rust scales, gasket fragments etc.	Dismantle evaporator/condenser section, and clean.
	Too low ejector pump pressure.	See instructions for "Low Sea Cooling water/Ejector pump flow / pressure", below.
	Leakages	Carry out a pressure test at max. 150 kPa (1.5 kp/cm ²) (21.8 PSI).a
	Foreign bodies in ejector nozzles.	Inspect nozzles, and clean. Replace nozzles, if damaged.
	Too high back pressure on ejector outlet side. Max 60 kPa (0.6 kp/cm ²) (8.7 PSI).	Check overboard pipe and valves for blocking / functionality.
	Non-return valve in air extraction pipe defect.	Replace non-return valve.
	Hot water temperature too high.	Reduce to specified temperature.
	Defective water clock.	Examine water clock. Let the produced water flow through water clock into a 10 l pail, and check production with a stop watch.

Trouble-Shooting

Problem	Cause	Action
Low Sea Cooling water/Ejector pump flow / pressure. Minimum pressure 300 kPa (3.0 kp/cm ²) (43.5 PSI). At inlet side of ejector.	Too low ejector pump pressure.	Clean, or replace pressure gauge.
	Suction strainer blocked.	Clean suction strainer.
	Valves on suction or pressure pipe defect.	Examine and overhaul defective valves.
	Leakage from suction pipe to pump.	Repair.
	Impeller / seal ring defective.	Check pump maximum clearance See "Maintenance of Ejector Pump"
	Clocked up condenser plate stack.	Dismantle condenser plate stack and clean.
	Pump rotating in wrong direction.	Interchange phases.
Sight glass overflow. Normal back pressure for freshwater pump is 120 - 160 kPa (1.2 - 1.6 kp/cm ²) (17.4 - 23.2 PSI). Except for JWP-16-C40 generator type, where the max. back pressure is 80 kPa (0.8 kp/cm ²) (11.6 PSI).	Suction pipe leakage.	Check suction pipe especially unions and connections. Repair.
	Mechanical seal in freshwater pump defect.	Replace mechanical seal.
	Impeller / seal ring in freshwater extraction pipe defect.	Check pump maximum clearance See "Maintenance of Freshwater Pump"
	Pump rotating in wrong direction.	Interchange phases.
	Valves to freshwater tank closed.	Check all valves.
	Inlet filter for water clock blocked.	Clean filter.
Salinity too high (more than 2.0 ppm).	Demister not fitted correctly.	Check that demister is fitted against baffle and front cover.
	Front cover gasket defect or not fitted correctly.	Replace front cover gasket.
	Insufficient brine extraction.	See separate instructions for insufficient brine extraction, below.
	Electrode unit defective or dirty.	Examine electrode unit for cracks. Check that it is fitted correctly. Clean, if necessary.

Problem	Cause	Action
	Leakage in condenser section.	Open distiller and pressure test condenser. Max. 600 kPa (6.0 kp/cm ²) (87 PSI). If there is a defective plate, remove together with adjacent plate assemble plate stack according to new plate number with reduced assembly measurements. Check plate gaskets and replace, if necessary.
Insufficient brine extraction - brine level in sight glass higher than 20 mm.	Ejector pump pressure too low.	See special instructions for "Low Sea Cooling water/Ejector pump flow / pressure", above.
	Foreign bodies in ejector nozzles.	Check nozzles, and clean. Replace damaged nozzles.
	Too high back pressure downstream of ejector.	Examine overboard pipe and valves.
	Wrong dimension of feedwater orifice.	Examine orifice dimension - check technical specification.
	Non-return valve in brine suction pipe of ejector defect.	Examine valve and repair, or replace.
Frequent refill of freshwater expansion tank due to loss of hot water.	Leakage in evaporator section.	Open distiller and pressure test condenser. Max. 600 kPa (6.0 kp/cm ²) (87 PSI). If there is a defective plate, remove together with adjacent plates assemble plate stack according to new plate number with reduced assembly measurements. Check plate gaskets and replace, if necessary.
Abnormal amperage consumption of ejector pump motor.	Ejector nozzles defective.	Replace nozzles.
	Wrong dimension of feedwater inlet orifice.	Check dimensions on spare parts list, See List of spare part drawings", and replace if necessary.
	Bearings in motor defective.	Examine with stethoscope, and replace bearings, if defective.
	Contactors defective.	Examine and replace contactor set, if defective.
	Breaking of phases.	Max. 5% difference in amperage between phases.

Maintenance of Freshwater Pump

1.0.0 Maintenance of Freshwater Pump Types PVVF 1525-1532-2040

The following instructions must be carefully observed whenever it becomes necessary to overhaul or repair the freshwater pump.

Please refer to drawing for item references in the text.

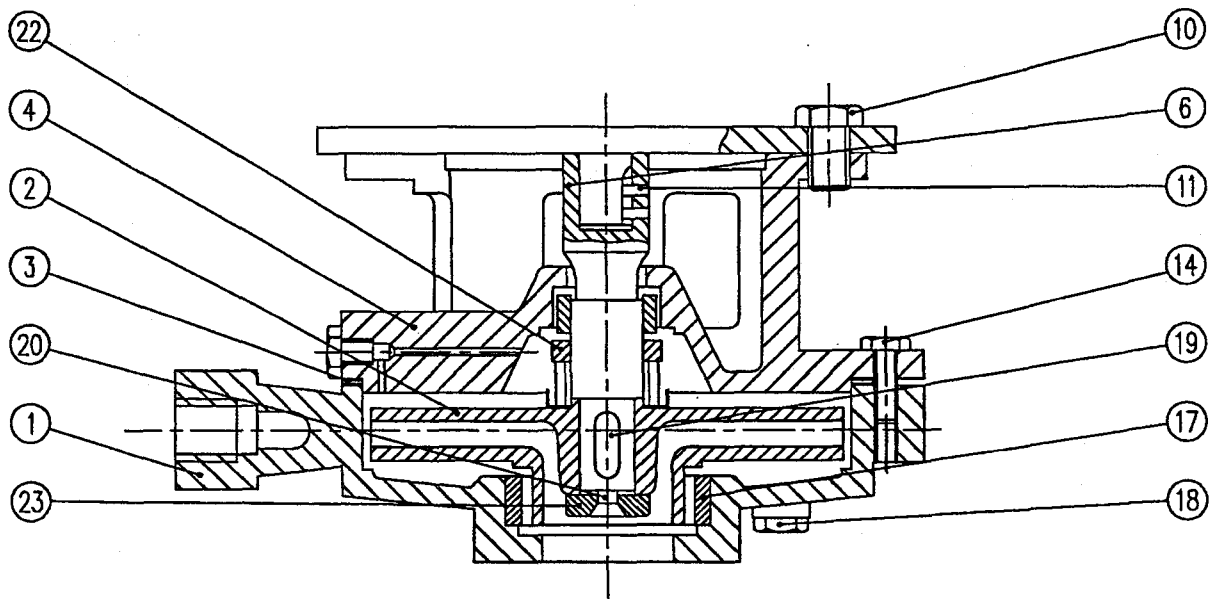

1.1.0 Overhaul of the Pump

1. Remove the nuts **14** on the pump casing **1**.
2. Lift motor with pump cover **4** and impeller **2** clear of pump casing **1**.
3. Unscrew countersunk screw **20** (right hand thread).
4. Remove impeller. Normally, it can be removed without using dismantling tools.
5. Remove key **19**.
6. Remove the mechanical shaft seal **22**.
7. Inspect the ceramic ring, the carbon ring and the spring.
8. Replace mechanical shaft seal, if necessary. It is recommended to grease the shaft and seat for the ceramic ring with glycerine in order to make it easier to assemble the mechanical shaft seal. Please also observe separate instructions for mechanical shaft seal delivered together with the seal.

Maintenance of Freshwater Pump

9. Fit carbon ring, spring and spring holder on pump shaft.
10. Inspect impeller and the drilled sealing water channel for clogging, and clean.
11. *Remember to replace gasket 3.*
12. Reassemble in reverse order.

1.1.1 Clearance

In connection with the inspection be sure to measure the **impeller and wear ring 17** in order to secure that the clearance is no more than 0.5 mm on the diameter.

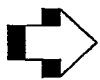

CAUTION

The **pump shaft 11** must only be dismantled, if pump shaft or electric motor bearing has to be replaced.

In this case carefully observe "Dismantling pump shaft".

1.1.2 Dismantling Pump Shaft

1. Dismantle the pump as described above.
2. Unscrew **pointed screws 11**.
3. Carefully insert two screw drivers behind the pump shaft, and loosen it.

If the pump shaft does not come loose, use the special dismantling tools shown below.

The tool is not Alfa Laval Desalt supply.

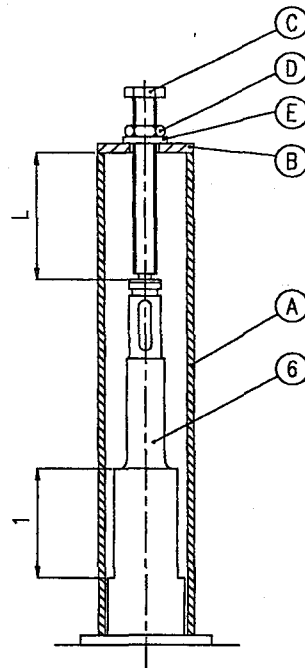

The tool consists of a pipe (A), a disc (B) with hole for the screw (C) and a nut (D), washer (E).

Please note that the length L must be longer than the length I.

Place pipe around the shaft. Fasten the screw with nut and washer into the threaded hole (M12) on the shaft end.

Loosen shaft by tightening the nut while holding on to the screw.

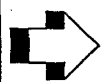

CAUTION

DO NOT grind the motor shaft.

4. Mount the new pump shaft on the motor shaft.
5. Make sure that the pump shaft fits the motor shaft without any obstructions, before final shaft fitting as follows:
 - Tap onto the end of the pump shaft slightly with a RUBBER hammer.
6. Tighten **pointed screws 11** as follows:

Maintenance of Freshwater Pump

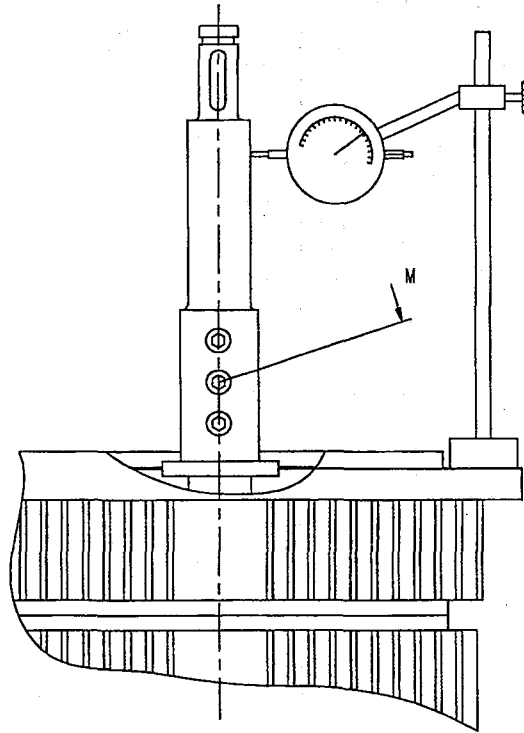

NOTE

The torque should be 5 Nm (0.5 kpm) and the maximum wobble 60 μ .m.

7. Check the wobble of the pump shaft with a dial indicator.
8. Assemble the pump as described above.

Maintenance of Ejector Pump

1.0.0 Maintenance of Ejector Pump

(If supplied from Alfa Laval)

The following instructions must be carefully observed whenever it becomes necessary to overhaul or repair the above mentioned pump. Please refer to drawing for item references in the text.

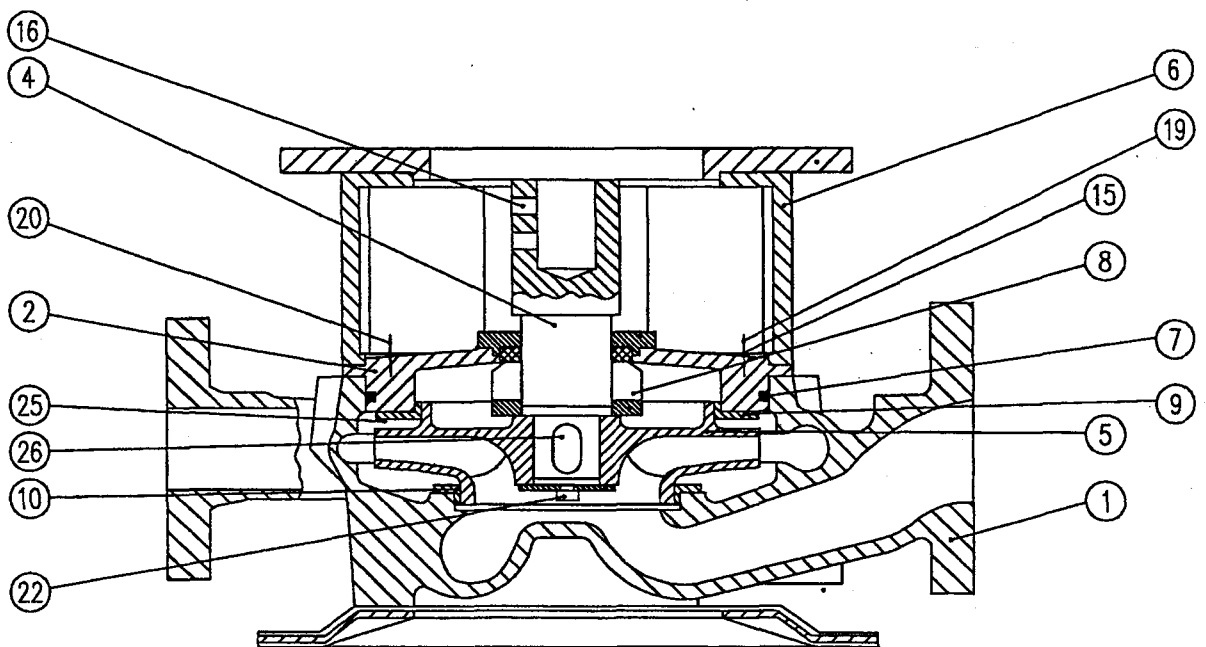

1.1.0 Overhaul of the Pump

1. Remove the **set screws 19** in **pump cover 2**.

*Motor with motor bracket 6, pump cover 2, and impeller 5 can now be lifted clear of the **pump casing 1**.*

2. Unscrew the **screw 22** (right-hand thread).
3. Remove impeller.

Maintenance of Ejector Pump

NOTE

Normally, the impeller can be removed without using dismantling tools.

If not, you can fit dismantling screws into the two threaded holes in the impeller.

4. Remove the key 26 and the mechanical seal 8 (including spring holder, spring and carbon ring).

5. Inspect the ceramic ring, the carbon ring and the spring. Replace, if necessary

If mechanical seal has to be replaced, proceed as follows:

- *Unscrew **set screw 20** to remove **pump cover 2** from **motor bracket 6** in order to gain access to ceramic ring.*

In order to make it easier to assemble the mechanical seal, the shaft and ring seat may be greased with glycerine. Please also refer to separate instructions for mechanical seal delivered together with the seal.

- *After fitting the ceramic ring, fit **pump cover 2** to **motor bracket 6**.*
- *Fit carbon ring, spring and spring holder.*

6. Clean drilled cooling water channel in **pump cover 2**.

7. Inspect impeller and threaded holes for clogging.

8. **Remember to change the O-ring 7.**

9. Reassemble in reverse order.

1.1.1 Clearance

In connection with the inspection, the **impeller 5** and **wear rings 10** are measured in order to secure that the clearance is not larger than stated in the diagram below.

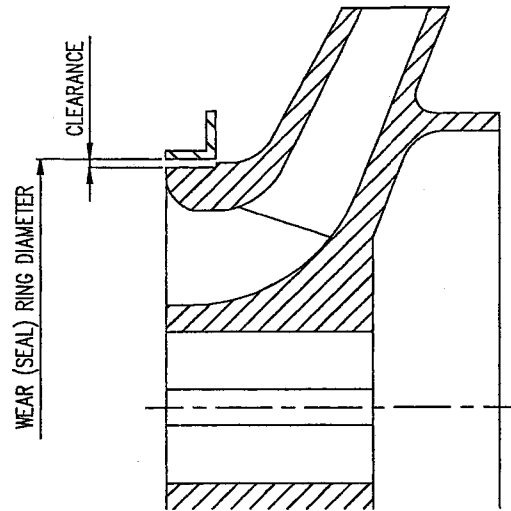

Wear ring Ø	Clearance maximum	Clearance minimum
100 mm	0.5 mm	0.15 mm
150 mm	0.6 mm	0.2 mm
200 mm	0.7 mm	0.25 mm
250 mm	0.8 mm	0.28 mm
300 mm	0.85 mm	0.3 mm
350 mm	0.9 mm	0.3 mm

If the clearance is too big, replace wear rings as follows:

1. Unscrew **countersunk screws 25**.
2. Pull out wear (seal) rings.
3. Fit new wear rings and tighten countersunk screws.



CAUTION

The pump shaft may only be dismantled, if pump shaft or bearings, in the electric motor have to be replaced.

Carefully observe instructions for "Dismantling pump shaft".

Maintenance of Ejector Pump

1.1.2 Dismantling Pump Shaft

If the **shaft 4** has to be dismantled due to a defect or if electric motor bearing has to be replaced, proceed as follows:

1. Unscrew **pointed screws 16**.
2. Remove **shaft 4**. Normally this can be done without using dismantling tools.



CAUTION

DO NOT grind the motor shaft.

3. Fit **shaft 4**.
4. In order to make sure that the coupling is fitted correctly, tap slightly at the shaft end with a RUBBER hammer.
5. Tighten **pointed screws 16** with a torque of 35 Nm (3.5 kpm).

Salinometer

1.0.0 Salinometer Type DS-20

1.1.0 Technical Specification

Function	Measuring (Dot Bar) and supervising salinity of freshwater produced by seawater desalination.
Supply voltage	90-120 V or 200-240 V AC.
Frequency	50/60 Hz
Power consumption	Salinometer 10 VA.
Relay contacts	Max. load 100 VA.
Salinity display	0,5 - 20 ppm (Dot Bar).
Temperature correction	Automatic in the range 5 - 85°C.
Alarm level	Can be set to any value between 0,5 - 20 ppm.
Test	Can be checked by test switch, 10 ppm.
Output	4-20 mA Current Loop.
Max. ambient temperature	55°C.
Protection degree	IP 54.

1.2.0 Installation (for DS-20)

1. Open front cover.
2. Select correct voltage select according to the main supply voltage 115 V or 230 VAC.
3. Screw salinometer on to bulkhead with six nuts.
4. Connect necessary cables to the terminals.
5. Close front cover.
6. Test salinometer function (see instructions for use).

Salinometer

1.3.0 Instructions for use

1. Switch on mains.
2. Switch on sec. alarm.

Green pilot LED should light up. Dot. Bar displays the measured salinity.

1.3.1 Testing the Instrument



WARNING

The salinometer must be tested at least once a month, and the electrode unit must be cleaned.

Push TEST switch on.

The Dot Bar should read 10 ppm.

If the alarm level is less than 10 ppm, the salinometer will give an alarm.

1.3.2 Adjustment of Alarm Level

1. Switch "MAINS" on.
2. Push sec. alarm off.
3. Adjust Alarm Set to desired alarm level by using the switches.
4. Switch "Sec. Alarm" on.

The salinometer is now ready for use.

If the salinity exceeds the alarm level,

- The two red alarm LEDS flash.
- Solenoid valve is activated.
- Buzzer (if fitted) and external alarm system is activated.

Cancel buzzer and external alarm system by switching "Sec. Alarm" off. Solenoid valve is not affected.

Switch "Sec. Alarm" on as soon as the salinity is normal again; i.e. when the two red

LEDS are off.

1.3.3 Maintenance



CAUTION

Remove electrode unit and inspect/clean after every 1000 hours of operation. Use a clean and dry rag. Avoid touching the electrodes with the fingers.

Spare Parts

1.0.0 Ordering Spare Parts

When ordering spare parts please always state:

1. Serial number.
2. Capacity.
3. Designation.
4. Spare parts drawing number.
5. Position number.
6. Article number.

In order to identify article numbers, please refer to FWG Order Specification and other drawings.

When ordering parts for pumps proceed as follows:

1. Find article number in the list of drawings.
2. Check spare part drawing and item list with corresponding article number to identify the item to be ordered.

1.1.0 Alfa Laval Service

The **Alfa Laval** group is represented in all major ports of the world.

DO NOT hesitate to contact your **Alfa Laval** representative if you have any questions, problems or require spare parts.

Index

A

Adjustment of alarm level	page 42
Adjustment of Jacket Water Flow	page 10
Adjustment of sea cooling water	page 11
Adjustment of the freshwater production	page 14
Alfa Laval service	page 45
Alternative Steam	page 8

B

Before starting up the plant with steam injection equipment	page 12
-------------------------------------------------------------------	---------

C

Changing from steam injection heating to jacket cooling water	page 15
Chemical dosage	page 25
Cleaning	page 22
Clearance	page 38
Condensation	page 14

D

Dismantling pump shaft	page 40
------------------------------	---------

E

Ejector Pump	page 37
Evaporation	page 13

F

Feed water ratio	page 25
Fitting new gaskets	page 23
Freshwater Pump Types PVVF 1525-1532-2040	page 33
Freshwater quality	page 7

I

Installation (for DS-20)	page 41
Instructions for use	page 42

L

Long term standstill	page 16
----------------------------	---------

Index

M	
Main components	page 7
Maintenance	page 43
Maintenance of condenser section	page 20
Maintenance of ejector pump	page 37
Maintenance of evaporator section	page 19
Maintenance of Freshwater pump	page 33
Maintenance of freshwater pump types PVVF 1525-1532-2040	page 33
Maintenance of separator vessel	page 18
O	
Ordering spare parts	page 45
Overhaul intervals	page 17
Overhaul of the pump	page 37
P	
Preparation of new gaskets	page 23
Prevention of scaling	page 25
R	
Removal of old gaskets	page 22
Renewal of plate heat exchanger gaskets	page 22
S	
Safety instructions and warnings	page 5
Safety precautions with the use of chemicals	page 27
Salinometer type DS-20	page 41
Scale inhibitor dosage equipment for feed water	page 26
Spare Parts	page 45
Starting and Stopping Procedure	page 9
Starting up the plant with steam injection equipment (AS)	page 13
Starting-up the Plant with Jacket Cooling Water Heating	page 9
Stopping the plant	page 11
Stopping the plant working with steam injection heating	page 14
T	
Technical specification	page 41
Telefax	page 5
Telephone	page 5
Test sheet	page 29
Testing the instrument	page 42
Trouble shooting table	page 29

W

Warning page 5
Why you need to perform regular maintenance duties page 17
Working principle page 7

FWG Order Specification

INI.: GNO	Date: 03.02.25	BPCS: 34167	Serial no.: N-010770	Page 1/2
--------------	-------------------	----------------	-------------------------	----------

Technical data

Type of generator: JWSP-26-C100	Capacity [m ³ /24h]: 25	NE/NK: 86/86
Power supply, main/control	Main [Volt / Hz]: 3 x 440/60	Control [Volt]: 220
Jacket water temperature	Inlet [°C]: 80	Outlet [°C]: 68,1
Jacket water flow/pressure drop	Flow [m ³ /h]: 54,4	Pressure drop [bar]: 0,4
Heat consumption from jacket water	[Mcal/h]: 649	or [kW]: 755
Seawater temperature	Inlet [°C]: 32	Outlet [°C]: 41,3
Seawater flow/pressure drop	Flow [m ³ /h]: 62	Pressure drop [bar]: 0,5
Alternative heating: steam:	Capacity [m ³ /24h]: 25	
Steam flow/pressure:	Flow [kg/h]: 1187	Pressure [bar]: 3

mp / motor data

	Fresh water	Ejector water	Brine water	Hot water
Nominal flow x pressure [m ³ /h x mwc]:	2,1 x 28	62 x 42	-	-
Marked output power [kW]:	0,75	21,4	-	-
Consumed electrical power [kW]:	0,75	15,9	-	-
Current [A]:	1,6	33,5	-	-
Rotating speed [rpm]:	3360	3515	-	-

Quality data

Certificate: Workshop	Connections: DIN
-----------------------	------------------

Extra / special equipment

Afventer "GO"
AL-Hong Kong
Penalty: NO

Note:

Max. inlet temperature for evaporator section must NEVER exceed 100°C (212°F)

Max. inlet pressure for condenser section must not exceed 4 bar g (400 kPa)

Max. ambient temperature for freshwater generator is 50°C (122°F)

FWG Order Specification

INI: GNO	Date: 03.02.25	BPCS no.: 34167	Serial no.: N-010770	Page 2/2
--------------------	--------------------------	---------------------------	--------------------------------	----------

Documentation

General description, freshwater generator	Doc.No. 9.2.2-1
Technical data, freshwater generator	Doc.No. 9.2.2.2-5
Dimension drawing, freshwater generator	Doc.No. 9.2.2.5-8
Technical data, pump and motor	Doc.No. 9.2.2.2-6
Dimension drawing, ejector pump	Doc.No. 9.2.5.2-3
Dimension drawing, control panel	Doc.No.9.2.6.2.4.1
Dimension drawing, salinometer	-
Dimension drawing, feed water treatment	Doc.No. 9.2.9.3-2
Flow chart, excl. options	Doc.No. 9.2.2.3-11
Equipmnt specification	Doc.No. 9.2.2.4-2
Vertical plant positioning	Doc.No. 9.2.8-1
Electric diagram	Doc.No.9.2.6.3.4.1
Assembly scheme	985 16610
Spare parts, generator	985 17909-81
Spare parts, steam arrangement	985 15594-80
Spare parts, steam injector	984 12510-00



Bill Of Material

Parent item no.: SPE-N-010770 R: 00	Description: SPECIFICATION PARTS LIST JWSP-26-C100 DRAWING NO. 985 17909	Date: 20031009	Page 1 of 1
Drawing no.:		Ini DKSOABK	

BUBL	QTY	U/M	DESCRIPTION	DRAWING NO.	ARTICLE NO.	MATERIAL	REMARKS
3	1.000000	EA	MOTOR 71B-2 380/440V 50/60HZ 0.55/0,75KW 1.4/1,6A, ABB		985 00057-37		
11	1.000000	EA	COMBINED BRINE/AIR EJECTOR BRINE/AIR EJECTOR	984.12200.00	984 12263-00		
31	1.000000	EA	ORIFICE D=12,1 (FEED WATER)	984 57863	984 57863-24		
46	1.000000	EA	FRESHWATER PUMP PVVF-2040.2X-012	984.10230.00	984 10253-00		
48	8.000000	EA	CLAMPING BOLT L=535 P-26	984 58083	984 58083-05	ISO 683/13/86 ; TYPE 20A	
51	1.000000	EA	PLATE P-26 KS/ES		119291-2183		ASS.MEASURE = 284 MM
51	1.000000	EA	PLATE P-26 KE/EE		119281-4116	TITAN/NITRIL	
51	42.000000	EA	PLATE P-26 KV		39502661-03	TITAN/NITRIL	
51	42.000000	EA	PLATE P-26 KD		39502665-03	TITAN/NITRIL	
53	4.000000	EA	SUPPORTING SHAFT L=535	984 58182	984 58182-05	ISO 683/13/74 ; TYPE 11	
57	1.000000	EA	PLATE P-26 KS/ES		119291-2183		ASS.MEASURE = 284 MM
57	1.000000	EA	PLATE P-26 KE/EE		119281-4116	TITAN/NITRIL	
57	42.000000	EA	PLATE P-26 EV		39502663-03	TITAN/NITRIL	
57	42.000000	EA	PLATE P-26 ED		39502664-03	TITAN/NITRIL	
95	1.000000	EA	SOLENOID VALVE 1/2" EV220B 15 220V 50/60 CS NO (EVS1 15)	984.23482.0	984 23486-00		
500	.000000	EA	ACCESSORIES:		ACCESSORIES		
501	1.000000	EA	CONTROL PANEL - FWG - OPT. A (DIAGR: 985 16645)	985 16646	985 00034-85		
501	1.000000	EA	CONTACTOR A50 220-240V/50-60CS A50 220-230V/230-240V 50/60CS		984 21620-58	8003	
501	1.000000	EA	THERMAL RELAY TA75 (29-42A) TA75 DU 42		984 21621-20	8073	
502	1.000000	EA	EJECTOR PUMP (STAINL.ST.IMP.) CNL-80-80/200 DIN/JIS 3500RPM	984.10302.00	985 00025-26		
502	1.000000	EA	MOTOR 160L-2 380/440V 50/60HZ 18,5/21KW IN 34A ABB		985 00057-36		
503	1.000000	EA	FEED WATER TREATMENT, SCALE INHIBITOR DOSAGE EQUIPMENT	985 14867	985 14867-80		
504	1.000000	EA	SPARE PARTS FOR 1 YEAR JWSP-26-C100		SPARES-N-010770		

Alfa Laval Copenhagen A/S

Maskinvej 5
DK-2860 Søborg, Denmark
CVR No. 10134285
V.A.T. No. 14646647

Telephone + 45 39 53 60 00
Telefax + 45 39 53 65 68
Bank DANSKE BANK Holmens Kanal Branch
Acc. No. DKK 3100-3117-108007
Acc. No. EUR 3100-3140-854301
Acc. No. USD 3100-3116-5794



9.2.2.1 General description, JW(S)P-26-C80(B)/C100

Application

Conversion of seawater into fresh water by vacuum distillation, for drinking, process water, and domestic use on ships and rigs, and in small power stations. Max. salinity 2 ppm.

Capacity

The JW(S)P-26-C80(B)/C100 covers a capacity range from 4 to 35 m³/24h, depending on the heating medium and seawater temperature. The capacities shown below are at a seawater temperature of 32°C.

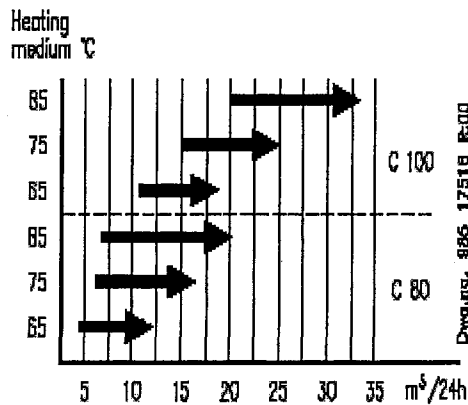

Working principle

The seawater to be distilled evaporates at a temperature of about 40°C as it passes between the hot plates in the evaporator. This evaporating temperature corresponds to a vacuum of approximately 93% which is maintained by the brine/air ejector. The vapours generated pass through a demister where any drops of seawater entrained are removed and fall to the bottom of the distiller chamber. The vapours continue to the condenser where they condense to fresh water as they pass between the cold plates.

Basic Equipment

Titanium plate heat exchanger in evaporator and condenser.
Red brass separator and stainless steel demister, front cover and pressure plates.
Seawater pipes in CuNi.
The freshwater generator is equipped for jacket water heating and with a combined condenser cooling and ejector water system. Furthermore the freshwater generator is equipped with dump valve, water clock, automatic feed water regulator, combined brine/air ejector, instruments, freshwater pump with electric motor, internal piping and bed frame.

Options

Flanges:	DIN, JIS or ANSI
Power/control:	3 x 380 V 50 Hz 100/110/220 V
	3 x 440 V 60 Hz 100/110/220 V
	3 x 460 V 60 Hz 110 V (ul)

Additional equipment necessary for operation

- Ejector pump/electric motor.
- Control panel with motorstarters and salinometer.
- Feed water treatment.

Optional equipment/design

- Steam heating systems type JWSP.
- Hot Water Loop Module for steam boosting of jacket water.
- Salinometer.
- Manual motor starters and salinometer.
- Remote start/stop.
- Water clock by-pass.
- Return pipe to brine sump.
- Electric panel build-on the unit.
- Optional spares kit for 1, 2 or 5 years of operation.
- Steel box for spares kit.
- Class test certificate.
- Freshwater treatment equipment.



9.2.2.2-5 Technical data, JW(S)P-26-C100

Power consumption

Ejector and freshwater pump:

NE/NK	50 Hz	60 Hz
62/62-70/70:	12.8 kW	13.0 kW
72/72-80/80:	13.5 kW	13.6 kW
82/82-90/90:	16.6 kW	16.7 kW
92/92-100/100:	17.2 kW	17.3 kW

Pressure

	bar(g)	lbs/in ²
Max. jacket water pressure:	4.0	58
Max. back pressure to freshwater tank:	1.6	23
Max. seawater pressure to inlet condenser:	4.0	58
Min. seawater pressure to ejector:	3.0	43
Max. back pressure at ejector outlet:	0.6	8.7
Max. back pressure for safety valve on steam equipment:	1.0	14.5
Max. steam pressure for steam equipment:	7.0	101
Normal operation pressure for steam equipment:	2-4.5	29-65
Back pressure to condensate well for steam equipment:	0.6-0.8	8.7-11.6

Temperature

Seawater temperature: 0-32°C

Jacket water temperature: 55-95°C

Flow

Seawater flow: 49-70 m³/h

Jacket water flow: 25-72 m³/h

Materials

Separator:	Red brass
Front cover:	Stainless steel
Bed frame:	Steel (hot dip galvanized)
Pipe for brine discharge:	Red brass
Evaporator/condenser plates:	Titanium
Demister:	Stainless steel
Pipe for seawater:	CuNi 90/10
Pipe for fresh water:	CuNi 90/10
Combined brine/air ejector housing:	Red brass
Combined brine/air ejector nozzle:	Stainless steel
Flange for evaporator/condenser:	SG-iron (hot dip galvanized)
Steam equipment type JWSP and SP.	
Pipe:	Steel (hot dip galvanized)
Steam injector housing:	Cast iron (painted)
Steam injector nozzle:	Stainless steel

Shipping data

Freshwater generator, complete with ejector pump, electrical panel, dosing unit and standard spares.

Weight:	net: 930 kg, gross: 1050 kg
Dimensions:	l x w x h: 2200 x 1300 x 1620 mm
Volume:	4.6 m ³



9.2.2.5-8 Dimensional drawing, JWSP-26-C100

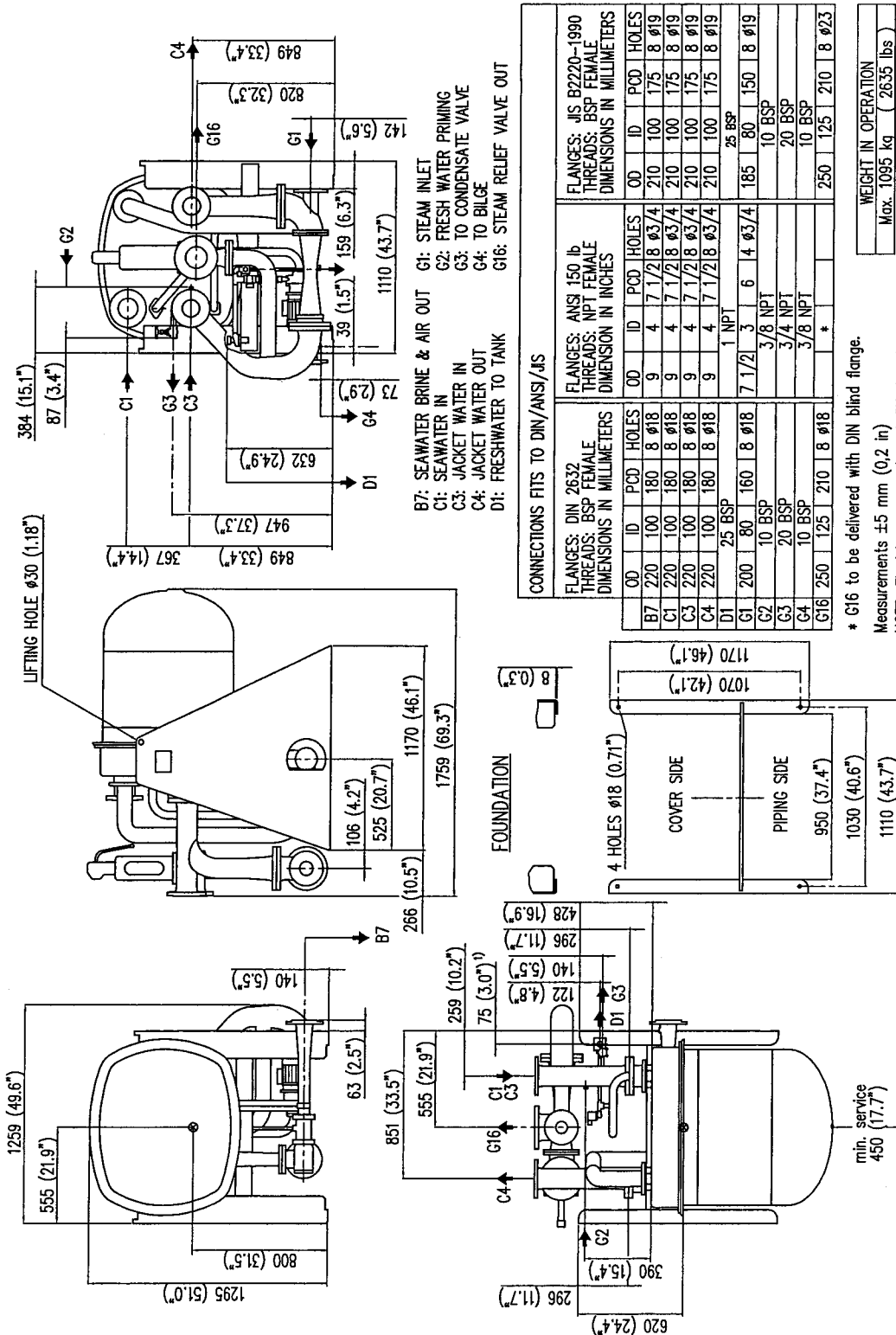

CONNECTIONS FITS TO DIN/ANSI/AS				FLANGES: ANSI 150 lb				FLANGES: JIS B2220-1990			
THREADS: BSP FEMALE				THREADS: NPT FEMALE				THREADS: BSP FEMALE			
DIMENSIONS IN MILLIMETERS				DIMENSION IN INCHES				DIMENSIONS IN MILLIMETERS			
OD	ID	PCD	HOLES	OD	ID	PCD	HOLES	OD	ID	PCD	HOLES
B7	220	100	8 $\phi 18$	9	4	7 1/2	$\phi 3/4$	210	100	175	8 $\phi 19$
C1	220	100	8 $\phi 18$	9	4	7 1/2	$\phi 3/4$	210	100	175	8 $\phi 19$
C3	220	100	8 $\phi 18$	9	4	7 1/2	$\phi 3/4$	210	100	175	8 $\phi 19$
C4	220	100	8 $\phi 18$	9	4	7 1/2	$\phi 3/4$	210	100	175	8 $\phi 19$
D1	25	BSP	1 NPT	1	NPT	25	BSP	185	80	150	8 $\phi 19$
G1	200	80	160 8 $\phi 18$	7 1/2	3	6	4 $\phi 3/4$	10	BSP	20	BSP
G2	20	BSP	3/8 NPT	3/8	NPT	20	BSP	10	BSP	20	BSP
G3	20	BSP	3/4 NPT	3/4	NPT	10	BSP	250	125	210	8 $\phi 23$
G4	10	BSP	3/8 NPT	3/8	NPT	*					
G16	250	125	210 8 $\phi 18$								

* G16 to be delivered with DIN blind flange.
 Measurements ± 5 mm (0.2 in)
 NOTE: Electric components not fitted and wired for DC.
 1) If by-pass option is included, freshwater pipe will be 127 mm (5.0 in) longer.
 ⓧ Centre of gravity

WEIGHT IN OPERATION
 Max. 1095 kg (2635 lbs)

Drw.no. 985 17469 R:01

Illustrations, indications of material, dimensions and weights etc. herein, do not constitute any commitment on our part. We reserve the right to change such specifications when necessary.



9.2.2.2-6 Technical data, Pump and Motor for JW(S)P-26-C100

No. of plates NE/NK:		62/62-70/70		72/72-80/80	
Pump function		Freshwater	Ejector	Freshwater	Ejector
Pump Type		PVVF-2040	CNL 80-80/200	PVVF-2040	CNL 80-80/200
Motor type		71 B	160 M	71 B	160 M
Nom. flow x pressure m ³ /h x mwc		2.1 x 28	49 x 42	2.1 x 28	56 x 42
Impeller size 50 Hz : mm		ø149	ø205	ø149	ø205
Impeller size 60 Hz : mm		ø128	ø172	ø128	ø172
Rotating speed 50 Hz : RPM		2820	2905	2820	2905
Rotating speed 60 Hz : RPM		3360	3505	3360	3505
3 x 380 V 50 Hz:					
Rated output power kW		0.55	15.5	0.55	15.5
Consumed power kW		0.67	12.1	0.67	12.8
Current (full load) A		1.4	28.5	1.4	28.5
Current (start) A		7	157	7	157
3 x 440 V 60 Hz:					
Rated output power kW		0.75	17.8	0.75	17.8
Consumed power kW		0.75	12.2	0.75	12.8
Current (full load) A		1.6	28.5	1.6	28.5
Current (start) A		7	157	7	157
3 x 460 V 60 Hz:					
Rated output power kW		0.75	17.8	0.75	17.8
Consumed power kW		0.75	12.2	0.75	12.8
Current (full load) A		1.5	27.2	1.5	27.2
Current (start) A		7	157	7	157

No. of plates NE/NK:		82/82-90/90		92/92-100/100	
Pump function		Freshwater	Ejector	Freshwater	Ejector
Pump Type		PVVF-2040	CNL 80-80/200	PVVF-2040	CNL 80-80/200
Motor type		71 B	160 L	71 B	160 L
Nom. flow x pressure m ³ /h x mwc		2.1 x 28	62 x 42	2.1 x 28	70 x 42
Impeller size 50 Hz : mm		ø149	ø192	ø149	ø192
Impeller size 60 Hz : mm		ø128	ø168	ø128	ø168
Rotating speed 50 Hz : RPM		2820	2915	2820	2915
Rotating speed 60 Hz : RPM		3360	3515	3360	3515
3 x 380 V 50 Hz:					
Rated output power kW		0.55	18.6	0.55	18.6
Consumed power kW		0.67	15.9	0.67	16.5
Current (full load) A		1.4	33.5	1.4	33.5
Current (start) A		7	211	7	211
3 x 440 V 60 Hz:					
Rated output power kW		0.75	21.4	0.75	21.4
Consumed power kW		0.75	15.9	0.75	16.5
Current (full load) A		1.6	33.5	1.6	33.5
Current (start) A		7	211	7	211
3 x 460 V 60 Hz:					
Rated output power kW		0.75	21.4	0.75	21.4
Consumed power kW		0.75	15.9	0.75	16.5
Current (full load) A		1.5	32	1.5	32
Current (start) A		7	211	7	211



9.2.5.2-3 Dimensional drawing, CNL 80-80/200

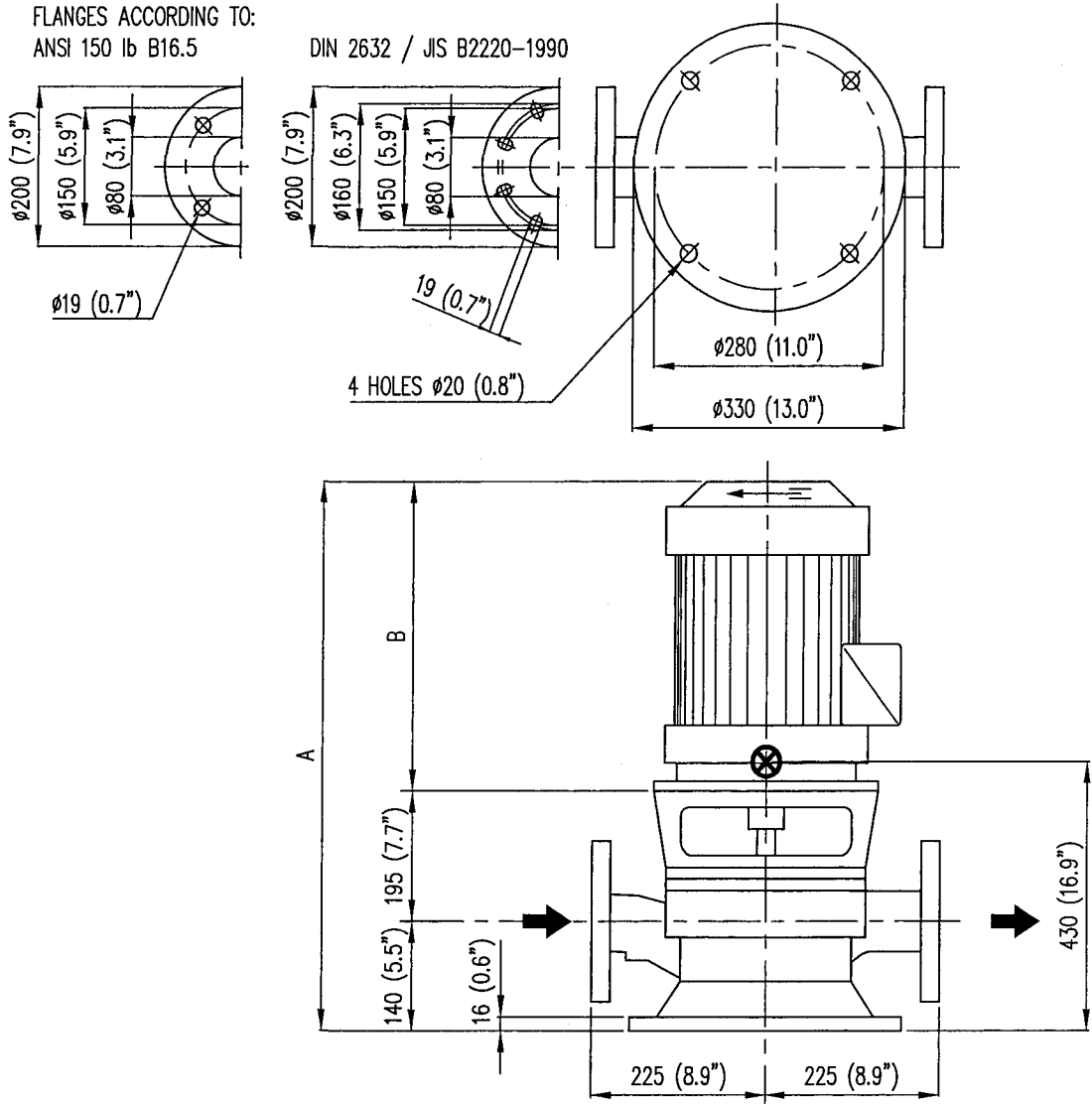

⊗ CENTRE OF GRAVITY

EJECTOR PUMP TYPE	MOTOR TYPE	FLANGE TYPE	A mm	B mm	WEIGHT (INCL. MOTOR) Kg	CABLE GLANDS KVM 36
CNL 80-80/200	160 M	DIN/JIS/ANSI	814 (30.05")	479 (18.9")	166 (366 lbs)	ϕ 22,5-24,5
CNL 80-80/200	160 L	DIN/JIS/ANSI	858 (33.8")	523 (20.6")	170 (375 lbs)	ϕ 22,5-24,5

MECHANICAL PROTECTION	INSULATION	COOLING SYSTEM	SHAFT SEAL	POLES FOR MOTOR
IP 55	CLASS F	FAN COOLED	MECH. SEAL	2 POLES

Dwg.no. 985 17500 R:02

9.2.6.2-41 Dimensional drawing, Panel for Single-stage FWG (option A)

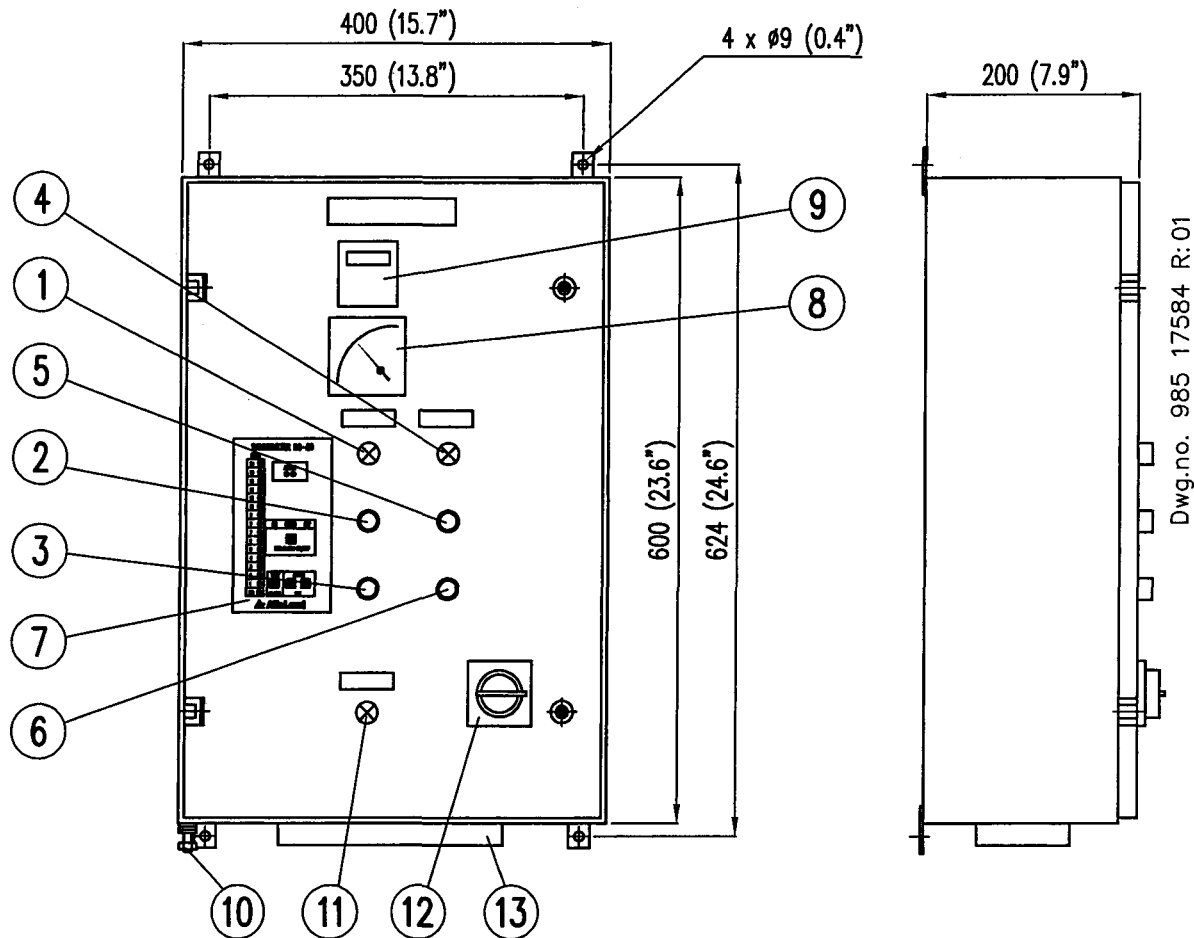

Dwg.no. 985 17584 R:01

Legend

- | | |
|------------------------------------|-----------------------------------|
| 1 Running light, ejector pump | 10 Earth connection point |
| 2 Start, ejector pump | 11 Source on |
| 3 Stop, ejector pump | 12 Main switch |
| 4 Running light, freshwater pump 1 | 13 Connections: 1 PG29 (20–27 mm) |
| 5 Start, freshwater pump 1 | 2 PG21 (14–20 mm) |
| 6 Stop, freshwater pump 1 | 2 PG16 (8–15 mm) |
| 7 Salinometer | 2 PG13,5 (7–13 mm) |
| 8 Ammeter | Additional 6 PG16 |
| 9 Running hour meter | |



9.2.9.3-2 Feed Water treatment - 130 liter

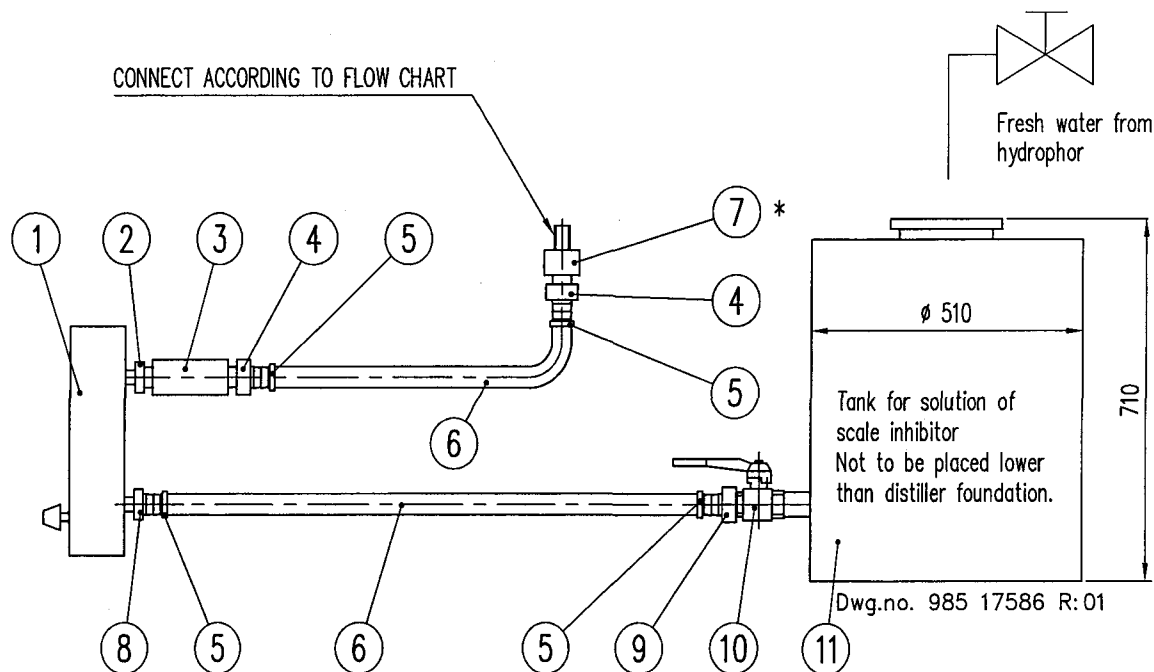

Recommendation

Use fully soluble scale inhibitor for instance on polymere basis.
 Mix quantity required for 24 hours operation in tank according to
 maker's instruction and adjust dosage to cover max. freshwater
 output from distiller.
 Flush regularly.

- | | | | |
|---|----------------------------|----|--------------------------|
| 1 | Flowmeter incl. reg. valve | 7 | Connection 3/8" x 1/4" * |
| 2 | Nipple 3/8" x 1/8" | 8 | Connection 1/8" x 10 |
| 3 | Non return valve 3/8" | 9 | Connection 1/2" x 10 |
| 4 | Hose connection 3/8" x 10 | 10 | Ball Valve 1/2" |
| 5 | Hose clip | 11 | PE tank (130 l) |
| 6 | Hose 3/8" (4000 mm) | | |

* Only for JWP-36-C



9.2.2.3-11 Flow Chart, JWSP-26-C100

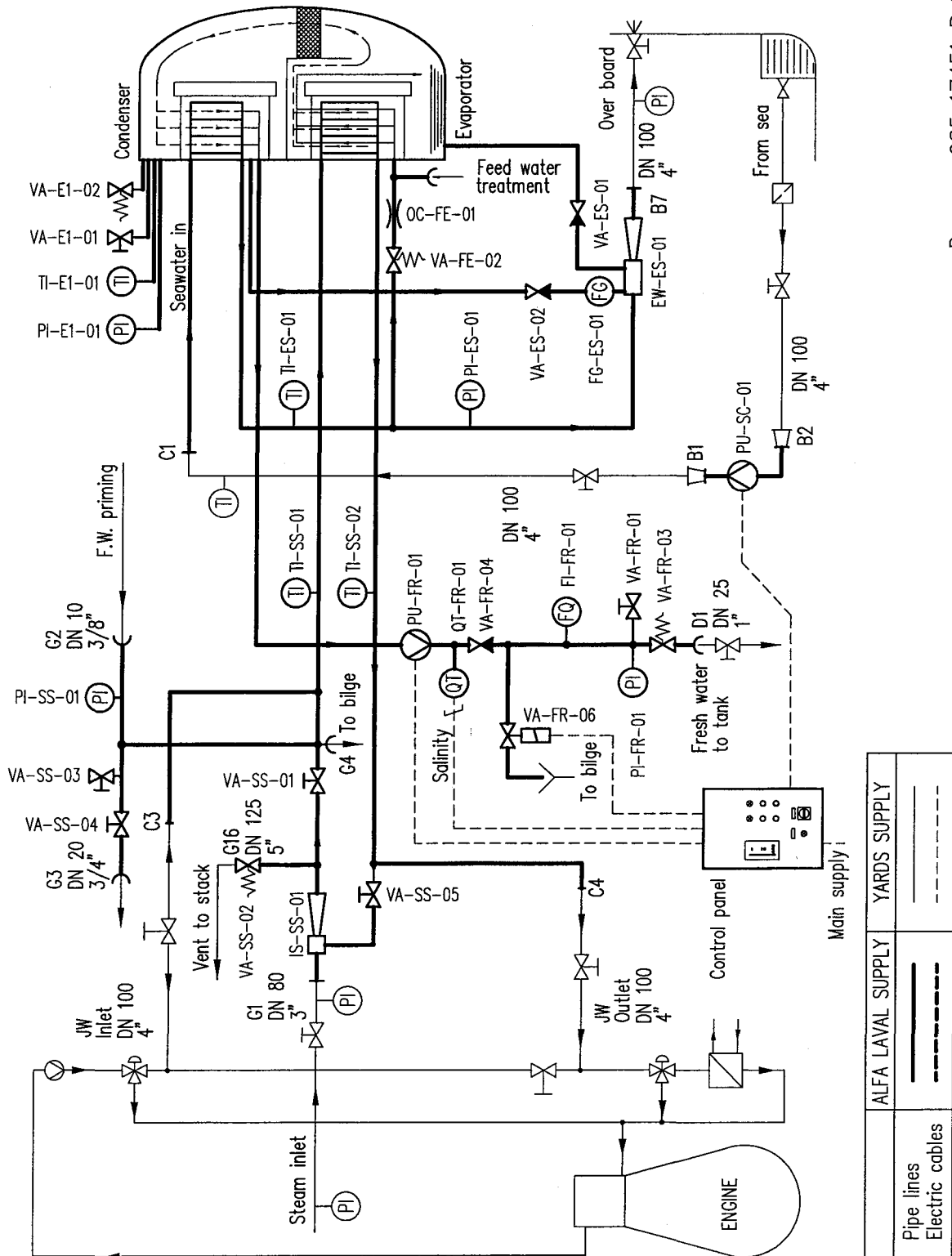

Dwg.no. 985 17451 R:02

Illustrations, indications of material, dimensions and weights etc. herein, do not constitute any commitment on our part. We reserve the right to change such specifications when necessary.



9.2.2.4-2 Equipment specification, JW(S)P-26-C100

Equipment supplied by Alfa Laval:

Tag No.	Description	Article No.	Connection
	<u>Unit:</u>		
EW-ES-01	Ejector	See specification	-
FG-ES-01	Flow sight glass	984 35686-00	1/2" BSP
FI-FR-01	Water meter	985 42600-04	3/4" BSP
OC-FE-01	Orifice	See specification	-
PI-ES-01	Pressure gauge	984 30297-00	1/4" BSP
PI-E1-01	Mano/vacuum gauge	984 30308-00	3/8" BSP
PI-FR-01	Pressure gauge	984 30298-00	1/4" BSP
PU-FR-01	Freshwater pump	See specification	-
PU-SC-01	Ejector pump	See specification	-
QT-FR-01	Electrode unit	984 22500-00	-
TI-ES-01	Thermometer	984 30366-00	1/2" BSP
TI-E1-01	Thermometer	984 30366-00	1/2" BSP
VA-ES-01	Non return valve	984 35501-01	DN 50
VA-ES-02	Non return valve	984 35686-00	1/2" BSP
VA-E1-01	Air screw	984 40939-03	1/4" BSP
VA-E1-02	Safety valve	984 35360-00	1" BSP
VA-FE-02	Spring loaded valve	984 35535-00	DN 40
VA-FR-01	Ball valve	984 35683-00	1/2" BSP
VA-FR-03	Spring loaded valve	984 35166-00	-
VA-FR-04	Non return valve	984 35672-00	1" BSP
VA-FR-06	Solenoid valve	See specification	-
	Control panel ¹⁾	See specification	-
	<u>Steam arrangement: ²⁾</u>		
IS-SS-01	Steam injector	See specification	-
PI-SS-01	Mano/vacuum gauge	984 30285-00	3/8" BSP
TI-SS-01	Thermometer	984 30366-00	1/2" BSP
TI-SS-02	Thermometer	984 30366-00	1/2" BSP
VA-SS-01	Butterfly valve	984 35620-00	DN 100
VA-SS-02	Safety valve	See specification	-
VA-SS-03	Ball valve	984 35618-00	3/8" BSP
VA-SS-04	Seated valve	985 56110-04	3/4" BSP
VA-SS-05	Butterfly valve	984 35620-00	DN 100

Dwg.no. 985 17470 R:01

¹⁾ Normally supplied by Alfa Laval

²⁾ Type JWSP



9.2.8-1 Vertical plant positioning, JWP-16/26 and D-PU-(2)-36

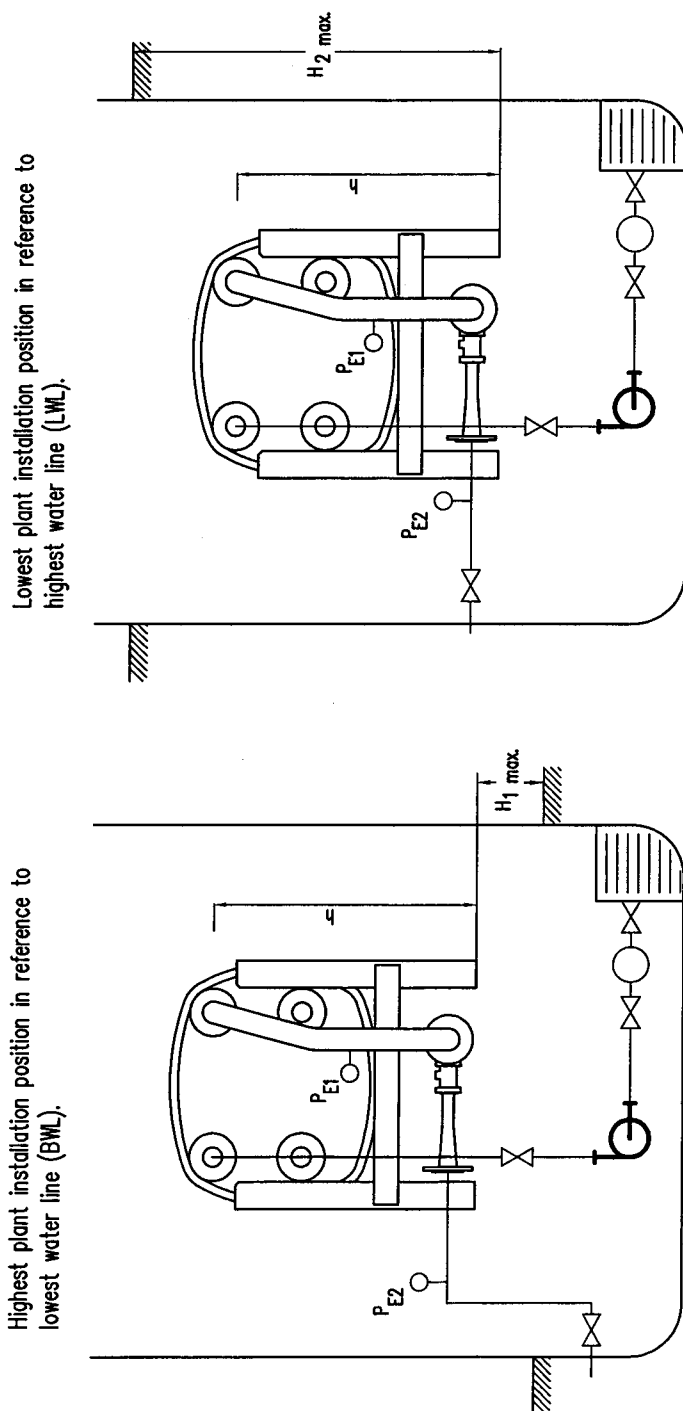

The stated installation heights are given under the conditions that the line pressure drop does not exceed 0.1 bar (1.5 lbs/in²) which should account for all normal installations. If the 0.1 bar (1.5 lbs/in²) is exceeded the heights must be diminished accordingly.

In order to minimize the pressure drop we recommend to avoid the use of seat valves in the system.
Ejector pump is not self priming.

Freshwater Generator type	P _{E2} max. bar (lbs/in ²)	h mm	Highest vertical plant positioning		Lowest vertical plant positioning	
			P _{E1} min. bar (lbs/in ²)	H ₁ max. mm	P _{E1} max. bar (lbs/in ²)	H ₂ max. mm
P-16	0.5 (7.3)	913	3 (43.5)	3000	3.85 (55.8)	5000
P-26	0.6 (8.7)	1100		4000		6000
D-PU-36			1500			
D-PU-2-36						

Dwg.no. 985 17495 R:00



9.2.6.3-41 Electrical diagram, Control panel for Single-stage FWG (option A)

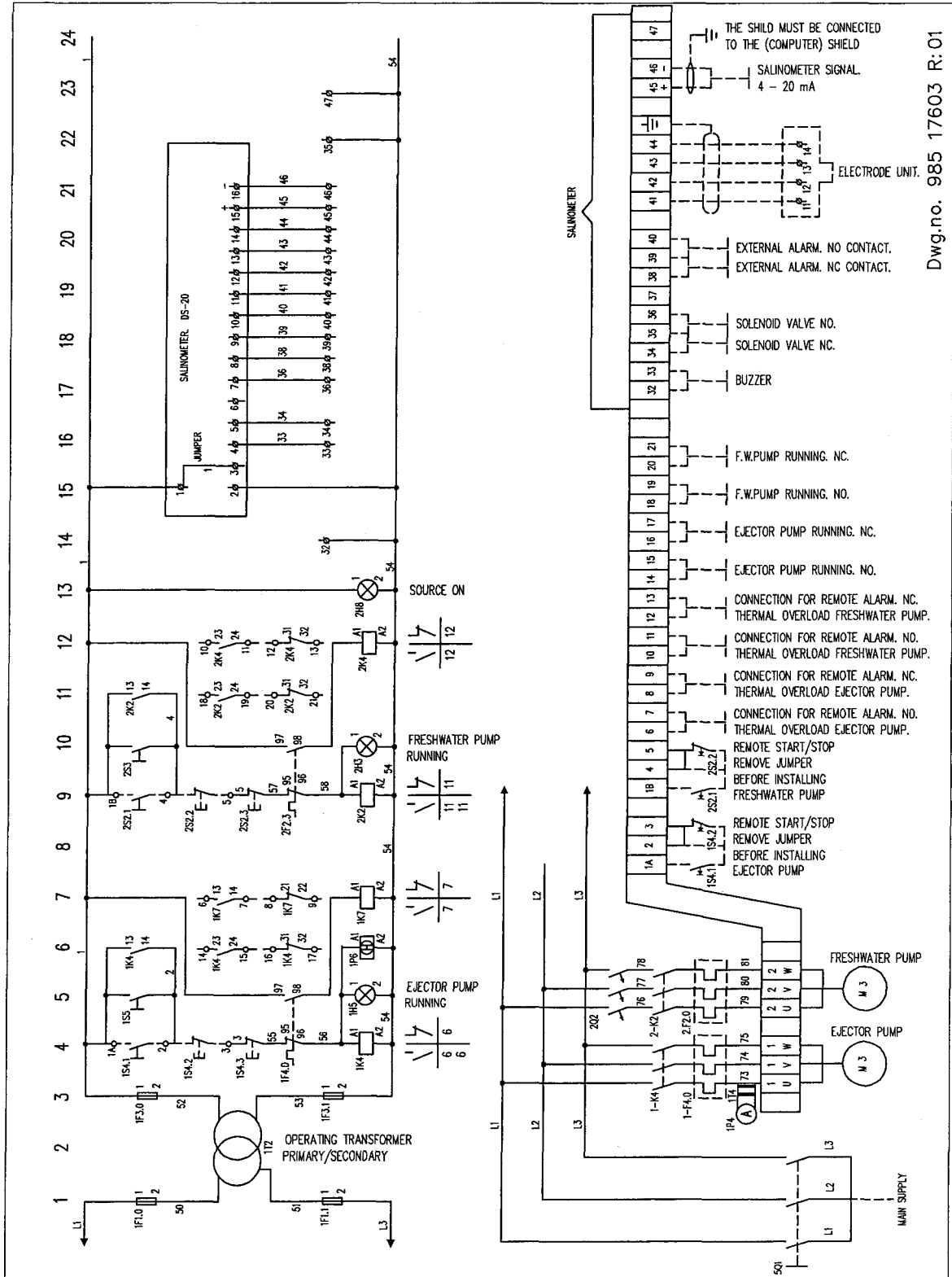

Dwg.no. 985 17603 R:01

Illustrations, indications of material, dimensions and weights etc. herein, do not constitute any commitment on our part. We reserve the right to change such specifications when necessary.

Rev. 02
 Drawing no. 985 16610

Only to the extent expressly agreed by us this document may constitute a contractual obligation on our part.

This document and its contents are our exclusive property and must not be copied, reproduced, transmitted or communicated to any other party or used for purposes not expressly permitted by us.

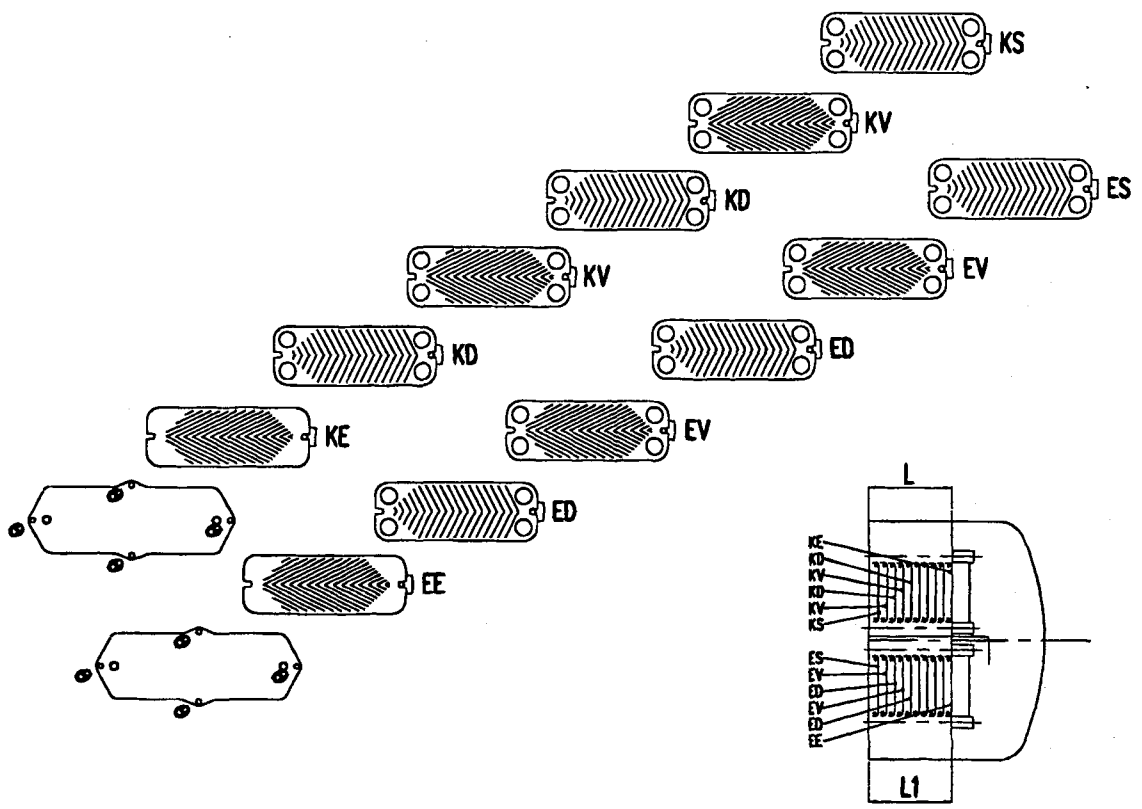
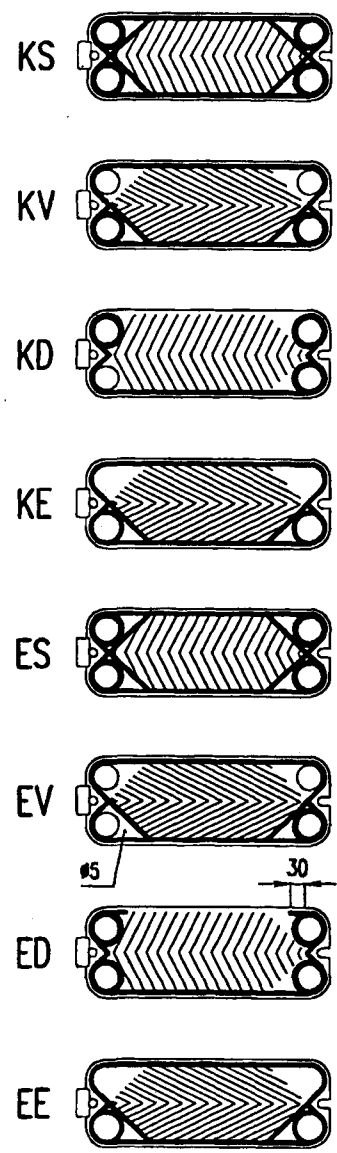

Sheet	Rev. no.	Revision			Date	Revised	Reviewed	Approved
Article no.	Title				Alfa Laval			
	ASSEMBLY SCHEME				Alfa Laval Desalt A/S			
	P-26-C				COPENHAGEN DENMARK			
	Date	Drawn	Reviewed	Approved	Repl. for 985 16610		rev. 01,	
ISO method E	Scale	Weight		Drawing No.				
CAD	Basic drawing no.	rev.		985 16610				
				Repl. by		rev.		

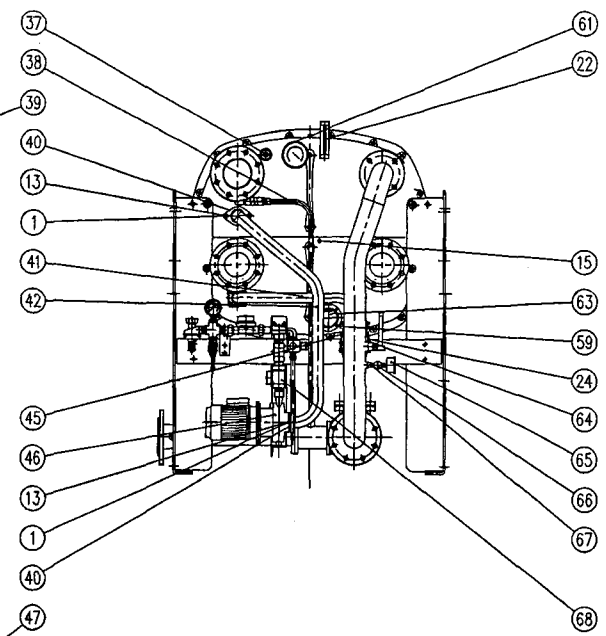
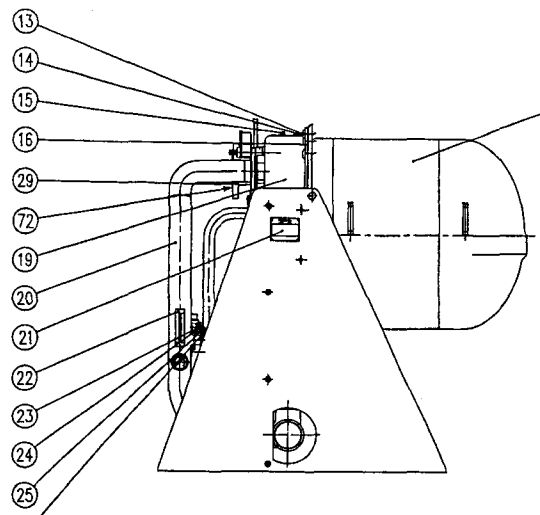
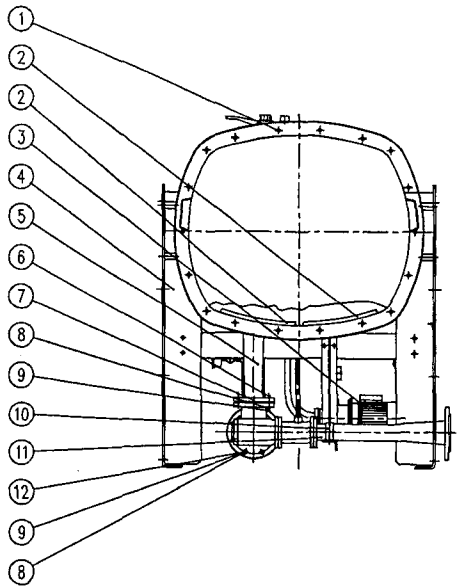

FRESHWATER PIPE (2,5:1)

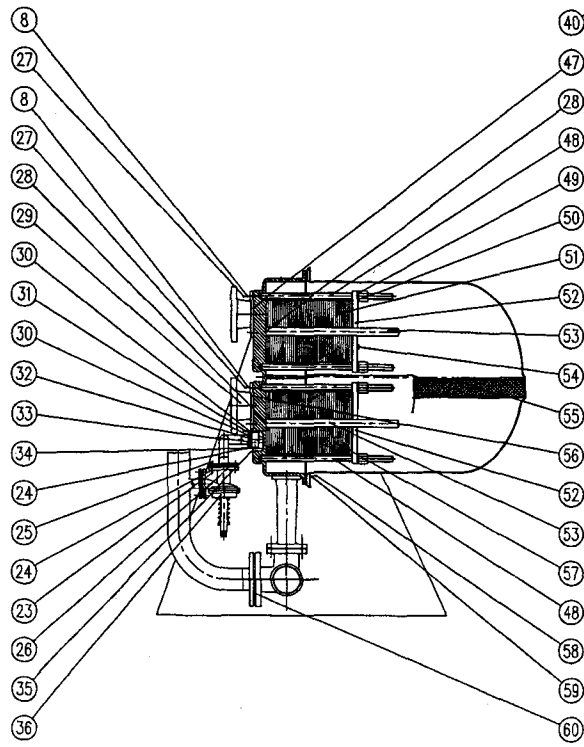
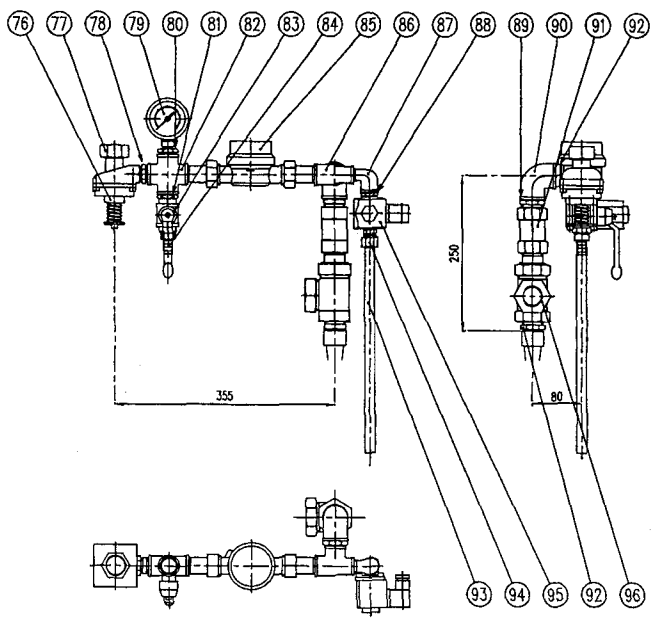

TEST PRESSURE ACCORDING TO TECH. SPEC. NO.: 985 14225.

985 17909-83	2	Rev.	01 Att. Artikelnummer		11.10.02 MFN			
	2		Revision	Datum	Revised	Reviewed	Approved	
985 17909-82	2	Rev.	ASSEMBLY DRAWING		ASSEMBLY DRAWING			
985 17909-81	2		Revision	Datum	Revised	Reviewed	Approved	
985 17909-80	2	Rev.	FRESHWATER GENERATOR		FRESHWATER GENERATOR			
			Revision	Datum	Revised	Reviewed	Approved	
Title			Project name			Project no.		
Drawing No.			Drawing No.			Drawing No.		
Date			Date			Date		
92.02.97			92.02.97			92.02.97		
985 17909-00			985 17909-00			985 17909-00		



Bill Of Material

Parent item no.: 985 17909-81 R: 00	Description: ASSEMBLY DRAWING NE/NK 92-100/92-100 P-26-C100 DIN / JIS	Date: 20031013	Page 1 of 4
Drawing no.: 985 17909-R01		Ini DKSOABK	

BUBL	QTY	U/M	DESCRIPTION	DRAWING NO.	ARTICLE NO.	MATERIAL	REMARKS
	.000000	EA	EJECTOR PUMP		SEE SPECIFIC.H		
	.000000	EA	MOTOR FOR EJECTOR PUMP		SEE SPECIFIC.I		
	.000000	EA	CONTROL PANEL		SEE SPECIFIC.P		
	1.000000	EA	CAUTION PLATE FOR EJECTOR PUMP		19.00000.01		
	1.000000	EA	A-L DESALT EMBLEM 50 X 323		19.00000.11		
	.000000	EA	MANOMETER SET	985 58196	SEE SPECIFIC.MS		
1	22.000000	EA	SCREW M12 x 40 DIN 912		985 00002-15	QUALITY 8.8 ; DELTA-MAGNI	
2	2.000000	EA	ZINC ANODE	984 58033-R04	984 58033-80		
3	.000000	EA	P-26-C80/C100 DPU-36-C100/125 MOTOR FOR FRESHWATER PUMP		SEE SPECIFIC.M		
4	1.000000	EA	BED FRAME	985 12564-R03	985 12564-80		
5	1.000000	EA	BRINE PIPE P-26-C100	984 58218	984 58218-01		
6	4.000000	EA	SCREW M16 X 40 DIN 933		985 80011-38	QUALITY 8.8 ; DELTA-MAGNI	
7	1.000000	EA	NON RETURN FLAP Ø 50 MED TEXTILINDLÆG	984 57281-R03	985 00036-39		
8	28.000000	EA	WASHER M16 DIN 125 A		985 32512-20	A4	
9	12.000000	EA	NUT M16 DIN 934 HOT DIP GALVANIZED		984 40910-45	HOT DIP GALVANIZED	
10	1.000000	EA	CLAMP Ø 60	984 58229-R04	984 58229-80		
11	.000000	EA	COMBINED BRINE/AIR EJECTOR		SEE SPECIFIC.B		
12	8.000000	EA	SCREW M16 X 60 DIN 933		984 40910-43	QUALITY 8.8 ; DELTA-MAGNI	
13	18.000000	EA	WASHER M12 ISO 887/83		985 32512-16	ISO 683/13/86 ; TYPE 20A	
14	18.000000	EA	NUT M12 DIN 934		985 00001-71	QUALITY 8.8 ; DELTA-MAGNI	
15	2.000000	EA	AIR VALVE 1/4" BSP	VVS 40 5501 002	984 40939-03	BRASS	
16	1.000000	EA	GASKET FOR FRONT COVER	984 58058-R02	984 58058-01		
19	1.000000	EA	SEPARATOR P-26	984 58215-R06	984 58215-01		

Alfa Laval Copenhagen A/S

Maskinevej 5
DK-2860 Søborg, Denmark
CVR No. 10134285
V.A.T. No. 14646647

Telephone + 45 39 53 60 00
Telefax + 45 39 53 65 68
Bank DANSKE BANK Holmens Kanal Branch
Acc. No. DKK 3100-3117-108007
Acc. No. EUR 3100-3140-854301
Acc. No. USD 3100-3140-854301



Bill Of Material

Parent item no.: 985 17909-81 R: 00	Description: ASSEMBLY DRAWING NE/NK 92-100/92-100 P-26-C100 DIN / JIS	Date: 20031013	Page 2 of 4
Drawing no.: 985 17909-R01		Ini DKSOABK	

BUBL	QTY	U/M	DESCRIPTION	DRAWING NO.	ARTICLE NO.	MATERIAL	REMARKS
20	1.000000	EA	SEAWATER PIPE FROM CONDENSER	985 16542-R00	985 16542-80	CuNi	
21	.000000	EA	NAME PLATE		SEE SPECIFIC.NP		
22	2.000000	EA	THERMOMETER W/POCKET - ANGLE 63 MM	984 30366-R01	984 30366-00	CuNi10Fe	
23	8.000000	EA	SCREW M10 X 40 DIN 933		984 40910-39	QUALITY 8.8 ; DELTA-MAGNI	
24	16.000000	EA	WASHER M10 DIN 125 A		985 32512-14	A4	
25	8.000000	EA	NUT M10 DIN 934		984 40900-27	QUALITY 8.8 ; DELTA-MAGNI	
26	2.000000	EA	GASKET Ø84/46 X 2	984 58335-R01	984 58335-01		
27	16.000000	EA	SCREW M16 x 40 DIN 912		985 00002-16	QUALITY 8.8 ; DELTA-MAGNI	
28	4.000000	EA	STUD BOLT M16 X 43	984 58183-R03	984 58183-01		
29	3.000000	EA	FLANGE Ø 100 DIN/ANSI/JIS FOR JW/SW	984 58207	984 58207-03		
30	2.000000	EA	GASKET Ø56/30 X 2	984 57843-R02	984 57843-01		
31	.000000	EA	ORIFICE FOR FEED WATER		SEE SPECIFIC.O		
32	1.000000	EA	RUBBER SLEEVE	984 58084-R02	984 58084-01		
33	1.000000	EA	CONNECTION Ø59/28 (FEED WATER) P-26-C	984 58065-R03	984 58065-01		
34	4.000000	EA	SCREW M10 x 55 DIN 933		985 00002-14	QUALITY 8.8 ; DELTA-MAGNI	
36	1.000000	EA	SPRING LOADED VALVE MVF-40-2.5	984 35535-02	984 35535-00	RG 5	
37	1.000000	EA	SAFETY VALVE 1" BSP	VVS 43 2240 108	984 35360-00	BRASS	
38	1.000000	EA	VACUUM PIPE P-26-C100	984 58296-R02	984 58296-80		
39	1.000000	EA	FRONT COVER P-26	984 58226	984 58226-80		
40	2.000000	EA	0,35 M2 GASKET Ø75/43 X 2	984 58093-R02	984 58093-01		
41	1.000000	EA	PIPE FOR FEED WATER	984 58209	984 58209-80	CuNi	
42	1.000000	EA	FRESHWATER PIPE TO PUMP	984 58213-R02	984 58213-80	CuNi	
45	1.000000	EA	GASKET Ø95/Ø70 X 2	984 58244-R02	984 58244-01		

Alfa Laval Copenhagen A/S

Maskinvej 5
DK-2860 Søborg, Denmark
CVR No. 10134285
V.A.T. No. 14646647

Telephone + 45 39 53 60 00
Telefax + 45 39 53 65 68
Bank DANSKE BANK Holmens Kanal Branch
Acc. No. DKK 3100-3117-108007
Acc. No. EUR 3100-3140-854301
Acc. No. USD 3100-3101-687094



Bill Of Material

Parent item no.: 985 17909-81 R: 00	Description: ASSEMBLY DRAWING NE/NK 92-100/92-100 P-26-C100 DIN / JIS	Date: 20031013	Page 3 of 4
Drawing no.: 985 17909-R01		Ini DKSOABK	

BUBL	QTY	U/M	DESCRIPTION	DRAWING NO.	ARTICLE NO.	MATERIAL	REMARKS
46	.000000	EA	FRESHWATER PUMP		SEE SPECIFIC.F		
47	2.000000	EA	RUBBER SLEEVE	984 58085-R02	984 58085-01		
48	.000000	EA	CLAMPING BOLT		SEE SPECIFIC.G		
49	8.000000	EA	WASHER M24 ISO 887/83 316L		985 32510-28	ISO 683/13/86 ; TYPE 20A Aisi 3	
50	8.000000	EA	NUT M24	984 57822-R01	984 57822-01	ISO 1338/77 ; CU PB5 SN5 ZN5	
51	.000000	EA	HEAT EXCHANGER-CONDENSER		SEE SPECIFIC.K		
52	2.000000	EA	PRESSURE PLATE	984 58024-R04	984 58024-01		
53	.000000	EA	SUPPORTING SHAFT		SEE SPECIFIC.A		
54	1.000000	EA	ASSEMBLY PLATE P-26-C	984.70140.00	19.00000.06		
55	1.000000	EA	DEMISTER 0,35 M2	984 58238	984 58238-80		
56	2.000000	EA	GASKET Ø127/77 X 2	VVS 00 0662 076	984 40942-02	NITRIL	
57	.000000	EA	HEAT EXCHANGER-EVAPORATOR		SEE SPECIFIC.E		
58	3.000000	EA	NUT M6 ISO 4032/86		985 32010-07	ISO 683/13/86 ; TYPE 20A	
59	7.000000	EA	WASHER M6 ISO 887/83		985 32510-08	A4	
60	1.000000	EA	GASKET Ø 162 / Ø 90 X 2	985 15932	985 15932-01		
61	1.000000	EA	COMPOUND GAUGE -100% - 2 BAR LB/IN2, BAR = KGF/CM2, Ø100, 3/8" BN	984 30308-R01	984 30308-00		
63	1.000000	EA	SIGHT GLASS WITHOUT INNER PART	984 57862-R03	984 57862-82		
64	4.000000	EA	SCREW M10 x 30 DIN 912		985 00002-17	QUALITY 8.8 ; DELTA-MAGNI	
65	1.000000	EA	PRESSURE GAUGE 0-6 BAR LB/IN2, BAR = KGF/CM2, Ø63, 1/4" BC	984 30297-R01	984 30297-00		
66	1.000000	EA	PRESSURE GAUGE COCK 1/4" BSP BRASS	EV 5100-8	984 35533-00	BRASS	
67	1.000000	EA	NIPPLE 1/4" BSP	EV 206 B	984 40941-29	ISO 426/2/83 ; CU ZN39 PB3	
68	1.000000	EA	ELECTRODE (FOR SL-3000, DS-20)		985 42985-05		
72	1.000000	EA	RUBBER SLEEVE Ø80/Ø100	985 17576	985 17576-01		

Alfa Laval Copenhagen A/S

Maskinvej 5
DK-2860 Søborg, Denmark
CVR No. 10134285
V.A.T. No. 14646647

Telephone + 45 39 53 60 00
Telefax + 45 39 53 65 68
Bank DANSKE BANK Holmens Kanal Branch
Acc. No. DKK 3100-3117-108007
Acc. No. EUR 3100-3140-854301
Acc. No. USD 3100-3016-076094



Bill Of Material

Parent item no.: 985 17909-81 R: 00	Description: ASSEMBLY DRAWING NE/NK 92-100/92-100 P-26-C100 DIN / JIS	Date: 20031013	Page 4 of 4
Drawing no.: 985 17909-R01		Ini DKSOABK	

BUBL	QTY	U/M	DESCRIPTION	DRAWING NO.	ARTICLE NO.	MATERIAL	REMARKS
76	1.000000	EA	SPRING LOADED VALVE MV-15-1.0	984.35166.00	984 35166-00	BRONZE	
77	1.000000	EA	RED. NIPPLE 1" BSP X 1/2" BSP	EV 120 B	984 40941-37	ISO 426/2/83 ; CU ZN39 PB3	
78	1.000000	EA	HEXAGON NIPPLE 3/4" X 1/2" BSP	B 3245	985 52722-03	ISO 1338/77 ; CU PB5 SN5 ZN5	
79	1.000000	EA	PRESSURE GAUGE 0-3 BAR	984 30298-R01	984 30298-00	AISI 316	
80	1.000000	EA	LB/IN2, BAR = KGF/CM2, Ø63, 1/4"N BUSHING 3/4" X 1/4" BSP	B 3241	985 52720-04	ISO 1338/77 ; CU PB5 SN5 ZN5	
81	1.000000	EA	BUSHING 3/4" X 1/2" BSP	B 3241	985 52720-06	ISO 1338/77 ; CU PB5 SN5 ZN5	
82	1.000000	EA	CROSS 3/4" BSP	B 3180	984 40943-27	ISO 1338/77 ; CU PB5 SN5 ZN5	
83	1.000000	EA	BALL VALVE 1/2" BSP		984 35683-00	BRASS	
84	1.000000	EA	BRASS HOSE CONNECTION 1/2" BSP X 15	VVS 74 4700 104	984 40939-01	ISO 426/2/83 ; CU ZN39 PB3	
85	1.000000	EA	WATER METER B&R TYPE EVW-DD		985 42600-04		
86	1.000000	EA	3/4" BPS CONNECTION TEE 3/4" x 3/4" x 1/2" BSP	B 3130	985 52710-12	ISO 1338/77 ; CU PB5 SN5 ZN5	
87	1.000000	EA	ELBOW 1/2" BSP	B 3092	985 52700-03	ISO 1338/77 ; CU PB5 SN5 ZN5	
88	1.000000	EA	HEXAGON NIPPLE 1/2" BSP	B 3280	985 52721-03	ISO 1338/77 ; CU PB5 SN5 ZN5	
89	1.000000	EA	HEXAGON NIPPLE 1" BSP	B 3280	985 52721-05	ISO 1338/77 ; CU PB5 SN5 ZN5	
90	1.000000	EA	ELBOW 1" BSP	B 3090	985 52690-05	ISO 1338/77 ; CU PB5 SN5 ZN5	
91	1.000000	EA	NON RETURN VALVE 1" BSP	985 13952	984 35672-00	BRASS	
92	2.000000	EA	HEXAGON NIPPLE 1" X 3/4" BSP	B 3245	985 52722-04	ISO 1338/77 ; CU PB5 SN5 ZN5	
93	350.000000	MM	PIPE Ø 16/12,7		984 40938-29	COPPER DIN 1754/1787/17671	
94	1.000000	EA	CONNECTION 1/2" BSP X 16	EV 68 F	984 40941-39	ISO 426/2/83 ; CU ZN39 PB3	
95	.000000	EA	SOLENOID VALVE		SEE SPECIFIC.S		
96	1.000000	EA	HOUSING FOR ELECTRODE	984 57672	984 22211-02		
99	.000000	EA	1" BSP PAINTED PARTS FOR BED FRAME		SEE SPECIFIC.PP		

Alfa Laval Copenhagen A/S

Maskinevej 5
DK-2860 Søborg, Denmark
CVR No. 10134285
V.A.T. No. 14646647

Telephone + 45 39 53 60 00
Telefax + 45 39 53 65 68
Bank DANSKE BANK Holmens Kanal Branch
Acc. No. DKK 3100-3117-108007
Acc. No. EUR 3100-3140-854301
Acc. No. USD 3100-3116-576294
www.alfalaval.com

Only to the extent expressly agreed by us in this document we shall not be liable for any damage or loss of profit or other consequences arising from the use of this document.

This document and its contents are our exclusive property and must not be copied, reproduced, transmitted or communicated to any other party without our prior written consent. Any use for purposes not expressly permitted by us.

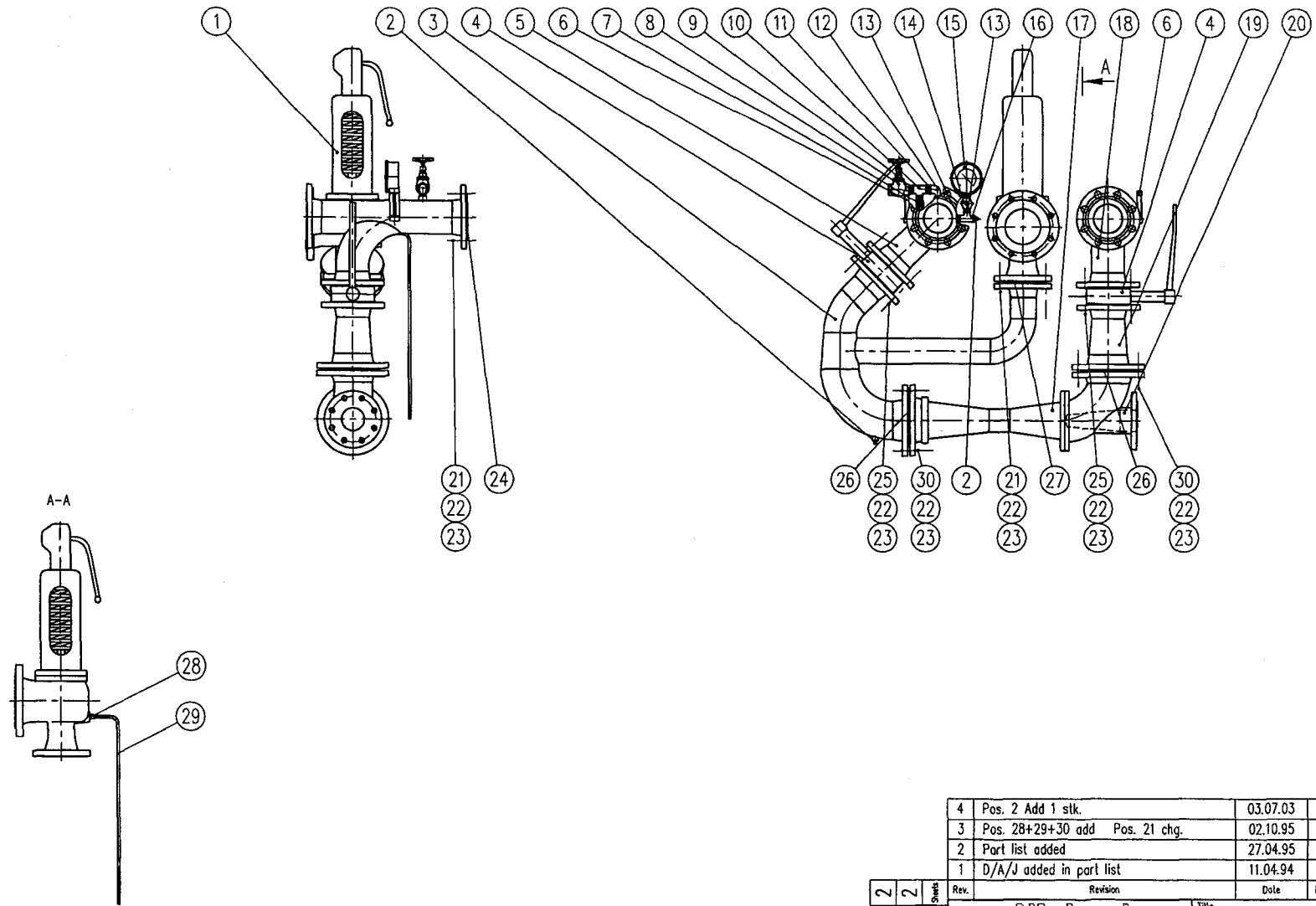

4	Pos. 2 Add 1 stk.	03.07.03	MFN		
3	Pos. 28+29+30 add Pos. 21 chg.	02.10.95	JOK		
2	Part list added	27.04.95	CSM		
1	D/A/J added in part list	11.04.94	AJE		
Rev.	Revision	Date	Revised	Reviewed	Approved

2	2	Shank	Alfa Laval Alfa Laval Copenhagen A/S DENMARK		Title MOUNTING DRAWING STEAM ARRANGEMENT	
985 15594-81	985 15594-80	Article no.	Dimensions without tolerances: DS/ISO 2768-M or ISO 13920-B	ISO method E 	Scale 1:10	Project name JWSP-26-C100/N2
Date	Drawn	Reviewed	Approved	Format	Project type	Project no.
11.11.93	AJE			A2		
Replace dwg. no.			Drawing No.		Rev.	
					985 15594	04



Bill Of Material

Parent item no.: 985 15594-80 R: 04	Description: MOUNTING DRAWING STEAM ARRANGEMENT DIN/ASA JWSP-26-C100/N2	Date: 20031013	Page 1 of 2
Drawing no.: 985 15594-R04		Ini DKSOABK	

BUBL	QTY	U/M	DESCRIPTION	DRAWING NO.	ARTICLE NO.	MATERIAL	REMARKS
	.000000	EA	PIPE PARTS FOR STEAM ARR.			SEE SPECIFIC.PS	
1	1.000000	EA	SAFETY VALVE DN80/125 DIN TYPE SV603-7 PRES 1.0 BAR		985 00010-68		
2	2.000000	EA	PLUG 3/8".	B 3291	985 52730-02	ISO 1338/77 ; CU PB5 SN5 ZN5	
3	.000000	EA	CONNECTION FOR SAFETY VALVE		PIPING PART.A		
4	2.000000	EA	BUTTERFLY VALVE DN100	984 35620-R00	984 35620-00	GG 22	
5	.000000	EA	STEAM ARRANGEMENT INLET		PIPING PART.B		
6	2.000000	EA	THERMOMETER W/POCKET - ANGLE 63 MM	984 30366-R01	984 30366-00	CuNi10Fe	
7	1.000000	EA	BALL VALVE 3/8" BSP		984 35618-00	BRASS	
8	1.000000	EA	VALVE 3/4". GLOBE		985 56110-04	CU PB5 SN5 ZN5 ISO 1338	
9	1.000000	EA	HEXAGON NIPPLE 3/4" X 1/2" BSP	B 3245	985 52722-03	ISO 1338/77 ; CU PB5 SN5 ZN5	
10	1.000000	EA	TEE 1/2" X 3/8" X 1/2" BSP	B 3130	985 00010-58	ISO 1338/77 ; CU PB5 SN5 ZN5	
11	1.000000	EA	NIPPLE PIPE 1/2" BSP X 60	B 3530	984 40943-11	ISO 1338/77 ; CU PB5 SN5 ZN5	
12	1.000000	EA	ELBOW 1/2" BSP	B 3092	985 52700-03	ISO 1338/77 ; CU PB5 SN5 ZN5	
13	2.000000	EA	HEXAGON NIPPLE 3/8" BSP	B 3280	985 52721-02	ISO 1338/77 ; CU PB5 SN5 ZN5	
14	1.000000	EA	PRESSURE GAUGE COCK 3/8" BSP		984 35538-00	BRASS	
15	1.000000	EA	COMPOUND GAUGE -100% - 2 BAR LB/IN2,BAR = KGF/CM2,Ø100,3/8"N	984 30285-R01	984 30285-00		
16	1.000000	EA	TEE 3/8" BSP	B 3130	985 52710-02	ISO 1338/77 ; CU PB5 SN5 ZN5	
17	.000000	EA	STEAM INJECTOR		SEE SPECIFIC.J		
18	.000000	EA	STEAM ARRANGEMENT OUTLET		PIPING PART.C		
19	.000000	EA	REDUCTION		PIPING PART.D		
20	.000000	EA	NOZZLE FOR STEAM INJECTOR		SEE SPECIFIC.N		
21	24.000000	EA	SCREW M16 X 65 DIN 933		984 40910-44	QUALITY 8.8 ; DELTA-MAGNI	
22	112.000000	EA	WASHER M16 DIN 125 A		985 32512-20	A4	

Alfa Laval Copenhagen A/S

Maskinevej 5
DK-2860 Søborg, Denmark
CVR No. 10134285
V.A.T. No. 14646647

Telephone + 45 39 53 60 00
Telefax + 45 39 53 65 68
Bank DANSKE BANK Holmens Kanal Branch
Acc. No. DKK 3100-3117-108007
Acc. No. EUR 3100-3140-854301
Acc. No. USD 3100-3116-870094

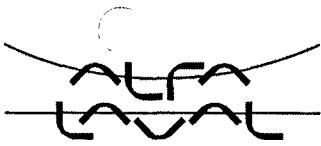

Bill Of Material

Parent item no.: 985 15594-80 R: 04	Description: MOUNTING DRAWING STEAM ARRANGEMENT DIN/ASA JWSP-26-C100/N2	Date: 20031013	Page 2 of 2
Drawing no.: 985 15594-R04		Ini DKSOABK	

BUBL	QTY	U/M	DESCRIPTION	DRAWING NO.	ARTICLE NO.	MATERIAL	REMARKS
23	56.000000	EA	NUT M16 DIN 934 HOT DIP GALVANIZED		984 40910-45	HOT DIP GALVANIZED	
24	2.000000	EA	GASKET DN100 Ø162/115 X 1,5 MM DIN 2690 PN10		985 80009-19	FERJOSEAL 2639	
25	16.000000	EA	SCREW M16 X 110 DIN 931		985 00012-43	QUALITY 8.8 ; DELTA-MAGNI	
26	2.000000	EA	GASKET DN125 Ø192/141 X 1,5 MM DIN 2690 PN10		985 80009-20	FERJOSEAL 2639	
27	1.000000	EA	GASKET DN80 Ø142/90 X 1,5 MM DIN 2690 PN10		985 80009-18	FERJOSEAL 2639	
28	1.000000	EA	CONNECTION 1/2" BSP X 8		985 00067-98	ISO 426/2/83 ; CU ZN39 PB3	
29	740.000000	MM	COPPER PIPE Ø 6/8	VVS 04 0104 008	984 40938-03	COPPER	
30	16.000000	EA	SCREW M16 X 70 DIN 933 HOT DIP GALVANIZED		985 80011-31	HOT DIP GALVANIZED	

Alfa Laval Copenhagen A/S

Maskinevej 5
DK-2860 Søborg, Denmark
CVR No. 10134285
V.A.T. No. 14646647

Telephone + 45 39 53 60 00
Telefax + 45 39 53 65 68
Bank DANSKE BANK Holmens Kanal Branch
Acc. No. DKK 3100-3117-108007
Acc. No. EUR 3100-3140-854301
Acc. No. USD 3100-3160-876794

This drawing is our property. Without our written consent it is not allowed to copy this drawing or to show it to third party. The drawing is to be returned when called for.

Denne tegning er vor ejendom og må ikke uden skriftlig tilladelse overføres til, benyttes eller kopieres af uvedkommende. Vi forbeholder os ret til at kræve tegningen returneret.

328 - (01) 58311

Rev. No.	Construction modification	constr.	check.

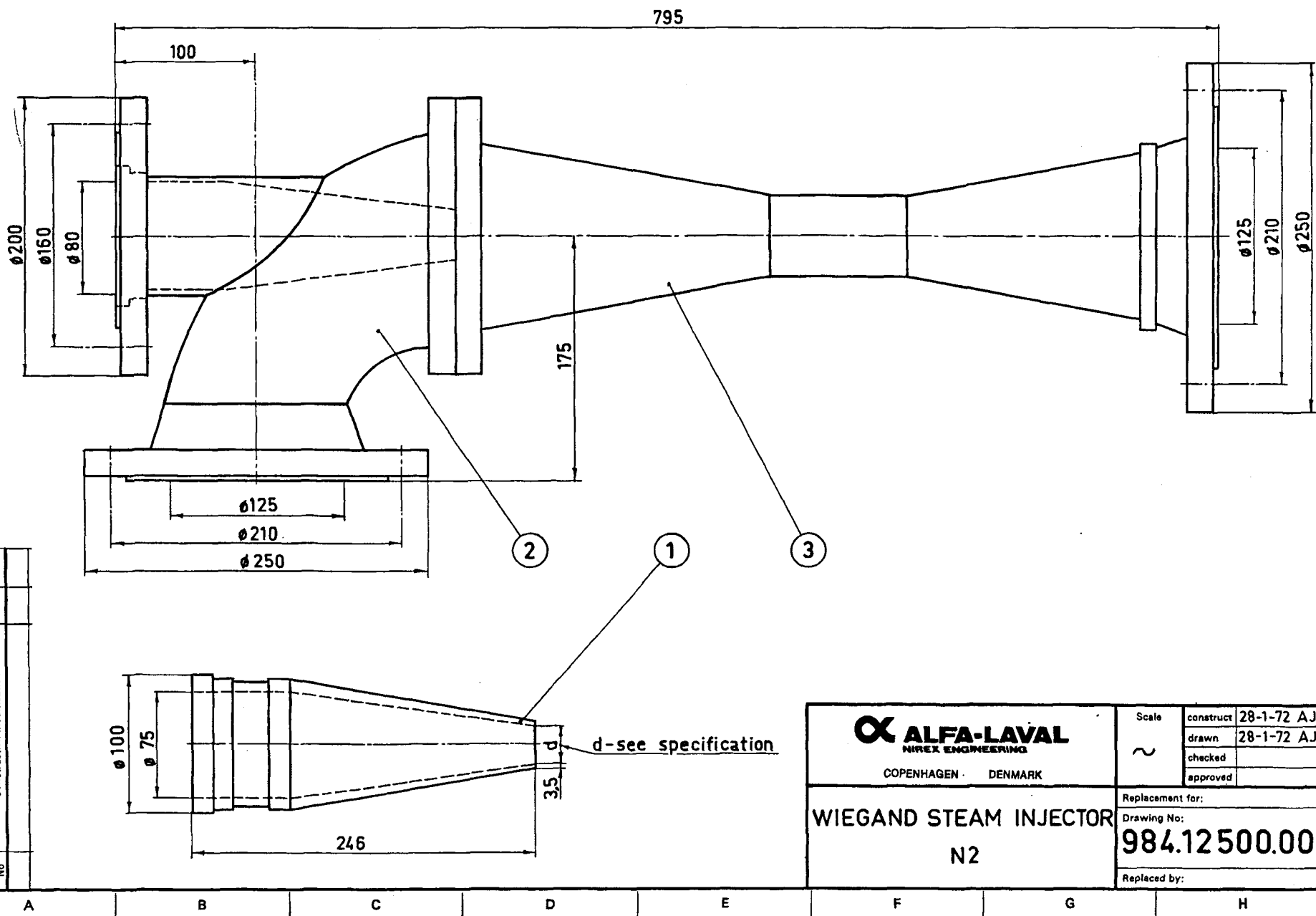

ALFA-LAVAL
NIREX ENGINEERING
COPENHAGEN · DENMARK

WIEGAND STEAM INJECTOR
N2

Scale ~	construct	28-1-72 AJ
	drawn	28-1-72 AJ
	checked	
	approved	
Replacement for:		
Drawing No: 984.12500.00		
Replaced by:		



Bill Of Material

Parent item no.: 984 12510-00 R: 00	Description: STEAM INJECTOR N 2 DIN GG20/RG5 28/45 MM	Date: 20031013	Page 1 of 1
Drawing no.: 984.12500.0		Ini DKSOABK	

BUBL	QTY	U/M	DESCRIPTION	DRAWING NO.	ARTICLE NO.	MATERIAL	REMARKS
1	1.000000	EA	INJECTOR NOZZLE Ø 28		984 12510-01	RG 5	
2	1.000000	EA	INJECTOR HOUSING DIN N2 FL.A UND B DIN 2632		984 12500-02	GG 20	
3	1.000000	EA	INJECTOR DIFFUSOR Ø 45		984 12510-03	GG 20	
4	1.000000	EA	GASKET Ø120/105 X 1,5	FJ 650	984 40942-06	NON-ASBESTOS	

Alfa Laval Copenhagen A/S

Maskinevej 5
DK-2860 Søborg, Denmark
CVR No. 10134285
V.A.T. No. 14646647

Telephone + 45 39 53 60 00
Telefax + 45 39 53 65 68
Bank DANSKE BANK Holmens Kanal Branch
Acc. No. DKK 3100-3117-108007
Acc. No. EUR 3100-3140-854301
Acc. No. USD 3100-3160-576794

984.12200.00 D.

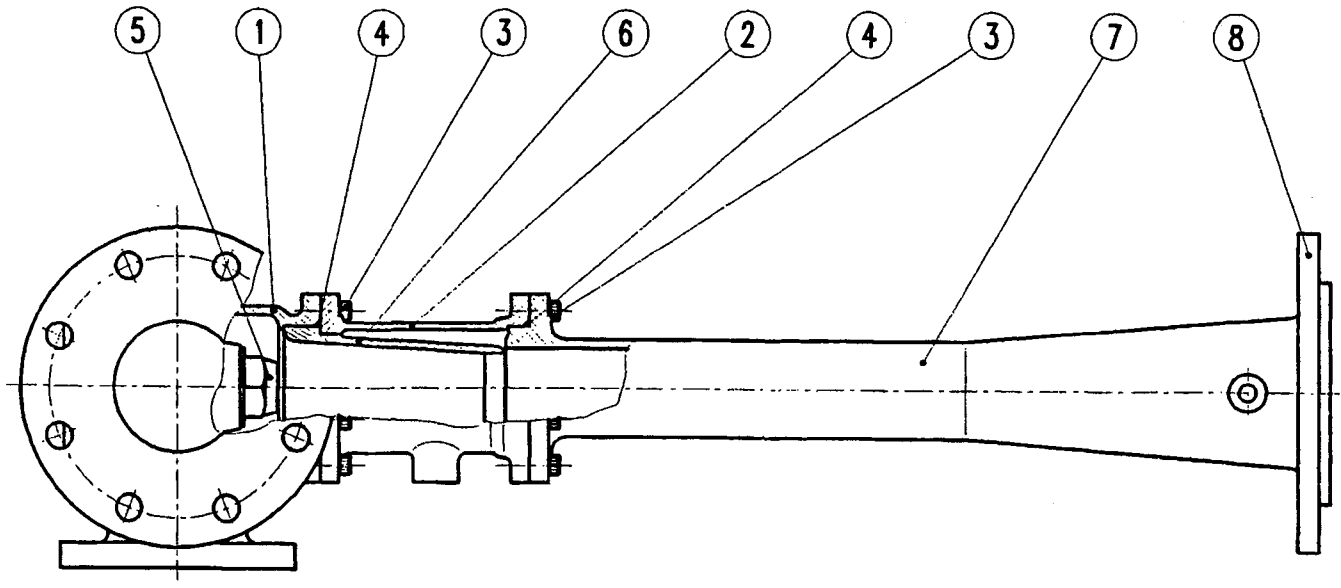

The dimensions of the lengths of the shafts
 are given in millimeters (mm) unless
 otherwise indicated. The tolerance on
 the dimensions of the shafts is
 ±0.05 mm.

985 00027-14	2
985 00008-36	2
985 00004-63	2
984 12268-00	2
984 12265-00	2
984 12272-00	2
984 12271-00	2
984 12270-00	2
984 12269-00	2
984 12268-00	2
984 12267-00	2
984 12266-00	2
984 12265-00	2
984 12264-00	2
984 12263-00	2
984 12262-00	2
984 12261-00	2
984 12259-00	2
984 12258-00	2
984 12257-00	2
984 12256-00	2
984 12255-00	2
984 12254-00	2
984 12253-00	2
984 12252-00	2
984 12251-00	2
984 12250-00	2
984 12249-00	2
984 12248-00	2
984 12247-00	2
984 12246-00	2
984 12245-00	2
984 12244-00	2
984 12243-00	2
984 12242-00	2
984 12241-00	2
984 12240-00	2
984 12239-00	2
984 12238-00	2
984 12237-00	2
984 12236-00	2
984 12235-00	2
984 12234-00	2
984 12233-00	2
984 12232-00	2
984 12231-00	2
984 12230-00	2
984 12229-00	2
984 12228-00	2
984 12227-00	2
984 12226-00	2
984 12225-00	2
984 12224-00	2
984 12223-00	2
984 12222-00	2
984 12221-00	2
984 12220-00	2
984 12219-00	2
984 12218-00	2
984 12217-00	2
984 12216-00	2
984 12215-00	2
984 12214-00	2
984 12213-00	2
984 12212-00	2
984 12211-00	2
984 12210-00	2
984 12209-00	2
984 12208-00	2
984 12207-00	2
984 12206-00	2
984 12205-00	2
984 12204-00	2
984 12203-00	2
984 12202-00	2
984 12201-00	2
984 12200-00	2

04	Art. no. 985 00027-14 added	8.07.99	RKS	AKJ	AKJ
03	Art. no. 985 00004-63 added	6.09.93	AJE	HJO	JEN
02	Art. no. 985 00008-36 added	6.02.93	AND	KIM	HFA
01	New drawing in CAD	0.02.92	AJE	HJO	EWA
Rev					
01	Revision				
02					
03					
04					
05					
06					
07					
08					
09					
10					
11					
12					
13					
14					
15					
16					
17					
18					
19					
20					
21					
22					
23					
24					
25					
26					
27					
28					
29					
30					
31					
32					
33					
34					
35					
36					
37					
38					
39					
40					
41					
42					
43					
44					
45					
46					
47					
48					
49					
50					
51					
52					
53					
54					
55					
56					
57					
58					
59					
60					
61					
62					
63					
64					
65					
66					
67					
68					
69					
70					
71					
72					
73					
74					
75					
76					
77					
78					
79					
80					
81					
82					
83					
84					
85					
86					
87					
88					
89					
90					
91					
92					
93					
94					
95					
96					
97					
98					
99					
100					



Bill Of Material

Parent item no.: 984 12263-00 R: 04	Description: COMBINED BRINE/AIR EJECTOR BRINE/AIR EJECTOR 26,1/39,4/46,1 DIN	Date: 20031013	Page 1 of 1
Drawing no.: 984.12200.00		Ini DKSOABK	

BUBL	QTY	U/M	DESCRIPTION	DRAWING NO.	ARTICLE NO.	MATERIAL	REMARKS
1	1.000000	EA	EJECTOR HOUSING		984 12215-10	RG 5	
2	1.000000	EA	EJECTOR INTERMEDIATE HOUSING		984 12215-20	RG 5	
3	16.000000	EA	SCREW M8 X 30 DIN 912	HFC 1790	984 40908-08	ISO 683/13/86 ; TYPE 20A	
4	2.000000	EA	O-RING 85.32 X 3.53		984 40999-02	NITRIL	
5	1.000000	EA	EJECTOR NOZZLE Ø 26.1		984 12263-40	AISI 329	
6	1.000000	EA	EJECTOR NOZZLE Ø 39.4		984 12263-50	RG 5	
7	1.000000	EA	DIFFUSOR Ø 46.1 MM		984 12263-70	RG 5	
8	1.000000	EA	FLANGE DIN Ø220/130 X 18		984 12215-80	ST.00	

Alfa Laval Copenhagen A/S

Maskinvej 5
DK-2860 Søborg, Denmark
CVR No. 10134285
V.A.T. No. 14646647

Telephone + 45 39 53 60 00
Telefax + 45 39 53 65 68
Bank DANSKE BANK Holmens Kanal Branch
Acc. No. DKK 3100-3117-108007
Acc. No. EUR 3100-3140-854301
Acc. No. USD 3100-3101-657694

Only to the extent expressly agreed by us this document may constitute a contractual obligation on our part.

This document and its contents are our exclusive property and must not be copied, reproduced, transmitted or communicated to any other party or used for purposes not expressly permitted by us.

Rev. 02
 Drawing no. 984.10230.00

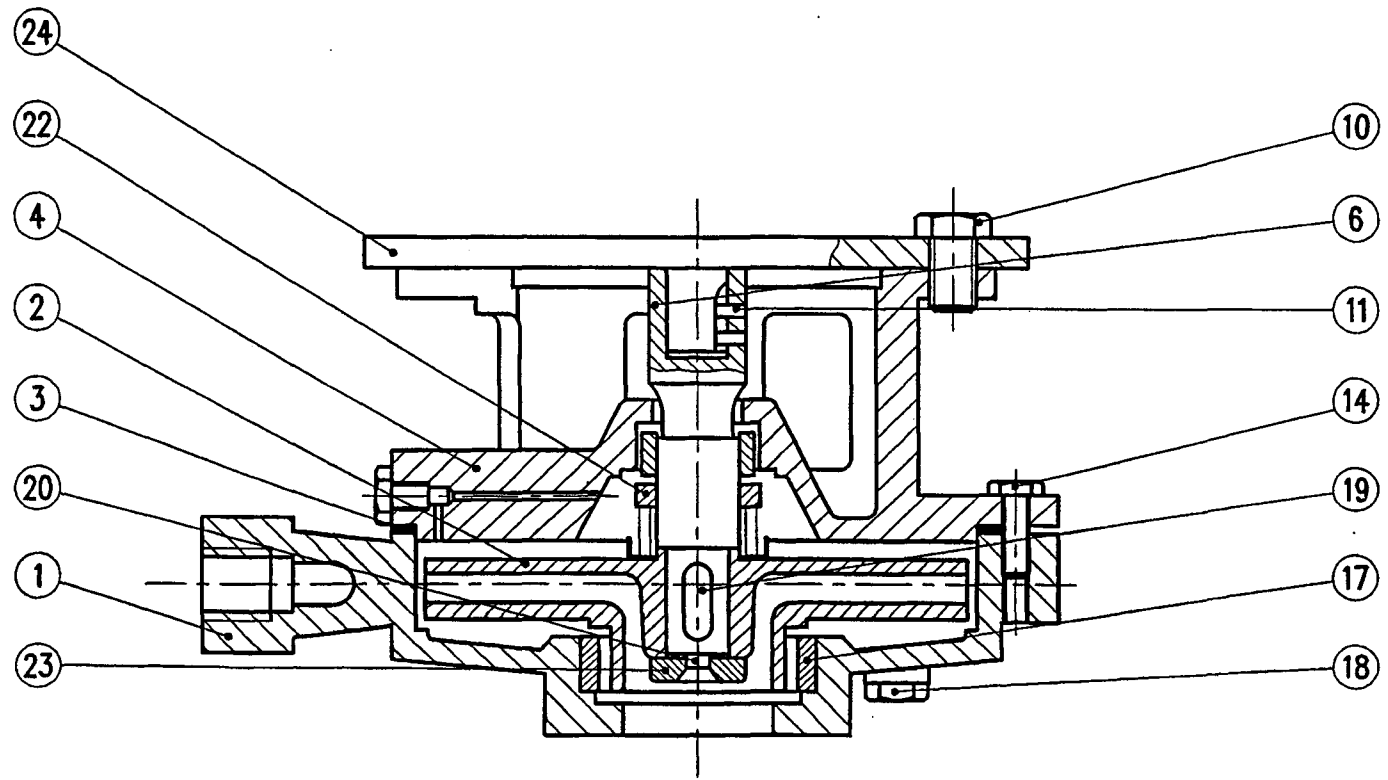

985 00027-60	2
985 00025-83	2
984.10270.00	2
984.10262.00	2
984.10255.00	2
984.10254.00	2
984.10253.00	2
984.10252.00	2
984.10241.00	2
984.10240.00	2
984.10231.00	2
984.10230.00	2

02	ART.NO.985 00025-83&0027-60 AD	281195	BGU	RP	RB
01	New drawing in CAD	29.02.92	AJE	HJO	EWA
Rev. no.	Revision	Date	Revised	Reviewed	Approved
Title		 Alfa Laval Alfa Laval Desalt A/S COPENHAGEN DENMARK			
Date	27.06.84	Drawn	AJ	Reviewed	Approved
ISO method E	Scale	Weight	X	Repl. for 984.10230.00 rev. 01	
CAD	Basic drawing no.	rev.	Drawing No. 984.10230.00		
Repl. by		rev.			



Bill Of Material

Parent item no.: 984 10253-00 R: 02	Description: FRESHWATER PUMP PVVF-2040.2X-012 35 L/MIN, 28 MWC, 3360 R	Date: 20031013	Page 1 of 1
Drawing no.: 984.10230.00		Ini DKSOABK	

BUBL	QTY	U/M	DESCRIPTION	DRAWING NO.	ARTICLE NO.	MATERIAL	REMARKS
1	1.000000	EA	HOUSING INCL. ITEM 3+17		984 10252-01	ISO 1338/77 ; CuPb5Sn5Zn5	
2	1.000000	EA	IMPELLER Ø 128		984 10253-02	RG 9	
3	1.000000	EA	GASKET PVVF 2040	985 13382	984 10252-03	NON-ASBESTOS	
4	1.000000	EA	COVER INCL. ITEM 3		984 10252-04	ISO 1338/77 ; CuPb5Sn5Zn5	
6	1.000000	EA	SHAFT COMPLETE		984 10230-05	AISI 316	
10	4.000000	EA	SCREW M8 X 16 DIN 933 KVAL. 8.8	HFC 473	984 40908-11	HARDENED STEEL ; EL. ZINCED	
11	2.000000	EA	SCREW M5 X 8 DIN 916	HFC 710	984 40905-03	STEEL ; KVAL. 45 H	
14	4.000000	EA	*SCREW M10 X 25 (SET) KVAL. 8.8	HFC 473	984 40910-03	HARDENED STEEL ; EL. ZINCED	
17	1.000000	EA	SEAL RING		984 10252-06	ISO 1338/77 ; CuPb5Sn5Zn5	
18	2.000000	EA	+ *PLUG 1/8" BSP UDGÆT. ERST. AF 984 10030-87	EV 109 B	984 40941-15	ISO 426/2/83 ; CU ZN39 PB3	
19	1.000000	EA	KEY 4 X 4 X 15		984 10230-07	ISO 683/13/86 ; TYPE 20A	
20	1.000000	EA	SCREW M5 X 16 DIN 7991	HFC 1795	984 40905-04	ISO 683/13/86 ; TYPE 20A	
22	1.000000	EA	MECH. SEAL Ø 16		984 10230-08	316 C/CE	
23	1.000000	EA	WASHER	984 57763	984 10230-09	ISO 683/13/86 ; TYPE 20A	

Alfa Laval Copenhagen A/S

Maskinevej 5
DK-2860 Søborg, Denmark
CVR No. 10134285
V.A.T. No. 14646647

Telephone + 45 39 53 60 00
Telefax + 45 39 53 65 68
Bank DANSKE BANK Holmens Kanal Branch
Acc. No. DKK 3100-3117-108007
Acc. No. EUR 3100-3140-854301
Acc. No. USD 3100-3116-576294
www.alfalaval.com

This drawing is our property. Without our written consent it is not allowed to copy, the drawing or to show it to third party. The drawing is to be returned when called for.

Denne tegning er vor ejendom og må ikke uden skriftlig tilladelse overlades til, benyttes eller kopieres af uvedkommende. Vi forbeholder os ret til at kræve tegningen returneret.

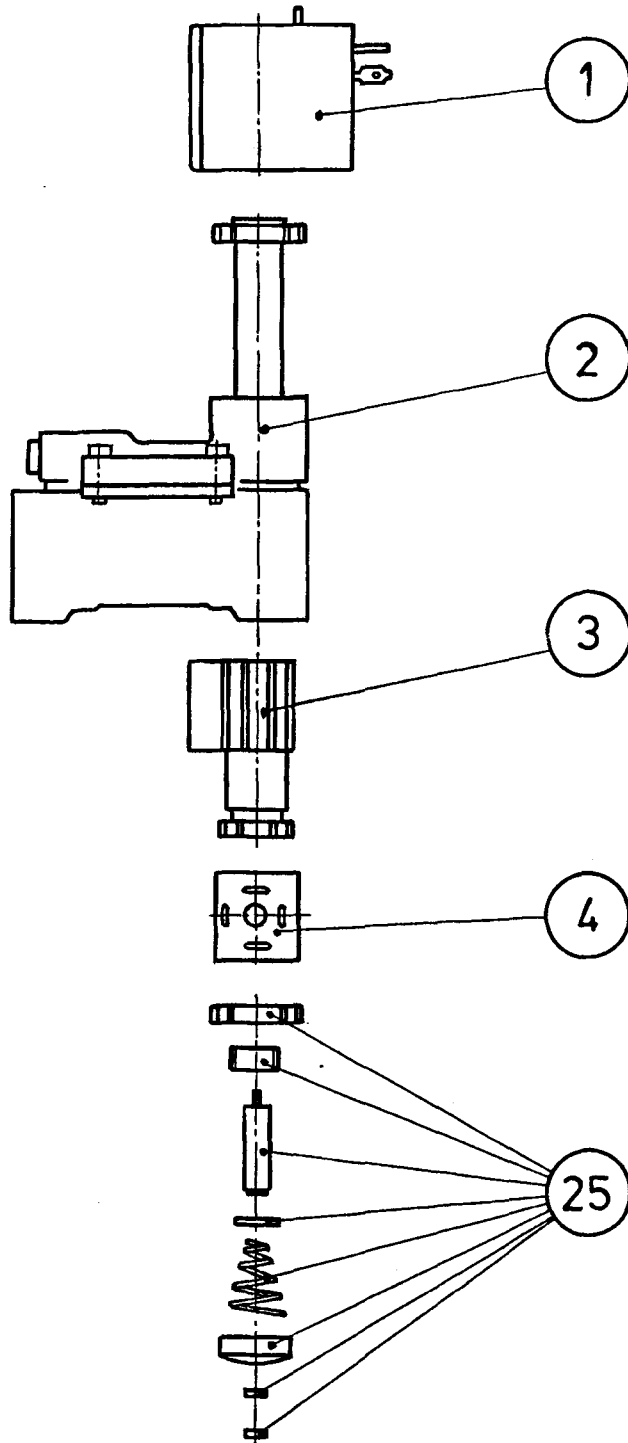

 ALFA-LAVAL NIREX ENGINEERING COPENHAGEN DENMARK	Scale	construct	
		drawn	14.11.86 AJ
SOLENOID VALVE DANFOSS	Replacement for: Drawing No: 984.23482.00	checked	14.11.86 JKP
		revised	
		Replaced by:	

1255 Tulein & Koch 01-13 36 30



Bill Of Material

Parent item no.: 984 23486-00 R: 01	Description: SOLENOID VALVE 1/2" EV220B 15 220V 50/60 CS NO (EVSI 15)	Date: 20031013	Page 1 of 1
Drawing no.: 984.23482.0		Ini DKSOABK	

BUBL	QTY	U/M	DESCRIPTION	DRAWING NO.	ARTICLE NO.	MATERIAL	REMARKS
1	1.000000	EA	COIL FOR SOLENOID VALVE 230V 50/60 CS		984 23480-01		
2	1.000000	EA	SOLENOID VALVE NO EV220B 15 (EVSI 15)		985 58810-18		
3	1.000000	EA	SEAL KIT N.O. FOR SOLENOID VALVE N.O.		985 00062-05		
25	.000000	EA	SPARE PART SET 1/2" NO		984 23486-25		

Alfa Laval Copenhagen A/S

Maskinvej 5
DK-2860 Søborg, Denmark
CVR No. 10134285
V.A.T. No. 14646647

Telephone + 45 39 53 60 00
Telefax + 45 39 53 65 68
Bank DANSKE BANK Holmens Kanal Branch
Acc. No. DKK 3100-3117-108007
Acc. No. EUR 3100-3140-854301
Acc. No. USD 3100-3016-576794
www.alfalaval.com

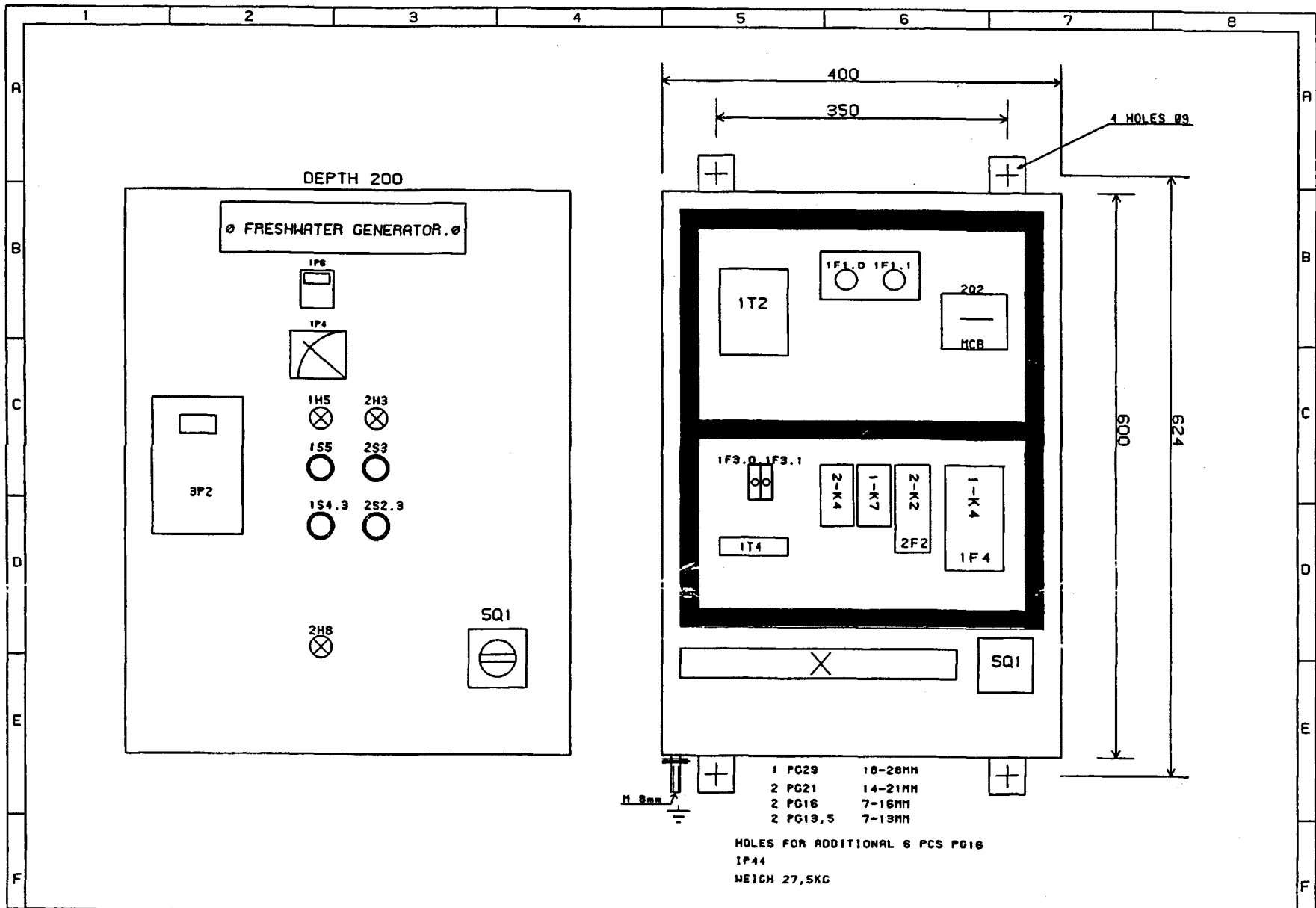

TYPE FRESHWATER GENERATOR.
ARRANGEMENT DRAWING.



DATO 07/03-95
SIGN. OZA

DRAWING NO. 985 16646 R:01



Bill Of Material

Parent item no.: 985 00034-85 R: 02	Description: CONTROL PANEL - FWG - OPT. A (DIAGR: 985 16645) 220/380/440V - 220V	Date: 20031013	Page 1 of 2
Drawing no.: 985 16646		Ini DKSOABK	

BUBL	QTY	U/M	DESCRIPTION	DRAWING NO.	ARTICLE NO.	MATERIAL	REMARKS
10	1.000000	EA	BOX 400 X 600 X 200		984 21625-20	2490	
20	1.000000	EA	+MAIN SWITCH OETL 63 K3		984 21622-82	6289	5Q1
30	1.000000	EA	+HANDLE OETL ZX104/150		984 21622-83		5Q1
40	3.000000	EA	AUX. CONTACT CA5-10 HJÆLPEKONTAKT FOR A9-A110-N		984 21621-80	5096	1K4,2K2
50	2.000000	EA	AUX. CONTACT CA5-01 HJÆLPEKONTAKT FOR A9-A110-N		984 21621-81	5095	1K4,2K2
60	1.000000	EA	CONTACTOR A9 220V/50-60CS A9 220-230/230-240 50/60CS		984 21620-02	362	2K2
70	1.000000	EA	CONTACTOR.		SEE SPECIFIC.CO		1K4
80	1.000000	EA	THERMAL RELAY TA25 (1.3-1.8A) TA25		984 21621-01	5252	2F2.0
90	1.000000	EA	THERMAL RELAY.		SEE SPECIFIC.TR		1K4
120	2.000000	EA	FUSE CAP KII 5SH 112		984 21624-61	121	1F1.0,1F1.1
130	2.000000	EA	FUSE 6A DZ II 6A DZ II		984 21624-44	182	1F1.0,1F1.1
141	1.000000	EA	+NO FUSE BREAKER C60H/C 6A 3PO C60H/C 6A 3POL ' MERLIN GERIN		985 00022-80	24998	2Q2
160	1.000000	EA	+*UNIVERSAL TRANSFORMER		985 00013-47		1T2
170	3.000000	EA	BULB FOR PILOT LAMP 240V 220-240V		984 21622-01	4494	1H5,2H3,2H8
180	2.000000	EA	GLASS FOR PILOT LAMP (GREEN)		984 21622-02	4621	1H5,2H3
190	1.000000	EA	GLASS FOR PILOT LAMP (WHITE)		984 21622-03	5232	2H8
200	2.000000	EA	PUSH BUTTON (ON)		984 21622-30	4489	1S5,2S3
210	2.000000	EA	PUSH BUTTON (OFF)		984 21622-31	4490	1S4.3,2S2.3
220	2.000000	EA	PLATE FOR PUSH BUTTON (GREEN)		984 21622-40	4618	1S5,2S3
230	2.000000	EA	PLATE FOR PUSH BUTTON (RED)		984 21622-41	4617	1S4.3,2S2.3
240	2.000000	EA	FUSE 1A 143-241 5X20MM 143-241 RUDOLPH SCHMIDT		985 00016-25		1F3.0,1F3.1
276	2.000000	EA	AUX.RELAY N22E 220-240V50/60CS N22E 220-230V/230-240V 50/60CS		984 21620-92	3538	1K7,2K4
390	1.000000	EA	SALINOMETER DS-20 MUNSELL 7.5		984 22510-00	7443	3P2

Alfa Laval Copenhagen A/S

Maskinvej 5
DK-2860 Søborg, Denmark
CVR No. 10134285
V.A.T. No. 14646647

Telephone + 45 39 53 60 00
Telefax + 45 39 53 65 68
Bank DANSKE BANK Holmens Kanal Branch
Acc. No. DKK 3100-3117-108007
Acc. No. EUR 3100-3140-854301
Acc. No. USD 3100-3116-576294



Bill Of Material

Parent item no.: 985 00034-85 R: 02	Description: CONTROL PANEL - FWG - OPT. A (DIAGR: 985 16645) 220/380/440V - 220V	Date: 20031013	Page 2 of 2
Drawing no.: 985 16646		Ini DKSOABK	

BUBL	QTY	U/M	DESCRIPTION	DRAWING NO.	ARTICLE NO.	MATERIAL	REMARKS
411	1.000000	EA	A-METER EQ72 0-50/5-250A		984 21623-21	6197	1P4
412	1.000000	EA	+CURRENT TRANSFORMER. 50/5A CELSA IBA ACL 9000018		985 00014-90		1T4
413	1.000000	EA	HOUR COUNTER 230V-50/60HZ UL BAUSER 633 UL.		984 21623-43	6494	1P6

Alfa Laval Copenhagen A/S

Maskinevej 5
DK-2860 Søborg, Denmark
CVR No. 10134285
V.A.T. No. 14646647

Telephone + 45 39 53 60 00
Telefax + 45 39 53 65 68
Bank DANSKE BANK Holmens Kanal Branch
Acc. No. DKK 3100-3117-108007
Acc. No. EUR 3100-3140-854301
Acc. No. USD 3100-3116-576294

984.10.302.00

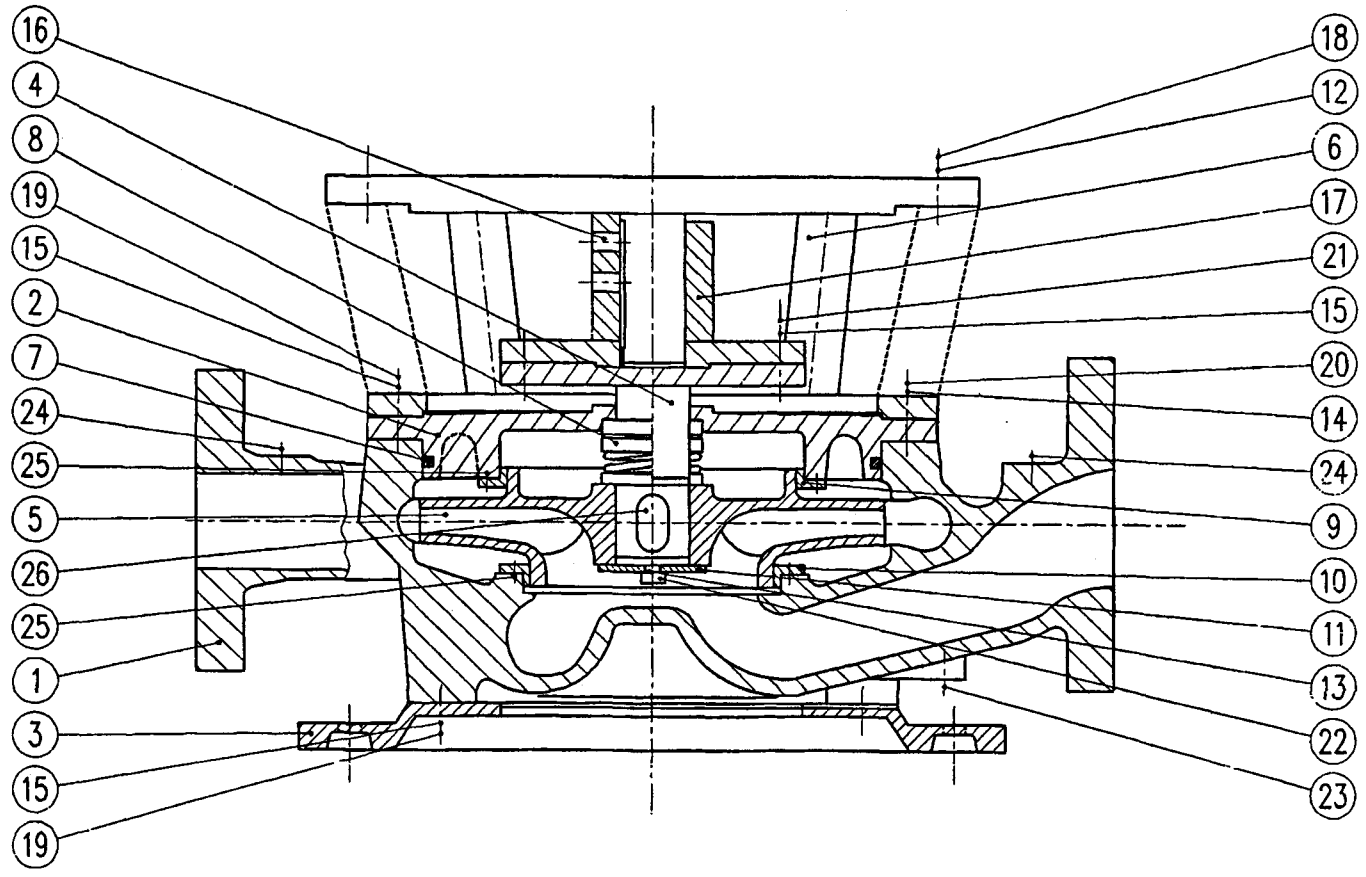

985 00009-89	3
985 00009-16	3
985 00005-51	3
985 00005-12	3
985 00004-59	3
985 20004-35	3
985 00004-54	3
985 00003-31	3
985 00002-12	3
984 10422-00	3
984 10407-00	3
984 10395-00	3
984 10394-00	3
984 10392-00	3
984 10383-00	3
984 10372-00	3
984 10370-00	3
984 10358-00	3
984 10357-00	3
984 10356-00	3
984 10355-00	3
984 10354-00	3
984 10353-00	3
984 10347-00	3
984 10346-00	3
984 10345-00	3
984 10340-00	3
984 10339-00	3
984 10338-00	3
984 10337-00	3
984 10336-00	3
984 10335-00	3
984 10334-00	3
984 10332-00	3
984 10326-00	3
984 10325-00	3
984 10324-00	3
984 10321-00	3
984 10319-00	3
984 10317-00	3
984 10316-00	3
984 10315-00	3
984 10313-00	3
984 10312-00	3
984 10311-00	3
984 10309-00	3
984 10308-00	3
984 10307-00	3
984 10306-00	3
984 10305-00	3
984 10304-00	3
984 10303-00	3
984 10302-00	3

06	New article no. added	6.09.93	ANO	AJE	JL
05	New article no. added	7.11.92	ANO	AJE	HJO
04	New article no. added	6.10.92	ANO	LS	HJO
03	New article no. added	31.08.92	FJO	ANO	EWA
02	New article no. added	29.06.92	SJO	ANO	EWA
01	New drawing in CAD	23.10.93	AJE	HJO	EWA
00					

EJECTOR PUMP

ENL-200

Alfa Laval Limited A/S
 Alfa Laval Street A/S
 Denmark

27.01.98
 CAD

984.10.302.00 Rev. 05
984.10.302.00



Bill Of Material

Parent item no.: 985 00025-26 R: 00	Description: EJECTOR PUMP (STAINL.ST.IMP.) CNL-80-80/200 DIN/JIS 3500RP 70/88 M3/H, 42/38 MWC,	Date: 20031013	Page 1 of 2
Drawing no.: 984.10302.00		Ini DKSOABK	

BUBL	QTY	U/M	DESCRIPTION	DRAWING NO.	ARTICLE NO.	MATERIAL	REMARKS
1	1.000000	EA	HOUSING INCL. ITEM 7+10+25		984 10308-01	RG 10	
2	1.000000	EA	COVER INCL. ITEM 7+9+25 241880112		984 10302-02	ISO 1338/77 ; CuSn10Zn2	
3	1.000000	EA	BASE		984 10301-03	ISO 185/61 ; GRADE 250	
4	1.000000	EA	SHAFT COMPLETE ITEM 11+13+15+21+22+26		984 10302-04	AISI 329	
5	1.000000	EA	IMPELLER Ø 168		985 00025-12	AISI 316	
6	1.000000	EA	MOTOR BRACKET		984 10306-06	ISO 185/61 ; GRADE 250	
7	1.000000	EA	O-RING		984 40999-03	NITRIL	
8	1.000000	EA	MECH. SEAL Ø 35		984 10724-11	316 C/CE	
9	1.000000	EA	WEAR RING INCL. SCREWS		984 10301-14	AL.BRZ.	
10	1.000000	EA	WEAR RING INCL. SCREWS		984 10301-15	AL.BRZ.	
11	1.000000	EA	WASHER		984 10301-16	AISI 329	
12	4.000000	EA	SPRING WASHER Ø16	HFC 1837 I	984 40901-12	ISO 683/13/74 ; TYPE 11	
13	1.000000	EA	SPRING WASHER Ø12	HFC 1842	984 40901-18	ISO 683/13/86 ; TYPE 20A	
14	4.000000	EA	SPRING WASHER Ø8	HFC 1837 I	984 40901-15	ISO 683/13/74 ; TYPE 11	
15	15.000000	EA	*SPRING WASHER Ø10 ISO 887/83	HFC 1837 I	984 40901-14	ISO 683/13/74 ; TYPE 11	
16	2.000000	EA	SCREW M10 X 12 DIN 916	HFC 1792	984 40910-22	ISO 683/13/86 ; TYPE 20A	
17	1.000000	EA	COUPLING INCL. POINTED SCREWS		984 10336-07	AL.BRZ.	
18	4.000000	EA	+ *SET SCREW M16 X 40	HFC 1886	984 40916-20	ISO 683/13/74 ; TYPE 11	
19	11.000000	EA	SCREW M10 X 35 DIN 912	HFC 1790	984 40910-13	ISO 683/13/86 ; TYPE 20A	
20	4.000000	EA	SCREW M8 X 20 DIN 912	HFC 1790	984 40908-06	ISO 683/13/86 ; TYPE 20A	
21	4.000000	EA	*SET SCREW M10 X 30	HFC 1886	984 40910-23	ISO 683/13/74 ; TYPE 11	
22	1.000000	EA	SCREW M12 X 30 DIN 912	HFC 1790	984 40912-15	ISO 683/13/86 ; TYPE 20A	
23	1.000000	EA	PLUG 3/8" BSP	FTHPT	984 40944-03	ISO 683/13/86 ; TYPE 20A	

Alfa Laval Copenhagen A/S

Maskinvej 5
DK-2860 Søborg, Denmark
CVR No. 10134285
V.A.T. No. 14646647

Telephone + 45 39 53 60 00
Telefax + 45 39 53 65 68
Bank DANSKE BANK Holmens Kanal Branch
Acc. No. DKK 3100-3117-108007
Acc. No. EUR 3100-3140-854301
Acc. No. USD 3100-3016-576794



Bill Of Material

Parent item no.: 985 00025-26 R: 00	Description: EJECTOR PUMP (STAINL.ST.IMP.) CNL-80-80/200 DIN/JIS 3500RP 70/88 M3/H, 42/38 MWC,	Date: 20031013	Page 2 of 2
Drawing no.: 984.10302.00		Ini DKSOABK	

BUBL	QTY	U/M	DESCRIPTION	DRAWING NO.	ARTICLE NO.	MATERIAL	REMARKS
24	2.000000	EA	PLUG 1/4" BSP	FTHPT	984 40944-04	ISO 683/13/86 ; TYPE 20A	
25	6.000000	EA	SCREW M5 X 12 DIN 963	HFC 1710	984 40905-06	ISO 683/13/86 ; TYPE 20A	
26	1.000000	EA	KEY 8 X 7 X 30		984 10724-16	AISI 316	

Alfa Laval Copenhagen A/S

Maskinevej 5
DK-2860 Søborg, Denmark
CVR No. 10134285
V.A.T. No. 14646647

Telephone + 45 39 53 60 00
Telefax + 45 39 53 65 68
Bank DANSKE BANK Holmens Kanal Branch
Acc. No. DKK 3100-3117-108007
Acc. No. EUR 3100-3140-854301
Acc. No. USD 3100-3101-6576794

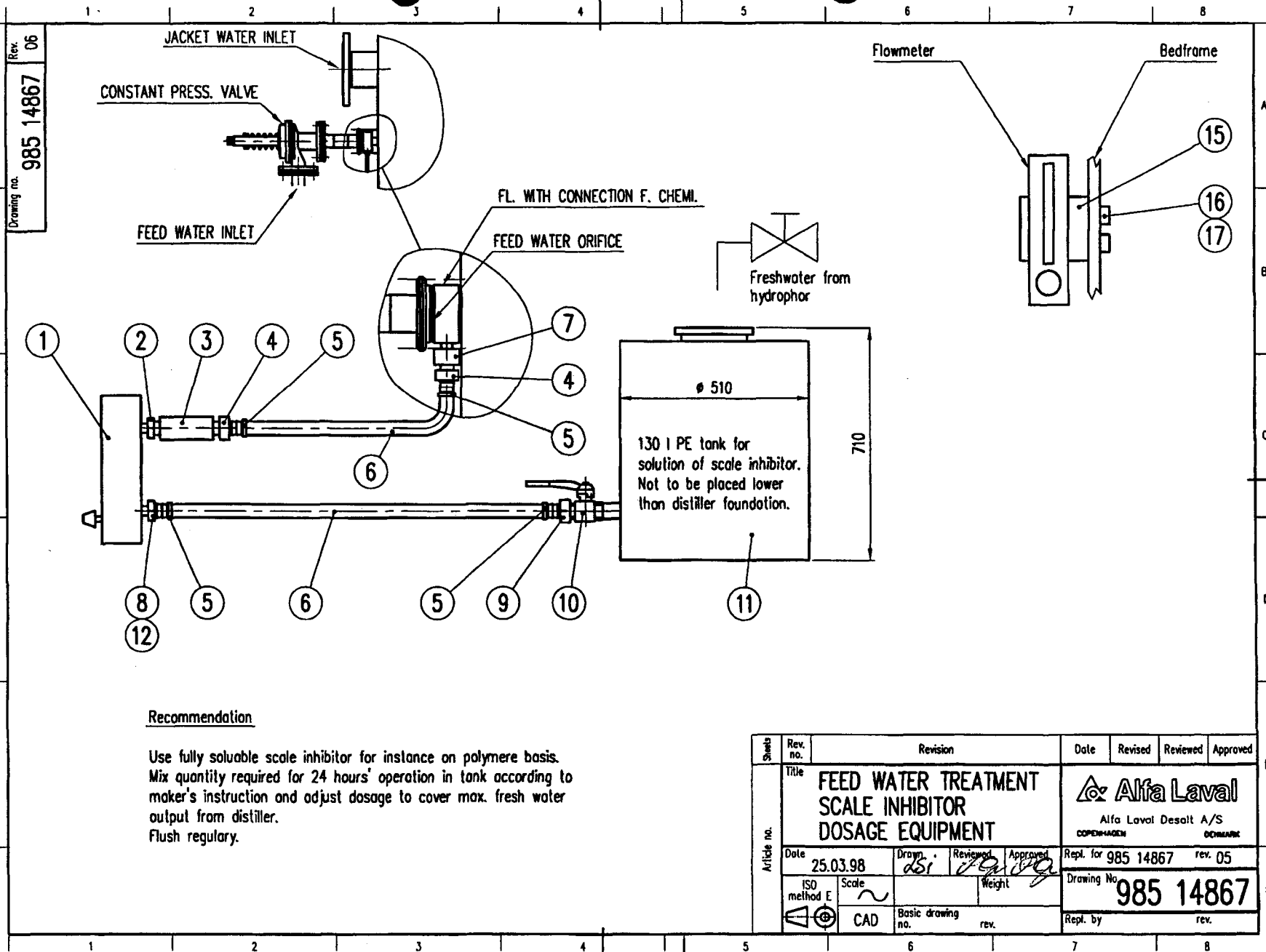

Rev. 06
 Drawing no. 985 14867

Only to the extent expressly
 agreed by us this document
 may constitute a contractual
 obligation on our part.

This document and its contents are our exclusive
 property and must not be copied, reproduced,
 transmitted or communicated to any other party
 or used for purposes not expressly permitted by us.

Recommendation

Use fully soluble scale inhibitor for instance on polymere basis.
 Mix quantity required for 24 hours' operation in tank according to
 maker's instruction and adjust dosage to cover max. fresh water
 output from distiller.
 Flush regulary.

Sheet	Rev. no.	Revision			Date	Revised	Reviewed	Approved
Article no.	Title				 Alfa Laval Desalt A/S COPENHAGEN DENMARK			
	FEED WATER TREATMENT SCALE INHIBITOR DOSAGE EQUIPMENT							
	Date	25.03.98	Drawn	dsi	Reviewed	Approved	Repl. for	985 14867 rev. 05
	ISO method E	Scale	~	Weight	Drawing No. 985 14867			
CAD		Basic drawing no.	rev.	Repl. by		rev.		



Bill Of Material

Parent item no.: 985 14867-80 R: 06	Description: FEED WATER TREATMENT, SCALE INHIBITOR DOSAGE EQUIPMENT P-26-C/D-PU-36-C	Date: 20031013	Page 1 of 1
Drawing no.: 985 14867		Ini DKSOABK	

BUBL	QTY	U/M	DESCRIPTION	DRAWING NO.	ARTICLE NO.	MATERIAL	REMARKS
	3.000000	EA	CABLE TIE 2,5 X 144 MM		985 00024-89		MOUNTED ON FWG
1	1.000000	EA	FLOWMETER INCL. REG. VALVE TILSLUTNING 1/8 NPT	985 20164-R00	985 00037-66	ACRYL	MOUNTED ON FWG
2	1.000000	EA	NIPPLE 3/8" BSP X 1/8" BSP	EV 206 B	984 40941-40	ISO 426/2/83 ; CU ZN39 PB3	MOUNTED ON FWG
3	1.000000	EA	NON RETURN VALVE 3/8" BSP		984 35623-00	BRASS	MOUNTED ON FWG
4	2.000000	EA	HOSE CONNECTION 3/8" BSP X 12	EV 265-2	984 40941-28	ISO 426/2/83 ; CU ZN39 PB3	MOUNTED ON FWG
5	4.000000	EA	HOSE CLIP		984 35543-00	ST.37	2PCS MOUNTED ON FWG
6	4.000000	ME	HOSE 3/8"		984 09607-01	Reinforced PVC-materiale	1PCS = 2ME
8	1.000000	EA	HOSE CONNECTION 1/8" BSP X 12	EV 265-1	984 40941-26	ISO 426/2/83 ; CU ZN39 PB3	MOUNTED ON UNIT
9	1.000000	EA	HOSE CONNECTION 1/2" BSP X 12	EV 265-3	984 40941-27	ISO 426/2/83 ; CU ZN39 PB3	
10	1.000000	EA	VALVE 1/2" BSP	VVS 744004 204	984 35542-00	RG 5	
11	1.000000	EA	TANK 130 L		985 00004-51	PE	
15	1.000000	EA	SUPPORT FOR FLOWMETER	985 18092	985 18092-01		MOUNTED ON FWG
16	2.000000	EA	SCREW M6 X 16 DIN 933 ISO 4017/88		985 30010-43	ISO 683/13/86 ; TYPE 20A	MOUNTED ON FWG
17	2.000000	EA	WASHER M6 ISO 887/83		985 32510-08	A4	MOUNTED ON FWG

Alfa Laval Copenhagen A/S

Maskinevej 5
DK-2860 Søborg, Denmark
CVR No. 10134285
V.A.T. No. 14646647

Telephone + 45 39 53 60 00
Telefax + 45 39 53 65 68
Bank DANSKE BANK Holmens Kanal Branch
Acc. No. DKK 3100-3117-108007
Acc. No. EUR 3100-3140-854301
Acc. No. USD 3100-3116-874394



Bill Of Material

Parent item no.: SPARES-N-010770 R: 00	Description: SPARE PARTS FOR 1 YEAR JWSP-26-C100 DRAWING NO. 985 17909	Date: 20031013	Page 1 of 1
Drawing no.:		Ini DKSOABK	

BUBL	QTY	U/M	DESCRIPTION	DRAWING NO.	ARTICLE NO.	MATERIAL	REMARKS
	1.000000	EA	GASKET FOR FRONT COVER	984 58058-R02	984 58058-01		
	1.000000	EA	GLUÉ		984 40002-00		
	1.000000	EA	COIL FOR SOLENOID VALVE 230V 50/60 CS		984 23480-01		
	1.000000	EA	MECH. SEAL Ø 16		984 10230-08	316 C/CE	FW-PUMP
	1.000000	EA	GASKET PVVF 2040	985 13382	984 10252-03	NON-ASBESTOS	FW-PUMP
	1.000000	EA	SEAL RING		984 10252-06	ISO 1338/77 ; CuPb5Sn5Zn5	FW-PUMP
	1.000000	EA	MECH. SEAL Ø 35		984 10724-11	316 C/CE	EJ PUMP
	1.000000	EA	O-RING		984 40999-03	NITRIL	EJ PUMP
	1.000000	EA	WEAR RING INCL. SCREWS		984 10301-14	AL.BRZ.	EJ PUMP
	1.000000	EA	WEAR RING INCL. SCREWS		984 10301-15	AL.BRZ.	EJ PUMP
	1.000000	EA	BALL BEARING 6203-2Z-C3		984 20645-00		PW-MOTOR D-END
	1.000000	EA	BALL BEARING 6202 2Z-C3		985 00004-56		FW-MOTOR N-END
	2.000000	EA	BALL BEARING 6209-C3		984 20643-00		EJ MOTOR D+N END
	1.000000	EA	CONTACTOR A50 220-240V/50-60CS A50 220-230V/230-240V 50/60CS		984 21620-58	8003	
	1.000000	EA	THERMAL RELAY TA75 (29-42A) TA75 DU 42		984 21621-20	8073	
	1.000000	EA	SPAREPART FOR EL-PANEL		N-010769/70-10		

Alfa Laval Copenhagen A/S

Maskinevej 5
DK-2860 Søborg, Denmark
CVR No. 10134285
V.A.T. No. 14646647

Telephone + 45 39 53 60 00
Telefax + 45 39 53 65 68
Bank DANSKE BANK Holmens Kanal Branch
Acc. No. DKK 3100-3117-108007
Acc. No. EUR 3100-3140-854301
Acc. No. USD 3100-3116-576594

This drawing is our property. Without our written consent it is not allowed to copy the drawing or to show it to third party. The drawing is to be returned when called for.

Denne tegning er vor ejendom og må ikke uden skriftlig tilladelse overlades til, benyttes eller kopieres af uvedkommende. Vi forbeholder os ret til at kræve tegningen returneret.

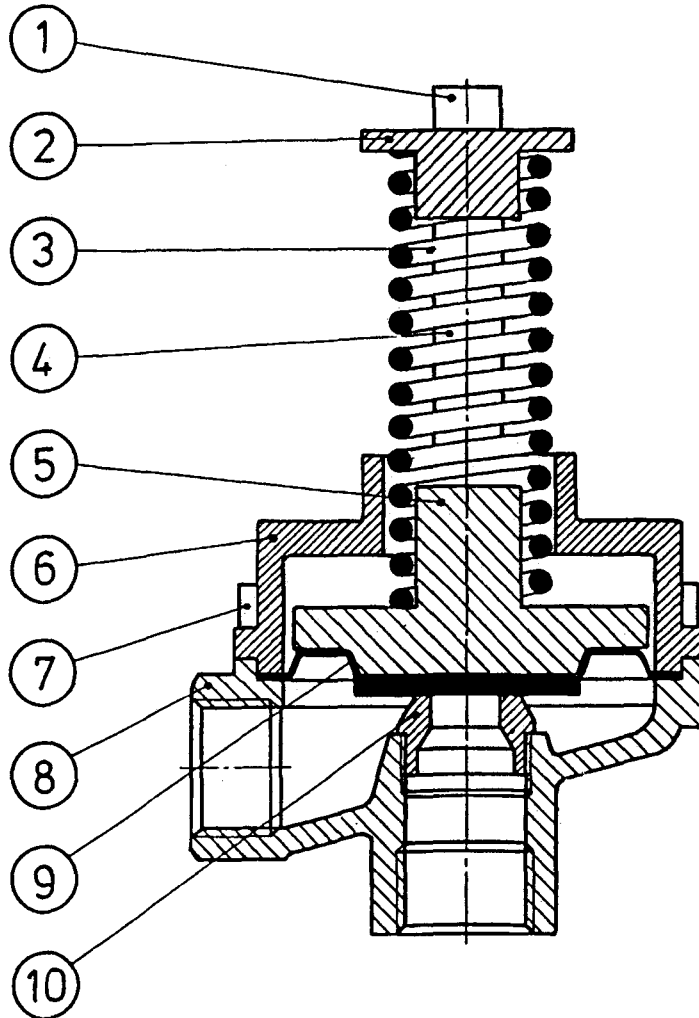

 ALFA-LAVAL NIREX ENGINEERING COPENHAGEN DENMARK	Scale	construct	
		drawn	28.9.88 AJE
		checked	
		revised	
SPRING LOADED VALVE MV-15		Replacement for:	
		Drawing No: 984.35166.00	
		Replaced by:	

1265 Tuttlein & Koch 01-13.36.30

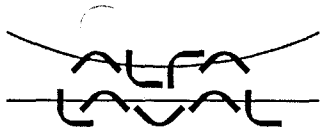

Bill Of Material

Parent item no.: 984 35166-00 R: 01	Description: SPRING LOADED VALVE MV-15-1.0	Date: 20030701	Page 1 of 1
Drawing no.: 984.35166.00		Ini DKSOABK	

BUBL	QTY	U/M	DESCRIPTION	DRAWING NO.	ARTICLE NO.	MATERIAL	REMARKS
1	2.000000	EA	SCREW M6 X 50 DIN 912	HFC 1790	984 40906-26	ISO 683/13/86 ; TYPE 20A	
2	1.000000	EA	SPRING GUIDE		984 35685-02	RG 5	
3	1.000000	EA	SPRING		984 35685-03	AISI 304	
4	1.000000	EA	DISTANCE BUSHING L=38 MM		984 35172-01	AISI 304	
5	1.000000	EA	DIAPHGRAM DISC.		984 35615-07	DELTRIN	
6	1.000000	EA	+SPRING HOUSING		984 35166-02	BRASS	
7	4.000000	EA	SCREW M6 X 12 DIN 912	HFC 1790	984 40906-14	ISO 683/13/86 ; TYPE 20A	
8	1.000000	EA	VALVE HOUSING		984 35166-03	RG 5	
9	1.000000	EA	DIAPHRAGM TYPE MVF 25	984 58197	984 35615-09		
10	1.000000	EA	VALVE SEAT		984 35166-04	DELTRIN	

Alfa Laval Copenhagen A/S

Maskinvej 5
 DK-2860 Søborg, Denmark
 CVR No. 10134285
 V.A.T. No. 14646647

Telephone + 45 39 53 60 00
 Telefax + 45 39 53 65 68
 Bank DANSKE BANK Holmens Kanal Branch
 Acc. No. DKK 3100-3117-108007
 Acc. No. EUR 3100-3140-854301
 Acc. No. USD 3100-3116-576794



Only the original copy may be used for the assembly and disassembly of the part.

This document and its contents are the exclusive property of Alfa Laval and must not be copied, reproduced, or used for purposes not expressly permitted by us.

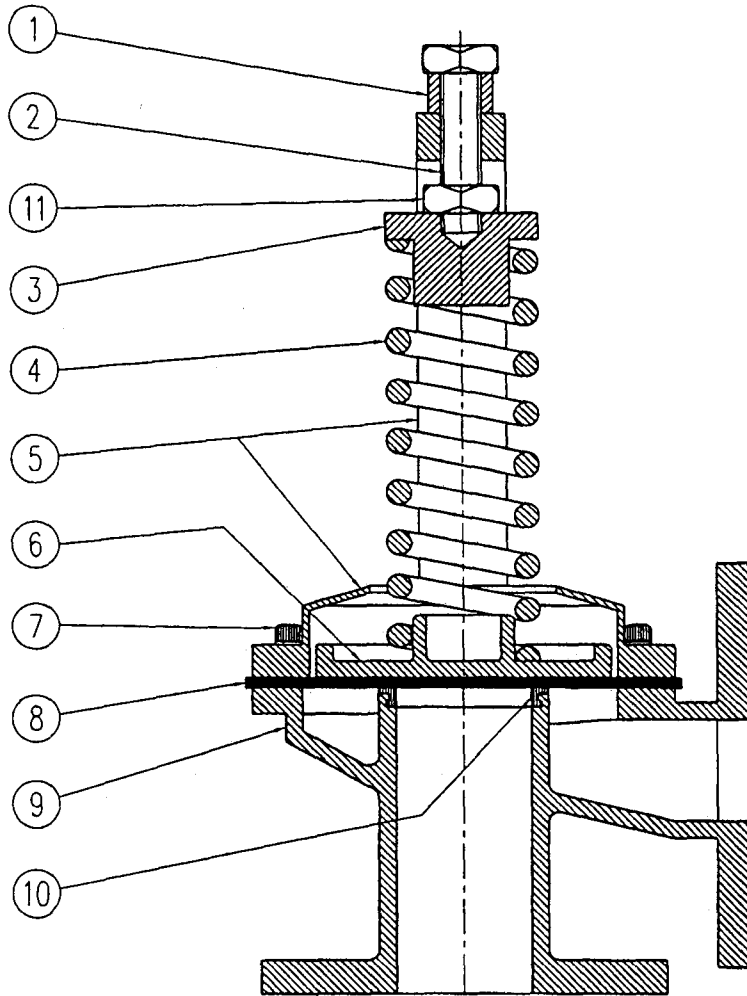

SPRING LOADED VALVE	
984 35535-00	MVF-40-2.5
984 35536-00	MVF-50-3.0

2		New drawing in CAD		26.06.03	MFN		
Rev.	Revision			Date	Revised	Reviewed	Approved
Alfa Laval Alfa Laval Copenhagen A/S DENMARK				Title Spring loaded valve MVF-40-2.5 50-3.0			
Dimensions without tolerances: DS/ISO 2768-M or ISO 13920-B		ISO method E	Scale 1:1	Project name		Project no.	
Date	Drawn	Revised	Approved	Drawing No.		Rev.	
26.06.03	MFN			984 35535		02	
Replace dwg. no.							



Bill Of Material

Parent item no.: 984 35535-00 R: 01	Description: SPRING LOADED VALVE MVF-40-2.	Date: 20030701	Page 1 of 1
Drawing no.: 984 35535-02		Ini DKSOABK	

BUBL	QTY	U/M	DESCRIPTION	DRAWING NO.	ARTICLE NO.	MATERIAL	REMARKS
1	1.000000	EA	ADJUSTING RING		984 35516-01	AISI304	
2	1.000000	EA	ADJUSTING SCREW		984 35516-02	AISI304	
3	1.000000	EA	SPRING RETAINER		984 35516-03	DELTRIN	
4	1.000000	EA	SPRING		984 35504-04	SPRING STEEL	
5	1.000000	EA	SPRING GUIDE		984 35516-05	ALU/RILSAN	
6	1.000000	EA	DIAPHRAGM WASHER		984 35516-06	ALU/RILSAN	
7	6.000000	EA	SCREW M8 X 20 DIN 912	HFC 1790	984 40908-06	ISO 683/13/86 ; TYPE 20A	
8	1.000000	EA	DIAPHRAGM		984 35504-08	EPDM	
9	1.000000	EA	VALVE HOUSING		984 35535-01	RG 5	
10	1.000000	EA	VALVE SEAT		984 35535-02	DELTRIN	
11	1.000000	EA	NUT M12 DIN 934		985 00001-71	QUALITY 8.8 ; DELTA-MAGNI	

Alfa Laval Copenhagen A/S

Maskinvej 5
DK-2860 Søborg, Denmark
CVR No. 10134285
V.A.T. No. 14646647

Telephone + 45 39 53 60 00
Telefax + 45 39 53 65 68
Bank DANSKE BANK Holmens Kanal Branch
Acc. No. DKK 3100-3117-108007
Acc. No. EUR 3100-3140-854301
Acc. No. USD 3100-3116-576794
www.alfalaval.com



TEST SHEET for Fresh water generator							
Vessel			Date			Location	
Distiller serial no.			Type			Capacity m ³ /24h	
Cleaning Schedule	No. of plates in evaporator				Date for latest cleaning		
	No. of plates in condenser				Date for latest cleaning		
Time	From						
	To						
	Difference min.						
Waterclock	To m ³						
	From m ³						
	Difference m ³						
	Total output m ³ /24h						
Evaporator Jacket water heating	Jacket water inlet °C						
	Jacket water outlet °C						
	Difference °C						
	Jacket water flow m ³ /H						
	Feed water °C						
	Boiling temperature °C						
	Vacuum %						
Evaporator Steam injector heating	Circulated water in °C						
	Circulated water out °C						
	Difference °C						
	Flow of circ.water m ³ /H						
	Feed water °C						
	Boiling temperature °C						
	Vacuum %						
	Steam pressure bar						
	Flow of steam kg/H						
Condenser	Sea water inlet °C						
	Sea water outlet °C						
	Difference °C						
	Sea water flow m ³ /H						

TEST SHEET for Freshwatergenerator								
Ejector pump	Inlet pressure	kPa						
	Discharge pressure	kPa						
Air/brine Ejector	Inlet pressure	kPa						
	Discharge pressure	kPa						
Fresh Water	Discharge pressure	kPa						
	Salinity	p.p.m.						
Other								
Comments	<div style="text-align: right; margin-top: 20px;"> <hr style="width: 20%; display: inline-block;"/> Sign. </div>							



Installation Manual for Freshwater Generator Type JWSP-26-C80/100

Serial No.: N-010770

Shipname/
Hull No.: JLZ020504

Customer: Jin Ling Shipyard

Book Number I26WSE07.fm

Alfa Laval reserve the right to make changes at any time without prior notice.

Any comments regarding possible errors and omissions or suggestions for improvement of this publication would be gratefully appreciated.

Copies of this publication can be ordered from your local Alfa Laval company.

Published by: Alfa Laval Desalt A/S
Maskinvej 5
DK-2860 Søborg
(Copenhagen) Denmark

© **Copyright Alfa Laval Desalt.**
This document and its content must not be copied, reproduced, transmitted or disclosed to any third party without consent of Alfa Laval Desalt.

Table of Contents

Safety Instructions and Warnings

1.0.0 Safety Instructions and Warnings	page 5
----------------------------------------------	--------

Storage

1.0.0 Storage	page 7
---------------------	--------

System Description

1.0.0 Working Principle	page 9
1.1.0 Freshwater Quality	page 9
1.2.0 Main Components	page 9
1.3.0 Alternative Steam	page 10

Installation

1.0.0 General Information	page 11
1.1.0 Extent of Delivery	page 11
1.2.0 Space Requirements	page 11
1.3.0 Ambient Conditions	page 11
1.4.0 Vibrations	page 11
1.5.0 Steam Quality	page 11
2.0.0 General Safety Precautions	page 11
2.1.0 Electric Equipment	page 12
2.2.0 Transportation	page 12
3.0.0 Installation Instructions	page 12
3.1.0 Jacket Water System	page 13
3.2.0 Sea Water System	page 13
3.3.0 Steam System	page 14
3.4.0 Ejector Pump	page 14
3.5.0 Brine/Cooling Water Discharge	page 15
3.6.0 Freshwater System	page 15
3.7.0 Control Panel	page 15
3.8.0 Discharge to Bilge	page 15

Salinometer

1.0.0 Salinometer DS-20	page 17
1.1.0 Electrode unit Cable Connection for Salinometer DS-20	page 17

Index

Safety Instructions and Warnings

Should you need further clarification regarding this manual, do not hesitate to contact your local Alfa Laval representative - or call Alfa Laval Desalt directly.

Telephone +45 (for Denmark) 39 53 60 00

Telefax +45 (for Denmark) 39 53 65 66

1.0.0 Safety Instructions and Warnings

The following symbols in this manual point out safety precautions. It means your attention is needed and your safety is involved.



WARNING

This symbol is used to indicate the presence of a hazard which can or will cause severe personal injury, if the warning is ignored.



CAUTION

Certain passages of the text will be marked with a caution mark. This mark indicates the presence of hazard which will or can cause property damage if the instructions are not observed.

NOTE

This type of instruction indicates a situation which, if not avoided, could result in damage to the equipment.

It is the owner's and operator's responsibility to see that any person involved with the use or operation of this equipment follow all safety instructions.

Read all safety instructions carefully and insist that they will be followed by those working with you and for you. Not following the instructions may cause severe personal injury or damage the equipment beyond repair.

Do not allow this equipment to be used if it is faulty or the operator does not understand the proper use.

Safety Instructions and Warnings



WARNING

The freshwater generator is not to be operated in polluted water or within 20 miles from the coast

Freshwater must not be produced from polluted water, as the produced water can be unsuitable for human consumption.

If manuals are translated to local language the unit comply with the EEC Machinery Directive and EN 292-1/2 standards. For EEC land installations manuals MUST be available in local language before installing and operating the unit.

The unit also comply with EN 50081-2 and EN 50082-2 "Industry" with regards to the EMC directive from EEC.



WARNING

Noise hazards

- Use ear protection in noisy environments.

Crush hazards

- Use correct lifting tools.
- Do not work under hanging load.

Burn hazard

- Wear gloves to avoid burns by hot surfaces.

Cut hazards

- Wear gloves to avoid cuts by sharp edges when handling machined parts.
- Wear helmet to avoid cuts by sharp edges during maintenance of the equipment.

NOTE

- Max. ambient temperature for the equipment is 50°C (122°F).
- Min. ambient temperature for the equipment is 0°C (32°F).

Storage

1.0.0 Storage

Unless otherwise agreed, Alfa Laval delivers the equipment ready to be put in service upon arrival and after installation.

However, should it be necessary to store the equipment for a longer period (1 month or more), certain precautions should be made in order to prevent unnecessary wear of the equipment.

Preferably, the equipment should be stored inside a room with temperature around 15°C to 20°C (59° to 68°F) and humidity around 70%.

NOTE

There should ABSOLUTELY NOT be any OZONEPRODUCING equipment in the room, like electric motors or arc-welding equipment, since ozone destroys many rubber materials (cracking).

Do not store organic solvents or acids in the room.

Avoid heat- or ultraviolet radiation.

The best solution is often to leave the equipment in the packing until it is time for installation.

In this case Alfa Laval should be informed, in order that proper preparation can be done prior to packing.

If the equipment must be stored outdoor, the precautions mention above should be taken as far as practical. The need for protection against the climate etc. is of course even more important in this case.

Also, if for any reason the equipment is closed down and taken out of service for a long period, it is advantageous to follow the advice above, even if it is not moved from the location.

The heat exchangers, pumps, piping and the separator vessel should be DRAINED and it is recommended to RINSE AND DRY the equipment by clean fresh water, before it is left for storage.

System Description

2. **Separator vessel**
The separator separates the brine from the vapour.
3. **Condenser section**
Just like the evaporator section the condenser section consists of a plate heat exchanger enclosed in the separator vessel.
4. **Combined brine/air ejector**
The ejector extracts brine and in condensable gases from the separator vessel.
5. **Ejector pump**
Normally, the ejector pump is delivered by Alfa Laval, and the ejector pump is a single-stage centrifugal pump. This pump supplies the condenser with sea water and the brine/air ejector with jet water as well as feed water for evaporation.
6. **Freshwater pump**
The freshwater pump is a single-stage centrifugal pump. The freshwater pump extracts the produced freshwater from the condenser, and pumps the water to the freshwater tank.
7. **Salinometer**
The salinometer continuously checks the salinity of the produced water. The alarm set point is adjustable.
8. **Control panel**
Normally, the control panel is delivered by Alfa Laval. It contains motor starters, running lights, salinometer, contacts for remote alarm and is prepared for start/stop.

1.3.0 Alternative Steam

1. **Steam injector**
Instead of jacket cooling water heating, saturated live steam can alternatively be used as heating medium for the freshwater generator. In the steam injector the steam transfers partly heat, partly kinetic energy to the circulating water.

The condensate produced in this circuit is transferred to the condensate well through G3.
2. **Safety valve**
If the pressure after the steam injector exceeds 1 bar g the safety valve will open to secure the vessel.
3. **Steam quality**
The steam supplied to the steam injector must be saturated steam.

System Description

1.0.0 Working Principle

The combined brine/air ejector driven by the ejector pump creates a vacuum in the system in order to lower the evaporation temperature of the feedwater.

The feedwater is introduced into the evaporator section through an orifice, and is distributed into every second plate channel (evaporation channels).

The hot water is distributed into the remaining channels, thus transferring its heat to the feedwater in the evaporation channels.

Having reached boiling temperature - which is lower than at atmospheric pressure - the feed water undergoes a partial evaporation, and the mixture of generated vapour and brine enters the separator vessel, where the brine is separated from the vapour and extracted by the combined brine/air ejector.

Having passed a demister the vapour enters every second plate channel in the condenser section.

The sea water supplied by the combined cooling/ejector water pump distributes itself into the remaining channels, thus absorbing the heat being transferred from the condensing vapour.

The produced freshwater is extracted by the freshwater pump and led to the freshwater tank.

1.1.0 Freshwater Quality

To continuously check the quality of the produced freshwater, a salinometer is provided together with an electrode unit fitted on the freshwater pump delivery side.

If the salinity of the produced freshwater exceeds the chosen maximum value, the dump valve and alarm are activated to automatically dump the produced freshwater to the bilge.

If there are no special requirements from the authorities, the produced freshwater can be used directly as drinking water.

1.2.0 Main Components

The freshwater generator consists of the following components:

1. Evaporator section

The evaporator section consists of a plate heat exchanger and is enclosed in the separator vessel.

Installation

1.0.0 General Information

1.1.0 Extent of Delivery

The extent of delivery appears from the installation (PI-) diagram, see "FWG Order Specification". The distiller is delivered as a unit which can be either bolted or welded to the floor plate.

The control panel with starters for electric motors is normally delivered separately to be fitted on site. The salinometer is delivered built into the control panel while terminals for the salinometer must be connected on site.

Please refer to installation diagram for recommended pipe dimensions.

1.2.0 Space Requirements

The space requirements are indicated on the dimensional drawings of the distiller and ejector pump, see "FWG Order Specification".

1.3.0 Ambient Conditions

When determining where to place the freshwater distiller in the engine room, due consideration must be paid to a number of ambient conditions such as vibrations, service space, allowable back pressure, and pressure loss. See also enclosed drawings.

1.4.0 Vibrations

It is recommended not to place the plant in an area known to be subjected to frequent and very high vibrations.

However, under normal engine room conditions no further precautions are necessary.

1.5.0 Steam Quality

The steam supplied to the steam injector must be saturated steam.

2.0.0 General Safety Precautions

Installation

Always handle the equipment with great care. Make sure not to damage the parts during transportation or installation.

During erection all inlets and outlets must be covered to be protected from dirt and particles.

2.1.0 Electric Equipment

All electric installations must be carried out by a professional electrician in full accordance with local regulations.

Before initial start-up

- check all connections and cables to make sure that the frequency and voltage agrees with the electrical specifications.



WARNING

Check that all connections are properly **earthened (grounded)** in accordance with local regulations, and properly **insulated**.

2.2.0 Transportation

All transportation of the equipment must be in accordance with local regulations.

The freshwater distiller must be lifted using lifting brackets as illustrated on drawing (See FWG Order Specification).



WARNING

Make sure that the straps have the required breaking strength to lift the unit in empty condition. See weight in dimension drawing (FWG Order Specification).

3.0.0 Installation Instructions

The distiller should be mounted according to diagram "Vertical plant positioning", see "FWG Order Specification".

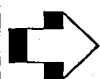

CAUTION

The pump/motor must be mounted vertically.

The ejector pump is not self-priming and must be mounted below lowest water line.

Pressure on suction side of ejector pump under working conditions must be minus 0.2 bar g minimum.

3.1.0 Jacket Water System

The branches for jacket water inlet and outlet to the evaporator section are marked C3 and C4, respectively. They should be connected to the jacket water system according to the PI-diagram, see "FWG Order Specification".

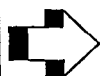

CAUTION

A thermometer must be fitted 0.5 m from branch C3 and branch C4 respectively.

3.2.0 Sea Water System

The sea water supplied to the unit has to pass a filter (Yard supply) in the sea water line before the ejector pump.

Fresh water generator type:	Filter mesh size:
D-PU-36-CAS100/125	3 - 3.5 mm
JWSP-26-C80/100	1 - 1.5 mm
JWSP-16-C40/50	1 mm

Installation



CAUTION

Pressure on suction side of ejector pump under working conditions must be minus 0.2 bar g minimum including pressure drop over filter.

The branch for sea water (cooling water) inlet to the condenser is marked C1. This branch has to be connected to the ejector pump according to the PI- diagram.



CAUTION

A thermometer must be fitted 0.5 m from branch C1.

3.3.0 Steam System

The branch for steam inlet is marked G1 and has to be connected to the steam system.



CAUTION

The outlet of the safety valve G16 should be led to a safe area. No valve at all must be fitted at the outlet line from the safety valve.

The steam condensate is led back to the condensate well through G3.

Max. back pressure in the condensate discharge line is 80 kPa (0,8 bar g)

- Fit a drain pipe at G4

To fill the system, a freshwater priming pipe should be connected from G2 to the ship's hydrophone system.

3.4.0 Ejector Pump

The inlet and outlet pipes must be fitted according to our PI-diagram. The suction branch B2 and the discharge branch B1 for the ejector pump have to be fitted with reducers if necessary. Branch dimensions in accordance with pump dimensional drawing, see "FWG Order Specification". Inlet and outlet pipes according to installation (PI) diagram.

3.5.0 Brine/Cooling Water Discharge

Cooling water and brine are discharged overboard through the same pipe (B7).

Maximum back pressure 0.6 bar g (60 kPa) (0,6 kp/cm²).

 CAUTION A pressure gauge must be fitted 0.5 m from branch B7.

3.6.0 Freshwater System

The discharge branch for produced water to tank is marked D1.

- Max. back pressure according to installation (PI) diagram.

Remember to establish a drain below the distiller in case the solenoid valve opens, e.g. due to high salinity of the produced freshwater.

3.7.0 Control Panel

The control panel is delivered for wall mounting.

3.8.0 Discharge to Bilge

Discharge branch D4. A drain from the foundation of the distiller should be made in case of opening of the solenoid valve. (High salinity of the produced water).

The distiller can as an optional extra be delivered with a return pipe. In this case it is not necessary to make drain.

 CAUTION In order to avoid malfunctions, we recommend to follow the pipe dimensions indicated in our PI-diagram, see "FWG Order Specification".

For further information please refer to the drawing "VERTICAL PLANT POSITIONING" drawing.

Salinometer

1.0.0 Salinometer DS-20

The salinometer is normally fitted in the control panel and wired internal.

1.1.0 Electrode unit Cable Connection for Salinometer DS-20

Use a four-wire screened cable (min. 4 x 0,75 mm) for connection between the Electrode unit and the control panel of the freshwater generator (or the salinometer, if this is supplied separately).

Use five wire plugs with numbers 1 to 5 to be fastened to their respective wire and screen as stated below, when the cable is cut to its correct length from the electrode unit to the panel.

The cable is then to be connected to the panel according to the electrical diagram of same.

To obtain maximal diastase from salinometer to electrode unit (20 m) 4 wires should be arranged in the cable as shown:

Terminals example:

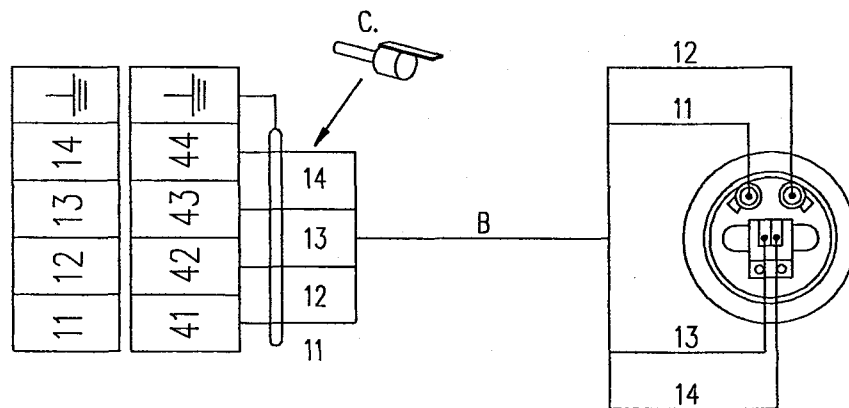

Tegn. 985 17834 REV. 00

Wire Colors:

1. Yellow to 41 or 11
2. White to 42 or 12
3. Green to 43 or 13
4. Brown to 44 or 14
5. Screen

- B. Four-wire cable with screen
- C. Wire Plugs

Index

A

Alternative Steam	page 10
Ambient conditions	page 11

B

Brine/cooling water discharge	page 15
-------------------------------------	---------

C

Cable Connection for Salinometer	page 17
Control panel	page 15

D

Discharge to bilge	page 15
--------------------------	---------

E

Ejector pump	page 14
Electric equipment	page 12
Electrode unit Cable	page 17
Extent of delivery	page 11

F

Freshwater quality	page 9
Freshwater system	page 15

G

General information	page 11
General safety precautions	page 11

I

Installation instructions	page 12
---------------------------------	---------

J

Jacket water system	page 13
---------------------------	---------

M

Main components	page 9
-----------------------	--------

Index

S

Safety instructions and warnings	page 5
Salinometer DS-20	page 17
Sea water system	page 13
Space requirements	page 11
Steam quality	page 11
Steam system	page 14
Storage	page 7

T

Telefax	page 5
Telephone	page 5
Transportation	page 12

V

Vibrations	page 11
------------------	---------

W

Warning	page 5
Wire Colors	page 17
Working principle	page 9

FWG Order Specification

/INI.: GNO	Date: 03.02.25	BPCS: 34167	Serial no.: N-010770
---------------	-------------------	----------------	-------------------------

Page 1/2

Technical data

Type of generator: JWSP-26-C100	Capacity [m ³ /24h]: 25	NE/NK: 86/86
Power supply, main/control	Main [Volt / Hz]: 3 x 440/60	Control [Volt]: 220
Jacket water temperature	Inlet [°C]: 80	Outlet [°C]: 68,1
Jacket water flow/pressure drop	Flow [m ³ /h]: 54,4	Pressure drop [bar]: 0,4
Heat consumption from jacket water	[Mcal/h]: 649	or [kW]: 755
Seawater temperature	Inlet [°C]: 32	Outlet [°C]: 41,3
Seawater flow/pressure drop	Flow [m ³ /h]: 62	Pressure drop [bar]: 0,5
Alternative heating: steam:	Capacity [m ³ /24h]: 25	
Steam flow/pressure:	Flow [kg/h]: 1187	Pressure [bar]: 3

hp / motor data

	Fresh water	Ejector water	Brine water	Hot water
Nominal flow x pressure [m ³ /h x mwc]:	2,1 x 28	62 x 42	-	-
Marked output power [kW]:	0,75	21,4	-	-
Consumed electrical power [kW]:	0,75	15,9	-	-
Current [A]:	1,6	33,5	-	-
Rotating speed [rpm]:	3360	3515	-	-

Quality data

Certificate: Workshop	Connections: DIN
-----------------------	------------------

Extra / special equipment

Afventer "GO"
AL-Hong Kong
Penalty: NO

Note:

Max. inlet temperature for evaporator section must NEVER exceed 100°C (212°F)

Max. inlet pressure for condenser section must not exceed 4 bar g (400 kPa)

Max. ambient temperature for freshwater generator is 50°C (122°F)

FWG Order Specification

<i>INI:</i> GNO	<i>Date:</i> 03.02.25	<i>BPCS no.:</i> 34167	<i>Serial no.:</i> N-010770	Page 2/2
--------------------	--------------------------	---------------------------	--------------------------------	----------

Documentation

General description, freshwater generator	Doc.No. 9.2.2-1
Technical data, freshwater generator	Doc.No. 9.2.2.2-5
Dimension drawing, freshwater generator	Doc.No. 9.2.2.5-8
Technical data, pump and motor	Doc.No. 9.2.2.2-6
Dimension drawing, ejector pump	Doc.No. 9.2.5.2-3
Dimension drawing, control panel	Doc.No.9.2.6.2.4.1
Dimension drawing, salinometer	-
Dimension drawing, feed water treatment	Doc.No. 9.2.9.3-2
Flow chart, excl. options	Doc.No. 9.2.2.3-11
Equipmnt specification	Doc.No. 9.2.2.4-2
Vertical plant positioning	Doc.No. 9.2.8-1
Electric diagram	Doc.No.9.2.6.3.4.1
Assembly scheme	985 16610
Spare parts, generator	985 17909-81
Spare parts, steam arrangement	985 15594-80
Spare parts, steam injector	984 12510-00

Parent item no.: SPE-N-010770 R: 00	Description: SPECIFICATION PARTS LIST JWSP-26-C100 DRAWING NO. 985 17909	Date: 20030311	Page 1 of 1
Drawing no.:		Ini DKSOABK	

BUBL	QTY	U/M	DESCRIPTION	DRAWING NO.	ARTICLE NO.	MATERIAL	REMARKS
3	1.000000	EA	MOTOR 71B-2 380/440V 50/60HZ 0.55/0,75KW 1.4/1.6A, ABB		985 00057-37		
11	1.000000	EA	COMBINED BRINE/AIR EJECTOR BRINE/AIR EJECTOR	984.12200.00	984 12263-00		
31	1.000000	EA	ORIFICE D=12,1 (FEED WATER)	984 57863	984 57863-24		
46	1.000000	EA	FRESHWATER PUMP PVVF-2040.2X-012	984.10230.00	984 10253-00		
48	8.000000	EA	CLAMPING BOLT L=535 P-26	984 58083	984 58083-05	ISO 683/13/86 ; TYPE 20A	
51	1.000000	EA	PLATE P-26 KS/ES		119291-2183		ASS.MEASURE = 284 MM
51	1.000000	EA	PLATE P-26 KE/EE		119281-4116	TITAN/NITRIL	
51	42.000000	EA	PLATE P-26 KV		39502661-03	TITAN/NITRIL	
51	42.000000	EA	PLATE P-26 KD		39502665-03	TITAN/NITRIL	
53	4.000000	EA	SUPPORTING SHAFT L=535	984 58182	984 58182-05	ISO 683/13/74 ; TYPE 11	
57	1.000000	EA	PLATE P-26 KS/ES		119291-2183		ASS.MEASURE = 284 MM
57	1.000000	EA	PLATE P-26 KE/EE		119281-4116	TITAN/NITRIL	
57	42.000000	EA	PLATE P-26 EV		39502663-03	TITAN/NITRIL	
57	42.000000	EA	PLATE P-26 ED		39502664-03	TITAN/NITRIL	
95	1.000000	EA	SOLENOID VALVE 1/2" EV220B 15 220V 50/60 CS NO (EVSI 15)	984.23482.0	984 23486-00		
500	.000000	EA	ACCESSORIES:		ACCESSORIES		
501	1.000000	EA	CONTROL PANEL - FWG - OPT. A (DIAGR: 985 16645)	985 16646	985 00034-85		
501	1.000000	EA	CONTACTOR A50 220-240V/50-60CS A50 220-230V/230-240V 50/60CS		984 21620-58	8003	
501	1.000000	EA	THERMAL RELAY TA75 (29-42A) TA75 DU 42		984 21621-20	8073	
502	1.000000	EA	EJECTOR PUMP (STAINL.ST.IMP.) CNL-80-80/200 DIN/JIS 3500RPM	984.10302.00	985 00025-26		
502	1.000000	EA	MOTOR 160L-2 380/440V 50/60HZ 18,5/21KW IN 34A ABB		985 00057-36		
503	1.000000	EA	FEED WATER TREATMENT, SCALE INHIBITOR DOSAGE EQUIPMENT	985 14867	985 14867-80		
504	1.000000	EA	SPARE PARTS FOR 1 YEAR JWSP-26-C100		SPARES-N-010770		

Alfa Laval Copenhagen A/S

Maskinevej 5
DK-2860 Søborg, Denmark
CVR No. 10134285
V.A.T. No. 14646647

Telephone + 45 39 53 60 00
Telefax + 45 39 53 65 68
Bank DANSKE BANK Holmens Kanal Branch
Acc. No. DKK 3100-3117-108007
Acc. No. EUR 3100-3140-854301
Acc. No. USD 3100-3010-579294





9.2.2.1 General description, JW(S)P-26-C80(B)/C100

Application

Conversion of seawater into fresh water by vacuum distillation, for drinking, process water, and domestic use on ships and rigs, and in small power stations. Max. salinity 2 ppm.

Capacity

The JW(S)P-26-C80(B)/C100 covers a capacity range from 4 to 35 m³/24h, depending on the heating medium and seawater temperature. The capacities shown below are at a seawater temperature of 32°C.

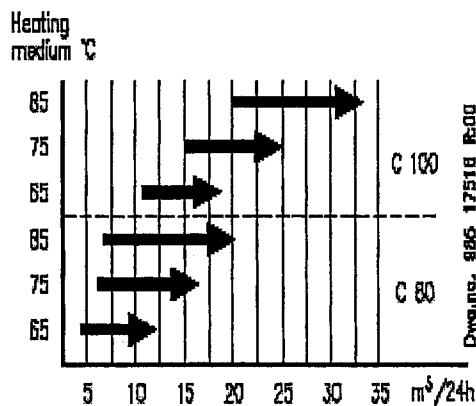

Working principle

The seawater to be distilled evaporates at a temperature of about 40°C as it passes between the hot plates in the evaporator.
 This evaporating temperature corresponds to a vacuum of approximately 93% which is maintained by the brine/air ejector.
 The vapours generated pass through a demister where any drops of seawater entrained are removed and fall to the bottom of the distiller chamber.
 The vapours continue to the condenser where they condense to fresh water as they pass between the cold plates.

Basic Equipment

Titanium plate heat exchanger in evaporator and condenser.
 Red brass separator and stainless steel demister, front cover and pressure plates.
 Seawater pipes in CuNi.
 The freshwater generator is equipped for jacket water heating and with a combined condenser cooling and ejector water system. Furthermore the freshwater generator is equipped with dump valve, water clock, automatic feed water regulator, combined brine/air ejector, instruments, freshwater pump with electric motor, internal piping and bed frame.

Options

Flanges:	DIN, JIS or ANSI
Power/control:	3 x 380 V 50 Hz 100/110/220 V 3 x 440 V 60 Hz 100/110/220 V 3 x 460 V 60 Hz 110 V (ul)

Additional equipment necessary for operation

- Ejector pump/electric motor.
- Control panel with motorstarters and salinometer.
- Feed water treatment.

Optional equipment/design

- Steam heating systems type JWSP.
- Hot Water Loop Module for steam boosting of jacket water.
- Salinometer.
- Manual motor starters and salinometer.
- Remote start/stop.
- Water clock by-pass.
- Return pipe to brine sump.
- Electric panel build-on the unit.
- Optional spares kit for 1, 2 or 5 years of operation.
- Steel box for spares kit.
- Class test certificate.
- Freshwater treatment equipment.



9.2.2.2-5 Technical data, JW(S)P-26-C100

Power consumption

Ejector and freshwater pump:

<u>NE/NK</u>	<u>50 Hz</u>	<u>60 Hz</u>
62/62-70/70:	12.8 kW	13.0 kW
72/72-80/80:	13.5 kW	13.6 kW
82/82-90/90:	16.6 kW	16.7 kW
92/92-100/100:	17.2 kW	17.3 kW

Pressure

	<u>bar(g)</u>	<u>lbs/in²</u>
Max. jacket water pressure:	4.0	58
Max. back pressure to freshwater tank:	1.6	23
Max. seawater pressure to inlet condenser:	4.0	58
Min. seawater pressure to ejector:	3.0	43
Max. back pressure at ejector outlet:	0.6	8.7
Max. back pressure for safety valve on steam equipment:	1.0	14.5
Max. steam pressure for steam equipment:	7.0	101
Normal operation pressure for steam equipment:	2-4.5	29-65
Back pressure to condensate well for steam equipment:	0.6-0.8	8.7-11.6

Temperature

Seawater temperature: 0-32°C

Jacket water temperature: 55-95°C

Flow

Seawater flow: 49-70 m³/h

Jacket water flow: 25-72 m³/h

Materials

Separator:	Red brass
Front cover:	Stainless steel
Bed frame:	Steel (hot dip galvanized)
Pipe for brine discharge:	Red brass
Evaporator/condenser plates:	Titanium
Demister:	Stainless steel
Pipe for seawater:	CuNi 90/10
Pipe for fresh water:	CuNi 90/10
Combined brine/air ejector housing:	Red brass
Combined brine/air ejector nozzle:	Stainless steel
Flange for evaporator/condenser:	SG-iron (hot dip galvanized)
Steam equipment type JWSP and SP.	
Pipe:	Steel (hot dip galvanized)
Steam injector housing:	Cast iron (painted)
Steam injector nozzle:	Stainless steel

Shipping data

Freshwater generator, complete with ejector pump, electrical panel, dosing unit and standard spares.

Weight:	net: 930 kg, gross:1050 kg
Dimensions:	l x w x h: 2200 x 1300 x 1620 mm
Volume:	4.6 m ³



9.2.2.5-8 Dimensional drawing, JWSP-26-C100

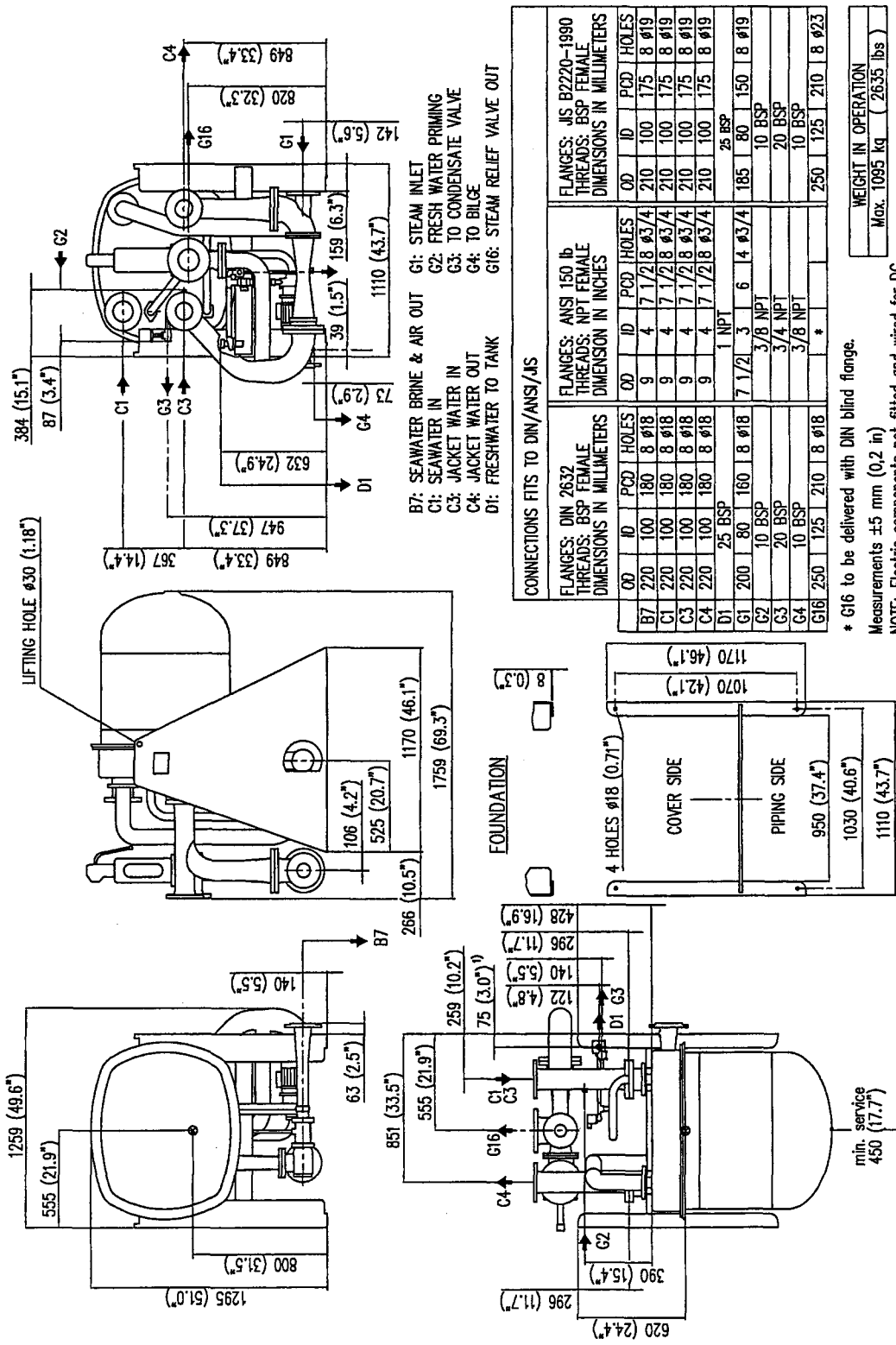

CONNECTIONS FITS TO DIN/ANSI/AS									
FLANGES: DIN 2632 THREADS: BSP FEMALE DIMENSIONS IN MILLIMETERS					FLANGES: ANSI 150 lb THREADS: NPT FEMALE DIMENSION IN INCHES				
OD	ID	PCD	HOLES		OD	ID	PCD	HOLES	
B7	220	100	180	8 ϕ 18	9	4	7 1/2	8 ϕ 3/4	FLANGES: JS B2220-1990 THREADS: BSP FEMALE DIMENSIONS IN MILLIMETERS
C1	220	100	180	8 ϕ 18	9	4	7 1/2	8 ϕ 3/4	OD
C3	220	100	180	8 ϕ 18	9	4	7 1/2	8 ϕ 3/4	ID
C4	220	100	180	8 ϕ 18	9	4	7 1/2	8 ϕ 3/4	PCD
D1	25	BSP			1	NPT			HOLES
G1	200	80	160	8 ϕ 18	7 1/2	3	6	4 ϕ 3/4	25 BSP
G2					3/8	NPT			10 BSP
G3					3/4	NPT			20 BSP
G4					3/8	NPT			10 BSP
G16	250	125	210	8 ϕ 18	*				250 125 210 8 ϕ 23

* G16 to be delivered with DIN blind flange.
 Measurements \pm 5 mm (0.2 in)
 NOTE: Electric components not fitted and wired for DC.
 1) If by-pass option is included, freshwater pipe will be 127 mm (5.0 in) longer.
 Ⓢ Centre of gravity
WEIGHT IN OPERATION
 Max. 1095 kg (2635 lbs)

Illustrations, indications of material, dimensions and weights etc. herein, do not constitute any commitment on our part. We reserve the right to change such specifications when necessary.



9.2.2.2-6 Technical data, Pump and Motor for JW(S)P-26-C100

No. of plates NE/NK:		62/62-70/70		72/72-80/80	
Pump function		Freshwater	Ejector	Freshwater	Ejector
Pump Type		PVVF-2040	CNL 80-80/200	PVVF-2040	CNL 80-80/200
Motor type		71 B	160 M	71 B	160 M
Nom. flow x pressure m ³ /h x mwc		2.1 x 28	49 x 42	2.1 x 28	56 x 42
Impeller size 50 Hz : mm		ø149	ø205	ø149	ø205
Impeller size 60 Hz : mm		ø128	ø172	ø128	ø172
Rotating speed 50 Hz : RPM		2820	2905	2820	2905
Rotating speed 60 Hz : RPM		3360	3505	3360	3505
3 x 380 V 50 Hz:					
Rated output power kW		0.55	15.5	0.55	15.5
Consumed power kW		0.67	12.1	0.67	12.8
Current (full load) A		1.4	28.5	1.4	28.5
Current (start) A		7	157	7	157
3 x 440 V 60 Hz:					
Rated output power kW		0.75	17.8	0.75	17.8
Consumed power kW		0.75	12.2	0.75	12.8
Current (full load) A		1.6	28.5	1.6	28.5
Current (start) A		7	157	7	157
3 x 460 V 60 Hz:					
Rated output power kW		0.75	17.8	0.75	17.8
Consumed power kW		0.75	12.2	0.75	12.8
Current (full load) A		1.5	27.2	1.5	27.2
Current (start) A		7	157	7	157

No. of plates NE/NK:		82/82-90/90		92/92-100/100	
Pump function		Freshwater	Ejector	Freshwater	Ejector
Pump Type		PVVF-2040	CNL 80-80/200	PVVF-2040	CNL 80-80/200
Motor type		71 B	160 L	71 B	160 L
Nom. flow x pressure m ³ /h x mwc		2.1 x 28	62 x 42	2.1 x 28	70 x 42
Impeller size 50 Hz : mm		ø149	ø192	ø149	ø192
Impeller size 60 Hz : mm		ø128	ø168	ø128	ø168
Rotating speed 50 Hz : RPM		2820	2915	2820	2915
Rotating speed 60 Hz : RPM		3360	3515	3360	3515
3 x 380 V 50 Hz:					
Rated output power kW		0.55	18.6	0.55	18.6
Consumed power kW		0.67	15.9	0.67	16.5
Current (full load) A		1.4	33.5	1.4	33.5
Current (start) A		7	211	7	211
3 x 440 V 60 Hz:					
Rated output power kW		0.75	21.4	0.75	21.4
Consumed power kW		0.75	15.9	0.75	16.5
Current (full load) A		1.6	33.5	1.6	33.5
Current (start) A		7	211	7	211
3 x 460 V 60 Hz:					
Rated output power kW		0.75	21.4	0.75	21.4
Consumed power kW		0.75	15.9	0.75	16.5
Current (full load) A		1.5	32	1.5	32
Current (start) A		7	211	7	211



9.2.5.2-3 Dimensional drawing, CNL 80-80/200

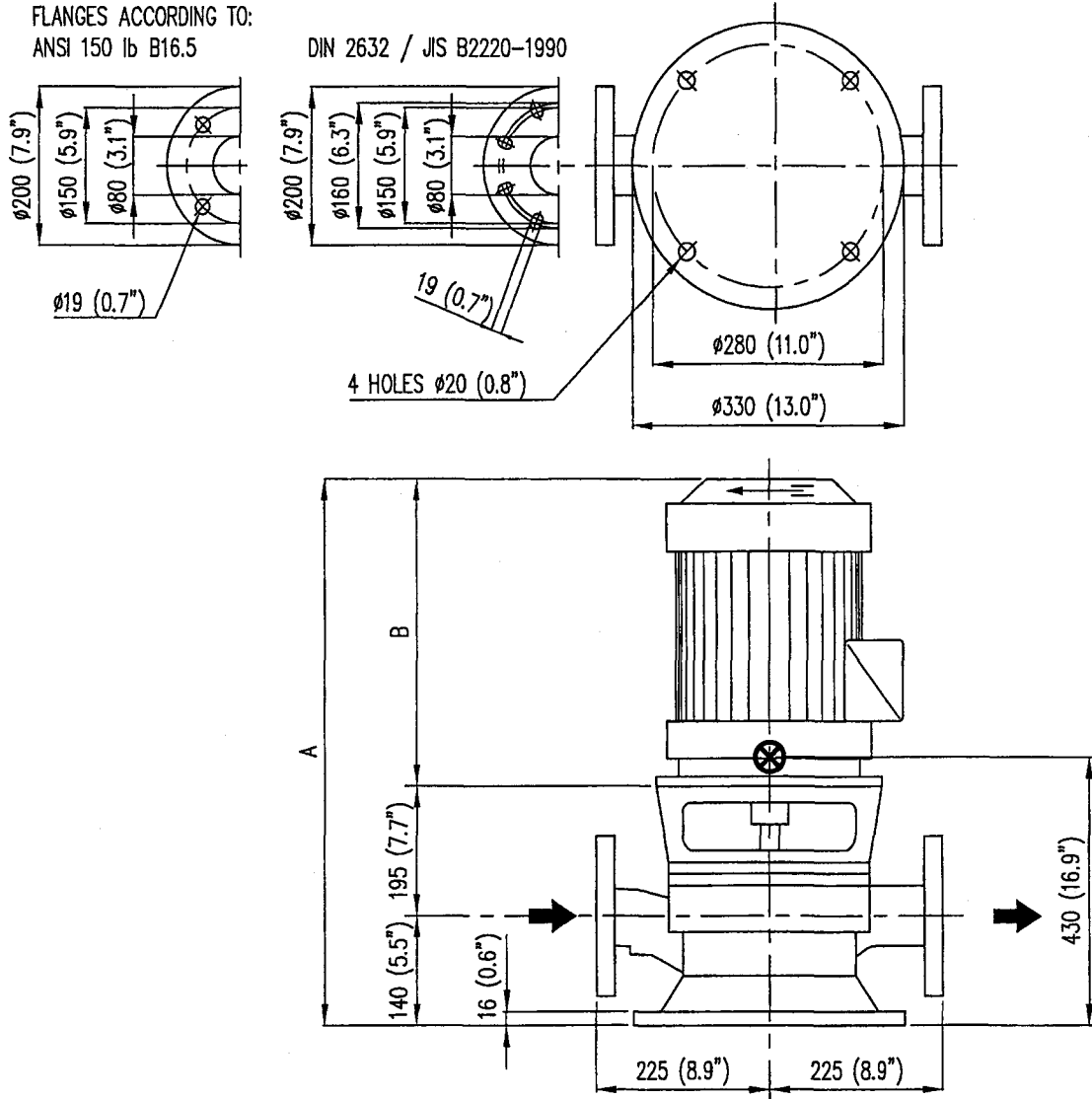

⊗ CENTRE OF GRAVITY

EJECTOR PUMP TYPE	MOTOR TYPE	FLANGE TYPE	A mm	B mm	WEIGHT (INCL. MOTOR) Kg	CABLE GLANDS KVM 36
CNL 80-80/200	160 M	DIN/JIS/ANSI	814 (30.05")	479 (18.9")	166 (366 lbs)	∅ 22,5-24,5
CNL 80-80/200	160 L	DIN/JIS/ANSI	858 (33.8")	523 (20.6")	170 (375 lbs)	∅ 22,5-24,5

MECHANICAL PROTECTION	INSULATION	COOLING SYSTEM	SHAFT SEAL	POLES FOR MOTOR
IP 55	CLASS F	FAN COOLED	MECH. SEAL	2 POLES

Dwg.no. 985 17500 R:02



9.2.6.2-41 Dimensional drawing, Panel for Single-stage FWG (option A)

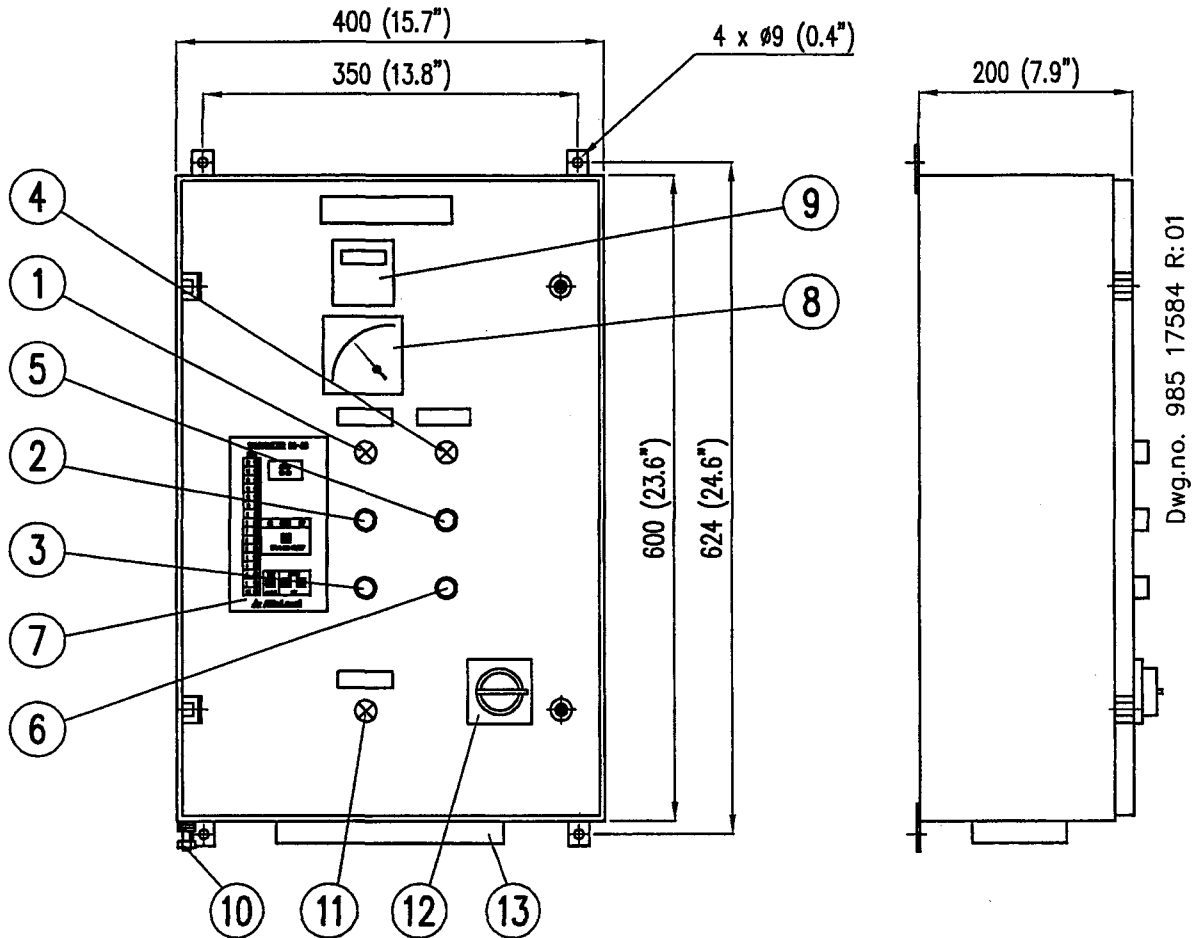

Dwg.no. 985 17584 R:01

Legend

- | | |
|------------------------------------|---------------------------|
| 1 Running light, ejector pump | 10 Earth connection point |
| 2 Start, ejector pump | 11 Source on |
| 3 Stop, ejector pump | 12 Main switch |
| 4 Running light, freshwater pump 1 | 13 Connections: |
| 5 Start, freshwater pump 1 | 1 PG29 (20–27 mm) |
| 6 Stop, freshwater pump 1 | 2 PG21 (14–20 mm) |
| 7 Salinometer | 2 PG16 (8–15 mm) |
| 8 Ammeter | 2 PG13,5 (7–13 mm) |
| 9 Running hour meter | Additional 6 PG16 |

Illustrations, indications of material, dimensions and weights etc. herein, do not constitute any commitment on our part. We reserve the right to change such specifications when necessary.



9.2.9.3-2 Feed Water treatment - 130 liter

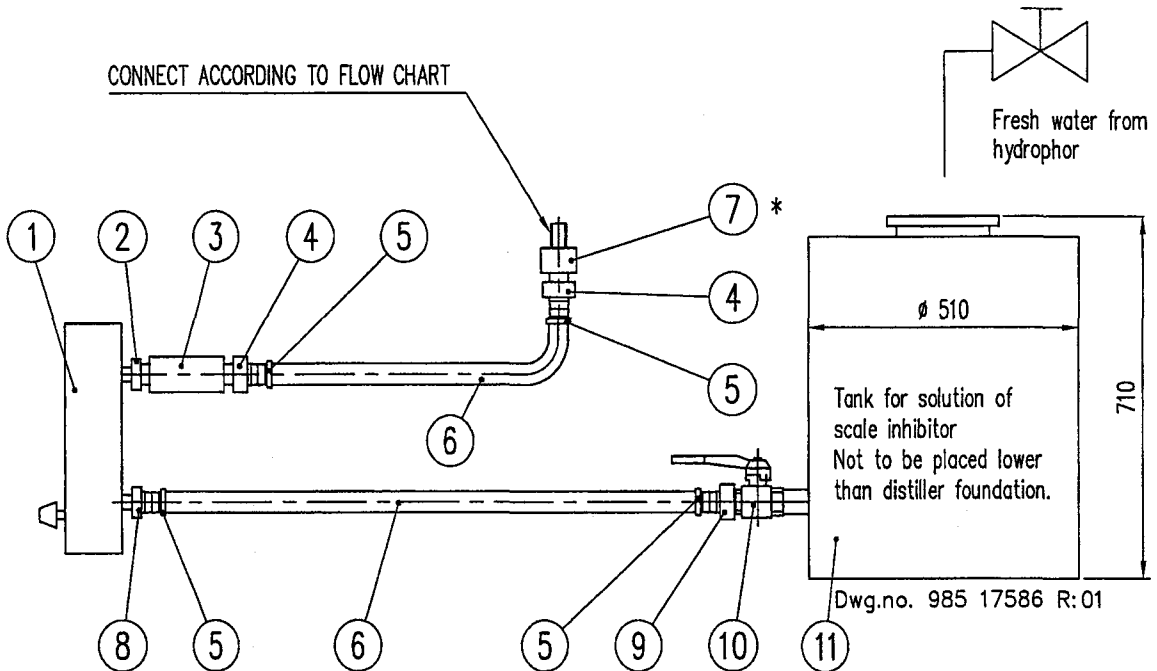

Recommendation

Use fully soluble scale inhibitor for instance on polymere basis.
 Mix quantity required for 24 hours operation in tank according to
 maker's instruction and adjust dosage to cover max. freshwater
 output from distiller.
 Flush regularly.

- | | | | |
|---|----------------------------|----|--------------------------|
| 1 | Flowmeter incl. reg. valve | 7 | Connection 3/8" x 1/4" * |
| 2 | Nipple 3/8" x 1/8" | 8 | Connection 1/8" x 10 |
| 3 | Non return valve 3/8" | 9 | Connection 1/2" x 10 |
| 4 | Hose connection 3/8" x 10 | 10 | Ball Valve 1/2" |
| 5 | Hose clip | 11 | PE tank (130 l) |
| 6 | Hose 3/8" (4000 mm) | | |

* Only for JWP-36-C



9.2.2.3-11 Flow Chart, JWSP-26-C100

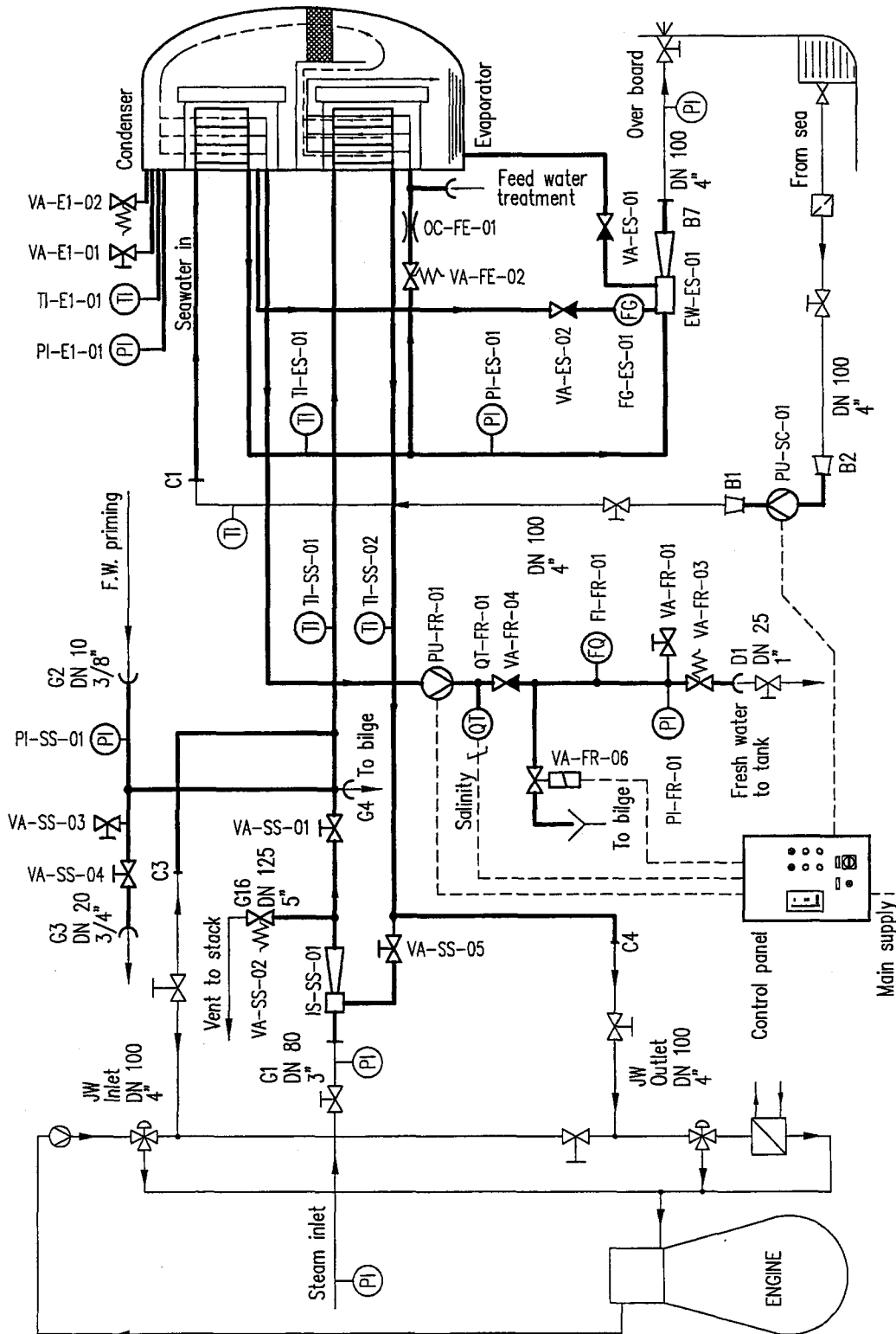

	ALFA LVAL SUPPLY	YARDS SUPPLY
Pipe lines	—————	—————
Electric cables	-----	-----

Dwg.no. 985 17451 R:02

Illustrations, indications of material, dimensions and weights etc. herein, do not constitute any commitment on our part. We reserve the right to change such specifications when necessary.



9.2.2.4-2 Equipment specification, JW(S)P-26-C100

Equipment supplied by Alfa Laval:

Tag No.	Description	Article No.	Connection
	<u>Unit:</u>		
EW-ES-01	Ejector	See specification	-
FG-ES-01	Flow sight glass	984 35686-00	1/2" BSP
FI-FR-01	Water meter	985 42600-04	3/4" BSP
OC-FE-01	Orifice	See specification	-
PI-ES-01	Pressure gauge	984 30297-00	1/4" BSP
PI-E1-01	Mano/vacuum gauge	984 30308-00	3/8" BSP
PI-FR-01	Pressure gauge	984 30298-00	1/4" BSP
PU-FR-01	Freshwater pump	See specification	-
PU-SC-01	Ejector pump	See specification	-
QT-FR-01	Electrode unit	984 22500-00	-
TI-ES-01	Thermometer	984 30366-00	1/2" BSP
TI-E1-01	Thermometer	984 30366-00	1/2" BSP
VA-ES-01	Non return valve	984 35501-01	DN 50
VA-ES-02	Non return valve	984 35686-00	1/2" BSP
VA-E1-01	Air screw	984 40939-03	1/4" BSP
VA-E1-02	Safety valve	984 35360-00	1" BSP
VA-FE-02	Spring loaded valve	984 35535-00	DN 40
VA-FR-01	Ball valve	984 35683-00	1/2" BSP
VA-FR-03	Spring loaded valve	984 35166-00	-
VA-FR-04	Non return valve	984 35672-00	1" BSP
VA-FR-06	Solenoid valve	See specification	-
	Control panel ¹⁾	See specification	-
	<u>Steam arrangement: ²⁾</u>		
IS-SS-01	Steam injector	See specification	-
PI-SS-01	Mano/vacuum gauge	984 30285-00	3/8" BSP
TI-SS-01	Thermometer	984 30366-00	1/2" BSP
TI-SS-02	Thermometer	984 30366-00	1/2" BSP
VA-SS-01	Butterfly valve	984 35620-00	DN 100
VA-SS-02	Safety valve	See specification	-
VA-SS-03	Ball valve	984 35618-00	3/8" BSP
VA-SS-04	Seated valve	985 56110-04	3/4" BSP
VA-SS-05	Butterfly valve	984 35620-00	DN 100

Dwg.no. 985 17470 R:01

¹⁾ Normally supplied by Alfa Laval

²⁾ Type JWSP



9.2.8-1 Vertical plant positioning, JWP-16/26 and D-PU-(2)-36

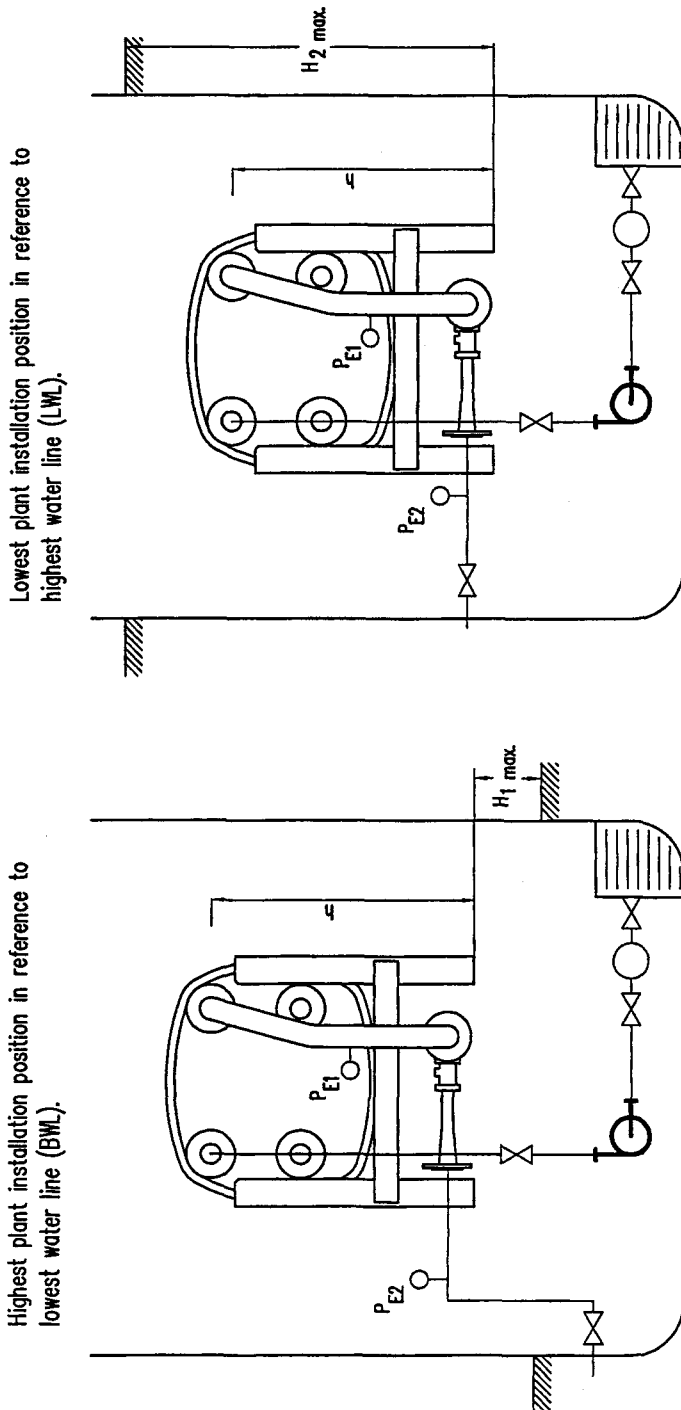

The stated installation heights are given under the conditions that the line pressure drop does not exceed 0.1 bar (1.5 lbs/in²) which should account for all normal installations. If the 0.1 bar (1.5 lbs/in²) is exceeded the heights must be diminished accordingly.

In order to minimize the pressure drop we recommend to avoid the use of seat valves in the system.
Ejector pump is not self priming.

Freshwater Generator type	P _{E2} max. bar (lbs/in ²)	h mm	Highest vertical plant positioning		Lowest vertical plant positioning	
			P _{E1} min. bar (lbs/in ²)	H ₁ max. mm	P _{E1} max. bar (lbs/in ²)	H ₂ max. mm
P-16	0.5 (7.3)	913	3 (43.5)	3000	3.85 (55.8)	5000
P-26	0.6 (8.7)	1100		4000		6000
D-PU-36			1500			
D-PU-2-36						

Dwg.no. 985 17495 R:00



9.2.6.3-41 Electrical diagram, Control panel for Single-stage FWG (option A)

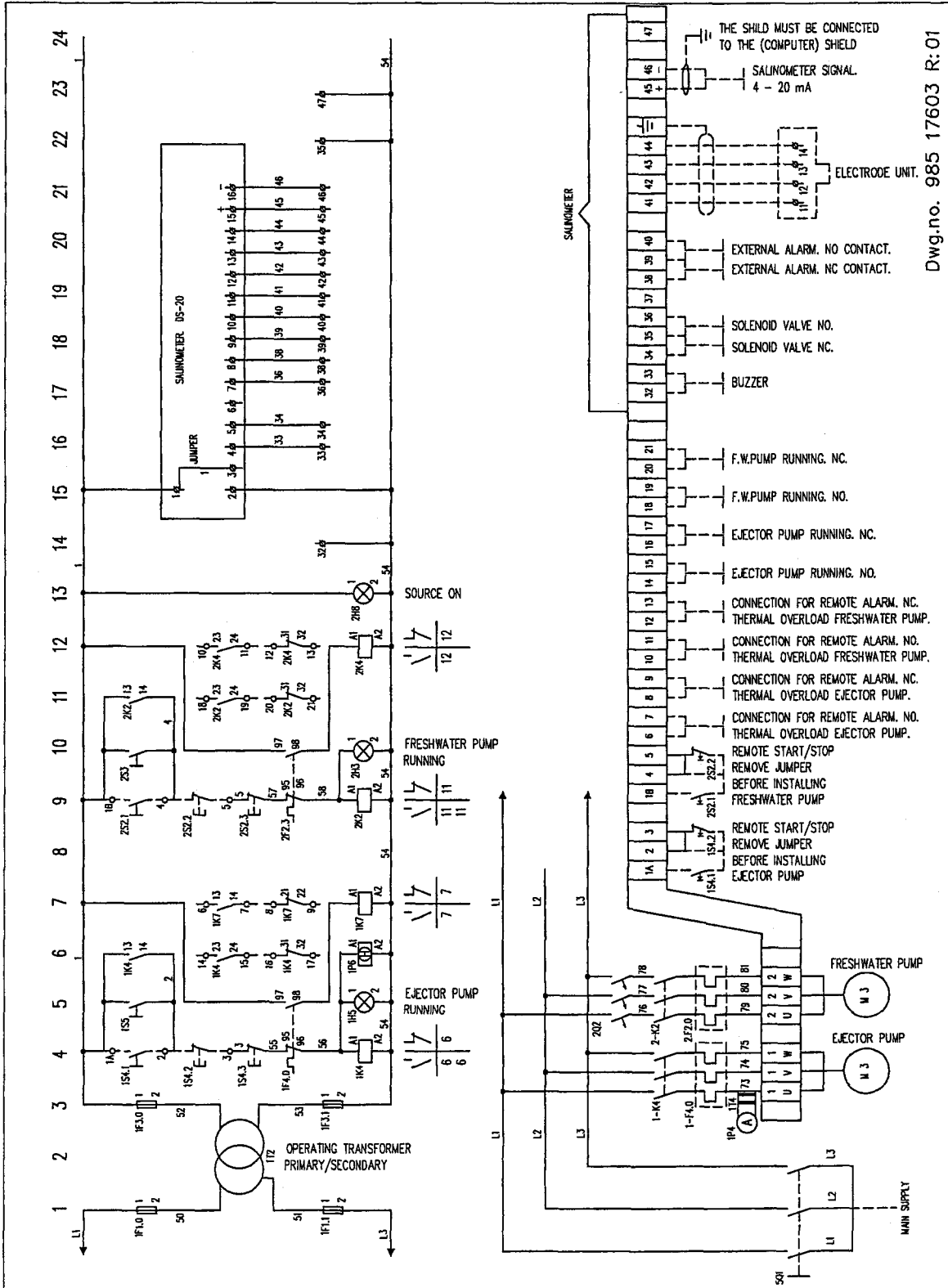

Illustrations, indications of material, dimensions and weights etc. herein, do not constitute any commitment on our part. We reserve the right to change such specifications when necessary.