

Wiring Manual | 2011

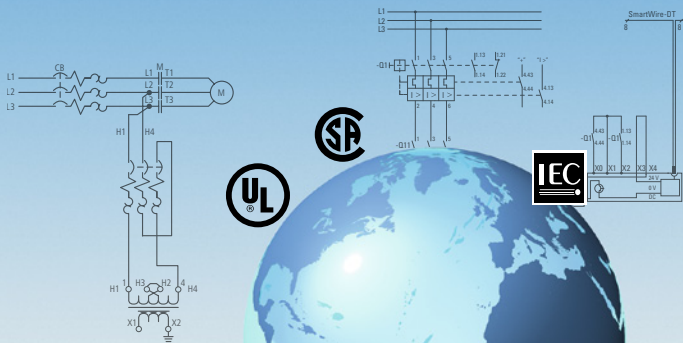

EATON

Powering Business Worldwide

All brand and product names are trade marks
or registered trademarks of the owner concerned

Updated edition 2011, publication date 06/11

© 2008 by Eaton Industries GmbH, 53105 Bonn

Editorial: Walter Heumann, Thomas Kracht, Barbara Petrick,
Heidrun Riege, René Wiegand

All the connections are designed according to our best expertise
and have been carefully tested. They serve as practical examples.
Eaton Industries GmbH does not accept any liability for any errors.

All rights reserved, also for the translation.

No part of this Wiring Manual may be reproduced in any form
(printed, photocopy, microfilm or any other process) or processed,
duplicated or distributed by means of electronic systems without
the written permission of Eaton Industries GmbH, Bonn, Germany.

Subject to alteration.

Printed on paper made from cellulose bleached without the use of
chlorine or acid.

Eaton Wiring Manual

	Chapter
Eaton Wiring Manual	0
Switching, control, visualization	1
Electronic motor starters and drives	2
Pilot devices	3
Cam switches	4
Contactors and relays	5
Motor-protective circuit-breakers	6
Circuit-breakers	7
All about Motors	8
Export to World Markets and North America	9
Standards, formulae, tables	10
Index	11

Eaton Wiring Manual

0

	Page
Moeller is Eaton	0-3
Eaton Stromversorgungsqualität	0-4
Eaton Medium Voltage Systems	0-6
What's new in this edition?	0-7
Competence and Experience from a Single Source	0-8
Support Portal	0-10
Eaton Online Catalog	0-11
After Sales Service	0-12
Photovoltaics in residential buildings	0-14
Eaton power distribution equipment	0-22

Moeller is Eaton

Moeller's strengths remain – and Eaton is building on them.

Now that the integration of Moeller in the global Eaton Corporation has been completed, it's not just the Moeller name that is being preserved. Our range of services also benefits from the alliance. The Moeller name will continue to exist as a product series designation. Recognizing the values transferred to Eaton, "Moeller®Series" appears on former Moeller products, while the packaging features the Eaton logo.

With our constantly growing range of services, we help you to meet the increasing demands of the market every day. We develop standards and remain true to our core competencies. You are holding a good example of this in your hands right now. With the latest version of the switching manual, we are proud to again provide you with a fit companion to your daily work.











Powering Business Worldwide

Eaton Wiring Manual

Eaton power supply quality

0

Get to know Eaton's products for power supply quality

Eaton Technologies

Eaton has been developing innovative technical solutions for protecting power supplies since 1962 (first patent application). With new, advanced and patented technologies, Eaton responds to customers' rapidly changing requirements.









Nine power supply problems at a glance

How a UPS is part of the solution

Eaton UPS systems offer protection against all nine typical power supply problems described below. They meet the requirements for assured power supply quality, energy distribution and power management for computer networks and data centers as well as for telecommunications, healthcare and industrial applications.

Eaton product overview

Eaton's product range for protecting power supply quality comprises an extensive selection of power management solutions from a single source. It includes UPS systems, surge protection equipment, power distribution units (ePDUs), remote monitoring, testing devices, interconnect materials, housings, cabinets and services. Our portfolio for power supply quality is designed to customers' specific requirements; comprehensive solutions are offered for both new systems as well as

Power supply problem		
1	Power supply failure	
2	Voltage dip	
3	Voltage surges	
4	Undervoltage (voltage drop)	
5	Overvoltage	
6	Electrical disturbance signals	
7	Frequency deviations	
8	Spikes due to switching operations	
9	Harmonic distortion (harmonic waves)	

existing ones. With all its products, Eaton strives for continuous success in advancing technical innovation in order

Eaton Wiring Manual

Eaton power supply quality

0

Definition	Cause	Solution
Total failure of supply network	Can occur from a number of events: lightning strike, breaking of transmission lines, network congestion, accidents and natural disasters	Single-phase UPS series 3 Single-phase UPS series 5 Single-phase and three-phase UPS series 9
Temporary under-voltage	Triggered by major power consumers being switched on, switching in the supply network, failure of grid facilities, lightning strike and power supply systems unable to meet requirements. In addition to possible device failure, hardware can also be damaged.	
Temporary voltage surge of more than 110 percent of the nominal value	Can be caused by lightning strike and temporarily increase mains voltage to over 6,000 volts. A voltage peak almost always causes data losses or hardware damage.	
Reduced mains voltage for a period of between a few minutes to a few days	Can occur if the mains voltage is intentionally reduced to reduce power during peak consumption periods or if the connected consumer load exceeds the supply capacity.	
Increased mains voltage for a period of between a few minutes and a few days	Triggered by strong load reduction, major power consumers being switched off and other switching operations in the network. Hardware can be destroyed as a result.	
Disturbance signals with higher frequencies	These can be triggered by electromagnetic interference (EMI) or radio frequency interference (RFI) from welding equipment, transmitting equipment, printers, thunderstorms etc.	
Instability of mains frequency	These occur as a result of load variations, in particular in smaller generator installations. Frequency deviations can cause processes to fail, data losses, system breakdowns and damage to equipment.	
Temporary voltage dips	Spikes of this kind last a very short time, within the nanosecond range.	
Distortion of sinusoidal waveform, usually caused by non-linear loads	Switching mode power supplies, stepper motors, copiers and fax machines are examples of non-linear consumer loads. They can cause communication errors, overheating and hardware damage.	

to develop next-generation solutions. The products and services listed below represent examples from our extensive

solutions range. To view the entire range or request a product catalog, please visit www.eaton.com/powerquality.

Eaton Wiring Manual

Eaton Medium Voltage Systems

0

Medium voltage systems

The quality of Eaton's medium voltage systems is founded on over 100 years of experience.

Vacuum Technology

Vacuum technology is at the heart of Eaton's switching systems. Eaton has over 30 years of experience in applying vacuum technology in circuit-breakers and load-break switches. The use of this technology results in a maximally environmentally-friendly switchgear solution.

Primary switchgear

As its name says, primary switchgear is the first stage in transmitting electrical current from the supply network to the end customer. The importance of the strategic position of the substation and its switchgear within the system reflects the fact that layout, construction and operation must be designed for maximum availability and reliability. For this reason, Eaton's portfolio includes the MMS – a compact stationary switchgear unit with single or double busbar – and PowerXpert® UX, a switchgear unit with removable circuit-breakers, switches and contactors.

Secondary switchgear

Eaton has developed universal, modular secondary switchgear under the SVS and Xiria product series. It is suitable for use in supply networks, business premises, infrastructure projects, industrial applications and for structures relating to renewables such as wind farms and

combined heat and power plants. The design of the SVS and Xiria is based on a combination of vacuum and epoxy resin technology. There are a multitude of different types of switchgear suitable for every kind of application. With its compact dimensions and SF₆-free design, SVS and Xiria are also the ideal solution for underground applications on infrastructure projects.

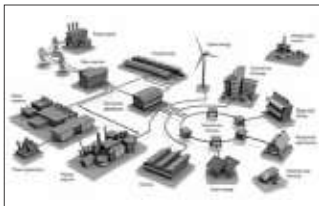

Ring main units

Electrical energy has become an indispensable element of modern society. A reliable and constant energy supply is increasing in importance every day. From the standpoint of energy companies and the industry, this means that the power distribution network must cope with ever increasing demand. It goes without saying that safety and operational reliability play a significant role.

www.eaton.com
www.eaton.com/electrical



Eaton Wiring Manual

What's new in this edition?

Export to the world market and to North America

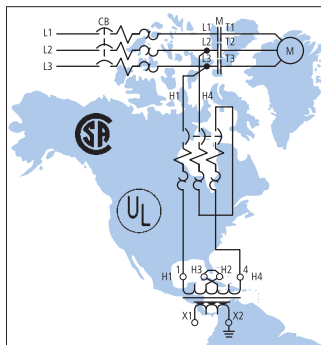

The target markets of machine and system builders are international. Eaton knows these markets and is a competent partner worldwide in all issues relating to the export of switchgear and switchgear systems. The special requirements on the export of products to North America (USA and Canada) are taking on increasing importance, see chapter 9.

Photovoltaics in residential buildings

The use of regenerative energy is becoming increasingly important. Eaton is a competent PV supplier and this publication describes the technical background information and range of components required, see → page 0-14.

The way to a safe machine



easySafety – Fulfills the highest safety demands.

The safety of people and machines must be taken into account for the total lifecycle of a machine/system. For personnel protection safety components such as position switches, light curtains, two-hand control switches or emergency switching off pushbuttons come into use. The safety information is monitored and evaluated by the new easySafety control relay which complies with the highest safety requirements, → Section "The way to the safe machine", page 1-29.

Always up-to-date

We make every effort to adapt and update every new edition of the Wiring Manual according to the ever increasing requirements of the markets.

The many example circuits in particular are continually being updated by our specialists to the best of their knowledge and carefully tested. They serve as practical examples. Eaton Industries GmbH does not accept any liability for any errors.

Eaton Wiring Manual

Competence and Experience from a Single Source

0

www.wiringmanual.com



Edition 1958

The Wiring Manual has been classic for over 50 years and is probably the most popular publication of the company. Worldwide distribution has given it new impetus in recent years. The 2005 edition was translated for the first time into nine languages:

- English,
- French,
- Italian,
- Spanish,
- Dutch,
- Russian,
- Czech,
- Romanian,
- Swedish



Edition 1986

Its contents are also available online at www.wiringmanual.com.

The online version combines the proven expertise with the latest Internet technology. For example, full text searches are also possible.

A special page with links to all the different language versions available is provided as a service to users from all over the world.

www.eaton.com/moeller/support
(Wiring Manual)

Eaton Wiring Manual

Competence and Experience from a Single Source

0

www.Eaton.com – the Products of the Moeller® series

Eaton offers you a range of products and services that can be optimally combined with one another. Visit our website on the Internet. You will find there everything about Eaton, such as:

- Up-to-date information about Eaton products,
- The addresses of the Eaton sales offices and representatives worldwide,
- Information about the European activities of Eaton,
- Publications in the press, specialist press,
- References,
- Exhibition dates and events,
- Technical support in the Eaton Support Portal.

www.eaton.com/moeller/support – The Support Portal

You can receive technical support for all Eaton products just by a mouse click. And tips und tricks, Frequently Asked Questions (FAQs), updates, software modules, PDF downloads, demo programs and much more.

You can also put your name down to receive the Eaton Newsletters.

Uncomplicated and quick way of finding the information you need:

- Selection aids
 - Motor starters → Section "Selection aids", page 8-3
- PDF downloads, Internet-supported browser catalogs, smartphone apps
 - Catalogs
 - Manuals and instructional leaflets
 - Product information, such as brochures, selection aids, technical essays, declarations of conformity and of course
 - Eaton Wiring Manual
- Software Downloads
 - Demo versions
 - Updates
 - Software modules and user modules

Eaton Wiring Manual Support Portal

0

You can also find a link to the Eaton After Sales Service via the Support Portal (→ Section "After Sales Service", page 0-12).

You can send your queries directly to the Technical Support/pre-sales service by e-mail. Simply select the e-mail form that meets your requirements to the -Eaton experts.



Eaton Wiring Manual

Eaton Online Catalog

0

The efficient way to detailed product information

From detailed product information right up to the enquiry for your products by email or fax from your Eaton product supplier. All this and more you can find in the Eaton Online Catalog.



This gives you fast access to new innovations as well as extensive information on the current Eaton ranges.

- Industrial switchgear,
- Drives,
- Automation systems, drives,
- Power distribution systems.

Create a comprehensive data sheet for a product and save it as a PDF document or print it out.

The Search tools

Several search options are available to enable the right access for any product search.

- The product group tree structure enables simple searching in just a few clicks of the mouse
- Selection tools provide logical filters in product groups containing several products
- A powerful search function with a proposal list ensures above-average search results

A number of links to additional product information and all aspects of it enable you to ensure optimum use of the product:

- Application examples and project design notes,
- Approvals
- Instructional leaflets,
- Manuals,
- Software etc.

Choose "Your" Online Catalog on the Internet.

http://ecat.moeller.net/?locale=en_EN

The Online Catalog on the Internet is updated regularly.

Eaton Wiring Manual

After Sales Service

0

As close as you wish

Service Specialists

Gain the benefit of our Service personnel. Comprehensive expertise linked with long term experience and modern equipment help you find the solution to your tasks.

Material characteristic

Components, cards and spare parts of our product range are available for your use.

Logistics

Personnel and material are furnished according to your requirements, professionally and on time.

Helpline

Hotline

You will receive competent and quick telephone assistance round the clock in the event of unscheduled machine stops and plant down-times, system faults and device break-downs.

Help desk

During business hours, you will receive support for commissioning, application queries right through to fault analysis, which can also be carried out using remote diagnostics.

Specialists are available in the areas of automation, drives, low-voltage power distribution or switchgear.

Onsite Service

Troubleshooting onsite

Qualified technicians and specialists can visit you in order to rectify faults quickly and reliably.

Mounting and commissioning support

Contact us if you require fast and competent support in installing and commissioning tasks.

Conversions and expansions

Whether with controllers, circuit-breakers or other components, we can bring your machines and plants up to the latest state-of-the-art.

Inspection and maintenance

The legal requirements and regulations demand the regular testing of electrical equipment in order to ensure its proper condition. Further information is available from our website.

www.eaton.com/moeller/aftersales

The After Sales Service therefore offers appropriate services for circuit-breakers and low-voltage distribution boards.

We support you in the inspection and maintenance of the circuit-breakers and low-voltage distribution boards supplied by us, determine the condition of your systems and carry out the necessary work. If required, thermography or network analysis are also carried out with this work.

Eaton Wiring Manual

After Sales Service

Service seminars

Tailored service seminars that meet your individual requirements to train up your personnel.

Thermography

Thermography gives us an efficient way of analysing your electrical systems and controls during operation.

Network analysis

Network analysis provides clear information about the specific state of your networks without the need for lengthy and expensive fault retrieval.

Bus monitoring

Please enquire whether we can inspect the communication networks of your systems with the latest technical equipment.

Repairs

Direct exchange

In the event of a fault, the direct exchange service for selective products considerably reduces the downtime of your production plant.

Repairs

The repair of products in our Service Center is an inexpensive alternative for fault rectification.

Share parts/Replacement devices

We reduce maintenance costs with selected spare parts and devices for current/discontinued product lines.

Online Service

Online troubleshooting

We can provide special assistance if you wish to analyse and rectify faults on products. You can carry out interactive troubleshooting via the Internet with direct access to our Service-database.

FAQ - Frequently Asked Questions

There are some questions about our products that our customers very often ask. You can benefit from the answers. You can read the FAQ with the corresponding answers on all aspects of automation.

Downloads

You're at the right place here if you require updates, software, documentation and declarations of conformity. Visit the Eaton Download Center to obtain all the information you require.

Contact

Hotline for faults

In the event of a fault contact your local representative

www.eaton.com/moeller/aftersales

or the After Sales Service directly

+49 (0) 180 522 3822, 24/7 (round the clock)

Help desk

Tel.: +49 (0) 228 602 3640

(Mon. – Fri. 08:00 – 16:00 CET).

email

AfterSalesEGBonn@eaton.com

Internet

www.eaton.com/moeller/aftersales

Eaton Wiring Manual

Photovoltaics in residential buildings

0 Using solar energy safely – Solutions from Eaton

Safe photovoltaic systems

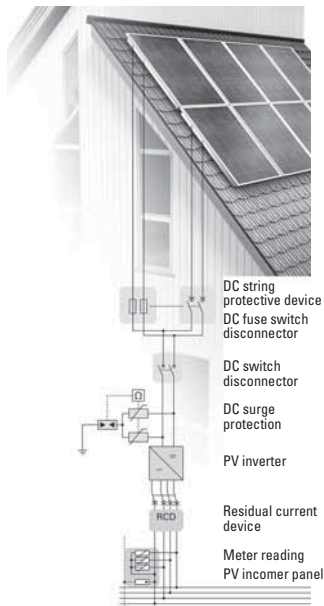

Photovoltaic systems use solar cells to convert solar energy into electrical energy. If the system is connected to the grid, the generated electricity is fed directly into it. Unlike grid independent systems the complicated temporary storage of electricity is not required, however, the generated DC current has to be converted to AC.

Apart from the PV panels, a grid-connected system consists of one or several inverters and switching devices, for operation, maintenance and protection in the event of a fault – such as:

- a DC string protective device,
- DC switch-disconnector
- DC surge protection
- PV inverter
- Residual current device (RCD),
- AC surge protection
- and xComfort system (optional).

The PV panels are connected in series (as a string) in order to provide the required input DC voltage for the inverter.

Two or several strings are connected in parallel to increase the power of the system. For safety reasons, all electrical equipment must be isolated, protected and secured with switching devices which must likewise be protected with enclosures. All these important protective devices can be sourced directly from Eaton.

Safe isolation, switching and protecting.

In order to feed the generated electricity into the public grid or even to use it, inverters are required to convert the DC current of the solar cells in the AC current. The frequency and voltage values are adjusted to the grid parameters at hand.

Also here, Eaton offers reliable protective and grid isolation devices such as inverters from 1500 to 4000 W for indoor use and from 4000 to 4600 W for outdoor applications.

Eaton Wiring Manual

Photovoltaics in residential buildings

0

Converting solar energy efficiently



Grid-connected power inverters from 1500 to 4600 W

Each photovoltaic installation is as individual as the requirements of its user.

Eaton therefore offers a complete line of single-phase power inverters from 1500 to 4600 W:

- Suitable for monocrystalline and polycrystalline PV generators.
- Maintenance free, highly reliable and very easy to install.
- Integrated LCD display simplifies operation.
- Optimum efficiency with maximum power point tracking (MPPT).
- Fan-free thanks to natural convection cooling.
- High performance compared to size.
- Particularly quiet and low pollution operation.
- Standard RS232 ENS interface in accordance with VDE0126-1-1/DK5940.
- Compact elegant modern design.

Indoor use

The ISG series with degree of protection IP43 is designed for indoor installation.

Outdoor use

The ISG series with degree of protection IP65 is designed for both indoor and outdoor applications.

Specifications

All power inverters are designed for ambient temperatures from -20 to +55 °C. Optimum operation is achieved at ambient air temperatures between 0 and +40 °C.

The power of the sun – used optimally

The total output of a photovoltaic system not only depends on the total area of the PV panels, their alignment and the inclination angle of the modules.

Components such as inverters play an important part in the efficiency of the system. Eaton inverters ensure you have the maximum output.

Requirements, the DC isolation gap

DC switch-disconnector

The IEC 60364-7-712 standard stipulates the installation of a switch-disconnector between the PV generator and the inverter. Eaton offers enclosed and open switch-disconnectors for DC voltages up to 1000V. In accordance with the regulations of VDI 6012 they can be used as separate switching points, so that a faulty inverter can be completely de-energized safely. All switch-disconnectors switch two poles and are therefore also suitable for ungrounded systems. All switches are TÜV certified.

Eaton Wiring Manual

Photovoltaics in residential buildings

0



Compact disconnectors for inverters

Eaton offers both enclosed and open switch-disconnectors in its range. The open P-SOL switch disconnectors are designed for mounting in customized enclosures or inverters. They are mounted on 35-mm top-hat rails, and their terminals enable a connection to all commonly used cable types.

Perfectly enclosed for outdoor installation

Eaton's enclosed SOL switch-disconnectors are ready to fit and are therefore very easy to install. Variants for 2, 3, 4 or 8 strings are available for the most common connector types such as MC4 or metric glands. The enclosure is protected to IP65 and is suitable for outdoor installation. The lockable mechanism ensures safety during maintenance work. A pressure-equalizing element prevents the formation of condensation, preventing malfunctions caused by flashovers.

Fireman's switch – small investment, massive protection

In the event of a house fire, the fire brigade can often only rescue persons or animals or prevent the fire spreading to neighboring buildings. This is due to the voltage of up to 1000 V generated by PV systems, which is still present after the inverter has been isolated. Rescue services are thus exposed to fatal risks when entering the building due to the possibility of damaged DC cables. Eaton's SOL30-SAFETY fireman's switch provides a solution here, and de-energizes the line from the solar modules to the inverter, this making safe any fire fighting activities.

Although VDE 0100-7-712 stipulates the use of a DC isolator, it does not stipulate the location. The isolator is frequently integrated in the inverter so that the cable between this and the house terminal is safe, whilst a DC voltage of up to 1000V is still present in the solar modules and DC cables up to that point, with up to ~8A for each string.

Eaton Wiring Manual

Photovoltaics in residential buildings



Simple installation

Fireman's switches are installed in direct proximity to the PV modules and inserted in the DC cable directly after the entry point into the building between the panels and the power inverter. The PV modules are disconnected automatically using undervoltage releases in the fireman's switch, when the AC voltage of the building is isolated either by the fire brigade or the local utility company or on site via a PV-OFF switch.

DC-string protection

If a PV installation has three or more strings, a string protection device using DC fuses or DC string circuit-breakers is recommended. These protect the PV panels from leakage and feedback currents that can occur on faulty strings, and prevent the feedback of good panels to panels with short-circuits. Compared to fuses, string circuit-breakers have the advantage that they are immediately operational again after the fault is rectified

as well as having the ability to send trip indications via auxiliary contacts to thus avoid any losses in yield. A further feature of the DC string circuit-breaker is the variable tripping range for short-circuit currents: it reacts already from 1.05 ... 1.3 times the residual current. Eaton offers both fuse switch-disconnectors as well as string circuit-breakers that can be combined easily with other components as required.

Fuse switch-disconnectors with integrated short-circuit protective device

The task of the FCFDC10DISOL fuse switch-disconnector for the ASFLC10-SOL cylindrical fuse cartridges for fuse sizes 10 x 38 is to protect PV panels from short-circuit currents. A flash function can optionally be used to indicate a blown fuse.

String circuit-breakers

The Eaton PKZ-SOL string circuit-breakers are the fuseless alternative for protection against short-circuit currents. Its variable tripping range enables optional settings to the actual short-circuit current of a string. A thermal release responds already at 1.05 ... 1.3 times the current, whilst the magnetic release responds at 6 times the current. Non-enclosed string circuit-breakers are designed for installation in customized generator terminal boxes.

Eaton Wiring Manual

Photovoltaics in residential buildings

0

DC surge protection

Surge protective devices for PV applications

The Eaton SPPT2PA surge arrester is specially developed for photovoltaic applications and offers protection from transient overvoltages that can occur through the indirect effect of lightning. Eaton offers types for both grounded and non-grounded systems in which the use of a spark gap ensures galvanic isolation. The units can be supplied pre-wired as ready to use connection units.

Increasing building safety and comfort

AC switching devices for buildings, such as miniature circuit-breakers and residual current devices offer maximum safety.

Eaton products of the xPole series combine all functional, mounting and safety benefits: intelligent design solutions exclude the possibility of mounting faults. They even offer optimum safety for the end user:

Personnel protection in the form of residual current devices and protection of the electrical installation in the form of overvoltage protection and MCBs. The portfolio is rounded off with an extensive range of intelligent switching devices such as remote switches, restart devices and others.

Digital residual current device FI

With the development of digital technology a new level of precision was achieved that enables the avoidance of nuisance tripping. This can occur for example with permanent residual currents of electrical devices or temporary faults caused by storms. Here too, Eaton is also one step ahead:

Eaton is the first company worldwide to offer a digital residual current device. The continuous status monitoring of the installation allows unwanted and annoying disconnections to be considerably reduced, thus guaranteeing optimum system availability. Three LEDs use the "traffic light" principle to indicate when a differential current has reached the 30% warning threshold. In this way, countermeasures can be taken in the installation before the situation gets worse. The installation user is thus provided with increased safety – with greater convenience.

Combination switch

The benefits of MCBs and RCDs combined in a single device – this is the Eaton combination switch. It saves space, whilst ensuring complete safety: reliable fire and personnel protection (30 mA) with enough space for flexible generous cabling.

The surge current proof design prevents unwanted disconnection and selective types enable the selective disconnection of faulty system sections.

Eaton Wiring Manual

Photovoltaics in residential buildings

Miniature circuit-breakers

Regardless of whether plug terminal connections or screw terminals are required, Eaton has the right MCB for residential buildings and for industrial applications. Extensive accessories such as auxiliary contacts, shunt releases, restart devices and intelligent busbar solutions enable a host of applications and automation solutions.

Distribution systems

From the compact distribution board to the meter cabinet and the data network cabinet, Eaton offers a complete product portfolio. All applications can thus be covered for the infrastructure in residential and non-residential buildings as well as in the industrial sector.

Surge protection

Lightning strikes and overvoltages not only pose a risk for electrical installations but also for their operators. Eaton offers an extensive range of surge protective devices. Attachable auxiliary contacts also enable the monitoring of device functions.

Wireless monitoring of PV installation and simple energy management

Energy measuring sensor up to 16 A and Room Manager

Convenient monitoring of electricity generation from your living room – modern home automation makes this possible. With xComfort, Eaton is offering the Room Manager with integrated energy management software (Energy Manager) for a powerful solution.

The connection of the Eaton energy sensor with the inverter enables the electrical energy currently fed into the grid to be measured.

This data is then transferred wirelessly to the Room-Manager which is installed in one of the living areas. Here, the user of the system can view values such as energy (kWh), power (kW), voltage (V) and amps (A) on a display.

Eaton Wiring Manual

Photovoltaics in residential buildings

0



Eaton Wiring Manual

Photovoltaics in residential buildings



Comfort, safety and energy management

Wireless home automation enables lighting management, shade control, monitoring and danger warnings, as well as energy saving control concepts for heating, cooling and ventilation.

Eaton's xComfort and Energy Manager thus offer transparency, comfort and safety combined:

- Consumption control
- Cost saving
- Reduction of CO₂ emission

EU regulations stipulate that the actual energy consumption must be clearly visible to end consumers. The Eaton Room Manager covers this requirement by displaying and controlling the energy consumption of specific electrical or gas devices in the entire home.

Entering the price per unit of measure makes it possible to calculate the costs for a consumption cycle quickly and simply, for example for a bath or a washing machine cycle.

More consumption and cost control is offered by a function that reads the history of the previous 24 hours right through to the last 12 months from the archive and shows it as a value or a trend on the display. It is also possible to output a warning message as soon as a user-defined limit value is exceeded. All this makes Eaton's energy management software a useful tool for identifying possible savings and reducing electricity costs for private system users.

Eaton Wiring Manual

Eaton power distribution equipment

0 xEnergy – Safe energy distribution up to 5000 A

The modular system consists of perfectly fitting function modules that are type tested to IEC/EN 61439 with Form 1 to Form

4 internal partitioning, and which take European and local (DIN, VDE, CEI, NF, UNE) installation practice into account.



xEnergy provides the panel builder with a flexibly combinable product range for power distribution systems up to 5000 A. The operation of the system couldn't be simpler, despite its complexity. The modular design enables the creation of intelligent combinations.

Switching and protective devices, as well as the associated mounting technology and extensive housing components are perfectly matched and form both a technical as well as an economic unit.

This practically oriented system platform enables individual project design, maximum flexibility and fast production in the workshop. On the one hand, this saves time, money and space, whilst type tested mounting units offer a higher level of safety. The modular system can furthermore be extended with little effort to meet future requirements.

Eaton Wiring Manual

Eaton power distribution equipment

The panel builder is provided with efficient tools for tasks ranging from planning to quotations, right through to ordering. The entire range is supplied in functional flat packs or as pre-assembled switch cabinets.

System features:

- Rated operational voltage 400 to 690 V AC
- Rated operational current 630 to 5000 A
- Rated short-time withstand current to 100kA (1 s)
- Main busbar current to 5000 A
- Dropper bar current up to 2000 A
- Sheet steel housing for combination and separate mounting
- Degree of protection to IP31 and IP55
- Colour RAL 7035
- Internal separation up to Form 4

- Dimensions: Height 2000 mm
Width 425, 600, 800, 850, 1000, 1100, 1200, 1350 mm
Depth 400, 600, 800, 1000 mm

0

Available technologies

- Fixed mounting
- Removable compartments
- Withdrawable compartments



xEnergy XP (Power)

- Incoming units/feeder units, outgoers and couplings with NZM or IZM circuit-breakers up to 5000 A
- Circuit-breakers in fixed mounting or withdrawable units
- 3 or 4 pole circuit-breakers
- Internal separation up to Form 4
- Cable connection from top or bottom
- Incomer system for drill-free cable connection

Eaton Wiring Manual

Eaton power distribution equipment

0

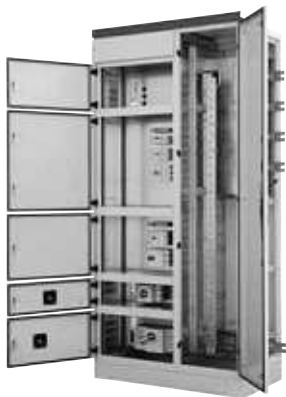

xEnergy XF (Fixed) compartment design

- Outgoers with PKZ or NZM circuit-breakers up to 630 A
- Circuit-breakers in fixed mounting or withdrawable units
- 3- or 4-pole circuit-breakers
- Outgoers with SL fuse-strip units up to 630 A
- Individual outgoers, e.g. controllers, motor starters, small energy outgoers, ...
- Internal separation up to Form 3 or Form 4
- Cable connection from top or bottom



xEnergy XR (Removable) removable compartment design

- Outgoers with PKZ and NZM circuit-breakers up to 630 A
- Outgoers with strip-type switch-fuse units up to 630 A
- Flexible surface mounting using plug-in contacts
- Plug-in modules and switch-fuse units exchangeable under conditions
- Straightforward maintenance, minimal downtime
- Internal separation up to Form 4
- Cable connection from top or bottom

Eaton Wiring Manual

Eaton power distribution equipment



xEnergy XW (Withdrawable) withdrawable compartment design

- Outgoers with PKZ and NZM circuit-breakers up to 630 A
- Outgoers for motor starters up to 250 kW
- Empty drawer-units for every application
- Uniform, straightforward operation for all drawer-unit sizes
- No special tool required
- Flexible assembly with plug-in contacts (incoming and outgoing)
- Withdrawable modules exchangeable whilst live
- Unambiguous position indication for Operation, Test, De-energized
- Straightforward maintenance, minimal downtime
- Internal separation up to Form 4
- Cable connection from top or bottom



xEnergy XG (General) empty sections

- Power factor correction
- Mounting system for subdistribution system with modular installation devices
- Control technology with Sasy60i and xStart
- Individual fixed mounted components on mounting plate

Eaton Wiring Manual

Eaton power distribution equipment

0

xVtl add-on board

The xVtl side-by-side distribution system is designed to take switchgear for applications up to 2500 A.

Typical uses are as power distribution systems in utility buildings or as control panel enclosures in industry. This is where the xVtl can demonstrate the benefits of its rugged design.



The xVtl is a stable, side-by-side mountable distributor made of sheet steel that is also best suited for stand-alone installation. It protects persons from coming into direct contact with conducting parts and even from possible electric shock, and reliably fends off damaging exterior influences. It carries out these functions according to the specific requirements, with protection degrees of IP40 or IP55. While the former is suited to diverse uses in functional buildings such as schools or hospitals, it is

also recommended for harsher conditions such as wind energy systems, or in industry, in a foam-type polyurethane sealing design. Abrasion-proof protection against corrosion is guaranteed thanks to structured paint finish using a powder coating RAL 7035.

Overall, the technical design of the xVtlL complies with the IEC/EN 62208 and EN 60529 standards, as well as with

Eaton Wiring Manual

Eaton power distribution equipment

IEC 60439-1, as long as it is used as a low-voltage energy distribution system.

System features:

- Common platform with xEnergy: Several design elements such as mounting frames, bottom and top plates, as well as side and rear panels can be used for both xVtl and xEnergy.
- Installation mounting systems: Profi+, EP and IVS
- Rated operational voltage 415 V AC
- Rated operational current to 2500 A



- Rated short-time withstand current to 65 kA (1 s)
- Sheet steel housing for combination and separate mounting
- Degree of protection to IP40 and IP55
- Colour RAL 7035
- Internal separation up to Form 2
- Dimensions:
Height 1400, 1600, 1800, 2000 mm
Width 425, 600, 800, 850, 1000, 1100, 1200, 1350 mm
Depth 400, 600, 800 mm

xVtl low-voltage energy distribution system

- Incoming units /feeder units, outgoers and couplings with NZM and IZM circuit-breakers up to 2500 A
- Outgoers with SL fuse-strip units up to 630 A
- Internal separation up to Form 2
- Circuit-breakers in fixed mounting or withdrawable units
- 3- or 4-pole circuit-breakers
- Cable connection from top or bottom
- Incomer system for drill-free cable connection
- Outgoers with NZM circuit-breakers
- Compensation sections
- Individual fixed mounted components on mounting plate

Eaton Wiring Manual

Eaton power distribution equipment

0



xVtl subdistribution system

- Installation mounting systems Profi+, EP and IVS
- Mounting modules for
 - for NZM
 - NH switch-disconnectors
 - Low-voltage h.b.c. fuse switch disconnectors
 - Busbar mounting fuses
 - Modular installation devices
 - Individual devices

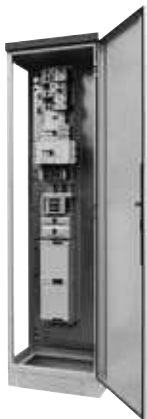

xVtl control centres

- Control technology with Sasy60i and xStart
- Individual fixed mounted components on mounting plate
- Air conditioning and ventilation
- Automation engineering

Eaton Wiring Manual

Eaton power distribution equipment

0

Modular switchgear systems MODAN®



The MODAN is a type-tested modular power distribution system in compliance with IEC/EN 61439-1. It is used wherever large amounts of energy have to be distributed safely and reliably or where motor controllers have to be integrated into processes.

MODAN combines the greatest possible flexibility with safety and reliability, as well as profitability for the long term. Straightforward engineering, effective commissioning and fault-free operation by the modular construction using Eaton products for switching, protection, control and visualization.

Full and comprehensive integration of the primary control is implemented on the basis of networked functional groups.

For personnel and system protection, the arc fault protection system ARCON® can be integrated without problems.

MODAN® P – Power

- Operating voltage 400 to 690 V AC
- Rated operational current 630 to 6300 A
- Short-circuit strength to 100 kA (1 s)
- Connection from top and bottom for cables and busbars (LX, LD, BD)
- Internal partitioning up to Form 4b



Eaton Wiring Manual

Eaton power distribution equipment

0

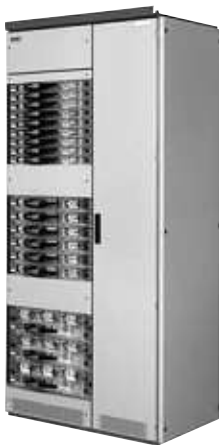

MODAN® R – Removable

- Section for up to 15 removable compartments for power outgoers and motor starters or
- Section for up to 27 fuse combination -units
- Flexible surface mounting using plug-in contacts
- Plug-in modules exchangeable whilst live
- Straightforward maintenance and reduced downtime

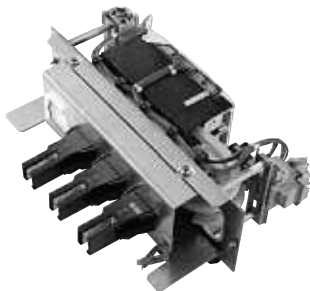

Removable compartments

- Power outgoers up to 630 A
- Motor starters up to 90 kW
- Module is for plugging in, i. e. the incoming unit is removable

Eaton Wiring Manual

Eaton power distribution equipment

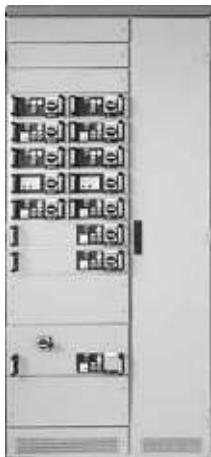

MODAN® W – Withdrawable

- Section for up to 30 drawer units for power outgoing and motor starters
- High packing density
- Uniform, straightforward operation for all drawer-unit sizes
- No special tool required
- Withdrawable modules exchangeable whilst live
- Straightforward maintenance and minimal downtime
- Internal partitioning up to Form 4b

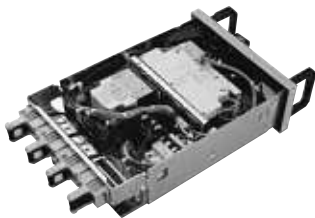

MODAN for withdrawable units

- Power outgoing up to 630 A
- Motor starters up to 200 kW
- Drawer-unit is withdrawable, i. e. all electrical connections are plug connections
- Exchangeable whilst live
- All drawer units positions lockable
- Unambiguous and clearly visible indication for all possible drawer unit positions (Operation, Test, De-energized)

Eaton Wiring Manual

Eaton power distribution equipment

0

ARCON® arc fault protective system

Maximum personnel and system safety, especially during continuous production processes, made possible using the ARCON arc-fault protection system. The system offers protection from 6 to 100 kA_{rms} arc fault current.

Detection of the arc faults is by light and current sensors. The evaluation unit

responds when light and current signals are present. A tripping signal is applied to the quenching device and to the feeder circuit-breakers. The fault arc is quenched in less than 2 ms. The system can be put back into operation as soon as the fault is eliminated and the quenching device is renewed.

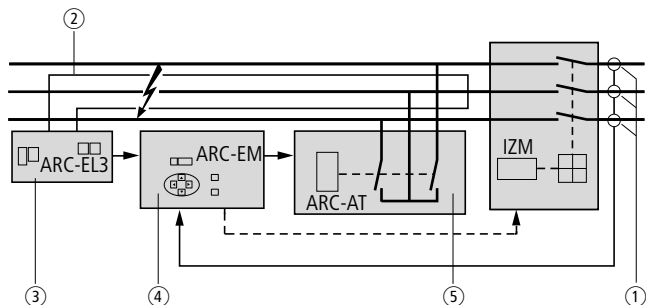

- ① Current transformer
- ② ARC-SL... linear light sensor
- ③ Electronic evaluation unit (slave)
ARC-EL3
- ④ Electronic evaluation unit (master)
ARC-EM
- ⑤ ARC-AT quenching device

ARCON® – Quenching device



Eaton Wiring Manual

Eaton power distribution equipment

Sheet steel wall-mounting enclosure CS with mounting plate

0



The robust CS enclosure series with solid sheet steel is used wherever a particularly effective protection against direct contact with live parts or the protection of all installed equipment from harmful external influences is required. Thanks to its high degree of protection to IP 66 (UL/CSA Types 1, 12) with a continuous foam polyurethane gasket, water, oil or dirt is prevented from penetrating inside the enclosure. This makes the CS enclosure particularly suitable for subdistribution boards in control panels in industrial and utility buildings, as well as for machine building applications.

The stable sheet steel enclosure meets the requirements of impact resistance category IK09 to EN 62262. Impact resistant metal locks provide additional safety. The hinge pins with quick change technology enable the door hinge to be replaced quickly since each metal pin can be

removed without any tools. Wall fixing brackets enable the switch cabinet to be mounted on a wall.

The PHZ-A comfort rotary handle with locked position indication clearly shows on the outside whether the cylinder is in the opened or closed position. The comfort rotary handle can be retrofitted quickly, without the need to remove the standard lock - thus eliminating the need for the use of rotary levers.

The galvanized sheet steel mounting plate with a maximum thickness of 3 mm ensures the safe installation of the switchgear and basic EMC protection.

The CS enclosure can be turned through 180°, so that the cables can be fed in either via the top or bottom. The large flange plate openings allow the fitter more flexible handling.

Eaton Wiring Manual

Eaton power distribution equipment

0

The foam gasket of the flange plate saves users the time required for gluing in foam rubber seals. Both flange and mounting plates are incorporated in the grounding concept, thus eliminating the need for an additional protective ground connection.

Their powder coated surface provides an abrasion and corrosion resistant protection. As a special service, Eaton also offers individual solutions tailored to customer specifications.

Compact distribution board for flush mounting and surface mounting

KLV-U flush mounted compact distribution board



The plastic enclosure suitable for cavity walls offers an outstanding level of stability whilst the flat design of the sheet steel door makes it inconspicuous in any room. An adjustment tolerance of up to 18 mm for compensating any unevenness in walls and plaster significantly simplifies flush mounting in wall openings.

The zero and protective ground terminals are already prefitted. The KVL-U distribution board enclosure with protection class II and degree of protection IP30 are available in 1 to 4-row versions each with 12 + 2 module widths.

The following door variants are available: Sheet steel door flat and super flat, plastic design door white and transparent.

BC-A surface mounted compact distribution board



Wherever it is not possible to install in cavity walls, the rugged BC-A surface mounted compact distribution board protects the inside from mechanical damage and harmful environmental influences. In addition to degree of protection IP30, the unit meets the requirements of protection class II when used in conjunction with the back plate and the cover plate.

In spite of its compact dimensions, up to 4 rows of 13 space units are available for each distribution board enclosure. The BC-A surface mounted compact distribution board comes standard with white and transparent doors.

Eaton Wiring Manual

Eaton power distribution equipment

IVS service distribution system



The IVS service distribution board up to 630 A is primarily used for the safe and economical power supply in industrial, building and commercial applications.

The range therefore includes wall and standard enclosures, each with protection to IP30 and IP54.

The mounting space with an even division into standard 250 x 375 mm sections ensures a particularly clear design. Planning, ordering and mounting are thus simplified accordingly.

- The link between the enclosure and the mounting units is the mounting system with insulated support brackets. The mounting system can be lifted out of the enclosure after the plates have been removed and the screws released.
- A number of mounting units that are tailored to original Eaton switching and protective devices allow for time saving and simple mounting.
- Insulated covers are used for protecting the mounting units from direct contact.

Applicable standard for manufacturing is IEC EN 60439-1 "Type-tested low-voltage switchgear assemblies".

Eaton Wiring Manual

Eaton power distribution equipment

0

K terminal



The connection terminal consists of a combination of several very stable terminal blocks. It is used for connecting two or several conductors.

A very wide range is available as standard with 6 sizes and terminal capacities from 16 to 3 x 240 mm² (160 to 1000 A).

Copper conductors can be inserted quickly into the box terminals from above without bending.

The Eaton terminals are designed for copper strips or busbars as well as copper conductors. Each terminal pair is moulded in a plastic Duroplast shell. Each of the 6 sizes is available from stock as a 1-pole, 3-pole, 4-pole or 5-pole terminal combination.

Accessories such as the transparent plastic cover, auxiliary conductor terminals or conversion kits also enable the creation of your own terminal variants.

Eaton Wiring Manual

Eaton power distribution equipment

CI insulated distribution boards, totally insulated

0



The assembly of the CI system demonstrates its flexibility. Whether as an individual enclosure, wall-mounted or floor standing distribution board of any size, the modular CI insulated distribution board up to 1600 A always offers the right solution in harsh ambient conditions.

The modular system makes it easy to adapt to a wide range of conditions.

- IP65 protection ensures protection from dust, humidity and water jets,
- Pressure relief by means of liftable covers with spring-loaded enclosure bolts,

- "Total insulation" provides maximum personnel protection and operational safety.
- Transparent neutral cover allows unrestricted view,
- Lock mechanism actuated with cylinder lock or tool,
- Floor standing distribution boards with base covers for routing, fixing or covering large cable cross-sections.

Enclosed distribution boards are type-tested switchgear assemblies (TTA) in accordance with VDE 0660 part 500 or Type Tested Assemblies (TTA) to IEC 60439.

Eaton Wiring Manual

Eaton power distribution equipment

0

SASY60i busbar system for the world market

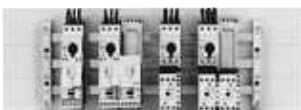
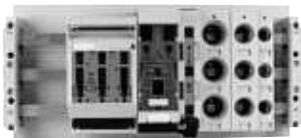
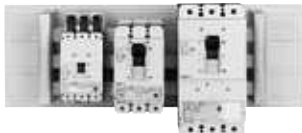

The SASY60i modular busbar system from Eaton is designed for effective power distribution in the control panel.

Thanks to the innovative mounting technology feeder and outgoing circuit-breakers can be mounted quickly and compactly. SASY60i is safe and reliable.

In conjunction with the latest generation of Eaton motor protective circuit-breakers and other circuit-breakers, the SASY 60i provides a universal, UL certified solution for switching, controlling, protecting and distributing energy. Together with the appropriate switching and protective devices, the busbar system is designed for worldwide use.

The larger clearances and creepage distances required in compliance with the UL 508A in America have been considered in the construction of the busbar components.

When used in North America, the insulated bottom plate must be mounted under the system. Components approved for IEC such as NH fuse switch-disconnectors or D busbar mounting fuses can also suitably fit for perfectly matched fitting.

As SASY60i requires few system components the new Eaton busbar system also reduces the stock-keeping and ordering required.

These benefits naturally also apply to Eaton's SASY185i and SASY Compact busbar systems.

Switching, control, visualization

	Page
SmartWire-DT communication system	1-2
The way to the safe machine	1-29
Timing relays	1-36
EMR measuring and monitoring relays	1-40
System overview easyRelay, MFD-Titan	1-43
Engineering easyRelay, MFD-Titan	1-50
Programming easyRelay, MFD-Titan	1-77
HMI-PLC - Systematic visualization and control	1-94
Compact PLC – universal compact controllers	1-108
Modular PLC	1-113
Modular I/O system	1-124
Software	1-130

Switching, control, visualization

SmartWire-DT communication system

1

Connect don't wire

The main part of a control system for a machine is these days carried out by a PLC. Typically the PLC is mounted in a control panel at a central position in the system. The control of the switchgear is carried out via special cables from the input and output terminals of the PLC for the control and return signals. With a decentralized configuration the switchgear and the remote input/output system are connected in the same way.

The SmartWire-DT communication system replaces the control wiring previously required between the PLC inputs/outputs and the switching devices. In this way, the inputs/outputs of the PLC are relocated to the switching devices. Pluggable communication modules are used for this task. The communication is implemented via an 8-pole ribbon cable. Special device plugs are used for connecting the communication modules to the cable. The switchgear is supplied on the control circuit side by the connection cable.

The SmartWire-DT system

- reduces the time required for the control wiring and wiring test,
- saves space in the control cabinet because cable ducts are unnecessary and
- reduces the number of inputs/outputs required at the PLC.

The length of a SmartWire-DT network can be extended up to 600 meters. Up to 99 stations can be connected.

You can use the SmartWire-DT technology flexibly. The connection via standard fieldbus systems (e.g. PROFIBUS, CANopen) enables SWD gateways to be used on the controller platforms of many manufacturers. Another option is the use of Eaton automation components (e.g. XV100 visualization system) with an integrated SmartWire-DT interface.

Switching, control, visualization

SmartWire-DT communication system

Evolution in the switchboard

Before

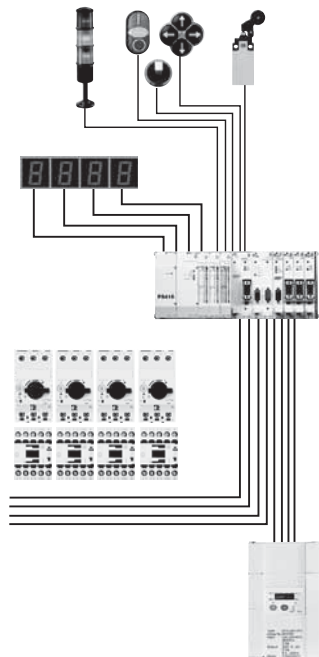

Today

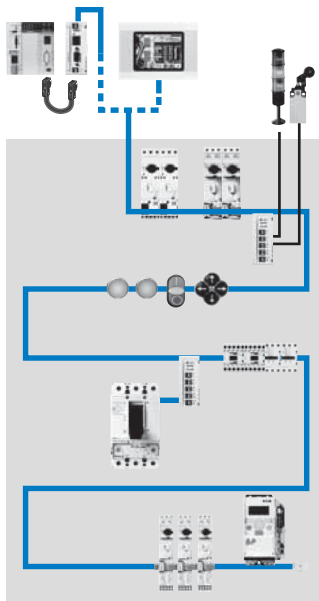

1

Switching, control, visualization

SmartWire-DT communication system

1

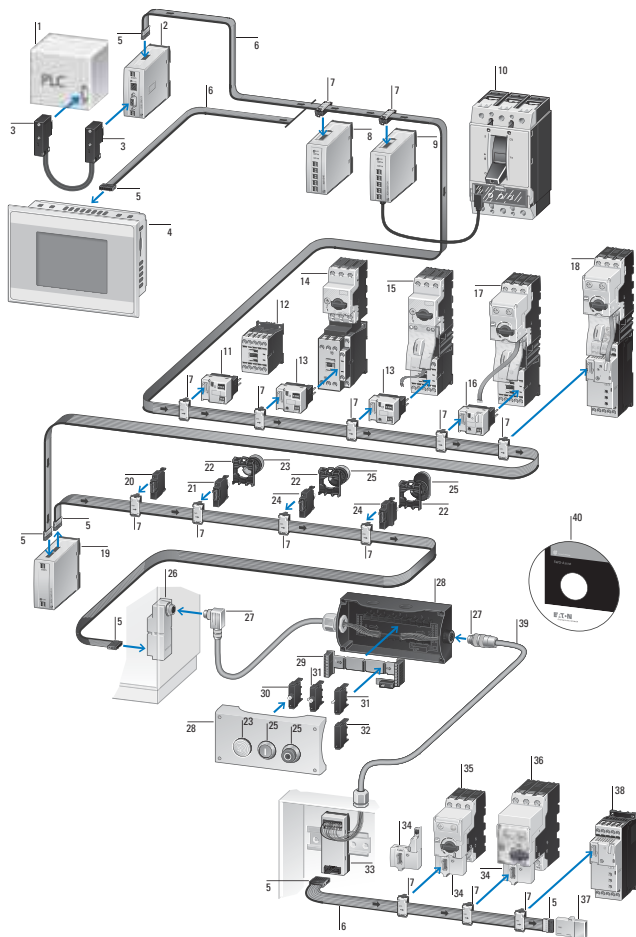

Switching, control, visualization

SmartWire-DT communication system

- | | |
|---|--|
| 1 Programmable logic controller PLC | 29 SmartWire-DT card for function elements, base-fixing |
| 2 SmartWire-DT gateway | 30 SmartWire-DT LED elements for base fixing |
| 3 Data plugs Sub-D 9 pole | 31 SmartWire-DT function elements for base fixing |
| 4 SmartWire-DT HMI-PLC | 32 SmartWire-DT universal station for base fixing |
| 5 SmartWire-DT blade terminal 8 pole | 33 SmartWire-DT adapter for ribbon/round cable for top-hat rail mounting |
| 6 SmartWire-DT ribbon cable 8 pole | 34 SmartWire-DT PKE module (motor-protective circuit-breaker) |
| 7 SmartWire-DT device plug 8 pole | 35 PKZ12, PKE32 motor-protective circuit-breaker |
| 8 SmartWire-DT I/O modules | 36 PKE 65 motor-protective circuit-breaker |
| 9 SmartWire-DT connection for NZM | 37 Network termination for 8 pole ribbon cable |
| 10 NZM circuit-breaker | 38 DS7 soft starter |
| 11 SmartWire-DT contactor module | 39 SmartWire-DT round cable, 8-pole |
| 12 DILM contactor | 40 SmartWire-DT planning and ordering aid, SWD-Assist |
| 13 SmartWire-DT contactor modules with Manual-0-Automatic switch | |
| 14 PKZM0 motor-protective circuit-breaker | |
| 15 SC motor-starter combination | |
| 16 SmartWire-DT PKE module (motor starter) | |
| 17 Motor-starter combination with PKE electronic motor-protective circuit-breaker | |
| 18 DS7 Softstarter with PKE electronic motor-protective circuit-breaker | |
| 19 SmartWire-DT powerfeed module | |
| 20 SmartWire-DT universal station, front fixing | |
| 21 SmartWire-DT LED elements, front fixing | |
| 22 RMQ-Titan fixing adapters for front mounting | |
| 23 RMQ-Titan indicator light | |
| 24 SmartWire-DT function elements for front fixing | |
| 25 SmartWire-DT operating elements | |
| 26 SmartWire-DT control panel cable entry for ribbon to round cable | |
| 27 SmartWire-DT plug connector | |
| 28 RMQ-Titan surface mounting enclosure | |

Switching, control, visualization

SmartWire-DT communication system

PKE communication via SmartWire-DT

Motor-starter combinations fitted with PKE can transfer the following information via SmartWire-DT:

1

I_max	Maximum motor current (relative): shows the single-phase current (single-phase load) or the maximum current in the appropriate phase (three-phase load).
Thermal image of the motor	Shows the temperature curve of the motor; stated in %, "Overload warning" function possible
Type of trip block display	Shows the type of trip block currently in use.
Display of set Overload value	Shows the currently set value for the overload release.
Display of time-lag class value	Shows the currently set time-lag class (Class 5...20).
PKE switching state display	Shows the currently set ON/OFF switching state.
DILM contactor switching state	Shows the currently set ON/OFF switching state.
Trip indication overload	Shows a differentiated "Overload" fault indication.
Trip indication short-circuit	Shows a differentiated "Short-circuit" fault indication.
Trip indication Phase failure	Shows a differentiated "Phase failure" fault indication.
Trip indication Test	Shows a differentiated "Tripping via test function" fault indication.
ZMR function	Overload relay function: When the ZMR function is set, the contactor disconnects in the event of an overload. The PKE motor-protective circuit-breaker remains switched on (ON setting). The contact is reset with the MANUAL/AUTO function via PKE-SWD-32.

Switching, control, visualization

SmartWire-DT communication system

Overload relay function (ZMR)

The ZMR function enables the motor to be switched off by the connected contactor in the event of an overload. To do this the PKE sends the switch off command for the contactor to the PKE-SWD-32 via the data cable of the PKE32-COM.

The trip in response to a motor overload occurs if the thermal motor image of the PKE reaches 110 %.

This value remains set until the thermal motor image has gone below the 100 % level and the operational readiness of the contactor is restored.

The reclosing readiness of the contactor can be selected by the two manual and automatic operating modes of the ZMR function.

The ZMR function can only be used in position "A" of the 1-0-A switch.

In the event of a phase unbalance and activated ZMR function, the value of the thermal motor image is raised from 100 % to 110 % after a trip.

The switched off contactor's readiness to reclose is restored when the value falls below 100 %.

The ZMR function must not be activated with reversing starters since this operation does not ensure the disconnection of the second contactor in the event of an overload.

ZMR Manual mode

In "manual" ZMR operating mode, the retriggering of the contactor must be acknowledged beforehand.

ZMR Automatic mode

In "automatic" ZMR mode, the contactor is ready to reclose immediately after the thermal image drops below 100 %.

Danger!

If the switch on command for the contactor is sent in "automatic" ZMR mode, the motor starts up automatically after the thermal motor image falls below 100 %.

Never disconnect the communication link between the PKE-SWD-32 and the PKE trip block after an overload with the ZMR function activated, as this can cause the contactor to switch on if a switch command is present.

Switching, control, visualization

SmartWire-DT communication system

DOL starter with PKZ

1

The DOL starters are assembled from a PKZM0 and a DILM7 to DILM32 contactor. The connection to SmartWire-DT is implemented with the DIL-SWD-32-.. module. This is fitted directly on the contactor and connected via the SWD device plug with the SWD communication cable.

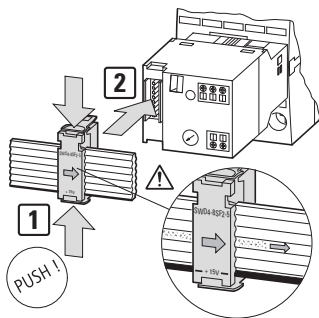

In addition to contactor control, two feedback signals can be sent to the SmartWire-DT system on each SmartWire-DT module for DILM.

The SmartWire-DT module for DILM drives the contactor so that terminals A1-A2 must no longer be wired.

The auxiliary contact X3-X4 is factory fitted with a link. If electrical interlocks are envisaged in the application, the link can be removed and a potential-free contact can be connected.

Two feedback inputs to the programmable logic controller are provided at the three-pole terminal X0-X1-X2. If required, potential-free auxiliary contacts of the PKZ

motor protective circuit-breaker can be connected to these two feedback inputs (e.g. NHI-E-...-PKZ0 standard auxiliary contact, AGM2-...-PKZ0 differential trip-indicating auxiliary contact).

→ Figure, page 1-10

Reversing starter with PKZ

The reversing starters are made up of a PKZM0 motor-protective circuit-breaker and two DILM7 to DILM32 contactors. A DIL-SWD-32-... SmartWire-DT module is fitted to each contactor and connected to the SWD communication cable via the SWD external device plug.

In addition to contactor control, two feedback signals can be sent to the SmartWire-DT system on each SmartWire-DT module for DILM.

The SmartWire-DT modules for DILM drive the contactors so that the connection terminals A1-A2 of the contactors need no further wiring, with the exception of the DILM12-XEV link. The auxiliary contact X3-X4 is factory fitted with a link. For the electrical interlocking of the two contactors this bridge is removed and the auxiliary breaker (contacts 21-22) of the other contactor is linked in as a potential-free contact.

Two feedback inputs to the programmable logic controller are provided at the three-pole terminal X0-X1-X2. If required, potential-free auxiliary contacts of the PKZ motor protective circuit-breaker can be connected to these two feedback inputs (e.g. NHI-E-...-PKZ0 standard auxiliary contact, AGM2-...-PKZ0 differential trip-indicating auxiliary contact).

Switching, control, visualization

SmartWire-DT communication system

The wiring sets DILM12-XRL and PKZM0-XRM12 must only be used to create a reversing starter when the reversing linksDOL starters with PKZ are replaced with DILM12-XR. The A2 connections of the contactors must not be bridged.

→ Figure, page 1-11

Switching, control, visualization

SmartWire-DT communication system

DOL starters with PKZ

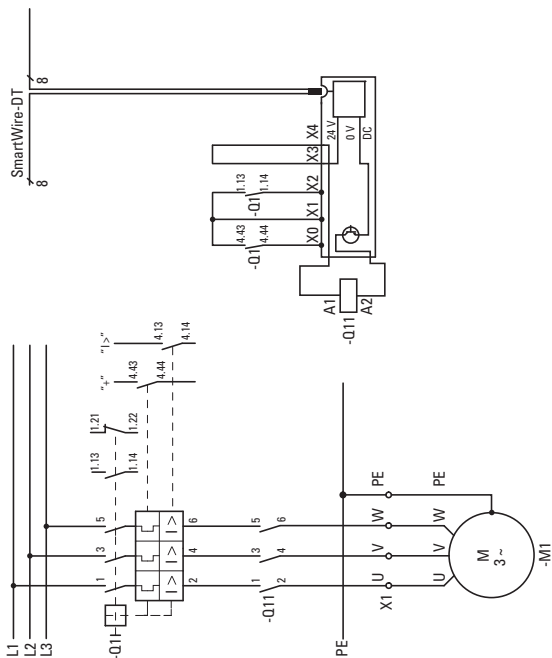
1

Switching, control, visualization

SmartWire-DT communication system

Reversing starter with PKE

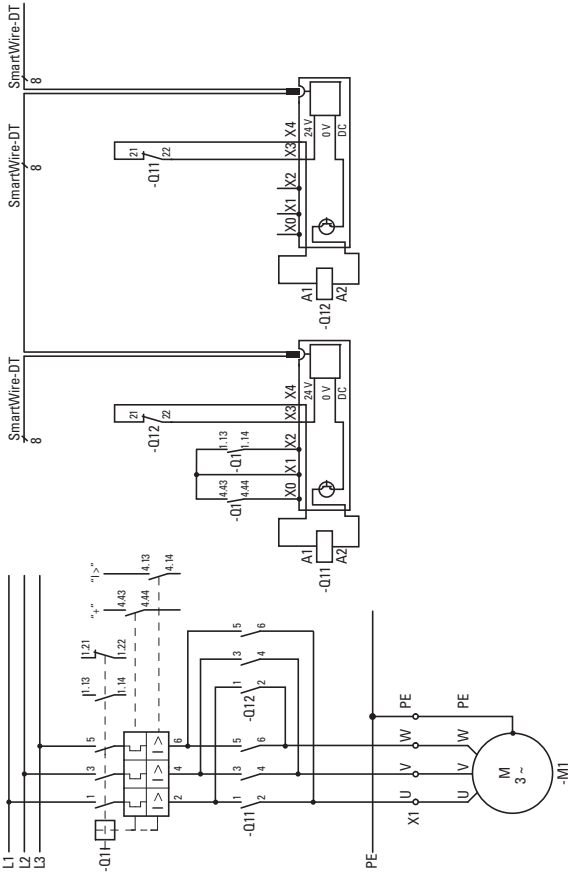

Switching, control, visualization

SmartWire-DT communication system

1

DOL starter with PKE

The DOL starters are assembled from a PKE12/ PKE32 with the PKE-XTUA-... trip block and a DILM7 to DILM32 contactor. The connection to SmartWire-DT is implemented with the PKE-SWD-32 module. This is fitted to the contactor and connected to the SWD communication cable via the SWD device plug.

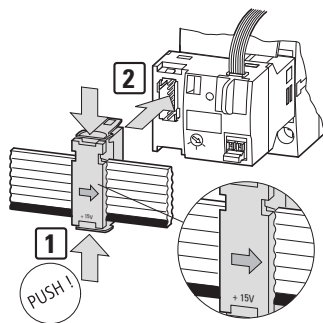

The PKE32-COM is used as a communication link between the PKE-SWD-32 and the PKE trip block. The PKE-SWD-32 receives the data of the PKE trip block via the PKE32-COM and makes this available as input data on the SmartWire-DT network.

The PKE32-COM is fitted on the PKE basic device (PKE12 or PKE32) and is connected with the appropriate interface of the PKE-SWD-32.

The auxiliary contact for the electrical enable X3-X4 is connected at the factory with a link. If electrical locks are envisaged in the application, the link can be removed and a potential-free contact can be connected.

The auxiliary contact for the electrical enable can be used on the PKE-SWD-32 for safety-related control sections (e.g. safety shutdown of the drive).

→ Figure, page 1-14

Switching, control, visualization

SmartWire-DT communication system

Reversing starter with PKE

The reversing starters are made up from a PKE12/PKE32 with a PKE-XTUA-... trip block and two contactors DILM7 to DILM32. The PKE-SWD-32 is fitted on one of the two contactors of the reversing starter. Unlike DOL starters, the control of the second contactor for reversing starters must be implemented with a SmartWire-DT contactor module (DIL-SWD-32-...). Both SWD modules are then connected to the SWD communication cable via the SWD device plug.

The "Enable" X3-X4 auxiliary contact is factory fitted with a link. For the electrical interlocking of the two contactors this link is removed and the auxiliary breaker (contacts 21-22) of the other contactor is linked in as a potential-free contact.

The auxiliary contact for the electrical enable X3-X4 can be used on the PKE_SWD-32 for safety-related control sections. The wiring sets DILM12-XRL and PKZM0-XRM12 must not be used for the assembly of the reversing starters.

The A2 connections of the contactors must not be bridged.

→ Figure, page 1-15

1

Switching, control, visualization

SmartWire-DT communication system

1

DOL starters with PKE

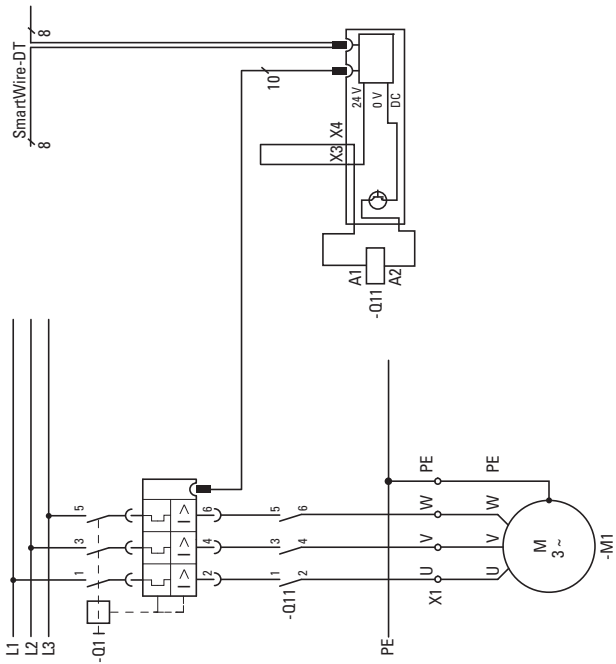

Switching, control, visualization

SmartWire-DT communication system

Reversing starter with PKE

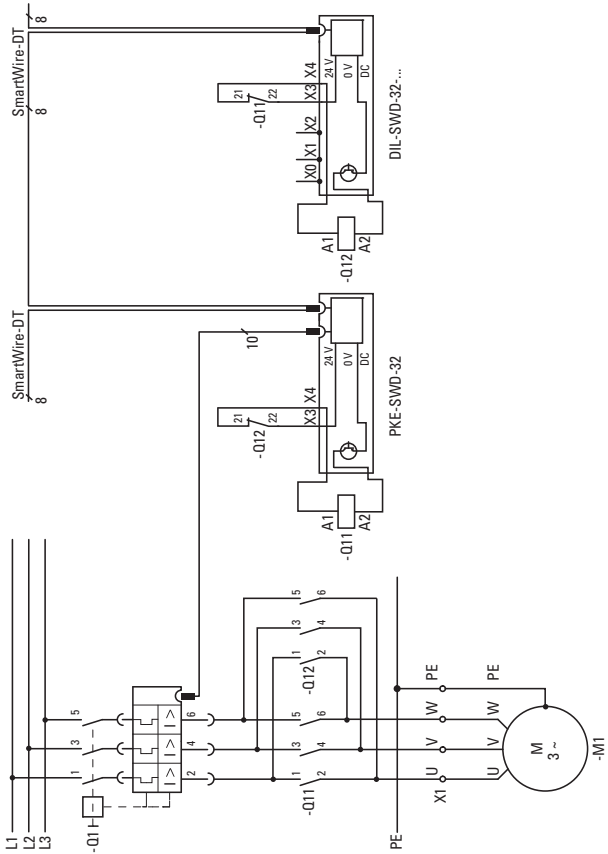

Switching, control, visualization

SmartWire-DT communication system

Star-delta starter

1

With SmartWire-DT modules for DILM

They control the contactors so that the terminals A1-A2 of the contactors do not have to be wired. A return signal is also given back to the SmartWire-DT system via the SWD contactor modules for DILM.

The terminals X3-X4 are supplied with a bridging connection. For the electrical interlocking of the two contactors this bridge is removed and the auxiliary breaker (contacts 21-22) of the other contactor is linked in as a potential-free contact.

→ Figure, page 1-18

With SmartWire-DT I/O-module EU5E-SWD-4D2R

The SmartWire-DT I/O module actuates the contactor Q11 via the digital relay output Q0. The further procedure is the same as that of a conventional star-delta starter.

The inputs of the SmartWire-DT I/O module are used to implement return signals to the SmartWire-DT system.

→ Figure, page 1-19

With SmartWire-DT contactor module and ETR4-51 timing relay

The SWD contactor module for DILM controls the mains contactor Q11 so that the terminals A1-A2 do not have to be wired. A return signal is also given back to the SmartWire-DT system via the SWD protective module for DILM.

The control and the changeover between star contactor and delta contactor have the same wiring and function as the conventional star-delta starter assembly.

→ Figure, page 1-20

Switching, control, visualization

SmartWire-DT communication system

With PKE and SWD modules for DILM

The star-delta starters are made up from a PKE12/PKE32 with a PKE-XTUA-... trip block and three contactors DILM7 to DILM32. The PKE-SWD-32 is fitted to the mains contactor of the star-delta starter. The star and delta contactor is actuated with SmartWire-DT contactor modules (DIL-SWD-32-...).

All SWD modules are then connected to the SWD communication cable via the SWD device plug.

The "Enable" X3-X4 auxiliary contact is factory fitted with a link. For the electrical interlocking of the star and delta contactor this link is removed and the auxiliary NC contact (contacts 21-22) of the other contactor is linked in as a potential-free contact.

The auxiliary contact for the electrical enable X3-X4 can be used on the PKE_SWD-32 for safety-related control sections.

The wiring sets DILM12-XRL and PKZM0-XRM12 must not be used for the assembly of a star-delta starter.

The A2 terminals of star and delta connections must not be bridged.

→ Figure, page 1-21

With PKE, SWD modules for mains contactor DILM and ETR4-51 timing relay

The star-delta starters are made up from a PKE12/PKE32 with a PKE-XTUA-... trip block and three contactors DILM7 to DILM32. The PKE-SWD-32 is fitted to the mains contactor of the star-delta starter. The star-delta contactor is actuated in a conventional circuit. The PKE-SWD-32 module is connected to the SWD communication cable via the SWD device plug. The wiring sets DILM12-XRL and PKZM0-XRM12 can be used for the assembly of a star-delta starter.

→ Figure, page 1-22

Switching, control, visualization

SmartWire-DT communication system

1

Star delta starter with 3 SmartWire-DT contactor modules

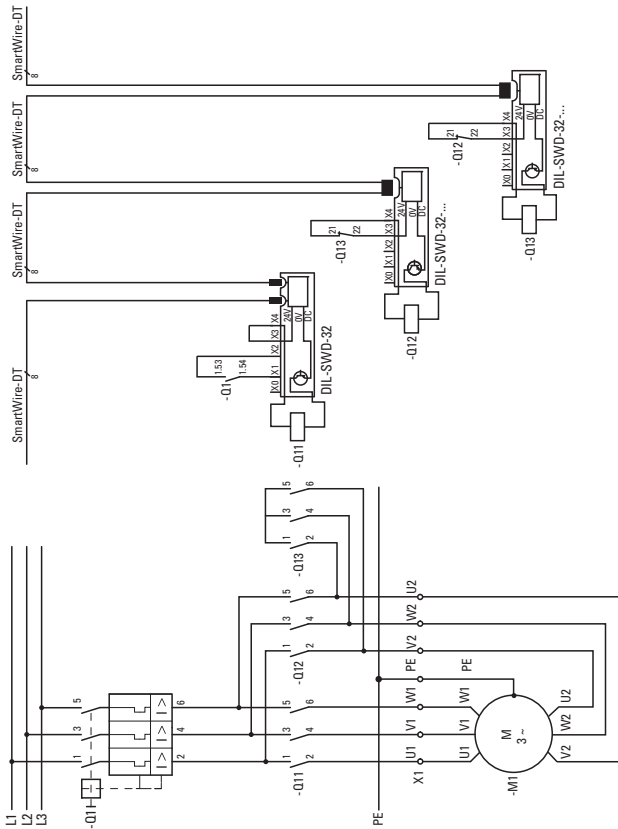

Switching, control, visualization

SmartWire-DT communication system

SmartWire-DT star-delta starter with EU5E-SWD-4D2R I/O module

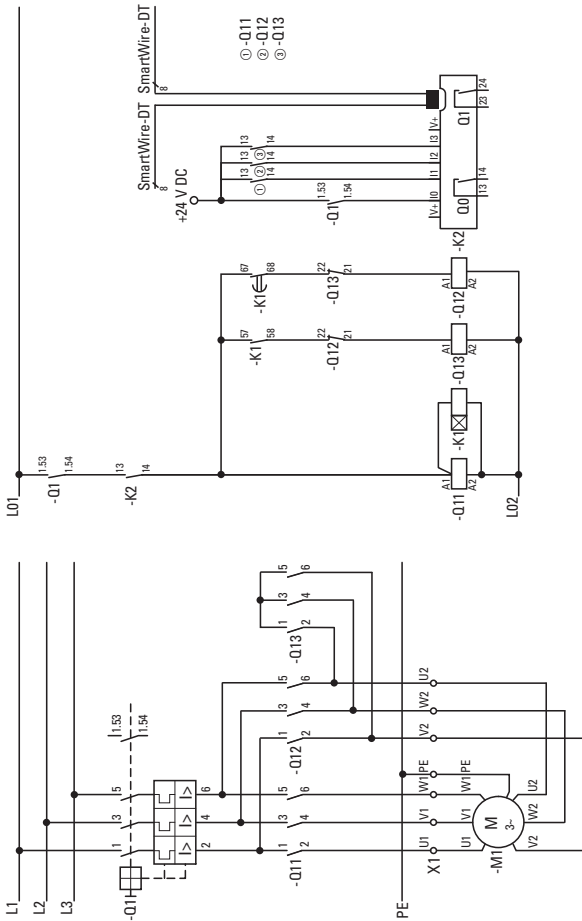

Switching, control, visualization

SmartWire-DT communication system

1

Star delta starter with SmartWire-DT contactor module and ETR4-51 timing relay

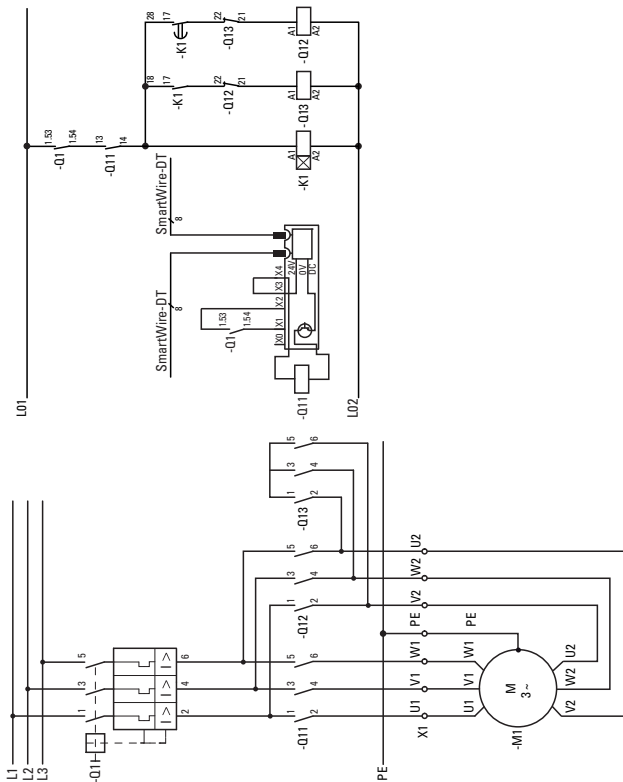

Switching, control, visualization

SmartWire-DT communication system

Star delta starter with PKE and SWD modules for DILM

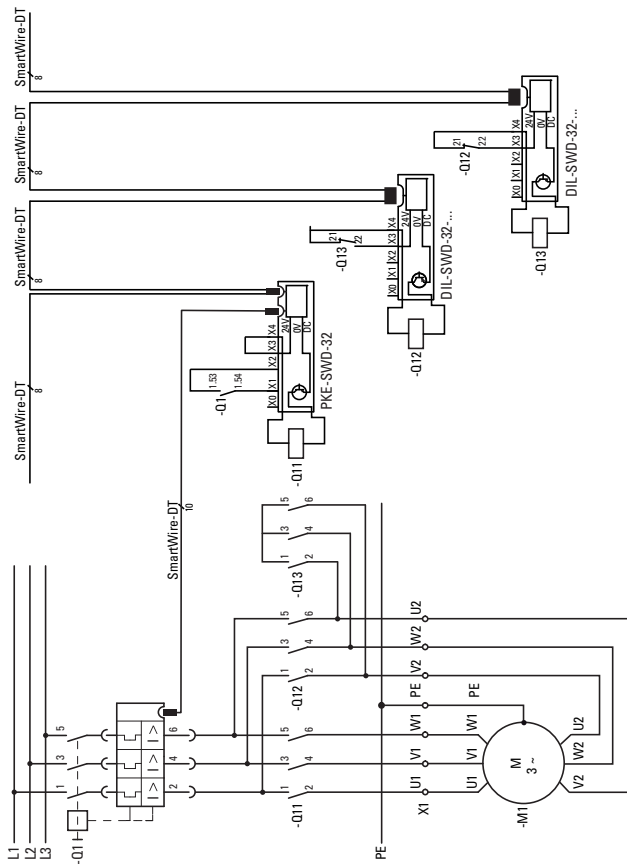

Switching, control, visualization

SmartWire-DT communication system

1

Star delta starter with PKE, SWD module for mains contactor DILM and ETR4-51 timing relay

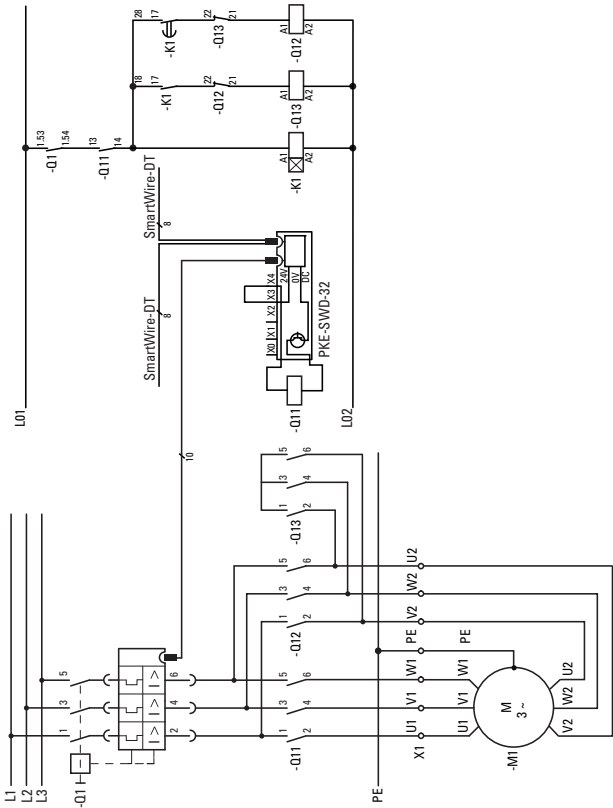

Switching, control, visualization

SmartWire-DT communication system

NZM circuit-breakers

The NZM-XSWD-704 SmartWire-DT module is used for querying a circuit-breaker with an electronic release (NZM2, 3, 4) via a PLC, i.e. the On/Off/Trip position of the switch and the actual currents. An optionally installed remote operator can also be actuated via the module. The NZM-XSWD-704 is fitted on a top-hat rail and is connected to the NZM via a 2.0 m data cable. The auxiliary contacts and the remote operator are wired separately. The connection to the SmartWire-DT ribbon cable is implemented via the SWD device plug.

- ① SmartWire-DT connection
- ② Data cable NZM with NZM-XSWD-704
- ③ Auxiliary contacts in NZM
- ④ XMC energy metering device (external)
- ⑤ Remote operator

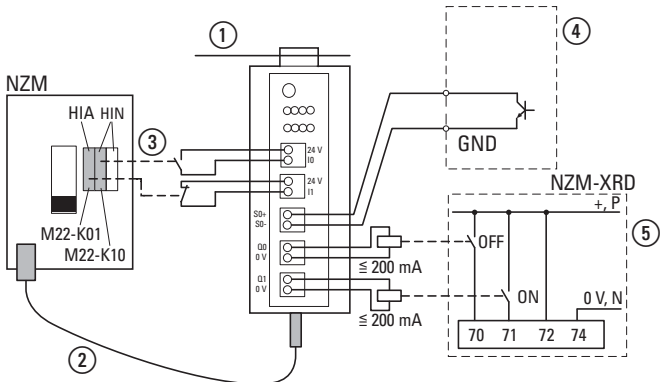
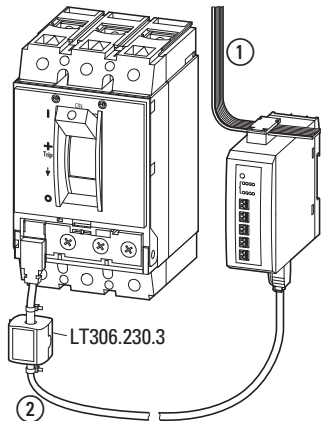

Switching, control, visualization

SmartWire-DT communication system

1

Pilot Devices

Simple pilot devices can be integrated directly in the SmartWire-DT communication system without any time consuming wiring. The function elements are snap fitted in the M22-A fixing adapter and then connected to the SWD communication cable via the SWD device plug.

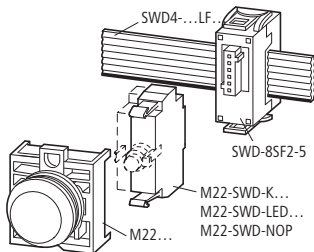

These function elements are each available in two versions for front or base fixing. Base fixing elements can be combined to form remote operating and display devices using the M22-SWD-I cards and the M22-I.. surface mounting enclosures to IP65.

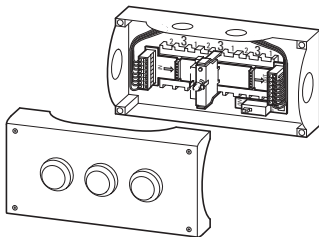

The switch position indications of the control elements and activation of the indicator are implemented with the SmartWire-DT communication system. The function elements stated in the table are available.

M22-SWD-K(C)11	Function element with one changeover contact
M22-SWD-K(C)22	Function element with two changeover contacts
M22-SWD-LED...	LED function elements in white (W), red (R), green (G) or blue (B)
M22-SWD-K11LED...	Function element with one changeover contact and one LED in white (W), red (R), green (G) or blue (B)
M22-SWD-K22LED...	Function element with two changeover contacts and one LED in white (W), red (R), green (G) or blue (B)

Switching, control, visualization

SmartWire-DT communication system

1

Digital and analog signal processing

The following SWD modules are available for processing digital or analog input/output signals:

EU5E-SWD-8DX	8 digital inputs
EU5E-SWD-4DX	4 digital inputs with transmitter supply
EU5E-SWD-4D4D	4 digital inputs and 4 digital outputs
EU5E-SWD-4D2R	4 digital inputs and 2 relay outputs 3 A
EU5E-SWD-X8D	8 digital outputs
EU5E-SWD-4AX	4 analog inputs 0 – 10 V, 0 – 20 mA
EU5E-SWD-2A2A	2 analog inputs and 2 analog outputs 0 – 10 V, 0 – 20 mA
EU5E-SWD-4PT	4 temperature inputs PT100, PT1000, Ni1000

The modules are fitted directly on the top-hat rail and then connected with the SWD communication cable via the SWD device plug.

The modules can be fitted directly in the proximity of the sensors/actuators to be connected. This also reduces the remaining wiring required.

The following applications are possible:

- Connection of AC contactors or high rated contactors > DILM32 that do not have a connection option for the DIL-SWD-... module. For this use the EU5E-SWD-4D2R module.
- Connection of auxiliary contacts to modules with digital inputs

- Connection of digital actuators without integrated SWD functionality (signal lights, timing relays ..)
- Connection of any analog inputs/outputs

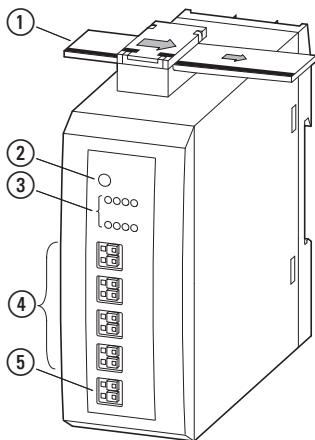

- ① SmartWire-DT cable with external device plug
- ② SmartWire-DT diagnostics LED
- ③ Status display of inputs and outputs (optional)
- ④ Input/output terminals
- ⑤ External supply (optional)

Switching, control, visualization

SmartWire-DT communication system

Safety-related applications

1

For most applications, disconnection in the event of an emergency or the disconnection by the opening of the protective doors is also required in addition to normal operational switching.

The SmartWire-DT system is not designed for the transfer of safety relevant signals. Using the configuration described below, the SmartWire-DT system can however be used for safety relevant switch offs.

In an emergency the control voltage for the contactor coils can be switched off via the enabling paths of the safety relay. By using additional SmartWire-DT Power modules, contactor groups are made that can be switched off together in an emergency. This type of circuit can be used to create control systems up to PL c in accordance with EN ISO 13849-1 (PL = Performance Level). The safety relay in this example must be PL c or higher (e.g. ESR5-NO-41-24VAC-DC).

→ Figure, page 1-27

Feedback circuit

The auxiliary contact integrated in the contactor is a mirror contact according to IEC/EC 60947-4-1. Using this contact the state of the main contacts can be reliably signalled. The mirror contact can be included into the feedback circuit of the safety relay so that the safety relay only gives a new enable signal when the contactor is open.

Measures for higher safety category

In many applications control systems with a performance level of PL d or PL e (PL = Performance Level) to EN ISO 13849-1 are required. Control systems with PL d can be set up using an additional group contactor which is connected in series upstream of the motor feeders. The control voltage for the motor contactors as well as for the group contactor is switched off in an emergency via the safety relay. This redundant disconnection circuit enables the implementation of PL d control systems. The safety relay used must comply with PL d or higher to achieve this safety category (e.g. ESR5-NO-31-24VAC-DC).

Further information on safety engineering for machines and plants is provided in the Eaton Safety Manual: www.eaton.eu/shb

Switching, control, visualization

SmartWire-DT communication system

Actuating circuit for safety relevant application

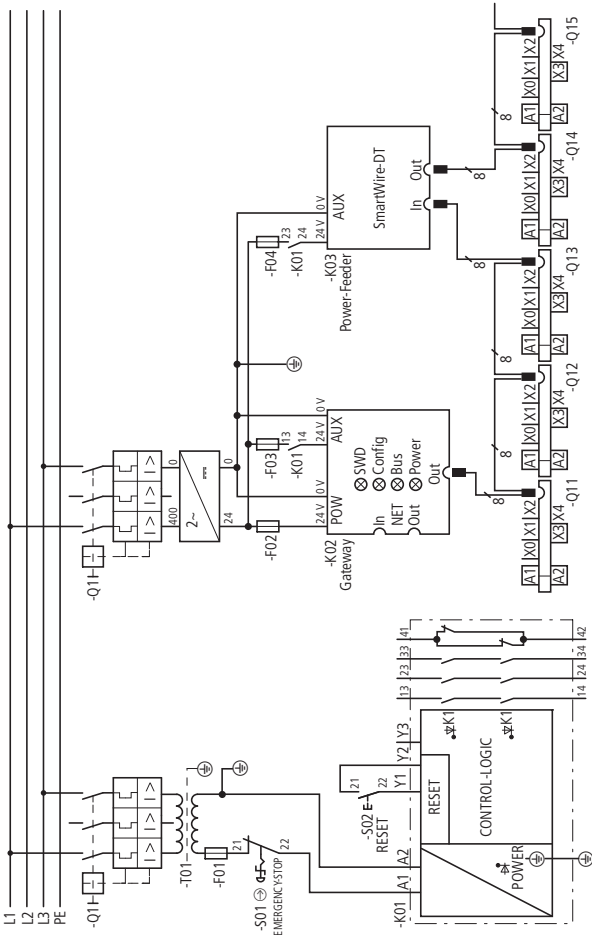

Switching, control, visualization

SmartWire-DT communication system

1

Mains circuit for safety relevant application

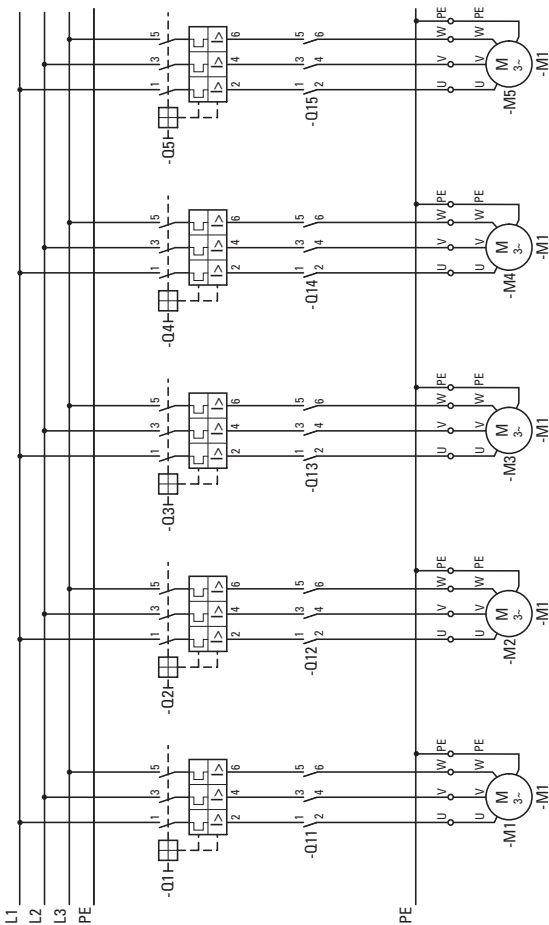

Switching, control, visualization

The way to the safe machine



Safety Technology

Control the unexpected

The international standard EN ISO 12100-1 "Safety of machinery - Basic concepts, general principles for design" provides the design engineer with detailed assistance in the identification of hazards and the resulting risks to be assessed.

This therefore lays down the technical measures for the reduction of hazards.

The parts of machine control systems that handle safety tasks are defined as the "safety-related parts of control systems" (SRP/CS). Safety-related control systems comprise the entire safety function consisting of the input level (sensor), the logic (safety signal processing) and the output level (actuator).

For reducing risks by means of SRP/CS, Eaton offers the right components with safety technology in accordance with the most stringent requirements stipulated in the safety standards EN 954-1, EN ISO 13849-1 and EN IEC 62061. The appropriate safety functions are used according to the application area and in compliance with the required risk reduction.

Further information on the previous and the new international safety standards as well as circuit examples for a wide range of applications are provided in the latest version of the Eaton Safety Applications Technical Guide PU05907001Z-EN.



The safety manual helps you by means of practical safety circuit examples and the associated calculations to determine safety performance in accordance with EN ISO 13849-1 and IEC 62061.

The Safety Manual is available online or in print:

- Register at www.eaton.eu/shb and work online with the Safety Manual or download the PDF version free of charge.
- Order the current printed version from your wholesalers or your Eaton customer service: PU05907001Z-EN, Article no. 119906

Switching, control, visualization

The way to the safe machine

1

Fast and secure detection

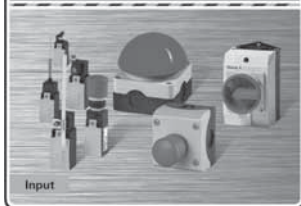

Detecting hazards quickly with RMQ-Titan and FAK emergency-stop buttons. Motion safety under control with LS-Titan® position switches. Safe switching, disconnection and control with T rotary switches and P switch-disconnectors.



Safe monitoring and processing

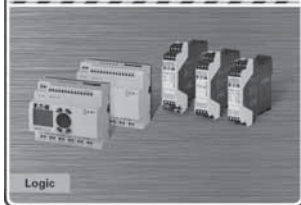

Safe monitoring and processing with ESR safety relays and easySafety control relay.



Reliable shut down



Reliable disconnection with DILM contactors and CMD contactor monitoring device.

Further technical information on the individual safety products is provided at www.eaton.com/moeller

Switching, control, visualization

The way to the safe machine

1

Logic units to ensure safety functions

Safety logic units enable the hardware required to be considerably reduced and primarily restricted to the sensor/actuator level. Eaton offers two logic series:

- ESR5 Electronic safety relays
- easySafety control relay suitable for safety circuits.

Safety relays of the ESR5 series offer the optimum solution for each application with tailored safety functions. The internal logic of the safety relay monitors the wired safety circuits and activates the enable contacts in fault-free condition.

The easySafety control relay offers a host of integrated safety relays in the form of safety function blocks in a single device, thus offering maximum flexibility in a considerable space saving design. easySafety is used for monitoring all typical safety devices and also implementing the control tasks required on the machine.

The ESR safety relays or the easySafety control relay enable applications to be implemented that meet the most stringent safety requirements in accordance with international standards:

- Category 4 to EN 954-1
- Performance level PL e acc. to EN ISO13849-1
- Safety Integrity Level SIL CL 3 according to IEC 62061
- Safety Integrity Level SIL 3 according to IEC 61508

Eaton ensures the required level of personal or process protection using the safety products approved by TÜV Rheinland – for both simple and complex machines.



Switching, control, visualization

The way to the safe machine

1

Monitoring a movable guard with ESR5

Moving guards such as safety doors, gates and flaps can be used to provide protection from accessible hazardous areas. The position of moving guards is detected with position switches or non-contacting contact sensors that are monitored and evaluated with a safety logic unit. A risk analysis supplies the necessary degree of risk reduction by the guard.

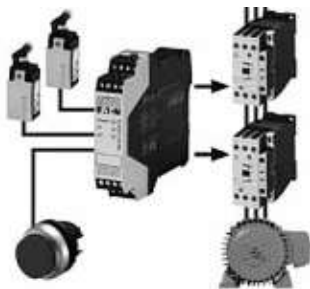

Function

The safety logic unit provides two separate input circuits for two-channel applications, which monitor the sensor (such as the position switch of an interlock device). After the input circuits are closed, the safety relay can be started by means of a reset button. This activates the enable and signal current paths and switches on the connected actuators. Positively driven auxiliary contacts of the actuators are used by the safety relay to diagnose possible safety states.

Safety technical assessment

Cat	B	1	2	3	4
PL	a	b	c	d	e
SIL	1	2	3		

Cat. according to EN 954-1

PL according to EN ISO 13849-1

SIL according to IEC 62061

Switching, control, visualization

The way to the safe machine

Circuit example: Two-channel guard door monitoring with ESR5

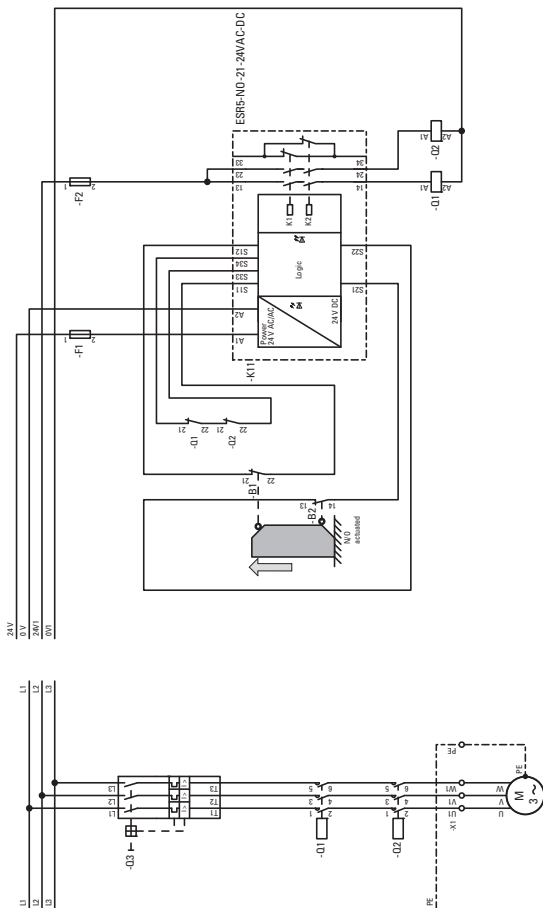

Switching, control, visualization

The way to the safe machine

1

Stopping in case of emergency with easySafety

The Emergency-stop function is an additional protective measure and is not permissible as the sole means of protection. Machinery Directive 2006/42/EC stipulates however that every machine must be provided with a device for stopping in an emergency (Emergency stop). The degree of risk reduction by the Emergency stop device must be determined by means of a risk assessment. If the immediate disconnection of the power supply does not cause hazardous states, you can use an uncontrolled Stop function in accordance with Stop category 0 to EN ISO 13850.

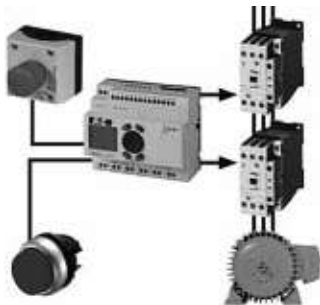

Function

The Emergency-stop actuator S4 must be in the enable position (NC contacts closed) so that the enable signal can be issued via the RESET pushbutton S3. Pressing the START pushbutton S1 starts the hazardous movement. The self-latching function and

its interruption are implemented in the program. The two contactors drop out, and a restart is possible by pressing the START actuator. If the hazardous movement is stopped by pressing the Emergency-stop actuator S4, the enable for outputs QS1 and QS2 is removed and the contactors drop out. A restart is only possible after the Emergency-stop actuator is reset and enabled by pressing the RESET pushbutton. The drive can be braked actively by using output QS4. However, this option is not included in the safety consideration since the frequency inverter does not support the safe braking operation.

Safety technical assessment

Cat	B	1	2	3	4
PL	a	b	c	d	e
SIL	1	2	3		

Cat. according to EN 954-1

PL according to EN ISO 13849-1

SIL according to IEC 62061

Switching, control, visualization

The way to the safe machine

Circuit example: Two-channel Emergency-stop monitoring with easySafety

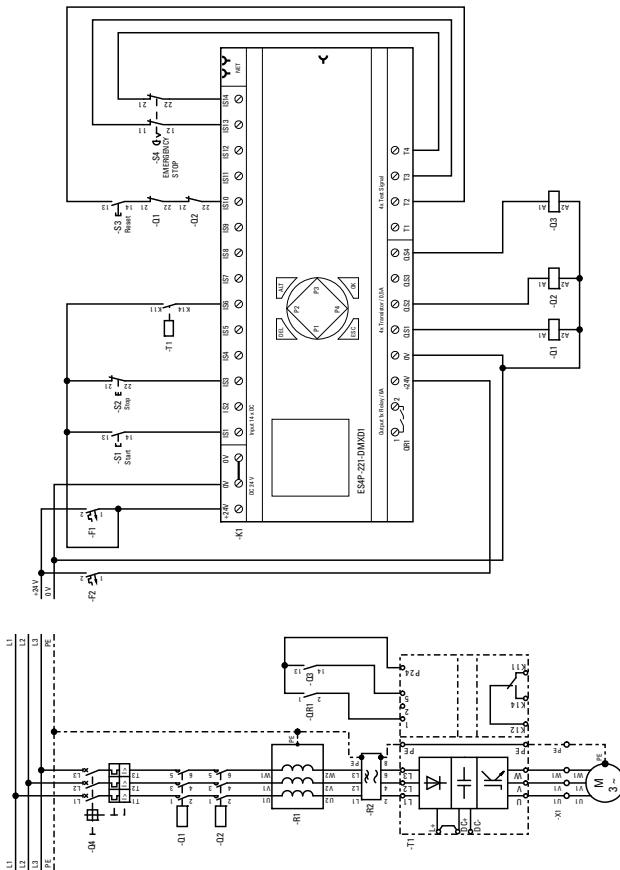

Switching, control, visualization

Timing relays

1

Electronic timing relays are used in contactor control systems which require short reset times, high repetition accuracy, high operating frequency, and a long component lifespan. Times between 0.05 s and 100 h can be easily selected and set.

The switching capacity of electronic timing relays complies with the utilization categories AC-15 and DC-13.

In terms of the actuating voltages there are with timing relays the following differences:

- **Version A** (DILET... and ETR4)
Universal devices:
DC 24 to 240 V
AC 24 to 240 V, 50/60 Hz
- **Version W** (DILET... and ETR4)
AC devices:
AC 346 to 440 V, 50/60 Hz
- **ETR2...** (as modular installation device to DIN 43880)
Universal devices:
DC 24 to 48 V
AC 24 to 240 V, 50/60 Hz
(ETR2-69-D: 12 to 240 V, 50/60 Hz)

The functions of each of the timing relays are as follows:

- DILET11, ETR4-11, ETR2-11
Function 11 (on-delayed)
- ETR2-12
Function 12 (off-delayed)
- ETR2-21
Function 21 (fleeting contact on energization)
- ETR2-42
Function 42 (flashing, pulse initiating)
- ETR2-44
Function 44 (flashing, two speeds; can be set to either pulse initiating or pause initiating)

- Multifunction relays DILET70, ETR 4-69/70
Function 11 (on-delayed)
Function 12 (off-delayed)
Function 16 (on- and off-delayed)
Function 21 (fleeting contact on energization)
Function 22 (fleeting contact on de-energization)
Function 42 (flashing, pulse initiating)
- **Function 81** (pulse generating)
Function 82 (pulse shaping)
ON, OFF
- Multifunction relay ETR2-69(-D)
Function 11 (on-delayed)
Function 12 (off-delayed)
Function 21 (fleeting contact on energization)
Function 22 (fleeting contact on de-energization)
Function 42 (flashing, pulse initiating)
Function 43 (flashing, pause initiating)
Function 82 (pulse initiating)
- Star-delta timing relays ETR4-51
Function 51 (on-delayed)

With both DILET70 and ETR4-70 an external potentiometer can be connected. Upon connection, both timing relays automatically recognize that a potentiometer is fitted.

The ETR4-70 has a special feature. Equipped with two changeover contacts which can be converted to two timing contacts 15-18 and 25-28 (A2-X1 linked) or one timing contact 15-18 and a non-delayed contact 21-24 (A2-X1 not linked). If the link A2-X1 is removed, only the timed contact 15-18 carries out the functions described below.

Switching, control, visualization

Timing relays

Function 11

On-delayed



The actuating voltage U_s is applied via an actuating contact to the terminals A1 and A2.

After the set delay time the changeover contact of the output relay goes to the position 15-18 (25-28).

Function 12

Off-delayed



After the supply voltage has been applied to the terminals A1 and A2, the changeover contact of the output relay remains in the original position 15-16 (25-26). If the terminals Y1 and Y2 in the DILET70 are linked by a potential-free N/O contact or, in the case of the ETR4-69/70 or ETR2-69, a potential is applied to B1, the changeover contact changes without delay to the position 15-18 (25-28).

If the connection between the terminals Y1–Y2 is now interrupted, or B1 is separated from the potential, once the set time has elapsed, the changeover contact returns to its original position 15-16 (25-26).

Function 16

On- and Off-delayed



The supply voltage U_s is applied directly to the terminals A1 and A2. If the terminals Y1 and Y2 in the DILET70 are linked by a potential-free N/O contact, or in the case of the ETR4-69/70 a potential is applied to B1, after a set time t the changeover contact goes to the position 15-18 (25-28).

If the connection Y1-Y2 is now interrupted, or B1 is separated from the potential, the changeover contact goes back to its original position 15-16 (25-26) after the same time t .

Function 21

Fleeting contact on energization

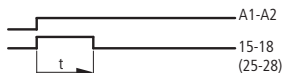

After the voltage U_s has been applied to A1 and A2, the changeover contact of the output relay goes to position 15-18 (25-28) and remains actuated for as long as the set fleeting contact time.

A fleeting pulse (terminals 1-2, 15-18) of defined duration is therefore produced from a two-wire control process (voltage on A25/A28) by this function.

Switching, control, visualization

Timing relays

Function 82

Pulse shaping



After the supply voltage has been applied to A1 and A2, the changeover contact of the output relay remains in the rest position 15-16 (25-26). If the terminals Y1 and Y2 in the DILET70 are linked by a potential-free N/O contact, or in the case of the ETR4-69/70 or ETR2-69, a potential is applied to B1, the changeover contact changes without delay to the position 15-18 (25-28).

If Y1–Y2 is now opened again, or B1 is kept with the potential, the changeover contact remains actuated until the set time has elapsed. If, instead, Y1–Y2 remain closed or B1 is separated from the potential for longer, the output relay likewise changes back to its rest position after the set time. An output pulse of precisely defined duration is thus produced in the pulse shaping function, irrespective of whether the input pulse via Y1–Y2 or B1 is shorter or longer than the set time.

Function 81

Pulse generating with fixed pulse

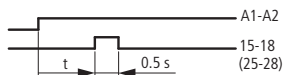

The actuating voltage is applied to the terminals A1 and A2 via an actuating

contact. After the set delay time has elapsed the changeover contact of the output relay goes to position 15-18 (25-28) and returns to its original position 15-16 (25-26) after 0.5 s. This function is therefore a fleeting pulse with a time delay.

Function 22

Fleeting contact on de-energization

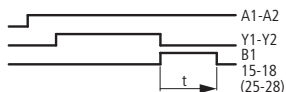

The supply voltage U_s is present directly at A1 and A2. If the terminals Y1 and Y2 of the DILET70 that have been shorted (DILET-70 potential-free) at any time beforehand are opened again, or with ETR4-69/70 or ETR2-69 the contact B1 becomes potential-free again, the contact 15-18 (25-28) closes for the duration of the set time.

Function 42

Flashing, pulse initiating



After the voltage U_s has been applied to A1 and A2, the changeover contact of the output relay changes to position 15-18 (25-28) and remains actuated for as long as the set flashing time. The subsequent pause duration corresponds to the flashing time.

Switching, control, visualization

Timing relays

Function 43

Flashing, pause initiated

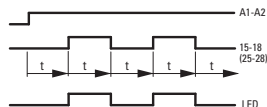

After the voltage U_s has been applied to A1 and A2 the changeover contact of the output relay stays in position 15-16 for the set flashing time and after the duration of this time goes to position 15-18 (the cycle begins with a pause phase).

Function 44

Flashing, two speeds

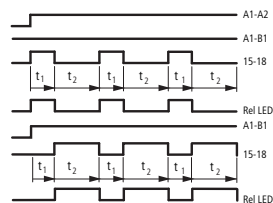

After the voltage U_s has been applied to A1 and A2 the changeover contact of the output relay goes to position 15-18 (pulse initiating). By bridging the contacts A1 and Y1 the relay can be switched to pause initiating. The times t_1 and t_2 can be set to different times.

Function 51 Star-delta

On-delayed

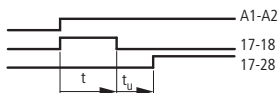

If the actuating voltage U_s is applied to A1 and A2, the instantaneous contact switches to position 17-18. After the set time duration the instantaneous contact opens; the timing contact 17-28 closes after a changeover time t_u of 50 ms.

On-Off Function

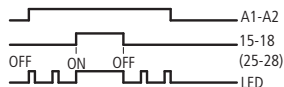

The On-Off function allows the operation of a control system to be tested and is an aid for example for commissioning. The Off function allows the output relay to be de-energized and it no longer reacts to the function sequence. The On function energizes the output relay. This function is dependent on the supply voltage being applied to the terminals A1/A2. The LED indicates the operating state.

Further information sources

- Instructional leaflets
→ www.eaton.com/moeller/support
(AWA / IL Installation Instructions)
Search terms: DILET, ETR4, ETR2
- Main Catalogue Industrial Control Systems (HPL) Section "Timing relays"

Switching, control, visualization

EMR measuring and monitoring relays

1

Measurement and monitoring relays are required for a wide range of applications. With the new EMR range Eaton covers a large number of requirements:

- general use, EMR...-I current monitoring relay
- space saving monitoring of the rotation field, EMR...-F phase sequence relay
- Protection against destruction or damage of single system parts, EMR...-(A)W(N) phase monitoring relay
- safe recognition of phase failure, EMR...-A phase imbalance monitoring relay
- enhanced safety by open-circuit principle, EMR...-N liquid level monitoring relay
- increase of the operational safety, EMR...-R insulation monitoring relay

EMR...-I Current monitoring relay

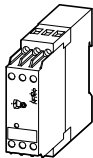

The EMR-I current monitoring relay is suitable for the monitoring of AC as well as DC current. Pumps and drill machines can be monitored for underload or overload. This is possible due to the selectable lower or upper threshold limit.

There are two versions each with three measuring ranges (30/100/1000 mA, 1.5/5/15 A). The multi-voltage coil allows universal use of the relay. The two auxiliary

changeover contacts allow for a direct feedback.

Selected bridging of short current peaks

By using the selectable response delay of between 0.05 and 30 s short current peaks can be bridged.

Phase monitoring relay EMR...-W

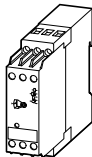

The EMR...-W phase monitoring relay monitors the voltage as well as the rotation field rotation. This provides protection from the destruction or damage of individual system parts. The minimum undervoltage and also the maximum overvoltage can be set here easily, within a defined range to the required voltage.

An on-delayed or off-delayed function can also be set. In the on-delayed position short voltage drops can be bridged. The off-delayed position allows for a fault storage for the set time.

The delay time can be set between 0.1 and 10 s.

The relay activates with the correct rotation field and voltage. After a drop-out the device does not reactive until the voltage exceeds a 5 % hysteresis.

Switching, control, visualization

EMR measuring and monitoring relays

1

EMR...-F phase sequence relay

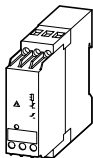

With the only 22.5 mm wide phase sequence relay, portable motors, with which the rotation direction is important (e. g. pumps, saws, drills), can be monitored for correct rotation. This provides space in the switchboard thanks to the narrow width and protection against damage due to the monitoring of the rotating field.

With correct rotating field the changeover contact releases the control voltage of the motor switching device. The EMR...-F500-2 covers the total voltage range from 200 to 500 V AC.

EMR...-A phase imbalance relay

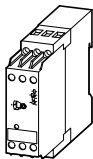

The 22.5 mm wide EMR...-A phase imbalance relay is the correct protection device against phase failure. The motor is then protected against destruction.

As the phase failure is monitored on the basis of phase displacement, this can be

detected even with a higher motor feedback and an overload of the motor can be prevented.

EMR...-N liquid level monitoring relay

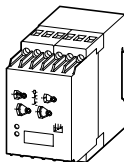

The EMR...-N liquid level monitoring relay is used mostly as dry running protection for pumps or for the level regulation of liquids. It operates with sensors that measure conductivity. One sensor is required for the maximum level and one sensor for the minimum level. A third sensor is used for earth potential.

The 22.5 mm wide EMR...-N100 device is suitable for conductive liquids. It can be switched from level regulation to dry running protection. Safety is increased as in both cases the open-circuit principle is used.

The EMR...-N500 liquid level monitoring relay has an increased sensitivity and is suitable for less conductive liquids. Due to an integrated pickup and drop-out delay of between 0.1 and 10 s moving liquids can also be monitored.

Switching, control, visualization

EMR measuring and monitoring relays

1

EMR...-R Insulation monitoring relay

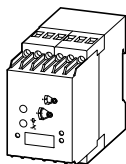

EN 60204 "Safety of machines" provides increased operational safety by the monitoring of the auxiliary circuit for earth-fault using an insulation monitoring relay. This is the main application for the EMR...-R. There are similar requirements in medically used areas.

An earth-fault is signalled via a changeover contact so that a fault can be cleared without expensive down time.

The device has a selectable fault memory so that the fault must be acknowledged after it's removal. The use of a Test button enables the device to be checked for correct operation at any time.

AC or DC control voltage

There is a device for AC and also DC. Therefore the total control voltage range is covered. Both devices have a multi-voltage source. This means that both AC and DC supplies are possible.

EMR...-AW(N) multifunctional three-phase monitors

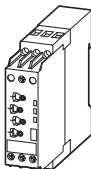

The multifunctional three-phase monitors provide the space saving monitoring of the rotation field with different functions..

These measure the phase parameters of phase sequence, phase failure, phase imbalance as well as undervoltage and overvoltage.

Depending on device type, the threshold value for phase imbalance can be set between 2 to 15 %. The threshold values for undervoltage and overvoltage are adjustable or permanently set.

The different options and set values are explained in the relevant instructional leaflet.

Further information sources

- Instructional leaflets
→ www.eaton.com/moeller/support
(AWA / IL Installation Instructions)
Search terms: EMR4, EMR5
- Main catalog industrial switchgear (HPL),
→ chapter "EMR measuring relays, EMR monitoring relays"

Switching, control, visualization

System overview easyRelay, MFD-Titan

500/700 control relays easy

1

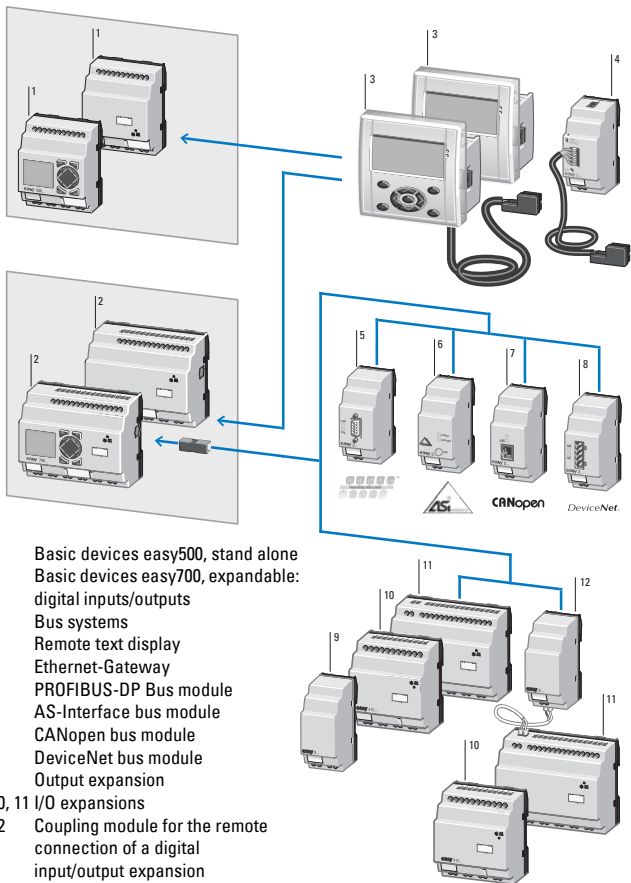

Switching, control, visualization

System overview easyRelay, MFD-Titan

800 control relay

1

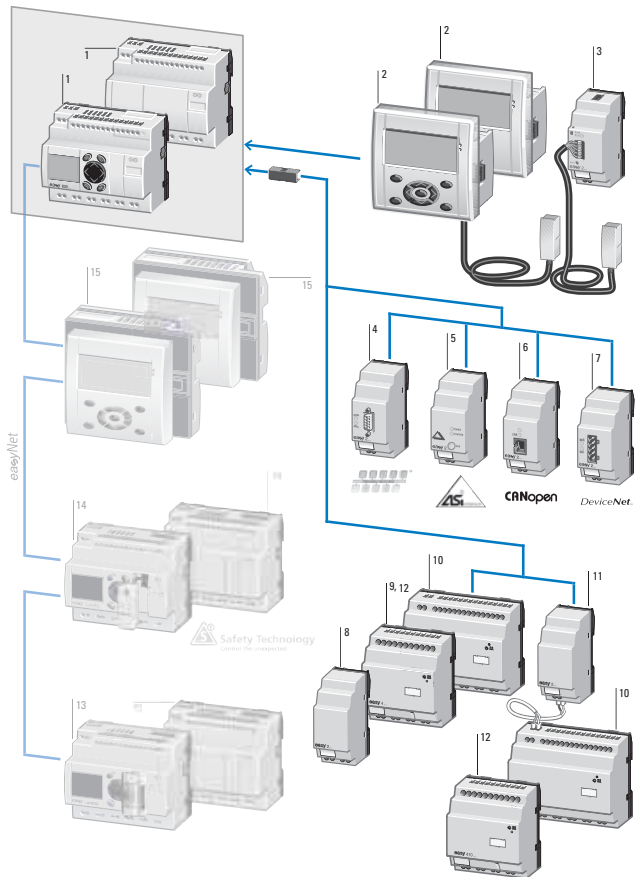

Switching, control, visualization

System overview easyRelay, MFD-Titan

- 1 easy800 basic devices, expandable:
Digital inputs/outputs and
Bus systems, easyNet onboard
- 2 Remote text display
- 3 Ethernet gateway
- 4 PROFIBUS-DP bus module
- 5 AS-Interface bus module
- 6 CANopen bus module
- 7 DeviceNet bus module
- 8 Output expansion
- 9, 10 I/O expansions
- 11 Coupling module for the remote
connection of a digital
input/output expansion
- 12 I/O expansion
- 13 easyControl compact PLC
- 14 easySafety control relay
- 15 MFD-Titan multi-function display

Switching, control, visualization

System overview easyRelay, MFD-Titan

MFD-Titan multi-function display

1

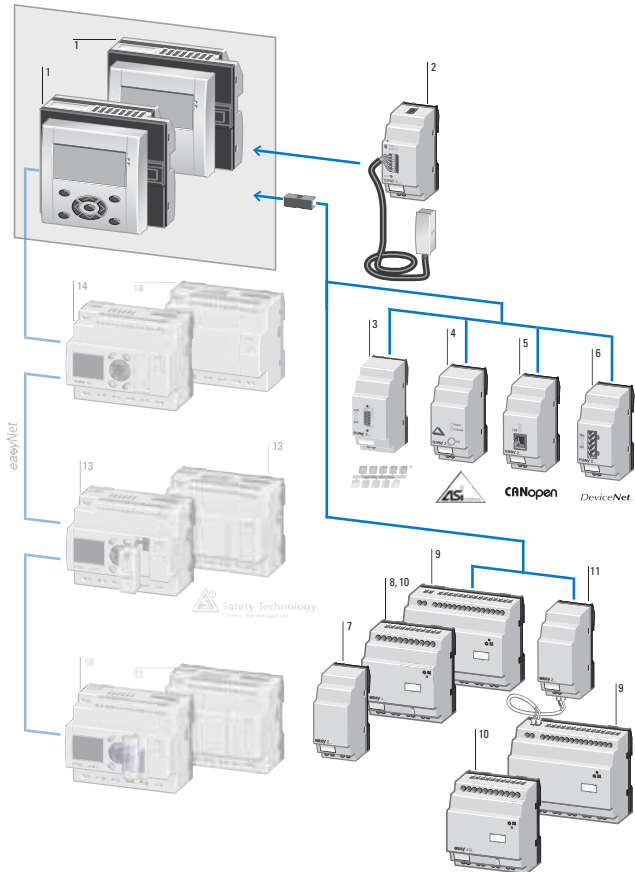

Switching, control, visualization

System overview easyRelay, MFD-Titan

- 1 MFD-Titan, consisting of:
 - Display/operating unit
 - Power supply unit/CPU module, I/O module
- 2 Ethernet gateway
- 3 PROFIBUS-DP bus module
- 4 AS-Interface bus module
- 5 CANopen bus module
- 6 DeviceNet bus module
- 7 Output expansion
- 8, 9, 10 I/O expansions
- 11 Coupling module for the remote connection of a digital input/output expansion
- 12 Compact PLC easyControl
- 13 easySafety
easycontrol relays
- 14 easy 800 control relays

Switching, control, visualization

System overview easyRelay, MFD-Titan

Functions

easy500 and easy700



easy500 and easy700 have the same functions. easy700 offers more inputs and outputs, is expandable and can be connected to a standard bus system. The contacts and coils are connected in series and in parallel in up to 128 current paths: max. three contacts and a coil in series. The display of 16 operating and message texts is implemented via an internal or external display.

The main functions are:

- Multi-function timing relays
- Current impulse relays,
- Counters
 - up and down,
 - high-speed counter,
 - frequency counters,
 - operating hours counter,
- Analog value comparators
- Week and year time switches,
- Automatic DST switch
- Retentive actual values of markers, counters and timing relays.

Customized inscription of easy500 and easy700 is possible.

MFD(-AC)-CP8... and 800



MFD(-AC)-CP8... and easy800 have the same functions. With IP65 MFD-80 can be used in harsh environments. Eight easy800 or MFD-Titan devices can also be networked via easyNet for expansions or connection to standard bus systems. Contacts and coils are linked in series or in parallel up to 256 rungs consisting of four contacts and a coil in series. The display of 32 operating and report message is implemented via an internal or external display.

The easy800 and MFD-Titan offer the following functions in addition to those of the easy700:

- PID controllers,
- Arithmetic modules,
- Value scaling,
- and much more.

Customized inscription on the MFD-80 and the easy800 is possible.

Switching, control, visualization

System overview easyRelay, MFD-Titan

Remote display, text display for easy relay

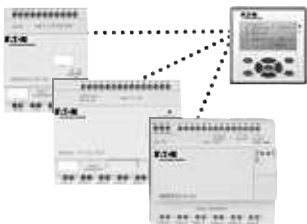

The plug & work functionality allows you to connect the MFD-80.. display to the easyRelays via the MFD-CP4.. power supply and communication module. The MFD-CP4... comes with a 5 m connection cable that can be cut to the required length. Another advantage is that no software or drivers are required for connection. The MFD-CP4.. offers genuine plug & work capabilities. The input and output wiring is connected to the easyRelay. The processing of the circuit diagram is also run in the easyRelay. The MFD-80.. is mounted using two 22.5 mm fixing holes. The IP65 display is backlit and offers an easy to read display. The display can be labeled to individual requirements.

Switching, control, visualization

Engineering easyRelay, MFD-Titan

Power supply connection

for AC devices

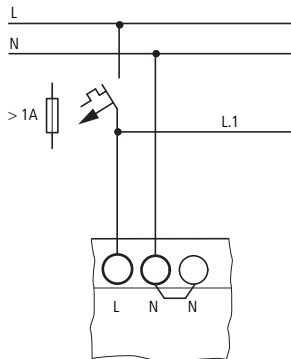

for DC devices

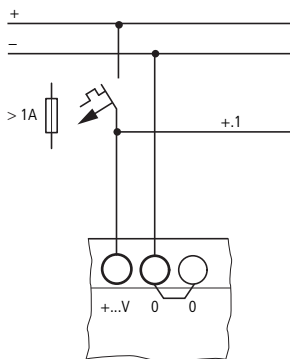

Basic devices

EASY512-AB-...	24 V AC
EASY719-AB-...	24 V AC
EASY512-AC-...	100 – 240 V AC
EASY719-AC-...	100 – 240 V AC
EASY819-AC-...	100 – 240 V AC

MFD-AC-CP8-...	100 – 240 V AC
----------------	----------------

Expansion units

EASY618-AC-...	100 – 240 V AC
----------------	----------------

Basic devices

EASY512-DA-...	12 V DC
EASY719-DA-...	12 V DC
EASY512-DC-...	24 V DC
EASY7...-DC-...	24 V DC
EASY819-DC-...	24 V DC
EASY82.-DC-...	24 V DC

MFD-CP8-...	24 V DC
MFD-CP10...	24 V DC

Expansion units

EASY410-DC...	24 V DC
EASY618-DC...	24 V DC
EASY620-DC...	24 V DC
EASY406-DC-ME	24 V DC
EASY411-DC-ME	24 V DC

Switching, control, visualization

Engineering easyRelay, MFD-Titan

Digital input connection of the AC devices

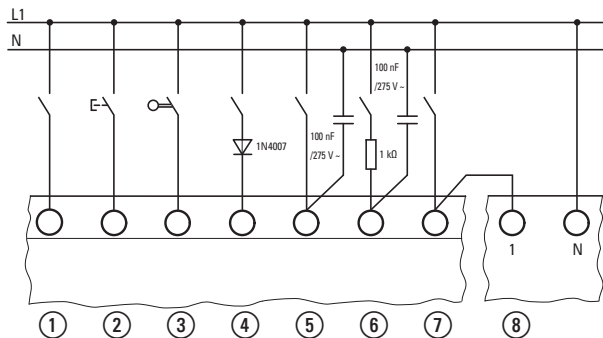

- ① Input signal via relay contact e.g. DILER
- ② Input signal via RMQ-Titan pushbutton
- ③ Input signal via position switch e.g. LS-Titan
- ④ Additional circuit with diode (→ Notes)
- ⑤ Increased input current
- ⑥ Limiting the input current
- ⑦ Increasing the input current with EASY256-HCI
- ⑧ EASY256-HCI upstream device with internal additional circuit (→ Notes)

Notes

- Due to the additional circuit the drop out delay of the input is increased.
- Length of input conductor without additional circuit ≤ 40 m, with additional circuit ≤ 100 m.
- Inputs I7, I8 already have an internal additional circuit.

Switching, control, visualization

Engineering easyRelay, MFD-Titan

Digital input connection of the DC devices

1

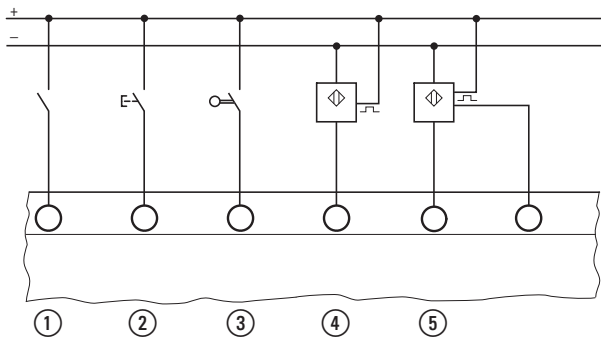

- ① Input signal via relay contact e.g. DILER
- ② Input signal via RMQ-Titan pushbutton
- ③ Input signal via position switch e.g. LS-Titan
- ④ Proximity switch, three wire
- ⑤ Proximity switch, four wire

Notes

- With conductor length consider also the voltage drop.
- Due to the high residual current do not use two-wire proximity switches.

Switching, control, visualization

Engineering easyRelay, MFD-Titan

Analog inputs

Depending upon the device two or four 0 to 10 V analog inputs are available.

The resolution is 10-bit = 0 to 1023.

The following applies:

I7 = IA01	}	EASY512-AB/DA/DC...
I8 = IA02		
	}	EASY719-AB/DA/DC... EASY721-DC...
I11 = IA03		
I12 = IA04	}	EASY819/820/821/822-DC... MFD-R16, MFD-R17, MFD-T16, MFD-TA17

- Supplying loads such as motors, solenoid valves or contactors and easy from the same supply voltage may cause interference of the analog input signals when switching. Connect therefore inductive loads to be switched via the easy outputs to a separate supply voltage, or use a suppressor circuit for motors and valves.

1

Warning!

Incorrect connection may lead to unwanted switching states. Analog signals are more sensitive to interference than digital signals, therefore the signal cables should be carefully routed and connected.

- Use shielded twisted pair cables to prevent interference with the analog signals.
- For short cable lengths, ground the shielding at both ends using a large contact area. If the cable length is more than around 30 m, grounding at both ends can result in equalization currents between the two grounding points and thus in the interference of analog signals. In this case, only ground the cable at one end.
- Do not lay signal lines parallel to power cables.

Switching, control, visualization

Engineering easyRelay, MFD-Titan

Connecting power supply and analog inputs for easy...AB device

1

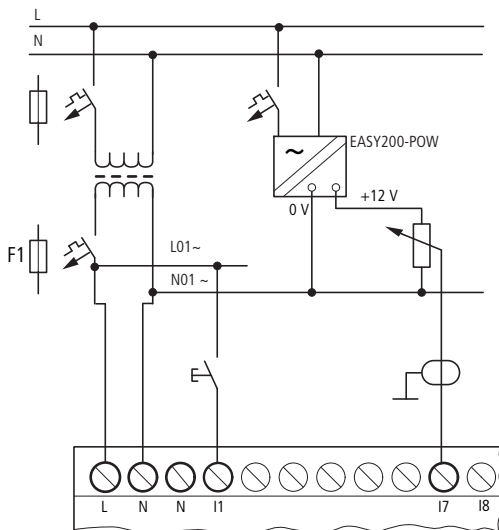

Notes

With easy... AB devices that process analog signals, the device must be fed via a transformer so that the device is galvanically isolated from the mains supply. The neutral conductor and the reference potential of the DC power feed for analog sensors must be electrically connected.

Ensure that the common reference potential is earthed or monitored by a ground fault monitoring device. Observe the applicable standards.

Switching, control, visualization

Engineering easyRelay, MFD-Titan

Analog input connections to easy...DA/DC ... or MFD-R.../T...

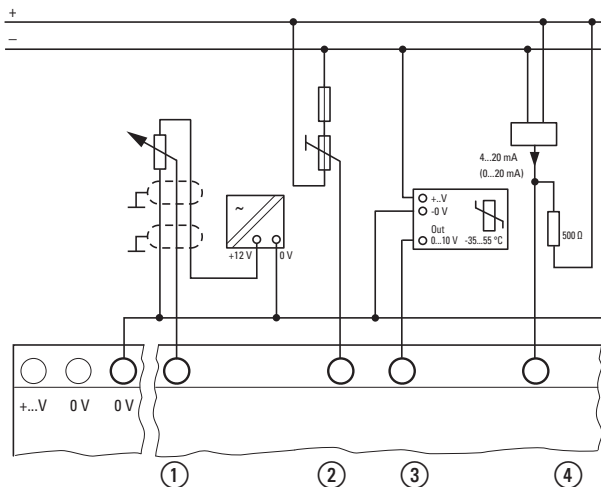

- ① Setpoint potentiometer via separate power supply and potentiometer ≤ 1 k Ω , e.g. 1 k Ω , 0.25 W
- ② Setpoint potentiometer with upstream resistor 1.3 k Ω , 0.25 W, potentiometer 1 k Ω , 0.25 W (values for 24 V DC)
- ③ Temperature monitoring via temperature sensor and transducer
- ④ Sensor 4 to 20 mA with resistor 500 Ω

Notes

- Pay attention to the differing number and designation of the analog inputs of each device type.
- Connect the 0 V of the or the MFD-Titan with the 0 V of the power supply of the analog transmitter.
- A 4(0) to 20 mA sensor and a resistor of 500 Ω give the following approx. values:
 - 4 mA \approx 1.9 V,
 - 10 mA \approx 4.8 V,
 - 20 mA \approx 9.5 V.
- Analog input 0 to 10 V, resolution 10 bit, 0 to 1023.

Switching, control, visualization

Engineering easyRelay, MFD-Titan

Connecting Pt100/Ni1000 with MFD-T(A)P...

1

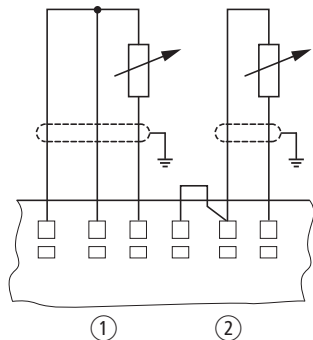

- ① Three wire connection ② Two wire connection

MFD-TAP13-PT-A	-40 °C ... +90 °C
MFD-TP12-PT-A	0 °C ... +250 °C
	0 °C ... +400 °C
MFD-TAP13-NI-A	0 °C ... +250 °C
MFD-TP12-NI-A	-40 °C ... +90 °C
MFD-TAP13-PT-B	0 °C ... +850 °C
MFD-TP12-PT-B	-200 °C ... +200 °C

Notes

Cable length, shielded < 10 m.

Switching, control, visualization

Engineering easyRelay, MFD-Titan

Connection options for the "High-speed counter" inputs on easy...DA/DC devices or MFD-R.../T...

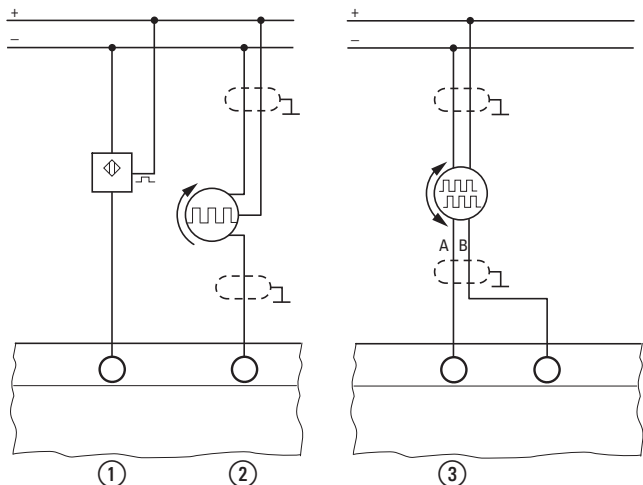

- ① High-speed counter, square wave signal via proximity switch, mark-to-space ratio should be 1:1
 easy500/700 max. 1 kHz
 easy800 max. 5 kHz
 MFD-R/T... max. 3 kHz
- ② Square wave signal via frequency generator, pulse pause relationship should be 1:1
 easy500/700 max. 1 kHz
 easy800 max. 5 kHz
 MFD-R/T... max. 3 kHz

- ③ Square wave signals via 24 V DC incremental encoder
 easy800-DC... max. 5 kHz and
 MFD-R/T... max. 3 kHz

Notes

Pay attention to the different number and designation of the inputs of the "high-speed counter", "frequency generator" and "incremental encoder" for each device type.

Switching, control, visualization

Engineering easyRelay, MFD-Titan

Connection of relay outputs for EASY...R MFD...R.

1

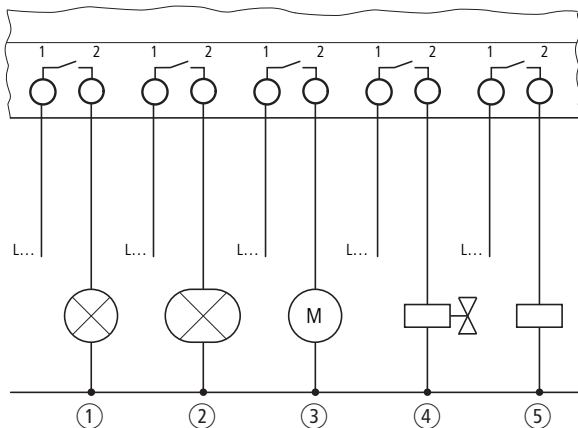

Protective element main pole L..

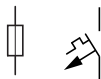

≤ 8 A/B16

Possible AC voltage range:

24 to 250 V, 50/60 Hz

e.g. L1, L2, L3 phase to zero conductor

Possible DC voltage range:

12 to 300 V DC





- ① Filament lamp, max. 1000 W at 230/240 V AC
- ② Fluorescent tube, max. 10 x 28 W with electronic upstream device, 1 x 58 W with conventional upstream device at 230/240 V AC
- ③ AC motor
- ④ Valve
- ⑤ Coil

Switching, control, visualization

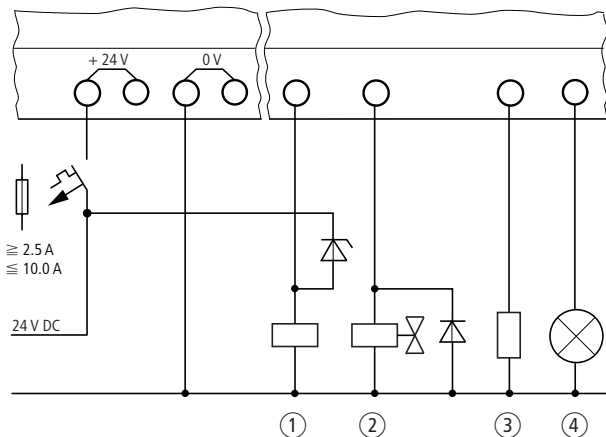
Engineering easyRelay, MFD-Titan

Connection of transistor outputs for EASY...T MFD T...



- ①  Contactor coil with zener diode as suppressor circuit, 0.5 A at 24 V DC
- ②  Valve with diode as suppressor circuit, 0.5 A at 24 V DC
- ③  Resistor, 0.5 A at 24 V DC
- ④  Indicator light 3 or 5 W at 24 V DC, Output dependent on device types and outputs

Notes

Please note the following when switching off inductive loads: Suppressed inductances cause less interference in the entire electrical system. It is generally recommended that the suppressor is

connected as close as possible to the inductance.

If inductances are not suppressed, the following applies:

Several inductances should not be switched off simultaneously to avoid overheating the driver blocks in the worst possible case. In the event of an emergency stop the +24 V DC power supply is to be switched off by means of a contact, and if this would mean switching off more than one controlled output with an inductance, these inductances must be provided with a suppressor circuit.

Switching, control, visualization

Engineering easyRelay, MFD-Titan

Parallel connection

1

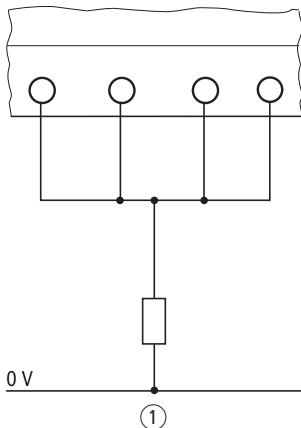

① Resistor

Notes

The outputs may only be connected in parallel within a group (Q1 to Q4 or Q5 to Q8, S1 to S4 or S5 to S8); Q1 and Q3 or Q5, Q7 and Q8. Parallel outputs must be activated simultaneously.



if 4 outputs in parallel,
max. 2 A at 24 V DC



if 4 outputs in parallel,
max. 2 A at 24 V DC
Inductances without suppression
circuit max. 16 mH



12 or 20 W at 24 V DC
Output dependent on device types
and outputs

Switching, control, visualization

Engineering easyRelay, MFD-Titan

Connection of analog outputs for EASY820-DC-RC..., EASY822-DC-TC..., MFD-RA..., MFD-TA...

1

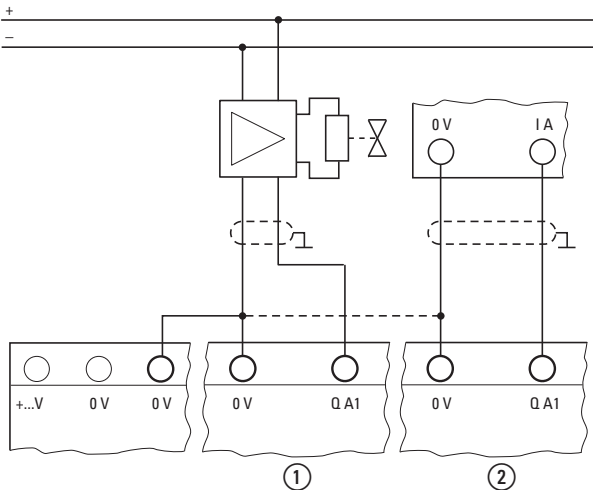

- ① Solenoid valve control
- ② Set value selection for drive control

Notes

- Analog signals are more sensitive to interference than digital signals, therefore the signal conductors should be carefully routed. Incorrect connection may lead to unwanted switching states.
- Analog output 0 to 10 V, resolution 10 bit, 0-1023.

Switching, control, visualization

Engineering easyRelay, MFD-Titan

I/O expansion

1

Central expansion, up to 40 I/O

easy700, easy800, MFD(-AC)-CP8... can be expanded via easy202, easy410, easy618 or easy620. Up to 24 inputs and 16 outputs are provided. An expansion is possible with each basic unit, → Section "easy central and remote expansion module", page 1-63.

Remote expansion, up to 40 I/O

easy700, easy800 and MFD-Titan can be expanded via the coupling module easy200-EASY with easy410, easy618 or easy620. The expansion unit can be operated up to 30 m from the basic device. There are a maximum of 24 inputs and 16 outputs available. One expansion unit per basic device is possible, → Section "easy central and remote expansion module", page 1-63.

Networking via easyNet, up to 320 I/O

Up to eight stations can be interconnected by expanding the inputs and outputs via easyNet. An expansion device can be added to each easy800 or MFD(-AC)-CP8... A network length of up to 1000 m is possible. There are two types of operation:

- A master (position 1, user address 1) and up to 7 other modules. The program is contained in the master.
- A master (position 1, user address 1) and up to 7 other "intelligent" or "dumb" modules. Each "intelligent" module has a program.

→ Section "easyNet, "loop through the device" network connection", page 1-64

Switching, control, visualization

Engineering easyRelay, MFD-Titan

easy central and remote expansion module

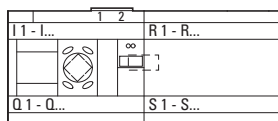

easy700
easy800

easy202...
easy410...
easy618..., easy620...

Central expansion

1

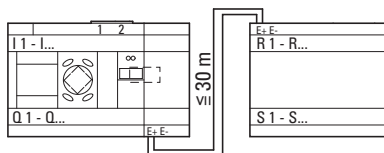

easy700
easy800

easy200

easy410...
easy618..., easy620...

Remote expansion



MFD-AC-CP8...
MFD-CP8...
MFD-CP10...

easy202...
easy410...
easy618..., easy620...

Central expansion

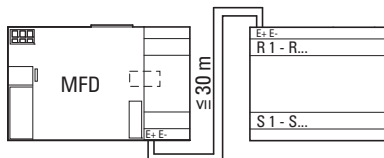

MFD-AC-CP8...
MFD-CP8...
MFD-CP10...

easy200

easy410...
easy618...
easy620...

Remote expansion

[] EASY-LINK-DS

Switching, control, visualization

Engineering easyRelay, MFD-Titan

easyNet, "loop through the device" network connection

1

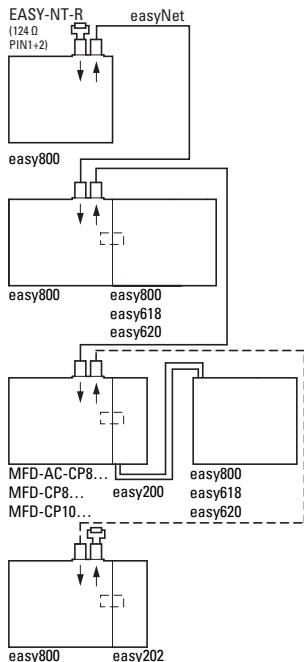

[] EASY-LINK-DS

- Addressing the stations:
 - Automatic addressing from station 1 or via easySoft... from the PC, **physical location = station**,
 - Single addressing on the corresponding station or via easySoft... on each station, **geographic location and station can be different**.

Geographic location, position ¹⁾	Stations Example 1	Example 2
1	1	1
2	2	3
3	3	8
[8]	(8)	(2)

¹⁾ The geographic location/position 1 **always** has the station address 1.

- The maximum length of easyNet is 1000 m.
- Should easyNet be interrupted or a station is not operational, the network is no longer active from the interrupted point.
- 4 core cable unshielded, each two cores twisted. Characteristic impedance of the cable must be 120 Ω.

Switching, control, visualization

Engineering easyRelay, MFD-Titan

easyNet, network connection "T connector with stub line"

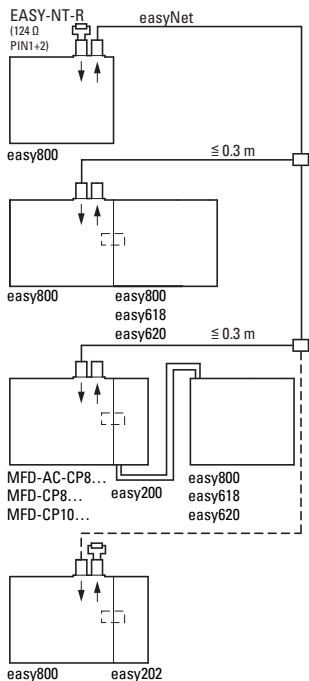

[] EASY-LINK-DS

- Addressing the stations:
 - Single addressing on corresponding station or via easySoft... on every station.
- The max. total length, including stub lines, with easyNet is 1000 m.
- The max. stub line's length of the T connector to easy800 or to MFD-Titan is 0.30 m.

Geographic location, position ¹⁾	Stations Example 1	Example 2
1	1	1
2	2	3
3	3	8
8	8	2

¹⁾ The geographic location/position 1 **always** has the station address 1.

- If easyNet is interrupted between the T connector and the station, or a station is not operational, the network is still active for the remaining stations.
- 4 core cable unshielded, each two cores twisted. Three cores are required. Characteristic impedance of the cable must be 120 Ω.

Switching, control, visualization

Engineering easyRelay, MFD-Titan

easyNet network connection

1

RJ45 sockets and plugs

Pin assignment of RJ45 socket on easy and MFD.

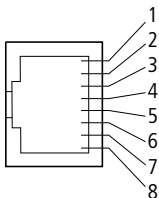

Pin assignment of the RJ45 plug on the easy, MFD(-AC)-CP8/CP10....

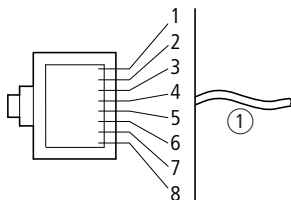

① Cable entry side
8-pole RJ45, EASY-NT-RJ45

Assignment with easyNET

- PIN 1: ECAN_H; Data cable;
conductor pair A
- PIN 2: ECAN_L; Data cable;
conductor pair A
- PIN 3: GND; ground conductor;
conductor pair B
- PIN 4: SEL_IN; Select conductor;
conductor pair B

Creating the network cable for easyNet

The characteristic impedance of the cable must be 120 Ω.

The network cable does not require any shielding braid.

However, if a shielding braid is used, it should be connected to PE.

Notes

Cable lengths and cross-sections

→ Table, page 1-68.

The minimum operation with easyNet functions with cables ECAN_H, ECAN_L, GND. The SEL_IN cable is only used for automatic addressing.

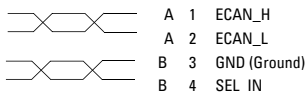

Bus terminating resistor

A bus terminal resistor must be connected to the geographical first and last station in the network:

- Value of the bus terminal resistor 124 Ω,
- Connect to PIN 1 and PIN 2 of the RJ45 plug,
- Terminating connector : EASY-NT-R.

Switching, control, visualization

Engineering easyRelay, MFD-Titan

Prefabricated cables, RJ45 plug at both ends

Cable length [cm]	Part no.
30	EASY-NT-30
80	EASY-NT-80
150	EASY-NT-150

User prepared cables

100 m, 4 x 0.14 mm²; twisted pair:
EASY-NT-CAB

RJ45 plug:
EASY-NT-RJ45

Crimping tool for RJ45 plug:
EASY-RJ45-TOOL

Calculating cross-section with known cable lengths

The minimum cross-section is determined for the known maximum expansion of the network.

l = Length of cable in m
 S_{\min} = Minimum cross-section in mm²
 ρ_{cu} = Resistivity of copper, if not otherwise stated 0.018 $\Omega\text{mm}^2/\text{m}$

$$S_{\min} = \frac{l \times \rho_{\text{cu}}}{12.4}$$

Notes

If the result of the calculation does not yield a standard cross-section, the next larger cross-section is used.

Calculating length with known cable cross-section

For a known conductor cross section the maximum conductor length is calculated.

l_{\max} = Length of cable in m
 S = Cable cross-section in mm²
 ρ_{cu} = Resistivity of copper, if not otherwise stated 0.018 $\Omega\text{mm}^2/\text{m}$

$$l_{\max} = \frac{S \times 12.4}{\rho_{\text{cu}}}$$

Switching, control, visualization

Engineering easyRelay, MFD-Titan

Permissible network lengths with easyNet

1

Total length of easyNet cable	Transmission speed	Cable cross-section, standardized		Bus cable, minimum cable cross-section
		EN	AWG	
m	Kbit/s	mm ²		mm ²
≤ 6	≤ 1000	0.14	26	0.10
≤ 25	≤ 500	0.14	26	0.10
≤ 40	≤ 250	0.14	26	0.10
≤ 125	≤ 125 ¹⁾	0.25	24	0.18
≤ 175	≤ 50	0.25	23	0.25
≤ 250	≤ 50	0.38	21	0.36
≤ 300	≤ 50	0.50	20	0.44
≤ 400	≤ 20	0.75	19	0.58
≤ 600	≤ 20	1.0	17	0.87
≤ 700	≤ 20	1.5	17	1.02
≤ 1 000	= 10	1.5	15	1.45

1) Default setting

Switching, control, visualization

Engineering easyRelay, MFD-Titan

Network connection on cable
cross-sections > 0.14 mm², AWG26

Network connect "through the device"

Example A, with terminals

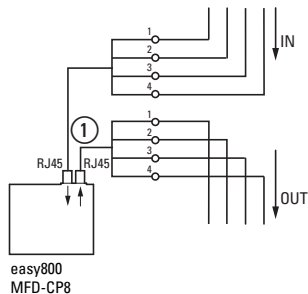

① Recommendation ≤ 0.3 m

Example B, with interface element

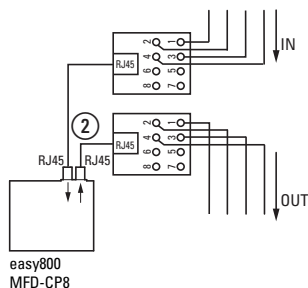

② Recommendation ≤ 0.3 m (EASY-NT-30)

Network connection "T connector with stub line"

Example A, with terminals

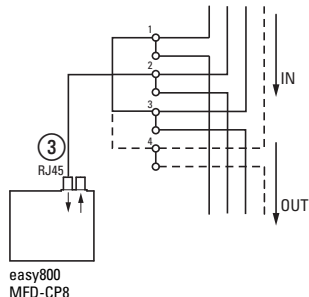

③ ≤ 0.3 m (3-core)

Example B, with interface element

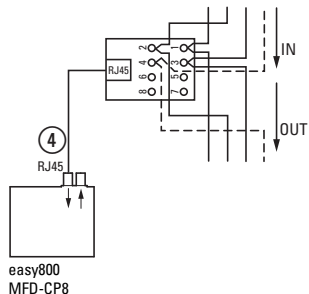

④ ≤ 0.3 m (EASY-NT-30)

Switching, control, visualization

Engineering easyRelay, MFD-Titan

Expansion units for networking

1

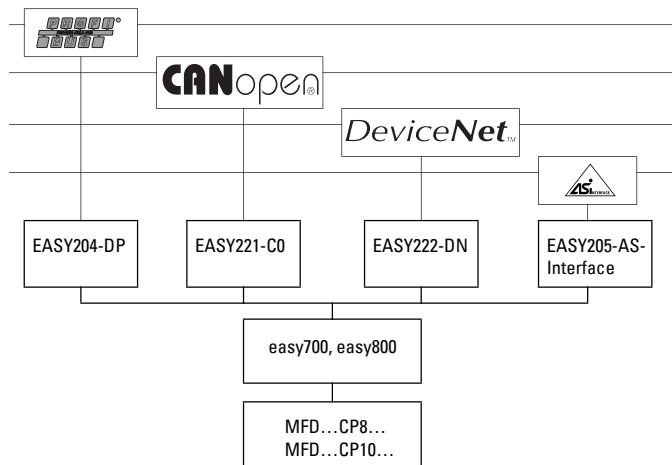

An expansion unit for networking can be connected with easy700, easy800 or MFD(-AC)-CP8-... The expansion unit for networking is integrated as slave in the configuration.

The inputs and output points can be expanded via easyNet (→ Section "easyNet, network connection "T connector with stub line"", page 1-65 and → Section "easyNet, network connection "T connector with stub line"", page 1-65).

Further information can be found in the manuals:

- MN05013003Z-EN
easy500, easy700, control relays
- MN04902001Z-EN
easy800, control relays
- MN05002001Z-EN
MFD-Titan multi-function display
- MN05013005Z-EN
EASY204-DP
- MN05013008Z-EN
EASY221-C0
- MN05013007Z-EN
EASY222-DN

Switching, control, visualization

Engineering easyRelay, MFD-Titan

Remote display in IP65

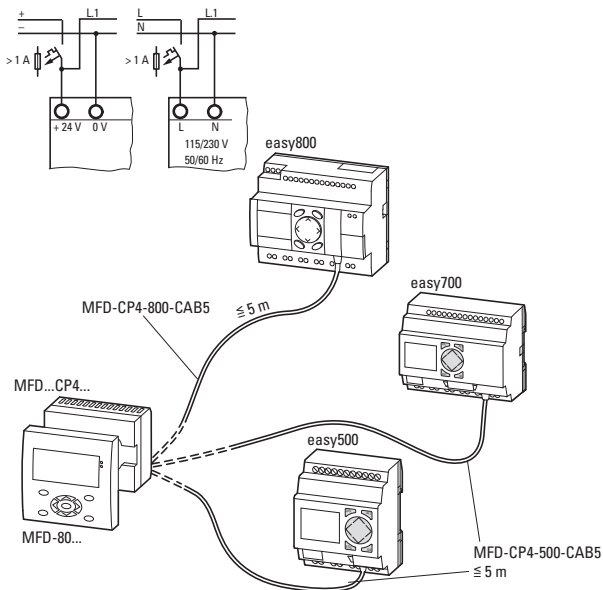

The display of the easyRelay is shown on the MFD-80... "remote display".

The easyRelay can also be operated with the MFD-80-B.

No extra software or programming is necessary to operate the "remote display".

The connection cable MFD-CP4-...-CAB5 can be shortened.

Switching, control, visualization

Engineering easyRelay, MFD-Titan

easy communication connections

1

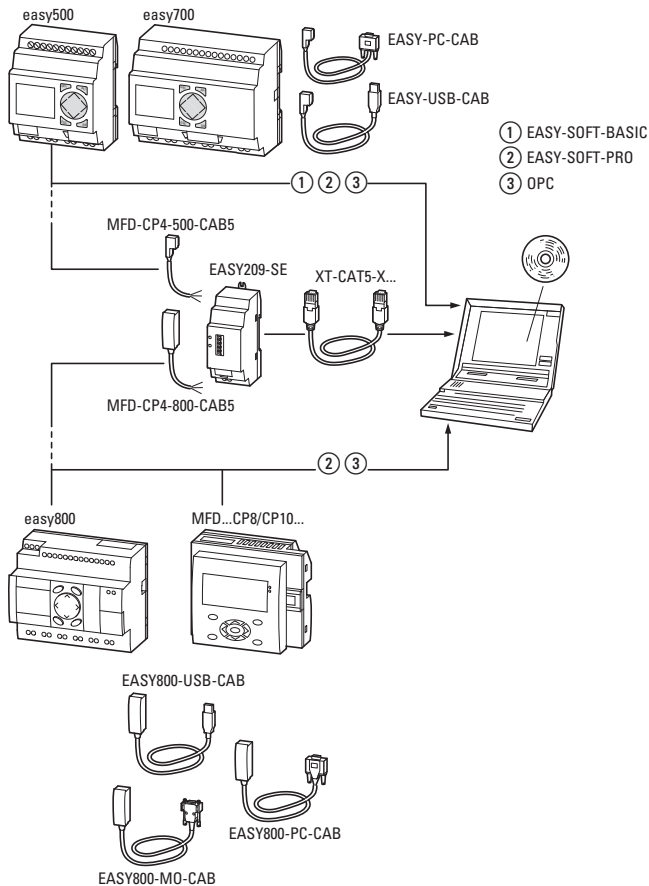

Switching, control, visualization

Engineering easyRelay, MFD-Titan

EASY209-SE standard connection

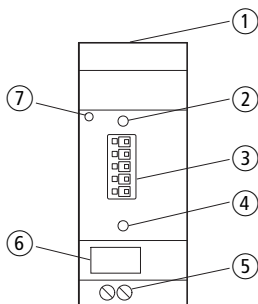

- ① Ethernet connection (RJ45 socket)
- ② Status LED (POW/RUN)
- ③ COM connection, spring-cage terminal 5-pole
- ④ RESET pushbutton
- ⑤ Power supply device 24 V DC V
- ⑥ Device label
- ⑦ Strain relief

24 V connection

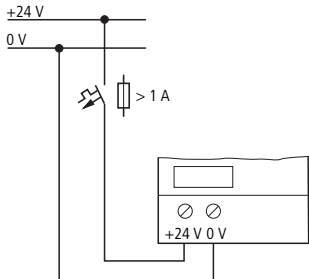

Ethernet connection

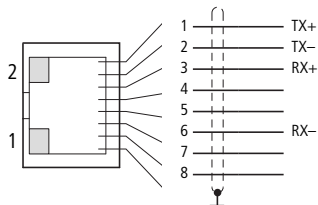

COM connection

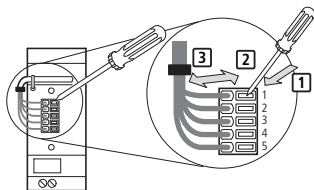

- ① press – ② insert – ③ remove
- 1 = grey
- 2 = brown
- 3 = yellow
- 4 = white
- 5 = green

Switching, control, visualization

Engineering easyRelay, MFD-Titan

COM-LINK connection

1

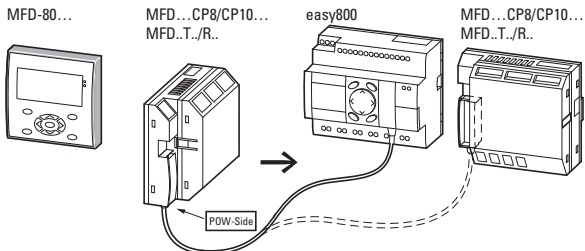

The COM-LINK is a point-to-point connection using the serial interface. Via this interface the status of the inputs and outputs are read as well as marker ranges read and written. Twenty marker double words read or written are possible. Read and write operations can be defined as required. This data can be used for setpoint entry or for display functions.

The stations of the COM-LINK have different functions. The active station is always a MFD...CP8/CP10... and controls the complete interface.

Remote stations can be an easy800 or an MFD...CP8/CP10.... The remote station responds to the requests of the active station. It does not recognize the difference whether COM-LINK is active or a PC with easySoft-PRO is using the interface.

The stations of the COM-LINK can be expanded locally or remotely with easy expansion units.

The remote station can also be a station in the easyNet.

Switching, control, visualization

Engineering easyRelay, MFD-Titan

1

Connecting and operating the 800 on the serial log printer

An SP (SP = serial protocol) module can be used to directly send data to the log printer via the serial PC interface on the front of the device. More information on this is provided in the easySoft-PRO help.

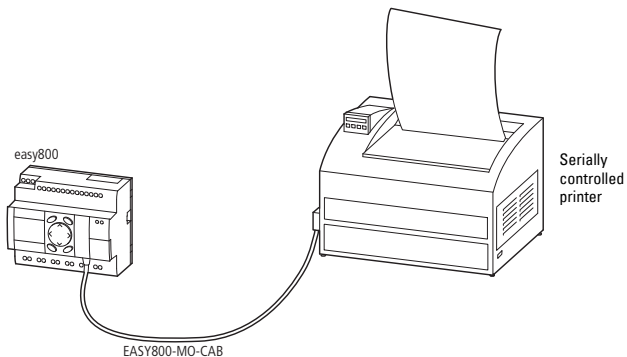

Pin assignment of EASY800-MO-CAB:

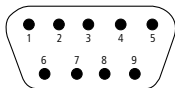

2 white T x D
3 brown R x D
5 green GND

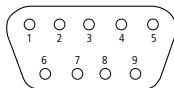

Information on EASY800-MO-CAB, see also IL05013021Z instructional leaflet.

Switching, control, visualization

Engineering easyRelay, MFD-Titan

Connection and modem operation with easy or MFD

1

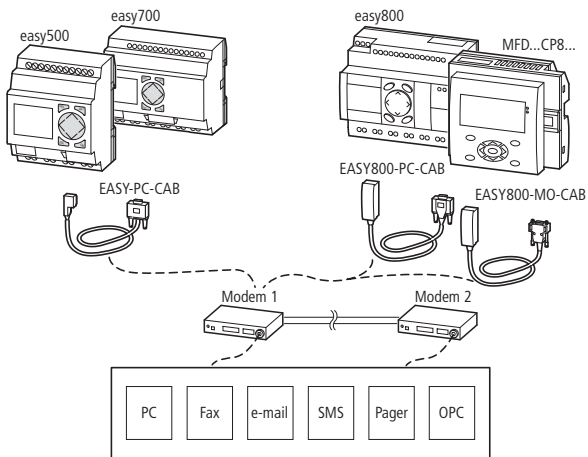

Information on EASY800-MO-CAB, see also
IL05013021Z instructional leaflet.

Switching, control, visualization

Programming easyRelay, MFD-Titan

Programming instead of wiring

Circuit diagrams are the basis of all electrotechnical applications. In practice this involves the wiring together of electrical switchgear. With the easy control relay this can be carried out simply at the push of a button or by using the convenient easySoft programming software on a PC. Simple menu navigation in many languages simplify the input. This saves time and therefore costs. easy and MFD-Titan are the professionals for the world market.

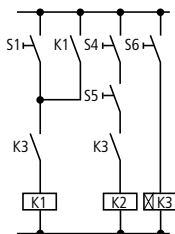

1

Contacts, coils, function blocks, operands

Operand	Description	easy500, easy700	easy800	MFD(-AC)-CP8... MFD(-AC)-CP10...
I	Bit input, basic device	x	x	x
nI	Bit input, basic device via easyNet	–	x	x
IÄ	Analog input	x	x	x
R	Bit input, expansion device ¹⁾	x	x	x
nR	Bit input, expansion unit via easyNet	–	x	x
Q	Bit output, basic device	x	x	x
nQ	Bit output, basic device via easyNet	–	x	x
QÄ	Analog output	–	x	x
S	Bit output, expansion unit	x	x	x
nS	Bit output, expansion unit via easyNet	–	x	x
ID	Diagnostic alarm	–	x	x
ID 1	COM-Link diagnostic alarm	–	–	x
LE	Bit output display backlight + Front plate LEDs	–	–	x
M	Marker	x	x	x
1M	Marker COM-Link	–	–	x
MB	Marker byte	–	x	x
MD	Marker double word	–	x	x
MW	Marker word	–	x	x
1MB/1MW /1MD	Marker operand COM-Link	–	–	x
N	Marker	x	–	–
P	P pushbuttons	x	x	x

Switching, control, visualization

Programming easyRelay, MFD-Titan

1

Operand	Description	easy500, easy700	easy800	MFD(-AC)-CP8... MFD(-AC)-CP10...
:	Jump	x	x	x
nRN	Bit input via easyNet	–	x	x
nSN	Bit output via easyNET easyNet	–	x	x
A	Analog value comparator	x	x	x
AR	Arithmetic functions	–	x	x
BC	Block comparison	–	x	x
BT	Block transfer	–	x	x
BV	Boolean sequence	–	x	x
C	Counter relay	x	x	x
CF	Frequency counter	x ²⁾	x	x
CH	High-speed counter	x ²⁾	x	x
CI	Incremental counter	–	x	x
CP	Comparator	–	x	x
D	Text display	x	x	–
DB	Data function block	–	x	x
DC	PID controller	–	x	x
FT	PT1 signal smoothing filter	–	x	x
GT	Get value from easyNet	–	x	x
⊙ H/HW	(Hour)/7-day time switch	x	x	x
Y/HY	Year time switch	x	x	x
JC	Conditional jump	–	x	x
LB	Jump label	–	x	x
LS	Value scaling	–	x	x
Z/MR	Master reset	x	x	x
MX	Data multiplexer	–	x	–
NC	Numerical converter	–	x	x
O/OT	Operating hours counter	x	x	x
PO	Pulse output	–	x	–
PW	Pulse width modulation	–	x	x
SC	Synchronize clock via network	–	x	x
ST	Set cycle time	–	x	x
SP	Serial protocol	–	x	–
SR	Shift register	–	x	x
T	Timing relays	x	x	x
TB	Table function	–	x	x
UC	Value limitation	–	x	x

1) With easy700, easy800 and MFD...CP8/CP10...

2) With easy500 and easy700 parameterizable as operating mode

n = NET station 1...8

Switching, control, visualization



Programming easyRelay, MFD-Titan

Coil functions

The switching behaviour of the relay coil is determined by the selected coil function. The specified function should for each relay coil only be used once in the wiring diagram.

Unused outputs Q and S can also be used as markers like M and N.

1

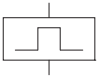
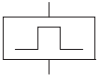
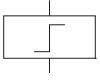
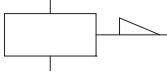
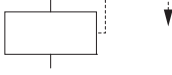
Circuit diagram symbol	easy display	Coil function	Example
	<code>[</code>	Contactor function	<code>{Q1, {D2, {S4, {I:1, {M7</code>
	<code>]</code>	Contactor function with negated result	<code>]Q1,]D2,]S4</code>
	<code>lr</code>	Cycle pulse on falling edge	<code>lrQ3, lrM4, lrD8, lrS7</code>
	<code>lP</code>	Cycle pulse with rising edge	<code>lPQ4, lPM5, lPD7, lPS3</code>
	<code>lJ</code>	Surge function	<code>lJQ3, lJM4, lJD8, lJS7</code>
	<code>S</code>	Latch (set)	<code>SQ8, SM2, SD3, SS4</code>
	<code>R</code>	Reset (unlatching)	<code>RQ4, RM5, RD7, RS3</code>

Switching, control, visualization

Programming easyRelay, MFD-Titan

Parameter sets for times

1

Parameters	Switch function
X	On-delayed switching
?X	On-delayed switching with random time range
■	Off-delayed switching
?■	Off-delayed switching with random time range
X■	Switching with on- and off-delayed
?X■	Switching with on- and off-delayed with random time
∩	Pulse shaping switching
∪	Switching with flashing

Possible coil functions:

- Trigger = TT..
- Reset = RT..
- Halt = HT..

Example based on EASY512

Depending up on the program the following parameters can be set:

- Switch function,
- Time range,
- Parameter display,
- Time 1 and
- Time 2.

```
T1  ∩  S  +
I1  30,000
I2  I7
□  T:00.00
```

T1 Relay no.

I1 Time setpoint 1

I2 Time setpoint 2

□ Output switch status:

□ N/O contact open,

■ N/C contact closed

∩ Switch function

S Time range

+ Parameter display

30,000 constant as value, e.g. 30 s

I7 Variable, e.g. analog value I7

T:00.00 actual time

Switching, control, visualization

Programming easyRelay, MFD-Titan

1

Parameter	Time range and setpoint time	Resolution
S 00.00	Seconds: 0.000 to 99,999	easy500, easy700 10 ms easy800, MFD...CP8/CP10... 5 ms
M:S 00:00	Minutes:Seconds 00:00 to 99:59	1 s
H:M 00:00	Hours:Minutes 00:00 to 99:59	1 min

Parameter set	Displaying the parameter set via menu item "Parameter"
+	Call enabled
-	Access disabled

Basic circuits

The easy circuit diagram is entered in ladder diagram. This chapter includes a few circuit examples which are intended to demonstrate the possibilities for your own circuit diagrams.

The values in the logic table have the following meanings for switching contacts

0 = N/O contact open,
N/C contact closed

1 = N/O contact closed,
N/C contact open

For relay coils Qx

0 = Coil not energized
1 = Coil energized

Note

The examples shown are based on easy500 and easy700. easy800 and MFD...CP8/CP10... provide four contacts and one coil per rung.

Negation

Negation means that the contact opens rather than closes when it is actuated (NOT connection).

In the easy circuit diagram, press the **ALT** button to toggle between N/C and N/O contact.

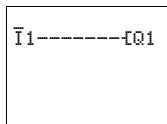

Logic table

I1	Q1
1	0
0	1

Switching, control, visualization

Programming easyRelay, MFD-Titan

1

Series connection

Q1 is controlled by a series connection consisting of three N/O contacts (AND connection).

$$I1-I2-I3-Q1$$

$$\bar{I}1-\bar{I}2-\bar{I}3-Q2$$

Q2 is actuated via three N/C contacts connected in series (NAND connection).

In the easy circuit diagram, you can connect up to three N/O or N/C contacts for easy500 and easy700 in series within a rung. Use M marker relays if you need to connect more than three N/O contacts in series.

Logic table

I1	I2	I3	Q1	Q2
0	0	0	0	1
1	0	0	0	0
0	1	0	0	0
1	1	0	0	0
0	0	1	0	0
1	0	1	0	0
0	1	1	0	0
1	1	1	1	0

Parallel switching

Q1 is actuated via a parallel connection of several N/O contacts (OR connection).

$$I1 \uparrow \text{-----} Q1$$

$$I2 \downarrow$$

$$I3 \downarrow$$

A parallel connection of closed N/Cs Q2 (NOR circuit).

$$\bar{I}1 \uparrow \text{-----} Q2$$

$$\bar{I}2 \downarrow$$

$$\bar{I}3 \downarrow$$

Logic table

I1	I2	I3	Q1	Q2
0	0	0	0	1
1	0	0	1	1
0	1	0	1	1
1	1	0	1	1
0	0	1	1	1
1	0	1	1	1
0	1	1	1	1
1	1	1	1	0

Switching, control, visualization

Programming easyRelay, MFD-Titan

Two way switch

A two way switch is made in easy using two series connections that are combined to form a parallel circuit (XOR).

XOR is the abbreviation of **exclusive Or** circuit. The coil is energized if only one contact is activated.

Logic table

I1	I2	Q1
0	0	0
1	0	1
0	1	1
1	1	0

Self-latching

A combination of a series and parallel connection is used to wire a latching circuit.

Latching is established by contact Q1

which is connected in parallel to I1. When I1 is actuated and reopened, the current flows via contact Q1 until I2 is actuated.

S1 N/O contact on I1
S2 N/C contact on I2

$$I1 \uparrow I2 \text{-----} [Q1 \\ Q1 \downarrow$$

Logic table

I1	I2	Contact Q1	Coil Q1
0	0	0	0
1	0	0	0
0	1	0	0
1	1	0	1
1	0	1	0
0	1	1	1
1	1	1	1

The latching (self-maintaining) circuit is used to switch machines on and off. The machine is switched on at the input terminals via N/O contact S1 and is switched off via N/C contact S2.

S2 breaks the connection to the control voltage in order to switch off the machine. This ensures that the machine can be switched off, even in the event of a wire breakage. I2 is always closed when not actuated.

A self-maintaining circuit with open-circuit monitoring can alternatively be wired using the Set and Reset coil functions.

S1 N/O contact on I1
S2 N/C contact on I2

$$I1 \text{-----} SQ1 \\ \bar{I}2 \text{-----} RQ1$$

Switching, control, visualization

Programming easyRelay, MFD-Titan

1

Coil Q1 latches if I1 is activated. I2 inverts the break contact signal of S2 and only switches if S2 is activated in order to disconnect the machine or in the event of a wire breakage.

Make sure that both coils are wired up in the correct order in the easy circuit diagram: first wire the S coil and then the R coil. This will ensure that the machine will be switched off when I2 is actuated, even if I1 is switched on.

Impulse relays

An impulse relay is often used for controlling lighting such as for stairwell lighting.

S1 N/O contact at I1



I1-----]Q1

Logic table

I1	Status Q1	Q1
0	0	0
1	0	1
0	1	1
1	1	0

On-delayed timing relay

The on-delay can be used to override short pulses or with a machine, to start a further operation after a time delay.

S1 N/O contact at I1

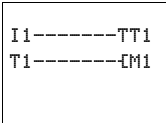

I1-----TT1
T1-----[M1

Permanent contact

To energize a relay coil continuously, make a connection of all contact fields from the coil to the leftmost position.

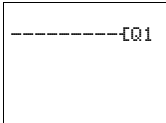

-----[Q1

Logic table

---	Q1
1	1

Switching, control, visualization

Programming easyRelay, MFD-Titan

Wiring of contacts and relays

Hardwired

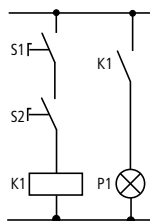

Wiring with easy

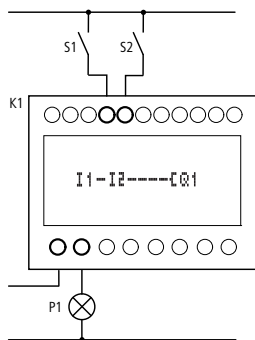

1

Star-delta starting

You can implement two star-delta circuits with easy. The advantage of easy is that it is possible to select the changeover time between star and delta contactors, and

also the time delay between switching off the star contactor and switching on the delta contactor.

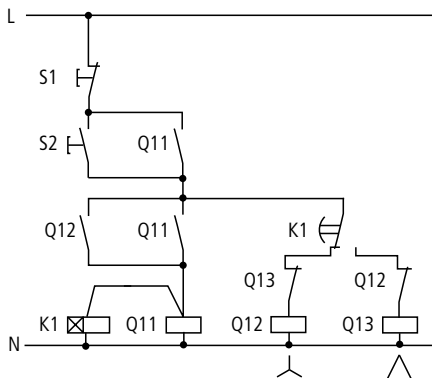

Switching, control, visualization

Programming easyRelay, MFD-Titan

1

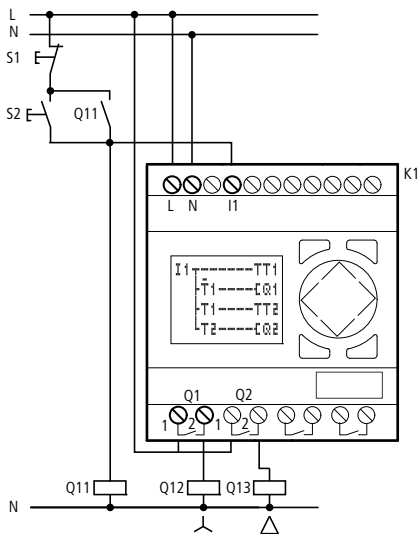

Function of the easycircuit diagram:

Start/Stop the connection with the external pushbuttons S1 and S2. The mains contactor starts the timing relay in easy.

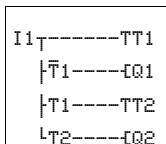

I1: Mains contactor switched on

Q1: Star contactor ON

Q2: Delta contactor ON

T1: Changeover time star-delta (10 to 30 s)

T2: Wait time between star off, delta on
(30, 40, 50, 60 ms)

If your easy has an integral time switch, you can combine star-delta starting with the time switch function. In this case, use easy to also switch the mains contactor.

Switching, control, visualization

Programming easyRelay, MFD-Titan

Stairway lighting

For a conventional connection a minimum of five space units are required in the distribution board, i.e. one impulse relay, two timing relays, two auxiliary relays.

easy requires only four space units. With five connections and the easy circuit the stairway lighting is operational.

1

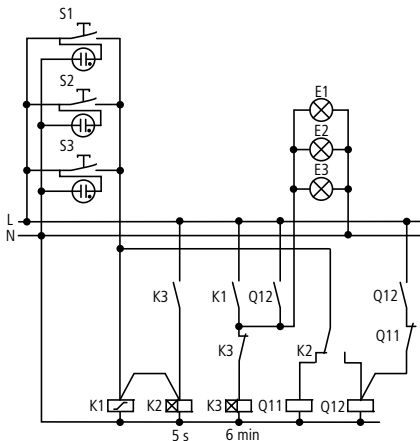

Important Note

Four such stairway circuits can be implemented with one easy device.

Switching, control, visualization

Programming easyRelay, MFD-Titan

1

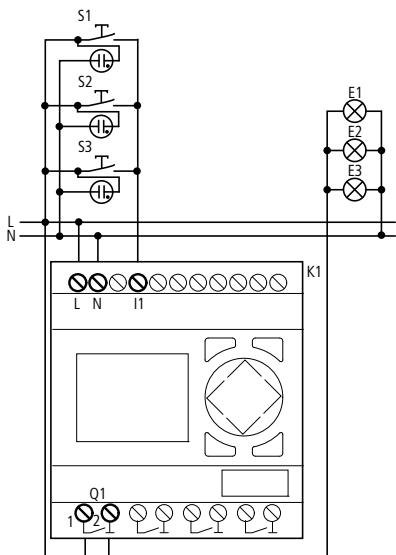

Pushbutton pressed briefly

Light ON or OFF. The impulse relay function will even switch off with continuous lighting.

Light off after 6 min

Switched off automatically. With continuous light this function is not active.

Pushbutton pressed for more than 5 s

Continuous light

Switching, control, visualization

Programming easyRelay, MFD-Titan

The easy circuit configuration for the described function below looks like this:

```

I1-----TT2
T2-----SM1
I1┐-----JQ1
T3┘
Q1-┐M1----TT3
Q1-┘-----RM1
  
```

The expanded easy circuit diagram: after four hours, the continuous lighting is also switched off.

```

I1-----┐TT1
          ┘TT2
T2-----SM1
T1┐-----JQ1
T3┘
T4┘
Q1┐M1----TT3
   ┘-----TT4
Q1-┘-----RM1
  
```

Meaning of the contacts and relays used

I1: ON/OFF pushbutton

Q1: Output relay for light ON/OFF

M1: Marker relay. This is used to block the "switch off automatically after 6 minutes" function for continuous lighting.

T1: Cyclical impulse for switching Q1 ON/OFF, (Π, pulse shaping with value 00.00 s)

T2: Scan to determine how long the pushbutton was pressed. When pressed for longer than 5 s, it changes to continuous light. (X, on-delayed, value 5 s)

T3: Switch off after the light has been on for von 6 min. (X, on-delayed, value 6:00 min.)

T4: Switch off after 4 hours continuously on. (X, on-delayed, value 4:00 h)

Switching, control, visualization

Programming easyRelay, MFD-Titan

4-way shift register

1

A shift register can be used for storing an item of information – e.g. sorting of items into “good” or “bad” – two, three or four transport steps further on.

A shift pulse and the value (0 or 1) to be shifted are required for the shift register.

Values which are no longer required are deleted via the reset input of the shift register. The values in the shift register pass through the register in the following order:

1st, 2nd, 3rd, 4th storage position.

Block diagram of the 4-way shift register

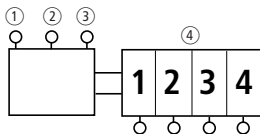

- ① Pulse
- ② Value
- ③ RESET
- ④ Storage position

Function

Pulse	Value	Storage position			
		1	2	3	4
1	1	1	0	0	0
2	0	0	1	0	0
3	0	0	0	1	0
4	1	1	0	0	1
5	0	0	1	0	0
Reset = 1		0	0	0	0

Allocate the value 0 with the information content bad. Should the shift register be accidentally deleted, no bad parts will be reused.

- I1: Shift pulse (PULSE)
- I2: Information (good/bad) to be shifted (VALUE)
- I3: Delete contents of the shift register (RESET)
- M1: 1st storage location
- M2: 2nd storage location
- M3: 3rd storage location
- M4: 4th storage location
- M7: Marker relay for cycle pulse
- M8: Cyclical pulse for shift pulse

Switching, control, visualization

Programming easyRelay, MFD-Titan

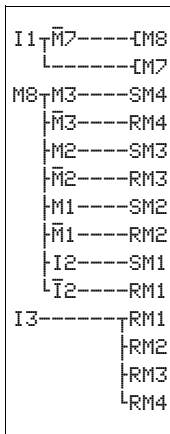

Generate shift pulse

- 4th storage location, set
- 4th storage location, delete
- 3rd storage location, set
- 3rd storage location, delete
- 2nd storage location, set
- 2nd storage location, delete
- 1st storage location, set
- 1st storage location, delete
- Delete all storage locations

1

Switching, control, visualization

Programming easyRelay, MFD-Titan

Display text and actual values , display and edit setpoint values

1

easy500 and easy700 can display 16 freely editable texts, easy800 can display 32.

These texts can be triggered by the actual values of function relays such as timing relays, counters, operating hours counters, analog value comparators, date, time or scaled analog values. Setpoint values of timing relays, counters, operating hours counters and analog value comparators can be altered on the device during the display of the texts.

Example of a text display:

```
SWITCHING;
CONTROL;
DISPLAY;
ALL EASY!
```

The text display can display the following:

```
RUNTIME M:S
T1 :012:46
C1 :0355 ST
PRODUCED
```

— Line 1, 12 characters

— Line 2, 12 characters, a setpoint value or an actual value

— Line 3, 12 characters, a setpoint value or actual value

— Line 4, 12 characters

The setpoint values can be edited:

- easy500 and easy700, two values
- easy800, four values

The text output function block D (D = Display, text display) functions in the circuit diagram like a normal marker M. Should a text be attached to a marker this would be shown at condition in the easy display when the coil is set to 1. For this easy must be in RUN mode and before the texts are displayed the Status display must be active.

D1 is defined as an alarm text and has therefore priority over text displays.

D2 to D16/D32 are displayed when activated. When several displays are activated they are shown in succession every 4 secs. When a setpoint value is edited the corresponding display stays active until the value is transferred.

Switching, control, visualization

Programming easyRelay, MFD-Titan

Visualization with MFD-Titan

The visualization with MFD-Titan is implemented with screen, on which the display is shown.

Example of a screen:

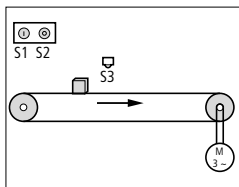

The following screen elements can be combined.

- Graphic elements
 - Bit display
 - Bitmap
 - Bargraph
 - Message bitmap
- Button elements
 - Latching pushbutton
 - Button field
- Text elements
 - Static text
 - Message text
 - Screen menu
 - Running text
 - Rolling text
- Value display elements
 - Date and time display
 - Numerical value
 - Timing relay value display
- Value entry elements
 - Value entry
 - Timing relay value entry
 - Date and time entry
 - 7-day time switch entry
 - Year time switch entry

Switching, control, visualization

HMI-PLC - Systematic visualization and control

System overview

1

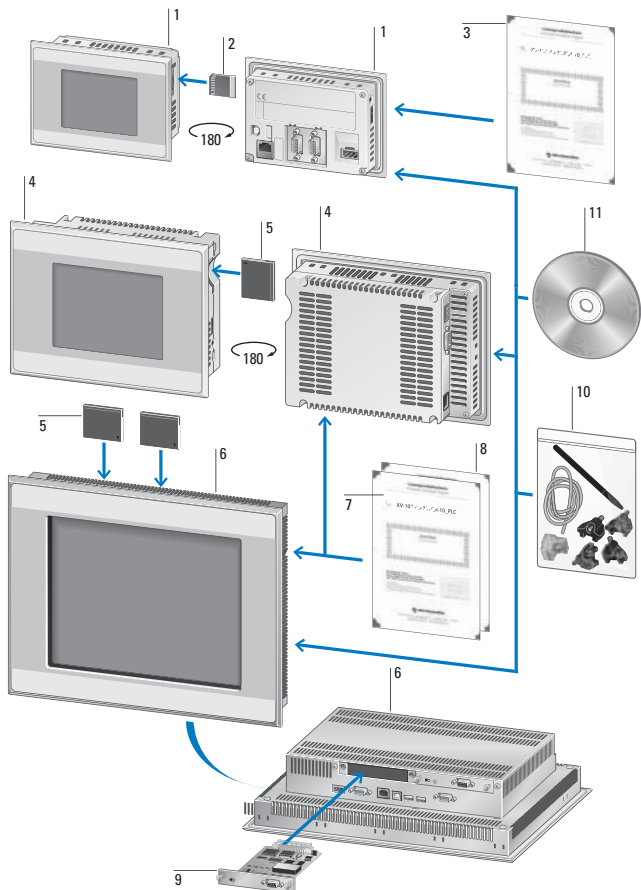

Switching, control, visualization

HMI-PLC - Systematic visualization and control

- 1 XV100 HMI/PLC with touch display:
Fully graphical 3.5", 5.7" or 7" wide
screen devices
- 2 SD memory card
- 3 XV license product certificates:
Expansion of device functionality
through assignment of license points.
- 4 XV200 HMI/PLC with touch display;
Fully graphical 5.7" devices
- 5 CompactFlash memory card
- 6 XV400 HMI/PLC with touch display:
5.7", 8.4", 10.4", 12.1", 15" devices with
infra-red or resistive touch
- 7 XV license product certificates:
Expansion of device functionality
through assignment of license points
- 8 OS Upgrade license
- 9 Communication module for XV400
- 10 Fixing kit
- 11 Software

Switching, control, visualization

HMI-PLC - Systematic visualization and control

General information

1



Each transmitter is assigned a receiver on the other side. The beams are directed slightly over the front panel. The simultaneous interruption of several infra-red channels on the X and Y axis is used to indicate where the panel was touched in order to trigger the appropriate switch function.

Whether in machine or system building or in individual applications, an HMI (Human Machine Interface) or HMI-PLC (HMI with PLC functionality) simplifies operation and reduces the workload for the operator.

Touch panels provide a clear, flexible menu navigation in any required language and enables the manufacturer to sell machinery worldwide with only one hardware and software solution.

Touch panels with resistive and infra-red technology are primarily used. Eaton offers devices with both technologies.

On the resistive touch panel, a conductive foil is stretched over the conductive screen surface. The foil is separated from the screen using several insulating pads. Only when a slight pressure is applied, does the foil touch the screen surface at this point and a current flows. A different current or resistance value is produced, based on the voltage divider principle according to where on the screen contact with the foil was made. The contact point is thus located unambiguously.

The infra-red touch panels uses a light matrix in the infra-red range.

Switching, control, visualization

HMI-PLC - Systematic visualization and control

Touch-technology	Infra-red	Resistive
Light permeability	100 %	70 – 85 %
Operable with	Fingers, gloves	Fingers, gloves, touch pen
Triggering of the function	Without pressure (interruption of the light matrix)	With slight pressure
Display front	Glass	Plastic film
Device front	Level determined by the infra-red frame	Fully flat
Sensitivity to scratches	No	Yes
Resistance to cleaning agent and chemicals	High	Average
Use in humid atmospheres	Yes	Yes

Devices with display sizes from 3.5" to 19" are used in automation applications. Eaton offers device versions in plastic and metal. The front on the metal devices is either in aluminium or stainless steel.

Front degree of protection: IP65

Most touch panels can also be used in portrait format (upright).

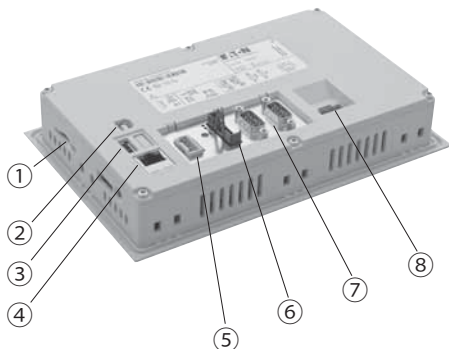

Switching, control, visualization**HMI-PLC - Systematic visualization and control****Engineering****1**

Rear view of a 7" resistive panel of the XV102 series with plastic housing

- ① SD memory card (Secure Digital memory card)
- ② USB device, page 1-98
- ③ USB host, page 1-98
- ④ Ethernet interface, page 1-99
- ⑤ 24 V DC power supply POW and AUX (for SmartWire-DT slaves, page 1-99)
- ⑥ SmartWire-DT interface (only specific devices) page 1-100
- ⑦ Onboard interfaces, depending upon the device:
 - RS232, page 1-100
 - RS485, page 1-101
 - CAN, page 1-102
 - PROFIBUS-DP, page 1-104
- ⑧ 24 V DC device supply, page 1-106

② USB device

The USB device interface supports USB 2.0.



• Cable

- Only use standard USB cables with a shield.
- Maximum cable length: 5 m

③ USB-Host

The USB Host interface supports USB 2.0.



• Cable

- Only use standard USB cables with a shield.
- Maximum cable length: 5 m

Switching, control, visualization

HMI-PLC - Systematic visualization and control

④ Ethernet interface

LINK ACT



LED	Signal	Meaning
ACT (yellow)	flashes	Ethernet is active (data traffic)
LINK (green)	On	Active network is connected and detected

• Cable

- Use shielded twisted pair (STP) cable for networking
- For device to device connection: cross over cable
- For connection to hub/switch: 1:1 patch cord
- Maximal cable length: 100 m

Ethernet interface according to EIA/TIA 568 TSB-36.

⑤ POW and AUX 24 V DC power supply (for SmartWire-DT slaves)

The POW/AUX interface is not galvanically isolated. The following power supplies are required for a SmartWire-DT network:

Supply voltage POW:

The device supply voltage for the electronics of all SWD slaves (15 V DC) is generated from the 24 V DC supply voltage that you apply to the POW terminal connection.

Supply voltage AUX:

If there are any contactors or motor starters in the SWD topology, a 24 V DC voltage AUX must be additionally supplied as a control voltage for the contactor coils.



• Wiring

WAGO plug connector, Art no. 734-104 is supplied with the device.

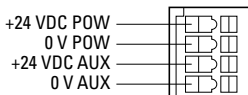

Connection	Assignment
+24 V DC POW	U_{POW} +24 V DC
0 V POW	U_{POW} 0 V
+24 V DC AUX	U_{AUX} +24 V DC
0 V AUX	U_{AUX} 0 V

Observe the following when preparing the wiring of the plug connector:

Terminal type:	Spring-loaded terminals
Connectable conductor, solid:	0.2 - 1.5 mm ² (AWG24 - 16)
Stripping length:	6 - 7 mm

Switching, control, visualization

HMI-PLC - Systematic visualization and control

1

External protection using a 24 V DC miniature circuit-breaker is required for U_{Aux} .

⑥ SmartWire-DT interface (only specific device types)

The SWD interface is not galvanically isolated.

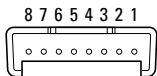

• Cabling

Only use the following cables to connect the SmartWire-DT network:

- SWD-4-100LF8-24 with the SWD-4-8MF2 blade terminals or
- SWD-4-(3/5/10)F8-24-25 (prefabricated cable)

Detailed instructions for fitting the SWD-4-8MF2 blade terminal is provided in the manual MN05006002Z-EN, chapter "Fitting the SWD4-8MF2 blade terminal".

The project configuration (SmartWire-DT configuration in XSoft-CoDeSys-2 project) is described in the manual MN04802091Z-EN, XSoft-CoDeSys-2: PLC programming XV100, chapter "SmartWire-DT Configuration".

⑦ RS232

The RS232 interface is not galvanically isolated. The device may be damaged by potential differences. The GND terminals of all bus stations must therefore be connected.

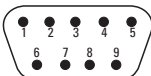

Pin	Signal	Assignment
1	DCD	Data Carrier Detected
2	RxD	Receive Data
3	TxD	Transmit Data
4	DTR	Data Terminal Ready
5	GND	Ground
6	DSR	Data Set Ready
7	RTS	Request to Send
8	CTS	Clear To Send
9	RI	Ring Indicator

• Wiring

- Shielded cables must be used.
- The maximum baud rate depends on the cable length:

Cable length	Max. baud rate
2.5 m	115200 bit/s
5 m	57600 bit/s
10 m	38400 bit/s
15 m	19200 bit/s
30 m	9600 bit/s

Switching, control, visualization

HMI-PLC - Systematic visualization and control

⑦ RS485

The RS485 interface is not galvanically isolated. The device may be damaged by potential differences. The GND terminals of all bus stations must therefore be connected.

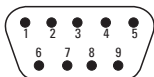

Pin	Signal	Assignment
1	-	nc
2	-	nc
3	B	Line B
4	-	nc
5	GND	Ground
6	-	nc
7	A	Line A
8	-	nc
9	-	nc

nc: Pin 1, 2, 4, 6, 8 and 9 must not be connected.

• Wiring

Screened twisted-pair cables must be used.

Cable specification

Rated cable impedance	120 Ω
Permissible impedance	108-132 Ω

Cable specification

Max. cable length	1200 m
Possible baud rates	9600 bit/s 19200 bit/s 38400 bit/s 57600 bit/s 115200 bit/s

When preparing connections, ensure that the cable shield has a low impedance connection with the connector housing.

• RS485-topology

- A bus segment can interconnect up to 32 slaves.
- Several bus segments can be connected via repeaters (bidirectional amplifiers). Refer to the documentation of the repeater manufacturer for more specific details.
- The use of repeaters enables the maximum cable length to be increased. Refer to the documentation of the repeater manufacturer for more specific details.
- A bus segment must be provided with cable termination (120 Ω) at both ends. These terminals must be connected in the connector directly between pin 3 and 7.
- The bus segment must be terminated at both ends.
- No more than two terminations must be provided for each bus segment.
- Operation without correct cable termination can cause transfer errors.

Switching, control, visualization

HMI-PLC - Systematic visualization and control

1

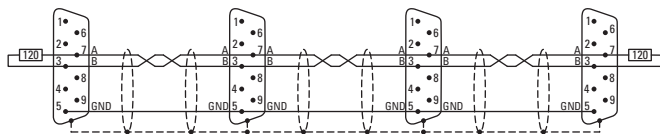

⑦ CAN

The CAN interface is not galvanically isolated. The device may be damaged by potential differences. The GND terminals of all bus stations must therefore be connected.

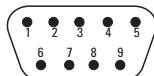

Pin	Signal	Assignment
1	-	nc
2	CAN-L	Bus line (dominant low)
3	CAN-GND	CAN ground
4	-	nc
5	-	nc
6	GND	Optional CAN ground
7	CAN-H	Bus line (dominant high)
8	-	nc
9	-	nc

Pin 3 (CAN-GND) and 6 (GND) are internally interconnected
nc: Pin 1, 4, 5, 8 and 9 must not be connected.

The power supply of the CAN bus drivers is implemented internally.

A power supply for third party devices is not provided on the CAN connector.

• Wiring

Shielded twisted pair cables must be used.

Cable specification

Rated cable impedance	120 Ω
Permissible impedance	108-132 Ω
Capacitance per unit length	< 60 pF/m
Conductor cross-section	≥ 0.25 mm ² /100 m
Max. cable length	≥ 0.34 mm ² /250 m
	≥ 0.75 mm ² /500 m

Switching, control, visualization

HMI-PLC - Systematic visualization and control

The maximal baud rate depends on the cable length

Cable length	Max. baud rate
25 m	1000 kbit/s
50 m	800 kbit/s
100 m	500 kbit/s
250 m	250 kbit/s
500 m	125 kbit/s
500 m	100 kbit/s
1000 m	50 kbit/s
2500 m	20 kbit/s
5000 m	10 kbit/s

- The use of repeaters is recommended for cable lengths over 1000 m. Repeaters can also be used for galvanic isolation. Refer to the documentation of the repeater manufacturer for more specific details.

- Observe the recommendations of CiA (CAN in Automation).

- When preparing connections, ensure that the cable shield has a low impedance connection with the connector housing.

- CAN-Bus-topology

- A bus segment can interconnect up to 32 slaves.
- Several bus segments can be connected via repeaters (bidirectional amplifiers). Refer to the documentation of the repeater manufacturer for more specific details.
- A bus segment must be provided with cable termination (120 Ω) at both ends. These terminals must be connected in the connector directly between pin 2 and 7.
- The bus segment must be terminated at both ends.
- No more than two terminations must be provided for each bus segment.
- Operation without correct cable termination can cause transfer errors.

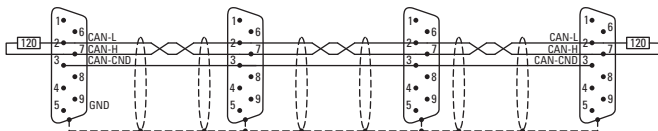

Switching, control, visualization

HMI-PLC - Systematic visualization and control

1

⑦ PROFIBUS-DP

The PROFIBUS interface is not galvanically isolated. The device may be damaged by potential differences. The GND terminals of all bus stations must therefore be connected.

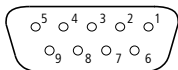

Pin	Signal	Assignment
1	-	nc
2	-	nc
3	B	EIA RS485 cable B
4	RTSAS	Output for controlling a repeater
5	M5EXT	Output 0 V for external termination
6	P5EXT	Output 5 V for external termination
7	-	nc
8	A	EIA RS485 cable A
9	-	nc

Pin 6 (5 V) must not be used as a power supply for external devices.

• Wiring

Screened twisted-pair cables, cable type A (acc. to the PROFIBUS standard EN 50170) must be used.

Cable specification

Rated cable impedance	150 Ω
Permissible impedance	135-165 Ω
Capacitance per unit length	< 30 pF/m
Loop resistance	< 110 Ω/km
Core cross section	≥ 0.34 mm ² (AWG22)

The maximal baud rate depends on the cable length

Cable length	Max. baud rate
200 m	1500 kbit/s
400 m	500 kbit/s
1000 m	187.5 kbit/s
1200 m	≤ 93.75 kbit/s

When preparing connections, ensure that the cable shield has a low impedance connection with the connector housing.

Switching, control, visualization

HMI-PLC - Systematic visualization and control

• PROFIBUS-topology

Shielded twisted-pair cables must be used.

- A bus segment can interconnect up to 32 slaves.
- Several bus segments can be connected via repeaters (bidirectional amplifiers). Refer to the documentation of the repeater manufacturer for more specific details.

Notes:

The use of repeaters enables the maximum cable length to be increased. Refer to the documentation of the repeater manufacturer for more specific details.

- Only use bus connector plugs that are specified for use in the PROFIBUS network. These combine both bus cables on a bus station and ensure that the cable shield is a low impedance connection and fed through to the shield reference potential of the bus station. The bus connector plug

contains the PROFIBUS-specific cable termination that can be activated if required.

- A bus segment must be provided with cable termination at both ends. The termination is passive but is fed from the bus station. It ensures a defined quiescent signal on the bus if no bus station is sending. These bus terminals are primarily implemented externally in the connector housing in accordance with the PROFIBUS standard.

Notes:

- The bus segment must be terminated at both ends.
- No more than two terminations must be provided for each bus segment.
- At least one of the two terminations must be fed by the bus station.
- Operation without correct termination of the PROFIBUS network can cause transfer errors.

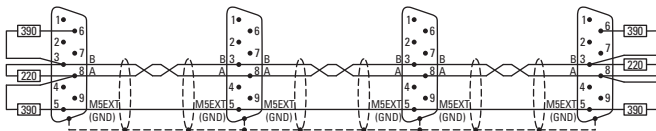

Switching, control, visualization

HMI-PLC - Systematic visualization and control

1

⑧ 24 V DC device supply

The device has an internal fuse and protection against polarity reversal. The functional earth must only be connected with the connector panel not the 0 V. The housing is plastic and is potential free. The power supply of the device is not galvanically isolated.

The device requires a power supply of 24 V DC from an AC/DC transformer with safe isolation (SELV).

- SELV (safety extra low voltage); circuit in which no dangerous voltage occurs even in the event of a single fault.



• Wiring

Plug connector Phoenix Contact MSTB 2.5/3-ST-5.08, Phoenix Art no. 1757022 is supplied with the device.

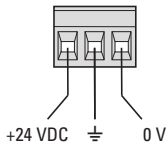

Connection	Assignment
+24 V DC	Supply voltage +24 V DC
E	Functional earth with connector panel. Does not have to be connected.
0 V	Supply voltage 0 V

Observe the following when preparing the wiring of the plug connector:

Terminal type:	Screw terminal plug-in
Cross-section:	min. 0.75 mm ² / max. 2.5 mm ² (lead or wire) min. AWG18 / max. AWG12
Stripping length:	7 mm
Max. tightening torque:	0.6-0.8 Nm / 5-7 lb in

Switching, control, visualization

HMI-PLC - Systematic visualization and control

1

Preparing the cables with the SUB-D connector

The design of the bus cabling is an essential factor for reliable operation and electromagnetic compatibility (EMC).

Wiring requirements

- The cables must be shielded.
- The cable shield must consist of a copper braid.
- The cable shield must have a large area and low-impedance connection to the connector housing. This is achieved by:
 - Using metal or metallized connector housings with a strap for strain relief.
 - The strap must be screw fastened with the connector.

- 5 - 8 mm shield braid must be exposed at the cable end.

- The folded shield braid end must be covered by the heat-shrink tubing or rubber grommet.

④ Fit the SUB-D connector to the cable end:

- The exposed screen braid must be connected to the connector housing with the cable clip.

Connecting the cable shield

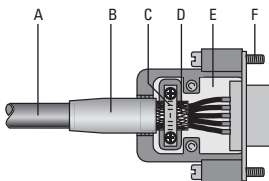
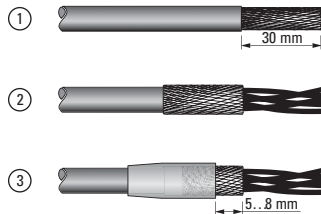

- A Cable with cable sheath
- B Heat-shrink tubing or rubber grommet
- C Gland plate
- D Shield braid
- E SUB-D plug
- F Fixing screw UNC

- ① Insulate the cable end so that approx. 3 cm of shield braid is exposed.
- ② Fold back the shield braid over the cable sheath.
- ③ Attach heat-shrink tubing approx. 3 cm in length over the folded shield braid or use a rubber grommet.

Switching, control, visualization

Compact PLC – universal compact controllers

System overview

1

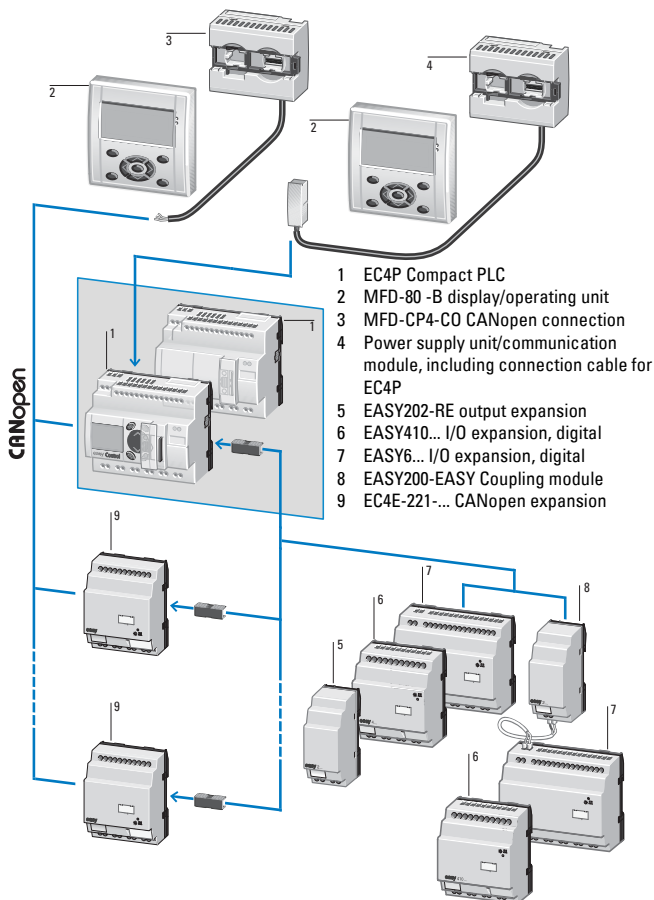

Switching, control, visualization

Compact PLC – universal compact controllers

General information

Compact controllers offer in a single device several functions that cover the automation of small and medium-sized applications.

For this sector Eaton offers the EC4P series. The controllers provide the functionality of a PLC in the housing of an easy800 control relay. Programming is carried out using CoDeSys software.

The controllers vary according to the number and type of inputs/outputs. Moreover, there are variants with and without display, as well as with and without an Ethernet interface. Ethernet allows remote programming via the network and communication via UDP and MODBUS.

All EC4P controllers are provided with a CAN/easyNet interface.

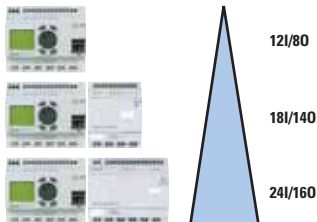



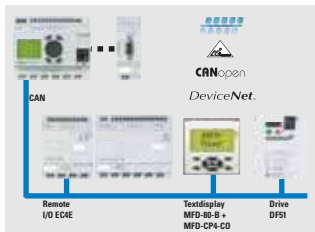

Flexible networking options:

- Remotely expandable via CANopen or easyNet
- Locally expandable via easyLink interface
- Remote programming via network
- Connection of one or several MFD-80-B via CANopen
- Connection of an MFD-80-B via RS232
- Pluggable memory modules for data archiving

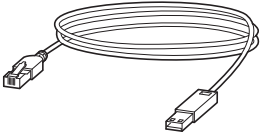

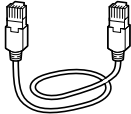
Switching, control, visualization**Compact PLC – universal compact controllers****Engineering****Cable connections****1**

Cable type/ Memory card	Device	Function
EU4A-RJ45-CAB1 	PC, terminal/ printer	Programming via serial interface COM1, transparent mode
EU4A-RJ45-USB-CAB1 	PC	Programming via USB interface
EU4A-RJ45-CAB2 	MFD-CP4-CO + MFD-80-B EC4E	CAN connection
XT-CAT5-X-2 	PC	Programming via Ethernet
MFD-CP4-800-CAB5 	MFD-CP4	Display extension, serial

Switching, control, visualization**Compact PLC – universal compact controllers**

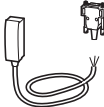
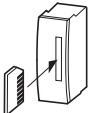
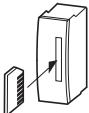
Cable type/ Memory card	Device	Function
easy800-USB-CAB 	PC	For programming via the USB interface
easy800-MO-CAB 	PC, terminal/ printer	Programming via serial interface COM1, transparent mode
EU4A-MEM-CARD1 	EC4P	Memory card
EU4A-MEM-CARD2 	EC4P	Memory card with battery for backing up the time

Switching, control, visualization

Compact PLC – universal compact controllers

1

Device arrangement

Install the PLC in a control cabinet, a service distribution board or in an enclosure so that the supply voltage terminals and the terminal capacities are protected against direct contact during operation.

The PLC can be installed vertically or horizontally on a top-hat rail in compliance with IEC/EN 60715 or on a mounting plate using fixing brackets. Ensure that the terminal side has a clearance of at least 3 cm from the wall and from neighbouring devices in order to simplify wiring.

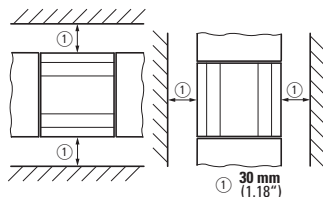

Connection examples

The connection examples listed here from the chapter “Engineering easyRelay, MFD-Titan” are also relevant for the EC4P compact controller.

- Connecting the power supply, → page 1-50
- Connecting the digital inputs, → page 1-51
- Connecting analog inputs, → page 1-55
- Connecting the incremental encoder, → page 1-57
- Connecting relay outputs, → page 1-58
- Connecting transistor outputs, → page 1-59
- Connecting analog outputs, → page 1-61

Further information → Manual
MN05003003Z-EN

Switching, control, visualization

Modular PLC

System overview

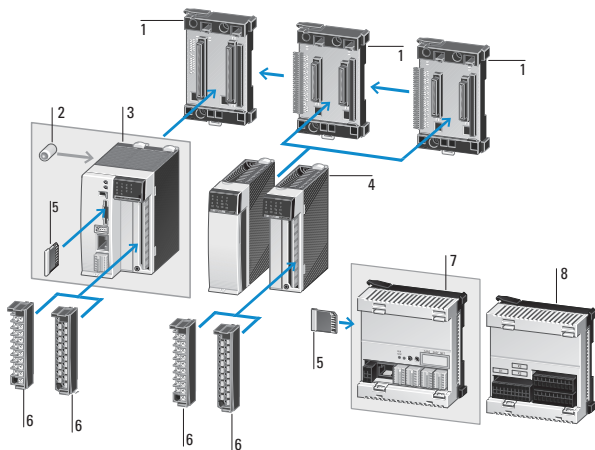

- 1 Racks
- 2 Battery
- 3 XC100/XC200 controllers
- 4 XI/OC I/O-modules, Communication modules
- 5 Memory card
- 6 XI/OC terminal block (screw or spring-cage terminal)
- 7 XC121 controller
- 8 XI/OC-EXT121-1 I/O-expansion for XC121 controller

Switching, control, visualization

Modular PLC

1

General information

Modular PLCs offer an outstanding level of scalability. This ensures a high level of flexibility for designing individual automation systems. Different CPU performance classes and a wide range of expansion modules are available.

The data exchange via an Ethernet interface to OPC clients or integrated WEB servers enables the creation of innovative solutions.



In this class Eaton offers the two XC100 and XC200 series.

XC100 modular PLCs

The controllers of the XC100 series are universal automation devices for small and medium-sized applications. They differ according to the size of the available program memory. One variant is provided with an optical CAN interface.

- Expandable by up to 15 XI/OC modules
- Data storage on SD card
- CAN interface for communication
- RS232 interface

Further information → Manual
MN05003004Z-EN

XC200 modular PLCs

The controllers of the XC200 series offer a high CPU performance and a wide range of communication options. These devices differ according to the size of the program memory, the cycle time and the integrated WEB server.

- Expandable by up to 15 XIOC modules
- Data storage on SD card or USB stick
- Ethernet interface for programming and communication
- CAN interface for communication
- RS232 interface
- Integrated web server

Further information → Manual
MN05003001Z-EN

XIOC signal modules

The XIOC signal modules can be connected to XC100 as well as to XC200 controllers (exception: XIOC-TC1 telecontrol module only to XC200). A wide range of different modules are available:

- Digital input/output modules
- Analog input/output modules
- Temperature measuring modules
- Counter modules
- Serial interface module (RS232, RS485, RS422; operating modes: Transparent mode, Modbus master/slave, Sucom-A, Suconet K slave)
- Telecontrol module
- Communication modules PROFIBUS-DP master, PROFIBUS-DP slave, Suconet-K master)

Further information → Manual
MN05002002Z-EN

Switching, control, visualization

Modular PLC

Engineering

Device arrangement

Build the module racks and the controls into the switchgear cabinet in a horizontal position.

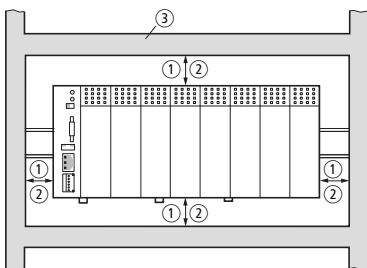

- ① Clearance > 50 mm
- ② Clearance > 75 mm to active elements
- ③ Cable duct

Power supply

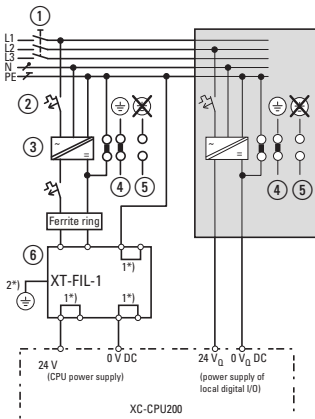

- ① Main switches
- ② Circuit protection device
- ③ 24 V DC supply voltage
- ④ Earthed operation
- ⑤ In floating (i.e. unearthed) operation, an isolation monitor must be used (IEC 204-1, EN 60204-1, DIN EN 60204-1)
- ⑥ 24 V DC line filter; ensures that a current of up to 2.2 A (maximum) is available at a rated operating voltage of 24 V DC. Use of the filter ensures that the EMC stipulations for devices.

1^{*)} Internally bridged

2^{*)} Additional PE connection via contact spring on rear

Switching, control, visualization Modular PLC

Terminal assignment on the CPU

1

The connections for the power supply and the local inputs/outputs have the following assignment:

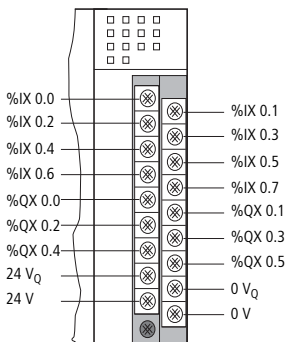

Connecting inputs/outputs to the central processing unit

The 0V_Q/24V_Q voltage terminal is intended exclusively for the power supply to the local inputs (8) and outputs (6), and is electrically isolated from the bus.

At a duty factor (DF) of 100 % and a utilization factor of 1, outputs 0 to 3 can each carry a load of 500 mA, and outputs 4 and 5 a load of 1 A.

The example shows the wiring with a separate power supply for controller and I/O terminals. If only one power supply is used, the following terminals must be connected:

24 V to 24V_Q and 0 V to 0V_Q.

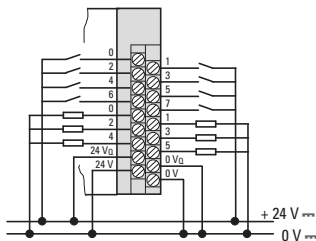

Switching, control, visualization

Modular PLC

Ethernet/RS232

(XC-CPU101, XC-CPU201)	(XC-CPU202)		RS232	ETH (XC-CPU201, XC-CPU202)
		8	RxD	–
		7	GND	–
		6	–	Rx–
		5	TxD	–
		4	GND	–
		3	–	Rx+
		2	–	Tx–
		1	–	Tx+

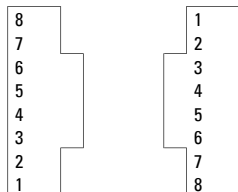

From a purely physical/mechanical point of view the programming devices interface is an RJ45 interface (socket). This means that normal commercial RJ45 connectors or Ethernet patch cables can be used.

- **Direct connection PC – XC200:**

The XC200 can be connected directly to the (programming) PC via a crossover Ethernet cable.

Crossover cables have the following design features:

- Connection set-up of 8-pole crossover cable

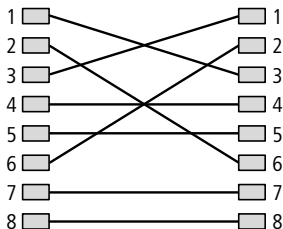

- Connection set-up of a 4-pole crossover cable

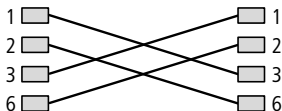

The following cross-over cables are available:

XT-CAT5-X-2 (2 m long)

XT-CAT5-X-5 (5 m long)

- **PC – XC200 via Hub/Switch connection:**
If you use a Hub or a Switch between the PC – XC200 connection, you must use a standard Ethernet cable which is connected 1:1 for the connection between PC – Hub/Switch and Hub/Switch – XC200.
The cable EU4A-RJ45-USB-CAB1 is provided for programming via the USB interface of a PC.

Switching, control, visualization

Modular PLC

1

Note!

Please note that when there is a double assignment of the RJ45 interface with the RS232 and Ethernet, the connections 4 and 7 are connected to "GND potential" because of the RS232 interface. For this reason, we recommend the use of 4-core cables for the connection of the XC200 to the Ethernet.

CANopen interface

Configuration of the 6-pole Combicon plug:

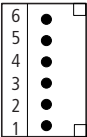
	Terminal	Signal
	6	GND
	5	CAN_L
	4	CAN_H
	3	GND
	2	CAN_L
	1	CAN_H

Connector type: 6-pole, pluggable spring-loaded terminal block

Connector terminals: up to 0.5 mm²

Terminals 1 and 4, 2 and 5 as well as 3 and 6 are internally connected.

The CAN interface is electrically isolated.

Bus termination resistors must be installed at the first or last station on the line (->Fig. below).

The bus terminating resistor on the XC-CPU202 can be switched. The switch is located above the battery.

Only use a cable that is permissible for CANopen with the following properties:

- Characteristic impedance 100 to 120 Ω
- Capacitance per unit length < 60 pF/m

Baud rate [Kbit/s]	Length [m]	Core cross-section [mm ²]	Loop resistance [Ω /km]
20	1000	0.75 – 0.80	16
125	500	0.50 – 0.60	40
250	250	0.50 – 0.60	40
500	100	0.34 – 0.60	60
1000	40	0.25 – 0.34	70

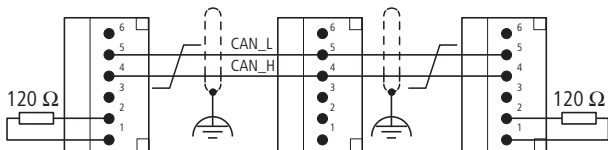

Switching, control, visualization

Modular PLC

1

Connection examples

Terminal blocks with either screw terminals or spring-loaded terminals can be optionally used for the wiring.

Conductor	Screw connection	Spring clamp connection
Solid	0.5-2.5 mm ²	0.14-1.0 mm ²
Flexible with ferrule	0.5-1.5 mm ²	The cables are to be inserted into the terminals with out the use of ferrules or cable lugs.
Flexible	–	0.34-1.0 mm ²

Notes:

- Cable lugs must not exceed 6 mm in diameter.
- Do not attach more than 2 cable lugs to one terminal.
- Use a cable with a maximum conductor cross-section of 0.75 mm², or 0.5 mm² if two cable lugs are going to be fixed to the same terminal.

Switching, control, visualization

Modular PLC

Wiring: digital input modules

1

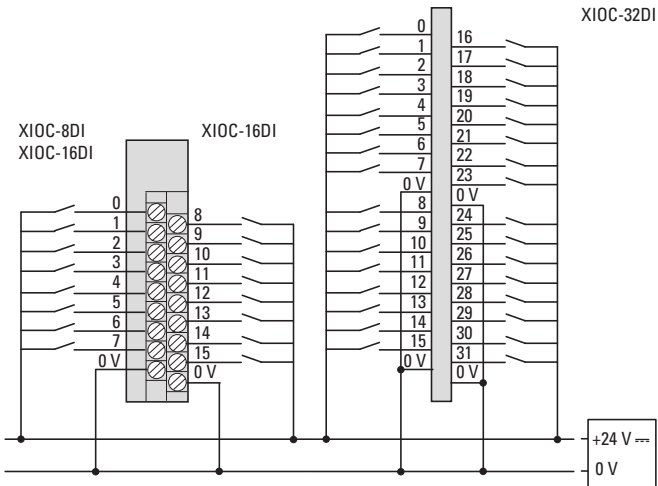

Switching, control, visualization

Modular PLC

Wiring digital output modules

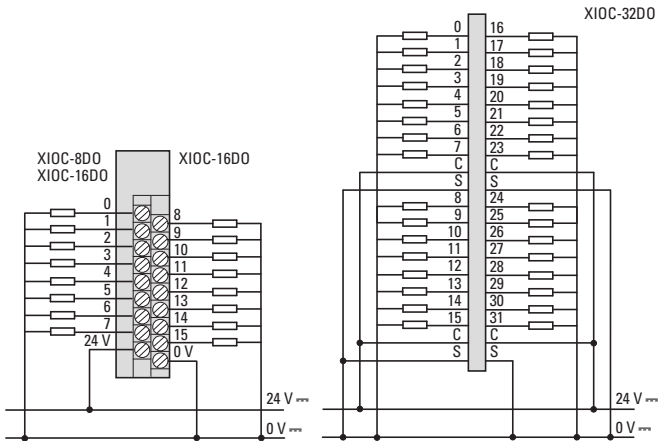

1

When using inductive loads, connect a free-wheel diode in parallel.

Wiring digital output modules (relays)

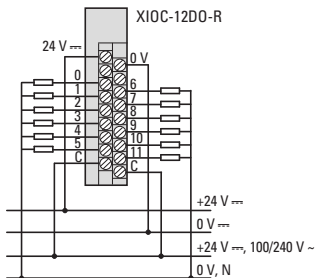

Switching, control, visualization

Modular PLC

Wiring analog input modules

1

Terminal assignment

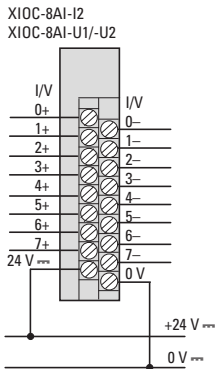

Module wiring

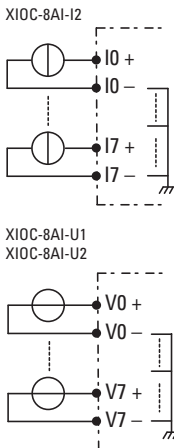

U/I diagram for the modules

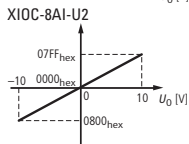
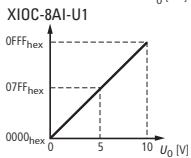
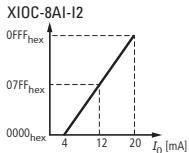

Switching, control, visualization

Modular PLC

Wiring analog output modules

Terminal assignment

Module wiring

U/I diagram for the modules

1

XIOC-2AO-U2
XIOC-4AO-U1/U2

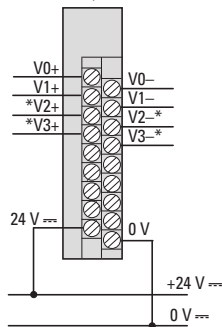

XIOC-2AO-U1-2AO-I1

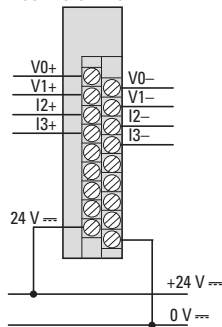

XIOC-2AO-U2
XIOC-4AO-U1/U2

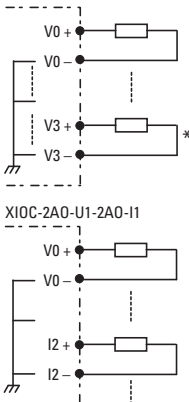

XIOC-2AO-U2
XIOC-4AO-U1/U2

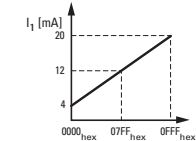

XIOC-2AO-U1-2AO-I1

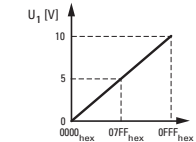

XIOC-2AO-U2
XIOC-4AO-U1

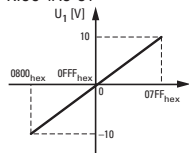

Switching, control, visualization

Modular I/O system

System overview

1

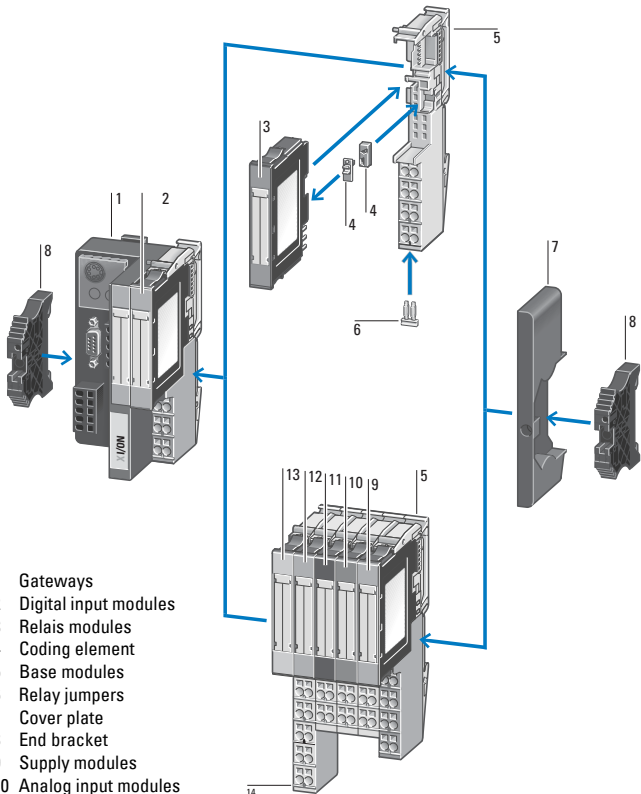

- 1 Gateways
- 2 Digital input modules
- 3 Relais modules
- 4 Coding element
- 5 Base modules
- 6 Relay jumpers
- 7 Cover plate
- 8 End bracket
- 9 Supply modules
- 10 Analog input modules
- 11 Digital output modules
- 12 Analog output modules
- 13 Technology modules
- 14 Marker

Switching, control, visualization

Modular I/O system

General information

Whether controlling movements, measuring temperature or speeds, logging currents and voltages – the application ranges for remote I/Os are varied. Remote I/Os can be found wherever remote signal processing is the key element of the automation concept.

The XI/ON I/O system has the following essential features:

- High modularity
- Field busses: CANopen, PROFIBUS-DP, DeviceNet and Ethernet
- Bus-independent, plug-in modules
- Low wiring requirement
- Effective diagnostics
- Space and cost savings with ECO modules
- Programmable CANopen coupling unit
- Standard and ECO modules can be mixed



The XI/ON I/O system provides an extensive range of digital and analog I/Os as well as technology modules:

- XI/ON ECO gateways and ECO modules
XI/ON ECO adds cost and space-optimized I/O modules and gateways to the XI/ON I/O system. The ECO gateways support the

CANopen, PROFIBUS-DP and Ethernet bus systems.

- ECO gateways with built-in bus termination resistors
- Full compatibility with the standard XI/ON system
- No base modules required
- High channel density: (up to 16 DI/DO over 12.5 mm width)
- Push-in spring-cage terminals
- Multi-functional slices
- Mini USB diagnostics interface
- XI/ON Default gateways and standard modules

The standard gateways support the CANopen, PROFIBUS-DP, DeviceNet and Ethernet bus systems.

- Use of the pluggable I/O modules is possible regardless of the fieldbus used
- Wiring implemented on base modules, fixed wiring
- Hot-swapping of modules
- Generation of diagnostics information for the higher-level controller
- Up to 74 slice modules can be connected per gateway
- Modules mechanical coding
- Programmable CANopen coupling unit
With the programmable CANopen gateway, PLC performance is now brought directly to the fieldbus terminal. The device is ideal for managing remote automation tasks and thus relieving the work load of a higher-level PLC. The serial onboard interface is used for programming onsite and as an interface for the I/Oassistant configuration and diagnostics tool. Alternatively this interface can also be

Switching, control, visualization Modular I/O system

1

used as a free user interface. The gateway is programmed with XSOFT-CODESYS-2.

- Base modules for every requirement
- The base modules are used for connecting the fieldbus wiring for the standard XI/ON

modules. They are available for 2-, 3- and 4-cable connections, as block or slice modules, either with spring-cage or screw terminals.

Engineering

I/Oassistant configuration and diagnostics tool

The I/Oassistant is integrated in the XSOFT-CODESYS-2 software and offers interactive support in the entire planning and implementation of an XI/ON system. You choose the gateways, electronics and basic modules, as well as the appropriate accessories. The individual stations are then either configured online or offline. You choose the gateways, electronics and basic modules, as well as the appropriate accessories. The individual stations are then either configured online or offline. When everything is set to your requirements, you put the system into operation. I/Oassistant automatically generates a full parts list for your order. The I/Oassistant checks the station, reads process data, outputs values and visualizes the diagnostics data of the channels. In this way, you can also commission your station without the need for a higher-level controller and ensure that one section of the installation is functioning correctly.

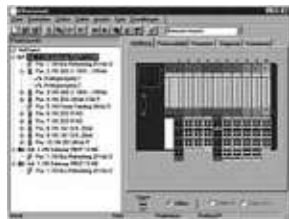

Safety due to coding

The pluggable modules also allow hot swapping for the fast and toolless exchange of modules. The mechanical coding of the modules prevents incorrect fitting.

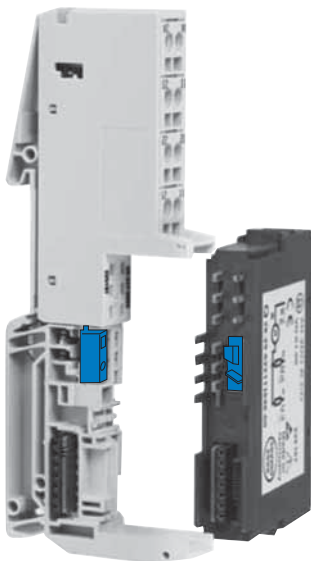

Switching, control, visualization

Modular I/O system

Connection examples

Power supply module (Bus Refreshing Module)

- Module for feeding the 24 V DC system power supply and the 24 V DC field voltage supply

XN-P4...-SBBC with gateway supply

XN-P4...-SBBC-B without gateway supply

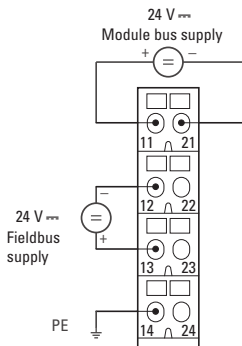

Feeder module (Power Feeding modules)

- Field power supply module 24 V

XN-P4...-SBBC for XN-PF-24VDC-D

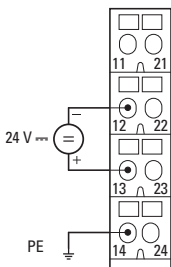

- Field power supply module 120/230 V AC

XN-P4...-SBB for XN-PF-120/230VAC-D

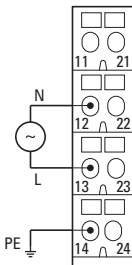

Switching, control, visualization

Modular I/O system

Digital input modules

- Positive switching
XN-S4...-SBBC for XN-2DI-24VDC-P

1

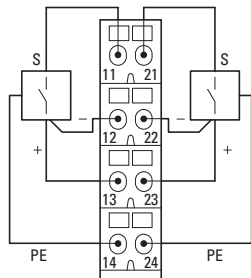

- Negative switching

XN-S4...-SBBC for XN-2DI-24VDC-N

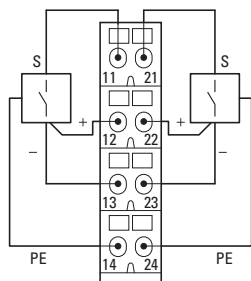

Digital output module

- Positive switching

*XN-S4...-SBCS for
XN-2DO-24VDC-0.5A-P
XN-2DO-24VDC-2A-P*

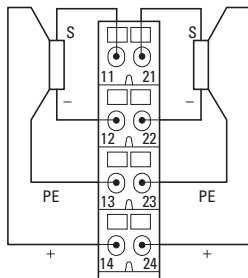

- Negative switching

*XN-S4...-SBCS for
XN-2DO-24VDC-0.5A-N*

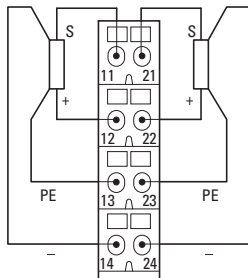

Switching, control, visualization

Modular I/O system

Analog input modules

XN-S4...-SBBS for XN-1AI-I(0/4...20MA)

XN-S4...-SBBS for

XN-1AI-U(-10/0...+10VDC)

Analog transmitter with non-isolated transmitter supply

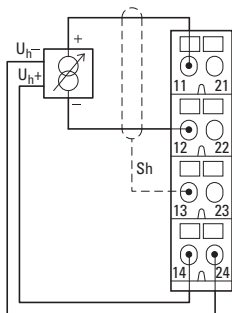

Further connection examples can be found in the manuals:

XI/ON digital I/O modules, power supply modules, MN05002010Z-EN (previously: M001735-02)

XI/ON analog I/O modules, MN05002011Z-EN (previously: M001756-04)

These manuals can be downloaded as PDF files at www.eaton.com/moellerproducts in the "Products & Solutions" area.

Analog output module

XN-S3...-SBB for XN-2AO-I(0/4...20MA)

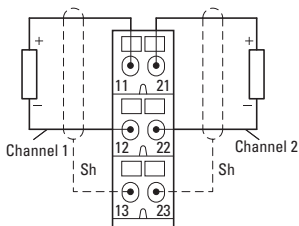

Switching, control, visualization Software

1



Users of automation components such as machine and system builders are increasingly no longer satisfied with single solutions. This is why standards such as IEC 61131-3 have become established as manufacturer-independent standards for PLC programming. CoDeSys supports all programming languages described in the IEC-61131 standard.

CoDeSys is based on a standard of 3S. Proven technical features, simple handling and a wide distribution of this software for programming automation components of different manufacturers guarantee its success.

All Eaton controllers are programmed with the CoDeSys software. Programming can be carried out in different programming languages. These are divided into text-based or graphic-based languages.

Text-oriented languages

Instruction List (IL)

An instruction list (IL) consists of a sequence of instructions. Each instruction starts on a new line and contains an operator and one or several comma separated operands – depending on the type of operation.

An identifier label followed by a colon (:) may be placed in front of an instruction. This is used for labelling the instruction which can then be used as a jump target.

A comment must always be the last element of a line.

Example:

```
LD 17
ST lint (* comment *)
GE 5
JMPC next
LD idword
EQ istruct.sdword
STN test
next:
```

Structured Text (ST)

Structured Text (ST) consists of a series of instructions that are arranged as in high level languages (IF...THEN...ELSE) or in loops (WHILE...DO).

Example:

```
IF value < 7 THEN
WHILE value < 8 DO
value := value + 1;
END_WHILE;
END_IF
```

Switching, control, visualization Software

1

Graphic-oriented languages

Sequential Function Chart (SFC)

Sequential function chart (SFC) is a graphical language. It enables the timing of different actions within a program to be defined. Different step elements are used for this which are assigned to specific actions and which are controlled by so-called transition elements.

Example of a network in a sequential function chart:

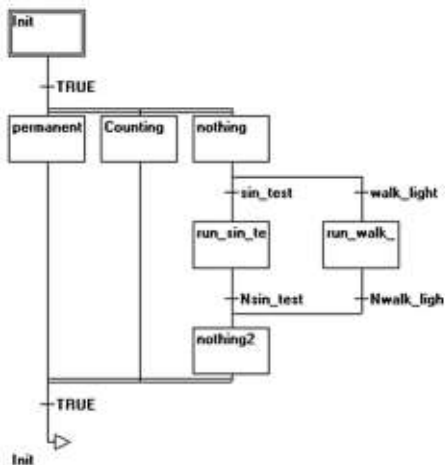

Switching, control, visualization Software

Ladder Diagram (LD)

1

Ladder diagram is a graphical programming language which closely follows the principle of an electrical circuit.

On the one hand, ladder diagram is suitable for designing logical switch systems, on the other hand, it is also possible to create networks as in FBD. LD is therefore very good for controlling the calling of other blocks. Ladder diagram consists of a

sequence of networks. A network is bordered on the left and right by a left and right vertical current path. A circuit diagram consisting of contacts, coils and connection lines is located in between.

Example of a network in ladder diagram consisting of contacts and coils:

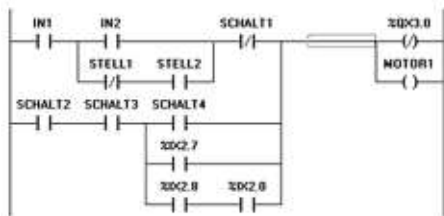

Function Block Diagram (FBD)

Function block diagram is a graphical programming language. It operates with a list of networks, in which each network contains a structure that may represent a logic and arithmetic expression, the calling of a function block, a jump or a return instruction.

Example of a network in a function block diagram:

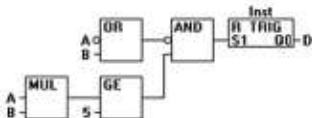

Switching, control, visualization Software

Continuous function chart (CFC)

The freely graphical function chart is based on function block diagram (FBD) but does not work like this with networks but with freely placable elements. This enables

for example the implementation of feedback paths.

Implementation example in freely graphical function block diagram editor:

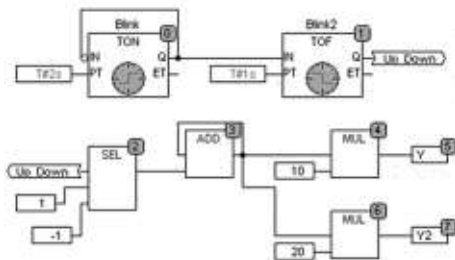

Integrated visualization

The CoDeSys programming system also contains a visualization editor as well as the programming tool. This offers a clear advantage:

Only one additional software package is required to visualize (i.e. for monitoring and operation) the data of a controller programmed in CoDeSys. Whilst the application is being developed, the user can already create visualization screens in the same user interface. The visualization integrated in CoDeSys can access the variables from the controller directly.

If the controller has a display (HMI-PLC), this visualization can be displayed directly on the panel (target visualization).

Many controllers are now equipped with a web server. If required CoDeSys generates from the visualization data an XML description which is stored on the controller together with a Java applet and

which can be shown on a browser using TCP/IP (WEB visualization).

GALILEO interactive visualization tool

For its HMI and HMI-PLCs Eaton offers an easy to learn project design environment that is nevertheless powerful and comprehensive – ideal for use in all machine and process-relevant applications in system and machine building. Galileo has a sector neutral design and offers seamless project design for all of Eaton's graphical HMI devices.

Notes

1

Electronic motor starters and drives

	Page
Drives engineering basic information	2-2
Soft starter basic information	2-9
Connection example DS7	2-26
DM4 connection example	2-44
Frequency inverter basic information	2-66
Connection example for M-Max™	2-85
Rapid Link System 4.0	2-98

Electronic motor starters and drives

Drives engineering basic information

2

Drives engineering selection criteria

Each drive task requires a drive motor. The speed, torque and controllability of each motor must fulfill the requirements of the task. As a general rule, the application determines the drive.

The drive motor most frequently used worldwide in industrial plants and large buildings is the three-phase asynchronous motor. Its robust and simple construction as well as its high degrees of protection and standard types are the main features of this inexpensive electric motor.

Three-phase asynchronous motor

Motor starting variants

• Direct-on-line start ①

In the simplest case the motor is connected directly with a contactor. The combination of motor protection and cable protection (fuse) is called a motor starter (MSC = Motor Starter Combination).

By applying the full mains voltage to the motor windings, DOL starting may produce large starting currents which may result in troublesome voltage changes. Direct-on-line starting three-phase motors must not cause interference voltage changes in the public utility grid. This requirement is generally fulfilled if the apparent power of a three-phase asynchronous motor does not exceed 5.2 kVA or its startup current does not exceed 60 A.

With a mains voltage of 400 V and 8 times the starting current, this corresponds to a rated motor current of around 7.5 A and thus a motor rating of 4 kW.

The motor rating denotes the mechanical output of the motor at the shaft.

• Star-delta starter ②

This is the most popular and commonly used starting method for motor ratings > 4 kW (400 V).

• Electronic motor starter (EMS) and soft starter ③

These enable the soft and low-noise starting of the motor. This eliminates interference producing current peaks and jerks during switching. The startup and deceleration phase of the motor can also be time-controlled depending on the load.

• Frequency inverter ④

This enables time-controlled motor starting, motor braking and operation with infinitely variable motor speeds. Depending on the application, different types of frequency inverters are used:

- with the voltage/frequency control (U/f) or vector control for frequency-controlled motor operation,
- with vector control or servo control for high speed accuracy and additional torque adjustment.

Associated circuit diagrams → page 2-3

Electronic motor starters and drives

Drives engineering basic information

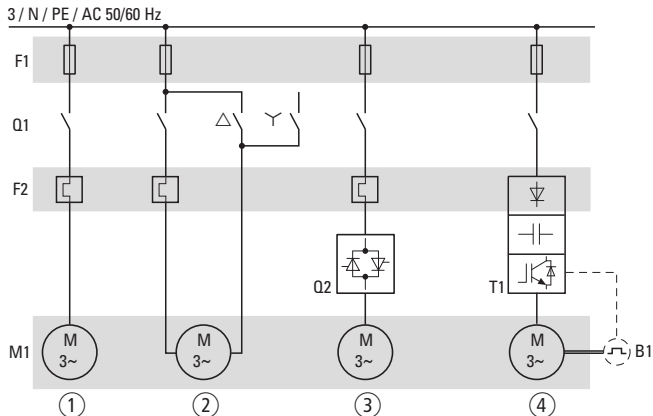

- B1: Speed measuring (pulse generator)
 F1: Fuse protection
 (short-circuit and cable protection)
 F2: Motor protection
 (protection from thermal overload,
 overload relay)
 M1: Three-phase asynchronous motor
 Q1: Switching
 (contactor, motor contactor)
 Q2: Soft starter, electronic motorstarter
 T1: Frequency inverter

Motor connection

When connecting a three-phase motor to the mains supply, the data on the rating plate of the motor must correspond to the mains voltage and frequency.

The standard connection is implemented via six screw terminals in the terminal box of the motor and with two types of circuit, the star connection and the delta connection, depending on the mains voltage.

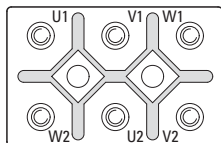

Electronic motor starters and drives

Drives engineering basic information

2

The rotation direction of a motor is always determined by directly looking at the drive shaft of the motor (from the drive end). On motors with two shaft ends, the driving end is denoted with D (= Drive), the non-driving end with N (= No drive).

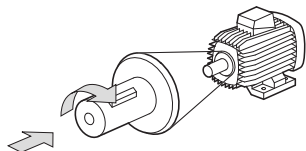

Regardless of the circuit type and the type of three-phase asynchronous motor, the connections must be labeled, so that their alphabetical sequence (e.g. U1, V1, W1) corresponds with the order of the mains voltage sequence (L1, L2, L3) and causes the motor to rotate clockwise.

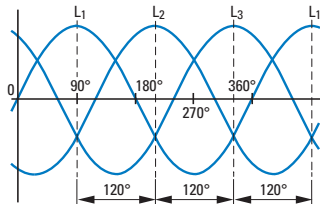

On the three-phase asynchronous motor, three windings are arranged offset from each other by $120^\circ/p$ (p = number of pole pairs). When a three-phase AC voltage with a 120° phase sequence is applied, this produces a rotation field in the motor.

The effect of inductance causes the rotation field and torque to be formed in the rotor winding. The speed of the motor thus depends on the number of pole pairs and the frequency of the supply voltage. The rotation direction can be reversed by swapping over two of the supply phases.

Clockwise (FWD)

Anticlockwise operation (REV)

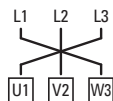
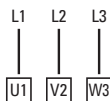

FWD = forward run (clockwise rotation field)

REV = reverse run (anticlockwise rotation field active)

Information on the rating plate

The electrical and mechanical rating data of the motor must be stated on its rating plate (IEC 34-1, VDE 0530). The data on the rating plate describes the stationary operation of the motor in the area of its operating point (M_N , e.g. at 400 V and 50 Hz). The operating data is unstable in the motor start phase.

The following examples show the rating plates for two motors with a motor shaft output of 4 kW and the respective connection circuits on a three-phase AC network with 400 V and 50 Hz.

Electronic motor starters and drives

Drives engineering basic information

Star circuit

230 / 400 V Δ / Y		14.5 / 8.5 A	
S1	4.0 KW	cos φ 0.82	
1410 min ⁻¹		50 Hz	
IP 54		Iso. KI F	

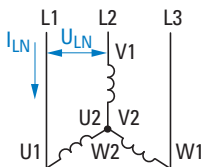

$$U_{LN} = \sqrt{3} \times U_W, I_{LN} = I_W$$

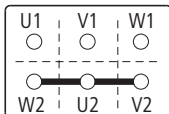

- With the specified 230/400 V voltage, this motor must be connected to the three-phase supply ($U_{LN} = 400$ V) in a star configuration.
- The voltage of each motor winding is designed for 230 V. The windings must therefore be connected in sequence to the phase voltage (400 V).
- The three winding phases (W2-U2-V2) are configured in the terminal box to the so-called star point. The voltage of the individual phases to the star point is 230 V ($= U_W$).

Delta circuit

400 / 690 V Δ / Y		8.5 / 4.9 A	
S1	4.0 KW	cos φ 0.82	
1410 min ⁻¹		50 Hz	
IP 54		Iso. KI F	

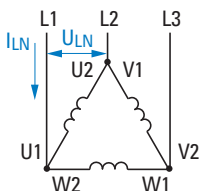

$$U_{LN} = U_W, I_{LN} = \sqrt{3} \times I_W$$

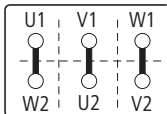

- With the specified 400/690 V voltage, this motor must be connected to the three-phase supply ($U_{LN} = 400$ V) in a delta configuration.
- Each motor winding is designed here for the maximum phase voltage of 400 V and can be connected directly.
- The three winding phases (U1 - W2, V1 - U2, W1 - V2) are combined in the terminal box and connected directly to the individual phases.

Electronic motor starters and drives

Drives engineering basic information

Startup characteristics

The following figure shows the characteristic startup curves of a three-phase asynchronous motor.

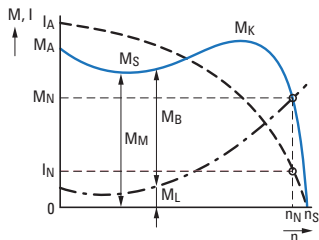

- I_A:** Starting current
I_N: Rated operational current at the operating point
M_A: Starting torque
M_B: Accelerating torque ($M_M > M_L$)
M_K: Breakdown torque
M_L: Load torque
M_M: Motor torque
M_N: Rated load torque, (stable operating point, intersection point of the three-phase speed torque characteristic with the load characteristic)
M_S: Pull-up torque
n: Speed (actual value)
n_N: Rated speed at the operating point
n_S: Synchronous speed
 ($n_S - n_N =$ slip speed s)

Synchronous speed:

$$n_s = \frac{f}{p}$$

Slip speed in %:

$$s = \frac{n_s - n}{n_s} \cdot 100\%$$

Three-phase asynchronous motor speed:

$$n = \frac{f}{p} \cdot (1 - s)$$

- f:** Frequency of voltage in Hz ($= s^{-1}$)
n: Speed in r.p.m.
p: Number of pole pairs
s: Slip speed in r.p.m.

Electric power:

$$P_1 = U \times I \times \sqrt{3} \times \cos \varphi$$

- P₁:** Electrical power in W
U: Rated operating voltage in V
I: Rated operational current in A
cos φ: Power factor

Motor output (power equation):

$$P_2 = \frac{M_N \times n}{9550}$$

- P₂:** Mechanical shaft output power in kW
M_N: Rated torque in Nm
n: Speed in r.p.m.

Efficiency:

$$\eta = \frac{P_2}{P_1}$$

Comparison of startup variants

The features of the startup variants ① to ④ described on page 2-2 are shown on the following pages 2-6 and 2-7.

The graphs show the typical characteristics.

Electronic motor starters and drives

Drives engineering basic information

Direct Motor start ①

Voltage curve

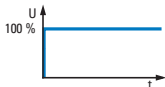

- Mains load high

Current curve

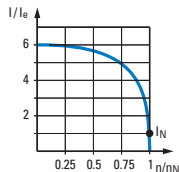

- Relative startup current
4 to 8 x I_e (depending on motor)

Torque behaviour

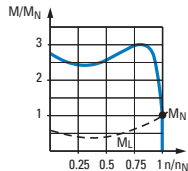

- Relative startup torque
1.5 to 3 x M_N (depending on the motor)
- Features:
 - Strong acceleration with large starting current
 - High mechanical load
- Scope of application:
Drives on powerful supply networks that allow high starting currents (torques)

Star-delta starter ②

Voltage curve

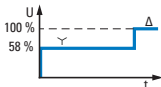

- Medium mains load

Current curve

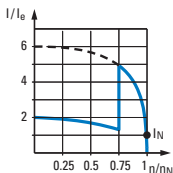

- Relative starting current
1.3 to 3 x I_e (~ 1/3 compared to DOL start)

Torque behaviour

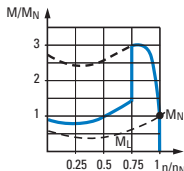

- Relative starting torque
0.5 to 1 x M_N (~ 1/3 compared to DOL start)
- Features:
 - Startup with reduced current and torque
 - Current, torque peak on switching
- Application range:
Drives that are only subject to loads after the startup

Electronic motor starters and drives

Drives engineering basic information

2

Soft starters ③

Voltage curve

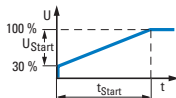

- Low to medium mains load

Current curve

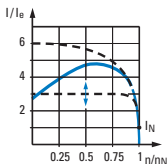

- Relative starting current
2 to 6 x I_e (reduced by voltage control)

Torque behaviour

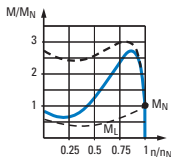

- Relative starting torque
0.1 to 1 x M_N ($M \sim U^2$, quadratically adjustable by voltage control)
- Features:
 - adjustable starting characteristics
 - controlled deceleration possible
- Application range
Drives with starting behavior adjusted to working machine.

Frequency inverter ④

Voltage curve

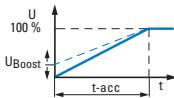

- Low mains load

Current curve

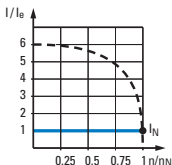

- Relative starting current
 ≤ 1 to 2 x I_e (adjustable)

Torque behaviour

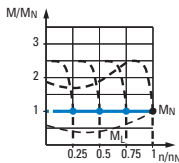

- Relative starting torque
 ~ 0.1 to 2 x M_N ($M \sim U/f$, adjustable torque)
- Features:
 - high torque at low current
 - adjustable starting characteristics
- Application range:
Drives requiring a controlled and infinitely variable speed adjustment.

Electronic motor starters and drives

Soft starter basic information

Soft starters

Soft starters are electronic devices for the soft starting of three-phase motors. Soft starters must comply with the product standard IEC/EN 60947-4-2.

During the startup phase of a motor, a soft starter controls the power supply smoothly and continuously up to the rated value (U_{LN}) by controlling the phase angle. This voltage control limits the starting current since the motor current behaves proportionally to the motor voltage. The resulting smooth torque increase enables the motor to be adapted to the load behavior of the motor.

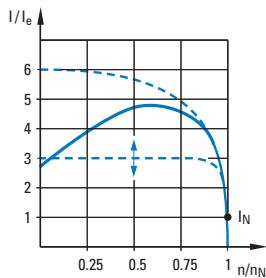

The mechanical components of this type of drive unit are therefore accelerated very smoothly. This has a positive effect on the lifespan, operating behavior and operating processes, and prevents any adverse effects such as:

- Impacting of cog edges in the gearbox
- Reduction of the water hammers in pipe systems
- Slipping of V belts
- Jitter with conveyor systems

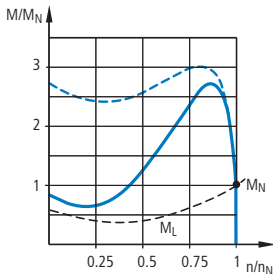

After a time controlled voltage change has elapsed (TOR = Top-of-Ramp), so-called bypass contacts can be used to bridge the phase angle control for the static continuous operation. The considerably lower transition resistance of the mechanical switch contacts compared to power semiconductors enables heat dissipation in the soft starter to be reduced and the lifespan of the power semiconductors to be extended.

Electronic motor starters and drives

Soft starter basic information

2

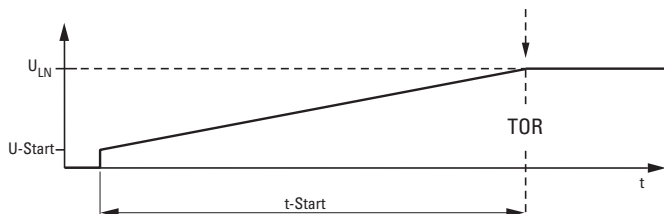
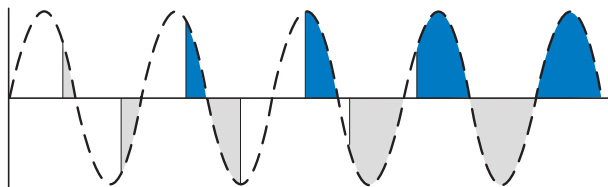

- U_{LN} = Mains voltage
 $U\text{-Start}$ = Start voltage
 $t\text{-Start}$ = Ramp time of the voltage change
 TOR = Top-of-Ramp (end point of the voltage control: $U = U_{LN}$)

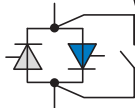

Note

The acceleration time of a drive with a soft starter always depends on the load and the breakaway torques. When commissioning this type of drive system, the required breakaway torque should be set first of all by means of the start voltage ($U\text{-Start}$) and then the shortest possible ramp time ($t\text{-Start}$) should be determined for the linear voltage change.

As well as the time-controlled startup of a motor, the soft starter also enables a time-controlled reduction of the motor voltage and thus a controlled stopping of the motor. This type of stop function is

primarily used for pumps in order to prevent pressure waves (water hammer). Jerky movements and therefore the wear on drive chains and drive belts as well as bearings and gears can be reduced.

Note

The set ramp time for the deceleration ($t\text{-Stop}$) must be greater than the load-dependent uncontrolled deceleration time of the machine.

Electronic motor starters and drives

Soft starter basic information

Control of the motor voltage

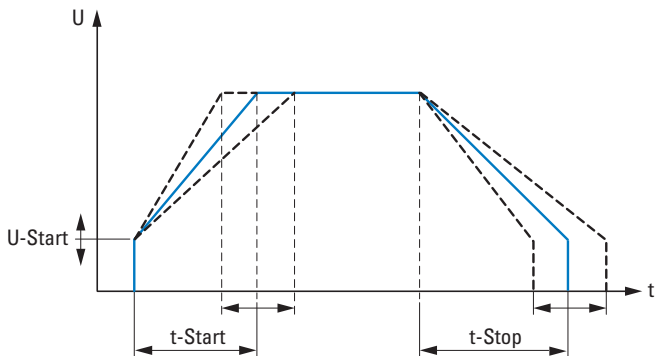

2

The ratio of the overload current to the rated operational current, the total of the times for the controlled overload current, as well as the duty factor and start cycle form the overload current profile of a soft starter; this data is stated on the rating plate in accordance with IEC/EN 60947-4-2.

Example

55A: AC-53a: 3·5 : 75·10

55A = Rated operational current of the soft starter

AC-53a = Load cycle in accordance with IEC/EN 60947-4-2

3 = 3-fold overcurrent at start
($3 \times 55 \text{ A} = 165 \text{ A}$)

5 = Overcurrent duration in seconds

75 = Duty factor within the load cycle in %

10 = Number of permissible starts per hour

Other overload cycles and operating frequencies can be calculated.

Further information on this is provided in the relevant soft starter manual.

Note

The controlled deceleration presents a similar load on the power semiconductors in the soft starter as the start phase. If therefore the deceleration ramp is activated on a soft starter with a maximum of 10 permissible starts per hour, the number of permissible starts is reduced to 5 per hour (plus 5 stops within the same hour).

Electronic motor starters and drives

Soft starter basic information

Types

Soft starters are usually divided into two types:

2

- Two-phase controlled, electronic soft starters for simple tasks:
 - Use is limited to small and medium rated motor (< 250 kW).
 - Simple handling with limited setting options and time controlled voltage ramps.
 - For simple applications where importance is placed on jerk-free operation in the starting phase.
 - They are an inexpensive alternative to the star-delta starter.
 - They can only be used in so-called In-Line configurations.
 - Three-phase controlled, electronic soft starters for complex tasks:
 - For medium to high motor ratings up to 800 kW as compact devices
 - The devices are provided with an adjustable current limitation and integrated motor protection functions.
 - They have preset application characteristics and can be parameterized for optimizing the machine start functions.
 - Control inputs, signal contacts and optional fieldbus interfaces enable a wide range of communication options to be implemented.
 - They can be used in both In-Line and In-Delta configurations.
- Example: see DM4 → page 2-57

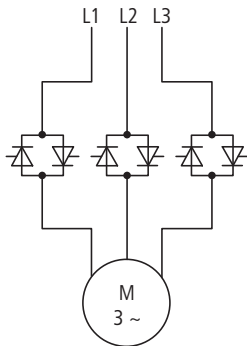
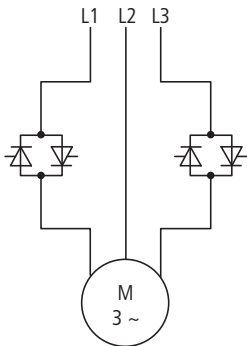

Electronic motor starters and drives

Soft starter basic information

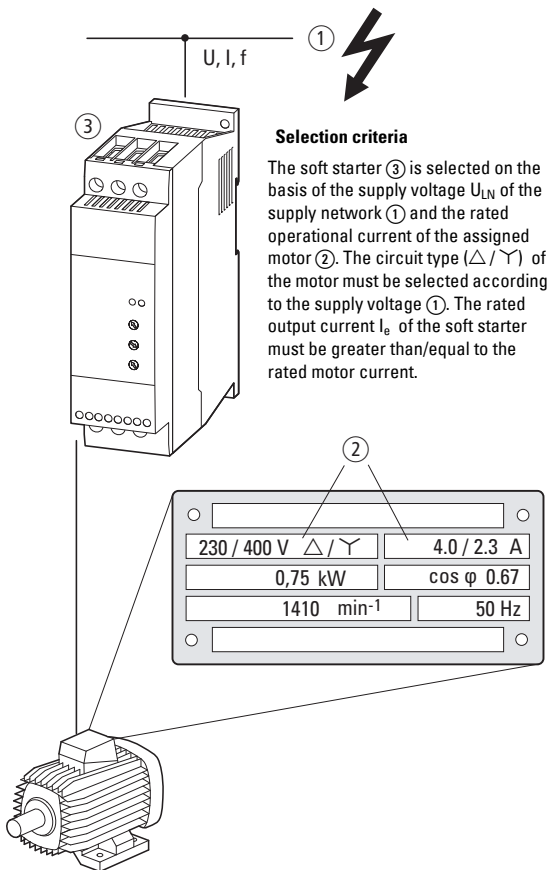

Electronic motor starters and drives

Soft starter basic information

Selection criteria

When selecting the drive, the following criteria must be known:

- Type of motor (three-phase asynchronous motor)
- Mains voltage = rated operating voltage of the motor (e.g. 3 AC ~ 400 V)
- Rated motor current (recommended value, dependent on the circuit type and the power supply)
- Load torque (quadratic, linear)
- Starting torque
- Ambient temperature (rated value +40 °C).

The switching and protective devices (electromechanical components) in the main circuit of the motor feeder are designed on the basis of the rated operational current (I_e) of the motor and the utilization category AC-3 (standard IEC 60947-4-1).

The utilization category here is AC-53a (IEC/EN 60947-4-2 standard).

- AC-3 = squirrel-cage motors: startup, switch off during operation.
- AC-53a = control of a squirrel-cage motor: eight-hour duty with starting currents for start processes, settings, operation

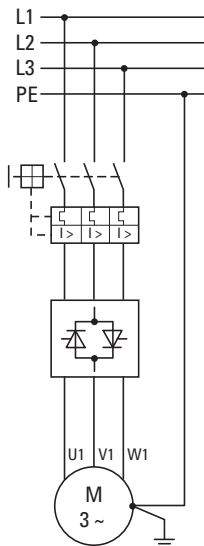

Motor feeder with DS7 soft starter combined with PKZM0 in In-Line circuit

Electronic motor starters and drives

Soft starter basic information

Permissible connection circuits of the motor

Three-phase asynchronous motors can be connected to a soft starter, depending on the mains voltage in a star or delta connection.

Example

2 phase controlled soft starter (DS7)

Star circuit

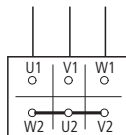
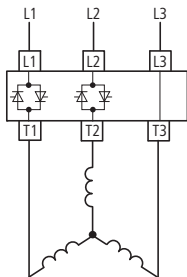

Delta circuit

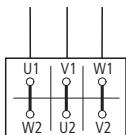
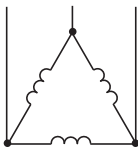

Electronic motor starters and drives

Soft starter basic information

Note

Three-phase motors with a neutral point (star circuit) must not be connected to a two-phase controlled soft starter as one phase is connected here directly to the mains voltage and causes impermissible overheating in the motor.

2

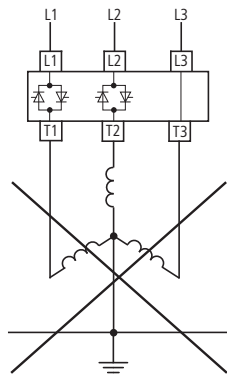

Caution!

Not permissible



Danger!

Dangerous voltage.

Risk of death or serious injury.

The power section of soft starters is formed with semi-conductors (thyristors). When a supply voltage (U_{LN}) is present, there is also a dangerous voltage present at the output to the motor in the OFF/STOP state.

This warning applies to all soft starter types.

Example

2 phase controlled soft starter

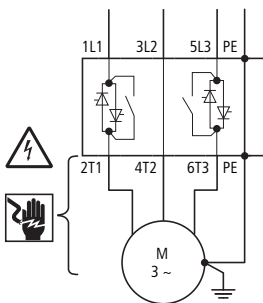

Electronic motor starters and drives

Soft starter basic information

Soft starters and coordination types to IEC/EN 60947-4-3

The following coordination types are defined in IEC/EN 60947-4-3, 8.2.5.1:

Type 1 coordination

In type 1 coordination, the device must not endanger persons or the installation in the event of a short-circuit and does not have to be capable of continued operation without repairs or parts replacements.

Type 2 coordination

In type 2 coordination, the device must not endanger persons or the installation in the event of a short-circuit and must be capable of continued use without repairs or parts

replacements. For hybrid control devices and contactors, there is a risk of contact welding, for which the manufacturer must give maintenance instructions.

The assigned short-circuit protective device (SCPД) must trip in the event of a short-circuit. If a fuse is used, this has to be replaced. This is part of the normal operation of the fuse, also for type 2 coordination.

Note

Superfast semiconductor fuses must always be arranged directly in front of the power semiconductors (short cable lengths).

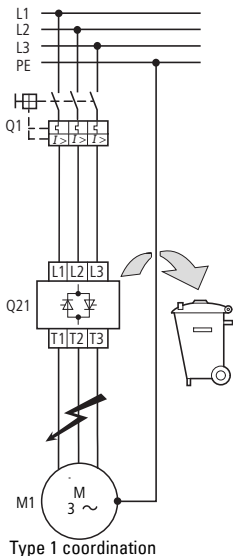

Type 1 coordination

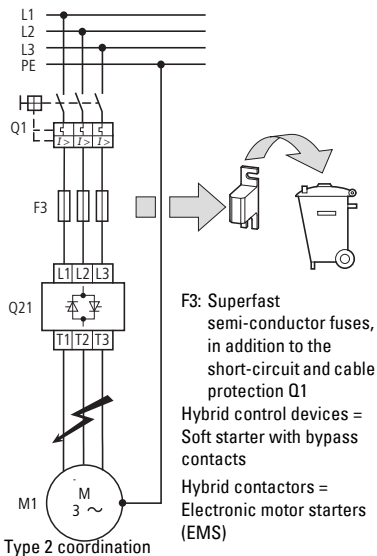

Type 2 coordination

Electronic motor starters and drives

Soft starter basic information

2

Residual current devices

Residual current devices (RCDs) protect persons and animals from the presence (not the creation!) of impermissibly high contact voltages. They prevent dangerous and fatal injuries caused by electrical accidents and also serve as fire prevention.

Standard residual current devices (RCD type A) with up to 30 mA and higher can be used with a soft starter.

F1: Residual current device (RCD)

F3: Optional semiconductor fuses for type 2 coordination

M1: Motor

Q1: Cable protection + motor protection

Q21: Soft starter

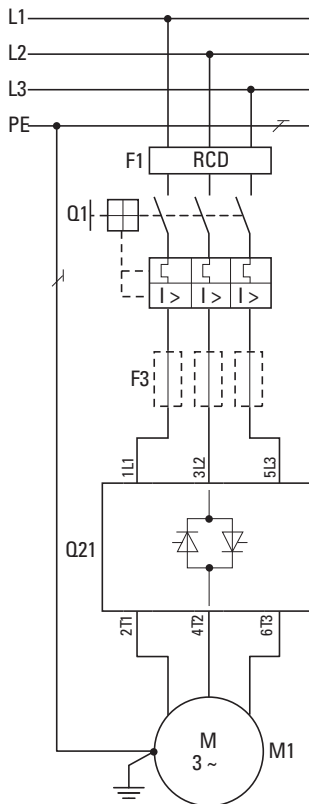

Electronic motor starters and drives

Soft starter basic information

Motor protection

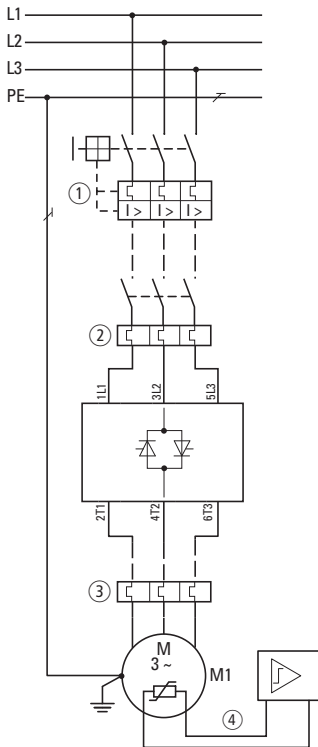

The motor protection protects the three-phase asynchronous motor from thermal overload caused by a mechanical overload or the failure of one or two connection cables.

There are two basic ways of protecting the three-phase motor from overload during operation:

- Monitoring of current consumption (motor protection, overload relay or bimetal relay)
- Direct temperature monitoring in the motor winding (PTC, thermistor)

- ① Motor-protective circuit-breaker (PKZ, PKE, NZM), disconnection with manual release
- ② Overload relay (ZB, ZEB) – here in combination with a contactor
- ③ Overload relay (ZB, ZEB) for indication of the thermal overload
- ④ Thermistor, PTC or positive temperature coefficient protection in the motor winding with external indication relay (EMT)

Note

The combination of the current monitoring motor protection variants ①, ② or ③ with the temperature monitoring variants ④ is also called full motor protection.

Note

After a motor protective device has tripped, the soft starter and the protective device cannot be switched on again until it has cooled down. The reset depends on the temperature.

Electronic motor starters and drives

Soft starter basic information

Parallel connection of several motors to a single soft starter

2

You can also use soft starters to start several motors connected in parallel. This does not, however, allow the startup behavior of the individual motors to be controlled.

Notes

- The current consumption of all connected motors must not exceed the rated operational current I_e of the soft starter.
- Each motor must be protected from thermal overload individually, e.g. with thermistors and/or overload relays (F11, F12) . Alternatively, motor-protective circuit-breakers (Q11, Q12) can also be used.
- It is advisable to use this circuit type only with motors of a similar rating (maximum deviation: one rating size). Problems may arise during starting if motors with significant rating differences (for example 1.5 kW and 11 kW) are connected to the output of a soft starter. The lower-rated motors may not be able to reach the required torque due to the relatively high ohmic resistance of their stators. During the startup these require a higher voltage.
- The last motor must not be switched off in operation since the resulting voltage peaks may cause damage to the electronic components in the soft starter and thus to its failure.

Electronic motor starters and drives

Soft starter basic information

2

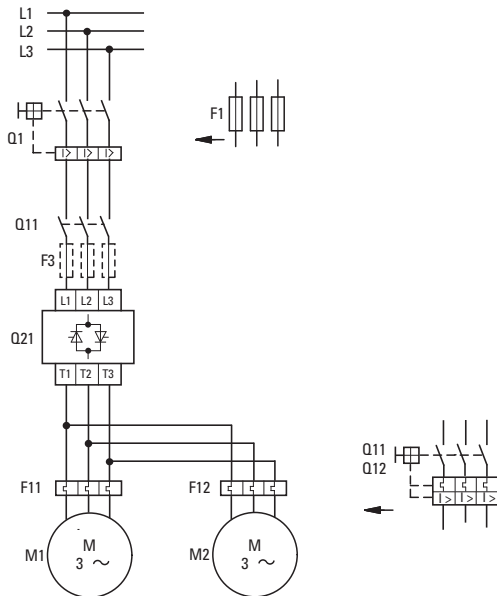

- F11, F12: Motor protection (overload relay) or motor-protective circuit-breaker (Q11, Q12)
- F3: Superfast semi-conductor fuses (optional, additionally to Q1 and F1)
- Q1 or F1: Short-circuit and cable protection

Electronic motor starters and drives

Soft starter basic information

2

Using soft starters with three-phase slipring motors

When upgrading or modernizing older installations, contactors and rotor resistors of multistage three-phase stator automatic starters can be replaced with soft starters.

This is done by removing the rotor resistors and assigned contactors and short-circuiting the slip rings of the motor's rotor. The soft starter is then connected into the feeder. The smooth starting of the motor can then be implemented.

→ Figure, page 2-23

Notes

- Slip ring motors develop a high starting torque with low starting current. They can thus be started at the rated load and this must be taken into account when selecting a soft starter. The soft starter cannot replace the rotor resistors in every application.
- Depending on the type of motor, it may be necessary to keep the last resistor group permanently connected to the slipring rotor terminal (K-L-M).

Q1: Cable and motor overload protection or

F1: Cable protection and

F2: Overload protection required (thermistor, bimetal relay) if the soft starter (Q21) does not include this function. Example: overload relay F2 in combination with contactor Q11.

M1: Slip-ring motor

Electronic motor starters and drives

Soft starter basic information

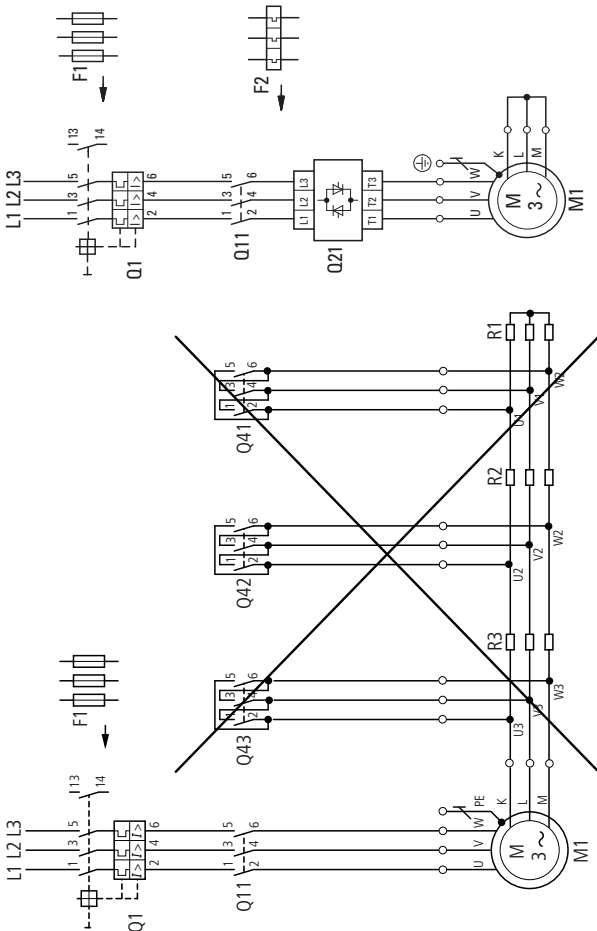

Electronic motor starters and drives

Soft starter basic information

2

Motors with compensation capacitors

As resistive-inductive loads, three-phase motors draw reactive power from the network. This reactive power can be compensated by means of capacitors (C_x) ① (improved power factor $\cos \varphi$).

WARNING

The output of a soft starter must not be connected to any capacitive loads (capacitors) ②. This would damage the soft starter.

If capacitors are to be used for reactive power compensation and thus to improve the power factor, they must be connected to the mains side of the soft starter ③.

If the soft starter is used together with an isolating or main contactor (Q11), the capacitors must be disconnected from the soft starter (Q12) when the contactor contacts are open.

The following figure ③ shows a safe arrangement. The compensation capacitors are switched via a capacitor contactor (Q12). The capacitor contactor is controlled via the TOR (Top-of-Ramp) signal of the soft starter. The capacitors are disconnected from the mains during the critical start and stop times.

Note

In networks with electronically controlled loads (e.g. soft starters), the compensation devices must always be connected with a series inductance.

C_x : Capacitors for reactive power compensation

Q1: Motor-protective circuit-breaker

Q11: Mains contactor

Q12: Contactor for capacitors

Q21: Soft starter

M1: Three-phase asynchronous motor

Electronic motor starters and drives

Soft starter basic information

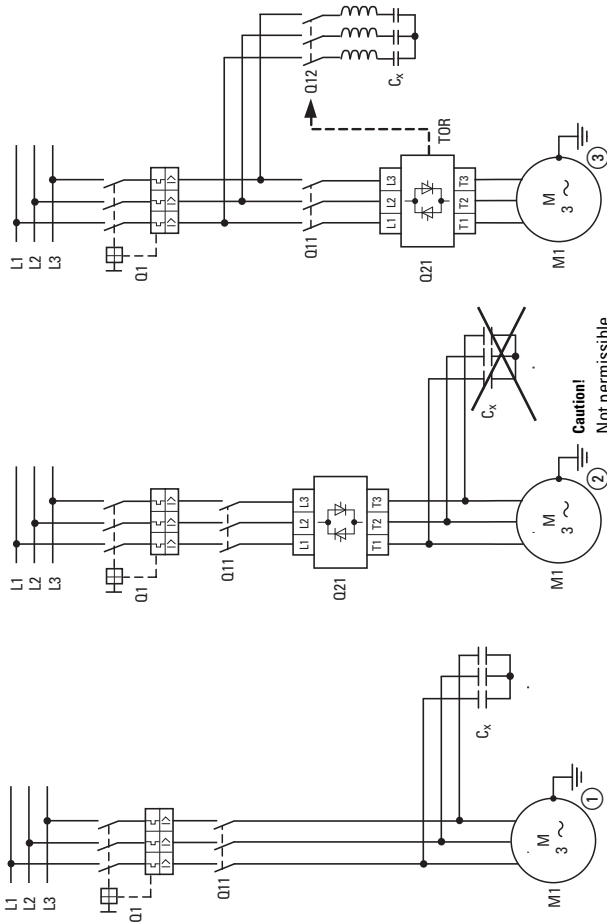

Electronic motor starters and drives

Connection example DS7

DS7 product features

- 2**
- Two-phase controlled soft starter, meets the requirements of the IEC/EN 60947-4-2 product standard
 - Power section and control section are galvanically isolated
 - Power section:
 - Rated operational voltage: 200 – 480 V, -15 % /+10 %
 - Mains frequency: 50/60 Hz ± 10 %
 - Overload cycle: AC53a: 3 – 5: 75 – 10
 - Control voltage/regulator supply voltage:
 - DS7-340...: 24 V AC/DC, -15 %/+10 %
 - DS7-342...: 120 - 230 V AC, -15 %/+10 %
 - AC: 50/60 Hz ± 10 %
 - Control voltage and controller power supply always have the same potential and voltage level.
 - Relay contacts (potential-free)
 - TOR (Top-of-Ramp): 230 V AC, 1 A, AC-11
In size 1 (to 12 A) with potential connection to the control section
 - RUN (operational signal): 230 V AC, 1 A, AC-11
In size 1 (to 12 A) this relay contact is not present.
 - Ambient temperature during operation: -5 to +40 °C, max. +60 °C with derating and device fan
 - Load cycle: 10 starts per hour, max. 40 starts per hour, with derating and integrated device fan (optional)
 - Status display (LEDs)
 - RUN = Operating signal (green)
 - Error = Error message (red)
 - Parameterization/setting via three parameters accessible on the front

DS7 with device fan DS7-FAN-032

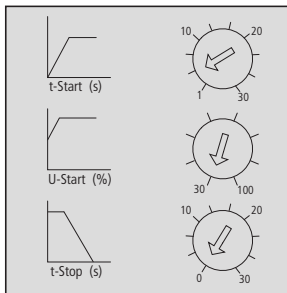
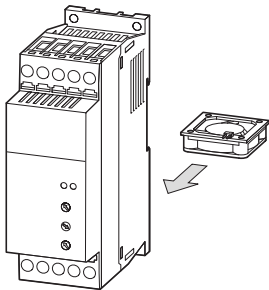

t-Start = Ramp time (1 - 30 s) for the voltage increase from the value U-Start up to mains voltage (U_{LN})

U-Start = The start voltage (30 - 100 %), determines the torque of the motor

t-Stop = Ramp time (0/1 - 30 s) for the voltage reduction from the mains voltage (U_{LN}) to the value U-Start

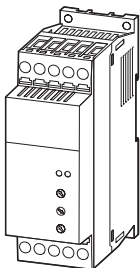
Electronic motor starters and drives**Connection example DS7****2****Sizes DS7****Size 1 (4 to 12 A)**

DS7-34...SX004...
 DS7-34...SX007...
 DS7-34...SX009...
 DS7-34...SX012...

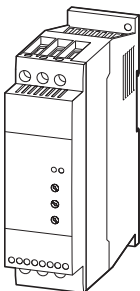
Size 2 (16 to 32 A)

DS7-34...SX016...
 DS7-34...SX024...
 DS7-34...SX032...

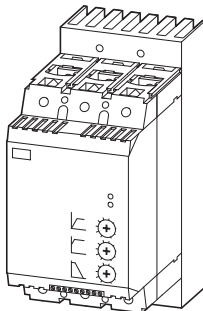
Size 3 + 4 (41 to 200 A)

DS7-34...SX041...
 DS7-34...SX055...
 DS7-34...SX070...
 DS7-34...SX081...
 DS7-34...SX100...
 DS7-34...SX135...
 DS7-34...SX160...
 DS7-34...SX200...

Documentation

Manual: MN03901001Z-EN

Instructional leaflet:

IL03902003Z (for size 1)

IL03902004Z (for size 2)

IL03902005Z (for size 3 und 4)

Electronic motor starters and drives

Connection example DS7

The number and arrangement of the control terminals, as well as the structure

in the power section of the individual sizes vary according to the power section.

Size 1 (4 to 12 A)

2

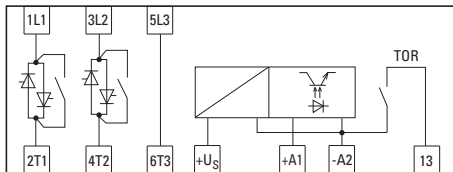

Size 2 (16 to 32 A)

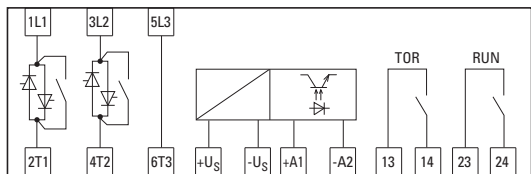

Size 3 and 4 (41 to 200 A)

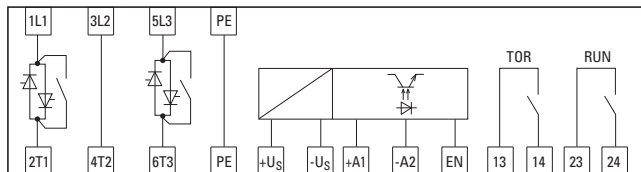

Electronic motor starters and drives

Connection example DS7

Standard connection with upstream mains contactor and soft stop ramp

Standard connection with mains contactor, size 1 (4 to 12 A)

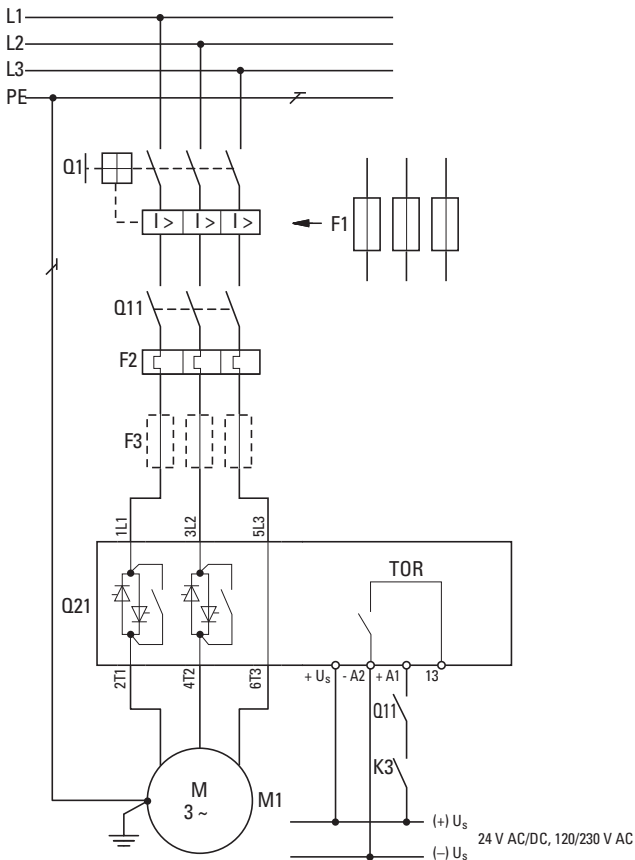

Electronic motor starters and drives

Connection example DS7

Control section with mains contactor

- Q1, F1: Short-circuit- and cable protection
- Q11: Mains contactor
- F2: Motor protection
- F3: Optional semiconductor fuse for type 2 coordination, in addition to Q1 and F1
- K3: Start/Stop

2

- ① Optional – if a stop is required without a SoftStop
Setting: t-Stop > 0

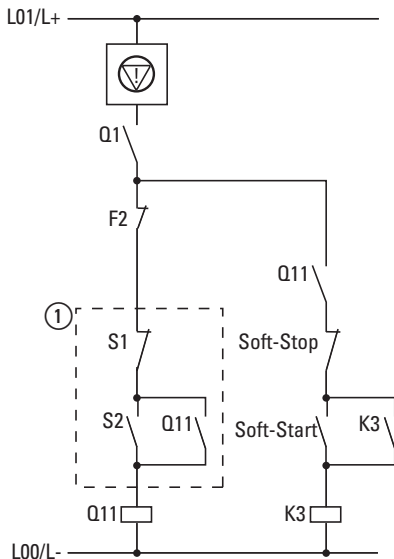

Electronic motor starters and drives

Connection example DS7

Rotation direction reversal with soft stop ramp

Size 1 (4 to 12 A)

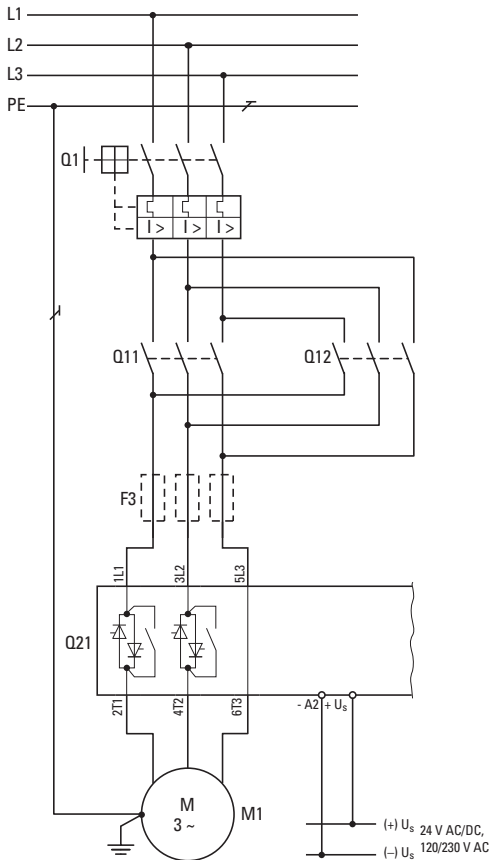

Electronic motor starters and drives

Connection example DS7

Control section for bidirectional operation

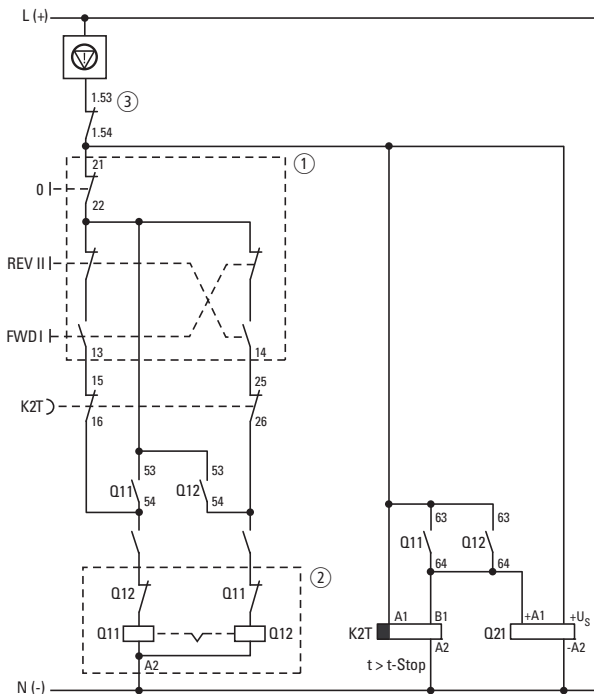

FWD = Clockwise rotation field
(Forward Run)

REV = Counterclockwise rotation field
(Reverse Run)

Q11 = Mains contactor FWD

Q12 = Mains contactor REV

① Assembled control station

② Reversing starter

③ Standard auxiliary contact

Electronic motor starters and drives

Connection example DS7

Control section for bidirectional operation

Note

The control voltages (+U_S) of the DS7 soft starter and the contactor control must have the same potential: 24 V DC/AC or 120/230 V AC

Q1, Q11, Q12 = MSC-R motor-starter combination ② is a compact device with electrical and mechanical interlocking.

The NHI-E-10-PKZ0 auxiliary contact ③ is added to Q1 for cable and motor protection.

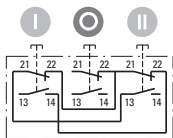

M22-I3-M1

- ① Contact sequence of assembled control station

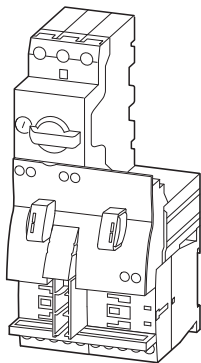

MSC-R...

- ② Reversing starter

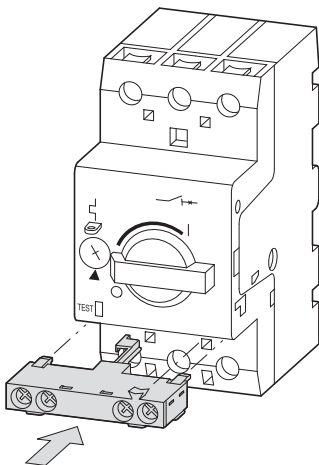

NHI-E-10-PKZ0

- ③ Standard auxiliary contact (grey)

Electronic motor starters and drives

Connection example DS7

2



DIL-XHI20

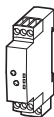

ETR2-11

Two DILA-XHI20 auxiliary contact modules are added to the two reversing contactors Q11 and Q12.

The NO contact 53/54 is used for the self-maintaining of reversing contactors Q11 and Q12; NO contact 63/64 activates the timing relay K2T and the soft starter Q21.

The pushbutton actuators 0, I, II as a complete device (M22-I3-M1) for surface mounting  enable the rotation direction change via the stop button.

K2T is an off-delayed timing relay (type ETR2) and simulates here the RUN signal. The drop-out time must be greater than the stop time (t_{Stop}) set on the DS7 soft starter. Switching to the other direction is only possible after the value set here has elapsed.

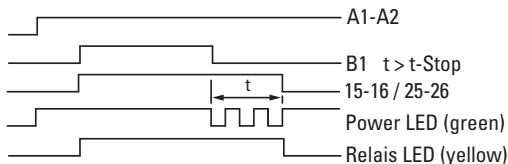

Electronic motor starters and drives

Connection example DS7

Compact motor starter with maintenance switch

Soft starter DS7, circuit-breaker NZM1 and maintenance switch P3, size 3 + 4 (41 to 200 A)

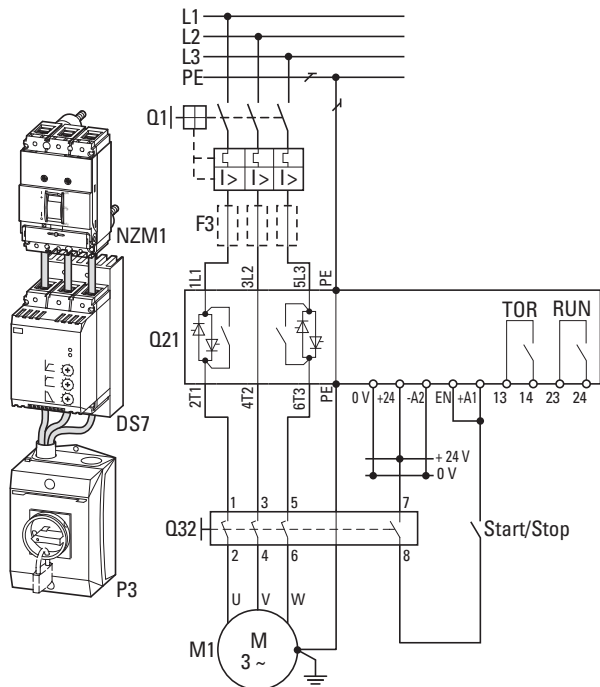

F3: Superfast semiconductor fuse
(optional for type 2 coordination,
additional to Q1)

Q1: Cable and motor protection

Q21: DS7 soft starters

Q32: Maintenance switch (local)

M1: Three-phase motor

Electronic motor starters and drives

Connection example DS7

NZM circuit-breaker with emergency-off function to IEC/EN 60204 and VDE 0113 Part 1, size 3 + 4 (41 to 200 A)

2

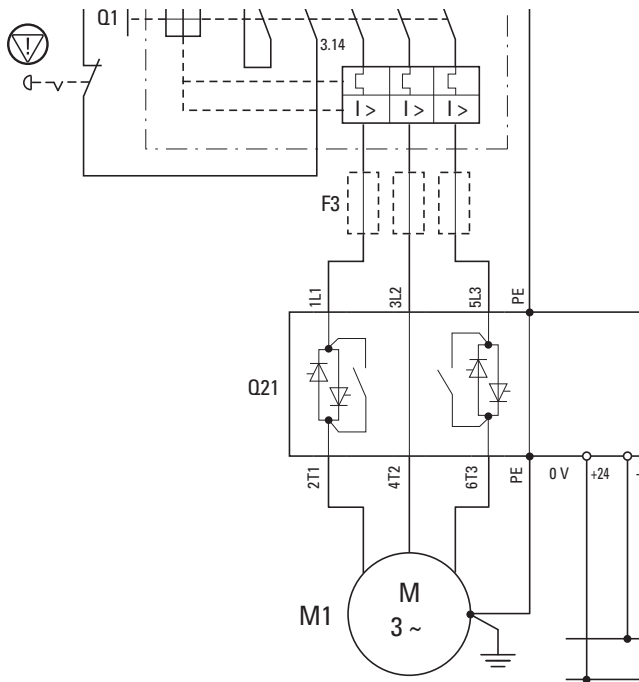

- Ⓢ Emergency switching off
- F3: Superfast semiconductor fuse (optional for type 2 coordination, additional to Q1)
- Q1: Cable and motor protection (NZM1, NZM2)
- Q21: DS7 soft starters
- M1: Motor

- ① Control circuit terminal
- ② Undervoltage release with early-make auxiliary contact

Electronic motor starters and drives

Connection example DS7

Bypass circuit

Note

The devices of the DS7-34... series are already provided with integrated bypass contacts. An external bypass for continuous operation with a DS7 soft starter is therefore not required.

Bypass circuit for emergency operation

In pump applications the bypass contactor is often required to provide emergency operation capability. A service switch is used to select between soft starter operation and DOL starter operation via a bypass contactor (Q22). This is used to fully isolate the soft starter. In this case, it is important that the output circuit is not opened during operation. The interlocks ensure that a switchover is only possible after a stop. An electrical and/or mechanical interlocking of contactors Q22 and Q31 ensures a safe operating state.

Note

Unlike simple bypass operation, the bypass contactor must be designed here in accordance with utilization category AC-3.

- F3: Superfast semiconductor fuse (optional) for type 2 coordination (additional to Q1)
- Q1: Cable and motor protection
- Q11: Mains contactor (optional) for disconnection in emergency operation
- Q21: Soft starters
- Q22: Bypass contactor
- Q31: Motor contactor
- M1: Motor

Electronic motor starters and drives

Connection example DS7

DS7 power section ≥ 41 A with bypass emergency operation (example: pump)

2

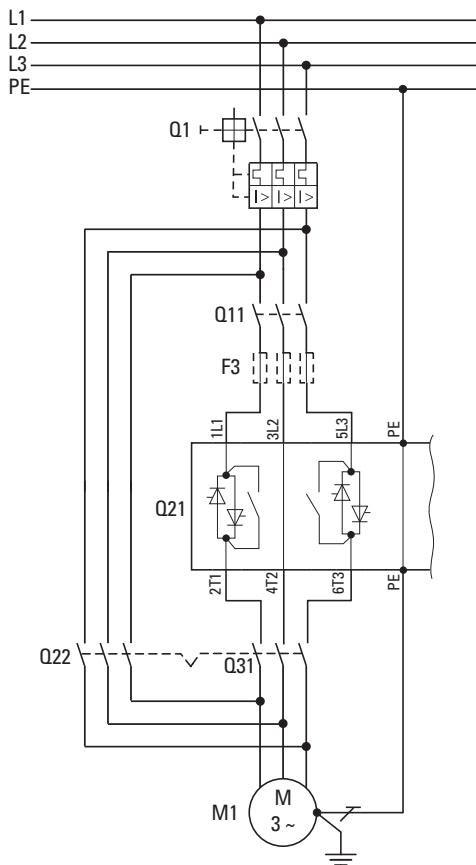

Electronic motor starters and drives

Connection example DS7

Actuation with bypass emergency operation – (pump operation)

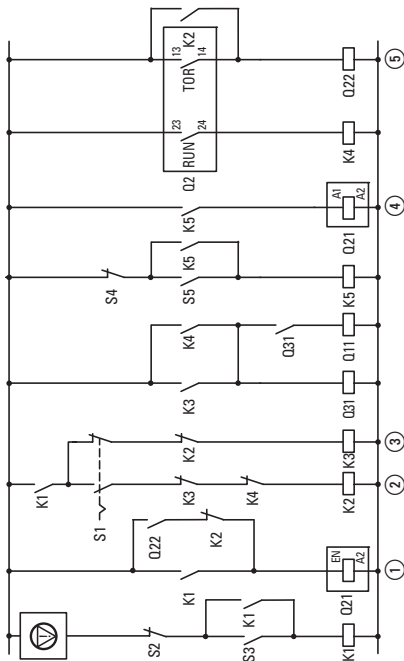

- ① Enable
 - ② Automatic operation (soft starter)
 - ③ Manual/bypass operation
 - ④ Softstart/Soft stop
 - ⑤ Bypass contactor
- S1: Operating mode switch
 - S2: Off
 - S3: On
 - S4: Stop (soft starter)
 - S5: Start (soft starter)

Note

The control system shown here can also be used for the DS7 soft starter in size 2 (16 to 32 A).

Electronic motor starters and drives

Connection example DS7

Starting several motors sequentially with a soft starter (cascaded control)

When starting several motors one after the other using a soft starter, keep to the following changeover sequence:

2

1. Start using soft starter
2. Switch on bypass contactor Qn2 via TOR (Top-of-Ramp)
3. Block soft starter
4. Switch soft starter output with Qn1 to the next motor
5. Restart

Notes

- When starting several motors with one soft starter the thermal load of the soft starter (starting frequency, current load) must be taken into account. If the starts are to occur in close succession, the soft starter must be dimensioned larger (i.e. the soft starter must be designed with an accordingly higher load cycle).
- Due to the thermal design of the DS7 soft starters, we recommend the use of an (optional) fan when using a DS7 series device for starting several motors.

F3: Superfast semiconductor fuse (optional for type 2 coordination, additional to Q1)

Q1: Cable protection

Q2: Soft starter DS7

Qn1: Contactor (1, 2, n)

Qn2: Mains bypass contactor for motor (1, 2, n)

Qn3: Motor protection (motor-protective circuit-breaker or bimetal relay)

Mn: Motor (1, 2, n)

Notes

- The control system shown here can also be used for the DS7 soft starter in size 2 (16 to 32 A), however without an enable signal ①.
- Bimetal relays can also be used as an alternative to the overload relays Q13, Q23, ... , Qn3 (see page 2-21).

Electronic motor starters and drives

Connection example DS7

Cascade control

Power section for motor cascade (example for size 3 and 4)

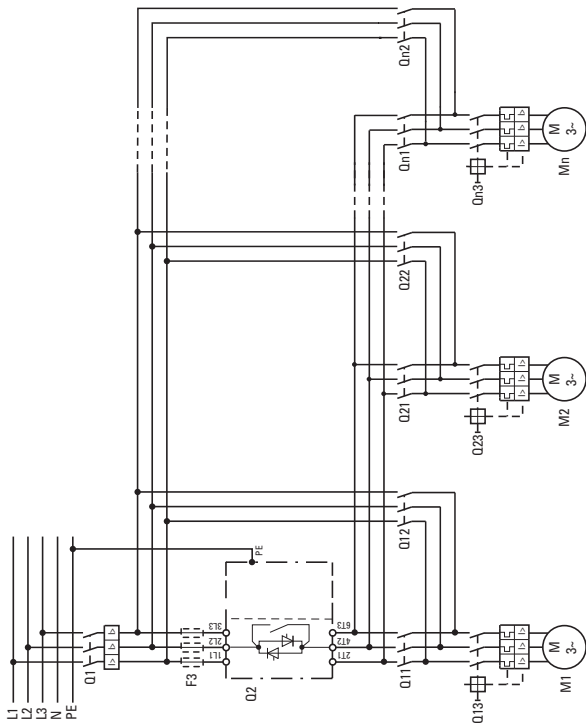

2

Electronic motor starters and drives

Connection example DS7

Actuation, motor cascade, part 1

2

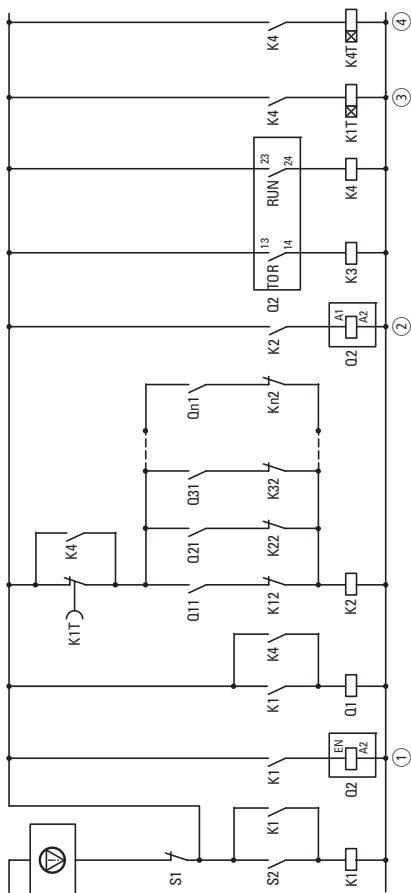

- ① Enable
- ② Softstart/Soft stop
- ③ Starting frequency monitoring. The timing relay must be set so that the soft starter does not have a temperature overload. The correct time is based on the permissible operating frequency of the selected soft starter. If necessary, use soft starters with a higher rating.
- ④ Set the timing relays to approx. 2 s off-delay. This ensures that the next motor branch can not be connected as long as the soft starter is running.

N/C contact S1 switches all motors off at the same time.

Electronic motor starters and drives

Connection example DS7

Actuation, motor cascade, part 2

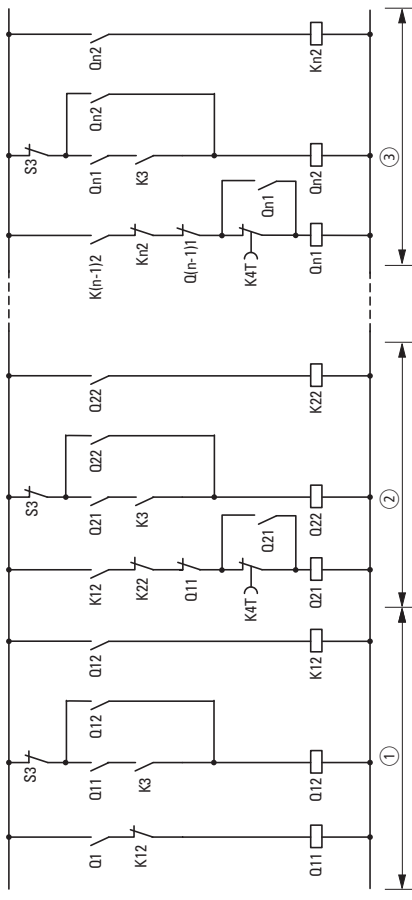

- ① Motor 1
- ② Motor 2
- ③ Motor n

The N/C contact S3 is required if motors also have to be switched off individually.

Electronic motor starters and drives

DM4 connection example

2

DM4 product features

- Three-phase controlled soft starter; meets the requirements of the IEC/EN 60947-4-2 product standard
- Configurable and communication-enabled with pluggable control signal terminals and interface for options:
 - Operator control and programming unit
 - Serial interface
 - Fieldbus connection
- Application selector switch with user-programmable parameter sets for 10 standard applications
- I²t controller
 - Current limitation
 - Overload protection
 - Idle/undercurrent detection (e.g. belt breakage)
- Kickstarting and heavy starting
- Automatic control voltage detection
- 3 relays, e.g. fault signal, TOR (Top-of-Ramp)
- Power section:
 - Rated operational voltage 230 - 480 V, -15 % / + 10 %
 - Mains frequency: 50/60 Hz ±10 %
- Control voltage/regulator supply voltage:
 - 24 V DC
 - 120 - 240 V AC, -15 % / +10 %, 50/60 Hz
- Ambient temperature during operation: 0 to +40 °C
- Load cycle: 10 starts per hour with 3.5 x I_e for max. 35 s

Pre-programmed parameter sets for ten typical applications can be simply called up with a selector switch (see page 2-48). Additional plant-specific settings can be defined with an optional keypad. This includes, for example, the three-phase AC power controller mode. In this mode three-phase resistive and inductive loads (heaters, lighting systems, transformers) can be controlled with the DM4. Both open-loop and – with measured value feedback – closed-loop control are possible.

Instead of the keypad, intelligent interfaces can also be used:

- RS232/RS485 serial interface (configuration with PC software)
- PROFIBUS-DP fieldbus connection

The DM4 soft starter provides the most convenient method of implementing soft starting. In addition to phase failure and motor current monitoring, the motor winding temperature is evaluated through the built-in thermistor input, so that the soft starters do not require additional external components, such as motor protective relays.

Note

The optional superfast semiconductor fuses (F3) for type 2 coordination can be used from size 2 (from 85 A) in the housing of the DM4 soft starter.

Electronic motor starters and drives

DM4 connection example

Sizes DM4

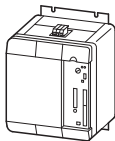

Size 1

16 - 72 A

Assigned motor power at 400 V

7.5/11 - 37 kW

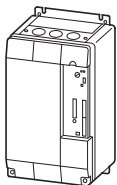

Size 2

85 - 146 A

Assigned motor power at 400 V

45/75 - 75/132 kW

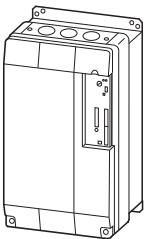

Size 3

174 - 370 A

Assigned motor power at 400 V

90/160 - 200/315 kW

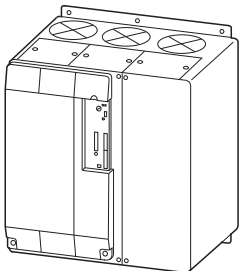

Size 4

500 - 900 A

Assigned motor power at 400 V

250/400 - 500/900 kW

Electronic motor starters and drives

DM4 connection example

Documentation

Manuals:

AWB8250-1346GB

("Soft Starter Design")

2

AWB8250-1341GB (DM4 "Soft Starter")

AWB8240-1398 ("DE8240-NET-DP2
interface module for PROFIBUS DP")

AWB823-1279

("DE4-COM-2X interface module")

AWB8240-1344GB

("DE4-KEY-2 Keypad")

Installation instructions:

AWA8250-1704 (up to 37 kW)

AWA8250-1751 (45 to 75 kW)

AWA8250-1752 (90 to 200 kW)

AWA8250-1783 (250 to 500 kW)

Notes

Electronic motor starters and drives

DM4 connection example

The application selector switch enables direct assignment without parameter entry.

2

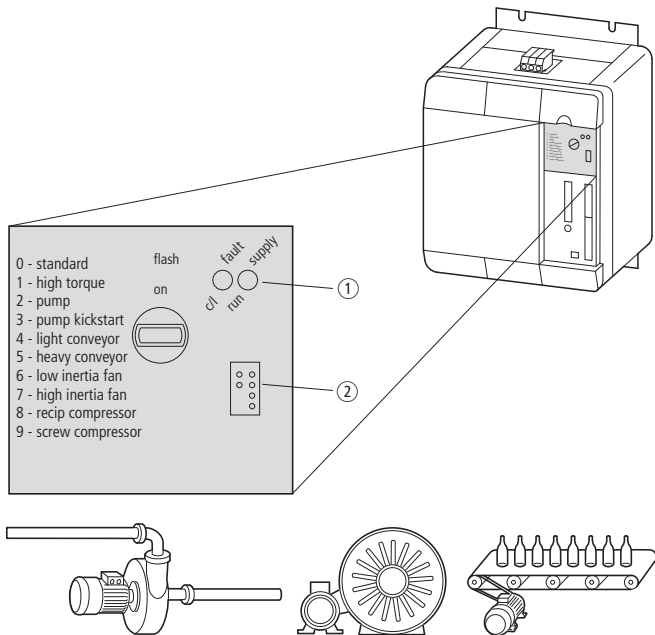

Electronic motor starters and drives

DM4 connection example

Standard applications (selector switch)

Labelling on device	Indication on keypad	Meaning	Notes
Standard	Standard	Standard	<ul style="list-style-type: none"> Default settings, suitable without adaptation for most applications
High torque ¹⁾	High Torque	High breakaway torque	<ul style="list-style-type: none"> Drives with higher breakaway torque
Pump	Small pump	Small pump	<ul style="list-style-type: none"> Pump drives up to 15 kW
Pump Kickstart	Large pump	Large pump	<ul style="list-style-type: none"> Pump drives over 15 kW Longer deceleration times
Light conveyor	Light conveyor	Light conveyor	–
Heavy conveyor	HeavyConvey	Heavy-duty conveyor	–
Low inertia fan	LowInert.fan	Low-inertia fan	<ul style="list-style-type: none"> Fan drive with relatively small mass inertia moment of up to 15 times the motor's inertia moment
High inertia fan	HighInertfan	High-inertia fan	<ul style="list-style-type: none"> Fan drive with relatively large mass inertia moment of over 15 times the motor's inertia moment. Longer ramp-up times
Recip compressor	RecipCompres	Reciprocal compressor	<ul style="list-style-type: none"> Higher start voltage p.f. optimization matched
Screw compressor	ScrewCompres	Screw compressor	<ul style="list-style-type: none"> Increased current consumption No current limitation

2

1) For the “High Torque” setting, the soft starter must be able to supply 1.5 times the motor's rated current.

Electronic motor starters and drives

DM4 connection example

Enable/immediate stop without ramp function (e.g. for Emergency-Stop)

The digital input E2 is factory set to switch the enable function. The soft starter is enabled only when a High signal is present at the terminal. The soft starter cannot be operated without the enable signal.

In the event of wire breakage or interruption of the signal by an Emergency-Stop circuit, the regulator in the soft starter is immediately blocked and the power circuit disconnected, and after that the "Run" relay drops out.

Normally the drive is always stopped via a ramp function.

When the operating conditions require an immediate de-energization, this is effected via the enabling signal.

Warning!

You must in all operating conditions always first stop the soft starter ("Run" relay scanning), before you mechanically interrupt the power conductors. Otherwise a flowing current is interrupted – thus resulting in voltage peaks, which in rare cases may destroy the thyristors of the soft starter.

2

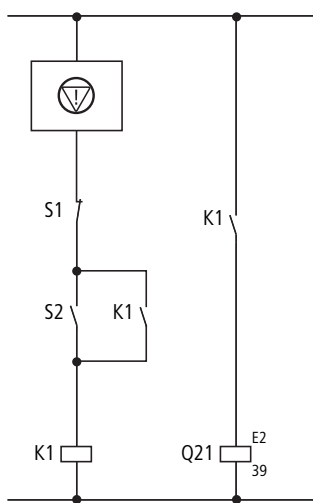

- ⊕ Emergency switching off
- E2: Digital input
- Q21: Soft starter (E2 = 1 + enabled)
- S1: Off
- S2: On

Electronic motor starters and drives

DM4 connection example

Linking the overload relay into the control system

We recommend using an external overload relay instead of a motor-protective circuit-breaker with built-in overload relay. This allows controlled ramping down of the soft starter through the control section in the event of an overload.

Warning!

The direct opening of the power lines may cause overvoltage and destruction of the soft starter's semi-conductors.

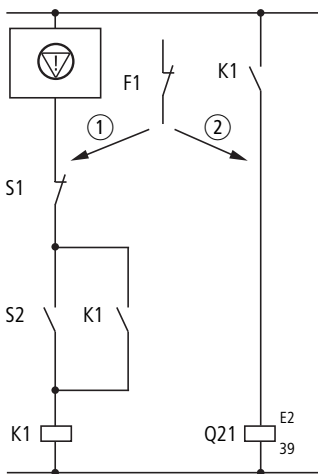

There are two ways of incorporating a motor-protective relay in the control system as shown in the diagram on the left:

- ① The signalling contacts of the overload relay are incorporated in the on/off circuit. In the event of a fault, the soft starter decelerates according to the set ramp time and stops.
- ② The signalling contacts of the overload relay are incorporated in the enable circuit. In the event of a fault, the soft starter's output is immediately de-energized. The soft starter switches off but the mains contactor remains on. In order to switch off the mains contactor, a second contact of the overload relay must be incorporated in the on/off circuit.

-  Emergency switching off
 S1: Off
 S2: On
 Q21: Soft starter (E2 = 1 → enabled)

Electronic motor starters and drives

DM4 connection example

With separate contactor and overload relay

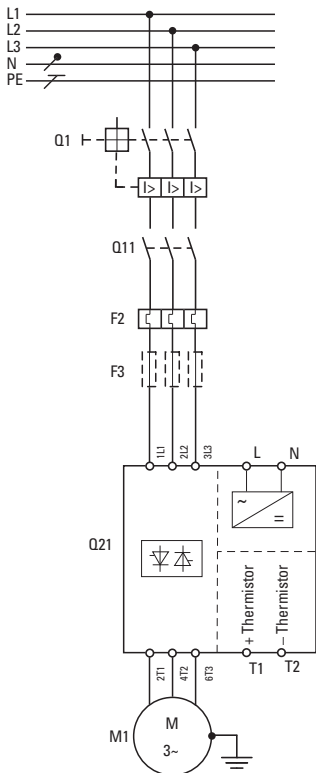

Standard connection

For isolation from the mains, either a mains contactor upstream of the soft starter or a central switching device (contactor or main switch) is necessary.

Actuation

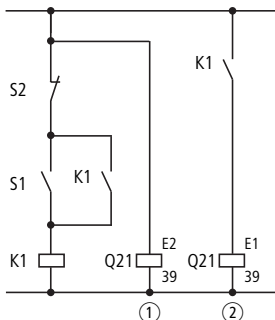

F2: Overload relays
F3: Superfast semiconductor fuses (optional)

M1: Motor
Q1: Cable protection
Q11: Mains contactor
Q21: Soft starter
S1: Soft-Start
S2: Soft-Stop

- ① Enable
② Softstart/soft stop

Electronic motor starters and drives

DM4 connection example

Without mains contactor

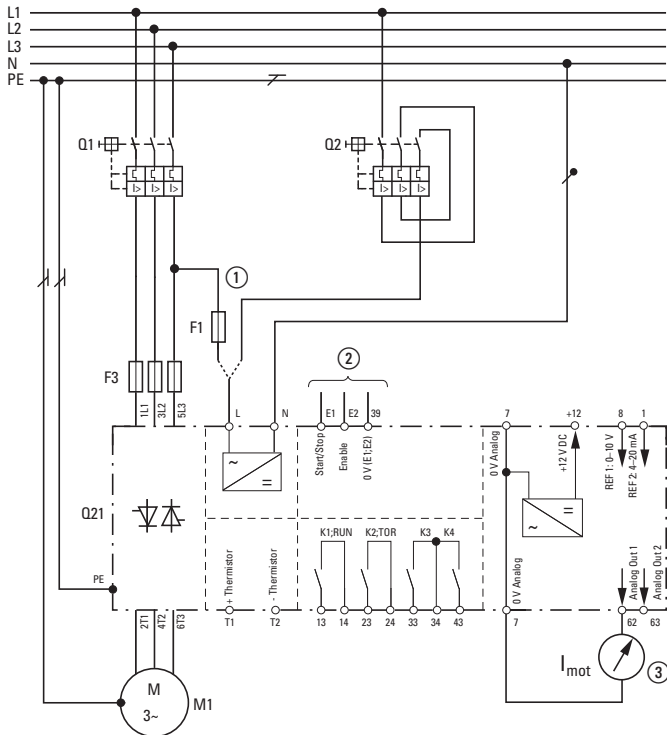

F3: Superfast semiconductor fuses (optional)

Q1: Cable and motor protection

Q21: Soft starter

M1: Motor

① Control voltage through Q1 and F11 or separately via Q2

② See Actuation

③ Motor current indication

Electronic motor starters and drives

DM4 connection example

Soft starters with separate mains contactor

Actuation

2

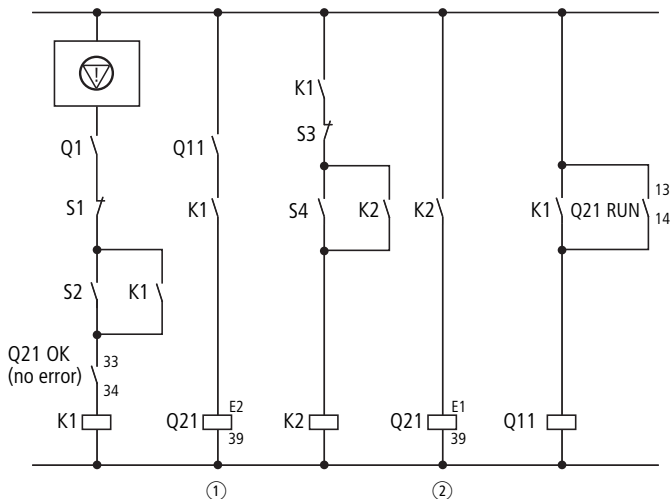

⊖ Emergency switching off

M1: Motor with temperature sensor (thermistor)

Q1: Cable and motor protection

Q21: Soft starter

S1: Off (uncontrolled deceleration)

S2: On

S3: Soft start

S4: Soft stop (deceleration ramp)

① Enable

② Softstart/soft stop

Electronic motor starters and drives

DM4 connection example

Soft starters with separate mains contactor

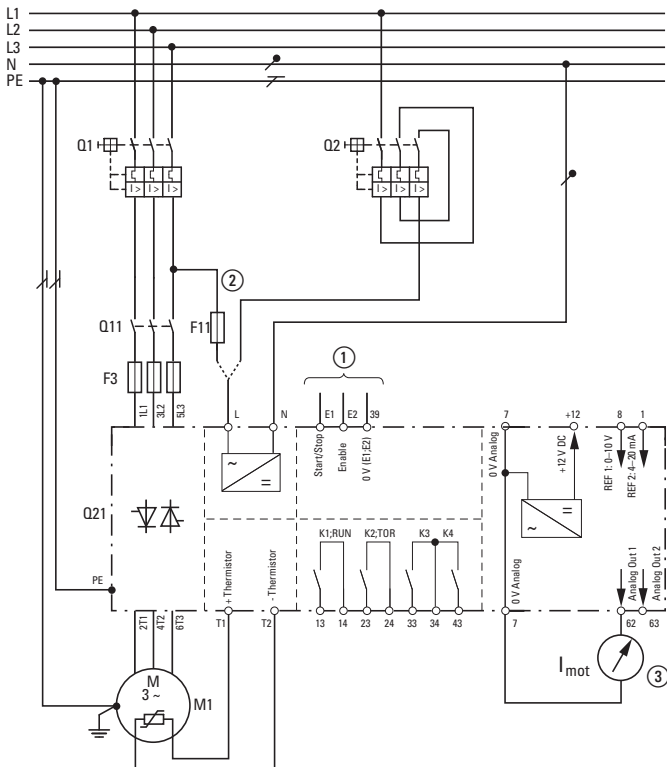

E1: Start/stop
 E2: Enable
 T1: + Thermistor
 T2: - Thermistor

- ① See Actuation
- ② Control voltage through Q1 and F11 or through Q2
- ③ Motor current indication

Electronic motor starters and drives

DM4 connection example

In-delta connection

2

Soft starters are normally connected directly in series with the motor (so-called "in-line connection"). The DM4 soft starter also allows operation in an in-delta connection.

The antiparallel thyristors are connected directly in series to the individual motor windings.

Advantages (compared with in-line connection):

- Inexpensive since the soft starter only has to be designed for approx. 58 % ($1/\sqrt{3}$) of the rated current – particularly with motor ratings > 30 kW and when replacing star-delta starters.
- For the same motor rating the required soft starter rating is reduced.

Disadvantages (compared with in-line connection):

- As in a star-delta circuit, the motor must be connected with six conductors.
- The DM4 soft starter overload protection is active only in one line so that additional motor protection must be fitted in the parallel phase or in the supply cable. The motor can be protected for example via thermistors.

Notes

- The voltage of the motor winding must match the rated voltage. For a 400 V mains voltage the motor must therefore be marked with 400 V/690 V.
- The soft starter can also be bridged in the in-delta connection for continuous operation with a bypass contactor (see page 2-60). This is actuated via TOR (Top-of-Ramp).

Electronic motor starters and drives

DM4 connection example

Inline/delta connection

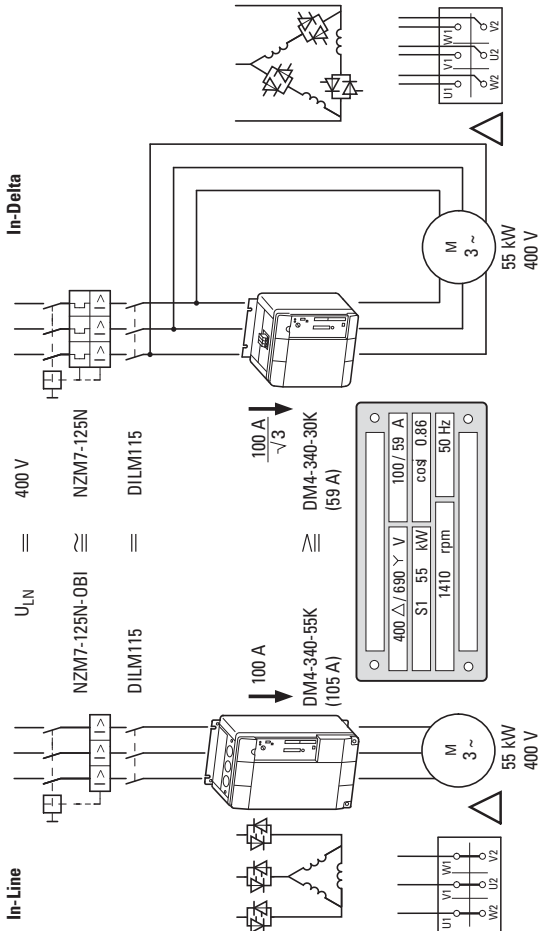

Electronic motor starters and drives

DM4 connection example

In-delta connection

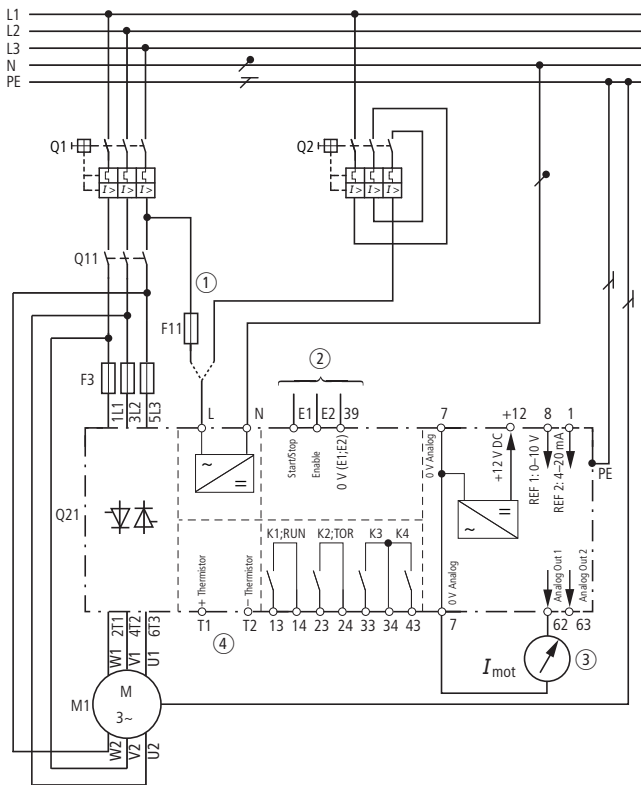

① Control voltage through Q1 and F11 or through Q2

③ Motor current indication

② See Actuation (→ page 2-61)

④ Thermistor connection

Electronic motor starters and drives

DM4 connection example

Actuation

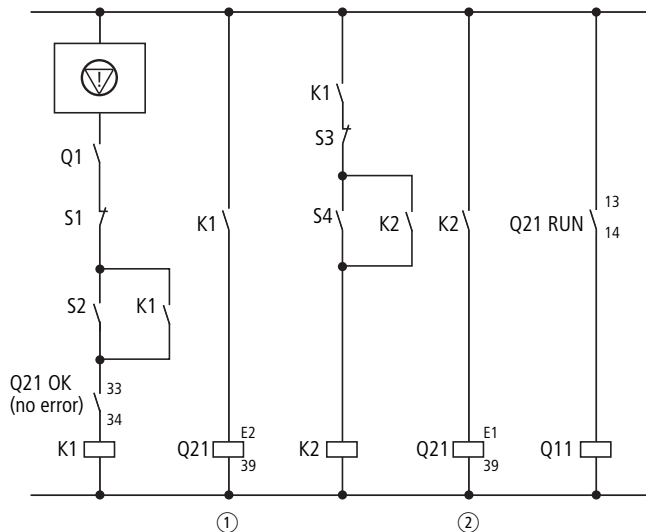

Ⓢ Emergency switching off

E2: Enable

Q1: Cable and motor protection

S1: OFF; uncontrolled deceleration of the motor

S2: ON/Start

S3: Soft stop

① Enable

② Soft start/soft stop

Electronic motor starters and drives

DM4 connection example

Bypass circuit

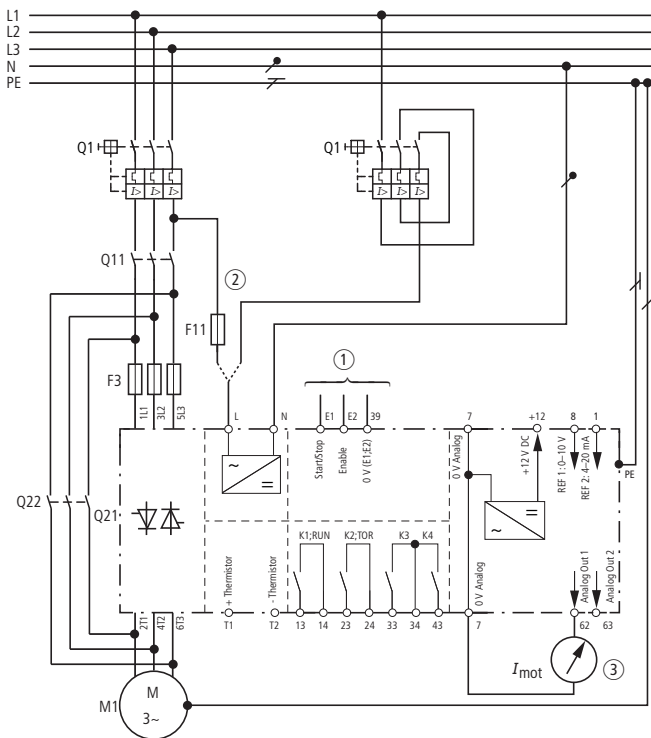

E1: Start/stop
 E2: Enable
 T1: + Thermistor
 T2: - Thermistor

- ① See Actuation (→ page 2-61)
- ② Control voltage through Q1 and F11 or through Q2
- ③ Motor current indication

Electronic motor starters and drives

DM4 connection example

Bypass circuit

After completion of the acceleration phase (full mains voltage reached), the soft starter M4 actuates the bypass contactor. Thus, the motor is directly connected with the mains.

Advantage:

- The soft starter's heat dissipation is reduced to the no-load dissipation.
- The limit values of radio interference class "B" are adhered to.

The bypass contactor is now switched to a de-energized state and can therefore be designed to utilization category AC-1.

If an immediate voltage switch-off is required in the event of an emergency stop, the bypass contactor must also switch the motor load. In this case a design to utilization category AC-3 is required.

2

Actuation

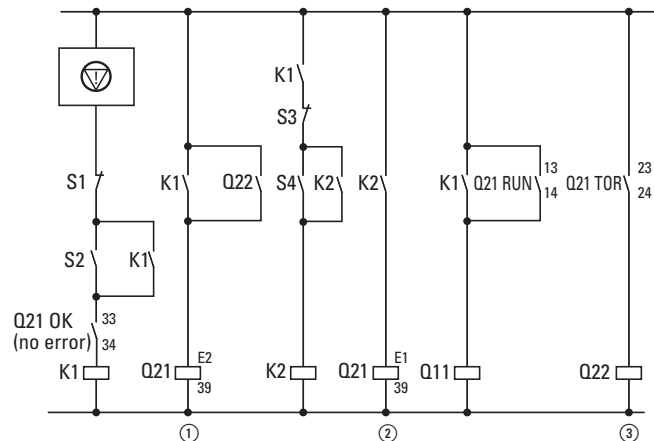

- ⊖ Emergency switching off
 S1: Off (uncontrolled deceleration)
 S2: On

- ① Enable
 ② Soft start/soft stop
 ③ Bypass contactor

Electronic motor starters and drives

DM4 connection example

2

Starting several motors sequentially with a soft starter (cascaded control)

When using a soft starter to start several motors in succession, keep to the following changeover sequence:

1. Start using soft starter
2. Switch on bypass contactor
3. Block soft starter
4. Switch soft starter output to the next motor
5. Restart

→ Section "Actuation part 1", page 2-64

- ⓧ Emergency switching off
- F3: Superfast semiconductor fuse (optional) for type 2 coordination
- Q1: Main switch / cable protection (NZM)
- Q2/F11: Optional control voltage supply
- Qn3: Motor-protective circuit-breakers
- Qn4: Motor protection Soft starter
- Qn5: Motor contactors bypass
- S1: Q11 Off
- S2: Q11 On

① Soft start/soft stop

② RUN

③ Off-time monitoring

Set the timing relay K1T so that the soft starter is not thermally overloaded: Calculate the time from the soft starter's permissible operating frequency or select a soft starter that allows the required time to be reached.

④ Changeover monitoring

Set the timing relay to a return time of about 2 s. This ensures that the next motor branch can not be connected as long as the soft starter is running.

→ Section "Actuation, part 2", page 2-65

① Motor 1

② Motor 2

③ Motor n

⑨ Switching off individual motors

The Off switch results in all motors being switched off at the same time. To switch off individual motors, you need to make use of N/C contact ⑨.

Observe the thermal load on the soft starter (starting frequency, current load). If motors are to be started at short intervals, you may have to select a soft starter with a higher load cycle.

Electronic motor starters and drives

DM4 connection example

Cascade control

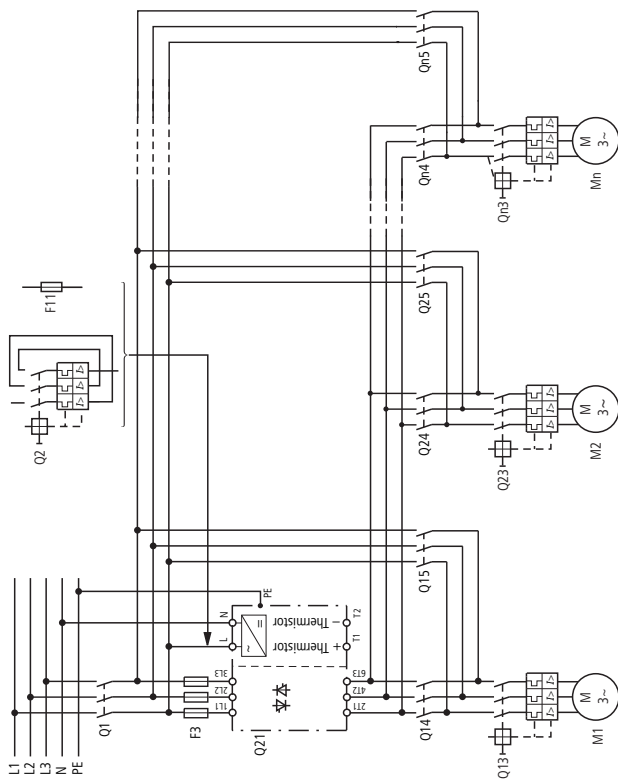

2

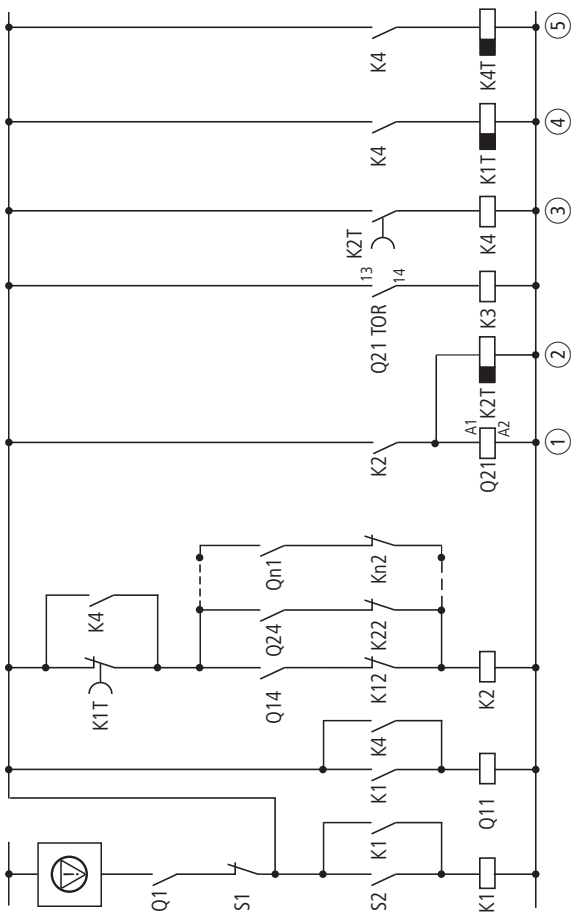
Electronic motor starters and drives**DM4 connection example****2****Actuation part 1**

→ Section "Starting several motors sequentially with a soft starter (cascaded control)", page 2-62

Electronic motor starters and drives

DM4 connection example

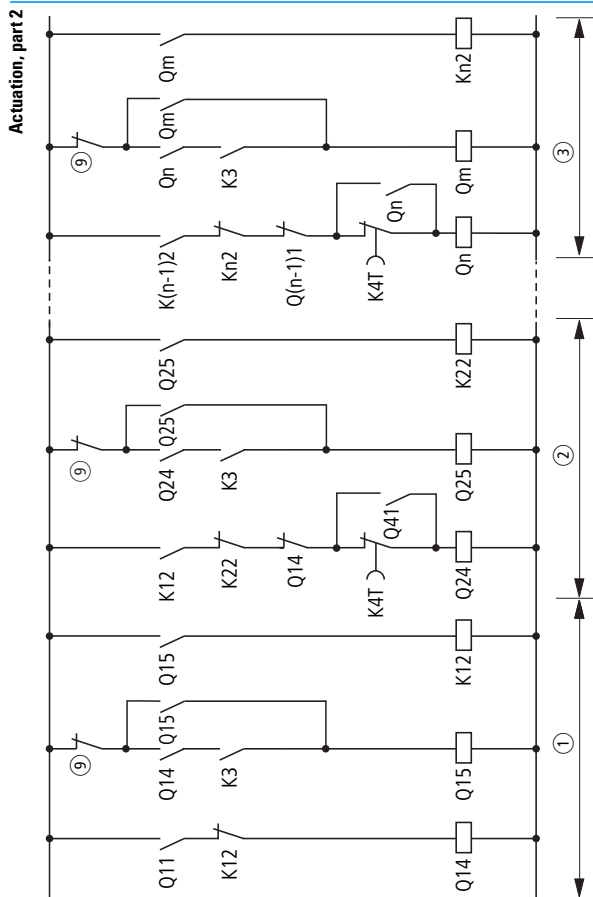

→ Section "Starting several motors sequentially with a soft starter (cascaded control)", page 2-62

Electronic motor starters and drives

Frequency inverter basic information

Design and mode of operation of frequency inverters

Frequency inverters provide variable and stepless speed control of three-phase motors.

2

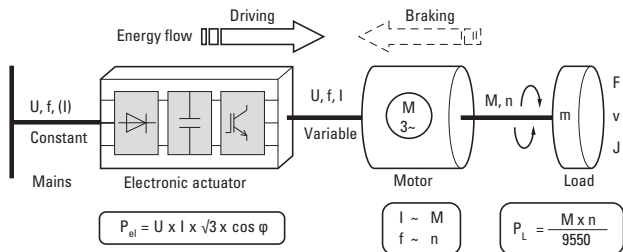

Frequency inverters convert the constant mains voltage and frequency into a DC voltage, from which they generate a new three-phase supply with variable voltage and frequency for the three-phase motor. The frequency inverter draws almost only active power (p.f. ~ 1) from the mains supply.

The reactive power needed for motor operation is supplied by the DC link. This eliminates the need for p.f. correction on the mains side.

Frequency inverters must comply with the product standard IEC/EN 60947-4-2.

U = Rated operating voltage [V]
 f = Frequency [Hz]
 I = Rated operational current [A]
 M = Torque [Nm]
 n = Speed [r.p.m.]
 F = Force [N]
 v = Speed [m/s]
 J = Moment of inertia [$\text{kg} \cdot \text{m}^2$]
 P_{el} = Electric power [kW]
 P_L = Mechanical shaft output power [kW]

$\cos \varphi$ = power factor (P/S)
with

P = Active power = $P_{el} = P_1$ [kW] and
 S = Apparent power [kVA]

η = $P_L/P_{el} = P_2/P_1$ = Efficiency

Electronic motor starters and drives

Frequency inverter basic information

Block diagram with main components of a frequency inverter

Internal open and closed-loop control circuits (central processing unit) monitor all variable values in the frequency inverter and automatically switch the process off if a value reaches a dangerous level.

The power section of a static compact frequency inverter consists of three subgroups:

- Rectifier (A)
- Internal DC link (B)
- Inverter module (C)

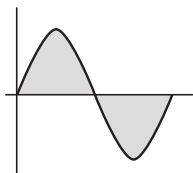
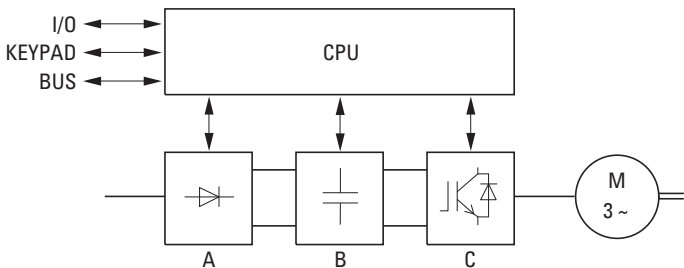

U_{LN} : Line supply
from mains
AC power supply

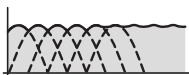

U_{DC} : DC link circuit voltage
 $U_{DC} = 1.41 \times U_{LN}$
 (single-phase line voltage)
 $U_{DC} = 1.35 \times U_{LN}$
 (three-phase line voltage)

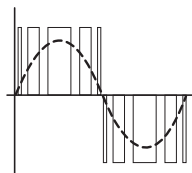

Output voltage = switched DC
link voltage with sinusoidal
pulse width modulation (PWM)

Electronic motor starters and drives

Frequency inverter basic information

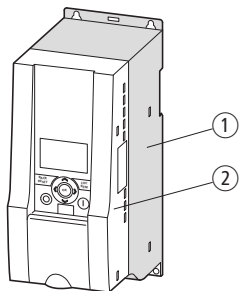
2

- ① Power section:
 - A = Rectifier
 - B = DC link
 - C = Inverter module
- ② Control section with:
 - I/O = analog and binary inputs and outputs
 - KEYPAD = keypad with display
 - BUS = serial interfaces (RS485, fieldbus, PC interface)

Electronic motor starters and drives

Frequency inverter basic information

Drive system (PDS) to EN 61800-3

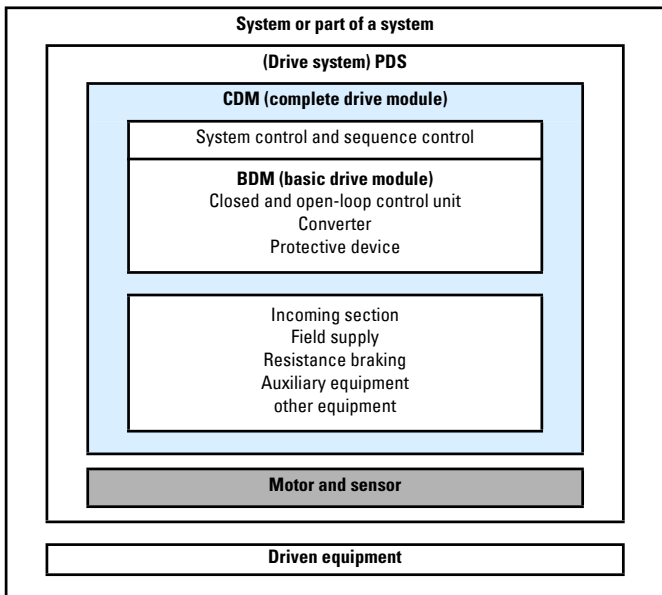

2

BDM (basic drive module)

Electronic power converter with associated control which is connected between the electrical power supply and a motor. The module controls speed, torque, force, position, current, frequency and voltage individually or jointly or all parameters together. The BDM can transfer the power from the electrical supply to the motor and also the power from the motor to the electrical supply.

CDM (complete drive module)

Drive module which consists of but is not restricted to the BDM and additional devices such as protective equipment, transformers, and auxiliary devices.

This, however, does not include the motor and the sensors that are mechanically connected to the motor shaft.

Electronic motor starters and drives

Frequency inverter basic information

The frequency-controlled three-phase motor is a standard component for infinitely variable speed and torque regulation - providing efficient, energy-saving power either as an individual drive or as part of an automated installation.

This not only refers to the frequency inverter as a component but also considers a complete drive system (PDS = Power Drives System) with motor, cables, EMC etc. (→ page 2-69).

2

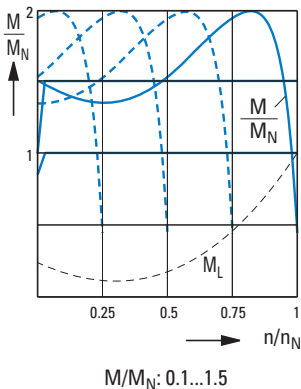
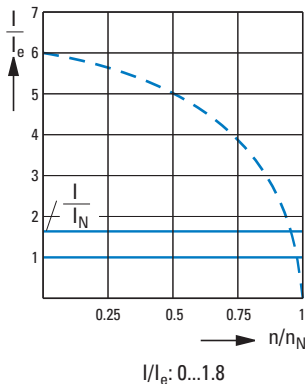

Electronic motor starters and drives

Frequency inverter basic information

Electrical mains connection

Frequency inverters can be connected and operated without restriction on star-point-grounded AC mains (according to IEC 60364).

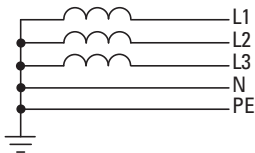
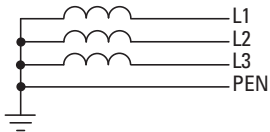

Connection and operation on asymmetrically grounded networks such as phase grounded delta networks (USA) or non-grounded or resistively grounded ($> 30 \Omega$) IT networks are only permissible with restrictions and require additional engineering measures.

The standardized rated operating voltages of the utility companies fulfil the following conditions at the point of transfer to the consumer:

- Maximum deviation from the rated voltage (U_{LN}): $\pm 10\%$
- Maximum deviation in the voltage symmetry: $\pm 3\%$
- Maximum deviation from the rated frequency: $\pm 4\%$

A further voltage drop of 4 % in the consumer networks is permissible in relation to the lower voltage value ($U_{LN} - 10\%$) of the supplying mains voltage. The power supply voltage at the consumer can therefore have a value of $U_{LN} - 14\%$.

In ring meshed networks (as used in the EU) the consumer voltages (230 V / 400 V / 690 V) are identical to the power supply voltages of the utility companies. In star networks (for example in North America/USA), the stated consumer voltages take the voltage drop from the utility company's infeed point to the last consumer into account.

Mains voltages in North America

Supply voltage U_{LN} of the utility company	Motor voltage according to UL 508 C	Consumer voltage (rated value for the motors)
120 V	110 - 120 V	115 V
240 V	220 - 240 V	230 V
480 V	440 - 480 V	460 V
600 V	550 - 600 V	575 V

Electronic motor starters and drives

Frequency inverter basic information

2

EMC compliance in PDS

The electrical components of a system (machine) are subject to reciprocal interference. Each device not only exerts interference on other devices but is also adversely affected by it. This occurs as a result of galvanic, capacitive and/or inductive coupling or through electromagnetic radiation. The border between line-conducted interference and radiated interference is around 30 MHz. Above 30 MHz the lines and cables act like antennas and radiate the electromagnetic waves.

The electromagnetic compatibility (EMC) for variable speed drives is implemented in accordance with product standard IEC/EN 61800-3.

This covers the entire drive system (PDS = Power Drives System) from the mains end supply to the motor, including all components and cables. This type of drive system can also consist of several individual drives.

The generic standards of the individual components in a PDS compliant with IEC/EN 61800-3 do not apply. These component manufacturers, however, must offer solutions that ensure standards-compliant use.

In Europe, maintaining the EMC Directive is mandatory.

A declaration of conformity (CE) refers always to a "typical" power drives system (PDS). The responsibility to comply with the legally stipulated limit values and thus the provision of electromagnetic compatibility is ultimately the responsibility of the end user or system operator.

Measures must be taken to remove or minimize emission in the associated environment. It must also be ensured that the immunity of the devices or systems is increased.

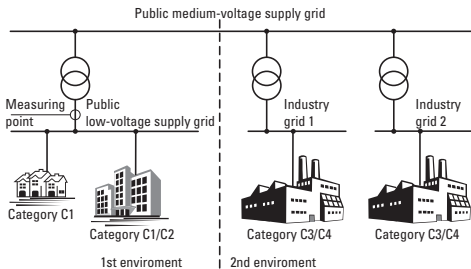

EMC environment and categories

Electronic motor starters and drives

Frequency inverter basic information

PDS categories

Drive systems (PDS) are divided into the following four categories.

PDS category C1

- PDS for use in the first environment
- Rated operating voltage < 1000 V

PDS category C2

- PDS for use in the first environment
- Rated operating voltage < 1000 V
- Not connected via plug-in devices
- No plug or movable equipment
- Connection and commissioning must be carried out by persons with suitable technical knowledge
- Hazard warning required ("This product may cause malfunctions in a domestic environment; in this case additional measures may be necessary.")

PDS category C3

- PDS for use in the second environment
- Not intended for use in the first environment
- Rated operating voltage < 1000 V
- Hazard warning required ("This PDS is not intended for connection to the public utility grid. Connection to these networks may cause electromagnetic interference.")

PDS category C4

- PDS for use in the second environment which fulfills at least one of the following criteria:
 - Rated operating voltage > 1000 V
 - Rated operational current > 400 A
 - Connection to IT networks
 - The required dynamic properties are not achieved due to EMC filter measures.
 - EMC plan required

Electronic motor starters and drives

Frequency inverter basic information

Equipment code

- 2**
- F: Fuses and circuit-breakers (cable protection)
 - Q: Controlled switching in power flow (contactor, circuit-breaker)
 - R: Limitation (choke, resistor)
 - K: Radio interference suppression filter
 - T: Frequency inverter
 - M: Motor

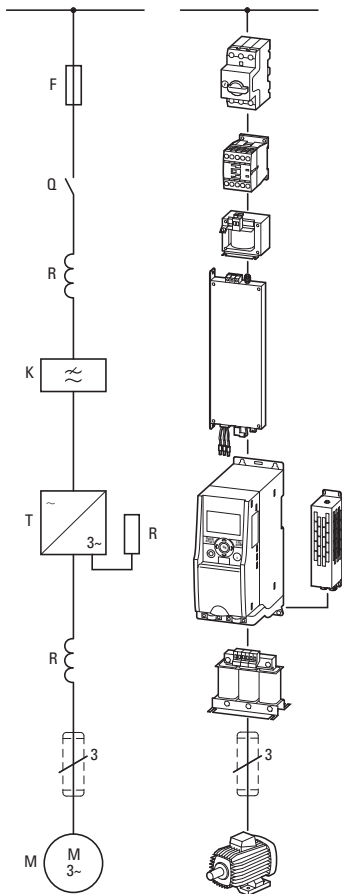

Electronic motor starters and drives

Frequency inverter basic information

Fuses (circuit-breakers) allow the protection of lines and electrical apparatus. For the protection of persons, AC/DC-sensitive residual current devices (RCD Type B) are required in addition.

Contactors are used for the on/off switching of the mains voltage.

Mains chokes suppress any current harmonics and peaks and limit the inrush current (link circuit capacitors).

RFI suppression filters attenuate high frequency electromagnetic emissions from devices. They ensure that the EMC limit values for conducted interference specified in the applicable product standards are observed (frequency inverters).

Frequency inverters enable the infinitely variable speed control of three-phase motors.

A **braking resistor** converts the frequency inverter's regenerative braking energy into heat.

The frequency inverter must be equipped with a brake chopper, which connects the braking resistor parallel to the internal DC link.

Motor reactors

- Compensate the capacitive capacitive currents,
- Reduce current ripple and the motor's current change noise,
- Attenuate the retroaction on parallel connection of several motors.

Sinusoidal filter

- Smoothen the output voltage sinusoidally,
- Reduce motor noise through du/dt reduction, and thereby increase the motor insulation's lifespan,
- Reduce the leakage currents to allow better motor performance at improved EMC values.

Shielded motor cables attenuate emitted and conducted high-frequency emissions within the limit values specified in the applicable product standard (EMC).

Three-phase asynchronous motor (standard motor)

Electronic motor starters and drives

Frequency inverter basic information

Notes about correct installation of frequency inverters

2

For an EMC-compliant installation, observe the following instructions. These enable electrical and magnetic interference fields to be limited to the required levels. The necessary measures work only in combination and should be taken into consideration at the engineering stage. To subsequently modify an installation to meet EMC requirements is possible only at considerable additional cost.

Measures for EMC-compliant installation are:

- Earthing measures,
- Shielding measures,
- Filtering measures,
- Chokes

They are described in more detail below.

Earthing measures

These must be implemented to comply with the legal standards and are a prerequisite for the effective use of further measures such as filters and shielding. All conducting metallic enclosure sections must be electrically connected to the earth potential. For EMC compliance, the important factor is not the cable's cross-section, but its surface, since this is where high frequency current flows to earth. All earth points must have a low impedance, be highly conductive and routed directly to the central earth point (potential equalization bar or star earth). The contact points must be free from paint and rust. Use galvanized mounting plates and materials.

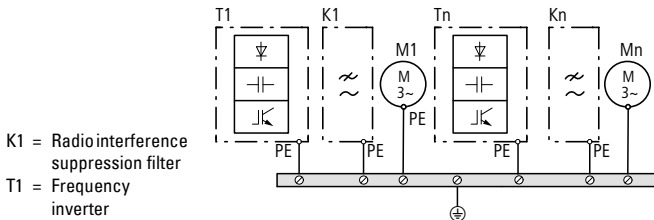

Electronic motor starters and drives

Frequency inverter basic information

Shielding measures

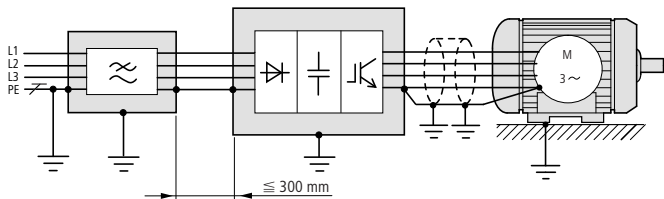

2

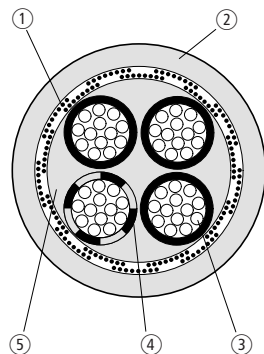
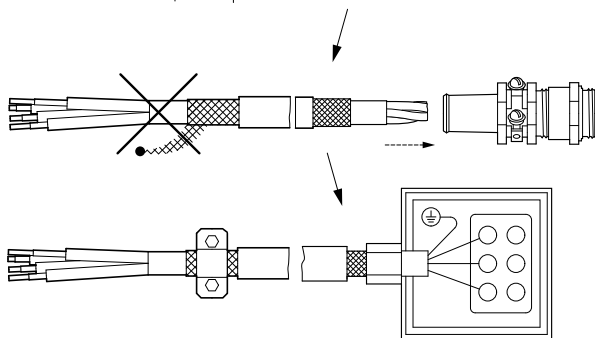

Four-core shielded motor supply cable:

- ① Copper shield braid, earth at both ends with large-area connections
- ② PVC outer casing
- ③ Drain wire (copper, U, V, W, PE)
- ④ PVC core insulation, 3 x black, 1 x green–yellow
- ⑤ Textile and PVC fillers

Electronic motor starters and drives

Frequency inverter basic information

2

Shielding reduces emitted interference (noise immunity of neighboring systems and devices against external influences). Cables between frequency inverters and motor must be shielded. However, the shield must not be considered a replacement for the PE cable. Four-wire motor cables are recommended (three phases plus PE). The shield must be connected to earth (PES) at both ends with a large-area connection. Do not connect the shield with pigtailed. Interruptions in the shield, such as terminals, contactors, chokes, etc., must have a low impedance and be bridged with a large contact area.

To do this, sever the shield near the module and establish a large-area contact with earth potential (PES, shield terminal). Free, unshielded cables should not be longer than about 100 mm.

Example: Shield attachment for maintenance switch

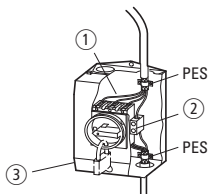

- ① Metal plate (e.g. MSB-I2)
- ② Earthing terminal
- ③ Maintenance switch

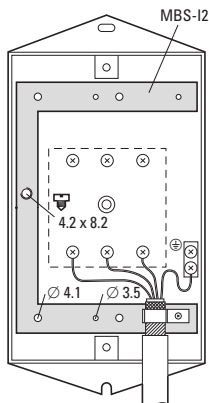

Note

Maintenance switches at of frequency inverter outputs must be operated only at zero current.

Control and signal lines must be twisted and may be double-shielded, the inner shield being connected to the voltage source at one end and the outer shield at both ends.

Electronic motor starters and drives

Frequency inverter basic information

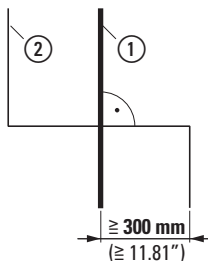

The motor cable must be laid separately from the control and signal lines (> 30 cm) and must not run parallel to any power cables.

Note

Inside control panels also cables should be shielded if they are more than 30 cm long.

2

- ① Power cables: network, motor, DC link circuit, braking resistor
- ② Signal cables: analog and digital control signals

Example of shielding control and signal cables:

Standard connection of a frequency inverter with setpoint potentiometer R11 (M22-4K7), control signals for clockwise and anticlockwise rotation (FWD, REV) and ZB4-102-KS1 mounting accessory

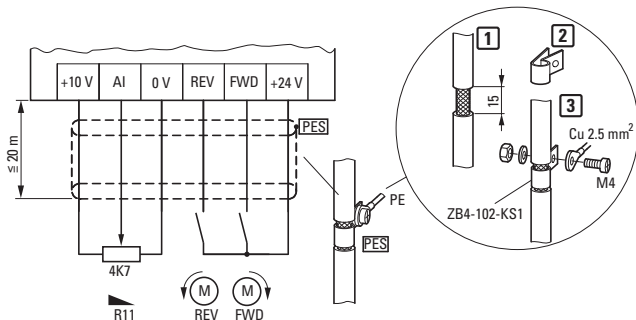

Electronic motor starters and drives

Frequency inverter basic information

2

Filtering measures

Radio interference filters and line filters (combinations of radio interference filter and mains choke) protect against conducted high-frequency interference (noise immunity) and reduce the frequency inverter's high-frequency interference which is transmitted through or emitted from the mains cable, and which must be limited to a prescribed and legal level (emitted interference).

Nowadays, filters are frequently integrated in the frequency inverter or should be installed in close proximity of the frequency inverter. When using externally installed RFI filters, the connection cable between the frequency inverter and filter must be kept short (≤ 30 cm).

Note

The mounting surfaces of frequency inverters and radio interference filters must be free from paint and must have good HF conductivity.

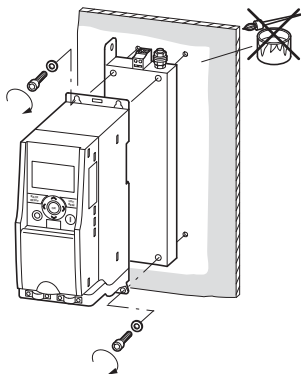

Electronic motor starters and drives

Frequency inverter basic information

EMC-compliant mounting and connection

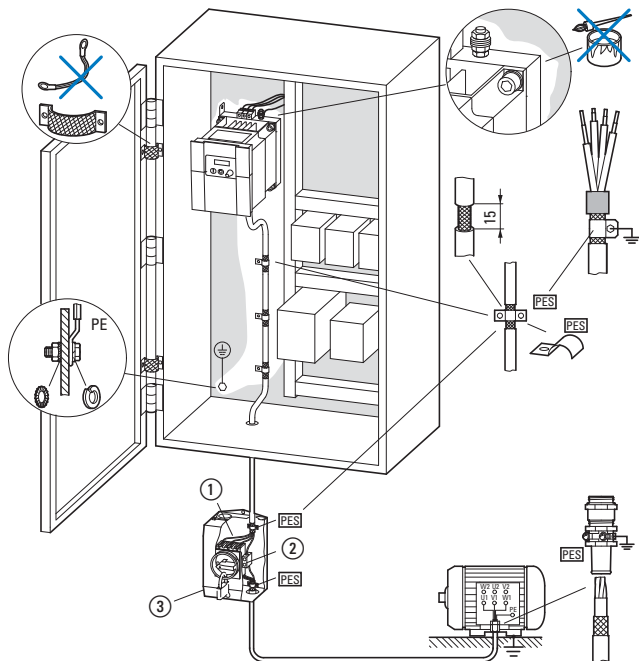

- ① Metal plate with PE connection
- ② Earthing terminal (connection of PE conductor and earthing of the plate ①)
- ③ Maintenance switch

Electronic motor starters and drives

Frequency inverter basic information

2

Residual-current device (RCD)

Radio interference filters produce leakage currents which, in the event of a fault (phase failure, load unbalance), can be considerably larger than the rated values.

To prevent dangerous voltages, all components (frequency inverter, RFI filter, motor, shielded motor cables) in the PDS must be earthed. As the leakage currents are high-frequency interference sources, the earthing connections and cables must have a low impedance and large contact surfaces.

The residual current device on the frequency inverter must be of type B as sinusoidal AC and pulsed DC residual currents may occur.

With leakage currents ≥ 3.5 mA, EN 60335 states that one of the following conditions must be fulfilled:

- The protective conductor must have a cross-section ≥ 10 mm²,
- The protective conductor must be open-circuit monitored, or
- An additional protective conductor must be fitted.

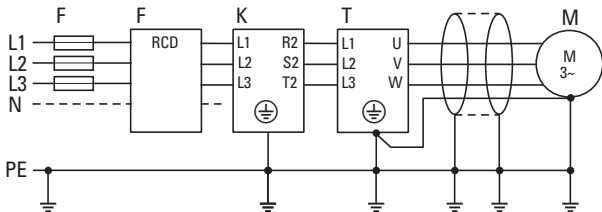

Electronic motor starters and drives

Frequency inverter basic information

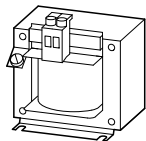

Single-phase chokes

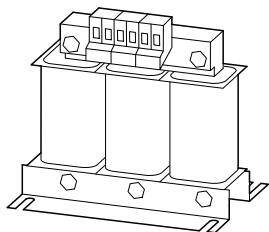

Three-phase chokes

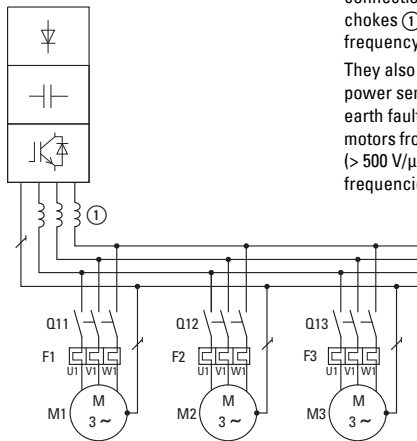

Mains chokes

Fitted on the frequency inverter's input side, chokes reduce the current-dependent mains feedback and improve the power factor. This reduces the current harmonics and improves the mains quality. The use of mains chokes is especially recommended when several frequency inverters are connected to a single mains supply point and when other electronic devices are also connected on the network.

A reduction of the mains current interference is also achieved by installing DC chokes in the frequency inverter's DC link. This eliminates the need for mains chokes.

Motor chokes

With long motor cables or the parallel connection of several motors, motor chokes ① are used at the output of the frequency inverter.

They also enhance the protection of the power semiconductors in the event of an earth fault or short-circuit, and protect the motors from excessive rates of voltage rise ($> 500 \text{ V}/\mu\text{s}$) resulting from high pulse frequencies.

Electronic motor starters and drives

Frequency inverter basic information

Sinusoidal filter

2

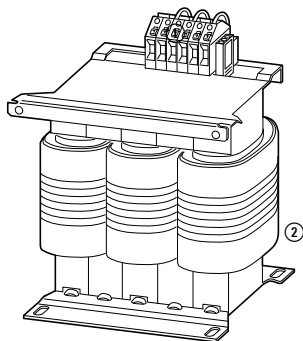

SFB400/...

Sinusoidal filters are a combination of choke and capacitor (low pass filter).

They improve the sinusoidal shape of the frequency inverter output voltage, thus reducing the noise and the temperature rise of the motor.

Advantages of the sinusoidal filter:

- Long shielded motor supply cables possible
 - max. 400 m on supply voltages up to 240 V +10 %
 - max. 200 m on supply voltages up to 480 V +10 %
- Extended lifespan – like that of a mains-operated motor
- Low noise generation of the motor
- Low motor temperature rise
- Reduced du/dt values (< 500 V/μs)

Disadvantages of a sinusoidal filter:

- Up to 30 V voltage drop
- Operation only with fixed pulse frequency possible

Electronic motor starters and drives

Connection example for M-Max™

M-Max™ product features

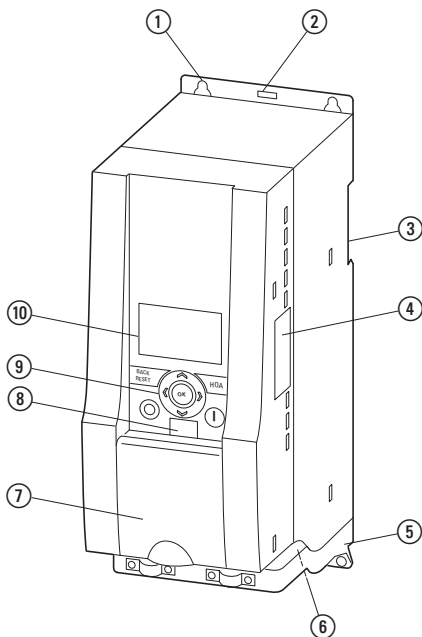

Designations on M-Max™

- | | |
|---|---|
| ① Fixing holes
(screw fastening) | ⑥ Power section terminals |
| ② Release (dismantling from mounting
rail) | ⑦ Cover flap of control signal terminals
and microswitches |
| ③ Cutout for mounting on mounting rail
(DIN EN 50022-35) | ⑧ Interface for PC connection module
MMX-COM-PC (Option) |
| ④ Interface for fieldbus connection
modules (optional, MMX-NET-XA) | ⑨ Keypad with 9 control buttons |
| ⑤ EMC installation accessories | ⑩ Display unit (LCD) |

Electronic motor starters and drives

Connection example for M-Max™

Functions

A comprehensive range of protection functions allow safe operation and the protection of frequency inverter, motor and application. They offer protection against:

- Overcurrent, earth fault
- Overload (electronic motor protection)
- Overtemperature
- Overvoltage, undervoltage

Further functions:

- Restart inhibit
- U/f control or sensorless vector control
- 2-fold starting current and 1.5 fold overcurrent
- PID controller
- Sequence control
- Braking control (DC braking)
- 8 fixed frequencies
- Electronic motor potentiometer
- Logic function (AND, OR, XOR)
- Upper and lower frequency and current limits
- Frequency hopping (frequency masking)
- DC braking before start and up to motor standstill
- 2 parameter sets

Documentation

Manual: MN04020001Z-EN

Instructional leaflet: IL04020001E

Electronic motor starters and drives

Connection example for M-Max™

M-Max™ sizes

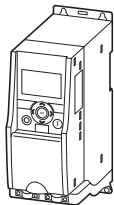

Size 1 (FS1)

MMX12...: 1.7 - 2.8 A

MMX32...: 1.7 - 2.8 A

MMX34...: 1.4 - 2.4 A

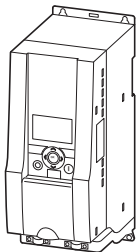

Size 2 (FS2)

MMX12...: 3.7 - 7 A

MMX32...: 3.7 - 7 A

MMX34...: 3.3 - 5.6 A

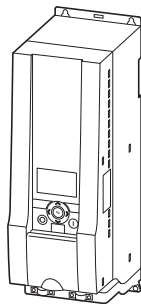

Size 3 (FS3)

MMX12...: 9.6 A

MMX32...: 9.6 A

MMX34...: 7.6 - 14 A

FS = Frame Size

MMX12...: Single-phase mains connection, rated operating voltage MMX230 V

MMX32...: Three-phase power supply, rated operating voltage 230 V

MMX34...: Three-phase power supply, rated operating voltage 400 V

Electronic motor starters and drives

Connection example for M-Max™

2

Application

M-Max™ frequency inverters allow the continuously variable speed control of three-phase asynchronous motors. They are especially suitable for applications where simple operation and profitability are important.

The characteristics-controlled voltage/frequency (U/f) control already allows a wide range of applications even with the default settings: from simple pump and fan drives, standard packaging applications right through to the operation of multiple motors in horizontal transportation and conveying. With sensorless vector control, an individual drive can also be used in demanding applications, in which a high torque and concentricity in the lower speed range are vital, for example in the plastics and metal industries, the textile, paper and printing industries or in crane and elevator systems.

Rated operating currents from 1.4 to 14 A allow the operation of standard 4 pole asynchronous motors in an assigned performance range of :

- 0.25 to 2.2 kW at 230 V (single-phase mains connection),
- 0.25 to 2.2 kW at 230 V (three-phase mains connection),
- 0.37 to 5.5 kW at 400 V (three-phase mains connection).

Instructions

- For UL®-compliant installation and operation, the mains side switching devices must allow for a 1.25 times higher input current.
- Mains contactors shown here take into account the rated operating current I_{LN} of the frequency inverter at the input without a mains choke. Their selection is based on the thermal current (AC-1).
- With frequency inverters, the inching range is not permitted via the mains contactor (pause time ≥ 60 s between switching off and on).

Electronic motor starters and drives

Connection example for M-Max™

Block diagram for MMX12...

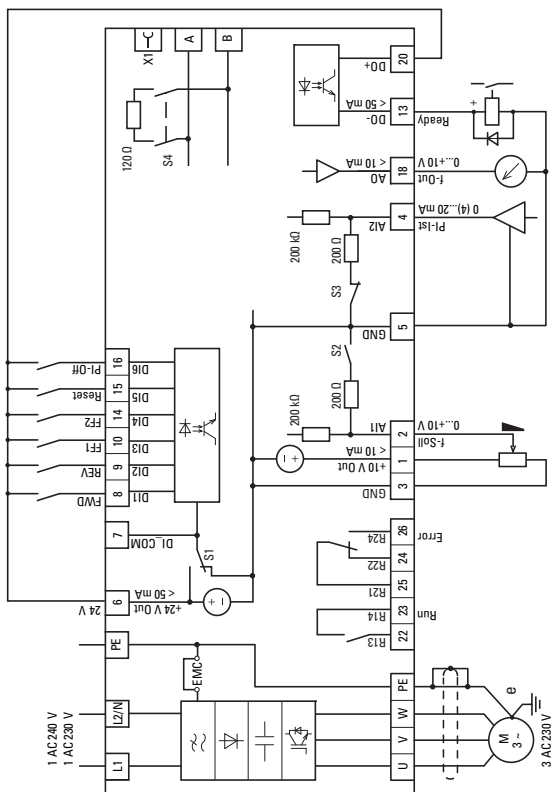

Electronic motor starters and drives

Connection example for M-Max™

Block diagram for MMX32... and MMX34 ...

2

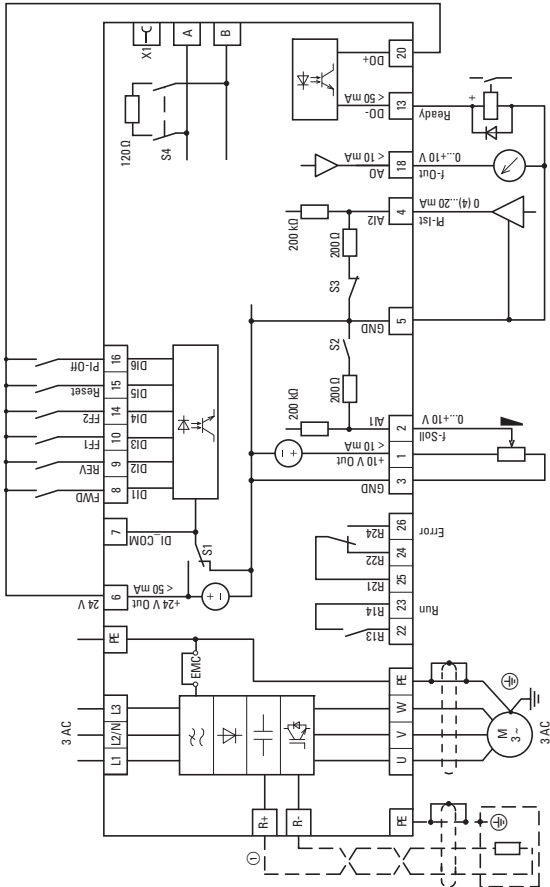

Electronic motor starters and drives

Connection example for M-Max™

Configuration of the control signal terminals

The control signal terminals are factory set as follows:

- 2: AI1: f-Set = Frequency setpoint
(0 - +10V)
- 4: AI2: PI-Act = Actual value for PID controller (process variable, 4 - 20 mA)
- 8: DI1: FWD = Clockwise rotation field enable (Forward)
- 9: DI2: REV = Anticlockwise rotation field enable (Reverse)
- 10: DI3: FF1 = Fixed frequency 1
- 13: DO-: Ready = Ready to start (transistor output with the voltage of terminal 20)
- 14: DI4: FF2 = Fixed frequency 2
- 15: DI5: Reset = Acknowledge fault message
- 16: DI6: PI-Off = PID controller deactivated
- 18: AO: f-Out = Output frequency to motor (0 - +10 V)
- 20: DO+: Input voltage for transistor output (+24 V DC)
- 22/23: R13/R14 (NO contact):
RUN = Operating signal (relay)
- 24/25/26: R21/R22/R24
(changeover contact):
Error = Fault signal (relay)

- ① Connection terminals R+ and R- for external braking resistor (optional) – for size 2 (FS2) and size 3 (FS3)

Electronic motor starters and drives

Connection example for M-Max™

Basic control

2

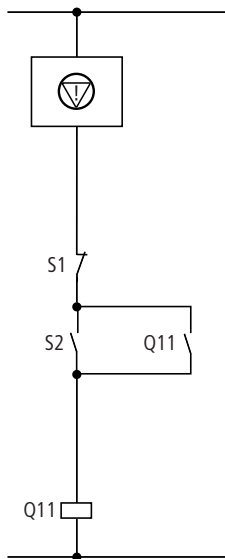

Example 1

Reference input through potentiometer R11. Enable (START/STOP) and direction control through terminals 1 and 2 with internal control voltage

- ⊖ Emergency switching off circuit
- F1: Cable protection
- PES: Cable shield PE connection
- Q11: Mains contactor
- M1: 230 V 3-phase motor
- S1: OFF
- S2: ON

Notes

- For EMC-compliant mains connection, suitable radio interference suppression measures must be implemented according to product standard IEC/EN 61800-3.
- With frequency inverters with a single-phase mains connection, the use of parallel links is recommended for equalizing the load on the contacts.

DILM12-XP1

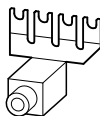

(4th pole can be broken off)

DILM

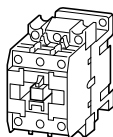

Electronic motor starters and drives

Connection example for M-Max™

Wiring (MMX12...)

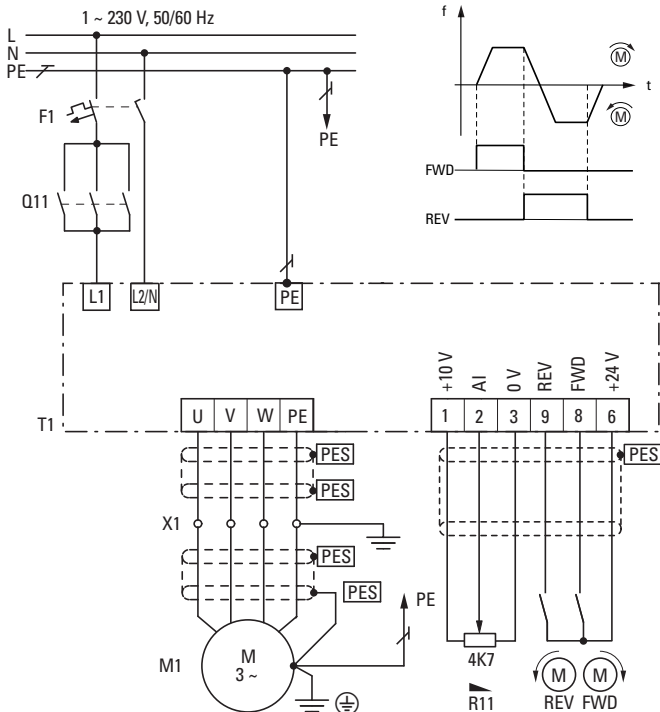

2

- MMX12... Single-phase frequency inverter
- Directional control through terminals 8 and 9
- External reference value input via R11

FWD: Clockwise rotation field enable
 REV: Anticlockwise rotation field enable

Electronic motor starters and drives

Connection example for M-Max™

Frequency inverters MMX34... with external RFI filter

Note

Only for MMX...N0-0 (without internal RFI filter)

2

Actuation

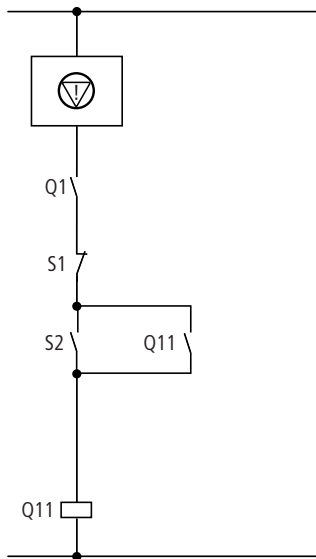

Example 2

Setpoint entry via potentiometer R11 (f_s) and fixed frequency (f_1, f_2, f_3) via terminal 10 and 14 with internal control voltage Enable (START/STOP) and rotation direction selection via terminal 8 (FWD)

- ⊕ Emergency switching off circuit
- FF1: Fixed frequency f_1
- FF2: Fixed frequency f_2
- FF1+ FF2: Fixed frequency f_3
- FWD: Enable clockwise rotation field, analog setpoint value frequency f_s
- K1: Radio interference suppression filter MMX-LZ...
- M1: 400 V 3-phase motor
- PES: Cable screen PE connection
- Q1: Cable protection
- Q11: Mains contactor
- R1: Main choke
- S1: OFF
- S2: ON

Electronic motor starters and drives

Connection example for M-Max™

Wiring (MMX34...)

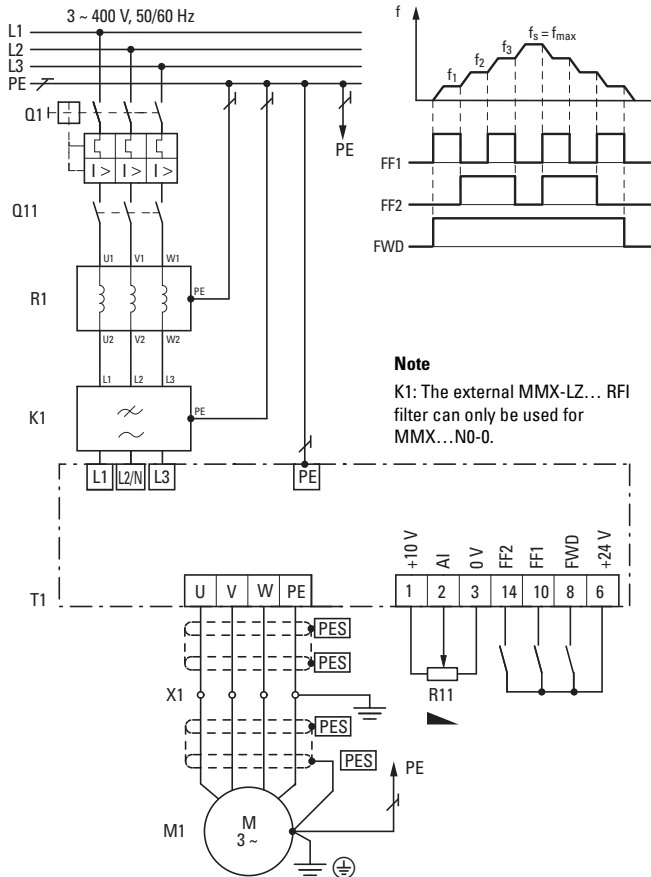

2

Electronic motor starters and drives

Connection example for M-Max™

Terminal Models

Version A:

Motor in delta circuit (MMX12...)

The 0.75 kW motor described below can be delta-connected to a single-phase 230 V

mains (version A) or star-connected to a 3-phase 400 V mains.

Motor: P = 0.75 kW

Mains: 1/N/PE 230 V 50/60 Hz

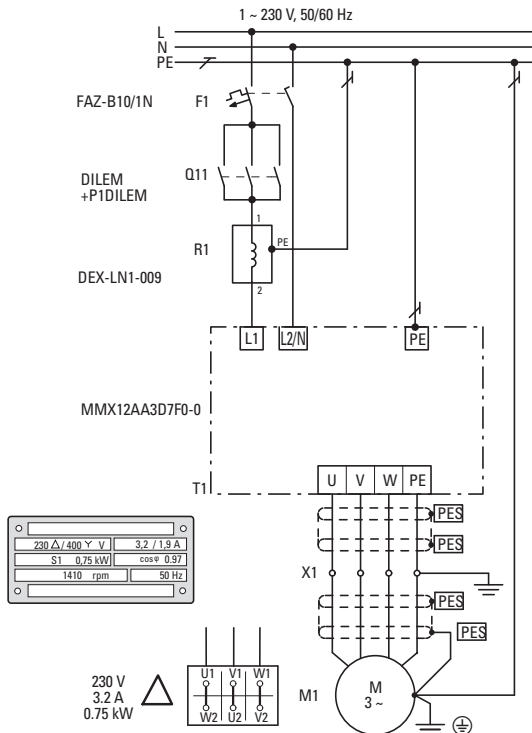

Electronic motor starters and drives

Connection example for M-Max™

Version B:

Motor in star circuit (MMX 34...)

Motor: P = 0.75 kW

Mains: 3/PE 400 V 50/60 Hz

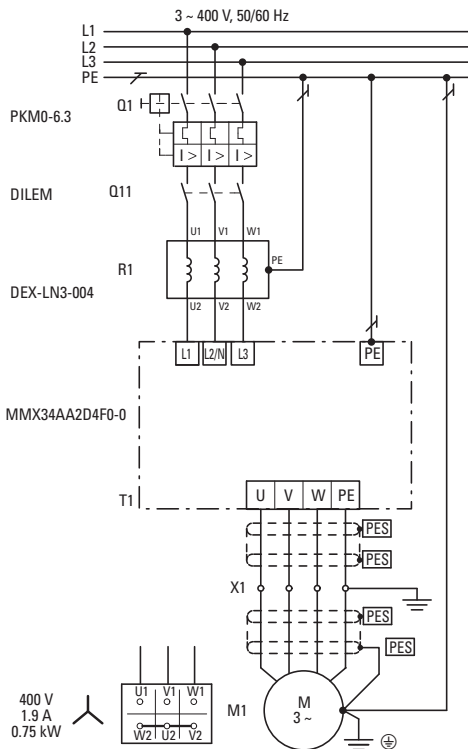

Electronic motor starters and drives

Rapid Link System 4.0

System overview of Rapid Link RA 4.0 modules

Rapid Link is a remote switching and installation system.

Thanks to its compact design and its high degree of protection to IP65 these motor starters can be installed in the direct vicinity of the motor.

Pluggable connection cables with standard terminals reduce the wiring requirement and provide the preferred installation technology for conveying system.

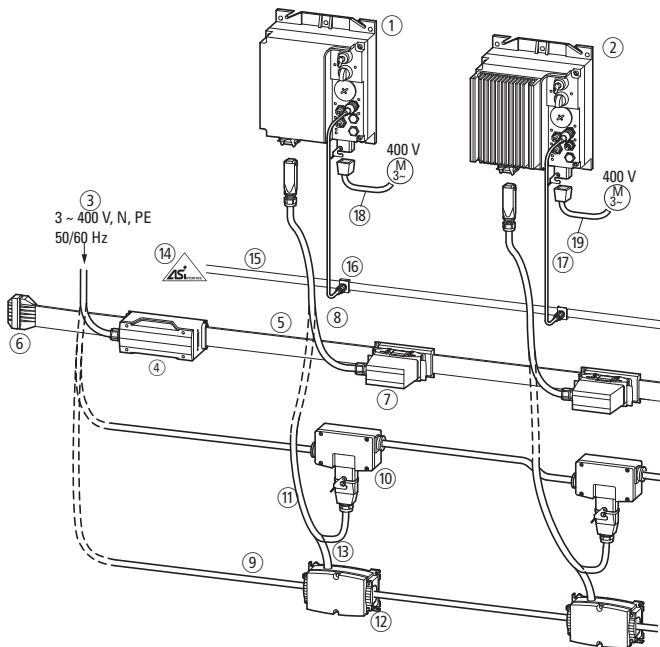

Electronic motor starters and drives

Rapid Link System 4.0

Function modules:

- ① RAMO motor starter (Motor Control Unit) → three-phase, electronic DOL starter or reversing starter, with electronic motor protection for the assigned ratings of 90 W to 3 kW (at 400 V).
- ② RASP speed control unit → three-phase, frequency controlled motor starter (fixed speeds, two rotation directions, soft starting), in four ratings (2.4 A/3.3 A/4.3 A/ 5.6 A) with electronic motor protection for assigned ratings from 0.18 kW to 2.2 kW (at 400 V).

Power bus:

- ③ Incoming supply (3 AC 400 V) via circuit-breaker for overload and short-circuit protection
 - ④ Incoming supply for ribbon cable
 - ⑤ Ribbon cable für 400 V AC
 - ⑥ End-piece for flat cable
 - ⑦ Flexible busbar junction
 - ⑧ Power adapter cable to flexible busbar junction
 - ⑨ Round cable for 400 V AC
 - ⑩ Plug-in link for round cable
 - ⑪ Power adapter cable to round cable junction
 - ⑫ Link for round cable
 - ⑬ Power adapter cable (round cable) to power box
 - ⑭ AS-Interface® – Supply via main cable
- Data bus:
- ⑮ AS-Interface® ribbon cable
 - ⑯ Link for M12 connector cables
 - ⑰ Extension M12

Motor connection:

- ⑱ Unshielded motor cable
- ⑲ Shielded motor cable (EMC)

Product features

The system is installed with a power bus and data bus that are plugged into all modules of the Rapid Link system.

Customer and sector-specific requirements for material handling applications are the main focus of system design.

Rapid Link version 4.0 provides modules with the following features:

- Degree of protection IP65
- Ambient temperature during operation from -10 °C to +55 °C
- Max. cable length 10 m
- AS-Interface® Profi 7.4 for communication and diagnostics
- Pluggable terminal design to ISO 23570
- Local operation/hand operation
- Maintenance and manual override switches (optional)
- RAMO-D electronic DOL starter
- RAMO-W electronic reversing starter
- RASP frequency controlled speed control

Documentation

Manual: MN03406003Z-EN

Installation instructions:

IL003406019Z

IL003406020Z

Electronic motor starters and drives

Rapid Link System 4.0

Block diagram RAMO-D...

Electronic DOL starter

2

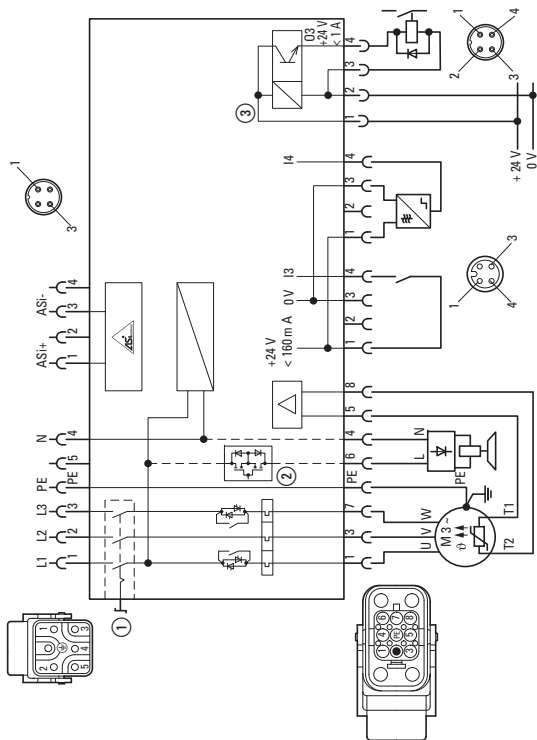

Optional variant:

- ① Repair switch
- ② Actuation of external brake (230 V)
- ③ Actuator output

Electronic motor starters and drives

Rapid Link System 4.0

Block diagram RAMO-W...

Electronic reversing starter

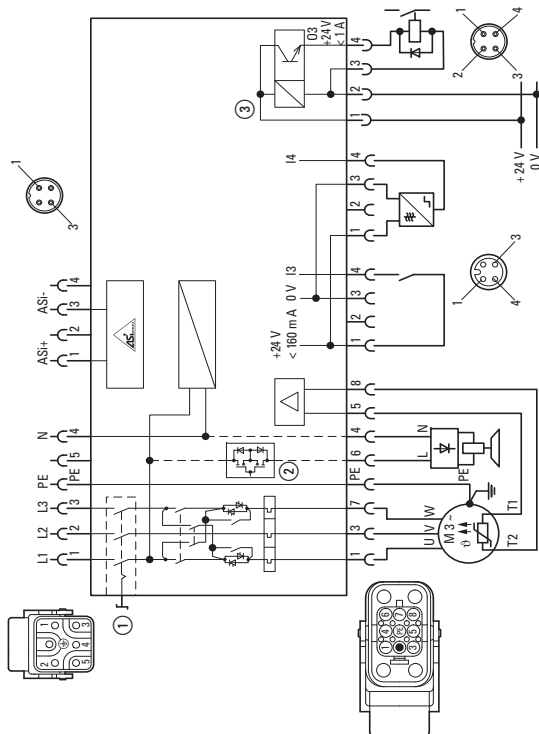

Optional variant:

- ① Repair switch
- ② Actuation of external brake (230 V)
- ③ Actuator output

Electronic motor starters and drives

Rapid Link System 4.0

Block diagram RASP-...

Frequency inverter

2

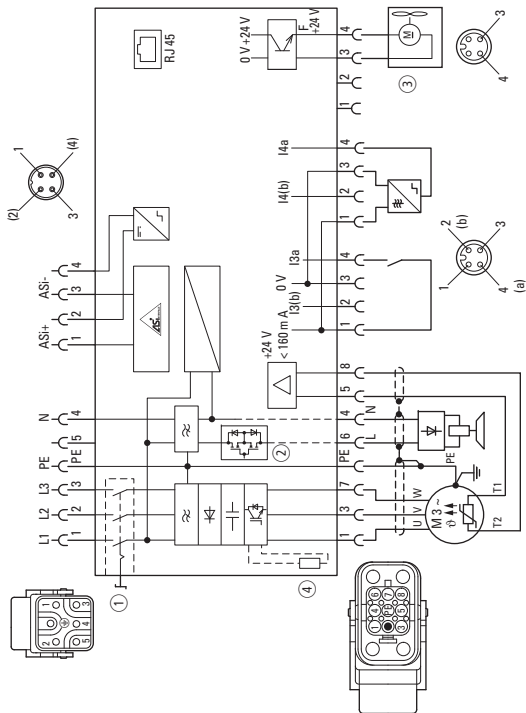

Optional variant:

- ① Repair switch
- ② Actuation of external brake (230 V)
- ③ Device fans
- ④ Internal braking resistor

Pilot devices

	Page
RMQ – System	3-2
RMQ – Engineering	3-9
RMQ – Inscription	3-13
Signal Towers SL	3-14
LS-Titan® position switches	3-16
LSE-Titan® electronic position switches	3-26
Analog electronic position switches	3-27
Sensors – Functionality	3-30
Sensors – Applications	3-37

Pilot devices

RMQ – System

3

Commands and signals are the fundamental functions for controlling machines and processes. The required control signals are produced either manually by pilot devices or mechanically by position switches. The respective application governs the protection type, the shape and color.

Advanced technology has been used consistently in control circuit devices „RMQ-Titan®“. The use of LED elements and laser inscription throughout offer maximum reliability, efficiency and flexibility. In detail, this means:

- High-quality optics for a uniform appearance,
- Highest degree of protection up to IP67 and IP69K (suitable for steam-jet cleaning),
- Clear contrast using LED element lighting, even in daylight,
- Up to 100,000 h, i.e. machine lifespan,
- Impact and vibration resistant,
- LED operating voltage from 12 to 500 V,
- Low power consumption – only 1/6 of filament lamps,
- Expanded operating temperature range -25 to +70 °C,
- Light testing circuit,
- Built-in safety circuits for highest operational reliability and accessibility,
- wear-resistant and clearly contrasting laser inscription,
- Customer-specific symbols and inscriptions from 1 off,
- Text and symbols can be freely combined,
- Terminal type using screws and Cage Clamp¹⁾ throughout,

- Spring-loaded Cage Clamp connections for reliable and maintenance free contact,
- Switching contacts suitable for use with electronic devices to EN 61131-2: 5 V/1 mA,
- user-programmable switching performance on all selector switch actuators: momentary/maintained
- All actuators in illuminated and non-illuminated version,
- Emergency switching off pushbuttons with pull and turn-to-release function,
- Emergency switching off pushbuttons with lighting option for active safety,
- Contacts switch differing potentials,
- For use also in safety-related circuits using positive operation and positive opening contacts,
- Complying with industry Standard IEC/EN60947.

¹⁾ Cage Clamp is a registered trade mark of Messrs. WAGO Kontakttechnik GmbH, Minden

RMQ16 system overview

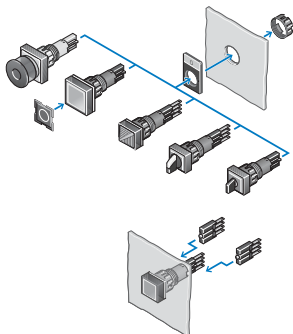

Pilot devices

RMQ – System

RMQ-Titan® system overview

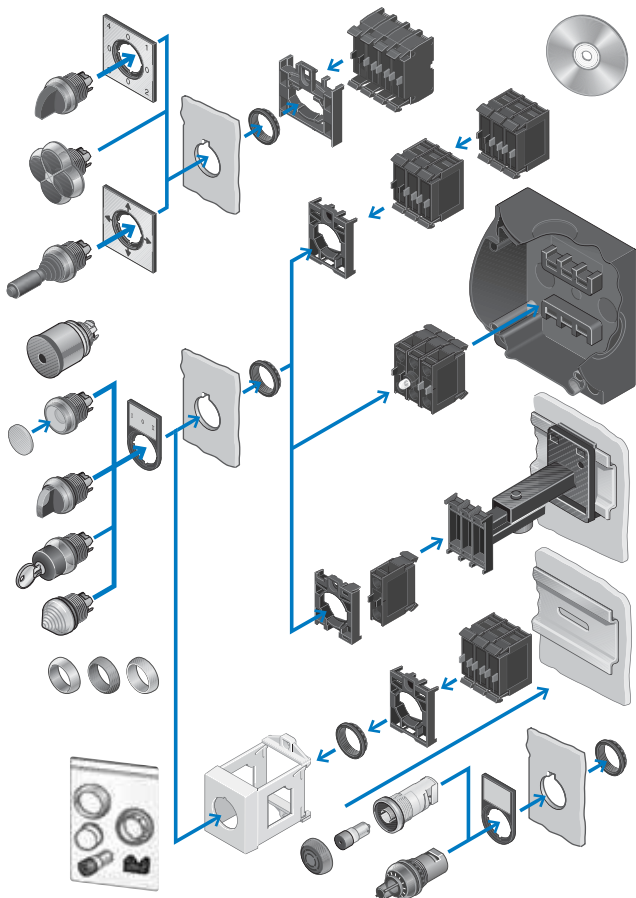

Pilot devices

RMQ – System

3

Four-way pushbutton

Eaton has added more operator elements to its highly successful range of pilot devices RMQ-Titan. It has a modular surface mounting. Contact elements from the RMQ-Titan range are used. The bezels and front frames are of the familiar RMQ-Titan format and color.

Four-way pushbutton

The four-way pushbuttons enable users to control machines and systems in four directions of movement. Each direction of movement is being assigned one contact element. The pushbutton has four individual button plates. They can be specifically selected for various applications and can be laser-inscribed to suit the customer's requirements.



Joystick with double contact

The joystick allows the control of up to four directions of movement on machines. Different variants of the joystick have 2/4 positions and other variants have 2 settings for each position. This allows for example two speed settings for each direction. For this a standard NO and an NO early-make are fitted in series. Momentary contact and latching contact versions are possible.

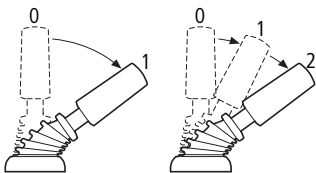

Selector switch actuators

The selector switch actuators have four positions. The actuator is available either as a rotary head or as a thumb-grip. One contact element is assigned to each On and each Off position.

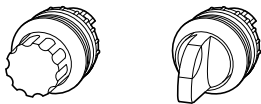

Pilot devices

RMQ – System

Labels

Eaton offers various types of labels for all operating elements. Versions available are:

- Blank,
- With direction arrows,
- With inscription 0–1–0–2–0–3–0–4.

Customised inscriptions are also possible. The software Labeleditor enables

customized inscriptions to be designed and these can be subsequently applied to the labels by laser, permanently and proof against wiping off. → Section "Labeleditor", page 3-13



3

Contact versions

Screw terminals	Spring-loaded terminals	Front fixing	Base fixing	Contact	Contact travel diagram ¹⁾
Contact elements					
x	x	x	x		 0 2.8 5.5 M22-(C)K(C)10
x	x	x	–		 0 1.2 5.5 M22-(C)K(C)01
x	x	x	x		 0 3.5 5.5 M22-(C)K01D ²⁾
x	–	x	–		 0 1.8 5.5 M22-K10P

1) Stroke in connection with front element.

2) N/C: Positive opening safety function according to IEC/EN 60947-5-1.

Pilot devices

RMQ – System

3

Screw terminals	Spring-loaded terminals	Front fixing	Base fixing	Contact	Contact travel diagram ¹⁾
Double contact elements					
–	x	x	–		
–	x	x	–		
–	x	x	–		
Self-monitoring contact elements					
x	–	x	x		
x	–	x	x		

1) Stroke in connection with front element.

2) N/C: Positive opening safety function according to IEC/EN 60947-5-1.

Pilot devices

RMQ – System

Emergency-stop/off pushbuttons, system overview

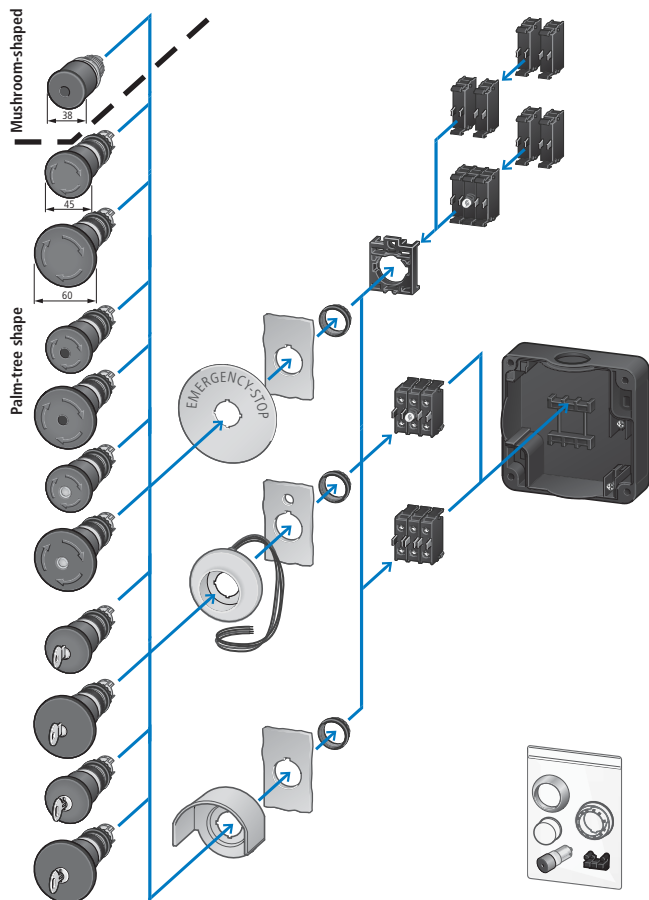

3

Pilot devices

RMQ – System

3

The new emergency stop or emergency-off pushbutton actuators for the RMQ-Titan range of pilot devices for global use have a palm shaped design with a 45 or 60 mm diameter. They are available with or without keys, turn-releasable, non-illuminated, illuminated with standard LEDs or with mechanical switch position indication (green/red) in the center of the actuator element. The self-monitoring contact elements ensure extensive operational safety; even with a faulty installation or after excessive force is used for actuation. As well as the emergency-off NC contact, the modular contact elements feature an integrated second contact for querying the mechanical connection to the emergency stop actuator element. The contact elements are available for front or bottom fixing, for single or dual-channel safety circuits up to SIL 3 in accordance with IEC 62061 or Performance Level PL e to EN ISO 13849-1.

An optional illuminated ring enables emergency-stop/off pushbutton actuators on a machine or a plant to be made more conspicuous. Even in darkened environments, the position of these pushbutton actuators is clearly indicated. The illuminated ring also clearly indicates the operating state from a considerable distance. When tripped, for example, it is possible to activate three separately controllable LED rows as a running light.

Pilot devices

RMQ – Engineering

Assembly and function

M22...SMC10

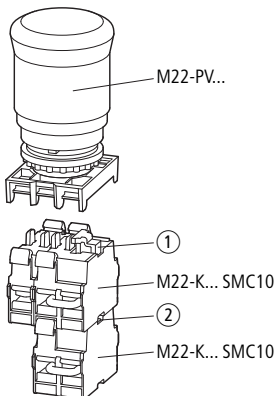
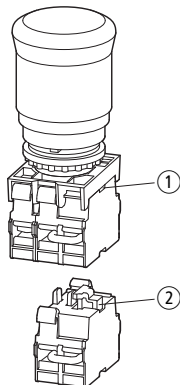

- ① The self-monitoring contact mechanically monitors the connection on the M22-PV...
- ② The self-monitoring contact mechanically monitors the interface on the M22-K...SMC10 safety contact above it; but NOT the connection on the M22-PV...

M22-K01SMC10 M22-KC01SMC10



M22-K02SMC10 M22-KC02SMC10



When the self-monitoring contact is mounted correctly, the N/O contact is closed.

The emergency switching off/Stop circuit is activated via series connection of N/C and N/Os if

- the emergency switching off/stop pushbutton is actuated or
- the self-monitoring contact is isolated mechanically from the pushbutton

Pilot devices

RMQ – Engineering

Terminal markings and function numbers (distinctive number/contact sequence), EN 50013

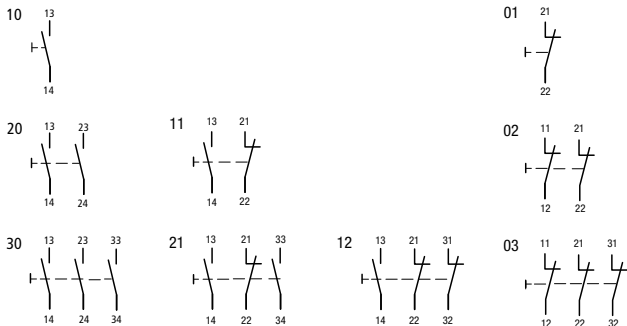

Voltage variants with series elements

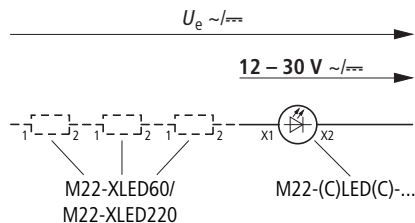

M22-XLED60 ¹⁾	$U_e \leq \text{AC/DC}$
1x	60 V
2x	90 V
3x	120 V
...	...
7x	240 V
M22-XLED220	$U_e \leq$
1 x	220 V DC

1) For increasing the voltage AC/DC.

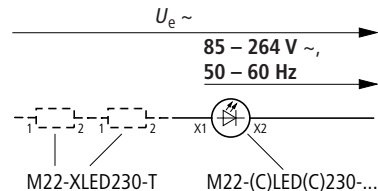

M22-XLED230-T ¹⁾	$U_e \leq$
1x	400 V~
2x	500 V~

1) AC~ for increasing the voltage 50/60 Hz.

Pilot devices

RMQ – Engineering

Connection for light test

The test button is used to check operation of the indicator lights independently of the respective control state. Decoupling elements prevent voltage feedback.

M22-XLED-T

for $U_e = 12$ to 240 V AC/DC (also for light test with signal towers SL)

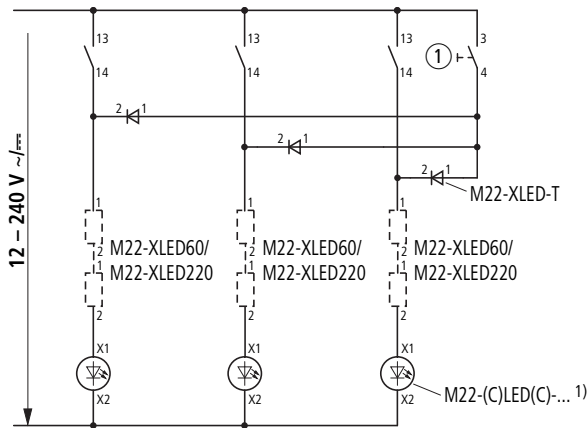

① Test button

1) Only for elements 12 to 30 V.

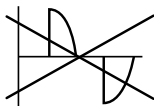
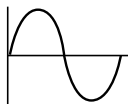
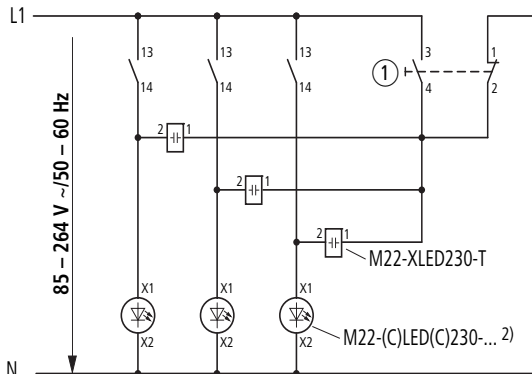
Pilot devices**RMQ – Engineering****M22-XLED230-T**for $U_e = 85$ to 264 V AC/50 – 60 Hz**3**

Pilot devices

RMQ – Inscription

Labeleditor



Customized inscription of devices using the Labeleditor software

You can label your device to your individual requirements in four simple steps:

- Download the inscription software: www.eaton.com/moeller/support
keyword: "Labeleditor"
- Creation of label template (menu-guided in the software)
- Send the label template to the factory by email. The email address is automatically set for the selected product by the program. When your template is sent, the Labeleditor issues a file name such as "RMQ_Silver_12345.zip". This file name is part of the article to be ordered (see Ordering examples).
- Send order to the Eaton sales office or the electrical engineering wholesaling.

Ordering examples

- M22-XST insert label for M22S-ST-X legend label mount with special inscription

Basic type: M22-XST-*

* = File name generated by Labeleditor

Please order:

1 x M22-XST-RMQ_Titan_xxxxxx.zip

- Button plate in green with special inscription

Basic type: M22-XDH-*

1. * = Colour (here „G“ for green),

2.* = File name generated by Labeleditor

Please order:

1 x M22-XDH-G-RMQ_Titan_xxxxx.zip

- Double actuator pushbutton with white pushbutton plates and special symbols
- Basic type: M22-DDL-*.*.*

1. * = Colour (here „W“ for white),

2. and 3. * = File name assigned by Labeleditor; must be stated here 2 x

Please order:

1 x M22-DDL-W-RMQ_Titan_xx
xxx.zip-RMQ_Titan_xxxxx.zip

- Key-operated button, 2 positions, individual lock mechanism no. MS1, individual symbol

Basic type: M22-WRS*-MS*-*

WRS*: * = Number of positions,

MS*: * = Number of individual lock mechanism,

-.*: * = File name assigned in Labeleditor

Please order:

1 x

M22-WRS2-MS1-RMQ_Titan_xxxxxx.zip

Pilot devices

Signal Towers SL

Signal Towers SL – everything under visual control at all times

Signal towers SL (IP65) indicate machine states using visible and acoustic signals. Mounted on control panels or on machines, they can be reliably recognized as continuous light, flashing light, strobe light or acoustic device even from a distance, and dealt with as necessary.

3

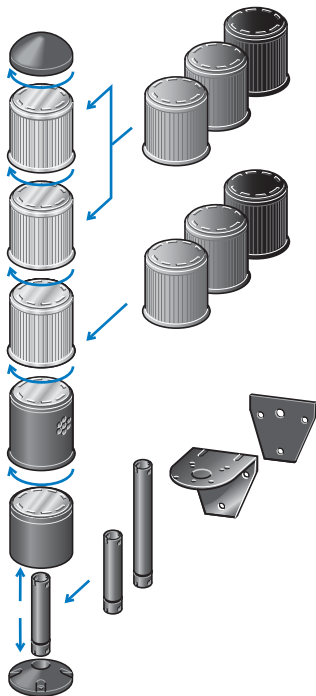

Product features

- Continuous light, flashing light, strobe light and acoustic device can be combined as required.
- Free programmability permits the actuation of five addresses.
- Simple assembly without tools by bayonet fitting.
- Automatic contacting by built-in contact pins.
- Excellent illumination by specially shaped lenses with Fresnel effect.
- Use of filament lamps or LEDs as required.
- A large number of complete devices simplifies selection, ordering and stockkeeping for standard applications.

The various colors of the light elements indicate the operating state in each case to IEC/EN 60204-1 an:

RED:

Dangerous state – Immediate action necessary

YELLOW:

Abnormal status – monitor or -action

GREEN:

Normal status – no action necessary

BLUE:

Discontinuity – action mandatory

WHITE:

Other status – can be used as required.

Pilot devices

Signal Towers SL

Programmability

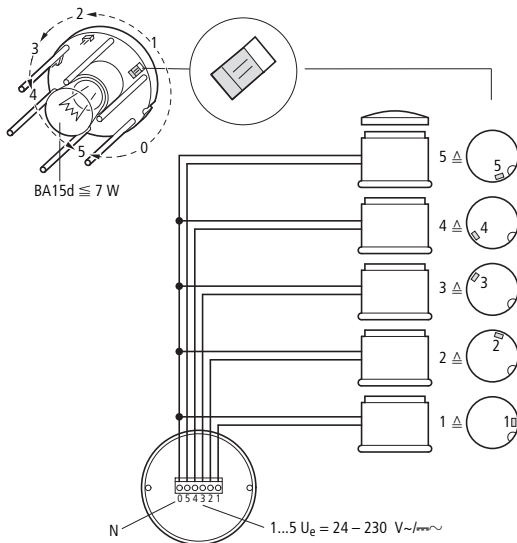

Five signal lines from a terminal strip in the base module run through each module. The module is addressed via a wire link (jumper) on each card. Five different addresses can also be allocated several times.

Thus, for example, a red strobe light and in parallel with it an acoustic device can indicate and announce the dangerous status of a machine. Plug both jumpers into the same position on the pcb – and it's done!

(→ Section "Connection for light test", page 3-11.)

Pilot devices

LS-Titan® position switches

New combinations for your solutions with LS-Titan®

3

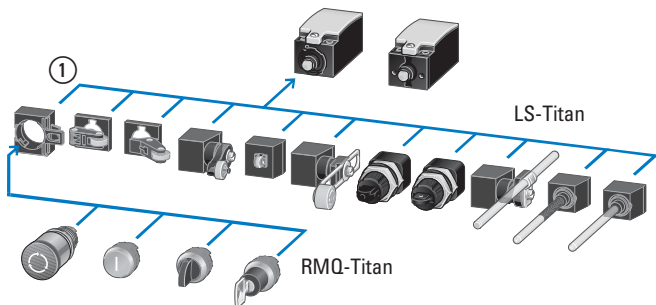

- ① Operating heads in four positions, each turned by 90°, can be fitted subsequently.

Actuating devices RMQ-Titan® simply snap fitting

Another unique feature is the possibility to combine actuators from the RMQ-Titan range with the position switches LS-Titan. Pushbuttons, selector switches or emergency switching off pushbuttons can all be directly snapped on to any position switch as operating head. The complete unit then has at least the high protection type IP66 at front and rear.

In addition, all the operating heads and the adapter for accepting the RMQ-Titan pushbuttons have a bayonet fitting that enables quick and secure fitting. Using the bayonet fitting, the heads can be attached in any of the four directions (4 x 90°).

Pilot devices

LS-Titan® position switches

Overview

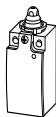

LS, LSM

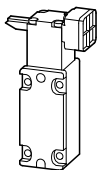

LS4...ZB

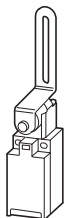

LSR...

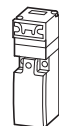
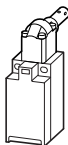

LS...ZB

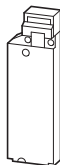

LS...ZBZ

3

Pilot devices

LS-Titan® position switches

3

Safety position switches LS4...ZB, LS...ZB

Eaton safety position switches have been specially designed for monitoring the position of protective guards such as doors, hinged flaps, shrouds and protective guards. They meet the requirements of the employers' liability insurance Association for the testing of positive opening position switches for safety functions (GS-ET-15). These requirements include:

“Position switches for safety functions must be designed so that the safety function cannot be bypassed manually or simple tools.” Simple tools are: pliers, screwdrivers, pins, nails, wire, scissors, penknives etc.

In addition to these requirements, LS...ZB position switches offer additional manipulation safety by means of an operating head which can rotate but cannot be removed.

Positive opening

Mechanically operated position switches in safety circuits must have positive opening contacts (see EN 60947-5-1). Here, the term positive opening is defined as follows: “The execution of a contact separation as the direct result of a predetermined motion of the keypad of the switch via non-spring operated parts (e.g. not dependent on a spring)”.

Positive opening is an opening movement by which it is ensured that the main contacts of a switch have attained the open position at the same time as the keypad assumes the Off position. Eaton position switches all meet these requirements.

Certification

All Eaton safety position switches are certified by the employers' liability insurance Association or by the Technical Monitoring Service (TÜV), Rheinland.



LS4...ZB



LS...ZBZ



LS...ZB



LSR-ZB...

Pilot devices

LS-Titan® position switches

“Personnel protection” by monitoring the protective device

LS...ZB LS4...ZB

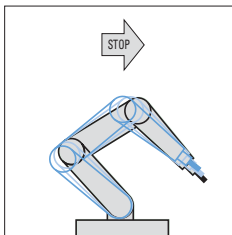
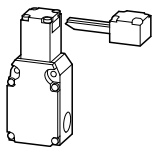
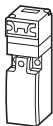

- Door open
- LS...ZB disconnects power
- No danger

3

LS...ZB

closed

Open

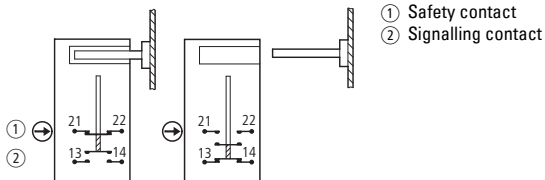

Door closed

→ Safety contact (21 - 22) closed
Signalling contact (13 - 14) open

Door open

→ Safety contact (21 - 22) open
Signalling contact (13 - 14) closed

Pilot devices

LS-Titan® position switches

„Enhanced personnel protection“ with separate signal for door position

LS...ZBZ

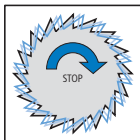

- Stop command
- Waiting time
- Machine is stopped
- Protective mechanism open
- No danger

3

LS...FT-ZBZ, spring-powered interlock (closed-circuit principle)

LS-S02...FT-ZBZ

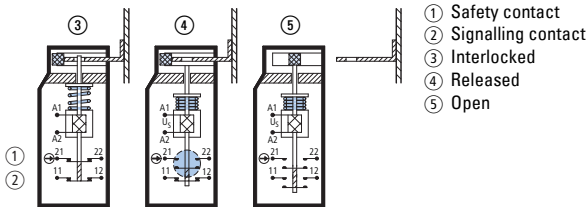

Door closed and interlocked

→ Coil at (A1, A2) de-energized also with mains failure or wire breakage:
Door interlocked = safe state
Safety contact (21 - 22) closed
Signalling contact (11 - 12) closed

Releasing of door

→ Apply voltage to coil (A1, A2)
e.g. via zero-speed monitor
Safety contact (21 - 22) opens
Signalling contact (11-12) remains closed

Door open

→ Only possible once it is released
Signalling contact (11 - 12) opens.

Door open

→ Both contacts in the open position
tamperproof against simple tools

Close door

→ Signalling contact (11 - 12) closes

Lock door

→ Switch off the voltage from coil (A1, A2)
1st actuator interlocked
2nd safety contact (21 - 22) closes

Pilot devices

LS-Titan® position switches

LS-S11-...FT-ZBZ

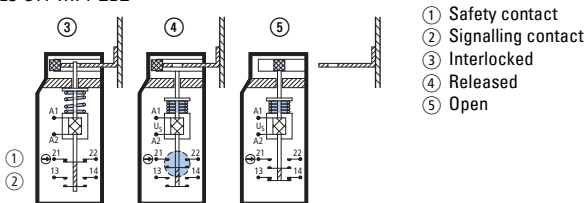

Door closed and interlocked

→ Coil at (A1, A2) de-energized also with mains failure or wire breakage:
 Door interlocked = safe state
 Safety contact (21 - 22) closed
 Signalling contact (13 - 14) open

Releasing of door

→ Apply voltage to coil (A1, A2)
 e.g. via zero-speed monitor
 Safety contact (21 - 22) opens
 Signalling contact (13 - 14) remains open

Door open

→ Only possible once it is released
 Signalling contact (13 - 14) closes.

Door open

→ Safety contact (21 - 22) open
 Signalling contact (13 - 14) closed

Close door

→ Signalling contact (13 - 14) opens

Lock door

→ Switch off the voltage from coil (A1, A2)
 1st actuator interlocked
 2nd safety contact (21 - 22) closes

3

Pilot devices

LS-Titan® position switches

„Process protection and enhanced personnel protection“ with separate signal for door position

LS...ZBZ

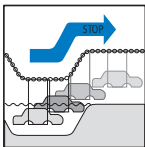

- Stop command
- Waiting time
- Process sequence halted
- Protective mechanism open
- Product OK

3

LS...MT-ZBZ, magnet-powered interlock (open-circuit principle)

LS-S02-...MT-ZBZ

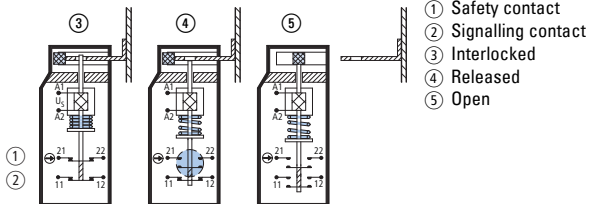

Door closed and interlocked

→ Voltage on coil (A1, A2)
Safety contact (21 - 22) closed
Signalling contact (11 - 12) closed

Releasing of door

→ Coil de-energized (A1, A2)
e.g. via zero-speed monitor,
Safety contact (21 - 22) opens
Signalling contact (11 - 12) remains closed

Door open

→ Only possible once it is released
Signalling contact (11 - 12) opens.

Door open

→ both contacts in the open position, even with tampering with simple tools

Close door

→ Signalling contact (11 - 12) closes

Lock door

→ Apply voltage to coil (A1, A2)
1st actuator interlocked
2nd safety contact (21 - 22) closes

Pilot devices

LS-Titan® position switches

LS-S11-...MT-ZBZ

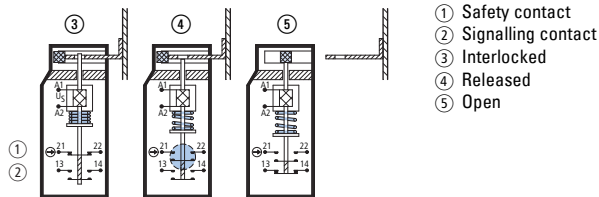

Door closed and interlocked

→ Voltage on coil (A1, A2)
 Safety contact (21 - 22) closed
 Signalling contact (13 - 14) open

Releasing of door

→ Coil de-energized (A1, A2)
 e.g. via zero-speed monitor,
 Safety contact (21 - 22) opens

Door open

→ Only possible once it is released
 Signalling contact (13 - 14) closes.

Door open

→ Safety contact (21 - 22) open
 Signalling contact (13 - 14) closed

Close door

→ Signalling contact (13 - 14) opens

Lock door

→ Apply voltage to coil (A1, A2)
 1st actuator interlocked
 2nd safety contact (21 - 22) closes

Pilot devices

LSR-Titan® position switches

“Personnel protection” by monitoring of the protective mechanism

LSR...I(A)/TKG LSR...I(A)/TS

3

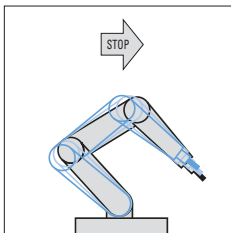
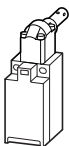
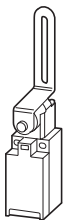

- Hinged protective cover open
- LSR... disconnects power
- No danger

LSR...TKG, LSR...TS

Closed

Open

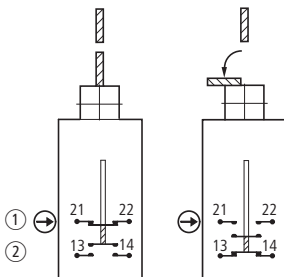

- ① Safety contact
- ② Signalling contact

Hinged protective cover closed

→ Safety contact (21 - 22) closed
Signalling contact (13 - 14) open

Protective flap open

→ Safety contact (21 - 22) open
Signalling contact (13 - 14) closed

Pilot devices

LS-Titan® position switches

	LS, LSM	LS4...ZB	LS...ZB	LS...ZBZ
Standards	<ul style="list-style-type: none"> • IEC 60947-5-1 → EN 50047 • Dimensions • Fixing dimensions • Operating points • Minimum IP65 	<ul style="list-style-type: none"> • IEC 60947-5-1 → EN 50041 • Dimensions • Fixing dimensions • Operating points • IP65 	<ul style="list-style-type: none"> • IEC 60947-5-1 • IP65 	<ul style="list-style-type: none"> • IEC 60947-5-1 • IP65
Suitable applications	<ul style="list-style-type: none"> • Also for use in safety circuits, by positive operation and positive opening contacts 	<ul style="list-style-type: none"> • Safety position switches for protection of personnel • with separate operating element for protective covers • Positive operation and positive opening contacts • Approval of employers' liability insurance Association 	<ul style="list-style-type: none"> • Safety position switches for protection of personnel • with separate operating element for protective covers • Positive operation and positive opening contacts • Approval of employers' liability insurance Association 	<ul style="list-style-type: none"> • Safety position switches for protection of personnel • with separate operating element for protective covers • Positive operation and positive opening contacts • electromagnetic interlock • Approval of employers' liability insurance Association
Drive	<ul style="list-style-type: none"> • Rounded plunger (centre fixing) • Roller plunger (centre fixing) • Rotary lever • Angled roller lever • Adjustable roller lever • Actuating rod • Spring-rod actuator • Operating heads adjustable in 90° steps 	<ul style="list-style-type: none"> • Coded actuating element • Operating head: <ul style="list-style-type: none"> – Can be rotated by 90° – Can be actuated from both sides • Actuating element <ul style="list-style-type: none"> – Convertible for vertical and horizontal fixing • With triple coding 	<ul style="list-style-type: none"> • Coded actuating element • Operating head: <ul style="list-style-type: none"> – Can be rotated by 90° – Can be actuated from four sides and from above 	<ul style="list-style-type: none"> • Coded actuating element • Operating head: <ul style="list-style-type: none"> – Can be rotated by 90° – Can be actuated from four sides

Pilot devices

LSE-Titan[®] electronic position switches

Operating point variably adjustable

The operating point on electronic position switches LSE-Titan is adjustable and variable. Two high-speed and bounce-free PNP switching outputs enable high switching frequencies.

3

The position switch is overload as well as conditionally short-circuit proof and has snap-action switching performance. This ensures a defined and reproducible switching point. The operating point lies in the range from 0.5 to 5.5 mm (as supplied = 3 mm).

Adjustment to a new operating point is carried out as follows:

Move the plunger from the original to the new switch position. For this purpose, press the setting pushbutton for 1 s. The LED now flashes with a high pulse frequency and the new operating point is retentively set.

The LSE-11 and LSE-02 complete devices can be used in safety-oriented connections. They have the same function as electromechanical position switches.

Note

This means that all the devices are also suitable for safety applications designed for personnel or process protection.

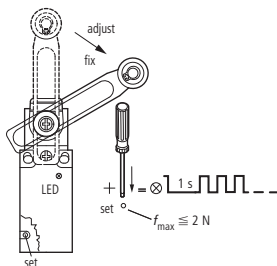
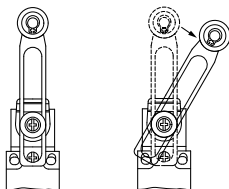

Contact travel diagram

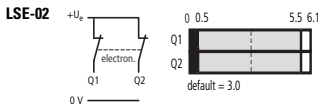
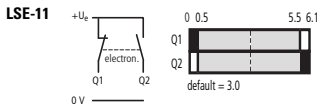

Pilot devices

Analog electronic position switches

Two part no. are available:

- LSE-AI with current output,
- LSE-AU with voltage output.

Analog, mechanically actuated position switches directly linked with the world of automation

Analog position switches LSE-AI (4 to 20 mA) and LSE-AU (0 to 10 V) represent another innovation in electronic position switches. Using them, it is now possible for the first time to monitor the actual position of a flue gas valve or an actuator continuously. The actual position is converted in analog fashion into voltage (0 to 10 V) or current (4 to 20 mA) and then continuously signalled to the electronics. Even objects of varying sizes or thicknesses, such as brake shoes, can be scanned and the results processed further.

Simple rotational-speed dependent control systems of fan motors or smoke-venting blowers signal the opening angle of the air damper (e.g. 25, 50 or 75 %) and thus save power and material wear. The analog position switches also have a diagnosis output for further processing of data. This means that the safe status can be monitored and analyzed at all times. The position switch also has a self-test function. The outputs Q1 and Q2 are constantly scanned for overload, short-circuit against 0 V and short-circuit against $+U_e$.

Contact travel diagram

LSE-AI

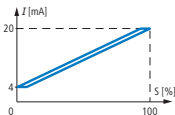

LSE-AU

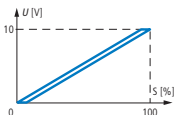

Pilot devices

Analog electronic position switches

Connection diagram

3

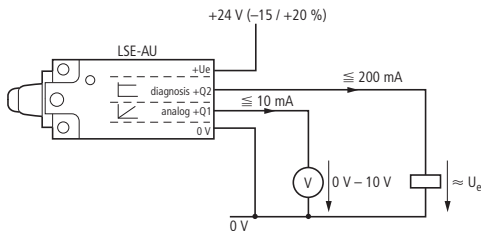
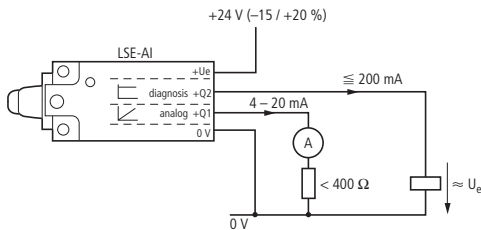

Pilot devices



Analog electronic position switches

Circuit symbol

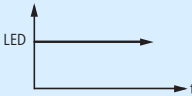
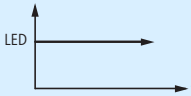
Normal scenario

	LSE-AI	LSE-AU
Q1	4 – 20 mA	0 – 10 V
Q2	$\approx U_e$	$\approx U_e$
LED		

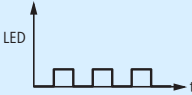
Fault scenario

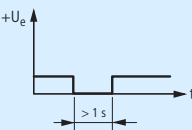
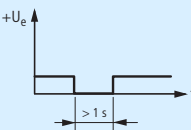
	LSE-AI	LSE-AU
Q1	0 mA	0 V
Q2	0 V	0 V
LED		
Reset		

Pilot devices

Sensors – Functionality

Inductive Sensors

Inductive sensors are used to detect metal objects. The objects are detected through an electromagnetic field.

With the ability to detect at close range, inductive proximity sensors are very useful for precision measurement and inspection applications.

3

How an inductive sensor works

Inductive sensors create an invisible high frequency oscillation field. When metal objects are brought into this field, this oscillating field is affected. Each sensor has a specific sensing range switch point so that metal target detection is very accurate and repeatable.

If a metal object is brought into the field created by the sensor, this is interrupted and causes a reduction in the current flowing through the sensor coil (eddy current damping). The detector circuit senses this change and sends a signal via the sensor output.

Assembly parts

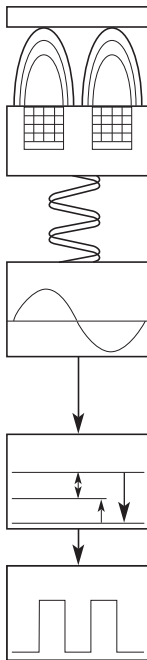

A metal object, or target, enters the sensing field.

The sensor coil is a coil of wire typically wound around a ferrite core. If you could see the electromagnetic field created by it, it would be cone shape. The target will pass through this field. The ferrite core

Pilot devices

Sensors – Functionality

shapes the field and the size of the coil determines the sensing range.

The resonance circuit creates a high frequency oscillation of the electromagnetic field (between 100 Hz and 1 MHz). If a metal object is located in the field, this causes a change in the magnetic field oscillation.

This change creates an eddy current which dampens the signal fed back to the sensor coil.

The detector circuit senses the change and switches ON at a particular set point (amplitude). This ON signal generates a signal to the solid-state output.

The output circuit remains active until the target leaves the sensing field. The oscillator responds with an increase in amplitude, and when it reaches the setpoint value, the detector circuit switches OFF. The output returns to its normal state.

Material wire of the target object

The sensing ranges stated by the sensor manufacturer are usually based upon ferrite targets made of carbon-rolled steel (IE FE 235) defined by ISO 630.

Sensing ranges to targets made of other materials have to have a correction factor applied as listed in the table below. To use this table, multiply the sensing distance of the device by the factor given below.

Correction factors

Multiply the sensing distance by the factor given below.

Target object	Sensor size			
	4–8 mm	12 mm	18 mm	30 mm
Stainless Steel 400 ¹⁾	0.90	0.90	1.0	1.0
Stainless Steel 300 ²⁾	0.65	0.70	0.70	0.75
Brass	0.35	0.45	0.45	0.45
Aluminium	0.35	0.40	0.45	0.40
Copper	0.30	0.25	0.35	0.30

¹⁾ Stainless steel 400 series to ASTM A240, martensitic or ferritic, magnetizable.

²⁾ Stainless steel 300 series to ASTM A240, austenitic, non-magnetizable.

The index of stainless steels is provided in EN 10088-1.

Pilot devices

Sensors – Functionality

Capacitive sensors

Capacitive sensors are designed to detect both metallic and nonmetallic targets. They are ideally suited for liquid level control and for sensing powdered or granulated material.

3

Operation of the capacitive sensors

Capacitive sensors operate using a capacitor. This consists of two metal plates that are separated by an insulating dielectric material. The function of this type of sensor is based on dielectric capacitance, which is the ability of a dielectric to store an electrical charge.

The distance between the plates determines the ability of the capacitor to store an electrical charge.

If an object is put into the electrical field, the capacitance of the capacitor changes. This change is used to implement the on/off switch function.

- Capacitor

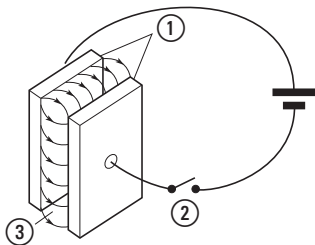

- ① Plates
- ② Switch
- ③ Dielectric

When this principle is applied to the capacitive sensor, one capacitive plate is part of the switch, the enclosure (the sensor face) is the insulator. The target is the other "plate". Ground is the common path.

Capacitive proximity sensors can detect any target that has a dielectric constant greater than air. Liquids have high dielectric constants. Metal also makes a good target.

Pilot devices

Sensors – Functionality

- Capacitive sensor

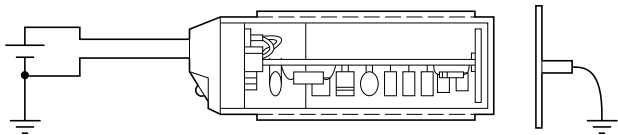

Capacitive sensors consist essentially of four basic elements:

- Sensor (Dielectric)
- Resonance circuit
- Detector circuit
- Output circuit.

As an object approaches the sensor, the dielectric constant of the capacitor changes. The oscillator circuit's vibration begins when feedback capacitance is detected. This is just the opposite in the inductive proximity sensor, where the vibration is damped when the target is present.

Effects

Capacitive sensors are activated both by conductive as well as non-conductive objects.

Metals achieve the greatest switching distances due to their high conductivity. Derating factors for various metals, such as are necessary with inductive sensors, need not be taken into account.

Actuation by objects made of non-conductive materials (insulators):

When an insulator is brought between the electrodes of a capacitor, the capacitance rises relative to the dielectric constant ϵ of the insulator. The dielectric constant for all

solid and liquid materials is greater than that for air.

Objects made of non-conductive materials affect the active surface of a capacitive proximity switch in the same way. The coupling capacitance is increased. Materials with a high dielectric constant achieve great switching distances.

Notes

When scanning organic materials (wood, grain, etc.) it must be noted that the attainable switching distance is greatly dependent on their moisture content. ($\epsilon_{\text{Water}} = 80!$)

Pilot devices

Sensors – Functionality

Influence of environmental conditions

As can be seen from the following diagram, the switching distance S_z is dependent on the dielectric constant ϵ_z of the object to be monitored.

Metal objects produce the maximum switching distance (100 %).

3

With other materials, it is reduced relative to the dielectric constant of the object to be monitored.

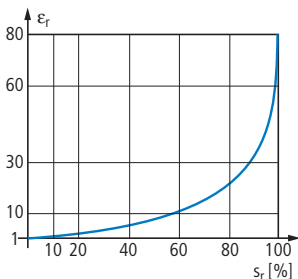

The following table lists the dielectric constants ϵ_z of some important materials. Due to the high dielectric value of water, the fluctuations with wood can be significant. Damp wood therefore is registered much more effectively by capacitive sensors than dry wood.

Material	ϵ_z
Air, vacuum	1
Teflon	2
Wood	2 - 7
Paraffin	2.2
Kerosene	2.2
Oil of terpentine	2.2
Transformer oil	2.2
Paper	2.3
Polyethylene	2.3
Polypropylene	2.3
Cable insulation	2.5
Soft rubber	2.5
Silicone rubber	2.8
Polyvinyl chloride	2.9
Polystyrene	3
Celluloid	3
Perspex	3.2
Araldite	3.6
Bakelite	3.6
Silica glass	3.7
Hard rubber	4
Oil-impregnated paper	4
Chipboard	4
Porcelain	4.4
Laminated paper	4.5
Quartz sand	4.5
Glass	5
Polyamide	5
Mica	6
Marble	8
Alcohol	25.8
water	80

Pilot devices

Sensors – Functionality

Optical sensors

Optical sensors use light to detect the presence or absence of an object. The main advantages of optical sensors are contactless sensing of objects and greatly extended sensing ranges.

Operating principle of the optical sensor

A LED sends a beam of light, which is picked up by a photodetector. An object is detected when it passes between the LED and photodetector, interrupting the light beam.

Let's look at how an optical sensor works.

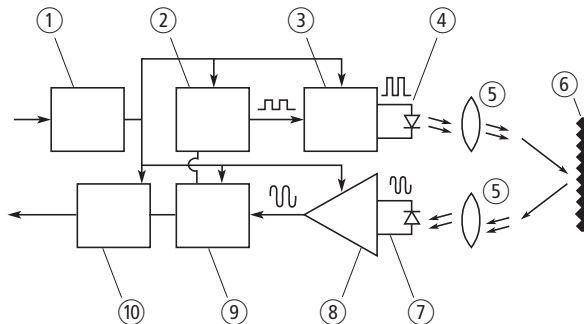

- ① **Power supply:**
Feeds the sensor circuit with a regulated DC voltage.
- ② **Modulator:**
generates pulses to cycle amplifier and LED at desired frequency.
- ③ **Source current amplifier**
- ④ **LED**
- ⑤ **Lens**
- ⑥ **Target object or reflector**
- ⑦ **Photodetector:**
Either a photodiode or a phototransistor device, selected for a maximum sensitivity at the source LED's emitted light wave-length. Both the source LED and the detector have protective lenses. When the sensor picks up the
- light, it sends a small amount of current to the detector amplifier.
- ⑧ **Detector Amplifier:**
Blocks current generated by the background light. It also provides amplification of the signal received to a usable level, and sends it through to the demodulator.
- ⑨ **Demodulator:**
Sorts out the light thrown out by the sensor from all other light in the area. If the demodulator decides the signals it receive are okay, it signals the output.
- ⑩ **Output:**
Performs switching routine when directed to do so by the demodulator.

Pilot devices

Sensors – Functionality

Detection methods

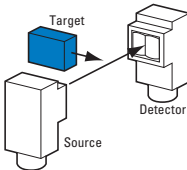
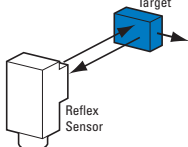
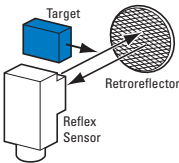
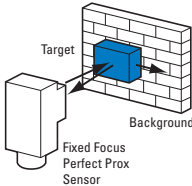
Operating Mode	Description	Operating Mode	Description
<p data-bbox="98 269 207 291">Light barriers</p> 	<p data-bbox="364 269 502 604">A source unit in one location sends a light beam to a detector unit in another location. An object is detected when it passes between the source unit and the detector unit, interrupting the light beam.</p>	<p data-bbox="533 269 709 291">Reflected-light beam</p> 	<p data-bbox="802 269 953 502">Light source and receiver are located in the same unit. If a target moves in front of the optical sensor, it reflects the light beam directly back to the receiver.</p>
<p data-bbox="98 626 310 647">Polarisation reflex sensor</p> 	<p data-bbox="364 626 502 910">Light source and receiver are located in the same unit. If a target moves in front of the optical sensor, a reflector reflects the light beam directly back to the receiver.</p>	<p data-bbox="533 626 714 669">Background rejection (Perfect Prox)</p> 	<p data-bbox="802 626 953 1099">This is a special type of diffuse reflective sensor that includes two detectors. This sensor offers reliable detection of target objects in a defined sensing range and at the same time ignores objects outside of this range. Unlike a standard diffuse reflective optical sensor, color or reflectivity has minimal effect on the sensing range of this sensor.</p>

Pilot devices

Sensors – Applications

Broken Tool Detection

Description	Catalog Number
E58 Perfect Prox Sensor	E58-30DP or E58-18DP Sensor

This sensor is used to sense for the presence of the bit on a mill. The high sensing power and background suppression of the Perfect Prox allows reliable detection through high levels of cutting fluids, while ignoring objects just beyond the bit. The rugged harsh duty sensor survives constant exposure to lubricants, cutting fluids and flying metal chips.

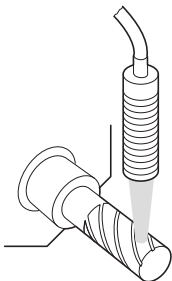

3

Broken Tool Detection

Description	Catalog Number
Tubular inductive sensor	E57 Product Family or iProx

A tubular sensor is used to detect the presence of a drill bit – should the drill bit be broken the sensor would signal a controller.

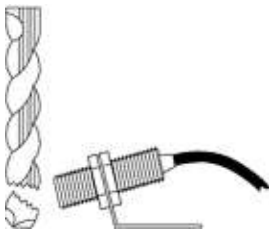

Pilot devices

Sensors – Applications

Machining process

Description	Catalog Number
Tubular inductive sensor	E57 Product Family or iProx

3 A ferrous only sensor is used in a process where aluminum is being machined. The ferrous only sensor ignores the aluminum (non-ferrous) chips from the machining process and only detects the ferrous target.

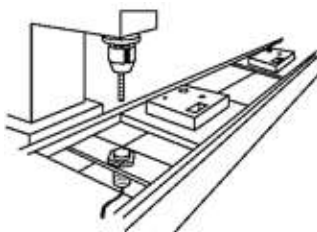

Tool Position

Description	Catalog Number
Tubular inductive sensor	E57 Product Family or iProx

A tubular sensor is used to detect the position of a tool chuck.

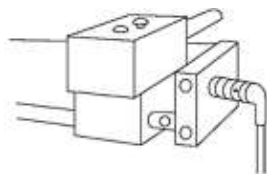

Pilot devices

Sensors – Applications

Bottle Filling Detection

Description	Catalog Number
E65 Clear Object Sensor	E71-C0N or E71-C0P

A clear object sensor is used to sense the presence of bottles at a filling operation. The sensor offers high reliability in sensing clear bottles of different colors and thicknesses.

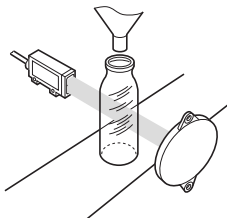

3

Process control engineering

Description	Catalog Number
Tubular capacitive Sensor	E53 Product Family

A capacitive sensor used to verify fill level of bottled water on a filling process line.

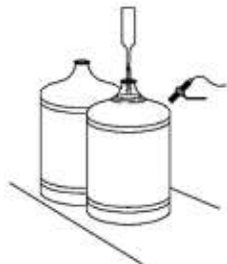

Pilot devices

Sensors – Applications

Conveyor System Control

Description	Catalog Number
Tubular inductive sensor	E57 Product Family or iProx

3 A tubular inductive sensor is used to detect the presence of metal carriers holding parts to be machined.

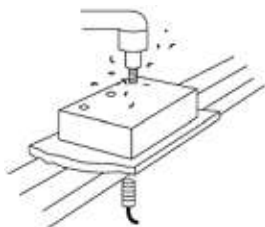

Stack Height Control

Description	Catalog Number
Comet Series Thru-Beam - source	11100A
Comet Series Thru-beam - detector	12100A

A set of thru-beam sensors determines the height of a scissor lift. For example, when the control is set for “dark-to-light” energize, the lift rises after a layer has been removed and stops when the next layer breaks the beam again.

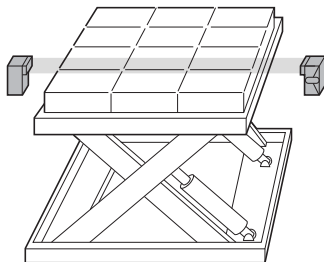

Pilot devices

Sensors – Applications

Carton Fill-Level Detection

Description	Catalog Number
Comet visible reflex photoelectric sensor	14102A
Comet reflected-light beam with background suppression (Perfect Prox)	13103A
Retro-reflector	6200A-6501

3

Two sensors work together to inspect the fill level in cartons on a conveyor. A reflex sensor senses the position of the carton and energizes the sensors located over the contents. If the sensor does not “see” the fill level, the carton does not pass inspection.

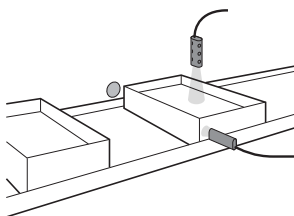

Lid Detection

Description	Catalog Number
Tubular inductive sensor	E57 Product Family or iProx

Two sensors are used to detect a can on a conveyor belt and to check whether it has a cover.

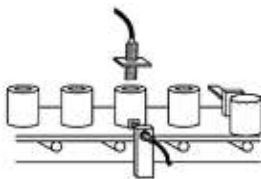

Pilot devices

Sensors – Applications

Tollbooth Control

Description	Catalog Number
E67 Perfect Prox long range sensor	E67-LRDP

3

The long range polarized reflex controls are used for the time control of a toll barrier. As soon as the car that has paid passes, the barrier closes in order to ensure that the next car stops. With the initiator E67 Long Range Perfect Prox you can mount the sensor on just one side instead of both. It detects cars with different colors and finishes whilst reliably ignoring all other background objects.

The rugged design makes it also suitable for continuous operation in extreme weather conditions.

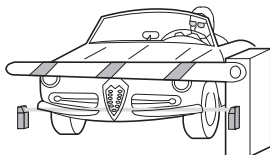

Liquid Level Detection

Description	Catalog Number
Tubular capacitive Sensor	E53 Product Family

A pair of capacitive sensors are used to sense high and low liquid levels in a tank through a sight glass. This arrangement starts a pump to fill the tank when the lower sensor is energized and shuts the pump off when the top sensor is energized.

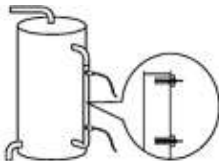

Pilot devices

Sensors – Applications

Bulk Material Detection

Description	Catalog Number
Tubular capacitive Sensor	E53 Product Family

A capacitive sensor is used to control fill level of solids such as plastic pellets in a hopper or bin.



3

Parts Presence

Description	Catalog Number
Limit switch, inductive sensor	E57 Product Family
Comet Perfect Prox	1310
Inductive sensor iProx	E59-M

A sensor configured as a limit switch can be used to detect whether a component is present in an automatic assembly machine. The Comet detects all materials, colors and services and masks out the background. The iProx can be programmed to detect a particular material and thus to ignore all other materials.



Pilot devices

Sensors – Applications

Parts Presence

Description	Catalog Number
Comet reflected-light beam (Perfect Prox), 100 mm	13101A

3

The sensor detects components with different heights from approx. 13 to 76 mm in a channel and can mask out the channel. Installation is simple and does not require any drilling or cutting of the channel.

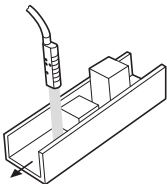

Filter Paper Length Control

Description	Catalog Number
A focused diffuse Comet reflective sensor	13102A

A focused diffuse reflective sensor interfaces with a programmable controller to measure a specific length of corrugated automotive filter paper. The controller detects the presence or absence of a corrugation. When a predetermined number of corrugations has been detected, the programmable controller directs a shear to cut the paper.

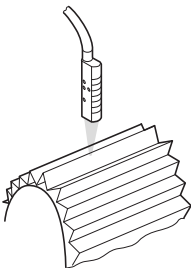

Pilot devices

Sensors – Applications

Speed monitoring

Description	Catalog Number
Tubular inductive sensor	E57 Product Family or iProx

A tubular sensor is used to detect the presence of set screws on a shaft hub providing a control device with signals for speed regulation or detection of rotation.



3

Motion Control

Description	Catalog Number
Tubular inductive sensor	E57 Product Family or iProx

A pair of tubular sensors is used to determine full open and fully closed valve position.

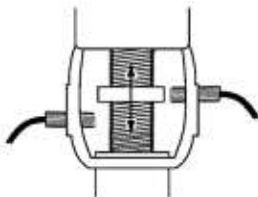

Pilot devices

Sensors – Applications

Clear Plastic Web Break Detection

Description	Catalog Number
Comet series 150 mm diffuse focus reflective light sensor	13107A

3

The clear web is detected by an extremely sensitive diffuse reflective sensor. Its short detection range makes it immune to reflective objects in the background. The extremely high excess gain helps it ignore reflection caused by fluttering of the web.

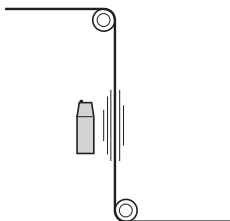

Paper detection

Description	Catalog Number
Comet Perfect Prox, 50 mm series, right angled	13104R

Right angle viewing and compact size allow the sensor to be mounted in the tight confines of paper handling systems. High resolution and sharp optical cut-off ensure that background machinery will be ignored while paper will be detected regardless of color and texture.

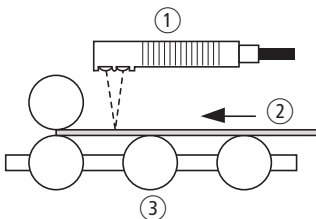

- ① Comet sensors
- ② Paper
- ③ Roller

Pilot devices

Sensors – Applications

Damage Warning

Description	Catalog Number
Comet E58 series Thru-Beam, Source	E58-30TS
Thru-beam sensor E58 series, detector	E58-30TD

Source and detector are mounted at opposite ends of a long warehouse storage shelf with the beam situated a safe distance below overhead obstacles (lighting, cable ducts, gas lines, etc.). If a forklift operator interrupts the beam while moving a load, a siren or flashing light will warn him to stop before any damage occurs.

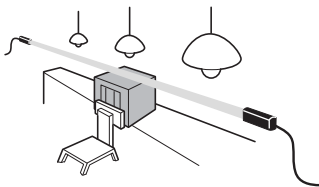

3

Notes

3

Cam switches

	Page
Overview	4-2
ON-OFF switches, main switches, maintenance switches	4-3
Changeover switches, reversing switches	4-5
(Reversing) star-delta switches	4-6
Multi-Speed Switches	4-7
Interlock circuits	4-11
Single-phase approach circuits	4-12
Meter changeover Switches	4-13
Heater switches	4-14
Step switches	4-15

Cam switches

Overview

Use and designs

Eaton cam switches and switch-disconnectors are used as:

- ① Main switches, main switches used as Emergency-Stop devices,
- ② ON-OFF switches,
- ③ Safety switches,
- ④ Changeover switches,
- ⑤ Reversing switches, star-delta switches, multi-speed switches,
- ⑥ Step switches, control switches, coding switches, meter selector switches.

The following designs are available:

- ⑦ Flush mounting,
- ⑧ Centre mounting,
- ⑨ Surface mounting,
- ⑩ Service distribution board mounting,
- ⑪ Rear mounting.

Refer to the latest issue of our main catalog for "Industrial Switchgear".

Other contact arrangements are listed in the K115 special catalog in addition to the switches listed in the main catalog.

(www.eaton.com/moeller/support (Catalogs)).

Basic part number	I _u [A]	Use as						Design				
		①	②	③	④	⑤	⑥	⑦	⑧	⑨	⑩	⑪
TM	10	–	x	–	x	–	x	○	○	–	○	–
T0	20	x	x	–	x	x	x	+	○	○	○	+
T3	32	x	x	–	x	x	–	+	○	○	○	+
T5B	63	x	x	x	x	x	–	+	–	○	–	+
T5	100	x	–	x	x	–	–	+	–	○	–	+
T6	160	x	–	–	x	–	–	–	–	+	–	+
T8	315 ¹⁾	x	–	–	x	–	–	–	–	+	–	+
P1-25	25	x	x	x	–	–	–	+	○	+	○	+
P1-32	32	x	x	x	–	–	–	+	○	+	○	+
P3-63	63	x	x	x	–	–	–	+	–	+	○	+
P3-100	100	x	x	x	–	–	–	+	–	+	○	+
P5-125	125	x	x	–	–	–	–	+	–	–	–	+
P5-160	160	x	x	–	–	–	–	+	–	–	–	+
P5-250	250	x	x	–	–	–	–	+	–	–	–	+
P5-315	315	x	x	–	–	–	–	+	–	–	–	+

I_u = max. Rated uninterrupted current

1) In enclosed version (surface mounting), max. 275 A.

○ Irrespective of the number of contact units, function and process.

+ Irrespective of the number of contact units, function and contact sequence.

Cam switches

ON-OFF switches, main switches, maintenance switches

On-Off switches, main switches

T0-2-1

P1-25

P1-32

P3-63

P3-100

P5-125

P5-160

P5-250

P5-315



FS 908

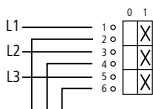

These switches can also be used as switch-disconnectors for lighting, heating or combined loads.

Main switches to IEC/EN 60204; for rear mounting switches with door interlock, padlocking feature, finger proof incoming terminals, N and PE terminal, red thumb-grip handle (black, if required), warning label.

If it is not clear which drive is associated with which main switch, an additional maintenance switch is required close to each drive.

4

Maintenance switches (safety switches) with auxiliary contacts

T0-3-15680



FS 908

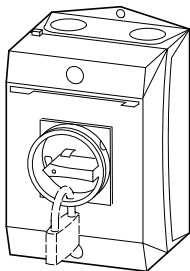
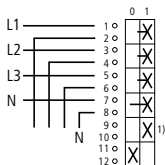

Maintenance switches are fitted to electrical machines or installations to provide safe working conditions in accordance with the safety regulations.

By attaching his own padlock to the SVB padlocking feature, the electrician can protect himself against anyone switching on without authorization

(→ Section "Circuit diagram example for maintenance switches with a load shedding contact and (or) switch position indicator", page 4-4).

P1-25/.../

P1-32/.../

P3-63/.../

P3-100/.../

...N/NH11



FS 908

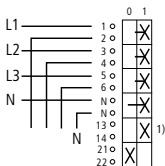

¹⁾ Load shedding contact

Cam switches

ON-OFF switches, main switches, maintenance switches

Circuit diagram example for maintenance T0(3)-3-15683 maintenance switch switches with a load shedding contact and (or) switch position indicator

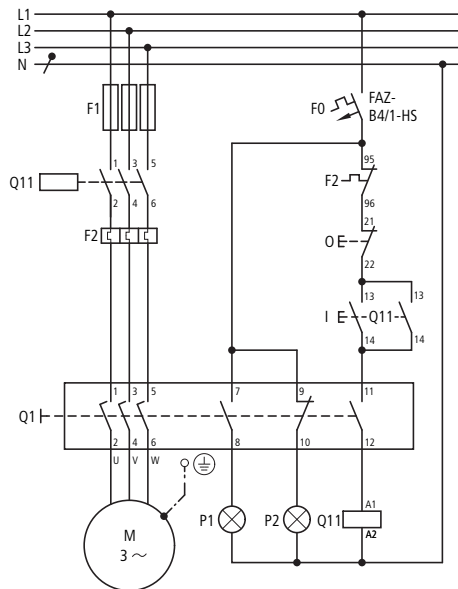

P1: On

P2: Off

Q11: Load shedding

T0(3)-3-15683 circuit symbol

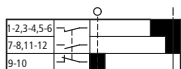

Function

Load shedding: When switching on, the main current contacts close first, then the contactor is activated via the late-make N/O contact. When switching off, the contactor is first disconnected by opening the early-make contact, then the main contacts isolate the motor supply.

Switch position indication: The position of the switch can be signalled to the control panel or control room via additional NO and NC contacts.

Cam switches

Changeover switches, reversing switches

Changeover switch

T0-3-8212

T3-3-8212

T5B-3-8212

T5-3-8212

T6-3-8212

T8-3-8212



FS 684

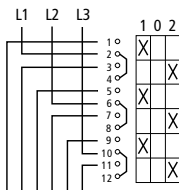

4

Reversing switches

T0-3-8401

T3-3-8401

T5B-3-8401

T5-3-8401



FS 684

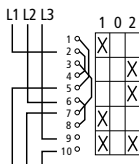

Cam switches (Reversing) star-delta switches

Star-delta switches

T0-4-8410

T3-4-8410



FS 635

T5B-4-8410

T5-4-8410

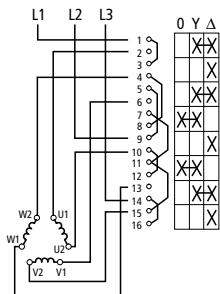

4

Reversing star-delta switches

T0-6-15877

T3-6-15877



FS 638

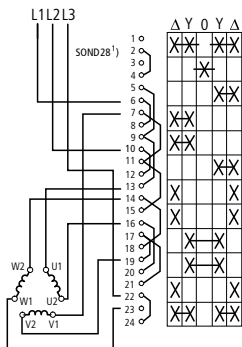

1) Standard contactor interlock

→ Section "Interlock circuits", page 4-11

Cam switches

Multi-Speed Switches

2 speeds, 1 operating direction

Tapped winding

T0-4-8440

T3-4-8440

T5B-4-8440

T5-4-8440



FS 644

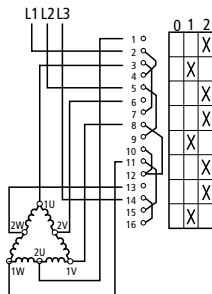

① without connections

2 separate windings

T0-3-8451

T3-3-8451

T5B-3-8451

T5-3-8451



FS 644

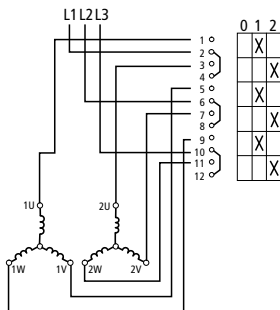

Cam switches

Multi-Speed Switches

2 speeds, 2 operating directions

Tapped winding

T0-6-15866

T3-6-15866



FS 629

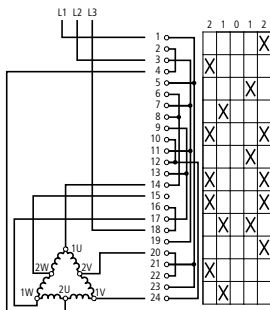

2 separate windings, 2 operating directions

T0-5-8453

T3-5-8453



FS 629

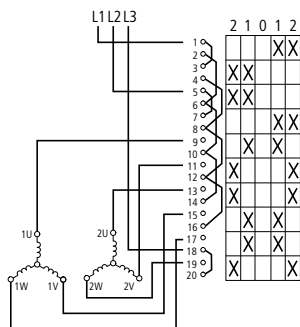

Cam switches

Multi-Speed Switches

3 speeds, 1 operating direction

Tapped winding arrangement, single winding for low speed

T0-6-8455

T3-6-8455

T5B-6-8455

T5-6-8455



FS 616

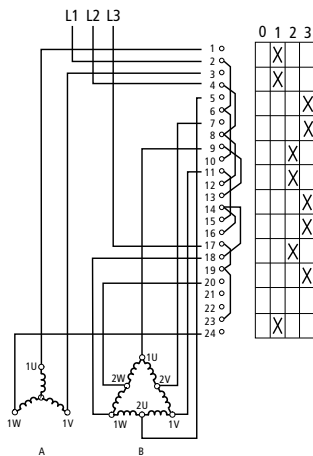

0-(A)Y - (B)Δ = (B)Y Y

Cam switches

Multi-Speed Switches

3 speeds, 1 operating direction

Tapped winding arrangement, single winding for high speed

T0-6-8459

T3-6-8459



FS 616

4

T5B-6-8459

T5-6-8459



FS 420

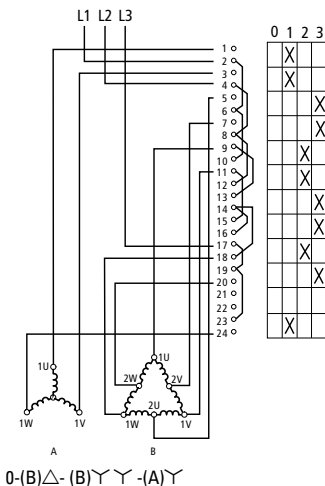

Cam switches

Interlock circuits

Interlock circuits between cam switches and contactors with overload relays provide neat and economical solutions for many switching drive tasks. The following points are common to all interlock circuits:

- Protection against automatic restarting after a motor overload or voltage failure
- The facility for remote disconnection (e.g. emergency-stop) can be provided by one or more Off pushbuttons.

Without mains disconnection (SOND 27)

Mains disconnection only by contactor primarily for star-delta connection

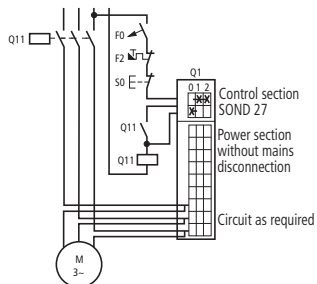

With mains disconnection (SOND 28)

Mains disconnection by contactor and switch

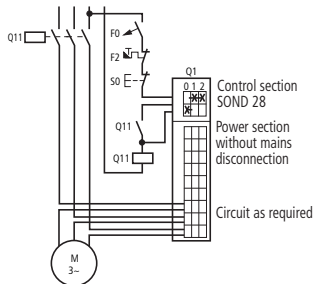

Interlock with contactor (SOND 29)

Contactor can be energized only when switch is in an operating position

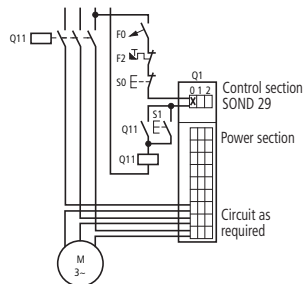

Interlock with contactor (SOND 30)

Contactor can be energized only when switch is in an operating position

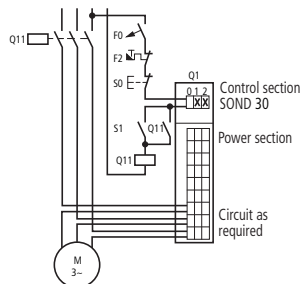

Cam switches

Single-phase approach circuits

Meter changeover switches enable you to measure currents, voltages and power in

three-phase systems with only one measuring device.

Voltmeter changeover switches

T0-3-8007

3 x phase to phase

3 x phase to neutral with off position



FS 1410759

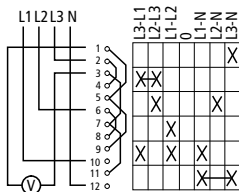

T0-2-15922

3 x phase to neutral without off position



FS 164854

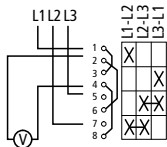

Ammeter changeover switches

T0-5-15925

T3-5-15925

For direct measurement



FS 9440

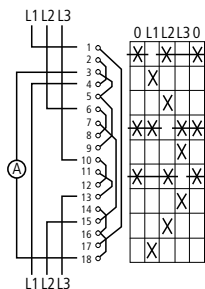

Cam switches

Meter changeover Switches

Ammeter changeover switch

T0-3-8048

T3-3-8048

For measurement via transformers, complete rotation possible



FS 9440

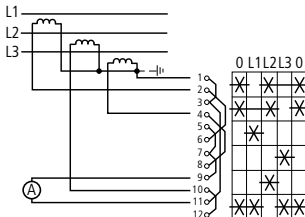

4

Power monitoring-changeover switches

T0-5-8043

T3-5-8043

Two-phase method (Aron circuit) for three-cable installations loaded as required. The total wattage is calculated by adding together the two wattages.



FS 953

The Aron circuit will give a correct result for four-cable systems only when the sum of the currents equals zero, i.e. only when the four-cable system is balanced.

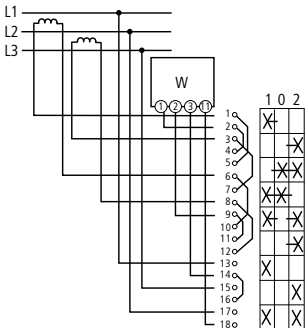

Cam switches

Heater switches

1 pole disconnection, 3 steps

T0-2-8316

T3-2-8316

T5B-2-8316



FS 420

4

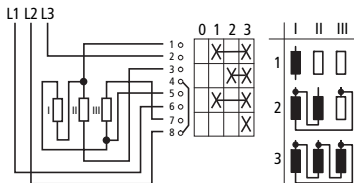

T0-2-15114, complete rotation possible



FS 193840

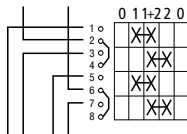

Further heater switches, 2 and 3 pole, with alternative circuitry, output stages, and number of steps are described in the main catalog, "Industrial Switchgear" and in the special catalog K 115D/F/GB (Article no. 077643).

Cam switches

Step switches

One step closed in each position, complete rotation possible

T0-6-8239

T3-6-8239



FS 301

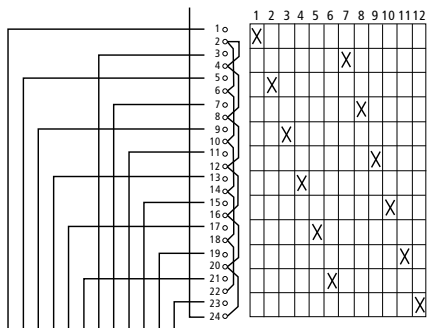

4

Cam switches

Step switches

Stay-put switches

On-Off stay-put switch

1 pole: T0-1-15401

2 pole: T0-1-15402

3-pole: T0-2-15403



FS 415



4

Changeover switches

1 pole: T0-1-15421

2 pole: T0-2-15422

3-pole: T0-3-15423



FS 429

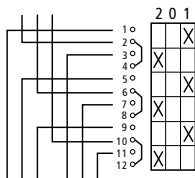

1 pole: T0-1-15431

2 pole: T0-2-15432

3-pole: T0-3-15433



FS 1401

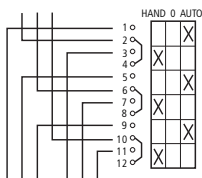

On-Off stay-put switches

1 pole: T0-1-15521

2 pole: T0-2-15522

3-pole: T0-3-15523

With pulsed contact in the intermediate position



FS 908

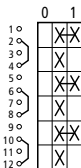

Contactors and relays

	Page
Contactor relays	5-2
Contactors DIL, overload relays Z	5-8
Contactors DIL	5-14
Overload relays Z	5-20
ZEB electronic overload relay	5-23
ZEV electronic motor-protective system	5-26
Thermistor overload relay for machine protection EMT6	5-33
CMD contactor monitoring device	5-36

Contactors and relays

Contactor relays

Contactor relays are often used in control and regulating functions. They are used in large quantities for the indirect control of motors, valves, clutches and heating equipment.

In addition to the simplicity which they offer in project engineering, panel building, commissioning and maintenance, the high level of safety which they afford is a major factor in their favor.

5

Security

The contactor relay contacts themselves constitute a considerable safety feature. By design and construction they ensure potential isolation between the actuating circuit and the operating circuit, in the de-energized state, between the contact

input and output. All DIL contactor relays have double-break contacts.

The Employers' liability insurance association demands that, for control systems of power-driven metalwork presses, the contacts of contactors must be interlocked and opposing. Interlocking means that the contacts are mechanically connected to one another such that N/C contacts and N/O contacts can never be closed simultaneously. At the same time, it is necessary to ensure that the contact gaps are at least 0.5 mm over the lifespan, even when defective (e.g. when a contact is welded). The contactor relays DILER and DILA fulfil this requirement.

Contactor relays DIL

Two contactor relay series are available as a modular system:

- Contactor relays DILER,
- Contactor relays DILA.

Modular system

The modular system has many advantages for the user. The system is formed around basic units, which are equipped with additional functions by means of modules. Basic units are intrinsically functional units, consisting of an AC or DC drive and four auxiliary contacts.

Modules having auxiliary functions

Auxiliary contact modules having 2 or 4 contacts. The combination of N/O and N/C contacts is according to EN 50011. The auxiliary contact modules of the contactors DILEM and DILM cannot be snapped onto the basic device to prevent duplication of terminal markings e.g. contact 21/22 on the basic device and 21/22 on the add-on auxiliary contact module.

The DILA and DILM7 to DILM38 contactors of the DILA-XHIR22 auxiliary contact are available specially for switching the smallest signals for electronic applications.

Contactors and relays

Contactor relays

The system and the Standard

European Standard EN 50011 "Terminal markings, distinctive numbers and reference letters for certain contactor relays" has a direct bearing on the use and application of the modular system. There are various types, which the Standard differentiates between by means of reference numbers and reference letters, depending on the number and position of the N/O and N/C contacts in the device, and their terminal markings.

Ideally devices with the reference letter E should be used. The basic devices DILA-40, DILA-31, DILA-22 as well as DILER-40, DILER-31 and DILER-22 comply with the E version.

For 6 and 8 pole contactor relays, the "E" version means that four N/O contacts must be arranged in the lower/rear contact level. If, for example, the available auxiliary contact modules are used in the DILA-22 and DILA-31, they result in contact configurations with reference letters X and Y.

Below are 3 examples of contactors with 4 N/O and 4 N/C contacts with different reference letters. Version E is to be preferred.

5

Example 1

DILA-XHI04



+

DILA-40



△ 44 E

DILA40/04

Example 2

DILA-XHI13



+

DILA-31

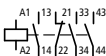

△ 44 X

DILA31/13

Example 3

DILA-XHI22



+

DILA-22

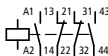

△ 44 Y

DILA22/22

Contactors and relays

Contactor relays

Coil connections

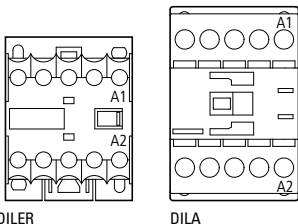

DILER

DILA

5

On the top positioned terminals A1–A2 of the contactor DILER the following accessories are connected to limit the relay coil switch off breaking voltage peaks:

- RC suppressors
- Free-wheel diode suppressors
- Varistor suppressors

On the contactor relay DILA the coil connection A1 is at the top and A2 at the bottom. As suppressor circuits the following are connected on the front:

- RC suppressors
- Varistor suppressors

The DC operated contactors DILER and DILA have an integrated suppressor circuit.

Suppressor circuit

Electronic equipment is nowadays being increasingly used in combination with conventional switching devices such as contactors. This equipment includes programmable logic controllers (PLCs) timing relays and coupling modules, whose operation can be adversely affected by disturbances from interactions between all the components.

One of the disturbance factors occurs when inductive loads, such as coils of electromagnetic switching devices, are switched off. High cut-off induction voltages can be produced when such devices are switched off and, under some circumstances, can destroy adjacent electronic devices or, via capacitive

coupling mechanisms, can generate interference voltage pulses and thus cause function disturbances.

Since interference-free disconnection is impossible without an accessory, the coils may be connected to a suppressor module, depending on the application. The advantages and disadvantages of the various suppressor circuits are explained in the following table.

Notes

Contactors and relays

Contactor relays

5

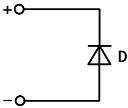
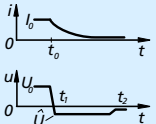
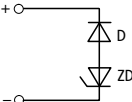
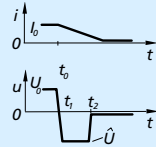
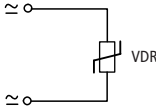
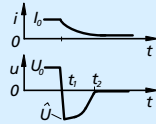
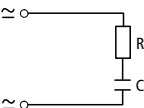
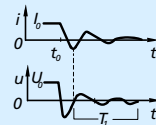
Circuit diagram	Load current and voltage responses	Protected against polarity reversal also for AC	Additional drop-out delay	Induction voltage limiting defined
		-	Very long	1 V
		-	average	U_{ZD}
		Yes	Short	U_{VDR}
		Yes	Short	-

Contactors and relays

Contactor relays

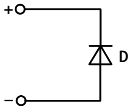
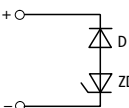
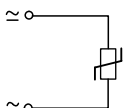
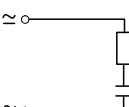
Circuit diagram	Damping also below U_{LIMIT}	Additional heat dissipation through circuitry	Notes	
	-	-	Advantages:	Dimensioning uncritical, minimum possible induction voltage, very simple and reliable
			Disadvantages:	Long drop-out delay
	-	-	Advantages:	Very short drop-out delay. Dimensioning uncritical. Simple construction
			Disadvantages:	No damping below U_{ZD}
	-	-	Advantages:	Dimensioning uncritical. High energy absorption. Very simple construction
			Disadvantages:	No damping below U_{VDR}
	Yes	Yes	Advantages:	HF damping due to stored energy, immediate de-energization, highly suitable for AC.
			Disadvantages:	Precise dimensioning required

Contactors and relays

Contactors DIL, overload relays Z

Overview of DIL contactors, 3-pole

5

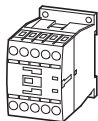

DILM7 ... DILM15

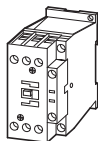

DILM17 ... DILM38

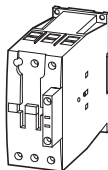

DILM40 ... DILM72

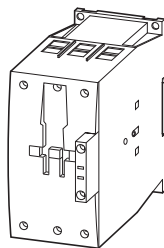

DILM80 ... DILM170

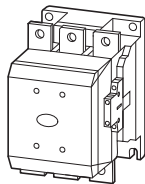
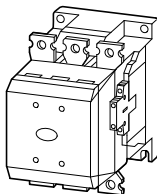
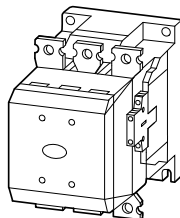
DILM185A,
DILM225ADILM250,
DILM300A

DILM400 ... DILM570

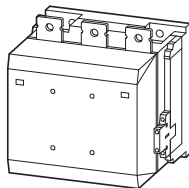
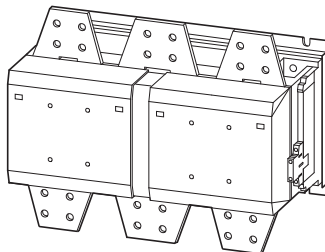
DILM580 ... DILM1000
DILH1400DILM1600
DILH2000, DILH2200, DILH2600

Contactors and relays

Contactors DIL, overload relays Z

Overview DILP contactors, 4 pole



DILEM4

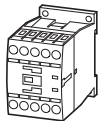

DILMP20

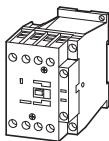
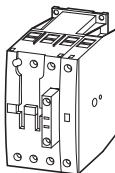
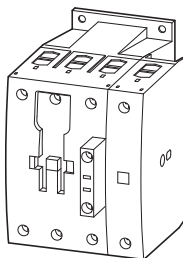
DILMP32 ...
DILMP45DILMP63 ...
DILMP80

DILMP125 ... DILMP200

5

Part no.	Rated operational current 50 – 60 Hz open		
	Conventional thermal current $I_{th} = I_{gr}$, AC-1 open		
	40 °C	50 °C	60 °C
	A	A	A
DILEM4	22	20	19 ¹⁾
DILMP20	22	21	20
DILMP32-10	32	30	28
DILMP45-10	45	41	39
DILMP63	63	60	54
DILMP80	80	76	69
DILMP125	125	116	108
DILMP160	160	150	138
DILMP200	200	188	172

1) At 55 °C

Contactors and relays

Contactors DIL, overload relays Z

Rated operating current I_n [A] AC-3 at 400 V	max. rating [kW] AC-3				1000 V	Conventional thermal current $I_{th} = I_e$ [A] AC-1 at 40 °C	Type
	220 V, 230 V	380 V, 400 V	660 V, 690 V				
6.6	1.5	3	3	–	22	DILEEM	
9	2.2	4	4	–	22	DILEM	
12	3.5	5.5	4	–	22	DILEM12	
7	2.2	3	3.5	–	22	DILM7	
9	2.5	4	4.5	–	22	DILM9	
12	3.5	5.5	6.5	–	22	DILM12	
15.5	4	7.5	7	–	22	DILM15	
17	5	7.5	11	–	40	DILM17	
25	7.5	11	14	–	45	DILM25	
32	10	15	17	–	45	DILM32	
38	11	18.5	17	–	45	DILM38	
40	12.5	18.5	23	–	60	DILM40	
50	15.5	22	30	–	80	DILM50	
65	20	30	35	–	98	DILM65	
72	25	37	35	–	98	DILM72	
80	25	37	63	–	110	DILM80	
95	30	45	75	–	130	DILM95	
115	37	55	90	–	160	DILM115	
150	48	75	96	–	190	DILM150	
170	52	90	140	–	225	DILM170	

Contactors and relays

Contactors DIL, overload relays Z

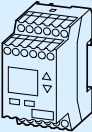
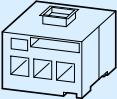
Part no.	Auxiliary contact blocks		Overload relays	Electronic motor protection system ZEV				
	For surface mounting	For side mounting						
DILEEM	02DILEM 11DILEM 22DILEM	–	ZE-0.16 up to ZE-12	ZEV + ZEV-XSW-25 ZEV-XSW-65 ZEV-XSW-145 ZEV-XSW-820				
DILEM								
DILEM12								
DILM7	DILA-XHI(V)... DILM32-XHI...	–	ZB12-0,16 up to ZB12-16 ZEB12-1.65 up to ZEB12-20					
DILM9								
DILM12								
DILM15								
DILM17					DILM32-XHI11-S	ZB32-0,16 up to ZB32-38 ZEB32-1.65 up to ZEB32-45		
DILM25								
DILM32								
DILM38								
DILM40								DILM150-XHI(V) ...
DILM50								
DILM65								
DILM72								
DILM80								
DILM95								
DILM115								
DILM150								
DILM170								

Contactors and relays

Contactors DIL, overload relays Z

Rated operating current I_n [A] AC-3 at 400 V	max. rating [kW] AC-3				1000 V	Conventional thermal current $I_{th} = I_n$ [A] AC-1 at 40 °C	Type
	220 V, 230 V	380 V, 400 V	660 V, 690 V				
185	55	90	140	108	337	DILM185A	
225	70	110	150	108	356	DILM225A	
250	75	132	195	108	400	DILM250	
300	90	160	195	132	430	DILM300A	
400	125	200	344	132	612	DILM400	
500	155	250	344	132	857	DILM500	
580	185	315	560	600	980	DILM580	
650	205	355	630	600	1041	DILM650	
750	240	400	720	800	1102	DILM750	
820	260	450	750	800	1225	DILM820	
1000	315	560	1000	1100	1225	DILM1000	
1600	500	900	1600	1770	2200	DILM1600	
1400	–	–	–	–	1714	DILH1400	
2000	–	–	–	–	2450	DILH2000	
2200	–	–	–	–	2700	DILH2200	
2600	–	–	–	–	3185	DILH2600	

Contactors and relays

Contactors DIL, overload relays Z

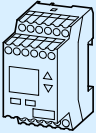
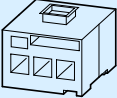
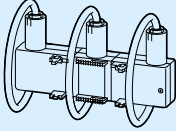
Part no.	Auxiliary contact blocks		Overload relays	Electronic motor protection system ZEV	
	For surface mounting	For side mounting			
DILM185A	-	DILM1000-XHI...	Z5-70/FF225A up to Z5-250/FF225A	ZEV + ZEV-XSW-25 ZEV-XSW-65 ZEV-XSW-145 ZEV-XSW-820   	
DILM225A					
DILM250		DILM820-XHI...	Z5-70/FF250 up to Z5-300/FF250		
DILM300A					
DILM400		-	-		-
DILM500					
DILM580					
DILM650					
DILM750					
DILM820					
DILM1000					
DILM1600					
DILH1400					
DILH2000					
DILH2200					
DILH2600					

Contactors and relays

Contactors DIL

Accessories

Device	DILE(E)M	DILM7 to DILM170		DILM185A to DILM500	DILM580 to DILM2000
		AC	DC		
Suppressor circuit	DC	–	✓	✓	✓
RC suppressors	✓	✓	–	–	–
Varistor suppressors	✓	✓	–	–	–
Motor suppressor module	–	to DILM15	to DILM15	–	–
Star-point bridge	✓	✓	✓	✓	–
Paralleling link	✓	✓	✓	to DILM185A	–
Mechanical interlock	✓	✓	✓	✓	✓
Sealable shroud	✓	–	–	–	–
Cable terminals	–	–	–	✓	to DILM820
Individual coils	–	from DILM17	from DILM17	✓	✓
Electronic modules	–	–	–	✓	✓
Electronic modules including coils	–	–	–	✓	✓
Terminal shroud	–	–	–	✓	✓ ¹⁾
Timer module	–	to DILM38	to DILM38	–	–

1) Terminal cover to DILM1000

Contactors and relays

Contactors DIL

Contactors DILM

These are designed and tested to IEC/EN 60 947, VDE 0660. For every motor rating between 3 kW and 900 kW (at 400 V) there is a suitable contactor available.

Equipment features

- **Magnet system**
Due to the new electronic operation the DC contactors from 17 to 72 A have a sealing power of only 0.5 W. Even for 170 A is only 2.1 W necessary.
- **Accessible control voltage connections**
The coil connections are on the front of the contactor. They are not covered by the main current wiring.
- **Can be controlled directly from the PLC**
The contactors DILA and DILM to 38 A can be controlled directly from the PLC.
- **Integrated suppressor DC**
With all DC contactors DILM a suppressor is integrated in the electronics.
- **Plug-in suppressor circuits AC**
With all AC contactors DILM up to 170 A a suppressor can be simply plugged in on the front when required.
- **Conventional control of contactors DILM185A to DILM2600 via coil terminals A1-A2.**
- **Additional actuation of contactors DILM250 to DILH2600:**
 - Directly from a PLC via terminals A3-A4
 - By a low-power contact via terminals A10-A11.
- **Conventional control of contactors DILM250-S to DILM500-S via coil connections A1-A2.** There are two coil terminals (110 to 120 V 50/60 Hz and 220 to 240 V 50/60 Hz).
- **All contactors up to DILM170 are finger and back-of-hand proof to VDE 0160 Part 100.** Additional terminal covers are available from DILM185 onwards.
- **Double-frame terminal for contactors DILM7 to DILM170**
With the new double frame-clamp the cable connection area is not limited by the screw. They give total security with varying cross sections and have protection against incorrect insertion to ensure safe connection.
- **Integrated auxiliary contact**
The contactors up to DILM32 have an integrated auxiliary contact as N/O or N/C contact.
- **Screw or spring-cage terminal**
The contactors DILE(E)M and DILA/DILM12, including the corresponding auxiliary contacts, up to 2000 A, are available with screw or spring terminals.
- **Contactors with screwless terminals**
They have spring-cage terminals in the mains current circuit as well as for the coil connections and auxiliary contacts. The shake proof and maintenance free spring-cage terminals can terminate two conductors each of 0.75 to 2.5 mm² with or without ferrules.
- **Connection terminals**
Up to DILM72 the connection terminals for all auxiliary contacts and coils as well as for main conductors can be tightened with a Pozidriv screwdriver size 2. For contactors DILM80 to DILM170 Allen screws are used.

Contactors and relays

Contactors DIL

- **Mounting**
All contactors can be fitted on to a mounting plate with fixing screws. DILE(E)M and DILM up to 72 A can also be snapped on to a 35 mm top-hat rail to IEC/EN 60715.
- **Mechanical interlock**
With two connectors and a mechanical interlock an interlocked contactor combination up to 170 A can be achieved without extra space requirement. The mechanical interlock ensures that both connected contactors cannot be simultaneously be operated. Even with a mechanical shock the contacts of both contactors cannot close simultaneously.

5

In addition to individual contactors, complete contactor combinations are also available:

- DIUL reversing contactors from 3 to 75 kW/400 V
- SDAINL star-delta starters from 5.5 to 132 kW/400 V

DC operated contactors

The market for DC operated contactors is growing due to the increasing use of electronics. Whilst AC operated contactors were used 20 years ago with additional resistors and specially wound DC coils with a lot of copper were used till recently, the next quantum leap has started. Electronic components are now in use for the drives of DC operated contactors.

The xStart contactor series DILM7 to DILM225A has been particularly optimized in the development of DC actuated contactors. The DILM17 to DILM225A DC

operated contactors are no longer switched on or off in the conventional way using a coil but by means of an electronic unit.

The integration of electronics in the contactor drives makes different technical features possible which enable the contactors to offer outstanding performance in their daily use.

Universal voltage coils

The DILM17 to DILM225A DC operated contactors cover the entire DC control voltage range with only 4 control voltage variants.

	Rated actuation voltage
RDC24	24 - 27 V DC
RDC60	48 - 60 V DC
RDC130	110 - 130 V DC
RDC240	200 - 240 V DC

Contactors and relays

Contactors DIL

Voltage tolerance

Contactors are built in compliance with the IEC/EN 60947-4-1 standard. The requirement for operational safety even with small mains supply fluctuations is implemented with the reliable switching of contactors at between 85 to 110 % of the rated control circuit voltage. The DC operated DILM17 to DILM225A contactors now cover an even wider range in which they switch reliably. They allow reliable operation between $0.7 \times U_{cmin}$ and $1.2 \times U_{cmax}$ of the rated actuation voltage. The greater voltage tolerance than stipulated by the standard increases operating safety even with less stable mains conditions.

Suppressor circuit

Conventionally operated contactors generate voltage peaks at the coil to current change di/dt which can have a negative effect on other components in the same actuating circuit. To prevent damage, contactor coils are often connected in parallel with additional suppressor circuits (RC suppressors, varistors or diodes).

Thanks to their electronics, the DC actuated contactors DILM17 to DILM225A switch without any effect on the network. An additional suppressor is therefore unnecessary since the coils do not generate any external overvoltages. The other DILM7 to DILM15 DC operated contactors have a built-in suppressor circuit.

When using DC operated contactors from Eaton in the project design, the issue of transient voltage surge suppression in control circuits is therefore unnecessary since all DC operated contactors are free of system disturbance or are provided with a suppressor circuit.

Contactors dimensions

The electronic circuit offers the coil a higher inrush consumption and reduces this after the closing operation to the required sealing power. This enables the AC and DC operated contactors to be implemented with the same dimensions. When designing AC and DC operated contactors for a project, the additional problem of different mounting depths is eliminated so that the same accessories can be used.

Contactors and relays

Contactors DIL

Pick-up and hold-in power

The electronic circuit on the DILM17 to DILM225A DC operated contactors controls their operation. A suitably high power is provided for the pickup to ensure the reliable switching of the contactor. A very low sealing power is required for holding the contactor. The electronics only provides this power.

5

Rated power ¹⁾	Contactor	Power consumption	
		Pick-up	Sealing
7.5- 15 kW	DILM17 DILM25 DILM32 DILM38	12 W	0.5 W
18.5- 37 kW	DILM40 DILM50 DILM65 DILM72	24 W	0.5 W
37- 45 kW	DILM80 DILM95	90 W	1.3 W
55- 90 kW	DILM115 DILM150 DILM170	149 W	2.1 W
90- 110 kW	DILM185A DILM225A	180 W	2.1 W

¹⁾ AC-3 at 400 V

For project design, the reduced sealing power also means a considerable reduction in the heat dissipation in the switch cabinet. This allows side by side mounting of the contactors in the switch cabinet.

Contactors and relays

Contactors DIL

Applications

The three-phase motor dominates the electric motor sector. Apart from individual low-power drives, which are often switched directly by hand, most motors are controlled using contactors and contactor combinations. The power rating in kilowatts (kW) or the current rating in amperes (A) is therefore the critical feature for correct contactor selection.

Physical motor design results in that rated currents for the same rating sometimes differ widely. Furthermore it determines the ratio of the transient peak current and the starting current to the rated operational current (I_e).

Switching electrical heating installations, lighting fittings, transformers and power factor correction installations, with their typical individual characteristics, increases the wide range of different uses for contactors.

The operating frequency can vary greatly in every application. The difference can be, for example, from less than one operation per day up to a thousand operations or more per hour. Quite often, in the case of motors, a high operating frequency coincides with inching and plugging duty.

Contactors are actuated by hand or automatically, using various types of command devices, depending on the travel, time, pressure or temperature. Any interrelationships required between a number of contactors can easily be produced by means of interlocks via their auxiliary contacts.

The auxiliary contact of the contactor DILM can be used as mirror contact to IEC/EN 60947-4-1 Appendix F to show the condition of the main contacts. A mirror contact is an N/C contact that cannot be simultaneously closed with the N/O main contacts.

Other applications

- Contactors for capacitors for power factor correction DILK for 12.5 to 50 kvar/400 V.
- Lighting contactors for DILL lighting systems for 12 to 20 A/400 V (AC-5a) or 14 to 27 A/400 V (AC-5b).

Contactors and relays

Overload relays Z

Motor protection using Z thermal overload relays

Overload relays are included in the group of current-dependent protective devices. They monitor the temperature of the motor winding indirectly via the current flowing in the supply cables, and offer proven and cost-efficient protection from destruction as a result of:

- Non starting,
- Overload,
- Phase failure.

5

Overload relays operate by using the characteristic changes of shape and state of the bimetal when subjected to heating. When a specific temperature is reached, they operate an auxiliary switch. The heating is caused by resistances through which the motor current flows. The equilibrium between the reference and actual value occurs at various

temperatures depending on the magnitude of the current.

Tripping occurs when the response temperature is reached. The tripping time depends on the magnitude of the current and preloading of the relay. Whatever the current, the relay must trip out before the motor insulation is endangered, which is why EN 60947-4-1 states maximum response times. To prevent nuisance tripping, minimum times are also given for the limit current and locked-rotor current.

Phase failure sensitivity

Overload relays Z offer, due to their design, an effective protection against phase failure. They have phase failure sensitivity to IEC 60947-4-1 and VDE 0660 part 102 and therefore can also provide protection for Ex e motors (→ following diagrams).

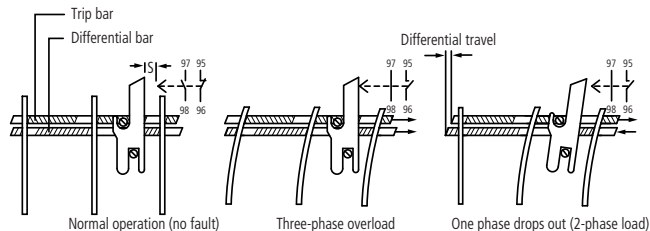

Normal operation (no fault)

- ① Trip bridge
- ② Differential bar
- ③ Differential travel

three-phase overload

One phase drops out

Contactors and relays

Overload relays Z

When the bimetallic strips in the main current section of the relay deflect as a result of three-phase motor overloading, all three act on a trip bar and a differential bar. A shared trip lever switches over the auxiliary contact when the limits are reached. The trip and differential bars lie against the bimetallic strips with uniform pressure. If, in the event of phase failure for instance, one bimetallic strip does not deflect (or recover) as strongly as the other two, then the trip and differential bars will

cover different distances. This differential movement is converted in the device by a step-up mechanism into a supplementary tripping movement, and thus accelerates the tripping action.

Design note → Section "Motor protection in special applications", page 8-8

Further information to motor protection → Section "All about Motors", page 8-1

Tripping characteristics

The overload relays ZE, ZB12, ZB32, ZB65 and the ZB150 up to 175 A are, due to the German Physical/Technical Bureau (PTB), suitable for protection of Ex e-motors to the ATEX-Guidelines 94/9 EG. In the relevant manual all tripping characteristics are printed for all currents.

These characteristic curves are mean values of the spreads at an ambient air temperature of 20 °C from cold. The tripping time is dependant upon the current. When units are warm, the tripping delay of the overload relay drops to about a quarter of the value shown.

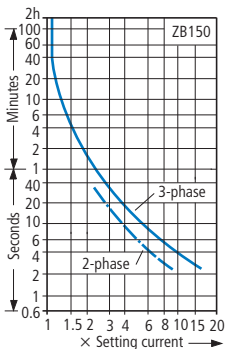
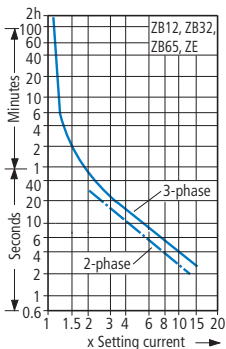

Contactors and relays

Overload relays Z

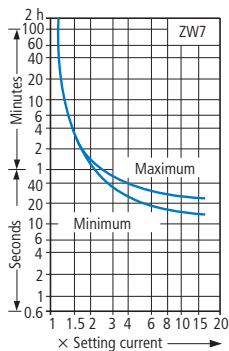

Contactors and relays

ZEB electronic overload relay

Operating principle and control

Like the thermal overload relays operating on the bimetallic operating principle, electronic motor-protective relays are current-dependent protective devices.

ZEB electronic motor-protective relays are an alternative to a bimetal overload relay.

The measuring of the actual motor current present in the three phase conductors of a motor feeder is implemented on the ZEB overload relay with integrated current transformers for the range from 0.3 to 100 A.

Like the ZEB, overload relays with electronic wide-range overload protection operate with a larger current transfer ratio. Compared to conventional bimetal relays, this provides the device with a wide current setting range ratio of 1:5.

The ZEB...-GF overload relay provides optional protection of the motor from earth faults. It adds the currents of the phases and evaluates any imbalance. If the imbalance is greater than 50 % of the set rated motor current, the relay trips.

By selecting one of the 4 tripping classes (CLASS 10A, 10, 20, 30) via DIP switches, the protected motor can be adapted to normal or heavy starting conditions. This allows the thermal reserves of the motor to be utilized safely. The overload relay does not require any auxiliary voltage and is fed internally via the current transformer.

Setting the DIP switches

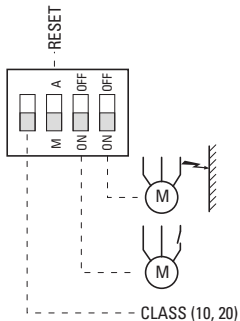
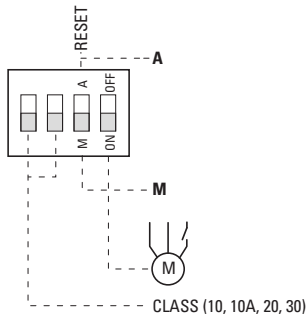

The ZEBs come with the usual NC contacts (95-96) and NO contacts (97-98) for overload relays.

Contactors and relays

ZEB electronic overload relay

The current of the motor is set via a setting dial. It is also possible to switch off phase failure sensitivity via the DIP switches when protecting single phase motors.

The manual or automatic reset can also be set on the DIP switch.

No external power supply is required thanks to the independently fed electronic circuit.

A diagnostics LED gives a visual warning of an overload.

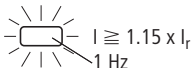
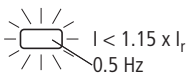

ZEB electronic overload relays can be fitted directly to DILM contactors up to 100 A.

Separate mounting (rail mounting) is only possible with ZEB.../KK.

5

Device overview

ZEB12, ZEB32
Direct mounting

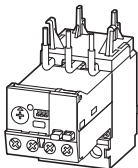

ZEB32.../KK
Separate mounting

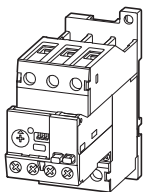

ZEB65
Direct mounting

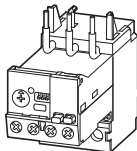

ZEB150
Direct mounting

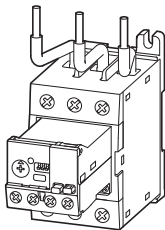

ZEB150.../KK
Separate mounting

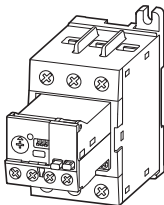

Contactors and relays

ZEB electronic overload relay

Tripping characteristics

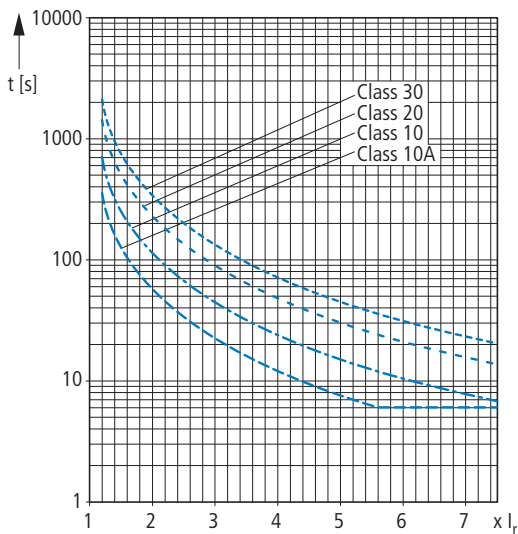

Class	t_A (s)						
	$x 3$	$x 4$	$x 5$	$x 6$	$x 7.2$	$x 8$	$x 10$
30	133.5	72.5	45.7	31.4	21.7	17.5	11.2
20	89.0	48.3	30.4	21.0	14.5	11.7	7.5
10	44.5	24.2	15.2	10.5	7.2	6.0	6.0
10A	22.3	12.1	7.6	6.0	6.0	6.0	6.0

Contactors and relays

ZEV electronic motor-protective system

Operating principle and control

Like electronic overload relays operating on the bimetallic strip principle, electronic motor-protective relays are current-dependent protective devices.

The acquisition of the actual flowing motor current in the three external conductors of the motor connections is with motor protection system ZEV with separate push-through sensors or a sensor belt.

These are combined with an evaluation unit so that separate arrangement of the current sensor and the evaluation unit is possible.

The current sensor is based on the Rogowski principle from the measurement technology. The sensor belt has no iron core, unlike a current transformer, therefore it doesn't become saturated and can measure a very wide current range.

Due to this inductive current detection, the conductor cross-sections used in the load circuit have no influence on the tripping accuracy. With electronic overload relays, it is possible to set higher current ranges than is possible with electromechanical thermal overload relays. In the ZEV System, the entire protected range from 1 to 820 A is covered using only an evaluation unit.

The ZEV electronic motor-protective system carries out motor protection both by means of indirect temperature measurement via the current and also by means of direct temperature measurement in motors with thermistors.

Indirectly, the motor is monitored for overload, phase failure and unbalanced current consumption.

With direct measurement, the temperature in the motor winding is detected by means of one or more PTC thermistors. In the event of excessive temperature rise, the signal is passed to the tripping unit and the auxiliary contacts are actuated. A reset is not possible until the thermistors cool to less than the response temperature. The built-in thermistor connection allows the relay to be used as complete motor protection.

In addition, the relay protects the motor against earth faults. Small currents flow out even in the event of minor damage to the motor winding insulation. These fault currents are registered on an external core-balance transformer which adds together the currents in the phases, evaluates them and reports fault currents to the microprocessor in the relay.

By selecting one of the eight tripping classes (CLASS) allows the motor to be protected to be adapted from normal to extended starting conditions. This allows the thermal reserves of the motor to be used safely.

Contactors and relays

ZEV electronic motor-protective system

The overload relay is supplied with an auxiliary voltage. The evaluation unit has a multi-voltage version, which enables all voltages between 24 V and 240 V AC or DC to be applied as supply voltage. The devices have monostable behavior; they trip out as soon as the supply voltage fails. In addition to the usual N/C contact (95-96) and the N/O contact (97-98) for overload relays the motor protection relay ZEV is equipped with a programmable N/O contact (07-08) and a programmable N/C contact (05-06). The above mentioned, usual contacts react directly via thermistors or indirectly via the current, to the detected temperature rise of the motor, including phase failure sensitivity.

The programmable contacts can be assigned to various signals, such as

- Earth-fault,
- Pre-warning at 105 % thermal overload,
- Separate indication of thermistor tripping,
- Internal device fault.

The function assignment is menu-guided using a display. The motor current is entered without tools using the function keys, and can be clearly verified on the display.

In addition the display allows a differential diagnostics of trip reasons, and therefore a faster error handling is possible.

Tripping in the event of a three-pole balanced overload at x-times the set current takes place within the time specified by the tripping class. The tripping delay in comparison with the cold state is reduced as a function of the preloading of the motor. Very good tripping accuracy is

achieved and the tripping delays are constant over the entire setting range.

If the motor current imbalance exceeds 50 %, the relay trips after 2.5 s.

The accreditation exists for overload protection of explosion proof motors of the explosion protection "enhanced safety" Ex e to guideline 94/9/EG as well as the report of the German Physical/Technical Bureau (PTB report) (EG-Prototype test certificate number PTB 10 ATEX 3007). Further information can be found in the manual MN03407008Z-DE/EN "Motor protection system ZEV, overload monitoring of motors in Ex e areas".

Contactors and relays

ZEV electronic motor-protective system

Device overview

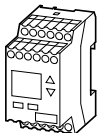

Evaluation unit
1 to 820 A

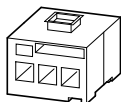

Current sensors
1 to 25 A
3 to 65 A
10 to 145 A

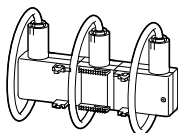

Sensor belt
40 to 820 A

5

Tripping characteristics

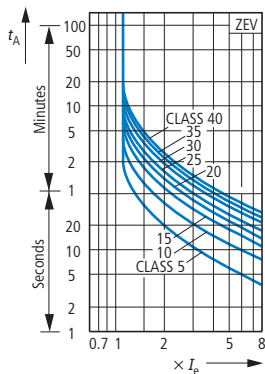

Tripping characteristics for 3-phase loads

These tripping characteristics show the relationship between the tripping time from cold to the current (multiples of set current I_E). After preloading with 100 % of the set current and the temperature rise to the operational warm state associated with it,

the stated tripping delays t_A are reduced to approx. 15 %.

Tripping limits for 3-pole balanced load

Pick-up time:

- < 30 min. at up to 115 % of the set current,
- > 2 h at up to 105 % of the set current from cold.

Contactors and relays

ZEV electronic motor-protective system

Electronic motor-protective system ZEV with earth-fault protection and thermistor monitored motor

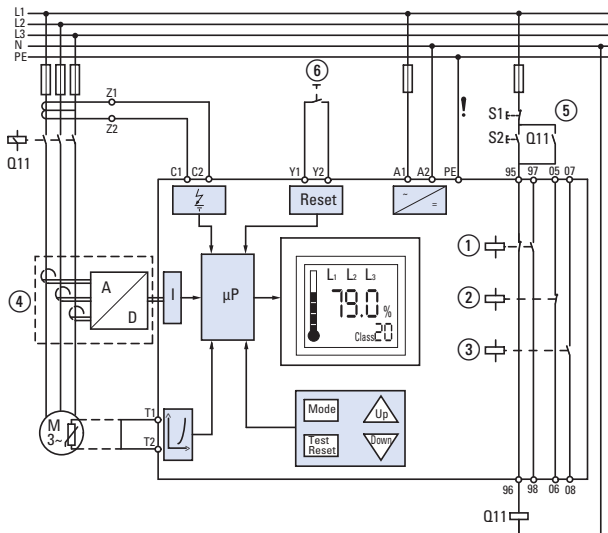

- ① Fault
- ② Parameterizable contact 1
- ③ Parameterizable contact 2
- ④ Current sensor with A/D transducer
- ⑤ Self hold-in of the contactor prevents an automatic re-start after the control voltage has failed and then returned (important for Ex e applications, → MN03407008Z-DE/EN)
- ⑥ Remote reset

Contactors and relays

ZEV electronic motor-protective system

Thermistor protection

With thermistor motor protection, to DIN 44081 and DIN 44082, up to six PTC thermistor temperature sensors with a

thermistor resistance of $R_K \leq 250 \Omega$ or nine with a $R_K \leq 100 \Omega$ can be connected to terminals T1-T2.

5

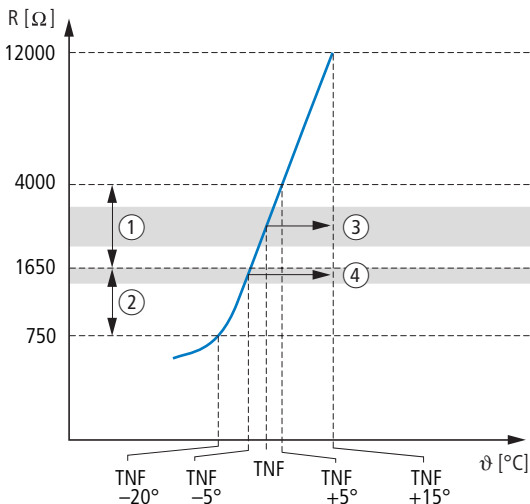

TNF = Nominal response temperature

- ① Tripping range IEC 60947-8
- ② Re-switch on range IEC 60947-8
- ③ Trip block at $3200 \Omega \pm 15\%$
- ④ Re-switch on at $1500 \Omega + 10\%$

The ZEV switches off at $R = 3200 \Omega \pm 15\%$ and switches on again at $R = 1500 \Omega + 10\%$. The contacts 95-96 and 97-98 change over in the event of a shutdown caused by a signal at the thermistor input.

Additionally, the thermistor tripping can be programmed to different trip messages on contacts 05-06 or 07-08.

With temperature monitoring with thermistors, no dangerous condition can occur should a sensor fail as the device would directly switch off.

Contactors and relays

ZEV electronic motor-protective system

Electronic motor-protective system ZEV with short-circuit monitoring at the thermistor input

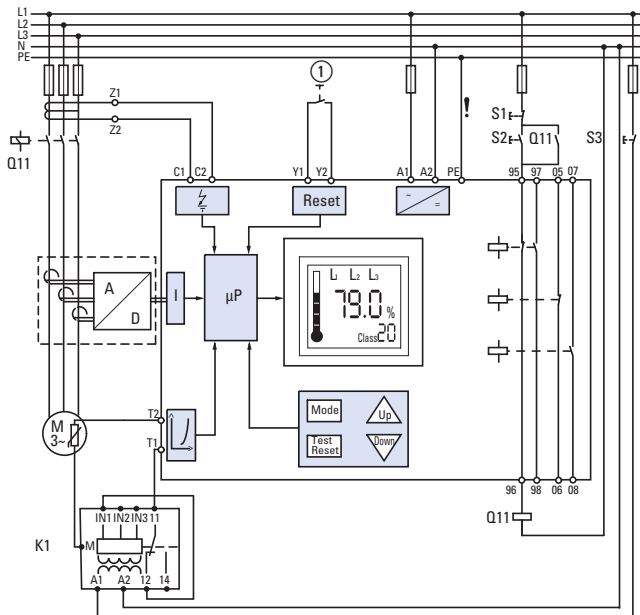

Short-circuits in the thermistor circuit can be detected if required by the additional use of a current monitoring relay K1 (e.g. type EIL 230 V AC from Crouzet).

Basic data

- Short-circuit current in the sensor circuit ≤ 2.5 mA,
- max. cable length to sensor 250 m (unscreened),
- Total cold resistance $\leq 1500 \Omega$,
- Programming ZEV: "Auto reset",
- Setting current monitoring relay:
 - Device to lowest current level,
 - Overload tripping,
 - Store the tripping,
- Confirmation of the short-circuit after clearing with pushbutton S3.

Contactors and relays

ZEV electronic motor-protective system

Device mounting

The mounting of the device is very simple due to the clip-on and the push-through cable entry.

Mounting details of every device can be found in the instructional leaflet IL03407080Z or the manual MN03407008Z-DE/EN.

ZEV mounting and current sensor

5

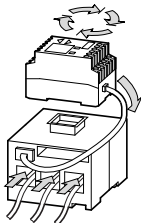

- Place the ZEV in the desired mounting position.
- Click the ZEV on the current sensor.
- Position motor conductors through the current sensor.

Mounting on the current conductors

Due to the fixing band the Rogowski sensor ZEV-XSW-820 is particularly easy to mount. And this saves the user time and money.

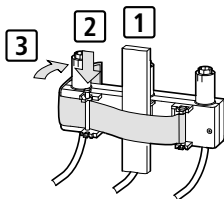

- 1 Wrap the band around the current conductors.
- 2 Engage the fixing pin.
- 3 Pull the fixing band tight and close with the velcro fastener.

Attaching the sensor coils → following figure

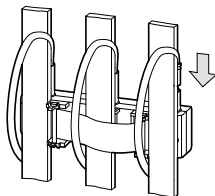

Contactors and relays

Thermistor overload relay for machine protection EMT6

EMT6 for PTC thermistors

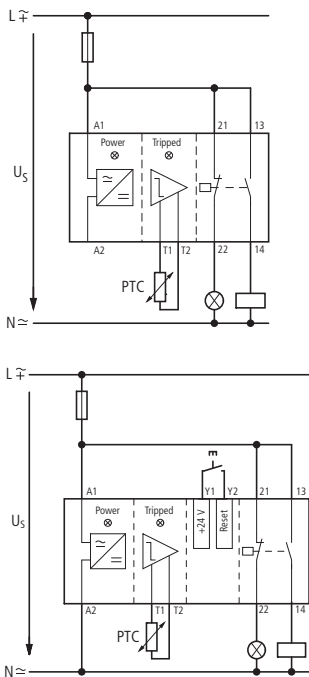

Method of operation

The output relay is actuated when the control voltage is switched on and the resistance of the PTC thermistor temperature sensor is low. The auxiliary contacts operate. On reaching the nominal response temperature (NAT), the sensor

resistance becomes high and causes the output relay to drop-out. The defect is indicated by an LED. As soon as the sensors have cooled enough so that the respective smaller resistance is reached the EMT6-(K) switches automatically on again. With the EMT6-(K)DB(K) the automatic re-switch on can be defeated by switching the device to "Hand". The unit is reset using the reset button.

The EMT6-K(DB) and EMT6-DBK are fitted with a short-circuit recognition in sensor circuit monitor. Should the resistance in the sensor circuit fall below 20 Ω it trips. The EMT6-DBK also has a zero voltage safe reclosing lockout and stores the fault by a voltage drop. Switching on again is possible only after the fault has been rectified and the control voltage is present again.

Since all the units use the closed-circuit principle, they also respond to a wire breakage in the sensor circuit.

The thermistor machine protection relays EMT6... are accredited for protection of Ex e motors to ATEX-Guideline 94/9 EG by the German Physical/Technical Bureau. For protection of Ex e motors the ATEX-Guidelines require short-circuit recognition in the sensor circuit. Because of their integrated short-circuit recognition the EMT6-K(DB) and EMT6-DBK are especially suitable for this application.

Contactors and relays

Thermistor overload relay for machine protection EMT6

EMT6 as contact protection relay

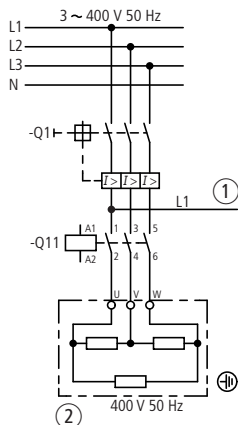

Application example

Control of a storage tank heater

① Actuating circuit

② Heater

Q11: Heater protection

5

Functional description

For this see circuit page 5-35.

Switching on the heater

The heater can be switched on provided the main switch Q1 is switched on, the safety thermostat F4 has not tripped and the condition $T \leq T_{\min}$ is satisfied. When S1 is actuated, the control voltage is applied to the contactor relay K1, which maintains itself via a N/O contact. The changeover contact of the contact thermometer has the position I-II. The low resistance sensor circuit of the EMT6 guarantees that Q11 is actuated via K2 N/O contact 13-14; Q11 goes to self-maintain.

Switching off the heater

The heater protection Q11 stays in self maintain until the main switch Q1 is switched off, the pushbutton S0 is pressed, the thermostat trips or $T = T_{\max}$.

When $T = T_{\max}$ the changeover contact of the contact thermometer has the position I-III. The sensor circuit of the EMT6 (K3) is low resistance, the N/C contact K3/21-22 open. The main protection Q11 drops out.

Contactors and relays

Thermistor overload relay for machine protection EMT6

Safety against wire breakage

Security against wire breakage in the sensor circuit of K3 (e.g. non-recognition of the limit value T_{max}) is guaranteed by the

use of a safety thermostat that when T_{max} is exceeded it's normally closed contact F4 switches off so that "switch off by de-energization" is carried out.

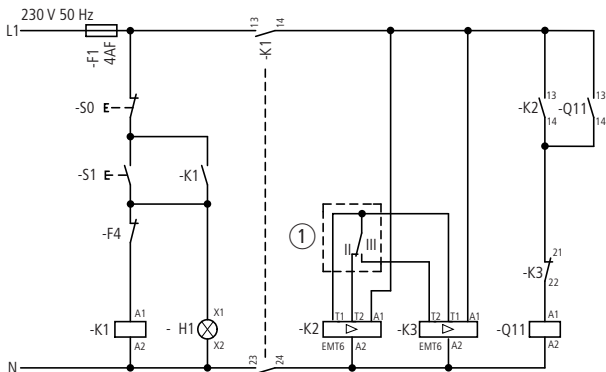

- ① Contact thermometer changeover contacts

I-II position at $T \leq T_{min}$

I-III position at $T \leq T_{max}$

S0: Off

S1: Start

F4: Safety thermostat

K1: Control voltage "On"

K2: Switch on at $T \leq T_{min}$

K3: Switch off at T_{max}

Contactors and relays

CMD contactor monitoring device

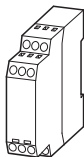

Operating principle

5

The CMD (Contactor Monitoring Device) monitors the main contacts of a contactor for welding. It compares the contactor control voltage with the state of the main contactors and indicates this reliably with a mirror contact (IEC EN 60947-4-1 Ann. F). If the contactor coil is de-energized and the contactor does not drop out, the CMD trips the backup circuit-breaker, motor-protective circuit-breaker or switch-disconnector via an undervoltage release.

The CMD also monitors the functioning of the internal relay using an additional auxiliary make contact of the monitored contactor. For this the auxiliary make and break contact is positively driven. The break contact is designed as a mirror contact.

Approved switchgear combinations

To ensure the functional reliability of the entire unit, consisting of contactor, circuit-breaker and CMD, the CMD is only approved for use with specific contactors as well as motor-protective circuit-breakers/circuit-breakers/or switch-disconnectors. CMD can be used for monitoring the welding of all DILEM and DILM7 to DILH2000 contactors. All auxiliary

break contacts of these contactors are designed as mirror contacts and can be used for monitoring tasks. The NZM1 to NZM4 or N1 to N4 can be used as backup motor-protective circuit-breakers/circuit-breakers or switch-disconnectors when fitted with a NZM...-XUVL undervoltage releases.

Applications

These combinations are used in safety-oriented applications. Previously, the series connection of two contactors was recommended with circuits of safety category 3 and 4. Now one contactor and the contactor monitoring device is sufficient for safety category 3. The CMD contactor monitoring relay is used for emergency-stop applications in compliance with EN 60204-1. It can also be used in the American automotive industry. In this sector there is a demand for solutions that reliably detect the welding of the motor starters and disconnect the motor feeder safely.

The CMD is approved as a safety module by the German employers' liability insurance association. It also has UL and CSA approval for the North American market.

Further information can be found in the manuals

- CMD(24VDC)
MN04913001Z-EN
- CMD(110-120VAC), CMD(220-240VAC)
MN04913002Z-EN

Contactors and relays

CMD contactor monitoring device

Circuit for DOL starters

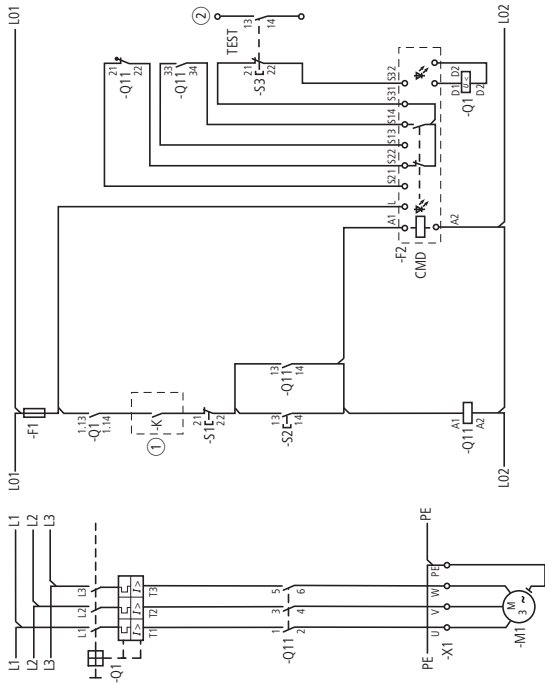

- ① Switching by safety relay or safety PLC
- ② Signal contact to PLC evaluation

Contactors and relays

CMD contactor monitoring device

Circuit for reversing starters

5

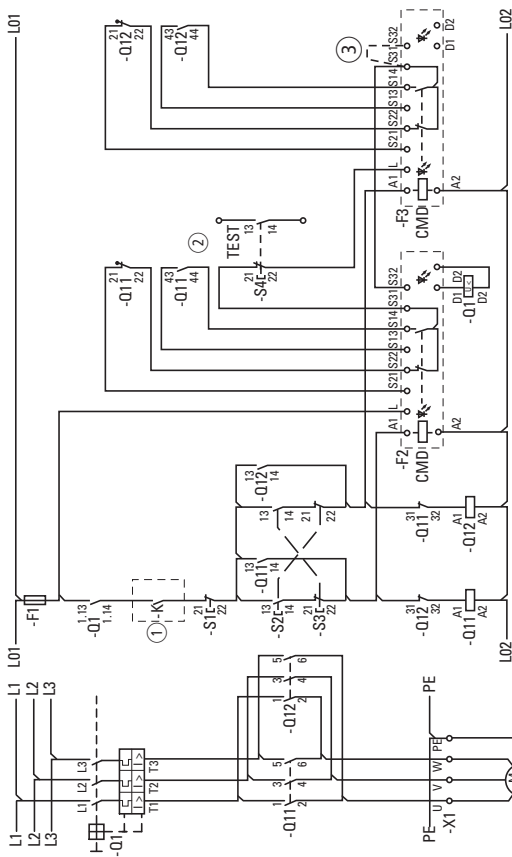

- ① Switching by safety relay or safety PLC
- ② Signal contact to PLC evaluation
- ③ CMD (24 V DC)

Motor-protective circuit-breakers

	Page
Overview	6-2
PKZM01, PKZM0 and PKZM4 – description	6-4
PKE – description	6-5
PKM0, PKZM0-...-T, PKZM0-...-...C – description	6-6
MSC Motor starters – description	6-7
PKZM0 and PKZM4 – current limiters	6-8
PKZM01, PKZM0, PKZM4 and PKE – auxiliary contacts	6-9
PKZM01, PKZM0, PKZM4 and PKE – trip blocks	6-10
PKZM01, PKZM0, PKZM4 and PKE – block diagram	6-11

Motor-protective circuit-breakers

Overview

Definition

Motor-protective circuit-breakers are circuit-breakers used for the switching, protection and isolation of circuits primarily associated with motor loads. At the same time, they protect these motors against destruction from locked-motor starting, overload, short-circuit and phase-failure in three-phase power supplies. They have a thermal trip block (PKZ) or an electronic release (PKE) for

protecting of the motor winding (overload protection) and an electromagnetic release (short-circuit protective device).

The following accessories can be fitted to motor-protective circuit-breakers:

- Undervoltage releases,
- Shunt release,
- Auxiliary contact,
- Trip-indicating auxiliary contact.

Motor-protective circuit-breakers at Eaton

6

PKZM01

The PKZM01 motor-protective circuit-breaker up to 25 A is supplied with the pushbutton actuator. The fitted mushroom button is available for emergency-off actuation on simple machines. The PKZM01 is primarily installed in surface-mounted or flush-mounted enclosures. Many accessories of the PKZM0 can be used.

PKZM4

The PKZM4 motor-protective circuit-breakers are a modular and efficient system for switching and protecting motor loads up to 63 A. It is the "big brother" of the PKZM0 and can be used with almost all PKZM0 accessory parts.

PKZM0

The PKZM0 motor-protective circuit-breaker is a modular and efficient system for switching and protecting motor loads up to 32 A and transformers up to 25 A.

Versions:

- Motor-protective circuit-breakers
 - Transformer-protective circuit-breaker
- Description → Section "The motor-protective circuit-breakers PKZM01, PKZM0 and PKZM4", page 6-4

PKE

PKE for motor and distribution circuit protection

The PKE is a modular and efficient system for protecting, switching and signalling of motors and systems in low-voltage switchgear systems up to 65 A, consisting of:

- Motor-protective circuit-breaker basic units
- Trip blocks

Description → Section "Motor and system protection with PKE", page 6-5

Motor-protective circuit-breakers

Overview

PKZM01

Circuit-breakers in surface mounting enclosure

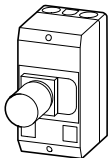

PKZM0

Circuit-breakers up to 32 A

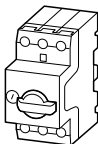

PKZM4

Circuit-breakers up to 63 A

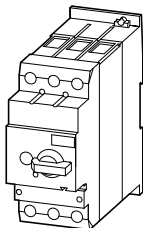

PKE

Circuit-breakers with electronic wide-range overload protection

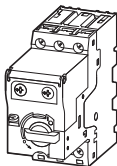

MSC-D

DOL starters



MSC-R

Reversing starters

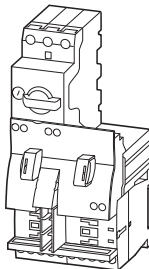

MSC-DEA

DOL starters (for SmartWire-DT)



Motor-protective circuit-breakers

PKZM01, PKZM0 and PKZM4 – description

The motor-protective circuit-breakers PKZM01, PKZM0 and PKZM4

The PKZM01, PKZM0 and PKZM4 with their bimetal releases with a current-dependent delay offer a proven technical solution for motor protection. The releases offer phase failure sensitivity and are temperature compensated. The rated currents of the PKZM0 up to 32 A are divided up into 15 ranges, 14 ranges on the PKZM01 and 7 on the PKZM4 up to 63 A. The installation (motor) and the supply cable are reliably protected and motor startup is ensured by the short-circuit releases, permanently set to $14 \times I_N$. The phase failure sensitivity of the PKZM0 and PKZM4 enables them to be used for the protection of Ex e motors. An ATEX certificate has been awarded. The motor-protective circuit-breakers are set to the rated motor current in order to protect the motors.

6

The following accessories complement the motor-protective circuit-breaker for the various secondary functions:

- Undervoltage release U,
- Shunt release A,
- Standard auxiliary contact NHI,
- Trip-indicating auxiliary contact AGM.

Motor-protective circuit-breakers

PKE – description

Motor and system protection with PKE

The PKE achieves its modularity by combining the motor or system-protective circuit-breaker with various accessories. The exchangeable motor-protective trip blocks with electronic wide range overload protection (current range 1:4) are available as a standard or enhanced version for connection to SmartWire-DT. This results in numerous application options and adaptation to widely differing requirements.

The circuit-breaker

The PKE circuit-breaker consists of:

- Basic device, 3 types for 12 A, 32 A and 65 A and
- Pluggable trip block.

There is a choice of trip blocks:

- Motor protective trip blocks (5 variants for the range 0.3 to 65 A)
- System protective trip block (for the range 5 to 36 A)

All trip blocks are provided with adjustable overload releases.

Overload from ... to...:

- Motor protective trip blocks:
also with adjustable tripping classes (CLASS 5, 10, 15 and 20) for protecting heavy starting motors.
- System protective trip block:
also with adjustable short-circuit release 5 to $8 \times I_n$.

The phase failure sensitivity of PKE allows for the use in the protection of Ex e motors.

An ATEX certificate has been awarded.

The motor-protective circuit-breakers are set to the rated motor current in order to protect the motors.

The following accessories of PKZMO complement the motor-protective circuit-breaker PKE for the various secondary functions:

- Undervoltage release U,
- Shunt release A,
- Standard auxiliary contact NHI,
- Trip-indicating auxiliary contact AGM.

Standards

The PKE motor-protective circuit-breaker is compliant with IEC/EN 60947 and VDE 0660. The PKE also meets the requirements for isolation and main switch functions stipulated in EN 60204.

Motor-protective circuit-breakers

PKM0, PKZM0-...-T, PKZM0-...-...C – description

Motor-protective circuit-breakers without overload release

PKM0

The PKM0 motor-protective circuit-breaker is a protective switch for starter combinations or for use as a basic unit in a short-circuit protective switch in the range 0.16 A to 32 A. The basic device is without overload release, but equipped with short-circuit release. This

circuit-breaker is used for protection of resistive loads where no overloading is to be expected.

These protective switches are also used in motor-starter combinations with and without reclosing lockout, where an overload relay or a thermistor overload relay is used as well.

Transformer-protective circuit-breakers

PKZM0-...-T

The transformer-protective circuit-breaker is designed for protecting transformer primaries. The short-circuit releases in the types from 0.16 A to 25 A are permanently set to $20 \times I_n$. The response ranges of the short-circuit releases are higher here than with motor-protective circuit-breakers in order to cope with the even higher inrush currents of idling transformers without tripping. The overload release in the PKZM0-T is set to the rated current of the transformer primary. All the PKZM0 system accessories can be combined with the PKZM0-T.

PKZM0-...-...C

The PKZM0 features a version with springloaded terminals. A version with springloaded terminals on both sides, and a combined version which features springloaded terminals on the outgoer side only can be chosen. The conductors can be connected here without ferrules. The connections are maintenance-free.

Motor-protective circuit-breakers

MSC Motor starters – description

Motor starter combinations

The MSC motor-starter combinations are available up to 32 A. Motor starters up to 16 A consist of a PKZM0 or PKE motor-protective circuit-breaker and a DILM contactor. Both are connected by a tool-less mechanical connection element. Furthermore, a plug-in electrical connector is used to establish the connection with the main circuit wiring. The PKZM0 or PKE motor-protective circuit-breaker and the DILM contactors up to 16 A are provided with the relevant interfaces for this purpose.

The MSC motor-starter combinations from 16 A consist of a motor-protective circuit-breaker PKZM0 or PKE and a contactor DILM. Both are fitted to a top-hat rail and mechanically and electrically interconnected by a connector element.

The MSC is available as a MSC-D DOL starter and as a MSC-R reversing starter.

The combinations of PKZM4 or PKE65 with the proven DILM contactors are available for motor ratings over 15 kW/400 V.

Motor-protective circuit-breakers

PKZM0 and PKZM4 – current limiters

CL-PKZ0

The current limiter module CL-PKZ0 is a short-circuit protective device specially developed for the PKZM0 and PKZM4 for non-intrinsically-safe areas. The CL module has the same base area and uses the same terminations as the PKZM0. When they are mounted on a top-hat rail alongside one another, it is possible to connect them using B3...-PKZ0 three-phase commoning links. The switching capacity of the series connected PKZM0 or PKZM4 + CL is 100 kA at 400 V. In the event of a short-circuit, the contacts of

the motor-protective circuit-breaker and CL will open. While the current limiter returns for the closed rest position, the motor protective-circuit breaker trips via the instantaneous release and produces a permanent isolating gap. The system is ready to operate again, once any defect has been rectified. The current limiter can conduct an uninterrupted current of 63 A. The module may be used for individual or group protection. Any direction of incoming supply may be used.

6

Individual and group protection using CL-PKZ0

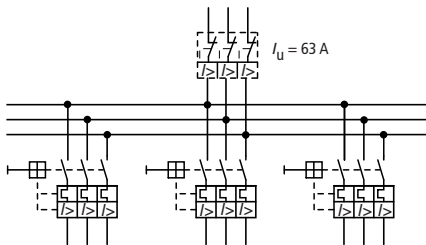

Use the BK25/3-PKZ0 for terminals > 6/4 mm²

For grouped connection with three-phase commoning link B3...PKZ0. Observe load factors in accordance with VDE 0660-600-2.

Examples:

PKZM0-16, PKZM4-16 or	PKZM0-16/20, PKZM4-16/20 or	PKZM0-20, PKZM4-20 or	PKZM0-25, PKZM4-25
4 x 16 A x 0.8 = 51.2 A	2 x (16 A + 20 A) x 0.8 = 57.6 A	3 x 20 A x 0.9 = 54 A	2 x 25 A x 0.9 = 45 A

Motor-protective circuit-breakers

PKZM01, PKZM0, PKZM4 and PKE – auxiliary contacts

Auxiliary contacts and standard auxiliary contacts NHI for PKZM01, PKZM0 PKZM4 and PKE

They switch at the same time as the main contacts. They are used for remote indication of the operating state, and

interlocking of switches between one another. They are available with screw connections or springloaded terminals.

Side mounted:

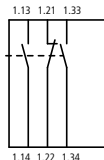
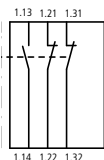
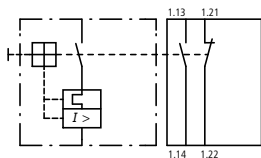

Integrated:

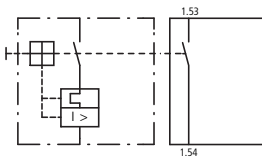
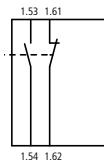

AGM trip-indicating auxiliary contacts for PKZM01, PKZM0 PKZM4 and PKE

These provide information about the reason for the circuit-breaker having tripped. In the event of a voltage/overload release (contact 4.43-4.44 or 4.31-4.32) or short-circuit release (contact 4.13-4.14 or

4.21-4.22) two potential-free contacts are actuated independently of one another. It is thus possible to indicate the difference between short-circuit and overload.

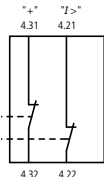
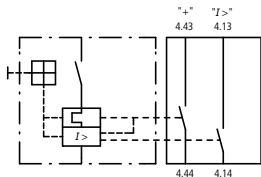

Motor-protective circuit-breakers

PKZM01, PKZM0, PKZM4 and PKE – trip blocks

Voltage releases

These operate according to the electromagnetic principle and act on the switch mechanism of the circuit-breaker.

Undervoltage release

These switch the circuit-breaker off when no voltage is present. They are used for safety tasks. The U-PKZ20 undervoltage release, which is connected to voltage via the VHI20-PKZ0 or VHI20-PKZ01 early-make auxiliary contacts, allows the circuit-breaker to be switched on. In the event of power failure the undervoltage release switches the circuit-breaker off via the switch mechanism. Uncontrolled restarting of machines is thus reliably prevented. The safety circuits are proof against wire breaks.

The VHI-PKZ0 cannot be used together with the PKZM4!

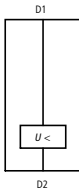

Shunt releases

These switch the circuit-breaker off when they are connected to voltage. Shunt releases can be provided in interlock circuits or for remote releases where voltage dips or interruptions are not to lead to unintentional switch off.

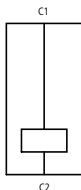

Motor-protective circuit-breakers

PKZM01, PKZM0, PKZM4 and PKE – block diagram

Motor-protective circuit-breakers PKZM01, PKZM0 and PKZM4

Manually operated motor starter

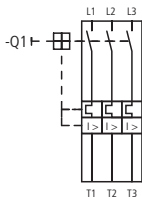

Motor-protective circuit-breakers PKE

Manually operated motor starter

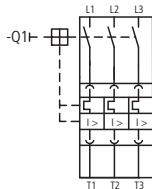

Motor-protective circuit-breakers

PKZM01, PKZM0, PKZM4 and PKE – block diagram

Motor-protective circuit-breakers with auxiliary contact and trip-indicating auxiliary contact

PKZM01(PKZM0-...)(PKZM4...) +
NHI11-PKZ0 + AGM2-10-PKZ0

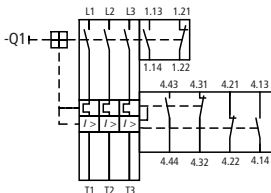

PKE... + NHI11-PKZ0 + AGM2-10-PKZ0

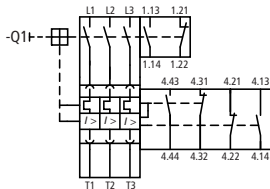

6

For differential fault indication

(Overload or short-circuit)

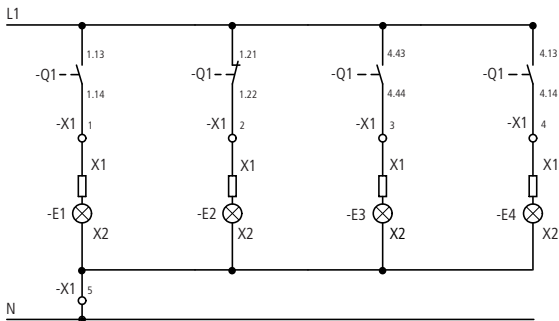

E1: circuit-breaker ON
E2: circuit-breaker OFF

E3: general fault, overload release
E4: short-circuit release

Motor-protective circuit-breakers

PKZM01, PKZM0, PKZM4 and PKE – block diagram

Remote switch off via shunt release

Motor starters with auxiliary contact and shunt release

PKZM0-... + DILM... + A-PKZO

PKE... + A-PKZO

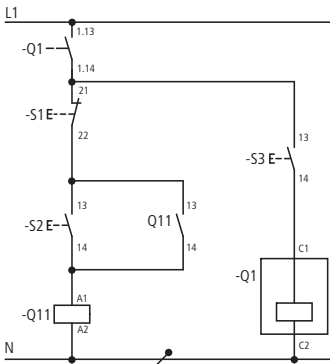
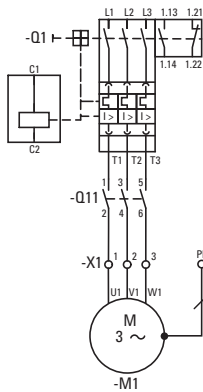
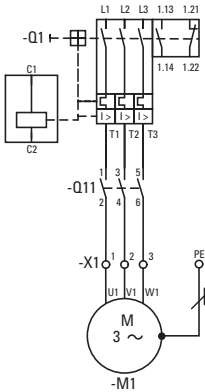

S1: OFF
S2: ON
S3: OFF circuit-breaker

Notes

Circuit-breakers

	Page
Overview	7-2
Shunt release	7-4
Undervoltage releases	7-5
Contact diagrams of the auxiliary contacts	7-6
Internal circuit diagrams NZM	7-8
Remote switch-off with voltage release	7-11
Applications of the undervoltage release	7-13
Switch off of the undervoltage release	7-14
Indication of the contactor state	7-15
Short-time delayed circuit-breaker – internal circuit diagrams	7-16
Mesh network circuit-breakers	7-17
Remote operation with motor operator	7-18
Circuit-breaker as transformer switch	7-19
Circuit-breaker with residual current device	7-20
Terminal assignments of IZMX circuit-breakers	7-25

Circuit-breakers

Overview

NZM circuit-breakers

Circuit-breakers are mechanical switching devices that switch currents in the circuit on or off and control them under normal operating conditions. These circuit-breakers protect electrical equipment from thermal overloads and in the event of a short-circuit.

The NZM circuit-breakers cover the rated current range from 20 to 1600 A.

Depending on the version, they have additional protective functions such as residual current device, earth-fault protection or the capability for energy management by detecting load peaks, and selective load shedding. NZM circuit-breakers stand on account of their compact shape and their current-limiting characteristics.

Switch-disconnectors without overload or tripping units are available in the same

sizes as the circuit-breakers and can be fitted with additional shunt or undervoltage release to suit the versions concerned.

NZM circuit-breakers and switch-disconnectors are built and tested to the specifications in standard IEC/EN 60947.

They feature isolating characteristics. In conjunction with a locking facility, they are suitable for use as main switches to IEC/EN 60204/VDE 0113, part 1.

The electronic release of frame sizes NZM2, NZM3 and NZM4 feature communication capabilities. The actual states of the circuit-breakers can be visualized locally via a Data Management Interface (DMI) or converted to digital output signals. Additionally, the circuit-breakers can be connected to a network, e.g. PROFIBUS-DP.

7

NZM1



NZM2



NZM3

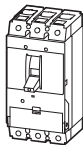

NZM4

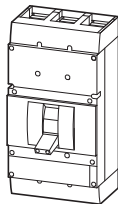

Notes

The NZM7, NZM10 and NZM14 circuit-breakers are no longer contained in the Eaton range. They have been replaced by a new generation of devices. Information on the above devices is provided in this chapter.

Circuit-breakers

Overview

IZMX circuit-breakers

The IZMX circuit-breakers are designed for use in the high rated current range from 630 A.

IZMX circuit-breakers and INX switch-disconnectors provide the main switch isolation functions required by the IEC/EN 60204-1 standard as they are lockable in the OFF position. They can therefore be used as mains switches. IZM circuit-breakers are built and tested in accordance with IEC/EN 60947.

Depending on the type of equipment protected, the following main areas of application are possible with different settings to the release electronics:

- System protection,
- Motor protection,
- Transformer protection,
- Generator protection.

IZMX circuit-breakers offer different electronic units from simple system protection with overload and short-circuit release right through to the digital release with graphical display and the possibility to create time selective networks.

They can be adapted to a wide range of requirements with a comprehensive range of mounted accessories such as auxiliary contacts, trip-indicating auxiliary contacts, motor operators or voltage release, fixed-mounted or withdrawable units.

With their communication capability, the IZMX circuit-breakers open up new possibilities in power distribution. Important information can be passed on, collected and evaluated, also for preventative maintenance. For example, by enabling rapid intervention in processes, system downtimes can be reduced or even prevented.

Selection criteria of an IZM circuit-breaker are:

- Max. short-circuit current I_{kmax} ,
- Rated operating current I_n ,
- Ambient temperature,
- 3 or 4-pole design,
- Fixed mounting or withdrawable units,
- Protective function,
- Min. short-circuit current.

Detailed information on the circuit-breakers is provided in chapter 18 of the Eaton Industrial Switchgear Catalog 2010.

IZMX16

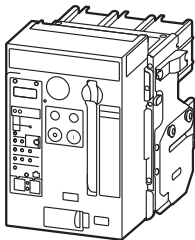

IZMX40

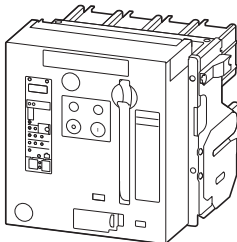

Circuit-breakers

Shunt release

Shunt release A

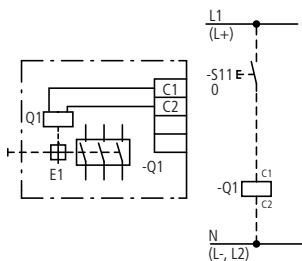

Module (Q1, solenoid) of a circuit-breaker or motor-protective circuit-breaker that actuates a release mechanism when voltage is applied. When de-energized, the system is in the rest position. A normally open contact actuates the system. If the shunt release is rated for intermittent duty (overexcited shunt release with 5 % DF), the intermittent operation must be ensured by connecting an appropriate auxiliary contact of the circuit-breaker upstream. This measure is not required when using a shunt release with 100 % DF.

Shunt releases are used for remote tripping when an interruption in the voltage is not intended to lead to automatic disconnection. Tripping does not occur in the event of wire breakage, loose contacts or undervoltage.

Circuit-breakers

Undervoltage releases

Undervoltage release U

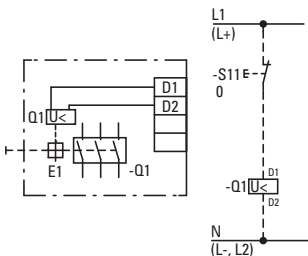

A passive electromagnetic relay (Q1) which actuates a release mechanism when the supply voltage drops or is interrupted, in order, for example, to prevent the automatic restarting of motors. Undervoltage releases are also suitable for very reliable interlocking and remote off switching since disconnection always occurs in the event of a fault (e.g. wire breakage in the control circuit). The circuit-breakers cannot be reclosed when the undervoltage releases are de-energized.

The system is in the rest position when energized. Actuation is produced by a normally closed contact. Undervoltage releases are always designed for uninterrupted operation. These are the ideal tripping elements for totally reliable interlocking tasks (e.g. emergency offswitching).

7

Off-delayed undervoltage release UV

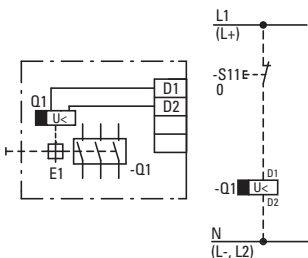

The off-delayed undervoltage release (Q1) is a combination of a separate delay unit (UVU) and the respective release. This release is used to prevent brief interruptions in power leading to disconnection of the circuit-breaker. The delay time can be set between 0.06 and 16 s.

Circuit-breakers

Contact diagrams of the auxiliary contacts

Auxiliary contact – standard HIN

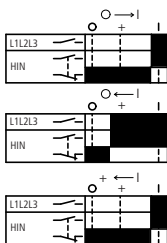

Auxiliary contacts are used to provide command or signal outputs from processes which are governed by the position of the contacts. They can be used for interlocking with other switches, and for the remote indication of the switching state.

Auxiliary contacts have the following properties:

- Standard auxiliary contacts behave like main switch contacts
- Switch position indication
- Interlocking
- Disconnection of the shunt release

7

Auxiliary contact – trip-indicating HIA

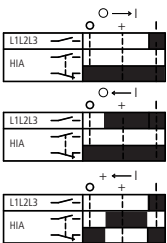

0 → I

Switch on

0 ← I

Switch off

+ ← I

Trip

■ Contact closed

□ Contact open

Used to provide command and signal output relating to electrical tripping of the circuit-breaker (trip position +) as is required, for example, for mesh network circuit-breakers. No pulse is produced when the switch is opened or closed manually or by a motor operator.

- Indication that the switch is in the tripped position
- Switch position indication only if tripping is caused by, for example, overcurrent, short-circuit, test or voltage release. No fleeting contact when switched on or off manually or switched off with the motor (exception: manual switch off with motor operator NZM2, NZM3, NZM4).

Circuit-breakers

Contact diagrams of the auxiliary contacts

Auxiliary contact – early make HIV

NZM1, NZM2, NZM3, NZM7



NZM10

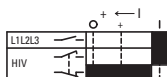

NZM4

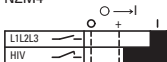

Early-make auxiliary contacts are used to provide command or signal outputs for processes which are initiated before the closure or opening of the main contact system. Because they close early, they can be used for interlocks with other switches. Furthermore, they allow a switch position indication.

With the circuit-breaker in the Tripped position, the HIV is in the same position as it is at OFF. Because of its early-make characteristics, it can be used to apply voltage to the undervoltage release.

→ Section "Undervoltage releases", page 7-5,

→ Section "Remote switch-off with voltage release", page 7-11,

→ Section "Applications of the undervoltage release", page 7-13.

0 → I

Switch on

0 ← I

Switch off

+ ← I

Trip

■ Contact closed

□ Contact open

Circuit-breakers

Internal circuit diagrams NZM

Maximum configuration

	NZM...			
	1	2	3	4
HIN: 1 NO, 1 NC, 2 NO, 2 NC or 1NO/1NC	1	2	3	3
HIA: 1 NO, 1 NC, 2 NO, 2 NC or 1NO/1NC	1	1	1	2
HIV: 2 S	1	1	1	1

If a motor operator is used at the same time, a configuration with 2 NO, 2 NC or 1 NO/1NC (double auxiliary contact) is restricted on the NZM3 circuit-breaker.

For this observe the latest installation instructions.

NZM1

7

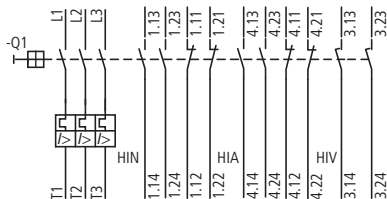

Contact elements M22-K10 (K01, K20, K02, K11) from the RMQ-Titan range from Eaton are used for the auxiliary contacts. Two early-make auxiliary contacts (2 NO) are also available.

NZM2

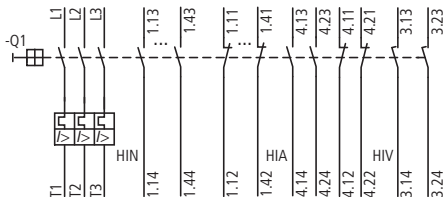

Information on the auxiliary contacts
 → Section "Maximum configuration", page 7-8

Circuit-breakers

Internal circuit diagrams NZM

NZM3

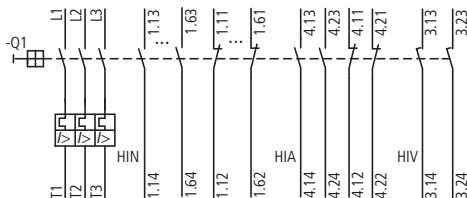

Details about the auxiliary contacts
 → Section "Maximum configuration", page 7-8

NZM4

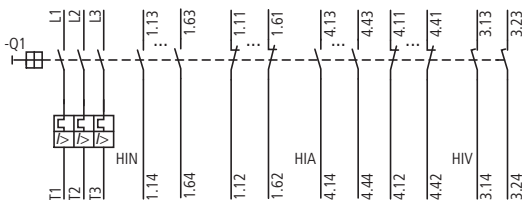

Details about the auxiliary contacts
 → Section "Maximum configuration", page 7-8

7

NZM7

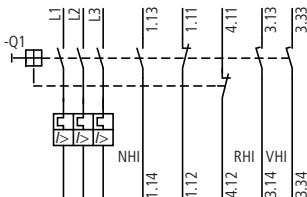

In the NZM7 circuit-breaker two auxiliary contact modules can be fitted as NHI (NC or NO) as well as a trip-indicating auxiliary contact RHI (NC or NO). Contact elements EK01/EK10 are used from the Eaton RMQ range of pilot devices. Early-make auxiliary contacts (2 NO) are also available.

Circuit-breakers

Internal circuit diagrams NZM

NZM10

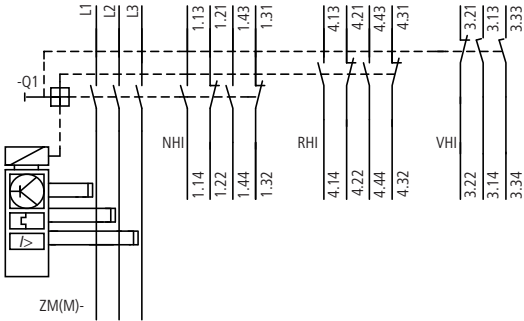

NZM14

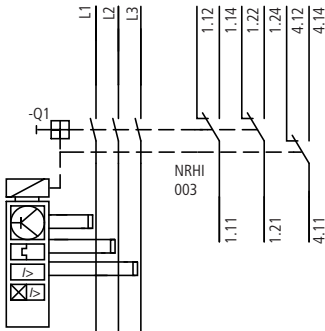

Circuit-breakers

Remote switch-off with voltage release

Remote switch-off with undervoltage releases

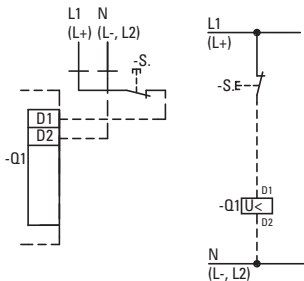

Remote switch-off with shunt release

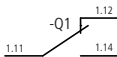
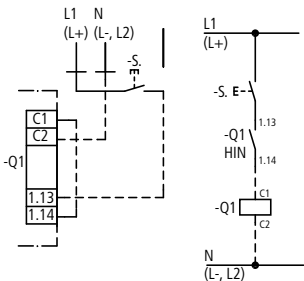

Terminal marking for NQM14

When the switch is in the Off position, the entire control circuit is live.

In order to de-energize the entire actuating circuit when using a shunt release, the control voltage must be connected downstream of the switch terminals.

Circuit-breakers

Remote switch-off with voltage release

Main switch application in processing machines with Emergency-Stop function conform to the IEC/EN 60204-1, VDE 0113 part 1

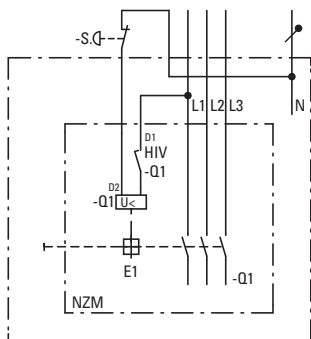

In the OFF position of the main switch all control elements and control cables which exit the control panel are de-energized. The only live components are the control-voltage tap-offs with the control lines to the early-make auxiliary contacts.

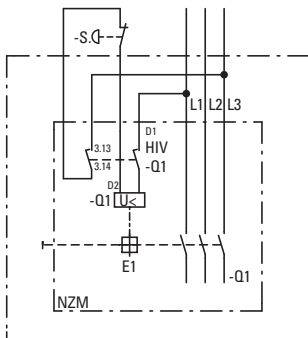

Circuit-breakers

Applications of the undervoltage release

Switch off of the undervoltage release

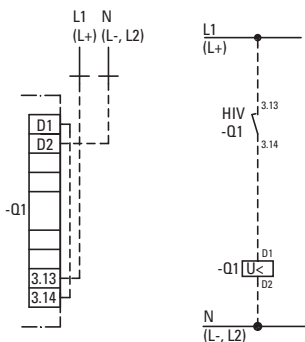

The early-make auxiliary contact HIV (Q1) can – as shown above – disconnect the undervoltage release from the control voltage when the circuit-breaker is in the Off position. If the undervoltage release is to be disconnected in 2 poles, then a further normally open contact of Q1 must be connected between terminals D2 and N. The early-make auxiliary contact HIV (Q1) will always apply voltage to the undervoltage release in time to permit closure.

7

Starting interlock of the undervoltage release

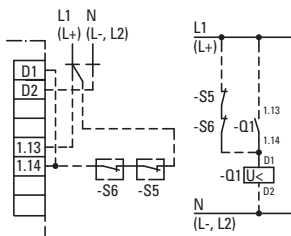

Circuit-breakers with an undervoltage release produce a positive Off position in conjunction with an interlocking auxiliary contact on the starter (S5), ancillary devices on the motor (e.g. brush lifting, S6) or on all switches in multi-motor drives.

The circuit-breaker can only be closed if the starter or switch is in the zero or OFF position.

Circuit-breakers

Switch off of the undervoltage release

Interlocking of several circuit-breakers using an undervoltage release

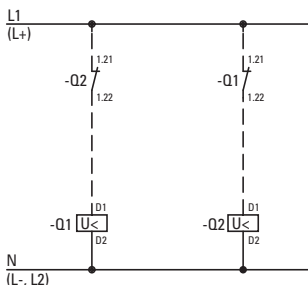
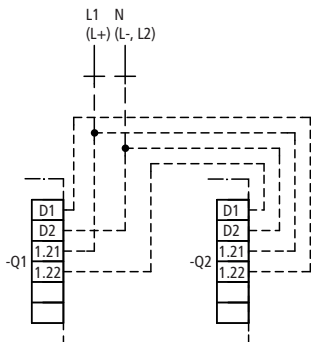

7

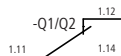

Terminal marking for NZM14

When interlocking 3 or more circuit-breakers, each circuit-breaker must be interlocked with the series-connected normally closed contacts of the auxiliary contacts on the other circuit-breakers using one contactor relay – for contact duplication – per auxiliary contact. If one of the circuit-breakers is closed, the others cannot be closed.

Circuit-breakers

Indication of the contactor state

ON and OFF indication with auxiliary contact – standard HIN (Q1)

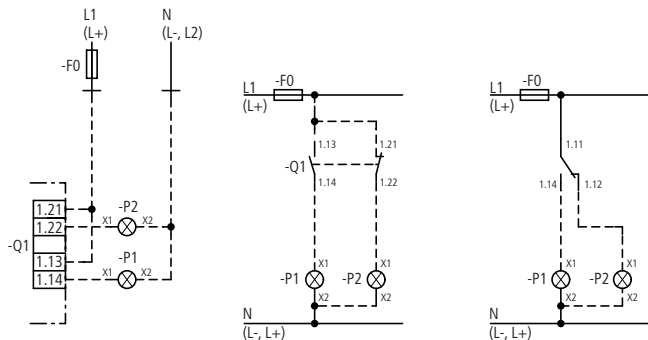

P1: On
P2: Off

Tripped indication using trip-indicating auxiliary contact HIA (Q1)

Trip-indicating auxiliary contacts for mesh network circuit-breaker

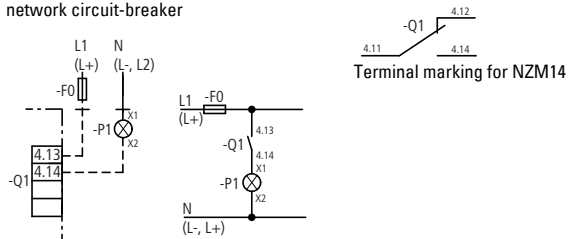

P1: Tripped

Circuit-breakers

Short-time delayed circuit-breaker – internal circuit diagrams

Time-discriminating network topology

Short-time delayed circuit-breakers NZM2(3)(4)/VE, NZM10/ZMV and NZM14 enable a time-discriminating network design with variable stagger times.

Where the prospective short-circuit currents are extremely high, additional installation protection is achieved by instantaneous releases, which respond without any delay.

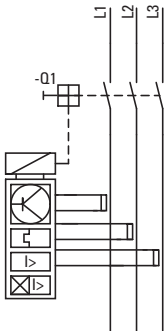

NZM2(3)(4)...-VE...

Trip block VE

Adjustable short-time delay:

0, 20, 60, 100, 200, 300, 500, 750, 1000 ms

NZM10../ZMV..

ZMV trip block only for circuit-breaker types:

NZM10-...N

NZM10...S

Adjustable short-time delay:

0, 10, 50, 100, 150, 200, 300, 500, 750, 1000 ms

NZM14-... S(H)

Standard circuit-breakers

NZM14-...S

NZM14-...H

Adjustable short-time delay:

100, 150, 200, 250, 300 ms

Circuit-breakers

Mesh network circuit-breakers

NZM1, NZM2, NZM3, NZM4, NZM7, NZM10, NZM14

Circuit with capacitor unit and shunt release 230 V, 50 Hz.

The configuration of the capacitor unit which provides the energy for the shunt release of the mesh network

circuit-breaker can be undertaken independently of the circuit-breaker.

Connect NZM-XCM to the supply side!

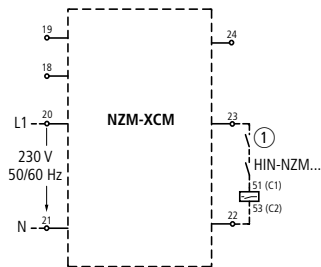
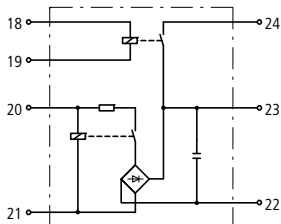

① Mesh network relay

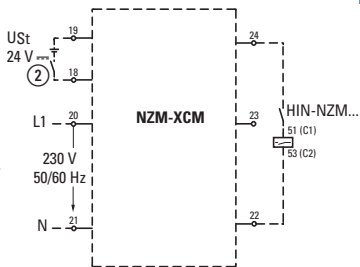

② Mesh network relay with low power contacts

Circuit-breakers

Remote operation with motor operator

Two-wire control (continuous contact)

Three-wire control (pulse contact)

Three-wire control with automatic return to the Off position after tripping

NZM2, NZM3, NZM4, NZM7, NZM10

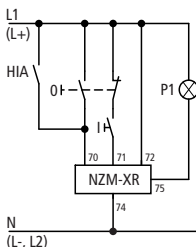
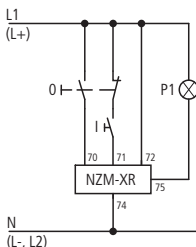
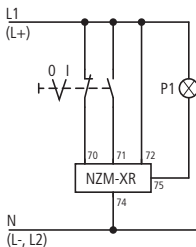

7

NZM14

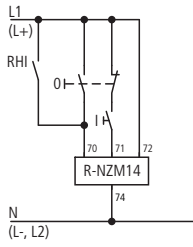
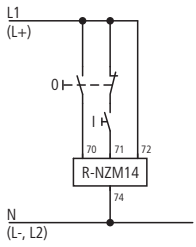
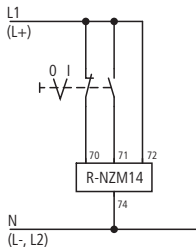

Circuit-breakers

Circuit-breaker as transformer switch

Faults upstream of the low-voltage circuit-breaker, e.g. in the transformer itself, are disconnected by suitable protective devices (e.g. a Buchholz relay) on the high-voltage side. The S7 auxiliary contact of the high-voltage circuit-breaker trips out the NZM transformer switch on the low-voltage side in order to prevent feedback to the high-voltage network. S7 thus isolates the transformer from the

network on both sides. This interlocking with the high-voltage circuit-breaker must always be provided when transformers are being operated in parallel.

If only one normally open contact is available as the auxiliary contact, an undervoltage release must be used instead of the shunt release. At the same time, this provides protection against undervoltage.

Circuit-breakers with shunt release (Q1)

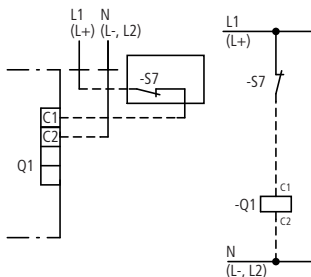

Circuit-breakers with undervoltage release (Q1)

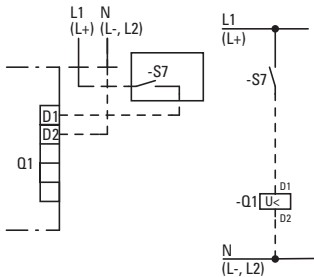

Circuit-breakers

Circuit-breaker with residual current device

Residual current releases combined with circuit-breakers are used for protection against the effects of fault currents. These device combinations fulfill the following tasks:

- Overload protection,
- Short-circuit protection,
- Fault-current protection.

Depending on type the earth-fault releases protect the following:

- Persons against direct contact (basic protection),
- Persons against indirect contact (fault protection),

- Dangers of an earth fault (fire etc.)
- These kinds of earth-fault releases can be attached to the NZM1 and NZM2 circuit-breakers. No auxiliary voltage is required. In the event of a fault, the earth-fault release trips the circuit-breaker, i.e. the main contacts are opened. The circuit-breaker and the earth-fault release must be reset to restore the supply.

7

Part no.	Rated current range A	Rated operational voltage U_e V	Response value of earth fault release $I_{\Delta n}$ A	Delay time t_v ms	Sensitivity
NZM1(-4)-XFI30(R)(U)	15 – 125	200 – 415	0.03	–	Pulsating current
NZM1(-4)-XFI300(R)(U)	15 – 125	200 – 415	0.3	–	
NZM1(-4)-XFI(R)(U)	15 – 125	200 – 415	0.03; 0.1; 0.3 0.5; 1; 3	10; 60; 150; 300; 450	
NZM2-4-XFI30 ¹⁾	15 – 250	280 – 690	0.03	–	
NZM2-4-XFI ¹⁾	15 – 250	280 – 690	0.1; 0.3; 1; 3	60; 150; 300; 450	
NZM2-4-XFI30A ¹⁾	15 – 250	50 – 400	0.03	–	AC/DC
NZM2-4-XFIA ¹⁾	15 – 250	50 – 400	0.1; 0.3; 1	60; 150; 300; 450	

¹⁾ Devices are not dependent on the supply voltage.

Circuit-breakers

Circuit-breaker with residual current device

Circuit-breakers can be used together with residual current releases in three-phase and single-phase systems.

With 2-pole operation it must be ensured that voltage is applied to both terminals required for test functions.

Trip indication is implemented via auxiliary contacts. Circuit-breaker NZM2-4-XFI... has fixed contacts. The NZM1(-4)-XFI... allows two M22-K... contact elements from the Eaton RMO-Titan range to be clipped in.

Contact representation for "not released"
NZM1(-4)-XFI...

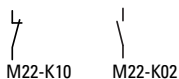

NZM2-4-XFI...

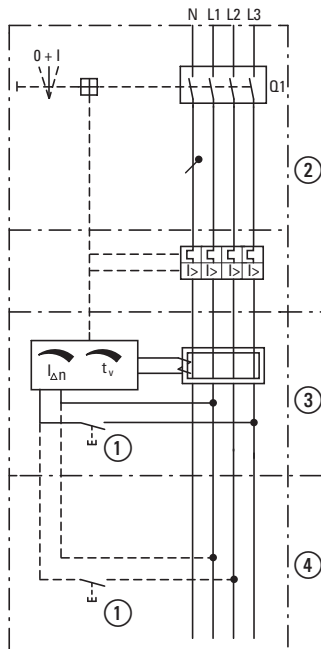

- ① Test button (T)
- ② NZM1(-4)..., NZM2-4...
- ③ +NZM2-4-XFI
- ④ NZM1(-4)-XFI

Circuit-breakers

Circuit-breaker with residual current device

Residual-current relays PFR with ring-type transformers

The area of application for the relay/transformer combination ranges – depending on the standards involved – from personnel protection to fire prevention to general protection of systems for 1 to 4-pole electrical power networks.

There are three different relay types and seven different transformer types available. They cover operating currents ranging from 1 to 1800 A.

The three relay types have the following features:

- Rated fault current 30 mA, permanently set,
- Rated fault current 300 mA, permanently set,

- Rated fault current from 30 mA to 5 A and a delay time from 20 ms to 5 s which is variable in stages.

The residual current relay indicates when a fault current has exceeded the predefined fault current by using a changeover contact. The contact signal can be processed further as a signal in programmable logic controllers or can initiate a trip via the undervoltage release of a circuit-breaker/switch-disconnector. The compact ring-type transformer is placed without any particular space requirement at a suitable position in the power chain.

7

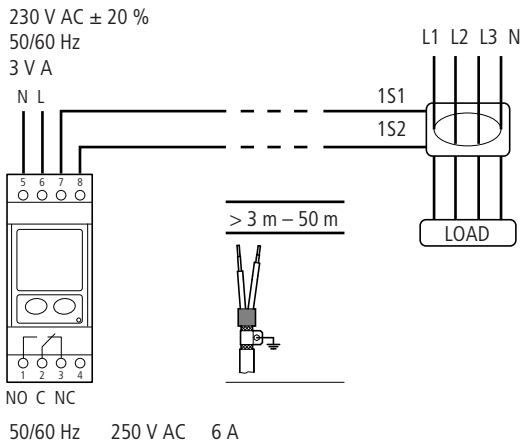

Circuit-breakers

Circuit-breaker with residual current device

Trip of circuit-breakers with shunt release and possible external reset of the relay by a pushbutton (NC contact)

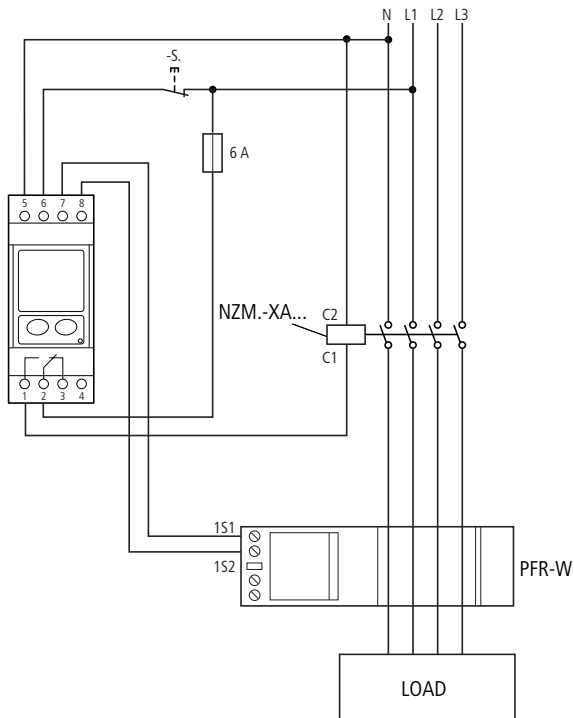

Circuit-breakers

Circuit-breaker with residual current device

Trip of circuit-breakers with undervoltage release and possible external reset of the relay by a pushbutton (NC contact)

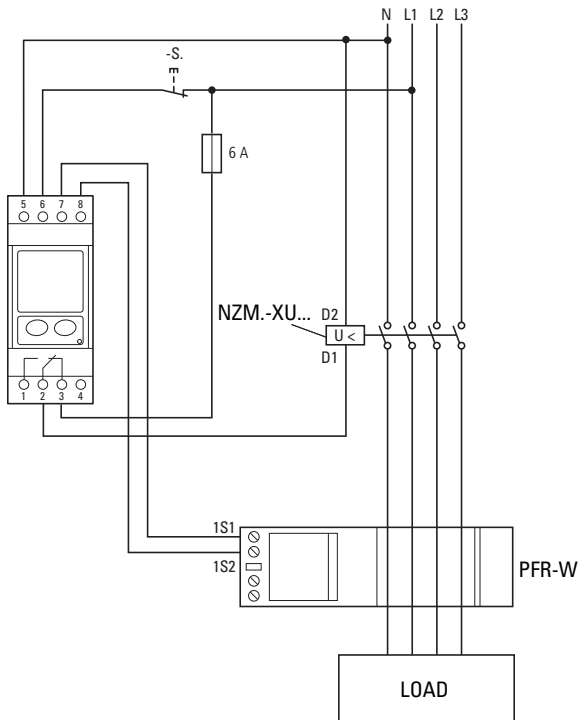

Circuit-breakers

Terminal assignments of IZMX circuit-breakers

Terminal assignment IZMX16

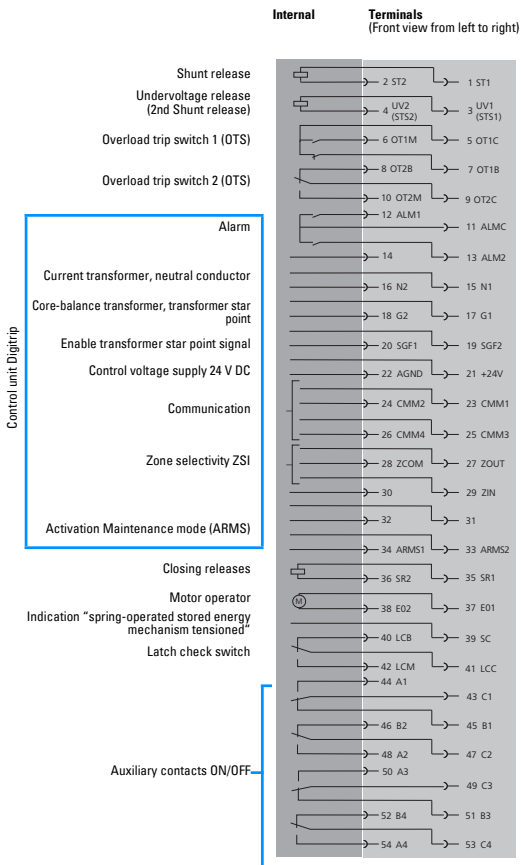

Circuit-breakers

Terminal assignments of IZMX circuit-breakers

Terminal assignment IZMX40

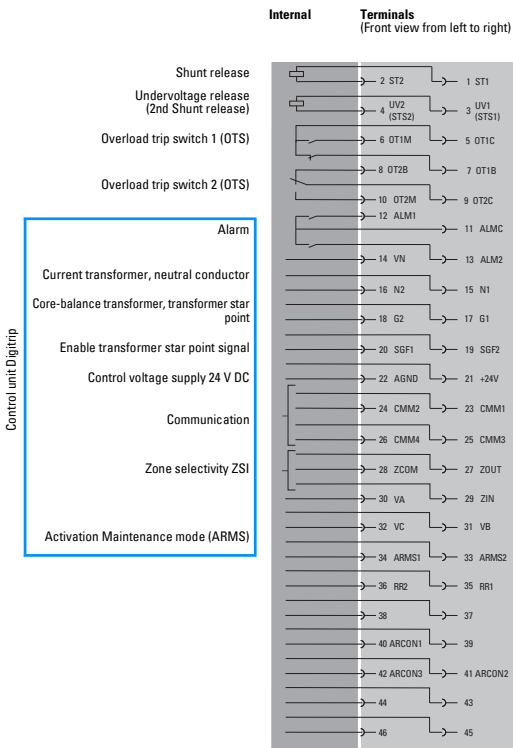

7

Control unit Digitrip

Communication
Wiring of ECAM,
MCAM, PCAM

Circuit-breakers

Terminal assignments of IZMX circuit-breakers

Terminal assignment IZMX40

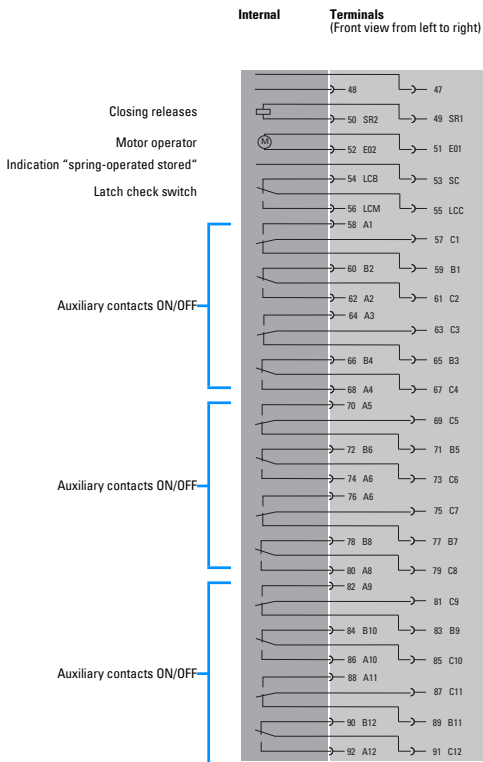

Circuit-breakers

Terminal assignments of IZMX circuit-breakers

Plan view of a mounted MCAM on IZMX...

Terminal diagram Modbus

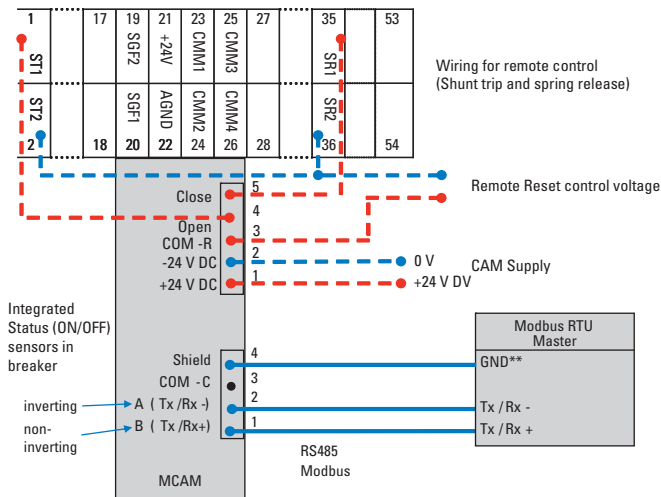

7

Circuit-breakers

Terminal assignments of IZMX circuit-breakers

Plan view of a mounted PCAM on IZMX...

Terminal diagram PROFIBUS DP

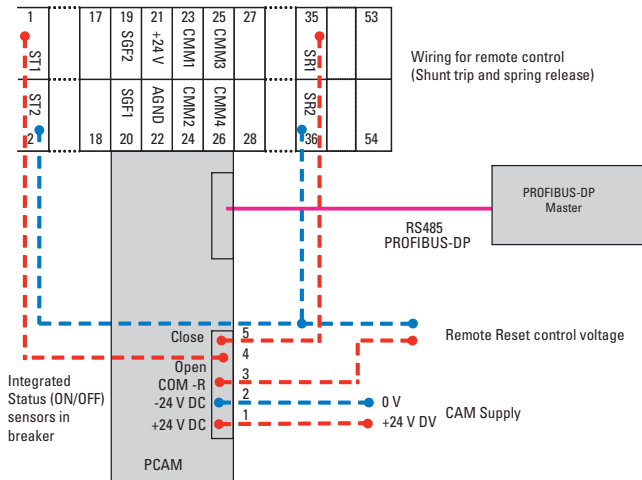

Circuit-breakers

Terminal assignments of IZMX circuit-breakers

Plan view of a mounted ECAM on IZMX...

Terminal diagram Ethernet

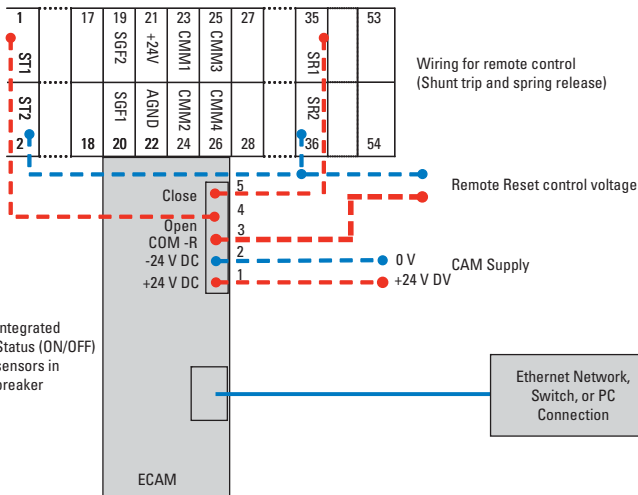

All about Motors

	Page
Motor protection	8-3
Notes on engineering	8-15
Circuit documents	8-19
Power supply	8-21
Control circuit supply	8-24
Contactor markings	8-25
Direct-on-line start of three-phase motors	8-26
Control circuit devices for direct-on-line start	8-34
Star-delta switching of three-phase motors	8-35
Control circuit devices for star-delta starting	8-45
Pole-changing motors	8-47
Motor windings	8-50
Multi-speed contactors	8-53
Multi-speed switch for three-phase motors	8-55
Control circuit devices for multi-speed contactors	8-63
Multi-speed switch for three-phase motors	8-68
Three-phase autotransformer starter	8-83
Three-phase automatic rotor starters	8-88

All about Motors

	Page
Switching of capacitors	8-92
Duplex pump control	8-96
Fully automatic pump control	8-98
Fully automatic main transfer switch with automatic release	8-102

All about Motors

Motor protection

Selection aids



The Eaton selector slide enables you to determine quickly and reliably which motor starter is the most suitable for the application concerned. For this only the operating voltage, the motor rating, the various short-circuit ratings and coordination types are required.

The selector slide can be used for dimensioning devices with short-circuit coordination types 1 and 2. Standard cable cross-sections and permissible cable lengths are stated for the tripping of protective devices in compliance with standards. They can vary according to the installation requirements. The selector slide has several variants of the movable section with numerical values for DOL and reversing starters or star-delta starters. The selector slide can be obtained free of charge. If you prefer to use the selection aid online, this is available at: [www.eaton.com/moeller/support/Online Selection Tools](http://www.eaton.com/moeller/support/Online%20Selection%20Tools)

All about Motors

Motor protection

Overload relay with reclosing lockout

They should always be used where continuous contact devices (two-wire control) are concerned (e.g. pressure and position switches), to prevent automatic restarting. The reset button can be fitted as an external feature in order to make it accessible to all personnel. Overload relays for example are always supplied with manual reset. but can be converted to automatic reset by the user.

Overload relays without reclosing lockout

They can be used only with pulsed contact devices (three-wire control) such as pushbuttons etc., because on these, the cooling of the bimetal strips cannot lead to automatic reconnection.

Special circuitry

Special circuitry such as is found in star-delta switches, individually compensated motors, current transformer-operated overload relays etc. may require that the relay settings deviates from the motor rated operational current.

Frequently recurring operating cycles

It makes motor protection difficult. The relay should be set to higher than rated motor current in view of its shorter time constant. Motors which are rated for a high operating frequency will stand this setting to a certain degree. Although this will not ensure complete protection against overload, it will nevertheless provide adequate protection against non-starting.

Back-up fuses and instantaneous releases

They are needed to protect not only the motor, but also the relay, against the effects of short-circuits. Their maximum rating is shown clearly on every relay and must be adhered to without fail. Higher ratings – chosen for instance according to the cable cross-section – would lead to the destruction of the motor and relay.

The following important questions and answers give a further guide to the behaviour of an installation with motor protection.

To what current must the overload relay properly be set?

To the rated motor current – no higher, no lower. A relay set to too low a figure will prevent the full utilization of the motor; set too high, it will not guarantee full overload protection. If a correctly set relay trips too frequently, then either the load on the motor should be reduced or the motor should be exchanged for a larger one.

When is it right for the overload relay to trip?

Only when the current consumption of the motor increases due to mechanical overloading of the motor, undervoltage or phase failure when the motor is under full load or thereabout, or when the motor fails to start due to a stalled rotor.

All about Motors

Motor protection

When does the overload relay fail to trip in good time although the motor is endangered?

With changes in the motor which do not cause an increase in current consumption: Effects of humidity, reduced cooling due to a reduction in speed or motor dirt, temporary additional external heating of the motor or bearing wear.

What causes destruction of the overload relay?

Destruction will take place only in the event of a short-circuit on the load side of the relay when the back-up fuse is rated too high. In most cases, this will also endanger the contactor and motor. Therefore, always adhere to the maximum fuse rating specified on every relay.

3-pole overload relays should be so connected in the case of single-phase and DC motors so that all three poles of the overload relay carry the current, whether in 1-pole or 2-pole circuits.

1 pole

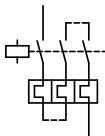

2 pole

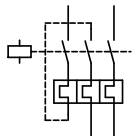

An important characteristic feature of overload relays conforming to IEC/EN 60947-4-1 are the tripping classes (CLASS 10 A, 10, 20, 30). They determine different tripping characteristics for the various starting conditions of motors (normal starting to heavy starting duty).

All about Motors

Motor protection

Pick-up times

Response limits of time-delayed overload relays at all-pole load.

Type of overload relay	Multiple of current setting						Reference ambient temperature
	A	B	C		D		
	t > 2 h starting from cold state of relay	t ≤ 2 h	Tripping classes	Tripping time in minutes	Tripping class	Tripping time in seconds	
			10 A	≤ 2	10 A	2 < T ≤ 10	
			10	≤ 4	10	4 < T ≤ 10	
			20	≤ 8	20	6 < T ≤ 20	
			30	≤ 12	30	9 < T ≤ 30	
Non-ambient temperature compensated thermal relays and magnetic relays	1.0	1.2	1.5		7.2		+40 °C
Ambient temperature compensated thermal relays	1.05	1.2	1.5		7.2		+20 °C

In the case of thermal overload relays with a current setting range, the response limits must apply equally to the highest and the lowest setting of the associated current.

All about Motors

Motor protection

Response limits of 3-pole thermal overload relays at 2-pole load

Type of thermal overload relay	Multiple of current setting				Reference ambient temperature
	A $t > 2$ h, starting from cold state of relay		B $t \leq 2$ h		
Ambient temperature compensated, without phase failure sensitivity	3 poles	1.0	2 poles 1 pole	1.32 0	+20 °C
Non-ambient temperature compensated, without phase failure sensitivity	3 poles	1.0	2 poles 1 pole	1.25 0	+40 °C
Ambient temperature compensated, with phase failure sensitivity	2 poles 1 pole	1.0 0.9	2 poles 1 pole	1.15 0	+20 °C

In the case of thermal overload relays with a current setting range, the response limits must apply equally to the highest and the lowest setting of the associated current.

The point of destruction is the point of intersection between the projected tripping characteristic curves and the multiple of the current.

Overload capacity

Overload relays and releases have heating coils which can be thermally destroyed by overheating. The making and breaking currents of the motor flow in thermal overload relays which are used for motor protection. These currents are between 6 and $12 \times I_e$ (rated operational current), depending on the utilization category and the size of the motor.

The point of destruction depends on the frame size and design. It is usually approximately 12 to $20 \times I_e$.

Short-circuit strength of the main circuit

With currents that exceed the breaking capacity of the motor starter in relation to the utilization category (EN 60947-1, VDE 0660, Section 102, Table 7), it is permissible for the current flowing during the break time of the protective device to damage the motor starter.

The permissible behaviour of starters under short-circuit conditions is defined in the so-called types of coordination (1 and 2). It is common practice to state in

All about Motors

Motor protection

the details of protective devices which type of coordination is ensured by them.

Type 1 coordination

In the event of a short circuit the starter must not endanger persons and installations. It does not have to be fit for renewed operation without repair.

Type 2 coordination

In the event of a short-circuit the starter must not endanger persons and installations. It must be fit for renewed operation. There is a risk of contact weld. for which the manufacturer must give maintenance instructions.

The tripping type of the overload relay must not differ from the given tripping characteristic after a short-circuit.

Short-circuit strength of the auxiliary contact

The manufacturer details the required overcurrent protective device. The combination is subjected to three test disconnection's at 1000 A prospective current with a power factor between 0.5 and 0.7 at rated operational voltage. Welding of the contacts may not occur (EN 60947-5-1, VDE 0660 Part 200).

Motor protection in special applications

Heavy starting duty

An adequate tripping time is essential in order to allow a motor to start up smoothly. In the majority of cases, overload relays such as motor-protective circuit-breakers PKZ(M) or circuit-breakers NZM can be used. The tripping time can be taken from the tripping characteristics in the main catalogue, Industrial Switchgear.

In the case of especially high-inertia motors, whose run-up time exceeds the tripping delay of the above devices, it would be completely wrong to adjust an overload relay which tripped out before the run-up time expired, to a current level higher than the rated motor current. This would, it is true, solve the starting problem, but the motor would no longer be adequately protected during run. However, there are other solutions to the problem:

Current transformer-operated overload relays ZW7

The ZW7 consists of three special saturable core current transformers, supplying an overload relay Z... It is used principally for medium and large motors. Up to two times rated operational current I_e , the transformation ratio I_1/I_2 of the saturable core current transformers is practically linear. Within this range it does not differ from the normal overload relay, i.e. it provides normal overload protection during normal operation. However, within the transformer characteristic range ($I > 2 \times I_e$), the secondary current no longer increases proportionally to the primary current.

This non-linear increase in the secondary current produces an extended tripping delay if overcurrents greater than twice rated operational current occur, and hence permits longer start-up times.

All about Motors

Motor protection

Adjusting the current transformer-operated overload relay ZW7 for lower rated motor current

The setting ranges quoted in the main catalogue, Industrial Switchgear, apply when the incoming cable is looped once through the transformer relay.

If the current transformer-operated overload relay ZW7 is required to provide protection to a motor of below 42 A rating (minimum value in the setting range of 42 A to 63 A), the necessary range adjustment is achieved by looping the incomer several times through the aperture in the relay. The change in the rated motor current quoted on the rating plate is inversely proportional to the number of loops.

Example:

With the ZW7-63 relay, which has a setting range from 42 A to 63 A, a rated motor current of 21 A to 31.5 A can be accommodated by looping the leads twice through the relay.

The motor is a limiting factor with regard to the tripping delay of the current transformer-operated relay and the bridging period. One must ensure that the motor is able to tolerate the high temperature generated by direct starting, for the prescribed starting time. Motor and starting procedure have to be selected carefully when dealing with machines having a very large rotating mass, which are practically the only ones subject to this problem when direct starting is used.

Depending on the operating conditions adequate protection of the motor winding may no longer be given by an overload relay. In that case it must be weighed up whether an electronic overload relay ZEV, ZEB or a thermistor overload relay EMT 6 in conjunction with an overload relay Z meets the requirements.

Example circuits → page 8-10

Bridging of motor protection during starting

For small motors the bridging of the motor protection during starting is more economical. Because of the additional parallel contactor, the overload relay does not carry the full current during starting. Only when the motor has reached full speed is the bridging contactor switched off and the full motor current is then carried by the overload relay. Provided it has been set correctly to the rated motor current, this will ensure full motor protection during operation. Starting must be monitored.

All about Motors

Motor protection

Star-delta switch (YΔ)

1 operating direction

Changeover time with overload relay in position

A: < 15 s

B: > 15 < 40 s

C: > 40 s

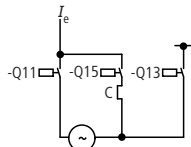
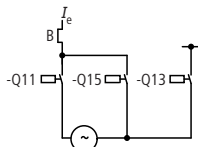
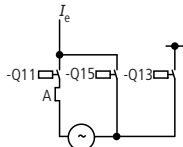

Setting of the overload relay

$0.58 \times I_e$

Full motor protection in

Y (star) position

$1 \times I_e$

Only partial motor protection

in Y position

$0.58 \times I_e$

Motor not protected in

Y position

Multi-speed switches

2 speeds

One tapped winding

3 speeds

2 separate

windings

1 x tapped winding

+ 1 winding

8

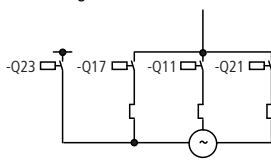
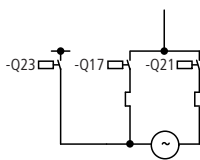
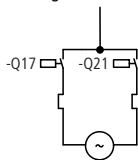

Attention must be paid to short-circuit protective device of the overload relays.

Separate supply input wirings should be provided if required.

All about Motors

Motor protection

Heavy starting duty

ZW7 current transformer-operated overload relays

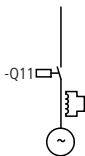

For medium and large motors

Bridging of motor protection during starting

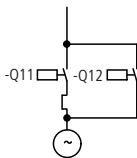

For small motors; no protection during starting

Bridging during starting using bridging relay

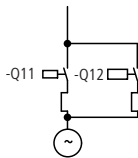

Automatic cut out of the bridging contactor

All about Motors

Motor protection

Individually compensated motor

$$I_w = I_e \times \cos \varphi \quad [\text{A}]$$

$$I_b = \sqrt{I_e^2 - I_w^2} \quad [\text{A}]$$

$$I_c = U_e \times \sqrt{3} \times 2\pi f \times C \times 10^{-6} \quad [\text{A}]$$

$$I_c = \frac{P_c \times 10^3}{\sqrt{3} \times U_e}$$

I_e = Rated motor operational current [A]

I_w = Active current

I_b = Reactive current

I_c = Capacitor-Rated operational current [A]

I_{EM} = Setting current of overload relay [A]

$\cos \varphi$ = Motor power factor

U_e = Rated operational voltage [V]

P_c = Rated capacitor output [kvar]

C = Capacitance of capacitor [μF]

} Proportion of motor rated operational current [A]

8

Capacitor connected

to protective conductor terminals

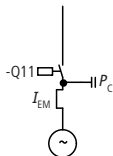

Setting I_{EM} of overload relay

$$I_{EM} = 1 \times I_e$$

Capacitor does not relieve loading of cable between contactor and motor.

to motor terminals

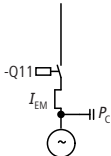

$$I_{EM} = \sqrt{I_w^2 + (I_b - I_c)^2}$$

Capacitor relieves loading of cable between contactor and motor; normal arrangement.

All about Motors

Motor protection

Thermistor overload relay for machine protection

Thermistor overload relays for machine protection are used in conjunction with temperature-dependent semi-conductor resistors (thermistors) for monitoring the temperature of motors, transformers, heaters, gases, oils, bearings etc.

Depending on the application, thermistors have positive (PTC thermistors) or negative (NTC thermistors) temperature coefficients. With PTC thermistors the resistance at low temperature is small. From a certain temperature it rises steeply. On the other hand, NTC thermistors have a falling resistance-temperature characteristic, which does not exhibit the pronounced change behaviour of the PTC thermistor characteristic.

Temperature monitoring of electric motors

Thermistor overload relays for machine protection EMT6 comply with the characteristics for the combination of protective devices and PTC sensors to EN 60947-8. They are therefore suitable for monitoring the temperature of series motors.

When designing motor protection, it is necessary to differentiate between stator-critical and rotor-critical motors:

- **Stator-critical**

Motors whose stator winding reaches the permissible temperature limit quicker than the rotor. The PTC sensor fitted in the stator winding ensures that the stator winding and rotor are adequately protected even with a stalled rotor.

- **Rotor-critical**

Squirrel-cage motors whose rotor in the event of stalling reaches the permissible temperature limit earlier than the stator winding. The delayed temperature rise in the stator can lead to a delayed tripping of the thermistor overload relay for machine protection. It is therefore advisable to supplement the protection of rotor-critical motors by a conventional overload relay. Three-phase motors above 15 kW are usually rotor-critical.

Overload protection for motors in accordance with IEC 204 and IEC/EN 60204. These standards specify that motors above 2 kW used for frequent starting and stopping should be adequately protected for this type of duty. This can be achieved by fitting temperature sensors. If the temperature sensor is not able to ensure adequate protection with stalled rotors, an overcurrent relay must also be provided.

Generally, where there is frequent starting and stopping of motors, intermittent operation and excessive frequency of operation, the use of overload relays in conjunction with thermistor overload relays is to be recommended. In order to avoid premature tripping out of the overload relay in these operating conditions, it is set higher than the predefined operating current. The overload relay then assumes stalling protection; the thermistor protection monitors the motor winding.

All about Motors

Motor protection

Thermistor overload relays for machine protection can be used in conjunction with up to six PTC sensors to DIN 44081 for direct monitoring of temperatures in Ex e

motors compliant with the ATEX directive (94/9 EC). An EC type testing certificate can be provided.

Protection of current and temperature-dependent motor-protective devices

Protection of the motor under the following conditions	Using bimetal	Using thermistor	Using bimetal and thermistor
Overload in continuous operation	+	+	+
Extended starting and stopping	(+)	+	+
Switching to stalled rotor (stator-critical motor)	+	+	+
Switching on stalled rotor (rotor-critical motor)	(+)	(+)	(+)
Single-phasing	+	+	+
Intermittent operation	-	+	+
Excessive operating frequency	-	+	+
Voltage and frequency fluctuations	+	+	+
Increased coolant temperature	-	+	+
Impaired cooling	-	+	+

- + Full protection
- (+) Partial protection
- No protection

All about Motors

Notes on engineering

Three-phase current-automatic starter

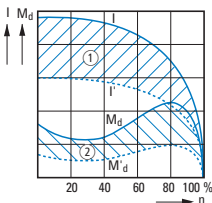

Three-phase autotransformer starter with starting resistors

Single or multi-step resistors are connected upstream of the three-phase squirrel-cage motors to reduce the inrush current and the tightening torque.

With single-step starters, the inrush current is approximately three times the rated motor current. With multi-stage starters, the resistors can be so designed that the inrush current is only 1.5 to 2 times the rated motor current, with a very low level of tightening torque.

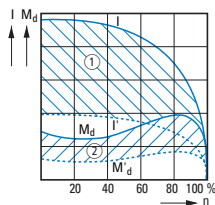

Three-phase autotransformer starters with starting transformers

This type of starting is preferable where the same tightening torque is to be obtained as with the primary series resistors but the inrush current taken from the mains is to be further reduced. A reduced voltage U_a (approximately 70 % of the rated operating voltage) is supplied to the motor when starting via the starting transformer. Thus, the current taken from the mains is reduced to approximately half the direct inrush current.

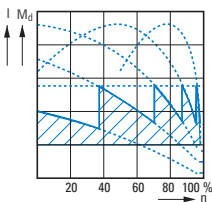

Three-phase automatic rotor starters with starting resistors

Resistors are connected in the rotor circuit of the motor to reduce the inrush current of motors with slipping rotors. The current taken from the mains is thus reduced. In contrast to stator resistance starters, the torque of the motor is practically proportional to the current taken from the mains. The number of steps of the automatic starter is determined by the maximum permissible inrush current and by the type of the motor.

I: Line current

M_d : Torque

n: Speed

① Reduction of the line current

② Reduction of the torque

All about Motors

Notes on engineering

Important data and features of three-phase automatic starters

1) Type of starter	Stator resistance starter (for squirrel-cage motors)			Rotor starter (for slipring rotors)
2) Part no. of starter	Star-delta switches	With starting resistors	With start-up transformers	Rotor resistance starter
3) Number of starting stages	1 only	Normally 1	Normally 1	Selectable (no longer selectable when current or torque have been determined)
4) Voltage reduction at the motor	0.58 x rated operational voltage	Selectable: a x rated operational voltage (a < 1) e.g. 0.58 as with $\Upsilon\Delta$ -switch	Selectable: 0.6/0.7/0.75 x U _a (transformer tappings)	None
5) Inrush current taken from mains	0.33 x inrush current at rated operational voltage	a x inrush current at rated operational voltage	Selectable (see 4) 0.36/0.49/0.56 x inrush current at rated operational voltage	Selectable: from 0.5 to about 2.5 x rated operational current
5a) Inrush current at the motor			Selectable (see 4) 0.6/0.7/0.75 x I _e	
6) Starting torque	0.33 x tightening torque at rated operational voltage	a ² x tightening torque at rated operational voltage	Selectable (see 4) 0.36/0.49/0.56 x tightening torque at rated operational voltage	Selectable (see 5) from 0.5 to pull-out torque
7) Current and torque reduction	Proportional	Current reduction less than torque reduction	Proportional	Current reduction much greater than torque reduction. From pull-out torque to rated speed almost proportional
8) Approximate price (for similar data) DOL starting = 100 (with overload relay, enclosed)	150 – 300	350 – 500	500 – 1500	500 – 1500

All about Motors

Notes on engineering

Switching of capacitors

DIL contactors for capacitors – individual switching

Individual compensation

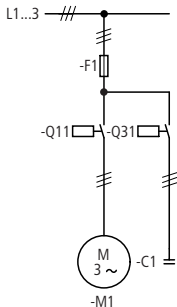

Group compensation

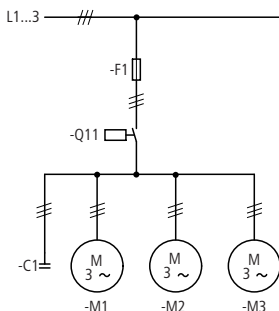

When capacitors are switched on, contactors are heavily stressed by transient current peaks. When a single capacitor is switched on, currents up to 30 times the rated operational current can occur; these can, however, be reliably switched by Eaton DIL contactors.

When installing capacitors, the VDE specification 0560 part 4 (Germany) and the standards which apply to each country should be observed. According to these, capacitors not directly connected to an electrical device which forms a discharge circuit, should be equipped with a rigidly connected discharge device. Capacitors connected in parallel to the motor do not require a discharge device, since discharging is performed via the motor winding. No switch-disconnectors or fuses

must be installed between the discharge circuit and the capacitor.

A discharge circuit or discharge device must reduce the residual voltage of the capacitor to less than 50 V within a minute of the capacitor being switched off.

All about Motors

Notes on engineering

Contactor for capacitor DILK... – Individual and group compensation

Group compensation

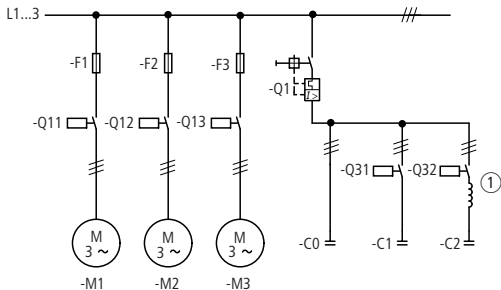

① Additional inductance with standard contactor

8

In the case of group compensation where capacitors are connected in parallel, it must be noted that the charging current is taken not only from the mains but also from the capacitors connected in parallel. This produces inrush current peaks which can exceed 150 times the rated operational current. A further reason for these peak currents is the use of low-loss capacitors as well as the compact construction, with short connecting elements between contactor and capacitor.

Where standard contactors are used, there is danger of welding. Special contactors for capacitors such as those available from Eaton in the DILK... range which can control inrush current peaks of up to 180 times the rated current, should be used here.

If no special contactors are available, the inrush currents can be damped by additional inductance's. This is achieved either by longer input wirings to the

capacitors or by inserting an air-cored coil with a minimum induction of approximately $6 \mu\text{H}$ (5 windings, diameter of the coil approximately 14 cm) between contactor and capacitor. The use of series resistors is another way of reducing high inrush currents.

Use of reactors

Frequently the capacitors in group compensation are provided with reactors to avoid harmonics. The reactors also act to limit the inrush current and normal contactor can be used.

All about Motors

Circuit documents

General

Circuit documents serve to explain the function of circuits or electrical connections. They provide information for the construction, installation and maintenance of electrical installations.

The supplier and the operator must agree on the form in which the circuit documents are to be produced: paper, film, diskette, etc. They must also agree on the language or languages in which the documentation is to be produced. In the case of machines, user information must be written in the official language of the country of use to comply with ISO 12100.

The circuit documents are divided into two groups:

Classification according to the purpose

Explanation of the mode of operation, the connections or the physical position of the apparatus. This consists of:

- Explanatory circuit diagrams,
- Block diagrams,
- Equivalent circuit diagrams,
- Explanatory tables or diagrams,
- Flow diagrams, tables
- Time flow diagrams, tables
- Wiring diagrams,
- Device wiring diagrams,
- Interconnection diagrams,
- Terminal diagrams,
- Assignment diagrams.

Classification according to the type of representation

Simplified or detailed :

- 1-pole or multi-pole representation,
- Connected, semi-connected or separate representation,
- Topographical representation.

In addition to this, there is the process-orientated representation with the function block diagram (see previous pages).

Examples for drawing up circuit documents are given in IEC/EN 61082-1.

Circuit diagrams

Diagrams indicate the voltage-free or current-free status of the electrical installation. A distinction is drawn between:

- Block diagram. Simplified representation of a circuit with its main parts. It shows how the electrical installation works and how it is subdivided.
- Circuit diagram. Detailed representation of a circuit with its individual components, which shows how the electrical installation works.
- Equivalent circuit diagram. Special version of an explanatory circuit diagram for the analysis and calculation of circuit characteristics.

All about Motors

Circuit documents

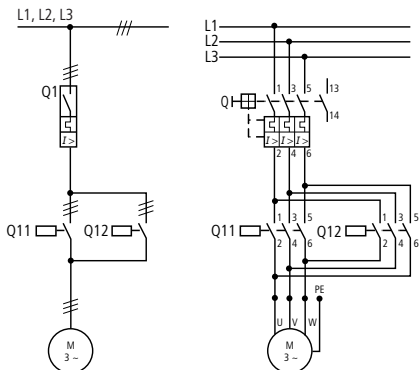

Circuit diagram: 1-pole and 3-pole representation

8

Wiring diagrams

Wiring diagrams show the conductive connections between electrical apparatus. They show the internal and/or external connections but, in general, do not give any information on the mode of operation. Instead of wiring diagrams, wiring tables can also be used.

- Unit wiring diagram. Representation of all the connections within the device or combination of devices.
- Interconnection diagram. Representation of the connections between the device or combination of devices within an installation.
- Terminal diagram. Representation of the connection points of an electrical installation and the internal and external

conductive connections connected to them.

- Location diagram (location diagram). Representation of the physical position of the electrical apparatus, which does not have to be to scale.

You will find notes on the marking of electrical apparatus in the diagram as well as further diagram details in the chapter "Specifications, Formulae, Tables".

All about Motors

Power supply

4-conductor system, TN-C-S

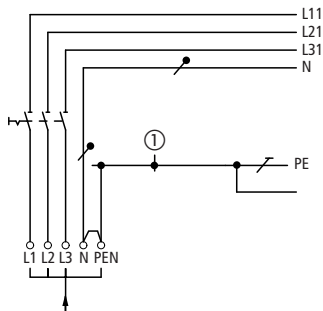

- ① Protective earth conductor
Protective earth terminal in enclosure (not totally insulated)

Overcurrent protective device is required in the input wiring for compliance to IEC/EN 60204-1

5-conductor system, TN-S

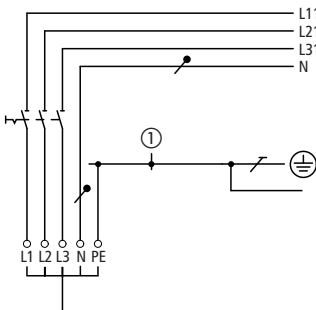

- ① Protective earth conductor
Protective earth terminal in enclosure (not totally insulated)

Overcurrent protective device is required in the input wiring for compliance to IEC/EN 60204-1

All about Motors

Power supply

3-conductor system, IT

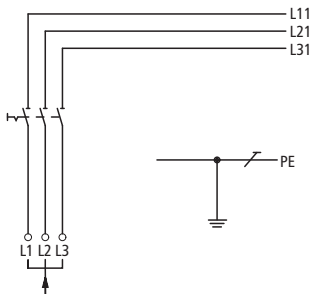

Overcurrent protective device is required in the input wiring for compliance to IEC/EN 60204-1

For all systems: use the N neutral conductor

8

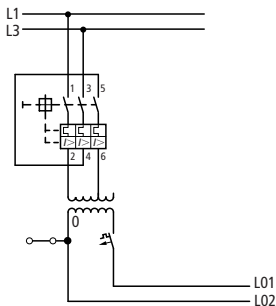

Separate primary and secondary protection

Grounded circuit. In non-grounded circuit, remove link and provide insulation monitoring.

All about Motors

Power supply

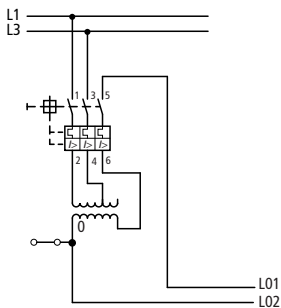

Combined primary and secondary protection

Grounded circuit. In non-grounded circuit, remove link and provide insulation monitoring.

Maximum ratio of $U1/U2 = 1/1.73$

Circuit not to be used with STI/STZ (safety or isolating transformers).

All about Motors

Control circuit supply

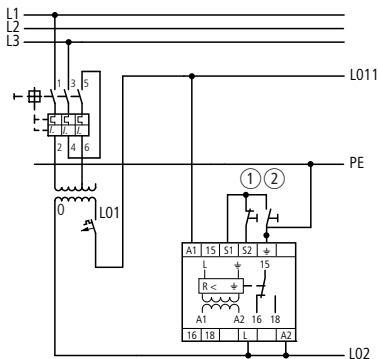

Separate primary and secondary protection, with insulation monitoring on the secondary side

- ① Clear button
- ② Test button

8

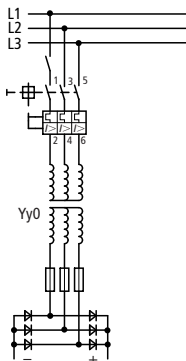

DC power supply with three-phase bridge rectifier

All about Motors

Contactors markings

The contactors in contactor combinations have, in accordance with EN 81346-2 for apparatus and function, the code letter Q, as well as numerical identification, which shows the function of the device (e.g. Q22 = mains contactor with anticlockwise operation for high speed).

With contactor combinations which are made up of several basic types, the basic type is always maintained. Thus, the circuit diagram for a reversing star-delta starter, for example, is formed by combining the basic circuit of the reversing contactor and that of the standard star-delta starter.

Other marking of electrical apparatus:

- for the IEC world → page 10-2
- for North America → page 9-14

All about Motors

Direct-on-line start of three-phase motors

Typical circuits with DIL contactors

Fuseless without overload relay

Short-circuit protection¹⁾ and overload protection by means of PKZM motor-protective circuit-breaker or NZM circuit-breaker.

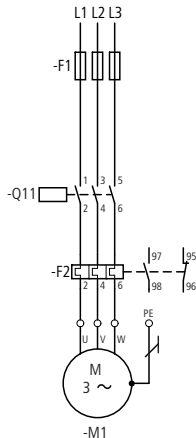
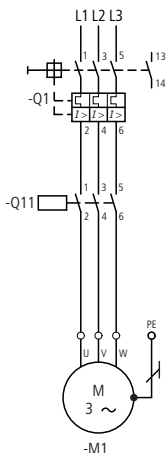

Fuses with overload relay

Short-circuit protection²⁾ for contactor and overload relay by means of fuses F1.

Short-circuit protection³⁾ for contactor by means of fuses F1.

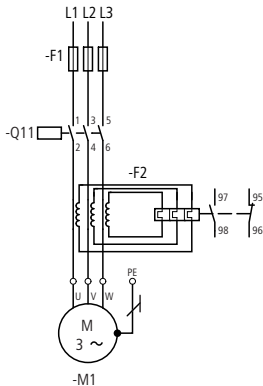

8

- 1) Protective device in the input wiring in accordance with the main catalogue, Industrial Switchgear or IL installation instructions.
- 2) Fuse size in accordance with data on the rating plate of the overload relay.
- 3) Fuse size in accordance with the main catalogue, Industrial Switchgear (Technical data for contactors)

All about Motors

Direct-on-line start of three-phase motors

Typical circuit with bridging of overload relay during starting

Without overload relay

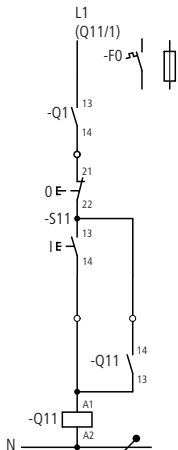

with overload relay

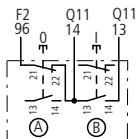
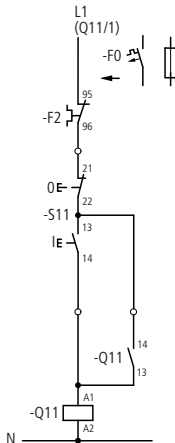

The short-circuit strength capacity of the contacts in the circuit has to be considered when selecting F0.

Double pushbutton

Control circuit device

I: ON

0: OFF

For connection of further actuators

→ Section "Three-wire control",
page 8-34

Method of operation: Actuation of pushbutton I energizes the coil of contactor Q11. The contactor switches on the motor and maintains itself after the

button is enabled via its own auxiliary contact Q11/14-13 and pushbutton 0 (three-wire control contact). Contactor Q11 is de-energized, in the normal course of events, by actuation of pushbutton 0. In the event of an overload, it is de-energized via the normally closed contact 95-96 on the overload relay F2. The coil current is interrupted, and contactor Q11 switches the motor off.

All about Motors

Direct-on-line start of three-phase motors

Application on drive motors with heavy starting duty

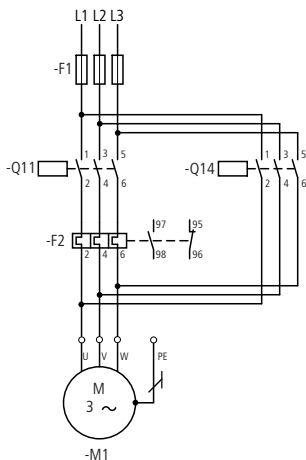

For connection when used with motor-protective circuit-breakers PKZM..., PKE and circuit-breakers NZM(H)... → Section "Fuses with overload relays", page 8-30

All about Motors

Direct-on-line start of three-phase motors

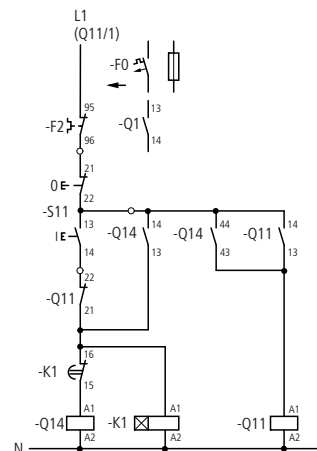

Q14: Bridging contactor
K1: Timing relays
Q11: Mains contactor

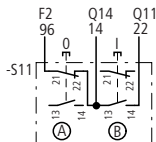

Control circuit device

I: ON

O: OFF

For connection of further actuators

→ Section "Three-wire control",
page 8-34

Function

Actuation of pushbutton I energizes bridging contactor Q14 which then maintains itself via Q14/13-14. At the same time, voltage is applied to the timing relay K1. The mains contactor Q11 is closed by Q14/44-43 and maintains itself via Q11/14-13. When the set time – which corresponds to the start-up time of the motor – has elapsed, the bridging contactor Q14 is disconnected by K1/16-15. K1 is likewise disconnected and, exactly as Q14, can only be energized again after the motor

has been switched off by pressing pushbutton O. The N/C Q11/22-21 prevents Q14 and K1 closing whilst the motor is running. In the event of an overload, normally closed contact 95-96 on the overload relay F2 effects de-energization.

All about Motors

Direct-on-line start of three-phase motors

2 operating directions, DIUL reversing contactor

Fuseless without overload relay

Short-circuit protective device and overload protection by means of motor-protective circuit-breaker PKZM, PKE or circuit-breaker NZM.

Fuse size in the input wiring in accordance with the main catalogue, Industrial Switchgear or AWA installation instructions.

Fuses with overload relays

Short-circuit protection¹⁾ for contactor and overload relay by means of fuses F1.

Short-circuit protection¹⁾ for contactor by means of fuses F1.

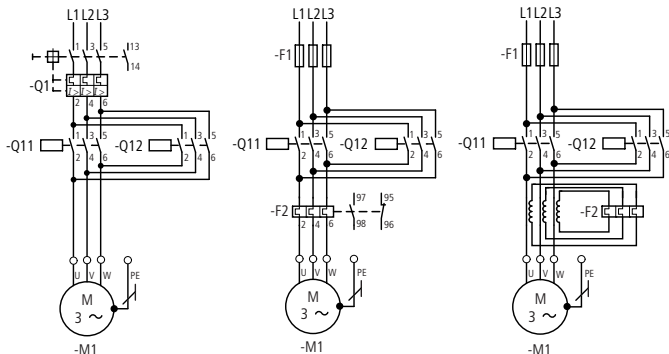

¹⁾ Fuse size in accordance with data on the rating plate of the overload relay F2

All about Motors

Direct-on-line start of three-phase motors

Changing direction of rotation **after** actuation of the 0 pushbutton

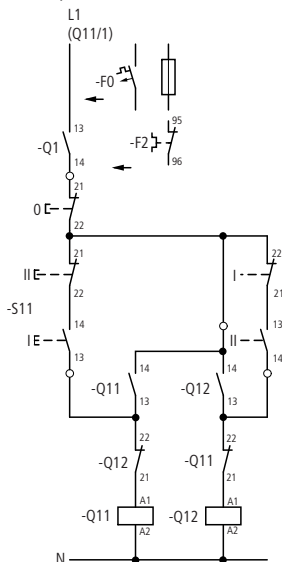

Q11: Mains contactor, clockwise

Q12: Mains contactor,
anticlockwise operation

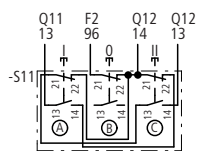

Control circuit device

(three-way pushbutton)
I = Clockwise
0 = Stop

II = anticlockwise operation

Changing direction of rotation **without** actuation of the 0 pushbutton

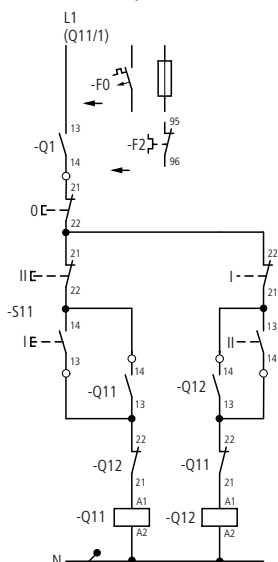

8

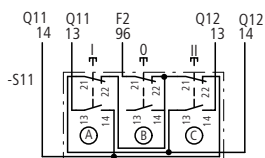

All about Motors

Direct-on-line start of three-phase motors

Method of operation: Actuation of pushbutton I energizes the coil of contactor Q11. It switches on the motor running clockwise and maintains itself after button I is enabled via its own auxiliary contact Q11/14-13 and pushbutton 0 (three-wire control). The normally closed contact Q11/22-21 electrically inhibits the closing of contactor Q12. When pushbutton II is pressed, contactor Q12 closes (motor running anticlockwise). Depending on the

circuit, direction can be changed from clockwise to anticlockwise either after pressing pushbutton 0, or by directly pressing the pushbutton for the reverse direction. In the event of an overload, normally closed contact 95-96 of the overload relay F2 or the normally open contact 13-14 of the motor-protective circuit-breaker or the circuit-breaker will switch.

Operating direction and two speeds (reversing contactor)

Special circuit (tapped winding) for feed drives, etc.

FORWARD: feed or high-speed
RETRACT: high-speed only
STOP: tapped winding

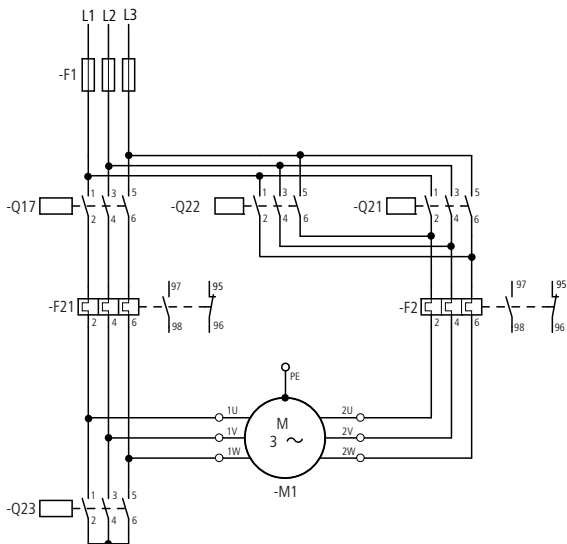

All about Motors

Direct-on-line start of three-phase motors

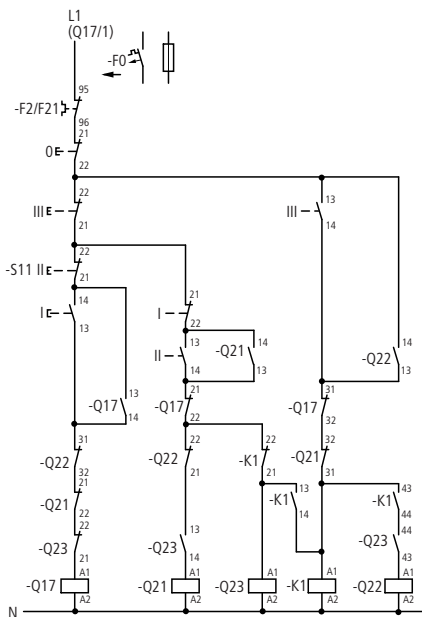

- 0: Stop
- I: Low speed – FORWARD (Q17)
- II: High speed – FORWARD (Q21 + Q23)
- III: High speed – BACK (Q22 + Q23)

- Q17: Feed forward
- Q21: High-speed forward
- Q23: Star contactor
- K1: Contactor relay
- Q22: Retract high-speed

8

Method of operation: Forward travel is initiated by pressing pushbutton I or II according to the speed required. Pushbutton I switches on the feed motion via Q17. Q17 maintains itself via its N/O 13-14. If the feed movement is to occur at high-speed star contactor Q23 is energized via pushbutton II which energizes the high speed contactor Q21 via its N/O Q23/13-14. Both of the contactors are maintained via Q21/13-14. A direct switch over from feed to high-speed during the process is possible.

High-speed reverse is initiated by pushbutton III. Contactor relay K1 picks up and energizes star contactor Q23 via K1/14-13. High-speed contactor Q22 is energized via normally open contacts K1/43-44 and Q23/44-43, and is maintained via Q22/14-13. The reverse motion can only be stopped via pushbutton 0. Direct changeover/reversal is not possible.

All about Motors

Control circuit devices for direct-on-line start

Typical example of circuits with contactors DILM...

Three-wire control

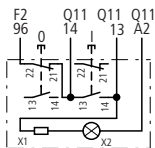

Illuminated pushbutton actuators

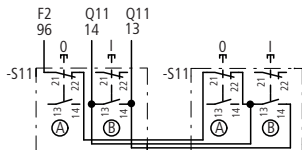

Two double actuator pushbuttons

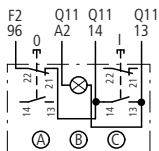

Double actuator pushbutton with indicator light

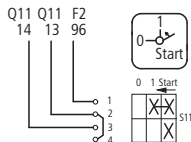

T0-1-15511 spring-return switch with automatic return to position 1

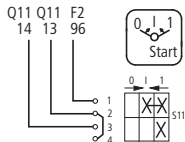

T0-1-15366 spring-return switch with automatic return to position of rest

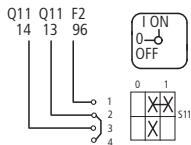

Changeover switch T0-1-15521 with fleeting contact in the intermediate position

Two-wire control

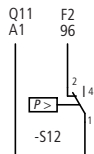

MCS pressure switches

All about Motors

Star-delta switching of three-phase motors

Star-delta switch with overload relay

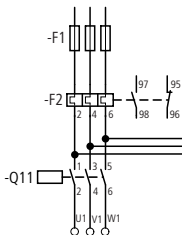
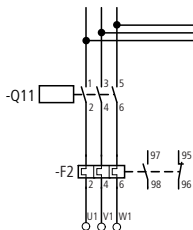

Arrangement in the motor line

In a standard circuit configuration, the star-delta switch with overload relay, i.e. a thermally delayed overcurrent relay, is installed in the cables leading to the motor terminals U1, V1, W1 or V2, W2, U2. The overload relay can also be operated in a star circuit as it is usually connected in series with the motor winding and the relay current flowing through it = rated motor current x 0.58.

The complete circuit diagram → Section "Automatic star-delta switches SDAINL", page 8-37.

Arrangement in the mains supply line

Instead of the arrangement in the motor line, the overload relay can be placed in the **mains supply line**. The section shown here indicates how the circuit diagram differs from that on → Section "Automatic star-delta switches SDAINL", page 8-37.

For drives where the F2 relay trips out when the motor is starting in the star connection, the F2 relay rated for the **rated motor current can be switched in the mains line**.

The tripping delay is thus increased by approximately four to six times. In the star connection, the current also flows through the relay but here the relay does not offer full protection since its limit current is increased to 1.73 times the phase current. It does, however, offer protection against non-starting.

All about Motors

Star-delta switching of three-phase motors

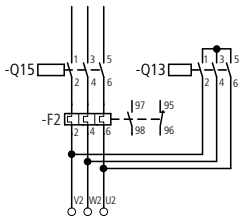

Configuration in the delta connection

Instead of the arrangement in the motor line or mains supply line, the overload relay can be placed in the delta connection. The cutout shown here indicates the modified circuit diagram from → Section "Automatic star-delta switches SDAINL", page 8-37. When heavy, long-starting procedures are involved (e.g. for centrifuges) the F0.58 relay, rated for relay current = rated motor current x 2, can also be connected in the connecting cables between the delta contactor Q15 and the star contactor Q13. In the star connection no current then flows through the F2 relay. The motor is therefore not protected when starting. This connection is always used when exceptionally heavy and long starting procedures are involved and when saturable core current transformer-operated relays react too quickly.

All about Motors

Star-delta switching of three-phase motors

Automatic star-delta switches SDAINL

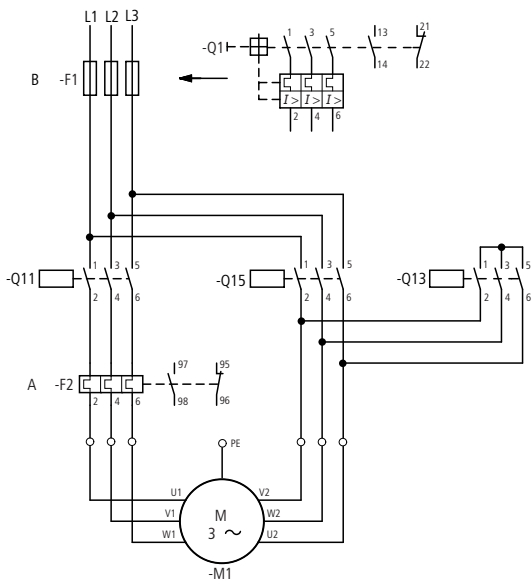

8

Arrangement and rating of protective devices

Position A	Position B
$F2 = 0.58 \times I_e$ with F1 in position B $t_a \leq 15$ s	$Q1 = I_e$ $t_a > 15 - 40$ s
Motor protection in Υ - and Δ -configuration	Only partial motor protection in Υ -configuration

Rating of switchgear

$$Q11, Q15 = 0.58 \times I_e$$

$$Q13 = 0.33 \times I_e$$

All about Motors

Star-delta switching of three-phase motors

Further notes on the configuration of the overload relay → Section "Automatic star-delta switches SDAINL", page 8-37

SDAINLM12 to SDAINLM55

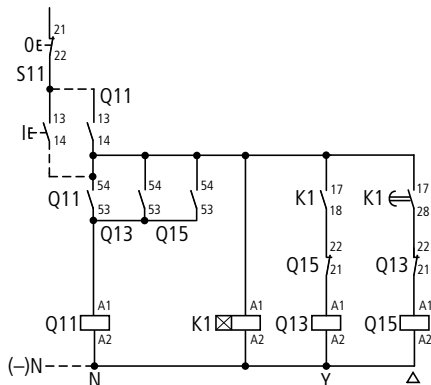

Pushbutton

- K1: Timing relay
approx. 10 s
- Q11: Mains contactor
- Q13: Star contactor
- Q15: Delta contactor
- Double pushbutton

Function

Pushbutton I energizes timing relay K1. The normally open contact K1/17-18 (instantaneous contact) which applies voltage to star contactor Q13, which closes and applies voltage to mains contactor Q11 via normally open contact Q13/14-13. Q11 and Q13 maintain themselves via the N/O Q11/14-13 and Q11/44-43. Q11 applies mains voltage to motor M1 in star connection.

SDAINLM70 to SDAINLM260

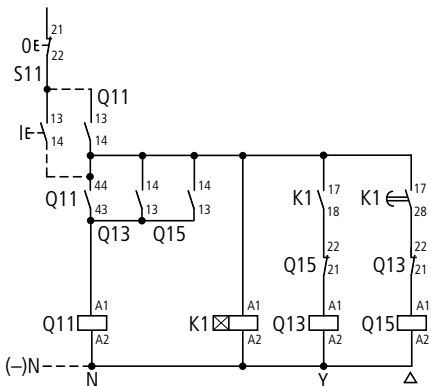

All about Motors

Star-delta switching of three-phase motors

SDAINLM12 to SDAINLM260

Two-wire control

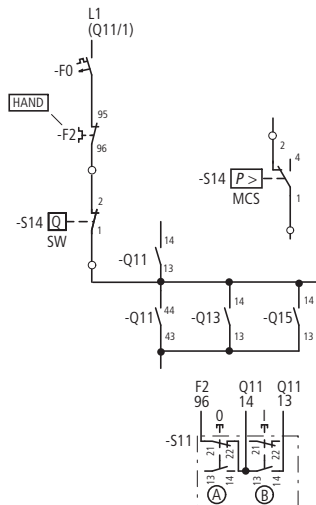

For connection of further control circuit

devices → Section "Control circuit devices for star-delta starting", page 8-45

Double pushbutton

Control circuit device

I = ON

O = OFF

When the set changeover time has elapsed, K1/17-18 opens the circuit of Q13 and after 50 ms closes the circuit of Q15 via K1/17-28. Star contactor Q13 drops out. Delta contactor Q15 closes and switches motor M1 to full mains voltage. At the same time, normally closed contact Q15/22-21 interrupts the circuit of Q13 thus interlocking against renewed switching on while the motor is running.

The motor cannot start up again unless it has previously been disconnected by pushbutton O, or in the event of an overload by the normally closed contact 95-96 of overload relay F2, or via normally open contact 13-14 of the motor-protective circuit-breaker or standard circuit-breaker.

All about Motors

Star-delta switching of three-phase motors

Automatic star-delta switches SDAINL EM

Pushbutton actuators

Maintained contact sensors

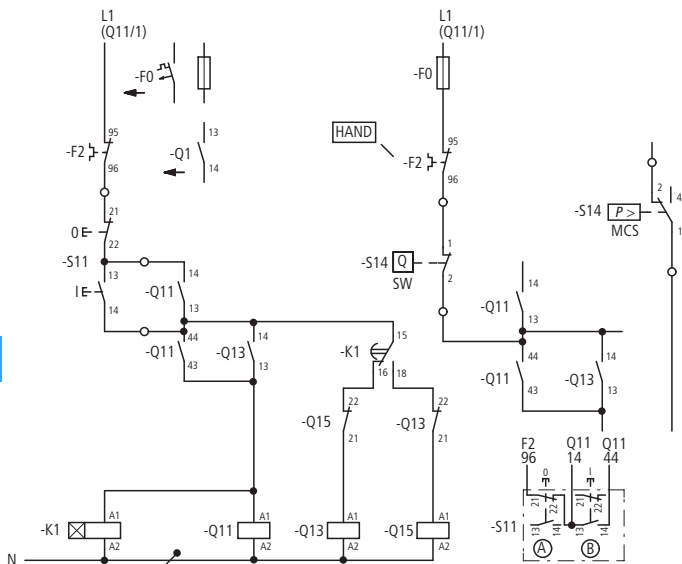

8

K1: Timing relay approx. 10 s
 Q11: Mains contactor
 Q13: Star contactor
 Q15: Delta contactor

Double pushbutton
Control circuit device
 I = ON
 O = OFF

All about Motors

Star-delta switching of three-phase motors

For connection of further control circuit devices → Section "Control circuit devices for star-delta starting", page 8-45

Function

Pushbutton I energizes star contactor Q13, the normally open contact Q13/14-13 applies voltage to mains contactor Q11. Q11 closes and applies mains voltage to motor M1 in star connection. Q11 and Q13 maintain themselves via normally open contact Q11/14-13 and Q11 additionally via Q11/44-43 and pushbutton 0. Timing relay Q11 is energized at the same time as mains contactor K1. When the set changeover time has elapsed, K1 opens the circuit of Q13 via the changeover contact 15-16 and closes the circuit of Q15 via 15-18.

Delta contactor Q15 closes and switches motor M1 to full mains voltage. At the same time, normally closed contact Q15/22-21 interrupts the circuit of Q13 thus interlocking against renewed switching on while the motor is running.

The motor cannot be started up again unless it has previously been disconnected by pushbutton 0, or in the event of an overload, by the normally closed contact 95-96 of the overload relay F2, or via the normally open contact 13-14 of the motor-protective circuit-breaker or circuit-breaker.

All about Motors

Star-delta switching of three-phase motors

Automatic reversing star-delta switches

2 operating directions

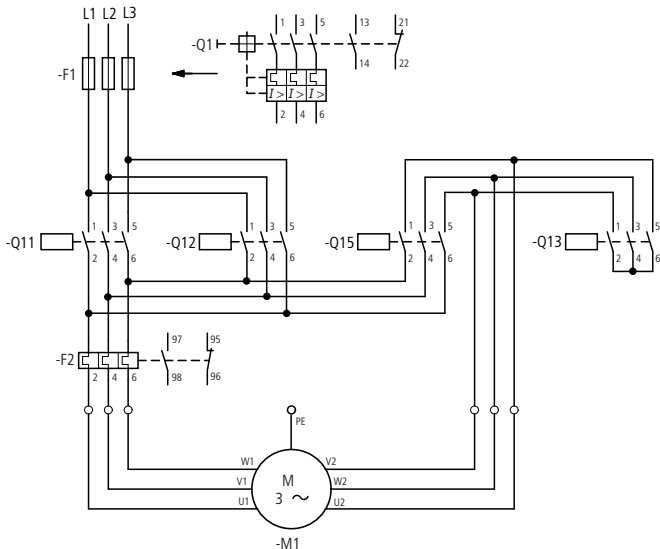

8

Rating of switchgear

Q11, Q12: I_e

F2, Q15: $0.58 \times I_e$

Q13: $0.33 \times I_e$

The maximum motor output is limited by the upstream reversing contactor, and is lower than with automatic star-delta switches for only one direction of operating direction.

Standard version: Relay current = motor rated operational current \times 0.58

For other arrangements of overload relay

→ Section "Star-delta switch with overload relay", page 8-35

All about Motors

Star-delta switching of three-phase motors

Changing direction of rotation after actuation of the 0 pushbutton

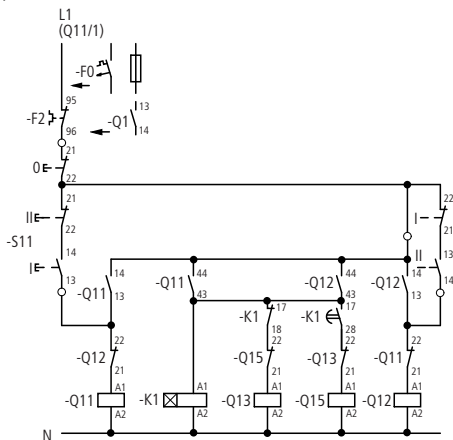

Three-way pushbutton
Control circuit devices

I = clockwise

0 = Stop

II = anticlockwise

operation

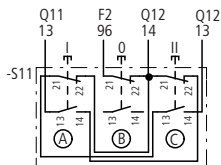

All about Motors

Star-delta switching of three-phase motors

Changing direction of rotation without actuation of the 0

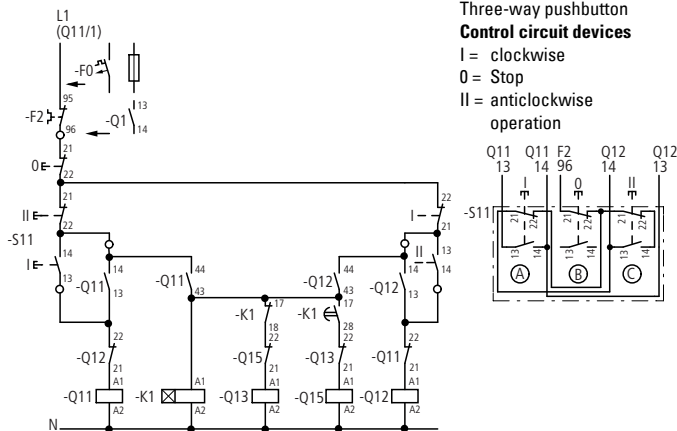

8

For connection of further actuators

→ Section "Control circuit devices for star-delta starting", page 8-45

Function

Pushbutton I energizes contactor Q11 (e.g. clockwise). Pushbutton II energizes contactor Q12 (e.g. anticlockwise operation). The contactor first energized applies voltage to the motor winding and maintains itself via its own auxiliary contact 14-13 and pushbutton 0. The normally open contact 44-43 fitted to each mains contactor energizes the star contactor Q13. Q13 energizes and switches on motor M1 in the star connection. At the same time, timing relay K1 is triggered. When the set changeover time has elapsed, K1/17-18 opens the circuit of Q13.

Q13 drops out. K1/17-28 closes the circuit of Q15.

Delta contactor Q15 energizes and switches motor M1 to the delta configuration, i.e. full mains voltage. At the same time, normally closed contact Q15/22-21 interrupts the circuit of Q13, thus interlocking against renewed switching on while the motor is running. Motor direction can be changed, either after pressing pushbutton 0, or by direct actuation of the reverse button, depending upon the circuit. In the event of an overload, disconnection is effected by the normally closed contact 95-96 of the overload relay F2.

All about Motors

Control circuit devices for star-delta starting

Automatic star-delta switches

Pulse encoder

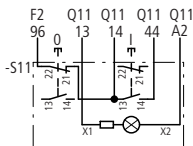

Illuminated pushbutton
actuators

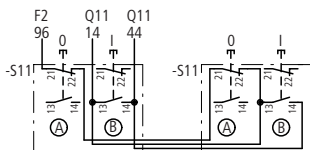

Two double actuator pushbuttons

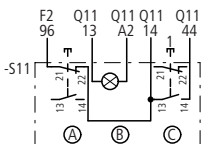

Double actuator pushbutton
with indicator light

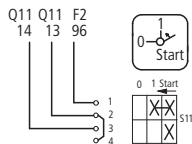

Spring-return switch
T0-1-15511 with automatic
return to position 1.

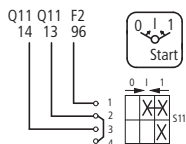

Spring-return switch
T0-1-15366 with automatic
return to position of rest.

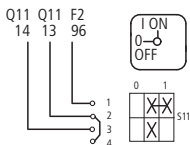

Changeover switch
T0-1-15521 with fleeting
contact in the intermediate
position

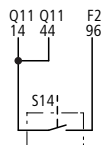

e.g. selector switch
Cam switch T
LS position switches
MCS pressure switches

All about Motors

Control circuit devices for star-delta starting

Three-phase current-reversing contactor-reversing star-delta switch

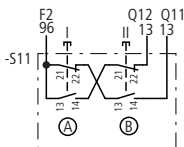

Two-way pushbutton¹⁾ without self-maintaining circuit (inching) for use only with reversing contactors

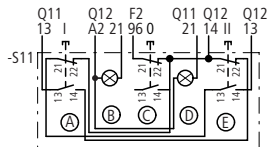

Three-way pushbutton with indicator light. Reversing after actuation of pushbutton 0

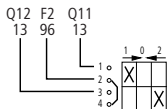

FS 4011



FS 684

Spring-return switch¹⁾
T0-1-8214, without self-maintaining circuit (inching)
automatic return to off position only for reversing contactors

Changeover switch¹⁾
Switch T0-1-8210 remains in position 1 or 2

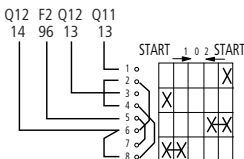

FS 140660

Spring-return switch
T0-2-8177 with automatic return to position 1 or 2

Limit switch

Connected by removing the links between the contactor terminals Q11/13 and Q12/22 and between Q12/13 and Q11/22 and interposing the position switches.

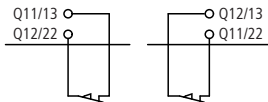

¹⁾ Overload relays always with reclosing lockout

All about Motors

Pole-changing motors

The speed is determined by the number of poles on three-phase asynchronous motors. Several speeds can be obtained by

altering the number of poles.
The usual types are:

two speeds 1:2	1 convertible tapped winding
2 speeds as required	2 separate windings
three speeds	1 convertible tapped winding 1:2, a separate winding
four speeds	2 convertible tapped windings 1:2
two speeds	Tapped winding

The various tapped winding configurations give differential output ratios for the two speeds.

Type of connection Δ/Y Y Y/Y Y
Output ratio 1/1.5–1.8 0.3/1

The $\Delta/$ -connection comes nearest to satisfying the most usual requirement for constant torque. It has the additional advantage that, because nine terminals are available, y/d starting can be used to provide smooth starting or to reduce the starting current for the low speed condition (→ Section "Motor windings", page 8-50).

The Y/Y -connection preferred for better matching of the motor to machines in which the torque increases by a quadratic factor (pumps, fans, rotary compressors). All multi-speed switches can be used for both types of connection.

2 speeds – separate windings

In theory, motors with separate windings allow any combination of speed and any output ratio. Both windings are arranged in y connection and are completely independent of one another.

Preferred speed combinations are:

Motors with tapped winding	1500/3000	–	750/1500	500/1000
Motors with separate windings	–	1000/1500	–	–
No. of poles	4/2	6/4	8/4	12/6
Code no. low/high	1/2	1/2	1/2	1/2

The code numbers are prefixed to the main notations to denote increasing speed.

Example: 1U, 1V, 1W, 2U, 2V, 2W
Comparable to EN 60034-8

All about Motors

Pole-changing motors

Motor circuit

Connection A

Selection of low and high speed only from zero. No return to low speed, only to zero.

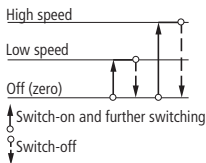

Connection B

Selection of either speed from zero. Switching from low to high speed possible. Return only to zero.

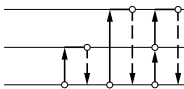

Connection C

Selection of either speed from zero. Switching back and forward between low and high speed (high braking torque). Return also to zero.

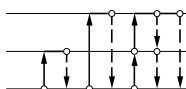

three speeds

The 1:2 - speeds tapped windings are supplemented by the speed of the separate winding. This speed can be below, between or above the two tapped winding

speeds. The connection must consider it (→ Figure, page 8-78).

Preferred speed combinations are:

Speeds	1000/1500/3000	750/1000/1500	750/1500/3000	= separate winding (in the circuit diagrams)
No. of poles	6/4/2	8/6/4	8/4/2	
Connection	X	Y	Z	

All about Motors

Pole-changing motors

Motor circuit

Connection A

Selection of any speed only from zero. Return only to zero.

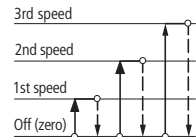

Connection B

Selection of any speed from zero and from low speed. Return only to zero.

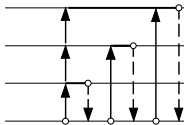

Connection C

Selection of any speed from zero and from low speed. Return to low speed (high braking torque) or to zero.

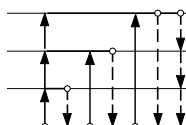

▲ Switch-on and further switching
 ▼ Switch-off

four speeds

The 1:2-speeds tapped windings can follow in sequence or overlap, as the following examples show:

1st winding	500/1000	2nd winding	1500/3000 = 500/1000/1500/3000
or			
1st winding	500/1000	2nd winding	750/1500 = 500/750/1000/1500

For motors having 3 or 4 speeds the non-connected winding has to be opened at certain pole ratios to avoid inductive circulating currents. This is achieved via additional motor terminals. A series of cam switches is equipped with this connection (→ Section "Multi-Speed Switches", page 4-7).

All about Motors

Motor windings

Tapped winding

2 speeds

Motor circuit

2 speeds

2 separate windings

Tapped winding

with Υ Δ -starting at low speed

Low speed Δ

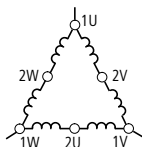

Low speed Υ

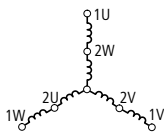

Low speed

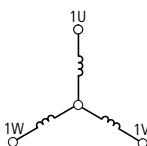

Low speed Υ

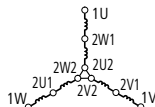

High speed

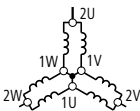

High speed

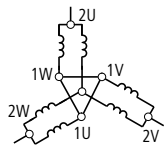

High speed

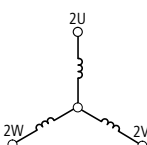

Low speed Δ

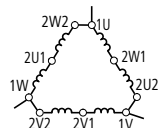

8

→ Figure, page 8-55

→ Figure, page 8-55

→ Figure, page 8-59

High speed

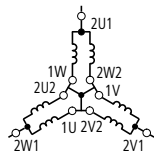

→ Figure, page 8-68

All about Motors

Motor windings

Tapped winding

3 speeds

Motor circuit X

2 windings, medium and high speed – tapped winding

2

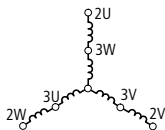

or 2

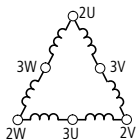

Low speed

Separate winding

1

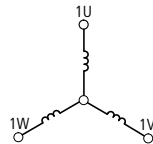

→ Figure, page 8-77

Motor circuit Y

2 windings, low and high speed – tapped winding

2

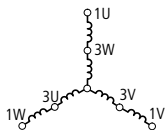

or 2

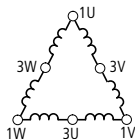

Medium speed

Separate winding

1

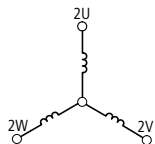

→ Figure, page 8-79

Motor circuit Z

2 windings, low and medium speed – tapped winding

2

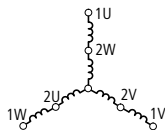

or 2

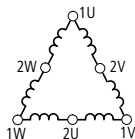

High speed

Separate winding

1

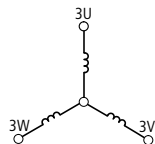

→ Figure, page 8-81

Notes

All about Motors

Multi-speed contactors

Certain operating sequences for pole-changing motors may be necessary, or undesirable, depending on the nature of the drive. If, for example, the starting temperature rise is to be reduced or high inertia loads are to be accelerated, it is advisable to switch to low speed first and then to high speed.

It may be necessary to prevent switching from high to low speed in order to avoid oversynchronous braking. In other cases, it should be possible to switch each speed on and off directly. The operating

sequence and indexing facilities of cam switches allow for these possibilities. Multi-speed contactor switches can achieve these connecting by interlocking with suitable control circuit devices.

Fuse protection of the overload relays

When a common fuse is used in the input wiring, it must not be larger than the back-up fuses specified on the nameplate of either overload relay, otherwise each relay must be protected by its own back-up fuse, as shown in the diagram.

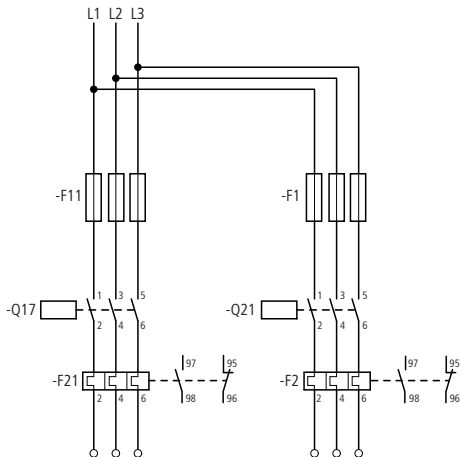

All about Motors

Multi-speed contactors

Fuseless surface mounting

Pole-changing motors can be protected against short-circuits and overloads by motor-protective circuit-breakers PKZ/PKE or circuit-breakers NZM. These provide all

the advantages of a fuseless circuit. Normally, the fuse in input wiring protects the switches from welding.

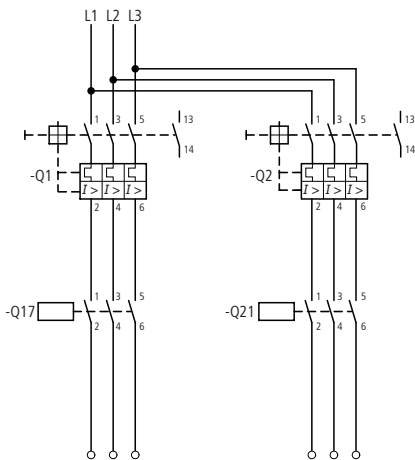

All about Motors

Multi-speed switch for three-phase motors

Tapped winding, 1 operating direction, 2 speeds

Multi-speed contactors

Fuseless, without overload relay, with motor-protective circuit-breaker or circuit-breaker.

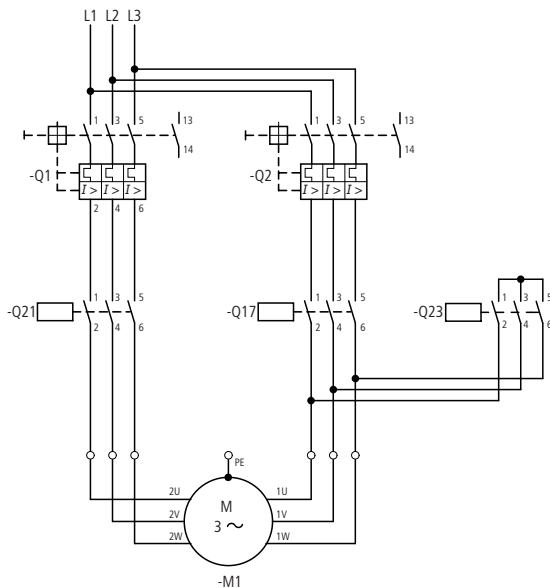

→ Section "Motor windings", page 8-50

Synchronous speeds

One multi-speed winding

All about Motors

Multi-speed switch for three-phase motors

Motor terminals	1U, 1V, 1W	2U, 2V, 2W
Amount of poles	12	6
rpm	500	1000
Amount of poles	8	4
rpm	750	1500
Amount of poles	4	2
rpm	1500	3000
Contactors	Q17	Q21, Q23

Rating of switchgear

Q2, Q17: I_1 (low speed)

Q1, Q21: I_2 (high speed)

Q23: $0.5 \times I_2$

All about Motors

Multi-speed switch for three-phase motors

Connection A (→ Figure, page 8-49)

1 three-way pushbutton

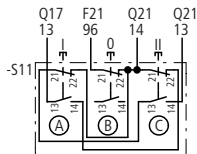
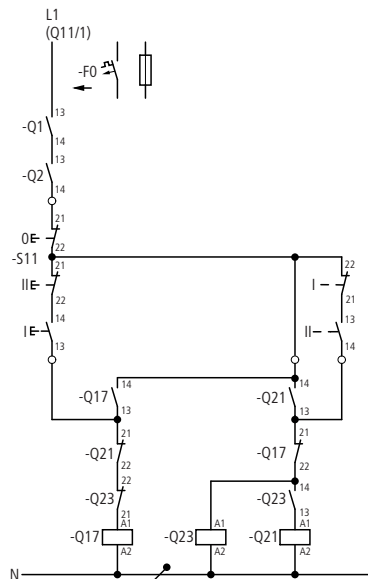

Three-way pushbutton

I: Low speed (Q17)

O: Stop

II: high speed (Q21 + Q23)

Q17: Mains contactor, low speed

Q23: Star contactor

Q21: Mains contactor, high speed

For connection of further actuators

→ Figure, page 8-63, → Figure, page 8-64, → Figure, page 8-65

Function

Pushbutton I energizes mains contactor Q17 (low speed). Q17 maintains itself via its N/O 13-14. Pushbutton II energizes star contactor Q23 and via its N/O 13-14 mains contactor Q21. Q21 and Q23 maintain themselves via N/O 13-14 of Q21.

Speed can be changed either after pressing pushbutton 0 (connection A) or directly by pressing the appropriate pushbutton (connection C), depending upon the circuit. The motor can be switched off either by pressing pushbutton 0, or in the event of an overload, by N/O 13-14 of the circuit-breaker.

All about Motors

Multi-speed switch for three-phase motors

Connection C (→ Figure, page 8-49)

1 three-way pushbutton

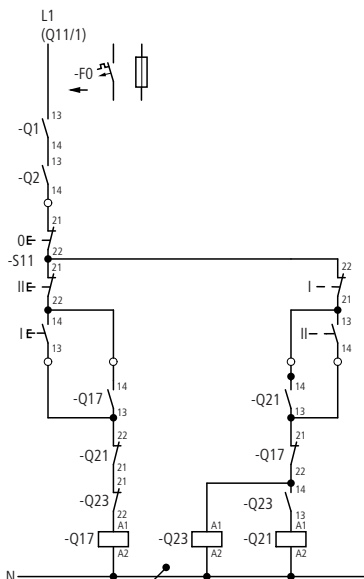

Q17: Mains contactor, low speed

Q23: Star contactor

Q21: Mains contactor, high speed

For connection of further actuators

→ Figure, page 8-66

Three-way pushbutton

I: Low speed (Q17)

O: Stop

II: High speed (Q21 + Q23)

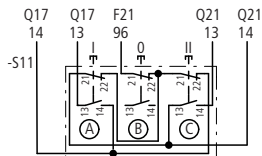

All about Motors

Multi-speed switch for three-phase motors

2 separate windings, an operating direction, 2 speeds

Multi-speed contactor , fuseless without
overload relay

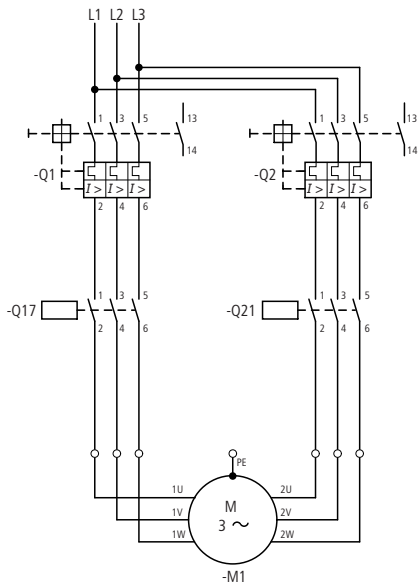

Rating of switchgear

Q1, Q17 = I_1 (low speed)

Q2, Q21 = I_2 (high speed)

Motor windings → Section "Motor
windings", page 8-50

All about Motors

Multi-speed switch for three-phase motors

2 separate windings, an operating direction, 2 speeds

Multi-speed contactor with fuses and overload relay

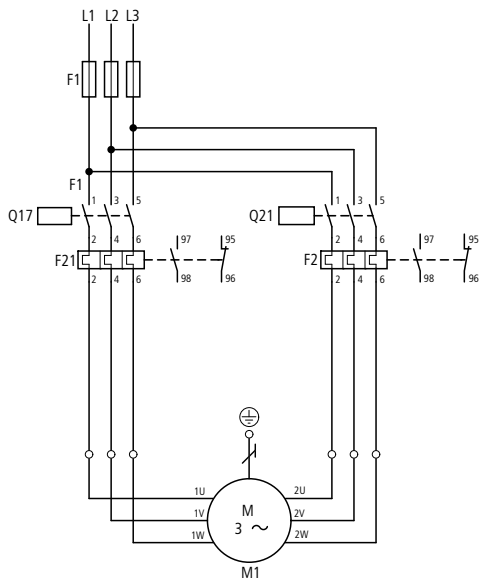

8

Fuse size in accordance with data on the nameplate of the overload relays F2 and F21. If overload relays F2 and F21 cannot be protected by a common fuse, then use connection → Figure, page 8-53.

Motor windings → Section "Motor windings", page 8-50

All about Motors

Multi-speed switch for three-phase motors

Connection A (→ Figure, page 8-49)

1 three-way pushbutton

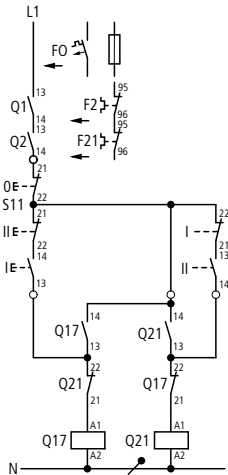

Q17: Mains contactor, low speed

Q21: Mains contactor, high speed

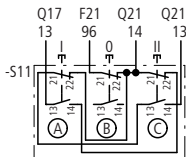

Three-way pushbutton

I: Low speed (Q17)

O: Stop

II: High speed (Q21 + Q23)

Connection C (→ Figure, page 8-49)

1 three-way pushbutton

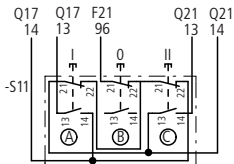
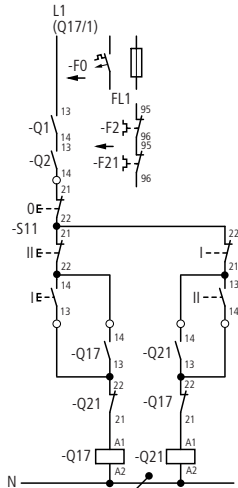

For connection of further actuators

→ Figure, page 8-67

All about Motors

Multi-speed switch for three-phase motors

Operating principle

Actuation of pushbutton I energizes the coil of contactor Q17. Q17 switches on the low speed of the motor and after pushbutton I is released, maintains itself via its auxiliary contact 13-14 and pushbutton 0.

Speed can be changed either after pressing pushbutton 0, or directly by pressing the appropriate pushbutton, depending upon the connection. The motor is switched off either by pressing pushbutton 0, or in the event of an overload, by normally closed contact 95-96 of overload relays F2 and F21.

All about Motors

Control circuit devices for multi-speed contactors

2 separate windings, an operating direction, 2 speeds

Connection A (→ Figure, page 8-49)

One three-way pushbutton with indicator lights

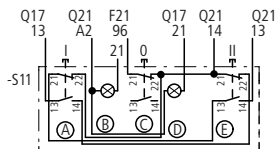
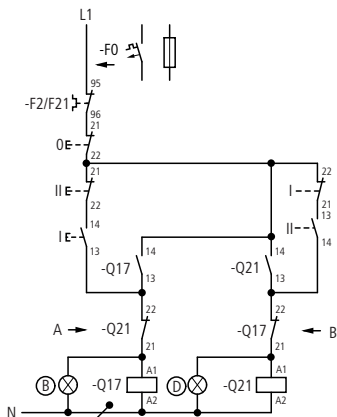

Control circuit devices

- I : Low speed (Q17)
- O : Stop
- II : High speed (Q21)

All about Motors

Control circuit devices for multi-speed contactors

Connection A (→ Figure, page 8-49)

2 three-way pushbuttons

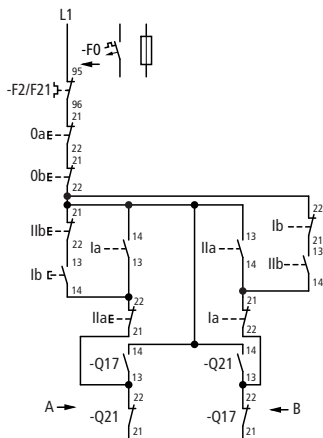

8

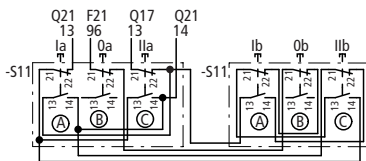

Control circuit devices

I: Low speed (Q17)

0: Stop

II: High speed (Q21)

Remove existing links and rewire

All about Motors

Control circuit devices for multi-speed contactors

Connection A (→ Figure, page 8-49)

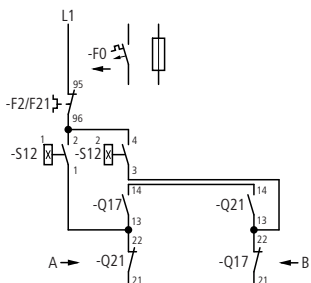

T0-1-8210 changeover switch

Always set overload relay to manual reset

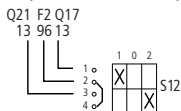

Connection B (→ Figure, page 8-49)

1 three-way pushbutton

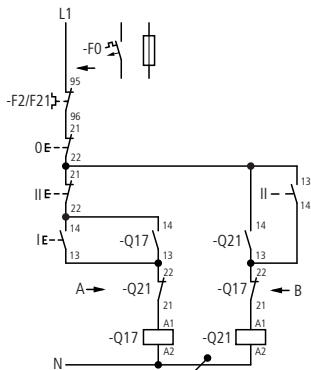

All about Motors

Control circuit devices for multi-speed contactors

Connection B (→ Figure, page 8-49)

2 three-way pushbuttons

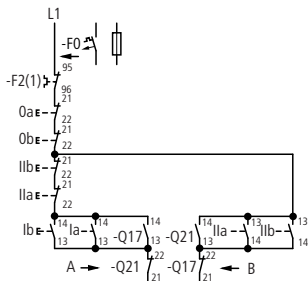

Control circuit device for connection B

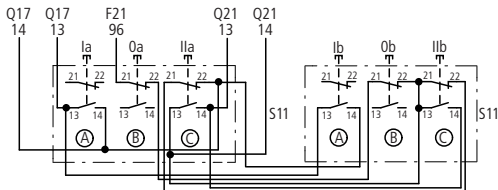

All about Motors

Control circuit devices for multi-speed contactors

Connection C (→ Figure, page 8-49)

2 three-way pushbuttons

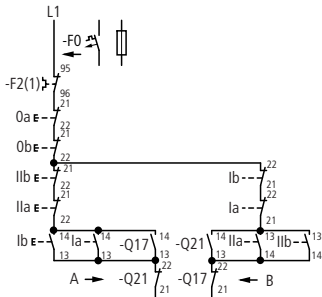

Control circuit device for connection C

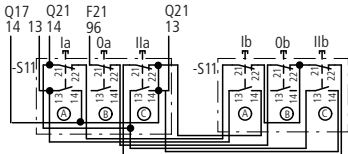

All about Motors

Multi-speed switch for three-phase motors

Tapped winding, 1 operating direction, 2 speeds

Multi-speed contactor

Star-delta startup at low speed

Fuseless

Without overload relay

8

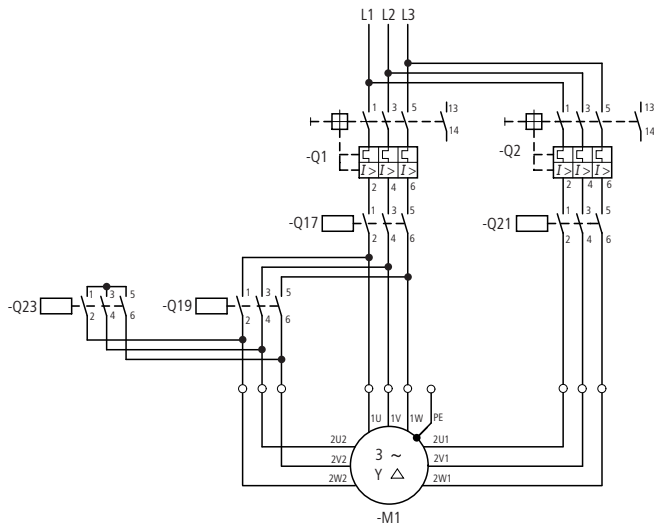

Rating of switchgear

Q1, Q17 = I_1

(low speed)

Q2, Q21 = I_2

(high speed)

Q19, Q23 = $0.5 \times I_2$

All about Motors

Multi-speed switch for three-phase motors

With **fuses** and overload relays

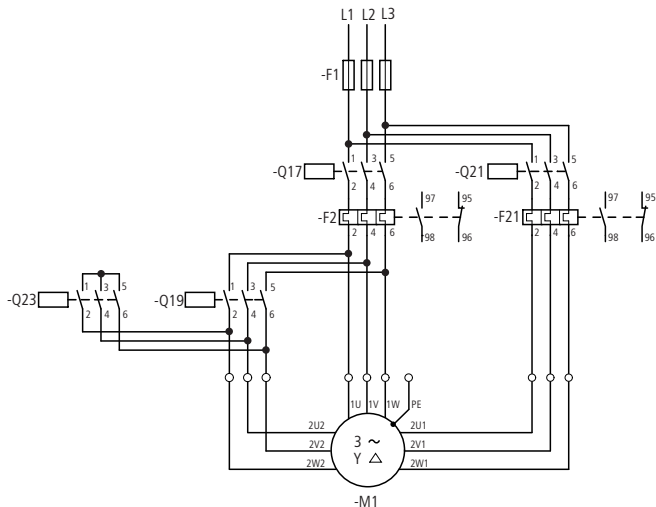

Rating of switchgear

$$F2, Q17 = I_1$$

(low speed)

$$F21, Q21 = I_2$$

(high speed)

$$Q19, Q23 = 0.5 \times I_2$$

$$F1 = I_2$$

Overload relays F2 and F21 are not used on multi-speed contactors without motor protection. If F2 and F21 cannot be protected by a common fuse, then use connection on → Figure, page 8-53.

Motor windings → Section "Motor windings", page 8-50

All about Motors

Multi-speed switch for three-phase motors

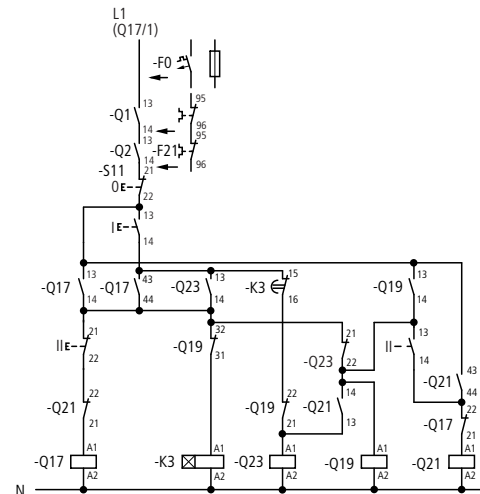

Q17: Mains contactor, low speed

K3: Timing relays

Q23: Star contactor

Q19: Delta contactor

Q21: Mains contactor, high speed

Function

Actuation of pushbutton I energizes the coil of star contactor Q23. Its N/O 13-14 energizes the coil of contactor Q17. The motor runs in star at low speed. The contactors are maintained via auxiliary contact Q17/13-14. At the same time, timing relay K3 is triggered. When the set time has elapsed, K3/15-16 opens the circuit of Q23. Q23 drops out, the coil of delta contactor Q19 is energized and maintains itself via Q19/13-14. The timing relay is de-energized via N/C Q19/32-31.

Connection

Low speed selected only from off position, high speed only via low speed without actuation of the Stop button.

Three-way

pushbutton

I: Low speed (Q17, Q19)

0: Stop

II: High speed (Q21, Q19, Q23)

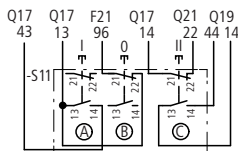

The motor runs in delta at low speed.

Actuation of pushbutton II de-energizes the coil of Q17 and via Q17/22-21 energizes the coil of Q21. This state is maintained by Q21/43-44: The coil of star contactor Q23 is re-energized by normally open contact Q21/14-13. The motor runs at high speed. Pushbutton 0 (= Stop) executes disconnection.

All about Motors

Multi-speed switch for three-phase motors

Tapped winding, 2 operating directions, 2 speeds (direction preselected)

Multi-speed contactors

Overload relays F2 and F21 are not used on multi-speed contactors without motor protection.

Rating of switchgear

Q11, Q12 = I_2 (low and high speed)

F2, Q17 = I_1 (low speed)

F1, Q21 = I_2

Q23 = $0.5 \times I_2$ (high speed)

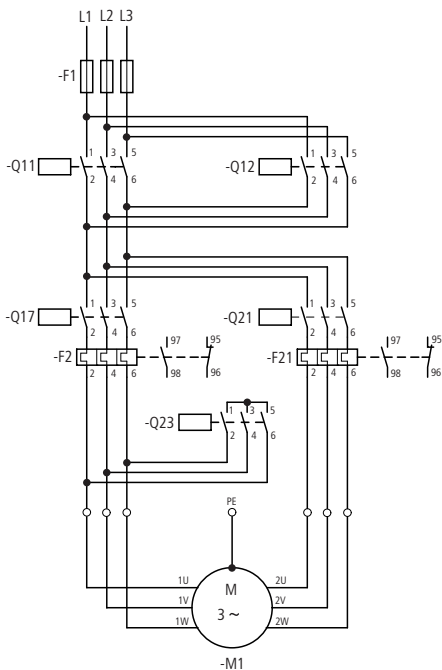

All about Motors

Multi-speed switch for three-phase motors

Five-way
pushbutton

Connection

Change of direction
FORWARD–REVERS
E after actuation of
Stop button,
optionally followed
by SLOW–FAST with
no return to low
speed.

8

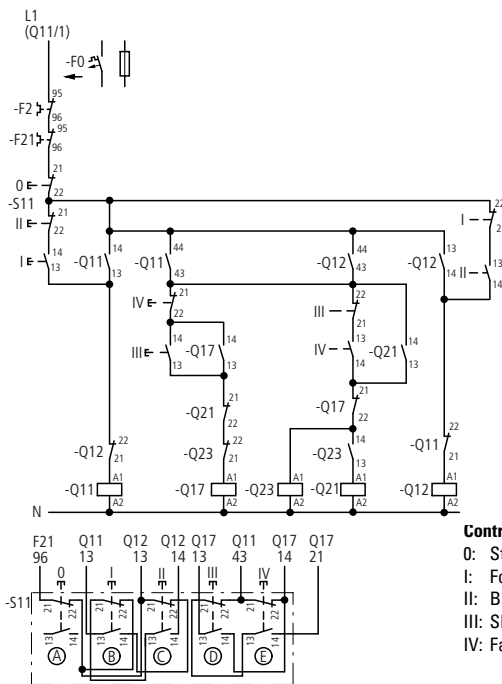

Control circuit device

- 0: Stop
- I: Forward (Q11)
- II: Back (Q12)
- III: Slow (Q17)
- IV: Fast (Q21 + Q23)

Function

Contactors Q11 is energized by pressing pushbutton I. Contactors Q11 selects the operating direction, and maintains itself after release of pushbutton I via its auxiliary contact 14-13 and pushbutton 0. Speed-selection buttons III and IV are made operative by Q11/44-43.

Pushbutton III energizes Q17, which maintains itself via its contact 14-13. Pushbutton IV energizes high speed contactors Q23 and Q21. Auxiliary contact Q21/21-22 makes low-speed pushbutton III inoperative. Pushbutton 0 must be pressed before any change in speed or direction.

All about Motors

Multi-speed switch for three-phase motors

Tapped winding, 2 operating directions, 2 speeds
(direction and speed selected simultaneously)

Multi-speed contactor

Fuseless without overload relay

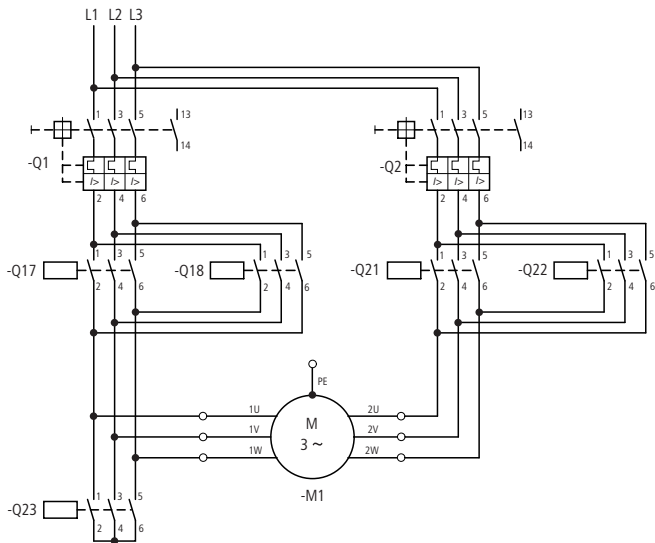

Rating of switchgear

Q1, Q17, Q18 = I_1 (low speed)

Q2, Q21, Q22 = I_2

Q23 = $0.5 \times I_2$ (high speed)

All about Motors

Multi-speed switch for three-phase motors

Multi-speed contactor

With fuses and overload relays

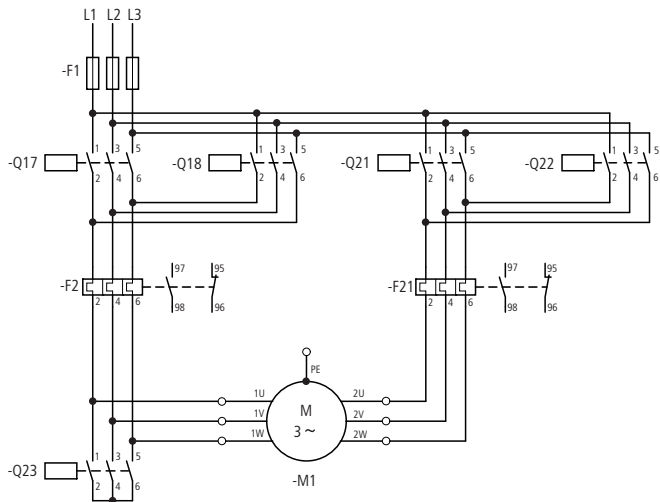

8

Rating of switchgear

$F2, Q17, Q18 = I_1$
(low speed)

$F21, Q21, Q22 = I_2$

$Q23 = 0.5 \times I_2$
(high speed)

Overload relays F2 and F21 are not used on multi-speed contactors without motor protection

All about Motors

Multi-speed switch for three-phase motors

Connection

Simultaneous selection of direction and speed via one pushbutton. Always operate Stop button before changeover.

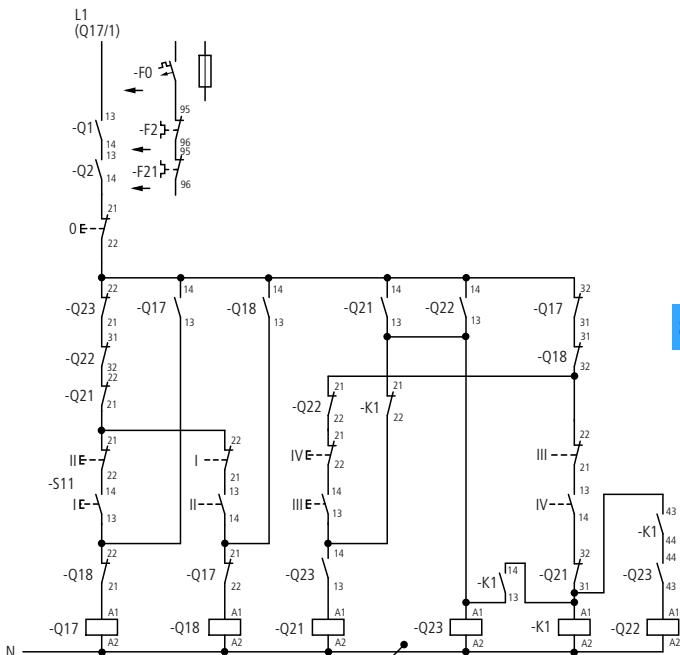

Q17: Slow forward

Q18: Slow back

Q21: Fast forward

Q23: Star contactor

K1: Contactor relay

Q22: Fast back

All about Motors

Multi-speed switch for three-phase motors

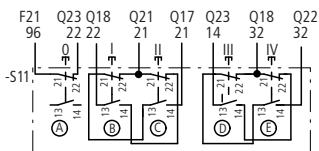

Five-way pushbutton

Control circuit device

0: Stop

I: Slow forward (Q17)

II: Slow back (Q18)

III: Fast forward (Q21 + Q23)

IV: Fast back (Q22 + Q23)

Function

Desired speed and operating direction can be selected by actuation of one of the four pushbutton. Contactors Q17, Q18, Q21 and Q23 maintain themselves by their contact 14-13 and can be de-energized only by actuation of pushbutton 0. Contactors Q21 and Q22 can maintain themselves only when Q23 has picked up and contact Q23/13-14 or 44-43 is closed.

All about Motors

Multi-speed switch for three-phase motors

Tapped winding, medium and high speed, 1 operating direction, 3 speeds, 2 windings

Multi-speed contactor

Multi-speed contactors **with** overload relay → Figure, page 8-79

Motor circuit X → Section "Motor circuit X", page 8-51

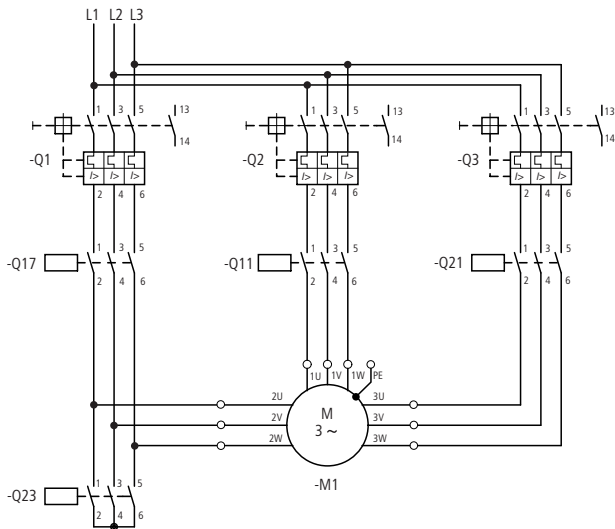

Synchronous Speed

Winding	1	2	2
Motor terminals	1U, 1V, 1W	2U, 2V, 2W	3U, 3V, 3W
Amount of poles	12	8	4
RPM	500	750	1500
Amount of poles	8	4	2
RPM	750	1500	3000

Amount of poles	6	4	2
RPM	1000	1500	3000
Contactors	Q11	Q17	Q21, Q23

Rating of switchgear

Q2, Q11 : I₁ (low speed)
 Q1, Q17 : I₂ (medium speed)
 Q3, Q21 : I₃ (high speed)
 Q23 : 0.5 x I₃

All about Motors

Multi-speed switch for three-phase motors

Connection of motor winding: X

Connection A

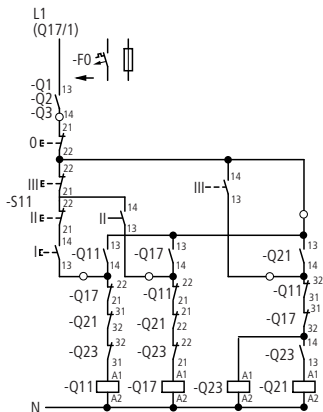

Q11: Low speed winding 1

Q17: Medium speed winding 2

Q23: High speed winding 2

Q21: High speed winding 2

Function

Pushbutton I energizes mains contactor Q17 (low speed), pushbutton II mains contactor Q11 (medium speed), pushbutton III star contactor Q23 and via its N/O Q23/14-13 mains contactor Q21 (high speed). All contactors maintain themselves by their auxiliary contact 13-14.

Connection A

Selection of any speed only from zero.

No return to low speed, only to zero.

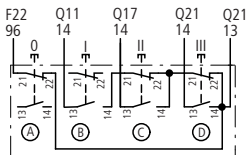

Connection B

Selection of any speed from zero or from low speed.

Return only to zero.

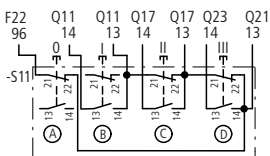

Four-way pushbuttons

O: Stop

I: Low speed (Q11)

II: Medium speed (Q17)

III: High speed (Q21 + Q23)

Speed sequence from low to high is optional. Switching in steps from high to medium or low speed is not possible. The motor is always switched off by pressing pushbutton 0. In the event of an overload, normally open contact 13-14 of the motor-protective circuit-breaker or circuit-breaker can also switch off.

All about Motors

Multi-speed switch for three-phase motors

Tapped winding, low and high speed, 1 operating direction, 3 speeds, 2 windings

Multi-speed contactor

Multi-speed contactor **without** overload relay → Figure, page 8-77

Motor circuit Y → Section "Motor circuit Y", page 8-51

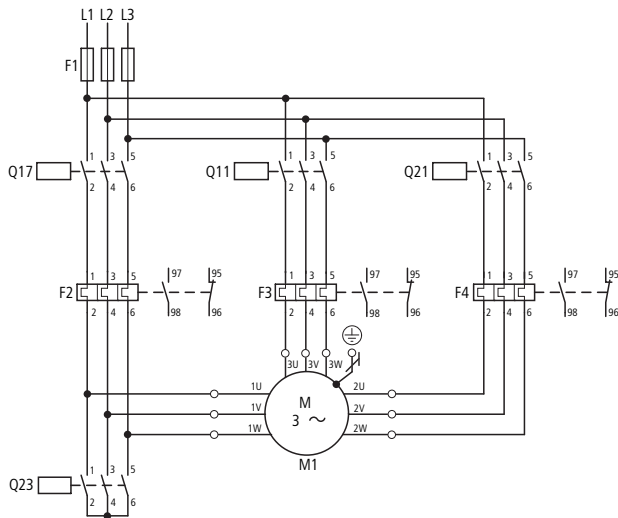

Synchronous Speed

Winding	2	1	2
Motor terminals	1U, 1V, 1W	2U, 2V, 2W	3U, 3V, 3W
Amount of poles	12	8	6
RPM	500	750	1000
Amount of poles	8	6	4

RPM	750	1000	1500
Contactors	Q17	Q11	Q21, Q23

Rating of switchgear

F2, Q17: I_1 (low speed)
 F3, Q11: I_2 (medium speed)
 F4, Q21: I_3 (high speed)
 Q23: $0.5 \times I_3$

All about Motors

Multi-speed switch for three-phase motors

Connection of motor winding: Y

Connection A

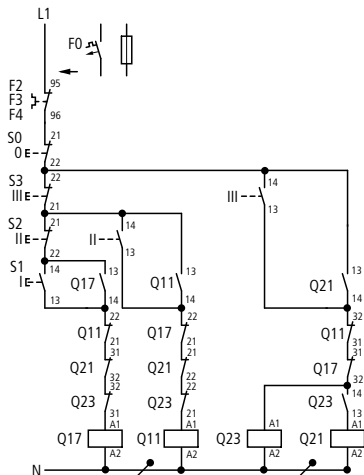

Q17: Low speed winding 1

Q11: Medium speed winding 1

Q23: High speed winding 2

Q21: High speed winding 2

Function

Pushbutton I energizes mains contactor Q17 (low speed), pushbutton II mains contactor Q11 (medium speed), pushbutton III star contactor Q23 and via its N/O Q23/14-13 mains contactor Q21 (high speed). All contactors maintain themselves by their auxiliary contact 13-14.

Connection A

Selection of any speed only from zero. No return to low speed, only to zero.

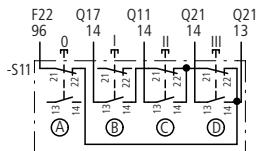

Connection B

Selection of any speed from zero or from low speed. Return only to zero. Four-way pushbuttons

O: Stop

I: Low speed (Q17)

II: Medium speed (Q11)

III: High speed (Q21 + Q22)

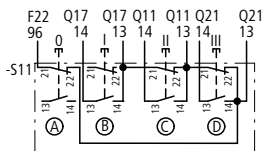

Speed sequence from low to high is optional. Switching in steps from high to medium or low speed is not possible. The motor is always switched off by pressing pushbutton O. In the event of an overload, normally closed contact 95-96 of overload relays F2, F21 and F22 can also switch off.

All about Motors

Multi-speed switch for three-phase motors

Tapped winding, low and medium speed, 1 operating direction, 3 speeds, 2 windings

Multi-speed contactor

Multi-speed contactor **without** overload relay → Figure, page 8-53

Motor circuit Z → Section "Motor circuit Z", page 8-51

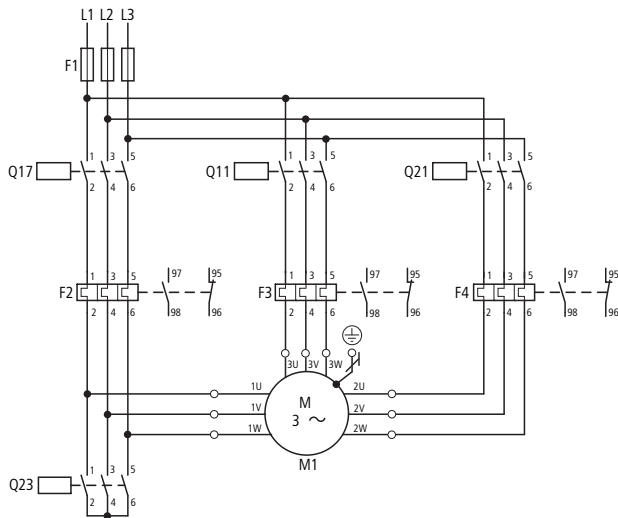

Synchronous Speed

Winding	2	2	1
Motor terminals	1U, 1V, 1W	2U, 2V, 2W	3U, 3V, 3W
Amount of poles	12	6	4
RPM	500	1000	1500
Amount of poles	12	6	2
RPM	500	1000	3000

Amount of poles	8	4	2
RPM	750	1500	3000
Contactors	Q17	Q21, Q23	Q11

Rating of switchgear

F2, Q17: I_1 (low speed)
 F4, Q21: I_2 (medium speed)
 F3, Q11: I_3 (high speed)
 Q23: $0.5 \times I_3$

All about Motors

Multi-speed switch for three-phase motors

Connection of motor winding: Z

Connection A

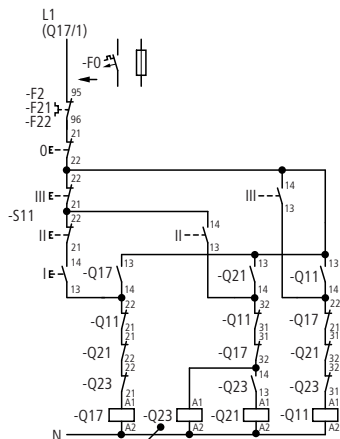

Q17: Low speed winding 1

Q23: Medium speed winding 2

Q21: Medium speed winding 2

Q11: High speed winding 1

Function

Pushbutton I energizes mains contactor Q17 (low speed), pushbutton II mains contactor Q23 (low speed) and via its N/O Q23/14-13 mains contactor Q21 (high speed), pushbutton III mains contactor Q11. All contactors maintain themselves by pushbutton I energizes m13n14co.

Connection A

Selection of any speed from zero.

No return to low speed, only to zero.

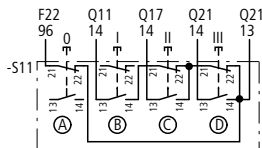

Connection B

Selection of any speed from zero or from low speed. Return only to zero.

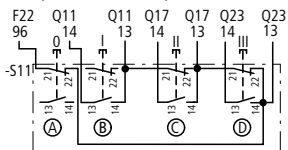

Four-way pushbuttons

0: Stop

I: Low speed (Q17)

II: Medium speed (Q21 + Q23)

III: High speed (Q11)

Speed sequence from low to high is optional. Switching in steps from high to medium or low speed is not possible. The motor is always switched off by pressing pushbutton 0. In the event of an overload, normally closed contact 95-96 of overload relays F2, F21 and F22 can also switch off.

All about Motors

Three-phase autotransformer starter

Three-phase autotransformer starter with mains contactor and resistors, 2-stage, 3-phase version

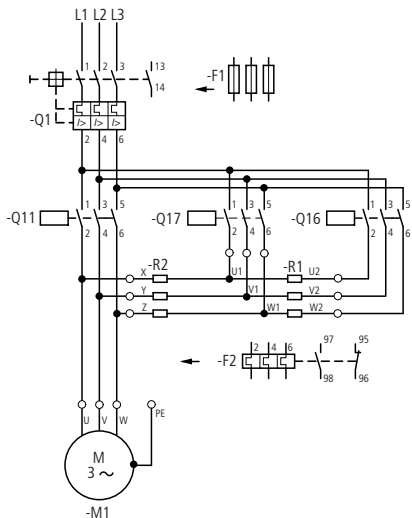

Use F2 when using Q1 instead of Q1.

Rating of switchgear:

Starting voltage: $0.6 \times U_e$

Inrush current: $0.6 \times$ direct switching system

Tightening torque: $0.36 \times$ direct switching system

Q1, Q11: I_e

Q16, Q17: $0.6 \times I_e$

All about Motors

Three-phase autotransformer starter

Three-phase autotransformer starter with mains contactor and resistors, 2-stage, 3-phase version

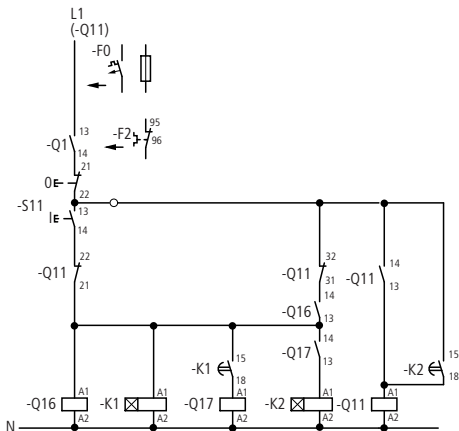

Q16: Step contactor

K1: Timing relay

Q17: Step contactor

K2: Timing relay

Q11: Mains contactor

Two-wire control

Always set overload relay to
reclosing lockout

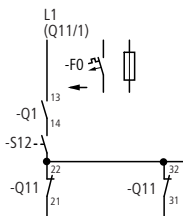

All about Motors

Three-phase autotransformer starter

Three-wire control

Double pushbutton

I = ON

0 = OFF

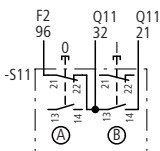

Two-wire control

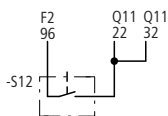

Function

Pushbutton I energizes step contactor Q16 and timing relay K1. Q16/14-13 – self-maintaining through Q11, Q11/32-31 and pushbutton 0. The motor is connected to the supply with upstream resistors R1 + R2. When the set starting time has elapsed, normally open contact K1/15-18 energizes Q17. Step contactor Q17 bypasses the starting stage R1. At the same time, normally open contact Q17/14-13 energizes K2. When the set starting time has elapsed, K2/15-18 energizes mains contactor Q11. This bypasses the second starting stage R2, and the motor runs at the rated speed. Q11

maintains itself via Q11/14-13. Q16, Q17, K1 and K2 are de-energized by normally closed contacts Q11/22-21 and Q11/32-31. The motor is switched off with pushbutton 0. In the event of an overload, normally closed contact 95-96 of the overload relay F2 or normally open contact 13-14 of the motor-protective circuit-breaker switch off the motor.

Step contactor Q17, resistor R2 and timing relay K1 are omitted in single-stage starting circuits. Timing relay K2 is connected directly to Q16/13 and resistor R2 is connected by means of its terminals U1, V1 and W1 to Q11/2, 4, 6.

All about Motors

Three-phase autotransformer starter

Three-phase autotransformer starter with mains contactor and starting transformer, 1-stage, 3-phase

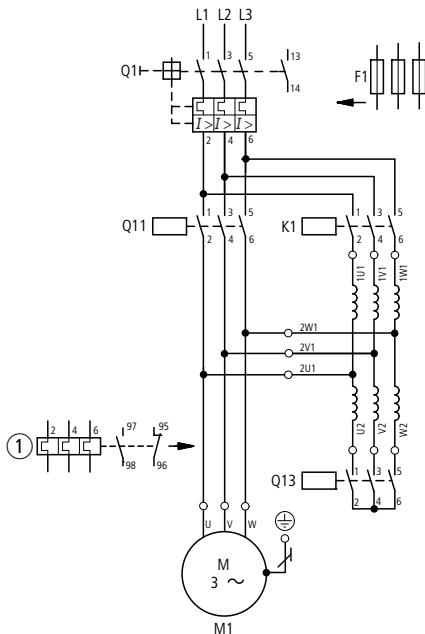

8

Use F2 when using F1 instead of Q1.

Rating of switchgear

Starting voltage	= $0.7 \times U_0$ (typical value)	Tightening torque	= $0.49 \times$ Direct switching
Inrush current	= $0.49 \times$ direct switching system	Q1, Q11	= I_0
I_A/I_0	= 6	Q16	= $0.6 \times I_0$
t_A	= 10 s	Q13	= $0.25 \times I_0$
ops./h	= 30		

All about Motors

Three-phase autotransformer starter

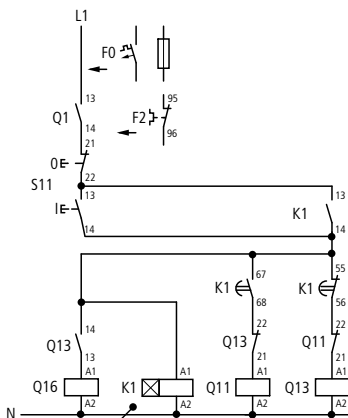

Three-wire control

I: ON
O: OFF

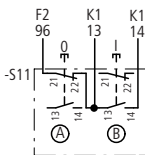

Two-wire control

Always set overload relay to reclosing lockout (manual reset)

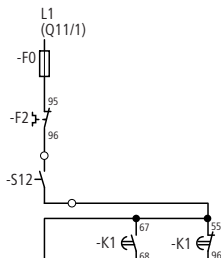

Q16: Step contactor
K1: Timing relay
Q11: Mains contactor
Q13: Star contactor

Two-wire control

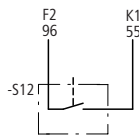

Function

Pressing pushbutton I simultaneously energizes star contactor Q13, timing relay K1 and, via normally open contact Q13/13-14, step contactor Q16, and are maintained via K1/13-14. When K1 has elapsed, normally closed contact K1/55-56 de-energizes star contactor Q13, and Q16 – via normally open contact Q13/13-14:

The starting transformer is disconnected, and the motor runs at the rated speed.

The motor cannot start up again unless previously switched off by actuation of pushbutton O, or in the event of an overload, by N/C 95-96 of the overload relay F2. With two-wire control, overload relay F2 must always be set to reclosing lockout. If the motor has been switched off by F2, the motor cannot start up again unless the reclosing lockout is released.

All about Motors

Three-phase automatic rotor starters

Three-phase automatic rotor starters

3-stage, rotor 3-phase

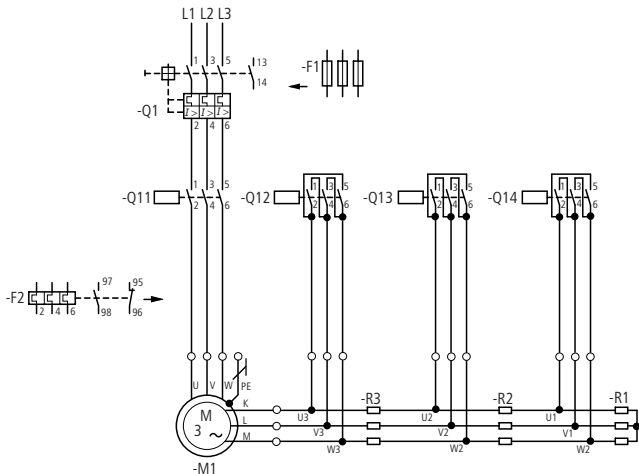

Use F2 when using F1 instead of Q1.

All about Motors

Three-phase automatic rotor starters

2-stage, rotor 2-phase

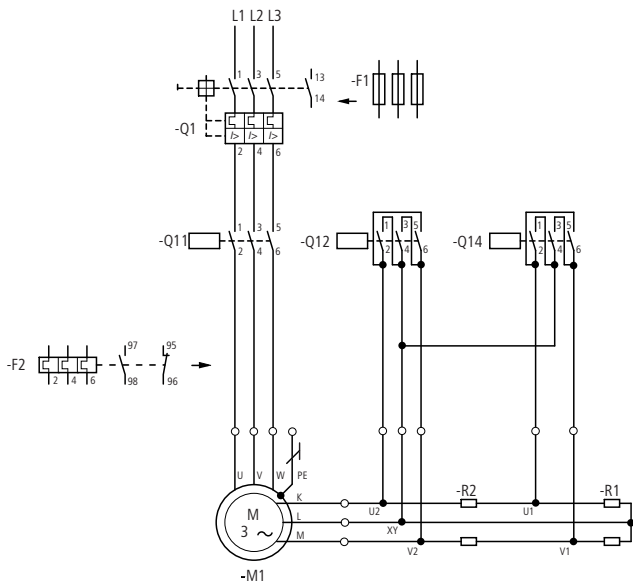

Use F2 when using F1 instead of Q1.

Rating of switchgear

Inrush current	$= 0.5 - 2.5 \times I_e$
Tightening torque	$= 0.5$ to pull-out torque
Q1, Q11	$= I_e$
Step contactors	$= 0.35 \times I_{rotor}$
Final step contactors	$= 0.58 \times I_{rotor}$

All about Motors

Three-phase automatic rotor starters

With mains contactor, style 3-stage, rotor 3-phase

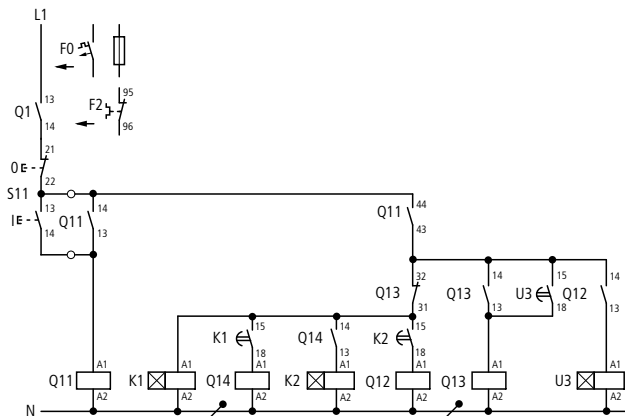

8

Q11: Mains contactor
K1: Timing relay
Q14: Step contactor
K2: Timing relay

Q12: Step contactor
Q13: Final step contactor
K3: Timing relay

Double
pushbutton
I: ON
O: OFF

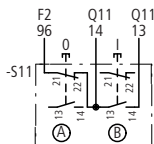

For connection of further actuators:
→ Section "Control circuit devices for star-delta starting", page 8-45

All about Motors

Three-phase automatic rotor starters

Function

Pushbutton I energizes mains contactor Q11: N/O Q11/14-13 transfers the voltage, Q11/44-43 energizes timing relay K1. The motor is connected to the supply system with rotor resistors R1 + R2 + R3 in series. When the set starting time has elapsed, normally open contact K1/15-18 energizes Q14. Step contactor Q14 short-circuits starting stage R1 and via Q14/14-13 energizes timing relay K2. When the set starting time has elapsed, K2/15-18 energizes step contactor Q12, which short-circuits starting stage R2 and via Q12/14-13 energizes timing relay K3. When the set starting time has elapsed, K3/15-18 energizes final step contactor Q13, which is maintained via Q13/14-13, Step contactors Q14 and Q12 as well as timing relays K1, K2 and K3 are de-energized via Q13. Final step contactor Q13 short-circuits

the rotor slip rings: the motor operates with rated speed.

The motor is switched off either by pushbutton 0, or in the event of an overload, by N/C 95-96 of the overload relay F2 or N/O 13-14 of the motor-protective circuit-breaker or circuit-breaker.

Step contactors Q13 and/or Q12 with their resistors R3, R2 and timing relays K3, K2 are omitted in single-stage or two-stage starting circuits. The rotor is then connected to the resistance terminals U, V, W2 or U, V, W1. The references for step contactors and timing relays in the wiring diagrams are then changed from Q13, Q12 to Q12, Q11 or to Q13, Q11 as appropriate.

When there are more than three stages, the additional step contactors, timing relays and resistors have appropriate increasing designations.

All about Motors

Switching of capacitors

Contactors for capacitors DIL

Individual circuit without
quick-discharge resistors

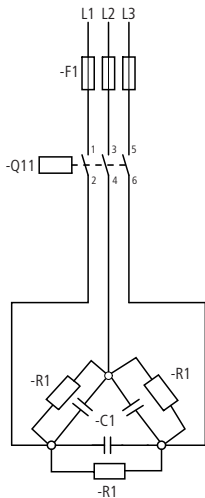

8

R1 discharge resistors fitted in
capacitor

All about Motors

Switching of capacitors

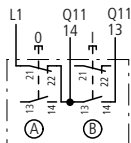
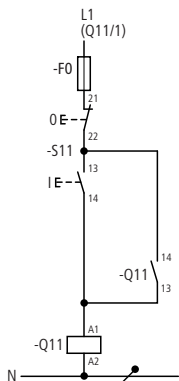

Double pushbutton

For connection of further actuators:

→ Section "Control circuit devices for star-delta starting", page 8-45

Maintained contact sensors

In the case of actuation by means of power factor correction relay, check that this has sufficient power to actuate the contactor coil. Interpose a contactor relay if necessary.

Function

Pushbutton I actuates contactor Q11, which picks up and maintains itself via its own auxiliary contact 14-13 and pushbutton 0 on voltage. Capacitor C1 is thus energized. Discharge resistors R1 are not active when contactor Q11 is energized. Actuation of pushbutton 0 effects de-energization. Normally closed contacts Q11/21-22 then switch discharge resistors R1 to capacitor C1.

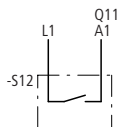

All about Motors

Switching of capacitors

Capacitor contactor combination

Capacitors contactor with pilot contactor and series resistors. Individual and parallel

circuit with and without discharge resistors and with series resistors.

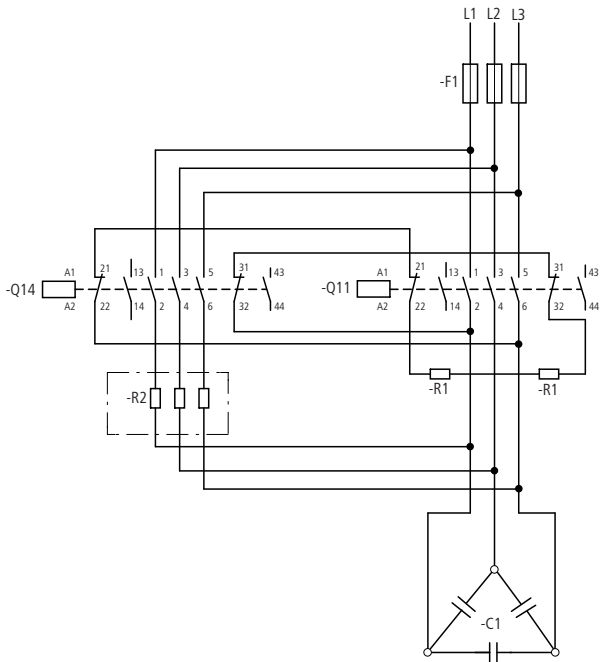

8

On the version without discharge resistors, resistors R1 and the connections to the auxiliary contacts 21-22 and 31-32 are omitted.

All about Motors

Switching of capacitors

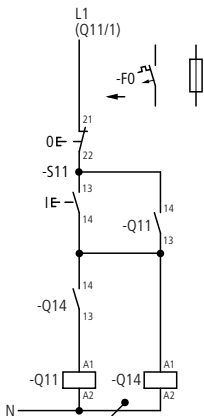

Q11: Mains contactor
 Q14: Pilot contactor
 Actuation by double pushbutton S11

Function

Actuation by double pushbutton S11:
 Pushbutton I energizes pilot contactor Q14.
 Q14 switches capacitor C1 in with bridged series resistors R2. N/O Q14/14-13 energizes mains contactor Q11. Capacitor C1 is then switched in with bridged series resistors R2. Q14 is maintained via Q11/14-13 when Q11 has closed.

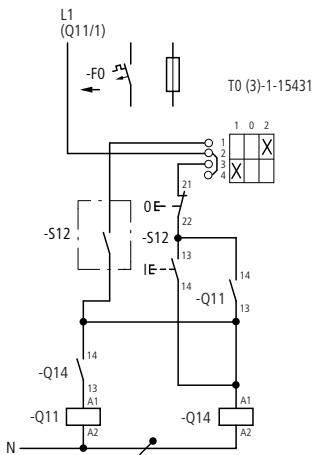

Actuation by selector switch S13, two-wire control S12 (power factor correction relay) and double pushbutton S11

Discharge resistors R1 are not operative when Q11 and Q14 are energized. Pushbutton 0 effects de-energization. N/C Q11/21-22 and 31-32 then switch discharge resistors R1 to capacitor C1

All about Motors

Duplex pump control

Fully automatic control for two pumps

Starting sequence of pumps 1 and 2 can be selected by control switch S12.

Control circuit wiring with two float switches for basic and peak loads (operation is also possible with two pressure switches)

P1 Auto = Pump 1 base load,
Pump 2 peak load

P2 Auto = Pump 2 base load,
Pump 1 peak load

P1 + P2 = Direct operation independent
of float switches (or pressure
switches)

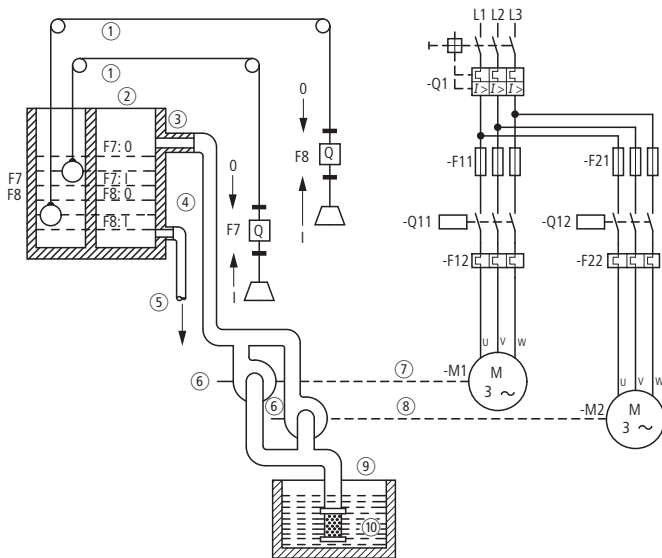

- ① Cable with float, counterweight, pulleys and clamps
- ② Storage tank
- ③ Inlet
- ④ Pressure pipe
- ⑤ Outlet

- ⑥ Centrifugal or reciprocating pump
- ⑦ Pump 1
- ⑧ Pump 2
- ⑨ Suction pipe with filter
- ⑩ Well

All about Motors

Duplex pump control

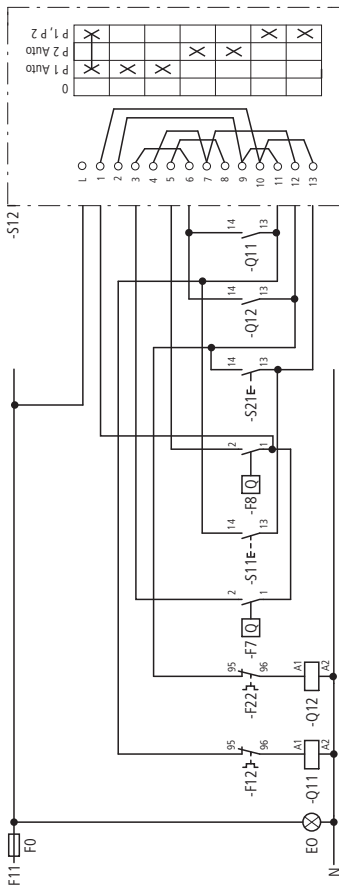

T0(3)-4-15833

Float switch F7 closes before F8

Function

The duplex pump control is designed for operation of two pump motors M1 and M2. Control is via float switches F7 and F8. Operating mode selector switch S12 in position P1 auto. The system operates as follows:
When the water level in the storage tank falls or rises, F7 switches pump 1 on or off (base load). If the water level drops below

Q11: Pump 1 mains contactor

the range of F7 (discharge is greater than intake), F8 starts pump 2 (peak load). When the water level rises again, F8 is deactivated. Pump 2 continues running until F7 stops both pumps. The operating sequence of pumps 1 and 2 can be determined using operating mode selector switch S12: Position P1 auto or P2 auto.

Q12: Pump 2 mains contactor

In position P1 + P2, both pumps are in operation, independent of the float switches (Caution! Tank may possibly overflow).
On the version of duplex pump control with cyclic load sharing (T0(3)-4-15915), S12 has a further state: the operating sequences are automatically reversed after each cycle.

P1 Auto

P2 Auto

P1, P2

0

X

X

X

X

X

X

X

X

X

X

X

X

X

X

X

X

X

X

X

X

X

X

X

X

X

X

X

X

X

X

X

X

X

X

X

X

X

X

X

X

All about Motors

Fully automatic pump control

With pressure switch for air tank and domestic water supply without water failure (run dry) safety device

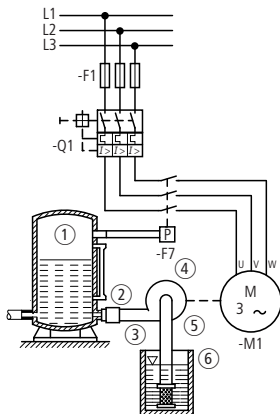

With 3-pole pressure switch MCSN (main circuit)

F1: Fuses (if required)

Q1: Motor-protective circuit-breaker switch, manual (e.g. PKZ)

F7: Pressure switch MCSN, 3-pole

M1: Pump motor

- ① Air or pressure tank
- ② Non-return valve
- ③ Pressure pipe
- ④ Centrifugal (or reciprocating) pump
- ⑤ Suction pipe with filter
- ⑥ Well

All about Motors

Fully automatic pump control

With 1 pole pressure switch MCS (control circuit)

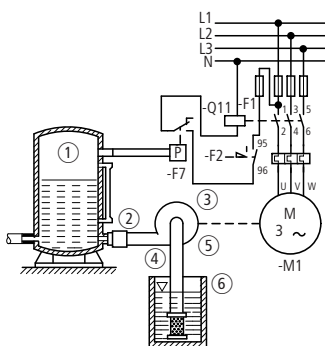

F1: Fuses

Q11: Contactor or automatic star-delta switch

F2: Overload relay with reclosing lockout

F7: Pressure switch MCS, 1 pole

M1: Pump motor

① Air or pressure tank

② Non-return valve

③ Centrifugal (or reciprocating) pump

④ Pressure pipe

⑤ Suction pipe with filter

⑥ Well

All about Motors

Fully automatic pump control

With 3-pole float switch SW (main circuit)

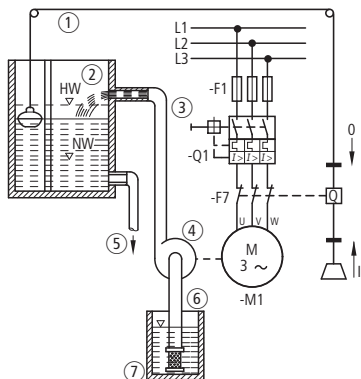

F1: Fuses (if required)
 Q1: Motor-protective circuit-breakers, manual (e.g. PKZ)

F7: Float switch 3-pole (connection: pump full)

M1: Pump motor

HW: Highest level

NW: Lowest value

① Cable with float, counterweight, pulleys and clamps

② Storage tank

③ Pressure pipe

④ Centrifugal (or reciprocating) pump

⑤ Outlet

⑥ Suction pipe with filter

⑦ Well

All about Motors

Fully automatic pump control

With 1 pole float switch SW (control circuit)

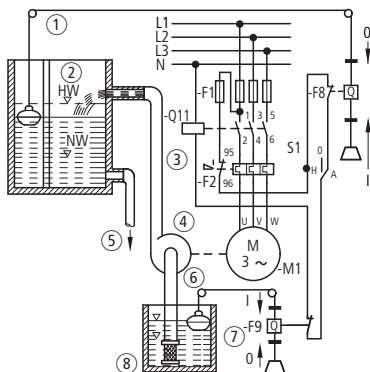

- F1: Fuses
 Q11: Contactor or automatic star-delta switch
 F2: Overload relay with reclosing lockout
 F8: Float switch 1 pole (connection pump full)
 S1: Changeover switch MANUAL-OFF-AUTO
 F9: Float switch 1 pole (connection: pump full)
 M1: Pump motor
- ① Cable with float, counterweight, pulleys and clamps
 ② Storage tank
 ③ Pressure pipe
 ④ Centrifugal (or reciprocating) pump
 ⑤ Outlet
 ⑥ Suction pipe with filter
 ⑦ Water-failure monitoring by means of a float switch
 ⑧ Well

All about Motors

Fully automatic main transfer switch with automatic release

Changeover device to DIN VDE 0100 – Erection of low-voltage installations

– ... – Part 718: Installations for gathering of people Automatic resetting, the phase monitoring relay is set to:

Pick-up voltage $U_{an} = 0.95 \times U_n$
Drop-out voltage $U_b = 0.85 \times U_{an}$

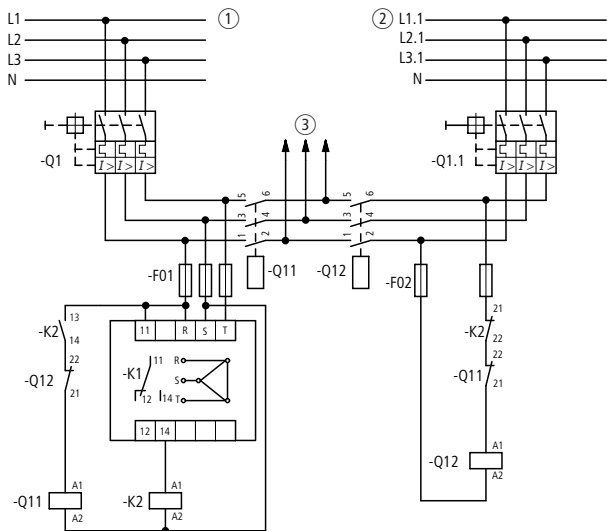

① Main supply

② Auxiliary supply

③ To load

Function

Main switch Q1 is closed first, followed by main switch Q1.1 (auxiliary supply).

Phase monitor K1 is energized via the main supply and immediately energizes contactor relay K2. N/C K2/21-22 blocks the circuit contactor. Q12 (auxiliary supply)

and N/O K2/13-14 closes the circuit of contactor Q11. Contactor Q11 energizes and switches the mains supply on the loads. Contactor Q12 is also interlocked against main supply contactor Q11 via N/C Q11/22-21.

Export to World Markets and North America

	Page
Approvals and certifications	9-2
Fuse classifications in North America	9-6
Global Codes and Standards Authorities	9-9
Testing Agencies and Certification Marks	9-14
Identification of electrical equipment in North America	9-16
Electrical circuit symbols, Europe – North America	9-25
Circuit diagram examples using North American graphic symbols	9-37
North American classification for control circuit contact ratings	9-40
North American motor full load current ratings (FLC)	9-42
North American environmental type ratings for electrical equipment	9-43
North American conductor cross-sections	9-46

Export to World Markets and North America

Approvals and certifications



Approval of electrical equipment is based on the conformity and certification of components and assemblies to regional and country specific product and installation standards that are geared towards the proper application of these products in those markets.

- Product testing conducted by nationally recognized certification agencies is often required, and product certification is also subject to periodic review and auditing by the certification agency.
- In the majority of cases, product certification is tied to the display of respective certification marks on the product themselves.
- Product certification ratings may differ from IEC based technical data and ratings.
- Product certifications are sometimes subject to additional and specific conditions of acceptability.
- Design flexibility on the part of manufacturers can sometimes be impacted by the possible need to re-certify each subsequent product modification.

Refer to Chapter 23 of the Main Industrial Switchgear catalogue for additional information on approvals and product certifications in general.

www.eaton.com/moeller/support
(Catalogs)

Successful exports are based on more than just using certified equipment.

In addition to product certifications, a firm understanding of the standards and market conventions involved is necessary to insure that electrical components and assemblies are also properly applied.

A checklist is a useful tool to clarify important issues and minimize costs during the engineering phase. Special requirements that are overlooked during the initial stages, and need to be remedied after the fact, will not only be costly but very time consuming as well.

Export to World Markets and North America

Approvals and certifications

Special characteristics for the export to North America (USA, Canada)

Technologies that have proven themselves reliable the world over are not guaranteed automatic acceptance in North America. Exports to North America must take into consideration the following:

- North American certification of electrical equipment,
- North American product, application, and installation standards,
- Particular and specialized market conventions,
- Approval of electrical installations by local inspectors (AHJ = **A**uthority **H**aving **J**urisdiction).

Particular aspects of the North American market, which are not readily known in the IEC world:

- Product groupings and fields of application
- Product specific differences and ratings based on certification
- Differentiation of power circuits (Feeder and Branch Circuits)
- Equipment limitations based on particular supply network configurations
- Application related differences affecting product selection

Export to World Markets and North America

Approvals and certifications

Electrical equipment groupings in North America

There is a differentiation made in North America between products used in Energy Distribution, such as molded case circuit breakers certified per the UL 489 product standard, and those found in Industrial Control, typically falling under UL 508.

Product standards such as UL 489 and CSA C22.2 No. 5-09 require significantly larger air and creepage clearances in component construction than do the IEC standards and their harmonized European counterparts (EN norms).

An example of its impact on component construction would be the European motor protective switch which, in North America, needs to be equipped with a large spacings terminal on its supply side whenever it is applied as a stand-alone protective device in individual motor branch circuits.

Industrial Control Equipment

UL 508 and CSA C22.2 No. 14

- Contactors
- Control Relays
- Overload Relays
- Cam Switches
- Pilot devices and Limit switches
- Solid State relays and equipment Programmable Controllers

9 Electrical components used in energy distribution

- Molded Case Circuit Breakers
UL 489, CSA C22.2 No. 5-09
- Molded Case Switches
UL 489, CSA C22.2 No. 5-09
- Enclosed Switches
UL 98, CSA C 22.2 No. 4
- Fusible Disconnect Switches
UL 98, CSA C 22.2 No. 4
- Fuses
UL 248, CSA C22.2 No. 248

Export to World Markets and North America

Approvals and certifications

Criteria for equipment selection particular to North American conventions

- Knowing the type of load and circuit is especially important in selecting the right equipment for the application. Motor starters are used exclusively for the protection and switching of motor loads.
- Motor starters mounted on busbar adapters that are supplied from a feeder must have the larger electrical clearances on their incoming supply side.¹⁾
- Motor starters mounted on busbar adapters within a branch circuit are permitted to have industrial control electrical clearances on their field terminations.¹⁾
- Supplementary handles are necessary for supply circuit disconnect switches equipped with door mounted rotary handles in applications such as industrial machinery.

¹⁾ Circuit examples: Refer to diagrams on page 9-35.

Comprehensive information and tips on exporting electrical equipment and controls to North America can be downloaded free of charge from the Internet.

www.eaton.com/moeller
(News/Press, Publications)



Export to World Markets and North America

Fuse classifications in North America

Additional comments on Table → page 9-8

Suitable for use in:		UL/CSA Standards	Characteristics	SCCR	Typical ranges in Amps
USA	Canada				
Class H, "Code"	Class H, No. 59 "Code"	UL 248-6/7, C22.2 248-6/7	Fast-Acting	10 kA, 250 V AC 10 kA, 600 V AC	0...600
Class CC	Class CC	UL 248-4, C22.2 248-4	Fast-Acting Time Delay	200 kA, 600 V AC	0.5...30
Class G	Class G	UL 248-5, C22.2 248-5	Fast-Acting Time Delay	100 kA, 480 V AC 100 kA, 600 V AC	21...60 0.5...20
Class J	Class J HRCI-J	UL 248-8, C22.2 248-8	Fast-Acting Time Delay	200 kA, 600 V AC	1...600
Class K K1, K5	Class K K1, K5	UL 248-9, C22.2 248-9	Fast-Acting Time Delay	50 kA/100 kA/ 200 kA, 600 V AC	0...600
Class L	Class L	UL 248-10, C22.2 248-10	Fast-Acting Time Delay	200 kA, 600 V AC	601...6000
Class R RK1, RK5	Class R HRCI-R RK1, RK5	UL 248-12, C22.2 248-12	Fast-Acting Time Delay	50 kA/100 kA/ 200 kA, 600 V AC	0...600
Class T	Class T	UL 248-15, C22.2 248-15	Fast-Acting	200 kA, 300 V AC 200 kA, 600 V AC	0...1200

Export to World Markets and North America

Fuse classifications in North America

Applications		Comments
Residential, Commercial, Industrial		Class H, K and No. 59 "Code" fuses are physically interchangeable and fit in the same fuseholders. Refer to comments below under Class K.
Fast-Acting: Protection of resistive and inductive loads. Appliances, Heaters, Lighting, Mixed loads in Feeders and Branch Circuits.	Time Delay: Protection of inductive and highly inductive loads.	Extremely compact size! Current limiting per UL/CSA Standards!
		Compact size! Current limiting per UL/CSA Standards! Non-interchangeable with any other fuse class.
		Compact size! Current limiting per UL/CSA Standards! Non-interchangeable with any other fuse class.
	Electrical Motors, Transformers, Lighting...	Not marked current limiting per UL/CSA Standards! That's why Class K fuses are often substituted by rejection -type Class RK... fuses.
		Current limiting per UL/CSA Standards! Non-interchangeable with any other fuse class.
		Current limiting per UL/CSA Standards! Types RK1, RK5 and HRCI-R fit in the same rejection-type fuseholders, and are non-interchangeable with any other fuse class. RK1 fuses have lower let through values than RK5 fuses.
—	Extremely compact size! Current limiting per UL/CSA Standards! Non-interchangeable with any other fuse class.	

Export to World Markets and North America

Fuse classifications in North America

The table contains selection and application information for feeder and branch circuit fuses commonly used in North America.

The fuse characteristics and application guidelines mentioned in the table provide a general overview only.

Most North American power circuit fuses also carry DC ratings per UL and CSA product certification standards.

Export to World Markets and North America

Global Codes and Standards Authorities

Code	Full title	Country
ABS	American Bureau of Shipping Ship classification association	USA
AEI	Assoiazione Elettrotecnica ed Elettronica Italiana Italian electrotechnical industry organisation	Italy
AENOR	Asociacion Española de Normalización y Certificación , Spanish organisation for standards and certification	Spain
ALPHA	Gesellschaft zur Prüfung und Zertifizierung von Niederspannungsgeräten German test laboratories association	Germany
ANSI	American National Standards Institute	USA
AS	Australian Standard	Australia
ASA	American Standards Association American association for standards	USA
ASTA	Association of Short-Circuit Testing Authorities Association of the testing authorities	Great Britain
BS	British Standard	Great Britain
BV	Bureau Veritas , Ship's classification association	France
CEBEC	Comité Electrotechnique Belge , Belgian electro-technical product quality mark	Belgium
CEC	Canadian Electrical Code	Canada
CEI	Comitato Elettrotecnico Italiano Italian standards organisation	Italy
CEI	Commission Electrotechnique Internationale International electrotechnical commission	Switzerland
CEN	Comité Européen de Normalisation European standards committee	Europe
CENELEC	Comité Européen de coordination de Normalisation Électrotechnique , European committee for electro-technical standards	Europe
CSA	Canadian Standards Association Canadian standards association, Canadian standard	Canada

Export to World Markets and North America

Global Codes and Standards Authorities

Code	Full title	Country
DEMKO	D anmarks E lektriske M ateriel K ontrol Danish material control for electrotechnical products	Denmark
DIN	D eutsches I nstitut für N ormung German institute for standardisation	Germany
DNA	D eutscher N ormenausschuss German standards committee	Germany
DNV	Det Norsk Veritas Ship classification association	Norway
EN	European standard	Europe
ECQAC	E lectronic C omponents Q uality A ssurance C ommittee Committee for components with a verified quality	Europe
EEMAC	E lectrical E quipment M anufacturers A ssociation of C anada	Canada
ELOT	Hellenic Organization for Standardization Greek organization for standardization	Greece
EOTC	E uropean O rganization for T esting and C ertification	Europe
ETCI	E lectrotechnical C ouncil of I reland Irish organization for standardization	Ireland
GL	G ermanischer L loyd Ship classification association	Germany
HD	Harmonization document	Europe
IEC	I nternational E lectrotechnical C ommission	–
IEEE	I nstitute of E lectrical and E lectronics E ngineers	USA

Export to World Markets and North America

Global Codes and Standards Authorities

Code	Full title	Country
IPQ	Instituto P ortuguês da Q ualidade Portuguese quality institute	Portugal
ISO	I nternational O rganization for S tandardization	–
JEM	J apanese E lectrical M anufacturers Association Electrical industry association	Japan
JIC	J oint I ndustry C onference Gesamtverband der Industrie	USA
JIS	J apanese I ndustrial S tandard	Japan
KEMA	K eurig van E lektrotechnische M aterialen Testing institute for electrotechnical products	Netherlands
LOVAG	L ow V oltage A greement G roup	–
LRS	L loyd's R egister of S hipping Ship classification association	Great Britain
MITI	M inistry of I nternational T rade and I ndustry	Japan
NBN	N orme B elge, Belgian standard	Belgium
NEC	N ational E lectrical C ode	USA
NEMA	N ational E lectrical M anufacturers A ssociation Electrical industry association	USA
NEMKO	N orges E lektriske M ateriell k ontroll Norwegian testing institute for electrotechnical products	Norway
NEN	N ederlands N orm, Dutch standard	Netherlands
NFPA	N ational F ire P rotection A ssociation	USA
NKK	N ippon K aiji K yakai Japanese classification association	Japan
OSHA	O ccupational S afety and H ealth A dministration	USA

Export to World Markets and North America

Global Codes and Standards Authorities

Code	Full title	Country
ÖVE	Ö sterreichischer V erband für E lektrotechnik Austrian electrotechnical association	Austria
PEHLA	P rüfstelle e lektrischer H ochleistungs a pparate der Gesellschaft für elektrische Hochleistungsprüfungen Electrical high-performance apparatus test laboratory of the association for electrical high-performance testing	Germany
PRS	P olski R ejestr S tatków Ship classification association	Poland
PTB	P hysikalisch- T echnische B undesanstalt German physical/technical federal agency	Germany
RINA	R egistro Italiano N avale Italian ship classification association	Italy
SAA	S tandards A ssociation of A ustralia	Australia
SABS	S outh A frican B ureau of S tandards	South Africa
SEE	S ervice de l' E nergie de l' E tat Luxemburg authority for standardisation, testing and certification	Luxemburg
SEMKO	S venska E lektriska M ateriel k ontrollanstalten Swedish test institute for electrotechnical products	Sweden
SEV	S chweizerischer E lektrotechnischer V erein Swiss electro-technical association	Switzerland
SFS	Suomen Standardisoimisliitto r.y. Finnish standardisation association, Finnish standard	Finland
SUVA	S chweizerische U nfallversicherungs- A nstalt Swiss accident insurance federal agency	Switzerland
TÜV	T echnischer Ü berwachungs v erein Technical inspection association	Germany
UL	U nderwriters' L aboratories Inc.	USA
UTE	U nion T echnique de l' E lectricité Electrotechnical federation	France

Export to World Markets and North America

Global Codes and Standards Authorities

Code	Full title	Country
VDE	Verband der Elektrotechnik, Elektronik, Informationstechnik (V erband D eutscher E lektrotechniker) Association of electrical, electronics and information technology	Germany
ZVEI	Zentralverband Elektrotechnik- und Elektronikindustrie Central association of the electrical and electronic industry	Germany

Export to World Markets and North America

Testing Agencies and Certification Marks

Testing agencies and certification marks encountered in Europe and North America

Nearly all of Eaton's electrical components in the Moeller line are compliant with global standards, including those in the USA and Canada.

Some components, like e.g. circuit-breakers, meet all relevant international standards in their base model versions and can be universally applied, except in the USA and Canada. A special line of circuit breakers, certified to UL and CSA standards, is available for export to North America.

An up-to-date listing of all component certifications and classifications can be accessed via the Internet:

www.moeller.net/eaton-approbationen/en

In some cases, certain country specific installation and operational requirements, wiring materials and practices, as well as special circumstances such as unusual environmental conditions, must be taken into consideration.

As of January 1997, all electrical equipment built in accordance with the European Low Voltage

Directive and destined for sale in the European Union must bear a CE mark.















The CE mark verifies that the marked component meets all the provisions of the relevant standards and requirements pertaining to that product. The marking obligation thus enables components to gain unfettered access to the European market place.

Because CE marked components are constructed in accordance with harmonized standards, certification in individual countries within the European Union is no longer necessary.

An exception would be components that could also be installed in non-industrial environments. Accordingly, components such as miniature circuit breakers and residual current protective devices are often expected to bear national certification marks. The following table provides a selection of the most commonly encountered certification marks from international testing authorities.

Export to World Markets and North America

Testing Agencies and Certification Marks

Country	Testing Authority	Certification Mark
Belgium	Comité Electrotechnique Belge Belgisch Elektrotechnisch Comité (CEBEC)	
China	China Compulsory Certification (CCC)	
Denmark	Danmarks Elektriske Materielkontrol (DEMKO)	
Germany	Association of electrical, electronics and information technology	
Finland	FIMKO	
France	Union Technique de l'Electricité (UTE)	
Netherlands	Naamloze Vennootschap tot Keuring van Electrotechnische Materialien (KEMA)	
Norway	Norges Elektriske Materiellkontrol (NEMKO)	
Austria	Österreichischer Verband für Elektrotechnik (ÖVE)	
Russia	Goststandart(GOST)-R	
Sweden	Svenska Elektriska Materielkontrollanstalten (SEMKO)	
Switzerland	Schweizerischer Elektrotechnischer Verein (SEV)	
USA	Underwriters Laboratories Listing Recognition	 
Canada	Canadian Standards Association (CSA)	

Export to World Markets and North America

Identification of electrical equipment in North America

Device designations in the USA and Canada to NEMA ICS 19-2002 (R 2007), ANSI Y32.2/IEEE 315/315 A

Suitable prefix numbers and/or letters, and suffix letters may be added to the basic device designations to differentiate between components performing similar functions.

Where two or more basic device designations are combined, the function designation is normally given first.

Example:

The first control relay initiating a jog function is designated: "1JCR", where:

1 = number prefix

J = Jogging function of the component

CR = The type of component is a Control Relay (Contactor Relay).

Export to World Markets and North America

Identification of electrical equipment in North America

Device or function designation letters in accordance with NEMA ICS 19-2002 (R 2007)

Designation	Device or function
A	Accelerating
AM	Ammeter
B	Braking
C or CAP	Capacitor, capacitance
CB	Circuit-breaker
CR	Control relay
CT	Current transformer
DM	Demand meter
D	Diode
DS or DISC	Disconnect switch
DB	Dynamic braking
FA	Field accelerating
FC	Field contactor
FD	Field decelerating
FL	Field-loss
F or FWD	Forward
FM	Frequency meter
FU	Fuse
GP	Ground protective
H	Hoist
J	Jog
LS	Limit switch
L	Lower
M	Main contactor
MCR	Master control relay

Export to World Markets and North America

Identification of electrical equipment in North America

Designation	Device or function
MS	Master switch
OC	Overcurrent
OL	Overload
P	Plugging, potentiometer
PFM	Power factor meter
PB	Pushbutton
PS	Pressure switch
REC	Rectifier
R or RES	Resistor, resistance
REV	Reverse
RH	Rheostat
SS	Selector switch
SCR	Silicon controlled rectifier
SV	Solenoid valve
SC	Squirrel cage
S	Starting contactor
SU	Suppressor
TACH	Tachometer generator
TB	Terminal block, board
TR	Time-delay relay
Q	Transistor
UV	Undervoltage
VM	Voltmeter
WHM	Watt-hour meter
WM	Wattmeter
X	Reactor, reactance

Export to World Markets and North America

Identification of electrical equipment in North America

The use of class designation code letters to appropriate ANSI/IEEE standards is permissible as an alternative to device designations per NEMA ICS19-2002 (R 2007). Class designation code letters

should simplify harmonization with international standards. The code letters are, in part, similar to those of IEC 61346-1 (1996-03).

Class designation code letter to ANSI Y32.2/IEEE 315, 315 A

Code letter	Device or function
A	Separate Assembly
B	Induction Machine, Squirrel Cage Induction Motor Synchro, General <ul style="list-style-type: none"> • Control transformer • Control transmitter • Control Receiver • Differential Receiver • Differential Transmitter • Receiver • Torque Receiver • Torque Transmitter Synchronous Motor Wound-Rotor Induction Motor or Induction Frequency Convertor
BT	Battery
C	Capacitor <ul style="list-style-type: none"> • Capacitor, General • Polarized Capacitor Shielded Capacitor
CB	Circuit-Breaker (all)

Export to World Markets and North America

Identification of electrical equipment in North America

Code letter	Device or function
D, CR	Diode <ul style="list-style-type: none"> • Bidirectional Breakdown Diode • Full Wave Bridge Rectifier • Metallic Rectifier • Semiconductor Photosensitive Cell • Semiconductor Rectifier • Tunnel Diode • Unidirectional Breakdown Diode
D, VR	Zener Diode
DS	Annunciator Light Emitting Diode Lamp <ul style="list-style-type: none"> • Fluorescent Lamp • Incandescent Lamp • Indicating Lamp
E	Armature (Commutator and Brushes) Lightning Arrester Contact <ul style="list-style-type: none"> • Electrical Contact • Fixed Contact • Momentary Contact Core <ul style="list-style-type: none"> • Magnetic Core Horn Gap Permanent Magnet Terminal Not Connected Conductor

Export to World Markets and North America

Identification of electrical equipment in North America

Code letter	Device or function
F	Fuse
G	Rotary Amplifier (all) A.C. Generator Induction Machine, Squirrel Cage Induction Generator
HR	Thermal Element Actuating Device
J	Female Disconnecting Device Female Receptacle
K	Contactors, Relay
L	Coil <ul style="list-style-type: none"> • Blowout Coil • Brake Coil • Operating Coil Field <ul style="list-style-type: none"> • Commutating Field • Compensating Field • Generator or Motor Field • Separately Excited Field • Series Field • Shunt Field Inductor Saturable Core Reactor Winding, General
LS	Audible Signal Device <ul style="list-style-type: none"> • Bell • Buzzer • Horn
M	Meter, Instrument

Export to World Markets and North America

Identification of electrical equipment in North America

Code letter	Device or function
P	<ul style="list-style-type: none"> • Male Disconnecting Device • Male Receptable
Q	Thyristor <ul style="list-style-type: none"> • NPN Transistor • PNP Transistor
R	Resistor <ul style="list-style-type: none"> • Adjustable Resistor • Heating Resistor • Tapped Resistor • Rheostat Shunt <ul style="list-style-type: none"> • Instrumental Shunt • Relay Shunt
S	Contact <ul style="list-style-type: none"> • Time Closing Contact • Time Opening Contact • Time Sequence Contact • Transfer Contact • Basic Contact Assembly • Flasher

Export to World Markets and North America

Identification of electrical equipment in North America

Code letter	Device or function
S	Switch <ul style="list-style-type: none"> • Combination Locking and Nonlocking Switch • Disconnect Switch • Double Throw Switch • Drum Switch • Flow-Actuated Switch • Foot Operated Switch • Key-Type Switch • Knife Switch • Limit Switch • Liquid-Level Actuated Switch • Locking Switch • Master Switch • Mushroom Head • Operated Switch • Pressure or Vacuum • Operated Switch • Pushbutton Switch • Pushbutton Illuminated Switch, Rotary Switch • Selector Switch • Single-Throw Switch • Speed Switch • Stepping Switch • Temperature-Actuated Switch • Time Delay Switch • Toggle Switch • Transfer Switch • Wobble Stick Switch Thermostat

Export to World Markets and North America

Identification of electrical equipment in North America

Code letter	Device or function
T	Transformer <ul style="list-style-type: none"> • Current Transformer • Transformer, General • Polyphase Transformer • Potential Transformer
TB	Terminal Board
TC	Thermocouple
U	Inseparable Assembly
V	Pentode, Equipotential Cathode Phototube, Single Unit, Vacuum Type Triode Tube, Mercury Pool
W	Conductor <ul style="list-style-type: none"> • Associated • Multiconductor • Shielded Conductor, General
X	Tube Socket







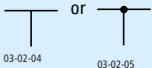
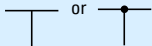

Export to World Markets and North America

Electrical circuit symbols, Europe – North America

Electrical circuit symbols to DIN EN, NEMA ICS/ANSI/IEEE/CSA





















The following comparison of electrical circuit symbols is based on the following international/national specifications:

- IEC 60617 graphic symbol database (DIN EN 60617-2 to DIN EN 60617-12)
- NEMA ICS 19-2002 (R 2007), ANSI Y32.2/IEEE 315/315 A, CSA Z99

Description	IEC (DIN EN)	NEMA ICS/ANSI/IEEE
Conductors, connectors		
Junction of conductors	 03-02-04 or 03-02-05	
Connection of conductors (node)	 03-02-01	
Terminal	 03-02-02	
Terminal strip/block	 03-02-03	
Conductors	 03-01-01	























Export to World Markets and North America

Electrical circuit symbols, Europe – North America

Description	IEC (DIN EN)	NEMA ICS/ANSI/IEEE
Conductor (for later expansion)	 103-01-01	
Line of application, general symbol	 02-12-01	
Line of application, optional, denoting small interval	 02-12-04	
Separation between two fields	 02-01-06	
Line of separation between functional units	 02-01-06	
Shielding	 02-01-07	
Earth, general symbol Ground, general symbol	 02-15-01	
Protective earth Protective ground	 02-15-03	
Connector with plug and socket	 or  03-03-05 03-03-06	
Isolating point, lug, closed	 03-03-18	





















Export to World Markets and North America

Electrical circuit symbols, Europe – North America

Description	IEC (DIN EN)	NEMA ICS/ANSI/IEEE
Passive components		
Resistor, general symbol	 or  04-01-02 04-01-02	 or 
Resistor with fixed tapings	 04-01-09	 or 
Variable resistor, general	 04-01-03	
Adjustable resistor		
Resistor with sliding contact, potentiometer	 04-01-07	
Winding, inductance, general	 or  04-03-01 04-03-02	
Winding with fixed tapping	 04-03-06	
Capacitor, general symbol	 or  04-02-01 04-02-02	 or 
Variable capacitor	 104-02-01	













Export to World Markets and North America

Electrical circuit symbols, Europe – North America



Description	IEC (DIN EN)	NEMA ICS/ANSI/IEEE
Control circuit devices		
Visual indicator, general symbol		 *with colour stated
Indicator light, general symbol	 08-10-01	 or  or  *with colour stated
Buzzers	 or  08-10-11 08-10-10	 ABU
Horn, claxon	 08-10-05	 HN
Drives		
Manual operation, general use	 02-13-01	
Operated by pushing	 02-13-05	
Operated by pulling	 02-13-03	
Operated by turning	 02-13-04	
Operated by key	 02-13-13	
Operated by rollers, sensors	 02-13-15	

Export to World Markets and North America

Electrical circuit symbols, Europe – North America



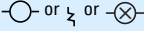

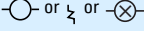





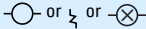

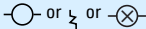

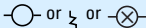

Description	IEC (DIN EN)	NEMA ICS/ANSI/IEEE
Stored energy mechanism, general symbol	 02-13-20	
Switch mechanism with mechanical release	 102-05-04	
Operated by motor	 02-13-26	
Emergency switch	 02-13-08	
Operated by electromagnetic overcurrent protection	 02-13-24	
Operated by thermal overcurrent protection	 02-13-25	
Electromagnetic operation	 02-13-23	
Control by fluid level	 02-14-01	

Electromechanical, electromagnetic operating devices

Electromechanical operating device, general symbol, relay coil, general symbol	 07-15-01	 x device code letter → table, page 9-17
Operating device with special features, general symbol		 x device code letter → table, page 9-17

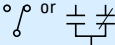



















Export to World Markets and North America

Electrical circuit symbols, Europe – North America

Description	IEC (DIN EN)	NEMA ICS/ANSI/IEEE
Electromechanical operating device with On-delay	 07-15-08	 x device code letter → table, page 9-17
Electromechanical device with Off-delay	 07-15-07	 x device code letter → table, page 9-17
Electromechanical device with On- and Off-delay	 07-15-09	 x device code letter → table, page 9-17
Electromechanical device of a thermal relay	 07-15-21	
Contacts		
N/O contact	 07-02-01 07-02-02	
N/C contact	 07-02-03	
Changeover contact with interruption	 07-02-04	
Early-make N/O contact of a contact assembly	 07-04-01	 TC or TDC
Late-break N/C contact of a contact assembly	 07-04-03	 T0 or TDO

















Export to World Markets and North America

Electrical circuit symbols, Europe – North America

Description	IEC (DIN EN)	NEMA ICS/ANSI/IEEE
N/O contact, delayed when closing	 or  07-05-02 07-05-01	 T.C.
N/C contact, delayed when reclosing	 or  07-05-03 07-05-04	 T.C.
Control devices		
Push-button (not stay-put)	 07-07-02	 PB
Spring-return switches with N/C contact, manually operated by pushing, e.g. push-button		 PB
Spring-return switches with N/O and N/C contacts, manually operated by pushing		 PB
Spring-return switches with latching position and one N/O contact, manually operated by pushing		 PB
Spring-return switches with latching position and one N/C contact, manually operated by striking (e.g. mushroom button)		
Position switches (N/O contacts) Limit switches (N/O contacts)	 07-08-01	 LS
Position switches (N/C contacts) Limit switches (N/C contacts)	 07-08-02	 LS
Spring-return switches with N/O contacts, mechanically operated, N/O contacts closed		 LS







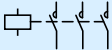
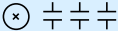
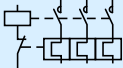
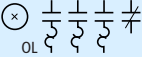

Export to World Markets and North America

Electrical circuit symbols, Europe – North America

Description	IEC (DIN EN)	NEMA ICS/ANSI/IEEE
Spring-return switches with N/C contacts, mechanically operated, N/C contacts open		
Proximity switches (N/C contacts), actuated by the proximity of iron	 Fe 07-20-04	
Proximity switches, inductive, N/O contacts	 Fe	
Proximity switches, block diagram	 07-19-02	
Under-pressure relays, N/O contacts	 P< 07-17-03	 or 
Pressure switches, N/C contact		 or 
Float switches, N/O contact		
Float switches, N/C contact		

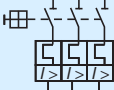



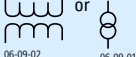
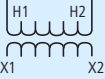















Export to World Markets and North America

Electrical circuit symbols, Europe – North America

Description	IEC (DIN EN)	NEMA ICS/ANSI/IEEE
Switchgear		
Contactors (N/O contacts)	 07-13-02	 x code letter
Three-pole contactor with bimetal relay (3 thermal elements)		 x code letter
Three-pole switch-disconnector	 07-13-06	 DISC
Three-pole circuit-breaker	 07-13-05	 CB
Three-pole breaker with switch mechanism with three thermoelectric overcurrent releases, three electromagnetic overcurrent releases, motor-protective circuit-breaker	 107-05-01	
Fuse, general symbol	 07-21-01	 FU
Transformers, current transformers		
Transformers with two windings	 06-09-02 or 06-09-01	 H1 H2 X1 X2



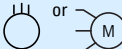

















Export to World Markets and North America

Electrical circuit symbols, Europe – North America

Description	IEC (DIN EN)	NEMA ICS/ANSI/IEEE
Autotransformer	 or  06-09-07 06-09-06	 or 
Current transformer	 or  06-09-11 06-09-10	 or  (X1)
Machines		
Generator	 06-04-01	 or 
Motor, general symbol	 06-04-01	 or  06-04-01
DC motor, general symbol	 06-04-01	
AC motor, general symbol	 06-04-01	
Three-phase asynchronous motor with squirrel-cage rotor	 06-08-01	
Three-phase asynchronous motor with slip-ring rotor	 06-08-03	





















Export to World Markets and North America

Electrical circuit symbols, Europe – North America

Description	IEC (DIN EN)	NEMA ICS/ANSI/IEEE
Semiconductor components		
Static input		
Static output		
Static input with negation	 12-07-01	
Static output with negation	 12-07-02	
Dynamic input, change of status from 0 to 1 (L/H)	 12-07-07	
Dynamic input with negation, change of status from 1 to 0 (H/L)	 12-07-08	
AND gate, general symbol	 12-27-02	
OR gate, general symbol	 12-27-01	
NOT gate, inverter	 12-27-11	
AND with negated output, NAND	 12-28-01	
OR with negated output, NOR	 12-28-02	

Export to World Markets and North America

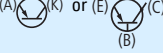
Electrical circuit symbols, Europe – North America

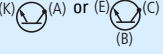
Description	IEC (DIN EN)	NEMA ICS/ANSI/IEEE
Exclusive OR gate, general	 12-27-09	
RS flip-flop	 12-42-01	
Monostable gate, cannot be triggered during the output pulse, general symbol	 12-44-02	
Delay, variable with indication of delay values	 02-08-05	
Semiconductor diode, general symbol	 05-03-01	
Limiting diode Zener diode	 05-03-06	
Light-emitting diode (LED), general symbol	 05-03-02	
Bi-directional diode, diac	 05-03-09	
Thyristor, general symbol	 05-04-04	
PNP transistor	 05-05-01	
NPN transistor, in which the collector is connected to the enclosure	 05-05-02	

Export to World Markets and North America

Circuit diagram examples using North American graphic symbols

Example of a North American wiring schematic using ANSI symbols

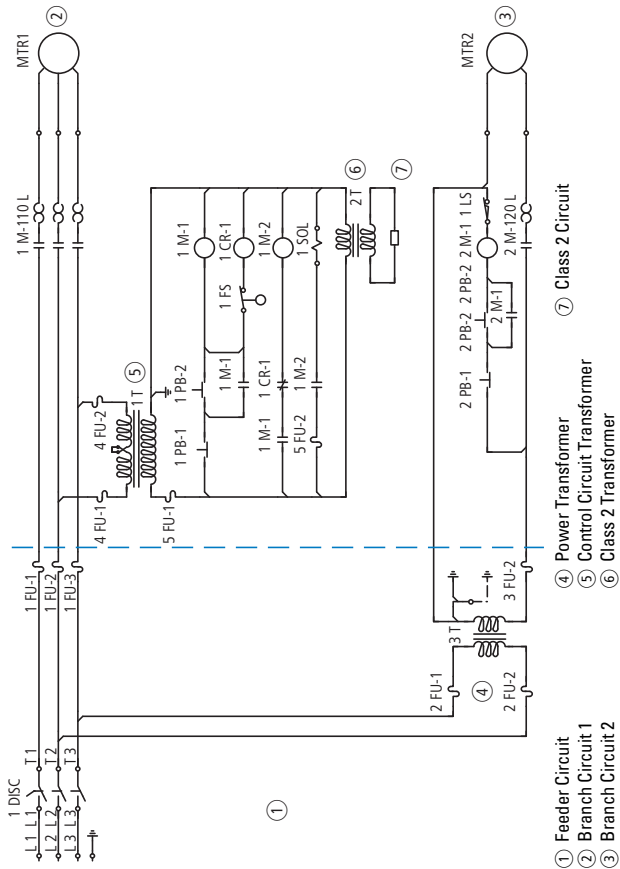

Export to World Markets and North America

Circuit diagram examples using North American graphic symbols

Direct motor starters, fuseless with circuit-breakers

Control circuit with fuse

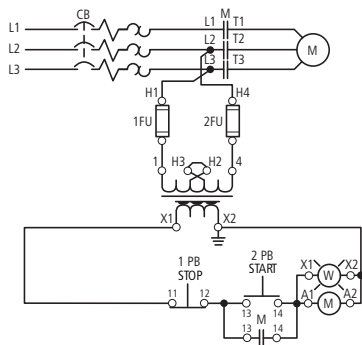

Control circuit, fuseless

9

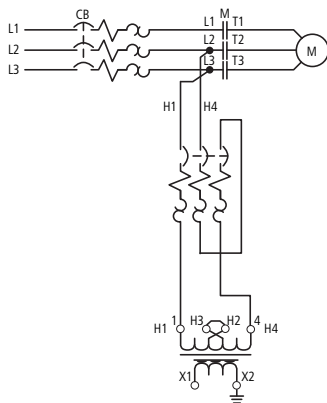

Notes

Export to World Markets and North America

North American classification for control circuit contact ratings

Classification	Designation At maximum rated voltage of			Thermal uninterrupted current
	600 V	300 V	150 V	
AC voltage	600 V	300 V	150 V	A
Heavy Duty	A600	A300	A150	10
	A600	A300	–	10
	A600	–	–	10
	A600	–	–	10
Standard Duty	B600	B300	B150	5
	B600	B300	–	5
	B600	–	–	5
	B600	–	–	5
	C600	C300	C150	2.5
	C600	C300	–	2.5
	C600	–	–	2.5
	C600	–	–	2.5
	–	D300	D150	1
	–	D300	–	1
	DC voltage			
	Heavy Duty	N600	N300	N150
N600		N300	–	10
N600		–	–	10
Standard Duty	P600	P300	P150	5
	P600	P300	–	5
	P600	–	–	5
	Q600	Q300	Q150	2.5
	Q600	Q300	–	2.5
	Q600	–	–	2.5
	–	R300	R150	1.0
	–	R300	–	1.0
	–	–	–	–

to UL 508, CSA C 22.2-14 and NEMA ICS 5

Export to World Markets and North America

North American classification for control circuit contact ratings

Switching capacity				
Rated voltage V	Make A	Break A	Make VA	Break VA
120	60	6	7200	720
240	30	3	7200	720
480	15	1.5	7200	720
600	12	1.2	7200	720
120	30	3	3600	360
240	15	1.5	3600	360
480	7.5	0.75	3600	360
600	6	0.6	3600	360
120	15	1.5	1800	180
240	7.5	0.75	1800	180
480	3.75	0.375	1800	180
600	3	0.3	1800	180
120	3.6	0.6	432	72
240	1.8	0.3	432	72
125	2.2	2.2	275	275
250	1.1	1.1	275	275
301 – 600	0.4	0.4	275	275
125	1.1	1.1	138	138
250	0.55	0.55	138	138
301 – 600	0.2	0.2	138	138
125	0.55	0.55	69	69
250	0.27	0.27	69	69
301 – 600	0.10	0.10	69	69
125	0.22	0.22	28	28
250	0.11	0.11	28	28
301 – 600	–	–	–	–

Export to World Markets and North America

North American motor full load current ratings (FLC)

Full Load Currents, North American Three-Phase Alternating-Current Motors¹⁾

Motor Rating	Motor full load currents in amperes ²⁾			
	115 V 120 V	230 V 240 V	460 V 480 V	575 V 600 V
1/2	4.4	2.2	1.1	0.9
3/4	6.4	3.2	1.6	1.3
1	8.4	4.2	2.1	1.7
1 1/2	12	6.0	3.0	2.4
2	13.6	6.8	3.4	2.7
3		9.6	4.8	3.9
5		15.2	7.6	6.1
7 1/2		22	11	9
10		28	14	11
15		42	21	17
20		54	27	22
25		68	34	27
30		80	40	32
40		104	52	41
50		130	65	52
60		154	77	62
75		192	96	77
100		248	124	99
125		312	156	125
150		360	180	144
200		480	240	192
250			302	242
300			361	289
350			414	336
400			477	382
450			515	412
500			590	472

¹⁾ Source: NEC Code, Table 430-250, with additional full load current values for 208 V and 200 V motors.

²⁾ The full load current values provided in the tables are used as guidelines for equipment selection. Also consult motor manufacturer data and actual motor nameplate ratings.

Export to World Markets and North America

North American environmental type ratings for electrical equipment

Comparison of North American and IEC/EN environmental ratings for electrical equipment

IP ratings per IEC/EN standards cannot be used as a substitute for North American Type ratings. **The IP ratings shown represent a rough comparison only.** A precise conversion is not possible since tests and evaluation criteria in the relevant standards differ greatly from one another.

UL/CSA and NEMA type ratings are often used interchangeably. The significant difference between the two is that a UL/CSA type rating represents third party certification by an approved testing

agency, which is the preferred manner in which ratings are verified in North America.

North American environmental type ratings are referenced in the following standards:

- NFPA 70 (National Electrical Code),
- CEC (Canadian Electrical Code),
- UL 50E, UL 508A,
- CSA-C22.2 No. 94-M91 (2006),
- NEMA 250-2008 (National Electrical Manufacturers Association).

North American environmental Type ratings	Application	Rough equivalency to IP ratings per IEC/EN 60529, DIN 40050
UL/CSA Type 1 Incidental contact with enclosed equipment; falling dirt	Indoor use	IP20
UL/CSA Type 2 Driptight	Indoor use	IP22
UL/CSA Type 3 Dusttight, raintight, degree of protection against rain, snow and sleet	Outdoor use	IP55
UL/CSA Type 3 R Rainproof, degree of protection against rain, snow and sleet	Outdoor use	IP24
UL/CSA Type 3 S Dust-tight, rain-tight, protection against sleet and ice	Outdoor use	IP55

Export to World Markets and North America

North American environmental type ratings for electrical equipment

North American environmental Type ratings	Application	Rough equivalency to IP ratings per IEC/EN 60529, DIN 40050
UL/CSA Type 3 X, 3 RX, 3 SX same as 3, 3 R and 3 S, but with corrosion resistance	Outdoor use	IP55
UL/CSA Type 4 Watertight, raintight, dusttight	Indoor or Outdoor use ¹⁾	IP66
UL/CSA Type 4 X Watertight, raintight, dusttight, corrosion resistant	Indoor or Outdoor use ¹⁾	IP66
UL/CSA Type 5 Driptight, dusttight	Indoor use	IP53
UL/CSA Type 6 Raintight, watertight, temporarily submersible	Indoor or Outdoor use ¹⁾	IP67
UL/CSA Type 12 Common industrial rating, driptight, dusttight	Indoor use	IP54
UL/CSA Type 13 driptight, dusttight, oiltight	Indoor use	IP54

¹⁾Take note of manufacturer instructions!

Export to World Markets and North America

North American environmental type ratings for electrical equipment

Terms German/English:

General purpose:	general purpose
tropfdicht:	drip-tight
staubdicht:	dust-tight
regendicht:	rain-tight
regensicher:	rain-proof
wettersicher:	weather-proof
wasserdicht:	water-tight
eintauchbar:	submersible
eisbeständig:	ice resistant
hagelbeständig:	sleet resistant
korrosionsbeständig:	corrosion resistant
öldicht:	oil-tight

Export to World Markets and North America

North American conductor cross-sections

Conversion of North American cable cross sections into mm²

USA/Canada AWG	Europe	
	mm ² (exact)	mm ² (nearest standard size)
22	0.324	0.4
20	0.519	0.5
18	0.823	0.75
16	1.31	1.5
14	2.08	
12	3.31	4
10	5.261	6
8	8.367	10
6	13.30	16
4	21.15	25
3	26.67	
2	33.62	35
1	42.41	
1/0 (0)	53.49	50
2/0 (00)	67.43	70
3/0 (000)	85.01	
4/0 (0000)	107.2	95

Export to World Markets and North America**North American conductor cross-sections**

USA/Canada	Europe	
	mm² (exact)	mm² (nearest standard size)
250	127	120
300	152	150
350	177	185
400	203	
450	228	
500	253	240
550	279	
600	304	300
650	329	
700	355	
750	380	
800	405	
900	456	
1,000	507	500

In addition to “circular mills”, cable sizes are often given in “MCM”:
250 000 circular mills = 250 MCM

Notes

Standards, formulae, tables

	Page
Marking of electrical equipment	10-2
Protective measures	10-4
Overcurrent protection of cables and conductors	10-12
Electrical equipment of machines	10-21
Measures for risk reduction	10-27
Protection types for electrical equipment	10-29
Utilization categories for switching elements	10-34
Utilization categories for contactors and motor starters	10-36
Utilization categories for switch-disconnectors	10-40
Rated motor currents	10-43
Conductors	10-46
Formulae	10-54
International Unit System	10-58

Standards, formulae, tables

Marking of electrical equipment

Marking to DIN EN 81346-2 (IEC 81346-2)

Eaton uses the above standard.

Unlike the method of marking up to now, the function of the electrical equipment in the respective circuit primarily determines the code letter. This means that there is some freedom in the selection of the code letters.

Example of a resistor

- Normal current limiter: R
- Heater resistor: E
- Measurement resistor: B

In addition to that, Eaton specific decisions have been made with regard to the interpretation of the standard that sometimes deviate from the standard.

- The marking of connection terminals are **not** readable from the right.
- A second code letter for the marking of the use of the equipment is **not** given, e.g.: timing relay K1T becomes K1.
- Circuit-breakers with the main function of protection are still marked with Q. They are numbered from 1 to 10 from the top left.
- Contactors are newly marked with Q and numbered from 11 to nn. e.g.: K91M becomes Q21.
- Contactor relays remain K and are numbered from 1 to n.

The marking appears in a suitable position as close as possible to the circuit symbol. The marking forms the link between the equipment in the installation and the various circuit documents (wiring diagrams, parts lists, circuit diagrams, instructions). For simpler maintenance, the complete marking or part of it, can be affixed on or near to the equipment.

Selected equipment with a comparison of the Eaton used code letters old – new
 → Table, page 10-3

Standards, formulae, tables

Marking of electrical equipment

Code letter	Purpose	Examples for electrical equipment
A	(several purposes)	(without main purpose)
B	Signal generation	Pressure switches; limit switches
C	Storage	Capacitors
D	(reserved for later)	
E	Energy supply	Heating resistor, lamps
F	Protection	Bimetal releases, fuses
G	Power supply	Generator, UPS
H	(reserved for later)	
I	(must not be used)	
J	(reserved for later)	
KP	Signal processing	Contactor relay, timing relays
L	(reserved for later)	
M	Drive energy	Motor
N	(reserved for later)	
O	(must not be used)	
P	Information display	Signalling and measuring devices
Q	Switching energy / signal flow	Soft starter, contactor, motor starter
R	Energy flow limitation	Reactor coils, diodes
S	Manual signal generation	Control circuit devices
T	Energy conversion	Frequency inverters, transformer
U	Object fixing	
V	Material processing	Electro filter
W	Power transmission	
X	Object connection	Terminal, plug connector
Y,Z	(reserved for later)	

Standards, formulae, tables

Protective measures

Protection against electrical shock to IEC 60364-4-41/DIN VDE 0100-410

This is divided into basic protection (previously protection against direct contact), fault protection (previously protection against indirect contact) and protection against both direct and indirect contact.

- **Basic protection**

These are all the measures for the protection of personnel and working animals from dangers which may arise from contact with live parts of electrical equipment.

- **Fault protection**

This is the protection of personnel and working animals from fault scenarios which may arise from accidental contact with components or extraneous conductive parts.

- **Additional protection**

If basic or fault protection fails or there is a greater potential danger, residual current protective devices with $I_{\Delta n} \leq 30$ mA offer additional protection.

Protection must be ensured by either a) the equipment itself or b) the use of protective measures when erecting the installation or c) a combination of a) and b).

If basic, fault and additional protection is combined in a suitable manner the following protective measures result and are covered in section 410 of DIN VDE 0100:

- Automatic disconnection of the power supply (0100-411)
- Double or reinforced insulation (0100-412)
- Protective separation (0100-413)
- Safety extra low voltage SELV or PELV (0100-414)

One of the key amendments to DIN VDE 0100-410 of June 2007 was the additional protection for final circuits for outdoor areas and sockets (411.3.3). This stipulates that an additional protection must be provided by means of residual current devices (RCDs) with $I_{\Delta n} \leq 30$ mA for sockets ≤ 20 A, as well as final current circuits for portable equipment ≤ 32 A used outdoors. The previous recommendation has therefore been changed to a mandatory requirement in order to increase safety.

Standards, formulae, tables

Protective measures

Protection against indirect contact by means of disconnection or indication

The conditions for disconnection are determined by the type of system in use and the protective device selected.

Systems to IEC 60364-1/DIN VDE 0100-100

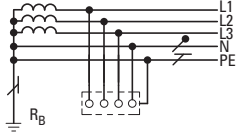
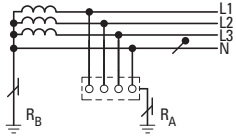
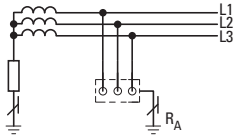
Earth continuity type systems	Meaning of designation
<p>TN system</p> 	<p>T: Direct earthing of a point N: Chassis (of electrical equipment) directly connected with the power supply system earth</p>
<p>TT system</p> 	<p>T: Direct earthing of a point T: Direct electrical connection of chassis to earth, independent of any existing earthing of the power supply system</p>
<p>IT system</p> 	<p>I: All live parts isolated from earth or one point connected to earth via a high impedance T: Direct electrical connection of chassis to earth, independent of any existing earthing of the power supply system</p>

R_B Earthing on the current source

R_A Earthing on chassis of electrical equipment

Standards, formulae, tables

Protective measures

Protective devices and conditions for disconnection to IEC 60364-4-41/ DIN VDE 0100-410

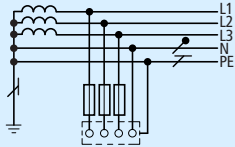
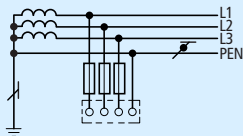
Type of distribution system	TN system	
Protection with	Circuit principle	Condition for disconnection
Overcurrent protective device	<p>TN-S system separated neutral and protective conductors throughout the system</p> 	<p>$Z_s \times I_a \leq U_0$ with Z_s = Impedance of the fault circuit I_a = Current, which causes switch off in (0100-411.3.2):</p> <ul style="list-style-type: none"> • ≤ 5 s • ≤ 0.2 s <p>U_0 = rated voltage against earthed conductor</p>
Fuses, miniature circuit-breakers, circuit-breakers	<p>TN-C system Neutral conductor and protection functions are combined throughout the system in a single PEN conductor.</p> 	

Standards, formulae, tables

Protective measures

Protective devices and conditions for disconnection to IEC 60364-4-41/DIN VDE 0100-410

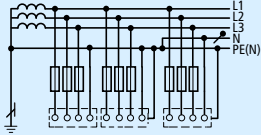
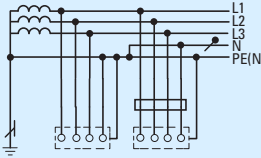
Type of distribution system	TN system	
Protection with	Circuit principle	Condition for disconnection
Overcurrent protective device	<p>TN-C-S system Neutral conductor and protective conductor functions are in a part of the system combined in a single PEN conductor.</p> 	
Fault current protective device		$Z_s \times I_{\Delta n} \leq U_0$ with $I_{\Delta n}$ = Rated fault current U_0 = Maximum permissible touch voltage ¹⁾ : (≤ 50 V AC, ≤ 120 V DC)

¹⁾ → Table, page 10-11

Standards, formulae, tables

Protective measures

Protective devices and conditions for disconnection to IEC 60364-4-41/ DIN VDE 0100-410

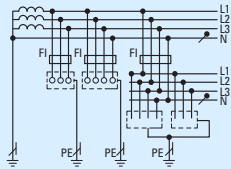
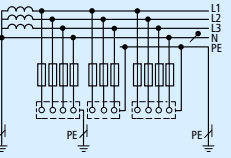
Type of distribution system	TT system	
Protection with	Circuit principle	Conditions for indication/disconnection
Residual current device (General case)		$R_A \times I_{\Delta n} \leq U_L$ with R_A = Earthing resistance of conductive parts of the chassis (total) $I_{\Delta n}$ = Rated fault current U_L = Maximum permissible touch voltage ¹⁾ : (≤ 50 V AC, ≤ 120 V DC)
Overcurrent protective device Fuses, miniature circuit-breakers, Circuit-breakers (special case)		$R_A \times I_a \leq U_L$ with I_a = Current which causes automatic disconnection in ≤ 5 s

¹⁾ → Table, page 10-11

Standards, formulae, tables

Protective measures

Protective devices and conditions for disconnection to IEC 60364-4-41/DIN VDE 0100-410

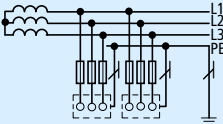
Type of distribution system	TT system	
Protection with	Circuit principle	Conditions for indication/ disconnection
Overcurrent protective device (always with additional insulation monitoring device, see below)		$R_A \times I_d \leq U_L$ (1) $Z_S \times I_a \leq U_o$ (2) R_A = Earthing resistance of all conductive parts connected to an earth I_d = Fault current in the event of the first fault with a negligible impedance between a phase conductor and the protective conductor or element connected to it U_L = Maximum permissible touch voltage ¹⁾ : ≤ 50 V AC, ≤ 120 V DC

¹⁾ → Table, page 10-11

Standards, formulae, tables

Protective measures

Protective devices and conditions for disconnection to IEC 60364-4-41/DIN VDE 0100-410

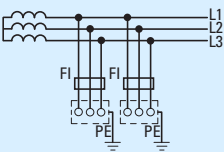
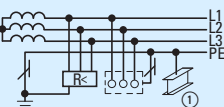
Type of distribution system	IT system	
Protection with	Circuit principle	Conditions for indication/disconnection
Residual current device (RCD) (always with additional insulation monitoring device, see below)		$R_A \times I_{\Delta n} \leq U_L$ $I_{\Delta n} = \text{Rated fault current}$
Insulation monitoring device (IMD)	 <p>① additional potential equalization</p>	<p>The insulation monitoring device is used to display the insulation state of all live parts to earth. An indication (visual/acoustic) is generated if the resistance goes below a specific value (R). The system is not disconnected but remains operational until a second earth fault occurs and the automatic disconnection takes place.</p>

Standards, formulae, tables

Protective measures

The protective device must automatically disconnect the faulty part of the installation. At no part of the installation

may there be a touch voltage or an effective duration greater than that specified in the table below.

Maximum disconnection times (s) as a function of the rated voltage. Phase conductors to earth and the system in accordance with VDE 0100-411.3.2.2

		System	
		TN Max. permissible disconnection time [s]	DD Max. permissible disconnection time [s]
$50\text{ V} < U_0 \leq 120\text{ V}$	AC	0.8	0.3
	DC	(see note)	(see note)
$120\text{ V} < U_0 \leq 230\text{ V}$	AC	0.4	0.2
	DC	5.0	0.4
$230\text{ V} < U_0 \leq 400\text{ V}$	AC	0.2	0.07
	DC	0.4	0.2
$U_0 > 400\text{ V}$	AC	0.1	0.04
	DC	0.1	0.1

U_0 is the rated operating voltage phase conductor to earth.

Note:

A disconnection may be necessary for different reasons than the protection from electric shock.

Standards, formulae, tables

Overcurrent protection of cables and conductors

Cables and conductors must be protected by means of overcurrent protective devices against excessive temperature rises, which may result both from operational overloading and from short-

circuit.
(in depth explanations on new DIN VDE 0100-430 contained in volume 143, 3rd edition, of the VDE publication series).

Overload protection

Overload protection involves the provision of protective devices which will interrupt overload currents in the conductors of a circuit before they can cause temperature rises which may damage the conductor insulation, the terminals and connections or the area around the conductors.

For the protection of conductors against overload the following conditions must be fulfilled (source: DIN VDE 0100-430)

$$I_B \leq I_n \leq I_Z$$

$$I_Z \leq 1.45 I_Z$$

- I_B Anticipated operating current of the circuit
- I_Z Current carrying capacity of conductor or cable
- I_n Rated operational current of the protective device

Remark:

For adjustable protective devices, I_n corresponds to the value set.

- I_Z The current which causes tripping of the protective device under the conditions specified in the equipment regulations.

10

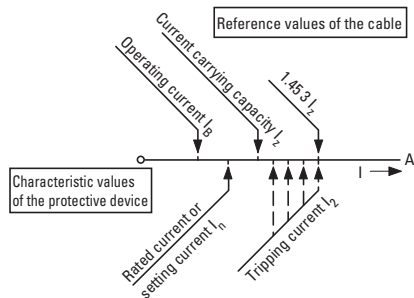

Arrangement of overload protective devices

Protection devices for overload protection must be fitted at the start of every circuit

and at every point where the current carrying capacity is reduced unless an upstream protection device can ensure protection.

Standards, formulae, tables

Overcurrent protection of cables and conductors

Note:

Reasons for the current carrying capacity being reduced:

Reduction of the conductor cross-section, a different installation method, different conductor insulation, a different number of conductors.

Protective devices for overload protection should not be fitted if interruption of the circuit could prove hazardous. The circuits must be laid out in such a way that no

possibility of overload currents occurring need be considered.

Examples:

Timing relay = function relay with contacts and coils

Time switch = function relay with contacts

- Energizing circuits for rotating machines
- Feeder circuits of solenoids
- Secondary circuits of current transformers
- Circuits for safety purposes

Short-circuit protection

Short-circuit protection means providing protective devices which will interrupt short-circuit currents in the conductors of a circuit before they can cause a temperature rise which may damage the conductor insulation, the terminals and connections, or the area around the cables and conductors.

In general, the permissible disconnection time t for short circuits of up to 5 s duration can be specified approximately using the following equation:

$$t = \left(k \times \frac{S}{I} \right)^2 \quad \text{or} \quad I^2 \times t = k^2 \times S^2$$

The meaning of the symbols is as follows:

- t : Permissible disconnection time in the event of short-circuit in s
 S : Conductor cross-section in mm²
 I : r.m.s. value of the current with a maximum short-circuit in A
 k : Constants with the values
- 115 for PVC-insulated copper conductors

- 76 for PVC-insulated aluminum conductors
- 141 for rubber-insulated copper conductors
- 93 for rubber-insulated aluminum conductors
- 115 for soft-solder connections in copper conductors
- Other values for k are given in Table 43A of DIN VDE 0100-430.

With very short permissible disconnection times (< 0.1 s) the product from the equation $k^2 \times S^2$ must be greater than the $I^2 \times t$ value of the current-limiting device stated by manufacturer.

Arrangement of protective devices for protection in the event of a short-circuit.

Protective devices for protection in the event of a short-circuit must be fitted at the start of every circuit and at every point at which the short-circuit current-carrying capacity is reduced unless a protective device fitted upstream can ensure the necessary protection in the event of a short circuit.

Standards, formulae, tables

Overcurrent protection of cables and conductors

Note:

Reasons for the reduction in the short-circuit current-carrying capacity can be: Reduction of the conductor cross-section, other conductor insulation.

Short-circuit protection must not be provided where an interruption of the

circuit could prove hazardous. In these cases two requirements must be fulfilled:

- The cable must be laid so that the risk of short-circuits is reduced to a minimum.
- The cable must not be laid in the vicinity of flammable materials.

Protection of the main poles and the neutral conductors

Protection of the main poles

Overcurrent protection devices must be provided in every main pole: they must disconnect the conductor in which the overcurrent occurs, but not necessarily also disconnect the other live conductors.

Note:

Where the disconnection of an individual main pole could prove hazardous, as for example, with three-phase motors, suitable precautions must be taken. Motor-protective circuit-breakers and circuit-breakers disconnect in 3 poles as standard.

Protection of the neutral conductor:

1. In installations with a directly earthed neutral point (**TN** or **TT** systems)

Where the cross-section of the neutral conductor is less than that of the main poles, an overcurrent monitoring device appropriate to its cross-section is to be provided in the neutral conductor; this overcurrent monitoring device must result in the disconnection of the phase conductors but not necessarily that of the neutral conductor.

An overcurrent monitoring device in the neutral conductor is not necessary where:

- the neutral conductor is protected in the event of a short-circuit by the protective device for the main poles
- the largest current which can flow through the neutral conductor is, in normal operation, considerably less than the current carrying capacity of this conductor.

Note:

This second condition is met provided that the power transferred is divided as evenly as possible among the main poles, for example where the total power consumption of the load connected between phase and neutral conductors, lamps and socket outlets is much less than the total power transferred via the circuit.

Standards, formulae, tables

Overcurrent protection of cables and conductors

2. In installations without a directly earthed neutral point (**IT system**)

Where it is necessary for the neutral conductor to be included, an overcurrent monitoring device must be provided in the neutral conductor of each circuit, to cause disconnection of all live conductors in the relevant circuit (including the neutral conductor).

The overcurrent monitoring device may however be omitted where the neutral conductor in question is protected against short-circuit by an upstream protective device, such as in the incoming unit of the installation.

Disconnection of the neutral conductor

Where disconnection of the neutral conductor is specified, the protective device used must be designed in such a way that the neutral conductor cannot under any circumstances be disconnected before the phase conductors and reconnected again after them. 4-pole NZM circuit-breakers always meet these conditions.

Standards, formulae, tables

Overcurrent protection of cables and conductors

10

Current carrying capacity and protection of cables and conductors with PVC insulation to DIN VDE 0298-4, at 25 °C ambient air temperature

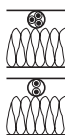
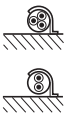
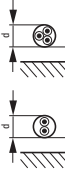
Type of cable or conductor	NYM, NYBWY, NYKY, NYM, NYMZ, NYMT, NYBUY, NYRUZY					
Type of installation	A1	b1	m2	C	E	
	In heat-insulating walls, in cable conduit under the surface	In cable conduits		On a wall	Exposed	
		Single-core cables	Multi-core cable			
	Multi-core cable under the surface	Cable cores in cable conduit on the wall	Multi-core cable in cable conduit on the wall surface	Single or multi-core cables or insulated cables	Multi-core cables or insulated cables with a minimum clearance of 0.3 x diameter d to wall	
Number of	2 3	2 3	2 3	2 3	2 3	
	Current-carrying capacity I_z in A for 25°C ambient air temperature and 70°C operating temperature.					

Standards, formulae, tables

Overcurrent protection of cables and conductors

Continued

Type of installation	A1			b1			m2			C			E		
	2	3	3	2	3	3	2	3	3	2	3	2	3	2	3
Number of cores	2	3	3	2	3	3	2	3	3	2	3	2	3	2	3
Copper conductor cross-section in mm ²	I_z	I_n	I_z	I_n	I_z	I_n	I_z	I_n	I_z	I_n	I_z	I_n	I_z	I_n	I_z
1.5	16.5	16	14.5	13	18.5	16	17.5	16	16	13	21	16	18.5	16	23
2.5	21	20	19.5	16	25	25	24	20	21	20	29	20	25	25	32
4	28	25	25	25	34	32	32	25	29	25	38	25	34	32	42
6	36	35	33	32	43	40	40	35	36	35	49	35	43	40	54
10	49	40	45	40	60	50	55	50	49	50	67	50	63	63	74
16	65	63	59	50	81	80	73	63	66	63	90	63	81	80	100
25	85	80	77	63	107	100	95	80	85	80	119	80	102	100	126
35	105	100	94	80	133	125	118	100	105	100	146	105	126	125	157
50	126	125	114	100	160	160	141	125	125	125	178	125	160	153	191
70	160	160	144	125	204	200	178	160	158	125	226	160	195	160	246
95	193	160	174	160	246	224	213	200	190	160	273	200	236	224	299
120	223	200	199	160	285	250	246	224	218	200	317	200	275	250	348

For overcurrent protective devices with a rated operational current I_n that does not conform to the values given in the table, select the next lower available rated operational current value.

Standards, formulae, tables

Overcurrent protection of cables and conductors

Minimum cross-sections for protective conductors to DIN VDE 0100-540

		Protective conductor or PEN conductor ¹⁾		Protective conductor ³⁾ laid separately		
		Insulated power cables	0.6/1-kV cable with 4 conductors	Protected		Unprotected ²⁾
mm ²		mm ²	mm ²	mm ² Cu	Al	mm ² Cu
To	0.5	0.5	–	2.5	4	4
	0.75	0.75	–	2.5	4	4
	1	1	–	2.5	4	4
	1.5	1.5	1.5	2.5	4	4
	2.5	2.5	2.5	2.5	4	4
	4	4	4	4	4	4
	6	6	6	6	6	6
	10	10	10	10	10	10
	16	16	16	16	16	16
	25	16	16	16	16	16
	35	16	16	16	16	16
	50	25	25	25	25	25
	70	35	35	35	35	35
	95	50	50	50	50	50
	120	70	70	70	70	70
	150	70	70	70	70	70
	185	95	95	95	95	95
	240	–	120	120	120	120
	300	–	150	150	150	150
400	–	185	185	185	185	

¹⁾ PEN conductor ≥ 10 mm² Cu or 18 mm² Al

²⁾ It is not permissible to lay aluminum conductors without protection.

³⁾ With main poles of ≥ 95 mm² or more, it is advisable to use non-insulated conductors.

Standards, formulae, tables**Overcurrent protection of cables and conductors****Conversion factors**

When the ambient temperature is not 30 °C; of wiring or cables in air to VDE 0298-4
to be used for the current carrying capacity Table 17.

Insulation material ¹⁾	NR/SR	PVC	EPR
Permissible operating temperature	60 °C	70 °C	80 °C
Ambient air temperature °C	Conversion factors		
10	1.29	1.22	1.18
15	1.22	1.17	1.14
20	1.15	1.12	1.10
25	1.08	1.06	1.05
30	1.00	1.00	1.00
35	0.91	0.94	0.95
40	0.82	0.87	0.89
45	0.71	0.79	0.84
50	0.58	0.71	0.77
55	0.41	0.61	0.71
60	–	0.50	0.63
65	–	0.35	0.55
70	–	–	0.45
75	–	–	0.32

¹⁾ Higher ambient air temperatures in accordance with information given by the manufacturer

Standards, formulae, tables**Overcurrent protection of cables and conductors****Conversion factors to DIN VDE 0298-4, Table 21**

Grouping of several circuits

Arrangement	Number of circuits								
	1	2	3	4	6	9	12	16	20
1 Embedded or enclosed	1.00	0.80	0.70	0.65	0.57	0.50	0.45	0.41	0.38
2 Fixed to walls or floors	1.00	0.85	0.79	0.75	0.72	0.70	0.70	0.70	0.70
3 Fixed under ceilings	0.95	0.81	0.72	0.68	0.64	0.61	0.61	0.61	0.61

Conversion factors for the grouping of multi-core cables or cables on cable troughs or trays as well as for other cases are provided in DIN VDE 0298-4, tables 22 to 27.

Standards, formulae, tables

Electrical equipment of machines

Extract from DIN EN 60204-1 (VDE 0113-1)

This standard is used for the electrical equipment of machines, unless there is a product standard (Type C) for the type of machine to be equipped.

Safety requirements regarding the protection of personnel, machines and material according to the European Machinery Safety Directive are highlighted under the heading "Safety of machines". The degree of possible danger is to be estimated by risk assessment. The standard also includes requirements for equipment, engineering and construction, as well as tests to ensure faultless function and the effectiveness of protective measures. The following paragraphs are an extract from the standard.

Mains isolating device (main switches)

Every machine must be equipped with a manually-operated mains isolating device. It must be possible to isolate the entire electrical equipment of the machine from the mains using the mains isolating device. The breaking capacity must be sufficient to simultaneously disconnect the stalled

current of the largest motor in the machine and the total current drawn by all the other loads in normal operation.

Its Off position must be lockable and must not be indicated until the specified clearances and creepage distances between all contacts have been achieved. It must have only one On and one Off position with associated stops. Star-delta, reversing and multi-speed switches are not permissible for use as mains isolating devices.

The tripped position of circuit-breakers is not regarded as a switch position, therefore there is no restriction on their use as mains isolating devices.

Where there are several incomers, each one must have a mains isolating device. Mutual interlocking must be provided where a hazard may result from only one mains isolating device being switched off. Only circuit-breakers may be used as remotely-operated switches. They must be provided with an additional handle and be lockable in the Off position.

Protection against electric shock

The following measures must be taken to protect personnel against electric shock.

Basic protection/protection against direct contact

This is understood as meaning protection by means of an enclosure which can only be opened by qualified personnel using a key or special tool. Such personnel is not obliged to disable the mains isolating

device before opening the enclosure. Live parts must be protected against direct contact in accordance with DIN EN 50274 or VDE 0660-514.

Where the mains isolating device is interlocked with the door, the restrictions mentioned in the previous paragraph cease to apply because the door can only be opened when the mains isolating device is switched off. It is permissible for an

Standards, formulae, tables

Electrical equipment of machines

interlock to be removable by an electrician using a tool, e.g. in order to search for a fault. Where an interlock has been removed, it must still be possible to switch off the mains isolating device.

Where it is possible for an enclosure to be opened without using a key and without disconnection of the mains isolating device, all live parts must at the very least comply with IP2X or IPXXB degree of

protection in accordance with DIN EN 60529; VDE 0470-1.

Fault protection – Protection against indirect contact

This involves prevention of a dangerous touch voltage resulting from faulty insulation. To meet this requirement, protective measures in accordance with IEC 60364-4-410; VDE 0100-410 must be used.

Protection of equipment

Protection in the event of power failure

When the power returns following a failure in the supply, machines or parts of machines must not start automatically where this would result in a dangerous situation or damage to property. With contactor controls this requirement can easily be met via self-maintaining circuits.

For circuits with two-wire control, an additional contactor relay with three-wire control in the input wiring to the actuating circuit can carry out this function. Mains isolating devices and motor-protective circuit-breakers with undervoltage releases also reliably prevent automatic restarting on return of voltage.

Overcurrent protection

No overcurrent protective device is normally required for the mains supply cable. Overcurrent protection is provided by the protective device at the head of the input wiring. All other circuits must be protected by means of fuses or circuit-breakers.

The stipulation for fuses is that replacement must be freely obtainable in the country in which the fuses are used.

This difficulty can be avoided by using circuit-breakers, with the added benefits of all-pole disconnection, rapid operational readiness and prevention of single-phasing.

Overload protection of motors

Continuously operating motors above 0.5 kW must be protected against overload. Overload protection is recommended for all other motors. Motors which are frequently starting and braking are difficult to protect and often require a special protective device. Built-in thermal sensors are particularly suitable for motors with restricted cooling. In addition, the fitting of overload relays is always recommended, particularly as protection in the event of a stalled rotor.

Standards, formulae, tables

Electrical equipment of machines

Control functions in the event of a fault

A fault in the electrical equipment must not result in a dangerous situation or in damage. Suitable measures must be taken to prevent danger from arising. The expense of using appropriate measures can be extremely high if applied generally. To permit a better assessment of the magnitude of the risk in conjunction with the respective application, the standard DIN EN ISO 13849-1 has been published: "Safety-related parts of control systems Part 1: General rules for design".

The use of risk assessment to DIN EN ISO 13849-1 is dealt with in the Eaton safety manual "Safety Technology for Machines and Systems" (Order No. PU05907001Z).

Emergency switching off device

Every machine which could potentially cause danger must be equipped with an emergency switching off device which, in a main circuit may be an emergency switching off switch, and in a control circuit an emergency switching off control circuit device.

Actuation of the Emergency-Stop device must result in all current loads which could directly result in danger, being disconnected by de-energization via another device or circuit, i.e. electromechanical devices such as contactors, contactor relays or the undervoltage release of the mains isolating device.

For direct manual operation, emergency switching off control circuit devices must have a mushroom-head push-button and positively opening contacts. Once the emergency switching off control circuit

device has been actuated, it must only be possible to restart the machine after local resetting. Resetting alone must not allow restarting.

Furthermore, the following apply for both emergency-stop switch and emergency switching off control circuit device:

- The handle must be red with a yellow background
- Emergency switching off devices must be quickly and easily accessible in the event of danger
- The emergency switching off function must take precedence over all other functions and operations
- It must be possible to determine functional capability by means of tests, especially in severe environmental conditions.
- Where there is separation into several Emergency-Stop areas, it must be clearly discernible to which area an Emergency-Stop device applies

Emergency operations

It is not clear however from the term emergency switching off which functions are carried out with this. In order to be able to give a more precise definition here, DIN EN 60204-1 describes two specific functions:

1. Devices for emergency stop
This involves the possibility of stopping hazardous motion as quickly as possible.
2. Devices for emergency switching off
Where there is a risk of an electric shock by direct contact, e.g. with live parts in electrical operating areas, then an Emergency-Off device shall be provided.

Standards, formulae, tables

Electrical equipment of machines

Colors of pushbuttons and their meanings

to DIN EN 60073; VDE 0199

DIN EN 60204-1; VDE 0113-1, Table 2

Color	Meaning	Typical application
RED	Emergency	<ul style="list-style-type: none"> • Emergency switching off • Fire fighting
YELLOW	Abnormal condition	Intervention, to suppress abnormal conditions or to avoid unwanted changes
BLUE	Enforced action	Resetting function
GREEN	Normal	Start from safe condition
WHITE	No specific meaning assigned	<ul style="list-style-type: none"> • Start/ON (preferred) • Stop/OFF
GREY		<ul style="list-style-type: none"> • Start/ON • Stop/OFF
BLACK		<ul style="list-style-type: none"> • Start/ON • Stop/Off (preferred)

Standards, formulae, tables

Electrical equipment of machines

Colors of indicator lights and their meanings

to DIN EN 60073; VDE 0199

DIN EN 60204-1; VDE 0113-1, Table 4

Color	Meaning	Description	Typical application
RED	Emergency	Warning of potential danger or a situation which requires immediate action	<ul style="list-style-type: none"> • Failure of pressure in the lubricating system • Temperature outside specified (safe) limits • Essential equipment stopped by action of a protective device
YELLOW	Abnormal condition	Impending critical condition	<ul style="list-style-type: none"> • Temperature (or pressure) different from normal level • Overload, which is permissible for a limited time
BLUE	Enforced action	Operator action essential	<ul style="list-style-type: none"> • Remove obstacle • Switch over to Advance
GREEN	Normal	Indication of safe operating conditions or authorization to proceed, clear way	<ul style="list-style-type: none"> • Cooling liquid circulating • Automatic tank control switched on • Machine ready to be started
WHITE	Neutral	Any meaning: may be used whenever doubt exists about the applicability of the colors RED, YELLOW or GREEN; or as confirmation	<ul style="list-style-type: none"> • Motor running • Indication of operating modes

Colors of illuminated pushbutton actuators and their meanings

Both tables are valid for illuminated pushbutton actuators, Table 1 relating to the function of the actuators.

Standards, formulae, tables

Electrical equipment of machines

Safety-related characteristic values to EN ISO 13849-1 and IEC 62061

A safety-related system can consist of one or several components. The assessment of the safety-related parts of a control system to EN ISO 13849-1 and IEC 62061 require the

use of characteristic values provided by the component manufacturer.

Eaton provides the characteristic values of all safety-related components in the area of safety technology.

Reliability values to EN ISO 13849-1

B10d	Number of operations until 10 % of the tested components fail dangerously.
MTTFd	Mean Time To Dangerous Failure. Average of the time expected up to a dangerous failure
PL	Performance Level

Reliability values to IEC 62061

B10	Number of operations until 10 % of the tested components fail.
PFHd	Probability of a Dangerous Failure per Hour Probability of a dangerous failure per hour
SIL CL	Safety Integrity Level Claim Limit. SIL claim limit (for a subsystem).

10

Further details are provided in the overview of the safety-related characteristic values for components:

http://www.moeller.net/binary/bl_supplements/bl8896de.pdf

Standards, formulae, tables

Measures for risk reduction

Risk reduction in the fault scenario

A fault in the electrical equipment must not result in a dangerous situation or in

damage. Suitable measures must be taken to prevent danger from arising.

The use of proven circuits and components

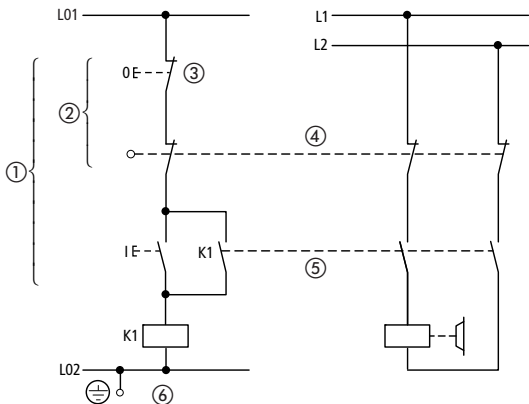

- ① All switching functions on the non-earthed side
- ② Use of break devices with positively opening contacts (not to be confused with interlocked opposing contacts)
- ③ Shut-down by de-excitation (fail-safe in the event of wire breakage)
- ④ Circuit engineering measures which make undesirable operating states in the fault scenario unlikely (in this instance, simultaneous interruption via contactor and position switch)
- ⑤ Switching of all live conductors to the device to be controlled

- ⑥ Chassis earth connection of the actuating circuit for operational purposes (not used as a protective measure)

Redundancy

This means the existence of an additional device or system which takes over the function in the fault scenario.

Standards, formulae, tables

Measures for risk reduction

Diversity

The construction of control circuits according to a range of function principles or using various types of device.

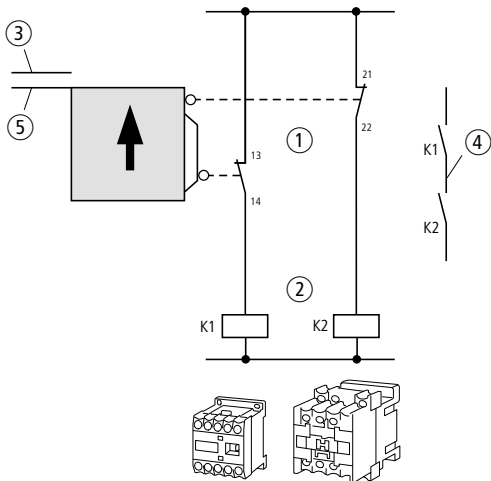

10

- ① Functional diversity by combination of N/O and N/C contacts
- ② Diversity of devices due to use of various types of device (here, various types of contactor relay)
- ③ Safety barrier open
- ④ Feedback circuit
- ⑤ Safety barrier closed

Performance tests

The correct functioning of the equipment can be tested either manually or automatically.

Standards, formulae, tables

Protection types for electrical equipment

Protection types for electrical equipment by enclosures, covers and similar to DIN EN 60529; VDE 0470-1

The designation to indicate degrees of enclosure protection consists of the characteristic letters **IP** (Ingress Protection) followed by two characteristic numerals. The first numeral indicates the

degree of protection of persons against contact with live parts and of equipment against ingress of solid foreign bodies and dust, the second numeral the degree of protection against the ingress of water.

Protection against contact and foreign bodies

First numeral	Degree of protection	
	Description	Explanation
0	Not protected	No special protection of persons against accidental contact with live or moving parts. No protection of the equipment against ingress of solid foreign bodies.
1	Protection against solid objects ≥ 50 mm	Protection against contact with live parts with back of hand. The access probe, sphere 50 mm diameter, must have enough distance from dangerous parts. The probe, sphere 50 mm diameter, must not fully penetrate.
2	Protection against solid objects ≥ 12.5 mm	Protection against contact with live parts with a finger. The articulated test finger, 12 mm diameter and 80 mm length, must have sufficient distance from dangerous parts. The probe, sphere 12.5 mm diameter, must not fully penetrate.

Standards, formulae, tables

Protection types for electrical equipment

Protection against contact and foreign bodies

First numeral	Degree of protection	
	Description	Explanation
3	Protection against solid objects ≥ 2.5 mm	Protection against contact with live parts with a tool. The entry probe, 2.5 mm diameter, must not penetrate. The probe, 2.5 mm diameter, must not penetrate.
4	Protection against solid objects ≥ 1 mm	Protection against contact with live parts with a conductor. The entry probe, 1.0 mm diameter, must not penetrate. The probe, 1.0 mm diameter, must not penetrate.
5	Protection against accumulation of dust	Protection against contact with live parts with a conductor. The entry probe, 1.0 mm diameter, must not penetrate. The ingress of dust is not totally prevented, but dust does not enter in sufficient quantity to interfere with satisfactory operation of the equipment or with safety.
6	Protection against the ingress of dust Dust-tight	Protection against contact with live parts with a conductor. The entry probe, 1.0 mm diameter, must not penetrate. No entry of dust.

10

Example for stating degree of protection:

IP

4

4

Characteristic letter

First numeral

Second numeral

Standards, formulae, tables**Protection types for electrical equipment****Protection against water**

Second numeral	Degree of protection	
	Description	Explanation
0	Not protected	No special protection
1	Protected against vertically dripping water	Dripping water (vertically falling drops) shall have no harmful effect.
2	Protected against dripping water when enclosure tilted up to 15°	Dripping water shall have no harmful effect when the enclosure is tilted at any angle up to 15° from the vertical.
3	Protected against sprayed water	Water falling as a spray at any angle up to 60° from the vertical shall have no harmful effect.
4	Protected against splashing water	Water splashed against the enclosure from any direction shall have no harmful effect.
5	Protected against water jets	Water projected by a nozzle against the equipment from any direction shall have no harmful effect.
6	Protected against powerful water jets	Water projected in powerful jets against the enclosure from any direction shall have no harmful effect.
7	Protected against the effects of occasional submersion	Ingress of water in harmful quantities shall not be possible when the enclosure is immersed in water under defined conditions of pressure and time.

Standards, formulae, tables**Protection types for electrical equipment**

Second numeral	Degree of protection	
	Description	Explanation
8	Protected against the effects of submersion	Ingress of water in harmful quantities must not be possible when the equipment is continuously submerged in water under conditions which are subject to agreement between manufacturer and user. These conditions must be more stringent than those for characteristic numeral 7.
9K ¹⁾	Protected during cleaning using high-pressure/steam jets	Water which is directed against the enclosure under extremely high pressure from any direction must not have any harmful effects. Water pressure of 100 bar Water temperature of 80 °C

¹⁾ This characteristic numeral originates from DIN 40050 9.

Notes

Standards, formulae, tables

Utilization categories for switching elements

To DIN EN 60947-5-1 (VDE 0660-200, Table 1)

Type of current	Utilization category	Typical applications	Normal conditions of use	
		I = Inrush current, I_c = Breaking current, I_e = Rated operational current, U = Voltage, U_e = Rated operational voltage U_r = Recovery voltage, $t_{0.95}$ = Time in ms, until 95 % of the steady-state current has been reached. $P = U_e \times I_e$ = Rated power in Watts	Switch on	
			$\frac{I}{I_e}$	$\frac{U}{U_e}$
Alternating current	AC-12	Control of resistive and solid state loads as in optocoupler input circuits	1	1
	AC-13	Control of solid state loads with transformer isolation	2	1
	AC-14	Control of small electromagnetic loads (max. 72 VA)	6	1
	AC-15	Control of electromagnetic loads (above 72 VA)	10	1
			$\frac{I}{I_e}$	$\frac{U}{U_e}$
DC current	DC-12	Control of resistive and solid state loads as in optocoupler input circuits	1	1
	DC-13	Control of electromagnets	1	1
	DC-14	Control of electromagnetic loads with economy resistors in the circuit	10	1

Standards, formulae, tables

Utilization categories for switching elements

				Abnormal conditions of use					
Switch off				Switch on			Switch off		
$\cos \varphi$	$\frac{I}{I_e}$	$\frac{U}{U_e}$	$\cos \varphi$	$\frac{I}{I_e}$	$\frac{U}{U_e}$	$\cos \varphi$	$\frac{I}{I_e}$	$\frac{U}{U_e}$	$\cos \varphi$
0.9	1	1	0.9	–	–	–	–	–	–
0.65	1	1	0.65	10	1.1	0.65	1.1	1.1	0.65
0.3	1	1	0.3	6	1.1	0.7	6	1.1	0.7
0.3	1	1	0.3	10	1.1	0.3	10	1.1	0.3
$t_{0.95}$	$\frac{I}{I_e}$	$\frac{U}{U_e}$	$T_{0.95}$	$\frac{I}{I_e}$	$\frac{U}{U_e}$	$T_{0.95}$	$\frac{I}{I_e}$	$\frac{U}{U_e}$	$T_{0.95}$
1 ms	1	1	1 ms	–	–	–	–	–	–
$6 \times P^{1)}$	1	1	$6 \times P^{1)}$	1.1	1.1	$6 \times P^{1)}$	1.1	1.1	$6 \times P^{1)}$
15 ms	1	1	15 ms	10	1.1	15 ms	10	1.1	15 ms

¹⁾ The value "6 x P" results from an empirical relationship that represents most DC magnetic loads to an upper limit of $P = 50 \text{ W}$, i.e. $6 [\text{ms}]/[\text{W}] = 300 [\text{ms}]$. Loads having a power consumption greater than 50 W are assumed to consist of smaller loads in parallel. Therefore, 300 ms is to be an upper limit, irrespective of the power consumption.

Standards, formulae, tables

Utilization categories for contactors and motor starters

To DIN EN 60947-4-1 (VDE 0660-102, Table 1)

Type of current	Utilization category	Typical applications: I = Inrush current, I _c = Breaking current, I _e = Rated operational current, U = Voltage, U _e = Rated operational voltage U _r = Recovery voltage	Verification of electrical lifespan		
			Switch on		
			I _e [A]	$\frac{I}{I_e}$	$\frac{U}{U_e}$
Alternating current	AC-1	Non-inductive or slightly inductive loads, resistance furnaces	All values	1	1
	AC-2	Slip-ring motors: starting, switch off	All values	2.5	1
	AC-3	Normal AC induction motors: starting, switch off during running ⁴⁾	I _e ≤ 17 I _e > 17	6 6	1 1
	AC-4	Normal AC induction motors: starting, plugging, reversing, inching	I _e ≤ 17 I _e > 17	6 6	1 1
	AC-5a	Switching of electric discharge lamp controls			
	AC-5b	Switching of filament lamps			
	AC-6a ³⁾	Switching of transformers			
	AC-6b ³⁾	Switching of capacitor banks			
	AC-7a	Slightly inductive loads in household appliances and similar applications		Data as supplied by the manufacturer	
	AC-7b	Motor load for domestic applications			
	AC-8a	Switching of hermetically enclosed refrigerant compressor motors with manual reset of overload releases ⁵⁾			
	AC-8b	Switching of hermetically enclosed refrigerant compressor motors with automatic reset of overload releases ⁵⁾			

Standards, formulae, tables

Utilization categories for contactors and motor starters

				Verification of switching capacity						
				Switch on				Switch off		
	Switch off			Switch on				Switch off		
cos φ	$\frac{I_c}{I_e}$	$\frac{U_r}{U_e}$	cos φ	I_e [A]	$\frac{I}{I_e}$	$\frac{U}{U_e}$	cos φ	$\frac{I_c}{I_e}$	$\frac{U_r}{U_e}$	cos φ
0.95	1	1	0.95	All values	1.5	1.05	0.8	1.5	1.05	0.8
0.65	2.5	1	0.65	All values	4	1.05	0.65	4	1.05	0.8
0.65	1	0.17	0.65	$I_e \leq 100$	8	1.05	0.45	8	1.05	0.45
0.35	1	0.17	0.35	$I_e > 100$	8	1.05	0.35	8	1.05	0.35
0.65	6	1	0.65	$I_e \leq 100$	10	1.05	0.45	10	1.05	0.45
0.35	6	1	0.35	$I_e > 100$	10	1.05	0.35	10	1.05	0.35
					3.0	1.05	0.45	3.0	1.05	0.45
					1.5 ²⁾	1.05	2)	1.5 ²⁾	1.05	2)
					1.5	1.05	0.8	1.5	1.05	0.8
					8.0	1.05	1)	8.0	1.05	1)
					6.0	1.05	1)	6.0	1.05	1)
					6.0	1.05	1)	6.0	1.05	1)

Standards, formulae, tables

Utilization categories for contactors and motor starters

To DIN EN 60947-4-1 (VDE 0660-102, Table 1)

Type of current	Utilization category	Typical applications: I = Inrush current, I _c = Breaking current, I _e = Rated operational current, U = Voltage, U _e = Rated operational voltage, U _r = Recovery voltage	Verification of electrical lifespan		
			Switch on		
			I _e [A]	$\frac{I}{I_e}$	$\frac{U}{U_e}$
DC current	DC-1	Non-inductive or slightly inductive loads, resistance furnaces	All values	1	1
	DC-3	Shunt motors: starting, plugging, reversing, inching, dynamic braking	All values	2.5	1
	DC-5	Series motors: starting, plugging, reversing, inching, dynamic braking	All values	2.5	1
	DC-6	Switching of filament lamps			

¹⁾ $\cos \varphi = 0.45$ for $I_e \leq 100$ A; $\cos \varphi = 0.35$ for $I_e > 100$ A

²⁾ Tests must be carried out with an filament bulb load connected.

³⁾ Here, the test data are to be derived from the AC-3 or AC-4 test values in accordance with particular table.

Standards, formulae, tables**Utilization categories for contactors and motor starters**

				Verification of switching capacity						
Switch off				Switch on				Switch off		
L/R [ms]	$\frac{I_c}{I_e}$	$\frac{U_r}{U_e}$	L/R [ms]	I_e [A]	$\frac{I}{I_e}$	$\frac{U}{U_e}$	L/R [ms]	$\frac{I_c}{I_e}$	$\frac{U_r}{U_e}$	L/R [ms]
1	1	1	1	All values	1.5	1.05	1	1.5	1.05	1
2	2.5	1	2	All values	4	1.05	2.5	4	1.05	2.5
7.5	2.5	1	7.5	All values	4	1.05	15	4	1.05	15
					1.5 ²⁾	1.05	2)	1.5 ²⁾	1.05	2)

⁴⁾ Devices for utilization category AC-3 may be used for occasional inching or plugging during a limited period such as for setting up a machine; during this limited time period, the number of operations must not exceed a total of five per minute or more than ten in a ten minute period.

⁵⁾ Hermetically enclosed refrigerant compressor motor means a combination of a compressor and a motor both of which are housed in the same enclosure with no external shaft or shaft seals, the motor running in the coolant.

Standards, formulae, tables

Utilization categories for switch-disconnectors

**For switches, switch-disconnectors and fuse-combination units to
DIN EN 60947-3 (VDE 0660-107, Table 2)**

Type of current	Utilization category	Typical applications: I = Inrush current, I _c = Breaking current, I _e = Rated operational current, U = Voltage, U _e = Rated operational voltage, U _r = Recovery voltage
Alternating current	AC-20 A(B) ¹⁾	Making and breaking without load
	AC-21 A(B) ¹⁾	Switching resistive loads including low overloads
	AC-22 A(B) ¹⁾	Switching mixed resistive and inductive loads including low overloads
	AC-23 A(B) ¹⁾	Switching motors and other highly inductive loads
DC current	DC-20 A(B) ¹⁾	Making and breaking without load
	DC-21 A(B) ¹⁾	Switching resistive loads including low overloads
	DC-22 A(B) ¹⁾	Switching mixed resistive and inductive loads, including low overloads (e.g. shunt motors)
	DC-23 A(B) ¹⁾	Switching highly inductive loads (e.g. series motors)

¹⁾ A: Frequent actuation, B: Occasional actuation

Switch-disconnectors that are suitable for switching motors are also tested according to the criteria stated in → Section "Utilization categories for contactors and motor starters", page 10-36.

Standards, formulae, tables

Utilization categories for switch-disconnectors

Verification of switching capacity						
Switch on				Switch off		
I_e [A]	$\frac{I}{I_e}$	$\frac{U}{U_e}$	$\cos \varphi$	$\frac{I_c}{I_e}$	$\frac{U_r}{U_e}$	$\cos \varphi$
All values	1)		1)	1)		1)
All values	1.5	1.05	0.95	1.5	1.05	0.95
All values	3	1.05	0.65	3	1.05	0.65
$I_e \leq 100$	10	1.05	0.45	8	1.05	0.45
$I_e > 100$	10	1.05	0.35	8	1.05	0.35
I_e [A]	$\frac{I}{I_e}$	$\frac{U}{U_e}$	L/R [ms]	$\frac{I_c}{I_e}$	$\frac{U_r}{U_e}$	L/R [ms]
All values	1)	1)	1)	1)	1)	1)
All values	1.5	1.05	1	1.5	1.05	1
All values	4	1.05	2.5	4	1.05	2.5
All values	4	1.05	15	4	1.05	15

Notes

Standards, formulae, tables

Rated motor currents

Rated motor currents for three-phase motors (recommended value for squirrel cage motors)

Minimum fuse size for short-circuit protection of three-phase motors

The maximum value is determined by the switching device or overload relay.

The rated motor currents are for standard 1500 r.p.m. three-phase motors with normal inner and outer surface cooling.

D.O.L. starting: Maximum starting current: 6 x rated motor current, maximum starting time: 5 sec.

Υ/Δ starting: Maximum starting current: 2 x rated motor current, maximum starting time: 15 sec. Motor overload relay in phase current: set to 0.58 x rated motor current.

Rated fuse currents for Υ/Δ starting also apply to three-phase motors with slip-ring rotors.

For higher rated currents, starting currents and/or longer starting times, larger fuses will be required.

This table applies to "slow" or "gL" fuses (VDE 0636).

In the case of NH fuses with aM characteristics, fuses are to be selected according to their rated operational current.

Standards, formulae, tables

Rated motor currents

Motor power			230 V			400 V		
			Rated motor current	Fuse Direct starting	Y/Δ	Rated motor current	Fuse Direct starting	Y/Δ
kW	cos φ	η [%]	A	A	A	A	A	A
0.06	0.7	58	0.37	2	–	0.21	2	–
0.09	0.7	60	0.54	2	–	0.31	2	–
0.12	0.7	60	0.72	4	2	0.41	2	–
0.18	0.7	62	1.04	4	2	0.6	2	–
0.25	0.7	62	1.4	4	2	0.8	4	2
0.37	0.72	66	2	6	4	1.1	4	2
0.55	0.75	69	2.7	10	4	1.5	4	2
0.75	0.79	74	3.2	10	4	1.9	6	4
1.1	0.81	74	4.6	10	6	2.6	6	4
1.5	0.81	74	6.3	16	10	3.6	6	4
2.2	0.81	78	8.7	20	10	5	10	6
3	0.82	80	11.5	25	16	6.6	16	10
4	0.82	83	14.8	32	16	8.5	20	10
5.5	0.82	86	19.6	32	25	11.3	25	16
7.5	0.82	87	26.4	50	32	15.2	32	16
11	0.84	87	38	80	40	21.7	40	25
15	0.84	88	51	100	63	29.3	63	32
18.5	0.84	88	63	125	80	36	63	40
22	0.84	92	71	125	80	41	80	50
30	0.85	92	96	200	100	55	100	63
37	0.86	92	117	200	125	68	125	80
45	0.86	93	141	250	160	81	160	100
55	0.86	93	173	250	200	99	200	125
75	0.86	94	233	315	250	134	200	160
90	0.86	94	279	400	315	161	250	200
110	0.86	94	342	500	400	196	315	200
132	0.87	95	401	630	500	231	400	250
160	0.87	95	486	630	630	279	400	315
200	0.87	95	607	800	630	349	500	400
250	0.87	95	–	–	–	437	630	500
315	0.87	96	–	–	–	544	800	630
400	0.88	96	–	–	–	683	1000	800
450	0.88	96	–	–	–	769	1000	800
500	0.88	97	–	–	–	–	–	–
560	0.88	97	–	–	–	–	–	–
630	0.88	97	–	–	–	–	–	–

Standards, formulae, tables**Rated motor currents**

440 V			500 V			690 V		
Rated motor current	Fuse Direct starting	Y/Δ	Rated motor current	Fuse Direct starting	Y/Δ	Rated motor current	Fuse Direct starting	Y/Δ
A	A	A	A	A	A	A	A	A
0.19	2	–	0.17	2	–	0.12	2	–
0.28	2	–	0.25	2	–	0.18	2	–
0.37	2	–	0.33	2	–	0.24	2	–
0.54	2	–	0.48	2	–	0.35	2	–
0.76	2	–	0.7	2	–	0.5	2	–
1	4	2	0.9	2	2	0.7	2	–
1.4	4	2	1.2	4	2	0.9	4	2
1.7	4	2	1.5	4	2	1.1	4	2
2.4	4	2	2.1	6	4	1.5	4	2
3.3	6	4	2.9	6	4	2.1	6	4
4.6	10	6	4	10	4	2.9	10	4
6	16	10	5.3	16	6	3.8	10	4
7.7	16	10	6.8	16	10	4.9	16	6
10.2	20	10	9	20	16	6.5	16	10
13.8	25	16	12.1	25	16	8.8	20	10
19.8	32	25	17.4	32	20	12.6	25	16
26.6	50	32	23.4	50	25	17	32	20
32.8	63	32	28.9	50	32	20.9	32	25
37	80	40	33	63	32	23.8	50	25
50	100	63	44	80	50	32	63	32
61	125	80	54	100	63	39	80	50
74	125	100	65	125	80	47	80	63
90	125	100	79	160	80	58	100	63
122	160	125	107	200	125	78	160	100
146	200	160	129	200	160	93	160	100
179	250	200	157	250	160	114	200	125
210	250	250	184	250	200	134	250	160
254	315	250	224	315	250	162	250	200
318	400	315	279	400	315	202	315	250
397	630	400	349	500	400	253	400	315
495	630	630	436	630	500	316	500	400
621	800	800	547	800	630	396	630	400
699	800	800	615	800	630	446	630	630
–	–	–	–	–	–	491	630	630
–	–	–	–	–	–	550	800	630
–	–	–	–	–	–	618	800	630

Standards, formulae, tables

Conductors

Wiring and cable entries with grommets

Cable entry into closed devices is considerably simplified and improved by using cable grommets.

Cable grommets

For direct and quick cable entry into an enclosure and as a plug.

Membrane grommets metric	Cable entry	Hole diameter	Cable external diameter	For use with NYM/NYY cables, 4-core	Cable grommet part no.
		mm	mm	mm ²	
 <ul style="list-style-type: none"> • IP66 with built-in push-through membrane • PE and thermo-plastic elastomer, halogen free 	M16	16.5	1 – 9	H03VV-F3 x 0.75 NYM 1 x 16/3 x 1.5	KT-M16
	M20	20.5	1 – 13	H03VV-F3 x 0.75 NYM 5 x 1.5/5 x 2.5	KT-M20
	M25	25.5	1 – 18	H03VV-F3 x 0.75 NYM 4x 10	KT-M25
	M32	32.5	1 – 25	H03VV-F3 x 0.75 NYM 4 x 16/5 x 10	KT-M32

10

Detailed information on material properties

→ Table, page 10-48.

Standards, formulae, tables

Conductors

Wiring and cable entries with cable glands

Metric cable glands to DIN EN 50262; VDE 0619

with 9, 10, 12, 14 or 15 mm long thread.

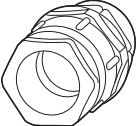
Cable glands	Cable entry	Hole diameter mm	Cable external diameter mm	For use with NYM/NYY cables, 4-core mm ²	Cable glands part no.
 <ul style="list-style-type: none"> • With lock nut and built-in strain relief • IP68 up to 5 bar, polyamide, halogen free 	M12	12.5	3 – 7	H03VV-F3 x 0.75 NYM 1 x 2.5	V-M12
	M16	16.5	4.5 – 10	H05VV-F3 x 1.5 NYM 1 x 16/3 x 1.5	V-M16
	M20	20.5	6 – 13	H05VV-F4 x 2.5/3 x 4 NYM 5 x 1.5/5 x 2.5	V-M20
	M25	25.5	9 – 17	H05VV-F5 x 2.5/5 x 4 NYM 5 x 2.5/5 x 6	V-M25
	M32	32.5	13 – 21	NYM 5 x 10	V-M32
	M32	32.5	18 – 25	NYM 5 x 16	V-M32G ¹⁾
	M40	40.5	16 – 28	NYM 5 x 16	V-M40
	M50	50.5	21 – 35	NYM 4 x 35/5 x 25	V-M50
	M63	63.5	34 – 48	NYM 4 x 35	V-M63
 <p>Ventilation cable glands IP69K</p>	M20	20.5	6 – 13	H05VV-F 4 x 2.5/3 x 4 NYM 5 x 1.5/5 x 2.5	V-M20-VENT

10

1) Not in compliance with DIN EN 50262.

Detailed information on material properties

→ Table, page 10-48.

Standards, formulae, tables**Conductors****Material properties**

	KT-M...	V-M...
Material	Polyethylene and thermoplastic elastomer, halogen free	Polyamide, halogen free
Color	grey, RAL 7035	grey, RAL 7035
Protection type	up to IP66	IP68 up to 5 bar (30 min)
Chemical resistance	Resistant to: <ul style="list-style-type: none"> • Alcohol, • Animal and plant-based oils, • Weak alkalis, • Weak acids, • water 	Resistant to: <ul style="list-style-type: none"> • Acetone, • Petrol, • paraffin, • Diesel oil, • Greases, • Oils, • Solvents for paints and lacquers
Danger of stress fracture	Relatively high	low
Temperature resistance	-40 °C...80 °C, short-time up to approx. 100 °C	-20 °C...100 °C, short-time up to approx. 120 °C
Flame retardant	-	Glow-wire test 750 °C to DIN EN 60695-2-11; VDE 0471-2-11
Flammability to UL94	-	V2

Standards, formulae, tables

Conductors

External diameter of conductors and cables

Number of conductors	Approximate external diameter (mean value of various makes)				
	NYM	NYY	H05 RR-F	H07 RN-F	NYCY NYCWY
Cross section mm ²	mm max.	mm	mm max.	mm max.	mm
2 x 1.5	10	11	9	10	12
2 x 2.5	11	13	13	11	14
3 x 1.5	10	12	10	10	13
3 x 2.5	11	13	11	12	14
3 x 4	13	17	–	14	15
3 x 6	15	18	–	16	16
3 x 10	18	20	–	23	18
3 x 16	20	22	–	25	22
4 x 1.5	11	13	9	11	13
4 x 2.5	12	14	11	13	15
4 x 4	14	16	–	15	16
4 x 6	16	17	–	17	18
4 x 10	18	19	–	23	21
4 x 16	22	23	–	27	24
4 x 25	27	27	–	32	30
4 x 35	30	28	–	36	31
4 x 50	–	30	–	42	34
4 x 70	–	34	–	47	38
4 x 95	–	39	–	53	43
4 x 120	–	42	–	–	46
4 x 150	–	47	–	–	52
4 x 185	–	55	–	–	60
4 x 240	–	62	–	–	70
5 x 1.5	11	14	12	14	15
5 x 2.5	13	15	14	17	17
5 x 4	15	17	–	19	18
5 x 6	17	19	–	21	20
5 x 10	20	21	–	26	–
5 x 16	25	23	–	30	–
8 x 1.5	–	15	–	–	–
10 x 1.5	–	18	–	–	–
16 x 1.5	–	20	–	–	–
24 x 1.5	–	25	–	–	–

NYM: light plastic-sheathed cable

NYY: plastic-sheathed cable

H05RR-F: light rubber-sheathed flexible cable (NLH + NSH)

NYCY: cable with concentric conductor and plastic sheath

NYCWY: cable with concentric wave-form conductor and plastic sheath

Standards, formulae, tables

Conductors

Cables and wiring, type abbreviation

Designation of specification

Harmonized specification H

Recognized national type A

Rated operational voltage U_0/U

300/300V 03

300/500 V 05

450/750V 07

Insulating material

PVC V

Natural- and/or synthetic rubber R

Silicon rubber S

Sheathing material

PVC V

Natural- and/or synthetic rubber R

Polychloroprene rubber N

Fibre-glass braid J

Textile braid T

Special construction feature

Flat, separable conductor H

Flat, non-separable conductor H2

Type of conductor

solid -U

stranded -R

Flexible with cables for fixed installation -K

Flexible with flexible cables -F

Highly flexible with flexible cables -H

Tinsel cord -Y

Number of cores ...

Protective conductor

Without protective conductors X

With protective conductors G

Rated conductor cross-section ...

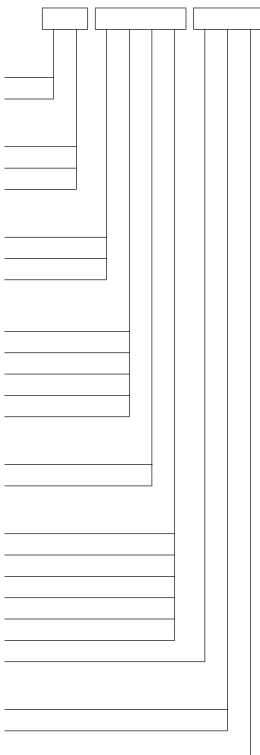

10

Examples for complete cable designation

PVC-sheathed wire, 0.75 mm² flexible,
H05V-K 0.75 black

Heavy rubber-sheathed cable, 3-core,
2.5 mm² without green/yellow protective
conductor A07RN-F3 x 2.5

Notes

Standards, formulae, tables

Conductors

Rated operational currents and short-circuit currents for standard transformers

Rated operating voltage

U _n	400/230 V			525 V
		4 %	6 %	
Short-circuit voltage U _k				
Rating	Rated operational current	Short-circuit current		Rated operational current
	I _n	I _k '		I _n
kVA	A	A	A	A
50	72	1967	–	55
63	91	2478	1652	69
100	144	3933	2622	110
125	180	4916	3278	137
160	231	6293	4195	176
200	289	7866	5244	220
250	361	9833	6555	275
315	455	12390	8260	346
400	577	15733	10489	440
500	722	19666	13111	550
630	909	24779	16519	693
800	1155	–	20977	880
1000	1443	–	26221	1100
1250	1804	–	32777	1375
1600	2309	–	41954	1760
2000	2887	–	52443	2199
2500	3608	–	65553	2749

Standards, formulae, tables

Conductors

		690/400 V		
4 %	6 %		4 %	6 %
Short-circuit current		Rated operational current	Short-circuit current	
I_k''		I_n	I_k''	
A	A	A	A	A
1498	–	42	1140	–
1888	1259	53	1436	958
2997	1998	84	2280	1520
3746	2497	105	2850	1900
4795	3197	134	3648	2432
5993	3996	167	4560	3040
7492	4995	209	5700	3800
9440	6293	264	7182	4788
11987	7991	335	9120	6080
14984	9989	418	11401	7600
18879	12586	527	14365	9576
–	15983	669	–	12161
–	19978	837	–	15201
–	24973	1046	–	19001
–	31965	1339	–	24321
–	39956	1673	–	30402
–	49945	2092	–	38002

Standards, formulae, tables**Formulae****Ohm's Law**

$$U = I \times R \text{ [V]}$$

$$I = \frac{U}{R} \text{ [A]}$$

$$R = \frac{U}{I} \text{ [\Omega]}$$

Resistance of a piece of wire

$$R = \frac{l}{\chi \times A} \text{ [\Omega]}$$

Copper:
$$\chi = 57 \frac{\text{m}}{\Omega \text{mm}^2}$$

$$l = \text{Length of conductor [m]}$$

Aluminum:
$$\chi = 33 \frac{\text{m}}{\Omega \text{mm}^2}$$

$$\chi = \text{Conductivity [m}/\Omega \text{mm}^2]$$

Iron:
$$\chi = 8,3 \frac{\text{m}}{\Omega \text{mm}^2}$$

$$A = \text{Conductor cross section [mm}^2]$$

Zinc:
$$\chi = 15,5 \frac{\text{m}}{\Omega \text{mm}^2}$$

Resistances

Transformer

$$X_L = 2 \times \pi \times f \times L \text{ [\Omega]}$$

Capacitors

$$X_C = \frac{1}{2 \times \pi \times f \times C} \text{ [\Omega]}$$

Impedance

$$Z = \sqrt{R^2 + (X_L - X_C)^2}$$

$$Z = \frac{R}{\cos \varphi} \text{ [\Omega]}$$

L = Inductance [H]

C = Capacitance [F]

 $X_L = \text{Inductive impedance [\Omega]}$ $X_C = \text{Capacitive impedance [\Omega]}$

f = Frequency [Hz]

 $\varphi = \text{Phase angle}$ **Parallel connection of resistances**

With 2 parallel resistances:

$$R_g = \frac{R_1 \times R_2}{R_1 + R_2} \text{ [\Omega]}$$

With 3 parallel resistances:

$$R_g = \frac{R_1 \times R_2 \times R_3}{R_1 \times R_2 + R_2 \times R_3 + R_1 \times R_3} \text{ [\Omega]}$$

General calculation of resistances:

$$\frac{1}{R} = \frac{1}{R_1} + \frac{1}{R_2} + \frac{1}{R_3} + \dots [1/\Omega]$$

$$\frac{1}{Z} = \frac{1}{Z_1} + \frac{1}{Z_2} + \frac{1}{Z_3} + \dots [1/\Omega]$$

$$\frac{1}{X} = \frac{1}{X_1} + \frac{1}{X_2} + \frac{1}{X_3} + \dots [1/\Omega]$$

Standards, formulae, tables**Formulae**

Electric power		
	Power	Current consumption
DC current	$P = U \times I$ [W]	$I = \frac{P}{U}$ [A]
Single-phase AC	$P = U \times I \times \cos\varphi$ [W]	$I = \frac{P}{U \times \cos\varphi}$ [A]
Alternating current	$P = \sqrt{3} \times U \times I \times \cos\varphi$ [W]	$I = \frac{P}{\sqrt{3} \times U \times \cos\varphi}$ [A]

Mechanical force between 2 parallel conductors2 conductors with currents I_1 and I_2

$$F_2 = \frac{0.2 \times I_1 \times I_2 \times s}{a} \text{ [N]}$$

s = Distance between supports [cm]

a = Distance between conductors [cm]

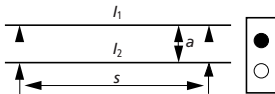
**Mechanical force between 3 parallel conductors**3 conductors with current I

$$F_3 = 0.808 \times F_2 \text{ [N]}$$

$$F_3 = 0.865 \times F_2 \text{ [N]}$$

$$F_3 = 0.865 \times F_2 \text{ [N]}$$

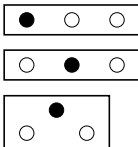

Standards, formulae, tables

Formulae

Voltage drop

	Known power	Known current
DC current	$\Delta U = \frac{2 \times l \times P}{\chi \times A \times U} \text{ [V]}$	$\Delta U = \frac{2 \times l \times I}{\chi \times A} \text{ [V]}$
Single-phase AC	$\Delta U = \frac{2 \times l \times P}{\chi \times A \times U} \text{ [V]}$	$\Delta U = \frac{2 \times l \times I}{\chi \times A} \times \cos \varphi \text{ [V]}$
Alternating current	$\Delta U = \frac{l \times P}{\chi \times A \times U} \text{ [V]}$	$\Delta U = \sqrt{3} \times \frac{l \times I}{\chi \times A} \times \cos \varphi \text{ [V]}$

Calculation of cross-section from voltage drop

DC current	Single-phase AC	Alternating current
Known power		
$A = \frac{2 \times l \times P}{\chi \times \Delta U \times U} \text{ [mm}^2\text{]}$	$A = \frac{2 \times l \times P}{\chi \times \Delta U \times U} \text{ [mm}^2\text{]}$	$A = \frac{l \times P}{\chi \times \Delta U \times U} \text{ [mm}^2\text{]}$
Known current		
$A = \frac{2 \times l \times I}{\chi \times \Delta U} \text{ [mm}^2\text{]}$	$A = \frac{2 \times l \times I}{\chi \times \Delta U} \times \cos \varphi \text{ [mm}^2\text{]}$	$A = \sqrt{3} \times \frac{l \times I}{\chi \times \Delta U} \times \cos \varphi \text{ [mm}^2\text{]}$

10

Power loss

DC current	Single-phase AC
$P_{\text{loss}} = \frac{2 \times l \times P \times P}{\chi \times A \times U \times U} \text{ [W]}$	$P_{\text{loss}} = \frac{2 \times l \times P \times P}{\chi \times A \times U \times U \times \cos \varphi \times \cos \varphi} \text{ [W]}$
Alternating current	
$P_{\text{loss}} = \frac{l \times P \times P}{\chi \times A \times U \times U \times \cos \varphi \times \cos \varphi} \text{ [W]}$	

l = Single length of conductor [m];

A = Conductor cross section [mm²]; χ = Conductivity (copper: $\chi = 57$; aluminum: $\chi = 33$; iron: $\chi = 8.3 \frac{\text{m}}{\Omega \text{mm}^2}$) ΔU = Voltage drop

Standards, formulae, tables**Formulae**

Power of electric motors		
	Output	Current consumption
DC current	$P_1 = U \times I \times \eta$ [W]	$I = \frac{P_1}{U \times \eta}$ [A]
Single-phase AC	$P_1 = U \times I \times \cos \varphi \times \eta$ [W]	$I = \frac{P_1}{U \times \cos \varphi \times \eta}$ [A]
Alternating current	$P_1 = 1.73 \times U \times I \times \cos \varphi \times \eta$ [W]	$I = \frac{P_1}{1.73 \times U \times \cos \varphi \times \eta}$ [A]
P_1 = Rated mechanical power at the motor shaft conform to rating plate P_2 = Electrical power consumption		
Efficiency	$\eta = \frac{P_1}{P_2} \times (100 \%)$	$P_2 = \frac{P_1}{\eta}$ [W]
Amount of poles	Synchronous speed	Full load speed
2	3000	2800 – 2950
4	1500	1400 – 1470
6	1000	900 – 985
8	750	690 – 735
10	600	550 – 585

Synchronous speed = approx. no-load speed

Standards, formulae, tables**International Unit System****International Unit System (SI)**

Basic parameters Physical parameters	Symbol	SI basic unit	Further related SI units
Length	l	m (Metre)	km, dm, cm, mm, μm , nm, pm
Mass	m	kg (Kilogram)	Mg, g, mg, μg
Time	t	s (Second)	ks, ms, μs , ns
Electrical current	I	A (Ampere)	kA, mA, μA , nA, pA
Thermo-dynamic temperature	T	K (Kelvin)	–
Amount of substance	n	mole (Mol)	Gmol, Mmol, kmol, mmol, μmol
Light intensity	I_v	cd (Candela)	Mcd, kcd, mcd

Factors for conversion of old units into SI units**Conversion factors**

Size	Old unit	SI unit exact	Approximate
Force	1 kp	9.80665 N	10 N
	1 dyn	$1 \cdot 10^{-5}$ N	$1 \cdot 10^{-5}$ N
Momentum of force	1 mkp	9.80665 Nm	10 Nm
Pressure	1 at	0.980665 bar	1 bar
	1 Atm = 760 Torr	1.01325 bar	1.01 bar
	1 Torr	1.3332 mbar	1.33 bar
	1 mWS	0.0980665 bar	0.1 bar
	1 mmWS	0.0980665 mbar	0.1 mbar
	1 mmWS	9.80665 Pa	10 Pa
Tension	$1 \frac{\text{kp}}{\text{mm}^2}$	$9.80665 \frac{\text{N}}{\text{mm}^2}$	$10 \frac{\text{N}}{\text{mm}^2}$
Energy	1 mkp	9.80665 J	10 J
	1 kcal	4.1868 kJ	4.2 kJ
	1 erg	$1 \cdot 10^{-7}$ J	$1 \cdot 10^{-7}$ J

Standards, formulae, tables**International Unit System**

Conversion factors			
Size	Old unit	SI unit exact	Approximate
Power	1 $\frac{\text{kcal}}{\text{h}}$	4.1868 $\frac{\text{kJ}}{\text{h}}$	4.2 $\frac{\text{kJ}}{\text{h}}$
	1 $\frac{\text{kcal}}{\text{h}}$	1.163 W	1.16 W
	1 PS	0.73549 kW	0.74 kW
Heat transfer coefficient	1 $\frac{\text{kcal}}{\text{m}^2\text{h}^\circ\text{C}}$	4.1868 $\frac{\text{kJ}}{\text{m}^2\text{hK}}$	4.2 $\frac{\text{kJ}}{\text{m}^2\text{hK}}$
	1 $\frac{\text{kcal}}{\text{m}^2\text{h}^\circ\text{C}}$	1.163 $\frac{\text{W}}{\text{m}^2\text{K}}$	1.16 $\frac{\text{W}}{\text{m}^2\text{K}}$
Dynamic viscosity	1 · 10 ⁻⁶ $\frac{\text{kps}}{\text{m}^2}$	0,980665 · 10 ⁻⁵ $\frac{\text{Ns}}{\text{m}^2}$	1 · 10 ⁻⁵ $\frac{\text{Ns}}{\text{m}^2}$
	1 Poise	0.1 $\frac{\text{Ns}}{\text{m}^2}$	0,1 $\frac{\text{Ns}}{\text{m}^2}$
	1 Poise 0.1	Pa · s	
Kinetic viscosity	1 Stokes	1 · 10 ⁻⁴ $\frac{\text{m}^2}{\text{s}}$	1 · 10 ⁻⁴ $\frac{\text{m}^2}{\text{s}}$
Angle (flat)	1	$\frac{1}{360}$ pla	2,78 · 10 ⁻³ pla
	1 gon	$\frac{1}{400}$ pla	2,5 · 10 ⁻³ pla
	1	$\frac{\pi}{180}$ rad	17,5 · 10 ⁻³ rad
	1 gon	$\frac{\pi}{200}$ rad	15,7 · 10 ⁻³ pla
	57,296		1 rad
	63,662 gon		1 rad

Standards, formulae, tables**International Unit System****Conversion of SI units**

Size	SI units name	Symbol	Basic unit	Conversion of SI units
Force	Newton	N	$1 \cdot \frac{\text{kg} \cdot \text{m}}{\text{s}^2}$	
Force momentum	Newton-metre	Nm	$1 \cdot \frac{\text{kg} \cdot \text{m}^2}{\text{s}^2}$	
Pressure	Bar	bar	$10^5 \frac{\text{kg}}{\text{m} \cdot \text{s}^2}$	$1 \text{ bar} = 10^5 \text{ Pa} = 10^5 \frac{\text{N}}{\text{m}^2}$
	Pascal	Pa	$1 \cdot \frac{\text{kg}}{\text{m} \cdot \text{s}^2}$	$1 \text{ Pa} = 10^{-5} \text{ bar}$
Energy, heat	Joule	J	$1 \cdot \frac{\text{kg} \cdot \text{m}^2}{\text{s}^2}$	$1 \text{ J} = 1 \text{ Ws} = 1 \text{ Nm}$
Power	Watt	W	$1 \cdot \frac{\text{kg} \cdot \text{m}^2}{\text{s}^3}$	$W = 1 \frac{\text{J}}{\text{s}} = 1 \frac{\text{N} \cdot \text{m}}{\text{s}}$
Tension		$\frac{\text{N}}{\text{mm}^2}$	$10^6 \frac{\text{kg}}{\text{m} \cdot \text{s}^2}$	$1 \frac{\text{N}}{\text{mm}^2} = 10^2 \frac{\text{N}}{\text{cm}^2}$
Angle (flat)	Degree	1		$360^\circ = 1 \text{ pla} = 2\pi \text{ rad}$
	Gon	gon		$400 \text{ gon} = 360^\circ$
	Radian	rad	$1 \frac{\text{m}}{\text{m}}$	
	Full circle	pla		$1 \text{ pla} = 2\pi \text{ rad} = 360^\circ$
Voltage	Volts	V	$1 \cdot \frac{\text{kg} \cdot \text{m}^2}{\text{s}^3 \cdot \text{A}}$	$1 \text{ V} = 1 \cdot \frac{\text{W}}{\text{A}}$
Resistance	Ohm	Ω	$1 \cdot \frac{\text{kg} \cdot \text{m}^2}{\text{s}^3 \cdot \text{A}^2}$	$1 \Omega = 1 \cdot \frac{\text{V}}{\text{A}} = 1 \cdot \frac{\text{W}}{\text{A}^2}$
Conductivity	Siemens	S	$1 \cdot \frac{\text{s}^3 \cdot \text{A}^2}{\text{kg} \cdot \text{m}^2}$	$1 \text{ S} = 1 \cdot \frac{\text{A}}{\text{V}} = 1 \cdot \frac{\text{A}^2}{\text{W}}$
Electric charge	Coulomb	C	$1 \cdot \text{A} \cdot \text{s}$	

Standards, formulae, tables**International Unit System****Conversion of SI units**

Size	SI units name	Symbol	Basic unit	Conversion of SI units
Capacity	Farad	F	$1 \cdot \frac{\text{s}^4 \cdot \text{A}}{\text{kg} \cdot \text{m}^2}$	$1 \text{ F} = 1 \cdot \frac{\text{C}}{\text{V}} = 1 \cdot \frac{\text{s} \cdot \text{A}^2}{\text{W}}$
Electrical field		$\frac{\text{V}}{\text{m}}$	$1 \cdot \frac{\text{kg} \cdot \text{m}}{\text{s}^3 \cdot \text{A}}$	$1 \frac{\text{V}}{\text{m}} = 1 \cdot \frac{\text{W}}{\text{A} \cdot \text{m}}$
Flux	Weber	W_b	$1 \cdot \frac{\text{kg} \cdot \text{m}^2}{\text{s}^2 \cdot \text{A}}$	$1 W_b = 1 \cdot \text{V} \cdot \text{s} = 1 \cdot \frac{\text{W} \cdot \text{s}}{\text{A}}$
Flux density	Tesla	T	$1 \cdot \frac{\text{kg}}{\text{s}^2 \cdot \text{A}}$	$1 \text{ T} = \frac{W_b}{\text{m}^2} = 1 \cdot \frac{\text{V} \cdot \text{s}}{\text{m}^2} = 1 \cdot \frac{\text{W} \cdot \text{s}}{\text{m}^2 \text{A}}$
Reactor	Henry	H	$1 \cdot \frac{\text{kg} \cdot \text{m}^2}{\text{s}^2 \cdot \text{A}^2}$	$1 \text{ H} = \frac{W_b}{\text{A}} = 1 \cdot \frac{\text{V} \cdot \text{s}}{\text{A}} = 1 \cdot \frac{\text{W} \cdot \text{s}}{\text{A}^2}$

Decimal powers (parts and multiples of units)

Power	Prefix	Symbol	Power	Prefix	Symbol
10^{-18}	Atto	a	10^{-1}	Deci	d
10^{-15}	Femto	f	10	Deca	da
10^{-12}	Pico	p	10^2	Hecto	h
10^{-9}	Nano	n	10^3	Kilo	k
10^{-6}	Micro	μ	10^6	Mega	M
10^{-3}	Milli	m	10^9	Giga	G
10^{-2}	Centi	c	10^{12}	Tera	T

Standards, formulae, tables**International Unit System****Physical units**

Obsolete units

Mechanical force

SI unit:	N (Newton) J/m (Joule/m)			
Previous unit:	kp (kilopond) dyn (Dyn)			
1 N	= 1 J/m	= 1 kg m/s ²	= 0.102 kp	= 10 ⁵ dyn
1 J/m	= 1 N	= 1 kg m/s ²	= 0.102 kp	= 10 ⁵ dyn
1 kg m/s ²	= 1 N	= 1 J/m	= 0.102 kp	= 10 ⁵ dyn
1 kp	= 9.81 N	= 9.81 J/m	= 9.81 kg m/s ²	= 0.981 10 ⁶ dyn
1 dyn	= 10 ⁻⁵ N	= 10 ⁻⁵ J/m	= 10 ⁻⁵ kg m/s ²	= 1.02 10 ⁻⁵ kp

Pressure

SI unit:	Pa (Pascal) bar (Bar)			
Previous unit:	at = kp/cm ² = 10 m Ws Torr = mm Hg atm			
1 Pa	= 1 N/m ²	= 10 ⁻⁵ bar		
1 Pa	= 10 ⁻⁵ bar	= 10.2 · 10 ⁻⁶ at	= 9.87 · 10 ⁻⁶ at	= 7.5 · 10 ⁻³ Torr
1 bar	= 10 ⁵ Pa	= 1.02 at	= 0.987 at	= 750 Torr
1 at	= 98.1 · 10 ³ Pa	= 0.981 bar	= 0.968 at	= 736 Torr
1 atm	= 101.3 · 10 ³ Pa	= 1.013 bar	= 1.033 at	= 760 Torr
1 Torr	= 133.3 Pa	= 1.333 · 10 ⁻³ bar	= 1.359 · 10 ⁻³ at	= 1.316 · 10 ⁻³ atm

Standards, formulae, tables**International Unit System****Work**

SI unit:			J (Joule) Nm (Newtonmeter)		
SI unit: (as before)			Ws (Wattsecond) kWh (Kilowatthour)		
Previous unit:			kcal (Kilocalorie) = cal · 10 ⁻³		
1 Ws	= 1 J	= 1 Nm	10 ⁷ erg		
1 Ws	= 278 · 10 ⁻⁹ kWh	= 1 Nm	= 1 J	= 0.102 kpm	= 0.239 cal
1 kWh	= 3.6 · 10 ⁶ Ws	= 3.6 · 10 ⁶ Nm	= 3.6 · 10 ⁶ J	= 367 · 10 ⁶ kpm	= 860 kcal
1 Nm	= 1 Ws	= 278 · 10 ⁻⁹ kWh	= 1 J	= 0.102 kpm	= 0.239 cal
1 J	= 1 Ws	= 278 · 10 ⁻⁹ kWh	= 1 Nm	= 0.102 kpm	= 0.239 cal
1 kpm	= 9.81 Ws	= 272 · 10 ⁻⁶ kWh	= 9.81 Nm	= 9.81 J	= 2.34 cal
1 kcal	= 4.19 · 10 ³ Ws	= 1.16 · 10 ⁻³ kWh	= 4.19 · 10 ³ Nm	= 4.19 · 10 ³ J	= 427 kpm

Power

SI unit:			Nm/s (Newtonmeter/s) J/s (Joule/s)		
SI unit: (as before)			W (Watt) kW (Kilowatt)		
Previous unit:			kcal/s (Kilocalorie/sec.) = cal/s · 10 ³ kcal/h (Kilocalorie/hour.) = cal/h · 10 ⁶ kpm/s (Kilopondmeter/Sec.) PS (metric horsepower)		
1 W	= 1 J/s	= 1 Nm/s			
1 W	= 10 ⁻³ kW	= 0.102 kpm/s	= 1.36 · 10 ⁻³ PS	= 860 cal/h	= 0.239 cal/s
1 kW	= 10 ³ W	= 102 kpm/s	= 1.36 PS	= 860 · 10 ³ cal/h	= 239 cal/s
1 kpm/s	= 9.81 W	= 9.81 · 10 ⁻³ kW	= 13.3 · 10 ⁻³ PS	= 8.43 · 10 ³ cal/h	= 2.34 cal/s
1 PS	= 736 W	= 0.736 kW	= 75 kpm/s	= 632 · 10 ³ cal/h	= 176 cal/s
1 kcal/h	= 1.16 W	= 1.16 · 10 ⁻³ kW	= 119 · 10 ⁻³ kpm/s	= 1.58 · 10 ⁻³ PS	= 277.8 · 10 ⁻³ cal/s
1 cal/s	= 4.19 W	= 4.19 · 10 ⁻³ kW	= 0.427 kpm/s	= 5.69 · 10 ⁻³ PS	= 3.6 kcal/h

Standards, formulae, tables**International Unit System****Magnetic field strength**

SI unit:

Previous unit:		Oe = (Oersted)
$1 \frac{\text{A}}{\text{m}}$	$= 0.001 \frac{\text{kA}}{\text{m}}$	$= 0.01256 \text{ Oe}$
$1 \frac{\text{kA}}{\text{m}}$	$= 1000 \frac{\text{A}}{\text{m}}$	$= 12.56 \text{ Oe}$
1 Oe	$= 79.6 \frac{\text{A}}{\text{m}}$	$= 0.0796 \frac{\text{kA}}{\text{m}}$

Magnetic flux

SI unit:

Wb (Weber)
 μWb (Microweber)

Previous unit:		M = Maxwell
1 Wb	$= 1 \text{ Tm}^2$	
1 Wb	$= 10^6 \mu\text{Wb}$	$= 10^8 \text{ M}$
$1 \mu\text{Wb}$	$= 10^{-6} \text{ Wb}$	$= 100 \text{ M}$
1 M	$= 10^{-8} \text{ Wb}$	$= 0.01 \mu\text{Wb}$

10**Magnetic flux density**

SI unit:

T (Tesla)
mT (Millitesla)

Previous unit:		G = Gauss
1 T	$= 1 \text{ Wb/m}^2$	
1 T	$= 10^3 \text{ mT}$	$= 10^4 \text{ G}$
1 mT	$= 10^{-3} \text{ T}$	$= 10 \text{ G}$
1 G	$= 0.1^{-3} \text{ T}$	$= 0.1 \text{ mT}$

Standards, formulae, tables**International Unit System****Conversion of Imperial/American units into SI units**

Length	1 in	1 ft	1 yd	1 mile Land mile	1 mile Sea mile	
m	$25.4 \cdot 10^{-3}$	0.3048	0.9144	$1.609 \cdot 10^3$	$1.852 \cdot 10^3$	
Weight	1 lb	1 ton (UK) long ton	1 cwt (UK) long cwt	1 ton (US) short ton	1 ounce	1 grain
kg	0.4536	1016	50.80	907.2	$28.35 \cdot 10^{-3}$	$64.80 \cdot 10^{-6}$
Area	1 sq.in	1 sq.ft	1 sq.yd	1 acre	1 sq.mile	
m ²	$0.6452 \cdot 10^{-3}$	$92.90 \cdot 10^{-3}$	0.8361	$4.047 \cdot 10^3$	$2.590 \cdot 10^3$	
Volume	1 cu.in	1 cu.ft	1 cu.yd	1 gal (US)	1 gal (UK)	
m ³	$16.39 \cdot 10^{-6}$	$28.32 \cdot 10^{-3}$	0.7646	$3.785 \cdot 10^{-3}$	$4.546 \cdot 10^{-3}$	
Force	1 lb	1 ton (UK) long ton	1 ton (US) short ton	1 pdl (poundal)		
N	4.448	$9.964 \cdot 10^3$	$8.897 \cdot 10^3$	0.1383		
Speed	$1 \frac{\text{mile}}{\text{h}}$	1 knot	$1 \frac{\text{ft}}{\text{s}}$	$1 \frac{\text{ft}}{\text{min}}$		
$\frac{\text{m}}{\text{s}}$	0.447	0.5144	0.3048	$5.080 \cdot 10^{-3}$		
Pressure		1 in Hg	1 ft H ₂ O	1 in H ₂ O		
bar	$65.95 \cdot 10^{-3}$	$33.86 \cdot 10^{-3}$	$29.89 \cdot 10^{-3}$	$2.491 \cdot 10^{-3}$		
Energy, Work	1 HPh	1 BTU	1 PCU			
J	$2.684 \cdot 10^6$	$1.055 \cdot 10^3$	$1.90 \cdot 10^3$			

Standards, formulae, tables**International Unit System****Conversion of Imperial/American units into SI units**

Length	1 cm	1 m	1 m	1 km	1 km
	0.3937 in	3.2808 ft	1.0936 yd	0.6214 mile (land mile)	0.5399 mile (sea mile)
Weight	1 g	1 kg	1 kg	1 t	1 t
	15.43 grain	35.27 ounce	2.2046 lb.	0.9842 long ton	1.1023 short ton
Area	1cm ²	1 m ²	1 m ²	1 m ²	1 km ²
	0.155 sq.in	10.7639 sq.ft	1.196 sq.yd	0.2471 · 10 ⁻³ acre	0.3861 sq.mile
Volume	1cm ³	1 l	1 m ³	1 m ³	1 m ³
	0.06102 cu.in	0.03531 cu.ft	1.308 cu.yd	264.2 gal (US)	219.97 gal (UK)
Force	1 N	1 N	1 N	1 N	1 N
	0.2248 lb	0.1003 · 10 ⁻³ long ton (UK)	0.1123 · 10 ⁻³ short ton (US)	7.2306 pdl (poundal)	
Speed	1 m/s	1 m/s	1 m/s	1 m/s	
	3.2808 ft/s	196.08 ft/min	1.944 knots	2.237 mph	
Pressure	1 bar	1 bar	1 bar	1 bar	
	14.50 psi	29.53 in Hg	33.45 ft H ₂ O	401.44 in H ₂ O	
Energy, Work	1 J	1 J	1 J	1 J	
	0.3725 · 10 ⁻⁶ HPh	0.9478 · 10 ⁻³ BTU	0.5263 · 10 ⁻³ PCU		

A	
AC/DC sensitive	7-20
Accelerating torque	2-6
Accessories contactors	5-14
Add-on board	0-26
Analog inputs, easy	1-53... 1-56
Analog output, easy	1-61
Anticlockwise rotation field	2-4
Arc fault protective system ARCON	0-32
ARCON quenching device	0-32
ATEX approval	
EMT6	8-14
Motor protection system ZEV	5-27
Motor-protective circuit-breakers PKZM0, PKZM4	6-4
Overload relays	5-20
Motor-protective circuit-breakers PKE	6-5
Thermistor overload relay for machine protection EMT6	5-33
Automatic stator starters	
Engineering starting resistor	8-15
Engineering start-up transformer	8-15
Example resistors	8-83
Example start-up transformer	8-86
Auxiliary contact	
Motor-protective circuit-breakers PKZ, PKE	6-9
Normal	7-6
Auxiliary contact module	5-2
Auxiliary switches	
Early make	7-7
Trip-indicating	7-6
B	
Basic circuits	
easy	1-81... 1-86
Bimetal	
Motor protection	8-14
Motor-protective circuit-breakers	6-4
Overload relay	5-20
Braking, oversynchronous	8-53
Breakdown Torque	2-6

Index

Bridging during starting	
Heavy starting duty	8-11
Motor contactor	8-9
Overload relays	8-27
Busbar system	0-38
Buzzer, general symbol	9-28
Bypass circuit	2-37
Bypass contactor	2-61
Bypass contacts	2-9
C	
Cable entries	10-46
Cables	
external diameters	10-49
type abbreviation	10-50
Cables, external diameters	10-49
Cables, type abbreviation	10-50
Cage Clamp	5-15
Cam switches	
Changeover switches, reversing switches	4-5
Heater switches	4-14
Interlock circuits	4-11
Main switch, maintenance switch	4-3
Meter changeover switches	4-12
Multi-speed switches	4-7
Speed switching	8-53
Star-delta, reversing star-delta	4-6
Step switches	4-15
Use, designs	4-2
Capacitive sensors	3-32
Capacitor	
General symbol	9-27
Group compensation, use of reactors	8-18
Single, group compensation	8-17
Capacitor group compensation	8-18
Cascade control	2-40
Changeover switch	4-5
Ammeter	4-12
Voltmeter	4-12
Wattmeter	4-13
CI insulated distribution boards	0-37

Circuit diagrams contactor relays	5-6
Circuit documents	
general	8-19
Wiring diagram	8-20
Circuit examples	
Bridging during starting	8-27
Contactors DIL	8-26
Circuit-breaker	
as transformer switches	7-19
Contactor state	7-15
Internal circuit diagrams	7-8
IZMX	7-3
Meshed network circuit-breakers	7-17
Meshed network circuit-breakers	7-17
Motor operated remote switch	7-18
NZM	7-2
NZM internal circuit diagrams	7-8
Remote operation with motor operator	7-18
Residual current device	7-20...7-21
Selection criteria	7-3
short-time delayed	7-16
Time-discriminating	7-16
Transformer switches	7-19
with residual current device	7-22
Circuit-breakers	
Clockwise rotation field	2-4
CMD (Contactor Monitoring Device)	5-36
Coil Functions	1-79
Coils	1-77
Colors	
of indicator lights	10-25
of pushbuttons	10-24
COM-LINK connection	1-74
Compact distribution board for flush mounting and surface mounting	0-34
Compact PLC	1-108
Compensated motor	8-12
Conductor	
General symbol	9-25, 9-26

Index

Connection examples	
DS4	2-65
Connection for overload relay 1 pole, 2 pole	8-5
Contact protection relay	5-34
Contact, self-monitoring	3-9
Contactor for capacitor	8-94
Contactor relays circuit diagrams	5-6
Contactor relays reference letters	5-3
Contactors	
DC operated	5-16
DILM	5-15
General symbol	9-33
Marking	8-25
Overview	5-8, 5-9
Contacts	1-77
Control circuit devices	1-24
For direct-on-line start	8-34
For multi-speed contactors	8-63, 8-67
For star-delta	8-45
RMQ	3-2
Control circuit supply motor	8-24
Control Relays	1-30
Control relays → easyRelays	1-43, 1-44
Core-balance transformer	5-26
Current Limiter	
→ Current limiters PKZM0, PKZM4	6-8
Current limiters PKZM0, PKZM4	6-8
Current monitoring relays	1-40
Current peaks	1-40
Current sensors ZEV	5-28
Current transformer integrated	5-23
D	
DC motors	8-5
Deceleration ramp	2-11
Deceleration time	1-38
Delta circuit	2-5, 2-15
Delta circuit, motor	2-96
Dielectric constant	3-34

Digital inputs, easy	
AC devices	1-51
DC devices	1-52
DIL contactors	
Overload protection	8-26
Direct Motor start	2-2
DOL starters	2-100
Motor-protective circuit-breakers	6-3
with PKE	1-12
with PKZ	1-8
Double-frame terminal	5-15
Drive system	2-69, 2-72
E	
Early-make auxiliary contacts	7-7
Early-make auxiliary switches	7-7
Earth, general symbol Ground	9-26
Earth-fault	
ZEB	5-23
ZEV	5-26
Earth-fault release	7-20
Earth-fault release circuit-breaker	7-20
easy	
Display	1-92
Power supply	1-50
Programming	1-77... 1-93
Relay outputs	1-58
easy expansion	1-62... 1-63
easy expansion units for networking	1-70
easy inputs	1-51... 1-57
easy local expansion	1-62
easy modem operation	1-76
easy outputs	1-58... 1-61
easy power supply	1-50
easy printer connection	1-75
easy remote expansion	1-62
easy system overview	1-43... 1-44
easyHMI	1-46
easyNet	1-64... 1-68
easyRelay	1-43, 1-44
Eaton selector slide for motor starter	8-3

Index

Eaton Wiring Manual	0-8
EC4P	1-108
Efficiency	2-6
Electrical connector	6-7
Electrical equipment of machines	10-21
Electronic Catalog	0-11
Electronic motor starter	2-2
Electronic overload relays ZEB	5-23...5-25
Electronic safety relays	1-29
Electronic timing relays	1-36
EMC compliance	
in PDS	2-72
Emergency stop function	1-34
Emergency stop pushbutton	3-8
Emergency switch, general symbol	9-29
Emergency-off pushbutton	3-9
Employers' liability insurance Association	3-25
EN 50011	5-3
Engineering	
easy	1-50...1-76
Motor	8-15...8-18
Switching of capacitors	8-17
Three-phase-automatic starter	8-15
Error message, differential	6-12
Ethernet module	1-73
Ex e motors	
Overload relays	5-20
PKZM0, PKZM4	6-4, 6-5
External diameters, cables	10-49
F	
Fast counters	1-57
Fault current	5-26
Feedback Circuit	1-26
First environment	2-73
Flashing	1-38
Fleeting contact	
on de-energization	1-38
on energization	1-37
Fleeting pulse	1-38
Float switch, general symbol	9-32

Floor-standing	
Distribution board	0-37
Enclosure	0-35
Formulae	10-54
Freely graphical function block diagram	1-133
Free-wheel diode suppressor	5-4
Frequency generators	1-57
Frequency inverter	2-2
Control section	2-68
Design	2-66
Earthing measures	2-76
Electrical mains connection	2-71
EMC-compliant surface mounting	2-76, 2-81
Filtering measures	2-80
Functions	2-86
Installation	2-76
M-Max™	2-85, 2-87
Operating principle	2-66
Power section	2-68
Shielded measures	2-78
Frequency-controlled three-phase motor	2-70
Function Block Diagram	1-132
Function blocks easy	1-77
Functions easy	1-48
Fuseless, Reversing contactor DIUL	8-30
G	
GALILEO Visualization tool	1-133
Generator, general symbol	9-34
Global Codes, Standards Authorities worldwide	9-9
Group compensation	8-17
Group protection Motor-protective circuit-breakers ...	6-8
Guard	1-32
H	
Hazard reduction	1-29
Heater switches	4-14

Index

Heavy starting duty	
Bridging during starting	8-11
Example	8-28
Motor protection	8-8
Protection	5-23
HMI-PLC	1-94

I

I/O modules	1-25
I/O system	1-124
I/Oassistant	1-126
IEC 62061	1-29
IL	1-130
Impulse relays	1-84
Incremental encoders	1-57
In-delta connection	2-56
Indicator light, general symbol	9-28
Individual compensation	8-17
Inductive sensors	3-30
Infra-red touch panel	1-96
In-line circuit	2-56
Input modules	1-25
Insulated enclosures	0-37
Insulation monitoring relays	1-42
Interlock circuits, cam switches	4-11
Internal DC link	2-67
International Unit System (SI)	10-58
Inverter module	2-67
Isolating point, general symbol	9-26

L

Labeleditor	3-13
Ladder diagram	1-132
Light barriers	3-36
Line filters	2-80
Liquid level monitoring relay	1-41
Load Torque	2-6
Load-shedding contact	4-4

M**Mains**

Chokes	2-83
Switches	7-12
Voltage	2-10
Voltages in North America	2-71
Maintenance switch	2-78
Maintenance switches	
Circuit diagram	4-4
Maintenance switches, cam switches	4-4
Marking of electrical equipment	10-2
Markings, contactor	8-25
Measurement and monitoring relay EMR4	1-40
Mechanical interlock	5-16
Minimum cross-sections for protective conductors	10-18
Mirror contact	5-19
MODAN	0-29...0-31
Modular PLC	1-113
Modular switchgear system	0-29
Monitoring relays	1-40
Motor	
Anticlockwise operation	2-4
Circuit documents	8-19
Clockwise operation	2-4
Control circuit devices for direct-on-line start	8-34
Control circuit supply	8-24
Engineering	8-15...8-18
General symbol	9-34
Information on the rating plate	2-4
Motor windings	8-50
Multi-speed contactors	8-53
Operating direction	2-4
Overload	5-26
Pole changing	8-47...8-49
Power supply	8-21
Separate windings	8-47
Star-delta of three-phase motors	8-35...8-44
Switching of capacitors	8-92...8-95
Switching on three-phase motors	8-26...8-33
Tapped winding	8-47

Index

Motor overload relay, motor-protection	5-20
Motor Power	2-6
Motor power supply	8-21
Motor protection	8-3... 8-14
Bridging during starting	8-9
Soft starter	2-19
Variants	2-19
Motor protective circuit breakers	2-19
Motor rating	5-15
Motor reactors	2-83
Motor starter, RAMO	2-99
Motor torque	2-6
Motor windings	8-50
Motor-protective circuit-breakers	
For starter combinations	6-6
Operating principle schematics PKZ, PKE	6-11... 6-13
Overview	6-1
Motor-protective trip blocks	6-5
Motor-starter combination MSC	6-7
Multi-function display	1-46
Multifunction relay	1-36
Multi-speed contactors	
Control circuit devices	8-63... 8-67
Star-delta	8-68
Multi-speed switch Bridging during starting	8-10
Multi-speed switch of three-phase motors	8-55... 8-62
Star-delta	8-68... 8-82
Multi-speed switches cam switches	4-7
Multi-speed switching, marking	8-25
N	
N/C contact, general symbol	9-30
N/O contact, general symbol	9-30
Networking easy	1-62... ??
Normal AC induction motor	2-14
Number of pole pairs	2-4
NZM circuit-breakers	1-23
O	
Off-delayed	1-37
Off-delayed undervoltage release	7-5

Ohm's Law	10-54
On-delayed	1-37
On-Off function	1-39
Operands	1-77
Operating frequency	8-4
Optical sensors	3-35
Overcurrent protection of cables and conductors ...	10-12
Overload motor	5-26
Overload motor-protective circuit-breaker	6-2
Overload protection	
Contactor	8-26
Electronic	5-23
Overload relay	
Function (ZMT)	1-7
Motor protection overload relay	5-20
Time-delayed	8-6
Tripping	8-4
Overload relay → Motor protection overload relay ..	5-20
Overload relay ZEB, tripping characteristics	5-25
Overload relays	2-19, 2-51
In delta connection	8-36
In motor circuit, in mains line	8-35
ZEB, electronic	5-23, 5-25
Overload relays ZEB	5-24
Oversynchronous braking	8-53
Overvoltage	2-51
P	
Parallel connection	1-82
Parameterizable contacts	5-27
PDS	2-72
Permanent contact	1-84
Personnel protection	
Enhanced	3-20
LS	3-19
LSR	3-24
Phase cutting	2-9
Phase failure	5-26
Phase failure motor protective relay Z	5-20
Phase failure sensitive	6-4
Phase imbalance relay	1-41

Index

Phase monitoring relays	1-40
Phase sequence relays	1-41
Photovoltaics in residential buildings	
Requirements, the DC isolation gap	0-15
Photovoltaics in residential buildings	
Combination switch	0-18
Comfort, safety and energy management	0-21
Compact isolator for inverter	0-16
Converting solar energy efficiently	0-15
DC string protective device	0-17
DC surge protection	0-18
DC switch-disconnector	0-15
Digital residual current device	0-18
Distribution board	0-19
Energy measuring sensor	0-19
Fireman's switch	0-16
Fuse switch-disconnector with integrated short-circuit protective device	0-17
Grid-connected power inverters	0-15
Increase building safety and comfort	0-18
Indoor use	0-15
Miniature circuit-breaker	0-19
Outdoor use	0-15
Overvoltage protection	0-19
Perfect enclosure for outdoor mounting	0-16
Safe isolation, switching and protecting	0-14
Safe photovoltaic systems	0-14
Simple mounting	0-17
Specifications	0-15
String circuit-breaker	0-17
Wireless monitoring of PV system and simple energy management	0-19
Point-to-point connection	1-74
Polarisation reflex sensor	3-36
Pole-changing motors	8-47, 8-49
Position switch LS-Titan®	3-18
Drive	3-25
Standards	3-25
Suitable applications	3-25
Positive opening	3-18
Potential isolation	5-2

Power distribution systems	0-22
Power Factor	2-6
Process protection	3-22
Programming easy	1-77... 1-93
Protection against earth fault	5-23, 5-26
Protection types for electrical equipment	10-29
Protective conductors, minimum cross-sections	10-18
Protective doors	1-32
Protective earth, Protective ground	9-26
Protective measures	10-4
Pt100/Ni1000 inputs, easy	1-56
PTC thermistors	
Motor protection	8-13
Thermistor overload relays for machine protection	5-33
Pull-up torque	2-6
Pulse generating	1-38
Pulse shaping	1-37
Pump control	2-37
Float switches	8-100
Pressure switches	8-98
Two pumps	8-96
Pump operation	2-37
Pushbutton actuators	8-63
R	
Radio interference suppression filters	2-76
Ramp time	2-10
Rapid Link	2-98
Rated motor current	2-13
of three-phase motors	10-43
Rated operational current	2-6
Rated speed	2-6
Rated torque	2-6
RC suppressor	5-4
RCD	2-18
Reclosing lockout	8-4
Rectifier	2-67
Reference letter contactor relays	5-3
Reflected-light beam	3-36
Relay outputs, easy	1-58

Index

Reliability values	10-26
Remote display	1-71
Remote operator circuit-breaker	7-18
Remote switch off	7-12
Remote switch off PKZ, PKE	6-13
Remote switch-off circuit-breaker	7-11
Remote tripping	7-4
Residual current protection	7-20
Residual-current protection relays	7-22
Residual-current relays	7-22
Resistive touch panel	1-96
Resistor, general symbol	9-27
Reversing combination → Reversing contactor	8-30
Reversing contactor	8-30
Reversing star-delta	
Cam switches	4-6
Direction change	8-43
Reversing star-delta switch	
2 operating directions	8-42
Reversing starter	2-101
Motor-protective circuit-breakers	6-3
Reversing starter with PKE	1-8, 1-13
Reversing switch	4-5
Risk reduction	1-29
in the fault scenario.....	10-27
SRP/CS	1-29
RMQ16	3-2
RMQ-Titan®	3-3
Rogowski principle	5-26
Rogowski sensor	5-32
Root -3 circuit	2-56
Rotor automatic starter	
Engineering starting resistor	8-15
Properties of slipping rotor	8-16
Slipping rotor	8-88
Rotor-critical	8-13
RS flip-flop, general symbol	9-36

S

Safety of machinery	
DIN EN 60204-1	10-21
EN ISO 12100-1	1-29
Safety position switches	3-18
Safety product	1-30
Safety Relays	1-29
Safety standards	1-29
Safety technical data	10-26
Safety Technology	1-29
Safety-related applications	1-26
SASY60	0-38
Sealing power	5-15
Second environment	2-73
Self maintaining	1-83
Sensor belt ZEV	5-28
Separate windings	
Multi-speed switch	8-59...8-62
Speeds	8-47
Separation galvanic	5-2
Sequential Function Chart	1-131
Series connection	1-82
Service distribution board	0-35
Shaft output	2-6
Sheet steel housing	
IVS	0-35
MODAN	0-29
Wall-mounting housing CS	0-33
xEnergy	0-22
xVtl	0-26
Shielding, general symbol	9-26
Shift register	1-90
short-circuit currents	10-52
Short-circuit monitoring	5-31
Short-circuit protective device	8-26
Short-circuit releases	6-4
Short-circuit strength	8-7

Index

Shunt releases	
Circuit-breaker remote tripping	7-4
Circuit-breakers	7-19
PKZ, PKE	6-10
Remote switch-off	7-11
Signal modules	1-114
Signalling units	1-24
Single-phase motors	8-5
Sinusoidal filter	2-84
SL signal towers	3-14
Slip speed	
.....	2-6
Slipping rotor → Rotor automatic starter	8-88
SmartWire-DT	1-2
SmartWire-DT Communication System	1-2
Soft starter	2-9
Bidirectional operation	2-33
Classification types	2-17
Controlled deceleration	2-11
DM4	2-44
DS7	2-27
Examples	2-20
Overload current profile	2-11
Parallel connection of several motors	2-20
Selection criteria	2-13
three-phase controlled	2-12
two-phase controlled	2-12
Soft stop ramp	2-29
Special purpose relays	1-36
Speed	2-6
Speeds, separate windings	8-47
Spring-cage terminal	5-15
Stairwell lighting	1-87
Standard auxiliary contact	7-6
ON-OFF indication	7-15
Standard transformers, rated and short-circuit currents	10-52
Star circuit	
Motor	2-97
Principle	2-5

Index

Star-delta	1-39
Bridging during starting	8-10
Cam switches	4-6
easy	1-85
Marking	8-25
Multi-speed contactors	8-68
SDAINL	8-37...8-41
Three-phase motors	8-35...8-44
Star-delta starter	1-16, 2-2
Star-delta starters	
with overload relays	8-35
Start voltage	2-10
Starting current	2-6
Starting torque	2-6, 2-14
Stator automatic starters	
Properties of squirrel cage rotor	8-16
Stopping in the event of an emergency	1-34
Structured Text	1-130
Support Portal	0-9
Suppressor circuit	5-4
Suppressor circuit integrated, pluggable	5-15
Switch position indication	4-4
Switch position indication circuit-breaker	7-15
Switch-disconnector, INX	7-3
Switch-disconnectors Use, mounting forms	4-2
Switching of capacitors	8-92...8-95
Switching on three-phase motors	8-26...8-33
Synchronous speed	2-6
System MODAN	0-29
System-protective circuit-breakers	6-2...6-5
System-protective trip block	6-5

Index

T

Tapped winding	8-10
Cam switch	4-7 .. 4-10
Feed drive	8-32
Four speeds	8-49
Marking	8-25
Multi-speed switch	8-55 .. 8-58
Multi-speed switch star-delta	8-68
Pole-changing motors	8-47
Three speeds	8-48
Temperature compensated	6-4
Temperature monitoring	8-13
Temperature, conversion factors	10-19
Terminal	0-36
Terminal assignment	
IZMX16	7-25
IZMX40	7-26
Terminal strip, general symbol	9-25
Testing Agencies, Certification Marks	9-14
Text display, easy	1-92
Thermal overload relays	5-20
Thermistor	8-13
Thermistor motor protection	2-19, 5-30
Thermistor overload relay for machine protection EMT6	5-33
Thermistor protection	5-30
Three-phase asynchronous motor	2-2
General symbol	9-34
Startup characteristics	2-6
Three-phase automatic rotor starter	8-88 .. 8-91
Three-phase autotransformer starter	8-15, 8-83 .. 8-87
Three-phase current slip-ring motor	2-22
Three-phase current-automatic starter	8-15
Three-phase monitor	1-42
Three-phase motors	
Connection	2-3
Multi-speed switch	8-55 .. 8-62
Rated motor currents	10-43
Star-delta Multi speed switch	8-68 .. 8-82
Time selectivity circuit-breaker	7-16

Time-discriminating network topology	7-16
Timing relay, on-delayed	1-84
Timing relays	1-36
Top of Ramp	2-9, 2-10
Touch display	1-95
Touch panel	1-96
Transformer-protective circuit-breaker	6-6
Transistor, general symbol	9-36
Trip blocks	6-5
Trip-indicating auxiliary contact circuit-breaker	7-6
Trip-indicating auxiliary contacts	
for mesh network circuit-breaker	7-15
for motor protective circuit-breakers PKZ, PKE	6-9
Tripping characteristics motor protection system	5-28
Tripping characteristics Overload relays	5-21, 5-25
Tripping CLASS	5-23, 5-26
Tripping classes CLASS	6-5
Two way switch	1-83
Type 1 coordination	2-17
Type 2 coordination	2-17
Type abbreviation, cables	10-50
Types of coordination motor protection	8-8
Types of coordination of soft starter	2-17
U	
U/f method	2-88
Unbalanced current consumption	5-23, 5-26
Undervoltage releases	
Circuit-breakers	7-19
Interlocking of multiple switches	7-14
Motor-protective circuit-breakers PKZ, PKE	6-10
Off-delayed	7-5
Remote switch-off	7-11
Starting interlock	7-13
Switch off	7-13
Use or reactor capacitor	8-18
Utilization categories	
contactors, motor starters	10-36
for switch-disconnectors	10-40
for switching elements	10-34
Utilization categories for switching elements	10-34

Index

V

Varistor suppressor	5-4
Visual indicator, general symbol	9-28
Visualization	1-94
Visualization, easyHMI	1-93
Voltage releases	
Interlock with undervoltage releases	7-14
Motor-protective circuit-breakers PKZ, PKE	6-10
Starting interlock Undervoltage releases	7-13

W

Wall-mounting	
Distribution system	0-37
Housing	0-33, 0-37
Wide-range overload protection	6-5
Wide-range overload protection, electronic	5-23
Winding, general symbol	9-27
Wiring diagrams	8-20
Interconnection diagram	8-20
Location diagram	8-20
Terminal diagram	8-20
Unit wiring diagram	8-20

X

XC PLCs	1-113
XI/ON	1-125
XIOC signal modules	1-114

Z

ZEV motor protection system	5-26...5-32
ZW7 current transformer-operated overload relays	8-8

**For service issues please contact your Eaton representative
or the After Sales Service.**

Hotline: +49 (0) 180 5 228322 (de, en) 24/7
Tel.: +49 (0) 228 602-3640
Fax: +49 (0) 228 602-61400

E-Mail: AfterSalesEGBonn@eaton.com
Internet:
www.eaton.com/moeller/aftersales

Eaton's Electrical Sector is a global leader in power distribution, power quality, control and automation, and monitoring products. When combined with Eaton's full-scale engineering services, these products provide customer-driven PowerChain™ solutions to serve the power system needs of the data center, industrial, institutional, public sector, utility, commercial, residential, IT, mission critical, alternative energy and OEM markets worldwide.

PowerChain solutions help enterprises achieve sustainable and competitive advantages through proactive management of the power system as a strategic, integrated asset throughout its life cycle, resulting in enhanced safety, greater reliability and energy efficiency.

For more information, visit
www.eaton.com/electrical

Addresses worldwide:
www.eaton.com/moellerproducts

E-Mail: info-bonn@eaton.com
Internet:
www.eaton.com/moellerproducts
www.eaton.com

Issued by:
Eaton Corporation
Electrical Sector – EMEA

Eaton Industries GmbH
Hein-Moeller-Str. 7-11
D-53115 Bonn

© 2008 by Eaton Industries GmbH
Subject to alterations
PU08703001Z-EN (09/11) bb/Doku/DHW/CPI
Printed in Germany
(09/2011)
Article No.: 165291



EATON

Powering Business Worldwide