

DT[®] Components

Drivetrain Products

Marketed by The Timken Corporation

DT2015

Differential, Transmission,
Transaxle & Transfer Case
Rebuild Kits and Related Products



Part Number	Part Type	Qty	Comment	Application
533078	Axle Bearing and Hub Assembly	2	F100 (8 Stud) Front 1101904	4WD
533079	Axle Bearing and Hub Assembly	2	F100 (8 Stud) Front 1101904	4WD
533080	Axle Bearing and Hub Assembly	2	F100 (7 Stud) Front 1101904	4WD
533081	Axle Bearing and Hub Assembly	2	F100 (7 Stud) Front 1101904	4WD
533251	Wheel Bearing	2		RWD
399397	Wheel Seal	2	4WD	
8196179	Wheel Bearing	2		
82168910	Wheel Bearing	2	Optional Repair Bearing, Sprockets, Sigs & Sigs	

View the DT Components E-Catalog for additional product listings by vehicle, the most current application information along with product specifications and images.

www.dtcomponents.com

North Coast Bearings markets and distributes differential rebuild kits, transmission rebuild kits and related products to the heavy, medium and light duty aftermarkets under the DT Components[®] product line. The brand was created through a strategic alliance with The Timken Company.



Over 2,500 Different Rebuild Kits

After more than fifteen years of success, Timken and North Coast Bearings have extended their strategic alliance to continue providing customers outstanding value into the future.

Our continually growing product line includes rebuild kits for the broadest range of on highway vehicles along with complementing gearing, axle shafts, u-joints and related products. Please visit our website for the latest news, information and literature on all of the North Coast Bearings products.

DT Components is the most recognized and respected brand of differential and transmission rebuild kits in North America. Our mission is to provide the best value in differential and transmission kits and components. Best value means Timken[®] tapered roller bearings, the best order fill, the fastest in-house turn-around time, US manufacturers' product where available, superior quality and personalized service.

North Coast Bearings is a member of the Bearingtech family of companies. These include:

- Bearing Technologies – Engineers and manufactures OEM quality wheel end products and OEM center support bearings,
- Micron Metalworks – Machining division for automotive wheel end products,
- Precision – Provider of competitively priced line of quality hub assemblies, bearings, seals and related products to automotive warehouse distributors.



North Coast Bearings services our customers from our 110,000 square foot Avon, Ohio facility along with a distribution center in Sparks, Nevada. The DT Components brand of kits are also available from additional Timken distribution centers throughout the world.

Snap this QR code with your smartphone app to visit our web site.



DT Components Web Site

The redesigned and more informative DT Components web site contains product information, literature, customer login, and a link to our web catalog.

DT Components Web Catalog

- Product Lookup by Application
- Kit Bill of Materials
- Interchanges
- Product Specifications
- Product Photos

Snap this QR code with your smartphone app to view our electronic catalog.



How To Use This Catalog

This catalog is divided into 6 main sections

1. Heavy Duty Differentials
2. Heavy Duty Transmissions and Transfer Cases
3. Light Duty Differentials
4. Light Duty Transmissions
5. Light Duty Transfer Cases
6. Driveshaft, Wheel End Products, Interchanges and Misc. Products

The Indexes for Heavy Duty Differentials, Transmissions and Transfer Cases are divided by the unit manufacturer and model number. Unless noted under the comments column, the rebuild kit services all ratios and variations for the model listed.

The Indexes for Light Duty Differentials, Transmissions and Transfer Cases are divided by vehicle manufacturer and model number/axle size. Make sure you have the correct date the vehicle was manufactured. Most models have evolved over time and there may be several kits for your particular vehicle depending upon when it was made.

Common Light Duty Differentials have their own product page by model number/axle size that lists gearing and other related products that are available.

Common Light Duty Transmissions also have their own product page by model number that lists gearing, synchronizers and related products.

We have also reprinted product information from our vendors with their permission on Heavy Duty Axles, Heavy Duty Differentials, Light Duty Limited Slip and Locking Differentials and Light Duty Transfer Cases for your convenience.

Kit Bill Of Materials are now split into four sections and printed immediately after their related indexes and are listed in numeric sequence.

View the DT Components E-Catalog for additional product listings by vehicle, the most current application information along with product specifications and images.

www.dtcomponents.com

The screenshot shows the DT Components website interface. At the top, there's a navigation bar with 'DT Components Drivetrain Products' and 'PARTS CATALOG'. Below that, there are search filters for Year (2008), Make (FORD), Model (F-150), Product (WHEEL BEARINGS, SEALS), and Engine (All). A table displays the search results with columns for Location, Part Number, Part Type, Qty, Comment, and Application.

Location	Part Number	Part Type	Qty	Comment	Application
FRONT	515079	Axle Bearing and Hub Assembly	2	F150 (6 Stud) From 11/29/04	AWD
FRONT	515079	Axle Bearing and Hub Assembly	2	F150 (6 Stud) From 11/29/04	4WD
FRONT	515080	Axle Bearing and Hub Assembly	2	F150 (7 Stud) From 11/29/04	AWD
FRONT	515080	Axle Bearing and Hub Assembly	2	F150 (7 Stud) From 11/29/04	4WD
FRONT	517014	Wheel Bearing	2		RWD
REAR	100357	Wheel Seal	2	Viton	
REAR	R1561TV	Wheel Bearing	2		
REAR	RP1561FO	Wheel Bearing	2	Optional Repair Bearing; Replaces Brg & Seal	

The DT2015 catalog provides rebuild kits and products for the most current models and vehicles. While the updates and additions are too numerous to list, below are highlights of some of the new items in this catalog.

Heavy Duty Differential

- Rebuild kits for the Mack C150 and C151 series of axles.
- Rebuild kits for 2013 and newer Dana 170/190 axles
- Rebuild kit for the Meritor RC26-720 transit axle.

Heavy Duty Transmission

- An easier to read index and a complete listing of every Eaton/Fuller transmission model variations makes it simple to identify the correct kit for the application.
- Over 70 different overhaul kits for Eaton/Fuller transmissions with input shafts and sliding clutches.
- Rebuild kits for the Eaton/Fuller Ultrashift and Ultrashift Plus transmissions.
- We now offer a suitcase style kit with additional content for most Spicer/TTC transmissions.
- Rebuild Kits and Master Kits for the Mack T309, T310 and T318 transmissions.

Light Duty Differential

- We now offer over 60 Wheel Kits (WK) and Axle Kits (AK) for most differential applications as a separate add on kit or included within the Standard Plus and Master Plus Kits. See pages 148-149 for details.
- A redesigned index makes it easier to identify the correct axle bearings and seals for your vehicle along with the different rebuild kit options.
- Rebuild kits for 2011 and newer Ford 8.8", 9.75" and 10.5" axles.
- Rebuild kits for 2001-2012 Ford Escape with the Dana 28 rear axle.
- Rebuild kits for 2015 Ford Transit Van with the 9.75" axle.
- Rebuild kits and gearing for Dodge/Freightliner Sprinter axles.
- Rebuild kits for the 2014 and newer GMC trucks with the 9.76" axle.
- Rebuild kits for 2013 and newer Chevy Camaro ZL1 with the 250mm axle.
- Rebuild kits for the 2004 and newer Nissan vehicles with the Dana 44 and Dana 205 axles.
- Rebuild kits for the 2014 and newer RAM trucks with the 11.5" axle.
- Rebuild kits for 2007 and newer Toyota 9.5" and 10.5" axles.

Light Duty Transmission & Transfer Case

- Exploded views and product listing for the most common transmission models.
- Rebuild kits for 2008 and newer GMC trucks with Magna-Steyr 1222, 1225, 1625, 1626, 3023 and, 3024 transfer case models.
- Rebuild kits for 2003 and newer Jeep Wrangler Rubicon with New Venture 241 transfer cases.
- Rebuild kits for 2007 and newer Dodge Caliber, Jeep Compass and Patriot vehicles with the T355 transmission.

Center Support Bearings

- New part number HB210661-1XSA is a self aligning version of the HB210661-1X and allows the bearing to pivot +/- 10° within the rubber cushion for easier alignment during installation.
- New part number HB68088 services 2007-2010 Chrysler/Mercedes Sprinter vans. The HB68088 services both the two-piece and three-piece drive shafts. Three-piece drive shafts require a boot kit, part number HB68088K, which is sold separately.

Please link to our electronic catalog through the DT Components website for the most current product listings and additional product lookups by vehicle.

DT Components Web Catalog

- Product Lookup by Application
- Kit Bill of Materials
- Interchanges
- Product Specifications
- Product Photos



**Snap this QR code
with your smartphone
app to view our
electronic catalog.**

SECTION	PAGE
NCB/DT Components Introduction	Inside Front Cover
How To Use This Catalog	i
What's New In This Catalog	ii
Warning	iv
Legal Disclosure	iv
Product Offering	v
Heavy Duty Rebuild Kits & Related Products	1
Differential Rebuild Kits	1
Alliance/Detroit/Freightliner Index	2
Dana/Eaton Index	2
GMC Index	11
International Harvester/Navistar Index	11
Mack Index	12
Meritor/Rockwell Index	15
Volvo Index	25
White Index	25
Rebuild Kit Bill of Materials	26
Tractech NoSPIN Differentials	41
Heavy Duty Axle Shafts	47
Heavy Duty Transmission Rebuild Kits	75
Clark/Eaton/Fuller Index	75
GMC Index	93
International Harvester/Navistar Index	93
Mack Index	93
Meritor/Rockwell Index	93
New Process Index	94
Spicer/TTC Index	95
Warner Index	99
Rebuild Kit Bill of Materials	103
Heavy Duty Transfer Case Rebuild Kits	100
Fabco Index	100
Meritor/Rockwell Index	100
Rebuild Kit Bill of Materials	103
Light Duty Differential Rebuild Kits & Related Products	148
Identification Help for Axles	150
Differential Cover Gaskets	151
Differential Applications by Vehicle	152
Rebuild Kit Bill of Materials	179
Ring & Pinion Sets by Axle Size	200
Open Cases & Internal Kits by Axle Size	200
Limited Slip Differentials by Axle Size	200
Axle Shafts by Axle Size	200
Eaton & Detroit Locker Differentials	224
Auburn Gear Differentials	238

SECTION	PAGE
Light Duty Transmission, Transaxle and Transfer Case Rebuild Kits & Related Products	259
Transmission & Transaxle Applications by Vehicle	259
Rebuild Kit Bill of Materials	319
Exploded Transmission Drawings.....	328
Transmission Gearing and Related Parts by Transmission Model.....	328
Transmission Small Parts Kits.....	354
Transfer Case Applications by Vehicle	345
Transfer Case Small Parts Kits	354
BorgWarner MORSE Transfer Case Chains	355
Additional Product Information and Interchanges	373
Rebuild Kits, Bearing and Seal Interchanges	373
Center Support Bearings	383
EZ Sleeve Repair Sleeves	391
Shim Stock Rolls.....	396
Barrel Style Roller Bearings.....	396
Timken MileMate® Set Information.....	397
Timken 454 Series of Wheel Bearings for Wide Single Tires	399
Timken Recommended Heavy Duty Wheel Bearing Adjustments Procedures.....	401
Timken Wheel Bearing Life Test Comparison	403
Timken Set-Right™ Heavy Duty Hub Rebuild Kits	405
Heavy Duty Clutch Pilot Bearings	407
Heavy Duty Clutch Installation Kits.....	409
Hand Installed Wheel Seals	411
Light Duty Wheel Set Interchanges	415
Rear Wheel Repair Package Bearings.....	416
Rear Wheel Bearings Installation Procedures.....	417
Timken P900™ Bearing Benefits.....	418
Timken Proper Tapered Bearing Settings	420
Timken Tapered Roller Bearing Damage Analysis.....	422
Timken Ball Bearing Damage Analysis.....	424
Permatex Products	428
Limited Warranty	Inside Back Cover

Pages 397 through 406, 418 through 427 provided by The Timken Company.

Every possible effort has been made to ensure that the data in this catalog is correct, but we cannot assume responsibility should there be any error.

References to original equipment part numbers are for cross reference and identification purposes and may not indicate that the actual part is an original equipment part.

Warning

Follow the manufacturer’s installation instructions. Never spin a bearing with compressed air. The rollers may be forcefully expelled, creating a risk of bodily harm. Failure to follow all instructions and to properly lubricate the bearing can cause equipment failure, creating a risk of serious bodily harm.

Heavy & Medium Duty Differential Products

- Bearing & Seal Rebuild Kits
- Tractech No Spin Differentials
- Axle Shafts
- Permatex[®] Adhesives & Sealants
- Individual Bearings & Seals
- Coverage for all Dana/Eaton, GMC, IH/Navistar, Mack, Meritor/Rockwell, Volvo & White Models



Heavy & Medium Duty Transmission & Transfer Case Products

- Bearing & Seal Rebuild Kits
- Permatex[®] Adhesives & Sealants
- Individual Bearings & Seals
- Coverage for all Clark, Eaton/Fuller, Fabco, Mack, Meritor/Rockwell, New Process, Spicer/TTC & ZF Models

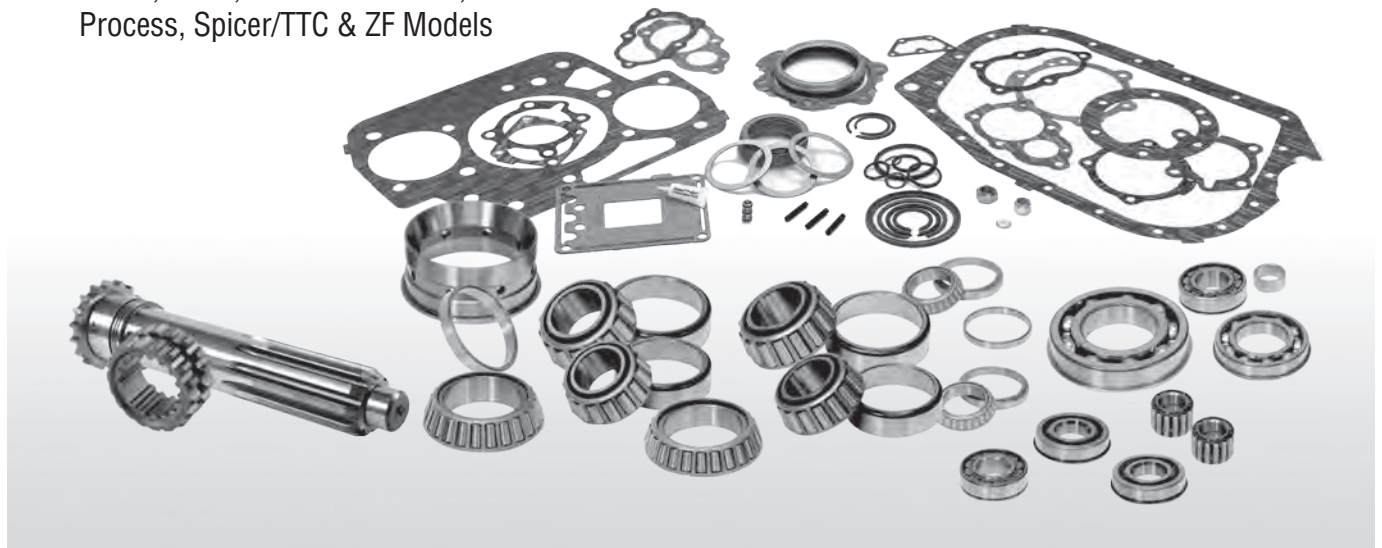

Light Duty Differential Products

- Bearing & Seal Rebuild Kits
- Ring & Pinion Sets
- Differential Cases & Internal Kits
- Auburn, Detroit Locker & Eaton Limited Slip & Locking Differentials
- Axle Shafts
- Axle Shaft Repair Bearings
- Permatex[®] Adhesives & Sealants
- Individual Bearings & Seals
- Coverage for all AMC, Chrysler, Ford, GM, Jeep, Nissan & Toyota Vehicles

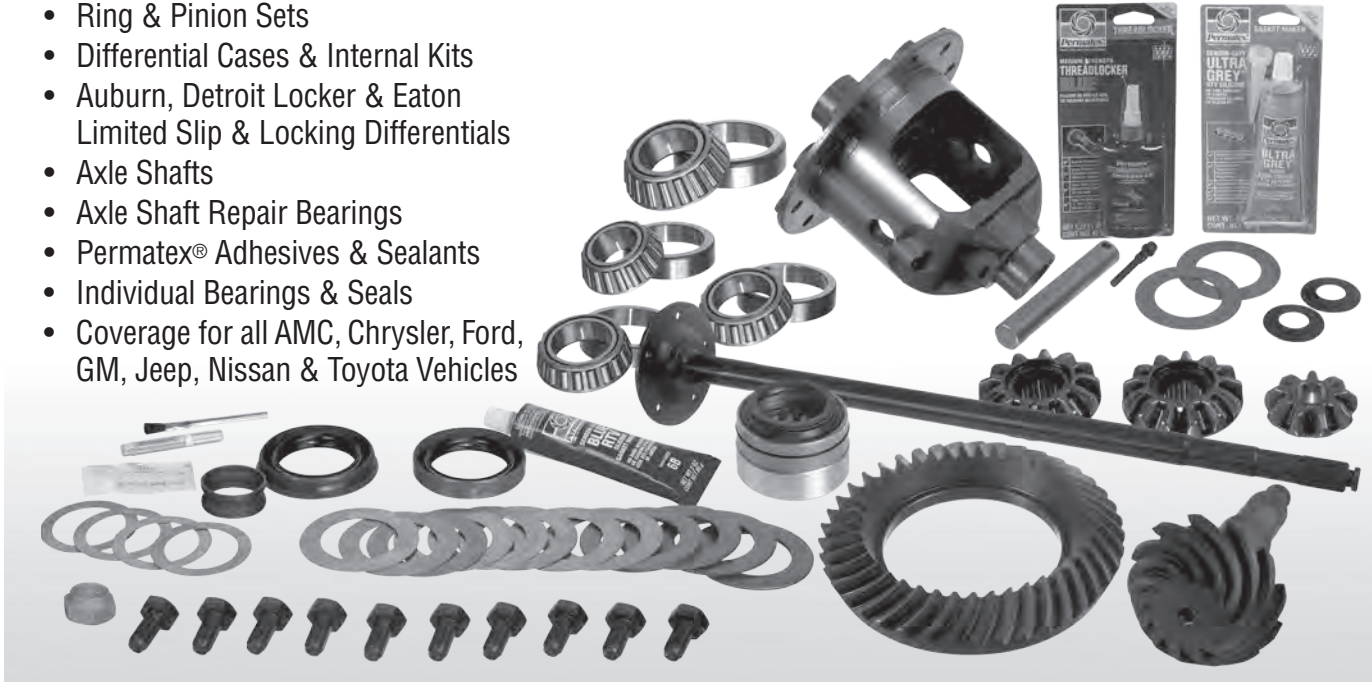

Light Duty Transmission & Transfer Case Products

- Bearing & Seal Rebuild Kits
- Synchronizer Rings & Assemblies
- Input Shafts & Counter Shafts
- Transfer Case & Automatic Transmission Chains
- Permatex[®] Adhesives & Sealants
- Individual Bearings & Seals
- Coverage for all Acura, AMC, Chrysler, Ford, GM, Honda, Hummer, Hyundai, Infiniti, Isuzu, Jeep, KIA, Lexus, Mazda, Mitsubishi, Nissan, Saturn, Suzuki & Toyota Vehicles



Driveline & Clutch Products

- Driveshaft Center Support Bearings
- Universal Joints
- Clutch Release Bearings
- Pilot Bearings
- EZ Sleeves[®]
- Individual Bearings & Seals
- Coverage for all Acura, AMC, Chrysler, Ford, GM, Honda, Hummer, Hyundai, Infiniti, Isuzu, Jeep, KIA, Lexus, Mazda, Mitsubishi, Nissan, Saturn, Suzuki, Volkswagen & Toyota Vehicles & Agricultural Applications

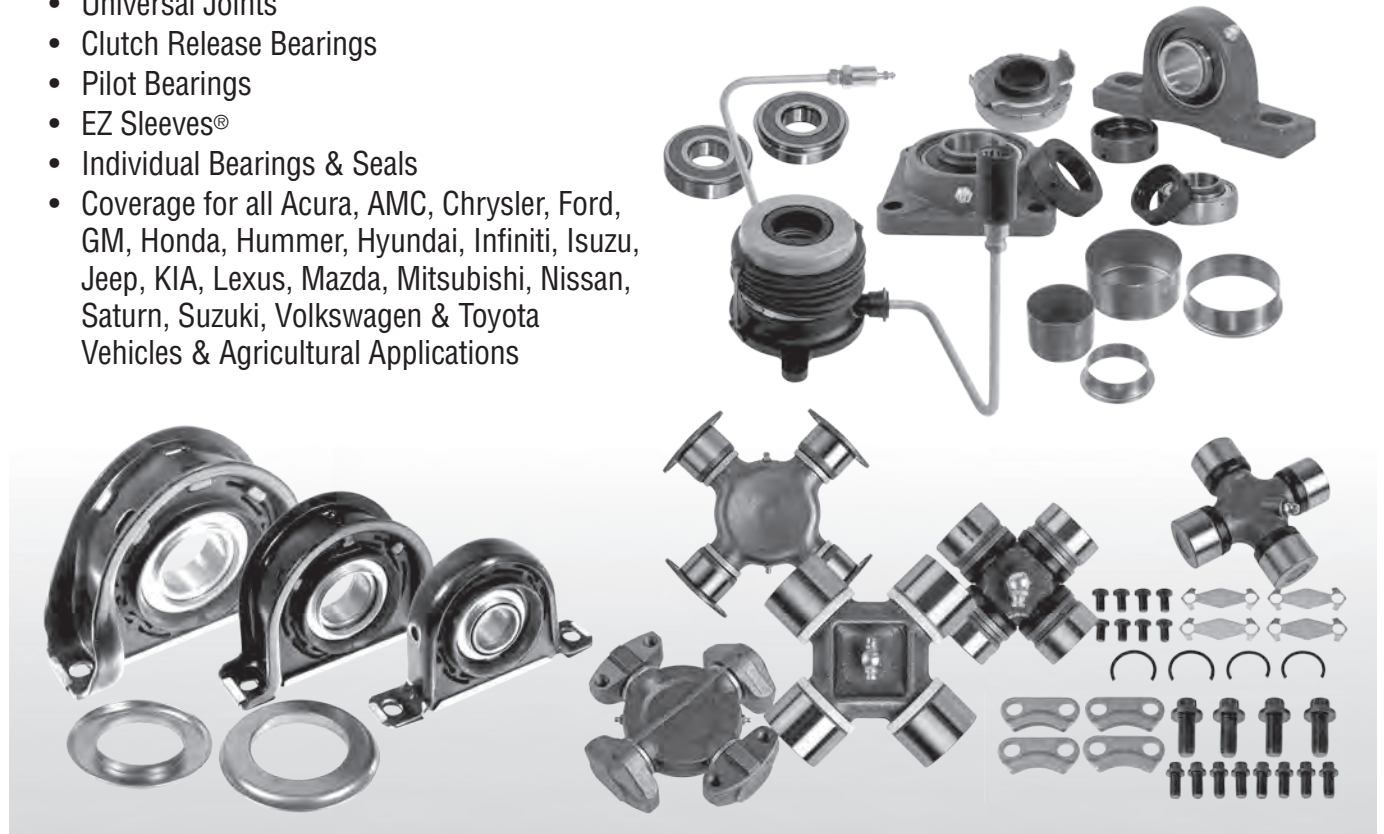

Heavy Duty, Light Truck & Automotive Wheel End Products

- Wheel Bearings & Sets
- Hand Installed Wheel Seals
- ABS & Non-ABS Hub Assemblies
- Axle Bearings, Axle Repair Bearings & Spindle Bearings
- Axle Seals & Wheel Seals



While this catalog is as current as possible at the time it was printed, it is quickly outdated due to our continued efforts of adding rebuild kits and related products for additional models and newer vehicles.

We also offer many additional products such as axle bearings, wheel hub assemblies, wheel seals, clutch release bearings, automatic transmission and engine seals that are not contained in this catalog.

Our E-Catalog also contains images and specifications on many of our products along with over 330,000 part number interchanges.

Please access our E-catalog via www.dtcomponents.com to look up information on these additional products and for models and years not included in this catalog.



DT Components Web Site

The redesigned and more informative DT Components web site contains product information, literature, customer login, and a link to our web catalog.



Snap this QR code with your smartphone app to visit our web site.

DT Components Web Catalog

- Product Lookup by Application
- Kit Bill of Materials
- Interchanges
- Product Specifications
- Product Photos

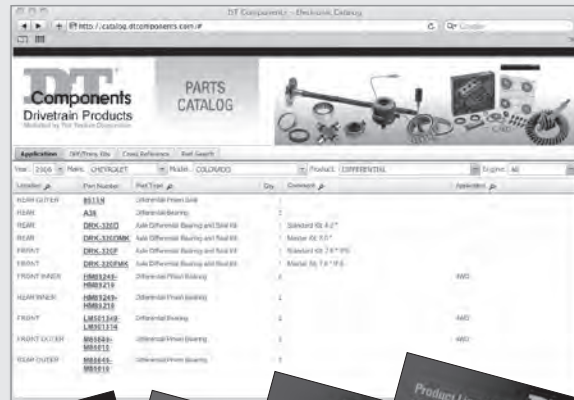

Snap this QR code with your smartphone app to view our electronic catalog.

Heavy Duty Differential Index

Dana Axle Identification

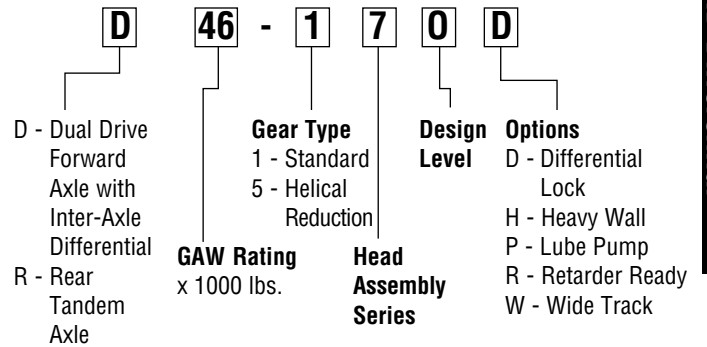
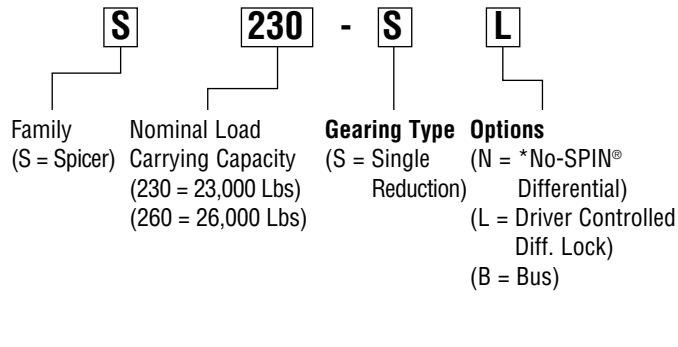

Eaton Axle Identification

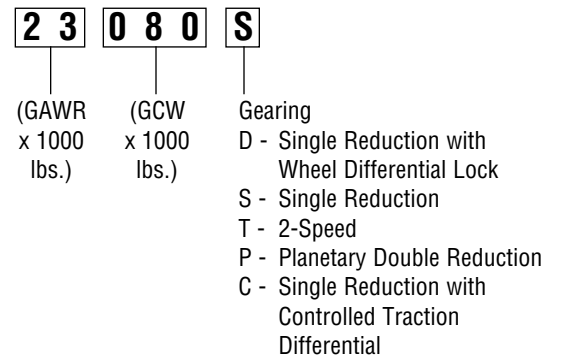
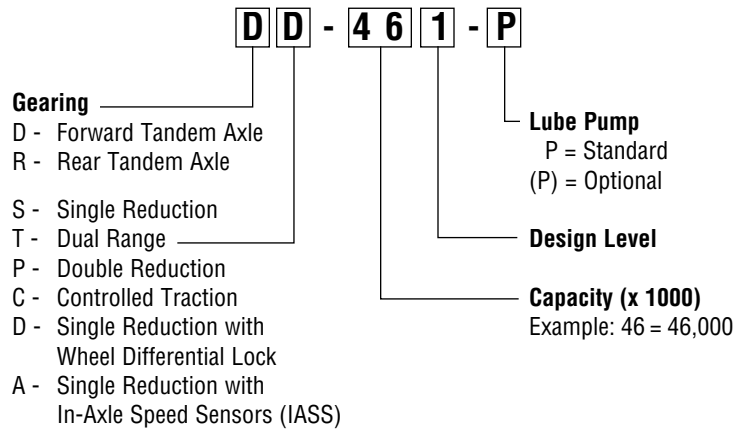

Heavy Duty Differential Index



HD Differential

Alliance / Detroit / Freightliner Index

Axle Model	Type/Cap.#	Comments	Kit
ARS13-2	R-13,000		DRK-651
ARS15-2	R-15,000		DRK-651
ARS17.5-2	R-17,500		DRK-651
ARS17.5-4	R-17,500		DRK-650R
ARS19-2	R-19,000		DRK-651
ARS19-4	R-19,000		DRK-650R
ARS20-4	R-20,000		DRK-650R
ARS21-2	R-21,000		DRK-651
ARS23-4	R-23,000		DRK-650R
ART34-4	RF-34,000		DRK-650F
	RR-34,000		DRK-650R
ART40-4	RF-44,000		DRK-650F
	RR-44,000		DRK-650R
ART44-4	RF-44,000		DRK-650F
	RR-44,000		DRK-650R

Dana Index

Axle Model	Type/Cap.#	Comments	Kit
S14-110	R-14,500		DRK-434
S14-111	R-14,500		DRK-434
S16-130	R-16,500		DRK-434
S16-132	R-16,500		DRK-434
S21-170	R-21,000	Before 6-10-13 and w/ 2.69-3.91 Ratios	DRK-438
	R-21,000	Before 6-10-13 and w/ 4.10-7.17 Ratios	DRK-439
	R-21,000	After 6-9-13 and w/ 2.69-3.91 Ratios	DRK-438A
	R-21,000	After 6-9-13 and w/ 4.10-7.17 Ratios	DRK-439A
S21-170D	R-21,000	Before 6-10-13 and w/ 2.69-3.91 Ratios	DRK-443
	R-21,000	Before 6-10-13 and w/ 4.10-7.17 Ratios	DRK-444
	R-21,000	After 6-9-13 and w/ 2.69-3.91 Ratios	DRK-443A
	R-21,000	After 6-9-13 and w/ 4.10-7.17 Ratios	DRK-444A
S23-170	R-23,000	Before 6-10-13 and w/ 2.69-3.91 Ratios	DRK-438
	R-23,000	Before 6-10-13 and w/ 4.10-7.17 Ratios	DRK-439
	R-23,000	After 6-9-13 and w/ 2.69-3.91 Ratios	DRK-438A
	R-23,000	After 6-9-13 and w/ 4.10-7.17 Ratios	DRK-439A

Dana Index

Axle Model	Type/Cap.#	Comments	Kit
S23-170D	R-23,000	Before 6-10-13 and w/ 2.69-3.91 Ratios	DRK-443
	R-23,000	Before 6-10-13 and w/ 4.10-7.17 Ratios	DRK-444
	R-23,000	After 6-9-13 and w/ 2.69-3.91 Ratios	DRK-443A
	R-23,000	After 6-9-13 and w/ 4.10-7.17 Ratios	DRK-444A
S26-190P	R-26,000	Before 6-10-13 and w/ 2.53-4.78 Ratios	DRK-443
	R-26,000	Before 6-10-13 and w/ 5.25-7.83 Ratios	DRK-441
	R-26,000	After 6-9-13 and w/ 2.53-4.78 Ratios	DRK-443A
	R-26,000	After 6-9-13 and w/ 5.25-7.83 Ratios	DRK-441A
S30-190P	R-30,000	Before 6-10-13 and w/ 2.53-4.78 Ratios	DRK-443
	R-30,000	Before 6-10-13 and w/ 5.25-7.83 Ratios	DRK-441
	R-30,000	After 6-9-13 and w/ 2.53-4.78 Ratios	DRK-443A
	R-30,000	After 6-9-13 and w/ 5.25-7.83 Ratios	DRK-441A
D40-170	RF-44,000	Before 6-10-13	DRK-442
	RF-44,000	After 6-9-13	DRK-442A
D40-170DP	RF-44,000	Before 6-10-13	DRK-436
	RF-44,000	After 6-9-13	DRK-436A
D40-170P	RF-44,000	Before 6-10-13	DRK-442
	RF-44,000	After 6-9-13	DRK-442A
R40-170	RR-44,000	Before 6-10-13 and w/ 2.69-3.91 Ratios	DRK-438
	RR-44,000	Before 6-10-13 and w/ 4.10-7.17 Ratios	DRK-439
	RR-44,000	After 6-9-13 and w/ 2.69-3.91 Ratios	DRK-438A
	RR-44,000	After 6-9-13 and w/ 4.10-7.17 Ratios	DRK-439A
R40-170D	RR-44,000	Before 6-10-13 and w/ 2.69-3.91 Ratios	DRK-443
	RR-44,000	Before 6-10-13 and w/ 4.10-7.17 Ratios	DRK-444
	RR-44,000	After 6-9-13 and w/ 2.69-3.91 Ratios	DRK-443A
	RR-44,000	After 6-9-13 and w/ 4.10-7.17 Ratios	DRK-444A
D46-170	RF-46,000	Before 6-10-13	DRK-442
	RF-46,000	After 6-9-13	DRK-442A
D46-170DP	RF-46,000	Before 6-10-13	DRK-436
	RF-46,000	After 6-9-13	DRK-436A
D46-170H	RF-46,000	Before 6-10-13	DRK-442
	RF-46,000	After 6-9-13	DRK-442A

Heavy Duty Differential Index

Dana Index

Axle Model	Type/Cap.#	Comments	Kit
D46-170HP	RF-46,000	Before 6-10-13	DRK-442
	RF-46,000	After 6-9-13	DRK-442A
D46-170P	RF-46,000	Before 6-10-13	DRK-442
	RF-46,000	After 6-9-13	DRK-442A
R46-170	RR-46,000	Before 6-10-13 and w/ 2.69-3.91 Ratios	DRK-438
	RR-46,000	Before 6-10-13 and w/ 4.10-7.17 Ratios	DRK-439
	RR-46,000	After 6-9-13 and w/ 2.69-3.91 Ratios	DRK-438A
	RR-46,000	After 6-9-13 and w/ 4.10-7.17 Ratios	DRK-439A
R46-170D	RR-46,000	Before 6-10-13 and w/ 2.69-3.91 Ratios	DRK-443
	RR-46,000	Before 6-10-13 and w/ 4.10-7.17 Ratios	DRK-444
	RR-46,000	After 6-9-13 and w/ 2.69-3.91 Ratios	DRK-443A
	RR-46,000	After 6-9-13 and w/ 4.10-7.17 Ratios	DRK-444A
D52-190DP	RF-52,000	Before 6-10-13	DRK-437
	RF-52,000	After 6-9-13	DRK-437A
D52-190P	RF-52,000	Before 6-10-13	DRK-437
	RF-52,000	After 6-9-13	DRK-437A
R52-190P	RR-52,000	Before 6-10-13 and w/ 2.53-4.78 Ratios	DRK-443
	RR-52,000	Before 6-10-13 and w/ 5.25-7.83 Ratios	DRK-441
	RR-52,000	After 6-9-13 and w/ 2.53-4.78 Ratios	DRK-443A
	RR-52,000	After 6-9-13 and w/ 5.25-7.83 Ratios	DRK-441A
D60-190P	RF-60,000	Before 6-10-13	DRK-437
	RF-60,000	After 6-9-13	DRK-437A
R60-190P	RR-60,000	Before 6-10-13 and w/ 2.53-4.78 Ratios	DRK-443
	RR-60,000	Before 6-10-13 and w/ 5.25-7.83 Ratios	DRK-441
	RR-60,000	After 6-9-13 and w/ 2.53-4.78 Ratios	DRK-443A
	RR-60,000	After 6-9-13 and w/ 5.25-7.83 Ratios	DRK-441A
S135-S	R-13,500		DRK-414
S150-S	R-15,500		DRK-414
F155-S	R-15,500		DRK-191R
G155-T	R-15,500		DRK-213
G160-D	R-16,000		DRK-213
G160-T	R-16,000		DRK-213
F170-S	R-17,000		DRK-191R
F175-D	R-17,500		DRK-213
G175-R	R-17,500		DRK-213
G175-T	R-17,500		DRK-213
J175-S	R-17,500		DRK-192RB
N175	R-17,500		DRK-223R

Dana Index

Axle Model	Type/Cap.#	Comments	Kit
G185-S	R-18,500		DRK-213
M185-D	R-18,500		DRK-214
M185-T	R-18,500		DRK-214
G190-S	R-19,000		DRK-213
J190-S	R-19,000		DRK-192RB
M190-T	R-19,000		DRK-214
N190	R-19,000		DRK-223R
M200-D	R-20,000		DRK-214
M200-T	R-20,000		DRK-214
J210-S	R-21,000		DRK-192RB
M210-T	R-21,000		DRK-214
J220-S	R-22,000		DRK-192RB
M220-D	R-22,000		DRK-214
M220-T	R-22,000		DRK-214
J230-S	R-23,000		DRK-192RB
J230-SB	R-23,000		DRK-192RB
M230-T	R-23,000		DRK-214
S230-S	R-23,000		DRK-416
S230-SB	R-23,000		DRK-416
S230-SL	R-23,000		DRK-416
W230-S	R-23,000		DRK-201R
S260-SB	R-26,000		DRK-416
G340-S	F-34,000		DRK-192FB
J340-S	F-34,000		DRK-200FA
	R-34,000		DRK-192RB
N340-S	F-34,000		DRK-223F
	R-34,000		DRK-223R
G380-S	F-38,000		DRK-192FB
J380-S	F-38,000		DRK-200FA
J400-S	R-38,000		DRK-192RB
	F-40,000		DRK-200FA
	R-40,000		DRK-192RB
	F-40,000		DRK-223F
N400-I	F-40,000		DRK-223R
	R-40,000		DRK-223R
S400-S	F-40,000		DRK-411F
	R-40,000		DRK-411R
W440-S	F-44,000		DRK-201FA
	R-44,000		DRK-201R
W460-S	F-46,000		DRK-201FA
	R-46,000		DRK-201R

Eaton Index

Axle Model	Type/Cap.#	Comments	Kit
30R3	R-30,000		DRK-23
30RP	R-30,000		DRK-23
30RS	R-30,000	w/ Ribbed Carrier	DRK-23
	R-30,000	w/ Conical Carrier	DRK-23B
30RT	R-30,000		DRK-23
34D3	F-34,000	w/ Ball Brg. On Input Shaft	DRK-64F
	F-34,000	w/ Taper Brg. On Input Shaft	DRK-64FE

Heavy Duty Differential Index

HD Differential

Eaton Index

Axle Model	Type/Cap.#	Comments	Kit
34DP	F-34,000	w/ Ball Brg. On Input Shaft	DRK-64F
	F-34,000	w/ Taper Brg. On Input Shaft	DRK-64FE
34DS	F-34,000	w/ Ribbed Carrier & Ball Brg. On Input Shaft	DRK-64F
	F-34,000	w/ Conical Carrier & Ball Brg. On Input Shaft	DRK-64FC
	F-34,000	w/ Conical Carrier & Taper Brg. On Input Shaft	DRK-64FD
34DT	F-34,000	w/ Ribbed Carrier & Taper Brg. On Input Shaft	DRK-64FE
	F-34,000	w/ Ball Brg. On Input Shaft	DRK-64F
34R3	R-34,000		DRK-1
34RP	R-34,000	w/ Ribbed Carrier	DRK-1
	R-34,000	w/ Conical Carrier	DRK-1A
34RS	R-34,000	w/ Conical Carrier	DRK-1A
34RSB	R-34,000		DRK-1A
34RT	R-34,000		DRK-1
38D3	F-38,000	w/ Ball Brg. On Input Shaft	DRK-64F
	F-38,000	w/ Taper Brg. On Input Shaft	DRK-64FE
38DP	F-38,000	w/ Ball Brg. On Input Shaft	DRK-64F
	F-38,000	w/ Taper Brg. On Input Shaft	DRK-64FE
38DS	F-38,000	w/ Ribbed Carrier & Ball Brg. On Input Shaft	DRK-64F
	F-38,000	w/ Conical Carrier & Ball Brg. On Input Shaft	DRK-64FC
	F-38,000	w/ Conical Carrier & Taper Brg. On Input Shaft	DRK-64FD
	F-38,000	w/ Ribbed Carrier & Taper Brg. On Input Shaft	DRK-64FE
38DT	F-38,000	w/ Ball Brg. On Input Shaft	DRK-64F
	F-38,000	w/ Taper Brg. On Input Shaft	DRK-64FE
38R3	R-38,000		DRK-1
38RP	R-38,000	w/ Ribbed Carrier	DRK-1
	R-38,000	w/ Conical Carrier	DRK-1A
38RS	R-38,000		DRK-1A
38RSB	R-38,000		DRK-1A
38RT	R-38,000		DRK-1
DDH40(P)	F-40,000	Before 6/16/08	DRK-428
	F-40,000	After 6/16/08	DRK-428A

Eaton Index

Axle Model	Type/Cap.#	Comments	Kit
DDP40(P)	F-40,000	Before 6/16/08	DRK-428
	F-40,000	After 6/16/08	DRK-428A
DDS40(P)	F-40,000		DRK-435
DDT40-P	F-40,000	Before 6/16/08	DRK-405F ⁴⁴
	F-40,000	After 6/16/08	DRK-405FA ⁴⁵
DSH40(P)	F-40,000	Before 6/16/08	DRK-427
	F-40,000	After 6/16/08	DRK-427A
DSP40(P)	F-40,000	Before 6/16/08	DRK-427
	F-40,000	After 6/16/08	DRK-427A
DSS40(P)	F-40,000		DRK-431
DST40(P)	F-40,000	Before 6/16/08	DRK-404F ⁴¹
	F-40,000	After 6/16/08	DRK-404FA ⁴²
RDH40	R-40,000		DRK-430
RDP40	R-40,000		DRK-430
RDS40	R-40,000		DRK-219R
RDT40	R-40,000		DRK-445
RSH40	R-40,000		DRK-429
RSP40	R-40,000		DRK-429
RSS40	R-40,000		DRK-449
RST40	R-40,000	Before 4/1/05 & 2.64-5.57 Ratios	DRK-445
		Before 4/1/05 & 6.17-7.17 Ratios	DRK-446
	R-40,000	After 4/1/05 & 2.64-5.57 Ratios	DRK-447
	R-40,000	After 4/1/05 & 6.17-7.17 Ratios	DRK-448
DDP41(P)	F-41,000	Before 6/16/08	DRK-428
	F-41,000	After 6/16/08	DRK-428A
DDT41(P)	F-41,000	Before 6/16/08	DRK-405F ⁴⁴
	F-41,000	After 6/16/08	DRK-405FA ⁴⁵
DSP41(P)	F-41,000	Before 6/16/08	DRK-427
	F-41,000	After 6/16/08	DRK-427A
DST41(P)	F-41,000	Before 6/16/08	DRK-404F ⁴¹
	F-41,000	After 6/16/08	DRK-404FA ⁴²
RDP41	R-41,000		DRK-430
RDT41	R-41,000		DRK-445
RSP41	R-41,000		DRK-429
RST41	R-41,000	Before 4/1/05 & 2.64-5.57 Ratios	DRK-445
		Before 4/1/05 & 6.17-7.17 Ratios	DRK-446
	R-41,000	After 4/1/05 & 2.64-5.57 Ratios	DRK-447
	R-41,000	After 4/1/05 & 6.17-7.17 Ratios	DRK-448
42D3	F-42,000	w/ Ball Brg. On Input Shaft	DRK-64F
	F-42,000	w/ Taper Brg. On Input Shaft	DRK-64FE
42DP	F-42,000	w/ Ball Brg. On Input Shaft	DRK-64F
	F-42,000	w/ Taper Brg. On Input Shaft	DRK-64FE

⁴¹Order DRK-404FMK for Master Kit
⁴²Order DRK-404FAMK for Master Kit

⁴⁴Order DRK-405FMK for Master Kit
⁴⁵Order DRK-405FAMK for Master Kit

Heavy Duty Differential Index

Eaton Index

Axle Model	Type/Cap.#	Comments	Kit
42DT	F-42,000	w/ Ball Brg. On Input Shaft	DRK-64F
	F-42,000	w/ Taper Brg. On Input Shaft	DRK-64FE
42R3	R-42,000		DRK-1
42RP	R-42,000		DRK-1
42RS	R-42,000		DRK-18D
42RT	R-42,000		DRK-1
44DP	F-44,000		DRK-209A
44DS	F-44,000		DRK-208A
44DSM	F-44,000		DRK-208A
44DT	F-44,000		DRK-72A
	F-44,000		DRK-209A
44RPB	R-44,000		DRK-72A
44RS	R-44,000	w/ Casting # C67854 / Bef. 2-1-79	DRK-413
	R-44,000	w/ Casting # C98493 / Aft. 2-1-79	DRK-219R
44RSM	R-44,000		DRK-413
44RSB	R-44,000	w/ Large Spherical Diff	DRK-18E
44RT	R-44,000	w/ 103537 Case	DRK-72B
	R-44,000	w/o 103537 Case	DRK-72A
44RTB	R-44,000		DRK-72A
DDH44(P)	F-44,000		DRK-427
DSH44(P)	F-44,000		DRK-428
RDH44	R-44,000		DRK-429
RSH44	R-44,000		DRK-429
50DP	F-50,000		DRK-193
50DT	F-50,000		DRK-193
50RP	R-50,000		DRK-1
50RT	R-50,000		DRK-1
190C4	R-19,000		DRK-419
190P4	R-19,000		DRK-419
190S4	R-19,000		DRK-417
190T4	R-19,000		DRK-419
220C4	R-22,000		DRK-419
220P4	R-22,000		DRK-419
220S4	R-22,000		DRK-417
220T4	R-22,000		DRK-419
230C4	R-23,000		DRK-420
230P4	R-23,000		DRK-421
230S4	R-23,000		DRK-418
230T4	R-23,000		DRK-421
260C4	R-26,000		DRK-420
260P4	R-26,000		DRK-421
260S4	R-26,000		DRK-418
260T4	R-26,000		DRK-421
300C4	R-30,000		DRK-420
300P4	R-30,000		DRK-420
300S4	R-30,000		DRK-418
300T4	R-30,000		DRK-421
DP340	F-34,000		DRK-193
DS340	F-34,000	2-Speed Carrier / Bef 4-30-78	DRK-193

Eaton Index

Axle Model	Type/Cap.#	Comments	Kit
DS340	F-34,000	1-Speed Carrier / Aft 4-30-78	DRK-193A
DT340	F-34,000		DRK-193
RP340	R-34,000		DRK-1
RS340	R-34,000	2-Speed Carrier / Bef 4-30-78	DRK-1
	R-34,000	1-Speed Carrier / Aft 4-30-78	DRK-1A
RT340	R-34,000		DRK-1
DC341(P)	F-34,000		DRK-207
DP341(P)	F-34,000		DRK-207
DS341(P)	F-34,000	Before 4-6-89	DRK-196
	F-34,000	4-6-89 thru 12-31-94	DRK-222F
	F-34,000	After 1-1-95	DRK-196
DT341(P)	F-34,000		DRK-207
RC341	R-34,000		DRK-1
RP341	R-34,000		DRK-1
RS341	R-34,000	Before 4-6-89	DRK-1A
	R-34,000	4-6-89 thru 12-31-94	DRK-222R
	R-34,000	After 1-1-95	DRK-412
RT341	R-34,000		DRK-1
DA344	F-34,000		DRK-404F ⁴¹
DS344	F-34,000	Before 6/16/08	DRK-404F ⁴¹
	F-34,000	After 6/16/08	DRK-404FA ⁴²
RA344	R-34,000		DRK-404R ⁴³
RS344	R-34,000		DRK-404R ⁴³
350C4	R-35,000		DRK-420
350P4	R-35,000		DRK-420
350S4	R-35,000		DRK-418
350T4	R-35,000		DRK-420
DP380-P	F-38,000		DRK-193
DS380(P)	F-38,000	2-Speed Carrier / Bef 4-30-78	DRK-193
	F-38,000	1-Speed Carrier / Aft 4-30-78	DRK-193A
DT380(P)	F-38,000		DRK-193
RP380(P)	R-38,000		DRK-1
RS380	R-38,000	2-Speed Carrier / Bef 4-30-78	DRK-1
	R-38,000	1-Speed Carrier / Aft 4-30-78	DRK-1A
RT380(P)	R-38,000		DRK-1
DC381(P)	F-38,000		DRK-207
DP381(P)	F-38,000		DRK-207
DS381(P)	F-38,000		DRK-196
DT381(P)	F-38,000		DRK-207
RC381	R-38,000		DRK-1
RP381(P)	R-38,000		DRK-1
RS381	R-38,000		DRK-1A
RT381(P)	R-38,000		DRK-1
DS385	F-38,000		DRK-1
DC386-P	F-38,000		DRK-424
DP386-P	F-38,000		DRK-424
DS386-P	F-38,000		DRK-422

⁴¹Order DRK-404FMK for Master Kit ⁴³Order DRK-404RMK for Master Kit
⁴²Order DRK-404FAMK for Master Kit

Heavy Duty Differential Index

HD Differential

Eaton Index

Axle Model	Type/Cap.#	Comments	Kit
DT386-P	F-38,000		DRK-424
RC386	R-38,000		DRK-1
RP386-P	R-38,000		DRK-1
RS386	R-38,000		DRK-1A
RT386-P	R-38,000		DRK-1
DP400(P)	F-40,000		DRK-193
DS400-P	F-40,000	2-Speed Carrier / Bef 4-30-78	DRK-193
	F-40,000	1-Speed Carrier / Aft 4-30-78	DRK-193A
DT400(P)	F-40,000		DRK-193
RP400(P)	R-40,000		DRK-1
RS400	R-40,000	2-Speed Carrier / Bef 4-30-78	DRK-1
	R-40,000	1-Speed Carrier / Aft 4-30-78	DRK-1A
RT400(P)	R-40,000		DRK-1
DC401-P	F-40,000		DRK-207
DP401(P)	F-40,000		DRK-207
DS401-P	F-40,000		DRK-196
DT401(P)	F-40,000		DRK-207
RC401	R-40,000		DRK-1
RP401(P)	R-40,000		DRK-1
RS401	R-40,000		DRK-1A
RT401(P)	R-40,000		DRK-1
DA402(P)	F-40,000	4-6-89 thru 12-31-94	DRK-222F
	F-40,000	After 1-1-95	DRK-196
DC402(P)	F-40,000		DRK-207
DP402(P)	F-40,000		DRK-207
DS402(P)	F-40,000	Before 4-6-89	DRK-196
	F-40,000	4-6-89 thru 12-31-94	DRK-222F
	F-40,000	After 1-1-95	DRK-196
DT402(P)	F-40,000		DRK-207
RA402	R-40,000	4-6-89 thru 12-31-94	DRK-222R
	R-40,000	After 1-1-95	DRK-412
RC402	R-40,000		DRK-1
RP402(P)	R-40,000		DRK-1
RS402	R-40,000	Before 4-6-89	DRK-1A
	R-40,000	4-6-89 thru 12-31-94	DRK-222R
	R-40,000	After 1-1-95	DRK-412
RT402(P)	R-40,000		DRK-1
DS403(P)	F-40,000	Before 4-6-89	DRK-196
	F-40,000	4-6-89 thru 12-31-94	DRK-222F
	F-40,000	After 1-1-95	DRK-196
RS403	R-40,000	Before 4-6-89	DRK-1A
	R-40,000	4-6-89 thru 12-31-94	DRK-222R
	R-40,000	After 1-1-95	DRK-412
DA404(P)	F-40,000	Before 6/16/08	DRK-404F ⁴¹
	F-40,000	After 6/16/08	DRK-404FA ⁴²
DD404(P)	F-40,000	Before 6/16/08	DRK-405F ⁴⁴
	F-40,000	After 6/16/08	DRK-405FA ⁴⁵
DS404(P)	F-40,000	Before 6/16/08	DRK-404F ⁴¹
	F-40,000	After 6/16/08	DRK-404FA ⁴²
RA404	R-40,000		DRK-404R ⁴³

Eaton Index

Axle Model	Type/Cap.#	Comments	Kit
RD404	R-40,000		DRK-405R ⁴⁶
RS404	R-40,000		DRK-404R ⁴³
DA405(P)	F-40,000	Before 6/16/08	DRK-404F ⁴¹
	F-40,000	After 6/16/08	DRK-404FA ⁴²
DD405(P)	F-40,000	Before 6/16/08	DRK-405F ⁴⁴
	F-40,000	After 6/16/08	DRK-405FA ⁴⁵
DS405(P)	F-40,000	Before 6/16/08	DRK-404F ⁴¹
	F-40,000	After 6/16/08	DRK-404FA ⁴²
RA405	R-40,000		DRK-404R ⁴³
RD405	R-40,000		DRK-405R ⁴⁶
RS405	R-40,000		DRK-404R ⁴³
DC406-P	F-40,000		DRK-424
DP406-P	F-40,000		DRK-424
DS406-P	F-40,000		DRK-422
DT406-P	F-40,000		DRK-424
RC406	R-40,000		DRK-1
RP406-P	R-40,000		DRK-1
RS406	R-40,000		DRK-1A
RT406-P	R-40,000		DRK-1
DP440-P	F-44,000	22 Spline & Case # 103530	DRK-209
	F-44,000	36 Spline & Case # 110500	DRK-210
DS440-P	F-44,000	22 Spline & Case # 103530	DRK-208A
	F-44,000	36 Spline & Case # 110500	DRK-208
DT440-P	F-44,000	22 Spline & Case # 103530	DRK-209
	F-44,000	36 Spline & Case # 110500	DRK-210
RP440	R-44,000		DRK-72B
RS440	R-44,000		DRK-18E
RT440	R-44,000		DRK-72B
DP446-P	F-44,000		DRK-426
DS446-P	F-44,000	w/ Traction Control	DRK-426
	F-44,000	w/o Traction Control	DRK-425
DT446-P	F-44,000		DRK-426
RP446-P	R-44,000		DRK-72B
RS446	R-44,000	w/ Traction Control	DRK-72B
	R-44,000	w/o Traction Control	DRK-18E
RT446-P	R-44,000		DRK-72B
DC451-P	F-45,000		DRK-207
DP451-P	F-45,000		DRK-207
DS451-P	F-45,000	Before 4-6-89	DRK-196
	F-45,000	4-6-89 thru 12-31-94	DRK-222F
	F-45,000	After 1-1-95	DRK-196
DT451-P	F-45,000		DRK-207
RC451	R-45,000		DRK-1
RP451-P	R-45,000		DRK-1
RS451	R-45,000	Before 4-6-89	DRK-1A
	R-45,000	4-6-89 thru 12-31-94	DRK-222R
	R-45,000	After 1-1-95	DRK-412
RT451-P	R-45,000		DRK-1

⁴¹Order DRK-404FMK for Master Kit
⁴²Order DRK-404FAMK for Master Kit

⁴³Order DRK-404RMK for Master Kit
⁴⁴Order DRK-405FMK for Master Kit

⁴⁵Order DRK-405FAMK for Master Kit
⁴⁶Order DRK-405RMK for Master Kit

Heavy Duty Differential Index

Eaton Index

Axle Model	Type/Cap.#	Comments	Kit
DA454(P)	F-45,000		DRK-404F ⁴¹
DD454(P)	F-45,000		DRK-405F ⁴⁴
DS454(P)	F-45,000		DRK-404F ⁴¹
RA454	R-45,000		DRK-404R ⁴³
RD454	R-45,000		DRK-405R ⁴⁶
RS454	R-45,000		DRK-404R ⁴³
DC460-P	F-46,000		DRK-211F
DP460-P	F-46,000	22 Spline & Case # 103530	DRK-209
	F-46,000	36 Spline & Case # 110500	DRK-210
DS460-P	F-46,000	22 Spline & Case # 103530	DRK-208A
	F-46,000	36 Spline & Case # 110500	DRK-208
DT460-P	F-46,000	22 Spline & Case # 103530	DRK-209
	F-46,000	36 Spline & Case # 110500	DRK-210
RC460	R-46,000		DRK-219R
RP460	R-46,000		DRK-72B
RS460	R-46,000		DRK-18E
RT460	R-46,000		DRK-72B
DC461-P	F-46,000	Prior 2/2000	DRK-211F
	F-46,000	After 2/2000	DRK-432
DD461-P	F-46,000	Prior 2/2000	DRK-211F
	F-46,000	After 2/2000	DRK-432
DP461-P	F-46,000	Prior 2/2000	DRK-211F
	F-46,000	After 2/2000	DRK-432
DS461-P	F-46,000	Prior 2/2000	DRK-208
	F-46,000	After 2/2000	DRK-433
DT461-P	F-46,000	Prior 2/2000	DRK-211F
	F-46,000	After 2/2000	DRK-432
RC461	R-46,000		DRK-219R
RD461	R-46,000		DRK-219R
RP461	R-46,000		DRK-219R
RS461	R-46,000		DRK-449
RT461	R-46,000		DRK-219R
SP461	R-46,000		DRK-220F
TP461	F-46,000		DRK-220F
DC462-P	F-46,000	Prior 2/2000	DRK-211F
	F-46,000	After 2/2000	DRK-432
DD462-P	F-46,000	Prior 2/2000	DRK-211F
	F-46,000	After 2/2000	DRK-432
DP462-P	F-46,000	Prior 2/2000	DRK-211F
	F-46,000	After 2/2000	DRK-432
DS462-P	F-46,000	Prior 2/2000	DRK-208
	F-46,000	After 2/2000	DRK-433
DT462-P	F-46,000	Prior 2/2000	DRK-211F
	F-46,000	After 2/2000	DRK-432
RC462	R-46,000		DRK-219R
RD462	R-46,000		DRK-219R
RP462	R-46,000		DRK-219R
RS462	R-46,000		DRK-449

Eaton Index

Axle Model	Type/Cap.#	Comments	Kit
RT462	R-46,000		DRK-219R
SP462	R-46,000		DRK-220F
TP462	F-46,000		DRK-220F
DC463-P	F-46,000	Prior 2/2000	DRK-211F
	F-46,000	After 2/2000	DRK-432
DD463-P	F-46,000	Prior 2/2000	DRK-211F
	F-46,000	After 2/2000	DRK-432
DP463-P	F-46,000	Prior 2/2000	DRK-211F
	F-46,000	After 2/2000	DRK-432
DS463-P	F-46,000	Prior 2/2000	DRK-208
	F-46,000	After 2/2000	DRK-433
DT463-P	F-46,000	Prior 2/2000	DRK-211F
	F-46,000	After 2/2000	DRK-432
RC463	R-46,000		DRK-219R
RD463	R-46,000		DRK-219R
RP463	R-46,000		DRK-219R
RS463	R-46,000		DRK-449
RT463	R-46,000		DRK-219R
SP463	R-46,000		DRK-220F
TP463	F-46,000		DRK-220F
DP466-P	F-46,000		DRK-426
DS466-P	F-46,000	w/ Traction Control	DRK-426
	F-46,000	w/o Traction Control	DRK-425
DT466-P	F-46,000		DRK-426
RP466-P	R-46,000		DRK-72B
RS466	R-46,000	w/ Traction Control	DRK-72B
	R-46,000	w/o Traction Control	DRK-18E
RT466-P	R-46,000		DRK-72B
DC480-P	F-48,000		DRK-211F
DP480-P	F-48,000	22 Spline & Case # 103530	DRK-209
	F-48,000	36 Spline & Case # 110500	DRK-210
DS480-P	F-48,000	22 Spline & Case # 103530	DRK-208A
	F-48,000	36 Spline & Case # 110500	DRK-208
DT480-P	F-48,000	22 Spline & Case # 103530	DRK-209
	F-48,000	36 Spline & Case # 110500	DRK-210
RC480	R-48,000		DRK-219R
RP480	R-48,000		DRK-72B
RS480	R-48,000		DRK-18E
RT480	R-48,000		DRK-72B
DP485-P	F-48,000		DRK-211F
DT485-P	F-48,000		DRK-211F
RP485	R-48,000		DRK-72B
RT485	R-48,000		DRK-72B
DC521-P	F-52,000	Prior 2/2000	DRK-211F
	F-52,000	After 2/2000	DRK-432
DD521-P	F-52,000	Prior 2/2000	DRK-211F
	F-52,000	After 2/2000	DRK-432

⁴¹Order DRK-404FMK for Master Kit
⁴³Order DRK-404RMK for Master Kit

⁴⁴Order DRK-405FMK for Master Kit
⁴⁶Order DRK-405RMK for Master Kit

Heavy Duty Differential Index

HD Differential

Eaton Index

Axle Model	Type/Cap.#	Comments	Kit
DP521-P	F-52,000	Prior 2/2000	DRK-211F
	F-52,000	After 2/2000	DRK-432
DS521-P	F-52,000	Prior 2/2000	DRK-208
	F-52,000	After 2/2000	DRK-433
DT521-P	F-52,000	Prior 2/2000	DRK-211F
	F-52,000	After 2/2000	DRK-432
RC521	R-52,000		DRK-219R
RD521	R-52,000		DRK-219R
RP521	R-52,000		DRK-219R
RS521	R-52,000		DRK-449
RT521	R-52,000		DRK-219R
SP521	R-52,000		DRK-220F
TP521	F-52,000		DRK-220F
DP550	F-55,000	22 Spline & Case # 103530	DRK-211FA
	F-55,000	36 Spline & Case # 110500	DRK-211F
RP550	R-55,000		DRK-72B
RT550	R-55,000		DRK-72B
SP550	F-55,000		DRK-220FA
TP550	F-55,000		DRK-220FA
DP580-P	F-58,000	22 Spline & Case # 103530	DRK-211FA
	F-58,000	36 Spline & Case # 110500	DRK-211F
DT580-P	F-58,000	22 Spline & Case # 103530	DRK-211FA
	F-58,000	36 Spline & Case # 110500	DRK-211F
RP580	R-58,000		DRK-219R
RS580	R-58,000	w/ Traction Control	DRK-219R
RT580	R-58,000		DRK-219R
SP580	F-58,000		DRK-220FA
TP580	F-58,000		DRK-220FA
DD581-P	F-58,000	Prior 2/2000	DRK-211F
	F-58,000	After 2/2000	DRK-432
DS581-P	F-58,000	Prior 2/2000	DRK-208
	F-58,000	After 2/2000	DRK-433
RD581	R-58,000		DRK-219R
RS581	R-58,000		DRK-449
DD601(P)	F-60,000	Prior 2/2000	DRK-211F
	F-60,000	After 2/2000	DRK-432
DP601-P	F-60,000	Prior 2/2000	DRK-211F
	F-60,000	After 2/2000	DRK-432
DS601(P)	F-60,000	Prior 2/2000	DRK-208
	F-60,000	After 2/2000	DRK-433
DT601-P	F-60,000	Prior 2/2000	DRK-211F
	F-60,000	After 2/2000	DRK-432
RC601	R-60,000		DRK-219R
RP601	R-60,000		DRK-219R
RS601	R-60,000		DRK-449
RT601	R-60,000		DRK-219R
SP601	R-60,000		DRK-220F
TP601	F-60,000		DRK-220F

Eaton Index

Axle Model	Type/Cap.#	Comments	Kit
DP650-P	F-65,000	22 Spline & Case # 103530	DRK-211FA
	F-65,000	36 Spline & Case # 110500	DRK-211F
DT650-P	F-65,000	22 Spline & Case # 103530	DRK-211FA
	F-65,000	36 Spline & Case # 110500	DRK-211F
RP650	R-65,000		DRK-219R
RS650	R-65,000	w/ Traction Control	DRK-219R
RT650	R-65,000		DRK-219R
SP650	F-65,000		DRK-220FA
TP650	F-65,000		DRK-220FA
DD651(P)	F-65,000	Prior 2/2000	DRK-211F
	F-65,000	After 2/2000	DRK-432
DP651-P	F-65,000	Prior 2/2000	DRK-211F
	F-65,000	After 2/2000	DRK-432
DS651-P	F-65,000	Prior 2/2000	DRK-208
	F-65,000	After 2/2000	DRK-433
DT651-P	F-65,000	Prior 2/2000	DRK-211F
	F-65,000	After 2/2000	DRK-432
RC651	R-65,000		DRK-219R
RP651	R-65,000		DRK-219R
RS651	R-65,000		DRK-449
RT651	R-65,000		DRK-219R
SP651	R-65,000		DRK-220F
TP651	F-65,000		DRK-220F
DC3416-P	F-34,000		DRK-424
DP3416-P	F-34,000		DRK-424
DS3416-P	F-34,000		DRK-422
DT3416-P	F-34,000		DRK-424
RC3416	R-34,000		DRK-1
RP3416-P	R-34,000		DRK-1
RS3416	R-34,000		DRK-1A
RT3416-P	R-34,000		DRK-1
DC4026-P	F-40,000		DRK-424
DP4026-P	F-40,000		DRK-424
DS4026-P	F-40,000		DRK-422
DT4026-P	F-40,000		DRK-424
RC4026	R-40,000		DRK-1
RP4026-P	R-40,000		DRK-1
RS4026	R-40,000		DRK-1A
RT4026-P	R-40,000		DRK-1
DC4616-P	F-46,000		DRK-426
DP4616-P	F-46,000		DRK-426
DS4616-P	F-46,000		DRK-423
DT4616-P	F-46,000		DRK-426
RC4616	R-46,000		DRK-72B
RP4616-P	R-46,000		DRK-219R
RS4616	R-46,000		DRK-449
RT4616-P	R-46,000		DRK-219R
DC5216-P	F-52,000		DRK-426
DP5216-P	F-52,000		DRK-426
DS5216-P	F-52,000		DRK-423

Heavy Duty Differential Index

Eaton Index

Axle Model	Type/Cap.#	Comments	Kit
DT5216-P	F-52,000		DRK-426
RC5216	R-52,000		DRK-72B
RP5216-P	R-52,000		DRK-219R
RS5216	R-52,000		DRK-449
RT5216-P	R-52,000		DRK-219R
DP6016-P	F-60,000		DRK-426
DT6016-P	F-60,000		DRK-426
RP6016-P	R-60,000		DRK-219R
RT6016-P	R-60,000		DRK-219R
DP6516-P	F-65,000		DRK-426
DT6516-P	F-65,000		DRK-426
RP6516-P	R-65,000		DRK-219R
RT6516-P	R-65,000		DRK-219R
350	R-		DRK-24
502	R-		DRK-72
503	R-		DRK-72
1350	R-10-15,000	Exc. Dodge 1957-1958	DRK-24
1618	R-16-17,000		DRK-23
1619	R-16-17,000		DRK-23
1880	R-19-22,000		DRK-1
1881	R-19-22,000		DRK-1
3800	R-15,000		DRK-24
3802	R-15,000		DRK-24
6802	R-16,000		DRK-23
6803	R-16,000		DRK-23
7500	F-		DRK-202
7800	R-18,000		DRK-1
7801	R-18,000		DRK-1
7810	R-18,000		DRK-1
8800	R-22,000		DRK-1
8802	R-22,000		DRK-1
8803	R-22,000		DRK-1
9000	F-		DRK-202
9502	R-23,000		DRK-72
9503	R-23,000		DRK-72
9512	R-23,000		DRK-72
10000	F-		DRK-202
12000	F-		DRK-202
13600	R-13,000		DRK-411
13602	R-13,000		DRK-411
13800	R-13,000		DRK-24
13802	R-13,000		DRK-24
13803	R-13,000		DRK-24
15040-P	R-15,000		DRK-24
15040-S	R-15,000		DRK-400
15040-T	R-15,000		DRK-24
15101	R-15,000		DRK-24
15200	R-15,000		DRK-24
15201	R-15,000		DRK-24
15300	R-15,000		DRK-24
15301	R-15,000		DRK-24
16120	R-16,000		DRK-23D
16123	R-16,000		DRK-23D

Eaton Index

Axle Model	Type/Cap.#	Comments	Kit
16220	R-16,000	w/ 15" Ring Gear	DRK-23
	R-16,000	w/ 15-1/2" Ring Gear	DRK-23D
16244	R-16,000		DRK-23D
16247	R-17,500		DRK-23D
16320	R-16,000		DRK-23
16321	R-16,000		DRK-23
16344	R-16,000		DRK-23D
16500	R-16,000		DRK-23
16501	R-16,000		DRK-23
16800	R-16,000		DRK-23
16802	R-16,000		DRK-23
16803	R-16,000		DRK-23
17060-S	R-17,000		DRK-404R ⁴³
17100	R-17,000		DRK-1A
17101	R-17,000		DRK-1A
17120	R-17,000		DRK-1A
17121	R-17,000		DRK-1A
17123	R-17,000		DRK-1A
17200	R-17,000		DRK-1
17201	R-17,000		DRK-1
17202	R-17,000		DRK-1
17220	R-17,000		DRK-1
17221	R-17,000		DRK-1
17300	R-17,000		DRK-1
17301	R-17,000		DRK-1
17302	R-17,000		DRK-1
17320	R-17,000		DRK-1
17321	R-17,000		DRK-1
17322	R-17,000		DRK-1
17401	R-17,000		DRK-1
17421	R-17,000		DRK-1
17500	R-17,000		DRK-1
17501	R-17,000		DRK-1
17800	R-17,000		DRK-1
17810	R-17,000		DRK-1
18100	R-18,000		DRK-1A
18101	R-18,000		DRK-1A
18103	R-18,000		DRK-1A
18120	R-18,000		DRK-1A
18121	R-18,000		DRK-1A
18123	R-18,000		DRK-1A
18200	R-18,000		DRK-1
18201	R-18,000		DRK-1
18202	R-18,000		DRK-1
18207	R-18,000		DRK-1
18220	R-18,000		DRK-1
18221	R-18,000		DRK-1
18227	R-18,000		DRK-1
18300	R-18,000		DRK-1
18301	R-18,000		DRK-1
18302	R-18,000		DRK-1
18320	R-18,000		DRK-1
18321	R-18,000		DRK-1
18322	R-18,000		DRK-1

⁴³Order DRK-404RMK for Master Kit

Heavy Duty Differential Index

HD Differential

Eaton Index

Axle Model	Type/Cap.#	Comments	Kit
18500	R-18,000		DRK-1
18501	R-18,000		DRK-1
18502	R-18,000		DRK-1
18503	R-18,000		DRK-1
18800	R-18,000		DRK-1
18802	R-18,000		DRK-1
18803	R-18,000		DRK-1
18812	R-18,000		DRK-1
18813	R-18,000		DRK-1
19050-D	R-19,000		DRK-221
19050-P	R-19,000		DRK-23D
19050-S	R-19,000		DRK-221
19050-T	R-19,000		DRK-23D
19055-D	R-19,000		DRK-406
19055-P	R-19,000		DRK-403
19055-S	R-19,000		DRK-406
19055-T	R-19,000		DRK-403
19060-D	R-19,000		DRK-405R ⁴⁶
19060-S	R-19,000		DRK-404R ⁴³
19060-T	R-19,000		DRK-1
19100	R-19,000		DRK-415
19120	R-19,000		DRK-18D
19121	R-19,000	Exc. Dodge	DRK-18D
19123	R-19,000		DRK-18D
19200	R-19,000		DRK-72
19201	R-19,000		DRK-72
19202	R-19,000		DRK-72
19220	R-19,000	w/ 103537 Case	DRK-72B
	R-19,000	w/o 103537 Case	DRK-72A
19221	R-19,000	w/ 103537 Case	DRK-72B
	R-19,000	w/o 103537 Case	DRK-72A
19223	R-19,000		DRK-72A
19227	R-19,000	Before 2-1-79	DRK-413
	R-19,000	After 2-1-79	DRK-219R
19237	R-19,000	After 2-1-79	DRK-219R
19300	R-19,000		DRK-72
19301	R-19,000		DRK-72
19320	R-19,000		DRK-72A
19321	R-19,000	w/ 103537 Case	DRK-72B
	R-19,000	w/o 103537 Case	DRK-72A
19323	R-19,000		DRK-72A
19327	R-19,000		DRK-413
19420	R-19,000		DRK-413
19426	R-19,000		DRK-413
19500	R-19,000		DRK-72
19501	R-19,000		DRK-72
19502	R-19,000		DRK-72
19503	R-19,000		DRK-72
19512	R-19,000		DRK-72
19513	R-19,000		DRK-72
19515	R-19,000		DRK-72
20000	R-20,000		DRK-72
20100	R-20,000		DRK-415
20120	R-20,000		DRK-18D

Eaton Index

Axle Model	Type/Cap.#	Comments	Kit
20121	R-20,000		DRK-18D
20123	R-20,000		DRK-18D
20200	R-20,000		DRK-72
20201	R-20,000		DRK-72
20220	R-20,000	w/ 103537 Case	DRK-72B
	R-20,000	w/o 103537 Case	DRK-72A
20221	R-20,000	w/ 103537 Case	DRK-72B
	R-20,000	w/o 103537 Case	DRK-72A
20223	R-20,000		DRK-72A
20300	R-20,000		DRK-72
20301	R-20,000		DRK-72
20320	R-20,000	w/ 103537 Case	DRK-72B
	R-20,000	w/o 103537 Case	DRK-72A
20321	R-20,000	w/ 103537 Case	DRK-72B
	R-20,000	w/o 103537 Case	DRK-72A
20323	R-20,000		DRK-72A
20500	R-20,000		DRK-72
20501	R-20,000		DRK-72
20502	R-20,000		DRK-72
20503	R-20,000		DRK-72
21060-D	R-21,000		DRK-405R ⁴⁶
21060-S	R-21,000		DRK-404R ⁴³
21060-T	R-21,000		DRK-1
21065-D	R-21,000		DRK-406
21065-P	R-21,000		DRK-403
21065-S	R-21,000		DRK-406
21065-T	R-21,000		DRK-403
21065-Y	R-21,000		DRK-403
21080-D	R-21,000		DRK-410
21080-S	R-21,000		DRK-410
21121	R-21,000		DRK-1A
21221	R-21,000		DRK-1
21321	R-21,000		DRK-1
21421	R-21,000		DRK-1
22060-D	R-22,000		DRK-405R ⁴⁶
22060-S	R-22,000		DRK-404R ⁴³
22060-SH	R-22,000		DRK-429
22065-D	R-22,000		DRK-406
22065-P	R-22,000		DRK-403
22065-S	R-22,000		DRK-406
22065-T	R-22,000		DRK-403
22120	R-22,000		DRK-412
22121	R-22,000		DRK-412
22220	R-22,000		DRK-403
22221	R-22,000		DRK-403
22320	R-22,000		DRK-403
22321	R-22,000		DRK-403
22420	R-22,000		DRK-403
22421	R-22,000		DRK-403
22427	R-22,000		DRK-403
23070-D	R-23,000		DRK-407
23070-P	R-23,000		DRK-408
23070-S	R-23,000		DRK-407
23070-T	R-23,000		DRK-408

⁴³Order DRK-404RMK for Master Kit

⁴⁶Order DRK-405RMK for Master Kit

Heavy Duty Differential Index

Eaton Index

Axle Model	Type/Cap.#	Comments	Kit
23080-D	R-23,000		DRK-410
23080-P	R-23,000	Before 4-6-88	DRK-72B
	R-23,000	After 4-6-88	DRK-219R
23080-S	R-23,000		DRK-410
23080-T	R-23,000	Before 4-6-88	DRK-72B
	R-23,000	After 4-6-88	DRK-219R
23085-C	R-23,000		DRK-219R
23085-D	R-23,000		DRK-410
23085-S	R-23,000		DRK-410
23105-C	R-23,000		DRK-401
23105-D	R-23,000		DRK-409
23105-S	R-23,000		DRK-402
23120	R-23,000	Large Spherical Differential	DRK-18E
23121	R-23,000	GMC Trucks	DRK-415
	R-23,000	Non-GMC Trucks	DRK-18E
23202	R-23,000		DRK-72
23220	R-23,000	w/ 27950 Case	DRK-72A
	R-23,000	w/103537 Case	DRK-72B
23221	R-23,000	w/ 27950 Case	DRK-72A
	R-23,000	w/103537 Case	DRK-72B
23227	R-23,000	Before 2-1-79	DRK-413
	R-23,000	After 2-1-79	DRK-219R
23302	R-23,000		DRK-72
23320	R-23,000	w/ 27950 Case	DRK-72A
	R-23,000	w/103537 Case	DRK-72B
23321	R-23,000	w/ 27950 Case	DRK-72A
	R-23,000	w/103537 Case	DRK-72B
23327	R-23,000	Before 2-1-79	DRK-413
	R-23,000	After 2-1-79	DRK-219R
23420	R-23,000	Before 2-1-79	DRK-413
	R-23,000	After 2-1-79	DRK-219R
23421	R-23,000		DRK-219R
23427	R-23,000		DRK-219R
23430	R-23,000	w/ CTD	DRK-219R
23433	R-23,000		DRK-219R
26080-D	R-26,000		DRK-410
26080-S	R-26,000		DRK-410
26085-P	R-26,000	Before 4-6-88	DRK-72B
	R-26,000	After 4-6-88	DRK-219R
26085-T	R-26,000	Before 4-6-88	DRK-72B
	R-26,000	After 4-6-88	DRK-219R
26105-C	R-26,000		DRK-401
26105-S	R-26,000		DRK-402
26120	R-26,000	Large Spherical Differential	DRK-18E
	R-26,000	Small Spherical Differential	DRK-18D
26121	R-26,000	Large Spherical Differential	DRK-18E
	R-26,000	Small Spherical Differential	DRK-18D
26123	R-26,000	Large Spherical Differential	DRK-18E

Eaton Index

Axle Model	Type/Cap.#	Comments	Kit
26123	R-26,000	Small Spherical Differential	DRK-18D
26220	R-26,000	w/ 27950 Case	DRK-72A
	R-26,000	w/103537 Case	DRK-72B
26221	R-26,000	w/ 27950 Case	DRK-72A
	R-26,000	w/103537 Case	DRK-72B
26223	R-26,000	w/ 27950 Case	DRK-72A
	R-26,000	w/103537 Case	DRK-72B
26320	R-26,000	w/ 27950 Case	DRK-72A
	R-26,000	w/103537 Case	DRK-72B
26321	R-26,000	w/ 27950 Case	DRK-72A
	R-26,000	w/103537 Case	DRK-72B
26323	R-26,000	w/ 27950 Case	DRK-72A
	R-26,000	w/103537 Case	DRK-72B
26420	R-26,000		DRK-413
26421	R-26,000		DRK-219R
26426	R-26,000		DRK-413
30055-P	R-30,000		DRK-219R
30105-C	R-30,000		DRK-401
30105-S	R-30,000		DRK-402
33321	R-33,000	w/ 27950 Case	DRK-72A
	R-33,000	w/103537 Case	DRK-72B
35055-P	R-35,000		DRK-219R
35227	R-35,000	w/ 27950 Case	DRK-413
	R-35,000	w/103537 Case	DRK-219R
35327	R-35,000	w/ 27950 Case	DRK-413
	R-35,000	w/103537 Case	DRK-219R

GMC Index

Axle Model	Type/Cap.#	Comments	Kit
H052	R-5,200	1968-On	DRK-700
H072	R-7,200	1968-On	DRK-700
H110	R-11,000	Before 1983	DRK-701
H130	R-13,000	Late Models	DRK-701
H150	R-15,000	Before 1982	DRK-702
T150	R-15,000	1996-1983	DRK-170
H170	R-17,000	Before 1979	DRK-702
T170	R-17,000	1966-On	DRK-170

International Harvester/ Navistar Index

Axle Model	Type/Cap.#	Comments	Kit
RA15	R-6,000		DRK-195
RA25	R-13,500		DRK-202
RA29	R-15,500		DRK-191R
RA30	R-15,000		DRK-202
RA35	R-16,000		DRK-191R
RA39	R-16,000		DRK-191R

International Harvester/ Navistar Index

Axle Model	Type/Cap.#	Comments	Kit
RA42	R-	w/ Involute Splines	DRK-192RB
	R-	w/o Involute Splines and Below Serial # 5141	DRK-192RA
	R-	w/o Involute Splines and Serial # 5141 & Above	DRK-192R
RA43	R-18,500	w/ Involute Splines	DRK-192RB
	R-18,500	w/o Involute Splines and Below Serial # 5141	DRK-192RA
	R-18,500	w/o Involute Splines and Serial # 5141 & Above	DRK-192R
RA44	R-18,500	w/ Involute Splines	DRK-192RB
	R-18,500	w/o Involute Splines and Below Serial # 5141	DRK-192RA
	R-18,500	w/o Involute Splines and Serial # 5141 & Above	DRK-192R
RA47	R-18,500	w/ Involute Splines	DRK-192RB
	R-18,500	w/o Involute Splines and Below Serial # 5141	DRK-192RA
	R-18,500	w/o Involute Splines and Serial # 5141 & Above	DRK-192R
RA48	R-18,500	w/ Involute Splines	DRK-192RB
	R-18,500	w/o Involute Splines and Below Serial # 5141	DRK-192RA
	R-18,500	w/o Involute Splines and Serial # 5141 & Above	DRK-192R
RA57	R-23,000	# G261412 & Up	DRK-198
	R-23,000	w/Involute Splines	DRK-201R
RA341	RF-30,000		DRK-191F
	RR-30,000		DRK-191R
RA351	RF-34,000	Below Diff Ser . #21453	DRK-192FC
	RF-34,000	Diff Ser . #21453 & Higher w/Tapered Drive Bearings	DRK-192FB
	RR-34,000	Involute Splines	DRK-192RB
RA355	RR-34,000	Below Serial # 18798	DRK-192RA
	RR-34,000	Serial # 18798 & Above	DRK-192R
	RF-38,000	Below Diff Ser . #21453	DRK-192FC
RA386	RF-	Diff Ser . #21453 & Higher w/Tapered Drive Bearings	DRK-192FB
	RR-	Involute Splines	DRK-192RB
	RR-	Below Diff Ser. # 18798	DRK-192RA
RA429	RR-	Diff Ser. # 18798 & Up	DRK-192R
	RF-	Below Diff Ser . #21453	DRK-192FC
	RF-	Diff Ser . #21453 & Higher w/Tapered Drive Bearings	DRK-192FB
RA472	RR-	w/Involute Splines	DRK-201R
	RF-	Involute Splines	DRK-200F
	RF-	Involute Splines (Late Design)	DRK-200FA
RA474	RR-	Involute Splines	DRK-192RB
	RF-46,000	Involute Splines	DRK-201F
	RF-46,000	Involute Splines (Late Design)	DRK-201FA
	RR-46,000	Involute Splines	DRK-201R

International Harvester/ Navistar Index

Axle Model	Type/Cap.#	Comments	Kit
RA386	RR-	w/Involute Splines	DRK-192RB
	RR-	Below Diff Ser. # 18798	DRK-192RA
	RR-	Diff Ser. # 18798 & Up	DRK-192R
RA387	RF-	Below Diff Ser . #21453	DRK-192FC
	RF-	Diff Ser . #21453 & Higher w/Tapered Drive Bearings	DRK-192FB
	RR-	w/Involute Splines	DRK-192RB
RA429	RR-	Below Diff Ser. # 18798	DRK-192RA
	RR-	Diff Ser. # 18798 & Up	DRK-192R
	RF-		DRK-198
RA472	RR-	w/Involute Splines	DRK-201R
	RF-	Involute Splines	DRK-200F
	RF-	Involute Splines (Late Design)	DRK-200FA
RA474	RR-	Involute Splines	DRK-192RB
	RF-46,000	Involute Splines	DRK-201F
	RF-46,000	Involute Splines (Late Design)	DRK-201FA
	RR-46,000	Involute Splines	DRK-201R

Mack Index

Axle Model	Type/Cap.#	Comments	Kit
RAD23	R-		DRK-117
SW29	RF-& RR-		DRK-205
SW30	RF-& RR-		DRK-205
SW31	RF-& RR-		DRK-205
CRDP32			DRK-504
SWD32	RF-& RR-		DRK-206
CRD33			DRK-505
AWDR48	RF-& RR-		DRK-117
SWS59	RF-		DRK-212F
	RR-		DRK-212R
SWW59	RF-		DRK-212F
	RR-		DRK-212R
SS65	RF-		DRK-212F
	RR-		DRK-212R
SW65	RF-		DRK-212F
	RR-		DRK-212R
SWD69	RF-		DRK-212F
	RR-		DRK-212R
SWW69	RF-		DRK-212F
	RR-		DRK-212R
SWW69W	RF-		DRK-212F
	RR-		DRK-212R
CRD78	R-22,000		DRK-117
SW80	RF-		DRK-212F
	RR-		DRK-212R
CRDLP92		w/11KH5312, 5313	DRK-206

Heavy Duty Differential Index

Mack Index

Axle Model	Type/Cap.#	Comments	Kit
CRDLP92		w/11KH5313	DRK-206
		w/11KH5316, 5317, 5318, 5319	DRK-206
SWS92	RF-		DRK-212F
	RR-		DRK-212R
CRD93		Non-Current	DRK-502
		w/11KH5326, 5327, 5330	DRK-205
CRD93A			DRK-503
CRDLP93			DRK-205
SWS93	RF-		DRK-212F
	RR-		DRK-212R
CRD94			DRK-117
CRDP95			DRK-212F
SWWP95	RF-		DRK-212F
	RR-		DRK-212R
CRD96			DRK-212R
CRDPC112		w/11KH5333, 5334, 5336	DRK-206
CRD113		Non-Current	DRK-502
		w/11KH5341, 5342	DRK-205
CRD116	R-22,000	Non-Current	DRK-117A
	R-22,000	w/11KHA4165, 4165A	DRK-117
CRD117		Non-Current	DRK-117A
		w/11KHA4159API-AP14	DRK-117
		w/11KHA45159CP12	DRK-117
CRD118			DRK-506
C150	F-		DRK-507
CRD150	F-		DRK-507
CRDPC150	F-		DRK-507
C151	R-		DRK-508
CRD151	R-		DRK-508
CRDP200			DRK-500
CRD201			DRK-501
CRD202			DRK-500
CRD203			DRK-501
RAD303	R-		DRK-117
RAD305	R-		DRK-117
RAD500	R-		DRK-117
RAS500	R-		DRK-117
RAD501	R-		DRK-117
RAD507	R-22,000		DRK-117
RAD508	R-22,000		DRK-117
RAD509	R-22,000		DRK-117
RAD512	R-22,000		DRK-117
RAD529	R-23,000		DRK-117
RAD529CW	R-		DRK-117
RADL529	R-23,000		DRK-117
RAD530	R-23,000		DRK-117
RAD530C	R-		DRK-117
SWS592	RF-		DRK-212F
	RR-		DRK-212R
SWW592	RR-		DRK-212R
	RF-		DRK-212F
RAD606	R-27,000		DRK-117
RAD606C	R-		DRK-117

Mack Index

Axle Model	Type/Cap.#	Comments	Kit
SWD691	RF-		DRK-212F
	RR-		DRK-212R
RAD705	R-41,000		DRK-117
CRD781	R-22,000		DRK-117
SWP801	RF-		DRK-212F
	RR-		DRK-212R
RADF1000	R-		DRK-117
RADP1000	R-		DRK-117
RADP1001	R-		DRK-117
CRD1161	R-22,000	Non-Current	DRK-117A
	R-22,000	w/11KHA4159,4159A,4166,4166A	DRK-117
CRD1171	R-22,000	Non-Current	DRK-117A
	R-22,000	w/11KHA4159C, 4167B	DRK-117
	R-22,000	w/11KHA4167, 4167A	DRK-117
CRDPC1501	F-		DRK-507
CRD1511	R-		DRK-508
RAD5291	R-23,000		DRK-117
RADL5291	R-23,000		DRK-117

Meritor/Rockwell Axle Identification

Nominal Axle Load Rating (GAWR):
In thousands of pounds. Individual forward and rear axles of a tandem set (**D, N, P, R**) are rated as single axles. A tandem set (**T**) is rated as the combination of the two axles and a tridem set (**Z**) as the combination of the three axles.

Manufacturing Location
A - Australia
B - Brazil
C - India
D - Mexico (Dirona)
E - Europe (C.V.C.)
M - Europe (Maudslay)
N - U.S.A.

Brake Type
C - Dura-Master® Air Disc Brake
D - RDA Stopmaster® Wedge Brake (Dual Air Chambers)
E - RDH Stopmaster® Wedge Brake (Dual Hydraulic Cylinders)
F - RSH Stopmaster® Wedge Brake (Single Hydraulic Cylinder)
L - Q Plus Cam Brake
N - None
P - Cam-Master® "P" Series Cam Brake
Q - Cam-Master® "Q" Series Cam Brake
S - RSA Stopmaster® Wedge Brake (Single Air Chamber)
T - Cam-Master® "T" Series Cam Brake
W - Cam-Master® "W" Series Cam Brake

Hub Type
A - Aluminum
F - Ferrous
N - None

Gearing Type
1 - Single Speed
2 - Two Speed
3 - Helical Double Reduction
4 - Salisbury Single Speed
5 - Planetary Double Reduction
6 - Hub Reduction

Main Differential Nest Type
B - Special Differential
C - Driver Controlled Differential Lock
F - Standard Differential
H - High Traction® Differential
N - NoSPIN™ Differential

RR 20 1 4 5 N C Q F 123

Axle Specification Number
Identifies specific customer axle configurations (variations from the original axle design). For information about the variation, see the Bill of Materials for that specific axle model.

Axle Type
C - Single Rear Drive Axle, Coach
D - Forward-Rear Axle of a Drive Tandem with Inter-Axle Differential
N - Forward-Rear Axle of a Drive Tandem or Tridem without Inter-Axle Differential
P - Forward-Rear Axle of a Drive Tandem with Inter-Axle Differential and Pump
R - Rear-Rear Axle of a Drive Tandem
S - Single Rear Drive Axle
T - Tandem Drive Axle Set
Z - Tridem Drive Axle Set

Carrier Type
Carrier size. Large numbers indicate a higher GCW rated carrier; i.e., larger ring gear, etc.

Axle Design Variation
Indicates axle design level or variation, (e.g., RS 23 161 has a thicker wall housing than the RS 23 160). For information, see the Bill of Materials for that specific axle model.

Heavy Duty Differential Index

14X Series Single Axles

Axle Model	Sub Model	Type/ Cap.#	Carriers	Notes	Kit
MS-17-14X		R-17,000	All	Hypoid w/o Diff Lock Hypoid w/ Diff Lock	DRK-4843 DRK-4844
MS-19-14X		R-17,000	All	Hypoid w/o Diff Lock Hypoid w/ Diff Lock	DRK-4843 DRK-4844
MS-21-14X		R-17,000	All	Hypoid w/o Diff Lock Hypoid w/ Diff Lock	DRK-4843 DRK-4844

14X Series Tandem Axles

Axle Model	Sub Model	Type/ Cap.#	Carriers	Notes	Kit
MD-34-14X	MD-17-14X	RF-17,000	All		DRK-4841
	MR-17-14X	RR-17,000	All	Amboid	DRK-4842
	MR-17-14X			Hypoid w/o Diff Lock	DRK-4843
	MR-17-14X			Hypoid w/ Diff Lock	DRK-4844
MD-40-14X	MD-20-14X	RF-20,000	All		DRK-4841
	MR-20-14X	RR-20,000	All	Amboid	DRK-4842
	MR-20-14X			Hypoid w/o Diff Lock	DRK-4843
	MR-20-14X			Hypoid w/ Diff Lock	DRK-4844
MT-44-14X	MD-22-14X	RF-22,000	All		DRK-4841
	MR-22-14X	RR-22,000	All	Hypoid w/o Diff Lock	DRK-4843
	MR-22-14X			Hypoid w/ Diff Lock	DRK-4844

113 Series Single Axles

Axle Model	Sub Model	Type/ Cap.#	Carriers	Notes	Kit
MS-10-113		R-10,000	All		DRK-4753
MS-11-113		R-11,000	All		DRK-4753
MS-12-113		R-12,000	All		DRK-4753

120, 125 Series Single Axles

Axle Model	Sub Model	Type/ Cap.#	Carriers	Notes	Kit
RS-13-120		R-13,000	All		DRK-218
RS-15-120		R-15,000	All		DRK-218
RS-15-125		R-15,000	All		DRK-218

140, 141, 143, 144 & 145 Series Single Axles

Axle Model	Sub Model	Type/ Cap.#	Carriers	Notes	Kit
RS-16-140		R-16,000	L1676 M1547		DRK-4350 DRK-4345
RS-16-141		R-16,000	All		DRK-217R
RS-17-140		R-17,000	L1676 M1547		DRK-4350 DRK-4345
RS-17-141		R-17,000	All		DRK-217R
RS-17-144		R-17,000	D1850 E1851 G1879 L1676 M1885 Q1785 R1500 S1895 X1558		DRK-217R DRK-217R DRK-4390 DRK-217R DRK-217R DRK-217R DRK-224 DRK-217R DRK-4390
RS-17-145		R-17,000	All		DRK-217R
RS-19-144		R-19,000	D1850 E1851 G1879 L1676 M1885		DRK-217R DRK-217R DRK-4390 DRK-217R DRK-217R

140, 141, 143, 144 & 145 Series Single Axles

Axle Model	Sub Model	Type/ Cap.#	Carriers	Notes	Kit
RS-19-144			Q1785 R1500 S1895 X1558		DRK-217R DRK-224 DRK-217R DRK-4390
RS-19-145		R-19,000	All		DRK-217R
RS-21-145		R-21,000	D1850 E1851 G1879 L1676 M1885 Q1785 R1500 S1895 X1558		DRK-217R DRK-217R DRK-4390 DRK-217R DRK-217R DRK-217R DRK-224 DRK-217R DRK-4390

140, 141, 143, 144 & 145 Series Tandem Axles

Axle Model	Sub Model	Type/ Cap.#	Carriers	Notes	Kit
RT-34-144	RD-17-144	RF-17,000	B1978	Prior to 11/93 w/ Original 39 Spline Input	DRK-217F
	RD-17-144				
	RD-17-144		B1978	Prior to 11/93 w/ New 46 Spline Input	DRK-4395
	RD-17-144		B1978	After 11/93	DRK-4396
	RD-17-144		C1979	Prior to 11/93 w/ Original 39 Spline Input	DRK-217F
	RD-17-144		C1979	Prior to 11/93 w/ New 46 Spline Input	DRK-4395
	RD-17-144		C1979	After 11/93	DRK-4396
	RD-17-144		E1903	Prior to 11/93	DRK-4405
	RD-17-144		E1903	After 11/93	DRK-4406
	RD-17-144		E1981	Prior to 11/93	DRK-4405
	RD-17-144		E1981	After 11/93	DRK-4406
	RD-17-144		F1852	Prior to 11/93 w/ Original 39 Spline Input	DRK-217F
	RD-17-144		F1852	Prior to 11/93 w/ New 46 Spline Input	DRK-4395
	RD-17-144		F1852	After 11/93	DRK-4396
	RD-17-144		G1645	Prior to 11/93 w/ Original 39 Spline Input	DRK-217F
	RD-17-144		G1645	Prior to 11/93 w/ New 46 Spline Input	DRK-4395
	RD-17-144		G1645	After 11/93	DRK-4396
	RD-17-144		M1677	Prior to 11/93	DRK-4405
	RD-17-144		M1677	After 11/93	DRK-4406
	RD-17-144		N1860	Prior to 11/93 w/ Original 39 Spline Input	DRK-217F
	RD-17-144		N1860	Prior to 11/93 w/ New 46 Spline Input	DRK-4395
	RD-17-144		N1860	After 11/93	DRK-4396
	RD-17-144		R1890	Prior to 11/93	DRK-4405
	RD-17-144		R1890	After 11/93	DRK-4406
	RD-17-144		S1917	Prior to 11/93 w/ Original 39 Spline Input	DRK-217F
	RD-17-144		S1917	Prior to 11/93 w/ New 46 Spline Input	DRK-4395
	RD-17-144		S1917	After 11/93	DRK-4396

Heavy Duty Differential Index

HD Differential

140, 141, 143, 144 & 145 Series Tandem Axles					
Axle Model	Sub Model	Type/ Cap.#	Carriers	Notes	Kit
RT-34-144	RD-17-144		T1814	Prior to 11/93 w/ Original 39 Spline Input	DRK-217F
	RD-17-144		T1814	Prior to 11/93 w/ New 46 Spline Input	DRK-4395
	RD-17-144		T1814	After 11/93	DRK-4396
	RD-17-144		U1815	Prior to 11/93	DRK-4405
	RD-17-144		U1815	After 11/93	DRK-4406
	RP-17-144	RF-17,000	D1902	Prior to 11/93	DRK-4405
	RP-17-144		D1902	After 11/93	DRK-4406
	RP-17-144		G1853	Prior to 11/93 w/ Original 39 Spline Input	DRK-217F
	RP-17-144		G1853	Prior to 11/93 w/ New 46 Spline Input	DRK-4395
	RP-17-144		G1853	After 11/93	DRK-4396
	RP-17-144		H1984	Prior to 11/93 w/ Original 39 Spline Input	DRK-217F
	RP-17-144		H1984	Prior to 11/93 w/ New 46 Spline Input	DRK-4395
	RP-17-144		H1984	After 11/93	DRK-4396
	RP-17-144		K1987	Prior to 11/93	DRK-4405
	RP-17-144		K1987	After 11/93	DRK-4406
	RP-17-144		L1624	Prior to 11/93	DRK-4405
	RP-17-144		L1624	After 11/93	DRK-4406
	RP-17-144		P1888	Prior to 11/93	DRK-4405
	RP-17-144		P1888	After 11/93	DRK-4406
	RP-17-144		V1816	Prior to 11/93 w/ Original 39 Spline Input	DRK-217F
	RP-17-144		V1816	Prior to 11/93 w/ New 46 Spline Input	DRK-4395
	RP-17-144		V1816	After 11/93	DRK-4396
	RP-17-144		W1817	Prior to 11/93	DRK-4405
	RP-17-144		W1817	After 11/93	DRK-4406
	RP-17-144		X1662	Prior to 11/93 w/ Original 39 Spline Input	DRK-217F
	RP-17-144		X1662	Prior to 11/93 w/ New 46 Spline Input	DRK-4395
	RP-17-144		X1662	After 11/93	DRK-4396
	RR-17-144	RR-17,000	D1850		DRK-217R
	RR-17-144		E1851		DRK-217R
	RR-17-144		G1879		DRK-4390
	RR-17-144		L1676		DRK-217R
	RR-17-144		M1885		DRK-217R
	RR-17-144		Q1785		DRK-217R
	RR-17-144		S1865		DRK-217R
	RR-17-144		X1558		DRK-4390
RT-34-145		RT-34,000	All	Prior to 11/93 w/ Original 39 Spline Input	DRK-217F
	RD-17-145	RF-17,000	All	Prior to 11/93 w/ New 46 Spline Input	DRK-4395
	RD-17-145		All	After 11/93	DRK-4396
	RP-17-145	RF-17,000	All	Prior to 11/93	DRK-4395
	RP-17-145		All	After 11/93	DRK-4396
	RR-17-145	RR-17,000	All		DRK-217R
RT-38-144	RD-19-144	RF-19,000	B1978	Prior to 11/93 w/ Original 39 Spline Input	DRK-217F

140, 141, 143, 144 & 145 Series Tandem Axles					
Axle Model	Sub Model	Type/ Cap.#	Carriers	Notes	Kit
	RD-19-144		B1978	Prior to 11/93 w/ New 46 Spline Input	DRK-4395
	RD-19-144		B1978	After 11/93	DRK-4396
	RD-19-144		C1979	Prior to 11/93 w/ Original 39 Spline Input	DRK-217F
	RD-19-144		C1979	Prior to 11/93 w/ New 46 Spline Input	DRK-4395
	RD-19-144		C1979	After 11/93	DRK-4396
	RD-19-144		E1903	Prior to 11/93	DRK-4405
	RD-19-144		E1903	After 11/93	DRK-4406
	RD-19-144		E1981	Prior to 11/93	DRK-4405
	RD-19-144		E1981	After 11/93	DRK-4406
	RD-19-144		F1852	Prior to 11/93 w/ Original 39 Spline Input	DRK-217F
	RD-19-144		F1852	Prior to 11/93 w/ New 46 Spline Input	DRK-4395
	RD-19-144		F1852	After 11/93	DRK-4396
	RD-19-144		G1645	Prior to 11/93 w/ Original 39 Spline Input	DRK-217F
	RD-19-144		G1645	Prior to 11/93 w/ New 46 Spline Input	DRK-4395
	RD-19-144		G1645	After 11/93	DRK-4396
	RD-19-144		M1677	Prior to 11/93	DRK-4405
	RD-19-144		M1677	After 11/93	DRK-4406
	RD-19-144		N1860	Prior to 11/93 w/ Original 39 Spline Input	DRK-217F
	RD-19-144		N1860	Prior to 11/93 w/ New 46 Spline Input	DRK-4395
	RD-19-144		N1860	After 11/93	DRK-4396
	RD-19-144		R1890	Prior to 11/93	DRK-4405
	RD-19-144		R1890	After 11/93	DRK-4406
	RD-19-144		S1917	Prior to 11/93 w/ Original 39 Spline Input	DRK-217F
	RD-19-144		S1917	Prior to 11/93 w/ New 46 Spline Input	DRK-4395
	RD-19-144		S1917	After 11/93	DRK-4396
	RD-19-144		T1814	Prior to 11/93 w/ Original 39 Spline Input	DRK-217F
	RD-19-144		T1814	Prior to 11/93 w/ New 46 Spline Input	DRK-4395
	RD-19-144		T1814	After 11/93	DRK-4396
	RD-19-144		U1815	Prior to 11/93	DRK-4405
	RD-19-144		U1815	After 11/93	DRK-4406
	RP-19-144	RF-19,000	D1902	Prior to 11/93	DRK-4405
	RP-19-144		D1902	After 11/93	DRK-4406
	RP-19-144		G1853	Prior to 11/93 w/ Original 39 Spline Input	DRK-217F
	RP-19-144		G1853	Prior to 11/93 w/ New 46 Spline Input	DRK-4395
	RP-19-144		G1853	After 11/93	DRK-4396
	RP-19-144		H1984	Prior to 11/93 w/ Original 39 Spline Input	DRK-217F
	RP-19-144		H1984	Prior to 11/93 w/ New 46 Spline Input	DRK-4395
	RP-19-144		H1984	After 11/93	DRK-4396
	RP-19-144		K1987	Prior to 11/93	DRK-4405

Heavy Duty Differential Index

140, 141, 143, 144 & 145 Series Tandem Axles						
Axle Model	Sub Model	Type/ Cap.#	Carriers	Notes	Kit	
RT-38-144	RP-19-144		K1987	After 11/93	DRK-4406	
	RP-19-144		L1624	Prior to 11/93	DRK-4405	
	RP-19-144		L1624	After 11/93	DRK-4406	
	RP-19-144		P1888	Prior to 11/93	DRK-4405	
	RP-19-144		P1888	After 11/93	DRK-4406	
	RP-19-144		V1816	Prior to 11/93 w/ Original 39 Spline Input	DRK-217F	
	RP-19-144		V1816	Prior to 11/93 w/ New 46 Spline Input	DRK-4395	
	RP-19-144		V1816	After 11/93	DRK-4396	
	RP-19-144		W1817	Prior to 11/93	DRK-4405	
	RP-19-144		W1817	After 11/93	DRK-4406	
	RP-19-144		X1662	Prior to 11/93 w/ Original 39 Spline Input	DRK-217F	
	RP-19-144		X1662	Prior to 11/93 w/ New 46 Spline Input	DRK-4395	
	RP-19-144		X1662	After 11/93	DRK-4396	
	RR-19-144	RR-19,000	D1850		DRK-217R	
	RR-19-144		E1851		DRK-217R	
	RR-19-144		G1879		DRK-4390	
	RR-19-144		L1676		DRK-217R	
	RR-19-144		M1885		DRK-217R	
	RR-19-144		Q1785		DRK-217R	
	RR-19-144		S1865		DRK-217R	
	RR-19-144		X1558		DRK-4390	
	RT-40-140	RD-20-140	RF-20,000	All	Prior to 11/93	DRK-4355
		RD-20-140		All	After 11/93	DRK-4356
		RR-20-140	RR-20,000	All		DRK-217R
	MT-40-143	MD-20-143	RF-20,000	B1978	Prior to 11/93 w/ Original 39 Spline Input	DRK-217F
		MD-20-143		B1978	Prior to 11/93 w/ New 46 Spline Input	DRK-4395
		MD-20-143		B1978	After 11/93	DRK-4396
MD-20-143			C1979	Prior to 11/93 w/ Original 39 Spline Input	DRK-217F	
MD-20-143			C1979	Prior to 11/93 w/ New 46 Spline Input	DRK-4395	
MD-20-143			C1979	After 11/93	DRK-4396	
MD-20-143			E1903	Prior to 11/93	DRK-4405	
MD-20-143			E1903	After 11/93	DRK-4406	
MD-20-143			E1981	Prior to 11/93	DRK-4405	
MD-20-143			E1981	After 11/93	DRK-4406	
MD-20-143			F1852	Prior to 11/93 w/ Original 39 Spline Input	DRK-217F	
MD-20-143			F1852	Prior to 11/93 w/ New 46 Spline Input	DRK-4395	
MD-20-143			F1852	After 11/93	DRK-4396	
MD-20-143			G1645	Prior to 11/93 w/ Original 39 Spline Input	DRK-217F	
MD-20-143			G1645	Prior to 11/93 w/ New 46 Spline Input	DRK-4395	
MD-20-143			G1645	After 11/93	DRK-4396	
MD-20-143			M1677	Prior to 11/93	DRK-4405	
MD-20-143			M1677	After 11/93	DRK-4406	
MD-20-143			N1860	Prior to 11/93 w/ Original 39 Spline Input	DRK-217F	

140, 141, 143, 144 & 145 Series Tandem Axles					
Axle Model	Sub Model	Type/ Cap.#	Carriers	Notes	Kit
	MD-20-143		N1860	Prior to 11/93 w/ 46 Spline Input	New DRK-4395
	MD-20-143		N1860	After 11/93	DRK-4396
	MD-20-143		R1890	Prior to 11/93	DRK-4405
	MD-20-143		R1890	After 11/93	DRK-4406
	MD-20-143		S1917	Prior to 11/93 w/ Original 39 Spline Input	DRK-217F
	MD-20-143		S1917	Prior to 11/93 w/ New 46 Spline Input	DRK-4395
	MD-20-143		S1917	After 11/93	DRK-4396
	MD-20-143		T1814	Prior to 11/93 w/ Original 39 Spline Input	DRK-217F
	MD-20-143		T1814	Prior to 11/93 w/ New 46 Spline Input	DRK-4395
	MD-20-143		T1814	After 11/93	DRK-4396
	MD-20-143		U1815	Prior to 11/93	DRK-4405
	MD-20-143		U1815	After 11/93	DRK-4406
	MP-20-143	RF-20,000	D1902	Prior to 11/93	DRK-4405
	MP-20-143		D1902	After 11/93	DRK-4406
	MP-20-143		G1853	Prior to 11/93 w/ Original 39 Spline Input	DRK-217F
	MP-20-143		G1853	Prior to 11/93 w/ New 46 Spline Input	DRK-4395
	MP-20-143		G1853	After 11/93	DRK-4396
	MP-20-143		H1984	Prior to 11/93 w/ Original 39 Spline Input	DRK-217F
	MP-20-143		H1984	Prior to 11/93 w/ New 46 Spline Input	DRK-4395
	MP-20-143		H1984	After 11/93	DRK-4396
	MP-20-143		K1987	Prior to 11/93	DRK-4405
	MP-20-143		K1987	After 11/93	DRK-4406
	MP-20-143		L1624	Prior to 11/93	DRK-4405
	MP-20-143		L1624	After 11/93	DRK-4406
	MP-20-143		P1888	Prior to 11/93	DRK-4405
	MP-20-143		P1888	After 11/93	DRK-4406
	MP-20-143		V1816	Prior to 11/93 w/ Original 39 Spline Input	DRK-217F
	MP-20-143		V1816	Prior to 11/93 w/ New 46 Spline Input	DRK-4395
	MP-20-143		V1816	After 11/93	DRK-4396
	MP-20-143		W1817	Prior to 11/93	DRK-4405
	MP-20-143		W1817	After 11/93	DRK-4406
	MP-20-143		X1662	Prior to 11/93 w/ Original 39 Spline Input	DRK-217F
	MP-20-143		X1662	Prior to 11/93 w/ New 46 Spline Input	DRK-4395
	MP-20-143		X1662	After 11/93	DRK-4396
	MR-20-143	RR-20,000	All		DRK-4461
	MR-20-143M	RR-20,000	All		DRK-4461
RT-40-145	RD-20-145	RF-20,000	B1978	Prior to 11/93 w/ Original 39 Spline Input	DRK-217F
	RD-20-145		B1978	Prior to 11/93 w/ New 46 Spline Input	DRK-4395
	RD-20-145		B1978	After 11/93	DRK-4396
	RD-20-145		C1979	Prior to 11/93 w/ Original 39 Spline Input	DRK-217F
	RD-20-145		C1979	After 11/93	DRK-4396
	RD-20-145		C1979	Prior to 11/93 w/ Original 39 Spline Input	DRK-217F
	RD-20-145		C1979	After 11/93	DRK-4396

Heavy Duty Differential Index



HD Differential

140, 141, 143, 144 & 145 Series Tandem Axles

Axle Model	Sub Model	Type/ Cap.#	Carriers	Notes	Kit
RT-40-145	RD-20-145		C1979	Prior to 11/93 w/ New 46 Spline Input	DRK-4395
	RD-20-145		C1979	After 11/93	DRK-4396
	RD-20-145		E1903	Prior to 11/93	DRK-4405
	RD-20-145		E1903	After 11/93	DRK-4406
	RD-20-145		E1981	Prior to 11/93	DRK-4405
	RD-20-145		E1981	After 11/93	DRK-4406
	RD-20-145		F1852	Prior to 11/93 w/ Original 39 Spline Input	DRK-217F
	RD-20-145		F1852	Prior to 11/93 w/ New 46 Spline Input	DRK-4395
	RD-20-145		F1852	After 11/93	DRK-4396
	RD-20-145		G1645	Prior to 11/93 w/ Original 39 Spline Input	DRK-217F
	RD-20-145		G1645	Prior to 11/93 w/ New 46 Spline Input	DRK-4395
	RD-20-145		G1645	After 11/93	DRK-4396
	RD-20-145		M1677	Prior to 11/93	DRK-4405
	RD-20-145		M1677	After 11/93	DRK-4406
	RD-20-145		N1860	Prior to 11/93 w/ Original 39 Spline Input	DRK-217F
	RD-20-145		N1860	Prior to 11/93 w/ New 46 Spline Input	DRK-4395
	RD-20-145		N1860	After 11/93	DRK-4396
	RD-20-145		R1890	Prior to 11/93	DRK-4405
	RD-20-145		R1890	After 11/93	DRK-4406
	RD-20-145		S1917	Prior to 11/93 w/ Original 39 Spline Input	DRK-217F
	RD-20-145		S1917	Prior to 11/93 w/ New 46 Spline Input	DRK-4395
	RD-20-145		S1917	After 11/93	DRK-4396
	RD-20-145		T1814	Prior to 11/93 w/ Original 39 Spline Input	DRK-217F
	RD-20-145		T1814	Prior to 11/93 w/ New 46 Spline Input	DRK-4395
	RD-20-145		T1814	After 11/93	DRK-4396
	RD-20-145		U1815	Prior to 11/93	DRK-4405
	RD-20-145		U1815	After 11/93	DRK-4406
	RP-20-145	RF-20,000	D1902	Prior to 11/93	DRK-4405
	RP-20-145		D1902	After 11/93	DRK-4406
	RP-20-145		G1853	Prior to 11/93 w/ Original 39 Spline Input	DRK-217F
	RP-20-145		G1853	Prior to 11/93 w/ New 46 Spline Input	DRK-4395
	RP-20-145		G1853	After 11/93	DRK-4396
	RP-20-145		H1984	Prior to 11/93 w/ Original 39 Spline Input	DRK-217F
	RP-20-145		H1984	Prior to 11/93 w/ New 46 Spline Input	DRK-4395
	RP-20-145		H1984	After 11/93	DRK-4396
	RP-20-145		K1987	Prior to 11/93	DRK-4405
	RP-20-145		K1987	After 11/93	DRK-4406
	RP-20-145		L1624	Prior to 11/93	DRK-4405
	RP-20-145		L1624	After 11/93	DRK-4406
	RP-20-145		P1888	Prior to 11/93	DRK-4405
	RP-20-145		P1888	After 11/93	DRK-4406

140, 141, 143, 144 & 145 Series Tandem Axles

Axle Model	Sub Model	Type/ Cap.#	Carriers	Notes	Kit
	RP-20-145		V1816	Prior to 11/93 w/ Original 39 Spline Input	DRK-217F
	RP-20-145		V1816	Prior to 11/93 w/ New 46 Spline Input	DRK-4395
	RP-20-145		V1816	After 11/93	DRK-4396
	RP-20-145		W1817	Prior to 11/93	DRK-4405
	RP-20-145		W1817	After 11/93	DRK-4406
	RP-20-145		X1662	Prior to 11/93 w/ Original 39 Spline Input	DRK-217F
	RP-20-145		X1662	Prior to 11/93 w/ New 46 Spline Input	DRK-4395
	RP-20-145		X1662	After 11/93	DRK-4396
	RR-20-145	RR-20,000	D1850		DRK-217R
	RR-20-145		E1851		DRK-217R
	RR-20-145		G1879		DRK-4390
	RR-20-145		L1676		DRK-217R
	RR-20-145		M1885		DRK-217R
	RR-20-145		Q1785		DRK-217R
	RR-20-145		S1865		DRK-217R
	RR-20-145		X1558		DRK-4390
RT-44-145	RD-22-145	RF-22,000	B1874	Prior to 11/93 w/ Original 39 Spline Input	DRK-217F
	RD-22-145		B1874	Prior to 11/93 w/ New 46 Spline Input	DRK-4395
	RD-22-145		B1874	After 11/93	DRK-4396
	RD-22-145		C1875	Prior to 11/93	DRK-4405
	RD-22-145		C1875	After 11/93	DRK-4406
	RD-22-145		D1980	Prior to 11/93 w/ Original 39 Spline Input	DRK-217F
	RD-22-145		D1980	Prior to 11/93 w/ New 46 Spline Input	DRK-4395
	RD-22-145		D1980	After 11/93	DRK-4396
	RD-22-145		F1982	Prior to 11/93	DRK-4405
	RD-22-145		F1982	After 11/93	DRK-4406
	RD-22-145		G1905	Prior to 11/93	DRK-4405
	RD-22-145		G1905	After 11/93	DRK-4406
	RP-22-145	RF-22,000	D1876	Prior to 11/93 w/ Original 39 Spline Input	DRK-217F
	RP-22-145		D1876	Prior to 11/93 w/ New 46 Spline Input	DRK-4395
	RP-22-145		D1876	After 11/93	DRK-4396
	RP-22-145		E1877	Prior to 11/93	DRK-4405
	RP-22-145		E1877	After 11/93	DRK-4406
	RP-22-145		H1906	Prior to 11/93	DRK-4405
	RP-22-145		H1906	After 11/93	DRK-4406
	RP-22-145		J1986	Prior to 11/93 w/ Original 39 Spline Input	DRK-217F
	RP-22-145		J1986	Prior to 11/93 w/ New 46 Spline Input	DRK-4395
	RP-22-145		J1986	After 11/93	DRK-4396
	RP-22-145		M1911	Prior to 11/93	DRK-4405
	RP-22-145		M1911	After 11/93	DRK-4406
	RP-22-145		P1914	Prior to 11/93 w/ Original 39 Spline Input	DRK-217F
	RP-22-145		P1914	Prior to 11/93 w/ New 46 Spline Input	DRK-4395
	RP-22-145		P1914	After 11/93	DRK-4396

Heavy Duty Differential Index

140, 141, 143, 144 & 145 Series Tandem Axles

Axle Model	Sub Model	Type/ Cap.#	Carriers	Notes	Kit
RT-44-145	RP-22-145		T1918	Prior to 11/93	DRK-4405
	RP-22-145		T1918	After 11/93	DRK-4406
	RR-22-145	RR-22,000	A1873		DRK-217R
	RR-22-145		F1904		DRK-4390

160, 161 & 164 Series Single Axles

Axle Model	Sub Model	Type/ Cap.#	Carriers	Notes	Kit
RC-23-160		R-23,000	A1821		DRK-4426
			C1511		DRK-4415
			C1823		DRK-4428
			D1928		DRK-4428
			E1825		DRK-4428
			E1929		DRK-4428
			H1854		DRK-4426
			J1856		DRK-4426
			P1706		DRK-4426
			R1708		DRK-4428
			T1658		DRK-4415
			T1892		DRK-4428
			V1660		DRK-4415
			V1712		DRK-4428
			Y1897		DRK-4428
		Z1560		DRK-4415	
RS-20-160		R-20,000	A1821		DRK-4426
			C1511		DRK-4415
			C1823		DRK-4428
			D1928		DRK-4428
			E1825		DRK-4428
			E1929		DRK-4428
			H1854		DRK-4426
			J1856		DRK-4426
			P1706		DRK-4426
			R1708		DRK-4428
			T1658		DRK-4415
			T1892		DRK-4428
			V1660		DRK-4415
			V1712		DRK-4428
			Y1897		DRK-4428
		Z1560		DRK-4415	
RS-21-160		R-21,000	A1821		DRK-4426
			C1511		DRK-4415
			C1823		DRK-4428
			D1928		DRK-4428
			E1825		DRK-4428
			E1929		DRK-4428
			H1854		DRK-4426
			J1856		DRK-4426
			P1706		DRK-4426
			R1708		DRK-4428
			T1658		DRK-4415
			T1892		DRK-4428
			V1660		DRK-4415
			V1712		DRK-4428
			Y1897		DRK-4428
		Z1560		DRK-4415	
RS-23-160		R-23,000	A1821		DRK-4426
			C1511		DRK-4415
			C1823		DRK-4428
			D1928		DRK-4428
			E1825		DRK-4428
			E1929		DRK-4428
			H1854		DRK-4426

160, 161 & 164 Series Single Axles

Axle Model	Sub Model	Type/ Cap.#	Carriers	Notes	Kit
RS-23-160			J1856		DRK-4426
			P1706		DRK-4426
			R1708		DRK-4428
			T1658		DRK-4415
			T1892		DRK-4428
			V1660		DRK-4415
			V1712		DRK-4428
			Y1897		DRK-4428
			Z1560		DRK-4415
	RS-23-161		R-23,000	A1821	
			C1511		DRK-4415
			C1823		DRK-4428
			D1928		DRK-4428
			E1825		DRK-4428
			E1929		DRK-4428
			H1854		DRK-4426
			J1856		DRK-4426
			P1706		DRK-4426
			R1708		DRK-4428
			T1658		DRK-4415
			T1892		DRK-4428
			V1660		DRK-4415
			V1712		DRK-4428
			Y1897		DRK-4428
		Z1560		DRK-4415	
RS-24-160		R-24,000	A1821		DRK-4426
			C1511		DRK-4415
			C1823		DRK-4428
			D1928		DRK-4428
			E1825		DRK-4428
			E1929		DRK-4428
			H1854		DRK-4426
			J1856		DRK-4426
			P1706		DRK-4426
			R1708		DRK-4428
			T1658		DRK-4415
			T1892		DRK-4428
			V1660		DRK-4415
			V1712		DRK-4428
			Y1897		DRK-4428
		Z1560		DRK-4415	
RS-25-160		R-25,000	A1821		DRK-4426
			C1511		DRK-4415
			C1823		DRK-4428
			D1928		DRK-4428
			E1825		DRK-4428
			E1929		DRK-4428
			H1854		DRK-4426
			J1856		DRK-4426
			P1706		DRK-4426
			R1708		DRK-4428
			T1658		DRK-4415
			T1892		DRK-4428
			V1660		DRK-4415
			V1712		DRK-4428
			Y1897		DRK-4428
		Z1560		DRK-4415	
RS-26-160		R-26,000	A1821		DRK-4426
			C1511		DRK-4415
			C1823		DRK-4428
			D1928		DRK-4428
			E1825		DRK-4428
			E1929		DRK-4428
			H1854		DRK-4426

Heavy Duty Differential Index

HD Differential

160, 161 & 164 Series Single Axles

Axle Model	Sub Model	Type/ Cap.#	Carriers	Notes	Kit
RS-26-160			J1856		DRK-4426
			P1706		DRK-4426
			R1708		DRK-4428
			T1658		DRK-4415
			T1892		DRK-4428
			V1660		DRK-4415
			V1712		DRK-4428
			Y1897		DRK-4428
			Z1560		DRK-4415

160, 161 & 164 Series Tandem Axles

Axle Model	Sub Model	Type/ Cap.#	Carriers	Notes	Kit			
RT-40-160	RD-20-160	RF-20,000	J1648		DRK-4420			
			J2116		DRK-4422			
			K1857		DRK-4422			
			L2118		DRK-4423			
			M1703		DRK-4422			
			P1628		DRK-4420			
			Q1837		DRK-4422			
			W1713		DRK-4423			
			W1895		DRK-4423			
			X1818		DRK-4422			
	Y1819		DRK-4423					
	RP-20-160	RF-20,000	K1701		DRK-4423			
			K2117		DRK-4423			
			V1894		DRK-4423			
			Z1820		DRK-4423			
			RR-20-160	RR-20,000	A1821		DRK-4426	
					C1511		DRK-4415	
					C1823		DRK-4428	
					D1928		DRK-4428	
					E1825		DRK-4428	
					E1929		DRK-4428	
	H1854				DRK-4426			
	J1856				DRK-4426			
	P1706				DRK-4426			
	R1708				DRK-4428			
	RR-20-160	RR-20,000	T1658		DRK-4415			
			T1892		DRK-4428			
			V1660		DRK-4415			
			V1712		DRK-4428			
			Y1897		DRK-4428			
			Z1560		DRK-4415			
			RT-46-160	RD-23-160	RF-23,000	J1648		DRK-4420
						J2116		DRK-4422
K1857							DRK-4422	
L2118							DRK-4423	
M1703		DRK-4422						
P1628		DRK-4420						
Q1837		DRK-4422						
W1713		DRK-4423						
W1895		DRK-4423						
X1818		DRK-4422						
Y1819		DRK-4423						
RP-23-160	RF-23,000	K1701					DRK-4423	
RP-23-160	RF-23,000	K2117		DRK-4423				
RP-23-160	RF-23,000	V1894		DRK-4423				
RP-23-160	RF-23,000	Z1820		DRK-4423				
RR-23-160	RR-23,000	A1821		DRK-4426				
		C1511		DRK-4415				
		C1823		DRK-4428				
		D1928		DRK-4428				

160, 161 & 164 Series Tandem Axles

Axle Model	Sub Model	Type/ Cap.#	Carriers	Notes	Kit			
RT-46-160	RR-23-160		E1825		DRK-4428			
			E1929		DRK-4428			
			H1854		DRK-4426			
			J1856		DRK-4426			
			P1706		DRK-4426			
			R1708		DRK-4428			
			T1658		DRK-4415			
			T1892		DRK-4428			
			V1660		DRK-4415			
			V1712		DRK-4428			
			Y1897		DRK-4428			
			Z1560		DRK-4415			
			RT-46-164	RD-23-164	RF-23,000	J1648		DRK-4420
						J2116		DRK-4422
						K1857		DRK-4422
L2118		DRK-4423						
M1703		DRK-4422						
P1628		DRK-4420						
Q1837		DRK-4422						
W1713		DRK-4423						
W1895		DRK-4423						
X1818		DRK-4422						
Y1819		DRK-4423						
RP-23-164	RF-23,000	K1701					DRK-4423	
RP-23-164	RF-23,000	K2117					DRK-4423	
RP-23-164	RF-23,000	V1894					DRK-4423	
RP-23-164	RF-23,000	Z1820					DRK-4423	
RR-23-164	RR-23,000		A1821		DRK-4426			
			C1511		DRK-4415			
			C1823		DRK-4428			
			D1928		DRK-4428			
			E1825		DRK-4428			
			E1929		DRK-4428			
			H1854		DRK-4426			
			J1856		DRK-4426			
			P1706		DRK-4426			
			R1708		DRK-4428			
			T1658		DRK-4415			
			T1892		DRK-4428			
			V1660		DRK-4415			
			V1712		DRK-4428			
			Y1897		DRK-4428			
Z1560		DRK-4415						
RT-50-160	RD-25-160	RF-25,000	J1648		DRK-4420			
			J2116		DRK-4422			
			K1857		DRK-4422			
			L2118		DRK-4423			
			M1703		DRK-4422			
			P1628		DRK-4420			
			Q1837		DRK-4422			
			W1713		DRK-4423			
			W1895		DRK-4423			
			X1818		DRK-4422			
			Y1819		DRK-4423			
			RP-25-160	RF-25,000	K1701		DRK-4423	
			RP-25-160	RF-25,000	K2117		DRK-4423	
			RP-25-160	RF-25,000	V1894		DRK-4423	
			RP-25-160	RF-25,000	Z1820		DRK-4423	
RR-25-160	RR-25,000		A1821		DRK-4426			
			C1511		DRK-4415			
			C1823		DRK-4428			
			D1928		DRK-4428			
			E1825		DRK-4428			
			E1929		DRK-4428			

Heavy Duty Differential Index

160, 161 & 164 Series Tandem Axles

Axle Model	Sub Model	Type/ Cap.#	Carriers	Notes	Kit
RT-50-160	RR-25-160		H1854		DRK-4426
	RR-25-160		J1856		DRK-4426
	RR-25-160		P1706		DRK-4426
	RR-25-160		R1708		DRK-4428
	RR-25-160		T1658		DRK-4415
	RR-25-160		T1892		DRK-4428
	RR-25-160		V1660		DRK-4415
	RR-25-160		V1712		DRK-4428
	RR-25-160		Y1897		DRK-4428
	RR-25-160		Z1560		DRK-4415
	RT-50-164	RD-25-164	RF-25,000	J1648	
RD-25-164			J2116		DRK-4422
RD-25-164			K1857		DRK-4422
RD-25-164			L2118		DRK-4423
RD-25-164			M1703		DRK-4422
RD-25-164			P1628		DRK-4420
RD-25-164			Q1837		DRK-4422
RD-25-164			W1713		DRK-4423
RD-25-164			W1895		DRK-4423
RD-25-164			X1818		DRK-4422
RD-25-164			Y1819		DRK-4423
RP-25-164		RF-25,000	K1701		DRK-4423
RP-25-164			K2117		DRK-4423
RP-25-164			V1894		DRK-4423
RP-25-164			Z1820		DRK-4423
RR-25-164		RR-25,000	A1821		DRK-4426
RR-25-164			C1511		DRK-4415
RR-25-164		C1823		DRK-4428	
RR-25-164		D1928		DRK-4428	
RR-25-164		E1825		DRK-4428	
RR-25-164		E1929		DRK-4428	
RR-25-164		H1854		DRK-4426	
RR-25-164		J1856		DRK-4426	
RR-25-164		P1706		DRK-4426	
RR-25-164		R1708		DRK-4428	
RR-25-164		T1658		DRK-4415	
RR-25-164		T1892		DRK-4428	
RR-25-164		V1660		DRK-4415	
RR-25-164		V1712		DRK-4428	
RR-25-164		Y1897		DRK-4428	
RR-25-164		Z1560		DRK-4415	
RT-52-160	RD-26-160	RF-26,000	J1648		DRK-4420
	RD-26-160		J2116		DRK-4422
	RD-26-160		K1857		DRK-4422
	RD-26-160		L2118		DRK-4423
	RD-26-160		M1703		DRK-4422
	RD-26-160		P1628		DRK-4420
	RD-26-160		Q1837		DRK-4422
	RD-26-160		W1713		DRK-4423
	RD-26-160		W1895		DRK-4423
	RD-26-160		X1818		DRK-4422
	RD-26-160		Y1819		DRK-4423
	RP-26-160	RF-26,000	K1701		DRK-4423
	RP-26-160		K2117		DRK-4423
	RP-26-160		V1894		DRK-4423
	RP-26-160		Z1820		DRK-4423
	RR-26-160	RR-26,000	A1821		DRK-4426
	RR-26-160		C1511		DRK-4415
	RR-26-160		C1823		DRK-4428
	RR-26-160		D1928		DRK-4428
	RR-26-160		E1825		DRK-4428
	RR-26-160		E1929		DRK-4428
	RR-26-160		H1854		DRK-4426
	RR-26-160		J1856		DRK-4426
RR-26-160		P1706		DRK-4426	
RR-26-160		R1708		DRK-4428	
RR-26-160		T1658		DRK-4415	
RR-26-160		T1892		DRK-4428	
RR-26-160		V1660		DRK-4415	
RR-26-160		V1712		DRK-4428	
RR-26-160		Y1897		DRK-4428	
RR-26-160		Z1560		DRK-4415	

160, 161 & 164 Series Tandem Axles

Axle Model	Sub Model	Type/ Cap.#	Carriers	Notes	Kit	
RT-52-160	RR-26-160		P1706		DRK-4426	
	RR-26-160		R1708		DRK-4428	
	RR-26-160		T1658		DRK-4415	
	RR-26-160		T1892		DRK-4428	
	RR-26-160		V1660		DRK-4415	
	RR-26-160		V1712		DRK-4428	
	RR-26-160		Y1897		DRK-4428	
	RR-26-160		Z1560		DRK-4415	
	RT-52-164	RD-26-164	RF-26,000	J1648		DRK-4420
		RD-26-164		J2116		DRK-4422
		RD-26-164		K1857		DRK-4422
RD-26-164			L2118		DRK-4423	
RD-26-164			M1703		DRK-4422	
RD-26-164			P1628		DRK-4420	
RD-26-164			Q1837		DRK-4422	
RD-26-164			W1713		DRK-4423	
RD-26-164			W1895		DRK-4423	
RD-26-164			X1818		DRK-4422	
RD-26-164			Y1819		DRK-4423	
RP-26-164		RF-26,000	K1701		DRK-4423	
RP-26-164			K2117		DRK-4423	
RP-26-164			V1894		DRK-4423	
RP-26-164			Z1820		DRK-4423	
RR-26-164		RR-26,000	A1821		DRK-4426	
RR-26-164			C1511		DRK-4415	
RR-26-164		C1823		DRK-4428		
RR-26-164		D1928		DRK-4428		
RR-26-164		E1825		DRK-4428		
RR-26-164		E1929		DRK-4428		
RR-26-164		H1854		DRK-4426		
RR-26-164		J1856		DRK-4426		
RR-26-164		P1706		DRK-4426		
RR-26-164		R1708		DRK-4428		
RR-26-164		T1658		DRK-4415		
RR-26-164		T1892		DRK-4428		
RR-26-164		V1660		DRK-4415		
RR-26-164		V1712		DRK-4428		
RR-26-164		Y1897		DRK-4428		
RR-26-164		Z1560		DRK-4415		

180, 185, 186 & 380 Series Single Axles

Axle Model	Sub Model	Type/ Cap.#	Carriers	Notes	Kit
RS-23-180		R-23,000	A1899	6.83, 7.17, 7.40 & 7.83 Ratios	DRK-4438
			A1899	All Other Ratios	DRK-4437
			C1381	6.83, 7.17, 7.40 & 7.83 Ratios	DRK-4436
			C1381	All Other Ratios	DRK-4435
			J1804	6.83, 7.17, 7.40 & 7.83 Ratios	DRK-4438
			J1804	All Other Ratios	DRK-4437
			K1753	6.83, 7.17, 7.40 & 7.83 Ratios	DRK-4436
			K1753	All Other Ratios	DRK-4435
			U1399	6.83, 7.17, 7.40 & 7.83 Ratios	DRK-4436
			U1399	All Other Ratios	DRK-4435
			W1791	6.83, 7.17, 7.40 & 7.83 Ratios	DRK-4438
RS-23-185		R-23,000	A1899	6.83, 7.17, 7.40 & 7.83 Ratios	DRK-4438
			A1899	All Other Ratios	DRK-4437

Heavy Duty Differential Index

HD Differential

Out of Production Double Reduction Axles

Axle Model	Sub Model	Type/ Cap.#	Carriers	Notes	Kit
SFDD4640	FDD		3200C122		DRK-4260
	FDD		5		
	FDD		3800F604		DRK-4255
	FDR		3200C122		DRK-4270
	FDR		5		
	FDR		3800F604		DRK-1910
SQDD	QDD		3800E473		DRK-4180
	QDD		3800H554		DRK-4180
	QDR		3800K557		DRK-11R
SRDD	RDD	RF-22,000	3200D122		DRK-4220
	RDD		6		
	RDD		3800A755		DRK-11FA
	RDD		3800H554		DRK-11FA
	RDR	RR-22,000	3200D122		DRK-4190
	RDR		6		
	RDR		3800A755		DRK-11R
	RDR		3800E473		DRK-11R
	RDR		3800H554		DRK-11R
STDD	TDD	RF-25,000	3200D122		DRK-4220
	TDD		6		
	TDD		3800D758		DRK-187F
	TDR	RR-25,000	3200D122		DRK-4190
	TDR		6		
	TDR		3800D758		DRK-187R
SUDD	UDD	RF-29,000	3200E122		DRK-204F
	UDD		7		
	UDD		3800G579		DRK-4245
	UDR	RR-29,000	3800G579		DRK-4240

Out of Production Single Reduction Single Axles

Axle Model	Sub Model	Type/ Cap.#	Carriers	Notes	Kit
59722					DRK-2108
59723					DRK-2108
59733					DRK-2108
C100					DRK-2111
C102					DRK-2111
C103					DRK-2111
D140		R-13,000	A1093	Prior to 1985	DRK-4290
			A1093	Prior to 1985	DRK-4295
			A1093	After 1985	DRK-4300
			R1110	After 1985	DRK-4300
F105		R-15,000			DRK-4315
F106		R-15,000			DRK-4315
F140		R-15,000			DRK-4310
F145		R-15,000			DRK-4310
F146		R-15,000			DRK-4310
F147		R-15,000			DRK-4310
F149		R-15,000			DRK-4310
H120		R-17,000		3.55 - 4.63 Ratios	DRK-9RC
H140		R-17,000			DRK-1918
H170		R-17,000			DRK-4325
H172		R-17,000			DRK-4330
H173		R-17,000			DRK-4330
L100		R-18,500		3.55 - 4.63 Ratios	DRK-9RC
L100A		R-18,500		3.55 - 4.63 Ratios	DRK-9RC
		R-18,500		Ratios above 4.63	DRK-9RB
L101		R-18,500		3.55 - 4.63 Ratios	DRK-9RC
L110		R-18,500		3.55 - 4.63 Ratios	DRK-9RC
L110A		R-18,500		3.55 - 4.63 Ratios	DRK-9RC
L140		R-18,500			DRK-1926
L145		R-18,500			DRK-1926
L172		R-18,500			DRK-4330

Out of Production Single Reduction Single Axles

Axle Model	Sub Model	Type/ Cap.#	Carriers	Notes	Kit
L173		R-18,500			DRK-4330
P174		R-20,000			DRK-4330
PL143		R-18,500			DRK-172R
QT140		R-22,000			DRK-600
QT143		R-22,000			DRK-600
QT145		R-22,000			DRK-600
QT148		R-22,000			DRK-600
R100		R-23,000			DRK-172R
R100A		R-23,000			DRK-172R
R110		R-23,000			DRK-172R
R110A		R-23,000			DRK-172R
R112		R-23,000			DRK-172R
R113		R-23,000			DRK-172R
R114		R-23,000			DRK-172R
R115		R-23,000			DRK-172R
R120		R-23,000			DRK-172R
R140		R-23,000			DRK-172R
R141		R-23,000			DRK-172R
R143		R-23,000			DRK-172R
R155		R-23,000			DRK-172R
R162		R-23,000	A1431		DRK-1984
		R-23,000	C679		DRK-1984
		R-23,000	Z1430		DRK-1984
		R-23,000	Z806		DRK-1984
R164		R-23,000	A1431		DRK-1984
		R-23,000	C679		DRK-1984
		R-23,000	Z1430		DRK-1984
		R-23,000	Z806		DRK-1984
R170		R-23,000		Prior to 12/1/83 Exc. 7.40 Ratio	DRK-50
R171		R-23,000			DRK-50A
R173		R-23,000			DRK-50A
R200		R-23,000		Old Style	DRK-1925
		R-23,000		New Style	DRK-1925A
RL170		R-20,000		Prior to 12/1/83 Exc. 7.40 Ratio	DRK-50
RT140		R-23,000			DRK-172R
S162		R-23,000	A1431		DRK-1984
		R-23,000	C679		DRK-1984
		R-23,000	Z1430		DRK-1984
		R-23,000	Z806		DRK-1984
S170		R-26,000		Prior to 12/1/83 Exc. 7.40 Ratio	DRK-50
U140		R-23,000			DRK-172R
U240		R-29,000		Old Style	DRK-1925
		R-29,000		New Style	DRK-1925A
U340		R-29,000		Old Style	DRK-1925
		R-29,000		New Style	DRK-1925A
W170		R-36-38,000			DRK-50

Out of Production Single Reduction Tandem Axles

Axle Model	Sub Model	Type/ Cap.#	Carriers	Notes	Kit
SL100	LD100	RF-17,000			DRK-194F
	LR100	RR-17,000			DRK-194RB
SL100P	LP100	RF-17,000			DRK-194F
	LR100	RR-17,000			DRK-194RB
SLHD	LHD	RF-17,000		3.55 - 4.63 Ratios	DRK-900F
	LHR	RR-17,000		3.55 - 4.63 Ratios	DRK-9RC
SQ100	QD100	RF-20,000			DRK-194F
	QR100	RR-20,000			DRK-194RB
SQ100P	QP100	RF-20,000			DRK-194F
	QR100	RR-20,000			DRK-194RB

Heavy Duty Differential Index

Out of Production Single Reduction Tandem Axles					
Axle Model	Sub Model	Type/Cap.#	Carriers	Notes	Kit
SQHD	QHD	RF-20,000		3.55 - 4.63 Ratios	DRK-900F
	QHR	RR-20,000		3.55 - 4.63 Ratios	DRK-9RC
SQHP	QAR	RR-20,000			DRK-194RA
	QHP	RF-20,000			DRK-194F
SQR100	QRD100	RF-22,000			DRK-194F
	QRR100	RR-22,000			DRK-194RB
SQR100P	QRP100	RF-22,000			DRK-194F
	QRR100	RR-22,000			DRK-194RB
SR170	R170		G1255	7.40 Ratio Only	DRK-4125
	R170		G1255	All ratios Exc. 7.40	DRK-203F
	R170		M1625	7.40 Ratio Only	DRK-4145
	R170		M1625	All ratios Exc. 7.40	DRK-4140
	R170		X1324	All ratios Exc. 7.40	DRK-4135
	R170R	RR-24,000		7.40 Ratio Only	DRK-4130
SR270	R270	RF-24,000	G1255	7.40 Ratio Only	DRK-4125
	R270		G1255	All ratios Exc. 7.40	DRK-203F
	R270		J1076	7.40 Ratio Only	DRK-4125
	R270		J1076	All ratios Exc. 7.40	DRK-203F
	R270		M1625	7.40 Ratio Only	DRK-4145
	R270		M1625	All ratios Exc. 7.40	DRK-4140
	R270		X1324	All ratios Exc. 7.40	DRK-4135
	R270R	RR-24,000	M1625	7.40 Ratio Only	DRK-4155A
	R270R		M1625	All ratios Exc. 7.40	DRK-4155
SR280	R280	RF-24,000	G1255	7.40 Ratio Only	DRK-4125
	R280		G1255	All ratios Exc. 7.40	DRK-203F
	R280		J1076	7.40 Ratio Only	DRK-4125
	R280		J1076	All ratios Exc. 7.40	DRK-203F
	R280		M1625	7.40 Ratio Only	DRK-4145
	R280		M1625	All ratios Exc. 7.40	DRK-4140
	R280		X1324	All ratios Exc. 7.40	DRK-4135
	R280R	RR-24,000	M1625	7.40 Ratio Only	DRK-4155A
	R280R		M1625	All ratios Exc. 7.40	DRK-4155
SSHD	SHD	RF-23,000		Ball Bearing Input & Output Shaft	DRK-172F
	SHD				
	SHR	RR-23,000		Early Style Seal	DRK-172R
SSHP	SHP	RF-23,000		Ball Bearing Input & Output Shaft	DRK-172F
	SHP				
	SHP	RF-23,000		Taper Bearing Input Output Shaft w/ Upgraded O/S Seal	DRK-4095
	SHP				
	SHR	RR-23,000		Early Style Seal	DRK-172R
STHD	THD	RF-25,000		Ball Bearing Input & Output Shaft	DRK-172F
	THD				
	THR	RR-25,000		Early Style Seal	DRK-172R
SU170	U170	RF-29,000	G1255	7.40 Ratio Only	DRK-4125
	U170		G1255	All ratios Exc. 7.40	DRK-203F
	U170		M1625	7.40 Ratio Only	DRK-4145
	U170		M1625	All ratios Exc. 7.40	DRK-4140
	U170		X1324	All ratios Exc. 7.40	DRK-4135
	U170R	RR-29,000		7.40 Ratio Only	DRK-4130
SU270	U270	RF-29,000	G1255	7.40 Ratio Only	DRK-4125
	U270		G1255	All ratios Exc. 7.40	DRK-203F
	U270		J1076	7.40 Ratio Only	DRK-4125
	U270		J1076	All ratios Exc. 7.40	DRK-203F
	U270		M1625	7.40 Ratio Only	DRK-4145
	U270		M1625	All ratios Exc. 7.40	DRK-4140
	U270	RF-29,000	X1324	All ratios Exc. 7.40	DRK-4135
	U270R	RR-29,000	M1625	7.40 Ratio Only	DRK-4155A
	U270R		M1625	All ratios Exc. 7.40	DRK-4155
SU280	U280	RF-29,000	G1255	7.40 Ratio Only	DRK-4125
	U280		G1255	All ratios Exc. 7.40	DRK-203F
	U280		J1076	7.40 Ratio Only	DRK-4125
	U280		J1076	All ratios Exc. 7.40	DRK-203F
	U280		M1625	7.40 Ratio Only	DRK-4145

Out of Production Single Reduction Tandem Axles					
Axle Model	Sub Model	Type/Cap.#	Carriers	Notes	Kit
SU280	U280		M1625	All ratios Exc. 7.40	DRK-4140
	U280		X1324	All ratios Exc. 7.40	DRK-4135
	U280R	RR-29,000	M1625	7.40 Ratio Only	DRK-4155A
	U280R		M1625	All ratios Exc. 7.40	DRK-4155
SUHD	UHD	RF-29,000		Ball Bearing Input & Output Shaft	DRK-172F
	UHD				
	UHR	RR-29,000		Early Style Seal	DRK-172R
SW170	W170	RF-35,000	G1255	7.40 Ratio Only	DRK-4125
	W170		G1255	All ratios Exc. 7.40	DRK-203F
	W170		J1076	7.40 Ratio Only	DRK-4125
	W170	RF-35,000	J1076	All ratios Exc. 7.40	DRK-203F
	W170		M1625	7.40 Ratio Only	DRK-4145
	W170		M1625	All ratios Exc. 7.40	DRK-4140
	W170		X1324	All ratios Exc. 7.40	DRK-4135
	W170R	RR-34,000		7.40 Ratio Only	DRK-4130
SW270	W270	RF-35,000	G1255	7.40 Ratio Only	DRK-4125
	W270		G1255	All ratios Exc. 7.40	DRK-203F
	W270		J1076	7.40 Ratio Only	DRK-4125
	W270		J1076	All ratios Exc. 7.40	DRK-203F
	W270		M1625	7.40 Ratio Only	DRK-4145
	W270		M1625	All ratios Exc. 7.40	DRK-4140
	W270		X1324	All ratios Exc. 7.40	DRK-4135
	W270R	RR-34,000	M1625	7.40 Ratio Only	DRK-4155A
	W270R		M1625	All ratios Exc. 7.40	DRK-4155
SW280	W280	RF-35,000	G1255	7.40 Ratio Only	DRK-4125
	W280		G1255	All ratios Exc. 7.40	DRK-203F
	W280		J1076	7.40 Ratio Only	DRK-4125
	W280		J1076	All ratios Exc. 7.40	DRK-203F
	W280		M1625	7.40 Ratio Only	DRK-4145
	W280		M1625	All ratios Exc. 7.40	DRK-4140
	W280		X1324	All ratios Exc. 7.40	DRK-4135
	W280R	RR-34,000	M1625	7.40 Ratio Only	DRK-4155A
	W280R		M1625	All ratios Exc. 7.40	DRK-4155

Volvo Index

Axle Model	Type/Cap.#	Comments	Kit
EV-80	Front		DRK-801
	Rear		DRK-802
EV-87	Front		DRK-801
	Rear		DRK-802

White Index

Axle Model	Type/Cap.#	Comments	Kit
124C	R-21,000		DRK-111
134C	R-23,000		DRK-111

Differential Rebuild Kits

HD Differential

DRK-1		
Position	Part Number	Qty
Differential Right Brg.	497-493	1
Differential Left Brg.	56425-56650	1
Pinion Head Brg.	55200C-55437	1
Pinion Tail Brg.	55200C-55437	1
Pinion Nose Brg.	MUSB1307UM	1
Electric Shift Brg.	200SL •	1
Pinion Seal	DT7721	1
Sealer	RTV Silicone	1

DRK-1A		
Position	Part Number	Qty
Differential Right Brg.	497-493	1
Differential Left Brg.	567-563	1
Pinion Head Brg.	55200C-55437	1
Pinion Tail Brg.	55200C-55437	1
Pinion Nose Brg.	MUSB1307UM	1
Pinion Seal	DT7721	1
Sealer	RTV Silicone	1

DRK-9F		
Position	Part Number	Qty
Differential Right Brg.	496-493	1
Differential Left Brg.	496-493	1
Pinion Head Brg.	72200C-72487	1
Pinion Tail Brg.	72200C-72487	1
Pinion Nose Brg.	MU1306TDM	1
Drive Gear Front Brg.	29675-29630	1
Drive Gear Rear Brg.	29675-29630	1
Idler Gear Brg.	31597-31520	2
Input Shaft Brg.	211B	1
Thrushaft Brg.	209 •	1
Pinion Seal	35949N (29288)	1
Thrushaft Seal	475322N (27295)	1
Sealer	RTV Silicone	1

DRK-9R		
Position	Part Number	Qty
Differential Right Brg.	496-493	1
Differential Left Brg.	496-493	1
Pinion Head Brg.	72200C-72487	1
Pinion Tail Brg.	72188C-72487	1
Pinion Nose Brg.	MU1306TDM	1
Pinion Seal	35009N (27452)	1
Sealer	RTV Silicone	1

DRK-9RB		
Position	Part Number	Qty
Differential Right Brg.	496-493	1
Differential Left Brg.	496-493	1
Pinion Head Brg.	72200C-72487	1
Pinion Tail Brg.	72188C-72487	1
Pinion Nose Brg.	RU1570UM	1
Pinion Seal	35009N (27452)	1
Sealer	RTV Silicone	1

DRK-9RC		
Position	Part Number	Qty
Differential Right Brg.	496-493	1
Differential Left Brg.	497-493	1
Pinion Head Brg.	72200C-72487	1
Pinion Tail Brg.	72188C-72487	1
Pinion Nose Brg.	RU1570UM	1
Pinion Seal	35009N (27452)	1
Sealer	RTV Silicone	1

DRK-11FA		
Position	Part Number	Qty
Differential Right Brg.	581-572	1
Differential Left Brg.	581-572	1
Pinion Head Brg.	42350-42584	1
Pinion Tail Brg.	497-493	1
Pinion Nose Brg.	MR1212EL	1
Cross Shaft Right Brg.	66225-66462	2
Cross Shaft Left Brg.	MU1218TDHM	1
Cross Shaft Left Brg.	5212W	1
Thrushaft Brg.	212	1
Input Shaft Seal	415086N (30055)	1
Thrushaft Seal	415086N (30055)	1
Sealer	RTV Silicone	1

DRK-11R		
Position	Part Number	Qty
Differential Right Brg.	581-572	1
Differential Left Brg.	581-572	1
Pinion Head Brg.	42350-42584	1
Pinion Tail Brg.	497-493	1
Pinion Nose Brg.	MR1212EL	1
Cross Shaft Right Brg.	66225-66462	2
Cross Shaft Left Brg.	MU1218TDHM	1
Pinion Seal	3592 (30144)	1
Pinion Seal	475012N (29322)	1
Sealer	RTV Silicone	1

DRK-18D		
Position	Part Number	Qty
Differential Right Brg.	42381-42584	1
Differential Left Brg.	665-653	1
Pinion Head Brg.	78215C-78551	1
Pinion Tail Brg.	72212C-72487	1
Pinion Nose Brg.	MU1309JGM	1
Pinion Seal	712937 (29471)	1
Sealer	RTV Silicone	1

DRK-18E		
Position	Part Number	Qty
Differential Right Brg.	42381-42584	1
Differential Left Brg.	665-653	1
Pinion Head Brg.	78215C-78551 ¹	1
Pinion Tail Brg.	72212C-72487	1
Pinion Nose Brg.	MU1308UM	1
Pinion Seal	712937 (29471)	1
Sealer	RTV Silicone	1

DRK-23		
Position	Part Number	Qty
Differential Right Brg.	495A-493	1
Differential Left Brg.	42381-42584	1
Pinion Head Brg.	HM903249-HM903210	1
Pinion Tail Brg.	HM903249-HM903210	1
Pinion Nose Brg.	MUSB1307UM	1
Electric Shift Brg.	200SL •	1
Pinion Seal (2.375" Shaft)	712375 (23857)	1
Pinion Seal (2.625" Shaft)	712625 (26358)	1
Sealer	RTV Silicone	1

DRK-23B		
Position	Part Number	Qty
Differential Right Brg.	3994-3920	1
Differential Left Brg.	567-563	1
Pinion Head Brg.	HM903249-HM903210	1
Pinion Tail Brg.	HM903249-HM903210	1
Pinion Nose Brg.	MUSB1307UM	1
Pinion Seal (2.375" Shaft)	712375 (23857)	1
Pinion Seal (2.625" Shaft)	712625 (26358)	1
Sealer	RTV Silicone	1

DRK-23D		
Position	Part Number	Qty
Differential Right Brg.	495A-493	1
Differential Left Brg.	42381-42584	1
Pinion Head Brg.	55175C-55437	1
Pinion Tail Brg.	55175C-55437	1
Pinion Nose Brg.	MUSB1307UM	1
Electric Shift Brg.	200SL •	1
Pinion Seal (2.375" Shaft)	475095N (23770)	1
Pinion Seal (2.625" Shaft)	9773 (26373)	1
Sealer	RTV Silicone	1

DRK-24		
Position	Part Number	Qty
Differential Right Brg.	33275-33472	1
Differential Left Brg.	498-493 ²⁵	1
Pinion Head Brg.	HM903249-HM903210	1
Pinion Tail Brg.	HM903249-HM903210	1
Pinion Nose Brg.	MU1305TDM	1
Electric Shift Brg.	200SL •	1
Pinion Seal (2.250" x 3.194")	470737N (22425)	1
Pinion Seal (2.250" x 4.069")	722250 (22653)	1
Pinion Seal (2.625" x 4.069")	712625 (26358)	1
Sealer	RTV Silicone	1

DRK-50		
Position	Part Number	Qty
Differential Right Brg.	598-592A	1
Differential Left Brg.	52387-52618	1
Pinion Head Brg.	H715343-H715311	1
Pinion Tail Brg.	H715334-H715311	1
Pinion Nose Brg.	MUB1309TM	1
Pinion Seal	415086N (30055)	1
Sealer	RTV Silicone	1

DRK-50A		
Position	Part Number	Qty
Differential Right Brg.	598-592A	1
Differential Left Brg.	52387-52618	1
Pinion Head Brg.	H715343-H715311	1
Pinion Tail Brg.	HM813843-HM813810	1
Pinion Nose Brg.	MUB1309TM	1
Pinion Seal	415086N (30055)	1
Sealer	RTV Silicone	1

DRK-64F		
Position	Part Number	Qty
Differential Right Brg.	56425-56650	1
Differential Left Brg.	497-493	1
Pinion Head Brg.	72200C-72487	1
Pinion Tail Brg.	72200C-72487	1
Pinion Nose Brg.	MUSB1307UM	1
Input Shaft Front Brg.	311	1
Output Shaft Front Brg.	34274-34492A	1
Output Shaft Rear Brg.	MA1209EL	1
Input Shaft Seal	DT7720	1
Thrushaft Seal	DT7720	1
Felt Seal	5M867 (654) •	1
Sealer	RTV Silicone	1

Differential Rebuild Kits

HD Differential

DRK-64FC		
Position	Part Number	Qty
Differential Right Brg.	567-563	1
Differential Left Brg.	497-493	1
Pinion Head Brg.	72200C-72487	1
Pinion Tail Brg.	72200C-72487	1
Pinion Nose Brg.	MUSB1307UM	1
Input Shaft Front Brg.	311	1
Output Shaft Front Brg.	34274-34492A	1
Output Shaft Rear Brg.	MA1209EL	1
Input Shaft Seal	DT7720	1
Thrushaft Seal	DT7720	1
Felt Seal	5M867 (654) •	1
Sealer	RTV Silicone	1

DRK-64FD		
Position	Part Number	Qty
Differential Right Brg.	567-563	1
Differential Left Brg.	497-493	1
Pinion Head Brg.	72200C-72487	1
Pinion Tail Brg.	72200C-72487	1
Pinion Nose Brg.	MUSB1307UM	1
Input Shaft Front Brg.	JM207049-JM207010	1
Output Shaft Front Brg.	34274-34492A	1
Output Shaft Rear Brg.	MA1209EL	1
Input Shaft Seal	DT7720	1
Thrushaft Seal	DT7720	1
Felt Seal	5M867 (654) •	1
Sealer	RTV Silicone	1

DRK-64FE		
Position	Part Number	Qty
Differential Right Brg.	56425-56650	1
Differential Left Brg.	497-493	1
Pinion Head Brg.	72200C-72487	1
Pinion Tail Brg.	72200C-72487	1
Pinion Nose Brg.	MUSB1307UM	1
Input Shaft Front Brg.	JM207049-JM207010	1
Output Shaft Front Brg.	34274-34492A	1
Output Shaft Rear Brg.	MA1209EL	1
Input Shaft Seal	DT7720	1
Thrushaft Seal	DT7720	1
Felt Seal	5M867 (654) •	1
Sealer	RTV Silicone	1

DRK-72		
Position	Part Number	Qty
Differential Right Brg.	42346-42584	1
Differential Left Brg.	68450-68712 ²	1
Pinion Head Brg.	72212C-72487	1
Pinion Tail Brg.	72212C-72487	1
Pinion Nose Brg.	MUB1308UM	1
Electric Shift Brg.	200SL •	1
Pinion Seal	475003N (26220)	1
Felt Seal	5M867 (654) •	1
Sealer	RTV Silicone	1

DRK-72A		
Position	Part Number	Qty
Differential Right Brg.	42346-42584	1
Differential Left Brg.	68450-68712	1
Pinion Head Brg.	78215C-78551	1
Pinion Tail Brg.	72212C-72487	1
Pinion Nose Brg.	MUB1308UM	1
Pinion Seal	712937 (29471)	1
Sealer	RTV Silicone	1

DRK-72B		
Position	Part Number	Qty
Differential Right Brg.	42346-42584	1
Differential Left Brg.	68462-68712	1
Pinion Head Brg.	78215C-78551	1
Pinion Tail Brg.	72212C-72487	1
Pinion Nose Brg.	MUB1308UM	1
Pinion Seal	712937 (29471)	1
Sealer	RTV Silicone	1

DRK-111		
Position	Part Number	Qty
Differential Right Brg.	685-672	1
Differential Left Brg.	685-672	1
Pinion Head Brg.	H913842-H913810	1
Pinion Tail Brg.	HM911245-HM911210	1
Pinion Nose Brg.	MUC1309UM	1
Pinion Seal	416470N (32385)	1
Sealer	RTV Silicone	1

DRK-117		
Position	Part Number	Qty
Differential Right Brg.	598A-592A	1
Differential Left Brg.	598A-592A	1
Pinion Head Brg.	H715340-H715310	1
Pinion Tail Brg.	65212-65500	1
Cross Shaft Right Brg.	6379-6320	1
Cross Shaft Left Brg.	6379-6320	1
Pinion Seal	35009N (27452)	1
Pinion Seal (2 Speed)	476283N (27601)	1
O-Ring	OR250	1
O-Ring	OR262	1
Sealer	RTV Silicone	1

DRK-117A		
Position	Part Number	Qty
Differential Right Brg.	598-592A	1
Differential Left Brg.	598-592A	1
Pinion Head Brg.	H715340-H715310	1
Pinion Tail Brg.	65212-65500	1
Cross Shaft Right Brg.	6379-6320	1
Cross Shaft Left Brg.	6379-6320	1
Pinion Seal	35009N (27452)	1
O-Ring	OR250	1
O-Ring	OR262	1
Sealer	RTV Silicone	1

DRK-170		
Position	Part Number	Qty
Differential Right Brg.	33287-33472	1
Differential Left Brg.	42381-42584	1
Pinion Head Brg.	55200C-55437	1
Pinion Tail Brg.	HM804848-HM804810	1
Pinion Nose Brg.	M5305TV	1
Electric Shift Brg.	200SL •	1
Pinion Seal	712598 (25990)	1
Shift Rod Seal	50419 •	1
Sealer	RTV Silicone	1

DRK-172F		
Position	Part Number	Qty
Differential Right Brg.	47890-47820	1
Differential Left Brg.	47890-47820	1
Pinion Head Brg.	H715343-H715311	1
Pinion Tail Brg.	65237-65500	1
Drive Gear Front Brg.	MU1015DCV	1
Input Shaft Brg.	313	1
Thrushaft Brg.	210	1
Input Shaft Seal	415086N (30055)	1
Thrushaft Seal	475322N (27295)	1
Sealer	RTV Silicone	1

DRK-172FA		
Position	Part Number	Qty
Differential Right Brg.	47890-47820	1
Differential Left Brg.	47890-47820	1
Pinion Head Brg.	H715343-H715311	1
Pinion Tail Brg.	65237-65500	1
Drive Gear Front Brg.	MU1015DCV	1
Input Shaft Brg.	313A	1
Thrushaft Brg.	210	1
Input Shaft Seal	415086N (30055)	1
Thrushaft Seal	475322N (27295)	1
Sealer	RTV Silicone	1

DRK-172FB		
Position	Part Number	Qty
Differential Right Brg.	47890-47820	1
Differential Left Brg.	47890-47820	1
Pinion Head Brg.	H715343-H715311	1
Pinion Tail Brg.	65237-65500	1
Inter Differential Brg.	JLM714149-JLM714110	1
Input Shaft Brg.	JH211749-JH211710	1
Thrushaft Brg.	LM104949-JLM104910	2
Input Shaft Seal	416470N (32385)	1
Thrushaft Seal	475322N (27295)	1
Sealer	RTV Silicone	1

DRK-172R		
Position	Part Number	Qty
Differential Right Brg.	47890-47820	1
Differential Left Brg.	47890-47820	1
Pinion Head Brg.	H715343-H715311	1
Pinion Tail Brg.	H715334-H715311	1
Pinion Nose Brg.	MU1308UM	1
Pinion Seal	3591 (27642)	1
Pinion Seal (SSHD, STHD, SUHD)	35009N (27452) •	1
Sealer	RTV Silicone	1

DRK-187F		
Position	Part Number	Qty
Differential Right Brg.	HM516449C-HM516410	1
Differential Left Brg.	HM516449C-HM516410	1
Pinion Head Brg.	42350-42584	1
Pinion Tail Brg.	497-493	1
Pinion Nose Brg.	MR1212EL	1
Cross Shaft Right Brg.	66225-66462	2
Cross Shaft Left Brg.	MU1218TDHM	1
Input Shaft Brg.	387A-382A	2
Thrushaft Brg.	212	1
Input Shaft Seal	3592 (30144)	1
Thrushaft Seal	415086N (30055)	2
Sealer	RTV Silicone	1

DRK-187R		
Position	Part Number	Qty
Differential Right Brg.	HM516449C-HM516410	1
Differential Left Brg.	HM516449C-HM516410	1
Pinion Head Brg.	42350-42584	1
Pinion Tail Brg.	497-493	1
Pinion Nose Brg.	MR1212EL	1
Cross Shaft Right Brg.	66225-66462	2
Cross Shaft Left Brg.	MU1218TDHM	1
Input Shaft Seal	3592 (30144)	1
Thrushaft Seal	415013N (29951)	1
Sealer	RTV Silicone	1

DRK-191F		
Position	Part Number	Qty
Differential Right Brg.	3984-3925	1
Differential Left Brg.	3984-3925	1
Pinion Head Brg.	55175C-55437	1
Pinion Tail Brg.	55175C-55437	1
Pinion Nose Brg.	MUB5206UM	1
Idler Gear Brg.	25877-25821	2
Thrust Brg. Race	W2840	1
Thrust Brg. Race	TRA2840	2
Input Shaft Brg.	122L	1
Output Shaft Brg.	210	1
Drive Gear Brg.	213SL	1
Input Shaft Brg.	310B	1
Input Shaft Seal	415281N (29870)	1
Thrushaft Seal	415147N (24989)	1
Sealer	RTV Silicone	1

²Use 68450 Cone with 27950 Case; use 68462 Cone with 103537 Case

•Not packed in kit

Differential Rebuild Kits



HD Differential

DRK-191R		
Position	Part Number	Qty
Differential Right Brg.	3984-3925	1
Differential Left Brg.	3984-3925	1
Pinion Head Brg.	55175C-55437	1
Pinion Tail Brg.	55175C-55437	1
Pinion Nose Brg.	MUB5206UM	1
Pinion Seal	714512 (23751)	1
Sealer	RTV Silicone	1

DRK-192FB		
Position	Part Number	Qty
Differential Right Brg.	47890-47820	1
Differential Left Brg.	47890-47820	1
Pinion Head Brg.	72225C-72487	1
Pinion Tail Brg.	72225C-72487	1
Pinion Nose Brg.	MUB1307UM	1
Idler Gear Brg.	25877-25821	2
Thrust Brg. Race	W2840	1
Thrust Brg. Race	TRA2840	2
Input Shaft Brg.	122L	1
Output Shaft Brg.	210	1
Driveshaft Brg.	L610549-L610510	2
Input Shaft Brg.	310B	1
Input Shaft Seal	415281N (29870)	1
Thrushaft Seal	415147N (24989)	1
Sealer	RTV Silicone	1

DRK-192FC		
Position	Part Number	Qty
Differential Right Brg.	47890-47820	1
Differential Left Brg.	47890-47820	1
Pinion Head Brg.	78225C-78551	1
Pinion Tail Brg.	78225C-78551	1
Pinion Nose Brg.	MUB1307UM	1
Idler Gear Brg.	25877-25821	2
Input Shaft Brg.	122SL	1
Output Shaft Brg.	210	1
Input Shaft Brg.	310B	1
Driveshaft Brg.	L610549-L610510	2
Input Shaft Seal	415281N (29870)	1
Thrushaft Seal	415147N (24989)	1
Sealer	RTV Silicone	1

DRK-192R		
Position	Part Number	Qty
Differential Right Brg.	47890-47820	1
Differential Left Brg.	47890-47820	1
Pinion Head Brg.	72225C-72487	1
Pinion Tail Brg.	72225C-72487	1
Pinion Nose Brg.	MUB1307UM	1
Pinion Seal	415013N (29925)	1
Pinion Seal	415147N (24989)	1
Sealer	RTV Silicone	1

DRK-192RA		
Position	Part Number	Qty
Differential Right Brg.	47890-47820	1
Differential Left Brg.	47890-47820	1
Pinion Head Brg.	78225C-78551	1
Pinion Tail Brg.	78225C-78551	1
Pinion Nose Brg.	MUB1307UM	1
Pinion Seal	415013N (29925)	1
Pinion Seal	415147N (24989)	1
Sealer	RTV Silicone	1

DRK-192RB		
Position	Part Number	Qty
Differential Right Brg.	47890-47820	1
Differential Left Brg.	47890-47820	1
Pinion Head Brg.	72225C-72487	1
Pinion Tail Brg.	72225C-72487	1
Pinion Nose Brg.	MUB1307UM	1
Pinion Seal	DTHH102	1
Sealer	RTV Silicone	1

DRK-193		
Position	Part Number	Qty
Differential Right Brg.	56425-56650	1
Differential Left Brg.	497-493	1
Pinion Head Brg.	72218C-72487 ³	1
Pinion Tail Brg.	72200C-72487	1
Pinion Nose Brg.	MUSB1307UM	1
Input Shaft Brg.	JH307749-JH307710	1
Output Shaft Front Brg.	34274-34492A	1
Output Shaft Rear Brg.	MA1209EL	1
Input Shaft Seal	DT7719	1
Thrushaft Seal	DT7720	1
Sealer	RTV Silicone	1

DRK-193A		
Position	Part Number	Qty
Differential Right Brg.	567-563	1
Differential Left Brg.	497-493	1
Pinion Head Brg.	72218C-72487 ³	1
Pinion Tail Brg.	72200C-72487	1
Pinion Nose Brg.	MUSB1307UM	1
Input Shaft Front Brg.	JH307749-JH307710	1
Output Shaft Front Brg.	34274-34492A	1
Output Shaft Rear Brg.	MA1209EL	1
Input Shaft Seal	DT7719	1
Thrushaft Seal	DT7720	1
Sealer	RTV Silicone	1

DRK-194F		
Position	Part Number	Qty
Differential Right Brg.	JM716649-JM716610	1
Differential Left Brg.	JM716649-JM716610	1
Pinion Head Brg.	72212C-72487	1
Pinion Tail Brg.	72212C-72487	1
Pinion Nose Brg.	RU1570UM	1
Drive Gear Front Brg.	JLM710949-JLM710910	1
Input Shaft Brg.	JM511946-JM511910	1
Thrushaft Brg.	LM603049-LM603011 •	2
Input Shaft Seal	DTP2590	1
Thrushaft Seal	4561V (24964)	1
Sealer	RTV Silicone	1

DRK-194R		
Position	Part Number	Qty
Differential Right Brg.	JM716649-JM716610	1
Differential Left Brg.	JM716649-JM716610	1
Pinion Head Brg.	65237-65500	1
Pinion Tail Brg.	72201C-72487	1
Pinion Seal	5603 (1245)	1
Sealer	RTV Silicone	1

DRK-194RA		
Position	Part Number	Qty
Differential Right Brg.	JM716649-JM716610	1
Differential Left Brg.	JM716649-JM716610	1
Pinion Head Brg.	65237-65500	1
Pinion Tail Brg.	72225C-72487	1
Pinion Seal	3905 (30145)	1
Sealer	RTV Silicone	1

DRK-194RB		
Position	Part Number	Qty
Differential Right Brg.	JM716649-JM716610	1
Differential Left Brg.	JM716649-JM716610	1
Pinion Head Brg.	72212C-72487	1
Pinion Tail Brg.	72212C-72487	1
Pinion Nose Brg.	RU1570UM	1
Pinion Seal	3905 (30145)	1
Sealer	RTV Silicone	1

DRK-195		
Position	Part Number	Qty
Differential Right Brg.	28584-28521	1
Differential Left Brg.	28584-28521	1
Pinion Head Brg.	27881-27820	1
Pinion Tail Brg.	27880-27820	1
Pinion Nose Brg.	MUB5204TM	1
Pinion Seal	410085N (19970)	1
Pinion Seal	710007 (20136)	1
Felt Seal	5M293 (573)	1
Sealer	RTV Silicone	1

DRK-196		
Position	Part Number	Qty
Differential Right Brg.	567-563	1
Differential Left Brg.	497-493	1
Pinion Head Brg.	72218C-72487 ⁴	1
Pinion Tail Brg.	HM807049-HM807010 ⁴	1
Pinion Nose Brg.	MUSB1307UM	1
Input Shaft Brg.	3979-JM511910	1
Output Shaft Front Brg.	29675-29620	1
Output Shaft Rear Brg.	MA1209EL	1
Input Shaft Seal	DT7719	1
Thrushaft Seal	DT7720	1
Sealer	RTV Silicone	1

DRK-198		
Position	Part Number	Qty
Differential Right Brg.	56425-56650	1
Differential Left Brg.	56425-56650	1
Pinion Head Brg.	H715343-H715311	1
Pinion Tail Brg.	H715343-H715311	1
Pinion Nose Brg.	MU1308UM	1
Pinion Seal	415013N (29925)	1
Sealer	RTV Silicone	1

DRK-200F		
Position	Part Number	Qty
Differential Right Brg.	47890-47820	1
Differential Left Brg.	47890-47820	1
Pinion Head Brg.	72225C-72487	1
Pinion Tail Brg.	72225C-72487	1
Pinion Nose Brg.	MUB1307UM	1
Idler Gear Brg.	3877-3820	2
Power Divider Front Side Gear Thrust Race	W4860	1
Power Divider Front Side Gear Thrust Brg.	TRA4860	2
Power Divider Case Intermediate Brg.	28985-28921	1
Power Divider Brg.	JLM710949-JLM710910	2
Power Divider Intermedial Disc Rear Brg.	XLS5-1/8AF	1
Output Shaft Brg.	210	1
Input Shaft Seal	415281N (29870)	1
Thrushaft Seal	415013N (29925)	1
Sealer	RTV Silicone	1

Differential Rebuild Kits

HD Differential

DRK-200FA		
Position	Part Number	Qty
Differential Right Brg.	47890-47820	1
Differential Left Brg.	47890-47820	1
Pinion Head Brg.	72225C-72487	1
Pinion Tail Brg.	72225C-72487	1
Pinion Nose Brg.	MUB1307UM	1
Idler Gear Brg.	M802048-M802011	2
Power Divider Front Side Gear Thrust Race	W4860	1
Power Divider Front Side Gear Thrust Brg.	TRA4860	2
Power Divider Case Intermediate Brg.	28985-28921	1
Power Divider Brg.	JLM710949-JLM710910	2
Power Divider Intermediate Disc Rear Brg.	XLS5-1/8AF	1
Output Shaft Brg.	210	1
Input Shaft Seal	415281N (29870)	1
Thrushaft Seal	415013N (29925)	1
Sealer	RTV Silicone	1

DRK-201F		
Position	Part Number	Qty
Differential Right Brg.	56425-56650	1
Differential Left Brg.	56425-56650	1
Pinion Head Brg.	H715343-H715311	1
Pinion Tail Brg.	HM813844-HM813810	1
Pinion Nose Brg.	MU1308UM	1
Idler Gear Brg.	3877-3820	2
Power Divider Front Side Gear Thrust Race	W4860	1
Power Divider Front Side Gear Thrust Brg.	TRA4860	2
Power Divider Case Intermediate Brg.	28985-28921	1
Power Divider Brg.	JLM710949-JLM710910	2
Power Divider Intermediate Disc Rear Brg.	XLS5-1/8AF	1
Output Shaft Brg.	210	1
Input Shaft Seal	415281N (29870)	1
Thrushaft Seal	415013N (29925)	1
Sealer	RTV Silicone	1

DRK-201FA		
Position	Part Number	Qty
Differential Right Brg.	56425-56650	1
Differential Left Brg.	56425-56650	1
Pinion Head Brg.	H715343-H715311	1
Pinion Tail Brg.	HM813844-HM813810	1
Pinion Nose Brg.	MU1308UM	1
Idler Gear Brg.	M802048-M802011	2
Power Divider Front Side Gear Thrust Race	W4860	1
Power Divider Front Side Gear Thrust Brg.	TRA4860	2
Power Divider Case Intermediate Brg.	28985-28921	1
Power Divider Brg.	JLM710949-JLM710910	2
Power Divider Intermediate Disc Rear Brg.	XLS5-1/8AF	1
Output Shaft Brg.	210	1
Input Shaft Seal	415281N (29870)	1
Thrushaft Seal	415013N (29925)	1
Sealer	RTV Silicone	1

DRK-201R		
Position	Part Number	Qty
Differential Right Brg.	56425-56650	1
Differential Left Brg.	56425-56650	1
Pinion Head Brg.	H715343-H715311	1
Pinion Tail Brg.	HM813844-HM813810	1
Pinion Nose Brg.	MU1308UM	1
Pinion Seal	DTHH102	1
Sealer	RTV Silicone	1

DRK-202		
Position	Part Number	Qty
Differential Right Brg.	3984-3925	1
Differential Left Brg.	3984-3925	1
Pinion Head Brg.	HM903249A-HM903210	1
Pinion Tail Brg.	HM903249A-HM903210	1
Pinion Nose Brg.	MUB5205UM	1
Pinion Seal (RA-25 & RA-30)	410686N (23756)	1
Pinion Seal	711553 (23806)	1
Sealer	RTV Silicone	1

DRK-203F		
Position	Part Number	Qty
Differential Right Brg.	598-592A	1
Differential Left Brg.	52387-52618	1
Pinion Head Brg.	78250AC-78551	1
Pinion Tail Brg.	78250AC-78551	1
Pinion Nose Brg.	MUB1309TM	1
Input Shaft Front Brg.	HM813841-HM813810	1
Input Shaft Rear Brg.	JM515649-JM515610	1
Thrushaft Brg.	385A-382A	2
Oil Pump Idler Gear Brg.	5204K	1
Input Shaft Seal	416470N (32385)	1
Input Shaft Seal (GMC)	3143N •	1
Thrushaft Seal	415013N (29925)	1
Sealer	RTV Silicone	1

DRK-204F		
Position	Part Number	Qty
Differential Right Brg.	HM516449C-HM516410	1
Differential Left Brg.	HM516449C-HM516410	1
Pinion Head Brg.	42350-42584	1
Pinion Tail Brg.	42350-42584	1
Pinion Nose Brg.	MR1213EL	1
Cross Shaft Right Brg.	641-632	2
Cross Shaft Left Brg.	MU1221UM	1
Input Shaft Brg.	394A-392	2
Thrushaft Brg.	385A-382A	2
Input Shaft Seal	415137 (32502)	1
Thrushaft Seal	415272N (27565)	1
Sealer	RTV Silicone	1

DRK-204R		
Position	Part Number	Qty
Differential Right Brg.	HM516449C-HM516410	1
Differential Left Brg.	HM516449C-HM516410	1
Pinion Head Brg.	H715345-H715311	1
Pinion Tail Brg.	HM807046-HM807010	1
Cross Shaft Right Brg.	65237-65500	1
Cross Shaft Left Brg.	65237-65500	1
Pinion Seal	476283N (27601)	1
Sealer	RTV Silicone	1

DRK-205		
Position	Part Number	Qty
Differential Right Brg.	47687-47623A	1
Differential Left Brg.	HM516448-HM516414B	1
Pinion Head Brg.	5760-5735	1
Pinion Tail Brg.	557S-552A	1
Cross Shaft Right Brg.	621-612	1
Cross Shaft Left Brg.	H715345-H715313W	1
Pinion Seal	415272N (27565)	1
O-Ring Set	OK205	1
Sealer	RTV Silicone	1

DRK-206		
Position	Part Number	Qty
Differential Right Brg.	47687-47623A	1
Differential Left Brg.	HM516448-HM516414B	1
Pinion Head Brg.	497-492A	1
Pinion Tail Brg.	576-572	1
Cross Shaft Right Brg.	621-612	1
Cross Shaft Left Brg.	H715345-H715313W	1
Drive Gear Front Brg.	1211	1
Input Shaft Brg.	1213L	1
Input Shaft Seal	415991N (34891)	1
Thrushaft Seal	475322N (27295)	1
O-Ring Set	OK206	1
Sealer	RTV Silicone	1

DRK-207		
Position	Part Number	Qty
Differential Right Brg.	56425-56650	1
Differential Left Brg.	497-493	1
Pinion Head Brg.	72218C-72487	1
Pinion Tail Brg.	HM807049-HM807010	1
Pinion Nose Brg.	MUSB1307UM	1
Input Shaft Brg.	3979-JM511910	1
Output Shaft Front Brg.	29675-29620	1
Output Shaft Rear Brg.	MA1209EL	1
Input Shaft Seal	DT7719	1
Thrushaft Seal	DT7720	1
Sealer	RTV Silicone	1

DRK-208		
Position	Part Number	Qty
Differential Right Brg.	665-653	1
Differential Left Brg.	42381-42584	1
Pinion Head Brg.	72212C-72487	1
Pinion Tail Brg.	72212C-72487	1
Pinion Nose Brg.	MUB1308UM	1
Output Shaft Front Brg.	33275-33472	1
Input Shaft Brg.	JM511946-JM511910	1
Output Shaft Rear Brg.	MA1211EL	1
Pinion Forward Brg.	MU1309CV	1
Input Shaft Seal	415164N (33699)	1
Thrushaft Seal	475012N (29322)	1
Sealer	RTV Silicone	1

DRK-208A		
Position	Part Number	Qty
Differential Right Brg.	665-653	1
Differential Left Brg.	42381-42584	1
Pinion Head Brg.	72212C-72487	1
Pinion Tail Brg.	72212C-72487	1
Pinion Nose Brg.	MUB1308UM	1
Output Shaft Front Brg.	33275-33472	1
Input Shaft Brg.	313	1
Output Shaft Rear Brg.	MA1211EL	1
Pinion Forward Brg.	MU1309CV	1
Input Shaft Seal	415164N (33699)	1
Thrushaft Seal	475012N (29322)	1
Sealer	RTV Silicone	1

DRK-209		
Position	Part Number	Qty
Differential Right Brg.	68462-68712	1
Differential Left Brg.	42346-42584	1
Pinion Head Brg.	72212C-72487	1
Pinion Tail Brg.	72212C-72487	1
Pinion Nose Brg.	MUB1308UM	1
Pinion Forward Brg.	MU1309CV	1
Input Shaft Brg.	313	1
Output Shaft Front Brg.	33275-33472	1
Output Shaft Rear Brg.	MA1211EL	1
Input Shaft Seal	415164N (33699)	1
Thrushaft Seal	475012N (29322)	1
Sealer	RTV Silicone	1

*Not packed in kit

Differential Rebuild Kits



HD Differential

DRK-209A		
Position	Part Number	Qty
Differential Right Brg.	68450-68712	1
Differential Left Brg.	42346-42584	1
Pinion Head Brg.	72212C-72487	1
Pinion Tail Brg.	72212C-72487	1
Pinion Nose Brg.	MUB1308UM	1
Pinion Forward Brg.	MU1309CV	1
Input Shaft Brg.	313	1
Output Shaft Front Brg.	33275-33472	1
Output Shaft Rear Brg.	MA1211EL	1
Input Shaft Seal	415164N (33699)	1
Thrushaft Seal	475012N (29322)	1
Sealer	RTV Silicone	1

DRK-210		
Position	Part Number	Qty
Differential Right Brg.	68462-68712	1
Differential Left Brg.	42346-42584	1
Pinion Head Brg.	72212C-72487	1
Pinion Tail Brg.	72212C-72487	1
Pinion Nose Brg.	MUB1308UM	1
Pinion Forward Brg.	MU1309CV	1
Input Shaft Brg.	JM511946-JM511910	1
Output Shaft Front Brg.	33275-33472	1
Output Shaft Rear Brg.	MA1211EL	1
Input Shaft Seal	415894 (33712)	1
Thrushaft Seal	475012N (29322)	1
Sealer	RTV Silicone	1

DRK-211F		
Position	Part Number	Qty
Differential Right Brg.	68462-68712	1
Differential Left Brg.	42381-42584	1
Pinion Head Brg.	72212C-72487	1
Pinion Tail Brg.	72212C-72487	1
Pinion Nose Brg.	MUB1308UM	1
Input Shaft Brg.	JM511946-JM511910	1
Pinion Forward Brg.	MU1309CV	1
Output Shaft Front Brg.	33275-33472	1
Output Shaft Rear Brg.	MA1211EL	1
Input Shaft Seal	210736	1
Thrushaft Seal	210737	1
Sealer	RTV Silicone	1

DRK-211FA		
Position	Part Number	Qty
Differential Right Brg.	68450-68712	1
Differential Left Brg.	42381-42584	1
Pinion Head Brg.	72212C-72487	1
Pinion Tail Brg.	72212C-72487	1
Pinion Nose Brg.	MUB1308UM	1
Input Shaft Brg.	JM511946-JM511910	1
Pinion Forward Brg.	MU1309CV	1
Output Shaft Front Brg.	33275-33472	1
Output Shaft Rear Brg.	MA1211EL	1
Input Shaft Seal	210736	1
Thrushaft Seal	210737	1
Sealer	RTV Silicone	1

DRK-212F		
Position	Part Number	Qty
Differential Right Brg.	766-753A	1
Differential Left Brg.	766-752B	1
Pinion Head Brg.	740-742	1
Pinion Tail Brg.	661-653	1
Cross Shaft Left Brg.	H414235-H414210	1
Cross Shaft Right Brg.	6580-6535W	1
Power Divider Brg.	7213BG	2
Output Shaft Brg.	1212	1
Input Shaft Seal	415991N (34891)	1
Thrushaft Seal	5578 (31173)	1
Power Divider O-Ring	OR247	1
Power Divider O-Ring	OR272	1
Gasket Set	BBK7124-300	1
Sealer	RTV Silicone	1

DRK-212R		
Position	Part Number	Qty
Differential Right Brg.	766-753A	1
Differential Left Brg.	766-752B	1
Pinion Head Brg.	6466-6420	1
Pinion Tail Brg.	65225-65500	1
Cross Shaft Right Brg.	H414235-H414210	1
Cross Shaft Left Brg.	6580-6535W	1
Pinion Seal	5578 (31173)	1
Gasket Set	BBK7143-300	1
Sealer	RTV Silicone	1

DRK-213		
Position	Part Number	Qty
Differential Right Brg.	495-493	1
Differential Left Brg.	42381-42584	1
Pinion Head Brg.	55200C-55437	1
Pinion Tail Brg.	55200C-55437	1
Pinion Nose Brg.	MUSB1307UM	1
Pinion Seal	455088V (30098)	1
Sealer	RTV Silicone	1

DRK-214		
Position	Part Number	Qty
Differential Right Brg.	JM716649-JM716610	1
Differential Left Brg.	JM822049-JM822010	1
Pinion Head Brg.	72225C-72487 ⁵	1
Pinion Tail Brg.	55200C-55437	1
Pinion Nose Brg.	MUB1308UM	1
Pinion Seal	455088V (30098)	1
Sealer	RTV Silicone	1

DRK-216		
Position	Part Number	Qty
Differential Right Brg.	JLM714149-JLM714110	1
Differential Left Brg.	42381-42584	1
Pinion Head Brg.	55200C-55437	1
Pinion Tail Brg.	M804049-M804010	1
Pinion Nose Brg.	RU1570UM	1
Pinion Seal	415082N (25102)	1
Sealer	RTV Silicone	1

DRK-217F		
Position	Part Number	Qty
Differential Right Brg.	JM716649-JM716610	1
Differential Left Brg.	JM716649-JM716610	1
Pinion Head Brg.	H715334-H715311	1
Pinion Tail Brg.	72212C-72487	1
Input Shaft Front Brg.	JM511946-JM511910	1
Input Shaft Rear Brg.	JLM710949-JLM710910	1
Output Shaft Brg.	LM104949-JLM104910	2
Input Shaft Seal	DTP2590	1
Thrushaft Seal	DTP2590	1
O-Ring	5X1034	2
Sealer	RTV Silicone	1

DRK-217R		
Position	Part Number	Qty
Differential Right Brg.	JM716649-JM716610	1
Differential Left Brg.	JM716649-JM716610	1
Pinion Head Brg.	72212C-72487	1
Pinion Tail Brg.	55206C-55437	1
Pinion Nose Brg.	RU1570UM	1
Pinion Seal	PN12588	1
Sealer	RTV Silicone	1

DRK-218		
Position	Part Number	Qty
Differential Right Brg.	34306-34478	1
Differential Left Brg.	3994-JM511910	1
Pinion Head Brg.	55200C-55437	1
Pinion Tail Brg.	HM804846-HM804810	1
Pinion Nose Brg.	MUB1305UDM	1
Pinion Seal	415082N (25102)	1
Sealer	RTV Silicone	1

DRK-219R		
Position	Part Number	Qty
Differential Right Brg.	42381-42584	1
Differential Left Brg.	68462-68712 ⁶	1
Pinion Head Brg.	78215C-78551	1
Pinion Tail Brg.	72212C-72487	1
Pinion Nose Brg.	MUB1308UM	1
Pinion Seal	712937 (29471)	1
Sealer	RTV Silicone	1

DRK-220F		
Position	Part Number	Qty
Differential Right Brg.	68450-68712	1
Differential Left Brg.	42381-42584	1
Pinion Head Brg.	72212C-72487	1
Pinion Tail Brg.	72212C-72487	1
Pinion Nose Brg.	MUB1308UM	1
Pinion Forward Brg.	MU1309CV	1
Input Shaft Front Brg.	JM511946-JM511910	1
Input Shaft Rear Brg.	JH211749-JH211710	1
Output Shaft Brg.	MA1211EL	1
Input Shaft Seal	415164N (33699)	1
Thrushaft Seal	475012N (29322)	1
Sealer	RTV Silicone	1

DRK-220FA		
Position	Part Number	Qty
Differential Right Brg.	68462-68712	1
Differential Left Brg.	42381-42584	1
Pinion Head Brg.	72212C-72487	1
Pinion Tail Brg.	72212C-72487	1
Pinion Nose Brg.	MUB1308UM	1
Pinion Forward Brg.	MU1309CV	1
Input Shaft Front Brg.	JM511946-JM511910	1
Input Shaft Rear Brg.	JH211749-JH211710	1
Output Shaft Brg.	MA1211EL	1
Input Shaft Seal	415164N (33699)	1
Thrushaft Seal	475012N (29322)	1
Sealer	RTV Silicone	1

DRK-221		
Position	Part Number	Qty
Differential Right Brg.	3994-3920	1
Differential Left Brg.	497-493	1
Pinion Head Brg.	72200C-72487	1
Pinion Tail Brg.	HM903249-HM903210	1
Pinion Nose Brg.	RUB1570UM	1
Pinion Seal	9773 (26373)	1
Sealer	RTV Silicone	1

DRK-222F		
Position	Part Number	Qty
Differential Right Brg.	567-563	1
Differential Left Brg.	497-493	1
Pinion Head Brg.	72218C-72487	1
Pinion Tail Brg.	HM807049-HM807010	1
Pinion Nose Brg.	MUSB7307UM	1
Input Shaft Brg.	3979-JM511910	1
Output Shaft Front Brg.	29675-29620	1
Output Shaft Rear Brg.	MA1209EL	1
Input Shaft Seal	DT7719	1
Thrushaft Seal	DT7720	1
Sealer	RTV Silicone	1

DRK-222R		
Position	Part Number	Qty
Differential Right Brg.	497-493	1
Differential Left Brg.	567-563	1
Pinion Head Brg.	72200C-72487	1
Pinion Tail Brg.	55200C-55437	1
Pinion Nose Brg.	MUSB7307UM	1
Pinion Seal	DT7721	1
Sealer	RTV Silicone	1

Differential Rebuild Kits

DRK-223F		
Position	Part Number	Qty
Differential Right Brg.	495-493	1
Differential Left Brg.	495-493	1
Pinion Head Brg.	72225C-72487	1
Pinion Tail Brg.	72225C-72487	1
Pinion Nose Brg.	RU1570UM	1
Input Shaft Brg.	HM807049-HM807010	1
Input Gear Brg.	J3624	1
Inter Axle Brg.	JLM710949-JLM710910	1
Output Shaft Brg.	A1400	1
Input Shaft Seal	415013N (29951)	1
Thrushaft Seal	4624V (25005)	1
O-Ring	OR230	1
Sealer	RTV Silicone	1

DRK-223R		
Position	Part Number	Qty
Differential Right Brg.	495-493	1
Differential Left Brg.	495-493	1
Pinion Head Brg.	72225C-72487	1
Pinion Tail Brg.	72225C-72487	1
Pinion Nose Brg.	RU1570UM	1
Pinion Seal	DTHH102	1
Sealer	RTV Silicone	1

DRK-224		
Position	Part Number	Qty
Differential Right Brg.	32020X	1
Differential Left Brg.	32020X	1
Pinion Head Brg.	72212C-72487	1
Pinion Tail Brg.	55206C-55437	1
Pinion Nose Brg.	RU1570UM	1
Pinion Seal	DTN2588	1
Sealer	RTV Silicone	1

DRK-225		
Position	Part Number	Qty
Differential Right Brg.	JM716649-JM716610	1
Differential Left Brg.	52400-52618	1
Pinion Head Brg.	HM804846-HM804810	1
Pinion Tail Brg.	55200C-55437	1
Pinion Nose Brg.	MUB1307UBM	1
Pinion Seal	415082N (25102)	1
Sealer	RTV Silicone	1

DRK-400		
Position	Part Number	Qty
Differential Right Brg.	3994-3920	1
Differential Left Brg.	497-493	1
Pinion Head Brg.	55175C-55437	1
Pinion Tail Brg.	HM903249-HM903210	1
Pinion Nose Brg.	MUB1305UDM	1
Pinion Seal	9773 (26373)	1
Sealer	RTV Silicone	1

DRK-401		
Position	Part Number	Qty
Differential Right Brg.	JM822049-JM822010	1
Differential Left Brg.	32024X	1
Pinion Head Brg.	H914841-H914811	1
Pinion Tail Brg.	HM813841-HM813810	1
Pinion Nose Brg.	MU1309UGM	1
Pinion Seal	210724	1
Shift Fork Seal	119855	1
Sealer	RTV Silicone	1

DRK-402		
Position	Part Number	Qty
Differential Right Brg.	JM822049-JM822010	1
Differential Left Brg.	52400-52618	1
Pinion Head Brg.	H914841-H914811	1
Pinion Tail Brg.	HM813841-HM813810	1
Pinion Nose Brg.	MU1309UGM	1
Pinion Seal	210724	1
Sealer	RTV Silicone	1

DRK-403		
Position	Part Number	Qty
Differential Right Brg.	497-493	1
Differential Left Brg.	56425-56650	1
Pinion Head Brg.	72200C-72487	1
Pinion Tail Brg.	55200C-55437	1
Pinion Nose Brg.	MUSB1307UM	1
Pinion Seal	9773 (26373)	1
Shift Fork Seal	119855	1
Sealer	RTV Silicone	1

DRK-404F		
Position	Part Number	Qty
Differential Right Brg.	567-563	1
Differential Left Brg.	497-493	1
Pinion Head Brg.	72218C-72487	1
Pinion Tail Brg.	55212C-55437	1
Pinion Nose Brg.	MUB1307UM	1
Input Shaft Brg.	555S-552A	1
Output Shaft Brg.	29675-29630	1
Output Shaft O-Ring	OR-232	2
Input Shaft Seal	DT7591	1
Input Shaft V-Ring	401300	1
Thrushaft Seal	DT7592	1
Sealer	RTV Silicone	1

DRK-404FMK		
Position	Part Number	Qty
Differential Right Brg.	567-563	1
Differential Left Brg.	497-493	1
Pinion Head Brg.	72218C-72487	1
Pinion Tail Brg.	55212C-55437	1
Pinion Nose Brg.	MUB1307UM	1
Input Shaft Brg.	555S-552A	1
Output Shaft Brg.	29675-29630	1
Output Shaft O-Ring	OR-232	2
Input Shaft Seal	DT7591	1
Input Shaft V-Ring	401300	1
Thrushaft Seal	DT7592	1
Sealer	RTV Silicone	1
Input Shaft Shim .003"	127595	1
Input Shaft Shim .005"	127596	1
Input Shaft Shim .010"	127597	1
Input Shaft Shim .020"	127598	1
Input Shaft Shim .030"	127599	1
Output Shaft Gear Snap Ring	85997	1
Side Gear Thrust Washer	127386	2
Pinion Gear Thrust Washer	129305	4
Helical Gear Thrust Washer	128702	1

DRK-404FA		
Position	Part Number	Qty
Differential Right Brg.	567-563	1
Differential Left Brg.	497-493	1
Pinion Head Brg.	72218C-72487	1
Pinion Tail Brg.	55212C-55437	1
Pinion Nose Brg.	MUB1307UM	1
Input Shaft Brg.	555S-552A	1
Output Shaft Brg.	29688-29620	1
Output Shaft O-Ring	OR-232	2
Input Shaft Seal	DT7591	1
Input Shaft V-Ring	401300	1
Thrushaft Seal	DT7592	1
Sealer	RTV Silicone	1

DRK-404FAMK		
Position	Part Number	Qty
Differential Right Brg.	567-563	1
Differential Left Brg.	497-493	1
Pinion Head Brg.	72218C-72487	1
Pinion Tail Brg.	55212C-55437	1
Pinion Nose Brg.	MUB1307UM	1
Input Shaft Brg.	555S-552A	1
Output Shaft Brg.	29688-29620	1
Output Shaft O-Ring	OR-232	2
Input Shaft Seal	DT7591	1
Input Shaft V-Ring	401300	1
Thrushaft Seal	DT7592	1
Sealer	RTV Silicone	1
Input Shaft Shim .003"	127595	1
Input Shaft Shim .005"	127596	1
Input Shaft Shim .010"	127597	1
Input Shaft Shim .020"	127598	1
Input Shaft Shim .030"	127599	1
Output Shaft Gear Snap Ring	85997	1
Side Gear Thrust Washer	127386	2
Pinion Gear Thrust Washer	129305	4
Helical Gear Thrust Washer	128702	1

DRK-404R		
Position	Part Number	Qty
Differential Right Brg.	497-493	1
Differential Left Brg.	567-563	1
Pinion Head Brg.	72212C-72487	1
Pinion Tail Brg.	55200C-55437	1
Pinion Nose Brg.	MUB7307UM	1
Pinion Seal	DT7591	1
Sealer	RTV Silicone	1

DRK-404RMK		
Position	Part Number	Qty
Differential Right Brg.	497-493	1
Differential Left Brg.	567-563	1
Pinion Head Brg.	72212C-72487	1
Pinion Tail Brg.	55200C-55437	1
Pinion Nose Brg.	MUB7307UM	1
Pinion Seal	DT7591	1
Sealer	RTV Silicone	1
Pinion Shim .003"	127595	1
Pinion Shim .005"	127596	1
Pinion Shim .010"	127597	1
Pinion Shim .020"	127598	1
Pinion Shim .030"	127599	1
Side Gear Thrust Washer	127386	2
Pinion Gear Thrust Washer	129305	4

DRK-405F		
Position	Part Number	Qty
Differential Right Brg.	567-563	1
Differential Left Brg.	42362-42584	1
Pinion Head Brg.	72218C-72487	1
Pinion Tail Brg.	55212C-55437	1
Pinion Nose Brg.	MUB1307UM	1
Input Shaft Brg.	555S-552A	1
Output Shaft Brg.	29675-29630	1
Output Shaft O-Ring	OR-232	2
Input Shaft Seal	DT7591	1
Input Shaft V-Ring	401300	1
Thrushaft Seal	DT7592	1
Sealer	RTV Silicone	1

Differential Rebuild Kits

HD Differential

DRK-405FMK		
Position	Part Number	Qty
Differential Right Brg.	567-563	1
Differential Left Brg.	42362-42584	1
Pinion Head Brg.	72218C-72487	1
Pinion Tail Brg.	55212C-55437	1
Pinion Nose Brg.	MUB1307UM	1
Input Shaft Brg.	555S-552A	1
Output Shaft Brg.	29675-29630	1
Thrushaft Brg.	LM104949-JLM104910	2
Output Shaft O-Ring	OR-232	2
Input Shaft Seal	DT7591	1
Input Shaft V-Ring	401300	1
Thrushaft Seal	DT7592	1
Sealer	RTV Silicone	1
Input Shaft Shim .003"	127595	1
Input Shaft Shim .005"	127596	1
Input Shaft Shim .010"	127597	1
Input Shaft Shim .020"	127598	1
Input Shaft Shim .030"	127599	1
Output Shaft Gear Snap Ring	85997	1
Output Shaft Gear Snap Ring	129594	1
Side Gear Thrust Washer	127386	2
Pinion Gear Thrust Washer	129305	4
Helical Gear Thrust Washer	132439	1

DRK-405FA		
Position	Part Number	Qty
Differential Right Brg.	567-563	1
Differential Left Brg.	42362-42584	1
Pinion Head Brg.	72218C-72487	1
Pinion Tail Brg.	55212C-55437	1
Pinion Nose Brg.	MUB1307UM	1
Input Shaft Brg.	555S-552A	1
Output Shaft Brg.	29688-29620	1
Output Shaft O-Ring	OR-232	2
Input Shaft Seal	DT7591	1
Input Shaft V-Ring	401300	1
Thrushaft Seal	DT7592	1
Sealer	RTV Silicone	1

DRK-405FAMK		
Position	Part Number	Qty
Differential Right Brg.	567-563	1
Differential Left Brg.	42362-42584	1
Pinion Head Brg.	72218C-72487	1
Pinion Tail Brg.	55212C-55437	1
Pinion Nose Brg.	MUB1307UM	1
Input Shaft Brg.	555S-552A	1
Output Shaft Brg.	29688-29620	1
Thrushaft Brg.	LM104949-JLM104910	2
Output Shaft O-Ring	OR-232	2
Input Shaft Seal	DT7591	1
Input Shaft V-Ring	401300	1
Thrushaft Seal	DT7592	1
Sealer	RTV Silicone	1
Input Shaft Shim .003"	127595	1
Input Shaft Shim .005"	127596	1
Input Shaft Shim .010"	127597	1
Input Shaft Shim .020"	127598	1
Input Shaft Shim .030"	127599	1
Output Shaft Gear Snap Ring	85997	1
Output Shaft Gear Snap Ring	129594	1
Side Gear Thrust Washer	127386	2
Pinion Gear Thrust Washer	129305	4
Helical Gear Thrust Washer	132439	1

DRK-405R		
Position	Part Number	Qty
Differential Right Brg.	42362-42584	1
Differential Left Brg.	567-563	1
Pinion Head Brg.	72212C-72487	1
Pinion Tail Brg.	55200C-55437	1
Pinion Nose Brg.	MUB7307UM	1
Pinion Seal	DT7591	1
Sealer	RTV Silicone	1

DRK-405RMK		
Position	Part Number	Qty
Differential Right Brg.	42362-42584	1
Differential Left Brg.	567-563	1
Pinion Head Brg.	72212C-72487	1
Pinion Tail Brg.	55200C-55437	1
Pinion Nose Brg.	MUB7307UM	1
Pinion Seal	DT7591	1
Sealer	RTV Silicone	1
Pinion Shim .003"	127595	1
Pinion Shim .005"	127596	1
Pinion Shim .010"	127597	1
Pinion Shim .020"	127598	1
Pinion Shim .030"	127599	1
Side Gear Thrust Washer	127386	2
Pinion Gear Thrust Washer	129305	4

DRK-406		
Position	Part Number	Qty
Differential Right Brg.	598-592A	1
Differential Left Brg.	497-493	1
Pinion Head Brg.	78215C-78551	1
Pinion Tail Brg.	55200C-55437	1
Pinion Nose Brg.	MUB1308UM	1
Pinion Seal	9773 (26373)	1
Sealer	RTV Silicone	1

DRK-407		
Position	Part Number	Qty
Differential Right Brg.	497-493	1
Differential Left Brg.	598-592A	1
Pinion Head Brg.	H913842-H913810	1
Pinion Tail Brg.	72212C-72487	1
Pinion Nose Brg.	MUB1308UM	1
Pinion Seal	210724	1
Sealer	RTV Silicone	1

DRK-408		
Position	Part Number	Qty
Differential Right Brg.	497-493	1
Differential Left Brg.	56425-56650	1
Pinion Head Brg.	78215C-78551	1
Pinion Tail Brg.	72212C-72487	1
Pinion Nose Brg.	MUB5207UM	1
Pinion Seal	210724	1
Shift Shaft Seal	119855	1
Sealer	RTV Silicone	1

DRK-409		
Position	Part Number	Qty
Differential Right Brg.	JM822049-JM822010	1
Differential Left Brg.	56425-56662	1
Pinion Head Brg.	H914841-H914811	1
Pinion Tail Brg.	HM813841-HM813810	1
Pinion Nose Brg.	MU1309UM	1
Pinion Seal	210724	1
Sealer	RTV Silicone	1

DRK-410		
Position	Part Number	Qty
Differential Right Brg.	497-493	1
Differential Left Brg.	598-592A	1
Pinion Head Brg.	H914841-H914811	1
Pinion Tail Brg.	HM813841-HM813810	1
Pinion Nose Brg.	RU9008UM	1
Pinion Seal	210724	1
Sealer	RTV Silicone	1

DRK-411		
Position	Part Number	Qty
Differential Right Brg.	33275-33472	1
Differential Left Brg.	498-493	1
Pinion Head Brg.	5583-5535	1
Pinion Tail Brg.	49576-49520	1
Pinion Seal	410686N (23756)	1
Pinion Seal	470737N (22425)	1
Sealer	RTV Silicone	1

DRK-411F		
Position	Part Number	Qty
Differential Right Brg.	495-493	1
Differential Left Brg.	495-493	1
Pinion Head Brg.	72225C-72487	1
Pinion Tail Brg.	72225C-72487	1
Pinion Nose Brg.	MUX5207UMV1	1
Input Shaft Brg.	HM807049-HM807010	1
Input Gear Brg.	J3624	1
Inter Axle Brg.	JLM710949-JLM710910	1
Input Shaft Seal	401HH104	1
Thrushaft Seal	472HH101	1
Sealer	RTV Silicone	1

DRK-411R		
Position	Part Number	Qty
Differential Right Brg.	495-493	1
Differential Left Brg.	495-493	1
Pinion Head Brg.	72225C-72487	1
Pinion Tail Brg.	72225C-72487	1
Pinion Nose Brg.	MUX5207UMV1	1
Pinion Seal	DTHH102	1
Sealer	RTV Silicone	1

DRK-412		
Position	Part Number	Qty
Differential Right Brg.	497-493	1
Differential Left Brg.	567-563	1
Pinion Head Brg.	72200C-72487	1
Pinion Tail Brg.	55200C-55437	1
Pinion Nose Brg.	MUB1307UM	1
Pinion Seal	DT7721	1
Sealer	RTV Silicone	1

DRK-413		
Position	Part Number	Qty
Differential Right Brg.	42381-42584	1
Differential Left Brg.	68450-68712	1
Pinion Head Brg.	78215C-78551	1
Pinion Tail Brg.	72212C-72487	1
Pinion Nose Brg.	MUB1308UM	1
Pinion Seal	712937 (29471)	1
Sealer	RTV Silicone	1

DRK-414		
Position	Part Number	Qty
Differential Right Brg.	3984-3920	1
Differential Left Brg.	3984-3920	1
Pinion Head Brg.	72225C-72487	1
Pinion Tail Brg.	55175C-55437	1
Pinion Seal	714512	1
Sealer	RTV Silicone	1

Differential Rebuild Kits

HD Differential

DRK-415		
Position	Part Number	Qty
Differential Right Brg.	42381-42584	1
Differential Left Brg.	665-653	1
Pinion Head Brg.	72212C-72487	1
Pinion Tail Brg.	72212C-72487	1
Pinion Nose Brg.	MU1309UGM	1
Pinion Seal	475003N (26220)	1
Felt Seal	5M867 (654)	1
Sealer	RTV Silicone	1

DRK-416		
Position	Part Number	Qty
Differential Right Brg.	56425-56650	1
Differential Left Brg.	56425-56650	1
Pinion Head Brg.	9185-9121	1
Pinion Tail Brg.	H715343-H715311	1
Pinion Nose Brg.	RU9008UM	1
Pinion Seal	300HH100	1
Sealer	RTV Silicone	1

DRK-417		
Position	Part Number	Qty
Differential Right Brg.	567-563	1
Differential Left Brg.	497-493	1
Pinion Head Brg.	72218C-72487	1
Pinion Tail Brg.	HM807049-HM807010	1
Pinion Nose Brg.	MUSB1307UM	1
Outer Pinion Support Brg.	MUF1208CBXV1	1
Input Shaft Front Brg.	3979-JM511910	1
Input Shaft Rear Brg.	3979-3920	1
Front Output Shaft Front Brg.	3780-3720	1
Front Output Shaft Rear Brg.	LM501349-LM501310	1
Input Shaft Seal	119429	1
Front Thrushaft Seal	475003N (26220)	1
Sealer	RTV Silicone	1

DRK-418		
Position	Part Number	Qty
Differential Right Brg.	665-653	1
Differential Left Brg.	42381-42584	1
Pinion Head Brg.	72212C-72487	1
Pinion Tail Brg.	72212C-72487	1
Pinion Nose Brg.	MUB1308UM	1
Outer Pinion Support Brg.	MU1309CV	1
Input Shaft Front Brg.	JH211749-JH211710	1
Input Shaft Rear Brg.	JM511946-JM511910	1
Front Output Shaft Front Brg.	3979-3920	1
Front Output Shaft Rear Brg.	3872-3820	1
Input Shaft Seal	119430	1
Front Thrushaft Seal	119429	1
Sealer	RTV Silicone	1

DRK-419		
Position	Part Number	Qty
Differential Right Brg.	497-493	1
Differential Left Brg.	56425-56650	1
Pinion Head Brg.	72218C-72487	1
Pinion Tail Brg.	HM807049-HM807010	1
Pinion Nose Brg.	MUSB1307UM	1
Outer Pinion Support Brg.	MUF1208CBXV1	1
Input Shaft Front Brg.	3979-JM511910	1
Input Shaft Rear Brg.	3979-3920	1
Front Output Shaft Front Brg.	3780-3720	1
Front Output Shaft Rear Brg.	LM501349-LM501310	1
Input Shaft Seal	119429	1
Front Thrushaft Seal	475003N (26220)	1
Sealer	RTV Silicone	1

DRK-420		
Position	Part Number	Qty
Differential Right Brg.	42381-42584	1
Differential Left Brg.	68462-68712	1
Pinion Head Brg.	72212C-72487	1
Pinion Tail Brg.	72212C-72487	1
Pinion Nose Brg.	MUB1308UM	1
Outer Pinion Support Brg.	MU1309CV	1
Input Shaft Front Brg.	JH211749-JH211710	1
Input Shaft Rear Brg.	JM511946-JM511910	1
Front Output Shaft Front Brg.	3979-3920	1
Front Output Shaft Rear Brg.	3872-3820	1
Input Shaft Seal	119430	1
Front Thrushaft Seal	119429	1
Sealer	RTV Silicone	1

DRK-421		
Position	Part Number	Qty
Differential Right Brg.	42346-42584	1
Differential Left Brg.	68462-68712	1
Pinion Head Brg.	72212C-72487	1
Pinion Tail Brg.	72212C-72487	1
Pinion Nose Brg.	MUB1308UM	1
Outer Pinion Support Brg.	MU1309CV	1
Input Shaft Front Brg.	JH211749-JH211710	1
Input Shaft Rear Brg.	JM511946-JM511910	1
Front Output Shaft Front Brg.	3979-3920	1
Front Output Shaft Rear Brg.	3872-3820	1
Input Shaft Seal	119430	1
Front Thrushaft Seal	119429	1
Sealer	RTV Silicone	1

DRK-422		
Position	Part Number	Qty
Differential Right Brg.	567-563	1
Differential Left Brg.	497-493	1
Pinion Head Brg.	72218C-72487	1
Pinion Tail Brg.	HM807049-HM807010	1
Pinion Nose Brg.	MUSB1307UM	1
Outer Pinion Support Brg.	MUF1208CBXV1	1
Input Shaft Front Brg.	3979-JM511910	1
Input Shaft Rear Brg.	29675-29620	1
Front Output Shaft Front Brg.	3780-3720	1
Front Output Shaft Rear Brg.	LM501349-LM501310	1
Rear Output Shaft Brg.	MA1209EL	1
Input Shaft Seal	119429	1
Front Thrushaft Seal	475003N (26220)	1
Rear Thrushaft Seal	475003N (26220)	1
Sealer	RTV Silicone	1

DRK-423		
Position	Part Number	Qty
Differential Right Brg.	665-653	1
Differential Left Brg.	42381-42584	1
Pinion Head Brg.	72212C-72487	1
Pinion Tail Brg.	72212C-72487	1
Pinion Nose Brg.	MUB1308UM	1
Outer Pinion Support Brg.	MU1309CV	1
Input Shaft Front Brg.	JM511946-JM511910	1
Input Shaft Rear Brg.	33275-33472	1
Front Output Shaft Front Brg.	3979-3920	1
Front Output Shaft Rear Brg.	HM88649-HM88610	1
Rear Output Shaft Brg.	MA1211EL	1
Input Shaft Seal	119430	1
Front Thrushaft Seal	119429	1
Rear Thrushaft Seal	119429	1
Sealer	RTV Silicone	1

DRK-424		
Position	Part Number	Qty
Differential Right Brg.	56425-56650	1
Differential Left Brg.	497-493	1
Pinion Head Brg.	72218C-72487	1
Pinion Tail Brg.	HM807049-HM807010	1
Pinion Nose Brg.	MUSB1307UM	1
Outer Pinion Support Brg.	MUF1208CBXV1	1
Input Shaft Front Brg.	3979-JM511910	1
Input Shaft Rear Brg.	29675-29620	1
Front Output Shaft Front Brg.	3780-3720	1
Front Output Shaft Rear Brg.	LM501349-LM501310	1
Rear Output Shaft Brg.	MA1209EL	1
Input Shaft Seal	119429	1
Front Thrushaft Seal	475003N (26220)	1
Rear Thrushaft Seal	475003N (26220)	1
Sealer	RTV Silicone	1

DRK-425		
Position	Part Number	Qty
Differential Right Brg.	42381-42584	1
Differential Left Brg.	68462-68712	1
Pinion Head Brg.	72212C-72487	1
Pinion Tail Brg.	72212C-72487	1
Pinion Nose Brg.	MUB1308UM	1
Outer Pinion Support Brg.	MU1309CV	1
Input Shaft Front Brg.	JM511946-JM511910	1
Input Shaft Rear Brg.	33275-33472	1
Front Output Shaft Front Brg.	3979-3920	1
Front Output Shaft Rear Brg.	HM88649-HM88610	1
Rear Output Shaft Brg.	MA1211EL	1
Input Shaft Seal	119430	1
Front Thrushaft Seal	119429	1
Rear Thrushaft Seal	119429	1
Sealer	RTV Silicone	1

Differential Rebuild Kits

HD Differential

DRK-426		
Position	Part Number	Qty
Differential Right Brg.	42346-42584	1
Differential Left Brg.	68462-68712	1
Pinion Head Brg.	72212C-72487	1
Pinion Tail Brg.	72212C-72487	1
Pinion Nose Brg.	MUB1308UM	1
Outer Pinion Support Brg.	MU1309CV	1
Input Shaft Front Brg.	JM511946-JM511910	1
Input Shaft Rear Brg.	33275-33472	1
Front Output Shaft Front Brg.	3979-3920	1
Front Output Shaft Rear Brg.	HM88649-HM88610	1
Rear Output Shaft Brg.	MA1211EL	1
Input Shaft Seal	119430	1
Front Thrushaft Seal	119429	1
Rear Thrushaft Seal	119429	1
Sealer	RTV Silicone	1

DRK-427		
Position	Part Number	Qty
Differential Right Brg.	NP799449-NP105857	1
Differential Left Brg.	NP380290-NP533133	1
Pinion Head Brg.	NP242732-NP611140	1
Pinion Tail Brg.	55212C-55437	1
Pinion Nose Brg.	MUB1307UM	1
Input Shaft Front Brg.	NP930036-NP193660	1
Input Shaft Rear Brg.	29675-29630	1
Output Shaft Front Brg.	LM104949-JLM104910	1
Output Shaft Rear Brg.	LM104949-JLM104910	1
Output Shaft O-Ring	OR-232	2
Input Shaft Seal	DT7591	1
Thrushaft Seal	DT7592	1
Sealer	RTV Silicone	1

DRK-427A		
Position	Part Number	Qty
Differential Right Brg.	NP799449-NP105857	1
Differential Left Brg.	NP380290-NP533133	1
Pinion Head Brg.	NP242732-NP611140	1
Pinion Tail Brg.	55212C-55437	1
Pinion Nose Brg.	MUB1307UM	1
Input Shaft Front Brg.	NP930036-NP193660	1
Input Shaft Rear Brg.	29688-29620	1
Output Shaft Front Brg.	LM104949-JLM104910	1
Output Shaft Rear Brg.	LM104949-JLM104910	1
Output Shaft O-Ring	OR-232	2
Input Shaft Seal	DT7591	1
Thrushaft Seal	DT7592	1
Sealer	RTV Silicone	1

DRK-428		
Position	Part Number	Qty
Differential Right Brg.	NP799449-NP105857	1
Differential Left Brg.	42362-42584	1
Pinion Head Brg.	NP242732-NP611140	1
Pinion Tail Brg.	55212C-55437	1
Pinion Nose Brg.	MUB1307UM	1
Input Shaft Front Brg.	NP930036-NP193660	1
Input Shaft Rear Brg.	29675-29630	1
Output Shaft Front Brg.	LM104949-JLM104910	1
Output Shaft Rear Brg.	LM104949-JLM104910	1
Input Shaft Seal	DT7591	1
Thrushaft Seal	DT7592	1
Sealer	RTV Silicone	1

DRK-428A		
Position	Part Number	Qty
Differential Right Brg.	NP799449-NP105857	1
Differential Left Brg.	42362-42584	1
Pinion Head Brg.	NP242732-NP611140	1
Pinion Tail Brg.	55212C-55437	1
Pinion Nose Brg.	MUB1307UM	1
Input Shaft Front Brg.	NP930036-NP193660	1
Input Shaft Rear Brg.	29688-29620	1
Output Shaft Front Brg.	LM104949-JLM104910	1
Output Shaft Rear Brg.	LM104949-JLM104910	1
Input Shaft Seal	DT7591	1
Thrushaft Seal	DT7592	1
Sealer	RTV Silicone	1

DRK-429		
Position	Part Number	Qty
Differential Right Brg.	NP799449-NP105857	1
Differential Left Brg.	NP380290-NP533133	1
Pinion Head Brg.	NP523912-NP611140	1
Pinion Tail Brg.	55200C-55437	1
Pinion Nose Brg.	MUB7307UM	1
Pinion Seal	DT7591	1
Sealer	RTV Silicone	1

DRK-430		
Position	Part Number	Qty
Differential Right Brg.	NP799449-NP105857	1
Differential Left Brg.	42362-42584	1
Pinion Head Brg.	NP523912-NP611140	1
Pinion Tail Brg.	55200C-55437	1
Pinion Nose Brg.	MUB7307UM	1
Pinion Seal	DT7591	1
Sealer	RTV Silicone	1

DRK-431		
Position	Part Number	Qty
Differential Right Brg.	665-653	1
Differential Left Brg.	42381-42584	1
Pinion Head Brg.	NP523912-NP611140	1
Pinion Tail Brg.	NP523912-NP611140	1
Pinion Nose Brg.	MUB1308UM	1
Outer Pinion Support Brg. (Pre 2/2000)	MU1309CV	1
Outer Pinion Support Brg. (Aft 2/2000)	MU1309UGM	1
Input Shaft Front Brg.	JM511946-JM511910	1
Output Shaft Front Brg.	33275-33472	1
Output Shaft Rear Brg.	MA1211EL	1
Input Shaft Seal	210736	1
Thrushaft Seal	210737	1
Sealer	RTV Silicone	1

DRK-432		
Position	Part Number	Qty
Differential Right Brg.	68462-68712	1
Differential Left Brg.	42381-42584	1
Pinion Head Brg.	72212C-72487	1
Pinion Tail Brg.	72212C-72487	1
Pinion Nose Brg.	MUB1308UM	1
Input Shaft Brg.	JM511946-JM511910	1
Outer Pinion Support Brg.	MU1309UGM	1
Output Shaft Front Brg.	33275-33472	1
Output Shaft Rear Brg.	MA1211EL	1
Input Shaft Seal	210736	1
Thrushaft Seal	210737	1
Sealer	RTV Silicone	1

DRK-433		
Position	Part Number	Qty
Differential Right Brg.	665-653	1
Differential Left Brg.	42381-42584	1
Pinion Head Brg.	72212C-72487	1
Pinion Tail Brg.	72212C-72487	1
Pinion Nose Brg.	MUB1308UM	1
Input Shaft Brg.	JM511946-JM511910	1
Output Shaft Front Brg.	33275-33472	1
Output Shaft Rear Brg.	MA1211EL	1
Outer Pinion Support Brg.	MU1309UGM	1
Input Shaft Seal	210736	1
Thrushaft Seal	210737	1
Sealer	RTV Silicone	1

DRK-434		
Position	Part Number	Qty
Differential Right Brg.	3984-3920	1
Differential Left Brg.	3984-3920	1
Pinion Head Brg.	72212C-72487	1
Pinion Tail Brg.	55200C-55437	1
Pinion Seal	DT7591	1
Sealer	RTV Silicone	1

DRK-435		
Position	Part Number	Qty
Differential Right Brg.	68462-68712	1
Differential Left Brg.	42381-42584	1
Pinion Head Brg.	NP523912-NP611140	1
Pinion Tail Brg.	NP523912-NP611140	1
Pinion Nose Brg.	MUB1308UM	1
Outer Pinion Support Brg. (Pre 2/2000)	MU1309CV	1
Outer Pinion Support Brg. (Aft 2/2000)	MU1309UGM	1
Input Shaft Front Brg.	JM511946-JM511910	1
Output Shaft Front Brg.	33275-33472	1
Output Shaft Rear Brg.	MA1211EL	1
Input Shaft Seal	210736	1
Thrushaft Seal	210737	1
Sealer	RTV Silicone	1

DRK-436		
Position	Part Number	Qty
Differential Right Brg.	NP237087-NP049312.904	1
Differential Left Brg.	NP374995-NP120322.904	1
Pinion Head Brg.	NP478770-NP547156	1
Pinion Tail Brg.	NP846736-NP166419	1
Input Shaft Front Brg.	HM813844-HM813810	1
Input Shaft Rear Brg.	NP171276-NP943289	1
Input Shaft Seal & Pinion Nut Kit	131008K	1
Input Shaft V-Ring	401300	1
Thrushaft Seal	210737	1
Input Shaft Thrust Washer	132440	1
Sealer	RTV Silicone	1

DRK-436A		
Position	Part Number	Qty
Differential Right Brg.	140019-14020	1
Differential Left Brg.	140014-140012	1
Pinion Head Brg.	NP478770-NP547156	1
Pinion Tail Brg.	NP846736-NP166419	1
Input Shaft Front Brg.	HM813844-HM813810	1
Input Shaft Rear Brg.	NP171276-NP943289	1
Input Shaft Seal & Pinion Nut Kit	131008K	1
Input Shaft V-Ring	401300	1
Thrushaft Seal	210737	1
Input Shaft Thrust Washer	132440	1
Sealer	RTV Silicone	1

Differential Rebuild Kits

HD Differential

DRK-437		
Position	Part Number	Qty
Differential Right Brg.	NP237087-NP049312.904	1
Differential Left Brg.	NP374995-NP120322.904	1
Pinion Head Brg.	NP478770-NP547156	1
Pinion Tail Brg.	NP846736-NP166419	1
Pinion Nose Brg.	WUB61308UM	1
Input Shaft Front Brg.	HM813844-HM813810	1
Input Shaft Rear Brg.	NP171276-NP943289	1
Input Shaft Seal & Pinion Nut Kit	131008K	1
Input Shaft V-Ring	401300	1
Thrushaft Seal	210737	1
Input Shaft Thrust Washer	132440	1
Sealer	RTV Silicone	1

DRK-437A		
Position	Part Number	Qty
Differential Right Brg.	140019-140020	1
Differential Left Brg.	140014-140012	1
Pinion Head Brg.	NP478770-NP547156	1
Pinion Tail Brg.	NP846736-NP166419	1
Pinion Nose Brg.	WUB61308UM	1
Input Shaft Front Brg.	HM813844-HM813810	1
Input Shaft Rear Brg.	NP171276-NP943289	1
Input Shaft Seal & Pinion Nut Kit	131008K	1
Input Shaft V-Ring	401300	1
Thrushaft Seal	210737	1
Input Shaft Thrust Washer	132440	1
Sealer	RTV Silicone	1

DRK-438		
Position	Part Number	Qty
Differential Right Brg.	NP374995-NP120322.904	1
Differential Left Brg.	NP374995-NP120322.904	1
Pinion Head Brg.	NP478770-NP547156	1
Pinion Tail Brg.	NP927527-NP547156	1
Pinion Nose Brg.	WUB61308UM	1
Pinion Seal & Nut Kit	131008K	1
Sealer	RTV Silicone	1

DRK-438A		
Position	Part Number	Qty
Differential Right Brg.	140014-140012	1
Differential Left Brg.	140014-140012	1
Pinion Head Brg.	NP478770-NP547156	1
Pinion Tail Brg.	NP927527-NP547156	1
Pinion Nose Brg.	WUB61308UM	1
Pinion Seal & Nut Kit	131008K	1
Sealer	RTV Silicone	1

DRK-439		
Position	Part Number	Qty
Differential Right Brg.	NP374995-NP120322.904	1
Differential Left Brg.	NP374995-NP120322.904	1
Pinion Head Brg.	NP478770-NP547156	1
Pinion Tail Brg.	NP927527-NP547156	1
Pinion Seal & Nut Kit	131008K	1
Sealer	RTV Silicone	1

DRK-439A		
Position	Part Number	Qty
Differential Right Brg.	140014-140012	1
Differential Left Brg.	140014-140012	1
Pinion Head Brg.	NP478770-NP547156	1
Pinion Tail Brg.	NP927527-NP547156	1
Pinion Seal & Nut Kit	131008K	1
Sealer	RTV Silicone	1

DRK-441		
Position	Part Number	Qty
Differential Right Brg.	NP237087-NP049312.904	1
Differential Left Brg.	NP374995-NP120322.904	1
Pinion Head Brg.	NP478770-NP547156	1
Pinion Tail Brg.	NP927527-NP547156	1
Pinion Nose Brg.	MUB1308UM	1
Pinion Seal & Nut Kit	131008K	1
Sealer	RTV Silicone	1

DRK-441A		
Position	Part Number	Qty
Differential Right Brg.	140019-140020	1
Differential Left Brg.	140014-140012	1
Pinion Head Brg.	NP478770-NP547156	1
Pinion Tail Brg.	NP927527-NP547156	1
Pinion Nose Brg.	MUB1308UM	1
Pinion Seal & Nut Kit	131008K	1
Sealer	RTV Silicone	1

DRK-442		
Position	Part Number	Qty
Differential Right Brg.	NP374995-NP120322.904	1
Differential Left Brg.	NP374995-NP120322.904	1
Pinion Head Brg.	NP478770-NP547156	1
Pinion Tail Brg.	NP846736-NP166419	1
Input Shaft Front Brg.	HM813844-HM813810	1
Input Shaft Rear Brg.	NP171276-NP943289	1
Input Shaft Seal & Pinion Nut Kit	131008K	1
Input Shaft V-Ring	401300	1
Thrushaft Seal	210737	1
Input Shaft Thrust Washer	132440	1
Sealer	RTV Silicone	1

DRK-442A		
Position	Part Number	Qty
Differential Right Brg.	140014-140012	1
Differential Left Brg.	140014-140012	1
Pinion Head Brg.	NP478770-NP547156	1
Pinion Tail Brg.	NP846736-NP166419	1
Input Shaft Front Brg.	HM813844-HM813810	1
Input Shaft Rear Brg.	NP171276-NP943289	1
Input Shaft Seal & Pinion Nut Kit	131008K	1
Input Shaft V-Ring	401300	1
Thrushaft Seal	210737	1
Input Shaft Thrust Washer	132440	1
Sealer	RTV Silicone	1

DRK-443		
Position	Part Number	Qty
Differential Right Brg.	NP237087-NP049312.904	1
Differential Left Brg.	NP374995-NP120322.904	1
Pinion Head Brg.	NP478770-NP547156	1
Pinion Tail Brg.	NP927527-NP547156	1
Pinion Nose Brg.	WUB61308UM	1
Pinion Seal & Nut Kit	131008K	1
Sealer	RTV Silicone	1

DRK-443A		
Position	Part Number	Qty
Differential Right Brg.	140019-140020	1
Differential Left Brg.	140014-140012	1
Pinion Head Brg.	NP478770-NP547156	1
Pinion Tail Brg.	NP927527-NP547156	1
Pinion Nose Brg.	WUB61308UM	1
Pinion Seal & Nut Kit	131008K	1
Sealer	RTV Silicone	1

DRK-444		
Position	Part Number	Qty
Differential Right Brg.	NP237087-NP049312.904	1
Differential Left Brg.	NP374995-NP120322.904	1
Pinion Head Brg.	NP478770-NP547156	1
Pinion Tail Brg.	NP927527-NP547156	1
Pinion Seal & Nut Kit	131008K	1
Sealer	RTV Silicone	1

DRK-444A		
Position	Part Number	Qty
Differential Right Brg.	140019-140020	1
Differential Left Brg.	140014-140012	1
Pinion Head Brg.	NP478770-NP547156	1
Pinion Tail Brg.	NP927527-NP547156	1
Pinion Seal & Nut Kit	131008K	1
Sealer	RTV Silicone	1

DRK-445		
Position	Part Number	Qty
Differential Right Brg.	567-563	1
Differential Left Brg.	NP380290-NP533133	1
Pinion Head Brg.	72200C-NP611140	1
Pinion Tail Brg.	55200C-55437	1
Pinion Nose Brg.	MUB7307UM	1
Pinion Seal	DT7591	1
Sealer	RTV Silicone	1

DRK-446		
Position	Part Number	Qty
Differential Right Brg.	567-563	1
Differential Left Brg.	NP380290-NP533133	1
Pinion Head Brg.	72200C-NP611140	1
Pinion Tail Brg.	55200C-55437	1
Pinion Nose Brg.	WUB61307UM	1
Pinion Seal	DT7591	1
Sealer	RTV Silicone	1

DRK-447		
Position	Part Number	Qty
Differential Right Brg.	567-563	1
Differential Left Brg.	NP380290-NP533133	1
Pinion Head Brg.	NP523912-NP611140	1
Pinion Tail Brg.	55200C-55437	1
Pinion Nose Brg.	MUB7307UM	1
Pinion Seal	DT7591	1
Sealer	RTV Silicone	1

DRK-448		
Position	Part Number	Qty
Differential Right Brg.	567-563	1
Differential Left Brg.	NP380290-NP533133	1
Pinion Head Brg.	NP523912-NP611140	1
Pinion Tail Brg.	55200C-55437	1
Pinion Nose Brg.	WUB61307UM	1
Pinion Seal	DT7591	1
Sealer	RTV Silicone	1

DRK-449		
Position	Part Number	Qty
Differential Right Brg.	42381-42584	1
Differential Left Brg.	665-653	1
Pinion Head Brg.	78215C-78551	1
Pinion Tail Brg.	72212C-72487	1
Pinion Nose Brg.	MUB1308UM	1
Pinion Seal	210724	1
Sealer	RTV Silicone	1

Differential Rebuild Kits



HD Differential

DRK-500		
Position	Part Number	Qty
Differential Right Brg.	47687-47623A	1
Differential Left Brg.	HM516448-HM516414B	1
Pinion Head Brg.	596-592A	1
Pinion Tail Brg.	H715348-H715311	1
Cross Shaft Right Brg.	H715334-H715311	1
Cross Shaft Left Brg.	H715345-H715311	1
Input Shaft Brg.	1213L	1
Inter Axle Brg.	1211	1
Input Shaft Seal	4491V (34882)	1
Thrushaft Seal	4492V (27558)	1
O-Ring	OR256	1
O-Ring	OR260	1
O-Ring	OR270	1
Gasket	GG53916	1
Gasket	GG53917	1
Sealer	RTV Silicone	1

DRK-501		
Position	Part Number	Qty
Differential Right Brg.	47687-47623A	1
Differential Left Brg.	HM516448-HM516414B	1
Pinion Head Brg.	6466-6420	1
Pinion Tail Brg.	H715334-H715311	1
Cross Shaft Right Brg.	H715334-H715311	1
Cross Shaft Left Brg.	H715345-H715311	1
Pinion Seal	4491V (34882)	1
O-Ring	OR256	1
O-Ring	OR270	1
Gasket Set	BGK3902	1
Sealer	RTV Silicone	1

DRK-502		
Position	Part Number	Qty
Differential Right Brg.	47681-47623A	1
Differential Left Brg.	47681-47623AB	1
Pinion Head Brg.	5760-5735	1
Pinion Tail Brg.	49585-49520	1
Cross Shaft Right Brg.	624-612	1
Cross Shaft Left Brg.	H414249-H414211W	1
Pinion Seal	35009N (27452)	1
Sealer	RTV Silicone	1

DRK-503		
Position	Part Number	Qty
Differential Right Brg.	47687-47623A	1
Differential Left Brg.	HM516448-HM516414B	1
Pinion Head Brg.	5760-5735	1
Pinion Tail Brg.	559-552A	1
Cross Shaft Right Brg.	621-612	1
Cross Shaft Left Brg.	H715345-H715313W	1
Pinion Seal	415991N (34891)	1
O-Ring Set	OK205	1
Gasket Set	GT-503	1
Sealer	RTV Silicone	1

DRK-504		
Position	Part Number	Qty
Differential Right Brg.	47681-47622W	1
Differential Left Brg.	47681-47622BW	1
Pinion Head Brg.	643-632	1
Pinion Tail Brg.	559-552A	1
Cross Shaft Right Brg.	624-612	1
Cross Shaft Left Brg.	645X-634W	1
Input Shaft Brg.	310	1
Power Divider Brg.	MU1211CL	1
Inter Axle Brg.	309	1
Input Shaft Seal	415013N (29925)	1
Thrushaft Seal	415001N (25065)	1
Sealer	RTV Silicone	1

DRK-505		
Position	Part Number	Qty
Differential Right Brg.	47681-47622W	1
Differential Left Brg.	47681-47622BW	1
Pinion Head Brg.	643-632	1
Pinion Tail Brg.	555-552A	1
Cross Shaft Right Brg.	624-612	1
Cross Shaft Left Brg.	645X-634W	1
Input Shaft Seal	415013N (29925)	1
Thrushaft Seal	415001N (25065)	1
Sealer	RTV Silicone	1

DRK-506		
Position	Part Number	Qty
Differential Right Brg.	77375-77676W	1
Differential Left Brg.	77375-77676BW	1
Pinion Head Brg.	6460-6420	1
Pinion Tail Brg.	65225-65550	1
Cross Shaft Right Brg.	835-833W	1
Cross Shaft Left Brg.	6576-6535W	1
Pinion Seal	415156N	1
Sealer	RTV Silicone	1

DRK-507		
Position	Part Number	Qty
Differential Right Brg.	47687-47623A	1
Differential Left Brg.	HM516448-HM516414B	1
Pinion Head Brg.	HM518437-HM518411	1
Pinion Tail Brg.	495S-492A	1
Cross Shaft Right Brg.	621-612	1
Cross Shaft Left Brg.	HM518437-HM518411W	1
Input Shaft Brg.	1213L	1
Thrushaft Brg.	1211	1
Input Shaft Seal	4491V	1
Thrushaft Seal	4492V	1
Oil Port Seal	21136471	1
O-Ring Set	OK507	1
Sealer	RTV Silicone	1

DRK-508		
Position	Part Number	Qty
Differential Right Brg.	47687-47623A	1
Differential Left Brg.	HM516448-HM516414B	1
Pinion Head Brg.	HM518437-HM518411	1
Pinion Tail Brg.	495S-492A	1
Cross Shaft Right Brg.	621-612	1
Cross Shaft Left Brg.	HM518437-HM518411W	1
Pinion Seal	21126859	1
Oil Port Seal	21136471	1
O-Ring Set	OK508	1
Sealer	RTV Silicone	1

DRK-600		
Position	Part Number	Qty
Differential Right Brg.	495-493	1
Differential Left Brg.	495-493	1
Pinion Tail Brg.	66212-66462	1
Pinion Head Brg.	72225C-72487	1
Pinion Seal	35009N (27452)	1
Pinion Nose Brg.	MUB1307UM	1
Sealer	RTV Silicone	1

DRK-601		
Position	Part Number	Qty
Differential Right Brg.	NP547288-NP478159	1
Differential Left Brg.	33214	1
Pinion Head Brg.	NP635208-NP160764	1
Pinion Tail Brg.	NP942787-NP378089	1
Pinion Seal	DTQ2591	1
Sealer	RTV Silicone	1

DRK-650F		
Position	Part Number	Qty
Differential Right Brg.	32022X	1
Differential Left Brg.	32017X	1
Pinion Head Brg.	805096	1
Pinion Tail Brg.	805097	1
Input Shaft Front Brg.	JM511945-3920	1
Input Shaft Rear Brg.	JLM714149-JLM714110	1
Helical Gear Thrust Brg.	ZN1213	1
Helical Gear Needle	ZN1212	2
Brg.		
Input Shaft Seal	P0139976646	1
Thrushaft Seal	P0139976746	1

DRK-650R		
Position	Part Number	Qty
Differential Right Brg.	32022X	1
Differential Left Brg.	32017X	1
Pinion Head Brg.	805096	1
Pinion Tail Brg.	805097	1
Pinion Seal	P0139976246	1

DRK-651		
Position	Part Number	Qty
Differential Right Brg.	32020X	1
Differential Left Brg.	32014X	1
Pinion Head Brg.	JW6049-JW6010	1
Pinion Tail Brg.	JW6049-JW6010	1
Pinion Seal	P0249978047	1

DRK-700		
Position	Part Number	Qty
Differential Right Brg.	388A-382	1
Differential Left Brg.	388A-382	1
Pinion Head and Tail Brg.	A1011(55197 Assy 90030) ⁹	1
Pinion Nose Brg.	MR5205EL	1
Pinion Seal	411330N (25970)	1
Felt Seal	5M89 (528)	1
Sealer	RTV Silicone	1

DRK-701		
Position	Part Number	Qty
Differential Right Brg.	28990-28919	1
Differential Left Brg.	28990-28919	1
Pinion Head Brg.	5310WA	1
Pinion Tail Brg.	MU1306TDM	1
Pinion Seal	411330N (25970)	1
Felt Seal	5M89 (528)	1

DRK-702		
Position	Part Number	Qty
Differential Right Brg.	KR12051Z	1
Differential Left Brg.	KR12051Z	1
Pinion Head and Tail Brg.	A1011(55197 Assy 90030) ⁹	1
Pinion Nose Brg.	MR5206EL	1
Pinion Seal	411330N (25970)	1
Felt Seal	5M89 (528)	1
Sealer	RTV Silicone	1

DRK-801		
Position	Part Number	Qty
Differential Right Brg.	594-592A	1
Differential Left Brg.	594-592A	1
Pinion Head Brg.	31315	1
Pinion Tail Brg.	HM911245-HM911210	1
Pinion Nose Brg.	MU1308UM	1
Input Shaft Front Brg.	30214	1
Input Shaft Rear Brg.	JLM714149-JLM714110	1
Input Shaft Front Needle Brg.	183788	1
Input Shaft Rear Needle Brg.	181632	1
Output Shaft Brg.	310	1
Input Shaft Seal	948642	1
Thrushaft Seal	948448	1

Differential Rebuild Kits

HD Differential

DRK-802

Position	Part Number	Qty
Differential Right Brg.	594-592A	1
Differential Left Brg.	594-592A	1
Pinion Head Brg.	H913843-H913810	1
Pinion Tail Brg.	HM911245-HM911210	1
Pinion Nose Brg.	MU1308UM	1
Pinion Seal	1522895	1

DRK-900F

Position	Part Number	Qty
Differential Right Brg.	496-493	1
Differential Left Brg.	497-493 ¹⁰	1
Pinion Head Brg.	72200C-72487	1
Pinion Tail Brg.	72200C-72487	1
Pinion Nose Brg.	RU1570UM	1
Drive Gear Front Brg.	29675-29630	1
Drive Gear Rear Brg.	29675-29630	1
Idler Gear Cone	31597	2
Idler Gear Cup	31520 •	2
Input Shaft Brg.	211B	1
Thrushaft Brg.	LM603049-LM603011 •	2
Input Shaft Seal	35949N (29288)	1
Thrushaft Seal	475322N (27295) •	1
Sealer	RTV Silicone	1

DRK-900FA

Position	Part Number	Qty
Differential Right Brg.	496-493	1
Differential Left Brg.	497-493 ¹⁰	1
Pinion Head Brg.	72200C-72487	1
Pinion Tail Brg.	72200C-72487	1
Pinion Nose Brg.	RU1570UM	1
Drive Gear Front Brg.	29675-29630	1
Drive Gear Rear Brg.	29675-29630	1
Idler Gear Brg.	31597-31520	2
Input Shaft Brg.	211B	1
Thrushaft Brg.	LM603049-LM603011	2
Input Shaft Seal	35949N (29288)	1
Thrushaft Seal	475322N (27295) •	1
Sealer	RTV Silicone	1

DRK-1910

Position	Part Number	Qty
Differential Right Brg.	683-672	1
Differential Left Brg.	683-672	1
Pinion Head Brg.	42350-42584	1
Pinion Tail Brg.	42350-42584	1
Cross Shaft Left Brg.	MU1221UM	1
Cross Shaft Right Brg.	641-632	2
Rear Pinion Brg.	MR1213EL	1
Pinion Seal	415086N (30055)	2
Sealer	RTV Silicone	1

DRK-1918

Position	Part Number	Qty
Differential Right Brg.	33281-33472	1
Differential Left Brg.	33281-33472	1
Pinion Head Brg.	55187C-55443	1
Pinion Tail Brg.	55176C-55443	1
Pinion Nose Brg.	RU1570UM	1
Pinion Seal	410101N	1
Sealer	RTV Silicone	1

DRK-1925

Position	Part Number	Qty
Differential Right Brg.	47686-47620	1
Differential Left Brg.	47686-47620	1
Pinion Head Brg.	H715345-H715311	1
Pinion Tail Brg.	HM807046-HM807010	1
Cross Shaft Right Brg.	65225-65500	1
Cross Shaft Left Brg.	65225-65500	1
Pinion Seal	476283N (27601)	1
Sealer	RTV Silicone	1

DRK-1925A

Position	Part Number	Qty
Differential Right Brg.	HM516449C-HM516410	1
Differential Left Brg.	HM516449C-HM516410	1
Pinion Head Brg.	H715345-H715311	1
Pinion Tail Brg.	HM807046-HM807010	1
Cross Shaft Right Brg.	65225-65500	1
Cross Shaft Left Brg.	65225-65500	1
Pinion Seal	476283N (27601)	1
Sealer	RTV Silicone	1

DRK-1926

Position	Part Number	Qty
Differential Right Brg.	34301-34500	1
Differential Left Brg.	42688-42620	1
Pinion Head Brg.	55200C-55437	1
Pinion Tail Brg.	55187C-55437	1
Pinion Nose Brg.	RU1570UM	1
Pinion Seal	35009N (27452)	1
Sealer	RTV Silicone	1

DRK-1984

Position	Part Number	Qty
Differential Right Brg.	47890-47820	1
Differential Left Brg.	47890-47820	1
Pinion Head Brg.	H715343-H715311	1
Pinion Tail Brg.	H715343-H715311	1
Pinion Nose Brg.	MU1308UM	1
Input Shaft Front Brg.	3767-3720	1
Input Shaft Rear Brg.	3775-3720	1
Idler Gear Front Brg.	49585-49520	1
Idler Gear Rear Brg.	HM807046-HM807010	1
Input Shaft Seal	4564V	1
Sealer	RTV Silicone	1

DRK-2108

Position	Part Number	Qty
Differential Right Brg.	687-672	1
Differential Left Brg.	687-672	1
Pinion Head Brg.	HM813844-HM813810	1
Pinion Tail Brg.	H715341-H715311	1
Pinion Nose Brg.	MU5208UM	1
Pinion Seal (C100)	6612S (35098)	1
Sealer	RTV Silicone	1

DRK-2111

Position	Part Number	Qty
Differential Right Brg.	395-394A	1
Differential Left Brg.	395-394A	1
Pinion Head Brg.	M903345-M903310	1
Pinion Tail Brg.	44143-44348	1
Pinion Nose Brg.	MU1305TDM	1
Pinion Seal (C100)	410308 (21213)	1
Pinion Seal (C102 & C103)	475080N (21379)	1
Sealer	RTV Silicone	1

DRK-4095

Position	Part Number	Qty
Differential Right Brg.	47890-47820	1
Differential Left Brg.	47890-47820	1
Pinion Head Brg.	H715343-H715311	1
Pinion Tail Brg.	65237-65500	1
Inter Differential Brg.	JLM714149-JLM714110	1
Input Shaft Brg.	JH211749-JH211710	1
Output Shaft Brg.	LM104949-JLM104910	2
Input Shaft Seal	416470N (32385)	1
Thrushaft Seal	4492V (27558)	1
Sealer	RTV Silicone	1

DRK-4100

Position	Part Number	Qty
Differential Right Brg.	47890-47820	1
Differential Left Brg.	47890-47820	1
Pinion Head Brg.	H715343-H715311	1
Pinion Tail Brg.	65237-65500	1
Inter Differential Brg.	JLM714149-JLM714110	1
Input Shaft Brg.	JH211749-JH211710	1
Thrushaft Brg.	210	1
Input Shaft Seal	416470N (32385)	1
Thrushaft Seal	475322N (27295)	1
O-Ring	5X591	1
Sealer	RTV Silicone	1
Threadlocker	TL1	1

DRK-4105

Position	Part Number	Qty
Differential Right Brg.	47890-47820	1
Differential Left Brg.	47890-47820	1
Pinion Head Brg.	H715343-H715311	1
Pinion Tail Brg.	H715334-H715311	1
Pinion Nose Brg.	MUB1308UM	1
Pinion Seal	4876N	1
Sealer	RTV Silicone	1

DRK-4125

Position	Part Number	Qty
Differential Right Brg.	598-592A	1
Differential Left Brg.	52387-52618	1
Pinion Head Brg.	78250AC-78551	1
Pinion Tail Brg.	78250AC-78551	1
Pinion Nose Brg.	MUC1309UM	1
Input Shaft Front Brg.	HM813841-HM813810	1
Input Shaft Rear Brg.	JM515649-JM515610	1
Thrushaft Brg.	385A-382A	2
Oil Pump Idler Gear Brg.	5204K	1
Input Shaft Seal	416470N (32385)	1
Thrushaft Seal	415013N (29925)	1
Sealer	RTV Silicone	1

DRK-4130

Position	Part Number	Qty
Differential Right Brg.	598-592A	1
Differential Left Brg.	52387-52618	1
Pinion Head Brg.	H715343-H715311	1
Pinion Tail Brg.	H715334-H715311	1
Pinion Nose Brg.	MUC1309UM	1
Pinion Seal	415086N (30055)	1
Sealer	RTV Silicone	1

DRK-4135

Position	Part Number	Qty
Differential Right Brg.	598-592A	1
Differential Left Brg.	52387-52618	1
Pinion Head Brg.	78250AC-78551	1
Pinion Tail Brg.	78250AC-78551	1
Pinion Nose Brg.	MUB1309UM	1
Input Shaft Front Brg.	HM813844-HM813810	1
Input Shaft Rear Brg.	JM515649-JM515610	1
Thrushaft Brg.	385A-382A	2
Oil Pump Idler Gear Brg.	LM11949-90013	1
Input Shaft Seal	416470N (32385)	1
Thrushaft Seal	415013N (29925)	1
Sealer	RTV Silicone	1

¹⁰Use 496 - 493 for ratios above 4.63:1

•Not packed in kit

Differential Rebuild Kits



HD Differential

DRK-4140		
Position	Part Number	Qty
Differential Right Brg.	598-592A	1
Differential Left Brg.	52387-52618	1
Pinion Head Brg.	78250AC-78551	1
Pinion Tail Brg.	78250AC-78551	1
Pinion Nose Brg.	MUB1309UM	1
Input Shaft Front Brg.	HM813844-HM813810	1
Input Shaft Rear Brg.	JM515649-JM515610	1
Thrushaft Brg.	385A-382A	2
Oil Pump Idler Gear Brg.	LM11949-90013	1
Input Shaft Seal	DTR2592	1
Thrushaft Seal	415013N (29925)	1
Sealer	RTV Silicone	1

DRK-4145		
Position	Part Number	Qty
Differential Right Brg.	598-592A	1
Differential Left Brg.	52387-52618	1
Pinion Head Brg.	78250AC-78551	1
Pinion Tail Brg.	78250AC-78551	1
Pinion Nose Brg.	MUC1309UM	1
Input Shaft Front Brg.	HM813844-HM813810	1
Input Shaft Rear Brg.	JM515649-JM515610	1
Thrushaft Brg.	385A-382A	2
Oil Pump Idler Gear Brg.	LM11949-90013	1
Input Shaft Seal	416470N (32385)	1
Thrushaft Seal	415013N (29925)	1
Sealer	RTV Silicone	1

DRK-4150		
Position	Part Number	Qty
Differential Right Brg.	598-592A	1
Differential Left Brg.	52387-52618	1
Pinion Head Brg.	H715343-H715311	1
Pinion Tail Brg.	H715334-H715311	1
Pinion Nose Brg.	MUB1309TM	1
Pinion Seal	3143N	1
Sealer	RTV Silicone	1

DRK-4155		
Position	Part Number	Qty
Differential Right Brg.	598-592A	1
Differential Left Brg.	52387-52618	1
Pinion Head Brg.	78250AC-78551	1
Pinion Tail Brg.	78250AC-78551	1
Pinion Nose Brg.	MUB1309UM	1
Input Shaft Front Brg.	496-493	1
Input Shaft Rear Brg.	29685-29620	1
Input Shaft Seal	DTP2590	1
Sealer	RTV Silicone	1

DRK-4155A		
Position	Part Number	Qty
Differential Right Brg.	598-592A	1
Differential Left Brg.	52387-52618	1
Pinion Head Brg.	78250AC-78551	1
Pinion Tail Brg.	78250AC-78551	1
Pinion Nose Brg.	MUC1309UM	1
Input Shaft Front Brg.	496-493	1
Input Shaft Rear Brg.	29685-29620	1
Input Shaft Seal	DTP2590	1
Sealer	RTV Silicone	1

DRK-4180		
Position	Part Number	Qty
Differential Right Brg.	581-572	1
Differential Left Brg.	581-572	1
Pinion Head Brg.	42350-42584	1
Pinion Tail Brg.	497-493	1
Pinion Nose Brg.	MR1212EL	1
Cross Shaft Right Brg.	66225-66462	2
Cross Shaft Left Brg.	MU1218TDHM	1
Cross Shaft Left Brg.	5211W	1
Thrushaft Brg.	210	1
Input Shaft Seal	475012N (29322)	1
Thrushaft Seal	475322N (27295)	1
Sealer	RTV Silicone	1

DRK-4190		
Position	Part Number	Qty
Differential Right Brg.	HM516449C-HM516410	1
Differential Left Brg.	HM516449C-HM516410	1
Pinion Head Brg.	42350-42584	1
Pinion Tail Brg.	497-493	1
Pinion Nose Brg.	MR1213EL	1
Cross Shaft Right Brg.	66225-66462	2
Cross Shaft Left Brg.	MU1218TDHM	1
Input Shaft Seal	3591 (27642)	1
Thrushaft Seal	415272N (27565)	1
Sealer	RTV Silicone	1

DRK-4220		
Position	Part Number	Qty
Differential Right Brg.	HM516449C-HM516410	1
Differential Left Brg.	HM516449C-HM516410	1
Pinion Head Brg.	42350-42584	1
Pinion Tail Brg.	497-493	1
Pinion Nose Brg.	MR1213EL	1
Cross Shaft Right Brg.	66225-66462	2
Cross Shaft Left Brg.	MU1218TDHM	1
Input Shaft Brg.	394A-392	2
Thrushaft Brg.	385A-382A	2
Input Shaft Seal	415137 (32502)	1
Thrushaft Seal	415272N (27565)	1
Sealer	RTV Silicone	1

DRK-4240		
Position	Part Number	Qty
Differential Right Brg.	HM516449C-HM516410	1
Differential Left Brg.	HM516449C-HM516410	1
Pinion Head Brg.	42350-42584	1
Pinion Tail Brg.	497-493	1
Pinion Nose Brg.	MR1213EL	1
Cross Shaft Right Brg.	641-632	2
Cross Shaft Left Brg.	MU1221UM	1
Input Shaft Seal	3591 (27642)	1
Thrushaft Seal	415272N (27565)	1
Sealer	RTV Silicone	1

DRK-4245		
Position	Part Number	Qty
Differential Right Brg.	HM516449C-HM516410	1
Differential Left Brg.	HM516449C-HM516410	1
Pinion Head Brg.	42350-42584	1
Pinion Tail Brg.	497-493	1
Pinion Nose Brg.	MR1213EL	1
Cross Shaft Right Brg.	641-632	2
Cross Shaft Left Brg.	MU1221UM	1
Input Shaft Brg.	387A-382A	1
Thrushaft Brg.	210	1
Input Shaft Seal	415086N (30055)	1
Thrushaft Seal	415004 (27370)	1
Sealer	RTV Silicone	1

DRK-4255		
Position	Part Number	Qty
Differential Right Brg.	683-672	1
Differential Left Brg.	683-672	1
Pinion Head Brg.	42350-42584	1
Pinion Tail Brg.	42350-42584	1
Pinion Nose Brg.	MR1213EL	1
Cross Shaft Right Brg.	641-632	2
Cross Shaft Left Brg.	MU1221UM	1
Input Shaft Brg.	5212W	1
Thrushaft Brg.	212	1
Input Shaft Seal	415086N (30055)	1
Thrushaft Seal	415004 (27370)	1
Sealer	RTV Silicone	1

DRK-4260		
Position	Part Number	Qty
Differential Right Brg.	683-672	1
Differential Left Brg.	683-672	1
Pinion Head Brg.	42350-42584	1
Pinion Tail Brg.	42350-42584	1
Pinion Nose Brg.	MR1213EL	1
Cross Shaft Right Brg.	641-632	2
Cross Shaft Left Brg.	MU1221UM	1
Input Shaft Brg.	394A-392	2
Thrushaft Brg.	385A-382A	2
Input Shaft Seal	415137 (32502)	1
Thrushaft Seal	415272N (27565)	1
Sealer	RTV Silicone	1

DRK-4270		
Position	Part Number	Qty
Differential Right Brg.	683-672	1
Differential Left Brg.	683-672	1
Pinion Head Brg.	42350-42584	1
Pinion Tail Brg.	497-493	1
Pinion Nose Brg.	MR1213EL	1
Cross Shaft Right Brg.	641-632	2
Cross Shaft Left Brg.	MU1221UM	1
Input Shaft Seal	3591 (27642)	1
Thrushaft Seal	415272N (27565)	1
Sealer	RTV Silicone	1

DRK-4290		
Position	Part Number	Qty
Differential Right Brg.	3994-JM511910	1
Differential Left Brg.	3994-JM511910	1
Pinion Head Brg.	HM903244-HM903210	1
Pinion Tail Brg.	44143-44348	1
Pinion Nose Brg.	MU1305TDM	1
Pinion Seal	410308 (21213)	1
Sealer	RTV Silicone	1

DRK-4295		
Position	Part Number	Qty
Differential Right Brg.	3994-JM511910	1
Differential Left Brg.	3994-JM511910	1
Pinion Head Brg.	HM903244-HM903216	1
Pinion Tail Brg.	44143-44348	1
Pinion Nose Brg.	MU1305TDM	1
Pinion Seal	410308 (21213)	1
Sealer	RTV Silicone	1

DRK-4300		
Position	Part Number	Qty
Differential Right Brg.	3994-JM511910	1
Differential Left Brg.	3994-JM511910	1
Pinion Head Brg.	HM803146-HM803110	1
Pinion Tail Brg.	44143-44348	1
Pinion Nose Brg.	MU1305TDM	1
Pinion Seal	475080N (21379)	1
Sealer	RTV Silicone	1
Threadlocker	TL1	1

Differential Rebuild Kits

HD Differential

DRK-4310		
Position	Part Number	Qty
Differential Right Brg.	3994-JM511910	1
Differential Left Brg.	3994-JM511910	1
Pinion Head Brg.	HM903249A-HM903216	1
Pinion Tail Brg.	HM903249A-HM903216	1
Pinion Nose Brg.	MUB1305UDM	1
Pinion Seal	470737N (22425)	1
Sealer	RTV Silicone	1
Threadlocker	TL1	1

DRK-4315		
Position	Part Number	Qty
Differential Right Brg.	3994-JM511910	1
Differential Left Brg.	3994-JM511910	1
Pinion Head Brg.	HM803149-HM803110	1
Pinion Tail Brg.	HM803149-HM803110	1
Pinion Nose Brg.	MUB1305UDM	1
Pinion Seal	475234N (22619)	1
Sealer	RTV Silicone	1
Threadlocker	TL1	1

DRK-4325		
Position	Part Number	Qty
Differential Right Brg.	33275-33472	1
Differential Left Brg.	47490-47420	1
Pinion Head Brg.	HM807044-HM807010	1
Pinion Tail Brg.	M804049-M804010	1
Pinion Nose Brg.	RU1570UM	1
Pinion Seal	470574N (23678)	1
Sealer	RTV Silicone	1

DRK-4330		
Position	Part Number	Qty
Differential Right Brg.	JLM714149-JLM714110	1
Differential Left Brg.	JLM714149-JLM714110	1
Pinion Head Brg.	55200C-55437	1
Pinion Tail Brg.	HM804846-HM804810	1
Pinion Nose Brg.	RU1570UM	1
Pinion Seal	415082N (25102)	1
Sealer	RTV Silicone	1

DRK-4345		
Position	Part Number	Qty
Differential Right Brg.	JP10049-JP10010A	1
Differential Left Brg.	JM716649-JM716610	1
Pinion Head Brg.	55200C-55437	1
Pinion Tail Brg.	M804049-M804010	1
Pinion Nose Brg.	RU1570UM	1
Pinion Seal	415082N (25102)	1
Sealer	RTV Silicone	1

DRK-4350		
Position	Part Number	Qty
Differential Right Brg.	JM716649-JM716610	1
Differential Left Brg.	JM716649-JM716610	1
Pinion Head Brg.	55200C-55437	1
Pinion Tail Brg.	M804049-M804010	1
Pinion Nose Brg.	RU1570UM	1
Pinion Seal	415082N (25102)	1
Sealer	RTV Silicone	1

DRK-4355		
Position	Part Number	Qty
Differential Right Brg.	JM716649-JM716610	1
Differential Left Brg.	JM716649-JM716610	1
Pinion Head Brg.	H715334-H715311	1
Pinion Tail Brg.	72212C-72487	1
Input Shaft Front Brg.	JM511946-JM511910	1
Input Shaft Rear Brg.	JLM710949-JLM710910	1
Output Shaft Brg.	LM603049-LM603011	2
Input Shaft Seal	4561V (24964)	1
Thrushaft Seal	DTP2590	1
O-Ring	5X1034	1
Sealer	RTV Silicone	1

DRK-4356		
Position	Part Number	Qty
Differential Right Brg.	JM716649-JM716610	1
Differential Left Brg.	JM716649-JM716610	1
Pinion Head Brg.	H715334-H715311	1
Pinion Tail Brg.	72212C-72487	1
Input Shaft Front Brg.	JM511945-JM511910	1
Input Shaft Rear Brg.	JLM710949-JLM710910	1
Output Shaft Brg.	LM603049-LM603011	2
Input Shaft Seal	4561V (24964)	1
Thrushaft Seal	DTP2590	1
O-Ring	5X1034	1
Sealer	RTV Silicone	1

DRK-4360		
Position	Part Number	Qty
Differential Right Brg.	JLM714149-JLM714110	1
Differential Left Brg.	JP10049-JP10010A	1
Pinion Head Brg.	55200C-55437	1
Pinion Tail Brg.	M804049-M804010	1
Pinion Nose Brg.	MUB1305UDM	1
Pinion Seal	415082N (25102)	1
Threadlocker	TL1	1
Sealer	RTV Silicone	1

DRK-4375		
Position	Part Number	Qty
Differential Right Brg.	JM716649-JM716610	1
Differential Left Brg.	JP12049-JP12010	1
Pinion Head Brg.	78225C-78551	1
Pinion Tail Brg.	55206C-55437	1
Pinion Nose Brg.	MUB1307UBM	1
Pinion Seal	DTN2588	1
Sealer	RTV Silicone	1
Threadlocker	TL1	1

DRK-4390		
Position	Part Number	Qty
Differential Right Brg.	JM716649-JM716610	1
Differential Left Brg.	JP10049-JP10010A	1
Pinion Head Brg.	72212C-72487	1
Pinion Tail Brg.	55206C-55437	1
Pinion Nose Brg.	RU1570UM	1
Pinion Seal	DTN2588	1
Threadlocker	TL1	1
Silicone	RTV Silicone	1

DRK-4395		
Position	Part Number	Qty
Differential Right Brg.	JM716649-JM716610	1
Differential Left Brg.	JM716649-JM716610	1
Pinion Head Brg.	H715334-H715311	1
Pinion Tail Brg.	72212C-72487	1
Input Shaft Front Brg.	JM511946-3920	1
Input Shaft Rear Brg.	JLM710949-JLM710910	1
Output Shaft Brg.	LM104949-JLM104910	2
Input Shaft Pinion Seal	DTP2590	1
Thrushaft Seal	DTP2590	1
O-Ring	5X1034	2
Threadlocker	TL1	1
Sealer	RTV Silicone	1

DRK-4396		
Position	Part Number	Qty
Differential Right Brg.	JM716649-JM716610	1
Differential Left Brg.	JM716649-JM716610	1
Pinion Head Brg.	H715334-H715311	1
Pinion Tail Brg.	72212C-72487	1
Input Shaft Front Brg.	JM511945-3920	1
Input Shaft Rear Brg.	JLM710949-JLM710910	1
Output Shaft Brg.	LM104949-JLM104910	2
Input Shaft Seal	DTR2592	1
Thrushaft Seal	DTP2590	1
O-Ring	5X1034	2
Threadlocker	TL1	1
Sealer	RTV Silicone	1

DRK-4405		
Position	Part Number	Qty
Differential Right Brg.	JM716649-JM716610	1
Differential Left Brg.	JP10049-JP10010A	1
Pinion Head Brg.	H715334-H715311	1
Pinion Tail Brg.	72212C-72487	1
Input Shaft Front Brg.	JM511946-JM511910	1
Input Shaft Front Cup - New	3920	1
Input Shaft Rear Brg.	JLM710949-JLM710910	1
Output Shaft Brg.	LM104949-JLM104910	2
Input Shaft Seal	DTR2592	1
Thrushaft Seal	DTP2590	1
Threadlocker	TL1	1
O-Ring	5X1034	2
Sealer	RTV Silicone	1

DRK-4406		
Position	Part Number	Qty
Differential Right Brg.	JM716649-JM716610	1
Differential Left Brg.	JP10049-JP10010A	1
Pinion Head Brg.	H715334-H715311	1
Pinion Tail Brg.	72212C-72487	1
Input Shaft Front Brg.	JM511945-3920	1
Input Shaft Rear Brg.	JLM710949-JLM710910	1
Output Shaft Brg.	LM104949-JLM104910	2
Input Shaft Seal	DTR2592	1
Thrushaft Seal	DTP2590	1
O-Ring	5X1034	2
Threadlocker	TL1	1
Sealer	RTV Silicone	1

DRK-4415		
Position	Part Number	Qty
Differential Right Brg.	32021X	1
Differential Left Brg.	32021X	1
Pinion Head Brg.	9278-9220	1
Pinion Tail Brg.	HM813843-HM813810	1
Pinion Nose Brg.	A11228-P1004	1
Pinion Seal	DTQ2591	1
Threadlocker	TL1	1
Sealer	RTV Silicone	1

DRK-4420		
Position	Part Number	Qty
Differential Right Brg.	32021X	1
Differential Left Brg.	32021X	1
Pinion Head Brg.	H715343-H715311	1
Pinion Tail Brg.	65237-65500	1
Input Shaft Front Brg.	HM813843-HM813810	1
Input Shaft Rear Brg.	JLM714149-JLM714110	1
Pinion Seal	DTR2592	1
O-Ring	5X1034	2
Threadlocker	TL1	1
Sealer	RTV Silicone	1

DRK-4422		
Position	Part Number	Qty
Differential Right Brg.	594A-592A	1
Differential Left Brg.	594A-592A	1
Pinion Head Brg.	H715343-H715311	1
Pinion Tail Brg.	65237-65500	1
Input Shaft Front Brg.	HM813843-HM813810	1
Input Shaft Rear Brg.	JLM714149-JLM714110	1
Pinion Seal	DTR2592	1
O-Ring	5X1034	1
Threadlocker	TL1	1
Sealer	RTV Silicone	1

Differential Rebuild Kits



HD Differential

DRK-4423		
Position	Part Number	Qty
Differential Right Brg.	594A-592A	1
Differential Left Brg.	52400-52618	1
Pinion Head Brg.	H715343-H715311	1
Pinion Tail Brg.	65237-65500	1
Input Shaft Front Brg.	HM813843-HM813810	1
Input Shaft Rear Brg.	JLM714149-JLM714110	1
Pinion Seal	DTR2592	1
O-Ring	5X1034	1
Threadlocker	TL1	1
Sealer	RTV Silicone	1

DRK-4426		
Position	Part Number	Qty
Differential Right Brg.	594A-592A	1
Differential Left Brg.	594A-592A	1
Pinion Head Brg.	9278-9220	1
Pinion Tail Brg.	HM813843-HM813810	1
Pinion Nose Brg.	RU9008UM	1
Pinion Seal	DTQ2591	1
Threadlocker	TL1	1
Sealer	RTV Silicone	1

DRK-4428		
Position	Part Number	Qty
Differential Right Brg.	594A-592A	1
Differential Left Brg.	52400-52618	1
Pinion Head Brg.	9278-9220	1
Pinion Tail Brg.	HM813843-HM813810	1
Pinion Nose Brg.	RU9008UM	1
Pinion Seal	DTQ2591	1
Threadlocker	TL1	1
Sealer	RTV Silicone	1

DRK-4435		
Position	Part Number	Qty
Differential Right Brg.	64450-64700	1
Differential Left Brg.	JHM720249-JHM720210	1
Pinion Head Brg.	9278-9220	1
Pinion Tail Brg.	H715334-H715311	1
Pinion Nose Brg.	MUB7309UM	1
Pinion Seal	DTQ2591	1
Threadlocker	TL1	1
Sealer	RTV Silicone	1

DRK-4436		
Position	Part Number	Qty
Differential Right Brg.	64450-64700	1
Differential Left Brg.	JHM720249-JHM720210	1
Pinion Head Brg.	9278-9220	1
Pinion Tail Brg.	H715334-H715311	1
Pinion Nose Brg.	MUC1309UM	1
Pinion Seal	DTQ2591	1
Threadlocker	TL1	1
Sealer	RTV Silicone	1

DRK-4437		
Position	Part Number	Qty
Differential Right Brg.	JM822049-JM822010	1
Differential Left Brg.	NP579116-NP022042	1
Pinion Head Brg.	9278-9220	1
Pinion Tail Brg.	H715334-H715311	1
Pinion Nose Brg.	MUB7309UM	1
Pinion Seal	DTQ2591	1
Sealer	RTV Silicone	1
Threadlocker	TL1	1

DRK-4438		
Position	Part Number	Qty
Differential Right Brg.	JM822049-JM822010	1
Differential Left Brg.	NP579116-NP022042	1
Pinion Head Brg.	9278-9220	1
Pinion Tail Brg.	H715334-H715311	1
Pinion Nose Brg.	MUC1309UM	1
Pinion Seal	DTQ2591	1
Sealer	RTV Silicone	1

DRK-4440		
Position	Part Number	Qty
Differential Right Brg.	NP928171-NP718759	1
Differential Left Brg.	52387-52618	1
Pinion Head Brg.	78250AC-78551	1
Pinion Tail Brg.	78250AC-78551	1
Pinion Nose Brg.	MRB7309GEXR	1
Pinion Nose Brg.	MRC7309	1
Input Shaft Brg.	HM813844-HM813810	1
Rear Side Gear Brg.	JM515649-JM515610	1
Output Shaft Brg.	385A-382A	2
Oil Pump Idler Gear Brg.	LM11949-90013	1
Input Shaft Seal	DTR2592	1
Thrushaft Seal	415013N (29925)	1
Snap Ring	1229T4076	1
Sealer	RTV Silicone	1

DRK-4441		
Position	Part Number	Qty
Differential Right Brg.	NP928171-NP718759	1
Differential Left Brg.	52387-52618	1
Pinion Head Brg.	78250AC-78551	1
Pinion Tail Brg.	78250AC-78551	1
Pinion Nose Brg.	MUB7309UM	1
Input Shaft Brg.	HM813844-HM813810	1
Rear Side Gear Brg.	JM515649-JM515610	1
Output Shaft Brg.	385A-382A	2
Oil Pump Idler Gear Brg.	LM11949-90013	1
Input Shaft Seal	DTR2592	1
Thrushaft Seal	415013N (29925)	1
Snap Ring	1229L1624	1
Sealer	RTV Silicone	1

DRK-4442		
Position	Part Number	Qty
Differential Right Brg.	NP928171-NP718759	1
Differential Left Brg.	52387-52618	1
Pinion Head Brg.	78250AC-78551	1
Pinion Tail Brg.	78250AC-78551	1
Pinion Nose Brg.	MUC1309UM	1
Input Shaft Brg.	HM813844-HM813810	1
Rear Side Gear Brg.	JM515649-JM515610	1
Output Shaft Brg.	385A-382A	2
Oil Pump Idler Gear Brg.	LM11949-90013	1
Input Shaft Seal	416470N (32385)	1
Thrushaft Seal	415013N (29925)	1
Snap Ring	1229K1623	1
Sealer	RTV Silicone	1

DRK-4443		
Position	Part Number	Qty
Differential Right Brg.	NP928171-NP718759	1
Differential Left Brg.	52387-52618	1
Pinion Head Brg.	78250AC-78551	1
Pinion Tail Brg.	78250AC-78551	1
Pinion Nose Brg.	MUB7309UM	1
Input Shaft Front Brg.	496-493	1
Input Shaft Rear Brg.	29685-29620	1
Input Shaft Seal	DTP2590	1
Snap Ring	1229L1624	1
Sealer	RTV Silicone	1

DRK-4444		
Position	Part Number	Qty
Differential Right Brg.	NP928171-NP718759	1
Differential Left Brg.	52387-52618	1
Pinion Head Brg.	78250AC-78551	1
Pinion Tail Brg.	78250AC-78551	1
Pinion Nose Brg.	MUC1309UM	1
Input Shaft Front Brg.	496-493	1
Input Shaft Rear Brg.	29685-29620	1
Input Shaft Seal	DTP2590	1
Snap Ring	1229K1623	1
Sealer	RTV Silicone	1

DRK-4450		
Position	Part Number	Qty
Differential Right Brg.	NP928171-NP718759	1
Differential Left Brg.	52387-52618	1
Pinion Head Brg.	78250AC-78551	1
Pinion Tail Brg.	78250AC-78551	1
Pinion Nose Brg.	MRB7309GEXR	1
Pinion Nose Brg.	MRC7309	1
Input Shaft Front Brg.	496-493	1
Input Shaft Rear Brg.	29685-29620	1
Input Shaft Seal	DTP2590	1
Snap Ring	1229T4076	1
Sealer	RTV Silicone	1

DRK-4461		
Position	Part Number	Qty
Differential Right Brg.	JM716649-JM716610	1
Differential Left Brg.	JM716649-JM716610	1
Pinion Head Brg.	H715334-H715311	1
Pinion Tail Brg.	72225C-72487	1
Pinion Seal	DTN2588	1
Sealer	RTV Silicone	1

DRK-4753		
Position	Part Number	Qty
Differential Right Brg.	28682-28622	1
Differential Left Brg.	28682-28622	1
Pinion Head Brg.	HM803149-HM803110	1
Pinion Tail Brg.	M86649-M86610	1
Pinion Seal	415082N (25102)	1
Sealer	RTV Silicone	1

DRK-4841		
Position	Part Number	Qty
Differential Right Brg.	594A-592A	1
Differential Left Brg.	594A-592A	1
Pinion Head Brg.	H715334-H715311	1
Pinion Tail Brg.	72212C-72487	1
Input Shaft Front Brg.	JM511945-3920	1
Input Shaft Rear Brg.	JLM714149-JLM714110	1
Helical Gear Thrust Brg.	ZN1213	1
Helical Gear Needle Brg.	ZN1212	2
Input Shaft Seal	DTR2592	1
Sealer	RTV Silicone	1

DRK-4842		
Position	Part Number	Qty
Differential Right Brg.	594A-592A	1
Differential Left Brg.	594A-592A	1
Pinion Head Brg.	H715334-H715311	1
Pinion Tail Brg.	72212C-72487	1
Pinion Seal	DTN2588	1
Sealer	RTV Silicone	1

DRK-4843		
Position	Part Number	Qty
Differential Right Brg.	NP293601-NP934397	1
Differential Left Brg.	NP293601-NP934397	1
Pinion Head Brg.	72212C-72487	1
Pinion Tail Brg.	55206C-55437	1
Pinion Nose Brg.	RU1570UM	1
Pinion Seal	DTN2588	1
Sealer	RTV Silicone	1

DRK-4844		
Position	Part Number	Qty
Differential Right Brg.	NP970652-NP563664	1
Differential Left Brg.	NP293601-NP934397	1
Pinion Head Brg.	72212C-72487	1
Pinion Tail Brg.	55206C-55437	1
Pinion Nose Brg.	RU1570UM	1
Pinion Seal	DTN2588	1
Sealer	RTV Silicone	1

Axle Description	Carrier	Axle Shaft Dia. (2) # Splines	NoSpin Model Number (1)
DEERE			
Series 1 444/A/B/C/D, 544A, 644A		2.06" 18	306S-60
Series 2 544/B/C/D, 740, 762		2.08" 32	306S-61
Series 3 644/B/C/D, 646 C		2.30" 22	306S-62
1100/1200		2.05" 22	306S-148
1200	544E Front	1.50" 23	225S-80
1400	624/644E Front	2.06" 18	306S-167
1600	744E Front	2.33" 22	306S-149
		2.33" 22	306S-173

EATON			
Single Rear Axles			
13101, 13107, 13802, 15040S/T/P		1.75" 34	250S-100
15101, 15107, 15201		1.87" 16	250S-37
15301		1.75" 19	250S-20
16120, 16121, 16221, 16244		1.85" 36	250S-109
16344		1.88" 16 (a)	250S-44
		1.88" 16 (b)	250S-45
(a) tapered spline (b) parallel spline			
16247		1.80" 30	250S-39
17060, 19060		2.00" 39	275S-63
17101, 17121, 17201, 17221,		2.00" 39	306S-108
17301, 17321, 17401*, 17421*		1.98" 16	306S-21
17201 (Mack)		2.12" 33	306S-56
18101, 18121, 18201, 18221,		2.10" 41	306S-109
18301		2.12" 16	306S-23
18127 (Mack)		2.12" 33	306S-53
185 S4/P4, 190 S4/T4/P4		2.00" 39	306S-108
19050 S/T/P		1.85" 36	275S-51
19055 S/T/P		2.00" 39	306S-108
19060S		2.00" 39	275S-63
19101, 19121, 19201		2.31" 36	306S-110
		2.30" 22	306S-39
21060 S/D/A		2.10" 41	275S-66
21065 S/D/T/P, 21121, 21221, 21321		2.10" 41	306S-109
21080 S		2.31" 36	350S-86
22060 S		2.10" 41	275S-66
22065 T		2.10" 41	306S-109
220 S4/P4, 22065 S/D/T/P,		2.10" 41	306S-109
22080 S		2.31" 36	350S-86
22121, 22221, 22321		2.12" 16	306S-23
23070 S/D		2.31" 36	350S-86
23070 T/P		2.12" 33	306S-56
23080 S		2.31" 36	350S-86
23080 T		2.31" 36	350S-88
23085 S/D		2.31" 36	350S-86
23070S, 23085 T/P		2.31" 36	350S-88
23105 S/D		2.50" 39	350S-40
(1996 & newer)		2.31" 36	350S-50
230 S4, 23121, 23421		2.31" 36	350S-47
		2.30" 22	350S-39
230 P4/T4, 23221, 23321		2.31" 36	306S-110
		2.30" 22	306S-39
E2300 S		2.50" 39	350S-40
25100		2.50" 39	350S-40
		2.31" 36	350S-47
		2.30" 22	350S-19
26080 T		2.31" 36	350S-88
260 S4, 26121		2.30" 36	350S-47
		2.30" 22	350S-39
260 P4, 26085, 26221, 26321		2.31" 36	306S-110
		2.30" 22	306S-39
26105 S/C		2.50" 39	350S-40
260 S4, 26121		2.31" 36	350S-47
		2.30" 22	350S-39
30055-P		2.31" 36	350S-88
30105 S/C, 30127		2.50" 39	350S-40
30227, 30327		2.5" 39	See Note (4)
35055-P		2.31" 36	350S-88
35327		2.50" 39	See Note (4)

*Requires case change. Use conventional differential case assembly.

Axle Description	Carrier	Axle Shaft Dia. (2) # Splines	NoSpin Model Number (1)
Tandem Axles			
34 RT		2.00" 39	306S-108
		2.00" 16	306S-21
34 DS/T, DP/S/T, 340, 341, 346,		2.00" 39	306S-108
DS/T/P 3416		2.00" 16	306S-21
DS/C/T/P-341		2.00" 39	306S-108
DS/A-344		2.00" 39	275S-63
38 DP/S/T, DP/S/T, 380, 381,		2.10" 41	306S-109
4026, 381, 386		2.12" 16	306S-23
DS/C/T/P 402, DS/T/P 4036		2.10" 41	306S-109
DS/P/T 400, 401, 406		2.13" 33	306S-56
42 DP		2.12" 16	306S-23
44 DT/P 440, 446		2.31" 36	306S-110
		2.30" 22	306S-39
DS 404/454		2.10" 41	275S-66
DS/C/T/P 451		2.10" 41	306S-109
		2.13" 33	306S-56
DS/T/P 460, 466		2.31" 36	306S-110
DS/C 461, DS 4616		2.31" 36	350S-47
DT/P 461, 4616		2.31" 36	350S-88
DS-466		2.31" 36	306S-110
DS-480, 486		2.31" 36	350S-47
		2.30" 22	350S-39
DT/P 480		2.31" 36	306S-110
		2.30" 22	306S-39
DT/P 485		2.31" 36 (6)	350S-71
50 DP		2.13" 33	306S-56
DS 520		2.50" 39	350S-40
DT/P 520		2.50" 39	See Note (4)
DS/C 521, DS 5216		2.31" 36	350S-47
DT/P 521, 5216		2.31" 36	350S-88
DP 580, 586		2.50" 39	See Note (4)
DS/C 581		2.31" 36	350S-47
DP 581, 601, 651, 652		2.31" 36	350S-88
		DP 650, 656 2.50" 39	See Note (4)

Planetary Axles			
WR 3, 5	13100	1.75" 34	250S-100
WR 7	16100 Front	1.85" 36	250S-109
	Rear	2.10" 41	306S-109
WR 10	DS402 Front	2.10" 41	306S-109
	21065 Rear	2.10" 41	306S-109
WR 12	23070	2.12" 33	306S-56
WR 31	13000	1.87" 16	250S-37
WR 51	15000	1.75" 19	250S-20
		1.87" 16	250S-37
WR 61	17000	1.87" 16	306S-119
WR 81	18000	2.12" 16	306S-23

CHEVROLET/GMC			
Single Rear Axles			
C100	Rockwell	1.62" 32	225S-52
		1.62" 16	225S-15
H110	12-1/4" dia. r.g.	1.75" 27	250S-27
H135	13-7/32" dia. r.g.	1.87" 29	250S-46
H150		1.87" 29	250S-46
H170		1.87" 29	250S-46
H175		2.00" 39	306S-79
T150		1.87" 29	275S-12
T170		1.87" 29	275S-12
T175	Eaton 16244	1.85" 36	250S-109
T185		1.87" 29	275S-12

See notes on last page.

Axle Description	Carrier	Axle Shaft Dia. (2) # Splines	NoSpin Model Number (1)	Axle Description	Carrier	Axle Shaft Dia. (2) # Splines	NoSpin Model Number (1)
------------------	---------	----------------------------------	----------------------------	------------------	---------	----------------------------------	----------------------------

INTERNATIONAL Single Rear Axles

14Axx			
CA CD DC DD DG		2.00"	39
DH DK DW DY NA	I-N190,210		
CE CG DB DL			
DM DV DX GD	I-N175	1.85"	36
CB CC DN DP	D-S100,122	1.85"	36
	135,150		
CH DZ	D-W230	2.35"	46
CJ EB EJ GH GL GS	D-23090	2.31"	36
DA DE DJ	D-F155	1.85"	36
DR	I-S230	2.35"	46
DT	D-N220	2.10"	41
DW DY	D-J210, I-N190	1.86"	36
EE GB	E-22065,22080	2.10"	41
EG	E-26105	2.31"	36
EH	E-19055	2.00"	39
EP GK	E-30105	2.50"	39
ET EY GG GP	D-21060,22060	2.10"	41
GA GE GM GN GT	D-19060	2.01"	39
	17060		
RA RG SR SU	R-R S21145	2.10"	41
RH SZ TB	R-RS18145,19145	2.00"	39
RB RC RD RE			
RK RR RS RV	R-RS23160	2.35"	46
	23161, 21162		
SE SG SH SK			
SM SN SP SX SY			
14Cxx			
DA	D-G155	1.85"	36
DB DC	D-M230	2.10"	41
DD	D-G175	1.85"	36
DE DG EH EJ			
EK EL ES ET EU	26080	2.10"	41
	23080		
EA	E-23070	2.31	36
EB	E-26085	2.31"	36
EG EP EV	D-19055	2.00"	39
EM EN ER	R-RS23240	2.10"	41
VA	R-RS19224/220	1.85"	36
VB	R-RS21230	2.00"	39
14Exx			
EB	E-26085	2.31"	36
RA RB	R-RS26/30380	2.35"	46
RC	R-RS38380	2.55"	50
140xx, 14xxx			
29 39	D-F155/170	1.85"	36
30	D-D135	1.85"	36
32	D-G190	2.00"	39
33 132	D-M220/230	2.10"	41
36 44	D-J210/190	2.00"	39
42	D-J175	1.85"	36
47	D-J220	2.05"	41
51 52	R-RS23160	2.35"	46
57	D-W230	2.35"	46
72 73 92	R-RS170	2.35"	46
77 91	E-23121/26121	2.31"	36
97	231055SL	2.50"	39
87 186	E17101/202	2.00"	39
88 193 194			
197 282 293	E-19/23/26 xxx	2.31"	36
118 119 192 292	E-17/18/22 xxx	2.10"	41
130	D-G175	1.85"	36
131 133	D-M190/210	2.00"	39
168 178 277	R-RS R/U xxx	2.38"	24
187	E-15201	1.75"	34
199	E-16244	1.85"	36
298	E-35327	2.50"	39

D=Dana/Spicer E=Eaton I=Int'l. R=Rockwell/Meritor

Tandem Axles

14Gxx			
DA	I-N340	2.00"	39
DC DE DG	DKI-N400, D-S400	2.10"	41
DL DM EL EN	D-DP/S402/7, DST41	2.10"	41
JD/E rear			
EB EH GE GP	D-DC/S461/2/3/521/540	2.31"	36
GT GW GZ HZ			
EC ED EW	D-DT 461/3/521, Dp463	2.31"	36
EY GU GV			
EE	E-DS 466	2.31"	36
EP ER ES ET EX GG	D-DS404/5/54	2.10"	41
GJ GL HA HC	DSH 44, DST 41		
JC JD/E front			
HD	D-DS344	2.00"	39
RARX	R-RT34140/145	2.00"	39
RB RC RU RW RY SB	R-RT40140/5	2.10"	41
SG SX TK TL UD UN UP	44145, 34144		
RD RE/RG/RH rear RP	R-RT23/48/52/	2.35"	46
RR SC SD SE SU TA	58180, 46/52160		
TG TM TN UE UM			
RE/RG/RH front	R-RT48/52/58180,	2.35"	46
RJ RL RV ST	52/58380		
RK RM	R-RT70380	2.55"	50
SY TV	R-RQ100, RC17350	2.10"	41
TE TY TZ	R-RS23/46157/8, 44158	2.35"	46
UG UH UJ			
UB	R-RS23240	2.10"	41
VA	D-BD71000	2.36"	27
14Hxx			
RA RB RC RD	R-RT 46160/4	2.35"	46
RE RH RJ RL RM			
RN RP	R-RT40145	2.10"	41
14xxx			
307, 467	E-DS 480, 44DS	2.31"	36
308, 309,	E-DS/DT 402, D 301	2.10"	41
494, 496, 497			
328	R-SLHD	2.00"	21
333, 334	R-SQHD	2.13"	22
337, 369, 431	R-SU270/DD, R170	2.35"	46
341	D-FIXX	1.85"	36
342	E-DT401	2.13"	33
343, 353, 354,			
377, 469	E-DP/S/T460, 44DP	2.31"	36
345, 350, 357, 434	R-SQ100, SQHP	2.10"	41
351, 475, 476	D-G/J340/380	2.00"	39
355, 472*	D-G380, J400	2.10"	41
364, 365, 389, 399,	R-SUD/DD	2.35"	46
431, 459	SS/STHD, R170		
367, 368	R-STD/DD	2.35"	46
372, 373, 382, 383	R-SFD/DD	2.55"	50
437, 474*	D-W230/460	2.35"	46
464, 502	E-DS401/451	2.13"	33
472*	D-J400	2.13"	20
474*	D-W460	2.30"	22
486, 500	E-DP580/650	2.50"	39
488, 493, 498	E=DS/T341	2.00"	39
Planetary Axles			
14Exx			
EC ED	E-3505SP	2.31"	36
EH	E-26080P	2.10"	41
RA RB	RS-26380,30380	2.35"	46
RC	Rs38380	2.50"	50

* Count splines to determine correct NoSPIN model. D=Dana/Spicer E=Eaton I=Int'l. R=Rockwell/Meritor See notes on last page.

Axle Description	Carrier	Axle Shaft Dia. (2) # Splines	NoSpin Model Number (1)
MERITOR			
Single Rear Axles			
RS-13/15-120		1.75" 34	250S-134
3.31-4.30 ratio			
4.56-7.17 ratio			
RS-15/17/19-220/224		1.95" 38	250S-128
RS-17/19-144		1.85" 36	275S-37
RS-17/19-145		2.10" 41	275S-43
RS-17/19-145		2.00" 39	275S-44
RS-19-220/224		1.85" 36	275S-37
RS-21-145		2.10" 41	275S-43
RS-21/23-160/160A/161/186		2.35" 46	350S-81
RS-21-230		2.00" 39	306S-127
RS-23-240		2.10" 41	306S-124
RS-23/26/30-380		2.35" 46	350S-93
RS-25/26-160/160A/185		2.35" 46	350S-81
RS-38-380		2.55" 50	350S-79
C-100, 102, 200		1.62" 32	225S-52
		1.62" 16	225S-15
D-100, 140		1.75" 34	250S-97
		1.75" 19	250S-13
		1.75" 16	250S-32
F-106, 140, 146		1.75" 34	250S-97
		1.75" 19	250S-13
FM-240		2.13" 22	306S-12
H-140, 145, 340		1.88" 20	275S-11
H-140E		2.25" 44	306S-136
H-162		2.00" 21	306S-11
H-170, 171		1.85" 36	275S-10
H-172, 173		2.00" 39	306S-79
L-145, 155		2.00" 21	306S-11
L-164		1.88" 20	276S-11
L-172		2.00" 39	306S-79
L-245, 345		2.00" 21	306S-25
L-362		2.00" 21	306S-25
M-172		2.00" 39	306S-79
M/FM-240		2.12" 16	306S-36
M/MD-240		2.13" 22	306S-12
P-140E		2.25" 44	306S-136
P-174		2.10" 41	306S-15
Q-100		2.10" 41	306S-15
Q-145		2.13" 22	306S-31
Q-345		2.13" 22	306S-38
R-140		2.25" 23	350S-25
R-140E		2.25" 44	306S-136
R-140, 155*, 200, 221,			
255*, 270, 300, 355		2.38" 24	350S-13
R-355/356		2.35" 46	350S-57
R-170		2.38" 16	350S-29
		2.38" 24	350S-13
RL-170		2.35" 46	350S-57
		2.38" 24	350S-13
RS-13-120, 15-120/125		1.75" 34	250S-134
4.56-7.17 ratio		1.95" 38	250S-128
RS-15-210		1.75" 34	250S-139
RS-17-140		2.00" 39	275S-44
		1.85" 36	275S-46
RS-17-144, 145		2.00" 39	275S-44
RS-17-220		1.85" 36	275S-37
RS-18-140, 145		2.00" 39	275S-44
		1.85" 36	275S-46
RS-19-145		2.00" 39	275S-44
RS-19-220		1.85" 36	275S-37
RS-20-145		2.25" 44	306S-136
		2.10" 41	275S-43
RS-20-230		2.00" 39	306S-127
RS-21-145		2.10" 41	275S-43
RS-21-230		2.00" 39	306S-127
RS-23-160, 180		2.35" 46	350S-81
		2.55" 50	350S-76
RS-23-240		2.10" 41	306S-124
RS-23-380		2.35 46	350S-93
RS-25/26-160, 180		2.35" 46	350S-81
RS-26-380		2.35" 46	350S-93
RS-30-180		2.35" 46	350S-81
RS-30-380		2.35" 46	350S-93

Axle Description	Carrier	Axle Shaft Dia. (2) # Splines	NoSpin Model Number (1)
RS-38-380		2.55" 50	350S-79
RS-410#		1.45" 29	225S-39A
S-162, 163		2.25" 23	350S-25
S-164, 165		2.38" 24	350S-13
S-170		2.35" 46	350S-57
		2.38" 24	350S-13
SL-100		2.00" 39	306S-79
SR-170		2.38" 24	350S-13
SW-170/180, 270/280		2.55" 50	350S-79
U-170, 180, 240, 340		2.38" 24	350S-13
U-270, 340		2.35" 46	350S-57
W/WP/WR-170		2.55" 50	350S-79
W-180, 270, 280		2.55" 50	350S-63
W-464		2.55" 50	(5) 350S-56
59732, 59733 (WT)		2.38" 16	350S-29
59742, 59743 (WT)		2.38" 24	350S-13
61142, 61143 (WT)		2.35" 46	350S-81
*Di Rona Mexico #Brazil See notes on last page.			
Tandem Axles			
RT-34/40-144/145/149		2.10" 41	275S-43
RT-40/46/50-160/164/169,		2.25" 44	306S-136
RT-40/44-145			
RT-48/50/52/58/70-185/380		2.35" 46	350S-93
RZ-166		2.35" 46	350S-81
RZ-186 front		2.35" 46	350S-93
rear		2.35" 46	350S-81
RZ-188		2.35" 46	350S-93
R-170/TKN 4670		2.35" 46	350S-57
		2.38" 24	350S-13
RT 34-140, 145		2.00" 39	275S-44
RT 46/48/52-160		2.55" 50	350S-76
		2.35" 46	350S-81
RT 48/52/58-180 front		2.35" 46	350S-93
rear		2.35" 46	350S-81
RT 48/52/58-380		2.35" 46	350S-93
RT 70-180		2.55" 50	350S-76
RT 70-380		2.55" 50	350S-79
SDH/SDHD		1.75" 16	250S-32
SFD (C-240)		1.62" 16	225S-15
SFD (M-240)		2.12" 16	306S-36
SFD/SFDD 4640, 47		2.55" 50	(5) 350S-56
		2.50" 16	(5) 350S-52
SFH/SFHD		1.75" 34	250S-97
		1.75" 19	250S-13
SHD, SHR		2.38" 24	350S-13
SHHD/SJHD		1.87" 20	275S-11
SLD/SLDD		2.00" 21	306S-11
		2.00" 16	306S-22
SL 100		2.00" 39	306S-79
SLHD		2.00" 21	306S-11
SLHR/T-3000		2.00" 21	306S-11
SQHD		2.13" 22	306S-12
		2.00" 21	306S-25
SQHP, SQ 100		2.10" 41	306S-15
SQR 100		2.10" 41	306S-15
SR 170, 270, 280		2.35" 46	350S-57
		2.38" 24	350S-13
SRD/SRDD		2.35" 46	306S-84
		2.25" 23	306S-35
SRHD		2.25" 23	306S-35
SSHD		2.35" 46	350S-57
		2.38" 24	350S-13
		2.25" 23	350S-25
ST 170		2.38" 24	350S-13
STD,STDD,STD-DD		2.35" 46	350S-55
		2.38" 24	350S-36
STHD		2.38" 46	350S-57
		2.38" 24	350S-13
SU 170, SUD/SUDD, SUHD		2.35" 46	350S-57
		2.38" 24	350S-13
SU 270, 280		2.35" 46	350S-57
		2.38" 24	350S-13
SW 170, 180, 270, 280		2.55" 50	350S-79
FLDD, LDD-240		2.13" 22	306S-12

Axle Description	Carrier	Axle Shaft Dia. (2) # Splines	NoSpin Model Number (1)
LDF		2.00" 21	306S-25
LDH/R		2.00" 21	306S-11
QHD/R		2.00" 21	306S-25
RDD/F/R		2.35" 46	306S-84
SHD/R		2.38" 24	350S-13
		2.35" 46	350S-57
TDD/F/R		2.35" 46	350S-55
UDD/F/R		2.38" 24	350S-13
		2.35" 46	350S-57

Planetary Axles

SINGLE - PR

204/5, 265	D/F-140	1.75" 19	250S-13
184, 824	H-172	1.88" 20	306S-42
673	L-172	2.13" 22	306S-12
352/3, 382	PRA Series	1.60" 31	225S-122
1736	QR-100	2.10" 41	306S-15
867	R-155	2.13" 22	350S-15
3805, 4805	R-155	2.38" 24	350S-15
594, 671	RS-120/125	1.75" 34	250S-134
	RS-120/125	1.95" 38	250S-128
416, 425, 673	RS-145	2.00" 39	275S-44
756, 775, 1314			
727, 866, 1206,	RS-145	2.10" 41	275S-43
1735, 1756, 1794			
5225, 7534	RS-186	2.55" 50	350S-76
674	RS-220	1.85" 36	275S-44
134	53500	1.75" 16	250S-23

TANDEM-SP

673	RT-145	2.00" 39	275S-44
1927	RT-160	2.35" 46	350S-81
4808	RT-380	2.55" 50	350S-79
1356, 1735	SQHP	2.10" 41	306S-15
1927	SR-170	2.38" 24	350S-15

STEER-PS

205, 594	F-140	1.75" 19	250S-13
824/5	H-172	1.88" 20	306S-42
824/5	L-172	2.13" 22	306S-12
1614	Q-100	2.13" 22	306S-31
		2.10" 41	306S-92
1044, 1617, 1794	QR-100	2.10" 41	306S-15
1485, 1875, 4564	R-155	2.13" 22	350S-19
		2.38" 24	350S-15
205, 594	RS-120/125	1.75" 34	250S-134
	RS-120/125	1.95" 38	250S-128
826, 1044, 1614,	RS-145	2.10" 41	275S-43
1794			
1876	RS-160	2.35" 46	350S-81
SVI 5000 series		1.71" 33	
717SV166			

SINGLE PR, TANDEM SP, STEER PS

134, 164, 267, 268	53500	1.75" 16	250S-23
274	C-100	1.62" 16	225S-15
203	C-102	1.65" 32	225N-52
165, 166, 175, 176,	D-140/142	1.75" 19	250S-13
204, 205#, 264, 265,	F-140/145		
353, 354, 515, 524			
574, 593, 594#, 595,			
671#, 723, 724, 823			
592, 596*, 614*, 672*	H-140/150/340	1.88" 20	275S-11
674, 824*, 863*, 1103*, 1374*			
184, 577#, 596*, 614*,	H-172	1.88" 20	306S-42
672*, 694#, 726, 824*, 825#,			
834, 863*, 1103*, 1374*			
784, F106		1.77" 19	250S-13
576, 595, 671#,	HHD Front	1.88" 20	275S-11
1743, 1753	H-172 Rear	1.88" 20	306S-42

Axle Description	Carrier	Axle Shaft Dia.(2) #Splines	NoSpin Model Number (1)
Planetary Axles			
150#, 154#, 158#,	L-172	2.13" 22	306S-12
202, 235#, 483,			
655, 673#, 695#, 825#, 864, 1104			
577#, 615, 673#,	L-172	2.00" 21	306S-11
695#, 803, 855			
362	L-172	2.00" 39	306S-79
673	L-345	2.00" 21	306S-11
150, 158#, 202, 235#, 413		2.00" 21	306S-25
5054, 7314#, 10253	PR-700	2.75" 54	450S-146
7314#	PR-700	2.63" 26	450S-129
1756#	Q-100	2.25" 23	306S-35
208, 209, 210	Q-100/145	2.13" 22	306S-31
250, 251, 266			
676, 804, 826, 1044,			
1314, 1355, 1614#			
1614#	Q-100	2.10" 41	306S-92
827, 1044, 1105, 1284,	Q-100	2.10" 41	306S-15
1357, 1617, 1736, 1794#			
207, 677, 827, 866,	R-140/155	2.13" 22	350S-19
867, 1315,			
1485, 1615, 1725, 1757#			
1757#, 1875, 1925,	R-140/155	2.38" 24	350S-15
1935, 3795, 3805, 4025,			
4564, 4805			
1045, 1737, 1757#	R-140/155	2.15" 23	350S-16
258#, 305#, 312#,	R-170	2.38" 24	350S-15
1927#, 3796, 4264, 4565,			
4807, 4874			
4824, 5814, 5095	R-170/180	2.45" 48	350S-75
677	R-355	2.38" 24	350S-15
205#, 265, 415, 454	RS-120/125	1.75" 34	250S-134
594#, 671#			
755, 775	RS-125	1.95" 38	250S-128
416, 673#, 756#, 1314	RS-140/145	2.00" 39	275S-44
673#, 727, 826, 866,	RS-145	2.10" 41	275S-43
867, 1044, 1105,	RT-146		
1614, 1735#, 1756, 1794			
756#	RS-145	1.85" 36	275S-46
1876, 1927#	RS-160	2.35" 46	350S-81
5225, 7534, 10253	RS-180/185/186	2.55" 50	350S-76
674	RS-220	1.85" 36	275S-37
230	RS-230	2.00" 39	306S-127
4808#	RN-380	2.38" 24	350S-15
	RP/RT-380	2.55" 50	350S-79
	RR-380	2.35" 46	350S-93
258#, 305#, 311#,	SR-170	2.38" 24	350S-15
1927#, 4806	SPR-570		
1356, 1357, 1616,	SQHP,	2.10" 41	306S-15
1735# 1736	SO-100		
1926, 4026	SSHD	2.38" 24	350S-13
	SSHP		
5324	WR-170	2.55" 50	350S-79

*May have either H-140 or H-172 carrier; check carrier to determine correct NoSPIN differential. #Produced with different axle shafts; count splines to determine correct NoSPIN differential.

Axle Description	Carrier	Axle Shaft Dia. (2) # Splines	NoSpin Model Number (1)
MERITOR			
Single Rear Axles			
RS-13/15-120		1.75" 34	250S-134
3.31-4.30 ratio			
4.56-7.17 ratio			
RS-15/17/19-220/224		1.95" 38	250S-128
RS-17/19-144		1.85" 36	275S-37
RS-17/19-144		2.10" 41	275S-43
RS-17/19-145		2.00" 39	275S-44
RS-19-220/224		1.85" 36	275S-37
RS-21-145		2.10" 41	275S-43
RS-21/23-160/160A/161/186		2.35" 46	350S-81
RS-21-230		2.00" 39	306S-127
RS-23-240		2.10" 41	306S-124
RS-23/26/30-380		2.35" 46	350S-93
RS-25/26-160/160A/185		2.35" 46	350S-81
RS-38-380		2.55" 50	350S-79
C-100, 102, 200		1.62" 32	225S-52
		1.62" 16	225S-15
D-100, 140		1.75" 34	250S-97
		1.75" 19	250S-13
		1.75" 16	250S-32
F-106, 140, 146		1.75" 34	250S-97
		1.75" 19	250S-13
FM-240		2.13" 22	306S-12
H-140, 145, 340		1.88" 20	275S-11
H-140E		2.25" 44	306S-136
H-162		2.00" 21	306S-11
H-170, 171		1.85" 36	275S-10
H-172, 173		2.00" 39	306S-79
L-145, 155		2.00" 21	306S-11
L-164		1.88" 20	276S-11
L-172		2.00" 39	306S-79
L-245, 345		2.00" 21	306S-25
L-362		2.00" 21	306S-25
M-172		2.00" 39	306S-79
M/FM-240		2.12" 16	306S-36
M/MD-240		2.13" 22	306S-12
P-140E		2.25" 44	306S-136
P-174		2.10" 41	306S-15
Q-100		2.10" 41	306S-15
Q-145		2.13" 22	306S-31
Q-345		2.13" 22	306S-38
R-140		2.25" 23	350S-25
R-140E		2.25" 44	306S-136
R-140, 155*, 200, 221, 255*, 270, 300, 355		2.38" 24	350S-13
R-355/356		2.35" 46	350S-57
R-170		2.38" 16	350S-29
		2.38" 24	350S-13
RL-170		2.35" 46	350S-57
		2.38" 24	350S-13
RS-13-120, 15-120/125		1.75" 34	250S-134
4.56-7.17 ratio		1.95" 38	250S-128
RS-15-210		1.75" 34	250S-139
RS-17-140		2.00" 39	275S-44
		1.85" 36	275S-46
RS-17-144, 145		2.00" 39	275S-44
RS-17-220		1.85" 36	275S-37
RS-18-140, 145		2.00" 39	275S-44
		1.85" 36	275S-46
RS-19-145		2.00" 39	275S-44
RS-19-220		1.85" 36	275S-37
RS-20-145		2.25" 44	306S-136
		2.10" 41	275S-43
RS-20-230		2.00" 39	306S-127
RS-21-145		2.10" 41	275S-43
RS-21-230		2.00" 39	306S-127
RS-23-160, 180		2.35" 46	350S-81
		2.55" 50	350S-76
RS-23-240		2.10" 41	306S-124
RS-23-380		2.35 46	350S-93
RS-25/26-160, 180		2.35" 46	350S-81
RS-26-380		2.35" 46	350S-93
RS-30-180		2.35" 46	350S-81
RS-30-380		2.35" 46	350S-93

Axle Description	Carrier	Axle Shaft Dia. (2) # Splines	NoSpin Model Number (1)
RS-38-380		2.55" 50	350S-79
RS-410#		1.45" 29	225S-39A
S-162, 163		2.25" 23	350S-25
S-164, 165		2.38" 24	350S-13
S-170		2.35" 46	350S-57
		2.38" 24	350S-13
SL-100		2.00" 39	306S-79
SR-170		2.38" 24	350S-13
SW-170/180, 270/280		2.55" 50	350S-79
U-170, 180, 240, 340		2.38" 24	350S-13
U-270, 340		2.35" 46	350S-57
W/WP/WR-170		2.55" 50	350S-79
W-180, 270, 280		2.55" 50	350S-63
W-464		2.55" 50 (5)	350S-56
59732, 59733 (WT)		2.38" 16	350S-29
59742, 59743 (WT)		2.38" 24	350S-13
61142, 61143 (WT)		2.35" 46	350S-81
*Di Rona Mexico #Brazil See notes on last page.			
Tandem Axles			
RT-34/40-144/145/149		2.10" 41	275S-43
RT-40/46/50-160/164/169,		2.25" 44	306S-136
RT-40/44-145			
RT-48/50/52/58/70-185/380		2.35" 46	350S-93
RZ-166		2.35" 46	350S-81
RZ-186 front		2.35" 46	350S-93
rear		2.35" 46	350S-81
RZ-188		2.35" 46	350S-93
R-170/TKN 4670		2.35" 46	350S-57
		2.38" 24	350S-13
RT 34-140, 145		2.00" 39	275S-44
RT 46/48/52-160		2.55" 50	350S-76
		2.35" 46	350S-81
RT 48/52/58-180 front		2.35" 46	350S-93
rear		2.35" 46	350S-81
RT 48/52/58-380		2.35" 46	350S-93
RT 70-180		2.55" 50	350S-76
RT 70-380		2.55" 50	350S-79
SDH/SDHD		1.75" 16	250S-32
SFD (C-240)		1.62" 16	225S-15
SFD (M-240)		2.12" 16	306S-36
SFD/SFDD 4640, 47		2.55" 50 (5)	350S-56
		2.50" 16 (5)	350S-52
SFH/SFHD		1.75" 34	250S-97
		1.75" 19	250S-13
SHD, SHR		2.38" 24	350S-13
SHHD/SJHD		1.87" 20	275S-11
SLD/SLDD		2.00" 21	306S-11
		2.00" 16	306S-22
SL 100		2.00" 39	306S-79
SLHD		2.00" 21	306S-11
SLHR/T-3000		2.00" 21	306S-11
SQHD		2.13" 22	306S-12
		2.00" 21	306S-25
SQHP, SQ 100		2.10" 41	306S-15
SQR 100		2.10" 41	306S-15
SR 170, 270, 280		2.35" 46	350S-57
		2.38" 24	350S-13
SRD/SRDD		2.35" 46	306S-84
		2.25" 23	306S-35
SRHD		2.25" 23	306S-35
SSHD		2.35" 46	350S-57
		2.38" 24	350S-13
		2.25" 23	350S-25
ST 170		2.38" 24	350S-13
STD,STDD,STD-DD		2.35" 46	350S-55
		2.38" 24	350S-36
STHD		2.38" 46	350S-57
		2.38" 24	350S-13
SU 170, SUD/SUDD, SUHD		2.35" 46	350S-57
		2.38" 24	350S-13
SU 270, 280		2.35" 46	350S-57
		2.38" 24	350S-13
SW 170, 180, 270, 280		2.55" 50	350S-79
FLDD, LDD-240		2.13" 22	306S-12

TABLE OF CONTENTS

Axle Type Illustration.....	Page 48
Eaton to NCB Interchange List.....	Page 49
Rockwell to NCB Interchange List.....	Page 51
Numerical Listing Rockwell Assemblies.....	Page 52
NCB Axle Shaft No. to Original Equipment Mfg. & Specifications.....	Page 53
Principal Applications & Approx. Shipping Weights.....	Page 71
Sample Identification.....	Page 73

SPECIAL AXLES & SHAFTS

Our Modern equipment and facilities enable us to produce all types of shafts for Trucks and Tractors as well as for other innumerable uses. Submit your drawings and specifications, and quotations will be promptly forwarded.

GENERAL INFORMATION

Our axles and drive shafts are manufactured for the replacement trade. It is not intended to convey the thoughts that they are original shafts made by the truck or assembly manufacturer. They are sold for use in replacing broken or worn shafts and should be resold by the vendor for such purposes only. Vehicles or assembly manufacturers' part numbers are used to aid in selection of our proper number.

AXLE-TYPES

The illustrations below classify the principal types of Axles listed in the Catalog. The symbols appear in the alphabetical listing in the column headed "Type and Number of Splines." The letter symbol identifies the type, and the numeral suffix the number of splines. Flanged axles, unless otherwise noted, are measured from inside of flange to end of spline.



TYPE B

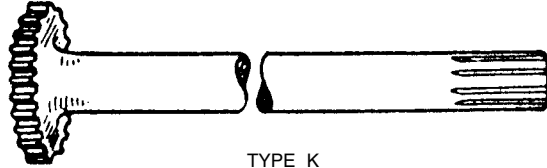

TYPE K

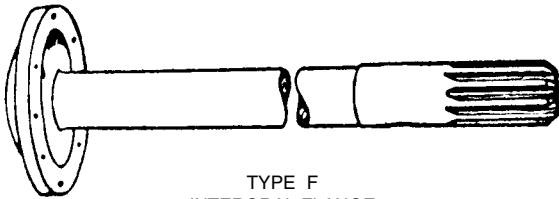

TYPE F
INTERGRAL FLANGE



TYPE M
MF-Type M with Press-on Flange



TYPE R

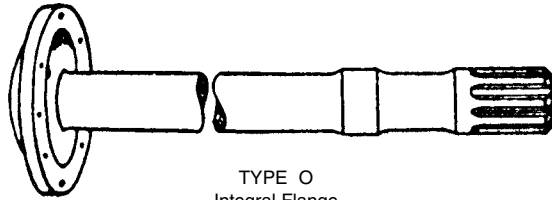

TYPE O
Integral Flange



TYPE J
JF-Type with Press-on Flange

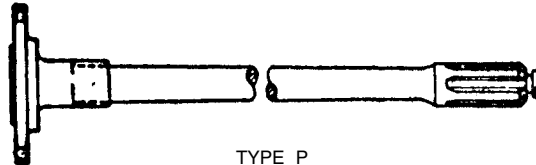

TYPE P

Type "T" same as Type "P", without lock key groove.

Heavy Duty Axle Shafts

EATON TO NCB INTERCHANGE LIST

Dana/Eaton Number	NCB Number	Dana/Eaton Assembly Series	Dana/Eaton Number	NCB Number	Dana/Eaton Assembly Series
15461	AS655	IHC	52281	AS1026	30
22586	AS872R	17	53597	AS1051	19-20-23
22619	AS729	19-20	54014	AS1040	19-23-26-44-440-480
22638	AS732A	17-18-34	55293	AS1022L	GMC
27847	AS834	18-38-42	55294	AS1022R	GMC
28429	AS732A	17-18-34	55957	AS1051	19-20-23
29130	AS732A	17-18-34	55987	AS1057	16
29458	AS732A	17-18-34	56203	AS864	18-38
30024	AS834	18-38-42	56979	AS1026	30
30470	AS847	16	56980	AS749	17-34-340
30562	AS864	18-38	56981	AS1052	18-38-380
30687	AS749	17-34-340	58975	AS1053	16
31136	AS855	16	59502	AS1058	16-30
31403	AS758	16-30	62164	AS1048	16-30-34
31673	AS763A	15	62165	AS1049	17-34-340
31928	AS842R	17	62166	AS1087	18-22-38-380
32586	AS846	13-15	62214	AS732A	17-18-34
32686	AS749	17-34-340	64130	AS1063	18-38-380
34689	AS732A	17-18-34	64893	AS732A	17-18-34
35310	AS858	13	64973	AS749	17-34-340
35332	AS866	13-15	65360	AS1054	13-15
37150	AS953	19	67591	AS1049	17-34-340
37303	AS864	18-38	67742	AS834	18-38-42
37311	AS729	19-20	67747	AS1040	19-32-26-44-440-480
37357	AS842R	17	67790	AS842R	17
37396	AS732A	17-18-34	72617	AS1058	16-30
37405	AS732A	17-18-34	76917	AS1104	38-380
37406	AS732A	17-18-34	79005	AS1128	18-23-26-44-440-480
37883	AS732A	17-18-34	79130	AS1131	18
38045	AS953	19	80929	AS1131	18
38208	AS892	18-38-42	81216	AS1083	18-22-38-380
38310	AS834	18-38-42	81683	AS1081	16-30
38928	AS953	19	88192	AS1129	50-400-401-480
40761	AS930	13	88987	AS1098	16
40934	AS732A	17-18-34	91133	AS1144	400
40935	AS729	19-20	99024	AS1114	23-26-34
42681	AS842R	17	110880	AS1137	13-15
42925	AS953	19	110881	AS1133	16
43776	AS846	13-15	110882	AS1134	17-34-340
43981	AS983	18	110883	AS1135	18-22-38-300-381-381P
43982	AS989L	18	110884	AS1135	18-22-38-380-381-381P
43983	AS989R	18	110885	AS1136	23-26
43984	AS985	IHC	110886	AS1140	17-34-340
44006	AS984L	17	110890	AS1138	19-23-26-44-440-480
44007	AS984R	17	111348	AS1132	16
44450	AS864	18-38	111544	AS1141	15
45960	AS866	13-15	111545	AS1142	15-16
46789	AS834	18-38-42	113334	AS1210	401
49934	AS732A	17-18-34	113335	AS1153	440
51084	AS729	19-20	113645	AS1139	16
51264	AS1051	19-20-23	118866	AS1167	13-15

EATON TO NCB INTERCHANGE LIST

Dana/Eaton Number	NCB Number	Dana/Eaton Assembly Series	Dana/Eaton Number	NCB Number	Dana/Eaton Assembly Series
119592	AS1160	15	210652	AS1253	19050S-19050T
119593	AS1158	16	129000	AS1254	DD/RD 461
119594	AS1150	17-341	129138	AS1255	462-463-23080D-26931-23941
119595	AS1207	18-22-381	129139	AS1256	461-462-21080D-23080D
119596	AS1208	23	129141	AS1257	462-463-23080D
119627	AS1200	23105	126880	AS1257	23080S
119949	AS1209	23105	129142	AS1258	23080A
126274	AS1201	19050S	131245	AS1259	170-190
210512	AS1202	19050S	128517	AS1260	404-405-454-20606S-21060L-22060S-22060L
210628	AS1203	19050S	128517HX	AS1260	404-405-454-20606S-21060L-22060S-22060L
110888	AS1214	38-380-381-402	128521	AS1261	404-405
110889	AS1215	19-23-26-44-440-460-480-461	128521HX	AS1261	404-405
111788	AS1224	35-580-650	126878	AS1262	21080S-26080S-23090S
119628	AS1225	35-580-650	126195	AS1263	26105S
127437	AS1226	21060S-404-405-454	126601	AS1264	23105S-26105S
127438	AS1227	21060S-404-405-454	126877	AS1265	403-451
128514	AS1228	404-405-454-20606S-21060D-22060S-22060D	128516	AS1266	404-405-454-20606S-21060D-22060S-22060D
128515	AS1229	404-405-454-21060S-22060S	129332	AS1266	402-403
129010	AS1230	344-19060S-19060D	130911	AS1267	344-17060S-19060S-21060S
129011	AS1231	344-19060S-17060S-19060L	129960	AS1268	23090S
210654	AS1232	19050S	130912	AS1269	344-17060S-19060S-21060S
128112	AS1236	15040S-15040T			
128516	AS1237	404-405-454-20606S-21060D-22060S-22060D			
128435	AS1252	404-405-454-21060D			
129331	AS1253	19050S-19050T			
128375	AS1253	19050S-19050T			

Heavy Duty Axle Shafts

ROCKWELL TO NCB INTERCHANGE LIST

Meritor/ Rockwell No.	NCB No.	Meritor/ Rockwell No.	NCB No.	Meritor/ Rockwell No.	NCB No.	Meritor/ Rockwell No.	NCB No.
Z2054	AS649	E8195	AS1015R	F6766	AS1115	H8666	AS1187*
R3710	AS649	N3056	AS1024	F7572	AS1122	Y8917	AS1188
K1779	AS681	L6564	AS1024	T6728	AS1126L	S8937	AS1189
H2686	AS762	Z3120	AS1028	U6729	AS1126S	H9342	AS1190*
N2536	AS863S	X6472	AS1028	S7975	AS1127	F9340	AS1191
Q2539	AS863L	W6549	AS1028	G6793	AS1130	G9341	AS1192
C8193	AS863S	X3508	AS1037	Z8190	AS1130	L9346	AS1193*
D8194	AS863L	Z3718	AS1037	A8191	AS1130	J9344	AS1194
Z2704	AS893	Z3771	AS1037	B8192	AS1130	K9345	AS1195
D2734	AS921	V6730	AS1037	Q8181	AS1143L	Q6361	AS1196
F2736	AS922	A3459	AS1042	R8182	AS1143S	C9519	AS1197
B2706	AS931	V6574	AS1042	Z7384	AS1145L	Y9047	AS1198
T2932	AS932	R3268	AS1043	C7387	AS1145R	X9046	AS1199
D2942	AS933	A3277	AS1043	P8050	AS1146	S6779	AS1204
G2971	AS950	Y4783	AS1043	O8051	AS1147	E9391	AS1205
S2983	AS951	Q5269	AS1043	J8070	AS1148	F9392	AS1206
C2993	AS952	Z3510	AS1044	N8048	AS1149	C8141	AS1211
L3002	AS955	O3423	AS1046	B3512	AS1159L	Q9117	AS1216
Z3692	AS955	B5228	AS1054	V6054	AS1159L	R9118	AS1217
A2513	AS965	K5107	AS1056	X6056	AS1159R	S9119	AS1218
Y3041	AS967L	W5197	AS1056	M8983	AS1166	T9484	AS1219
K3053	AS967L	X5407	AS1057	B8790	AS1170	U9485	AS1220
W3039	AS967R	L2976	AS1060L	Z8788	AS1171	G9393	AS1235
L3054	AS967R	J2974	AS1060R	O8389	AS1172	S9483	AS1238
N3212	AS968	D4450	AS1068	P8362	AS1173	E4555	AS1239
S3035	AS969	B4448	AS1080	F9002	AS1174L	H6768	AS1240
X3742	AS969	Z3666	AS1084L	E9001	AS1174R	H6794	AS1241
H3888	AS969	A3667	AS1084R	J8902	AS1175R	J6796	AS1242
K3911	AS969	N6098	AS1090	L8904	AS1176L	A8191	AS1243
U3921	AS969	P6100	AS1090	B9050	AS1176L	S9041	AS1244
M2873	AS972L	L6356	AS1101S	C9051	AS1176R	C9129	AS1245
Q3943	AS972L	N6358	AS1101L	T9042	AS1177	P9142	AS1246
L2872	AS972R	T7820	AS1106	S9041	AS1178	Q9143	AS1247
P3942	AS972R	E7415	AS1108	U9043	AS1179	P9246	AS1248
J3026	AS995	D6712	AS1109	W8915	AS1180	R9248	AS1249
Z2262	AS999	P7816	AS1110	Q8935	AS1181	S9249	AS1250
S3269	AS1012	F6792	AS1111	G9003	AS1182	N9374	AS1251
D3462	AS1013	Y8189	AS1111	Q8805	AS1183	A9491	AS1252
S2593	AS1015L	G6780	AS1112R	B8816	AS1184*	N9608	AS1253
F8196	AS1015L	W6783	AS1112L	Y8111	AS1185*	Q9611	AS1254
Q2591	AS1015R	G6767	AS1113	F7745	AS1186		

NOTE: ALL ROCKWELL NUMBERS CARRY 3202 AS A PREFIX IN THEIR NUMBERING SYSTEMS

NUMERICAL LISTING OF ROCKWELL REAR AXLE ASSEMBLIES FOR WHICH WE CAN SUPPLY REPLACEMENT AXLES

Meritor/Rockwell Assembly Series	NCB No.	Meritor/Rockwell No.
B140	AS932	T2932
D100-40	AS762	H2686
F106	AS1054	B5228
F130	AS1056	K5107-W5197
F140-145-240-340-345	AS933	D2942
F140D-147	AS1056	K5107-W5197
G161-341-361	AS968	N3212
G361	AS969	S6065-X3742
H100-110	AS936	CHEV-GMC
H110	AS1149	N8048
H130-150	AS937	CHEV-GMC
H135	AS1146	P8050
H140-240-340-350-370	AS955	L3002
H141-(DODGE)	AS1080	B4448
H150	AS938R-L	CHEV-GMC
H150	AS1022R-L	CHEV
H150	AS1147	Q8051
H170	AS1022R-L	CHEV
H170(FORD)	AS1090	N6098-P6100
H172	AS1109	D6712
H172(DODGE)	AS1122	F7572
H175	AS1148	J8070
L140-145-240-245-340-345	AS950	G2971
L162-351-362	AS969	X3742
L346	AS1028	Z3120
L351	AS969	S3035
L361	AS969	H3888
Q145-345	AS951	S2983
Q246P-346P	AS1024	N3056
Q345	AS1043	Q5269
QT140-240-340-345	AS951	S2983
QT340	AS1043	R3268
R100-101-110-200-201-210-20300-310-330	AS649	Z2054
R101-201-301	AS999	Z2262
R140	AS952	C2993
R160-390	AS967R-L	L-3054-K3053
RL170	AS1037	X3508
R2090-1	AS681	K1779
RS13-120	AS1174R-L	E9001-F9002
RS15-120	AS1174R-L	E9001-F9002
RS15-210	AS1174R-L	E9001-F9002
RS17-140	AS1176R-L	C9051-B9050
RS17-220	AS1175R-L	J8902-L8904
RS21-145	AS1178	S9041
RS21-145	AS1177	T9042
RS21-230	AS1180	W8915
RS23-160	AS1183	Q8805
RS23-160	AS1182	G9003
RS23-180	AS1183	Q8805
RS23-180	AS1185	Y8111
RS26-180	AS1186	W7745
RS23-180	AS1187	H8666

Meritor/Rockwell Assembly Series	NCB No.	Meritor/Rockwell No.
RS23-240	AS1188	Y8917
RT140-240-340	AS952	C2993
RT340	AS1037	X3508
S170(GMC)	AS1159R-L	X6056-V6054
S200-300	AS649	Z2054
SL100	AS1143L-S	Q8181-R8182
SQ100	AS1101L-S	N6358-L6356
SR170-270-380	AS1159R-L	X6056-V6054
T1550	AS1141	GMC
T150-170-185	AS937	CHEV-GMC
T150-170	AS1022R-L	CHEV
T155(GMC)	AS1145R-L	C7387-Z7384
T185	AS1125	GMC
U200-300	AS649	Z2054
D&D D4640	AS1015R-L	Q2591-S2593
HQDA-QHAR	AS1024	N3056
LHAR-LHDA	AS1028	Z3120
SFD154	AS681	K1779
SFD450-60-D461-SFD4600-SFDD4600	AS863L-S	Q2539-N2536
SFD4640	AS1111-1130	F6792-G6793
SFHD	AS995	J3026
SHHD	AS955	L3002-Z3692
SHHD(DODGE)	AS1080	B4448
SHHR	AS995	J3026
SJHD	AS1040	Z3510
SL100	AS1143L-S	Q8181-R8182
SLD(21 SPL.)	AS1060R-L	J2974-L2976
SLHD	AS950	G2971
SLHD(GMC)	AS969	X3742
SLHD	AS1143L-S	Q8181-R8182
SLHD(GMC)	AS1028	X6472
SQS-SQDD	AS921	D2734
SQD-SQDD	AS922	F2736
SQDD(GMC)	AS972R-L	L2872-M2873
SQHD	AS951	S2983
SQHD(IHC)	AS1024	N3056
SQHD(GMC)	AS1012	Q5269-S3269
SQHD(GMC)	AS1043	A3277
SQHD(GMC)	AS1101L-S	N6358-L6356
SQHD(Wide Track)	AS1046	Q3423
SQHP	AS1101L-S	N6358-L6356
SR270-280	AS1159R-L	X6056-V6054
SRDD	AS1112R-L	T6780-W6783
SSDD	AS1111RH-1130LH	F6792-G6793
SSHD	AS1042-967R	A3459-W3039
SSHD(CHEV-GMC)	AS1084R-L	A3667-Z3666
SSHD(GMC)	AS1126L-S	T6728-U6729
SSHR	AS955	L3002
STHD(GMC)	AS1145R-L	C7387-Z7384
SUD-SUDD	AS1035L-S	P3500-N3498
SUDD	AS1113-1115	G6767-F6766
SUHD	AS1035L-1159L	P3500-V6054

Heavy Duty Axle Shafts

NCB AXLE SHAFT NUMBER TO ORIGINAL EQUIPMENT MANUFACTURER NUMBER

NCB NO.	TYPE	ROC.	EATON	FORD	CHEVY	NAVISTAR	WHITE	MACK	DODGE
AS649	F16	Z2054		B8QH4234F	208920 2428108	56151R1 51896C1	461403 718416		127750
AS655	F16		15461			54088H 58662H 219891R1			
AS681	F16	K1779					427472		1090629
AS691L	F16								1268811
AS691R	F16								1268810
AS701L	F10				3660093				
AS701R	F10				3660094				
AS729	F16		22619 37311 40935 51084		2426738 2291543		814789		
AS732A	F16		37883 40934 62214 64893		57408R1 57689R1 94050HA 109389R1	718062 879934 879937 879938 294292C1 298187C1 298188C1 875186R1 3237548R1	881220 898001		
AS749	F16		30689 32686 56980 64973	8QH4235 B1QH4235A C3TZ4234N		79951R1	846775 330305008		
AS750L	K16				3685193 3702205 3702227				
AS750R	K16				3685194 3702206 3702228				

SPECIFICATIONS OF NCB AXLES

NCB No.	Type	Length	Spline O.D.	Flange O.D.	Bolt Circle	STUD BOLT HOLES			
						QTY	SIZE	STR	TAPER
AS649	F16	40-5/8	2.375	8-3/8	7	8	41/64		8
AS655	F16	36	1.812	6-3/8	5-3/8	6	33/64	6	
AS681	F16	40-3/4	1.955	6-1/2	5-1/2	12	17/32	9	3
AS691L	F16	40-1/2	1.375	4-3/4	4	6	29/64	6	
AS691R	F16	29-1/4	1.375	4-3/4	4	6	29/64	6	
AS701L	F10	33	1.638	5-5/16	4-17/32	8	29/64	8	
AS701R	F10	39-5/6	1.638	5-5/16	4-17/32	8	29/64	8	
AS729	F16	40-5/8	2.245	8-1/2	7	8	41/64		8
AS732A	F16	40-11/16	1.975	6-5/8	5-1/2	8	41/64	8	
AS749	F16	40-3/4	1.975	6-1/8	5-1/4	12	17/32		12
†AS750L	K16	36-7/16	1.727	3-3/4		20			TEETH
†AS750R	K16	40-5/8	1.727	3-3/4		20			TEETH

Heavy Duty Axle Shafts



HD Differential

NCB AXLE SHAFT NUMBER TO ORIGINAL EQUIPMENT MANUFACTURER NUMBER

NCB NO.	TYPE	ROC.	EATON	FORD	CHEVY	NAVISTAR	WHITE	MACK	DODGE
AS751L	K10				3685191				
AS751R	K10				3685192				
AS755	F16							1194486	
AS758	F16		31403					1196202	
AS762	F16	H2686	31413	7RT4235A					
AS815	F16	N1417 J1466			2108953				
AS834	F16		27847 30024 38310 46789 67742		2486050	111658R1 205490R1 259684C1 305236C1 312075C1	716741 716742 875248	365SP86	
AS837	F16		45961			68932R1 111653R1 205468R1			
AS842R	F16		22586 31928 37357 42681 67790		2120072 2240328 2291542 2479192 3730536Z		861512		
AS843	F16					82778R1			
AS844	F16		45960			69187R1 111651R1 205463R1 229166R1			
AS846	F16		32586 43776			77609R1 108117R1 171093R1	718167		
AS847	F16		30470		2241439		819050		

SPECIFICATIONS OF NCB AXLES

NCB No.	Type	Length	Spline O.D.	Flange O.D.	Bolt Circle	STUD BOLT HOLES			
						QTY	SIZE	STR	TAPER
†AS751L	K10	34-3/32	1.638	3-3/4		20			TEETH
†AS751R	K10	40-15/32	1.638	3-3/4		20			TEETH
AS755	F16	37-3/32	1.750	5-13/16	5-3/64	8	7/16	8	
AS758	F16	37-9/32	1.875	5-3/4	5-3/64	8	7/16	8	
AS762	F16	36-9/16	1.750	5-1/2	4-3/4	8	29/64		8
AS815	F16	37	1.625	5-3/4	4-7/8	8	29/64		8
AS834	F16	39-3/4	2.125	8-1/2	7	8	49/64	8	
AS837	F16	39-1/12	1.875	6-1/4	5.225	6	41/64	6	
AS842R	F16	40-15/16	1.985	6-1/8	5-1/4	12	33/64		12
AS843	F16	36-3/16	1.510	5-1/4	4-3/8	6	33/64	6	
AS844	F16	36-13/16	1.743	5-3/4	4-7/8	8	33/64	8	
AS846	F16	36-3/4	1.745	5-3/4	4-7/8	8	33/64	8	
AS847	F16	38-1/2	1.875	6-3/16	5-5/16	8	37/64		8

Heavy Duty Axle Shafts

NCB AXLE SHAFT NUMBER TO ORIGINAL EQUIPMENT MANUFACTURER NUMBER

NCB NO.	TYPE	ROC.	EATON	FORD	CHEVY	NAVISTAR	WHITE	MACK	DODGE
AS855	F16		31136			66017R1 108459R1 171628R1 336471C1	861577		
AS863L	F16	Q2539 D8194		C3TZ4234F	2272615	340568C1 698646R1	718873		
AS863S	F16	N2536 C8193		C3TZ4234E	2272614	340569C1 698647R1	718872		
AS864	F16		30562 37303 44450 56203		2290550 2359830 2431537		846681		
AS866	F16		35332 45059			95287R1 101716R1 179882R1			
AS892	F16		38208	TUAA4235A	5727159	205490R1	875248 256011		
AS895L	J17							68KHC356P1	
AS895S	J17							68KHC356P2	
AS921	F16	D2734				138764R1	843670		
AS922	F16	F2736				138765R1	843671		
AS933	F19	D2942		B4T4235A B6T4235A			883520		
AS936	K27				3762916				
AS937	K29				3709890 3762885 3762907				

SPECIFICATIONS OF NCB AXLES

NCB No.	Type	Length	Splines O.D.	Flange O.D.	Bolt Circle	STUD BOLT HOLES			
						QTY	SIZE	STR	TAPER
AS855	F16	38-1/2	1.875	6-1/4	5.225	6	41/64	6	
AS863L	F16	46-1/16	2.490	8-3/8	7	8	41/64		8
AS863S	F16	37-7/8	2.490	8-3/8	7	8	41/64		8
AS864	F16	40-13/16	2.125	8-1/2	7	8	41/64		8
AS866	F16	38-5/8	1.750	6-1/4	5.225	6	41/64	6	
AS892	F16	39-3/4	2.125	8-1/2	7	8	49/64	8	
†AS895L	J17	50-1/8	2.190						
†AS895S	J17	39-11/16	2.190						
AS921	F16	45-5/8	2.120	7-15/32	6-1/2	12	33/64	6	6
AS922	F16	34-7/16	2.120	7-15/32	6-1/2	12	33/64	6	6
AS933	F19	37-1/2	1.770	6-1/8	5-1/8	8	29/64		8
†AS936	K27	37-7/16	1.730	3-3/4		20			Teeth
†AS937	K29	39-7/16	1.855	4-3/16		40			Teeth

†Dagger denotes length measured overall, NOT under flange.

Heavy Duty Axle Shafts



HD Differential

NCB AXLE SHAFT NUMBER TO ORIGINAL EQUIPMENT MANUFACTURER NUMBER

NCB NO.	TYPE	ROC.	EATON	FORD	CHEVY	NAVISTAR	WHITE	MACK	DODGE
AS938L	K29				3711457 3762891				
AS938R	K29				3711458 3762892				
AS950	F21	G2971			2468584	172052R1 211626R1	870558		1665635
AS951	F22	S2983				983610R1	871899		1665719
AS952	F23	C2993				168425R1 898212R1	878109		1665822
AS953	F16		37150 38045 38928 42925	B8QH4235		111045R1 123741R1 284147C1	839118A	365SP84	
AS955	F20	L3002 Z3692		C3TZ4234K C7TZ4234B	675889 237286		870562		
AS957L	J17							68KH3129P1	
AS957S	J17							68KH3129P2	
AS959L	J17							68KH358P1-4	
AS959S	J17							68KH358P2-3	
AS960L	F17							68KH3120P3 68KH3121P3	
AS960S	F17							68KH3120P2 68KH3121P2	

SPECIFICATIONS OF NCB AXLES

NCB No.	Type	Length	Spline O.D.	Flange O.D.	Bolt Circle	STUD BOLT HOLES			
						QTY	SIZE	STR	TAPER
†AS938L	K29	38-1/16	1.855	4-3/16		40			Teeth
†AS938R	K29	40-9/16	1.855	4-3/16		40			Teeth
AS950	F21	40-3/8	1.995	6-3/8	5-11/16	12	15/32		12
AS951	F22	40	2.120	4-15/32	6-1/2	12	33/64	6	6
AS952	F23	40-7/8	2.245	8-3/8	7	8	41/64		8
AS953	F16	39-5/8	2.245	8-1/2	7	8	49/64	8	
AS955	F20	38-3/16	1.872	6-1/4	5-5/16	8	33/64		8
AS957L	J17	50-1/8	2.190						
AS957S	J17	39-11/16	2.190						
AS959L	J17	51-5/8	2.625						
AS959S	J17	40-5/8	2.625						
AS960L	F17	45-1/8	2.190	7-11/32	6-3/8	8	9/16	8	
AS960S	F17	34-3/4	2.190	7-11/32	6-3/8	8	9/16	8	

Heavy Duty Axle Shafts

NCB AXLE SHAFT NUMBER TO ORIGINAL EQUIPMENT MANUFACTURER NUMBER

NCB NO.	TYPE	ROC.	EATON	FORD	CHEVY	NAVISTAR	WHITE	MACK	DODGE
AS965	F16	Q2513					852108		
AS967L	F23	K3053 Y3041				358879C1 983452R1 983717R1	861141 887574		
AS967R	F23	W3039 L3054			2350221 2398830	358880C1 983451R1 983718R1	861142 881632		2560424
AS968	K20	N3212			2358251				
AS969	F21	S3035 X3742 H3888 U3921			2349682 2417717 2431395				
AS972L	F16	Q3943 M2873			2319812 2448043	297337C1	297337C1	3103964	
AS972R	F16	L2872 P3942			2319811 2448042	297338C1	3103965		
AS983	F20		43981			157518R1			
AS984R	F16		44007			175395R1 272120C1			
AS984L	F16		44006			175394R1 272119C1			
AS985	F22		43984			161087R1 892604C1			
AS989L	F20		43982			172714R1			
AS989R	F20		43983			172715R1			
AS991	F16								7922317
AS995	F16	J3026							

SPECIFICATIONS OF NCB AXLES

NCB No.	Type	Length	Splines O.D.	Flange O.D.	Bolt Circle	STUD BOLT HOLES			
						QTY	SIZE	STR	TAPER
AS965	F16	39-3/16	1.625	6-3/8	5-9/16	8	17/32	8	
AS967L	F23	37-15/16	2.250	8-3/8	7	8	41/64		8
AS967R	F23	43-1/2	2.250	8-3/8	7	8	41/64		8
†AS968	K20	39-1/8	1.875	4-3/16		40			Teeth
AS969	F21	40-11/16	2.000	6-1/8	5-1/4	12	33/64		12
AS972L	F16	46-1/4	2.120	8-3/8	7	8	41/64		8
AS972R	F16	35	2.120	8-3/8	7	8	41/64		8
AS983	F20	39-5/8	2.093	8-1/2	7	8	49/64	8	
AS984R	F16	38	1.980	6-5/8	5-1/2	8	41/64	8	
AS984L	F16	43	1.980	6-5/8	5-1/2	8	41/64	8	
AS985	F22	39-3/8	2.302	8-1/2	7	8	49/64	8	
AS989L	F20	42-1/16	2.093	8-1/2	7	8	49/64	8	
AS989R	F20	37	2.093	8-1/2	7	8	49/64	8	
AS991	F16	33-5/16	1.310	4-3/4	3-31/32	8	29/64		8
AS995	F19	38-3/8	1.770	6-1/4	5-5/16	8	33/64		8

†Dagger denotes length measured overall, NOT under flange.

Heavy Duty Axle Shafts



HD Differential

NCB AXLE SHAFT NUMBER TO ORIGINAL EQUIPMENT MANUFACTURER NUMBER

NCB NO.	TYPE	ROC.	EATON	FORD	CHEVY	NAVISTAR	WHITE	MACK	DODGE
AS999	F20	Z2262					619787		
AS1012	F22	S3269			2365637 2408387 2472266				
AS1015L	F16	S2593 F8196			2402207	974557R1	877262		
AS1015R	F16	Q2591 E8195			2402206	974558R1	877261		
AS1022L	F29		55293		3796175				
AS1022R	F29		55294		3796176				
AS1024	F22	N3056 L6564		C1TT4235A D5HZ4235A		175542R1 353064R1	027089999		
AS1025	F29				3796177				
AS1026	F16		52281 56979	C1TT4235C C3TZ4234R			887997 1728392		3736653
AS1028	F21	Z3120 X6472 W6549		C1TT4235E D4HZ4234A	2005145	213526R1 579418C91	027075968		
AS1037	F24	X3058 Z3718 Z3771 V6730		D3HZ4234A	2431515 2418918	436422R1 752895C1 257266C1	1715590	365SP87 365SP96	2505729 2560620
AS1040	F22		54014 67747	D8HZ4234A	2428133 2491259		330305003		2239744 2552579
AS1042	F23	A3459 V6574			2398829	242942R1	881633		2560425
AS1043	F22	A3277 R3268 Y4783 Q5269		D7HZ4235A	2366740 2472266	464373C1	027087695 3120157-9		3496241

SPECIFICATIONS OF NCB AXLES

NCB No.	Type	Length	Spline O.D.	Flange O.D.	Bolt Circle	STUD BOLT HOLES			
						QTY	SIZE	STR	TAPER
AS999	F20	40-5/8	2.375	8-3/8	7	8	41/64		8
AS1012	F22	41	2.125	8-3/8	7	8	41/64		8
AS1015L	F16	49-7/8	2.485	8-3/8	7	8	41/64		8
AS1015R	F16	41-3/4	2.485	8-3/8	7	8	41/64		8
AS1022L	F29	37-1/4	1.860	6-3/16	5-5/16	8	37/64		8
AS1022R	F29	39-3/4	1.860	6-3/16	5-5/16	8	37/64		8
AS1024	F22	39-3/16	2.125	8-1/2	7	8	49/64	8	
AS1025	F29	38-1/2	1.860	6-3/16	5-5/16	8	37/64		8
AS1026	F16	39-1/8	1.883	6-1/4	5-5/6	8	33/64		8
AS1028	F21	40-5/16	2.000	6-1/8	5-1/4	12	33/64		12
AS1037	F24	40-11/16	2.375	8-3/8	7	8	41/64		8
AS1040	F22	41	2.302	8-1/2	7	8	41/64		8
AS1042	F23	38-7/16	2.250	8-3/8	7	8	41/64		8
AS1043	F22	40-9/16	2.125	8-3/8	7	8	41/64		8

Heavy Duty Axle Shafts

NCB AXLE SHAFT NUMBER TO ORIGINAL EQUIPMENT MANUFACTURER NUMBER

NCB NO.	TYPE	ROC.	EATON	FORD	CHEVY	NAVISTAR	WHITE	MACK	DODGE
AS1044	F20	Z3510					864017	365SP85	
AS1046	F22	Q3423				281409C1 333453C1			
AS1048	F16		62164		2457690				
AS1049	F16		62165 67591		2458460 2477769 2477790		V1112035		
AS1051	F22		51264 53597 55957 102560	C4TZ4234A		436957R1	888728		
AS1052	F16		56981	C3TZ4234P		288345C1 352528C1	891918		
AS1053	F16		58675		8QH4235A C3TZ42434S		863905A		
AS1054	F19	B5228	65360	C4TZ24234D		1677097C1	700890		
AS1055	F23			C7TZ4234A C9TZ4234D					2587864
AS1056	F19	K5107							2512525 2512065 2506987 2585378
AS1057	F16	X5406	55987				3101307	365SP94	2808205 2232205
AS1058	F16		59502 72617		2448315 8871758				
AS1060L	F21	L2976				878774			

SPECIFICATIONS OF NCB AXLES

NCB No.	Type	Length	Splines O.D.	Flange O.D.	Bolt Circle	STUD BOLT HOLES			
						QTY	SIZE	STR	TAPER
AS1044	F20	40-1/4	1.875	6-7/16	5-11/16	12	15/32		12
AS1046	F22	43-1/4	2.125	7-15/32	6-1/2	12	33/64	6	6
AS1048	F16	39	1.875	6-3/16	5-5/16	8	9/16		8
AS1049	F16	41-5/16	1.980	6-1/8	5-1/4	12	9/16		12
AS1051	F22	39-7/8	2.302	8-1/2	7	8	49/64	8	
AS1052	F16	40-1/8	2.125	8-1/2	7	8	49/64	8	
AS1053	F16	38-7/16	1.8756	6-1/4	5-5/16	8	33/64		8
AS1054	F19	38-3/16	1.770	6-1/8	5-1/8	8	29/64		8
AS1055	F23	35-1/16	1.498	4-3/4	3-31/32	8	29/64		8
AS1056	F19	38-1/16	1.770	5-15/16	5-3/64	8	29/64		8
AS1057	F16	38-3/4	1.875	5-15/16	5-3/64	8	29/64		8
AS1058	F16	39-1/2	1.875	6-3/6	5-5/16	8	9/16		8
AS1060L	F21	34-3/4	2.000	6-7/16	5-11/16	12	15/32		12
AS1060R	F21	46	2.000	6-7/16	5-11/16	12	15/32		12

Heavy Duty Axle Shafts



HD Differential

NCB AXLE SHAFT NUMBER TO ORIGINAL EQUIPMENT MANUFACTURER NUMBER

NCB NO.	TYPE	ROC.	EATON	FORD	CHEVY	NAVISTAR	WHITE	MACK	DODGE
AS1063	F16		64130	C3TZ4234P		288345C1 352528C1	891918		
AS1068	F16	D4450							2960024
AS1070	F30								3491431 3633824 4036684
AS1076	F35								3633829
AS1077	F35								2910941
AS1078	F35								2952475
AS1080	F20	B4448							2960026
AS1081	F16		81683						2960025
AS1083	F16		81216	D7HZ4234A	669415		330305002		
AS1084L	F24	Z3666		D8HZ4234E	795824	581594C1	893514	365SP91	
AS1084R	F24	A3667		D8HZ4234D	795825		893515	365SP90	
AS1087	F16		62166		2461392		330305037		3496240
AS1088	F16			D3TZ4234N					
AS1089	F16			C9TZ4234C					
AS1090	F36	N6098 P6100		C8TZ4234E					

SPECIFICATIONS OF NCB AXLES

NCB No.	Type	Length	Spline O.D.	Flange O.D.	Bolt Circle	STUD BOLT HOLES			
						QTY	SIZE	STR	TAPER
AS1063	F16	40-1/8	2.120	8-1/2	7	8	49/64	8	
AS1068	F16	38-5/8	1.875	6-1/4	5-5/16	8	33/64		8
AS1070	F30	34-5/16	1.292	4-3/4	3-31/32	8	29/64		8
AS1076	F35	36-15/16	1.500	4-3/4	3-31/32	8	29/64		8
AS1077	F35	36-1/8	1.500	4-3/4	3-31/32	8	29/64		8
AS1078	F35	36	1.500	5-1/4	4-3/8	6	33/64		6
AS1080	F20	37-15/16	1.875	6-3/16	5-5/16	8	33/64		8
AS1081	F16	39	1.875	6-3/16	5-5/16	8	33/64		8
AS1083	F16	41-11/16	2.125	8-1/2	7	8	41/64		8
AS1084L	F24	43-9/16	2.375	8-3/8	7	8	41/64		8
AS1084R	F24	38-1/16	2.375	8-3/8	7	8	41/64		8
AS1087	F16	41-5/16	2.125	8-1/2	7	8	41/64		8
AS1088	F16	33-5/16	1.310	4-3/4	3-31/32	8	29/64	8	
AS1089	F16	33-5/16	1.310	4-3/4	3-31/32	8	29/64	8	
AS1090	F36	38-7/16	1.835	6-1/4	5-5/16	8	33/64		8

Heavy Duty Axle Shafts

HD Differential

NCB AXLE SHAFT NUMBER TO ORIGINAL EQUIPMENT MANUFACTURER NUMBER

NCB NO.	TYPE	ROC.	EATON	FORD	CHEVY	NAVISTAR	WHITE	MACK	DODGE
AS1091	F35			D5UZ4234E					
AS1092	F35			D5UZ4234F					
AS1095	F35			D5TZ4234B					
AS1096	F30			D4TZ4234A					
AS1097	F30			D5TZ4234A					
AS1098	F16		88987						3893152
AS1099	F16					455462C1			
AS1100	F16					455463C1			
AS1101L	F41	N6358		D8HZ4234C	791454	799567C1	Q27075387		
AS1101S	F41	L6356		D8HZ4234B	791453	799568C1	Q27075386		
AS1102	F16					455461C1			
AS1103	F16					455460C1			
AS1104	F16		76917			792886C1	330305056		
AS1105	F16					455464C1			
AS1106	F34	T7820		EOHZ4234D					
AS1107	F36			EOHZ4234A					
AS1108	F19	E7415		D6TZ4235A	793224				
AS1109	F39	D6712		D7HZ4234C		573296C1			
AS1110	F34	P7816		EOHZ4234C					

SPECIFICATIONS OF NCB AXLES

NCB No.	Type	Length	Splines O.D.	Flange O.D.	Bolt Circle	STUD BOLT HOLES			
						QTY	SIZE	STR	TAPER
AS1091	F35	34-1/8	1.500	4-3/4	3-31/32	8	29/64	8	
AS1092	F35	37-1/2	1.500	4-3/4	3-31/32	8	29/64	8	
AS1095	F35	35-1/8	1.500	4-3/4	3-31/32	8	29/64	8	
AS1096	F30	34-11/16	1.292	4-3/4	3-31/32	8	29/64	8	
AS1097	F30	33-5/16	1.250	4-3/4	3-31/32	8	29/64	8	
AS1098	F16	40-1/2	1.875	6-1/8	5-1/4	12	37/64		12
AS1099	F16	38-5/8	1.745	6-3/16	5.225	8	37/64	8	
AS1100	F16	39-1/12	1.875 Straight	6-3/16	5.225	8	37/64	8	
AS1101L	F41	42-3/8	2.100	8-1/2	7	8	41/64		8
AS1101S	F41	38-3/8	2.100	8-1/2	7	8	41/64		8
AS1102	F16	39-1/12	1.875 Taper	6-3/16	5.225	8	37/64	8	
AS1103	F16	38-5/8	1.750	6-3/16	5.225	8	37/64	8	
AS1104	F16	41-5/16	2.125	8-1/12	7	8	41/64	8	
AS1105	F16	39-15/16	1.875	6-3/16	5.225	8	37/64	8	
AS1106	F34	36-5/16	1.750	5-9/16	4-3/4	8	29/64		8
AS1107	F36	38-11/16	1.835	6-1/4	5-5/16	8	33/64		8
AS1108	F19	36-5/16	1.770	5-9/16	4-3/4	8	29/64		8
AS1109	F39	38-3/4	2.000	6-1/4	5-5/16	8	17/32		8
AS1110	F34	38-3/8	1.750	6-1/8	5-1/8	8	29/64		8

Heavy Duty Axle Shafts



HD Differential

NCB AXLE SHAFT NUMBER TO ORIGINAL EQUIPMENT MANUFACTURER NUMBER

NCB NO.	TYPE	ROC.	EATON	FORD	CHEVY	NAVISTAR	WHITE	MACK	DODGE
AS1111	F50	F6792 Y8189		D7HZ4234F		4884418C1			
AS1112L	F46	W6783		D7HZ4234J		496682C1			
AS1112R	F46	G6780		D7HZ4234H		496683C1			
AS1113	F46	G6767		D7HZ4234E		485472C1			
AS1114	F22		99024	D7HZ42348	2010874	577243C1	330305016		
AS1115	F46	F6766		D7HZ4234D		485473C1			
AS1122	F39	F7572		EOHZ4234B E3HZ4234C	2088183		V1111164		4037914 2096038
AS1123L	F41	N6358				799567C1			
AS1123R	F41	L6356				799568C1			
AS1124L	F24				94025968				
AS1124R	F24				94025967				
AS1125	F29				794363				
AS1126L	F24	T6728			2033901	471822C1			
AS1126S	F24	U6729			2033902	471821C1			
AS1127	F39	S7975			2064176				
AS1128	F22		79005				027090062		
AS1129	F33		88192	E1HZ4234A	2014079		027092513		
AS1130	F50	G6793 Z8190		D7HZ4234G		484417C2 484420C2			

SPECIFICATIONS OF NCB AXLES

NCB No.	Type	Length	Spline O.D.	Flange O.D.	Bolt Circle	STUD BOLT HOLES			
						QTY	SIZE	STR	TAPER
AS1111	F50	37-9/16	2.540	8-3/8	7	8	41/64		8
AS1112L	F46	46-7/16	2.340	8-3/8	7	8	41/64		8
AS1112R	F46	35	2.340	8-3/8	7	8	41/64		8
AS1113	F46	45-1/8	2.340	8-3/8	7	8	41/64		8
AS1114	F22	41-1/4	2.290	8-1/2	7	8	41/64		8
AS1115	F46	37-3/8	2.340	8-3/8	7	8	41/64		8
AS1122	F39	40-13/16	2.000	6-1/4	5-1/4	12	17/32		12
AS1123L	F41	42-1/2	2.100	8-3/8	7	8	41/64		8
AS1123R	F41	38-3/8	2.100	8-3/8	7	8	41/64		8
AS1124L	F24	43-9/16	2.062	6-1/8	5-1/4	12	17/32		12
AS1124R	F24	37-9/16	2.062	6-1/8	5-1/4	12	17/32		12
AS1125	F29	40-11/16	1.860	6-3/16	5-1/4	12	17/32		12
AS1126L	F24	43-3/16	2.370	8-3/8	7	8	41/64		8
AS1126S	F24	38	2.370	8-3/8	7	8	41/64		8
AS1127	F39	38-3/4	2.000	6-1/4	5-1/4	8	33/64		8
AS1128	F22	40-7/8	2.298	8-1/2	7	8	41/64		8
AS1129	F33	41-7/16	2.125	8-1/2	7	8	41/64		8
AS1130	F50	45-5/8	2.540	8-3/8	7	8	41/64		8

Heavy Duty Axle Shafts

NCB AXLE SHAFT NUMBER TO ORIGINAL EQUIPMENT MANUFACTURER NUMBER

NCB NO.	TYPE	ROC.	EATON	FORD	CHEVY	NAVISTAR	WHITE	MACK	DODGE
AS1131	F16		79130 80929			792927C1	31109544 027091269		2953172
AS1132	F36		111348		2084246				
AS1133	F36		110881 111347	E1HZ4234B			330305068		
AS1134	F39		110882	E1HZ4234C			330305054		
AS1135	F41		110883 110884	E1HZ4234D	2099148 15585167		330305045 330305046		
AS1136	F36		110885	E1HZ4234E	2095394	592439C1	330305041		
AS1137	F34		110880	E1HZ4234F					
AS1138	F36		110890	E2HZ4234A	2099842				
AS1139	F36		113645	E3HZ4234B			330305075		
AS1140	F39		110886		2093185		330305078		
AS1141	F34		111544		2078076				
AS1142	F36		111545		2078077				
AS1143L	F39	Q8181		E3HZ4234D	15515252	592500C1	330305052		
AS1143S	F39	R8182		C3HZ4234E	55152959	592501C1	330305053		
AS1144	F33		91133						
AS1145L	F24	Z7384			2017542	466122C1	330305001		
AS1145R	F24	C7387			2017541	466121C1	330305000		
AS1146	F34	P8050			2088210				
AS1147	F34	Q8051			2086307				

SPECIFICATIONS OF NCB AXLES

NCB No.	Type	Length	Splines O.D.	Flange O.D.	Bolt Circle	STUD BOLT HOLES			
						QTY	SIZE	STR	TAPER
AS1131	F16	40-3/4	2.125	7-15/32	6-1/2	12	33/64	6	6
AS1132	F36	38-3/8	1.850	6-1/4	5-5/16	8	33/64		8
AS1133	F36	38-3/8	1.850	6-1/4	5-5/16	8	33/64		8
AS1134	F39	40-7/8	2.000	6-1/8	5-1/4	12	17/32		12
AS1135	F41	41-1/2	2.100	8-1/2	7	8	41/64		8
AS1136	F36	41-1/2	2.312	8-1/2	7	8	41/64		8
AS1137	F34	38-3/16	1.750	6-1/8	5-1/8	8	29/64		8
AS1138	F36	41-1/8	2.312	8-1/2	7	8	41/64		8
AS1139	F36	40-9/16	1.850	6-1/8	5-1/4	12	17/32		12
AS1140	F39	41-5/16	2.000	6-1/8	5-1/4	12	17/32		12
AS1141	F34	38-3/4	1.850	6-1/4	5-5/16	8	33/64		8
AS1142	F36	38-11/16	1.850	6-1/4	5-5/16	8	33/64		8
AS1143L	F39	42-5/16	2.000	6-1/4	5-1/4	12	17/32		12
AS1143S	F39	38-5/16	2.000	6-1/4	5-1/4	12	17/32		12
AS1144	F33	41-7/16	2.125	8-1/2	7	8	41/64	8	
AS1145L	F24	38-3/4	2.375	8-3/8	7	8	41/64		8
AS1145R	F24	44-1/2	2.375	8-3/8	7	8	41/64		8
AS1146	F34	38-1/2	1.750	5-5/8	4-3/4	8	5/8		8
AS1147	F34	38-5/16	1.750	6-1/4	5-5/16	8	5/8		8

Heavy Duty Axle Shafts



HD Differential

NCB AXLE SHAFT NUMBER TO ORIGINAL EQUIPMENT MANUFACTURER NUMBER

NCB NO.	TYPE	ROC.	EATON	FORD	CHEVY	NAVISTAR	WHITE	MACK	DODGE
AS1148	F39	J8070			2086366 2099893				
AS1149	F32	N8048			2088185				
AS1150	F39		119594			578778C1 2502177C1			
AS1151	F41		119595			577506C1			
AS1152L	F41					577504C1			
AS1152R	F41					577505C1			
AS1153	F36		113335						
AS1154	F36					571348C1 2502178C1			
AS1155L 1155R	F39 F39					578776C1 578777C1			
AS1156	F41					571350C1			
AS1157	F46					571351C1			
AS1158	F36		119593			577549C1			
AS1159L	F24	B3512 V6054			2095179 793937	574508C1 521710C1	027093212		
AS1159R	F24	X6056			2095180	574507C1	33030522		
AS1160	F34		119592			577548C1			
AS1161	F39					571349C1 2502179C1			

SPECIFICATIONS OF NCB AXLES

NCB No.	Type	Length	Spline O.D.	Flange O.D.	Bolt Circle	STUD BOLT HOLES			
						QTY	SIZE	STR	TAPER
AS1148	F39	38-3/16	2.000	6-1/4	5-5/16	8	5/8		8
AS1149	F32	38-1/8	1.650	5-5/8	4-3/4	8	5/8		8
AS1150	F39	41	2.000	6-5/8	5-1/2	8	41/64	8	
AS1151	F41	40-3/4	2.100	8-1/2	7	8	49/64	8	
AS1152L	F41	42-3/4	2.100	8-1/2	7	8	49/64	8	
AS1152R	F41	37-3/4	2.100	8-1/2	7	8	49/64	8	
AS1153	F36	40-11/16	2.312	8-1/2	7	8	49/64	8	
AS1154	F36	39-7/8	1.850	6-3/16	5.225	8	37/64	8	
AS1155L	F39	43-1/8	2.000	6-5/8	5-1/2	8	41/64	8	
AS1155R	F39	38-1/8	2.000	6-5/8	5-1/2	8	41/64	8	
AS1156	F41	40-3/16	2.100	8-1/2	7	8	49/64	8	
AS1157	F46	40-1/8	2.350	8-1/2	7	8	49/64	8	
AS1158	F36	39-3/8	1.850	6-3/16	5.225	8	37/64	8	
AS1159L	F24	39-3/8	2.375	8-3/8	7	8	41/64		8
AS1159R	F24	41-5/8	2.375	8-3/8	7	8	41/64		8
AS1160	F34	38-5/8	1.750	6-3/16	5.225	8	37/64	8	
AS1161	F39	40-5/8	2.000	6-5/8	5-1/2	8	41/64	8	

Heavy Duty Axle Shafts

NCB AXLE SHAFT NUMBER TO ORIGINAL EQUIPMENT MANUFACTURER NUMBER

NCB NO.	TYPE	ROC.	EATON	FORD	CHEVY	NAVISTAR	WHITE	MACK	DODGE
AS1162L	F30				3977383				
AS1162R	F30				3977384				
AS1163	F36					571347C1			
AS1164	F41			E4HZ4234B	15510267				
AS1165L	F16					463338C1			
AS1165R	F16					463339C1			
AS1166	F39	M8983		E6HZ4234E					
AS1167	F34		118866	E6HZ4234A					
AS1168	F36	101431-5		E6HZ4234A					
AS1169	F39	101437-4		E6HZ4234B					
AS1170	F41	B8790		E6HZ4234C		1648891C1			
AS1171	F41	Z8788		E6HZ4234D		1648890C1			
AS1172	F34	Q8389		E0HZ4234E					
AS1173	F41	P8362							
AS1174L	F34	F9002		E7HZ4234A					
AS1174R	F34	E9001		E7HZ4234B					
AS1175L	F36	L8904		E7HZ4234F					
AS1175R	F36	J8902		E7HZ4234E					
AS1176L	F36	B9050		E7HZ4234D					
AS1176R	F36	C9051		E7HZ4234C					

SPECIFICATIONS OF NCB AXLES

NCB No.	Type	Length	Splines O.D.	Flange O.D.	Bolt Circle	STUD BOLT HOLES			
						QTY	SIZE	STR	TAPER
AS1162L	F30	31-11/16	1.550	4-1/2	3.562	8	33/64	8	
AS1162R	F30	37-9/16	1.550	4-1/2	3.562	8	33/64	8	
AS1163	F36	39-1/8	1.850	6-3/16	5.225	8	37/64	8	
AS1164	F41	41	2.100	8-1/2	7	8	41/64		8
AS1165L	F16	38	1.745	6-3/16	5.225	8	37/64	8	
AS1165R	F16	39	1.745	6-3/16	5.225	8	37/64	8	
AS1166	F39	39-3/4	2.000	6-1/4	5-1/4	12	17/32		12
AS1167	F34	38-1/4	1.750	6-1/4	5-5/16	8	5/8		8
AS1168	F36	40-11/16	1.850	6-1/4	5-1/4	12	17/32		12
AS1169	F39	41	2.000	8-3/8	7	8	41/64		8
AS1170	F41	41-1/4	2.092	8-3/8	7	8	41/64		8
AS1171	F41	40-3/8	2.092	8-3/8	7	8	41/64		8
AS1172	F34	38-1/4	1.750	6-1/4	5-5/16	8	5/8		8
AS1173	F41	40-7/8	2.100	8-3/8	7	8	41/64		8
AS1174R	F34	38-5/8	1.750	6-1/4	5-5/16	8	33/64		8
AS1174L	F34	37-1/4	1.750	6-1/4	5-5/16	8	33/64		8
AS1175L	F36	40-7/16	1.850	6-1/4	5-1/4	12	17/32		12
AS1175R	F36	41-7/16	1.850	6-1/4	5-1/4	12	17/32		12
AS1176L	F36	38-1/16	1.850	6-1/4	5-1/4	12	17/32		12
AS1176R	F36	44-1/16	1.850	6-1/4	5-1/4	12	17/32		12

Heavy Duty Axle Shafts



HD Differential

NCB AXLE SHAFT NUMBER TO ORIGINAL EQUIPMENT MANUFACTURER NUMBER

NCB NO.	TYPE	ROC.	EATON	FORD	CHEVY	NAVISTAR	WHITE	MACK	DODGE
AS1177	F41	T9042		E7HZ4234G	15617637				
AS1178	F41	S9041		E7HZ4234H	15617636				
AS1179	F41	U9043		E8HZ4234A					
AS1180	F39	W8915		E7HZ4234J					
AS1181	F39	Q8935		E9HZ4234G					
AS1182	F46	G9003		E7HZ4234K	15575921	1651230C1			
AS1183	F46	Q8805		E7HZ4234L	15575920	1651231C1			
AS1184	F46	B8816		E8HZ4234B		1651232C1			
AS1185	F46	Y8111		E7HZ4234M	15576035				
AS1186	F46	W7745		E7HZ4234N	15583980				
AS1187	F46	H8666		E8HZ4234C					
AS1188	F41	Y8917		E7HZ4234P					
AS1189	F41	S8937		E9HZ4234H					
AS1190	F41	H9342		E9HZ4234A					
AS1191	F41	F9340		E9HZ4234K		1677098C1			
AS1192	F41	G9341		E9HZ4234J		1677099C1			
AS1193	F46	L9346		E9HZ4234B					
AS1194	F46	J9344		E9HZ4234M					
AS1195	F46	K9345		E9HZ4234L					
AS1196	F41	Q6361		E9HZ4234C					
AS1197	F41	C9519		E9HZ4234D					
AS1198	F39	Y9047		E9HZ4234E					

SPECIFICATIONS OF NCB AXLES

NCB No.	Type	Length	Spline O.D.	Flange O.D.	Bolt Circle	STUD BOLT HOLES			
						QTY	SIZE	STR	TAPER
AS1177	F41	44-1/16	2.100	8-3/8	7	8	41/64		8
AS1178	F41	38-1/8	2.100	8-3/8	7	8	41/64		8
‡AS1179	F41	44-1/16	2.100	8-3/8	7	8	41/64		8
AS1180	F39	41	2.000	8-3/8	7	8	41/64		8
AS1181	F39	40-3/16	2.000	8-3/8	7	8	41/64		8
AS1182	F46	43-7/8	2.340	8-3/8	7	8	41/64		8
AS1183	F46	37-5/16	2.340	8-3/8	7	8	41/64		8
‡AS1184	F46	44-1/8	2.340	8-3/8	7	8	41/64		8
‡AS1185	F46	42-7/8	2.340	8-3/8	7	8	41/64		8
AS1186	F46	38-3/4	2.340	8-3/8	7	8	41/64		8
‡AS1187	F46	43	2.340	8-3/8	7	8	41/64		8
AS1188	F41	41-1/8	2.100	8-3/8	7	8	41/64		8
AS1189	F41	40-3/8	2.100	8-3/8	7	8	41/64		8
‡AS1190	F41	43-1/4	2.100	8-3/8	7	8	41/64		8
AS1191	F41	37-1/4	2.310	8-3/8	7	8	41/64		8
AS1192	F41	43-1/4	2.100	8-3/8	7	8	41/64		8
‡AS1193	F46	43-1/4	2.340	8-3/8	7	8	41/64		8
AS1194	F46	36-3/4	2.340	8-3/8	7	8	41/64		8
AS1195	F46	43	2.340	8-3/8	7	8	41/64		8
AS1196	F41	41-9/16	2.100	8-3/8	7	8	41/64		8
AS1197	F41	37-7/16	2.100	8-3/8	7	8	41/64		8
AS1198	F39	43-1/2	2.000	6-1/4	5-1/4	12	17/32		12

Heavy Duty Axle Shafts

NCB AXLE SHAFT NUMBER TO ORIGINAL EQUIPMENT MANUFACTURER NUMBER

NCB NO.	TYPE	ROC.	EATON	FORD	CHEVY	NAVISTAR	WHITE	MACK	DODGE
AS1199	F39	X9046		E9HZ4234F					
AS1200	F39		119627		15584538		33030-507	4	
AS1201	F36		126274 129331 210652		15601462				
AS1202	F36		210512		15584981				
AS1203	F36		210628		15577003				
AS1204	F46	S6779		E9HZ4234N					
AS1205	F46	E9391		E9HZ4234R					
AS1206	F46	F9392		E9HZ4234P					
AS1207	F41		119595			596737C1			
AS1208	F36		119596			574679C1			
AS1209	F39		113889 119949			1608185C1			
AS1210	F33		113334			577538C1			
AS1211	F24	C8141				574555C1			
AS1212L	J17							68KH316P2	
AS1212S	J17							68KH316P1	
AS1213L	J17							68KH3202P	1
AS1213S	J17							68KH3202P	2
AS1214	F41		110888			512974C1			
AS1215	F36		110889						
AS1216	F41	Q9117				1665497C1			
AS1217	F41	R9118				1665496C1			
AS1218	F41	S9119				1686034C1			

SPECIFICATIONS OF NCB AXLES

NCB No.	Type	Length	Spline O.D.	Flange O.D.	Bolt Circle	STUD BOLT HOLES			
						QTY	SIZE	STR	TAPER
AS1199	F39	37-5/8	2.000	6-1/4	5-1/4	12	17/32		12
AS1200	F39	41-1/4	2.500	8-1/2	7	8	41/61		8
AS1201	F36	40-15/16	1.850	6-1/8	5-1/4	12	17/32		12
AS1202	F36	41-1/4	1.850	6-1/8	5-1/4	12	17/32		12
AS1203	F36	41-1/4	1.850	6-1/8	5-1/4	12	17/32		12
AS1204	F46	41-7/8	2.340	8-3/8	7	8	41/64		8
AS1205	F46	37-3/4	2.340	8-3/8	7	8	41/64		8
‡AS1206	F46	41-15/16	2.340	8-3/8	7	8	41/64		8
AS1207	F41	40-3/4	2.100	8-3/8	7	8	25/32	8	
AS1208	F36	40-3/4	2.312	8-3/8	7	8	25/32	8	
AS1209	F39	40-9/16	2.500	8-3/8	7	8	25/32	8	
AS1210	F33	40-3/4	2.125	8-3/8	7	8	49/64	8	
AS1211	F24	40-1/16	2.375	8-3/8	7	8	19/64	8	
‡AS1212L	J17	50-3/16	2.375						
‡AS1212S	J17	39-11/16	2.375						
‡AS1213S	J17	39-11/16	2.187						
AS1214	F41	41-5/16	2.100	8.5	7	8	41/64	8	
AS1215	F36	40-7/8	2.310	8.5	7	8	41/64	8	
AS1216	F41	37-3/16	2.100	8.38	7	8	25/32	8	
AS1217	F41	43-9/64	2.100	8.38	7	8	25/32	8	
AS1218	F41	43-9/64	2.100	8.38	7	8	25/32		8

‡Double dagger denotes double spline.

Heavy Duty Axle Shafts



HD Differential

NCB AXLE SHAFT NUMBER TO ORIGINAL EQUIPMENT MANUFACTURER NUMBER

NCB NO.	TYPE	ROC.	EATON	FORD	CHEVY	NAVISTAR	WHITE	MACK	DODGE
AS1219	F41	T9484							
AS1220	F41	U9485							
AS1224	F41	111778		E8HZ4234H		1686033C1			
AS1225	F39		119628						
AS1226	F41		127437						
AS1227	F41		127438						
AS1228	F41		128514						
AS1229	F41		128515						
AS1230	F39		129010						
AS1231	F39		129011						
AS1232	F36		210654		15535797				
AS1233	F17							68KH48	i
AS1234	F36					1699568C1			
AS1235	F46	G9393							
AS1236			128112						
AS1237			128516						
AS1238		S9483							
AS1239		E4555							
AS1240		H6768							
AS1241		H6794							

SPECIFICATIONS OF NCB AXLES

NCB No.	Type	Length	Spline O.D.	Flange O.D.	Bolt Circle	STUD BOLT HOLES			
						QTY	SIZE	STR	TAPER
AS1219	F41	44	2.100	8.38	7	8	41/64	8	
AS1220	F41	44	2.100	8.38	7	8	41/64	8	
AS1224	F41	40-5/8	2.000	7.49	6.5	12	33/24		12
AS1225	F39	41-5/16	2.500	8.5	7	8	41/64	8	
AS1226	F41	39	2.100	8.5	7	8	41/64	8	
AS1227	F41	43-3/8	2.100	8.5	7	8	41/64	8	
AS1228	F41	38-3/32	2.100	8.5	7	8	25/32	8	
AS1229	F41	42-7/16	2.100	8.5	7	8	25/32	8	
AS1230	F39	38-1/2	2.000	6-1/8	5.25	12	17/32		12
AS1231	F39	42-5/8	2.000	6-1/8	5.25	12	17/32		12
AS1232	F36	40.91	1.850	6-1/8	5.25	12	25/32	12	
AS1233	F17	35-9/16	2.367	8.38	7	8	41/64		8
AS1234	F36	40-1/4	1.850	6.62	5-1/2	8	41/64	8	
AS1235	F46	37-3/8	2.350	8.38	7	8	41/64		8
AS1236	F34	40.375	1.750	6.25	5.13	8	19/32		8
AS1237	F41	39.000	2.100	8.5	7	8	41/64		8
AS1238	F41	38 1/16	2.100	8.38	7	8	25/32	8	
AS1239	F41	40 18/25	2.350	6.50	6.50	8	25/32		8
AS1240	F46	41 1/4	2.550	8.38	7	8	25/32		8
AS1241	F50	49 5/8	2.550	8.38	7	8	41/64		8

Heavy Duty Axle Shafts

NCB AXLE SHAFT NUMBER TO ORIGINAL EQUIPMENT MANUFACTURER NUMBER

NCB NO.	TYPE	ROC.	EATON	FORD	CHEVY	NAVISTAR	WHITE	MACK	DODGE
AS1242		J6796							
AS1243		A8191							
AS1244		S9041							
AS1245		C9129							
AS1246		P9142							
AS1247		Q9143							
AS1248		P9246							
AS1249		R9248							
AS1250		S9249							
AS1251		N9374							
AS1252		A9491							
AS1253		N9608							
AS1254		Q9611							
AS1255			129138						
AS1256			129139						
AS1257			129141						
AS1257			126880						
AS1258			129142						
AS1259			131245						
AS1260			128517						
AS1260			128517HX						

SPECIFICATIONS OF NCB AXLES

NCB No.	Type	Length	Splines O.D.	Flange O.D.	Bolt Circle	STUD BOLT HOLES			
						QTY	SIZE	STR	TAPER
AS1242	F50	49-5/8	2.550	8.38	7	8	41/64		8
AS1243	F41	41-1/4	2.550	8.38	7	8	33/24		8
AS1244	F50	38-1/25	2.100	8.38	7	8	41/64		8
AS1245	F46	43-4/57	2.350	8.38	7	8	41/64	8	
AS1246	F46	36-4/7	2.350	8.38	7	8	41/64	8	
AS1247	F50	41-37/50	2.550	8.5 0	7.25	8	25/32		8
AS1248	F50	56-4/19	2.550	8.5 0	7.25	8	25/32		8
AS1249	F50	48-17/50	2.550	8.50	7.25	8	17/32		8
AS1250	F50	45-4/57	2.550	8.50	7.25	8	17/32		8
AS1251	F46	45-21/50	2.350	8.38	7	8	25/32		8
AS1252	F46	42-1/10	2.880	8.38	7	8	41/64	8	
AS1253	F39	40-17/20	2.100	8.38	7	8	41/64		8
AS1254	F41	46-4/5	2.100	8.38	7	8	46/63		8
AS1255	F36	41.375	1.750	8.50	7.000	8	45/64		8
AS1256	F36	41.375	2.100	8.5 0	7.000	8	41/64	8	
AS1257	F36	40.600	2.100	8.38	8.50	8	45/64		8
AS1257	F36	40.600	2.350	6.50	8.50	8	45/64		8
AS1258	F36	41.375	2.550	8.38	7	8	25/32	8	
AS1259	F46	46.000	2.550	8.38	7	8	15/16		8
AS1260	F41	43.307	2.550	8.38	7	8	45/64		8
AS1260	F41	43.307	2.550	8.38	7	8	45/64		8

Heavy Duty Axle Shafts

NCB AXLE SHAFT NUMBER TO ORIGINAL EQUIPMENT MANUFACTURER NUMBER

NCB NO.	TYPE	ROC.	EATON	FORD	CHEVY	NAVISTAR	WHITE	MACK	DODGE
AS1261			125821						
AS1261			128521HX						
AS1262			126878						
AS1263			126195						
AS1264			126601						
AS1265			126877						
AS1266			128516						
AS1267			129322						
AS1267			130911						
AS1268			129960						
AS1269			130912						

SPECIFICATIONS OF NCB AXLES

NCB No.	Type	Length	Spline O.D.	Flange O.D.	Bolt Circle	STUD BOLT HOLES			
						QTY	SIZE	STR	TAPER
AS1261	F41	38.130	2.100	8.38	8.50	8	45/64		8
AS1261	F41	38.130	2.350	8.38	8.50	8	45/64		8
AS1262	F36	40.630	2.350	8.38	8.50	8	45/64		8
AS1263	F36	42.250	2.550	8.5 0	8.50	8	41/64	8	
AS1264	F36	42.250	2.550	8.5 0	8.50	8	45/64		8
AS1265	F41	40.630	2.550	8.50	8.50	8	45/64		8
AS1266	F41	38.976	2.550	8.50	8.50	8	45/64		8
AS1267	F39	42.875	2.350	8.38	6.625	8	41/64	8	
AS1267	F39	42.875	2.880	8.38	6.625	8	41/64	8	
AS1268	F36	42.000	2.100	8.38	8.500	8	41/64	8	
AS1269	F39	38.690	2.100	8.38	6.625	8	41/64	8	

Heavy Duty Axle Shafts

NUMERICAL LISTING PRINCIPAL APPLICATION AND APPROXIMATE SHIPPING WEIGHT TRUCK AND BUS AXLES

Our No.	Application	Weight	Our No.	Application	Weight	Our No.	Application	Weight
AS649	Diamond T Dodge Federal Ford GMC IHC Kenworth Peterbilt Reo White	51		GMC IHC Kenworth Peterbilt Reo White			Reo White	
AS655	IHC	26.5	AS864	Diamond T GMC White	42	AS955	Autocar Diamond T Ford GMC Reo White	27
AS664	IHC	14	AS866	IHC	25	AS957L-S	Mack	L-40 S-32
AS681	Autocar Diamond T dodge Federal Reo White	34	AS892	Autocar Diamond T Dodge Ford GMC IHC Reo White	40	AS959L-S	Mack	L-60.5 S-42.5
AS691	Dodge	15	AS893	Ford	12	AS960L-S	Mack	L-40.5 S-34.5
AS691L-R	Dodge	L-12 R-16	AS894	Ford	13	AS965	Reo Army White	25
AS700	Dodge	22.5	AS895L-S	Mack	L-40 S-32	AS967R-L	Dodge GMC IHC White	R-53 L-46
AS701R-L	Chevrolet	R-22.5 L-19.5	AS909	IHC	13	AS968	Chevrolet GMC	27.5
AS703R-L	GMC	R-24.5 L-19	AS917	Chevrolet	22.5	AS969	GMC	31
AS729	GMC White	46	AS921	Autocar Diamond T Federal IHC Kenworth Reo White	43	AS972R-L	GMC IHC White	R-37.5 L-46
AS732A	Diamond T IHC Reo White	34				AS983	IHC	41
AS749	Dodge Ford IHC White	31	AS922	Autocar Diamond T Federal IHC Kenworth Reo White	34	AS984R-L	IHC	R-30 L-34
AS750R-L	Chevrolet GMC	R-23.5 L-19.5				AS985	IHC	45
AS751R-L	Chevrolet GMC	R-20.5 L-17.5	AS932	Ford	17	AS989R-L	IHC	R-38 L-42
AS754R-L	Dodge	R-11 L-17.5	AS933	Ford Reo White	25	AS991	Dodge	12
AS755	Dodge	23	AS936	Chevrolet GMC	19	AS995	Reo	28
AS758	Dodge	20.5	AS937	Chevrolet GMC	26	AS999	Autocar White	51
AS762	Ford	22.5	AS938R-L	Chevrolet GMC	R-26.5 L-25	AS1012	GMC	44
AS763A	IHC	27.5	AS950	Autocar Diamond T Dodge Federal IHC Reo White	32	AS1015R-L	GMC IHC White	R-67 L-57
AS828	White	39.5				AS1022R-L	Chevrolet	R-30.5 L-29
AS834	Diamond T IHC White	40	AS951	Autocar Diamond T Dodge Federal IHC Kenworth Peterbilt Reo White	38.5	AS1024	Ford IHC White	40
AS837	IHC	28.5				AS1025	Chevrolet	29.5
AS842R	Chevrolet Diamond T GMC Reo White	31				AS1026	Autocar Diamond T Ford Reo White	29
AS843	IHC	18.5				AS1028	Ford GMC IHC White	31
AS844	IHC	23				AS1030	Ford	17.5
AS845	IHC	25.5				AS1037	Dodge Diamond T Ford GMC IHC Kenworth Peterbilt White	51
AS846	IHC	23						
AS847	White Chevrolet GMC White	29.5						
AS854	White	49.5	AS952	Diamond T Dodge Federal IHC Reo White	51	AS1040	Dodge GMC	46
AS855	IHC	28.5				AS1042	Dodge GMC IHC Reo White	47
AS858	GMC	22						
AS859R-L	Chevrolet GMC	R-23 L-20.5	AS953	Diamond T Ford IHC	45	AS1043	Dodge Ford	45
AS863L-S	Autocar Diamond T Federal Ford	L-56.5 S-47.5						

HD Differential

Heavy Duty Axle Shafts



NUMERICAL LISTING PRINCIPAL APPLICATION AND APPROXIMATE SHIPPING WEIGHT TRUCK AND BUS AXLES

HD Differential

Our No.	Application	Weight	Our No.	Application	Weight	Our No.	Application	Weight
AS1044	GMC White Mack Reo White	31	AS1107	Ford	28	AS1161	IHC	35.5
AS1046	IHC	41	AS1108	Ford	23	AS1162L-R	GMC	L-15 R-17.5
AS1048	Chevrolet GMC White	29	AS1109	Ford	33	AS1163	IHC	27.5
AS1049	Chevrolet GMC	32	AS1110	Ford	25	AS1164	GMC	46
AS1051	Autocar Diamond T Ford IHC Reo White	45	AS1111	Ford	52	AS1165R-L	IHC	R-23 L-22.5
AS1052	Ford IHC White	41	AS1112R-L	Ford	R-47 L-60	AS1166	Ford	34
AS1053	Ford White	28	AS1113	Ford GMC IHC White	58.5	AS1167	Ford	25
AS1054	Ford	25	AS1115	Ford	51	AS1168	Ford	29
AS1055	Dodge Ford	17	AS1122	Dodge Ford GMC White	34.5	AS1169	Ford IHC	40
AS1056	Dodge	25	AS1123L-R	IHC	L-46 R-43	AS1171	Ford IHC	45
AS1057	Dodge White	28	AS1124L-S	GMC	L-33 S-29.5	AS1172	Ford	25
AS1058	Chevrolet GMC	30	AS1125	GMC	28	AS1173	Ford	46
AS1060R-L	Diamond T White	R-41 L-32	AS1126L-S	GMC	L-53 S-48	AS1174R-L	Ford	R-28 L-27 R
AS1063	Ford IHC White	41	AS1127	GMC	33	AS1175R-L	Ford	L-32 R-33 L-30
AS1068	Dodge	29	AS1128	Freightliner Kenworth Peterbilt White	46	AS1176R-L	Ford	48
AS1070	Dodge	15	AS1129	Ford GMC White	47	AS1177	GMC Ford	43
AS1076	Dodge	18	AS1130	Ford	59	AS1178	GMC Ford	48
AS1077	Dodge	17.5	AS1131	Dodge IHC White	38	AS1179	Ford	41.5
AS1078	Dodge	19	AS1132	GMC	28	AS1180	Ford	41
AS1080	Dodge	28	AS1133	Ford	29	AS1181	Ford	60
AS1081	Dodge	30	AS1134	Ford	31	AS1182	GMC Ford IHC	50
AS1083	Ford GMC White	42.5	AS1135	Ford	42.5	AS1183	GMC Ford IHC	59
AS1084R-L	Ford GMC White	R-48 L-52	AS1136	Ford GMC	48	AS1184	Ford IHC	58
AS1085R-L	Dodge	R-11.5 L-13-12	AS1137	Ford	25	AS1185	GMC Ford	53
AS1087	Dodge GMC White	42.5	AS1138	Ford GMC	47	AS1186	GMC Ford	58
AS1088	Ford	14	AS1139	Ford	29	AS1187	Ford	46
AS1089	Ford	12	AS1140	GMC	32	AS1188	Ford	45
AS1090	Ford	27.5	AS1141	GMC	25.5	AS1189	Ford	48
AS1091	Ford	17.5	AS1142	GMC	28	AS1190	Ford	41
AS1092	Ford	17.5	AS1143L-R	Ford GMC IHC	L-36 R-33	AS1191	Ford IHC	48
AS1095	Ford	17	AS1144	Eaton	47	AS1192	Ford IHC	59
AS1096	Ford	12.5	AS1145R-L	GMC	R-54 L-49	AS1193	Ford	51
AS1097	Ford	13	AS1146	GMC	23	AS1194	Ford	58
AS1098	Dodge	29	AS1147	GMC	25	AS1195	Ford	46
AS1099	IHC	24	AS1148	GMC	33	AS1196	Ford	43
AS1100	IHC	28	AS1149	GMC	23	AS1197	ford	38
AS1101L-S	Ford GMC Kenworth White	L-46 S-43	AS1150	IHC	35	AS1198	Ford	57
AS1102	IHC	28	AS1151	IHC	42	AS1199	Ford	34
AS1103	IHC	24	AS1152L-R	IHC	L-42.5 R-38-12	AS1200	GMC	37
AS1104	IHC	42	AS1153	IHC	47	AS1201	GMC	29
AS1105	IHC	28	AS1154	IHC	28	AS1202	GMC	58
AS1106	Ford	23	AS1155L-R	IHC	L-37 R-33	AS1203	GMC	58
			AS1156	IHC	40.5	AS1204	Ford	58
			AS1157	IHC	51	AS1205	Ford	58
			AS1158	IHC	28.5	AS1206	Ford	42
			AS1159L-R	GMC IHC	L-52 R-54.5	AS1207	IHC	50
			AS1160	IHC	24	AS1208	IHC	56
						AS1209	IHC	45
						AS1210	IHC	55
						AS1211	IHC	L-45 S-36 L-40
						AS1212L-S	Mack	L-40
						AS1213L-S	Mack	L-40

To Identify a Heavy Duty Axle Shaft... follow these time saving steps:

1 Look for Manufacturers Numbers.

They are stamped as shown with the following codes:

Foote = $\diamond F$ + 3 or 4 digit number

Eaton = 5 or 6 digit number

Rockwell = Letter + 4 digit number

If you are able to read these numbers clearly, phone your local **NCB** distributor listed below and give them the flange numbers to cross reference in

our catalog. The distributor can quickly give you the interchange number and cost.

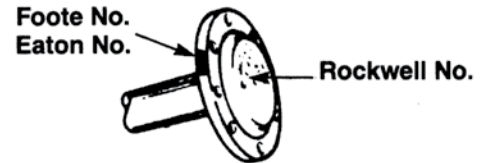

2 If numbers are unavailable or illegible.

Measure diameter and count number of splines on shaft.

Measure diameter of bolt circle. (Center of hole to center of hole on opposite side of flange.)

Count the number of straight and the number of tapered holes in flange.

Measure length of shaft from inside face of flange to end of spline.

Note whether flange is flat or dome shaped.

Note whether splines are straight or tapered.

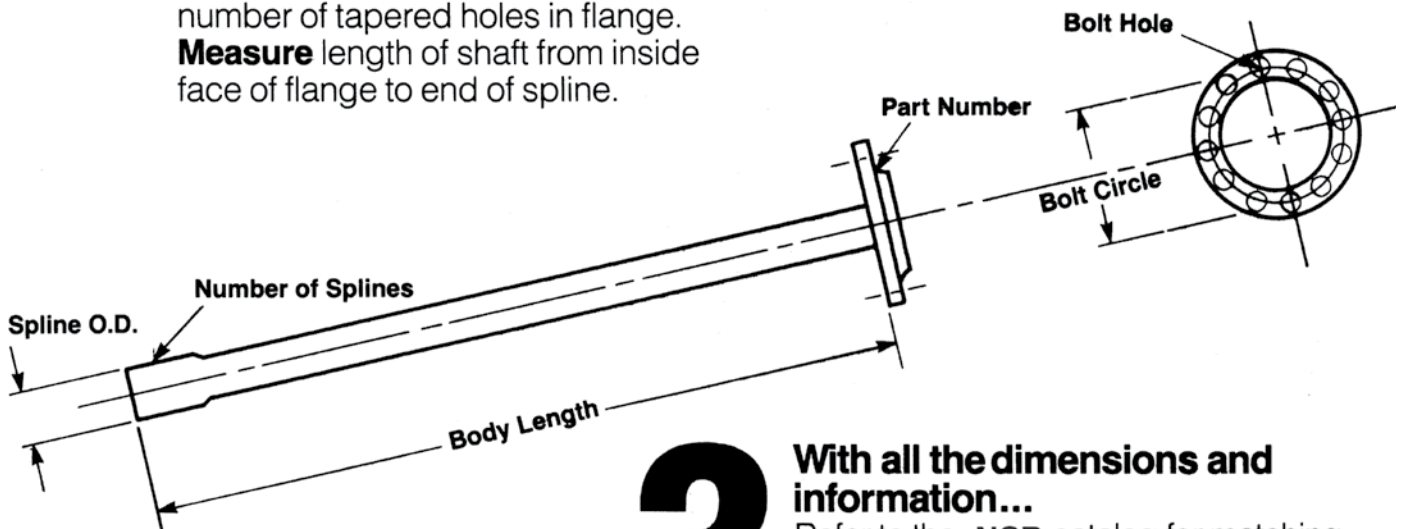

3 With all the dimensions and information...

Refer to the **NCB** catalog for matching specifications or call your local **NCB** distributor listed below for assistance and availability. **One phone call is all it takes to cut your downtime.**

Heavy Duty Transmission Index

Clark/Eaton/Fuller Transmission Identification

HD Transmission

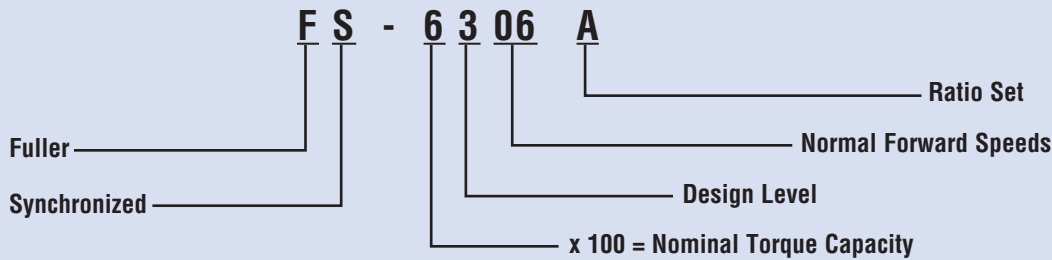
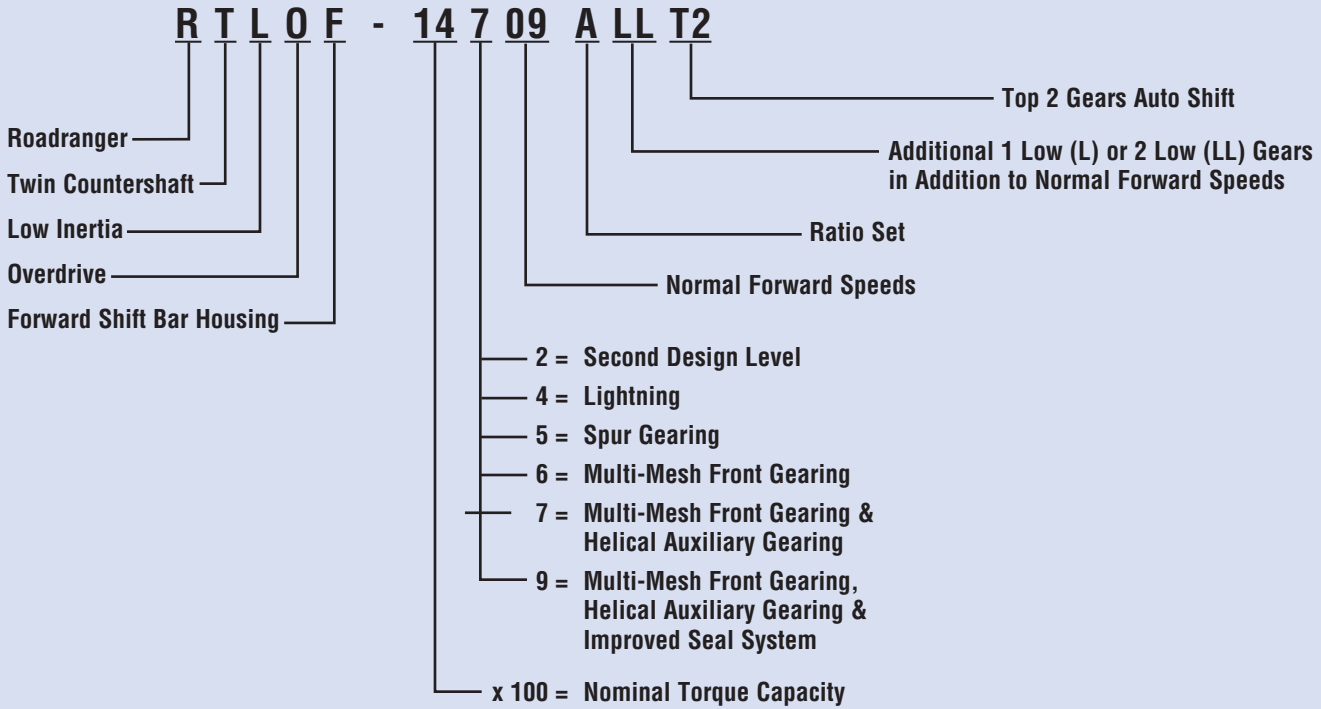

Heavy Duty Transmission Index

Clark Medium Duty Models

Clark 5 Speed Models

Model No.	Comments	Standard Kit	Suitcase Kit	Overhaul Kit	Clutch Install Kit
250-V	1959 & Later	TRK-23			
250-V18		TRK-23B			
250-VO	1959 & Later	TRK-23			
251-V	1959 & Later	TRK-23			
251-VO	1959 & Later	TRK-23			
251-VO18		TRK-23B			
259-V		TRK-23B			
264-V	1959 & Later	TRK-23			
264-VO	1959 & Later	TRK-23			
264-VO48		TRK-23			
264-VO49		TRK-23			
265-V	1959 & Later	TRK-23			
265-VO	1959 & Later	TRK-23			
267-V	1959 & Later	TRK-23			
267-VO	1959 & Later	TRK-23			
268-V	1959 & Later	TRK-23			
269-V	1959 & Later w/ Narrow Output Shaft Brg.	TRK-23B			
269-V	1959 & Later w/o Narrow Output Shaft Brg.	TRK-23			
269-V35	1959 & Later	TRK-23			
280-V	1959 & Later	TRK-148	TRK-2127		
280-VHD	1959 & Later	TRK-190	TRK-2128		
280-VO	1959 & Later	TRK-148	TRK-2127		
280-VO18	1959 & Later	TRK-148	TRK-2127		
280-VO3	1959 & Later	TRK-148	TRK-2127		
280-VO4	1959 & Later	TRK-148	TRK-2127		
282-V		TRK-148	TRK-2127		
282-V11		TRK-148	TRK-2127		
282-V55		TRK-148	TRK-2127		
282-VHD		TRK-190	TRK-2128		
282-VHD12		TRK-190	TRK-2128		
282-VHD13		TRK-190	TRK-2128		
282-VHD2		TRK-190	TRK-2128		
285-V		TRK-148	TRK-2127		
285-V54		TRK-148	TRK-2127		
285-V9		TRK-148	TRK-2127		
285-VHD		TRK-190	TRK-2128		
285-VHD13		TRK-190	TRK-2128		
285-VHD2		TRK-190	TRK-2128		
305-V		TRK-48			
307-V		TRK-48			
315-V		TRK-48			
318-V		TRK-48			
320-V		TRK-132			
325-V		TRK-132			
327-V		TRK-132			
328-V		TRK-132			
380-V		TRK-133			
380-VO		TRK-133			
381-V		TRK-133			
385-V		TRK-133			
387-V		TRK-133			
388-V		TRK-133			
390-V	1-1/2" Input Shaft & 2" Output Shaft	TRK-390F	TRK-2124		
390-V	1-3/4" Input Shaft & 2" Output Shaft	TRK-390G	TRK-2125		

Heavy Duty Transmission Index

Clark Medium Duty Models

Clark 5 Speed Models (cont.)

Model No.	Comments	Standard Kit	Suitcase Kit	Overhaul Kit	Clutch Install Kit
390-V	1-1/2" Input Shaft & 1-3/4" Output Shaft	TRK-390H	TRK-2126		
397-V	1-1/2" Input Shaft & 2" Output Shaft	TRK-390F	TRK-2124		
397-V	1-3/4" Input Shaft & 2" Output Shaft	TRK-390G	TRK-2125		
397-V	1-1/2" Input Shaft & 1-3/4" Output Shaft	TRK-390H	TRK-2126		
2621-V	w/ Narrow Output Shaft Brg.	TRK-23B			
2621-V	w/o Narrow Output Shaft Brg.	TRK-23			
2621-V1	w/ Narrow Output Shaft Brg.	TRK-23B			
2621-V1	w/o Narrow Output Shaft Brg.	TRK-23			
2622-V12		TRK-23B			
2622-V7		TRK-23B			
2651-V	w/ Narrow Output Shaft Brg.	TRK-23B			
2651-V	w/o Narrow Output Shaft Brg.	TRK-23			
2651-V1	w/ Narrow Output Shaft Brg.	TRK-23B			
2651-V1	w/o Narrow Output Shaft Brg.	TRK-23			
2653-V		TRK-23B			
2653-V10		TRK-23B			
2653-V5		TRK-23B			
2653-V9		TRK-23B			
2653-VO		TRK-23B			
CL450	1-1/4" or 1-1/2" Input Shaft	TRK-208	TRK-2120		
CL450	1-3/4" Input Shaft	TRK-208D	TRK-2129		
CL455	1-1/4" or 1-1/2" Input Shaft	TRK-208	TRK-2120		
CL455	1-3/4" Input Shaft	TRK-208D	TRK-2129		
CL457	1-1/4" or 1-1/2" Input Shaft	TRK-208	TRK-2120		
CL457	1-3/4" Input Shaft	TRK-208D	TRK-2129		
CL550	1-1/2" Input Shaft & 2" Output Shaft	TRK-390F	TRK-2124		
CL550	1-3/4" Input Shaft & 2" Output Shaft	TRK-390G	TRK-2125		
CL550	1-1/2" Input Shaft & 1-3/4" Output Shaft	TRK-390H	TRK-2126		
CL551	1-1/2" Input Shaft & 2" Output Shaft	TRK-390F	TRK-2124		
CL551	1-3/4" Input Shaft & 2" Output Shaft	TRK-390G	TRK-2125		
CL551	1-1/2" Input Shaft & 1-3/4" Output Shaft	TRK-390H	TRK-2126		
CL557	1-1/2" Input Shaft & 2" Output Shaft	TRK-390F	TRK-2124		
CL557	1-3/4" Input Shaft & 2" Output Shaft	TRK-390G	TRK-2125		
CL557	1-1/2" Input Shaft & 1-3/4" Output Shaft	TRK-390H	TRK-2126		
CL558	1-1/2" Input Shaft & 2" Output Shaft	TRK-390F	TRK-2124		
CL558	1-3/4" Input Shaft & 2" Output Shaft	TRK-390G	TRK-2125		
CL558	1-1/2" Input Shaft & 1-3/4" Output Shaft	TRK-390H	TRK-2126		

HD Transmission

Heavy Duty Transmission Index

Eaton/Fuller Medium & Heavy Duty Models

2 Speed Auxiliary Models

Model No.	Comments	Standard Kit	Suitcase Kit	Overhaul Kit	Clutch Install Kit
2-A-92			TRK-400		
AT-1202			TRK-401		

5 Speed Models

F-5405B-DM3			TRK-3440		
F-5505B-DM3			TRK-3440		
F-6405B-DM3			TRK-3440		
F-6505B-DM3			TRK-3440		
FS-4005A	w/ 1.375" or 1.5" I/S	TRK-208	TRK-2120		
FS-4005A	w/ 1.75" I/S	TRK-208D	TRK-2129		
FS-4005B	w/ 1.375" or 1.5" I/S	TRK-208	TRK-2120		
FS-4005B	w/ 1.75" I/S	TRK-208D	TRK-2129		
FS-4005C	w/ 1.375" or 1.5" I/S	TRK-208	TRK-2120		
FS-4005C	w/ 1.75" I/S	TRK-208D	TRK-2129		
FS-4205A	w/ 1.5" I/S & 2" O/S		TRK-7000		
FS-4205A	w/ 1.75" I/S		TRK-7013		
FS-4205B	w/ 1.5" I/S & 2" O/S		TRK-7000		
FS-4205B	w/ 1.75" I/S		TRK-7013		
FS-4205C	w/ 1.5" I/S & 2" O/S		TRK-7000		
FS-4205C	w/ 1.75" I/S		TRK-7013		
FS-5005A	w/ 1.5" I/S & 2" O/S	TRK-395F	TRK-2121		
FS-5005A	w/ 1.5" I/S & 1.75" O/S	TRK-395G	TRK-2122		
FS-5005A	w/ 1.75" I/S & 2" O/S	TRK-395H	TRK-2123		
FS-5005B	w/ 1.5" I/S & 2" O/S	TRK-395F	TRK-2121		
FS-5005B	w/ 1.5" I/S & 1.75" O/S	TRK-395G	TRK-2122		
FS-5005B	w/ 1.75" I/S & 2" O/S	TRK-395H	TRK-2123		
FS-5005C	w/ 1.5" I/S & 2" O/S	TRK-395F	TRK-2121		
FS-5005C	w/ 1.5" I/S & 1.75" O/S	TRK-395G	TRK-2122		
FS-5005C	w/ 1.75" I/S & 2" O/S	TRK-395H	TRK-2123		
FS-5205A	w/ 1.5" I/S		TRK-7032		
FS-5205A	w/ 1.75" I/S		TRK-7033		
FS-5205B	w/ 1.5" I/S		TRK-7032		
FS-5205B	w/ 1.75" I/S		TRK-7033		
FS-5205C	w/ 1.5" I/S		TRK-7032		
FS-5205C	w/ 1.75" I/S		TRK-7033		
FS-6205A			TRK-7035		
FS-6205B			TRK-7035		
FS-6305A			TRK-7035		
FS-6305B			TRK-7035		
T-11605A	w/ 2" Pull Type I/S	TRK-58A	TRK-1873	TRK-1984	
T-11605B	w/ 2" Pull Type I/S	TRK-58A	TRK-1873	TRK-1984	
T-11605C	w/ 2" Pull Type I/S	TRK-58A	TRK-1873	TRK-1984	
T-11605D	w/ 2" Pull Type I/S	TRK-58A	TRK-1873	TRK-1984	
T-11605F	w/ 2" Pull Type I/S	TRK-58A	TRK-1873	TRK-1984	
T-11605M	w/ 2" Pull Type I/S	TRK-58A	TRK-1873	TRK-1984	
TO-11605A	w/ 2" Pull Type I/S	TRK-58A	TRK-1873	TRK-1984	
TO-11605B	w/ 2" Pull Type I/S	TRK-58A	TRK-1873	TRK-1984	
TO-11605C	w/ 2" Pull Type I/S	TRK-58A	TRK-1873	TRK-1984	
TO-11605D	w/ 2" Pull Type I/S	TRK-58A	TRK-1873	TRK-1984	

6 Speed Models

FO-5406B-DM3			TRK-3440		
FO-5506B-DM3			TRK-3440		
FO-6406A-ASX			TRK-3440		
FO-6406B-DM3			TRK-3440		
FO-6506B-DMW			TRK-3440		

Heavy Duty Transmission Index

Eaton/Fuller Medium & Heavy Duty Models

6 Speed Models (cont.)

Model No.	Comments	Standard Kit	Suitcase Kit	Overhaul Kit	Clutch Install Kit
FO-8406A-ASX			TRK-3440		
FS-5106A			TRK-2041		
FS-5306A			TRK-7052		
FS-5406A			TRK-3423		
FS-5406N			TRK-3423		
FS-6206A			TRK-2041		
FS-6306A			TRK-7052		
FS-6406A			TRK-3423		
FS-6406N			TRK-3423		
FS-8206A			TRK-2490		
FSB-5406B			TRK-3423		
FSO-6406A			TRK-3423		
FSO-8406A			TRK-3423		

7 Speed Models

RTO-11607L		TRK-201	TRK-1866	TRK-1980	
RTO-11607LL			TRK-1867	TRK-1981	
RTO-11707DLL			TRK-2045	TRK-1986	
RTO-11707LL			TRK-2045	TRK-1986	
RTO-13707DLL			TRK-2855		
RTO-13707MLL			TRK-2855		
RTOF-11607L		TRK-201	TRK-1866	TRK-1980	
RTOF-11607LL			TRK-1867	TRK-1981	
RTOF-11707LL			TRK-2045	TRK-1986	
RTOF-13707DLL			TRK-2855		
RTOF-13707MLL			TRK-2855		
T-11607A			TRK-2771	TRK-1982	
T-11607B			TRK-2771	TRK-1982	
T-14607A			TRK-2771	TRK-1982	
T-14607B			TRK-2771	TRK-1982	
T-8607A			TRK-1877	TRK-1765	
T-8607B			TRK-1877	TRK-1765	
TX-14607B			TRK-2771	TRK-1982	
TX-8607B			TRK-1877	TRK-1765	

8 Speed Models

FO-10E308LL-VCS			TRK-3942		
FO-11E308LL-VCS			TRK-3942		
FO-12E308LL-VCS			TRK-3942		
FO-14E308LL-VCS			TRK-3942		
FO-16E308LL-VCS			TRK-3942		
FO-17E308LL-VCS			TRK-3942		
RT-11608	w/ 1.75" Push Type I/S	TRK-202	TRK-2283	TRK-2345	
RT-11608	w/ 2" Pull Type I/S	TRK-202	TRK-2283	TRK-2761	TRK-2468 ⁵⁵
RT-7608LL			TRK-2047	TRK-1995	
RT-8608L	w/ 1.75" Push Type I/S	TRK-202	TRK-2283	TRK-2345	
RT-8608L	w/ 2" Pull Type I/S	TRK-202	TRK-2283	TRK-2761	TRK-2468 ⁵⁵
RT-8908LL			TRK-3273	TRK-3272	TRK-2468 ⁵⁵
RTF-11608	w/ 1.75" Push Type I/S	TRK-202	TRK-2283	TRK-2345	
RTF-11608	w/ 2" Pull Type I/S	TRK-202	TRK-2283	TRK-2761	TRK-2468 ⁵⁵
RTF-8608L	w/ 1.75" Push Type I/S	TRK-202	TRK-2283	TRK-2345	
RTF-8608L	w/ 2" Pull Type I/S	TRK-202	TRK-2283	TRK-2761	TRK-2468 ⁵⁵
RTF-8908LL			TRK-3273	TRK-3272	TRK-2468 ⁵⁵
RTO-11608L	w/ 1.75" Push Type I/S	TRK-203	TRK-3659	TRK-3655	
RTO-11608L	w/ 2" Pull Type I/S	TRK-203	TRK-3659	TRK-3656	TRK-2468 ⁵⁵
RTO-11708LL			TRK-3660	TRK-3657	TRK-2468 ⁵⁵

Heavy Duty Transmission Index

Eaton/Fuller Medium & Heavy Duty Models

8 Speed Models (cont.)

Model No.	Comments	Standard Kit	Suitcase Kit	Overhaul Kit	Clutch Install Kit
RTO-11908LL			TRK-3256	TRK-3258	TRK-2468 ⁵⁵
RTO-14608LL		TRK-207	TRK-1872	TRK-1979	TRK-2468 ⁵⁵
RTO-14708LL			TRK-2043	TRK-1992	TRK-2468 ⁵⁵
RTO-14908LL	w/ 85mm Aux Drive Gear Brg.		TRK-3233	TRK-4092	TRK-2468 ⁵⁵
RTO-14908LL	w/ 90mm Aux Drive Gear Brg.		TRK-3256	TRK-3258	TRK-2468 ⁵⁵
RTO-16908LL			TRK-3233	TRK-4092	TRK-2468 ⁵⁵
RTOF-11608LL	w/ 1.75" Push Type I/S	TRK-203	TRK-3659	TRK-3655	
RTOF-11608LL	w/ 2" Pull Type I/S	TRK-203	TRK-3659	TRK-3656	TRK-2468 ⁵⁵
RTOF-11708LL			TRK-3660	TRK-3657	TRK-2468 ⁵⁵
RTOF-11908LL			TRK-3256	TRK-3258	TRK-2468 ⁵⁵
RTOF-14608LL		TRK-207	TRK-1872	TRK-1979	TRK-2468 ⁵⁵
RTOF-14708LL			TRK-2043	TRK-1992	TRK-2468 ⁵⁵
RTOF-14908LL	w/ 85mm Aux Drive Gear Brg.		TRK-3233	TRK-4092	TRK-2468 ⁵⁵
RTOF-14908LL	w/ 90mm Aux Drive Gear Brg.		TRK-3256	TRK-3258	TRK-2468 ⁵⁵
RTOF-16908LL			TRK-3233	TRK-4092	TRK-2468 ⁵⁵
RTX-11608LL	w/ 1.75" Push Type I/S	TRK-203	TRK-3659	TRK-3655	
RTX-11608LL	w/ 2" Pull Type I/S	TRK-203	TRK-3659	TRK-3656	TRK-2468 ⁵⁵
RTX-11708LL			TRK-3660	TRK-3657	TRK-2468 ⁵⁵
RTX-14608LL		TRK-207	TRK-1872	TRK-1979	TRK-2468 ⁵⁵
RTX-14708LL			TRK-2043	TRK-1992	TRK-2468 ⁵⁵
RTXF-11608LL	w/ 1.75" Push Type I/S	TRK-203	TRK-3659	TRK-3655	
RTXF-11608LL	w/ 2" Pull Type I/S	TRK-203	TRK-3659	TRK-3656	TRK-2468 ⁵⁵
RTXF-11708LL			TRK-3660	TRK-3657	TRK-2468 ⁵⁵
RTXF-14608LL		TRK-207	TRK-1872	TRK-1979	TRK-2468 ⁵⁵
RTXF-14708LL			TRK-2043	TRK-1992	TRK-2468 ⁵⁵

9 Speed Models

FO-10E309ALL-VMW			TRK-3942		
FO-11309ALL-VMS			TRK-3942		
FO-12E309ALL-VMS			TRK-3942		
FO-14E309ALL-VMS			TRK-3942		
FO-16E309ALL-VMS			TRK-3942		
FO-17E309ALL-VMS			TRK-3942		
RT-11509			TRK-1858	TRK-1063	TRK-2468 ⁵⁵
RT-11609A	w/ 1.75" Push Type I/S	TRK-202	TRK-2283	TRK-2345	
RT-11609A	w/ 2" Pull Type I/S	TRK-202	TRK-2283	TRK-2761	TRK-2468 ⁵⁵
RT-11709A			TRK-2049	TRK-1996	TRK-2468 ⁵⁵
RT-11709H			TRK-2049	TRK-1996	TRK-2468 ⁵⁵
RT-12509		TRK-160	TRK-1861	TRK-1064	TRK-2468 ⁵⁵
RT-12609A	w/ 1.75" Push Type I/S	TRK-202	TRK-2283	TRK-2345	
RT-12609A	w/ 2" Pull Type I/S	TRK-202	TRK-2283	TRK-2761	TRK-2468 ⁵⁵
RT-12709A			TRK-2049	TRK-1996	TRK-2468
RT-12709H			TRK-2049	TRK-1996	TRK-2468
RT-13609A			TRK-2282	TRK-2344	TRK-2468 ⁵⁵
RT-13709H			TRK-2284	TRK-2762	TRK-2468 ⁵⁵
RT-14609A		TRK-205	TRK-1870	TRK-1971	TRK-2468 ⁵⁵
RT-14709A			TRK-2275	TRK-1999	TRK-2468 ⁵⁵
RT-14709H			TRK-2275	TRK-1999	TRK-2468 ⁵⁵
RT-6609			TRK-2048		
RT-8609			TRK-1876		TRK-2468
RT-8709B			TRK-3322	TRK-3323	TRK-2468 ⁵⁵
RTF-11509			TRK-1858	TRK-1063	TRK-2468 ⁵⁵
RTF-11609A	w/ 1.75" Push Type I/S	TRK-202	TRK-2283	TRK-2345	
RTF-11609A	w/ 2" Pull Type I/S	TRK-202	TRK-2283	TRK-2761	TRK-2468 ⁵⁵
RTF-11709H			TRK-2049	TRK-1996	TRK-2468 ⁵⁵

Heavy Duty Transmission Index

Eaton/Fuller Medium & Heavy Duty Models

9 Speed Models (cont.)

Model No.	Comments	Standard Kit	Suitcase Kit	Overhaul Kit	Clutch Install Kit
RTF-12509		TRK-160	TRK-1861	TRK-1064	TRK-2468 ⁵⁵
RTF-12609A	w/ 1.75" Push Type I/S	TRK-202	TRK-2283	TRK-2345	
RTF-12609A	w/ 2" Pull Type I/S	TRK-202	TRK-2283	TRK-2761	TRK-2468 ⁵⁵
RTF-12709H			TRK-2049	TRK-1996	TRK-2468 ⁵⁵
RTF-13609A			TRK-2282	TRK-2344	TRK-2468 ⁵⁵
RTF-13709H			TRK-2284	TRK-2762	TRK-2468 ⁵⁵
RTF-14609A		TRK-205	TRK-1870	TRK-1971	TRK-2468 ⁵⁵
RTF-14709H			TRK-2275	TRK-1999	TRK-2468 ⁵⁵
RTF-8709B			TRK-3322	TRK-3323	TRK-2468 ⁵⁵
RTLC-16609E			TRK-3586	TRK-3585	TRK-2468 ⁵⁵
RTLFC-16609E			TRK-3586	TRK-3585	TRK-2468 ⁵⁵
RTLOC-16909A-T2			TRK-3598	TRK-3597	TRK-2468 ⁵⁵
RTLOFC-16909A-T2			TRK-3598	TRK-3597	TRK-2468 ⁵⁵
RTO-11509			TRK-1858	TRK-1063	TRK-2468 ⁵⁵
RTO-11609A	w/ 1.75" Push Type I/S	TRK-202	TRK-2283	TRK-2345	
RTO-11609A	w/ 2" Pull Type I/S	TRK-202	TRK-2283	TRK-2761	TRK-2468 ⁵⁵
RTO-11609B	w/ 1.75" Push Type I/S	TRK-202	TRK-2283	TRK-2345	
RTO-11609B	w/ 2" Pull Type I/S	TRK-202	TRK-2283	TRK-2761	TRK-2468 ⁵⁵
RTO-11709A			TRK-2284	TRK-2763	TRK-2468 ⁵⁵
RTO-11709B			TRK-2284	TRK-2763	TRK-2468 ⁵⁵
RTO-11709MLL			TRK-2847	TRK-2848	TRK-2468 ⁵⁵
RTO-11909ALL			TRK-3283	TRK-3661	TRK-2468 ⁵⁵
RTO-11909MLL			TRK-3283	TRK-3282	TRK-2468 ⁵⁵
RTO-12509		TRK-160	TRK-1861	TRK-1064	TRK-2468 ⁵⁵
RTO-12609A	w/ 1.75" Push Type I/S	TRK-202	TRK-2283	TRK-2345	
RTO-12609A	w/ 2" Pull Type I/S	TRK-202	TRK-2283	TRK-2761	TRK-2468 ⁵⁵
RTO-12609B	w/ 1.75" Push Type I/S	TRK-202	TRK-2283	TRK-2345	
RTO-12609B	w/ 2" Pull Type I/S	TRK-202	TRK-2283	TRK-2761	TRK-2468 ⁵⁵
RTO-12709A			TRK-2284	TRK-2763	TRK-2468 ⁵⁵
RTO-12709B			TRK-2284	TRK-2763	TRK-2468 ⁵⁵
RTO-14609A		TRK-205	TRK-1870	TRK-1971	TRK-2468 ⁵⁵
RTO-14609B		TRK-205	TRK-1870	TRK-1971	TRK-2468 ⁵⁵
RTO-14709A			TRK-2275	TRK-1999	TRK-2468 ⁵⁵
RTO-14709B			TRK-2275	TRK-1999	TRK-2468 ⁵⁵
RTO-14709H			TRK-2275	TRK-1999	TRK-2468 ⁵⁵
RTO-14709MLL			TRK-2847	TRK-2848	TRK-2468 ⁵⁵
RTO-14909ALL	w/ 90mm Aux Drive Gear Brg.		TRK-3283	TRK-3282	TRK-2468 ⁵⁵
RTO-14909ALL	w/ 85mm Aux Drive Gear Brg.		TRK-3413	TRK-3414	TRK-2468 ⁵⁵
RTO-14909MLL			TRK-3283	TRK-3282	TRK-2468 ⁵⁵
RTO-16909ALL			TRK-3413	TRK-3414	TRK-2468 ⁵⁵
RTOC-16709A			TRK-3596	TRK-3595	TRK-2468 ⁵⁵
RTOC-16909A			TRK-3598	TRK-3597	TRK-2468 ⁵⁵
RTOC-18909A			TRK-4057	TRK-4056	TRK-2468 ⁵⁵
RTOCF-16709A			TRK-3596	TRK-3595	TRK-2468 ⁵⁵
RTOF-11509			TRK-1858	TRK-1063	TRK-2468 ⁵⁵
RTOF-11609A	w/ 1.75" Push Type I/S	TRK-202	TRK-2283	TRK-2345	
RTOF-11609A	w/ 2" Pull Type I/S	TRK-202	TRK-2283	TRK-2761	TRK-2468 ⁵⁵
RTOF-11609B	w/ 1.75" Push Type I/S	TRK-202	TRK-2283	TRK-2345	
RTOF-11609B	w/ 2" Pull Type I/S	TRK-202	TRK-2283	TRK-2761	TRK-2468 ⁵⁵
RTOF-11709MLL			TRK-2847	TRK-2848	TRK-2468 ⁵⁵
RTOF-11909ALL			TRK-3283	TRK-3661	TRK-2468 ⁵⁵
RTOF-11909MLL			TRK-3283	TRK-3282	TRK-2468 ⁵⁵
RTOF-12509		TRK-160	TRK-1861	TRK-1064	TRK-2468 ⁵⁵
RTOF-12609A	w/ 1.75" Push Type I/S	TRK-202	TRK-2283	TRK-2345	

HD Transmission

Heavy Duty Transmission Index

Eaton/Fuller Medium & Heavy Duty Models

9 Speed Models (cont.)

Model No.	Comments	Standard Kit	Suitcase Kit	Overhaul Kit	Clutch Install Kit
RTOF-12609A	w/ 2" Pull Type I/S	TRK-202	TRK-2283	TRK-2761	TRK-2468 ⁵⁵
RTOF-12609B	w/ 1.75" Push Type I/S	TRK-202	TRK-2283	TRK-2345	
RTOF-12609B	w/ 2" Pull Type I/S	TRK-202	TRK-2283	TRK-2761	TRK-2468 ⁵⁵
RTOF-14609A		TRK-205	TRK-1870	TRK-1971	TRK-2468 ⁵⁵
RTOF-14609B		TRK-205	TRK-1870	TRK-1971	TRK-2468 ⁵⁵
RTOF-14709MLL			TRK-2847	TRK-2848	TRK-2468 ⁵⁵
RTOF-14909ALL	w/ 90mm Aux Drive Gear Brg.		TRK-3283	TRK-3282	TRK-2468 ⁵⁵
RTOF-14909ALL	w/ 85mm Aux Drive Gear Brg.		TRK-3413	TRK-3414	TRK-2468 ⁵⁵
RTOF-14909MLL			TRK-3283	TRK-3282	TRK-2468 ⁵⁵
RTOF-16909ALL			TRK-3413	TRK-3414	TRK-2468 ⁵⁵
RTOFC-16909A			TRK-3598	TRK-3597	TRK-2468 ⁵⁵
RTX-11509			TRK-1858	TRK-1063	TRK-2468 ⁵⁵
RTX-11609A	w/ 1.75" Push Type I/S	TRK-202	TRK-2283	TRK-2345	
RTX-11609A	w/ 2" Pull Type I/S	TRK-202	TRK-2283	TRK-2761	TRK-2468 ⁵⁵
RTX-11609B	w/ 1.75" Push Type I/S	TRK-202	TRK-2283	TRK-2345	
RTX-11609B	w/ 2" Pull Type I/S	TRK-202	TRK-2283	TRK-2761	TRK-2468 ⁵⁵
RTX-11609P	w/ 1.75" Push Type I/S	TRK-202	TRK-2283	TRK-2345	
RTX-11609P	w/ 2" Pull Type I/S	TRK-202	TRK-2283	TRK-2761	TRK-2468 ⁵⁵
RTX-11609R	w/ 1.75" Push Type I/S	TRK-202	TRK-2283	TRK-2345	
RTX-11609R	w/ 2" Pull Type I/S	TRK-202	TRK-2283	TRK-2761	TRK-2468 ⁵⁵
RTX-11709A			TRK-2284	TRK-2763	TRK-2468 ⁵⁵
RTX-11709B			TRK-2284	TRK-2763	TRK-2468 ⁵⁵
RTX-11709H			TRK-2284	TRK-2763	TRK-2468 ⁵⁵
RTX-12509		TRK-160	TRK-1861	TRK-1064	
RTX-12609A	w/ 1.75" Push Type I/S	TRK-202	TRK-2283	TRK-2345	
RTX-12609A	w/ 2" Pull Type I/S	TRK-202	TRK-2283	TRK-2761	TRK-2468 ⁵⁵
RTX-12609B	w/ 1.75" Push Type I/S	TRK-202	TRK-2283	TRK-2345	
RTX-12609B	w/ 2" Pull Type I/S	TRK-202	TRK-2283	TRK-2761	TRK-2468 ⁵⁵
RTX-12609P	w/ 1.75" Push Type I/S	TRK-202	TRK-2283	TRK-2345	
RTX-12609P	w/ 2" Pull Type I/S	TRK-202	TRK-2283	TRK-2761	TRK-2468 ⁵⁵
RTX-12609R	w/ 1.75" Push Type I/S	TRK-202	TRK-2283	TRK-2345	
RTX-12609R	w/ 2" Pull Type I/S	TRK-202	TRK-2283	TRK-2761	TRK-2468 ⁵⁵
RTX-12709A			TRK-2284	TRK-2763	TRK-2468 ⁵⁵
RTX-12709B			TRK-2284	TRK-2763	TRK-2468 ⁵⁵
RTX-12709H			TRK-2284	TRK-2763	TRK-2468 ⁵⁵
RTX-13609A			TRK-2282	TRK-2343	TRK-2468 ⁵⁵
RTX-13609B			TRK-2282	TRK-2343	TRK-2468 ⁵⁵
RTX-13609P			TRK-2282	TRK-2343	TRK-2468 ⁵⁵
RTX-13609R			TRK-2282	TRK-2343	TRK-2468 ⁵⁵
RTX-13709H			TRK-2284	TRK-2763	TRK-2468 ⁵⁵
RTX-14609A		TRK-205	TRK-1870	TRK-1971	TRK-2468 ⁵⁵
RTX-14609B		TRK-205	TRK-1870	TRK-1971	TRK-2468 ⁵⁵
RTX-14609P		TRK-205	TRK-1870	TRK-1971	TRK-2468 ⁵⁵
RTX-14609R		TRK-205	TRK-1870	TRK-1971	TRK-2468 ⁵⁵
RTX-16709B			TRK-2275	TRK-1999	TRK-2468 ⁵⁵
RTX-16709H			TRK-2275	TRK-1999	TRK-2468 ⁵⁵
RTXF-11509			TRK-1858	TRK-1063	TRK-2468 ⁵⁵
RTXF-11609A	w/ 1.75" Push Type I/S	TRK-202	TRK-2283	TRK-2345	
RTXF-11609A	w/ 2" Pull Type I/S	TRK-202	TRK-2283	TRK-2761	TRK-2468 ⁵⁵
RTXF-11609B	w/ 1.75" Push Type I/S	TRK-202	TRK-2283	TRK-2345	
RTXF-11609B	w/ 2" Pull Type I/S	TRK-202	TRK-2283	TRK-2761	TRK-2468 ⁵⁵
RTXF-11609P	w/ 1.75" Push Type I/S	TRK-202	TRK-2283	TRK-2345	
RTXF-11609P	w/ 2" Pull Type I/S	TRK-202	TRK-2283	TRK-2761	TRK-2468 ⁵⁵
RTXF-11609R	w/ 1.75" Push Type I/S	TRK-202	TRK-2283	TRK-2345	

HD Transmission

⁵⁵ Exc. Hyd. Release

Heavy Duty Transmission Index

Eaton/Fuller Medium & Heavy Duty Models

9 Speed Models (cont.)

Model No.	Comments	Standard Kit	Suitcase Kit	Overhaul Kit	Clutch Install Kit
RTXF-11609R	w/ 2" Pull Type I/S	TRK-202	TRK-2283	TRK-2761	TRK-2468 ⁵⁵
RTXF-11709H			TRK-2284	TRK-2763	TRK-2468 ⁵⁵
RTXF-12509		TRK-160	TRK-1861	TRK-1064	TRK-2468 ⁵⁵
RTXF-12609A	w/ 1.75" Push Type I/S	TRK-202	TRK-2283	TRK-2345	
RTXF-12609A	w/ 2" Pull Type I/S	TRK-202	TRK-2283	TRK-2761	TRK-2468 ⁵⁵
RTXF-12609B	w/ 1.75" Push Type I/S	TRK-202	TRK-2283	TRK-2345	
RTXF-12609B	w/ 2" Pull Type I/S	TRK-202	TRK-2283	TRK-2761	TRK-2468 ⁵⁵
RTXF-12609P	w/ 1.75" Push Type I/S	TRK-202	TRK-2283	TRK-2345	
RTXF-12609P	w/ 2" Pull Type I/S	TRK-202	TRK-2283	TRK-2761	TRK-2468 ⁵⁵
RTXF-12609R	w/ 1.75" Push Type I/S	TRK-202	TRK-2283	TRK-2345	
RTXF-12609R	w/ 2" Pull Type I/S	TRK-202	TRK-2283	TRK-2761	TRK-2468 ⁵⁵
RTXF-12709H			TRK-2284	TRK-2763	TRK-2468 ⁵⁵
RTXF-13609A			TRK-2282	TRK-2343	TRK-2468 ⁵⁵
RTXF-13609B			TRK-2282	TRK-2343	TRK-2468 ⁵⁵
RTXF-13609P			TRK-2282	TRK-2343	TRK-2468 ⁵⁵
RTXF-13609R			TRK-2282	TRK-2343	TRK-2468 ⁵⁵
RTXF-13709H			TRK-2284	TRK-2763	TRK-2468 ⁵⁵
RTXF-14609A		TRK-205	TRK-1870	TRK-1971	TRK-2468 ⁵⁵
RTXF-14609B		TRK-205	TRK-1870	TRK-1971	TRK-2468 ⁵⁵
RTXF-14609P		TRK-205	TRK-1870	TRK-1971	TRK-2468 ⁵⁵
RTXF-14609R		TRK-205	TRK-1870	TRK-1971	TRK-2468 ⁵⁵
RTXF-14709H			TRK-2275	TRK-1999	TRK-2468 ⁵⁵
RTXF-16709B			TRK-2275	TRK-1999	TRK-2468 ⁵⁵
RTXF-16709H			TRK-2275	TRK-1999	TRK-2468 ⁵⁵

10 Speed Models

FM-14D310B-LST			TRK-3522	TRK-3519	
FM-14E310B-LAS			TRK-4010		
FM-15D310B-LST			TRK-3522	TRK-3519	
FM-15E310B-LAS			TRK-4010		
FO-10E310C-VAS			TRK-4010		
FO-12E310C-VAS			TRK-4010		
FO-14E310C-LAS			TRK-4010		
FO-14E310C-VAS			TRK-4010		
FO-16E310C-LAS			TRK-4010		
FO-16E310C-VAS			TRK-4010		
FOM-14E310C-LAS			TRK-4010		
FOM-14E310C-VAS			TRK-4010		
FOM-15E310C-LAS			TRK-4010		
FOM-15E310C-VAS			TRK-4010		
FOM-16E310C-LAS			TRK-4010		
FOM-16E310C-VAS			TRK-4010		
FR-11210B	w/ Electronic Speedometer		TRK-2924		TRK-3600 ^{55 60}
FR-11210B	w/ Mechanical Speedometer		TRK-3132		TRK-3600 ^{55 60}
FR-12210B	w/ Electronic Speedometer		TRK-2924		TRK-3600 ^{55 60}
FR-12210B	w/ Mechanical Speedometer		TRK-3132		TRK-3600 ^{55 60}
FR-13210B	w/ Electronic Speedometer		TRK-2924		TRK-3600 ^{55 60}
FR-13210B	w/ Mechanical Speedometer		TRK-3132		TRK-3600 ^{55 60}
FR-14210B	w/ Electronic Speedometer		TRK-2924		TRK-3600 ^{55 60}
FR-14210B	w/ Mechanical Speedometer		TRK-3132		TRK-3600 ^{55 60}
FR-15210B	w/ Electronic Speedometer		TRK-2924		TRK-3600 ^{55 60}
FR-15210B	w/ Mechanical Speedometer		TRK-3132		TRK-3600 ^{55 60}
FR-9210B	w/ Electronic Speedometer		TRK-2924		TRK-3600 ^{55 60}
FR-9210B	w/ Mechanical Speedometer		TRK-3132		TRK-3600 ^{55 60}
FRF-11210B	w/ Electronic Speedometer		TRK-2924		TRK-3600 ^{55 60}

Heavy Duty Transmission Index

Eaton/Fuller Medium & Heavy Duty Models

10 Speed Models (cont.)

Model No.	Comments	Standard Kit	Suitcase Kit	Overhaul Kit	Clutch Install Kit
FRF-11210B	w/ Mechanical Speedometer		TRK-3132		TRK-3600 ^{55 60}
FRF-12210B	w/ Electronic Speedometer		TRK-2924		TRK-3600 ^{55 60}
FRF-12210B	w/ Mechanical Speedometer		TRK-3132		TRK-3600 ^{55 60}
FRF-13210B	w/ Electronic Speedometer		TRK-2924		TRK-3600 ^{55 60}
FRF-13210B	w/ Mechanical Speedometer		TRK-3132		TRK-3600 ^{55 60}
FRF-14210B	w/ Electronic Speedometer		TRK-2924		TRK-3600 ^{55 60}
FRF-14210B	w/ Mechanical Speedometer		TRK-3132		TRK-3600 ^{55 60}
FRF-15210B	w/ Electronic Speedometer		TRK-2924		TRK-3600 ^{55 60}
FRF-15210B	w/ Mechanical Speedometer		TRK-3132		TRK-3600 ^{55 60}
FRF-9210B	w/ Electronic Speedometer		TRK-2924		TRK-3600 ^{55 60}
FRF-9210B	w/ Mechanical Speedometer		TRK-3132		TRK-3600 ^{55 60}
FRO-11210B	w/ Electronic Speedometer		TRK-2924		TRK-3600 ^{55 60}
FRO-11210B	w/ Mechanical Speedometer		TRK-3132		TRK-3600 ^{55 60}
FRO-11210C	w/ Electronic Speedometer		TRK-2924		TRK-3600 ^{55 60}
FRO-11210C	w/ Mechanical Speedometer		TRK-3132		TRK-3600 ^{55 60}
FRO-12210B	w/ Electronic Speedometer		TRK-2924		TRK-3600 ^{55 60}
FRO-12210B	w/ Mechanical Speedometer		TRK-3132		TRK-3600 ^{55 60}
FRO-12210C	w/ Electronic Speedometer		TRK-2924		TRK-3600 ^{55 60}
FRO-12210C	w/ Mechanical Speedometer		TRK-3132		TRK-3600 ^{55 60}
FRO-13210B	w/ Electronic Speedometer		TRK-2924		TRK-3600 ^{55 60}
FRO-13210B	w/ Mechanical Speedometer		TRK-3132		TRK-3600 ^{55 60}
FRO-13210C	w/ Electronic Speedometer		TRK-2924		TRK-3600 ^{55 60}
FRO-13210C	w/ Mechanical Speedometer		TRK-3132		TRK-3600 ^{55 60}
FRO-14210B	w/ Electronic Speedometer		TRK-2924		TRK-3600 ^{55 60}
FRO-14210B	w/ Mechanical Speedometer		TRK-3132		TRK-3600 ^{55 60}
FRO-14210C	w/ Electronic Speedometer		TRK-2924		TRK-3600 ^{55 60}
FRO-14210C	w/ Mechanical Speedometer		TRK-3132		TRK-3600 ^{55 60}
FRO-15210B	w/ Electronic Speedometer		TRK-2924		TRK-3600 ^{55 60}
FRO-15210B	w/ Mechanical Speedometer		TRK-3132		TRK-3600 ^{55 60}
FRO-15210C	w/ Electronic Speedometer		TRK-2924		TRK-3600 ^{55 60}
FRO-15210C	w/ Mechanical Speedometer		TRK-3132		TRK-3600 ^{55 60}
FRO-16210B	w/ Electronic Speedometer		TRK-2924		TRK-3600 ^{55 60}
FRO-16210B	w/ Mechanical Speedometer		TRK-3132		TRK-3600 ^{55 60}
FRO-16210C	w/ Electronic Speedometer		TRK-2924		TRK-3600 ^{55 60}
FRO-16210C	w/ Mechanical Speedometer		TRK-3132		TRK-3600 ^{55 60}
FRO-17210C	w/ Electronic Speedometer		TRK-2924		TRK-3600 ^{55 60}
FRO-17210C	w/ Mechanical Speedometer		TRK-3132		TRK-3600 ^{55 60}
FRO-18210C	w/ Electronic Speedometer		TRK-2924		TRK-3600 ^{55 60}
FRO-18210C	w/ Mechanical Speedometer		TRK-3132		TRK-3600 ^{55 60}
FROF-11210B	w/ Electronic Speedometer		TRK-2924		TRK-3600 ^{55 60}
FROF-11210B	w/ Mechanical Speedometer		TRK-3132		TRK-3600 ^{55 60}
FROF-11210C	w/ Electronic Speedometer		TRK-2924		TRK-3600 ^{55 60}
FROF-11210C	w/ Mechanical Speedometer		TRK-3132		TRK-3600 ^{55 60}
FROF-12210B	w/ Electronic Speedometer		TRK-2924		TRK-3600 ^{55 60}
FROF-12210B	w/ Mechanical Speedometer		TRK-3132		TRK-3600 ^{55 60}
FROF-12210C	w/ Electronic Speedometer		TRK-2924		TRK-3600 ^{55 60}
FROF-12210C	w/ Mechanical Speedometer		TRK-3132		TRK-3600 ^{55 60}
FROF-13210B	w/ Electronic Speedometer		TRK-2924		TRK-3600 ^{55 60}
FROF-13210B	w/ Mechanical Speedometer		TRK-3132		TRK-3600 ^{55 60}
FROF-13210C	w/ Electronic Speedometer		TRK-2924		TRK-3600 ^{55 60}
FROF-13210C	w/ Mechanical Speedometer		TRK-3132		TRK-3600 ^{55 60}
FROF-14210B	w/ Electronic Speedometer		TRK-2924		TRK-3600 ^{55 60}
FROF-14210B	w/ Mechanical Speedometer		TRK-3132		TRK-3600 ^{55 60}
FROF-14210C	w/ Electronic Speedometer		TRK-2924		TRK-3600 ^{55 60}

HD Transmission

Heavy Duty Transmission Index

Eaton/Fuller Medium & Heavy Duty Models

10 Speed Models (cont.)

Model No.	Comments	Standard Kit	Suitcase Kit	Overhaul Kit	Clutch Install Kit
FROF-14210C	w/ Mechanical Speedometer		TRK-3132		TRK-3600 ^{55 60}
FROF-15210B	w/ Electronic Speedometer		TRK-2924		TRK-3600 ^{55 60}
FROF-15210B	w/ Mechanical Speedometer		TRK-3132		TRK-3600 ^{55 60}
FROF-15210C	w/ Electronic Speedometer		TRK-2924		TRK-3600 ^{55 60}
FROF-15210C	w/ Mechanical Speedometer		TRK-3132		TRK-3600 ^{55 60}
FROF-16210B	w/ Electronic Speedometer		TRK-2924		TRK-3600 ^{55 60}
FROF-16210B	w/ Mechanical Speedometer		TRK-3132		TRK-3600 ^{55 60}
FROF-16210C	w/ Electronic Speedometer		TRK-2924		TRK-3600 ^{55 60}
FROF-16210C	w/ Mechanical Speedometer		TRK-3132		TRK-3600 ^{55 60}
FRWF-15210B			TRK-2924		TRK-3600 ⁵⁵
FRWF-15210B			TRK-2924		TRK-3600 ⁵⁵
RT-11610	w/ 1.75" Push Type I/S	TRK-202	TRK-2283	TRK-2345	
RT-11610	w/ 2" Pull Type I/S	TRK-202	TRK-2283	TRK-2761	TRK-2468 ⁵⁵
RT-11710B			TRK-2049	TRK-1996	TRK-2468 ⁵⁵
RT-12510		TRK-160	TRK-1861	TRK-1064	TRK-2468 ⁵⁵
RT-12610	w/ 1.75" Push Type I/S	TRK-202	TRK-2283	TRK-2345	
RT-12610	w/ 2" Pull Type I/S			TRK-2761	TRK-2468 ⁵⁵
RT-12710B			TRK-2049	TRK-1996	TRK-2468 ⁵⁵
RT-13710B			TRK-2284	TRK-2762	TRK-2468 ⁵⁵
RT-14610		TRK-205	TRK-1870	TRK-1971	TRK-2468 ⁵⁵
RT-14710B			TRK-2277	TRK-2335	TRK-2468 ⁵⁵
RT-14910B-AS2			TRK-3522	TRK-3524	TRK-2468 ⁵⁵
RT-6610		TRK-145A	TRK-1850		
RT-9710B			TRK-3322	TRK-3323	TRK-2468 ⁵⁵
RTF-11610	w/ 1.75" Push Type I/S	TRK-202	TRK-2283	TRK-2345	
RTF-11610	w/ 2" Pull Type I/S	TRK-202	TRK-2283	TRK-2761	TRK-2468 ⁵⁵
RTF-11710B			TRK-2049	TRK-1996	TRK-2468 ⁵⁵
RTF-12510		TRK-160	TRK-1861	TRK-1064	TRK-2468 ⁵⁵
RTF-12610		TRK-202	TRK-2283	TRK-2345	TRK-2468 ⁵⁵
RTF-12610		TRK-202	TRK-2283	TRK-2761	TRK-2468 ⁵⁵
RTF-12710B			TRK-2049	TRK-1996	TRK-2468 ⁵⁵
RTF-13710B			TRK-2284	TRK-2762	TRK-2468 ⁵⁵
RTF-14610		TRK-205	TRK-1870	TRK-1971	TRK-2468 ⁵⁵
RTF-14710B			TRK-2277	TRK-2335	TRK-2468 ⁵⁵
RTF-9710B			TRK-3322	TRK-3323	TRK-2468 ⁵⁵
RTL-13710B			TRK-2284		TRK-2468 ⁵⁵
RTL-14710B			TRK-3553	TRK-3554	TRK-2468 ⁵⁵
RTL-13710B			TRK-2284		TRK-2468 ⁵⁵
RTL-14710B			TRK-3553	TRK-3554	TRK-2468 ⁵⁵
RTLO-11610B			TRK-2772	TRK-2764	TRK-2468 ⁵⁵
RTLO-11610B-T2			TRK-2772	TRK-2764	TRK-2468 ⁵⁵
RTLO-12610B			TRK-2772	TRK-2764	TRK-2468 ⁵⁵
RTLO-12610B-T2			TRK-2772	TRK-2764	TRK-2468 ⁵⁵
RTLO-13610B			TRK-2772	TRK-2764	TRK-2468 ⁵⁵
RTLO-13610B-T2			TRK-2772	TRK-2764	TRK-2468 ⁵⁵
RTLO-14610A			TRK-2998		TRK-2468 ⁵⁵
RTLO-14610B			TRK-2773	TRK-2765	TRK-2468 ⁵⁵
RTLO-14610B-T2			TRK-2773	TRK-2765	TRK-2468 ⁵⁵
RTLO-15610B			TRK-2773	TRK-2765	TRK-2468 ⁵⁵
RTLO-15610B-T2			TRK-2773	TRK-2765	
RTLO-16610B			TRK-2773	TRK-2765	TRK-2468 ⁵⁵
RTLO-16610B-T2			TRK-2773	TRK-2765	
RTLO-17610B			TRK-2773	TRK-2765	
RTLO-17610B-T2			TRK-2773	TRK-2765	

HD Transmission

Heavy Duty Transmission Index

Eaton/Fuller Medium & Heavy Duty Models

10 Speed Models (cont.)

Model No.	Comments	Standard Kit	Suitcase Kit	Overhaul Kit	Clutch Install Kit
RTLO-18610B			TRK-2773	TRK-2765	
RTLO-18610B-T2			TRK-2773	TRK-2765	
RTLO-18610B-T2			TRK-3522	TRK-3519	
RTLOF-11610B			TRK-2772	TRK-2764	TRK-2468 ⁵⁵
RTLOF-11610B-T2			TRK-2772	TRK-2764	TRK-2468 ⁵⁵
RTLOF-12610B			TRK-2772	TRK-2764	TRK-2468 ⁵⁵
RTLOF-12610B-T2			TRK-2772	TRK-2764	TRK-2468 ⁵⁵
RTLOF-13610B			TRK-2772	TRK-2764	TRK-2468 ⁵⁵
RTLOF-13610B-T2			TRK-2772	TRK-2764	TRK-2468 ⁵⁵
RTLOF-14610B			TRK-2773	TRK-2765	TRK-2468 ⁵⁵
RTLOF-14610B-T2			TRK-2773	TRK-2765	
RTLOF-15610B			TRK-2773	TRK-2765	TRK-2468 ⁵⁵
RTLOF-15610B-T2			TRK-2773	TRK-2765	
RTLOF-16610B			TRK-2773	TRK-2765	TRK-2468 ⁵⁵
RTLOF-16610B-T2			TRK-2773	TRK-2765	
RTLOF-17610B			TRK-2773	TRK-2765	
RTLOF-17610B-T2			TRK-2773	TRK-2765	
RTLOF-18610B			TRK-2773	TRK-2765	
RTO-10710B-AS2			TRK-3488		
RTO-10910B-AS2			TRK-3522	TRK-3524	TRK-2468 ⁵⁵
RTO-10910B-AS3			TRK-3522	TRK-3519	
RTO-10910B-DM2			TRK-3522	TRK-3519	
RTO-10910B-DM3			TRK-3522	TRK-3519	
RTO-11610	w/ 1.75" Push Type I/S	TRK-202	TRK-2283	TRK-2345	
RTO-11610	w/ 2" Pull Type I/S	TRK-202	TRK-2283	TRK-2761	TRK-2468 ⁵⁵
RTO-12510		TRK-160	TRK-1861	TRK-1064	TRK-2468 ⁵⁵
RTO-12610	w/ 1.75" Push Type I/S	TRK-202	TRK-2283	TRK-2345	
RTO-12610	w/ 2" Pull Type I/S	TRK-202	TRK-2283	TRK-2761	TRK-2468 ⁵⁵
RTO-12710B-AS2			TRK-3488		TRK-2468 ⁵⁵
RTO-12910B-AS2			TRK-3522	TRK-3524	TRK-2468 ⁵⁵
RTO-12910B-AS3			TRK-3522	TRK-3519	
RTO-12910B-DM2			TRK-3522	TRK-3519	
RTO-12910B-DM3			TRK-3522	TRK-3519	
RTO-14610		TRK-205	TRK-1870	TRK-1971	TRK-2468 ⁵⁵
RTO-14710B-AS2			TRK-3487	TRK-3486	TRK-2468 ⁵⁵
RTO-14710C-AS2			TRK-3487	TRK-3486	TRK-2468 ⁵⁵
RTO-14910B-AS2			TRK-3522	TRK-3519	TRK-2468 ⁵⁵
RTO-14910B-AS3			TRK-3522	TRK-3519	
RTO-14910B-DM2			TRK-3522	TRK-3519	
RTO-14910B-DM3			TRK-3522	TRK-3519	
RTO-14910C-AS2			TRK-3522	TRK-3519	TRK-2468 ⁵⁵
RTO-14910C-AS3			TRK-3522	TRK-3519	
RTO-15210C	w/ Electronic Speedometer		TRK-2924		TRK-3600 ^{55 60}
RTO-15210C	w/ Mechanical Speedometer		TRK-3132		TRK-3600 ^{55 60}
RTO-16210C	w/ Electronic Speedometer		TRK-2924		TRK-3600 ^{55 60}
RTO-16210C	w/ Mechanical Speedometer		TRK-3132		TRK-3600 ^{55 60}
RTO-16710B-AS2			TRK-3487	TRK-3486	TRK-2468 ⁵⁵
RTO-16710C-AS2			TRK-3487	TRK-3486	TRK-2468 ⁵⁵
RTO-16910B-AS2			TRK-3522	TRK-3519	TRK-2468 ⁵⁵
RTO-16910B-AS3			TRK-3522	TRK-3519	
RTO-16910B-DM2			TRK-3522	TRK-3519	
RTO-16910B-DM3			TRK-3522	TRK-3519	
RTO-16910C-AS2			TRK-3522	TRK-3519	TRK-2468 ⁵⁵
RTO-16910C-AS3			TRK-3522	TRK-3519	

Heavy Duty Transmission Index

Eaton/Fuller Medium & Heavy Duty Models

10 Speed Models (cont.)

Model No.	Comments	Standard Kit	Suitcase Kit	Overhaul Kit	Clutch Install Kit
RTO-18910B-AS2			TRK-3522	TRK-3519	TRK-2468 ⁵⁵
RTO-18910B-AS3			TRK-3522	TRK-3519	
RTO-6610		TRK-145A	TRK-1850		
RTOF-11610	w/ 1.75" Push Type I/S	TRK-202	TRK-2283	TRK-2345	
RTOF-11610	w/ 2" Pull Type I/S	TRK-202	TRK-2283	TRK-2761	TRK-2468 ⁵⁵
RTOF-12510		TRK-160	TRK-1861	TRK-1064	TRK-2468 ⁵⁵
RTOF-12610	w/ 1.75" Push Type I/S	TRK-202	TRK-2283	TRK-2345	
RTOF-12610	w/ 2" Pull Type I/S	TRK-202	TRK-2283	TRK-2761	TRK-2468 ⁵⁵
RTOF-14610		TRK-205	TRK-1870	TRK-1971	TRK-2468 ⁵⁵
RTOF-15210C	w/ Electronic Speedometer		TRK-2924		TRK-3600 ^{55 60}
RTOF-15210C	w/ Mechanical Speedometer		TRK-3132		TRK-3600 ^{55 60}
RTOF-16210C	w/ Electronic Speedometer		TRK-2924		TRK-3600 ^{55 60}
RTOF-16210C	w/ Mechanical Speedometer		TRK-3132		TRK-3600 ^{55 60}
RTOM-16910B-DM3			TRK-3522	TRK-3519	
RTX-11610	w/ 1.75" Push Type I/S	TRK-202	TRK-2283	TRK-2345	
RTX-11610	w/ 2" Pull Type I/S	TRK-202	TRK-2283	TRK-2761	TRK-2468 ⁵⁵
RTX-11710B			TRK-2284	TRK-2763	TRK-2468 ⁵⁵
RTX-11710C			TRK-2284	TRK-2763	TRK-2468 ⁵⁵
RTX-12510		TRK-160	TRK-1861	TRK-1064	
RTX-12610	w/ 1.75" Push Type I/S	TRK-202	TRK-2283	TRK-2345	
RTX-12610	w/ 2" Pull Type I/S	TRK-202	TRK-2283	TRK-2761	TRK-2468 ⁵⁵
RTX-12710B			TRK-2284	TRK-2763	TRK-2468 ⁵⁵
RTX-12710C			TRK-2284	TRK-2763	TRK-2468 ⁵⁵
RTX-13710B			TRK-2284	TRK-2763	TRK-2468 ⁵⁵
RTX-13710C			TRK-2284	TRK-2763	TRK-2468 ⁵⁵
RTX-14610		TRK-205	TRK-1870	TRK-1971	TRK-2468 ⁵⁵
RTX-14710B			TRK-2277	TRK-2336	TRK-2468 ⁵⁵
RTX-14710C			TRK-2277	TRK-2336	TRK-2468 ⁵⁵
RTX-15710B			TRK-2277	TRK-2336	TRK-2468 ⁵⁵
RTX-15710C			TRK-2277	TRK-2336	TRK-2468 ⁵⁵
RTX-16710B			TRK-2277	TRK-2336	TRK-2468 ⁵⁵
RTX-16710C			TRK-2277	TRK-2336	TRK-2468 ⁵⁵
RTXF-11610	w/ 1.75" Push Type I/S	TRK-202	TRK-2283	TRK-2345	
RTXF-11610	w/ 2" Pull Type I/S	TRK-202	TRK-2283	TRK-2761	TRK-2468 ⁵⁵
RTXF-11710B			TRK-2284	TRK-2763	TRK-2468 ⁵⁵
RTXF-11710C			TRK-2284	TRK-2763	TRK-2468 ⁵⁵
RTXF-12510		TRK-160	TRK-1861	TRK-1064	TRK-2468 ⁵⁵
RTXF-12610	w/ 1.75" Push Type I/S	TRK-202	TRK-2283	TRK-2345	TRK-2468
RTXF-12610	w/ 2" Pull Type I/S	TRK-202	TRK-2283	TRK-2761	TRK-2468 ⁵⁵
RTXF-12710B			TRK-2284	TRK-2763	TRK-2468 ⁵⁵
RTXF-12710C			TRK-2284	TRK-2763	TRK-2468 ⁵⁵
RTXF-13710B			TRK-2284	TRK-2763	TRK-2468 ⁵⁵
RTXF-13710C			TRK-2284	TRK-2763	TRK-2468 ⁵⁵
RTXF-14610		TRK-205	TRK-1870	TRK-1971	TRK-2468 ⁵⁵
RTXF-14710C			TRK-2277	TRK-2336	TRK-2468 ⁵⁵
RTXF-15710B			TRK-2277	TRK-2336	TRK-2468 ⁵⁵
RTXF-15710C			TRK-2277	TRK-2336	TRK-2468 ⁵⁵
RTXF-16710B			TRK-2277	TRK-2336	TRK-2468 ⁵⁵
RTXF-16710C			TRK-2277	TRK-2336	TRK-2468 ⁵⁵

13 Speed Models

FO-14E313A-MHP			TRK-3941		
FO-16D313E-LEP			TRK-3512	TRK-3513	
FO-16E313A-MHP			TRK-3941		
FO-16E313A-VHP			TRK-3941		

Heavy Duty Transmission Index

Eaton/Fuller Medium & Heavy Duty Models

13 Speed Models (cont.)

Model No.	Comments	Standard Kit	Suitcase Kit	Overhaul Kit	Clutch Install Kit
FO-18E313A-MHP			TRK-3941		
FO-18E313A-VHP			TRK-3941		
FO-20E313A-MHP			TRK-3941		
FO-20E313A-VHP			TRK-3941		
FOM-16D313E-LEP			TRK-3512	TRK-3513	
RT-11613	w/ Tapered Aux. C/S Brgs.		TRK-2281	TRK-2342	TRK-2468 ⁵⁵
RT-11613	w/ 1.75" Push Type I/S & w/o Tapered Aux. C/S Brgs.	TRK-202	TRK-2283	TRK-2345	
RT-11613	w/ 2" Pull Type I/S & w/o Tapered Aux. C/S Brgs.	TRK-202	TRK-2283	TRK-2761	TRK-2468 ⁵⁵
RT-14613	w/o Tapered Aux. C/S Brgs.	TRK-206	TRK-1871	TRK-1972	TRK-2468 ⁵⁵
RT-14613	w/ Tapered Aux. C/S Brgs.		TRK-2280	TRK-2341	TRK-2468 ⁵⁵
RT-15613	w/o Tapered Aux. C/S Brgs.		TRK-1874	TRK-1972	TRK-2468 ⁵⁵
RT-15613	w/ Tapered Aux. C/S Brgs.		TRK-2280	TRK-2341	TRK-2468 ⁵⁵
RT-6613		TRK-146	TRK-1851		
RTF-11613	w/ Tapered Aux. C/S Brgs.		TRK-2281	TRK-2342	TRK-2468 ⁵⁵
RTF-11613	w/ 1.75" Push Type I/S & w/o Tapered Aux. C/S Brgs.	TRK-202	TRK-2283	TRK-2345	
RTF-11613	w/ 2" Pull Type I/S & w/o Tapered Aux. C/S Brgs.	TRK-202	TRK-2283	TRK-2761	TRK-2468 ⁵⁵
RTF-12513		TRK-149	TRK-1862		
RTF-14613	w/o Tapered Aux. C/S Brgs.	TRK-206	TRK-1871	TRK-1972	TRK-2468 ⁵⁵
RTF-14613	w/ Tapered Aux. C/S Brgs.		TRK-2280	TRK-2341	TRK-2468 ⁵⁵
RTF-15613	w/o Tapered Aux. C/S Brgs.		TRK-1874	TRK-1972	TRK-2468 ⁵⁵
RTF-15613	w/ Tapered Aux. C/S Brgs.		TRK-2280	TRK-2341	TRK-2468 ⁵⁵
RTLO-12713A			TRK-2285	TRK-2767	TRK-2468 ⁵⁵
RTLO-12913A	w/ Forced Lubrication		TRK-3343	TRK-3342	TRK-2468 ⁵⁵
RTLO-12913A	w/o Forced Lubrication		TRK-3351	TRK-3350	TRK-2468 ⁵⁵
RTLO-14613B			TRK-2996	TRK-2993	TRK-2468 ⁵⁵
RTLO-14713A			TRK-2286	TRK-2758	TRK-2468 ⁵⁵
RTLO-14913A	w/ Forced Lubrication		TRK-3343	TRK-3342	TRK-2468 ⁵⁵
RTLO-14913A	w/o Forced Lubrication		TRK-3348	TRK-3347	TRK-2468 ⁵⁵
RTLO-16713A	w/ Serial # 51126220 & Lower		TRK-2287	TRK-2770	TRK-2468 ⁵⁵
RTLO-16713A	w/ Serial # 51126221 & Higher or Beginning with a Letter		TRK-3346	TRK-3345	TRK-2468 ⁵⁵
RTLO-16713A-T2			TRK-3596	TRK-3595	TRK-2468 ⁵⁵
RTLO-16913A			TRK-3343	TRK-3342	TRK-2468 ⁵⁵
RTLO-16913A-T2			TRK-3426	TRK-3425	TRK-2468 ⁵⁵
RTLO-16913L-DM3			TRK-3512	TRK-3513	
RTLO-18913A	w/ Serial # 51126220 & Lower		TRK-3286	TRK-3287	TRK-2468 ⁵⁵
RTLO-18913A	w/ Serial # 51126221 & Higher or Beginning with a Letter		TRK-3343	TRK-3342	TRK-2468 ⁵⁵
RTLO-18913A-T2	w/ Serial # 51126220 & Lower		TRK-3286	TRK-3287	TRK-2468 ⁵⁵
RTLO-18913A-T2	w/ Serial # 51126221 & Higher or Beginning with a Letter		TRK-3426	TRK-3425	TRK-2468 ⁵⁵
RTLO-20913A			TRK-3460	TRK-3459	TRK-2468 ⁵⁵
RTLOF-12713A			TRK-2285	TRK-2767	TRK-2468 ⁵⁵
RTLOF-12913A	w/ Forced Lubrication		TRK-3343	TRK-3342	TRK-2468 ⁵⁵
RTLOF-12913A	w/o Forced Lubrication		TRK-3351	TRK-3350	TRK-2468 ⁵⁵
RTLOF-14613B			TRK-2996	TRK-2993	TRK-2468 ⁵⁵
RTLOF-14713A			TRK-2286	TRK-2758	TRK-2468 ⁵⁵
RTLOF-14913A	w/ Forced Lubrication		TRK-3343	TRK-3342	TRK-2468 ⁵⁵
RTLOF-14913A	w/o Forced Lubrication		TRK-3348	TRK-3347	TRK-2468 ⁵⁵
RTLOF-16713A	w/ Serial # 51126220 & Lower		TRK-2287	TRK-2770	TRK-2468 ⁵⁵
RTLOF-16713A	w/ Serial # 51126221 & Higher or Beginning with a Letter		TRK-3346	TRK-3345	TRK-2468 ⁵⁵

Heavy Duty Transmission Index

Eaton/Fuller Medium & Heavy Duty Models

13 Speed Models (cont.)

Model No.	Comments	Standard Kit	Suitcase Kit	Overhaul Kit	Clutch Install Kit
RTLOF-16713A-T2			TRK-3596	TRK-3595	TRK-2468 ⁵⁵
RTLOF-16913A			TRK-3343	TRK-3342	TRK-2468 ⁵⁵
RTLOF-16913A-T2			TRK-3426	TRK-3425	TRK-2468 ⁵⁵
RTLOF-18913A	w/ Serial # 51126220 & Lower		TRK-3286	TRK-3287	TRK-2468 ⁵⁵
RTLOF-18913A	w/ Serial # 51126221 & Higher or Beginning with a Letter		TRK-3343	TRK-3342	TRK-2468 ⁵⁵
RTLOF-18913A-T2	w/ Serial # 51126220 & Lower		TRK-3286	TRK-3287	TRK-2468 ⁵⁵
RTLOF-18913A-T2	w/ Serial # 51126221 & Higher or Beginning with a Letter		TRK-3426	TRK-3425	TRK-2468 ⁵⁵
RTLOF-20913A			TRK-3460	TRK-3459	TRK-2468 ⁵⁵
RTLOM-16913L-DM3			TRK-3512	TRK-3513	TRK-2468 ⁵⁵
RTO-11613	w/ Tapered Aux. C/S Brgs.		TRK-2281	TRK-2342	TRK-2468 ⁵⁵
RTO-11613	w/ 1.75" Push Type I/S & w/o Tapered Aux. C/S Brgs.	TRK-202	TRK-2283	TRK-2345	
RTO-11613	w/ 2" Pull Type I/S & w/o Tapered Aux. C/S Brgs.	TRK-202	TRK-2283	TRK-2761	TRK-2468 ⁵⁵
RTO-11813	w/ Tapered Aux. C/S Brgs.		TRK-2281	TRK-2342	TRK-2468 ⁵⁵
RTO-11813	w/ 1.75" Push Type I/S & w/o Tapered Aux. C/S Brgs.	TRK-202	TRK-2283	TRK-2345	
RTO-11813	w/ 2" Pull Type I/S & w/o Tapered Aux. C/S Brgs.	TRK-202	TRK-2283	TRK-2761	TRK-2468 ⁵⁵
RTO-12513		TRK-149	TRK-1862		
RTO-14613	w/o Tapered Aux. C/S Brgs.	TRK-206	TRK-1871	TRK-1972	TRK-2468 ⁵⁵
RTO-14613	w/ Tapered Aux. C/S Brgs.		TRK-2280	TRK-2341	TRK-2468 ⁵⁵
RTO-14813	w/o Tapered Aux. C/S Brgs.	TRK-206	TRK-1871	TRK-1972	TRK-2468 ⁵⁵
RTO-14813	w/ Tapered Aux. C/S Brgs.		TRK-2280	TRK-2341	TRK-2468 ⁵⁵
RTO-15613	w/o Tapered Aux. C/S Brgs.		TRK-1874	TRK-1972	TRK-2468 ⁵⁵
RTO-15613	w/ Tapered Aux. C/S Brgs.		TRK-2280	TRK-2341	TRK-2468 ⁵⁵
RTO-15813	w/o Tapered Aux. C/S Brgs.		TRK-1874	TRK-1972	TRK-2468 ⁵⁵
RTO-15813	w/ Tapered Aux. C/S Brgs.		TRK-2280	TRK-2341	TRK-2468 ⁵⁵
RTO-6613		TRK-146	TRK-1851		
RTOF-11613	w/ Tapered Aux. C/S Brgs.		TRK-2281	TRK-2342	TRK-2468 ⁵⁵
RTOF-11613	w/ 1.75" Push Type I/S & w/o Tapered Aux. C/S Brgs.	TRK-202	TRK-2283	TRK-2345	
RTOF-11613	w/ 2" Pull Type I/S & w/o Tapered Aux. C/S Brgs.	TRK-202	TRK-2283	TRK-2761	TRK-2468 ⁵⁵
RTOF-11813	w/ Tapered Aux. C/S Brgs.		TRK-2281	TRK-2342	TRK-2468 ⁵⁵
RTOF-11813	w/ 1.75" Push Type I/S & w/o Tapered Aux. C/S Brgs.	TRK-202	TRK-2283	TRK-2345	
RTOF-11813	w/ 2" Pull Type I/S & w/o Tapered Aux. C/S Brgs.	TRK-202	TRK-2283	TRK-2761	TRK-2468 ⁵⁵
RTOF-12513		TRK-149	TRK-1862		
RTOF-14613	w/o Tapered Aux. C/S Brgs.	TRK-206	TRK-1871	TRK-1972	TRK-2468 ⁵⁵
RTOF-14613	w/ Tapered Aux. C/S Brgs.		TRK-2280	TRK-2341	TRK-2468 ⁵⁵
RTOF-14813	w/o Tapered Aux. C/S Brgs.	TRK-206	TRK-1871	TRK-1972	TRK-2468 ⁵⁵
RTOF-14813	w/ Tapered Aux. C/S Brgs.		TRK-2280	TRK-2341	TRK-2468 ⁵⁵
RTOF-15613	w/o Tapered Aux. C/S Brgs.		TRK-1874	TRK-1972	TRK-2468 ⁵⁵
RTOF-15613	w/ Tapered Aux. C/S Brgs.		TRK-2280	TRK-2341	TRK-2468 ⁵⁵
RTOF-15813	w/o Tapered Aux. C/S Brgs.		TRK-1874	TRK-1972	TRK-2468 ⁵⁵
RTOF-15813	w/ Tapered Aux. C/S Brgs.		TRK-2280	TRK-2341	TRK-2468 ⁵⁵
RTOO-11613	w/ Tapered Aux. C/S Brgs.		TRK-2281	TRK-2342	
RTOO-11613	w/ 1.75" Push Type I/S & w/o Tapered Aux. C/S Brgs.	TRK-202	TRK-2283	TRK-2345	
RTOO-11613	w/ 2" Pull Type I/S & w/o Tapered Aux. C/S Brgs.	TRK-202	TRK-2283	TRK-2761	
RTOO-14613	w/o Tapered Aux. C/S Brgs.	TRK-206	TRK-1871	TRK-1972	TRK-2468 ⁵⁵
RTOO-14613	w/ Tapered Aux. C/S Brgs.		TRK-2280	TRK-2341	TRK-2468 ⁵⁵
RTOOF-11613	w/ Tapered Aux. C/S Brgs.		TRK-2281	TRK-2342	TRK-2468 ⁵⁵

HD Transmission

Heavy Duty Transmission Index

Eaton/Fuller Medium & Heavy Duty Models

13 Speed Models (cont.)

Model No.	Comments	Standard Kit	Suitcase Kit	Overhaul Kit	Clutch Install Kit
RTOOF-11613	w/ 1.75" Push Type I/S & w/o Tapered Aux. C/S Brgs.	TRK-202	TRK-2283	TRK-2345	
RTOOF-11613	w/ 2" Pull Type I/S & w/o Tapered Aux. C/S Brgs.	TRK-202	TRK-2283	TRK-2761	TRK-2468 ⁵⁵
RTOOF-14613	w/o Tapered Aux. C/S Brgs.	TRK-206	TRK-1871	TRK-1972	TRK-2468 ⁵⁵
RTOOF-14613	w/ Tapered Aux. C/S Brgs.		TRK-2280	TRK-2341	TRK-2468 ⁵⁵
RTOX-11613	w/ Tapered Aux. C/S Brgs.		TRK-2281	TRK-2342	TRK-2468 ⁵⁵
RTOX-11613	w/ 1.75" Push Type I/S & w/o Tapered Aux. C/S Brgs.	TRK-202	TRK-2283	TRK-2345	
RTOX-11613	w/ 2" Pull Type I/S & w/o Tapered Aux. C/S Brgs.	TRK-202	TRK-2283	TRK-2761	TRK-2468 ⁵⁵
RTOX-14613	w/o Tapered Aux. C/S Brgs.	TRK-206	TRK-1871	TRK-1972	TRK-2468 ⁵⁵
RTOX-14613	w/ Tapered Aux. C/S Brgs.		TRK-2280	TRK-2341	TRK-2468 ⁵⁵
RTOXF-11613	w/ Tapered Aux. C/S Brgs.		TRK-2281	TRK-2342	TRK-2468 ⁵⁵
RTOXF-11613	w/ 1.75" Push Type I/S & w/o Tapered Aux. C/S Brgs.	TRK-202	TRK-2283	TRK-2345	
RTOXF-11613	w/ 2" Pull Type I/S & w/o Tapered Aux. C/S Brgs.	TRK-202	TRK-2283	TRK-2761	TRK-2468 ⁵⁵
RTOXF-14613	w/o Tapered Aux. C/S Brgs.	TRK-206	TRK-1871	TRK-1972	TRK-2468 ⁵⁵
RTOXF-14613	w/ Tapered Aux. C/S Brgs.		TRK-2280	TRK-2341	TRK-2468 ⁵⁵
13 Speed Models Aux Section Only					
RT-11613 AUX		TRK-1000AUX	TRK-1555		
RT-14613 AUX	w/o Tapered Aux. C/S Brgs.	TRK-149AUX	TRK-1554		
RT-14613 AUX	w/ Tapered Aux. C/S Brgs.		TRK-2340		
RT-15613 AUX	w/o Tapered Aux. C/S Brgs.	TRK-149AUX	TRK-1554		
RT-15613 AUX	w/ Tapered Aux. C/S Brgs.		TRK-2340		
RTF-11613 AUX		TRK-1000AUX	TRK-1555		
RTF-14613 AUX	w/o Tapered Aux. C/S Brgs.	TRK-149AUX	TRK-1554		
RTF-14613 AUX	w/ Tapered Aux. C/S Brgs.		TRK-2340		
RTF-15613 AUX	w/o Tapered Aux. C/S Brgs.	TRK-149AUX	TRK-1554		
RTF-15613 AUX	w/ Tapered Aux. C/S Brgs.		TRK-2340		
RTLO-12713A AUX			TRK-2768		
RTLO-14613B AUX			TRK-2338		
RTLO-14713A AUX			TRK-2759		
RTLO-16713A AUX	w/ Serial # 51126220 & Lower		TRK-2769		
RTLO-16713A AUX	w/ Serial # 51126221 & Higher or Beginning with a Letter		TRK-3344		
RTLOF-12713A AUX			TRK-2768		
RTLOF-14613B AUX			TRK-2338		
RTLOF-14713A AUX			TRK-2759		
RTLOF-16713A AUX	w/ Serial # 51126220 & Lower		TRK-2769		
RTLOF-16713A AUX	w/ Serial # 51126221 & Higher or Beginning with a Letter		TRK-3344		
RTO-11613 AUX			TRK-1555		
RTO-11813 AUX			TRK-1555		
RTO-14613 AUX	w/o Tapered Aux. C/S Brgs.	TRK-149AUX	TRK-1554		
RTO-14613 AUX	w/ Tapered Aux. C/S Brgs.		TRK-2340		
RTO-14813 AUX	w/o Tapered Aux. C/S Brgs.	TRK-149AUX	TRK-1554		
RTO-14813 AUX	w/ Tapered Aux. C/S Brgs.		TRK-2340		
RTO-15613 AUX	w/o Tapered Aux. C/S Brgs.	TRK-149AUX	TRK-1554		
RTO-15613 AUX	w/ Tapered Aux. C/S Brgs.		TRK-2340		
RTO-15813 AUX	w/o Tapered Aux. C/S Brgs.	TRK-149AUX	TRK-1554		
RTO-15813 AUX	w/ Tapered Aux. C/S Brgs.		TRK-2340		
RTOF-11613 AUX		TRK-1000AUX	TRK-1555		
RTOF-11813 AUX		TRK-1000AUX	TRK-1555		
RTOF-14613 AUX	w/o Tapered Aux. C/S Brgs.	TRK-149AUX	TRK-1554		
RTOF-14613 AUX	w/ Tapered Aux. C/S Brgs.		TRK-2340		

Heavy Duty Transmission Index

Eaton/Fuller Medium & Heavy Duty Models

13 Speed Models Aux Section Only (cont.)

Model No.	Comments	Standard Kit	Suitcase Kit	Overhaul Kit	Clutch Install Kit
RTOF-14813 AUX	w/o Tapered Aux. C/S Brgs.	TRK-149AUX	TRK-1554		
RTOF-14813 AUX	w/ Tapered Aux. C/S Brgs.		TRK-2340		
RTOF-15613 AUX	w/o Tapered Aux. C/S Brgs.	TRK-149AUX	TRK-1554		
RTOF-15613 AUX	w/ Tapered Aux. C/S Brgs.		TRK-2340		
RTOF-15813 AUX	w/o Tapered Aux. C/S Brgs.	TRK-149AUX	TRK-1554		
RTOF-15813 AUX	w/ Tapered Aux. C/S Brgs.		TRK-2340		
RTOO-11613 AUX		TRK-1000AUX	TRK-1555		
RTOO-14613 AUX	w/o Tapered Aux. C/S Brgs.	TRK-149AUX	TRK-1554		
RTOO-14613 AUX	w/ Tapered Aux. C/S Brgs.		TRK-2340		
RTOOF-11613 AUX		TRK-1000AUX	TRK-1555		
RTOOF-14613 AUX	w/o Tapered Aux. C/S Brgs.	TRK-149AUX	TRK-1554		
RTOOF-14613 AUX	w/ Tapered Aux. C/S Brgs.		TRK-2340		
RTOX-11613 AUX		TRK-1000AUX	TRK-1555		
RTOX-14613 AUX	w/o Tapered Aux. C/S Brgs.	TRK-149AUX	TRK-1554		
RTOX-14613 AUX	w/ Tapered Aux. C/S Brgs.		TRK-2340		
RTOXF-11613 AUX		TRK-1000AUX	TRK-1555		
RTOXF-14613 AUX	w/o Tapered Aux. C/S Brgs.	TRK-149AUX	TRK-1554		
RTOXF-14613 AUX	w/ Tapered Aux. C/S Brgs.		TRK-2340		

15 Speed Models

RT-11615	w/ 1.75" Push Type I/S	TRK-203	TRK-3659	TRK-3655	
RT-11615	w/ 2" Pull Type I/S	TRK-203	TRK-3659	TRK-3656	TRK-2468 ⁵⁵
RT-11715			TRK-3660	TRK-3658	TRK-2468 ⁵⁵
RT-12515		TRK-159A	TRK-1863	TRK-1079	TRK-2468 ⁵⁵
RT-14615		TRK-207	TRK-1872	TRK-1979	TRK-2468 ⁵⁵
RT-14715			TRK-2043	TRK-1991	TRK-2468 ⁵⁵
RT-14915			TRK-3256	TRK-3257	TRK-2468 ⁵⁵
RT-15615		TRK-202	TRK-1875	TRK-1763	TRK-2468 ⁵⁵
RT-15715			TRK-2043	TRK-1991	TRK-2468 ⁵⁵
RTF-11615	w/ 1.75" Push Type I/S	TRK-203	TRK-3659	TRK-3655	
RTF-11615	w/ 2" Pull Type I/S	TRK-203	TRK-3659	TRK-3656	TRK-2468 ⁵⁵
RTF-11715			TRK-3660	TRK-3658	TRK-2468 ⁵⁵
RTF-12515		TRK-159A	TRK-1863	TRK-1079	TRK-2468 ⁵⁵
RTF-14615		TRK-207	TRK-1872	TRK-1979	TRK-2468 ⁵⁵
RTF-14715			TRK-2043	TRK-1991	TRK-2468 ⁵⁵
RTF-14915			TRK-3256	TRK-3257	TRK-2468 ⁵⁵
RTF-15615		TRK-202	TRK-1875	TRK-1763	TRK-2468 ⁵⁵
RTF-15715			TRK-2043	TRK-1991	TRK-2468 ⁵⁵
RTO-11615	w/ 1.75" Push Type I/S	TRK-203	TRK-3659	TRK-3655	
RTO-11615	w/ 2" Pull Type I/S	TRK-203	TRK-3659	TRK-3656	TRK-2468 ⁵⁵
RTO-11715			TRK-3660	TRK-3657	TRK-2468 ⁵⁵
RTO-12515		TRK-159A	TRK-1863	TRK-1079	TRK-2468 ⁵⁵
RTO-14615		TRK-207	TRK-1872	TRK-1979	TRK-2468 ⁵⁵
RTO-14715			TRK-2043	TRK-1992	TRK-2468 ⁵⁵
RTO-14915	w/ 85mm Aux Drive Gear Brg.		TRK-3233	TRK-3234	TRK-2468 ⁵⁵
RTO-14915	w/ 90mm Aux Drive Gear Brg.		TRK-3256	TRK-3258	TRK-2468 ⁵⁵
RTO-15615		TRK-202	TRK-1875	TRK-1763	TRK-2468 ⁵⁵
RTO-15715			TRK-2043	TRK-1992	TRK-2468 ⁵⁵
RTO-16915			TRK-3233	TRK-3234	TRK-2468 ⁵⁵
RTOF-11615	w/ 1.75" Push Type I/S	TRK-203	TRK-3659	TRK-3655	
RTOF-11615	w/ 2" Pull Type I/S	TRK-203	TRK-3659	TRK-3656	TRK-2468 ⁵⁵
RTOF-11715			TRK-3660	TRK-3657	TRK-2468 ⁵⁵
RTOF-12515		TRK-159A	TRK-1863	TRK-1079	TRK-2468 ⁵⁵
RTOF-14615		TRK-207	TRK-1872	TRK-1979	TRK-2468 ⁵⁵
RTOF-14715			TRK-2043	TRK-1992	TRK-2468 ⁵⁵

Heavy Duty Transmission Index

Eaton/Fuller Medium & Heavy Duty Models

15 Speed Models (cont.)

Model No.	Comments	Standard Kit	Suitcase Kit	Overhaul Kit	Clutch Install Kit
RTOF-14915	w/ 85mm Aux Drive Gear Brg.		TRK-3233	TRK-3234	TRK-2468 ⁵⁵
RTOF-14915	w/ 90mm Aux Drive Gear Brg.		TRK-3256	TRK-3258	TRK-2468 ⁵⁵
RTOF-15615		TRK-202	TRK-1875	TRK-1763	TRK-2468 ⁵⁵
RTOF-15715			TRK-2043	TRK-1992	TRK-2468 ⁵⁵
RTOF-16915			TRK-3233	TRK-3234	TRK-2468 ⁵⁵
RTX-11615	w/ 1.75" Push Type I/S	TRK-203	TRK-3659	TRK-3655	
RTX-11615	w/ 2" Pull Type I/S	TRK-203	TRK-3659	TRK-3656	TRK-2468 ⁵⁵
RTX-11715			TRK-3660	TRK-3657	TRK-2468 ⁵⁵
RTX-12515		TRK-159A	TRK-1863	TRK-1079	TRK-2468 ⁵⁵
RTX-14615		TRK-207	TRK-1872	TRK-1979	TRK-2468 ⁵⁵
RTX-14715			TRK-2043	TRK-1992	TRK-2468 ⁵⁵
RTX-15615		TRK-202	TRK-1875	TRK-1763	TRK-2468 ⁵⁵
RTX-15715			TRK-2043	TRK-1992	TRK-2468 ⁵⁵
RTXF-11615	w/ 1.75" Push Type I/S	TRK-203	TRK-3659	TRK-3655	
RTXF-11615	w/ 2" Pull Type I/S	TRK-203	TRK-3659	TRK-3656	TRK-2468 ⁵⁵
RTXF-11715			TRK-3660	TRK-3657	TRK-2468 ⁵⁵
RTXF-12515		TRK-159A	TRK-1863	TRK-1079	TRK-2468 ⁵⁵
RTXF-14615		TRK-207	TRK-1872	TRK-1979	TRK-2468 ⁵⁵
RTXF-14715			TRK-2043	TRK-1992	TRK-2468 ⁵⁵
RTXF-15615		TRK-202	TRK-1875	TRK-1763	TRK-2468 ⁵⁵
RTXF-15715			TRK-2043	TRK-1992	TRK-2468 ⁵⁵

18 Speed Models

FO-14E318B-MXP			TRK-3941		
FO-14E318B-VXP			TRK-3941		
FO-16E318B-MXP			TRK-3941		
FO-16E318B-VXP			TRK-3941		
FO-18E318B-MXP			TRK-3941		
FO-18E318B-VXP			TRK-3941		
FO-20E318B-MXP			TRK-3941		
FO-20E318B-VXP			TRK-3941		
FO-22E318B-MXP			TRK-3941		
FO-22E318B-VXP			TRK-3941		
RTLO-14618A			TRK-2996	TRK-2993	TRK-2468 ⁵⁵
RTLO-14718B			TRK-2288	TRK-2779	TRK-2468 ⁵⁵
RTLO-14918A-AS2			TRK-3512	TRK-3513	
RTLO-14918A-AS3			TRK-3512	TRK-3513	
RTLO-14918B	w/ Forced Lubrication		TRK-3340	TRK-3339	TRK-2468 ⁵⁵
RTLO-14918B	w/o Forced Lubrication		TRK-3355	TRK-3354	TRK-2468 ⁵⁵
RTLO-14918B-AS			TRK-3534	TRK-3533	
RTLO-14918B-T2			TRK-3355	TRK-3354	TRK-2468 ⁵⁵
RTLO-16618A			TRK-2996	TRK-2993	TRK-2468 ⁵⁵
RTLO-16718B			TRK-2288	TRK-2779	TRK-2468 ⁵⁵
RTLO-16918A-AS2			TRK-3512	TRK-3513	
RTLO-16918A-AS3			TRK-3512	TRK-3513	
RTLO-16918B			TRK-3340	TRK-3339	TRK-2468 ⁵⁵
RTLO-16918B-AS			TRK-3534	TRK-3533	
RTLO-16918B-T2			TRK-3340	TRK-3339	TRK-2468 ⁵⁵
RTLO-18718B			TRK-2865	TRK-2866	TRK-2468 ⁵⁵
RTLO-18718B-T2			TRK-2865	TRK-2866	TRK-2468 ⁵⁵
RTLO-18918A-AS2			TRK-3512	TRK-3513	
RTLO-18918A-AS3			TRK-3512	TRK-3513	
RTLO-18918B			TRK-3340	TRK-3339	TRK-2468 ⁵⁵
RTLO-18918B-AS			TRK-3534	TRK-3533	
RTLO-18918B-T2			TRK-3340	TRK-3339	TRK-2468 ⁵⁵

Heavy Duty Transmission Index

Eaton/Fuller Medium & Heavy Duty Models

18 Speed Models (cont.)

Model No.	Comments	Standard Kit	Suitcase Kit	Overhaul Kit	Clutch Install Kit
RTLO-20918A-AS2			TRK-3512	TRK-3513	
RTLO-20918A-AS3			TRK-3512	TRK-3513	
RTLO-20918B			TRK-3340	TRK-3339	TRK-2468 ⁵⁵
RTLO-20918B-AS			TRK-3534	TRK-3533	
RTLO-20918B-T2			TRK-3340	TRK-3339	TRK-2468 ⁵⁵
RTLO-22918A-AS2			TRK-3514	TRK-3515	
RTLO-22918A-AS3			TRK-3514	TRK-3515	
RTLO-22918B			TRK-3462	TRK-3461	
RTLOF-14618A			TRK-2996	TRK-2993	TRK-2468 ⁵⁵
RTLOF-14718B			TRK-2288	TRK-2779	TRK-2468 ⁵⁵
RTLOF-14918B	w/ Forced Lubrication		TRK-3340	TRK-3339	TRK-2468 ⁵⁵
RTLOF-14918B	w/o Forced Lubrication		TRK-3355	TRK-3354	TRK-2468 ⁵⁵
RTLOF-14918B-T2			TRK-3355	TRK-3354	TRK-2468 ⁵⁵
RTLOF-16618A			TRK-2996	TRK-2993	TRK-2468 ⁵⁵
RTLOF-16718B			TRK-2288	TRK-2779	TRK-2468 ⁵⁵
RTLOF-16918B			TRK-3340	TRK-3339	TRK-2468 ⁵⁵
RTLOF-16918B-T2			TRK-3340	TRK-3339	TRK-2468 ⁵⁵
RTLOF-18718B			TRK-2865	TRK-2866	TRK-2468 ⁵⁵
RTLOF-18718B-T2			TRK-2865	TRK-2866	TRK-2468 ⁵⁵
RTLOF-18918B			TRK-3340	TRK-3339	TRK-2468 ⁵⁵
RTLOF-18918B-T2			TRK-3340	TRK-3339	TRK-2468 ⁵⁵
RTLOF-20918B			TRK-3340	TRK-3339	TRK-2468 ⁵⁵
RTLOF-20918B-T2			TRK-3340	TRK-3339	TRK-2468 ⁵⁵
RTLOF-22918B			TRK-3462	TRK-3461	
RTO-15618			TRK-2997	TRK-2994	TRK-2468 ⁵⁵
RTOF-15618			TRK-2997	TRK-2994	TRK-2468 ⁵⁵

18 Speed Models Aux Section Only

RTLO-14618A AUX			TRK-2338		
RTLO-14718B AUX			TRK-2769		
RTLO-16618A AUX			TRK-2338		
RTLO-16718B AUX			TRK-2769		
RTLO-18718B AUX			TRK-2769		
RTLOF-14618A AUX			TRK-2338		
RTLOF-14718B AUX			TRK-2769		
RTLOF-16618A AUX			TRK-2338		
RTLOF-16718B AUX			TRK-2769		
RTLOF-18718B AUX			TRK-2769		
RTO-15618 AUX			TRK-1993		
RTOF-15618 AUX			TRK-1993		

Heavy Duty Transmission Index

GMC Index

Model No.	Speeds	Comments	Kit No.	Kit No. With Rings
CH465	4	Early/Late	TRK-157A	TRK-157AWS
CH465	4	1979 - 1990	TRK-157L	TRK-157LWS
CH465	4	1990 and Later	TRK-157B	TRK-157BWS
SM465	4	Early/Late	TRK-157A	TRK-157AWS
SM465	4	1979 - 1990	TRK-157L	TRK-157LWS
SM465	4	1990 and Later	TRK-157B	TRK-157BWS

International Harvester/Navistar Index

Model No.	Speeds	Comments	Kit
T32	5		TRK-156
T33	5		TRK-156
T34	5		TRK-156
T35	5		TRK-156
T36	5		TRK-156
T494	5		TRK-156
T495	5		TRK-156
T496	5		TRK-156
T698	5		TRK-183
T699	5		TRK-183

Mack Index

Model No.	Speeds	Comments	Kit
TRQP72	20	w/o Clutch Brake	TRK-65
TR107	5		TRK-185
TRDXL107	6		TRK-500
TRTXL107	12	Super Duty	TRK-213SD
TRXL107	6		TRK-187
TRXL107A	6		TRK-187
TC150	-	Transfer Case	TRK-504
T309L	9		TRK-505
	9	Master Kit	TRK-505MK
T310	10		TRK-506
	10	Master Kit	TRK-506
T318	18		TRK-507
	18	Master Kit	TRK-507MK
TRQ720	20	w/o Clutch Brake	TRK-65
TRQP720	20	w/o Clutch Brake	TRK-65
TRDL1070	10		TRK-187
TRTXL1070	12	Super Duty	TRK-213SD
	12		TRK-213
TRXL1070	-		TRK-502
TRTXL1070	12		TRK-213
TRXL1071	6		TRK-187
TRXL1071A	6		TRK-187
TRL1076	5		TRK-185
TRL1078	5		TRK-185
T2090	9		TRK-214
T2050	5		TRK-503
T2060	6		TRK-214
	6	Master Kit	TRK-214MK
T2070	7		TRK-214

Mack Index

Model No.	Speeds	Comments	Kit
T2070	7	Master Kit	TRK-214MK
T2080	8		TRK-214
T2090	9		TRK-214
	9	Master Kit	TRK-214MK
T2100	10		TRK-214
	10	Master Kit	TRK-214MK
T2130	13		TRK-214
	13	Master Kit	TRK-214MK
T2180	18		TRK-214
	18	Master Kit	TRK-214MK1
TRQ7210	20	w/o Clutch Brake	TRK-65
TRQL7220	20	w/o Clutch Brake	TRK-65
TRXL10710	-		TRK-502
TRL10760	-		TRK-501
TRL10780	-		TRK-501

Meritor/Rockwell

Model No.	Speeds	Comments	Suitcase Kit	Clutch Install Kit
RM9-115	9		TRK-5356 ⁶¹	TRK-5000CK
RM9-125	9		TRK-5356 ⁶¹	TRK-5000CK
RM9-135	9		TRK-5357 ⁶¹	TRK-5000CK
RM9-145	9		TRK-5357 ⁶¹	TRK-5000CK
RM9-155	9		TRK-5357 ⁶¹	TRK-5000CK
RM10-115	10		TRK-5356 ⁶¹	TRK-5000CK
RM10-125	10		TRK-5356 ⁶¹	TRK-5000CK
RM10-135	10		TRK-5357 ⁶¹	TRK-5000CK
RM10-145	10		TRK-5357 ⁶¹	TRK-5000CK
RM10-155	10		TRK-5357 ⁶¹	TRK-5000CK
RM10-165	10		TRK-5357 ⁶¹	TRK-5000CK
RM13-145	10		TRK-5358 ⁶¹	TRK-5000CK
M-15G9	9		TRK-5406	TRK-5000CK
M-15G10	10		TRK-5406	TRK-5000CK
MO-14G9	9		TRK-5406	TRK-5000CK
MO-15G9	9		TRK-5406	TRK-5000CK
MO-16G10	10		TRK-5406	TRK-5000CK

⁶¹Design Level 2 w/ Serial # LB93017865 and Higher

Heavy Duty Transmission Index

HD Transmission

New Process Transmissions

Model No.	Speeds	Comments	Kit
435	4	w/ Tapered Bearing on Drive Shaft	TRK-127
	4	Ford only w/ Tapered Bearing on Drive Shaft	TRK-127F
	4	w/ Ball Bearing on Drive Shaft	TRK-127G
435FE	4	w/ Tapered Bearing on Drive Shaft	TRK-127
435FL	4	w/ Tapered Bearing on Drive Shaft	TRK-127
435GL	4	w/ Tapered Bearing on Drive Shaft	TRK-127
436	4	w/ Tapered Bearing on Drive Shaft	TRK-127
	4	Ford only w/ Tapered Bearing on Drive Shaft	TRK-127F
	4	w/ Ball Bearing on Drive Shaft	TRK-127G
540	5		TRK-27
540C	5		TRK-27
540D	5		TRK-27
540G	5		TRK-27
540GD	5		TRK-27
540GL	5		TRK-27
540GO	5		TRK-27
541	5	Early	TRK-27
	5	Late (Exc. Ford)	TRK-29
541DD11	5		TRK-29
541DD12	5		TRK-29
541DD13	5		TRK-29
541DD14	5		TRK-29
541DD15	5		TRK-29
541DD16	5		TRK-29
541DD17	5		TRK-29
541FD	5	Early	TRK-27
	5	Late	TRK-29
541FL	5	Early	TRK-27
	5	Late	TRK-29
541FO	5	Early	TRK-27
	5	Late	TRK-29
541G	5	Early	TRK-27
	5	Late	TRK-29
541GD	5	Early	TRK-27
	5	Late	TRK-29
541GD24	5	Early	TRK-27
	5	Late	TRK-29
541GL	5	Early	TRK-27
	5	Late	TRK-29
541GO	5	Early	TRK-27
	5	Late	TRK-29
541GO-11	5	Early	TRK-27
	5	Late	TRK-29
542	5	Early	TRK-27
	5	Late (Exc. Ford)	TRK-29
	5	Late (w/Ford)	TRK-29B
542D	5	w/GMC	TRK-29
542FD	5	Early	TRK-27
	5	Late (Exc. Ford)	TRK-29

New Process Transmissions

Model No.	Speeds	Comments	Kit
542FD	5	Late (w/Ford)	TRK-29B
542FL	5	Early	TRK-27
	5	Late (Exc. Ford)	TRK-29
	5	Late (w/Ford)	TRK-29B
542FO	5	Early	TRK-27
	5	Late (Exc. Ford)	TRK-29
	5	Late (w/Ford)	TRK-29B
542GD	5	w/GMC	TRK-29
542GL	5	w/GMC	TRK-29
542L	5	w/GMC	TRK-29
4590(IH)	4		TRK-174
7531	5		TRK-177
7550	5		TRK-177
7551	5		TRK-177
7590	5		TRK-177
7591	5		TRK-177

Heavy Duty Transmission Index

Spicer/TTC Transmissions

Model No.	Speeds	Comments	Standard Kit	Suitcase Kit
1007	7		TRK-189	
1010	10		TRK-152	
1020	20		TRK-189	
1052	5		TRK-147	TRK-313432-25X
1062	6		TRK-147	TRK-313432-25X
1064	6		TRK-147	
1107	7		TRK-181	
1207	7		TRK-191	
1214	14		TRK-189	
1252	5		TRK-147	TRK-313432-25X
1253	5		TRK-147	TRK-313432-25X
1262	6		TRK-147	
1263	6		TRK-147	TRK-313432-25X
1272	7		TRK-189	
1352	5		TRK-192	TRK-313432-1X
1362	6		TRK-192	TRK-313432-1X
1364	6		TRK-192	TRK-313432-1X
1372	7		TRK-193	TRK-313432-2X
1412	12		TRK-194	
1414	14		TRK-194	
1420	20		TRK-194	
1452	5		TRK-192	TRK-313432-1X
1453	5		TRK-192	TRK-313432-1X
1463	6		TRK-192	TRK-313432-1X
4054	5		TRK-210	TRK-313432-11X
4652	5		TRK-28	
4752	5		TRK-28	
4753	5		TRK-28	
4756	5		TRK-28	
4852	5		TRK-28	
4853	5		TRK-28	
4954	5		TRK-221	TRK-313432-30X
5052	5		TRK-180	TRK-313432-10X
5252	5		TRK-180	TRK-313432-10X
5552	5		TRK-180	TRK-313432-10X
5650	5		TRK-28	
5652	5		TRK-28	
5750	5		TRK-28	
5752	5		TRK-28	
5753	5		TRK-28	
5756	5		TRK-28	
5850	5		TRK-28	
5852	5		TRK-180	TRK-313432-10X
5853	5		TRK-28	
6052	5		TRK-186	TRK-313432-20X
6252	5		TRK-186	TRK-313432-20X
6253	5		TRK-186	TRK-313432-20X
6350	5		TRK-72	
6352	5		TRK-72	
6354	5		TRK-72	
6450	5		TRK-72	
6452	5		TRK-72	
6453	5		TRK-72	
6454	5		TRK-72	
6455	5		TRK-72	
6456	5		TRK-72	

Heavy Duty Transmission Index

Spicer/TTC Transmissions

Model No.	Speeds	Comments	Standard Kit	Suitcase Kit
6458	5		TRK-72	
6850	5		TRK-72	
6852	5		TRK-72	
6853	5		TRK-72	
6854	5		TRK-72	
6855	5		TRK-72	
7041	4		TRK-73	TRK-313432-21X
8012	12		TRK-74	
8016	16		TRK-74	
8051	5	w/ Spherical Pilot Brg., exc. some late models	TRK-2	
	5	w/ Cylindrical Pilot Brg., exc. some late models	TRK-2A	
8055	5	w/ Spherical Pilot Brg., exc. some late models	TRK-2	
	5	w/ Cylindrical Pilot Brg., exc. some late models	TRK-2A	
8212	12		TRK-74	
8216	16		TRK-74	
8251	5	w/ Spherical Pilot Brg., exc. some late models	TRK-2	
	5	w/ Cylindrical Pilot Brg., exc. some late models	TRK-2A	
8255	5	w/ Spherical Pilot Brg., exc. some late models	TRK-2	
	5	w/ Cylindrical Pilot Brg., exc. some late models	TRK-2A	
8516	16		TRK-130	
8542	4		TRK-139	
8544	4		TRK-139	
8552	5		TRK-140	
8553	5		TRK-141	
8554	5		TRK-140	
8555	5		TRK-141	
8716	16		TRK-130	
8742	4		TRK-139	
8744	4		TRK-139	
8753	5		TRK-141	
8755	5		TRK-141	
8842	4		TRK-139	
8844	4		TRK-139	
CM40	5		TRK-210	TRK-313432-11X
CM49	5		TRK-221	TRK-313432-30X
CM50	5		TRK-180	TRK-313432-10X
CM55	5		TRK-180	TRK-313432-10X
CM60	5		TRK-186	TRK-313432-20X
CM62	5		TRK-186	TRK-313432-20X
CM4054	5		TRK-210	TRK-313432-11X
CM4954	5		TRK-221	TRK-313432-30X
CM5052	5		TRK-180	TRK-313432-10X
CM5252	5		TRK-180	TRK-313432-10X
CM5552	5		TRK-180	TRK-313432-10X
CM5852	5		TRK-180	TRK-313432-10X
CM5952	5		TRK-180	TRK-313432-10X
CM6052	5		TRK-186	TRK-313432-20X
CM6253	5		TRK-186	TRK-313432-20X
ES066-7B	7		TRK-222	TRK-101-432-1X
ES42-5	5		TRK-219	TRK-313432-34X
ES43-5	5		TRK-221	TRK-313432-46X
ES46-5A	5		TRK-704	TRK-56-432-1X
ES52-5	5		TRK-221	TRK-313432-30X
ES52-7	7		TRK-222	TRK-101-432-1X
ES53-5	5		TRK-221	TRK-313432-46X
ES56-5A	5		TRK-704	TRK-56-432-1X

Heavy Duty Transmission Index

Spicer/TTC Transmissions

Model No.	Speeds	Comments	Standard Kit	Suitcase Kit
ES56-7	7		TRK-222	TRK-101-432-1X
ES60-5	5		TRK-180	TRK-313432-10X
ES62-5	5		TRK-180	TRK-313432-31X
ES65-5	5		TRK-186	TRK-313432-20X
ES65-7	7		TRK-222	TRK-101-432-1X
ESO66-7	7		TRK-222	TRK-101-432-1X
ES70-5	5		TRK-186	TRK-313432-20X
LLPS145-10	10		TRK-700	TRK-313432-33X
LLPSO140-10	10		TRK-700	TRK-313432-33X
LLPSO150-10	10		TRK-700	TRK-313432-33X
LPS100-10	10		TRK-700	TRK-313432-33X
LPS125-10	10		TRK-700	TRK-313432-33X
PS125-9	9		TRK-700	TRK-313432-33X
LPS135-10	10		TRK-700	TRK-313432-33X
LPS145-10	10		TRK-700	TRK-313432-33X
LPSO125-10	10		TRK-700	TRK-313432-33X
LPSO140-10	10		TRK-700	TRK-313432-33X
LPSO150-10	10		TRK-700	TRK-313432-33X
PS100-10	10		TRK-700	TRK-313432-33X
PS105-7LL	7		TRK-705	
PS110-7	7		TRK-702	TRK-313432-35X
PS125-9	9		TRK-700	TRK-313432-33X
PS130-6L	6		TRK-705	
PS135-10	10		TRK-700	TRK-313432-33X
PS145-10	10		TRK-700	TRK-313432-33X
PS145-7	7		TRK-702	TRK-313432-35X
PS95-9	9		TRK-700	TRK-313432-33X
PS97-7	7		TRK-706	TRK-313432-14X
PSO100-10	10		TRK-700	TRK-313432-33X
PSO125-10	10		TRK-700	TRK-313432-33X
PSO140-10	10		TRK-700	TRK-313432-33X
PSO140-9	9		TRK-700	TRK-313432-33X
PSO150-10	10		TRK-700	TRK-313432-33X
PSO150-16	16		TRK-194	
PSO150-9	9		TRK-700	TRK-313432-33X
PSO165-10	10		TRK-700	TRK-313432-33X
PSO165-16	16		TRK-194	
PSO175-16	16		TRK-194	
SST5	5	Old Version	TRK-147	
SST6	6	Old Version	TRK-147	
	6	New Version	TRK-192	
SST6+1	7	New Version	TRK-191	
SST7	7	Old Version	TRK-181	
	7	New Version	TRK-193	
SST10	10	Old Version	TRK-152	
SST12	12	New Version	TRK-194	
SST14	14	Old Version	TRK-189	
	14	New Version	TRK-194	
SST20	20		TRK-189	

Heavy Duty Transmission Index

HD Transmission

Spicer/TTC Auxiliary Transmissions

Model No.	Speeds	Comments	Standard Kit	Suitcase Kit
1241	4		TRK-158	TRK-98-432-1X
6041	4		TRK-70	
7041	4		TRK-73	TRK-313432-21X
7231	3		TRK-86	
8031	3	w/ Steel Caged Brgs.	TRK-3	
	3	w/ Bronze Caged Brgs.	TRK-4	
8035	3	w/ Steel Caged Brgs.	TRK-3	
	3	w/ Bronze Caged Brgs.	TRK-4	
8341	4	w/ Steel Caged Brgs.	TRK-3	
	4	w/ Bronze Caged Brgs.	TRK-4	
8341L	4		TRK-155	
8345	4	w/ Steel Caged Brgs.	TRK-3	
	4	w/ Bronze Caged Brgs.	TRK-4	
AMO1000	4		TRK-703	TRK-98-432-1X
AMO1750	4		TRK-703	TRK-98-432-1X
APO1000	4		TRK-703	TRK-98-432-1X
APO1750	4		TRK-703	TRK-98-432-1X
R8341C	4		TRK-155	
R8341L	4		TRK-155	
RP8341	4		TRK-155	

Spicer/TTC Power Take Offs for Auxiliary Transmissions

Model No.	Speeds	Comments	Standard Kit	Suitcase Kit
1241		Tapered Output Bearings	TRK-707	
		Cylindrical Output Bearings	TRK-226	TRK-312476-22X
7041		Tapered Output Bearings	TRK-708	
		Cylindrical Output Bearings	TRK-709	
8031		Tapered Output Bearings	TRK-708	
		Cylindrical Output Bearings	TRK-709	
8341		Tapered Output Bearings	TRK-708	
		Cylindrical Output Bearings	TRK-709	
AMO1000		Tapered Output Brgs.	TRK-707	
		Cylindrical Output Brgs.	TRK-226	TRK-312476-22X
AMO1750		Tapered Output Brgs.	TRK-707	
		Cylindrical Output Brgs.	TRK-226	TRK-312476-22X
APO1000		Tapered Output Brgs.	TRK-707	
		Cylindrical Output Brgs.	TRK-226	TRK-312476-22X
APO1750		Tapered Output Brgs.	TRK-707	
		Cylindrical Output Brgs.	TRK-226	TRK-312476-22X
R8031		Tapered Output Brgs.	TRK-708	
		Cylindrical Output Brgs.	TRK-709	
R8341		Tapered Output Brgs.	TRK-708	
		Cylindrical Output Brgs.	TRK-709	

Heavy Duty Transmission Index

Warner Index

Model No.	Speeds	Comments	Kit
T18	4	w/Willys Jeep	TRK-82F
	4	w/Ford	TRK-82F
T184	4	w/l.H.	TRK-82D
T18A	4	w/Willys Jeep	TRK-82F
	4	w/Ford	TRK-82F
	4	w/l.H.	TRK-82D
T18B	4	w/Willys Jeep	TRK-82F
	4	w/Ford	TRK-82F
	4	w/l.H.	TRK-82D
T18C	4	w/Willys Jeep	TRK-82F
	4	w/Ford	TRK-82F
	4	w/l.H.	TRK-82D
T19	4	w/Ford (Gas)	TRK-82F
	4	w/Ford (Diesel)	TRK-82FD
	4	w/l.H.	TRK-82D
T19A	4	w/Ford (Gas)	TRK-82F
	4	w/Ford (Diesel)	TRK-82FD
	4	w/l.H.	TRK-82D
T98	4	w/.9055" Wide Driveshaft Bearing	TRK-82
T98A	4	w/.9055" Wide Driveshaft Bearing w/LH PTO	TRK-82
T98B	4	w/.9055" Wide Driveshaft Bearing	TRK-82
T98D	4	w/.9055" Wide Driveshaft Bearing	TRK-82

Heavy Duty Transfer Case Index

Fabco

Fabco transfer cases are available with multiple combinations of the options for the particular model. Rebuild kits are for individual sections of the transfer case. You will need to purchase kits for each individual section that are applicable to your transfer case.

Model No.	Comments	Kit
TC-170	Upper Shaft w/ PTO	TCRK-170A1
	Intermediate Shaft w/ & w/o Lube Pump	TCRK-170B
	Lower Shaft w/ Neutral	TCRK-170C
	Lower Shaft w/o Neutral	TCRK-170C1
TC-170PD	Upper Shaft w/o PTO	TCRK-170A
	Upper Shaft w/ PTO	TCRK-170A1
	Intermediate Shaft w/ & w/o Lube Pump	TCRK-170B
	Lower Shaft w/ Proportional Differential	TCRK-170C2
	Upper Shaft w/o PTO	TCRK-170A

Meritor/Rockwell

Rockwell transfer cases have sub model numbers that specify what options each transfer case are equipped with. Rebuild kits contain all of the bearings and seals for the particular sub model.

Model No.	Comments	Kit
MTC-4208		TCRK-929
MTC-4210		TCRK-929
MTC-4213		TCRK-930
T-2120-D		TCRK-926
T-221-A1		TCRK-221
T-221-M6		TCRK-221
T-221-M7		TCRK-221
T-221-N4		TCRK-221
T-223-A102		TCRK-903
T-223-A103		TCRK-900
T-223-A104		TCRK-900
T-223-A105		TCRK-900
T-223-A84		TCRK-900
T-223-A88		TCRK-900
T-223-A89		TCRK-900
T-223-A90		TCRK-900
T-223-A92		TCRK-900
T-223-A94		TCRK-900
T-223-C22		TCRK-900
T-223-C35		TCRK-903
T-223-C41		TCRK-901
T-223-C42		TCRK-903
T-223-C43		TCRK-901
T-223-C44		TCRK-901
T-223-E22		TCRK-900
T-223-E23		TCRK-900
T-223-H29		TCRK-903
T-223-H31		TCRK-903
T-223-H33		TCRK-903
T-223-H39		TCRK-902
T-223-H40		TCRK-903
T-223-H41		TCRK-903
T-223-H42		TCRK-903
T-223-H43		TCRK-903
T-223-H44		TCRK-902
T-223-H45		TCRK-903
T-223-H52		TCRK-903
T-223-H53		TCRK-903
T-223-H54		TCRK-903
T-223-H55		TCRK-903
T-223-H56		TCRK-903
T-223-H57		TCRK-903
T-223-M4		TCRK-900
T-226-103		TCRK-907
T-226-118		TCRK-906

Meritor/Rockwell

Model No.	Comments	Kit
T-226-132		TCRK-909
T-226-133		TCRK-908
T-226-136		TCRK-906
T-226-138		TCRK-907
T-226-139		TCRK-906
T-226-140		TCRK-906
T-226-148		TCRK-908
T-226-149		TCRK-909
T-226-155		TCRK-906
T-226-156		TCRK-906
T-226-159		TCRK-913
T-226-160		TCRK-906
T-226-161		TCRK-907
T-226-163		TCRK-906
T-226-164		TCRK-906
T-226-166		TCRK-906
T-226-167		TCRK-913
T-226-168		TCRK-907
T-226-169		TCRK-907
T-226-170		TCRK-906
T-226-171		TCRK-907
T-226-172		TCRK-908
T-226-173		TCRK-907
T-226-174		TCRK-906
T-226-175		TCRK-906
T-226-176		TCRK-913
T-226-177		TCRK-906
T-226-26		TCRK-906
T-226-28		TCRK-906
T-226-41		TCRK-906
T-226-65		TCRK-906
T-226-69		TCRK-906
T-226-80		TCRK-906
T-226-83		TCRK-906
T-226-85		TCRK-906
T-226-86		TCRK-906
T-226-A1		TCRK-904
T-226-A12		TCRK-904
T-226-A13		TCRK-904
T-226-A16		TCRK-904
T-226-A22		TCRK-905
T-226-A23		TCRK-904
T-226-AB1		TCRK-904
T-226-AB3		TCRK-904
T-226-AB5		TCRK-905
T-226-B28		TCRK-906
T-226-B30		TCRK-906
T-226-B48		TCRK-906
T-226-B67		TCRK-906
T-226-B68		TCRK-906
T-226-B70		TCRK-906
T-226-B73		TCRK-906
T-226-B74		TCRK-906
T-226-B76		TCRK-906
T-226-B77		TCRK-906
T-226-B78		TCRK-906
T-226-B79		TCRK-906
T-226-B80		TCRK-906
T-226-C17		TCRK-904
T-226-C3		TCRK-904
T-226-CB12		TCRK-904
T-226-CB13		TCRK-905
T-226-CB4		TCRK-904
T-226-CB9		TCRK-905
T-226-D4		TCRK-906

Heavy Duty Transfer Case Index

Meritor/Rockwell

Model No.	Comments	Kit
T-226-D6		TCRK-907
T-226-E26		TCRK-917
T-226-E33		TCRK-917
T-226-E38		TCRK-910
T-226-E43		TCRK-917
T-226-E45		TCRK-910
T-226-E49		TCRK-917
T-226-E50		TCRK-910
T-226-E51		TCRK-910
T-226-E7		TCRK-917
T-226-F		TCRK-916
T-226-F19		TCRK-916
T-226-F2		TCRK-916
T-226-F20		TCRK-916
T-226-F25		TCRK-916
T-226-F26		TCRK-916
T-226-F31		TCRK-916
T-226-F33		TCRK-916
T-226-F34		TCRK-915
T-226-G		TCRK-906
T-226-G1		TCRK-906
T-226-G3		TCRK-906
T-226-H		TCRK-913
T-226-H3		TCRK-913
T-226-HB		TCRK-913
T-226-HB1		TCRK-913
T-226-J		TCRK-911
T-226-K4		TCRK-913
T-226-K7		TCRK-913
T-226-L		TCRK-913
T-226-L1		TCRK-913
T-226-L10		TCRK-913
T-226-L19		TCRK-913
T-226-L30		TCRK-913
T-226-L35		TCRK-913
T-226-L37		TCRK-914
T-226-L4		TCRK-913
T-226-L40		TCRK-914
T-226-L42		TCRK-913
T-226-L43		TCRK-913
T-226-L45		TCRK-913
T-226-L46		TCRK-913
T-226-L47		TCRK-913
T-226-L48		TCRK-913
T-226-L49		TCRK-913
T-226-L50		TCRK-913
T-226-L51		TCRK-913
T-226-L52		TCRK-914
T-226-L53		TCRK-913
T-226-L54		TCRK-913
T-226-L8		TCRK-913
T-226-M		TCRK-913
T-226-M1		TCRK-913
T-226-M3		TCRK-913
T-226-M4		TCRK-913
T-226-M5		TCRK-913
T-226-N		TCRK-911
T-226-N1		TCRK-912
T-226-N2		TCRK-912
T-226-P4		TCRK-913
T-226-P7		TCRK-913
T-226-Q		TCRK-913

Meritor/Rockwell

Model No.	Comments	Kit
T-226-Q1		TCRK-913
T-226-Q2		TCRK-914
T-226-R10		TCRK-918
T-226-R11		TCRK-918
T-226-R8		TCRK-918
T-226-S		TCRK-913
T-226-S1		TCRK-913
T-226-T		TCRK-911
T-226-T1		TCRK-911
T-226-W		TCRK-904
T-228-12		TCRK-919
T-228-19		TCRK-922
T-228-36		TCRK-919
T-228-37		TCRK-922
T-228-D100		TCRK-921
T-228-D101		TCRK-920
T-228-D102		TCRK-920
T-228-D103		TCRK-920
T-228-D104		TCRK-920
T-228-D106		TCRK-921
T-228-D107		TCRK-920
T-228-D108		TCRK-920
T-228-D109		TCRK-920
T-228-D25		TCRK-920
T-228-D27		TCRK-920
T-228-D31		TCRK-920
T-228-D38		TCRK-920
T-228-D58		TCRK-920
T-228-D60		TCRK-920
T-228-D77		TCRK-920
T-228-D81		TCRK-920
T-228-D82		TCRK-920
T-228-D85		TCRK-921
T-228-D88		TCRK-921
T-228-D89		TCRK-920
T-228-D90		TCRK-920
T-228-D92		TCRK-920
T-228-D93		TCRK-920
T-228-D94		TCRK-920
T-228-D95		TCRK-920
T-228-D97		TCRK-920
T-228-D98		TCRK-920
T-228-D99		TCRK-920
T-228-E		TCRK-925
T-228-E1		TCRK-925
T-228-F		TCRK-920
T-228-F1		TCRK-921
T-228-F2		TCRK-920
T-228-PD16		TCRK-923
T-228-PD37		TCRK-923
T-228-PD38		TCRK-924
T-32-42		TCRK-933
T-32-43		TCRK-933
T-32-46		TCRK-931
T-32-47		TCRK-933
T-32-57		TCRK-933
T-32-63		TCRK-933
T-32-65		TCRK-932
T-32-69		TCRK-933
T-32-70		TCRK-933
T-32-75		TCRK-931
T-32-78		TCRK-931

Heavy Duty Transfer Case Index

Meritor/Rockwell

Model No.	Comments	Kit
T-32-79		TCRK-933
T-32-80		TCRK-933
T-32-83		TCRK-932
T-32-84		TCRK-931
T-32-85		TCRK-931
T-32-86		TCRK-931
T-32-87		TCRK-931
T-32-88		TCRK-931
TG-2213	Built 6/01 & Prior	TCRK-927
	Built After 6/01	TCRK-928

HD Transmission

Heavy Duty Transfer Case Rebuild Kits

TCRK-170		
Position	Part Number	Qty
Intermediate Shaft Front Brg.	643-633	1
Intermediate Shaft Rear Brg.	643-633	1

TCRK-170A		
Position	Part Number	Qty
Input Shaft Front Brg.	639-633	1
Input Shaft Rear Brg.	576-572	1
Input Shaft Seal	415991N (34891)	1

TCRK-170A1		
Position	Part Number	Qty
Input Shaft Front Brg.	639-633	1
Input Shaft Rear Brg.	576-572	1
PTO Output Shaft Front Brg.	33212	1
PTO Output Shaft Rear Brg.	33212	1
Input Shaft Seal	415991N (34891)	1
PTO Output Shaft Seal	415027N (35083)	1

TCRK-170B		
Position	Part Number	Qty
Intermediate Shaft Brg.	643-633	2

TCRK-170C		
Position	Part Number	Qty
Front Output Shaft Front Brg.	JH211749-JH211710	1
Front Output Shaft Rear Brg.	JH211749-JH211710	1
Rear Output Shaft Front Brg.	576-572	1
Rear Output Shaft Rear Brg.	5584-5535	1
Front Output Shaft Seal	415027N (35083)	1
Rear Output Shaft Seal	415991N (34891)	1
O-Ring (Shifter Shaft)	OR316	1
O-Ring (Piston to Shaft)	OR012	2
O-Ring (Piston)	OR326	2
O-Ring (Cap)	OR032	1
O-Ring (Shift Cylinder)	OR224	3
Felt Wiper	339-0223	2

TCRK-170C1		
Position	Part Number	Qty
Front Output Shaft Front Brg.	JH211749-JH211710	1
Front Output Shaft Rear Brg.	JH211749-JH211710	1
Rear Output Shaft Front Brg.	576-572	1
Rear Output Shaft Rear Brg.	639-633	1
Front Output Shaft Seal	415027N (35083)	1
Rear Output Shaft Seal	415991N (34891)	1
O-Ring (Shifter Shaft)	OR316	1
O-Ring (Piston to Shaft)	OR012	2
O-Ring (Piston)	OR326	2
O-Ring (Cap)	OR032	1
O-Ring (Shift Cylinder)	OR224	3
Felt Wiper	339-0223	2

TCRK-170C2		
Position	Part Number	Qty
Front Output Shaft Brg.	5310KL	1
Differential Front Brg.	575-572	1
Differential Rear Brg.	580-572	1
Rear Output Shaft Front Brg.	32213	1
Rear Output Shaft Rear Brg.	32213	1
Front Output Shaft Seal	413248	1
Rear Output Shaft Seal	415027N (35083)	1
O-Ring (Shifter Shaft)	OR316	1
O-Ring (Piston to Shaft)	OR012	2
O-Ring (Piston)	OR326	2
O-Ring (Cap)	OR032	1
O-Ring (Shift Cylinder)	OR224	3
Felt Wiper	339-0223	2

TCRK-221		
Position	Part Number	Qty
Input Shaft Front Brg.	207S	1
Input Shaft Rear Brg.	206S	1
Front Output Shaft Front Brg.	207L	1
Front Output Shaft Rear Brg.	209L	1
Rear Output Shaft Front Brg.	15126-15245	1
Rear Output Shaft Rear Brg.	15126-15245	1
Idler Shaft Front Brg.	02476-02420	1
Idler Shaft Rear Brg.	15126-15245	1
Input Shaft Seal	482164N (17379)	1
Front Output Shaft Seal	482164N (17379)	1
Rear Output Shaft Seal	482164N (17379)	1
Shift Shaft Seal	6835S (7440)	2
PTO Shaft Seal	471424	2

TCRK-792		
Position	Part Number	Qty
Input Shaft Front Brg.	312	1
Input Shaft Rear Brg.	314	1
Lower Output Shaft Front Brg.	J401648	1
Lower Output Shaft Rear Brg.	312	1
Upper Mainshaft Front Brg.	312	1
Upper Mainshaft Rear Brg.	314	1
Upper Front Output Shaft Front Brg.	312	1
Upper Front Output Shaft Rear Brg.	WJ162116	1
Upper Rear Output Shaft Front Brg.	J401648	2
Upper Rear Output Shaft Rear Brg.	312	1
Idler Gear Brg.	315	2
Input Shaft Seal	415013N	1
Lower Output Shaft Seal	415013N	1
Upper Front Output Shaft Seal	415013N	1
Upper Rear Output Shaft Seal	415013N	1

TCRK-900		
Position	Part Number	Qty
Input Shaft Front Brg.	357-353	1
Input Shaft Rear Brg.	339-332	1
Idler Shaft Front Brg.	31597-31521	1
Idler Shaft Rear Brg.	31597-31521	1
Front Output Shaft Front Brg.	208L	1
Front Output Shaft Rear Brg.	211L	1
Front Output Shaft Needle Brg.	B2414-IR2016	1
Rear Output Shaft Front Brg.	25878-25821	1
Rear Output Shaft Rear Brg.	25584-25520	1
Input Shaft Seal	45031S (37525)	1
Front Output Shaft Seal	45031S (37525)	1
Front Output Shaft Seal	415483	1
Rear Output Shaft Seal	471341N (22340)	1
Transfer Shift Shaft Seal	470954	2

TCRK-901		
Position	Part Number	Qty
Input Shaft Front Brg.	376-372	1
Input Shaft Rear Brg.	339-332	1
Idler Shaft Front Brg.	31597-31521	1
Idler Shaft Rear Brg.	31597-31521	1
Front Output Shaft Front Brg.	208L	1
Front Output Shaft Rear Brg.	211L	1
Front Output Shaft Needle Brg.	B2414-IR2016	1
Rear Output Shaft Front Brg.	25878-25821	1
Rear Output Shaft Rear Brg.	25584-25520	1
Input Shaft Seal	A1205T1242	1
Input Shaft Seal	471341N (22340)	1
Front Output Shaft Seal	45031S (37525)	1
Front Output Shaft Seal	415483	1
Rear Output Shaft Seal	471341N (22340)	1
Transfer Shift Shaft Seal	470954	2

Heavy Duty Transfer Case Rebuild Kits



HD Transmission

TCRK-902

Position	Part Number	Qty
Input Shaft Front Brg.	376-372	1
Input Shaft Rear Brg.	339-332	1
Idler Shaft Front Brg.	HM89449-HM89411	1
Idler Shaft Rear Brg.	31597-31521	1
Front Output Shaft Front Brg.	208L	1
Front Output Shaft Rear Brg.	211L	1
Front Output Shaft Needle Brg.	B2414-IR2016	1
Rear Output Shaft Front Brg.	25878-25821	1
Rear Output Shaft Rear Brg.	25584-25520	1
Declutch Front Brg.	385A-382A	1
Declutch Rear Brg.	385A-382A	1
PTO Front Brg.	335-332	1
PTO Rear Brg.	335-332	1
Input Shaft Seal	A1205T1242	1
Input Shaft Seal	471341N (22340)	1
Front Output Shaft Front Seal	45031S (37525)	1
Front Output Shaft Rear Seal	415483	1
Rear Output Shaft Seal	471341N (22340)	1
PTO Output Shaft Seal	473445	1
Transfer Shift Shaft Seal	470954	2
PTO Shift Shaft Seal	455151	1

TCRK-903

Position	Part Number	Qty
Input Shaft Front Brg.	376-372	1
Input Shaft Rear Brg.	339-332	1
Idler Shaft Front Brg.	HM89449-HM89411	1
Idler Shaft Rear Brg.	31597-31521	1
Front Output Shaft Front Brg.	208L	1
Front Output Shaft Rear Brg.	211L	1
Front Output Shaft Needle Brg.	B2414-IR2016	1
Rear Output Shaft Front Brg.	25878-25821	1
Rear Output Shaft Rear Brg.	25584-25520	1
Declutch Front Brg.	385A-382A	1
Declutch Rear Brg.	385A-382A	1
Input Shaft Seal	A1205T1242	1
Input Shaft Seal	471341N (22340)	1
Front Output Shaft Front Seal	45031S (37525)	1
Front Output Shaft Rear Seal	415483	1
Rear Output Shaft Seal	471341N (22340)	1
Transfer Shift Shaft Seal	470954	2

TCRK-904

Position	Part Number	Qty
Mainshaft Front Brg.	59201-59412	1
Mainshaft Rear Brg.	3782-3732	1
Driving Idler Gear Brg.	1209A	2
Idler Shaft Front Brg.	59201-59412	1
Idler Shaft Rear Brg.	3767-3732	1
Front Output Shaft Brg.	33225-33472	1
Rear Output Shaft Brg.	59201-59412	1
Mainshaft Front Seal	416654	1
Front Output Shaft Seal	416654	1
Rear Output Shaft Seal	416654	1
Transfer Shift Shaft Seal	340483	1

TCRK-905

Position	Part Number	Qty
Mainshaft Front Brg.	59201-59412	1
Mainshaft Rear Brg.	3782-3732	1
Driving Idler Gear Brg.	1209A	2
Idler Shaft Front Brg.	59201-59412	1
Idler Shaft Rear Brg.	3767-3732	1
Front Output Shaft Brg.	33225-33472	1
Rear Output Shaft Brg.	59201-59412	1
PTO Front Brg.	342S-332	1
PTO Rear Brg.	342S-332	1
Mainshaft Front Seal	416654	1
Front Output Shaft Seal	416654	1
Rear Output Shaft Seal	416654	1
PTO Output Shaft Seal (1.500 Shaft)	473228	1
PTO Output Shaft Seal (1.750 Shaft)	450352	1
Transfer Shift Shaft Seal	340483	1
PTO Shift Shaft Seal	330699	1

TCRK-906

Position	Part Number	Qty
Mainshaft Front Brg.	59201-59412	1
Mainshaft Rear Brg.	3782-3732	1
Driving Idler Gear Brg.	1209A	2
Idler Shaft Front Brg.	59201-59412	1
Idler Shaft Rear Brg.	3767-3732	1
Front Output Shaft Brg.	33225-33472	1
Rear Output Shaft Brg.	59201-59412	1
Declutch Front Brg.	385A-382A	1
Declutch Rear Brg.	385A-382A	1
Mainshaft Front Seal (1.937" Shaft)	416654	1
Mainshaft Front Seal (3.187 Shaft)	456105	1
Front Output Shaft Seal	416654	1
Rear Output Shaft Seal	416654	1
Transfer Shift Shaft Seal	340483	1
Declutch Shift Shaft Seal	7750 (7414)	1

TCRK-907

Position	Part Number	Qty
Mainshaft Front Brg.	59201-59412	1
Mainshaft Rear Brg.	3782-3732	1
Driving Idler Gear Brg.	1209A	2
Idler Shaft Front Brg.	59201-59412	1
Idler Shaft Rear Brg.	3767-3732	1
Front Output Shaft Brg.	33225-33472	1
Rear Output Shaft Brg.	59201-59412	1
Declutch Front Brg.	385A-382A	1
Declutch Rear Brg.	385A-382A	1
PTO Front Brg.	342S-332	1
PTO Rear Brg.	342S-332	1
Mainshaft Front Seal	416654	1
Front Output Shaft Seal	416654	1
Rear Output Shaft Seal	416654	1
PTO Output Shaft Seal (1.500 Shaft)	473228	1
PTO Output Shaft Seal (1.750 Shaft)	450352	1
Transfer Shift Shaft Seal	340483	1
Declutch Shift Shaft Seal	7750 (7414)	1
PTO Shift Shaft Seal	330699	1

TCRK-908

Position	Part Number	Qty
Mainshaft Front Brg.	59201-59412	1
Mainshaft Rear Brg.	3782-3732	1
Driving Idler Gear Brg.	1209A	2
Idler Shaft Front Brg.	HM807046-HM807010	1
Idler Shaft Rear Brg.	39578-39528	1
Front Output Shaft Brg.	33225-33472	1
Rear Output Shaft Brg.	59201-59412	1
Declutch Front Brg.	385A-382A	1
Declutch Rear Brg.	385A-382A	1
Mainshaft Front Seal	456105	1
Front Output Shaft Seal	416654	1
Rear Output Shaft Seal	416654	1
Transfer Shift Shaft Seal	340483	1
Declutch Shift Shaft Seal	543351	1

TCRK-909

Position	Part Number	Qty
Mainshaft Front Brg.	59201-59412	1
Mainshaft Rear Brg.	3782-3732	1
Driving Idler Gear Brg.	1209A	2
Idler Shaft Front Brg.	HM807046-HM807010	1
Idler Shaft Rear Brg.	39578-39528	1
Front Output Shaft Brg.	33225-33472	1
Rear Output Shaft Brg.	59201-59412	1
Declutch Front Brg.	385A-382A	1
Declutch Rear Brg.	385A-382A	1
PTO Front Brg.	342S-332	1
PTO Rear Brg.	342S-332	1
Mainshaft Front Seal	456105	1
Front Output Shaft Seal	416654	1
Rear Output Shaft Seal	416654	1
PTO Output Shaft Seal	450352	1
Transfer Shift Shaft Seal	340483	1
Declutch Shift Shaft Seal	543351	1
PTO Shift Shaft Seal	330699	1

TCRK-910

Position	Part Number	Qty
Mainshaft Front Brg.	59201-59412	1
Mainshaft Rear Brg.	3782-3732	1
Driving Idler Gear Brg.	1209A	2
Idler Shaft Front Brg.	HM807046-HM807010	1
Idler Shaft Rear Brg.	39578-39528	1
Front Output Shaft Brg.	211B	1
Rear Output Shaft Brg.	211B	1
Differential Front Brg.	33287-33472	1
Differential Rear Brg.	42688-42620	1
Declutch Front Brg.	385A-382A	1
Declutch Rear Brg.	385A-382A	1
Mainshaft Front Seal (1.937" Shaft)	416654	1
Mainshaft Front Seal (3.187 Shaft)	456105	1
Front Output Shaft Seal	416654	1
Rear Output Shaft Seal	416654	1
Transfer Shift Shaft Seal	340483	1
Declutch Shift Shaft Seal	543351	1
Declutch Shift Shaft Seal	7750 (7414)	1
Differential Shift Shaft Seal	471570	1

Heavy Duty Transfer Case Rebuild Kits

TCRK-911

Position	Part Number	Qty
Mainshaft Front Brg.	59201-59412	1
Mainshaft Rear Brg.	3782-3732	1
Driving Idler Gear Brg.	1209A	2
Idler Shaft Front Brg.	HM807046-HM807010	1
Idler Shaft Rear Brg.	39578-39528	1
Front Output Shaft Brg.	211B	1
Rear Output Shaft Brg.	211B	1
Differential Front Brg.	33287-33472	1
Differential Rear Brg.	42688-42620	1
Declutch Front Brg.	385A-382A	1
Declutch Rear Brg.	385A-382A	1
PTO Front Brg.	342S-332	1
PTO Rear Brg.	342S-332	1
Mainshaft Front Seal	456105	1
Front Output Shaft Seal	416654	1
Rear Output Shaft Seal	416654	1
PTO Output Shaft Seal	473228	1
(1.500 Shaft)		
PTO Output Shaft Seal	450352	1
(1.750 Shaft)		
Transfer Shift Shaft Seal	340483	1
Declutch Shift Shaft Seal	543351	1
Differential Shift Shaft Seal	471570	1
PTO Shift Shaft Seal	330699	1

TCRK-912

Position	Part Number	Qty
Mainshaft Front Brg.	59201-59412	1
Mainshaft Rear Brg.	3782-3732	1
Driving Idler Gear Brg.	1209A	2
Idler Shaft Front Brg.	HM807046-HM807010	1
Idler Shaft Rear Brg.	45287-45220	1
Front Output Shaft Brg.	33225-33472	1
Rear Output Shaft Brg.	59201-59412	1
Mainshaft Front Seal	416654	1
Front Output Shaft Seal	416654	1
Rear Output Shaft Seal	416654	1
Transfer Shift Shaft Seal	340483	1

TCRK-913

Position	Part Number	Qty
Mainshaft Front Brg.	59201-59412	1
Mainshaft Rear Brg.	3782-3732	1
Driving Idler Gear Brg.	1209A	2
Idler Shaft Front Brg.	HM807046-HM807010	1
Idler Shaft Rear Brg.	45287-45220	1
Front Output Shaft Brg.	33225-33472	1
Rear Output Shaft Brg.	59201-59412	1
PTO Front Brg.	342S-332	1
PTO Rear Brg.	342S-332	1
Mainshaft Front Seal	416654	1
Front Output Shaft Seal	416654	1
Rear Output Shaft Seal	416654	1
PTO Output Shaft Seal	473228	1
(1.500 Shaft)		
PTO Output Shaft Seal	450352	1
(1.750 Shaft)		
Transfer Shift Shaft Seal	340483	1
PTO Shift Shaft Seal	330699	1

TCRK-914

Position	Part Number	Qty
Mainshaft Front Brg.	59201-59412	1
Mainshaft Rear Brg.	3782-3732	1
Driving Idler Gear Brg.	1209A	2
Idler Shaft Front Brg.	HM807046-HM807010	1
Idler Shaft Rear Brg.	45287-45220	1
Front Output Shaft Brg.	33225-33472	1
Rear Output Shaft Brg.	59201-59412	1
Declutch Front Brg.	385A-382A	1
Declutch Rear Brg.	385A-382A	1
Mainshaft Front Seal	416654	1
(1.937" Shaft)		
Mainshaft Front Seal	456105	1
(3.187" Shaft)		
Front Output Shaft Seal	416654	1
Rear Output Shaft Seal	416654	1
Transfer Shift Shaft Seal	340483	1
Declutch Shift Shaft Seal	543351	1
Declutch Shift Shaft Seal	7750 (7414)	1

TCRK-915

Position	Part Number	Qty
Mainshaft Front Brg.	59201-59412	1
Mainshaft Rear Brg.	3782-3732	1
Driving Idler Gear Brg.	1209A	2
Idler Shaft Front Brg.	HM807046-HM807010	1
Idler Shaft Rear Brg.	45287-45220	1
Front Output Shaft Brg.	33225-33472	1
Rear Output Shaft Brg.	59201-59412	1
Declutch Front Brg.	385A-382A	1
Declutch Rear Brg.	385A-382A	1
PTO Front Brg.	342S-332	1
PTO Rear Brg.	342S-332	1
Mainshaft Front Seal	416654	1
(1.937" Shaft)		
Mainshaft Front Seal	456105	1
(3.187" Shaft)		
Front Output Shaft Seal	416654	1
Rear Output Shaft Seal	416654	1
PTO Output Shaft Seal	473228	1
Transfer Shift Shaft Seal	340483	1
Declutch Shift Shaft Seal	7750 (7414)	1
PTO Shift Shaft Seal	330699	1

TCRK-916

Position	Part Number	Qty
Mainshaft Front Brg.	59201-59412	1
Mainshaft Rear Brg.	3782-3732	1
Driving Idler Gear Brg.	1209A	2
Idler Shaft Front Brg.	HM807046-HM807010	1
Idler Shaft Rear Brg.	45287-45220	1
Front Output Shaft Brg.	211B	1
Rear Output Shaft Brg.	211B	1
Differential Front Brg.	33287-33472	1
Differential Rear Brg.	42688-42620	1
Mainshaft Front Seal	416654	1
Front Output Shaft Seal	416654	1
Rear Output Shaft Seal	415984	1
(2.750 Shaft)		
Rear Output Shaft Seal	416654	1
(2.937" Shaft)		
Transfer Shift Shaft Seal	340483	1
Differential Shift Shaft Seal	471570	1

TCRK-917

Position	Part Number	Qty
Mainshaft Front Brg.	59201-59412	1
Mainshaft Rear Brg.	3782-3732	1
Driving Idler Gear Brg.	1209A	2
Idler Shaft Front Brg.	HM807046-HM807010	1
Idler Shaft Rear Brg.	45287-45220	1
Front Output Shaft Brg.	211B	1
Rear Output Shaft Brg.	211B	1
Differential Front Brg.	33287-33472	1
Differential Rear Brg.	42688-42620	1
Declutch Front Brg.	385A-382A	1
Declutch Rear Brg.	385A-382A	1
Mainshaft Front Seal	416654	1
(1.937" Shaft)		
Mainshaft Front Seal	456105	1
(3.187" Shaft)		
Front Output Shaft Seal	416654	1
Rear Output Shaft Seal	416654	1
Transfer Shift Shaft Seal	340483	1
Differential Shift Shaft Seal	471570	1
Declutch Shift Shaft Seal	7750 (7414)	1

TCRK-918

Position	Part Number	Qty
Mainshaft Front Brg.	59201-59412	1
Mainshaft Rear Brg.	3782-3732	1
Idler Shaft Front Brg.	59201-59412	1
Idler Shaft Rear Brg.	3767-3732	1
Front Output Shaft Brg.	33225-33472	1
Rear Output Shaft Brg.	59201-59412	1
Declutch Front Brg.	385A-382A	1
Declutch Rear Brg.	385A-382A	1
Mainshaft Front Seal	416654	1
Mainshaft Rear Seal	415147	1
Rear Output Shaft Seal	416654	1
Transfer Shift Shaft Seal	340483	1
Declutch Shift Shaft Seal	7750 (7414)	1

TCRK-919

Position	Part Number	Qty
Mainshaft Front Brg.	HM212044-HM212011	1
Mainshaft Rear Brg.	28682-28622	1
Idler Shaft Front Brg.	5584-5535	1
Idler Shaft Rear Brg.	HM212046-HM212011	1
Front Output Shaft Brg.	594-592A	1
Brg.		
Rear Output Shaft Front Brg.	1828U307	1
Brg.		
Rear Output Shaft Rear Brg.	590A-592A	1
Brg.		
Mainshaft Front Seal	417487	1
Rear Output Shaft Inner Seal	416130	1
Rear Output Shaft Outer Seal	A1205W2415	1
Transfer Shift Shaft Seal	471570	1

Heavy Duty Transfer Case Rebuild Kits



HD Transmission

TCRK-920		
Position	Part Number	Qty
Mainshaft Front Brg.	HM212044-HM212011	1
Mainshaft Rear Brg.	28682-28622	1
Idler Shaft Front Brg.	5584-5535	1
Idler Shaft Rear Brg.	HM212046-HM212011	1
Front Output Shaft Rear Brg.	594-592A	1
Rear Output Shaft Front Brg.	1828U307	1
Rear Output Shaft Rear Brg.	590A-592A	1
Declutch Brg.	1311L	1
Mainshaft Front Seal (3.000 Shaft)	417487	1
Mainshaft Front Seal (3.250 Shaft)	A1205W2415	1
Rear Output Shaft Inner Seal	416130	1
Rear Output Shaft Outer Seal	A1205W2415	1
Declutch Seal	416654	1
Transfer Shift Shaft Seal	471570	1
Declutch Shift Shaft Seal	470954	1

TCRK-921		
Position	Part Number	Qty
Mainshaft Front Brg.	HM212044-HM212011	1
Mainshaft Rear Brg.	28682-28622	1
Idler Shaft Front Brg.	5584-5535	1
Idler Shaft Rear Brg.	HM212046-HM212011	1
Front Output Shaft Rear Brg.	594-592A	1
Rear Output Shaft Front Brg.	1828U307	1
Rear Output Shaft Rear Brg.	590A-592A	1
Declutch Brg.	1311L	1
PTO Front Brg.	1311L	1
PTO Rear Brg.	211B	1
Mainshaft Front Seal (3.000 Shaft)	417487	1
Mainshaft Front Seal (3.250 Shaft)	A1205W2415	1
Rear Output Shaft Inner Seal	416130	1
Rear Output Shaft Outer Seal	A1205W2415	1
Declutch Seal	416654	1
PTO Input Shaft Seal	470737N (22425)	1
PTO Output Shaft Seal	416654	1
Transfer Shift Shaft Seal	471570	1
Declutch Shift Shaft Seal	470954	1
PTO Shift Shaft Seal	470954	1

TCRK-922		
Position	Part Number	Qty
Mainshaft Front Brg.	HM212044-HM212011	1
Mainshaft Rear Brg.	28682-28622	1
Idler Shaft Front Brg.	5584-5535	1
Idler Shaft Rear Brg.	HM212046-HM212011	1
Front Output Shaft Rear Brg.	594-592A	1
Rear Output Shaft Front Brg.	1828U307	1
Rear Output Shaft Rear Brg.	590A-592A	1
PTO Front Brg.	1311L	1
PTO Rear Brg.	211B	1
Mainshaft Front Seal	417487	1
Rear Output Shaft Inner Seal	416130	1
Rear Output Shaft Outer Seal	A1205W2415	1
PTO Input Shaft Seal	470737N (22425)	1
PTO Output Shaft Seal	416654	1
Transfer Shift Shaft Seal	471570	1
PTO Shift Shaft Seal	470954	1

TCRK-923		
Position	Part Number	Qty
Mainshaft Front Brg.	HM212044-HM212011	1
Mainshaft Rear Brg.	28682-28622	1
Idler Shaft Front Brg.	5584-5535	1
Idler Shaft Rear Brg.	HM212046-HM212011	1
Front Output Shaft Front Brg.	1311L	1
Front Output Shaft Rear Brg.	594-592A	1
Rear Output Shaft Front Brg.	1828U307	1
Rear Output Shaft Rear Brg.	590A-592A	1
Mainshaft Front Seal	417487	1
Front Output Shaft Seal	416654	1
Rear Output Shaft Seal	A1205W2415	1
Transfer Shift Shaft Seal	471570	1

TCRK-924		
Position	Part Number	Qty
Mainshaft Front Brg.	HM212044-HM212011	1
Mainshaft Rear Brg.	28682-28622	1
Idler Shaft Front Brg.	5584-5535	1
Idler Shaft Rear Brg.	HM212046-HM212011	1
Front Output Shaft Front Brg.	1311L	1
Front Output Shaft Rear Brg.	594-592A	1
Rear Output Shaft Front Brg.	1828U307	1
Rear Output Shaft Rear Brg.	590A-592A	1
PTO Front Brg.	1311L	1
PTO Rear Brg.	211B	1
Mainshaft Front Seal	417487	1
Front Output Shaft Seal	416654	1
Rear Output Shaft Seal	A1205W2415	1
PTO Input Shaft Seal	470737N (22425)	1
PTO Output Shaft Seal	416654	1
Transfer Shift Shaft Seal	471570	1
PTO Shift Shaft Seal	470954	1

TCRK-925		
Position	Part Number	Qty
Mainshaft Front Brg.	HM212044-HM212011	1
Mainshaft Rear Brg.	28682-28622	1
Idler Shaft Front Brg.	5584-5535	1
Idler Shaft Rear Brg.	HM212046-HM212011	1
Declutch Brg.	1311L	1
Front Output Shaft Rear Brg.	594-592A	1
Rear Output Shaft Rear Brg.	590A-592A	1
Mainshaft Front Seal	417487	1
Mainshaft Rear Seal	55563	1
Rear Output Shaft Seal	415995	1
Declutch Seal	416654	1
Declutch Shift Shaft Seal	470954	1

TCRK-926		
Position	Part Number	Qty
Input Shaft Front Brg.	835-832	1
Input Shaft Rear Brg.	835-832	1
Idler Gear Front Brg.	835-832	1
Idler Gear Rear Brg.	835-832	1
Output Shaft Front Brg.	843-832	1
Output Shaft Rear Brg.	843-832	1
Declutch Brg.	1228N1262	1
Input Shaft Seal	A1205D2422	2
Rear Output Shaft Seal	A1205D2422	2
Declutch Inner Seal	45013S	1
Declutch Outer Seal	A1205U1529	1

TCRK-927		
Position	Part Number	Qty
Input Shaft Front Brg.	H715334-H715311	1
Input Shaft Rear Brg.	H715334-H715311	1
Output Shaft Front Brg.	H715334-H715311	1
Output Shaft Rear Brg.	H715334-H715311	1
Declutch Brg.	212	1
Declutch Pilot Brg.	1228Z1222	1
Input Shaft Seal	DTR2592	1
Output Shaft Seal	DTR2592	1
Declutch Seal	DTR2592	1

TCRK-928		
Position	Part Number	Qty
Input Shaft Front Brg.	H715334-H715311	1
Input Shaft Rear Brg.	H715334-H715311	1
Output Shaft Front Brg.	H715334-H715311	1
Output Shaft Rear Brg.	H715334-H715311	1
Declutch Brg.	JLM506849-JLM506810	2
Input Shaft Seal	DTR2592	1
Output Shaft Seal	DTR2592	1
Declutch Seal	DTP2590	1

TCRK-929		
Position	Part Number	Qty
Input Shaft Front Brg.	HM813843	1
Input Shaft Rear Brg.	HM813843-HM813810	1
Idler Gear Front Brg.	HM212049-HM212011	1
Idler Gear Rear Brg.	HM212049-HM212011	1
Front Output Shaft Front Brg.	HM212049-HM212011	1
Front Output Shaft Rear Brg.	HM813843-HM813810	1
Rear Output Shaft Front Brg.	HM212049-HM212011	1
Rear Output Shaft Rear Brg.	HM212049-HM212011	1
Input Shaft Seal	R945007	1
Front Output Shaft Seal	DTR2592	1
Rear Output Shaft Seal	DTR2592	1
PTO Output Shaft Seal	DTP2590	1

Heavy Duty Transmission Rebuild Kits

TCRK-930

Position	Part Number	Qty
Input Shaft Front Brg.	HM813843	1
Input Shaft Rear Brg.	NP674708-NP682041	1
Idler Gear Front Brg.	HM212049-HM212011	1
Idler Gear Rear Brg.	HM212049-HM212011	1
Transfer Gear Front Brg.	HM212049-HM212011	1
Transfer Gear Rear Brg.	HM212049-HM212011	1
Front Output Shaft Front Brg.	HM212049-HM212011	1
Front Output Shaft Rear Brg.	HM813843-HM813810	1
Rear Output Shaft Front Brg.	HM212049-HM212011	1
Rear Output Shaft Rear Brg.	HM212049-HM212011	1
Input Shaft Seal	R945007	1
Front Output Shaft Seal	DTR2592	1
Rear Output Shaft Seal	DTQ2591	1

TCRK-931

Position	Part Number	Qty
Mainshaft Front Brg.	1307S	1
Mainshaft Rear Brg.	1307S	1
Idler Shaft Front Brg.	339-332	1
Idler Shaft Rear Brg.	339-332	1
Output Shaft Front Brg.	342S-332	1
Output Shaft Rear Brg.	339-332	1
Declutch Front Brg.	14137A-14274	1
Declutch Rear Brg.	14137A-14274	1
Mainshaft Front Seal	472394	1
Mainshaft Rear Seal	472394	1
Declutch Seal	472394	1
Rear Output Shaft Seal (2.880 Housing)	415281N (29870)	1
Rear Output Shaft Seal (3.000 Housing)	472394	1
Transfer Shift Shaft Seal	340483	1
Declutch Shift Shaft Seal	455151	1

TCRK-932

Position	Part Number	Qty
Mainshaft Front Brg.	1307S	1
Mainshaft Rear Brg.	1307S	1
Idler Shaft Front Brg.	339-332	1
Idler Shaft Rear Brg.	339-332	1
Output Shaft Front Brg.	342S-332	1
Output Shaft Rear Brg.	339-332	1
PTO Front Brg.	335-332	1
PTO Rear Brg.	335-332	1
Mainshaft Front Seal	472394	1
Mainshaft Rear Seal	472394	1
Front Output Shaft Seal	472394	1
Rear Output Shaft Seal (2.880 Housing)	415281N (29870)	1
Rear Output Shaft Seal (3.000 Housing)	472394	1
PTO Output Shaft Seal	473445	1
Transfer Shift Shaft Seal	340483	1
PTO Shift Shaft Seal	455151	1

TCRK-933

Position	Part Number	Qty
Mainshaft Front Brg.	1307S	1
Mainshaft Rear Brg.	1307S	1
Idler Shaft Front Brg.	339-332	1
Idler Shaft Rear Brg.	339-332	1
Output Shaft Front Brg.	339-332	1
Output Shaft Rear Brg.	339-332	1
Mainshaft Front Seal	472394	1
Mainshaft Rear Seal	472394	1
Front Output Shaft Seal	472394	1
Rear Output Shaft Seal (2.880 Housing)	415281N (29870)	1
Rear Output Shaft Seal (3.000 Housing)	472394	1
Transfer Shift Shaft Seal	340483	1

TRK-2

Position	Part Number	Qty
Input Shaft Brg.	1313S	1
Input Shaft Pilot Brg.	22207	1
Output Shaft Center Brg.	MU1312TM	1
Output Shaft Rear Brg.	5215WL	1
Countershaft Front Brg.	MR1309EAL	1
Countershaft Rear Brg.	MSN1311GELR	1
Rev. Idler Gear Brg.	J402480	2
1st Gear Brg.	F53539 ¹¹	1
2nd Gear Brg.	F53540 ¹¹	1
3rd Gear Brg.	F53540 ¹¹	1
Input Shaft Seal	455995N (29950)	1
Output Shaft Seal	415013N (29925)	1
Remote Control Seal	350567 (8648) •	2
Sealer	RTV Silicone	1

TRK-2A

Position	Part Number	Qty
Input Shaft Brg.	1313S	1
Input Shaft Pilot Brg.	MU5207UM	1
Output Shaft Center Brg.	MU1312TM	1
Output Shaft Rear Brg.	5215WL	1
Countershaft Front Brg.	MR1309EAL	1
Countershaft Rear Brg.	MSN1311GELR	1
Rev. Idler Gear Brg.	J402480	2
1st Gear Brg.	F53539	1
2nd Gear Brg.	F53540	1
3rd Gear Brg.	F53540	1
Input Shaft Seal	455995N (29950)	1
Output Shaft Seal	415013N (29925)	1
Remote Control Seal	350567 (8648)	2
Sealer	RTV Silicone	1

TRK-3

Position	Part Number	Qty
Input Shaft Front Brg.	5212W	1
Input Shaft Rear Brg.	MR1313EL	1
Input Shaft Pilot Brg.	MR1308TV	1
Output Shaft Brg.	1412L	1
Countershaft Front Brg.	MSN1311GELR	1
Countershaft Rear Brg.	MR1311EAHL	1
1st Gear Brg.	F53543-S444Q ¹²	1
2nd Gear Brg.	F53543-S444Q ¹²	1
3rd Gear Brg.	F53542-S444Q ¹²	1
Input Shaft Seal	415281N (29870)	1
Output Shaft Seal (Except Ford)	415281N (29870)	1
Output Shaft Seal (with Ford)	415013N (29925)	1
Remote Control Seal	450680 (8702) •	2
Gasket Set	GT155	1

TRK-4

Position	Part Number	Qty
Input Shaft Front Brg.	5212W	1
Input Shaft Rear Brg.	MR1313EJ	1
Input Shaft Pilot Brg.	MR1308EJ	1
Output Shaft Brg.	1412L	1
Countershaft Front Brg.	MSN1311GELR	1
Countershaft Rear Brg.	MR1311EAHL	1
1st Gear Brg.	F53543-S444Q ¹²	1
2nd Gear Brg.	F53543-S444Q ¹²	1
3rd Gear Brg.	F53542-S444Q ¹²	1
Input Shaft Seal	415281N (29870)	1
Output Shaft Seal (Except Ford)	415281N (29870)	1
Output Shaft Seal (with Ford)	415013N (29925)	1
Remote Control Seal	450032 (8703) •	2
Gasket Set	GT155	1

TRK-19

Position	Part Number	Qty
Input Shaft Brg.	1310SL	1
Input Shaft Pilot Brg.	RU1549L	1
Output Shaft Brg.	310L	1
Countershaft Front Brg.	M1307EL	1
Countershaft Rear Brg.	1309SL	1
Rev. Idler Gear Brg.	J402064	2
Input Shaft Seal	452554N (14832)	1
Output Shaft Seal	415013N (29925)	1
Shift Rod Seal	240735 (7409)	1
Gasket Set	GT82D	1

TRK-23

Position	Part Number	Qty
Input Shaft Brg.	211SL	1
Input Shaft Pilot Brg.	SRA5304	1
Output Shaft Brg.	309L	1
Countershaft Front Brg.	M28161	1
Countershaft Rear Brg.	308SL	1
Rev. Idler Gear Brg.	F54970	2
Output Shaft Seal (3.256" O.D.)	471271 (24898)	1
Output Shaft Seal (2.879" O.D.)	450867 (21098)	1
Gasket Set	GT23	1

TRK-23B

Position	Part Number	Qty
Input Shaft Brg.	1211SL	1
Input Shaft Pilot Brg.	SRA5304	1
Output Shaft Brg.	N309L	1
Countershaft Front Brg.	M28161	1
Countershaft Rear Brg.	1308SL	1
Rev. Idler Gear Brg.	F54970	2
Output Shaft Seal (3.256" O.D.)	450519 (24910)	1
Output Shaft Seal (2.879" O.D.)	450867 (21098)	1
Gasket Set	GT23	1

TRK-25

Position	Part Number	Qty
Input Shaft Brg.	212SL	1
Input Shaft Pilot Brg.	RU1549L	1
Output Shaft Brg.	309L	1
Countershaft Front Brg.	M1306EL	1
Countershaft Rear Brg.	1308SL	1
Rev. Idler Gear Brg.	J401656	2
Input Shaft Seal (with 1.5" O.D.)	452554N (14832)	1
Input Shaft Seal (with 1.25" O.D.)	7412S (12363)	1
Output Shaft Seal	411143N (26110)	1
Remote Control Seal	471267 (8660)	2
Shift Rod Seal	240735 (7409)	1
Sealer	RTV Silicone	1

¹¹Some Models will use S456Q Loose Needles instead of F53539 or F53540 Caged Needles. S456Q not packed in kit.
¹²Optional for 8341 & 8345; S444Q (186) for 1st Gear & (124) each for 2nd & 3rd Gears(included in kit)

• Not Packed In Kit

Heavy Duty Transmission Rebuild Kits

HD Transmission

TRK-27		
Position	Part Number	Qty
Input Shaft Brg.	1211SL	1
Input Shaft Pilot Brg.	Q15902-F	1
Output Shaft Brg.	1308L	1
Countershaft Front Brg.	1207L	1
Countershaft Rear Brg.	B2816	1
Input Shaft Seal	7412S (12363)	1
Output Shaft Seal	6879H (21103)	1
Remote Control Seal	6835S (7440)	1
Gasket Set	GT26	1

TRK-28		
Position	Part Number	Qty
Input Shaft Brg.	1213SL	1
Input Shaft Pilot Brg.	0513Q	1
Output Shaft Brg.	1310L	1
Countershaft Front Brg.	M1208EL	1
Countershaft Rear Brg.	1308SL	1
Rev. Idler Gear Brg.	J322064	2
Input Shaft Seal (except GMC)	481181N (16054)	1
Input Shaft Seal	452742 (17810) •	1
Output Shaft Seal	471271 (24898)	1
Remote Control Seal	350567 (8648) •	2
Gasket Set	GT28	1

TRK-29		
Position	Part Number	Qty
Input Shaft Brg.	1211SL	1
Input Shaft Pilot Brg.	Q15902-F	1
Output Shaft Brg.	1308L	1
Countershaft Front Brg.	1208L	1
Countershaft Rear Brg.	Q15902-F	2
Rev. Idler Front Brg.	B1412	1
Rev. Idler Rear Brg.	B1816	1
Rev. Idler Thrust Brg.	NTA815	1
Input Shaft Seal	481181N (16054) ¹³	1
Output Shaft Seal	6879H (21103)	1
Output Shaft Seal	471271 (24898)	1
(542-D, 542-L)		
Remote Control Seal	350679 (7439) •	1
Gasket Set	GT26	1

TRK-29B		
Position	Part Number	Qty
Input Shaft Brg.	1211SL	1
Input Shaft Pilot Brg.	Q15902-F	1
Output Shaft Brg.	309L	1
Countershaft Front Brg.	1208L	1
Countershaft Rear Brg.	Q15902-F	2
Rev. Idler Front Brg.	B1412	1
Rev. Idler Rear Brg.	B1816	1
Rev. Idler Thrust Brg.	NTA815	1
Output Shaft Seal	471271 (24898)	1
Remote Control Seal	350679 (7439) •	1
Gasket Set	GT26	1

TRK-43		
Position	Part Number	Qty
Input Shaft Front Brg.	211	1
Input Shaft Rear Brg.	1311L	1
Input Shaft Pilot Brg.	MU1307UM	1
Output Shaft Brg.	313L	1
Countershaft Front Brg.	3578-3525	1
Countershaft Rear Brg.	3578-3525	1
Input Shaft Seal	415137 (32502)	1
Output Shaft Seal	415991N (34891)	1
Remote Control Seal	240735 (7409)	2
Sealer	RTV Silicone	1

TRK-45		
Position	Part Number	Qty
Input Shaft Brg.	1311SL	1
Input Shaft Pilot Brg.	RU1549L ¹⁴	1
Output Shaft Brg.	311L	1
Countershaft Front Brg.	M1307EL	1
Countershaft Rear Brg.	1310SL	1
Rev. Idler Gear Brg.	J402064	2
Input Shaft Seal	452554N (14832)	1
Output Shaft Seal	415013N (29925)	1
Shift Rod Seal	240735 (7409)	1
Sealer	RTV Silicone	1

TRK-48		
Position	Part Number	Qty
Input Shaft Brg.	1212SL	1
Input Shaft Pilot Brg.	J401652	1
Output Shaft Brg.	1310L	1
Countershaft Front Brg.	M32161	1
Countershaft Rear Brg.	1309SL	1
Rev. Idler Gear Brg.	J401652	2
Output Shaft Seal	450316 (22446) (Except Ford)	1
Output Shaft Seal (Ford)	471271 (24898)	1
Remote Control Seal	6835S (7440)	1
Gasket Set	GT133	1

TRK-52		
Position	Part Number	Qty
Input Shaft Brg.	1312SV	1
Input Shaft Pilot Brg.	MUC1308J	1
Output Shaft Brg.	312L	1
Countershaft Rear Brg.	MR1307EL	1
Countershaft Front Brg.	45285 Assy 90011 (A1598)	1
Crossover Lever Brg.	B1612	1
Rev. Idler Gear Brg.	J402064	2
Input Shaft Seal	452554N (14832)	1
Output Shaft Seal (4.5" O.D.)	415137 (32502)	1
Output Shaft Seal (4" O.D.)	415013N (29925)	1
Remote Control Seal	471267 (8660)	1
Sealer	RTV Silicone	1

TRK-58		
Position	Part Number	Qty
Input Shaft Brg.	212SLV	1
Input Shaft Pilot Bushing	BS59 ²⁶	1
Output Shaft Center Brg.	118L	1
Output Shaft Rear Brg.	213	1
Countershaft Front Brg.	MSN1211REX	2
Countershaft Rear Brg.	MU1308TVWS	2
Rev. Idler Gear Brg.	HJ223020-IR18200H	2
Input Shaft Nut	CN1 (8997)	1
Output Shaft Seal (3.5" Shaft)	415991N (34891)	1
Output Shaft Seal (3" Shaft)	415013N (29925) •	1
Shift Rod Seal	350567 (8648) •	1
Snap Ring Set	SR58	1
Gasket Set	GT58	1

TRK-58A		
Position	Part Number	Qty
Input Shaft Brg.	212SLV	1
Input Shaft Pilot Bushing	BS59	1
Output Shaft Center Brg.	118L	1
Output Shaft Rear Brg.	213	1
Countershaft Front Brg.	BS500192SX	2
Countershaft Rear Brg.	MU1308TVWS	2
Rev. Idler Gear Brg.	HJ223020-IR18200H	2
Mainshaft Rear Seal	415991N (34891)	1
Snap Ring Set	SR58	1
Gasket Set	GT58	1

TRK-65		
Position	Part Number	Qty
Input Shaft Brg.	1313SL	1
Input Shaft Pilot Brg.	MRB1308EL	1
Mainshaft Brg.	496-493	2
Mainshaft Pilot Brg.	MA1308TV	1
Output Shaft Brg.	66589-66521DB ¹⁵	1
Countershaft Front Brg.	MR1309EL	1
Countershaft Rear Brg.	621-613B	1
Rear Countershaft Front Brg.	621-612	1
Rear Countershaft Rear Brg.	621-612	1
Rev. Idler Gear Brg.	J482064	2
Output Shaft Seal	416470N (32385)	1
Remote Control Seal	41224S (9876) •	1
Shift Rail Seal	471570 (8702)	2
Sealer	RTV Silicone	1

TRK-70		
Position	Part Number	Qty
Input Shaft Front Brg.	28580-28521	1
Input Shaft Rear Brg.	28580-28521	1
Input Shaft Pilot Brg.	1209A	1
Output Shaft Brg.	1310	1
Countershaft Front Brg.	3479-3420	1
Countershaft Rear Brg.	3479-3420	1
Input Shaft Seal	475322N (27295)	1
Output Shaft Seal	475322N (27295)	1
Remote Control Seal	450680 (8702) •	2
Gasket Set	GT70	1

TRK-72		
Position	Part Number	Qty
Input Shaft Brg.	1216SL	1
Input Shaft Pilot Brg.	0513Q	1
Output Shaft Brg.	1311L	1
Countershaft Front Brg.	MR1209EL	1
Countershaft Rear Brg.	1310SL	1
Rev. Idler Gear Brg.	J402464	2
Input Shaft Seal	475322N (27295)	1
Output Shaft Seal (with brake)	452742 (17810)	1
Output Shaft Seal (without brake)	415004 (27370)	1
Remote Control Seal	450567 (8660) •	2
Shift Rod Seal	450032 (8703) •	2
Shift Rod Seal (with Solenoid Shift)	6835S (7440) •	4
Shift Solenoid Seal	450009 (6203) •	1
Input Shaft Seal	475012N (29322) •	1
Gasket Set	GT72	1

TRK-73		
Position	Part Number	Qty
Input Shaft Front Brg.	1210	1
Input Shaft Rear Brg.	MSN1312EL	1
Input Shaft Pilot Brg.	MU1209TV	1
Output Shaft Brg.	1312L	1
Countershaft Front Brg.	3877-3820	1
Countershaft Rear Brg.	462-453A	1
Speed Gear Brg.	F54540	1
Input Shaft Seal	415004 (27370)	1
Input Shaft Seal (Chevy/GMC)	475322N (27295)	1
Output Shaft Seal (without brake)	415013N (29925)	1
Output Shaft Seal (with brake)	415281N (29870)	1
Output Shaft Seal	475322N (27295) •	1
Remote Control Seal	471570 (8702)	2
Shift Rod Seal	350567 (8648) •	4
Gasket Set	GT73	1

¹³Some Models use 7412S
¹⁵Two Cones and One Cup

¹⁴Special built I.H. & Mack units use # RU1557J

²⁶Early Models use BR717

• Not Packed In Kit

Heavy Duty Transmission Rebuild Kits

TRK-74		
Position	Part Number	Qty
Input Shaft Brg.	1313S	1
Input Shaft Pilot Brg.	22207	1
Mainshaft Front Brg.	WSN61219EV	1
Mainshaft Rear Brg.	MR1308EJ	1
Output Shaft Brg.	1412L	1
Countershaft Front Brg.	MR1309EAL	1
Countershaft Rear Brg.	MSN1311GELR	1
Rev. Idler Gear Brg.	J402480	2
1st Gear Brg.	F53541	1
2nd Gear Brg.	S456Q	1
3rd Gear Brg.	F53540	1
Aux. Countershaft Front Brg.	MSN1311GELR	1
Aux. Countershaft Rear Brg.	MR1311EAHL	1
Aux. 1st Gear Brg.	F53543 ¹⁶	1
Aux. 2nd Gear Brg.	F53543 ¹⁶	1
Aux. 3rd Gear Brg.	F53542 ¹⁶	1
Input Shaft Seal	415013N (29925)	1
Output Shaft Seal	415281N (29870)	1
Remote Control Seal	350567 (8648) •	2
Sealer	RTV Silicone	1

TRK-82		
Position	Part Number	Qty
Input Shaft Brg.	1308L	1
Input Shaft Pilot Brg.	W1590Q	1
Output Shaft Brg.	308L	1
Countershaft Front Brg.	C436Q	1
Countershaft Rear Brg.	C436Q	1
Rev. Idler Gear Brg.	B1316Q	2
2nd Gear Brg.	Q6086	1
Input Shaft Seal	471413 (12364)	1
Output Shaft Seal	473463 (20045)	1
Gasket Set	GT82D	1

TRK-82D		
Position	Part Number	Qty
Driveshaft Rear Brg.	308L1	1
Input Shaft Brg.	C436Q	1
Input Shaft Pilot Brg.	1308L	1
Output Shaft Brg.	C436Q	1
Countershaft Rear Brg.	C436Q	1
Rev. Idler Gear Brg.	B1316Q	2
Input Shaft Seal	471413 (12364)	1
Output Shaft Seal	473463 (20045)	1
Output Shaft Seal	450308 (21210)	1
External Housing Seal (Ford Only)	470380 (15005)	1
O-Ring	OR111	1
Gasket Set	GT82D	1

TRK-82F		
Position	Part Number	Qty
Input Shaft Brg.	308L1	1
Input Shaft Pilot Brg.	C436Q	1
Output Shaft Brg.	1308L	1
Countershaft Front Brg.	C436Q	1
Countershaft Rear Brg.	C436Q	1
Rev. Idler Gear Brg.	B1316Q	2
Input Shaft Seal	51083 (12363)	1
Output Shaft Seal (Diesel)	450308 (21210)	1
Output Shaft Seal (Gas & 2.378" O.D.)	470380 (15005)	1
Output Shaft Seal (Gas & 2.879" O.D.)	473442 (15773)	1
Output Shaft Seal (Gas & 3.256" O.D.)	471271 (24898)	1
Gasket Set	GT82D	1

TRK-82FD		
Position	Part Number	Qty
Input Shaft Brg.	M802048-M802011	1
Input Shaft Pilot Brg.	C436Q	1
Output Shaft Brg.	1308L	1
Countershaft Front Brg.	C436Q	1
Countershaft Rear Brg.	C436Q	1
Rev. Idler Gear Brg.	B1316Q	2
Input Shaft Seal	51083 (12363)	1
Output Shaft Seal	471271 (24898)	1
Output Shaft Seal	472189A (15041)	1
Gasket Set	GT82D	1

TRK-86		
Position	Part Number	Qty
Input Shaft Front Brg.	210	1
Input Shaft Rear Brg.	1311L	1
Input Shaft Pilot Brg.	MU1209TV	1
Output Shaft Brg.	1311L	1
Countershaft Front Brg.	3479-3420	1
Countershaft Rear Brg.	3479-3420	1
Input Shaft Seal	415004 (27370)	1
Output Shaft Seal	415004 (27370)	1
(Except Ford)		
Output Shaft Seal (Ford)	475322N (27295)	1
Remote Control Seal	471570 (8702)	2
Gasket Set	GT86	1

TRK-127		
Position	Part Number	Qty
Input Shaft Brg.	HM88649-HM88610	1
Input Shaft Pilot Brg.	Q15902-F	1
Output Shaft Brg.	1308L	1
Countershaft Front Brg.	M24161X1	1
Countershaft Rear Brg.	B3216	1
Countershaft Rear Thrust Brg.	NTA2031	1
Synchro Hub Thrust Brg.(3rd & 4th Gears)	FA35688	1
Rev. Idler Gear Brg.	C407Q •	1
Input Shaft Seal (1.375" Shaft)	470380 (15005)	1
Input Shaft Seal (1.375" Shaft)	482163N (13557)	1
Input Shaft Seal (1.25 shaft)	450140N (12340) •	1
Input Shaft Seal (except Ford)	470898 (21100)	1
Output Shaft Seal (with Ford)	471271 (24898)	1
Output Shaft Seal	473243 (21302) •	1
Remote Control Seal	350679 (7439) •	1
Gasket Set	GT127	1

TRK-127F		
Position	Part Number	Qty
Input Shaft Brg.	HM88649-HM88610	1
Input Shaft Pilot Brg.	Q15902-F	1
Output Shaft Brg.	1308L	1
Countershaft Front Brg.	M24161X1	1
Countershaft Rear Brg.	B3216	1
Countershaft Rear Thrust Brg.	NTA2031	1
Synchro Hub Thrust Brg.(3rd & 4th Gears)	FA35688	1
Input Shaft Seal	482163N (13557)	1
Output Shaft Seal	471271 (24898)	1
Gasket Set	GT127	1

TRK-127G		
Position	Part Number	Qty
Input Shaft Brg.	1308L	1
Input Shaft Pilot Brg.	Q15902-F	1
Output Shaft Brg.	1308L	1
Countershaft Front Brg.	M24161X1	1
Countershaft Rear Brg.	B3216	1
Countershaft Rear Thrust Brg.	NTA2031	1
Synchro Hub Thrust Brg.(3rd & 4th Gears)	FA35688	1
Output Shaft Seal	471271 (24898)	1
Input Shaft Seal (1.375" Shaft)	470380 (15005)	1
Input Shaft Seal	470898 (21100)	1
Gasket Set	GT127	1

TRK-130		
Position	Part Number	Qty
Input Shaft Brg.	MSN1314GELR	1
Input Shaft Pilot Brg.	MU7308L	1
Mainshaft Front Brg.	WSN61219EV	1
Mainshaft Rear Brg.	MR1308TV	1
Output Shaft Brg.	1412L	1
Countershaft Front Brg.	25590-25520	2
Countershaft Rear Brg.	MR1311GTAVR	2
Rev. Idler Gear Brg.	J402480	1
1st Gear Brg.	F53541	1
2nd Gear Brg.	F53540	1
3rd Gear Brg.	F53540	1
Aux. Countershaft Front Brg.	MSN1311GELR	1
Aux. Countershaft Rear Brg.	MR1311EAHL	1
Aux. 1st Gear Brg.	F53543 ¹⁶	1
Aux. 2nd Gear Brg.	F53543 ¹⁶	1
Aux. 3rd Gear Brg.	F53542 ¹⁶	1
Input Shaft Seal	456744N (36158)	1
Output Shaft Seal	415281N (29870)	1
Output Shaft Seal	415013N (29925)	1
Output Shaft Seal	415147 (24989)	1
Remote Control Seal	471267 (8660) •	2
Gasket Set	GT130	1

TRK-132		
Position	Part Number	Qty
Input Shaft Brg.	213SL	1
Input Shaft Pilot Brg.	R5206SK20	1
Output Shaft Brg.	N310L	1
Countershaft Front Brg.	M32161	1
Countershaft Rear Brg.	1310SL	1
Rev. Idler Gear Brg.	J401652	2
Input Shaft Seal	7412S (12363)	1
Output Shaft Seal	450316 (22446)	1
Remote Control Seal	6835S (7440)	1
Gasket Set	GT133	1

TRK-133		
Position	Part Number	Qty
Input Shaft Brg.	213SLV	1
Input Shaft Pilot Brg.	R5206SK20	1
Output Shaft Brg.	1311L	1
Countershaft Front Brg.	M32161	1
Countershaft Rear Brg.	1310SL	1
Rev. Idler Gear Brg.	J401652	2
Input Shaft Seal	450494 (17386) •	1
Output Shaft Seal	415483 (26190)	1
Output Shaft Seal (Ford)	475322N (27295)	1
Gasket Set	GT133	1

HD Transmission

¹⁶Some Models will use S456Q Loose Needles instead of F53542 or F53543 Caged Needles. S456Q not packed

• Not Packed In Kit

Heavy Duty Transmission Rebuild Kits



HD Transmission

TRK-139		
Position	Part Number	Qty
Input Shaft Brg.	MSN1314GELR	1
Input Shaft Pilot Brg.	MU7308L	1
Output Shaft Brg.	1312L	1
Countershaft Front Brg.	25590-25520	2
Countershaft Rear Brg.	MR1311GTAVR	1
Rev. Idler Gear Brg.	J402480	2
1st Gear Brg.	F53541	1
2nd Gear Brg.	F53540	1
3rd Gear Brg.	F53540	1
Input Shaft Seal	456744N (36158)	1
Output Shaft Seal	415013N (29925)	1
Remote Control Seal	350567 (8648) •	2
Gasket Set	GT141	1
Gasket Set	GT141A ¹⁷	1

TRK-140		
Position	Part Number	Qty
Input Shaft Brg.	MSN1314GELR	1
Input Shaft Pilot Brg.	MU7308L	1
Output Shaft Front Brg.	MU1312UM	1
Output Shaft Rear Brg.	MSNB1312GELR	1
Countershaft Front Brg.	25590-25520	2
Countershaft Rear Brg.	MR1312GEALR	1
Rev. Idler Gear Brg.	J402480	2
1st Gear Brg.	F53539	1
2nd Gear Brg.	F53539	1
3rd Gear Brg.	F53540	1
4th Gear Brg.	F53540	1
Input Shaft Seal	456744N (36158)	1
Output Shaft Seal	415013N (29925)	1
Remote Control Seal	350567 (8648)	2
Gasket Set	GT141	1

TRK-141		
Position	Part Number	Qty
Input Shaft Brg.	MSN1314GELR	1
Input Shaft Pilot Brg.	MU7308L	1
Output Shaft Front Brg.	MU1312UM	1
Output Shaft Rear Brg.	MSNB1312GELR	1
Countershaft Front Brg.	25590-25520	2
Countershaft Rear Brg.	MR1311GTAVR	1
Rev. Idler Gear Brg.	J402480	2
1st Gear Brg.	F53541	1
2nd Gear Brg.	F53540	1
3rd Gear Brg.	F53540	1
Input Shaft Seal	456744N (36158)	1
Output Shaft Seal	415013N (29925)	1
Remote Control Seal	350567 (8648) •	2
Gasket Set	GT141	1

TRK-145		
Position	Part Number	Qty
Input Shaft Brg.	209SLV	1
Input Shaft Pilot Bushing	BS61	1
Aux. Drive Gear Brg.	117L	1
Aux. Mainshaft Front Brg.	MU1307V	1
Aux. Mainshaft Rear Brg.	1212L	1
Countershaft Front Brg.	MU1207UGV	2
Countershaft Rear Brg.	MU1306UGV	2
Aux. Countershaft Front Brg.	M1305GGTV	2
Aux. Countershaft Rear Brg.	MU1308TVWS	2
Rev. Idler Gear Brg.	WJ162116	2
Input Shaft Seal (Dodge, Ford & I.H.)	452554N (14832)	1
Output Shaft Seal (Ford)	455088V (30098)	1
Aux. Output Shaft Seal	415991N (34891)	1
Snap Ring Set	SR145	1
Gasket Set	GT131A	1

TRK-145A		
Position	Part Number	Qty
Input Shaft Brg.	MU1209UGMR	1
Input Shaft Pilot Bushing	BS61	1
Aux. Drive Gear Brg.	117L	1
Aux. Mainshaft Front Brg.	MU1307V	1
Aux. Mainshaft Rear Brg.	1212L	1
Countershaft Front Brg.	MU1207UGV	2
Countershaft Rear Brg.	MU1306UGV	2
Aux. Countershaft Front Brg.	MR1206RUGV	2
Aux. Countershaft Rear Brg.	MR1308TV	2
Rev. Idler Gear Brg.	WJ162116	2
Input Shaft Seal	452554N (14832) •	1
Output Shaft Seal (Ford)	455088V (30098)	1
Aux. Output Shaft Seal	415991N (34891)	1
O-Ring	OK15092	1
O-Ring	OK15093	1
Snap Ring Set	SR145A	1
Gasket Set	GT131A	1

TRK-146		
Position	Part Number	Qty
Input Shaft Brg.	MU1209UGMR	1
Input Shaft Pilot Bushing	BS61	1
Aux. Drive Gear Brg.	117L	1
Aux. Mainshaft Brg.	390A Assy 902A2 (A3071)	1
Countershaft Front Brg.	MU1207UGV	2
Countershaft Rear Brg.	MU1306UGV	2
Aux. Countershaft Front Brg.	MU1306UV	2
Aux. Countershaft Rear Brg.	1310L	2
Rev. Idler Gear Brg.	WJ162116	2
Input Shaft Seal	452554N (14832)	1
Output Shaft Seal (Ford)	455088V (30098)	1
Aux. Output Shaft Seal	415983N (37330)	1
O-Ring Set	OK1000V	1
Snap Ring Set	SR146	1
Snap Ring	15980	1
Gasket Set	GT146	1

TRK-147		
Position	Part Number	Qty
Input Shaft Brg.	217SLE	1
Input Shaft Pilot Brg.	JH1812	1
Output Shaft Brg.	312LE	1
Countershaft Front Brg.	311L	2
Countershaft Rear Brg.	WR61209EX	2
Rev. Idler Gear Brg.	WJ162116	4
Countershaft Rear Snap Rings	SR348-1	2
Input Shaft Seal	412015V (21167)	1
Output Shaft Seal	3893V (37405)	1
Remote Control Seal	350567 (8648) •	2
Gasket Set	GT-147	1

TRK-148		
Position	Part Number	Qty
Input Shaft Brg.	N309L	1
Input Shaft Pilot Brg.	SRA5304	1
Output Shaft Brg.	N309L	1
Countershaft Front Brg.	M28161	1
Countershaft Rear Brg.	N309L	1
Rev. Idler Gear Brg.	F54970	2
Input Shaft Seal	7412S (12363) •	1
(1966-1972)		
Input Shaft Seal (1972 & Later)	472164 (17387)	1
Output Shaft Seal (2.5" I.D.)	471271 (24898)	1
Output Shaft Seal (2.25" I.D.)	450316 (22446)	1
Output Shaft Seal (2.625" I.D.)	411143N (26110)	1
Remote Control Seal	471267 (8660) •	1
Gasket Set	GT148	1

TRK-149		
Position	Part Number	Qty
Input Shaft Brg.	212SLV	1
Input Shaft Pilot Bushing	BS59	1
Aux. Drive Gear Brg.	118L	1
Aux. Mainshaft Brg.	29675 Assy 902A8 (A2892)	1
Countershaft Front Brg.	MSN1211REX	2
Countershaft Rear Brg.	MU1308TVWS	2
Aux. Countershaft Front Brg.	MU61307GUM ¹⁸	2
Aux. Countershaft Rear Brg.	1310SLV	2
Rev. Idler Gear Brg.	HJ223020-IR18200H	2
Aux. Range Shaft Quill Front Brg.	204	1
Aux. Range Shaft Quill Rear Bushing	BS60	1
Input Shaft Nut	CN1 (8997)	1
Output Shaft Seal	415983N (37330)	1
Aux. Output Shaft Seal	415991N (34891)	1
O-Ring Set	OK1000V	1
O-Ring Set	OK17453	1
Snap Ring Set	SR149	1
Gasket Set	GT200N	1
O-Ring	OR217V	1
O-Ring	OR221V	1

TRK-149/2		
Position	Part Number	Qty
Input Shaft Brg.	212SLV	1
Input Shaft Pilot Bushing	BS59	1
Aux. Drive Gear Brg.	118L	1
Aux. Mainshaft Brg.	29675 Assy 902A8 (A2892)	1
Countershaft Front Brg.	MSN1211REX	2
Countershaft Rear Brg.	MU1308TVWS	2
Aux. Countershaft Front Brg.	MR1307EX ¹⁸	2
Aux. Countershaft Rear Brg.	1310SLV	2
Rev. Idler Gear Brg.	HJ223020-IR18200H	2
Aux. Range Shaft Quill Front Brg.	204	1
Aux. Range Shaft Quill Rear Bushing	BS60	1
Input Shaft Nut	CN1 (8997)	1
Output Shaft Seal (3.75" Shaft)	415983N (37330)	1
Aux. Output Shaft Seal	415991N (34891)	1
O-Ring Set	OK1000V	1
O-Ring Set	OK17453	1
O-Ring	OR217V	1
O-Ring	OR221V	1
Snap Ring Set	SR149	1
Gasket Set	GT200N	1

¹⁷For Spicer Model 8844-A application only (Not packed in kit)

¹⁸Models before 1973; use MR5208EL

• Not Packed In Kit

Heavy Duty Transmission Rebuild Kits

TRK-149AUX		
Position	Part Number	Qty
Aux. Mainshaft Brg.	29675 Assy 902A8 (A2892)	1
Aux. Countershaft Front Brg.	MU61307GUM ¹⁸	2
Aux. Countershaft Rear Brg.	1310SLV	2
Aux. Range Shaft Quill Front Brg.	204	1
Aux. Range Shaft Quill Rear Bushing	BS60	1
Aux. Output Shaft Seal (3.75" I.D.)	415983N (37330)	1
O-Ring Set	OK1000V	1
O-Ring	OR217V	1
O-Ring	OR221V	1
Snap Ring Set	SR1000	1
Gasket Set	GT200N	1

TRK-149AUX/2		
Position	Part Number	Qty
Aux. Mainshaft Brg.	29675 Assy 902A8 (A2892)	1
Aux. Countershaft Front Brg.	MR1307EX ¹⁸	2
Aux. Countershaft Rear Brg.	1310SLV	2
Aux. Range Shaft Quill Front Brg.	204	1
Aux. Range Shaft Quill Rear Bushing	BS60	1
Aux. Output Shaft Seal	415983N (37330)	1
O-Ring Set	OK1000V	1
O-Ring	OR217V	1
O-Ring	OR221V	1
Snap Ring Set	SR1000	1
Gasket Set	GT200N	1

TRK-152		
Position	Part Number	Qty
Input Shaft Front Brg.	217SLE	1
Input Shaft Rear Brg.	1911S	1
Input Shaft Pilot Brg.	JH1812	1
Output Shaft Brg.	312LE	1
Countershaft Front Brg.	311L	2
Countershaft Rear Brg.	WR61209EX	2
Rev. Idler Gear Brg.	WJ162116	4
Countershaft Rear Snap Rings	SR348-1	2
Input Shaft Seal	412015V (21167)	1
Output Shaft Seal	3893V (37405)	1
Gasket Set	GT147	1

TRK-155		
Position	Part Number	Qty
Input Shaft Front Brg.	MR1212EL	1
Input Shaft Rear Brg.	MRB1313EL	1
Input Shaft Pilot Brg.	MR1308TV	1
Output Shaft Brg.	1412L	1
Countershaft Front Brg.	MR1311EAHL	1
Countershaft Rear Brg.	MR1311EAHL	1
Mainshaft 1st Gear Brg.	F53543	1
Mainshaft 2nd Gear Brg.	F53543	1
Mainshaft 3rd Gear Brg.	F53542	1
Input Shaft Seal	415281N (29870)	1
Output Shaft Seal	415281N (29870)	1
Shift Shaft Seal (Side Mount)	350567 (8648) •	4
Shift Shaft Seal (Top Mount)	450680 (8702) •	2
Gasket Set	GT155	1

TRK-156		
Position	Part Number	Qty
Input Shaft Brg.	212ASLB	1
Input Shaft Pilot Brg.	J362048	1
Input Shaft Pilot Brg.(T-495/T-496 Models)	WJ182420	1
Output Shaft Brg.	309L	1
Countershaft Front Brg.	M1207EL	1
Countershaft Rear Brg.	1308SL	1
Rev. Idler Gear Brg.	J361652	2
Input Shaft Seal (1.25 shaft)	471413 (12364)	1
Input Shaft Seal (1.375" Shaft)	452554N (14832)	1
Output Shaft Seal	411143N (26110)	1
Remote Control Seal	6835S (7440)	1
Shift Shaft Seal	240735 (7409)	1
Gasket Set	GT156	1

TRK-157A		
Position	Part Number	Qty
Input Shaft Brg.	N1211L	1
Input Shaft Pilot Brg.	QAR34604	1
Output Shaft Brg.	1308L	1
Countershaft Front Brg. (1978 & Earlier)	M1305GGTV	1
Countershaft Front Brg.(1979 & Later)	R1563TAV	1
Countershaft Rear Brg.	1308L	1
Input Shaft Seal	481181N (16054)	1
Output Shaft Seal	410085N (19970)	1
Gasket Set	GT157	1

TRK-157AWS		
Position	Part Number	Qty
Input Shaft Brg.	N1211L	1
Input Shaft Pilot Brg.	QAR34604	1
Output Shaft Brg.	1308L	1
Countershaft Front Brg. (1978 & Earlier)	M1305GGTV	1
Countershaft Front Brg.(1979 & Later)	R1563TAV	1
Countershaft Rear Brg.	1308L	1
Input Shaft Seal	481181N (16054)	1
Output Shaft Seal	410085N (19970)	1
Gasket Set	GT157	1
2nd Gear Synchro Ring	ZSY1001	1
3rd Gear Synchro Ring	ZSY1000	1
4th Gear Synchro Ring	ZSY1000	1

TRK-157B		
Position	Part Number	Qty
Input Shaft Brg.	211FFLE	1
Input Shaft Pilot Brg.	QAR34604	1
Output Shaft Brg.	1308L	1
Countershaft Front Brg.(1979 & Later)	R1563TAV	1
Countershaft Rear Brg.	1308L	1
Input Shaft Seal	481181N (16054)	1
Output Shaft Seal	410085N (19970)	1
Gasket Set	GT157	1

TRK-157BWS		
Position	Part Number	Qty
Input Shaft Brg.	211FFLE	1
Input Shaft Pilot Brg.	QAR34604	1
Output Shaft Brg.	1308L	1
Countershaft Front Brg.	R1563TAV	1
Countershaft Rear Brg.	1308L	1
Input Shaft Seal	481181N (16054)	1
Output Shaft Seal	410085N (19970)	1
Gasket Set	GT157	1
2nd Gear Synchro Ring	ZSY1001	1
3rd Gear Synchro Ring	ZSY1000	1
4th Gear Synchro Ring	ZSY1000	1

TRK-157L		
Position	Part Number	Qty
Input Shaft Brg.	N1211L	1
Input Shaft Pilot Brg.	QAR34604	1
Output Shaft Brg.	1308L	1
Countershaft Front Brg.(1979 & Later)	R1563TAV	1
Countershaft Rear Brg.	1308L	1
Input Shaft Seal	481181N (16054)	1
Output Shaft Seal	410085N (19970)	1
Gasket Set	GT157	1

TRK-157LWS		
Position	Part Number	Qty
Input Shaft Brg.	N1211L	1
Input Shaft Pilot Brg.	QAR34604	1
Output Shaft Brg.	1308L	1
Countershaft Front Brg.	R1563TAV	1
Countershaft Rear Brg.	1308L	1
Input Shaft Seal	481181N (16054)	1
Output Shaft Seal	410085N (19970)	1
Gasket Set	GT157	1
2nd Gear Synchro Ring	ZSY1001	1
3rd Gear Synchro Ring	ZSY1000	1
4th Gear Synchro Ring	ZSY1000	1

TRK-158		
Position	Part Number	Qty
Input Shaft Front Brg.	212	1
Input Shaft Rear Brg.	MR1213EL	1
Input Shaft Pilot Brg.	JH1812	1
Output Shaft Brg.	214LH	1
Countershaft Front Brg.	MU1311UGMR	2
Countershaft Rear Brg.	MR1309EAL	2
Input Shaft Seal	415281N (29870)	1
Output Shaft Seal	415035 (39934)	1
Shift Rail Seal	471570 (8702)	2
Gasket Set	GT158	1

TRK-159		
Position	Part Number	Qty
Input Shaft Brg.	212SLV	1
Input Shaft Pilot Bushing	BS59	1
Aux. Drive Gear Brg.	118L	1
Aux. Mainshaft Brg.	29675 Assy 902A8 (A2892)	1
Countershaft Front Brg.	MSN1211REX	2
Countershaft Rear Brg.	MU1308TVWS	2
Aux. Countershaft Front Brg.	MR1307EL ¹⁸	2
Aux. Countershaft Rear Brg.	5310WL	2
Rev. Idler Gear Brg.	HJ223020-IR18200H	2
Range Shaft Quill Front Brg.	204	1
Range Shaft Quill Rear Bushing	BS60	1
Input Shaft Nut	CN1 (8997)	1
Output Shaft Seal	415983N (37330)	1
Aux. Mainshaft Rear Seal	415991N (34891) •	1
O-Ring Set	OK1000V	1
Snap Ring Set	SR159	1
Gasket Set	GT200N	1

¹⁸Models before 1973; use MR5208EL

• Not Packed In Kit

Heavy Duty Transmission Rebuild Kits



HD Transmission

TRK-159A		
Position	Part Number	Qty
Input Shaft Brg.	212SLV	1
Input Shaft Pilot Bushing	BS59 •	1
Aux. Drive Gear Brg.	118L	1
Aux. Mainshaft Brg.	29675 Assy 902A8 (A2892)	1
Countershaft Front Brg.	BS500192SX	2
Countershaft Rear Brg.	MU1308TVWS	2
Rev. Idler Gear Brg.	HJ223020-IR18200H	2
Aux. Countershaft Brg.	MR1307EL	2
Aux. Countershaft Rear Brg.	5310WL	2
Range Shaft Quill Front Brg.	204	1
Range Shaft Quill Rear Bushing	BS60	1
Input Shaft Nut	CN1 (8997)	1
Output Shaft Seal	415983N (37330)	1
Aux. Mainshaft Rear Seal	415991N (34891) •	1
O-Ring Set	OK1000V	1
Snap Ring Set	SR159	1
Gasket Set	GT200N	1

TRK-160		
Position	Part Number	Qty
Input Shaft Brg.	212SLV	1
Input Shaft Pilot Bushing	BS59 •	1
Aux. Drive Gear Brg.	118L	1
Aux. Mainshaft Brg.	29675 Assy 902A8 (A2892)	1
Countershaft Front Brg.	MSN1211REX	2
Countershaft Rear Brg.	MU1308TVWS	2
Rev. Idler Gear Brg.	HJ223020-IR18200H	2
Aux. Countershaft Front Brg.	MR1307EL ¹⁸	2
Aux. Countershaft Rear Brg.	1311L	2
Input Shaft Nut	CN1 (8997)	1
Aux. Output Shaft Seal	415991N (34891)	1
Output Shaft Seal	415983N (37330)	1
O-Ring Set	OK1000V	1
Snap Ring Set	SR160	1
Gasket Set	GT200N	1

TRK-161		
Position	Part Number	Qty
Rear Output Shaft Front Brg.	14131-14276	1
Rear Output Shaft Rear Brg.	14131-14276	1
Intermediate Gear Brg.	Q13367	1
Intermediate Shaft Front Brg.	J361644	1
Intermediate Shaft Rear Brg.	J361644	1
Front Output Shaft Front Brg.	206	1
Shift Shaft Seal	450009 (6203)	2
Output Shaft Seal	472635 (15450)	2
Sealer	RTV Silicone	1

TRK-166A		
Position	Part Number	Qty
Front Output Shaft Front Brg.	14116-14276	1
Front Output Shaft Rear Brg.	14116-14276	1
Rear Output Shaft Front Brg.	25877-25821	1
Rear Output Shaft Rear Brg.	15117-15245	1
Intermediate Gear Brg.	Q13367	1
Shift Shaft Seal	450009 (6203)	1
Output Shaft Seal	472635 (15450)	2
Sealer	RTV Silicone	1

TRK-167		
Position	Part Number	Qty
Input Shaft Front Brg.	1309S	1
Input Shaft Rear Brg.	1307S	1
Idler Gear Front Brg.	HM89449-HM89411	1
Idler Gear Rear Brg.	31597-31521	1
Upper Output Shaft Front Brg.	25878-25821	1
Upper Output Shaft Rear Brg.	25584-25520	1
Lower Output Shaft Front Brg.	208L	1
Lower Output Shaft Rear Brg.	211L	1
Input Shaft Seal	471341N (22340)	1
Output Shaft Rear Seal	471341N (22340)	1
Declutch Shaft Seal	415483 (26190)	1
PTO Shaft Seal	470898 (21100)	1
Shift Shaft Seal	6835S (7440)	2
Sealer	RTV Silicone	1

TRK-174		
Position	Part Number	Qty
Input Shaft Brg.	HM88649-HM88610	1
Input Shaft Pilot Brg.	QBR42536	1
Output Shaft Brg.	25581-25520	1
Countershaft Front Brg.	M24161X1	1
Countershaft Rear Brg.	B3216	1
Rev. Idler Gear Brg.	Q8324	1
Rev. Idler Thrust Brg.	FA35688	1
Input Shaft Seal	471413 (12364)	1
Output Shaft Seal	470898 (21100)	1
Output Shaft Seal	473243 (21302)	1
Gasket Set	GT172	1

TRK-177		
Position	Part Number	Qty
Input Shaft Brg.	1213SL	1
Input Shaft Pilot Brg.	QBR35171	1
Output Shaft Brg.	1310L1	1
Countershaft Front Brg.	M28161	1
Countershaft Rear Brg.	MU1209UBM	1
Rev. Idler Gear Brg.	Q8321	4
Input Shaft Seal	481181N (16054)	1
Output Shaft Seal	450329 (26123)	1
Sealer	RTV Silicone	1

TRK-180		
Position	Part Number	Qty
Input Shaft Brg.	JM511946-JM511910	1
Input Shaft Pilot Brg.	2580	1
Output Shaft Brg.	JM511946-JM511910	1
Countershaft Front Brg.	25584-25520	1
Countershaft Rear Brg.	25584-25520	1
Rev. Idler Gear Brg.	WJ162116	2
Mainshaft 1st Gear Brg.	F81205	1
Mainshaft 2nd Gear Brg.	C437Q	1
Mainshaft Rev. Gear Brg.	F81205	1
Input Shaft Seal	452742 (17810)	1
Output Shaft Seal	471271 (24898)	1
Output Shaft Seal	415004 (27370)	1
Output Shaft Seal	475322N (27295) •	1
Remote Control Seal	350567 (8648) •	2
Gasket Set	GT180	1

TRK-181		
Position	Part Number	Qty
Input Shaft Brg.	217SLE	1
Input Shaft Pilot Brg.	JH1812	1
Output Shaft Brg.	312L	1
Countershaft Front Brg.	311L	2
Countershaft Rear Brg.	WR61209EX	2
Rev. Idler Gear Brg.	WJ162116	4
Output Shaft Rear Brg.	214L	1
Countershaft Rear Snap Rings	SR348-1	2
Input Shaft Seal	412015V (21167)	1
Output Shaft Seal	3893V (37405)	1
Gasket Set	GT181	1

TRK-182		
Position	Part Number	Qty
Input Shaft Front Brg.	209	1
Front Output Shaft Front Brg.	M86649-M86610	1
Front Output Shaft Rear Brg.	M86649-M86610	1
Rear Output Shaft Front Brg.	25877-25821	1
Rear Output Shaft Rear Brg.	15117-15245	1
Rear Output Shaft Pilot Brg.	JH1612	1
Intermediate Shaft Brg.	Q13367	48
Shift Rail Seal	450009 (6203)	2
Output Shaft Front Seal	711552 (15635)	1
Output Shaft Rear Seal	711552 (15635)	1
Input Shaft Seal	471689 (9998)	1
Gasket Set	GT181	1

TRK-183		
Position	Part Number	Qty
Input Shaft Brg.	212ASLB	1
Input Shaft Pilot Brg.	WJ182420	1
Output Shaft Brg.	309L	1
Countershaft Front Brg.	M1207EL	1
Countershaft Rear Brg.	1308SL	1
Rev. Idler Gear Brg.	J361652	4
1st Gear Brg.	Q8308	1
2nd Gear Brg.	Q8371	1
Rev. Gear Brg.	Q8308	1
1st Gear Thrust Brg.	RA53421 •	1
Rev. Gear Thrust Brg.	RA53422 •	1
Thrust Brg. Spacer	JB53851	1
Input Shaft Seal (1.25 shaft)	471413 (12364)	1
Input Shaft Seal (1.5 shaft)	452554N (14832)	1
Output Shaft Seal	411143N (26110)	1
Gasket Set	GT156	1

Heavy Duty Transmission Rebuild Kits

TRK-184			TRK-187			TRK-190				
Position	Part Number	Qty	Position	Part Number	Qty	Position	Part Number	Qty		
Input Shaft Brg.	212SLV	1	Input Shaft Brg.	214SL	1	Input Shaft Brg.	M802048-M802011	1		
Input Shaft Pilot Bushing	BS59 •	1	Input Shaft Pilot Brg.	7205TA	1	Input Shaft Pilot Brg.	QBR49845	1		
Aux. Drive Gear Brg.	117L	1	Output Shaft Pilot Brg.	IR2016-B2416	1	Output Shaft Brg.	25584-25547RB	1		
Aux. Mainshaft Brg.	29675 Assy 902A8 (A2892)	1	Output Shaft Front Brg.	214L	1	Countershaft Front Brg.	M28161	1		
Countershaft Front Brg.	MSN1211REX	2	Output Shaft Rear Brg.	MA1213EL	1	Countershaft Rear Brg.	MU1309SGNV	1		
Rev. Idler Gear Brg.	HJ223020-IR18200H	2	Countershaft Front Brg.	308L	3	Rev. Idler Gear Brg.	J361644 ²⁰	2		
Countershaft Rear Brg.	MU1308TVWS	2	Countershaft Rear Brg.	MAR5209-M5209EL	3	4th & 5th Shift Hub Brg.	FA35688	1		
Aux. Countershaft Front Brg.	MR1307EL	2	Rear Countershaft Front Brg.	MAR5209-M1209EL	3	4th & 5th Shift Hub Race	TR235383	1		
Aux. Countershaft Rear Brg.	5310WL	2	Rear Countershaft Rear Brg.	1208L	3	Input Shaft Seal	473010N (16247)	1		
Range Shaft Quill Front Brg.	204	1	Rev. Idler Gear Brg.	J361648	3	Output Shaft Seal	471271 (24898)	1		
Range Shaft Quill Rear Brg.	BS60	1	Shift Rail Brg.	SCE2014P	3	Output Shaft Seal	475322N (27295)	1		
Input Shaft Nut	CN1 (8997)	1	Input Shaft Seal	415027N (35083)	1	Gasket Set	GT148	1		
Output Shaft Seal	415983N (37330)	1	Output Shaft Seal	2822V (20599)	1	TRK-191				
O-Ring Set	OK1000V	1	Clutch Release Seal	343186 (12330)	1	Position	Part Number	Qty		
Snap Ring Set	SR184	1	Shift Rail Seal	7750 (7414)	2	Input Shaft Brg.	MR1211GEL	1		
Gasket Set	GT200N	1	O-Ring	OK6561	1	Input Shaft Pilot Brg.	MR1205EL	1		
TRK-185			TRK-188			Mainshaft Rear Brg.			214L	1
Position	Part Number	Qty	Position	Part Number	Qty	Aux. Mainshaft Pilot Brg.			MU1207TV	1
Input Shaft Brg.	214L	1	Input Shaft Brg.	212SLV	1	Aux. Mainshaft Rear Brg.			214L	1
Input Shaft Pilot Brg.	MA1205EL	1	Input Shaft Pilot Bushing	BS59 •	1	Countershaft Front Brg.			1311L	2
Output Shaft Brg.	214L	1	Aux. Drive Gear Brg.	117L	1	Countershaft Rear Brg.			WR61209EX	2
Countershaft Front Brg.	308L	3	Aux. Mainshaft Brg.	29675 Assy 902A8 (A2892)	1	Rev. Idler Gear Brg.			WJ162116	4
Countershaft Rear Brg.	MA1209EL	3	Countershaft Front Brg.	MSN1211REX	2	Aux. Countershaft Front Brg.			JLM104948-JLM104910	2
Rear Countershaft Rear Brg.	1208L ¹⁹	2	Countershaft Rear Brg.	MU1308TVWS	2	Aux. Countershaft Rear Brg.			JLM506849-JLM506810	2
Rev. Idler Gear Brg.	J361648	3	Rev. Idler Gear Brg.	HJ223020-IR18200H	2	Input Shaft Seal			412015V (21167)	1
Shift Rail Brg.	SCE2014P	3	Aux. Countershaft Front Brg.	MR1307EL	2	Output Shaft Seal			3893V (37405)	1
Input Shaft Seal	2822V (20599)	1	Aux. Countershaft Rear Brg.	1311L	2	Countershaft Rear Snap Rings			SR348-1	2
Output Shaft Seal	415991N (34891)	1	Input Shaft Nut	CN1 (8997)	1	Gasket Set			GT191	1
Clutch Release Seal	343186 (12330)	1	Output Shaft Seal	415983N (37330)	1	TRK-192				
Shift Rail Seal	7750 (7414)	2	O-Ring Set	OK1000V	1	Position	Part Number	Qty		
O-Ring	OK6561	1	Snap Ring Set	SR185	1	Input Shaft Brg.	MR1211GEL	1		
Snap Ring Set	SR184	1	Gasket Set	GT213	1	Input Shaft Pilot Brg.	MR1205EL	1		
Gasket Set	GT213	1	TRK-186			Output Shaft Brg.			214L	1
Position	Part Number	Qty	Position	Part Number	Qty	Countershaft Front Brg.			1311L	2
Input Shaft Brg.	JM511946-JM511910	1	Input Shaft Brg.	217SLE	1	Countershaft Rear Brg.			WR61209EX	2
Input Shaft Pilot Brg.	25877-25821	1	Input Shaft Pilot Brg.	JH1812	1	Countershaft Rear Brg.			MU1209TM •	2
Output Shaft Brg.	3979-JM511910	1	Mainshaft Rear Brg.	312L	1	(GMC Models)				
Countershaft Front Brg.	M804049-M804010	1	Aux. Mainshaft Pilot Brg.	1911S	1	Rev. Idler Gear Brg.			WJ162116	4
Countershaft Rear Brg.	JLM506849-JLM506810	1	Aux. Mainshaft Rear Brg.	214L	1	Input Shaft Seal			412015V (21167)	1
Rev. Idler Gear Brg.	WJ162116	2	Brg.			Input Shaft Seal			473010N (16247)	1
Mainshaft 1st & Rev. Gear Brg.	F56619	2	Countershaft Front Brg.	MSN1311GELR	2	Mainshaft Rear Seal			3893V (37405)	1
Input Shaft Seal	452742 (17810)	1	Countershaft Rear Brg.	WR61209EX	2	Countershaft Rear Snap Rings			SR348-1	2
Output Shaft Seal	415004 (27370)	1	Rev. Idler Gear Brg.	WJ162116	4	Gasket Set			GT192	1
Output Shaft Seal	475322N (27295) •	1	Output Shaft Brg.	MU1207UGV	1	TRK-193				
Gasket Set	GT186	1	Aux. Countershaft Front Brg.	JLM104948-JLM104910	2	Position	Part Number	Qty		
			Aux. Countershaft Rear Brg.	JLM104948-JLM104910	2	Input Shaft Brg.	217SLE ²¹	1		
			Input Shaft Seal	415013N (29925)	1	Input Shaft Pilot Brg.	JH1812	1		
			Input Shaft Seal	412015V (21167)	1	Output Shaft Brg.	214LH	1		
			Output Shaft Seal	3893V (37405)	1	Countershaft Front Brg.	1311L	2		
			Countershaft Rear Snap Rings	SR348-1	2	Countershaft Rear Brg.	WR61209EX	2		
			Gasket Set	GT189	1	Countershaft Rear Brg.	MU1209TM •	2		
						(GMC Models)				
						Rev. Idler Gear Brg.			WJ162116	4
						Input Shaft Seal			412015V (21167)	1
						Mainshaft Rear Seal			455379V (37405)	1
						Countershaft Rear Snap Rings			SR348-1	2
						Gasket Set			GT193	1

HD Transmission

¹⁹Model TRL1078 requires 1 additional 1208L not packed in kit
²¹For 1986 & Later Models; use MR1211GEL (Not packed in kit)

²⁰Some Late GMC may use F54970
 • Not Packed In Kit

Heavy Duty Transmission Rebuild Kits



HD Transmission

TRK-194		
Position	Part Number	Qty
Input Shaft Brg.	MR1211GEL	1
Input Shaft Pilot Brg.	JH1812	1
Mainshaft Rear Brg.	214L	1
Aux. Mainshaft Pilot Brg.	MU1207UGV	1
Aux. Mainshaft Rear Brg.	214L	1
Countershaft Front Brg.	MU1311UGMR	2
Countershaft Rear Brg.	WR61209EX	2
Countershaft Rear Brg.	MU1209TM •	2
(GMC Models)		
Rev. Idler Gear Brg.	WJ162116	4
Aux. Countershaft Front Brg.	JLM104948-JLM104910	2
Aux. Countershaft Rear Brg.	JLM506849-JLM506810	2
Input Shaft Seal	412015V (21167)	1
Output Shaft Seal	3893V (37405)	1
Countershaft Rear Snap Rings	SR348-1	2
Gasket Set	GT191	1

TRK-201		
Position	Part Number	Qty
Input Shaft Brg.	212SLV	1
Input Shaft Pilot Bushing	BS59	1
Aux. Drive Gear Brg.	118L	1
Aux. Mainshaft Brg.	29675 Assy 902A8 (A2892)	1
Countershaft Front Brg.	BS500192SX	2
Countershaft Rear Brg.	MU1308TVWS	2
Rev. Idler Gear Brg.	HJ223020-IR18200H	2
Aux. Countershaft Front Brg.	MR1307EL	2
Aux. Countershaft Rear Brg.	1311L	2
Input Shaft Nut	CN1 (8997)	1
Output Shaft Seal	415983N (37330)	1
O-Ring Set	OK1000V	1
O-Ring Set	OK17453	1
Snap Ring Set	SR201	1
Gasket Set	GT200N	1

TRK-202		
Position	Part Number	Qty
Input Shaft Brg.	212SLV	1
Input Shaft Pilot Bushing	BS59	1
Aux. Drive Gear Brg.	118L	1
Aux. Mainshaft Brg.	29675 Assy 902A8 (A2892)	1
Countershaft Front Brg.	BS500192SX	2
Countershaft Rear Brg.	MU1308TVWS	2
Rev. Idler Gear Brg.	HJ223020-IR18200H	2
Aux. Countershaft Front Brg.	MR1307EL	2
Aux. Countershaft Rear Brg.	5310WLB	2
Range Shaft Quill Front Brg.	204	1
Range Shaft Quill Rear Bushing	BS60	1
Input Shaft Nut	CN1 (8997)	1
Aux. Mainshaft Rear Seal	415983N (37330)	1
O-Ring Set	OK1000V	1
O-Ring Set	OK17453	1
Snap Ring Set	SR202	1
Gasket Set	GT200N	1

TRK-203		
Position	Part Number	Qty
Input Shaft Brg.	212SLV	1
Input Shaft Pilot Bushing	BS59	1
Aux. Drive Gear Brg.	118L	1
Aux. Mainshaft Brg.	390A Assy 902A2 (A3071)	1
Countershaft Front Brg.	BS500192SX	2
Countershaft Rear Brg.	MU1308TVWS	2
Countershaft Rear Brg.	MR1308TV ²²	2
Rev. Idler Gear Brg.	HJ223020-IR18200H	2
Aux. Countershaft Front Brg.	MR1307EL	2
Aux. Countershaft Rear Brg.	1310L	2
Range Shaft Quill Front Brg.	204	1
Range Shaft Quill Rear Bushing	BS60	1
Input Shaft Nut	CN1 (8997)	1
Aux. Mainshaft Rear Seal	415983N (37330)	1
O-Ring Set	OK1000V	1
O-Ring Set	OK17453	1
Snap Ring Set	SR159	1
Gasket Set	GT200N	1

TRK-204		
Position	Part Number	Qty
Input Shaft Brg.	212SLV	1
Input Shaft Pilot Bushing	BS59	1
Output Shaft Brg.	214LB	1
Countershaft Front Brg.	BS500192SX	2
Countershaft Rear Brg.	BS500192SX	2
Countershaft Front Brg.	1213A	1
Countershaft Rear Brg.	1213A	1
Rev. Idler Gear Brg.	WJ162116	4
Input Shaft Nut	CN1 (8997)	1
Output Shaft Seal	415983N (37330)	1
O-Ring Set	OK20128	1
Snap Ring Set	SR204	1
Gasket Set	GT200N	1

TRK-205		
Position	Part Number	Qty
Input Shaft Brg.	212SLV	1
Input Shaft Pilot Bushing	BS59	1
Aux. Drive Gear Brg.	118L	1
Aux. Mainshaft Brg.	29675 Assy 902A8 (A2892)	1
Countershaft Front Brg.	BS500192SX	2
Countershaft Rear Brg.	MU1308TVWS	2
Rev. Idler Gear Brg.	HJ223020-IR18200H	2
Aux. Countershaft Front Brg.	MR1307EL	2
Aux. Countershaft Rear Brg.	1311L	2
Input Shaft Nut	CN1 (8997)	1
Aux. Mainshaft Rear Seal	415983N (37330)	1
O-Ring Set	OK1000V	1
O-Ring Set	OK17453	1
Snap Ring Set	SR160	1
Gasket Set	GT200N	1

TRK-206		
Position	Part Number	Qty
Input Shaft Brg.	212SLV	1
Input Shaft Pilot Bushing	BS59	1
Aux. Drive Gear Brg.	118L	1
Aux. Mainshaft Brg.	29675 Assy 902A8 (A2892)	1
Countershaft Front Brg.	BS500192SX	2
Countershaft Rear Brg.	MU1308TVWS	2
Rev. Idler Gear Brg.	HJ223020-IR18200H	2
Aux. Countershaft Front Brg.	MU61307GUM	2
Aux. Countershaft Rear Brg.	1310SLV	2
Range Shaft Quill Front Brg.	204	1
Range Shaft Quill Rear Bushing	BS60	1
Input Shaft Nut	CN1 (8997)	1
Aux. Mainshaft Rear Seal	415983N (37330)	1
O-Ring Set	OK1000V	1
O-Ring Set	OK17453	1
O-Ring	OR217V	1
O-Ring	OR221V	1
Snap Ring Set	SR159	1
Gasket Set	GT200N	1

TRK-206/2		
Position	Part Number	Qty
Input Shaft Brg.	212SLV	1
Input Shaft Pilot Bushing	BS59	1
Aux. Drive Gear Brg.	118L	1
Aux. Mainshaft Brg.	29675 Assy 902A8 (A2892)	1
Countershaft Front Brg.	BS500192SX	2
Countershaft Rear Brg.	MU1308TVWS	2
Rev. Idler Gear Brg.	HJ223020-IR18200H	2
Aux. Countershaft Front Brg.	MR1307EX	2
Aux. Countershaft Rear Brg.	1310SLV	2
Range Shaft Quill Front Brg.	204	1
Range Shaft Quill Rear Bushing	BS60	1
Input Shaft Nut	CN1 (8997)	1
Aux. Mainshaft Rear Seal	415983N (37330)	1
O-Ring Set	OK1000V	1
O-Ring Set	OK17453	1
O-Ring	OR217V	1
O-Ring	OR221V	1
Snap Ring Set	SR159	1
Gasket Set	GT200N	1

Heavy Duty Transmission Rebuild Kits

TRK-207			TRK-210			TRK-214			
Position	Part Number	Qty	Position	Part Number	Qty	Position	Part Number	Qty	
Input Shaft Brg.	212SLV	1	Input Shaft Brg.	7211HL	1	Input Shaft Brg.	214S	1	
Input Shaft Pilot Bushing	BS59	1	Input Shaft Pilot Brg.	SCE2420	1	Input Shaft Pilot Brg.	MA1205EL	1	
Aux. Drive Gear Brg.	118L	1	Output Shaft Brg.	7211HL	1	Output Shaft Pilot Brg.	IR1816-SCH2216	1	
Aux. Mainshaft Brg.	29675 Assy 902A8 (A2892)	1	Countershaft Front Brg.	LM48548-LM48510	1	Output Shaft Front Brg.	118L	1	
Countershaft Front Brg.	BS500192SX	2	Countershaft Rear Brg.	LM102949-LM102910	1	Output Shaft Rear Brg.	83B043C3	1	
Countershaft Rear Brg.	MU1308TVWS	2	Mainshaft 1st and Rev. Gear Brg.	F93290	2	Countershaft Front Brg.	JLM104948-JLM104910	3	
Rev. Idler Gear Brg.	HJ223020-IR18200H	2	Mainshaft 2nd Gear Brg.	F95407	1	Countershaft Rear Brg.	LM501349-LM501310	3	
Aux. Countershaft Front Brg.	MR1307EL	2	Rev. Idler Gear Brg.	WJ162116	2	Rear Countershaft Front Brg.	LM501349-LM501310	3	
Aux. Countershaft Rear Brg.	5310WLB	2	Drive Gear Seal	330749V (15506)	1	Rear Countershaft Rear Brg.	3780-3720	3	
Range Shaft Quill Front Brg.	204	1	Drive Gear Seal	5133 (18049) ²⁴	1	Rev. Idler Gear Brg.	JH1818	3	
Range Shaft Quill Rear Bushing	BS60	1	Output Shaft Seal	415322V (27293)	1	Countershaft Rear Brg.	IR1816	1	
Input Shaft Nut	CN1 (8997)	1	Gasket Set	GT210	1	Shift Rail Brg.	B1612	2	
Aux. Mainshaft Rear Seal	415983N (37330)	1	TRK-213			Input Shaft Seal	2822V (20599)	1	
O-Ring Set	OK1000V	1	Position	Part Number	Qty	Output Shaft Seal	415983N (37330)	1	
O-Ring Set	OK17453	1	Input Shaft Brg.	214SL	1	Shift Rail Seal	240731 (9815)	1	
Snap Ring Set	SR207	1	Input Shaft Pilot Brg.	MA1205EL	1	Snap Ring Set	SR214	1	
Gasket Set	GT200N	1	Main Drive Gear Brg.	214L	1	Gasket Set	GT214	1	
TRK-208			Main Drive Gear Pilot Brg.	7205TA	1	TRK-214MK			
Position	Part Number	Qty	Output Shaft Pilot Brg.	IR2016-B2416	1	Position	Part Number	Qty	
Input Shaft Brg.	M802048-M802011	1	Output Shaft Front Brg.	214L	1	Input Shaft Brg.	214S	1	
Input Shaft Pilot Brg.	QBR49845	1	Output Shaft Rear Brg.	MA1213EL	1	Input Shaft Pilot Brg.	MA1205EL	1	
Output Shaft Brg.	25581-25520	1	Compound Case	308L	3	Output Shaft Pilot Brg.	IR1816-SCH2216	1	
Countershaft Front Brg.	25877-25821	1	Countershaft Front Brg.	Countershaft Front Brg.	308LH	3	Output Shaft Front Brg.	118L	1
Countershaft Rear Brg.	2689-2631	1	Countershaft Rear Brg.	MAR5209-M5209EL	3	Output Shaft Rear Brg.	83B043C3	1	
Rev. Idler Gear Brg.	QA48181A	1	Rear Countershaft Front Brg.	MAR5209-M1209EL	3	Countershaft Front Brg.	JLM104948-JLM104910	3	
Mainshaft 1st & 2nd Gear Brg.	F94490	2	Rear Countershaft Rear Brg.	1208L	3	Countershaft Rear Brg.	LM501349-LM501310	3	
Mainshaft 3rd & Rev. Gear Brg.	F84003	2	Rev. Idler Gear Brg.	J361648	3	Rear Countershaft Front Brg.	LM501349-LM501310	3	
Mainshaft 4th Gear Brg.	F94488	1	Shift Rail Brg.	SCE2014P	2	Rear Countershaft Rear Brg.	3780-3720	3	
4th & 5th Shift Hub Brg.	FA35688	1	Input Shaft Seal	2822V (20599)	1	Rev. Idler Gear Brg.	JH1818	3	
4th & 5th Shift Hub Race	TR235383	1	Output Shaft Seal	415027N (35083)	1	Countershaft Rear Brg.	IR1816	1	
Input Shaft Seal	473010N (16247)	1	Clutch Release Shaft Seal	343186 (12330)	1	Shift Rail Brg.	B1612	2	
Output Shaft Seal	471271 (24898)	1	Shift Rail Seal	7750 (7414)	1	Input Shaft Seal	2822V (20599)	1	
Output Shaft Seal	712512	1	O-Ring Set	OK213	1	Output Shaft Seal	415983N (37330)	1	
Gasket Set	GT208	1	Snap Ring Set	SR213	1	Shift Rail Seal	240731 (9815)	1	
TRK-208D			Gasket Set	GT213	1	Snap Ring Set	SR214	1	
Position	Part Number	Qty	TRK-213SD			Gasket Set	GT214	1	
Input Shaft Brg.	M804049-M804010	1	Position	Part Number	Qty	Washer Set	WK214	1	
Input Shaft Pilot Brg.	QBR49845	1	Input Shaft Brg.	214SL	1	Shim Set	SH214	1	
Output Shaft Brg.	25581-25520	1	Input Shaft Pilot Brg.	MA1205EL	1	Small Parts Kit	SPK214	1	
Countershaft Front Brg.	25877-25821	1	Main Drive Gear Brg.	214L	1	TRK-214MK1			
Countershaft Rear Brg.	2689-2631	1	Main Drive Gear Pilot Brg.	7205TA	1	Position	Part Number	Qty	
4th & 5th Shift Hub Brg.	FA35688	1	Output Shaft Pilot Brg.	IR2016-B2416	1	Input Shaft Brg.	214S	1	
4th & 5th Shift Hub Race	TR235383	1	Output Shaft Front Brg.	214L	1	Input Shaft Pilot Brg.	MA1205EL	1	
Mainshaft 1st & 2nd Gear Brg.	F94490	2	Output Shaft Rear Brg.	MA1213EL	1	Output Shaft Pilot Brg.	IR1816-SCH2216	1	
Mainshaft 3rd & Rev. Gear Brg.	F84003	2	Compound Case	MU1308RUMW3	3	Output Shaft Front Brg.	118L	1	
Mainshaft 4th Gear Brg.	F94488	1	Countershaft Front Brg.	Countershaft Front Brg.	206	Output Shaft Rear Brg.	83B043C3	1	
Rev. Idler Gear Brg.	QA48181A	1	Compound Case	206	Countershaft Rear Brg.	JLM104948-JLM104910	3		
Input Shaft Seal	710211	1	Countershaft Rear Brg.	MAR5209-M5209EL	3	Countershaft Rear Brg.	LM501349-LM501310	3	
Output Shaft Seal	712512	1	Rear Countershaft Front Brg.	MAR5209-M1209EL	3	Rear Countershaft Front Brg.	LM501349-LM501310	3	
Gasket Set	GT208	1	Rear Countershaft Rear Brg.	MU1208RUMW3	3	Rear Countershaft Rear Brg.	3780-3720	3	
			Rev. Idler Gear Brg.	J361648	3	Rev. Idler Gear Brg.	JH1818	3	
			Shift Rail Brg.	SCE2014P	2	Countershaft Rear Brg.	IR1816	1	
			Input Shaft Seal	2822V (20599)	1	Shift Rail Brg.	B1612	2	
			Output Shaft Seal	415027N (35083)	1	Input Shaft Seal	2822V (20599)	1	
			Clutch Release Shaft Seal	343186 (12330)	1	Output Shaft Seal	415983N (37330)	1	
			Shift Rail Seal	7750 (7414)	1	Shift Rail Seal	240731 (9815)	1	
			O-Ring Set	OK213	1	Snap Ring Set	SR214	1	
			Snap Ring Set	SR213	1	Gasket Set	GT214	1	
			Gasket Set	GT213	1	Washer Set	WK214-1	1	
						Shim Set	SH214	1	
						Small Parts Kit	SPK214-1	1	

HD Transmission

²⁴With Ford E4HT7003ATA, BNA, E5HT-JA, KA

Heavy Duty Transmission Rebuild Kits

HD Transmission

TRK-219		
Position	Part Number	Qty
Input Shaft Brg.	7211HFL	1
Input Shaft Pilot Brg.	MU5206L	1
Output Shaft Brg.	7211HL	1
Countershaft Front Brg.	LM48548-LM48510	1
Countershaft Rear Brg.	LM102949-LM102910	1
1st Gear Brg.	F93290	1
2nd Gear Brg.	F95407	1
3rd Gear Brg.	FW505520	2
4th Gear Brg.	FW455017	2
Rev. Gear Brg.	F93290	1
Rev. Idler Gear Brg.	WJ162116	2
Input Shaft Seal	39920	1
Input Shaft Seal	39930	1
Output Shaft Seal	415322V (27293)	1
Snap Ring Set	SR219	1
Gasket Set	GT210	1

TRK-221		
Position	Part Number	Qty
Input Shaft Brg.	7211HFL	1
Input Shaft Pilot Brg.	MU5206L	1
Output Shaft Brg.	7211HL	1
Countershaft Front Brg.	LM48548-LM48510	1
Countershaft Rear Brg.	2788A-2729	1
Rev. Idler Gear Brg.	WJ162116	2
1st Gear Brg.	F208323	1
2nd Gear Brg.	F93290	2
3rd Gear Brg.	F95407	1
4th Gear Brg.	F209348	1
Input Shaft Seal	39920	1
Input Shaft Seal	39930	1
Output Shaft Seal	415322V (27293)	1
Snap Ring Set	SR220	1
Gasket Set	GT221	1

TRK-222		
Position	Part Number	Qty
Input Shaft Brg.	1213L	1
Input Shaft Pilot Brg.	MU5206L	1
Output Shaft Center Brg.	1213L	1
Output Shaft Rear Brg.	7211HL	1
Countershaft Front Brg.	2788A-2729	1
Countershaft Center Brg.	MB1212GEXR	1
Countershaft Rear Brg.	2788A-2729	1
Rev. Idler Gear Brg.	WJ162116	2
1st Gear Brg.	F208323	1
2nd Gear Brg.	F208323	1
3rd Gear Brg.	F208323	1
4th Gear Brg.	FW657020	1
4th Gear Brg.	FW657030	1
4th/5th Shift Hub Brg.	FWH556320	2
6th Gear Brg.	FW475325	2
Rev. Gear Brg.	F208323	1
Input Shaft Seal	39925	1
Output Shaft Seal	415322V (27293)	1
Snap Ring Set	SR221	1
Gasket Set	GT221	1

TRK-226		
Position	Part Number	Qty
Intermediate Shaft Front Brg.	2788-2720	1
Intermediate Shaft Rear Brg.	25877-25821	1
Output Shaft Brg.	MR1307EX	2
Rev. Shaft Brg.	MR1307EXW927	2
Shift Rod Seal	471570 (8702)	4
Output Shaft Seal	472015 (21164)	1
Gasket Set	GT226	1

TRK-390F		
Position	Part Number	Qty
Input Shaft Brg.	M802048-M802011	1
Input Shaft Pilot Brg.	QBR49845	1
Output Shaft Brg.	28580-28527RB	1
Countershaft Front Brg.	DD46386	1
Countershaft Rear Brg.	MU1309UGM	1
Rev. Idler Gear Brg.	QA47838	1
Mainshaft Gear Brg.	QA48181A	1
4th & 5th Shift Hub Brg.	FA35688	1
4th & 5th Shift Hub Race	TR235383	1
Input Shaft Seal	473010N (16247)	1
Mainshaft Rear Seal	475322N (27295)	1
Mainshaft 4th Gear Brg.	F94488	1
Mainshaft 2nd, 3rd & Rev. Gear Brg.	F94490	3
Gasket Set	GT390FGH	1

TRK-390G		
Position	Part Number	Qty
Input Shaft Brg.	M802048-M802011	1
Input Shaft Pilot Brg.	QBR49845	1
Output Shaft Brg.	25584-25547RB	1
Countershaft Front Brg.	DD46386	1
Countershaft Rear Brg.	MU1309UGM	1
Rev. Idler Gear Brg.	QA47838	1
Mainshaft Gear Brg.	QA48181A	1
4th & 5th Shift Hub Brg.	FA35688	1
4th & 5th Shift Hub Race	TR235383	1
Input Shaft Seal (with 1.625" Shaft)	473010N (16247)	1
Driveshaft Rear Seal (w/ 1.875" Shaft)	482041N (18555)	1
Mainshaft Rear Seal (w/ 2.750" Shaft)	485364N (27272)	1
Mainshaft Rear Seal (w/ 2.500" Shaft)	471271 (24898)	1
Mainshaft 4th Gear Brg.	F94488	1
Mainshaft 2nd, 3rd & Rev. Gear Brg.	F94490	3
Gasket Set	GT390FGH	1

TRK-390H		
Position	Part Number	Qty
Input Shaft Brg.	M804049-M804010	1
Input Shaft Pilot Brg.	QBR49845	1
Output Shaft Brg.	28580-28527RB	1
Countershaft Front Brg.	DD46386	1
Countershaft Rear Brg.	MU1309UGM	1
Rev. Idler Gear Brg.	QA47838	1
Mainshaft Gear Brg.	QA48181A	1
4th & 5th Shift Hub Brg.	FA35688	1
4th & 5th Shift Hub Race	TR235383	1
Input Shaft Seal	482041N (18555)	1
Output Shaft Seal (GMC)	485364N (27272)	1
Output Shaft Seal (I.H.)	411143N (26110)	1
Mainshaft 4th Gear Brg.	F94488	1
Mainshaft 2nd, 3rd & Rev. Gear Brg.	F94490	3
Gasket Set	GT390FGH	1

TRK-395F		
Position	Part Number	Qty
Input Shaft Brg.	M802048-M802011	1
Input Shaft Pilot Brg.	QBR49845	1
Output Shaft Brg.	28580-28527RB	1
Countershaft Front & Rear Brg.	25590-25520	2
4th & 5th Shift Hub Brg.	FA35688	1
4th & 5th Shift Hub Race	TR235383	1
Mainshaft 1st Gear Brg.	QA48181A	2
Mainshaft 2nd, 3rd & Rev. Gear Brg.	F94490	3
Mainshaft 4th Gear Brg.	F94488	1
Rev. Idler Gear Brg.	QA47838	1
Input Shaft Seal	473010N (16247)	1
Output Shaft Seal	475322N (27295)	1
Gasket Set	GT390FGH	1

TRK-395G		
Position	Part Number	Qty
Input Shaft Brg.	M802048-M802011	1
Input Shaft Pilot Brg.	QBR49845	1
Output Shaft Brg.	25584-25547RB	1
Countershaft Front & Rear Brg.	25590-25520	2
4th & 5th Shift Hub Brg.	FA35688	1
4th & 5th Shift Hub Race	TR235383	1
Mainshaft 1st Gear Brg.	QA48181A	2
Mainshaft 2nd, 3rd & Rev. Gear Brg.	F94490	3
Mainshaft 4th Gear Brg.	F94488	1
Rev. Idler Gear Brg.	QA47838	1
Input Shaft Seal	473010N (16247)	1
Output Shaft Seal	712512	1
Gasket Set	GT390FGH	1

TRK-395H		
Position	Part Number	Qty
Input Shaft Brg.	M804049-M804010	1
Input Shaft Pilot Brg.	QBR49845	1
Output Shaft Brg.	28580-28527RB	1
Countershaft Front & Rear Brg.	25590-25520	2
4th & 5th Shift Hub Brg.	FA35688	1
4th & 5th Shift Hub Race	TR235383	1
Mainshaft 1st Gear Brg.	QA48181A	2
Mainshaft 2nd, 3rd & Rev. Gear Brg.	F94490	3
Mainshaft 4th Gear Brg.	F94488	1
Rev. Idler Gear Brg.	QA47838	1
Input Shaft Seal	482041N (18555)	1
Output Shaft Seal	411143N (26110)	1
Output Shaft Seal	475322N (27295)	1
Gasket Set	GT390FGH	1

TRK-400		
Position	Part Number	Qty
Input Shaft Brg.	1212S	1
Input Shaft Rear Brg.	MU1313RUMW3	1
Input Shaft Seal	308	1
Aux. Mainshaft Front Brg.	MU1313RUMW3	1
Aux. Mainshaft Rear Brg.	MU1308UM	1
Aux. Countershaft Front Brg.	MU1312RUMW3	1
Aux. Countershaft Rear Brg.	20920	1
Output Shaft Seal	20920	1
Gasket Set	K-1568	1

Heavy Duty Transmission Rebuild Kits

TRK-401		
Position	Part Number	Qty
Input Shaft Brg.	MU1214UMW3	1
Aux. Drive Gear Brg.	117L	1
Aux. Mainshaft Front Brg.	17406	1
Aux. Mainshaft Rear Brg.	29675 Assy 902A8 (A2892)	1
Aux. Countershaft Front Brg.	MU1309UV	2
Aux. Countershaft Rear Brg.	1311L	2
Input Shaft Seal (3.5" Shaft)	415027N (35083)	1
Input Shaft Seal (3.75" Shaft)	416339 (37533)	1
Output Shaft Seal Kit	K-2256	1
Output Shaft Seal Kit	K-2262	1
O-Ring Kit	K-1552	1
Gasket Kit	K-1479	1

TRK-500		
Position	Part Number	Qty
Clutch Release Brg.	2756T	1
Input Shaft Brg.	214SL	1
Input Shaft Pilot Brg.	MA1205EL	1
Main Drive Gear Brg.	214L	1
Main Drive Gear Pilot Brg.	MA1205EL	1
Output Shaft Brg.	214L	1
Compound Case Countershaft Front Brg.	308L	3
Compound Case Countershaft Rear Brg.	206	3
Countershaft Front Brg.	308L	3
Countershaft Rear Brg.	MA1209EL	3
Rear Countershaft Brg.	1208L	3
Rev. Idler Gear Brg.	J361648	3
Shift Rail Brg.	SCE2014P	3
Input Shaft Seal	332134	1
Output Shaft Seal	415991N (34891)	1
Output Shaft Seal	410312N (21245)	1
Clutch Release Seal	343186 (12330)	4
Shift Rail Seal	7750 (7414)	2
Gasket Set	GT213	1

TRK-501		
Position	Part Number	Qty
Input Shaft Brg.	218L	1
Input Shaft Pilot Brg.	MA1305EL	1
Output Shaft Brg.	214L	1
Countershaft Front Brg.	308L	3
Countershaft Rear Brg.	MA1209EL	3
Rear Countershaft Rear Brg.	1208L	3
Rev. Idler Gear Brg.	J361648	3
Shift Rail Brg.	SCE2014P	2
Input Shaft Seal	2822V (20599)	1
Output Shaft Seal	415991N (34891)	1
Clutch Release Seal	343186 (12330)	1
Shift Rail Seal	7750 (7414)	3
Snap Ring Set	SR501	1
O-Ring Set	OK501	1
Bushing	BS52	1
Gasket Set	GT501	1

TRK-502		
Position	Part Number	Qty
Input Shaft Brg.	218L	1
Input Shaft Pilot Brg.	SCE2014P	2
Countershaft Front Brg.	308L	3
Countershaft Rear Brg.	MAR5209-M5209EL	3
Rear Countershaft Front Brg.	MAR5209-M1209EL	3
Rear Countershaft Rear Brg.	1208L	3
Rev. Idler Gear Brg.	J361648	3
Input Shaft Seal	2822V (20599)	1
Output Shaft Seal	332134	2
Clutch Release Seal	343186 (12330)	1
Shift Rail Seal	7750 (7414)	3
Snap Ring Set	SR502	1
O-Ring Set	OK502	1
Gasket Set	GT502	1

TRK-503		
Position	Part Number	Qty
Input Shaft Brg.	214L	1
Input Shaft Pilot Brg.	MA1205EL	1
Output Shaft Brg.	1213A	1
Countershaft Front Brg.	JLM104948-JLM104910	3
Countershaft Rear Brg.	LM501349-LM501310	3
Rev. Idler Gear Brg.	JH1818	3
Clutch Release Shaft Brg.	B1612	2
Bushing	BS52	1
Input Shaft Seal	2822V (20599)	1
Output Shaft Seal	713750 (37332)	1
Snap Ring Set	SR503	1
O-Ring Set	OK503	1
Gasket Set	GT503	1

TRK-503MK		
Position	Part Number	Qty
Input Shaft Brg.	214L	1
Input Shaft Pilot Brg.	MA1205EL	1
Output Shaft Brg.	1213A	1
Countershaft Front Brg.	JLM104948-JLM104910	3
Countershaft Rear Brg.	LM501349-LM501310	3
Rev. Idler Gear Brg.	JH1818	3
Clutch Release Shaft Brg.	B1612	2
Bushing	BS52	1
Input Shaft Seal	2822V (20599)	1
Output Shaft Seal	713750 (37332)	1
Snap Ring Set	SR503	1
O-Ring Set	OK503	1
Gasket Set	GT503	1
Washer Set	WK503	1
Small Parts Kit	SPK503	1
Shim Set	SH503	1

TRK-504		
Position	Part Number	Qty
Input Shaft Front Brg.	H715341-H715311	1
Input Shaft Rear Brg.	H715341-H715311	1
Countershaft Front Brg.	H715341-H715311	1
Countershaft Rear Brg.	H715341-H715311	1
Countershaft High - Low Range Brg.	WJ485424	4
Front Driveshaft Front Brg.	458S-453X	1
Front Driveshaft Rear Brg.	4559-4535	1
Rear Driveshaft Front Brg.	6461A-JH415610	1
Rear Driveshaft Rear Brg.	HM516449C-HM516410	1
Rear Output Shaft Front Brg.	570-563	1
Rear Output Shaft Rear Brg.	570-563	1
Front Output Shaft Front Brg.	JH307749-JH307710	1
Front Output Shaft Rear Brg.	JH307749-JH307710	1
Gasket Kit	GT-504	1

TRK-505		
Position	Part Number	Qty
Input Shaft Brg.	214S	1
Input Shaft Pilot Brg.	MA1205EL	1
Output Shaft Pilot Brg.	IR1816-SCH2216	1
Output Shaft Front Brg.	118L	1
Output Shaft Rear Brg.	83B043C3	1
Countershaft Front Brg.	JLM104948-JLM104910	3
Countershaft Rear Brg.	LM501349-LM501310	3
Rear Countershaft Front Brg.	LM501349-LM501310	3
Rear Countershaft Rear Brg.	3780-3720	3
Rev. Idler Gear Brg.	JH1818	3
Countershaft Rear Brg.	IR1816	1
Shift Rail Brg.	B1612	2
Input Shaft Seal	2822V (20599)	1
Output Shaft Seal	713750 (37332)	1
Shift Rail Seal	240731 (9815)	1
Snap Ring Set	SR505	1
O-Ring Kit	OK214A	1
Gasket Set	GT505	1

TRK-505MK		
Position	Part Number	Qty
Input Shaft Brg.	214S	1
Input Shaft Pilot Brg.	MA1205EL	1
Output Shaft Pilot Brg.	IR1816-SCH2216	1
Output Shaft Front Brg.	118L	1
Output Shaft Rear Brg.	83B043C3	1
Countershaft Front Brg.	JLM104948-JLM104910	3
Countershaft Rear Brg.	LM501349-LM501310	3
Rear Countershaft Front Brg.	LM501349-LM501310	3
Rear Countershaft Rear Brg.	3780-3720	3
Rev. Idler Gear Brg.	JH1818	3
Countershaft Rear Brg.	IR1816	1
Shift Rail Brg.	B1612	2
Input Shaft Seal	2822V (20599)	1
Output Shaft Seal	713750 (37332)	1
Shift Rail Seal	240731 (9815)	1
Snap Ring Set	SR505	1
O-Ring Kit	OK214A	1
Gasket Set	GT505	1
Washer Set	WK505	1
Shim Set	SH505	1
Small Parts Kit	SPK505	1

HD Transmission

Heavy Duty Transmission Rebuild Kits



HD Transmission

TRK-506		
Position	Part Number	Qty
Input Shaft Brg.	214L	1
Input Shaft Pilot Brg.	MA1205EL	1
Output Shaft Pilot Brg.	IR1816-SCH2216	1
Output Shaft Front Brg.	118L	1
Output Shaft Rear Brg.	83B043C3	1
Countershaft Front Brg.	JLM104948-JLM104910	3
Countershaft Rear Brg.	LM501349-LM501310	3
Rear Countershaft Front Brg.	LM501349-LM501310	3
Rear Countershaft Rear Brg.	3780-3720	3
Rev. Idler Gear Brg.	HJ182620	3
Countershaft Rear Brg.	IR1816	1
High-Low Hub Brg.	6912	1
Shift Rail Brg.	B1612	2
Input Shaft Seal	2822V (20599)	1
Output Shaft Seal	713750 (37332)	1
Shift Rail Seal	240731 (9815)	1
Snap Ring Set	SR506	1
O-Ring Kit	OK214A	1
Gasket Set	GT505	1

TRK-506MK		
Position	Part Number	Qty
Input Shaft Brg.	214L	1
Input Shaft Pilot Brg.	MA1205EL	1
Output Shaft Pilot Brg.	IR1816-SCH2216	1
Output Shaft Front Brg.	118L	1
Output Shaft Rear Brg.	83B043C3	1
Countershaft Front Brg.	JLM104948-JLM104910	3
Countershaft Rear Brg.	LM501349-LM501310	3
Rear Countershaft Front Brg.	LM501349-LM501310	3
Rear Countershaft Rear Brg.	3780-3720	3
Rev. Idler Gear Brg.	HJ182620	3
Countershaft Rear Brg.	IR1816	1
High-Low Hub Brg.	6912	1
Shift Rail Brg.	B1612	2
Input Shaft Seal	2822V (20599)	1
Output Shaft Seal	713750 (37332)	1
Shift Rail Seal	240731 (9815)	1
Snap Ring Set	SR506	1
O-Ring Kit	OK214A	1
Gasket Set	GT505	1
Washer Set	WK507	1
Shim Set	SH214	1
Small Parts Kit	SPK506	1

TRK-507		
Position	Part Number	Qty
Input Shaft Brg.	214L	1
Input Shaft Pilot Brg.	MA1205EL	1
Output Shaft Pilot Brg.	IR1816-SCH2216	1
Output Shaft Front Brg.	118L	1
Output Shaft Rear Brg.	83B043C3	1
Countershaft Front Brg.	JLM104948-JLM104910	3
Countershaft Rear Brg.	LM501349-LM501310	3
Rear Countershaft Front Brg.	LM501349-LM501310	3
Rear Countershaft Rear Brg.	3780-3720	3
Rev. Idler Gear Brg.	JH1818	3
Countershaft Rear Brg.	IR1816	1
High-Low Hub Brg.	6912	1
Shift Rail Brg.	B1612	2
Input Shaft Seal	2822V (20599)	1
Output Shaft Seal	713750 (37332)	1
Shift Rail Seal	240731 (9815)	1
Snap Ring Set	SR505	1
O-Ring Kit	OK214A	1
Gasket Set	GT505	1

TRK-507MK		
Position	Part Number	Qty
Input Shaft Brg.	214L	1
Input Shaft Pilot Brg.	MA1205EL	1
Output Shaft Pilot Brg.	IR1816-SCH2216	1
Output Shaft Front Brg.	118L	1
Output Shaft Rear Brg.	83B043C3	1
Countershaft Front Brg.	JLM104948-JLM104910	3
Countershaft Rear Brg.	LM501349-LM501310	3
Rear Countershaft Front Brg.	LM501349-LM501310	3
Rear Countershaft Rear Brg.	3780-3720	3
Rev. Idler Gear Brg.	JH1818	3
Countershaft Rear Brg.	IR1816	1
High-Low Hub Brg.	6912	1
Shift Rail Brg.	B1612	2
Input Shaft Seal	2822V (20599)	1
Output Shaft Seal	713750 (37332)	1
Shift Rail Seal	240731 (9815)	1
Snap Ring Set	SR505	1
O-Ring Kit	OK214A	1
Gasket Set	GT505	1
Washer Set	WK507	1
Shim Set	SH214	1
Small Parts Kit	SPK507	1

TRK-700		
Position	Part Number	Qty
Input Shaft Brg.	BS500262R	1
Countershaft Front Brg.	25581-25520	2
Countershaft Rear Brg.	25590-25520	2
Aux. Countershaft Front Brg.	MR1307EX	2
Aux. Countershaft Rear Brg.	MR1309UV	2
Aux. Mainshaft Brg.	JLM710949C (90KA3)	1
Rev. Idler Gear Brg.	K55X63X25A	2
Low Range Brg.	K73X79X20B	2
Input Shaft Seal	97-463-36-1X	1
Output Shaft Seal	37410	1
Snap Ring	201-381-1	1
Snap Ring	201-381-3	1
Shim Kit	313667X	1
Gasket Set	312475-45X	1

TRK-702		
Position	Part Number	Qty
Input Shaft Brg.	MU1211GUM	1
Input Shaft Pilot Brg.	JH1416	1
Output Shaft Brg.	214LH	1
Countershaft Front Brg.	1311L	2
Countershaft Rear Brg.	MU1209UGMR	2
Rev. Idler Gear Brg.	WJ162116	2
Input Shaft Seal	97-463-36-1X	1
Output Shaft Seal	714713 (39933)	1
Gasket Set	GT193	1

TRK-703		
Position	Part Number	Qty
Input Shaft Front Brg.	114	1
Input Shaft Rear Brg.	MU1215TV	1
Input Shaft Pilot Brg.	JH1812	1
Output Shaft Brg.	214LH	1
Countershaft Front Brg.	MU1311UGMR	2
Countershaft Rear Brg.	MR1309EAL	2
Input Shaft Seal	415281N (29870)	1
Output Shaft Seal	415035 (39934)	1
Shift Rod Seal	471570 (8702)	2
Gasket Set	GT158	1

TRK-704		
Position	Part Number	Qty
Input Shaft Brg.	1213L	1
Input Shaft Pilot Brg.	MU5206L	1
Output Shaft Brg.	7211HL	1
Countershaft Front Brg.	2788A-2729	1
Countershaft Rear Brg.	2788A-2729	1
1st Gear Brg.	F208323	1
2nd Gear Brg.	F93290	1
3rd Gear Brg.	F95407	1
4th Gear Brg.	F209348	1
Rev. Gear Brg.	F93290	1
Rev. Idler Gear Brg.	WJ162116	2
Input Shaft Seal	39925	1
Output Shaft Seal	415322V	1
Shift Fork Clip	101-486-1-1X	3
Gasket Set	312475-47X	1

TRK-705		
Position	Part Number	Qty
Input Shaft Brg.	MR1211GEL	1
Input Shaft Pilot Brg.	MR1205EL	1
Mainshaft Rear Brg.	214LH	1
Output Shaft Front Brg.	MU1207UGV	1
Output Shaft Rear Brg.	214LH	1
Countershaft Front Brg.	1311L	2
Countershaft Rear Brg.	WR61209EX	2
Aux. Countershaft Front Brg.	JLM104948-JLM104910	2
Aux. Countershaft Rear Brg.	JLM506849-JLM506810	2
Rev. Idler Gear Brg.	WJ162116	4
Range Gear Brg.	F81205	1
Input Shaft Seal	412015V (21167)	1
Output Shaft Seal	3893V (37405)	1
Snap Ring Set	SR705	1
Gasket Set	GT705	1

TRK-706		
Position	Part Number	Qty
Input Shaft Front Brg.	MU1211GUM	1
Input Shaft Pilot Brg.	JH1416	1
Output Shaft Brg.	214LH	1
Countershaft Front Brg.	MU1209UGMR	2
Countershaft Rear Brg.	MU1209UGMR	2
Rev. Idler Gear Brg.	WJ162116	4
Input Shaft Seal	97-463-36-1X	1
Output Shaft Seal	3893V (37405)	1
Gasket Set	GT192	1

TRK-707		
Position	Part Number	Qty
Intermediate Shaft Front Brg.	2788-2720	1
Intermediate Shaft Rear Brg.	25877-25821	1
Output Shaft Brg.	23691-23620	2
Rev. Shaft Brg.	26883-26824	2
Shift Rod Seal	471570 (8702)	4
Output Shaft Seal	472015 (21164)	1
Gasket Set	GT226	1

TRK-708		
Position	Part Number	Qty
Intermediate Shaft Front Brg.	MR1308TV	1
Intermediate Shaft Rear Brg.	5306W	1
Output Shaft Brg.	23691-23620	2
Rev. Shaft Brg.	26883-26824	2
Shift Rod Seal	471570 (8702)	4
Output Shaft Seal	472015 (21164)	1
Gasket Set	GT226	1

Heavy Duty Transmission Rebuild Kits

TRK-709

Position	Part Number	Qty
Intermediate Shaft Front Brg.	MR1308TV	1
Intermediate Shaft Rear Brg.	5306W	1
Output Shaft Brg.	MR1307EX	2
Rev. Shaft Brg.	MR1307EXW927	2
Shift Rod Seal	471570 (8702)	4
Output Shaft Seal	472015 (21164)	1
Gasket Set	GT226	1

TRK-1000

Position	Part Number	Qty
Input Shaft Brg.	212SLV	1
Input Shaft Pilot Bushing	BS59	1
Aux. Drive Gear Brg.	117L	1
Aux. Mainshaft Brg.	390A Assy 902A2 (A3071)	1
Countershaft Front Brg.	MSN1211REX	2
Countershaft Rear Brg.	MU1308TVWS	2
Aux. Countershaft Front Brg.	MR1307EL ¹⁸	2
Aux. Countershaft Rear Brg.	1310L	2
Rev. Idler Gear Brg.	HJ223020-IR18200H	2
Aux. Range Shaft Quill Front Brg.	204	1
Aux. Range Shaft Quill Rear Bushing	BS60	1
Aux. Output Shaft Seal	415983N (37330)	1
Auxiliary Drive Gear Brg Retainer Seal	452554N (14832)	1
Input Shaft Nut	CN1 (8997)	1
O-Ring Set	OK1000V	1
Snap Ring Set	SR1000	1
Gasket Set	GT200N	1

TRK-1000AUX

Position	Part Number	Qty
Aux. Mainshaft Brg.	390A Assy 902A2 (A3071)	1
Aux. Countershaft Front Brg.	MR1307EL ¹⁸	2
Aux. Countershaft Rear Brg.	1310L	2
Aux. Range Shaft Quill Front Brg.	204	1
Aux. Range Shaft Quill Rear Bushing	BS60	1
Aux. Output Shaft Seal	415983N (37330)	1
O-Ring Set	OK1000V	1
Snap Ring Set	SR1000	1
Gasket Set	GT200N	1

TRK-1063

Position	Part Number	Qty
Input Shaft Brg.	212SLV	1
Input Shaft Pilot Bushing	BS59	1
Aux. Drive Gear Brg.	5566507	1
Aux. Mainshaft Brg.	390A Assy 902A2 (A3071)	1
Countershaft Front Brg.	MSN1211REX	2
Countershaft Rear Brg.	MU1308TVWS	2
Rev. Idler Gear Brg.	HJ223020-IR18200H	2
Aux. Countershaft Front Brg.	MR1307EL	2
Aux. Countershaft Rear Brg.	1310L	2
Spring	14897	3
Output Shaft Seal Kit	K-2256	1
O-Ring Kit	K-1450	1
Snap Ring	14317	2
Snap Ring	14750	1
Snap Ring	16723	2
Snap Ring	16763	2
Gasket Kit	K-2199	1
Spring	15918	3
Input Shaft Nut	CN1 (8997)	1
Sliding Clutch	16118	1
Collet	83001	4
Connector	84002	2
Connector	85002	1
Sealer	LC54505	1
Input Shaft	S1128	1

TRK-1064

Position	Part Number	Qty
Input Shaft Brg.	212SLV	1
Input Shaft Pilot Bushing	BS59	1
Aux. Drive Gear Brg.	5566507	1
Aux. Mainshaft Brg.	29675 Assy 902A8 (A2892)	1
Countershaft Front Brg.	MSN1211REX	2
Countershaft Rear Brg.	MU1308TVWS	2
Rev. Idler Gear Brg.	HJ223020-IR18200H	2
Aux. Countershaft Front Brg.	MR1307EL	2
Aux. Countershaft Rear Brg.	1311L	2
Spring	14897	3
Output Shaft Seal Kit	K-2256	1
O-Ring Kit	K-1450	1
Snap Ring	11364	2
Snap Ring	14317	2
Snap Ring	14750	1
Snap Ring	16763	2
Gasket Kit	K-2199	1
Spring	15918	3
Input Shaft Nut	CN1 (8997)	1
Sliding Clutch	16118	1
Collet	83001	4
Connector	84002	2
Connector	85002	1
Sealer	LC54505	1
Input Shaft	S1128	1

TRK-1079

Position	Part Number	Qty
Input Shaft Brg.	MU1212RUMW3	1
Aux. Drive Gear Brg.	5566507	1
Aux. Mainshaft Brg.	29675 Assy 902A8 (A2892)	1
Countershaft Front Brg.	BS500192SX	2
Countershaft Rear Brg.	MU1308TVWS	2
Rev. Idler Gear Brg.	HJ223020-IR18200H	2
Aux. Countershaft Front Brg.	MR1307EL	2
Aux. Countershaft Rear Brg.	5310WL	2
Aux. Range Shaft Quill Front Brg.	204	1
Aux. Range Shaft Quill Rear Bushing	BS60	1
Spring	14897	3
Output Shaft Seal Kit	K-2256	1
O-Ring Kit	K-1447	1
Snap Ring	14291	1
Snap Ring	14317	2
Snap Ring	14750	1
Snap Ring	16723	2
Snap Ring	16763	2
Gasket Kit	K-2199	1
Spring	15918	3
Input Shaft Nut	CN1 (8997)	1
Sliding Clutch	16118	1
Collet	83001	4
Connector	84002	2
Connector	85002	1
Sealer	LC54505	1
Input Shaft	S1228	1

TRK-1554

Position	Part Number	Qty
Aux. Mainshaft Brg.	29675 Assy 902A8 (A2892)	1
Aux. Countershaft Front Brg.	MU61307GUM	2
Aux. Countershaft Rear Brg.	1310SLV	2
Aux. Range Shaft Quill Front Brg.	204	1
Output Shaft Seal Kit	K-2256	1
O-Ring Set	K-1447	1
O-Ring	OR217V	1
O-Ring	OR221V	1
Snap Ring	14291	1
Snap Ring	16723	2
Key Assembly	A3697	1
Spring	14897	3
Insert Valve	19974	1
Connector	85002	1
Gasket Set	K-1603	1
Threadlocker	TL1	1

TRK-1555

Position	Part Number	Qty
Aux. Mainshaft Brg.	390A Assy 902A2 (A3071)	1
Aux. Countershaft Front Brg.	MR1307EL ¹⁸	2
Aux. Countershaft Rear Brg.	1310L	2
Aux. Range Shaft Quill Front Brg.	204	1
Output Shaft Seal Kit	K-2256	1
O-Ring Set	K-1447	1
O-Ring	OR217V	1
O-Ring	OR221V	1
Snap Ring	14291	1
Snap Ring	16723	2
Key Assembly	A3697	1
Spring	14897	3
Insert Valve	19974	1
Connector	85002	1
Gasket Set	K-1603	1

¹⁸Models before 1973; use MR5208EL

Heavy Duty Transmission Rebuild Kits



HD Transmission

TRK-1763		
Position	Part Number	Qty
Input Shaft Brg.	MU1212RUMW3	1
Aux. Drive Gear Brg.	5566507	1
Aux. Mainshaft Brg.	29675 Assy 902A8 (A2892)	1
Aux. Mainshaft Front Brg.	BS500192SX	1
Aux. Mainshaft Rear Brg.	MU1308TVWS	1
Rev. Idler Gear Brg.	HJ223020-IR18200H	2
Aux. Countershaft Front Brg.	MR1307EL	2
Aux. Countershaft Rear Brg.	5310WLB	2
Aux. Range Shaft Quill Front Brg.	204	1
Aux. Range Shaft Quill Rear Bushing	BS60	1
Spring	14897	3
Output Shaft Seal Kit	K-2256	1
Oil Seal	16977	1
O-Ring Kit	K-1447	1
O-Ring Kit	OK17453	1
O-Ring	OR217V	1
O-Ring	OR221V	1
Snap Ring	14291	1
Snap Ring	14317	2
Snap Ring	14750	1
Snap Ring	15253	1
Snap Ring	16763	2
Snap Ring	16980	1
Gasket Kit	K-2199	1
Spring	15918	3
Sliding Clutch	16118	1
Collet	83001	4
Connector	85002	1
Input Shaft	S1409	1

TRK-1765		
Position	Part Number	Qty
Input Shaft Brg.	212SLV	1
Output Shaft Brg.	1212L	1
Countershaft Front Brg.	1309L	2
Countershaft Rear Brg.	1309L	2
Aux. Countershaft Brg.	MU1213UMW3	2
Rev. Idler Gear Brg.	WJ162116	4
Output Shaft Seal Kit	K-2256	1
Snap Ring	14289	1
Snap Ring	15253	4
Snap Ring	16798	3
O-Ring	OK20128	1
Gasket Kit	K-1846	1
Spring	15918	4
Sliding Clutch	18747	1
Sealer	LC54505	1
Threadlocker	TL1	1
Input Shaft	S1661	1

TRK-1766		
Position	Part Number	Qty
Input Shaft Brg.	MSN1212REXW619	1
Input Shaft Pilot Brg.	20702	1
Output Shaft Brg.	MSN1212REXW619	1
Countershaft Front Brg.	MSN1309REXW619	1
Countershaft Rear Brg.	MU1309UV	1
1st, 2nd, 3rd & Rev. Gear Brg.	FW808840	4
4th Gear Brg.	FW687430	1
5th Gear Brg.	F206252	1
Rev. Idler Gear Brg.	F11739	2
Detent Shaft	20770	1
Pin	20772	1
Spring	8774	1
Input Shaft Seal	470625V (14940)	1
Output Shaft Seal	415004V (27365)	1
Shift Rail Seal	472311V (9847)	2
O-Ring	OR123	1
Gasket Set	K-1955	1

TRK-1850		
Position	Part Number	Qty
Input Shaft Brg.	MU1209UGMR	1
Input Shaft Pilot Bushing	BS61	1
Aux. Drive Gear Brg.	117L	1
Aux. Mainshaft Front Brg.	MU1307V	1
Aux. Mainshaft Rear Brg.	1212L	1
Countershaft Front Brg.	MU1207UGV	2
Countershaft Rear Brg.	MU1306UGV	2
Rev. Idler Gear Brg.	WJ162116	2
Aux. Countershaft Front Brg.	MR1206RUGV	2
Aux. Countershaft Rear Brg.	MR1308TV	2
Spring	14897	3
Oil Seal	20920	1
Oil Seal	15095	1
O-Ring	OK15092	1
O-Ring	OK15093	1
Snap Ring	14993	1
Snap Ring	15046	1
Snap Ring	15253	1
Snap Ring	15973	1
Snap Ring	15980	1
Snap Ring	15994	1
Lock Washer	15748	2
Gasket Kit	K-1931	1

TRK-1851		
Position	Part Number	Qty
Input Shaft Brg.	MU1209UGMR	1
Input Shaft Pilot Bushing	BS61	1
Aux. Drive Gear Brg.	117L	1
Aux. Mainshaft Brg.	390A Assy 902A2 (A3071)	1
Countershaft Front Brg.	MU1207UGV	2
Countershaft Rear Brg.	MU1306UGV	2
Rev. Idler Gear Brg.	WJ162116	2
Aux. Countershaft Front Brg.	MU1306UV	2
Aux. Countershaft Rear Brg.	1310L	2
Spring	14897	3
Insert Valve	19974	1
Output Shaft Seal Kit	K-2256	1
O-Ring Kit	K-1447	1
Snap Ring Set	SR146	1
Lock Washer	15748	2
Gasket Kit	K-2110	1

TRK-1852		
Position	Part Number	Qty
Input Shaft Brg.	212SLV	1
Input Shaft Pilot Bushing	BS59	1
Output Shaft Front Brg.	5566507	1
Output Shaft Rear Brg.	213	1
Countershaft Front Brg.	MSN1211REX	2
Countershaft Rear Brg.	MU1308TVWS	2
Rev. Idler Gear Brg.	HJ223020-IR18200H	2
Input Shaft Nut	14754	1
Oil Seal	20920	1
Snap Ring Set	SR1852	1
Snap Ring	15011	1
Gasket Kit	K-1782	1

TRK-1855		
Position	Part Number	Qty
Input Shaft Brg.	212SLV	1
Input Shaft Pilot Bushing	BS59	1
Aux. Drive Gear Brg.	117L	1
Aux. Mainshaft Brg.	390A Assy 902A2 (A3071)	1
Countershaft Front Brg.	MSN1211REX	2
Countershaft Rear Brg.	MU1308TVWS	2
Rev. Idler Gear Brg.	HJ223020-IR18200H	2
Aux. Countershaft Front Brg.	M1307EL	2
Aux. Countershaft Rear Brg.	1310L	2
Aux. Range Shaft Quill Front Brg.	204	1
Aux. Range Shaft Quill Rear Bushing	BS60	1
Spring	14897	3
Insert Valve	19974	1
Output Shaft Seal Kit	K-2256	1
O-Ring Kit	K-1447	1
Snap Ring Set	SR1855	1
Gasket Kit	K-2199	1

TRK-1857		
Position	Part Number	Qty
Input Shaft Brg.	212SLV	1
Input Shaft Pilot Bushing	BS59	1
Output Shaft Brg.	390A Assy 902A2 (A3071)	1
Countershaft Front Brg.	MSN1211REX	2
Countershaft Rear Brg.	MU1309UV	2
Rev. Idler Gear Brg.	HJ223020-IR18200H	2
Output Shaft Seal Kit	K-2256	1
Snap Ring Set	SR1857	1
Gasket Kit	K-2199	1

TRK-1858		
Position	Part Number	Qty
Input Shaft Brg.	212SLV	1
Input Shaft Pilot Bushing	BS59	1
Aux. Drive Gear Brg.	5566507	1
Aux. Mainshaft Brg.	390A Assy 902A2 (A3071)	1
Countershaft Front Brg.	MSN1211REX	2
Countershaft Rear Brg.	MU1308TVWS	2
Rev. Idler Gear Brg.	HJ223020-IR18200H	2
Aux. Countershaft Front Brg.	MR1307EL	2
Aux. Countershaft Rear Brg.	1310L	2
Spring	14897	3
Output Shaft Seal Kit	K-2256	1
O-Ring Kit	K-1450	1
Snap Ring	14317	2
Snap Ring	14750	1
Snap Ring	16723	2
Snap Ring	16763	2
Gasket Kit	K-2199	1

Heavy Duty Transmission Rebuild Kits



HD Transmission

TRK-1870		
Position	Part Number	Qty
Input Shaft Brg.	212SLV	1
Input Shaft Pilot Bushing	BS59	1
Aux. Drive Gear Brg.	5566507	1
Aux. Mainshaft Brg.	29675 Assy 902A8 (A2892)	1
Countershaft Front Brg.	BS500192SX	2
Countershaft Rear Brg.	MU1308TVWS	2
Rev. Idler Gear Brg.	HJ223020-IR18200H	2
Aux. Countershaft Front Brg.	MR1307EL	2
Aux. Countershaft Rear Brg.	1311L	2
Spring	14897	3
Output Shaft Seal Kit	K-2256	1
O-Ring Kit	K-1450	1
O-Ring Kit	OK17453	1
Snap Ring	11364	2
Snap Ring	14317	2
Snap Ring	14750	1
Snap Ring	16763	2
Gasket Kit	K-2199	1

TRK-1871		
Position	Part Number	Qty
Input Shaft Brg.	212SLV	1
Input Shaft Pilot Bushing	BS59	1
Aux. Drive Gear Brg.	5566507	1
Aux. Mainshaft Brg.	29675 Assy 902A8 (A2892)	1
Countershaft Front Brg.	BS500192SX	2
Countershaft Rear Brg.	MU1308TVWS	2
Rev. Idler Gear Brg.	HJ223020-IR18200H	2
Aux. Countershaft Front Brg.	MU61307GUM	2
Aux. Countershaft Rear Brg.	1310SLV	2
Aux. Range Shaft Quill Front Brg.	204	1
Aux. Range Shaft Quill Rear Bushing	BS60	1
Spring	14897	3
Insert Valve	19974	1
Output Shaft Seal Kit	K-2256	1
O-Ring Kit	K-1447	1
O-Ring Kit	OK17453	1
O-Ring	OR217V	1
O-Ring	OR221V	1
Snap Ring	14291	1
Snap Ring	14317	2
Snap Ring	14750	1
Snap Ring	16723	2
Snap Ring	16763	2
Gasket Kit	K-2199	1
Threadlocker	TL1	1

TRK-1872		
Position	Part Number	Qty
Input Shaft Brg.	MU1212RUMW3	1
Aux. Drive Gear Brg.	5566507	1
Aux. Mainshaft Brg.	29675 Assy 902A8 (A2892)	1
Countershaft Front Brg.	BS500192SX	2
Countershaft Rear Brg.	MU1308TVWS	2
Rev. Idler Gear Brg.	HJ223020-IR18200H	2
Aux. Countershaft Front Brg.	MR1307EL	2
Aux. Countershaft Rear Brg.	5310WLB	2
Aux. Range Shaft Quill Front Brg.	204	1
Aux. Range Shaft Quill Rear Bushing	BS60	1
Spring	14897	3
Insert Valve	19974	1
Output Shaft Seal Kit	K-2256	1
O-Ring Kit	K-1447	1
O-Ring Kit	OK17453	1
O-Ring	OR217V	1
O-Ring	OR221V	1
Snap Ring	14291	1
Snap Ring	14317	2
Snap Ring	14750	1
Snap Ring	16723	2
Snap Ring	16763	2
Gasket Kit	K-2199	1
Threadlocker	TL1	1

TRK-1873		
Position	Part Number	Qty
Input Shaft Brg.	212SLV	1
Input Shaft Pilot Bushing	BS59	1
Output Shaft Front Brg.	5566507	1
Output Shaft Rear Brg.	213	1
Countershaft Front Brg.	1309L	2
Countershaft Rear Brg.	MU1308TVWS	2
Rev. Idler Gear Brg.	HJ223020-IR18200H	2
Oil Seal	20920	1
Snap Ring	14289	1
Snap Ring	15253	2
Snap Ring	16763	1
Snap Ring	20085	2
Input Shaft Nut	14754	1
Gasket Kit	K-1782	1

TRK-1874		
Position	Part Number	Qty
Input Shaft Brg.	212SLV	1
Input Shaft Pilot Bushing	BS59	1
Aux. Drive Gear Brg.	5566507	1
Aux. Mainshaft Brg.	29675 Assy 902A8 (A2892)	1
Countershaft Front Brg.	BS500192SX	2
Countershaft Rear Brg.	MU1308TVWS	2
Rev. Idler Gear Brg.	HJ223020-IR18200H	2
Aux. Countershaft Front Brg.	MU61307GUM	2
Aux. Countershaft Rear Brg.	1310SLV	2
Aux. Range Shaft Quill Front Brg.	204	1
Aux. Range Shaft Quill Rear Bushing	BS60	1
Spring	14897	3
Insert Valve	19974	1
Output Shaft Seal Kit	K-2256	1
Oil Seal	16977	1
O-Ring Kit	K-1447	1
O-Ring Kit	OK17453	1
O-Ring	OR217V	1
O-Ring	OR221V	1
Snap Ring	14291	1
Snap Ring	14317	2
Snap Ring	14750	1
Snap Ring	16723	1
Snap Ring	16763	2
Snap Ring	16980	1
Gasket Kit	K-2199	1
Threadlocker	TL1	1

TRK-1875		
Position	Part Number	Qty
Input Shaft Brg.	MU1212RUMW3	1
Input Shaft Pilot Bushing	BS59	1
Aux. Drive Gear Brg.	5566507	1
Aux. Mainshaft Brg.	29675 Assy 902A8 (A2892)	1
Aux. Mainshaft Front Brg.	BS500192SX	1
Aux. Mainshaft Rear Brg.	MU1308TVWS	1
Rev. Idler Gear Brg.	HJ223020-IR18200H	2
Aux. Countershaft Front Brg.	MR1307EL	2
Aux. Countershaft Rear Brg.	5310WLB	2
Aux. Range Shaft Quill Front Brg.	204	1
Aux. Range Shaft Quill Rear Bushing	BS60	1
Spring	14897	3
Output Shaft Seal Kit	K-2256	1
Oil Seal	16977	1
O-Ring Kit	K-1447	1
O-Ring Kit	OK17453	1
O-Ring	OR217V	1
O-Ring	OR221V	1
Snap Ring	14291	1
Snap Ring	14317	2
Snap Ring	14750	1
Snap Ring	15253	1
Snap Ring	16763	2
Snap Ring	16980	1
Gasket Kit	K-2199	1

Heavy Duty Transmission Rebuild Kits



HD Transmission

TRK-1982		
Position	Part Number	Qty
Input Shaft Brg.	212SLV	1
Output Shaft Brg.	214LB	1
Countershaft Front Brg.	1309L	2
Countershaft Rear Brg.	1309L	2
Aux. Countershaft Brg.	MU1213UMW3	2
Rev. Idler Gear Brg.	WJ162116	4
Output Shaft Seal Kit	K-2262	1
Snap Ring	14289	1
Snap Ring	15253	4
Snap Ring	16798	3
Snap Ring	16980	1
O-Ring	OK20128	2
Gasket Kit	K-1846	1
Sliding Clutch	18747	1
Front Brg. Cover	20550	1
Sealer	LC54505	1
Input Shaft	S1661	1

TRK-1984		
Position	Part Number	Qty
Input Shaft Brg.	212SLV	1
Output Shaft Front Brg.	5566507	1
Output Shaft Rear Brg.	213	1
Countershaft Front Brg.	1309L	2
Countershaft Rear Brg.	MU1308TVWS	2
Rev. Idler Gear Brg.	HJ223020-IR18200H	2
Oil Seal	20920	1
Snap Ring	14289	1
Snap Ring	15253	2
Snap Ring	16763	1
Snap Ring	16980	1
Snap Ring	20085	2
Input Shaft Nut	14754	1
Gasket Kit	K-1782	1
Sliding Clutch	14654	1
Nut	14754	1
Front Brg. Cover	20550	1
Input Shaft	S1661	1

TRK-1986		
Position	Part Number	Qty
Input Shaft Brg.	212SLV	1
Aux. Drive Gear Brg.	5566507	1
Aux. Mainshaft Bushing	AA1512-12	2
Aux. Mainshaft Brg.	21356	1
Countershaft Front Brg.	1309L	2
Countershaft Rear Brg.	MU1308TVWS	2
Rev. Idler Gear Brg.	HJ223020-IR18200H	2
Aux. Countershaft Front Brg.	4302074	2
Aux. Countershaft Rear Brg.	4302074	2
Snap Ring Retainer	21320	1
Spring	14897	3
Insert Valve	19974	1
Output Shaft Seal Kit	K-2262	1
O-Ring Kit	K-2054	1
Snap Ring	14289	1
Snap Ring	14317	2
Snap Ring	15253	2
Snap Ring	16763	2
Snap Ring	20085	2
Shim Kit	K-2805	1
Gasket Kit	K-2061	1
Sliding Clutch	14654	1
Spring	15918	3
Snap Ring	16980	1
Collet	83002	4
Connector	84004	1
Connector	85001	1
Sealer	LC54505	1
Input Shaft	S1661	1

TRK-1991		
Position	Part Number	Qty
Input Shaft Brg.	MU1212RUMW3	1
Aux. Drive Gear Brg.	5566507	1
Aux. Mainshaft Bushing	AA1512-12	2
Aux. Mainshaft Brg.	21356	1
Countershaft Front Brg.	BS500192SX	2
Countershaft Rear Brg.	MU1308TVWS	2
Rev. Idler Gear Brg.	HJ223020-IR18200H	2
Aux. Countershaft Front Brg.	4302074	2
Aux. Countershaft Rear Brg.	4302074	2
Spring	14897	3
Insert Valve	19974	1
Output Shaft Seal Kit	K-2262	1
O-Ring Kit	K-2054	1
Snap Ring	14317	2
Snap Ring	14750	1
Snap Ring	16763	2
Shim Kit	K-2805	1
Gasket Kit	K-2061	1
Spring	15918	3
Sliding Clutch	16118	1
Snap Ring	16980	1
Collet	83002	4
Connector	84004	2
Connector	85001	1
Sealer	LC54505	1
Input Shaft	S1659	1

TRK-1992		
Position	Part Number	Qty
Input Shaft Brg.	MU1212RUMW3	1
Aux. Drive Gear Brg.	5566507	1
Aux. Mainshaft Bushing	AA1512-12	2
Aux. Mainshaft Brg.	21356	1
Countershaft Front Brg.	BS500192SX	2
Countershaft Rear Brg.	MU1308TVWS	2
Rev. Idler Gear Brg.	HJ223020-IR18200H	2
Aux. Countershaft Front Brg.	4302074	2
Aux. Countershaft Rear Brg.	4302074	2
Spring	14897	3
Insert Valve	19974	1
Output Shaft Seal Kit	K-2262	1
O-Ring Kit	K-2054	1
Snap Ring	14317	2
Snap Ring	14750	1
Snap Ring	16763	2
Shim Kit	K-2805	1
Gasket Kit	K-2061	1
Spring	15918	3
Snap Ring	16980	1
Sliding Clutch	4304317	1
Collet	83002	4
Connector	84004	2
Connector	85001	1
Sealer	LC54505	1
Input Shaft	S1659	1

TRK-1993		
Position	Part Number	Qty
Aux. Mainshaft Brg.	29675 Assy 902A8 (A2892)	1
Aux. Countershaft Front Brg.	MU61307GUM	2
Aux. Countershaft Rear Brg.	1310SLV	2
Insert Valve	19974	1
Connector	85001	1
Spring	14897	3
Gasket Kit	K-1603	1
Output Shaft Seal Kit	K-2262	1
O-Ring Kit	K-2002	1

TRK-1995		
Position	Part Number	Qty
Input Shaft Brg.	MU1210RUMW772	1
Aux. Drive Gear Brg.	117L	1
Aux. Mainshaft Brg.	390A Assy 902A2 (A3071)	1
Countershaft Front Brg.	MU1307GUM	2
Countershaft Rear Brg.	MU1307GUM	2
Rev. Idler Gear Brg.	WJ162116	2
Aux. Countershaft Front Brg.	MR1306UVW745	2
Aux. Countershaft Rear Brg.	1310L	2
Range Shaft Quill Front Brg.	204	1
Range Shaft Quill Rear Bushing	BS60	1
Spring	14897	3
Insert Valve	19974	1
Output Shaft Seal Kit	K-2256	1
O-Ring Kit	K-2002	1
Snap Ring	14291	1
Snap Ring	14993	1
Snap Ring	15973	1
Snap Ring	15980	1
Snap Ring	16723	2
Lock Screw Kit	K-2425	1
Gasket Kit	K-2110	1
Spring	1064	3
Snap Ring	15980	1
Sliding Clutch	21662	1
Input Shaft	A5022	1
Sealer	LC54505	1

TRK-1996		
Position	Part Number	Qty
Input Shaft Brg.	212SLV	1
Aux. Drive Gear Brg.	5566507	1
Aux. Mainshaft Brg.	21355	1
Countershaft Front Brg.	BS500192SX	2
Countershaft Rear Brg.	MU1308TVWS	2
Rev. Idler Gear Brg.	HJ223020-IR18200H	2
Aux. Countershaft Front Brg.	4302074	2
Aux. Countershaft Rear Brg.	4302074	2
Spring	14897	3
Output Shaft Seal Kit	K-2262	1
O-Ring Kit	K-1450	1
Snap Ring	14317	2
Snap Ring	14750	1
Snap Ring	16763	2
Snap Ring	16980	1
Gasket Kit	K-2061	1
Spring	15918	3
Sliding Clutch	4306648	1
Collet	83001	4
Connector	84002	1
Connector	85002	1
Input Shaft	S1659	1

Heavy Duty Transmission Rebuild Kits

TRK-1999

Position	Part Number	Qty
Input Shaft Brg.	212SLV	1
Aux. Drive Gear Brg.	5566507	1
Aux. Mainshaft Brg.	21356	1
Countershaft Front Brg.	BS500192SX	2
Countershaft Rear Brg.	MU1308TVWS	2
Rev. Idler Gear Brg.	HJ223020-IR18200H	2
Aux. Countershaft Front Brg.	4302074	2
Aux. Countershaft Rear Brg.	4302074	2
Spring	14897	3
Output Shaft Seal Kit	K-2262	1
O-Ring Kit	K-1450	1
Snap Ring	14317	2
Snap Ring	14750	1
Snap Ring	16763	2
Snap Ring	16980	1
Shim Kit	K-2805	1
Gasket Kit	K-2061	1
Spring	15918	3
Sliding Clutch	4306647	1
Collet	83001	4
Connector	84002	1
Connector	85002	1
Sealer	LC54505	1
Input Shaft	S1659	1

TRK-2041

Position	Part Number	Qty
Input Shaft Brg.	39590-39520	1
Mainshaft Pilot Brg.	31594	1
Output Shaft Brg.	45284-45220	1
Countershaft Front Brg.	25590-25522	1
Countershaft Rear Brg.	3782-3720	1
1st, 2nd & Rev. Gear Brg.	FW707620	6
3rd Gear Brg.	FW657020	2
4th Gear Brg.	FW556020	2
5th Gear Brg.	FW505520	2
Rev. Idler Gear Brg.	FW404820	2
Countershaft Plug	3315679	1
Spring	3315765	4
Snap Ring	3313798	1
Snap Ring	3315686	1
Snap Ring	3315725	1
Input Shaft Seal	710211	1
Output Shaft Seal	4300119	1
Shim Kit	K-2183	1
Gasket Set	K-2181	1

TRK-2043

Position	Part Number	Qty
Input Shaft Brg.	MU1212RUMW3	1
Input Shaft Pilot Bushing	BS59	1
Aux. Drive Gear Brg.	5566507	1
Aux. Mainshaft Bushing	AA1512-12	2
Aux. Mainshaft Brg.	21356	1
Countershaft Front Brg.	BS500192SX	2
Countershaft Rear Brg.	MU1308TVWS	2
Rev. Idler Gear Brg.	HJ223020-IR18200H	2
Aux. Countershaft Front Brg.	4302074	2
Aux. Countershaft Rear Brg.	4302074	2
Spring	14897	3
Insert Valve	19974	1
Output Shaft Seal Kit	K-2262	1
O-Ring Kit	K-2054	1
Snap Ring	14317	2
Snap Ring	14750	1
Snap Ring	16763	2
Shim Kit	K-2805	1
Gasket Kit	K-2061	1

TRK-2045

Position	Part Number	Qty
Input Shaft Brg.	212SLV	1
Input Shaft Pilot Bushing	BS59	1
Aux. Drive Gear Brg.	5566507	1
Aux. Mainshaft Bushing	AA1512-12	2
Aux. Mainshaft Brg.	21356	1
Countershaft Front Brg.	1309L	2
Countershaft Rear Brg.	MU1308TVWS	2
Rev. Idler Gear Brg.	HJ223020-IR18200H	2
Aux. Countershaft Front Brg.	4302074	2
Aux. Countershaft Rear Brg.	4302074	2
Snap Ring Retainer	21320	1
Spring	14897	3
Insert Valve	19974	1
Output Shaft Seal Kit	K-2262	1
O-Ring Kit	K-2054	1
Snap Ring	14289	1
Snap Ring	14317	2
Snap Ring	15253	2
Snap Ring	16763	2
Snap Ring	20085	2
Shim Kit	K-2805	1
Gasket Kit	K-2061	1

TRK-2047

Position	Part Number	Qty
Input Shaft Brg.	MU1210RUMW772	1
Input Shaft Pilot Bushing	BS61	1
Aux. Drive Gear Brg.	117L	1
Aux. Mainshaft Brg.	390A Assy 902A2 (A3071)	1
Countershaft Front Brg.	MU1307GUM	2
Countershaft Rear Brg.	MU1307GUM	2
Rev. Idler Gear Brg.	WJ162116	2
Aux. Countershaft Front Brg.	MR1306UVW745	2
Aux. Countershaft Rear Brg.	1310L	2
Range Shaft Quill Front Brg.	204	1
Range Shaft Quill Rear Bushing	BS60	1
Spring	14897	3
Insert Valve	19974	1
Output Shaft Seal Kit	K-2256	1
O-Ring Kit	K-2002	1
Snap Ring	14291	1
Snap Ring	14993	1
Snap Ring	15973	1
Snap Ring	15980	1
Snap Ring	16723	2
Lock Screw Kit	K-2425	1
Gasket Kit	K-2110	1

TRK-2048

Position	Part Number	Qty
Input Shaft Brg.	MU1209UGMR	1
Input Shaft Pilot Bushing	BS61	1
Mainshaft Rear Brg.	117L	1
Aux. Mainshaft Pilot Brg.	MU1307V	1
Aux. Mainshaft Rear Brg.	MU1212RUMW3	1
Countershaft Front Brg.	MU1306UGV	2
Countershaft Rear Brg.	MU1306UGV	2
Rev. Idler Gear Brg.	WJ162116	2
Aux. Countershaft Front Brg.	MR1206RUGV	2
Aux. Countershaft Rear Brg.	MR1308TV	2
Spring	14897	3
Oil Seal	20920	1
Oil Seal	15095	1
O-Ring	OK15092	1
O-Ring	OK15093	1
O-Ring	OR016V	1
Snap Ring	14993	1
Snap Ring	15253	1
Snap Ring	15973	1
Snap Ring	15980	1
Snap Ring	15994	1
Lock Washer	15748	2
Silicone Lubricant	SL1	1
Gasket Kit	K-1931	1

TRK-2049

Position	Part Number	Qty
Input Shaft Brg.	212SLV	1
Input Shaft Pilot Bushing	BS59	1
Aux. Drive Gear Brg.	5566507	1
Aux. Mainshaft Brg.	21355	1
Countershaft Front Brg.	BS500192SX	2
Countershaft Rear Brg.	MU1308TVWS	2
Rev. Idler Gear Brg.	HJ223020-IR18200H	2
Aux. Countershaft Front Brg.	4302074	2
Aux. Countershaft Rear Brg.	4302074	2
Spring	14897	3
Output Shaft Seal Kit	K-2262	1
O-Ring Kit	K-1450	1
Snap Ring	14317	2
Snap Ring	14750	1
Snap Ring	16763	2
Snap Ring	16980	1
Gasket Kit	K-2061	1

TRK-2120

Position	Part Number	Qty
Input Shaft Brg.	M802048-M802011	1
Input Shaft Pilot Brg.	QBR49845	1
Output Shaft Brg.	25581-25520	1
Countershaft Front Brg.	25877-25821	1
Countershaft Rear Brg.	2689-2631	1
Rev. Idler Gear Brg.	QA48181A	1
Mainshaft 1st & 2nd Gear Brg.	F94490	2
Mainshaft 3rd & Rev. Gear Brg.	F84003	2
Mainshaft 4th Gear Brg.	F94488	1
4th & 5th Shift Hub Brg.	FA35688	1
4th & 5th Shift Hub Race	TR235383	1
Input Shaft Seal	473010N (16247)	1
Output Shaft Seal	471271 (24898)	1
Output Shaft Seal	712512	1
Threadlocker	TL1	1
Gasket Set	K-2143	1

Heavy Duty Transmission Rebuild Kits



HD Transmission

TRK-2121		
Position	Part Number	Qty
Input Shaft Brg.	M802048-M802011	1
Input Shaft Pilot Brg.	QBR49845	1
Output Shaft Brg.	28580A-28527RB	1
Countershaft Front & Rear Brg.	25590-25520	2
4th & 5th Shift Hub Brg.	FA35688	1
4th & 5th Shift Hub Race	TR235383	1
Mainshaft 1st Gear Brg.	QA48181A	2
Mainshaft 2nd, 3rd & Rev. Gear Brg.	F94490	3
Mainshaft 4th Gear Brg.	F94488	1
Rev. Idler Gear Brg.	QA47838	1
Input Shaft Seal	473010N (16247)	1
Output Shaft Seal	4300119	1
Output Shaft Seal	485364N (27272)	1
Snap Ring	226331	1
Threadlocker	TL1	1
Gasket Set	K-2085	1

TRK-2122		
Position	Part Number	Qty
Input Shaft Brg.	M802048-M802011	1
Input Shaft Pilot Brg.	QBR49845	1
Output Shaft Brg.	25584-25547RB	1
Countershaft Front & Rear Brg.	25590-25520	2
4th & 5th Shift Hub Brg.	FA35688	1
4th & 5th Shift Hub Race	TR235383	1
Mainshaft 1st Gear Brg.	QA48181A	2
Mainshaft 2nd, 3rd & Rev. Gear Brg.	F94490	3
Mainshaft 4th Gear Brg.	F94488	1
Rev. Idler Gear Brg.	QA47838	1
Input Shaft Seal	473010N (16247)	1
Output Shaft Seal	712512	1
Snap Ring	226331	1
Threadlocker	TL1	1
Gasket Set	K-2085	1

TRK-2123		
Position	Part Number	Qty
Input Shaft Brg.	M804049-M804010	1
Input Shaft Pilot Brg.	QBR49845	1
Output Shaft Brg.	28580A-28527RB	1
Countershaft Front & Rear Brg.	25590-25520	2
4th & 5th Shift Hub Brg.	FA35688	1
4th & 5th Shift Hub Race	TR235383	1
Mainshaft 1st Gear Brg.	QA48181A	2
Mainshaft 2nd, 3rd & Rev. Gear Brg.	F94490	3
Mainshaft 4th Gear Brg.	F94488	1
Rev. Idler Gear Brg.	QA47838	1
Snap Ring	226331	1
Input Shaft Seal	4300204	1
Input Shaft Seal	710211	1
Output Shaft Seal	411143N (26110)	1
Output Shaft Seal	485364N (27272)	1
Output Shaft Seal	4300119	1
Snap Ring	226331	1
Threadlocker	TL1	1
Gasket Set	K-2085	1

TRK-2124		
Position	Part Number	Qty
Input Shaft Brg.	M802048-M802011	1
Input Shaft Pilot Brg.	QBR49845	1
Output Shaft Brg.	28580A-28527RB	1
Countershaft Front Brg.	DD46386	1
Countershaft Rear Brg.	MU1309UGM	1
Rev. Idler Gear Brg.	QA47838	1
Mainshaft Gear Brg.	QA48181A	2
4th & 5th Shift Hub Brg.	FA35688	1
4th & 5th Shift Hub Race	TR235383	1
Mainshaft 2nd, 3rd & Rev. Gear Brg.	F94490	3
Mainshaft 4th Gear Brg.	F94488	1
Input Shaft Seal	473010N (16247)	1
Output Shaft Seal	411143N (26110)	1
Output Shaft Seal	416664 (27264)	1
Output Shaft Seal	471271 (24898)	1
Output Shaft Seal	475322N (27295)	1
Threadlocker	TL1	1
Gasket Set	K-2085	1

TRK-2125		
Position	Part Number	Qty
Input Shaft Brg.	M804049-M804010	1
Input Shaft Pilot Brg.	QBR49845	1
Output Shaft Brg.	28580A-28527RB	1
Countershaft Front Brg.	DD46386	1
Countershaft Rear Brg.	MU1309UGM	1
Rev. Idler Gear Brg.	QA47838	1
Mainshaft Gear Brg.	QA48181A	2
4th & 5th Shift Hub Brg.	FA35688	1
4th & 5th Shift Hub Race	TR235383	1
Mainshaft 2nd, 3rd & Rev. Gear Brg.	F94490	3
Mainshaft 4th Gear Brg.	F94488	1
Input Shaft Seal	482041N (18555)	1
Output Shaft Seal	411143N (26110)	1
Output Shaft Seal	4300119	1
Threadlocker	TL1	1
Gasket Set	K-2085	1

TRK-2126		
Position	Part Number	Qty
Input Shaft Brg.	M802048-M802011	1
Input Shaft Pilot Brg.	QBR49845	1
Output Shaft Brg.	25584-25547RB	1
Countershaft Front Brg.	DD46386	1
Countershaft Rear Brg.	MU1309UGM	1
Rev. Idler Gear Brg.	QA47838	1
Mainshaft Gear Brg.	QA48181A	2
4th & 5th Shift Hub Brg.	FA35688	1
4th & 5th Shift Hub Race	TR235383	1
Mainshaft 2nd, 3rd & Rev. Gear Brg.	F94490	3
Mainshaft 4th Gear Brg.	F94488	1
Input Shaft Seal	473010N (16247)	1
Output Shaft Seal	416664 (27264)	1
Output Shaft Seal	471271 (24898)	1
Threadlocker	TL1	1
Gasket Set	K-2085	1

TRK-2127		
Position	Part Number	Qty
Input Shaft Brg.	N309L	1
Input Shaft Pilot Brg.	SRA5304	1
Output Shaft Brg.	N309L	1
Countershaft Front Brg.	M28161	1
Countershaft Rear Brg.	N309L	1
Rev. Idler Gear Brg.	F54970	2
Input Shaft Seal	472164 (17387)	1
Output Shaft Seal	471271 (24898)	1
Output Shaft Seal	450316 (22446)	1
Output Shaft Seal	411143N (26110)	1
Output Shaft Seal	471271 (24898)	1
Gasket Set	K-2136	1

TRK-2128		
Position	Part Number	Qty
Input Shaft Brg.	M802048-M802011	1
Input Shaft Pilot Brg.	QBR49845	1
Output Shaft Brg.	25584-25547RB	1
Countershaft Front Brg.	M28161	1
Countershaft Rear Brg.	MU1309SGNV	1
Rev. Idler Gear Brg.	J361644	2
4th & 5th Shift Hub Brg.	FA35688	1
4th & 5th Shift Hub Race	TR235383	1
Input Shaft Seal	473010N (16247)	1
Output Shaft Seal	471271 (24898)	1
Output Shaft Seal	482041N (18555)	1
Output Shaft Seal	411143N (26110)	1
Output Shaft Seal	471271 (24898)	1
Gasket Set	K-2138	1

TRK-2129		
Position	Part Number	Qty
Input Shaft Brg.	M804049-M804010	1
Input Shaft Pilot Brg.	QBR49845	1
Output Shaft Brg.	25581-25520	1
Countershaft Front Brg.	25877-25821	1
Countershaft Rear Brg.	2689-2631	1
4th & 5th Shift Hub Brg.	FA35688	1
4th & 5th Shift Hub Race	TR235383	1
Rev. Idler Gear Brg.	QA48181A	1
Mainshaft 1st & 2nd Gear Brg.	F94490	2
Mainshaft 3rd & Rev. Gear Brg.	F84003	2
Mainshaft 4th Gear Brg.	F94488	1
Input Shaft Seal	710211	1
Output Shaft Seal	471271 (24898)	1
Output Shaft Seal	712512	1
Gasket Set	K2143	1
Threadlocker	TL1	1

TRK-2130		
Position	Part Number	Qty
Input Shaft Brg.	39590-39520	1
Input Shaft Pilot Brg.	31594	1
Output Shaft Brg.	45284-45220	1
Countershaft Front Brg.	25590-25522	1
Countershaft Rear Brg.	3782-3720	1
1st, 2nd, 3rd & Rev. Gear Brg.	FW808840	4
4th Gear Brg.	FW687430	1
5th Gear Brg.	F206252	1
Rev. Idler Gear Brg.	F11739	2
Countershaft Plug	3315679	1
Spring	1064	4
Snap Ring	20712	1
Snap Ring	3313798	1
Snap Ring	3315686	1
Rev. Idler O-Ring	OR123	1
Input Shaft Seal	22329	1
Input Shaft Seal	4300119	1
Output Shaft Seal	4300119	1
Shim Kit	K-2183	1
Gasket Set	K-2181	1

Heavy Duty Transmission Rebuild Kits

TRK-2131

Position	Part Number	Qty
Input Shaft Brg.	39590-39520	1
Input Shaft Pilot Brg.	31594	1
Output Shaft Brg.	45284-45220	1
Countershaft Front Brg.	25590-25522	1
Countershaft Rear Brg.	3782-3720	1
1st & Rev. Gear Brg.	FW707620	4
2nd Gear Brg.	FW657020	2
3rd Gear Brg.	FW556020	2
4th Gear Brg.	FW505520	2
Rev. Idler Gear Brg.	FW404820	2
Countershaft Plug	3315679	1
Spring	3315765	4
Snap Ring	3313798	1
Snap Ring	3315686	1
Snap Ring	3315725	1
Input Shaft Seal	710211	1
Output Shaft Seal	475322N (27295)	1
Shim Kit	K-2183	1
Gasket Set	K-2181	1

TRK-2275

Position	Part Number	Qty
Input Shaft Brg.	212SLV	1
Input Shaft Pilot Bushing	BS59	1
Aux. Drive Gear Brg.	5566507	1
Aux. Mainshaft Brg.	21356	1
Countershaft Front Brg.	BS500192SX	2
Countershaft Rear Brg.	MU1308TVWS	2
Rev. Idler Gear Brg.	HJ223020-IR18200H	2
Aux. Countershaft Front Brg.	4302074	2
Aux. Countershaft Rear Brg.	4302074	2
Spring	14897	3
Output Shaft Seal Kit	K-2262	1
O-Ring Kit	K-1450	1
Snap Ring	14317	2
Snap Ring	14750	1
Snap Ring	16763	2
Snap Ring	16980	1
Shim Kit	K-2805	1
Gasket Kit	K-2061	1

TRK-2277

Position	Part Number	Qty
Input Shaft Brg.	212SLV	1
Input Shaft Pilot Bushing	BS59	1
Aux. Drive Gear Brg.	5566507	1
Aux. Mainshaft Brg.	21356	1
Countershaft Front Brg.	BS500192SX	2
Countershaft Rear Brg.	MU1308TVWS	2
Rev. Idler Gear Brg.	HJ223020-IR18200H	2
Aux. Countershaft Front Brg.	4302074	2
Aux. Countershaft Rear Brg.	4302074	2
Spring	14897	3
Output Shaft Seal Kit	K-2262	1
O-Ring Kit	K-1450	1
Snap Ring	14317	2
Snap Ring	14750	1
Snap Ring	16763	2
Shim Kit	K-2805	1
Gasket Kit	K-2061	1

TRK-2280

Position	Part Number	Qty
Input Shaft Brg.	212SLV	1
Input Shaft Pilot Bushing	BS59	1
Aux. Drive Gear Brg.	5566507	1
Aux. Mainshaft Brg.	29675 Assy 902A8 (A2892)	1
Countershaft Front Brg.	BS500192SX	2
Countershaft Rear Brg.	MU1308TVWS	2
Rev. Idler Gear Brg.	HJ223020-IR18200H	2
Range Shaft Quill Front Brg.	204	1
Range Shaft Quill Rear Bushing	BS60	1
Aux. Countershaft Front Brg.	4302074	2
Aux. Countershaft Rear Brg.	4302074	2
Spring	14897	3
Insert Valve	19974	1
Output Shaft Seal Kit	K-2262	1
O-Ring Kit	K-1447	1
O-Ring	OR217V	1
O-Ring	OR221V	1
Snap Ring	14291	1
Snap Ring	14317	2
Snap Ring	14750	1
Snap Ring	16763	2
Snap Ring	16980	1
Shim Kit	K-2430	1
Gasket Kit	K-2199	1

TRK-2281

Position	Part Number	Qty
Input Shaft Brg.	212SLV	1
Input Shaft Pilot Bushing	BS59	1
Aux. Drive Gear Brg.	118L	1
Aux. Mainshaft Brg.	390A Assy 902A2 (A3071)	1
Countershaft Front Brg.	BS500192SX	2
Countershaft Front Retainer	4304605	2
Countershaft Rear Brg.	MU1308TVWS	2
Rev. Idler Gear Brg.	HJ223020-IR18200H	2
Range Shaft Quill Front Brg.	204	1
Range Shaft Quill Rear Bushing	BS60	1
Aux. Countershaft Front Brg.	4302074	2
Aux. Countershaft Rear Brg.	4302074	2
Spring	14897	3
Insert Valve	19974	1
Output Shaft Seal Kit	K-2262	1
O-Ring Kit	K-1447	1
O-Ring Kit	OK1000V	1
O-Ring Kit	OK17453	1
O-Ring	OR217V	1
O-Ring	OR221V	1
Snap Ring	14291	1
Snap Ring	14317	2
Snap Ring	14750	1
Snap Ring	16763	2
Shim Kit	K-2430	1
Gasket Kit	K-2199	1

TRK-2282

Position	Part Number	Qty
Input Shaft Brg.	212SLV	1
Input Shaft Pilot Bushing	BS59	1
Aux. Drive Gear Brg.	5566507	1
Aux. Mainshaft Brg.	390A Assy 902A2 (A3071)	1
Countershaft Front Brg.	BS500192SX	2
Countershaft Rear Brg.	MU1308TVWS	2
Rev. Idler Gear Brg.	HJ223020-IR18200H	2
Aux. Countershaft Front Brg.	MR1307EL	2
Aux. Countershaft Rear Brg.	1310SLV	2
Spring	14897	3
Output Shaft Seal Kit	K-2262	1
O-Ring Kit	K-1450	1
O-Ring Kit	OK17453	1
Snap Ring	14317	2
Snap Ring	14750	1
Snap Ring	16723	2
Snap Ring	16763	2
Gasket Kit	K-2199	1

TRK-2283

Position	Part Number	Qty
Input Shaft Brg.	212SLV	1
Input Shaft Pilot Bushing	BS59	1
Aux. Drive Gear Brg.	5566507	1
Aux. Mainshaft Brg.	390A Assy 902A2 (A3071)	1
Countershaft Front Brg.	BS500192SX	2
Countershaft Front Retainer	4304605	2
Countershaft Rear Brg.	MU1308TVWS	2
Rev. Idler Gear Brg.	HJ223020-IR18200H	2
Range Shaft Quill Front Brg.	204	1
Range Shaft Quill Rear Bushing	BS60	1
Aux. Countershaft Front Brg.	MR1307EL	2
Aux. Countershaft Rear Brg.	1310L	2
Spring	14897	3
Insert Valve	19974	1
Output Shaft Seal Kit	K-2256	1
O-Ring Kit	K-1447	1
O-Ring Kit	OK17453	1
O-Ring	OR217V	1
O-Ring	OR221V	1
Snap Ring	14291	1
Snap Ring	14317	2
Snap Ring	14750	1
Snap Ring	16723	2
Snap Ring	16763	2
Gasket Kit	K-2199	1

Heavy Duty Transmission Rebuild Kits



HD Transmission

TRK-2284		
Position	Part Number	Qty
Input Shaft Brg.	212SLV	1
Input Shaft Pilot Bushing	BS59	1
Aux. Drive Gear Brg.	5566507	1
Aux. Mainshaft Brg.	21355	1
Countershaft Front Brg.	BS500192SX	2
Countershaft Rear Brg.	MU1308TVWS	2
Rev. Idler Gear Brg.	HJ223020-IR18200H	2
Aux. Countershaft Front Brg.	4302074	2
Aux. Countershaft Rear Brg.	4302074	2
Retainer Assembly	4304605	2
Spring	14897	3
Insert Valve	19974	1
Output Shaft Seal Kit	K-2262	1
O-Ring Kit	K-2054	1
Snap Ring	14317	2
Snap Ring	14750	1
Snap Ring	16763	2
Snap Ring	16980	1
Snap Ring Retainer	21320	1
Shim Kit	K-2805	1
Gasket Kit	K-2061	1

TRK-2285		
Position	Part Number	Qty
Input Shaft Brg.	212SLV	1
Input Shaft Pilot Bushing	BS59	1
Aux. Drive Gear Brg.	5566508	1
Aux. Mainshaft Brg.	21355	1
Countershaft Front Brg.	BS500192SX	2
Countershaft Rear Brg.	MU1308TVWS	2
Rev. Idler Gear Brg.	HJ223020-IR18200H	2
Aux. Countershaft Front Brg.	4302074	2
Aux. Countershaft Rear Brg.	4302074	2
Spring	14897	3
Insert Valve	19974	1
Output Shaft Seal Kit	K-2262	1
O-Ring Kit	K-2804	1
Snap Ring	14317	2
Snap Ring	14750	1
Snap Ring	16980	1
Snap Ring	4301254	2
Shim Kit	K-2805	1
Gasket Kit	K-2199	1

TRK-2286		
Position	Part Number	Qty
Input Shaft Brg.	212SLV	1
Input Shaft Pilot Bushing	BS59	1
Aux. Drive Gear Brg.	5566508	1
Aux. Mainshaft Brg.	21356	1
Countershaft Front Brg.	BS500192SX	2
Countershaft Rear Brg.	MU1308TVWS	2
Rev. Idler Gear Brg.	HJ223020-IR18200H	2
Aux. Countershaft Front Brg.	4302074	2
Aux. Countershaft Rear Brg.	4302074	2
Spring	14897	3
Insert Valve	19974	1
Output Shaft Seal Kit	K-2262	1
O-Ring Kit	K-2804	1
Snap Ring	14317	2
Snap Ring	14750	1
Snap Ring	16980	1
Snap Ring	4301254	2
Shim Kit	K-2805	1
Gasket Kit	K-2199	1

TRK-2287		
Position	Part Number	Qty
Input Shaft Brg.	212SLV	1
Input Shaft Pilot Bushing	BS59	1
Aux. Drive Gear Brg.	5566508	1
Aux. Mainshaft Brg.	21356	1
Countershaft Front Brg.	BS500192SX	2
Countershaft Rear Brg.	MU1308TVWS	2
Rev. Idler Gear Brg.	HJ223020-IR18200H	2
Aux. Countershaft Front Brg.	NP656227-NP896049	2
Aux. Countershaft Rear Brg.	NP656227-NP896049	2
Spring	14897	3
Insert Valve	19974	1
Output Shaft Seal Kit	K-2262	1
O-Ring Kit	K-2804	1
Snap Ring	14317	2
Snap Ring	14750	1
Snap Ring	16980	1
Snap Ring	4301254	1
Shim Kit	K-2805	1
Gasket Kit	K-2199	1

TRK-2288		
Position	Part Number	Qty
Input Shaft Brg.	212SLV	1
Input Shaft Pilot Bushing	BS59	1
Aux. Drive Gear Brg.	5566508	1
Aux. Mainshaft Brg.	21356	1
Splitter Gear Brg.	4300902	1
Countershaft Front Brg.	BS500192SX	2
Countershaft Rear Brg.	MU1308TVWS	2
Rev. Idler Gear Brg.	HJ223020-IR18200H	2
Aux. Countershaft Front Brg.	NP656227-NP896049	2
Aux. Countershaft Rear Brg.	NP656227-NP896049	2
Spring	14897	3
Insert Valve	19974	1
Output Shaft Seal Kit	K-2262	1
O-Ring Kit	K-2804	1
Snap Ring	14317	2
Snap Ring	14750	1
Snap Ring	16980	1
Snap Ring	4301254	1
Snap Ring	4303424	1
Shim Kit	K-2805	1
Gasket Kit	K-2199	1

TRK-2335		
Position	Part Number	Qty
Input Shaft Brg.	212SLV	1
Aux. Drive Gear Brg.	5566507	1
Aux. Mainshaft Brg.	21356	1
Countershaft Front Brg.	BS500192SX	2
Countershaft Rear Brg.	MU1308TVWS	2
Rev. Idler Gear Brg.	HJ223020-IR18200H	2
Aux. Countershaft Front Brg.	4302074	2
Aux. Countershaft Rear Brg.	4302074	2
Spring	14897	3
Output Shaft Seal Kit	K-2262	1
O-Ring Kit	K-1450	1
Snap Ring	14317	2
Snap Ring	14750	1
Snap Ring	16763	2
Snap Ring	16980	1
Shim Kit	K-2805	1
Gasket Kit	K-2061	1
Spring	15918	3
Sliding Clutch	16118	1
Collet	83002	4
Connector	84004	2
Connector	85001	1
Sealer	LC54505	1
Input Shaft	S1659	1

TRK-2336		
Position	Part Number	Qty
Input Shaft Brg.	212SLV	1
Aux. Drive Gear Brg.	5566507	1
Aux. Mainshaft Brg.	21356	1
Countershaft Front Brg.	BS500192SX	2
Countershaft Rear Brg.	MU1308TVWS	2
Rev. Idler Gear Brg.	HJ223020-IR18200H	2
Aux. Countershaft Front Brg.	4302074	2
Aux. Countershaft Rear Brg.	4302074	2
Spring	14897	3
Output Shaft Seal Kit	K-2262	1
O-Ring Kit	K-1450	1
Snap Ring	14317	2
Snap Ring	14750	1
Snap Ring	16763	2
Shim Kit	K-2805	1
Gasket Kit	K-2061	1
Spring	15918	3
Snap Ring	16980	1
Sliding Clutch	4304317	1
Collet	83002	4
Connector	84004	2
Connector	85001	1
Sealer	LC54505	1
Input Shaft	S1659	1

TRK-2338		
Position	Part Number	Qty
Aux. Mainshaft Brg.	29675 Assy 902A8 (A2892)	1
Aux. Countershaft Front Brg.	4302074	2
Aux. Countershaft Rear Brg.	4302074	2
Spring	14897	3
Insert Valve	19974	1
Output Shaft Seal Kit	K-2262	1
O-Ring Kit	K-2002	1
Shim Kit	K-2805	1
Gasket Kit	K-1603	1
Threadlocker	TL1	1
Connector	85001	1

Heavy Duty Transmission Rebuild Kits

TRK-2340			TRK-2342			TRK-2344		
Position	Part Number	Qty	Position	Part Number	Qty	Position	Part Number	Qty
Aux. Mainshaft Brg.	29675 Assy 902A8 (A2892)	1	Input Shaft Brg.	212SLV	1	Input Shaft Brg.	212SLV	1
Aux. Countershaft Front Brg.	4302074	2	Aux. Drive Gear Brg.	118L	1	Aux. Drive Gear Brg.	5566507	1
Aux. Countershaft Rear Brg.	4302074	2	Aux. Mainshaft Brg.	390A Assy 902A2 (A3071)	1	Aux. Mainshaft Brg.	390A Assy 902A2 (A3071)	1
Aux. Range Shaft Quill Front Brg.	204	1	Countershaft Front Brg.	BS500192SX	2	Countershaft Front Brg.	BS500192SX	2
Spring	14897	3	Countershaft Front	4304605	2	Countershaft Rear Brg.	MU1308TVWS	2
Insert Valve	19974	1	Retainer		2	Rev. Idler Gear Brg.	HJ223020-IR18200H	2
Output Shaft Seal Kit	K-2262	1	Countershaft Rear Brg.	MU1308TVWS	2	Aux. Countershaft Front Brg.	MR1307EL	2
O-Ring Kit	K-1447	1	Rev. Idler Gear Brg.	HJ223020-IR18200H	2	Aux. Countershaft Rear Brg.	1310SLV	2
O-Ring	OR217V	1	Range Shaft Quill Front Brg.	204	1	Spring	14897	3
O-Ring	OR221V	1	Range Shaft Quill Rear Bushing	BS60	1	Output Shaft Seal Kit	K-2262	1
Snap Ring	14291	1	Aux. Countershaft Front Brg.	4302074	2	O-Ring Kit	K-1450	1
Key Assembly	A3697	1	Aux. Countershaft Rear Brg.	4302074	2	O-Ring Kit	OK17453	1
Connector	85002	1	Spring	14897	3	Snap Ring	14317	2
Shim Kit	K-2430	1	Insert Valve	19974	1	Snap Ring	14750	1
Gasket Kit	K-1603	1	Output Shaft Seal Kit	K-2262	1	Snap Ring	16723	2
Threadlocker	TL1	1	O-Ring Kit	K-1447	1	Snap Ring	16763	2
TRK-2341			O-Ring Kit	OK1000V	1	Snap Ring	16980	1
Position	Part Number	Qty	O-Ring Kit	OK17453	1	Gasket Kit	K-2199	1
Input Shaft Brg.	212SLV	1	O-Ring	OR217V	1	Spring	15918	3
Aux. Drive Gear Brg.	5566507	1	O-Ring	OR221V	1	Sliding Clutch	4306648	1
Aux. Mainshaft Brg.	29675 Assy 902A8 (A2892)	1	Snap Ring	14291	1	Collet	83001	4
Countershaft Front Brg.	BS500192SX	2	Snap Ring	14317	2	Connector	84002	2
Countershaft Rear Brg.	MU1308TVWS	2	Snap Ring	14750	1	Connector	85002	1
Rev. Idler Gear Brg.	HJ223020-IR18200H	2	Snap Ring	16763	2	Sealer	LC54505	1
Range Shaft Quill Front Brg.	204	1	Snap Ring	16980	1	Input Shaft	S1659	1
Range Shaft Quill Rear Bushing	BS60	1	Shim Kit	K-2430	1	TRK-2345		
Aux. Countershaft Front Brg.	4302074	2	Gasket Kit	K-2199	1	Position	Part Number	Qty
Aux. Countershaft Rear Brg.	4302074	2	Spring	15918	3	Input Shaft Brg.	212SLV	1
Spring	14897	3	Sliding Clutch	4306648	1	Aux. Drive Gear Brg.	5566507	1
Insert Valve	19974	1	Collet	83001	4	Aux. Mainshaft Brg.	390A Assy 902A2 (A3071)	1
Output Shaft Seal Kit	K-2262	1	Connector	84002	1	Countershaft Front Brg.	BS500192SX	2
O-Ring Kit	K-1447	1	Connector	85002	1	Countershaft Front	4304605	2
O-Ring	OR217V	1	Sealer	LC54505	1	Retainer		2
O-Ring	OR221V	1	Input Shaft	S1659	1	Countershaft Rear Brg.	MU1308TVWS	2
Snap Ring	14291	1	TRK-2343			Rev. Idler Gear Brg.	HJ223020-IR18200H	2
Snap Ring	14317	2	Position	Part Number	Qty	Range Shaft Quill Front Brg.	204	1
Snap Ring	14750	1	Input Shaft Brg.	212SLV	1	Range Shaft Quill Rear Bushing	BS60	1
Snap Ring	16763	2	Aux. Drive Gear Brg.	5566507	1	Aux. Countershaft Front Brg.	MR1307EL	2
Snap Ring	16980	1	Aux. Mainshaft Brg.	390A Assy 902A2 (A3071)	1	Aux. Countershaft Rear Brg.	1310L	2
Shim Kit	K-2430	1	Countershaft Front Brg.	BS500192SX	2	Spring	14897	3
Gasket Kit	K-2199	1	Countershaft Rear Brg.	MU1308TVWS	2	Insert Valve	19974	1
Spring	15918	3	Rev. Idler Gear Brg.	HJ223020-IR18200H	2	Output Shaft Seal Kit	K-2256	1
Sliding Clutch	4306648	1	Aux. Countershaft Front Brg.	MR1307EL	2	O-Ring Kit	K-1447	1
Collet	83001	4	Aux. Countershaft Rear Brg.	1310SLV	2	O-Ring Kit	OK17453	1
Connector	84002	2	Spring	14897	3	O-Ring	OR217V	1
Connector	85002	1	Output Shaft Seal Kit	K-2262	1	O-Ring	OR221V	1
Sealer	LC54505	1	O-Ring Kit	K-1450	1	Snap Ring	14291	1
Input Shaft	S1659	1	O-Ring Kit	OK17453	1	Snap Ring	14317	2
			Snap Ring	14317	2	Snap Ring	14750	1
			Snap Ring	14750	1	Snap Ring	16723	2
			Snap Ring	16723	2	Snap Ring	16763	2
			Snap Ring	16763	2	Snap Ring	16980	1
			Gasket Kit	K-2199	1	Gasket Kit	K-2199	1
			Spring	15918	3	Spring	15918	3
			Snap Ring	16980	1	Front Brg. Cover	20552	1
			Sliding Clutch	4306647	1	Sliding Clutch	4306648	1
			Connector	85001	2	Collet	83001	4
			Sealer	LC54505	1	Connector	84002	1
			Input Shaft	S1659	1	Connector	85002	1
						Sealer	LC54505	1
						Input Shaft	S2928	1

HD Transmission

Heavy Duty Transmission Rebuild Kits



HD Transmission

TRK-2464		
Position	Part Number	Qty
Input Shaft Brg.	39590-39520	1
Input Shaft Pilot Brg.	31594	1
Output Shaft Brg.	39585-39520	1
Countershaft Front Brg.	25590-25522	1
Countershaft Rear Brg.	3782-3720	1
1st, 2nd, 3rd & Rev. Gear Brg.	FW808840	4
4th Gear Brg.	FW687430	1
5th Gear Brg.	FW505520	2
Rev. Idler Gear Brg.	F11739	2
Countershaft Plug	3315679	1
Input Shaft Seal	19110	1
Output Shaft Seal Kit	K-2256	1
Threadlocker	TL1	1
Shim Kit	K-2183	1
Gasket Set	K-2465	1

TRK-2468		
Position	Part Number	Qty
Clutch Pilot Brg.	306VV	1
Input Shaft Brg.	212SLV	1
Front Brg. Cover	20550	1
Clutch Yoke	85533	1
Clutch Yoke Bushing	12815	4
Clutch Brake Disc	85541	1
Input Shaft	S1659	1
Snap Ring	14750	1
Snap Ring	16980	1
Gasket	14311	1
Gasket	4305294	1
Gasket	4306584	1

TRK-2490		
Position	Part Number	Qty
Input Shaft Brg.	39590-39520	1
Input Shaft Pilot Brg.	31594	1
Output Shaft Brg.	39585-39520	1
Countershaft Front Brg.	25590-25522	1
Countershaft Rear Brg.	3782-3720	1
1st, 2nd, 3rd & Rev. Gear Brg.	FW808840	4
4th Gear Brg.	FW687430	1
5th Gear Brg.	F206252	1
Rev. Idler Gear Brg.	F11739	2
Countershaft Plug	3315679	1
Spring	1064	4
Snap Ring	17399	1
Snap Ring	20712	1
Snap Ring	22328	1
Snap Ring	22360	1
Snap Ring	3315686	1
Input Shaft Seal	22329	1
Output Shaft Seal Kit	K-2256	1
Threadlocker	TL1	1
Shim Kit	K-2183	1
Gasket Set	K-2465	1

TRK-2758		
Position	Part Number	Qty
Input Shaft Brg.	212SLV	1
Aux. Drive Gear Brg.	5566508	1
Aux. Mainshaft Brg.	21356	1
Countershaft Front Brg.	BS500192SX	2
Countershaft Rear Brg.	MU1308TVWS	2
Rev. Idler Gear Brg.	HJ223020-IR18200H	2
Aux. Countershaft Front Brg.	4302074	2
Aux. Countershaft Rear Brg.	4302074	2
Spring	14897	3
Insert Valve	19974	1
Output Shaft Seal Kit	K-2262	1
O-Ring Kit	K-2804	1
Snap Ring	14317	2
Snap Ring	14750	1
Snap Ring	16980	1
Snap Ring	4301254	2
Shim Kit	K-2805	1
Gasket Kit	K-2199	1
Spring	15918	3
Sliding Clutch	4304317	1
Connector	84005	2
Connector	85003	1
Sealer	LC54505	1
Input Shaft	S1659	1

TRK-2759		
Position	Part Number	Qty
Aux. Mainshaft Brg.	21356	1
Aux. Countershaft Front Brg.	4302074	2
Aux. Countershaft Rear Brg.	4302074	2
Spring	14897	3
Insert Valve	19974	1
Output Shaft Seal Kit	K-2262	1
O-Ring Kit	K-2804	1
Gasket Kit	K-1603	1
Connector	85003	1
Shim Kit	K-2805	1

TRK-2761		
Position	Part Number	Qty
Input Shaft Brg.	212SLV	1
Aux. Drive Gear Brg.	5566507	1
Aux. Mainshaft Brg.	390A Assy 902A2 (A3071)	1
Countershaft Front Brg.	BS500192SX	2
Countershaft Front Retainer	4304605	2
Countershaft Rear Brg.	MU1308TVWS	2
Rev. Idler Gear Brg.	HJ223020-IR18200H	2
Range Shaft Quill Front Brg.	204	1
Range Shaft Quill Rear Bushing	BS60	1
Aux. Countershaft Front Brg.	MR1307EL	2
Aux. Countershaft Rear Brg.	1310L	2
Spring	14897	3
Insert Valve	19974	1
Output Shaft Seal Kit	K-2256	1
O-Ring Kit	K-1447	1
O-Ring Kit	OK17453	1
O-Ring	OR217V	1
O-Ring	OR221V	1
Snap Ring	14291	1
Snap Ring	14317	2
Snap Ring	14750	1
Snap Ring	16723	2
Snap Ring	16763	2
Gasket Kit	K-2199	1
Spring	15918	3
Snap Ring	16980	1
Front Brg. Cover	20550	1
Sliding Clutch	4306648	1
Collet	83001	4
Connector	84002	1
Connector	85002	1
Input Shaft	S1659	1

TRK-2762		
Position	Part Number	Qty
Input Shaft Brg.	212SLV	1
Aux. Drive Gear Brg.	5566507	1
Aux. Mainshaft Brg.	21355	1
Countershaft Front Brg.	BS500192SX	2
Countershaft Rear Brg.	MU1308TVWS	2
Rev. Idler Gear Brg.	HJ223020-IR18200H	2
Aux. Countershaft Front Brg.	4302074	2
Aux. Countershaft Rear Brg.	4302074	2
Retainer Assembly	4304605	2
Spring	14897	3
Insert Valve	19974	1
Output Shaft Seal Kit	K-2262	1
O-Ring Kit	K-2054	1
Snap Ring	14317	2
Snap Ring	14750	1
Snap Ring	16763	2
Snap Ring	16980	1
Snap Ring Retainer	21320	1
Shim Kit	K-2805	1
Gasket Kit	K-2061	1
Spring	15918	3
Sliding Clutch	4306648	1
Collet	83002	4
Connector	84004	1
Connector	85001	1
Sealer	LC54505	1
Input Shaft	S1659	1

Heavy Duty Transmission Rebuild Kits

TRK-2763

Position	Part Number	Qty
Input Shaft Brg.	212SLV	1
Aux. Drive Gear Brg.	5566507	1
Aux. Mainshaft Brg.	21355	1
Countershaft Front Brg.	BS500192SX	2
Countershaft Rear Brg.	MU1308TVWS	2
Rev. Idler Gear Brg.	HJ223020-IR18200H	2
Aux. Countershaft Front Brg.	4302074	2
Aux. Countershaft Rear Brg.	4302074	2
Retainer Assembly	4304605	2
Spring	14897	3
Insert Valve	19974	1
Output Shaft Seal Kit	K-2262	1
O-Ring Kit	K-2054	1
Snap Ring	14317	2
Snap Ring	14750	1
Snap Ring	16763	2
Snap Ring	16980	1
Snap Ring Retainer	21320	1
Shim Kit	K-2805	1
Gasket Kit	K-2061	1
Sliding Clutch	4306647	1
Collet	83002	4
Connector	84004	1
Connector	85001	1
Sealer	LC54505	1
Input Shaft	S1659	1

TRK-2764

Position	Part Number	Qty
Input Shaft Brg.	212SLV	1
Aux. Drive Gear Brg.	5566507	1
Aux. Mainshaft Brg.	390A Assy 902A2 (A3071)	1
Aux. Mainshaft Thrust Brg.	AXK5070	2
Countershaft Front Brg.	BS500192SX	2
Countershaft Rear Brg.	MU1308TVWS	2
Rev. Idler Gear Brg.	HJ223020-IR18200H	2
Aux. Countershaft Front Brg.	4302074	2
Aux. Countershaft Rear Brg.	4302074	2
Spring	14897	3
Insert Valve	19974	1
Insert Valve	4300810	2
Output Shaft Seal Kit	K-2262	1
O-Ring Kit	K-2298	1
O-Ring Kit	OK17453	1
Snap Ring	14317	2
Snap Ring	14750	1
Snap Ring	16763	2
Snap Ring	16980	1
Retainer Assembly	4304605	1
Shim Kit	K-2430	1
Gasket Kit	K-2295	1
Spring	15918	2
Sliding Clutch	16118	1
Connector	84005	2
Connector	85003	1
Sealer	LC54505	1
Input Shaft	S1659	1

TRK-2765

Position	Part Number	Qty
Input Shaft Brg.	212SLV	1
Aux. Drive Gear Brg.	5566507	1
Aux. Mainshaft Brg.	29675 Assy 902A8 (A2892)	1
Aux. Mainshaft Thrust Brg.	AXK5070	2
Countershaft Front Brg.	BS500192SX	2
Countershaft Rear Brg.	MU1308TVWS	2
Rev. Idler Gear Brg.	HJ223020-IR18200H	2
Aux. Countershaft Brg.	4302074	4
Spring	14897	3
Insert Valve	19974	1
Insert Valve	4300810	2
Output Shaft Seal Kit	K-2262	1
O-Ring Kit	K-2298	1
O-Ring Kit	OK17453	1
Snap Ring	14317	2
Snap Ring	14750	1
Snap Ring	16763	2
Snap Ring	16980	1
Retainer Assembly	4304605	1
Shim Kit	K-2430	1
Gasket Kit	K-2295	1
Spring	15918	2
Sliding Clutch	16118	1
Connector	84005	2
Connector	85003	1
Sealer	LC54505	1
Input Shaft	S1659	1

TRK-2767

Position	Part Number	Qty
Input Shaft Brg.	212SLV	1
Aux. Drive Gear Brg.	5566508	1
Aux. Mainshaft Brg.	21355	1
Countershaft Front Brg.	BS500192SX	2
Countershaft Rear Brg.	MU1308TVWS	2
Rev. Idler Gear Brg.	HJ223020-IR18200H	2
Aux. Countershaft Front Brg.	4302074	2
Aux. Countershaft Rear Brg.	4302074	2
Spring	14897	3
Insert Valve	19974	1
Output Shaft Seal Kit	K-2262	1
O-Ring Kit	K-2804	1
Snap Ring	14317	2
Snap Ring	14750	1
Snap Ring	16980	1
Snap Ring	4301254	2
Shim Kit	K-2805	1
Gasket Kit	K-2199	1
Spring	15918	3
Sliding Clutch	16118	1
Connector	84005	2
Connector	85003	1
Sealer	LC54505	1
Input Shaft	S1659	1

TRK-2768

Position	Part Number	Qty
Aux. Mainshaft Brg.	21355	1
Aux. Countershaft Front Brg.	4302074	2
Aux. Countershaft Rear Brg.	4302074	2
Insert Valve	19974	1
Connector	85003	1
Spring	14897	3
Gasket Kit	K-1603	1
Output Shaft Seal Kit	K-2262	1
O-Ring Kit	K-2804	1
Shim Kit	K-2805	1

TRK-2769

Position	Part Number	Qty
Aux. Mainshaft Brg.	21356	1
Aux. Countershaft Front Brg.	NP896049-NP656227	2
Aux. Countershaft Rear Brg.	NP896049-NP656227	2
Spring	14897	3
Insert Valve	19974	1
Output Shaft Seal Kit	K-2262	1
O-Ring Kit	K-2804	1
Gasket Kit	K-1603	1
Connector	85003	1
Shim Kit	K-2805	1

TRK-2770

Position	Part Number	Qty
Input Shaft Brg.	212SLV	1
Aux. Drive Gear Brg.	5566508	1
Aux. Mainshaft Brg.	21356	1
Countershaft Front Brg.	BS500192SX	2
Countershaft Rear Brg.	MU1308TVWS	2
Rev. Idler Gear Brg.	HJ223020-IR18200H	2
Aux. Countershaft Front Brg.	NP656227-NP896049	2
Aux. Countershaft Rear Brg.	NP656227-NP896049	2
Spring	14897	3
Insert Valve	19974	1
Output Shaft Seal Kit	K-2262	1
O-Ring Kit	K-2804	1
Snap Ring	14317	2
Snap Ring	14750	1
Snap Ring	16980	1
Snap Ring	4301254	1
Shim Kit	K-2805	1
Gasket Kit	K-2199	1
Sliding Clutch	4304317	1
Connector	84005	2
Connector	85003	1
Sealer	LC54505	1
Input Shaft	S1659	1

TRK-2771

Position	Part Number	Qty
Input Shaft Brg.	212SLV	1
Input Shaft Pilot Bushing	BS59	1
Output Shaft Brg.	214LB	1
Countershaft Front Brg.	1309L	2
Countershaft Rear Brg.	1309L	2
Aux. Countershaft Brg.	MU1213UMW3	2
Rev. Idler Gear Brg.	WJ162116	4
Output Shaft Seal Kit	K-2262	1
Snap Ring	14289	1
Snap Ring	15253	4
Snap Ring	16798	3
O-Ring	OK20128	2
Gasket Kit	K-1846	1
Sealer	LC54505	1

HD Transmission

Heavy Duty Transmission Rebuild Kits



HD Transmission

TRK-2772		
Position	Part Number	Qty
Input Shaft Brg.	212SLV	1
Input Shaft Pilot Bushing	BS59	1
Aux. Drive Gear Brg.	5566507	1
Aux. Mainshaft Brg.	390A Assy 902A2 (A3071)	1
Aux. Mainshaft Thrust Brg.	AXK5070	2
Countershaft Front Brg.	BS500192SX	2
Countershaft Rear Brg.	MU1308TVWS	2
Rev. Idler Gear Brg.	HJ223020-IR18200H	2
Aux. Countershaft Front Brg.	4302074	2
Aux. Countershaft Rear Brg.	4302074	2
Spring	14897	3
Insert Valve	19974	1
Insert Valve	4300810	2
Output Shaft Seal Kit	K-2262	1
O-Ring Kit	K-2298	1
O-Ring Kit	OK17453	1
Snap Ring	14317	2
Snap Ring	14750	1
Snap Ring	16763	2
Snap Ring	16980	1
Retainer Assembly	4304605	1
Shim Kit	K-2430	1
Gasket Kit	K-2295	1

TRK-2773		
Position	Part Number	Qty
Input Shaft Brg.	212SLV	1
Input Shaft Pilot Bushing	BS59	1
Aux. Drive Gear Brg.	5566507	1
Aux. Mainshaft Brg.	29675 Assy 902A8 (A2892)	1
Aux. Mainshaft Thrust Brg.	AXK5070	2
Countershaft Front Brg.	BS500192SX	2
Countershaft Rear Brg.	MU1308TVWS	2
Rev. Idler Gear Brg.	HJ223020-IR18200H	2
Aux. Countershaft Brg.	4302074	4
Spring	14897	3
Insert Valve	19974	1
Insert Valve	4300810	2
Output Shaft Seal Kit	K-2262	1
O-Ring Kit	K-2298	1
O-Ring Kit	OK17453	1
Snap Ring	14317	2
Snap Ring	14750	1
Snap Ring	16763	2
Snap Ring	16980	1
Retainer Assembly	4304605	1
Shim Kit	K-2430	1
Gasket Kit	K-2295	1

TRK-2779		
Position	Part Number	Qty
Input Shaft Brg.	212SLV	1
Aux. Drive Gear Brg.	5566508	1
Aux. Mainshaft Brg.	21356	1
Splitter Gear Brg.	4300902	1
Countershaft Front Brg.	BS500192SX	2
Countershaft Rear Brg.	MU1308TVWS	2
Rev. Idler Gear Brg.	HJ223020-IR18200H	2
Aux. Countershaft Front Brg.	NP656227-NP896049	2
Aux. Countershaft Rear Brg.	NP656227-NP896049	2
Spring	14897	3
Insert Valve	19974	1
Output Shaft Seal Kit	K-2262	1
O-Ring Kit	K-2804	1
Snap Ring	14317	2
Snap Ring	14750	1
Snap Ring	16980	1
Snap Ring	4301254	1
Snap Ring	4303424	1
Shim Kit	K-2805	1
Gasket Kit	K-2199	1
Spring	15918	3
Sliding Clutch	4304317	1
Connector	84005	2
Connector	85003	1
Sealer	LC54505	1
Input Shaft	S1659	1

TRK-2780		
Position	Part Number	Qty
Input Shaft Brg.	212SLV	1
Input Shaft Pilot Bushing	BS59	1
Aux. Drive Gear Brg.	117L	1
Aux. Mainshaft Brg.	390A Assy 902A2 (A3071)	1
Countershaft Front Brg.	MSN1211REX	2
Countershaft Rear Brg.	MU1308TVWS	2
Rev. Idler Gear Brg.	HJ223020-IR18200H	2
Aux. Countershaft Front Brg.	MR1307EL	2
Aux. Countershaft Rear Brg.	1310L	2
Aux. Range Shaft Quill Front Brg.	204	1
Aux. Range Shaft Quill Rear Bushing	BS60	1
Spring	14897	3
Insert Valve	19974	1
Output Shaft Seal Kit	K-2256	1
O-Ring Kit	K-1447	1
Snap Ring Set	SR1000	1
Gasket Kit	K-2199	1

TRK-2847		
Position	Part Number	Qty
Input Shaft Brg.	212SLV	1
Input Shaft Pilot Bushing	BS59	1
Aux. Drive Gear Brg.	5566507	1
Aux. Mainshaft Brg.	21356	1
Countershaft Front Brg.	BS500192SX	2
Countershaft Rear Brg.	MU1308TVWS	2
Rev. Idler Gear Brg.	HJ223020-IR18200H	2
Aux. Countershaft Front Brg.	4302074	2
Aux. Countershaft Rear Brg.	4302074	2
Spring	14897	3
Output Shaft Seal Kit	K-2262	1
O-Ring Kit	K-2846	1
Snap Ring	14317	2
Snap Ring	14750	1
Snap Ring	16763	2
Snap Ring	16980	1
Shim Kit	K-2805	1
Gasket Kit	K-2061	1

TRK-2848		
Position	Part Number	Qty
Input Shaft Brg.	212SLV	1
Aux. Drive Gear Brg.	5566507	1
Aux. Mainshaft Brg.	21356	1
Countershaft Front Brg.	BS500192SX	2
Countershaft Rear Brg.	MU1308TVWS	2
Rev. Idler Gear Brg.	HJ223020-IR18200H	2
Aux. Countershaft Front Brg.	4302074	2
Aux. Countershaft Rear Brg.	4302074	2
Spring	14897	3
Output Shaft Seal Kit	K-2262	1
O-Ring Kit	K-2846	1
Snap Ring	14317	2
Snap Ring	14750	1
Snap Ring	16763	2
Snap Ring	16980	1
Shim Kit	K-2805	1
Gasket Kit	K-2061	1
Spring	15918	3
Sliding Clutch	4304317	1
Connector	84006	1
Connector	85003	1
Sealer	LC54505	1
Input Shaft	S1659	1

TRK-2855		
Position	Part Number	Qty
Input Shaft Brg.	212SLV	1
Input Shaft Pilot Bushing	BS59	1
Aux. Drive Gear Brg.	5566507	1
Aux. Mainshaft Brg.	21356	1
Aux. Mainshaft Bushing	AA1512-12	2
Countershaft Front Brg.	1309L	2
Countershaft Rear Brg.	MU1308TVWS	2
Rev. Idler Gear Brg.	HJ223020-IR18200H	2
Aux. Countershaft Front Brg.	4302074	2
Aux. Countershaft Rear Brg.	4302074	2
Insert Valve	19974	1
Spring	14897	3
Output Shaft Seal Kit	K-2262	1
O-Ring Kit	K-2846	1
Snap Ring	14289	1
Snap Ring	14317	2
Snap Ring	15253	2
Snap Ring	16763	2
Snap Ring	20085	2
Snap Ring	21320	1
Shim Kit	K-2805	1
Gasket Kit	K-2061	1

Heavy Duty Transmission Rebuild Kits

TRK-2865			TRK-2924			TRK-2994		
Position	Part Number	Qty	Position	Part Number	Qty	Position	Part Number	Qty
Input Shaft Brg.	212SLV	1	Input Shaft Brg.	MU1212RUMW3	1	Input Shaft Brg.	212SLV	1
Input Shaft Pilot Bushing	BS59	1	Input Shaft Pilot Bushing	BS59	1	Aux. Drive Gear Brg.	5566507	1
Aux. Drive Gear Brg.	5566508	1	Aux. Drive Gear Brg.	5566507	1	Aux. Mainshaft Brg.	29675 Assy 902A8 (A2892)	1
Aux. Mainshaft Brg.	21356	1	Aux. Mainshaft Brg.	5556503	1	Aux. Mainshaft Thrust Brg.	AXK5070	2
Splitter Gear Brg.	4300902	1	Countershaft Front Brg.	BS226539V	2	Countershaft Front Brg.	BS500192SX	2
Countershaft Front Brg.	BS500192SX	2	Countershaft Rear Brg.	BS226539V	2	Countershaft Rear Brg.	MU1308TVWS	2
Countershaft Rear Brg.	BS500052V	2	Rev. Idler Gear Brg.	HJ223020-IR18200H	2	Rev. Idler Gear Brg.	HJ223020-IR18200H	2
Rev. Idler Gear Brg.	HJ223020-IR18200H	2	Aux. Countershaft Front Brg.	4302074	2	Aux. Countershaft Front Brg.	MU61307GUM	2
Aux. Countershaft Front Brg.	NP656227-NP896049	2	Aux. Countershaft Rear Brg.	4302074	2	Aux. Countershaft Rear Brg.	1310SLV	2
Aux. Countershaft Rear Brg.	NP656227-NP896049	2	Spring	14897	3	Spring	14897	3
Spring	14897	3	Output Shaft Seal Kit	K-2918	1	Insert Valve	19974	1
Insert Valve	19974	1	Snap Ring	16980	1	Retainer Assembly	A6340	1
Output Shaft Seal Kit	K-2262	1	Snap Ring	17399	1	Output Shaft Seal Kit	K-2262	1
O-Ring Kit	K-2804	1	Snap Ring	4302082	2	O-Ring Kit	K-2002	1
Snap Ring	14750	1	Snap Ring	4303362	2	O-Ring Kit	OK17453	1
Snap Ring	16980	1	Shim Kit	K-2805	1	Snap Ring	14317	2
Snap Ring	4301254	1	Piston Range Kit	K-2923	1	Snap Ring	14750	1
Snap Ring	4303424	2	Gasket Kit	K-2921	1	Snap Ring	16723	1
Snap Ring	4302082	2	TRK-2993			Snap Ring	16763	2
Shim Kit	K-2805	1	Position	Part Number	Qty	Snap Ring	16980	1
Gasket Kit	K-2199	1	Input Shaft Brg.	212SLV	1	Gasket Kit	K-2199	1
TRK-2866			Aux. Drive Gear Brg.	5566507	1	Threadlocker	TL1	1
Position	Part Number	Qty	Aux. Mainshaft Brg.	29675 Assy 902A8 (A2892)	1	Spring	15918	3
Input Shaft Brg.	212SLV	1	Aux. Mainshaft Thrust Brg.	AXK5070	2	Sliding Clutch	16118	1
Aux. Drive Gear Brg.	5566508	1	Countershaft Front Brg.	BS500192SX	2	Collet	83002	4
Aux. Mainshaft Brg.	21356	1	Countershaft Rear Brg.	MU1308TVWS	2	Connector	84003	2
Splitter Gear Brg.	4300902	1	Rev. Idler Gear Brg.	HJ223020-IR18200H	2	Connector	85001	1
Countershaft Front Brg.	BS500192SX	2	Aux. Countershaft Front Brg.	4302074	2	Input Shaft	S1659	1
Countershaft Rear Brg.	BS500052V	2	Aux. Countershaft Rear Brg.	4302074	2	TRK-2996		
Rev. Idler Gear Brg.	HJ223020-IR18200H	2	Spring	14897	3	Position	Part Number	Qty
Aux. Countershaft Front Brg.	NP656227-NP896049	2	Insert Valve	19974	1	Input Shaft Brg.	212SLV	1
Aux. Countershaft Rear Brg.	NP656227-NP896049	2	Retainer Assembly	4304605	1	Input Shaft Pilot Bushing	BS59	1
Spring	14897	3	Output Shaft Seal Kit	K-2262	1	Aux. Drive Gear Brg.	5566507	1
Insert Valve	19974	1	O-Ring Kit	K-2002	1	Aux. Mainshaft Brg.	29675 Assy 902A8 (A2892)	1
Output Shaft Seal Kit	K-2262	1	O-Ring Kit	OK17453	1	Aux. Mainshaft Thrust Brg.	AXK5070	2
O-Ring Kit	K-2804	1	Snap Ring	14317	2	Countershaft Front Brg.	BS500192SX	2
Snap Ring	14750	1	Snap Ring	14750	1	Countershaft Rear Brg.	MU1308TVWS	2
Snap Ring	16980	1	Snap Ring	16763	2	Rev. Idler Gear Brg.	HJ223020-IR18200H	2
Snap Ring	4301254	1	Snap Ring	16980	1	Aux. Countershaft Front Brg.	4302074	2
Snap Ring	4303424	2	Shim Kit	K-2430	1	Aux. Countershaft Rear Brg.	4302074	2
Snap Ring	4302082	2	Gasket Kit	K-2199	1	Spring	14897	3
Shim Kit	K-2805	1	Threadlocker	TL1	1	Insert Valve	19974	1
Gasket Kit	K-2199	1	Spring	15918	3	Retainer Assembly	4304605	1
Spring	15918	3	Sliding Clutch	16118	1	Output Shaft Seal Kit	K-2262	1
Sliding Clutch	4304317	1	Collet	83002	4	O-Ring Kit	K-2002	1
Connector	84005	2	Connector	84003	2	O-Ring Kit	OK17453	1
Connector	85003	1	Connector	85001	1	Snap Ring	14317	2
Sealer	LC54505	1	Sealer	LC54505	1	Snap Ring	14750	1
Input Shaft	S1659	1	Input Shaft	S1659	1	Snap Ring	16763	2
						Snap Ring	16980	1
						Shim Kit	K-2430	1
						Gasket Kit	K-2199	1
						Threadlocker	TL1	1

Heavy Duty Transmission Rebuild Kits



HD Transmission

TRK-2997			TRK-3132			TRK-3256		
Position	Part Number	Qty	Position	Part Number	Qty	Position	Part Number	Qty
Input Shaft Brg.	212SLV	1	Input Shaft Brg.	MU1212RUMW3	1	Input Shaft Brg.	MU1212RUMW3	1
Input Shaft Pilot Bushing	BS59	1	Input Shaft Pilot Bushing	BS59	1	Input Shaft Pilot Bushing	BS59	1
Aux. Drive Gear Brg.	5566507	1	Aux. Drive Gear Brg.	5566507	1	Aux. Drive Gear Brg.	5566507	1
Aux. Mainshaft Brg.	29675 Assy 902A8 (A2892)	1	Aux. Mainshaft Brg.	5556503	1	Aux. Mainshaft Brg.	5556503	1
Aux. Mainshaft Thrust Brg.	AXK5070	2	Countershaft Front Brg.	BS226539V	2	Aux. Mainshaft Bushing	AA1512-12	2
Countershaft Front Brg.	BS500192SX	2	Countershaft Rear Brg.	BS226539V	2	Countershaft Front Brg.	BS500192SX	2
Countershaft Rear Brg.	MU1308TVWS	2	Rev. Idler Gear Brg.	HJ223020-IR18200H	2	Countershaft Rear Brg.	MU1308TVWS	2
Rev. Idler Gear Brg.	HJ223020-IR18200H	2	Aux. Countershaft Front Brg.	4302074	2	Rev. Idler Gear Brg.	HJ223020-IR18200H	2
Aux. Countershaft Front Brg.	MU61307GUM	2	Aux. Countershaft Rear Brg.	4302074	2	Aux. Countershaft Front Brg.	4302074	2
Aux. Countershaft Rear Brg.	1310SLV	2	Spring	14897	3	Aux. Countershaft Rear Brg.	4302074	2
Spring	14897	3	Output Shaft Seal Kit	K-2262	1	Spring	14897	3
Insert Valve	19974	1	Snap Ring	16980	1	Insert Valve	19974	1
Retainer Assembly	4304605	1	Snap Ring	17399	1	O-Ring Kit	K-2054	1
Output Shaft Seal Kit	K-2262	1	Snap Ring	4302082	2	Output Shaft Seal Kit	K-2918	1
O-Ring Kit	K-2002	1	Snap Ring	4303362	1	Snap Ring	14317	2
O-Ring Kit	OK17453	1	Shim Kit	K-2805	1	Snap Ring	14750	1
Snap Ring	14317	2	Piston Range Kit	K-2923	1	Snap Ring	16763	1
Snap Ring	14750	1	Gasket Kit	K-2921	1	Shim Kit	K-2805	1
Snap Ring	16723	1	TRK-3233			Gasket Kit	K-2061	1
Snap Ring	16763	2	Position	Part Number	Qty	TRK-3257		
Snap Ring	16980	1	Input Shaft Brg.	MU1212RUMW3	1	Position	Part Number	Qty
Gasket Kit	K-2199	1	Input Shaft Pilot Bushing	BS59	1	Input Shaft Brg.	MU1212RUMW3	1
Threadlocker	TL1	1	Aux. Drive Gear Brg.	5566508	1	Aux. Drive Gear Brg.	5566507	1
TRK-2998			Aux. Mainshaft Brg.	5556503	1	Aux. Mainshaft Brg.	5556503	1
Position	Part Number	Qty	Aux. Mainshaft Bushing	AA1512-12	2	Aux. Mainshaft Bushing	AA1512-12	2
Input Shaft Brg.	212SLV	1	Countershaft Front Brg.	BS500192SX	2	Countershaft Front Brg.	BS500192SX	2
Input Shaft Pilot Bushing	BS59	1	Countershaft Rear Brg.	MU1308TVWS	2	Countershaft Rear Brg.	MU1308TVWS	2
Aux. Drive Gear Brg.	5566507	1	Rev. Idler Gear Brg.	HJ223020-IR18200H	2	Rev. Idler Gear Brg.	HJ223020-IR18200H	2
Aux. Mainshaft Brg.	29675 Assy 902A8 (A2892)	1	Aux. Countershaft Front Brg.	4302074	2	Aux. Countershaft Front Brg.	4302074	2
Aux. Mainshaft Thrust Brg.	AXK5070	2	Aux. Countershaft Rear Brg.	4302074	2	Aux. Countershaft Rear Brg.	4302074	2
Countershaft Front Brg.	BS500192SX	2	Spring	14897	3	Spring	14897	3
Countershaft Rear Brg.	MU1308TVWS	2	Insert Valve	19974	1	Insert Valve	19974	1
Rev. Idler Gear Brg.	HJ223020-IR18200H	2	O-Ring Kit	K-2054	1	O-Ring Kit	K-2054	1
Aux. Countershaft Front Brg.	MR1307EX	2	Output Shaft Seal Kit	K-2918	1	Output Shaft Seal Kit	K-2918	1
Aux. Countershaft Rear Brg.	1310SLV	2	Snap Ring	14317	2	Snap Ring	14317	2
Spring	14897	3	Snap Ring	14750	1	Snap Ring	14750	1
Insert Valve	19974	1	Snap Ring	16763	1	Snap Ring	16763	1
Insert Valve	4300810	2	Shim Kit	K-2805	1	Snap Ring	16980	1
Retainer Assembly	A6340	1	Gasket Kit	K-2061	1	Shim Kit	K-2805	1
Output Shaft Seal Kit	K-2262	1	TRK-3234			Gasket Kit	K-2061	1
O-Ring Kit	K-2298	1	Position	Part Number	Qty	Spring	15918	3
O-Ring Kit	OK17453	1	Input Shaft Brg.	MU1212RUMW3	1	Spring	15918	3
Snap Ring	14317	2	Aux. Drive Gear Brg.	5566508	1	Sliding Clutch	4306648	1
Snap Ring	14750	1	Aux. Mainshaft Brg.	5556503	1	Collet	83002	4
Snap Ring	16763	1	Aux. Mainshaft Bushing	AA1512-12	2	Connector	84004	2
Snap Ring	16980	1	Countershaft Front Brg.	BS500192SX	2	Connector	85001	1
Gasket Kit	K-2295	1	Countershaft Rear Brg.	MU1308TVWS	2	Sealer	LC54505	1
Threadlocker	TL1	1	Rev. Idler Gear Brg.	HJ223020-IR18200H	2	Input Shaft	S1659	1
			Aux. Countershaft Front Brg.	4302074	2			
			Aux. Countershaft Rear Brg.	4302074	2			
			Spring	14897	3			
			Insert Valve	19974	1			
			O-Ring Kit	K-2054	1			
			Output Shaft Seal Kit	K-2918	1			
			Snap Ring	14317	2			
			Snap Ring	14750	1			
			Snap Ring	16763	1			
			Snap Ring	16980	1			
			Shim Kit	K-2805	1			
			Gasket Kit	K-2061	1			
			Spring	15918	3			
			Sliding Clutch	4306647	1			
			Collet	83002	4			
			Connector	84004	2			
			Connector	85001	1			
			Sealer	LC54505	1			
			Input Shaft	S1659	1			

Heavy Duty Transmission Rebuild Kits

TRK-3258			TRK-3273			TRK-3286		
Position	Part Number	Qty	Position	Part Number	Qty	Position	Part Number	Qty
Input Shaft Brg.	MU1212RUMW3	1	Input Shaft Brg.	MU1212RUMW3	1	Input Shaft Brg.	212SLV	1
Aux. Drive Gear Brg.	5566507	1	Input Shaft Pilot Bushing	BS59	1	Input Shaft Pilot Bushing	BS59	1
Aux. Mainshaft Brg.	5556503	1	Aux. Drive Gear Brg.	5566507	1	Aux. Drive Gear Brg.	5566508	1
Aux. Mainshaft Bushing	AA1512-12	2	Aux. Mainshaft Brg.	5556503	1	Aux. Mainshaft Brg.	5556503	1
Countershaft Front Brg.	BS500192SX	2	Aux. Mainshaft Bushing	AA1512-12	2	Splitter Gear Brg.	4300902	1
Countershaft Rear Brg.	MU1308TVWS	2	Countershaft Front Brg.	BS500192SX	2	Countershaft Front Brg.	BS500192SX	2
Rev. Idler Gear Brg.	HJ223020-IR18200H	2	Countershaft Rear Brg.	MU1308TVWS	2	Countershaft Rear Brg.	MU1308TMWS	2
Aux. Countershaft Front Brg.	4302074	2	Rev. Idler Gear Brg.	HJ223020-IR18200H	2	Rev. Idler Gear Brg.	HJ223020-IR18200H	2
Aux. Countershaft Rear Brg.	4302074	2	Aux. Countershaft Front Brg.	4302074	2	Aux. Countershaft Front Brg.	4302074	2
Spring	14897	3	Aux. Countershaft Rear Brg.	4302074	2	Aux. Countershaft Rear Brg.	4302074	2
Insert Valve	19974	1	Spring	14897	3	Spring	14897	3
O-Ring Kit	K-2054	1	Insert Valve	19974	1	Insert Valve	19974	1
Output Shaft Seal Kit	K-2918	1	O-Ring Kit	K-2054	1	O-Ring Kit	K-2804	1
Snap Ring	14317	2	Output Shaft Seal Kit	K-2918	1	Output Shaft Seal Kit	K-2918	1
Snap Ring	14750	1	Snap Ring	14317	2	Snap Ring	14317	2
Snap Ring	16763	1	Snap Ring	14750	1	Snap Ring	14750	1
Shim Kit	K-2805	1	Snap Ring	16763	1	Snap Ring	16980	1
Gasket Kit	K-2061	1	Shim Kit	K-2805	1	Snap Ring	4301254	1
Snap Ring	16980	1	Gasket Kit	K-2061	1	Snap Ring	4303424	1
Sliding Clutch	4306647	1				Shim Kit	K-2805	1
Collet	83002	4				Gasket Kit	K-3288	1
Connector	84004	2						
Connector	85001	1						
Sealer	LC54505	1						
Input Shaft	S1659	1						
TRK-3272			TRK-3282			TRK-3287		
Position	Part Number	Qty	Position	Part Number	Qty	Position	Part Number	Qty
Input Shaft Brg.	MU1212RUMW3	1	Input Shaft Brg.	MU1212RUMW3	1	Input Shaft Brg.	212SLV	1
Aux. Drive Gear Brg.	5566507	1	Aux. Drive Gear Brg.	5566507	1	Aux. Drive Gear Brg.	5566508	1
Aux. Mainshaft Brg.	5556503	1	Aux. Mainshaft Brg.	5556503	1	Aux. Mainshaft Brg.	5556503	1
Aux. Mainshaft Bushing	AA1512-12	2	Aux. Mainshaft Bushing	AA1512-12	2	Splitter Gear Brg.	4300902	1
Countershaft Front Brg.	BS500192SX	2	Countershaft Front Brg.	BS500192SX	2	Countershaft Front Brg.	BS500192SX	2
Countershaft Rear Brg.	MU1308TVWS	2	Countershaft Rear Brg.	MU1308TVWS	2	Countershaft Rear Brg.	MU1308TMWS	2
Rev. Idler Gear Brg.	HJ223020-IR18200H	2	Rev. Idler Gear Brg.	HJ223020-IR18200H	2	Rev. Idler Gear Brg.	HJ223020-IR18200H	2
Aux. Countershaft Front Brg.	4302074	2	Aux. Countershaft Front Brg.	4302074	2	Aux. Countershaft Front Brg.	4302074	2
Aux. Countershaft Rear Brg.	4302074	2	Aux. Countershaft Rear Brg.	4302074	2	Aux. Countershaft Rear Brg.	4302074	2
Spring	14897	3	Spring	14897	3	Spring	14897	3
Insert Valve	19974	1	Insert Valve	19974	1	Insert Valve	19974	1
O-Ring Kit	K-2054	1	O-Ring Kit	K-2846	1	O-Ring Kit	K-2804	1
Output Shaft Seal Kit	K-2918	1	Output Shaft Seal Kit	K-2918	1	Output Shaft Seal Kit	K-2918	1
Snap Ring	14317	2	Snap Ring	14317	2	Snap Ring	14317	2
Snap Ring	14750	1	Snap Ring	14750	1	Snap Ring	14750	1
Snap Ring	16763	1	Snap Ring	16763	1	Snap Ring	16980	1
Snap Ring	16980	1	Shim Kit	K-2805	1	Snap Ring	4301254	1
Shim Kit	K-2805	1	Gasket Kit	K-2061	1	Snap Ring	4303424	1
Gasket Kit	K-2061	1	Spring	15918	3	Shim Kit	K-2805	1
Spring	15918	3	Snap Ring	16980	1	Gasket Kit	K-3288	1
Sliding Clutch	4306648	1	Sliding Clutch	4306647	1	Spring	15918	3
Collet	83002	4	Connector	84006	1	Sliding Clutch	4304317	1
Connector	84004	2	Connector	85003	1	Connector	84006	2
Connector	85001	1	Sealer	LC54505	1	Connector	85003	1
Sealer	LC54505	1	Input Shaft	S1659	1	Sealer	LC54505	1
Input Shaft	S1659	1				Input Shaft	S1659	1
			TRK-3283					
			Position	Part Number	Qty			
			Input Shaft Brg.	MU1212RUMW3	1			
			Input Shaft Pilot Bushing	BS59	1			
			Aux. Drive Gear Brg.	5566507	1			
			Aux. Mainshaft Brg.	5556503	1			
			Aux. Mainshaft Bushing	AA1512-12	2			
			Countershaft Front Brg.	BS500192SX	2			
			Countershaft Rear Brg.	MU1308TVWS	2			
			Rev. Idler Gear Brg.	HJ223020-IR18200H	2			
			Aux. Countershaft Front Brg.	4302074	2			
			Aux. Countershaft Rear Brg.	4302074	2			
			Spring	14897	3			
			Insert Valve	19974	1			
			O-Ring Kit	K-2846	1			
			Output Shaft Seal Kit	K-2918	1			
			Snap Ring	14317	2			
			Snap Ring	14750	1			
			Snap Ring	16763	1			
			Shim Kit	K-2805	1			
			Gasket Kit	K-2061	1			

HD Transmission

Heavy Duty Transmission Rebuild Kits



HD Transmission

TRK-3322		
Position	Part Number	Qty
Input Shaft Brg.	MU1212RUMW3	1
Input Shaft Pilot Bushing	BS59	1
Aux. Drive Gear Brg.	5566507	1
Aux. Mainshaft Brg.	21355	1
Countershaft Front Brg.	BS500192SX	2
Countershaft Rear Brg.	MU1308TVWS	2
Rev. Idler Gear Brg.	HJ223020-IR18200H	2
Aux. Countershaft Front Brg.	4302074	2
Aux. Countershaft Rear Brg.	4302074	2
Spring	14897	3
O-Ring Kit	K-1450	1
Output Shaft Seal Kit	K-2262	1
Snap Ring	14317	2
Snap Ring	14750	1
Snap Ring	16763	2
Snap Ring	16980	1
Shim Kit	K-2805	1
Gasket Kit	K-2061	1

TRK-3323		
Position	Part Number	Qty
Input Shaft Brg.	MU1212RUMW3	1
Aux. Drive Gear Brg.	5566507	1
Aux. Mainshaft Brg.	21355	1
Countershaft Front Brg.	BS500192SX	2
Countershaft Rear Brg.	MU1308TVWS	2
Rev. Idler Gear Brg.	HJ223020-IR18200H	2
Aux. Countershaft Front Brg.	4302074	2
Aux. Countershaft Rear Brg.	4302074	2
Spring	14897	3
O-Ring Kit	K-1450	1
Output Shaft Seal Kit	K-2262	1
Snap Ring	14317	2
Snap Ring	14750	1
Snap Ring	16763	2
Snap Ring	16980	1
Shim Kit	K-2805	1
Gasket Kit	K-2061	1
Spring	15918	3
Sliding Clutch	4306648	1
Collet	83001	4
Connector	84002	1
Connector	85002	1
Sealer	LC54505	1
Input Shaft	S1659	1

TRK-3339		
Position	Part Number	Qty
Input Shaft Brg.	212SLV	1
Aux. Drive Gear Brg.	5566510	1
Aux. Mainshaft Brg.	5566503	1
Splitter Gear Brg.	4300902	1
Countershaft Front Brg.	BS500192SX	2
Countershaft Rear Brg.	BS500052V	2
Rev. Idler Gear Brg.	HJ223020-IR18200H	2
Aux. Countershaft Front Brg.	NP656227-NP896049	2
Aux. Countershaft Rear Brg.	NP656227-NP896049	2
Spring	14897	3
O-Ring Kit	K-3341	1
Output Shaft Seal Kit	K-2918	1
Snap Ring	14750	1
Snap Ring	16980	1
Snap Ring	4301254	1
Snap Ring	4302082	2
Snap Ring	4303424	1
Shim Kit	K-2805	1
Gasket Kit	K-3288	1
Spring	15918	3
Sliding Clutch	4304317	1
Connector	84006	2
Connector	85003	1
Sealer	LC54505	1
Input Shaft	S1659	1

TRK-3340		
Position	Part Number	Qty
Input Shaft Brg.	212SLV	1
Input Shaft Pilot Bushing	BS59	1
Aux. Drive Gear Brg.	5566510	1
Aux. Mainshaft Brg.	5566503	1
Splitter Gear Brg.	4300902	1
Countershaft Front Brg.	BS500192SX	2
Countershaft Rear Brg.	BS500052V	2
Rev. Idler Gear Brg.	HJ223020-IR18200H	2
Aux. Countershaft Front Brg.	NP656227-NP896049	2
Aux. Countershaft Rear Brg.	NP656227-NP896049	2
Spring	14897	3
O-Ring Kit	K-3341	1
Output Shaft Seal Kit	K-2918	1
Snap Ring	14750	1
Snap Ring	16980	1
Snap Ring	4301254	1
Snap Ring	4302082	2
Snap Ring	4303424	1
Shim Kit	K-2805	1
Gasket Kit	K-3288	1

TRK-3342		
Position	Part Number	Qty
Input Shaft Brg.	212SLV	1
Aux. Drive Gear Brg.	5566508	1
Aux. Mainshaft Brg.	5566503	1
Countershaft Front Brg.	BS500192SX	2
Countershaft Rear Brg.	BS500052V	2
Rev. Idler Gear Brg.	HJ223020-IR18200H	2
Aux. Countershaft Front Brg.	4302074	2
Aux. Countershaft Rear Brg.	4302074	2
Spring	14897	3
Output Shaft Seal Kit	K-2918	1
O-Ring Kit	K-3341	1
Snap Ring Set	SR3340	1
Snap Ring	4302082	2
Shim Kit	K-2805	1
Gasket Kit	K-3288	1
Spring	15918	3
Sliding Clutch	4304317	1
Connector	84006	2
Connector	85003	1
Sealer	LC54505	1
Input Shaft	S1659	1

TRK-3343		
Position	Part Number	Qty
Input Shaft Brg.	212SLV	1
Input Shaft Pilot Bushing	BS59	1
Aux. Drive Gear Brg.	5566508	1
Aux. Mainshaft Brg.	5566503	1
Countershaft Front Brg.	BS500192SX	2
Countershaft Rear Brg.	BS500052V	2
Rev. Idler Gear Brg.	HJ223020-IR18200H	2
Aux. Countershaft Front Brg.	4302074	2
Aux. Countershaft Rear Brg.	4302074	2
Spring	14897	3
Output Shaft Seal Kit	K-2918	1
O-Ring Kit	K-3341	1
Snap Ring Set	SR3340	1
Snap Ring	4302082	2
Shim Kit	K-2805	1
Gasket Kit	K-3288	1

TRK-3344		
Position	Part Number	Qty
Aux. Mainshaft Brg.	21356	1
Aux. Countershaft Front Brg.	4302074	2
Aux. Countershaft Rear Brg.	4302074	2
Spring	14897	3
Insert Valve	19974	1
Output Shaft Seal Kit	K-2262	1
O-Ring Kit	K-2804	1
Connector	85003	1
Shim Kit	K-2805	1
Gasket Kit	K-1603	1

Heavy Duty Transmission Rebuild Kits

TRK-3345			TRK-3347			TRK-3350		
Position	Part Number	Qty	Position	Part Number	Qty	Position	Part Number	Qty
Input Shaft Brg.	212SLV	1	Input Shaft Brg.	212SLV	1	Input Shaft Brg.	212SLV	1
Aux. Drive Gear Brg.	5566508	1	Aux. Drive Gear Brg.	5566508	1	Aux. Drive Gear Brg.	5566508	1
Aux. Mainshaft Brg.	21356	1	Aux. Mainshaft Brg.	5556503	1	Aux. Mainshaft Brg.	5556503	1
Countershaft Front Brg.	BS500192SX	2	Countershaft Front Brg.	BS500192SX	2	Countershaft Front Brg.	BS500192SX	2
Countershaft Rear Brg.	MU1308TVWS	2	Countershaft Rear Brg.	MU1308TVWS	2	Countershaft Rear Brg.	MU1308TVWS	2
Rev. Idler Gear Brg.	HJ223020-IR18200H	2	Rev. Idler Gear Brg.	HJ223020-IR18200H	2	Rev. Idler Gear Brg.	HJ223020-IR18200H	2
Aux. Countershaft Front Brg.	4302074	2	Aux. Countershaft Front Brg.	4302074	2	Aux. Countershaft Front Brg.	4302074	2
Aux. Countershaft Rear Brg.	4302074	2	Aux. Countershaft Rear Brg.	4302074	2	Aux. Countershaft Rear Brg.	4302074	2
Spring	14897	3	Spring	14897	3	Spring	14897	3
Insert Valve	19974	1	Output Shaft Seal Kit	K-2918	1	Output Shaft Seal Kit	K-2918	1
Output Shaft Seal Kit	K-2262	1	O-Ring Kit	K-3341	1	O-Ring Kit	K-3341	1
O-Ring Kit	K-2804	1	Snap Ring	14317	2	Snap Ring	14317	2
Snap Ring	14317	2	Snap Ring	14750	1	Snap Ring	14750	1
Snap Ring	14750	1	Snap Ring	16980	1	Snap Ring	16980	1
Snap Ring	16980	1	Snap Ring	4301254	1	Snap Ring	4301254	1
Snap Ring	4301254	2	Shim Kit	K-2805	1	Shim Kit	K-2805	1
Shim Kit	K-2805	1	Gasket Kit	K-3288	1	Gasket Kit	K-3288	1
Gasket Kit	K-2199	1	Spring	15918	3	Spring	15918	3
Spring	15918	3	Sliding Clutch	4304317	1	Sliding Clutch	4304317	1
Sliding Clutch	4304317	1	Connector	84006	2	Connector	84006	2
Connector	84005	2	Connector	85003	1	Connector	85003	1
Connector	85003	1	Sealer	LC54505	1	Sealer	LC54505	1
Sealer	LC54505	1	Input Shaft	S1659	1	Input Shaft	S1659	1
Input Shaft	S1659	1						
TRK-3346			TRK-3348			TRK-3351		
Position	Part Number	Qty	Position	Part Number	Qty	Position	Part Number	Qty
Input Shaft Brg.	212SLV	1	Input Shaft Brg.	212SLV	1	Input Shaft Brg.	212SLV	1
Input Shaft Pilot Bushing	BS59	1	Input Shaft Pilot Bushing	BS59	1	Input Shaft Pilot Bushing	BS59	1
Aux. Drive Gear Brg.	5566508	1	Aux. Drive Gear Brg.	5566508	1	Aux. Drive Gear Brg.	5566508	1
Aux. Mainshaft Brg.	21356	1	Aux. Mainshaft Brg.	5556503	1	Aux. Mainshaft Brg.	5556503	1
Countershaft Front Brg.	BS500192SX	2	Countershaft Front Brg.	BS500192SX	2	Countershaft Front Brg.	BS500192SX	2
Countershaft Rear Brg.	MU1308TVWS	2	Countershaft Rear Brg.	MU1308TVWS	2	Countershaft Rear Brg.	MU1308TVWS	2
Rev. Idler Gear Brg.	HJ223020-IR18200H	2	Rev. Idler Gear Brg.	HJ223020-IR18200H	2	Rev. Idler Gear Brg.	HJ223020-IR18200H	2
Aux. Countershaft Front Brg.	4302074	2	Aux. Countershaft Front Brg.	4302074	2	Aux. Countershaft Front Brg.	4302074	2
Aux. Countershaft Rear Brg.	4302074	2	Aux. Countershaft Rear Brg.	4302074	2	Aux. Countershaft Rear Brg.	4302074	2
Spring	14897	3	Spring	14897	3	Spring	14897	3
Insert Valve	19974	1	Output Shaft Seal Kit	K-2918	1	Output Shaft Seal Kit	K-2918	1
Output Shaft Seal Kit	K-2262	1	O-Ring Kit	K-3341	1	O-Ring Kit	K-3341	1
O-Ring Kit	K-2804	1	Snap Ring	14317	2	Snap Ring	14317	2
Snap Ring	14317	2	Snap Ring	14750	1	Snap Ring	14750	1
Snap Ring	14750	1	Snap Ring	16980	1	Snap Ring	16980	1
Snap Ring	16980	1	Snap Ring	4301254	1	Snap Ring	4301254	1
Snap Ring	4301254	2	Shim Kit	K-2805	1	Shim Kit	K-2805	1
Shim Kit	K-2805	1	Gasket Kit	K-3288	1	Gasket Kit	K-3288	1
Gasket Kit	K-2199	1						

HD Transmission

Heavy Duty Transmission Rebuild Kits



HD Transmission

TRK-3354			TRK-3414			TRK-3425		
Position	Part Number	Qty	Position	Part Number	Qty	Position	Part Number	Qty
Input Shaft Brg.	212SLV	1	Input Shaft Brg.	MU1212RUMW3	1	Input Shaft Brg.	212SLV	1
Aux. Drive Gear Brg.	5566508	1	Aux. Drive Gear Brg.	5566508	1	Aux. Drive Gear Brg.	5566508	1
Aux. Mainshaft Brg.	5556503	1	Aux. Mainshaft Bushing	AA1512-12	2	Aux. Mainshaft Brg.	5566503	1
Splitter Gear Brg.	4300902	1	Aux. Mainshaft Brg.	5556503	1	Splitter Gear Brg.	4300902	1
Countershaft Front Brg.	BS500192SX	2	Countershaft Front Brg.	BS500192SX	2	Countershaft Front Brg.	BS500192SX	2
Countershaft Rear Brg.	MU1308TVWS	2	Countershaft Rear Brg.	MU1308TVWS	2	Countershaft Rear Brg.	BS500052V	2
Rev. Idler Gear Brg.	HJ223020-IR18200H	2	Rev. Idler Gear Brg.	HJ223020-IR18200H	2	Rev. Idler Gear Brg.	HJ223020-IR18200H	2
Aux. Countershaft Front Brg.	NP656227-NP896049	2	Aux. Countershaft Front Brg.	4302074	2	Aux. Countershaft Front Brg.	4302074	2
Aux. Countershaft Rear Brg.	NP656227-NP896049	2	Aux. Countershaft Rear Brg.	4302074	2	Aux. Countershaft Rear Brg.	4302074	2
Spring	14897	3	Spring	14897	3	Spring	14897	3
Output Shaft Seal Kit	K-2918	1	Insert Valve	19974	1	Output Shaft Seal Kit	K-2918	1
O-Ring Kit	K-3341	1	Output Shaft Seal Kit	K-2918	1	O-Ring Kit	K-3341	1
Snap Ring	14317	2	O-Ring Kit	K-2846	1	Snap Ring	14750	1
Snap Ring	14750	2	Snap Ring	14317	2	Snap Ring	16980	1
Snap Ring	16980	1	Snap Ring	14750	1	Snap Ring	4301254	1
Snap Ring	4301254	1	Snap Ring	16763	1	Snap Ring	4302082	2
Snap Ring	4303424	1	Shim Kit	K-2805	1	Snap Ring	4303424	2
Shim Kit	K-2805	1	Gasket Kit	K-2061	1	Gasket Kit	K-3288	1
Gasket Kit	K-3288	1	Spring	15918	3	Shim Kit	K-2805	1
Spring	15918	3	Sliding Clutch	4306647	1	Spring	15918	3
Connector	84006	2	Connector	84006	1	Sliding Clutch	4304317	1
Connector	85003	1	Connector	85003	1	Connector	84006	2
Sliding Clutch	4304317	1	Sealer	LC54505	1	Connector	85003	1
Input Shaft	S1659	1	Input Shaft	S1659	1	Sealer	LC54505	1
						Input Shaft	S1659	1
TRK-3355			TRK-3423			TRK-3426		
Position	Part Number	Qty	Position	Part Number	Qty	Position	Part Number	Qty
Input Shaft Brg.	212SLV	1	Input Shaft Brg.	39590-39520	1	Input Shaft Brg.	212SLV	1
Input Shaft Pilot Bushing	BS59	1	Input Shaft Pilot Brg.	31594	1	Input Shaft Pilot Bushing	BS59	1
Aux. Drive Gear Brg.	5566508	1	Output Shaft Brg.	45285A-45220	1	Aux. Drive Gear Brg.	5566508	1
Aux. Mainshaft Brg.	5556503	1	Mainshaft 6th Gear Brg.	FW505520	2	Aux. Mainshaft Brg.	5566503	1
Splitter Gear Brg.	4300902	1	Mainshaft 4th Gear Brg.	FW556020	2	Splitter Gear Brg.	4300902	1
Countershaft Front Brg.	BS500192SX	2	Mainshaft 3rd Gear Brg.	FW657020	2	Countershaft Front Brg.	BS500192SX	2
Countershaft Rear Brg.	MU1308TVWS	2	Mainshaft 2nd Gear Brg.	FW707620	2	Countershaft Rear Brg.	BS500052V	2
Rev. Idler Gear Brg.	HJ223020-IR18200H	2	Mainshaft 1st Gear Brg.	FW707620	2	Rev. Idler Gear Brg.	HJ223020-IR18200H	2
Aux. Countershaft Front Brg.	NP656227-NP896049	2	Mainshaft Rev. Gear Brg.	4304555	1	Aux. Countershaft Front Brg.	4302074	2
Aux. Countershaft Rear Brg.	NP656227-NP896049	2	Countershaft Front Brg.	25590-25522	1	Aux. Countershaft Rear Brg.	4302074	2
Spring	14897	3	Countershaft Rear Brg.	3782-3720	1	Spring	14897	3
Output Shaft Seal Kit	K-2918	1	Rev. Idler Gear Brg.	FW404820	2	Output Shaft Seal Kit	K-2918	1
O-Ring Kit	K-3341	1	Snap Ring	3315686	2	O-Ring Kit	K-3341	1
Snap Ring	14317	2	Snap Ring	3315725	2	Snap Ring	14750	1
Snap Ring	14750	1	Spring	3315765	4	Snap Ring	16980	1
Snap Ring	16980	1	Plug	3315679	1	Snap Ring	4301254	1
Snap Ring	4301254	1	Shim Kit	K-2183	1	Snap Ring	4302082	2
Snap Ring	4303424	1	Output Shaft Seal	4300119	1	Snap Ring	4303424	2
Shim Kit	K-2805	1	Input Shaft Seal	710211	1	Gasket Kit	K-3288	1
Gasket Kit	K-3288	1	Gasket Kit	K-7028	1	Shim Kit	K-2805	1
TRK-3413			TRK-3440					
Position	Part Number	Qty	Position	Part Number	Qty			
Input Shaft Brg.	MU1212RUMW3	1	Input Shaft Brg.	39590-39520	1			
Input Shaft Pilot Bushing	BS59	1	Input Shaft Pilot Brg.	31594	1			
Aux. Drive Gear Brg.	5566508	1	Output Shaft Brg.	45285A-45220	1			
Aux. Mainshaft Bushing	AA1512-12	2	Countershaft Front Brg.	25590-25522	1			
Aux. Mainshaft Brg.	5556503	1	Countershaft Rear Brg.	3782-3720	1			
Countershaft Front Brg.	BS500192SX	2	1st Gear Brg.	FW707620	2			
Countershaft Rear Brg.	MU1308TVWS	2	2nd Gear Brg.	FW707620	2			
Rev. Idler Gear Brg.	HJ223020-IR18200H	2	3rd Gear Brg.	FW657020	2			
Aux. Countershaft Front Brg.	4302074	2	4th Gear Brg.	FW556020	2			
Aux. Countershaft Rear Brg.	4302074	2	5th Gear Brg.	FW505520	2			
Spring	14897	3	Rev. Gear Brg.	FW556020	2			
Insert Valve	19974	1	Rev. Idler Gear Brg.	FW404820	2			
Output Shaft Seal Kit	K-2918	1	Countershaft Plug	3315679	1			
O-Ring Kit	K-2846	1	Spring	691644	4			
Snap Ring	14317	2	Snap Ring	3315686	1			
Snap Ring	14750	1	Snap Ring	3315725	2			
Snap Ring	16763	1	Input Shaft Seal	710211	1			
Shim Kit	K-2805	1	Output Shaft Seal	4300119	1			
Gasket Kit	K-2061	1	Shim Kit	K-2183	1			
			Gasket Set	K-3738	1			

Heavy Duty Transmission Rebuild Kits

TRK-3459

Position	Part Number	Qty
Input Shaft Brg.	212SLV	1
Aux. Drive Gear Brg.	5566510	1
Aux. Mainshaft Brg.	5556503	1
Countershaft Front Brg.	BS500192SX	2
Countershaft Rear Brg.	BS500052V	2
Rev. Idler Gear Brg.	HJ223020-IR18200H	2
Aux. Countershaft Front Brg.	NP656227-NP896049	2
Aux. Countershaft Rear Brg.	NP656227-NP896049	2
Spring	14897	3
Output Shaft Seal Kit	K-2918	1
O-Ring Kit	K-3341	1
Snap Ring	14750	1
Snap Ring	16980	1
Snap Ring	4301254	1
Snap Ring	4302082	2
Shim Kit	K-2805	1
Gasket Kit	K-3458	1
Spring	15918	3
Sliding Clutch	4304317	1
Connector	84006	2
Connector	85003	1
Sealer	LC54505	1
Input Shaft	S1659	1

TRK-3460

Position	Part Number	Qty
Input Shaft Brg.	212SLV	1
Input Shaft Pilot Bushing	BS59	1
Aux. Drive Gear Brg.	5566510	1
Aux. Mainshaft Brg.	5556503	1
Countershaft Front Brg.	BS500192SX	2
Countershaft Rear Brg.	BS500052V	2
Rev. Idler Gear Brg.	HJ223020-IR18200H	2
Aux. Countershaft Front Brg.	NP656227-NP896049	2
Aux. Countershaft Rear Brg.	NP656227-NP896049	2
Spring	14897	3
Output Shaft Seal Kit	K-2918	1
O-Ring Kit	K-3341	1
Snap Ring	14750	1
Snap Ring	16980	1
Snap Ring	4301254	1
Snap Ring	4302082	2
Shim Kit	K-2805	1
Gasket Kit	K-3458	1

TRK-3461

Position	Part Number	Qty
Input Shaft Brg.	MU1212RUMW3	1
Aux. Drive Gear Brg.	5566510	1
Aux. Mainshaft Brg.	5556503	1
Splitter Gear Brg.	4300902	1
Countershaft Front Brg.	BS500192SX	2
Countershaft Rear Brg.	BS500052V	2
Rev. Idler Gear Brg.	HJ223020-IR18200H	2
Aux. Countershaft Front Brg.	NP656227-NP896049	2
Aux. Countershaft Rear Brg.	NP656227-NP896049	2
Spring	14897	3
Output Shaft Seal Kit	K-2918	1
O-Ring Kit	K-3341	1
Snap Ring	14750	1
Snap Ring	16980	1
Snap Ring	4301254	1
Snap Ring	4302082	1
Snap Ring	4303424	1
Shim Kit	K-2805	1
Gasket Kit	K-3458	1
Spring	15918	3
Sliding Clutch	4304317	1
Connector	85003	3
Sealer	LC54505	1
Input Shaft	S2890	1

TRK-3462

Position	Part Number	Qty
Input Shaft Brg.	MU1212RUMW3	1
Input Shaft Pilot Bushing	BS59	1
Aux. Drive Gear Brg.	5566510	1
Aux. Mainshaft Brg.	5556503	1
Splitter Gear Brg.	4300902	1
Countershaft Front Brg.	BS500192SX	2
Countershaft Rear Brg.	BS500052V	2
Rev. Idler Gear Brg.	HJ223020-IR18200H	2
Aux. Countershaft Front Brg.	NP656227-NP896049	2
Aux. Countershaft Rear Brg.	NP656227-NP896049	2
Spring	14897	3
Output Shaft Seal Kit	K-2918	1
O-Ring Kit	K-3341	1
Snap Ring	14750	1
Snap Ring	16980	1
Snap Ring	4301254	1
Snap Ring	4302082	1
Snap Ring	4303424	1
Shim Kit	K-2805	1
Gasket Kit	K-3458	1

TRK-3486

Position	Part Number	Qty
Input Shaft Brg.	212SLV	1
Aux. Drive Gear Brg.	5566507	1
Aux. Mainshaft Brg.	21356	1
Countershaft Front Brg.	BS500192SX	2
Countershaft Rear Brg.	MU1308TVWS	2
Rev. Idler Gear Brg.	HJ223020-IR18200H	2
Aux. Countershaft Front Brg.	4302074	2
Aux. Countershaft Rear Brg.	4302074	2
Spring	14897	3
Output Shaft Seal Kit	K-2262	1
O-Ring Kit	K-3484	1
Snap Ring	14317	2
Snap Ring	14750	1
Snap Ring	16763	2
Snap Ring	16980	1
Snap Ring Retainer	21320	1
Shim Kit	K-2805	1
Gasket Kit	K-3485	1
Sliding Clutch	4305996	1
Sealer	LC54505	1
Input Shaft	S1659	1

TRK-3487

Position	Part Number	Qty
Input Shaft Brg.	212SLV	1
Input Shaft Pilot Bushing	BS59	1
Aux. Drive Gear Brg.	5566507	1
Aux. Mainshaft Brg.	21356	1
Countershaft Front Brg.	BS500192SX	2
Countershaft Rear Brg.	MU1308TVWS	2
Rev. Idler Gear Brg.	HJ223020-IR18200H	2
Aux. Countershaft Front Brg.	4302074	2
Aux. Countershaft Rear Brg.	4302074	2
Spring	14897	3
Output Shaft Seal Kit	K-2262	1
O-Ring Kit	K-3484	1
Snap Ring	14317	2
Snap Ring	14750	1
Snap Ring	16763	2
Snap Ring Retainer	21320	1
Shim Kit	K-2805	1
Gasket Kit	K-3485	1

TRK-3488

Position	Part Number	Qty
Input Shaft Brg.	212SLV	1
Input Shaft Pilot Bushing	BS59	1
Aux. Drive Gear Brg.	5566507	1
Aux. Mainshaft Brg.	21355	1
Countershaft Front Brg.	BS500192SX	2
Countershaft Rear Brg.	MU1308TVWS	2
Rev. Idler Gear Brg.	HJ223020-IR18200H	2
Aux. Countershaft Front Brg.	4302074	2
Aux. Countershaft Rear Brg.	4302074	2
Spring	14897	3
Output Shaft Seal Kit	K-2262	1
O-Ring Kit	K-3484	1
Snap Ring	14317	2
Snap Ring	14750	1
Snap Ring	16763	2
Snap Ring Retainer	21320	1
Shim Kit	K-2805	1
Gasket Kit	K-3485	1

HD Transmission

Heavy Duty Transmission Rebuild Kits



HD Transmission

TRK-3512		
Position	Part Number	Qty
Input Shaft Brg.	212SLV	1
Input Shaft Pilot Bushing	BS59	1
Aux. Drive Gear Brg.	5566510	1
Aux. Mainshaft Brg.	5565503	1
Splitter Gear Brg.	4300902	1
Countershaft Front Brg.	BS500192SX	2
Countershaft Rear Brg.	BS500052V	2
Rev. Idler Gear Brg.	HJ223020-IR18200H	2
Aux. Countershaft Front Brg.	NP656227-NP896049	2
Aux. Countershaft Rear Brg.	NP656227-NP896049	2
Spring	14897	3
O-Ring Kit	K-3510	1
Output Shaft Seal Kit	K-2918	1
Snap Ring	14750	1
Snap Ring	16980	1
Snap Ring	4301254	1
Snap Ring	4302082	2
Snap Ring	4303424	1
Shim Kit	K-2805	1
Gasket Kit	K-3509	1

TRK-3513		
Position	Part Number	Qty
Input Shaft Brg.	212SLV	1
Aux. Drive Gear Brg.	5566510	1
Aux. Mainshaft Brg.	5565503	1
Splitter Gear Brg.	4300902	1
Countershaft Front Brg.	BS500192SX	2
Countershaft Rear Brg.	BS500052V	2
Rev. Idler Gear Brg.	HJ223020-IR18200H	2
Aux. Countershaft Front Brg.	NP656227-NP896049	2
Aux. Countershaft Rear Brg.	NP656227-NP896049	2
Spring	14897	3
O-Ring Kit	K-3510	1
Output Shaft Seal Kit	K-2918	1
Snap Ring	14750	1
Snap Ring	16980	1
Snap Ring	4301254	1
Snap Ring	4302082	2
Snap Ring	4303424	1
Shim Kit	K-2805	1
Gasket Kit	K-3509	1
Spring	691661	3
Sliding Clutch	4305996	1
Sealer	LC54505	1
Input Shaft	S1659	1

TRK-3514		
Position	Part Number	Qty
Input Shaft Brg.	MU1212RUMW3	1
Input Shaft Pilot Bushing	BS59	1
Aux. Drive Gear Brg.	5566510	1
Aux. Mainshaft Brg.	5565503	1
Splitter Gear Brg.	4300902	1
Countershaft Front Brg.	BS500192SX	2
Countershaft Rear Brg.	BS500052V	2
Rev. Idler Gear Brg.	HJ223020-IR18200H	2
Aux. Countershaft Front Brg.	NP656227-NP896049	2
Aux. Countershaft Rear Brg.	NP656227-NP896049	2
Spring	14897	3
O-Ring Kit	K-3510	1
Output Shaft Seal Kit	K-2918	1
Snap Ring	14750	1
Snap Ring	16980	1
Snap Ring	4301254	1
Snap Ring	4302082	2
Snap Ring	4303424	1
Shim Kit	K-2805	1
Gasket Kit	K-3509	1

TRK-3515		
Position	Part Number	Qty
Input Shaft Brg.	MU1212RUMW3	1
Aux. Drive Gear Brg.	5566510	1
Aux. Mainshaft Brg.	5565503	1
Splitter Gear Brg.	4300902	1
Countershaft Front Brg.	BS500192SX	2
Countershaft Rear Brg.	BS500052V	2
Rev. Idler Gear Brg.	HJ223020-IR18200H	2
Aux. Countershaft Front Brg.	NP656227-NP896049	2
Aux. Countershaft Rear Brg.	NP656227-NP896049	2
Spring	14897	3
O-Ring Kit	K-3510	1
Output Shaft Seal Kit	K-2918	1
Snap Ring	14750	1
Snap Ring	16980	1
Snap Ring	4301254	1
Snap Ring	4302082	2
Snap Ring	4303424	1
Shim Kit	K-2805	1
Gasket Kit	K-3509	1
Spring	691661	3
Sliding Clutch	4305996	1
Sealer	LC54505	1
Input Shaft	S2890	1

TRK-3519		
Position	Part Number	Qty
Input Shaft Brg.	212SLV	1
Aux. Drive Gear Brg.	5566507	1
Aux. Mainshaft Brg.	5565503	1
Countershaft Front Brg.	BS500192SX	2
Countershaft Rear Brg.	MU1308TVWS	2
Rev. Idler Gear Brg.	HJ223020-IR18200H	2
Aux. Countershaft Brg.	4302074	4
Spring	14897	3
Output Shaft Seal Kit	K-2918	1
O-Ring Kit	K-3484	1
O-Ring Kit	OK17453	1
Snap Ring	14317	2
Snap Ring	14750	1
Snap Ring	16763	2
Snap Ring	16980	1
Snap Ring Retainer	21320	1
Shim Kit	K-2805	1
Gasket Kit	K-3518	1
Sliding Clutch	4305996	1
Sealer	LC54505	1
Input Shaft	S1659	1

TRK-3522		
Position	Part Number	Qty
Input Shaft Brg.	212SLV	1
Input Shaft Pilot Bushing	BS59	1
Aux. Drive Gear Brg.	5566507	1
Aux. Mainshaft Brg.	5565503	1
Countershaft Front Brg.	BS500192SX	2
Countershaft Rear Brg.	MU1308TVWS	2
Rev. Idler Gear Brg.	HJ223020-IR18200H	2
Aux. Countershaft Brg.	4302074	4
Spring	14897	3
Output Shaft Seal Kit	K-2918	1
O-Ring Kit	K-3484	1
O-Ring Kit	OK17453	1
Snap Ring	14317	2
Snap Ring	14750	1
Snap Ring	16763	2
Snap Ring Retainer	21320	1
Shim Kit	K-2805	1
Gasket Kit	K-3518	1

TRK-3524		
Position	Part Number	Qty
Input Shaft Brg.	212SLV	1
Aux. Drive Gear Brg.	5566507	1
Aux. Mainshaft Brg.	5565503	1
Countershaft Front Brg.	BS500192SX	2
Countershaft Rear Brg.	MU1308TVWS	2
Rev. Idler Gear Brg.	HJ223020-IR18200H	2
Aux. Countershaft Brg.	4302074	4
Spring	14897	3
Output Shaft Seal Kit	K-2918	1
O-Ring Kit	K-3484	1
O-Ring Kit	OK17453	1
Snap Ring	14317	2
Snap Ring	14750	1
Snap Ring	16763	2
Snap Ring	16980	1
Snap Ring Retainer	21320	1
Shim Kit	K-2805	1
Gasket Kit	K-3518	1
Sliding Clutch	4305997	1
Sealer	LC54505	1
Input Shaft	S1659	1

TRK-3533		
Position	Part Number	Qty
Input Shaft Brg.	212SLV	1
Aux. Drive Gear Brg.	5566510	1
Aux. Mainshaft Brg.	5565503	1
Splitter Gear Brg.	4300902	1
Countershaft Front Brg.	BS500192SX	2
Countershaft Rear Brg.	BS500052V	2
Rev. Idler Gear Brg.	HJ223020-IR18200H	2
Aux. Countershaft Front Brg.	4302074	2
Aux. Countershaft Rear Brg.	4302074	2
Spring	14897	3
O-Ring Kit	K-3510	1
Output Shaft Seal Kit	K-2918	1
Snap Ring	14750	1
Snap Ring	16980	1
Snap Ring	4301254	1
Snap Ring	4302082	2
Snap Ring	4303424	1
Shim Kit	K-2805	1
Gasket Kit	K-3532	1
Spring	1069	3
Sliding Clutch	4305996	1
Sealer	LC54505	1
Input Shaft	S1659	1

TRK-3534		
Position	Part Number	Qty
Input Shaft Brg.	212SLV	1
Input Shaft Pilot Bushing	BS59	1
Aux. Drive Gear Brg.	5566510	1
Aux. Mainshaft Brg.	5565503	1
Splitter Gear Brg.	4300902	1
Countershaft Front Brg.	BS500192SX	2
Countershaft Rear Brg.	BS500052V	2
Rev. Idler Gear Brg.	HJ223020-IR18200H	2
Aux. Countershaft Front Brg.	4302074	2
Aux. Countershaft Rear Brg.	4302074	2
Spring	14897	3
O-Ring Kit	K-3510	1
Output Shaft Seal Kit	K-2918	1
Snap Ring	14750	1
Snap Ring	16980	1
Snap Ring	4301254	1
Snap Ring	4302082	2
Snap Ring	4303424	1
Shim Kit	K-2805	1
Gasket Kit	K-3532	1

Heavy Duty Transmission Rebuild Kits

TRK-3553

Position	Part Number	Qty
Input Shaft Brg.	212SLV	1
Input Shaft Pilot Bushing	BS59	1
Aux. Drive Gear Brg.	5566507	1
Aux. Mainshaft Brg.	21356	1
Splitter Gear Brg.	4300902	1
Countershaft Front Brg.	BS500192SX	2
Countershaft Rear Brg.	MU1308TVWS	2
Rev. Idler Gear Brg.	HJ223020-IR18200H	2
Aux. Countershaft Front Brg.	4302074	2
Aux. Countershaft Rear Brg.	4302074	2
Spring	14897	3
Insert Valve	19974	1
Insert Valve	4300810	2
Output Shaft Seal Kit	K-2262	1
O-Ring Kit	K-2298	1
Snap Ring	14317	2
Snap Ring	14750	1
Snap Ring	16980	1
Shim Kit	K-2805	1
Gasket Kit	K-3552	1

TRK-3554

Position	Part Number	Qty
Input Shaft Brg.	212SLV	1
Aux. Drive Gear Brg.	5566507	1
Aux. Mainshaft Brg.	21356	1
Splitter Gear Brg.	4300902	1
Countershaft Front Brg.	BS500192SX	2
Countershaft Rear Brg.	MU1308TVWS	2
Rev. Idler Gear Brg.	HJ223020-IR18200H	2
Aux. Countershaft Front Brg.	4302074	2
Aux. Countershaft Rear Brg.	4302074	2
Spring	14897	3
Insert Valve	19974	1
Insert Valve	4300810	2
Output Shaft Seal Kit	K-2262	1
O-Ring Kit	K-2298	1
Snap Ring	14317	2
Snap Ring	14750	1
Snap Ring	16980	1
Shim Kit	K-2805	1
Gasket Kit	K-3552	1
Spring	15918	2
Sliding Clutch	16118	1
Connector	84005	2
Connector	85003	1
Sealer	LC54505	1
Input Shaft	S1659	1

TRK-3585

Position	Part Number	Qty
Input Shaft Brg.	212SLV	1
Aux. Drive Gear Brg.	5566507	1
Aux. Mainshaft Brg.	29675 Assy 902A8 (A2892)	1
Aux. Mainshaft Thrust Brg.	AXK5070	2
Countershaft Front Brg.	BS500192SX	2
Countershaft Rear Brg.	MU1308TVWS	2
Rev. Idler Gear Brg.	HJ223020-IR18200H	2
Aux. Countershaft Front Brg.	4302074	2
Aux. Countershaft Rear Brg.	4302074	2
Spring	14897	3
Output Shaft Seal Kit	K-2262	1
O-Ring Kit	K-3583	1
O-Ring Kit	OK17453	1
Snap Ring	14317	2
Snap Ring	14750	1
Snap Ring	16763	2
Snap Ring	16980	1
Retainer Assembly	4304605	1
Shim Kit	K-2430	1
Gasket Kit	K-3584	1
Spring	15918	3
Sliding Clutch	16118	1
Connector	84003	2
Connector	85001	1
Sealer	LC54505	1
Input Shaft	S1659	1

TRK-3586

Position	Part Number	Qty
Input Shaft Brg.	212SLV	1
Input Shaft Pilot Bushing	BS59	1
Aux. Drive Gear Brg.	5566507	1
Aux. Mainshaft Brg.	29675 Assy 902A8 (A2892)	1
Aux. Mainshaft Thrust Brg.	AXK5070	2
Countershaft Front Brg.	BS500192SX	2
Countershaft Rear Brg.	MU1308TVWS	2
Rev. Idler Gear Brg.	HJ223020-IR18200H	2
Aux. Countershaft Front Brg.	4302074	2
Aux. Countershaft Rear Brg.	4302074	2
Spring	14897	3
Output Shaft Seal Kit	K-2262	1
O-Ring Kit	K-3583	1
O-Ring Kit	OK17453	1
Snap Ring	14317	2
Snap Ring	14750	1
Snap Ring	16763	2
Snap Ring	16980	1
Retainer Assembly	4304605	1
Shim Kit	K-2430	1
Gasket Kit	K-3584	1

TRK-3595

Position	Part Number	Qty
Input Shaft Brg.	212SLV	1
Aux. Drive Gear Brg.	5566508	1
Aux. Mainshaft Brg.	21356	1
Splitter Gear Brg.	4300902	1
Countershaft Front Brg.	BS500192SX	2
Countershaft Rear Brg.	MU1308TVWS	2
Rev. Idler Gear Brg.	HJ223020-IR18200H	2
Aux. Countershaft Front Brg.	4302074	2
Aux. Countershaft Rear Brg.	4302074	2
Spring	14897	3
Output Shaft Seal Kit	K-2262	1
O-Ring Kit	K-3594	1
Snap Ring	14317	2
Snap Ring	14750	1
Snap Ring	16980	1
Shim Kit	K-2805	1
Gasket Kit	K-3593	1
Spring	15918	3
Sliding Clutch	16118	1
Connector	84005	2
Connector	85003	1
Input Shaft	S1659	1

TRK-3596

Position	Part Number	Qty
Input Shaft Brg.	212SLV	1
Input Shaft Pilot Bushing	BS59	1
Aux. Drive Gear Brg.	5566508	1
Aux. Mainshaft Brg.	21356	1
Splitter Gear Brg.	4300902	1
Countershaft Front Brg.	BS500192SX	2
Countershaft Rear Brg.	MU1308TVWS	2
Rev. Idler Gear Brg.	HJ223020-IR18200H	2
Aux. Countershaft Front Brg.	4302074	2
Aux. Countershaft Rear Brg.	4302074	2
Spring	14897	3
Output Shaft Seal Kit	K-2262	1
O-Ring Kit	K-3594	1
Snap Ring	14317	2
Snap Ring	14750	1
Snap Ring	16980	1
Shim Kit	K-2805	1
Gasket Kit	K-3593	1

TRK-3597

Position	Part Number	Qty
Input Shaft Brg.	212SLV	1
Aux. Drive Gear Brg.	5566508	1
Aux. Mainshaft Brg.	5556503	1
Splitter Gear Brg.	4300902	1
Countershaft Front Brg.	BS500192SX	2
Countershaft Rear Brg.	BS500052V	2
Rev. Idler Gear Brg.	HJ223020-IR18200H	2
Aux. Countershaft Front Brg.	4302074	2
Aux. Countershaft Rear Brg.	4302074	2
Spring	14897	3
Output Shaft Seal Kit	K-2918	1
O-Ring Kit	K-3341	1
Snap Ring	14750	1
Snap Ring	16980	1
Snap Ring	4301254	1
Snap Ring	4302082	2
Shim Kit	K-2805	1
Gasket Kit	K-3458	1
Spring	15918	3
Sliding Clutch	4306647	1
Connector	84005	2
Connector	85003	1
Input Shaft	S1659	1

HD Transmission

Heavy Duty Transmission Rebuild Kits



HD Transmission

TRK-3598		
Position	Part Number	Qty
Input Shaft Brg.	212SLV	1
Input Shaft Pilot Bushing	B559	1
Aux. Drive Gear Brg.	5566508	1
Aux. Mainshaft Brg.	5556503	1
Splitter Gear Brg.	4300902	1
Countershaft Front Brg.	BS500192SX	2
Countershaft Rear Brg.	BS500052V	2
Rev. Idler Gear Brg.	HJ223020-IR18200H	2
Aux. Countershaft Front Brg.	4302074	2
Aux. Countershaft Rear Brg.	4302074	2
Spring	14897	3
Output Shaft Seal Kit	K-2918	1
O-Ring Kit	K-3341	1
Snap Ring	14750	1
Snap Ring	16980	1
Snap Ring	4301254	1
Snap Ring	4302082	2
Shim Kit	K-2805	1
Gasket Kit	K-3458	1

TRK-3599		
Position	Part Number	Qty
Clutch Pilot Brg.	306VVL	1
Input Shaft Brg.	212SLV	1
Front Brg. Cover	20550	1
Clutch Yoke	85533	1
Clutch Yoke Bushing	12815	4
Clutch Brake Disc	85541	1
Input Shaft	S1659	1
Snap Ring	14750	1
Snap Ring	16980	1
Gasket	14311	1
Gasket	4305294	1
Gasket	4306584	1

TRK-3600		
Position	Part Number	Qty
Clutch Pilot Brg.	306VV	1
Input Shaft Brg.	MU1212RUMW3	1
Front Brg. Cover	20550	1
Clutch Yoke	85533	1
Clutch Yoke Bushing	12815	4
Clutch Brake Disc	85541	1
Input Shaft	S2822	1
Snap Ring	16980	1
Snap Ring	4303362	1
Gasket	14311	1
Gasket	4305294	1
Gasket	4306584	1

TRK-3601		
Position	Part Number	Qty
Clutch Pilot Brg.	306VVL	1
Input Shaft Brg.	MU1212RUMW3	1
Front Brg. Cover	20550	1
Clutch Yoke	85533	1
Clutch Yoke Bushing	12815	4
Clutch Brake Disc	85541	1
Input Shaft	S2822	1
Snap Ring	16980	1
Snap Ring	4303362	1
Gasket	14311	1
Gasket	4305294	1
Gasket	4306584	1

TRK-3655		
Position	Part Number	Qty
Input Shaft Brg.	MU1212RUMW3	1
Aux. Drive Gear Brg.	5566507	1
Aux. Mainshaft Brg.	390A Assy 902A2 (A3071)	1
Countershaft Front Brg.	BS500192SX	2
Countershaft Front Retainer	4304605	2
Countershaft Rear Brg.	MU1308TVWS	2
Rev. Idler Gear Brg.	HJ223020-IR18200H	2
Range Shaft Quill Front Brg.	204	1
Range Shaft Quill Rear Bushing	BS60	1
Aux. Countershaft Front Brg.	MR1307EL	2
Aux. Countershaft Rear Brg.	1310L	2
Spring	14897	3
Insert Valve	19974	1
Output Shaft Seal Kit	K-2256	1
O-Ring Kit	K-1447	1
O-Ring Kit	OK17453	1
O-Ring	OR217V	1
O-Ring	OR221V	1
Snap Ring	14291	1
Snap Ring	14317	2
Snap Ring	14750	1
Snap Ring	16723	2
Snap Ring	16763	2
Snap Ring	16980	1
Gasket Kit	K-2199	1
Spring	15918	3
Front Brg. Cover	20552	1
Sliding Clutch	16118	1
Collet	83001	4
Connector	84002	1
Connector	85002	1
Sealer	LC54505	1
Input Shaft	S2928	1

TRK-3656		
Position	Part Number	Qty
Input Shaft Brg.	MU1212RUMW3	1
Aux. Drive Gear Brg.	5566507	1
Aux. Mainshaft Brg.	390A Assy 902A2 (A3071)	1
Countershaft Front Brg.	BS500192SX	2
Countershaft Front Retainer	4304605	2
Countershaft Rear Brg.	MU1308TVWS	2
Rev. Idler Gear Brg.	HJ223020-IR18200H	2
Range Shaft Quill Front Brg.	204	1
Range Shaft Quill Rear Bushing	BS60	1
Aux. Countershaft Front Brg.	MR1307EL	2
Aux. Countershaft Rear Brg.	1310L	2
Spring	14897	3
Insert Valve	19974	1
Output Shaft Seal Kit	K-2256	1
O-Ring Kit	K-1447	1
O-Ring Kit	OK17453	1
O-Ring	OR217V	1
O-Ring	OR221V	1
Snap Ring	14291	1
Snap Ring	14317	2
Snap Ring	14750	1
Snap Ring	16723	2
Snap Ring	16763	2
Snap Ring	16980	1
Gasket Kit	K-2199	1
Spring	15918	3
Front Brg. Cover	20550	1
Sliding Clutch	16118	1
Collet	83001	4
Connector	84002	1
Connector	85002	1
Sealer	LC54505	1
Input Shaft	S1659	1

TRK-3657		
Position	Part Number	Qty
Input Shaft Brg.	MU1212RUMW3	1
Aux. Drive Gear Brg.	5566507	1
Aux. Mainshaft Brg.	21355	1
Countershaft Front Brg.	BS500192SX	2
Countershaft Rear Brg.	MU1308TVWS	2
Rev. Idler Gear Brg.	HJ223020-IR18200H	2
Aux. Countershaft Front Brg.	4302074	2
Aux. Countershaft Rear Brg.	4302074	2
Spring	14897	3
Insert Valve	19974	1
Output Shaft Seal Kit	K-2262	1
O-Ring Kit	K-2054	1
Snap Ring	14317	2
Snap Ring	14750	1
Snap Ring	16763	2
Snap Ring	16980	1
Shim Kit	K-2805	1
Gasket Kit	K-2061	1
Spring	15918	3
Collet	83002	4
Connector	84004	1
Connector	85001	1
Sliding Clutch	4304317	1
Sealer	LC54505	1
Input Shaft	S1659	1

Heavy Duty Transmission Rebuild Kits

TRK-3658

Position	Part Number	Qty
Input Shaft Brg.	MU1212RUMW3	1
Aux. Drive Gear Brg.	5566507	1
Aux. Mainshaft Brg.	21355	1
Countershaft Front Brg.	BS500192SX	2
Countershaft Front Retainer	4304605	2
Countershaft Rear Brg.	MU1308TVWS	2
Rev. Idler Gear Brg.	HJ223020-IR18200H	2
Aux. Countershaft Front Brg.	4302074	2
Aux. Countershaft Rear Brg.	4302074	2
Spring	14897	3
Insert Valve	19974	1
Output Shaft Seal Kit	K-2262	1
O-Ring Kit	K-2054	1
Snap Ring	14317	2
Snap Ring	14750	1
Snap Ring	16763	2
Snap Ring	16980	1
Shim Kit	K-2805	1
Gasket Kit	K-2061	1
Spring	15918	3
Sliding Clutch	16118	1
Collet	83002	4
Connector	84004	1
Connector	85001	1
Sealer	LC54505	1
Input Shaft	S1659	1

TRK-3659

Position	Part Number	Qty
Input Shaft Brg.	MU1212RUMW3	1
Input Shaft Pilot Bushing	BS59	1
Aux. Drive Gear Brg.	5566507	1
Aux. Mainshaft Brg.	390A Assy 902A2 (A3071)	1
Countershaft Front Brg.	BS500192SX	2
Countershaft Front Retainer	4304605	2
Countershaft Rear Brg.	MU1308TVWS	2
Rev. Idler Gear Brg.	HJ223020-IR18200H	2
Range Shaft Quill Front Brg.	204	1
Range Shaft Quill Rear Bushing	BS60	1
Aux. Countershaft Front Brg.	MR1307EL	2
Aux. Countershaft Rear Brg.	1310L	2
Spring	14897	3
Insert Valve	19974	1
Output Shaft Seal Kit	K-2256	1
O-Ring Kit	K-1447	1
O-Ring Kit	OK17453	1
O-Ring	OR217V	1
O-Ring	OR221V	1
Snap Ring	14291	1
Snap Ring	14317	2
Snap Ring	14750	1
Snap Ring	16723	2
Snap Ring	16763	2
Gasket Kit	K-2199	1

TRK-3660

Position	Part Number	Qty
Input Shaft Brg.	MU1212RUMW3	1
Input Shaft Pilot Bushing	BS59	1
Aux. Drive Gear Brg.	5566507	1
Aux. Mainshaft Brg.	21355	1
Countershaft Front Brg.	BS500192SX	2
Countershaft Front Retainer	4304605	2
Countershaft Rear Brg.	MU1308TVWS	2
Rev. Idler Gear Brg.	HJ223020-IR18200H	2
Aux. Countershaft Front Brg.	4302074	2
Aux. Countershaft Rear Brg.	4302074	2
Spring	14897	3
Insert Valve	19974	1
Output Shaft Seal Kit	K-2262	1
O-Ring Kit	K-2054	1
Snap Ring	14317	2
Snap Ring	14750	1
Snap Ring	16763	2
Snap Ring	16980	1
Shim Kit	K-2805	1
Gasket Kit	K-2061	1

TRK-3661

Position	Part Number	Qty
Input Shaft Brg.	MU1212RUMW3	1
Aux. Drive Gear Brg.	5566507	1
Aux. Mainshaft Brg.	5556503	1
Aux. Mainshaft Bushing	AA1512-12	2
Countershaft Front Brg.	BS500192SX	2
Countershaft Rear Brg.	MU1308TVWS	2
Rev. Idler Gear Brg.	HJ223020-IR18200H	2
Aux. Countershaft Front Brg.	4302074	2
Aux. Countershaft Rear Brg.	4302074	2
Spring	14897	3
Insert Valve	19974	1
O-Ring Kit	K-2846	1
Output Shaft Seal Kit	K-2918	1
Snap Ring	14317	2
Snap Ring	14750	1
Snap Ring	16763	1
Snap Ring	16980	1
Shim Kit	K-2805	1
Gasket Kit	K-2061	1
Spring	15918	3
Sliding Clutch	4306647	1
Connector	84006	1
Connector	85003	1
Sealer	LC54505	1
Input Shaft	S1659	1

TRK-3762

Position	Part Number	Qty
Clutch Pilot Brg.	306VV	1
Input Shaft Brg.	MU1212RUMW3	1
Front Brg. Cover	20550	1
Clutch Yoke	85533	1
Clutch Yoke Bushing	12815	4
Clutch Brake Disc	85541	1
Input Shaft	S1659	1
Snap Ring	14750	1
Snap Ring	16980	1
Gasket	14311	1
Gasket	4305294	1
Gasket	4306584	1

TRK-3941

Position	Part Number	Qty
Input Shaft Brg.	BS500419	1
Input Shaft Pilot Bushing	BS59	1
Aux. Drive Gear Brg.	5566510	1
Aux. Mainshaft Brg.	5556507	1
Splitter Gear Brg.	4300902	1
Splitter Gear Brg. Sleeve	4301844	1
Countershaft Front Brg.	BS500192SX	2
Countershaft Rear Brg.	BS500052V	2
Rev. Idler Gear Brg.	HJ223020-IR18200H	2
Aux. Countershaft Front Brg.	NP656227-NP896049	2
Aux. Countershaft Rear Brg.	NP656227-NP896049	2
Spring	14897	3
O-Ring Kit	K-3510	1
Output Shaft Seal Kit	K-2918	1
Snap Ring	14750	1
Snap Ring	16980	1
Snap Ring	19198	2
Snap Ring	4301254	1
Snap Ring	4302082	2
Snap Ring	4306308	1
Shim Kit	K-2805	1
Gasket Kit	K-3939	1

TRK-3942

Position	Part Number	Qty
Input Shaft Brg.	BS500419	1
Input Shaft Pilot Bushing	BS59	1
Aux. Drive Gear Brg.	5566508	1
Aux. Mainshaft Brg.	5556507	1
Aux. Mainshaft Bushing	AA1512-12	1
Countershaft Front Brg.	BS500192SX	2
Countershaft Rear Brg.	MU1308TVWS	2
Rev. Idler Gear Brg.	HJ223020-IR18200H	2
Aux. Countershaft Front Brg.	4302074	2
Aux. Countershaft Rear Brg.	4302074	2
Spring	14897	3
O-Ring Kit	K-2846	1
Output Shaft Seal Kit	K-2918	1
Snap Ring	14317	2
Snap Ring	14750	1
Snap Ring	16763	1
Snap Ring	16980	1
Snap Ring	19198	2
Snap Ring	4306308	1
Shim Kit	K-2805	1
Gasket Kit	K-3940	1

TRK-4010

Position	Part Number	Qty
Input Shaft Brg.	BS500419	1
Input Shaft Pilot Bushing	BS59	1
Aux. Drive Gear Brg.	5566508	1
Aux. Mainshaft Brg.	5556507	1
Countershaft Front Brg.	BS500192SX	2
Countershaft Rear Brg.	BS500052V	2
Rev. Idler Gear Brg.	HJ223020-IR18200H	2
Aux. Countershaft Front Brg.	4302074	2
Aux. Countershaft Rear Brg.	4302074	2
Spring	14897	3
O-Ring Kit	K-3484	1
Output Shaft Seal Kit	K-2918	1
Snap Ring	14750	1
Snap Ring	16763	1
Snap Ring	16980	1
Snap Ring	19198	2
Snap Ring	4302082	1
Shim Kit	K-2805	1
Gasket Kit	K-4011	1

HD Transmission

Heavy Duty Transmission Rebuild Kits



HD Transmission

TRK-4056			TRK-4092			TRK-5357		
Position	Part Number	Qty	Position	Part Number	Qty	Position	Part Number	Qty
Input Shaft Brg.	MU1212RUMW3	1	Input Shaft Brg.	MU1212RUMW3	1	Input Shaft Brg.	212SLV	1
Aux. Drive Gear Brg.	5566508	1	Aux. Drive Gear Brg.	5566508	1	Input Shaft Pilot Brg.	1225A1171	1
Aux. Mainshaft Brg.	5556503	1	Aux. Mainshaft Brg.	5556503	1	Aux. Drive Gear Brg.	119L	1
Splitter Gear Brg.	4300902	1	Aux. Mainshaft Bushing	AA1512-12	2	Aux. Mainshaft Brg.	29675 Assy 902B7	1
Countershaft Front Brg.	BS500192SX	2	Countershaft Front Brg.	BS500192SX	2	Countershaft Front Brg.	NP418109-NP525386	2
Countershaft Rear Brg.	BS500052V	2	Countershaft Rear Brg.	MU1308TVWS	2	Countershaft Rear Brg.	NP449281-NP357215	2
Rev. Idler Gear Brg.	HJ223020-IR18200H	2	Rev. Idler Gear Brg.	HJ223020-IR18200H	2	Rev. Idler Gear Brg.	A1228E1175	2
Aux. Countershaft Front Brg.	4302074	2	Aux. Countershaft Front Brg.	4302074	2	Aux. Countershaft Front Brg.	NP449281-NP357215	2
Aux. Countershaft Rear Brg.	4302074	2	Aux. Countershaft Rear Brg.	4302074	2	Aux. Countershaft Rear Brg.	3782-3720	2
Spring	14897	3	Spring	14897	3	Spring	2258Z1144	3
O-Ring Kit	K-3341	1	Insert Valve	19974	1	Output Shaft Seal Kit	KIT5389	1
Output Shaft Seal Kit	K-2918	1	O-Ring Kit	K-2054	1	O-Ring	1205T1268	3
Snap Ring	14750	1	Output Shaft Seal Kit	K-2918	1	O-Ring	OR014V	1
Snap Ring	16980	1	Snap Ring	14317	2	O-Ring	OR017V	1
Snap Ring	4301254	1	Snap Ring	14750	1	O-Ring	OR119	3
Snap Ring	4302082	2	Snap Ring	16763	1	O-Ring	OR316V	1
Shim Kit	K-2805	1	Snap Ring	16980	1	O-Ring	OR334V	1
Gasket Kit	K-3458	1	Shim Kit	K-2805	1	O-Ring	OR340V	2
Spring	15918	3	Gasket Kit	K-2061	1	Lock Nut	NL17-1	1
Sliding Clutch	4306647	1	Spring	15918	1	Lock Nut	NL25-1	1
Connector	84005	2	Sliding Clutch	4306647	3	Lock Nut	NL110-1	2
Connector	85003	1	Collet	83002	4	Snap Ring Set	KIT5452	1
Sealer	LC54505	1	Connector	84004	2	Spacer Kit	KIT5331	1
Input Shaft	S1659	1	Connector	85001	1	Shim Kit	KIT5364	1
			Sealer	LC54505	1	Small Parts Kit	KIT5291	1
			Input Shaft	S1659	1	Gasket	2208K1051	1
						Output Shaft Nut	1227T1554	1
TRK-4057			TRK-5000CK			TRK-5358		
Position	Part Number	Qty	Position	Part Number	Qty	Position	Part Number	Qty
Input Shaft Brg.	MU1212RUMW3	1	Clutch Pilot Brg.	306VV	1	Input Shaft Brg.	212SLV	1
Input Shaft Pilot Bushing	BS59	1	Input Shaft Brg.	212SLV	1	Input Shaft Pilot Brg.	1225A1171	1
Aux. Drive Gear Brg.	5566508	1	Front Brg. Cover	3105K1155	1	Aux. Drive Gear Brg.	119L	1
Aux. Mainshaft Brg.	5556503	1	Clutch Yoke	85533	1	Aux. Mainshaft Brg.	29675 Assy 902B7	1
Splitter Gear Brg.	4300902	1	Clutch Yoke Bushing	12815	4	Countershaft Front Brg.	NP418109-NP525386	2
Countershaft Front Brg.	BS500192SX	2	Clutch Brake Disc	85541	1	Countershaft Rear Brg.	NP449281-NP357215	2
Countershaft Rear Brg.	BS500052V	2	Input Shaft	KIT5367	1	Rev. Idler Gear Brg.	A1228E1175	2
Rev. Idler Gear Brg.	HJ223020-IR18200H	2	Gasket	3208L1078	1	Aux. Countershaft Front Brg.	NP449281-NP357215	2
Aux. Countershaft Front Brg.	4302074	2				Aux. Countershaft Rear Brg.	3782-3720	2
Aux. Countershaft Rear Brg.	4302074	2				Aux. Countershaft Rear Brg.	3782-3720	2
Spring	14897	3				Spring	2258Z1144	3
O-Ring Kit	K-3341	1				Output Shaft Seal Kit	KIT5389	1
Output Shaft Seal Kit	K-2918	1				O-Ring	1205T1268	3
Snap Ring	14750	1				O-Ring	OR009V	1
Snap Ring	16980	1				O-Ring	OR014V	1
Snap Ring	4301254	1				O-Ring	OR017V	1
Snap Ring	4302082	2				O-Ring	OR119	3
Shim Kit	K-2805	1				O-Ring	OR316V	1
Gasket Kit	K-3458	1				O-Ring	OR320V	1
						O-Ring	OR323V	1
						O-Ring	OR334V	1
						O-Ring	OR340V	2
						O-Ring	5X889	1
						Lock Nut	NL17-1	1
						Lock Nut	NL25-1	1
						Lock Nut	NL110-1	2
						Snap Ring Set	KIT5452	1
						Snap Ring	1229V4234	1
						Spacer Kit	KIT5331	1
						Shim Kit	KIT5364	1
						Small Parts Kit	KIT5291	1
						Gasket	3208S1059	1
						Output Shaft Nut	1227T1554	1
						Nut	1227A1405	1
						Valve Assembly	A2297K5965	1

Heavy Duty Transmission Rebuild Kits

TRK-5406		
Position	Part Number	Qty
Input Shaft Brg.	212SLV	1
Input Shaft Pilot Brg.	1225A1171	1
Aux. Drive Gear Brg.	119L	1
Aux. Mainshaft Brg.	NP301337 Assy 902A2	1
Countershaft Front Brg.	NP418109-NP525386	2
Countershaft Rear Brg.	NP449281-NP357215	2
Rev. Idler Gear Brg.	A1228E1175	2
Aux. Countershaft Front Brg.	NP449281-NP357215	2
Aux. Countershaft Rear Brg.	NP449281-NP357215	2
Spring	2258Z1144	3
Spring	2258F1332	1
Ball	2297R6986	1
Snap Ring Set	KIT5452	1
Snap Ring	16980	1
Output Shaft Seal Kit	KIT5389	1
O-Ring	OR016V	2
O-Ring	OR119	3
O-Ring	OR340V	2
Lock Nut	NL25-1	1
Lock Nut	NL110-1	2
Spacer Kit	KIT5404	1
Shim Kit	KIT5364	1
Output Shaft Nut	1227T1554	1
Piston Seal Kit	KIT5401	1

TRK-7000		
Position	Part Number	Qty
Input Shaft Brg.	M802048-M802011	1
Input Shaft Pilot Brg.	QBR49845	1
Output Shaft Brg.	25581-25520	1
Countershaft Front Brg.	25877-25821	1
Countershaft Rear Brg.	2689-2631	1
Rev. Idler Gear Brg.	QA48181A	1
Mainshaft 1st & 2nd Gear Brg.	F94490	2
Mainshaft 3rd & Rev. Gear Brg.	F84003	2
Mainshaft 4th Gear Brg.	F94488	1
4th & 5th Shift Hub Brg.	FA35688	1
4th & 5th Shift Hub Race	TR235383	1
Input Shaft Seal	473010N (16247)	1
Output Shaft Seal	471271V	1
Output Shaft Seal	712512	1
Countershaft Case Plug	239783	1
Threadlocker	TL1	1
Gasket Set	K-7001	1

TRK-7013		
Position	Part Number	Qty
Input Shaft Brg.	M804049-M804010	1
Input Shaft Pilot Brg.	QBR49845	1
Output Shaft Brg.	25581-25520	1
Countershaft Front Brg.	25877-25821	1
Countershaft Rear Brg.	2689-2631	1
Rev. Idler Gear Brg.	QA48181A	1
Mainshaft 1st & 2nd Gear Brg.	F94490	2
Mainshaft 3rd & Rev. Gear Brg.	F84003	2
Mainshaft 4th Gear Brg.	F94488	1
4th & 5th Shift Hub Brg.	FA35688	1
4th & 5th Shift Hub Race	TR235383	1
Input Shaft Seal	473010N (16247)	1
Output Shaft Seal	471271V	1
Output Shaft Seal	712512	1
Countershaft Case Plug	239783	1
Threadlocker	TL1	1
Gasket Set	K-7001	1

TRK-7032		
Position	Part Number	Qty
Input Shaft Brg.	M802048-M802011	1
Input Shaft Pilot Brg.	QBR49845	1
Output Shaft Brg.	28580A-28527RB	1
Countershaft Front & Rear Brg.	25590-25520	2
4th & 5th Shift Hub Brg.	FA35688	1
4th & 5th Shift Hub Race	TR235383	1
Mainshaft 1st Gear Brg.	F84003	1
Mainshaft 2nd, 3rd & Rev. Gear Brg.	F94490	3
Mainshaft 4th Gear Brg.	F94488	1
Rev. Idler Gear Brg.	QA47838	1
Input Shaft Seal	473010N (16247)	1
Input Shaft Seal	4300204	1
Input Shaft Seal	710211	1
Output Shaft Seal	4300119	1
Output Shaft Seal	416664 (27269)	1
Output Shaft Seal	415001N (25065)	1
Threadlocker	TL1	1
Gasket Set	K-7030	1
Snap Ring	226331	1

TRK-7033		
Position	Part Number	Qty
Input Shaft Brg.	M804049-M804010	1
Input Shaft Pilot Brg.	QBR49845	1
Output Shaft Brg.	28580A-28527RB	1
Countershaft Front & Rear Brg.	25590-25520	2
4th & 5th Shift Hub Brg.	FA35688	1
4th & 5th Shift Hub Race	TR235383	1
Mainshaft 1st Gear Brg.	F84003	1
Mainshaft 2nd, 3rd & Rev. Gear Brg.	F94490	3
Mainshaft 4th Gear Brg.	F94488	1
Rev. Idler Gear Brg.	QA47838	1
Snap Ring	226331	1
Input Shaft Seal	473010N (16247)	1
Input Shaft Seal	4300204	1
Input Shaft Seal	710211	1
Output Shaft Seal	4300119	1
Output Shaft Seal	416664 (27269)	1
Output Shaft Seal	415001N (25065)	1
Threadlocker	TL1	1
Gasket Set	K-7030	1

TRK-7035		
Position	Part Number	Qty
Input Shaft Brg.	39590-39520	1
Input Shaft Pilot Brg.	31594	1
Output Shaft Brg.	45285A-45220	1
Countershaft Front Brg.	25590-25522	1
Countershaft Rear Brg.	3782-3720	1
1st & Rev. Gear Brg.	FW707620	4
2nd Gear Brg.	FW657020	2
3rd Gear Brg.	FW556020	2
4th Gear Brg.	FW505520	2
Rev. Idler Gear Brg.	FW404820	2
Countershaft Plug	3315679	1
Spring	3315765	4
Snap Ring	3315686	1
Snap Ring	3315725	1
Input Shaft Seal	710211	1
Output Shaft Seal	4300119	1
Shim Kit	K-2183	1
Gasket Set	K-7028	1

TRK-7052		
Position	Part Number	Qty
Input Shaft Brg. 1.750"	39590-39520	1
Input Shaft Brg. 1.500"	45284-45220	1
Input Shaft Pilot Brg.	31594	1
Output Shaft Brg.	45285A-45220	1
Countershaft Front Brg.	25590-25522	1
Countershaft Rear Brg.	3782-3720	1
1st & 2nd Gear Brg.	FW707620	4
3rd Gear Brg.	FW657020	2
4th & Rev. Gear Brg.	FW556020	2
5th Gear Brg.	FW505520	2
Rev. Idler Gear Brg.	FW404820	2
Countershaft Plug	3315679	1
Spring	3315765	4
Snap Ring	3315686	1
Snap Ring	3315725	2
Snap Ring	3315752	1
Input Shaft Seal	710211	1
Output Shaft Seal	4300119	1
Shim Kit	K-2183	1
Gasket Set	K-7028	1

TRK-312476-22X		
Position	Part Number	Qty
Intermediate Shaft Front Brg.	2788-2720	1
Intermediate Shaft Rear Brg.	25877-25821	1
Output Shaft Brg.	MR1307EX	2
Rev. Shaft Brg.	MR1307EXW927	2

TRK-313432-1X		
Position	Part Number	Qty
Input Shaft Brg.	MR1211GEL	1
Input Shaft Pilot Brg.	MR1205EL	1
Output Shaft Brg.	214LH	1
Countershaft Front Brg.	1311L	2
Countershaft Rear Brg.	WR61209EX	2
Rev. Idler Gear Brg.	WJ162116	4
Input Shaft Seal	412015V (21167)	1
Mainshaft Rear Seal	3893V (37405)	1
Countershaft Rear Snap Rings	SR348-1	2
Snap Ring Set	313024-6X	1
Gasket Set	GT192	1

TRK-313432-2X		
Position	Part Number	Qty
Input Shaft Brg.	217SLE	1
Input Shaft Pilot Brg.	JH1812	1
Output Shaft Brg.	214LH	1
Countershaft Front Brg.	1311L	2
Countershaft Rear Brg.	MU1209UGMR	2
Rev. Idler Gear Brg.	WJ162116	4
Input Shaft Seal	412015V (21167)	1
Mainshaft Rear Seal	3893V (37405)	1
Countershaft Rear Snap Rings	SR348-1	2
Snap Ring Set	313024-11X	1
Gasket Set	GT193	1

HD Transmission

Heavy Duty Transmission Rebuild Kits



HD Transmission

TRK-313432-10X		
Position	Part Number	Qty
Input Shaft Brg.	JM511946-JM511910	1
Input Shaft Pilot Brg.	2580	1
Output Shaft Brg.	JM511946-JM511910	1
Countershaft Front Brg.	25584-25520	1
Countershaft Rear Brg.	25584-25520	1
Rev. Idler Gear Brg.	WJ162116	2
Mainshaft 1st Gear Brg.	F81205	1
Mainshaft 2nd Gear Brg.	C437Q	1
Mainshaft Rev. Gear Brg.	F81205	1
Input Shaft Seal	39925	1
Output Shaft Seal	471271 (24898)	1
Output Shaft Seal	415004 (27370)	1
Output Shaft Seal	415322V (27293)	1
Snap Ring Set	313024-13X	1
Baffle And Shim Set	313240-3X	1
Shim Kit	SK47	1
Threadlocker	TL1	1
Gasket Set	GT180	1

TRK-313432-11X		
Position	Part Number	Qty
Input Shaft Brg.	7211HL	1
Input Shaft Pilot Brg.	SCE2420	1
Output Shaft Brg.	7211HL	1
Countershaft Front Brg.	LM48548-LM48510	1
Countershaft Rear Brg.	LM102949-LM102910	1
Mainshaft 1st and Rev. Gear Brg.	F93290	2
Mainshaft 2nd Gear Brg.	F95407	1
Rev. Idler Gear Brg.	WJ162116	2
Drive Gear Seal	330749V (15506)	1
Drive Gear Seal	5133 (18049)	1
Output Shaft Seal	415322V (27293)	1
Snap Ring Set	313024-14X	1
Shim Kit	SK54	1
Shift Fork Clip	40-486-1	4
Shift Fork Clip	46-486-2	2
Shift Shoe Set	49-486-2	2
Flange Sealant	PE51531	1
Threadlocker	TL1	1
Gasket Set	GT210	1

TRK-313432-14X		
Position	Part Number	Qty
Input Shaft Front Brg.	MU1211GUM	1
Input Shaft Pilot Brg.	JH1416	1
Output Shaft Brg.	214LH	1
Countershaft Front Brg.	MU1209UGMR	2
Countershaft Rear Brg.	MU1209UGMR	2
Rev. Idler Gear Brg.	WJ162116	4
Input Shaft Seal	97-463-36-1X	1
Output Shaft Seal	3893V (37405)	1
Output Shaft Seal	714713 (39933)	1
Snap Ring Set	313024-16X	1
Threadlocker	TL1	1
Gasket Set	GT192	1

TRK-313432-20X		
Position	Part Number	Qty
Input Shaft Brg.	JM511946-JM511910	1
Input Shaft Pilot Brg.	25877-25821	1
Output Shaft Brg.	3979-JM511910	1
Countershaft Front Brg.	M804049-M804010	1
Countershaft Rear Brg.	JLM506849-JLM506810	1
Rev. Idler Gear Brg.	WJ162116	2
Mainshaft 1st & Rev. Gear Brg.	F56619	2
Mainshaft 2nd Gear Needle Brg.	F87946	1
Input Shaft Seal	39925	1
Output Shaft Seal	415004V (27365)	1
Snap Ring Set	313024-22X	1
Baffle And Shim Set	313240-3X	1
Shim Kit	SK15	1
Threadlocker	TL1	1
Gasket Set	GT186	1

TRK-313432-21X		
Position	Part Number	Qty
Input Shaft Front Brg.	1210	1
Input Shaft Rear Brg.	MSN1312EL	1
Input Shaft Pilot Brg.	MU1209TV	1
Output Shaft Brg.	1312L	1
Countershaft Front Brg.	3877-3820	1
Countershaft Rear Brg.	462-453A	1
Speed Gear Brg.	F54540	1
Input Shaft Seal	415004V (27365)	1
Input Shaft Seal (Chevy/GMC)	475322N (27295)	1
Output Shaft Seal (without brake)	415013N (29925)	1
Output Shaft Seal (with brake)	415281N (29870)	1
Output Shaft Seal	475322N (27295)	1
Remote Control Seal	471570 (8702)	2
Snap Ring	60-381-7	1
Snap Ring	60-381-8	1
Snap Ring	60-381-9	1
Snap Ring	82-381-1	1
Gasket Set	GT73	1

TRK-313432-25X		
Position	Part Number	Qty
Input Shaft Brg.	217SLE	1
Input Shaft Pilot Brg.	JH1812	1
Output Shaft Brg.	312LE	1
Countershaft Front Brg.	311L	2
Countershaft Rear Brg.	WR61209EX	2
Rev. Idler Gear Brg.	WJ162116	4
Countershaft Rear Snap Rings	SR348-1	2
Input Shaft Seal	412015V (21167)	1
Output Shaft Seal	3893V (37405)	1
Snap Ring Set	313024-2X	1
Spacer	330737	1
Flange Sealant	PE51531	1
Threadlocker	TL1	1
Gasket Set	GT-147	1

TRK-313432-30X		
Position	Part Number	Qty
Input Shaft Brg.	7211HFL	1
Input Shaft Pilot Brg.	MU5206L	1
Output Shaft Brg.	7211HL	1
Countershaft Front Brg.	LM48548-LM48510	1
Countershaft Rear Brg.	2788A-2729	1
Rev. Idler Gear Brg.	WJ162116	2
1st Gear Brg.	F208323	1
2nd Gear Brg.	F93290	2
3rd Gear Brg.	F95407	1
4th Gear Brg.	F209348	1
Input Shaft Seal	39920	1
Input Shaft Seal	39930	1
Output Shaft Seal	415322V (27293)	1
Snap Ring Set	SR220	1
Shim Kit	313438-3X	1
Shift Fork Clip	40-486-1	2
Shift Fork Clip	49-486-3	2
Shift Fork Clip	101-486-1-1X	3
Shift Shoe Set	49-486-2	2
Flange Sealant	PE51531	1
Gasket Set	GT210	1

TRK-313432-31X		
Position	Part Number	Qty
Input Shaft Brg.	JM511946-JM511910	1
Input Shaft Pilot Brg.	2580	1
Output Shaft Brg.	JM511946-JM511910	1
Countershaft Front Brg.	25584-25520	1
Countershaft Rear Brg.	25584-25520	1
Rev. Idler Gear Brg.	WJ162116	2
Mainshaft 1st Gear Brg.	F81205	1
Mainshaft 2nd Gear Brg.	C437Q	1
Mainshaft Rev. Gear Brg.	F81205	1
Input Shaft Seal	39925	1
Output Shaft Seal	415004 (27370)	1
Output Shaft Seal	415322V (27293)	1
Snap Ring Set	313024-18X	1
Shim Kit	SK47	1
Baffle And Shim Set	313240-3X	1
Threadlocker	TL1	1
Gasket Set	GT180	1

TRK-313432-33X		
Position	Part Number	Qty
Input Shaft Brg.	BS500262R	1
Countershaft Front Brg. (Early)	LM501349-LM501310	2
Countershaft Front Brg. (Late)	25581-25520	2
Countershaft Rear Brg.	25590-25520	2
Aux. Countershaft Front Brg.	MR1307EX	2
Aux. Countershaft Rear Brg.	MR1309UV	2
Aux. Mainshaft Brg.	JLM710949C (90KA3)	1
Rev. Idler Gear Brg.	K55X63X25A	2
Low Range Brg.	K73X79X20B	2
Input Shaft Seal	97-463-36-1X	1
Output Shaft Seal	37410	1
Snap Ring	201-381-1	1
Snap Ring	201-381-3	1
Shim Kit	313667X	1
Gasket Set	312475-45X	1

Heavy Duty Transmission Rebuild Kits

TRK-313432-34X

Position	Part Number	Qty
Input Shaft Brg.	7211HFL	1
Input Shaft Pilot Brg.	MU5206L	1
Output Shaft Brg.	7211HL	1
Countershaft Front Brg.	LM48548-LM48510	1
Countershaft Rear Brg.	LM102949-LM102910	1
1st Gear Brg.	F93290	1
2nd Gear Brg.	F95407	1
3rd Gear Brg.	FW505520	2
4th Gear Brg.	FW455017	2
Rev. Gear Brg.	F93290	1
Rev. Idler Gear Brg.	WJ162116	2
Input Shaft Seal	39920	1
Input Shaft Seal	39930	1
Output Shaft Seal	415322V (27293)	1
Snap Ring Set	313024-14X	1
Shim Kit	SK54	1
Shift Fork Clip	40-486-1	4
Shift Fork Clip	49-486-3	2
Shift Fork Clip	101-486-1-1X	2
Flange Sealant	PE51531	1
Threadlocker	TL1	1
Gasket Set	GT210	1

TRK-313432-35X

Position	Part Number	Qty
Input Shaft Brg.	MU1211GUM	1
Input Shaft Pilot Brg.	JH1416	1
Output Shaft Brg.	214LH	1
Countershaft Front Brg.	1311L	2
Countershaft Rear Brg.	MU1209UGMR	2
Rev. Idler Gear Brg.	WJ162116	2
Input Shaft Seal	97-463-36-1X	1
Output Shaft Seal	714713 (39933)	1
Snap Ring Set	313024-27X	1
Flange Sealant	PE51531	1
Threadlocker	TL1	1
Gasket Set	GT193	1

TRK-313432-46X

Position	Part Number	Qty
Input Shaft Brg.	7211HFL	1
Input Shaft Pilot Brg.	MU5206L	1
Output Shaft Brg.	7211HL	1
Countershaft Front Brg.	LM48548-LM48510	1
Countershaft Rear Brg.	2788A-2729	1
Rev. Idler Gear Brg.	WJ162116	2
1st Gear Brg.	F208323	1
2nd Gear Brg.	F93290	2
3rd Gear Brg.	F95407	1
4th Gear Brg.	F209348	1
Input Shaft Seal	39920	1
Input Shaft Seal	39930	1
Output Shaft Seal	415322V (27293)	1
Snap Ring Set	SR220	1
Shim Kit	313438-3X	1
Shift Fork Clip	101-486-1-1X	3
Flange Sealant	PE51531	1
Gasket Set	GT221	1

TRK-56-432-1X

Position	Part Number	Qty
Input Shaft Brg.	1213L	1
Input Shaft Pilot Brg.	MU5206L	1
Output Shaft Brg.	7211HL	1
Countershaft Front Brg.	2788A-2729	1
Countershaft Rear Brg.	2788A-2729	1
1st Gear Brg.	F208323	1
2nd Gear Brg.	F93290	1
3rd Gear Brg.	F95407	1
4th Gear Brg.	F209348	1
Rev. Gear Brg.	F93290	1
Rev. Idler Gear Brg.	WJ162116	2
Input Shaft Seal	39925	1
Output Shaft Seal	415322V	1
Shift Fork Clip	101-486-1-1X	3
Snap Ring Set	56-381-2X	1
Shim Kit	313438-3X	1
Flange Sealant	PE51531	1
Threadlocker	TL1	1
Gasket Set	GT221	1

TRK-98-432-1X

Position	Part Number	Qty
Input Shaft Front Brg.	114	1
Input Shaft Front Brg.	212	1
Input Shaft Rear Brg.	MU1215TV	1
Input Shaft Rear Brg.	MR1213EL	1
Input Shaft Pilot Brg.	JH1812	1
Output Shaft Brg.	214LH	1
Countershaft Front Brg.	MU1311UGMR	2
Countershaft Rear Brg.	MR1309EAL	2
Input Shaft Seal	415281N (29870)	1
Output Shaft Seal	415035 (39934)	1
Snap Ring Set	313024-24X	1
Flange Sealant	PE51531	1
Threadlocker	TL1	1
Gasket Set	GT158	1

TRK-101-432-1X

Position	Part Number	Qty
Input Shaft Brg.	1213L	1
Input Shaft Pilot Brg.	MU5206L	1
Output Shaft Center Brg.	1213L	1
Output Shaft Rear Brg.	7211HL	1
Countershaft Front Brg.	2788A-2729	1
Countershaft Center Brg.	MB1212GEXR	1
Countershaft Rear Brg.	2788A-2729	1
Rev. Idler Gear Brg.	WJ162116	2
1st Gear Brg.	F208323	1
2nd Gear Brg.	F208323	1
3rd Gear Brg.	F208323	1
4th Gear Brg.	FW657020	1
4th Gear Brg.	FW657030	1
4th/5th Shift Hub Brg.	FWH556320	2
6th Gear Brg.	FW475325	2
Rev. Gear Brg.	F208323	1
Input Shaft Seal	39925	1
Output Shaft Seal	415322V (27293)	1
Snap Ring Set	SR221	1
Shim Kit	313438-3X	1
Shift Fork Clip	101-486-1-1X	4
Shift Shoe Set	101-486-4-1X	1
Flange Sealant	PE51531	1
Threadlocker	TL1	1
Gasket Set	GT221	1

Light Duty Differential Rebuild Kits

DT Components Differential Rebuild Kits are available in four kit types; Standard Kit, Master Kit, Standard Kit Plus and Master Kit Plus. Each kit type has a different level of kit content.

Axle bearings and seals are available individually and within an Axle Kit (both sides) and a Wheel Kit (single side).

These four kit types allows you to choose what level of kit content you stock and enables you to easily stock the axle bearings and seals as an add on kit.

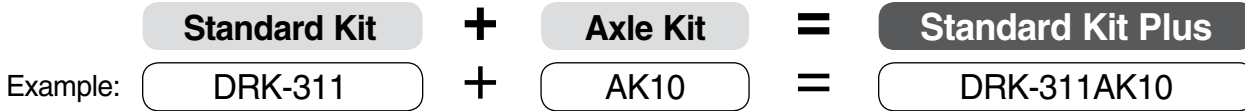

Below is a typical semi-floating rear axle and what is contained within the Standard Kit type.

Standard Kit DRK-311 Shown

- Differential Brgs.
- Pinion Head Brg.
- Pinion Tail Brg.
- Pinion Seal
- Crush Sleeve
- Pinion Nut
- Gear Marking Compound & Brush
- Threadlocker
- Sealer



+

Axle Kit AK10 Shown

- Axle Brgs.
- Axle Seals



=

Standard Kit Plus DRK-311AK10 Shown

Contains entire contents from both Standard and Axle kits



Light Duty Differential Rebuild Kits

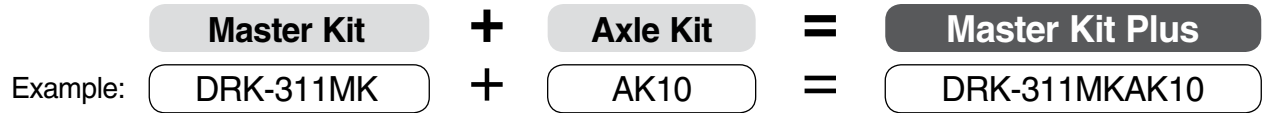

Below is a typical semi-floating rear axle and what is contained within the Master Kit type.

Master Kit DRK-311MK Shown

- Differential Brgs.
- Pinion Head Brg.
- Pinion Tail Brg.
- Pinion Seal
- Crush Sleeve
- Pinion Nut
- Gear Marking Compound & Brush
- Threadlocker
- Sealer
- Pinion Depth Shims
- Differential Shims
- Ring Gear Bolts



+

Axle Kit AK10 Shown

- Axle Brgs.
- Axle Seals



=

Master Kit Plus DRK-311MKAK10 Shown

Contains entire contents from both Master and Axle kits



Axle Identification

Accurate axle identification is critical when ordering repair parts for rear axles in car, truck & SUV applications as well as for front axles used in four wheel drive truck & SUV applications. The axles used in each individual vehicle can vary based on vehicle options. For example, a typical GM 1/2-ton truck will be equipped with the GM 8.5" axle, but this same truck may be built with a larger GM 9.5" axle if optioned with a larger engine, heavy duty chassis or towing packages. Therefore, the axle must be identified by the vehicle owner or mechanic prior to ordering parts.

Vehicles can be equipped with either corporate axles (built by the vehicle manufacturer) or Dana axles. Corporate axles from Chrysler, Ford & GM are identified by the ring gear diameter and are frequently referred to as a "Ford 8.8" or "GM 8.5". Ford axles may have an identification tag that specifies ring gear diameter and ratio.

Most corporate axles can be easily identified by the bolt pattern on the differential cover when you have more than one axle option for your vehicle. The following illustrations show the typical bolt pattern for the common corporate axles. You may still need to measure the ring gear diameter in order to positively identify the corporate axle.

To Determine Ring Gear Diameter

you need to measure the outside diameter of the ring gear.



Dana axles are identified by model number. The model number (i.e. "44") is usually cast into the webbing of the axle center housing as shown in the illustration below.

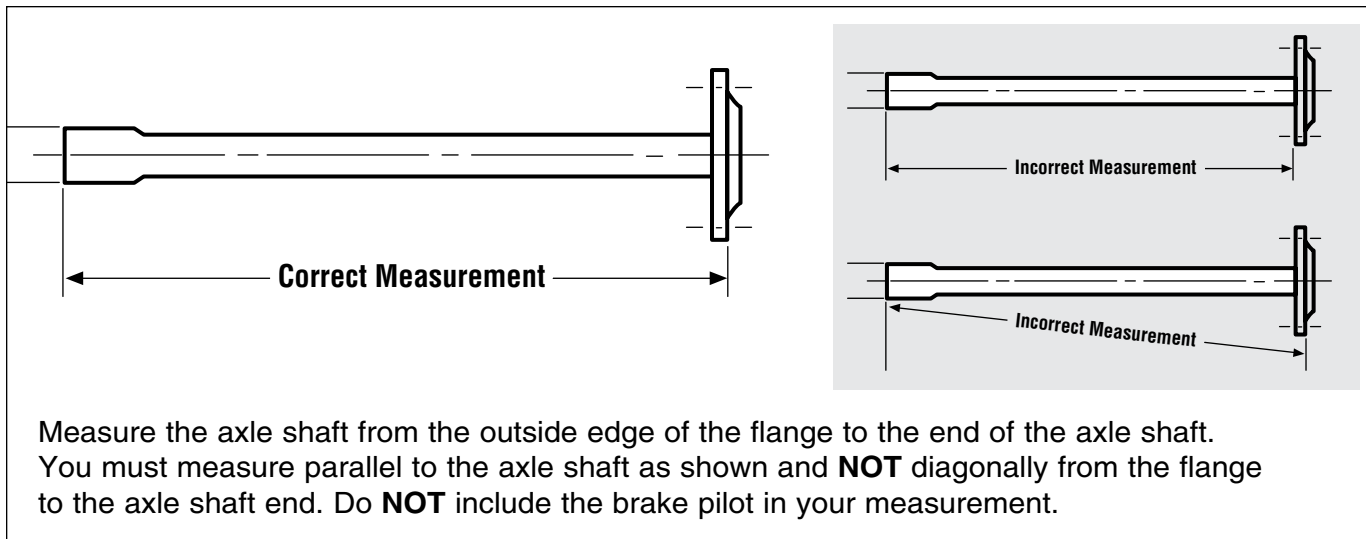
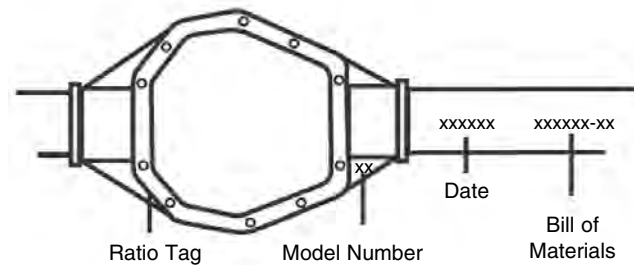

Measure the axle shaft from the outside edge of the flange to the end of the axle shaft. You must measure parallel to the axle shaft as shown and **NOT** diagonally from the flange to the axle shaft end. Do **NOT** include the brake pilot in your measurement.

Differential Gaskets

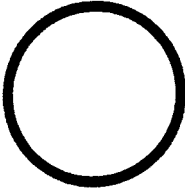
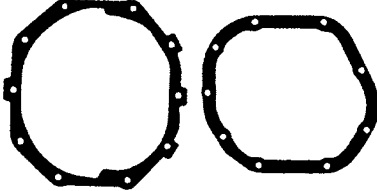
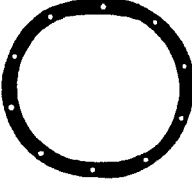
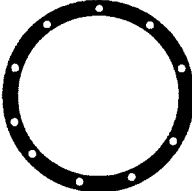
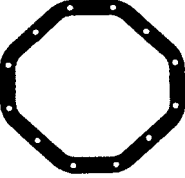
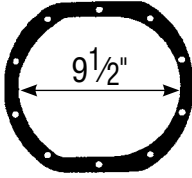
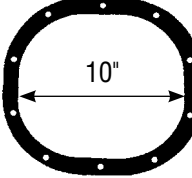
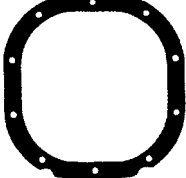
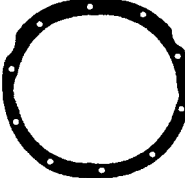
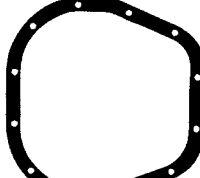
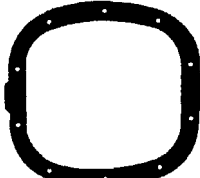
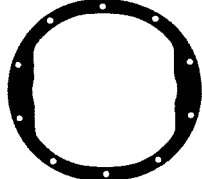
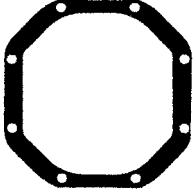
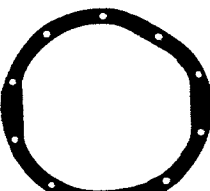
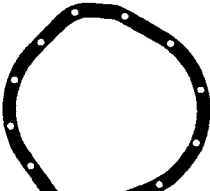
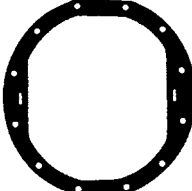
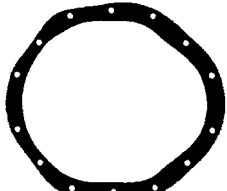
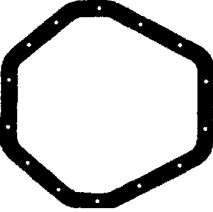
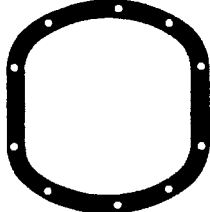
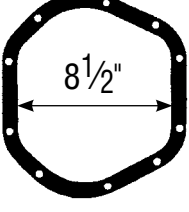
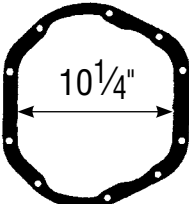
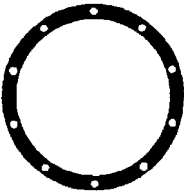
<p>AMC 20 NO HOLES 10½" DIA.</p> 	<p>CHRYSLER 7.25" 10 HOLES 9 HOLES (2 GASKETS IN SET)</p> 	<p>CHRYSLER 8.25" 10 HOLES OVAL</p> 	<p>CHRYSLER 8.75" 10 HOLES ROUND</p> 	
<p>CHRYSLER 9.25" 12 HOLES</p> 	<p>FORD 7.5" 10 HOLES</p> 	<p>FORD 8" 10 HOLES</p> 	<p>FORD 8.8" 10 HOLES</p> 	
<p>FORD 9" 10 HOLES</p> 	<p>FORD 10.25" & 10.5" 12 HOLES</p> 	<p>GM 7.5" 10 HOLES</p> 	<p>GM 8.5" 10 HOLES All Exc. Corvette & 80-81 Truck</p> 	
<p>GM 8.5" CORVETTE 8 HOLES CORVETTE</p> 	<p>GM 8.5" TRUCK 10 HOLES TRUCK (80-81)</p> 	<p>GM 8.875" TRUCK 12 HOLES TRUCK</p> 	<p>GM 8.875" AUTO 12 HOLES CAR</p> 	<p>GM 9.5" 14 HOLES</p> 
<p>GM 10.5" 14 HOLES</p> 	<p>DANA 30, 36-ICA 10 HOLES</p> 	<p>DANA 44 10 HOLES</p> 	<p>DANA 60, 70 10 HOLES DANA 60,70</p> 	<p>TOYOTA 7.5", 8" V6/TURBO 10 HOLES</p> 

Light Duty Differential Applications

Make/Model	Year	Position/ Ring Gear Size	Standard Kit	Master Kit	Axle Kit	Standard Kit Plus	Master Kit Plus
AM GENERAL							
Hummer	01-92	Front - AMC 20	DRK-311H	DRK-311HMK	AK27	DRK-311HAK27	DRK-311HMKAK27
Hummer	01-92	Rear - AMC 20	DRK-311H	DRK-311HMK	AK27	DRK-311HAK27	DRK-311HMKAK27
AMC							
AMX	1970	Rear - AMC 20	DRK-311J	DRK-311JMK ▲			
Concord	88-80	Rear - Dana 35	DRK-335	DRK-335MK ▲			
Concord	79-78	Rear - AMC 20	DRK-311J	DRK-311JMK ▲			
Eagle	88-80	Rear - Dana 35	DRK-335	DRK-335MK ▲			
Gremlin V8	76-72	Rear - AMC 20	DRK-311J	DRK-311JMK ▲			
Hornet V8	75-70	Rear - AMC 20	DRK-311J	DRK-311JMK ▲			
Javelin	1970	Rear - AMC 20	DRK-311J	DRK-311JMK ▲			
Rambler	1969	Rear - AMC 20	DRK-311J	DRK-311JMK ▲			
Rebel	70-67	Rear - AMC 20	DRK-311J	DRK-311JMK ▲			
Spirit	88-80	Rear - Dana 35	DRK-335	DRK-335MK ▲			
Spirit V8	1979	Rear - AMC 20	DRK-311J	DRK-311JMK ▲			
BUICK							
Apollo	75-73	Rear - 8.5"	DRK-321R	DRK-321RMK ▲			
Century	81-77	Rear - 7.5"	DRK-320B	DRK-320BMK ▲			
Century	77-73	Rear - 8.5"	DRK-321R	DRK-321RMK ▲			
Electra	84-73	Rear - 8.5"	DRK-321R	DRK-321RMK ▲	AK11	DRK-321RAK11	DRK-321RMKAK11 ▲
Electra	72-65	Rear - 8.875"	DRK-323A	DRK-323AMK ▲			
Estate Wagon	83-82	Rear - 7.5"	DRK-320	DRK-320MK ▲	AK11	DRK-320AK11	DRK-320MKAK11 ▲
Estate Wagon	83-80	Rear - 8.5"	DRK-321R	DRK-321RMK ▲	AK10	DRK-321RAK10	DRK-321RMKAK10 ▲
Estate Wagon	81-80	Rear - 7.5"	DRK-320B	DRK-320BMK ▲	AK11	DRK-320BAK11	DRK-320BMKAK11 ▲
Estate Wagon	79-73	Rear - 8.5"	DRK-321R	DRK-321RMK ▲	AK10	DRK-321RAK10	DRK-321RMKAK10 ▲
Estate Wagon	72-71	Rear - 8.875"	DRK-323A	DRK-323AMK ▲			
Lesabre	85-82	Rear - 8.5"	DRK-321R	DRK-321RMK ▲	AK10	DRK-321RAK10	DRK-321RMKAK10 ▲
Lesabre	85-82	Rear - 7.5"	DRK-320	DRK-320MK ▲	AK10	DRK-320AK10	DRK-320MKAK10 ▲
Lesabre	81-77	Rear - 7.5"	DRK-320B	DRK-320BMK ▲	AK11	DRK-320BAK11	DRK-320BMKAK11 ▲
Lesabre	81-73	Rear - 8.5"	DRK-321R	DRK-321RMK ▲	AK10	DRK-321RAK10	DRK-321RMKAK10 ▲
Ranier	07-04	Front - 7.25"	DRK-320K	DRK-320KMK	AK87	DRK-320KAK87	DRK-320KMKAK87
Ranier	07-04	Rear - 8"	DRK-320D	DRK-320DMK ▲	AK12	DRK-320DAK12	DRK-320DMKAK12 ▲
Ranier	07-04	Rear - 8.5"	DRK-321C	DRK-321CMK ▲	AK12	DRK-321CAK12	DRK-321CMKAK12 ▲
Regal	87-82	Rear - 7.5"	DRK-320	DRK-320MK ▲	AK11	DRK-320AK11	DRK-320MKAK11 ▲
Regal	87-78	Rear - 8.5"	DRK-321R	DRK-321RMK ▲	AK11	DRK-321RAK11	DRK-321RMKAK11 ▲
Regal	81-78	Rear - 7.5"	DRK-320B	DRK-320BMK ▲	AK11	DRK-320BAK11	DRK-320BMKAK11 ▲
Regal	77-73	Rear - 8.5"	DRK-321R	DRK-321RMK ▲	AK11	DRK-321RAK11	DRK-321RMKAK11 ▲
Roadmaster	96-91	Rear - 7.5"	DRK-320	DRK-320MK ▲	AK10	DRK-320AK10	DRK-320MKAK10 ▲
Skyhawk	80-75	Rear - 7.5"	DRK-320B	DRK-320BMK ▲			
Skylark	79-76	Rear - 7.5"	DRK-320B	DRK-320BMK ▲			
Skylark	79-71	Rear - 8.5"	DRK-321R	DRK-321RMK ▲	AK11	DRK-321RAK11	DRK-321RMKAK11 ▲
CADILLAC							
Brougham	92-87	Rear - 8.5"	DRK-321R	DRK-321RMK ▲	AK11	DRK-321RAK11	DRK-321RMKAK11 ▲
DeVille	84-77	Rear - 8.5"	DRK-321R	DRK-321RMK ▲	AK10	DRK-321RAK10	DRK-321RMKAK10 ▲
Escalade	14-99	Front - 8.25"	DRK-321T	DRK-321TMK	AK83	DRK-321TAK83	DRK-321TMKAK83
Escalade	00-99	Front - 9.25"	DRK-324C	DRK-324CMK			
Escalade	14-09	Rear - 8.5"	DRK-321Q	DRK-321QMK ▲	AK12	DRK-321QAK12	DRK-321QMKAK12 ▲
Escalade	08-02	Rear - 8.5"	DRK-321C	DRK-321CMK ▲	AK12	DRK-321CAK12	DRK-321CMKAK12 ▲
Escalade	00-99	Rear - 8.5"	DRK-321R	DRK-321RMK ▲	AK12	DRK-321RAK12	DRK-321RMKAK12 ▲
Escalade	00-99	Rear - 9.5"	DRK-324B	DRK-324BMK			

LD Differential

Light Duty Differential Applications

Make/Model	Year	Position/ Ring Gear Size	Standard Kit	Master Kit	Axle Kit	Standard Kit Plus	Master Kit Plus
CADILLAC (cont'd)							
Escalade EXT	14-02	Front - 8.25"	DRK-321T	DRK-321TMK	AK83	DRK-321TAK83	DRK-321TMKAK83
Escalade EXT	14-09	Rear - 8.5"	DRK-321Q	DRK-321QMK ▲	AK12	DRK-321QAK12	DRK-321QMKAK12 ▲
Escalade EXT	08-02	Rear - 8.5"	DRK-321C	DRK-321CMK ▲	AK12	DRK-321CAK12	DRK-321CMKAK12 ▲
Escalade ESV	14-03	Front - 8.25"	DRK-321T	DRK-321TMK	AK83	DRK-321TAK83	DRK-321TMKAK83
Escalade ESV	14-09	Rear - 8.5"	DRK-321Q	DRK-321QMK ▲	AK12	DRK-321QAK12	DRK-321QMKAK12 ▲
Escalade ESV	08-03	Rear - 8.5"	DRK-321C	DRK-321CMK ▲	AK12	DRK-321CAK12	DRK-321CMKAK12 ▲
Fleetwood	96-94	Rear - 9.5"	DRK-324	DRK-324MK	AK16	DRK-324AK16	DRK-324MKAK16
Fleetwood	96-77	Rear - 8.5"	DRK-321R	DRK-321RMK ▲	AK10	DRK-321RAK10	DRK-321RMKAK10 ▲
CHEVROLET							
150 Series	57-55	Rear - 8.2" Axle Shaft w/1.781" Differential Brgs.	DRK-321G	DRK-321GMK			
210 Series	57-55	Rear - 8.2" Axle Shaft w/1.781" Differential Brgs.	DRK-321G	DRK-321GMK			
Astro	05-90	Front - 7.25"	DRK-320A	DRK-320AMK			
Astro	05-03	Rear - 7.5"	DRK-320C	DRK-320CMK ▲	AK12	DRK-320CAK12	DRK-320CMKAK12 ▲
Astro	02-99	Rear - 7.5"	DRK-320C	DRK-320CMK ▲	AK14	DRK-320CAK14	DRK-320CMKAK14 ▲
Astro	98-85	Rear - 7.5"	DRK-320	DRK-320MK ▲	AK14	DRK-320AK14	DRK-320MKAK14 ▲
Avalanche 1500	14-02	Front - 8.25"	DRK-321T	DRK-321TMK	AK83	DRK-321TAK83	DRK-321TMAK83
Avalanche 1500	13-09	Rear - 8.5"	DRK-321Q	DRK-321QMK ▲	AK12	DRK-321QAK12	DRK-321QMKAK12 ▲
Avalanche 1500	11-02	Rear - 9.5"	DRK-324B	DRK-324BMK	AK16	DRK-324BAK16	DRK-324BMKAK16
Avalanche 1500	08-02	Rear - 8.5"	DRK-321C	DRK-321CMK ▲	AK12	DRK-321CAK12	DRK-321CMKAK12 ▲
Avalanche 2500	06-02	Front - 9.25"	DRK-324C	DRK-324CMK			
Avalanche 2500	06-02	Rear - 10.5"	DRK-325B	DRK-325BMK	AK29	DRK-325BAK29	DRK-325BMKAK29
Belair	64-55	Rear - 8.2" Axle Shaft w/1.781" Differential Brgs.	DRK-321G	DRK-321GMK			
Biscayne	72-71	Rear - 8.5"	DRK-321R	DRK-321RMK ▲			
Biscayne	64-58	Rear - 8.2" Axle Shaft w/1.781" Differential Brgs.	DRK-321G	DRK-321GMK			
Blazer Full Size	94-92	Front - 8.25"	DRK-321A	DRK-321AMK			
Blazer Full Size	91-80	Front - 8.5"	DRK-321R	DRK-321RMK ▲			
Blazer Full Size	79-69	Front - Dana 44	DRK-339B	DRK-339BMK			
Blazer Full Size	94-82	Rear - 8.5"	DRK-321R	DRK-321RMK ▲			
Blazer Full Size	91-82	Rear - 8.5"	DRK-321R	DRK-321RMK ▲	AK10	DRK-321RAK10	DRK-321RMKAK10 ▲
Blazer Full Size	81-69	Rear - 8.875"	DRK-322	DRK-322MK ▲	AK10	DRK-322AK10	DRK-322MKAK10 ▲
Blazer S10 Size	05-97	Front - 7.25"	DRK-320A	DRK-320AMK	AK86	DRK-320AAK86	DRK-320AMKAK86
Blazer S10 Size	96-83	Front - 7.25"	DRK-320A	DRK-320AMK	AK86	DRK-320AAK86	DRK-320AMKAK86
Blazer S10 Size	05-99	Rear - 7.5"	DRK-320C	DRK-320CMK ▲	AK11	DRK-320CAK11	DRK-320CMKAK11 ▲
Blazer S10 Size	05-99	Rear - 8.5"	DRK-321C	DRK-321CMK ▲	AK10	DRK-321CAK10	DRK-321CMKAK10 ▲
Blazer S10 Size	98-95	Rear - 8.5"	DRK-321R	DRK-321RMK ▲	AK10	DRK-321RAK10	DRK-321RMKAK10 ▲
Blazer S10 Size	98-83	Rear - 7.5"	DRK-320	DRK-320MK ▲	AK11	DRK-320AK11	DRK-320MKAK11 ▲
Camaro	14-13	Rear - 250MM Ring Gear ZL1	DRK-325C	DRK-325CMK			
Camaro	14-10	Rear - 195MM Ring Gear	DRK-320J	DRK-320JMK ▲			
Camaro	14-10	Rear - 218MM Ring Gear	DRK-321S	DRK-321SMK ▲			
Camaro	02-99	Rear - 7.5"	DRK-320C	DRK-320CMK ▲	AK11	DRK-320CAK11	DRK-320CMKAK11 ▲
Camaro	98-82	Rear - 7.5"	DRK-320	DRK-320MK ▲	AK11	DRK-320AK11	DRK-320MKAK11 ▲
Camaro	90-87	Rear - Borg Warner 7.75"	DRK-326	DRK-326MK			

▲ Add "S" suffix to kit number to receive stackable differential shims in kit.

Light Duty Differential Applications

Make/Model	Year	Position/ Ring Gear Size	Standard Kit	Master Kit	Axle Kit	Standard Kit Plus	Master Kit Plus
CHEVROLET (cont'd)							
Camaro	81-70	Rear - 8.5"	DRK-321R	DRK-321RMK [▲]	AK11	DRK-321RAK11	DRK-321RMKAK11 [▲]
Camaro	72-67	Rear - 8.875"	DRK-323A	DRK-323AMK [▲]			
Camaro	70-67	Rear - 8.2" Axle Shaft w/1.781" Differential Brgs.	DRK-321B	DRK-321BMK [▲]			
Caprice	14-11	Rear - 8.25"	DRK-326B	DRK-326BMK			
Caprice	96-81	Rear - 7.5"	DRK-320	DRK-320MK [▲]	AK11	DRK-320AK11	DRK-320MKAK11 [▲]
Caprice	96-73	Rear - 8.5"	DRK-321R	DRK-321RMK [▲]	AK10	DRK-321RAK10	DRK-321RMKAK10 [▲]
Caprice	81-77	Rear - 7.5"	DRK-320B	DRK-320BMK [▲]	AK11	DRK-320BAK11	DRK-320BMKAK11 [▲]
Caprice	72-66	Rear - 8.875"	DRK-323A	DRK-323AMK [▲]			
Caprice	71-66	Rear - 8.2" Axle Shaft w/1.781" Differential Brgs.	DRK-321B	DRK-321BMK [▲]			
Chevelle	77-73	Rear - 8.5"	DRK-321R	DRK-321RMK [▲]			
Chevelle	72-64	Rear - 8.2" Axle Shaft w/1.781" Differential Brgs.	DRK-321B	DRK-321BMK [▲]			
Chevelle	72-64	Rear - 8.875"	DRK-323A	DRK-323AMK [▲]			
Chevy II	68-65	Rear - 8.875"	DRK-323A	DRK-323AMK [▲]			
Chevy II	68-64	Rear - 8.2" Axle Shaft w/1.625" Differential Brgs.	DRK-321B	DRK-321BMK [▲]			
Chevy II	1964	Rear - 8.2" Axle Shaft w/1.781" Differential Brgs.	DRK-321G	DRK-321GMK			
Colorado	12-04	Front - 7.6" IFS	DRK-320L	DRK-320LMK [▲]	AK85	DRK-320LAK85	DRK-320LMKAK85 [▲]
Colorado	12-09	Rear - 8.5"	DRK-321Q	DRK-321QMK [▲]	AK12	DRK-321QAK12	DRK-321QMKAK12 [▲]
Colorado	12-04	Rear - 8.0"	DRK-320D	DRK-320DMK [▲]	AK12	DRK-320DAK12	DRK-320DMKAK12 [▲]
Corvette	11-97	Rear - Getrag	DRK-328				
Corvette	96-85	Rear - Dana 36, w/ Auto Trans	DRK-338	DRK-338MK			
Corvette	96-85	Rear - Dana 44, w/ Man Trans	DRK-339A	DRK-339AMK [▲]			
Corvette	1984	Rear - Dana 44	DRK-339A	DRK-339AMK [▲]			
Corvette	82-80	Rear - Dana 44	DRK-339	DRK-339MK [▲]			
Corvette	79-63	Rear - 8.5"	DRK-323	DRK-323MK [▲]	AK39	DRK-323AK39	DRK-323MKAK39 [▲]
Corvette	62-55	Rear - 8.2" Axle Shaft w/1.781" Differential Brgs.	DRK-321G	DRK-321GMK			
El Camino	87-82	Rear - 7.5"	DRK-320	DRK-320MK [▲]	AK11	DRK-320AK11	DRK-320MKAK11 [▲]
El Camino	87-77	Rear - 8.5"	DRK-321R	DRK-321RMK [▲]	AK10	DRK-321RAK10	DRK-321RMKAK10 [▲]
El Camino	81-77	Rear - 7.5"	DRK-320B	DRK-320BMK [▲]	AK11	DRK-320BAK11	DRK-320BMKAK11 [▲]
El Camino	76-71	Rear - 8.5"	DRK-321R	DRK-321RMK [▲]	AK10	DRK-321RAK10	DRK-321RMKAK10 [▲]
El Camino	72-65	Rear - 8.875"	DRK-323A	DRK-323AMK [▲]			
El Camino	71-64	Rear - 8.2" Axle Shaft w/1.625" Differential Brgs.	DRK-321B	DRK-321BMK [▲]			
El Camino	64-59	Rear - 8.2" Axle Shaft w/1.781" Differential Brgs.	DRK-321G	DRK-321GMK			
Impala	96-82	Rear - 7.5"	DRK-320	DRK-320MK [▲]	AK11	DRK-320AK11	DRK-320MKAK11 [▲]
Impala	96-73	Rear - 8.5"	DRK-321R	DRK-321RMK [▲]	AK11	DRK-321RAK11	DRK-321RMKAK11 [▲]
Impala	81-77	Rear - 7.5"	DRK-320B	DRK-320BMK [▲]	AK11	DRK-320BAK11	DRK-320BMKAK11 [▲]
Impala	72-65	Rear - 8.2" Axle Shaft w/1.781" Differential Brgs.	DRK-321B	DRK-321BMK [▲]			

LD Differential

Light Duty Differential Applications

Make/Model	Year	Position/ Ring Gear Size	Standard Kit	Master Kit	Axle Kit	Standard Kit Plus	Master Kit Plus
CHEVROLET (cont'd)							
Impala	72-65	Rear - 8.875"	DRK-323A	DRK-323AMK ▲			
Impala	64-59	Rear - 8.2" Axle Shaft w/1.781" Differential Brgs.	DRK-321G	DRK-321GMK			
Malibu	83-82	Rear - 7.5"	DRK-320	DRK-320MK ▲	AK11	DRK-320AK11	DRK-320MKAK11 ▲
Malibu	81-77	Rear - 7.5"	DRK-320B	DRK-320BMK ▲	AK11	DRK-320BAK11	DRK-320BMKAK11 ▲
Monte Carlo	88-82	Rear - 7.5"	DRK-320	DRK-320MK ▲	AK11	DRK-320AK11	DRK-320MKAK11 ▲
Monte Carlo	81-77	Rear - 7.5"	DRK-320B	DRK-320BMK ▲	AK11	DRK-320BAK11	DRK-320BMKAK11 ▲
Monte Carlo	77-71	Rear - 8.5"	DRK-321R	DRK-321RMK ▲	AK11	DRK-321RAK11	DRK-321RMKAK11 ▲
Monte Carlo	72-70	Rear - 8.2" Axle Shaft w/1.781" Differential Brgs.	DRK-321B	DRK-321BMK ▲			
Monte Carlo	72-70	Rear - 8.875"	DRK-323A	DRK-323AMK ▲			
Monza	80-75	Rear - 7.5"	DRK-320B	DRK-320BMK ▲			
Nova	79-70	Rear - 8.5"	DRK-321R	DRK-321RMK ▲			
Nova	72-70	Rear - 8.875"	DRK-323A	DRK-323AMK ▲			
Nova	72-64	Rear - 8.2"	DRK-321B	DRK-321BMK ▲			
S10	04-97	Front - 7.25"	DRK-320A	DRK-320AMK	AK86	DRK-320AAK86	DRK-320AMKAK86
S10	96-83	Front - 7.25"	DRK-320A	DRK-320AMK	AK86	DRK-320AAK86	DRK-320AMKAK86
S10	04-99	Rear - 7.5"	DRK-320C	DRK-320CMK ▲	AK11	DRK-320CAK11	DRK-320CMKAK11 ▲
S10	04-99	Rear - 8.5"	DRK-321C	DRK-321CMK ▲	AK10	DRK-321CAK10	DRK-321CMKAK10 ▲
S10	98-94	Rear - 8.5"	DRK-321R	DRK-321RMK ▲	AK10	DRK-321RAK10	DRK-321RMKAK10 ▲
S10	98-82	Rear - 7.5"	DRK-320	DRK-320MK ▲	AK11	DRK-320AK11	DRK-320MKAK11 ▲
S10	81-77	Rear - 7.5"	DRK-320B	DRK-320BMK ▲			
SS	2014	Rear - 8.25"	DRK-326B	DRK-326BMK			
SSR	06-03	Rear - 8.5"	DRK-321C	DRK-321CMK ▲	AK12	DRK-321CAK12	DRK-321CMKAK12 ▲
SSR	06-03	Rear - 9.5"	DRK-324B	DRK-324BMK			
Suburban 1500	14-98	Front - 8.25"	DRK-321T	DRK-321TMK	AK83	DRK-321TAK83	DRK-321TMKAK83
Suburban 1500	97-90	Front - 8.25"	DRK-321A	DRK-321AMK			
Suburban 1500	91-77	Front - 8.5"	DRK-321	DRK-321MK ▲			
Suburban 1500	80-73	Front - Dana 44	DRK-339B	DRK-339BMK			
Suburban 1500	14-09	Rear - 8.5"	DRK-321Q	DRK-321QMK ▲	AK12	DRK-321QAK12	DRK-321QMKAK12 ▲
Suburban 1500	08-00	Rear - 8.5"	DRK-321C	DRK-321CMK ▲	AK12	DRK-321CAK12	DRK-321CMKAK12 ▲
Suburban 1500	08-98	Rear - 9.5"	DRK-324B	DRK-324BMK			
Suburban 1500	99-82	Rear - 8.5"	DRK-321R	DRK-321RMK ▲	AK12	DRK-321RAK12	DRK-321RMKAK12 ▲
Suburban 1500	81-73	Rear - 8.875"	DRK-322	DRK-322MK ▲	AK17	DRK-322AK17	DRK-322MKAK17 ▲
Suburban 2500	13-11	Front - 9.25"	DRK-324D	DRK-324DMK	AK92	DRK-324DAK92	DRK-324DMKAK92
Suburban 2500	10-98	Front - 9.25"	DRK-324C	DRK-324CMK	AK92	DRK-324CAK92	DRK-324CMKAK92
Suburban 2500	97-92	Front - 9.25"	DRK-324A	DRK-324AMK			
Suburban 2500	91-77	Front - 8.5"	DRK-321	DRK-321MK ▲			
Suburban 2500	80-73	Front - Dana 44	DRK-339B	DRK-339BMK			
Suburban 2500	13-08	Rear - 10.5"	DRK-325B	DRK-325BMK	AK29	DRK-325BAK29	DRK-325BMKAK29
Suburban 2500	13-98	Rear - 9.5"	DRK-324B	DRK-324BMK			
Suburban 2500	05-02	Rear - Dana 60 Quadrasteer	DRK-331C	DRK-331CMK			
Suburban 2500	97-81	Rear - 9.5"	DRK-324	DRK-324MK	AK16	DRK-324AK16	DRK-324MKAK16
Suburban 2500	81-73	Rear - 8.875"	DRK-322	DRK-322MK ▲	AK17	DRK-322AK17	DRK-322MKAK17 ▲
Tahoe	14-98	Front - 8.25"	DRK-321T	DRK-321TMK	AK83	DRK-321TAK83	DRK-321TMKAK83
Tahoe	97-95	Front - 8.25"	DRK-321A	DRK-321AMK			
Tahoe	14-09	Rear - 8.5"	DRK-321Q	DRK-321QMK ▲	AK12	DRK-321QAK12	DRK-321QMKAK12 ▲
Tahoe	08-00	Rear - 8.5"	DRK-321C	DRK-321CMK ▲	AK12	DRK-321CAK12	DRK-321CMKAK12 ▲
Tahoe	99-95	Rear - 8.5"	DRK-321R	DRK-321RMK ▲	AK12	DRK-321RAK12	DRK-321RMKAK12 ▲
Trailblazer	09-02	Front - 7.25"	DRK-320K	DRK-320KMK	AK87	DRK-320KAK87	DRK-320KMKAK87
Trailblazer	09-06	Rear - 9.5"	DRK-324B	DRK-324BMK			

▲ Add "S" suffix to kit number to receive stackable differential shims in kit.

Light Duty Differential Applications

Make/Model	Year	Position/ Ring Gear Size	Standard Kit	Master Kit	Axle Kit	Standard Kit Plus	Master Kit Plus
CHEVROLET (cont'd)							
Trailblazer	09-02	Rear - 8"	DRK-320D	DRK-320DMK [▲]	AK12	DRK-320DAK12	DRK-320DMKAK12 [▲]
Trailblazer	08-02	Rear - 8.5"	DRK-321C	DRK-321CMK [▲]	AK12	DRK-321CAK12	DRK-321CMKAK12 [▲]
Truck 1/2 Ton	14-98	Front - 8.25"	DRK-321T	DRK-321TMK	AK83	DRK-321TAK83	DRK-321TMKAK83
Truck 1/2 Ton	97-88	Front - 8.25"	DRK-321A	DRK-321AMK			
Truck 1/2 Ton	87-77	Front - 8.5"	DRK-321	DRK-321MK [▲]			
Truck 1/2 Ton	80-69	Front - Dana 44	DRK-339B	DRK-339BMK			
Truck 1/2 Ton	2014	Rear - 9.5"	DRK-324E	DRK-324EMK	AK12	DRK-324EAK12	DRK-324EMKAK12
Truck 1/2 Ton	2014	Rear - 9.75"	DRK-324H	DRK-324HMK	AK12	DRK-324HAK12	DRK-324HMKAK12
Truck 1/2 Ton	13-09	Rear - 8.5"	DRK-321Q	DRK-321QMK [▲]	AK12	DRK-321QAK12	DRK-321QMKAK12 [▲]
Truck 1/2 Ton	13-98	Rear - 9.5"	DRK-324B	DRK-324BMK			
Truck 1/2 Ton	08-99	Rear - 8.5"	DRK-321C	DRK-321CMK [▲]	AK12	DRK-321CAK12	DRK-321CMKAK12 [▲]
Truck 1/2 Ton	05-02	Rear - Dana 60 Quadrasteer	DRK-331C	DRK-331CMK			
Truck 1/2 Ton	99-88	Rear - 8.5"	DRK-321R	DRK-321RMK [▲]	AK12	DRK-321RAK12	DRK-321RMKAK12 [▲]
Truck 1/2 Ton	99-70	Rear - 8.5" w/ Limited Slip Differential	DRK-321D	DRK-321DMK [▲]			
Truck 1/2 Ton	97-88	Rear - 9.5"	DRK-324	DRK-324MK	AK16	DRK-324AK16	DRK-324MKAK16
Truck 1/2 Ton	87-80	Rear - 8.5"	DRK-321R	DRK-321RMK [▲]	AK10	DRK-321RAK10	DRK-321RMKAK10 [▲]
Truck 1/2 Ton	82-80	Rear - 8.875"	DRK-322	DRK-322MK [▲]			
Truck 1/2 Ton	81-80	Rear - 8.75"	DRK-323	DRK-323MK [▲]			
Truck 1/2 Ton	79-71	Rear - 8.5"	DRK-321R	DRK-321RMK [▲]	AK10	DRK-321RAK10	DRK-321RMKAK10 [▲]
Truck 1/2 Ton	79-64	Rear - 8.875"	DRK-322	DRK-322MK [▲]			
Truck 1/2 Ton	72-65	Rear - Dana 44	DRK-339B	DRK-339BMK			
Truck 3/4 Ton	14-11	Front - 9.25"	DRK-324D	DRK-324DMK	AK92	DRK-324DAK92	DRK-324DMKAK92
Truck 3/4 Ton	10-98	Front - 9.25"	DRK-324C	DRK-324CMK	AK92	DRK-324CAK92	DRK-324CMKAK92
Truck 3/4 Ton	97-88	Front - 9.25"	DRK-324A	DRK-324AMK			
Truck 3/4 Ton	91-77	Front - 8.5"	DRK-321	DRK-321MK [▲]			
Truck 3/4 Ton	80-68	Front - Dana 44	DRK-339B	DRK-339BMK			
Truck 3/4 Ton	2014	Rear - 9.5"	DRK-324E	DRK-324EMK	AK12	DRK-324EAK12	DRK-324EMKAK12
Truck 3/4 Ton	14-11	Rear - 11.5" 2nd Design w/4.375" Pinion Brg.	DRK-327A	DRK-327AMK	AK44	DRK-327AAK44	DRK-327AMKAK44
Truck 3/4 Ton	13-11	Rear - 9.5"	DRK-324B	DRK-324BMK			
Truck 3/4 Ton	13-00	Rear - 10.5"	DRK-325B	DRK-325BMK	AK29	DRK-325BAK29	DRK-325BMKAK29
Truck 3/4 Ton	11-01	Rear - 11.5" 1st Design w/4.125" Pinion Brg.	DRK-327	DRK-327MK	AK29	DRK-327AK29	DRK-327MKAK29
Truck 3/4 Ton	10-98	Rear - 9.5"	DRK-324B	DRK-324BMK			
Truck 3/4 Ton	05-02	Rear - Dana 60 Quadrasteer	DRK-331C	DRK-331CMK			
Truck 3/4 Ton	99-98	Rear - 10.5"	DRK-325B	DRK-325BMK			
Truck 3/4 Ton	97-89	Rear - 10.5"	DRK-325A	DRK-325AMK			
Truck 3/4 Ton	97-81	Rear - 9.5"	DRK-324	DRK-324MK	AK16	DRK-324AK16	DRK-324MKAK16
Truck 3/4 Ton	1988	Rear - 10.5" 1st Design	DRK-325	DRK-325MK	AK21	DRK-325AK21	DRK-325MKAK21
Truck 3/4 Ton	1988	Rear - 10.5" 2nd Design	DRK-325A	DRK-325AMK			
Truck 3/4 Ton	87-73	Rear - 10.5"	DRK-325	DRK-325MK	AK21	DRK-325AK21	DRK-325MKAK21
Truck 3/4 Ton	81-80	Rear - 8.5"	DRK-323	DRK-323MK [▲]	AK17	DRK-323AK17	DRK-323MKAK17 [▲]
Truck 3/4 Ton	81-69	Rear - 8.875"	DRK-322	DRK-322MK [▲]			
Truck 3/4 Ton	72-67	Rear - Dana 60	DRK-331	DRK-331MK			
Truck 1 Ton	14-11	Front - 9.25"	DRK-324D	DRK-324DMK	AK92	DRK-324DAK92	DRK-324DMKAK92
Truck 1 Ton	10-98	Front - 9.25"	DRK-324C	DRK-324CMK	AK92	DRK-324CAK92	DRK-324CMKAK92
Truck 1 Ton	97-88	Front - 9.25"	DRK-324A	DRK-324AMK			
Truck 1 Ton	91-77	Front - Dana 60	DRK-331	DRK-331MK	AK42	DRK-331AK42	DRK-331MKAK42

LD Differential

Light Duty Differential Applications

Make/Model	Year	Position/ Ring Gear Size	Standard Kit	Master Kit	Axle Kit	Standard Kit Plus	Master Kit Plus
CHEVROLET (cont'd)							
Truck 1 Ton	14-11	Rear - 11.5" 2nd Design w/4.375" Pinion Brg.	DRK-327A	DRK-327AMK	AK44	DRK-327AAK44	DRK-327AMKAK44
Truck 1 Ton	11-01	Rear - 11.5" 1st Design w/4.125" Pinion Brg.	DRK-327	DRK-327MK	AK29	DRK-327AK29	DRK-327MKAK29
Truck 1 Ton	00-98	Rear - 10.5"	DRK-325B	DRK-325BMK			
Truck 1 Ton	99-91	Rear - Dana 80	DRK-337	DRK-337MK			
Truck 1 Ton	97-89	Rear - 10.5"	DRK-325A	DRK-325AMK			
Truck 1 Ton	95-83	Rear - 9.5"	DRK-324	DRK-324MK	AK16	DRK-324AK16	DRK-324MKAK16
Truck 1 Ton	94-73	Rear - Dana 70HD	DRK-332HD	DRK-332HDMK			
Truck 1 Ton	91-84	Rear - Dana 70U	DRK-332U	DRK-332UMK			
Truck 1 Ton	91-73	Rear - Dana 60	DRK-331	DRK-331MK			
Truck 1 Ton	90-73	Rear - Dana 70	DRK-332	DRK-332MK			
Truck 1 Ton	1988	Rear - 10.5" 1st Design	DRK-325	DRK-325MK	AK21	DRK-325AK21	DRK-325MKAK21
Truck 1 Ton	1988	Rear - 10.5" 2nd Design	DRK-325A	DRK-325AMK			
Truck 1 Ton	87-72	Rear - 10.5"	DRK-325	DRK-325MK	AK21	DRK-325AK21	DRK-325MKAK21
Van 1/2 Ton	13-03	Front - 7.25"	DRK-320A	DRK-320AMK			
Van 1/2 Ton	13-09	Rear - 8.5"	DRK-321Q	DRK-321QMK ▲	AK12	DRK-321QAK12	DRK-321QMKAK12 ▲
Van 1/2 Ton	08-99	Rear - 8.5"	DRK-321C	DRK-321CMK ▲	AK12	DRK-321CAK12	DRK-321CMKAK12 ▲
Van 1/2 Ton	08-98	Rear - 9.5"	DRK-324B	DRK-324BMK	AK16	DRK-324BAK16	DRK-324BMKAK16
Van 1/2 Ton	98-96	Rear - 8.5"	DRK-321R	DRK-321RMK ▲	AK12	DRK-321RAK12	DRK-321RMKAK12 ▲
Van 1/2 Ton	97-81	Rear - 9.5"	DRK-324	DRK-324MK	AK16	DRK-324AK16	DRK-324MKAK16
Van 1/2 Ton	95-77	Rear - 8.5"	DRK-321R	DRK-321RMK ▲	AK10	DRK-321RAK10	DRK-321RMKAK10 ▲
Van 1/2 Ton	81-64	Rear - 8.875"	DRK-322	DRK-322MK ▲			
Van 3/4 Ton	14-11	Rear - 11.5"	DRK-327A	DRK-327AMK			
Van 3/4 Ton	13-01	Rear - 10.5"	DRK-325B	DRK-325BMK	AK29	DRK-325BAK29	DRK-325BMKAK29
Van 3/4 Ton	13-98	Rear - 9.5"	DRK-324B	DRK-324BMK	AK16	DRK-324BAK16	DRK-324BMKAK16
Van 3/4 Ton	10-01	Rear - 11.5"	DRK-327	DRK-327MK	AK29	DRK-327AK29	DRK-327MKAK29
Van 3/4 Ton	08-04	Rear - Dana 60/61	DRK-331B	DRK-331BMK			
Van 3/4 Ton	00-98	Rear - 10.5"	DRK-325B	DRK-325BMK			
Van 3/4 Ton	97-89	Rear - 10.5"	DRK-325A	DRK-325AMK			
Van 3/4 Ton	97-80	Rear - 9.5"	DRK-324	DRK-324MK	AK16	DRK-324AK16	DRK-324MKAK16
Van 3/4 Ton	1988	Rear - 10.5" 1st Design	DRK-325	DRK-325MK	AK21	DRK-325AK21	DRK-325MKAK21
Van 3/4 Ton	1988	Rear - 10.5" 2nd Design	DRK-325A	DRK-325AMK			
Van 3/4 Ton	87-73	Rear - 10.5"	DRK-325	DRK-325MK	AK21	DRK-325AK21	DRK-325MKAK21
Van 3/4 Ton	81-69	Rear - 8.875"	DRK-322	DRK-322MK ▲			
Van 1 Ton	14-11	Rear - 11.5"	DRK-327A	DRK-327AMK			
Van 1 Ton	13-98	Rear - 10.5"	DRK-325B	DRK-325BMK	AK29	DRK-325BAK29	DRK-325BMKAK29
Van 1 Ton	10-01	Rear - 11.5"	DRK-327	DRK-327MK	AK29	DRK-327AK29	DRK-327MKAK29
Van 1 Ton	08-04	Rear - Dana 60/61	DRK-331B	DRK-331BMK			
Van 1 Ton	97-89	Rear - 10.5"	DRK-325A	DRK-325AMK			
Van 1 Ton	91-80	Rear - Dana 60	DRK-331	DRK-331MK			
Van 1 Ton	1988	Rear - 10.5" 1st Design	DRK-325	DRK-325MK	AK21	DRK-325AK21	DRK-325MKAK21
Van 1 Ton	1988	Rear - 10.5" 2nd Design	DRK-325A	DRK-325AMK			
Van 1 Ton	87-73	Rear - 10.5"	DRK-325	DRK-325MK	AK21	DRK-325AK21	DRK-325MKAK21

▲ Add "S" suffix to kit number to receive stackable differential shims in kit.

Light Duty Differential Applications

Make/Model	Year	Position/ Ring Gear Size	Standard Kit	Master Kit	Axle Kit	Standard Kit Plus	Master Kit Plus
CHRYSLER							
300	10-05	Rear - H226 SRT-8	DRK-370	DRK-370MK			
300	71-69	Rear - 8.75" w/1.875" Pin. Shaft O.D.	DRK-301	DRK-301MK			
300	68-57	Rear - 8.75" w/1.75" Pin. Shaft O.D.	DRK-300	DRK-300MK			
Aspen	09-07	Front - 8"	DRK-305	DRK-305MK			
Aspen	09-07	Rear - 8.25"	DRK-303B	DRK-303BMK	AK26	DRK-303BAK26	DRK-303BMKAK26
Aspen	09-07	Rear - 9.25"	DRK-304A	DRK-304AMK	AK26	DRK-304AAK26	DRK-304AMKAK26
Cordoba	83-80	Rear - 7.25"	DRK-302	DRK-302MK			
Cordoba	83-75	Rear - 8.25"/8.375"	DRK-303	DRK-303MK			
Cordoba	79-75	Rear - 9.25"	DRK-304	DRK-304MK	AK10	DRK-304AK10	DRK-304MKAK10
Fifth Avenue	89-83	Rear - 7.25"	DRK-302	DRK-302MK			
Fifth Avenue	89-83	Rear - 8.25"/8.375"	DRK-303	DRK-303MK	AK10	DRK-303AK10	DRK-303MKAK10
Imperial	83-81	Rear - 8.25"/8.375"	DRK-303	DRK-303MK	AK10	DRK-303AK10	DRK-303MKAK10
Imperial	75-74	Rear - 9.25"	DRK-304	DRK-304MK	AK10	DRK-304AK10	DRK-304MKAK10
Imperial	75-71	Rear - 8.25"/8.375"	DRK-303	DRK-303MK	AK10	DRK-303AK10	DRK-303MKAK10
Imperial	74-69	Rear - 8.75" w/1.875" Pin. Shaft O.D.	DRK-301	DRK-301MK			
Imperial	68-57	Rear - 8.75" w/1.75" Pin. Shaft O.D.	DRK-300	DRK-300MK			
LeBaron	81-77	Rear - 7.25"	DRK-302	DRK-302MK			
LeBaron	81-77	Rear - 8.25"/8.375"	DRK-303	DRK-303MK	AK10	DRK-303AK10	DRK-303MKAK10
New Yorker	83-82	Rear - 7.25"	DRK-302	DRK-302MK			
New Yorker	83-82	Rear - 8.25"/8.375"	DRK-303	DRK-303MK	AK10	DRK-303AK10	DRK-303MKAK10
New Yorker	81-75	Rear - 8.25"/8.375"	DRK-303	DRK-303MK	AK10	DRK-303AK10	DRK-303MKAK10
New Yorker	81-75	Rear - 9.25"	DRK-304	DRK-304MK	AK10	DRK-304AK10	DRK-304MKAK10
New Yorker	74-72	Rear - 8.25"/8.375"	DRK-303	DRK-303MK	AK10	DRK-303AK10	DRK-303MKAK10
New Yorker	74-72	Rear - 8.75" w/1.875" Pin. Shaft O.D.	DRK-301	DRK-301MK			
New Yorker	74-72	Rear - 9.25"	DRK-304	DRK-304MK	AK10	DRK-304AK10	DRK-304MKAK10
New Yorker	71-69	Rear - 8.75" w/1.875" Pin. Shaft O.D.	DRK-301	DRK-301MK			
New Yorker	68-57	Rear - 8.75" w/1.75" Pin. Shaft O.D.	DRK-300	DRK-300MK			
Newport	81-75	Rear - 8.25"/8.375"	DRK-303	DRK-303MK	AK10	DRK-303AK10	DRK-303MKAK10
Newport	81-75	Rear - 9.25"	DRK-304	DRK-304MK	AK10	DRK-304AK10	DRK-304MKAK10
Newport	74-72	Rear - 8.25"/8.375"	DRK-303	DRK-303MK	AK10	DRK-303AK10	DRK-303MKAK10
Newport	74-72	Rear - 8.75" w/1.875" Pin. Shaft O.D.	DRK-301	DRK-301MK			
Newport	71-69	Rear - 8.75" w/1.875" Pin. Shaft O.D.	DRK-301	DRK-301MK			
Newport	68-57	Rear - 8.75" w/1.75" Pin. Shaft O.D.	DRK-300	DRK-300MK			
Town & Country	81-78	Rear - 8.25"/8.375"	DRK-303	DRK-303MK	AK10	DRK-303AK10	DRK-303MKAK10
Town & Country	77-69	Rear - 8.75" w/1.875" Pin. Shaft O.D.	DRK-301	DRK-301MK			
Town & Country	68-57	Rear - 8.75" w/1.75" Pin. Shaft O.D.	DRK-300	DRK-300MK			

LD Differential

Light Duty Differential Applications

Make/Model	Year	Position/ Ring Gear Size	Standard Kit	Master Kit	Axle Kit	Standard Kit Plus	Master Kit Plus
DODGE							
Aspen	1980	Rear - 8.25"/8.375"	DRK-303	DRK-303MK	AK10	DRK-303AK10	DRK-303MKAK10
Aspen	79-76	Rear - 7.25"	DRK-302	DRK-302MK			
Challenger	74-70	Rear - 8.75" w/1.875" Pin. Shaft O.D.	DRK-301	DRK-301MK			
Challenger	71-70	Rear - 7.25"	DRK-302	DRK-302MK			
Challenger	71-70	Rear - Dana 60	DRK-331	DRK-331MK			
Charger	10-06	Rear - H226 SRT-8	DRK-370	DRK-370MK			
Charger	78-74	Rear - 8.25"/8.375"	DRK-303	DRK-303MK	AK10	DRK-303AK10	DRK-303MKAK10
Charger	78-74	Rear - 9.25"	DRK-304	DRK-304MK	AK10	DRK-304AK10	DRK-304MKAK10
Charger	1974	Rear - 8.75" w/1.875" Pin. Shaft O.D.	DRK-301	DRK-301MK			
Charger	73-69	Rear - 8.25"/8.375"	DRK-303	DRK-303MK	AK10	DRK-303AK10	DRK-303MKAK10
Charger	73-69	Rear - 8.75" w/1.875" Pin. Shaft O.D.	DRK-301	DRK-301MK			
Charger	71-69	Rear - 7.25"	DRK-302	DRK-302MK			
Charger	1968	Rear - 7.25"	DRK-302	DRK-302MK			
Charger	1968	Rear - 8.75" w/1.75" Pin. Shaft O.D.	DRK-300	DRK-300MK			
Charger	1968	Rear - Dana 60	DRK-331	DRK-331MK			
Charger	67-66	Rear - 8.75" w/1.75" Pin. Shaft O.D.	DRK-300	DRK-300MK			
Charger	67-66	Rear - Dana 60	DRK-331	DRK-331MK			
Coronet	76-74	Rear - 8.25"/8.375"	DRK-303	DRK-303MK	AK10	DRK-303AK10	DRK-303MKAK10
Coronet	76-73	Rear - 9.25"	DRK-304	DRK-304MK	AK10	DRK-304AK10	DRK-304MKAK10
Coronet	74-73	Rear - 8.75" w/1.875" Pin. Shaft O.D.	DRK-301	DRK-301MK			
Coronet	73-69	Rear - 8.25"/8.375"	DRK-303	DRK-303MK	AK10	DRK-303AK10	DRK-303MKAK10
Coronet	72-69	Rear - 8.75" w/1.875" Pin. Shaft O.D.	DRK-301	DRK-301MK			
Coronet	71-66	Rear - 7.25"	DRK-302	DRK-302MK			
Coronet	68-66	Rear - 8.75" w/1.75" Pin. Shaft O.D.	DRK-300	DRK-300MK			
Coronet	1966	Rear - Dana 60	DRK-331	DRK-331MK			
Coronet	1965	Rear - 8.75" w/1.75" Pin. Shaft O.D.	DRK-300	DRK-300MK			
Dakota	11-00	Front - 8"	DRK-305	DRK-305MK			
Dakota	99-97	Front - Dana 35	DRK-335	DRK-335MK ▲			
Dakota	96-87	Front - 7.25"	DRK-302	DRK-302MK			
Dakota	11-01	Rear - 9.25"	DRK-304A	DRK-304AMK	AK10	DRK-304AAK10	DRK-304AMKAK10
Dakota	11-00	Rear - 8.25"	DRK-303B	DRK-303BMK			
Dakota	00-98	Rear - 9.25"	DRK-304	DRK-304MK	AK10	DRK-304AK10	DRK-304MKAK10
Dakota	99-87	Rear - 8.25"	DRK-303	DRK-303MK			
Dakota	96-87	Rear - 7.25"	DRK-302	DRK-302MK			
Dart	76-73	Rear - 8.25"/8.375"	DRK-303	DRK-303MK	AK10	DRK-303AK10	DRK-303MKAK10
Dart	1972	Rear - 7.25"	DRK-302	DRK-302MK			
Dart	1972	Rear - 8.25"/8.375"	DRK-303	DRK-303MK	AK10	DRK-303AK10	DRK-303MKAK10
Dart	1972	Rear - 8.75" w/1.875" Pin. Shaft O.D.	DRK-301	DRK-301MK			
Dart	71-69	Rear - 7.25"	DRK-302	DRK-302MK			

▲ Add "S" suffix to kit number to receive stackable differential shims in kit.

Light Duty Differential Applications

Make/Model	Year	Position/ Ring Gear Size	Standard Kit	Master Kit	Axle Kit	Standard Kit Plus	Master Kit Plus
DODGE (cont'd)							
Dart	71-69	Rear - 8.75" w/1.875" Pin. Shaft O.D.	DRK-301	DRK-301MK			
Dart	68-66	Rear - 7.25"	DRK-302	DRK-302MK			
Dart	68-66	Rear - 8.75" w/1.75" Pin. Shaft O.D.	DRK-300	DRK-300MK			
Dart	65-63	Rear - 7.25"	DRK-302	DRK-302MK			
Diplomat	89-77	Rear - 7.25"	DRK-302	DRK-302MK			
Diplomat	89-77	Rear - 8.25"/8.375"	DRK-303	DRK-303MK	AK10	DRK-303AK10	DRK-303MKAK10
Durango	09-00	Front - 8"	DRK-305	DRK-305MK			
Durango	99-98	Front - Dana 35	DRK-335	DRK-335MK ▲			
Durango	09-04	Rear - 8.25"	DRK-303B	DRK-303BMK	AK26	DRK-303BAK26	DRK-303BMKAK26
Durango	09-04	Rear - 9.25"	DRK-304A	DRK-304AMK	AK26	DRK-304AAK26	DRK-304AMKAK26
Durango	03-01	Rear - 9.25"	DRK-304A	DRK-304AMK	AK10	DRK-304AAK10	DRK-304AMKAK10
Durango	03-00	Rear - 8.25"	DRK-303B	DRK-303BMK	AK10	DRK-303BAK10	DRK-303BMKAK10
Durango	00-98	Rear - 9.25"	DRK-304	DRK-304MK	AK10	DRK-304AK10	DRK-304MKAK10
Durango	99-98	Rear - 8.25"	DRK-303	DRK-303MK			
Magnum	79-78	Rear - 8.25"/8.375"	DRK-303	DRK-303MK	AK10	DRK-303AK10	DRK-303MKAK10
Magnum	79-78	Rear - 9.25"	DRK-304	DRK-304MK	AK10	DRK-304AK10	DRK-304MKAK10
Mirada	83-80	Rear - 7.25"	DRK-302	DRK-302MK			
Mirada	83-80	Rear - 8.25"/8.375"	DRK-303	DRK-303MK	AK10	DRK-303AK10	DRK-303MKAK10
Monaco	78-74	Rear - 9.25"	DRK-304	DRK-304MK	AK10	DRK-304AK10	DRK-304MKAK10
Monaco	78-71	Rear - 8.25"/8.375"	DRK-303	DRK-303MK	AK10	DRK-303AK10	DRK-303MKAK10
Monaco	73-69	Rear - 8.75" w/1.875" Pin. Shaft O.D.	DRK-301	DRK-301MK			
Monaco	68-67	Rear - 9.25"	DRK-304	DRK-304MK			
Monaco	68-65	Rear - 8.75" w/1.75" Pin. Shaft O.D.	DRK-300	DRK-300MK			
Nitro	11-07	Front - Dana 30	DRK-340	DRK-340MK ▲			
Nitro	11-09	Rear - 8.25"	DRK-303B	DRK-303BMK	AK26	DRK-303BAK26	DRK-303BMKAK26
Nitro	08-07	Rear - 8.25"	DRK-303B	DRK-303BMK	AK10	DRK-303BAK10	DRK-303BMKAK10
Polara	73-71	Rear - 8.25"/8.375"	DRK-303	DRK-303MK	AK10	DRK-303AK10	DRK-303MKAK10
Polara	73-69	Rear - 8.75" w/1.875" Pin. Shaft O.D.	DRK-301	DRK-301MK			
Polara	68-67	Rear - 9.25"	DRK-304	DRK-304MK			
Polara	68-63	Rear - 8.75" w/1.75" Pin. Shaft O.D.	DRK-300	DRK-300MK			
Ramcharger	93-74	Front - Dana 44	DRK-339B	DRK-339BMK			
Ramcharger	93-74	Rear - 9.25"	DRK-304	DRK-304MK	AK10	DRK-304AK10	DRK-304MKAK10
Sprinter	12-07	Rear - All	DRK-307A	DRK-307AMK			
Sprinter	06-03	Rear - All	DRK-307	DRK-307MK			
St. Regis	81-79	Rear - 7.25"	DRK-302	DRK-302MK			
St. Regis	81-79	Rear - 8.25"/8.375"	DRK-303	DRK-303MK	AK10	DRK-303AK10	DRK-303MKAK10
St. Regis	81-79	Rear - 9.25"	DRK-304	DRK-304MK	AK10	DRK-304AK10	DRK-304MKAK10
Truck 1/2 Ton	10-02	Front - 8"	DRK-305A	DRK-305AMK			
Truck 1/2 Ton	08-94	Front - Dana 44	DRK-339C	DRK-339CMK			
Truck 1/2 Ton	93-69	Front - Dana 44	DRK-339B	DRK-339BMK			
Truck 1/2 Ton	10-07	Rear - 9.25" Corporate Axle	DRK-304A	DRK-304AMK	AK26	DRK-304AAK26	DRK-304AMKAK26
Truck 1/2 Ton	10-06	Rear - 11.5"	DRK-327	DRK-327MK	AK30	DRK-327AK30	DRK-327MKAK30
Truck 1/2 Ton	09-06	Rear - 10.5"	DRK-306	DRK-306MK	AK30	DRK-306AK30	DRK-306MKAK30
Truck 1/2 Ton	06-01	Rear - 9.25" Light Duty Axle	DRK-304A	DRK-304AMK	AK10	DRK-304AAK10	DRK-304AMKAK10

LD Differential

Light Duty Differential Applications

Make/Model	Year	Position/ Ring Gear Size	Standard Kit	Master Kit	Axle Kit	Standard Kit Plus	Master Kit Plus
DODGE (cont'd)							
Truck 1/2 Ton	06-01	Rear - 9.25" Heavy Duty Axle	DRK-304A	DRK-304AMK	AK22	DRK-304AAK22	DRK-304AMKAK22
Truck 1/2 Ton	06-00	Rear - 8.25"	DRK-303B	DRK-303BMK	AK10	DRK-303BAK10	DRK-303BMKAK10
Truck 1/2 Ton	00-74	Rear - 9.25" Light Duty Axle	DRK-304	DRK-304MK	AK10	DRK-304AK10	DRK-304MKAK10
Truck 1/2 Ton	00-74	Rear - 9.25" Heavy Duty Axle	DRK-304	DRK-304MK	AK22	DRK-304AK22	DRK-304MKAK22
Truck 1/2 Ton	99-69	Rear - 8.25"	DRK-303	DRK-303MK	AK10	DRK-303AK10	DRK-303MKAK10
Truck 1/2 Ton	74-68	Rear - 8.75" w/1.875" Pin. Shaft O.D.	DRK-301	DRK-301MK			
Truck 1/2 Ton	68-60	Rear - 8.75" w/1.75" Pin. Shaft O.D.	DRK-300	DRK-300MK			
Truck 3/4 Ton	10-03	Front - 9.25" AAM axle	DRK-324G	DRK-324GMK			
Truck 3/4 Ton	08-94	Front - Dana 44	DRK-339C	DRK-339CMK			
Truck 3/4 Ton	08-94	Front - Dana 60	DRK-331	DRK-331MK			
Truck 3/4 Ton	93-75	Front - Dana 60	DRK-331	DRK-331MK	AK42	DRK-331AK42	DRK-331MKAK42
Truck 3/4 Ton	84-69	Front - Dana 44	DRK-339B	DRK-339BMK			
Truck 3/4 Ton	10-03	Rear - 11.5"	DRK-327	DRK-327MK	AK30	DRK-327AK30	DRK-327MKAK30
Truck 3/4 Ton	10-01	Rear - 9.25"	DRK-304A	DRK-304AMK			
Truck 3/4 Ton	09-03	Rear - 10.5"	DRK-306	DRK-306MK	AK30	DRK-306AK30	DRK-306MKAK30
Truck 3/4 Ton	08-94	Rear - Dana 60	DRK-331A	DRK-331AMK			
Truck 3/4 Ton	08-94	Rear - Dana 70U	DRK-332U	DRK-332UMK			
Truck 3/4 Ton	02-94	Rear - Dana 80	DRK-337	DRK-337MK			
Truck 3/4 Ton	00-74	Rear - 9.25"	DRK-304	DRK-304MK	AK10	DRK-304AK10	DRK-304MKAK10
Truck 3/4 Ton	93-61	Rear - Dana 60	DRK-331	DRK-331MK			
Truck 3/4 Ton	74-69	Rear - 8.75" w/1.875" Pin. Shaft O.D.	DRK-301	DRK-301MK			
Truck 3/4 Ton	68-65	Rear - 8.75" w/1.75" Pin. Shaft O.D.	DRK-300	DRK-300MK			
Truck 1 Ton	10-03	Front - 9.25" AAM axle	DRK-324G	DRK-324GMK			
Truck 1 Ton	08-94	Front - Dana 60	DRK-331	DRK-331MK			
Truck 1 Ton	93-75	Front - Dana 60	DRK-331	DRK-331MK	AK42	DRK-331AK42	DRK-331MKAK42
Truck 1 Ton	10-03	Rear - 11.5"	DRK-327	DRK-327MK	AK30 ⁴⁹	DRK-327AK30 ⁴⁹	DRK-327MKAK30 ⁴⁹
Truck 1 Ton	10-01	Rear - 9.25"	DRK-304A	DRK-304AMK			
Truck 1 Ton	08-60	Rear - Dana 60	DRK-331	DRK-331MK			
Truck 1 Ton	02-94	Rear - Dana 80	DRK-337	DRK-337MK			
Truck 1 Ton	00-74	Rear - 9.25"	DRK-304	DRK-304MK	AK10	DRK-304AK10	DRK-304MKAK10
Truck 1 Ton	93-84	Rear - Dana 70U	DRK-332U	DRK-332UMK			
Truck 1 Ton	84-60	Rear - Dana 70	DRK-332	DRK-332MK			
Ram 4500	10-08	Front - Magna Steyr 275mm	DRK-365				
Ram 4500	10-08	Rear - Dana S111	DRK-434				
Ram 5500	10-08	Front - Magna Steyr 275mm	DRK-365				
Ram 5500	10-08	Rear - Dana S111	DRK-434				
Van 1/2 Ton	03-00	Rear - 8.25"	DRK-303B	DRK-303BMK	AK10	DRK-303BAK10	DRK-303BMKAK10
Van 1/2 Ton	03-00	Rear - 9.25"	DRK-304A	DRK-304AMK	AK10	DRK-304AK10	DRK-304MKAK10
Van 1/2 Ton	99-74	Rear - 9.25"	DRK-304	DRK-304MK	AK10	DRK-304AK10	DRK-304MKAK10
Van 1/2 Ton	99-71	Rear - 8.25"	DRK-303	DRK-303MK	AK10	DRK-303AK10	DRK-303MKAK10
Van 1/2 Ton	74-64	Rear - 8.75"	DRK-301	DRK-301MK			
Van 3/4 Ton	03-00	Rear - 9.25"	DRK-304A	DRK-304AMK	AK10	DRK-304AK10	DRK-304MKAK10
Van 3/4 Ton	99-90	Rear - 8.25"	DRK-303	DRK-303MK	AK10	DRK-303AK10	DRK-303MKAK10
Van 3/4 Ton	99-74	Rear - 9.25"	DRK-304	DRK-304MK	AK10	DRK-304AK10	DRK-304MKAK10
Van 3/4 Ton	74-71	Rear - 8.75"	DRK-301	DRK-301MK			

⁴⁹With Single Rear Wheels

Light Duty Differential Applications

Make/Model	Year	Position/ Ring Gear Size	Standard Kit	Master Kit	Axle Kit	Standard Kit Plus	Master Kit Plus
DODGE (cont'd)							
Van 1 Ton	03-00	Rear - 9.25"	DRK-304A	DRK-304AMK	AK10	DRK-304AK10	DRK-304MKAK10
Van 1 Ton	99-74	Rear - 9.25"	DRK-304	DRK-304MK	AK10	DRK-304AK10	DRK-304MKAK10
Viper	00-93	Rear - Dana 44	DRK-339A	DRK-339AMK ▲			
FORD							
Aerostar	97-90	Front - Dana 28	DRK-333	DRK-333MK			
Aerostar	97-90	Rear - 7.5"	DRK-315	DRK-315MK ▲	AK11	DRK-315AK11	DRK-315MKAK11 ▲
Aerostar	97-90	Rear - 8.8"	DRK-311	DRK-311MK ▲	AK10	DRK-311AK10	DRK-311MKAK10 ▲
Aerostar	89-86	Rear - Dana 30, To 1989-1/2 Model	DRK-339	DRK-339MK ▲			
Bronco	96-80	Front - Dana 44	DRK-339B	DRK-339BMK	AK41	DRK-339BAK41	DRK-339BMKAK41
Bronco	79-67	Front - Dana 44	DRK-339B	DRK-339BMK			
Bronco	96-83	Rear - 8.8"	DRK-311	DRK-311MK ▲	AK10	DRK-311AK10	DRK-311MKAK10 ▲
Bronco	86-70	Rear - 9" 31 spline From 05/11/70	DRK-313	DRK-313MK			
Bronco	70-67	Rear - 9" 28 spline To 5/10/70	DRK-312	DRK-312MK			
Bronco II	1990	Front - Dana 35	DRK-335	DRK-335MK ▲			
Bronco II	89-84	Front - Dana 28	DRK-333	DRK-333MK			
Bronco II	90-84	Rear - 7.5"	DRK-315	DRK-315MK ▲	AK11	DRK-315AK11	DRK-315MKAK11 ▲
Country Squire	91-81	Rear - 8.8"	DRK-311	DRK-311MK ▲	AK11	DRK-311AK11	DRK-311MKAK11 ▲
Country Squire	80-73	Rear - 9" 31 spline From 05/11/70	DRK-313	DRK-313MK			
Crown Victoria	11-92	Rear - 8.8"	DRK-311	DRK-311MK ▲	AK11	DRK-311AK11	DRK-311MKAK11 ▲
Escape	12-01	Rear - Dana 28	DRK-333A	DRK-333AMK	AK89	DRK-333AAK89	DRK-333AMKAK89
Excursion	05-00	Front - Dana 50	DRK-336A	DRK-336AMK			
Excursion	05-00	Rear - 10.5"	DRK-317 ⁵⁰	DRK-317MK ⁵⁰ ▲			
Expedition	10-09	Front - 8.8"	DRK-311	DRK-311MK ▲	AK91	DRK-311AK91	DRK-311MKAK91 ▲
Expedition	08-97	Front - 8.8"	DRK-311	DRK-311MK ▲	AK88	DRK-311AK88	DRK-311MKAK88 ▲
Expedition	14-11	Rear - 9.75" from 04/30/2011 w/ 3.73 Axle Ratio	DRK-316B	DRK-316BMK ▲	AK36	DRK-316BAK36	DRK-316BMKAK36 ▲
Expedition	14-11	Rear - 9.75" from 04/30/2011 w/ 3.31 Axle Ratio	DRK-316D	DRK-316DMK ▲	AK36	DRK-316DAK36	DRK-316DMKAK36 ▲
Expedition	11-07	Rear - 9.75" To 04/29/2011	DRK-316B	DRK-316BMK ▲	AK36	DRK-316BAK36	DRK-316BMKAK36 ▲
Expedition	06-03	Rear - 9.75"	DRK-316A	DRK-316AMK ▲	AK36	DRK-316AAK36	DRK-316AMKAK36 ▲
Expedition	05-03	Rear - 8.8" IRS	DRK-311	DRK-311MK ▲	AK36	DRK-311AK36	DRK-311MKAK36 ▲
Expedition	02-00	Rear - 9.75"	DRK-316A	DRK-316AMK ▲	AK15	DRK-316AAK15	DRK-316AMKAK15 ▲
Expedition	02-97	Rear - 8.8"	DRK-311	DRK-311MK ▲	AK15	DRK-311AK15	DRK-311MKAK15 ▲
Expedition	1999	Rear - 9.75" w/ 2.688" OD Pinion Tail Cup	DRK-316	DRK-316MK ▲	AK15	DRK-316AK15	DRK-316MKAK15 ▲
Expedition	1999	Rear - 9.75" w/ 3.000" OD Pinion Tail Cup	DRK-316A	DRK-316AMK ▲	AK15	DRK-316AAK15	DRK-316AMKAK15 ▲
Expedition	98-97	Rear - 9.75"	DRK-316	DRK-316MK ▲	AK15	DRK-316AK15	DRK-316MKAK15 ▲
Explorer	10-06	Front - Dana 30	DRK-334E	DRK-334EMK ▲			
Explorer	05-01	Front - Dana 30	DRK-334B	DRK-334BMK			
Explorer	04-95	Front - Dana 35	DRK-335B	DRK-335BMK ▲			
Explorer	94-91	Front - Dana 35	DRK-335	DRK-335MK ▲			
Explorer	10-08	Rear - 8.8" IRS	DRK-311L	DRK-311LMK ▲	AK36	DRK-311LAK36	DRK-311LMKAK36 ▲
Explorer	07-06	Rear - 8.8" IRS	DRK-311K	DRK-311KMK ▲	AK36	DRK-311KAK36	DRK-311KMKAK36 ▲
Explorer	05-02	Rear - 8.8" IRS	DRK-311	DRK-311MK ▲	AK36	DRK-311AK36	DRK-311MKAK36 ▲

162 ▲ Add "S" suffix to kit number to receive stackable differential shims in kit.
⁵⁰For use with OEM 10.5" R/P only-use kit DRK-314AMK if using aftermarket 10.25" R/P

Light Duty Differential Applications

Make/Model	Year	Position/ Ring Gear Size	Standard Kit	Master Kit	Axle Kit	Standard Kit Plus	Master Kit Plus
FORD (cont'd)							
Explorer	01-91	Rear - 8.8"	DRK-311	DRK-311MK [▲]	AK10	DRK-311AK10	DRK-311MKAK10 [▲]
Explorer	97-91	Rear - 7.5"	DRK-315	DRK-315MK [▲]	AK10	DRK-315AK10	DRK-315MKAK10 [▲]
Explorer Sport Trac	10-07	Front - Dana 30	DRK-334E	DRK-334EMK [▲]			
Explorer Sport Trac	06-01	Front - Dana 35	DRK-335B	DRK-335BMK [▲]			
Explorer Sport Trac	10-08	Rear - 8.8" IRS	DRK-311L	DRK-311LMK [▲]	AK36	DRK-311LAK36	DRK-311LMKAK36 [▲]
Explorer Sport Trac	2007	Rear - 8.8" IRS	DRK-311K	DRK-311KMK [▲]	AK36	DRK-311KAK36	DRK-311KMKAK36 [▲]
Explorer Sport Trac	05-01	Rear - 8.8"	DRK-311	DRK-311MK [▲]	AK10	DRK-311AK10	DRK-311MKAK10 [▲]
Fairlane	1970	Rear - 9" 31 spline From 05/11/70	DRK-313	DRK-313MK			
Fairlane	70-62	Rear - 8"	DRK-310	DRK-310MK			
Fairlane	70-62	Rear - 9" 28 spline To 5/10/70	DRK-312	DRK-312MK			
Fairmont	83-78	Rear - 7.5"	DRK-315	DRK-315MK [▲]	AK11	DRK-315AK11	DRK-315MKAK11 [▲]
Falcon	70-62	Rear - 8"	DRK-310	DRK-310MK			
Granada	82-81	Rear - 7.5"	DRK-315	DRK-315MK [▲]	AK11	DRK-315AK11	DRK-315MKAK11 [▲]
Granada	80-75	Rear - 8"	DRK-310	DRK-310MK			
Granada	80-75	Rear - 9"	DRK-313	DRK-313MK	AK11	DRK-313AK11	DRK-313MKAK11
LTD	86-83	Rear - 7.5"	DRK-315	DRK-315MK [▲]	AK11	DRK-315AK11	DRK-315MKAK11 [▲]
LTD	82-81	Rear - 8.8"	DRK-311	DRK-311MK [▲]	AK11	DRK-311AK11	DRK-311MKAK11 [▲]
LTD	80-73	Rear - 9" 31 spline From 05/11/70	DRK-313	DRK-313MK	AK11	DRK-313AK11	DRK-313MKAK11
LTD II	79-77	Rear - 9"	DRK-313	DRK-313MK			
LTD Crown Victoria	91-87	Rear - 8.8"	DRK-311	DRK-311MK [▲]	AK11	DRK-311AK11	DRK-311MKAK11 [▲]
Maverick	77-71	Rear - 8"	DRK-310	DRK-310MK			
Mustang	13-05	Rear - 8.8"	DRK-311E	DRK-311EMK [▲]	AK10	DRK-311EAK10	DRK-311EMKAK10 [▲]
Mustang	10-79	Rear - 7.5"	DRK-315	DRK-315MK [▲]	AK11	DRK-315AK11	DRK-315MKAK11 [▲]
Mustang	04-86	Rear - 8.8"	DRK-311	DRK-311MK [▲]	AK11	DRK-311AK11	DRK-311MKAK11 [▲]
Mustang	78-64	Rear - 8"	DRK-310	DRK-310MK			
Mustang	73-70	Rear - 9" 31 spline From 05/11/70	DRK-313	DRK-313MK			
Mustang	70-65	Rear - 9" 28 spline To 5/10/70	DRK-312	DRK-312MK			
Pinto	80-71	Rear - 8"	DRK-310	DRK-310MK			
Ranger	89-83	Front - Dana 28	DRK-333	DRK-333MK			
Ranger	89-83	Rear - 7.5"	DRK-315	DRK-315MK [▲]	AK11	DRK-315AK11	DRK-315MKAK11 [▲]
Ranger 4.0 L	11-98	Front - Dana 35	DRK-335B	DRK-335BMK [▲]			
Ranger 4.0 L	97-90	Front - Dana 35	DRK-335	DRK-335MK [▲]			
Ranger 4.0 L	11-07	Rear - 8.8"	DRK-311G	DRK-311GMK [▲]	AK10	DRK-311GAK10	DRK-311GMKAK10 [▲]
Ranger 4.0 L	06-90	Rear - 8.8"	DRK-311	DRK-311MK [▲]	AK10	DRK-311AK10	DRK-311MKAK10 [▲]
Ranger w/o 4.0 L	11-98	Front - Dana 35	DRK-335B	DRK-335BMK [▲]			
Ranger w/o 4.0 L	97-93	Front - Dana 28	DRK-333	DRK-333MK			
Ranger w/o 4.0 L	11-10	Rear - 7.5"	DRK-315	DRK-315MK [▲]	AK10	DRK-315AK10	DRK-315MKAK10 [▲]
Ranger w/o 4.0 L	09-90	Rear - 7.5"	DRK-315	DRK-315MK [▲]	AK11	DRK-315AK11	DRK-315MKAK11 [▲]
Thunderbird	05-02	Rear - 8.8" IRS	DRK-311N	DRK-311NMK [▲]	AK90	DRK-311NAK90	DRK-311NMKAK90 [▲]
Thunderbird	97-89	Rear - 7.5"	DRK-315	DRK-315MK [▲]			
Thunderbird	97-89	Rear - 8.8"	DRK-311	DRK-311MK [▲]			
Thunderbird	1988	Rear - 8.8"	DRK-311	DRK-311MK [▲]	AK11	DRK-311AK11	DRK-311MKAK11 [▲]
Thunderbird	88-80	Rear - 7.5"	DRK-315	DRK-315MK [▲]	AK11	DRK-315AK11	DRK-315MKAK11 [▲]
Thunderbird	79-70	Rear - 9" 31 spline From 05/11/70	DRK-313	DRK-313MK			
Thunderbird	70-57	Rear - 9" 28 spline To 5/10/70	DRK-312	DRK-312MK			
Torino	76-68	Rear - 9"	DRK-313	DRK-313MK			
Torino	74-71	Rear - 8"	DRK-310	DRK-310MK			
Transit 150	2015	Rear - 9.75"	DRK-316E	DRK-316EMK [▲]			

▲ Add "S" suffix to kit number to receive stackable differential shims in kit.

Light Duty Differential Applications

Make/Model	Year	Position/ Ring Gear Size	Standard Kit	Master Kit	Axle Kit	Standard Kit Plus	Master Kit Plus
FORD (cont'd)							
Transit 250	2015	Rear - 9.75"	DRK-316E	DRK-316EMK [▲]			
Transit 350	2015	Rear - 9.75"	DRK-316E	DRK-316EMK [▲]			
Transit 350 HD	2015	Rear - 9.75"	DRK-316E	DRK-316EMK [▲]			
Truck 1/2 Ton	10-09	Front - 8.8"	DRK-311	DRK-311MK [▲]	AK91	DRK-311AK91	DRK-311MKAK91 [▲]
Truck 1/2 Ton	08-97	Front - 8.8"	DRK-311	DRK-311MK [▲]	AK88	DRK-311AK88	DRK-311MKAK88 [▲]
Truck 1/2 Ton	96-92	Front - Dana 44 w/2.844" Pinion Head Brg.	DRK-339D	DRK-339DMK	AK41	DRK-339DAK41	DRK-339DMKAK41
Truck 1/2 Ton	92-83	Front - Dana 44 w/3.000" Pinion Head Brg.	DRK-339B	DRK-339BMK	AK41	DRK-339BAK41	DRK-339BMKAK41
Truck 1/2 Ton	82-67	Front - Dana 44 w/3.000" Pinion Head Brg.	DRK-339B	DRK-339BMK			
Truck 1/2 Ton	14-12	Rear - 9.75"	DRK-316C	DRK-316CMK [▲]	AK15	DRK-316CAK15	DRK-316CMKAK15 [▲]
Truck 1/2 Ton	14-11	Rear - 8.8"	DRK-311L	DRK-311LMK [▲]	AK15	DRK-311LAK15	DRK-311LMKAK15 [▲]
Truck 1/2 Ton	2011	Rear - 9.75" From 12/20/10	DRK-316C	DRK-316CMK [▲]	AK15	DRK-316CAK15	DRK-316CMKAK15 [▲]
Truck 1/2 Ton	2011	Rear - 9.75" To 12/19/2010	DRK-316B	DRK-316BMK [▲]	AK15	DRK-316BAK15	DRK-316BMKAK15 [▲]
Truck 1/2 Ton	10-09	Rear - 8.8"	DRK-311L	DRK-311LMK [▲]	AK15	DRK-311LAK15	DRK-311LMKAK15 [▲]
Truck 1/2 Ton	10-08	Rear - 10.5"	DRK-317A ⁵⁰	DRK-317AMK ^{50▲}			
Truck 1/2 Ton	10-07	Rear - 9.75"	DRK-316B	DRK-316BMK [▲]	AK15	DRK-316BAK15	DRK-316BMKAK15 [▲]
Truck 1/2 Ton	08-07	Rear - 8.8"	DRK-311G	DRK-311GMK [▲]	AK15	DRK-311GAK15	DRK-311GMKAK15 [▲]
Truck 1/2 Ton	07-04	Rear - 10.5"	DRK-317 ⁵⁰	DRK-317MK ^{50▲}			
Truck 1/2 Ton	06-04	Rear - 8.8"	DRK-311	DRK-311MK [▲]	AK15	DRK-311AK15	DRK-311MKAK15 [▲]
Truck 1/2 Ton	06-00	Rear - 9.75"	DRK-316A	DRK-316AMK [▲]	AK15	DRK-316AAK15	DRK-316AMKAK15 [▲]
Truck 1/2 Ton	03-00	Rear - 10.25"	DRK-314	DRK-314MK [▲]			
Truck 1/2 Ton	03-00	Rear - 8.8"	DRK-311	DRK-311MK [▲]	AK10	DRK-311AK10	DRK-311MKAK10 [▲]
Truck 1/2 Ton	1999	Rear - 9.75" w/ 2.688" OD Pinion Tail Cup	DRK-316	DRK-316MK [▲]	AK15	DRK-316AK15	DRK-316MKAK15 [▲]
Truck 1/2 Ton	1999	Rear - 9.75" w/ 3.000" OD Pinion Tail Cup	DRK-316A	DRK-316AMK [▲]	AK15	DRK-316AAK15	DRK-316AMKAK15 [▲]
Truck 1/2 Ton	99-97	Rear - 8.8"	DRK-311	DRK-311MK [▲]	AK10	DRK-311AK10	DRK-311MKAK10 [▲]
Truck 1/2 Ton	98-97	Rear - 9.75"	DRK-316	DRK-316MK [▲]	AK15	DRK-316AK15	DRK-316MKAK15 [▲]
Truck 1/2 Ton	96-83	Rear - 8.8"	DRK-311	DRK-311MK [▲]	AK10	DRK-311AK10	DRK-311MKAK10 [▲]
Truck 1/2 Ton	86-71	Rear - 9" 31 spline	DRK-313	DRK-313MK			
Truck 1/2 Ton	79-70	Rear - Dana 44	DRK-339B	DRK-339BMK			
Truck 1/2 Ton	1970	Rear - 9" 28 spline To 5/10/70	DRK-312	DRK-312MK			
Truck 1/2 Ton	1970	Rear - 9" 31 spline From 05/11/70	DRK-313	DRK-313MK			
Truck 1/2 Ton	69-67	Rear - Dana 44	DRK-339B	DRK-339BMK			
Truck 1/2 Ton	69-57	Rear - 9" 28 spline	DRK-312	DRK-312MK			
Truck 3/4 Ton	14-99	Front - Dana 60	DRK-331A	DRK-331AMK			
Truck 3/4 Ton	02-99	Front - Dana 50	DRK-336A	DRK-336AMK			
Truck 3/4 Ton	98-80	Front - Dana 50	DRK-336A	DRK-336AMK	AK41	DRK-336AAK41	DRK-336AMKAK41
Truck 3/4 Ton	88-67	Front - Dana 44	DRK-339B	DRK-339BMK			
Truck 3/4 Ton	79-73	Front - Dana 60	DRK-331	DRK-331MK			
Truck 3/4 Ton	14-11	Rear - 10.5"	DRK-317B	DRK-317BMK [▲]			
Truck 3/4 Ton	10-08	Rear - 10.5"	DRK-317A ⁵⁰	DRK-317AMK ^{50▲}			

LD Differential

164 [▲] Add "S" suffix to kit number to receive stackable differential shims in kit.
⁵⁰For use with OEM 10.5" R/P only-use kit DRK-314AMK if using aftermarket 10.25"R/P

Light Duty Differential Applications

Make/Model	Year	Position/ Ring Gear Size	Standard Kit	Master Kit	Axle Kit	Standard Kit Plus	Master Kit Plus
FORD (cont'd)							
Truck 3/4 Ton	08-98	Rear - Dana 60/61	DRK-331B	DRK-331BMK			
Truck 3/4 Ton	07-99	Rear - 10.5"	DRK-317 ⁵⁰	DRK-317MK ⁵⁰ ▲			
Truck 3/4 Ton	99-85	Rear - 10.25"	DRK-314	DRK-314MK ▲	AK22	DRK-314AK22	DRK-314MKAK22 ▲
Truck 3/4 Ton	97-54	Rear - Dana 60/61	DRK-331	DRK-331MK			
Truck 3/4 Ton	89-83	Rear - 8.8"	DRK-311	DRK-311MK ▲	AK10	DRK-311AK10	DRK-311MKAK10 ▲
Truck 3/4 Ton	85-83	Rear - Dana 70U	DRK-332U	DRK-332UMK	AK23	DRK-332UAK23	DRK-332UMKAK23
Truck 3/4 Ton	85-80	Rear - Dana 60/61	DRK-331	DRK-331MK	AK22	DRK-331AK22	DRK-331MKAK22
Truck 3/4 Ton	74-70	Rear - 9" 31 spline From 05/11/70	DRK-313	DRK-313MK			
Truck 3/4 Ton	70-69	Rear - 9" 28 spline To 5/10/70	DRK-312	DRK-312MK			
Truck 1 Ton	14-99	Front - Dana 60	DRK-331A	DRK-331AMK			
Truck 1 Ton	02-86	Front - Dana 50	DRK-336A	DRK-336AMK			
Truck 1 Ton	97-92	Front - Dana 60	DRK-331	DRK-331MK			
Truck 1 Ton	91-79	Front - Dana 60	DRK-331	DRK-331MK	AK42	DRK-331AK42	DRK-331MKAK42
Truck 1 Ton	85-81	Front - Dana 44	DRK-339B	DRK-339BMK			
Truck 1 Ton	85-80	Front - Dana 50	DRK-336A	DRK-336AMK	AK41	DRK-336AAK41	DRK-336AMKAK41
Truck 1 Ton	14-11	Rear - 10.5"	DRK-317B	DRK-317BMK ▲			
Truck 1 Ton	10-08	Rear - 10.5"	DRK-317A ⁵⁰	DRK-317AMK ⁵⁰ ▲			
Truck 1 Ton	10-98	Rear - Dana 80	DRK-337A	DRK-337AMK			
Truck 1 Ton	08-98	Rear - Dana 60/61	DRK-331B	DRK-331BMK			
Truck 1 Ton	08-98	Rear - Dana 70U	DRK-332A	DRK-332AMK	AK23	DRK-332AAK23	DRK-332AMKAK23
Truck 1 Ton	08-72	Rear - Dana 70HD	DRK-332HD	DRK-332HDMK	AK23	DRK-332HDAK23	DRK-332HDMKAK23
Truck 1 Ton	07-99	Rear - 10.5"	DRK-317 ⁵⁰	DRK-317MK ⁵⁰ ▲			
Truck 1 Ton	99-85	Rear - 10.25"	DRK-314	DRK-314MK ▲	AK22	DRK-314AK22	DRK-314MKAK22 ▲
Truck 1 Ton	98-88	Rear - Dana 80	DRK-337	DRK-337MK			
Truck 1 Ton	98-54	Rear - Dana 60/61	DRK-331	DRK-331MK			
Truck 1 Ton	97-82	Rear - Dana 70U	DRK-332U	DRK-332UMK	AK23	DRK-332UAK23	DRK-332UMKAK23
Truck 1 Ton	85-80	Rear - Dana 60/61	DRK-331	DRK-331MK	AK22	DRK-331AK22	DRK-331MKAK22
Truck 1 Ton	83-61	Rear - Dana 70	DRK-332	DRK-332MK			
Van 1/2 Ton	13-01	Rear - Dana 60/61	DRK-331	DRK-331MK	AK22	DRK-331AK22	DRK-331MKAK22
Van 1/2 Ton	08-87	Rear - 8.8"	DRK-311	DRK-311MK ▲	AK10	DRK-311AK10	DRK-311MKAK10 ▲
Van 1/2 Ton	06-00	Rear - 9.75"	DRK-316A	DRK-316AMK ▲	AK10	DRK-316AAK10	DRK-316AMKAK10 ▲
Van 1/2 Ton	1999	Rear - 9.75" w/ 2.688" OD Pinion Tail Cup	DRK-316	DRK-316MK ▲	AK10	DRK-316AK10	DRK-316MKAK10 ▲
Van 1/2 Ton	1999	Rear - 9.75" w/ 3.000" OD Pinion Tail Cup	DRK-316A	DRK-316AMK ▲	AK10	DRK-316AAK10	DRK-316AMKAK10 ▲
Van 1/2 Ton	98-97	Rear - 9.75"	DRK-316	DRK-316MK ▲	AK10	DRK-316AK10	DRK-316MKAK10 ▲
Van 3/4 Ton	13-75	Rear - Dana 60/61	DRK-331	DRK-331MK	AK22	DRK-331AK22	DRK-331MKAK22
Van 1 Ton	13-81	Rear - Dana 60/61	DRK-331	DRK-331MK	AK22	DRK-331AK22	DRK-331MKAK22
Van 1 Ton	10-98	Rear - Dana 70U	DRK-332A	DRK-332AMK	AK23	DRK-332AAK23	DRK-332AMKAK23
Van 1 Ton	08-79	Rear - Dana 70HD	DRK-332HD	DRK-332HDMK	AK23	DRK-332HDAK23	DRK-332HDMKAK23
Van 1 Ton	01-98	Rear - Dana 80 w/4.375" Pinion Bearing	DRK-337A	DRK-337AMK			
Van 1 Ton	98-96	Rear - Dana 80 w/4.125" Pinion Bearing	DRK-337	DRK-337MK			
Van 1 Ton	97-82	Rear - Dana 70U	DRK-332U	DRK-332UMK	AK23	DRK-332UAK23	DRK-332UMKAK23
Van 1 Ton	83-79	Rear - Dana 70	DRK-332	DRK-332MK	AK23	DRK-332AK23	DRK-332MKAK23
E 450 Super Duty	10-01	Rear - Dana 70HD	DRK-332HD	DRK-332HDMK	AK23	DRK-332HDAK23	DRK-332HDMKAK23

LD Differential

▲ Add "S" suffix to kit number to receive stackable differential shims in kit.

⁵⁰For use with OEM 10.5" R/P only-use kit DRK-314AMK if using aftermarket 10.25"R/P

Light Duty Differential Applications

Make/Model	Year	Position/ Ring Gear Size	Standard Kit	Master Kit	Axle Kit	Standard Kit Plus	Master Kit Plus
GMC							
Caballero	87-82	Rear - 7.5"	DRK-320	DRK-320MK [▲]	AK11	DRK-320AK11	DRK-320MKAK11 [▲]
Caballero	87-78	Rear - 8.5"	DRK-321R	DRK-321RMK [▲]	AK10	DRK-321RAK10	DRK-321RMKAK10 [▲]
Caballero	81-78	Rear - 7.5"	DRK-320B	DRK-320BMK [▲]	AK11	DRK-320BAK11	DRK-320BMKAK11 [▲]
Canyon	12-04	Front - 7.6" IFS	DRK-320L	DRK-320LMK [▲]	AK85	DRK-320LAK85	DRK-320LMKAK85 [▲]
Canyon	12-09	Rear - 8.5"	DRK-321Q	DRK-321QMK [▲]	AK12	DRK-321QAK12	DRK-321QMKAK12 [▲]
Canyon	12-04	Rear - 8.0"	DRK-320D	DRK-320DMK [▲]	AK12	DRK-320DAK12	DRK-320DMKAK12 [▲]
Envoy	09-02	Front - 7.25"	DRK-320K	DRK-320KMK			
Envoy	2009	Rear - 8.5"	DRK-321Q	DRK-321QMK [▲]	AK12	DRK-321QAK12	DRK-321QMKAK12 [▲]
Envoy	09-02	Rear - 8"	DRK-320D	DRK-320DMK [▲]	AK12	DRK-320DAK12	DRK-320DMKAK12 [▲]
Envoy	08-02	Rear - 8.5"	DRK-321C	DRK-321CMK [▲]	AK12	DRK-321CAK12	DRK-321CMKAK12 [▲]
Jimmy Full Size	91-80	Front - 8.5"	DRK-321R	DRK-321RMK [▲]			
Jimmy Full Size	79-70	Front - Dana 44	DRK-339B	DRK-339BMK			
Jimmy Full Size	91-82	Rear - 8.5"	DRK-321R	DRK-321RMK [▲]	AK10	DRK-321RAK10	DRK-321RMKAK10 [▲]
Jimmy Full Size	81-70	Rear - 8.875"	DRK-322	DRK-322MK [▲]	AK10	DRK-322AK10	DRK-322MKAK10 [▲]
Jimmy S15 Size	05-97	Front - 7.25"	DRK-320A	DRK-320AMK	AK86	DRK-320AAK86	DRK-320AMKAK86
Jimmy S15 Size	96-83	Front - 7.25"	DRK-320A	DRK-320AMK	AK86	DRK-320AAK86	DRK-320AMKAK86
Jimmy S15 Size	05-99	Rear - 7.5"	DRK-320C	DRK-320CMK [▲]	AK11	DRK-320CAK11	DRK-320CMKAK11 [▲]
Jimmy S15 Size	05-99	Rear - 8.5"	DRK-321C	DRK-321CMK [▲]	AK10	DRK-321CAK10	DRK-321CMKAK10 [▲]
Jimmy S15 Size	98-95	Rear - 8.5"	DRK-321R	DRK-321RMK [▲]	AK10	DRK-321RAK10	DRK-321RMKAK10 [▲]
Jimmy S15 Size	98-83	Rear - 7.5"	DRK-320	DRK-320MK [▲]	AK11	DRK-320AK11	DRK-320MKAK11 [▲]
S15	90-83	Front - 7.25"	DRK-320A	DRK-320AMK	AK86	DRK-320AAK86	DRK-320AMKAK86
S15	90-82	Rear - 7.5"	DRK-320	DRK-320MK [▲]	AK11	DRK-320AK11	DRK-320MKAK11 [▲]
Safari	05-90	Front - 7.25"	DRK-320A	DRK-320AMK			
Safari	05-03	Rear - 7.5"	DRK-320C	DRK-320CMK [▲]	AK12	DRK-320CAK12	DRK-320CMKAK12 [▲]
Safari	02-99	Rear - 7.5"	DRK-320C	DRK-320CMK [▲]	AK14	DRK-320CAK14	DRK-320CMKAK14 [▲]
Safari	98-85	Rear - 7.5"	DRK-320	DRK-320MK [▲]	AK14	DRK-320AK14	DRK-320MKAK14 [▲]
Sonoma	04-97	Front - 7.25"	DRK-320A	DRK-320AMK	AK86	DRK-320AAK86	DRK-320AMKAK86
Sonoma	96-91	Front - 7.25"	DRK-320A	DRK-320AMK	AK86	DRK-320AAK86	DRK-320AMKAK86
Sonoma	04-99	Rear - 7.5"	DRK-320C	DRK-320CMK [▲]	AK11	DRK-320CAK11	DRK-320CMKAK11 [▲]
Sonoma	04-99	Rear - 8.5"	DRK-321C	DRK-321CMK [▲]	AK10	DRK-321CAK10	DRK-321CMKAK10 [▲]
Sonoma	98-94	Rear - 8.5"	DRK-321R	DRK-321RMK [▲]	AK10	DRK-321RAK10	DRK-321RMKAK10 [▲]
Sonoma	98-91	Rear - 7.5"	DRK-320	DRK-320MK [▲]	AK11	DRK-320AK11	DRK-320MKAK11 [▲]
Syclone	1991	Front - 7.25"	DRK-320A	DRK-320AMK	AK86	DRK-320AAK86	DRK-320AMKAK86
Syclone	1991	Rear - 7.5"	DRK-320	DRK-320MK [▲]	AK11	DRK-320AK11	DRK-320MKAK11 [▲]
Truck 1/2 Ton	14-98	Front - 8.25"	DRK-321T	DRK-321TMK	AK83	DRK-321TAK83	DRK-321TMKAK83
Truck 1/2 Ton	97-88	Front - 8.25"	DRK-321A	DRK-321AMK			
Truck 1/2 Ton	87-77	Front - 8.5"	DRK-321	DRK-321MK [▲]			
Truck 1/2 Ton	80-69	Front - Dana 44	DRK-339B	DRK-339BMK			
Truck 1/2 Ton	2014	Rear - 9.5"	DRK-324E	DRK-324EMK	AK12	DRK-324EAK12	DRK-324EMKAK12
Truck 1/2 Ton	2014	Rear - 9.75"	DRK-324H	DRK-324HMK	AK12	DRK-324HAK12	DRK-324HMKAK12
Truck 1/2 Ton	13-09	Rear - 8.5"	DRK-321Q	DRK-321QMK [▲]	AK12	DRK-321QAK12	DRK-321QMKAK12 [▲]
Truck 1/2 Ton	13-98	Rear - 9.5"	DRK-324B	DRK-324BMK			
Truck 1/2 Ton	08-99	Rear - 8.5"	DRK-321C	DRK-321CMK [▲]	AK12	DRK-321CAK12	DRK-321CMKAK12 [▲]
Truck 1/2 Ton	05-02	Rear - Dana 60 Quadrasteer	DRK-331C	DRK-331CMK			
Truck 1/2 Ton	99-88	Rear - 8.5"	DRK-321R	DRK-321RMK [▲]	AK12	DRK-321RAK12	DRK-321RMKAK12 [▲]
Truck 1/2 Ton	99-70	Rear - 8.5" w/ Limited Slip Differential	DRK-321D	DRK-321DMK [▲]			
Truck 1/2 Ton	97-88	Rear - 9.5"	DRK-324	DRK-324MK	AK16	DRK-324AK16	DRK-324MKAK16
Truck 1/2 Ton	87-80	Rear - 8.5"	DRK-321R	DRK-321RMK [▲]	AK10	DRK-321RAK10	DRK-321RMKAK10 [▲]
Truck 1/2 Ton	82-80	Rear - 8.875"	DRK-322	DRK-322MK [▲]			
Truck 1/2 Ton	81-80	Rear - 8.75"	DRK-323	DRK-323MK [▲]			
Truck 1/2 Ton	79-71	Rear - 8.5"	DRK-321R	DRK-321RMK [▲]	AK10	DRK-321RAK10	DRK-321RMKAK10 [▲]
Truck 1/2 Ton	79-64	Rear - 8.875"	DRK-322	DRK-322MK [▲]			
Truck 1/2 Ton	72-65	Rear - Dana 44	DRK-339B	DRK-339BMK			

LD Differential

Light Duty Differential Applications

Make/Model	Year	Position/ Ring Gear Size	Standard Kit	Master Kit	Axle Kit	Standard Kit Plus	Master Kit Plus
GMC (cont'd)							
Truck 3/4 Ton	14-11	Front - 9.25"	DRK-324D	DRK-324DMK	AK92	DRK-324DAK92	DRK-324DMKAK92
Truck 3/4 Ton	08-98	Front - 9.25"	DRK-324C	DRK-324CMK	AK92	DRK-324CAK92	DRK-324CMKAK92
Truck 3/4 Ton	97-88	Front - 9.25"	DRK-324A	DRK-324AMK			
Truck 3/4 Ton	91-77	Front - 8.5"	DRK-321	DRK-321MK ▲			
Truck 3/4 Ton	80-68	Front - Dana 44	DRK-339B	DRK-339BMK			
Truck 3/4 Ton	2014	Rear - 9.5"	DRK-324E	DRK-324EMK	AK12	DRK-324EAK12	DRK-324EMKAK12
Truck 3/4 Ton	14-11	Rear - 11.5" 2nd Design w/4.375" Pinion Brg.	DRK-327A	DRK-327AMK	AK44	DRK-327AAK44	DRK-327AMKAK44
Truck 3/4 Ton	13-11	Rear - 9.5"	DRK-324B	DRK-324BMK			
Truck 3/4 Ton	13-00	Rear - 10.5"	DRK-325B	DRK-325BMK	AK29	DRK-325BAK29	DRK-325BMKAK29
Truck 3/4 Ton	11-01	Rear - 11.5" 1st Design w/4.125" Pinion Brg.	DRK-327	DRK-327MK	AK29	DRK-327AK29	DRK-327MKAK29
Truck 3/4 Ton	10-98	Rear - 9.5"	DRK-324B	DRK-324BMK			
Truck 3/4 Ton	05-02	Rear - Dana 60 Quadrasteer	DRK-331C	DRK-331CMK			
Truck 3/4 Ton	99-98	Rear - 10.5"	DRK-325B	DRK-325BMK			
Truck 3/4 Ton	97-89	Rear - 10.5"	DRK-325A	DRK-325AMK			
Truck 3/4 Ton	97-81	Rear - 9.5"	DRK-324	DRK-324MK	AK16	DRK-324AK16	DRK-324MKAK16
Truck 3/4 Ton	1988	Rear - 10.5" 1st Design	DRK-325	DRK-325MK	AK21	DRK-325AK21	DRK-325MKAK21
Truck 3/4 Ton	1988	Rear - 10.5" 2nd Design	DRK-325A	DRK-325AMK			
Truck 3/4 Ton	87-73	Rear - 10.5"	DRK-325	DRK-325MK	AK21	DRK-325AK21	DRK-325MKAK21
Truck 3/4 Ton	81-80	Rear - 8.5"	DRK-323	DRK-323MK ▲	AK17	DRK-323AK17	DRK-323MKAK17 ▲
Truck 3/4 Ton	81-69	Rear - 8.875"	DRK-322	DRK-322MK ▲			
Truck 3/4 Ton	72-67	Rear - Dana 60	DRK-331	DRK-331MK			
Truck 1 Ton	14-11	Front - 9.25"	DRK-324D	DRK-324DMK	AK92	DRK-324DAK92	DRK-324DMKAK92
Truck 1 Ton	08-98	Front - 9.25"	DRK-324C	DRK-324CMK	AK92	DRK-324CAK92	DRK-324CMKAK92
Truck 1 Ton	97-88	Front - 9.25"	DRK-324A	DRK-324AMK			
Truck 1 Ton	91-77	Front - Dana 60	DRK-331	DRK-331MK	AK42	DRK-331AK42	DRK-331MKAK42
Truck 1 Ton	14-11	Rear - 11.5" 2nd Design w/4.375" Pinion Brg.	DRK-327A	DRK-327AMK	AK44	DRK-327AAK44	DRK-327AMKAK44
Truck 1 Ton	11-01	Rear - 11.5" 1st Design w/4.125" Pinion Brg.	DRK-327	DRK-327MK	AK29	DRK-327AK29	DRK-327MKAK29
Truck 1 Ton	00-98	Rear - 10.5"	DRK-325B	DRK-325BMK			
Truck 1 Ton	99-91	Rear - Dana 80	DRK-337	DRK-337MK			
Truck 1 Ton	97-89	Rear - 10.5"	DRK-325A	DRK-325AMK			
Truck 1 Ton	95-83	Rear - 9.5"	DRK-324	DRK-324MK	AK16	DRK-324AK16	DRK-324MKAK16
Truck 1 Ton	94-73	Rear - Dana 70HD	DRK-332HD	DRK-332HDMK			
Truck 1 Ton	91-84	Rear - Dana 70U	DRK-332U	DRK-332UMK			
Truck 1 Ton	91-73	Rear - Dana 60	DRK-331	DRK-331MK			
Truck 1 Ton	90-73	Rear - Dana 70	DRK-332	DRK-332MK			
Truck 1 Ton	1988	Rear - 10.5" 1st Design	DRK-325	DRK-325MK	AK21	DRK-325AK21	DRK-325MKAK21
Truck 1 Ton	1988	Rear - 10.5" 2nd Design	DRK-325A	DRK-325AMK			
Truck 1 Ton	87-72	Rear - 10.5"	DRK-325	DRK-325MK	AK21	DRK-325AK21	DRK-325MKAK21
Typhoon	93-92	Front - 7.25"	DRK-320A	DRK-320AMK	AK86	DRK-320AAK86	DRK-320AMKAK86
Typhoon	93-92	Front - 7.5"	DRK-320	DRK-320MK ▲	AK11	DRK-320AK11	DRK-320MKAK11 ▲
Van 1/2 Ton	13-03	Front - 7.25"	DRK-320A	DRK-320AMK			
Van 1/2 Ton	13-09	Rear - 8.5"	DRK-321Q	DRK-321QMK ▲	AK12	DRK-321QAK12	DRK-321QMKAK12 ▲
Van 1/2 Ton	08-99	Rear - 8.5"	DRK-321C	DRK-321CMK ▲	AK12	DRK-321CAK12	DRK-321CMKAK12 ▲

▲ Add "S" suffix to kit number to receive stackable differential shims in kit.

Light Duty Differential Applications

Make/Model	Year	Position/ Ring Gear Size	Standard Kit	Master Kit	Axle Kit	Standard Kit Plus	Master Kit Plus
GMC (cont'd)							
Van 1/2 Ton	08-98	Rear - 9.5"	DRK-324B	DRK-324BMK			
Van 1/2 Ton	98-96	Rear - 8.5"	DRK-321R	DRK-321RMK ▲	AK12	DRK-321RAK12	DRK-321RMKAK12 ▲
Van 1/2 Ton	97-81	Rear - 9.5"	DRK-324	DRK-324MK	AK16	DRK-324AK16	DRK-324MKAK16
Van 1/2 Ton	95-77	Rear - 8.5"	DRK-321R	DRK-321RMK ▲	AK10	DRK-321RAK10	DRK-321RMKAK10 ▲
Van 1/2 Ton	81-64	Rear - 8.875"	DRK-322	DRK-322MK ▲			
Van 3/4 Ton	14-11	Rear - 11.5"	DRK-327A	DRK-327AMK			
Van 3/4 Ton	13-98	Rear - 10.5"	DRK-325B	DRK-325BMK	AK29	DRK-325BAK29	DRK-325BMKAK29
Van 3/4 Ton	13-98	Rear - 9.5"	DRK-324B	DRK-324BMK	AK16	DRK-324BAK16	DRK-324BMKAK16
Van 3/4 Ton	10-01	Rear - 11.5"	DRK-327	DRK-327MK	AK29	DRK-327AK29	DRK-327MKAK29
Van 3/4 Ton	08-04	Rear - Dana 60/61	DRK-331B	DRK-331BMK			
Van 3/4 Ton	97-89	Rear - 10.5"	DRK-325A	DRK-325AMK			
Van 3/4 Ton	97-80	Rear - 9.5"	DRK-324	DRK-324MK	AK16	DRK-324AK16	DRK-324MKAK16
Van 3/4 Ton	1988	Rear - 10.5" 1st Design	DRK-325	DRK-325MK	AK21	DRK-325AK21	DRK-325MKAK21
Van 3/4 Ton	1988	Rear - 10.5" 2nd Design	DRK-325A	DRK-325AMK			
Van 3/4 Ton	87-73	Rear - 10.5"	DRK-325	DRK-325MK	AK21	DRK-325AK21	DRK-325MKAK21
Van 3/4 Ton	81-69	Rear - 8.875"	DRK-322	DRK-322MK ▲			
Van 1 Ton	14-11	Rear - 11.5"	DRK-327A	DRK-327AMK			
Van 1 Ton	13-98	Rear - 10.5"	DRK-325B	DRK-325BMK	AK29	DRK-325BAK29	DRK-325BMKAK29
Van 1 Ton	10-01	Rear - 11.5"	DRK-327	DRK-327MK	AK29	DRK-327AK29	DRK-327MKAK29
Van 1 Ton	08-04	Rear - Dana 60/61	DRK-331B	DRK-331BMK			
Van 1 Ton	97-89	Rear - 10.5"	DRK-325A	DRK-325AMK			
Van 1 Ton	91-80	Rear - Dana 60	DRK-331	DRK-331MK			
Van 1 Ton	1988	Rear - 10.5" 1st Design	DRK-325	DRK-325MK	AK21	DRK-325AK21	DRK-325MKAK21
Van 1 Ton	1988	Rear - 10.5" 2nd Design	DRK-325A	DRK-325AMK			
Van 1 Ton	87-73	Rear - 10.5"	DRK-325	DRK-325MK	AK21	DRK-325AK21	DRK-325MKAK21
Yukon	14-98	Front - 8.25"	DRK-321T	DRK-321TMK	AK83	DRK-321TAK83	DRK-321TMKAK83
Yukon	97-92	Front - 8.25"	DRK-321A	DRK-321AMK			
Yukon	14-09	Rear - 8.5"	DRK-321Q	DRK-321QMK ▲	AK12	DRK-321QAK12	DRK-321QMKAK12 ▲
Yukon	08-01	Rear - 8.5"	DRK-321C	DRK-321CMK ▲	AK12	DRK-321CAK12	DRK-321CMKAK12 ▲
Yukon	00-92	Rear - 8.5"	DRK-321R	DRK-321RMK ▲	AK12	DRK-321RAK12	DRK-321RMKAK12 ▲
Yukon XL 1500	14-00	Front - 8.25"	DRK-321T	DRK-321TMK	AK83	DRK-321TAK83	DRK-321TMKAK83
Yukon XL 1500	14-09	Rear - 8.5"	DRK-321Q	DRK-321QMK ▲	AK12	DRK-321QAK12	DRK-321QMKAK12 ▲
Yukon XL 1500	08-01	Rear - 8.5"	DRK-321C	DRK-321CMK ▲	AK12	DRK-321CAK12	DRK-321CMKAK12 ▲
Yukon XL 1500	08-00	Rear - 9.5"	DRK-324B	DRK-324BMK			
Yukon XL 1500	2000	Rear - 8.5"	DRK-321R	DRK-321RMK ▲	AK12	DRK-321RAK12	DRK-321RMKAK12 ▲
Yukon XL 2500	13-11	Front - 9.25"	DRK-324D	DRK-324DMK	AK92	DRK-324DAK92	DRK-324DMKAK92
Yukon XL 2500	10-00	Front - 9.25"	DRK-324C	DRK-324CMK	AK92	DRK-324CAK92	DRK-324CMKAK92
Yukon XL 2500	13-08	Rear - 10.5"	DRK-325B	DRK-325BMK	AK29	DRK-325BAK29	DRK-325BMKAK29
Yukon XL 2500	13-00	Rear - 9.5"	DRK-324B	DRK-324BMK			
Yukon XL 2500	05-02	Rear - Dana 60 Quadrasteer	DRK-331C	DRK-331CMK			

HUMMER

H1	06-02	Front - AMC 20	DRK-311H	DRK-311HMK	AK27	DRK-311HAK27	DRK-311HMKAK27
H1	06-02	Rear - AMC 20	DRK-311H	DRK-311HMK	AK27	DRK-311HAK27	DRK-311HMKAK27
H2	09-03	Front - 9.25"	DRK-324C	DRK-324CMK	AK92	DRK-324CAK92	DRK-324CMKAK92
H2	09-03	Rear - 9.5"	DRK-324B	DRK-324BMK	AK16	DRK-324BAK16	DRK-324BMKAK16
H3	10-06	Front - 7.6" IFS	DRK-320L	DRK-320LMK ▲	AK85	DRK-320LAK85	DRK-320LMKAK85 ▲
H3	10-09	Rear - 8.5"	DRK-321Q	DRK-321QMK ▲	AK12	DRK-321QAK12	DRK-321QMKAK12 ▲
H3	10-06	Rear - 8.0"	DRK-320D	DRK-320DMK ▲	AK12	DRK-320DAK12	DRK-320DMKAK12 ▲
H3T	10-09	Front - 7.6" IFS	DRK-320L	DRK-320LMK ▲	AK85	DRK-320LAK85	DRK-320LMKAK85 ▲

Light Duty Differential Applications

Make/Model	Year	Position/ Ring Gear Size	Standard Kit	Master Kit	Axle Kit	Standard Kit Plus	Master Kit Plus
HUMMER (cont'd)							
H3T	10-09	Rear - 8.0"	DRK-320D	DRK-320DMK [▲]	AK12	DRK-320DAK12	DRK-320DMKAK12 [▲]
H3T	10-09	Rear - 8.5"	DRK-321Q	DRK-321QMK [▲]	AK12	DRK-321QAK12	DRK-321QMKAK12 [▲]
INFINITI							
QX56	10-04	Front - Dana 205	DRK-339T	DRK-339TMK			
QX56	10-04	Rear - Dana 44	DRK-339N	DRK-339NMK			
ISUZU							
Ascender	08-03	Rear - 8.5"	DRK-321C	DRK-321CMK [▲]	AK12	DRK-321CAK12	DRK-321CMKAK12 [▲]
Ascender	08-03	Rear - 8"	DRK-320D	DRK-320DMK [▲]	AK12	DRK-320DAK12	DRK-320DMKAK12 [▲]
Ascender	08-03	Front - 7.25"	DRK-320K	DRK-320KMK	AK87	DRK-320KAK87	DRK-320KMKAK87
Hombre	98-96	Rear - 8.5"	DRK-321R	DRK-321RMK [▲]	AK10	DRK-321RAK10	DRK-321RMKAK10 [▲]
Hombre	98-96	Rear - 7.5"	DRK-320	DRK-320MK [▲]	AK11	DRK-320AK11	DRK-320MKAK11 [▲]
Hombre	00-99	Rear - 8.5"	DRK-321C	DRK-321CMK [▲]	AK10	DRK-321CAK10	DRK-321CMKAK10 [▲]
Hombre	00-99	Rear - 7.5"	DRK-320C	DRK-320CMK [▲]	AK11	DRK-320CAK11	DRK-320CMKAK11 [▲]
Hombre	00-96	Front - 7.25"	DRK-320A	DRK-320AMK	AK86	DRK-320AAK86	DRK-320AMKAK86
i-280	2006	Rear - 8.0"	DRK-320D	DRK-320DMK [▲]	AK12	DRK-320DAK12	DRK-320DMKAK12 [▲]
i-350	2006	Rear - 8.0"	DRK-320D	DRK-320DMK [▲]	AK12	DRK-320DAK12	DRK-320DMKAK12 [▲]
i-350	2006	Front - 7.6" IFS	DRK-320L	DRK-320LMK [▲]	AK85	DRK-320LAK85	DRK-320LMKAK85 [▲]
i-290	08-07	Rear - 8.0"	DRK-320D	DRK-320DMK [▲]	AK12	DRK-320DAK12	DRK-320DMKAK12 [▲]
i-370	08-07	Rear - 8.0"	DRK-320D	DRK-320DMK [▲]	AK12	DRK-320DAK12	DRK-320DMKAK12 [▲]
i-370	08-07	Front - 7.6" IFS	DRK-320L	DRK-320LMK [▲]	AK85	DRK-320LAK85	DRK-320LMKAK85 [▲]
JEEP							
Cherokee SJ	83-74	Front - Dana 44	DRK-339B	DRK-339BMK			
Cherokee SJ	83-80	Rear - AMC 20	DRK-311J	DRK-311JMK [▲]			
Cherokee SJ	79-74	Rear - Dana 44	DRK-339B	DRK-339BMK			
Cherokee XJ	01-00	Front - Dana 30 Low Pinion	DRK-334TJ	DRK-334TJMK			
Cherokee XJ	2000	Front - Dana 30 High Pinion	DRK-334	DRK-334MK			
Cherokee XJ	99-90	Front - Dana 30	DRK-334	DRK-334MK			
Cherokee XJ	89-84	Front - Dana 30	DRK-334	DRK-334MK	AK40	DRK-334AK40	DRK-334MKAK40
Cherokee XJ	85-84	Front - Dana 44	DRK-339B	DRK-339BMK			
Cherokee XJ	01-97	Rear - 8.25"	DRK-303A	DRK-303AMK			
Cherokee XJ	01-90	Rear - Dana 35	DRK-335	DRK-335MK [▲]	AK11	DRK-335AK11	DRK-335MKAK11 [▲]
Cherokee XJ	96-91	Rear - 8.25"	DRK-303	DRK-303MK			
Cherokee XJ	89-88	Rear - Dana 35	DRK-335	DRK-335MK [▲]			
Cherokee XJ	1987	Rear - Dana 35	DRK-335	DRK-335MK [▲]			
Cherokee XJ	1987	Rear - Dana 44	DRK-339B	DRK-339BMK			
Cherokee XJ	86-84	Rear - Dana 35	DRK-335	DRK-335MK [▲]			
CJ5	83-71	Front - Dana 30	DRK-334	DRK-334MK			
CJ5	83-76	Rear - AMC 20	DRK-311J	DRK-311JMK [▲]			
CJ5	75-67	Rear - Dana 44	DRK-339B	DRK-339BMK			
CJ7	86-76	Front - Dana 30	DRK-334	DRK-334MK			
CJ7	1986	Rear - Dana 44	DRK-339B	DRK-339BMK			
CJ7	86-76	Rear - AMC 20	DRK-311J	DRK-311JMK [▲]			
Comanche	92-90	Front - Dana 30	DRK-334	DRK-334MK			
Comanche	89-86	Front - Dana 30	DRK-334	DRK-334MK	AK40	DRK-334AK40	DRK-334MKAK40
Comanche	92-90	Rear - Dana 35	DRK-335	DRK-335MK [▲]	AK11	DRK-335AK11	DRK-335MKAK11 [▲]
Comanche	92-90	Rear - Dana 44	DRK-339B	DRK-339BMK			
Comanche	89-86	Rear - Dana 35	DRK-335	DRK-335MK [▲]			
Comanche	89-86	Rear - Dana 44	DRK-339B	DRK-339BMK			

▲ Add "S" suffix to kit number to receive stackable differential shims in kit.

Light Duty Differential Applications

Make/Model	Year	Position/ Ring Gear Size	Standard Kit	Master Kit	Axle Kit	Standard Kit Plus	Master Kit Plus
JEEP (cont'd)							
Commander	10-06	Front - C200 IFS	DRK-308				
Commander	10-06	Rear - 8.25"	DRK-303B	DRK-303BMK			
Commander	10-06	Rear - Dana 44	DRK-339J	DRK-339JMK			
Grand Cherokee	10-05	Front - C200 IFS	DRK-308				
Grand Cherokee	04-99	Front - Dana 30	DRK-334C	DRK-334CMK			
Grand Cherokee	98-97	Front - Dana 30	DRK-334TJ	DRK-334TJMK			
Grand Cherokee	96-93	Front - Dana 30	DRK-334A	DRK-334AMK			
Grand Cherokee	10-06	Rear - Dana 44	DRK-339J	DRK-339JMK			
Grand Cherokee	10-05	Rear - 8.25"	DRK-303B	DRK-303BMK			
Grand Cherokee	04-99	Rear - Dana 35	DRK-335C	DRK-335CMK ▲			
Grand Cherokee	04-99	Rear - Dana 44	DRK-339A	DRK-339AMK ▲			
Grand Cherokee	98-96	Rear - Dana 44	DRK-339A	DRK-339AMK ▲			
Grand Cherokee	98-93	Rear - Dana 35	DRK-335	DRK-335MK ▲	AK11	DRK-335AK11	DRK-335MKAK11 ▲
Grand Wagoneer	91-84	Front - Dana 44	DRK-339B	DRK-339BMK			
Grand Wagoneer	91-87	Rear - Dana 44	DRK-339B	DRK-339BMK			
Grand Wagoneer	86-84	Rear - AMC 20	DRK-311J	DRK-311JMK ▲			
J10	88-70	Front - Dana 44	DRK-339B	DRK-339BMK			
J10	86-80	Rear - AMC 20	DRK-311J	DRK-311JMK ▲			
J20	88-70	Front - Dana 44	DRK-339B	DRK-339BMK			
J20	88-70	Rear - Dana 60	DRK-331	DRK-331MK			
Jeepster	73-71	Front - Dana 30	DRK-334	DRK-334MK			
Jeepster	73-67	Rear - Dana 44	DRK-339B	DRK-339BMK			
Liberty	12-02	Front - Dana 30	DRK-340	DRK-340MK ▲			
Liberty	12-09	Rear - 8.25"	DRK-303	DRK-303MK	AK26	DRK-303AK26	DRK-303MKAK26
Liberty	08-02	Rear - 8.25"	DRK-303	DRK-303MK	AK10	DRK-303AK10	DRK-303MKAK10
Liberty	08-02	Rear - Dana 35	DRK-335C	DRK-335CMK ▲			
Scrambler CJ8	85-81	Front - Dana 30	DRK-334	DRK-334MK			
Scrambler CJ8	85-81	Rear - AMC 20	DRK-311J	DRK-311JMK ▲			
Wagoneer SJ	83-74	Front - Dana 44	DRK-339B	DRK-339BMK			
Wagoneer SJ	73-71	Front - Dana 30	DRK-334	DRK-334MK			
Wagoneer SJ	83-80	Rear - AMC 20	DRK-311J	DRK-311JMK ▲			
Wagoneer SJ	79-72	Rear - Dana 44	DRK-339B	DRK-339BMK			
Wagoneer XJ	89-84	Front - Dana 30	DRK-334	DRK-334MK	AK40	DRK-334AK40	DRK-334MKAK40
Wagoneer XJ	85-84	Front - Dana 44	DRK-339B	DRK-339BMK			
Wagoneer XJ	89-88	Rear - Dana 35	DRK-335	DRK-335MK ▲			
Wagoneer XJ	1987	Rear - Dana 35	DRK-335	DRK-335MK ▲			
Wagoneer XJ	1987	Rear - Dana 44	DRK-339B	DRK-339BMK			
Wagoneer XJ	86-84	Rear - Dana 35	DRK-335	DRK-335MK ▲			
Wrangler YJ	95-90	Front - Dana 30	DRK-334	DRK-334MK			
Wrangler YJ	89-87	Front - Dana 30	DRK-334	DRK-334MK	AK40	DRK-334AK40	DRK-334MKAK40
Wrangler YJ	95-87	Rear - Dana 44	DRK-339B	DRK-339BMK			
Wrangler YJ	93-90	Rear - Dana 35	DRK-335	DRK-335MK ▲	AK11	DRK-335AK11	DRK-335MKAK11 ▲
Wrangler YJ	89-87	Rear - Dana 35	DRK-335	DRK-335MK ▲			
Wrangler TJ	06-97	Front - Dana 30	DRK-334TJ	DRK-334TJMK			
Wrangler TJ	06-01	Rear - Dana 44	DRK-339E	DRK-339EMK			
Wrangler TJ	06-97	Rear - Dana 35	DRK-335	DRK-335MK ▲	AK43	DRK-335AK43	DRK-335MKAK43 ▲
Wrangler TJ	00-97	Rear - Dana 44	DRK-339B	DRK-339BMK			
Wrangler TJ Rubicon	06-03	Front - Dana 44	DRK-339E	DRK-339EMK			
Wrangler TJ Rubicon	06-03	Rear - Dana 44	DRK-339E	DRK-339EMK			
Wrangler JK	14-07	Front - Dana 30	DRK-334D	DRK-334DMK			
Wrangler JK	14-07	Front - Dana 44	DRK-339F	DRK-339FMK			
Wrangler JK	14-07	Rear - Dana 44	DRK-339H	DRK-339HMK			
Wrangler JK	14-07	Rear - Dana 44	DRK-339G	DRK-339GMK			
Wrangler JK Rubicon	14-07	Front - Dana 44	DRK-339F	DRK-339FMK			

LD Differential

Light Duty Differential Applications

Make/Model	Year	Position/ Ring Gear Size	Standard Kit	Master Kit	Axle Kit	Standard Kit Plus	Master Kit Plus
JEEP (cont'd)							
Wrangler JK Rubicon	14-07	Rear - Dana 44 w/ E-Loc	DRK-339G	DRK-339GMK			
LINCOLN							
Aviator	05-03	Front - Dana 30	DRK-334B	DRK-334BMK			
Aviator	05-03	Front - Dana 35	DRK-335B	DRK-335BMK ▲			
Aviator	05-03	Rear - 8.8" IRS	DRK-311	DRK-311MK ▲	AK36	DRK-311AK36	DRK-311MKAK36 ▲
Blackwood	03-02	Front - 8.8"	DRK-311	DRK-311MK ▲	AK88	DRK-311AK88	DRK-311MKAK88 ▲
Blackwood	03-02	Rear - 9.75"	DRK-316A	DRK-316AMK ▲	AK15	DRK-316AAK15	DRK-316AMKAK15 ▲
Continental	87-80	Rear - 8.8"	DRK-311	DRK-311MK ▲	AK11	DRK-311AK11	DRK-311MKAK11 ▲
Continental	79-70	Rear - 9" 31 spline From 05/11/70	DRK-313	DRK-313MK			
LS	06-00	Rear - 8.8" IRS	DRK-311N	DRK-311NMK ▲	AK90	DRK-311NAK90	DRK-311NMKAK90 ▲
Mark LT	08-06	Front - 8.8"	DRK-311	DRK-311MK ▲	AK88	DRK-311AK88	DRK-311MKAK88 ▲
Mark LT	08-07	Rear - 9.75"	DRK-316B	DRK-316BMK ▲	AK15	DRK-316BAK15	DRK-316BMKAK15 ▲
Mark LT	2006	Rear - 9.75"	DRK-316A	DRK-316AMK ▲	AK15	DRK-316AAK15	DRK-316AMKAK15 ▲
Mark VI	83-80	Rear - 8.8"	DRK-311	DRK-311MK ▲	AK11	DRK-311AK11	DRK-311MKAK11 ▲
Mark VII	92-84	Rear - 8.8"	DRK-311	DRK-311MK ▲	AK11	DRK-311AK11	DRK-311MKAK11 ▲
Mark VII	87-84	Rear - 7.5"	DRK-315	DRK-315MK ▲	AK11	DRK-315AK11	DRK-315MKAK11 ▲
Mark VIII	98-93	Rear - 8.8"	DRK-311	DRK-311MK ▲			
Navigator	10-09	Front - 8.8"	DRK-311	DRK-311MK ▲	AK91	DRK-311AK91	DRK-311MKAK91 ▲
Navigator	08-98	Front - 8.8"	DRK-311	DRK-311MK ▲	AK88	DRK-311AK88	DRK-311MKAK88 ▲
Navigator	14-11	Rear - 9.75" from 04/30/2011 w/ 3.73 Axle Ratio	DRK-316B	DRK-316BMK ▲	AK36	DRK-316BAK36	DRK-316BMKAK36 ▲
Navigator	14-11	Rear - 9.75" from 04/30/2011 w/ 3.31 Axle Ratio	DRK-316D	DRK-316DMK ▲	AK36	DRK-316DAK36	DRK-316DMKAK36 ▲
Navigator	11-07	Rear - 9.75" To 04/29/2011	DRK-316B	DRK-316BMK ▲	AK36	DRK-316BAK36	DRK-316BMKAK36 ▲
Navigator	06-03	Rear - 9.75"	DRK-316A	DRK-316AMK ▲	AK36	DRK-316AAK36	DRK-316AMKAK36 ▲
Navigator	02-00	Rear - 9.75"	DRK-316A	DRK-316AMK ▲	AK15	DRK-316AAK15	DRK-316AMKAK15 ▲
Navigator	1999	Rear - 9.75" w/ 2.688" OD Pinion Tail Cup	DRK-316	DRK-316MK ▲	AK15	DRK-316AK15	DRK-316MKAK15 ▲
Navigator	1999	Rear - 9.75" w/ 3.000" OD Pinion Tail Cup	DRK-316A	DRK-316AMK ▲	AK15	DRK-316AAK15	DRK-316AMKAK15 ▲
Navigator	1998	Rear - 9.75"	DRK-316	DRK-316MK ▲	AK15	DRK-316AK15	DRK-316MKAK15 ▲
Town Car	11-81	Rear - 8.8"	DRK-311	DRK-311MK ▲	AK11	DRK-311AK11	DRK-311MKAK11 ▲
Versailles	80-77	Rear - 9"	DRK-313	DRK-313MK			
Zephyr	83-78	Rear - 7.5"	DRK-315	DRK-315MK ▲			
MAZDA							
Tribute	11-01	Rear - Dana 28	DRK-333A	DRK-333AMK	AK89	DRK-333AAK89	DRK-333AMKAK89
MERCURY							
Bobcat	80-75	Rear - 8"	DRK-310	DRK-310MK			
Capri	1986	Rear - 8.8"	DRK-311	DRK-311MK ▲	AK11	DRK-311AK11	DRK-311MKAK11 ▲
Capri	86-79	Rear - 7.5"	DRK-315	DRK-315MK ▲	AK11	DRK-315AK11	DRK-315MKAK11 ▲
Colony Park	91-81	Rear - 8.8"	DRK-311	DRK-311MK ▲	AK11	DRK-311AK11	DRK-311MKAK11 ▲
Colony Park	80-73	Rear - 9" 31 spline From 05/11/70	DRK-313	DRK-313MK			

▲ Add "S" suffix to kit number to receive stackable differential shims in kit.

Light Duty Differential Applications

Make/Model	Year	Position/ Ring Gear Size	Standard Kit	Master Kit	Axle Kit	Standard Kit Plus	Master Kit Plus
MERCURY (cont'd)							
Comet	72-64	Rear - 8"	DRK-310	DRK-310MK			
Cougar	97-89	Rear - 7.5"	DRK-315	DRK-315MK ▲			
Cougar	97-89	Rear - 8.8"	DRK-311	DRK-311MK ▲			
Cougar	88-80	Rear - 7.5"	DRK-315	DRK-315MK ▲	AK11	DRK-315AK11	DRK-315MKAK11 ▲
Cougar	79-70	Rear - 9" 31 spline From 05/11/70	DRK-313	DRK-313MK			
Cougar	70-67	Rear - 9" 28 spline To 5/10/70	DRK-312	DRK-312MK			
Cougar	68-67	Rear - 8"	DRK-310	DRK-310MK			
Grand Marquis	11-83	Rear - 8.8"	DRK-311	DRK-311MK ▲	AK11	DRK-311AK11	DRK-311MKAK11 ▲
Marauder	04-03	Rear - 8.8"	DRK-311	DRK-311MK ▲	AK11	DRK-311AK11	DRK-311MKAK11 ▲
Mariner	10-05	Rear - Dana 28	DRK-333A	DRK-333AMK	AK89	DRK-333AAK89	DRK-333AMKAK89
Marquis	86-81	Rear - 7.5"	DRK-315	DRK-315MK ▲			
Marquis	82-81	Rear - 8.8"	DRK-311	DRK-311MK ▲	AK11	DRK-311AK11	DRK-311MKAK11 ▲
Marquis	80-73	Rear - 9" 31 spline From 05/11/70	DRK-313	DRK-313MK			
Monarch	80-75	Rear - 8"	DRK-310	DRK-310MK			
Monarch	80-75	Rear - 9"	DRK-313	DRK-313MK			
Mountaineer	10-06	Front - Dana 30	DRK-334E	DRK-334EMK ▲			
Mountaineer	05-01	Front - Dana 30	DRK-334B	DRK-334BMK			
Mountaineer	05-97	Front - Dana 35	DRK-335B	DRK-335BMK ▲			
Mountaineer	10-08	Rear - 8.8" IRS	DRK-311L	DRK-311LMK ▲	AK36	DRK-311LAK36	DRK-311LMKAK36 ▲
Mountaineer	07-06	Rear - 8.8" IRS	DRK-311K	DRK-311KMK ▲	AK36	DRK-311KAK36	DRK-311KMKAK36 ▲
Mountaineer	05-02	Rear - 8.8" IRS	DRK-311	DRK-311MK ▲	AK36	DRK-311AK36	DRK-311MKAK36 ▲
Mountaineer	01-97	Rear - 8.8"	DRK-311	DRK-311MK ▲	AK10	DRK-311AK10	DRK-311MKAK10 ▲
Montego	76-70	Rear - 9" 31 spline From 05/11/70	DRK-313	DRK-313MK			
Montego	70-68	Rear - 9" 28 spline To 5/10/70	DRK-312	DRK-312MK			
MITSUBISHI							
Raider	09-06	Front - 8.0"	DRK-305	DRK-305MK			
Raider	09-06	Rear - 8.25"	DRK-303B	DRK-303BMK			
Raider	09-06	Rear - 9.25"	DRK-304A	DRK-304AMK	AK10	DRK-304AAK10	DRK-304AMKAK10
NISSAN							
Armada	14-05	Front - Dana 205	DRK-339T	DRK-339TMK			
Armada	14-05	Rear - Dana 44	DRK-339N	DRK-339NMK			
Frontier	12-03	Rear - Dana 44	DRK-339N	DRK-339NMK			
Pathfinder	12-06	Front - Dana 205	DRK-339T	DRK-339TMK			
Pathfinder	12-03	Rear - Dana 44	DRK-339N	DRK-339NMK			
Titan	14-04	Front - Dana 205	DRK-339T	DRK-339TMK			
Titan	14-04	Rear - Dana 44	DRK-339N	DRK-339NMK			
Xterra	12-03	Rear - Dana 44	DRK-339N	DRK-339NMK			
OLDSMOBILE							
88	1957	Rear - 9.3" C axle	DRK-329	DRK-329MK			
98	84-82	Rear - 7.5"	DRK-320	DRK-320MK ▲	AK11	DRK-320AK11	DRK-320MKAK11 ▲
98	84-73	Rear - 8.5"	DRK-321R	DRK-321RMK ▲			
98	81-77	Rear - 7.5"	DRK-320B	DRK-320BMK ▲	AK11	DRK-320BAK11	DRK-320BMKAK11 ▲
98	72-65	Rear - 8.875"	DRK-323A	DRK-323AMK ▲			
98	62-58	Rear - 9.3" C axle	DRK-329	DRK-329MK			

Light Duty Differential Applications

Make/Model	Year	Position/ Ring Gear Size	Standard Kit	Master Kit	Axle Kit	Standard Kit Plus	Master Kit Plus
OLDSMOBILE (cont'd)							
442	70-68	Rear - 8.5" "O"	DRK-321N	DRK-321NMK ▲			
Bravada	04-97	Front - 7.25"	DRK-320K	DRK-320KMK	AK87	DRK-320KAK87	DRK-320KMKAK87
Bravada	96-91	Front - 7.25"	DRK-320A	DRK-320AMK	AK86	DRK-320AAK86	DRK-320AMKAK86
Bravada	04-02	Rear - 8"	DRK-320D	DRK-320DMK ▲	AK12	DRK-320DAK12	DRK-320DMKAK12 ▲
Bravada	04-99	Rear - 7.5"	DRK-320C	DRK-320CMK ▲	AK11	DRK-320CAK11	DRK-320CMKAK11 ▲
Bravada	98-91	Rear - 7.5"	DRK-320	DRK-320MK ▲	AK11	DRK-320AK11	DRK-320MKAK11 ▲
Custom Cruiser	92-80	Rear - 8.5"	DRK-321R	DRK-321RMK ▲	AK10	DRK-321RAK10	DRK-321RMKAK10 ▲
Cutlass	81-78	Rear - 7.5"	DRK-320	DRK-320MK ▲	AK11	DRK-320AK11	DRK-320MKAK11 ▲
Cutlass	77-71	Rear - 8.5"	DRK-321R	DRK-321RMK ▲	AK10	DRK-321RAK10	DRK-321RMKAK10 ▲
Cutlass	70-68	Rear - 8.5" "O"	DRK-321N	DRK-321NMK ▲			
Cutlass	1962	Rear - 9.3" C axle	DRK-329	DRK-329MK			
Cutlass Cruiser	83-82	Rear - 7.5"	DRK-320	DRK-320MK ▲	AK11	DRK-320AK11	DRK-320MKAK11 ▲
Cutlass Cruiser	81-80	Rear - 7.5"	DRK-320B	DRK-320BMK ▲	AK11	DRK-320BAK11	DRK-320BMKAK11 ▲
Cutlass Supreme	88-82	Rear - 7.5"	DRK-320	DRK-320MK ▲	AK11	DRK-320AK11	DRK-320MKAK11 ▲
Cutlass Supreme	81-77	Rear - 7.5"	DRK-320B	DRK-320BMK ▲	AK11	DRK-320BAK11	DRK-320BMKAK11 ▲
Cutlass Supreme	77-71	Rear - 8.5"	DRK-321R	DRK-321RMK ▲	AK10	DRK-321RAK10	DRK-321RMKAK10 ▲
Cutlass Supreme	70-68	Rear - 8.5" "O"	DRK-321N	DRK-321NMK ▲			
Delta 88	85-82	Rear - 7.5"	DRK-320	DRK-320MK ▲	AK10	DRK-320AK10	DRK-320MKAK10 ▲
Delta 88	85-73	Rear - 8.5"	DRK-321R	DRK-321RMK ▲	AK10	DRK-321RAK10	DRK-321RMKAK10 ▲
Delta 88	81-77	Rear - 7.5"	DRK-320B	DRK-320BMK ▲	AK11	DRK-320BAK11	DRK-320BMKAK11 ▲
Delta 88	72-65	Rear - 8.875"	DRK-323A	DRK-323AMK ▲			
Dynamic	62-58	Rear - 9.3" C axle	DRK-329	DRK-329MK			
F85	72-70	Rear - 8.5"	DRK-321R	DRK-321RMK ▲			
F85	70-68	Rear - 8.875"	DRK-323A	DRK-323AMK ▲			
F85	70-64	Rear - 8.2" B-O-P	DRK-321H	DRK-321HMK ▲			
F85	62-61	Rear - 9.3" C axle	DRK-329	DRK-329MK			
Omega	81-75	Rear - 7.5"	DRK-320B	DRK-320BMK ▲			
Omega	79-73	Rear - 8.5"	DRK-321R	DRK-321RMK ▲			
Starfire	80-75	Rear - 7.5"	DRK-320B	DRK-320BMK ▲			
Starfire	62-61	Rear - 9.3" C axle	DRK-329	DRK-329MK			
Super 88	62-57	Rear - 9.3" C axle	DRK-329	DRK-329MK			
PLYMOUTH							
Barracuda	74-72	Rear - 8.25"/8.375"	DRK-303	DRK-303MK	AK10	DRK-303AK10	DRK-303MKAK10
Barracuda	74-72	Rear - 8.75" w/1.875" Pin. Shaft O.D.	DRK-301	DRK-301MK			
Barracuda	71-70	Rear - 7.25"	DRK-302	DRK-302MK			
Barracuda	71-70	Rear - 8.25"/8.375"	DRK-303	DRK-303MK	AK10	DRK-303AK10	DRK-303MKAK10
Barracuda	71-70	Rear - 8.75" w/1.875" Pin. Shaft O.D.	DRK-301	DRK-301MK			
Barracuda	71-70	Rear - Dana 60	DRK-331	DRK-331MK			
Barracuda	1969	Rear - 7.25"	DRK-302	DRK-302MK			
Barracuda	1969	Rear - 8.75" w/1.875" Pin. Shaft O.D.	DRK-301	DRK-301MK			
Barracuda	68-64	Rear - 7.25"	DRK-302	DRK-302MK			
Barracuda	68-64	Rear - 8.75" w/1.75" Pin. Shaft O.D.	DRK-300	DRK-300MK			
Belvedere	70-69	Rear - 7.25"	DRK-302	DRK-302MK			
Belvedere	70-69	Rear - 8.25"/8.375"	DRK-303	DRK-303MK	AK10	DRK-303AK10	DRK-303MKAK10
Belvedere	70-69	Rear - 8.75" w/1.875" Pin. Shaft O.D.	DRK-301	DRK-301MK			

▲ Add "S" suffix to kit number to receive stackable differential shims in kit.

Light Duty Differential Applications

Make/Model	Year	Position/ Ring Gear Size	Standard Kit	Master Kit	Axle Kit	Standard Kit Plus	Master Kit Plus
PLYMOUTH (cont'd)							
Belvedere	70-66	Rear - 7.25"	DRK-302	DRK-302MK			
Belvedere	68-67	Rear - 8.75" w/1.75" Pin. Shaft O.D.	DRK-300	DRK-300MK			
Belvedere	1966	Rear - Dana 60	DRK-331	DRK-331MK			
Belvedere	65-57	Rear - 8.75" w/1.75" Pin. Shaft O.D.	DRK-300	DRK-300MK			
Duster	76-73	Rear - 8.25"/8.375"	DRK-303	DRK-303MK	AK10	DRK-303AK10	DRK-303MKAK10
Duster	74-70	Rear - 8.75" w/1.875" Pin. Shaft O.D.	DRK-301	DRK-301MK			
Fury	78-74	Rear - 9.25"	DRK-304	DRK-304MK			
Fury	78-70	Rear - 8.25"/8.375"	DRK-303	DRK-303MK	AK10	DRK-303AK10	DRK-303MKAK10
Fury	73-69	Rear - 8.75" w/1.875" Pin. Shaft O.D.	DRK-301	DRK-301MK			
Fury	68-57	Rear - 8.75" w/1.75" Pin. Shaft O.D.	DRK-300	DRK-300MK			
Gran Fury	89-82	Rear - 7.25"	DRK-302	DRK-302MK			
Gran Fury	89-75	Rear - 8.25"/8.375"	DRK-303	DRK-303MK	AK10	DRK-303AK10	DRK-303MKAK10
Gran Fury	81-75	Rear - 9.25"	DRK-304	DRK-304MK	AK10	DRK-304AK10	DRK-304MKAK10
GTX	71-69	Rear - 8.75" w/1.875" Pin. Shaft O.D.	DRK-301	DRK-301MK			
GTX	71-67	Rear - Dana 60	DRK-331	DRK-331MK			
GTX	68-67	Rear - 8.75" w/1.75" Pin. Shaft O.D.	DRK-300	DRK-300MK			
Road Runner	75-74	Rear - 9.25"	DRK-304	DRK-304MK	AK10	DRK-304AK10	DRK-304MKAK10
Road Runner	75-73	Rear - 8.25"/8.375"	DRK-303	DRK-303MK	AK10	DRK-303AK10	DRK-303MKAK10
Road Runner	74-69	Rear - 8.75" w/1.875" Pin. Shaft O.D.	DRK-301	DRK-301MK			
Road Runner	72-69	Rear - Dana 60	DRK-331	DRK-331MK			
Road Runner	1968	Rear - Dana 60	DRK-331	DRK-331MK			
Road Runner	1968	Rear - 8.75" w/1.75" Pin. Shaft O.D.	DRK-300	DRK-300MK			
Satellite	74-73	Rear - 9.25"	DRK-304	DRK-304MK	AK10	DRK-304AK10	DRK-304MKAK10
Satellite	74-69	Rear - 8.25"/8.375"	DRK-303	DRK-303MK	AK10	DRK-303AK10	DRK-303MKAK10
Satellite	74-69	Rear - 8.75" w/1.875" Pin. Shaft O.D.	DRK-301	DRK-301MK			
Satellite	71-68	Rear - 7.25"	DRK-302	DRK-302MK			
Satellite	1968	Rear - 8.75" w/1.75" Pin. Shaft O.D.	DRK-300	DRK-300MK			
Satellite	67-66	Rear - 7.25"	DRK-302	DRK-302MK			
Satellite	1966	Rear - Dana 60	DRK-331	DRK-331MK			
Trailduster	81-74	Front - Dana 44	DRK-339B	DRK-339BMK			
Trailduster	81-74	Rear - 9.25"	DRK-304	DRK-304MK	AK10	DRK-304AK10	DRK-304MKAK10
Valiant	76-73	Rear - 8.25"/8.375"	DRK-303	DRK-303MK	AK10	DRK-303AK10	DRK-303MKAK10
Valiant	76-69	Rear - 7.25"	DRK-302	DRK-302MK			
Valiant	72-69	Rear - 8.75" w/1.875" Pin. Shaft O.D.	DRK-301	DRK-301MK			
Valiant	68-60	Rear - 7.25"	DRK-302	DRK-302MK			
Valiant	68-60	Rear - 8.75" w/1.75" Pin. Shaft O.D.	DRK-300	DRK-300MK			
Volare	80-76	Rear - 7.25"	DRK-302	DRK-302MK			

Light Duty Differential Applications

Make/Model	Year	Position/ Ring Gear Size	Standard Kit	Master Kit	Axle Kit	Standard Kit Plus	Master Kit Plus
PLYMOUTH (cont'd)							
Volare	80-76	Rear - 8.25"/8.375"	DRK-303	DRK-303MK	AK10	DRK-303AK10	DRK-303MKAK10
PONTIAC							
Bonneville	86-82	Rear - 7.5"	DRK-320	DRK-320MK ▲	AK11	DRK-320AK11	DRK-320MKAK11 ▲
Bonneville	81-77	Rear - 7.5"	DRK-320B	DRK-320BMK ▲	AK11	DRK-320BAK11	DRK-320BMKAK11 ▲
Bonneville	81-73	Rear - 8.5"	DRK-321R	DRK-321RMK ▲			
Bonneville	72-65	Rear - 8.875"	DRK-323A	DRK-323AMK ▲	AK10	DRK-323AAK10	DRK-323AMKAK10 ▲
Bonneville	62-57	Rear - 9.3" C axle	DRK-329	DRK-329MK			
Catalina	81-77	Rear - 7.5"	DRK-320B	DRK-320BMK ▲	AK11	DRK-320BAK11	DRK-320BMKAK11 ▲
Catalina	81-73	Rear - 8.5"	DRK-321R	DRK-321RMK ▲	AK10	DRK-321RAK10	DRK-321RMKAK10 ▲
Catalina	72-65	Rear - 8.2" Axle Shaft w/1.781" Differential Brgs.	DRK-321B	DRK-321BMK ▲			
Catalina	72-65	Rear - 8.875"	DRK-323A	DRK-323AMK ▲			
Catalina	62-57	Rear - 9.3" C axle	DRK-329	DRK-329MK			
Chieftain	58-57	Rear - 9.3" C axle	DRK-329	DRK-329MK			
Firebird	02-99	Rear - 7.5"	DRK-320C	DRK-320CMK ▲	AK11	DRK-320CAK11	DRK-320CMKAK11 ▲
Firebird	98-82	Rear - 7.5"	DRK-320	DRK-320MK ▲	AK11	DRK-320AK11	DRK-320MKAK11 ▲
Firebird	81-71	Rear - 8.5"	DRK-321R	DRK-321RMK ▲	AK11	DRK-321RAK11	DRK-321RMKAK11 ▲
Firebird	81-67	Rear - 8.2" B-O-P	DRK-321H	DRK-321HMK ▲			
Firebird	72-67	Rear - 8.875"	DRK-323A	DRK-323AMK ▲			
Firebird Trans Am	02-99	Rear - 7.5"	DRK-320C	DRK-320CMK ▲	AK11	DRK-320CAK11	DRK-320CMKAK11 ▲
Firebird Trans Am	98-82	Rear - 7.5"	DRK-320	DRK-320MK ▲	AK11	DRK-320AK11	DRK-320MKAK11 ▲
Firebird Trans Am	90-85	Rear - Borg Warner 7.75"	DRK-326	DRK-326MK			
Firebird Trans Am	81-71	Rear - 8.5"	DRK-321R	DRK-321RMK ▲	AK11	DRK-321RAK11	DRK-321RMKAK11 ▲
Firebird Trans Am	72-67	Rear - 8.875"	DRK-323A	DRK-323AMK ▲			
Firebird Trans Am	71-67	Rear - 8.2" B-O-P	DRK-321H	DRK-321HMK ▲			
G8	09-08	Rear - 8.25"	DRK-326B	DRK-326BMK			
GTO	06-04	Rear - 8"	DRK-326A	DRK-326AMK			
GTO	72-65	Rear - 8.875"	DRK-323A	DRK-323AMK ▲			
GTO	71-64	Rear - 8.2" B-O-P	DRK-321H	DRK-321HMK ▲			
Grand Am	80-78	Rear - 7.5"	DRK-320	DRK-320MK ▲	AK11	DRK-320AK11	DRK-320MKAK11 ▲
Grand Am	80-73	Rear - 8.5"	DRK-321R	DRK-321RMK ▲			
Grand Prix	87-82	Rear - 7.5"	DRK-320	DRK-320MK ▲	AK11	DRK-320AK11	DRK-320MKAK11 ▲
Grand Prix	81-78	Rear - 7.5"	DRK-320B	DRK-320BMK ▲	AK11	DRK-320BAK11	DRK-320BMKAK11 ▲
Grand Prix	77-71	Rear - 8.5"	DRK-321R	DRK-321RMK ▲	AK11	DRK-321RAK11	DRK-321RMKAK11 ▲
Grand Prix	72-70	Rear - 8.875"	DRK-323A	DRK-323AMK ▲			
Grand Prix	1962	Rear - 9.3" C axle	DRK-329	DRK-329MK			
LeMans	81-78	Rear - 7.5"	DRK-320B	DRK-320BMK ▲	AK11	DRK-320BAK11	DRK-320BMKAK11 ▲
LeMans	77-71	Rear - 8.5"	DRK-321R	DRK-321RMK ▲	AK11	DRK-321RAK11	DRK-321RMKAK11 ▲
LeMans	72-65	Rear - 8.875"	DRK-323A	DRK-323AMK ▲			
Parisienne	86-83	Rear - 7.5"	DRK-320	DRK-320MK ▲	AK11	DRK-320AK11	DRK-320MKAK11 ▲
Parisienne	86-83	Rear - 8.5"	DRK-321R	DRK-321RMK ▲	AK11	DRK-321RAK11	DRK-321RMKAK11 ▲
Phoenix	79-77	Rear - 7.5"	DRK-320B	DRK-320BMK ▲			
Star Chief	62-57	Rear - 9.3" C axle	DRK-329	DRK-329MK			
Safari	89-87	Rear - 7.5"	DRK-320	DRK-320MK ▲	AK10	DRK-320AK10	DRK-320MKAK10 ▲
Sunbird	80-76	Rear - 7.5"	DRK-320B	DRK-320BMK ▲			
Super Chief	58-57	Rear - 9.3" C axle	DRK-329	DRK-329MK			
Tempest	70-64	Rear - 8.2" B-O-P	DRK-321H	DRK-321HMK ▲			
Tempest	62-61	Rear - 9.3" C axle	DRK-329	DRK-329MK			
Ventura	77-71	Rear - 8.5"	DRK-321R	DRK-321RMK ▲	AK11	DRK-321RAK11	DRK-321RMKAK11 ▲
Ventura	61-60	Rear - 9.3" C axle	DRK-329	DRK-329MK			

▲ Add "S" suffix to kit number to receive stackable differential shims in kit.

Light Duty Differential Applications

Make/Model	Year	Position/ Ring Gear Size	Standard Kit	Master Kit	Axle Kit	Standard Kit Plus	Master Kit Plus
RAM							
1500	12-11	Front - 8"	DRK-305A	DRK-305AMK			
2500	14-11	Front - 9.25" AAM axle	DRK-324G	DRK-324GMK			
2500	2014	Rear - 11.5"	DRK-327B	DRK-327BMK	AK30	DRK-327BAK30	DRK-327BMKAK30
2500	13-11	Rear - 11.5"	DRK-327A	DRK-327AMK	AK30	DRK-327AAK30	DRK-327AMKAK30
3500	14-11	Front - 9.25" AAM axle	DRK-324G	DRK-324GMK			
3500	14-13	Rear - 11.8" AAM	DRK-327A	DRK-327AMK	AK30 ⁴⁹	DRK-327AAK30 ⁴⁹	DRK-327AMKAK30 ⁴⁹
3500	14-11	Rear - 11.5"	DRK-327A	DRK-327AMK	AK30 ⁴⁹	DRK-327AAK30 ⁴⁹	DRK-327AMKAK30 ⁴⁹
4500	14-11	Front - Magna Steyr 275mm	DRK-365				
4500	14-11	Rear - Dana S111	DRK-434				
5500	14-11	Front - Magna Steyr 275mm	DRK-365				
5500	14-11	Rear - Dana S111	DRK-434				
Dakota	2011	Front - 8.0"	DRK-305	DRK-305MK			
Dakota	2011	Rear - 8.25"	DRK-303B	DRK-303BMK			
Dakota	2011	Rear - 9.25"	DRK-304A	DRK-304AMK	AK10	DRK-304AAK10	DRK-304AMKAK10
SAAB							
9-7X	09-05	Front - 7.25"	DRK-320K	DRK-320KMK	AK87	DRK-320KAK87	DRK-320KMKAK87
9-7X	2009	Rear - 8.5"	DRK-321Q	DRK-321QMK ▲	AK12	DRK-321QAK12	DRK-321QMKAK12 ▲
9-7X	2008	Rear - 9.5"	DRK-324B	DRK-324BMK			
9-7X	08-05	Rear - 8"	DRK-320D	DRK-320DMK ▲	AK12	DRK-320DAK12	DRK-320DMKAK12 ▲
9-7X	08-05	Rear - 8.5"	DRK-321C	DRK-321CMK ▲	AK12	DRK-321CAK12	DRK-321CMKAK12 ▲
SUZUKI							
SAMURAI	95-85	Front - All	DRK-360	DRK-360MK			
SAMURAI	95-85	Rear - All	DRK-360	DRK-360MK			
TOYOTA							
4 Runner	14-03	Front - 7.5"	DRK-359	DRK-359MK			
4 Runner	02-96	Front - 7.5"	DRK-350A	DRK-350AMK ▲			
4 Runner	95-88	Front - 7.5" IFS	DRK-350A	DRK-350AMK ▲			
4 Runner	87-86	Front - 7.5" IFS	DRK-350	DRK-350MK			
4 Runner	85-84	Front - 8" Solid Axle	DRK-351	DRK-351MK			
4 Runner	2009	Rear - 8" w/o Locking Diff	DRK-352A	DRK-352AMK			
4 Runner	08-03	Rear - 8"	DRK-352A	DRK-352AMK			
4 Runner	02-01	Rear - 8"	DRK-352	DRK-352MK	AK35	DRK-352AK35	DRK-352MKAK35
4 Runner	00-96	Rear - 8" 4 Cyl. w/ABS	DRK-352	DRK-352MK	AK34	DRK-352AK34	DRK-352MKAK34
4 Runner	00-96	Rear - 8" 4 Cyl. w/o ABS	DRK-352	DRK-352MK	AK33	DRK-352AK33	DRK-352MKAK33
4 Runner	00-96	Rear - 8" V6 & w/ Locking Diff w/o ABS	DRK-354	DRK-354MK	AK33	DRK-354AK33	DRK-354MKAK33
4 Runner	00-96	Rear - 8" V6 & w/ Locking Diff w/ABS	DRK-354	DRK-354MK	AK34	DRK-354AK34	DRK-354MKAK34
4 Runner	00-96	Rear - 8" V6 & w/o Locking Diff w/o ABS	DRK-352	DRK-352MK	AK33	DRK-352AK33	DRK-352MKAK33
4 Runner	00-96	Rear - 8" V6 & w/o Locking Diff w/ABS	DRK-352	DRK-352MK	AK34	DRK-352AK34	DRK-352MKAK34
4 Runner	95-90	Rear - 7.5" 4 Cyl. 2WD w/ABS	DRK-350	DRK-350MK	AK34	DRK-350AK34	DRK-350MKAK34

Light Duty Differential Applications

Make/Model	Year	Position/ Ring Gear Size	Standard Kit	Master Kit	Axle Kit	Standard Kit Plus	Master Kit Plus
TOYOTA (cont'd)							
4 Runner	95-90	Rear - 8" 4 Cyl. 4WD w/ABS	DRK-353	DRK-353MK	AK34	DRK-353AK34	DRK-353MKAK34
4 Runner	95-90	Rear - 8" V6 w/ABS	DRK-352	DRK-352MK	AK34	DRK-352AK34	DRK-352MKAK34
4 Runner	95-88	Rear - 7.5" 4 Cyl. 2WD w/o ABS	DRK-350	DRK-350MK	AK33	DRK-350AK33	DRK-350MKAK33
4 Runner	95-88	Rear - 8" 4 Cyl. 4WD w/o ABS	DRK-353	DRK-353MK	AK33	DRK-353AK33	DRK-353MKAK33
4 Runner	95-88	Rear - 8" V6 w/o ABS	DRK-352	DRK-352MK	AK33	DRK-352AK33	DRK-352MKAK33
4 Runner	87-86	Rear - 7.5" 4 Cyl. Non Turbo 2WD	DRK-350	DRK-350MK	AK33	DRK-350AK33	DRK-350MKAK33
4 Runner	87-86	Rear - 8" 4 Cyl. Non Turbo 4WD	DRK-353	DRK-353MK	AK33	DRK-353AK33	DRK-353MKAK33
4 Runner	87-86	Rear - 8" 4 Cyl. Turbo 4WD	DRK-352	DRK-352MK	AK33	DRK-352AK33	DRK-352MKAK33
4 Runner	85-84	Rear - 7.5" 2WD	DRK-350	DRK-350MK	AK33	DRK-350AK33	DRK-350MKAK33
4 Runner	85-84	Rear - 8" 4WD	DRK-351	DRK-351MK	AK33	DRK-351AK33	DRK-351MKAK33
FJ Cruiser	14-07	Front - 8" IFS	DRK-359	DRK-359MK			
FJ Cruiser	09-07	Rear - 8" w/ Locking Diff	DRK-354A	DRK-354AMK			
FJ Cruiser	09-07	Rear - 8" w/o Locking Diff	DRK-352A	DRK-352AMK			
Landcruiser	08-75	Front - FJ40/60/62 w/ Open Differential	DRK-358	DRK-358MK			
Landcruiser	97-90	Front - FJ80 w/Locking Differential	DRK-356	DRK-356MK			
Landcruiser	97-90	Front - FJ80 w/Open Differential	DRK-356A	DRK-356AMK			
Landcruiser	97-90	Rear - FJ80 w/Locking Differential	DRK-357	DRK-357MK			
Landcruiser	97-90	Rear - FJ80 w/Open Differential	DRK-357A	DRK-357AMK			
Pickup	95-88	Front - 7.5" IFS	DRK-350A	DRK-350AMK [▲]			
Pickup	88-86	Front - 7.5" IFS	DRK-350	DRK-350MK			
Pickup	85-84	Front - 8" Solid Axle	DRK-351	DRK-351MK			
Pickup	95-90	Rear - 7.5" 4 Cyl. Non Turbo 2WD w/ABS	DRK-350	DRK-350MK	AK34	DRK-350AK34	DRK-350MKAK34
Pickup	95-90	Rear - 8" 4 Cyl. 4WD w/ABS	DRK-353	DRK-353MK	AK34	DRK-353AK34	DRK-353MKAK34
Pickup	95-90	Rear - 8" V6 w/ABS	DRK-352	DRK-352MK	AK34	DRK-352AK34	DRK-352MKAK34
Pickup	95-89	Rear - 7.5" 4 Cyl. Non Turbo 2WD w/o ABS	DRK-350	DRK-350MK	AK33	DRK-350AK33	DRK-350MKAK33
Pickup	95-89	Rear - 8" 4 Cyl. 4WD w/o ABS	DRK-353	DRK-353MK	AK33	DRK-353AK33	DRK-353MKAK33
Pickup	95-89	Rear - 8" V6 w/o ABS	DRK-352	DRK-352MK	AK33	DRK-352AK33	DRK-352MKAK33
Pickup	1988	Rear - 7.5" 4 Cyl. Non Turbo 2WD	DRK-350	DRK-350MK	AK33	DRK-350AK33	DRK-350MKAK33
Pickup	1988	Rear - 8" 4 Cyl. Non Turbo 4WD	DRK-353	DRK-353MK	AK33	DRK-353AK33	DRK-353MKAK33
Pickup	1988	Rear - 8" 4 Cyl. Turbo 4WD	DRK-352	DRK-352MK	AK33	DRK-352AK33	DRK-352MKAK33
Pickup	1988	Rear - 8" V6	DRK-352	DRK-352MK	AK33	DRK-352AK33	DRK-352MKAK33

▲ Add "S" suffix to kit number to receive stackable differential shims in kit.

Light Duty Differential Applications

Make/Model	Year	Position/ Ring Gear Size	Standard Kit	Master Kit	Axle Kit	Standard Kit Plus	Master Kit Plus
TOYOTA (cont'd)							
Pickup	87-86	Rear - 7.5" 4 Cyl. Non Turbo 2WD	DRK-350	DRK-350MK	AK33	DRK-350AK33	DRK-350MKAK33
Pickup	87-86	Rear - 8" 4 Cyl. Non Turbo 4WD	DRK-353	DRK-353MK	AK33	DRK-353AK33	DRK-353MKAK33
Pickup	87-86	Rear - 8" 4 Cyl. Turbo 4WD	DRK-352	DRK-352MK	AK33	DRK-352AK33	DRK-352MKAK33
Pickup	85-84	Rear - 7.5" 2WD	DRK-350	DRK-350MK	AK33	DRK-350AK33	DRK-350MKAK33
Pickup	85-84	Rear - 8" 4WD	DRK-351	DRK-351MK	AK33	DRK-351AK33	DRK-351MKAK33
Pickup	83-79	Rear - 7.5"	DRK-350	DRK-350MK	AK33	DRK-350AK33	DRK-350MKAK33
Sequoia	14-08	Front - 9"	DRK-380	DRK-380MK			
Sequoia	07-01	Front - 7.5" IFS	DRK-350A	DRK-350AMK ▲			
Sequoia	14-08	Rear - 10.5"	DRK-382A	DRK-382AMK			
Sequoia	07-01	Rear - 8.4"	DRK-355	DRK-355MK			
Supra	95-87	Rear - 7.5" w/o Turbo	DRK-350	DRK-350MK			
T100	98-93	Front - 7.5" IFS	DRK-350A	DRK-350AMK ▲			
T100	98-93	Rear - 8.4" w/ABS	DRK-355	DRK-355MK	AK34	DRK-355AK34	DRK-355MKAK34
T100	98-93	Rear - 8.4" w/o ABS	DRK-355	DRK-355MK	AK33	DRK-355AK33	DRK-355MKAK33
Tacoma	14-05	Front - 8" IFS	DRK-359	DRK-359MK			
Tacoma	04-95	Front - 7.5" IFS	DRK-350A	DRK-350AMK ▲			
Tacoma	14-05	Rear - 8.4" w/o Locking Diff	DRK-355	DRK-355MK			
Tacoma	04-03	Rear - 8.4" w/o Locking Diff	DRK-355	DRK-355MK	AK35	DRK-355AK35	DRK-355MKAK35
Tacoma	2002	Rear - 8" w/ Locking Diff To 1/2002	DRK-354	DRK-354MK	AK35	DRK-354AK35	DRK-354MKAK35
Tacoma	2002	Rear - 8" w/ Locking Diff From 2/2002	DRK-354A	DRK-354AMK	AK35	DRK-354AAK35	DRK-354AMKAK35
Tacoma	2001	Rear - 8" w/ Locking Diff	DRK-354	DRK-354MK	AK35	DRK-354AK35	DRK-354MKAK35
Tacoma	2001	Rear - 8.4" w/o Locking Diff	DRK-355	DRK-355MK	AK35	DRK-355AK35	DRK-355MKAK35
Tacoma	00-96	Rear - 8" w/ Locking Diff w/ABS	DRK-354	DRK-354MK	AK34	DRK-354AK34	DRK-354MKAK34
Tacoma	00-96	Rear - 8" w/ Locking Diff w/o ABS	DRK-354	DRK-354MK	AK33	DRK-354AK33	DRK-354MKAK33
Tacoma	00-96	Rear - 8.4" w/o Locking Diff w/o ABS	DRK-355	DRK-355MK	AK33	DRK-355AK33	DRK-355MKAK33
Tacoma	00-96	Rear - 8.4" w/o Locking Diff w/ABS	DRK-355	DRK-355MK	AK34	DRK-355AK34	DRK-355MKAK34
Tacoma	1995	Rear - 8.4" w/o Locking Diff w/o ABS	DRK-355	DRK-355MK	AK33	DRK-355AK33	DRK-355MKAK33
Tacoma	1995	Rear - 8.4" w/o Locking Diff w/ABS	DRK-355	DRK-355MK	AK34	DRK-355AK34	DRK-355MKAK34
Tundra	14-07	Front - 9"	DRK-380	DRK-380MK			
Tundra	06-00	Front - 7.5" IFS	DRK-350A	DRK-350AMK ▲			
Tundra	14-07	Rear - 10.5"	DRK-382	DRK-382MK			
Tundra	14-07	Rear - 9.5"	DRK-381	DRK-381MK			
Tundra	06-00	Rear - 8.4"	DRK-355	DRK-355MK	AK35	DRK-355AK35	DRK-355MKAK35

LD Differential

Light Duty Differential Rebuild Kits

AK10		
Position	Part Number	Qty
Axle Shaft Brg.	R1559TV	2
Axle Shaft Seal	8835S	2

AK11		
Position	Part Number	Qty
Axle Shaft Brg.	R1563TAV	2
Axle Shaft Seal	8660S	2

AK12		
Position	Part Number	Qty
Axle Shaft Brg.	513067	2
Axle Shaft Seal	4762N	2

AK14		
Position	Part Number	Qty
Axle Shaft Brg.	513023	2
Axle Shaft Seal	4795V	2

AK15		
Position	Part Number	Qty
Axle Shaft Brg.	R1561TV	2
Axle Shaft Seal	100357V	2

AK16		
Position	Part Number	Qty
Axle Shaft Brg.	R1561TV	2
Axle Shaft Seal	710105	2

AK17		
Position	Part Number	Qty
Axle Shaft Brg.	R1561TV	2
Axle Shaft Seal	8835S	2

AK18		
Position	Part Number	Qty
Axle Shaft Brg.	LM104949-LM104911	4
Axle Shaft Seal	4250	2

AK21		
Position	Part Number	Qty
Axle Shaft Brg. (Inner)	387AS-382A	2
Axle Shaft Brg. (Outer)	LM104949-LM104911	2
Axle Shaft Seal	2081	2

AK22		
Position	Part Number	Qty
Axle Shaft Brg.	R1561TV	2
Axle Shaft Seal	710067	2

AK23		
Position	Part Number	Qty
Axle Shaft Brg. (Inner)	387AS-382A	2
Axle Shaft Brg. (Outer)	LM104949-LM104911	2
Axle Shaft Seal	9864S	2

AK24		
Position	Part Number	Qty
Axle Shaft Brg.	A9	2
Axle Shaft Seal	710179	2

AK25		
Position	Part Number	Qty
Axle Shaft Brg.	R1563TAV	2
Axle Shaft Seal (With Axle Code "C")	710166	2
Axle Shaft Seal (With Axle Code "K")	8660S	2

AK26		
Position	Part Number	Qty
Axle Shaft Brg.	6410	2
Axle Shaft Seal	710498	2

AK27		
Position	Part Number	Qty
Axle Shaft Brg.	207	2
Axle Shaft Seal	DS48675	2

AK29		
Position	Part Number	Qty
Axle Shaft Brg. (Inner)	387AS-382A	2
Axle Shaft Brg. (Outer)	LM104949-LM104911	2
Axle Shaft Seal	710568	2

AK30		
Position	Part Number	Qty
Axle Shaft Brg. (Outer)	LM104949-LM104911	2
Axle Shaft Brg. (Inner)	28682-28622	2
Axle Shaft Seal	710564	2

AK33		
Position	Part Number	Qty
Axle Shaft Brg.	RW130R	2
Axle Shaft Seal (Outer)	1956	2
Axle Shaft Seal (Inner)	1960	2

AK34		
Position	Part Number	Qty
Axle Shaft Brg.	511021	2
Axle Shaft Seal (Outer)	1956	2
Axle Shaft Seal (Inner)	1960	2

AK35		
Position	Part Number	Qty
Axle Shaft Brg.	511031	2
Axle Shaft Seal (Inner)	1960	2
Axle Shaft Seal (Outer)	710574	2

AK36		
Position	Part Number	Qty
Axle Shaft Brg.	FC66998	2
Axle Shaft Seal	100537V	2

AK37		
Position	Part Number	Qty
Axle Shaft Brg.	A9	2
Axle Shaft Seal	712146	2

AK38		
Position	Part Number	Qty
Axle Shaft Brg.	513067	2
Axle Shaft Seal	8835S	2

AK39		
Position	Part Number	Qty
Axle Shaft Brg.	BH2212	2
Axle Shaft Seal	5872S	2

AK40		
Position	Part Number	Qty
Axle Shaft Brg.	JLM603048F-JLM603013Z	4
Axle Shaft Seal (Inner)	470547	2
Axle Shaft Seal (Outer)	3942	2

AK41		
Position	Part Number	Qty
Axle Shaft Brg.	R1563TAV	1
Axle Shaft Seal Left	710043	1
Axle Shaft Seal Right	DS40773	1

AK42		
Position	Part Number	Qty
Axle Shaft Brg. (Inner)	387AS-382A	2
Axle Shaft Brg. (Outer)	LM104949-LM104911	2
Axle Shaft Seal	35009N	2

AK43		
Position	Part Number	Qty
Axle Shaft Brg.	R1563TAV	2
Axle Shaft Seal	4857	2

AK44		
Position	Part Number	Qty
Axle Shaft Brg. (Inner)	NP080525-NP543803	2
Axle Shaft Brg. (Outer)	NP622157-NP382209	2
Axle Shaft Seal	710568	2

AK81		
Position	Part Number	Qty
Axle Shaft Brg.	SCH78	1
Axle Shaft Brg.	BH208	1
Axle Shaft Brg.	J2010	2
Axle Shaft Seal	710101	2

AK83		
Position	Part Number	Qty
Front Axle Clutch Shaft Brg.	SCH78	1
Front Axle Shaft Outer Brg.	BH208	1
Front Axle Shaft Inner Brg.	J2010	2
Axle Shaft Seal	710475	2

AK84		
Position	Part Number	Qty
Front Axle Shaft Inner Brg.	J2010	1
Front Axle Shaft Outer Brg.	BH208	1
Axle Shaft Seal	710475	2

AK85		
Position	Part Number	Qty
Axle Shaft Brg.	HK4012	2
Axle Shaft Seal	40037764	2

AK86		
Position	Part Number	Qty
Front Axle Clutch Shaft Brg.	SCH78	2
Front Axle Shaft Inner Brg.	J2010	1
Front Axle Shaft Outer Brg.	HK4012	2
Axle Shaft Seal	40007630	2

AK87		
Position	Part Number	Qty
Axle Shaft Brg. (Inner)	BH208	2
Axle Shaft Brg. (Outer)	HK4012	3
Axle Shaft Seal Left	40050495	1
Axle Shaft Seal Right	46002024	1

AK88		
Position	Part Number	Qty
Axle Shaft Brg.	FC66998	2
Front Axle Shaft Inner Brg.	HK1816B	1
Front Axle Shaft Outer Brg.	HK4012	1
Axle Shaft Seal	SL260030	2

AK89		
Position	Part Number	Qty
Axle Shaft Brg.	BH2212	2
Axle Shaft Seal	710429	2

AK90		
Position	Part Number	Qty
Axle Shaft Brg.	FC66998	2
Axle Shaft Seal	714569	2

LD Differential

Light Duty Differential Rebuild Kits



AK91		
Position	Part Number	Qty
Axle Shaft Brg.	FC66998	2
Front Axle Shaft Inner Brg.	HK1816B	1
Front Axle Shaft Outer Brg.	HK4012	1
Axle Shaft Seal	100537	1

AK92		
Position	Part Number	Qty
Front Axle Shaft Pilot Brg.	SCH78	1
Front Axle Shaft Inner Brg.	B2610	2
Front Axle Shaft Outer Brg.	B2410	1
Axle Shaft Seal	710497	2

WK10		
Position	Part Number	Qty
Axle Shaft Brg.	R1559TV	1
Axle Shaft Seal	8835S	1

WK11		
Position	Part Number	Qty
Axle Shaft Brg.	R1563TAV	1
Axle Shaft Seal	8660S	1

WK12		
Position	Part Number	Qty
Axle Shaft Brg.	513067	1
Axle Shaft Seal	4762N	1

WK14		
Position	Part Number	Qty
Axle Shaft Brg.	513023	1
Axle Shaft Seal	4795V	1

WK15		
Position	Part Number	Qty
Axle Shaft Brg.	R1561TV	1
Axle Shaft Seal	100357V	1

WK16		
Position	Part Number	Qty
Axle Shaft Brg.	R1561TV	1
Axle Shaft Seal	710105	1

WK17		
Position	Part Number	Qty
Axle Shaft Brg.	R1561TV	1
Axle Shaft Seal	8835S	1

WK18		
Position	Part Number	Qty
Axle Shaft Brg.	LM104949-LM104911	2
Axle Shaft Seal	4250	1

WK21		
Position	Part Number	Qty
Axle Shaft Brg. (Inner)	387AS-387A	1
Axle Shaft Brg. (Outer)	LM104949-LM104911	1
Axle Shaft Seal	2081	1

WK22		
Position	Part Number	Qty
Axle Shaft Brg.	R1561TV	1
Axle Shaft Seal	710067	1

WK23		
Position	Part Number	Qty
Axle Shaft Brg. (Inner)	387AS-382A	1
Axle Shaft Brg. (Outer)	LM104949-LM104911	1
Axle Shaft Seal	9864S	1

WK24		
Position	Part Number	Qty
Axle Shaft Brg.	A9	1
Axle Shaft Seal	710179	1

WK25		
Position	Part Number	Qty
Axle Shaft Brg.	R1563TAV	1
Axle Shaft Seal (With Axle Code "C")	710166	1
Axle Shaft Seal (With Axle Code "K")	8660S	1

WK26		
Position	Part Number	Qty
Axle Shaft Brg.	6410	2
Axle Shaft Seal	710498	2

WK27		
Position	Part Number	Qty
Axle Shaft Brg.	207	1
Axle Shaft Seal	DS48675	1

WK29		
Position	Part Number	Qty
Axle Shaft Brg. (Inner)	387AS-382A	1
Axle Shaft Brg. (Outer)	LM104949-LM104911	1
Axle Shaft Seal	710568	1

WK30		
Position	Part Number	Qty
Axle Shaft Brg. (Outer)	LM104949-LM104911	1
Axle Shaft Brg. (Inner)	28682-28622	1
Axle Shaft Seal	710564	1

WK33		
Position	Part Number	Qty
Axle Shaft Brg.	308FF	1
Lock Collar	R130	1
Axle Shaft Seal (Outer)	1956	1
Axle Shaft Seal (Inner)	1960	1

WK34		
Position	Part Number	Qty
Axle Shaft Brg.	308FF	1
Lock Collar	R130	2
Axle Shaft Seal (Outer)	1956	1
Axle Shaft Seal (Inner)	1960	1

WK35		
Position	Part Number	Qty
Axle Shaft Brg.	511031	1
Axle Shaft Seal (Inner)	1960	1
Axle Shaft Seal (Outer)	710574	1

WK36		
Position	Part Number	Qty
Axle Shaft Brg.	FC66998	1
Axle Shaft Seal	100537V	2

WK37		
Position	Part Number	Qty
Axle Shaft Brg.	A9	1
Axle Shaft Seal	712146	1

WK38		
Position	Part Number	Qty
Axle Shaft Brg.	513067	1
Axle Shaft Seal	8835S	1

WK40		
Position	Part Number	Qty
Axle Shaft Brg.	JLM603048F-JLM603013Z	2
Axle Shaft Seal (Inner)	470547	1
Axle Shaft Seal (Outer)	3942	1

WK42		
Position	Part Number	Qty
Axle Shaft Brg. (Inner)	387AS-382A	1
Axle Shaft Brg. (Outer)	LM104949-LM104911	1
Axle Shaft Seal	35009N	1

WK43		
Position	Part Number	Qty
Axle Shaft Brg.	R1563TAV	1
Axle Shaft Seal	4857	1

WK44		
Position	Part Number	Qty
Axle Shaft Brg. (Inner)	NP080525-NP543803	1
Axle Shaft Brg. (Outer)	NP622157-NP382209	1
Axle Shaft Seal	710568	1

DRK-300		
Position	Part Number	Qty
Differential Brg.	25590-25520	2
Pinion Head Brg.	HM803149-HM803110	1
Pinion Tail Brg.	HM89443-HM89410	1
Pinion Seal	7216 (18912)	1
Pinion Nut	PN8-F	1
Gear Marking & Brush	GMC1-BR1	1
Threadlocker	TL1	1
Sealer	RTV Silicone	1

DRK-300MK		
Position	Part Number	Qty
Differential Brg.	25590-25520	2
Pinion Head Brg.	HM803149-HM803110	1
Pinion Tail Brg.	HM89443-HM89410	1
Pinion Seal	7216 (18912)	1
Pinion Nut	PN8-F	1
Gear Marking & Brush	GMC1-BR1	1
Threadlocker	TL1	1
Sealer	RTV Silicone	1
Pinion Brg. Shims	SK2	1
Pinion Depth Shims	SK1	1
Ring Gear Bolts	RGB1	12

DRK-301		
Position	Part Number	Qty
Differential Brg.	LM104949-LM104912	2
Pinion Head Brg.	M804049-M804010	1
Pinion Tail Brg.	M88048-M88010	1
Pinion Seal	5126 (18708)	1
Crush Sleeve	CS301	1
Pinion Nut	PN8-F	1
Pinion Nut	PN3	1
Gear Marking & Brush	GMC1-BR1	1
Threadlocker	TL1	1
Sealer	RTV Silicone	1

DRK-301MK		
Position	Part Number	Qty
Differential Brg.	LM104949-LM104912	2
Pinion Head Brg.	M804049-M804010	1
Pinion Tail Brg.	M88048-M88010	1
Pinion Seal	5126 (18708)	1
Crush Sleeve	CS301	1
Pinion Nut	PN8-F	1
Pinion Nut	PN3	1
Gear Marking & Brush	GMC1-BR1	1
Threadlocker	TL1	1
Sealer	RTV Silicone	1
Pinion Depth Shims	SK3	1
Ring Gear Bolts	RGB1	12

LD Differential

Light Duty Differential Rebuild Kits

DRK-302			DRK-303AMK			DRK-304AMK		
Position	Part Number	Qty	Position	Part Number	Qty	Position	Part Number	Qty
Differential Brg.	LM501349-LM501310	2	Differential Brg.	LM603049-LM603012	2	Differential Brg.	JLM704649-JLM704610	2
Pinion Head Brg.	HM88649-HM88610	1	Pinion Head Brg.	M802048-M802011	1	Pinion Head Brg.	NP524102-NP912904	1
Pinion Tail Brg.	M86649-M86610	1	Pinion Tail Brg.	M86649-M86610	1	Pinion Tail Brg.	M88048-M88010	1
Pinion Seal	8516N (16805)	1	Pinion Seal	5126 (18708)	1	Pinion Seal	710481	1
Crush Sleeve	CS310	1	Crush Sleeve	CS310	1	Crush Sleeve	CS303	1
Pinion Nut	PN3	1	Pinion Nut	PN3	1	Pinion Nut	PN3	1
Gear Marking & Brush	GMC1-BR1	1	Gear Marking & Brush	GMC1-BR1	1	Gear Marking & Brush	GMC1-BR1	1
Threadlocker	TL1	1	Threadlocker	TL1	1	Threadlocker	TL1	1
Sealer	RTV Silicone	1	Sealer	RTV Silicone	1	Sealer	RTV Silicone	1
DRK-302MK			DRK-303B			DRK-305		
Position	Part Number	Qty	Position	Part Number	Qty	Position	Part Number	Qty
Differential Brg.	LM501349-LM501310	2	Differential Brg.	LM603049-LM603012	2	Differential Brg.	LM102949-LM102911	2
Pinion Head Brg.	HM88649-HM88610	1	Pinion Head Brg.	M802048-M802011	1	Pinion Head Brg.	NP722065-NP1013743	1
Pinion Tail Brg.	M86649-M86610	1	Pinion Tail Brg.	M86649-M86610	1	Pinion Tail Brg.	M88048-M88010	1
Pinion Seal	8516N (16805)	1	Pinion Seal	710480	1	Pinion Seal	710476	1
Crush Sleeve	CS310	1	Crush Sleeve	CS310	1	Crush Sleeve	CS303	1
Pinion Nut	PN3	1	Pinion Nut	PN3	1	Pinion Nut	PN3	1
Gear Marking & Brush	GMC1-BR1	1	Gear Marking & Brush	GMC1-BR1	1	Gear Marking & Brush	GMC1-BR1	1
Threadlocker	TL1	1	Threadlocker	TL1	1	Threadlocker	TL1	1
Sealer	RTV Silicone	1	Sealer	RTV Silicone	1	Sealer	RTV Silicone	1
Pinion Depth Shims	SK12	1	Pinion Depth Shims	SK4	1	Pinion Depth Shims	SK20	1
Ring Gear Bolts	RGB1	8	Ring Gear Bolts	RGB1	10	Ring Gear Bolts	RGB1	10
DRK-303			DRK-303BMK			DRK-305MK		
Position	Part Number	Qty	Position	Part Number	Qty	Position	Part Number	Qty
Differential Brg.	LM603049-LM603012	2	Differential Brg.	LM603049-LM603012	2	Differential Brg.	LM102949-LM102911	2
Pinion Head Brg.	M802048-M802011	1	Pinion Head Brg.	M802048-M802011	1	Pinion Head Brg.	NP722065-NP1013743	1
Pinion Tail Brg.	M86649-M86610	1	Pinion Tail Brg.	M86649-M86610	1	Pinion Tail Brg.	M88048-M88010	1
Pinion Seal	8516N (16805)	1	Pinion Seal	710480	1	Pinion Seal	710476	1
Pinion Seal	3638 (11111)	1	Crush Sleeve	CS310	1	Crush Sleeve	CS303	1
Crush Sleeve	CS310	1	Pinion Nut	PN3	1	Pinion Nut	PN3	1
Pinion Nut	PN3	1	Gear Marking & Brush	GMC1-BR1	1	Gear Marking & Brush	GMC1-BR1	1
Gear Marking & Brush	GMC1-BR1	1	Threadlocker	TL1	1	Threadlocker	TL1	1
Threadlocker	TL1	1	Sealer	RTV Silicone	1	Sealer	RTV Silicone	1
Sealer	RTV Silicone	1	Pinion Depth Shims	SK4	1	Pinion Depth Shims	SK20	1
DRK-303MK			DRK-304			DRK-305A		
Position	Part Number	Qty	Position	Part Number	Qty	Position	Part Number	Qty
Differential Brg.	LM603049-LM603012	2	Differential Brg.	JLM704649-JLM704610	2	Differential Brg.	LM102949-LM102911	2
Pinion Head Brg.	M802048-M802011	1	Pinion Head Brg.	M804049-M804010	1	Pinion Head Brg.	NP682887-NP307044	1
Pinion Tail Brg.	M86649-M86610	1	Pinion Tail Brg.	M88048-M88010	1	Pinion Tail Brg.	NP270758-NP378971	1
Pinion Seal	8516N (16805)	1	Pinion Seal	5126 (18708)	1	Pinion Seal	52070457AA	1
Pinion Seal	3638 (11111)	1	Crush Sleeve	CS303	1	Crush Sleeve	CS303	1
Crush Sleeve	CS310	1	Pinion Nut	PN3	1	Pinion Nut	PN3	1
Pinion Nut	PN3	1	Gear Marking & Brush	GMC1-BR1	1	Gear Marking & Brush	GMC1-BR1	1
Gear Marking & Brush	GMC1-BR1	1	Threadlocker	TL1	1	Threadlocker	TL1	1
Threadlocker	TL1	1	Sealer	RTV Silicone	1	Sealer	RTV Silicone	1
Sealer	RTV Silicone	1	DRK-304MK			DRK-305AMK		
Pinion Depth Shims	SK4	1	Position	Part Number	Qty	Position	Part Number	Qty
Ring Gear Bolts	RGB1	10	Differential Brg.	JLM704649-JLM704610	2	Differential Brg.	LM102949-LM102911	2
DRK-303A			DRK-304A			DRK-305AMK		
Position	Part Number	Qty	Position	Part Number	Qty	Position	Part Number	Qty
Differential Brg.	LM603049-LM603012	2	Differential Brg.	JLM704649-JLM704610	2	Differential Brg.	LM102949-LM102911	2
Pinion Head Brg.	M802048-M802011	1	Pinion Head Brg.	M804049-M804010	1	Pinion Head Brg.	NP682887-NP307044	1
Pinion Tail Brg.	M86649-M86610	1	Pinion Tail Brg.	M88048-M88010	1	Pinion Tail Brg.	NP270758-NP378971	1
Pinion Seal	8516N (16805)	1	Pinion Seal	5126 (18708)	1	Pinion Seal	52070457AA	1
Pinion Seal	5126 (18708)	1	Crush Sleeve	CS303	1	Crush Sleeve	CS303	1
Crush Sleeve	CS310	1	Pinion Nut	PN3	1	Pinion Nut	PN3	1
Pinion Nut	PN3	1	Gear Marking & Brush	GMC1-BR1	1	Gear Marking & Brush	GMC1-BR1	1
Gear Marking & Brush	GMC1-BR1	1	Threadlocker	TL1	1	Threadlocker	TL1	1
Threadlocker	TL1	1	Sealer	RTV Silicone	1	Sealer	RTV Silicone	1
Sealer	RTV Silicone	1	Pinion Depth Shims	SK3	1	Pinion Depth Shims	SK20	1
DRK-304A			DRK-304A			DRK-305AMK		
Position	Part Number	Qty	Position	Part Number	Qty	Position	Part Number	Qty
Differential Brg.	JLM704649-JLM704610	2	Differential Brg.	JLM704649-JLM704610	2	Differential Brg.	LM102949-LM102911	2
Pinion Head Brg.	NP524102-NP912904	1	Pinion Head Brg.	NP524102-NP912904	1	Pinion Head Brg.	NP682887-NP307044	1
Pinion Tail Brg.	M88048-M88010	1	Pinion Tail Brg.	M88048-M88010	1	Pinion Tail Brg.	NP270758-NP378971	1
Pinion Seal	710481	1	Pinion Seal	710481	1	Pinion Seal	52070457AA	1
Crush Sleeve	CS303	1	Crush Sleeve	CS303	1	Crush Sleeve	CS303	1
Pinion Nut	PN3	1	Pinion Nut	PN3	1	Pinion Nut	PN3	1
Gear Marking & Brush	GMC1-BR1	1	Gear Marking & Brush	GMC1-BR1	1	Gear Marking & Brush	GMC1-BR1	1
Threadlocker	TL1	1	Threadlocker	TL1	1	Threadlocker	TL1	1
Sealer	RTV Silicone	1	Sealer	RTV Silicone	1	Sealer	RTV Silicone	1

LD Differential

Light Duty Differential Rebuild Kits



DRK-306		
Position	Part Number	Qty
Differential Brg.	387AS-382A	2
Pinion Head Brg.	NP598002-NP284552	1
Pinion Tail Brg.	M802048-M802011	1
Pinion Seal	710508	1
Crush Sleeve	CS347	1
Pinion Nut	PN17	1
Gear Marking & Brush	GMC1-BR1	1
Threadlocker	TL1	1
Sealer	RTV Silicone	1

DRK-306MK		
Position	Part Number	Qty
Differential Brg.	387AS-382A	2
Pinion Head Brg.	NP598002-NP284552	1
Pinion Tail Brg.	M802048-M802011	1
Pinion Seal	710508	1
Crush Sleeve	CS347	1
Pinion Nut	PN17	1
Gear Marking & Brush	GMC1-BR1	1
Threadlocker	TL1	1
Sealer	RTV Silicone	1
Pinion Depth Shims	SK3	1
Ring Gear Bolts	RGB21	12

DRK-307		
Position	Part Number	Qty
Differential Brg.	LM806649-LM806610	2
Pinion Head Brg.	HM803146-HM803110	1
Pinion Tail Brg.	M88043-M88010	1
Pinion Seal	5103900AA	1
Crush Sleeve	CS352	1
Pinion Nut	PN19	1
Gear Marking & Brush	GMC1-BR1	1
Threadlocker	TL1	1
Sealer	RTV Silicone	1

DRK-307MK		
Position	Part Number	Qty
Differential Brg.	LM806649-LM806610	2
Pinion Head Brg.	HM803146-HM803110	1
Pinion Tail Brg.	M88043-M88010	1
Pinion Seal	5103900AA	1
Crush Sleeve	CS352	1
Pinion Nut	PN19	1
Gear Marking & Brush	GMC1-BR1	1
Threadlocker	TL1	1
Sealer	RTV Silicone	1
Pinion Depth Shims	SK1	1
Differential Shims	SK13	1
Ring Gear Bolts	RGB26	10

DRK-307A		
Position	Part Number	Qty
Differential Brg.	32012-JR/1B	2
Pinion Head Brg.	T7FC045	1
Pinion Tail Brg.	30307-DJR	1
Pinion Seal	68019031AB	1
Crush Sleeve	CS354	1
Pinion Nut	PN21	1
Gear Marking & Brush	GMC1-BR1	1
Threadlocker	TL1	1
Sealer	RTV Silicone	1

DRK-307AMK		
Position	Part Number	Qty
Differential Brg.	32012-JR/1B	2
Pinion Head Brg.	T7FC045	1
Pinion Tail Brg.	30307-DJR	1
Pinion Seal	68019031AB	1
Crush Sleeve	CS354	1
Pinion Nut	PN21	1
Gear Marking & Brush	GMC1-BR1	1
Threadlocker	TL1	1
Sealer	RTV Silicone	1
Pinion Depth Shims	SK1	1
Differential Shims	SK13	1
Ring Gear Bolts	RGB26	10

DRK-308		
Position	Part Number	Qty
Differential Brg.	LM603049-LM603012	2
Pinion Head Brg.	HM803146-HM803110	1
Pinion Tail Brg.	M88043-M88010	1
Pinion Seal	52111953AC	1
Crush Sleeve	CS304	1
Pinion Nut	PN19	1
Gear Marking & Brush	GMC1-BR1	1
Threadlocker	TL1	1
Sealer	RTV Silicone	1

DRK-310		
Position	Part Number	Qty
Differential Brg.	LM501349-LM501310	2
Pinion Head Brg.	M86649-M86610	1
Pinion Tail Brg.	M86649-M86610	1
Pinion Nose Brg.	R1558TAV	1
Pinion Seal	8181-NA (18100)	1
Crush Sleeve	CS310	1
Pinion Nut	PN2	1
Gear Marking & Brush	GMC1-BR1	1
Threadlocker	TL1	1
Sealer	RTV Silicone	1
O-Ring	OR241	1

DRK-310MK		
Position	Part Number	Qty
Differential Brg.	LM501349-LM501310	2
Pinion Head Brg.	M86649-M86610	1
Pinion Tail Brg.	M86649-M86610	1
Pinion Nose Brg.	R1558TAV	1
Pinion Seal	8181-NA (18100)	1
Crush Sleeve	CS310	1
Pinion Nut	PN2	1
Gear Marking & Brush	GMC1-BR1	1
Threadlocker	TL1	1
Sealer	RTV Silicone	1
Pinion Depth Shims	SK6	1
Ring Gear Bolts	RGB3	10
O-Ring	OR241	1

DRK-311		
Position	Part Number	Qty
Differential Brg.	LM603049-LM603012	2
Pinion Head Brg.	M802048-M802011	1
Pinion Tail Brg.	M88048-M88010	1
Pinion Seal	3604 (18190)	1
Crush Sleeve	CS311	1
Pinion Nut	PN2	1
Gear Marking & Brush	GMC1-BR1	1
Threadlocker	TL1	1
Sealer	RTV Silicone	1

DRK-311MK		
Position	Part Number	Qty
Differential Brg.	LM603049-LM603012	2
Pinion Head Brg.	M802048-M802011	1
Pinion Tail Brg.	M88048-M88010	1
Pinion Seal	3604 (18190)	1
Crush Sleeve	CS311	1
Pinion Nut	PN2	1
Gear Marking & Brush	GMC1-BR1	1
Threadlocker	TL1	1
Sealer	RTV Silicone	1
Pinion Depth Shims	SK4	1
Differential Shims	SK7 ²⁷	1
Ring Gear Bolts	RGB3	10

DRK-311E		
Position	Part Number	Qty
Differential Brg.	LM603049-LM603012	2
Pinion Head Brg.	STD4183KELFT	1
Pinion Tail Brg.	M88048-M88010	1
Pinion Seal	3604 (18190)	1
Crush Sleeve	CS311	1
Pinion Nut	PN2	1
Gear Marking & Brush	GMC1-BR1	1
Threadlocker	TL1	1
Sealer	RTV Silicone	1

DRK-311EMK		
Position	Part Number	Qty
Differential Brg.	LM603049-LM603012	2
Pinion Head Brg.	STD4183KELFT	1
Pinion Tail Brg.	M88048-M88010	1
Pinion Seal	3604 (18190)	1
Crush Sleeve	CS311	1
Pinion Nut	PN2	1
Gear Marking & Brush	GMC1-BR1	1
Threadlocker	TL1	1
Sealer	RTV Silicone	1
Pinion Depth Shims	SK4	1
Differential Shims	SK7 ²⁷	1
Ring Gear Bolts	RGB3	10

DRK-311G		
Position	Part Number	Qty
Differential Brg.	LM603049-LM603012	2
Pinion Head Brg.	STD4183KELFT	1
Pinion Tail Brg.	NP966883-NP759177	1
Pinion Seal	3604 (18190)	1
Crush Sleeve	CS311	1
Pinion Nut	PN2	1
Gear Marking & Brush	GMC1-BR1	1
Threadlocker	TL1	1
Sealer	RTV Silicone	1

DRK-311GMK		
Position	Part Number	Qty
Differential Brg.	LM603049-LM603012	2
Pinion Head Brg.	STD4183KELFT	1
Pinion Tail Brg.	NP966883-NP759177	1
Pinion Seal	3604 (18190)	1
Crush Sleeve	CS311	1
Pinion Nut	PN2	1
Gear Marking & Brush	GMC1-BR1	1
Threadlocker	TL1	1
Sealer	RTV Silicone	1
Pinion Depth Shims	SK4	1
Differential Shims	SK7 ²⁷	1
Ring Gear Bolts	RGB3	10

LD Differential

Light Duty Differential Rebuild Kits



DRK-313A		
Position	Part Number	Qty
Differential Brg.	LM603049-LM603011	2
Pinion Head Brg.	HM89443-HM89410	1
Pinion Tail Brg.	M88048-M88010	1
Pinion Nose Brg.	R1535TAV	1
Pinion Nose Brg.	R1535-CLIP	1
Retainer		
Pinion Seal	7044NA (18833)	1
Solid Spacer Kit	SS9	1
Pinion Nut	PN2	1
Gear Marking & Brush	GMC1-BR1	1
Threadlocker	TL1	1
Sealer	RTV Silicone	1
O-Ring	OR248	1

DRK-313AMK		
Position	Part Number	Qty
Differential Brg.	LM603049-LM603011	2
Pinion Head Brg.	HM89443-HM89410	1
Pinion Tail Brg.	M88048-M88010	1
Pinion Nose Brg.	R1535TAV	1
Pinion Nose Brg.	R1535-CLIP	1
Retainer		
Pinion Seal	7044NA (18833)	1
Solid Spacer Kit	SS9	1
Pinion Nut	PN2	1
Gear Marking & Brush	GMC1-BR1	1
Threadlocker	TL1	1
Sealer	RTV Silicone	1
Pinion Depth Shims	SK8	1
Ring Gear Bolts	RGB4	10
O-Ring	OR248	1

DRK-313B		
Position	Part Number	Qty
Differential Brg.	LM104949-LM104911	2
Pinion Head Brg.	HM89443-HM89410	1
Pinion Tail Brg.	M88048-M88010	1
Pinion Nose Brg.	R1535TAV	1
Pinion Nose Brg.	R1535-CLIP	1
Retainer		
Pinion Seal	7044NA (18833)	1
Solid Spacer Kit	SS9	1
Pinion Nut	PN2	1
Gear Marking & Brush	GMC1-BR1	1
Threadlocker	TL1	1
Sealer	GR-F900	1
O-Ring	OR248	1
Washer	5138	1

DRK-313BMK		
Position	Part Number	Qty
Differential Brg.	LM104949-LM104911	2
Pinion Head Brg.	HM89443-HM89410	1
Pinion Tail Brg.	M88048-M88010	1
Pinion Nose Brg.	R1535TAV	1
Pinion Nose Brg.	R1535-CLIP	1
Retainer		
Pinion Seal	7044NA (18833)	1
Solid Spacer Kit	SS9	1
Pinion Nut	PN2	1
Gear Marking & Brush	GMC1-BR1	1
Threadlocker	TL1	1
Sealer	GR-F900	1
Pinion Depth Shims	SK8	1
Ring Gear Bolts	RGB4	10
O-Ring	OR248	1
Washer	5138	1

DRK-313C		
Position	Part Number	Qty
Differential Brg.	LM603049-LM603011	2
Pinion Head Brg.	M88048-M88010	1
Pinion Tail Brg.	M88048-M88010	1
Pinion Nose Brg.	R1535TAV	1
Pinion Nose Brg.	R1535-CLIP	1
Retainer		
Pinion Seal	7044NA (18833)	1
Crush Sleeve	CS311	1
Pinion Nut	PN2	1
Gear Marking & Brush	GMC1-BR1	1
Threadlocker	TL1	1
Sealer	RTV Silicone	1
O-Ring	OR248	1

DRK-313CMK		
Position	Part Number	Qty
Differential Brg.	LM603049-LM603011	2
Pinion Head Brg.	M88048-M88010	1
Pinion Tail Brg.	M88048-M88010	1
Pinion Nose Brg.	R1535TAV	1
Pinion Nose Brg.	R1535-CLIP	1
Retainer		
Pinion Seal	7044NA (18833)	1
Crush Sleeve	CS311	1
Pinion Nut	PN2	1
Gear Marking & Brush	GMC1-BR1	1
Threadlocker	TL1	1
Sealer	RTV Silicone	1
Pinion Depth Shims	SK8	1
Ring Gear Bolts	RGB4	10
O-Ring	OR248	1

DRK-313D		
Position	Part Number	Qty
Differential Brg.	LM104949-LM104911	2
Pinion Head Brg.	HM89444-HM89410	1
Pinion Tail Brg.	M88048-M88010	1
Pinion Nose Brg.	R1535TAV	1
Pinion Nose Brg.	R1535-CLIP	1
Retainer		
Pinion Seal	7044NA (18833)	1
Solid Spacer Kit	SS9	1
Pinion Nut	PN2	1
Gear Marking & Brush	GMC1-BR1	1
Threadlocker	TL1	1
Sealer	RTV Silicone	1
O-Ring	OR248	1

DRK-313DMK		
Position	Part Number	Qty
Differential Brg.	LM104949-LM104911	2
Pinion Head Brg.	HM89444-HM89410	1
Pinion Tail Brg.	M88048-M88010	1
Pinion Nose Brg.	R1535TAV	1
Pinion Nose Brg.	R1535-CLIP	1
Retainer		
Pinion Seal	7044NA (18833)	1
Solid Spacer Kit	SS9	1
Pinion Nut	PN2	1
Gear Marking & Brush	GMC1-BR1	1
Threadlocker	TL1	1
Sealer	RTV Silicone	1
O-Ring	OR248	1
Pinion Depth Shims	SK8	1
Ring Gear Bolts	RGB4	10

DRK-314		
Position	Part Number	Qty
Differential Brg.	469-453X	2
Pinion Head Brg.	HM807044-HM807010	1
Pinion Tail Brg.	HM89443-HM89411	1
Pinion Seal	4278 (18024)	1
Crush Sleeve	CS311	1
Pinion Nut	PN6	1
Gear Marking & Brush	GMC1-BR1	1
Threadlocker	TL1	1
Sealer	RTV Silicone	1

DRK-314MK		
Position	Part Number	Qty
Differential Brg.	469-453X	2
Pinion Head Brg.	HM807044-HM807010	1
Pinion Tail Brg.	HM89443-HM89411	1
Pinion Seal	4278 (18024)	1
Crush Sleeve	CS311	1
Pinion Nut	PN6	1
Gear Marking & Brush	GMC1-BR1	1
Threadlocker	TL1	1
Sealer	RTV Silicone	1
Pinion Depth Shims	SK3	1
Differential Shims	SK10 ⁵³	1
Ring Gear Bolts	RGB6	12

DRK-314AMK		
Position	Part Number	Qty
Differential Brg.	469-453X	2
Pinion Head Brg.	HM807044-HM807010	1
Pinion Tail Brg.	HM89443-HM89411	1
Pinion Seal	4278 (18024)	1
Crush Sleeve	CS311	1
Pinion Nut	PN6	1
Gear Marking & Brush	GMC1-BR1	1
Threadlocker	TL1	1
Sealer	RTV Silicone	1
Pinion Depth Shims	SK7	1
Differential Shims	SK10 ⁵³	1
Ring Gear Bolts	RGB6	12
Pinion Nut Washer	DS30275	1

DRK-315		
Position	Part Number	Qty
Differential Brg.	LM501349-LM501314	2
Pinion Head Brg.	M802048-M802011	1
Pinion Tail Brg.	M88048-M88010	1
Pinion Seal	3604 (18190)	1
Crush Sleeve	CS311	1
Pinion Nut	PN2	1
Gear Marking & Brush	GMC1-BR1	1
Threadlocker	TL1	1
Sealer	RTV Silicone	1

DRK-315MK		
Position	Part Number	Qty
Differential Brg.	LM501349-LM501314	2
Pinion Head Brg.	M802048-M802011	1
Pinion Tail Brg.	M88048-M88010	1
Pinion Seal	3604 (18190)	1
Crush Sleeve	CS311	1
Pinion Nut	PN2	1
Gear Marking & Brush	GMC1-BR1	1
Threadlocker	TL1	1
Sealer	RTV Silicone	1
Pinion Depth Shims	SK4	1
Differential Shims	SK11 ²⁸	1
Ring Gear Bolts	RGB3	10

LD Differential

184 ²⁸ Order SSK11 for stackable differential shims.
⁵³ Order SSK10 for stackable differential shims.

Light Duty Differential Rebuild Kits

DRK-316			DRK-316BMK			DRK-316E		
Position	Part Number	Qty	Position	Part Number	Qty	Position	Part Number	Qty
Differential Brg.	NP343847-NP372019	2	Differential Brg.	NP912771-NP847706	2	Differential Brg.	NP912771-NP847706	2
Pinion Head Brg.	NP576375-NP434567	1	Pinion Head Brg.	NP665996-NP244986	1	Pinion Head Brg.	TRD1010040R4	1
Pinion Tail Brg.	M88048-M88010	1	Pinion Tail Brg.	HM89443-HM89411	1	Pinion Tail Brg.	STD3776-2	1
Pinion Seal	3604 (18190)	1	Pinion Seal	4278	1	Pinion Seal	4278	1
Crush Sleeve	CS311	1	Crush Sleeve	CS311	1	Crush Sleeve	CS355	1
Pinion Nut	PN13	1	Pinion Nut	PN6	1	Pinion Nut	PN6	1
Gear Marking & Brush	GMC1-BR1	1	Gear Marking & Brush	GMC1-BR1	1	Gear Marking & Brush	GMC1-BR1	1
Threadlocker	TL1	1	Threadlocker	TL1	1	Threadlocker	TL1	1
Sealer	RTV Silicone	1	Sealer	RTV Silicone	1	Sealer	RTV Silicone	1
DRK-316MK			DRK-316C			DRK-316EMK		
Position	Part Number	Qty	Position	Part Number	Qty	Position	Part Number	Qty
Differential Brg.	NP343847-NP372019	2	Differential Brg.	NP912771-NP847706	2	Differential Brg.	NP912771-NP847706	2
Pinion Head Brg.	NP576375-NP434567	1	Pinion Head Brg.	TRD101004UR4	1	Pinion Head Brg.	TRD1010040R4	1
Pinion Tail Brg.	M88048-M88010	1	Pinion Tail Brg.	HM89448-HM89411	1	Pinion Tail Brg.	STD3776-2	1
Pinion Seal	3604 (18190)	1	Pinion Seal	4278	1	Pinion Seal	4278	1
Crush Sleeve	CS311	1	Crush Sleeve	CS355	1	Crush Sleeve	CS355	1
Pinion Nut	PN13	1	Pinion Nut	PN6	1	Pinion Depth Shims	SK41	1
Gear Marking & Brush	GMC1-BR1	1	Gear Marking & Brush	GMC1-BR1	1	Differential Shims	SK42 ⁵²	1
Threadlocker	TL1	1	Threadlocker	TL1	1	Pinion Nut	PN6	1
Sealer	RTV Silicone	1	Sealer	RTV Silicone	1	Ring Gear Bolts	RGB18	12
Pinion Depth Shims	SK41	1	Pinion Depth Shims	SK41	1	Gear Marking & Brush	GMC1-BR1	1
Differential Shims	SK42 ⁵²	1	Differential Shims	SK42 ⁵²	1	Threadlocker	TL1	1
Ring Gear Bolts	RGB18	12	Ring Gear Bolts	RGB18	12	Sealer	RTV Silicone	1
DRK-316A			DRK-316CMK			DRK-317		
Position	Part Number	Qty	Position	Part Number	Qty	Position	Part Number	Qty
Differential Brg.	NP343847-NP372019	2	Differential Brg.	NP912771-NP847706	2	Differential Brg.	469-453X	2
Pinion Head Brg.	NP576375-NP434567	1	Pinion Head Brg.	TRD101004UR4	1	Pinion Head Brg.	NP504493-NP949481	1
Pinion Tail Brg.	HM89443-HM89411	1	Pinion Tail Brg.	HM89448-HM89411	1	Pinion Tail Brg.	HM89443-HM89411	1
Pinion Seal	4278 (18024)	1	Pinion Seal	4278	1	Pinion Seal	4278 (18024)	1
Crush Sleeve	CS311	1	Crush Sleeve	CS355	1	Crush Sleeve	CS311	1
Pinion Nut	PN6	1	Pinion Nut	PN6	1	Pinion Nut	PN6	1
Gear Marking & Brush	GMC1-BR1	1	Gear Marking & Brush	GMC1-BR1	1	Gear Marking & Brush	GMC1-BR1	1
Threadlocker	TL1	1	Threadlocker	TL1	1	Threadlocker	TL1	1
Sealer	RTV Silicone	1	Sealer	RTV Silicone	1	Sealer	RTV Silicone	1
DRK-316AMK			DRK-316D			DRK-317MK		
Position	Part Number	Qty	Position	Part Number	Qty	Position	Part Number	Qty
Differential Brg.	NP343847-NP372019	2	Differential Brg.	NP343847-NP372019	2	Differential Brg.	469-453X	2
Pinion Head Brg.	NP576375-NP434567	1	Pinion Head Brg.	NP576375-NP434567	1	Pinion Head Brg.	NP504493-NP949481	1
Pinion Tail Brg.	HM89443-HM89411	1	Pinion Tail Brg.	HM89448-HM89411	1	Pinion Tail Brg.	HM89443-HM89411	1
Pinion Seal	4278 (18024)	1	Pinion Seal	4278	1	Pinion Seal	4278 (18024)	1
Crush Sleeve	CS311	1	Crush Sleeve	CS355	1	Crush Sleeve	CS311	1
Pinion Nut	PN6	1	Pinion Nut	PN6	1	Pinion Nut	PN6	1
Gear Marking & Brush	GMC1-BR1	1	Gear Marking & Brush	GMC1-BR1	1	Gear Marking & Brush	GMC1-BR1	1
Threadlocker	TL1	1	Threadlocker	TL1	1	Threadlocker	TL1	1
Sealer	RTV Silicone	1	Sealer	RTV Silicone	1	Sealer	RTV Silicone	1
Pinion Depth Shims	SK41	1	Pinion Depth Shims	SK41	1	Pinion Depth Shims	SK3	1
Differential Shims	SK42 ⁵²	1	Differential Shims	SK42 ⁵²	1	Differential Shims	SK10 ⁵³	1
Ring Gear Bolts	RGB18	12	Ring Gear Bolts	RGB18	12	Ring Gear Bolts	RGB6	12
DRK-316B			DRK-316DMK			DRK-317A		
Position	Part Number	Qty	Position	Part Number	Qty	Position	Part Number	Qty
Differential Brg.	NP912771-NP847706	2	Differential Brg.	NP343847-NP372019	2	Differential Brg.	469-453X	2
Pinion Head Brg.	NP665996-NP244986	1	Pinion Head Brg.	NP576375-NP434567	1	Pinion Head Brg.	NP761271-NP998236	1
Pinion Tail Brg.	HM89443-HM89411	1	Pinion Tail Brg.	HM89448-HM89411	1	Pinion Tail Brg.	HM89443-HM89411	1
Pinion Seal	4278	1	Pinion Seal	4278	1	Pinion Seal	4278 (18024)	1
Crush Sleeve	CS311	1	Crush Sleeve	CS355	1	Crush Sleeve	CS311	1
Pinion Nut	PN6	1	Pinion Nut	PN6	1	Pinion Nut	PN6	1
Gear Marking & Brush	GMC1-BR1	1	Gear Marking & Brush	GMC1-BR1	1	Gear Marking & Brush	GMC1-BR1	1
Threadlocker	TL1	1	Threadlocker	TL1	1	Threadlocker	TL1	1
Sealer	RTV Silicone	1	Sealer	RTV Silicone	1	Sealer	RTV Silicone	1
DRK-316C			DRK-316E			DRK-317MK		
Position	Part Number	Qty	Position	Part Number	Qty	Position	Part Number	Qty
Differential Brg.	NP912771-NP847706	2	Differential Brg.	NP912771-NP847706	2	Differential Brg.	469-453X	2
Pinion Head Brg.	TRD101004UR4	1	Pinion Head Brg.	TRD101004UR4	1	Pinion Head Brg.	NP761271-NP998236	1
Pinion Tail Brg.	HM89448-HM89411	1	Pinion Tail Brg.	HM89448-HM89411	1	Pinion Tail Brg.	HM89443-HM89411	1
Pinion Seal	4278	1	Pinion Seal	4278	1	Pinion Seal	4278 (18024)	1
Crush Sleeve	CS355	1	Crush Sleeve	CS355	1	Crush Sleeve	CS311	1
Pinion Nut	PN6	1	Pinion Nut	PN6	1	Pinion Nut	PN6	1
Gear Marking & Brush	GMC1-BR1	1	Gear Marking & Brush	GMC1-BR1	1	Gear Marking & Brush	GMC1-BR1	1
Threadlocker	TL1	1	Threadlocker	TL1	1	Threadlocker	TL1	1
Sealer	RTV Silicone	1	Sealer	RTV Silicone	1	Sealer	RTV Silicone	1
DRK-316D			DRK-316E			DRK-317A		
Position	Part Number	Qty	Position	Part Number	Qty	Position	Part Number	Qty
Differential Brg.	NP343847-NP372019	2	Differential Brg.	NP912771-NP847706	2	Differential Brg.	469-453X	2
Pinion Head Brg.	NP576375-NP434567	1	Pinion Head Brg.	NP665996-NP244986	1	Pinion Head Brg.	NP761271-NP998236	1
Pinion Tail Brg.	HM89443-HM89411	1	Pinion Tail Brg.	HM89448-HM89411	1	Pinion Tail Brg.	HM89443-HM89411	1
Pinion Seal	4278 (18024)	1	Pinion Seal	4278	1	Pinion Seal	4278 (18024)	1
Crush Sleeve	CS311	1	Crush Sleeve	CS355	1	Crush Sleeve	CS311	1
Pinion Nut	PN6	1	Pinion Nut	PN6	1	Pinion Nut	PN6	1
Gear Marking & Brush	GMC1-BR1	1	Gear Marking & Brush	GMC1-BR1	1	Gear Marking & Brush	GMC1-BR1	1
Threadlocker	TL1	1	Threadlocker	TL1	1	Threadlocker	TL1	1
Sealer	RTV Silicone	1	Sealer	RTV Silicone	1	Sealer	RTV Silicone	1
Pinion Depth Shims	SK41	1	Pinion Depth Shims	SK41	1	Pinion Depth Shims	SK3	1
Differential Shims	SK42 ⁵²	1	Differential Shims	SK42 ⁵²	1	Differential Shims	SK10 ⁵³	1
Ring Gear Bolts	RGB18	12	Ring Gear Bolts	RGB18	12	Ring Gear Bolts	RGB6	12

LD Differential

⁵² Order SSK42 for stackable differential shims.

⁵³ Order SSK10 for stackable differential shims.

Light Duty Differential Rebuild Kits



DRK-317AMK		
Position	Part Number	Qty
Differential Brg.	469-453X	2
Pinion Head Brg.	NP761271-NP998236	1
Pinion Tail Brg.	HM89443-HM89411	1
Pinion Seal	4278 (18024)	1
Crush Sleeve	CS311	1
Pinion Nut	PN6	1
Gear Marking & Brush	GMC1-BR1	1
Threadlocker	TL1	1
Sealer	RTV Silicone	1
Pinion Depth Shims	SK3	1
Differential Shims	SK10 ⁵³	1
Ring Gear Bolts	RGB6	12

DRK-317B		
Position	Part Number	Qty
Differential Brg.	469-453X	2
Pinion Head Brg.	M802047-M802011	1
Pinion Tail Brg.	TRD101004UR4	1
Pinion Seal	BC324676A	1
Crush Sleeve	CS317K	1
Gear Marking & Brush	GMC1-BR1	1
Threadlocker	TL1	1
Sealer	RTV Silicone	1

DRK-317BMK		
Position	Part Number	Qty
Differential Brg.	469-453X	2
Pinion Head Brg.	M802047-M802011	1
Pinion Tail Brg.	TRD101004UR4	1
Pinion Seal	BC324676A	1
Crush Sleeve	CS317K	1
Gear Marking & Brush	GMC1-BR1	1
Threadlocker	TL1	1
Sealer	RTV Silicone	1
Pinion Depth Shims	SK41	1
Differential Shims	SK10 ⁵³	1
Ring Gear Bolts	RGB32	12

DRK-320		
Position	Part Number	Qty
Differential Brg.	LM501349-LM501314	2
Pinion Head Brg.	HM89249-HM89210	1
Pinion Tail Brg.	M86649-M86610	1
Pinion Seal	8610 (15305)	1
Crush Sleeve	CS320	1
Pinion Nut	PN3	1
Gear Marking & Brush	GMC1-BR1	1
Threadlocker	TL1	1
Sealer	RTV Silicone	1

DRK-320MK		
Position	Part Number	Qty
Differential Brg.	LM501349-LM501314	2
Pinion Head Brg.	HM89249-HM89210	1
Pinion Tail Brg.	M86649-M86610	1
Pinion Seal	8610 (15305)	1
Crush Sleeve	CS320	1
Pinion Nut	PN3	1
Gear Marking & Brush	GMC1-BR1	1
Threadlocker	TL1	1
Sealer	RTV Silicone	1
Pinion Depth Shims	SK12	1
Differential Shims	SK11 ²⁸	1
Ring Gear Bolts	RGB2	10

DRK-320A		
Position	Part Number	Qty
Differential Brg.	JL69349-JL69310	2
Pinion Head Brg.	M88048S-M88010	1
Pinion Tail Brg.	M86649-M86610	1
Pinion Seal	8610 (15305)	1
Crush Sleeve	CS326	1
Pinion Nut	PN3	1
Gear Marking & Brush	GMC1-BR1	1
Threadlocker	TL1	1
Sealer	RTV Silicone	1

DRK-320AMK		
Position	Part Number	Qty
Differential Brg.	JL69349-JL69310	2
Pinion Head Brg.	M88048S-M88010	1
Pinion Tail Brg.	M86649-M86610	1
Pinion Seal	8610 (15305)	1
Crush Sleeve	CS326	1
Pinion Nut	PN3	1
Gear Marking & Brush	GMC1-BR1	1
Threadlocker	TL1	1
Sealer	RTV Silicone	1
Pinion Depth Shims	SK12	1
Ring Gear Bolts	RGB2	10

DRK-320B		
Position	Part Number	Qty
Differential Brg.	LM501349-LM501314	2
Pinion Head Brg.	HM89449-HM89410	1
Pinion Tail Brg.	M86649-M86610	1
Pinion Seal	8610 (15305)	1
Crush Sleeve	CS320	1
Pinion Nut	PN3	1
Gear Marking & Brush	GMC1-BR1	1
Threadlocker	TL1	1
Sealer	RTV Silicone	1

DRK-320BMK		
Position	Part Number	Qty
Differential Brg.	LM501349-LM501314	2
Pinion Head Brg.	HM89449-HM89410	1
Pinion Tail Brg.	M86649-M86610	1
Pinion Seal	8610 (15305)	1
Crush Sleeve	CS320	1
Pinion Nut	PN3	1
Gear Marking & Brush	GMC1-BR1	1
Threadlocker	TL1	1
Sealer	RTV Silicone	1
Pinion Depth Shims	SK12	1
Differential Shims	SK11 ²⁸	1
Ring Gear Bolts	RGB2	10

DRK-320C		
Position	Part Number	Qty
Differential Brg.	LM501349-LM501314	2
Pinion Head Brg.	HM89249-HM89210	1
Pinion Tail Brg.	M86649-M86610	1
Pinion Seal	710474	1
Crush Sleeve	CS320	1
Pinion Nut	PN3	1
Gear Marking & Brush	GMC1-BR1	1
Threadlocker	TL1	1
Sealer	RTV Silicone	1

DRK-320CMK		
Position	Part Number	Qty
Differential Brg.	LM501349-LM501314	2
Pinion Head Brg.	HM89249-HM89210	1
Pinion Tail Brg.	M86649-M86610	1
Pinion Seal	710474	1
Crush Sleeve	CS320	1
Pinion Nut	PN3	1
Gear Marking & Brush	GMC1-BR1	1
Threadlocker	TL1	1
Sealer	RTV Silicone	1
Pinion Depth Shims	SK12	1
Differential Shims	SK11 ²⁸	1
Ring Gear Bolts	RGB2	10

DRK-320D		
Position	Part Number	Qty
Differential Brg.	LM603049-LM603012	2
Pinion Head Brg.	NP457992-NP926068	1
Pinion Tail Brg.	M86649-M86610	1
Pinion Seal	710474	1
Crush Sleeve	CS320	1
Pinion Nut	PN3	1
Gear Marking & Brush	GMC1-BR1	1
Threadlocker	TL1	1
Sealer	RTV Silicone	1

DRK-320DMK		
Position	Part Number	Qty
Differential Brg.	LM603049-LM603012	2
Pinion Head Brg.	NP457992-NP926068	1
Pinion Tail Brg.	M86649-M86610	1
Pinion Seal	710474	1
Crush Sleeve	CS320	1
Pinion Nut	PN3	1
Gear Marking & Brush	GMC1-BR1	1
Threadlocker	TL1	1
Sealer	RTV Silicone	1
Pinion Depth Shims	SK4	1
Differential Shims	SK7 ²⁷	1
Ring Gear Bolts	RGB22	10

DRK-320J		
Position	Part Number	Qty
Differential Brg.	LM501349-LM501314	2
Pinion Head Brg.	HM89249-HM89210	1
Pinion Tail Brg.	M86649-M86610	1
Pinion Seal	92230622	1
Crush Sleeve	CS320	1
Pinion Nut	PN13	1
Gear Marking & Brush	GMC1-BR1	1
Threadlocker	TL1	1
Sealer	RTV Silicone	1

DRK-320JMK		
Position	Part Number	Qty
Differential Brg.	LM501349-LM501314	2
Pinion Head Brg.	HM89249-HM89210	1
Pinion Tail Brg.	M86649-M86610	1
Pinion Seal	92230622	1
Crush Sleeve	CS320	1
Pinion Nut	PN13	1
Gear Marking & Brush	GMC1-BR1	1
Threadlocker	TL1	1
Sealer	RTV Silicone	1
Pinion Depth Shims	SK12	1
Differential Shims	SK11 ²⁸	1
Ring Gear Bolts	RGB2	10

LD Differential

186 ²⁷ Order SSK7 for stackable differential shims. ⁵³ Order SSK10 for stackable differential shims.
²⁸ Order SSK11 for stackable differential shims.

Light Duty Differential Rebuild Kits

DRK-320K			DRK-321MK			DRK-321C		
Position	Part Number	Qty	Position	Part Number	Qty	Position	Part Number	Qty
Differential Brg.	JL69349-JL69310	2	Differential Brg.	LM501349-LM501314	2	Differential Brg.	LM603049-LM603012	2
Pinion Head Brg.	M88048S-M88010	1	Pinion Head Brg.	M802048-M802011	1	Pinion Head Brg.	STD4183KELFT	1
Pinion Tail Brg.	M86649-M86610	1	Pinion Tail Brg.	M88048-M88010	1	Pinion Tail Brg.	M88048-M88010	1
Pinion Seal	46002006	1	Pinion Seal (Rear Axles)	2043 (19273)	1	Pinion Seal	26064028	1
Crush Sleeve	CS326	1	Pinion Seal (Front Axles)	8622 (19277)	1	Crush Sleeve	CS321	1
Pinion Nut	PN3	1	Crush Sleeve	CS321	1	Pinion Nut	PN3	1
Gear Marking & Brush	GMC1-BR1	1	Pinion Nut	PN3	1	Gear Marking & Brush	GMC1-BR1	1
Threadlocker	TL1	1	Gear Marking & Brush	GMC1-BR1	1	Threadlocker	TL1	1
Sealer	RTV Silicone	1	Threadlocker	TL1	1	Sealer	RTV Silicone	1
DRK-320MKM			DRK-321A			DRK-321CMK		
Position	Part Number	Qty	Position	Part Number	Qty	Position	Part Number	Qty
Differential Brg.	JL69349-JL69310	2	Differential Brg.	LM501349-LM501314	2	Differential Brg.	LM603049-LM603012	2
Pinion Head Brg.	M88048S-M88010	1	Pinion Head Brg.	M802048-M802011	1	Pinion Head Brg.	STD4183KELFT	1
Pinion Tail Brg.	M86649-M86610	1	Pinion Tail Brg.	M88048-M88010	1	Pinion Tail Brg.	M88048-M88010	1
Pinion Seal	46002006	1	Pinion Seal	710281 (19428)	1	Pinion Seal	26064028	1
Crush Sleeve	CS326	1	Crush Sleeve	CS321	1	Crush Sleeve	CS321	1
Pinion Nut	PN3	1	Pinion Nut	PN3	1	Pinion Nut	PN3	1
Gear Marking & Brush	GMC1-BR1	1	Gear Marking & Brush	GMC1-BR1	1	Gear Marking & Brush	GMC1-BR1	1
Threadlocker	TL1	1	Threadlocker	TL1	1	Threadlocker	TL1	1
Sealer	RTV Silicone	1	Sealer	RTV Silicone	1	Sealer	RTV Silicone	1
Pinion Depth Shims	SK12	1	Pinion Depth Shims	SK4	1	Pinion Depth Shims	SK4	1
Ring Gear Bolts	RGB2	10	Differential Shims	SK11 ²⁸	1	Differential Shims	SK7 ²⁷	1
DRK-320L			DRK-321AMK			DRK-321D		
Position	Part Number	Qty	Position	Part Number	Qty	Position	Part Number	Qty
Differential Brg.	LM501349-LM501314	2	Differential Brg.	LM501349-LM501314	2	Differential Brg.	LM102949-LM102911	2
Pinion Head Brg.	HM89449-HM89410	1	Pinion Head Brg.	M802048-M802011	1	Pinion Head Brg.	M802048-M802011	1
Pinion Tail Brg.	M86649-M86610	1	Pinion Tail Brg.	M88048-M88010	1	Pinion Tail Brg.	M88048-M88010	1
Pinion Seal	40024218	1	Pinion Seal	710281 (19428)	1	Pinion Seal	2043 (19273)	1
Crush Sleeve	CS320	1	Crush Sleeve	CS321	1	Crush Sleeve	CS321	1
Pinion Nut	PN3	1	Pinion Nut	PN3	1	Pinion Nut	PN3	1
Gear Marking & Brush	GMC1-BR1	1	Gear Marking & Brush	GMC1-BR1	1	Gear Marking & Brush	GMC1-BR1	1
Threadlocker	TL1	1	Threadlocker	TL1	1	Threadlocker	TL1	1
Sealer	RTV Silicone	1	Sealer	RTV Silicone	1	Sealer	RTV Silicone	1
DRK-320LMK			DRK-321B			DRK-321DMK		
Position	Part Number	Qty	Position	Part Number	Qty	Position	Part Number	Qty
Differential Brg.	LM501349-LM501314	2	Differential Brg.	LM501349-LM501314	2	Differential Brg.	LM102949-LM102911	2
Pinion Head Brg.	HM89449-HM89410	1	Pinion Head Brg.	HM89449-HM89410	1	Pinion Head Brg.	M802048-M802011	1
Pinion Tail Brg.	M86649-M86610	1	Pinion Tail Brg.	M86649-M86610	1	Pinion Tail Brg.	M88048-M88010	1
Pinion Seal	40024218	1	Pinion Seal	8610 (15305)	1	Pinion Seal	2043 (19273)	1
Crush Sleeve	CS320	1	Crush Sleeve	CS320 ⁷	1	Crush Sleeve	CS321	1
Pinion Nut	PN3	1	Pinion Nut	PN4	1	Pinion Nut	PN3	1
Gear Marking & Brush	GMC1-BR1	1	Gear Marking & Brush	GMC1-BR1	1	Gear Marking & Brush	GMC1-BR1	1
Threadlocker	TL1	1	Threadlocker	TL1	1	Threadlocker	TL1	1
Sealer	RTV Silicone	1	Sealer	RTV Silicone	1	Sealer	RTV Silicone	1
Pinion Depth Shims	SK12	1	Pinion Depth Shims	SK4	1	Pinion Depth Shims	SK4	1
Differential Shims	SK11 ²⁸	1	Ring Gear Bolts	RGB2	10	Differential Shims	SK11 ²⁸	1
Ring Gear Bolts	RGB2	10	DRK-321BMK			Ring Gear Bolts	RGB2	10
DRK-321			Position	Part Number	Qty	Position	Part Number	Qty
Position	Part Number	Qty	Differential Brg.	LM501349-LM501314	2	Differential Brg.	LM603049-LM603014	2
Differential Brg.	LM501349-LM501314	2	Pinion Head Brg.	HM89449-HM89410	1	Pinion Head Brg.	HM89449-HM89410	1
Pinion Head Brg.	M802048-M802011	1	Pinion Tail Brg.	M86649-M86610	1	Pinion Tail Brg.	HM88547-HM88510	1
Pinion Tail Brg.	M88048-M88010	1	Pinion Seal	8610 (15305)	1	Pinion Seal	6818 (17727)	1
Pinion Seal (Rear Axles)	2043 (19273)	1	Crush Sleeve	CS320 ⁷	1	Pinion Seal	26064028	1
Pinion Seal (Front Axles)	8622 (19277)	1	Pinion Nut	PN4	1	Crush Sleeve	CS331	1
Crush Sleeve	CS321	1	Gear Marking & Brush	GMC1-BR1	1	Pinion Nut	PN4	1
Pinion Nut	PN3	1	Threadlocker	TL1	1	Gear Marking & Brush	GMC1-BR1	1
Gear Marking & Brush	GMC1-BR1	1	Sealer	RTV Silicone	1	Threadlocker	TL1	1
Threadlocker	TL1	1	Pinion Depth Shims	SK12	1	Sealer	RTV Silicone	1
Sealer	RTV Silicone	1	Differential Shims	SK11 ²⁸	1			
			Ring Gear Bolts	RGB5	10			

LD Differential

²⁷ Order SSK7 for stackable differential shims. ⁷ Order CS322 if using OEM Ring & Pinion Set
²⁸ Order SSK11 for stackable differential shims.

Light Duty Differential Rebuild Kits



DRK-321GMK		
Position	Part Number	Qty
Differential Brg.	LM603049-LM603014	2
Pinion Head Brg.	HM89449-HM89410	1
Pinion Tail Brg.	HM88547-HM88510	1
Pinion Seal	6818 (1727)	1
Crush Sleeve	CS331	1
Pinion Nut	PN4	1
Gear Marking & Brush	GMC1-BR1	1
Threadlocker	TL1	1
Sealer	RTV Silicone	1
Pinion Depth Shims	SK12	1
Ring Gear Bolts	RGB5	10

DRK-321H		
Position	Part Number	Qty
Differential Brg.	LM501349-LM501314	2
Pinion Head Brg.	HM89449-HM89410	1
Pinion Tail Brg.	M86649-M86610	1
Pinion Seal	2043 (19273)	1
Crush Sleeve	CS320	1
Pinion Nut	PN3	1
Gear Marking & Brush	GMC1-BR1	1
Threadlocker	TL1	1
Sealer	RTV Silicone	1

DRK-321HMK		
Position	Part Number	Qty
Differential Brg.	LM501349-LM501314	2
Pinion Head Brg.	HM89449-HM89410	1
Pinion Tail Brg.	M86649-M86610	1
Pinion Seal	2043 (19273)	1
Crush Sleeve	CS320	1
Pinion Nut	PN3	1
Gear Marking & Brush	GMC1-BR1	1
Threadlocker	TL1	1
Sealer	RTV Silicone	1
Pinion Depth Shims	SK12	1
Differential Shims	SK11 ²⁸	1
Ring Gear Bolts	RGB5	10

DRK-321N		
Position	Part Number	Qty
Differential Brg.	LM501349-LM501314	2
Pinion Head Brg.	M802048-M802011	1
Pinion Tail Brg.	M86649-M86610	1
Pinion Seal	2043	1
Crush Sleeve	CS348	1
Pinion Nut	PN3	1
Gear Marking & Brush	GMC1-BR1	1
Threadlocker	TL1	1
Sealer	RTV Silicone	1

DRK-321NMK		
Position	Part Number	Qty
Differential Brg.	LM501349-LM501314	2
Pinion Head Brg.	M802048-M802011	1
Pinion Tail Brg.	M86649-M86610	1
Pinion Seal	2043	1
Crush Sleeve	CS348	1
Pinion Nut	PN3	1
Gear Marking & Brush	GMC1-BR1	1
Threadlocker	TL1	1
Sealer	RTV Silicone	1
Pinion Depth Shims	SK4	1
Differential Shims	SK11 ²⁸	1
Ring Gear Bolts	RGB2	10

DRK-321Q		
Position	Part Number	Qty
Differential Brg.	LM603049-LM603012	2
Pinion Head Brg.	STA4195	1
Pinion Tail Brg.	STB3372	1
Pinion Seal	710507	1
Crush Sleeve	CS321	1
Pinion Nut	PN3	1
Gear Marking & Brush	GMC1-BR1	1
Threadlocker	TL1	1
Sealer	RTV Silicone	1

DRK-321QM		
Position	Part Number	Qty
Differential Brg.	LM603049-LM603012	2
Pinion Head Brg.	STA4195	1
Pinion Tail Brg.	STB3372	1
Pinion Seal	710507	1
Crush Sleeve	CS321	1
Pinion Nut	PN3	1
Gear Marking & Brush	GMC1-BR1	1
Threadlocker	TL1	1
Sealer	RTV Silicone	1
Pinion Depth Shims	SK4	1
Differential Shims	SK7 ²⁷	1
Ring Gear Bolts	RGB2	10

DRK-321R		
Position	Part Number	Qty
Differential Brg.	LM501349-LM501314	2
Pinion Head Brg.	M802048-M802011	1
Pinion Tail Brg.	M88048-M88010	1
Pinion Seal	2043 (19273)	1
Crush Sleeve	CS321	1
Pinion Nut	PN3	1
Gear Marking & Brush	GMC1-BR1	1
Threadlocker	TL1	1
Sealer	RTV Silicone	1

DRK-321RMK		
Position	Part Number	Qty
Differential Brg.	LM501349-LM501314	2
Pinion Head Brg.	M802048-M802011	1
Pinion Tail Brg.	M88048-M88010	1
Pinion Seal	2043 (19273)	1
Crush Sleeve	CS321	1
Pinion Nut	PN3	1
Gear Marking & Brush	GMC1-BR1	1
Threadlocker	TL1	1
Sealer	RTV Silicone	1
Pinion Depth Shims	SK4	1
Differential Shims	SK11 ²⁸	1
Ring Gear Bolts	RGB2	10

DRK-321S		
Position	Part Number	Qty
Differential Brg.	KETR100802A/STA0Z	2
Pinion Head Brg.	HM804846-HM804810	1
Pinion Tail Brg.	32207	1
Pinion Seal	DT53191	1
Crush Sleeve	CS324	1
Pinion Nut	PN13	1
Gear Marking & Brush	GMC1-BR1	1
Threadlocker	TL1	1
Sealer	RTV Silicone	1

DRK-321SMK		
Position	Part Number	Qty
Differential Brg.	KETR100802A/STA0Z	2
Pinion Head Brg.	HM804846-HM804810	1
Pinion Tail Brg.	32207	1
Pinion Seal	DT53191	1
Crush Sleeve	CS324	1
Pinion Nut	PN13	1
Gear Marking & Brush	GMC1-BR1	1
Threadlocker	TL1	1
Sealer	RTV Silicone	1
Pinion Depth Shims	SK3	1
Differential Shims	SK7 ²⁷	1
Ring Gear Bolts	RGB2	10

DRK-321T		
Position	Part Number	Qty
Differential Brg.	LM501349-LM501314	2
Pinion Head Brg.	M802048-M802011	1
Pinion Tail Brg.	M88048-M88010	1
Pinion Seal	710536	1
Crush Sleeve	CS321	1
Pinion Nut	PN3	1
Gear Marking & Brush	GMC1-BR1	1
Threadlocker	TL1	1
Sealer	RTV Silicone	1

DRK-321TMK		
Position	Part Number	Qty
Differential Brg.	LM501349-LM501314	2
Pinion Head Brg.	M802048-M802011	1
Pinion Tail Brg.	M88048-M88010	1
Pinion Seal	710536	1
Crush Sleeve	CS321	1
Pinion Nut	PN3	1
Gear Marking & Brush	GMC1-BR1	1
Threadlocker	TL1	1
Sealer	RTV Silicone	1
Pinion Depth Shims	SK4	1
Ring Gear Bolts	RGB2	10

DRK-322		
Position	Part Number	Qty
Differential Brg.	LM603049-LM603012	2
Pinion Head Brg.	HM89449-HM89410	1
Pinion Tail Brg.	M88048-M88010	1
Pinion Seal	8460N (17190)	1
Crush Sleeve	CS322	1
Pinion Nut	PN4	1
Gear Marking & Brush	GMC1-BR1	1
Threadlocker	TL1	1
Sealer	RTV Silicone	1

DRK-322MK		
Position	Part Number	Qty
Differential Brg.	LM603049-LM603012	2
Pinion Head Brg.	HM89449-HM89410	1
Pinion Tail Brg.	M88048-M88010	1
Pinion Seal	8460N (17190)	1
Crush Sleeve	CS322	1
Pinion Nut	PN4	1
Gear Marking & Brush	GMC1-BR1	1
Threadlocker	TL1	1
Sealer	RTV Silicone	1
Pinion Depth Shims	SK12	1
Differential Shims	SK7 ²⁷	1
Ring Gear Bolts	RGB5	12

LD Differential

188 ²⁷ Order SSK7 for stackable differential shims.
²⁸ Order SSK11 for stackable differential shims.

Light Duty Differential Rebuild Kits

DRK-323			DRK-324MK			DRK-324C		
Position	Part Number	Qty	Position	Part Number	Qty	Position	Part Number	Qty
Differential Brg.	LM603049-LM603012	2	Differential Brg.	JLM506849A-JLM506811	2	Differential Brg.	JLM506849A-JLM506811	2
Pinion Head Brg.	M802048-M802011	1	Pinion Head Brg.	HM804846-HM804810	1	Pinion Head Brg.	HM804846-HM804810	1
Pinion Tail Brg.	M88048-M88010	1	Pinion Tail Brg.	HM88649-HM88610	1	Pinion Tail Brg.	HM88649-HM88610	1
Pinion Seal (1963-1972)	6109	1	Pinion Seal	3896 (BH1030EO)	1	Pinion Seal	710536	1
Pinion Seal (1973 and Later)	2043 (19273)	1	Crush Sleeve	CS324	1	Crush Sleeve	CS324	1
Crush Sleeve	CS321	1	Pinion Nut	PN3	1	Pinion Nut	PN3	1
Crush Sleeve (Corvette)	CS323C	1	Gear Marking & Brush	GMC1-BR1	1	Gear Marking & Brush	GMC1-BR1	1
Pinion Nut	PN4	1	Threadlocker	TL1	1	Threadlocker	TL1	1
Gear Marking & Brush	GMC1-BR1	1	Sealer	RTV Silicone	1	Sealer	RTV Silicone	1
Threadlocker	TL1	1	Pinion Depth Shims	SK3	1			
Sealer	RTV Silicone	1	Differential Shims	SK13	1			
			Ring Gear Bolts	RGB8	12			
DRK-323MK			DRK-324A			DRK-324CMK		
Position	Part Number	Qty	Position	Part Number	Qty	Position	Part Number	Qty
Differential Brg.	LM603049-LM603012	2	Differential Brg.	JLM506849A-JLM506811	2	Differential Brg.	JLM506849A-JLM506811	2
Pinion Head Brg.	M802048-M802011	1	Pinion Head Brg.	HM804846-HM804810	1	Pinion Head Brg.	HM804846-HM804810	1
Pinion Tail Brg.	M88048-M88010	1	Pinion Tail Brg.	HM88649-HM88610	1	Pinion Tail Brg.	HM88649-HM88610	1
Pinion Seal (1963-1972)	6109	1	Pinion Seal	710281 (19428)	1	Pinion Seal	710536	1
Pinion Seal (1973 and Later)	2043 (19273)	1	Crush Sleeve	CS324	1	Crush Sleeve	CS324	1
Crush Sleeve	CS321	1	Pinion Nut	PN3	1	Pinion Nut	PN3	1
Crush Sleeve (Corvette)	CS323C	1	Gear Marking & Brush	GMC1-BR1	1	Gear Marking & Brush	GMC1-BR1	1
Pinion Nut	PN4	1	Threadlocker	TL1	1	Threadlocker	TL1	1
Gear Marking & Brush	GMC1-BR1	1	Sealer	RTV Silicone	1	Sealer	RTV Silicone	1
Threadlocker	TL1	1	Pinion Depth Shims	SK4	1	Pinion Depth Shims	SK3	1
Sealer	RTV Silicone	1	Differential Shims	SK7 ²⁷	1	Differential Shims	SK13	1
Pinion Depth Shims	SK4	1	Ring Gear Bolts	RGB5	12	Ring Gear Bolts	RGB8	12
Differential Shims	SK7 ²⁷	1	Pinion Seal - Corvette	6109	1			
Ring Gear Bolts	RGB5	12						
Pinion Seal - Corvette	6109	1						
DRK-323A			DRK-324AMK			DRK-324D		
Position	Part Number	Qty	Position	Part Number	Qty	Position	Part Number	Qty
Differential Brg.	LM603049-LM603012	2	Differential Brg.	JLM506849A-JLM506811	2	Differential Brg.	JLM506849A-JLM506811	2
Pinion Head Brg.	M802048-M802011	1	Pinion Head Brg.	HM804846-HM804810	1	Pinion Head Brg.	NP256771-NP468253	1
Pinion Tail Brg.	M88048-M88010	1	Pinion Tail Brg.	HM88649-HM88610	1	Pinion Tail Brg.	HM88649-HM88610	1
Pinion Seal	8460N (17190)	1	Pinion Seal	710281 (19428)	1	Pinion Seal	710536	1
Crush Sleeve	CS323	1	Crush Sleeve	CS324	1	Crush Sleeve	CS324	1
Pinion Nut	PN4	1	Pinion Nut	PN3	1	Pinion Nut	PN3	1
Gear Marking & Brush	GMC1-BR1	1	Gear Marking & Brush	GMC1-BR1	1	Gear Marking & Brush	GMC1-BR1	1
Threadlocker	TL1	1	Threadlocker	TL1	1	Threadlocker	TL1	1
Sealer	RTV Silicone	1	Sealer	RTV Silicone	1	Sealer	RTV Silicone	1
			Pinion Depth Shims	SK3	1			
			Differential Shims	SK13	1			
			Ring Gear Bolts	RGB8	12			
DRK-323AMK			DRK-324BMK			DRK-324DMK		
Position	Part Number	Qty	Position	Part Number	Qty	Position	Part Number	Qty
Differential Brg.	LM603049-LM603012	2	Differential Brg.	JLM506849A-JLM506811	2	Differential Brg.	JLM506849A-JLM506811	2
Pinion Head Brg.	M802048-M802011	1	Pinion Head Brg.	HM804846-HM804810	1	Pinion Head Brg.	NP256771-NP468253	1
Pinion Tail Brg.	M88048-M88010	1	Pinion Tail Brg.	HM88649-HM88610	1	Pinion Tail Brg.	HM88649-HM88610	1
Pinion Seal	8460N (17190)	1	Pinion Seal	710507 (26064029)	1	Pinion Seal	710536	1
Crush Sleeve	CS323	1	Crush Sleeve	CS324	1	Crush Sleeve	CS324	1
Pinion Nut	PN4	1	Pinion Nut	PN3	1	Pinion Nut	PN3	1
Gear Marking & Brush	GMC1-BR1	1	Gear Marking & Brush	GMC1-BR1	1	Gear Marking & Brush	GMC1-BR1	1
Threadlocker	TL1	1	Threadlocker	TL1	1	Threadlocker	TL1	1
Sealer	RTV Silicone	1	Sealer	RTV Silicone	1	Sealer	RTV Silicone	1
Pinion Depth Shims	SK4	1				Pinion Depth Shims	SK3	1
Differential Shims	SK7 ²⁷	1				Differential Shims	SK13	1
Ring Gear Bolts	RGB5	12				Ring Gear Bolts	RGB8	12
DRK-324			DRK-324G					
Position	Part Number	Qty	Position	Part Number	Qty	Position	Part Number	Qty
Differential Brg.	JLM506849A-JLM506811	2	Differential Brg.	JLM506849A-JLM506811	2	Differential Brg.	JLM506849A-JLM506811	2
Pinion Head Brg.	HM804846-HM804810	1	Pinion Head Brg.	HM804846-HM804810	1	Pinion Head Brg.	HM804846-HM804810	1
Pinion Tail Brg.	HM88649-HM88610	1	Pinion Tail Brg.	HM88649-HM88610	1	Pinion Tail Brg.	HM88649-HM88610	1
Pinion Seal	3896 (BH1030EO)	1	Pinion Seal	710507 (26064029)	1	Pinion Seal	710558	1
Crush Sleeve	CS324	1	Crush Sleeve	CS324	1	Crush Sleeve	CS324	1
Pinion Nut	PN3	1	Pinion Nut	PN3	1	Pinion Nut	PN3	1
Gear Marking & Brush	GMC1-BR1	1	Gear Marking & Brush	GMC1-BR1	1	Gear Marking & Brush	GMC1-BR1	1
Threadlocker	TL1	1	Threadlocker	TL1	1	Threadlocker	TL1	1
Sealer	RTV Silicone	1	Sealer	RTV Silicone	1	Sealer	RTV Silicone	1
			Pinion Depth Shims	SK13	1			
			Differential Shims	SK3	1			
			Ring Gear Bolts	RGB8	12			

LD Differential

27 Order SSK7 for stackable differential shims.

Light Duty Differential Rebuild Kits



DRK-324GMK

Position	Part Number	Qty
Differential Brg.	JLM506849A-JLM506811	2
Pinion Head Brg.	HM804846-HM804810	1
Pinion Tail Brg.	HM88649-HM88610	1
Pinion Seal	710558	1
Crush Sleeve	CS324	1
Pinion Nut	PN3	1
Gear Marking & Brush	GMC1-BR1	1
Threadlocker	TL1	1
Sealer	RTV Silicone	1
Pinion Depth Shims	SK3	1
Differential Shims	SK13	1
Ring Gear Bolts	RGB8	12

DRK-324H

Position	Part Number	Qty
Differential Brg.	JLM506849A-JLM506811	2
Pinion Head Brg.	HM907643-HM907614	1
Pinion Tail Brg.	HM89249-HM89210	1
Pinion Seal	22943111	1
Crush Sleeve	CS313	1
Pinion Nut	PN13	1
Gear Marking & Brush	GMC1-BR1	1
Threadlocker	TL1	1
Sealer	RTV Silicone	1

DRK-324HMK

Position	Part Number	Qty
Differential Brg.	JLM506849A-JLM506811	2
Pinion Head Brg.	HM907643-HM907614	1
Pinion Tail Brg.	HM89249-HM89210	1
Pinion Seal	22943111	1
Crush Sleeve	CS313	1
Pinion Nut	PN13	1
Gear Marking & Brush	GMC1-BR1	1
Threadlocker	TL1	1
Sealer	RTV Silicone	1
Pinion Depth Shims	SK22	1
Differential Shims	SK15A	1
Ring Gear Bolts	RGB8	12

DRK-325

Position	Part Number	Qty
Differential Brg.	387AS-382A	2
Pinion Head Brg.	HM803149-HM803110	1
Pinion Tail Brg.	M802048-M802011	1
Pinion Nose Brg.	R1581TV	1
Pinion Seal	2286 (21955)	1
Crush Sleeve	CS325	1
Pinion Nut	PN7	1
Gear Marking & Brush	GMC1-BR1	1
Threadlocker	TL1	1
Sealer	RTV Silicone	1

DRK-325MK

Position	Part Number	Qty
Differential Brg.	387AS-382A	2
Pinion Head Brg.	HM803149-HM803110	1
Pinion Tail Brg.	M802048-M802011	1
Pinion Nose Brg.	R1581TV	1
Pinion Seal	2286 (21955)	1
Crush Sleeve	CS325	1
Pinion Nut	PN7	1
Gear Marking & Brush	GMC1-BR1	1
Threadlocker	TL1	1
Sealer	RTV Silicone	1
Pinion Depth Shims	SK14	1
Ring Gear Bolts	RGB9 ⁸	12

DRK-325A

Position	Part Number	Qty
Differential Brg.	387AS-382A	2
Pinion Head Brg.	HM903249-HM903210	1
Pinion Tail Brg.	M802048-M802011	1
Pinion Nose Brg.	R1581TV	1
Pinion Seal	2286 (21955)	1
Crush Sleeve	CS325A	1
Pinion Nut	PN7	1
Gear Marking & Brush	GMC1-BR1	1
Threadlocker	TL1	1
Sealer	RTV Silicone	1

DRK-325AMK

Position	Part Number	Qty
Differential Brg.	387AS-382A	2
Pinion Head Brg.	HM903249-HM903210	1
Pinion Tail Brg.	M802048-M802011	1
Pinion Nose Brg.	R1581TV	1
Pinion Seal	2286 (21955)	1
Crush Sleeve	CS325A	1
Pinion Nut	PN7	1
Gear Marking & Brush	GMC1-BR1	1
Threadlocker	TL1	1
Sealer	RTV Silicone	1
Pinion Depth Shims	SK14	1
Ring Gear Bolts	RGB9 ⁸	12

DRK-325B

Position	Part Number	Qty
Differential Brg.	387AS-382A	2
Pinion Head Brg.	HM903249-HM903210	1
Pinion Tail Brg.	M802048-M802011	1
Pinion Nose Brg.	R1581TV	1
Pinion Seal	710508 (26064030)	1
Crush Sleeve	CS325A	1
Pinion Nut	PN7	1
Gear Marking & Brush	GMC1-BR1	1
Threadlocker	TL1	1
Sealer	RTV Silicone	1

DRK-325BMK

Position	Part Number	Qty
Differential Brg.	387AS-382A	2
Pinion Head Brg.	HM903249-HM903210	1
Pinion Tail Brg.	M802048-M802011	1
Pinion Nose Brg.	R1581TV	1
Pinion Seal	710508 (26064030)	1
Crush Sleeve	CS325A	1
Pinion Nut	PN7	1
Gear Marking & Brush	GMC1-BR1	1
Threadlocker	TL1	1
Sealer	RTV Silicone	1
Pinion Depth Shims	SK14	1
Ring Gear Bolts	RGB9	12

DRK-325C

Position	Part Number	Qty
Differential Brg.	JLM506849A-JLM506811	2
Pinion Head Brg.	HM807046-HM807010	1
Pinion Tail Brg.	STD4183KELFT	1
Pinion Seal	20964040	1
Crush Sleeve	CS312	1
Pinion Nut	PN25	1
Gear Marking & Brush	GMC1-BR1	1
Threadlocker	TL1	1
Sealer	RTV Silicone	1

DRK-325CMK

Position	Part Number	Qty
Differential Brg.	JLM506849A-JLM506811	2
Pinion Head Brg.	HM807046-HM807010	1
Pinion Tail Brg.	STD4183KELFT	1
Pinion Seal	20964040	1
Crush Sleeve	CS312	1
Pinion Nut	PN25	1
Gear Marking & Brush	GMC1-BR1	1
Threadlocker	TL1	1
Sealer	RTV Silicone	1
Pinion Depth Shims	SK54	1
Differential Shims	SK13	1
Ring Gear Bolts	RGB34	12

DRK-326

Position	Part Number	Qty
Differential Brg.	LM102949-LM102911	2
Pinion Head Brg.	HM89446-HM89410	1
Pinion Tail Brg.	M86649-M86610	1
Pinion Seal	7457N (16545)	1
Crush Sleeve	CS310	1
Pinion Nut	PN12	1
Gear Marking & Brush	GMC1-BR1	1
Threadlocker	TL1	1
Sealer	RTV Silicone	1

DRK-326MK

Position	Part Number	Qty
Differential Brg.	LM102949-LM102911	2
Pinion Head Brg.	HM89446-HM89410	1
Pinion Tail Brg.	M86649-M86610	1
Pinion Seal	7457N (16545)	1
Crush Sleeve	CS310	1
Pinion Nut	PN12	1
Gear Marking & Brush	GMC1-BR1	1
Threadlocker	TL1	1
Sealer	RTV Silicone	1
Pinion Depth Shims	SK12	1
Differential Shims	SK11 ²⁸	1
Ring Gear Bolts	RGB2	8

DRK-326A

Position	Part Number	Qty
Differential Brg.	LM102949-LM102910	2
Pinion Head Brg.	HM89446-HM89410	1
Pinion Tail Brg.	M86649-M86610	1
Pinion Seal	7457N (16545)	1
Crush Sleeve	CS310	1
Pinion Nut	PN13	1
Gear Marking & Brush	GMC1-BR1	1
Threadlocker	TL1	1
Sealer	RTV Silicone	1

DRK-326AMK

Position	Part Number	Qty
Differential Brg.	LM102949-LM102910	2
Pinion Head Brg.	HM89446-HM89410	1
Pinion Tail Brg.	M86649-M86610	1
Pinion Seal	7457N (16545)	1
Crush Sleeve	CS310	1
Pinion Nut	PN13	1
Gear Marking & Brush	GMC1-BR1	1
Threadlocker	TL1	1
Sealer	RTV Silicone	1
Pinion Depth Shims	SK12	1
Differential Shims	SK25	1
Ring Gear Bolts	RGB2	8

LD Differential

190 ⁸ Order RGB10 for ratios 4.56 and higher.

²⁸ Order SSK11 for stackable differential shims.

Light Duty Differential Rebuild Kits

DRK-326B			DRK-327AMK			DRK-329MK		
Position	Part Number	Qty	Position	Part Number	Qty	Position	Part Number	Qty
Differential Brg.	JLM104948-9X147	2	Differential Brg.	3984-3920	2	Differential Brg.	25584-25520	2
Pinion Head Brg.	HM803149-HM803110	1	Pinion Head Brg.	NP516549-NP673386	1	Pinion Head Brg.	HM804846-HM804810	1
Pinion Tail Brg.	HM89449-HM89410	1	Pinion Tail Brg.	M802048-M802011	1	Pinion Tail Brg.	HM89446-HM89410	1
Pinion Seal	92191954	1	Pinion Seal	710508 (26064030)	1	Pinion Seal	473461 (19380)	1
Crush Sleeve	CS353	1	Crush Sleeve	CS341	1	Crush Sleeve	CS329	1
Pinion Nut	PN20	1	Pinion Nut	PN17	1	Pinion Nut	PN3	1
Gear Marking & Brush	GMC1-BR1	1	Gear Marking & Brush	GMC1-BR1	1	Gear Marking & Brush	GMC1-BR1	1
Threadlocker	TL1	1	Threadlocker	TL1	1	Threadlocker	TL1	1
Sealer	RTV Silicone	1	Sealer	RTV Silicone	1	Sealer	RTV Silicone	1
DRK-326BMK			DRK-327B			DRK-331		
Position	Part Number	Qty	Position	Part Number	Qty	Position	Part Number	Qty
Differential Brg.	JLM104948-9X147	2	Differential Brg.	3984-3920	2	Differential Brg.	387A-382S	2
Pinion Head Brg.	HM803149-HM803110	1	Pinion Head Brg.	NP848872-NP673386	1	Pinion Head Brg.	HM803146-HM803110	1
Pinion Tail Brg.	HM89449-HM89410	1	Pinion Tail Brg.	HM807046-HM807010	1	Pinion Tail Brg.	HM88542-HM88510	1
Pinion Seal	92191954	1	Pinion Seal	710508 (26064030)	1	Pinion Seal (1958-1972)	6808N (18888)	1
Crush Sleeve	CS353	1	Crush Sleeve	CS356	1	Pinion Seal (1971 and later)	9316 (18891)	1
Pinion Nut	PN20	1	Pinion Nut	PN17	1	Pinion Nut	PN5	1
Pinion Depth Shims	SK1	1	Gear Marking & Brush	GMC1-BR1	1	Gear Marking & Brush	GMC1-BR1	1
Differential Shims	SK50	1	Threadlocker	TL1	1	Threadlocker	TL1	1
Ring Gear Bolts	RGB30	10	Sealer	RTV Silicone	1	Sealer	RTV Silicone	1
Gear Marking & Brush	GMC1-BR1	1	DRK-327BMK			DRK-331MK		
Threadlocker	TL1	1	Position	Part Number	Qty	Position	Part Number	Qty
Sealer	RTV Silicone	1	Differential Brg.	3984-3920	2	Differential Brg.	387A-382S	2
DRK-327			Pinion Head Brg.	NP848872-NP673386	1	Pinion Head Brg.	HM803146-HM803110	1
Position	Part Number	Qty	Pinion Tail Brg.	HM807046-HM807010	1	Pinion Tail Brg.	HM88542-HM88510	1
Differential Brg.	3984-3920	2	Pinion Seal	710508 (26064030)	1	Pinion Seal (1958-1972)	6808N (18888)	1
Pinion Head Brg.	HM807046-HM807010	1	Crush Sleeve	CS356	1	Pinion Seal (1971 and later)	9316 (18891)	1
Pinion Tail Brg.	M802048-M802011	1	Pinion Nut	PN17	1	Pinion Nut	PN5	1
Pinion Seal	710508 (26064030)	1	Gear Marking & Brush	GMC1-BR1	1	Gear Marking & Brush	GMC1-BR1	1
Crush Sleeve	CS341	1	Threadlocker	TL1	1	Threadlocker	TL1	1
Pinion Nut	PN17	1	Sealer	RTV Silicone	1	Sealer	RTV Silicone	1
Gear Marking & Brush	GMC1-BR1	1	Pinion Depth Shims	SK54	1	Pinion Brg. Shims	SK17	1
Threadlocker	TL1	1	Ring Gear Bolts	RGB21	12	Pinion Depth Shims	SK15	1
Sealer	RTV Silicone	1	DRK-328			Differential Shims	SK54	1
DRK-327MK			Position	Part Number	Qty	Ring Gear Bolts	SK54	1
Position	Part Number	Qty	Differential Brg.	387A-382A	2	DRK-331A		
Differential Brg.	3984-3920	2	Pinion Head Brg.	NP201062-NP101912	1	Position	Part Number	Qty
Pinion Head Brg.	HM807046-HM807010	1	Pinion Tail Brg.	NP568415-NP908986	1	Differential Brg.	387A-382S	2
Pinion Tail Brg.	M802048-M802011	1	Output Shaft Seal (w/Parking Brake)	12369460	2	Pinion Head Brg.	HM803146-HM803110	1
Pinion Seal	710508 (26064030)	1	Gear Marking & Brush	GMC1-BR1	1	Pinion Tail Brg.	HM88542-HM88510	1
Crush Sleeve	CS341	1	Threadlocker	TL1	1	Pinion Seal (1958-1972)	6808N (18888)	1
Pinion Nut	PN17	1	Sealer	RTV Silicone	1	Pinion Seal (1971 and later)	9316 (18891)	1
Gear Marking & Brush	GMC1-BR1	1	Needle Brg.	HK4020	1	Pinion Seal (w/ end yoke 3-4-12771-1)		1
Threadlocker	TL1	1	O-Ring	OR162	1	Pinion Seal (w/ end yoke 3-4-14531-1)		1
Sealer	RTV Silicone	1	O-Ring	OR170X2	1	Crush Sleeve	CS342	1
Pinion Depth Shims	SK54	1	O-Ring	OR264	2	Pinion Nut	PN5	1
Differential Shims	SK18	1	DRK-329			Gear Marking & Brush	GMC1-BR1	1
Ring Gear Bolts	RGB21	12	Position	Part Number	Qty	Threadlocker	TL1	1
DRK-327A			Differential Brg.	25584-25520	2	Sealer	RTV Silicone	1
Position	Part Number	Qty	Pinion Head Brg.	HM804846-HM804810	1	Pinion Depth Shims	SK15	1
Differential Brg.	3984-3920	2	Pinion Tail Brg.	HM89446-HM89410	1	Differential Shims	SK54	1
Pinion Head Brg.	NP516549-NP673386	1	Pinion Seal	473461 (19380)	1	DRK-329MK		
Pinion Tail Brg.	M802048-M802011	1	Crush Sleeve	CS329	1	Position	Part Number	Qty
Pinion Seal	710508 (26064030)	1	Pinion Nut	PN3	1	Differential Brg.	25584-25520	2
Crush Sleeve	CS341	1	Gear Marking & Brush	GMC1-BR1	1	Pinion Head Brg.	HM804846-HM804810	1
Pinion Nut	PN17	1	Threadlocker	TL1	1	Pinion Tail Brg.	HM89446-HM89410	1
Gear Marking & Brush	GMC1-BR1	1	Sealer	RTV Silicone	1	Pinion Seal	473461 (19380)	1
Threadlocker	TL1	1				Crush Sleeve	CS329	1
Sealer	RTV Silicone	1				Pinion Nut	PN3	1

LD Differential

Light Duty Differential Rebuild Kits

DRK-331AMK		
Position	Part Number	Qty
Differential Brg.	387A-382S	2
Pinion Head Brg.	HM803146-HM803110	1
Pinion Tail Brg.	HM88542-HM88510	1
Pinion Seal (w/ end yoke 3-4-12771-1)	9316 (18891)	1
Pinion Seal (w/ end yoke 3-4-14531-1)	DS50574	1
Crush Sleeve	CS342	1
Pinion Nut	PN5	1
Gear Marking & Brush	GMC1-BR1	1
Threadlocker	TL1	1
Sealer	RTV Silicone	1
Pinion Depth Shims	SK15	1
Differential Shims	SK54	1
Ring Gear Bolts	RGB6	12

DRK-331B		
Position	Part Number	Qty
Differential Brg.	NP197868-NP802507	2
Pinion Head Brg.	HM803146-HM803110	1
Pinion Tail Brg.	HM88542-HM88510	1
Pinion Seal (1998-2000)	719316 (42449)	1
Pinion Seal (2001 and Later)	DS50637	1
Pinion Nut	PN5	1
Gear Marking & Brush	GMC1-BR1	1
Threadlocker	TL1	1
Sealer	RTV Silicone	1

DRK-331BMK		
Position	Part Number	Qty
Differential Brg.	NP197868-NP802507	2
Pinion Head Brg.	HM803146-HM803110	1
Pinion Tail Brg.	HM88542-HM88510	1
Pinion Seal (1998-2000)	719316 (42449)	1
Pinion Seal (2001 and Later)	DS50637	1
Pinion Nut	PN5	1
Gear Marking & Brush	GMC1-BR1	1
Threadlocker	TL1	1
Sealer	RTV Silicone	1
Pinion Brg. Shims	SK17	1
Pinion Depth Shims	SK15	1
Differential Shims	SK54	1
Ring Gear Bolts	RGB6	12

DRK-331C		
Position	Part Number	Qty
Differential Brg.	NP197868-NP802507	2
Pinion Head Brg.	HM803146-HM803110	1
Pinion Tail Brg.	HM88542-HM88510	1
Pinion Seal	DS2001243	1
Pinion Nut	PN5	1
Gear Marking & Brush	GMC1-BR1	1
Threadlocker	TL1	1
Sealer	RTV Silicone	1

DRK-331CMK		
Position	Part Number	Qty
Differential Brg.	NP197868-NP802507	2
Pinion Head Brg.	HM803146-HM803110	1
Pinion Tail Brg.	HM88542-HM88510	1
Pinion Seal	DS2001243	1
Pinion Nut	PN5	1
Gear Marking & Brush	GMC1-BR1	1
Threadlocker	TL1	1
Sealer	RTV Silicone	1
Pinion Brg. Shims	SK17	1
Pinion Depth Shims	SK15	1
Differential Shims	SK54	3
Ring Gear Bolts	RGB6	12

DRK-332		
Position	Part Number	Qty
Differential Brg.	387A-382S	2
Pinion Head Brg.	HM807040-HM807010	1
Pinion Tail Brg.	HM88542-HM88510	1
Pinion Seal (1957-1970)	6808N (18888)	1
Pinion Seal (1970 and Later)	9316 (18891)	1
Pinion Nut	PN5	1
Gear Marking & Brush	GMC1-BR1	1
Threadlocker	TL1	1
Sealer	RTV Silicone	1
Pinion Brg. Shims	SK17	1
Pinion Depth Shims	SK18	1
Differential Shims	SK54	1

DRK-332MK		
Position	Part Number	Qty
Differential Brg.	387A-382S	2
Pinion Head Brg.	HM807040-HM807010	1
Pinion Tail Brg.	HM88542-HM88510	1
Pinion Seal (1957-1970)	6808N (18888)	1
Pinion Seal (1970 and Later)	9316 (18891)	1
Pinion Nut	PN5	1
Gear Marking & Brush	GMC1-BR1	1
Threadlocker	TL1	1
Sealer	RTV Silicone	1
Pinion Brg. Shims	SK17	1
Pinion Depth Shims	SK18	1
Differential Shims	SK54	1
Ring Gear Bolts	RGB12	12

DRK-332A		
Position	Part Number	Qty
Differential Brg.	NP197868-NP802507	2
Pinion Head Brg.	HM803149-HM803110	1
Pinion Tail Brg.	HM88542-HM88510	1
Pinion Seal	719316 (42449)	1
Pinion Nut	PN5	1
Gear Marking & Brush	GMC1-BR1	1
Threadlocker	TL1	1
Sealer	RTV Silicone	1
Pinion Brg. Shims	SK17	1
Pinion Depth Shims	SK15	1
Differential Shims	SK54	1
Spacer	DS46176	1

DRK-332AMK		
Position	Part Number	Qty
Differential Brg.	NP197868-NP802507	2
Pinion Head Brg.	HM803149-HM803110	1
Pinion Tail Brg.	HM88542-HM88510	1
Pinion Seal	719316 (42449)	1
Pinion Nut	PN5	1
Gear Marking & Brush	GMC1-BR1	1
Threadlocker	TL1	1
Sealer	RTV Silicone	1
Pinion Brg. Shims	SK17	1
Pinion Depth Shims	SK15	1
Differential Shims	SK54	1
Ring Gear Bolts	RGB12	12
Spacer	DS46176	1

DRK-332HD		
Position	Part Number	Qty
Differential Brg.	469-453X	2
Pinion Head Brg.	HM807040-HM807010	1
Pinion Tail Brg.	HM88542-HM88510	1
Pinion Seal	9316 (18891)	1
Pinion Nut	PN5	1
Gear Marking & Brush	GMC1-BR1	1
Threadlocker	TL1	1
Sealer	RTV Silicone	1
Pinion Brg. Shims	SK17	1
Pinion Depth Shims	SK18	1
Differential Shims	SK54	1

DRK-332HDMK		
Position	Part Number	Qty
Differential Brg.	469-453X	2
Pinion Head Brg.	HM807040-HM807010	1
Pinion Tail Brg.	HM88542-HM88510	1
Pinion Seal	9316 (18891)	1
Pinion Nut	PN5	1
Gear Marking & Brush	GMC1-BR1	1
Threadlocker	TL1	1
Sealer	RTV Silicone	1
Pinion Brg. Shims	SK17	1
Pinion Depth Shims	SK18	1
Differential Shims	SK54	1
Ring Gear Bolts	RGB12	12

DRK-332U		
Position	Part Number	Qty
Differential Brg.	387A-382S	2
Pinion Head Brg.	HM803149-HM803110	1
Pinion Tail Brg.	HM88542-HM88510	1
Pinion Seal	9316 (18891)	1
Pinion Nut	PN5	1
Gear Marking & Brush	GMC1-BR1	1
Threadlocker	TL1	1
Sealer	RTV Silicone	1
Pinion Brg. Shims	SK17	1
Pinion Depth Shims	SK15	1
Differential Shims	SK54	1

DRK-332UMK		
Position	Part Number	Qty
Differential Brg.	387A-382S	2
Pinion Head Brg.	HM803149-HM803110	1
Pinion Tail Brg.	HM88542-HM88510	1
Pinion Seal	9316 (18891)	1
Pinion Nut	PN5	1
Gear Marking & Brush	GMC1-BR1	1
Threadlocker	TL1	1
Sealer	RTV Silicone	1
Pinion Brg. Shims	SK17	1
Pinion Depth Shims	SK15	1
Differential Shims	SK54	1
Ring Gear Bolts	RGB12	12

DRK-333		
Position	Part Number	Qty
Differential Brg.	LM29749-LM29710	2
Pinion Head Brg.	M88048-M88010	1
Pinion Tail Brg.	M86649-M86610	1
Pinion Seal	4244 (UZ0147G1)	1
Crush Sleeve	CS330	1
Pinion Nut	PN8-F	1
Gear Marking & Brush	GMC1-BR1	1
Threadlocker	TL1	1
Sealer	RTV Silicone	1

DRK-333MK		
Position	Part Number	Qty
Differential Brg.	LM29749-LM29710	2
Pinion Head Brg.	M88048-M88010	1
Pinion Tail Brg.	M86649-M86610	1
Pinion Seal	4244 (UZ0147G1)	1
Crush Sleeve	CS330	1
Pinion Nut	PN8-F	1
Gear Marking & Brush	GMC1-BR1	1
Threadlocker	TL1	1
Sealer	RTV Silicone	1
Pinion Depth Shims	SK24	1
Differential Shims	SK25	1
Ring Gear Bolts	RGB5	10

LD Differential

Light Duty Differential Rebuild Kits



DRK-334TJMK		
Position	Part Number	Qty
Differential Brg.	LM501349-LM501314	2
Pinion Head Brg.	HM88649-HM88610	1
Pinion Tail Brg.	M86649-M86610	1
Pinion Seal	5778 (15788)	1
Pinion Seal	DS50660	1
Crush Sleeve	CS335	1
Pinion Nut	PN8-F	1
Gear Marking & Brush	GMC1-BR1	1
Threadlocker	TL1	1
Sealer	RTV Silicone	1
Pinion Depth Shims	SK54	1
Differential Shims	SK20	1
Ring Gear Bolts	RGB5	10
Slinger	13575	1
Pinion Nut Washer	30186	1

DRK-335		
Position	Part Number	Qty
Differential Brg.	LM501349-LM501314	2
Pinion Head Brg.	HM88648-HM88610	1
Pinion Tail Brg.	M86649-M86610	1
Pinion Seal	714675	1
Crush Sleeve	CS310	1
Pinion Nut	PN6	1
Gear Marking & Brush	GMC1-BR1	1
Threadlocker	TL1	1
Sealer	RTV Silicone	1

DRK-335MK		
Position	Part Number	Qty
Differential Brg.	LM501349-LM501314	2
Pinion Head Brg.	HM88648-HM88610	1
Pinion Tail Brg.	M86649-M86610	1
Pinion Seal	714675	1
Crush Sleeve	CS310	1
Pinion Nut	PN6	1
Gear Marking & Brush	GMC1-BR1	1
Threadlocker	TL1	1
Sealer	RTV Silicone	1
Pinion Depth Shims	SK54	1
Differential Shims	SK28 ⁵¹	1
Ring Gear Bolts	RGB5	8

DRK-335B		
Position	Part Number	Qty
Differential Brg.	LM501349-LM501310	2
Pinion Head Brg.	HM88648-HM88610	1
Pinion Tail Brg.	M86649-M86610	1
Pinion Seal	DS51501	1
Crush Sleeve	CS310	1
Pinion Nut	PN6	1
Gear Marking & Brush	GMC1-BR1	1
Threadlocker	TL1	1
Sealer	RTV Silicone	1

DRK-335BMK		
Position	Part Number	Qty
Differential Brg.	LM501349-LM501310	2
Pinion Head Brg.	HM88648-HM88610	1
Pinion Tail Brg.	M86649-M86610	1
Pinion Seal	DS51501	1
Crush Sleeve	CS310	1
Pinion Nut	PN6	1
Gear Marking & Brush	GMC1-BR1	1
Threadlocker	TL1	1
Sealer	RTV Silicone	1
Pinion Depth Shims	SK54	1
Differential Shims	SK28 ⁵¹	1
Ring Gear Bolts	RGB5	8

DRK-335C		
Position	Part Number	Qty
Differential Brg.	LM501349-LM501314	2
Pinion Head Brg.	HM88648-HM88610	1
Pinion Tail Brg.	M86649-M86610	1
Pinion Seal	DS49153	1
Crush Sleeve	CS344	1
Pinion Nut	PN6	1
Gear Marking & Brush	GMC1-BR1	1
Threadlocker	TL1	1
Sealer	RTV Silicone	1

DRK-335CMK		
Position	Part Number	Qty
Differential Brg.	LM501349-LM501314	2
Pinion Head Brg.	HM88648-HM88610	1
Pinion Tail Brg.	M86649-M86610	1
Pinion Seal	DS49153	1
Crush Sleeve	CS344	1
Pinion Nut	PN6	1
Gear Marking & Brush	GMC1-BR1	1
Threadlocker	TL1	1
Sealer	RTV Silicone	1
Pinion Depth Shims	SK54	1
Differential Shims	SK28 ⁵¹	1
Ring Gear Bolts	RGB5	8

DRK-336A		
Position	Part Number	Qty
Differential Brg.	JLM104948-LM104911A	2
Pinion Head Brg.	HM88649-HM88610	1
Pinion Tail Brg.	02872-02820	1
Pinion Seal	5778 (15788)	1
Pinion Seal	50531	1
Crush Sleeve	CS338	1
Pinion Brg. Shims	SK5	1
Pinion Nut	PN8-F	1
Gear Marking & Brush	GMC1-BR1	1
Threadlocker	TL1	1
Sealer	RTV Silicone	1

DRK-336AMK		
Position	Part Number	Qty
Differential Brg.	JLM104948-LM104911A	2
Pinion Head Brg.	HM88649-HM88610	1
Pinion Tail Brg.	02872-02820	1
Pinion Seal	5778 (15788)	1
Pinion Seal	50531	1
Crush Sleeve	CS338	1
Pinion Brg. Shims	SK5	1
Pinion Nut	PN8-F	1
Gear Marking & Brush	GMC1-BR1	1
Threadlocker	TL1	1
Sealer	RTV Silicone	1
Pinion Depth Shims	SK54	1
Differential Shims	SK21	1
Ring Gear Bolts	RGB14	10
Pinion Nut Washer	30186	1

DRK-337		
Position	Part Number	Qty
Differential Brg.	469-453X	2
Pinion Head Brg.	HM807046-HM807010	1
Pinion Tail Brg.	M802048-M802011	1
Pinion Seal	4525V (25140)	1
Pinion Nut	PN10	1
Gear Marking & Brush	GMC1-BR1	1
Threadlocker	TL1	1
Sealer	RTV Silicone	1

DRK-337MK		
Position	Part Number	Qty
Differential Brg.	469-453X	2
Pinion Head Brg.	HM807046-HM807010	1
Pinion Tail Brg.	M802048-M802011	1
Pinion Seal	4525V (25140)	1
Pinion Nut	PN10	1
Gear Marking & Brush	GMC1-BR1	1
Threadlocker	TL1	1
Sealer	RTV Silicone	1
Pinion Brg. Shims	SK44	1
Pinion Depth Shims	SK43	1
Differential Shims	SK54	1
Ring Gear Bolts	RGB13	12

DRK-337A		
Position	Part Number	Qty
Differential Brg.	469-453X	2
Pinion Head Brg.	NP516549-NP673386	1
Pinion Tail Brg.	M802048-M802011	1
Pinion Seal	DS51180	1
Pinion Nut	PN10	1
Gear Marking & Brush	GMC1-BR1	1
Threadlocker	TL1	1
Sealer	RTV Silicone	1

DRK-337AMK		
Position	Part Number	Qty
Differential Brg.	469-453X	2
Pinion Head Brg.	NP516549-NP673386	1
Pinion Tail Brg.	M802048-M802011	1
Pinion Seal	DS51180	1
Pinion Nut	PN10	1
Gear Marking & Brush	GMC1-BR1	1
Threadlocker	TL1	1
Sealer	RTV Silicone	1
Pinion Brg. Shims	SK44	1
Pinion Depth Shims	SK54	1
Differential Shims	SK54	1
Ring Gear Bolts	RGB13	12

DRK-338		
Position	Part Number	Qty
Differential Brg.	LM501349-LM501314	2
Pinion Head Brg.	HM88649-HM88610	1
Pinion Tail Brg.	M86647-M86610	1
Pinion Seal	5778 (15788)	1
Pinion Nut	PN8-F	1
Gear Marking & Brush	GMC1-BR1	1
Threadlocker	TL1	1
Sealer	RTV Silicone	1

DRK-338MK		
Position	Part Number	Qty
Differential Brg.	LM501349-LM501314	2
Pinion Head Brg.	HM88649-HM88610	1
Pinion Tail Brg.	M86647-M86610	1
Pinion Seal	5778 (15788)	1
Pinion Nut	PN8-F	1
Gear Marking & Brush	GMC1-BR1	1
Threadlocker	TL1	1
Sealer	RTV Silicone	1
Pinion Brg. Shims	SK5	1
Pinion Depth Shims	SK54	1
Differential Shims	SK20	1
Ring Gear Bolts	RGB5	10

DRK-339		
Position	Part Number	Qty
Differential Brg.	LM603049-LM603011	2
Pinion Head Brg.	HM88649-HM88610	1
Pinion Tail Brg.	M86647-M86610	1
Pinion Seal	5778 (15788)	1
Pinion Nut	PN8-F	1
Gear Marking & Brush	GMC1-BR1	1
Threadlocker	TL1	1
Sealer	RTV Silicone	1

LD Differential

Light Duty Differential Rebuild Kits

DRK-339MK			DRK-339C			DRK-339EMK		
Position	Part Number	Qty	Position	Part Number	Qty	Position	Part Number	Qty
Differential Brg.	LM603049-LM603011	2	Differential Brg.	25590-25523	2	Differential Brg.	25590-25523	2
Pinion Head Brg.	HM88649-HM88610	1	Pinion Head Brg.	HM88649-HM88610	1	Pinion Head Brg.	31594-31520	1
Pinion Tail Brg.	M88647-M88610	1	Pinion Tail Brg.	02872-02820	1	Pinion Tail Brg.	02872-02820	1
Pinion Seal	5778 (15788)	1	Pinion Seal	5778 (15788)	1	Pinion Seal	DS50660	1
Pinion Nut	PN8-F	1	Crush Sleeve	CS338	1	Pinion Nut	PN8-F	1
Gear Marking & Brush	GMC1-BR1	1	Pinion Nut	PN8-F	1	Gear Marking & Brush	GMC1-BR1	1
Threadlocker	TL1	1	Gear Marking & Brush	GMC1-BR1	1	Threadlocker	TL1	1
Sealer	RTV Silicone	1	Threadlocker	TL1	1	Sealer	RTV Silicone	1
Pinion Brg. Shims	SK5	1	Sealer	RTV Silicone	1	Pinion Brg. Shims	SK5	1
Pinion Depth Shims	SK4	1	Pinion Nut Washer	30186	1	Pinion Depth Shims	SK22	1
Differential Shims	SK7 ²⁷	1				Differential Shims	SK47	1
						Ring Gear Bolts	RGB14	10
DRK-339A			DRK-339CMK			DRK-339F		
Position	Part Number	Qty	Position	Part Number	Qty	Position	Part Number	Qty
Differential Brg.	LM603049-LM603012	2	Differential Brg.	25590-25523	2	Differential Brg.	JLM704649-JLM704610	2
Pinion Head Brg.	M802048-M802011	1	Pinion Head Brg.	HM88649-HM88610	1	Pinion Head Brg.	M802048-M802011	1
Pinion Tail Brg.	M88048-M88010	1	Pinion Tail Brg.	02872-02820	1	Pinion Tail Brg.	HM88649-HM88610	1
Pinion Seal	719316	1	Pinion Seal	5778 (15788)	1	Pinion Seal	DS2004670	1
Crush Sleeve	CS333	1	Crush Sleeve	CS338	1	Crush Sleeve	CS345	1
Pinion Nut	PN5	1	Pinion Nut	PN8-F	1	Pinion Nut	PN6	1
Gear Marking & Brush	GMC1-BR1	1	Gear Marking & Brush	GMC1-BR1	1	Gear Marking & Brush	GMC1-BR1	1
Threadlocker	TL1	1	Threadlocker	TL1	1	Threadlocker	TL1	1
Sealer	RTV Silicone	1	Sealer	RTV Silicone	1	Sealer	RTV Silicone	1
			Pinion Depth Shims	SK38	1	Pinion Depth Shims	SK4	1
			Differential Shims	SK23	1	Differential Shims	SK47	1
			Ring Gear Bolts	RGB5	10	Ring Gear Bolts	RGB24	10
			Pinion Nut Washer	30186	1			
DRK-339AMK			DRK-339D			DRK-339FMK		
Position	Part Number	Qty	Position	Part Number	Qty	Position	Part Number	Qty
Differential Brg.	LM603049-LM603012	2	Differential Brg.	25590-25523	2	Differential Brg.	JLM704649-JLM704610	2
Pinion Head Brg.	M802048-M802011	1	Pinion Head Brg.	HM88649-HM88610	1	Pinion Head Brg.	M802048-M802011	1
Pinion Tail Brg.	M88048-M88010	1	Pinion Tail Brg.	02872-02820	1	Pinion Tail Brg.	HM88649-HM88610	1
Pinion Seal	719316	1	Pinion Seal	5778 (15788)	1	Pinion Seal	DS2004670	1
Crush Sleeve	CS333	1	Pinion Nut	PN8-F	1	Crush Sleeve	CS345	1
Pinion Nut	PN5	1	Gear Marking & Brush	GMC1-BR1	1	Pinion Nut	PN6	1
Gear Marking & Brush	GMC1-BR1	1	Threadlocker	TL1	1	Gear Marking & Brush	GMC1-BR1	1
Threadlocker	TL1	1	Sealer	RTV Silicone	1	Threadlocker	TL1	1
Sealer	RTV Silicone	1	Pinion Shims	SK38	1	Sealer	RTV Silicone	1
Pinion Depth Shims	SK4	1	Differential Shims	SK23	1	Pinion Depth Shims	SK4	1
Differential Shims	SK7 ²⁷	1	Ring Gear Bolts	RGB5	10	Differential Shims	SK47	1
Ring Gear Bolts	RGB5	10	Pinion Nut Washer	30186	1	Ring Gear Bolts	RGB24	10
DRK-339B			DRK-339DMK			DRK-339G		
Position	Part Number	Qty	Position	Part Number	Qty	Position	Part Number	Qty
Differential Brg.	25590-25523	2	Differential Brg.	25590-25523	2	Differential Brg.	JLM704649-JLM704610	2
Pinion Head Brg.	31594-31520	1	Pinion Head Brg.	HM88649-HM88610	1	Pinion Head Brg.	M802048-M802011	1
Pinion Tail Brg.	02872-02820	1	Pinion Tail Brg.	02872-02820	1	Pinion Tail Brg.	HM88649-HM88610	1
Pinion Seal	5778 (15788)	1	Pinion Seal	5778 (15788)	1	Pinion Seal	DS2004101	1
Pinion Nut	PN8-F	1	Pinion Nut	PN8-F	1	Crush Sleeve	CS349	1
Gear Marking & Brush	GMC1-BR1	1	Gear Marking & Brush	GMC1-BR1	1	Pinion Nut	PN5	1
Threadlocker	TL1	1	Threadlocker	TL1	1	Gear Marking & Brush	GMC1-BR1	1
Sealer	RTV Silicone	1	Sealer	RTV Silicone	1	Threadlocker	TL1	1
			Pinion Shims	SK38	1	Sealer	RTV Silicone	1
			Differential Shims	SK23	1			
			Ring Gear Bolts	RGB5	10			
			Pinion Nut Washer	30186	1			
DRK-339BMK			DRK-339E			DRK-339GMK		
Position	Part Number	Qty	Position	Part Number	Qty	Position	Part Number	Qty
Differential Brg.	25590-25523	2	Differential Brg.	25590-25523	2	Differential Brg.	JLM704649-JLM704610	2
Pinion Head Brg.	31594-31520	1	Pinion Head Brg.	31594-31520	1	Pinion Head Brg.	M802048-M802011	1
Pinion Tail Brg.	02872-02820	1	Pinion Tail Brg.	02872-02820	1	Pinion Tail Brg.	HM88649-HM88610	1
Pinion Seal	5778 (15788)	1	Pinion Seal	02872-02820	1	Pinion Seal	DS2004101	1
Pinion Nut	PN8-F	1	Pinion Seal	DS50660	1	Crush Sleeve	CS349	1
Gear Marking & Brush	GMC1-BR1	1	Pinion Nut	PN8-F	1	Pinion Nut	PN5	1
Threadlocker	TL1	1	Gear Marking & Brush	GMC1-BR1	1	Gear Marking & Brush	GMC1-BR1	1
Sealer	RTV Silicone	1	Threadlocker	TL1	1	Threadlocker	TL1	1
Pinion Brg. Shims	SK5	1	Sealer	RTV Silicone	1	Sealer	RTV Silicone	1
Pinion Depth Shims	SK22	1				Pinion Depth Shims	SK4	1
Differential Shims	SK23	1				Differential Shims	SK47	1
Ring Gear Bolts	RGB5	10				Ring Gear Bolts	RGB24	10

LD Differential

27 Order SSK7 for stackable differential shims.

Light Duty Differential Rebuild Kits



DRK-339H

Position	Part Number	Qty
Differential Brg.	25590-25523	2
Pinion Head Brg.	M802048-M802011	1
Pinion Tail Brg.	M88048-M88010	1
Pinion Seal	DS2004101	1
Crush Sleeve	CS349	1
Pinion Nut	PN5	1
Gear Marking & Brush	GMC1-BR1	1
Threadlocker	TL1	1
Sealer	RTV Silicone	1

DRK-339HMK

Position	Part Number	Qty
Differential Brg.	25590-25523	2
Pinion Head Brg.	M802048-M802011	1
Pinion Tail Brg.	M88048-M88010	1
Pinion Seal	DS2004101	1
Crush Sleeve	CS349	1
Pinion Nut	PN5	1
Gear Marking & Brush	GMC1-BR1	1
Threadlocker	TL1	1
Sealer	RTV Silicone	1
Pinion Depth Shims	SK4	1
Differential Shims	SK23	1
Ring Gear Bolts	RGB24	10

DRK-339J

Position	Part Number	Qty
Differential Brg.	JLM104948-JLM104910	2
Pinion Head Brg.	NP784953-NP396414	1
Pinion Tail Brg.	M88048-M88010	1
Pinion Seal	DS2004101	1
Crush Sleeve	CS349	1
Pinion Nut	PN5D	1
Gear Marking & Brush	GMC1-BR1	1
Threadlocker	TL1	1
Sealer	RTV Silicone	1

DRK-339JMK

Position	Part Number	Qty
Differential Brg.	JLM104948-JLM104910	2
Pinion Head Brg.	NP784953-NP396414	1
Pinion Tail Brg.	M88048-M88010	1
Pinion Seal	DS2004101	1
Crush Sleeve	CS349	1
Pinion Nut	PN5D	1
Pinion Depth Shims	SK4	1
Differential Shims	SK21	1
Gear Marking & Brush	GMC1-BR1	1
Threadlocker	TL1	1
Sealer	RTV Silicone	1
Ring Gear Bolts	RGB24	10

DRK-339N

Position	Part Number	Qty
Differential Brg.	JLM704649-JLM704610	2
Pinion Head Brg.	HM803146-HM803110	1
Pinion Tail Brg.	M88048-M88010	1
Pinion Seal	DS50574	1
Crush Sleeve	CS349	1
Pinion Nut	PN5	1
Gear Marking & Brush	GMC1-BR1	1
Threadlocker	TL1	1
Sealer	RTV Silicone	1
Washer	DS30275	1

DRK-339NMK

Position	Part Number	Qty
Differential Brg.	JLM704649-JLM704610	2
Pinion Head Brg.	HM803146-HM803110	1
Pinion Tail Brg.	M88048-M88010	1
Pinion Seal	DS50574	1
Crush Sleeve	CS349	1
Pinion Nut	PN5	1
Gear Marking & Brush	GMC1-BR1	1
Threadlocker	TL1	1
Sealer	RTV Silicone	1
Pinion Depth Shims	SK4	1
Differential Shims	SK47	1
Ring Gear Bolts	RGB25	10
Washer	DS30275	1

DRK-339NJ

Position	Part Number	Qty
Differential Brg.	JLM704649-JLM704610	2
Pinion Head Brg.	HM803146-HM803110	1
Pinion Tail Brg.	M88048-M88010	1
Pinion Seal	DS50574	1
Crush Sleeve	CS333	1
Pinion Nut	PN5	1
Gear Marking & Brush	GMC1-BR1	1
Threadlocker	TL1	1
Sealer	RTV Silicone	1

DRK-339NJMK

Position	Part Number	Qty
Differential Brg.	JLM704649-JLM704610	2
Pinion Head Brg.	HM803146-HM803110	1
Pinion Tail Brg.	M88048-M88010	1
Pinion Seal	DS50574	1
Crush Sleeve	CS333	1
Pinion Nut	PN5	1
Gear Marking & Brush	GMC1-BR1	1
Threadlocker	TL1	1
Sealer	RTV Silicone	1
Pinion Depth Shims	SK4	1
Differential Shims	SK47	1
Ring Gear Bolts	RGB5-D	10
Ring Gear Bolts	RGB24	10
Ring Gear Bolts	RGB25	10

DRK-339T

Position	Part Number	Qty
Differential Brg.	LM603049-LM603011	2
Pinion Head Brg.	M88048-M88010	1
Pinion Tail Brg.	M802048-802011	1
Pinion Seal	38189-8S110	1
Crush Sleeve	CS339	1
Pinion Nut	PN26	1
Gear Marking & Brush	GMC1-BR1	1
Threadlocker	TL1	1
Sealer	RTV Silicone	1

DRK-339TMK

Position	Part Number	Qty
Differential Brg.	LM603049-LM603011	2
Pinion Head Brg.	M88048-M88010	1
Pinion Tail Brg.	M802048-802011	1
Pinion Seal	38189-8S110	1
Crush Sleeve	CS339	1
Pinion Nut	PN26	1
Gear Marking & Brush	GMC1-BR1	1
Threadlocker	TL1	1
Sealer	RTV Silicone	1
Pinion Depth Shims	SK4	1
Ring Gear Bolts	RGB24	10

DRK-340

Position	Part Number	Qty
Differential Brg.	LM501349-LM501314	2
Pinion Head Brg.	M802048-M802011	1
Pinion Tail Brg.	HM88649-HM88610	1
Pinion Seal	DS50619	1
Crush Sleeve	CS345	1
Pinion Nut	PN6	1
Gear Marking & Brush	GMC1-BR1	1
Threadlocker	TL1	1
Sealer	RTV Silicone	1

DRK-340MK

Position	Part Number	Qty
Differential Brg.	LM501349-LM501314	2
Pinion Head Brg.	M802048-M802011	1
Pinion Tail Brg.	HM88649-HM88610	1
Pinion Seal	DS50619	1
Crush Sleeve	CS345	1
Pinion Nut	PN6	1
Gear Marking & Brush	GMC1-BR1	1
Threadlocker	TL1	1
Sealer	RTV Silicone	1
Pinion Depth Shims	SK4	1
Differential Shims	SK28 ⁵¹	1
Ring Gear Bolts	RGB5-D	10

DRK-350

Position	Part Number	Qty
Differential Brg.	LM603049-LM603014	2
Pinion Head Brg.	32307C	1
Pinion Tail Brg.	30306	1
Pinion Seal	1177 (14768)	1
Crush Sleeve	CS332	1
Pinion Nut	PN11	1
Gear Marking & Brush	GMC1-BR1	1
Threadlocker	TL1	1
Sealer	RTV Silicone	1

DRK-350MK

Position	Part Number	Qty
Differential Brg.	LM603049-LM603014	2
Pinion Head Brg.	32307C	1
Pinion Tail Brg.	30306	1
Pinion Seal	1177 (14768)	1
Crush Sleeve	CS332	1
Pinion Nut	PN11	1
Gear Marking & Brush	GMC1-BR1	1
Threadlocker	TL1	1
Sealer	RTV Silicone	1
Pinion Depth Shims	SK32	1
Ring Gear Bolts	RGB15	10

DRK-350A

Position	Part Number	Qty
Differential Brg.	90368-50006	2
Pinion Head Brg.	32307C	1
Pinion Tail Brg.	30306	1
Pinion Seal	1177 (14768)	1
Crush Sleeve	CS332	1
Pinion Nut	PN11	1
Gear Marking & Brush	GMC1-BR1	1
Threadlocker	TL1	1
Sealer	RTV Silicone	1

LD Differential

Light Duty Differential Rebuild Kits

DRK-350AMK			DRK-352A			DRK-354MK		
Position	Part Number	Qty	Position	Part Number	Qty	Position	Part Number	Qty
Differential Brg.	90368-50006	2	Differential Brg.	JLM104948-LM104912	2	Differential Left Brg.	90366-75001	1
Pinion Head Brg.	32307C	1	Pinion Head Brg.	90366-35028	1	Differential Right Brg.	90366-50007	1
Pinion Tail Brg.	30306	1	Pinion Tail Brg.	90366-30025	1	Pinion Head Brg.	90366-35028	1
Pinion Seal	1177 (14768)	1	Pinion Seal	90311-41009	1	Pinion Tail Brg.	90366-30025	1
Crush Sleeve	CS332	1	Crush Sleeve	CS334	1	Pinion Seal	1177 (14768)	1
Pinion Nut	PN11	1	Pinion Nut	PN18	1	Crush Sleeve	CS334	1
Gear Marking & Brush	GMC1-BR1	1	Gear Marking & Brush	GMC1-BR1	1	Pinion Nut	PN14	1
Threadlocker	TL1	1	Threadlocker	TL1	1	Gear Marking & Brush	GMC1-BR1	1
Sealer	RTV Silicone	1	Sealer	RTV Silicone	1	Threadlocker	TL1	1
Pinion Depth Shims	SK32	1	Spacer	SP2043	1	Sealer	RTV Silicone	1
Differential Shims	SK7 ²⁷	1	DRK-352AMK			Pinion Depth Shims	SK32	1
Ring Gear Bolts	RGB15	10	Position	Part Number	Qty	Ring Gear Bolts	RGB19	12
DRK-351			Differential Brg.	JLM104948-LM104912	2	DRK-354A		
Position	Part Number	Qty	Pinion Head Brg.	90366-35028	1	Position	Part Number	Qty
Differential Brg.	LM603049-LM603014	2	Pinion Tail Brg.	90366-30025	1	Differential Left Brg.	90366-75001	1
Pinion Head Brg.	32307C	1	Pinion Seal	90311-41009	1	Differential Right Brg.	90366-50007	1
Pinion Tail Brg.	30306	1	Crush Sleeve	CS334	1	Pinion Head Brg.	90366-30067	1
Pinion Seal	1177 (14768)	1	Pinion Nut	PN18	1	Pinion Tail Brg.	90366-35028	1
Crush Sleeve	CS331	1	Gear Marking & Brush	GMC1-BR1	1	Pinion Seal	1177 (14768)	1
Pinion Nut	PN9	1	Threadlocker	TL1	1	Crush Sleeve	CS334	1
Gear Marking & Brush	GMC1-BR1	1	Sealer	RTV Silicone	1	Pinion Nut	PN14	1
Threadlocker	TL1	1	Pinion Depth Shims	SK32	1	Gear Marking & Brush	GMC1-BR1	1
Sealer	RTV Silicone	1	Ring Gear Bolts	RGB15	10	Threadlocker	TL1	1
DRK-351MK			Spacer	SP2043	1	Sealer	RTV Silicone	1
Position	Part Number	Qty	DRK-353			DRK-354AMK		
Differential Brg.	LM603049-LM603014	2	Position	Part Number	Qty	Position	Part Number	Qty
Pinion Head Brg.	32307C	1	Differential Brg.	LM603049-LM603014	2	Differential Left Brg.	90366-75001	1
Pinion Tail Brg.	30306	1	Pinion Head Brg.	30306	1	Differential Right Brg.	90366-50007	1
Pinion Seal	1177 (14768)	1	Pinion Tail Brg.	90366-35044-77	1	Pinion Head Brg.	90366-30067	1
Crush Sleeve	CS331	1	Pinion Seal	1177 (14768)	1	Pinion Tail Brg.	90366-35028	1
Pinion Nut	PN9	1	Crush Sleeve	CS331	1	Pinion Seal	1177 (14768)	1
Gear Marking & Brush	GMC1-BR1	1	Pinion Nut	PN9	1	Crush Sleeve	CS334	1
Threadlocker	TL1	1	Gear Marking & Brush	GMC1-BR1	1	Pinion Nut	PN14	1
Sealer	RTV Silicone	1	Threadlocker	TL1	1	Gear Marking & Brush	GMC1-BR1	1
Pinion Depth Shims	SK32	1	Sealer	RTV Silicone	1	Threadlocker	TL1	1
Ring Gear Bolts	RGB15	10	DRK-353MK			Sealer	RTV Silicone	1
DRK-352			Position	Part Number	Qty	Pinion Depth Shims	SK32	1
Position	Part Number	Qty	Differential Brg.	LM603049-LM603014	2	Ring Gear Bolts	RGB19	12
Differential Brg.	JLM104948-LM104912	2	Pinion Head Brg.	30306	1	DRK-355		
Pinion Head Brg.	90366-35028	1	Pinion Tail Brg.	90366-35044-77	1	Position	Part Number	Qty
Pinion Tail Brg.	90366-30025	1	Pinion Seal	1177 (14768)	1	Differential Brg.	90366-51001	2
Pinion Seal	1177 (14768)	1	Crush Sleeve	CS331	1	Pinion Head Brg.	HM88649-HM88610	1
Crush Sleeve	CS334	1	Pinion Nut	PN9	1	Pinion Tail Brg.	90366-40068	1
Pinion Nut	PN9	1	Gear Marking & Brush	GMC1-BR1	1	Pinion Seal	90311-44007	1
Gear Marking & Brush	GMC1-BR1	1	Threadlocker	TL1	1	Crush Sleeve	CS327	1
Threadlocker	TL1	1	Sealer	RTV Silicone	1	Pinion Nut	PN15	1
Sealer	RTV Silicone	1	Pinion Depth Shims	SK32	1	Gear Marking & Brush	GMC1-BR1	1
DRK-352MK			Ring Gear Bolts	RGB15	10	Threadlocker	TL1	1
Position	Part Number	Qty	DRK-354			Sealer	RTV Silicone	1
Differential Brg.	JLM104948-LM104912	2	Position	Part Number	Qty	DRK-355MK		
Pinion Head Brg.	90366-35028	1	Differential Left Brg.	90366-75001	1	Position	Part Number	Qty
Pinion Tail Brg.	90366-30025	1	Differential Right Brg.	90366-50007	1	Differential Brg.	90366-51001	2
Pinion Seal	1177 (14768)	1	Pinion Head Brg.	90366-35028	1	Pinion Head Brg.	HM88649-HM88610	1
Crush Sleeve	CS334	1	Pinion Tail Brg.	90366-30025	1	Pinion Tail Brg.	90366-40068	1
Pinion Nut	PN9	1	Pinion Seal	1177 (14768)	1	Pinion Seal	90311-44007	1
Gear Marking & Brush	GMC1-BR1	1	Crush Sleeve	CS334	1	Crush Sleeve	CS327	1
Threadlocker	TL1	1	Pinion Nut	PN14	1	Pinion Nut	PN15	1
Sealer	RTV Silicone	1	Gear Marking & Brush	GMC1-BR1	1	Gear Marking & Brush	GMC1-BR1	1
Pinion Depth Shims	SK32	1	Threadlocker	TL1	1	Threadlocker	TL1	1
Ring Gear Bolts	RGB15	10	Sealer	RTV Silicone	1	Sealer	RTV Silicone	1
Spacer	SP2043	1				Pinion Depth Shims	SK49	1
						Ring Gear Bolts	RGB19	12

LD Differential

27 Order SSK7 for stackable differential shims.

Light Duty Differential Rebuild Kits



DRK-355A		
Position	Part Number	Qty
Differential Brg.	90368-50006	2
Pinion Head Brg.	32307	1
Pinion Tail Brg.	30306	1
Pinion Seal	1177 (14768)	1
Crush Sleeve	CS332	1
Pinion Nut	PN11	1
Gear Marking & Brush	GMC1-BR1	1
Threadlocker	TL1	1
Sealer	RTV Silicone	1

DRK-355AMK		
Position	Part Number	Qty
Differential Brg.	90368-50006	2
Pinion Head Brg.	32307	1
Pinion Tail Brg.	30306	1
Pinion Seal	1177 (14768)	1
Crush Sleeve	CS332	1
Pinion Nut	PN11	1
Gear Marking & Brush	GMC1-BR1	1
Threadlocker	TL1	1
Sealer	RTV Silicone	1
Pinion Depth Shims	SK32	1
Differential Shims	SK7 ²⁷	1
Ring Gear Bolts	RGB15	10

DRK-356		
Position	Part Number	Qty
Differential Left Brg.	90366-75001	1
Differential Right Brg.	90366-50007	1
Pinion Head Brg.	90366-30025	1
Pinion Tail Brg.	90366-35028	1
Pinion Seal	1177 (14768)	1
Crush Sleeve	CS334	1
Pinion Nut	PN9	1
Gear Marking & Brush	GMC1-BR1	1
Threadlocker	TL1	1
Sealer	RTV Silicone	1
Gasket	GR-TFJ80F	1

DRK-356MK		
Position	Part Number	Qty
Differential Left Brg.	90366-75001	1
Differential Right Brg.	90366-50007	1
Pinion Head Brg.	90366-30025	1
Pinion Tail Brg.	90366-35028	1
Pinion Seal	1177 (14768)	1
Crush Sleeve	CS334	1
Pinion Nut	PN9	1
Gear Marking & Brush	GMC1-BR1	1
Threadlocker	TL1	1
Sealer	RTV Silicone	1
Pinion Depth Shims	SK32	1
Ring Gear Bolts	RGB20	12
Gasket	GR-TFJ80F	1

DRK-356A		
Position	Part Number	Qty
Differential Brg.	90366-50007	2
Pinion Head Brg.	90366-30025	1
Pinion Tail Brg.	90366-35028	1
Pinion Seal	1177 (14768)	1
Crush Sleeve	CS334	1
Pinion Nut	PN9	1
Gear Marking & Brush	GMC1-BR1	1
Threadlocker	TL1	1
Gasket	GR-TFJ80F	1
Sealer	RTV Silicone	1

DRK-356AMK		
Position	Part Number	Qty
Differential Brg.	90366-50007	2
Pinion Head Brg.	90366-30025	1
Pinion Tail Brg.	90366-35028	1
Pinion Seal	1177 (14768)	1
Crush Sleeve	CS334	1
Pinion Nut	PN9	1
Gear Marking & Brush	GMC1-BR1	1
Threadlocker	TL1	1
Gasket	GR-TFJ80F	1
Sealer	RTV Silicone	1
Pinion Depth Shims	SK32	1
Ring Gear Bolts	RGB20	12

DRK-357		
Position	Part Number	Qty
Differential Brg.	32012X	2
Pinion Head Brg.	30308	1
Pinion Tail Brg.	30306	1
Pinion Seal	1177 (14768)	1
Crush Sleeve	CS340	1
Pinion Nut	PN16	1
Gear Marking & Brush	GMC1-BR1	1
Threadlocker	TL1	1
Gasket	GR-TFJ80R	1
Hub Gasket For Full	GR-TFJ80HUB	1
Float		
Sealer	RTV Silicone	1

DRK-357MK		
Position	Part Number	Qty
Differential Brg.	32012X	2
Pinion Head Brg.	30308	1
Pinion Tail Brg.	30306	1
Pinion Seal	1177 (14768)	1
Crush Sleeve	CS340	1
Pinion Nut	PN16	1
Gear Marking & Brush	GMC1-BR1	1
Threadlocker	TL1	1
Gasket	GR-TFJ80R	1
Hub Gasket For Full	GR-TFJ80HUB	1
Float		
Sealer	RTV Silicone	1
Pinion Depth Shims	SK15	1
Ring Gear Bolts	RGB20	12

DRK-357A		
Position	Part Number	Qty
Differential Brg.	32010X	2
Pinion Head Brg.	30308	1
Pinion Tail Brg.	30306	1
Pinion Seal	1177 (14768)	1
Crush Sleeve	CS340	1
Pinion Nut	PN16	1
Gear Marking & Brush	GMC1-BR1	1
Threadlocker	TL1	1
Gasket	GR-TFJ80	1
Hub Gasket For Full	GR-TFJ80HUB	1
Float		
Sealer	RTV Silicone	1

DRK-357AMK		
Position	Part Number	Qty
Differential Brg.	32010X	2
Pinion Head Brg.	30308	1
Pinion Tail Brg.	30306	1
Pinion Seal	1177 (14768)	1
Crush Sleeve	CS340	1
Pinion Nut	PN16	1
Gear Marking & Brush	GMC1-BR1	1
Threadlocker	TL1	1
Gasket	GR-TFJ80	1
Hub Gasket For Full	GR-TFJ80HUB	1
Float		
Sealer	RTV Silicone	1
Pinion Depth Shims	SK15	1
Ring Gear Bolts	RGB20	12

DRK-358		
Position	Part Number	Qty
Differential Brg.	LM603049-LM603014	2
Pinion Head Brg.	30308	1
Pinion Tail Brg.	30306	1
Pinion Seal	1177 (14768)	1
Crush Sleeve	CS340	1
Pinion Nut	PN16	1
Gear Marking & Brush	GMC1-BR1	1
Threadlocker	TL1	1
Gasket	GR-TFJ80HUB	1

DRK-358MK		
Position	Part Number	Qty
Differential Brg.	LM603049-LM603014	2
Pinion Head Brg.	30308	1
Pinion Tail Brg.	30306	1
Pinion Seal	1177 (14768)	1
Crush Sleeve	CS340	1
Pinion Nut	PN16	1
Gear Marking & Brush	GMC1-BR1	1
Threadlocker	TL1	1
Gasket	GR-TFJ80R	1
Pinion Depth Shims	SK15	1
Ring Gear Bolts	RGB20	12

DRK-359		
Position	Part Number	Qty
Differential Brg.	90366-53004	2
Pinion Head Brg.	90366-35028	1
Pinion Tail Brg.	90366-30067	1
Pinion Seal	710114	1
Crush Sleeve	CS351	1
Pinion Nut	PN18	1
Gear Marking & Brush	GMC1-BR1	1
Threadlocker	TL1	1
Sealer	RTV Silicone	1

DRK-359MK		
Position	Part Number	Qty
Differential Brg.	90366-53004	2
Pinion Head Brg.	90366-35028	1
Pinion Tail Brg.	90366-30067	1
Pinion Seal	710114	1
Crush Sleeve	CS351	1
Pinion Nut	PN18	1
Gear Marking & Brush	GMC1-BR1	1
Threadlocker	TL1	1
Sealer	RTV Silicone	1
Pinion Depth Shims	SK32	1
Differential Shims	SK47	1
Ring Gear Bolts	RGB19	12

LD Differential

Light Duty Differential Rebuild Kits

DRK-360			DRK-380MK			DRK-382A		
Position	Part Number	Qty	Position	Part Number	Qty	Position	Part Number	Qty
Differential Brg.	LM603049-LM603014	2	Differential Brg.	90366-58013	2	Differential Brg.	90366-60021	2
Pinion Head Brg.	30307	1	Pinion Head Brg.	90366-40114	1	Pinion Head Brg.	90366-45044	1
Pinion Tail Brg.	30306	1	Pinion Tail Brg.	90363-35063	1	Pinion Tail Brg.	90366-40123	1
Pinion Seal	710523	1	Pinion Seal	90311-46006	1	Pinion Seal	225275	1
Crush Sleeve	CS332	1	Crush Sleeve	CS357	1	Crush Sleeve	CS360	1
Pinion Nut	PN9	1	Pinion Nut	PN24	1	Pinion Nut	PN24	1
Gear Marking & Brush	GMC1-BR1	1	Gear Marking & Brush	GMC1-BR1	1	Gear Marking & Brush	GMC1-BR1	1
Threadlocker	TL1	1	Threadlocker	TL1	1	Threadlocker	TL1	1
Sealer	RTV Silicone	1	Sealer	RTV Silicone	1	Sealer	RTV Silicone	1
DRK-360MK			DRK-381			DRK-382AMK		
Position	Part Number	Qty	Position	Part Number	Qty	Position	Part Number	Qty
Differential Brg.	LM603049-LM603014	2	Differential Brg.	32010X	2	Differential Brg.	90366-60021	2
Pinion Head Brg.	30307	1	Pinion Head Brg.	30308	1	Pinion Head Brg.	90366-45044	1
Pinion Tail Brg.	30306	1	Pinion Tail Brg.	90366-A0014	1	Pinion Tail Brg.	90366-40123	1
Pinion Seal	710523	1	Pinion Seal	90311-A0007	1	Pinion Seal	225275	1
Crush Sleeve	CS332	1	Crush Sleeve	CS358	1	Crush Sleeve	CS360	1
Pinion Nut	PN9	1	Pinion Nut	PN24	1	Pinion Nut	PN24	1
Gear Marking & Brush	GMC1-BR1	1	Gear Marking & Brush	GMC1-BR1	1	Gear Marking & Brush	GMC1-BR1	1
Threadlocker	TL1	1	Threadlocker	TL1	1	Threadlocker	TL1	1
Sealer	RTV Silicone	1	Sealer	RTV Silicone	1	Sealer	RTV Silicone	1
Pinion Depth Shims	SK32	1	Pinion Depth Shims	SK4	1	Pinion Depth Shims	SK10	1
Ring Gear Bolts	RGB28	10	Ring Gear Bolts	RGB31	12	Differential Shims	SK42	1
DRK-365			DRK-381MK			DRK-434		
Position	Part Number	Qty	Position	Part Number	Qty	Position	Part Number	Qty
Differential Right Brg.	32012X	1	Differential Brg.	32010X	2	Differential Right Brg.	3984-3920	1
Differential Left Brg.	32017X	1	Pinion Head Brg.	30308	1	Differential Left Brg.	3984-3920	1
Pinion Head Brg.	805177	1	Pinion Tail Brg.	90366-A0014	1	Pinion Head Brg.	72212C-72487	1
Pinion Tail Brg.	805177	1	Pinion Seal	90311-A0007	1	Pinion Tail Brg.	55200C-55437	1
Pinion Seal	68034401AA	1	Crush Sleeve	CS358	1	Pinion Seal	DT7591	1
Pinion Nut	PN22	1	Pinion Nut	PN24	1	Sealer	RTV Silicone	1
Gear Marking & Brush	GMC1-BR1	1	Gear Marking & Brush	GMC1-BR1	1			
Threadlocker	TL1	1	Threadlocker	TL1	1			
Sealer	RTV Silicone	1	Sealer	RTV Silicone	1			
DRK-370			DRK-382					
Position	Part Number	Qty	Position	Part Number	Qty			
Differential Brg.	32010X	2	Differential Brg.	90366-A0020	2			
Pinion Head Brg.	M802048-M802011	1	Pinion Head Brg.	90366-A0017	1			
Pinion Tail Brg.	NP922169-NP2330028	1	Pinion Tail Brg.	90366-A0023	1			
Pinion Seal	68049798AA	1	Pinion Seal	90311-A0008	1			
Gear Marking & Brush	GMC1-BR1	1	Crush Sleeve	CS359	1			
Threadlocker	TL1	1	Pinion Nut	PN24	1			
Sealer	RTV Silicone	1	Gear Marking & Brush	GMC1-BR1	1			
DRK-370MK			DRK-382MK					
Position	Part Number	Qty	Position	Part Number	Qty			
Differential Brg.	32010X	2	Differential Brg.	90366-A0020	2			
Pinion Head Brg.	M802048-M802011	1	Pinion Head Brg.	90366-A0017	1			
Pinion Tail Brg.	NP922169-NP2330028	1	Pinion Tail Brg.	90366-A0023	1			
Pinion Seal	68049798AA	1	Pinion Seal	90311-A0008	1			
Gear Marking & Brush	GMC1-BR1	1	Crush Sleeve	CS359	1			
Threadlocker	TL1	1	Pinion Nut	PN24	1			
Sealer	RTV Silicone	1	Gear Marking & Brush	GMC1-BR1	1			
Pinion Brg. Shims	SK3	1	Threadlocker	TL1	1			
Differential Shims	SK52	1	Sealer	RTV Silicone	1			
Spacer	SK53	1	DRK-380					
DRK-380			Position	Part Number	Qty			
Differential Brg.	90366-58013	2	Differential Brg.	90366-58013	2			
Pinion Head Brg.	90366-40114	1	Pinion Head Brg.	90366-40114	1			
Pinion Tail Brg.	90363-35063	1	Pinion Tail Brg.	90363-35063	1			
Pinion Seal	90311-46006	1	Pinion Seal	90311-46006	1			
Crush Sleeve	CS357	1	Crush Sleeve	CS357	1			
Pinion Nut	PN24	1	Pinion Nut	PN24	1			
Gear Marking & Brush	GMC1-BR1	1	Gear Marking & Brush	GMC1-BR1	1			
Threadlocker	TL1	1	Threadlocker	TL1	1			
Sealer	RTV Silicone	1	Sealer	RTV Silicone	1			
			Pinion Depth Shims	SK23	1			
			Pinion Brg. Shims	SK44	1			
			Differential Shims	SK13	3			
			Ring Gear Bolts	RGB33	12			

Axle Product by Axle Size

AMC Model 20 Axle (12 Bolt Cover)

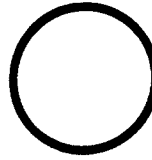

GR-A20J
NO HOLES
10½" DIA.

Rebuild Kit	Description
DRK-311J	Standard Kit
DRK-311JMK	Master Kit
Open Case	Ratio
AMC20-CASE	3.08-4.88 Ratios
Internal Kit	Description
AMC20-IK	

Ring & Pinion	Ratio
AMC273	2.73 (41-15)
AMC308	3.08 (40-14)
AMC331	3.31 (43-13)
AMC354	3.54 (39-11)
AMC373	3.73 (41-11)
AMC410	4.10 (41-10)
AMC456	4.56 (41-9)
AMC488	4.88 (39-8)

Limited Slip & Locking Differential	Description
542081	Auburn Pro 3.07 & Higher, 29 Spline (66-86)

Application	Years	2WD/4WD	Axle Shaft	Comments	Length	Studs	Spline	Side
N/A								

Chrysler 7.25" Axle (9 or 10 Bolt Cover)

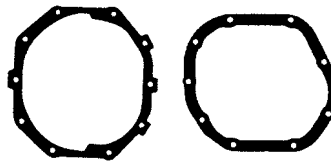

GR-C725
10 HOLES/9 HOLES
(2 Gaskets in Set)

Rebuild Kit	Description
DRK-302	Standard Kit
DRK-302MK	Master Kit
Open Case	Description
C725-CASE	
Internal Kit	Description
C725-IK	

Ring & Pinion	Ratio
C725293	2.93 (41-11)
C725323	3.23 (42-13)
C725355	3.55 (39-11)
C725391	3.91 (39-10)

Limited Slip Differential	Description
N/A	

Application	Years	2WD/4WD	Axle Shaft	Comments	Length	Studs	Spline	Side
Dakota	91-96	2	AS4506147		30¼"	6	25	R&L
Dakota	91-96	2	AS4348511		30¼"	5	25	R&L

Call for all other applications or dimensions.

Axle Product by Axle Size

Chrysler 8.25" Axle (10 Bolt Cover)

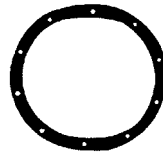

GR-C825
10 HOLES
OVAL

Rebuild Kit	Description
-------------	-------------

Due to multiple model splits, refer to the vehicle index for proper kit selection.

Open Case	Ratio
-----------	-------

C825-CASE

Internal Kit	Description
--------------	-------------

C825-IK 27 Spline

C825-IKB 29 Spline

Ring & Pinion	Ratio
---------------	-------

C825321 3.21 (45-14)

C825323 3.23 (42-13)

C825355 3.55 (39-11)

C825390 3.90 (43-11)

C825410 4.10 (41-10)

C825456 4.56 (41-9)

Limited Slip & Locking Differential	Description
-------------------------------------	-------------

542072 Auburn HP 2.71 & Higher, 27 Spline (66-96)

542074 Auburn HP 2.71 & Higher, 29 Spline (97-0n)

187C151A Detroit Locker 2.73 & Higher, 27 Spline (69-96)

187C179A Detroit Locker 2.73 & Higher, 29 Spline (97-09)

912A553 Detroit Truetrac 2.73 & Higher, 29 Spline (97-09)

Application	Years	2WD/4WD	Axle Shaft	Comments	Length	Studs	Spline	Side
Dakota	87-90	2/4	AS4348510		30 ³ / ₄ "	5	27	R&L
Dakota	91-96	2/4	AS4506115		30 ³ / ₄ "	6	27	R&L
Jeep Cherokee	91-96	2/4	AS53008134		29 ³ / ₄ "	5	27	R&L
Jeep Cherokee	97-01	4	AS5015393		29 ³ / ₄ "	5	29	R&L
Van 1/2 Ton	85-96	2/4	AS4137670		32 ⁹ / ₁₆ "	5	27	R&L
Van 3/4 Ton	85-96	2/4	AS4137670		32 ⁹ / ₁₆ "	5	27	R&L

Call for all other applications or dimensions.

LD Differential

Axle Product by Axle Size

Chrysler 8.75" Axle Early 1.75" Pinion Shaft (12 Bolt Cover)

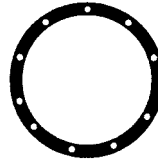

GR-C875
10 HOLES
ROUND

Rebuild Kit	Description	Ring & Pinion	Ratio
DRK-300	Standard Kit	C875391E	3.90 (43-11)
DRK-300MK	Master Kit	C875410E	4.10 (41-10)
		C875430E	4.30 (43-10)
		C875457E	4.57 (32-7)
		C875486E	4.86 (34-7)
		C875513E	5.13 (41-8)
		C875538E	5.38 (43-8)
		C875557E	5.57 (39-7)

Limited Slip & Locking Differential	Description
542051	Auburn Pro 30 Spline (57-74)

Application	Years	2WD/4WD	Axle Shaft	Comments	Length	Studs	Spline	Side
N/A								

Chrysler 8.75" Axle Late 1.875" Pinion Shaft (12 Bolt Cover)

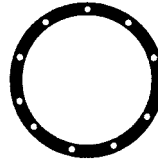

GR-C875
10 HOLES
ROUND

Rebuild Kit	Description	Ring & Pinion	Ratio
DRK-301	Standard Kit	C875355L	3.55 (39-11)
DRK-301MK	Master Kit	C875390L	3.90 (43-11)
		C875410L	4.10 (41-10)
		C875430L	4.30 (43-10)
		C875457L	4.57 (32-7)
		C875486L	4.86 (34-7)
		C875513L	5.13 (41-8)
		C875538L	5.38 (43-8)

Limited Slip & Locking Differential	Description
542051	Auburn Pro 30 Spline (57-74)
187SL14A	Detroit Locker 2.76-4.56, 30 Spline (69-74)
913A572	Detroit Truetrac 2.76-4.56, 30 Spline (69-74)

Application	Years	2WD/4WD	Axle Shaft	Comments	Length	Studs	Spline	Side
N/A								

LD Differential

Axle Product by Axle Size

Chrysler 9.25" Axle (12 Bolt Cover)

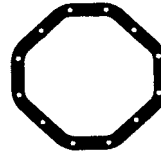

GR-C925
12 HOLES

Rebuild Kit	Description
DRK-304	Standard Kit – (69-00)
DRK-304MK	Master Kit – (69-00)
DRK-304A	Standard Kit – (01-10)
DRK-304AMK	Master Kit – (01-10)

Open Case	Description
C925-CASE	

Internal Kit	Description
C925-IK	

Ring & Pinion	Ratio
C925323	3.23 (45-14)
C925355	3.55 (39-11)
C925390	3.90 (43-11)
C925410	4.10 (41-10)
C925456	4.56 (41-9)

Limited Slip & Locking Differential	Description
542071	Auburn HP 2.71 & Higher, 31 Spline (68-83)
542070	Auburn HP 2.71 & Higher, 31 Spline (84-10)
187C172A	Detroit Locker 2.76–4.56, 31 Spline (74-10)
913A368	Detroit Truetrac 2.76–4.56, 31 Spline (74-10)

Application	Years	2WD/4WD	Axle Shaft	Comments	Length	Studs	Spline	Side
Passenger Car	73-78	2	AS3723824		31 ¹¹ / ₁₆ "	5	31	R&L
Ram Charger	74-82	2	AS3723824		31 ¹¹ / ₁₆ "	5	31	R&L
Ram Charger	85 -93	2	AS4137429		31 ⁵ / ₈ "	5	31	R&L
Ram Charger	74-79	4	AS3723824		31 ¹¹ / ₁₆ "	5	31	R&L
Ram Charger	80-84	4	AS4037726	Thru 4/2/84	31 ⁵ / ₈ "	5	31	R&L
Ram Charger	84 -93	4	AS4137429	After 4/3/84	31 ⁵ / ₈ "	5	31	R&L
Trail Duster	74-81	2	AS3723824		31 ¹¹ / ₁₆ "	5	31	R&L
Trail Duster	74-79	4	AS3723824		31 ¹¹ / ₁₆ "	5	31	R&L
Trail Duster	80-81	4	AS4037726		31 ⁵ / ₈ "	5	31	R&L
Truck 1/2 Ton	74-83	2	AS3723824		31 ¹¹ / ₁₆ "	5	31	R&L
Truck 1/2 Ton	85 -93	2	AS4137429		31 ⁵ / ₈ "	5	31	R&L
Truck 1/2 Ton	75-79	4	AS3723824		31 ¹¹ / ₁₆ "	5	31	R&L
Truck 1/2 Ton	80-84	4	AS4037726	Thru 4/2/84	31 ⁵ / ₈ "	5	31	R&L
Truck 1/2 Ton	84 -93	4	AS4137429	After 4/3/84	31 ⁵ / ₈ "	5	31	R&L
Truck 1/2 Ton	94-05	2/4	AS52067614		34"	5	31	R&L
Van 1/2 Ton	98-03	2	AS52067708AB		32 ⁹ / ₁₆ "	5	31	R&L
Van 3/4 Ton	92-99	2	AS52067708AB		32 ⁹ / ₁₆ "	5	31	R&L
Van 1 Ton	92-94	2	AS52067708AB		32 ⁹ / ₁₆ "	5	31	R&L

Call for all other applications or dimensions.

LD Differential

Chrysler 9.25" Axle-Front-AAM (14 Bolt Cover)

Rebuild Kit	Description	Ring & Pinion	Ratio
DRK-324G	Standard Kit – (03-14)	C925373F	3.73
DRK-324GMK	Master Kit – (03-14)	C925410F	4.10
Open Case	Description	Limited Slip & Locking Differential	Description
GM95-CASE-LOAD (03-06)		914A643	Detroit Truetrac, 33 Spline (03-10)*
C925-CASEB (07-14)			
Internal Kit	Description	*2007 and newer vehicles must use 03-06 ring and pinion	
GM95-IK (03-06)			
C925-IKA (07-14)			

Application	Years	2WD/4WD	Axle Shaft	Comments	Length	Studs	Spline	Side
N/A								

Chrysler 10.5" Rear Axle-AAM (14 Bolt Cover)

Rebuild Kit	Description	Ring & Pinion	Ratio
DRK-306	Standard Kit – (03-09)	C105373	3.73
DRK-306MK	Master Kit – (03-09)	C105410	4.10
Loaded Open Case	Description	Limited Slip & Locking Differential	Description
C105-CASE (03-09)		N/A	
Internal Kit	Description		
C105-IK (03-10)			

Application	Years	2WD/4WD	Axle Shaft	Comments	Length	Studs	Spline	Side
N/A								

Chrysler 11.5" Rear Axle (14 Bolt Cover)

Rebuild Kit	Description	Ring & Pinion	Ratio
DRK-327	Standard Kit – (03-11 1st Design)	C115373	3.73
DRK-327MK	Master Kit – (03-11 1st Design)	C112410	4.10
DRK-32A7	Standard Kit – (11-14 2nd Design)		
DRK-327AMK	Master Kit – (11-14 2nd Design)		
Loaded Open Case	Description	Limited Slip & Locking Differential	Description
GM115-CASE	3.73, 4.10 & 4.63 Gear Ratios	250SL195A	Detroit Locker 30 Spline (03-09)
		915A568	Detroit Truetrac 30 Spline (03-09)
		40025134	OEM Limited Slip
Internal Kit	Description		
GM115-IKA (03-10)			

Application	Years	2WD/4WD	Axle Shaft	Comments	Length	Studs	Spline	Side
N/A								

Axle Product by Axle Size

Ford 7.5" Axle (10 Bolt Cover)

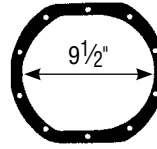

GR-F750
10 HOLES

Rebuild Kit	Description
DRK-315	Standard Kit
DRK-315MK	Master Kit
Open Case	Ratio
FD75-CASE	
Internal Kit	Description
FD75-IK	78-On (28 Spline)

Ring & Pinion	Ratio
FD75308	3.08 (37-12)
FD75345	3.45 (38-11)
FD75373†	3.73 (41-11)
FD75410†	4.10 (41-10)
FD75456†	4.56 (41-9)

†Requires cross shaft FD75CS

Limited Slip & Locking Differential	Description
542023	Auburn HP (28 Spline)
542048	Auburn Pro (28 Spline)
162C57A	Detroit Locker (28 Spline)
912A316	Detroit Truetrac (28 Spline)

Application	Years	2WD/4WD	Axle Shaft	Comments	Length	Studs	Spline	Side
Aerostar	86-97	2/4	ASE3TZ4234C		29 ¹ / ₈ "	5	28	R
Aerostar	86-97	2/4	ASE69Z4234A		32 ¹ / ₄ "	5	28	L
Bronco II	84-90	2/4	ASE4TZ4234A		27 ¹ / ₁₆ "	5	28	R
Bronco II	84-90	2/4	ASE3TZ4234C		29 ¹ / ₈ "	5	28	L
Mazda B-Series	98-09	2/4	ASF87Z4234AC		27 ¹ / ₄ "	5	28	R
Mazda B-Series	98-09	2/4	ASF87Z4234AD		30 ¹ / ₄ "	5	28	L
Ranger	83-84	2	ASE3TZ4324A		28"	5	28	R&L
Ranger	85-92	2	ASE3TZ4234B		26 ¹ / ₄ "	5	28	R
Ranger	85-92	2	ASE3TZ4234C		29 ¹ / ₈ "	5	28	L
Ranger	83-92	4	ASE3TZ4234B		26 ¹ / ₄ "	5	28	R
Ranger	83-92	4	ASE3TZ4234C		29 ¹ / ₈ "	5	28	L
Ranger	93-97	2/4	ASF37Z4234A		27 ¹ / ₄ "	5	28	R
Ranger	93-97	2/4	ASF37Z4234B		30 ¹ / ₈ "	5	28	L
Ranger	98-09	2/4	ASF87Z4234AC		27 ¹ / ₄ "	5	28	R
Ranger	98-09	2/4	ASF87Z4234AD		30 ¹ / ₄ "	5	28	L

Call for all other applications or dimensions.

LD Differential

Axle Product by Axle Size

Ford 8" Axle (10 Bolt Cover)

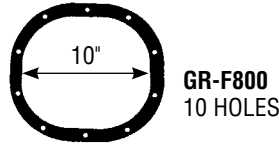

Rebuild Kit	Description
DRK-310	Standard Kit
DRK-310MK	Master Kit
Open Case	Description
N/A	
Internal Kit	Description
N/A	

Ring & Pinion	Ratio
FD8300	3.00 (39-13)
FD8325	3.25 (39-12)
FD8340	3.40 (34-10)
FD8355	3.55 (39-11)
FD8380	3.80 (38-10)
FD8411	4.11 (37-9)

Limited Slip & Locking Differential	Description
542059†	Auburn Pro (28 Spline)
5420115†	Auburn Pro (31 Spline)
187S13D	Detroit Locker (28 Spline)
912A580	Detroit Truetrac (28 Spline)

†Requires two LM102949-LM102910 Brgs.

Application	Years	2WD/4WD	Axle Shaft	Comments	Length	Studs	Spline	Side
N/A								

Ford 8.8" IFS Axle

Rebuild Kit	Description
DRK-311	Standard Kit (97-14)
DRK-311	Master Kit (97-14)
Open Case	Ratio
N/A	
Internal Kit	Description
FD88-IKIFS	

Ring & Pinion	Ratio
FD88331IFS	3.31
FD88355IFS	3.55
FD88373IFS	3.73
FD88410IFS	4.10
FD88456IFS	4.56
FD88488IFS	4.88

Limited Slip & Locking Differential	Description
187C147A	Detroit Locker, 28 Spline (97-08)
912A563	Detroit Truetrac, 28 Spline (97-08)

Application	Years	2WD/4WD	Axle Shaft	Comments	Length	Studs	Spline	Side
N/A								

Axle Product by Axle Size

Ford 8.8" Solid Axle & IRS (10 Bolt Cover)

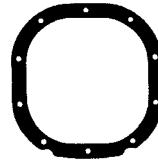

GR-F880
10 HOLES

Rebuild Kit	Description
Due to multiple model splits, refer to the vehicle index for proper kit selection.	
Open Case	Ratio
FD 88-CASE	
Internal Kit	Description
FD88-IK	87-14 (31 Spline)

Ring & Pinion	Ratio
FD88308	3.08 (40-13)
FD88327	3.27 (36-11)
FD88331	3.31 (43-13)
FD88355	3.55 (39-11)
FD88373	3.73 (41-11)
FD88390	3.90 (43-11)
FD88410	4.10 (41-10)
FD88430	4.30 (43-10)
FD88456	4.56 (41-9)
FD88488	4.88 (39-8)

Limited Slip & Locking Differential	Description
542079	Auburn HP, 28 Spline (79-14)
542025	Auburn HP, 31 Spline (83-14)
542080	Auburn Pro, 28 Spline (79-14)
542054	Auburn Pro, 31 Spline (83-14)
5420116	Auburn Pro, 33 Spline (83-14)
545001	Auburn ECTED, 28 Spline (78-14)
545002	Auburn ECTED, 31 Spline - Non-IRS (83-14)
545005	Auburn ECTED, 31 Spline - IRS (83-14)
19605-010	Eaton, 28 Spline (82-11)
19558-010	Eaton, 31 Spline (83-86)
19660-010	Eaton E-locker, 31 Spline (83-86)
187C147A	Detroit Locker, 28 Spline (82-11)
187C145A†	Detroit Locker, 31 Spline (86-11)
912A562	Detroit Truetrac, 28 Spline (82-11)
913A561†‡	Detroit Truetrac, 31 Spline (86-11)

† Fits 1987 & Later Models
‡ 2005 & Later Mustangs Require Axle Spacer Modification

Truck Application	Years	2WD/4WD	Axle Shaft	Comments	Length	Studs	Spline	Side
Aerostar	86-97	2/4	ASE3TZ4234C		29 ¹ / ₈ "	5	28	R
Aerostar	86-97	2/4	ASE69Z4234A		32 ¹ / ₄ "	5	28	L
Bronco	83-86	2/4	ASE3TZ4234D		31 ¹ / ₁₆ "	5	31	R
Bronco	83-86	2/4	ASE3TZ4234E		33 ³ / ₁₆ "	5	31	L
Bronco	87-96	2/4	ASE7TZ4234A		31 ¹ / ₁₆ "	5	31	R
Bronco	87-96	2/4	ASE7TZ4234B		33 ³ / ₁₆ "	5	31	L
Expedition	97-02	2/4	ASF75Z4234AA	w/ 1.620" Brg. Surface	31 ³ / ₄ "	5	31	R
Expedition	97-02	2/4	ASF75Z4234AB	w/ 1.620" Brg. Surface	33 ³ / ₈ "	5	31	L
Expedition	97-02	2/4	ASF75Z4234KA	w/ 1.705" Brg. Surface	31 ³ / ₄ "	5	31	R
Expedition	97-02	2/4	ASF75Z4234KB	w/ 1.705" Brg. Surface	33 ³ / ₈ "	5	31	L
Explorer	90 ¹ / ₂ -94	2/4	ASF1TZ4234A		27 ³ / ₄ "	5	31	R
Explorer	90 ¹ / ₂ -94	2/4	ASF1TZ4234B		30 ⁵ / ₈ "	5	31	L
Explorer	95-01	2/4	ASF5TZ4234A		27 ⁵ / ₈ "	5	31	R
Explorer	95-01	2/4	ASF5TZ4234B		30 ¹ / ₂ "	5	31	L
Exploror Sport Trac	01-05	2/4	ASF5TZ4234A		27 ⁵ / ₈ "	5	31	R
Exploror Sport Trac	01-05	2/4	ASF5TZ4234B		30 ¹ / ₂ "	5	31	L
Exploror Sport	02-03	2/4	ASF5TZ4234A		27 ⁵ / ₈ "	5	31	R
Exploror Sport	02-03	2/4	ASF5TZ4234B		30 ¹ / ₂ "	5	31	L
Mazda B-Series	98-01	2/4	ASF87Z4234AC		27 ¹ / ₄ "	5	28	R
Mazda B-Series	98-01	2/4	ASF87Z4234AD		30 ¹ / ₄ "	5	28	L
Mazda Navajo	91-94	2/4	ASF1TZ4234A		27 ³ / ₄ "	5	31	R
Mazda Navajo	91-94	2/4	ASF1TZ4234B		30 ⁵ / ₈ "	5	31	L

LD Differential

Axle Product by Axle Size

Ford 8.8" Solid Axle & IRS (10 Bolt Cover) continued

Truck Applications	Years	2WD/4WD	Axle Shaft	Comments	Length	Studs	Spline	Side
Mountaineer	97-01	2/4	ASF5TZ4234A		27 ⁵ / ₈ "	5	31	R
Mountaineer	97-01	2/4	ASF5TZ4234B		30 ¹ / ₂ "	5	31	L
Ranger	83-84	2	ASE3TZ4234A		28"	5	28	R & L
Ranger	85-92	2	ASE3TZ4234B		26 ¹ / ₄ "	5	28	R
Ranger	85-92	2	ASE3TZ4234C		29 ¹ / ₈ "	5	28	L
Ranger	83-92	4	ASE3TZ4234B		26 ¹ / ₄ "	5	28	R
Ranger	83-92	4	ASE3TZ4234C		29 ¹ / ₈ "	5	28	L
Ranger	93-97	2/4	ASF37Z4234A		27 ¹ / ₄ "	5	28	R
Ranger	93-97	2/4	ASF37Z4234B		30 ¹ / ₈ "	5	28	L
Ranger	98-09	2/4	ASF87Z4234AC		27 ¹ / ₄ "	5	28	R
Ranger	98-09	2/4	ASF87Z4234AD		30 ¹ / ₄ "	5	28	L
Ranger	98-09	2/4	ASF87Z4234BA		27 ¹ / ₄ "	5	31	R
Ranger	98-09	2/4	ASF87Z4234BB		30 ¹ / ₄ "	5	31	L
Truck 1/2 Ton	83-86	2/4	ASE3TZ4234D		31 ¹ / ₁₆ "	5	31	R
Truck 1/2 Ton	83-86	2/4	ASE3TZ4234E		33 ³ / ₁₆ "	5	31	L
Truck 1/2 Ton	87-96	2/4	ASE7TZ4234A		31 ¹ / ₁₆ "	5	31	R
Truck 1/2 Ton	87-96	2/4	ASE7TZ4234B		33 ³ / ₁₆ "	5	31	L
Truck 1/2 Ton	97-04	2/4	ASF75Z4234AA	2004 Heritage	31 ³ / ₄ "	5	31	R
Truck 1/2 Ton	97-04	2/4	ASF75Z4234AB	2004 Heritage	33 ³ / ₈ "	5	31	L
Truck 1/2 Ton	04-08	2/4	AS7L3Z4234A	2004 Non-Heritage	33 ³ / ₄ "	5	31	R
Truck 1/2 Ton	04-08	2/4	AS7L3Z4234C	2004 Non-Heritage	35 ⁷ / ₁₆ "	5	31	L
Van 1/2 Ton	88-96	2	ASE7TZ4234A		31 ¹ / ₁₆ "	5	31	R
Van 1/2 Ton	88-96	2	ASE7UZ4234E		35 ⁵ / ₈ "	5	31	L
Van 1/2 Ton	97-99	2	ASF75Z4234BA		31 ¹ / ₁₆ "	5	31	R
Van 1/2 Ton	97-99	2	ASF75Z4234BB		35 ⁵ / ₈ "	5	31	L

Call for all other applications or dimensions.

Car Applications	Years	2WD/4WD	Axle Shaft	Comments	Length	Studs	Spline	Side
Capri	80-86	2	ASD9BZ4234C		29"	4	28	R&L
Capri	80-86	2	ASE3TZ4234C		29 ¹ / ₈ "	5	28	R&L
Cougar	86-88	2	ASE5SZ4234A		30"	4	28	R&L
Crown Victoria	92-95	2	ASF2AZ4234C	w/o ABS	31 ³ / ₄ "	5	28	R&L
Crown Victoria	92-97	2	ASF2AZ4234B	w/ABS	31 ³ / ₄ "	5	28	R&L
Crown Victoria	98-02	2	ASF8AZ4234DA	w/ABS	32 ⁷ / ₁₆ "	5	28	R&L
Crown Victoria	03-06	2	AS3W1Z4234A		34 ⁷ / ₁₆ "	5	28	R&L
Crown Victoria	03-10	2	AS6W1Z4234A		35 ¹ / ₄ "	5	31	R&L
Ford Full Size	79-89	2	ASD9AZ4234A		30 ⁷ / ₈ "	5	28	R&L
Grand Marquis	92-95	2	ASF2AZ4234C	w/o ABS	31 ³ / ₄ "	5	28	R&L
Grand Marquis	92-97	2	ASF2AZ4234B	w/ABS	31 ³ / ₄ "	5	28	R&L
Grand Marquis	98-02	2	ASF8AZ4234DA	w/ABS	32 ⁷ / ₁₆ "	5	28	R&L
Grand Marquis	03-05	2	AS3W1Z4234A		34 ⁷ / ₁₆ "	5	28	R&L
Grand Marquis	05-10	2	AS6W1Z4234A		35 ¹ / ₄ "	5	31	R&L
Marauder	03-04	2	AS3W1Z4234A		34 ⁷ / ₁₆ "	5	28	R&L
Mercury Full Size	79-89	2	ASD9AZ4234A		30 ⁷ / ₈ "	5	28	R&L
Lincoln Mark VI	80-83	2	ASD9AZ4234A		30 ⁷ / ₈ "	5	28	R&L
Lincoln Town Car	81-89	2	ASD9AZ4234A		30 ⁷ / ₈ "	5	28	R&L
Lincoln Town Car	92-95	2	ASF2AZ4234C	w/o ABS	31 ³ / ₄ "	5	28	R&L
Lincoln Town Car	92-97	2	ASF2AZ4234B	w/ABS	31 ³ / ₄ "	5	28	R&L
Lincoln Town Car	98-02	2	ASF8AZ4234DA	w/ABS	32 ⁷ / ₁₆ "	5	28	R&L
Lincoln Town Car	03-04	2	AS3W1Z4234A		34 ⁷ / ₁₆ "	5	28	R&L
Lincoln Town Car	05-10	2	AS6W1Z4234A		35 ¹ / ₄ "	5	31	R&L
Mustang	79-83	2	ASD9BZ4234C		29"	4	28	R&L
Mustang	79-83	2	ASE3TZ4234C		29 ¹ / ₈ "	5	28	R&L
Mustang	94-98	2	ASF4ZZ4234A	w/o ABS	29 ¹⁵ / ₁₆ "	5	28	R&L
Mustang	94-98	2	ASF4ZZ4234B	w/ABS	29 ¹⁵ / ₁₆ "	5	28	R&L
Mustang	99-04	2	ASXR3Z4234AA	Exc. Cobra	31 ⁵ / ₈ "	5	28	R&L
Thunderbird	86-88	2	ASE5SZ4234A		30"	4	28	R&L
Thunderbird	87-88	2	ASE7SZ4234A	w/ABS	30"	4	28	R&L

Axle Product by Axle Size

Ford 9" Axle (Removable 10 Bolt Carrier)

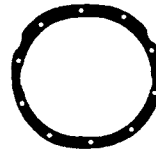

GR-F900
10 HOLES

Rebuild Kit	Description
DRK-312	Standard Kit – (57-70)
DRK-312MK	Master Kit – (57-70)
DRK-313	Standard Kit – (70-86)
DRK-313MK	Master Kit – (70-86)

Open Case	Description
FD9-CASE	28 & 31 Spline-All

Internal Kit	Description
FD9-1K31-2	2 Pinion, 31 Spline
FD9-1K31-4	4 Pinion, 31 Spline
FD9-1K28-2	2 Pinion, 28 Spline
FD9-1K28-4	4 Pinion, 28 Spline

Call for all other applications.

Ring & Pinion	Ratio
FD9280	2.80 (42-15)
FD9286	2.86 (40-14)
FD9294	2.94 (47-16)
FD9300	3.00 (39-13)
FD9315	3.15 (41-13)
FD9325	3.25 (39-12)
FD9350	3.50 (35-10)
FD9355	3.55 (39-11)
FD9360	3.60 (36-10)
FD9370	3.70 (37-10)
FD9375	3.75 (45-12)
FD9382	3.82 (42-11)
FD9389	3.89 (35-9)
FD9400	4.00 (36-9)
FD9411	4.11 (37-9)
FD9422	4.22 (38-9)
FD9430	4.30 (43-10)
FD9433	4.33 (39-9)
FD9444	4.44 (40-9)
FD9456	4.56 (41-9)
FD9457	4.57 (32-7)
FD9463	4.63 (37-8)
FD9471	4.71 (33-7)
FD9486	4.86 (34-7)
FD9500	5.00 (35-7)
FD9514	5.14 (36-7)
FD9529	5.29 (37-7)
FD9543	5.43 (38-7)
FD9567	5.67 (34-6)
FD9583	5.83 (35-6)
FD9600	6.00 (36-6)
FD9620	6.20 (31-5)
FD9633	6.33 (38-6)
FD9650	6.50 (39-6)

Limited Slip & Locking Differential	Description
542043	Auburn Pro (28 Spline)
542036	Auburn Pro (31 Spline)

Axle Shaft	Application	Length	Studs	Spline	Side
ASD6TZ4234A	9" F150 & E150, 74-86	31 ²⁷ / ₃₂ "	5	31	R&L
AS5781L	Bronco 2WD & 4x4 w/ Small Wheel Bearing (66-75)	27 ¹ / ₄ "	5	28	L
AS5781R	Bronco 2WD & 4x4 w/ Small Wheel Bearing (66-75)	29 ⁵ / ₈ "	5	28	R
AS5783L	Bronco 2WD & 4x4 w/ Large Wheel Bearing (66-75)	26 ¹⁵ / ₁₆ "	5	28	L
AS5783R	Bronco 2WD & 4x4 w/ Large Wheel Bearing (66-75)	29 ⁵ / ₁₆ "	5	28	R
AS5785L	Bronco 2WD & 4x4 w/ Large Wheel Bearing (74-75)	27 ¹ / ₄ "	5	28	L
AS5785R	Bronco 2WD & 4x4 w/ Large Wheel Bearing (74-75)	29 ³ / ₄ "	5	28	R
AS5787L	Bronco 2WD & 4x4 w/ Large Wheel Bearing (76-77)	27 ¹ / ₄ "	5	28	L
AS5787R	Bronco 2WD & 4x4 w/ Large Wheel Bearing (76-77)	29 ¹¹ / ₁₆ "	5	28	R
AS6070A	Fairlane (63)	26"	5	31	L
AS6070A	Mustang (64-66)	26"	5	31	L
AS6070B	Fairlane (63)	30 ¹ / ₈ "	5	31	R
AS6070B	Mustang (64-66)	30 ¹ / ₈ "	5	31	R
ASC90Z4234D	Mustang & Cougar (66-70)	27 ¹ / ₈ "	5	31	L
ASC90Z4234C	Mustang & Cougar (66-70)	31 ¹ / ₄ "	5	31	R
ASD1ZZ4234B	Mustang & Cougar (71-72)	27 ⁷ / ₈ "	5	31	L
ASD1ZZ4234A	Mustang & Cougar (71-72)	31 ⁷ / ₈ "	5	31	R
ASD6TZ4234A	1/2 Ton 2WD & 4x4 Truck w/ Small Wheel Bearing (74-86)	31 ²⁷ / ₃₂ "	5	31	R&L
ASD6TZ4234A	1/2 Ton 2WD & 4x4 Van w/ Small Wheel Bearing (74-86)	31 ²⁷ / ₃₂ "	5	31	R&L

Call for all other applications or dimensions.

LD Differential

Axle Product by Axle Size

Ford 9.75" Axle (12 Bolt Cover)

Rebuild Kit	Description
Due to multiple model splits, refer to the vehicle index for proper kit selection.	
Open Case	Ratio
N/A	
Internal Kit	Description
FD975-IK	97-99 1/2
FD975-IKA	99 1/2-11

Ring & Pinion	Ratio
FD975355	3.55 (39-11)
FD975373	3.73 (41-11)
FD975410	4.10 (41-10)
FD975430	4.30 (43-10)
FD975456	4.56 (41-9)
FD975488	4.88 (39-8)

Limited Slip & Locking Differential	Description
542090	Auburn HP (97-14)
225C194A	Detroit Locker (97-12)
913A477	Detroit Truetrac (97-12)

Application	Years	2WD/4WD	Axle Shaft	Comments	Length	Studs	Spline	Side
Blackwood†	02	2	ASYL1Z4234CA		31-3/4"	5	34	R
Blackwood†	02	2	ASYL1Z4234CB		33-3/8"	5	34	L
Expedition‡	97-00	2/4	ASF75Z4234LA		31-3/4"	5	34	R
Expedition‡	97-00	2/4	ASF75Z4234LB		33-3/8"	5	34	L
Expedition†	00-02	2/4	ASYL1Z4234CA		31-3/4"	5	34	R
Expedition†	00-02	2/4	ASYL1Z4234CB		33-3/8"	5	34	L
Mark LT 1/2 Ton	06-08	2/4	AS7L3Z4234B		33-3/4"	6	34	R
Mark LT 1/2 Ton	06-08	2/4	AS7L3Z4234D		35-3/8"	6	34	L
Navigator‡	98-99	2/4	ASF75Z4234LA		31-3/4"	5	34	R
Navigator‡	98-99	2/4	ASF75Z4234LB		33-3/8"	5	34	L
Navigator†	99-02	2/4	ASYL1Z4234CA		31-3/4"	5	34	R
Navigator†	99-02	2/4	ASYL1Z4234CB		33-3/8"	5	34	L
Truck 1/2 Ton!	97-00	2/4	ASF75Z4234MA		31-3/4"	5	34	R
Truck 1/2 Ton!	97-00	2/4	ASF75Z4234MB		33-3/8"	5	34	L
Truck 1/2 Ton‡	1999	2/4	ASF75Z4234LA		31-3/4"	5	34	R
Truck 1/2 Ton‡	1999	2/4	ASF75Z4234LB		33-3/8"	5	34	L
Truck 1/2 Ton†	00-04	2/4	ASYL1Z4234CA	2004 Heritage	31-3/4"	5	34	R
Truck 1/2 Ton†	00-04	2/4	ASYL1Z4234CB	2004 Heritage	33-3/8"	5	34	L
Truck 1/2 Ton	04-08	2/4	AS7L3Z4234B	2004 Non-Heritage	33-3/4"	6	34	R
Truck 1/2 Ton	04-08	2/4	AS7L3Z4234D	2004 Non-Heritage	35-3/8"	6	34	L

† w/ 1.705" Wheel Brg. & .610" Wheel Stud Hole
 ‡ w/ 1.705" Wheel Brg. & .568" Wheel Stud Hole
 ! w/ 1.618" Wheel Brg.
 Call for all other applications or dimensions.

LD Differential

Axle Product by Axle Size

Ford 10.25" Axle (12 Bolt Cover)

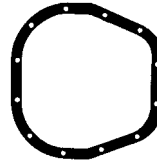

GR-F1025
12 HOLES

Rebuild Kit	Description
DRK-314	Standard Kit (85-03)
DRK-314MK	Master Kit (85-03)
Open Case	Ratio
FD1025-CASE	83-99 (2 Pinion)
Internal Kit	Description
FD1025-IK	83-99 (2 Pinion)

Ring & Pinion	Ratio
FD10355-A	3.55 (39-11)
FD10373-A	3.73 (41-11)
FD10410-A	4.10 (41-10)
FD10456-A	4.56 (41-9)
FD10488-A	4.88 (41-8)

Limited Slip & Locking Differential	Description
542089	Auburn HP (83-14)
19694-010†	Eaton (85-12)
225SL56A†	Detroit Locker (85-12)
915A550†	Detroit Truetrac (85-12)

† Full-Float Style Axle Only

Application	Years	2WD/4WD	Axle Shaft	Comments	Length	Studs	Spline	Side
N/A								

Ford 10.5" Axle (12 Bolt Cover)

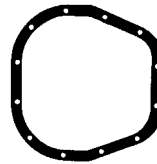

GR-F1025
12 HOLES

Rebuild Kit	Description
DRK-317	Standard Kit (99-07)
DRK-317MK	Master Kit (99-07)
DRK-317A	Standard Kit (08-10)
DRK-317AMK	Master Kit (08-10)
DRK-317B	Standard Kit (11-14)
DRK-317BMK	Master Kit (11-14)

Ring & Pinion	Ratio
FD10355-A	3.55 (39-11)
FD10373-A	3.73 (41-11)
FD10410-A	4.10 (41-10)
FD10456-A	4.56 (41-9)
FD10488-A	4.88 (41-8)

Above Ring & Pinion Sets are Aftermarket 10.25" sets that will work in place of OE 10.5" sets. When using these Ring & Pinion Sets, you will need to use DRK-314AMK kit instead of DRK-317 kit.

Conversion Kit 10.5" R/P to 10.25" R/P
DRK-317AMK

Limited Slip & Locking Differential	Description
542089	Auburn HP (83-14)
19694-010†	Eaton (85-12)
225SL56A†	Detroit Locker (85-12)
915A550†	Detroit Truetrac (85-12)

† Full-Float Style Axle Only

Open Case	Description
N/A	
Internal Kit	Description
N/A	

Application	Years	2WD/4WD	Axle Shaft	Comments	Length	Studs	Spline	Side
N/A								

LD Differential

Axle Product by Axle Size

GMC 7.25" IFS Axle

Rebuild Kit	Description
Due to multiple model splits, refer to the vehicle index for proper kit selection.	
Open Case	Ratio
GM725-CASE	
Internal Kit	Description
GM725-IK	

Ring & Pinion	Ratio
GM725308	3.08 (40-13)
GM725342	3.42 (41-12)
GM725373	3.73 (41-11)
Limited Slip & Locking Differential	Description
N/A	

Application	Years	2WD/4WD	Axle Shaft	Comments	Length	Studs	Spline	Side
N/A								

LD Differential

GMC 7.5"/7.625" Axle

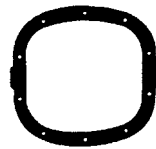

GR-G750
10 HOLES

Rebuild Kit	Description
Due to multiple model splits, refer to the vehicle index for proper kit selection.	
Open Case	Ratio
GM75-CASE	3.23 & higher 26 spline (89-04)
GM76-CASEL	3.08 & lower 28 spline (89-04)
GM76-CASEH	3.23 & higher 28 spline (89-04)
Internal Kit	Description
GM75-IK	7.5" (89-earlier, 26 Spline)
GM76-IK	7.6" (89-04, 28 Spline)

Ring & Pinion	Ratio
GM75273	2.73 (41-15)
GM75308	3.08 (40-13)
GM75323	3.23 (42-13)
GM75342	3.42 (41-12)
GM75373	3.73 (41-11)
GM75410	4.10 (41-10)
GM75456	4.56 (41-9)

Axle Product by Axle Size

GMC 7.5"/7.625" Axle continued

Limited Slip Differential	Description
542044	Auburn Pro 3.23 & Higher, 26 Spline (76-88)
542045	Auburn Pro 3.08 & Lower, 26 Spline (76-88)
542046	Auburn Pro 3.23 & Higher, 28 Spline (88-04)
542047	Auburn Pro 3.08 & Lower, 28 Spline (88-04)
542057	Auburn HP 3.23 & Higher, 26 Spline (76-88)
542058	Auburn HP 3.08 & Lower, 26 Spline (76-88)
542040	Auburn HP 3.23 & Higher, 28 Spline (88-04)
542041	Auburn HP 3.08 & Lower, 28 Spline (88-04)
19663-010	Eaton 3.23 & Higher, 26 Spline (76-88)

Limited Slip & Locking Differential	Description
19599-010	Eaton 3.23 & Higher, 28 Spline (88-04)
40004010	Trac Rite LSD (GMC OE) 2.73 Ratio (90-04)
40004011	Trac Rite LSD (GMC OE) 3.23, 3.42 Ratio (90-04)
162C58A	Detroit Locker 3.23 & Higher, 26 Spline
162C59A	Detroit Locker 3.23 & Higher, 28 Spline
911A415	Detroit Truetrac 3.08 & Lower, 26 Spline
911A319	Detroit Truetrac 3.23 & Higher, 26 Spline
912A317	Detroit Truetrac 3.23 & Higher, 28 Spline

Application	Years	2WD/4WD	Axle Shaft	Comments	Length	Studs	Spline	Side
Astro Van	85-89	2	AS14074822		30 ⁵ / ₁₆ "	5	26	R
Astro Van	85-89	2	AS14074821		34 ³ / ₄ "	5	26	L
Astro Van	90-98	2/4	AS26011055		30 ⁵ / ₁₆ "	5	28	R
Astro Van	90-98	2/4	AS26011054		34 ¹³ / ₁₆ "	5	28	L
Astro Van	03-04	4	AS12479211		31"	6	28	R
Astro Van	03-04	4	AS12479210		35 ¹ / ₂ "	6	28	L
Bravada	93-96	4	AS26013882		29"	5	28	R&L
Bravada	91-93	4	AS26015260		29"	5	28	R&L
Camaro	90-92	2	AS26031252		30 ⁵ / ₁₆ "	5	28	R&L
Camaro	93-96	2	AS26027588		32"	5	28	R&L
Camaro	98-02	2	AS26059972		32"	5	28	R&L
Firebird	90-92	2	AS26031252		30 ⁵ / ₁₆ "	5	28	R&L
Firebird	93-96	2	AS26027588		32"	5	28	R&L
Firebird	98-02	2	AS26059972		32"	5	28	R&L
Jimmy	83-90	2	AS14030355		26 ⁹ / ₁₆ "	5	26	R&L
Jimmy	88-97	2	AS26015759		26 ⁵ / ₈ "	5	28	R&L
Jimmy	98-01	2	AS26058696		26 ⁵ / ₁₆ "	5	28	R&L
Jimmy	83-89	4	AS14035368		29"	5	26	R&L
Jimmy	88-97	4	AS26013882		29"	5	28	R&L
Jimmy	91-93	4	AS26015260		29"	5	28	R&L
Jimmy	98-01	4	AS26050549		28 ¹³ / ₁₆ "	5	28	R&L
S10 & S15 Pick-Up	82-93	2	AS14030355		26 ⁹ / ₁₆ "	5	26	R&L
S10 & S15 Pick-Up	88-97	2	AS26015759		26 ⁵ / ₈ "	5	28	R&L
S10 Pick-Up	98-03	2	AS26064388		26 ⁵ / ₈ "	5	28	R&L
S10 & S15 Pick-Up	83-89	4	AS14035368		29"	5	26	R&L
S10 & S15 Pick-Up	88-97	4	AS26013882		29"	5	28	R&L
S10 Pick-Up	98-04	4	AS26050549		28 ¹³ / ₁₆ "	5	28	R&L
S10 Blazer	83-90	2	AS14030355		26 ⁹ / ₁₆ "	5	26	R&L
S10 Blazer	88-97	2	AS26015759		26 ⁵ / ₈ "	5	28	R&L
S10 Blazer	98-05	2	AS26058696		26 ⁵ / ₁₆ "	5	28	R&L
S10 Blazer	83-89	4	AS14035368		29"	5	26	R&L
S10 Blazer	88-97	4	AS26013882		29"	5	28	R&L
S10 Blazer	91-93	4	AS26015260		29"	5	28	R&L
S10 Blazer	98-05	4	AS26050549		28 ¹³ / ₁₆ "	5	28	R&L
Safari Van	85-89	2	AS14074822		30 ⁵ / ₁₆ "	5	26	R
Safari Van	85-89	2	AS14074821		34 ³ / ₄ "	5	26	L
Safari Van	90-98	2/4	AS26011055		30 ⁵ / ₁₆ "	5	28	R
Safari Van	90-98	2/4	AS26011054		34 ¹³ / ₁₆ "	5	28	L
Safari Van	03-04	4	AS12479211		31"	6	28	R
Safari Van	03-04	4	AS12479210		35 ¹ / ₂ "	6	28	L
Sonoma	91-93	2	AS14030355		26 ⁹ / ₁₆ "	5	26	R&L
Sonoma	91-97	2	AS26015759		26 ⁵ / ₈ "	5	28	R&L
Sonoma	98-03	2	AS26064388		26 ⁵ / ₈ "	5	28	R&L
Sonoma	91-97	4	AS26013882		29"	5	28	R&L
Sonoma	98-04	4	AS26050549		28 ¹³ / ₁₆ "	5	28	R&L

Call for all other applications or dimensions.

LD Differential

Axle Product by Axle Size

GMC 8" Axle

Rebuild Kit	Description
DRK-320D	Standard Kit
DRK-320DMK	Master Kit
Open Case	Ratio
GM8-CASE	
Internal Kit	Description
GM8-IK	

Ring & Pinion	Ratio
GM8342	3.42
GM8373	3.73
GM8410	4.10

Limited Slip & Locking Differential	Description
912A654	Detroit Truetrac 28 Spline (02-10)

Application	Years	2WD/4WD	Axle Shaft	Comments	Length	Studs	Spline	Side
Bravada	02-04	4	AS12479017		31 ¹ / ₂ "	6	28	R
Bravada	02-04	4	AS12479016		33 ³ / ₈ "	6	28	L
Canyon	04-08	4	AS12479337		30 ³ / ₄ "	6	28	L
Colorado	04-08	4	AS12479337		30 ³ / ₄ "	6	28	L
Envoy	02-08	4	AS12479017		31 ¹ / ₂ "	6	28	R
Envoy	02-08	4	AS12479016		33 ³ / ₈ "	6	28	L
Ranier	02-07	4	AS12479017		31 ¹ / ₂ "	6	28	R
Ranier	02-07	4	AS12479016		33 ³ / ₈ "	6	28	L
Trailblazer	02-08	4	AS12479017		31 ¹ / ₂ "	6	28	R
Trailblazer	02-08	4	AS12479016		33 ³ / ₈ "	6	28	L

Call for all other applications or dimensions.

LD Differential

GMC 8.25" IFS Axle

Rebuild Kit	Description
Due to multiple model splits, refer to the vehicle index for proper kit selection.	
Open Case	Ratio
GM825-CASE	
Internal Kit	Description
GM825-IK	

Ring & Pinion	Ratio
GM825342	3.42 (41-12)
GM825373	3.73 (41-11)
GM825410	4.10 (41-10)
GM825456	4.56 (41-9)

Limited Slip & Locking Differential	Description
N/A	

Application	Years	2WD/4WD	Axle Shaft	Comments	Length	Studs	Spline	Side
N/A								

Axle Product by Axle Size

GMC 8.2" Axle

Rebuild Kit	Description
DRK-321B	Standard Kit (64-72)
DRK-321BMK	Master Kit (64-72)
DRK-321G	Standard Kit (55-64)
DRK-321GMK	Master Kit (55-64)
DRK-321H	Standard Kit (64-71) Buick, Olds & Pontiac
DRK-321HMK	Master Kit (64-71) Buick, Olds & Pontiac

Open Case	Ratio
N/A	

Internal Kit	Description
N/A	

Ring & Pinion	Ratio
GM82308	3.08 (40-13)
GM82336	3.36 (37-11)
GM82355	3.55 (39-11)
GM82355-BOP	3.55 (39-11)
GM82373	3.73 (41-11)
GM82390-BOP	3.90 (39-10)
GM82410	4.10 (41-10)
GM82411-BOP	4.11 (37-9)
GM82456	4.56 (41-9)
GM82456-BOP	4.56 (41-9)
GM82488	4.88 (39-8)
GM82513	5.13 (41-8)

Limited Slip & Locking Differential	Description
542061	Auburn Pro - Chevrolet 3.08 & Higher, 25 Spline (64-72)
542099	Auburn Pro - Buick, Olds, Pontiac 2.93-3.23, 27 Spline (64-71)
542060	Auburn Pro - Buick, Olds, Pontiac 3.36 & Higher, 27 Spline, (64-71)
5420108	Auburn HP - Chevrolet 3.08 & Higher, 25 Spline (64-72)
5420114	Auburn HP - Buick, Olds, Pontiac 2.93-3.23, 27 Spline (64-71)
5420113	Auburn HP - Buick, Olds, Pontiac 3.36 & Higher, 27 Spline, (64-71)
19674-010	Eaton Buick, Oldsmobile & Pontiac 3.36 & Higher
19603-010	Eaton Chevy 3.08 & Higher (64-72)
19686-010	Eaton Chevy 3.90 & Lower (55-64)

Application	Years	2WD/4WD	Axle Shaft	Comments	Length	Studs	Spline	Side
Camaro	67-69		AS1255803		29 ⁵ / ₈ "	5	28	R&L
Camaro	70-81		AS1255802		30 ¹ / ₈ "	5	28	R&L
Chevelle	65-67		AS1255803		29 ⁵ / ₈ "	5	28	R&L
Chevelle	68-72		AS1255802		30 ¹ / ₈ "	5	28	R&L
El Camino	68-72		AS1255802		30 ¹ / ₈ "	5	28	R&L
Firebird	66-69		AS6062		30"	5	28	R&L
GTO	66-69		AS6062		30"	5	28	R&L
Nova	65-67		AS3863726		28 ⁵ / ₈ "	5	28	R&L
Nova	70-75		AS1255803		29 ⁵ / ₈ "	5	28	R&L

Call for all other applications or dimensions.

LD Differential

Axle Product by Axle Size

GMC 8.5"/8.6" Axle (10 Bolt Cover)

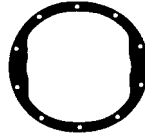

GR-G850
10 HOLES
All Exc. Corvette
& Truck (80-81)

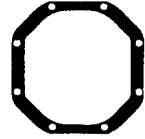

GR-G850C
8 HOLES
Corvette

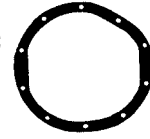

GR-G850T
10 HOLES
Truck (80-81)

Rebuild Kit	Description
Due to multiple model splits, refer to the vehicle index for proper kit selection.	

Open Case	Description
GM85-Case	(98-Earlier)
GM85-Case B ***	(99-00 ¹ / ₂) (Case Open Both Sides)
GM85-CASEC-LOAD	(00 ¹ / ₂ -On) (Case Closed One Side)

***GM85-Case B is OBSOLETE -Replaced by GM85-Case C but you must update internals to GM85-IKC.

Internal Kit	Description
GM85-IK28	(89-Earlier) (28 Spl.)
GM85-IK30	(89-98) (30 Spl.)
GM85-IKB	(99-00 ¹ / ₂) (30 Spl.)
GM85-IKC	(00 ¹ / ₂ -08) (30 Spl.)
GM85-IKD	(09-14) (30 Spl.)

Ring & Pinion	Ratio
GM85308	3.08 (40-13)
GM85308-V	3.08 (40-13)
GM85323 (1986-96 Only)	3.23 (42.13)
GM85323-V (1986-96 Only)	3.23 (42-13)
GM85342	3.42 (41-13)
GM85355-V	3.55 (39-11)
GM85370	3.70 (37-10)
GM85373	3.73 (41-11)
GM85390	3.90 (39-10)
GM85390-V	3.90 (39-10)
GM85410	4.10 (41-10)
GM85411-V	4.11 (37-9)
GM85456	4.56 (41-9)
GM85488	4.88 (39-08)
GM85513	5.13 (41-08)
GM85538**	5.38 (43-08)
GM85557**	5.57 (39-07)

**Requires a modified cross shaft for installation.
-V Are for corvette only

Limited Slip & Locking Differential	Description
542050	Auburn Pro 2.73 & Higher, 28 Spline (71-88)
542052	Auburn Pro 2.73 & Higher, 30 Spline (89-14)
542062	Auburn Pro-Corvette Only 2.41-3.70, 17 Spline (63-79)
542063	Auburn Pro-Corvette Only 4.10 & Higher, 17 Spline (63-79)
542018	Auburn HP 2.73 & Higher, 28 Spline (71-88)
542022	Auburn HP 2.73 & Higher, 30 Spline (89-98)
542097	Auburn HP 2.73 & Higher, 30 Spline (99-14)
19557-010	Eaton 2.73 & Higher, 28 Spline (71-89)
19559-010	Eaton 2.73 & Higher, 30 Spline (88-09)
19670-010	Eaton-Corvette Only 3.08-3.70 Ratios (63-79)
19659-010	Eaton E-Locker 2.73 & Higher, 30 Spline (88-09)
187C149A	Detroit Locker 2.73 & Higher, 28 Spline (72-89)
187C148A	Detroit Locker 2.73 & Higher, 30 Spline (88-09)
912A557	Detroit Truetrac-Front 2.73 & Lower, 28 Spline (77-88)
913A481	Detroit Truetrac 2.73 & Higher, 30 Spline (88-09)

Axle Product by Axle Size

GMC 8.5"/8.6" Axle continued

Application	Years	2WD/4WD	Axle Shaft	Comments	Length	Studs	Spline	Side
Avalanche	02-04	2/4	AS12471369	Fits models w/o active brake control	33 ⁵ / ₈ "	6	30	R&L
Blazer	79-89	2	AS14035542		31 ³ / ₈ "	5	28	R&L
Blazer	88-91	2	AS26010415		31 ³ / ₈ "	5	30	R&L
Blazer	82-88	4	AS14039547		31 ⁵ / ₁₆ "	6	28	R&L
Blazer	88-91	4	AS26010414	Non-IFS	31 ⁵ / ₁₆ "	6	30	R&L
Blazer	92-94	2/4	AS26010416		33"	6	30	R&L
Caprice	91-96	2	AS26018080	w/Disc Brake	30 ⁷ / ₁₆ "	5	30	R&L
Camaro	67-69	2	AS1255803		29 ⁵ / ₈ "	5	28	R&L
Camaro	70-81	2	AS1255802		30 ¹ / ₈ "	5	28	R&L
Chevelle	65-67	2	AS1255803		29 ⁵ / ₈ "	5	28	R&L
Chevelle	68-72	2	AS1255802		30 ¹ / ₈ "	5	28	R&L
Chevelle	63-77	2	AS1255801		30 ⁷ / ₁₆ "	5	28	R&L
Denali	00	4	AS26010416		33"	6	30	R&L
El Camino	68-72	2	AS1255802		30 ¹ / ₈ "	5	28	R&L
El Camino	73-77	2	AS1255801		30 ⁷ / ₁₆ "	5	28	R&L
Envoy	02-08	4	AS12479161		31 ³ / ₄ "	6	30	R
Envoy	02-08	4	AS12479160		33 ¹ / ₄ "	6	30	L
Escalade	99-00	4	AS26010416		33"	6	30	R&L
Escalade	02	2/4	AS12471369		33 ⁵ / ₈ "	6	30	R&L
Escalade EXT	02	2/4	AS12471369		33 ⁵ / ₈ "	6	30	R&L
Jimmy	79-89	2	AS14035542		31 ³ / ₈ "	5	28	R&L
Jimmy	88-91	2	AS26010415		31 ³ / ₈ "	5	30	R&L
Jimmy	82-88	4	AS14039547		31 ⁵ / ₁₆ "	6	28	R&L
Jimmy	88-91	4	AS26010414	Non-IFS	31 ⁵ / ₁₆ "	6	30	R&L
Nova	70-75	2	AS1255803		29 ⁵ / ₈ "	5	28	R&L
Ranier	04-07	4	AS12479161		31 ³ / ₄ "	6	30	R
Ranier	04-07	4	AS12479160		33 ¹ / ₄ "	6	30	L
SSR	03-06	2	AS12479161		31 ³ / ₄ "	6	30	R
SSR	03-06	2	AS12479160		33 ¹ / ₄ "	6	30	L
Suburban	78-88	2	AS14035542		31 ³ / ₈ "	5	28	R&L
Suburban	88-91	2	AS26010415		31 ³ / ₈ "	5	30	R&L
Suburban	92-99	2	AS26010417		31 ¹³ / ₁₆ "	5	30	R&L
Suburban	81-88	4	AS14039547		31 ⁵ / ₁₆ "	6	28	R&L
Suburban	88-91	4	AS26010414	Non-IFS	31 ⁵ / ₁₆ "	6	30	R&L
Suburban	92-99	4	AS26010416		33"	6	30	R&L
Suburban	00-04	2/4	AS12471369	Fits models w/o active brake control	33 ⁵ / ₈ "	6	30	R&L
Tahoe	95-00	2	AS26010417	For 2000 -fits Classic models only	31 ¹³ / ₁₆ "	5	30	R&L
Tahoe	95-00	4	AS26010416	For 2000 -fits Classic models only	33"	6	30	R&L
Tahoe	00-04	2/4	AS12471369		33 ⁵ / ₈ "	6	30	R&L
Yukon	92-94	2/4	AS26010416		33"	6	30	R&L
Yukon	95-99	4	AS26010416		33"	6	30	R&L
Yukon	95-99	2	AS26010417		31 ¹³ / ₁₆ "	5	30	R&L
Yukon	00	2/4	AS12471369	Exc Denali	33 ⁵ / ₈ "	6	30	R&L
Yukon	01-04	2/4	AS12471369	Fits models w/o active brake control	33 ⁵ / ₈ "	6	30	R&L
Yukon XL	00-04	2/4	AS12471369	Fits models w/o active brake control	33 ⁵ / ₈ "	6	30	R&L
Trailblazer	02-08	4	AS12479161		31 ³ / ₄ "	6	30	R
Trailblazer	02-08	4	AS12479160		33 ¹ / ₄ "	6	30	L
Truck 1/2 Ton	78-87	2	AS14035542		31 ³ / ₈ "	5	28	R&L
Truck 1/2 Ton	88-99	2	AS26010417	For 1999 -fits Classic models only	31 ¹³ / ₁₆ "	5	30	R&L
Truck 1/2 Ton	88-99	4	AS26010416	For 1999 -fits Classic models only	33"	6	30	R&L
Truck 1/2 Ton	88	4	AS15521892	IFS; Standard Cab	33"	6	28	R&L
Truck 1/2 Ton	99-00	2/4	AS12471369		33 ⁵ / ₈ "	6	30	R&L
Truck 1/2 Ton	01-02	2/4	AS12471369	Exc 01-02 Crew Cab 4x4	33 ⁵ / ₈ "	6	30	R&L
Truck 1/2 Ton	03-04	2/4	AS12471369	Fits models w/o active brake control	33 ⁵ / ₈ "	6	30	R&L
Truck 1/2 Ton	81-87	4	AS14039547		31 ⁵ / ₁₆ "	6	28	R&L
Van 1/2 Ton	75-88	2	AS14042690		33 ⁵ / ₁₆ "	5	28	R&L
Van 1/2 Ton	88-95	2	AS26013313		33 ⁵ / ₁₆ "	5	30	R&L
Van 1/2 Ton	96-02	2	AS26042818		33 ¹ / ₄ "	5	30	R&L
Van 1/2 Ton	03-10	2	AS12479175	Fits models w/o active brake control	34 ¹ / ₂ "	5	30	R&L
Van 3/4 Ton	75-88	2	AS14042690		33 ⁵ / ₁₆ "	5	28	R&L
Van 3/4 Ton	88-95	2	AS26013313		33 ⁵ / ₁₆ "	5	30	R&L

Call for all other applications or dimensions.

ID Differential

Axle Product by Axle Size

GMC 8.875" Axle (12 Bolt Cover) Car

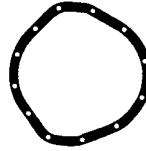

GR-G887A
12 HOLES
CAR

Rebuild Kit	Description
DRK-323A	Standard Kit
DRK-323AMK	Master Kit

Open Case	Ratio
N/A	

Internal Kit	Description
GM12-IK	

Ring & Pinion	Ratio
GM12308-C	3.08 (40-13)
GM12342-C	3.42 (41-12)
GM12355-C	3.55 (39-11)
GM12373-C	3.73 (41-11)
GM12373-XC*	3.73 (41-11)
GM12390-C	3.90 (39-10)
GM12410-C	4.10 (41-10)
GM12410-XC**	4.10 (41-10)
GM12430-C	4.30 (43-10)
GM12433-C	4.33 (39-9)
GM12456-C	4.56 (41-9)
GM12456-XC**	4.56 (41-9)
GM12488-C	4.88 (39-8)
GM12488-XC**	4.88 (39-8)
GM12514-C	5.14 (36-7)
GM12538-C	5.38 (43-8)
GM12557-C	5.57 (39-7)
GM12586-C	5.86 (41-7)
GM12614-C	6.14 (43-7)

* Fits 3.90 ratio and numerically higher carrier.

** Fits 3.07 – 3.73 ratio carrier.

Limited Slip & Locking Differential	Description
542031	Auburn Pro 4.10 & Higher, 30 Spline (64-72)
5420117	Auburn Pro 4.10 & Higher, 33 Spline (64-72)
5420104	Auburn HP 4.10 & Higher, 30 Spline (64-72)
19554-010	Eaton 3.08-3.90, 30 Spline
19555-010	Eaton 4.10 & Higher, 30 Spline
187C197A	Detroit Locker 3.08-3.90, 30 Spline
187C198A	Detroit Locker 3.08-3.90, 33 Spline
187S196A	Detroit Locker 3.08-3.90, 35 Spline w/ 3.25" bearing
913A555!	Detroit Truetrac 3.08-3.90, 30 Spline
914A576!	Detroit Truetrac 3.08-3.90, 33 Spline
914A575!	Detroit Truetrac 4.10 & Higher, 33 Spline

!Fits axles with 45 degree pressure angle.

Application	Years	2WD/4WD	Axle Shaft	Comments	Length	Studs	Spline	Side
Camaro	67-69		AS3969349		29 ⁹ / ₁₆ "	5	30	R&L
Camaro	70-72		AS3969285		30 ¹ / ₁₆ "	5	30	R&L
Chevelle	65-67		AS3969349		29 ⁹ / ₁₆ "	5	30	R&L
Chevelle	68-72		AS3969285		30 ¹ / ₁₆ "	5	30	R&L
Chevy II	68-72		AS3969349		29 ⁹ / ₁₆ "	5	30	R&L
El Camino	68-72		AS3969285		30 ¹ / ₁₆ "	5	30	R&L

Call for all other applications or dimensions.

Axle Product by Axle Size

GMC 8.875" Axle (12 Bolt Cover) Truck

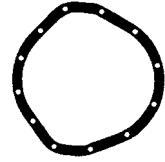

GR-G887
12 HOLES
TRUCK

Rebuild Kit	Description
DRK-322	Standard Kit
DRK-322MK	Master Kit
Open Case	Ratio
N/A	
Internal Kit	Description
GM12-1K	

Ring & Pinion	Ratio
GM12308	3.08 (40-13)
GM12342	3.42 (41-12)
GM12373	3.73 (41-11)
GM12410	4.10 (41-10)
GM12456	4.56 (41-9)
GM12488	4.88 (39-8)
GM12513 **	5.13 (41-8)
GM12538 **	5.38 (43-8)

**Requires a modified cross shaft.

Limited Slip & Locking Differential	Description
542034	Auburn Pro 2.76-3.42, 30 Spline (64-82)
542032	Auburn Pro 3.73 & Higher, 30 Spline (64-82)
5420107	Auburn HP 2.76-3.42, 30 Spline (64-82)
5420105	Auburn HP 3.73 & Higher, 30 Spline (64-82)
19587-010	Eaton 2.76-3.42, 30 Spline
19556-010	Eaton 3.73 & Higher, 30 Spline
187C150A	Detroit Locker 3.73 & Higher, 30 Spline
916A315	Detroit Truetrac 3.73 & Higher, 30 Spline

Application	Years	2WD/4WD	Axle Shaft	Comments	Length	Studs	Spline	Side
Truck	65-69	2/4	AS3893605		30-3/4"	5/6	30	R&L
Truck	65-69	2/4	AS5855	6 Lug to 5 Lug Conversion	30 3/4"	5	30	R&L
Truck	70-81	2	AS14071751		31 5/16"	5	30	R&L
Truck	70-81	4	AS14071750		31 9/132"	6	30	R&L

Call for all other applications or dimensions.

GMC 9.25" IFS Axle

Rebuild Kit	Description
DRK-324A	Standard Kit (88-97)
DRK-324AMK	Master Kit (88-97)
DRK-324C	Standard Kit (98-10)
DRK-324CMK	Master Kit (98-10)
DRK-324D	Standard Kit (11-14)
DRK-324DMK	Master Kit (11-14)

Ring & Pinion	Ratio
GM925342	3.42 (41-12)
GM925373	3.73 (41-11)
GM925410	4.10 (41-10)
GM925456	4.56 (41-9)

Open Case	Ratio
GM95-CASE (88-06)	

Limited Slip & Locking Differential	Description
19622-010	Eaton (82-11) E-locker

Internal Kit	Description
GM95-1K (88-06)	
GM95-1KA (07-14)	

Application	Years	2WD/4WD	Axle Shaft	Comments	Length	Studs	Spline	Side
N/A								

LD Differential

Axle Product by Axle Size

GMC 9.3" "C" Axle

Round Cover
12 HOLES
10³/₁₆" Dia.

Rebuild Kit	Description	Ring & Pinion	Ratio
DRK-329	Standard Kit	GM93410	4.10 (41-10)
DRK-329MK	Master Kit	GM93456	4.56 (41-9)
		GM93488	4.88 (39-8)
Open Case	Ratio	Limited Slip & Locking Differential	Description
N/A		N/A	
Internal Kit	Description		
N/A			

Application	Years	2WD/4WD	Axle Shaft	Comments	Length	Studs	Spline	Side
N/A								

GMC 9.5" Axle (14 Bolt Cover)

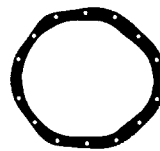

GR-G950
14 HOLES

Rebuild Kit	Description	Ring & Pinion	Ratio
DRK-324	Standard Kit – (81-97)	GM95342	3.42 (41-12)
DRK-324MK	Master Kit – (81-97)	GM95373	3.73 (41-11)
DRK-324B	Standard Kit – (98-13)	GM95410	4.10 (41-10)
DRK-324BMK	Master Kit – (98-13)	GM95456	4.56 (41-9)
Open Case	Ratio	Limited Slip & Locking Differential	Description
GM95-CASE-LOAD		542087	Auburn HP 33 Spline (81-14)
		19590-010	Eaton 33 Spline (81-09)
		19684-010	Eaton E-Locker 33 Spline (81-09)
		225C135A	Detroit Locker 33 Spline (81-09)
		914A538	Detroit Truetrac 33 Spline (81-09)
Internal Kit	Description		
GM95-1K (88-06)			
GM95-1KA (07-13)			

Application	Years	2WD/4WD	Axle Shaft	Comments	Length	Studs	Spline	Side
Suburban	81-91	2/4	AS14035395	Semi-float style	32 ⁹ / ₁₆ "	8	33	R&L
Suburban	92-99	2/4	AS15522070	Semi-float style	31 ¹³ / ₁₆ "	8	33	R&L
Truck 1/2 Ton	88-99	4	AS15521928	For 1999 -fits Classic models only	33 ¹ / ₈ "	6	33	R&L
Truck 3/4 Ton	88-98	2	AS15522068		31 ⁹ / ₁₆ "	6	33	R&L
Truck 3/4 Ton	88-95	4	AS15521928		33 ¹ / ₈ "	6	33	R&L
Truck 3/4 Ton	81-89	2/4	AS14035395	Semi-float style	32 ⁹ / ₁₆ "	8	33	R&L
Truck 3/4 Ton	89-00	2/4	AS15522070	Semi-float style	31 ¹³ / ₁₆ "	8	33	R&L
Truck 1 Ton	88-89	2/4	AS15522070	Semi-float style	31 ¹³ / ₁₆ "	8	33	R&L
Van 1 Ton	86-96	2	AS14035395	Semi-float style, Exc. Express/Savana	32 ⁹ / ₁₆ "	8	33	R&L

Call for all other applications or dimensions.

Axle Product by Axle Size

GMC 10.5" Axle (14 Bolt Cover)

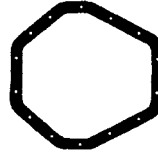

GR-G1050
14 HOLES

Rebuild Kit	Description
DRK-325	Standard Kit – (72-88) 1st design
DRK-325MK	Master Kit – (72-88) 1st design
DRK-325A	Standard Kit – (88-97) 2nd design
DRK-325AMK	Master Kit – (88-97) 2nd design
DRK-325B	Standard Kit – (98-13)
DRK-325BMK	Master Kit – (98-13)

Open Case	Ratio
GM105-CASEL	4.10 & Lower Ratios
GM105-CASE	4.56 & Higher Ratios

Internal Kit	Description
GM105-IK	

Ring & Pinion	Ratio
GM105342	3.42 (41-12)
GM105373	3.73 (41-11)
GM105410	4.10 (41-10)
GM105456	4.56 (41-9)
GM105456X *	4.56 (41-9)
GM105488	4.88 (39-8)
GM105488X *	4.88 (39-8)

* Fits 4.10 and down case.

Limited Slip & Locking Differential	Description
19689-010	Eaton 4.10 & Lower, 30 Spline (72-09)
19610-010	Eaton 4.56 & Higher, 30 Spline (73-09)

Application	Years	2WD/4WD	Axle Shaft	Comments	Length	Studs	Spline	Side
Truck 3/4 Ton	73-89	2/4	AS3977384	Full-float style	37 ⁹ / ₁₆ "	8	30	R
Truck 3/4 Ton	73-00	2/4	AS3977383	Full-float style	31 ¹¹ / ₁₆ "	8	30	L
Truck 1 Ton	73-91	2/4	AS3977384	Full-float style	37 ⁹ / ₁₆ "	8	30	R
Truck 1 Ton	73-91	2/4	AS3977383	Full-float style	31 ¹¹ / ₁₆ "	8	30	L
Suburban	73-91	2/4	AS3977384	Full-float style	37 ⁹ / ₁₆ "	8	30	R
Suburban	73-91	2/4	AS3977383	Full-float style	31 ¹¹ / ₁₆ "	8	30	L
Van 1 Ton	93-96	2/4	AS3977384	Full-float style, Exc. Express/Savana	37 ⁹ / ₁₆ "	8	30	R
Van 1 Ton	93-96	2/4	AS3977383	Full-float style, Exc. Express/Savana	31 ¹¹ / ₁₆ "	8	30	L

Call for all other applications or dimensions.

LD Differential

Axle Product by Axle Size

GMC 11.5" Axle

Rebuild Kit	Description	Ring & Pinion	Ratio
DRK-327	Standard Kit – (01-11)	GM115373	3.73 (41-11)
DRK-327MK	Master Kit – (01-11)	GM115410	4.10 (41-10)
DRK-327A	Standard Kit – (11-14)	GM115463	4.63 (37-8)
DRK-327AMK	Master Kit – (11-14)		
Open Case	Ratio	Limited Slip & Locking Differential	Description
GM115-CASE	3.73, 4.10 & 4.63 Gear Ratios	250SL195A	Detroit Locker 30 Spline (01-12)
GM115-CASE-LOAD	3.73, 4.10 & 4.63 Gear Ratios	915A568	Detroit Truetrac 30 Spline (01-12)
		40025134	OEM Limited Slip
Internal Kit	Description		
GM115-IK – (01-06)			
GM115-IKA – (07-14)			

Application	Years	2WD/4WD	Axle Shaft	Comments	Length	Studs	Spline	Side
Truck 3/4 Ton	01-02	2/4	AS40003202	Semi-float style	39 ³ / ₄ "	8	30	R & L
Truck 3/4 Ton	01-10	2/4	AS40003201	Full-float style	35 ¹ / ₂ "	8	30	R & L
Truck 1 Ton	01-06	2/4	AS40003202	Verify axle length	39 ³ / ₄ "	8	30	R & L
Truck 1 Ton	04-10	2/4	AS40003201	Verify axle length	35 ¹ / ₂ "	8	30	R & L
Truck 1 Ton	01-06	2/4	AS40003204	Verify axle length	35 ³ / ₄ "	8	30	R & L

Dodge Sprinter

Rebuild Kit	Description	Ring & Pinion	Ratio
DRK-307A	Standard Kit – (07-12)	Sprinter-373	3.73(01-06)
DRK-307AMK	Master Kit – (07-12)		
DRK-307	Standard Kit – (01-06)		
DRK-307MK	Master Kit – (01-06)		
Open Case	Ratio	Center Support Bearings	Description
Sprinter-CaseLoaded	Case with Internal Kit-(01-06)	HB5104574	Center Support Bearings (01-06)
		HB68088	Center Support Bearings (07-10) Must also use HB68088K for 3 piece driveshafts
		HB68088K	Center Support Bearings (07-10) Boot Kit for 3 piece driveshafts
Internal Kit	Description		
Sprinter-IK	Internal Kit-(01-06)		

Application	Years	2WD/4WD	Axle Shaft	Comments	Length	Studs	Spline	Side
N/A								

LD Differential

Axle Product by Axle Size

Toyota 7.5" Axle (8 Bolt Cover) for Pickup & 4-Runner

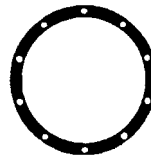

GR-T8V6
10 HOLES

Front Axle Rebuild Kit	Description
DRK-350	Standard Kit (86-88 IFS Front Axle)
DRK-350MK	Master Kit (86-88 IFS Front Axle)
DRK-350A	Standard Kit (88-95 IFS Front Axle)
DRK-350AMK	Master Kit (88-95 IFS Front Axle)

Rear Axle Rebuild Kit	Description
DRK-350	Standard Kit (79-95) 4 Cyl. Non Turbo 2WD
DRK-350MK	Master Kit (79-95) 4 Cyl. Non Turbo 2WD

Open Case	Ratio
N/A	

Internal Kit	Description
N/A	

Application	Years	2WD/4WD	Axle Shaft	Comments	Length	Studs	Spline	Side
N/A								

Ring & Pinion	Ratio
T75410	4.10 (41-10)
T75456	4.56 (41-9)
T75488	4.88 (39-8)
T75529	5.29 (37-7)

Limited Slip & Locking Differential	Description
N/A	

Toyota 8" Axle (10 Bolt Cover) for Pickup & 4-Runner

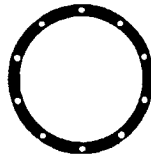

GR-T8V6
10 HOLES

Rebuild Kit	Description
DRK-351	Standard Kit (84-85)
DRK-351MK	Master Kit (84-85)
DRK-352	Standard Kit (86-95 – 4 Cyl. Turbo & V6)
DRK-352MK	Master Kit (86-95 – 4 Cyl. Turbo & V6)
DRK-353	Standard Kit (86-95 – 4 Cyl. 4WD)
DRK-353MK	Master Kit (86-95 – 4 Cyl. 4WD)
DRK-354	Standard Kit (96-02 – w/locking diff)
DRK-354MK	Master Kit (96-02 – w/locking diff)

Open Case	Ratio
N/A	

Internal Kit	Description
TOY8-1K	

Application	Years	2WD/4WD	Axle Shaft	Comments	Length	Studs	Spline	Side
N/A								

Ring & Pinion	Ratio
TOY411	4.11 (37-9)
TOY488	4.88 (39-8)
TOY529	5.29 (37-7)
TOY571	5.71 (40-7)

Limited Slip & Locking Differential	Description
19614-010	Eaton

LD Differential

Application Guide

March 2012

LD Differential



Year	Description	Axle Shaft Dia.-Spline	Gear Ratio	Detroit Locker	Detroit Truetrac	Eaton Posi	Eaton ELocker
GM							
Passenger Car • Chevrolet • Pontiac • Buick • Oldsmobile							
1964-72	GM 12 bolt car	8.875"	1.29" 30	3.08-3.90	187C197A	913A555 (pa)	19554-010
1964-72	GM 12 bolt car	8.875"	1.29 30	4.10 & up			19555-010
1964-72	GM 12 bolt car	8.875"	1.41" 33	3.08-3.90	187C198A	914A576 (pa)	
1964-72	GM 12 bolt car	8.875"	1.41" 33	4.10 & up		914A575 (pa)	
	GM 12 bolt car	8.875"	1.50" 35	3.08-3.90	187S196A (ch)		
1955-64	GM 3rd member	8.2"	17	3.90 & dn			19686-010
1988-96	GM 10 bolt C-Clip	8.5/8.6"	1.32" 30	2.73 & up	187C148A	913A481	19559-010
1971-89	GM 10 bolt C-Clip	8.5"	1.20" 28	2.73 & up	187C149A	912A556	19557-010
1964-71	GM 10 bolt Buick, Olds, Pontiac 8.2"		28	3.36 & up			19674-010
1964-72	GM 10 bolt Chevrolet 8.2"		28	3.08 & up			19603-010
1988-05	GM 10 bolt	7.5/7.6"	1.20" 28	3.23 & up	162C59A	912A317	19599-010
1975-89	GM 10 bolt C-Clip	7.5"	1.16" 26	3.23 & up	162C58A	911A319	19663-010
				3.08 & dn		911A415	
2004-06	GTO / Monaro		28			912A642	
2010-11	Camaro	218mm	32	3.45, 3.73	"NEW" 912A686		
(ch) custom housing with 3.25" bearing bore.							
(pa) 30 and 33 spline units are made to fit axles cut with 45 degree pressure angle.							
All GM 8.5"/8.6" Eaton differentials require special bearings. For axles with small bearing bores (race O.D. of 2.89"), usually found on vehicles prior to 1999, bearing LM102949 and race LM102911 are required. For axles with large bearing bores (race O.D. of 3.06"), usually found on vehicles from 1999 to present, bearing LM603049 and race LM603012 are required.							
Corvette							
1963-79	8.5" Cast Iron 3rd Member		17	3.08-3.90			19670-010
				4.11-4.56			19673-010
1985-96	Dana 44		30		913A614		
1997-10	Transaxle C5/C6/Z06		41	3.15 & up			QPS-70-P-20001
2006-07 Z06 and 2008 & up requires use of 28682/28621 bearing and race on long shaft side							
CHEVROLET / GMC							
10/1500 • Truck • SUV • Van							
1977-88	GM 10 bolt	8.5"	1.20" 28	2.73-5.13	187C149A	912A557	19557-010
To 1980	Dana 44	8.5"	1.31" 30	3.73 & dn	187SL16D	913A591	19695-010
			30	3.92 & up	187SL16C	913A592	19747-010
1988-92	GM 10 Bolt	8.5"	1.30" 30	2.73-5.13	187C148A		19559-010
1982-07	GM 14 Bolt IFS (HD)	9.25"	33	All			19622-010
10/1500 • Truck • SUV • Van							
1988-09	GM 10 bolt	7.5/7.6"	1.20" 28	3.23 & up	162C59A	912A317	19599-010
1982-89	GM 10 bolt C-Clip	7.5"	1.16" 26	3.23 & up	162C58A	911A319	19663-010
				3.08 & dn		911A415	
2002-10	GM 10 bolt C-Clip	8"	1.20" 28	All		912A654	
1988-09	GM 10 bolt C-Clip	8.5/8.6"	1.32" 30	2.73 & up	187C148A	913A481	19559-010
1972-89	GM 10 bolt C-Clip	8.5"	1.20" 28	2.73 & up	187C149A	912A556	19557-010
To 1982	GM 12 bolt C-Clip	8.875"	1.30" 30	3.73 & up	187C150A	913A315	19556-010
				2.76-3.42			19587-010
1981-07	GM 14 bolt C-Clip	9.5"	1.37" 33	All	225C135A	914A538	19590-010
GM 8.5"/8.6" Eaton differentials require special bearings. For axles with small bearing bores (race O.D. of 2.89"), usually found on vehicles prior to 1999, bearing LM102949 and race LM102911 are required. For axles with large bearing bores (race O.D. of 3.06"), usually found on vehicles from 1999 to present, bearing LM603049 and race LM603012 are required.							

FRONT

REAR

LD Differential

Light Truck & Performance Car Application Guide



Year	Description	Axle Shaft Dia.-Spline	Gear Ratio	Detroit Locker	Detroit Truetrac	Eaton Posi	Eaton ELocker
CHEVROLET / GMC							
20/2500 • Truck • Suburban • Rally/Sport • Van							
1977-91	GM 10 bolt	8.5"	1.20" 28	2.73 & up	187C149A	912A557	19557-010(mh)
1988-91	GM 10 bolt	8.5"	1.31" 30	2.73 & up			19559-010(mh) 19659-010
To 1980	Dana 44	8.5"	1.31" 30	3.73 & dn	187SL16D	913A591	19695-010
				3.92 & up	187SL16C	913A592	19747-010
1982-10	GM 14 Bolt IFS	9.25"	33	All			19622-010
1988-07	GM 10 bolt C-Clip (Van) 8.5/8.6"	1.32"	30	2.73-5.13+	187C148A	913A481	19559-010 19659-010
1978-89	GM 10 bolt C-Clip (Van) 8.5"	1.20"	28	2.73-5.13+	187C149A	912A556	
1981-119	GM 14 bolt C-Clip	9.5"	1.37" 33	All	225C135A	914A538	19590-010 19684-010
1972-11	GM 14 bolt	10.5"	1.50" 30	4.10 & dn	225S10 (a)	*NEW* 915A545	19689-010
1973-11	GM 14 bolt	10.5"	1.50" 30	4.56 & up	225S10 (a)	*NEW* 915A547	19610-010(rgbl)
1975-77	Dana 60HD	9.75"	1.50" 35	4.10 & dn	225SL29B	915A385	
				4.56 & up	225SL29A	915A386	
To 1974	Dana 60	9.75"	1.31" 30	4.10 & dn	225SL19B	913A389	19722-010
	Dana Super 60	9.75"	1.70" 40	4.56 & up	225SL19A	913A390	19734-010 19737-010
	Dana Super 60	9.75"	1.70" 40	4.56 & up	225SL193A		
					225SL193B		
2001-11	AAM	11.5"	30	All	*NEW* 250S195A	915A568	
All GM 8.5"/8.6"Eaton differentials require special bearings. For axles with small bearing bores (race O.D. of 2.89"), usually found on vehicles prior to 1999, bearing LM102949 and race LM102911 are required. For axles with large bearing bores (race O.D. of 3.06"), usually found on vehicles from 1999 to present, bearing LM603049 and race LM603012 are required.							
(a) 225S10 differential replaces the conventional differential internals used in certain 1973 thru present GM axles. If it is to be installed in a GM axle equipped with an optional Eaton differential, it will also be necessary to purchase a new gear support case assembly, GM #6258336 or #6258340, depending upon gear ratio.							
(rgbl) Requires ring gear bolt - GM part #12479387							
30/3500 R/V • Cab & Chassis • Motor Home • Bus Chassis • Truck C/K • Van							
1977-87	Dana 60HD	9.75"	1.50" 35	4.10 & dn	225SL29B	915A387	19760-010
				4.56 & up	225SL29A	915A388	19761-010
1982-10	GM 14 Bolt IFS	9.25"	33	All			19622-010
1988-11	GM 14 bolt C-Clip	9.5"	1.37" 33	All	225C135A	914A538	19590-010 19684-010
1973-11	GM 14 bolt	10.5"	1.50" 30	4.10 & dn	225S10 (a)	*NEW* 915A545	19689-010
				4.56 & up	225S10 (a)	*NEW* 915A547	19610-010(rgbl)
1973-94	Dana 70HD with 4" dia. axle tubes FLAT STYLE CAB	10.5"					
	5/8" Pinion Offset	1.50"	35	4.10 & dn	225SL58B	*NEW* 915A670	
	5/8" Pinion Offset	1.50"	35	4.56 & up	225SL58A		
1988-89	Dana 70-3U HD w/3.5" dia. axle tubes AERODYNAMIC CAB:	10.5"					
	5/8" Pinion Offset	1.50"	35	3.21, 3.42	225SL58A		
	31/32" Pinion Offset	1.50"	35	3.54-4.56	225SL58E		
1973-91	Dana 60HD (G Series)	9.75"	1.50" 35	4.10 & dn	225SL29B	915A385	19760-010
				4.56 & up	225SL29A	915A386	19761-010
1984-86	Dana 70U	10.5"	1.50" 35	4.10 & dn	225SL58D		
1979-80	Dana 70B	10.5"	1.50" 35	4.56 & up	225SL58C		
2001-11	AAM	11.5"	1.55" 30	All	*NEW* 250SL195A	915A568	
(mh) manual locking hubs recommended							
(a) 225S10 differential replaces the conventional differential internals used in certain 1973 thru present GM axles. If it is to be installed in a GM axle equipped with an optional Eaton differential, it will also be necessary to purchase a new gear support case assembly, GM #6258336 or #6258340, depending upon gear ratio.							
(rgbl) Requires ring gear bolt - GM part #12479387							
3500 HD							
1992-07	Dana 80	11.5"	1.60" 37	4.10 & up	225SL105A	916A427	
				3.73 & dn		916A566	
To 1986	GM 11000 lb. Rockwell 100/102/200	12" 1.62"	1.75" 27 1.62" 16	All All	250S-27 225S15		
2001-11	AAM	11.5"	1.55" 30	All	*NEW* 250S195A	915A568	

LD Differential

Light Truck & Performance Car Application Guide



Year	Description	Axle Shaft Dia.	Shaft Spline	Gear Ratio	Detroit Locker	Detroit Truetrac	Eaton Posi	Eaton ELocker	
CHRYSLER / DODGE / PLYMOUTH									
D-50, 100, 150, 200 & 250, A, B, D, W									
Passenger Car • Truck • Power Wagon • Ramcharger • Sportvan • Van • Viper									
FRONT	1984-01	Dana 44	8.5"	1.31"	30	3.73 & dn 3.92 & up 4.10 & dn 4.56 & up	187SL16D 187SL16C	913A591 913A592	19695-010 19747-010 19722-010 19737-010
	1994-99	Dana 60	9.75"	1.31"	30				
	1971-93	Dana 60HD	9.75"	1.50"	35	4.10 & dn 4.56 & up	225SL29B 225SL29A	915A387 915A388	19760-010 19761-010
	To 1972	Dana 70	10.5"	1.50"	23	All	225S14		
	1997-09	Chrysler C-Clip	8.375"	1.21"	29	2.73 & up	187C179A	912A553	
	1969-96	Chrysler C-Clip	8.375"	1.17"	27	2.73 & up	187C151A		
	1974-11	Chrysler C-Clip	9.25"	1.32"	31	2.76-4.56	187C172A	913A368	
	1969-74	Chrysler	8.75"	1.28"	30	2.76-4.56	187SL14A	913A572	
	1969-74	Chrysler	8.75"	1.31"	33	2.76-4.56		914A583 (pa)	
	1994-01	Dodge Viper						913A614	
(pa) 33 spline units are made to fit axles cut with 45 degree pressure angle.									
REAR	1972-02	Dana 60	9.75"	1.31"	30	4.10 & dn 4.56 & up	225SL19B 225SL19A	913A389 913A390	19734-010 19722-010 19737-010
	To 1971	Dana 60	9.75"	1.24"	16	4.10 & dn 4.56 & up	225S12C 225S12A		
	1972-90	Dana 70	10.5"	1.50"	35	4.10-3.54 4.56 & up	225SL58D 225SL58C		
	1991-02	Dana 70	10.5"	1.41"	32	4.10 & dn 4.56 & up	225SL107D 225SL107C		
		Dana Super 60	9.75"	1.70"	40	4.10 & dn	225SL-193A		
		Dana Super 60	9.75"	1.70"	40	4.56 & up	225SL-193B		
	2003-09	AAM	11.5"		30	All	*NEW* 250S-195A	915A568	
	300, 350, 400, B, C, M, W								
	Cab & Chassis • Motor Home • Truck • Power Wagon • Van								
	FRONT	2003-09(rp)	AAM Dodge	9.5"		33			914A643
1976-00		Dana 60HD	9.75"	1.50"	35	4.10 & dn 4.56 & up	225SL29B 225SL29A	915A387 915A388	19760-010 19761-010
1971-76		Dana 70	10.5"	1.50"	35	4.56 & up (7)	225SL58C		
To 1974		Dana 70	10.5"	1.50"	23	All	225S14		
(rp) 2007 and newer requires 2003-2006 ring and pinion									
1975-02		Dana 60, 60HD, 60M	9.75"	1.31"	30	4.10 & dn 4.56 & up	225SL19B 225SL19A	913A389 913A390	19722-010 19737-010
1991-02		Dana 70	10.5"	1.41"	32	4.10 & dn 4.56 & up	225SL107D 225SL107C		
1972-90		Dana 70	10.5"	1.50"	35	4.10 & dn (7) 4.56 & up (7)	225SL58D 225SL58C		
1972-85		Dana 70HD	10.5"	1.50"	35	4.10 & dn (7) 4.56 & up (7)	225SL58B 225SL58A	*NEW* 915A670	
1971-74		Dana 70	10.5"	1.50"	35	All	225S18		
To 1974	Dana 70	10.5"	1.50"	23	All	225S14			
1994-02	Dana 80	11.5"	1.52"	35	4.10 & up 3.73 & dn	225SL131A	915A450 915A567		
2003-09(rp)	AAM	11.5"		30	All	*NEW* 250S-195A	915A568		
(rp) 2007 and newer requires 2003-2006 ring and pinion									
FORD / LINCOLN / MERCURY									
Small Truck • Mini Van • SUV									
FRONT	1991-95	Dana 35 IFS Snap ring		1.14"	27	3.54 & up	162C56A		19821-010(b)
	1983-96	Dana 44 C-Clip	8.5"	1.31"	30	3.73 & dn 3.92 & up		913A591 913A592	19695-010 19747-010
	1997-09	Ford IFS	8.8"	1.20"	28	All		912A563	19685-010
	To 1982	Dana 44	8.5"	1.31"	30	3.73 & dn 3.92 & up	187SL16D 187SL16C	913A591 913A592	19695-010 19747-010
	(b) Bearing LM102949 and race LM102911								

LD Differential

Light Truck & Performance Car Application Guide



Year	Description	Axle Shaft Dia.-Spline	Gear Ratio	Detroit Locker	Detroit Truetrac	Eaton Posi	Eaton ELocker
FORD / LINCOLN / MERCURY							
Passenger Car • Small Truck • Mini Van • SUV (continued)							
1978-09	Ford C-Clip	7.5"	1.20" 28	All	162C57A	912A316	
1987-11	Ford C-Clip	8.8"	1.32" 31	All	187C145A(+)	913A561	19588-010
1987-11	Ford	8.8"	33			TBD 913A701	19660-010
1983-11	Ford C-Clip	8.8"	1.20" 28	All	187C147A(+)	912A562	19605-010
1983-86	Ford C-Clip	8.8"	1.32" 31	All	187C146A(+)		19588-010
To 1979	Ford	9"	1.20" 28	3.25 & up	187SL13A	912A587	
1957-78	Ford	9"	1.32" 31	3.25 & up	187SL17B	913A586	
	Ford	9"	1.50" 35	3.25 & up	187S160A		
To 1978	Ford	8"	1.20" 28	3.25 & up	187S13D	912A616*	
* Ford 8" Truetrac application requires LM102949 and LM102910							
F/E-100/150 • Truck • SUV • Van							
1977-79	Dana 44	8.5"	1.31" 30	3.73 & dn	187SL16D	913A589	19695-010
			1.31" 30	3.92 & up	187SL16C	913A590	19747-010
1987-11	Ford C-Clip	8.8"	1.32" 31	All	187C145A(+)	913A561	19588-010
1983-86	Ford C-Clip	8.8"	1.32" 31	All	187C146A(+)		19660-010
1957-87	Ford	9"	1.20" 28	3.25 & up	187SL13A	912A587	
1957-87	Ford	9"	1.32" 31	3.25 & up	187SL17B	913A586	
To 1974	Ford 9" 1.62" bearing hub dia.	1.20"	28	3.25 & up	187S13A		
1997-11	Ford	9.75"	1.37" 34	All	225C194A	913A477	
F/E-250 (98' Super Duty) • Truck • Van • Excursion							
1983-97	Dana 44 C-Clip IFS	8.5"	1.31" 30	3.73 & dn		913A591	
				3.92 & up		913A592	
To 1982	Dana 44	8.5"	1.31" 30	3.73 & dn	187SL16D	913A591	19695-010
				3.92 & up	187SL16C	913A592	19747-010
1997-08	Ford IFS Snap ring	8.8"	1.20" 28	All	187C147A(+)	912A563	
1979	Dana 60 (f)	9.75"	1.50" 35	4.10 & dn	225SL29B	915A387	19760-010
				4.56 & up	225SL29A	915A388	19761-010
1983-84	Ford C-Clip	8.8"	1.32" 31	All	187C145A(+)		19588-010
To 1974	Dana 60	9.75"	1.31" 16	4.10 & dn	225S12C		19660-010
				4.56 & up	225S12A		
	Dana Super 60	9.75"	1.70" 40	4.10 & dn	225SL193A		
	Dana Super 60	9.75"	1.70" 40	4.56 & up	225SL193B		
1975-84	Dana 60-3	9.75"	1.31" 30	4.10 & dn	225SL19B	913A389	19722-010
				4.56 & up	225SL19A	913A390	19737-010
1974-87	Dana 61-1	9.75"	1.31" 30		See Note (6)		
1985-11	Ford	10.25"/10.5"	1.50" 35	All	225SL56A(ff)	915A550(ff)	19694-010(ff)
1983-85	Dana 70U	10.5"	1.50" 35	4.10 & dn (7)	225SL58D		
				4.56 & up (7)	225SL58C		
(ff) Full Float only							
F/E 350, 450, 550 • (98' & up Super Duty) • Truck • Van • Wagon • Cab & Chassis							
1979-07	Dana 60	9.75"	1.50" 35	4.10 & dn	225SL29B	915A387	19760-010
1978-79	Dana 60	9.75"		4.56 & up	225SL29A	915A388	19761-010
1981-87	Dana 61-1	9.75"	1.31" 30		See Note (6)		
1978-79	Dana 60 Snowplow package only	9.75"	1.31" 30	4.10 & dn	225SL19B	913A389	19722-010
				4.56 & up	225SL19A	913A390	19737-010
To 1974	Dana 60	9.75"	1.31" 16	4.10 & dn	225S12C		
				4.56 & up	225S12A		
To 1972	Dana 70	10.5"	1.50" 23	All	225S14		
1975-85	Dana 70HD	10.5"	1.50" 35	4.10 & dn (7)	225SL58B	*NEW* 915A670	
				4.56 & up (7)	225SL58A		
1983-97	Dana 70-U-1,-2	10.5"	1.50" 35	4.10 & dn (7)	225SL58D		
				4.56 & up (7)	225SL58C		
1985-11	Ford	10.25"/10.5"	1.50" 35	All	225SL56A(ff)	915A550(ff)	19694-010(ff)
1990-98	Dana 80	11.5"	1.60" 37	3.73 & dn		916A566	
1990-98	Dana 80	11.5"	1.60" 37	4.10 & up(tn)	225SL105A	916A427	
1998-09	Dana 80	11.5"	1.50" 35	3.73 & dn		915A567	
1998-09	Dana 80	11.5"	1.50" 35	4.10 & up(tn)	225SL131A	915A450	
1998-09	Dana S135	1.84"	36	4.63-5.38	250SL166		
(ff) Full Float only							
(tn) will fit OE 3.73 thin gear sets							

LD Differential

Light Truck & Performance Car Application Guide

Year	Description	Axle Shaft Dia.-Spline	Gear Ratio	Detroit Locker	Detroit Truetrac	Eaton Posi	Eaton ELocker
HUMMER							
H1, H2, H3							
2003-09	H1(military / other) AMC IFS	8.875"	1.27" 29	2.73 & dn 3.08 & up	187SL163A 187SL47A	912A549	
	H2 IFS	9.25"	33	All			19622-010
2003-09	H1(military / other) AMC IRS	8.875"	1.27" 29	2.73 & dn 3.08 & up	187SL163A 187SL47A	912A573 912A579	
	H2	9.5"	1.37" 33	All	225C135A	914A538	19590-010 19684-010
2006-09	H3	8.6"	1.32" 30	2.73 & up	187C148A	913A481	19559-010 19659-010
ISUZU							
Rodeo							
1993-00	Dana 44	8.5"/9"	1.31" 30	3.73 & dn 3.92 & up	187SL16D 187SL16C	913A589 913A590	19695-010 19747-010
(US only)							
1989-93	GM 10 bolt	7.5"	1.20" 28	3.23 & up	162C59A	912A317	
JEEP							
Cherokee • Grand Cherokee • Liberty • Post Office Truck • Scrambler • Wagoneer • Wrangler							
1971-06	Dana 30	7.2"	1.16" 27	3.54 & dn 3.73 & up	162SL60A(g) 162SL60B(g)	912A584(g) 912A585(g)	19817-010(b) 19818-010(b)
1970-09	Dana M-44-IF, IFHD	8.5"	1.31" 30	3.73 & dn 3.92 & up	187SL16D(g) 187SL16C(g)	913A591(g) 913A592(g)	19695-010 19747-010
2007-11	JK Dana 30	7.2"	1.16" 27	3.54 & dn 3.73 & up	162SL60A(g) 162SL60B(g)	912A584(g) 912A585(g)	19817-010(b) 19818-010(b)
1997-09	Chrysler C-Clip	8.375"	1.21" 29	All	187C179A	912A553	
1991-96	Chrysler C-Clip	8.375"	1.17" 27	All	187C151A		
1984-09	Dana 35 C-Clip	7.56"	1.18" 27	3.54 & up	162C56A	912A569	19821-010(b)
1985-89	Dana 35 non C-Clip	7.56"	1.18" 27	3.54 & up	162C56A	912A569	19821-010(b)
	Dana Super 35	7.56"	30	3.54 & up	162C-66A(b)		19822-010(b)
2007-11	JK Dana 44	8.5"	1.31" 30	All	187SL16D	913A589	19695-010
1997-06	Wrangler Dana 44	8.5"	1.31" 30	3.73 & dn	187SL16D	913A589	19695-010
1969-09	Various Dana 44	8.5"	1.31" 30	3.92 & up	187SL16C	913A590	19747-010
	Various Dana 44	8.5"	1.31" 30	3.73 & dn	187SL16D	913A589	19695-010
1964-70	Dana 44	8.5"	1.25" 19	3.73 & dn 3.92 & up			*NEW* 19961-010 *NEW* 19960-010
					187SL12A		
1974-88	Dana Super 44	8.5"	1.36" 33	4.10 & dn	187SL192A		
	Dana M60-3R	9.75"	1.31" 30	4.56 & up	225SL19B 225SL19A	913A389 913A390	19734-010 19722-010 19737-010
1976-86	AMC 20	8.875"	1.27" 29	3.08 & up 2.73 & dn	187SL47A 187SL163A	912A579 912A573	

(b) Bearing LM102949 and race LM102911 and unique shims are required.
(g) Applies to non disconnect only.

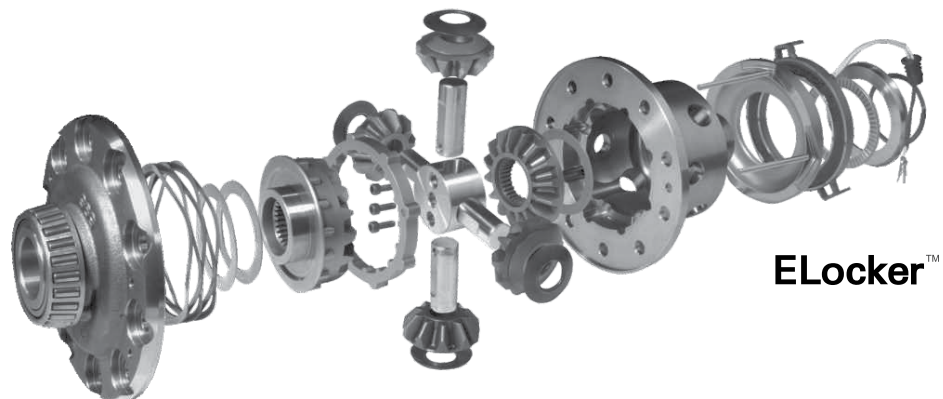

ELocker™

LD Differential

Light Truck & Performance Car Application Guide



	Year	Description	Axle Shaft Dia.-Spline	Gear Ratio	Detroit Locker	Detroit Truetrac	Eaton Posi	Eaton ELocker
LAND ROVER								
Rover Type & Salisbury								
FRONT	1993-00	Rover Type	1.24" 24	3.54	187SL173A(k)	912A407(k)		
	1985-93	Rover Type	1.11" 10	3.54	187SL174A(m)	910A416(m)		
		Salisbury 8HA	1.24" 24	3.54	225SL36			
REAR	1993-00	Rover Type	1.24" 24	3.54	187SL173A(n)	912A383(n)		
	1985-93	Rover Type	1.11" 10	3.54	187SL174A(p)	910A400(p)		
		Salisbury 8HA	1.24" 24	3.54	225SL36			
		Salisbury Defender	24	4.10 & dn		912A593		
(k) Axle serial numbers 49L11363C or 57L05188B and later								
(m) Axle serial numbers and later: Range Rover - suffix H, 88/109 4 cyl. ¾ ton - suffix H, 109 V8/1ton - suffix D								
(n) Axle serial numbers 35S18135C or 37S08651B and later								
(p) Axle serial numbers and later: Range Rover - suffix F, 88 -suffix G, 109 V8/1ton - (Salisbury standard), 109 4 cyl. ¾ ton - (Salisbury optional)								
NISSAN								
Titan • Truck • Xterra • Frontier								
REAR	2003-07	Titan M226	1.38" 32	All		913A582(m)		
		H233	1.25" 31	All	187SL167A			
	2003-07	Xterra M226 w/manual trans.	1.38" 32	All		913A582(m)		
	2005-07	Frontier w/M226 option	1.38" 32	All		913A582(m)		
(m) All vehicles equipped with OE Electric Locker require modification.								
SAAB								
9-7X								
REAR	2005 1/2-07	8.6"	1.32" 30	2.73 & up	187C148A	913A481	19559-010	19659-010
TOYOTA								
4 Cylinder - Hilux • 4 Runner • Celica • Celica GT								
FRONT	1974-85	8" 2 pinion	1.30" 30	All	187SL61A	913A609(v)		
	1986-88	7.5" IFS	1.10" 27	All		911A445(t)(v)		
	1986-04	7.5" IFS (v) 4 Runner only	1.10" 27	All		911A445		
	1989-04	7.5"	1.30" 27	All		911A644(w)		
REAR	1974-96	8" 2 pinion (v) non turbo	1.30" 30	All	187SL61A	913A611		
	1986-96	8" 4 pinion 4x4 turbo/gas/diesel	1.30" 30	All	187SL61B*	913A610*		
	1995-05	8.4" Tacoma, Tundra, T-100	1.29" 30	3.54-5.29	187SL199A	913A541		
6 Cylinder - Hilux • 4 Runner								
REAR	1986-95	8" 4 pinion (w) 4x4 turbo/gas/diesel, 4x2 cab chassis	1.30" 30	All	187SL61B	913A610		
	1995-05	8.4" Tacoma, Tundra, T-100	1.29" 30	3.54-5.29	187SL199A	913A541		
		Toyota Legend Race Series	1.08" 27	All		911A565		
911A644 - will not fit clamshell housing								
* 32010X bearing allows 913A610 in place of 913A611								
(t) Will not fit selector disconnect "shift on the fly"								
(v) "Small" hub bearing dia. 45 mm								
(w) "Large" hub bearing dia. 50 mm - uses Toyota bearing #90368-50006								
Land Cruiser II • FJ								
FRONT	1990-07	8" 4 pinion (w)	1.30" 30	All	187SL61B	913A612		
	1967-89	9.5" 2 pinion C-Clip	1.30" 30	All	187C152A			
REAR	1967-97	9.5" C-Clip	1.30" 30	All	187C152A			
		Australian 8 7/8"	1.31" 30	All	225SL124A			
	2005-09	FJ80	1.30" 30	All		913A610		

LD Differential

Year	Description	Axle Shaft Dia.-Spline	Gear Ratio	Detroit Locker	Detroit Truetrac	Eaton Posi	Eaton ELocker
PERFORMANCE							
	Toyota Legend/Celica 7.5"	27	All		911A565(w)		
	Dana 30, Volvo/RWD 7.2"	1.15" 27	3.73 & up		912A588		
	Dana Super 35 7.56"	1.15" 30	3.54 & up	162C66A(b)			19822-010(b)
	Chrysler 8.75"	1.20" 30	2.76-5.57	187SL14A	913A572		
	Chrysler 8.75"	1.31" 33	2.76-4.56		914A583 (pa)		
	Dodge Viper	30			913A614		
	GM 12 Bolt car 8.875"	1.32" 30	4.10 & up			19510-010(pl)	
	GM 12 Bolt truck 8.875"	1.32" 30	3.73 & up			19512-010(pl)	
	Dana Super 44 8.5"/9"	1.36" 33	3.92 & up	187SL192A(CB)			
1964-72	GM 12 Bolt car 8.875"	1.41" 33	3.08-3.90	187C198A	914A576 (pa)		
1964-72	GM 12 Bolt car 8.875"	1.41" 33	4.10 & up		914A575 (pa)		
1964-72	GM 12 Bolt car 8.875"	1.50" 35	4.10 & up	187S196A(ch) 187SL188A			
	Ford 8.8"	33	All		TBD 913A701		
	Ford 9"	1.50" 35	All exc. 2.72	187SL188A			
	Ford 9"	1.32" 31	All exc. 2.72	187S160A			
				187SL-188A (2" Bearing Journal)			
	Dana 60 rear 9.75"	1.50 35	4.10 & dn 4.56 & up		915A385 915A386	19760-010 19761-010	
	Dana Super 60 9.75"	1.70" 40	4.10 & dn	225SL193B			
	Dana Super 60 9.75"	1.70" 40	4.56 & up	225SL193A			

(pa) 33 spline units are made to fit axles cut with 45 degree pressure angle.
 (b) Bearing LM102949 and race LM102911 and unique shims are required.
 (ch) custom housing with 3.25" bearing bore.
 (w) "Large" hub bearing dia. 50 mm - uses bearing #90368-50006
 (pa) 33 spline units are made to fit axles cut with 45 degree pressure angle.
 (pl) includes 800# preload springs.
 (CB) LM104949 / LM104912

Circle Track Racing Applications

Ford 9" CTR only	1.32" 31	All exc. 2.72	R18703A
Ford 9" 2.00 Large Bearing	1.32" 31	All	R18715A (was R18707A)
Quick Change (Franklin, Halibrand, Richmond, Winters, etc.) CTR only	1.32" 31	All	R18705A (aluminum housing)

The Detroit Locker CTR (Circle Track Racing) version of the Detroit Locker is made exclusively for left hand turn racing only. Designed for use of asphalt or concrete tracks being 1/2 mile or larger.

INDEPENDENT TESTING OF DIFFERENTIALS

- check it out at EatonPerformance.com

Independent Testing Firm, National Technical Systems, tested a group of Eaton's differentials along with competitor's differentials. The baseline for testing was established using Eaton's differentials. All differentials were held to the same exact parameters during testing. According to the test results, NTS has determined,

"Eaton differentials outperformed the competitor's differentials nearly two to one."

Light Truck & Performance Car Application Guide



LD Differential

Part Number	Description	Standard Package	GM 7.5"	GM 7.625"	GM 8.2"	GM 8.2"	GM 8.2"	GM 8.2"	GM 8.5"	C5 Corvette
			19663-010	19599-010	19686-010	19670-010	19673-010	19674-010	19603-010	19557-010
Posi Limited Slip Service Kits										
29402-00S	Disc & Shim Kit	Steel discs, guides, shims, 24 steel discs			X	X	X	X	X	X
29403-00S	Disc & Shim Kit	Steel discs, guides, shims, 18 steel discs			X	X	X	X	X	X
29406-00S	Disc & Shim Kit	Carbon discs, guides, shims								
29408-00S	Disc & Shim Kit	Carbon discs, guides, shims								
29417-00S	Disc & Shim Kit	Carbon discs, guides, shims	X	X						
29418-00S	Disc & Shim Kit	Carbon discs, guides, shims								
29422-00S	Disc & Shim Kit	Carbon discs, guides, shims								X
29426-00S	Disc & Shim Kit	Carbon discs, guides, shims			X	X	X	X	X	X
29366-00S	Gear Service Kit	Side gear, pinion gears, washers, shaft screw								
29404-00S	Gear Service Kit	Side gear, pinion gears, washers, shaft screw			X					
29405-00S	Gear Service Kit	Side gear, pinion gears, washers, shaft screw	X							
29407-00S	Gear Service Kit	Side gear, pinion gears, washers, shaft screw								
29409-00S	Gear Service Kit	Side gear, pinion gears, washers, shaft screw								
29410-00S	Gear Service Kit	Side gear, pinion gears, washers, shaft screw							X	
29411-00S	Gear Service Kit	Side gear, pinion gears, washers, shaft screw								
29412-00S	Gear Service Kit	Side gear, pinion gears, washers, shaft screw								
29414-00S	Gear Service Kit	Side gear, pinion gears, washers, shaft screw		X						
29415-00S	Gear Service Kit	Side gear, pinion gears, washers, shaft screw								
29416-00S	Gear Service Kit	Side gear, pinion gears, washers, shaft screw								
29419-00S	Gear Service Kit	Side gear, pinion gears, washers, shaft screw						X		
29420-00S	Gear Service Kit	Side gear, pinion gears, washers, shaft screw								
29421-00S	Gear Service Kit	Side gear, pinion gears, washers, shaft screw								
29423-00S	Gear Service Kit	Side gear, pinion gears, washers, shaft screw								
29424-00S	Gear Service Kit	Side gear, pinion gears, washers, shaft screw					X			
29425-00S	Gear Service Kit	Side gear, pinion gears, washers, shaft screw			X	X				
PS-97-P-20007	Gear Service Kit	Side gear, pinion gears, washers, shaft screw								X
29239-00S	Preload Kit (400#)	Springs, plates								
29255-00S	Preload Kit (400#)	Springs, plates								
29589-00S	Preload Kit (200#)	Springs, plates			X	X	X	X	X	
29590-00S	Preload Kit (400#)	Springs, plates			X	X	X	X	X	
29591-00S	Preload Kit (800#)	Springs, plates			X	X	X	X	X	
29713-00S	Preload Kit (400#)	Springs, plates	X	X						
29716-00S	Preload Kit (400#)	Springs, plates								
29793-00S	Preload Kit (300#)	Springs, plates								X
PS97P20004	LH stub shaft									X
PS97P20005	RH stub shaft									X
99434-00S	Lock Screw Kit	10 Lock screws								
99942-01S	Lock Screw Kit	10 Lock screws (19559, 19557, 19663, 19599)								
29587-01S	Lock Screw Kit	10 Lock screws and locker washers								
29789-01S	Lock Screw Kit	10 Lock screws and locker washers								

Light Truck & Performance Car Application Guide



LD Differential

Part Number	Description	Standard Package	GM 8.5"/8.6"	GM 9.25"	GM 9.5"	Ford 8.8"	Ford 8.8"	Various	Various	Various
			19659-010	19622-010	19684-010	19660-010	19685-010	Dana 30/35	Dana 44	Dana 60
ELocker Service Kits										
29235-00S	Universal Wiring Kit	Dash switch , fuse & holder, relay, suppression device, wiring harness & connectors, conduit	X	X	X	X	X	X	X	X
26881-00S	Gear Service Kit Dana 60, 30 spline	Side gear, pinion gears, shims, pinion thrust washers ramp pins, ramp pin retainer, pinion shaft, shaft lock screw								X
26882-00S	Gear Service Kit Dana 60, 35 spline	Side gear, pinion gears, shims, pinion thrust washers ramp pins, ramp pin retainer, pinion shaft, shaft lock screw								X
26883-00S	Gear Service Kit Dana 44, 30 spline	Side gear, pinion gears, shims, pinion thrust washers ramp pins, ramp pin retainer, pinion shaft, shaft lock screw							X	
29296-00S	Gear Service Kit	Side gear, pinion gears, shims, pinion thrust washers, ramp pins, ramp pin retainer, pinion shaft, shaft lock screw	X							
29308-00S	Gear Service Kit	Side gear, pinion gears, shims, pinion thrust washers, ramp pins, ramp pin retainer, pinion shaft, shaft lock screw				X				
29309-00S	Gear Service Kit	Side gear, pinion gears, shims, pinion thrust washers ramp pins, ramp pin retainer, pinion shaft, shaft lock screw					X			
29394-00S	Gear Service Kit	Side gear, pinion gears, shims, pinion thrust washers ramp pins, ramp pin retainer, pinion shaft, shaft lock screw		X	X					
26884-00S	Locking Mechanism Kit	Ball ramp set, ball bearings, preload springs, thrust bearing, bearing race, retaining ring								X
26885-00S	Locking Mechanism Kit	Ball ramp set, ball bearings, preload springs, thrust bearing, bearing race, retaining ring							X	
29305-00S	Locking Mechanism Kit	Ball ramp set, ball bearings, preload springs, thrust bearing, bearing race, retaining ring	X			X	X			
29396-00S	Locking Mechanism Kit	Ball ramp set, ball bearings, preload springs, thrust bearing, bearing race, retaining ring		X	X					
26663-00S	Stator/Armature Kit	Stator assembly, armature, retaining bracket						X		
26664-00S	Stator/Armature Kit	Stator assembly, armature, retaining bracket							X	
26665-00S	Stator/Armature Kit	Stator assembly, armature, retaining bracket								X
29393-00S	Stator/Armature Kit	Stator assembly, armature, retaining bracket	X			X	X			
29395-00S	Stator/Armature Kit	Stator assembly, armature, retaining bracket			X					
29397-00S	Stator/Armature Kit	Stator assembly, armature, retaining bracket		X						

NOTES

- (+) +4.56, 4.88 and 5.13 require some modification for install.
- (1) "dia. r.g." is the pitch diameter of the ring gear. "10 bolt" means number of bolts in the differential housing cover.
- (2) The axle shaft diameter is the "major diameter" measured over the splines at the outer end of the shaft.
- (3) "& up" after the ring gear/pinion ratio means that all numerically higher ratios, in addition to the one designated, are also accommodated.
"& dn" after the ratio means that all numerically lower ratios are accommodated.
- (4) A "letter" after the model indicates a two-piece differential support case is supplied by Eaton with the differential. All other models (no letter) fit the two-piece differential case supplied by the axle/vehicle manufacturer. Bolts, bearings, shims & gaskets are not supplied.
The "Detroit SofLocker" differential indicated by an "SL" in the model number (187SL16D), provides smooth and reduced noise operation in the drive-coast mode. A dampening device has been inserted into the inboard end of each side gear.
The "Detroit C-Locker" differential indicated by a "C" in the model number (187C149A), accommodates axles with C-Clip axle shaft retainers inside the differential.
- (5) Detroit Locker differentials should not be used in front-drive axles or light on-highway vehicles unless used with unlocking hubs that are fully unlocked on-highway.
- (6) Dana 61-1 FULL FLOAT 1.31" dia. r.g./30 axle spline:
3.31 & down ratios, use Detroit SofLocker 225SL19B
- 3.54, 3.73, 4.10 ratios, THIN RING GEAR with standard differential;
- | | | |
|-------------------------|--------------------|--------------------------------|
| Number on ring gear is: | 32503 = 3.54 ratio | |
| | 34508 = 3.73 ratio | Use Detroit SofLocker 225SL19C |
| | 30360 = 4.10 ratio | |
- 3.54, 3.73, 4.10 & 4.56 ratios, THICK RING GEAR with limited slip differential;
- | | | |
|-------------------------|--------------------|--------------------------------|
| Number on ring gear is: | 39211 = 3.54 ratio | |
| | 37875 = 3.73 ratio | Use Detroit SofLocker 225SL19A |
| | 39300 = 4.10 ratio | |
| | 39299 = 4.56 ratio | Use Detroit SofLocker 225SL19C |
- (7) Dana 70/70 HD, 35 splines: Use Detroit Locker 225S-18 if two piece case; use 225SL58 A, B, C, D if a one piece case.

For Drag Racing applications:

When using a Locker with trans brake - take the lash out of the Locker before pre-staging.

Differential Cover Identifier

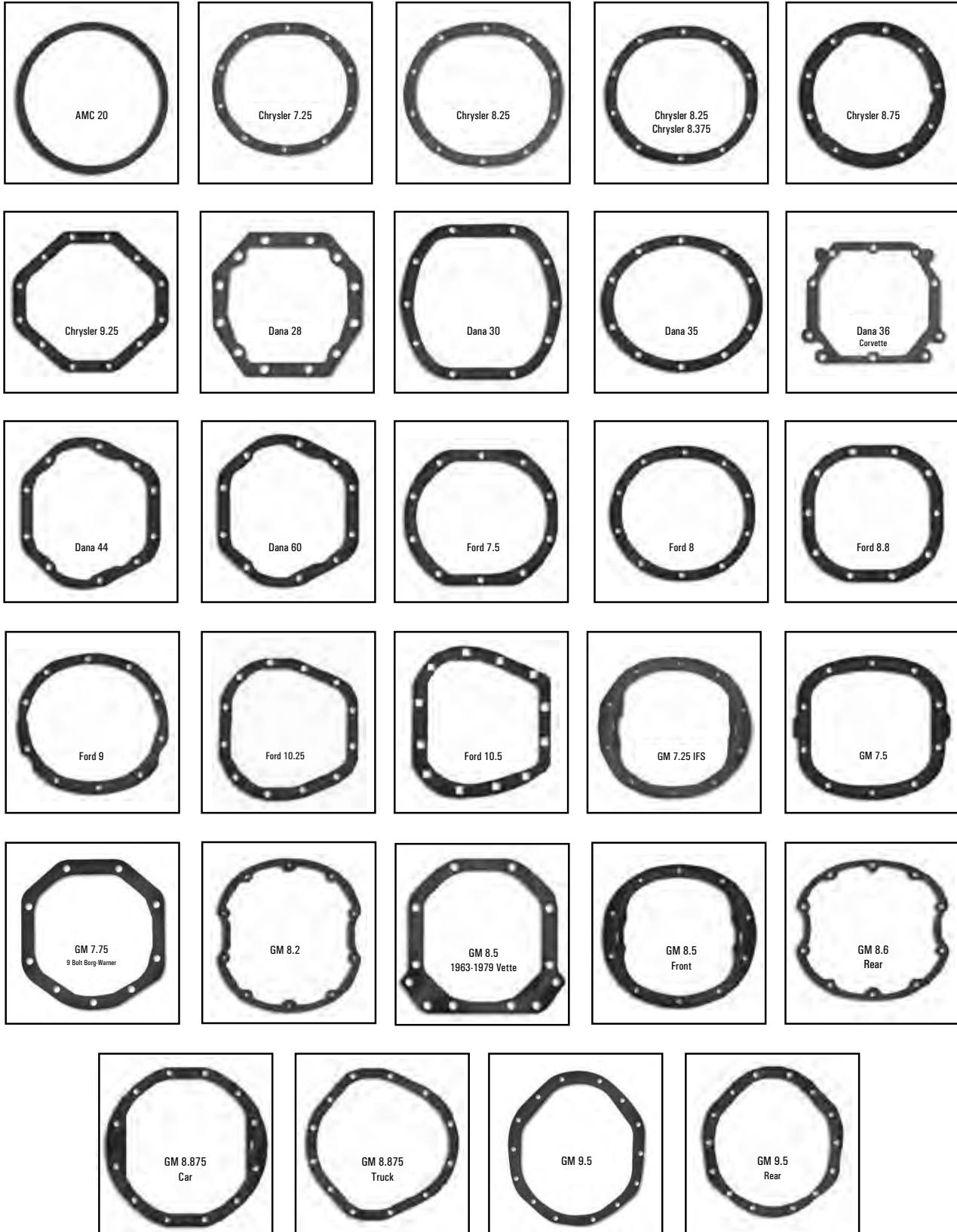



LD Differential



Eaton Performance
26101 Northwestern Highway
Southfield, MI 48076 USA
800-328-3850
EatonPerformance.com

While this model list is believed to be accurate, we cannot guarantee accuracy (errors or omissions) of the data. Customer is responsible to identify the correct part number for their particular application.



Made
in the
USA

Performance Differentials

Equipped Max Lockers | Limited-Slip Differentials

LD Differential





Nothing delivers superior traction capability like an Auburn Gear performance differential!

For nearly 55 years, Auburn Gear has been the leader in performance limited-slip differentials.

Today, no matter what you drive—dragsters, performance cars, everyday passenger vehicles, light-duty trucks, vans, sport utilities, off-road or recreational vehicles—there is an Auburn Gear performance differential engineered to maximize your vehicle's tractive capability.



High Performance Limited-Slip Differentials

Street, track or muddy trail—Get smooth torque-sensing operation with the correct bias ratios to outperform the competition.

Pro Series Limited-Slip Differentials

Rev it up and pop the clutch! By design, the Pro Series gives you an even higher bias torque than Auburn's High-Performance models, with lightning-fast reaction to changing conditions for the very best in controlled power transfer.

The Auburn Gear Ected Max Selectable Locker

This is the only aftermarket locker that delivers on-the-go system engage! And it's the only one that offers both the traction control of a limited-slip differential and the capability of a true locker. All other aftermarket differentials must be operated in either the "open" differential mode or the "locked" mode. But not Ected Max!

Caution: Ected Max is a high-performance locker. Auburn Gear highly recommends upgrading to stronger ring and pinions and axles if you're thinking about installing an Ected Max on your vehicle. Engage Ected Max on the fly at any reasonable speed when all four wheels are on the ground.



D-REX

Best Warranty in the Industry

With Auburn Gear, you get a full one-year manufacturer's warranty, plus D-REX coverage for four years from date of purchase. D-REX stands for Differential-Replacement Exchange—which means Auburn Gear will replace your unit within the first four (4) years after purchase. Every part you get will be brand new. The unit comes assembled, tested, certified and ready for installation. No more rebuilding and mixing old worn parts with new parts!

LD Differential

Why Auburn Gear performance differentials?

Auburn Gear Pro Series and High Performance Series differentials provide superior performance through a unique cone-clutch design that transfers more power to the high-traction wheel for quick acceleration and tight cornering.

All Auburn Gear limited-slip differentials are designed to provide the maximum amount of torque transfer without compromising the performance requirements of the vehicle in situations where torque transfer is not required.

How does Auburn Gear's design work?

Torque transfer is achieved through the use of cone clutches coupled to beveled side gears. As torque is transmitted through the differential side gears to the axle shafts, the side-gear-separating forces and spring preload firmly seat the cones into the differential case.

The cone design, along with the applied force, determines the torque transfer capability of the differential. When torque levels decrease, as in a cornering maneuver, the gear-separating forces also decrease, allowing the axle shafts to rotate independently. This unequally divides the torque between the two wheels, delivering more torque (or bias torque) to the wheel with the most traction.





Get Limited-Slip Plus the Power of a True Locker

Ected | Electronically Controlled Traction Enhancing Differential (*pronounced "ek-ted"*)

The Ected Max is a revolutionary traction-technology product that provides you with a selectable limited-slip or locker mode. When selected "off" – the Ected Max functions as a performance limited-slip differential for on- and off-road excitement. When selected "on" the Ected Max becomes a locker, ideal for the quarter-mile or the nastiest off-road terrain.

How does the Ected Max work?

The Ected Max is a selectable traction device. An on/off switch is mounted near the driver. When "off," the clutch pack (7), located behind the side gear (6), activates the limited-slip mode. As torque increases, the separating forces within the differential gears increase, causing the clutch pack to be compressed and, thereby, providing bias torque to the high traction wheel—your performance limited-slip differential action.

When selected "on," current is sent to the electromagnetic coil (8). The coil is retained by a clip that fits over one of the bearing cap bolts, making it non-rotational. The coil rides on a ball bearing (9). The ball bearings spin with the differential case

(10). The coil creates a magnetic flux so that the pilot cone (1) is pulled into engagement with the differential case (10). This frictional engagement causes the bearing balls (2) to ride up on a ramp machined into the side gear (3). This radial travel of the balls (2) also causes lateral movement of the side gear (3). The lateral movement of the side gear (3) applies a force onto the center block (4). The center block (4) has an elongated hole that the center pin (5) fits through, allowing it to float. The center block (4) applies force to the opposite side gear (6), compressing the clutch pack (7) giving the user a solid axle assembly and the locker performance desired at the strip or off-road.

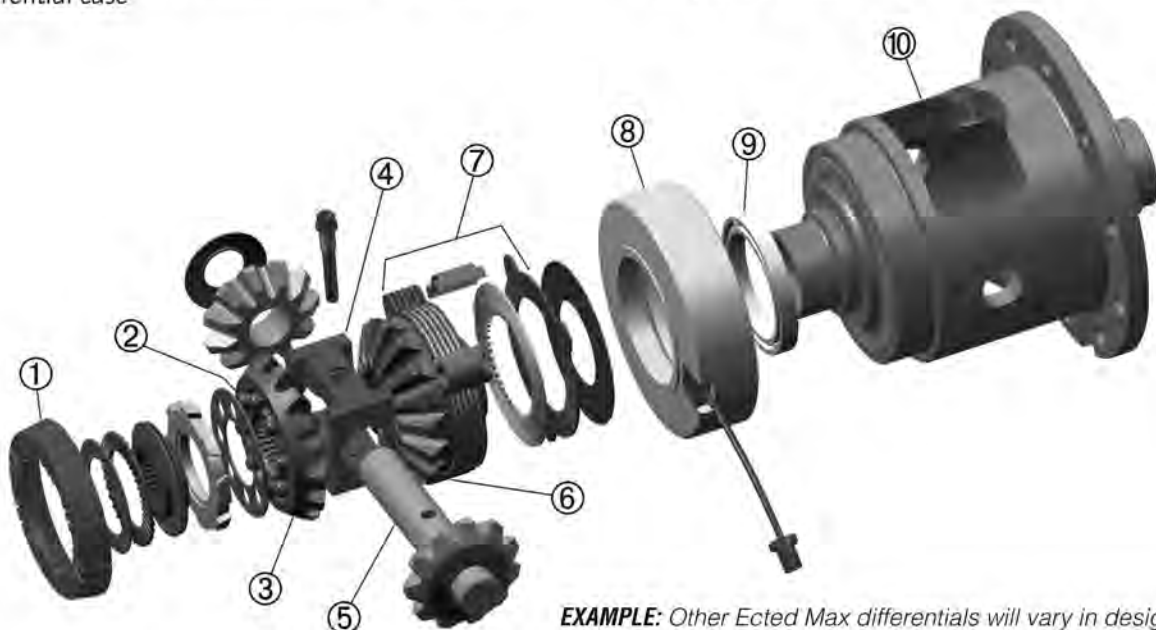

EXAMPLE: Other Ected Max differentials will vary in design layout.



Ected Max™ Advantages

- Gearing is made from aircraft-quality 9310 heat-treated billet steel to make it as tough as nails!
- Can be switched on or off "on the fly," at any safe road speed.
- Does not have any shift forks or pins that must be lined up to obtain locker mode.
- Operates quietly – say good-bye to noisy lockers!
- Backed by a one-year warranty plus the industry's only D-REX Program (see page 28).
- Can be used in front-axle applications, with or without lockout hubs. (**Important Note:** The Ected Max is NOT recommended for use in front axles that feature an "inter-axle disconnect.")



LD Differential

	Open Diff	Limited-Slip Diff	Locker
Auburn Gear Ected Max		X	X
ARB Air Locker	X		X
Eaton Elocker	X		X

The Ected Max is the only selectable locker that offers both limited-slip and locker modes.

Service kits: See complete details for service kits on page 142.



IMPORTANT NOTE: Bearings not included unless specifically stated. Applications listed (make & year) are for reference only. Always verify axle/ring gear size, the ratio to be used and the number of axle splines prior to purchase and installation.

AMC 20, 12 Bolt



10 1/32" x 10 25/64" 12 Holes, Round

Make	Year
Ambassador	68-74
AMX	68-79
Coricord	78-79
Gremlin	70-78
Hornet	72-78
Javelin	68-74
Jeep C101	67-72
Jeep CJ5 & CJ7	67-86
Jeep Wagoneer	67-86
Jeep J-10	66-86
Matador	72-78
Pacer V8	78-79
Rambler	69-72
Scrambler	76-78
Spirit V6	79

IMPORTANT NOTE: Be certain that the axle shaft extends beyond the side gear face. Some after-market one-piece axle shafts are shorter than the stock shaft. Using an axle shaft that is too short will promote failure to the axle shaft spline.



542081, Pro Series

Model Years: 1966-1986

Applications: All AMC 20 Axles

Ratios	Side Gear Spline	Bearing Cone	Bearing Cup
3.07:1 & Up	29 Teeth	LM603049	LM603012

Special Note: Some AMC 20 applications require the differential pin bolts included with the unit.

545006-Fits H1 Hummer

Model Years: 1966-Present

Applications: All AMC 20 axles

Ratios	Side Gear Spline	Bearing Cone	Bearing Cup
2.73:1 & Down	29 Teeth	LM60304	LM603012

545007

Model Years: 1966-1986

Applications: All AMC 20 axles

Ratios	Side Gear Spline	Bearing Cone	Bearing Cup
3.07:1 & Up	29 Teeth	LM603049	LM603012

Chrysler 8 1/4" & 8 3/8" 10 Bolt



11 3/8" 10 Holes, Oval

Make	Year
Passenger Cars, Various	73-97
B100, 150, 200, 250	69-Present
B.D.W-100	66-97
B.D.W-200	69-97
B.D.W-300	66-97
Aspen/Volare	78-80
Barracuda/Challenger	70-74
Charger/Coronet	73-76
Chrysler 300	72-79
Cordoba	75-83
Dakota	87-Present
Dart	72-76
Diplomat/LeBaron	77-83
Fifth Avenue/New Yorker	72-88
Imperial	61-83
Fury	70-81
Mirada/Magnum	78-83
Newport	72-73
Polaris/Satellite	70-74
St. Regis	79-81
W100, 150	86-Present
Jeep Liberty	02-Present

542072, High Performance Series

Model Years: 1966-1996

Applications: All Chrysler products with 8 1/4" & 8 3/8" ring gear. Accepts tone ring for ABS applications.

Ratios	Side Gear Spline	Bearing Cone	Bearing Cup
2.71:1 & Up	27 Teeth	LM603049	LM603012

542074, High Performance Series

Model Years: 1997-Present

Applications: All Chrysler products with 8 1/4" & 8 3/8" ring gear. Accepts tone ring for ABS applications.

Ratios	Side Gear Spline	Bearing Cone	Bearing Cup
2.71:1 & Up	29 Teeth	LM603049	LM603012

Chrysler 8 1/4" applications require modification to the axle housing as shown to provide clearance for the differential case. Clean housing after grinding.

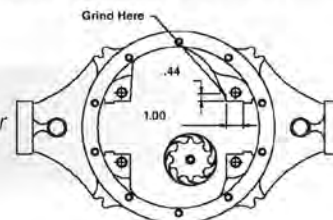

Chrysler 8 3/4" 10 Bolt



8 1/16" x 10 19/32" 10 Holes, Round.

Make	Year
Belvedere	57-70
Coronet	69-70
300	57-73
Fury	57-74
Imperial	57-74
Town & Country	57-74
Valiant	60-74
Concord	63-68
Monaco	63-74
Polara	63-74
Barracuda	64-74
B200/B250	65-74
W100/W150	65-74
Charger (Daytona)	66-74
Dart/Swinger	66-72
Road Runner/Satellite	67-74
Super Bee	68-70
Newport/New Yorker	69-74
Challenger/Duster	70-74

542051, Pro Series

Model Years: 1957-1974

Applications: All Chrysler products with 8 3/4" ring gear.

Ratios	Side Gear Spline	Bearing Cone	Bearing Cup
All ratios	30 Teeth	LM104949	LM104912



Best Warranty in the Industry—

D-REX stands for Differential-Replacement Exchange Program. Auburn Gear's limited-slip differentials are designed and manufactured with a robust and unique cone clutch mechanism. However, due to machining and assembly processes, the differential case and side gear/cone clutch mechanism are a matched set and therefore non-rebuildable. All other components within the Auburn Gear differential are replaceable and service kits are available. In order to address the non-rebuildable components within our limited-slip differentials we offer the D-REX unit.

Chrysler 9 1/4" 12 Bolt



12 3/8" x 11 1/2" 12 Holes, Irregular

Make	Year
Polara	70-74
Fifth Avenue/Fury	73-81
Newport/New Yorker	73-81
Imperial	74-75
Charger	74-76
Cordeba	75-79
Monaco	75-85
B350	84-Present
D200	66-Present
D300/D350	74-Present
Dakota W/V8	98-Present
Durango	97-Present
Ramcharger/Trailduster	74-Present
W100/W150/W200/W250	66-Present

542071, High Performance Series

Model Years: 1968-1983

Applications: All Chrysler products with 9 1/4" ring gear.

Ratios	Side Gear Spline	Bearing Cone	Bearing Cup
2.71:1 & Up	31 Teeth	JLM704649	JLM704610

542070, High Performance Series

Model Years: 1984-Present

Applications: All Chrysler products with 9 1/4" ring gear. Accepts tone ring for ABS applications.

Ratios	Side Gear Spline	Bearing Cone	Bearing Cup
2.71:1 & Up	31 Teeth	JLM704649	JLM704610

Every effort has been made to ensure accuracy of the contents of this catalog. However, we assume no responsibility for errors or omissions.

Dana 30



9 1/4" x 8 3/4" 10 Holes

Make	Year
Jeep C-101 Jeepster	67-72
Jeep Cherokee/Wagoneer Full Size	71-73
Jeep CJ	71-86
Jeep YJ	87-96
Jeep TJ	86- Present
Jeep XJ Cherokee	84-01
Jeep MJ Comanche	84-91 1/2
Jeep ZJ/WJ Grand Cherokee	93- Present
Ford Aerostar (F)	85-89
Ford Bronco (F)	67-71
International Scout (F)	67-78
Couner* (F)	79-80
Mazda* (F)	79-80
Toyota* (F)	79-80
Nissan* (F)	79-80

*Above vehicles that are equipped with conversion front ends.

Applications: All Dana 30 models without "C" clips.



545016

Model Years: 1967-Present

Ratios	Side Gear Spline	Bearing Cone	Bearing Cup
3.55:1 & Down	27 Teeth	LM501349	LM501314



545017

Model Years: 1967-Present

Ratios	Side Gear Spline	Bearing Cone	Bearing Cup
3.73:1 & Up	27 Teeth	LM501349	LM501314

IMPORTANT NOTE: Model 30 setup bearing kit available, part number 541074.

Dana 35



9 1/4" x 10 3/8" 10 Holes

Make	Year
Jeep YJ	87-96
Jeep TJ	97- Present
Jeep XJ Cherokee	84-01
Jeep MJ Comanche	84-91 1/2
Jeep ZJ/WJ Grand Cherokee	93- Present
Ford Explorer/Mountaineer 4.0L* (F)	90-95 1/2
Ford Ranger 4.0L* (F)	90-97
Mazda B4000* (F)	90-97

* Above units will work by adding coil spring in right side axle slip yoke assembly.

Applications: All Dana 35 models.

IMPORTANT NOTE: These are not stock bearings. Bearings are available from Auburn Gear. Bearing kit part number 541070.

** 30 teeth requires aftermarket axle shafts.



545012

Model Years: 1987-Present

Ratios	Side Gear Spline	Bearing Cone	Bearing Cup
3.31:1 & Down	27 Teeth	LM102949	LM102911



545013

Model Years: 1987-Present

Ratios	Side Gear Spline	Bearing Cone	Bearing Cup
3.55:1 & Up	27 Teeth	LM102949	LM102911



545014

Model Years: 1987-Present

Ratios	Side Gear Spline	Bearing Cone	Bearing Cup
3.31:1 & Down	**30 Teeth	LM102949	LM102949



545015

Model Years: 1987-Present

Ratios	Side Gear Spline	Bearing Cone	Bearing Cup
3.55:1 & Up	**30 Teeth	LM102949	LM102911

Dana 44



9 3/8" x 10 1/4" 10 Holes

Make	Year
Chevrolet K10, 25 Front	60-80
Chevrolet K30, 35 Front	67-76
Chevrolet C10, 5 Rear	60-70
Blazer Front	75-79
Chrysler W100, 150	
200, 300 & 350 Front	69-Present
Ford Bronco Front	71-97
L100 Front	71-78
Ford F100/F150 4x4 Rear	67-78
Ford F100 Front	67-97
Ford F250 Front	67-97
Ford F150 Front	75-97
Cobra	63-67
Thunderbird	55-56
IHC Scout Front	67-80
IHC Scout Rear	67-80
IHC 100, 150, 200, 1100, 1110, 1200, 1210 Front & Rear	65-75
Jeep C101 Rear	67-72
Jeep Wagoneer Front	67-83
Jeep J10, 20 Front	74-86
Jeep CJ5 Front & Rear	67-75
Jeep CJ7 Front & Rear	67-75
Jeep CJ7 Rear	85-86
Jeep Comanche Rear	86-92
Jeep Cherokee Rear	76-92
Jeep Grand Wagoneer Front	84-92
Jeep Wagoneer Front & Rear	67-83
Jeep "LJ"	2001

Applications: All Dana 44 models without "C" clips.

IMPORTANT NOTE:

Model 44 setup bearing kit available, part #541075.

Also: For models 2007 and newer, check your vehicle axle shaft spline before ordering. Some vehicles may have a 31 tooth configuration.



5420111, High Performance Series 542084, Pro Series

Model Years: 1970 & Prior

Ratios	Side Gear Spline	Bearing Cone	Bearing Cup
3.92:1 & Up	19 Teeth	25590	25523

5420112, High Performance Series 542085, Pro Series

Model Years: 1970 & Prior

Ratios	Side Gear Spline	Bearing Cone	Bearing Cup
3.73:1 & Down	19 Teeth	25590	25523

Special Note: Some Dana 44 applications (19 tooth axle splines) require the use of an axle spacer, which is included with the unit.

5420109, High Performance Series 542082, Pro Series

Model Years: 1971-Present

Ratios	Side Gear Spline	Bearing Cone	Bearing Cup
3.92:1 & Up	30 Teeth	25590	25523

5420110, High Performance Series 542083, Pro Series

Model Years: 1971-Present

Ratios	Side Gear Spline	Bearing Cone	Bearing Cup
3.73:1 & Down	30 Teeth	25590	25523

545018

Model Years: 1971-Present

Ratios	Side Gear Spline	Bearing Cone	Bearing Cup
3.73:1 & Down	30 Teeth (only)	25590	25523

For the 2003-2006 Rubicon, all ratios, please specify part #545018.

545019

Model Years: 1971-Present

Ratios	Side Gear Spline	Bearing Cone	Bearing Cup
3.92:1 & Up	30 Teeth (only)	25590	25523

545021, Dana Super 44

Model Years: 2007-Present

Ratios	Side Gear Spline	Bearing Cone	Bearing Cup
All ratios	35 Teeth	JLM704649	JLM704610

Make	Year
Jeep JK, non-Rubicon	07-Present



Dana 50

Make	Year
F250/F35	81-04
Excursion	2000-05



545020

Model Years: All years

Applications: Ford F-250, F-350 and Excursion front axles.

Ratios	Side Gear Spline	Bearing Cone	Bearing Cup
All Ratios	30 Teeth	JLM104948	LM104911A

Ford 7 1/2" 10 Bolt



10 3/4" x 9 3/16" 10 Holes, Oval

Make	Year
Aerostar	86-96
Bronco II	83-90
Ranger without 4.0L	83-99
Ford Full Size	79-86
Fairmont	78-83
Granada	79-94
Mustang 4 & 6 Cylinder	79-Present
Thunderbird	80-94
Mercury Full Size	79-85
Bobcat	75-80
Capri except 86 with V8	79-86
Cougar	80-87
Zephyr	79-83

542023, High Performance Series

542048, Pro Series

Model Years: 1978-Present

Applications: All Ford products with 7 1/2" ring gear. Accepts tone ring for ABS applications.

Ratios	Side Gear Spline	Bearing Cone	Bearing Cup
All ratios	28 Teeth	LM501349	LM501314

Special Note: Ford 7.5" applications require special "C" washers, which are supplied with the differential. Includes milled pinion shaft to accept 3.73-4.56 ratios.

Ford 8" 10 Bolt



11" 10 Holes, Oval

Make	Year
Falcon	62-70
Mustang	65-79
Comet	64-72
Cougar	67-72
Fairlane	60-72

542059, Pro Series

Model Years: 1960-1979

Ratios	Side Gear Spline	Bearing Cone	Bearing Cup
3.0 and higher	28 Teeth	LM102949	LM102910

5420115, Pro Series

Model Years: 1960-1979

Ratios	Side Gear Spline	Bearing Cone	Bearing Cup
3.0 and higher	31 Teeth	LM102949	LM102910

Applications: All Ford products with 7 1/4" & 8" ring gear. Use Ford M-4216-B ring gear bolts for an open-type differential. Limited-slip type bolts are too long.

Ford 8.8" 10 Bolt



10 ⁹/₁₆" x 10 ¹³/₁₆" 10 Holes, Oval

Make	Year
Aerostar with 4.0L	90-96
Bronco	81-94
Explorer	90-Present
Ranger with 4.0L	90-Present
E150 - E250	83-99
F100	81-97
F150-250	81-Present
F150 Front	97-Present
Mustang V8	85-Present
Thunderbird	87-94
Capri V8	86-97
Cougar	88-01
Mercury Full Size	82-Present
Expedition Front	97-Present

Applications: All Ford products with 8.8" ring gear including IRS (Independent Rear Suspension) applications. Accepts tone ring for ABS applications

542079, High Performance Series

542080, Pro Series

Model Years: 1979-Present

Ratios	Side Gear Spline	Bearing Cone	Bearing Cup
All ratios	28 Teeth	LM603049	LM603012

542025, High Performance Series

542054, Pro Series—9310 Gear Material

Model Years: 1983-Present

Ratios	Side Gear Spline	Bearing Cone	Bearing Cup
All ratios	31 Teeth	LM603049	LM603012

5420116, Pro Series—9310 Gear Material

Model Years: 1983-Present

Ratios	Side Gear Spline	Bearing Cone	Bearing Cup
All ratios	33 Teeth	LM603049	LM603012

545001

Model Years: 1978-Present

Applications: All Ford products with 8.8" ring gear including IRS & IFS (Independent Rear & Front Suspension) applications. Accepts tone ring for ABS applications.



Ratios	Side Gear Spline	Bearing Cone	Bearing Cup
All ratios	28 Teeth	LM603049	LM603012

545002

545005 (for IRS applications only)

Model Years: 1983-Present

Applications: All Ford products with 8.8" ring gear. Accepts tone ring for ABS applications.



Ratios	Side Gear Spline	Bearing Cone	Bearing Cup
All ratios	31 Teeth	LM603049	LM603012

Every effort has been made to ensure accuracy of the contents of this catalog. However, we assume no responsibility for errors or omissions.

Ford 9 " 10 Bolt



11 3/4" 10 Holes, Oval

Make	Year
Bronco	67-86
E200	68-74
E100/150	86-87
Mercury	57-73
Ford	57-80
Thunderbird	57-73
All Light Trucks	57-87
Fairlane	62-73
Comet	65-67
Cougar	65-79
Mustang	65-73
Montego	68-76
Ltd II	71-79
Torino	71-79
Granada	75-80
Monarch	75-80
Versailles	77-80

Applications: All Ford products with 8 3/4" & 9" ring gear. Use Ford M-4216-A210 ring gear bolts for an open-type differential. Limited-slip type bolts are too long.

542043, Pro Series

Model Years: 1957-1987

Ratios	Side Gear Spline	Bearing Cone	Bearing Cup
All ratios	28 Teeth	LM102949	LM102910

542036, Pro Series

Model Years: 1957-1987

Ratios	Side Gear Spline	Bearing Cone	Bearing Cup
All ratios	31 Teeth	LM603049	LM603011

Ford 9 3/4 " 12 Bolt

Make	Year
Navigator	97-Present
Expedition	97-Present
E150	97-Present
E250	97-Present
E350	97-Present
F150	97-Present
Lightning	99-Present

542090, High Performance Series

Model Years: 1997-Present

Applications: All Ford products with 9 3/4" ring gear. Accepts tone ring for ABS applications. Fits IRS applications.

Ratios	Side Gear Spline	Bearing Cone	Bearing Cup
All ratios	34 Teeth	NP343847	NP372019

Ford 10 1/4 " & 10 1/2 " 12 Bolt



12 1/8" x 13 5/16" 12 Holes, Irregular

Make	Year
F250	83-Present
F350	83-Present
F450	83-Present

542089, High Performance Series

Model Years: 1983-Present

Applications: All Ford products with 10 1/4" & 10 1/2" ring gear. Accepts tone ring for ABS applications.

Ratios	Side Gear Spline	Bearing Cone	Bearing Cup
All ratios	35 Teeth	469	453X

LD Differential

Toyota 8 7/8" 12 Bolt

542030, Pro Series

Model Years: 1968-1989

Applications: Land Cruiser.

Ratios	Side Gear Spline	Bearing Cone	Bearing Cup
All ratios	30 Teeth	LM603049	LM603012

Special Note: 1967 & prior must update to 30 tooth axle shafts.

Toyota 8.0" 10 Bolt

Make	Year
Pickup	86-96
Land Cruiser II	90-07
Land Cruiser	98-Present
T-100	04-Present
Tacoma	04-Present
Tundra	05-07
FJ Cruiser	05-Present

5420131, Pro Series, 4-pinion design

Model Years: 1974-Present

Ratios	Side Gear Spline	V-6 Bearing Cone	Bearing Cup
All ratios	30 Teeth	LM104948	LM104912

Toyota 8.4" 10 Bolt

Make	Year
Pickup	86-96
Lexus GX	95-Present
Tacoma	95-05
Tundra	95-05
T-100	95-05

5420132, Pro Series, 4-pinion design

Model Years: 1990-Present

Ratios	Side Gear Spline	V-6 Bearing Cone	Bearing Cup
All ratios	30 Teeth	ST5186-N set	ST5186-N set

Toyota 9.5" 12 Bolt

Make	Year
Tundra	07-Present
T-100	96-Present
200 Land Cruiser	98-Present
Lexus LX470	07-Present

5420133, High Performance Series

Model Years: 2007-Present

Applications: Tundra's with 4.7 liter V-8, T100 & 200 Land Cruisers 1998-present and Lexus LX470.

Ratios	Side Gear Spline	V-8 Bearing Cone	Bearing Cup
All ratios	32 Teeth	570064-1	32010J (Koyo)

Toyota 10.5" 12 Bolt

Make	Year
Tundra	07-Present

5420134, High Performance Series

Model Years: 2007-Present

Applications: Tundra's with 5.7 liter V-8.

Ratios	Side Gear Spline	V-8 Bearing Cone	Bearing Cup
All ratios	36 Teeth	HR32011Xja4	R55-34 (NSK)

GM 7 1/2" & 7 5/8" 10 Bolt



8 5/16" x 10 9/16" 10 Holes, Oval

Make	Year
Omega	75-79
Skyark	76-79
Buick/Olds/Pontiac	
Full Size	77-86
Chevrolet Full Size	77-86
Century/Phoenix/Ventura	78-81
Cutlass/Grand Prix	78-87
Monte Carlo/Regal	78-87
Camaro/Firebird	82-88
S10/S15	82-88
Astro/Safari	85-88
El Camino	77-87

Applications: All GM products with 7 1/2" & 7 5/8" ring gear.

542057, High Performance Series 542044, Pro Series

Model Years: 1976-1988

Ratios	Side Gear Spline	Bearing Cone	Bearing Cup
3.23:1 & Up	26 Teeth	LM501349	LM501314

542058, High Performance Series 542045, Pro Series

Model Years: 1976-1988

Ratios	Side Gear Spline	Bearing Cone	Bearing Cup
3.08:1 & Down	26 Teeth	LM501349	LM501314



8 5/16" x 10 9/16" 10 Holes, Oval

Make	Year
Buick/Olds/Pontiac	
Full Size	86-90
Chevrolet Full Size	88-96
Camaro/Firebird	88-02
S10/S15	88-Present
Astro/Safari	88-Present
Isuzu Rodeo	89-93
Olds Bravada	91-02

Applications: All GM products with 7 1/2" & 7 5/8" ring gear. Accepts tone ring for ABS applications.

542040, High Performance Series 542046, Pro Series

Model Years: 1988-Present

Ratios	Side Gear Spline	Bearing Cone	Bearing Cup
3.23:1 & Up	28 Teeth	LM501349	LM501314

542041, High Performance Series 542047, Pro Series

Model Years: 1988-Present

Ratios	Side Gear Spline	Bearing Cone	Bearing Cup
3.08:1 & Down	28 Teeth	LM501349	LM501314

Special Note: GM 7 5/8" applications use (2) different tone wheels depending on the differential case series. 3.08:1 & down gear ratios—Series 2 Case. 3.23:1 & up gear ratios—Series 3 Case.

Chevy 8.2" 10 Bolt



11 1/2" 10 Holes

Make	Year
Chevrolet	65-70
Chevelle	64-72
Camaro	67-70
Chevy II	64-70
Nova	70-72

5420108, High Performance Series 542061, Pro Series

Model Years: 1964-1972

Applications: Chevrolet with 8.2" ring gear. "C" lock axle. 25 tooth pinion spline.

Ratios	Side Gear Spline	Bearing Cone	Bearing Cup
3.08:1 & Up	28 Teeth	LM501349	LM501314

Buick - Olds - Pontiac 8.2 " 10 Bolt



11 1/2" 10 Holes

Make	Year
Tempest/GTO	64-71
Firebird	67-71
Olds F85	64-70

*Will not fit "D" axle with 12-bolt cover and 10-bolt ring gear.

Applications: Buick, Olds, Pontiac with 8.2" ring gear. Non "C" lock axle-27 tooth pinion spline.

5420113, High Performance Series 542060, Pro Series

Model Years: 1964-1971

Ratios	Side Gear Spline	Bearing Cone	Bearing Cup
3.36:1 & Up	28 Teeth	LM501349	LM501314

5420114, High Performance Series 542099, Pro Series

Model Years: 1964-1971

Ratios	Side Gear Spline	Bearing Cone	Bearing Cup
2.93:1 to 3.23:1	28 Teeth	LM501349	LM501314

Special Note: Differential bearings provided with 542099 and 5420114.

GM 8.2 " / 8.4 " 10 Bolt 1955-1964 Chevy

Make	Year
Bel Air	55-64
Impala	55-64
Biscayne	55-64
Corvette	55-62
Series 150/210	55-64
El Camino	55-64
Chevy II	55-64

5420100, Pro Series

Model Years: 1955-1964

Ratios	Side Gear Spline	Bearing Cone	Bearing Cup
3.70:1 & Down <i>3 Series Case</i>	17 Teeth	LM603049	LM603014

LD Differential

Housing modification for non-posi housings

Axle housings not originally equipped with a posi-traction will require modification to provide necessary clearance for the limited-slip differential.

No modifications are required if using an original posi housing.

Modify the non-posi housing by removing a portion of the rib as shown below.



Unmodified non-posi Housing



Modified non-posi Housing

remove material

Corvette 10 Bolt 1963-1979

542062, Pro Series

Model Years: 1963-1979

Ratios	Side Gear Spline	Bearing Cone	Bearing Cup
2.41:1 to 3.70:1	17 Teeth	LM603049	LM603012

542063, Pro Series

Model Years: 1963-1979

Ratios	Side Gear Spline	Bearing Cone	Bearing Cup
4.10:1 & Up	17 Teeth	LM603049	LM603012

GM 8.5" & 8.6" 10 Bolt

front



11" 10 Holes, Irregular

rear



10 5/8" 10 Holes, Irregular

Make	Year
Apollo/Regal/Century	73-77
Biscayne/Roadmaster	71-74
Buick full size	77-present
Camaro	70-81
Chevelle	70-76
Chevy full size	77-96
Chevy I/Nova	70-79
Cutlass/Grand Prix/LeMans/GTO/Ventura/Phoenix	71-77
El Camino/ Monte Carlo	71-77
Electra	73-78
Grand National	84-87
Grand Sport	73-84
GTO/Firebird/Trans Am	70-81
Hurst Olds	85-88
Impala/Roadmaster	91-96
LeSabre	73-74
Olds F-85	70-76
Olds/Pontiac full size	71-89
Omega	73-75
Omega	77-79
Skylark/GS	71-75
Skylark/GS	77-79
Z-28	72-81
Blazer front/rear	77-91
Suburban	
C10/C15/G10/G15	78-present
G20/G25	79-present
K10/K15/K20/K26 front	77-87
K10/K15 rear	82-present

Applications: All GM products with 8.5" & 8.6" ring gear.

NOTE: 542097 can be substituted for 542022 with a bearing change. Use LM102949, LM102911. The reverse case will not fit. 542022 cannot be substituted for the 542097.

542018, High Performance Series

Model Years: 1971-1988

Ratios	Side Gear Spline	Bearing Cone	Bearing Cup
2.73:1 & Up	28 Teeth	LM501349	LM501314

542050, Pro Series—Large bearing hub—unit includes differential bearings

Model Years: 1971-1988

Ratios	Side Gear Spline	Bearing Cone	Bearing Cup
2.73:1 & Up	28 Teeth	LM102949	LM102911

Special Note: Bearings provided with 542050, Pro Series Unit.

542022, High Performance Series

Model Years: 1989-1998

Ratios	Side Gear Spline	Bearing Cone	Bearing Cup
2.73:1 & Up	30 Teeth	LM501349	LM501314

542052, Pro Series—Large bearing hub—unit includes differential bearings

Model Years: 1989-1998

Ratios	Side Gear Spline	Bearing Cone	Bearing Cup
2.73:1 & Up	30 Teeth	LM102949	LM102911

Special Note: Bearings provided with 542052, Pro Series Unit.

542097, High Performance Series

Model Years: 1999-Present

Ratios	Side Gear Spline	Bearing Cone	Bearing Cup
2.73:1 & Up	30 Teeth	LM603049	LM603012

542052, Pro Series

Model Years: 1999-Present

Ratios	Side Gear Spline	Bearing Cone	Bearing Cup
2.73:1 & Up	30 Teeth	LM603049	LM603012

Special Note: Bearings provided in 542052, however if vehicle is '99 model year or newer, bearings will not be used. Use bearings specified above.

GM 8.5" & 8.6" 10 Bolt . . . continued

NOTE: 541070 bearing kit contains: (2) LM102949 (2) LM102911.



545003
Model Years: 1971-1988

Ratios	Side Gear Spline	Bearing Cone	Bearing Cup
2.73:1 & Up	28 Teeth	LM102949	LM102911



545004
Model Years: 1989-1998

Ratios	Side Gear Spline	Bearing Cone	Bearing Cup
2.73:1 & Up	30 Teeth	LM102949	LM102911



Model Years: 1999-Present

Ratios	Side Gear Spline	Bearing Cone	Bearing Cup
2.73:1 & Up	30 Teeth	LM603049	LM603012

GM 8 7/8" 12 Bolt – Car



10 7/8" 12 Holes, Oval

Make	Year
Chevrolet	64-72
Chevy II	64-72
Chevalla	64-72
Camaro	67-72
El Camino	65-72
Firebird	67-72
Grand Prix	70-72
GTO/LeMans	65-72
Monte Carlo	70-72
Nova	70-72
Olds F85	68-70

Applications: Chevrolet passenger car with 8 7/8" ring gear.

* "C" axle-3 Series Case
** "C" axle-4 Series Case

****5420104, High Performance Series**
****542031, Pro Series**

Model Years: 1964-1972

Ratios	Side Gear Spline	Bearing Cone	Bearing Cup
4.10:1 & Up	30 Teeth	LM603049	LM603012

****5420117, Pro Series—9310 Gear Material**
Model Years: 1964-1972

Ratios	Side Gear Spline	Bearing Cone	Bearing Cup
4.10:1 & Up	33 Teeth	LM603049	LM603012

***5420106, High Performance Series**
***542033, Pro Series**

Model Years: 1964-1972

Ratios	Side Gear Spline	Bearing Cone	Bearing Cup
3.07:1 to 3.73:1	30 Teeth	LM603049	LM603012

***5420118, Pro Series—9310 Gear Material**
Model Years: 1964-1972

Ratios	Side Gear Spline	Bearing Cone	Bearing Cup
	33 Teeth	LM603049	LM603012

LD Differential

GM 8 7/8" 12 Bolt – Car ... continued



10 1/4" 12 Holes, Oval

Make	Year
Chevrolet	64-72
Chevy II	64-72
Chevelle	64-72
Camaro	67-72
El Camino	65-72
Firebird	67-72
Grand Prix	70-72
GTO/LeMans	65-72
Monte Carlo	70-72
Nova	70-72
Olds F85	68-70

Applications: Chevrolet passenger car with 8 7/8" ring gear.

* "C" axle-3 Series Case

** "C" axle-4 Series Case



*545008

Model Years: 1964-1972

Ratios	Side Gear Spline	Bearing Cone	Bearing Cup
3.07:1 to 3.73:1	30 Teeth	LM603049	LM603012



**545010

Model Years: 1964-1972

Ratios	Side Gear Spline	Bearing Cone	Bearing Cup
4.10:1 & Up	30 Teeth	LM603049	LM603012

GM 8 7/8" 12 Bolt – Truck



11 1/2" 12 Holes, Irregular

Make	Year
1/2 ton Truck	64-82
3/4 ton Truck	64-82
G20, G25	69-81
G10, G15	69-81
K10, K15	64-82
C10, C15	64-82

Applications: Chevrolet truck with 8 7/8" ring gear.

* 3 Series Case

** 4 Series Case



**5420105, High Performance Series

**542032, Pro Series

Model Years: 1964-1982 1/2

Ratios	Side Gear Spline	Bearing Cone	Bearing Cup
3.73:1 & Up	30 Teeth	LM603049	LM603012

*5420107, High Performance Series

*542034, Pro Series

Model Years: 1964-1982 1/2

Ratios	Side Gear Spline	Bearing Cone	Bearing Cup
2.76:1 to 3.42:1	30 Teeth	LM603049	LM603012

*545009

Model Years: 1964-1982 1/2

Ratios	Side Gear Spline	Bearing Cone	Bearing Cup
2.76:1 to 3.42:1	30 Teeth	LM603049	LM603012



**545011

Model Years: 1964-1982 1/2

Ratios	Side Gear Spline	Bearing Cone	Bearing Cup
3.73:1 & Up	30 Teeth	LM603049	LM603012

GM 9 1/2" 14 Bolt



12 1/8" x 13 5/16" 14 Holes, Irregular

Make	Year
C10, C15, C20	88-present
C30, C35	83-present
G20, G25	88-present
G10, G15	81-present
K10, K15	89-present
C10, C15	81-present

542087, High Performance Series

Model Years: 1981-Present

Applications: All GM products with 9 1/2" ring gear.

Ratios	Side Gear Spline	Bearing Cone	Bearing Cup
All ratios	33 Teeth	Set 42	Set 42

Autocross Road Race Units

Auburn Gear, Inc. has developed a performance limited-slip differential specifically for road racing—a differential case designed to allow the center pin to float along with the axle shafts. This design feature aids the driver when cornering, so that when the driver is turning, the outside wheel axle shaft will apply a force to the center pin, hence, the pinion gears will firmly seat the inside cone/side gear assembly giving the racer an extremely "tight" rear axle. The greater the G-force the more bite you get! If you are an avid road racer you'll want this unit. It'll allow you to pass your competition. **Hook Up** with an Auburn Road Race Performance Differential—you won't be disappointed.



10 9/16" x 10 3/16" 10 Holes, Oval

542039, Autocross Road Race Series

Model Years: 1979-Present

Applications: All Ford products with 8.8" ring gear. Accepts tone ring for ABS applications.

Ratios	Side Gear Spline	Bearing Cone	Bearing Cup
All ratios	28 Teeth	LM603049	LM603012

5420135, Autocross Road Race Series

Model Years: 1983-Present

Ratios	Side Gear Spline	Bearing Cone	Bearing Cup
All ratios	31 Teeth	LM603049	LM603012

542088, Autocross Road Race Series

Model Years: 1988-Present

Applications: All GM products with 7 1/2" & 7 5/8" ring gear. Accepts tone ring for ABS applications.

Ratios	Side Gear Spline	Bearing Cone	Bearing Cup
3.23:1 & Up	28 Teeth	LM501349	LM501314

Every effort has been made to ensure accuracy of the contents of this catalog. However, we assume no responsibility for errors or omissions.

LD Differential

TIRE CHART

LISTED ARE THE MAXIMUM TIRE SIZES FOR THE AUBURN GEAR TRACTION DIFFERENTIAL APPLICATIONS											
TIRE SIZE CHART	MAXIMUM TIRE SIZE										
Application	30"	31"	32"	33"	34"	35"	36"	37"	38"	39"	40"
AMC 20 12 bolt											
Chrysler 8 ¹ / ₄ " & 8 ³ / ₈ " 10 bolt											
Chrysler 8 ³ / ₄ " 10 bolt											
Chrysler 9 ¹ / ₄ " 12 bolt											
Dana 30											
Dana 35											
Dana 44											
Dana 50 front axle											
Dana 60											
Ford 7 ¹ / ₂ " 10 bolt											
Ford 8" 10 bolt											
Ford 8.8" 10 bolt											
Ford 9" 10 bolt											
Ford 9 ³ / ₄ " 12 bolt											
Ford 10 ¹ / ₄ " & 10 ¹ / ₂ " 12 bolt											
GM 7 ¹ / ₂ " & 7 ⁵ / ₈ " 10 bolt											
Chevy 8.2" 10 bolt											
B.O.P. 8.2" 10 bolt											
GM 8.2" / 8.4" 1955-64 10 bolt											
Corvette 1963-79 10 bolt											
GM 8.5" & 8.6" 10 bolt											
GM 8 ⁷ / ₈ " 12 bolt Car											
GM 8 ⁷ / ₈ " 12 bolt Truck											
GM 9 ¹ / ₂ " 14 bolt											
Toyota 8 ⁷ / ₈ " 12 bolt											
Toyota 8.0" 10 bolt											
Toyota 8.4" 10 bolt											
Toyota 9.5" 12 bolt											
Toyota 10.5" 12 bolt											

LD Differential

DIFFERENTIAL SERVICE KITS

APPLICATION	AG DIFF. PART NUMBER	SPRING RETAINER SERVICE KIT	PINION GEAR SERVICE KIT	PINION SHAFT SERVICE KIT
GM 7.5" & 7 1/8"	542040, 41, 57, 58 542044, 45, 46, 47	541016 541017	541011 541011	541005 541005
GM 8.5" & 8.6"	542018, 22, 29, 97 542050, 52	541018 541019	541012 541012	541007 541007
GM 8.2"	542061, 108	541035	541036	541037
1963 -79 Corvette	542062, 63	541035	541036	541037
GM 8 7/8" 12 Bolt, Car & Truck	542031, 32, 33, 34 5420104, 105, 106, 107	541022	541014	541009
GM 9.5"	542087	541043	541044	541042
Ford 7.5"	542023 542048	541016 541017	541011 541011	541006 541006
Ford 8.8", 28 Tooth	542024, 79 542053, 80	541018 541019	541012 541012	541007 541007
Ford 8.8", 31 Tooth	542025 542054	541020 541021	541013 541013	541008 541008
Ford 8" & 9"	542036, 43, 59	541023	541015	541010
Ford 9.75"	542090	541043	541044	541042
Ford 10 1/4"	542089	541045	541046	541047
Chrysler 9 1/4"	542070, 71	541038	541039	541040
Chrysler 8 1/4"	542072, 74	541041	541012	541007
Chrysler 8 3/4"	542051	541022	541014	541024
AMC Model 20	542081	541019	541012	541007
Toyota Landcruiser	542030	541022	541014	541009
Toyota 8.0" & 8.4"	5420131, 32	541079	541080	541081
Toyota 9.5"	5420133	541038	541039	541082
Toyota 10.5"	5420134	541045	541046	541083
Dana Model 44	542082, 83, 84, 85 109,110,111,112	541019	541012	541007
Buick/Olds/Pontiac 8.2"	542060, 542099, 113, 114	541035	541036	541048
Chevy 8.4"	5420100	541041	541012	541049



NOTE: Also Available
Additive 504102
Single = (1) 6 oz. Bottle
Case = (25) 6 oz. Bottles

ECTED MAX SERVICE KITS

ECTED MAX APPLICATION	ECTED MAX PART NUMBER	WIRE HARNESS & SWITCH KIT	(8) COIL ASSEMBLY	(9) COIL BEARING	(7) CLUTCH KIT	(5) PINION SHAFT KIT	(1 THRU 7) MASTER KIT	AXLE SHAFT SPACER	DIFFERENTIAL BEARING KIT
Ford 8.8" with 28 Spline Axles	545001	541051	541052	541053	541054	541055	541057	N/A	N/A
Ford 8.8" with 31 Spline Axles (C-clip only)	545002	541051	541052	541053	541054	541056	541059	N/A	N/A
GM 8.5" with 28 Spline Axles	545003	541051	541052	541053	541054	541055	541057	N/A	541070
GM 8.5" with 30 Spline Axles	545004	541051	541052	541053	541054	541055	541058	N/A	(thru 1998) 541070
Ford 8.8" with 31 Spline Axles (IRS only)	545005	541051	541052	541053	541054	541056	541060	N/A	N/A
AMC 20	545006 & 07	541051	541052	541053	541054	541055	541061	541050	N/A
Chevrolet 12 Bolt, Car & Truck, 30 Spline Axles	545008, 09, 10, 11	541051	541052	541053	541054	541055	541062	N/A	N/A
Dana 35, 27 Spline Axles	545012 & 13	541051	541063	541053	541064	541065	541066	N/A	541070
Dana 35, 30 Spline Axles	545014 & 15	541051	541063	541053	541064	541065	541067	N/A	541070
Dana 30, 27 Spline Axles	545016 & 17	541051	541063	541053	541069	541065	541068	N/A	N/A
Dana 44, 30 Spline Axles	545018 & 19	541051	541063	541053	541072	541071	541073	N/A	N/A
Dana 50, 30 Spline Axles	545020	541051	541063	541053	541072	541071	541077	N/A	N/A

Note: 541070 Contains: (2)LM102949, (2)LM102911. See Page for Part Number Kit Illustration.

Light Duty Transmission Applications

Speed	Model #	Year	Fwd/Rwd	Engine	Notes	Kit	w/Synchro Rings
AMC/Eagle							
All Car Models (82 & Earlier)							
5	T5	85-82	4x4			TRK-5	TRK-5WS
4	T4	84-82	4x4			TRK-4J	TRK-4JWS
4	SR4	82-78	4x4			TRK-BWSR4J	TRK-BWSR4JWS
4	SR4	81-76	RWD			TRK-BWSR4	TRK-BWSR4WS
3	T150	79-74	RWD		9 Bolt Top Cover	TRK-150A	TRK-150AWS
3	T86	78-67	RWD		9 Bolt Top Cover	TRK-BW86JA	TRK-BW86JAWS
3 w/ O/D	T86	78-67	RWD		9 Bolt Top Cover	TRK-BW86JB	TRK-BW86JBWS
3	T14	76-68	RWD		6 Bolt Top Cover, AMC Only Not Jeep	TRK-BW14	TRK-BW14WS
3 w/ O/D	T14	76-68	RWD		6 Bolt Top Cover, AMC Only Not Jeep	TRK-BW14A	TRK-BW14AWS
4	T10	74-65	RWD			TRK-10W	TRK-10WWS
3	T15	72-68	RWD		8 Bolt Top Cover	TRK-BW15	TRK-BW15WS
3 w/ O/D	T15	72-68	RWD		8 Bolt Top Cover	TRK-BW15A	TRK-BW15AWS
3	T96	72-67	RWD	199		TRK-BW96A	TRK-BW96AWS
3 w/ O/D	T96	72-67	RWD	199		TRK-BW96B	TRK-BW96BWS
3	T96	72-67	RWD	232		TRK-BW96C	TRK-BW96CWS
3 w/ O/D	T96	72-67	RWD	232		TRK-BW96D	TRK-BW96DWS
Summit							
5	F5M22/KM206	96-95	FWD	1.8L	Taper Diff Brgs. (Synchro Rev.)	TRK-FM150	TRK-FM150WS1
5	F5M31	96-94	FWD	2.4L	Taper Diff Brgs.	TRK-FM360	TRK-FM360WS
5	W5M33/KM201	96-94	4x4	2.4L	Ball Diff Brgs. (Synchro Rev.)	TRK-FM160	TRK-FM160WS1
5	F5M21/KM201	96-93	FWD	1.5L	Ball Diff Brgs. (3-4 Synchro Rings 36 Teeth)	TRK-FM100	TRK-FM100WS2
5	F5M22/KM206	94-89	FWD	1.8L	Taper Diff Brgs.	TRK-FM150	TRK-FM150WS
5	W5M33/KM201	93-92	4x4	2.4L	Ball Diff Brgs. (Synchro Rev.)	TRK-FM160	TRK-FM160WS
5	F5M21/KM201	92-89	FWD	1.5L	Ball Diff Brgs. (3-4 Synchro Rings 30 Teeth)	TRK-FM100	TRK-FM100WS
5	F5M22/KM206	90-89	FWD	1.6L	Taper Diff Brgs.	TRK-FM150	TRK-FM150WS
5	F5M31	1993	FWD	2.4L	Taper Diff Brgs.	TRK-FM360	TRK-FM360WS1
4	F4M21/KM200	1992	FWD	1.5L	Ball Diff Brgs.	TRK-FM100	TRK-FM100WS1
Talon							
5	F5MC1/NVT350/ A578	98-95	FWD	2.0L	Taper Diff Brgs. (3 Pc.1-2 Synchro Rings.)	TRK-350	TRK-350WS
5	F5M33	98-94	FWD	2.0L Turbo	Brass 1-2 Rings, Synchro Rev.	TRK-FM180	TRK-FM180WS4
5	W5M33	98-93	4x4	2.0L Turbo	Ball Diff Brgs. (3 Pc. 2nd Synchro Ring, 39 Teeth 3-4 Rings, Synchro Rev.)	TRK-FM160	TRK-FM160WS3
	KM272	98-90			Transfer Case Section Only	TRK-FM350	
5	F5M22	94-93	FWD	1.8L, 2.0L	3-4 Synchro Rings 36 Teeth, Synchro Rev.	TRK-FM150	TRK-FM150WS2
5	W5M33	5/93-6/93	4x4	2.0L Turbo	Ball Diff Brgs. (3 Pc. 2nd Synchro Ring, 24 Teeth 3-4 Rings, Synchro Rev.)	TRK-FM160	TRK-FM160WS2
5	F5M33	93-90	FWD	2.0L Turbo	Fiber Lined 1-2 Rings, Synchro Rev.	TRK-FM180	TRK-FM180WS

Light Duty Transmission Applications

Speed	Model #	Year	Fwd/Rwd	Engine	Notes	Kit	w/Synchro Rings
AMC/Eagle (cont.)							
Talon (cont.)							
5	F5M22	92-90	FWD	1.8L	3-4 Synchro Rings 30 Teeth	TRK-FM150	TRK-FM150WS
5	F5M22	92-90	FWD	2.0L	3-4 Synchro Rings 30 Teeth, Synchro Rev.	TRK-FM150	TRK-FM150WS1
5	W5M33	4/91-5/91	4x4	2.0L Turbo	Ball Diff Brgs. (Fiber Lined 1-2 Rings, Synchro Rev.)	TRK-FM160	TRK-FM160WS
Acura							
2.2CL							
5	S2A4	1997	FWD			TRK-FH180	TRK-FH180WS
2.3CL							
5	S2A8	99-98	FWD			TRK-FH180	TRK-FH180WS1
3.2CL							
6	YZC6	2003	FWD			TRK-FH410	
Integra							
5	Y80, S80	01-98	FWD	1.8L V-Tech	Ball Diff Brg.	TRK-FH400	TRK-FH400WS
5	Y80, S80	01-94	FWD	1.8L	Ball Diff Brg.	TRK-FH260	TRK-FH260WS
5	Y80, S80	98-94	FWD	1.8L V-Tech	Taper Diff Brg.	TRK-FH220	TRK-FH220WS
5	YS1	93-92	FWD	1.7L V-Tech	3pc. 2nd Gear Synchro	TRK-FH260	TRK-FH260WS1
5	SSO	93-92	FWD	1.8L	4 Door	TRK-FH260	TRK-FH260WS
5	YS1	93-92	FWD	1.8L		TRK-FH260	TRK-FH260WS
5	CG	89-86	FWD		Black Tin Cover Over 5th Gears	TRK-FH120	TRK-FH120WS
5	A1	1991	FWD			TRK-FH280	TRK-FH280WS1
5	S1	1990	FWD			TRK-FH280	TRK-FH280WS
Legend							
6	K4F6	95-93	FWD			TRK-FH230	TRK-FH230WS
5	K4A6	95-91	FWD			TRK-FH230	TRK-FH230WS
5	G3T4	90-89	FWD			TRK-FH190	TRK-FH190WS
5	C3P4	88-86	FWD			TRK-FH190	TRK-FH190WS
RSX							
5	W2M5	05-02	FWD			TRK-FH420	
6	X2M5	05-02	FWD	Type S		TRK-FH420	
TL							
6		06-04	FWD			TRK-FH430	
TSX							
6	ASU5	08-04	FWD			TRK-FH440	
Vigor							
5	L3A3	94-92	FWD			TRK-FH330	
Buick							
All Car Models (82 & Earlier)							
3	Saginaw	85-66	RWD		7 Bolt Side Cover	TRK-301	TRK-301WS1
5	T5	82-81	RWD		Cylindrical Countershaft Brgs.	TRK-5	TRK-5WS
4	MR2	82-80	FWD		2 Piece Case	TRK-FG110	Obsolete
4	T10W	82-74	RWD		9 Bolt Side Cover (6307 I/S Brg., 1" C/S)	TRK-10WA	TRK-10WAWS
4	T10W	82-74	RWD		9 Bolt Side Cover (6307 I/S Brg., 1" C/S, Max-Type Ball Brgs.)	TRK-10WAHD	TRK-10WAHDWS
4	Saginaw	82-66	RWD		7 Bolt Side Cover	TRK-301	TRK-301WS
3	Tremec	74-68	RWD		9 Bolt Top Cover	TRK-150F	TRK-150FWS
4	M21	74-66	RWD		7 Bolt Side Cover (1" Countershaft)	TRK-297A	TRK-297AWS
4	M21	74-66	RWD		7 Bolt Side Cover (1" Countershaft and Max-Type Brgs.)	TRK-297AHD	TRK-297AHDWS

LD Transmission

Light Duty Transmission Applications

Speed	Model #	Year	Fwd/Rwd	Engine	Notes	Kit	w/Synchro Rings
Buick (cont.)							
All Car Models (82 & Earlier) (cont.)							
4	T10W	73-66	RWD		9 Bolt Side Cover (6307 I/S Brg., 7/8" C/S, No Thrust Brg. Between 2nd & 3rd Gears)	TRK-10W	TRK-10WWS
3 w/ O/D	Saginaw	72-66	RWD		with R10 Overdrive Unit	TRK-301A	TRK-301AWS
4	M22	71-67	RWD		7 Bolt Side Cover (1" Countershaft)	TRK-297A	TRK-297AWS
4	M22	71-67	RWD		7 Bolt Side Cover (1" Countershaft and Max-Type Brgs.)	TRK-297AHD	TRK-297AHDWS
3 w/ O/D	Muncie 319	68-55	RWD		4 Bolt Side Cover	TRK-G110	
4	T10	66-62	RWD		9 Bolt Side Cover (6307 I/S Brg., 7/8" C/S, Thrust Brg. Between 2nd & 3rd Gears)	TRK-10E	TRK-10EWS
4	T10	66-57	RWD		9 Bolt Side Cover (6207 I/S Brg.)	TRK-10A	TRK-10AWS
4	M20	65-63	RWD		7 Bolt Side Cover (7/8" Countershaft)	TRK-297	TRK-297WS
4	M20	65-63	RWD		7 Bolt Side Cover (7/8" Countershaft and Max-Type Brgs.)	TRK-297HD	TRK-297HDWS
4	M20	63-62	RWD		7 Bolt Side Cover (6207 I/S Brg.)	TRK-297B	TRK-297BWS
3	Muncie 318	54-40	RWD		4 Bolt Side Cover	TRK-G100	
4	T4	1982	RWD			TRK-5	TRK-5WS1
Skyhawk							
5	76mm Isuzu	89-88	FWD		7 Bolt Cover (3 Pc. 1-2 Synchro Rings)	TRK-FI120	TRK-FI120WS1
4	MR2	87-83	FWD		2 Piece Case	TRK-FG110	Obsolete
5	76mm Isuzu	87-83	FWD		7 Bolt Cover	TRK-FI120	TRK-FI120WS
Skylark							
5	76mm Isuzu	87-86	FWD		7 Bolt Cover	TRK-FI120	TRK-FI120WS
4	MR2	85-83	FWD		2 Piece Case	TRK-FG110	Obsolete
Somerset							
5	76mm Isuzu	87-86	FWD		7 Bolt Cover	TRK-FI120	TRK-FI120WS
Cadillac							
All Car Models (82 & Earlier)							
3	Saginaw	85-66	RWD		7 Bolt Side Cover	TRK-301	TRK-301WS1
5	T5	82-81	RWD		Cylindrical Countershaft Brgs.	TRK-5	TRK-5WS
4	MR2	82-80	FWD		2 Piece Case	TRK-FG110	Obsolete
4	T10W	82-74	RWD		9 Bolt Side Cover (6307 I/S Brg., 1" C/S)	TRK-10WA	TRK-10WAWS
4	T10W	82-74	RWD		9 Bolt Side Cover (6307 I/S Brg., 1" C/S, Max-Type Ball Brgs.)	TRK-10WAHD	TRK-10WAHDWS
4	Saginaw	82-66	RWD		7 Bolt Side Cover	TRK-301	TRK-301WS
3	Tremec	74-68	RWD		9 Bolt Top Cover	TRK-150F	TRK-150FWS
4	M21	74-66	RWD		7 Bolt Side Cover (1" Countershaft)	TRK-297A	TRK-297AWS
4	M21	74-66	RWD		7 Bolt Side Cover (1" Countershaft and Max-Type Brgs.)	TRK-297AHD	TRK-297AHDWS

Light Duty Transmission Applications

Speed	Model #	Year	Fwd/Rwd	Engine	Notes	Kit	w/Synchro Rings
Cadillac (cont.)							
All Car Models (82 & Earlier) (cont.)							
4	T10W	73-66	RWD		9 Bolt Side Cover (6307 I/S Brg., 7/8" C/S, No Thrust Brg. Between 2nd & 3rd Gears)	TRK-10W	TRK-10WWS
3 w/ O/D	Saginaw	72-66	RWD		with R10 Overdrive Unit	TRK-301A	TRK-301AWS
4	M22	71-67	RWD		7 Bolt Side Cover (1" Countershaft)	TRK-297A	TRK-297AWS
4	M22	71-67	RWD		7 Bolt Side Cover (1" Countershaft and Max-Type Brgs.)	TRK-297AHD	TRK-297AHDWS
3 w/ O/D	Muncie 319	68-55	RWD		4 Bolt Side Cover	TRK-G110	
4	T10	66-62	RWD		9 Bolt Side Cover (6307 I/S Brg., 7/8" C/S, Thrust Brg. Between 2nd & 3rd Gears)	TRK-10E	TRK-10EWS
4	T10	66-57	RWD		9 Bolt Side Cover (6207 I/S Brg.)	TRK-10A	TRK-10AWS
4	M20	65-63	RWD		7 Bolt Side Cover (7/8" Countershaft)	TRK-297	TRK-297WS
4	M20	65-63	RWD		7 Bolt Side Cover (7/8" Countershaft and Max-Type Brgs.)	TRK-297HD	TRK-297HDWS
4	M20	63-62	RWD		7 Bolt Side Cover (6207 I/S Brg.)	TRK-297B	TRK-297BWS
3	Muncie 318	54-40	RWD		4 Bolt Side Cover	TRK-G100	
4	T4	1982	RWD			TRK-5	TRK-5WS1
Cimarron							
5	NVT550/HM282	88-87	FWD		9 Bolt Cover	TRK-550	TRK-550WS
4	MR2	86-85	FWD		2 Piece Case	TRK-FG110	Obsolete
5	76mm Isuzu	86-83	FWD		7 Bolt Cover	TRK-FI120	TRK-FI120WS
Chevrolet							
All Car Models (82 & Earlier)							
3	Saginaw	85-66	RWD		7 Bolt Side Cover	TRK-301	TRK-301WS1
5	T5	82-81	RWD		Cylindrical Countershaft Brgs.	TRK-5	TRK-5WS
4	MR2	82-80	FWD		2 Piece Case	TRK-FG110	Obsolete
4	T10W	82-74	RWD		9 Bolt Side Cover (6307 I/S Brg., 1" C/S)	TRK-10WA	TRK-10WAWS
4	T10W	82-74	RWD		9 Bolt Side Cover (6307 I/S Brg., 1" C/S, Max-Type Ball Brgs.)	TRK-10WAHD	TRK-10WAHDWS
4	Saginaw	82-66	RWD		7 Bolt Side Cover	TRK-301	TRK-301WS
3	Tremec	74-68	RWD		9 Bolt Top Cover	TRK-150F	TRK-150FWS
4	M21	74-66	RWD		7 Bolt Side Cover (1" Countershaft)	TRK-297A	TRK-297AWS
4	M21	74-66	RWD		7 Bolt Side Cover (1" Countershaft and Max-Type Brgs.)	TRK-297AHD	TRK-297AHDWS
4	T10W	73-66	RWD		9 Bolt Side Cover (6307 I/S Brg., 7/8" C/S, No Thrust Brg. Between 2nd & 3rd Gears)	TRK-10W	TRK-10WWS
3 w/ O/D	Saginaw	72-66	RWD		with R10 Overdrive Unit	TRK-301A	TRK-301AWS
4	M22	71-67	RWD		7 Bolt Side Cover (1" Countershaft)	TRK-297A	TRK-297AWS

Light Duty Transmission Applications

Speed	Model #	Year	Fwd/Rwd	Engine	Notes	Kit	w/Synchro Rings
Chevrolet (cont.)							
All Car Models (82 & Earlier) (cont.)							
4	M22	71-67	RWD		7 Bolt Side Cover (1" Countershaft and Max-Type Brgs.)	TRK-297AHD	TRK-297AHDWS
3 w/ O/D	Muncie 319	68-55	RWD		4 Bolt Side Cover	TRK-G110	
4	T10	66-62	RWD		9 Bolt Side Cover (6307 I/S Brg., 7/8" C/S, Thrust Brg. Between 2nd & 3rd Gears)	TRK-10E	TRK-10EWS
4	T10	66-57	RWD		9 Bolt Side Cover (6207 I/S Brg.)	TRK-10A	TRK-10AWS
4	M20	65-63	RWD		7 Bolt Side Cover (7/8" Countershaft)	TRK-297	TRK-297WS
4	M20	65-63	RWD		7 Bolt Side Cover (7/8" Countershaft and Max-Type Brgs.)	TRK-297HD	TRK-297HDWS
4	M20	63-62	RWD		7 Bolt Side Cover (6207 I/S Brg.)	TRK-297B	TRK-297BWS
3	Muncie 318	54-40	RWD		4 Bolt Side Cover	TRK-G100	
4	T4	1982	RWD			TRK-5	TRK-5WS1
Astro							
5	T5 World Class	89-85			Taper Countershaft Brgs.	TRK-5W	TRK-5WWS
Beretta							
5	76mm Isuzu	96-88	FWD	4 Cyl.	7 Bolt Cover (3 Pc. 1-2 Synchro Rings)	TRK-FI120	TRK-FI120WS1
5	NVT550/HM282	93-87	FWD	6 Cyl.	9 Bolt Cover	TRK-550	TRK-550WS
5	76mm Isuzu	1987	FWD	4 Cyl.	7 Bolt Cover	TRK-FI120	TRK-FI120WS
Blazer (Full Size)							
5	HM290, MG5, NV3500	1994	2WD & 4x4		Getrag 3rd Design (Standard Ball I/S & O/S Brgs.) Includes M/S Needle Brgs.	TRK-235BN1	TRK-235BN1WS
5	HM290, MG5, NV3500	94-92	2WD & 4x4		Getrag 3rd Design (Standard Ball I/S & O/S Brgs.)	TRK-235B	TRK-235BWS
5	HM290, MG5, NV3500	93-92	2WD & 4x4		Getrag 3rd Design (Standard Ball I/S & O/S Brgs.) Includes M/S Needle Brgs.	TRK-235BN	TRK-235BNWS
4	SM465	91-90	2WD & 4x4		211FFLE I/S Brg.	TRK-157B	TRK-157BWS
4	SM465	90-79	2WD & 4x4		Contains R1563TAV Front C/S Brg.	TRK-157L	TRK-157LWS
4	SM465	90-68	2WD & 4x4		Contains M1305GGTV & R1563TAV Front C/S Brg.	TRK-157A	TRK-157AWS
4	SM465	90-68	2WD & 4x4		Master Kit w/ Small Parts Kit, Keys, & Springs	TRK-157ASPK	TRK-157ASPKWS
4 w/ O/D	NP833	87-81	2WD & 4x4		10 Bolt Side Cover, Case 10-5/8" Long Overall	TRK-833	TRK-833WS
3	Saginaw	81-77	2WD & 4x4		7 Bolt Side Cover, Case 9-5/8" Long Overall	TRK-301	TRK-301WS1
Blazer (S10 Size)							
5	HM290, MG5, NV3500	05-96	2WD & 4x4		Getrag 3rd Design (Standard Ball I/S & O/S Brgs. And 3 Pc. 1-2 Synchro Rings) & 1.180 ID C/S Brgs.	TRK-235B	TRK-235BWS1

Light Duty Transmission Applications

Speed	Model #	Year	Fwd/Rwd	Engine	Notes	Kit	w/Synchro Rings
Chevrolet (cont.)							
Blazer (S10 Size) (cont.)							
5	M50,NV3500	05-96	2WD & 4x4		Getrag 3rd Design (Standard Ball I/S & O/S Brgs. And 3 Pc. 1-2 Synchro Rings) & 1.300 ID C/S Brgs.	TRK-235E	TRK-235EWS
5	NV1500	03-96	2WD & 4x4	2.2L	6306 I/S Brg.	TRK-1500GM	TRK-1500GMWS
5	HM290, MG5, NV3500	96-95	2WD & 4x4		Getrag 3rd Design (Standard Ball I/S & O/S Brgs.) Includes M/S Needle Brgs.	TRK-235BN2	TRK-235BN2WS
5	HM290, MG5, NV3500	1995	2WD & 4x4		Getrag 3rd Design (Standard Ball I/S & O/S Brgs. And 3 Pc. 1-2 Synchro Rings)	TRK-235B	TRK-235BWS1
5	HM290, MG5, NV3500	1994	2WD & 4x4		Getrag 3rd Design (Standard Ball I/S & O/S Brgs.) Includes M/S Needle Brgs.	TRK-235BN1	TRK-235BN1WS
5	HM290, MG5, NV3500	94-91	2WD & 4x4		Getrag 3rd Design (Standard Ball I/S & O/S Brgs.)	TRK-235B	TRK-235BWS
5	HM290, MG5, NV3500	93-91	2WD & 4x4		Getrag 3rd Design (Standard Ball I/S & O/S Brgs.) Includes M/S Needle Brgs.	TRK-235BN	TRK-235BNWS
5	HM290, MG5	91-90	2WD & 4x4		Getrag 2nd Design (3 Pc. I/S & Standard Ball O/S Brgs.)	TRK-235A	TRK-235AWS
5	HM290, MG5	91-90	2WD & 4x4		Getrag 2nd Design (3 Pc. I/S & Standard Ball O/S Brgs.) Includes M/S Needle Brgs.	TRK-235AN	TRK-235ANWS
5	T5 World Class	90-88	2WD & 4x4		Taper Countershaft Brgs.	TRK-5W	TRK-5WWS
4	T4	87-85	2WD & 4x4		Taper I/S & O/S Brgs.	TRK-5	TRK-5WS1
5	T5	87-83	2WD & 4x4		Cylindrical Countershaft Brgs.	TRK-5	TRK-5WS
4	S101	85-83	2WD & 4x4		Isuzu Design 6208 I/S Brg.	TRK-FI240	TRK-FI240WS
4	T4C	84-83	2WD & 4x4		Ball I/S & O/S Brgs.	TRK-4C	TRK-4CWS
Camaro							
5	T5 World Class	02-93	RWD	V6	Taper Countershaft Brgs.	TRK-5W	TRK-5WWS
6	T56	02-93	RWD	V8		TRK-56	TRK-56WS
5	T5 World Class	92-88	RWD		Taper Countershaft Brgs.	TRK-5W	TRK-5WWS
5	T5	87-83	RWD		Cylindrical Countershaft Brgs.	TRK-5	TRK-5WS
4	Saginaw	84-83	RWD		7 Bolt Side Cover	TRK-301	TRK-301WS
Cavalier							
5	Getrag / Opel	04-00	FWD			TRK-FG140	TRK-FG140WS
5	76mm Isuzu	99-95	FWD		7 Bolt Cover (Hydraulic Clutch Release Brg.)	TRK-FI210	TRK-FI210WS2
5	76mm Isuzu	94-88	FWD	4 Cyl.	7 Bolt Cover (3 Pc. 1-2 Synchro Rings)	TRK-FI120	TRK-FI120WS1
5	NVT550/HM282	94-84	FWD	6 Cyl.	9 Bolt Cover	TRK-550	TRK-550WS
4	MR2	87-83	FWD		2 Piece Case	TRK-FG110	Obsolete
5	76mm Isuzu	87-83	FWD	4 Cyl.	7 Bolt Cover	TRK-FI120	TRK-FI120WS

Light Duty Transmission Applications

Speed	Model #	Year	Fwd/Rwd	Engine	Notes	Kit	w/Synchro Rings
Chevrolet (cont.)							
Celebrity							
5	NVT550/HM282	88-87	FWD	6 Cyl.	9 Bolt Cover	TRK-550	TRK-550WS
Chevette							
5	T5	87-83	RWD		With DC51932 Front C/S Brg.	TRK-5A	TRK-5AWS
4	70mm	87-76	RWD			TRK-G120	TRK-G120WS
5	MSG-5K	86-83	RWD	Diesel		TRK-FI110	TRK-FI110WS
Citation							
4	MR2	85-83	FWD		2 Piece Case	TRK-FG110	Obsolete
Colorado							
5	AR5	12-04	2WD&4x4			TRK-FG150	
Corsica							
5	76mm Isuzu	93-88	FWD	4 Cyl.	7 Bolt Cover (3 Pc. 1-2 Synchro Rings)	TRK-FI120	TRK-FI120WS1
5	NVT550/HM282	92-87	FWD	6 Cyl.	9 Bolt Cover	TRK-550	TRK-550WS
5	76mm Isuzu	1987	FWD	4 Cyl.	7 Bolt Cover	TRK-FI120	TRK-FI120WS
Corvette							
6	T56	04-97	RWD		3 Pc. 1-6 Gear Synchro Rings	TRK-56A	TRK-56AWS
6	S6-40	96-89	RWD		ZF	TRK-S6-40	TRK-S6-40WS
4	T10	87-84	RWD		9 Bolt Side Cover	TRK-10WB	TRK-10WBWS
4	Saginaw	84-83	RWD		7 Bolt Side Cover	TRK-301	TRK-301WS
LUV							
5	MSG-5ET	1982	4X4		Kit Includes Transfer Case Parts	TRK-FI100	TRK-FI100WS
4	MSG-4ET	82-81	4X4		Helical Cut Reverse Gear (Kit Includes Transfer Case Parts)	TRK-FI180	TRK-FI180WS
5	MSG-5K	82-81	2WD			TRK-FI110	TRK-FI110WS
4	MSG-4K	82-76	2WD		Rear Load	TRK-FI140	TRK-FI140WS
4	MSG-4ET	80-76	4X4		Straight Cut Reverse Gear (Kit Includes Transfer Case Parts)	TRK-FI150	TRK-FI150WS
4	MSG-4E	75-71	2WD		Alum. Top Cover	TRK-FI230	TRK-FI230WS
Metro							
5	MV3	01-89	FWD		8 Bolt Cover	TRK-FS110	TRK-FS110WS
Nova							
5	C51	88-85	FWD		Toyota Transaxle	TRK-FT270	TRK-FT270WS
Prizm							
5	C51	02-88	FWD	Twin Cam	9 Bolt Cover	TRK-FT320	TRK-FT320WS3
5	C51	87-85	FWD		9 Bolt Cover	TRK-FT320	TRK-FT320WS
S10 Pickup							
5	HM290, MG5, NV3500	03-96	2WD & 4x4	4.3L	Getrag 3rd Design (Standard Ball IS & O/S Brgs. And 3 Pc. 1-2 Synchro Rings) & 1.180 ID C/S Brgs.	TRK-235B	TRK-235BWS1
5	M50, NV3500	03-96	2WD & 4x4	4.3L	Getrag 3rd Design (Standard Ball IS & O/SBrgs. And 3 Pc. 1-2 Synchro Rings) & 1.300 ID C/S Brgs.	TRK-235E	TRK-235EWS
5	NV1500	03-96	2WD & 4x4	2.2L	6306 I/S Brg.	TRK-1500GM	TRK-1500GMWS
5	HM290, MG5, NV3500	96-95	2WD & 4x4		Getrag 3rd Design (Standard Ball I/S& O/S Brgs.) Includes M/S Needle Brgs.	TRK-235BN2	TRK-235BN2WS

Light Duty Transmission Applications

Speed	Model #	Year	Fwd/Rwd	Engine	Notes	Kit	w/Synchro Rings
Chevrolet (cont.)							
S10 Pickup (cont.)							
5	HM290, MG5, NV3500	1995	2WD & 4x4		Getrag 3rd Design (Standard Ball I/S & O/S Brgs. And 3 Pc. 1-2 Synchro Rings)	TRK-235B	TRK-235BWS1
5	T5 World Class	95-88	2WD & 4x4		Taper Countershaft Brgs.	TRK-5W	TRK-5WWS
5	HM290, MG5, NV3500	1994	2WD & 4x4		Getrag 3rd Design (Standard Ball I/S & O/S Brgs.) Includes M/S Needle Brgs.	TRK-235BN1	TRK-235BN1WS
5	HM290, MG5, NV3500	94-91	2WD & 4x4		Getrag 3rd Design (Standard Ball I/S & O/S Brgs.)	TRK-235B	TRK-235BWS
5	HM290, MG5, NV3500	93-91	2WD & 4x4		Getrag 3rd Design (Standard Ball I/S & O/S Brgs.) Includes M/S Needle Brgs.	TRK-235BN	TRK-235BNWS
5	HM290, MG5	91-90	2WD & 4x4		Getrag 2nd Design (3 Pc. I/S & Standard Ball O/S Brgs.)	TRK-235A	TRK-235AWS
5	HM290, MG5	91-90	2WD & 4x4		Getrag 2nd Design (3 Pc. I/S & Standard Ball O/S Brgs.) Includes M/S Needle Brgs.	TRK-235AN	TRK-235ANWS
4	T4	87-85	2WD & 4x4		Taper I/S & O/S Brgs.	TRK-5	TRK-5WS1
5	T5	87-82	2WD & 4x4		Cylindrical Countershaft Brgs.	TRK-5	TRK-5WS
4	S101	85-82	2WD & 4x4		Isuzu Design 6208 I/S Brg.	TRK-FI240	TRK-FI240WS
4	T4C	84-82	2WD & 4x4		Ball I/S & O/S Brgs.	TRK-4C	TRK-4CWS
Spectrum							
5	76mm Isuzu	87-85	FWD	4 Cyl.	7 Bolt Cover	TRK-FI120	TRK-FI120WS
5	76mm Isuzu	1988	FWD	4 Cyl.	7 Bolt Cover (3 Pc. 1-2 Synchro Rings)	TRK-FI120	TRK-FI120WS1
Sprint							
5	MV2	88-85	FWD		7 Bolt Cover	TRK-FG100	
Tahoe							
5	HM290, MG5, NV3500	96-95	2WD & 4x4			TRK-235B	TRK-235BWS1
5	HM290, MG5, NV3500	96-95	2WD & 4x4		Includes M/S Needle Brgs.	TRK-235BN2	TRK-235BN2WS
Tracker							
5	TRACK	02-99	2WD & 4WD		8 Bolt Cover	TRK-FS150	TRK-FS150WS
5	TRACK	98-89	2WD & 4WD		8 Bolt Cover	TRK-FS130	TRK-FS130WS
Trucks, Vans & SUV's (82 & Earlier)							
4 w/ O/D	NP833	86-80	2WD & 4x4		10 Bolt Side Cover, Case 10-5/8" Long Overall	TRK-833	TRK-833WS
5	NP542	84-70	2WD & 4x4		6 Bolt Front C/S Retainer	TRK-29	
5	Clark 280HD	82-79	2WD & 4x4		Case 15-1/16" Long Overall (Taper I/S Brg.)	TRK-190	
5	Clark 390	82-76	2WD & 4x4		Case 15-1/4" Long Overall	TRK-390G	
5	Clark 280	82-68	2WD & 4x4		Case 15-1/16" Long Overall (Ball I/S Brg.)	TRK-148	
3	Saginaw	82-66	2WD & 4x4		7 Bolt Side Cover, Case 9-5/8" Long Overall	TRK-301	TRK-301WS1
3	Tremec	82-65	2WD & 4x4		9 Bolt Top Cover, Case 9-5/8" Long Overall	TRK-150F	TRK-150FWS1

Light Duty Transmission Applications

Speed	Model #	Year	Fwd/Rwd	Engine	Notes	Kit	w/Synchro Rings
Chevrolet (cont.)							
Trucks, Vans & SUV's (82 & Earlier) (cont.)							
5	NP540	78-60	2WD & 4x4		4 Bolt Front C/S Retainer	TRK-27	
5	Clark 320	75-68	2WD & 4x4		Case 17-1/32" Long Overall	TRK-132	
5	Clark 380	75-68	2WD & 4x4		Case 17-1/32" Long Overall	TRK-133	
3	SM330	74-68	2WD & 4x4		7 Bolt Side Cover, Case 11" Long Overall	TRK-G140	Obsolete
5	Clark 300	69-60	2WD & 4x4		Case 16-1/2" Long Overall	TRK-48	
5	NP541	69-60	2WD & 4x4		6 Bolt Front C/S Retainer	TRK-29	
3	318	68-55	2WD & 4x4		4 Bolt Side Cover	TRK-G110	
3 w/ O/D	319	68-55	2WD & 4x4		4 Bolt Side Cover (With R10 Overdrive Unit)	TRK-G110	
5	Clark 260	67-60	2WD & 4x4		Case 14-1/4" Long Overall	TRK-23	
4	SM420	67-48	2WD & 4x4		1 PTO Opening, Case 10-1/2" Long Overall	TRK-G160	
3	318	54-40	2WD & 4x4		4 Bolt Side Cover (Enclosed Driveline)	TRK-G100	
3 w/ O/D	319	54-40	2WD & 4x4		4 Bolt Side Cover (With R10 Overdrive Unit)	TRK-G100	
4	185	47-40	2WD & 4x4		6 Bolt Top Cover	TRK-G150	
Truck 1/2 Ton							
5	M50,NV3500	07-96	2WD & 4x4		Getrag 3rd Design (Standard Ball I/S & O/S Brgs. And 3 Pc. 1-2 Synchro Rings) & 1.300 ID C/S Brgs.	TRK-235E	TRK-235EWS
5	HM290, MG5, NV3500	07-96	2WD & 4x4		Getrag 3rd Design (Standard Ball I/S & O/S Brgs. And 3 Pc. 1-2 Synchro Rings) & 1.180 ID C/S Brgs.	TRK-235B	TRK-235BWS1
5	NV4500	98-97	2WD & 4x4		Flat Front Brg. Retainer (Kit Includes M/S Needles & Small Parts Kit)	TRK-4500GM1N1SPK	TRK-4500GM1N1SPKWS
5	NV4500	98-97	2WD & 4x4		Flat Front Brg. Retainer (Kit Includes M/S Needles)	TRK-4500GM1N1	TRK-4500GM1N1WS
5	NV4500	98-96	2WD & 4x4		Flat Front Brg. Retainer (Kit Includes Small Parts Kit)	TRK-4500GM1SPK	TRK-4500GM1SPKWS
5	NV4500	98-96	2WD & 4x4		Flat Front Brg. Retainer	TRK-4500GM1	TRK-4500GM1WS
5	NV4500	1996	2WD & 4x4		Kit Includes M/S Needles & Small Parts Kit	TRK-4500GM1NSPK	TRK-4500GM1NSPKWS
5	NV4500	1996	2WD & 4x4		Flat Front Brg. Retainer (Kit Includes M/S Needles)	TRK-4500GM1N	TRK-4500GM1NWS
5	HM290, MG5, NV3500	96-95	2WD & 4x4		Getrag 3rd Design (Standard Ball I/S & O/S Brgs.) Includes M/S Needle Brgs.	TRK-235BN2	TRK-235BN2WS
5	HM290, MG5, NV3500	1995	2WD & 4x4		Getrag 3rd Design (Standard Ball I/S & O/S Brgs.)	TRK-235B	TRK-235BWS1
5	NV4500	95-92	2WD & 4x4		Kit Includes Small Parts Kit	TRK-4500GMSPK	TRK-4500GMSPKWS

Light Duty Transmission Applications

Speed	Model #	Year	Fwd/Rwd	Engine	Notes	Kit	w/Synchro Rings
Chevrolet (cont.)							
Truck 1/2 Ton (cont.)							
5	NV4500	95-92	2WD & 4x4		Flat Front Brg. Retainer (Kit Includes M/S Needles)	TRK-4500GMNSPK	TRK-4500GMNSPKWS
5	NV4500	95-92	2WD & 4x4		Kit Includes M/S Needles	TRK-4500GMN	TRK-4500GMNWS
5	NV4500	95-92	2WD & 4x4			TRK-4500GM	TRK-4500GMWS
5	HM290, MG5, NV3500	1994	2WD & 4x4		Getrag 3rd Design (Standard Ball I/S & O/S Brgs.) Includes M/S Needle Brgs.	TRK-235BN1	TRK-235BN1WS
5	HM290, MG5, NV3500	94-91	2WD & 4x4		Getrag 2nd Design (3 Pc. I/S & Standard Ball O/S Brgs.)	TRK-235B	TRK-235BWS
5	HM290, MG5, NV3500	93-91	2WD & 4x4		Standard Ball O/S Brgs.) Includes M/S Needle Brgs.	TRK-235BN	TRK-235BNWS
4	SM465	91-90	2WD & 4x4		211FFLE I/S Brg.	TRK-157B	TRK-157BWS
5	HM290, MG5	91-90	2WD & 4x4		Getrag 2nd Design (3 Pc. I/S & Standard Ball O/S Brgs.) Includes M/S Needle Brgs.	TRK-235AN	TRK-235ANWS
5	HM290, MG5	91-90	2WD & 4x4		Getrag 1st Design (3 Pc. I/S & O/S Brgs.) Includes M/S Needle Brgs.	TRK-235A	TRK-235AWS
4	SM465	90-79	2WD & 4x4		Contains R1563TAV Front C/S Brg.	TRK-157L	TRK-157LWS
4	SM465	90-68	2WD & 4x4		10 Bolt Side Cover, Case 10-5/8" Long Overall	TRK-157A	TRK-157AWS
4	SM465	90-68	2WD & 4x4		Contains M1305GGTV & R1563TAV Front C/S Brg.	TRK-157ASPK	TRK-157ASPKWS
5	HM290, MG5	89-88	2WD & 4x4		Getrag 1st Design (3 Pc. I/S & O/S Brgs.)	TRK-235N	TRK-235NWS
5	HM290, MG5	89-88	2WD & 4x4		Contains R1563TAV Front C/S Brg. 211FFLE I/S Brg.	TRK-235	TRK-235WS
4 w/ O/D	NP833	87-82	2WD & 4x4		7 Bolt Side Cover, Case 9-5/8" Long Overall	TRK-833	TRK-833WS
3	Saginaw	87-77	2WD & 4x4		6 Bolt Front C/S Retainer	TRK-301	TRK-301WS1
4	NP435	72-67	2WD & 4x4		Kit Includes Small Parts Kit	TRK-127SPK	TRK-127WS
4	NP435				With Taper I/S Brg.	TRK-127	
4	NP435	72-67	2WD & 4x4		With Ball I/S Brg.	TRK-127G	TRK-127GWS
Truck 3/4 Ton							
6	S6-650ZF	06-01	4x4			TRK-S6-650ZFC	TRK-S6-650ZFCWS
5	NV4500	07-97	2WD & 4x4		Flat Front Brg. Retainer (Kit Includes M/S Needles)	TRK-4500GM1N1	TRK-4500GM1N1WS
5	NV4500	07-97	2WD & 4x4		Flat Front Brg. Retainer (Kit Includes M/S Needles & Small Parts Kit)	TRK-4500GM1N1SPK	TRK-4500GM1N1SPKWS
5	NV4500	07-96	2WD & 4x4		Flat Front Brg. Retainer	TRK-4500GM1	TRK-4500GM1WS
5	NV4500	07-96	2WD & 4x4		Flat Front Brg. Retainer (Kit Includes Small Parts Kit)	TRK-4500GM1SPK	TRK-4500GM1SPKWS
6	S6-650ZF	06-01	2WD			TRK-S6-650ZFA	TRK-S6-650ZFAWS

LD Transmission

Light Duty Transmission Applications

Speed	Model #	Year	Fwd/Rwd	Engine	Notes	Kit	w/Synchro Rings
Chevrolet (cont.)							
Truck 3/4 Ton (cont.)							
5	M50,NV3500	98-96	2WD & 4x4		Getrag 3rd Design (Standard Ball I/S & O/S Brgs. And 3 Pc. 1-2 Synchro Rings) & 1.300 ID C/S Brgs.	TRK-235E	TRK-235EWS
5	HM290, MG5, NV3500	98-96	2WD & 4x4		Getrag 3rd Design (Standard Ball I/S & O/S Brgs. And 3 Pc. 1-2 Synchro Rings) & 1.180 ID C/S Brgs.	TRK-235B	TRK-235BWS1
5	NV4500	1996	2WD & 4x4		Flat Front Brg. Retainer (Kit Includes M/S Needles)	TRK-4500GM1N	TRK-4500GM1NWS
5	NV4500	1996	2WD & 4x4		Kit Includes M/S Needles & Small Parts Kit	TRK-4500GM1NSPK	TRK-4500GM1NSPKWS
5	HM290, MG5, NV3500	96-95	2WD & 4x4		Getrag 3rd Design (Standard Ball I/S & O/S Brgs.) Includes M/S Needle Brgs.	TRK-235BN2	TRK-235BN2WS
5	HM290, MG5, NV3500	1995	2WD & 4x4		Getrag 3rd Design (Standard Ball I/S & O/S Brgs.)	TRK-235B	TRK-235BWS1
5	NV4500	95-91	2WD & 4x4			TRK-4500GM	TRK-4500GMWS
5	NV4500	95-91	2WD & 4x4		Kit Includes M/S Needles	TRK-4500GMN	TRK-4500GMNWS
5	NV4500	95-91	2WD & 4x4		Flat Front Brg. Retainer (Kit Includes M/S Needles)	TRK-4500GMNSPK	TRK-4500GMNSPKWS
5	NV4500	95-91	2WD & 4x4		Kit Includes Small Parts Kit	TRK-4500GMSPK	TRK-4500GMSPKWS
5	HM290, MG5, NV3500	1994	2WD & 4x4		Getrag 3rd Design (Standard Ball I/S & O/S Brgs.) Includes M/S Needle Brgs.	TRK-235BN1	TRK-235BN1WS
5	HM290, MG5, NV3500	94-91	2WD & 4x4		Getrag 2nd Design (3 Pc. I/S & Standard Ball O/S Brgs.)	TRK-235B	TRK-235BWS
5	HM290, MG5, NV3500	93-91	2WD & 4x4		Standard Ball O/S Brgs.) Includes M/S Needle Brgs.	TRK-235BN	TRK-235BNWS
4	SM465	91-90	2WD & 4x4		211FFLE I/S Brg.	TRK-157B	TRK-157BWS
5	HM290, MG5	91-90	2WD & 4x4		Getrag 2nd Design (3 Pc. I/S & Standard Ball O/S Brgs.) Includes M/S Needle Brgs.	TRK-235AN	TRK-235ANWS
5	HM290, MG5	91-90	2WD & 4x4		Getrag 1st Design (3 Pc. I/S & O/S Brgs.) Includes M/S Needle Brgs.	TRK-235A	TRK-235AWS
4	SM465	90-79	2WD & 4x4		Contains R1563TAV Front C/S Brg.	TRK-157L	TRK-157LWS
4	SM465	90-68	2WD & 4x4		10 Bolt Side Cover, Case 10-5/8" Long Overall	TRK-157A	TRK-157AWS
4	SM465	90-68	2WD & 4x4		Contains M1305GGTV & R1563TAV Front C/S Brg.	TRK-157ASPK	TRK-157ASPKWS
5	HM290, MG5	89-88	2WD & 4x4		Getrag 1st Design (3 Pc. I/S & O/S Brgs.)	TRK-235N	TRK-235NWS

Light Duty Transmission Applications

Speed	Model #	Year	Fwd/Rwd	Engine	Notes	Kit	w/Synchro Rings
Chevrolet (cont.)							
Truck 3/4 Ton (cont.)							
5	HM290, MG5	89-88	2WD & 4x4		Contains R1563TAV Front C/S Brg. 211FFLE I/S Brg.	TRK-235	TRK-235WS
4 w/ O/D	NP833	87-82	2WD & 4x4		7 Bolt Side Cover, Case 9-5/8" Long Overall	TRK-833	TRK-833WS
3	Saginaw	87-77	2WD & 4x4		6 Bolt Front C/S Retainer	TRK-301	TRK-301WS1
4	NP435	72-67	2WD & 4x4		With Taper I/S Brg.	TRK-127SPK	TRK-127WS
4	NP435	72-67	2WD & 4x4		With Taper I/S Brg.	TRK-127	
4	NP435	72-67	2WD & 4x4		With Ball I/S Brg.	TRK-127G	TRK-127GWS
Truck 1 Ton							
6	S6-650ZF	06-01	4x4			TRK-S6-650ZFC	TRK-S6-650ZFCWS
5	NV4500	07-97	2WD & 4x4		Flat Front Brg. Retainer (Kit Includes M/S Needles)	TRK-4500GM1N1	TRK-4500GM1N1WS
5	NV4500	07-97	2WD & 4x4		Flat Front Brg. Retainer (Kit Includes M/S Needles & Small Parts Kit)	TRK-4500GM1N1SPK	TRK-4500GM1N1SPKWS
5	NV4500	07-96	2WD & 4x4		Flat Front Brg. Retainer	TRK-4500GM1	TRK-4500GM1WS
5	NV4500	07-96	2WD & 4x4		Flat Front Brg. Retainer (Kit Includes Small Parts Kit)	TRK-4500GM1SPK	TRK-4500GM1SPKWS
6	S6-650ZF	06-01	2WD			TRK-S6-650ZFA	TRK-S6-650ZFAWS
5	NV4500	1996	2WD & 4x4		Flat Front Brg. Retainer (Kit Includes M/S Needles)	TRK-4500GM1N	TRK-4500GM1NWS
5	NV4500	1996	2WD & 4x4		Kit Includes M/S Needles & Small Parts Kit	TRK-4500GM1NSPK	TRK-4500GM1NSPKWS
5	NV4500	95-91	2WD & 4x4			TRK-4500GM	TRK-4500GMWS
5	NV4500	95-91	2WD & 4x4		Kit Includes M/S Needles	TRK-4500GMN	TRK-4500GMNWS
5	NV4500	95-91	2WD & 4x4		Flat Front Brg. Retainer (Kit Includes M/S Needles)	TRK-4500GMNSPK	TRK-4500GMNSPKWS
5	NV4500	95-91	2WD & 4x4		Kit Includes Small Parts Kit	TRK-4500GMSPK	TRK-4500GMSPKWS
4	SM465	91-90	2WD & 4x4		211FFLE I/S Brg.	TRK-157B	TRK-157BWS
4	SM465	90-79	2WD & 4x4		Contains R1563TAV Front C/S Brg.	TRK-157L	TRK-157LWS
4	SM465	90-68	2WD & 4x4		10 Bolt Side Cover, Case 10-5/8" Long Overall	TRK-157A	TRK-157AWS
4	SM465	90-68	2WD & 4x4		Contains M1305GGTV & R1563TAV Front C/S Brg.	TRK-157ASPK	TRK-157ASPKWS
4	NP435	72-67	2WD & 4x4		With Taper I/S Brg.	TRK-127SPK	TRK-127WS
4	NP435	72-67	2WD & 4x4		With Taper I/S Brg.	TRK-127	
4	NP435	72-67	2WD & 4x4		With Ball I/S Brg.	TRK-127G	TRK-127GWS
Van 1/2 Ton							
4	SM465	87-79	2WD & 4x4		Contains R1563TAV Front C/S Brg.	TRK-157L	TRK-157LWS
4	SM465	87-71	2WD & 4x4		10 Bolt Side Cover, Case 10-5/8" Long Overall	TRK-157A	TRK-157AWS
4	SM465	87-71	2WD & 4x4		Contains M1305GGTV & R1563TAV Front C/S Brg.	TRK-157ASPK	TRK-157ASPKWS
4	NP435	72-67	2WD & 4x4		With Taper I/S Brg.	TRK-127SPK	TRK-127WS
4	NP435	72-67	2WD & 4x4		With Taper I/S Brg.	TRK-127	
4	NP435	72-67	2WD & 4x4		With Ball I/S Brg.	TRK-127G	TRK-127GWS

LD Transmission

Light Duty Transmission Applications

Speed	Model #	Year	Fwd/Rwd	Engine	Notes	Kit	w/Synchro Rings
Chevrolet (cont.)							
Van 3/4 Ton							
4	SM465	87-79	2WD & 4x4		Contains R1563TAV Front C/S Brg.	TRK-157L	TRK-157LWS
4	SM465	87-71	2WD & 4x4		10 Bolt Side Cover, Case 10-5/8" Long Overall	TRK-157A	TRK-157AWS
4	SM465	87-71	2WD & 4x4		Contains M1305GGTV & R1563TAV Front C/S Brg.	TRK-157ASPK	TRK-157ASPKWS
4	NP435	72-67	2WD & 4x4		With Taper I/S Brg.	TRK-127SPK	TRK-127WS
4	NP435				With Taper I/S Brg.	TRK-127	
4	NP435	72-67	2WD & 4x4		With Ball I/S Brg.	TRK-127G	TRK-127GWS
Van 1 Ton							
4	SM465	87-79	2WD & 4x4		Contains R1563TAV Front C/S Brg.	TRK-157L	TRK-157LWS
4	SM465	87-71	2WD & 4x4		10 Bolt Side Cover, Case 10-5/8" Long Overall	TRK-157A	TRK-157AWS
4	SM465	87-71	2WD & 4x4		Contains M1305GGTV & R1563TAV Front C/S Brg.	TRK-157ASPK	TRK-157ASPKWS
4	NP435	72-67	2WD & 4x4		With Taper I/S Brg.	TRK-127SPK	TRK-127WS
4	NP435				With Taper I/S Brg.	TRK-127	
4	NP435	72-67	2WD & 4x4		With Ball I/S Brg.	TRK-127G	TRK-127GWS
Chrysler							
All Car Models (82 & Earlier)							
4	NP460	82-81	FWD		1-4 Synchro Rings Same Size	TRK-465	TRK-465WS2
4 w/ O/D	NP833	80-75	RWD		10 Bolt Side Cover	TRK-833B	TRK-833BWS
3	NP230	80-70	RWD		9 Bolt Side Cover With 35 x 80 x21 I/S & O/S Brgs.	TRK-NP100	TRK-NP100WS
3	NP230	80-70	RWD		9 Bolt Side Cover With 35 x 90 x 21 I/S & O/S Brgs.	TRK-NP100A	TRK-NP100AWS
3	390	76-74	RWD		9 Bolt Top Cover	TRK-150A	TRK-150AWS
3	NP250	74-72	RWD		6 Bolt Side Cover & 4 Bolt Front Retainer (14mm Wide O/S Brg.)	TRK-NP110A	TRK-NP110AWS
3	NP250	74-72	RWD		6 Bolt Side Cover & 4 Bolt Front Retainer (17mm Wide O/S Brg.)	TRK-NP110	TRK-NP110WS
4	NP833	72-64	RWD		10 Bolt Side Cover	TRK-833A	TRK-833AWS
Cirrus							
5	F5MC1/NVT350/ A578	2000	FWD			TRK-350	TRK-350WS
Daytona							
5	NP523	93-90	FWD		07NU0720/23B Front O/S Brg.	TRK-568	TRK-568WS
5	NP543	93-90	FWD		07NU0720/23B Front O/S Brg.	TRK-568	TRK-568WS
5	NP568	93-90	FWD		07NU0720/23B Front O/S Brg.	TRK-568	TRK-568WS
5	NP520	89-87	FWD		RNU070618-6 Front O/S Brg.	TRK-520	TRK-520WS
5	NP520	89-87	FWD		RNU070618-6 Front O/S Brg. (3 Pc. 2nd Synchro Ring)	TRK-520	TRK-520WS1

Light Duty Transmission Applications

Speed	Model #	Year	Fwd/Rwd	Engine	Notes	Kit	w/Synchro Rings
Chrysler (cont.)							
Daytona (cont.)							
5	NP555	89-87	FWD		RNU070618-6 Front O/S Brg.	TRK-520	TRK-520WS
5	NP555	89-87	FWD		RNU070618-6 Front O/S Brg. (3 Pc. 2nd Synchro Ring)	TRK-520	TRK-520WS1
5	NP525	86-84	FWD		1-2 Synchro Rings Larger than 3-4 Synchro Rings	TRK-465	TRK-465WS
LeBaron							
5	NP543	93-90	FWD		07NU0720/23B Front O/S Brg.	TRK-568	TRK-568WS
5	NP568	93-90	FWD		07NU0720/23B Front O/S Brg.	TRK-568	TRK-568WS
5	NP520	89-87	FWD		RNU070618-6 Front O/S Brg.	TRK-520	TRK-520WS
5	NP520	89-87	FWD		RNU070618-6 Front O/S Brg. (3 Pc. 2nd Synchro Ring)	TRK-520	TRK-520WS1
5	NP525	86-84	FWD		1-2 Synchro Rings Larger than 3-4 Synchro Rings	TRK-465	TRK-465WS
4	NP460	83-82	FWD		1-4 Synchro Rings Same Size	TRK-465	TRK-465WS2
Neon							
5	T850	05-03	FWD		SRT-4	TRK-850	TRK-850WS
5	F5MC1/NVT350/ A578	04-01	FWD		Including Assy #4668604AD	TRK-350A	TRK-350AWS
5	F5MC1/NVT350/ A578	2000	FWD		Except Assy #4668604AD	TRK-350	TRK-350WS
5	F5MC1/NVT350/ A578	2000	FWD		Including Assy #4668604AD	TRK-350A	TRK-350AWS
5	F5MC1/NVT350/ A578	99-95	FWD		Except Assy #4668604AD	TRK-350	TRK-350WS
Sebring							
5	F5M42	04-03		In Line 4 Cyl.		TRK-FM450	TRK-FM450WS
5	F5M51	04-03		V-6		TRK-FM440	TRK-FM440WS
5	F5MC1/NVT350/ A578	00-95				TRK-350	TRK-350WS
Stratus							
5	T850	06-02	FWD	V-6		TRK-850	TRK-850WS
5	F5M42	04-01	FWD	In Line 4 Cyl.		TRK-FM450	TRK-FM450WS
5	F5M51	04-01	FWD	V-6		TRK-FM440	TRK-FM440WS
5	F5MC1/ NVT350/A578	00-95	FWD			TRK-350	TRK-350WS
Truck 1/2 Ton							
5	Getrag 238	08-05	2WD & 4x4			TRK-FC130	
5	NV3500	04-97	2WD & 4X4		1 pc. Case & Bellhousing (Synchronized Rev., 3 Piece 2nd Synchro)	TRK-235C	TRK-235CWS1
5	NV4500 / MT8	04-97	2WD & 4X4	Gas or Diesel	Kit Includes M/S Needles	TRK-4500DN1	TRK-4500DN1WS
5	NV4500 / MT8	04-97	2WD & 4X4	Gas or Diesel	Kit Includes M/S Needles & Small Parts Kit	TRK-4500DN1SPK	TRK-4500DN1SPKWS
5	NV4500 / MT8	04-92	2WD & 4X4	Gas or Diesel		TRK-4500D	TRK-4500DWS
5	NV4500 / MT8	04-92	2WD & 4X4	Gas or Diesel	Kit Includes Small Parts Kit	TRK-4500DSPK	TRK-4500DSPKWS
5	NV3500	96-94	2WD & 4X4		1 pc. Case & Bellhousing (Synchronized Rev.)	TRK-235C	TRK-235CWS

LD Transmission

Light Duty Transmission Applications

Speed	Model #	Year	Fwd/Rwd	Engine	Notes	Kit	w/Synchro Rings
Chrysler (cont.)							
Truck 1/2 Ton (cont.)							
5	NV4500 / MT8	96-92	2WD & 4X4	Gas or Diesel	Kit Includes M/S Needles	TRK-4500DN	TRK-4500DNWS
5	NV4500 / MT8	96-92	2WD & 4X4	Gas or Diesel	Kit Includes M/S Needles & Small Parts Kit	TRK-4500DNSPK	TRK-4500DNSPKWS
5	NV2500 / 535	91-88	2WD	V6	2 Pc. Case (35mm ID Input Shaft Brg.)	TRK-535	TRK-535WS
4	NP435	91-86	2WD & 4X4		Alum. Shift Cover (Ball I/S Brg.)	TRK-127G	TRK-127GWS
4	NP833	90-76	2WD & 4X4		10 Bolt Side Cover	TRK-833	TRK-833WS
4	NP435	86-65	2WD & 4X4		Alum. Shift Cover (Tapered I/S Brg.)	TRK-127B	TRK-127BWS
3	390	79-75	2WD & 4X4		Tremec	TRK-150A	TRK-150AWS
4	NP445	79-72	2WD & 4X4			TRK-NP140	
3	NP230	79-70	2WD & 4X4		9 Bolt Side Cover	TRK-NP100A	TRK-NP100AWS
4	NP435	1965	2WD & 4X4		Alum. Shift Cover (Ball I/S Brg.)	TRK-127G	TRK-127GWS
Truck 3/4 Ton							
6	G56	14-05	2WD & 4x4			TRK-FC200	
6	NV5600	05-01	2WD & 4X4	Diesel		TRK-5600	TRK-5600WS
5	NV4500 / MT8	05-97	2WD & 4X4	Gas or Diesel	Kit Includes M/S Needles & Small Parts Kit	TRK-4500DN1SPK	TRK-4500DN1SPKWS
5	NV4500 / MT8	05-97	2WD & 4X4	Gas or Diesel	Kit Includes M/S Needles	TRK-4500DN1	TRK-4500DN1WS
5	NV4500 / MT8	05-92	2WD & 4X4	Gas or Diesel	Kit Includes Small Parts	TRK-4500DSPK	TRK-4500DSPKWS
5	NV4500 / MT8	05-92	2WD & 4X4	Gas or Diesel		TRK-4500D	TRK-4500DWS
6	NV5600	00-98	2WD & 4X4	Diesel		TRK-5600	Obsolete
5	NV3500	96-94	2WD & 4X4		1 pc. Case & Bellhousing (Synchronized Rev.)	TRK-235C	TRK-235CWS
5	NV4500 / MT8	96-92	2WD & 4X4	Gas or Diesel	Kit Includes M/S Needles & Small Parts Kit	TRK-4500DNSPK	TRK-4500DNSPKWS
5	NV4500 / MT8	96-92	2WD & 4X4	Gas or Diesel	Kit Includes M/S Needles	TRK-4500DN	TRK-4500DNWS
5	G360	93-89	2WD & 4X4	Diesel	w/ Cummins Diesel, Kit Includes M/S Needles	TRK-261N	TRK-261NWS
5	G360	93-89	2WD & 4X4	Diesel	w/ Cummins Diesel	TRK-261	TRK-261WS
4	NP435	91-86	2WD & 4X4		Alum. Shift Cover (Ball I/S Brg.)	TRK-127G	TRK-127GWS
4	NP435	86-65	2WD & 4X4		Alum. Shift Cover (Tapered I/S Brg.)	TRK-127B	TRK-127BWS
3	NP230	79-75	2WD & 4X4		9 Bolt Side Cover	TRK-NP100A	TRK-NP100AWS
4	NP445	79-72	2WD & 4X4			TRK-NP140	
3	390	79-70	2WD & 4X4		Tremec	TRK-150A	TRK-150AWS
4	NP435	1965	2WD & 4X4		Alum. Shift Cover (Ball I/S Brg.)	TRK-127G	TRK-127GWS
Truck 1 Ton							
6	G56	14-05	2WD & 4x4			TRK-FC200	
6	NV5600	05-01	2WD & 4X4	Diesel		TRK-5600	TRK-5600WS
5	NV4500 / MT8	05-97	2WD & 4X4	Gas or Diesel	Kit Includes M/S Needles & Small Parts Kit	TRK-4500DN1SPK	TRK-4500DN1SPKWS
5	NV4500 / MT8	05-97	2WD & 4X4	Gas or Diesel	Kit Includes M/S Needles	TRK-4500DN1	TRK-4500DN1WS
5	NV4500 / MT8	05-92	2WD & 4X4	Gas or Diesel	Kit Includes Small Parts	TRK-4500DSPK	TRK-4500DSPKWS
5	NV4500 / MT8	05-92	2WD & 4X4	Gas or Diesel		TRK-4500D	TRK-4500DWS
6	NV5600	00-98	2WD & 4X4	Diesel		TRK-5600	Obsolete
5	NV4500 / MT8	96-92	2WD & 4X4	Gas or Diesel	Kit Includes M/S Needles & Small Parts Kit	TRK-4500DNSPK	TRK-4500DNSPKWS
5	NV4500 / MT8	96-92	2WD & 4X4	Gas or Diesel	Kit Includes M/S Needles	TRK-4500DN	TRK-4500DNWS
5	G360	93-89	2WD & 4X4	Diesel	w/ Cummins Diesel	TRK-261	TRK-261WS
5	G360	93-89	2WD & 4X4	Diesel	w/ Cummins Diesel, Kit Includes M/S Needles	TRK-261N	TRK-261NWS

Light Duty Transmission Applications

Speed	Model #	Year	Fwd/Rwd	Engine	Notes	Kit	w/Synchro Rings
Chrysler (cont.)							
Truck 1 Ton (cont.)							
4	NP435	91-86	2WD & 4X4		Alum. Shift Cover (Ball I/S Brg.)	TRK-127G	TRK-127GWS
4	NP435	86-65	2WD & 4X4		Alum. Shift Cover (Tapered I/S Brg.)	TRK-127B	TRK-127BWS
4	NP435	65-64	2WD & 4X4		Alum. Shift Cover (Ball I/S Brg.)	TRK-127G	TRK-127GWS
Truck 1-1/2 Ton							
4	NP435	81-78	2WD & 4X4		Alum. Shift Cover (Tapered I/S Brg.)	TRK-127B	TRK-127BWS
Van (1/2 & 3/4 Ton)							
5	AX15	93-92	2WD	V6	3 Pc. Case & 7 Bolt Front Retainer	TRK-FT420	TRK-FT420WS
5	NV2500 / 535	91-88	2WD	V6	2 Pc. Case (35mm ID Input Shaft Brg.)	TRK-535	TRK-535WS
4	NP833	89-88	2WD	V8		TRK-833	TRK-833WS
4	NP833	87-76	2WD			TRK-833	TRK-833WS
Dodge							
All Car Models (82 & Earlier)							
4	NP460	82-81	FWD		1-4 Synchro Rings Same Size	TRK-465	TRK-465WS2
4 w/ O/D	NP833	80-75	RWD		10 Bolt Side Cover	TRK-833B	TRK-833BWS
3	NP230	80-70	RWD		9 Bolt Side Cover With 35 x 80 x21 I/S & O/S Brgs.	TRK-NP100	TRK-NP100WS
3	NP230	80-70	RWD		9 Bolt Side Cover With 35 x 90 x 21 I/S & O/S Brgs.	TRK-NP100A	TRK-NP100AWS
3	390	76-74	RWD		9 Bolt Top Cover	TRK-150A	TRK-150AWS
3	NP250	74-72	RWD		6 Bolt Side Cover & 4 Bolt Front Retainer (14mm Wide O/S Brg.)	TRK-NP110A	TRK-NP110AWS
3	NP250	74-72	RWD		6 Bolt Side Cover & 4 Bolt Front Retainer (17mm Wide O/S Brg.)	TRK-NP110	TRK-NP110WS
4	NP833	72-64	RWD		10 Bolt Side Cover	TRK-833A	TRK-833AWS
400							
5	NP465	1983	FWD			TRK-465	TRK-465WS1
4	NP460	1982	FWD		1-4 Synchro Rings Same Size	TRK-465	TRK-465WS2
600							
5	NP525	1984	FWD		1-2 Synchro Rings Larger than 3-4 Synchro Rings	TRK-465	TRK-465WS
5	NP465	1983	FWD			TRK-465	TRK-465WS1
Aries							
5	NP520	89-87	FWD		RNU070618-6 Front O/S Brg.	TRK-520	TRK-520WS
5	NP520	89-87	FWD		RNU070618-6 Front O/S Brg. (3 Pc. 2nd Synchro Ring)	TRK-520	TRK-520WS1
5	NP525	86-84	FWD		1-2 Synchro Rings Larger than 3-4 Synchro Rings	TRK-465	TRK-465WS
4	NP460	85-84	FWD		1-2 Synchro Rings Larger than 3-4 Synchro Rings	TRK-465	TRK-465WS3

LD Transmission

Light Duty Transmission Applications

Speed	Model #	Year	Fwd/Rwd	Engine	Notes	Kit	w/Synchro Rings
Dodge (cont.)							
Aries (cont.)							
4	NP460	83-81	FWD		1-4 Synchro Rings Same Size	TRK-465	TRK-465WS2
5	NP465	1983	FWD			TRK-465	TRK-465WS1
Avenger							
5	F5MC1/NVT350/A578	00-95	FWD			TRK-350	TRK-350WS
Challenger							
5	KM131	83-79	RWD	2.0L	Stamped Steel Bottom Pan(6207-N M/S Front Brg.)	TRK-FM140	TRK-FM140WS
5	KM131	83-79	RWD	2.6L	Stamped Steel Bottom Pan (35BVV072 M/S Front Brg.)	TRK-FM110	TRK-FM110WS
Charger							
5	NP525	87-84	FWD		1-2 Synchro Rings Larger than 3-4 Synchro Rings	TRK-465	TRK-465WS
4	NP460	86-84	FWD		1-2 Synchro Rings Larger than 3-4 Synchro Rings	TRK-465	TRK-465WS3
3	NP903	72-70	RWD		6 Bolt Side Cover & 3 Bolt Front Retainer	TRK-NP150	TRK-NP150WS
4	NP460	1983	FWD		1-4 Synchro Rings Same Size	TRK-465	TRK-465WS2
5	NP465	1983	FWD		1-5 Synchro Rings Same Size	TRK-465	TRK-465WS1
Colt							
5	F5M22	94-93	FWD	1.8L	Taper Diff Brgs.	TRK-FM150	TRK-FM150WS
5	F5M21	94-92	FWD	1.5L	Ball Diff Brgs. (3-4 Synchro Rings 36 Teeth)	TRK-FM100	TRK-FM100WS2
4	F4M21	92-90	FWD	1.6L	Ball Diff Brgs.	TRK-FM100	TRK-FM100WS1
5	F5M21	91-90	FWD	1.5L	Ball Diff Brgs. (3-4 Synchro Rings 30 Teeth)	TRK-FM100	TRK-FM100WS
4	KM200	89-87	FWD	1.5L	Ball Diff Brgs. & Ball Int. Shaft Brgs.	TRK-FM340	TRK-FM340WS
5	KM201	89-87	FWD	1.5L	Taper Diff Brgs. (Small 30T 3-4 Synchro Rings)	TRK-FM100	TRK-FM100WS
5	KM206	89-87	FWD	1.6L	Taper Diff Brgs. & Taper Int. Shaft Brgs.	TRK-FM150	TRK-FM150WS
4	KM161	86-85	FWD	1.5L	Ball Diff Brgs. & Taper Int. Shaft Brgs.	TRK-FM390	TRK-FM390WS
5	KM162	86-85	FWD	1.5L	Ball Diff Brgs.	TRK-FC110	TRK-FC110WS
5	KM163	86-85	FWD	1.6L	Taper Diff Brgs.	TRK-FM170	TRK-FM170WS
8	KM166	84-83	FWD	1.6L	Taper Diff Brgs.	TRK-FM170	TRK-FM170WS
4	KM160	84-82	FWD	1.4L	Ball Diff Brgs. & Taper Int. Shaft Brgs.	TRK-FC110	TRK-FC110WS1
8	KM165	84-82	FWD	1.4L	Ball Diff Brgs.	TRK-FC110	TRK-FC110WS
5	F5M22	1990	FWD	1.6L	Taper Diff Brgs.	TRK-FM150	TRK-FM150WS
5	KM210	1989	FWD	1.6L Turbo	Taper Diff Brgs. (7 Bolt Back Cover)	TRK-FM210	TRK-FM210WS
Colt Vista							
5	F5M31	94-92	FWD	2.4L		TRK-FM210	TRK-FM210WS
5	W5M33	94-92	4x4	2.4L	Transfer Case Components Not Included	TRK-FM290	TRK-FM290WS
5	F5M22	94-90	FWD	1.8L, 2.0L	Taper Diff Brgs.	TRK-FM150	TRK-FM150WS
	KM272	94-89			Transfer Case Section Only	TRK-FM350	

Light Duty Transmission Applications

Speed	Model #	Year	Fwd/Rwd	Engine	Notes	Kit	w/Synchro Rings
Dodge (cont.)							
Colt Vista (cont.)							
5	W5M31	93-90	4x4	1.8L	Transfer Case Components Not Included	TRK-FM240	TRK-FM240WS
5	KM182	91-87	4x4	2.0L	Transfer Case Components Not Included	TRK-FC100	TRK-FC100WS1
5	KM201	89-11/86	FWD	1.5L	Taper Diff Brgs. (Small 30T 3-4 Synchro Rings)	TRK-FM100	TRK-FM100WS
5	KM206	89-86	FWD	2.0L	Taper Diff Brgs. & Taper Int. Shaft Brgs.	TRK-FM150	TRK-FM150WS
	KM271	89-85			Transfer Case Section Only	TRK-FM330	
5	KM182	10/87	4x4	2.0L	Transfer Case Components Not Included	TRK-FC100	TRK-FC100WS
5	KM163	11/86-84	FWD	2.0L		TRK-FM170	TRK-FM170WS
5	F5M21	1990	FWD	1.5L	Ball Diff Brgs. (3-4 Synchro Rings 30 Teeth)	TRK-FM100	TRK-FM100WS
5	KM221	1989	4x4	1.8L	7 Bolt Back Cover, Transfer Case Components Not Included	TRK-FM240	TRK-FM240WS
8	KM166	1984	FWD	2.0L	Taper Diff Brgs.	TRK-FM170	TRK-FM170WS
Conquest							
5	KM132-N	86-85	RWD		With Intercooler, Steel Bottom Pan(TMSC07887 I/S Brg.)	TRK-FM310	TRK-FM310WS
5	KM132-M	86-84	RWD	2.6L Turbo	Without Intercooler	TRK-FM300	TRK-FM300WS
Dakota							
5	Getrag 238	09-05	2WD & 4x4			TRK-FC130	
5	NV3500	04-00	2WD & 4x4	V6	2 Pc. Case & 6 Bolt Front Retainer	TRK-235C	TRK-235CWS1
5	NV3500	04-97	2WD & 4x4	V8	2 Pc. Case & 6 Bolt Front Retainer	TRK-235C	TRK-235CWS1
5	NV1500	02-99	2WD	2.5L	2 Pc. Case (30mm ID Input Shaft Brg.)	TRK-1500D	TRK-1500DWS
5	AX15	99-92	2WD & 4x4	4 Cyl. & V6	3 Pc. Case & 7 Bolt Front Retainer	TRK-FT420	TRK-FT420WS
5	NV3500	96-94	2WD & 4x4	V8	2 Pc. Case & 6 Bolt Front Retainer	TRK-235C	TRK-235CWS
5	NV2500/535	93-92	2WD & 4x4	4 Cyl.	2 Pc. Case (35mm ID Input Shaft Brg.)	TRK-535	TRK-535WS
5	NV2500/535	91-87	2WD & 4x4		2 Pc. Case (35mm ID Input Shaft Brg.)	TRK-535	TRK-535WS
Dart							
3	NP903	72-66	RWD		6 Bolt Side Cover & 3 Bolt Front Retainer	TRK-NP150	TRK-NP150WS
Daytona							
5	NP523	93-90	FWD		07NU0720/23B Front O/S Brg.	TRK-568	TRK-568WS
5	NP543	93-90	FWD		07NU0720/23B Front O/S Brg.	TRK-568	TRK-568WS
5	NP568	93-90	FWD		07NU0720/23B Front O/S Brg.	TRK-568	TRK-568WS
5	NP520	89-87	FWD		RNU070618-6 Front O/S Brg.	TRK-520	TRK-520WS
5	NP520	89-87	FWD		RNU070618-6 Front O/S	TRK-520	TRK-520WS1

Light Duty Transmission Applications

Speed	Model #	Year	Fwd/Rwd	Engine	Notes	Kit	w/Synchro Rings
Dodge (cont.)							
Daytona (cont.)							
5	NP555	89-87	FWD		RNU070618-6 Front O/S Brg.	TRK-520	TRK-520WS
5	NP555	89-87	FWD		RNU070618-6 Front O/S Brg. (3 Pc. 2nd Synchro Ring)	TRK-520	TRK-520WS1
5	NP525	86-84	FWD		1-2 Synchro Rings Larger than 3-4 Synchro Rings	TRK-465	TRK-465WS
Lancer							
5	NP520	89-87	FWD		RNU070618-6 Front O/S Brg.	TRK-520	TRK-520WS
5	NP525	86-85	FWD		1-2 Synchro Rings Larger than 3-4 Synchro Rings	TRK-465	TRK-465WS
Neon							
5	T850	05-03	FWD		SRT-4	TRK-850	TRK-850WS
5	F5MC1/NVT350/ A578	04-01	FWD		Including Assy #4668604AD	TRK-350A	TRK-350AWS
5	F5MC1/NVT350/ A578	2000	FWD		Except Assy #4668604AD	TRK-350	TRK-350WS
5	F5MC1/NVT350/ A578	2000	FWD		Including Assy #4668604AD	TRK-350A	TRK-350AWS
5	F5MC1/NVT350/ A578	99-95	FWD		Except Assy #4668604AD	TRK-350	TRK-350WS
Nitro							
6	NSG370	08-07				TRK-FC120	TRK-FC120WS
Omni							
5	NP525	90-84	FWD		1-2 Synchro Rings Larger than 3-4 Synchro Rings	TRK-465	TRK-465WS
4	NP460	86-84	FWD		1-2 Synchro Rings Larger than 3-4 Synchro Rings	TRK-465	TRK-465WS3
4	NP460	83-81	FWD		1-4 Synchro Rings Same Size	TRK-465	TRK-465WS2
5	NP465	1983	FWD		1-5 Synchro Rings Same Size	TRK-465	TRK-465WS1
Ramcharger							
5	NV4500	1992	2WD & 4X4		Alum. Shift Cover (Tapered I/S Brg.)	TRK-4500D	TRK-4500DWS
4	435	91-86	2WD & 4X4		Alum. Shift Cover (Ball I/S Brg.)	TRK-127G	TRK-127GWS
4	435	86-74	2WD & 4X4		Alum. Shift Cover (Tapered I/S Brg.)	TRK-127B	TRK-127BWS
4	NP445	79-74	2WD & 4X4			TRK-NP140	
3	NP230	79-74	2WD & 4X4		9 Bolt Side Cover	TRK-NP100A	TRK-NP100AWS
Rampage							
4	NP460	84-82	FWD			TRK-465	TRK-465WS2
Shadow							
5	NP543	94-92	FWD		07NU0720/23B Front O/S Brg.	TRK-568	TRK-568WS
5	NP523	94-90	FWD		07NU0720/23B Front O/S Brg.	TRK-568	TRK-568WS
5	NP568	91-90	FWD		07NU0720/23B Front O/S Brg.	TRK-568	TRK-568WS
5	NP520	89-87	FWD		RNU070618-6 Front O/S Brg.	TRK-520	TRK-520WS

Light Duty Transmission Applications

Speed	Model #	Year	Fwd/Rwd	Engine	Notes	Kit	w/Synchro Rings
Dodge (cont.)							
Shadow (cont.)							
5	NP520	89-87	FWD		RNU070618-6 Front O/S Brg. (3 Pc. 2nd Synchro Ring)	TRK-520	TRK-520WS1
5	NP525	1987	FWD		1-2 Synchro Rings Larger than 3-4 Synchro Rings	TRK-465	TRK-465WS
Spirit							
5	NP523	94-90	FWD		07NU0720/23B Front O/S Brg.	TRK-568	TRK-568WS
5	NP568	93-91	FWD		07NU0720/23B Front O/S Brg.	TRK-568	TRK-568WS
5	NP520	1989	FWD		RNU070618-6 Front O/S Brg.	TRK-520	TRK-520WS
5	NP520	1989	FWD		RNU070618-6 Front O/S Brg. (3 Pc. 2nd Synchro Ring)	TRK-520	TRK-520WS1
Stealth							
6	W6MG1	96-94	4x4	3.0L Turbo		TRK-FM530	TRK-FM530WS
5	F5M33	96-93	FWD	3.0L	3 Piece 2nd Ring	TRK-FM180	TRK-FM180WS4
	W5MG1	93-92			Transfer Case Section Only Late 18 Spline & All 25 Spline O/S	TRK-FM270	
5	F5M33	4/93-5/93	FWD	3.0L	3 Piece 2nd Ring	TRK-FM180	TRK-FM180WS3
5	W5MG1	93-91	4x4	3.0L Turbo		TRK-FM250	TRK-FM250WS
	W5MG1	92-91			Transfer Case Section Only Early 18 Spline O/S	TRK-FM280	
5	F5M33	5/92-6/92	FWD	3.0L	3 Piece 2nd Ring	TRK-FM180	TRK-FM180WS2
5	F5M33	4/91-5/91	FWD	3.0L	Brass 1-2 Rings	TRK-FM180	TRK-FM180WS1
5	F5M33	11/90-12/90	FWD	3.0L	Fiber Lined 1-2 Rings	TRK-FM180	TRK-FM180WS
Stratus							
5	T850	06-02	FWD	V-6		TRK-850	TRK-850WS
5	F5M42	04-01	FWD	In Line 4 Cyl.		TRK-FM450	TRK-FM450WS
5	F5M51	04-01	FWD	V-6		TRK-FM440	TRK-FM440WS
5	F5MC1/ NVT350/A578	00-95	FWD			TRK-350	TRK-350WS
Truck 1/2 Ton							
5	Getrag 238	08-05	2WD & 4x4			TRK-FC130	
5	NV3500	04-97	2WD & 4X4		1 pc. Case & Bellhousing (Synchronized Rev., 3 Piece 2nd Synchro)	TRK-235C	TRK-235CWS1
5	NV4500 / MT8	04-97	2WD & 4X4	Gas or Diesel	Kit Includes M/S Needles	TRK-4500DN1	TRK-4500DN1WS
5	NV4500 / MT8	04-97	2WD & 4X4	Gas or Diesel	Kit Includes M/S Needles & Small Parts Kit	TRK-4500DN1SPK	TRK-4500DN1SPKWS
5	NV4500 / MT8	04-92	2WD & 4X4	Gas or Diesel		TRK-4500D	TRK-4500DWS
5	NV4500 / MT8	04-92	2WD & 4X4	Gas or Diesel	Kit Includes Small Parts	TRK-4500DSPK	TRK-4500DSPKWS
5	NV3500	96-94	2WD & 4X4		1 pc. Case & Bellhousing (Synchronized Rev.)	TRK-235C	TRK-235CWS
5	NV4500 / MT8	96-92	2WD & 4X4	Gas or Diesel	Kit Includes M/S Needles	TRK-4500DN	TRK-4500DNWS
5	NV4500 / MT8	96-92	2WD & 4X4	Gas or Diesel	Kit Includes M/S Needles & Small Parts Kit	TRK-4500DNSPK	TRK-4500DNSPKWS
5	NV2500 / 535	91-88	2WD	V6	2 Pc. Case (35mm ID Input Shaft Brg.)	TRK-535	TRK-535WS
4	NP435	91-86	2WD & 4X4		Alum. Shift Cover (Ball I/S Brg.)	TRK-127G	TRK-127GWS
4	NP833	90-76	2WD & 4X4		10 Bolt Side Cover	TRK-833	TRK-833WS
4	NP435	86-65	2WD & 4X4		Alum. Shift Cover (Tapered I/S Brg.)	TRK-127B	TRK-127BWS

Light Duty Transmission Applications

Speed	Model #	Year	Fwd/Rwd	Engine	Notes	Kit	w/Synchro Rings
Dodge (cont.)							
Truck 1/2 Ton (cont.)							
3	390	79-75	2WD & 4X4		Tremec	TRK-150A	TRK-150AWS
4	NP445	79-72	2WD & 4X4			TRK-NP140	
3	NP230	79-70	2WD & 4X4		9 Bolt Side Cover	TRK-NP100A	TRK-NP100AWS
4	NP435	1965	2WD & 4X4		Alum. Shift Cover (Ball I/S Brg.)	TRK-127G	TRK-127GWS
Truck 3/4 Ton							
6	G56	14-05	2WD & 4x4			TRK-FC200	
6	NV5600	05-01	2WD & 4X4	Diesel		TRK-5600	TRK-5600WS
5	NV4500 / MT8	05-97	2WD & 4X4	Gas or Diesel	Kit Includes M/S Needles & Small Parts Kit	TRK-4500DN1SPK	TRK-4500DN1SPKWS
5	NV4500 / MT8	05-97	2WD & 4X4	Gas or Diesel	Kit Includes M/S Needles	TRK-4500DN1	TRK-4500DN1WS
5	NV4500 / MT8	05-92	2WD & 4X4	Gas or Diesel	Kit Includes Small Parts	TRK-4500DSPK	TRK-4500DSPKWS
5	NV4500 / MT8	05-92	2WD & 4X4	Gas or Diesel		TRK-4500D	TRK-4500DWS
6	NV5600	00-98	2WD & 4X4	Diesel		TRK-5600	Obsolete
5	NV3500	96-94	2WD & 4X4		1 pc. Case & Bellhousing (Synchronized Rev.)	TRK-235C	TRK-235CWS
5	NV4500 / MT8	96-92	2WD & 4X4	Gas or Diesel	Kit Includes M/S Needles & Small Parts Kit	TRK-4500DNSPK	TRK-4500DNSPKWS
5	NV4500 / MT8	96-92	2WD & 4X4	Gas or Diesel	Kit Includes M/S Needles	TRK-4500DN	TRK-4500DNWS
5	G360	93-89	2WD & 4X4	Diesel	w/ Cummins Diesel, Kit Includes M/S Needles	TRK-261N	TRK-261NWS
5	G360	93-89	2WD & 4X4	Diesel	w/ Cummins Diesel	TRK-261	TRK-261WS
4	NP435	91-86	2WD & 4X4		Alum. Shift Cover (Ball I/S Brg.)	TRK-127G	TRK-127GWS
4	NP435	86-65	2WD & 4X4		Alum. Shift Cover (Tapered I/S Brg.)	TRK-127B	TRK-127BWS
3	NP230	79-75	2WD & 4X4		9 Bolt Side Cover	TRK-NP100A	TRK-NP100AWS
4	NP445	79-72	2WD & 4X4			TRK-NP140	
3	390	79-70	2WD & 4X4		Tremec	TRK-150A	TRK-150AWS
4	NP435	1965	2WD & 4X4		Alum. Shift Cover (Ball I/S Brg.)	TRK-127G	TRK-127GWS
Truck 1 Ton							
6	G56	14-05	2WD & 4x4			TRK-FC200	
6	NV5600	05-01	2WD & 4X4	Diesel		TRK-5600	TRK-5600WS
5	NV4500 / MT8	05-97	2WD & 4X4	Gas or Diesel	Kit Includes M/S Needles & Small Parts Kit	TRK-4500DN1SPK	TRK-4500DN1SPKWS
5	NV4500 / MT8	05-97	2WD & 4X4	Gas or Diesel	Kit Includes M/S Needles	TRK-4500DN1	TRK-4500DN1WS
5	NV4500 / MT8	05-92	2WD & 4X4	Gas or Diesel	Kit Includes Small Parts	TRK-4500DSPK	TRK-4500DSPKWS
5	NV4500 / MT8	05-92	2WD & 4X4	Gas or Diesel		TRK-4500D	TRK-4500DWS
6	NV5600	00-98	2WD & 4X4	Diesel		TRK-5600	Obsolete
5	NV4500 / MT8	96-92	2WD & 4X4	Gas or Diesel	Kit Includes M/S Needles & Small Parts Kit	TRK-4500DNSPK	TRK-4500DNSPKWS
5	NV4500 / MT8	96-92	2WD & 4X4	Gas or Diesel	Kit Includes M/S Needles	TRK-4500DN	TRK-4500DNWS
5	G360	93-89	2WD & 4X4	Diesel	w/ Cummins Diesel	TRK-261	TRK-261WS
5	G360	93-89	2WD & 4X4	Diesel	w/ Cummins Diesel, Kit Includes M/S Needles	TRK-261N	TRK-261NWS
4	NP435	91-86	2WD & 4X4		Alum. Shift Cover (Ball I/S Brg.)	TRK-127G	TRK-127GWS
4	NP435	86-65	2WD & 4X4		Alum. Shift Cover (Tapered I/S Brg.)	TRK-127B	TRK-127BWS
4	NP435	65-64	2WD & 4X4		Alum. Shift Cover (Ball I/S Brg.)	TRK-127G	TRK-127GWS

Light Duty Transmission Applications

Speed	Model #	Year	Fwd/Rwd	Engine	Notes	Kit	w/Synchro Rings
Dodge (cont.)							
Truck 1-1/2 Ton							
4	NP435	81-78	2WD & 4X4		Alum. Shift Cover (Tapered I/S Brg.)	TRK-127B	TRK-127BWS
Van (1/2 & 3/4 Ton)							
5	AX15	93-92	2WD	V6	3 Pc. Case & 7 Bolt Front Retainer	TRK-FT420	TRK-FT420WS
5	NV2500 / 535	91-88	2WD	V6	2 Pc. Case (35mm ID Input Shaft Brg.)	TRK-535	TRK-535WS
4	NP833	89-88	2WD	V8		TRK-833	TRK-833WS
4	NP833	87-76	2WD			TRK-833	TRK-833WS
Viper							
6	T56	08-92	RWD		Borg Warner	TRK-56	TRK-56WS
Ford							
All Car Models (82 & Earlier)							
4 w/ O/D	SROD	82-81	RWD		Top Loader 10 Bolt Top Cover	TRK-170	TRK-170WS1
4	MTX4	82-80	FWD		Codes RGT	TRK-FMZ160	TRK-FMZ160WS
3	Tremec RAB, RAC, RAN, RAT, HEF	82-65	RWD		9 Bolt Top Cover (1st Ring Larger than 2nd & 3rd)	TRK-150F	TRK-150FWS
3	Tremec RAB, RAC, RAN, RAT, HEF	82-65	RWD		9 Bolt Top Cover (All Rings Same Size)	TRK-150F	TRK-150FWS1
4 w/ O/D	RUG	81-78	RWD		Top Loader 10 Bolt Top Cover	TRK-170	TRK-170WS
4	ENG	76-71	RWD		4 Bolt Alum. Top Cover	TRK-F150	
4	RUG/HEH	73-64	RWD		Top Loader 10 Bolt Top Cover	TRK-170A	TRK-170AWS
4	RUG/HEH	73-64	RWD		Top Loader 10 Bolt Top Cover (w/ Max-Type Brgs.)	TRK-170AHD	TRK-170AHDWS
3	T86	70-64	RWD			TRK-BW86	
4	T10	69-66	RWD		7/8" Countershaft w/o Thrust Brg. Between 2nd & 3rd Gears	TRK-10W	TRK-10WWS
4	DAG	68-63	RWD		10 Bolt Side Cover (Includes Small Parts Kit)	TRK-F140	TRK-F140WS
4	DAG	68-63	RWD		10 Bolt Side Cover (Does Not Include M/S & C/S Needles)	TRK-F140A	TRK-F140AWS
3	HED	67-64	RWD		4 Bolt Top Cover	TRK-F130	TRK-F130WS
4	T10	65-57	RWD		7/8" Countershaft w/ Thrust Brg. Between 2nd & 3rd Gears	TRK-10E	TRK-10EWS
3	259	64-48	RWD		9 Bolt Rectangular Side Cover	TRK-259	
3 w/ O/D	259	64-48	RWD		9 Bolt Rectangular Side Cover	TRK-259A	
Aerostar							
5	M5R1	95-90	RWD		Updated 30 Tooth 5th Gear Synchro	TRK-247	TRK-247WS1
5	M5R1	1/90	RWD		36 Tooth 5th Gear Synchro	TRK-247	TRK-247WS
5	TK5L	87-86	RWD		14 Bolt Bottom Pan 42 Teeth Synchro Rings (Codes E67A, E757A)	TRK-12	TRK-12WS1

Light Duty Transmission Applications

Speed	Model #	Year	Fwd/Rwd	Engine	Notes	Kit	w/Synchro Rings
Ford (cont.)							
Aspire							
5	Aspire	97-94	FWD			TRK-FF100	Obsolete
Bronco							
5	M5R2	96-90	2WD & 4x4		Updated 33 Tooth 5th Gear Synchro	TRK-248	TRK-248WS1
5	S5-42	92-88	2WD & 4x4			TRK-300ZF/1	TRK-300ZF/1WS
5	S5-42	92-88	2WD & 4x4		Kit Includes Mainshaft Needles	TRK-300ZF	TRK-300ZFWS
4	T18	91-87	2WD & 4x4		23mm Wide I/S Brg.	TRK-BW18A	TRK-BW18AWS
5	M5R2	1/90	2WD & 4x4		42 Tooth 5th Gear Synchro	TRK-248	TRK-248WS
4	T18	90-79	2WD & 4x4		20mm Wide I/S Brg.	TRK-BW18	TRK-BW18WS
4	T18				20mm Wide I/S Brg.	TRK-82F	
4	RTS	87-85	4x4		Top Loader 10 Bolt Top Cover Alum. Forks	TRK-174F	TRK-174FWS1
4	NP435	87-78	2WD & 4x4		Alum. Top Cover	TRK-127F	TRK-127FWS
4	RUG	1983	2WD & 4x4		Top Loader 10 Bolt Top Cover Steel Forks	TRK-174F	TRK-174FWS
Bronco II							
5	M5R1	1990	2WD & 4x4		Updated 30 Tooth 5th Gear Synchro	TRK-247	TRK-247WS1
5	FM146	90-88	2WD & 4x4		12 Bolt Bottom Pan, Synchronized Rev.	TRK-50	TRK-50WS1
5	M5R1	1/90	2WD & 4x4		36 Tooth 5th Gear Synchro	TRK-247	TRK-247WS
5	FM145	87-86	2WD & 4x4		12 Bolt Bottom Pan	TRK-50	TRK-50WS
5	TK5L	87-86	2WD & 4x4		14 Bolt Bottom Pan 42 Teeth Synchro Rings (Codes E67A, E757A)	TRK-12	TRK-12WS1
5	TK5	85-84	2WD & 4x4		14 Bolt Bottom Pan 30 Teeth Synchro Rings (Codes E37A, E47A, E57A)	TRK-12	TRK-12WS
4	TK4	84-83	2WD & 4x4		14 Bolt Bottom Pan	TRK-12C	TRK-12CWS
Capri							
5	CAP5	94-91	FWD	Non-Turbo		TRK-FMZ130	TRK-FMZ130WS
5	CAP5	94-91	FWD	Turbo		TRK-FMZ150	TRK-FMZ150WS
4	German	86-83	RWD		6008 O/S Brg.	Obsolete	
5	T5	84-83	RWD		LM48548/10 I/S Brg. & Cylindrical C/S Brgs.	TRK-5	TRK-5WS
5	RAP	83-81	RWD		10 Bolt Top Cover	TRK-F190	Obsolete
4	RUG	83-80	RWD		Top Loader 10 Bolt Top Cover	TRK-170	TRK-170WS
Contour							
5	MTX5	00-95	FWD		6 Bolt Shift Tower	TRK-FMZ350	Obsolete
EXP							
5	MTX5	88-83	FWD			TRK-FMZ140	
4	MTX4	83-82	FWD			TRK-FMZ160	TRK-FMZ160WS
Escort							
5	MTX5	00-98	FWD	2.0L		TRK-FMZ150	TRK-FMZ150WS
5	MTX5	96-93	FWD	1.9L	I/S Ball Brg. Has 25.0mm I.D.	TRK-FMZ260	TRK-FMZ260WS
5	MTX5	96-91	FWD	1.8L	Taper I/S Brg.	TRK-FMZ150	TRK-FMZ150WS
5	MTX5	11/93	FWD	1.9L	I/S Ball Brg. Has 25.4mm I.D.	TRK-FMZ130	TRK-FMZ130WS
4	MTX4	90-86	FWD			TRK-FMZ330	TRK-FMZ330WS
5	MTX5	90-83	FWD			TRK-FMZ140	

Light Duty Transmission Applications

Speed	Model #	Year	Fwd/Rwd	Engine	Notes	Kit	w/Synchro Rings
Ford (cont.)							
Escort (cont.)							
4	MTX4	84-81	FWD			TRK-FMZ160	TRK-FMZ160WS
4	MTX4	1985	FWD	1.6L, 1.9L	Trans ID RGT	TRK-FMZ160	TRK-FMZ160WS
4	MTX4	1985	FWD	1.9L	Trans ID RJS	TRK-FMZ330	TRK-FMZ330WS
Explorer							
5	M5R4	03-02	2WD & 4x4			TRK-FMZ360	TRK-FMZ360WS
5	M5R1	01-91	2WD & 4x4		Updated 30 Tooth 5th Gear Synchro	TRK-247	TRK-247WS1
5	M5R1	01-91	2WD & 4x4		Contains M/S Needle Brgs., Thrust Washers & Locking Nuts	TRK-247N	TRK-247NWS1
Explorer Sport / Trac							
5	M5R1	03-01	2WD & 4x4		Codes E87A, E97A, F07A, F17A (Updated 5th Rings 30 Teeth)	TRK-247	TRK-247WS1
Festiva							
5	Festiva 5	93-89	FWD			TRK-FF100	Obsolete
4	Festiva 4	89-88	FWD			TRK-FF100	Obsolete
Focus							
5	MTX5	03-00	FWD	DOHC	6 Bolt Shift Tower	TRK-FMZ350	Obsolete
5	MTX5	03-00	FWD	SOHC		TRK-FMZ370	TRK-FMZ370WS
Granada							
4 w/ O/D	SROD	84-81	RWD		Top Loader 10 Bolt Top Cover	TRK-170	TRK-170WS1
4 w/ O/D	RUG	81-78	RWD		Top Loader 10 Bolt Top Cover	TRK-170	TRK-170WS
Mustang							
5	TR-3650	08-02	RWD	8 Cyl GT, Bullitt, Mach-1		TRK-3650	TRK-3650WS
5	T5 World Class	08-94	RWD	6 Cyl	LM48548/10 I/S Brg, Rev Synchro	TRK-5W	TRK-5WWS1
6	T56	04-03	RWD	8 Cyl, Cobra		TRK-56	TRK-56WS
5	T45	02-96	RWD	8 Cyl GT		TRK-BW45	TRK-BW45WS
5	T45	00-96	RWD	8 Cyl, Cobra		TRK-BW45	TRK-BW45WS
5	T5 World Class	95-93	RWD	8 Cyl, Cobra	LM48548/10 I/S Brg, Rev Synchro, Taper Pilot Brg	TRK-5WC	TRK-5WCWS
5	T5 World Class	95-92	RWD	8 Cyl	LM48548/10 I/S Brg, Rev Synchro	TRK-5W	TRK-5WWS1
5	T5 World Class	93-87	RWD	4 Cyl	M88048/10 I/S Brg	TRK-5WA	TRK-5WAWS
5	T5 World Class	91-85	RWD	8 Cyl	LM48548/10 I/S Brg. & Taper C/S Brgs.	TRK-5W	TRK-5WWS
5	T5 World Class	86-85	RWD	4, 6 Cyl	LM48548/10 I/S Brg. & Taper C/S Brgs.	TRK-5W	TRK-5WWS
4	German	86-83	RWD		6008 O/S Brg.	Obsolete	
5	T5	84-83	RWD	4, 6, 8 Cyl	LM48548/10 I/S Brg. & Cylindrical C/S Brgs.	TRK-5	TRK-5WS
5	TR-3650	2001	RWD	8 Cyl, Cobra		TRK-3650	TRK-3650WS
4 w/ O/D	RUG	1983	RWD		Top Loader 10 Bolt Top Cover	TRK-170	TRK-170WS
5	RAP	1983	RWD		10 Bolt Top Cover	TRK-F190	Obsolete
Pinto							
4 w/ O/D	SROD	84-81	RWD		Top Loader 10 Bolt Top Cover	TRK-170	TRK-170WS1
4 w/ O/D	RUG	81-78	RWD		Top Loader 10 Bolt Top Cover	TRK-170	TRK-170WS

Light Duty Transmission Applications

Speed	Model #	Year	Fwd/Rwd	Engine	Notes	Kit	w/Synchro Rings
Ford (cont.)							
Probe							
5	PR5	97-93	FWD	2.0L & 2.5L	With 32008 Diff Brgs.	TRK-FMZ150	TRK-FMZ150WS
5	PR5	92-89	FWD	2.2L Turbo	With 32009 Diff Brgs.	TRK-FMZ170	TRK-FMZ170WS
5	PR5	92-88	FWD	2.2L, 3.0L	With 32008 Diff Brgs.	TRK-FMZ150	TRK-FMZ150WS
Ranger							
5	M5R1	11-90	2WD & 4x4		Updated 30 Tooth 5th Gear Synchro	TRK-247	TRK-247WS1
5	M5R1	11-90	2WD & 4x4		Contains M/S Needle Brgs., Thrust Washers & Locking Nuts	TRK-247N	TRK-247NWS1
5	M5R1	03-87	2WD & 4x4		I/S Brgs, Seal & Baffle Kit	TRK-247F	
5	FM146	92-88	4x4		12 Bolt Bottom Pan, Synchronized Rev.	TRK-50	TRK-50WS1
5	FM132	92-85	2WD		12 Bolt Bottom Pan	TRK-50A	TRK-50AWS
5	M5R1	90-87	2WD & 4x4		36 Tooth 5th Gear Synchro	TRK-247	TRK-247WS
5	M5R1	1/90	2WD & 4x4		Contains M/S Needle Brgs., Thrust Washers & Locking Nuts	TRK-247N	TRK-247NWS
5	FM145	87-86	4x4		12 Bolt Bottom Pan	TRK-50	TRK-50WS
5	TK5L	87-86	2WD & 4x4	Gas	14 Bolt Bottom Pan 42 Teeth Synchro Rings (Codes E67A, E757A)	TRK-12	TRK-12WS1
5	TK5	85-83	2WD & 4x4	Gas	14 Bolt Bottom Pan 30 Teeth Synchro Rings (Codes E37A, E47A, E57A)	TRK-12	TRK-12WS
4	TK4D	84-83	2WD & 4x4	Diesel	14 Bolt Bottom Pan	TRK-12A	TRK-12AWS
5	TK5D	84-83	2WD & 4x4	Diesel	14 Bolt Bottom Pan	TRK-12B	TRK-12BWS
4	TK4	84-83	2WD & 4x4	Gas	14 Bolt Bottom Pan	TRK-12C	TRK-12CWS
Taurus							
5	MTX5	88-86	FWD			TRK-FMZ140	Obsolete
Taurus SHO							
5	MTX5	95-89	FWD	3.0L		TRK-FMZ190	Obsolete
Tempo							
5	MTX5	94-92	FWD	3.0L		TRK-FMZ190	Obsolete
5	MTX5	94-84	FWD	2.3L		TRK-FMZ140	Obsolete
4	MTX4	85-84	FWD			TRK-FMZ160	TRK-FMZ160WS
Thunderbird							
5	RKE	95-89	RWD		Mazda M5R2 or M50D	TRK-248B	Obsolete
5	T5 World Class	88-85	RWD	4 Cyl	LM48548/10 I/S Brg. & Taper C/S Brgs.	TRK-5W	TRK-5WWS
5	T5	84-83	RWD	4 Cyl	LM48548/10 I/S Brg. & Cylindrical C/S Brgs.	TRK-5	TRK-5WS
Trucks, Vans & SUV's (82 & Earlier)							
4	SROD	82-81	2WD & 4x4		Top Loader 10 Bolt Top Cover Brass Forks	TRK-174F	TRK-174FWS1
4	T19D	82-80	2WD & 4x4		Tapered I/S Brg.	TRK-BW19B	TRK-BW19BWS
5	Clark 280HD, 282VHD, 285VHD	82-79	2WD & 4x4		Case 15-1/16" Long Overall (Taper I/S Brg.)	TRK-190	
4	RUG	82-77	2WD & 4x4		Top Loader 10 Bolt Top Cover Steel Forks	TRK-174F	TRK-174FWS
5	Clark 390/CL550	82-76	2WD & 4x4		Case 15-1/4" Long Overall	TRK-390F	
4	CR1	82-72	2WD & 4x4		Courier Case Splits Lengthwise	TRK-F100	TRK-F100WS

Light Duty Transmission Applications

Speed	Model #	Year	Fwd/Rwd	Engine	Notes	Kit	w/Synchro Rings
Ford (cont.)							
Trucks, Vans & SUV's (82 & Earlier) (cont.)							
5	NP542	82-69	2WD & 4x4		6 Bolt Front C/S Retainer	TRK-29B	
4	T19	82-68	2WD & 4x4		20mm Wide I/S Brg.	TRK-BW19	TRK-BW19WS
4	T19	82-68	2WD & 4x4		23mm Wide I/S Brg.	TRK-BW19A	TRK-BW19AWS
5	Clark 260	82-68	2WD & 4x4		Case 15-1/16" Long Overall(Ball I/S Brg.)	TRK-148	
3	Tremec RAB, RAC, RAN, RAT, HEF	82-65	2WD & 4x4		1st Ring Larger than 2nd & 3rd	TRK-150F	TRK-150FWS
3	Tremec RAB, RAC, RAN, RAT, HEF	82-65	2WD & 4x4		All Rings Same Size	TRK-150F	TRK-150FWS1
4	T18	82-65	2WD & 4x4		20mm Wide I/S Brg.	TRK-BW18	TRK-BW18WS
4	T18	82-65	2WD & 4x4		23mm Wide I/S Brg.	TRK-BW18A	TRK-BW18AWS
5	CR2	81-76	2WD & 4x4		Courier Alum. Bottom Pan	TRK-F110	TRK-F110WS
5	Clark 380, 385, 387	75-68	2WD & 4x4		Case 17-1/32" Long Overall	TRK-133	
3	T89	71-67	2WD & 4x4		9 Bolt Side Cover	TRK-BW85	TRK-BW85WS
3	T87	71-66	2WD & 4x4		9 Bolt Side Cover	TRK-BW87	TRK-BW87WS
3 w/ O/D	T85	71-65	2WD & 4x4		9 Bolt Side Cover	TRK-BW8	
5	NP541	71-60	2WD & 4x4		6 Bolt Front C/S Retainer	TRK-27	
3	T85	71-56	2WD & 4x4		9 Bolt Side Cover	TRK-BW85	TRK-BW85WS
3	T86	70-62	2WD & 4x4		9 Bolt Side Cover	TRK-BW86	TRK-BW86WS
5	Clark 300, 305, 307	69-65	2WD & 4x4		Case 16-1/2" Long Overall	TRK-48	
5	Clark 260	68-60	2WD & 4x4		Case 13-7/8" Long Overall (With 21mm Wide Rear M/S Brg.)	TRK-23B	
5	Clark 260	68-60	2WD & 4x4		Case 13-7/8" Long Overall (With 25mm Wide Rear M/S Brg.)	TRK-23	
5	Clark 250, 251V	67-60	2WD & 4x4		Case 13-7/8" Long Overall	TRK-23	
3	259	64-48	2WD & 4x4		9 Bolt Rectangular Side Cover	TRK-259	Obsolete
3 w/ O/D	259A	64-48	2WD & 4x4		9 Bolt Rectangular Side Cover	TRK-259A	Obsolete
4	T98	64-48	2WD & 4x4			TRK-BW98	TRK-BW98WS
4	T8	55-40	2WD & 4x4		6 Bolt Top Cover	TRK-F120	Obsolete
4	T9	55-40	2WD & 4x4		6 Bolt Top Cover	TRK-F120	Obsolete
Truck 1/2 Ton							
5	M5R2	08-99	2WD & 4x4		3 Pc 2nd Synchro Ring, Synchro Rev.	TRK-248	TRK-248WS2
5	M5R2	08-99	2WD & 4x4		Contains M/S Needle Brgs., Thrust Washers & Locking Nuts	TRK-248N	TRK-248NWS2
5	M5R2	08-87	2WD & 4x4		I/S Brgs, Seal & Baffle Kit	TRK-248F	
5	M5R2	98-90	2WD & 4x4		Updated 33 Tooth 5th Gear Synchro	TRK-248	TRK-248WS1
5	M5R2	98-90	2WD & 4x4		Contains M/S Needle Brgs., Thrust Washers & Locking Nuts	TRK-248N	TRK-248NWS1
5	S5-42	96-88	2WD & 4x4			TRK-300ZF/1	TRK-300ZF/1WS
5	S5-42	96-88	2WD & 4x4		Kit Includes Mainshaft Needles	TRK-300ZF	TRK-300ZFWS

LD Transmission

Light Duty Transmission Applications

Speed	Model #	Year	Fwd/Rwd	Engine	Notes	Kit	w/Synchro Rings
Ford (cont.)							
Truck 1/2 Ton (cont.)							
5	S5-42, S5-47, S5-47M	96-88	2WD & 4x4		Brake Drum Section	TRK-300ZFBD	
4	T18	93-83	2WD & 4x4		23mm Wide I/S Brg.	TRK-BW18A	TRK-BW18AWS
4	T18	92-65	2WD & 4x4		20mm Wide I/S Brg.	TRK-BW18	TRK-BW18WS
5	M5R2	90-87	2WD & 4x4		42 Tooth 5th Gear Synchro	TRK-248	TRK-248WS
5	M5R2	1/90	2WD & 4x4		Contains M/S Needle Brgs., Thrust Washers & Locking Nuts	TRK-248N	TRK-248NWS
4	RUG	87-83	2WD & 4x4		Top Loader 10 Bolt Top Cover Steel Forks	TRK-174F	TRK-174FWS
4	RTS	87-83	2WD & 4x4		Top Loader 10 Bolt Top Cover Alum. Forks	TRK-174F	TRK-174FWS1
4	NP435	87-65	2WD & 4x4		Alum. Top Cover	TRK-127F	TRK-127FWS
3	Tremec RAB, RAC, RAN, RAT, HEF	86-83	2WD & 4x4		1st Ring Larger than 2nd & 3rd	TRK-150F	TRK-150FWS
3	Tremec RAB, RAC, RAN, RAT, HEF	86-83	2WD & 4x4		All Rings Same Size	TRK-150F	TRK-150FWS1
4	T98	64-60	2WD & 4x4			TRK-BW98	TRK-BW98WS
Truck 3/4 Ton							
6	S6-650	08-99	2WD & 4x4			TRK-S6-650ZF	TRK-S6-650ZFWS
6	S6-650	08-99	2WD & 4x4		Brake Drum Section	TRK-300ZFBDL	
6	S6-750ZF	07-03	2WD & 4x4			TRK-S6-650ZFB	TRK-S6-650ZFBWS
5	S5-47M	01-99	2WD & 4x4			TRK-300ZF/1	TRK-300ZF/1WS1
5	S5-47M	01-99	2WD & 4x4		Kit Includes Mainshaft Needles	TRK-300ZF	TRK-300ZFWS1
5	S5-42, S5-47, S5-47M	01-88	2WD & 4x4		Brake Drum Section	TRK-300ZFBD	
5	M5R2	1999	2WD & 4x4		3 Pc 2nd Synchro Ring, Synchro Rev.	TRK-248	TRK-248WS2
5	M5R2	1999	2WD & 4x4		Contains M/S Needle Brgs., Thrust Washers & Locking Nuts	TRK-248N	TRK-248NWS2
5	M5R2	99-87	2WD & 4x4		I/S Brgs, Seal & Baffle Kit	TRK-248F	
5	S5-47	98-96	2WD & 4x4			TRK-300ZF/1	TRK-300ZF/1WS1
5	S5-47	98-96	2WD & 4x4		Kit Includes Mainshaft Needles	TRK-300ZF	TRK-300ZFWS1
5	M5R2	98-90	2WD & 4x4		Updated 33 Tooth 5th Gear Synchro	TRK-248	TRK-248WS1
5	M5R2	98-90	2WD & 4x4		Contains M/S Needle Brgs., Thrust Washers & Locking Nuts	TRK-248N	TRK-248NWS1
5	S5-42	95-88	2WD & 4x4			TRK-300ZF/1	TRK-300ZF/1WS
5	S5-42	95-88	2WD & 4x4		Kit Includes Mainshaft Needles	TRK-300ZF	TRK-300ZFWS
4	T18	93-83	2WD & 4x4		23mm Wide I/S Brg.	TRK-BW18A	TRK-BW18AWS
4	T19	93-83	2WD & 4x4		20mm Wide I/S Brg.	TRK-BW19	TRK-BW19WS
4	T19	93-83	2WD & 4x4		23mm Wide I/S Brg.	TRK-BW19A	TRK-BW19AWS
4	T19D	93-83	2WD & 4x4		Tapered I/S Brg.	TRK-BW19B	TRK-BW19BWS
4	T18	92-65	2WD & 4x4		20mm Wide I/S Brg.	TRK-BW18	TRK-BW18WS
5	M5R2	90-87	2WD & 4x4		42 Tooth 5th Gear Synchro	TRK-248	TRK-248WS
5	M5R2	1/90	2WD & 4x4		Contains M/S Needle Brgs., Thrust Washers & Locking Nuts	TRK-248N	TRK-248NWS

Light Duty Transmission Applications

Speed	Model #	Year	Fwd/Rwd	Engine	Notes	Kit	w/Synchro Rings
Ford (cont.)							
Truck 3/4 Ton (cont.)							
4	NP435	87-65	2WD & 4x4		Alum. Top Cover	TRK-127F	TRK-127FWS
3	Tremec RAB, RAC, RAN, RAT, HEF	86-83	2WD & 4x4		1st Ring Larger than 2nd & 3rd	TRK-150F	TRK-150FWS
3	Tremec RAB, RAC, RAN, RAT, HEF	86-83	2WD & 4x4		All Rings Same Size	TRK-150F	TRK-150FWS1
Truck 1 Ton							
6	S6-650	10-99	2WD & 4x4			TRK-S6-650ZF	TRK-S6-650ZFWS
6	S6-650	08-99	2WD & 4x4		Brake Drum Section	TRK-300ZFBDL	
6	S6-750ZF	10-03	2WD & 4x4			TRK-S6-650ZFB	TRK-S6-650ZFBWS
5	S5-47M	01-99	2WD & 4x4			TRK-300ZF/1	TRK-300ZF/1WS1
5	S5-47M	01-99	2WD & 4x4		Kit Includes Mainshaft Needles	TRK-300ZF	TRK-300ZFWS1
5	S5-42, S5-47, S5-47M	01-88	2WD & 4x4		Brake Drum Section	TRK-300ZFBD	
5	S5-47	97-96	2WD & 4x4			TRK-300ZF/1	TRK-300ZF/1WS1
5	S5-47	97-96	2WD & 4x4		Kit Includes Mainshaft Needles	TRK-300ZF	TRK-300ZFWS1
5	S5-42	95-88	2WD & 4x4			TRK-300ZF/1	TRK-300ZF/1WS
5	S5-42	95-88	2WD & 4x4		Kit Includes Mainshaft Needles	TRK-300ZF	TRK-300ZFWS
4	T18	93-83	2WD & 4x4		23mm Wide I/S Brg.	TRK-BW18A	TRK-BW18AWS
4	T19	93-83	2WD & 4x4		20mm Wide I/S Brg.	TRK-BW19	TRK-BW19WS
4	T19	93-83	2WD & 4x4		23mm Wide I/S Brg.	TRK-BW19A	TRK-BW19AWS
4	T19D	93-83	2WD & 4x4		Tapered I/S Brg.	TRK-BW19B	TRK-BW19BWS
4	NP435	87-65	2WD & 4x4		Alum. Top Cover	TRK-127F	TRK-127FWS
4	T18	87-65	2WD & 4x4		20mm Wide I/S Brg.	TRK-BW18	TRK-BW18WS
3	Tremec RAB, RAC, RAN, RAT, HEF	84-83	2WD & 4x4		1st Ring Larger than 2nd & 3rd	TRK-150F	TRK-150FWS
3	Tremec RAB, RAC, RAN, RAT, HEF	84-83	2WD & 4x4		All Rings Same Size	TRK-150F	TRK-150FWS1
Van 1 Ton							
4	NP435	87-84	2WD & 4x4		Alum. Top Cover	TRK-127F	TRK-127FWS
Geo							
Metro							
5	MV3	01-89	FWD		8 Bolt Cover	TRK-FS110	TRK-FS110WS
Prizm							
5	C51	02-88	FWD	Twin Cam	9 Bolt Cover	TRK-FT320	TRK-FT320WS3
5	C51	87-85	FWD		9 Bolt Cover	TRK-FT320	TRK-FT320WS
Spectrum							
5	76mm Isuzu	87-85	FWD	4 Cyl.	7 Bolt Cover	TRK-FI120	TRK-FI120WS
5	76mm Isuzu	1988	FWD	4 Cyl.	7 Bolt Cover (3 Pc. 1-2 Synchro Rings)	TRK-FI120	TRK-FI120WS1
Storm							
5	MV4	93-90	FWD		Alum. Cover over 5th Gears (3 PC. 1-2 Synchro Rings)	TRK-FI120	TRK-FI120WS1
Tracker							
5	TRACK	02-99	2WD & 4WD		8 Bolt Cover	TRK-FS150	TRK-FS150WS
5	TRACK	98-89	2WD & 4WD		8 Bolt Cover	TRK-FS130	TRK-FS130WS

LD Transmission

Light Duty Transmission Applications

Speed	Model #	Year	Fwd/Rwd	Engine	Notes	Kit	w/Synchro Rings
GMC							
All Car Models (82 & Earlier)							
3	Saginaw	85-66	RWD		7 Bolt Side Cover	TRK-301	TRK-301WS1
5	T5	82-81	RWD		Cylindrical Countershaft Brgs.	TRK-5	TRK-5WS
4	MR2	82-80	FWD		2 Piece Case	TRK-FG110	Obsolete
4	T10W	82-74	RWD		9 Bolt Side Cover (6307 I/S Brg., 1" C/S)	TRK-10WA	TRK-10WAWS
4	T10W	82-74	RWD		9 Bolt Side Cover (6307 I/S Brg., 1" C/S, Max-Type Ball Brgs.)	TRK-10WAHD	TRK-10WAHDWS
4	Saginaw	82-66	RWD		7 Bolt Side Cover	TRK-301	TRK-301WS
3	Tremec	74-68	RWD		9 Bolt Top Cover	TRK-150F	TRK-150FWS
4	M21	74-66	RWD		7 Bolt Side Cover (1" Countershaft)	TRK-297A	TRK-297AWS
4	M21	74-66	RWD		7 Bolt Side Cover (1" Countershaft and Max-Type Brgs.)	TRK-297AHD	TRK-297AHDWS
4	T10W	73-66	RWD		9 Bolt Side Cover (6307 I/S Brg., 7/8" C/S, No Thrust Brg. Between 2nd & 3rd Gears)	TRK-10W	TRK-10WWS
3 w/ O/D	Saginaw	72-66	RWD		with R10 Overdrive Unit	TRK-301A	TRK-301AWS
4	M22	71-67	RWD		7 Bolt Side Cover (1" Countershaft)	TRK-297A	TRK-297AWS
4	M22	71-67	RWD		7 Bolt Side Cover (1" Countershaft and Max-Type Brgs.)	TRK-297AHD	TRK-297AHDWS
3 w/ O/D	Muncie 319	68-55	RWD		4 Bolt Side Cover	TRK-G110	
4	T10	66-62	RWD		9 Bolt Side Cover (6307 I/S Brg., 7/8" C/S, Thrust Brg. Between 2nd & 3rd Gears)	TRK-10E	TRK-10EWS
4	T10	66-57	RWD		9 Bolt Side Cover (6207 I/S Brg.)	TRK-10A	TRK-10AWS
4	M20	65-63	RWD		7 Bolt Side Cover (7/8" Countershaft)	TRK-297	TRK-297WS
4	M20	65-63	RWD		7 Bolt Side Cover (7/8" Countershaft and Max-Type Brgs.)	TRK-297HD	TRK-297HDWS
4	M20	63-62	RWD		7 Bolt Side Cover (6207 I/S Brg.)	TRK-297B	TRK-297BWS
3	Muncie 318	54-40	RWD		4 Bolt Side Cover	TRK-G100	
4	T4	1982	RWD			TRK-5	TRK-5WS1
1000							
5	T5	87-83	RWD		With DC51932 Front C/S Brg.	TRK-5A	TRK-5AWS
5	MSG-5K	87-83	RWD	Diesel		TRK-FI110	TRK-FI110WS
4	70mm	87-76	RWD			TRK-G120	TRK-G120WS
4	T4	84-83	RWD			TRK-5	TRK-5WS1
2000							
4	MR2	84-83	FWD		2 Piece Case	TRK-FG110	Obsolete
Canyon							
5	AR5	12-04	2WD&4x4			TRK-FG150	

Light Duty Transmission Applications

Speed	Model #	Year	Fwd/Rwd	Engine	Notes	Kit	w/Synchro Rings
GMC (cont.)							
H3							
5	AR5	10-04	2WD&4x4			TRK-FG150	
H3T							
5	AR5	10-09	2WD&4x4			TRK-FG150	
Jimmy (Full Size)							
4	SM465	91-90	2WD & 4x4		211FFLE I/S Brg.	TRK-157B	TRK-157BWS
4	SM465	90-79	2WD & 4x4		Contains R1563TAV Front C/S Brg.	TRK-157L	TRK-157LWS
4	SM465	90-70	2WD & 4x4		Contains M1305GGTV & R1563TAV Front C/S Brg.	TRK-157A	TRK-157AWS
4	SM465	90-70	2WD & 4x4		Master Kit w/ Small Parts Kit, Keys, & Springs	TRK-157ASPK	TRK-157ASPKWS
4 w/ O/D	NP833	87-81	2WD & 4x4		10 Bolt Side Cover, Case 10-5/8" Long Overall	TRK-833	TRK-833WS
3	Saginaw	81-77	2WD & 4x4		6 Bolt Front C/S Retainer	TRK-301	TRK-301WS1
Jimmy (S15 Size)							
5	HM290, MG5, NV3500	01-96	2WD & 4x4		Getrag 3rd Design (Standard Ball I/S & O/S Brgs. And 3 Pc. 1-2 Synchro Rings) & 1.180 ID C/S Brgs.	TRK-235B	TRK-235BWS1
5	M50,NV3500	01-96	2WD & 4x4		Getrag 3rd Design (Standard Ball I/S & O/S Brgs. And 3 Pc. 1-2 Synchro Rings) & 1.300 ID C/S Brgs.	TRK-235E	TRK-235EWS
5	HM290, MG5, NV3500	96-95	2WD & 4x4		Getrag 3rd Design (Standard Ball I/S & O/S Brgs.) Includes M/S Needle Brgs.	TRK-235BN2	TRK-235BN2WS
5	HM290, MG5, NV3500	1995	2WD & 4x4		Getrag 3rd Design (Standard Ball I/S & O/S Brgs. And 3 Pc. 1-2 Synchro Rings)	TRK-235B	TRK-235BWS1
5	HM290, MG5, NV3500	1994	2WD & 4x4		Getrag 3rd Design (Standard Ball I/S & O/S Brgs.) Includes M/S Needle Brgs.	TRK-235BN1	TRK-235BN1WS
5	HM290, MG5, NV3500	94-91	2WD & 4x4		Getrag 3rd Design (Standard Ball I/S & O/S Brgs.)	TRK-235B	TRK-235BWS
5	HM290, MG5, NV3500	93-91	2WD & 4x4		Getrag 3rd Design (Standard Ball I/S & O/S Brgs.) Includes M/S Needle Brgs.	TRK-235BN	TRK-235BNWS
5	HM290, MG5	91-90	2WD & 4x4		Getrag 2nd Design (3 Pc. I/S & Standard Ball O/S Brgs.)	TRK-235A	TRK-235AWS
5	HM290, MG5	91-90	2WD & 4x4		Getrag 2nd Design (3 Pc. I/S & Standard Ball O/S Brgs.) Includes M/S Needle Brgs.	TRK-235AN	TRK-235ANWS
5	T5 World Class	91-88	2WD & 4x4		Taper Countershaft Brgs.	TRK-5W	TRK-5WWS
4	T4	87-85	2WD & 4x4		Taper I/S & O/S Brgs.	TRK-5	TRK-5WS1
5	T5	87-83	2WD & 4x4		Cylindrical Countershaft Brgs.	TRK-5	TRK-5WS

LD Transmission

Light Duty Transmission Applications

Speed	Model #	Year	Fwd/Rwd	Engine	Notes	Kit	w/Synchro Rings
GMC (cont.)							
Jimmy (S15 Size) (cont.)							
4	S101	84-83	2WD & 4x4		Isuzu Design 6208 I/S Brg.	TRK-FI240	TRK-FI240WS
4	T4C	84-83	2WD & 4x4		Ball I/S & O/S Brgs.	TRK-4C	TRK-4CWS
S15, Sonoma Pickup							
5	HM290, MG5, NV3500	03-96	2WD & 4x4	4.3L	Getrag 3rd Design (Standard Ball IS & O/S Brgs. And 3 Pc. 1-2 Synchro Rings) & 1.180 ID C/S Brgs.	TRK-235B	TRK-235BWS1
5	M50, NV3500	03-96	2WD & 4x4	4.3L	Getrag 3rd Design (Standard Ball IS & O/SBrgs. And 3 Pc. 1-2 Synchro Rings) & 1.300 ID C/S Brgs.	TRK-235E	TRK-235EWS
5	NV1500	03-96	2WD & 4x4	2.2L	6306 I/S Brg.	TRK-1500GM	TRK-1500GMWS
5	HM290, MG5, NV3500	96-95	2WD & 4x4		Getrag 3rd Design (Standard Ball I/S& O/S Brgs.) Includes M/S Needle Brgs.	TRK-235BN2	TRK-235BN2WS
5	HM290, MG5, NV3500	1995	2WD & 4x4		Getrag 3rd Design (Standard Ball IS & O/SBrgs. And 3 Pc. 1-2 Synchro Rings)	TRK-235B	TRK-235BWS1
5	T5 World Class	95-88	2WD & 4x4		Taper Countershaft Brgs.	TRK-5W	TRK-5WWS
5	HM290, MG5, NV3500	1994	2WD & 4x4		Getrag 3rd Design (Standard Ball I/S& O/S Brgs.) Includes M/S Needle Brgs.	TRK-235BN1	TRK-235BN1WS
5	HM290, MG5, NV3500	94-91	2WD & 4x4		Getrag 3rd Design (Standard Ball I/S & O/S Brgs.)	TRK-235B	TRK-235BWS
5	HM290, MG5, NV3500	93-91	2WD & 4x4		Getrag 3rd Design (Standard Ball I/S& O/S Brgs.) Includes M/S Needle Brgs.	TRK-235BN	TRK-235BNWS
5	HM290, MG5	91-90	2WD & 4x4		Getrag 2nd Design (3 Pc. I/S & Standard Ball O/S Brgs.)	TRK-235A	TRK-235AWS
5	HM290, MG5	91-90	2WD & 4x4		Getrag 2nd Design (3 Pc. I/S & Standard Ball O/S Brgs.) Includes M/S Needle Brgs.	TRK-235AN	TRK-235ANWS
4	T4	87-85	2WD & 4x4		Taper I/S & O/S Brgs.	TRK-5	TRK-5WS1
5	T5	87-82	2WD & 4x4		Cylindrical Countershaft Brgs.	TRK-5	TRK-5WS
4	S101	85-82	2WD & 4x4		Isuzu Design 6208 I/S Brg.	TRK-FI240	TRK-FI240WS
4	T4C	84-82	2WD & 4x4		Ball I/S & O/S Brgs.	TRK-4C	TRK-4CWS
Suburban							
4	SM465	1990	2WD & 4x4		211FFLE I/S Brg.	TRK-157B	TRK-157BWS
4	SM465	90-83	2WD & 4x4		N1211-L I/S Brg.	TRK-157L	TRK-157LWS
4	SM465	90-68	2WD & 4x4		Contains M1305GGTV & R1563TAV Front C/S Brg.	TRK-157A	TRK-157AWS
4	SM465	90-68	2WD & 4x4		Master Kit w/ Small Parts Kit, Keys, & Springs	TRK-157ASPK	TRK-157ASPKWS

Light Duty Transmission Applications

Speed	Model #	Year	Fwd/Rwd	Engine	Notes	Kit	w/Synchro Rings
GMC (cont.)							
Suburban (cont.)							
4	NP435	72-67	2WD & 4x4		With Ball I/S Brg.	TRK-127G	TRK-127GWS
4	NP435	72-67	2WD & 4x4		With Taper I/S Brg.	TRK-127SPK	TRK-127WS
4	NP435				With Taper I/S Brg.	TRK-127	
Trucks, Vans & SUV's (82 & Earlier)							
4 w/ O/D	NP833	86-80	2WD & 4x4		10 Bolt Side Cover, Case 10-5/8" Long Overall	TRK-833	TRK-833WS
5	NP542	84-70	2WD & 4x4		6 Bolt Front C/S Retainer	TRK-29	
5	Clark 280HD	82-79	2WD & 4x4		Case 15-1/16" Long Overall (Taper I/S Brg.)	TRK-190	
5	Clark 390	82-76	2WD & 4x4		Case 15-1/4" Long Overall	TRK-390G	
5	Clark 280	82-68	2WD & 4x4		Case 15-1/16" Long Overall (Ball I/S Brg.)	TRK-148	
3	Saginaw	82-66	2WD & 4x4		7 Bolt Side Cover, Case 9-5/8" Long Overall	TRK-301	TRK-301WS1
3	Tremec	82-65	2WD & 4x4		9 Bolt Top Cover, Case 9-5/8" Long Overall	TRK-150F	TRK-150FWS1
5	NP540	78-60	2WD & 4x4		4 Bolt Front C/S Retainer	TRK-27	
5	Clark 320	75-68	2WD & 4x4		Case 17-1/32" Long Overall	TRK-132	
5	Clark 380	75-68	2WD & 4x4		Case 17-1/32" Long Overall	TRK-133	
3	SM330	74-68	2WD & 4x4		7 Bolt Side Cover, Case 11" Long Overall	TRK-G140	Obsolete
5	Clark 300	69-60	2WD & 4x4		Case 16-1/2" Long Overall	TRK-48	
5	NP541	69-60	2WD & 4x4		6 Bolt Front C/S Retainer	TRK-29	
3	318	68-55	2WD & 4x4		4 Bolt Side Cover	TRK-G110	
3 w/ O/D	319	68-55	2WD & 4x4		4 Bolt Side Cover (With R10 Overdrive Unit)	TRK-G110	
5	Clark 260	67-60	2WD & 4x4		Case 14-1/4" Long Overall	TRK-23	
4	SM420	67-48	2WD & 4x4		1 PTO Opening, Case 10-1/2" Long Overall	TRK-G160	
3	318	54-40	2WD & 4x4		4 Bolt Side Cover (Enclosed Driveline)	TRK-G100	
3 w/ O/D	319	54-40	2WD & 4x4		4 Bolt Side Cover (With R10 Overdrive Unit)	TRK-G100	
4	185	47-40	2WD & 4x4		6 Bolt Top Cover	TRK-G150	
Truck 1/2 Ton							
5	M50,NV3500	07-96	2WD & 4x4		Getrag 3rd Design (Standard Ball I/S & O/S Brgs. And 3 Pc. 1-2 Synchro Rings) & 1.300 ID C/S Brgs.	TRK-235E	TRK-235EWS
5	HM290, MG5, NV3500	07-96	2WD & 4x4		Getrag 3rd Design (Standard Ball I/S & O/S Brgs. And 3 Pc. 1-2 Synchro Rings) & 1.180 ID C/S Brgs.	TRK-235B	TRK-235BWS1
5	NV4500	98-97	2WD & 4x4		Flat Front Brg. Retainer (Kit Includes M/S Needles & Small Parts Kit)	TRK-4500GM1N1SPK	TRK-4500GM1N1SPKWS
5	NV4500	98-97	2WD & 4x4		Flat Front Brg. Retainer (Kit Includes M/S Needles)	TRK-4500GM1N1	TRK-4500GM1N1WS

LD Transmission

Light Duty Transmission Applications

Speed	Model #	Year	Fwd/Rwd	Engine	Notes	Kit	w/Synchro Rings
GMC (cont.)							
Truck 1/2 Ton (cont.)							
5	NV4500	98-96	2WD & 4x4		Flat Front Brg. Retainer (Kit Includes Small Parts Kit)	TRK-4500GM1SPK	TRK-4500GM1SPKWS
5	NV4500	98-96	2WD & 4x4		Flat Front Brg. Retainer	TRK-4500GM1	TRK-4500GM1WS
5	NV4500	1996	2WD & 4x4		Kit Includes M/S Needles & Small Parts Kit	TRK-4500GM1NSPK	TRK-4500GM1NSPKWS
5	NV4500	1996	2WD & 4x4		Flat Front Brg. Retainer (Kit Includes M/S Needles)	TRK-4500GM1N	TRK-4500GM1NWS
5	HM290, MG5, NV3500	96-95	2WD & 4x4		Getrag 3rd Design (Standard Ball I/S & O/S Brgs.) Includes M/S Needle Brgs.	TRK-235BN2	TRK-235BN2WS
5	HM290, MG5, NV3500	1995	2WD & 4x4		Getrag 3rd Design (Standard Ball I/S & O/S Brgs.)	TRK-235B	TRK-235BWS1
5	NV4500	95-92	2WD & 4x4		Kit Includes Small Parts Kit	TRK-4500GMSPK	TRK-4500GMSPKWS
5	NV4500	95-92	2WD & 4x4		Flat Front Brg. Retainer (Kit Includes M/S Needles)	TRK-4500GMNSPK	TRK-4500GMNSPKWS
5	NV4500	95-92	2WD & 4x4		Kit Includes M/S Needles	TRK-4500GMN	TRK-4500GMNWS
5	NV4500	95-92	2WD & 4x4			TRK-4500GM	TRK-4500GMWS
5	HM290, MG5, NV3500	1994	2WD & 4x4		Getrag 3rd Design (Standard Ball I/S & O/S Brgs.) Includes M/S Needle Brgs.	TRK-235BN1	TRK-235BN1WS
5	HM290, MG5, NV3500	94-91	2WD & 4x4		Getrag 2nd Design (3 Pc. I/S & Standard Ball O/S Brgs.)	TRK-235B	TRK-235BWS
5	HM290, MG5, NV3500	93-91	2WD & 4x4		Standard Ball O/S Brgs.) Includes M/S Needle Brgs.	TRK-235BN	TRK-235BNWS
4	SM465	91-90	2WD & 4x4		211FFLE I/S Brg.	TRK-157B	TRK-157BWS
5	HM290, MG5	91-90	2WD & 4x4		Getrag 2nd Design (3 Pc. I/S & Standard Ball O/S Brgs.) Includes M/S Needle Brgs.	TRK-235AN	TRK-235ANWS
5	HM290, MG5	91-90	2WD & 4x4		Getrag 1st Design (3 Pc. I/S & O/S Brgs.) Includes M/S Needle Brgs.	TRK-235A	TRK-235AWS
4	SM465	90-79	2WD & 4x4		Contains R1563TAV Front C/S Brg.	TRK-157L	TRK-157LWS
4	SM465	90-68	2WD & 4x4		10 Bolt Side Cover, Case 10-5/8" Long Overall	TRK-157A	TRK-157AWS
4	SM465	90-68	2WD & 4x4		Contains M1305GGTV & R1563TAV Front C/S Brg.	TRK-157ASPK	TRK-157ASPKWS
5	HM290, MG5	89-88	2WD & 4x4		Getrag 1st Design (3 Pc. I/S & O/S Brgs.)	TRK-235N	TRK-235NWS
5	HM290, MG5	89-88	2WD & 4x4		Contains R1563TAV Front C/S Brg. 211FFLE I/S Brg.	TRK-235	TRK-235WS
4 w/ O/D	NP833	87-82	2WD & 4x4		7 Bolt Side Cover, Case 9-5/8" Long Overall	TRK-833	TRK-833WS
3	Saginaw	87-77	2WD & 4x4		6 Bolt Front C/S Retainer	TRK-301	TRK-301WS1

Light Duty Transmission Applications

Speed	Model #	Year	Fwd/Rwd	Engine	Notes	Kit	w/Synchro Rings
GMC (cont.)							
Truck 1/2 Ton (cont.)							
4	NP435	72-67	2WD & 4x4		With Taper I/S Brg.	TRK-127SPK	TRK-127WS
4	NP435				With Taper I/S Brg.	TRK-127	
4	NP435	72-67	2WD & 4x4		With Ball I/S Brg.	TRK-127G	TRK-127GWS
Truck 3/4 Ton							
6	S6-650ZF	06-01	4x4			TRK-S6-650ZFC	TRK-S6-650ZFCWS
5	NV4500	07-97	2WD & 4x4		Flat Front Brg. Retainer (Kit Includes M/S Needles)	TRK-4500GM1N1	TRK-4500GM1N1WS
5	NV4500	07-97	2WD & 4x4		Flat Front Brg. Retainer (Kit Includes M/S Needles & Small Parts Kit)	TRK-4500GM1N1SPK	TRK-4500GM1N1SPKWS
5	NV4500	07-96	2WD & 4x4		Flat Front Brg. Retainer	TRK-4500GM1	TRK-4500GM1WS
5	NV4500	07-96	2WD & 4x4		Flat Front Brg. Retainer (Kit Includes Small Parts Kit)	TRK-4500GM1SPK	TRK-4500GM1SPKWS
6	S6-650ZF	06-01	2WD			TRK-S6-650ZFA	TRK-S6-650ZFAWS
5	M50,NV3500	98-96	2WD & 4x4		Getrag 3rd Design (Standard Ball I/S & O/S Brgs. And 3 Pc. 1-2 Synchro Rings) & 1.300 ID C/S Brgs.	TRK-235E	TRK-235EWS
5	HM290, MG5, NV3500	98-96	2WD & 4x4		Getrag 3rd Design (Standard Ball I/S & O/S Brgs. And 3 Pc. 1-2 Synchro Rings) & 1.180 ID C/S Brgs.	TRK-235B	TRK-235BWS1
5	NV4500	1996	2WD & 4x4		Flat Front Brg. Retainer (Kit Includes M/S Needles)	TRK-4500GM1N	TRK-4500GM1NWS
5	NV4500	1996	2WD & 4x4		Kit Includes M/S Needles & Small Parts Kit	TRK-4500GM1NSPK	TRK-4500GM1NSPKWS
5	HM290, MG5, NV3500	96-95	2WD & 4x4		Getrag 3rd Design (Standard Ball I/S & O/S Brgs.) Includes M/S Needle Brgs.	TRK-235BN2	TRK-235BN2WS
5	HM290, MG5, NV3500	1995	2WD & 4x4		Getrag 3rd Design (Standard Ball I/S & O/S Brgs.)	TRK-235B	TRK-235BWS1
5	NV4500	95-91	2WD & 4x4			TRK-4500GM	TRK-4500GMWS
5	NV4500	95-91	2WD & 4x4		Kit Includes M/S Needles	TRK-4500GMN	TRK-4500GMNWS
5	NV4500	95-91	2WD & 4x4		Flat Front Brg. Retainer (Kit Includes M/S Needles)	TRK-4500GMNSPK	TRK-4500GMNSPKWS
5	NV4500	95-91	2WD & 4x4		Kit Includes Small Parts Kit	TRK-4500GMSPK	TRK-4500GMSPKWS
5	HM290, MG5, NV3500	1994	2WD & 4x4		Getrag 3rd Design (Standard Ball I/S & O/S Brgs.) Includes M/S Needle Brgs.	TRK-235BN1	TRK-235BN1WS
5	HM290, MG5, NV3500	94-91	2WD & 4x4		Getrag 2nd Design (3 Pc. I/S & Standard Ball O/S Brgs.)	TRK-235B	TRK-235BWS
5	HM290, MG5, NV3500	93-91	2WD & 4x4		Standard Ball O/S Brgs.) Includes M/S Needle Brgs.	TRK-235BN	TRK-235BNWS
4	SM465	91-90	2WD & 4x4		211FFLE I/S Brg.	TRK-157B	TRK-157BWS

Light Duty Transmission Applications

Speed	Model #	Year	Fwd/Rwd	Engine	Notes	Kit	w/Synchro Rings
GMC (cont.)							
Truck 3/4 Ton (cont.)							
5	HM290, MG5	91-90	2WD & 4x4		Getrag 2nd Design (3 Pc. I/S & Standard Ball O/S Brgs.) Includes M/S Needle Brgs.	TRK-235AN	TRK-235ANWS
5	HM290, MG5	91-90	2WD & 4x4		Getrag 1st Design (3 Pc. I/S & O/S Brgs.) Includes M/S Needle Brgs.	TRK-235A	TRK-235AWS
4	SM465	90-79	2WD & 4x4		Contains R1563TAV Front C/S Brg.	TRK-157L	TRK-157LWS
4	SM465	90-68	2WD & 4x4		10 Bolt Side Cover, Case 10-5/8" Long Overall	TRK-157A	TRK-157AWS
4	SM465	90-68	2WD & 4x4		Contains M1305GGTV & R1563TAV Front C/S Brg.	TRK-157ASPK	TRK-157ASPKWS
5	HM290, MG5	89-88	2WD & 4x4		Getrag 1st Design (3 Pc. I/S & O/S Brgs.)	TRK-235N	TRK-235NWS
5	HM290, MG5	89-88	2WD & 4x4		Contains R1563TAV Front C/S Brg. 211FFLE I/S Brg.	TRK-235	TRK-235WS
4 w/ O/D	NP833	87-82	2WD & 4x4		7 Bolt Side Cover, Case 9-5/8" Long Overall	TRK-833	TRK-833WS
3	Saginaw	87-77	2WD & 4x4		6 Bolt Front C/S Retainer	TRK-301	TRK-301WS1
4	NP435	72-67	2WD & 4x4		With Taper I/S Brg.	TRK-127SPK	TRK-127WS
4	NP435	72-67	2WD & 4x4		With Taper I/S Brg.	TRK-127	
4	NP435	72-67	2WD & 4x4		With Ball I/S Brg.	TRK-127G	TRK-127GWS
Truck 1 Ton							
6	S6-650ZF	06-01	4x4			TRK-S6-650ZFC	TRK-S6-650ZFCWS
5	NV4500	07-97	2WD & 4x4		Flat Front Brg. Retainer (Kit Includes M/S Needles)	TRK-4500GM1N1	TRK-4500GM1N1WS
5	NV4500	07-97	2WD & 4x4		Flat Front Brg. Retainer (Kit Includes M/S Needles & Small Parts Kit)	TRK-4500GM1N1SPK	TRK-4500GM1N1SPKWS
5	NV4500	07-96	2WD & 4x4		Flat Front Brg. Retainer	TRK-4500GM1	TRK-4500GM1WS
5	NV4500	07-96	2WD & 4x4		Flat Front Brg. Retainer (Kit Includes Small Parts Kit)	TRK-4500GM1SPK	TRK-4500GM1SPKWS
6	S6-650ZF	06-01	2WD			TRK-S6-650ZFA	TRK-S6-650ZFAWS
5	NV4500	1996	2WD & 4x4		Flat Front Brg. Retainer (Kit Includes M/S Needles)	TRK-4500GM1N	TRK-4500GM1NWS
5	NV4500	1996	2WD & 4x4		Kit Includes M/S Needles & Small Parts Kit	TRK-4500GM1NSPK	TRK-4500GM1NSPKWS
5	NV4500	95-91	2WD & 4x4			TRK-4500GM	TRK-4500GMWS
5	NV4500	95-91	2WD & 4x4		Kit Includes M/S Needles	TRK-4500GMN	TRK-4500GMNWS
5	NV4500	95-91	2WD & 4x4		Flat Front Brg. Retainer (Kit Includes M/S Needles)	TRK-4500GMNSPK	TRK-4500GMNSPKWS
5	NV4500	95-91	2WD & 4x4		Kit Includes Small Parts Kit	TRK-4500GMSPK	TRK-4500GMSPKWS
4	SM465	91-90	2WD & 4x4		211FFLE I/S Brg.	TRK-157B	TRK-157BWS
4	SM465	90-79	2WD & 4x4		Contains R1563TAV Front C/S Brg.	TRK-157L	TRK-157LWS
4	SM465	90-68	2WD & 4x4		10 Bolt Side Cover, Case 10-5/8" Long Overall	TRK-157A	TRK-157AWS

Light Duty Transmission Applications

Speed	Model #	Year	Fwd/Rwd	Engine	Notes	Kit	w/Synchro Rings
GMC (cont.)							
Truck 1 Ton (cont.)							
4	SM465	90-68	2WD & 4x4		Contains M1305GGTV & R1563TAV Front C/S Brg.	TRK-157ASPK	TRK-157ASPKWS
4	NP435	72-67	2WD & 4x4		With Taper I/S Brg.	TRK-127SPK	TRK-127WS
4	NP435				With Taper I/S Brg.	TRK-127	
4	NP435	72-67	2WD & 4x4		With Ball I/S Brg.	TRK-127G	TRK-127GWS
Van 1/2 Ton							
4	SM465	87-79	2WD & 4x4		Contains R1563TAV Front C/S Brg.	TRK-157L	TRK-157LWS
4	SM465	87-71	2WD & 4x4		10 Bolt Side Cover, Case 10-5/8" Long Overall	TRK-157A	TRK-157AWS
4	SM465	87-71	2WD & 4x4		Contains M1305GGTV & R1563TAV Front C/S Brg.	TRK-157ASPK	TRK-157ASPKWS
4	NP435	72-67	2WD & 4x4		With Taper I/S Brg.	TRK-127SPK	TRK-127WS
4	NP435				With Taper I/S Brg.	TRK-127	
4	NP435	72-67	2WD & 4x4		With Ball I/S Brg.	TRK-127G	TRK-127GWS
Van 3/4 Ton							
4	SM465	87-79	2WD & 4x4		Contains R1563TAV Front C/S Brg.	TRK-157L	TRK-157LWS
4	SM465	87-71	2WD & 4x4		10 Bolt Side Cover, Case 10-5/8" Long Overall	TRK-157A	TRK-157AWS
4	SM465	87-71	2WD & 4x4		Contains M1305GGTV & R1563TAV Front C/S Brg.	TRK-157ASPK	TRK-157ASPKWS
4	NP435	72-67	2WD & 4x4		With Taper I/S Brg.	TRK-127SPK	TRK-127WS
4	NP435				With Taper I/S Brg.	TRK-127	
4	NP435	72-67	2WD & 4x4		With Ball I/S Brg.	TRK-127G	TRK-127GWS
Van 1 Ton							
4	SM465	87-79	2WD & 4x4		Contains R1563TAV Front C/S Brg.	TRK-157L	TRK-157LWS
4	SM465	87-71	2WD & 4x4		10 Bolt Side Cover, Case 10-5/8" Long Overall	TRK-157A	TRK-157AWS
4	SM465	87-71	2WD & 4x4		Contains M1305GGTV & R1563TAV Front C/S Brg.	TRK-157ASPK	TRK-157ASPKWS
4	NP435	72-67	2WD & 4x4		With Taper I/S Brg.	TRK-127SPK	TRK-127WS
4	NP435				With Taper I/S Brg.	TRK-127	
4	NP435	72-67	2WD & 4x4		With Ball I/S Brg.	TRK-127G	TRK-127GWS
Yukon							
5	HM290, MG5, NV3500	1996	2WD & 4x4		Getrag 3rd Design (Standard Ball I/S & O/S Brgs. And 3 Pc. 1-2 Synchro Rings) & 1.180 ID C/S Brgs.	TRK-235B	TRK-235BWS1
5	HM290, MG5, NV3500	96-95	2WD & 4x4		Getrag 3rd Design (Standard Ball I/S & O/S Brgs.) Includes M/S Needle Brgs.	TRK-235BN2	TRK-235BN2WS
5	HM290, MG5, NV3500	1995	2WD & 4x4		Getrag 3rd Design (Standard Ball I/S & O/S Brgs. And 3 Pc. 1-2 Synchro Rings)	TRK-235B	TRK-235BWS1
5	HM290, MG5, NV3500	1994	2WD & 4x4		Getrag 3rd Design (Standard Ball I/S & O/S Brgs.) Includes M/S Needle Brgs.	TRK-235BN1	TRK-235BN1WS

LD Transmission

Light Duty Transmission Applications

Speed	Model #	Year	Fwd/Rwd	Engine	Notes	Kit	w/Synchro Rings
GMC (cont.)							
Yukon (cont.)							
5	HM290, MG5, NV3500	94-92	2WD & 4x4		Getrag 3rd Design (Standard Ball I/S & O/S Brgs.)	TRK-235B	TRK-235BWS
5	HM290, MG5, NV3500	93-92	2WD & 4x4		Getrag 3rd Design (Standard Ball I/S & O/S Brgs.) Includes M/S Needle Brgs.	TRK-235BN	TRK-235BNWS
Honda							
Accord							
5	APG6	05-03	FWD	4 Cyl.		TRK-FH370	TRK-FH370WS
5	ATC6	05-03	FWD	V-6		TRK-FH380	TRK-FH380WS
5	P2A5	02-98	FWD			TRK-FH180	TRK-FH180WS1
5	P2A8	02-98	FWD			TRK-FH180	TRK-FH180WS1
5	P2U5	02-98	FWD			TRK-FH180	TRK-FH180WS2
5	P2A4	97-94	FWD			TRK-FH180	TRK-FH180WS
5	P2A5	97-94	FWD			TRK-FH180	TRK-FH180WS
5	P2U5	97-94	FWD			TRK-FH180	TRK-FH180WS
5	H2A5	93-92	FWD			TRK-FH180	TRK-FH180WS
5	H2C4	93-92	FWD			TRK-FH180	TRK-FH180WS
5	H2U4	93-92	FWD			TRK-FH180	TRK-FH180WS
5	H2U5	93-92	FWD			TRK-FH180	TRK-FH180WS
5	HWU4	93-92	FWD			TRK-FH180	TRK-FH180WS
5	H2A5	91-90	FWD			TRK-FH170	TRK-FH170WS
5	H2C4	91-90	FWD			TRK-FH170	TRK-FH170WS
5	H2U4	91-90	FWD			TRK-FH170	TRK-FH170WS
5	H2U5	91-90	FWD			TRK-FH170	TRK-FH170WS
5	HWU4	91-90	FWD			TRK-FH170	TRK-FH170WS
5	A2Q5	89-86	FWD		8 Bolt Black Tin Cover Over 5th Gears	TRK-FH120	TRK-FH120WS
5	A2Q6	89-86	FWD		8 Bolt Black Tin Cover Over 5th Gears	TRK-FH120	TRK-FH120WS
5	E2Q5	89-86	FWD		8 Bolt Black Tin Cover Over 5th Gears	TRK-FH120	TRK-FH120WS
5	E2Q6	89-86	FWD		8 Bolt Black Tin Cover Over 5th Gears	TRK-FH120	TRK-FH120WS
5	E2R5	89-86	FWD		8 Bolt Black Tin Cover Over 5th Gears	TRK-FH120	TRK-FH120WS
5	E2R6	89-86	FWD		8 Bolt Black Tin Cover Over 5th Gears	TRK-FH120	TRK-FH120WS
5	GS	85-84	FWD		8 Bolt Black Tin Cover Over	TRK-FH140	TRK-FH140WS
5	GY	85-84	FWD		8 Bolt Black Tin Cover Over 5th Gears	TRK-FH140	TRK-FH140WS
5	GK	83-79	FWD		8 Bolt Gold Tin Cover Over 5th Gears	TRK-FH100	TRK-FH100WS
4/5	GF	78-75	FWD		4 Bolt Alum. Rear Cover	TRK-FH250	TRK-FH250WS
CR-V							
5	SBXM	01-97	4x4			TRK-FH340	
CRX							
5	L3	91-88	FWD	1.5L	6207 Diff Brgs.	TRK-FH150	TRK-FH150WS
5	L3	91-88	FWD	1.6L	6208 Diff Brgs.	TRK-FH130	TRK-FH130WS
4/5	GV	87-84	FWD		Alum Cover Over 5th Gears	TRK-FH110	TRK-FH110WS
4/5	GW	87-84	FWD		Alum Cover Over 5th Gears	TRK-FH110	TRK-FH110WS

Light Duty Transmission Applications

Speed	Model #	Year	Fwd/Rwd	Engine	Notes	Kit	w/Synchro Rings
Honda (cont.)							
Civic							
6	L3-SL	00-85	4x4			TRK-FH290	TRK-FH290WS
5	SZB	05-02	FWD			TRK-FH470	
5	NRH3	05-02	FWD	Si, DOHC VTEC		TRK-FH460	
5	SLW	05-01	FWD	1.7L		TRK-FH390	
5	S4C	00-99	FWD	Si DOHC VTEC (Code B16A2)	6208 Diff Brgs., 28x60x15 I/S Brg.	TRK-FH260	TRK-FH260WS1
5	S40	00-98	FWD	1.6L VTEC-E (Code D16Y5)	6208 Diff Brgs., 26x58x15 I/S Brg.	TRK-FH200	TRK-FH200WS
5	S40	00-96	FWD	1.6L (Code D16Y7)	6207 Diff Brgs.	TRK-FH150	TRK-FH150WS
5	S40	00-96	FWD	1.6L VTEC (Code D16Y8)	6208 Diff Brgs., 26x58x15 I/S Brg.	TRK-FH200	TRK-FH200WS
5	S40	00-96	FWD	1.6L VTEC-E (Code D16Y5)	6207 Diff Brgs.	TRK-FH150	TRK-FH150WS
5	S20	95-92	FWD	1.5L	6207 Diff Brgs.	TRK-FH150	TRK-FH150WS
5	S20	95-92	FWD	1.6L	6208 Diff Brgs.	TRK-FH200	TRK-FH200WS
4	L3	91-88	FWD		6207 Diff Brgs.	TRK-FH150	TRK-FH150WS
5	L3	91-88	FWD	1.5L	6207 Diff Brgs.	TRK-FH150	TRK-FH150WS
5	L3	91-88	FWD	1.6L	6208 Diff Brgs.	TRK-FH130	TRK-FH130WS
4/5	GV	87-84	FWD		Alum Cover Over 5th Gears	TRK-FH110	TRK-FH110WS
4/5	GW	87-84	FWD		Alum Cover Over 5th Gears	TRK-FH110	TRK-FH110WS
4/5	GJ	83-80	FWD		Small Round Tin Back Cover	TRK-FH160	
4/5	GM	83-80	FWD		Small Round Tin Back Cover	TRK-FH160	
4/5	GB	79-73	FWD		4 Bolt Alum. Rear Cover	TRK-FH250	TRK-FH250WS
4/5	GC	79-73	FWD		4 Bolt Alum. Rear Cover	TRK-FH250	TRK-FH250WS
4/5	GD	79-73	FWD		4 Bolt Alum. Rear Cover	TRK-FH250	TRK-FH250WS
4/5	GE	79-73	FWD		4 Bolt Alum. Rear Cover	TRK-FH250	TRK-FH250WS
4/5	GF	79-73	FWD		4 Bolt Alum. Rear Cover	TRK-FH250	TRK-FH250WS
Del Sol							
5	SG8	97-96	FWD	1.5L, 1.6L SOHC VTEC	6208 Diff Brgs., 26x58x15 I/S Brg.	TRK-FH200	TRK-FH200WS
5	S21	97-96	FWD	1.6L DOHC V-TEC	6208 Diff Brgs., 28x60x15 I/S Brg.	TRK-FH260	TRK-FH260WS1
5	S20	95-93	FWD	1.5L	6207 Diff Brgs.	TRK-FH150	TRK-FH150WS
5	Y21	95-93	FWD	1.6L DOHC V-TEC	6208 Diff Brgs., 28x60x15 I/S Brg.	TRK-FH260	TRK-FH260WS1
5	S20	95-93	FWD	1.6L SOHC VTEC	6208 Diff Brgs., 26x58x15 I/S Brg.	TRK-FH200	TRK-FH200WS
Element							
5		05-02				TRK-FH480	
Passport							
5	MSG-5	02-94	4x4		4x4 Kit includes Transfer Case Parts	TRK-FI160	TRK-FI160WS
5	MSG-5	02-94	2WD	V6		TRK-FI200	TRK-FI200WS
5	T5 World Class	96-94	2WD	4 Cyl.		TRK-5W	TRK-5WWS1
Prelude							
5	M2U4	01-97	FWD			TRK-FH350	TRK-FH350WS
5	M2Y4	01-97	FWD			TRK-FH360	TRK-FH360WS
5	M2F4	96-94	FWD	2.2L DOHC, V-TEC		TRK-FH180	TRK-FH180WS1
5	M2L5	96-92	FWD	2.2L SOHC		TRK-FH180	TRK-FH180WS1
5	M2S4	96-92	FWD	2.3L DOHC		TRK-FH180	TRK-FH180WS1
5	D2A4	91-90	FWD	2.0L		TRK-FH210	TRK-FH210WS
5	D2J3	89-88	FWD			TRK-FH240	TRK-FH240WS
5	D2J4	89-88	FWD			TRK-FH240	TRK-FH240WS

Light Duty Transmission Applications

Speed	Model #	Year	Fwd/Rwd	Engine	Notes	Kit	w/Synchro Rings
Honda (cont.)							
Prelude (cont.)							
5	D2J5	89-88	FWD			TRK-FH240	TRK-FH240WS
5	D2M4	89-88	FWD			TRK-FH240	TRK-FH240WS
5	A1B5	87-85	FWD		8 Bolt Black Tin Cover Over 5th Gears	TRK-FH120	TRK-FH120WS
5	A2K5	87-85	FWD		8 Bolt Black Tin Cover Over 5th Gears	TRK-FH120	TRK-FH120WS
5	GM	85-83	FWD			TRK-FH140	TRK-FH140WS
5	GK	82-79	FWD			TRK-FH100	TRK-FH100WS
Hummer							
H3							
5	AR5	10-04	2WD&4x4			TRK-FG150	
H3T							
5	AR5	10-09	2WD&4x4			TRK-FG150	
Hyundai							
Accent							
5	KM302	03-11/95	FWD			TRK-FM420	TRK-FM420WS
5	KM302	10/95-8/94	FWD			TRK-FM260	TRK-FM260WS
Elantra							
5	M5AF3	00-12/95	FWD			TRK-FM400	TRK-FM400WS
5	KM303	11/95-6/93	FWD			TRK-FM150	TRK-FM150WS3
5	KM303	93-91	FWD			TRK-FM150	TRK-FM150WS1
Excel							
5	KM206	94-89	FWD	1.5L		TRK-FM100	TRK-FM100WS
4	KM200	93-89	FWD	1.5L		TRK-FM100	TRK-FM100WS1
4	KM160	4/89-12/85	FWD	1.5L		TRK-FC110	TRK-FC110WS1
5	KM162	4/89-12/85	FWD	1.5L		TRK-FC110	TRK-FC110WS
Scoupe							
5	KM301	95-92	FWD			TRK-FM380	TRK-FM380WS
5	KM210	7/92-5/90	FWD			TRK-FM100	TRK-FM100WS
Sonata							
5	KM212	98-92	FWD	2.4L		TRK-FM210	TRK-FM210WS
5	KM208	91-89	FWD	2.0L		TRK-FM150	TRK-FM150WS
Infiniti							
G20							
5	RS5F32A	00-90	FWD		Standard Differential	TRK-FN360	TRK-FN360WS
5	RS5F32V	00-90	FWD		With Limited Slip Differential	TRK-FN200	TRK-FN200WS
I30							
5	RS5F50A	00-11/95	FWD		Standard Differential	TRK-FN370	TRK-FN370WS
5	RS5F50A	00-11/95	FWD		With Limited Slip Differential	TRK-FN380	TRK-FN380WS
International							
Truck							
5	T698	85-80	2WD & 4x4			TRK-183	
4	T19	85-74	2WD & 4x4			TRK-BW19I	TRK-BW19IWS
5	T495	80-75	2WD & 4x4		Without 1st-Rev. Sliding Gear	TRK-156	
3	T15	80-74	2WD & 4x4			TRK-BW15I	TRK-BW15IWS
4	NP445	78-70	2WD & 4x4		Alum. Top Cover & Fully Synchronized	TRK-NP140I	
5	T33	75-62	2WD & 4x4		With 1st-Rev. Sliding Gear	TRK-156	
4	T18	73-65	2WD & 4x4			TRK-BW18I	TRK-BW18IWS
3	T90	73-61	2WD & 4x4			TRK-BW90I	TRK-BW90IWS
4	T98	69-56	2WD & 4x4			TRK-BW98I	TRK-BW98IWS

Light Duty Transmission Applications

Speed	Model #	Year	Fwd/Rwd	Engine	Notes	Kit	w/Synchro Rings
Isuzu							
i-290							
5	AR5	08-07	2WD&4x4			TRK-FG150	
i-280							
5	AR5	2006	2WD&4x4			TRK-FG150	
Amigo							
5	MSG-5F	5/91-7/87	4x4			TRK-FI130	TRK-FI130WS
5	MSG-5F	00-91	4x4		3 PC. 1-2 Synchro Rings	TRK-FI160	TRK-FI160WS
5	MSG-5G	00-91	2WD	6 Cyl.		TRK-FI200	TRK-FI200WS
5	MSG-5G	91-87	2WD	6 Cyl.		TRK-FI170	TRK-FI170WS
5	MSG-5K	87-81	2WD	4 Cyl.	1-2 Rings 36 Teeth	TRK-FI110	TRK-FI110WS
5	MSG-5K	87-81	2WD	4 Cyl.	1-2 Rings 45 Teeth	TRK-FI110	TRK-FI110WS1
Hombre							
5	NV1500	00-96	2WD			TRK-1500GM	TRK-1500GMWS
I-Mark							
5	MSG-5G	89-85	FWD			TRK-FI120	TRK-FI120WS
5	MSG-5G	89-85	FWD		3 PC. 1-2 Synchro Rings	TRK-FI120	TRK-FI120WS1
4	MSG-4K	85-81	RWD			TRK-FI220	TRK-FI220WS
5	MSG-5K	85-81	RWD			TRK-FI110	TRK-FI110WS
Impulse							
5	MSG-5G	92-90	FWD			TRK-FI120	TRK-FI120WS
5	MSG-5G	92-90	FWD		3 PC. 1-2 Synchro Rings	TRK-FI120	TRK-FI120WS1
5	MSG-5T	90-12/87	RWD		1-2 Rings 45 Teeth	TRK-FI110	TRK-FI110WS1
5	MSG-5T	12/87-83	RWD		1-2 Rings 36 Teeth	TRK-FI110	TRK-FI110WS
Rodeo							
5	MSG-5F	04-91	4x4		3 PC. 1-2 Synchro Rings	TRK-FI160	TRK-FI160WS
5	MSG-5G	04-91	2WD	6 Cyl.		TRK-FI200	TRK-FI200WS
5	T5 World Class	98-90	2WD			TRK-5W	TRK-5WWS
5	MSG-5F	5/91-7/87	4x4			TRK-FI130	TRK-FI130WS
5	MSG-5G	91-87	2WD	6 Cyl.		TRK-FI170	TRK-FI170WS
Stylus							
5	MSG-5G	93-91	FWD			TRK-FI120	TRK-FI120WS
5	MSG-5G	93-91	FWD		3 PC. 1-2 Synchro Rings	TRK-FI120	TRK-FI120WS1
Trooper							
5	MSG-5F	97-91	4x4		3 PC. 1-2 Synchro Rings	TRK-FI160	TRK-FI160WS
5	MSG-5F	5/91-7/87	4x4			TRK-FI130	TRK-FI130WS
5	MSG-5ET	87-84	4x4			TRK-FI100	TRK-FI100WS
4	MSG-4ET	87-81	4x4			TRK-FI180	TRK-FI180WS
Truck							
5	MSG-5F	95-91	4x4		3 PC. 1-2 Synchro Rings	TRK-FI160	TRK-FI160WS
5	MSG-5G	95-91	2WD	6 Cyl.		TRK-FI200	TRK-FI200WS
5	MSG-5F	5/91-7/87	4x4			TRK-FI130	TRK-FI130WS
5	MSG-5G	91-87	2WD	6 Cyl.		TRK-FI170	TRK-FI170WS
5	MSG-5ET	87-84	4x4			TRK-FI100	TRK-FI100WS
4	MSG-4ET	87-81	4x4		4x4	TRK-FI180	TRK-FI180WS
4	MSG-4K	87-81	2WD			TRK-FI220	TRK-FI220WS
5	MSG-5K	87-81	2WD	4 Cyl.	1-2 Rings 36 Teeth	TRK-FI110	TRK-FI110WS
5	MSG-5K	87-81	2WD	4 Cyl.	1-2 Rings 45 Teeth	TRK-FI110	TRK-FI110WS1
4	MSG-4K	81-76	2WD			TRK-FI140	TRK-FI140WS
Jeep							
All Models (82 & Earlier)							
4	T4J	86-82	2WD & 4x4		Taper I/S Brg., Alum. Top Cover	TRK-4J	TRK-4JWS
4	T18J	86-65	2WD & 4x4			TRK-BW18J	TRK-BW18JWSO
4	T176	84-80	2WD & 4x4		10 Bolt Alum. Cover with Brass Forks	TRK-175	TRK-175WS
4	T177	84-80	2WD & 4x4		10 Bolt Alum. Cover with Brass Forks	TRK-175	TRK-175WS

Light Duty Transmission Applications

Speed	Model #	Year	Fwd/Rwd	Engine	Notes	Kit	w/Synchro Rings
Jeep (cont.)							
All Models (82 & Earlier) (cont.)							
4	T178	84-80	2WD & 4x4		10 Bolt Alum. Cover with Brass Forks	TRK-175	TRK-175WS
4	SR4J	81-79	2WD & 4x4		Ball I/S Brg., Alum. Top Cover	TRK-BWSR4J	TRK-BWSR4JWS
3	T150	80-75	2WD & 4x4			TRK-150J	TRK-150JWS
3	T15	79-67	2WD & 4x4			TRK-BW15J	TRK-BW15JWS
3	T14	76-68	2WD & 4x4		6 Bolt Top Cover	TRK-BW14J	TRK-BW14JWS
4	T98J	73-55	2WD & 4x4		Iron Top Cover	TRK-BW98J	TRK-BW98JWS
3	T90	72-46	2WD & 4x4		6 Bolt Top Cover	TRK-BW90	TRK-BW90WS
3	T86	71-65	2WD & 4x4		6 Bolt Top Cover	TRK-BW86JA	TRK-BW86JAWS
3	T86	64-54	2WD & 4x4		6 Bolt Top Cover	TRK-BW86J	TRK-BW86JWS
3	T85	64-52	2WD & 4x4			TRK-BW85	TRK-BW85WS
3	T84	45-41	2WD & 4x4			TRK-BW84	TRK-BW84WS
Cherokee							
5	NV3550	01-00	2WD & 4x4	6 Cyl.		TRK-NV3550	TRK-NV3550WS
5	AX5	00-11/5/88	2WD & 4x4	4 Cyl.		TRK-FT160	TRK-FT160WS
5	AX15	99-90	2WD & 4x4	6 Cyl.	Serial # 00705123 and higher	TRK-FT300	TRK-FT300WS1
5	AX15	90-89	2WD & 4x4	6 Cyl.	Serial # 00705122 and lower	TRK-FT300	TRK-FT300WS
4	AX4	90-11/5/88	2WD & 4x4	4 Cyl.	23mm Wide I/S Brg.	TRK-FT170	TRK-FT170WS
5	BA10 / AX18	89-87	2WD & 4x4	6 Cyl.	Case Splits Lengthwise	TRK-FP100	TRK-FP100WS
5	AX5	11/4/88-86	2WD & 4x4	4 Cyl. , 6 Cyl.	23mm Wide I/S Brg.	TRK-FT170	TRK-FT170WS
4	AX4	11/4/88-84	2WD & 4x4	4 Cyl. , 6 Cyl.	23mm Wide I/S Brg.	TRK-FT170	TRK-FT170WS
4	T4J	85-84	2WD & 4x4		Taper I/S Brg., Alum. Top Cover	TRK-4J	TRK-4JWS
5	T5J	85-84	2WD & 4x4			TRK-5	TRK-5WS
4	AX4	85-84	2WD & 4x4	4 Cyl. , 6 Cyl.	20mm Wide I/S Brg.	TRK-FT180	TRK-FT180WS
5	AX5	85-84	2WD & 4x4	4 Cyl. , 6 Cyl.	20mm Wide I/S Brg.	TRK-FT180	TRK-FT180WS
4	T18	79-74	4x4	6 Cyl. & 8 Cyl.		TRK-BW18J	TRK-BW18JWS
CJ Series							
4	T18	79-70	2WD & 4x4		20mm Wide I/S Brg.	TRK-BW18	TRK-BW18WS
4	T98	71-57	2WD & 4x4			TRK-BW98	TRK-BW98WS
Comanche/ MJ							
5	AX15	93-90	2WD & 4x4	6 Cyl.	Serial # 00705123 and higher	TRK-FT300	TRK-FT300WS1
5	AX5	92-11/5/88	2WD & 4x4	4 Cyl.		TRK-FT160	TRK-FT160WS
5	AX15	90-89	2WD & 4x4	6 Cyl.	Serial # 00705122 and lower	TRK-FT300	TRK-FT300WS
4	AX4	90-11/5/88	2WD & 4x4	4 Cyl.	23mm Wide I/S Brg.	TRK-FT170	TRK-FT170WS
5	BA10 / AX18	89-87	2WD & 4x4	6 Cyl.	Case Splits Lengthwise	TRK-FP100	TRK-FP100WS
5	AX5	11/4/88-86	2WD & 4x4	4 Cyl. , 6 Cyl.	23mm Wide I/S Brg.	TRK-FT170	TRK-FT170WS
4	AX4	11/4/88-84	2WD & 4x4	4 Cyl. , 6 Cyl.	23mm Wide I/S Brg.	TRK-FT170	TRK-FT170WS
4	AX4	85-84	2WD & 4x4	4 Cyl. , 6 Cyl.	20mm Wide I/S Brg.	TRK-FT180	TRK-FT180WS
5	AX5	85-84	2WD & 4x4	4 Cyl. , 6 Cyl.	20mm Wide I/S Brg.	TRK-FT180	TRK-FT180WS
Grand Cherokee							
5	AX15	94-93	4x4	6 Cyl.	Serial # 00705123 and higher	TRK-FT300	TRK-FT300WS1
Liberty							
6	NSG370	08-05				TRK-FC120	TRK-FC120WS
5	NV1500	04-02	2WD & 4x4			TRK-1500D	TRK-1500DWS
5	NV3550	04-02	4x4	6 Cyl.	2 Pc. Case & 6 Bolt Front Retainer	TRK-235C	TRK-235CWS1

Light Duty Transmission Applications

Speed	Model #	Year	Fwd/Rwd	Engine	Notes	Kit	w/Synchro Rings
Jeep (cont.)							
Truck J10 / J20							
4	T177	87-81	4x4	6 Cyl.	10 Bolt Alum. Cover with Brass Forks	TRK-175	TRK-175WS
4	T176	87-81	4x4	8 Cyl.	10 Bolt Alum. Cover with Brass Forks	TRK-175	TRK-175WS
5	T5J	83-82	4x4			TRK-5	TRK-5WS
4	T18	83-65	4x4	6 Cyl. & 8 Cyl.		TRK-BW18J	TRK-BW18JWS
4	T98J	64-63	2WD & 4x4		Iron Top Cover	TRK-BW98J	TRK-BW98JWS
Wagoneer							
4	T18	79-71	4x4	6 Cyl. & 8 Cyl.		TRK-BW18J	TRK-BW18JWS
Wrangler							
6	NSG370	00-05				TRK-FC120	TRK-FC120WS
5	NV3550	04-00	4x4	6 Cyl.		TRK-NV3550	TRK-NV3550WS
5	AX15	99-90	2WD & 4x4	6 Cyl.	Serial # 00705123 and higher	TRK-FT300	TRK-FT300WS1
5	AX5	92-11/5/88	2WD & 4x4	4 Cyl.		TRK-FT160	TRK-FT160WS
5	AX15	90-89	2WD & 4x4	6 Cyl.	Serial # 00705122 and lower	TRK-FT300	TRK-FT300WS
5	BA10 / AX18	89-87	4x4	6 Cyl.	Case Splits Lengthwise	TRK-FP100	TRK-FP100WS
5	AX5	11/4/88-87	2WD & 4x4	4 Cyl. & 6 Cyl.	23mm Wide I/S Brg.	TRK-FT170	TRK-FT170WS
4	T4J	86-82	4x4	4 Cyl. & 6 Cyl.	Taper I/S Brg., Alum. Top Cover	TRK-4J	TRK-4JWS
5	T5J	86-82	4x4	4 Cyl. & 6 Cyl.		TRK-5	TRK-5WS
4	T177	86-81	4x4		10 Bolt Alum. Cover with Brass Forks	TRK-175	TRK-175WS
4	SR4J	1981	4x4	4 Cyl. & 6 Cyl.	Ball I/S Brg., Alum. Top Cover	TRK-BWSR4J	TRK-BWSR4JWS
Kia							
Car							
5		08-94	FWD	1.6L		TRK-FMZ130	TRK-FMZ130WS
5		08-94	FWD	1.8L		TRK-FMZ150	TRK-FMZ150WS
Sephia							
5		01-95	FWD	1.8L		TRK-FMZ150	TRK-FMZ150WS
5		97-94	FWD	1.6L		TRK-FMZ130	TRK-FMZ130WS
Sportage							
5	Sport	02-95	4x4			TRK-FK110	TRK-FK110WS
Lexus							
ES250							
5	E52	91-89	FWD			TRK-FT520	Obsolete
ES300							
5	E53	93-91	FWD			TRK-FT520	TRK-FT520WS1
SC300							
5	W58	97-11/91	RWD			TRK-FT210	TRK-FT210WS5
Lincoln							
All Car Models (82 & Earlier)							
4 w/ O/D	SROD	82-81	RWD		Top Loader 10 Bolt Top Cover	TRK-170	TRK-170WS1
4	MTX4	82-80	FWD		Codes RGT	TRK-FMZ160	TRK-FMZ160WS
3	Tremec RAB, RAC, RAN, RAT, HEF	82-65	RWD		9 Bolt Top Cover (1st Ring Larger than 2nd & 3rd)	TRK-150F	TRK-150FWS
3	Tremec RAB, RAC, RAN, RAT, HEF	82-65	RWD		9 Bolt Top Cover (All Rings Same Size)	TRK-150F	TRK-150FWS1
4 w/ O/D	RUG	81-78	RWD		Top Loader 10 Bolt Top Cover	TRK-170	TRK-170WS
4	ENG	76-71	RWD		4 Bolt Alum. Top Cover	TRK-F150	

Light Duty Transmission Applications

Speed	Model #	Year	Fwd/Rwd	Engine	Notes	Kit	w/Synchro Rings
Lincoln (cont.)							
All Car Models (82 & Earlier) (cont.)							
4	RUG/HEH	73-64	RWD		Top Loader 10 Bolt Top Cover	TRK-170A	TRK-170AWS
4	RUG/HEH	73-64	RWD		Top Loader 10 Bolt Top Cover (w/ Max-Type Brgs.)	TRK-170AHD	TRK-170AHDWS
3	T86	70-64	RWD			TRK-BW86	
4	T10	69-66	RWD		7/8" Countershaft w/o Thrust Brg. Between 2nd & 3rd Gears	TRK-10W	TRK-10WWS
4	DAG	68-63	RWD		10 Bolt Side Cover (Includes Small Parts Kit)	TRK-F140	TRK-F140WS
4	DAG	68-63	RWD		10 Bolt Side Cover (Does Not Include M/S & C/S Needles)	TRK-F140A	TRK-F140AWS
3	HED	67-64	RWD		4 Bolt Top Cover	TRK-F130	TRK-F130WS
4	T10	65-57	RWD		7/8" Countershaft w/ Thrust Brg. Between 2nd & 3rd Gears	TRK-10E	TRK-10EWS
3	259	64-48	RWD		9 Bolt Rectangular Side Cover	TRK-259	
3 w/ O/D	259	64-48	RWD		9 Bolt Rectangular Side Cover	TRK-259A	
Mazda							
323							
5	G5M-R	94-89	FWD	1.6L SOHC		TRK-FMZ130	TRK-FMZ130WS
5	F5M-R	94-89	FWD	1.8L DOHC		TRK-FMZ150	TRK-FMZ150WS
5	F5M-R	94-88	FWD	Turbo		TRK-FMZ150	TRK-FMZ150WS
5	G5MX-R	89-88	4x4			Obsolete	Obsolete
4	323	88-86	FWD			TRK-FMZ180	TRK-FMZ180WS1
5	323	88-86	FWD			TRK-FMZ180	TRK-FMZ180WS
626							
5	F5M-R, G25M-R H5M-R	02-88	FWD		Synchronized in Rev.	TRK-FMZ150	TRK-FMZ150WS
5	F5M-R, G25M-R H5M-R	92-88	FWD	Turbo		TRK-FMZ170	TRK-FMZ170WS
5	626	88-83	FWD			TRK-FMZ150	TRK-FMZ150WS
5	F5M-R	87-86	FWD	Turbo		TRK-FMZ150	TRK-FMZ150WS
5	R Type	82-76	RWD			TRK-FMZ100	TRK-FMZ100WS
929							
5	R-Type	89-88	RWD			TRK-FMZ210	TRK-FMZ210WS
GLC							
4	GLC	85-81	FWD			TRK-FMZ180	TRK-FMZ180WS1
5	GLC-5F	85-81	FWD			TRK-FMZ180	TRK-FMZ180WS
4	GLC	82-77	RWD			TRK-FMZ240	TRK-FMZ240WS
5	GLC-5F	82-77	RWD			TRK-FMZ250	TRK-FMZ250WS
MX3							
5	F25M-R	95-93	FWD	4 Cyl		TRK-FMZ130	TRK-FMZ130WS
5	G25M-R	95-93	FWD	6 Cyl		TRK-FMZ150	TRK-FMZ150WS
5	F5M-R	1992	FWD	4 Cyl		TRK-FMZ130	TRK-FMZ130WS
5	G5M-R	1992	FWD	6 Cyl		TRK-FMZ150	TRK-FMZ150WS
MX6							
5	H5M-R, G25M-R	97-88	FWD			TRK-FMZ150	TRK-FMZ150WS
5	MX6	92-88	FWD	Turbo		TRK-FMZ170	TRK-FMZ170WS

Light Duty Transmission Applications

Speed	Model #	Year	Fwd/Rwd	Engine	Notes	Kit	w/Synchro Rings
Mazda (cont.)							
Miata							
6	Y16M-D	05-99	RWD			TRK-FMZ400	TRK-FMZ400WS
5	M15M-D	05-95	RWD		3 Pc. 2nd Gear Synchro Ring	TRK-FMZ300	TRK-FMZ300WS1
5	M15M-D	94-90	RWD			TRK-FMZ300	TRK-FMZ300WS
Navajo							
5	M5R1	94-91	2WD & 4x4			TRK-247	TRK-247WS1
Protégé							
5	G15M-R	03-3/16/02	FWD	2.0L		TRK-FMZ390	TRK-FMZ390WS
5	F25M-R	03-92	FWD	1.5L, 1.6L SOHC		TRK-FMZ130	TRK-FMZ130WS
5	G15M-R	3/15/02-01	FWD	2.0L		TRK-FMZ380	TRK-FMZ380WS
5	G25M-R	98-92	FWD	1.8L DOHC		TRK-FMZ150	TRK-FMZ150WS
RX7							
5	R15M-D	95-93	RWD	Turbo		TRK-FMZ210	TRK-FMZ210WS1
5	R5M-D	92-89	RWD		Single Ball Front C/S Brg.	TRK-FMZ120	TRK-FMZ120WS2
5	R5M-D	92-89	RWD		Double Ball Front C/S Brg.	TRK-FMZ200	TRK-FMZ200WS2
5	R5M-D	92-87	RWD	Turbo		TRK-FMZ210	TRK-FMZ210WS
5	R Type	88-86	RWD		Single Ball Front C/S Brg.	TRK-FMZ120	TRK-FMZ120WS1
5	R Type	88-86	RWD		Double Ball Front C/S Brg.	TRK-FMZ200	TRK-FMZ200WS1
5	R Type	85-81	RWD		Single Ball Front C/S Brg.	TRK-FMZ120	TRK-FMZ120WS
5	R Type	85-81	RWD		Double Ball Front C/S Brg.	TRK-FMZ200	TRK-FMZ200WS
5	R Type	80-79	RWD		Single Ball Front C/S Brg.	TRK-FMZ100	TRK-FMZ100WS
5	R Type	80-79	RWD		Double Ball Front C/S Brg.	TRK-FMZ110	TRK-FMZ110WS
Truck B2000							
4	B4	84-79	2WD & 4x4			TRK-FMZ290	TRK-FMZ290WS
5	B2000	84-79	2WD & 4x4		Single Ball Front C/S Brg.	TRK-FMZ100	TRK-FMZ100WS
5	B2000	84-79	2WD & 4x4		Double Ball Front C/S Brg.	TRK-FMZ110	TRK-FMZ110WS
Truck B2200							
5	B2200	93-90	2WD & 4x4		Double Ball Front C/S Brg.	TRK-FMZ200	TRK-FMZ200WS2
5	B2200	90-86	2WD & 4x4		Single Ball Front C/S Brg.	TRK-FMZ120	TRK-FMZ120WS
5	B2200	90-86	2WD & 4x4		Double Ball Front C/S Brg.	TRK-FMZ200	TRK-FMZ200WS
Truck B2300							
5	M5R1	10-94	2WD & 4x4			TRK-247	TRK-247WS1
Truck B2600							
5	B2600	93-87	2WD & 4x4			TRK-FMZ210	TRK-FMZ210WS
Truck B3000							
5	M5R1	08-94	2WD & 4x4			TRK-247	TRK-247WS1
Truck B4000							
5	M5R1	09-94	2WD & 4x4			TRK-247	TRK-247WS1
Van							
5	B5V	93-88	RWD			TRK-FMZ210	TRK-FMZ210WS

LD Transmission

Light Duty Transmission Applications

Speed	Model #	Year	Fwd/Rwd	Engine	Notes	Kit	w/Synchro Rings
Mercury							
All Car Models (82 & Earlier)							
4 w/ O/D	SROD	82-81	RWD		Top Loader 10 Bolt Top Cover	TRK-170	TRK-170WS1
4	MTX4	82-80	FWD		Codes RGT	TRK-FMZ160	TRK-FMZ160WS
3	Tremec RAB, RAC, RAN, RAT, HEF	82-65	RWD		9 Bolt Top Cover (1st Ring Larger than 2nd & 3rd)	TRK-150F	TRK-150FWS
3	Tremec RAB, RAC, RAN, RAT, HEF	82-65	RWD		9 Bolt Top Cover (All Rings Same Size)	TRK-150F	TRK-150FWS1
4 w/ O/D	RUG	81-78	RWD		Top Loader 10 Bolt Top Cover	TRK-170	TRK-170WS
4	ENG	76-71	RWD		4 Bolt Alum. Top Cover	TRK-F150	
4	RUG/HEH	73-64	RWD		Top Loader 10 Bolt Top Cover	TRK-170A	TRK-170AWS
4	RUG/HEH	73-64	RWD		Top Loader 10 Bolt Top Cover (w/ Max-Type Brgs.)	TRK-170AHD	TRK-170AHDWS
3	T86	70-64	RWD			TRK-BW86	
4	T10	69-66	RWD		7/8" Countershaft w/o Thrust Brg. Between 2nd & 3rd Gears	TRK-10W	TRK-10WWS
4	DAG	68-63	RWD		10 Bolt Side Cover (Includes Small Parts Kit)	TRK-F140	TRK-F140WS
4	DAG	68-63	RWD		10 Bolt Side Cover (Does Not Include M/S & C/S Needles)	TRK-F140A	TRK-F140AWS
3	HED	67-64	RWD		4 Bolt Top Cover	TRK-F130	TRK-F130WS
4	T10	65-57	RWD		7/8" Countershaft w/ Thrust Brg. Between 2nd & 3rd Gears	TRK-10E	TRK-10EWS
3	259	64-48	RWD		9 Bolt Rectangular Side Cover	TRK-259	
3 w/ O/D	259	64-48	RWD		9 Bolt Rectangular Side Cover	TRK-259A	
Capri							
5	CAP5	94-91	FWD	Non-Turbo		TRK-FMZ130	TRK-FMZ130WS
5	CAP5	94-91	FWD	Turbo		TRK-FMZ150	TRK-FMZ150WS
4	German	86-83	RWD		6008 O/S Brg.	Obsolete	
5	T5	84-83	RWD		LM48548/10 I/S Brg. & Cylindrical C/S Brgs.	TRK-5	TRK-5WS
5	RAP	83-81	RWD		10 Bolt Top Cover	TRK-F190	Obsolete
4	RUG	83-80	RWD		Top Loader 10 Bolt Top Cover	TRK-170	TRK-170WS
Cougar							
5	MTX5	02-99	FWD		6 Bolt Shift Tower	TRK-FMZ350	Obsolete
5	T5 World Class	86-85	RWD	4 Cyl	LM48548/10 I/S Brg. & Taper C/S Brgs.	TRK-5W	TRK-5WWS
5	T5	1984	RWD	4 Cyl	LM48548/10 I/S Brg. & Cylindrical C/S Brgs.	TRK-5	TRK-5WS
LN7							
4	MTX4	1983	FWD			TRK-FMZ160	TRK-FMZ160WS
Lynx							
4	MTX4	87-86	FWD			TRK-FMZ330	TRK-FMZ330WS
5	MTX5	87-83	FWD			TRK-FMZ140	
4	MTX4	84-83	FWD			TRK-FMZ160	TRK-FMZ160WS
4	MTX4	1985	FWD	1.6L, 1.9L	Trans ID RGT	TRK-FMZ160	TRK-FMZ160WS

Light Duty Transmission Applications

Speed	Model #	Year	Fwd/Rwd	Engine	Notes	Kit	w/Synchro Rings
Mercury (cont.)							
Lynx (cont.)							
4	MTX4	1985	FWD	1.9L	Trans ID RJS	TRK-FMZ330	TRK-FMZ330WS
Mystique							
5	MTX5	00-95	FWD		6 Bolt Shift Tower	TRK-FMZ350	Obsolete
Topaz							
5	MTX5	94-92	FWD	3.0L		TRK-FMZ340	Obsolete
5	MTX5	94-84	FWD	2.3L	2 Pinion Differential	TRK-FMZ140	Obsolete
5	MTX5	94-84	FWD	2.3L	4 Pinion Differential	TRK-FMZ190	Obsolete
4	MTX4	1984	FWD			TRK-FMZ160	TRK-FMZ160WS
Tracer							
5	TR5C	99-97	FWD	2.0L		TRK-FMZ150	TRK-FMZ150WS
5	TR5A	96-91	FWD	1.8L		TRK-FMZ150	TRK-FMZ150WS
5	TR5B	96-91	FWD	1.9L		TRK-FMZ130	TRK-FMZ130WS
5	TR5	89-88	FWD	1.6L		TRK-FMZ180	TRK-FMZ180WS
Mitsubishi							
3000GT							
6	W6MG1	99-94	4x4	3.0L Turbo		TRK-FM530	TRK-FM530WS
5	F5M33	12/99-5/93	FWD	3.0L	3 Piece 2nd Ring	TRK-FM180	TRK-FM180WS4
	W5MG1	99-92			Transfer Case Section Only Late 18 Spline & All 25 Spline O/S	TRK-FM270	
5	F5M33	4/93-6/92	FWD	3.0L	3 Piece 2nd Ring	TRK-FM180	TRK-FM180WS3
5	W5MG1	93-91	4x4	3.0L Turbo		TRK-FM250	TRK-FM250WS
	W5MG1	92-91			Transfer Case Section Only Early 18 Spline O/S	TRK-FM280	
5	F5M33	5/92-5/91	FWD	3.0L	3 Piece 2nd Ring	TRK-FM180	TRK-FM180WS2
5	F5M33	4/91-12/90	FWD	3.0L	Brass 1-2 Rings	TRK-FM180	TRK-FM180WS1
5	F5M33	11/90-4/90	FWD	3.0L	Fiber Lined 1-2 Rings	TRK-FM180	TRK-FM180WS
Cordia							
4	KM165	88-83	FWD	1.8L	Ball Diff Brgs.	TRK-FC110	TRK-FC110WS1
5	KM162	88-83	FWD	1.8L	Ball Diff Brgs.	TRK-FC110	TRK-FC110WS
5	KM163	88-83	FWD	2.0L	Tapered Diff Brgs.	TRK-FM170	TRK-FM170WS
8	KM166	88-83	FWD	2.0L	Tapered Diff Brgs.	TRK-FM170	TRK-FM170WS
5	KM163	11/86-6/83	FWD	1.8L Turbo	Tapered Diff Brgs.	TRK-FM170	TRK-FM170WS
Eclipse							
5	W5M33	00-90	4x4	2.0L Turbo	Ball Diff Brgs. (Fiber Lined 1-2 Rings, Synchro Rev.)	TRK-FM160	TRK-FM160WS
5	F5M42	12-00	FWD	4 Cyl.		TRK-FM450	TRK-FM450WS
5	F5M51	04-00	FWD	V-6		TRK-FM440	TRK-FM440WS
5	F5M31	99-96	FWD	2.4L	3 Pc 2nd Synchro Ring, Synchro Rev.	TRK-FM180	TRK-FM180WS4
5	F5MC1/NVT350/ A578	99-95	FWD	2.0L	New Venture Transaxle	TRK-350	TRK-350WS
5	F5M33	99-94	FWD	2.0L Turbo	3 Pc 2nd Synchro Ring, Synchro Rev.	TRK-FM180	TRK-FM180WS4
5	W5M33	99-93	4x4	2.0L Turbo	Ball Diff Brgs. (3 Pc. 2nd Synchro Ring, 39 Teeth 3-4 Rings, Synchro Rev.)	TRK-FM160	TRK-FM160WS3
	KM272	99-90			Transfer Case Section Only	TRK-FM350	
5	F5M22	94-93	FWD	1.8L, 2.0L	3-4 Synchro Rings 36 Teeth, Synchro Rev.	TRK-FM150	TRK-FM150WS2
5	W5M33	5/93-6/92	4x4	2.0L Turbo	Ball Diff Brgs. (3 Pc. 2nd Synchro Ring, 24 Teeth 3-4 Rings, Synchro Rev.)	TRK-FM160	TRK-FM160WS2

LD Transmission

Light Duty Transmission Applications

Speed	Model #	Year	Fwd/Rwd	Engine	Notes	Kit	w/Synchro Rings
Mitsubishi (cont.)							
Eclipse (cont.)							
5	F5M33	93-88	FWD	2.0L Turbo	Fiber Lined 1-2 Rings, Synchro Rev.	TRK-FM180	TRK-FM180WS
5	W5M33	5/92-5/91	4x4	2.0L Turbo	Ball Diff Brgs. (Brass 1-2 Rings, Synchro Rev.)	TRK-FM160	TRK-FM160WS1
5	F5M22	92-90	FWD	1.8L, 2.0L	3-4 Synchro Rings 30 Teeth	TRK-FM150	TRK-FM150WS1
Expo							
5	F5M22	94-93	FWD	1.8L		TRK-FM150	TRK-FM150WS3
5	W5M31	94-91	4x4	1.8L	Transfer Case Section Not Included	TRK-FM240	TRK-FM240WS
5	F5M31	94-91	FWD	2.4L		TRK-FM210	TRK-FM210WS
5	F5M22	92-91	FWD	1.8L		TRK-FM150	TRK-FM150WS1
5	W5M33	92-91	4x4	2.4L	Transfer Case Section Not Included	TRK-FM290	TRK-FM290WS
Galant							
5	F5M31	98-94	FWD	2.4L		TRK-FM500	TRK-FM500WS
5	F5M22	93-88	FWD	2.0L		TRK-FM150	TRK-FM150WS1
5	W5M33	92-91	4x4	2.0L	Ball Diff Brgs., Transfer Case Section Not Included	TRK-FM160	TRK-FM160WS
5	W5M31	92-90	4x4	2.0L	Taper Diff Brgs., Transfer Case Section Not Included	TRK-FM240	TRK-FM240WS
5	F5M22	92-90	FWD	2.0L Turbo		TRK-FM150	TRK-FM150WS1
5	F5M33	92-88	FWD	2.0L Turbo		TRK-FM210	TRK-FM210WS1
Lancer							
5	F5M42	04-04	FWD			TRK-FM490	TRK-FM490WS1
Mirage							
5	F5M41	02-97	FWD	1.5L		TRK-FM480	TRK-FM480WS
5	F5M42	02-97	FWD	1.8L		TRK-FM490	TRK-FM490WS
5	F5M21	96-93	FWD	1.5L		TRK-FM460	TRK-FM460WS
5	F5M22	96-93	FWD	1.8L		TRK-FM470	TRK-FM470WS
5	KM210	92-89	FWD	1.6L Turbo		TRK-FM210	TRK-FM210WS
4	KM200	92-86	FWD	1.5L		TRK-FM100	TRK-FM100WS1
5	KM201	92-86	FWD	1.5L		TRK-FM100	TRK-FM100WS
5	KM206	88-86	FWD	1.6L Turbo		TRK-FM150	TRK-FM150WS
4	KM161	86-85	FWD	1.5L		TRK-FM390	TRK-FM390WS
5	KM162	86-85	FWD	1.5L		TRK-FC110	TRK-FC110WS
5	KM163	86-85	FWD	1.6L Turbo		TRK-FM170	TRK-FM170WS
Montero							
5	V5MT2	97-10/91	4x4	V6	3 Pc. 1-2 Gear Synchro Rings	TRK-FM200	TRK-FM200WS2
5	R5M21	99-97	2WD			TRK-FM130	TRK-FM130WS1
5	LD42GL	96-86	2WD		Steel Bottom Pan (TMS0788N I/S Brg.)	TRK-FM130	TRK-FM130WS
5	V5MT2	9/91-5/89	4x4	V6	Fiber Lined 1-4 Gear Syncho Rings	TRK-FM200	TRK-FM200WS1
5	V5MT2	4/89-5/88	4x4	V6	Brass Synchro Rings	TRK-FM200	TRK-FM200WS
5	LD42G	3/86-1/83	2WD		Steel Bottom Pan (6307 I/S Brg.)	TRK-FM110	TRK-FM110WS
Montero Sport							
5	R5M21	99-98		4 Cyl.		TRK-FM510	TRK-FM510WS
5	V5MT1	00-97		V6		TRK-FM520	TRK-FM520WS
5	R5M21	98-97		4 Cyl.		TRK-FM500	TRK-FM500WS

Light Duty Transmission Applications

Speed	Model #	Year	Fwd/Rwd	Engine	Notes	Kit	w/Synchro Rings
Mitsubishi (cont.)							
Precis							
4	KM200	92-88	FWD			TRK-FM100	TRK-FM100WS1
5	KM201	92-88	FWD	1.5L		TRK-FM100	TRK-FM100WS
5	KM162	4/89-1/87	FWD	1.8L		TRK-FC110	TRK-FC110WS
Raider							
5	Getrag 238	09-06	2WD & 4x4			TRK-FC130	
5	KM145-9	90-87	4x4	4 Cyl.	TMSC0788N I/S Brg.	TRK-FM130	TRK-FM130WS
5	V5MT2	90-86	4x4	V6		TRK-FM200	TRK-FM200WS
5	KM145-1	87-85	4x4	4 Cyl.	6307 I/S Brg.	TRK-FM110	TRK-FM110WS
Starion							
5	KM132-M	89-88	RWD		With Intercooler, Alum. Bottom Pan (TMSX07B40 I/S Brg. w/ flange), Synchro Rev.	TRK-FM320	TRK-FM320WS
5	KM132-G	87-85	RWD		With Intercooler, Steel Bottom Pan(TMSC0788 I/S Brg.w/ snap ring)	TRK-FM310	TRK-FM310WS
5	KM132-B	87-84	RWD		Without Intercooler	TRK-FM300	TRK-FM300WS
Tredia							
4	KM165	88-83	FWD	1.8L	Ball Diff Brgs.	TRK-FC110	TRK-FC110WS1
5	KM162	88-83	FWD	1.8L	Ball Diff Brgs.	TRK-FC110	TRK-FC110WS
5	KM163	88-83	FWD	2.0L	Tapered Diff Brgs.	TRK-FM170	TRK-FM170WS
8	KM166	88-83	FWD	2.0L	Tapered Diff Brgs.	TRK-FM170	TRK-FM170WS
5	KM163	11/86-6/83	FWD	1.8L Turbo	Tapered Diff Brgs.	TRK-FM170	TRK-FM170WS
Truck							
5	KM145-8	96-87	4x4			TRK-FM120	TRK-FM120WS
5	KM132-9	96-87	2WD	2.6L	F6307X1-1 I/S Brg	TRK-FM120	TRK-FM120WS
5	V5MT2	96-86	4x4	V6		TRK-FM200	TRK-FM200WS
5	KM132-8	88-82	2WD	2.0L		TRK-FM140	TRK-FM140WS
5	KM132-9	88-82	2WD	2.6L	6307 I/S Brg	TRK-FM110	TRK-FM110WS
5	KM132-E	86-82	2WD			TRK-FM110	TRK-FM110WS
5	KM145-1	86-82	4x4			TRK-FM110	TRK-FM110WS
5	KM145-2	86-82	4x4	Diesel		TRK-FM110	TRK-FM110WS
4	KM144	85-82	4x4			TRK-FM190	TRK-FM190WS
4	KM130	85-81	2WD			TRK-FM190	TRK-FM190WS
Nissan							
1200							
4	F4W56A	77-71	RWD			TRK-FN310	
200SX							
5	FS5W71S	88-87	RWD	Turbo & Non-Turbo	3 Pc. 2nd Gear Synchro Ring	TRK-FN110	TRK-FN110WS2
5	FS5W71M	8/87-7/84	RWD		2.440" O.D. Front C/S Ball Brg.	TRK-FN110	TRK-FN110WS1
5	FS5W71C	84-80	RWD		2.200" O.D. Front C/S Ball Brg.	TRK-FN100	TRK-FN100WS
5	FS5W63A	79-77	RWD		Tapered C/S Brgs.	TRK-FN350	TRK-FN350WS
210							
5	FS5W71H	93-88	RWD		2 Piece 2nd Gear Synchro Ring	TRK-FN110	TRK-FN110WS2
5	FS5W60A	82-79	RWD		1st Gear is Toward Dashboard	TRK-FN330	TRK-FN330WS
4	F4W60	82-75	RWD			TRK-FN320	
5	FS5W60L	79-76	RWD		1st Gear is Toward Driver	TRK-FN340	

LD Transmission

Light Duty Transmission Applications

Speed	Model #	Year	Fwd/Rwd	Engine	Notes	Kit	w/Synchro Rings
Nissan (cont.)							
240Z							
4	F4W70B	73-70	RWD			TRK-FN280	TRK-FN280WS
260Z							
4	F4W71B	80-74	RWD			TRK-FN230	TRK-FN230WS
5	FS5W71A	80-74	RWD		5th Gear Synchro Ring Not Included	TRK-FN100	TRK-FN100WS
280Z							
4	F4W71B	80-74	RWD			TRK-FN230	TRK-FN230WS
5	FS5W71A	80-74	RWD		5th Gear Synchro Ring Not Included	TRK-FN100	TRK-FN100WS
280ZX							
5	FS5W71C	83-81	RWD			TRK-FN100	TRK-FN100WS
5	FS5R90A/T-5	1983	RWD	Turbo	Borg Warner T-5	TRK-5NA	TRK-5NAWS
300ZX							
5	FS5R30A	89-2/889	RWD	Non Turbo & Twin Turbo	3 Piece 2nd & 3rd Ring	TRK-FN150	TRK-FN150WS1
5	FS5W71N	2/89-8/87	RWD		2 Piece 2nd Gear Synchro Ring	TRK-FN110	TRK-FN110WS2
5	FS5R30A	2/89-9/86	RWD	Single Turbo		TRK-FN150	TRK-FN150WS2
5	FS5W71N	8/87-7/83	RWD			TRK-FN110	TRK-FN110WS1
5	FS5R90A/T-5	86-84	RWD	Turbo	Borg Warner T-5	TRK-5N	TRK-5NWS
310							
4	RN4F30A	1/84-2/82	FWD			TRK-FN130	TRK-FN130WS
5	RS5F30A	1/84-2/82	FWD			TRK-FN130	TRK-FN130WS
510, 610, 710							
4	F4W63	81-70	RWD			TRK-FN260	TRK-FN260WS
Altima							
6	RS6F51A	06-05	FWD	SE-R		TRK-FN610	TRK-FN610WS
5	RS5F51A	06-02	FWD			TRK-FN600	TRK-FN600WS
5	RS5F50A	01-93	FWD	2.4L DOHC		TRK-FN220	TRK-FN220WS
5	RS5F50V	01-93	FWD	2.4L DOHC	Limited Slip Differential	TRK-FN470	TRK-FN470WS
Axxess							
5	RS5F50A	1990	2WD		Two 32008 Diff Brgs.	TRK-FN120	TRKFN120WS1
5	RS5F50A	1990	2WD		One 32008 & One 32008J/1D-57407N Diff Brgs.	TRK-FN210	TRK-FN210WS
5	RS5F50V	1990	4x4			TRK-FN250	TRK-FN250WS
	TY10B	1990			Transfer Case Section	TRK-FN500	
Frontier							
5	FS5W71C	04-97	2WD	4 Cyl.		TRK-FN530	TRK-FN530WS
5	FS5W71C	00-97	4x4	4 Cyl.		TRK-FN540	TRK-FN540WS
Maxima							
5	RS5F50A	00-93	FWD	3.0L		TRK-FN370	TRK-FN370WS
5	RS5F50V	00-93	FWD	3.0L	Limited Slip Differential	TRK-FN380	TRK-FN380WS
5	RS5F50A	86-85	FWD	3.0L	Two 32008 Diff Brgs.	TRK-FN120	TRK-FN120WS
6	RS6F51A	06-02	FWD	3.5L		TRK-FN580	TRK-FN580WS
5	RS5F50A	92-91	FWD	3.0L	Two 32008J/1D-57407N Diff Brgs.	TRK-FN220	TRK-FN220WS
5	RS5F50A	90-88	FWD	3.0L	Two 32008 Diff Brgs., Synchronized Rev.	TRK-FN120	TRK-FN120WS1
5	RS5F50A	90-85	FWD	3.0L	One 32008 & One 32008J/1D-57407N Diff Brgs.	TRK-FN210	TRK-FN210WS
5	FS5W71C	85-81	RWD	2.4L		TRK-FN100	TRK-FN100WS

Light Duty Transmission Applications

Speed	Model #	Year	Fwd/Rwd	Engine	Notes	Kit	w/Synchro Rings
Nissan (cont.)							
Pathfinder							
5	FS5R30A	02-12/98	2WD & 4x4	6 Cyl.		TRK-FN150	TRK-FN150WS11
5	FS5R30A	12/98-10/97	2WD & 4x4	6 Cyl.		TRK-FN150	TRK-FN150WS10
5	FS5R30A	10/97-5/97	2WD & 4x4	6 Cyl.		TRK-FN150	TRK-FN150WS9
5	FS5R30A	5/97-7/92	2WD & 4x4	6 Cyl.		TRK-FN150	TRK-FN150WS8
5	FS5R30A	7/92-3/87	2WD & 4x4	6 Cyl.		TRK-FN150	TRK-FN150WS7
5	FS5R30A	87-87	2WD & 4x4	6 Cyl.		TRK-FN150	TRK-FN150WS6
5	FS5W71C	1987	4x4	4 Cyl.		TRK-FN160	TRK-FN160WS
Pulsar							
5	RS5F50A	90-88	FWD	1.8L		TRK-FN120	TRK-FN120WS
5	RS5F31A	90-87	FWD	1.6L SOHC		TRK-FN140	TRK-FN140WS
5	RS5F31A	88-87	FWD	1.6L DOHC		TRK-FN440	TRK-FN440WS
5	RS5F30A	86-83	FWD	1.6L SOHC		TRK-FN130	TRK-FN130WS
5	RS5F31A	85-83	FWD	1.5L Turbo		TRK-FN140	TRK-FN140WS
Sentra							
5	RS5F51A	06-02	FWD	2.5L DOHC (SE-R)		TRK-FN570	TRK-FN570WS
6	RS6F51A	06-02	FWD	2.5L DOHC (SE-R, SPEC-V)		TRK-FN580	TRK-FN580WS
5	RS5F70A	02-00	FWD	1.8L DOHC		TRK-FN550	TRK-FN550WS
5	RS5F70A	01-00	FWD	2.0L DOHC		TRK-FN550	TRK-FN550WS
5	RS5F70V	01-00	FWD	2.0L DOHC		TRK-FN560	TRK-FN560WS
5	RS5F31A	99-91	FWD	1.6L DOHC	Two 32010 Differential Brgs.	TRK-FN170	TRK-FN170WS
5	RS5F32V	99-91	FWD	2.0L DOHC	With Limited Slip Differential, Uses One 32010 & One R8018 Differential Brg.	TRK-FN200	TRK-FN200WS
5	RS5F32V	99-91	FWD	2.0L DOHC	With Limited Slip Differential, Uses Two 32010 Differential Brgs.	TRK-FN520	TRK-FN520WS
4	RN4F31A	92-91	FWD			TRK-FN170	TRK-FN170WS
4	RN4F31A	90-88	FWD			TRK-FN140	TRK-FN140WS
5	RS5F31A	90-86	FWD			TRK-FN140	TRK-FN140WS
5	RS5F31E	89-87	4x4			TRK-FN420	TRK-FN420WS
	TY10A	89-87			Transfer Case Section Only	TRK-FN430	
4	RN4F30A	87-82	FWD			TRK-FN130	TRK-FN130WS
4	RN4G30	87-82	FWD	Diesel		TRK-FN130	TRK-FN130WS
5	RS5F30A	86-82	FWD			TRK-FN130	TRK-FN130WS
Stanza Car							
5	RS5F50A	92-91	FWD			TRK-FN220	TRK-FN220WS
5	RS5F50V	92-91	FWD		Limited Slip Differential	TRK-FN470	TRK-FN470WS
5	RS5F50A	90-86	FWD		2" Plug At Back	TRK-FN120	TRK-FN120WS
	TY10	88-86			Transfer Case Section Only	TRK-FN460	
5	RS5F31A	86-82	FWD		3-1/2" Plate At Back	TRK-FN140	TRK-FN140WS
Stanza Wagon							
	TY10	88-86			Transfer Case Section Only	TRK-FN460	
5	RS5F50A	88-86	4x4	2.0L		TRK-FN450	TRK-FN450WS
Truck							
5	FS5W71C	97-97	2WD	4 Cyl.		TRK-FN530	TRK-FN530WS
5	FS5W71C	97-97	4x4	4 Cyl.		TRK-FN540	TRK-FN540WS
5	FS5W71C	3/97-1/96	2WD	4 Cyl.		TRK-FN110	TRK-FN110WS12
5	FS5W71C	3/97-1/93	4x4	4 Cyl.		TRK-FN190	TRK-FN190WS2
5	FS5W71C	1/96-8/94	2WD	4 Cyl.		TRK-FN110	TRK-FN110WS11
5	FS5R30A	1/96-1/92	2WD & 4x4	6 Cyl.		TRK-FN150	TRK-FN150WS11
5	FS5W71C	8/94-7/93	2WD	4 Cyl.		TRK-FN110	TRK-FN110WS10

Light Duty Transmission Applications

Speed	Model #	Year	Fwd/Rwd	Engine	Notes	Kit	w/Synchro Rings
Nissan (cont.)							
Truck (cont.)							
5	FS5W71C	1/93-1/92	4x4	4 Cyl.		TRK-FN190	TRK-FN190WS1
5	FS5W71C	7/93-8/89	2WD	4 Cyl.		TRK-FN110	TRK-FN110WS9
5	FS5R30A	1/92-3/87	2WD & 4x4	6 Cyl.		TRK-FN150	TRK-FN150WS8
5	FS5W71C	1/92-6/86	4x4	4 Cyl.		TRK-FN190	TRK-FN190WS
4	F4W71C	89-86	2WD			TRK-FN270	TRK-FN110WS5
5	FS5W71C	89-84	2WD	4 Cyl.		TRK-FN110	TRK-FN110WS8
5	FS5R30A	3/87-11/85	2WD & 4x4	6 Cyl.		TRK-FN150	TRK-FN150WS7
5	FS5W71C	86-84	4x4	4 Cyl.		TRK-FN110	TRK-FN110WS13
5	FS5W71C	84-81	2WD	4 Cyl.		TRK-FN100	TRK-FN100WS
5	FS5W71C	84-81	4x4	4 Cyl.		TRK-FN100	TRK-FN100WS
4	F4W71B	83-80	4x4			TRK-FN270	TRK-FN270WS
4	F4W71B	83-74	2WD			TRK-FN230	TRK-FN230WS
5	FS5W71A	80-74	2WD		Does Not Include 5th Gear Crush Style Synchro Ring	TRK-FN100	TRK-FN100WS
4	F4W63	73-67	2WD			TRK-FN260	TRK-FN260WS
Van							
5	FS5W71V	00-86	2WD			TRK-FN110	TRK-FN110WS1
X-Terra							
5	FS5W71C	07-02	2WD	4 Cyl.	Ball Rear C/S Brg., 1 Piece 2nd & 3rd Synchro Ring	TRK-FN590	TRK-FN590WS
5	FS5R30A	00-99	4x4	6 Cyl.		TRK-FN150	TRK-FN150WS11
5	FS5W71C	9/02-10/00	2WD	4 Cyl.	Ball Rear C/S Brg., 3 Piece 2nd & 3rd Synchro Ring	TRK-FN590	TRK-FN590WS1
5	FS5W71C	10/00-5/99	2WD	4 Cyl.	Cylindrical Rear C/S Brg.	TRK-FN530	TRK-FN530WS
Oldsmobile							
All Car Models (82 & Earlier)							
3	Saginaw	85-66	RWD		7 Bolt Side Cover	TRK-301	TRK-301WS1
5	T5	82-81	RWD		Cylindrical Countershaft Brgs.	TRK-5	TRK-5WS
4	MR2	82-80	FWD		2 Piece Case	TRK-FG110	Obsolete
4	T10W	82-74	RWD		9 Bolt Side Cover (6307 I/S Brg., 1" C/S)	TRK-10WA	TRK-10WAWS
4	T10W	82-74	RWD		9 Bolt Side Cover (6307 I/S Brg., 1" C/S, Max-Type Ball Brgs.)	TRK-10WAHD	TRK-10WAHDWS
4	Saginaw	82-66	RWD		7 Bolt Side Cover	TRK-301	TRK-301WS
3	Tremec	74-68	RWD		9 Bolt Top Cover	TRK-150F	TRK-150FWS
4	M21	74-66	RWD		7 Bolt Side Cover (1" Countershaft)	TRK-297A	TRK-297AWS
4	M21	74-66	RWD		7 Bolt Side Cover (1" Countershaft and Max-Type Brgs.)	TRK-297AHD	TRK-297AHDWS
4	T10W	73-66	RWD		9 Bolt Side Cover (6307 I/S Brg., 7/8" C/S, No Thrust Brg. Between 2nd & 3rd Gears)	TRK-10W	TRK-10WWS
3 w/ O/D	Saginaw	72-66	RWD		with R10 Overdrive Unit	TRK-301A	TRK-301AWS
4	M22	71-67	RWD		7 Bolt Side Cover (1" Countershaft)	TRK-297A	TRK-297AWS
4	M22	71-67	RWD		7 Bolt Side Cover (1" Countershaft and Max-Type Brgs.)	TRK-297AHD	TRK-297AHDWS
3 w/ O/D	Muncie 319	68-55	RWD		4 Bolt Side Cover	TRK-G110	

Light Duty Transmission Applications

Speed	Model #	Year	Fwd/Rwd	Engine	Notes	Kit	w/Synchro Rings
Oldsmobile (cont.)							
All Car Models (82 & Earlier) (cont.)							
4	T10	66-62	RWD		9 Bolt Side Cover (6307 I/S Brg., 7/8" C/S, Thrust Brg. Between 2nd & 3rd Gears)	TRK-10E	TRK-10EWS
4	T10	66-57	RWD		9 Bolt Side Cover (6207 I/S Brg.)	TRK-10A	TRK-10AWS
4	M20	65-63	RWD		7 Bolt Side Cover (7/8" Countershaft)	TRK-297	TRK-297WS
4	M20	65-63	RWD		7 Bolt Side Cover (7/8" Countershaft and Max-Type Brgs.)	TRK-297HD	TRK-297HDWS
4	M20	63-62	RWD		7 Bolt Side Cover (6207 I/S Brg.)	TRK-297B	TRK-297BWS
3	Muncie 318	54-40	RWD		4 Bolt Side Cover	TRK-G100	
4	T4	1982	RWD			TRK-5	TRK-5WS1
Achieva							
5	76mm Isuzu	97-95	FWD		7 Bolt Cover (Hydraulic Clutch Release Brg.)	TRK-FI210	TRK-FI210WS2
5	76mm Isuzu	94-92	FWD		7 Bolt Cover (3 Pc. 1-2 Synchro Rings)	TRK-FI120	TRK-FI120WS1
5	NVT550/HM282	94-92	FWD		9 Bolt Cover	TRK-550	TRK-550WS
Alero							
5	Getrag / Opel	03-00	FWD			TRK-FG140	TRK-FG140WS
Cutlass Calais							
5	76mm Isuzu	91-88	FWD		7 Bolt Cover (3 Pc. 1-2 Synchro Rings)	TRK-FI120	TRK-FI120WS1
5	NVT550/HM282	91-88	FWD		9 Bolt Cover	TRK-550	TRK-550WS
5	76mm Isuzu	87-85	FWD		7 Bolt Cover	TRK-FI120	TRK-FI120WS
Cutlass Supreme							
5	NVT550/HM282	90-88	FWD		9 Bolt Cover	TRK-550	TRK-550WS
Firenza							
4	MR2	87-83	FWD		2 Piece Case	TRK-FG110	Obsolete
5	76mm Isuzu	87-83	FWD		7 Bolt Cover	TRK-FI120	TRK-FI120WS
5	76mm Isuzu	1988	FWD		7 Bolt Cover (3 Pc. 1-2 Synchro Rings)	TRK-FI120	TRK-FI120WS1
5	NVT550/HM282	1987	FWD	6 Cyl.	9 Bolt Cover	TRK-550	TRK-550WS
Omega							
4	MR2	84-83	FWD		2 Piece Case	TRK-FG110	Obsolete
Plymouth							
All Car Models (82 & Earlier)							
4	NP460	82-81	FWD		1-4 Synchro Rings Same Size	TRK-465	TRK-465WS2
4 w/ O/D	NP833	80-75	RWD		10 Bolt Side Cover	TRK-833B	TRK-833BWS
3	NP230	80-70	RWD		9 Bolt Side Cover With 35 x 80 x 21 I/S & O/S Brgs.	TRK-NP100	TRK-NP100WS
3	NP230	80-70	RWD		9 Bolt Side Cover With 35 x 90 x 21 I/S & O/S Brgs.	TRK-NP100A	TRK-NP100AWS
3	390	76-74	RWD		9 Bolt Top Cover	TRK-150A	TRK-150AWS
3	NP250	74-72	RWD		6 Bolt Side Cover & 4 Bolt Front Retainer (14mm Wide O/S Brg.)	TRK-NP110A	TRK-NP110AWS
3	NP250	74-72	RWD		6 Bolt Side Cover & 4 Bolt Front Retainer (17mm Wide O/S Brg.)	TRK-NP110	TRK-NP110WS

Light Duty Transmission Applications

Speed	Model #	Year	Fwd/Rwd	Engine	Notes	Kit	w/Synchro Rings
Plymouth (cont.)							
All Car Models (82 & Earlier) (cont.)							
4	NP833	72-64	RWD		10 Bolt Side Cover	TRK-833A	TRK-833AWS
Acclaim							
5	NP523	94-90	FWD		07NU0720/23B Front O/S Brg.	TRK-568	TRK-568WS
5	NP568	93-91	FWD		07NU0720/23B Front O/S Brg.	TRK-568	TRK-568WS
5	NP520	1989	FWD		RNU070618-6 Front O/S Brg.	TRK-520	TRK-520WS
5	NP520	1989	FWD		RNU070618-6 Front O/S Brg. (3 Pc. 2nd Synchro Ring)	TRK-520	TRK-520WS1
Barracuda							
3	NP903	69-66	RWD		6 Bolt Side Cover & 3 Bolt Front Retainer	TRK-NP150	TRK-NP150WS
Breeze							
5	F5MC1/NVT350/A578	00-96	FWD			TRK-350	TRK-350WS
Horizon							
5	NP525	90-84	FWD		1-2 Synchro Rings Larger than 3-4 Synchro Rings	TRK-465	TRK-465WS
4	NP460	86-84	FWD		1-2 Synchro Rings Larger than 3-4 Synchro Rings	TRK-465	TRK-465WS3
4	NP460	83-81	FWD		1-4 Synchro Rings Same Size	TRK-465	TRK-465WS2
5	NP465	1983	FWD		1-5 Synchro Rings Same Size	TRK-465	TRK-465WS1
Laser							
5	F5M22	94-93	FWD	1.8L, 2.0L	3-4 Synchro Rings 36 Teeth, Synchro Rev.	TRK-FM150	TRK-FM150WS2
	KM272	94-90			Transfer Case Section Only	TRK-FM350	
5	F5M33	94-90	FWD	2.0L Turbo	Taper Diff Brgs. (Fiber Lined 1-2 Rings, Synchro Rev.)	TRK-FM180	TRK-FM180WS
5	W5M33	94-90	4x4	2.0L Turbo	Ball Diff Brgs. (Fiber Lined 1-2 Rings, Synchro Rev.)	TRK-FM160	TRK-FM160WS
5	F5M22	92-90	FWD	1.8L	3-4 Synchro Rings 30 Teeth	TRK-FM150	TRK-FM150WS
5	F5M22	92-90	FWD	2.0L	3-4 Synchro Rings 30 Teeth, Synchro Rev.	TRK-FM150	TRK-FM150WS1
5	NP525	86-84	FWD		1-2 Synchro Rings Larger than 3-4 Synchro Rings	TRK-465	TRK-465WS
Reliant							
5	NP520	89-87	FWD		RNU070618-6 Front O/S Brg.	TRK-520	TRK-520WS
5	NP520	89-87	FWD		RNU070618-6 Front O/S Brg. (3 Pc. 2nd Synchro Ring)	TRK-520	TRK-520WS1
5	NP525	86-84	FWD		1-2 Synchro Rings Larger than 3-4 Synchro Rings	TRK-465	TRK-465WS
4	NP460	85-84	FWD		1-2 Synchro Rings Larger than 3-4 Synchro Rings	TRK-465	TRK-465WS3

Light Duty Transmission Applications

Speed	Model #	Year	Fwd/Rwd	Engine	Notes	Kit	w/Synchro Rings
Plymouth (cont.)							
Reliant (cont.)							
4	NP460	83-81	FWD		1-4 Snchro Rings Same Size	TRK-465	TRK-465WS2
5	NP465	1983	FWD		1-5 Snchro Rings Same Size	TRK-465	TRK-465WS1
Sapporo							
5	KM131	83-79	RWD	2.0L	Stamped Steel Bottom Pan (6207-N M/S Front Brg.)	TRK-FM140	TRK-FM140WS
5	KM131	83-79	RWD	2.6L	Stamped Steel Bottom Pan (35BVV072 M/S Front Brg.)	TRK-FM110	TRK-FM110WS
Scamp							
4	NP460	83-82	FWD			TRK-465	TRK-465WS2
Sundance							
5	NP543	94-92	FWD		07NU0720/23B Front O/S Brg.	TRK-568	TRK-568WS
5	NP523	94-90	FWD		07NU0720/23B Front O/S Brg.	TRK-568	TRK-568WS
5	NP568	91-90	FWD		07NU0720/23B Front O/S Brg.	TRK-568	TRK-568WS
5	NP520	89-87	FWD		RNU070618-6 Front O/S Brg.	TRK-520	TRK-520WS
5	NP520	89-87	FWD		RNU070618-6 Front O/S Brg. (3 Pc. 2nd Synchro Ring)	TRK-520	TRK-520WS1
5	NP525	1987	FWD		1-2 Synchro Rings Larger than 3-4 Synchro Rings	TRK-465	TRK-465WS
Trailduster							
4	NP435	81-74	2WD & 4X4		Alum. Shift Cover (Tapered I/S Brg.)	TRK-127B	TRK-127BWS
4	NP445	79-74	2WD & 4X4			TRK-NP140	
3	NP230	79-74	2WD & 4X4		9 Bolt Side Cover	TRK-NP100A	TRK-NP100AWS
Turismo							
5	NP525	87-84	FWD		1-2 Synchro Rings Larger than 3-4 Synchro Rings	TRK-465	TRK-465WS
4	NP460	86-84	FWD		1-2 Synchro Rings Larger than 3-4 Synchro Rings	TRK-465	TRK-465WS3
4	NP460	1983	FWD		1-4 Synchro Rings Same Size	TRK-465	TRK-465WS2
5	NP465	1983	FWD		1-5 Synchro Rings Same Size	TRK-465	TRK-465WS1
Valiant							
3	NP903	72-66	RWD		6 Bolt Side Cover & 3 Bolt Front Retainer	TRK-NP150	TRK-NP150WS
Pontiac							
All Car Models (82 & Earlier)							
3	Saginaw	85-66	RWD		7 Bolt Side Cover	TRK-301	TRK-301WS1
5	T5	82-81	RWD		Cylindrical Countershaft Brgs.	TRK-5	TRK-5WS
4	MR2	82-80	FWD		2 Piece Case	TRK-FG110	Obsolete
4	T10W	82-74	RWD		9 Bolt Side Cover (6307 I/S Brg., 1" C/S)	TRK-10WA	TRK-10WAWS
4	T10W	82-74	RWD		9 Bolt Side Cover (6307 I/S Brg., 1" C/S, Max-Type Ball Brgs.)	TRK-10WAHD	TRK-10WAHDWS

Light Duty Transmission Applications

Speed	Model #	Year	Fwd/Rwd	Engine	Notes	Kit	w/Synchro Rings
Pontiac (cont.)							
All Car Models (82 & Earlier) (cont.)							
4	Saginaw	82-66	RWD		7 Bolt Side Cover	TRK-301	TRK-301WS
3	Tremec	74-68	RWD		9 Bolt Top Cover	TRK-150F	TRK-150FWS
4	M21	74-66	RWD		7 Bolt Side Cover (1" Countershaft)	TRK-297A	TRK-297AWS
4	M21	74-66	RWD		7 Bolt Side Cover (1" Countershaft and Max-Type Brgs.)	TRK-297AHD	TRK-297AHDWS
4	T10W	73-66	RWD		9 Bolt Side Cover (6307 I/S Brg., 7/8" C/S, No Thrust Brg. Between 2nd & 3rd Gears)	TRK-10W	TRK-10WWS
3 w/ O/D	Saginaw	72-66	RWD		with R10 Overdrive Unit	TRK-301A	TRK-301AWS
4	M22	71-67	RWD		7 Bolt Side Cover (1" Countershaft)	TRK-297A	TRK-297AWS
4	M22	71-67	RWD		7 Bolt Side Cover (1" Countershaft and Max-Type Brgs.)	TRK-297AHD	TRK-297AHDWS
3 w/ O/D	Muncie 319	68-55	RWD		4 Bolt Side Cover	TRK-G110	
4	T10	66-62	RWD		9 Bolt Side Cover (6307 I/S Brg., 7/8" C/S, Thrust Brg. Between 2nd & 3rd Gears)	TRK-10E	TRK-10EWS
4	T10	66-57	RWD		9 Bolt Side Cover (6207 I/S Brg.)	TRK-10A	TRK-10AWS
4	M20	65-63	RWD		7 Bolt Side Cover (7/8" Countershaft)	TRK-297	TRK-297WS
4	M20	65-63	RWD		7 Bolt Side Cover (7/8" Countershaft and Max-Type Brgs.)	TRK-297HD	TRK-297HDWS
4	M20	63-62	RWD		7 Bolt Side Cover (6207 I/S Brg.)	TRK-297B	TRK-297BWS
3	Muncie 318	54-40	RWD		4 Bolt Side Cover	TRK-G100	
4	T4	1982	RWD			TRK-5	TRK-5WS1
6000							
5	NVT550/HM282	91-87	FWD	6 Cyl.	9 Bolt Cover	TRK-550	TRK-550WS
Fiero							
5	76mm Isuzu	87-84	FWD		7 Bolt Cover	TRK-FI120	TRK-FI120WS
4	MR2	86-85	FWD		2 Piece Case	TRK-FG110	Obsolete
5	76mm Isuzu	1988	FWD		7 Bolt Cover (3 Pc. 1-2 Synchro Rings)	TRK-FI120	TRK-FI120WS1
Firebird							
5	T5 World Class	02-93	RWD	V6	Taper Countershaft Brgs.	TRK-5W	TRK-5WWS
6	T56	02-93	RWD	V8		TRK-56	TRK-56WS
5	T5 World Class	92-88	RWD	All	Taper Countershaft Brgs.	TRK-5W	TRK-5WWS
5	T5	87-83	RWD		Cylindrical Countershaft Brgs.	TRK-5	TRK-5WS
4	T4	84-83	RWD			TRK-5	TRK-5WS1
Grand Am							
5	Getrag / Opel	04-00	FWD			TRK-FG140	TRK-FG140WS
5	76mm Isuzu	99-95	FWD		7 Bolt Cover (Hydraulic Clutch Release Brg.)	TRK-FI210	TRK-FI210WS2
5	76mm Isuzu	94-88	FWD	4 Cyl.	7 Bolt Cover (3 Pc. 1-2 Synchro Rings)	TRK-FI120	TRK-FI120WS1
5	NVT550/HM282	94-84	FWD	6 Cyl.	9 Bolt Cover	TRK-550	TRK-550WS
5	76mm Isuzu	87-83	FWD	4 Cyl.	7 Bolt Cover	TRK-FI120	TRK-FI120WS

Light Duty Transmission Applications

Speed	Model #	Year	Fwd/Rwd	Engine	Notes	Kit	w/Synchro Rings
Pontiac (cont.)							
GTO							
6	T56	06-04	RWD	V8		TRK-56	TRK-56WS
Phoenix							
4	MR2	84-83	FWD		2 Piece Case	TRK-FG110	Obsolete
Sunbird							
5	76mm Isuzu	94-88	FWD	4 Cyl.	7 Bolt Cover (3 Pc. 1-2 Synchro Rings)	TRK-FI120	TRK-FI120WS1
5	NVT550/HM282	94-87	FWD	6 Cyl.	9 Bolt Cover	TRK-550	TRK-550WS
5	76mm Isuzu	87-85	FWD	4 Cyl.	7 Bolt Cover	TRK-FI120	TRK-FI120WS
4	MR2	84-80	FWD		2 Piece Case	TRK-FG110	Obsolete
4	MR2	84-80	FWD		2 Piece Case	TRK-FG110	Obsolete
Sunfire							
5	Getrag / Opel	05-00	FWD			TRK-FG140	TRK-FG140WS
5	76mm Isuzu	99-95	FWD		7 Bolt Cover (Hydraulic Clutch Release Brg.)	TRK-FI210	TRK-FI210WS2
T1000							
5	MSG-5K	88-81	RWD	Diesel		TRK-FI110	TRK-FI110WS
4	70mm	86-76	RWD			TRK-G120	TRK-G120WS
5	T5	85-82	RWD		With DC51932 Front C/S Brg.	TRK-5A	TRK-5AWS
Vibe							
5	C59	10-03	FWD	1.8L		TRK-FT900	TRK-FT900WS1
6	C60	05-03	FWD	1.8L	GT	TRK-FT790	TRK-FT790WS
5	C59	1/03-03	FWD	1.8L		TRK-FT900	TRK-FT900WS
Saturn							
Ion							
5	Ion	04-03/04	FWD			TRK-FG140	TRK-FG140WS
L Series							
5	L Series	04-02/04	FWD			TRK-F130	TRK-F130WS
S Series							
5	S Series	02-91	FWD			TRK-FG120	TRK-FG120WS
Vue							
5	Vue	04-02/04	FWD			TRK-FG140	TRK-FG140WS
Sterling							
Sterling							
5	C3	91-88	FWD			TRK-FH190	TRK-FH190WS
Suzuki							
Esteem							
5	EST	02-99	FWD	1.8L		TRK-FS160	TRK-FS160WS
5	EST	99-96	FWD	1.6L		TRK-FS110	TRK-FS110WS
Samurai							
5	SAM	95-86	4x4			TRK-FS100	TRK-FS100WS
Sidekick							
5	SIDE	01-99	2WD & 4x4			TRK-FS150	TRK-FS150WS
5	SIDE	98-91	2WD			TRK-FS130	TRK-FS130WS
5	SIDE	98-87	4x4			TRK-FS130	TRK-FS130WS
Swift							
5	SWIFT	01-89	FWD			TRK-FS110	TRK-FS110WS
Vitara							
5	TRACK	03-99	2WD & 4WD		8 Bolt Cover	TRK-FS150	TRK-FS150WS
X-90							
5	X-90	98-96	FWD			TRK-FS130	TRK-FS130WS

Light Duty Transmission Applications

Speed	Model #	Year	Fwd/Rwd	Engine	Notes	Kit	w/Synchro Rings
Toyota							
4-Runner							
5	W59	8/00-10/96	4x4	4 Cyl.		TRK-FT210	TRK-FT210WS7
5	R150	8/00-11/95	4x4	V6	w/ 3 Pc. 2nd Gear Synchro	TRK-FT340	TRK-FT340WS5
5	R150	1/98-11/95	4x4	V6	w/ 1 Pc. 2nd Gear Synchro & 33T 5th Gear Synchro	TRK-FT340	TRK-FT340WS3
5	W59	10/96-11/95	4x4	4 Cyl.		TRK-FT210	TRK-FT210WS6
5	R150	11/95-5/94	4x4	V6	Changes to 30T 5th Gear Synchro	TRK-FT340	
5	W56	11/95-8/92	4x4	4 Cyl.		TRK-FT210	TRK-FT210WS5
5	R150	4/94-3/94	4x4	V6	Changes to Triangular Teeth on 3rd Gear Synchro	TRK-FT200	TRK-FT200WS4
5	R150	5/94-4/94	4x4	V6	Changes to Anti-Rotation Tabs on 1/2 Gear Synchro	TRK-FT200	
5	R150	3/94-4/89	4x4	V6		TRK-FT200	TRK-FT200WS3
5	W56	8/92-10/91	4x4	4 Cyl.		TRK-FT210	TRK-FT210WS4
5	W56	10/91-8/84	4x4	4 Cyl.		TRK-FT150	TRK-FT150WS
5	W56	10/91-8/84	4x4	4 Cyl.	With I/S Brg that has 21mm wide outer race and 23mm wide inner race	TRK-FT230	TRK-FT230WS
5	G58	8/90-8/88	2WD & 4x4	EFI Gas or Diesel	Snap Ring On End of C/S	TRK-FT190	TRK-FT190WS
5	G52	88-84	4x4	Gas or Diesel	B32-14 I/S Brg, Nut On End of C/S	TRK-FT140	TRK-FT140WS
5	G52	88-84	4x4	Gas or Diesel	32TM03 I/S Brg, Nut On End of C/S	TRK-FT130	TRK-FT130WS
Camry							
5	E56	91-87	4x4			TRK-FT540	TRK-FT540WS
5	S51	4/84-1/83	FWD	4 Cyl.		TRK-FT560	TRK-FT560WS
5	E351	05-02	FWD	4 Cyl.		TRK-FT840	TRK-FT840WS
5	E153	01-00	FWD	6 Cyl.		TRK-FT830	TRK-FT830WS1
5	S51	01-97	FWD	4 Cyl.		TRK-FT880	TRK-FT880WS
5	E153	99-97	FWD	6 Cyl.		TRK-FT830	TRK-FT830WS
5	S51	96-92	FWD	4 Cyl.		TRK-FT330	TRK-FT330WS1
5	E52	93-93	FWD	6 Cyl.		TRK-FT520	TRK-FT520WS1
5	E52	8/93-6/91	FWD	6 Cyl.		TRK-FT520	Obsolete
5	S51	8/92-6/91	FWD	4 Cyl.		TRK-FT330	TRK-FT330WS
5	E52	6/91-2/88	FWD	6 Cyl.		TRK-FT530	TRK-FT530WS
5	S51	6/91-4/84	FWD	4 Cyl.		TRK-FT280	TRK-FT280WS
Celica							
5	E50	93-86	4x4			TRK-FT610	TRK-FT610WS
6	C60	05-00	FWD	1.8L	GT-S	TRK-FT790	TRK-FT790WS
5	C56	03-00	FWD	1.8L		TRK-FT810	TRK-FT810WS1
5	C52	99-93	FWD	1.8L		TRK-FT570	TRK-FT570WS
5	S54	99-93	FWD	2.2L		TRK-FT580	TRK-FT580WS
5	C52	8/93-4/91	FWD	1.6L		TRK-FT320	TRK-FT320WS2
5	S53	9/93-9/89	FWD	2.2L		TRK-FT330	TRK-FT330WS
5	C52	4/91-9/89	FWD	1.6L		TRK-FT320	TRK-FT320WS1
5	S53	89-85	FWD	2.0L		TRK-FT280	TRK-FT280WS
5	W55	84-81	RWD			TRK-FT150	TRK-FT150WS
5	W58	84-81	RWD			TRK-FT150	TRK-FT150WS
4	W40	80-72	RWD			TRK-FT370	TRK-FT370WS
5	W50	80-72	RWD			TRK-FT100	TRK-FT100WS
5	C56	01-1/2/01	FWD	1.8L		TRK-FT810	TRK-FT810WS

Light Duty Transmission Applications

Speed	Model #	Year	Fwd/Rwd	Engine	Notes	Kit	w/Synchro Rings
Toyota (cont.)							
Corolla							
5	C59	02-00	FWD			TRK-FT780	TRK-FT780WS
5	C59	99-98	FWD			TRK-FT780	TRK-FT780WS1
5	C50, C51, C52	97-95	FWD	1.6L, 1.8L		TRK-FT590	TRK-FT590WS1
5	C50, C51, C52	94-93	FWD	1.6L, 1.8L		TRK-FT590	TRK-FT590WS
5	E57	92-88	4x4			TRK-FT410	TRK-FT410WS
5	C50, C51, C52	6/92-8/86	FWD			TRK-FT320	TRK-FT320WS
5	C50, C51, C52	8/86-8/83	FWD			TRK-FT270	TRK-FT270WS
5	T51	86-83	RWD			TRK-FT670	TRK-FT670WS
5	C50, C51, C52	8/85-4/84	FWD	Diesel		TRK-FT280	TRK-FT280WS
5	C50, C51, C52	4/84-8/83	FWD	Diesel		TRK-FT620	TRK-FT620WS
5	T50A	4/83-6/81	RWD			TRK-FT250	TRK-FT250WS
4	K40	81-75	RWD			TRK-FT640	TRK-FT640WS1
5	K50	81-75	RWD			TRK-FT640	TRK-FT640WS
5	T50	81-72	RWD			TRK-FT660	TRK-FT660WS
4	T40	81-71	RWD			TRK-FT650	TRK-FT650WS
4	T41	81-71	RWD			TRK-FT650	TRK-FT650WS
4	K40	75-70	RWD			TRK-FT630	TRK-FT630WS1
5	K50	75-70	RWD			TRK-FT630	TRK-FT630WS
5	C59	03-03	FWD	1.8L	XR	TRK-FT900	TRK-FT900WS1
5	C59	1/03-03	FWD	1.8L	XR	TRK-FT900	TRK-FT900WS
Corona							
5	W55	82-80	RWD			TRK-FT150	TRK-FT150WS
4	W40	80-72	RWD			TRK-FT370	TRK-FT370WS
5	W50	80-72	RWD			TRK-FT100	TRK-FT100WS
Cressida							
5	W58	87-82	RWD			TRK-FT150	TRK-FT150WS
5	W50	82-78	RWD			TRK-FT100	TRK-FT100WS
Echo							
5	C150	05-00	FWD			TRK-FT850	TRK-FT850WS
Landcruiser							
4	H42	87-86	4x4			TRK-FT470	
4	H42	86-81	4x4			TRK-FT310	
4	H41	80-73	4x4			TRK-FT290	
3	J30	73-58	4x4		Countershaft & Idler Shaft Needles	TRK-FT480	
MR2							
5	C56	03-00	FWD	1.8L		TRK-FT810	TRK-FT810WS1
5	E153	95-93	RWD	Turbo		TRK-FT520	TRK-FT520WS2
5	S54	95-92	RWD	2.2L		TRK-FT330	TRK-FT330WS1
5	E153	8/93-1/92	RWD	Turbo		TRK-FT520	TRK-FT520WS1
5	S54	8/92-1/90	RWD			TRK-FT330	TRK-FT330WS
5	E153	1/92-1/90	RWD	Turbo		TRK-FT520	Obsolete
5	S54	1/92-1/90	RWD	Twin Cam		TRK-FT520	Obsolete
5	E51	1/90-4/88	RWD	1.6L		TRK-FT550	TRK-FT550WS
5	E51	1/90-3/88	RWD	1.6L Supercharged		TRK-FT870	TRK-FT870WS
5	C52	1/90-8/86	RWD			TRK-FT320	TRK-FT320WS
5	E51	2/28/88-88	RWD	1.6L Supercharged		TRK-FT870	TRK-FT870WS1
5	E51	3/88-8/87	RWD			TRK-FT510	TRK-FT510WS
5	C52	8/86-8/83	RWD			TRK-FT270	TRK-FT270WS
6	C65	05-04	FWD			TRK-FT790	TRK-FT790WS
5	C56M	02-04	FWD	1.8L	Sequential Manual T/M - No Clutch Pedal	TRK-FT810	TRK-FT810WS2
5	C56	05-03	FWD	1.8L		TRK-FT810	TRK-FT810WS

Light Duty Transmission Applications

Speed	Model #	Year	Fwd/Rwd	Engine	Notes	Kit	w/Synchro Rings
Toyota (cont.)							
Matrix							
6	C60	05-03	FWD	1.8L	XRS	TRK-FT790	TRK-FT790WS
5	C59	10-03	FWD	1.8L	XR	TRK-FT900	TRK-FT900WS1
5	C59	1/03-03	FWD	1.8L	XR	TRK-FT900	TRK-FT900WS
Paseo							
5	C150	97-92	FWD	1.5L		TRK-FT430	TRK-FT430WS2
Previa							
5	G57	97-90	2WD & 4x4			TRK-FT190	TRK-FT190WS
5	G59	97-90	2WD & 4x4			TRK-FT190	TRK-FT190WS
RAV4							
5	E352	05-01	2WD			TRK-FT890	TRK-FT890WS
5	E352	05-01	4x4			TRK-FT800	TRK-FT800WS
5	E250	00-96	4x4			TRK-FT410	TRK-FT410WS1
Solara							
5	S51	01-99	FWD	4 Cyl.		TRK-FT880	TRK-FT880WS
5	E351	08-04	FWD	4 Cyl.		TRK-FT840	TRK-FT840WS
5	E153	1999	FWD	6 Cyl.		TRK-FT830	TRK-FT830WS
Starlett							
4	K40	84-83	RWD			TRK-FT710	TRK-FT710WS1
5	K50	84-81	RWD			TRK-FT710	TRK-FT710WS
Supra							
5	W58	98-93	RWD		21mm Wide M/S Front Brg.	TRK-FT210	TRK-FT210WS4
5	R154	93-85	RWD		23mm Wide M/S Front Brg.	TRK-FT200	TRK-FT200WS
5	W58	93-82	RWD			TRK-FT150	TRK-FT150WS
5	W50	81-79	RWD			TRK-FT100	TRK-FT100WS
T100							
5	R150	96-94	2WD & 4x4	V6		TRK-FT340	TRK-FT340WS3
5	W56	95-10/93	2WD	4 Cyl.		TRK-FT210	TRK-FT210WS6
5	R150	8/94-4/94	2WD & 4x4	V6		TRK-FT200	TRK-FT200WS5
5	R150	4/94-3/93	2WD & 4x4	V6		TRK-FT200	TRK-FT200WS4
5	R150	93-92	2WD & 4x4	V6		TRK-FT200	TRK-FT200WS3
Tacoma							
5	R150	02-00	4x4	V6		TRK-FT340	TRK-FT340WS6
5	W59	7/01-10/96	4X4	4 Cyl.		TRK-FT210	TRK-FT210WS7
5	W59	01-95	2WD	4 Cyl.		TRK-FT210	TRK-FT210WS5
5	R150	01-95	2WD	V6		TRK-FT340	TRK-FT340WS7
5	R150	9/00-4/96	4x4	V6		TRK-FT340	TRK-FT340WS5
5	W59	10/96-95	4X4	4 Cyl.		TRK-FT210	TRK-FT210WS6
5	R150	96-95	4x4	V6		TRK-FT340	TRK-FT340WS4
5	W59	98-6/30/98	2WD	4 Cyl.		TRK-FT210	TRK-FT210WS9
5	W59	98-6/30/98	4X4	4 Cyl.		TRK-FT210	TRK-FT210WS8
Tercel							
5	C151	98-94	FWD	1.5L		TRK-FT430	TRK-FT430WS2
4	C140	96-86	FWD			TRK-FT430	TRK-FT430WS1
5	C150	9/94-8/86	FWD			TRK-FT430	TRK-FT430WS
6	Z52F, Z54F	88-83	4x4			TRK-FT700	TRK-FT700WS
	Front Diff.	88-83	4x4			TRK-FT720	
Section							
5	Z51, Z52, Z53	88-10/82	4x4			TRK-FT690	TRK-FT690WS1
	Front Diff.	88-80	FWD			TRK-FT730	
Section							
4	Z41, Z44, Z46	86-78	FWD			TRK-FT680	TRK-FT680WS
5	Z51, Z52, Z53	82-80	4x4			TRK-FT690	TRK-FT690WS

Light Duty Transmission Applications

Speed	Model #	Year	Fwd/Rwd	Engine	Notes	Kit	w/Synchro Rings
Toyota (cont.)							
Truck							
5	W55	12/94-8/92	2WD & 4x4	4 Cyl.		TRK-FT210	TRK-FT210WS5
5	W56	12/94-8/92	2WD & 4x4	4 Cyl.		TRK-FT210	TRK-FT210WS5
5	R150	12/94-8/88	2WD & 4x4	V6		TRK-FT200	TRK-FT200WS3
5	W55	8/92-10/91	2WD & 4x4	4 Cyl.		TRK-FT210	TRK-FT210WS4
5	W56	8/92-10/91	2WD & 4x4	4 Cyl.		TRK-FT210	TRK-FT210WS4
5	W55	10/91-8/85	2WD & 4x4	4 Cyl.		TRK-FT150	TRK-FT150WS
5	W55	10/91-8/85	2WD & 4x4	4 Cyl.	With I/S Brg that has 21mm wide outer race and 23mm wide inner race	TRK-FT230	TRK-FT230WS
5	W56	10/91-84	2WD & 4x4	4 Cyl.		TRK-FT150	TRK-FT150WS
5	W56	10/91-84	2WD & 4x4	4 Cyl.	With I/S Brg that has 21mm wide outer race and 23mm wide inner race	TRK-FT230	TRK-FT230WS
5	G58	8/90-8/88	2WD & 4x4		Snap Ring On End of C/S	TRK-FT190	TRK-FT190WS
5	R150	8/88-8/85	2WD & 4x4	V6 or 4 Cyl. Turbo		TRK-FT200	TRK-FT200WS2
5	R151	8/88-8/85	2WD & 4x4	V6 or 4 Cyl. Turbo		TRK-FT200	TRK-FT200WS2
5	G52	8/88-8/82	2WD & 4x4		B32-14 I/S Brg, Nut On End of C/S	TRK-FT140	TRK-FT140WS
5	G52	8/88-8/82	2WD & 4x4		32TM03 I/S Brg, Nut On End of C/S	TRK-FT130	TRK-FT130WS
5	W50	86-74	2WD			TRK-FT100	TRK-FT100WS
4	W40	86-71	2WD			TRK-FT370	TRK-FT370WS
4	L45	84-80	2WD & 4x4		B32-14 I/S Brg, Alum Top Cover	TRK-FT120	TRK-FT120WS
4	L45	84-80	2WD & 4x4		032-2 I/S Brg, Alum Top Cover	TRK-FT220	TRK-FT220WS
4	L45	84-80	2WD & 4x4		63/32 I/S Brg, Alum Top Cover	TRK-FT110	TRK-FT110WS
5	L52	84-80	2WD & 4x4		B32-14 I/S Brg	TRK-FT120	TRK-FT120WS
5	L52	84-80	2WD & 4x4		032-2 I/S Brg	TRK-FT220	TRK-FT220WS
5	L52	84-80	2WD & 4x4		63/32 I/S Brg	TRK-FT110	TRK-FT110WS
4	L43	80-74	2WD & 4x4		Side Load Case, 0.75" Countershaft	TRK-FT350	TRK-FT350WS
4	L42	74-72	2WD		Side Load Case, 0.69" Countershaft	TRK-FT450	TRK-FT450WS
4	L40	11/71-69	2WD		Side Load Case, Countershaft Needles Not Included	TRK-FT460	TRK-FT460WS
Tundra							
5	R150	04-99	2WD	V6		TRK-FT340	TRK-FT340WS6
Van							
5	G57	97-90	2WD & 4x4		Snap Ring On End of C/S	TRK-FT190	TRK-FT190WS
5	G59	97-90	2WD & 4x4		Snap Ring On End of C/S	TRK-FT190	TRK-FT190WS
5	G53	89-83	2WD & 4x4		Nut On End of C/S	TRK-FT440	TRK-FT440WS

Light Duty Transmission Rebuild Kits

TRK-247

Position	Part Number	Qty
Input Shaft Brg.	ZT1047	1
Mainshaft Pilot Brg.	ZN1044	1
Mainshaft Thrust Brg.	ZN1028	1
Mainshaft Front Brg.	30207	1
Mainshaft Rear Brg.	ZB1060	1
Countershaft Front Brg.	ZC1021	1
Countershaft Center Brg.	ZC1033	1
Countershaft Rear Brg.	304L	1
Input Shaft Seal	1990	1
Input Shaft Oil Ring	BZ3541E	1
Input Shaft Oil Baffle	ZM1014	1
Output Shaft Seal (2WD)	14900	1
Output Shaft Seal (4x4)	1981	1
Expansion Plug	ZM1013	3
Shift Socket	ZM1008	2
Gasket Set	GT247	1
Top Cover Pins	M50P1	2
Top Cover Gasket	GT247R	1

TRK-247WS

Position	Part Number	Qty
Input Shaft Brg.	ZT1047	1
Mainshaft Pilot Brg.	ZN1044	1
Mainshaft Thrust Brg.	ZN1028	1
Mainshaft Front Brg.	30207	1
Mainshaft Rear Brg.	ZB1060	1
Countershaft Front Brg.	ZC1021	1
Countershaft Center Brg.	ZC1033	1
Countershaft Rear Brg.	304L	1
Input Shaft Seal	1990	1
Input Shaft Oil Ring	BZ3541E	1
Input Shaft Oil Baffle	ZM1014	1
Output Shaft Seal (2WD)	14900	1
Output Shaft Seal (4x4)	1981	1
Expansion Plug	ZM1013	3
Shift Socket	ZM1008	2
Gasket Set	GT247	1
Top Cover Pins	M50P1	2
Top Cover Gasket	GT247R	1
1st, 2nd, 3rd & 4th Gear Synchro Ring	ZSY1054	4
5th Gear Synchro Ring	ZSY1055	1
Rev. Gear Synchro Ring	ZSY1077	1

TRK-247WS1

Position	Part Number	Qty
Input Shaft Brg.	ZT1047	1
Mainshaft Pilot Brg.	ZN1044	1
Mainshaft Thrust Brg.	ZN1028	1
Mainshaft Front Brg.	30207	1
Mainshaft Rear Brg.	ZB1060	1
Countershaft Front Brg.	ZC1021	1
Countershaft Center Brg.	ZC1033	1
Countershaft Rear Brg.	304L	1
Input Shaft Seal	1990	1
Input Shaft Oil Ring	BZ3541E	1
Input Shaft Oil Baffle	ZM1014	1
Output Shaft Seal (2WD)	14900	1
Output Shaft Seal (4x4)	1981	1
Expansion Plug	ZM1013	3
Shift Socket	ZM1008	2
Gasket Set	GT247	1
Top Cover Pins	M50P1	2
Top Cover Gasket	GT247R	1
1st, 2nd, 3rd & 4th Gear Synchro Ring	ZSY1054	4
5th Gear Synchro Ring	ZSY1057	1
Rev. Gear Synchro Ring	ZSY1058	1

TRK-248

Position	Part Number	Qty
Input Shaft Brg.	ZT1087	1
Mainshaft Pilot Brg.	ZN1034	1
Mainshaft Thrust Brg.	ZN1035	1
Mainshaft Center Brg.	ZT1088	1
Mainshaft Rear Brg.	ZB1061	1
Countershaft Front Brg.	ZC1010	1
Countershaft Center Brg.	ZC1023	1
Countershaft Rear Brg.	304L	1
Input Shaft Seal	223012	1
Input Shaft Oil Baffle	ZM1015	1
Input Shaft Oil Ring	BZ3421E	1
Output Shaft Seal (2WD)	14900	1
Output Shaft Seal (4x4)	223608	1
Gasket Set	GT248	1
Top Cover Gasket	GT248R	1
Top Cover Pins	M50P1	2
Expansion Plug	ZM1013	4
Shift Socket	ZM1008	2

TRK-248WS

Position	Part Number	Qty
Input Shaft Brg.	ZT1087	1
Mainshaft Pilot Brg.	ZN1034	1
Mainshaft Thrust Brg.	ZN1035	1
Mainshaft Center Brg.	ZT1088	1
Mainshaft Rear Brg.	ZB1061	1
Countershaft Front Brg.	ZC1010	1
Countershaft Center Brg.	ZC1023	1
Countershaft Rear Brg.	304L	1
Input Shaft Seal	223012	1
Input Shaft Oil Baffle	ZM1015	1
Input Shaft Oil Ring	BZ3421E	1
Output Shaft Seal (2WD)	14900	1
Output Shaft Seal (4x4)	223608	1
Gasket Set	GT248	1
Top Cover Gasket	GT248R	1
Top Cover Pins	M50P1	2
Expansion Plug	ZM1013	4
Shift Socket	ZM1008	2
1st, 2nd, 3rd & 4th Gear Synchro Ring	ZSY1059	4
5th Gear Synchro Ring	ZSY1054	1
Rev. Gear Synchro Ring	ZSY1056	1

TRK-248WS1

Position	Part Number	Qty
Input Shaft Brg.	ZT1087	1
Mainshaft Pilot Brg.	ZN1034	1
Mainshaft Thrust Brg.	ZN1035	1
Mainshaft Center Brg.	ZT1088	1
Mainshaft Rear Brg.	ZB1061	1
Countershaft Front Brg.	ZC1010	1
Countershaft Center Brg.	ZC1023	1
Countershaft Rear Brg.	304L	1
Input Shaft Seal	223012	1
Input Shaft Oil Baffle	ZM1015	1
Input Shaft Oil Ring	BZ3421E	1
Output Shaft Seal (2WD)	14900	1
Output Shaft Seal (4x4)	223608	1
Gasket Set	GT248	1
Top Cover Gasket	GT248R	1
Top Cover Pins	M50P1	2
Expansion Plug	ZM1013	4
Shift Socket	ZM1008	2
1st, 2nd, 3rd & 4th Gear Synchro Ring	ZSY1059	4
5th Gear Synchro Ring	ZSY1060	1
Rev. Gear Synchro Ring	ZSY1061	1

TRK-248WS2

Position	Part Number	Qty
Input Shaft Brg.	ZT1087	1
Mainshaft Pilot Brg.	ZN1034	1
Mainshaft Thrust Brg.	ZN1035	1
Mainshaft Center Brg.	ZT1088	1
Mainshaft Rear Brg.	ZB1061	1
Countershaft Front Brg.	ZC1010	1
Countershaft Center Brg.	ZC1023	1
Countershaft Rear Brg.	304L	1
Input Shaft Seal	223012	1
Input Shaft Oil Baffle	ZM1015	1
Input Shaft Oil Ring	BZ3421E	1
Output Shaft Seal (2WD)	14900	1
Output Shaft Seal (4x4)	223608	1
Gasket Set	GT248	1
Top Cover Gasket	GT248R	1
Top Cover Pins	M50P1	2
Expansion Plug	ZM1013	4
Shift Socket	ZM1008	2
1st Gear Synchro Ring	ZSY1059	1
2nd Gear Synchro Ring	ZSY1303	1
3rd Gear Synchro Ring	ZSY1304	1
4th Gear Synchro Ring	ZSY1059	1
5th Gear Synchro Ring	ZSY1305	1
Rev. Gear Synchro Ring	ZSY1306	1

TRK-300ZF

Position	Part Number	Qty
Input Shaft Brg.	28580-28581	1
Mainshaft Pilot Brg.	JH13349	1
Output Shaft Brg.	J28573-28521	1
Countershaft Front Brg.	2580-2520	1
Countershaft Rear Brg.	2580-2520	1
Front Brg. Retainer	ZM1004	1
O-Ring		
Input Shaft Seal	3771	1
Input Shaft Seal (S5-47M Only)	14703	1
Oil Baffle	E7TZ7040A	1
Oil Ring	F4TZ7046A	1
Output Shaft Seal (2WD)	225010	1
Output Shaft Seal (4x4)	15803	1
Gasket Set	GT300ZF	1
Sealing Cap (Small)	ZM1035	4
Sealing Cap (Large)	ZM1036	3
Mainshaft 1st Gear Brg.	ZN1055	1
Mainshaft 3rd Gear Brg.	ZN1057	1
Mainshaft 3rd Gear Brg. Inner Race	ZN1056	1
Mainshaft 2nd Gear Brg.	ZN1057	1
Mainshaft 5th Gear Brg.	ZN1058	1
Mainshaft Rev. Gear	ZN1055	1
Needle Brg.		
Rev. Idler Gear Brg.	ZN1059	2
Shift Rail Brg.	ZN1060	2

Light Duty Transmission Rebuild Kits



TRK-300ZF/1

Position	Part Number	Qty
Input Shaft Brg.	28580-28521	1
Mainshaft Pilot Brg.	JH13349	1
Output Shaft Brg.	J28573-28521	1
Countershaft Front Brg.	2580-2520	1
Countershaft Rear Brg.	2580-2520	1
Front Brg. Retainer	ZM1004	1
O-Ring		
Input Shaft Seal	3771	1
Input Shaft Seal (S5-47M Only)	14703	1
Oil Baffle	E7TZ7040A	1
Oil Ring	F4TZ7046A	1
Output Shaft Seal (2WD)	225010	1
Output Shaft Seal (4x4)	15803	1
Gasket Set	GT300ZF	1
Sealing Cap (Small)	ZM1035	4
Sealing Cap (Large)	ZM1036	3

TRK-300ZF/1WS

Position	Part Number	Qty
Input Shaft Brg.	28580-28581	1
Mainshaft Pilot Brg.	JH13349	1
Output Shaft Brg.	J28573-28521	1
Countershaft Front Brg.	2580-2520	1
Countershaft Rear Brg.	2580-2520	1
Front Brg. Retainer	ZM1004	1
O-Ring		
Input Shaft Seal	3771	1
Input Shaft Seal (S5-47M Only)	14703	1
Oil Baffle	E7TZ7040A	1
Oil Ring	F4TZ7046A	1
Output Shaft Seal (2WD)	225010	1
Output Shaft Seal (4x4)	15803	1
Gasket Set	GT300ZF	1
Sealing Cap (Small)	ZM1035	4
Sealing Cap (Large)	ZM1036	3
1st Gear Synchro Ring	ZSY1198	1
2nd Gear Synchro Ring	ZSY1198	1
2nd Gear Synchro Ring	ZSY1198	1
3rd Gear Synchro Ring	ZSY1199	1
4th Gear Synchro Ring	ZSY1199	1
5th Gear Synchro Ring	ZSY1199	1
Rev. Gear Synchro Ring	ZSY1200	1

TRK-300ZF/1WS1

Position	Part Number	Qty
Input Shaft Brg.	28580-28581	1
Mainshaft Pilot Brg.	JH13349	1
Output Shaft Brg.	J28573-28521	1
Countershaft Front Brg.	2580-2520	1
Countershaft Rear Brg.	2580-2520	1
Front Brg. Retainer	ZM1004	1
O-Ring		
Input Shaft Seal	3771	1
Input Shaft Seal (S5-47M Only)	14703	1
Oil Baffle	E7TZ7040A	1
Oil Ring	F4TZ7046A	1
Output Shaft Seal (2WD)	225010	1
Output Shaft Seal (4x4)	15803	1
Gasket Set	GT300ZF	1
Sealing Cap (Small)	ZM1035	4
Sealing Cap (Large)	ZM1036	3
1st Gear Synchro Ring	ZSY1203	1
2nd Gear Synchro Ring	ZSY1203	1
3rd Gear Synchro Ring	ZSY1204	1
4th Gear Synchro Ring	ZSY1204	1
5th Gear Synchro Ring	ZSY1204	1
Rev. Gear Synchro Ring	ZSY1205	1

TRK-300ZFB

Position	Part Number	Qty
Input Shaft Brg.	JLM704649-JLM704610	1
Output Shaft Brg.	JLM508748-JLM508710	1
Input Shaft Seal	226530	1
Output Shaft Seal	75X100X12	1
O-Ring	ZM1004	1
Adapter Gasket	GTCNP1	1

TRK-300ZBFL

Position	Part Number	Qty
Input Shaft Brg.	JLM506849-JLM506811	1
Output Shaft Brg.	JLM508748-JLM508710	1
Input Shaft Seal	75X100X12	1
Output Shaft Seal	75X100X12	1
O-Ring	ZM1004	1
Adapter Gasket	GTCNP1	1

TRK-300ZFS

Position	Part Number	Qty
Input Shaft Brg.	28580-28581	1
Mainshaft Pilot Brg.	JH13349	1
Output Shaft Brg.	J28573-28521	1
Countershaft Front Brg.	2580-2520	1
Countershaft Rear Brg.	2580-2520	1
Front Brg. Retainer	ZM1004	1
O-Ring		
Input Shaft Seal	3771	1
Input Shaft Seal (S5-47M Only)	14703	1
Oil Baffle	E7TZ7040A	1
Oil Ring	F4TZ7046A	1
Output Shaft Seal (2WD)	225010	1
Output Shaft Seal (4x4)	15803	1
Gasket Set	GT300ZF	1
Sealing Cap (Small)	ZM1035	4
Sealing Cap (Large)	ZM1036	3
Mainshaft 1st Gear Brg.	ZN1055	1
Mainshaft 3rd Gear Brg.	ZN1057	1
Mainshaft 3rd Gear Brg. Inner Race	ZN1056	1
Mainshaft 2nd Gear Brg.	ZN1057	1
Mainshaft 5th Gear Brg.	ZN1058	1
Mainshaft Rev. Gear	ZN1055	1
Needle Brg.		
Rev. Idler Gear Brg.	ZN1059	2
Shift Rail Brg.	ZN1060	2
1st Gear Synchro Ring	ZSY1198	1
2nd Gear Synchro Ring	ZSY1198	1
3rd Gear Synchro Ring	ZSY1199	1
4th Gear Synchro Ring	ZSY1199	1
5th Gear Synchro Ring	ZSY1199	1
Rev. Gear Synchro Ring	ZSY1200	1

TRK-300ZFS1

Position	Part Number	Qty
Input Shaft Brg.	28580-28581	1
Mainshaft Pilot Brg.	JH13349	1
Output Shaft Brg.	J28573-28521	1
Countershaft Front Brg.	2580-2520	1
Countershaft Rear Brg.	2580-2520	1
Front Brg. Retainer	ZM1004	1
O-Ring		
Input Shaft Seal	3771	1
Input Shaft Seal (S5-47M Only)	14703	1
Oil Baffle	E7TZ7040A	1
Oil Ring	F4TZ7046A	1
Output Shaft Seal (2WD)	225010	1
Output Shaft Seal (4x4)	15803	1
Gasket Set	GT300ZF	1
Sealing Cap (Small)	ZM1035	4
Sealing Cap (Large)	ZM1036	3
Mainshaft 1st Gear Brg.	ZN1055	1
Mainshaft 3rd Gear Brg.	ZN1057	1
Mainshaft 3rd Gear Brg. Inner Race	ZN1056	1
Mainshaft 2nd Gear Brg.	ZN1057	1
Mainshaft 5th Gear Brg.	ZN1058	1
Mainshaft Rev. Gear	ZN1055	1
Needle Brg.		
Rev. Idler Gear Brg.	ZN1059	2
Shift Rail Brg.	ZN1060	2
1st Gear Synchro Ring	ZSY1203	1
2nd Gear Synchro Ring	ZSY1203	1
3rd Gear Synchro Ring	ZSY1204	1
4th Gear Synchro Ring	ZSY1204	1
5th Gear Synchro Ring	ZSY1204	1
Rev. Gear Synchro Ring	ZSY1205	1

TRK-4500D

Position	Part Number	Qty
Input Shaft Brg.	ZT1010-ZT1009	1
Mainshaft Pilot Brg.	ZN1003	1
Mainshaft Thrust Brg.	ZN1013	1
Mainshaft Rear Brg.	M804049-M804010	1
Extension Housing Brg.	B5020	1
Countershaft Front Brg.	ZT1006-ZT1005	1
Countershaft Rear Brg.	ZT1008-ZT1007	1
Input Shaft Seal	714655	1
Output Shaft Seal (2WD)	7300S	1
Output Shaft Seal (4x4)	4741	1
Countershaft Plug	ZM1005	1
Fork Pads	4219073	1
Fork Pads	ZM1006	2
Transfer Case Adapter Gasket	GTCNP1	1
PTO Cover Gasket	GTPT055	2

LD Transmission

Light Duty Transmission Rebuild Kits

TRK-4500DN

Position	Part Number	Qty
Input Shaft Brg.	ZT1010-ZT1009	1
Mainshaft Pilot Brg.	ZN1003	1
Mainshaft Thrust Brg.	ZN1013	1
Mainshaft Rear Brg.	M804049-M804010	1
Extention Housing Brg.	B5020	1
Countershaft Front Brg.	ZT1006-ZT1005	1
Countershaft Rear Brg.	ZT1008-ZT1007	1
Input Shaft Seal	714655	1
Output Shaft Seal (2WD)	7300S	1
Output Shaft Seal (4x4)	4741	1
Countershaft Plug	ZM1005	1
Fork Pads	4219073	1
Fork Pads	ZM1006	2
Transfer Case Adapter Gasket	GTCNP1	1
PTO Cover Gasket	GTPT055	2
Mainshaft 1st & 2nd Gear Needle Brg.	ZN1005	2
Mainshaft 3rd Gear Needle Brg.	ZN1006	1
Mainshaft Rev. Gear Needle Brg.	ZN1004	1
Countershaft 5th Gear Needle Brg.	ZN1010	1
Idler Gear Brg.	ZN1007	2

TRK-4500DN1

Position	Part Number	Qty
Input Shaft Brg.	ZT1010-ZT1009	1
Mainshaft Pilot Brg.	ZN1003	1
Mainshaft Thrust Brg.	ZN1013	1
Mainshaft Rear Brg.	M804049-M804010	1
Extention Housing Brg.	B5020	1
Countershaft Front Brg.	ZT1006-ZT1005	1
Countershaft Rear Brg.	ZT1008-ZT1007	1
Input Shaft Seal	714655	1
Output Shaft Seal (2WD)	7300S	1
Output Shaft Seal (4x4)	4741	1
Countershaft Plug	ZM1005	1
Fork Pads	4219073	1
Fork Pads	ZM1006	2
Transfer Case Adapter Gasket	GTCNP1	1
PTO Cover Gasket	GTPT055	2
Mainshaft 1st & 2nd Gear Needle Brg.	ZN1005	2
Mainshaft 3rd Gear Needle Brg.	ZN1006	1
Mainshaft Rev. Gear Needle Brg.	ZN1004	1
Countershaft 5th Gear Needle Brg.	ZN1010	1
Idler Gear Brg.	ZN1109	2

TRK-4500DN1SPK

Position	Part Number	Qty
Input Shaft Brg.	ZT1010-ZT1009	1
Mainshaft Pilot Brg.	ZN1003	1
Mainshaft Thrust Brg.	ZN1013	1
Mainshaft Rear Brg.	M804049-M804010	1
Extention Housing Brg.	B5020	1
Countershaft Front Brg.	ZT1006-ZT1005	1
Countershaft Rear Brg.	ZT1008-ZT1007	1
Input Shaft Seal	714655	1
Output Shaft Seal (2WD)	7300S	1
Output Shaft Seal (4x4)	4741	1
Countershaft Plug	ZM1005	1
Fork Pads	4219073	1
Fork Pads	ZM1006	2
Transfer Case Adapter Gasket	GTCNP1	1
PTO Cover Gasket	GTPT055	2
Mainshaft 1st & 2nd Gear Needle Brg.	ZN1005	2
Mainshaft 3rd Gear Needle Brg.	ZN1006	1
Mainshaft Rev. Gear Needle Brg.	ZN1004	1
Countershaft 5th Gear Needle Brg.	ZN1010	1
Idler Gear Brg.	ZN1109	2
Small Parts Kit	SPK4500	1

TRK-4500DN1SPKWS

Position	Part Number	Qty
Input Shaft Brg.	ZT1010-ZT1009	1
Mainshaft Pilot Brg.	ZN1003	1
Mainshaft Thrust Brg.	ZN1013	1
Mainshaft Rear Brg.	M804049-M804010	1
Extention Housing Brg.	B5020	1
Countershaft Front Brg.	ZT1006-ZT1005	1
Countershaft Rear Brg.	ZT1008-ZT1007	1
Input Shaft Seal	714655	1
Output Shaft Seal (2WD)	7300S	1
Output Shaft Seal (4x4)	4741	1
Countershaft Plug	ZM1005	1
Fork Pads	4219073	1
Fork Pads	ZM1006	2
Transfer Case Adapter Gasket	GTCNP1	1
PTO Cover Gasket	GTPT055	2
Mainshaft 1st & 2nd Gear Needle Brg.	ZN1005	2
Mainshaft 3rd Gear Needle Brg.	ZN1006	1
Mainshaft Rev. Gear Needle Brg.	ZN1004	1
Countershaft 5th Gear Needle Brg.	ZN1010	1
Idler Gear Brg.	ZN1109	2
Small Parts Kit	SPK4500	1
1st & 2nd Gear Synchro Ring	ZSY1115	2
3rd & 4th Gear Synchro Ring	ZSY1116	2
5th & Rev. Gear Synchro Ring	ZSY1114	2

TRK-4500DN1WS

Position	Part Number	Qty
Input Shaft Brg.	ZT1010-ZT1009	1
Mainshaft Pilot Brg.	ZN1003	1
Mainshaft Thrust Brg.	ZN1013	1
Mainshaft Rear Brg.	M804049-M804010	1
Extention Housing Brg.	B5020	1
Countershaft Front Brg.	ZT1006-ZT1005	1
Countershaft Rear Brg.	ZT1008-ZT1007	1
Input Shaft Seal	714655	1
Output Shaft Seal (2WD)	7300S	1
Output Shaft Seal (4x4)	4741	1
Countershaft Plug	ZM1005	1
Output Shaft Seal (4x4)	710058	1
Fork Pads	4219073	1
Fork Pads	ZM1006	2
Transfer Case Adapter Gasket	GTCNP1	1
PTO Cover Gasket	GTPT055	2
Mainshaft 1st & 2nd Gear Needle Brg.	ZN1005	2
Mainshaft 3rd Gear Needle Brg.	ZN1006	1
Mainshaft Rev. Gear Needle Brg.	ZN1004	1
Countershaft 5th Gear Needle Brg.	ZN1010	1
Idler Gear Brg.	ZN1109	2
1st & 2nd Gear Synchro Ring	ZSY1115	2
3rd & 4th Gear Synchro Ring	ZSY1116	2
5th & Rev. Gear Synchro Ring	ZSY1114	2

TRK-4500DNSPK

Position	Part Number	Qty
Input Shaft Brg.	ZT1010-ZT1009	1
Mainshaft Pilot Brg.	ZN1003	1
Mainshaft Thrust Brg.	ZN1013	1
Mainshaft Rear Brg.	M804049-M804010	1
Extention Housing Brg.	B5020	1
Countershaft Front Brg.	ZT1006-ZT1005	1
Countershaft Rear Brg.	ZT1008-ZT1007	1
Input Shaft Seal	714655	1
Output Shaft Seal (2WD)	7300S	1
Output Shaft Seal (4x4)	4741	1
Countershaft Plug	ZM1005	1
Fork Pads	4219073	1
Fork Pads	ZM1006	2
Transfer Case Adapter Gasket	GTCNP1	1
PTO Cover Gasket	GTPT055	2
Mainshaft 1st & 2nd Gear Needle Brg.	ZN1005	2
Mainshaft 3rd Gear Needle Brg.	ZN1006	1
Mainshaft Rev. Gear Needle Brg.	ZN1004	1
Countershaft 5th Gear Needle Brg.	ZN1010	1
Idler Gear Brg.	ZN1007	2
Small Parts Kit	SPK4500	1

Light Duty Transmission Rebuild Kits



TRK-4500NSPKWS

Position	Part Number	Qty
Input Shaft Brg.	ZT1010-ZT1009	1
Mainshaft Pilot Brg.	ZN1003	1
Mainshaft Thrust Brg.	ZN1013	1
Mainshaft Rear Brg.	M804049-M804010	1
Extention Housing Brg.	B5020	1
Countershaft Front Brg.	ZT1006-ZT1005	1
Countershaft Rear Brg.	ZT1008-ZT1007	1
Input Shaft Seal	714655	1
Output Shaft Seal (2WD)	7300S	1
Output Shaft Seal (2WD-V10)	4741	1
Output Shaft Seal (4x4)	710058	1
Countershaft Plug	ZM1005	1
Fork Pads	4219073	1
Fork Pads	ZM1006	2
Transfer Case Adapter Gasket	GTCNP1	1
PTO Cover Gasket	GTPT055	2
Mainshaft 1st & 2nd Gear Needle Brg.	ZN1005	2
Mainshaft 3rd Gear Needle Brg.	ZN1006	1
Mainshaft Rev. Gear Needle Brg.	ZN1004	1
Countershaft 5th Gear Needle Brg.	ZN1010	1
Idler Gear Brg.	ZN1007	2
Small Parts Kit	SPK4500	1
1st & 2nd Gear Synchro Ring	ZSY1115	2
3rd & 4th Gear Synchro Ring	ZSY1116	2
5th & Rev. Gear Synchro Ring	ZSY1114	2

TRK-4500DNWS

Position	Part Number	Qty
Input Shaft Brg.	ZT1010-ZT1009	1
Mainshaft Pilot Brg.	ZN1003	1
Mainshaft Thrust Brg.	ZN1013	1
Mainshaft Rear Brg.	M804049-M804010	1
Extention Housing Brg.	B5020	1
Countershaft Front Brg.	ZT1006-ZT1005	1
Countershaft Rear Brg.	ZT1008-ZT1007	1
Input Shaft Seal	714655	1
Output Shaft Seal (2WD)	7300S	1
Output Shaft Seal (2WD-V10)	4741	1
Output Shaft Seal (4x4)	710058	1
Countershaft Plug	ZM1005	1
Fork Pads	4219073	1
Fork Pads	ZM1006	2
Transfer Case Adapter Gasket	GTCNP1	1
PTO Cover Gasket	GTPT055	2
Mainshaft 1st & 2nd Gear Needle Brg.	ZN1005	2
Mainshaft 3rd Gear Needle Brg.	ZN1006	1
Mainshaft Rev. Gear Needle Brg.	ZN1004	1
Countershaft 5th Gear Needle Brg.	ZN1010	1
Idler Gear Brg.	ZN1007	2
1st & 2nd Gear Synchro Ring	ZSY1115	2
3rd & 4th Gear Synchro Ring	ZSY1116	2
5th & Rev. Gear Synchro Ring	ZSY1114	2

TRK-4500SPK

Position	Part Number	Qty
Input Shaft Brg.	ZT1010-ZT1009	1
Mainshaft Pilot Brg.	ZN1003	1
Mainshaft Thrust Brg.	ZN1013	1
Mainshaft Rear Brg.	M804049-M804010	1
Extention Housing Brg.	B5020	1
Countershaft Front Brg.	ZT1006-ZT1005	1
Countershaft Rear Brg.	ZT1008-ZT1007	1
Input Shaft Seal	714655	1
Output Shaft Seal (2WD)	7300S	1
Output Shaft Seal (2WD-V10)	4741	1
Output Shaft Seal (4x4)	710058	1
Countershaft Plug	ZM1005	1
Fork Pads	4219073	1
Fork Pads	ZM1006	2
Transfer Case Adapter Gasket	GTCNP1	1
PTO Cover Gasket	GTPT055	2
Small Parts Kit	SPK4500	1

TRK-4500SPKWS

Position	Part Number	Qty
Input Shaft Brg.	ZT1010-ZT1009	1
Mainshaft Pilot Brg.	ZN1003	1
Mainshaft Thrust Brg.	ZN1013	1
Mainshaft Rear Brg.	M804049-M804010	1
Extention Housing Brg.	B5020	1
Countershaft Front Brg.	ZT1006-ZT1005	1
Countershaft Rear Brg.	ZT1008-ZT1007	1
Input Shaft Seal	714655	1
Output Shaft Seal (2WD)	7300S	1
Output Shaft Seal (2WD-V10)	4741	1
Output Shaft Seal (4x4)	710058	1
Countershaft Plug	ZM1005	1
Fork Pads	4219073	1
Fork Pads	ZM1006	2
Transfer Case Adapter Gasket	GTCNP1	1
PTO Cover Gasket	GTPT055	2
Small Parts Kit	SPK4500	1
1st & 2nd Gear Synchro Ring	ZSY1115	2
3rd & 4th Gear Synchro Ring	ZSY1116	2
5th & Rev. Gear Synchro Ring	ZSY1114	2

TRK-4500DWS

Position	Part Number	Qty
Input Shaft Brg.	ZT1010-ZT1009	1
Mainshaft Pilot Brg.	ZN1003	1
Mainshaft Thrust Brg.	ZN1013	1
Mainshaft Rear Brg.	M804049-M804010	1
Extention Housing Brg.	B5020	1
Countershaft Front Brg.	ZT1006-ZT1005	1
Countershaft Rear Brg.	ZT1008-ZT1007	1
Input Shaft Seal	714655	1
Output Shaft Seal (2WD)	7300S	1
Output Shaft Seal (2WD-V10)	4741	1
Output Shaft Seal (4x4)	710058	1
Countershaft Plug	ZM1005	1
Fork Pads	4219073	1
Fork Pads	ZM1006	2
Transfer Case Adapter Gasket	GTCNP1	1
PTO Cover Gasket	GTPT055	2
1st & 2nd Gear Synchro Ring	ZSY1115	2
3rd & 4th Gear Synchro Ring	ZSY1116	2
5th & Rev. Gear Synchro Ring	ZSY1114	2

TRK-4500GM

Position	Part Number	Qty
Input Shaft Brg.	ZT1010-ZT1009	1
Mainshaft Pilot Brg.	ZN1003	1
Mainshaft Thrust Brg.	ZN1013	1
Mainshaft Rear Brg.	M804049-M804010	1
Extention Housing Brg.	B5020	1
Countershaft Front Brg.	ZT1006-ZT1005	1
Countershaft Rear Brg.	ZT1008-ZT1007	1
Input Shaft Seal	714655	1
Output Shaft Seal (with brake)	4670N	1
Output Shaft Seal (without brake)	410085N	1
Output Shaft Seal (P Series w/Parking Brake)	1943	1
Output Shaft Seal (P Series w/o Parking Brake)	224850	1
Countershaft Plug	ZM1005	1
Fork Pads	4219073	1
Fork Pads	ZM1006	2
Transfer Case Adapter Gasket	GTCNP1	1
PTO Cover Gasket	GTPT055	2

LD Transmission

Light Duty Transmission Rebuild Kits

TRK-4500GM1			TRK-4500GM1N1			TRK-4500GM1N1SPKWS		
Position	Part Number	Qty	Position	Part Number	Qty	Position	Part Number	Qty
Input Shaft Brg.	ZT1010-NP728109	1	Input Shaft Brg.	ZT1010-NP728109	1	Input Shaft Brg.	ZT1010-NP728109	1
Mainshaft Pilot Brg.	ZN1003	1	Mainshaft Pilot Brg.	ZN1003	1	Mainshaft Pilot Brg.	ZN1003	1
Mainshaft Thrust Brg.	ZN1013	1	Mainshaft Thrust Brg.	ZN1013	1	Mainshaft Thrust Brg.	ZN1013	1
Mainshaft Rear Brg.	M804049-M804010	1	Mainshaft Rear Brg.	M804049-M804010	1	Mainshaft Rear Brg.	M804049-M804010	1
Extention Housing Brg.	B5020	1	Extention Housing Brg.	B5020	1	Extention Housing Brg.	B5020	1
Countershaft Front Brg.	ZT1006-ZT1005	1	Countershaft Front Brg.	ZT1006-ZT1005	1	Countershaft Front Brg.	ZT1006-ZT1005	1
Countershaft Rear Brg.	ZT1008-ZT1007	1	Countershaft Rear Brg.	ZT1008-ZT1007	1	Countershaft Rear Brg.	ZT1008-ZT1007	1
Input Shaft Seal	21901	1	Input Shaft Seal	21901	1	Input Shaft Seal	21901	1
Output Shaft Seal (with brake)	4670N	1	Output Shaft Seal (with brake)	4670N	1	Output Shaft Seal (with brake)	4670N	1
Output Shaft Seal (without brake)	410085N	1	Output Shaft Seal (without brake)	410085N	1	Output Shaft Seal (without brake)	410085N	1
Output Shaft Seal (P Series w/Parking Brake)	1943	1	Output Shaft Seal (P Series w/Parking Brake)	1943	1	Output Shaft Seal (P Series w/Parking Brake)	1943	1
Output Shaft Seal (P Series w/o Parking Brake)	224850	1	Output Shaft Seal (P Series w/o Parking Brake)	224850	1	Output Shaft Seal (P Series w/o Parking Brake)	224850	1
Countershaft Plug	ZM1005	1	Countershaft Plug	ZM1005	1	Countershaft Plug	ZM1005	1
Fork Pads	4219073	1	Fork Pads	4219073	1	Fork Pads	4219073	1
Fork Pads	ZM1006	2	Fork Pads	ZM1006	2	Fork Pads	ZM1006	2
Transfer Case Adapter Gasket	GTCNP1	1	Transfer Case Adapter Gasket	GTCNP1	1	Transfer Case Adapter Gasket	GTCNP1	1
PTO Cover Gasket	GTPTO55	2	PTO Cover Gasket	GTPTO55	2	PTO Cover Gasket	GTPTO55	2
TRK-4500GM1N			TRK-4500GM1N1SPK					
Position	Part Number	Qty	Position	Part Number	Qty	Position	Part Number	Qty
Input Shaft Brg.	ZT1010-NP728109	1	Input Shaft Brg.	ZT1010-NP728109	1	Input Shaft Brg.	ZT1010-NP728109	1
Mainshaft Pilot Brg.	ZN1003	1	Mainshaft Pilot Brg.	ZN1003	1	Mainshaft Pilot Brg.	ZN1003	1
Mainshaft Thrust Brg.	ZN1013	1	Mainshaft Thrust Brg.	ZN1013	1	Mainshaft Thrust Brg.	ZN1013	1
Mainshaft Rear Brg.	M804049-M804010	1	Mainshaft Rear Brg.	M804049-M804010	1	Mainshaft Rear Brg.	M804049-M804010	1
Extention Housing Brg.	B5020	1	Extention Housing Brg.	B5020	1	Extention Housing Brg.	B5020	1
Countershaft Front Brg.	ZT1006-ZT1005	1	Countershaft Front Brg.	ZT1006-ZT1005	1	Countershaft Front Brg.	ZT1006-ZT1005	1
Countershaft Rear Brg.	ZT1008-ZT1007	1	Countershaft Rear Brg.	ZT1008-ZT1007	1	Countershaft Rear Brg.	ZT1008-ZT1007	1
Input Shaft Seal	21901	1	Input Shaft Seal	21901	1	Input Shaft Seal	21901	1
Output Shaft Seal (with brake)	4670N	1	Output Shaft Seal (with brake)	4670N	1	Output Shaft Seal (with brake)	4670N	1
Output Shaft Seal (without brake)	410085N	1	Output Shaft Seal (without brake)	410085N	1	Output Shaft Seal (without brake)	410085N	1
Output Shaft Seal (P Series w/Parking Brake)	1943	1	Output Shaft Seal (P Series w/Parking Brake)	1943	1	Output Shaft Seal (P Series w/Parking Brake)	1943	1
Output Shaft Seal (P Series w/o Parking Brake)	224850	1	Output Shaft Seal (P Series w/o Parking Brake)	224850	1	Output Shaft Seal (P Series w/o Parking Brake)	224850	1
Countershaft Plug	ZM1005	1	Countershaft Plug	ZM1005	1	Countershaft Plug	ZM1005	1
Fork Pads	4219073	1	Fork Pads	4219073	1	Fork Pads	4219073	1
Fork Pads	ZM1006	2	Fork Pads	ZM1006	2	Fork Pads	ZM1006	2
Transfer Case Adapter Gasket	GTCNP1	1	Transfer Case Adapter Gasket	GTCNP1	1	Transfer Case Adapter Gasket	GTCNP1	1
PTO Cover Gasket	GTPTO55	2	PTO Cover Gasket	GTPTO55	2	PTO Cover Gasket	GTPTO55	2
Mainshaft 1st & 2nd Gear Needle Brg.	ZN1005	2	Mainshaft 1st & 2nd Gear Needle Brg.	ZN1005	2	Mainshaft 1st & 2nd Gear Needle Brg.	ZN1005	2
Mainshaft 3rd Gear Needle Brg.	ZN1006	1	Mainshaft 3rd Gear Needle Brg.	ZN1006	1	Mainshaft 3rd Gear Needle Brg.	ZN1006	1
Mainshaft Rev. Gear Needle Brg.	ZN1004	1	Mainshaft Rev. Gear Needle Brg.	ZN1004	1	Mainshaft Rev. Gear Needle Brg.	ZN1004	1
Countershaft 5th Gear Needle Brg.	ZN1010	1	Countershaft 5th Gear Needle Brg.	ZN1010	1	Countershaft 5th Gear Needle Brg.	ZN1010	1
Idler Gear Brg.	ZN1109	2	Idler Gear Brg.	ZN1109	2	Idler Gear Brg.	ZN1109	2
						Small Parts Kit	SPK4500	1
						1st & 2nd Gear Synchro Ring	ZSY1115	2
						3rd & 4th Gear Synchro Ring	ZSY1116	2
						5th Gear Synchro Ring	ZSY1114	1

Light Duty Transmission Rebuild Kits



TRK-4500GM1N1WS			TRK-4500GM1NSPKWS			TRK-4500GM1NWS		
Position	Part Number	Qty	Position	Part Number	Qty	Position	Part Number	Qty
Input Shaft Brg.	ZT1010-NP728109	1	Input Shaft Brg.	ZT1010-NP728109	1	Input Shaft Brg.	ZT1010-NP728109	1
Mainshaft Pilot Brg.	ZN1003	1	Mainshaft Pilot Brg.	ZN1003	1	Mainshaft Pilot Brg.	ZN1003	1
Mainshaft Thrust Brg.	ZN1013	1	Mainshaft Thrust Brg.	ZN1013	1	Mainshaft Thrust Brg.	ZN1013	1
Mainshaft Rear Brg.	M804049-M804010	1	Mainshaft Rear Brg.	M804049-M804010	1	Mainshaft Rear Brg.	M804049-M804010	1
Extention Housing Brg.	B5020	1	Extention Housing Brg.	B5020	1	Extention Housing Brg.	B5020	1
Countershaft Front Brg.	ZT1006-ZT1005	1	Countershaft Front Brg.	ZT1006-ZT1005	1	Countershaft Front Brg.	ZT1006-ZT1005	1
Countershaft Rear Brg.	ZT1008-ZT1007	1	Countershaft Rear Brg.	ZT1008-ZT1007	1	Countershaft Rear Brg.	ZT1008-ZT1007	1
Input Shaft Seal	21901	1	Input Shaft Seal	21901	1	Input Shaft Seal	21901	1
Output Shaft Seal (with brake)	4670N	1	Output Shaft Seal (with brake)	4670N	1	Output Shaft Seal (with brake)	4670N	1
Output Shaft Seal (without brake)	410085N	1	Output Shaft Seal (without brake)	410085N	1	Output Shaft Seal (without brake)	410085N	1
Output Shaft Seal (P Series w/Parking Brake)	1943	1	Output Shaft Seal (P Series w/Parking Brake)	1943	1	Output Shaft Seal (P Series w/Parking Brake)	1943	1
Output Shaft Seal (P Series w/o Parking Brake)	224850	1	Output Shaft Seal (P Series w/o Parking Brake)	224850	1	Output Shaft Seal (P Series w/o Parking Brake)	224850	1
Countershaft Plug	ZM1005	1	Countershaft Plug	ZM1005	1	Countershaft Plug	ZM1005	1
Fork Pads	4219073	1	Fork Pads	4219073	1	Fork Pads	4219073	1
Fork Pads	ZM1006	2	Fork Pads	ZM1006	2	Fork Pads	ZM1006	2
Transfer Case Adapter Gasket	GTCNP1	1	Transfer Case Adapter Gasket	GTCNP1	1	Transfer Case Adapter Gasket	GTCNP1	1
PTO Cover Gasket	GTPT055	2	PTO Cover Gasket	GTPT055	2	PTO Cover Gasket	GTPT055	2
Mainshaft 1st & 2nd Gear Needle Brg.	ZN1005	2	Mainshaft 1st & 2nd Gear Needle Brg.	ZN1005	2	Mainshaft 1st & 2nd Gear Needle Brg.	ZN1005	2
Mainshaft 3rd Gear Needle Brg.	ZN1006	1	Mainshaft 3rd Gear Needle Brg.	ZN1006	1	Mainshaft 3rd Gear Needle Brg.	ZN1006	1
Mainshaft Rev. Gear Needle Brg.	ZN1004	1	Mainshaft Rev. Gear Needle Brg.	ZN1004	1	Mainshaft Rev. Gear Needle Brg.	ZN1004	1
Countershaft 5th Gear Needle Brg.	ZN1010	1	Countershaft 5th Gear Needle Brg.	ZN1010	1	Countershaft 5th Gear Needle Brg.	ZN1010	1
Idler Gear Brg.	ZN1109	2	Idler Gear Brg.	ZN1007	2	Idler Gear Brg.	ZN1007	2
1st & 2nd Gear Synchro Ring	ZSY1115	2	Small Parts Kit	SPK4500	1	1st & 2nd Gear Synchro Ring	ZSY1115	2
3rd & 4th Gear Synchro Ring	ZSY1116	2	1st & 2nd Gear Synchro Ring	ZSY1115	2	3rd & 4th Gear Synchro Ring	ZSY1116	2
5th Gear Synchro Ring	ZSY1114	1	3rd & 4th Gear Synchro Ring	ZSY1116	2	5th Gear Synchro Ring	ZSY1114	1
TRK-4500GM1NSPK			TRK-4500GM1NSPK			TRK-4500GM1SPK		
Position	Part Number	Qty	Position	Part Number	Qty	Position	Part Number	Qty
Input Shaft Brg.	ZT1010-NP728109	1	Input Shaft Brg.	ZT1010-NP728109	1	Input Shaft Brg.	ZT1010-NP728109	1
Mainshaft Pilot Brg.	ZN1003	1	Mainshaft Pilot Brg.	ZN1003	1	Mainshaft Pilot Brg.	ZN1003	1
Mainshaft Thrust Brg.	ZN1013	1	Mainshaft Thrust Brg.	ZN1013	1	Mainshaft Thrust Brg.	ZN1013	1
Mainshaft Rear Brg.	M804049-M804010	1	Mainshaft Rear Brg.	M804049-M804010	1	Mainshaft Rear Brg.	M804049-M804010	1
Extention Housing Brg.	B5020	1	Extention Housing Brg.	B5020	1	Extention Housing Brg.	B5020	1
Countershaft Front Brg.	ZT1006-ZT1005	1	Countershaft Front Brg.	ZT1006-ZT1005	1	Countershaft Front Brg.	ZT1006-ZT1005	1
Countershaft Rear Brg.	ZT1008-ZT1007	1	Countershaft Rear Brg.	ZT1008-ZT1007	1	Countershaft Rear Brg.	ZT1008-ZT1007	1
Input Shaft Seal	21901	1	Input Shaft Seal	21901	1	Input Shaft Seal	21901	1
Output Shaft Seal (with brake)	4670N	1	Output Shaft Seal (with brake)	4670N	1	Output Shaft Seal (with brake)	4670N	1
Output Shaft Seal (without brake)	410085N	1	Output Shaft Seal (without brake)	410085N	1	Output Shaft Seal (without brake)	410085N	1
Output Shaft Seal (P Series w/Parking Brake)	1943	1	Output Shaft Seal (P Series w/Parking Brake)	1943	1	Output Shaft Seal (P Series w/Parking Brake)	1943	1
Output Shaft Seal (P Series w/o Parking Brake)	224850	1	Output Shaft Seal (P Series w/o Parking Brake)	224850	1	Output Shaft Seal (P Series w/o Parking Brake)	224850	1
Countershaft Plug	ZM1005	1	Countershaft Plug	ZM1005	1	Countershaft Plug	ZM1005	1
Fork Pads	4219073	1	Fork Pads	4219073	1	Fork Pads	4219073	1
Fork Pads	ZM1006	2	Fork Pads	ZM1006	2	Fork Pads	ZM1006	2
Transfer Case Adapter Gasket	GTCNP1	1	Transfer Case Adapter Gasket	GTCNP1	1	Transfer Case Adapter Gasket	GTCNP1	1
PTO Cover Gasket	GTPT055	2	PTO Cover Gasket	GTPT055	2	PTO Cover Gasket	GTPT055	2
Mainshaft 1st & 2nd Gear Needle Brg.	ZN1005	2	Mainshaft 1st & 2nd Gear Needle Brg.	ZN1005	2	Small Parts Kit	SPK4500	1
Mainshaft 3rd Gear Needle Brg.	ZN1006	1	Mainshaft 3rd Gear Needle Brg.	ZN1006	1			
Mainshaft Rev. Gear Needle Brg.	ZN1004	1	Mainshaft Rev. Gear Needle Brg.	ZN1004	1			
Countershaft 5th Gear Needle Brg.	ZN1010	1	Countershaft 5th Gear Needle Brg.	ZN1010	1			
Idler Gear Brg.	ZN1007	2	Idler Gear Brg.	ZN1007	2			
Small Parts Kit	SPK4500	1	Small Parts Kit	SPK4500	1			

LD Transmission

Light Duty Transmission Rebuild Kits

TRK-4500GM1SPKWS

Position	Part Number	Qty
Input Shaft Brg.	ZT1010-NP728109	1
Mainshaft Pilot Brg.	ZN1003	1
Mainshaft Thrust Brg.	ZN1013	1
Mainshaft Rear Brg.	M804049-M804010	1
Extention Housing Brg.	B5020	1
Countershaft Front Brg.	ZT1006-ZT1005	1
Countershaft Rear Brg.	ZT1008-ZT1007	1
Input Shaft Seal	21901	1
Output Shaft Seal (with brake)	4670N	1
Output Shaft Seal (without brake)	410085N	1
Output Shaft Seal (P Series w/Parking Brake)	1943	1
Output Shaft Seal (P Series w/o Parking Brake)	224850	1
Countershaft Plug	ZM1005	1
Fork Pads	4219073	1
Fork Pads	ZM1006	2
Transfer Case Adapter Gasket	GTCNP1	1
PTO Cover Gasket	GTPTO55	2
Small Parts Kit	SPK4500	1
1st & 2nd Gear Synchro Ring	ZSY1115	2
3rd & 4th Gear Synchro Ring	ZSY1116	2
5th Gear Synchro Ring	ZSY1114	1

TRK-4500GM1WS

Position	Part Number	Qty
Input Shaft Brg.	ZT1010-NP728109	1
Mainshaft Pilot Brg.	ZN1003	1
Mainshaft Thrust Brg.	ZN1013	1
Mainshaft Rear Brg.	M804049-M804010	1
Extention Housing Brg.	B5020	1
Countershaft Front Brg.	ZT1006-ZT1005	1
Countershaft Rear Brg.	ZT1008-ZT1007	1
Input Shaft Seal	21901	1
Output Shaft Seal (with brake)	4670N	1
Output Shaft Seal (without brake)	410085N	1
Output Shaft Seal (P Series w/Parking Brake)	1943	1
Output Shaft Seal (P Series w/o Parking Brake)	224850	1
Countershaft Plug	ZM1005	1
Fork Pads	4219073	1
Fork Pads	ZM1006	2
Transfer Case Adapter Gasket	GTCNP1	1
PTO Cover Gasket	GTPTO55	2
1st & 2nd Gear Synchro Ring	ZSY1115	2
3rd & 4th Gear Synchro Ring	ZSY1116	2
5th Gear Synchro Ring	ZSY1114	1

TRK-4500GMN

Position	Part Number	Qty
Input Shaft Brg.	ZT1010-ZT1009	1
Mainshaft Pilot Brg.	ZN1003	1
Mainshaft Thrust Brg.	ZN1013	1
Mainshaft Rear Brg.	M804049-M804010	1
Extention Housing Brg.	B5020	1
Countershaft Front Brg.	ZT1006-ZT1005	1
Countershaft Rear Brg.	ZT1008-ZT1007	1
Input Shaft Seal	714655	1
Output Shaft Seal (with brake)	4670N	1
Output Shaft Seal (without brake)	410085N	1
Output Shaft Seal (P Series w/Parking Brake)	1943	1
Output Shaft Seal (P Series w/o Parking Brake)	224850	1
Countershaft Plug	ZM1005	1
Fork Pads	4219073	1
Fork Pads	ZM1006	2
Transfer Case Adapter Gasket	GTCNP1	1
PTO Cover Gasket	GTPTO55	2
Mainshaft 1st & 2nd Gear Needle Brg.	ZN1005	2
Mainshaft 3rd Gear Needle Brg.	ZN1006	1
Mainshaft Rev. Gear Needle Brg.	ZN1004	1
Countershaft 5th Gear Needle Brg.	ZN1010	1
Idler Gear Brg.	ZN1007	2

TRK-4500GMNSPK

Position	Part Number	Qty
Input Shaft Brg.	ZT1010-ZT1009	1
Mainshaft Pilot Brg.	ZN1003	1
Mainshaft Thrust Brg.	ZN1013	1
Mainshaft Rear Brg.	M804049-M804010	1
Extention Housing Brg.	B5020	1
Countershaft Front Brg.	ZT1006-ZT1005	1
Countershaft Rear Brg.	ZT1008-ZT1007	1
Input Shaft Seal	714655	1
Output Shaft Seal (with brake)	4670N	1
Output Shaft Seal (without brake)	410085N	1
Output Shaft Seal (P Series w/Parking Brake)	1943	1
Output Shaft Seal (P Series w/o Parking Brake)	224850	1
Countershaft Plug	ZM1005	1
Fork Pads	4219073	1
Fork Pads	ZM1006	2
Transfer Case Adapter Gasket	GTCNP1	1
PTO Cover Gasket	GTPTO55	2
Mainshaft 1st & 2nd Gear Needle Brg.	ZN1005	2
Mainshaft 3rd Gear Needle Brg.	ZN1006	1
Mainshaft Rev. Gear Needle Brg.	ZN1004	1
Countershaft 5th Gear Needle Brg.	ZN1010	1
Idler Gear Brg.	ZN1007	2
Small Parts Kit	SPK4500	1

TRK-4500GMNSPKWS

Position	Part Number	Qty
Input Shaft Brg.	ZT1010-ZT1009	1
Mainshaft Pilot Brg.	ZN1003	1
Mainshaft Thrust Brg.	ZN1013	1
Mainshaft Rear Brg.	M804049-M804010	1
Extention Housing Brg.	B5020	1
Countershaft Front Brg.	ZT1006-ZT1005	1
Countershaft Rear Brg.	ZT1008-ZT1007	1
Input Shaft Seal	714655	1
Output Shaft Seal (with brake)	4670N	1
Output Shaft Seal (without brake)	410085N	1
Output Shaft Seal (P Series w/Parking Brake)	1943	1
Output Shaft Seal (P Series w/o Parking Brake)	224850	1
Countershaft Plug	ZM1005	1
Fork Pads	4219073	1
Fork Pads	ZM1006	2
Transfer Case Adapter Gasket	GTCNP1	1
PTO Cover Gasket	GTPTO55	2
Mainshaft 1st & 2nd Gear Needle Brg.	ZN1005	2
Mainshaft 3rd Gear Needle Brg.	ZN1006	1
Mainshaft Rev. Gear Needle Brg.	ZN1004	1
Countershaft 5th Gear Needle Brg.	ZN1010	1
Idler Gear Brg.	ZN1007	2
Small Parts Kit	SPK4500	1
1st & 2nd Gear Synchro Ring	ZSY1115	2
3rd & 4th Gear Synchro Ring	ZSY1116	2
5th Gear Synchro Ring	ZSY1114	1

Light Duty Transmission Rebuild Kits



TRK-4500GMNWS

Position	Part Number	Qty
Input Shaft Brg.	ZT1010-ZT1009	1
Mainshaft Pilot Brg.	ZN1003	1
Mainshaft Thrust Brg.	ZN1013	1
Mainshaft Rear Brg.	M804049-M804010	1
Extention Housing Brg.	B5020	1
Countershaft Front Brg.	ZT1006-ZT1005	1
Countershaft Rear Brg.	ZT1008-ZT1007	1
Input Shaft Seal	714655	1
Output Shaft Seal (with brake)	4670N	1
Output Shaft Seal (without brake)	410085N	1
Output Shaft Seal (P Series w/Parking Brake)	1943	1
Output Shaft Seal (P Series w/o Parking Brake)	224850	1
Countershaft Plug	ZM1005	1
Fork Pads	4219073	1
Fork Pads	ZM1006	2
Transfer Case Adapter Gasket	GTCNP1	1
PTO Cover Gasket	GTPT055	2
Mainshaft 1st & 2nd Gear Needle Brg.	ZN1005	2
Mainshaft 3rd Gear Needle Brg.	ZN1006	1
Mainshaft Rev. Gear Needle Brg.	ZN1004	1
Countershaft 5th Gear Needle Brg.	ZN1010	1
Idler Gear Brg.	ZN1007	2
1st & 2nd Gear Synchro Ring	ZSY1115	2
3rd & 4th Gear Synchro Ring	ZSY1116	2
5th Gear Synchro Ring	ZSY1114	1

TRK-4500GMSPK

Position	Part Number	Qty
Input Shaft Brg.	ZT1010-ZT1009	1
Mainshaft Pilot Brg.	ZN1003	1
Mainshaft Thrust Brg.	ZN1013	1
Mainshaft Rear Brg.	M804049-M804010	1
Extention Housing Brg.	B5020	1
Countershaft Front Brg.	ZT1006-ZT1005	1
Countershaft Rear Brg.	ZT1008-ZT1007	1
Input Shaft Seal	714655	1
Output Shaft Seal (with brake)	4670N	1
Output Shaft Seal (without brake)	410085N	1
Output Shaft Seal (P Series w/Parking Brake)	1943	1
Output Shaft Seal (P Series w/o Parking Brake)	224850	1
Countershaft Plug	ZM1005	1
Fork Pads	4219073	1
Fork Pads	ZM1006	2
Transfer Case Adapter Gasket	GTCNP1	1
PTO Cover Gasket	GTPT055	2
Small Parts Kit	SPK4500	1

TRK-4500GMSPKWS

Position	Part Number	Qty
Input Shaft Brg.	ZT1010-ZT1009	1
Mainshaft Pilot Brg.	ZN1003	1
Mainshaft Thrust Brg.	ZN1013	1
Mainshaft Rear Brg.	M804049-M804010	1
Extention Housing Brg.	B5020	1
Countershaft Front Brg.	ZT1006-ZT1005	1
Countershaft Rear Brg.	ZT1008-ZT1007	1
Input Shaft Seal	714655	1
Output Shaft Seal (with brake)	4670N	1
Output Shaft Seal (without brake)	410085N	1
Output Shaft Seal (P Series w/Parking Brake)	1943	1
Output Shaft Seal (P Series w/o Parking Brake)	224850	1
Countershaft Plug	ZM1005	1
Fork Pads	4219073	1
Fork Pads	ZM1006	2
Transfer Case Adapter Gasket	GTCNP1	1
PTO Cover Gasket	GTPT055	2
Small Parts Kit	SPK4500	1
1st & 2nd Gear Synchro Ring	ZSY1115	2
3rd & 4th Gear Synchro Ring	ZSY1116	2
5th Gear Synchro Ring	ZSY1114	1

TRK-4500GMWS

Position	Part Number	Qty
Input Shaft Brg.	ZT1010-ZT1009	1
Mainshaft Pilot Brg.	ZN1003	1
Mainshaft Thrust Brg.	ZN1013	1
Mainshaft Rear Brg.	M804049-M804010	1
Extention Housing Brg.	B5020	1
Countershaft Front Brg.	ZT1006-ZT1005	1
Countershaft Rear Brg.	ZT1008-ZT1007	1
Input Shaft Seal	714655	1
Output Shaft Seal (with brake)	4670N	1
Output Shaft Seal (without brake)	410085N	1
Output Shaft Seal (P Series w/Parking Brake)	1943	1
Output Shaft Seal (P Series w/o Parking Brake)	224850	1
Countershaft Plug	ZM1005	1
Fork Pads	4219073	1
Fork Pads	ZM1006	2
Transfer Case Adapter Gasket	GTCNP1	1
PTO Cover Gasket	GTPT055	2
1st & 2nd Gear Synchro Ring	ZSY1115	2
3rd & 4th Gear Synchro Ring	ZSY1116	2
5th Gear Synchro Ring	ZSY1114	1

TRK-5600

Position	Part Number	Qty
Input Shaft Brg.	HM804849-HM804810	1
Mainshaft Pilot Brg.	32305	1
Mainshaft Front Brg.	45290-45220	1
Mainshaft Rear Brg.	209	1
Countershaft Front Brg.	LM102949-LM102910	1
Countershaft Center Brg.	25590-25520	1
Countershaft Rear Brg.	LM48548-LM48510	1
Input Shaft Seal	21901	1
Input Shaft Seal	14703	1
Output Shaft Seal	4741	1
(2WD)		
Output Shaft Seal (4x4)	710058	1

TRK-5600N

Position	Part Number	Qty
Input Shaft Brg.	HM804849-HM804810	1
Mainshaft Pilot Brg.	32305	1
Mainshaft Front Brg.	45290-45220	1
Mainshaft Rear Brg.	209	1
Countershaft Front Brg.	LM102949-LM102910	1
Countershaft Center Brg.	25590-25520	1
Countershaft Rear Brg.	LM48548-LM48510	1
Mainshaft 1st Gear Needle Brg.	ZN1142	1
Mainshaft 2nd Gear Needle Brg.	ZN1142	1
Mainshaft 3rd Gear Needle Brg.	ZN1005	1
Mainshaft 4th Gear Needle Brg.	ZN1005	1
Mainshaft 6th Gear Needle Brg.	ZN1141	1
Mainshaft Rev. Gear Needle Brg.	ZN1004	1
Rev. Idler Gear Brg.	ZN1143	2
Input Shaft Seal	14703	1
Input Shaft Seal	21901	1
Output Shaft Seal	4741	1
(2WD)		
Output Shaft Seal (4x4)	710058	1

TRK-5600NWS

Position	Part Number	Qty
Input Shaft Brg.	HM804849-HM804810	1
Mainshaft Pilot Brg.	32305	1
Mainshaft Front Brg.	45290-45220	1
Mainshaft Rear Brg.	209	1
Countershaft Front Brg.	LM102949-LM102910	1
Countershaft Center Brg.	25590-25520	1
Countershaft Rear Brg.	LM48548-LM48510	1
Mainshaft 1st Gear Needle Brg.	ZN1142	1
Mainshaft 2nd Gear Needle Brg.	ZN1142	1
Mainshaft 3rd Gear Needle Brg.	ZN1005	1
Mainshaft 4th Gear Needle Brg.	ZN1005	1
Mainshaft 6th Gear Needle Brg.	ZN1141	1
Mainshaft Rev. Gear Needle Brg.	ZN1004	1
Rev. Idler Gear Brg.	ZN1143	2
Input Shaft Seal	14703	1
Input Shaft Seal	21901	1
Output Shaft Seal	4741	1
(2WD)		
Output Shaft Seal (4x4)	710058	1
1st, 2nd, 3rd, 4th, 5th, 6th & Rev. Synchro Rin	ZSY1216	7

LD Transmission

Light Duty Transmission Rebuild Kits

TRK-5600WS

Position	Part Number	Qty
Input Shaft Brg.	HM804849-HM804810	1
Mainshaft Pilot Brg.	32305	1
Mainshaft Front Brg.	45290-45220	1
Mainshaft Rear Brg.	209	1
Countershaft Front Brg.	LM102949-LM102910	1
Countershaft Center Brg.	25590-25520	1
Countershaft Rear Brg.	LM48548-LM48510	1
Input Shaft Seal	21901	1
Input Shaft Seal	14703	1
Output Shaft Seal	4741	1
(2WD)		
Output Shaft Seal (4x4)	710058	1
1st, 2nd, 3rd, 4th, 5th, 6th & Rev. Synchro Rin	ZSY1216	7

TRK-FC200

Position	Part Number	Qty
Input Shaft Brg.	32210	1
Input Shaft Pilot Brg.	33206	1
Output Shaft Rear Brg.	32210	1
Countershaft Front Brg.	30307	1
Countershaft Rear Brg.	32208	1
Input Shaft Seal	5179736AA	1
Output Shaft Seal	5142723AA	1
(2WD)		
Output Shaft Seal (4x4)	5142724AA	1

TRK-S6-650ZF

Position	Part Number	Qty
Input Shaft Brg.	45285-45220	1
Mainshaft Pilot Brg.	JH13349	1
Mainshaft Center Brg.	NP957859-NP771105	1
Mainshaft Rear Brg.	309L	1
Countershaft Front Brg.	4302074	1
Countershaft Center Brg.	JLM508748-JLM508710	1
Countershaft Rear Brg.	FC69178	1
Input Shaft Seal	UH5019E0	1
Output Shaft Seal	UH5020G0	1
(2WD)		
Output Shaft Seal (4x4)	UH5021E0	1
Oil Baffle	F81Z7046AA	1
Oil Ring	F4TZ7046A	1
Sealing Cap (Large)	ZM1036	4

TRK-S6-650ZFA

Position	Part Number	Qty
Input Shaft Brg.	45285-45220	1
Mainshaft Pilot Brg.	JH13349	1
Mainshaft Center Brg.	NP957859-NP771105	1
Mainshaft Rear Brg.	309L	1
Countershaft Front Brg.	4302074	1
Countershaft Center Brg.	JLM508748-JLM508710	1
Countershaft Rear Brg.	FC69178	1
Input Shaft Seal	UH5019E0	1
Output Shaft Seal	UH5020G0	1
(2WD)		
Oil Baffle	F81Z7046AA	1
Oil Ring	F4TZ7046A	1
Sealing Cap (Large)	ZM1036	4

TRK-S6-650ZFB

Position	Part Number	Qty
Input Shaft Brg.	45285-45220	1
Mainshaft Pilot Brg.	JH13349	1
Mainshaft Center Brg.	NP957859-NP771105	1
Mainshaft Rear Brg.	309L	1
Countershaft Front Brg.	4302074	1
Countershaft Center Brg.	JLM508748-JLM508710	1
Countershaft Rear Brg.	R1563TAV	1
Input Shaft Seal	UH5019E0	1
Output Shaft Seal	UH5020G0	1
(2WD)		
Output Shaft Seal (4x4)	UH5021E0	1
Oil Baffle	F81Z7046AA	1
Oil Ring	F4TZ7046A	1
Sealing Cap (Large)	ZM1036	4

TRK-S6-650ZFC

Position	Part Number	Qty
Input Shaft Brg.	45285-45220	1
Mainshaft Pilot Brg.	JH13349	1
Mainshaft Center Brg.	NP957859-NP771105	1
Mainshaft Rear Brg.	ZB1181	1
Countershaft Front Brg.	4302074	1
Countershaft Center Brg.	JLM508748-JLM508710	1
Countershaft Rear Brg.	R1563TAV	1
Input Shaft Seal	UH5019E0	1
Output Shaft Seal	UH5020G0	1
(2WD)		
Oil Baffle	F81Z7046AA	1
Oil Ring	F4TZ7046A	1
Sealing Cap (Large)	ZM1036	4
O-Ring	OR-100X3V	1

TRK-S6-650ZFN

Position	Part Number	Qty
Input Shaft Brg.	45285-45220	1
Mainshaft Pilot Brg.	JH13349	1
Mainshaft Center Brg.	NP957859-NP771105	1
Mainshaft Rear Brg.	309L	1
Countershaft Front Brg.	4302074	1
Countershaft Center Brg.	JLM508748-JLM508710	1
Countershaft Rear Brg.	FC69178	1
Input Shaft Seal	UH5019E0	1
Output Shaft Seal	UH5020G0	1
(2WD)		
Output Shaft Seal (4x4)	UH5021E0	1
Oil Baffle	F81Z7046AA	1
Oil Ring	F4TZ7046A	1
Sealing Cap (Large)	ZM1036	4
1st Gear Brg.	ZN1189	1
2nd Gear Brg.	ZN1189	1
2nd Gear Brg. Inner Race	ZN1190	1
3rd Gear Brg.	Zn1189	1
3rd Gear Brg.	ZN1189	1
3rd Gear Inner Brg. Race	ZN1190	1
5th Gear Brg.	ZN1191	1
5th Gear Inner Brg. Race	ZN1192	1
5th Gear Thrust Washer	ZN1193	1
Creeper Gear Brg.	ZN1194	2
Rev. Gear Brg.	ZN1194	2
Rev. Gear Brg. Inner Race	ZN1195	1
Rev. Idler Gear Brg.	ZN1196	2
Shift Shaft Brg.	ZN1160	3
2nd/3rd Gear Thrust Washer	ZN1197	1
Rev. Gear Thrust Brg.	ZN1198	1

TRK-S6-650ZFNWS

Position	Part Number	Qty
Input Shaft Brg.	45285-45220	1
Mainshaft Pilot Brg.	JH13349	1
Mainshaft Center Brg.	NP957859-NP771105	1
Mainshaft Rear Brg.	309L	1
Countershaft Front Brg.	4302074	1
Countershaft Center Brg.	JLM508748-JLM508710	1
Countershaft Rear Brg.	FC69178	1
Input Shaft Seal	UH5019E0	1
Output Shaft Seal	UH5020G0	1
(2WD)		
Output Shaft Seal (4x4)	UH5021E0	1
Oil Baffle	F81Z7046AA	1
Oil Ring	F4TZ7046A	1
1st & 2nd Gear Synchro Ring	ZSY1230	2
3rd, 4th & 5th Gear Synchro Ring	ZSY1204	3
Rev. & Creeper Gear Synchro Ring	ZSY1203	2
Sealing Cap (Large)	ZM1036	4
1st Gear Brg.	ZN1189	1
2nd Gear Brg.	ZN1189	1
2nd Gear Brg. Inner Race	ZN1190	1
3rd Gear Brg.	Zn1189	1
3rd Gear Brg.	ZN1189	1
3rd Gear Inner Brg. Race	ZN1190	1
5th Gear Brg.	ZN1191	1
5th Gear Inner Brg. Race	ZN1192	1
5th Gear Thrust Washer	ZN1193	1
Creeper Gear Brg.	ZN1194	2
Rev. Gear Brg.	ZN1194	2
Rev. Gear Brg. Inner Race	ZN1195	1
Rev. Idler Gear Brg.	ZN1196	2
Shift Shaft Brg.	ZN1160	3
2nd/3rd Gear Thrust Washer	ZN1197	1
Rev. Gear Thrust Brg.	ZN1198	1

TRK-S6-650ZFW

Position	Part Number	Qty
Input Shaft Brg.	45285-45220	1
Mainshaft Pilot Brg.	JH13349	1
Mainshaft Center Brg.	NP957859-NP771105	1
Mainshaft Rear Brg.	309L	1
Countershaft Front Brg.	4302074	1
Countershaft Center Brg.	JLM508748-JLM508710	1
Countershaft Rear Brg.	FC69178	1
Input Shaft Seal	UH5019E0	1
Output Shaft Seal	UH5020G0	1
(2WD)		
Output Shaft Seal (4x4)	UH5021E0	1
Oil Baffle	F81Z7046AA	1
Oil Ring	F4TZ7046A	1
Sealing Cap (Large)	ZM1036	4
1st & 2nd Gear Synchro Ring	ZSY1230	2
3rd, 4th & 5th Gear Synchro Ring	ZSY1204	3
Rev. & Creeper Gear Synchro Ring	ZSY1203	2

Transmission Gearing & Related Parts

Aisin Warner AX5 and AX15

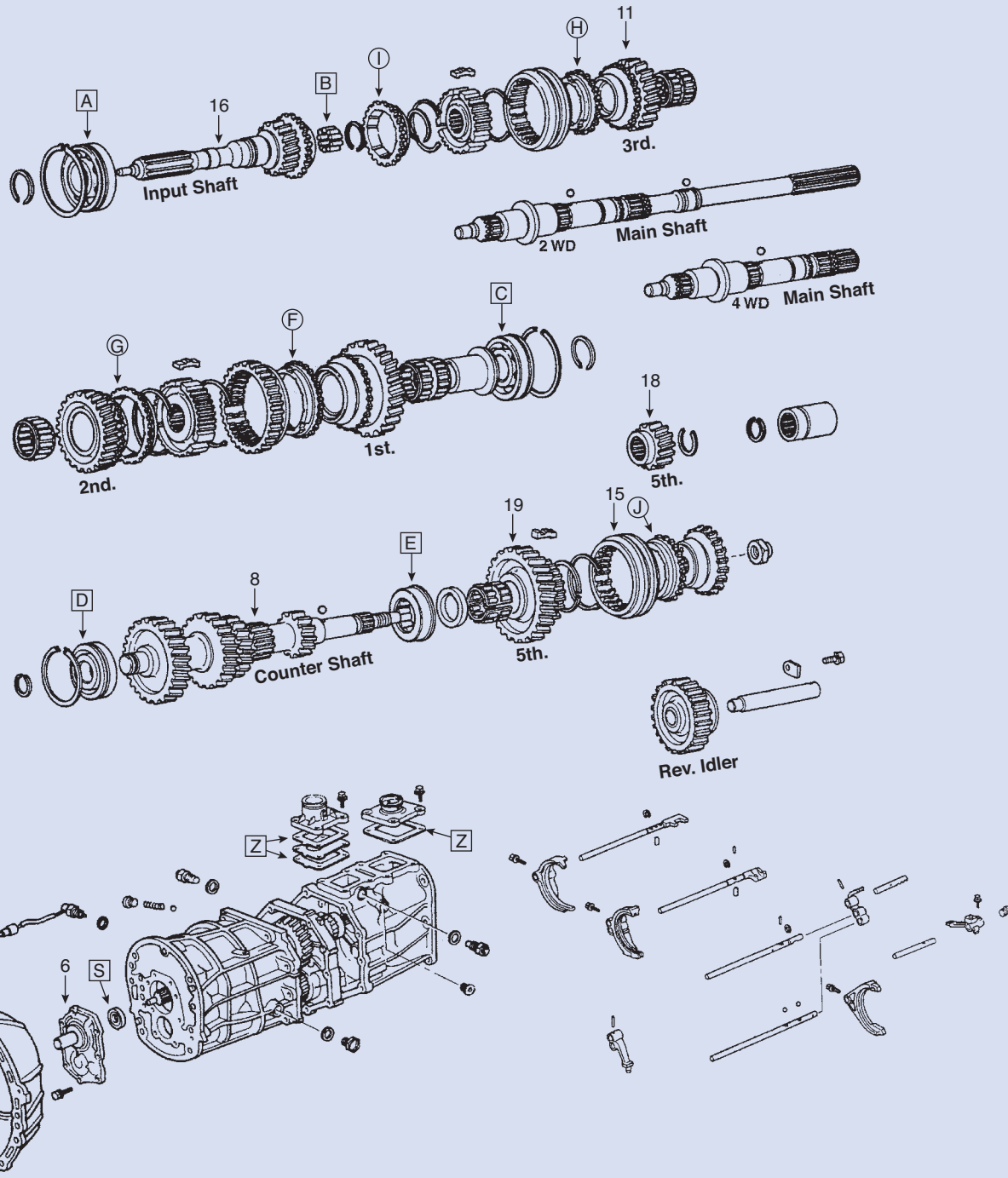

□ = Contained in all kits.

○ = Contained in WS (With Synchros) kits.

△ = Contained in N (With Needle Brgs.) kits

References to original equipment part numbers are for cross reference and identification purpose only.

Transmission Gearing & Related Parts

Aisin Warner AX5

Position	Description	Specifications	Applications	Part Number
6	Front Bearing Retainer	w/Snout		83502685
6	Front Bearing Retainer	w/o Snout		83503112
8	Counter Shaft	Uses Nut	84-10/88	AX5-8
8	Counter Shaft	Uses Snap Ring	10/88-On	AX5-8A
11	3rd Gear	27T		G52-11
15	Slider, 5th/Reverse Gear	For Aluminum Fork Only		G52-15
16	Input Shaft	Uses 20mm Wide I/S Brg.	84-87	AX5-16
16	Input Shaft	Uses 23mm Wide I/S Brg.	84-10/88	AX5-16A
16	Input Shaft	Uses 23mm Wide I/S Brg.	10/88-On	AX5-16B
18 & 19	5th Gear Kit	Includes M/S (24T) & C/S (45T)		G52-5
	5th Gear Needle Brg.			83500644
A	Input Shaft Brg.	20mm Wide I/S Brg.	84-87	ZB1043
A	Input Shaft Brg.	23mm Wide I/S Brg.	84-On	ZB1049
B	Main Shaft Pilot Brg.			N6X17-13
C	Main Shaft Rear Brg.	20mm Wide	84-87	ZB1044
C	Main Shaft Rear Brg.	21mm Wide	87-On	ZB1048
D	Countershaft Front Brg.			ZC1027
E	Countershaft Rear Brg.	18mm Wide	84-87	ZC1015
E	Countershaft Rear Brg.	20mm Wide	87-On	ZC1016
F	1st Gear Synchro Ring			ZSY1052
G	2nd Gear Synchro Ring			ZSY1052
H	3rd Gear Synchro Ring			ZSY1053
I	4th Gear Synchro Ring			ZSY1053
J	5th Gear Synchro Ring			ZSY1053
S	Input Shaft Seal			1981
S	Output Shaft Seal		2WD	223840
S	Output Shaft Seal		4x4	225010
Z	Gasket			Part of GT-FT130
Z	Adapter Gasket			GTC-NP1

Aisin Warner AX15

Position	Description	Specifications	Applications	Part Number
8	Counter Shaft		86-On	AX15-8
16	Input Shaft	29T, 10 spl., 10½ OAL	86-91	AX15-16
16	Input Shaft		92-On	AX15-16A
19	5th Gear (Counter Shaft)	47T, Includes Keys & Springs		AX15-19
A	Input Shaft Brg.			
B	Main Shaft Pilot Brg.			ZN1025
C	Main Shaft Rear Brg.			ZB1053
D	Countershaft Front Brg.			ZC1002
E	Countershaft Rear Brg.			ZC1017
F	1st Gear Synchro Ring			ZSY1096
G	2nd Gear Synchro Ring			ZSY1096
H	3rd Gear Synchro Ring			ZSY1097
I	4th Gear Synchro Ring			ZSY1097
J	5th Gear Synchro Ring	36T		ZSY1097
J	5th Gear Synchro Ring	33T		ZSY1098
S	Input Shaft Seal			223253
S	Output Shaft Seal		2WD	223840
S	Output Shaft Seal		4x4	225010
Z	Adapter Gasket			GTC-NP1

Transmission Gearing & Related Parts

M5R1 and M5R2

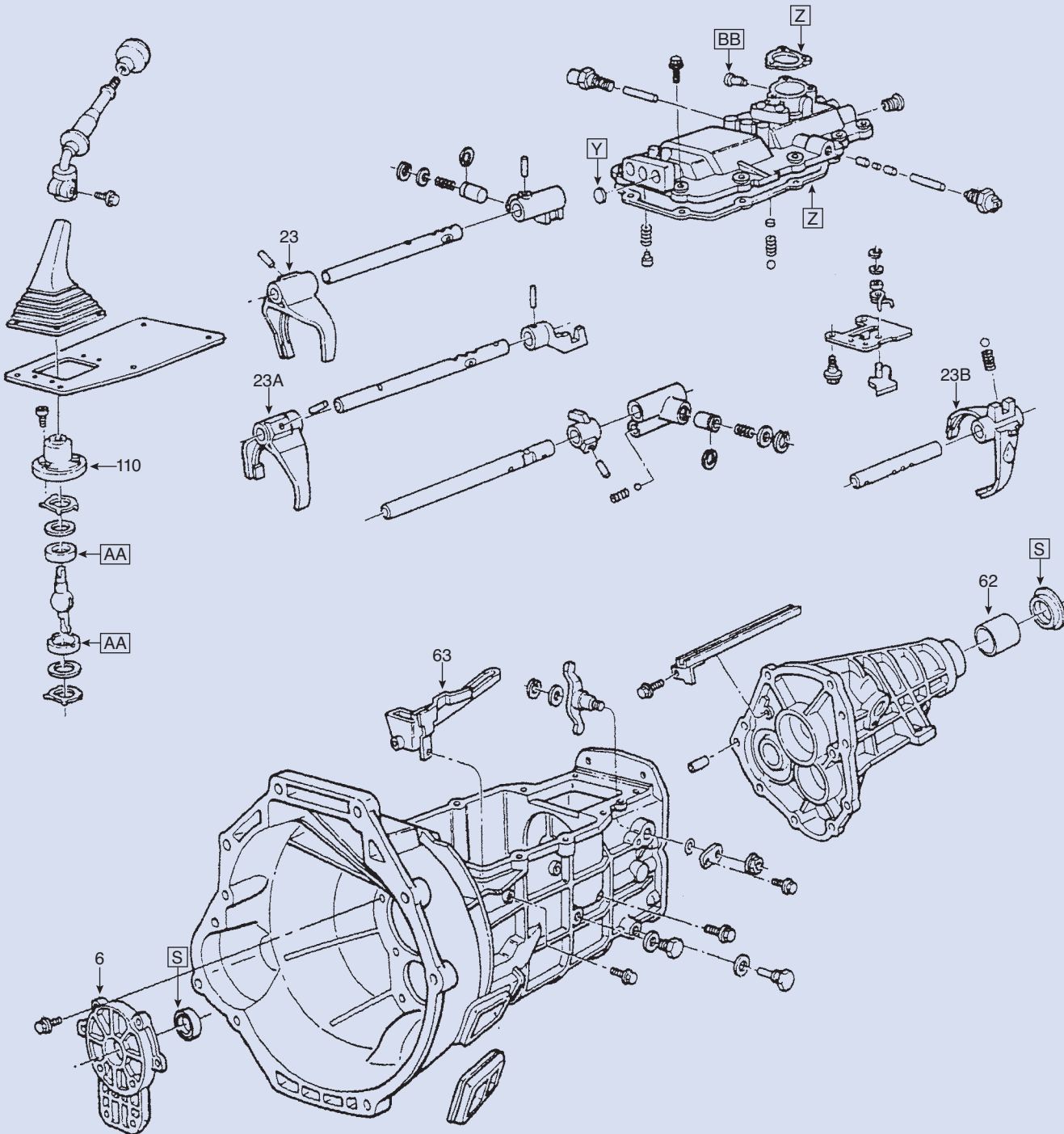

□ = Contained in all kits.

○ = Contained in WS (With Synchros) kits.

△ = Contained in N (With Needle Brgs.) kits

References to original equipment part numbers are for cross reference and identification purpose only.

Transmission Gearing & Related Parts

M5R1 and M5R2

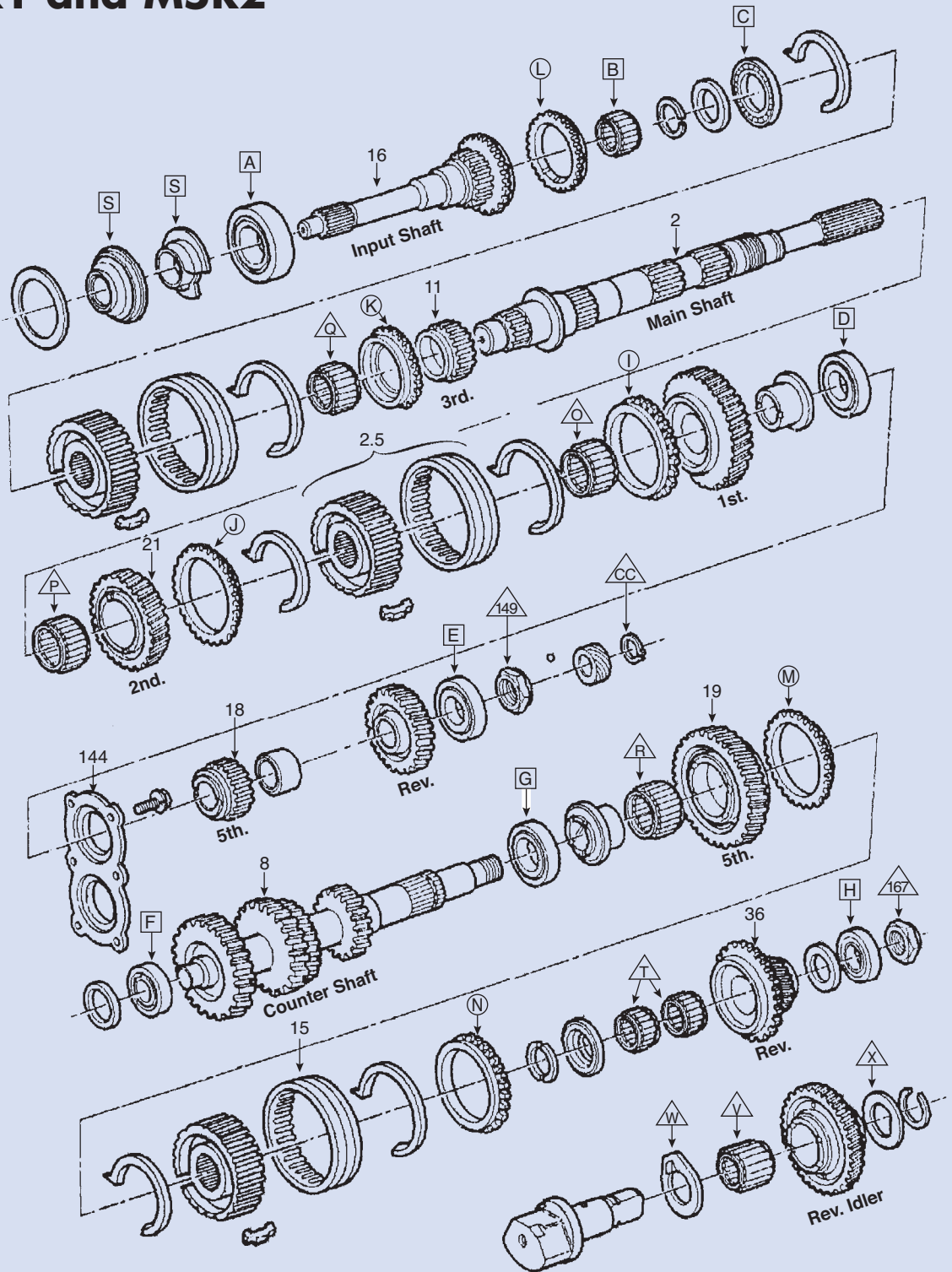

- ☐ = Contained in all kits.
- = Contained in WS (With Synchros) kits.
- △ = Contained in N (With Needle Brgs.) kits

LD Transmission

Transmission Gearing & Related Parts

M5R1

Position	Description	Specifications	Applications	Part Number
2	Main Shaft	28 Spl. (Yoke End) 21-1/2" OAL	2WD	M5R1-2A
2	Main Shaft	25 Spl. (Yoke End) 20" OAL	4x4	M5R1-2
2.5	Synchro Assy. (3rd-4th)	Hub, Slider, Springs & Keys and Synchro Ring		M5R1-2.5A
6	Front Bearing Retainer			M5R1-6
8	Counter Shaft	38-32-24-16	2.3L, 2.9L & 3.0L	M5R1-8
8	Counter Shaft	38-34-25-17	4.0L	M5R1-8A
11	3rd Gear	29T		M5R1-11
11	3rd Gear	27T		M5R1-11A
15	Slider	5th-Rev. Non-Updated 36T	87-/1/90	M5R1-15
15	Slider	5th-Rev. Updated 30T	1/90-On	M5R1-15A
16	Input Shaft	23T, 23 Spline	2.3L, 2.9L & 3.0L	M5R1-16
16	Input Shaft	23T, 23 Spline	4.0L	M5R1-16A
18	5th Gear (Main Shaft)	Updated w/Spacer	1/90-On	M5R1-18A
19	5th Gear (Counter Shaft)	48T, Updated	1/90-On	M5R1-19A
21	2nd Gear	32T		M5R1-21
21	2nd Gear	31T		M5R1-21A
23	Shift Fork	1st-2nd Gear		M5R1-23
23A	Shift Fork	3rd-4th Gear		M5R1-23A
36	Rev. Gear	Non-Updated 17T, 36 Synchro Teeth	87-/1/90	M5R1-36
36	Rev. Gear	Updated 17T, 30 Synchro Teeth	1/90-On	M5R1-36A
62	Ext. Housing Bushing			M5R1-62
63	Oil Trough			M5R1-63
110	Shift Stick Rubber Retainer			E8TZ7277A-R
144	Rear Retainer Plate			M5R1-144
149	Main Shaft Nut			ZM1027
167	Counter Shaft Nut			ZM1029
15, 36 & N	Rev. Gear Kit	Rev. Gear, Slider and Synchro Ring (Non-Updated)	87-/1/90	M5R1-RK
15, 36 & N	Rev. Gear Kit	Rev. Gear, Slider and Synchro Ring (Updated)	1/90-On	M5R1-RKL
	Spring & Key Kit	1st-2nd & 3rd-4th Gear		M5R1-K3
A	Input Shaft Brg.			ZT1047
B	Main Shaft Pilot Brg.			ZN1044
C	Main Shaft Thrust Brg.			ZN1028
D	Main Shaft Front Brg.			ZT1036
E	Main Shaft Rear Brg.			ZB1060
F	Countershaft Front Brg.			ZC1021
G	Countershaft Center Brg.			ZC1033
H	Countershaft Rear Brg.			ZB1034
I	1st Gear Synchro Ring			ZSY1054
J	2nd Gear Synchro Ring			ZSY1054
K	3rd Gear Synchro Ring			ZSY1054
L	4th Gear Synchro Ring			ZSY1054
M	5th Gear Synchro Ring	36T Non-Updated	87-/1/90	ZSY1055
M	5th Gear Synchro Ring	30T Updated	1/90-On	ZSY1057
N	Rev. Gear Synchro Ring	30T Non-Updated	87-/1/90	ZSY1077
N	Rev. Gear Synchro Ring	24T Updated	1/90-On	ZSY1058
O	1st Gear Needle Brg.			ZN1124
P	2nd Gear Needle Brg.			ZN1124
Q	3rd Gear Needle Brg.			ZN1133
R	5th Gear Needle Brg.			ZN1126
S	Input Shaft Seal			1990
S	Input Shaft Oil Ring			BZ3541E
S	Input Shaft Oil Baffle			ZM1014
S	Output Shaft Seal		2WD	14900
S	Output Shaft Seal		4x4	1981
T	Rev. Gear Needle Brg.			ZN1134
U	Rev. Gear Thrust Washer			ZN1128
V	Rev. Idler Gear Needle Brg.			ZN1125
W	Rev. Idler Gear Thrust Washer			ZN1135
X	Rev. Idler Gear Thrust Washer			ZN1129
Y	Expansion Plug			ZM1013
Z	Gasket Set			GT-247
Z	Top Cover Gasket			GT-247R
AA	Shift Socket			ZM1008
BB	Shift Pin			M50-P1
CC	Main Shaft Snap Ring			ZM1028

References to original equipment part numbers are for cross reference and identification purpose only.

Transmission Gearing & Related Parts

M5R2

Position	Description	Specifications	Applications	Part Number
2	Main Shaft		4x4	M5R2-2
2.5	Synchro Assy. (3rd-4th)	Hub & Slider		M5R2-2.5
2.5	Synchro Assy. (3rd-4th)	Hub, Slider, Keys & Springs		M5R2-2.5A
8	Counter Shaft	37-31-24-15		M5R2-8
11	3rd Gear	30T		M5R2-11
15	Slider	5th-Rev. Non-Updated 42T	87-/1/90	M5R2-15
15	Slider	5th-Rev. Updated 33T	1/90-On	M5R2-15A
16	Input Shaft	24T, 10 Spl, 11" OAL	88-95	M5R2-16
16	Input Shaft	24T, 10 Spl, 11-5/8" OAL	96-On	M5R2-16A
18	5th Gear (Main Shaft)	27T		M5R2-18
19	5th Gear (Counter Shaft)	Non-Updated	87-/1/90	M5R2-19
19	5th Gear (Counter Shaft)	52T, 33 Synchro Teeth, Updated	1/90-On	M5R2-19A
23	Shift Fork	1st-2nd Gear	88-95	M5R2-23
23	Shift Fork	1st-2nd Gear	96-On	M5R2-23AA
23A	Shift Fork	3rd-4th Gear	88-95	M5R2-23A
23A	Shift Fork	3rd-4th Gear	96-On	M5R2-23AB
23B	Shift Fork	5th-Rev. Gear Updated	1/90-On	M5R2-23B
36	Rev. Gear	15T Non-Updated	87-/1/90	M5R2-36
36	Rev. Gear	15T, 33 Synchro Teeth, Updated	1/90-On	M5R2-36A
62	Ext. Housing Bushing			M5R1-62
63	Oil Trough			M5R2-63
110	Shift Stick Rubber Retainer			E8TZ7277A-R
144	Rear Retainer Plate			M5R2-144
149	Main Shaft Nut			M5R2-149
167	Counter Shaft Nut			ZM1029
15, 36 & N	Rev. Gear Kit	Rev. Gear, Slider and Synchro Ring (Non-Updated)	87-/1/90	M5R2-RK
15, 36 & N	Rev. Gear Kit	Rev. Gear, Slider and Synchro Ring (Updated)	1/90-On	M5R2-RKL
	Spring & Key Kit	1st-2nd & 3rd-4th Gear		M5R2-K3
A	Input Shaft Brg.			ZT1087
B	Main Shaft Pilot Brg.			ZN1034
C	Main Shaft Thrust Brg.			ZN1035
D	Main Shaft Front Brg.			ZT1088
E	Main Shaft Rear Brg.			ZB1061
F	Countershaft Front Brg.			ZC1010
G	Countershaft Center Brg.			ZC1023
H	Countershaft Rear Brg.			ZB1034
I	1st Gear Synchro Ring			ZSY1059
J	2nd Gear Synchro Ring			ZSY1059
K	3rd Gear Synchro Ring			ZSY1059
L	4th Gear Synchro Ring			ZSY1059
M	5th Gear Synchro Ring	42T Non-Updated	87-/1/90	ZSY1054
M	5th Gear Synchro Ring	33T Updated	1/90-On	ZSY1060
N	Rev. Gear Synchro Ring	36T Non-Updated	87-/1/90	ZSY1056
N	Rev. Gear Synchro Ring	30T Updated	1/90-On	ZSY1061
O	1st Gear Needle Brg.			ZN1124
P	2nd Gear Needle Brg.			ZN1124
Q	3rd Gear Needle Brg.			ZN1123
R	5th Gear Needle Brg.			ZN1126
S	Input Shaft Seal			223012
S	Input Shaft Oil Ring			ZM1015
S	Input Shaft Oil Baffle			BZ3421E
S	Output Shaft Seal		2WD	14900
S	Output Shaft Seal		4x4	223608
T	Rev. Gear Needle Brg.			ZN1071
U	Rev. Gear Thrust Washer			ZN1128
V	Rev. Idler Gear Needle Brg.			ZN1132
W	Rev. Idler Gear Thrust Washer			ZN1130
X	Rev. Idler Gear Thrust Washer			ZN1131
Y	Expansion Plug			ZM1013
Z	Gasket Set			GT-248
Z	Top Cover Gasket			GT-248R
AA	Shift Socket			ZM1008
BB	Shift Pin			M50-P1
CC	Main Shaft Snap Ring			ZM1028

References to original equipment part numbers are for cross reference and identification purpose only.

Transmission Gearing & Related Parts

New Venture 3500/Getrag HM290/5LM60

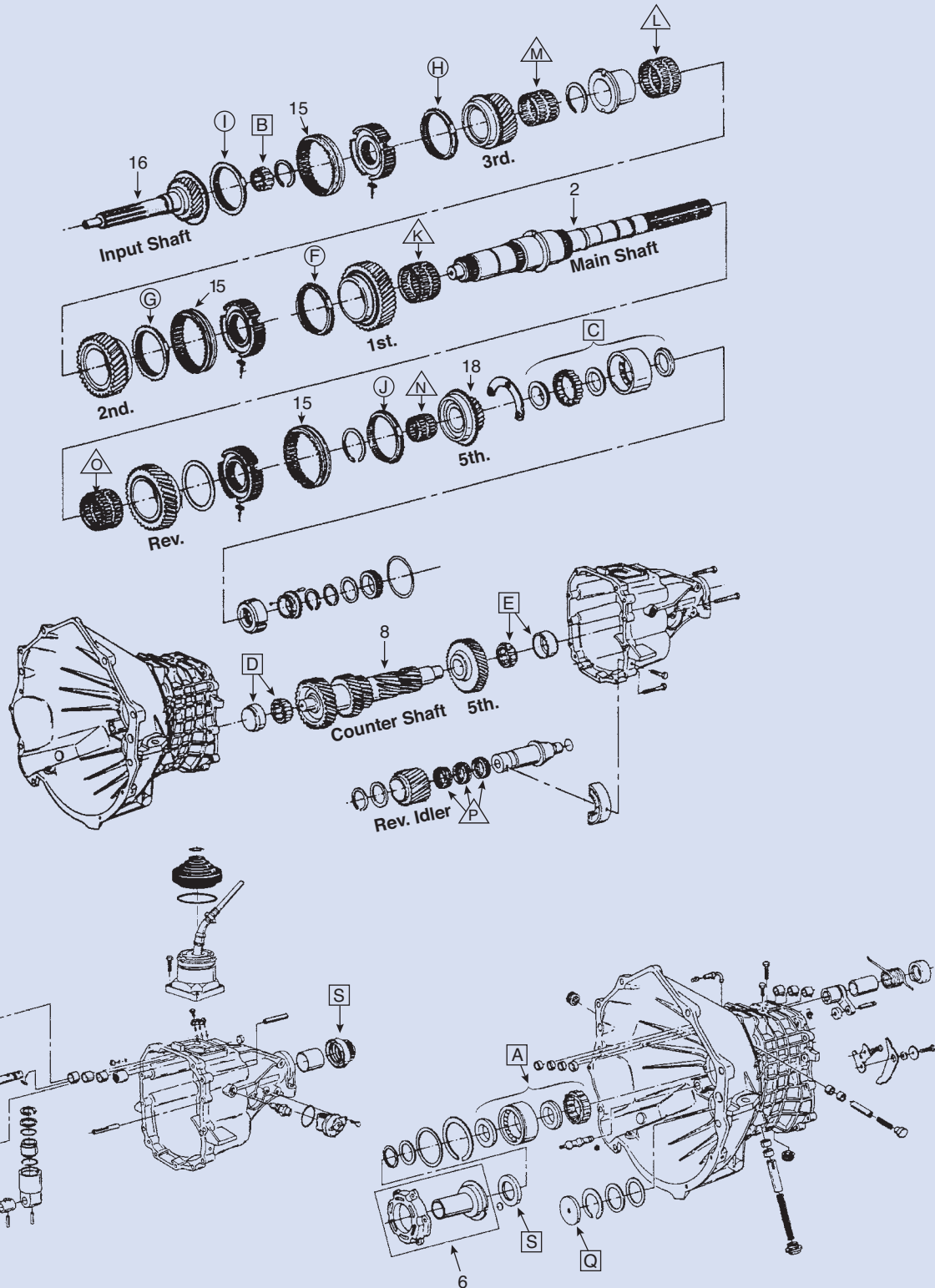

LD Transmission

- = Contained in all kits.
- = Contained in WS (With Synchros) kits.
- △ = Contained in N (With Needle Brgs.) kits

References to original equipment part numbers are for cross reference and identification purpose only.

Transmission Gearing & Related Parts

New Venture 3500/Getrag HM290/5LM60

Position	Description	Specifications	Applications	Part Number
2	Main Shaft	Fits 1st & 2nd Design	4x4, 88-91	290-2
2	Main Shaft	Fits 3rd Design	4x4, 91-On	290-2A
6	Front Bearing Retainer	Fits 1st & 2nd Design	88-91	290-6N
6	Front Bearing Retainer	Fits 3rd Design	91-On	290-6A
8	Counter Shaft	34-28-22-14-43, 1" Journal	88-91, GM	290-8R
8	Counter Shaft	34-28-22-14-14, 1.18" Journal	91-93, GM	290-8AR
8	Counter Shaft	34-28-22-14(Long), 1.18" Journal	94-On, GM & Dodge	290-8BR
8	Counter Shaft	34-28-23-15-14(1.2" wide)-37, 1.18" Journal	96-On, GM S-10	290-8CR
8	Counter Shaft	34-28-23-15-14(2.4" wide)-37, 1.18" Journal	94-On, GM & Dodge	290-8DR
8	Counter Shaft	34-28-23-15-14-43, 1.31" Journal	96-On, GM	290-8ER
8	Counter Shaft	46-37-22-14(Long)-52, 1.18" Journal	97-On Dodge	290-8FR
15	Slider	42T, 1st-2nd Gear		290-15
15	Slider	42T, 3rd-4th Gear		290-15
15	Slider	42T, 5th-Rev. Gear		290-15
16	Input Shaft	26T, 10 Spl, 9-5/8" OAL (w/Step, Fits 1st & 2nd Design)	88-91, GM	290-16R
16	Input Shaft	26T, 10 Spl, 9-5/8" OAL (w/o Step, Fits 3rd Design)	91-95, GM	290-16AR
16	Input Shaft	26T, 10 Spl, 10-5/8" OAL	94-On, Dodge	290-16BR
16	Input Shaft	26T, w/o Step, 3 id Rings	96-On, GM	290-16CR
16	Input Shaft	35T, 10 Spl, 10-1/2" OAL	97-On, Dodge	290-16FR
18	5th Gear (Main Shaft)	24T, Fits 1st & 2nd Design	88-91, GM	290-18
23	Shift Fork	1st-2nd Gear	88-92, GM	290-23
23A	Shift Fork	3rd-4th Gear	88-92, GM	290-23A
23B	Shift Fork	5th-Rev. Gear	88-92, GM	290-23B
A	Input Shaft Brg.	3 Piece Brg., 1st & 2nd Design	88-91	ZB1024
A	Input Shaft Brg.	Ball Brg., 3rd Design	91-On	ZB1055
B	Main Shaft Pilot Brg.	Fits 1" Pilot Journal		ZN1036
B	Main Shaft Pilot Brg.	Fits 1.18" Pilot Journal	96-On GM	ZN1037
C	Main Shaft Brg.	3 Piece Brg., 1st Design	88-89	ZB1024
C	Main Shaft Brg.	Ball Brg., 2nd & 3rd Design	90-On	ZB1055
D	Countershaft Front Brg.	1st & 2nd Design, Fits 1" Journal	88-91	ZN1036
D	Countershaft Front Brg.	3rd Design, Fits 1.18" Journal	91-On	ZN1037
D	Countershaft Front Brg.	Fits 1.31" Journal	96-On GM	ZN1114
E	Countershaft Rear Brg.	1st & 2nd Design, Fits 1" Journal	88-91	ZN1036
E	Countershaft Rear Brg.	3rd Design, Fits 1.18" Journal	91-On	ZN1037
E	Countershaft Rear Brg.	Fits 1.31" Journal	96-On GM	ZN1114
F	1st Gear Synchro Ring	1-Piece Ring		ZSY1076
F	1st Gear Synchro Ring	3-Piece Ring		ZSY1173
G	2nd Gear Synchro Ring	1-Piece Ring		ZSY1076
G	2nd Gear Synchro Ring	3-Piece Ring		ZSY1173
H	3rd Gear Synchro Ring			ZSY1076
I	4th Gear Synchro Ring			ZSY1076
J	5th Gear Synchro Ring			ZSY1076
	Rev. Gear Synchro Ring			ZSY1210
K	1st Gear Needle Brg.		88-94	ZN1115
K	1st Gear Needle Brg.		95	ZN1117
L	2nd Gear Needle Brg.		88-94	ZN1115
L	2nd Gear Needle Brg.		95	ZN1116
M	3rd Gear Needle Brg.		88-95	ZN1118
N	5th Gear Needle Brg.		88-93	ZN1120
N	5th Gear Needle Brg.		94-95	ZN1119
O	Rev. Gear Needle Brg.		88-95	ZN1115
P	Rev. Idler Needle Brg.		88-89	FW404820
P	Rev. Idler Needle Brg.		89-93	ZN1122
P	Rev. Idler Needle Brg.		94-95	ZN1121
Q	Countershaft Plug			AD2285
S	Input Shaft Seal			4529-N
S	Output Shaft Seal		2WD Full Size GM	4528-N
S	Output Shaft Seal		2WD S-10	4530
S	Output Shaft Seal		4x4 GM	4532-N
S	Output Shaft Seal		2WD Dodge	7300-S
S	Output Shaft Seal		4x4 Dodge	4528-N
	Small Parts Kit			SPK-235

References to original equipment part numbers are for cross reference and identification purpose only.

Transmission Gearing & Related Parts

New Venture 4500

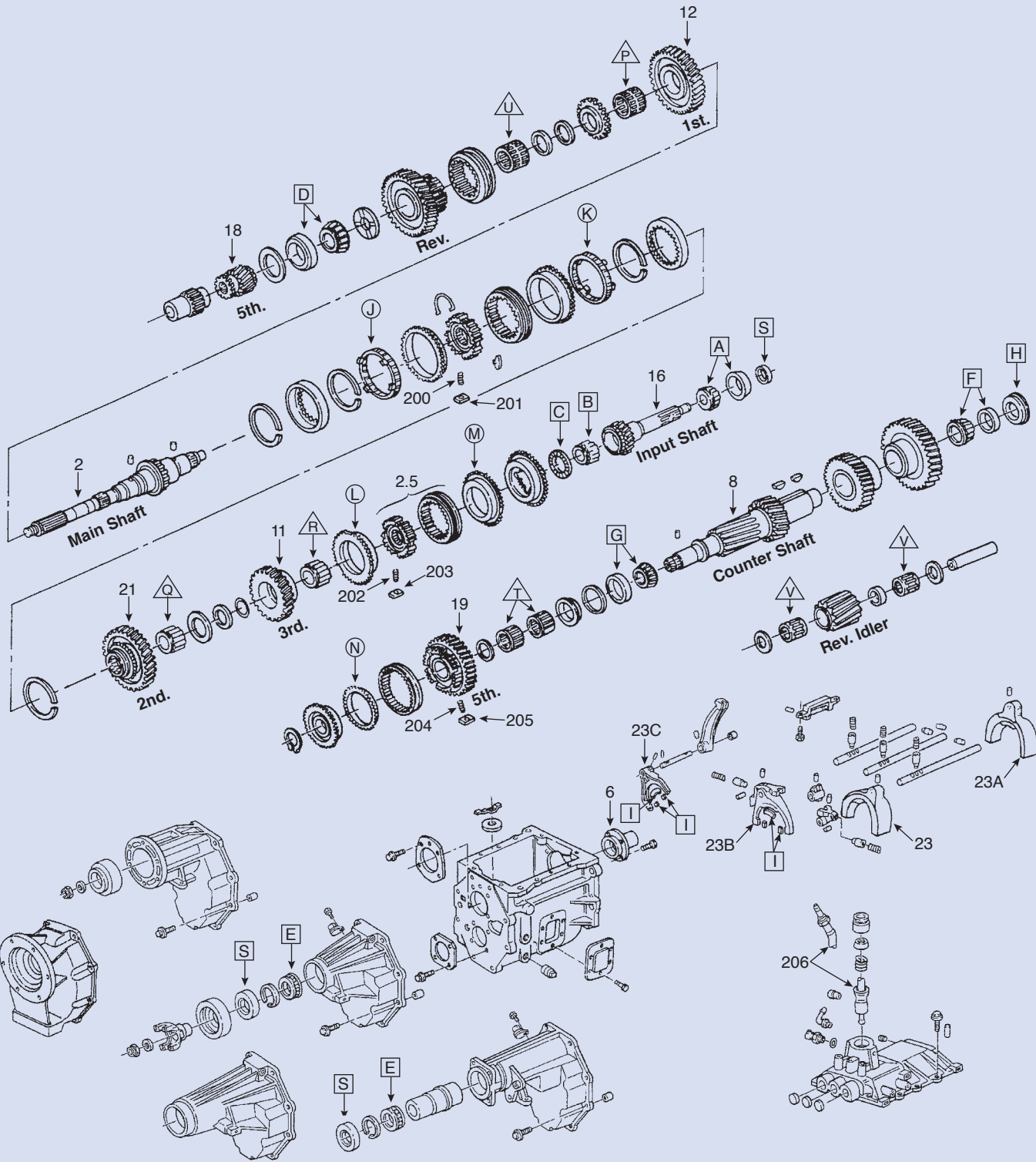

LD Transmission

- = Contained in all kits.
- = Contained in WS (With Synchros) kits.
- △ = Contained in N (With Needle Brgs.) kits

Transmission Gearing & Related Parts

New Venture 4500

Position	Description	Specifications	Applications	GMC Reference #	Dodge Reference #	Part Number
2	Main Shaft		GMC 2WD (91-93)	15637463		NV17276
2	Main Shaft	20-1/4" OAL	GMC 2WD (94-00) w/o Parking Brake	12382817		NV25330
2	Main Shaft		GMC 2WD (94-00) w/Parking Brake	12382819		NV25332
2	Main Shaft		GMC 2WD (01-02)	12382892		NV33308
2	Main Shaft		GMC 4x4 (91-00)	12382861		NV27170
2	Main Shaft		GMC 4x4 (01-02)	12382891		NV33290
2	Main Shaft		Dodge 2WD (92-93)		4637711	NV17281
2	Main Shaft		Dodge 4x4 (92-93)		4637714	NV17280
2	Main Shaft		Dodge 2WD (94-99) 5.9L Gas		5003037AA	NV27174
2	Main Shaft		Dodge 2WD (94-99) 5.9L Diesel, 8.0L		5003038AA	NV27175
2	Main Shaft		Dodge 4x4 (94-99) 5.9L Gas		5003215AA	NV27171
2	Main Shaft		Dodge 4x4 (94-99) 5.9L Diesel, 8.0L		5003218AA	NV27173(-R)
2	Main Shaft		Dodge 2WD (00-02) 5.9L Gas		5016383AA	NV33293
2	Main Shaft		Dodge 2WD (00-02) 5.9L Diesel, 8.0L		5016384AA	NV33294
2	Main Shaft		Dodge 4x4 (00-02) 5.9L Gas		5016385AA	NV33291
2	Main Shaft		Dodge 4x4 (00-02) 5.9L Diesel, 8.0L		5016386AA	NV33292
2	Main Shaft	31 Spl, 24-5/16" OAL	Dodge 2WD Diesel			NV27176(-R)
2	Main Shaft		Dodge 4x4 Gas			NV27171
2	Main Shaft	29 Spl, 14-1/2" OAL	Dodge 4x4 Diesel			NV27173(-R)
2.5	Synchro Assy. (3rd-4th)		GMC (91-93)	15637287		NV17301
2.5	Synchro Assy. (3rd-4th)		GMC (94-03)	12542865		NV18412
2.5	Synchro Assy. (3rd-4th)		Dodge (94-03)		4740824	NV18412
6	Front Bearing Retainer		GMC (91-96)	15665238		NV17507(-R)
6	Front Bearing Retainer		GMC (97-02)	12549369		NV22414
6	Front Bearing Retainer		Dodge (92-93)		4713787	NV17508
6	Front Bearing Retainer		Dodge (94-02) 5.2L, 5.9L Gas		4741542	NV18347
6	Front Bearing Retainer		Dodge (94-02) 5.9L Diesel, 8.0L		4741543	NV18161
8	Counter Shaft		Dodge (92-11/95)		4637700	NV14015
8	Counter Shaft		Dodge (11/95-96)		4856072	NV22415
8	Counter Shaft	38-30-21-12	Dodge (97-02)		4882367	NV22657
8	Counter Shaft		GMC (91-95)	12542557		NV18317
8	Counter Shaft	38-30-21-12	GMC (96-03)	12382834		NV22657
11	3rd Gear		Dodge (92-93)		4637735	NV17296
11	3rd Gear		Dodge (94-96)		4773011	NV18918
11	3rd Gear		Dodge (97-02)		4874369	NV23712
11	3rd Gear		GMC (91-94)	12547205		NV18922
11	3rd Gear	29T	GMC (95-03)	12382792		NV23712
12	1st Gear		Dodge (92-02)	15637279	4637728	NV17290
12	1st Gear		GMC (91-03)	15637279		NV17290
16	Input Shaft		Dodge (92-93)	4637756	NV17303	4637772
16	Input Shaft		Dodge (94-96) 5.2L, 5.9L Gas		4741540	NV18358
16	Input Shaft		Dodge (94-96) 5.9L Diesel, 8.0L		4741541	NV18160
16	Input Shaft	22T 10 Spl, 10" OAL (1.104" Clutch Spline Diameter)	Dodge (97-02) 5.9L Gas		4882357	NV25354
16	Input Shaft	22T 10 Spl, 10" OAL (1.205" Clutch Spline Diameter)	Dodge (97-02) 5.9L Diesel, 8.0L		4882358	NV25356
16	Input Shaft	20T 10 Spl, 9" OAL	GMC (91-94)	15637293		NV17310
16	Input Shaft	20T 10 Spl, 9" OAL	GMC (95)	15637293		NV17310
16	Input Shaft		GMC (95)	12382877		NV26205
16	Input Shaft		GMC (96-03)	12382877		NV26205
18	5th Gear (Main Shaft)		Dodge (92-93)		4637798	NV16999(-R)
18	5th Gear (Main Shaft)		Dodge (94-00) 5.2L, 5.9L Gas		4637798	NV16999(-R)

References to original equipment part numbers are for cross reference and identification purpose only.

Transmission Gearing & Related Parts

New Venture 4500 Continued

Position	Description	Specifications	Applications	GMC Reference #	Dodge Reference #	Part Number
18	5th Gear (Main Shaft)		Dodge (01-02) 5.9L Gas	4741551	NV18164	4637798
18	5th Gear (Main Shaft)		Dodge (94-02) 5.9L Diesel, 8.0L		4741551	NV18164(-R)
18	5th Gear (Main Shaft)		GMC (91-93)	15635278		NV16799
18	5th Gear (Main Shaft)		GMC (94-03)	12548339		NV16999(-R)
19	5th Gear (Counter Shaft)	51T	Dodge (92-02)		4637786	NV17318
19	5th Gear (Counter Shaft)		GMC (91-94)	15637296		NV17317
19	5th Gear (Counter Shaft)		GMC (95)	12548338		NV17318
19	5th Gear (Counter Shaft)	50T with Slider and Keys	GMC (96-03)	12548337		NV17582(-R)
21	2nd Gear		Dodge (92-02)		4637730	NV17293(-R)
21	2nd Gear		GMC (91-03)	15637281		NV17293(-R)
A	Input Shaft Brg.		Dodge (92-02)			ZT1010-ZT1009
A	Input Shaft Brg.		GMC (91-95)			ZT1010-ZT1009
A	Input Shaft Brg.		GMC (96-03)			ZT1010-NP728109
B	Main Shaft Pilot Brg.					ZN1003
C	Main Shaft Thrust Brg.					ZN1013
D	Main Shaft Brg.					ZT1084-ZT1083
E	Extension Housing Brg.					ZN1030
F	Countershaft Front Brg.					ZT1006-ZT1005
G	Countershaft Rear Brg.					ZT1008-ZT1007
H	Countershaft Plug					ZM1005
I	Fork Pads		Center			ZM1007
I	Fork Pads		Tip			ZM1006
J	1st Gear Synchro Ring					ZSY1115
K	2nd Gear Synchro Ring					ZSY1115
L	3rd Gear Synchro Ring					ZSY1116
M	4th Gear Synchro Ring					ZSY1116
N	5th Gear Synchro Ring					ZSY1114
O	Rev. Gear Synchro Ring		Req'd for Dodge Only			ZSY1114
P	1st Gear Needle Brg.					ZN1005
Q	2nd Gear Needle Brg.					ZN1005
R	3rd Gear Needle Brg.					ZN1006
S	Input Shaft Seal		Dodge (92-02)			714655
S	Input Shaft Seal		GMC (91-95)			714655
S	Input Shaft Seal		GMC (96-02)			21901
S	Output Shaft Seal		Dodge (2WD)			7300-S
S	Output Shaft Seal		Dodge (2WD-V10)			4741
S	Output Shaft Seal		Dodge (4x4)			710058
S	Output Shaft Seal		GMC (With Parking Brake)			4670-N
S	Output Shaft Seal		GMC (Without Parking Brake)			410085-N
S	Output Shaft Seal		GMC (P Series With Parking Brake)			1943
S	Output Shaft Seal		GMC (P Series Without Parking Brake)			224850
T	5th Gear Needle Brg.					ZN1010
U	Rev. Gear Needle Brg.					ZN1004
V	Rev. Idler Needle Brg.		(91-96)			ZN1007
V	Rev. Idler Needle Brg.		(97-0n)			ZN1109
	Small Parts Kit					5PK-4500

LD Transmission

References to original equipment part numbers are for cross reference and identification purpose only.

Transmission Gearing & Related Parts

ZF S5-42, S5-47, S5-47M

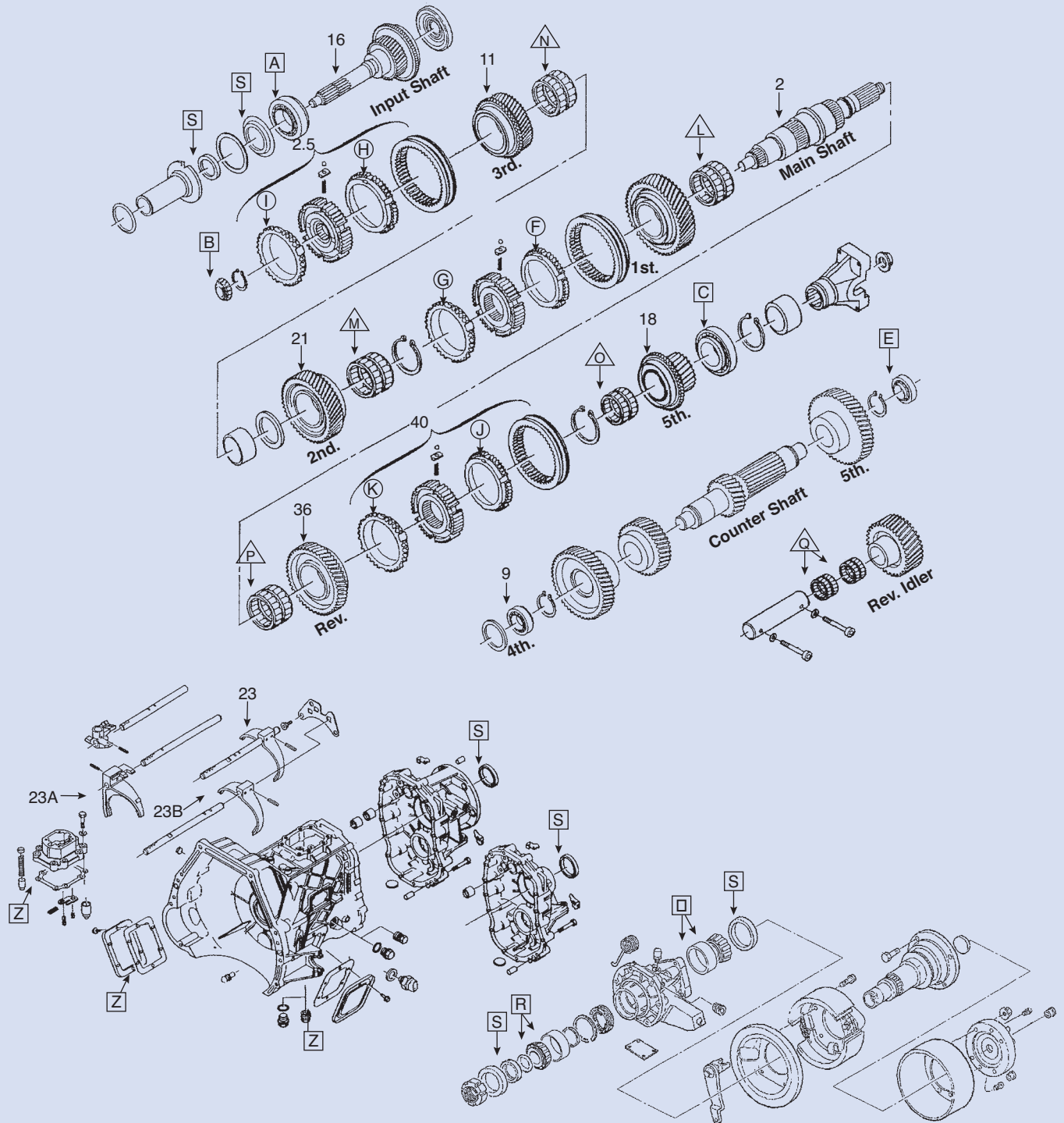

- = Contained in all kits.
- = Contained in WS (With Synchros) kits.
- △ = Contained in N (With Needle Brgs.) kits

Transmission Gearing & Related Parts

ZF S5-42, S5-47 & S5-47M

Position	Description	Specifications	Applications	Part Number	Model#s	Assembly#s
2	Mainshaft	20" Length	4x4	1307-304-353	S5-42	118
2	Mainshaft	20" Length	4x4	1307-304-353	S5-47	002
2	Mainshaft	18 3/4" Length	4x4	ZF42-2	S5-42	100, 102, 103, 109, 111, 120
2	Mainshaft	16 3/8" Length	4x2	ZF42-2A	S5-42	050, 051, 053, 054, 056, 057, 059, 064, 108, 110
2	Mainshaft	18 3/4" Length	4x4	ZF42-2	S5-47/S5-47M	004, 007, 012, 013, 008, 016, 020
2	Mainshaft	16 3/8" Length	4x2	ZF42-2A	S5-47/S5-47M	001, 003, 006, 014, 016, 020
2.5	3rd/4th Gear Synchro. Assy.			ZF42-2.5	S5-42	All
2.5	3rd/4th Gear Synchro. Assy.- Includes Synchro. Rings			ZF42-2.5A	S5-42	All
2.5	3rd/4th Gear Synchro. Assy.			ZF47-2.5	S5-47/S5-47M	All
2.5	3rd/4th Gear Synchro. Assy.- Includes Synchro. Rings			ZF47-2.5A	S5-47/S5-47M	All
3	Countershaft (w/o press on gears) 1st,2nd,Rev.	21T/14T		ZF42-3	S5-42	All
3	Countershaft (w/o press on gears) 1st,2nd,Rev.	26T/14T		ZF42-3A	S5-42	All
6	Bearing Retainer			ZF42-6	S5-42	All
6	Bearing Retainer	1317-302-041		ZF47-6	S5-47/S5-47M	003/004/006/007/012/013
9	Countershaft 4th Gear	45T		ZF42-9	S5-42	050, 051, 053, 054, 059, 064, 102, 110, 111, 118, 120
9	Countershaft 4th Gear	45T		ZF42-9	S5-47/S5-47M	001, 002, 006, 007, 013, All S5-47M
9	Countershaft 4th Gear	41T		ZF42-9A	S5-42	056, 057, 100, 103, 108, 109
9	Countershaft 4th Gear	43T		ZF47-9B	S5-47	003, 004, 012
11	3rd Gear	30T		ZF42-11	S5-42	050, 051, 053, 054, 059, 064, 102, 110, 111, 118, 120
11	3rd Gear	40T		ZF42-11A	S5-42	056, 057, 100, 103, 108, 109
11	3rd Gear	31T		ZF47-11	S5-47	3,004,012
11	3rd Gear	1317-204-006, 30T		ZF47-11A	S5-47/S5-47M	001, 002, 006, 007, 013, All S5-47M
12	1st Gear	48T		ZF42-12	S5-42	All
12	1st Gear	48T		1317-204-032	S5-47/S5-47M	All
16	Input Shaft	27T, 10 Spl, 11-3/4" OAL		ZF42-16B	S5-42	050, 051, 064, 118
16	Input Shaft	27T 9-1/2" OAL		ZF42-16	S5-42	053, 054, 059, 102, 110, 111, 120
16	Input Shaft	34T, 10 Spl, 9-5/8" OAL		ZF42-16A	S5-42	056, 057, 100, 103, 108, 109
16	Input Shaft	1317-202-016, 29T, 9-1/2" OAL		ZF47-16B	S5-47	003, 004, 012
16	Input Shaft	27T, 11-3/4" OAL		1317-202-015	S5-47	001, 002
16	Input Shaft	27T, 9-1/2" OAL		1317-202-017	S5-47	006, 007, 013
16	Input Shaft	1317-202-033, 27T, 12-3/8" OAL		ZF47-16C	S5-47M	All
18	Mainshaft 5th Gear	26T		ZF42-18	S5-42	050, 051, 053, 054, 059, 064, 102,
18	Mainshaft 5th Gear	30T		ZF42-18A	S5-42	056, 057, 100, 103, 108, 109
18	Mainshaft 5th Gear	25T		ZF47-18	S5-47	30,040,120
18	Mainshaft 5th Gear	25T		1317-204-018	S5-47/S5-47M	001, 002, 006, 007, 013, All S5-47M
19	Countershaft 5th Gear	57T		ZF42-19	S5-42	050/051/053/054/059/064/102/110/111/118/120

Transmission Gearing & Related Parts

ZF S5-42, S5-47 & S5-47M Continued

Position	Description	Specifications	Applications	Part Number	Model#’s	Assembly#’s
19	Countershaft 5th Gear	47T		ZF42-19A	S5-42	056/057/100/103/108/109
19	Countershaft 5th Gear	1317-303-016, 48T		N/A	S5-47/S5-47M	003/004/012
21	2nd Gear	37T		ZF42-21A	S5-42	050, 051, 053, 054, 059, 064, 102,
21	2nd Gear	51T		ZF42-21	S5-42	056, 057, 100, 103, 108, 109
21	2nd Gear	37T		ZF47-21	S5-47/S5-47M	All
23	1st/2nd Gear Shift	1307-298-933	Fork Only, No Rail Included, Fits only S5-42 and S5-47	ZF42-23	S5-42/S5-47/S5-47M	All
23	1st/2nd Gear Shift		Fork Only, No Rail Included, Fits only S5-47	ZF47-23	S5-47/S5-47M	All
23A	3rd/4th Gear Shift Fork	1307-206-003		ZF42-23A	S5-42/S5-47/S5-47M	All
23B	5th/Rev. Gear Shift Fork	1307-306-019		ZF42-23B	S5-42/S5-47/S5-47M	All
34	Countershaft 3rd gear	34T		ZF42-34	S5-42	All
34	Countershaft 3rd gear	31T		ZF42-34A	S5-42	All
34	Countershaft 3rd gear	1317-303-013, 30T		N/A	S5-47/S5-47M	All
34	Countershaft 3rd gear	31T		1317-303-012	S5-47/S5-47M	All
36	Mainshaft Rev. Gear	1307-304-590, 44T		ZF42-36	S5-42	All
36	Mainshaft Rev. Gear	44T		ZF47-36A	S5-47/S5-47M	All
40	5th/Rev. Gear Synchro. Assy.	1307-204-239		ZF42-40	S5-42	All
40	5th/Rev. Gear Synchro. Assy.-Includes Synchro. Rings			ZF47-40A	S5-47/S5-47M	All
40	5th/Rev. Gear Synchro. Assy.-Includes Synchro. Rings			ZF42-40A	S5-42	All
40	5th/Rev. Gear Synchro. Assy.			ZF47-40	S5-47/S5-47M	All
80	1-2 Hub and Slider			ZF42-80	S5-42	All
80	1-2 Hub and Slider-Includes Synchro. Rings			1307-204-243	S5-47/S5-47M	All
80	1-2 Hub and Slider			ZF47-80	S5-47/S5-47M	All
80	1-2 Hub and Slider-Includes Synchro. Rings			ZF47-80A	S5-47/S5-47M	All
111	3-4 Synchro.. Hub			ZF42-111	S5-42	All
111	3-4 Synchro.. Hub			ZF47-111	S5-47/S5-47M	All
116	3-4, 5th-Rev. Slider			ZF42-116	S5-42	All
128	1-2 Slider			ZF47-128	S5-47/S5-47M	All
128	1-2 Slider			ZF42-128	S5-42	All
131	5th-Rev. Synchro. Hub			ZF42-131	S5-42	All
131	5th-Rev. Synchro. Hub			ZF47-131	S5-47/S5-47M	All
136	3-4, 5th-Rev. Slider	1307-304-372		ZF42-136	S5-42	All
136	3-4, 5th-Rev. Slider	1317-304-158		ZF47-136A	S5-47/S5-47M	All
	Key, Spring and Ball Kit			ZF42-K	S5-42/47/47M	All
	Synchro. Ring Kit			SK-ZF1A	S5-42	All
	Synchro. Ring Kit			SK-ZF2A	S5-47/S5-47M	All
	Input Shim Kit			ZF42-SMK	S5-42/47/47M	All
	Snap Ring Kit	SRK1307		1052-SRK		

Transmission Gearing & Related Parts

ZF S5-42, S5-47 & S5-47M Continued

Position	Description	Applications	Part Number	Models
A	Input Shaft Brg.		ZT1096-ZT1097	S5-42/S5-47/S5-47M
B	Mainshaft Pilot Brg.		ZT1101	S5-42/S5-47/S5-47M
C	Mainshaft Rear Brg.		ZT1098-ZT1097	S5-42/S5-47/S5-47M
D	Countershaft Front Brg.		ZT1099-ZT1100	S5-42/S5-47/S5-47M
E	Countershaft Rear Brg.		ZT1099-ZT1100	S5-42/S5-47/S5-47M
F	1st Gear Synchro. Ring		ZSY1198	S5-42
F	1st Gear Synchro. Ring		ZSY1203	S5-47/S5-47M
G	2nd Gear Synchro. Ring		ZSY1198	S5-42
G	2nd Gear Synchro. Ring		ZSY1203	S5-47/S5-47M
H	3rd Gear Synchro. Ring		ZSY1199	S5-42
H	3rd Gear Synchro. Ring		ZSY1204	S5-47/S5-47M
I	4th Gear Synchro. Ring		ZSY1199	S5-42
I	4th Gear Synchro. Ring		ZSY1204	S5-47/S5-47M
J	Mainshaft 5th Gear Synchro. Ring		ZSY1199	S5-42
J	Mainshaft 5th Gear Synchro. Ring		ZSY1204	S5-47/S5-47M
K	Mainshaft Rev. Gear Synchro. Ring		ZSY1200	S5-42
K	Mainshaft Rev. Gear Synchro. Ring		ZSY1205	S5-47/S5-47M
L	1st Gear Brg.		ZN1055	S5-42/S5-47/S5-47M
M	2nd Gear Brg.		ZN1057	S5-42/S5-47/S5-47M
N	3rd Gear Brg.		ZN1057	S5-42/S5-47/S5-47M
N	3rd Gear Brg. Inner Race		ZN1056	S5-42/S5-47/S5-47M
O	Mainshaft 5th Gear Brg.		ZN1058	S5-42/S5-47/S5-47M
P	Mainshaft Rev. Gear Brg.		ZN1055	S5-42/S5-47/S5-47M
Q	Rev. Idler Gear Brg.		ZN1059	S5-42/S5-47/S5-47M
R	Shift Lever Brg.		ZN1060	S5-42/S5-47/S5-47M
S	Input Shaft Seal	35x50x7	3771	S5-42/S5-47
S	Input Shaft Seal	38x50x7	14703	S5-47M
S	Ext. Housing Seal	4x4	15803	S5-42/S5-47/S5-47M
S	Ext. Housing Seal	2WD	225010	S5-42/S5-47/S5-47M
S	Oil Baffle		E7TZ7040A	S5-42/S5-47/S5-47M
S	Oil Ring		F4TZ7046A	S5-42/S5-47/S5-47M
S	Front Brg. Retainer O-Ring		ZM1004	S5-42/S5-47/S5-47M
S	Detent Pin Plug		ZM1035	S5-42/S5-47/S5-47M
S	Detent Pin Plug		ZM1036	S5-42/S5-47/S5-47M
S	Sealing Plug		ZM1035	S5-42/S5-47/S5-47M
Z	Gear Shift Gasket		Part of GT-300ZF	S5-42
Z	PTO Cover Gasket		Part of GT-300ZF	S5-42
	Needle Bearing Kit		NK-ZF1	S5-42/S5-47/S5-47M

Transmission Gearing & Related Parts

ZF S6-650/750

Description	Specifications	Applications	Part Number	Model#’s	Assembly#’s
Mainshaft	1319-304-069	2WD	ZFS6-2	S6-650	004/005/022
Mainshaft	1319-304-094	4x4	ZFS6-2A	S6-650	025/036/044/046
Mainshaft	1319-304-099	2WD	1319-304-099	S6-750	001/004/006/008/010
Mainshaft	1319-304-108	4x4	ZFS6-2B	S6-750	003/005/007/009/011
3-4 Synchro. Assembly	1319-304-125		ZFS6-2.5	S6-650	All
3-4 Synchro. Assembly	1319-204-039		1319-204-039	S6-750	All
Countershaft 3rd Gear	1319-303-050		ZFS6-34	S6-650/S6-750	All
Front Bearing Retainer	1319-302-009	Ford Only	ZFS6-6	S6-650/S6-750	All
Input Shim			1319SMK	S6-650	All
Cluster Gear	1319-203-024, 39-35-25-19-12 Tooth Counts		ZFS6-8	S6-650/S6-750	001/003/004/005/006/007 008/009/010/011-does not fit 083/084/085/086
4th Gear	1319-303-049, 39T		ZFS6-9	S6-650/S6-750	001/003/004/005/006/007 008/009/010/011-does not fit 083/084/085/086
3rd Gear	1319-204-011, 27T		ZFS6-11	S6-650/S6-750	All
1st Gear	37T		ZFS6-12	S6-650/S6-750	
Input Shaft	1319-202-026, 23T, 10 3/8" Length	Ford Only	ZFS6-16	S6-650	004/005/006/022/023/0 24/025/036/037/045/04 6/049/
Input Shaft	1319-202-023		N/A	S6-650	
Input Shaft	1319-202-017	GM	N/A	N/A	N/A
Input Shaft	1319-202-024, 23T, 11.375" Length, .970" Pilot	Ford Only	ZFS6-16B	S6-750	001/003/004/005/006/007
Input Shaft	1319-202-018, 23T, 14.5" Length, 1.5" Clutch splines	GM	N/A	S6-650	
5th Gear	1319-303-052, 54T		ZFS6-18	S6-650/S6-750	All
2nd,3rd Gear Inner Bearing Race	0730-162-812		ZN1190	S6-650/S6-750	All
2nd Gear	1319-204-013, 31T		ZFS6-21	S6-650	004/005/006/022/023/02 4/025/036/037/043/044/ 045/046
2nd Gear	1319-204-042		1319-204-042	S6-750	All
2nd/3rd Thrust Washer	0730-162-813		ZFS6-22	S6-650	All
2nd/3rd Thrust Washer	0730-112-261		ZFS6-22A	S6-750	All
Low-Rev Shift Fork	1319-306-045		ZFS6-23	S6-650/S6-750	All
1-2 Slider	1319-204-056, 1319 304 092		ZFS6-28	S6-650/S6-750	All
1st, 2nd, 3rd Needle Bearing	0735-321-480		ZN1189	S6-650/S6-750	All
Reverse Gear	1319-204-026, 37T		ZFS6-36	S6-650/S6-750	All
1/2 Synchro. Hub	1317-304-125		ZFS6-37	S6-650/S6-750	All
Creeper Rev. Synchro. Assembly	1319-204-040		ZFS6-40	S6-650/S6-750	All
Creeper Gear	1319-204-056, 41T		ZFS6-48	S6-650/S6-750	All
Rev. Gear Inner Bearing Race	0730-162-730		ZN1195	S6-650/S6-750	All
5th Synchro. Hub and Slider	1319-203-029		ZFS6-50	S6-650/S6-750	All
5th Synchro. Hub and Slider	1319-203-029-Includes Synchro. Rings		ZFS6-50A	S6-650/S6-750	All
Reverse Gear Bearing Race	0730-109-432		ZN1198	S6-650/S6-750	All
3rd Gear C/S	1319-303-050		ZFS6-34	S6-650/S6-750	All
5th Synchro. Hub	1319-303-047		1319-303-047	S6-650/S6-750	All
5th Gear Inner Bearing Race	0730-162-731		ZN1192	S6-650/S6-750	All
5th Gear Needle Bearing	0735-321-453		ZN1191	S6-650/S6-750	All
1-2 Synchro. Assembly	1319-204-045		ZFS6-80A	S6-650	004/005/006/022/023
1st and 2nd Gear hub and Slider	1319-204-045		ZFS6-80	S6-650/S6-750	All
1-2 Synchro. Assembly	1319-204-050		1319-204-050	S6-750	All
Low and Reverse Gear Slider	1317-304-157		ZF47-128	S6-650/S6-750	All
3-4,5th Gear Slider	1317-304-158		ZF47-136A	S6-650	All
3-4, 5th Gear Slider	1317-304-125		N/A	S6-750	All
5th Shift Fork	1319-306-047		1319-306-047	S6-650/S6-750	All
1-2, 3-4 Shift Fork	1307-306-019		ZF42-23B	S6-650/S6-750	All
Synchro. Key and Spring Kit	S547-K		ZFS6-K1	S6-650/S6-750	All
Synchro. Ring Kit	1319SK		SK-ZF47A	S6-650/S6-750	All
Pump Housing	1319-220-008		1319-220-008	S6-650/S6-750	S6-650/S6-750
Snap Ring Kit	1319SRK		1319SRK	S6-650/S6-750	All

Transmission Gearing & Related Parts

ZF S6-650/750 Continued

Description	Applications	Part Number	Models
Input Shaft Brg.		NP007430-NP423135	S6-650/S6-750
Mainshaft Pilot Brg.		JH13349	S6-650/S6-750
Mainshaft Center Brg.		NP957859-NP771105	S6-650/S6-750
Mainshaft Rear Brg.		309-L	S6-650/S6-750
Mainshaft Rear Brg.	4x4 GM Applications	ZB1181	S6-650/S6-750
Countershaft Front Brg.		DTP2074	S6-650
Countershaft Front Brg.		1319-203-032	S6-750
Countershaft Center Brg.		NP043905-NP547779	S6-650/S6-750
Countershaft Rear Brg.	Ford Applications	FC69178	S6-650
Countershaft Rear Brg.	GM Applications	R1563TAV	S6-650
Countershaft Rear Brg.		R1563TAV	S6-750
Input Shaft Seal		UH5019-E0	S6-650/S6-750
Output Shaft Seal	2WD All	UH5020-G0	S6-650/S6-750
Output Shaft Seal	4x4 Ford Applications	UH5021-E0	S6-650/S6-750
Rear O ring	4x4 GM Applications	OR-100X3V	S6-650/S6-750
Oil Baffle		F81Z7046AA	S6-650/S6-750
Oil Ring		F4TZ7046A	S6-650/S6-750
Sealing Cap (Large)		ZM1036	S6-650/S6-750
Synchro. Ring Kit		SK-ZF4A	S6-650/S6-750
1st Gear Brg.		ZN1189	S6-650/S6-750
2nd Gear Brg.		ZN1189	S6-650/S6-750
2nd Gear Brg. Inner Race		ZN1190	S6-650/S6-750
3rd Gear Brg.		ZN1189	S6-650/S6-750
3rd Gear Inner Brg. Race		ZN1190	S6-650/S6-750
5th Gear Brg.		ZN1191	S6-650/S6-750
5th Gear Inner Brg. Race		ZN1192	S6-650/S6-750
5th Gear Thrust Washer		ZN1193	S6-650/S6-750
Creeper Gear Brg.		ZN1194	S6-650/S6-750
Rev. Gear Brg.		ZN1194	S6-650/S6-750
Rev. Gear Brg. Inner Race		ZN1195	S6-650/S6-750
Rev. Idler Gear Brg.		ZN1196	S6-650/S6-750
Shift Shaft Brg.		ZN1160	S6-650/S6-750
2nd/3rd Gear Thrust Washer		ZN1197	S6-650/S6-750
Rev. Gear Thrust Brg.		ZN1198	S6-650/S6-750
Gasket Kit		GT-PT055	S6-650/S6-750

Light Duty Transfer Case Applications

Vehicle	Model #	Years	Notes	Bearing, Seal & Gasket Kit	Seal & Gasket Kit
Chrysler (Dodge, Plymouth)					
1/2, 3/4 & 1 Ton Truck	246	10-06		TCRK-246AA	DTK-246AA
1/2, 3/4 & 1 Ton Truck	271	08-03		TCRK-271AA	DTK-271AA
1/2, 3/4 & 1 Ton Truck	273	08-03		TCRK-271AA	DTK-271AA
1/2, 3/4 & 1 Ton Truck	243	08-02	Electric Shift	TCRK-241CC	DTK-241
1/2, 3/4 & 1 Ton Truck	244	05-04	Electric Shift	TCRK-242EE	DTK-242EE
1/2, 3/4 & 1 Ton Truck	241	05-00		TCRK-241CC	DTK-241
1/2, 3/4 & 1 Ton Truck	241	05-00	241 DHD (Heavy Duty)	TCRK-241DD	DTK-241
1/2, 3/4 & 1 Ton Truck	231	01-97		TCRK-231EE	DTK-231EE
1/2, 3/4 & 1 Ton Truck	241	99-97		TCRK-241EE	DTK-241
1/2, 3/4 & 1 Ton Truck	241	99-97	241 DHD (Heavy Duty)	TCRK-241FF	DTK-241
1/2, 3/4 & 1 Ton Truck	241	96-95		TCRK-241BB	DTK-241
1/2, 3/4 & 1 Ton Truck	231	96-94		TCRK-231DD	DTK-231DD
1/2, 3/4 & 1 Ton Truck	205	93-88	w/ 6210N Input Bearing	TCRK-205D	DTK-205D
1/2, 3/4 & 1 Ton Truck	241	93-88		TCRK-241AA	DTK-241
1/2, 3/4 & 1 Ton Truck	208	87-80	Includes Small Parts Kit	TCRK-208SPK	DTK-208
1/2, 3/4 & 1 Ton Truck	205	87-69	w/ 6307N Input Bearing	TCRK-205G	DTK-205G
1/2, 3/4 & 1 Ton Truck	203	79-73		TCRK-203G	DTK-203G
1/2, 3/4 & 1 Ton Truck	201	68-60		TCRK-201	DTK-201
1/2, 3/4 & 1 Ton Truck	241	1994		TCRK-241	DTK-241
Ramcharger	241	93-88		TCRK-241AA	DTK-241
Ramcharger	208	87-80	Includes Small Parts Kit	TCRK-208SPK	DTK-208
Ramcharger	203	79-74		TCRK-203G	DTK-203G
Caravan	Steyr	03-91		TCRK-STEYR100	DTK-STEYR100
Dakota	243	08-06	Electric Shift	TCRK-241CC	DTK-241
Dakota	233	08-01	Electric Shift	TCRK-233AA	DTK-233AA
Dakota	244	08-01	Electric Shift	TCRK-242EE	DTK-242EE
Dakota	242	2000	w/ BD50-8 I/S Brg	TCRK-242EE	DTK-242EE
Dakota	231	00-94	w/ 6010N I/S Brg	TCRK-231EE	DTK-231EE
Dakota	242	99-98	w/ 6010N I/S Brg	TCRK-242DD	DTK-242DD
Dakota	231	93-88	w/ BD50-8 I/S Brg	TCRK-231	DTK-231
Dakota	207	1987		TCRK-207	DTK-207
Durango	244	08-01	Electric Shift	TCRK-242EE	DTK-242EE
Durango	233	03-01	Electric Shift	TCRK-233AA	DTK-233AA
Durango	242	2000	w/ BD50-8 I/S Brg	TCRK-242EE	DTK-242EE
Durango	231	00-98		TCRK-231EE	DTK-231EE
Durango	242	99-98	w/ 6010N I/S Brg	TCRK-242DD	DTK-242DD
Grand Caravan	Steyr	03-91		TCRK-STEYR100	DTK-STEYR100
Grand Voyager	Steyr	03-91		TCRK-STEYR100	DTK-STEYR100
Town & Country	Steyr	03-91		TCRK-STEYR100	DTK-STEYR100
Trailduster	208	81-80	Includes Small Parts Kit	TCRK-208SPK	DTK-208
Trailduster	203	79-74		TCRK-203G	DTK-203G
Voyager	Steyr	03-91		TCRK-STEYR100	DTK-STEYR100
Daihatsu					
Rocky		92-88		TCRK-FD120	DTK-FD120
Ford (Lincoln, Mercury)					
Aerostar	Dana 28	97-90		TCRK-28	DTK-28
Bronco	1356	96-92	Electric Shift	TCRK-1356	DTK-1356
Bronco	1356	96-87	Manual Shift	TCRK-1356	DTK-1356
Bronco	1345	86-81		TCRK-1345	DTK-1345
Bronco	208	86-80	Includes Small Parts Kit	TCRK-208SPK	DTK-208
Bronco	205	79-78	Direct Mount	TCRK-205F	DTK-205F

Light Duty Transfer Case Applications

Vehicle	Model #	Years	Notes	Bearing, Seal & Gasket Kit	Seal & Gasket Kit
Ford (Lincoln, Mercury) (cont.)					
Bronco	203	79-78	Direct Mount	TCRK-203F	DTK-203F
Bronco	Dana 20	77-73		TCRK-20C	DTK-20F
Bronco	Dana 20	72-66		TCRK-20B	DTK-20F
Bronco II	1354	1990	Manual Shift or Electric Shift	TCRK-1354	DTK-1354
Bronco II	1359	90-84	Dummy Case used in 2WD Applications	TCRK-1359	DTK-1359
Bronco II	1359				
Bronco II	1350	90-84	Manual Shift or Electric Shift	TCRK-1350	DTK-1350
Excursion	273	05-00	Electric Shift	TCRK-271	DTK-271
Expedition	4416	08-03		TCRK-4416	DTK-4416
Expedition	4406	02-97	Torque on Demand	TCRK-4406	DTK-4406
Explorer	4412 w/ 6 Spd. Auto Trans.	10-06		TCRK-4412A	DTK-4412A
Explorer	4412 w/ 5 Spd. Auto Trans.	10-06		TCRK-4412	DTK-4412
Explorer	4411	05-02	V-6	TCRK-4411	DTK-4411
Explorer	4410	05-02	V-8	TCRK-4410	DTK-4410
Explorer	4403	01-99	AWD	TCRK-4403	DTK-4403
Explorer	4405	01-97	V-6 w/ Electric Shift	TCRK-4405AA	DTK-4405
Explorer	4404	01-96	V-8 w/ TOD	TCRK-4404	DTK-4404
Explorer	4405	96-95	V-6 w/ Electric Shift	TCRK-4405	DTK-4405
Explorer	1354	95-91	Manual Shift or Electric Shift	TCRK-1354	DTK-1354
Explorer Sport	1354	03-01	Manual Shift or Electric Shift	TCRK-1354	DTK-1354
Explorer Sport Trac	4412 w/ 6 Spd. Auto Trans.	10-06		TCRK-4412A	DTK-4412A
Explorer Sport Trac	4412 w/ 5 Spd. Auto Trans.	10-06		TCRK-4412	DTK-4412
Explorer Sport Trac	1354	06-01	Electric Shift	TCRK-1354	DTK-1354
F-150	4406	08-96	Manual Shift, Electric Shift & Torque on Demand	TCRK-4406	DTK-4406
F-150	4406				
F-150	1356	97-92	Electric Shift	TCRK-1356	DTK-1356
F-150	1356	97-87	Manual Shift	TCRK-1356	DTK-1356
F-150	1345	92-82		TCRK-1345	DTK-1345
F-150	205	89-71	Direct Mount	TCRK-205F	DTK-205F
F-150	208	86-80	Includes Small Parts Kit	TCRK-208SPK	DTK-208
F-150	203	79-73	Direct Mount	TCRK-203F	DTK-203F
F-150	203	77-74	Remote Mount	TCRK-203FA	DTK-203FA
F-150	205	77-73	Remote Mount	TCRK-205FA	DTK-205R
F-150	Dana 21	76-65		TCRK-21	DTK-21
F-150	Dana 24	1965		TCRK-24	DTK-24
F-250	271	08-99		TCRK-271	DTK-271
F-250	273	08-99	Electric Shift	TCRK-271	DTK-271
F-250	4406	99-96	Manual Shift, Electric Shift & Torque on Demand	TCRK-4406	DTK-4406
F-250	4406				
F-250	4407	97-96		TCRK-4407	DTK-4407
F-250	1356	97-87	Manual Shift	TCRK-1356	DTK-1356
F-250	1345	92-81		TCRK-1345	DTK-1345
F-250	208	86-80	Includes Small Parts Kit	TCRK-208SPK	DTK-208
F-250	203	79-74	Direct Mount	TCRK-203F	DTK-203F
F-250	205	79-73	Direct Mount	TCRK-205F	DTK-205F
F-250	205	77-73	Remote Mount	TCRK-205FA	DTK-205R
F-250	203	75-74	Remote Mount	TCRK-203FA	DTK-203FA
F-250	Dana 24	72-65		TCRK-24	DTK-24
F-350	271	08-99		TCRK-271	DTK-271
F-350	273	08-99	Electric Shift	TCRK-271	DTK-271
F-350	1356	97-87	Manual Shift	TCRK-1356	DTK-1356
F-350	1345	87-80		TCRK-1345	DTK-1345

Light Duty Transfer Case Applications

Vehicle	Model #	Years	Notes	Bearing, Seal & Gasket Kit	Seal & Gasket Kit
Ford (Lincoln, Mercury) (cont.)					
F-350	208	86-84	Includes Small Parts Kit	TCRK-208SPK	DTK-208
F-350	203	79-72	Direct Mount	TCRK-203F	DTK-203F
F-350	205	79-71	Direct Mount	TCRK-205F	DTK-205F
F-350	205	77-71	Remote Mount	TCRK-205FA	DTK-205R
F-350	203	75-72	Remote Mount	TCRK-203FA	DTK-203FA
F-350	Dana 21	74-65		TCRK-21	DTK-21
F-350	Dana 24	72-62		TCRK-24	DTK-24
Mountaineer	4412 w/ 5 Spd. Auto Trans.	10-06		TCRK-4412	DTK-4412
Mountaineer	4412 w/ 6 Spd. Auto Trans.	10-06		TCRK-4412A	DTK-4412A
Mountaineer	4410	05-02	V-8	TCRK-4410	DTK-4410
Mountaineer	4403	01-99	AWD	TCRK-4403	DTK-4403
Mountaineer	4405	01-98	V-6 w/ Electric Shift	TCRK-4405AA	DTK-4405
Mountaineer	4404	01-97	V-8 w/ TOD	TCRK-4404	DTK-4404
Navigator	4416	08-03		TCRK-4416	DTK-4416
Navigator	4406	02-98	Torque on Demand	TCRK-4406	DTK-4406
Ranger	1354	11-91	Electric Shift	TCRK-1354	DTK-1354
Ranger	1354	98-90	Manual Shift	TCRK-1354	DTK-1354
Ranger	4405	1997	V-6 w/ Electric Shift	TCRK-4405AA	DTK-4405
Ranger	4405	96-95	V-6 w/ Electric Shift	TCRK-4405	DTK-4405
Ranger	1350	93-83	Manual Shift or Electric Shift	TCRK-1350	DTK-1350
GM (Chevrolet, GMC, Buick, Cadillac, Oldsmobile, Hummer, Geo)					
1/2 Ton Truck	1222	14-07		TCRK-1222	DTK-1222
1/2 Ton Truck	3023	14-07		TCRK-3023	DTK-3023
1/2 Ton Truck	4485	13-07	One Speed	TCRK-4485	DTK-4485
1/2 Ton Truck	149	07-01	One Speed	TCRK-149	DTK-149
1/2 Ton Truck	246	07-98		TCRK-246	DTK-246
1/2 Ton Truck	261HD	07-01	Heavy Duty	TCRK-261AA	DTK-261
1/2 Ton Truck	261	07-99		TCRK-261	DTK-261
1/2 Ton Truck	241	99-94	w/ 6010N I/S Brg	TCRK-241BB	DTK-241
1/2 Ton Truck	243	99-91	Electric Shift	TCRK-241BB	DTK-241
1/2 Ton Truck	241	94-88	w/ BD50-8 I/S Brg	TCRK-241	DTK-241
1/2 Ton Truck	208	87-81	Includes Small Parts Kit	TCRK-208SPK	DTK-208
1/2 Ton Truck	205	80-70	w/ 6307N Input Bearing	TCRK-205G	DTK-205G
1/2 Ton Truck	205	80-70	w/ 6210N Input Bearing	TCRK-205GDM4	DTK-205G
1/2 Ton Truck	203	79-73		TCRK-203G	DTK-203G
1/2 Ton Truck	Dana 20 w/ 1.3125" ID Front Output Cones	75-73		TCRK-20A	
1/2 Ton Truck	Dana 20 w/ 1.1875" ID Front Output Cones	73-69		TCRK-20	
1/2 Ton Truck	4481	2003	AWD, One Speed	TCRK-4481	DTK-4481
1/2 Ton Truck	4482	2003	AWD, Two Speed	TCRK-4482	DTK-4482
3/4 Ton Truck	1225	14-12		TCRK-1225A	DTK-1225A
3/4 Ton Truck	1226	14-12		TCRK-1225A	DTK-1225A
3/4 Ton Truck	1625	14-12		TCRK-1625A	DTK-1625A
3/4 Ton Truck	1626	14-12		TCRK-1625A	DTK-1625A
3/4 Ton Truck	3024	14-08		TCRK-3024	DTK-3024
3/4 Ton Truck	1225 w/ 29 Tooth Input Shaft	2011		TCRK-1225	DTK-1225
3/4 Ton Truck	1225 w/ 33 Tooth Input Shaft	2011		TCRK-1225A	DTK-1225A
3/4 Ton Truck	1226 w/ 29 Tooth Input Shaft	2011		TCRK-1225	DTK-1225
3/4 Ton Truck	1226 w/ 33 Tooth Input Shaft	2011		TCRK-1225A	DTK-1225A
3/4 Ton Truck	1625 w/ 29 Tooth Input Shaft	2011		TCRK-1625	DTK-1625

Light Duty Transfer Case Applications

Vehicle	Model #	Years	Notes	Bearing, Seal & Gasket Kit	Seal & Gasket Kit
GM (Chevrolet, GMC, Buick, Cadillac, Oldsmobile, Hummer, Geo) (cont.)					
3/4 Ton Truck	1625 w/ 33 Tooth Input Shaft	2011		TCRK-1625A	DTK-1625A
3/4 Ton Truck	1626 w/ 29 Tooth Input Shaft	2011		TCRK-1625	DTK-1625
3/4 Ton Truck	1626 w/ 33 Tooth Input Shaft	2011		TCRK-1625A	DTK-1625A
3/4 Ton Truck	1225	10-07		TCRK-1225	DTK-1225
3/4 Ton Truck	1226	10-07		TCRK-1225	DTK-1225
3/4 Ton Truck	1625	10-07		TCRK-1625	DTK-1625
3/4 Ton Truck	1626	10-07		TCRK-1625	DTK-1625
3/4 Ton Truck	246	07-98		TCRK-246	DTK-246
3/4 Ton Truck	261SHD	07-01	Super Heavy Duty	TCRK-261BB	DTK-261
3/4 Ton Truck	263SHD	07-01	Super Heavy Duty	TCRK-261BB	DTK-261
3/4 Ton Truck	261HD	07-99	Heavy Duty	TCRK-261AA	DTK-261
3/4 Ton Truck	263HD	07-99	Heavy Duty	TCRK-261AA	DTK-261
3/4 Ton Truck	261	00-99		TCRK-261	DTK-261
3/4 Ton Truck	241	99-94	w/ 6010N I/S Brg	TCRK-241BB	DTK-241
3/4 Ton Truck	243	99-91	Electric Shift	TCRK-241BB	DTK-241
3/4 Ton Truck	241	94-88	w/ BD50-8 I/S Brg	TCRK-241	DTK-241
3/4 Ton Truck	208	87-81	Includes Small Parts Kit	TCRK-208SPK	DTK-208
3/4 Ton Truck	205	80-70	w/ 6307N Input Bearing	TCRK-205G	DTK-205G
3/4 Ton Truck	205	80-70	w/ 6210N Input Bearing	TCRK-205GDM4	DTK-205G
3/4 Ton Truck	203	79-73		TCRK-203G	DTK-203G
3/4 Ton Truck	Dana 20 w/ 1.3125" ID Front Output Cones	75-73		TCRK-20A	
3/4 Ton Truck	Dana 20 w/ 1.1875" ID Front Output Cones	73-69		TCRK-20	
1 Ton Truck	1226	14-12		TCRK-1225A	DTK-1625A
1 Ton Truck	1626	14-12		TCRK-1625A	DTK-1625A
1 Ton Truck	1226 w/ 29 Tooth Input Shaft	2011		TCRK-1225	DTK-1225
1 Ton Truck	1226 w/ 33 Tooth Input Shaft	2011		TCRK-1225A	DTK-1225A
1 Ton Truck	1626 w/ 29 Tooth Input Shaft	2011		TCRK-1625	DTK-1625
1 Ton Truck	1626 w/ 33 Tooth Input Shaft	2011		TCRK-1625A	DTK-1625A
1 Ton Truck	1226	10-07		TCRK-1225	DTK-1225
1 Ton Truck	1626	10-07		TCRK-1625	DTK-1625
1 Ton Truck	261HD	07-01	Heavy Duty	TCRK-261AA	DTK-261
1 Ton Truck	263HD	07-01	Heavy Duty	TCRK-261AA	DTK-261
1 Ton Truck	261SHD	07-01	Super Heavy Duty	TCRK-261BB	DTK-261
1 Ton Truck	263SHD	07-01	Super Heavy Duty	TCRK-261BB	DTK-261
1 Ton Truck	4401	00-94		TCRK-1356	DTK-1356
1 Ton Truck	4470	00-90		TCRK-4470	DTK-1356
1 Ton Truck	1370	93-89		TCRK-1356	DTK-1356
1 Ton Truck	241	91-88	w/ BD50-8 I/S Brg	TCRK-241	DTK-241
1 Ton Truck	205	87-70	w/ 6307N Input Bearing	TCRK-205G	DTK-205G
1 Ton Truck	205	87-70	w/ 6210N Input Bearing	TCRK-205GDM4	DTK-205G
1 Ton Truck	203	79-73		TCRK-203G	DTK-203G
1 Ton Truck	Dana 20 w/ 1.3125" ID Front Output Cones	75-73		TCRK-20A	
1 Ton Truck	Dana 20 w/ 1.1875" ID Front Output Cones	73-69		TCRK-20	
Astro	136	05-98	One Speed	TCRK-236	DTK-236
Astro	4472	98-90		TCRK-1372	DTK-4472
Avalanche	3023	13-08		TCRK-3023	DTK-3023

LD Transmission

Light Duty Transfer Case Applications

Vehicle	Model #	Years	Notes	Bearing, Seal & Gasket Kit	Seal & Gasket Kit
GM (Chevrolet, GMC, Buick, Cadillac, Oldsmobile, Hummer, Geo) (cont.)					
Avalanche	4485	13-07	One Speed	TCRK-4485	DTK-4485
Avalanche	4485				
Avalanche	246	07-02		TCRK-246	DTK-246
Blazer	241	94-89		TCRK-241	DTK-241
Blazer	208	88-81	Includes Small Parts Kit	TCRK-208SPK	DTK-208
Blazer	205	80-69	w/ 6307N Input Bearing	TCRK-205G	DTK-205G
Blazer	205	80-69	w/ 6210N Input Bearing	TCRK-205GDM4	DTK-205G
Blazer	203	79-73		TCRK-203G	DTK-203G
Blazer	Dana 20 w/ 1.3125" ID Front Output Cones	75-73		TCRK-20A	
Blazer	Dana 20 w/ 1.1875" ID Front Output Cones	73-69		TCRK-20	
Blazer	236	05-99	Two Speed	TCRK-236	DTK-236
Blazer	233	05-94	Electric Shift	TCRK-231CC	DTK-231CC
Blazer	136	01-98	One Speed	TCRK-236	DTK-236
Blazer	231	97-95		TCRK-231CC	DTK-231CC
Blazer	4472	97-95		TCRK-1372	DTK-4472
Blazer	231	94-92		TCRK-231BB	DTK-231
Blazer	233	93-92	Electric Shift	TCRK-231BB	DTK-231
Blazer	231	91-89		TCRK-231	DTK-231
Blazer	207	88-83		TCRK-207	DTK-207
Bravada	126	04-02		TCRK-226	DTK-226
Bravada	136	01-98	One Speed	TCRK-236	DTK-236
Bravada	4472	97-91		TCRK-1372	DTK-4472
Canyon	T150	12-04		TCRK-T150	DTK-T150
Colorado	T150	12-04		TCRK-T150	DTK-T150
Envoy	226	08-02		TCRK-226	DTK-226
Escalade EXT	4485	13-07	One Speed	TCRK-4485	DTK-4485
Escalade EXT	4481	06-03	AWD, One Speed	TCRK-4481	DTK-4481
Escalade ESV	4485	14-07	One Speed	TCRK-4485	DTK-4485
Escalade ESV	4481	06-03	AWD, One Speed	TCRK-4481	DTK-4481
Escalade	4485	14-07	One Speed	TCRK-4485	DTK-4485
Escalade	4481	06-03	AWD, One Speed	TCRK-4481	DTK-4481
Escalade	149	2002	One Speed	TCRK-149	DTK-149
Escalade	246	00-99		TCRK-246	DTK-246
Express 1500	4473	14-03		TCRK-4473	DTK-4473
Express 2500	4473	05-03		TCRK-4473	DTK-4473
Hummer H-1	242	08-92		TCRK-242AA	DTK-242
Hummer H-1	218	99-92		TCRK-218	DTK-218
Hummer H-2	4484	09-03	AWD, Two Speed	TCRK-4484	DTK-4484
Jimmy	241	91-89		TCRK-241	DTK-241
Jimmy	208	88-81	Includes Small Parts Kit	TCRK-208SPK	DTK-208
Jimmy	205	80-70	w/6307N Input Bearing	TCRK-205G	DTK-205G
Jimmy	205	80-70	w/6210N Input Bearing	TCRK-205GDM4	DTK-205G
Jimmy	203	79-73		TCRK-203G	DTK-203G
Jimmy	Dana 20 w/ 1.3125" ID Front Output Cones	75-73		TCRK-20A	
Jimmy	Dana 20 w/ 1.1875" ID Front Output Cones	73-70		TCRK-20	
Jimmy	236	05-99	Two Speed	TCRK-236	DTK-236
Jimmy	231	05-95		TCRK-231CC	DTK-231CC
Jimmy	233	05-94	Electric Shift	TCRK-231CC	DTK-231CC
Jimmy	136	01-98	One Speed	TCRK-236	DTK-236
Jimmy	4472	97-95		TCRK-1372	DTK-4472
Jimmy	231	94-92		TCRK-231BB	DTK-231
Jimmy	233	93-92	Electric Shift	TCRK-231BB	DTK-231

Light Duty Transfer Case Applications

Vehicle	Model #	Years	Notes	Bearing, Seal & Gasket Kit	Seal & Gasket Kit
GM (Chevrolet, GMC, Buick, Cadillac, Oldsmobile, Hummer, Geo) (cont.)					
Jimmy	231	91-89		TCRK-231	DTK-231
Jimmy	207	88-83		TCRK-207	DTK-207
S-10/S-15 Pick-Up	233	04-94	Electric Shift, All	TCRK-231CC	DTK-231CC
S-10/S-15 Pick-Up	236	1999	Two Speed	TCRK-236	DTK-236
S-10/S-15 Pick-Up	231	97-95	All	TCRK-231CC	DTK-231CC
S-10/S-15 Pick-Up	231	93-92	Extended Cab	TCRK-231	DTK-231
S-10/S-15 Pick-Up	231	93-92	Standard Cab	TCRK-231BB	DTK-231
S-10/S-15 Pick-Up	233	93-92	Electric Shift, Extended Cab	TCRK-231	DTK-231
S-10/S-15 Pick-Up	233	93-92	Electric Shift, Standard Cab	TCRK-231BB	DTK-231
S-10/S-15 Pick-Up	231	91-89	All	TCRK-231	DTK-231
S-10/S-15 Pick-Up	207	88-83	All	TCRK-207	DTK-207
S-10/S-15 Pick-Up	231	1994	All	TCRK-231BB	DTK-231
Safari	136	05-99	One Speed	TCRK-236	DTK-236
Safari	4472	98-90		TCRK-1372	DTK-4472
Savana 1500	4473	14-03		TCRK-4473	DTK-4473
Savana 2500	4473	05-03		TCRK-4473	DTK-4473
Sonoma	233	04-94	Electric Shift, All	TCRK-231CC	DTK-231CC
Sonoma	236	1999	Two Speed	TCRK-236	DTK-236
Sonoma	231	97-95	All	TCRK-231CC	DTK-231CC
Sonoma	231	1994	All	TCRK-231BB	DTK-231
Sonoma	231	93-92	Extended Cab	TCRK-231	DTK-231
Sonoma	231	93-92	Standard Cab	TCRK-231BB	DTK-231
Sonoma	233	93-92	Electric Shift, Standard Cab	TCRK-231BB	DTK-231
Sonoma	233	93-92	Electric Shift, Extended Cab	TCRK-231	DTK-231
Suburban	1225	14-12		TCRK-1225A	DTK-1225A
Suburban	1226	14-12		TCRK-1225A	DTK-1225A
Suburban	1222	14-09	One Speed	TCRK-1222	DTK-1222
Suburban	3024	14-09		TCRK-3024	DTK-3024
Suburban	3023	14-08		TCRK-3023	DTK-3023
Suburban	4485	14-07	One Speed	TCRK-4485	DTK-4485
Suburban	1225 w/ 29 Tooth Input Shaft	2011		TCRK-1225	DTK-1225
Suburban	1225 w/ 33 Tooth Input Shaft	2011		TCRK-1225A	DTK-1225A
Suburban	1226 w/ 29 Tooth Input Shaft	2011		TCRK-1225	DTK-1225
Suburban	1226 w/ 33 Tooth Input Shaft	2011		TCRK-1225A	DTK-1225A
Suburban	1225	10-09		TCRK-1225	DTK-1225
Suburban	1226	10-09		TCRK-1225	DTK-1225
Suburban	4481	08-03	AWD, One Speed	TCRK-4481	DTK-4481
Suburban	4482	08-03	AWD, Two Speed	TCRK-4482	DTK-4482
Suburban	246	07-98		TCRK-246	DTK-246
Suburban	243	99-96	Electric Shift	TCRK-241BB	DTK-241
Suburban	241	99-94	w/ 6010N I/S Brg	TCRK-241BB	DTK-241
Suburban	241	94-89	w/ BD50-8 I/S Brg	TCRK-241	DTK-241
Suburban	208	88-81	Includes Small Parts Kit	TCRK-208SPK	DTK-208
Suburban	205	80-70	w/ 6307N Input Bearing	TCRK-205G	DTK-205G
Suburban	205	80-70	w/ 6210N Input Bearing	TCRK-205GDM4	DTK-205G
Suburban	203	79-73		TCRK-203G	DTK-203G
Suburban	Dana 20 w/ 1.3125" ID Front Output Cones	75-73		TCRK-20A	
Suburban	Dana 20 w/ 1.1875" ID Front Output Cones	1973		TCRK-20	
Syclone	4472	1991		TCRK-1372	DTK-4472
Tahoe	3023	14-08		TCRK-3023	DTK-3023

LD Transmission

Light Duty Transfer Case Applications

Vehicle	Model #	Years	Notes	Bearing, Seal & Gasket Kit	Seal & Gasket Kit
GM (Chevrolet, GMC, Buick, Cadillac, Oldsmobile, Hummer, Geo) (cont.)					
Tahoe	4485	14-07	One Speed	TCRK-4485	DTK-4485
Tahoe	246	07-98		TCRK-246	DTK-246
Tahoe	241	00-95		TCRK-241BB	DTK-241
Tahoe	243	99-96	Electric Shift	TCRK-241BB	DTK-241
Tracker	G130	97-87		TCRK-FS140	DTK-FS140
Trailblazer	226	08-02		TCRK-226	DTK-226
Typhoon	4472	93-92		TCRK-1372	DTK-4472
Yukon XL	1225	14-12		TCRK-1225A	DTK-1225A
Yukon XL	1226	14-12		TCRK-1225A	DTK-1225A
Yukon XL	1222	14-09		TCRK-1222	DTK-1222
Yukon XL	3023	14-08		TCRK-3023	DTK-3023
Yukon XL	3024	14-08		TCRK-3024	DTK-3024
Yukon XL	4485	14-07	One Speed	TCRK-4485	DTK-4485
Yukon XL	1225 w/ 33 Tooth Input Shaft	2011		TCRK-1225A	DTK-1225A
Yukon XL	1225 w/ 29 Tooth Input Shaft	2011		TCRK-1225	DTK-1225
Yukon XL	1226 w/ 29 Tooth Input Shaft	2011		TCRK-1225	DTK-1225
Yukon XL	1226 w/ 33 Tooth Input Shaft	2011		TCRK-1225A	DTK-1225A
Yukon XL	1225	10-09		TCRK-1225	DTK-1225
Yukon XL	1226	10-09		TCRK-1225	DTK-1225
Yukon XL	246	07-00		TCRK-246	DTK-246
Yukon XL	149	05-01	One Speed	TCRK-149	DTK-149
Yukon XL	4481	04-03	AWD, One Speed	TCRK-4481	DTK-4481
Yukon	3023	14-08		TCRK-3023	DTK-3023
Yukon	4485	14-07	One Speed	TCRK-4485	DTK-4485
Yukon	246	07-98		TCRK-246	DTK-246
Yukon	243	97-96	Electric Shift	TCRK-241BB	DTK-241
Yukon	241	97-94	w/ 6010N I/S Brg	TCRK-241BB	DTK-241
Yukon	241	94-92	w/ BD50-8 I/S Brg	TCRK-241	DTK-241
Infiniti					
QX4		03-97		TCRK-FN510	DTK-FN510
Isuzu					
i-370	T150	08-07		TCRK-T150	DTK-T150
i-350	T150	2006		TCRK-T150	DTK-T150
Jeep					
CJ	Dana 300	86-80		TCRK-300	DTK-300
CJ	1305	79-76	Quadra-Trac	TCRK-1305	DTK-1305
CJ	1339	79-76	Quadra-Trac	TCRK-1305	DTK-1305
CJ	Dana 20	79-74		TCRK-20A	DTK-20J
CJ	Dana 20	73-72		TCRK-20	DTK-20J
CJ	Dana 18	71-61		TCRK-18	DTK-18
CJ	Dana 18	61-46		TCRK-18B	DTK-18
CJ	Dana 18	45-41		TCRK-18A	DTK-18
Cherokee	231	01-94	w/ 6010N I/S Brg	TCRK-231FF	DTK-231FF
Cherokee	242	01-94	w/ 6010N I/S Brg	TCRK-242BB	DTK-242BB
Cherokee	231	94-87	w/ BD50-8 I/S Brg	TCRK-231	DTK-231
Cherokee	242	93-87	w/ BD50-8 I/S Brg	TCRK-242	DTK-242
Cherokee	207	86-84		TCRK-207	DTK-207
Cherokee	229	85-82		TCRK-229	DTK-208
Cherokee	208	83-80	Includes Small Parts Kit	TCRK-208SPK	DTK-208
Cherokee	219	82-80		TCRK-229	DTK-208
Cherokee	Dana 20	79-74		TCRK-20A	DTK-20J
Cherokee	1305	79-74	Quadra-Trac	TCRK-1305	DTK-1305

Light Duty Transfer Case Applications

Vehicle	Model #	Years	Notes	Bearing, Seal & Gasket Kit	Seal & Gasket Kit
Jeep (cont.)					
Cherokee	1339	79-74	Quadra-Trac	TCRK-1305	DTK-1305
Cherokee	228	1986		TCRK-229	DTK-208
Comanche	231	92-87		TCRK-231	DTK-231
Comanche	242	92-87		TCRK-242	DTK-242
Comanche	207	86-84		TCRK-207	DTK-207
Comanche	228	1986		TCRK-229	DTK-208
Grand Cherokee	247	08-99		TCRK-247	DTK-247
Grand Cherokee	242	08-94	w/ 6010N I/S Brg	TCRK-242BB	DTK-242BB
Grand Cherokee	249	98-94	w/ 6010N I/S Brg	TCRK-249JA	DTK-249
Grand Cherokee	249	94-93	w/ BD50-8 I/S Brg	TCRK-249J	DTK-249
Grand Cherokee	242	1993	w/ BD50-8 I/S Brg	TCRK-242	DTK-242
Grand Wagoneer	249	1993	w/ BD50-8 I/S Brg	TCRK-249J	DTK-249
Grand Wagoneer	229	91-84		TCRK-229	DTK-208
Grand Wagoneer	208	88-84	Includes Small Parts Kit	TCRK-208SPK	DTK-208
Liberty	231	07-02		TCRK-231GG	DTK-231GG
Liberty	242	08-02		TCRK-242CC	DTK-242CC
SJ	229	88-82		TCRK-229	DTK-208
SJ	208	88-80	Includes Small Parts Kit	TCRK-208SPK	DTK-208
SJ	119	82-80		TCRK-229	DTK-208
SJ	219	82-80		TCRK-229	DTK-208
SJ	Dana 20	79-74		TCRK-20A	DTK-20J
SJ	1305	79-74	Quadra-Trac	TCRK-1305	DTK-1305
SJ	1339	79-74	Quadra-Trac	TCRK-1305	DTK-1305
SJ	Dana 20	73-62		TCRK-20	DTK-20J
SJ	Dana 18	65-61		TCRK-18	DTK-18
SJ	228	1986		TCRK-229	DTK-208
Wagoneer	231	90-87		TCRK-231	DTK-231
Wagoneer	242	90-87		TCRK-242	DTK-242
Wagoneer	207	86-84		TCRK-207	DTK-207
Wagoneer	229	85-82		TCRK-229	DTK-208
Wagoneer	208	83-80	Includes Small Parts Kit	TCRK-208SPK	DTK-208
Wagoneer	219	82-80		TCRK-229	DTK-208
Wagoneer	1305	79-74	Quadra-Trac	TCRK-1305	DTK-1305
Wagoneer	1339	79-74	Quadra-Trac	TCRK-1305	DTK-1305
Wagoneer	Dana 20	79-74		TCRK-20A	DTK-20J
Wagoneer	Dana 20	73-62		TCRK-20	DTK-20J
Wagoneer	228	1986		TCRK-229	DTK-208
Wrangler	241	13-03	Rubicon	TCRK-241GG	DTK-241GG
Wrangler	231	08-94	w/ 6010N I/S Brg	TCRK-231FF	DTK-231FF
Wrangler	242	08-94	w/ 6010N I/S Brg	TCRK-242BB	DTK-242BB
Wrangler	231	94-87	w/ BD50-8 I/S Brg	TCRK-231	DTK-231
Wrangler	242	93-87	w/ BD50-8 I/S Brg	TCRK-242	DTK-242
Kia					
Sportage		02-95		TCRK-FK100	DTK-FK100
Mazda					
MPV Van		98-91		TCRK-FMZ230	DTK-FMZ230
Truck		08-86		TCRK-FMZ220	DTK-FMZ220
Lexus					
LX470	LEXTR	07-98		TCRK-FT500	DTK-FT500
LX450	LEXTR	97-96		TCRK-FT500	DTK-FT500
Mitsubishi					
Montero	KM120	06-92		TCRK-FM220	DTK-FM220
Truck	KM100	96-80		TCRK-FM230	DTK-FM230

Light Duty Transfer Case Applications

Vehicle	Model #	Years	Notes	Bearing, Seal & Gasket Kit	Seal & Gasket Kit
Nissan					
Truck	TY10B	08-89		TCRK-FN500	DTK-FN500
Truck	TX10	08-86	Direct Mount Transfer Case	TCRK-FN240	DTK-FN240
Truck	TY10	08-86		TCRK-FN460	DTK-FN460
Truck	TY10A	08-85		TCRK-FN430	DTK-FN430
Truck	T100L	86-81	Remote Transfer Case	TCRK-FN180	DTK-FN180
Suzuki					
Samurai	TS45	90-85	Remote Transfer Case	TCRK-FS120	DTK-FS120
Sidekick	G130	98-87		TCRK-FS140	DTK-FS140
Land Rover					
Range Rover	BW1361	95-89		TCRK-1361	DTK-1361
Toyota					
Camry	S110; From 10/87	91-87		TCRK-FT740	DTK-FT740
Camry	S120; From 10/87	91-87		TCRK-FT750	DTK-FT750
Celica	S100	93-89		TCRK-FT740	DTK-FT740
Landcruiser	LC18; From 2/90	08-90		TCRK-FT500	DTK-FT500
Landcruiser	LC16; To 1/90	90-87		TCRK-FT400	DTK-FT400
Landcruiser	LC14; From 8/80	87-80		TCRK-FT240	DTK-FT240
Landcruiser	LC12; To 7/80	80-73		TCRK-FT360	DTK-FT360
Landcruiser	LC10	75-69		TCRK-FT490	DTK-FT490
Truck	R100	08-86	Chain Driven, Manual T/M Only	TCRK-FT390	DTK-FT390
Truck	W100	86-78	Gear Driven, Manual T/M Only	TCRK-FT260	DTK-FT260
Van	T100	97-90	Chain Driven, Manual T/M Only	TCRK-FT770	DTK-FT770

Transmission & Transfer Case Small Parts Kits

Part No.	Industry Part No.	Application	Years
SPK-4C	SP1104-50C	Warner T4 GM Truck Only	1982-1988
SPK-5	SP1105-50	Warner T4 & T5	1982-1985
SPK-5W	SP1105-50A	Warner T5 World Class	1985-On
SPK-10	SP10-50	Warner T10	1957-1966
SPK-10W	SP10W-50	Warner Super T10	1974-1982
SPK-14	SP14-50	Warner T14	1967-1975
SPK-15	SP15-50	Warner T15	1967-1979
SPK-18	SP18-50	Warner T18	1965-
SPK-19	SP19-50	Warner T19	1968-
SPK-27	SP277-50	New Process 540, 541	1966-1969
SPK-29	SP310-50	New Process 542	1970-1984
SPK-127	SP291-50	New Process 435, 436	1963-
SPK-150F	SP287-50	Tremec RAB, RAN, RAT	1965-1982
SPK-150J	SP150-50B	Tremec T150 Jeep	1975-1980
SPK-170	SP170-50	Warner T170	1978-1985
SPK-170A	SP296-50	Ford 3 Speed HEH	1964-1973
SPK-205	SP205-50	New Process 205	1983-1987
SPK-208	SP208-50	New Process 208	1980-1986
SPK-231	SP231-50	New Process 231 & 241	1988-On
SPK-235	SP3500-50A	NVG3500, 5LM60, HM290	1988-1996
SPK-259	SP259-50B	Ford 3 Speed 259	1951-1962
SPK-280	SP280-50	Ford 3 Speed HED	1960-1967
SPK-285	SP305-50	Clark 280V, 282V, 285V	1968-1982
SPK-297	SP297-50	Muncie 4 Speed M22, Small Bore	1963-1965
SPK-297A	SP297-50A	Muncie 4 Speed M22, Large Bore	1966-1974
SPK-301	SP301-50	Saginaw SM326	1966-1985
SPK-318/319	SP266-50B	Muncie 318/319	1955-1968
SPK-318/319A	SP242-50B	Muncie 318/319	1940-1954
SPK-833	SP294-50	New Process 833	1975-1980
SPK-4500	SP4500-50	NVG 4500 Dodge & GM	1992-
SPK-AX5	SPAX5-50	Aisan Warner AX5, G52 Toyota	1985-
SPK-BW90	SP90A-50	Warner T90A, T90B	1946-1971
SPK-M465	SP304-50	Muncie CH465, SM465, M20	1968-1982



Morse® Hy-Vo® Chain*

2007 Morse® Application Guide Automatic Transmission and Transfer Case Chains



Full Product Line Offering



Gemini® Systems

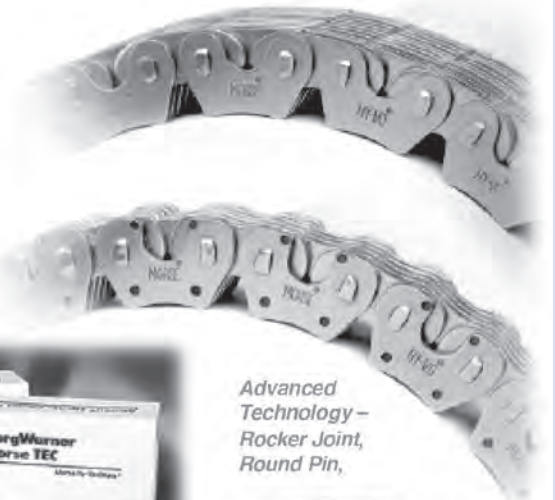

Advanced Technology –
Rocker Joint,
Round Pin,

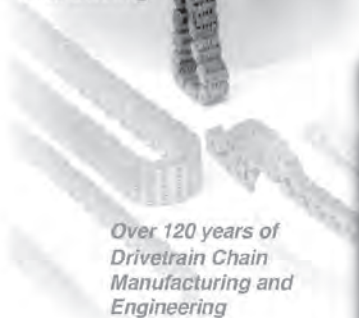

Over 120 years of
Drivetrain Chain
Manufacturing and
Engineering



ET Guide,
ZX Link Design

Patented Randomization
Patterns

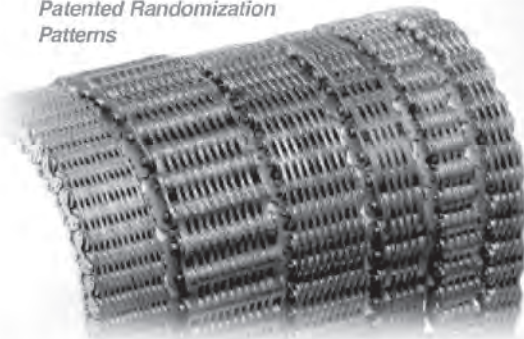

OEM Quality



Availability

Engineering Support



Drivetrain
Leadership

*Morse®, Hy-Vo®, BorgWarner and  are registered trademarks of BorgWarner Inc.
© Copyright 2007 BW
All Rights Reserved

LD Transmission



Table of Contents

Link and Pin Nomenclature	356
Chain Components	357
Chain Quality Parameters	357
Chain Operating & Measurement Terms	357
Why Morse® Hy-Vo® Chain?	
Design Features and Benefits	358
Quality Features and Benefits	358
Important Rebuilding Notes	358
Application Listings for Morse Hy-Vo Chain (Automatic Transmission Chains)	
GM	359
GM Racing Applications/Special Order	360
Ford	361
DaimlerChrysler	362
Imports	362
Transfer Case Chains by Transfer Case Model to Corresponding OEM	
New Process/New Venture Gear	363
Magna Steyr	364
BorgWarner Torque Transfer Systems	365
Other Applications: 100 Series Are Manufactured by Morse TEC, Japan	367
Interchange	368
Troubleshooting Guide for Transmission and Transfer Case Hy-Vo Chain and Sprockets ...	370
Features and Benefits in Chain Design — Spanish	371
BorgWarner TTS Transfer Case Photo Gallery	372

Link and Pin Nomenclature

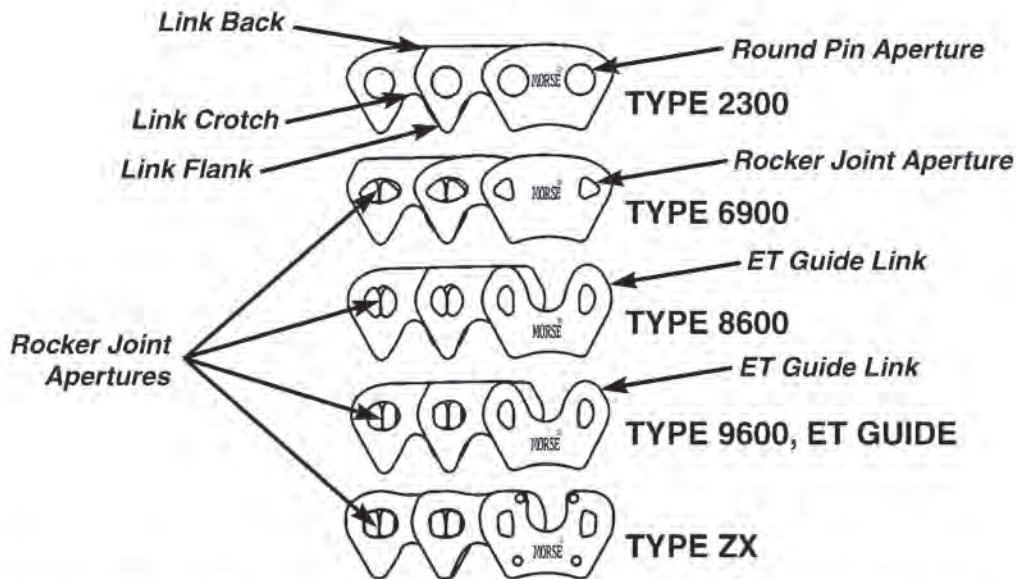

NOTE: A round pin chain can be rolled into a ball. A rocker pin chain cannot be. Each type requires certain sprockets and should not be interchanged. ET guide (elastically tuned) type guide links began in 1995 on certain applications. ET guide links more evenly distribute load for better wear characteristics.

Chain Components

- **Link Apertures:** Holes in Links either round or Rocker Joint shaped to match the connecting Pins. This is the area of articulation in the chain.
- **Guide Link:** Link plate positioned on the outside of the chain. This pilots the chain on the sprocket.
- **Link Flank:** Lower portion of link which engages the sprocket teeth.
- **Link Crotch:** Space between link flanks which clear the sprocket tooth tip.
- **Link Back:** The outside curvature of the Link design to provide strength and operating smoothness. Some are designed flat rather than curved.
- **Round Pin:** Singular round pin used to articulate the chain.
- **Rocker Joint Pin:** Two pins are utilized to articulate the chain.
- **Rocker Pin Styles:**
 - **Type 6900** two triangular pins that rock in the aperture
 - **Type 8600** two ovular-shaped pins that rock in the aperture (Some may be ET Guide.)
 - **Type 9600** two ovular-shaped pins that rock in the aperture. The guide link is an ET design riveted link.
 - **Type ZX** two ovular-shaped pins that rock in the aperture. The guide link is an ET design riveted link. Enhanced link closure design.

Chain Quality Parameters

- **Tensile Strength:** The ability of the chain to endure under the loads that are applied during sprocket engagement and operation. It is measured as the ultimate strength of the chain which is the load at which it would break or fail. There are centrifugal forces created during operation. The steel quality of the links and pins and the chain design are important in contributing to a high tensile strength.
- **Fatigue Strength:** The ability of the chain to endure the loads and operating conditions repeatedly over time.
- **Wear Rating:** The amount of wear that occurs during operation.

Chain Operating & Measurement Terms

- **Pitch:** Effective length between the centerpoints of the apertures, which are the points of joint articulation.
- **Width:** The approximate dimension between the inside and outside guide links.
- **Random Chain:** Certain patterns are interlaced in a random link pattern utilizing two different link styles in rows across the chain.
- **Chordal Action:** Radial or transverse motion of the chain strand resulting from sprocket engagement. Sound is created from this engagement.
- **Decibel Measurements:** The measurement of the total sound coming from the system in operation.
- **Chain Description:** Nominal measurements for a chain:
 - Example: 3/8P x 1-1/4 W x 72P
 - 3/8 pitch by 1-1/4 approximate width by 72 total pitches
 - 72 pitches would be 36 total guide plates per side



Why Morse® Hy-Vo® Chain?

Design Features and Benefits

Application Specific Design Styles: Morse offers a full line of applications which include round pin, three styles of rocker joint pin chain, ET guide links, and the new patented Morse Gemini® system. Each of these are specified by application based upon loads, operating conditions, and operating space. (Substituting design styles is not recommended since sprocket engagement would be affected.)

ET Guide Links: A patented guide link design which offers more even load distribution during operation. Chain designs will be upgraded based upon OE service conversions.

Chain Randomization: This is a patented design utilizing two different link styles to break up frequencies created from sprocket engagement. Patterns are selected at the time of OE design to minimize noise and vibration levels and to optimize operating strengths for each application.

Quality Features and Benefits

Quality and OEM Certification: In addition to having QS 9000 Certification, Morse Hy-Vo Products utilize only the finest grades of steel for the links and pins. This means no inclusions or dirt in the steel itself. This contributes to the highest Tensile, Fatigue, and Wear characteristics. Proprietary Design and Manufacturing Techniques also create the highest quality chain in the aftermarket.

Important Rebuilding Notes

Chain Elongation: Even though Morse Hy-Vo Products are built to last, when the rebuilder has the unit down, the sprockets and chain should be checked thoroughly.

Remember that it is very difficult for the aftermarket customer to measure chain elongation. One reason for this is shaft movement when the unit is apart. In certain cases, when the shafts are fixed with the cover off, an experienced field estimate may be acceptable.

Morse has special equipment to measure elongation parameters. In addition, each application could be different depending upon the application parameters.

The accuracy rate or error rate is 50% without using the right equipment to measure elongation of a chain. Every application has its own variations and the manufacturer's recommended specifications for chain tolerances should be referenced.

**If the chain has been in service for over 60,000 miles,
if the unit is torn down, or if the unit shows
signs of problems, neglect, or abuse – replace the chain.**

Application Listings for Morse Hy-Vo Chain

Automatic Transmission Chains

Transmission	Description	Year	Morse Part Number
General Motors			
125/125C	3/8 Pitch x 3/4 Wide x 84 Pitches, Round Pin Type	80-83	HV-019
125C	3/8 Pitch x 7/8 Wide x 84 Pitches, Round Pin Type	80-Up	HV-018
325	3/8 Pitch x 1-3/4 Wide x 110 Pitches, Rocker Joint Type	79-81	HV-010
325-4L	3/8 Pitch x 1-1/4 Wide x 102 Pitches, Rocker Joint Type	82-85	HV-016
425	3/8 Pitch x 2 Wide x 124 Pitches, Rocker Joint Type	66-78	HV-001
4T40E (4 Cylinder)	3/8 Pitch x 3/4 Wide x 84 Pitches, Rocker Joint Type	95-03	HV-039
4T40E (4 Cylinder)	3/8 Pitch x 5/8 Wide x 84 Pitches, Rocker Joint Type – New ZX Design	11/03-Up	HV-079
4T45E (6 Cylinder)	3/8 Pitch x 7/8 Wide x 84 Pitches, Rocker Joint Type, ET guide	99-2/04, 7/04-Up	HV-058
4T45E (6 Cylinder)	3/8 Pitch x 5/8 Wide x 84 Pitches, Rocker Joint Type – New ZX Design	3/04-6/04	HV-079
4T45E (6 Cylinder)			
4T45E Saturn LS	3/8 Pitch x 7/8 Wide x 84 Pitches, Rocker Joint Type, ET Guide	99-6/04	HV-058
4T60/4T60E	3/8 Pitch x 7/8 Wide x 84 Pitches, Round Pin Type	83-93	HV-018
4T60E	3/8 Pitch x 7/8 Wide x 84 Pitches, Rocker Joint Type, ET Guide (Previously HV035)	94-99	HV-058
4T60E (Riviera)	3/8 Pitch x 7/8 Wide x 84 Pitches, Rocker Joint Type (Previously HV036 with a Special Lacing Pattern for Riviera only – The HV058 accommodates this)	95-99	HV-058
4T60 Allante Only	1990 Cadillac GM # 8661010 is not available. Discontinued.	90	
4T65 Gemini Design (Excludes 05 V8)	3/8 Pitch x 1/2 Wide x 84 Pitch – Two per Application, One Blue Guide Link	97-Up	HV-065
4T65E Gemini Design S (V8 and retro HV-065)	3/8 Pitch x 1/2 Wide x 84 Pitch – S Design, Two per Application, Two Blue Guide Links	05-Up	HV-093 can replace HV-065
4T65 Gemini Kit	With 33 Drive & 37 Driven Sprockets – Kit Sprockets and Gemini Chains (Volvo)	97-Up	TK001*
4T65 Gemini Kit	With 35 Drive & 35 Driven Sprockets – Kit Sprockets and Gemini Chains	97-Up	TK002*
4T65 Gemini Kit	With 37 Drive & 33 Driven Sprockets – Kit Sprockets and Gemini Chains (3.8L, L67 Grand Prix)	97-Up	TK003*
4T80E	.436 Pitch x 1 Wide x 84 Pitches, Rocker Joint Type	93-Up	HV-038

Morse Gemini® Chain System

*Use with new thrust washers from GM #24213762, Volvo #24213761 and reluctor wheel #24212217.



Morse Gemini® systems are a set of 2 chains which run on phased sprockets. This patented design significantly reduces the overall NVH (noise) in the system.

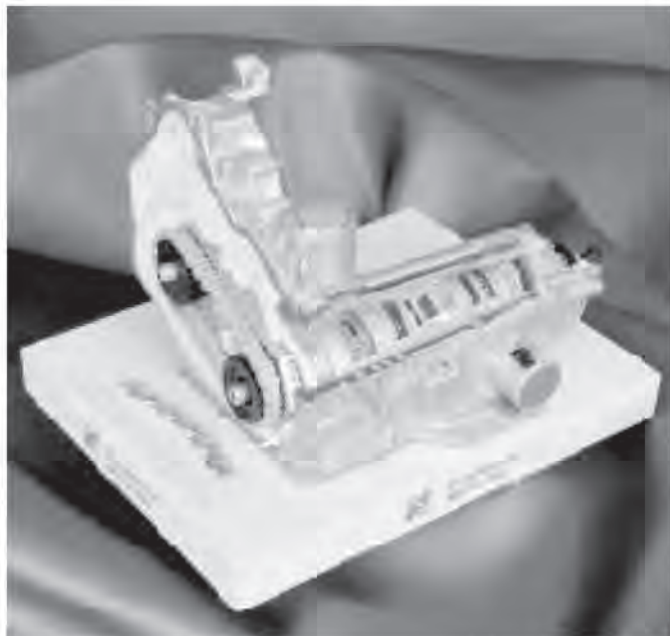

**Morse TEC
 Limited Edition
 GM 4T65E Replica
 Part Number 5002116
 Watch for Promotions
 During the year!**

Transmission	Description	Year	Morse Part Number
GM Racing Applications/Special Order			
4T65E Racing	Spring Link, .4375 Pitch x 1 Wide x 72 Pitches Made in Japan in prototype lab, Special Application 201 HV 3504-72 MTS.		5005 747 HV-121



Transmission	Description	Year	Morse Part Number
Ford			
AXOD/AXODE	3/8 Pitch x 3/4 Wide x 86 Pitches, Round Pin Type (one copper guide link)	86-7/03	HV-021
AXOD	3/8 Pitch x 7/8 Wide x 86 Pitches, Round Pin Type (one green guide link)	86-88	HV-029
AX4S-SHO/AX4N	3/8 Pitch x 3/4 Wide x 86 Pitches, Rocker Joint Type 9600 Series, ET Guide (three copper guide links)	93-03	HV-040, (Can Use HV-075)
AX4N With 2.5, 3.0 Liter Vulcan and Duratec Engines	3/8 Pitch x 3/4 Wide x 86 Pitches, Rocker Joint 8600 Series (2 blue links side by side)	04-Up	HV-075
AX4N 4.6L 4V, 4.2L	3/8 Pitch x 7/8 Wide x 88 Pitches, Rocker Joint Type 9600 or 8600 Series (one blue guide link) 2004 change to 8600 Series from 9600 (Both will work)	95-Up	HV-042
AX4S (Windstar) (Freestar AX4N)	3/8 Pitch x 3/4 Wide x 88 Pitches, Round Pin Type (two copper guide links)	96-11/04	HV-041
4F50N With 3.9 Liter Engine	3/8 Pitch x 3/4 Wide x 88 Pitches, Rocker Joint 8600 Series (two copper guide links)	05-Up	HV-092
CD4E (Contour/Mondeo 2.0L)	.4346 Pitch x 3/4 Wide x 90 Pitches, Rocker Joint Type, ET Guide (one copper guide link)	94-02	HV-043
CD4E (Mystique/Cougar 2.0L)	.4346 Pitch x 3/4 Wide x 90 Pitches, Rocker Joint Type, ET Guide (one copper guide link)	98-02	HV-043
CD4E (2.5L/3.0L V6)	.4346 Pitch x 1 Wide x 92 Pitches, Rocker Joint Type 8600, ET Guide (two copper guides separated by two silver guide links)	94-Up	HV-044
CD4E (1.8L/2.0L I4) Mazda	.4346 Pitch x 3/4 Wide x 92 Pitches, Rocker Joint Type, ET Guide (two copper guide links next to each other)	94-04 (2.5L 2000-04)	HV-045

AXOD



Note: CD4E ET Guide Upgrade:

HV043 Used with the 2.0 Liter Engine, F3RZ7G249A, F6RZ7G249AA

HV044 Used with the 2.5 and 3.0 Liter Engines through 99, F5RZ7G249C, F6RZ7G249CA

HV045 Used with 2.0 Liter Probe, the later 2000 Model Yr 2.5L are 3/4 Wide, F5RZ7G249B, F6RZ7G249BA

The latest CD4E chains use the ET Guide Technology for better wear characteristics and load distribution. The earlier non ET Guide chains should be replaced with the newer chains when the unit is down.

Transmission	Description	Year	Morse Part Number
DaimlerChrysler			
A606	One Chain – 1-3/4 Wide x 62 Pitches, Rocker Joint Type – 4539777 Discontinued, convert to TK004 and update sprockets	93-94	TK004
A606	Two Chain – (Gemini® Design) 3/4 Wide x 62 Pitches, Rocker Joint Type, ET Guide – 4659190	95-03	HV-047
A606 Gemini Kit	Chain/Sprocket/Snubber Package (to update) 93-94 (Except Prowler Application)	93-03	TK004
A606	Sprocket - 32 Teeth - 4659232 Drive (3.2L and 3.5L Engines)	95-03	HS001
A606	Sprocket - 33 Teeth - 4659233 Driven (3.2L and 3.5L Engines)	95-03	HS002
A606 Prowler	Sprocket - 31 Teeth - 4659831 Drive (2.7L and 3.5L Prowler Engines)	97-03	HS009
A606 Prowler	Sprocket - 34 Teeth - 4659834 Drive (2.7L and 3.5L Prowler Engines)	97-03	HS010
A606 Prowler Kit	Chain/Sprocket/Snubber Package (31 Drive, 34 Driven Sprockets)	97-03	TK005
A606	Snubber - 4659187	all	HVS-047

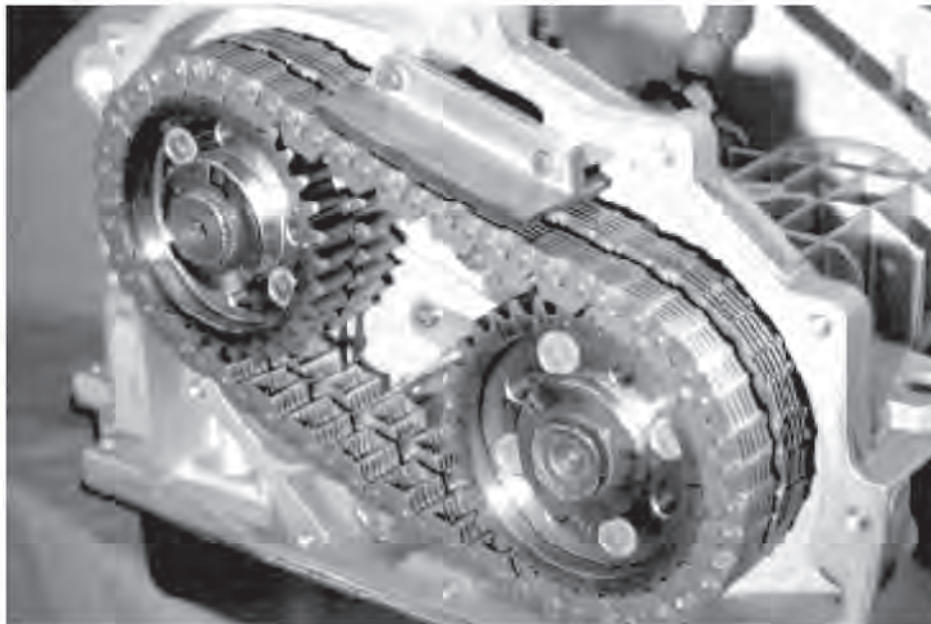
42LE Morse Gemini® A606

Imports

Saab T37 (Special Order)	Non-Turbo - 3/8 Pitch x 1 Wide x 76 Pitches, Rocker Joint Type	72-78	HV-003
Saab T37 (Special Order)	Turbo - 3/8 Pitch x 1 Wide x 76 Pitches, Rocker Joint Type	79-Up	HV-023
Tercel A55	3/8 Pitch x 3/4 Wide x 62 Pitches, FWD 4WD	79-86	HV-101
Volvo XE90 PTU	.4346 x 1-1/4 Wide x 62 Pitches, Rocker Joint Type	04-Up	HV-094

Transfer Case Chains by Transfer Case Model to Corresponding OEM

NEW PROCESS/NEW VENTURE GEAR

Case Model	OEM Mfg	Notes	Morse Part Number	Nominal Chain Dimensions
119	Chrysler Jeep	80-88 Jeep	HV-015	3/8 Pitch x 1-3/4 W x 98 Pitches - RJ
120	GM	GMT360, Trailblazer SS, Special Lacing Pattern	HV-512	.375 Pitch x 1-1/4 W x 86 Pitches - RJ
125 / 140 WK	Ford & Jeep	Ford Australia, Full Time, Jeep Grand Cherokee 2005	HV-059	.375 Pitch x 1-1/4 W x 86 Pitches - RJ
129	Chrysler Jeep	80-88 Jeep	HV-015	3/8 Pitch x 1-3/4 W x 98 Pitches - RJ
140	Chrysler Jeep	Single speed Grand Cherokee 2005-Up (Snubber HVS-071)	HV-089	3/8 Pitch x 1-1/4 W x 86 Pitches - RJ
144HB	Chrysler	Dodge Durango ST	HV-072	.375 Pitch x 1-1/4 W x 98 Pitches - RJ
149	GM	Full Time full size truck, Silverado SS and GMC Sierra Denali	HV-072	.375 Pitch x 1-1/4 W x 98 Pitches - RJ
203	Chrys/Ford/GM	73-78	HV-005	3/8 Pitch x 2-1/2 W x 98 Pitches - RJ
203	Chrys/Ford/GM	78-79	HV-009	.5033 Pitch x 2 W x 72 Pitches - RJ
207	Chrysler	84-88 Jeep	HV-022	.5033 Pitch x 1-1/4 W x 62 Pitches - RP
208	Chrysler Jeep	80-88 Jeep	HV-014 (RJ)/ HV-025 (RP)	.5033 Pitch x 1-1/4 W x 72 Pitches
208	Ford	80-88	HV-012	.5033 Pitch x 1-1/4 W x 84 Pitches - RP
218	GM/AM General	86-99 (Hummer)	HV-026	.5033 Pitch x 1-1/2 W x 72 Pitches - RP
219	Chrysler Jeep	80-90 Jeep	HV-015	3/8 Pitch x 1-3/4 W x 98 Pitches - RJ
225	Ford	Land Rover	HV-083	3/8 Pitch x 1-3/4 W x 90 Pitches - RJ
226/126	GM	Active on Demand, GM 360, 370 Envoy and Trailbrazer	HV-059	.375 Pitch x 1-1/4 W x 86 Pitches - RJ
228, 229	Chrysler Jeep	80-90 Jeep	HV-015	3/8 Pitch x 1-3/4 W x 98 Pitches - RJ
231A	Chrysler Jeep	89-up Jeep	HV-027	.5033 Pitch x 1 W x 62 Pitches - RP
231C/233C	GM	W2.8L 89-Up	HV-027	.5033 Pitch x 1 W x 62 Pitches - RP
231C/233C	GM	W4.3L 89-98	HV-022	.5033 Pitch x 1-1/4 W x 62 Pitches - RP
231D	Chrysler	89-up Jeep	HV-027	.5033 Pitch x 1 W x 62 Pitches - RP
233 Electric	Chrysler Jeep	95-Up Jeep	HV-027	.5033 Pitch x 1 W x 62 Pitches - RP
231/233HD	GM	T Truck S10, Dodge Dakota	HV-022	.5033 Pitch x 1-1/4 W x 62 Pitches - RP
236/136	GM	98-Up Blazer, Bravada, & Astro Van	HV-062	3/8 Pitch x 1 W x 98 Pitches - RJ
235	VW Parsche	VW and Porsche SUV	HV-082	3/8 Pitch x 1.5 W x 98 Pitches - RJ
241	Jeep	Part Time Jeep Rubicon	HV-081	.4346 Pitch x 1-1/4 W x 84 Pitches - RJ
241C/243C	Chrysler/GM	GM 89-98, 243 Electric Shift, Dodge Full 93-98	HV-025	.5033 Pitch x 1-1/4 W x 72 Pitches - RP
241G2	Dodge	Part time electric Shift, Ram 1500 Standard 2002 - May 2004	HV081	.4346 Pitch x 1-1/4 W x 84 Pitches - RJ
241G2 + Off Road	Dodge	Part time electric Shift, Ram 1500 Standard, June 2004 and up	HV-072	.375 Pitch x 1-1/4 W x 98 Pitches - RJ
241HD	Chrysler	Dodge 90-99	HV-031	.5033 Pitch x 1-1/2 W x 72 Pitches - RP
242/244	Chrysler Jeep	89-2000 Jeep	HV-028	.5033 Pitch x 1 W x 72 Pitches - RP
242 / 242 WJ	Chrysler	Durango, Dakota and Jeep with 5.2L and 5.9L Engines 98-04	HV-063	3/8 Pitch x 1-1/4 W x 98 Pitches - RJ

NEW PROCESS/NEW VENTURE GEAR

Case Model	DEM Mfg	Notes	Morse Part Number	Nominal Chain Dimensions
242KJ	Jeep	Jeep Liberty Select Trac 02-Up	HV-062	3/8 Pitch x 1 W x 98 Pitches - RJ
242ECE	Chrysler Jeep	Jeep Europe XJ & ZJ	HV-061	.5033 Pitch x 1 W x 72 Pitches - RJ
242H	GM/AM General	AMG Hummer H1	HV-060	.5033 Pitch x 1-1/4 W x 72 Pitches - RP
243G2	Dodge	Part time electric Shift Ram 1500, 2002 - May 2004	HV-081	.4346 Pitch x 1-1/4 W x 84 Pitches - RJ
243G2	Dodge	Part time electric Shift, Ram 1500 Optional All 4WD June 2004 and up	HV-072	.375 Pitch x 1-1/4 W x 98 Pitches - RJ
244DR (Heavy Duty)	Dodge	2004 Dod Dakota w/4.7L and 5.9L on Quad Cab	HV-072	.375 Pitch x 1-1/4 W x 98 Pitches - RJ
244HB	Dodge	Dodge Durango Gemini System, 2004 and up	TK006	Two Sprockets (HS014) and Two Chains (HV084)
244HB	Dodge	Chains (2)	HV-084	.375 Pitch x .625 W x 98 Pitches - RJ
245	Jeep	2-Speed Low Range Grand Cherokee 2005-Up (Snubber HVS-071)	HV-090	3/8 Pitch x 1-1/4 W x 86 Pitches - ZX Design
246	GM	99 SUV Only, One Blue Guide Link	HV-063	3/8 Pitch x 1-1/4 W x 98 Pitches - RJ
246	GM	99-Up GMT 800, 2000-Up Full Size SUV (3 Blue Guide Links)	HV-072	3/8 Pitch x 1-1/4 W x 98 Pitches - RJ
247	Chrysler Jeep	99 Jeep Grd Cherokee	HV-071	3/8 Pitch x 1 W x 98 Pitches - RJ
			HVS-071 Snubber	5-1/2 Long x 1.125 W x 3/4 High (2 holes)
249	Chrysler Jeep	92-98 Jeep	HV-034	3/8 Pitch x 1-1/4 W x 98 Pitches - RJ
261/263	GM Full Time	GMT 800 (3 Blue Guide Links) 99+	HV-072	3/8 Pitch x 1-1/4 W x 98 Pitches - RJ
261HD/263HD	GM Part Time	GMT 800 Full Size K Truck	HV-069	3/8 Pitch x 1-1/2 W x 98 Pitches - RJ
261SHD/263 SHD/HD2	Chrysler D/C	2001-Current	HV-074	.4346 Pitch x 1-1/2 W x 84 Pitches - RP
271/273 Electric Shift	Ford	98-Up F250/350/450/550 (03 Dodge)	HV-064	.4346 Pitch x 1-1/2 W x 98 Pitches - RP
276	Land Rover	Land Rover 6x6 Third Axle	HV-506	.5033 Pitch x 1-3/4 W x 40 Pitches - RP

RJ = Rocker Joint RP = Round Pin

MAGNA STEYR

Transfer Case Application	Description	Year	Morse Part Number
BMW — Snubber used with ATC 400, ATC 500	Short Snubber Design	03-Up	HVS-072
BMW X3 — Single Speed Case with TOD (ATC 400)	.375 Pitch x 1-1/4 W x 80 Pitches - RJ	03-Up	HV-086
BMW X5 — Single Speed with TOD (ATC 500)	.375 Pitch x 1-1/4 W x 86 Pitches - RJ Special Lacing Pattern, 2 Blue Links	03-Up	HV-087
BMW X5 — Single Speed Case with TOD (LWX500)	.375 Pitch x 1-1/4 W x 86 Pitches - RJ, One Blue Link	01-02	HV-088/ HV-059
GM — NP8, NP1 & NP2 (LD)	.4346 Pitch x 1-1/4 W x 84 Pitches - RJ	2008-UP	HV-501
GM — NP8, NP1 & NP2 (HD)	.4346 Pitch x 1-1/2 W x 84 Pitches - RJ	2008-UP	HV-502
GM — NP1 & NP2 (SHD)	.4346 Pitch x 1-1/2 W x 84 Pitches - RP	2008-UP	HV-074
Land Rover — 2-Speed Case with Locking Center Differential	.375 Pitch x 1-3/4 W x 84 Pitches - RJ	04-Up	HV-085
Mercedes M	.375 Pitch x 1-1/2 W x 84 Pitches - RJ	03-Up	HV-091
Mercedes M — Dual Clutch 2-Speed	.375 Pitch x 1-3/4 W x 84 Pitches - RJ	2005-Up	HV-098

BORG WARNER TORQUE TRANSFER SYSTEMS

Case Model	OEM Mfg	Notes	Morse Part Number	Nominal Chain Dimensions
1305	Chrysler Jeep	73-79 Jeep	HV-007	3/8 Pitch x 2-1/2 W x 96 Pitches - RJ
1345	Chrysler Jeep	CJ7 w/Auto Overdrive	HV-007X	3/8 Pitch x 2-1/2 W x 92 Pitches - RJ
1345	Ford	Fd 80-82, 150, 250, 350	HV-013	.5033 Pitch x 1-1/2 W x 86 Pitches - RJ
1350	Ford, Chrysler	Fd 80-83, Jeep 84-88	HV-022	.5033 Pitch x 1-1/4 W x 62 Pitches - RP
1354 ES Part Time	Ford	2005-UP Sport Trac, Explorer Sport	HV-505	.5033 Pitch x 1 W x 62 Pitches - RP
1354	Ford	Fd 90-Up	HV-022	.5033 Pitch x 1-1/4 W x 62 Pitches - RP
1354	Ford	2000 Sport Trac, Explorer Sport	HV-068	.0533 Pitch x 1 1/4 W x 62 Pitches - RP
1356	Ford	Fd 80-96 F Series/Bronco	HV-012	.5033 Pitch x 1-1/4 W x 84 Pitches - RP
1361	Range Rover	Range Rover 88-96	HV-049	.5033 Pitch x 2 W x 74 Pitches - RJ Spring Lk
1370	GM	80-Up Full Size Truck	HV-025	.5033 Pitch x 1-1/4 W x 72 Pitches - RP
1372*	GM	90-95 L Van All WD with Straight Pitch	HV-032	3/8 Pitch x 1-3/4 W x 86 Pitches - RJ Note: 2 blue links & rounded link backs
1372*	GM	90-97 S Blazer Trk/Bravada/ Cyclone/Typhoon with random pitch	HV-033	3/8 Pitch x 1-3/4 W x 86 Pitches - RJ Note: 1 blue link & combination round/ square link backs
4401	GM	GMC 3500	HV-025	.5033 Pitch x 1-1/4 W x 72 Pitches - RP Block Lace
4402	Hyundai	A1 Van, Galloper	HV-027	.5033 Pitch x 1 W x 62 Pitches - RP
4404	Ford	Explorer/ Mountaineer to 97	HV-051	.4346 Pitch x 1-1/4 W x 74 Pitches - RJ Note: 1 blue link
4404 w/5 Liter	Ford	Explorer/ Mountaineer with 5 Liter Engines 98-2000	HV-070	.4346 Pitch x 1-1/4 W x 74 Pitches - RJ Note: 2 blue links separated by one link
4405	Ford	Explorer to 97	HV-051	.4346 Pitch x 1-1/4 W x 74 Pitches - RJ
4405	Ford	Explorer 9/98-Up (width chg) TOD	HV-067	.4346 Pitch x 1 W x 74 Pitches - RJ
4406	Ford	F150/250 Man & Electronic Shift 96-4/98	HV-052	.4346 Pitch x 1-1/4 W x 86 Pitches - RP
4406	Ford	May 98-Up F150, F250 LD, F150 Manual Shift, Electronic Shift, Width change 5/98	HV-066	.4346 Pitch x 1 W x 86 Pitches - RP
4406 TOD	Ford	F250 96-Up, Expedition and Navigator 99+	HV-053	.4346 Pitch x 1-1/4 W x 86 Pitches - RJ
4407	Ford	F350/F250 HD	HV-054	.5033 Pitch x 1-1/2 W x 84 Pitches - RP
4408	Daewoo	Previously Sang Yang	HV-022	.5033 Pitch x 1-1/4 W x 62 Pitches - RP
4409	Mercedes	Mercedes 97-Up	HV-055	.4346 Pitch x 1-1/2 W x 70 Pitches - RJ
4410	Ford	Explorer 5.0L 2001	HV-078	.4346 Pitch x 1-1/4 W x 74 Pitches - RJ
4411	Ford	Explorer 4.0L 2001	HV-067	.4346 Pitch x 1 W x 74 Pitches - RJ
4411 TOD	Ford	2002 Aviator, Mountaineer	HV-067	.4346 Pitch x 1 W x 74 Pitches - RJ
4412 TOD	Ford	2005 Explorer/Mountaineer	HV-067	.4346 Pitch x 1 W x 74 Pitches - RJ
4414 OD	Ford	2006 Explorer/Mountaineer	HV-078	.4346 Pitch x 1-1/4 W x 74 Pitches - RJ
4416 TOD	Ford	Expedition, Navigator 2001	HV-053	.4346 Pitch x 1-1/4 W x 86 Pitches - RJ
4417 TOD	Ford	2006 Expedition/Navigator	HV-076	.4346 Pitch x 1-1/4 W x 84 Pitches - RJ
4422	Isuzu	Isuzu 95-Up	HV-056	.4346 Pitch x 1-1/4 W x 70 Pitches - RJ
4423/4421	Ssangyong	Sport utility vehicle - Ssangyong 4400143015	HV-051	.4346 Pitch x 1-1/4 W x 74 Pitches - RJ
4424 ESOF	Hyundai	Terracan, Highlander, A1, Kia BL 2001 and up	HV-027	.5033 Pitch x 1 W x 62 Pitches - RP
4424 TOD	Hyundai	Terracan, Highlander, A1, Kia BL 2001 and up	HV-070	.4346 Pitch x 1-1/4 W x 74 Pitches - RJ Note: 2 blue links separated by one link
4426 TOD	Ssangyong	2003-Up Ssangyong A100 Rodius, Y250 Rexton	HV-067	.4346 Pitch x 1 W x 74 Pitches - RJ

BORG WARNER TORQUE TRANSFER SYSTEMS

Case Model	OEM Mfg	Notes	Morse Part Number	Nominal Chain Dimensions
4426 2-Sp ESDF PT	Ssangyong	Ssangyong Y250 Rexton, C100 Actyon, Q100PU, D100 Kron	HV-027	.5033 Pitch x 1 W x 62 Pitches - RP
4427	Ssangyong	2005-Up D100, Y250, Y300	HV-070	.4346 Pitch x 1-1/4 W x 74 Pitches - RJ Note: 2 Blue links separated by one link
4430 FT 1-Sp TORSON	Audi	AU 756	HV-096	.4346 Pitch x 1-1/4 W x 80 Pitches - RJ
4454 ES/MS PT	Telco	Telco India 1999-Up	HV-022	.5033 Pitch x 1-1/4 W x 62 Pitches - RP
4462	Range Rover	Land rover 97-Up	HV-057	.5033 Pitch x 2 W x 80 Pitches - RJ
4455 ES/MS PT	Mahindra	Mahindra India	HV-022	.5033 Pitch x 1-1/4 W x 62 Pitches - RP
4470	GM	Full Size Truck 3500/K30 90-96	HV-031	.5033 Pitch x 1-1/2 W x 72 Pitches - RP
4472	GM	90-97 L Van	HV-032	3/8 Pitch x 1-3/4 W x 86 Pitches - RP Note: 2 blue links & rounded link backs straight pitch
4472	GM	90-97 S10/96 Van Safari	HV-033	3/8 Pitch x 1-3/4 W x 86 Pitches - RJ Note: 1 blue link & combination round/square link backs random pitch
4473	GM	GM 610 G Van (Silverado) 2002 and up	HV-076	.4346 Pitch x 1-1/4 W x 84 Pitches - RJ
4476	GM	Full Time	HV-076	.4346 Pitch x 1-1/4 W x 84 Pitches - RJ
4476	GM	Cadillac SRX 2003 and up	HV-080	.375 Pitch x 1-1/2 W x 74 Pitches - RJ
4477 TOD	GM	Cadillac CTS	HV-099	.375 Pitch x 1-1/4 W x 74 Pitches - RJ ZX
4479 FT 1-Sp	GM	2006 Cadillac STS 6 sp w/V8	HV-097	.375 Pitch x 1-1/2 W x 74 Pitches - RJ ZX
4476, 4479	GM	Cadillac 265, 295 2004 and up	HV-095	.375 Pitch x 1-1/2 W x 74 Pitches - RJ
4481, 4482	GM	GMT820, LD, Tahoe, Yukon, Warrior, Avalanche	HV-076	.4346 Pitch x 1-1/4 W x 84 Pitches - RJ
4484	Hummer/GM	Full Time Hummer 2	HV-077	.4346 Pitch x 1-1/2 W x 84 Pitches - RJ
4484 FT 2-Sp	GM	2007 Hummer 2	HV-502	.4346 Pitch x 1-1/2 W x 84 Pitches - RJ
4485 FT 1-Sp	GM	2007 Excalade, Tahoe, Yukon	HV-502	.4346 Pitch x 1-1/2 W x 84 Pitches - RJ
4493, 4494 FT 2-Sp	GM	2005 Hummer 3 GM 345	HV-055	.4346 Pitch x 1-1/2 W x 70 Pitches - RJ

* Important Noise Situation RJ = Rocker Joint RP = Round Pin

GM L Van All Wheel Drive Astro, Safari, and Cargo Applications with BW 1372/4472 Transfer Case - HV032 (Straight Pitch)

The HV032 and the HV033 applications should not be consolidated or substituted for each other. The HV032 is a straight pitch design, and the HV033 is a random pitch design. If the rebuilder uses the HV033 Random Patterned Chain in the L Van application, the vehicle operator may hear an unsatisfactory "moan" or "boom" noise from the vehicle's driveline during operation.

Conversely, if the HV032 straight pitch chain (all rounded back links) is used in the GM S Blazer truck, the Bravada, Cyclone, and Typhoon applications that use the BW 1372/4472 with a random chain design, the vehicle owner will hear a whistle or whining noise.



Morse TEC
Limited Edition
BorgWarner, Torque-On-Demand®
Transfer Case
Part Number 5005831
Watch for promotions during the year!



OTHER APPLICATIONS: 100 SERIES ARE MANUFACTURED BY MORSE TEC, JAPAN
(This series is special order)

OEM Mfg	Notes	Morse Part Number	Nominal Chain Dimensions
Austin	Maxi Allegro	HV-008	3/8 Pitch x 1 W x 74 Pitches - RJ
BMW 325 I	4WD Pre 1988	HV-024	3/8 Pitch x 1-3/4 W x 68 Pitches - RJ Straight Pitch (All rounded Link Backs)
BMW 325 I	4WD 89-90	HV-024R	3/8 Pitch x 1-3/4 W x 68 Pitches - RJ Random Pitch, Rounded & Square Link Backs
Dodge Ram 50	4WD 80-Up	HV104	3/8 Pitch x 1-3/4 W x 82 Pitches - RJ
Ford Aerostar	(Dana TC28) 90-97	HV-048	3/8 Pitch x 1-1/4 W x 86 Pitches - RP
Geo Tracker	Suzuki Sidekick 88-Up	HV-110	3/8 Pitch x 1 W x 68 Pitches - RP
Isuzu Trooper	Truck 84-Up	HV-102	.5033 Pitch x 1-1/4 W x 62 Pitches - RP
Mazda	Van & Pickup 84-Up	HV-105	3/8 Pitch x 1-3/4 W x 80 Pitches - RJ
Mazda	MPV 89-Up	HV-111	7/16 Pitch x 1-1/2 W x 84 Pitches - RJ
Mitsubishi	Montero (4WD) 80-Up	HV-104	3/8 Pitch x 1-3/4 W x 82 Pitches - RJ
Mitsubishi	Forte, Montero, Montero Sports Nov 90+	HV-112*	7/16 Pitch x 1-1/2 W x 70 Pitches - RJ
Mitsubishi	Forte, Montero, Montero Sports Nov 90+	HV-113*	7/16 Pitch x 1-1/4 W x 68 Pitches - RJ
Mitsubishi	Montero, Montero Sports Jul 93+	HV-114*	7/16 Pitch x 1-3/4 W x 70 Pitches - RJ
Mitsubishi	Montero Sports 8/98+	HV-115*	3/8 Pitch x 1-1/2 W x 80 Pitches - RJ
Nissan	Pathfinder/Truck 85-Up	HV-106	3/8 Pitch x 1-3/4 W x 88 Pitches - RJ
Nissan	Pathfinder 7/95-Up	HV-116*	7/16 Pitch x 1-1/4 W x 76 Pitches - RJ
Nissan	Van 86-Up	HV-107	3/8 Pitch x 1-1/4 W x 88 Pitches - RJ
Safari	Safari 87-Up	HV-108	3/8 Pitch x 1-7/8 W x 88 Pitches - RP
Scout II, IHC	(4WD) 73-79	HV-006	3/8 Pitch x 2 W x 92 Pitches - RJ
Suzuki, Chev Tracker	Suzuki Vitara/Chev Tracker 8/96-Up	HV-118*	3/8 Pitch x 1 W x 68 Pitches - RJ
Toyota	4-Runner/Truck 84-86	HV-102	.5033 Pitch x 1-1/4 W x 62 Pitches - RP
Toyota	4-Runner/Truck 87-7/88	HV-1098*	7/16 Pitch x 1-1/2 W x 74 Pitches - RJ Random pattern, springload
Toyota	4-Runner/Truck 87-93	HV-1098*	7/16 Pitch x 1-1/2 W x 74 Pitches - RJ Random pattern, springload
Toyota	4-Runner, Tacoma 4/93-Up	HV-117*	7/16 Pitch x 1-1/4 W x 74 Pitches - RJ Latest Link Profile
Toyota	Van 85-Up	HV-103	.5033 Pitch x 1 W x 62 Pitches - RP
Getrag	Specialty Gearbox	372828	3/8 Pitch x 1-1/4 W x 66 Pitches - RJ

*Special Order Only RJ = Rocker Joint RP = Round Pin

**Interchange**

OEM	NAME	MORSE #	OEM	NAME	MORSE #	OEM	NAME	MORSE #
11428	NVG	HV005	4659187	CHRYSLER	HVS047	15547422	GM	HV025
13433	NVG	HV009	4659190	CHRYSLER	HV047	15580279	GM	HV025
13797	NVG	HV012	4659232	CHRYSLER	S123B	15581813	GM	HV027
13798	NVG	HV014	4659233	CHRYSLER	S122A	15619392	GM	HV031
15027	NVG	HV015	4728159	CHRYSLER	HV034	15634064	GM	HV033
15569	NVG	HV022	4746147	CHRYSLER	HV031	15635937	GM	HV022
15908	NVG	HV022	4746257	CHRYSLER	HV025	15963558	GM	HV032
16067	NVG	HV026	5003453AA	CHRYSLER	HV063	19132837	GM	HV097
16417	NVG	HV027	5012322AB	CHRYSLER	HV071	19151772	GM	HV502
16418	NVG	HV028	5080215AA	CHRYSLER	HV081	24200738	GM	HV039
16624	NVG	HV025	5086328AA	CHRYSLER	HV064	24200771	GM	HV036
16977	NVG	HV061	5740090	AM GENERAL	HV026	24202447	GM	HV035
17167	NVG	HV022	6273991	GM	HV005	24206043	GM	HV038
17536	NVG	HV031	8130977	CHRYSLER	HV014	24206266	GM	HS003
17550	NVG	HV034	8134471	CHRYSLER	HV022	24206267	GM	HS004
17577	NVG	HV060	8624944	GM	HV001	24206268	GM	HS005
21967	NVG	HV074	8625946	GM	HV001	24206269	GM	HS006
22182	NVG	HV069	8632901	GM	HV010	24206270	GM	HS007
22500	NVG	HV062	8635171	GM	HV016	24206271	GM	HS008
23750	NVG	HV063	8637187	GM	HV019	24206434	GM	HV065
24273	NVG	HV064	8643337	GM	HV019	24210129	GM	HV058
26976	NVG	HVS071	8646116	GM	HV018	24229085	(2) GM	HV093
27293	NVG	HV059	8653991	GM	HV019	30651660	VOLVO	HV094
30965	NVG	HV071	8660099	GM	HV018	2922560A01	SUZUKI	HV110
31534	NVG	HV072	8679627	GM	HV037	2922560A00	GEO	HV110
38985	NVG	HV081	8682603	GM	HV035	35735010	ISUZU	HV102
433782	DANA	HV048	8685784	GM	HV038	83503146	CHRYSLER	HV027
474613	GM	HV009	8709272	SAAB	HV003	83504575	CHRYSLER	HV028
801145	CHRYSLER	HV007	12384954	GM	HV074	88935661	GM	HV059
2922578	SUZUKI	HV118	12473234	GM	HV069	89059571	GM	HV055
3821373	CHRYSLER	HV005	12474602	GM	HV072	96067054	SUZUKI	HV110
4115334	GM	HV009	12544311	GM	HV025	3315201J00	NISSAN	HV108
4167995	CHRYSLER	HV025*	12544694	GM	HV031	3315230C00	NISSAN	HV107
4338935	CHRYSLER	HV027	12544695	GM	HV025	3315233G01	NISSAN	HV106
4446464	AMC	HV022	12547628	GM	HV062	331520W410	NISSAN	HV116
4539777	CHRYSLER	HV046	14037982	GM	HV014	3315230C00	NISSAN	HV107
4636961	CHRYSLER	HV022	14071706	GM	HV022	501309297	BMW	HV024
4638890	CHRYSLER	HV028	14079006	GM	HV022	501311424	BMW	HV024R



Interchange (Continued)

OEM	NAME	MORSE #	OEM	NAME	MORSE #	OEM	NAME	MORSE #
1345143002	WARNER GEAR	HV012	4472143001	WARNER GEAR	HV032	F6RZ7G249BA	FORD PROBE	HV045
1350143001	WARNER GEAR	HV022	8971292370	ISUZU	HV056	F5T7A029A	FORD	HV054
13611343001R	WARNER GEAR	HV049	13630591010	HONDA	HV004	F65Z7A029AA	FORD	HV052
1370143001	WARNER GEAR	HV025	25780016010	TOYOTA	HV101	F68P7G249AA	FORD	HV041
1370143002	WARNER GEAR	HV031	27241226319	BMW	HV024	F70Z7G249AA	FORD	HV042
1372143001	WARNER GEAR	HV033	0435143002V	BLMC/WOLSELEY	HV002	F75Z7A029AA	FORD	HV053
3578116010	TOYOTA	HV101	0437143001X	SAAB	HV023	F87Z7A029BB	FORD	HV070
3629328010A	TOYOTA	HV103	12352L1101	NISSAN	HV020	J8130831	CHRYSLER	HV015
3629328010	TOYOTA	HV103	13611343001R	RANGE ROVER	HV049	J8134471	CHRYSLER	HV022
3629335010	TOYOTA	HV109B	3080173001DA	ISUZU	HV102	M50117945	MAZDA	HV105
3629335020	TOYOTA	HV109B	3090173001DA	TOYOTA	HV102	MD446415	MITSUBISHI	HV115
3629335010	TOYOTA	HV109B	3315201J00	NISSAN	HV108	MD704196	CHRYSLER	HV104
3629335021	TOYOTA	HV109B	3315233G01	NISSAN	HV106	MD738550	MITSUBISHI	HV113
3629335030	TOYOTA	HV117	3629328010A	TOYOTA	HV103	MD886422	MITSUBISHI	HV112
3629335031	TOYOTA	HV117	42169C1	IHC	HV006	MD936280	MITSUBISHI	HV114
4351430021	SAAB	HV003	D4T7A029A	FORD	HV005	RTC6041	LR/RR	HV049
4400143002	WARNER GEAR	HV051	D8T7A029A	FORD	HV009	R50117945B	MAZDA	HV111
4400143005	WARNER GEAR	HV053	E0T7A029A	FORD	HV012	XL2Z7A029AA	FORD	HV051
4400143006	WARNER GEAR	HV056	E0T7A029B	FORD	HV013	XL2Z7A029BB	FORD	HV067
4400143007	WARNER GEAR	HV052	E2T7A029A	FORD	HV012	XL3Z7A029AA	FORD	HV066
4400143009	WARNER GEAR	HV055	E3T7A029A	FORD	HV022	XR83320	LR/RR	HV049
4400143010	WARNER GEAR	HV027	E6DZ7G249A	FORD	HV021	1L2Z7A029LA	FORD	HV078
4400143013B	WARNER GEAR	HV066	E6SP7G249AA	FORD	HV021	1L5Z7A029AA	FORD	HV068
4400143014	WARNER GEAR	HV067	E8DZ7G249A	FORD	HV029	3L5Z7A029AA	FORD	HV022
4400143015	WARNER GEAR	HV051	F09Z7A029A	FORD	HV048	5F2P7G249AA	FORD	HV092
4400143017	WARNER GEAR	HV070	F3DZ7G249A	FORD	HV040	5L5Z7A029AA	FORD	HV505
4400143021B	WARNER GEAR	HV068	F3RP7G249DA	FORD	HV043	4F2Z7G249AA	FORD	HV042
4400143023A	WARNER GEAR	HV076	F3RP7G249FA	FORD	HV045	4F1Z7G249AA	FORD	HV075
4400143024A	WARNER GEAR	HV080	F3RP7G249GA	FORD	HV044	473564B000	HYUNDAI	HV027
4400143025A	WARNER GEAR	HV077	F3RZ7G249A	FORD	HV043	47356H1000	HYUNDAI	HV070
4400143027	WARNER GEAR	HV078	F5DZ7G249A	FORD	HV042	88996485	GM	HV076
4401143001	WARNER GEAR	HV025	F50P7G249AA	FORD	HV042	88996668	GM	HV080
4407143001	WARNER GEAR	HV054	F57Z7A029A	FORD	HV051	88984521	GM	HV077
4411143003	WARNER GEAR	HV067	F5RZ7G249B	FORD	HV045	7L1Z7A029A	FORD	HV076
4411143005	WARNER GEAR	HV067	F5RZ7G249C	FORD	HV044	8L8Z6G249A	FORD	HV044
4462143001	WARNER GEAR	HV057	F6RZ7G249AA	FORD 2.0L	HV043			
4470143001	WARNER GEAR	HV031	F6RZ7G249CA	FORD 2.5L	HV044			

*HV025 is a round pin design which is the latest for the NVG 208 Dodge and NVG 241 GM & Dodge applications. The HV025 can replace the HV014 without sprocket problems in these applications.

Troubleshooting Guide for Transmission and Transfer Case Hy-Vo Chain and Sprockets

SYMPTOM	CAUSE(S)	CURE(S)
Excessive Chain Wear on the guide link inside flank area	Sprockets misaligned or out of parallel.	Realign sprockets.
Chain wear on Outside/Back of chain	Interference with case and/or excessive elongation.	Replace chain and sprockets.
Burnt Chain	Overheating, lack of lubrication.	Replace chain and inspect the lubrication situation.
Rusty Chain	There may be corrosion in the system or inadequate lubrication.	Avoid abuse, replace sprockets, check for water in oil, replace any faulty seals or breather elements, and correct lubrication situation.
Broken Links, Turned Pins	Drive system may be overloaded or there may be excessive slack in the chain causing it to "jump teeth." Or, there may be a foreign object in the system.	Replace the chain, remove and repair the damage. Avoid overloading the drive system.
Extreme flank wear	Worn sprockets, lack of proper lubrication.	Replace sprockets and chain and correct the lubrication problem.
Excessive premature Sprocket Wear	Mismatched new and old sprocket.	Always replace both sprockets.
Sprocket wear — Light Wear — Heavy Wear - Pitting	A certain amount is normal.	For heavy wear: Replace both the sprocket and chain.
Lubrication smells bad and is dark in color.	Overheating.	Drain and flush the case, check for cause of overheating and damaged components, replace the chain, refill lubricant to manufacturer specifications. In automatic transmissions, check for slipping clutches or a failed torque converter.
Excessive noise or vibration	Broken links, inadequate lubrication, misalignment, or eccentricity/face runout in sprocket.	Replace with properly machined sprockets, replace chain, check shafts of sprockets and realign, check bearings, correct any lubrication situation to manufacturer specifications.
Milky or muddy Lubrication	Probable water contamination.	Drain and flush case several times (at least three), check seals and breather components, check for other damaged components, replace chain and refill lubrication to manufacturer specs.



Porque la Cadena Morse® Hy-VO®?

Características y Beneficios de Diseño:

Estilos de Diseño específicos de Aplicaciones: Morse ofrece una completa línea de aplicaciones que incluye perno redondo, tres estilos de cadena con unión de perno oscilante, eslabones guía ET, y el nuevo sistema patentado Morse Gemini® system. Cada uno de estos estilos son específicos por aplicación dependiendo de las cargas, las condiciones operativas, y el espacio de operación. (No se recomienda substituir estilos de diseño, puesto que el acoplamiento con los engranes se vería afectado.)

Eslabones Guía ET: El nuevo diseño patentado de eslabones guía ofrece una mejor distribución de la carga durante la operación. El diseño de cadenas será perfeccionado basados en las conversiones de servicio en Equipo Original.

Aleatorización de la Cadena: Este es un diseño patentado que utiliza dos diferentes estilos de eslabones para eliminar las frecuencias creadas en el acoplamiento con el engrane. Los patrones son seleccionados cuando se realiza el diseño de Equipo Original para minimizar el ruido y los niveles de vibración, así como para optimizar las fuerzas operativas de cada aplicación.

Características y Beneficios de Calidad:

Calidad y Certificación de Equipo Original: Además de tener la certificación QS 9000, los productos Morse HyVo, utilizan sólo aceros de la más alta calidad para los eslabones y los pernos. Esto significa que la lámina no tiene en sí inclusiones ni impurezas, contribuyendo a mejores características de tensión, fatiga y desgaste. Así mismo, el diseño y las tecnologías de manufactura especiales crean la cadena de mejor calidad en el mercado de refacciones.

Notas Importantes para los Reconstructores:

Elongación de Cadena: A pesar de los productos Morse HyVo, son fabricados para tener una máxima duración, cuando el reconstructor tiene la unidad desmontada, los engranes y las cadenas deben ser verificados.

Recuerde que es muy difícil para el cliente de refacciones medir la elongación de la cadena. Una razón para esto es el movimiento del árbol de levas cuando la unidad se encuentra separada. En algunos casos, cuando el árbol de levas está fijo y sin cubierta, la estimación de una persona experimentada en el campo puede ser aceptable.

Morse cuenta con equipo especial para medir los parámetros de elongación. Además cada aplicación puede ser diferente dependiendo de los parámetros de la aplicación.

Si no se utiliza el equipo adecuado para medir la elongación de la cadena, el rango de precisión o de error es de 50%. Cada aplicación tiene sus propias variaciones y las especificaciones recomendadas por el fabricante para las tolerancias de la cadena deben ser referenciadas.

**Si la cadena ha estado en servicio por más de 60,000 millas (95,000 kms),
si la unidad está rasgada, si muestra
signos de problemas, descuido o desgaste – reemplace la cadena.**

BorgWarner TTS Transfer Case Photo Gallery

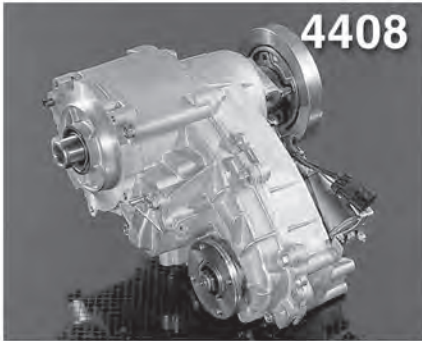
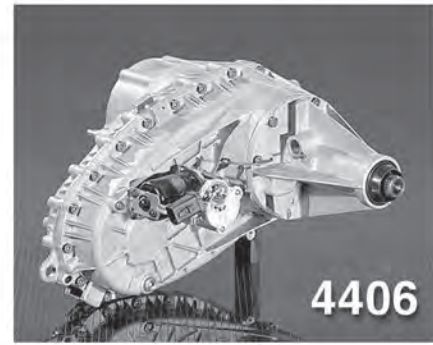
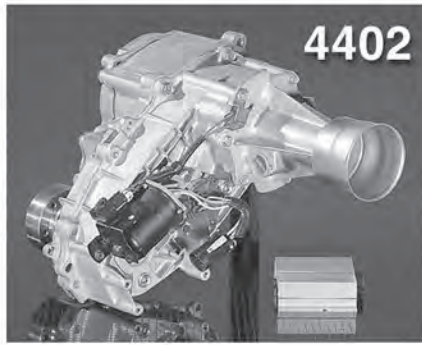
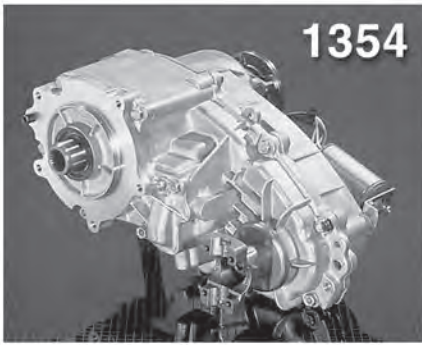

Notes:

Rebuild Kits and Components Interchanges

Manufacturer	Part #	Manufacturer	NCB Part #
	029HH100	Dana	714512
	1008360	Dana	T1910
	1008585	Dana	HM212049
	1008586	Dana	3782
	1008911	Dana	HM212011
	101-432-1X	TTC	TRK-101-432-1X
	101-482-1	TTC	1213-L
	101-486-1-1X	TTC	101-486-1-1X
	101-486-4-1X	TTC	101-486-4-1X
	102611	Dana	102611
	102620	Dana	OR-146
	102660	Dana	68462
	105C-137	TTC	85533
	1064	Eaton	1064
	1069	Eaton	1069
	107276S	Dana	30ZRTVGREY
	10737	Dana	3820
	107567	Dana	107567
	107568	Dana	107568
	107569	Dana	107569
	107570	Dana	107570
	107670	Dana	DRK-72B
	108145	Dana	108145
	109368	Dana	DRK-412
	110555	Dana	DRK-1AMK
	110811	Dana	29620
	110812	Dana	29675
	110846	Dana	HM807049
	111355	Dana	HM88610
	111356	Dana	HM88649
	111374	Dana	3872
	113130	Dana	113130
	11364	Eaton	11364
	113866	Dana	113866
	113868	Dana	HM813841
	113869	Dana	HM813810
	114394	Dana	DRK-196
	114399	Dana	DRK-196MK
	115125	Dana	DRK-207
	118118	Dana	DRK-210
	118122	Dana	DRK-208
	118787	Dana	MA1211
	118788	Dana	M1211EL
	119427	Dana	119427
	119429	Dana	119429
	119430	Dana	119430
	119681	Dana	33262
	119797	Dana	DRK-402
	119855	Dana	119855
	120080	Dana	MU1309UM
	120098	Dana	772
	122421	Dana	DRK-211FMK1
	122437	Dana	DRK-208MK
	122448	Dana	DRK-219RMK
	122657	Dana	DRK-211FMK2
	1228A183	Meritor	B2414
	1228A261	Meritor	MUC1309UM
	1228B1042	Meritor	RU9008UM
	1228B262	Meritor	MUB1309UM
	1228C3	Meritor	1209-A
	1228C55	Meritor	MU1305TDM
	1228D524	Meritor	5204-K
	1228E1045	Meritor	MUB1307UBM
	1228F136	Meritor	MU1307TM
	1228F1722	Meritor	ZN1213
	1228F552	Meritor	RU1570UM
	1228G1203	Meritor	212-SLV
	1228G1723	Meritor	ZN1212
	1228H190	Meritor	MR1213EL
	1228H580	Meritor	MUB1305UDM

Manufacturer	Part #	Manufacturer	NCB Part #
	1228J192	Meritor	210
	1228L1130	Meritor	JP10010
	1228L1728	Meritor	NP934397
	1228L194	Meritor	212
	1228N1262	Meritor	1211
	1228N1938	Meritor	JLM714110
	1228P250	Meritor	313
	1228Q1473	Meritor	592-A
	1228R200	Meritor	209
	1228S1267	Meritor	MUB7309UM
	1228U1217	Meritor	3920
	1228U645	Meritor	55437
	1228V204	Meritor	211-B
	1228V594	Meritor	9278
	1228W179	Meritor	MU1221UM
	1228X154	Meritor	MU1308UM
	1228Z1716	Meritor	H715311
	1228Z52	Meritor	MU1306TDM
	1229K1623	Meritor	1229K1623
	1229L1624	Meritor	1229L1624
	1229T4076	Meritor	1229T4076
	12303	Meritor	12303
	123297	Dana	DRK-409MK
	124487	Dana	DRK-222FMK
	12495	Dana	55437
	12496	Dana	55200-C
	12500	Dana	52618
	12501	Dana	52400
	126003	Dana	126003
	126004	Dana	126004
	126180	Dana	126180
	126187	Dana	MUB1308UM
	126242	Dana	126242
	126286	Dana	H914811
	126287	Dana	H914841
	126924	Dana	56662
	126987	Dana	6580
	126988	Dana	6535
	127051	Dana	MUSB7307UM
	127386	Dana	127386
	127484	Dana	MUB1307UM
	127485	Dana	MUB7307UM
	127535	Dana	55212-C
	127536	Dana	29630
	127539	Dana	JLM104910
	127540	Dana	LM104949
	127545	Dana	OR-232
	127591	Dana	DT7591
	127592	Dana	DT7592
	127595	Dana	127595
	127596	Dana	127596
	127597	Dana	127597
	127598	Dana	127598
	127599	Dana	127599
	127719	Dana	DT7719
	127720	Dana	DT7720
	127721	Dana	DT7721
	12815	Eaton	12815
	128604	Dana	42362
	128700	Dana	128700
	128703	Dana	401300
	129293	Dana	LC27105
	129305	Dana	129305
	129374	Dana	NP975161
	129375	Dana	NP577914
	129377	Dana	NP107783
	129378	Dana	NP568900
	129380	Dana	NP720703
	129381	Dana	NP431952
	129383	Dana	NP378092

Manufacturer	Part #	Manufacturer	NCB Part #
	129384	Dana	NP555065
	129558	Dana	NP930036
	129559	Dana	NP193660
	129560	Dana	NP242732
	129561	Dana	NP611140
	129562	Dana	NP523912
	129563	Dana	NP799449
	129564	Dana	NP105857
	129565	Dana	NP380290
	129566	Dana	NP533133
	129594	Dana	129564
	129847	Dana	NP723977
	129848	Dana	NP751735
	129947	Dana	WUB61308UM
	131008K	Dana	DT131008K
	131041	Dana	NP374995
	131042	Dana	NP237087
	131044	Dana	NP120322.904A5
	131048	Dana	NP049312.904A4
	131050	Dana	NP478770
	131051	Dana	NP547156
	131052	Dana	NP927527
	131095	Dana	131095
	131095	Dana	131095
	131095K	Dana	131095
	131203	Dana	NP166419
	131208	Dana	NP171276
	131209	Dana	NP943289
	131211	Dana	NP197868
	131212	Dana	NP802507
	131333	Dana	401300
	132060	Dana	29688
	13224	Dana	MU1305UBM
	132439	Dana	132439
	134323	Dana	DT134323
	139980	Dana	NP910345
	140012	Dana	140012
	140014	Dana	140014
	140019	Dana	140019
	140020	Dana	140020
	14218	Dana	72212-C
	14276	Meritor	14276
	14287	Eaton	HJ223020/1R1820
	14289	Eaton	14289
	14291	Eaton	14291
	14311	Eaton	14311
	14317	Eaton	14317
	14354	Eaton	127831
	14366	Eaton	MU1308TV
	14367	Eaton	A3071
	14654	Eaton	14654
	14750	Eaton	14750
	14754	Eaton	14754
	14897	Eaton	14897
	14993	Eaton	14993
	15011	Eaton	15011
	15045	Eaton	WJ162116
	15046	Eaton	15046
	15092	Dana	42584
	15093	Eaton	OK-15093
	15094	Dana	495-A
	15095	Eaton	15095
	15101	Meritor	15101
	15117	Meritor	15117
	15126	Meritor	15126
	15243	Meritor	15243
	15245	Meritor	15245
	15253	Eaton	15253
	15260	Eaton	A2892
	15571	Eaton	340483

Additional Info

Rebuild Kits and Components Interchanges

Manufacturer Part #	Manufacturer	NCB Part #
15748	Eaton	15748
15918	Eaton	15918
15973	Eaton	15973
15977	Eaton	BS61
15980	Eaton	15980
15982	Eaton	MU1307V
15994	Eaton	15994
16118	Eaton	16118
16244	Eaton	MR1308TV
16516	Eaton	BS60
16566	Eaton	BS59
16723	Eaton	16723
16763	Eaton	16763
16798	Eaton	16798
16817	Eaton	MU1306UV
16977	Eaton	470737-N
16980	Eaton	16980
17399	Eaton	17399
17406	Eaton	17406
17425	Eaton	415027-N
17453	Eaton	OK-17453
17553	Eaton	MR1206RUGV
1828K219	Meritor	1311-L
1828P68	Meritor	MR1212EL
1828S149	Meritor	211-L
1828S201	Meritor	1309-S
1828V74	Meritor	208-L
1828Z234	Meritor	307-S
18408	Eaton	416339
18657	Eaton	MU1207UGV
18658	Eaton	MU1306UGV
18720	Meritor	18720
18747	Eaton	18747
19110	Eaton	19110
19198	Eaton	19198
19529	Dana	653
19974	Eaton	19974
2001153	Dana	PN5D
2001243	Dana	DS2001243
20015	Eaton	MR1307EX
2001855	Dana	PN10
2003431	Dana	RGB25
2004101	Dana	DS2004101
2004670	Dana	DS2004670
2005082	Dana	JLM104948-JLM104910
2005899	Dana	NP784953-NP396414
2007293	Dana	JLM704649-JLM704610
20085	Eaton	20085
2008910	Dana	DS50574
2009802	Dana	DS50574
201-210-4-1	TTC	201-210-4-1
201-210-4-2	TTC	201-210-4-2
201-210-4-3	TTC	201-210-4-3
20128	Eaton	OK-20128
201-381-1	TTC	201-381-1
201-381-3	TTC	201-381-3
201-463-26	TTC	OR-340V
201-463-8	TTC	37410.1
201-47-4	TTC	201-47-4
201-47-6	TTC	201-47-6
20171	Eaton	BS59
201989	Eaton	J361644
20550	Eaton	20550
20552	Eaton	20552
20606	Eaton	MR1306RUGVW140
20607	Eaton	MU1308UM
20674	Eaton	OR-123
20701	Eaton	MSN1212REXW619
20703	Eaton	MSN1309REXW619
20704	Eaton	F206252

Manufacturer Part #	Manufacturer	NCB Part #
20705	Eaton	FW687430
20706	Eaton	FW808840
20707	Eaton	F11739
20712	Eaton	20712
20715	Eaton	415004-V
20716	Eaton	470625-V
20762	Eaton	472311-V
20770	Eaton	20770
20772	Eaton	20772
20832	Eaton	MU1307GUM
208385	Eaton	450316
20899	Eaton	MSN1211REX
20920	Eaton	20920
210084-2X	Dana	HB210084-2X
210088-1X	Dana	HB210088-1X
210090-1X	Dana	HB210090-1X
210111	Dana	RUB1570UM
210121-1X	Dana	HB210121-1X
210140-1X	Dana	HB210140-1X
210144-1X	Dana	HB210144-1X
210207-1X	Dana	HB210207-1X
210353	Dana	MUB1305UDM
210367-1X	Dana	HB210367-1X
210370-1X	Dana	HB210370-1X
210391-1X	Dana	HB210391-1X
210433-1X	Dana	HB210433-1X
210474	Dana	H913810
210475	Dana	H913842
210527X	Dana	HB210527X
210588	Dana	MUB5207UM
210724	Dana	210724
210736	Dana	210736
210737	Dana	210737
21075	Meritor	21075
210866-1X	Dana	HB210866-1X
210873-1X	Dana	HB210873-1X
210881-1X	Dana	HB210881-1X
211218	Dana	DRK-222RMK
211222	Dana	DRK-222F
211223	Dana	DRK-222R
211431X	Dana	HB211431X
211590-1X	Dana	HB211590-1X
211848-1X	Dana	HB211848-1X
211963-1X	Dana	HB211963-1X
212028-1X	Dana	HB212028-1X
212030-1X	Dana	HB212030-1X
212032-1X	Dana	HB212032-1X
21208	Eaton	OR-217V
21209	Eaton	OR-221V
21320	Eaton	21320
21352	Eaton	AA1512-12
21355	Eaton	NCB355
21356	Eaton	NCB356
216220	Dana	DRK-404FMK
216221	Dana	DRK-404RMK
216234	Dana	DRK-404F
216248	Dana	DRK-404R
21632	Dana	68712
21633	Dana	68450
21635	Dana	42346
21662	Eaton	21662
217463	Dana	DRK-405FMK
217464	Dana	DRK-405RMK
217621	Dana	DRK-211FMK
217622	Dana	DRK-219RMK1
22328	Eaton	22328
22329	Eaton	22329
22360	Eaton	22360
22-463-13	TTC	472015
226331	Eaton	226331

Manufacturer Part #	Manufacturer	NCB Part #
227080	Eaton	N309-L
227081	Eaton	SRA5304
228285	Eaton	M28161
229367	Eaton	472164
230166	Dana	230166
230746	Dana	230746
23261	Eaton	MR1306UVW745
23484	Eaton	415001-N
235130	Eaton	MU1309SGNV
235376	Eaton	QA48181-A
235402	Eaton	DD46386
235411	Eaton	MU1309UGM
235412	Eaton	QA47838
235414	Eaton	QBR49845
235655	Eaton	416664
23613	Eaton	MU1310RUMW3
237919	Eaton	411143-N
239651	Eaton	F94488
239653	Eaton	F94490
239783	Eaton	239783
239818	Eaton	F84003
24328	Dana	33472
24330	Dana	33275
25520	Meritor	25520
25523	Meritor	25523
25580	Meritor	25580
25584	Meritor	25584
2580	Meritor	2580
25820	Meritor	25820
25821	Meritor	25821
258452C1	Dana	28921
258453C91	Dana	28985
25877	Meritor	25877
25878	Meritor	25878
25880	Meritor	25880
2720	Meritor	2720
27238	Dana	78551
27239	Dana	78215
27666	Dana	665
27810	Dana	27810
27813	Dana	497
27816	Dana	56650
27817	Dana	56425
27876	Dana	42381
28521	Meritor	28521
28580	Meritor	28580
28622	Meritor	28622
28682	Meritor	28682
28921	Meritor	28921
28985	Meritor	28985
28995	Meritor	28995
29620	Meritor	29620
29630	Meritor	29630
29675	Meritor	29675
29685	Meritor	29685
300HA100	Dana	9121
300HB100	Dana	9185
300HD100	Dana	RU9008UM
300HH100	Dana	300HH100
300KS100-X	Dana	DRK-416
30185	Dana	PN8A
30271	Dana	PN5D
30275	Dana	DS30275
30316	Dana	782
30689	Dana	39590
30692	Dana	47686
30703	Dana	30703
312475-16X	TTC	GT-147
312475-25X	TTC	GT-158
312475-28X	TTC	GT-180

Additional Info

Rebuild Kits and Components Interchanges

Manufacturer Part #	Manufacturer	NCB Part #
312475-29X	TTC	GT-186
312475-33X	TTC	GT-193
312475-35X	TTC	312475-35X
312475-40X	TTC	GT-210
312475-45X	TTC	312475-45X
312475-46X	TTC	GT-221
312475-47X	TTC	GT-221
312476-22X	TTC	TRK-312476-22X
313024-17X	TTC	313024-17X
313024-18X	TTC	313024-18X
313024-24X	TTC	313024-24X
313024-27X	TTC	313024-27X
313024-28X	TTC	SR-221
313240-3X	TTC	313240-3X
313401-13X	TTC	313401-13X
313401-33X	TTC	313401-33X
313401-34X	TTC	313401-34X
313429-21X	TTC	313429-21X
313429-23X	TTC	313429-23X
313429-25X	TTC	313429-25X
313429-26X	TTC	313429-26X
313429-6X	TTC	313429-6X
313432-10X	TTC	TRK-313432-10X
313432-1X	TTC	TRK-192
313432-20X	TTC	TRK-313432-20X
313432-25X	TTC	TRK-313432-25X
313432-30X	TTC	TRK-313432-30X
313432-31X	TTC	TRK-313432-31X
313432-33X	TTC	TRK-313432-33X
313432-34X	TTC	TRK-313432-34X
313432-35X	TTC	TRK-313432-35X
313432-43X	TTC	TRK-313432-43X
313432-46X	TTC	TRK-313432-46X
313438-3X	TTC	313438-3X
313438X	TTC	SK47
313628X	TTC	JLM710949C90KA3
313645X	TTC	BS500262R
313667X	TTC	313667X
313668X	TTC	K73X79X20B
31520	Meritor	31520
31521	Meritor	31521
31594	Meritor	31594
31597	Meritor	31597
31824	Dana	592-A
31825	Dana	598
32210	Meritor	32210
330734	TTC	330734
330810	TTC	330810
330869	TTC	330869
3313798	Eaton	3313798
3315624	Eaton	712512
3315674	Eaton	FW404820
3315679	Eaton	3315679
3315686	Eaton	3315686
3315703	Eaton	FW707620
3315722	Eaton	FW657020
3315725	Eaton	3315725
3315737	Eaton	FW505520
3315765	Eaton	3315765
332	Meritor	332
33208	Meritor	33208
33211	Meritor	33211
33212	Meritor	33212
33225	Meritor	33225
33275	Meritor	33275
33281	Meritor	33281
33287	Meritor	33287
33462	Meritor	33462
33472	Meritor	33472
33699	Dana	55175

Manufacturer Part #	Manufacturer	NCB Part #
339	Meritor	339
341KS101	Dana	DRK-191R
34274	Meritor	34274
34300	Meritor	34300
34306	Meritor	34306
34368	Dana	580
34478	Meritor	34478
34539	Dana	749
3520	Meritor	3520
3525	Meritor	3525
353	Meritor	353
35502	Dana	HM807010
3585	Meritor	3585
360HA100	Dana	72487
360HB100	Dana	72225-C
360KS100-X	Dana	DRK-414
3620	Meritor	3620
36487	Dana	DS36487
37082	Dana	PN10
3720	Meritor	3720
3732	Meritor	3732
37625	Meritor	37625
3767	Meritor	3767
3775	Meritor	3775
3782	Meritor	3782
382	Meritor	382
3820	Meritor	3820
382A	Meritor	382-A
382S	Meritor	382-S
383271C91	Dana	MUB5206UM
385	Meritor	385
385A	Meritor	385-A
387	Meritor	387
3877	Meritor	3877
387A	Meritor	387-A
387AS	Meritor	387-AS
390	Meritor	390
390A	Meritor	390-A
390HA100	Dana	JLM710910
390HA101	Dana	NP692588
390HB101	Dana	JLM710949
390HB102	Dana	NP064206
390HD100	Dana	MUX5207UMV1
390HD103	Dana	SC1084C4
390KS103-X	Dana	DRK-411R
390KS105-X	Dana	DRK-411F
392	Meritor	392
3920	Meritor	3920
3925	Meritor	3925
394A	Meritor	394-A
394AS	Meritor	394-AS
394CS	Meritor	394-CS
395	Meritor	395
39520	Meritor	39520
39578	Meritor	39578
39580	Meritor	39580
39581	Meritor	39581
39585	Meritor	39585
39590	Meritor	39590
395A	Meritor	395-A
396	Meritor	396
3979	Meritor	3979
3982	Meritor	3982
3984	Meritor	3984
3992	Meritor	3992
3994	Meritor	3994
399A	Meritor	399-A
401HA100	Dana	HM807010
401HC101	Dana	A1400
401HD101	Dana	B3624

Manufacturer Part #	Manufacturer	NCB Part #
401HH102	Dana	DTHH102
401HH103	Dana	4624-V
401HH104	Dana	401HH104
401KS100-X	Dana	DRK-223F
401KS101-X	Dana	DRK-223R
40-463-4-1X	TTC	39930
40-463-6-1X	TTC	39920
40-486-1	TTC	40-486-1
40638	Dana	RGB12
40679	Dana	3994
41221	Dana	RGB5D
4124075	Eaton	FW556020
42346	Meritor	42346
42350	Meritor	42350
42381	Meritor	42381
42433	Dana	RGB13
42449	Dana	719316
42584	Meritor	42584
425-SP	TTC	425-SP
42620	Meritor	42620
42687	Meritor	42687
42688	Meritor	42688
4300119	Eaton	4300119
4300121	Eaton	710211
4300203	Eaton	471271-V
4300204	Eaton	4300204
4300329	Meritor	4300329
4300798	Eaton	473010-N
4300810	Eaton	4300810
4300828	Eaton	MU61307GUM
4300902	Eaton	NCB0902
4301254	Eaton	4301254
4301417	Eaton	MU1212RUMW3
4301844	Eaton	4301844
4301851	Eaton	NP656227-NP896049
4301851	Eaton	NCB1851
4301855	Eaton	MU1210RUMW772
4301863	Eaton	MU1209UGMR
4302058	Eaton	AXK5070
4302074	Eaton	NCB2074
4302082	Eaton	4302082
4302712	Eaton	BS500052V
4303031	Eaton	MU1308TVWS
4303362	Eaton	4303362
4303424	Eaton	4303424
4303667	Eaton	MU1308TMWS
4303920	Eaton	MU1214UMW3
4303921	Eaton	MU1213UMW3
4304080	Eaton	BS226539V
4304101	Eaton	4304101
4304113	Eaton	4304113
4304184	Eaton	MR61014W617
4304185	Eaton	M61014GEVW617
4304189	Eaton	4304189
4304202	Eaton	K25X33X20B
4304211	Eaton	BS500156
4304212	Eaton	BS5001563
4304214	Eaton	M5206VW603
4304217	Eaton	4304217
4304317	Eaton	4304317
4304555	Eaton	4304555
4304599	Eaton	BS500192SX
4304600	Eaton	MU1313RUMW3
4304601	Eaton	MU1312RUMW3
4304605	Eaton	4304605
4305294	Eaton	4305294
4305625	Eaton	4305625
4305996	Eaton	4305996
4305997	Eaton	4305997
4306308	Eaton	4306308

Additional Info

Rebuild Kits and Components Interchanges



Manufacturer Part #	Manufacturer	NCB Part #
4306584	Eaton	4306584
4306647	Eaton	4306647
4306648	Eaton	4306648
4308161	Eaton	BS500419
4308403	Eaton	HJ223020/IR1820
43085	Dana	714675
4327	Dana	4327
43270	Dana	43270
44143	Meritor	44143
44189	Dana	PN6
44348	Meritor	44348
44895	Dana	5778-V
44896	Dana	CS338
45220	Meritor	45220
45280	Meritor	45280
45282	Meritor	45282
45284	Meritor	45284
45285	Meritor	45285
45287	Meritor	45287
45290	Meritor	45290
45291	Meritor	45291
4535	Meritor	4535
453X	Meritor	453-X
454	Meritor	454
45460	Dana	72200-C
45461	Dana	45461
45462	Dana	45462
45463	Dana	45463
45478	Dana	45478
45498	Dana	45498
45499	Dana	45499
45516	Dana	45516
45658	Dana	CS342
45784	Dana	RGB14
46194	Dana	CS335
462	Meritor	462
46-486-2	TTC	46-486-2
46526	Dana	46526
46584	Dana	MA1209EL
46720	Meritor	46720
469	Meritor	469
46925	Dana	CS349
47-210-1	TTC	47-210-1
472KS101	Dana	DRK-192RB
472KS113	Dana	DRK-200FA
47420	Meritor	47420
47490	Meritor	47490
474KS101	Dana	DRK-201R
474KS102	Dana	DRK-201FA
47620	Meritor	47620
47623A	Meritor	47623-A
47679	Meritor	47679
47686	Meritor	47686
47687	Meritor	47687
47761	Dana	DS47761
47820	Meritor	47820
47885	Dana	DS47885
47890	Meritor	47890
47896	Meritor	47896
48220	Meritor	48220
48286	Meritor	48286
48290	Meritor	48290
483067C91	Dana	HM813844
483068C1	Dana	HM813810
48717	Dana	CS344
492A	Meritor	492-A
493	Meritor	493
49-486-2	TTC	49-486-2
49-486-3	TTC	49-486-3
495	Meritor	495

Manufacturer Part #	Manufacturer	NCB Part #
495A	Meritor	495-A
495AX	Meritor	495-AX
496	Meritor	496
497	Meritor	497
49848	Dana	HM903249
49849	Dana	HM903210
500008-37	TTC	500008-37
500010-8	TTC	500010-8
5003323	Dana	HB210661-1XSA
500898	TTC	500898
501200	TTC	501200
50313	Dana	CS339
50366	Dana	PN26
504030	Dana	DRK-427AMK
504031	Dana	DRK-405FAMK
504033	Dana	DRK-427AMK
504034	Dana	DRK-405FAMK
504117	Dana	DRK-405F
504118	Dana	DRK-404FMK
504119	Dana	DRK-404R
504120	Dana	DRK-404F
504121	Dana	DRK-404RMK
504126	Dana	DRK-442A
504127	Dana	DRK-436A
504128	Dana	DRK-437A
504129	Dana	DRK-438A
504130	Dana	DRK-439A
504131	Dana	DRK-443A
504132	Dana	DRK-444A
504133	Dana	DRK-441A
50531	Dana	DS50531
50614	Dana	CS345
50619	Dana	DS50619
50637	Dana	DS50637
50660	Dana	DS50660
50660	Dana	DS50660
509689	Dana	DRK-412
509690	Dana	DRK-412MK
509691	Dana	DRK-196MK1
510393	Dana	DRK-427MK
510398	Dana	DRK-429MK
510399	Dana	DRK-428MK
510400	Dana	DRK-430MK
511891	Dana	DRK-451MK
51232	Dana	34492-A
51233	Dana	34274
512800	Dana	DRK-428
512803	Dana	DRK-400
512804	Dana	DRK-221
512805	Dana	DRK-430
512806	Dana	DRK-429
512812	Dana	DRK-427
512814	Dana	DRK-449
512828	Dana	DRK-445
512829	Dana	DRK-446
514011	Dana	DRK-436
514012	Dana	DRK-437
514013	Dana	DRK-438
514014	Dana	DRK-439
514015	Dana	DRK-443
514016	Dana	DRK-441
514059	Dana	DRK-447
514238	Dana	DRK-442
514240	Dana	DRK-444
51501	Dana	DS51501
51690	Dana	DS51690
52148	Dana	RGB24
52148	Dana	DS52148
522	Meritor	522
52375	Meritor	52375

Manufacturer Part #	Manufacturer	NCB Part #
52387	Meritor	52387
52387P	Meritor	52387-P
52400	Meritor	52400
52618	Meritor	52618
52618P	Meritor	52618-P
52637	Meritor	52637
528	Meritor	528
53-205-1	TTC	53-205-1
54128	Dana	RGB24
54414	Dana	38189-8S110
545021	TTC	545021
545047	TTC	545047
545065	TTC	545065
545132	TTC	SN13
550031	TTC	311-L
550182	Dana	25590
550182	TTC	25590
550225	Dana	25523
550228	TTC	25821
550348	Dana	39520
550375	TTC	25520
550720	TTC	MR1309EAL
550868	TTC	2788-A
550886	TTC	WJ162116
550889	TTC	JH1812
550900	TTC	JLM104948
550908	TTC	212
550914	TTC	MR1213EL
550921	TTC	MU1207TV
550924	TTC	217-SLE
550925	TTC	214-LH
550927	TTC	25584
550929	TTC	JM511910
550930	TTC	JM511946
550931	TTC	2580
550932	TTC	F81205
550940	TTC	MR1307EX
550941	TTC	MR1307EBX
550952	TTC	MU1311UGMR
550953	TTC	JH1416
550963	TTC	F93290
550978	TTC	2729
550981	TTC	MU1215TV
550982	TTC	114
550988	TTC	7211-HFL
550989	TTC	7211-HL
550991	TTC	F208323
550992	TTC	MU1211GUM
550996	TTC	MR1307EX
550998	TTC	MR1309UV
551003	TTC	K47X53X25A
551004	TTC	K55X63X20B
551005	TTC	K65X70X30A
551006	TTC	FW657020
551007	TTC	MB1212GEXR
551013	TTC	25581
55175C	Meritor	55175-C
55176C	Meritor	55176-C
55187C	Meritor	55187-C
55200C	Meritor	55200-C
55206C	Meritor	55206-C
552A	Meritor	552-A
55437	Meritor	55437
55443	Meritor	55443
5556503	Eaton	NCB6503
5556507	Eaton	5556507
5557005	Eaton	NP317848
5557503	Eaton	NP525140
555S	Meritor	555-S
5566505	Eaton	306-VV

Additional Info

Rebuild Kits and Components Interchanges

Manufacturer Part #	Manufacturer	NCB Part #
5566507	Eaton	DTP6507
5566508	Eaton	DTP6508
5566510	Eaton	DTP6510
5566511	Eaton	306-VVL
557S	Meritor	557-S
563	Meritor	563
56-381-2X	TTC	56-381-2X
56-429-1X	TTC	56-429-1X
56-429-3X	TTC	56-429-3X
56-432-1X	TTC	TRK-56-432-1X
56-482-1	TTC	MU5206L
565903	Dana	A10
566	Meritor	566
566071	Dana	33281
566117	Dana	R1561TV
56650	Meritor	56650
567	Meritor	567
572	Meritor	572
572A	Meritor	572-A
5735	Meritor	5735
575	Meritor	575
576	Meritor	576
5760	Meritor	5760
580	Meritor	580
581	Meritor	581
582	Meritor	582
592	Meritor	592
59201	Meritor	59201
592A	Meritor	592-A
593	Meritor	593
593A	Meritor	593-A
593X	Meritor	593-X
594	Meritor	594
59412	Meritor	59412
59-482-1-1X	TTC	C437-Q
594A	Meritor	594-A
595	Meritor	595
596	Meritor	596
598	Meritor	598
598A	Meritor	598-A
5X1034	Meritor	5X1034
5X591	Meritor	5X591
60-463-10-1X	TTC	39925
60-463-8	TTC	415004-V
6082	Dana	567
612	Meritor	612
61-463-4	TTC	471570
621	Meritor	621
62829	Dana	62829
62830	Dana	62830
632	Meritor	632
6320	Meritor	6320
633	Meritor	633
63-463-1	TTC	415322-V
6379	Meritor	6379
6389	Meritor	6389
641	Meritor	641
6420	Meritor	6420
643	Meritor	643
64450	Meritor	64450
6461	Meritor	6461
6461A	Meritor	6461-A
64700	Meritor	64700
6488	Eaton	MU1309UV
652	Meritor	652
65225	Meritor	65225
65237	Meritor	65237
653	Meritor	653
6535	Meritor	6535
65390	Meritor	65390

Manufacturer Part #	Manufacturer	NCB Part #
65500	Meritor	65500
6580	Meritor	6580
663	Meritor	663
665	Meritor	665
665A	Meritor	665-A
672	Meritor	672
67322	Meritor	67322
67388	Meritor	67388
67390	Meritor	67390
67391	Meritor	67391
67720	Meritor	67720
67782	Meritor	67782
67787	Meritor	67787
681A	Meritor	681-A
683	Meritor	683
68462	Meritor	68462
687	Meritor	687
68712	Meritor	68712
691644	Eaton	691644
691661	Eaton	691661
6984	Eaton	MU1308TM
701071	Dana	RGB24
706003X	Dana	DS706003X
706015X	Dana	HM88649-HM88610
706016X	Dana	LM501349-LM501314 (2)
706030X	Dana	02872-02820
706031X	Dana	31594-31520
706032X	Dana	25590-25520 (2)
706045X	Dana	HM88542-HM88510
706046X	Dana	HM803146-HM803110
706047X	Dana	387A-382S (2)
706060X	Dana	HM807040-HM807010
706070X	Dana	469-453X (2)
706123X	Dana	M88048-M88010
706861X	Dana	HM803149-HM803110
706894X	Dana	M86649-M86610
707064X	Dana	M802048-M802011
707065X	Dana	M802048-M802011
707066X	Dana	HM807046-HM807010
70709	Dana	70709
707162X	Dana	HM88648-HM88610
707447X	Dana	NP516549-NP673386
707489X	Dana	NP197868-NP802507 (2)
708243	Dana	M88048-M88010
708244	Dana	M802048-M802011
708245	Dana	LM603049-LM603011
710787	Eaton	31594
71204	Eaton	TL1
71205	Eaton	LC54505
71206	Eaton	SL1
71450	Meritor	71450
71750	Meritor	71750
72188C	Meritor	72188-C
72200C	Meritor	72200-C
72212C	Meritor	72212-C
72218C	Meritor	72218-C
72225C	Meritor	72225-C
72487	Meritor	72487
740	Meritor	740
742	Meritor	742
747-D	TTC	747-D
749	Meritor	749
749A	Meritor	749-A
752	Meritor	752
755	Meritor	755
759	Meritor	759
760	Meritor	760
766	Meritor	766
772	Meritor	772
780	Meritor	780

Manufacturer Part #	Manufacturer	NCB Part #
782	Meritor	782
78214C	Meritor	78214-C
78215C	Meritor	78215-C
78225C	Meritor	78225-C
78250AC	Meritor	78250-AC
78551	Meritor	78551
787	Meritor	787
78904	Dana	78904
78909	Dana	78909
78930	Dana	313
78931	Dana	OR-331
78936	Dana	MA1211EL
78937	Dana	78937
81012	Eaton	1311-L
81017	Eaton	1212-S
81022	Eaton	1309-L
81029	Eaton	1212-L
81052	Eaton	1310-L
81057	Eaton	1310-SLV
81058	Eaton	309-MG5
811523	Dana	T189
81504	Eaton	212-SLV
81505	Eaton	117-L
81511	Eaton	308
81547	Eaton	204
81549	Eaton	213
81557	Eaton	5310-WL
81559	Eaton	117
81566	Eaton	5310-WLB
81567	Eaton	214-LB
820642	Dana	6461-A
820643	Dana	555-S
82-463-4	TTC	415281-N
83001	Eaton	83001
83002	Eaton	83002
830392	Dana	RU6805UM
830398	Dana	WUB61307UM
83726	Dana	83726
83824	Dana	JM822010
83825	Dana	JM822049
84002	Eaton	84002
84003	Eaton	84003
84004	Eaton	84004
84005	Eaton	84005
84006	Eaton	84006
843	Meritor	843
85001	Eaton	85001
85001	Meritor	85001
85002	Eaton	85002
85003	Eaton	85003
85003	Meritor	85003
854	Meritor	854
85404	Dana	85404
85406	Dana	85406
85425	Dana	JH307749
85429	Dana	85429
85437	Dana	85437
85439	Dana	72218-C
85533	Eaton	85533
85541	Eaton	85541
85991	Dana	85991
85994	Dana	85994
85997	Dana	85997
864	Meritor	864
8774	Eaton	8774
8879	Eaton	MR1307EL
8997	Eaton	CN1
90943	Dana	563
90951	Dana	3920
90954	Dana	575

Additional Info

Rebuild Kits and Components Interchanges



Manufacturer Part #	Manufacturer	NCB Part #
90955	Dana	572
91136	Dana	3979
917217R1	Dana	HM903210
9220	Meritor	9220
9278	Meritor	9278
932	Meritor	932
936	Meritor	936
938	Meritor	938
95215	Dana	95215
97-381-4	TTC	SR348-1
97-463-32	TTC	412015-V
97-463-33	TTC	455379-V
97-463-36-1X	TTC	97-463-36-1X
97-463-39	TTC	714713
9797	Dana	9797
9803	Dana	493
9804	Dana	498
98-210-2	TTC	98-210-2
98384	Dana	JH211749
98385	Dana	JH211710
98387	Dana	JM511946
98388	Dana	JM511910
98-432-1X	TTC	TRK-98-432-1X
98-463-1	TTC	415953
99041	Dana	DRK-1A
99048	Dana	DRK-24
99050	Dana	DRK-23D
99051	Dana	DRK-1
99053	Dana	DRK-72A
99096	Dana	DRK-18E
99906	Dana	594-A
A11228B600	Meritor	32021-X
A11228J1414	Meritor	NP301337.902A2
A11228R486	Meritor	MU1218TDHM
A11805S149	Meritor	3591
A1199S1917	Meritor	502234
A1205A1925	Meritor	4492-V
A1205A2107	Meritor	45013S
A1205B1198	Meritor	410101-N
A1205B1328	Meritor	3136-N
A1205C1927	Meritor	A1205C1927
A1205D1928	Meritor	415082-N
A1205D706	Meritor	6612-S
A1205E1227	Meritor	476023-N
A1205E1929	Meritor	475234-N
A1205G2425	Meritor	4561-V
A1205G683	Meritor	470308-N
A1205J1544	Meritor	415082-N
A1205J1934	Meritor	4564-V
A1205K1779	Meritor	475322-N
A1205K401	Meritor	417316
A1205K635	Meritor	470737-N
A1205K713	Meritor	3592
A1205L714	Meritor	4563-V
A1205M325	Meritor	415137
A1205N1132	Meritor	470954
A1205N1496	Meritor	415013-N
A1205N612	Meritor	5406
A1205P1758	Meritor	471224
A1205P1914	Meritor	4876-N
A1205Q1915	Meritor	3143-N
A1205S1527	Meritor	475080-N
A1205S1761	Meritor	410101-N
A1205U1529	Meritor	416654
A1205U1685	Meritor	3905
A1205U1737	Meritor	475012-N
A1205V1374	Meritor	473274-N
A1205V1686	Meritor	CR543351
A1205W1349	Meritor	370023-A
A1205Y727	Meritor	475012-N

Manufacturer Part #	Manufacturer	NCB Part #
A1228A1717	Meritor	H715334
A1228E1175	Meritor	A1228E1175
A1228G1307	Meritor	390A-902B1
A1228H1204	Meritor	119-L
A1228H1308	Meritor	29675-902B7
A1228K1207	Meritor	390A-902B8
A1228L1130	Meritor	JP10049
A1228M1209	Meritor	29675-902B4
A1228M1729	Meritor	NP293601
A1228N2068	Meritor	55206-C
A1228N326	Meritor	MU1015DCV
A1228P1940	Meritor	JLM714149
A1228R1474	Meritor	594-A
A1228S1345	Meritor	NP449281-NP357215
A1228T1346	Meritor	NP418109-NP525386
A1228U1347	Meritor	3782-3720
A1228W1713	Meritor	JM511945
A1228Z572	Meritor	LM11949-90013
A1805A157	Meritor	473228
A1805A261	Meritor	415272-N
A1805A573	Meritor	471341-N
A1805B522	Meritor	CR540636
A1805B80	Meritor	35009-N
A1805D212	Meritor	475322-N
A1805F162	Meritor	417487
A1805P536	Meritor	415483
A1805R408	Meritor	45031-S
A1805S149	Meritor	476283-N
A1805S279	Meritor	471570
A1805T488	Meritor	415984
A1805X466	Meritor	456105
A1805Z26	Meritor	340483
A-3697	Eaton	A3697
A-5022	Eaton	A5022
A-6340	Eaton	A6340
ABG-9121	PAI	45280
ABG-9122	PAI	555-S
ABG-9130	PAI	HM212049
ABG-9131	PAI	6461-A
ACU-9041	PAI	432
ACU-9061	PAI	563
BBG-6039	PAI	LM104949
BBG-6149	PAI	495
BBG-7070	PAI	310
BBG-7080	PAI	MU1211CL
BBG-7090	PAI	559
BBG-7150	PAI	643
BBG-7154	PAI	JM511945
BBG-7155	PAI	JLM710949
BBG-7157	PAI	JM511946
BBG-7159	PAI	3979
BBG-7160	PAI	309
BBG-7180	PAI	624
BBG-7190	PAI	645-X
BBG-7257	PAI	64450
BBG-7277	PAI	JM822049
BBG-7280	PAI	47681
BBG-7320	PAI	1213-L
BBG-7330	PAI	HM516448
BBG-7331	PAI	JM716649
BBG-7334	PAI	MU1307GUM
BBG-7336	PAI	JH211749
BBG-7338	PAI	JLM714149
BBG-7340	PAI	47687
BBG-7341	PAI	47686
BBG-7343	PAI	47890
BBG-7372	PAI	567
BBG-7373	PAI	52387
BBG-7400	PAI	557-S
BBG-7419	PAI	55206-C

Manufacturer Part #	Manufacturer	NCB Part #
BBG-7421	PAI	598-A
BBG-7430	PAI	5760
BBG-7435	PAI	H715334
BBG-7436	PAI	H715343
BBG-7469	PAI	H715348
BBG-7470	PAI	H715345
BBG-7490	PAI	497
BBG-7510	PAI	576
BBG-7511	PAI	65237
BBG-7623	PAI	HM813843
BBG-7634	PAI	42362
BBG-7640	PAI	1211
BBG-7642	PAI	1213-A
BBG-7750	PAI	555
BBG-8941	PAI	28985
BBG-8943	PAI	3877
BBG-8974	PAI	L610549
BBK-7119	PAI	DRK-500
BBK-7121	PAI	DRK-206
BBK-7124	PAI	DRK-212F
BBK-7124-100	PAI	DRK-212F
BBK-7125	PAI	DRK-206
BBK-7139	PAI	DRK-501
BBK-7141	PAI	DRK-205
BBK-7142	PAI	DRK-502
BBK-7143	PAI	DRK-212R
BBK-7144	PAI	DRK-117
BBK-7145	PAI	DRK-117A
BBK-7153	PAI	DRK-503
BCU-7112	PAI	HM807010
BCU-7120	PAI	552-A
BCU-7140	PAI	632
BCU-7170	PAI	612
BCU-7252	PAI	9220
BCU-7256	PAI	64700
BCU-7276	PAI	JM822010
BCU-7318	PAI	66462
BCU-7332	PAI	JM207010
BCU-7335	PAI	JH711710
BCU-7337	PAI	JLM714110
BCU-7342	PAI	47820
BCU-7350	PAI	HM516414-B
BCU-7353	PAI	592-A
BCU-7356	PAI	56650
BCU-7390	PAI	47623-A
BCU-7392	PAI	JM716610
BCU-7480	PAI	572
BCU-7481	PAI	6420
BCU-7500	PAI	492-A
BCU-7501	PAI	65500
BCU-7502	PAI	653
BCU-7622	PAI	HM813810
BCU-7820	PAI	H715313-W
BCU-8942	PAI	28921
BCU-8944	PAI	3820
BCU-8973	PAI	25821
BCU-8975	PAI	L610510
BOS-7695	PAI	4492-V
BOS-7696	PAI	4490-V
BOS-7697	PAI	4491-V
BSR-0385	PAI	30ZRTVBL
EBG-8639	PAI	306-DDL
EM73700	PAI	5754
GBG-6011	PAI	J2416
GBG-6033	PAI	3780
GBG-6035	PAI	JLM104948
GBG-6040	PAI	621
GBG-6071	PAI	JH1818
GBG-6087	PAI	212-SLV
GBG-6088	PAI	A3071

Additional Info

Rebuild Kits and Components Interchanges

Manufacturer Part #	Manufacturer	NCB Part #
GBG-6089	PAI	HJ223020/IR1820
GBG-6090	PAI	A2892
GBG-6091	PAI	NCB356
GBG-6092	PAI	NCB355
GBG-6100	PAI	SCE2014P
GBG-6102	PAI	B1612
GBG-6133	PAI	SCH2216
GBG-6172	PAI	NCB0902
GBG-6590	PAI	214-SL
GBG-6593	PAI	214-L
GBG-6594	PAI	214-S
GBG-6610	PAI	1208-L
GBG-6620	PAI	MA1205EL
GBG-6621	PAI	205
GBG-6631	PAI	M1209EL
GBG-6655	PAI	6912
GBG-6798	PAI	NCB6503
GBG-7319	PAI	DTP043
GBG-7321	PAI	MA1213EL
GBG-8954	PAI	BS500052V
GBG-8965	PAI	BS226539V
GBG-8966	PAI	MU1212RUMW3
GBG-8967	PAI	390-A
GBG-8968	PAI	399-A
GBK-6560	PAI	TRK-185
GBK-6561	PAI	TRK-187
GBK-6562	PAI	TRK-213
GBK-6563	PAI	TRK-185
GBK-6564	PAI	TRK-500
GBK-6565	PAI	TRK-214MK
GBK-6565-400	PAI	GBK6565-400
GBK-6571	PAI	TRK-501
GBK-6572	PAI	TRK-502
GBK-6573	PAI	TRK-503
GBK-6574	PAI	TRK-213SD
GBK-6605	PAI	TRK-504
GBK-6637	PAI	TRK-214MK1
GCU-6020	PAI	493
GCU-6034	PAI	3720
GCU-6036	PAI	JLM104910
GCU-7453	PAI	H715311
GDB-1566	PAI	GDB1566
GDB-1665	PAI	GDB1665
GDB-1666	PAI	GDB1666
GGA-2937	PAI	OR-217V
GGA-2942	PAI	OR-157
GGA-2949	PAI	OR-151
GGAHA100	Dana	42584
GGAHA101	Dana	493
GGAHA109	Dana	M802011
GGAHB100	Dana	42381
GGAHB101	Dana	495
GGAHB102	Dana	39590
GGAHB104	Dana	555-S
GGAHB105	Dana	HM807049
GGAHB106	Dana	M802048
GGAKA101-X	Dana	DRK-213
GOS-6201	PAI	240731
GOS-6720	PAI	2822-V
GOS-6951	PAI	713750
GRI-2735	PAI	GRI2735
GSP-1672	PAI	GSP1672
GSP-1673	PAI	GSP1673
GSP-5988	PAI	GSP5988
GTW-1021	PAI	GTW1021
GTW-1022	PAI	GTW1022
GTW-5998	PAI	GTW5998
GWA-5919	PAI	GWA5919
GWA-5972	PAI	GWA5972
H500445	Dana	3782

Manufacturer Part #	Manufacturer	NCB Part #
H715311	Meritor	H715311
H715313W	Meritor	H715313-W
H715334	Meritor	H715334
H715341	Meritor	H715341
H715343	Meritor	H715343
H715345	Meritor	H715345
HA100	Dana	H715311
HA101	Dana	56650
HA102	Dana	3920
HA105	Dana	6420
HB101	Dana	782
HB102	Dana	56425
HB103	Dana	H715343
HB104	Dana	55175-C
HB105	Dana	3984
HB106	Dana	H715343
HBG-4815	PAI	582
HBG-4817	PAI	594-A
HBG-4840	PAI	596
HBG-4850	PAI	594
HBG-4860	PAI	580
HBG-6029	PAI	3782
HBG-6031	PAI	3582
HBG-7163	PAI	28682
HBG-7174	PAI	39581
HBG-7175	PAI	39590
HBG-7371	PAI	52400
HBG-7520	PAI	663
HBG-7550	PAI	47679
HBG-7570	PAI	HM516449
HBG-7571	PAI	HM516449-A
HBG-9065	PAI	560
HBG-9129	PAI	HM212047
HCU-4830	PAI	592
HCU-4880	PAI	HM212010
HCU-5010	PAI	47620
HCU-5020	PAI	HM516410
HCU-7162	PAI	28622
HD100	Dana	XLS5-1/8-AF
HH221410	Meritor	HH221410
HH221442	Meritor	HH221442
HH506310	Meritor	HH506310
HH506348	Meritor	HH506348
HM212010	Meritor	HM212010
HM212011	Meritor	HM212011
HM212044	Meritor	HM212044
HM212047	Meritor	HM212047
HM212049	Meritor	HM212049
HM212049X	Meritor	HM212049-X
HM218210	Meritor	HM218210
HM218248	Meritor	HM218248
HM516410	Meritor	HM516410
HM516414B	Meritor	HM516414-B
HM516448	Meritor	HM516448
HM516449A	Meritor	HM516449-A
HM516449C	Meritor	HM516449-C
HM518410	Meritor	HM518410
HM518445	Meritor	HM518445
HM617010	Meritor	HM617010
HM617049	Meritor	HM617049
HM801310	Meritor	HM801310
HM801346X	Meritor	HM801346-X
HM803110	Meritor	HM803110
HM803146	Meritor	HM803146
HM803149	Meritor	HM803149
HM804810	Meritor	HM804810
HM804840	Meritor	HM804840
HM804846	Meritor	HM804846
HM807010	Meritor	HM807010
HM807040	Meritor	HM807040

Manufacturer Part #	Manufacturer	NCB Part #
HM807046	Meritor	HM807046
HM807049	Meritor	HM807049
HM813810	Meritor	HM813810
HM813842	Meritor	HM813842
HM813843	Meritor	HM813843
HM813844	Meritor	HM813844
HM88510	Meritor	HM88510
HM88542	Meritor	HM88542
HM88610	Meritor	HM88610
HM88649	Meritor	HM88649
HM89411	Meritor	HM89411
HM89448	Meritor	HM89448
HM89449	Meritor	HM89449
HM903210	Meritor	HM903210
HM903216	Meritor	HM903216
HM903249	Meritor	HM903249
HM911210	Meritor	HM911210
HM911242	Meritor	HM911242
HM911245	Meritor	HM911245
JCB-6895	PAI	HB210370-1X
JCB-6896	PAI	HB210140-1X
JCB-6897	PAI	HB210144-1X
JCB-6898	PAI	HB210433-1X
JCB-6899	PAI	HB210866-1X
JF7049A	Meritor	JF7049-A
JH211710	Meritor	JH211710
JH211749	Meritor	JH211749
JH217210	Meritor	JH217210
JH217249	Meritor	JH217249
JH307710	Meritor	JH307710
JH307749	Meritor	JH307749
JH415610	Meritor	JH415610
JH415647	Meritor	JH415647
JHM720210	Meritor	JHM720210
JHM720249	Meritor	JHM720249
JL69310	Meritor	JL69310
JL69349	Meritor	JL69349
JLM104910	Meritor	JLM104910
JLM104948	Meritor	JLM104948
JLM506810	Meritor	JLM506810
JLM506849	Meritor	JLM506849
JLM508748	Meritor	JLM508748
JLM710910	Meritor	JLM710910
JLM710949C	Meritor	JLM710949
JLM714110	Meritor	JLM714110
JLM714149	Meritor	JLM714149
JM205110	Meritor	JM205110
JM205149A	Meritor	JM205149A
JM207010	Meritor	JM207010
JM207049	Meritor	JM207049
JM207049A	Meritor	JM207049-A
JM511910	Meritor	JM511910
JM511945	Meritor	JM511945
JM511946	Meritor	JM511946
JM515610	Meritor	JM515610
JM515649	Meritor	JM515649
JM612910	Meritor	JM612910
JM612949	Meritor	JM612949
JM716610	Meritor	JM716610
JM716648	Meritor	JM716648
JM716649	Meritor	JM716649
JM720210	Meritor	JM720210
JM720249	Meritor	JM720249
JM822010	Meritor	JM822010
JM822049	Meritor	JM822049
JP12010	Meritor	JP12010
JP12049	Meritor	JP12049
JRM3535	Meritor	JRM3535
K-1063	Eaton	TRK-1063
K-1064	Eaton	TRK-1064

Additional Info

Rebuild Kits and Components Interchanges



Manufacturer Part #	Manufacturer	NCB Part #
K-1079	Eaton	TRK-1079
K-1447	Eaton	K-1447
K-1450	Eaton	K-1450
K-1479	Eaton	K-1479
K-1552	Eaton	K-1552
K-1554	Eaton	TRK-1554
K-1555	Eaton	TRK-1555
K-1568	Eaton	k-1568
K-1603	Eaton	K-1603
K-1763	Eaton	TRK-1763
K-1765	Eaton	TRK-1765
K-1782	Eaton	K-1782
K-1846	Eaton	K-1846
K-1850	Eaton	TRK-1850
K-1851	Eaton	TRK-1851
K-1852	Eaton	TRK-1852
K-1855	Eaton	TRK-1855
K-1858	Eaton	TRK-1858
K-1859	Eaton	TRK-1859
K-1860	Eaton	TRK-1860
K-1861	Eaton	TRK-1861
K-1862	Eaton	TRK-1862
K-1863	Eaton	TRK-1863
K-1866	Eaton	TRK-1866
K-1867	Eaton	TRK-1867
K-1870	Eaton	TRK-1870
K-1871	Eaton	TRK-1871
K-1872	Eaton	TRK-1872
K-1873	Eaton	TRK-1873
K-1874	Eaton	TRK-1874
K-1875	Eaton	TRK-1875
K-1876	Eaton	TRK-1876
K-1877	Eaton	TRK-1877
K-1931	Eaton	K-1931
K-1955	Eaton	K-1955
K-1971	Eaton	TRK-1971
K-1972	Eaton	TRK-1972
K-1979	Eaton	TRK-1979
K-1980	Eaton	TRK-1980
K-1981	Eaton	TRK-1981
K-1982	Eaton	TRK-1982
K-1984	Eaton	TRK-1984
K-1986	Eaton	TRK-1986
K-1991	Eaton	TRK-1991
K-1992	Eaton	TRK-1992
K-1993	Eaton	TRK-1993
K-1995	Eaton	TRK-1995
K-1996	Eaton	TRK-1996
K-1999	Eaton	TRK-1999
K-2002	Eaton	K-2002
K-2041	Eaton	TRK-2041
K-2043	Eaton	TRK-2043
K-2045	Eaton	TRK-2045
K-2047	Eaton	TRK-2047
K-2048	Eaton	TRK-2048
K-2049	Eaton	TRK-2049
K-2054	Eaton	K-2054
K-2061	Eaton	K-2061
K-2085	Eaton	K-2085
K-2110	Eaton	K-2110
K-2120	Eaton	TRK-2120
K-2121	Eaton	TRK-2121
K-2122	Eaton	TRK-2122
K-2123	Eaton	TRK-2123
K-2124	Eaton	TRK-2124
K-2125	Eaton	TRK-2125
K-2126	Eaton	TRK-2126
K-2127	Eaton	TRK-2127
K-2128	Eaton	TRK-2128
K-2129	Eaton	TRK-2129

Manufacturer Part #	Manufacturer	NCB Part #
K-2130	Eaton	TRK-2130
K-2131	Eaton	TRK-2131
K-2136	Eaton	K-2136
K-2138	Eaton	K-2138
K-2143	Eaton	K-2143
K-2144	Eaton	K-2144
K-2181	Eaton	K-2181
K-2183	Eaton	K-2183
K-2199	Eaton	K-2199
K-2256	Eaton	DTK2256
K-2262	Eaton	DTK2262
K-2275	Eaton	TRK-2275
K-2277	Eaton	TRK-2277
K-2280	Eaton	TRK-2280
K-2281	Eaton	TRK-2281
K-2282	Eaton	TRK-2282
K-2283	Eaton	TRK-2283
K-2284	Eaton	TRK-2284
K-2285	Eaton	TRK-2285
K-2286	Eaton	TRK-2286
K-2287	Eaton	TRK-2287
K-2288	Eaton	TRK-2288
K-2295	Eaton	K-2295
K-2298	Eaton	K-2298
K-2335	Eaton	TRK-2335
K-2336	Eaton	TRK-2336
K-2338	Eaton	TRK-2338
K-2340	Eaton	TRK-2340
K-2341	Eaton	TRK-2341
K-2342	Eaton	TRK-2342
K-2343	Eaton	TRK-2343
K-2344	Eaton	TRK-2344
K-2345	Eaton	TRK-2345
K-2425	Eaton	K-2425
K-2430	Eaton	K-2430
K-2464	Eaton	TRK-2464
K-2465	Eaton	K-2465
K-2468	Eaton	TRK-2468
K-2490	Eaton	TRK-2490
K-2758	Eaton	TRK-2758
K-2759	Eaton	TRK-2759
K-2761	Eaton	TRK-2761
K-2762	Eaton	TRK-2762
K-2763	Eaton	TRK-2763
K-2764	Eaton	TRK-2764
K-2765	Eaton	TRK-2765
K-2767	Eaton	TRK-2767
K-2768	Eaton	TRK-2768
K-2769	Eaton	TRK-2769
K-2770	Eaton	TRK-2770
K-2771	Eaton	TRK-2771
K-2772	Eaton	TRK-2772
K-2773	Eaton	TRK-2773
K-2779	Eaton	TRK-2779
K-2780	Eaton	TRK-2780
K-2802	Eaton	K-2802
K-2804	Eaton	K-2804
K-2805	Eaton	K-2805
K-2838	Eaton	TRK-2838
K-2839	Eaton	K-2839
K-2846	Eaton	K-2846
K-2847	Eaton	TRK-2847
K-2848	Eaton	TRK-2848
K-2855	Eaton	TRK-2855
K-2860	Eaton	K-2860
K-2865	Eaton	TRK-2865
K-2866	Eaton	TRK-2866
K-2918	Eaton	DTK2918
K-2921	Eaton	K-2921
K-2923	Eaton	K-2923

Manufacturer Part #	Manufacturer	NCB Part #
K-2924	Eaton	TRK-2924
K-2993	Eaton	TRK-2993
K-2994	Eaton	TRK-2994
K-2996	Eaton	TRK-2996
K-2997	Eaton	TRK-2997
K-2998	Eaton	TRK-2998
K-3132	Eaton	TRK-3132
K-3233	Eaton	TRK-3233
K-3234	Eaton	TRK-3234
K-3256	Eaton	TRK-3256
K-3257	Eaton	TRK-3257
K-3258	Eaton	TRK-3258
K-3272	Eaton	TRK-3272
K-3273	Eaton	TRK-3273
K-3282	Eaton	TRK-3282
K-3283	Eaton	TRK-3283
K-3286	Eaton	TRK-3286
K-3287	Eaton	TRK-3287
K-3288	Eaton	K-3288
K-3322	Eaton	TRK-3322
K-3323	Eaton	TRK-3323
K-3339	Eaton	TRK-3339
K-3340	Eaton	TRK-3340
K-3341	Eaton	K-3341
K-3342	Eaton	TRK-3342
K-3343	Eaton	TRK-3343
K-3344	Eaton	TRK-3344
K-3345	Eaton	TRK-3345
K-3346	Eaton	TRK-3346
K-3347	Eaton	TRK-3347
K-3348	Eaton	TRK-3348
K-3350	Eaton	TRK-3350
K-3351	Eaton	TRK-3351
K-3354	Eaton	TRK-3354
K-3355	Eaton	TRK-3355
K-3413	Eaton	TRK-3413
K-3414	Eaton	TRK-3414
K-3423	Eaton	TRK-3423
K-3425	Eaton	TRK-3425
K-3426	Eaton	TRK-3426
K-3440	Eaton	TRK-3440
K-3458	Eaton	K-3458
K-3459	Eaton	TRK-3459
K-3460	Eaton	TRK-3460
K-3461	Eaton	TRK-3461
K-3462	Eaton	TRK-3462
K-3484	Eaton	K-3484
K-3485	Eaton	K-3485
K-3486	Eaton	TRK-3486
K-3487	Eaton	TRK-3487
K-3488	Eaton	TRK-3488
K-3509	Eaton	K-3509
K-3510	Eaton	K-3510
K-3512	Eaton	TRK-3512
K-3513	Eaton	TRK-3513
K-3514	Eaton	TRK-3514
K-3515	Eaton	TRK-3515
K-3518	Eaton	K-3518
K-3519	Eaton	TRK-3519
K-3522	Eaton	TRK-3522
K-3524	Eaton	TRK-3524
K-3532	Eaton	K-3532
K-3533	Eaton	TRK-3533
K-3534	Eaton	TRK-3534
K-3552	Eaton	K-3552
K-3553	Eaton	TRK-3553
K-3554	Eaton	TRK-3554
K-3583	Eaton	K-3583
K-3584	Eaton	K-3584
K-3585	Eaton	TRK-3585

Additional Info

Rebuild Kits and Components Interchanges

Manufacturer	Part #	Manufacturer	NCB Part #
Eaton	K-3586	TRK	3586
Eaton	K-3593	K	3593
Eaton	K-3594	K	3594
Eaton	K-3595	TRK	3595
Eaton	K-3596	TRK	3596
Eaton	K-3597	TRK	3597
Eaton	K-3598	TRK	3598
Eaton	K-3600	TRK	3600
Eaton	K-3655	TRK	3655
Eaton	K-3656	TRK	3656
Eaton	K-3657	TRK	3657
Eaton	K-3658	TRK	3658
Eaton	K-3659	TRK	3659
Eaton	K-3660	TRK	3660
Eaton	K-3661	TRK	3661
Eaton	K-3738	K	3738
Eaton	K-3919	25581-25520	
Eaton	K-3939	K	3939
Eaton	K-3940	K	3940
Eaton	K-3941	TRK	3941
Eaton	K-3942	TRK	3942
Eaton	K-4010	TRK	4010
Eaton	K-4011	TRK	4011
Eaton	K-4056	TRK	4056
Eaton	K-4057	TRK	4057
Eaton	K-4092	TRK	4092
Eaton	K-4152	39590-39520	
Eaton	K-4154	M802048-M802011	
Eaton	K-7000	TRK	7000
Eaton	K-7001	K	7001
Eaton	K-7013	TRK	7013
Eaton	K-7028	K	7028
Eaton	K-7030	K	7030
Eaton	K-7032	TRK	7032
Eaton	K-7033	TRK	7033
Eaton	K-7035	TRK	7035
Eaton	K-7052	TRK	7052
PAI	KBG-4816	HM518445	
PAI	KBG-9127	HM218248	
PAI	KCU-4814	HM518410	
PAI	KCU-9128	HM218210	
Meritor	KIT1918	DRK	1918
Meritor	KIT1984	DRK	1984
Meritor	KIT2108	DRK	2108
Meritor	KIT2111	DRK	2111
Meritor	KIT4005	DRK-9RC	
Meritor	KIT4010	DRK-9RB	
Meritor	KIT4015	DRK-900F	
Meritor	KIT4020	DRK-9F	
Meritor	KIT4025	DRK-9R	
Meritor	KIT4035	DRK-194F	
Meritor	KIT4040	DRK-194R	
Meritor	KIT4045	DRK-194RA	
Meritor	KIT4050	DRK-194RA	
Meritor	KIT4055	DRK-194F	
Meritor	KIT4060	DRK-194RB	
Meritor	KIT4065	DRK-194RB	
Meritor	KIT4075	DRK-172R	
Meritor	KIT4080	DRK-172FB	
Meritor	KIT4095	DRK-4095	
Meritor	KIT4100	DRK-4100	
Meritor	KIT4105	DRK-4105	
Meritor	KIT4110	DRK-50	
Meritor	KIT4115	DRK-50A	
Meritor	KIT4120	DRK-203F	
Meritor	KIT4135	DRK-4135	
Meritor	KIT4140	DRK-4140	
Meritor	KIT4145	DRK-4145	
Meritor	KIT4150	DRK-4150	
Meritor	KIT4155	DRK-4155	

Manufacturer	Part #	Manufacturer	NCB Part #
Meritor	KIT4190	DRK	4190
Meritor	KIT4220	DRK	4220
Meritor	KIT4230	DRK	204F
Meritor	KIT4235	DRK	204R
Meritor	KIT4240	DRK	4240
Meritor	KIT4245	DRK	4245
Meritor	KIT4260	DRK	4260
Meritor	KIT4265	DRK	1910
Meritor	KIT4270	DRK	4270
Meritor	KIT4300	DRK	4300
Meritor	KIT4315	DRK	4315
Meritor	KIT4330	DRK	4330
Meritor	KIT4340	DRK	218
Meritor	KIT4345	DRK	4345
Meritor	KIT4350	DRK	4350
Meritor	KIT4355	DRK	4355
Meritor	KIT4356	DRK	4356
Meritor	KIT4360	DRK	4360
Meritor	KIT4365	DRK	216
Meritor	KIT4370	DRK	225
Meritor	KIT4375	DRK	4375
Meritor	KIT4385	DRK	224
Meritor	KIT4390	DRK	4390
Meritor	KIT4395	DRK	4395
Meritor	KIT4396	DRK	4396
Meritor	KIT4400	DRK	217R
Meritor	KIT4405	DRK	4405
Meritor	KIT4406	DRK	4406
Meritor	KIT4415	DRK	4415
Meritor	KIT4420	DRK	4420
Meritor	KIT4422	DRK	4422
Meritor	KIT4423	DRK	4423
Meritor	KIT4426	DRK	4426
Meritor	KIT4428	DRK	4428
Meritor	KIT4437	DRK	4437
Meritor	KIT4438	DRK	4438
Meritor	KIT4440	DRK	4440
Meritor	KIT4441	DRK	4441
Meritor	KIT4442	DRK	4442
Meritor	KIT4443	DRK	4443
Meritor	KIT4444	DRK	4444
Meritor	KIT4445	KIT4445	
Meritor	KIT4446	KIT4446	
Meritor	KIT4450	DRK	4450
Meritor	KIT4459	DRK	4435
Meritor	KIT4460	DRK	4436
Meritor	KIT4461	DRK	4461
Meritor	KIT4463	L4463	
Meritor	L44649	L44649	
Meritor	L68111	L68111	
Meritor	L68149	L68149	
Meritor	L812148	L812148	
Meritor	LM102910	LM102910	
Meritor	LM102949	LM102949	
Meritor	LM104911A	LM104911-A	
Meritor	LM11910	LM11910	
Meritor	LM11949	LM11949	
Meritor	LM12710	LM12710	
Meritor	LM48510	LM48510	
Meritor	LM48548	LM48548	

Manufacturer	Part #	Manufacturer	NCB Part #
Meritor	LM48548A	LM48548-A	
Meritor	LM501310	LM501310	
Meritor	LM501314	LM501314	
Meritor	LM501349	LM501349	
Meritor	LM522510	LM522510	
Meritor	LM522548	LM522548	
Meritor	LM603011	LM603011	
Meritor	LM603049	LM603049	
Meritor	LM67010	LM67010	
Meritor	LM67048	LM67048	
Dana	M10HB109	787	
Meritor	M802011	M802011	
Meritor	M802048	M802048	
Meritor	M804010	M804010	
Meritor	M804049	M804049	
Meritor	M86610	M86610	
Meritor	M86649	M86649	
Meritor	M88010	M88010	
Meritor	M88048	M88048	
Meritor	M903345	M903345	
Meritor	MER0103	TM350	
Meritor	MER0103B20	TM350	
Meritor	MER0104	TM318	
Meritor	MER0104B20	TM318	
Meritor	MER0112	TM309	
Meritor	MER0112B20	TM309	
Meritor	MER0113	TM329	
Meritor	MER0113B20	TM329	
Meritor	MER0123	TM302	
Meritor	MER0123B20	TM302	
Meritor	MER0136	TM312	
Meritor	MER0136B40	TM312	
Meritor	MER0143	TM305	
Meritor	MER0143B20	TM305	
Meritor	MER0164	TM315	
Meritor	MER0164B20	TM315	
Meritor	MER0173	TM333	
Meritor	MER0173B20	TM333	
Dana	MJAJA100	JM822010	
Dana	MJAJA103	JM716610	
Dana	MJAJHB100	JM822049	
Dana	MJAJHB103	JM716649	
Dana	MJAJA101-X	DRK-214	
Meritor	NP160764	NP160764	
Meritor	NP293601	NP293601	
Meritor	NP378089	NP378089	
Meritor	NP414535	NP414535	
Meritor	NP478159	NP478159	
Meritor	NP528108	NP528108	
Meritor	NP547288	NP547288	
Meritor	NP563664	NP563664	
Meritor	NP611140	NP611140	
Meritor	NP621196	NP621196	
Meritor	NP635208	NP635208	
Meritor	NP655898	NP655898	
Meritor	NP674708	NP674708	
Meritor	NP682041	NP682041	
Meritor	NP934397	NP934397	
Meritor	NP942787	NP942787	
Meritor	NP970652	NP970652	
PAI	PAP806869	TRK-505MK	
PAI	PAP806870	TRK-506MK	
PAI	PAP806871	TRK-507MK	
PAI	PAP806929	932	
PAI	PAP806930	27820	
PAI	PAP806933	382-A	
PAI	PAP806934	JM515610	
PAI	PAP806963	WJ243024	
PAI	PAP806989	938	
PAI	PAP806994	385-A	

Additional Info

Rebuild Kits and Components Interchanges

Manufacturer Part #	Manufacturer	NCB Part #
PAP806995	PAI	78250-AC
PAP806996	PAI	JM515649
S-1128	Eaton	S1128
S-1409	Eaton	S1409
S-1659	Eaton	S1659
S-1661	Eaton	S-1661
S-2822	Eaton	S2822
S-2838	Eaton	S-1661
S-2890	Eaton	S2890
S-2928	Eaton	S2928
SET401	Meritor	SET401
SET402	Meritor	SET402
SET403	Meritor	SET403
SET404	Meritor	SET404
SET405	Meritor	SET405
SET406	Meritor	SET406
SET407	Meritor	SET407
SET408	Meritor	SET408
SET409	Meritor	SET409
SET410	Meritor	SET410

Manufacturer Part #	Manufacturer	NCB Part #
SET411	Meritor	SET411
SET412	Meritor	SET412
SET413	Meritor	SET413
SET414	Meritor	SET414
SET415	Meritor	SET415
SET416	Meritor	SET416
SET417	Meritor	SET417
SET418	Meritor	SET418
SET419	Meritor	SET419
SET420	Meritor	SET420
SET421	Meritor	SET421
SET422	Meritor	SET422
SET423	Meritor	SET423
SET424	Meritor	SET424
SET425	Meritor	SET425
SET426	Meritor	SET426
SET427	Meritor	SET427
SET428	Meritor	SET428
SET429	Meritor	SET429
SET430	Meritor	SET430

Manufacturer Part #	Manufacturer	NCB Part #
SET431	Meritor	SET431
SET432	Meritor	SET432
SET433	Meritor	SET433
SET434	Meritor	SET434
SET437	Meritor	SET437
SET45	Meritor	A35
SET6	Meritor	A6
ST2161	Dana	47820
ST2162	Dana	47890
ST264	Dana	210
ST741	Dana	122-L
ST791	Dana	3877
ST951	Dana	3820

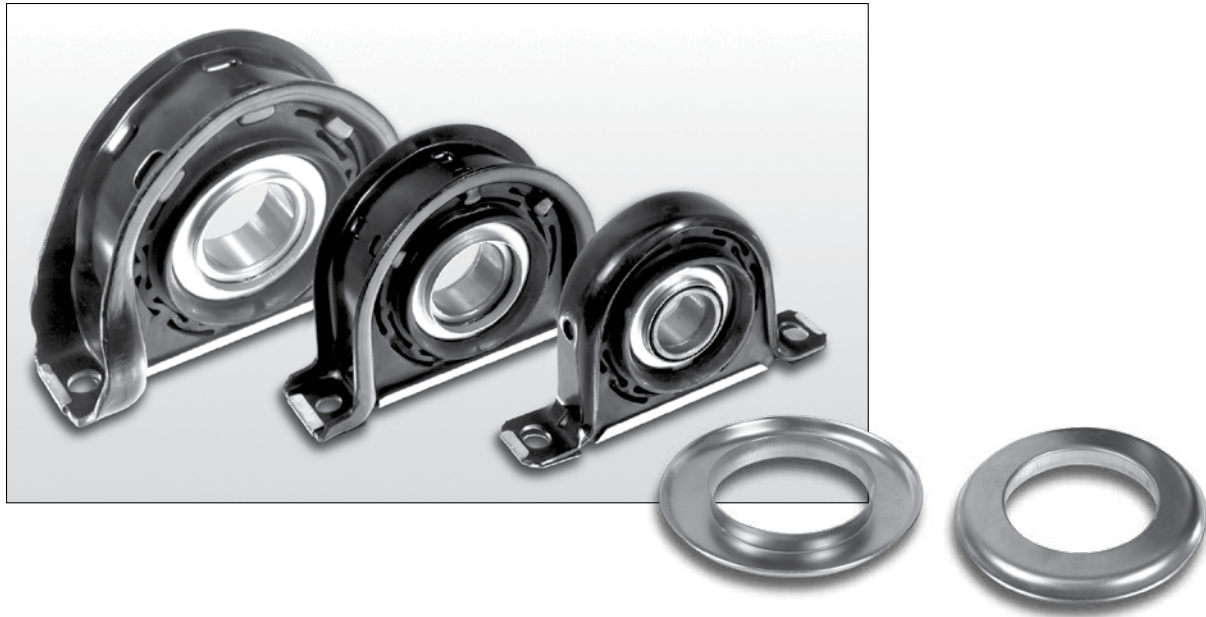

Center Support Bearings

DT Components center support bearings are available for a broad range of domestic and foreign passenger cars, SUV's, pickup trucks as well as medium and heavy duty truck applications. Each center support bearing is engineered and constructed for the specific vehicle application ensuring precise driveshaft alignment and support. All center support bearing components are manufactured at ISO9001 certified or higher factories and go through rigorous testing throughout the manufacturing process to ensure the highest possible quality is built into every unit.

The bearings contained within the center supports are designed to provide smooth and quiet operation under the harshest conditions. Every bearing is pre-lubricated for life and sealed with metal reinforced seals preventing moisture and contaminants from entering the bearing. The center support rubber cushions are manufactured using a special formula that blends the highest quality materials into a rubber compound that provides support while absorbing and isolating vibrations that could damage the driveline.

Center support frames are constructed from cold rolled steel for additional strength and feature a protective corrosion resistant coating to protect it from the elements and road salt. DT Components center support bearings are available with and without flingers where applicable.

This DT Components catalog is organized by U-Joint series and vehicle specific applications. Photos of each center support bearing are arranged in numeric order so customers can visually confirm the correct part identification before ordering. Complete interchange and vehicle application information is located in our electronic catalog that is accessible through the DT Components website.

Center Support Bearings

Assembly Style

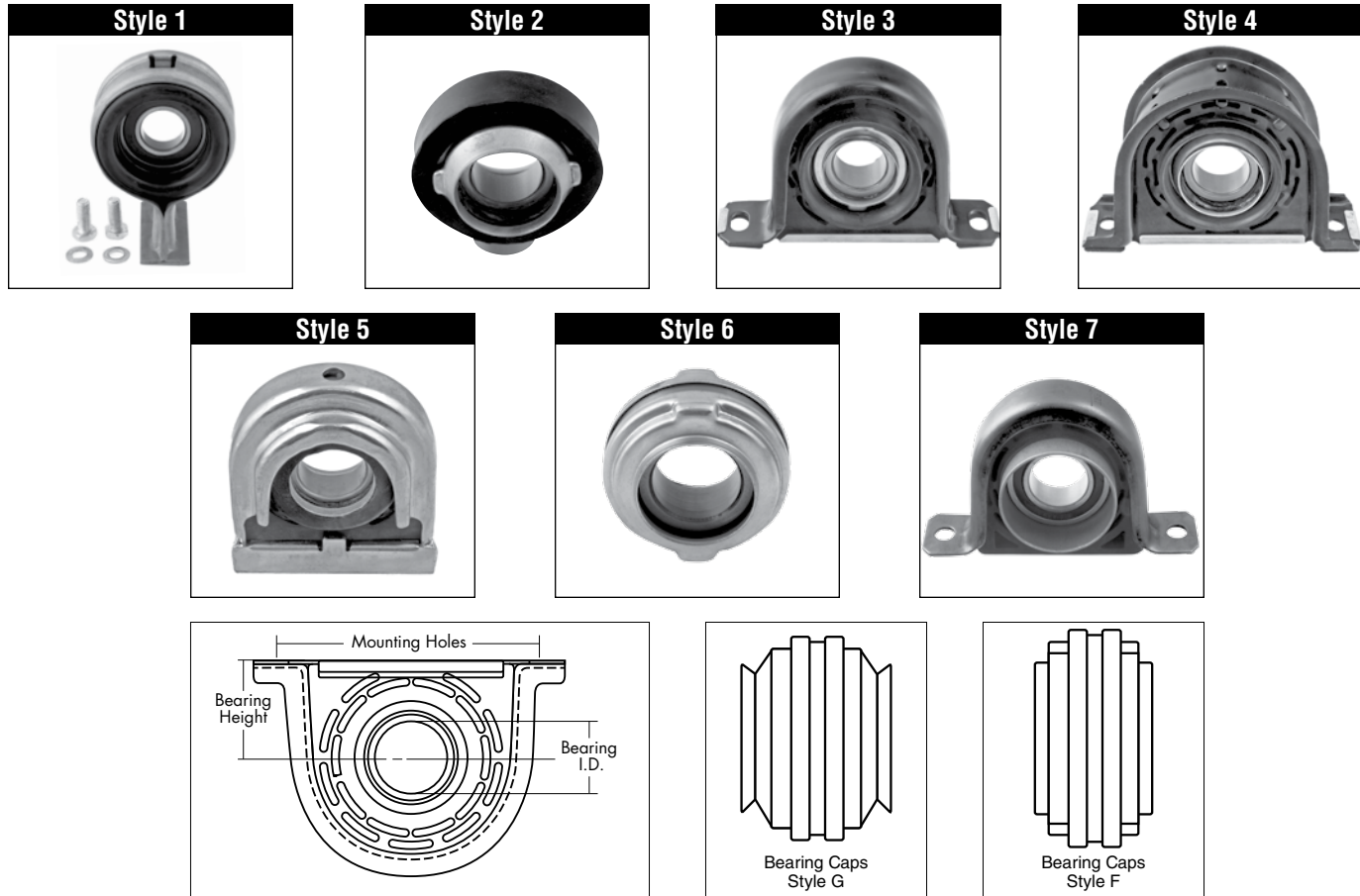

Flinger Specifications

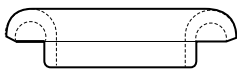

1

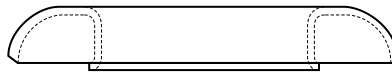

2

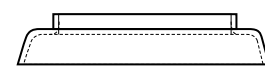

3

Part Number	Type	I.D.	O.D.	Width
230104	1	1.375	2.562	0.750
230118	2	2.057	4.000	0.562
230121	1	1.374	2.437	0.625
230124	2	2.306	4.375	0.562
230141	2	1.757	4.000	0.828
230151	2	2.556	4.562	0.562
230166	2	2.807	4.812	0.562
230192	2	2.370	4.625	1.190
230193	3	2.370	3.125	0.560
230207	2	2.525	4.375	0.875
230208	1	1.569	2.875	0.938

Part Number	Type	I.D.	O.D.	Width
230209	1	1.569	2.625	0.594
230363	1	1.765	2.875	0.594
230746	2	3.312	5.562	0.578
231000	1	1.569	2.437	0.562
231004	2	2.149	4.000	0.440
231217	2	2.057	3.687	0.300
231256	1	1.374	2.093	0.470
231286	2	2.055	3.701	0.299
231696	2	1.692	3.012	0.472
98-1473	3	1.747	2.500	0.500

Additional Info

Center Support Bearings

Center Support Bearing by U-Joint Series

Center Support w/Flingers	Center Support w/o Flingers	Style	Center Height	Mounting Holes	Cap Style	Flingers
1210 Series 1.259" (32mm) Bearing I.D.						
HB211431-X	N/A	3	1.940"	5.880"	F	231669 (2)
1310 Series 1.181" (30mm) Bearing I.D.						
HB211590-1X	N/A	3	1.940"	5.880"	F	231669 (2)
1280 thru 1310 Series 1.181" (30mm) Bearing I.D.						
	HB210527X	1	3.560"	1.500"	N/A	N/A
1280 thru 1330 Series 1.378" (35mm) Bearing I.D.						
	HB5	2	N/A	N/A	N/A	N/A
1280 thru 1410 Series 1.378" (35mm) Bearing I.D.						
HB210088-1X	88107-AF	3	2.250"	6.620"	F	230121, 230217
HB210090-1X	88107-AF	3	2.250"	6.620"	F	230217 (2)
HB210367-1X	88107-AG	3	2.250"	6.620"	G	230141, 98-1473 (2)
HB210370-1X	88107-AG	3	2.250"	6.620"	G	230104, 230141, 98-1473
HB211187-X	HB88107-A	3	2.250"	6.625"	F	231217, 231256
	HB211985X	7	2.750"	6.620"	N/A	N/A
1310 thru 1550 Series 1.575" (40mm) Bearing I.D. (*Includes Balancing Ring)						
HB210140-1X	HB88508-G	4	2.440"	6.620"	G	230207, 230208
HB210144-1X	HB88508-G	4	2.440"	6.620"	G	230207 (2)
HB210391-1X	HB88508	4	2.440"	6.620"	F	230124 (2)
HB210433-1X	HB88508	4	2.440"	6.620"	F	230124, 230209
HB210866-1X	HB88508-A	4	2.250"	6.620"	F	231000, 231004
HB210873-1X	HB88508-A	4	2.250"	6.620"	F	231004 (2)
HB211848-1X	N/A	5	3.250"	3.380"	F	231286, 232662
HB211963-1X	N/A	5	3.250"	3.380"	F	231286, 232662
HB212093-1X	N/A	4	2.250"	6.620"	F	231000, 231286
	HB108	6			F	N/A
	HB212028-1X*	7	2.250"	6.620"	N/A	N/A
	HB212030-1X*	7	2.250"	6.620"	N/A	N/A
	HB212032-1X*	7	2.630"	6.620"	N/A	N/A
1410 thru 1650/SPL90 Series 1.772" (45mm) Bearing I.D.						
HB210084-2X	HB88509	4	2.690"	7.620"	F	230151 (2)
HB210130-1X	HB88509-G	4	2.690"	7.620"	G	230151, 230363
HB210207-1X	HB88509	4	2.690"	7.620"	F	230151, 230363
HB210209-1X	HB88509-G	4	2.690"	7.620"	G	230192, 230193, 230380
1700 thru 1710/SPL140 Series 1.969" (50mm) Bearing I.D.						
HB210121-1X	N/A	4	2.780"	7.620"	F	230166 (2)
HB210881-1X	N/A	4	2.780"	7.620"	F	230166 (2)
1760 thru 1810/SPL140 thru SPL250 Series 2.362" (60mm) Bearing I.D.						
HB210661-1X	N/A	4	3.380"	8.620"	F	230746 (2)
HB210875-1X	N/A	4	3.380"	8.620"	F	230746 (2)
1850 thru 1880 Series 2.756" (70mm) Bearing I.D.						
HB210748-1X	N/A	4	3.380"	8.620"	F	230746 (2)

Center Support Bearings

Non-Dana Series Center Support Bearings for Cars & Light Trucks

BMW		
325i	90-98	HB2780-60
E30	82-95	HB1700-10
E32	82-95	HB1700-10
E34	82-95	HB1700-10
E36	90-98	HB2780-60
E46	90-98	HB2780-60
Chrysler, Dodge, Plymouth		
Arrow	80-82	HB14
D50	80-82	HB14
Dakota	00-02	HB12479237
Pickup 1/2 Ton	00-04	HB12479237
Pickup 3/4 Ton	02-09	HB40021334
Pickup 1 Ton	02-09	HB40021334
Power Ram 50	83-86	HB14
Ram 50	83-89	HB14
Sprinter	03-06	HB5104574
Freightliner/Mercedes		
Sprinter	03-06	HB5104574
GM (Buick, Cadillac, Chevrolet, GMC, Oldsmobile, Pontiac)		
Avalanche	02-03	HB12471505
Blazer	94-03	HB12479237
Camaro	93-02	HB26067390
Firebird	93-02	HB26067390
Jimmy	94-03	HB12479237
LUV 2WD	80-82	HB20
LUV 4x4	80-82	HB21
Pickup 1/2 Ton 2WD	99-03	HB12471505
S10/S15	94-03	HB12479237
Suburban 1/2 Ton 2WD	99-03	HB12471505
Tahoe	99-03	HB12471505
Honda		
Passport 2WD	93-97	HB32
Passport 4x4	93-97	HB33
Infinity		
J30	93-96	HB6
M30	90-93	HB6
Isuzu		
Pickup 2WD	81-87	HB20
Pickup 4x4	81-87	HB21
Rodeo 2WD	91-97	HB32
Rodeo 4x4	91-97	HB33
Trooper	84-87	HB21

Mazda		
B2200	82-84	HB29
Mitsubishi		
Mighty Max 2WD	83-89	HB14
Mighty Max 2WD	90-92	HB30
Nissan		
200SX	80-83	HB19
200SX	84-88	HB6
240SX	89-95	HB6
620 Pickup	75-78	HB1280-50
620 Pickup	80-86	HB18
720 Pickup	80-86	HB12
810	80-81	HB19
Maxima	82-84	HB6
Pathfinder 2WD L4 Eng.	87-95	HB6
Pathfinder 4x4 V6 Eng.	87-95	HB13
Pickup 2WD L4 Eng.	86-95	HB6
Pickup 4x4 V6 Eng.	86-95	HB13
Stanza Wagon AWD	86-88	HB6
Toyota		
4-Runner 2WD	89-95	HB9
4-Runner 2WD	89-95	HB27
4-Runner 4x4	89-95	HB24
Celica	82-85	HB7
Corolla	71-83	HB31
Corolla	80-83	HB11
Cressida	80-84	HB8
Pickup	80-83	HB9
Pickup 2WD	84-88	HB10
Pickup 2WD	89-95	HB9
Pickup 2WD	89-95	HB27
Pickup 4x4	84-88	HB17
Pickup 4x4	89-95	HB24
Pre-Runner	99-03	HB31
S-Runner	01-03	HB31
T100 2WD	93-98	HB26
T100 4x4	93-98	HB28
Tacoma	95-04	HB26
Tacoma 4x4	95-03	HB31
Terrel Wagon AWD	83-88	HB7
Tundra	00-03	HB26

Center Support Bearings

Product Images

HB5



HB6



HB7

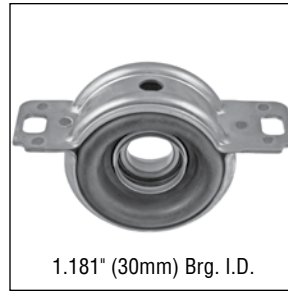

HB8

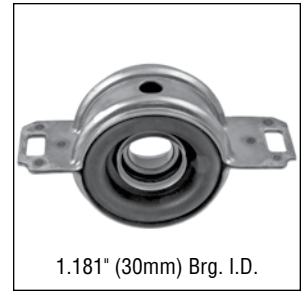

HB9

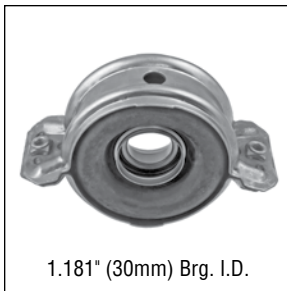

HB10



HB11

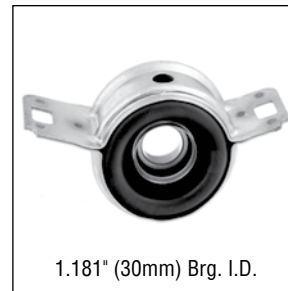

HB12



HB13



HB14

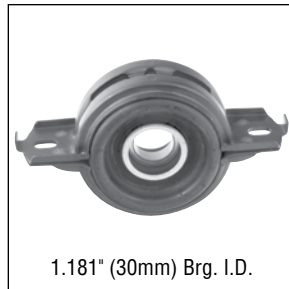

HB17



HB18



HB19



HB20



HB21



HB24



Center Support Bearings

Product Images (continued)

HB26



HB27



HB28

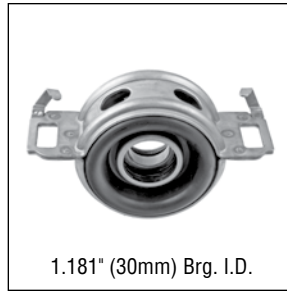

HB29

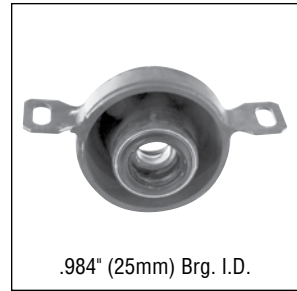

HB30



HB31



HB32



HB33



HB108



HB1280-50



HB1700-10



HB2780-60



HB88107-A

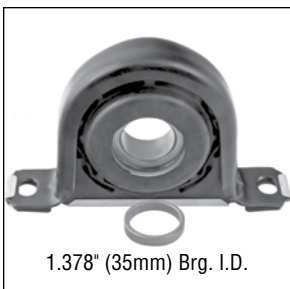

88107-AF



88107-AG



HB88508



Center Support Bearings

Product Images (continued)

HB88508-A

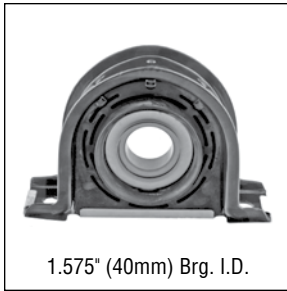

1.575" (40mm) Brg. I.D.

HB88508-G



1.575" (40mm) Brg. I.D.

HB88509



1.772" (45mm) Brg. I.D.

HB88509-G



1.772" (45mm) Brg. I.D.

HB210121-1X

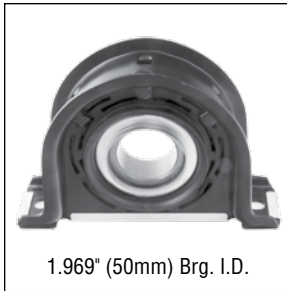

1.969" (50mm) Brg. I.D.

HB210527X



1.181" (30mm) Brg. I.D.

HB210661-1X



2.362" (60mm) Brg. I.D.

HB210748-1X



2.756" (70mm) Brg. I.D.

HB210875-1X



2.362" (60mm) Brg. I.D.

HB210881-1X



1.969" (50mm) Brg. I.D.

HB211431-X



1.259" (32mm) Brg. I.D.

HB211590-1X



1.181" (30mm) Brg. I.D.

HB211848-1X

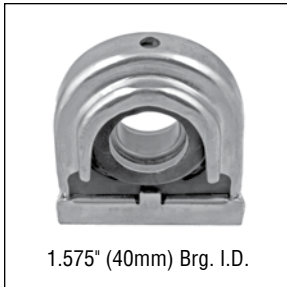

1.575" (40mm) Brg. I.D.

HB211963-1X



1.575" (40mm) Brg. I.D.

HB211985X

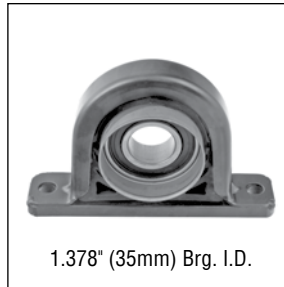

1.378" (35mm) Brg. I.D.

HB212028-1X



1.575" (40mm) Brg. I.D.

Center Support Bearings

Product Images (continued)

HB212030-1X

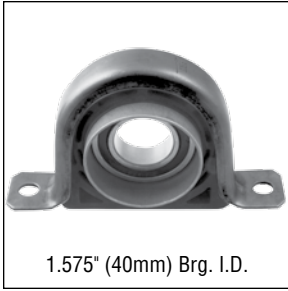

HB212032-1X

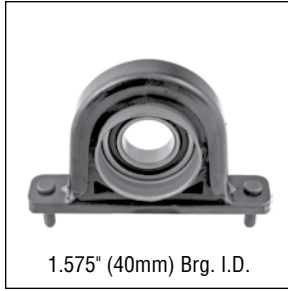

HB212093-1X



HB5104574

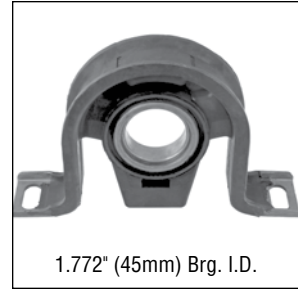

HB12471505



HB12479237



HB26067390

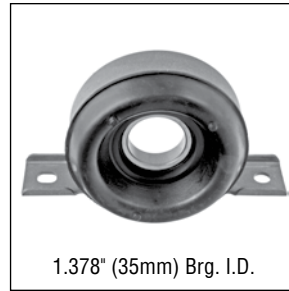

HB40021334

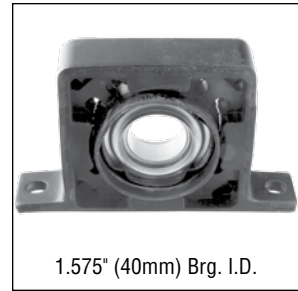

DT COMPONENTS WEB SITE

The informative DT Components web site contains product information, literature, customer login, and a link to our web catalog.



Snap this QR code with your smartphone app to visit our web site.

DT COMPONENTS WEB CATALOG

- Product Lookup by Application
- Kit Bill of Materials
- Interchanges
- Product Specifications
- Product Photos



Snap this QR code with your smartphone app to view our electronic catalog.





FOR WORN YOKES & SHAFTS RESLEEVEING

E-Z SLEEVE restores your worn yokes and shafts to give them new life. E-Z SLEEVE is so hard, wear resistant and friction free, it will set new standards for trouble free sleeving.

The concept of a thin wall flanged sleeve is very popular for fast sleeving of shafts and yokes. However the results often fall short of expectations. The soft sleeves lack durability and operate with too much resistance (resulting in excessive heat and failures).

E-Z SLEEVE eliminates these problems and provides a long life sleeve at an affordable price.

E-Z SLEEVE's innovative technology will set the new standard in the industry.

What sets E-Z SLEEVE apart from other sleeves?

- **HARD CHROME COATING**
E-Z SLEEVE stainless steel sleeves are hard chromed to a hardness of 68RC.
- **LOWER COEFFICIENT OF FRICTION**
Hard chrome provides a smoother surface and has a lower coefficient of friction that reduces heat and seal wear.
- **BETTER SEAL FIT**
E-Z SLEEVE minimize the change to the original shaft diameter. This provides a better fit between the repaired shaft and the seal.



E-Z Sleeve Repair Sleeves

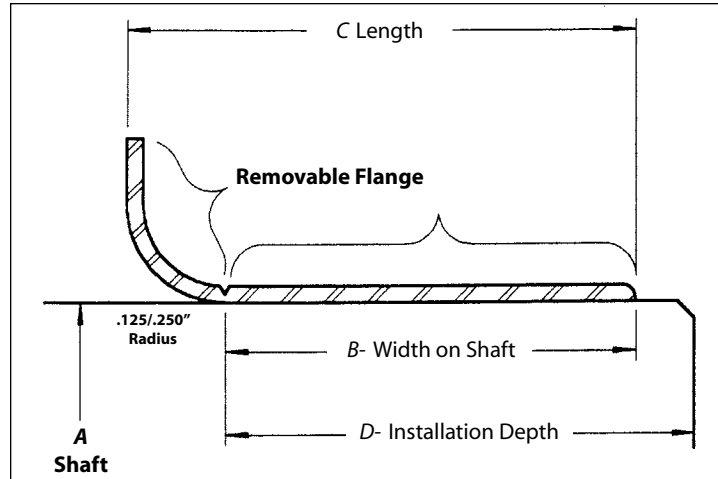

E-Z SLEEVE SPECIFICATIONS

Part Number	A Shaft Diameter Range		B Width	C Length	D Installation Tool Depth
	Minimum	Maximum			
99058	0.624	0.630	0.315	0.437	2.032
99062	0.621	0.627	0.312	0.406	2.032
99076	0.746	0.752	0.312	0.437	2.032
99078	0.785	0.789	0.312	0.437	2.032
99087	0.871	0.877	0.312	0.437	2.032
99098	0.980	0.986	0.312	0.437	2.032
99100	0.995	1.002	0.312	0.437	2.032
99101	0.995	1.002	0.312	0.437	2.032
99112	1.123	1.127	0.312	0.438	0.688
99116	1.123	1.127	0.375	0.500	0.688
99125	1.245	1.253	0.312	0.437	0.875
99128	1.254	1.263	0.312	0.437	0.875
99131	1.310	1.316	0.500	0.625	0.813
99138	1.368	1.374	0.500	0.625	1.000
99139	1.372	1.378	0.500	0.063	1.000
99143	1.432	1.438	0.563	0.688	1.016
99144	1.435	1.441	0.375	0.500	1.016
99149	1.496	1.503	0.562	0.688	1.016
99150	1.497	1.503	0.375	0.500	1.016
99152	1.519	1.526	0.438	0.563	1.016
99155	1.549	1.555	0.438	0.563	1.016
99156	1.559	1.565	0.563	0.688	1.016
99157	1.572	1.578	0.512	0.630	1.023
99162	1.622	1.628	0.562	0.688	0.812
99168	1.684	1.690	0.563	0.688	0.875
99169	1.647	1.653	0.563	0.689	0.827
99170	1.735	1.742	0.375	0.500	1.032
99172	1.745	1.753	0.375	0.500	1.032

Additional Info

E-Z Sleeve Repair Sleeves

Part Number	A Shaft Diameter Range		B	C	D
	Minimum	Maximum	Width	Length	Installation Tool Depth
99173	1.745	1.753	0.875	1.000	1.032
99174	1.745	1.753	0.562	0.688	1.032
99175	1.745	1.753	0.750	0.875	1.032
99176	1.759	1.767	0.562	0.688	1.032
99177	1.767	1.775	0.550	0.669	1.032
99181	1.807	1.815	0.562	0.688	1.250
99187	1.869	1.878	0.562	0.688	1.250
99189	1.887	1.893	0.550	0.668	0.984
99192	1.909	1.915	0.375	0.500	1.000
99193	1.932	1.940	0.562	0.688	1.250
99196	1.965	1.971	0.550	0.668	0.984
99199	1.996	2.003	0.562	0.688	2.060
99200	1.996	2.003	0.875	1.000	2.060
99205	2.057	2.063	0.813	0.938	1.375
99210	2.123	2.128	0.500	0.750	1.280
99212	2.122	2.130	0.780	0.937	1.375
99215	2.162	2.168	0.787	0.905	1.375
99218	2.185	2.192	0.781	0.938	1.312
99220	2.198	2.205	0.500	0.625	1.312
99225	2.248	2.255	0.780	0.937	1.375
99227	2.249	2.255	0.303	0.438	1.312
99235	2.359	2.365	0.787	0.905	1.375
99237	2.372	2.378	0.780	0.937	1.375
99238	2.372	2.378	0.594	0.750	1.375
99240	2.374	2.380	0.526	0.683	1.375
99241	2.359	2.365	0.370	0.450	1.375
99242	2.435	2.441	0.500	0.625	1.425
99243	2.434	2.440	0.781	0.938	1.393
99244	2.433	2.441	0.500	0.625	1.425
99248	2.497	2.506	0.500	0.656	1.393
99249	2.487	2.506	0.780	0.937	1.393
99250	2.497	2.506	0.780	0.937	1.375
99251	2.509	2.516	0.780	0.906	1.375
99253	2.497	2.506	0.555	0.650	0.890
99254	2.554	2.562	0.787	0.905	1.375
99256	2.559	2.566	0.781	0.938	1.375
99259	2.595	2.601	0.781	0.938	1.250
99261	2.618	2.624	0.781	0.938	1.375
99262	2.623	2.631	0.780	0.937	1.500
99264	2.620	2.627	0.780	0.906	1.500
99272	2.748	2.756	0.406	0.563	1.250
99274	2.743	2.751	0.780	0.937	1.375
99275	2.748	2.756	0.780	0.937	1.375

Additional Info

E-Z Sleeve Repair Sleeves

Part Number	A Shaft Diameter Range		B Width	C Length	D Installation Tool Depth
	Minimum	Maximum			
99276	2.750	2.759	0.787	0.945	1.375
99282	2.837	2.844	0.500	0.656	1.250
99284	2.826	2.836	0.748	0.868	1.339
99287	2.871	2.879	0.780	0.937	1.375
99289	2.949	2.956	0.594	0.689	1.102
99290	2.935	2.943	0.500	0.640	1.331
99291	2.987	2.996	0.484	0.625	1.331
99293	2.935	2.943	0.780	0.938	1.500
99294	2.949	2.956	0.866	1.024	1.312
99296	2.997	3.005	0.812	0.938	1.281
99298	2.987	2.996	0.563	0.688	1.375
99299	2.987	2.996	0.812	1.000	1.250
99300	2.998	3.006	0.812	1.000	1.281
99303	2.998	3.006	0.625	0.812	1.063
99307	3.123	3.132	0.550	0.709	2.031
99311	3.119	3.126	0.688	0.813	2.000
99312	3.119	3.126	0.812	1.000	2.000
99313	3.141	3.150	0.750	0.886	1.375
99315	3.145	3.153	0.827	0.945	1.375
99317	3.145	3.153	0.433	0.591	1.375
99322	3.246	3.253	0.812	1.000	1.375
99324	3.248	3.256	0.595	0.720	1.500
99325	3.248	3.256	0.812	1.000	1.500
99332	3.337	3.347	0.669	0.827	1.378
99333	3.337	3.347	0.827	0.894	1.378
99337	3.371	3.379	0.812	1.000	1.500
99346	3.495	3.503	0.625	0.812	1.348
99347	3.498	3.506	0.312	0.500	1.348
99349	3.499	3.507	0.625	0.812	1.348
99350	3.498	3.506	0.812	1.000	1.347
99351	3.540	3.546	0.710	0.906	1.812
99353	3.540	3.546	0.526	0.667	1.750
99354	3.540	3.546	0.906	1.102	1.750
99356	3.560	3.566	0.812	1.000	1.750
99360	3.618	3.629	0.812	1.000	1.750
99362	3.622	3.629	0.812	1.000	1.750
99363	3.622	3.629	0.500	0.625	1.750
99364	3.739	3.746	0.469	0.594	1.750
99367	3.748	3.756	0.344	0.500	1.750
99369	3.736	3.743	0.827	0.945	1.750
99372	3.748	3.756	0.688	0.875	1.875
99374	3.739	3.746	0.344	0.500	1.750
99376	3.745	3.752	0.563	0.688	1.750
99387	3.873	3.879	0.812	1.000	1.875

Additional Info

E-Z Sleeve Repair Sleeves

Part Number	A Shaft Diameter Range		B	C	D
	Minimum	Maximum	Width	Length	Installation Tool Depth
99393	3.935	3.491	0.812	1.000	2.050
99395	3.995	4.006	0.600	0.725	2.125
99399	3.995	4.006	0.812	1.000	2.125
99400	3.995	4.006	0.650	0.775	2.125
99401	3.995	4.006	0.500	0.625	2.125
99424	4.248	4.256	0.812	1.000	1.438
99437	4.370	4.378	0.812	1.000	1.650
99450	4.496	4.504	0.813	1.000	1.250
99452	4.523	4.531	0.813	0.938	1.250
99492	4.916	4.925	1.024	1.260	1.438
99498	4.998	5.006	0.688	0.875	1.438
99499	4.998	5.006	0.813	1.000	1.438
99525	5.246	5.254	0.812	1.000	1.250
99549	5.498	5.506	0.812	1.000	1.250
99550	5.498	5.506	0.578	0.705	1.250
99552	5.508	5.516	0.807	1.000	1.250
99599	5.995	6.004	1.000	1.250	1.750
99601	5.995	6.004	0.500	0.750	1.750
99650	6.495	6.505	1.000	1.250	1.375
99700	6.994	7.005	1.000	1.250	1.688

Shim Stock Rolls

Size	Cold Rolled Steel Part Number	Brass Part Number	Stainless Steel Part Number
.001	001CRS	001BR	001SS
.0015	0015CRS	0015BR	0015SS
.002	002CRS	002BR	002SS
.003	003CRS	003BR	003SS
.004	004CRS	004BR	004SS
.005	005CRS	005BR	005SS
.006	006CRS	006BR	006SS
.007	007CRS	007BR	007SS
.008	008CRS	008BR	008SS
.009	009CRS	009BR	009SS
.010	010CRS	010BR	010SS
.012	012CRS	012BR	012SS
.015	015CRS	015BR	015SS
.020	020CRS	020BR	020SS

	Width	Length
Cold Rolled Steel Rolls	6"	100"
Brass Rolls	6"	100"
Stainless Steel Rolls	6"	50"

New Departure - Hyatt Barrel Style Roller Bearings

NDH Part #	DT Components Part #	Cone Part #	Cup Part #
KC-11445-Y	KC11445Y	17887	17831
KB-11630-Z	KB11630Z	368S	362
KB-11786-Y	KB11786Y	387	382
KD-11786-Y	KD11786Y	388A	382
KA-11820-Z	KA11820Z	28990	28919
KA-11950-Z	KA11950Z	M111048	M111012
KD-12051-Z	KD12051Z	395CS	394CS
KR-12051-Z	KR12051Z [^]	395ES	394CS
[^] Components Not Sold Separately			

Additional Info

MileMate®



ONE SIMPLE GOAL:

Keep Your Trucks Up and Moving

Timken® MileMate® sets – the original matched wheel bearing sets – are designed to keep your trucks up and moving. Our 44 matched cup and cone sets are built for superior results and less downtime. When you use the original MileMate sets from Timken, you know you're getting bearing sets specifically designed for your application that meet or exceed the original equipment manufacturer's specifications. This includes the ConMet® PreSet® and Spicer® LMS™, as well as the new wide single tire applications.

Features

- Made from quality Timken certified steel
- Perfectly matched sets for correct installation every time
- Original equipment technology

Benefits

- Matched sets mean less inventory and the bearing parts in one box to perform the job
- Lengthens maintenance intervals
- Optimizes bearing performance
- Allows bearings to carry evenly distributed loads
- Original equipment on ConMet PreSet and Spicer LMS enhances performance

Timken Proprietary “NP” Part Numbers

Meeting the growing original and aftermarket performance demands.

Features

- Enhanced surfaces
- Proprietary Timken design
- More precise internal bearing geometry
- Exceed industry standards

Benefits

- Designed to provide longer life and reliability
- Many heavy-duty, pre-adjusted hubs are serviceable such as ConMet PreSet and Spicer LMS
- Rebuilding with Timken proprietary parts ensures you get all the advantages that were originally engineered into the heavy-duty, pre-adjusted hub systems
- Specifically designed to handle the 2" outset loads found in wide single tire configurations

Timken Set Number	Timken Part Number	Common Application Description
Manually Adjusted Wheel Ends		
SET401	580, 572	Industry Standard R Drive Axle Outer Bearing
SET402	582, 572	Potential R Drive Axle Outer Bearing (Mack Special Radius)
SET403	594A, 592A	Industry Standard R Drive Axle Inner Bearing
SET404	598A, 592A	Potential R Drive Axle Inner Bearing (Mack Special Radius)
SET405	663, 653	Trailer Axle Inner Bearing / Potential Rear (drive or trailer) Axle Outer Bearing
SET406	3782, 3720	Industry Standard FF Steer Axle Outer Bearing
SET407	28682, 28622	Rear Axle Inner Bearing / Front Steer Axle Outer Bearing
SET408	39590, 39520	Industry Standard L Drive Axle Outer Bearing
SET409	45280, 45220	Front Steer Axle Outer Bearing (Mack)
SET410	45284, 45220	Front Steer Axle Inner Bearing
SET411	47686, 47620	Industry Standard L Drive Axle Inner Bearing
SET412	HM212047, HM212011	Potential FF Steer Axle Inner Bearing / Potential N Trailer Axle Outer Bearing (bore and radius change)
SET413	HM212049, HM212011	Industry Standard FF Steer Axle Inner Bearing / Industry Standard N Trailer Axle Outer Bearing
SET414	HM218248, HM218210	Industry Standard N Trailer Axle Inner Bearing
SET415	HM518445, HM518410	Industry Standard P Trailer Axle Inner and Outer Bearing
SET416	45291, 45220	Trailer Axle Bearing
SET417	47890, 47820	Trailer Axle Bearing
SET418	H715334, H715311	Front Steer Axle Inner Bearing
SET419	H715343, H715311	Front Steer Axle Inner Bearing
SET420	H715345, H715311	Front Steer Axle Inner Bearing
SET421	HM516449A, HM516410	Rear Axle Inner Bearing (Mack)
SET422	HM516449C, HM516410	Rear Axle Inner Bearing (Mack)
SET423	6461A, 6420	Industry Standard FL Steer Axle Inner Bearing
SET424	555-S, 552A	Industry Standard FL Steer Axle Outer Bearing
SET425	567, 563	Front Steer Axle Inner Bearing / Trailer Axle Inner Bearing / Rear Axle Outer Bearing (Mack)
SET426	47679, 47620	Rear Axle Outer Bearing (Mack)

Timken Set Number	Timken Part Number	Common Application Description
Pre-Adjusted Wheel Ends		
SET427*	NP899357, NP026773	Set-Right FF Steer Axle Inner Bearing / Set-Right N Trailer Axle Outer Bearing (ConMet PreSet)
SET428*	NP874005, NP435398	Set-Right FF Steer Axle Outer Bearing (ConMet PreSet)
SET429*	NP034946, NP363298	Set-Right R Drive Axle Inner Bearing (ConMet PreSet)
SET430*	NP840302, NP053874	Set-Right R Drive Axle Outer Bearing (ConMet PreSet)
SET431*	NP965350, NP503727	Set-Right N Trailer Axle Inner Bearing (ConMet PreSet)
SET432*	NP174964, NP593561	Set-Right P Trailer Axle Inner and Outer Bearing (ConMet PreSet)
SET433*	NP431952, NP378092	Set-Right FF Steer Axle Inner Bearing / Set-Right N Trailer Axle Outer Bearing (Dana LMS))
SET434*	NP555065, NP720703	Set-Right FF Steer Axle Outer Bearing (Dana LMS)
SET435*	NP568900, NP107783	Set-Right R Drive Axle Inner Bearing (Dana LMS)
SET436*	NP577914, NP975161	Set-Right R Drive Axle Outer Bearing (Dana LMS)
SET437*	NP022333, NP250023	Set-Right N Trailer Axle Inner Bearing (Dana LMS)
SET438*	NP417549, NP156827	Set-Right P Trailer Axle Inner and Outer Bearing (Dana LMS)
SET439	HM212049X, HM212011	FF Steer Axle Inner Bearing (Volvo Special Radius)
SET445*	NP294109, NP039695	Timken Set-Right FL Steer Axle Inner Bearing (ConMet PreSet)
SET446*	NP107091, NP183330	Timken Set-Right FL Steer Axle Outer Bearing (ConMet PreSet)
Manually Adjusted / 454-Series for Wide Single Tires		
SET440*	NP454049, NP454011	Timken 454-Series FF Steer Axle Inner Bearing / Timken 454-Series N Trailer Axle Outer Bearing
SET441*	NP454248, NP454210	Timken 454-Series N Trailer Axle Inner Bearing
SET442*	NP454580, NP454572	Timken 454-Series R Drive Axle Outer Bearing
SET443*	NP454594, NP454592	Timken 454-Series R Drive Axle Inner Bearing
SET444*	NP454445, NP454410	Timken 454-Series P Trailer Axle Inner and Outer Bearing
Pre-Adjusted / 454-Series for Wide Single Tires		
SET600*	NP454946, NP454298	Timken 454-Series Set-Right R Drive Axle Inner Bearing
SET601*	NP454302, NP454874	Timken 454-Series Set-Right R Drive Axle Outer Bearing
SET602*	NP454350, NP454727	Timken 454-Series Set-Right N Trailer Axle Inner Bearing
SET603*	NP454357, NP454773	Timken 454-Series Set-Right FF Steer Axle Inner Bearing / Timken 454-Series Set-Right N Trailer Axle Outer Bearing
SET604*	NP454964, NP454561	Timken 454-Series Set-Right P Trailer Axle Inner and Outer Bearing

* Includes proprietary Timken part numbers

TIMKEN® 454-SERIES™ WHEEL BEARINGS FOR COMMERCIAL VEHICLES

Bearings for dual tires and wide single tires

- Specially designed to handle the 2-inch outset loads
- Allows consistency within fleets
- Provides flexibility of wheel arrangements

Compatible with industry-standard components

- Use with popular axle and hub designs
- Can retrofit into existing equipment

Designed to improve bearing life

- Highly-engineered internal raceway profiles for optimal stress distribution
- Proprietary enhanced surface finishes

At Timken, we recognize the need of commercial vehicle customers to conserve fuel, carry greater loads, standardize components and maximize uptime. These are the driving factors behind Timken® 454-Series™ wheel bearings. These bearings are geared toward helping your fleet operate more efficiently and cost effectively.

Our 454-Series wheel bearings deliver tomorrow's high-performance wheel-end technology today.

For additional information, contact your Timken sales representative or our dedicated team of automotive and heavy-duty customer service representatives at: phone (866) 9-TIMKEN (984-6536), or fax (877) TIMKEN-9 (846-5369).

Effect of Wheel Outset

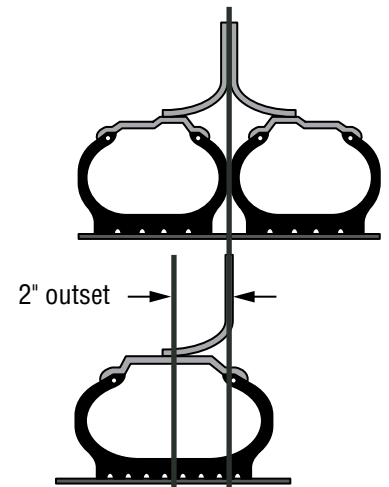

These wheel images represent the shift in load line location from a standard dual tire to a 2-inch outset wide single tire.

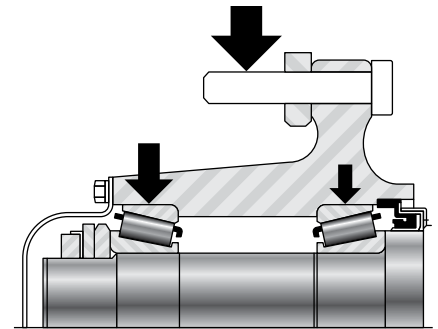

This wheel-end cross section represents the increased loading present on the outer bearing, when using a wide single tire.

Application	Manual Adjusted			Pre-Adjusted			
	Cone	Cup	MileMate® Set	Cone	Cup	MileMate® Set	Kit**
R Drive Inner	NP454594	NP454592	SET443*	NP454946	NP454298	SET600*	RDTC2
R Drive Outer	NP454580	NP454572	SET442*	NP454302	NP454874	SET601*	
N Trailer Inner	NP454248	NP454210	SET441*	NP454350	NP454727	SET602*	TNTC2
N Trailer Outer	NP454049	NP454011	SET440*	NP454357	NP454773	SET603*	
P Trailer Inner & Outer	NP454445	NP454410	SET444*	NP454964	NP454561	SET604*	TPTC2

* Includes proprietary Timken part numbers

** Each kit includes two MileMate® Sets and a spacer.

Note: A wheel bearing is one component of a wheel-end system. Consult your other wheel-end suppliers (i.e., axle, hub and wheel) for the ratings of their products.

Factors that can affect tapered roller bearing life

Uniform Internal Geometry

Industry bearing standards set only I.D., O.D., overall bearing width and cup angle of a tapered roller bearing. The angle of contact for cones and rollers varies by brand. Timken internal geometry is uniform and consistent, helping to ensure a perfect match every time. Tight manufacturing tolerances on the cup, cone and rollers help to optimize bearing life.

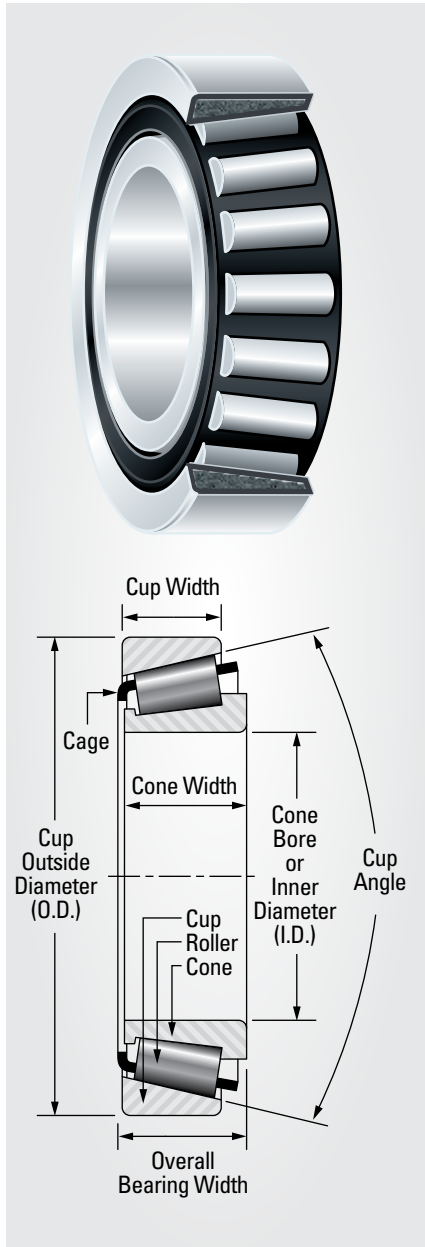

Enhanced Surface Finishes

We employ advanced finishing processes, which result in more consistent, smoother surface finishes on our bearing races and rollers. Smoother surface finishes mean less friction and greater efficiency.

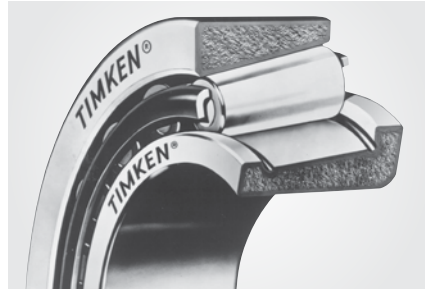

Timken – The Right Choice

Timken technology offers uniform internal geometry, enhanced surface finishes, special profiles and quality steel to help fleets maximize bearing life.

Special Profiles

Special profiles reduce stress on Timken bearing races and rollers by providing even distribution of loads across contact surfaces, increasing load-carrying capacity.

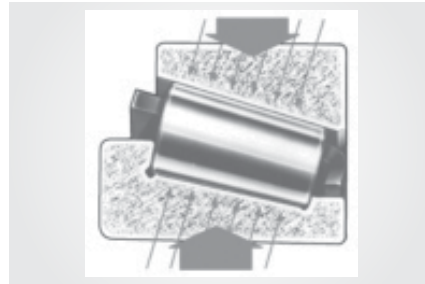

If your fleet can't afford downtime associated with lower bearing life, then you need Timken.

Steel Quality

Timken provides customers around the world with high-quality steel. Capitalizing on the synergy between our bearing and steel businesses, we use our expertise to select bearing materials that meet the most demanding application requirements and help extend bearing life.

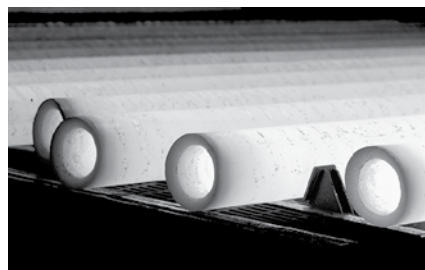

Manual Wheel Bearing Adjustment Procedures

The goal of this recommended procedure is to achieve a verifiable wheel bearing end play of 0.001" to 0.005" (.025 mm to .127 mm). This procedure applies to steer, drive and trailer axle assemblies using conventional double nut or single nut systems on Class 6, 7 and 8 trucks. This refers only to torque specifications and bearing adjustment. Please refer to the original equipment manufacturer's recommended procedures for complete installation details.

NOTE: For single nut self-locking systems, consult manufacturers' instructions. If you have a system that differs from what is indicated in this procedure, consult the vehicle manufacturer's recommended procedure.

Tapered Roller Bearing Adjustment Procedure RP618A

Step 1: Lubricate the tapered roller bearing with clean axle lubricant of the same type used in the axle sump or hub assembly. NOTE: Never use an impact wrench when tightening or loosening lug nuts or bolts during the procedure.									
Initial Adjusting Nut Torque	Initial Back Off	Final Adjusting Nut Torque	Axle Type	Threads Per Inch	Final Back Off	Nut Size	Torque Specifications	Acceptable End Play	
Step 2	Step 3	Step 4	Step 5		Step 6	Step 7		Step 8	
200 lbf•ft (271 N•m) While Rotating Wheel	One Full Turn	50 lbf•ft (68 N•m) While Rotating Wheels	Steer (Front) Non-Drive	12	1/6 Turn*	Install Cotter Pin to Lock Axle Nut in Position		0.001" - 0.005" (.025 - .127 mm)	
				18	1/4 Turn*				
				12	1/3 Turn*	Less Than 2 5/8" (66.7 mm)	200-300 lbf•ft (271-407 N•m)		
				14	1/2 Turn*				
			Drive	12	1/4 Turn*	Dowel Type Washer	300-400 lbf•ft (407-542 N•m)		As Measured Per Procedure With Dial Indicator
				16		Tang Type Washer**	200-275 lbf•ft (271-373 N•m)		
			Trailer	12	1/4 Turn*	Less Than 2 5/8" (66.7 mm)	300-400 lbf•ft (407-542 N•m)		
				16					

* If dowel pin and washer (or washer tang and nut flat) are not aligned, remove the washer, turn it over and reinstall. If required, loosen the inner (adjusting) nut just enough for alignment.
** Bendable type washer lock only: Secure nuts by bending one wheel nut washer tang over the inner and outer nut. Bend the tangs over the closest flat perpendicular to the tang.

Verify end play with a dial indicator. Wheel end play is the free movement of the tire and wheel assembly along the spindle axis.

- Make sure the brake drum-to-hub fasteners are tightened to the manufacturers' specifications.
 - Attach the dial indicator with its magnetic base to the hub or brake drum.
 - Adjust the dial indicator so that its plunger or pointer is against the end of the spindle with its line of action approximately parallel to the axis of the spindle.
 - Grasp the wheel assembly at the 3 o'clock and 9 o'clock positions. Push the wheel assembly in and out while oscillating it to seat the bearings. Read the bearing end play as the total indicator movement.
- NOTE: If end play is not within specification, readjustment is required.

Common Wheel End Sets

Timken Set Number	Timken Part Number	Common Application Description
SET401	580, 572	Industry Standard R Drive Axle: Outer Bearing
SET403	594A, 592A	Industry Standard R Drive Axle: Inner Bearing
SET406	3782, 3720	Industry Standard FF Steer Axle: Outer Bearing
SET413	HM212049, HM212011	Industry Standard FF Steer Axle: Inner Bearing / Industry Standard N Trailer Axle Outer Bearing
SET414	HM218248, HM218210	Industry Standard N Trailer Axle: Inner Bearing
SET415	HM518445, HM518410	Industry Standard P Trailer Axle Inner and Outer Bearing
SET423	6461A, 6420	Industry Standard FL Steer Axle: Inner Bearing
SET424	555-S, 552A	Industry Standard FL Steer Axle: Outer Bearing



TMC RP 618A, Wheel Bearing Adjustment Procedure, appears in TMC's 2010-2011 Recommended Practices Manual, and is published by the Technology & Maintenance Council (TMC) of American Trucking Associations; 950 N. Glebe Road, Arlington, VA 22203; (703) 838-1763; <http://tmc.truckline.com>. Reprinted with permission.

Additional Info



Pre-Adjusted Wheel Bearing Adjustment Procedures

NOTE: This refers only to torque specifications and bearing adjustment. Please refer to the original equipment manufacturer's recommended procedures for complete installation details.

- Mount the hub assembly onto the axle spindle, while holding the outer cone in place. Make sure the bearing cones, spacer and spindle are aligned to avoid seal damage.

⚠️WARNING Do not remove the outer bearing once it has been installed on the spindle. Removing it could cause the seal to become misaligned and lead to a seal failure or loss of a wheel, creating a risk of death or serious bodily injury.

- Install the inner spindle nut and torque to 300 ft-lbs.

NOTE: Do not back off the spindle nut.

- Engage the locking device that is part of the spindle nut system.

If the locking system cannot be engaged when the nut is at 300 ft-lbs, advance the nut until the locking system can be engaged (reference note above). If a double nut or jam nut system is being used, bend the lock tab or install the set screw after the outer nut is torqued to 200 ft-lbs.

For one-piece spindle nut systems, torque the nut to a minimum of 250 ft-lbs. Do not back off the spindle nut. Engage any locking device that is part of the spindle nut system. If the locking device cannot be engaged when the nut is at 250 ft-lbs, advance the nut until engagement takes place and the nut is locked.

⚠️WARNING Always follow wheel torque recommendations. Excessive or inadequate wheel torque can lead to failure of the wheel mounting system and loss of a wheel, creating a risk of death or serious bodily injury.

Timken Set-Right® Heavy-Duty Hub Rebuild Kits and Components

FFTC1 - FF Steer Kit			
Kit Contents	MileMate® P/N	Component P/N	General / Hyatt P/N
Inner half-stand NP cone	SET427*	NP899357	HM212049 PS
Inner half-stand NP cup		NP026773	HM212011 PS
Outer half-stand NP cone	SET428*	NP874005	3782 PS
Outer half-stand NP cup		NP435398	3720 PS
Spacer**			
RDTTC1 - R Drive Kit			
Kit Contents	MileMate® P/N	Component P/N	General / Hyatt P/N
Inner half-stand NP cone	SET429*	NP034946	594A PS
Inner half-stand NP cup		NP363298	592A PS
Outer half-stand NP cone	SET430*	NP840302	580 PS
Outer half-stand NP cup		NP053874	572 PS
Spacer**			
TNTTC1 - N Trailer Kit			
Kit Contents	MileMate® P/N	Component P/N	General / Hyatt P/N
Inner half-stand NP cone	SET431*	NP965350	HM218248 PS
Inner half-stand NP cup		NP503727	HM218210 PS
Outer half-stand NP cone	SET427*	NP899357	HM212049 PS
Outer half-stand NP cup		NP026773	HM212011 PS
Spacer**			
TPTTC1 - P Trailer Kit			
Kit Contents	MileMate® P/N	Component P/N	General / Hyatt P/N
Half-stand NP cone	SET432*	NP174964	HM518445 PS
Half-stand NP cup		NP593561	HM518410 PS
Spacer**			

* Includes proprietary Timken part numbers

** Spacer not sold separately

FLTTC1 - FL Steer Kit		
Kit Contents	MileMate® P/N	Component P/N
Inner half-stand NP cone	SET445*	NP294109
Inner half-stand NP cup		NP039695
Outer half-stand NP cone	SET446*	NP107091
Outer half-stand NP cup		NP183330
Spacer**		
RDTTC2 - 454-Series™ R Drive Kit		
Kit Contents	MileMate® P/N	Component P/N
Inner half-stand NP cone	SET600*	NP454946
Inner half-stand NP cup		NP454298
Outer half-stand NP cone	SET601*	NP454302
Outer half-stand NP cup		NP454874
Spacer**		
TNTTC2 - 454-Series™ N Trailer Kit		
Kit Contents	MileMate® P/N	Component P/N
Inner half-stand NP cone	SET602*	NP454350
Inner half-stand NP cup		NP454727
Outer half-stand NP cone	SET603*	NP454357
Outer half-stand NP cup		NP454773
Spacer**		
TPTTC2 - 454-Series™ P Trailer Kit		
Kit Contents	MileMate® P/N	Component P/N
Half-stand NP cone	SET604*	NP454964
Half-stand NP cup		NP454561
Spacer**		

Additional Info

⚠️WARNING Failure to observe the following warnings could create a risk of serious injury.

Proper maintenance and handling procedures are critical. Always follow installation instructions and maintain proper lubrication.

Never spin a bearing with compressed air. The rollers may be forcefully expelled.

This information is not intended to substitute for the specific recommendations of your equipment suppliers. Every reasonable effort has been made to ensure the accuracy of the information contained in this writing, but no liability is accepted for errors, omissions or for any other reason.

Timken #1 in Comparison Test:

Tapered Roller Bearings
Commonly used in Heavy-Truck
Axles and Wheel-Ends

Setting new standards in bearing life

Since its beginning, Timken has led the industry with significant breakthroughs in bearing technology designed to enhance bearing life. Every Timken® bearing is the result of more than 100 years of experience, knowledge and analysis. This gives us the expertise to explain and, most critically, to analyze and predict bearing life.

While determining bearing life sounds simple enough, it is actually a complex problem that demands a range of technological solutions. At Timken, we have developed highly sensitive tests that help us analyze and validate bearing life.

Timken case-carburized tapered roller bearings: #1 in comparison test

We originally formulated the case-carburizing process for our alloy steel in 1924 to produce a hard, fatigue-resistant surface and a tough, crack-resistant core. Material composition and microstructure play a significant role in enhancing bearing life. Controlled retained austenite optimizes surface hardness of high-carbon steels and improves surface ductility, resulting in better rolling-contact fatigue life.



We recently tested case-carburized tapered roller bearings commonly used in heavy-truck axles and wheel-ends. All the bearings tested were case-carburized and all are commercially available and produced in North America.

The result: Timken bearings out-performed all others. The bearing life of the closest competitor was 13% of that of Timken product. In other words, the life of Timken product was more than 7 times longer than that of the closest competitor.

Are we proud? Absolutely. Surprised? Not a bit. Timken engineers and scientists work around the world continuing the push toward new levels of bearing life.

Comparison of Bearing Life:

Case-carburized tapered roller bearings commonly used in heavy-truck axles and wheel-ends

BEARING LIFE TEST RESULTS:
MEDIAN LIFE RELATIVE TO TIMKEN

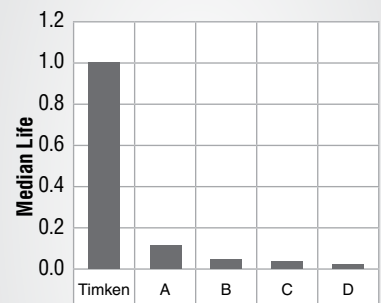

All the bearings tested* were case-carburized and all are commercially available and produced in North America. Bearings A, B, C and D are manufactured by top competitors. Information derived from Timken Standard Life Testing, using significant statistical samplings of bearings in a controlled test environment.

*HM212049/011; 594A/592A; 580/572; 575/572; NP840302/NP053874

Factors that can affect tapered roller bearing life

Uniform Internal Geometry

Industry bearing standards set only I.D., O.D., overall bearing width and cup angle of a tapered roller bearing. The angle of contact for cones and rollers varies by brand. Timken internal geometry is uniform and consistent, helping to ensure a perfect match every time. Tight manufacturing tolerances on the cup, cone and rollers help to optimize bearing life.

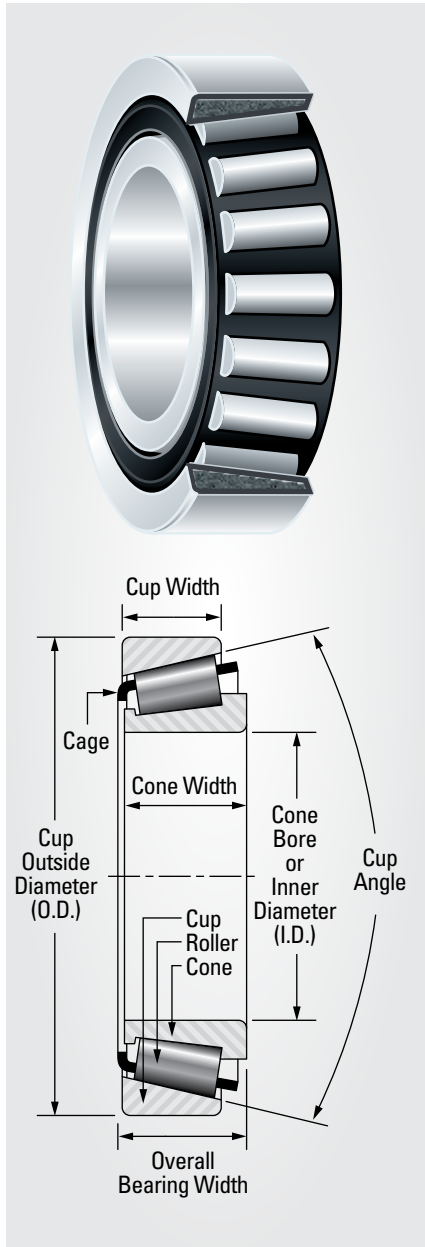

Enhanced Surface Finishes

We employ advanced finishing processes, which result in more consistent, smoother surface finishes on our bearing races and rollers. Smoother surface finishes mean less friction and greater efficiency.

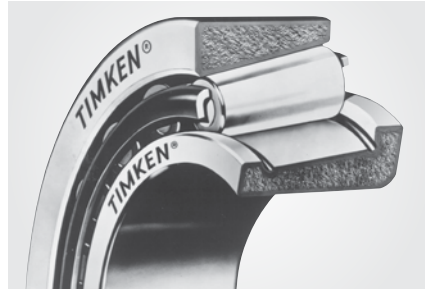

Timken – The Right Choice

Timken technology offers uniform internal geometry, enhanced surface finishes, special profiles and quality steel to help fleets maximize bearing life.

Special Profiles

Special profiles reduce stress on Timken bearing races and rollers by providing even distribution of loads across contact surfaces, increasing load-carrying capacity.

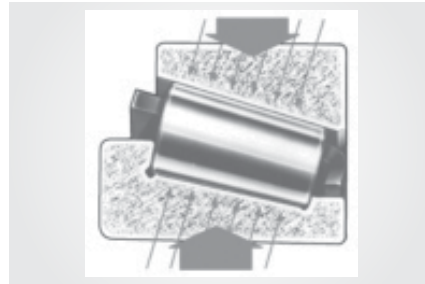

If your fleet can't afford downtime associated with lower bearing life, then you need Timken.

Steel Quality

Timken provides customers around the world with high-quality steel. Capitalizing on the synergy between our bearing and steel businesses, we use our expertise to select bearing materials that meet the most demanding application requirements and help extend bearing life.

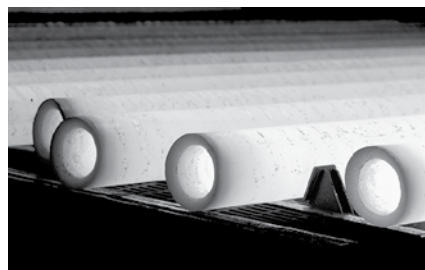

Set-Right™ Heavy-Duty Hub Rebuild Kits

Rebuild Your Hubs & Get the Timken Advantage

Go With the Proven Leader

To make it easier and more convenient for you to rebuild hubs, Timken now offers Set-Right™ Heavy-Duty Hub Rebuild Kits incorporating two Timken® MileMate® sets – the original matched wheel bearing sets produced in North America – and a precision OE spacer.

Using our specially toleranced bearings in conjunction with a precision OE-machined spacer allows you to achieve the proper wheel bearing end-play, eliminating the need for manual bearing adjustment. The repeatability of the bearing setting range provides for optimum seal and bearing life. This consistency could help reduce fleet fuel costs.

We understand what the heavy-duty industry demands from their bearings and provide quality products that help keep fleets operating more efficiently and cost effectively. In fact, if you look inside your wheel-ends, the odds are in your favor that you'll find Timken bearings. Why not replace them with the original? Go with the proven leader.

Timken is where you turn for original matched wheel bearing sets and the assurance that your bearings are Set-Right.

Set-Right Kits – The Right Choice for You

- Enable faster and more reliable wheel-end builds; help improve up-time
- Reduce inventory with lower component counts
- Help optimize seal performance and life
- Eliminate manual adjustment, one of the leading causes of wheel end issues

Timken Technology

In the mid-1970s, Timken engineers developed the Set-Right setting method to help optimize bearing

performance. Then, in the mid-1990s, working with the leader in heavy-duty hub innovation, this pre-adjusted bearing technology was launched into the North American marketplace. The bearings used in these applications are known as half-stand bearings; they have half the stand tolerance (measurement tolerance) of that used in standard bearings. This means that the stand tolerance is twice as stringent (see diagram on backside). Timken has been supplying these bearings for the North American heavy-duty industry's most popular pre-adjusted wheel ends since 1995.

Kit Components

Quality Timken® MileMate® Bearings

- Original equipment used in heavy-duty, pre-adjusted wheel hub assemblies since 1995
- Engineered exclusively for pre-adjusted wheel hubs
- Precise half-stand tolerancing provides accurate setting every time
- Consistent and reliable internal geometry equals known performance
- Helps lengthen maintenance intervals
- Helps optimize bearing performance
- Timken "NP" part numbers
 - Proprietary design
 - Enhanced surfaces
 - More precise internal bearing geometry
 - Exceed industry standards
 - Rebuilding with NP parts helps ensure you get all the advantages that were originally engineered into the heavy-duty, pre-adjusted hub systems

Precision Machined Cone Spacer

- Designed for the rigorous demands of the heavy-duty wheel market
- Made from high-strength alloy
- Manufactured to precise tolerances
- Combined with Timken half-stand bearings and a special toleranced hub, the need for manual adjustment is eliminated



Additional Info

Set-Right Heavy-Duty Hub Rebuild Kits and Components

FFTC1 - FF Steer Kit			
Kit Contents	MileMate® P/N	Component P/N	Qty
Inner half-stand NP cone	SET427*	NP899357	1
Inner half-stand NP cup		NP026773	1
Outer half-stand NP cone	SET428*	NP874005	1
Outer half-stand NP cup		NP435398	1
Spacer**			1

TNTC1 - N Trailer Kit			
Kit Contents	MileMate® P/N	Component P/N	Qty
Inner half-stand NP cone	SET431*	NP965350	1
Inner half-stand NP cup		NP503727	1
Outer half-stand NP cone	SET427*	NP899357	1
Outer half-stand NP cup		NP026773	1
Spacer**			1

FLTC1 - FL Steer Kit			
Kit Contents	MileMate® P/N	Component P/N	Qty
Inner half-stand NP cone	SET445*	NP294109	1
Inner half-stand NP cup		NP039695	1
Outer half-stand NP cone	SET446*	NP107091	1
Outer half-stand NP cup		NP183330	1
Spacer**			1

TNTC2 - 454-Series™ N Trailer Kit			
Kit Contents	MileMate® P/N	Component P/N	Qty
Inner half-stand NP cone	SET602*	NP454350	1
Inner half-stand NP cup		NP454727	1
Outer half-stand NP cone	SET603*	NP454357	1
Outer half-stand NP cup		NP454773	1
Spacer**			1

RDTC1 - R Drive Kit			
Kit Contents	MileMate® P/N	Component P/N	Qty
Inner half-stand NP cone	SET429*	NP034946	1
Inner half-stand NP cup		NP363298	1
Outer half-stand NP cone	SET430*	NP840302	1
Outer half-stand NP cup		NP053874	1
Spacer**			1

TPTC1 - P Trailer Kit			
Kit Contents	MileMate® P/N	Component P/N	Qty
Half-stand NP cone	SET432*	NP174964	2
Half-stand NP cup		NP593561	2
Spacer**			1

RDTC2 - 454-Series™ R Drive Kit			
Kit Contents	MileMate® P/N	Component P/N	Qty
Inner half-stand NP cone	SET600*	NP454946	1
Inner half-stand NP cup		NP454298	1
Outer half-stand NP cone	SET601*	NP454302	1
Outer half-stand NP cup		NP454874	1
Spacer**			1

TPTC2 - 454-Series™ P Trailer Kit			
Kit Contents	MileMate® P/N	Component P/N	Qty
Half-stand NP cone	SET604*	NP454964	2
Half-stand NP cup		NP454561	2
Spacer**			1

* Includes proprietary Timken part numbers
 ** Spacer not sold separately

CAUTION

Prior to retrofitting or rebuilding your existing pre-adjusted wheel-end, you must start with the proper hub. Hubs designed for use with the Set-Right kits have special internal tolerancing that helps achieve maximum performance. Contact your hub supplier if you are unsure. The use of a standard hub will create an undesirable setting range, which may result in component damage.

Controlled Width Bearing Description

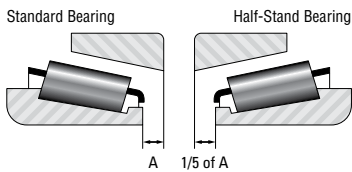

Assembled Stand Tolerance = Measurement between the cone front face and cup back face
 Standard bearing tolerance = A
 Half-stand bearing tolerance = 1/5 of A

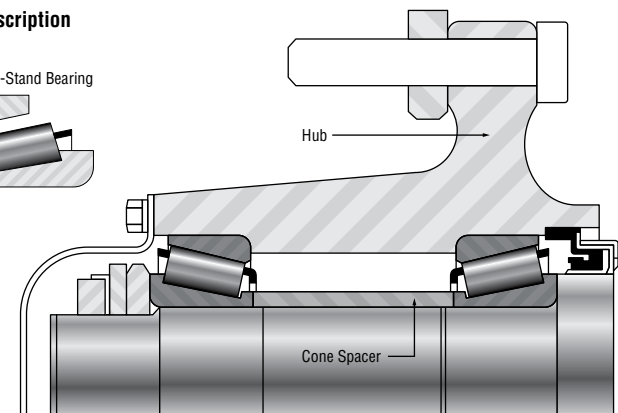

Additional Info

Heavy Duty Clutch Pilot Bearings

DT Components heavy duty clutch pilot bearings are specifically designed to withstand the higher temperatures encountered in today's demanding applications and meet or exceed the OEM's recommended ratings.

Due to the increasing demands of newer engines and transmissions, clutch pilot bearings operate at higher temperatures than previously encountered. OEM's have been specifying clutch pilot bearings with higher temperature rated seals and grease for nearly 20 years in order to prevent premature bearing failure.

When standard clutch pilot bearings are operated in these higher temperature environments, the seals start to breakdown and the grease liquefies. This allows the grease to be purged past the bearing's seals and a loss of lubricant inside of the bearing. Bearings operating without any lubricant quickly become noisy and ultimately fail.

We recommend that DT Components heavy duty clutch pilot bearings be used in all applications to reduce the risk of premature bearing failure.

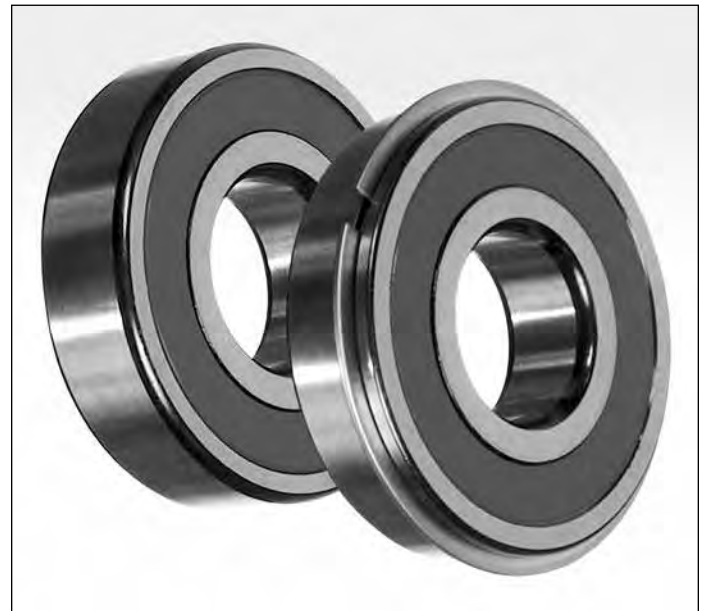

	Part Numbers	Seal Temperature Rating	Grease Temperature Rating
Standard Bearings	205FF, 306DD & 306DDL	+248° F / +120° C	+347° F / +177° C
Heavy Duty Bearings	205VV, 306VV & 306VVL	+419° F / +215° C	+400° F / +204° C

Heavy Duty Clutch Pilot Bearings

North Coast Bearings markets and distributes differential rebuild kits, transmission rebuild kits and related products to the heavy, medium and light duty aftermarkets under the DT Components[®] product line. The brand was created through a strategic alliance with The Timken Company.

Our continually growing product line includes rebuild kits for the broadest range of on highway vehicles along with complementing gearing, axle shafts, u-joints and related products. Please visit our website for the latest news, information and literature on all of the North Coast Bearings products.

DT Components is the most recognized and respected brand of differential and transmission rebuild kits in North America. Our mission is to provide the best value in differential and transmission kits and components. Best value means Timken[®] tapered roller bearings, the best order fill, the fastest in-house turn-around time, US manufacturers' product where available, superior quality and personalized service.



Over 2,500 Different Rebuild Kits

DT COMPONENTS WEB SITE

The informative DT Components web site contains product information, literature, customer login, and a link to our web catalog.



Snap this QR code with your smartphone app to visit our web site.

DT COMPONENTS WEB CATALOG

- Product Lookup by Application
- Kit Bill of Materials
- Interchanges
- Product Specifications
- Product Photos



Snap this QR code with your smartphone app to view our electronic catalog.

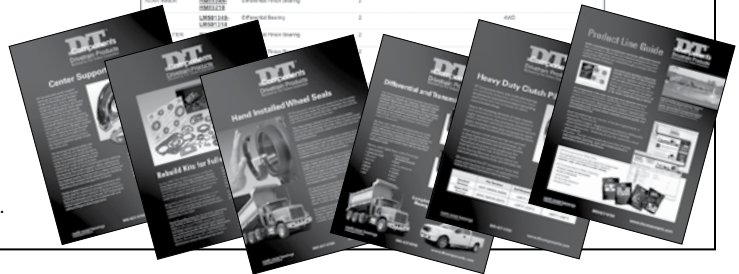
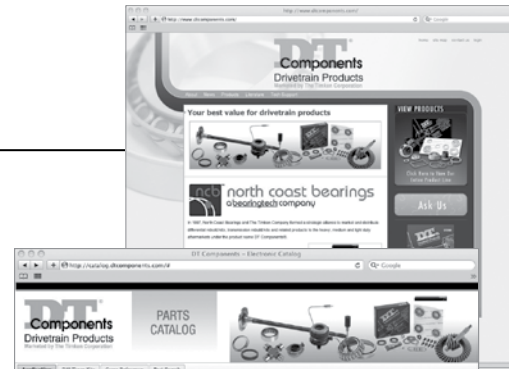

Clutch Installation Kits

DT Components® Clutch Installation Kits contain all of the wear components that are related to the function of the clutch assembly. Replacing these components during a clutch installation provides a complete overhaul of the entire clutch system and enables a full clutch life.

Kits are available for the popular RT and FR series of transmissions without hydraulic clutch release systems.

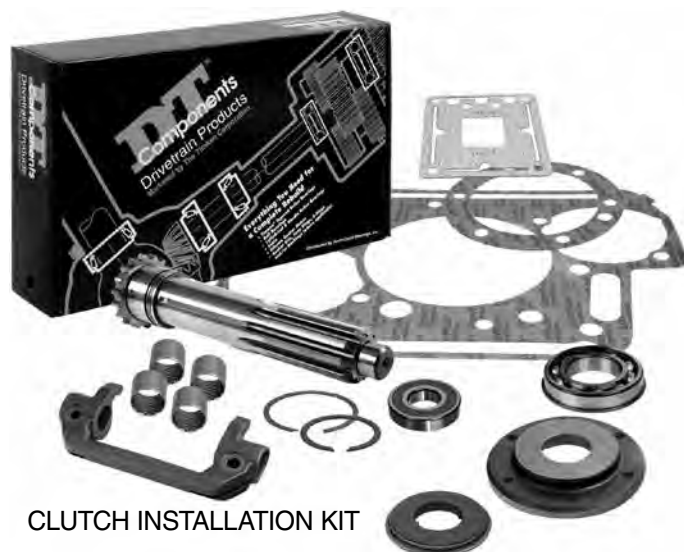

DT Components Clutch Installation Kits Feature

- OEM Gaskets
- Pilot Bearings with High Temperature Grease and Seals are rated to over 400° F to meet or exceed the demands of today's hotter running applications
- OEM Style 1 Piece Clutch Brake
- Standard Kits Contain 4 of the Short Style Clutch Yoke Bushings
- Kits with a /1 Suffix Contain 2 of the Long Style Clutch Yoke Bushings
- Kits with a /2 Suffix Contain 2 of the Short Style and 4 of the Long Style Clutch Yoke Bushings



/1 STYLE KIT



/2 STYLE KIT

TRK-2468 Services RT Series of Transmissions Without Hydraulic Clutch Release Systems

Position	Part Number	Qty.
Clutch Pilot Bearing	306VV	1
Input Shaft Bearing	212SLV	1
Front Bearing Cover	20550	1
Clutch Yoke	85533	1
Clutch Yoke Bushing	12815	4
Clutch Brake Disc	85541	1
Input Shaft	S1659	1
Input Shaft Inner Snap Ring	16980	1
Input Shaft Outer Snap Ring	14750	1
Front Bearing Cover Gasket	14311	1
Shift Tower Gasket	4305294	1
Clutch Housing Gasket	4306584	1

TRK-3600 Services FR Series of Transmissions Without Hydraulic Clutch Release Systems

Position	Part Number	Qty.
Clutch Pilot Bearing	306VV	1
Input Shaft Bearing	MU1212RUMW3	1
Front Bearing Cover	20550	1
Clutch Yoke	85533	1
Clutch Yoke Bushing	12815	4
Clutch Brake Disc	85541	1
Input Shaft	S2822	1
Input Shaft Inner Snap Ring	4303362	1
Input Shaft Outer Snap Ring	16980	1
Front Bearing Cover Gasket	14311	1
Shift Tower Gasket	4305294	1
Clutch Housing Gasket	4306584	1

Clutch Installation Kits

North Coast Bearings markets and distributes differential rebuild kits, transmission rebuild kits and related products to the heavy, medium and light duty aftermarkets under the DT Components[®] product line. The brand was created through a strategic alliance with The Timken Company.



North Coast Bearings services our customers from our 110,000 square foot Avon, Ohio facility along with a distribution center in Sparks, Nevada. The DT Components brand of kits are also available from additional Timken distribution centers throughout the world.



Over 2,500 Different Rebuild Kits

Our continually growing product line includes rebuild kits for the broadest range of on highway vehicles along with complementing gearing, axle shafts, u-joints and related products. Please visit our website for the latest news, information and literature on all of the North Coast Bearings products.

DT Components is the most recognized and respected brand of differential and transmission rebuild kits in North America. Our mission is to provide the best value in differential and transmission kits and components. Best value means Timken[®] tapered roller bearings, the best order fill, the fastest in-house turn-around time, US manufacturers' product where available, superior quality and personalized service.

DT COMPONENTS WEB SITE

The informative DT Components web site contains product information, literature, customer login, and a link to our web catalog.



Snap this QR code with your smartphone app to visit our web site.

DT COMPONENTS WEB CATALOG

- Product Lookup by Application
- Kit Bill of Materials
- Interchanges
- Product Specifications
- Product Photos



Snap this QR code with your smartphone app to view our electronic catalog.

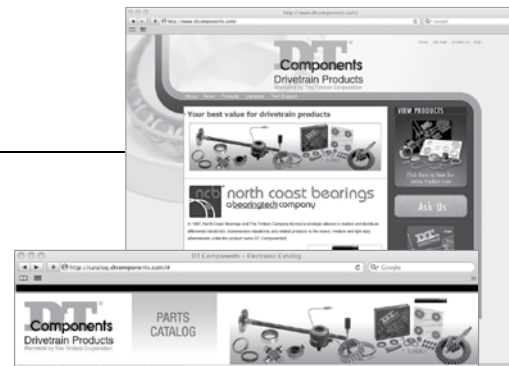

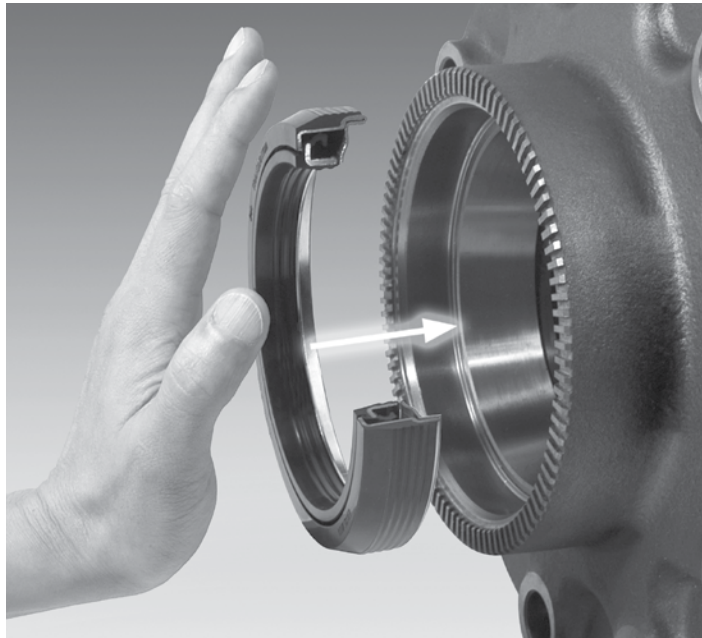

Hand Installed Wheel Seals

DT Components[®] wheel seals are designed to be the easiest seal you will ever install. No tools are necessary. You simply lubricate the rubber outside diameter; align the seal with the hub, and hand press the seal into hub.

The ribbed design allows the seal to be easily installed without tools, but grips the hub bore so the seal cannot back out once the seal is seated. The wide rubber outside diameter completely seals inside the wheel hub and helps seal hub bore imperfections.

While being designed to be easily hand installed, the three piece cartridge outer wall provides maximum strength to support installation with any wheel seal manufacturer's installation tool. This enables the installer to choose the installation method and tool that he prefers.

DT Components wheel seals were designed in England by a billion dollar global company that supplies products to OEM's and aftermarket customers worldwide. Manufactured in a state of the art ISO/TS 16949 certified facility, DT Components wheel seals are subjected to strict quality control procedures during every step of the manufacturing process to ensure OEM's and aftermarket customers alike will receive the highest quality product.

DT Components is the most recognized and respected brand of differential and transmission rebuild kits in North America. The brand was created through a strategic alliance formed in 1997 by North Coast Bearings and The Timken Company to sell and market rebuild kits and drivetrain products to the heavy, medium and light duty aftermarkets.

Our mission is to provide the best value in differential and transmission kits and related components. Best value means Timken[®] tapered roller bearings, the best order fill, the fastest in-house turn-around time, US manufacturers' product where available, superior quality and personalized service.



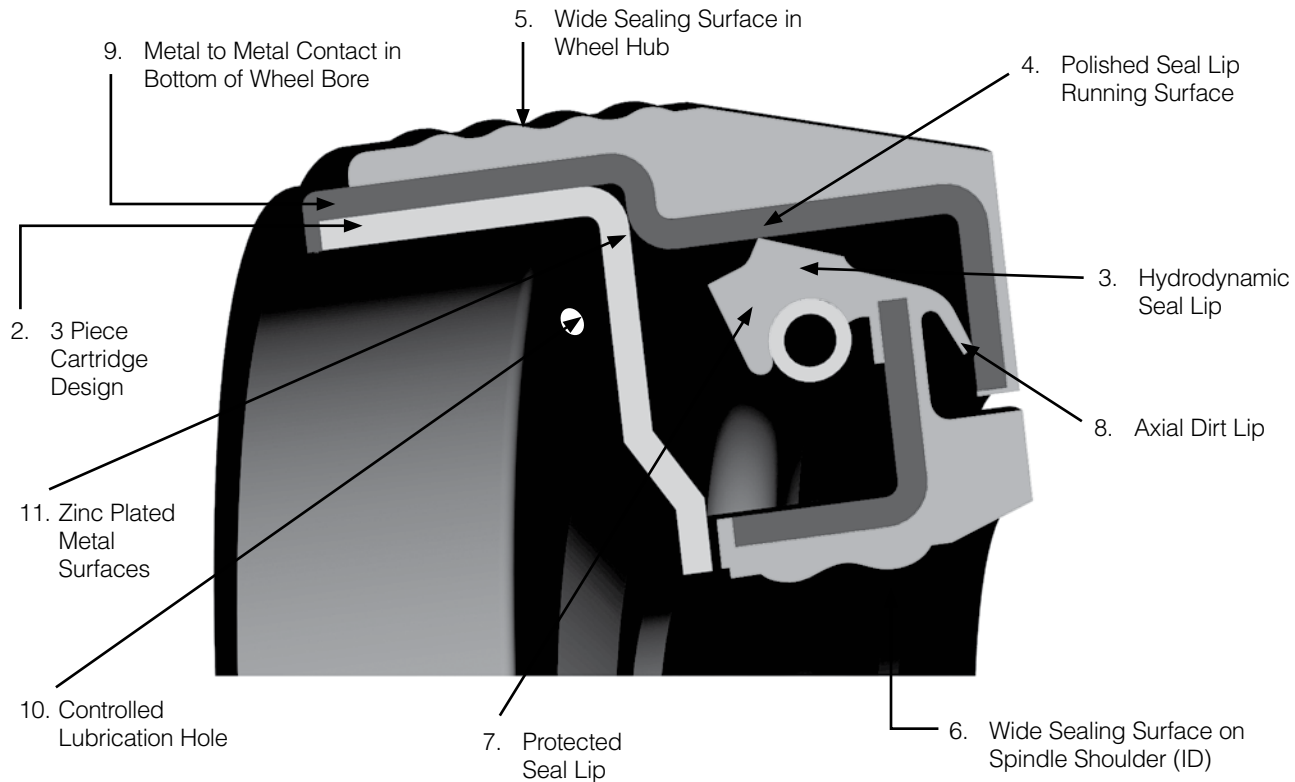

Wheel Seal Key Features

1. The wheel seals are designed to be easily hand installed or installed using any brand of wheel seal installation tools which reduces installation time and costs.
2. The seals outer wall is constructed with a robust 3 piece cartridge design to provide maximum strength.
3. The primary sealing lip is a hydrodynamic lip that pumps the oil back to the bearings helping with the bearing lubrication and has a centrifugal lip configuration that provides constant lip load at varying wheel speeds.
4. The primary sealing lip makes contact with a polished running surface which insures consistent seal contact and reduces friction and heat and extends the seals life.
5. The wheel seal has a wide sealing surface contact in the wheel hub providing maximum sealing and helps seal imperfections in the wheel hub.
6. The wheel seal also has a wide sealing surface on the spindle shoulder which helps seal spindle imperfections and provides maximum sealing.
7. The primary sealing lip is completely enclosed to prevent contamination and installation damage.
8. The axial dirt lip has a fixed wiper lip interference that excludes dirt and prevents pre-installation contamination.
9. The steel outer wall makes a metal to metal contact in the bottom of the wheel hub to insure proper seating and helps dissipate heat through the wheel hub.
10. Controlled lubrication holes maintains proper lubrication to the sealings lips and directs the oil back to the bearings.
11. All exposed metal surfaces are zinc plated to prevent corrosion.

Slurry Test

Extensive testing has been performed on the DT Components wheel seals to guarantee that our seals will out perform other brands of seals no matter how harsh the environment.

We installed the DT Components wheel seals and the competitor's wheel seals in an environmental testing rig and ran them head to head to see which seal would fail first. The seals were tested running half buried in sand as well as being submerged in a slurry consisting of a mixture of salt, sand, aggressive dust and seawater to simulate the worst possible conditions for a wheel seal.

The DT Components wheel seal's hydrodynamic pumping lip and polished running surface kept contaminants from penetrating the seal and lasted up to three times longer than the competitor's wheel seals.

DT Components wheel seals superior design and simple installation provides customers a trouble free and better performing life than other brands of wheel seals.

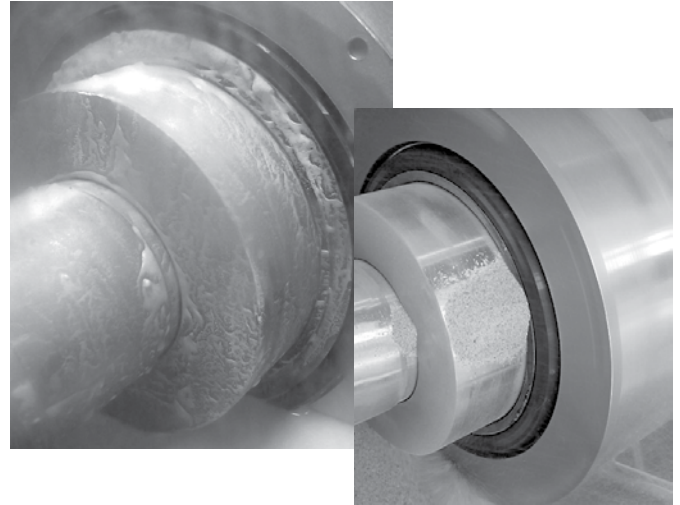
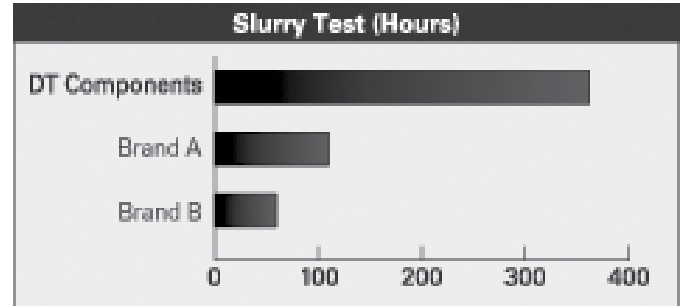

Quality

Manufactured in a state of the art ISO/TS 16949 certified facility, DT Components wheel seals are subjected to strict quality control procedures during every step of the manufacturing process to ensure OEM's and aftermarket customers alike will receive the highest quality product.

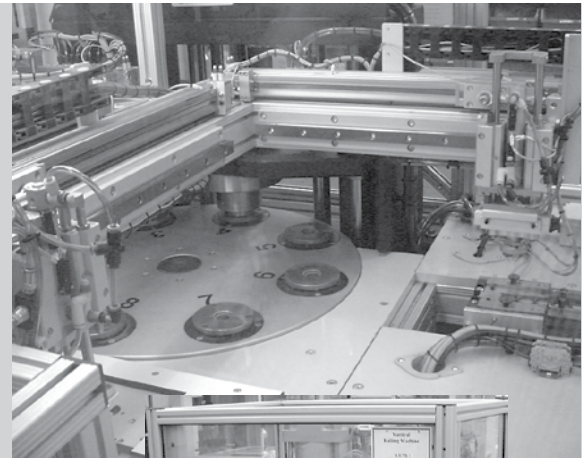

Interchange

DT Components	CR Scotseal Scotseal Plus	National Standard Design	Stemco Guardian Grit Guard	Triseal Standard Service Unitized	Dana Outrunner
TM301	34387 34384	370047A	309-0935 392-9035	69785 65111U	—
TM302	42623 42622	370065A	307-0723 372-7099	69596 65262U	851
TM305	46305 46304	370025A	307-0743 372-7097	69598 65060U	859
TM309	38780 38779	370023A	309-0912 392-9099	69794 65152U	849
TM312	35066 35059	370001A	308-0836 382-8036	69699 65263U	847
TM315	43764 43763	370048A	308-0864 382-8064	69697 65092U	863
TM317	45103 45102	370131A	308-0856 382-8056	69696 65078U	857
TM318	42672 42671	370031A	309-0904 392-9112	69788 65071U	852
TM329	40136 40133	370036A	307-0713 372-7098	69561 65261U	850
TM333	47697 47695	370003A	309-0973 392-9131	69799 65156U	861
TM350	45099 45097	370022A	309-0903 392-9094	69796 65270U	856

DT COMPONENTS WEB SITE

The informative DT Components web site contains product information, literature, customer login, and a link to our web catalog.



Snap this QR code with your smartphone app to visit our web site.

DT COMPONENTS WEB CATALOG

- Product Lookup by Application
- Kit Bill of Materials
- Interchanges
- Product Specifications
- Product Photos



Snap this QR code with your smartphone app to view our electronic catalog.

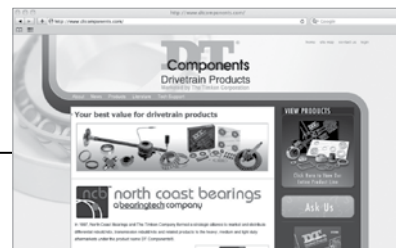

Wheel Set Interchange

Part Number	Timken Number	Federal Mogul Number	SKF Number	Cone/Cup
A1	SET1	A-1	BR1	LM11749/LM11710
A2	SET2	A-2	BR2	LM11949/LM11910
A3	SET3	A-3	BR3	M12649/M12610
A4	SET4	A-4	BR4	L44649/L44610
A5	SET5	A-5	BR5	LM48548/LM48510
A6	SET6	A-6	BR6	LM67048/LM67010
A7	SET7	A-7	BR7	M201047/M201011 w/locking collar
A9	SET9	A-9	BR9	**U298/U261L w/locking collar
A10	SET10	A-10	BR10	**U399/U360L w/locking collar
A12	SET12	A-12	BR12	LM12749/LM12710
A13	SET13	A-13	BR13	L68149/L68110
A14	SET14	A-14	BR14	L44643/L44610
A15	SET8	A-15	BR8	L45449/L45410
A16	SET16	A-16	BR16	LM12749/LM12711
A17	SET17	A-17	BR17	L68149/L68111
A18	SET11	A-18	BR11	JL69349/JL69310
A19	SET15	A-19	BR15	07100/07196
A20	SET20	A-20	BR20	Not Sold Separately
A21	SET21	A-21	BR21	1988/1922
A22	SET25	A-22	BR25	JLM506848E-90K02
A23	SET23	A-23	BR23	LM104949E-904A2
A24	SET27	A-24	BR31	Not Sold Separately
A28	SET28	A-28	BR28	J15585/15520 Not Sold Separately
A29	SET22	A-29	BR22	2 of LM67045/ 2 of LM67010-Z
A30	SET30	A-30	BR30	JLM67042/LM67010 Not Sold Separately
A31	SET24	A-31	BR24	JL68145/JL68111-Z SOLD AS SET ONLY
A32	SET32	A-32	BR32	Not Sold Separately
A33	SET33	A-33	BR33	Not Sold Separately
A34	SET34	A-34	BR34	LM12748F/LM12710
A35	SET45	A-35	BR35	LM501349/LM501310
A36	SET36	A-36	BR36	LM603049/LM603012
A37	SET37	A-37	BR37	LM603049/LM603011
A38	SET38	A-38	BR38	LM104949/LM104911
A39	SET46	A-39	BR39	JL26749F/JL26710
A40	SET26	A-40	BR26	JLM104946/JLM104910-Z
A41	SET41	A-41	BR41	Not Sold Separately
A42	SET42	A-42	BR42	JLM506849A/JLM506811
A43	SET43	A-43	BR43	Not Sold Separately
A44	SET449	A-44		Not Sold Separately
A45	A45	A-45		Not Sold Separately
A46	NP706218-NP910345	A-46		Not Sold Separately
A47	NP145100-NP913325	A-47		Not Sold Separately
A48	SET251	A-48		Not Sold Separately
A49	NP182140-904A1	A-49	BR103	Not Sold Separately
A50	NP197868-NP802507	A-50		Not Sold Separately
A51		A-51		14585/14525
A53	NP114036-NP064306	A-53		NP114036-NP064306
A80	SET47	A-80	BR50	LM102949/LM102910
A81	LM29748/10	A-81	BR51	LM29748/LM29710
A82	M88048/10	A-82	BR52	M88048/M88010
A140	A140	A-140	32008-X	Not Sold Separately
A149	A149	A-149	GRW250	Not Sold Separately

*Not sold separately

REAR WHEEL REPAIR PACKAGE BEARINGS



SIX PART NUMBERS NOW AVAILABLE

RP1561FO	Cylindrical roller bearing – replaces R 1561 TV bearing and seal used on Ford and Dodge 1.700" axles.
RP1561G	Cylindrical roller bearing – replaces R 1561 TV bearing and seal used on Chevrolet and GMC 1.700" axles.
RP513023	Cylindrical roller bearing – replaces 513023 TV bearing and seal used on Chevrolet and GMC van axles.
RP1559	Cylindrical roller bearing – replaces R 1559 TV bearing and seal used on a variety of GM , Ford and Chrysler cars and pickup trucks with 1.399" axles. 10 bolts.
RP5707	Cylindrical roller bearing – replaces R 1563 TAV bearing and seal used on a variety of GM , Ford and Chrysler cars and pickup trucks with 1.399" axles. 10 bolts.
RP513067	Cylindrical roller bearing – replaces 513067 bearing and seal used on a variety of Chevrolet and GM trucks axles with 8.5" ring gear. Available only as a repair package bearing.

REAR WHEEL REPAIR PACKAGE BEARING

Repair package bearings replace the original bearing and seal on axles which are still in good condition whose original bearing and/or seal contact paths are not suitable for continued use. The extra-wide Repair Package Bearing repositions the rollers and seal to ride on unworn portions of the axle closer to the flange. The Repair Package Bearing is lubricated through the axle tube by differential fluid, just like the original equipment design.

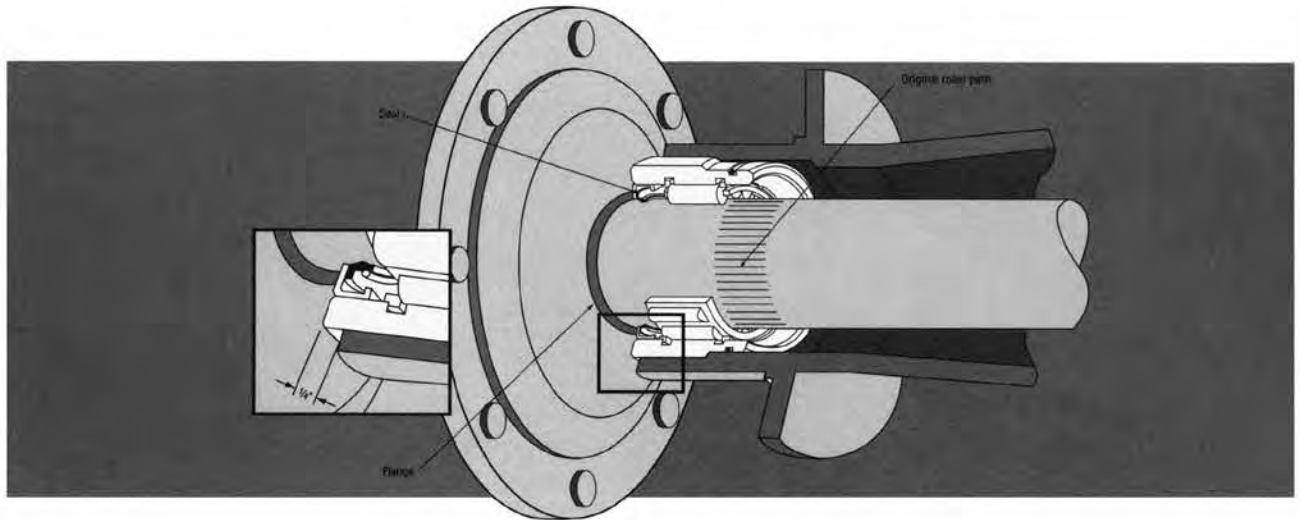

BEFORE INSTALLATION

Assess the shaft's general condition as not all axles are fit for reuse. Look for any signs of damage or wear. DO NOT REUSE axles that exhibit the following conditions:

- BENT OR DISTORTED AXLES, even if they could be straightened.
- AXLES WITH SURFACE CRACKS. Surface cracks may indicate impending failure, as cracks may grow and cause weakening of the axle or complete breakage.
- DISCOLORED AXLES. Discoloration (usually blue or black) may result from overheating while in operation.
- NOTICEABLE WEAR ON AXLES at the original bearing path. Wear may be indicated by a worn groove, heavy corrosion or surface spalling.

NOTE: Axles unfit for reuse are not limited to those exhibiting these conditions. Other conditions may also render an axle unfit for reuse.

INSTALLATION PROCEDURE

1. Follow the manufacturer's procedures for disassembling the axle, seal and bearing.
2. Clean and polish the axle between the flange and the original roller path using a fine grade emery paper. Smooth any nicks or burrs. The repair bearing and seal will ride on this area. Check the axle housing and clean it as necessary. WARNING: DO NOT reuse any axles that are distorted or bent, discolored, have surface cracks or have noticeable wear at the original bearing path.
3. Remove the replacement bearing from its box and remove its protective wrapping. Dip the bearing in clean differential oil and allow to drain.
4. Install the bearing in the axle housing with the seal facing out. Use an installation tool that rides on the face of the bearing. If you use the wrong installation tool, you will damage the seal which may cause a failure. No force should be applied to the seal. Once an axle shaft seal has been removed, never reuse it.
5. Reinstall the axle following the vehicle manufacturer's assembly procedures.
6. Finally, fill the differential with fluid to the level recommended by the vehicle manufacturer.

INTERCHANGE INFORMATION FOR REPAIR PACKAGE

DT Components Part No.	Federal-Mogul Part No.	Green Ball Bearing Part No.
RP1561FO	RP 1561-FO	FO-1561
RP1561GM	RP 1561-GM	GM-1561
RP513023	RP 153023	RP-57509
RP1559	RP 6408	RP-1559
RP5707	RP 5707	RP-1563
RP513067	RP 513067	RP-59047

Maximum
Performance,
Minimum Size



- LONGER BEARING LIFE
- INCREASED BEARING RELIABILITY
- INCREASED LOAD-CARRYING CAPACITY
- RESISTANCE TO HOSTILE ENVIRONMENTS
- IMPROVED FATIGUE LIFE

P900™ Bearings

Reduce size, weight and cost ... or increase power for your application

The world's most demanding applications require the world's best-performing bearings. Timken® P900™ bearings handle greater loads than traditional bearings, cost-effectively improving your product's performance and efficiency.

The technology behind P900 offers you the advantage of a benefit we call "power density." Simply put, power density allows you to use smaller bearings that can handle the same load as the original or pack more fatigue endurance into an existing envelope. You can now specify bearings without compromise.

Think of the cost-saving advantages of power density. You can downsize the bearings and related components, reaping the benefits of a lower system cost while handling the same loads. Or, you can increase power for your application without the costly process of retooling the system.

Do more with less

P900 bearings are designed to help manufacturers do more with less. For manufacturers of automobiles, P900 bearings offer the advantages of reduced weight in transmissions, transaxles, drive axles and other components. These advanced bearings meet industry demands for greater reliability, improved performance and extended life in power transmission designs that are smaller and operate at higher temperatures and with greater deflection than ever before.

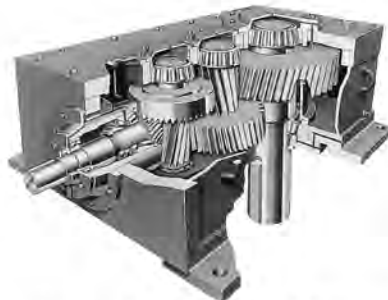

Gear drive manufacturers downsize with P900 bearings for substantial savings in total system cost.

TIMKEN®



For heavy-duty trucks, P900 bearings allow more payload per vehicle and the potential for generating more revenue.

P900 bearings benefit manufacturers of heavy-duty trucks by allowing for reduced weight in transmissions and drive axles. They also allow more payload per vehicle and offer the potential for generating more revenue.

The same benefits apply to off-highway equipment, where P900 bearings help manufacturers design equipment that consumes less energy while performing more efficiently and reliably.

P900 bearings are now being used by gear drive manufacturers and in other industrial applications, where they facilitate increased power throughput. In applications where diminished size is an advantage, downsized P900 bearings allow manufacturers to replace critical-application bearings with smaller bearings that handle the same loads as the originals. This allows for reduced dimensions of related components and can mean substantial savings in total system cost.

Timken innovations have made these cost and performance advantages a reality as P900 advances set industry standards for increased power throughput, efficiency and durability.

TM — A trademark of The Timken Company.



P900 bearings boost the efficiency and reliability of off-highway equipment.

Super-clean steel

Every P900 bearing begins with an important advantage — Timken's super-clean air-melt steel. This benefit is a Timken original: The Timken Company is the only American bearing manufacturer that makes its own steel. Our state-of-the-art facilities and the knowledge gained from more than 80 years of steel-making experience have allowed us to dramatically raise the level of bearing performance worldwide by offering decreased inclusion content, prolonged bearing life, increased reliability and improved resistance to hostile environments.

Advanced bearing geometry

The advanced geometry of Timken P900 bearings virtually eliminates edge stress concentrations caused by high loads or misalignment. In most high-load applications, P900 bearings perform more than 50 percent better than conventional bearings. In Figure 1, the bearings with the enhanced geometry, under certain conditions of load and misalignment, perform more than four times better than their standard counterpart.

Enhanced finishes

P900 bearings feature special finishes on the rollers, cups and cones to reduce surface-related modes of damage. This finishing process dramatically improves rolling contact surface finish and fatigue life when limited by surface distress and can add years to the relative life of a bearing. In design applications limited by surface distress, our finishing process can increase bearing life more than four times as shown in Figure 2.

Designed for your application

Timken engineers work with original equipment manufacturers to specify P900 bearings for the appropriate applications. To maintain the performance of these applications, you must replace a P900 bearing with a P900 bearing.

When replacing bearings, always order by part number to be sure you have the right bearing. If no part number is visible, contact your Timken sales representative for assistance.

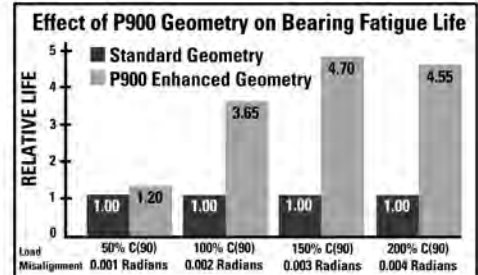

Fig. 1

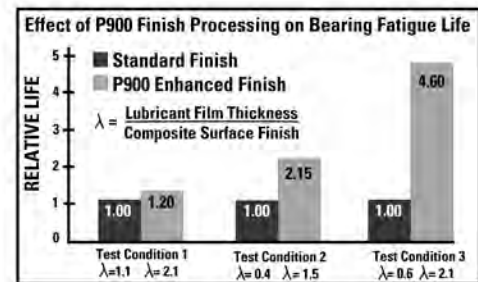

Fig. 2

Automotive TechTips

Maximizing bearing performance and life remains an objective throughout The Timken Company, from design teams and manufacturing associates to our field sales team and distributors. TechTips helps you install and maintain Timken® bearings, seals and components to maximize the life and performance of your bearings and the systems in which they operate. For more information regarding Timken automotive products and services, visit www.timken.com or contact your local Timken distributor.

PROPER TAPERED BEARING SETTINGS



The amount of end play or preload existing in a mounted pair of bearings is critical to performance. If incorrectly set, bearings may prematurely damage, and seals, brake components and tire operation may also be affected.

In addition, improper bearing setting can negatively impact factory settings of camber and toe. The Timken Company recommends installing all bearings to proper setting specifications to avoid issues.

Several mounting methods for tapered single roller bearings exist, some are more common than others. One of the most popular methods is mounting and adjusting bearing setting with a bottle-cap stamping, hexagonal nut, cotter pin and threaded shaft (see *Figure 1*).

This approach is typically used on passenger car front wheels in conjunction with a hardened tongue washer between the outboard bearing's inner ring and the adjusting nut.

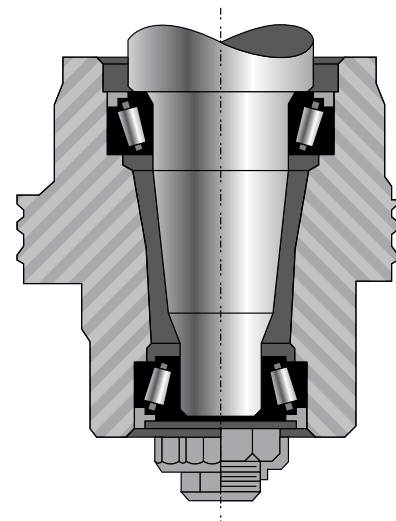

Figure 1: Passenger car non-driven wheel setting method

Setting For Passenger Car
Non-Driven Wheel

Additional Info

To adjust the setting of this bearing:

Step 1: Tighten the nut while turning the hub. When there is a slight bind on the bearing, the parts are seated correctly.

Step 2: Back the nut off 1/6 to 1/4 of a turn or sufficiently to allow .001" to .007" end play.

Note: Failure to back off adjusting nut could cause bearing to run hot and be damaged. Wheel could lock or separate.

Step 3: Place the bottle-cap-type stamping over the nut and insert the cotter pin to prevent the nut from backing off.

Setting For Independent Suspension Rear Axles

Hardened surface nuts, tongue washers and outerjam nuts or lock nuts are commonly used for wheels with full floating rear axles and some front-wheel applications (see Figure 2).

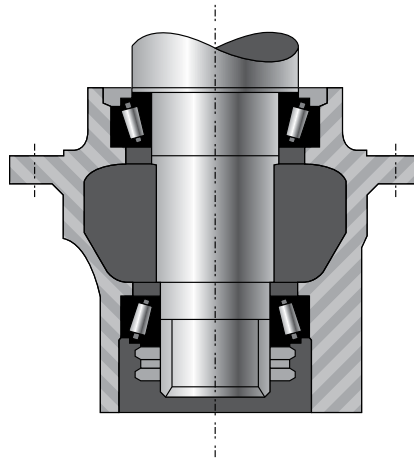

Figure 2: Independent suspension rear axle setting method

To adjust the setting of this bearing:

Step 1: Tighten the nut while turning the hub. When there is a slight bind on the bearing, the parts are seated correctly.

Step 2: Back the nut off 1/6 to 1/4 of a turn or sufficiently to allow .001" to .007" end play.

Note: Failure to back off adjusting nut could cause bearing to run hot and be damaged. Wheel could lock or separate.

Step 3: Tighten the jam nut to remove the thread clearance and to prevent the nut from backing off.

Proper bearing setting practices ensure maximum performance and life for bearings and all related wheel components. Contact your Timken sales representative or distributor with additional bearing setting questions.

Additional information regarding Timken bearings, seals and hub assemblies can be found at www.timken.com or by calling 1-800-223-1954 and asking for Aftermarket.

⚠ WARNING Failure to observe the following warnings could create a risk of serious injury.

Proper maintenance and handling procedures are critical. Always follow installation instructions and maintain proper lubrication.

Never spin a bearing with compressed air. The rollers may be forcefully expelled.

This information is not intended to substitute for the specific recommendations of your equipment suppliers.

Every reasonable effort has been made to ensure the accuracy of the information contained in this writing, but no liability is accepted for errors, omissions or for any other reason.

Automotive TechTips

Maximizing bearing performance and life remains an objective throughout The Timken Company, from design teams and manufacturing associates to our field sales team and distributors. TechTips help you install and maintain Timken® bearings, seals and components to maximize their life and performance and the systems in which they operate. For more information regarding Timken automotive products and services, visit www.timken.com or contact your local Timken distributor.

TAPERED ROLLER BEARING DAMAGE ANALYSIS



The most common types of bearing damage that may result in a reduction of bearing or application life are often caused by:

- *insufficient maintenance practices*
- *mishandling*
- *improper installation and adjustment practices*
- *inadequate lubrication*

The following offers a quick reference to the common causes of bearing damage.

FATIGUE SPALLING



Geometric stress concentration: Spalling from misalignment, deflections or heavy loading.



Inclusion origin: Spalling from oxides or other hard inclusions in bearing steel.



Point surface origin: Spalling from debris or raised metal exceeding the lubricant film thickness.

FOREIGN MATERIAL



Abrasive wear: Fine abrasive particle contamination.

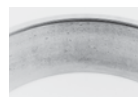

Bruising: Debris from other fatigued parts, inadequate sealing or poor maintenance.



Grooving: Large particle contamination embedding into soft cage material.

INADEQUATE LUBRICATION*



Roller end scoring: Metal-to-metal contact from breakdown of lubricant film.



'Welding' and heat damage from metal-to-metal contact.



Cone large rib face scoring:



Cone large rib face deformation: Metal flow from excessive heat generation.

Timken Automotive TechTips



Total bearing lock-up: Rollers

skew, slide sideways and lock-up bearing.

*** Excessive preload can cause damage similar to inadequate lubrication damage.**

CORROSION/ETCHING



Staining: Surface stain with no

significant corrosion from moisture exposure.



Etching: Rusting with pitting and corrosion

from moisture/water exposure.



Line spalling: Roller spaced

spalling from bearings operating after etching damage.

FALSE BRINELLING



Wear caused by vibration or relative axial movement between rollers and races.

HANDLING DAMAGE



Roller spaced nicking: Raised metal

on races from contact with roller edges.



Roller nicking/denting: Rough

handling or installation damage.

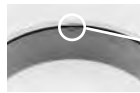

Cup-face denting: Indentations from hardened driver.

CAGE DAMAGE



Cage Deformation: Improperly installed or

dropped bearing.



Rollers binding and skewing: Cage

ring compressed during installation or interference during service.

MISALIGNMENT



Irregular roller path from deflection, inaccurate machining or wear of bearing seats.

PEELING



Micro-spalling due to thin lubricant film from high loads/low RPM or elevated temperatures.

HIGH SPOTS IN CUP SEATS



Localized spalling on the cup race from stress riser created by split housing pinch point.

IMPROPER FIT



Cone bore damage: Fractured cone due to

out-of-round or oversized shaft.



Cup spinning: Loose cup fit in a

rotating wheel hub.

EXCESSIVE PRELOAD OR OVERLOAD



Rapid and deep spalling caused by unusually high stresses. Full race width fatigue spalling is caused by heavy loads creating a thin lubricant film and elevated temperatures.

TRUE BRINELLING

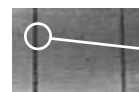

Damage from shock or impact.

ELECTRIC CURRENT



Electric arc pitting: Small burns created by arcs from improper electric grounding while the bearing is stationary.



Fluting: Series of small axial burns

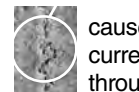

caused by electric current passing through the bearing while it is rotating.

EXCESSIVE END PLAY



Cup scalloping: Uneven localized wear

resulting from excessive end play.



Cage pocket wear: Heavy contact

between the rollers and cage pocket surfaces caused by bearing operating too loosely.

⚠ WARNING Failure to observe the following warnings could create a risk of serious injury.

Proper maintenance and handling procedures are critical. Always follow installation instructions and maintain proper lubrication.

Never spin a bearing with compressed air. The rollers may be forcefully expelled.

This information is not intended to substitute for the specific recommendations of your equipment suppliers.

Every reasonable effort has been made to ensure the accuracy of the information contained in this writing, but no liability is accepted for errors, omissions or for any other reason.

Automotive TechTips

Maximizing bearing performance and life remains an objective throughout The Timken Company, from design teams and manufacturing associates to our field sales team and distributors. TechTips help you install and maintain Timken® bearings, seals and components to maximize their life and performance and the systems in which they operate. For more information regarding Timken automotive products and services, visit www.timken.com or contact your local Timken distributor.

BALL BEARING DAMAGE ANALYSIS



The most common types of bearing damage that may result in a reduction of bearing or application life are often caused by:

- *insufficient maintenance practices*
- *mishandling*
- *improper installation and fitting practices*
- *inadequate lubrication*
- *excessive application loads*
- *contamination*

The following offers a quick reference to the common types/causes of bearing damage.

INADEQUATE LUBRICATION

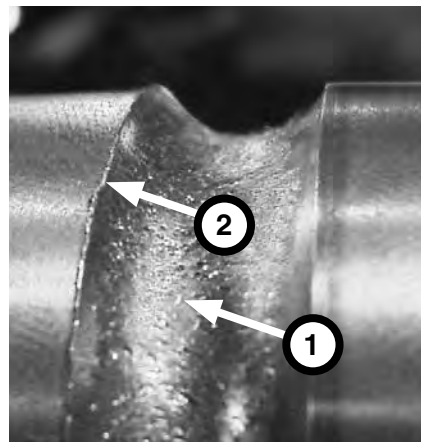

Metal-to-metal contact from lubricant film breakdown resulting in a: 1) polished appearance on the inner race followed by an orange peel texture and, 2) raised edge on the thrust shoulder.

OVERLOAD



Softening and deformation of the thrust shoulder caused by excessive loads. The discoloration on the inner ring is the result of elevated temperatures.

Timken Automotive TechTips

IMPROPER INSTALLATION

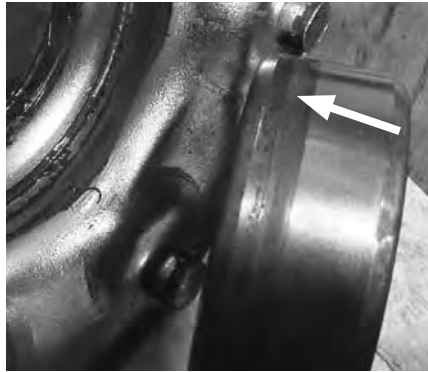

Bearing supported by only one-third of its outer ring width within housing.



Distorted seal due to interference with adjacent mating parts.



Seal damage due to improper installation procedure and/or tools.

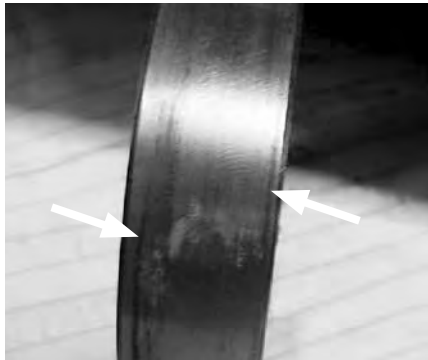

Irregular marks on the outer ring caused by improper seating in the housing.

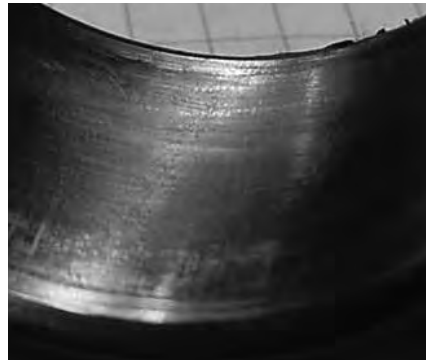

Loose inner ring fit on a rotating shaft resulting in discoloration from heat generation.

CAGE DAMAGE



Metal cage damage due to misalignment or excessive speed.

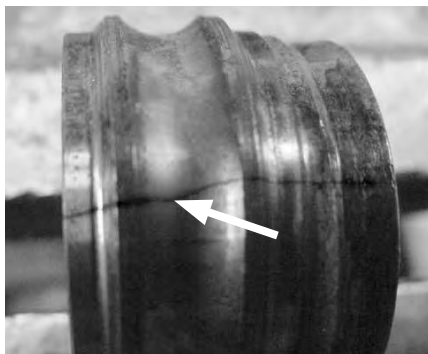

Axial crack on inner ring due to oversized or out-of-round shaft.



Inner ring cracking due to excessive taper on the shaft.



Polymer cage damage due to improper installation procedure. The bearing seal was pressed into the cage.

⚠ WARNING Failure to observe the following warnings could create a risk of serious injury.

Proper maintenance and handling procedures are critical. Always follow installation instructions and maintain proper lubrication.

Never spin a bearing with compressed air. The rollers may be forcefully expelled.

This information is not intended to substitute for the specific recommendations of your equipment suppliers. Every reasonable effort has been made to ensure the accuracy of the information contained in this writing, but no liability is accepted for errors, omissions or for any other reason.

Automotive TechTips

Maximizing bearing performance and life remains an objective throughout The Timken Company, from design teams and manufacturing associates to our field sales team and distributors. TechTips help you install and maintain Timken® bearings, seals and components to maximize their life and performance and the systems in which they operate. For more information regarding Timken automotive products and services, visit www.timken.com or contact your local Timken distributor.

BALL BEARING DAMAGE ANALYSIS



The most common types of bearing damage that may result in a reduction of bearing or application life are often caused by:

- *insufficient maintenance practices*
- *mishandling*
- *improper installation and fitting practices*
- *inadequate lubrication*
- *excessive application loads*
- *contamination*

The following offers a quick reference to the common types/causes of bearing damage.

FRETTING CORROSION



Fretting on inner ring due to out-of-round shaft.



Fretting on the outer ring due to out-of-round housing bore.

Timken Automotive TechTips

FOREIGN MATERIAL / CONTAMINATION



Fine particle abrasive wear on the inner race, commonly known as 'frosting'.



Gross contamination resulting from harsh operating conditions and/or seal failure.



Lubrication characteristics of the grease are compromised by water ingress.

FATIGUE SPALLING



Inclusion origin: spalling from oxides or other hard inclusions in bearing steel.



Geometric stress concentration (GSC): spalling from misalignment, system deflections or heavy loading.

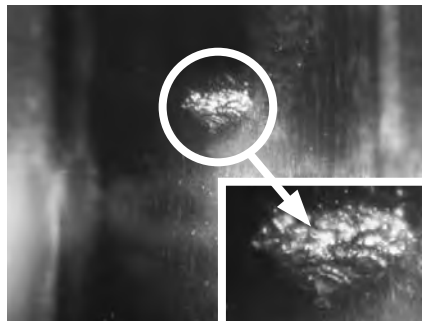

Point surface origin (PSO): spalling from contamination in the ball path or raised metal exceeding the lubricant film thickness.

GREASE ETCHING



Chemical reaction of grease and moisture in a prolonged static condition resulting in pitting and corrosion. A 'witness mark' is generated at each ball location on the inner race.

TRUE BRINELLING

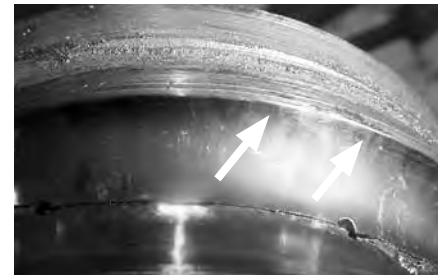

Damage from shock or excessive loads.

FALSE BRINELLING

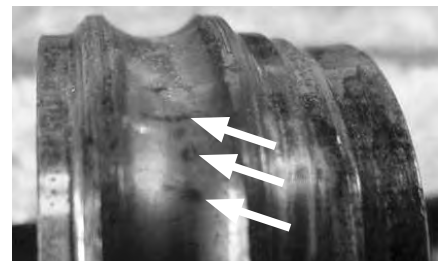

Wear caused by vibration or axial movement between the balls and races in a static condition.

⚠ WARNING Failure to observe the following warnings could create a risk of serious injury.

Proper maintenance and handling procedures are critical. Always follow installation instructions and maintain proper lubrication.

Never spin a bearing with compressed air. The rollers may be forcefully expelled.

This information is not intended to substitute for the specific recommendations of your equipment suppliers.

Every reasonable effort has been made to ensure the accuracy of the information contained in this writing, but no liability is accepted for errors, omissions or for any other reason.

Gasket Maker

Permatex® High Strength Threadlocker RED

OEM specified. High strength threadlocker for heavy-duty applications 3/8 inch to 1 inch (10mm to 25mm). Especially well-suited for permanently locking studs and press fits. Adds 3,000 PSI holding power on slip and press fit assemblies. Replaces set screws and snap rings. Locks against vibration loosening. May require heat or special tools for removal.

Available in 1 ml individual pouches, 6 ml carded tubes, 36 ml carded bottles and 90 ml bottles. Large diameter threadlocker for bolts larger than 1 inch in diameter is available in 36 ml carded bottles. High temperature, high strength threadlockers suited for temperatures up to 450° F is available in 6 ml carded tubes, 10 ml carded bottles and 36 ml carded bottles. High temperature, permanent strength threadlocker for high vibration and heavy shock applications is available in 6 ml carded tubes and 36 ml carded bottles.



Permatex® Medium Strength Threadlocker BLUE

OEM specified. All-purpose, medium strength threadlocker. Ideal for all nut and bolt applications 1/4" to 3/4" (6mm to 20mm). Eliminates need for stocking expensive lock nuts and lock washers. Locks and seals while preventing parts loosening due to vibration. Protects threads from corrosion. Removable with hand tools for easy disassembly.

Available in 1 ml individual pouches, 2.5 ml carded bottles, 6 ml carded tubes, 36 ml carded bottles and 90 ml bottles.



Permatex® Low Strength Threadlocker PURPLE

OEM specified. Low strength threadlocker designed for fasteners under 1/4" (6mm) that require occasional adjustment. Removable with hand tools for easy disassembly. Noncorrosive. Conforms to ASTM D 5363 AN0311 (Mil-S-46163A, Type II, Grade M).

Available in 6 ml carded tubes



Gasket Maker

Permatex® Anaerobic Gasket Maker

OEM specified. Noncorrosive gasketing material designed primarily for use on aluminum, iron, and steel flanged mating surfaces. Ideal for on-the-spot and emergency repairs, or when a conventional gasket is unavailable. Fills gaps up to .015" and cures to a solvent-resistant seal that will not tear or decay during service. Parts disassemble easily even after extended service and old gasket material can be removed in minutes with a simple putty knife.

Available in 6 ml carded tubes, 50 ml carded tubes and 300 ml cartridges



Permatex® Ultra Blue® Multipurpose RTV Silicone Gasket Maker

OEM specified. Permatex® Ultra silicones were developed to meet today's technology changes. Sensor-safe, low odor, noncorrosive. Outstanding oil resistance and joint movement values. Eight times more flexible than cork/composite gaskets; three times more oil resistant than conventional silicones. Temperature range -65°F to 500°F (-54°C to 260°C) intermittent; resists auto and shop fluids and vibration.

Available in 3.35 oz carded tubes, 9.5 oz Powerbead cans and 13 oz cartridges



Permatex® Ultra Black® Maximum Oil Resistance RTV Silicone Gasket Maker

OEM specified. For dealership warranty requirements, ensures extended drivetrain warranty compliance. Fast-curing formula. Sensor safe, low odor, noncorrosive. Meets performance specs of OE silicone gaskets. Retains high flexibility, oil resistance properties through use of a patented adhesion system. Temperature range -65°F to 500°F (-54°C to 260°C) intermittent; resists auto and shop fluids and vibration.

Available in 3.35 oz carded tubes, 8.75 oz Automatic Tubes, 9.5 oz Powerbead cans and 13 oz cartridges



Gasket Maker

Permatex® Ultra Grey® Rigid High-Torque RTV Silicone Gasket Maker

OEM specified. Designed specially for high-torque and high vibration applications, like those common in import engines, this premium RTV gasket maker exceeds manufacturers' performance requirements. Noncorrosive and low-odor. Maximum vibration resistance, with outstanding resistance to oils, cooling and shop fluids. Guaranteed not to leak. Temperature range -65°F to 500°F (-54°C to 260°C) intermittent.

Available in 3.35 oz carded tubes, 9.5 oz Powerbead cans and 13 oz cartridges



Permatex® High-Temp Red RTV Silicone Gasket

OEM specified. Formulated for hi-temp applications, or heavy-duty use (such as towing, etc.). Replaces almost any cut gasket by making reliable "formed-in-place" gaskets that resist cracking, shrinking and migrating caused by thermal cycling. Coats pre-cut gaskets to increase reliability. Temperature range -65°F to 650°F (-54°C to 343°C) intermittent; resists auto and shop fluids. First generation 1970-1980 gasket maker.

Available in 3 oz carded tubes, 7.25 oz Automatic Tubes, 7.25 oz Powerbead cans and 11 oz cartridges



Permatex® the Right Stuff® Gasket Maker

Return equipment to service immediately when you make leak-proof gaskets in just one minute with the Right Stuff.® This latest elastomeric rubber gasket technology is blowout resistant and outperforms pre-cut gaskets. Specified on production lines by GM, Ford, DaimlerChrysler and Mercedes-Benz. Temperature range -75°F to 450°F (-59°C to 232°C) continuous, 500°F (260°C) intermittent.; resists ATF, coolant, oil and other shop fluids. Protects against leaks caused by vibration and thermal expansion. Sensor-safe

Available in 4 & 7 oz Automatic Tubes, 7.5 oz Powerbead cans and 5 & 10.1 oz cartridges



Gasket Maker

Permatex® Bearing Mount for Close Fits

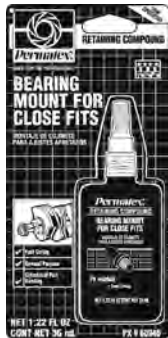

OEM specified. A low viscosity, rapid-curing anaerobic adhesive that augments the strength of press fit assemblies or slip fit assemblies up to .005" in diameter. Adds up to 3,000 PSI holding power.

Available in 36 ml carded bottles

Permatex® Bearing Mount for Relaxed Fits



OEM specified. High strength, medium viscosity anaerobic adhesive for slip fit assemblies. Provides 2,800 PSI shear strength on steel. Cures in 10 minutes at room temperature.

Available in 36 ml carded bottles

Permatex® High Temperature Sleeve Retainer



OEM specified. High temperature (up to 400°F / 204°C) anaerobic adhesive that secures slip and press fit assemblies. Adds up to 3,000 PSI holding power. Restores fit to worn or out-of-tolerance assemblies. Prevents surface corrosion.

Available in 6 ml carded tubes and 36 ml carded bottles

Permatex® Prussian Blue



Aids precision-fitting of machined surfaces. Locates high spots on bearings, valves, gears and other close-to-tolerance components. Nondrying. Easy clean-up.

Available in .75 oz tubes

Permatex® Anaerobic Flange Sealant



Flexible, gasketing material for use on rigid machined flanges with less than .015" gap. OEM approved – use where OE's specify "anaerobic" gasket (cures in the absence of air). Withstands temperatures to 300°F (149°C). Eliminates preformed, pre-cut, paper, rubber and cork gaskets. Flexes with flanges that move in service.

Available in 50 ml carded tubes and 300 ml cartridges

Permatex® High Temperature Anaerobic Flange Sealant



A high temperature sealant specially engineered for making or dressing gaskets in rigid assemblies. Able to withstand temperatures to 400°F (204°C), fills gaps up to 0.020" (primed) and permits clamping loads to be maintained for strong, leakproof assemblies.

Available in 50 ml carded tubes

Light, Medium & Heavy Duty Products for Domestic & Foreign Applications

- Light, Medium & Heavy Duty Products for Domestic & Foreign Applications
- Differential Rebuild Kits
- Transmission / Transaxle Rebuild Kits
- Transfer Case Rebuild Kits
- Timken® Tapered Roller Bearings
- MileMate® Matched Wheel Bearing Sets
- DT Components Wheel Seals
- Ring & Pinion Sets
- Eaton Limited Slip Differentials and Service Kits
- Detroit Locker Locking Differentials and Detroit Truetrac Limited Slip Differentials
- Auburn Gear Limited Slip Differentials, Service Kits, Spools & Mini Spools
- Tractech No Spin Heavy Duty Differentials
- Differential Internal Kits & Cases
- Axle Shafts
- Center Support Bearings
- U-Joints & Yokes
- EZ Sleeve™ Repair Sleeves
- Seal & Gasket Kits
- Input Shafts & Counter Shafts
- Transmission Gears & Related Parts
- Synchronizer Rings & Assemblies
- Synchronizer Ring Kits
- Transfer Case & Automatic Transmission Chains
- Ball Bearings
- Clutch Installation Kits
- Clutch Release & Pilot Bearings
- Cylindrical & Needle Roller Bearings
- Shim Stock Rolls
- Small Parts Kits
- Permatex® Adhesives & Sealants
- Hub Assemblies

DT[®]
Components
Drivetrain Products
Marketed by The Timken Corporation



Snap this QR code with your smartphone app to visit our web site.

**For order placement contact:
North Coast Bearings**

Toll Free: 800-627-0700

Toll Free Fax: 800-627-9401

www.dtcomponents.com

Timken, DT Components and MileMate are registered trademarks of The Timken Company. North Coast Bearings and EZ Sleeve are trademarks of North Coast Bearings, LLC Eaton is a registered trademark of The Eaton Corporation.