

Service Manual

SD / HDD Video Camera

Model No. **SDR-H85P**

SDR-H85PC

SDR-H85EB

SDR-H85EC

SDR-H85EE

SDR-H85EF

SDR-H85EG

SDR-H85EP

SDR-H85GA

SDR-H85GC

SDR-H85GK

SDR-H85GN

SDR-H85GT

SDR-H86EB

SDR-H86PR

SDR-H86PU

SDR-H95EE

SDR-H95GA

SDR-H95GC

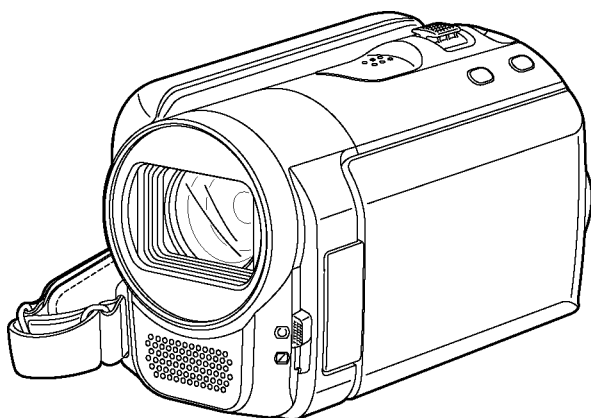

VOL.1

Colours

(K).....Black Type (except SDR-H86EB)

(S).....Silver Type (only SDR-H85P/EC/EE/EG/EP/GA/
GC/GK, H86PU)

(A).....Blue Type (only SDR-H85P/PC/GT)

Panasonic[®]

© Panasonic Corporation 2010.
Unauthorized copying and distribution is a violation
of law.

 **WARNING**

This service information is designed for experienced repair technicians only and is not designed for use by the general public. It does not contain warnings or cautions to advise non-technical individuals of potential dangers in attempting to service a product. Products powered by electricity should be serviced or repaired only by experienced professional technicians. Any attempt to service or repair the product or products dealt with in this service information by anyone else could result in serious injury or death.

TABLE OF CONTENTS

	PAGE	PAGE
1 Safety Precautions	3	
1.1. General Guidelines	3	
2 Warning	4	
2.1. Prevention of Electrostatic Discharge (ESD) to Electrostatic Sensitive (ES) Devices	4	
2.2. Service caution based on legal restrictions	5	
2.3. Caution for AC Cord (For EB/GC/GA)	6	
2.4. How to Replace the Lithium Battery (PROCEDURE)	7	
2.5. How to Recycle the Lithium Battery (U.S. Only)	8	
3 Service Navigation	9	
3.1. Service Information	9	
3.2. How to Define the Model Suffix (NTSC or PAL model)	10	
3.3. Precautions for Handling HDD	11	
3.4. Formatting HDD	15	
4 Specifications	16	
5 Location of Controls and Components	17	
6 Service Mode	20	
6.1. HDD Self Check	21	
6.2. Lock Search History Indication	21	
6.3. Power ON Self Check Result Display	22	
6.4. Lock Search History Clear	22	
7 Service Fixture & Tools	23	
7.1. Service Tools and Equipment	23	
8 Disassembly and Assembly Instructions	24	
8.1. Disassembly Flow Chart	24	
8.2. P.C.B. Layout	24	
8.3. Disassembly Procedures	25	
8.4. Disassembly Procedures of Camera Lens Unit	34	
9 Measurements and Adjustments	36	
9.1. EEPROM Data for spare parts of the MAIN P.C.B.	36	
9.2. Service Positions	36	
9.3. Location for Connectors of the Main P.C.B.	38	
9.4. Electrical Adjustment	39	
10 Maintenance	41	
10.1. Cleaning Lens and LCD Panel	41	
11 Factory Setting	42	
11.1. How to turn on the factory setting?	42	
11.2. What is the factory settings?	42	

1 Safety Precautions

1.1. General Guidelines

1. IMPORTANT SAFETY NOTICE

There are special components used in this equipment which are important for safety. These parts are marked by \triangle in the Schematic Diagrams, Circuit Board Layout, Exploded Views and Replacement Parts List. It is essential that these critical parts should be replaced with manufacturer's specified parts to prevent X-RADIATION, shock fire, or other hazards. Do not modify the original design without permission of manufacturer.

2. An Isolation Transformer should always be used during the servicing of AC Adaptor whose chassis is not isolated from the AC power line. Use a transformer of adequate power rating as this protects the technician from accidents resulting in personal injury from electrical shocks. It will also protect AC Adaptor from being damaged by accidental shorting that may occur during servicing.
3. When servicing, observe the original lead dress. If a short circuit is found, replace all parts which have been overheated or damaged by the short circuit.
4. After servicing, see to it that all the protective devices such as insulation barriers, insulation papers shields are properly installed.
5. After servicing, make the following leakage current checks to prevent the customer from being exposed to shock hazards.

1.1.1. Leakage Current Cold Check

1. Unplug the AC cord and connect a jumper between the two prongs on the plug.
2. Measure the resistance value, with an ohmmeter, between the jumpered AC plug and each exposed metallic cabinet part on the equipment such as screwheads, connectors, control shafts, etc. When the exposed metallic part has a return path to the chassis, the reading should be between $1M\Omega$ and $5.2M\Omega$. When the exposed metal does not have a return path to the chassis, the reading must be infinity.

1.1.2. Leakage current hot check (See Figure 1)

1. Plug the AC cord directly into the AC outlet. Do not use an isolation transformer for this check.
2. Connect "A" to exposed metallic part on the set. And connect "B" to a good earth ground, as shown in Figure 1.
3. Use an AC voltmeter, with $1\text{ k}\Omega/V$ or more sensitivity, to measure the potential across the resistor.
4. Check each exposed metallic part, and measure the voltage at each point.
5. Reverse the AC plug in the AC outlet and repeat each of the above measurements.
6. The potential at any point should not exceed 0.25 V RMS . A leakage current tester (Simpson Model 229 or equivalent) may be used to make the hot checks, leakage current must not exceed $1/2\text{ mA}$. In case a measurement is outside of the limits specified, there is a possibility of a shock hazard, and the equipment should be repaired and rechecked before it is returned to the customer.

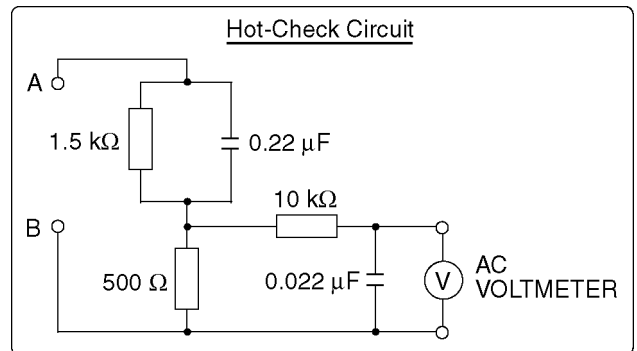

Figure 1

2 Warning

2.1. Prevention of Electrostatic Discharge (ESD) to Electrostatic Sensitive (ES) Devices

Some semiconductor (solid state) devices can be damaged easily by static electricity. Such components commonly are called Electrostatic Sensitive (ES) Devices. Examples of typical ES devices are integrated circuits and some field-effect transistors and semiconductor “chip” components. The following techniques should be used to help reduce the incidence of component damage caused by electrostatic discharge (ESD).

1. Immediately before handling any semiconductor component or semiconductor-equipped assembly, drain off any ESD on your body by touching a known earth ground. Alternatively, obtain and wear a commercially available discharging ESD wrist strap, which should be removed for potential shock reasons prior to applying power to the unit under test.
2. After removing an electrical assembly equipped with ES devices, place the assembly on a conductive surface such as aluminum foil, to prevent electrostatic charge buildup or exposure of the assembly.
3. Use only a grounded-tip soldering iron to solder or unsolder ES devices.
4. Use only an antistatic solder removal device. Some solder removal devices not classified as “antistatic (ESD protected)” can generate electrical charge sufficient to damage ES devices.
5. Do not use freon-propelled chemicals. These can generate electrical charges sufficient to damage ES devices.
6. Do not remove a replacement ES device from its protective package until immediately before you are ready to install it. (Most replacement ES devices are packaged with leads electrically shorted together by conductive foam, aluminum foil or comparable conductive material).
7. Immediately before removing the protective material from the leads of a replacement ES device, touch the protective material to the chassis or circuit assembly into which the device will be installed.

CAUTION:

Be sure no power is applied to the chassis or circuit, and observe all other safety precautions.

8. Minimize bodily motions when handling unpackaged replacement ES devices. (Otherwise harmless motion such as the brushing together of your clothes fabric or the lifting of your foot from a carpeted floor can generate static electricity (ESD) sufficient to damage an ES device).

IMPORTANT SAFETY NOTICE

There are special components used in this equipment which are important for safety. These parts are marked by \triangle in the schematic diagrams, Exploded Views and replacement parts list. It is essential that these critical parts should be replaced with manufacturer's specified parts to prevent shock, fire, or other hazards. Do not modify the original design without permission of manufacturer.

2.2. Service caution based on legal restrictions

2.2.1. General description about Lead Free Solder (PbF)

The lead free solder has been used in the mounting process of all electrical components on the printed circuit boards used for this equipment in considering the globally environmental conservation.

The normal solder is the alloy of tin (Sn) and lead (Pb). On the other hand, the lead free solder is the alloy mainly consists of tin (Sn), silver (Ag) and Copper (Cu), and the melting point of the lead free solder is higher approx.30 degrees C (86°F) more than that of the normal solder.

Definition of PCB Lead Free Solder being used

The letter of "PbF" is printed either foil side or components side on the PCB using the lead free solder. (See right figure)

PbF

Service caution for repair work using Lead Free Solder (PbF)

- The lead free solder has to be used when repairing the equipment for which the lead free solder is used.
(Definition: The letter of "PbF" is printed on the PCB using the lead free solder.)
- To put lead free solder, it should be well molten and mixed with the original lead free solder.
- Remove the remaining lead free solder on the PCB cleanly for soldering of the new IC.
- Since the melting point of the lead free solder is higher than that of the normal lead solder, it takes the longer time to melt the lead free solder.
- Use the soldering iron (more than 70W) equipped with the temperature control after setting the temperature at 350±30 degrees C (662±86°F).

Recommended Lead Free Solder (Service Parts Route.)

- The following 3 types of lead free solder are available through the service parts route.
RFKZ03D01KS----- (0.3mm 100g Reel)
RFKZ06D01KS----- (0.6mm 100g Reel)
RFKZ10D01KS----- (1.0mm 100g Reel)

Note:

- * Ingredient: tin (Sn), 96.5%, silver (Ag) 3.0%, Copper (Cu) 0.5%, Cobalt (Co) / Germanium (Ge) 0.1 to 0.3%

2.3. Caution for AC Cord (For EB/GC/GA)

2.3.1. Information for your safety

IMPORTANT

Your attention is drawn to the fact that recording of pre-recorded tapes or discs or other published or broadcast material may infringe copyright laws.

WARNING

To reduce the risk of fire or shock hazard, do not expose this equipment to rain or moisture.

CAUTION

To reduce the risk of fire or shock hazard and annoying interference, use the recommended accessories only.

FOR YOUR SAFETY

DO NOT REMOVE THE OUTER COVER

To prevent electric shock, do not remove the cover. No user serviceable parts inside. Refer servicing to qualified service personnel.

2.3.2. Caution for AC mains lead

For your safety, please read the following text carefully.

This appliance is supplied with a moulded three-pin mains plug for your safety and convenience.

A 5-ampere fuse is fitted in this plug.

Should the fuse need to be replaced please ensure that the replacement fuse has a rating of 5 amperes and it is approved by ASTA or BSI to BS1362

Check for the ASRA mark or the BSI mark on the body of the fuse.



If the plug contains a removable fuse cover you must ensure that it is refitted when the fuse is replaced.

If you lose the fuse cover, the plug must not be used until a replacement cover is obtained.

A replacement fuse cover can be purchased from your local Panasonic Dealer.

If the fitted moulded plug is unsuitable for the socket outlet in your home then the fuse should be removed and the plug cut off and disposed of safely.

There is a danger of severe electrical shock if the cut off plug is inserted into any 13-ampere socket.

If a new plug is to be fitted please observe the wiring code as shown below.

If in any doubt, please consult a qualified electrician.

2.3.2.1. Important

The wires in this mains lead are coloured in accordance with the following code:

Blue	Neutral
Brown	Live

As the colours of the wires in the mains lead of this appliance may not correspond with the coloured markings identifying the terminals in your plug, proceed as follows:

The wire which is coloured BLUE must be connected to the terminal in the plug which is marked with the letter N or coloured BLACK.

The wire which is coloured BROWN must be connected to the terminal in the plug which is marked with the letter L or coloured RED.

Under no circumstances should either of these wires be connected to the earth terminal of the three pin plug, marked with the letter E or the Earth Symbol.

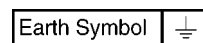

2.3.2.2. Before use

remove the Connector Cover as follows.

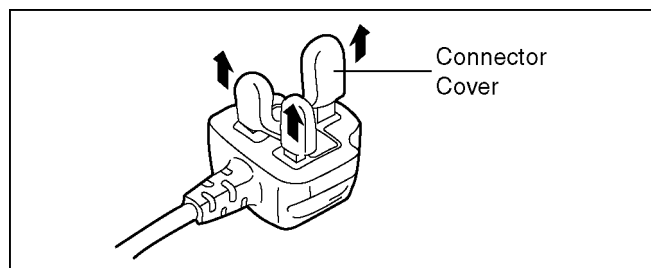

2.3.2.3. How to replace the Fuse

1. Remove the Fuse Cover with a screwdriver.

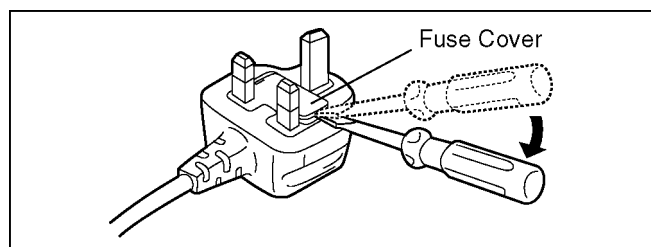

2. Replace the fuse and attach the Fuse cover.

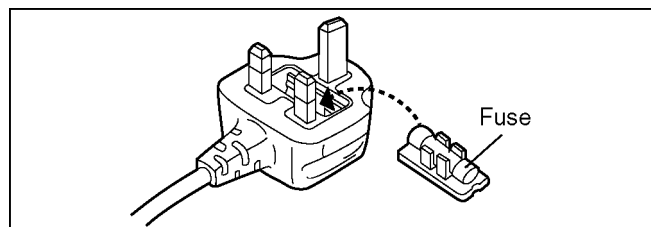

2.4. How to Replace the Lithium Battery (PROCEDURE)

1. Remove the Monitor P.C.B. (Refer to Disassembly Procedures.)
2. Unsolder the Lithium Battery "ML-614S/DN" and then replace the new one. (See Fig. B1.)

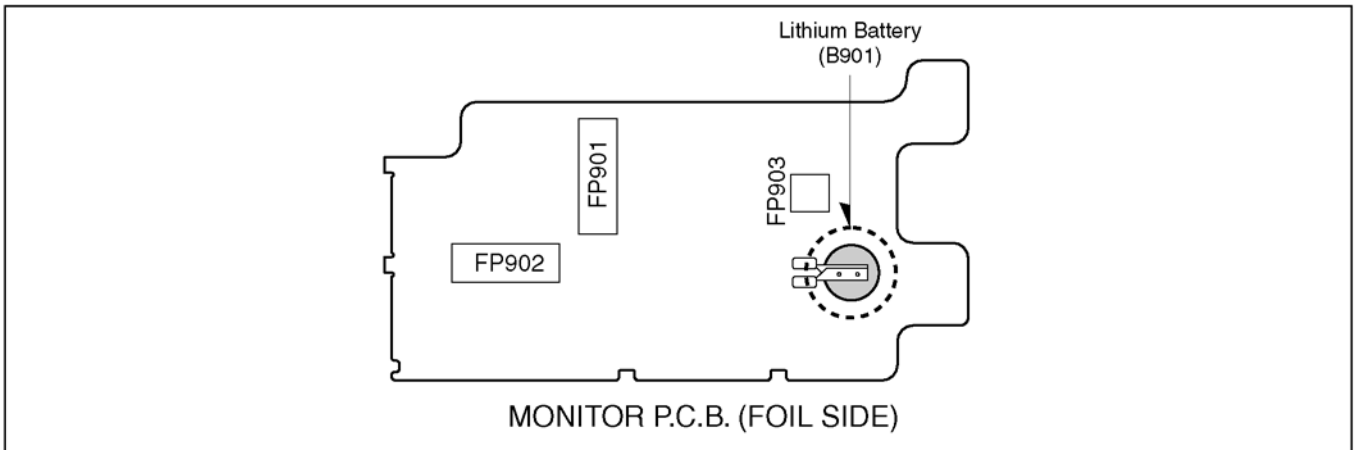

CAUTION

Danger of explosion if battery is incorrectly replaced.
Replace only with the same or equivalent type.

CAUTION

The battery used in this device may present a risk of fire or chemical burn if mistreated.
Do not recharge, disassemble, heat above 100°C (212°F), or incinerate.
Replace battery with Panasonic part number ML-614S/DN only.
Use of another battery may present a risk of fire or explosion.
Dispose of used battery promptly.
Keep away from children.
Do not disassemble and do not dispose of in fire.

Fig. B1

Note:

The lithium battery is a critical component.

(Type No.: ML-614S/DN **Manufactured by Energy Company, Panasonic Corporation**)

It must never be subjected to excessive heat or discharge.

It must therefore only be fitted in equipment designed specifically for its use.

Replacement batteries must be of the same type and manufacture.

They must be fitted in the same manner and location as the original battery, with the correct polarity contacts observed.

Do not attempt to re-charge the old battery or re-use it for any other purpose.

It should be disposed of in waste products destined for burial rather than incineration.

(For English)

CAUTION

Danger of explosion if battery is incorrectly replaced.
Replace only with the same or equivalent type recommended by the equipment manufacturer.
Discard used batteries according to manufacturer's instructions.

(For French)

PRECAUTION

Le fait de remplacer incorrectement la pile peut présenter des risques d'explosion.
Remplacer la pile uniquement par une pile identique ou de type équivalent recommandée par le fabricant. Se débarrasser des piles usagées conformément aux instructions du fabricant.

(For German)

VORSICHT

Bei einer falsch eingesetzten Batterie besteht Explosionsgefahr. Nur mit einer vom gleichen Typ ersetzen.
Verbrauchte Batterien beim Fachhändler oder einer Sammelstelle für Sonderstoffe abliefern.

(For Swedish)

VARNING

Explosionsfara vid felaktigt batteribyte.
Använd samma batterityp eller en ekvivalent typ som rekommenderas av apparattillverkaren.
Kassera använt batteri enligt fabrikantens instruktion.

(For Norwegian)

ADVARSEL!

Lithiumbatteri-Eksplodingsfare ved feilagtig håndtering.
Udskiftning må kun ske med batteri af samme fabrikat og type.
Levér det brugte batteri tilbage til leverandøren.

(For Finnish)

VAROITUS

Paristo voi räjähtää, jos se on virheellisesti asennettu.
Vaihda paristo ainoastaan laitevalmistajan suositteluun tyypin.
Hävitätä käytetty paristo valmistajan ohjeiden mukaisesti.

Note:

Above caution is applicable for a battery pack which is for SDR-H85/H86/H95 series, as well.

2.5. How to Recycle the Lithium Battery (U.S. Only)

U.S.A./CANADA CONSUMERS: ATTENTION:



A lithium ion/polymer battery that is recyclable powers the product you have purchased. Please call 1-800-8-BATTERY for information on how to recycle this battery.

3 Service Navigation

3.1. Service Information

This service manual contains technical information which will allow service personnel's to understand and service this model.

Please place orders using the parts list and not the drawing reference numbers.

If the circuit is changed or modified, this information will be followed by supplement service manual to be filed with original service manual.

Notes 1:

1) This service manual does not contain the following information, because of the impossibility of servicing at component level.

1. Schematic Diagram, Block Diagram and P.C.B. layout of Main P.C.B.
2. Parts List for individual parts of Main P.C.B.

2) The following category are recycle module part. Please send them to Central Repair Center.

- *Main P.C.B. (VEP03H83AM: SDR-H86PR/PU)
- (VEP03H83AN: SDR-H85P/PC/GT)
- (VEP03H83AP: SDR-H85EB/EC/EF/EG/EP)
- (VEP03H83AQ: SDR-H85EE/GA/GC/GK/GN, H95EE/GA/GC)
- (VEP03H83AR: SDR-H86EB)

3.2. How to Define the Model Suffix (NTSC or PAL model)







There are seven kinds of SDR-H85/H86/H95, regardless of the colours.

- a) SDR-H85P
- b) SDR-H85PC
- c) SDR-H85EB/EC/EF/EG/EP/GN, SDR-H86EB
- d) SDR-H85EE, SDR-H95EE
- e) SDR-H85GT
- f) SDR-H85GK
- g) SDR-H85GA/GC, SDR-H86PR/PU, SDR-H95GA/GC

What is the difference is that the "INITIAL SETTINGS" data which is stored in Flash ROM mounted on Main P.C.B.

3.2.1. Defining methods

To define the model suffix to be serviced, refer to the nameplate which is putted on the bottom side of the Unit.

<p>a) SDR-H85P The nameplate for this model shows the following Safety registration mark.</p> 	 <p>Safety registration mark</p>
<p>b) SDR-H85PC The nameplate for these models show the following Safety registration mark.</p> 	
<p>c) SDR-H85EB/ EC/ EF/ EG/ EP/ GN, SDR-H86EB The nameplate for these models show the following Safety registration mark.</p> 	
<p>d) SDR-H85EE, SDR-H95EE The nameplate for this model show the following Safety registration mark.</p> 	<p>f) SDR-H85GK The nameplate for these models show the following Safety registration mark.</p> 
<p>e) SDR-H85GT The nameplate for this model show the following Safety registration mark.</p> 	<p>g) SDR-H85GA/ GC, SDR-H86PR/PU, SDR-H95GA/ GC The nameplate for these models do not show any above safety registration mark.</p>

Note:



After replacing the MAIN P.C.B., be sure to achieve adjustment.

The adjustment instruction is available at "software download" on the "Support Information from NWBG/VDBG-AVC" web-site in "TSN system", together with Maintenance software.

3.3. Precautions for Handling HDD

1. Handle HDD very carefully to prevent the static electricity and shock.
2. Set the HDD quickly after taking it out from the package. Make sure to put the HDD on buffer materials, etc.

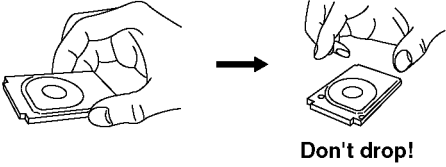
3.3.1. Precautions at incoming process and for opening packages

Preventing shock	<ul style="list-style-type: none"> • Do not throw down HDD from luggage carrier or avoid dropping accidentally when unloading. The HDD may not be reliable when impacts of dropping, throwing or rolling occur. • Avoid HDD hitting other equipment or other HDD. Hold HDD firmly but do not apply excessive force when taking out from the package because it is particularly slippery. • When taking out HDD from the package, make sure to put buffer materials such as conductive urethane materials on a work table. Also, a stable place is recommended to avoid impacts or vibration.
Preventing condensation	<ul style="list-style-type: none"> • To prevent dew condensation on HDD due to sharp temperature change, keep it indoors without unpacking, and adjust the package of HDD to room temperature completely before unpacking. • Avoid entrance or window areas where temperature changes easily for storage.
Holding example	<ul style="list-style-type: none"> • Take out HDD holding both sides, not to press the top cover and the center of the device label. <div style="text-align: center;"> <p><OK></p>  <p>Don't drop!</p> <p><NG></p>  </div>
Preventing static electricity	<ul style="list-style-type: none"> • After opening package, HDD must be handled only by a specified worker in E.S.D.* free environment on a conductive mat. It may cause damage on HDD components due to overvoltage such as electrostatic discharge, etc.

*E.S.D. = Electrostatically Sensitive Devices

3.3.2. Precautions for installing HDD

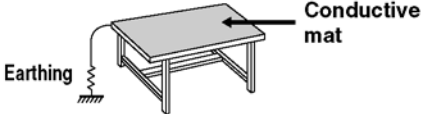
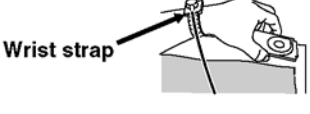
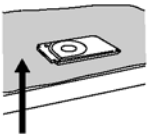
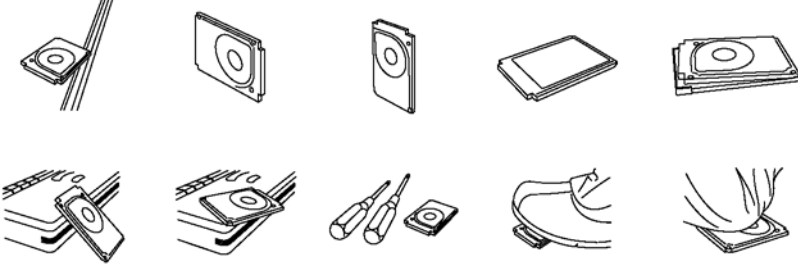
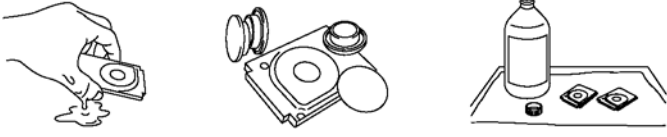
<p>Preventing static electricity</p>	<ul style="list-style-type: none"> HDD may be destroyed by static electricity charged to clothes or human body. Place a conductive mat with removed earthing and use the wrist strap to prevent static charge. <p><OK></p>  <p><OK></p> 
<p>Preventing shock</p>	<ul style="list-style-type: none"> Place HDD with its face upward (the device label upward) on the flat and stable surface using buffer materials, etc. Do not stand HDD. If it falls down, the excessive impacts may damage HDD. Do not store or carry HDD close to other HDD or other components. The components may be distorted due to impacts or weight, which may result in the performance deterioration of the HDD. Do not put HDD in the working area. Do not put HDD close to industrial tools in particular or temporarily put it on the floor. Be extremely careful not to drop HDD when working on it because even dropping HDD down on the work table with a mat on it may cause damage to HDD. <p><OK></p>  <p><NG></p> 
<p>No water / solvent</p>	<ul style="list-style-type: none"> Do not hold HDD with a wet hand or put magnets, solvent, tea, coffee, etc, close to HDD. This affects internal components and outside of HDD <p><NG></p> 
<p>Connector</p>	<ul style="list-style-type: none"> The interface connector pin is easily damaged. Push it lightly and firmly to the end along the connector guide. For further details, refer to "Precautions for inserting and removing HDD FPC".

3.3.3. Precautions for inserting and removing HDD FPC

Make sure to use the tool (LSVQ0112) when locking and unlocking the lock lever of HDD FPC connector. Do not lock the lock lever without inserting HDD FPC. Otherwise, the connector may be damaged.

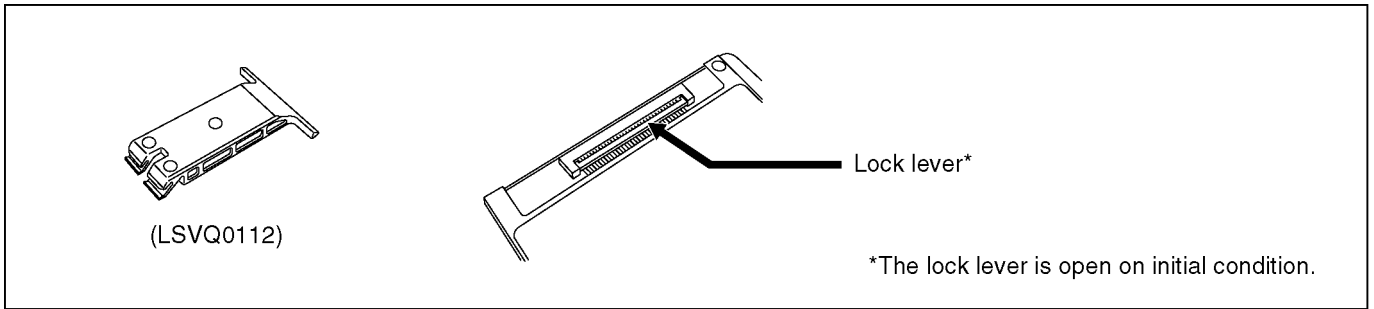

Insert HDD FPC

- ① Place HDD so that HDD device label (CAUTION label) faces up.
Caution: Do not set the HDD cushion when installing HDD FPC.
- ② Insert HDD FPC straight to the connector, and make sure if HDD FPC has been inserted to the end.
Caution: The connector surface of HDD FPC must face down and the letter "HDD" and the arrow must be seen as shown.

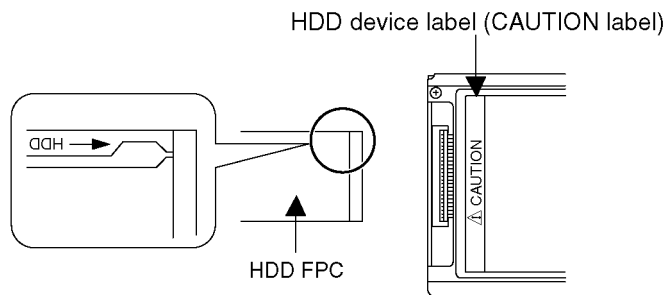

Check HDD FPC

Make sure if HDD FPC has been correctly inserted by confirming the FPC pattern boundary line.

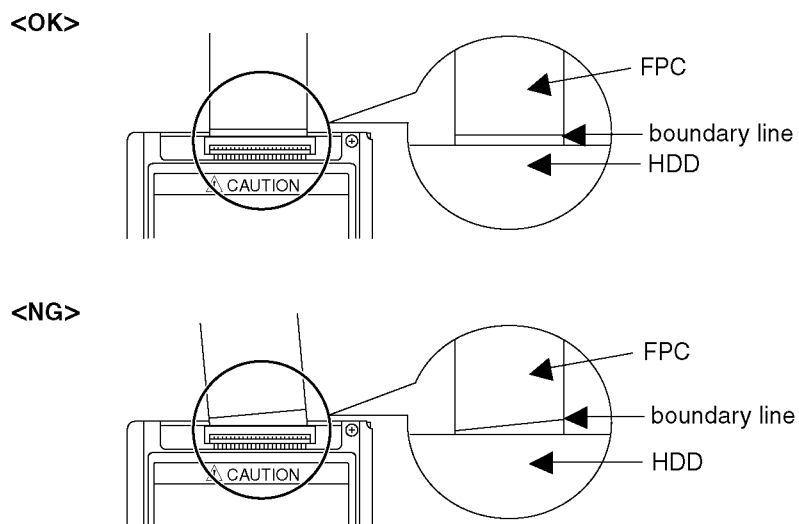

Tool operation

Lock using the tool after inserting HDD FPC.

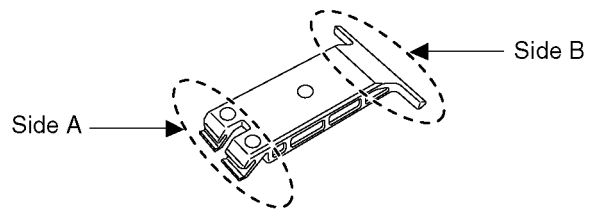

<How to lock>

After inserting HDD FPC, put the tool (Side B) on the connector and slide it slightly to the direction as shown to lock the lock lever.

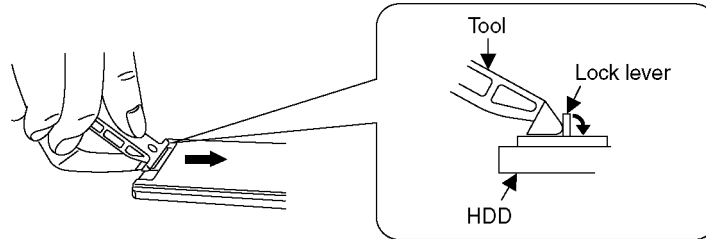

<How to unlock>

Hook up the tip of the tool (Side A) and unlock the lock lever.
The angle of the tool must be less than 45 degree.

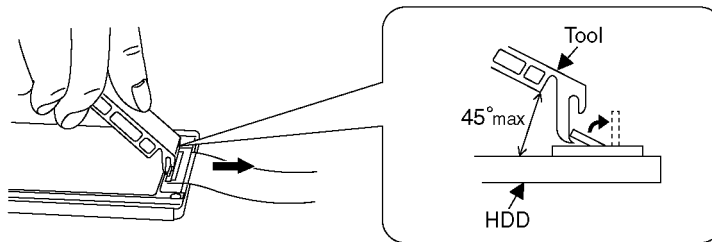

Make sure to use the tool (LSVQ0112) when opening and closing the lock lever.

*When install the HDD to main unit, necessary install the HDD FPC and HDD damper.

3.4. Formatting HDD

When HDD is exchanged, format HDD as the procedure below.

Without formatting, the error message appears on the LCD display when accessing HDD.

<Formatting procedure>

The Mode Switch to select .

Select [HDD] and press the joystick.

Press the MENU button, then

select [SETUP] →

[FORMAT MEDIA] → [HDD] → [YES] and

press the joystick.

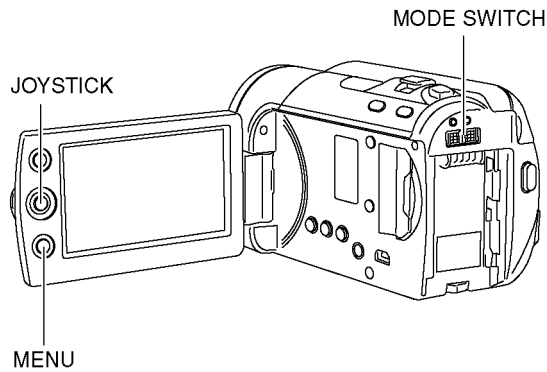

When the confirmation message appears, select [YES], then press the joystick.

- When formatting is complete, press the MENU button to exit the message screen.

Note:

- During formatting, do not turn this unit off.
- When you format the HDD, use a battery with sufficient battery power or the AC adaptor.
- During formatting, do not cause any vibrations or impacts to this unit.

4 Specifications

SD/HDD Video Camera

ITEM	SPECIFICATION			ITEM	SPECIFICATION																												
POWER	SD/HDD Video Camera: Power Source: DC 5.0 V (When using AC adaptor) DC 3.6 V (When using battery) Power Consumption: 3.5 W (Recording) 7.7 W (Charging) AC Adaptor: Power Source: AC 110-240 V, 50/60 Hz Power Consumption: 12 W DC Output: DC 5.0V, 1.6 A (Unit Operation)			STILL PICTURES	Recording Media: SD Memory Card (removable type): 8 MB /16 MB /32 MB /64 MB /128 MB /256 MB / 512 MB /1 GB/2 GB (FAT12 and FAT16 system compliant) SDHC Memory Card (removable type): 4 GB /6 GB /8 GB /12 GB /16 GB /32 GB (FAT32 system compliant) SDXC Memory Card (removable type): 48 GB /64 GB (exFAT system compliant) HDD (fixed): 80 GB (SDR-H85,H86) : 120 GB (SDR-H95) Compression: JPEG (Design rule for Camera File system, based on Exif 2.2 standard), DPOF corresponding Picture Size: 640 × 480 (4:3), 640 × 360 (16:9)																												
RECORDING FORMAT	SD Card	Normal recording mode: Based on the SD-Video standard			STANDARD ILLUMINATION	1,400 lx																											
	HDD	Normal recording mode: Independent standard Long recording mode: Independent standard				MINIMUM REQUIRED ILLUMINATION	Approx. 5lx (1/25 in low light mode) Approx. 2lx with the colour night view function																										
CAMERA	Zoom: 70X optical, 78X enhanced Optical zoom, 100X/3500X digital				MINIMUM REQUIRED ILLUMINATION	Approx. 5lx (1/25 in low light mode) Approx. 2lx with the colour night view function																											
	Monitor: 2.7 - inch wide LCD (approx. 123K pixels)																																
	Lens: Auto Iris, F1.9 - F5.7, Focal Length; 1.48 - 104 mm Macro (Wide Range AF)																																
VIDEO	Image Sensor: 1/8 - inch CCD Image Sensor			USB	SD Card Read/Write (No copyright protection support) HDD Read only																												
	Television System : EIA Standard : 525 Lines, 60 Fields NTSC Colour Signal (SDR-H85P/PC/GT, H86PR/PU) CCIR : 625 Lines, 50 Fields PAL Colour Signal (Except SDR-H85P/PC/GT, H86PR/PU)					Hi-Speed USB (USB 2.0) compliant USB terminal Type Mini AB USB host function (for DVD burner).																											
	Video Output Level: 1.0 Vp-p, 75 ohm, NTSC/PAL System (AV Multi Jack)			MICROPHONE	Stereo (with a zoom function)																												
AUDIO	Audio Output Level (Line): 316 mV, 600 ohm, 2 ch (AV Multi Jack)			SPEAKER	1 round speaker																												
MOTION PICTURES	Recording media: SD Memory Card (removable type) : 512 MB/1 GB/2 GB (FAT12 and FAT16 system compliant) SDHC Memory Card (removable type) : 4 GB /6 GB /8 GB /12 GB /16 GB /32 GB (FAT32 system compliant) SDXC Memory Card (removable type) : 48 GB /64 GB (exFAT system compliant) HDD (fixed type): 80 GB (SDR-H85,H86) : 120 GB (SDR-H95) Compression: Normal recording mode: MPEG-2 Long recording mode: MPEG-4 AVC/H.264 Recoding mode and transfer rate: XP: Approx. 10 Mbps (VBR) SP: Approx. 5 Mbps (VBR) LP: Approx. 2.5 Mbps (VBR) LXP: Approx. 5 Mbps (VBR) LSP: Approx. 2.5 Mbps (VBR) LLP: Approx. 1.25 Mbps (VBR) Recordable time: Approx.			OPERATING TEMPERATURE	0°C - 40°C (32 °F - 104 °F)																												
	<table border="1"> <thead> <tr> <th></th> <th>SD Card (1GB)</th> <th>HDD (80GB)</th> <th>HDD (120GB)</th> </tr> </thead> <tbody> <tr> <td>XP</td> <td>12 minutes</td> <td>18h.30min.</td> <td>27h.45min.</td> </tr> <tr> <td>SP</td> <td>25 minutes</td> <td>37 hours</td> <td>55h.30min.</td> </tr> <tr> <td>LP</td> <td>50 minutes</td> <td>74h.30min.</td> <td>112 hours</td> </tr> <tr> <td>LXP</td> <td>24 minutes</td> <td>37 hours</td> <td>55h.30min.</td> </tr> <tr> <td>LSP</td> <td>50 minutes</td> <td>74 hours</td> <td>111 hours</td> </tr> <tr> <td>LLP</td> <td>1h.40min.</td> <td>149 hours</td> <td>224 hours</td> </tr> </tbody> </table>				SD Card (1GB)	HDD (80GB)	HDD (120GB)	XP	12 minutes	18h.30min.	27h.45min.	SP	25 minutes	37 hours	55h.30min.	LP	50 minutes	74h.30min.	112 hours	LXP	24 minutes	37 hours	55h.30min.	LSP	50 minutes	74 hours	111 hours	LLP	1h.40min.	149 hours	224 hours	OPERATING HUMIDITY	10 % - 80 %
		SD Card (1GB)	HDD (80GB)	HDD (120GB)																													
	XP	12 minutes	18h.30min.	27h.45min.																													
	SP	25 minutes	37 hours	55h.30min.																													
	LP	50 minutes	74h.30min.	112 hours																													
	LXP	24 minutes	37 hours	55h.30min.																													
	LSP	50 minutes	74 hours	111 hours																													
	LLP	1h.40min.	149 hours	224 hours																													
	MASS (WEIGHT)			MASS (WEIGHT)	SD/HDD Video Camera: Approx. 273 g (Approx. 0.6lbs) (without battery and SD Card) AC Adaptor: Approx. 115 g (0.25 lbs)																												
DIMENSIONS			DIMENSIONS	SD/HDD Video Camera: (excluding projecting parts) 55.1 mm (W) × 64 mm (H) × 107.3 mm (D) 2.17 inch (W) × 2.52 inch (H) × 4.22 inch (D) AC Adaptor: 46 mm (W) × 25 mm (H) × 75.5 mm (D) 1.8 inch (W) × 1.0 inch (H) × 3.0 inch (D)																													
STANDARD ACCESSORIES			STANDARD ACCESSORIES	1 pc. AC Adaptor 1 pc. Battery Pack Unit 1 pc. AC Cord (Except SDR-H85GC, H95GC) 2 pcs. AC Cord (SDR-H80GC, H95GC) 1 pc. AV Cable 1 pc. CD-ROM 1 pc. USB Cable																													
SOLDER			SOLDER	This model use lead free solder (PbF).																													
Picture size: 640 x 480 (4:3), 640 x 360 (16:9) Audio compression: Normal recording mode: MPEG - 1 Audio Layer 2 Long recording mode: AAC 16 bit (48kHz)																																	

Specifications may change without prior notice.

5 Location of Controls and Components

Followings are the Location of Controls and Components for SDR-H85P/PC as a sample. For other models, refer to each Operating Instructions.

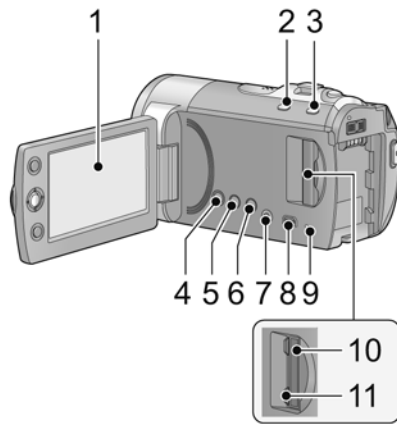

1 LCD monitor

- Pull the LCD monitor out in the direction of the arrow with your fingers.



- It can open up to 90°.

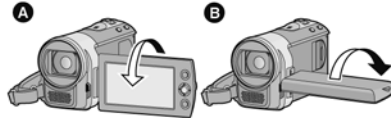

- It can rotate up to 180° **A** towards the lens or 90° **B** towards the opposite direction.
- The brightness and color level of the LCD monitor can be adjusted.

Due to limitations in LCD production technology, there may be some tiny bright or dark spots on the LCD monitor screen. However, this is not a malfunction and does not affect the recorded picture.

2 Intelligent auto/Manual button [iA/MANUAL]

3 Optical image stabilizer button [(O.I.S.)]

4 Power button [⏻/⏻]

5 Delete button [🗑️]

6 Long recording button [LONG REC.]

7 Audio-video output terminal [A/V]

- Use the AV cable (only the supplied cable).

8 USB terminal [⏏]

9 Access lamp [ACCESS]

10 SD card slot

11 SD card cover [SD CARD]

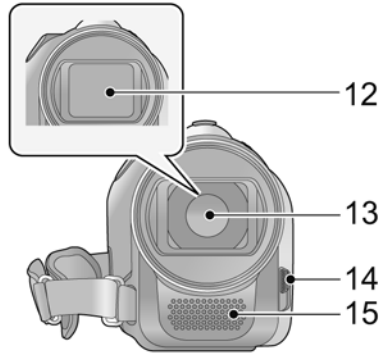

12 Lens cover
13 Lens
14 Open/close switch for the lens cover
 For the lens protection, be sure to close the lens cover when not in use.
Slide open/close switch for the lens cover.

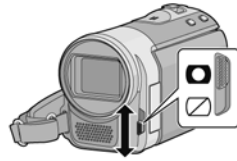

15 Microphone (built-in, stereo)

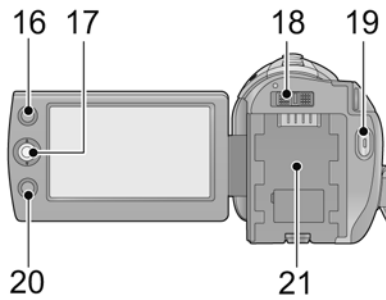

16 AF/AE button [AF/AE]
17 Joystick
 Use the joystick to select the recording functions and playback operations, and to operate the menu screen.
Move the joystick up, down, left, or right to select a setting or scene and then press the joystick to set it.

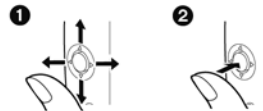

- 1** Select by moving up, down, left or right.
- 2** Set by pressing the center.
- Menu screen operations
- To select the recording functions
- To adjust manually
- Playback operations
- 18 Mode switch**
- 19 Recording start/stop button**
- 20 Menu button [MENU]**
- 21 Battery holder**

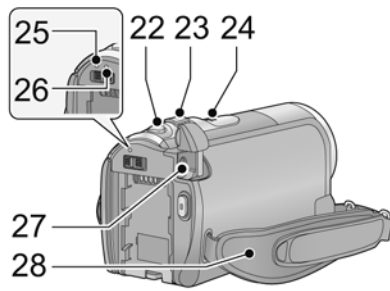

- 22 Photoshot button []
 - 23 When recording: Zoom lever [W/T]
When playing back: Thumbnail display switch [/]/
Volume lever [-VOL+]
 - 24 Speaker
 - 25 Status indicator
 - 26 HDD access lamp [ACCESS HDD]
 - 27 DC input terminal [DC IN]
 - 28 Grip belt
- Adjust the belt length and the pad position.

(U.S.A. only):
When this unit is purchased, a sensor tag is attached to the grip belt. Remove the tag before use.

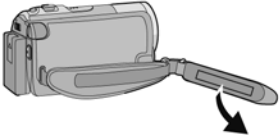
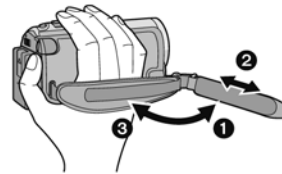
- ❶ Flip the belt.
- ❷ Adjust the length.
- ❸ Replace the belt.

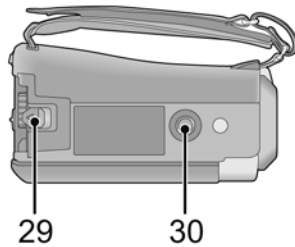

- 29 Battery release lever [BATTERY]
- 30 Tripod receptacle

6 Service Mode

1. Indication method of the service menu

Set the mode switch "  Recording" mode.

- While keep pressing the "Intelligent auto/Manual" button and "Menu" button, hold left the Zoom Lever towards to "[W]" position for more than 3 seconds until the top screen of the Service Menu being displayed.

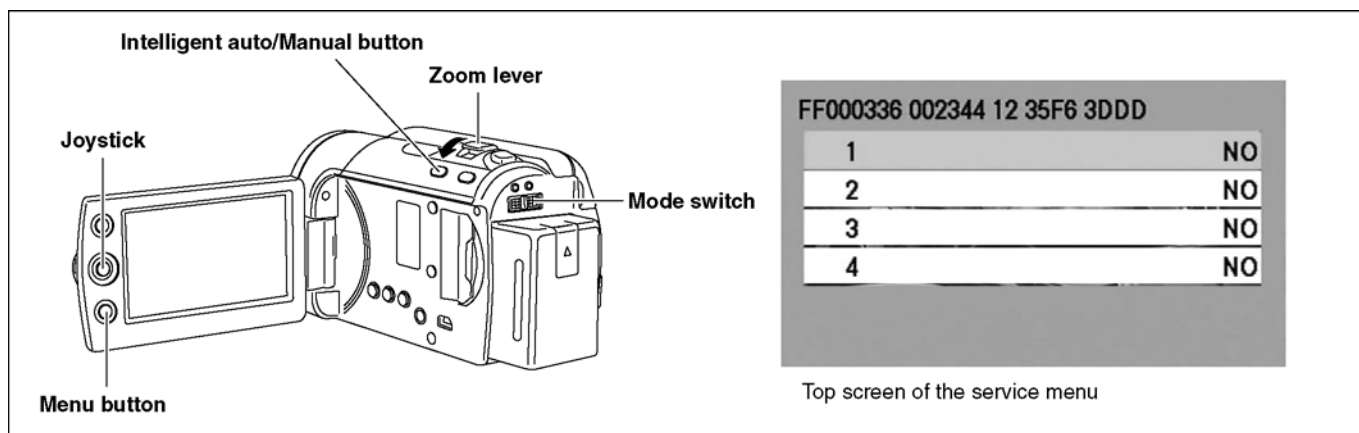

Service mode menu

Screen display	Contents	Function
1	Factory settings	Function to throw a product up in a factory shipment state
3	Self check execution	Function to check self as for the state of HDD
4	Lock search history indication	Display an error code for three histories saved in EEPROM
5	Power ON self check result display	Power ON self check (function to diagnose correct function of the device and interface between devices) result display
10	Lock search history clear	An error code for three histories in EEPROM is cleared

Note:

Do not using service mode except above table of Service Menu.

3. End method of the top screen of the service menu

Push the menu button to end the service mode, and then POWER OFF.

6.1. HDD Self Check

1. Select [3] HDD self check.

Operation specifications

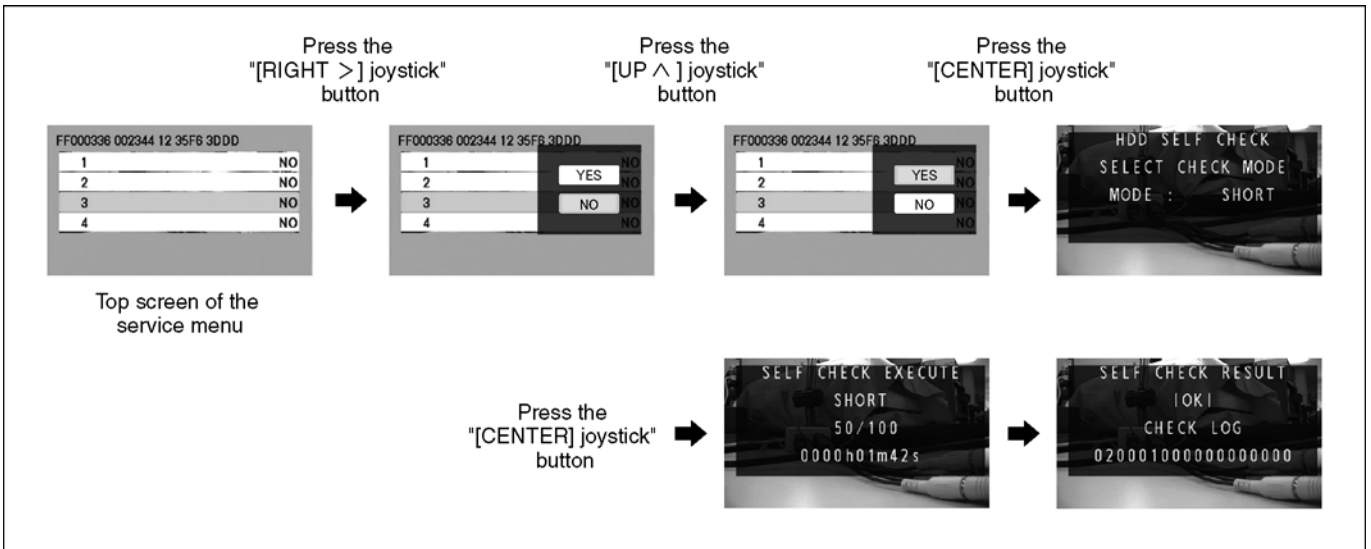

Indication contents

- HDD self check result display
 - Display the HDD self check result information.
 - Displays other than "OK" are abnormalities of HDD.
- Push the menu button to end the service mode, and then POWER OFF.

6.2. Lock Search History Indication

1. Select [4] Lock search history indication.

Operation specifications

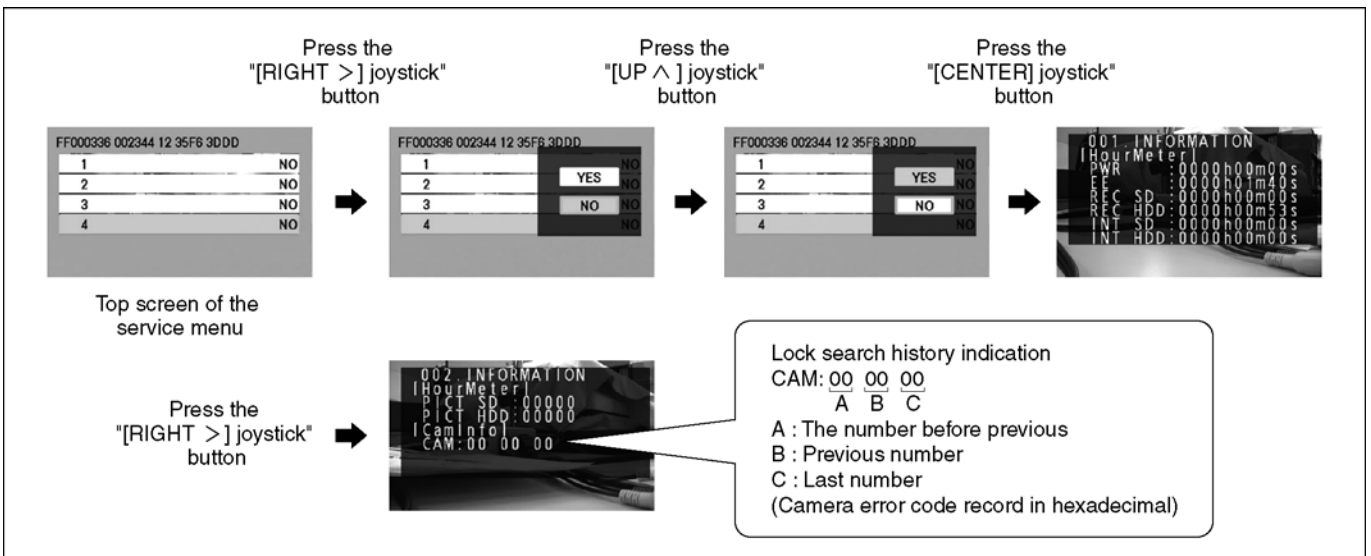

Indication contents

- Lock search history indication
 - Display the camera system error code for three histories saved in EEPROM.
- The error code contents which are displayed

Error code	Function
51	Focus control is abnormal
52	Zoom control is abnormal
53	OIS lens control is abnormal
73	High temperature is abnormal
33	Communication between camera to ARM is abnormal

Lock search history indication is finished by POWER OFF.

6.3. Power ON Self Check Result Display

1. Select [5] Power ON self check result display.

Operation specifications

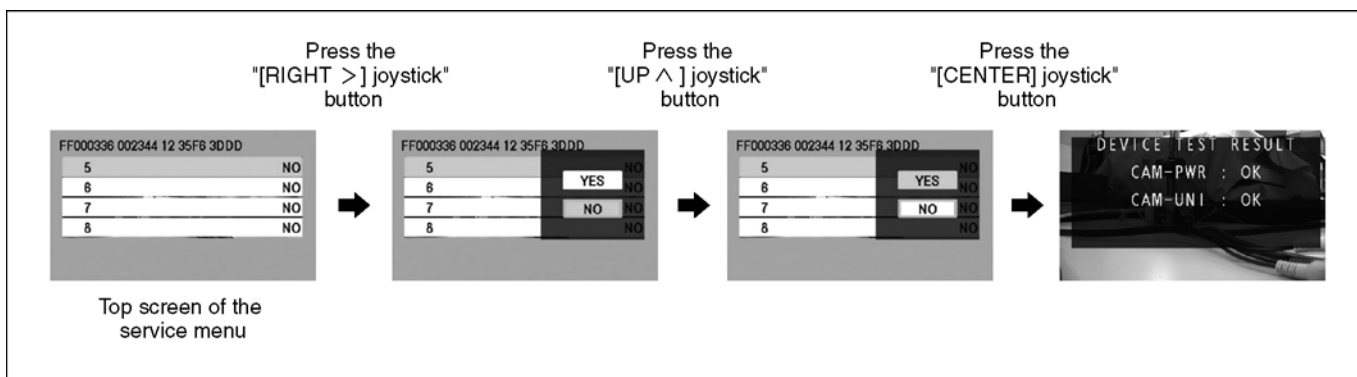

Indication contents

- Power ON self check result display

Function to diagnose correct function of the device and interface between devices result display.

Display the following communication test result.

- CAM-PWR : Communication test between IC2304 to IC2006
- CAM-UNI : Communication test between IC3401 to IC2006

Display other than "OK" are abnormalities of each lines.

Power ON self check result display is finished by POWER OFF.

6.4. Lock Search History Clear

1. Select [10] Lock Search History Clear.

Operation specifications

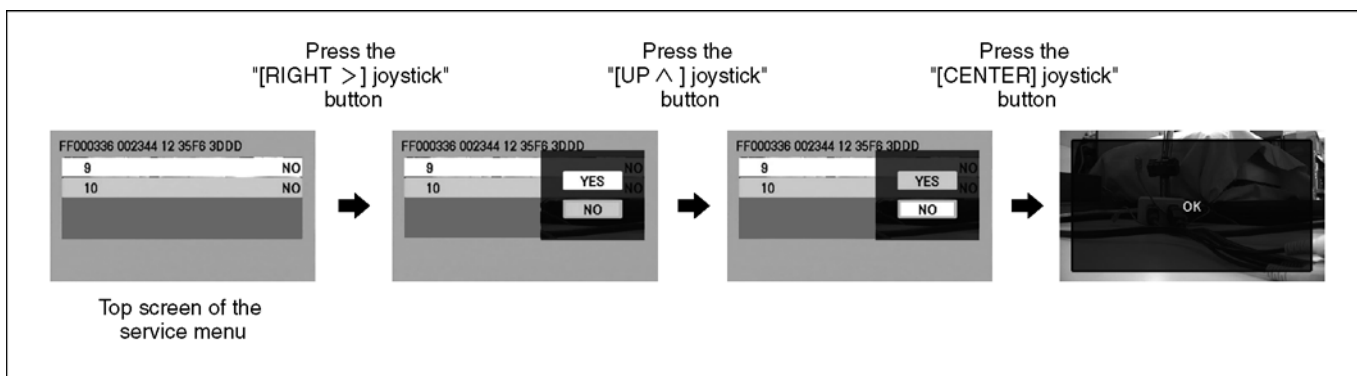

- Lock Search History Clear

An error code for three histories in EEPROM is cleared.

Push the menu button to end the service mode, and then POWER OFF.

7 Service Fixture & Tools

7.1. Service Tools and Equipment

Parts Name	Parts No.	Q'ty	Remarks
PC	---	1	
AC Adaptor	---	1	
DC Cable	---	1	
AV Multi Cable	---	1	
USB Cable	---	1	
PC-Adjustment Program	---	1	
Light Box	VFK1164LBX1	1	
Infinity Lens	VFK1164TCM02 or VFK1164TCM03	1	With Focus Chart
Color Bar Chart	VFK1164TFCB2	1	
Gray Scale Chart	VFK1164TFGS2	1	
Color Conversion	VFK1164TFCT2	1	
Light Box	VFK1164TDVLB or RFKZ0523	1	
Color Conversion (C12)	VFK1164LBB12	1	
Color Conversion (C2)	VFK1164LBB2	1	
Color Conversion (C4)	VFK1164LBB4	1	
Color Conversion (C8)	VFK1164LBB8	1	
Tripod	RFKZ0333B	1	
Adapter for infinity Lens	RFKZ0333H	1	
Grease	LSUQ0050	1	
Plier	LSUQ0028	1	
HDD Connector Tool	LSVQ0112	1	
Pin For CCD	RFKZ0476	1	
Extension Flat Cable (6pin)	VFK1480	1	FP6009 (Main) - Front Case/Mic Unit
Extension Flat Cable (27pin)	VFK1491	1	FP6001 (Main) - Side Case R/LCD Unit
Extension Flat Cable (33pin)	VFK1950	1	FP6008 (Main) - Lens Unit
Extension Flat Cable (18pin)	VFK1443	1	FP6007 (Main) - Prism Unit
Extension Flat Cable (22pin)	VFK1282	1	FP6004 (Main) - FP3901 (Rear)
Extension Flat Cable (40pin)	RFKZ0379	1	FP6002 (Main) - FP6701 (DC BATT OP FPC)
Extension Flat Cable (40pin)	RFKZ0379	1	FP6006 (Main) - HDD Unit

8 Disassembly and Assembly Instructions

8.1. Disassembly Flow Chart

This flow chart indicates the disassembly steps the cabinet parts and P.C.B. Unit in order to access to be serviced. When reinstalling, perform the steps in the reverse order.

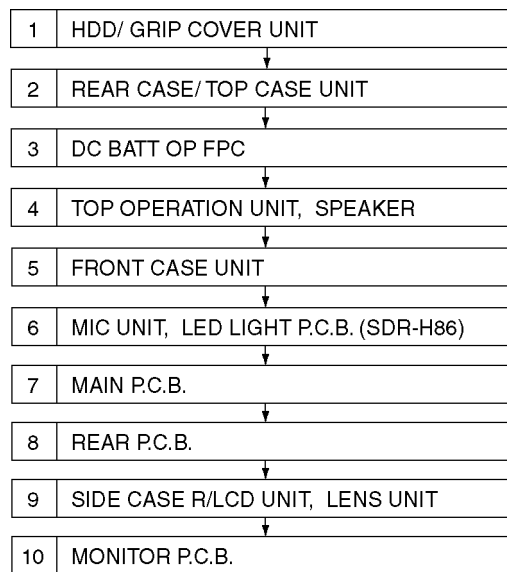

8.2. P.C.B. Layout

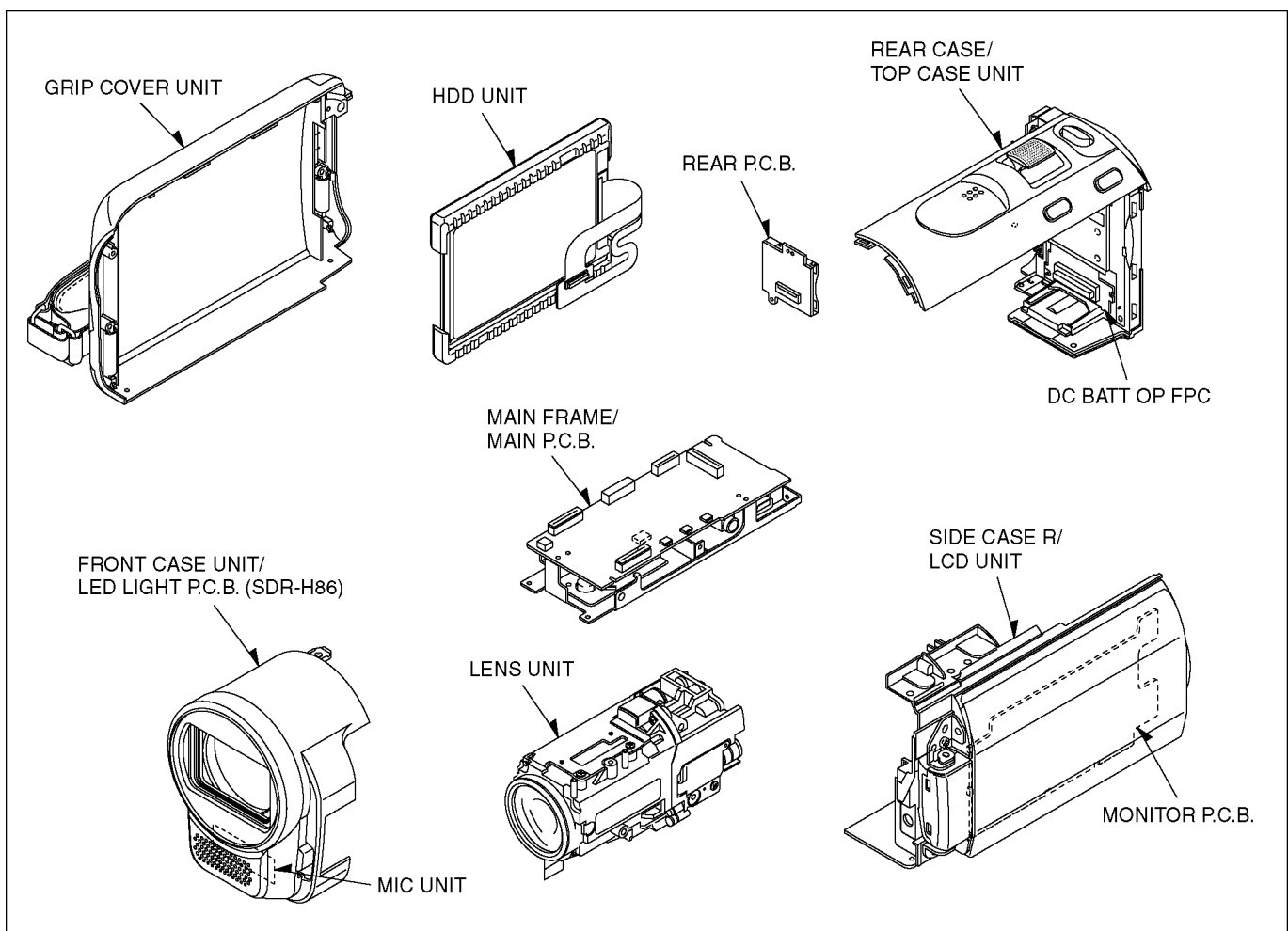

Fig. F1

8.3. Disassembly Procedures

Flow-Chart for Disassembly Procedure

No.	Item / Part	Fig.	Removal (Screw, Connector, FPC. & Other)	
1	HDD/ Grip Cover Unit	Fig.D2	2-Screws (A)	
		Fig.D3	4-Screws (B)	
			3-Tabs 1-Connector FP6006 HDD/ Grip Cover Unit	
		Fig.D4	1-Screw (C)	
			3-Tabs Grip Piece Grip Cover Unit HDD Unit	
			Fig.D5	Note for replacing HDD 1) How to Remove HDD Damper HDD
		Fig.D6	Note for replacing HDD 2) How to Attach	
2	Rear Case/ Top Case Unit	Fig.D7	4-Screws (D) 1-Connector FP6002 2-Tabs Rear Case/ Top Case Unit	
		Fig.D8	2-Connectors FP6703, P6702 1-Screw (E) Top Case Unit Rear Case Unit	
			Fig.D9	2-Screws (F) Earth Plate DC BATT OP FPC
4	Top Operation Unit, Speaker	Fig.D10	3-Screws (G) Top Operation Unit	
		Fig.D11	Note for attaching Top Operation Unit	
		Fig.D12	1-Screw (H) Speaker Angle Speaker	
		Fig.D13	Note for attaching Speaker Angle	
5	Front Case Unit	Fig.D14	2-Connectors FP6009, P6003 (SDR-H86)	
		Fig.D15	1-Screw (I) 2-Screws (J) 1-Tab Front Case Unit	
			Fig.D16	3-Screws (K) (1-Screw: SDR-H86) Shutter Unit LED Light P.C.B. (SDR-H86)
				Fig.D17
6	Mic Unit, LED Light P.C.B. (SDR-H86)	Fig.D18	Mic Unit	
		Fig.D19	1-Screw (L) 3-Screws (M) Side L Angle	
			Fig.D20	4-Connectors FP6001, FP6004, FP6007, FP6008 1-Screw (N) Main Frame
7	Main P.C.B.	Fig.D21	2-Screws (O) Main P.C.B.	
		Fig.D22	1-Screw (P) Rear P.C.B.	

No.	Item / Part	Fig.	Removal (Screw, Connector, FPC. & Other)
9	Side Case R/LCD Unit, Lens Unit	Fig.D23	1-Screw (Q) Side Case R/LCD Unit Lens Unit
			Fig.D24
Fig.D25	2-Connectors FP902, FP903 1-Screw (S) Menu Selector Unit 6-Tabs LCD Unit Monitor P.C.B.		

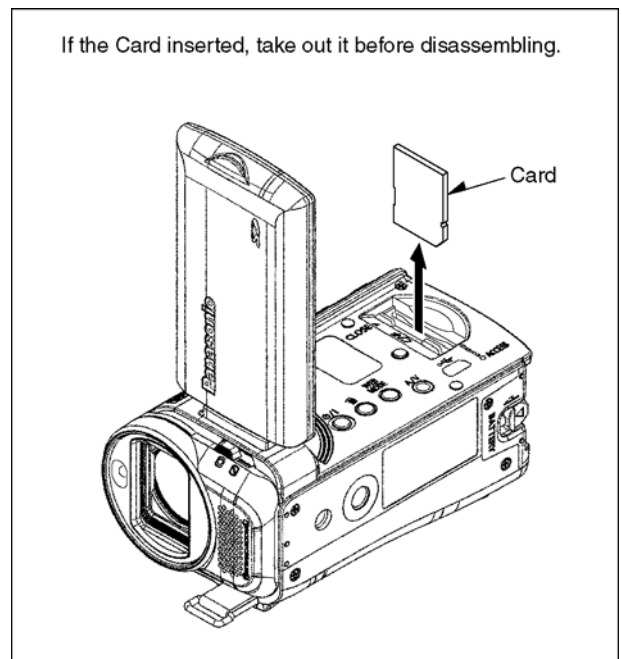

Fig. D1

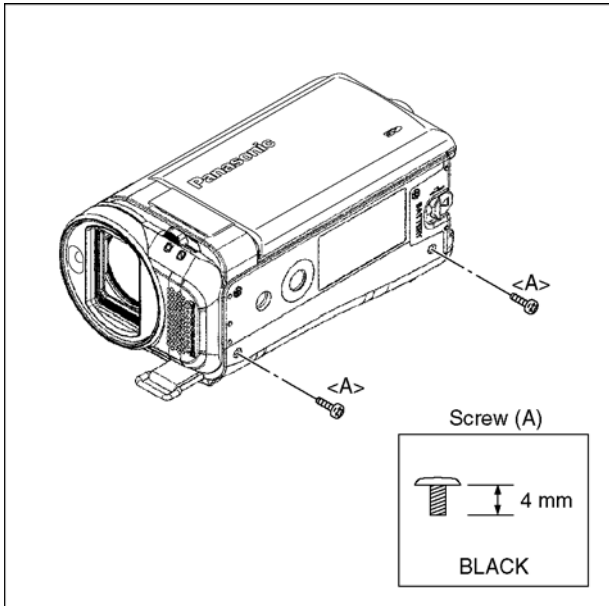

Fig. D2

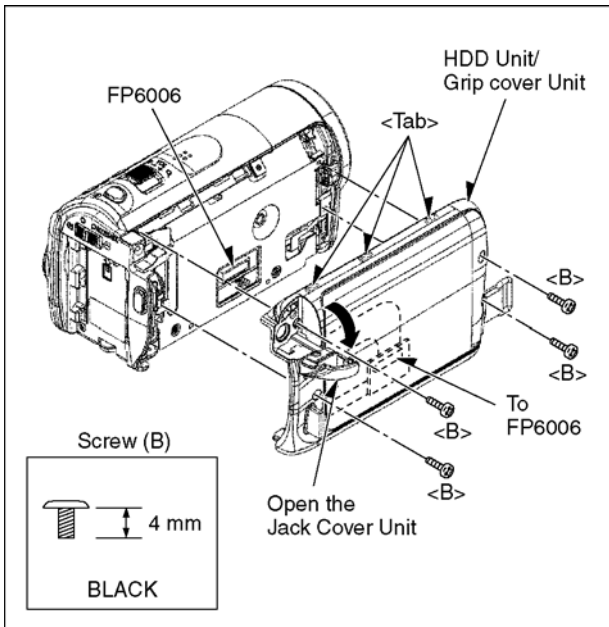

Fig. D3

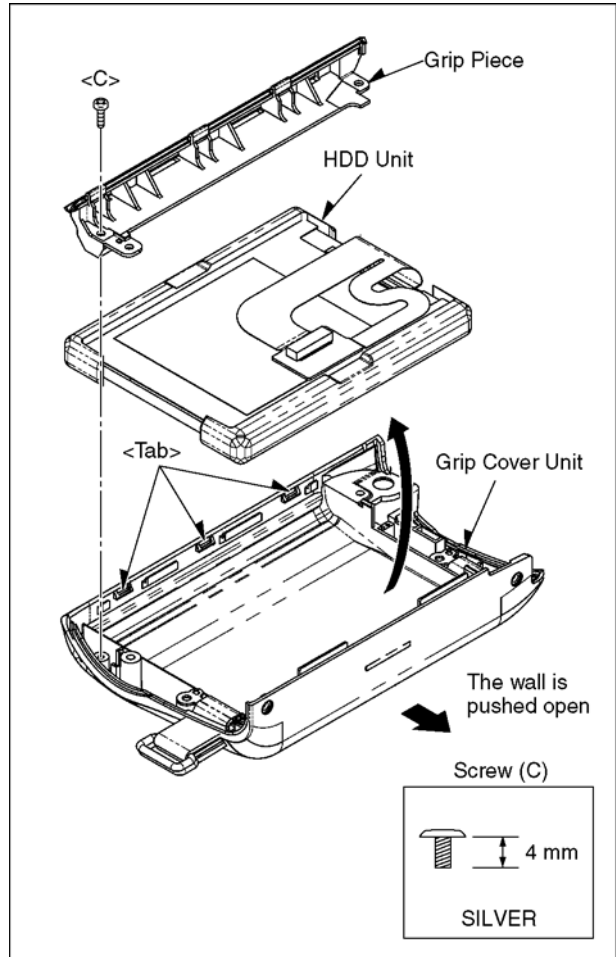

Fig. D4

Note for replacing HDD

- Be sure to use the tool when inserting and removing HDD FPC.

After replacing the HDD, be sure to format the new HDD.
See "Formatting HDD" in Service Navigation.

1) How to Remove

- ① Remove the HDD Damper from the HDD.
- ② Remove the HDD FPC from HDD using the tool.

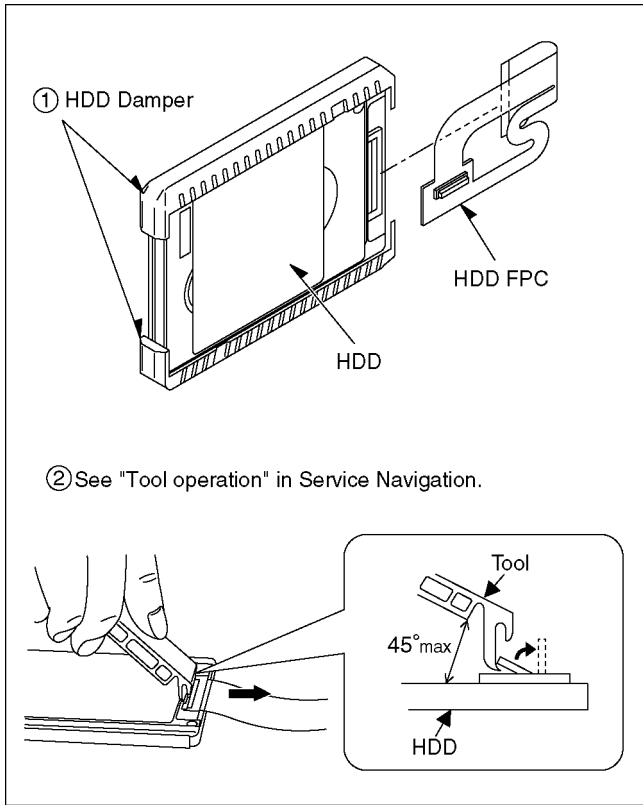

Fig. D5

2) How to Attach

- ① Attach the HDD FPC to the new HDD using the tool.
- ② Attach the HDD Damper to the HDD.

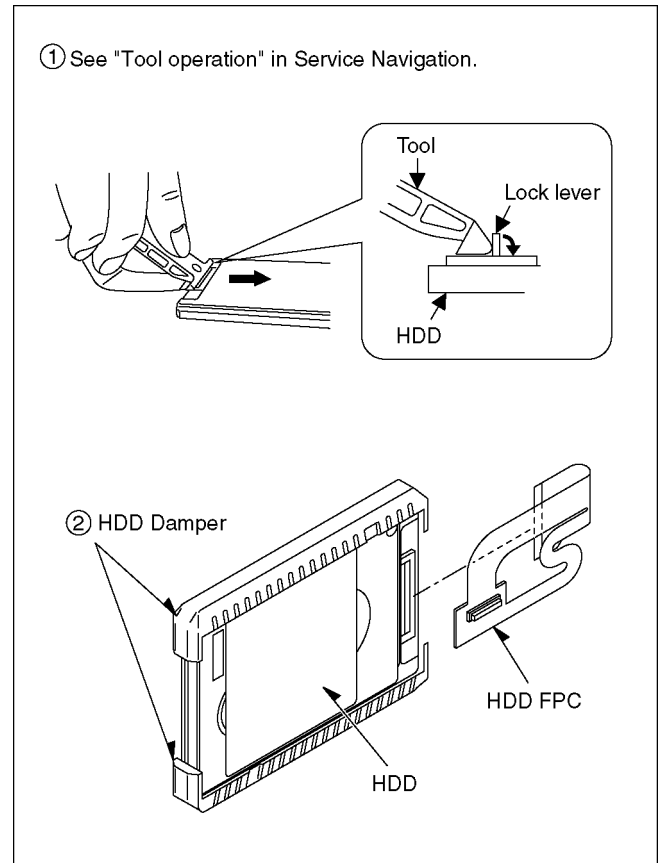

Fig. D6

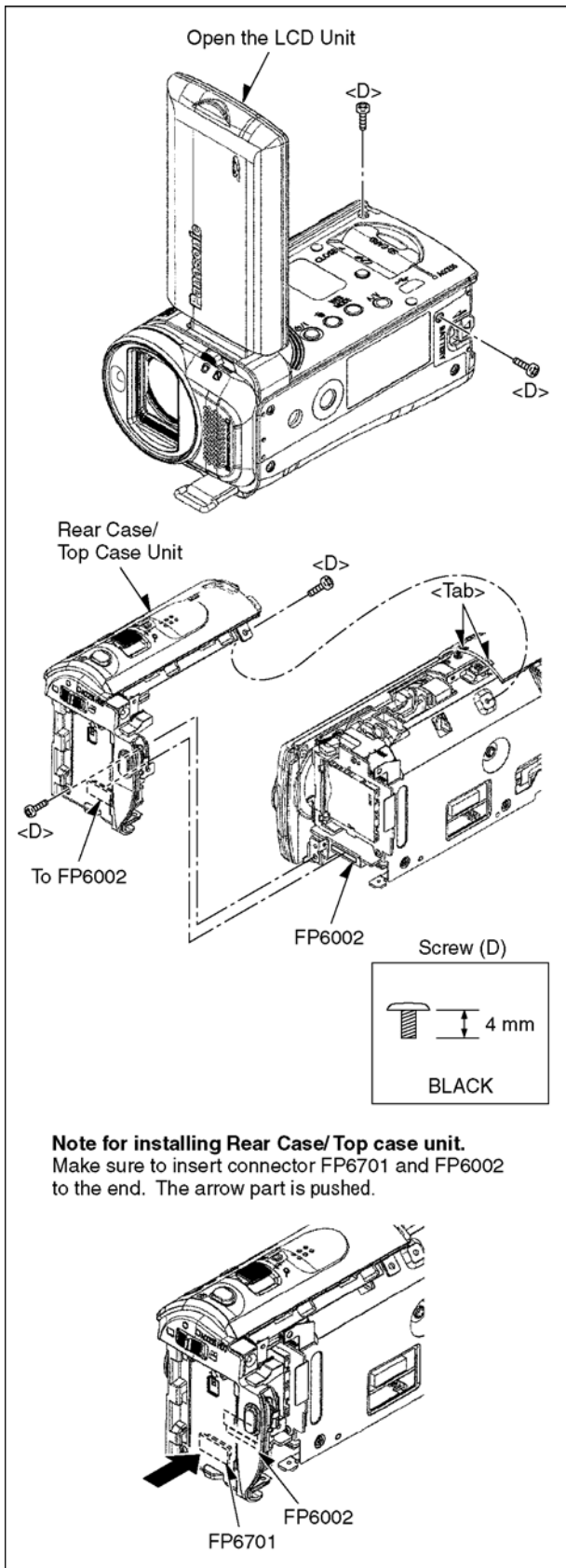

Fig. D7

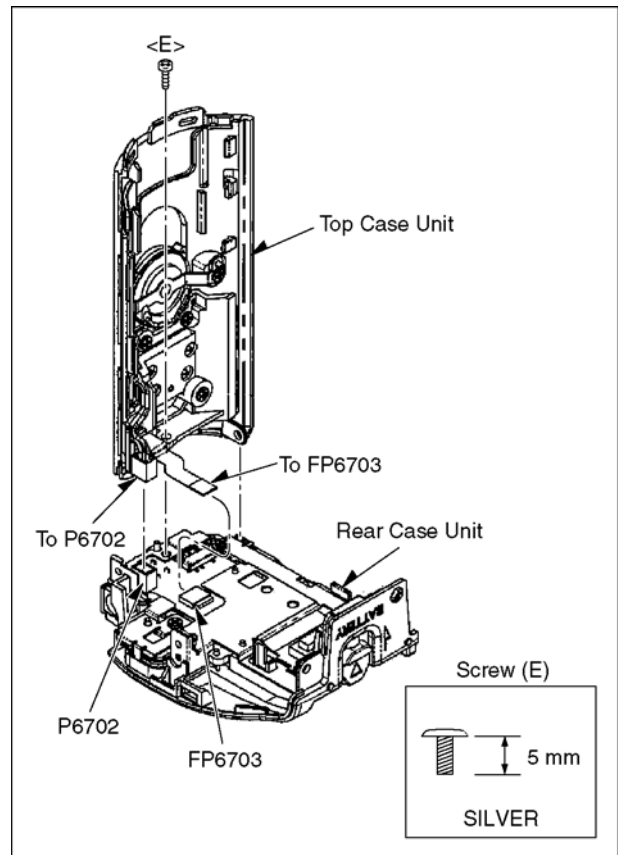

Fig. D8

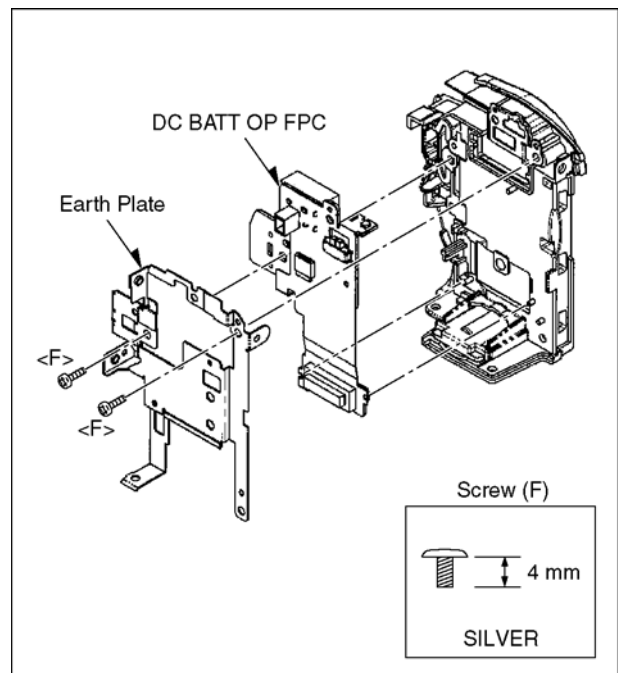

Fig. D9

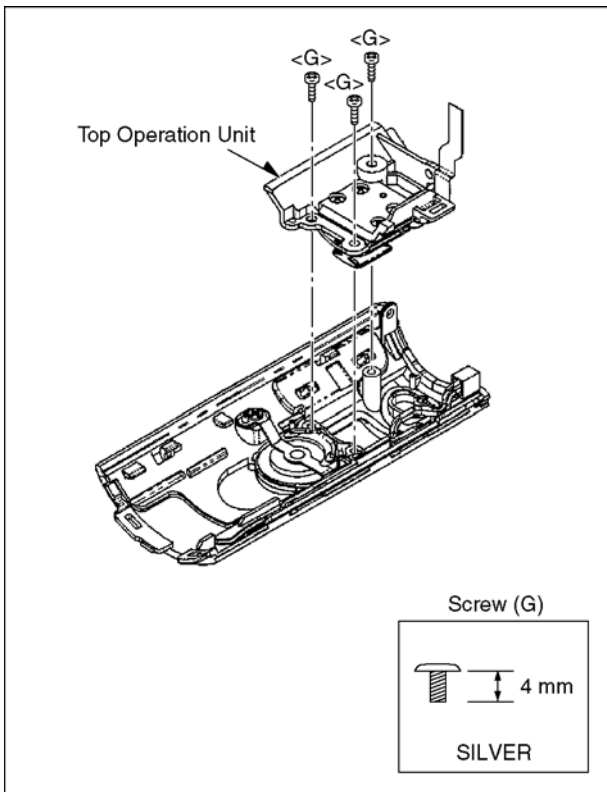

Fig. D10

Note for attaching Top Operation Unit

- Top Operation Unit is installed and the following wire rod is a thing that becomes like Fig.D11.

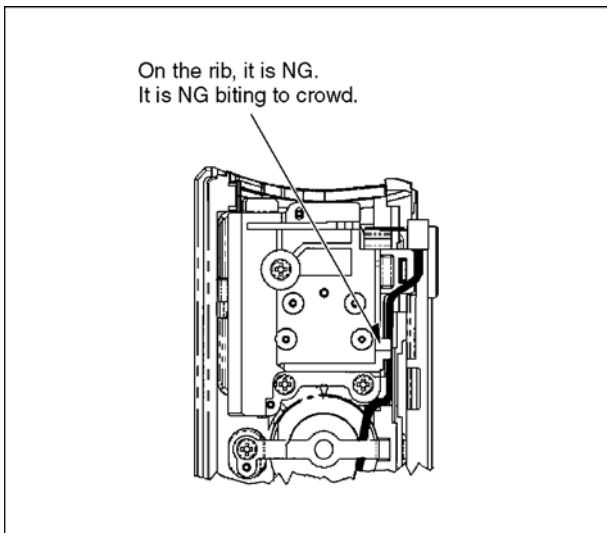

Fig. D11

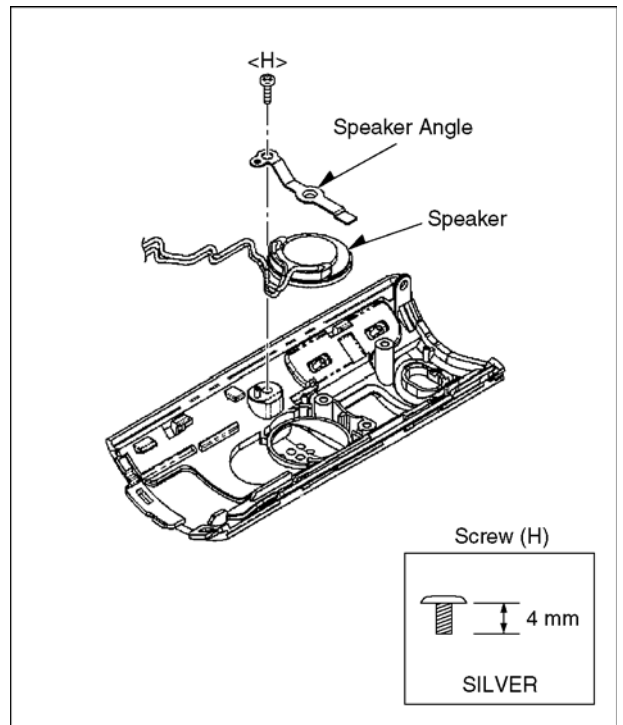

Fig. D12

Note for attaching Speaker Angle

- Make sure that speaker wire is under Speaker Angle.

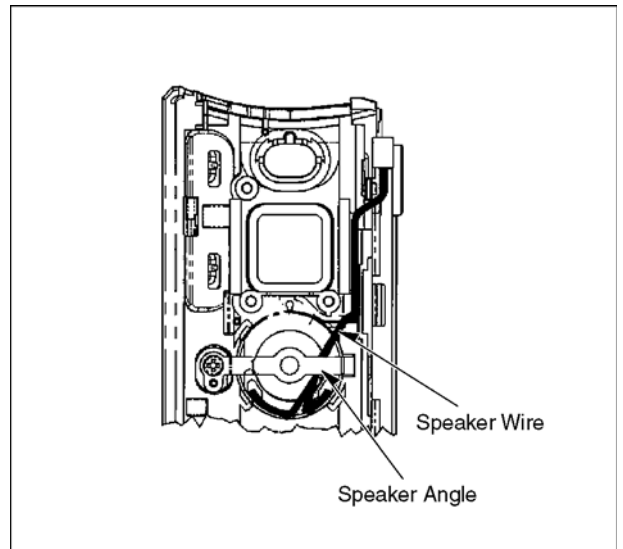

Fig. D13

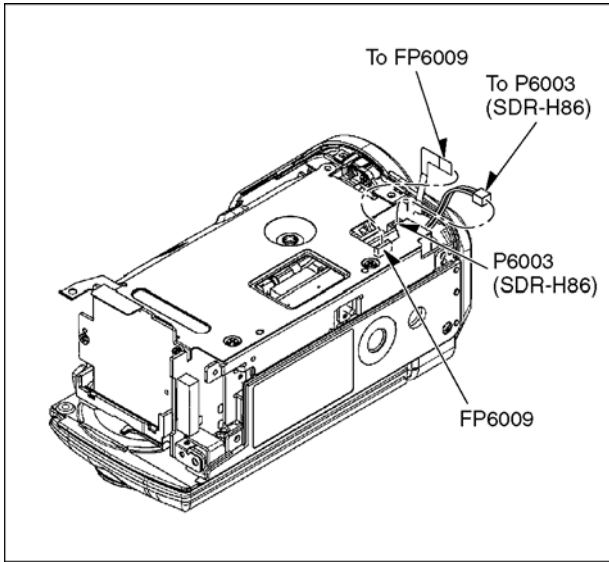

Fig. D14

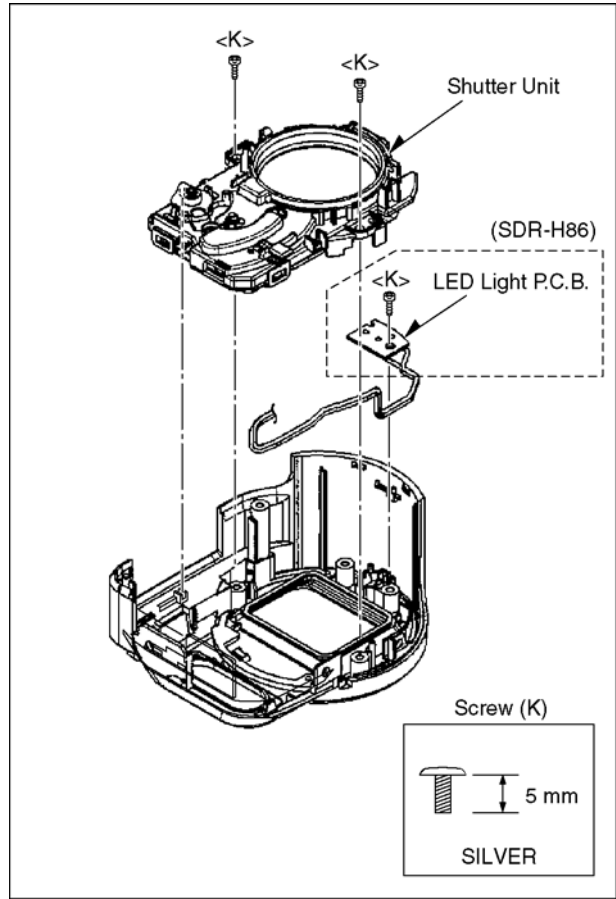

Fig. D16

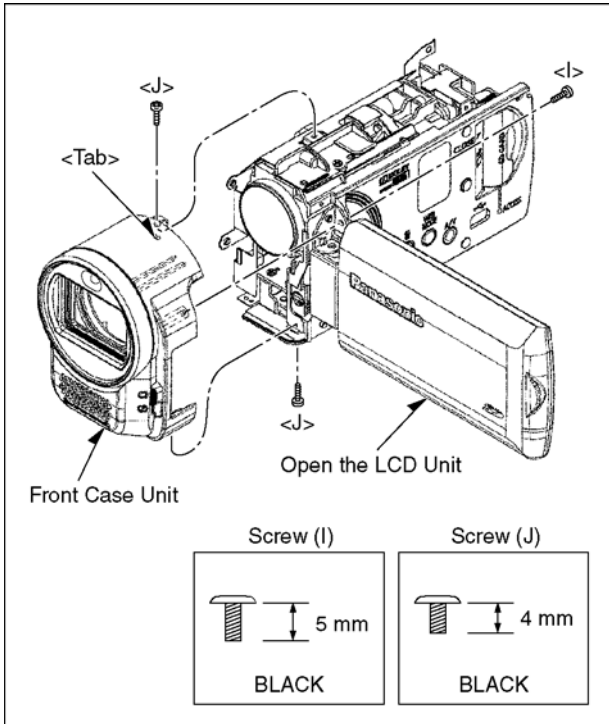

Fig. D15

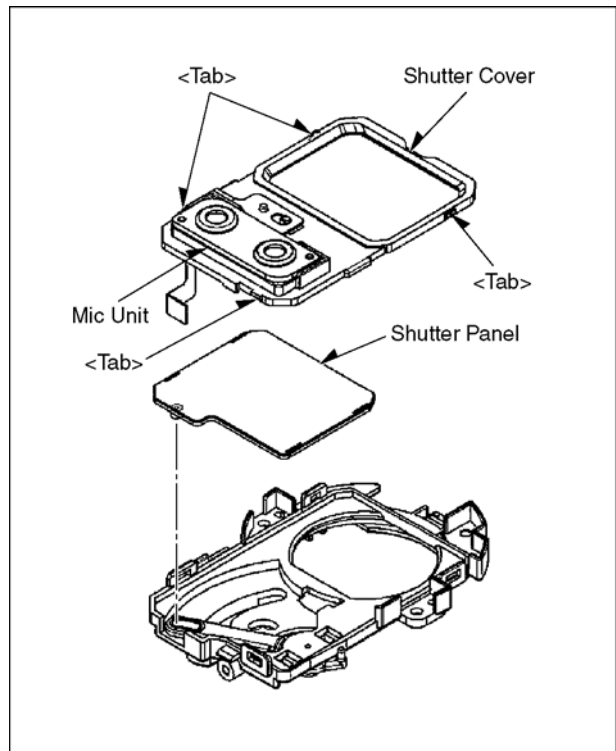

Fig. D17

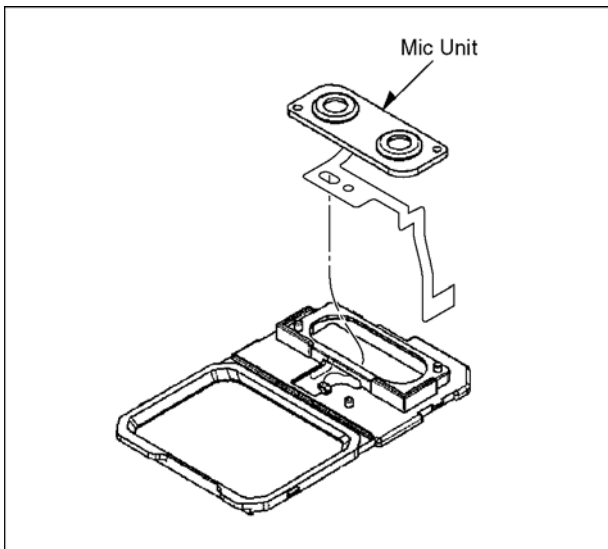

Fig. D18

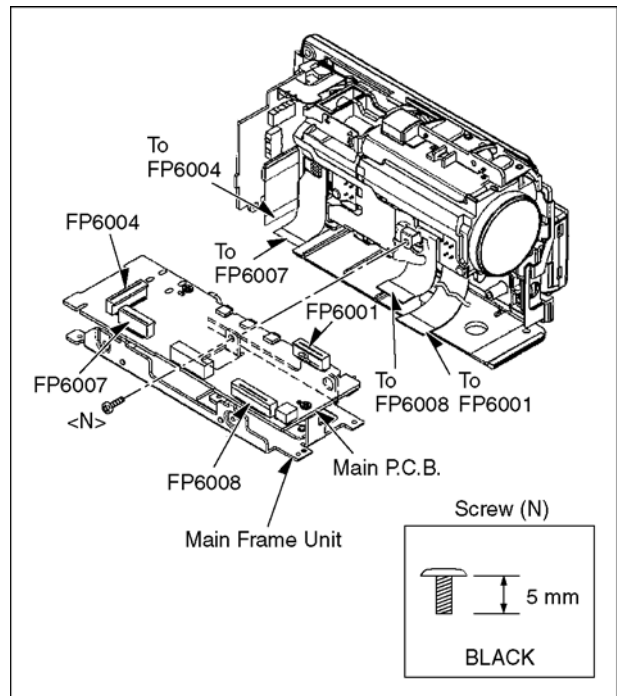

Fig. D20

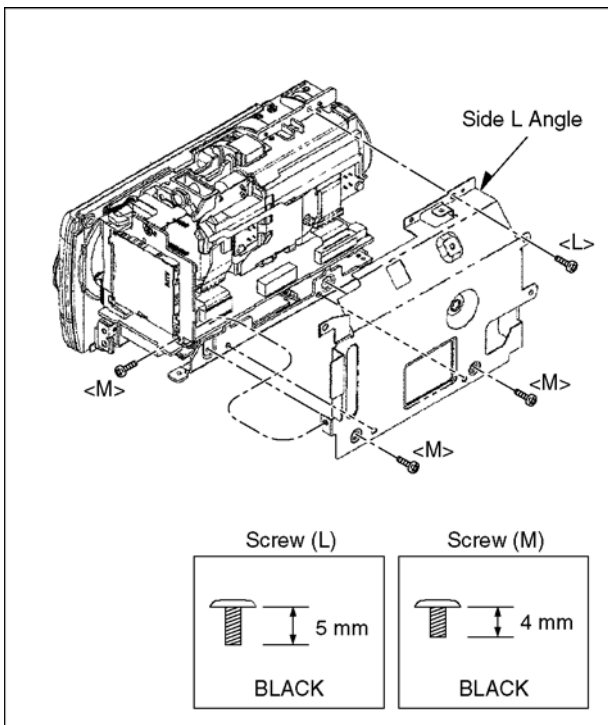

Fig. D19

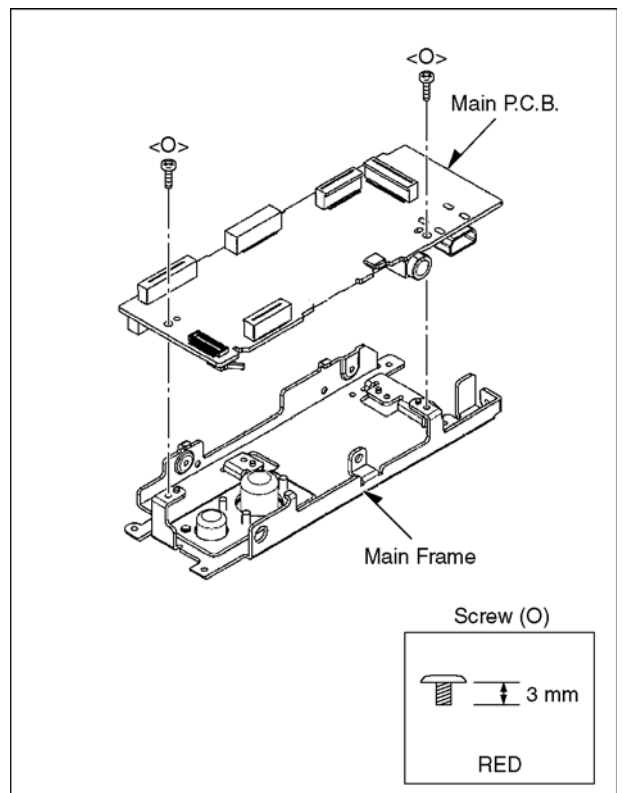

Fig. D21

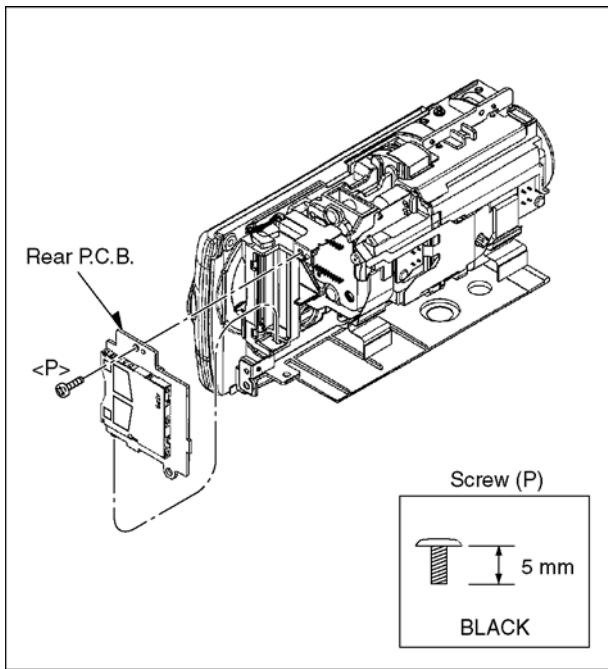

Fig. D22

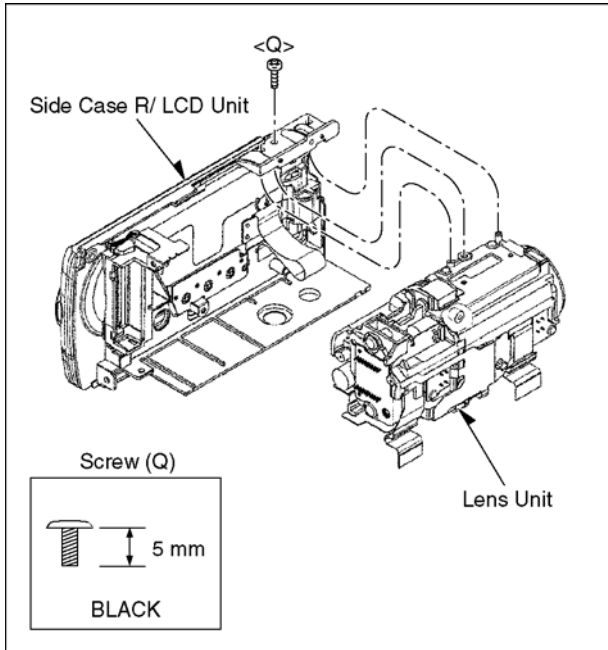

Fig. D23

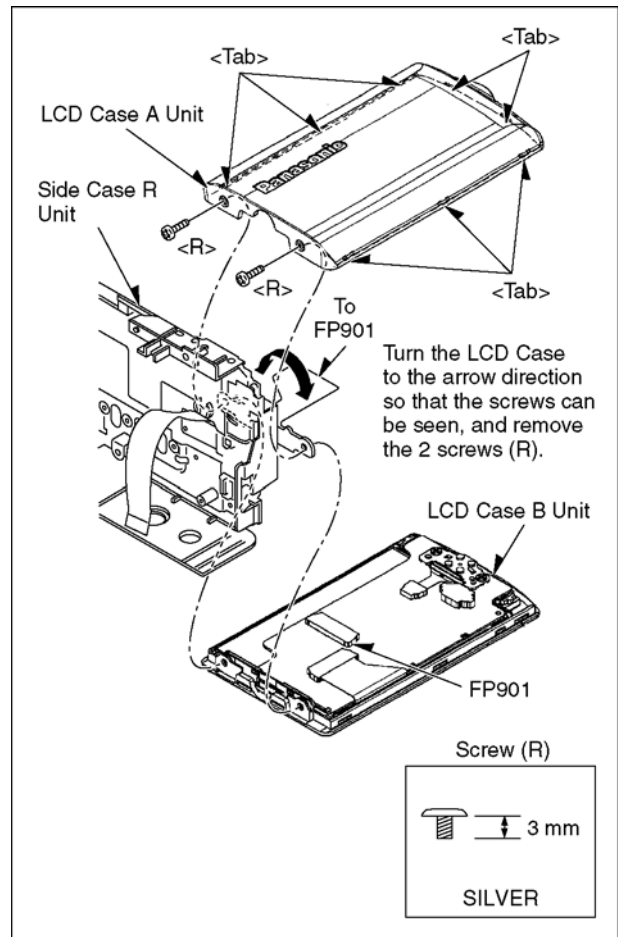

Fig. D24

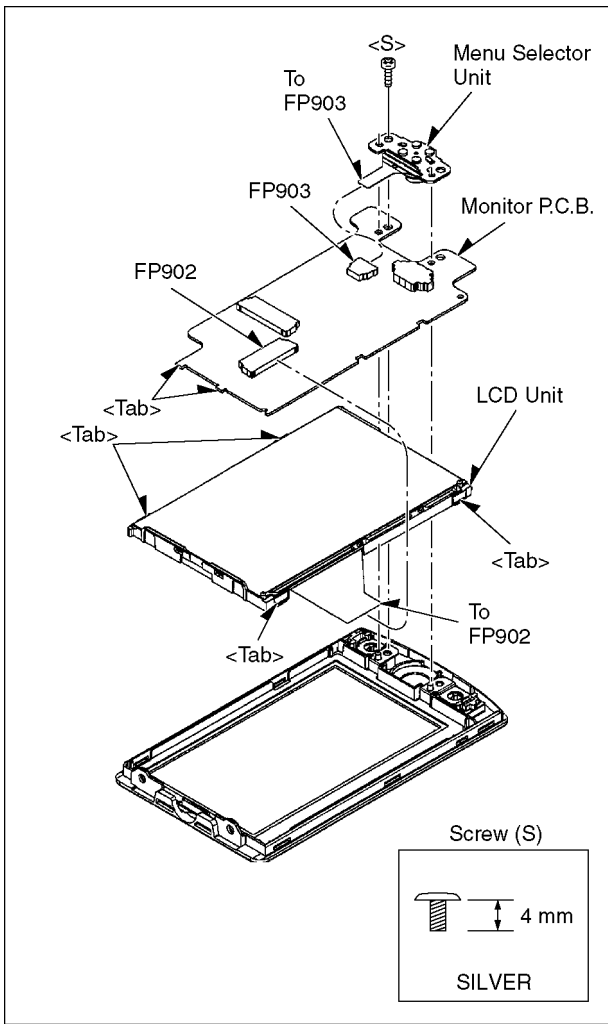

Fig. D25

8.4. Disassembly Procedures of Camera Lens Unit

The following flowchart describes order or steps for removing the Camera lens unit and certain printed circuit boards in order to make access to the item needing service.

To reassemble the unit follow the steps in reverse order.

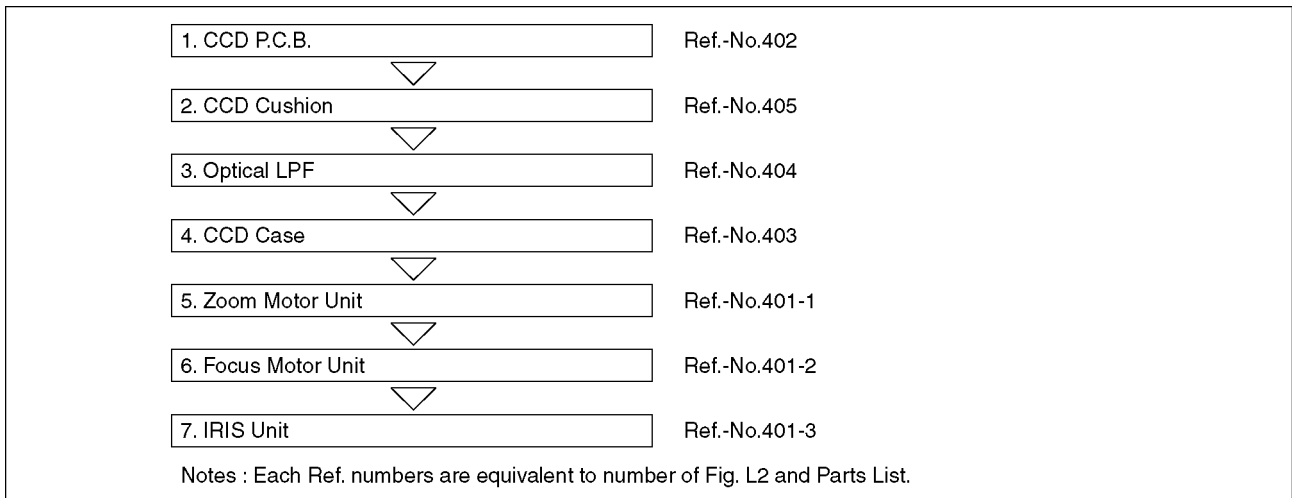

Fig. L1

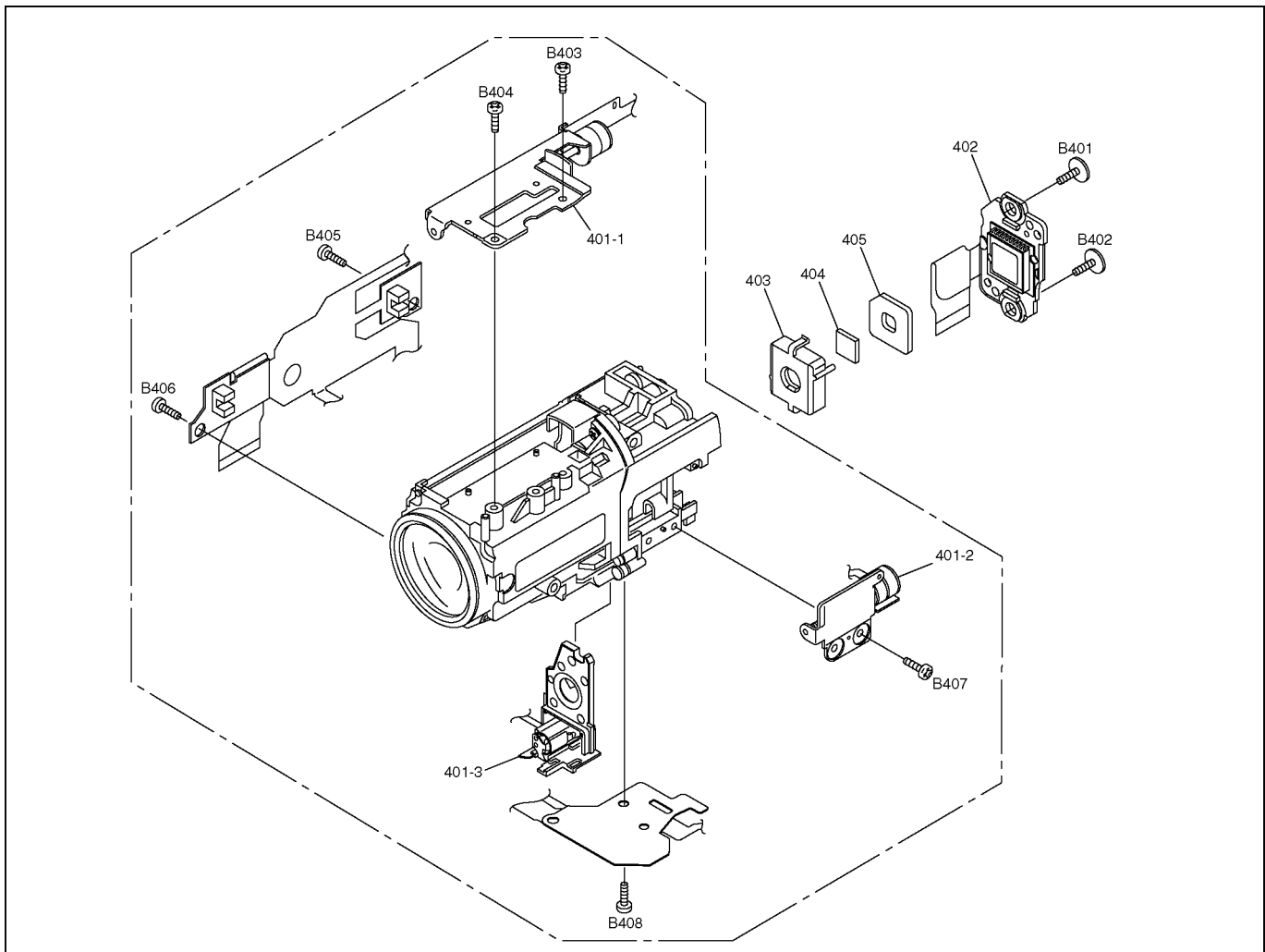
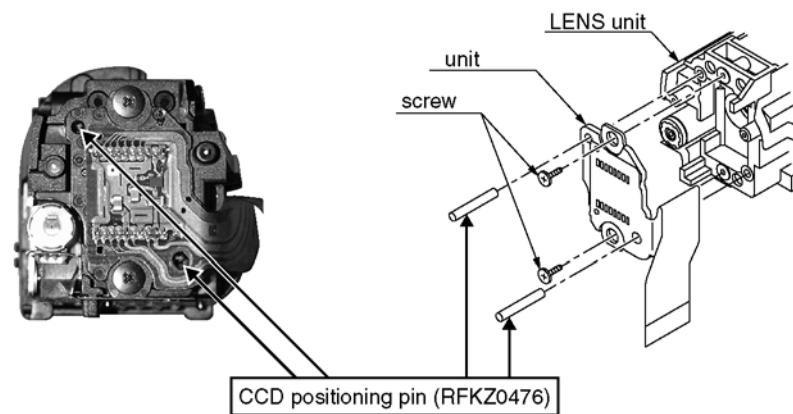

Fig. L2

8.4.1. How to use of CCD positioning pin (RFKZ0476)

The CCD unit and the LENS unit are fixed by using two CCD positioning pins as shown in figure, and the screw two places for CCD fixation are tightened.



Note:

Please remove the positioning pin after installing CCD Unit.

Please tighten tightening two screws uniformly.

(Recommendation 8Ncm : In the torque driver at the time of tightening)

Please execute an optical adjustment for TATSUJIN Software after it exchanges CCD unit.

9 Measurements and Adjustments

9.1. EEPROM Data for spare parts of the MAIN P.C.B.

After replacing the MAIN P.C.B., be sure to achieve adjustment.

As for Adjustment condition/procedure, consult the "Adjustment Manual" which is available in Adjustment software.

The adjustment instruction is available at "Software download" on the "Support Information from NWBG/VDBG-AVC" web-site in "TSN System".

9.2. Service Positions

9.2.1. List of the extension cables

Use the following extension cables when checking or adjusting individual circuit boards except module Parts (Main P.C.B.).

Ref.	Part No.	Pin	Part Name	Connection	Q'ty
1	RFKZ0379	40	Flat Cable	FP6006 (Main) - HDD Unit	1
2	VFK1480	6	Flat Cable	FP6009 (Main) - Front Case/Mic Unit	1
3	VFK1491	27	Flat Cable	FP6001 (Main) - Side Case R/LCD Unit	1
4	VFK1950	33	Flat Cable	FP6008 (Main) - Lens Unit	1
5	VFK1443	18	Flat Cable	FP6007 (Main) - Prism Unit	1
6	VFK1282	22	Flat Cable	FP6004 (Main) - FP3901 (Rear)	1
7	RFKZ0379	40	Flat Cable	FP6002 (Main) - FP6701 (DC BATT OP FPC)	1

9.2.2. Checking and repairing individual circuit boards except module parts (Main P.C.B.)

How to use extension cables.

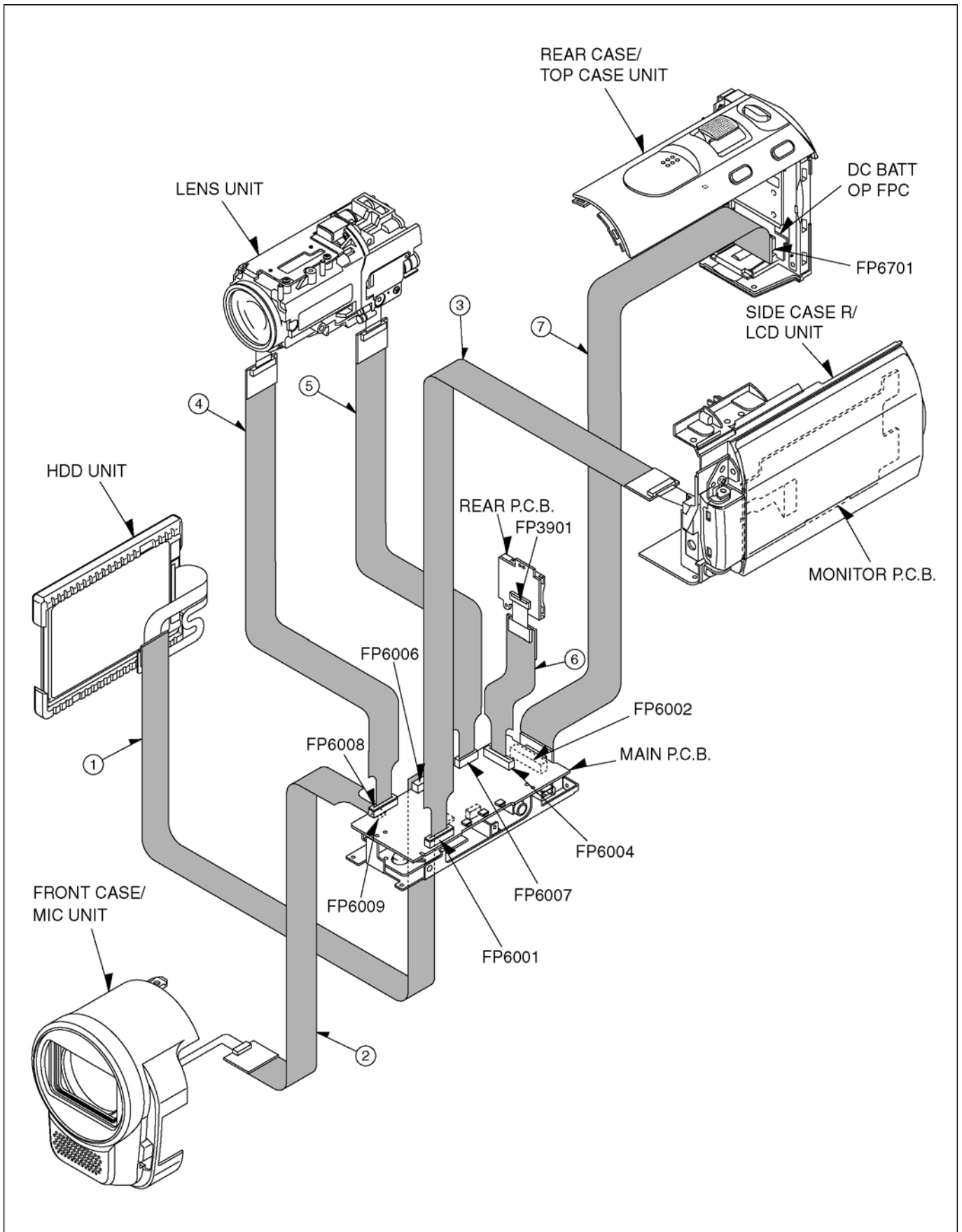

9.3. Location for Connectors of the Main P.C.B.

9.3.1. Main P.C.B.

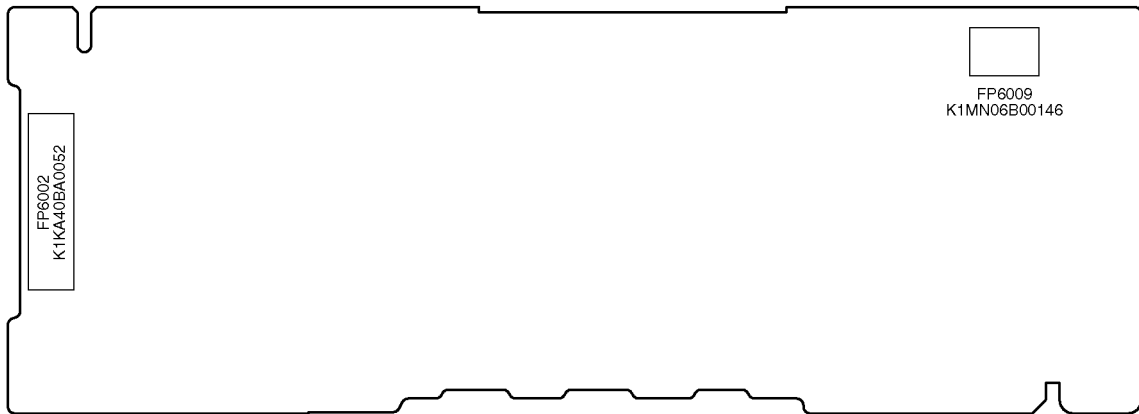

(COMPONENT SIDE)

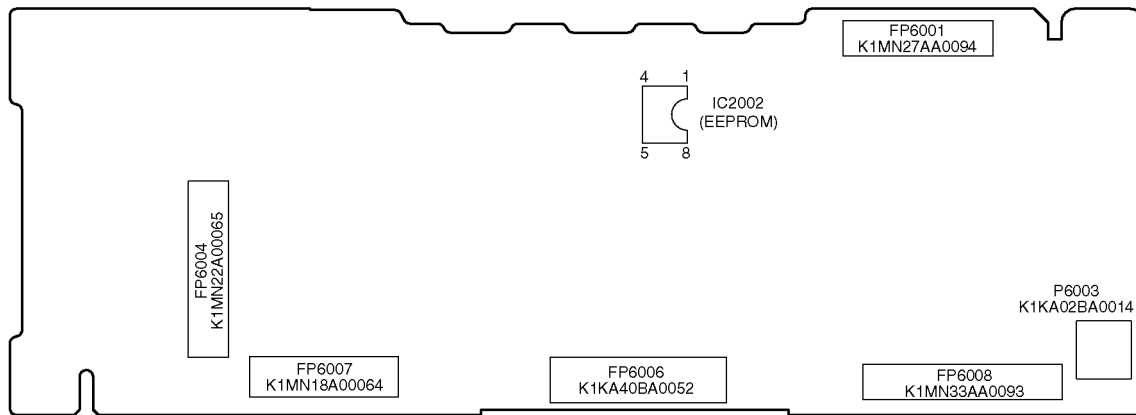

(FOIL SIDE)

9.4. Electrical Adjustment

- Adjustment method is different from a conventional SD/HDD video camera.
- An exclusive jig and PC (including software for adjustment “tatsujin”) are necessary for electric adjustment.
- A USB driver for service is necessary to communication with PC.
- Connection method of the main unit and an exclusive adjustment jig as follows.

9.4.1. Adjustment Procedure

- Connect the main unit to PC with USB.

The adjustment instruction is available at “Software download” on the “Support Information from NWBG/VDBG-AVC” web-site in “TSN System”.

Figure of connection

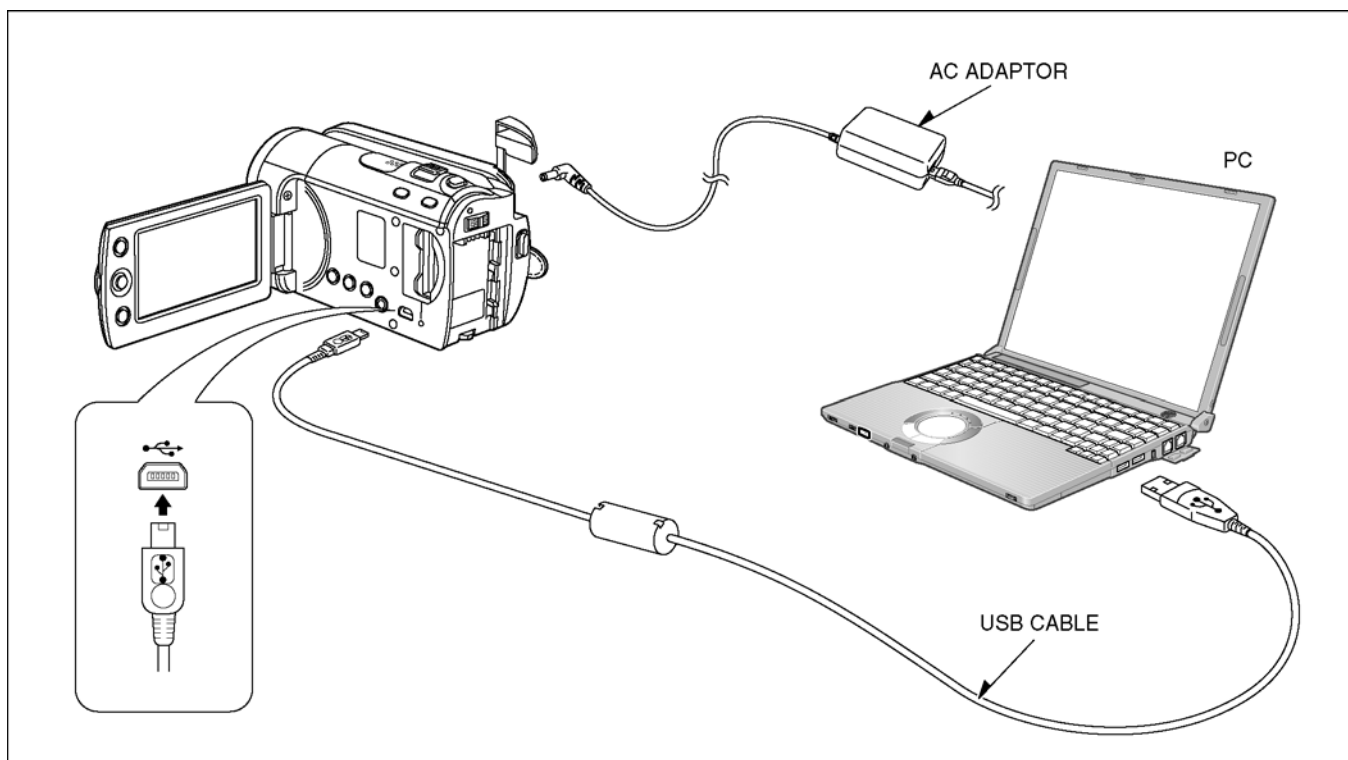
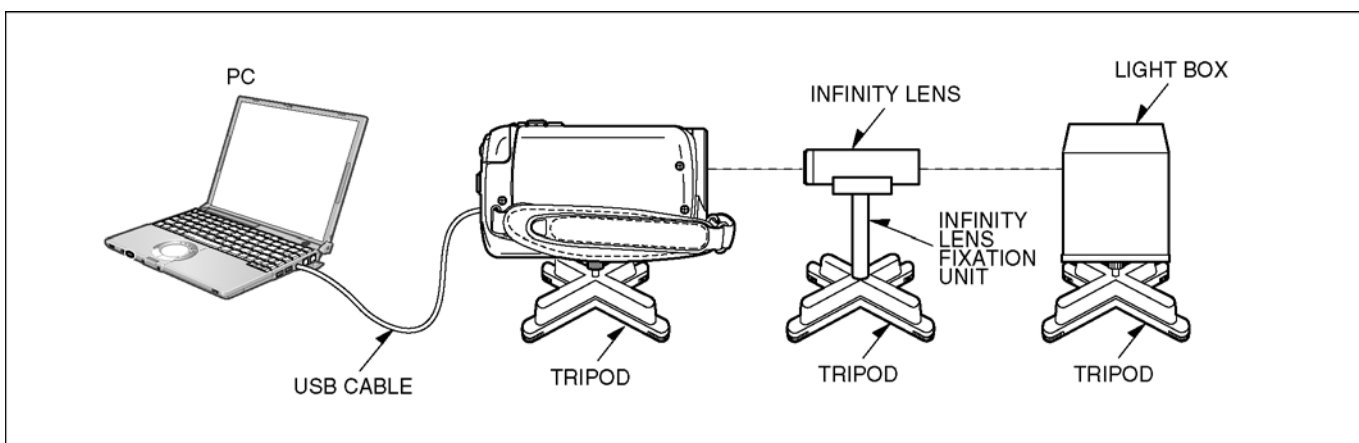

Figure of Image when adjustment



Part Number of jig

- Only a necessary jig mentions it setup electric adjustment

Ref	Parts Name	Parts No.	Q'ty	Remarks
1	Personal Computer	---	1	With Tatsujin Software
2	AC Adaptor	---	1	The AC Adaptor for SD/HDD Video Camera
3	USB Cable	---	1	
4	Adjustment Software (Tatsujin)	---	1	

Adjustment Items

- Adjustment item as follows.

The adjustment instruction is available at "Software download" on the "Support Information from NWBG/VDBG-AVC" web-site in "TSN System".

		Replacement Parts									
		Main P.C.B.	IC101 (CAMERA SIGNAL PROCESS)	IC701 (FOCUS/ZOOM/MOTOR DRIVE & OIS/IRIS/HALL AMP CONTROL)	IC3401 (CAMERA DIGITAL SIGNAL PROCESS/SHUFFLING)	IC3701 (VIDEO/AUDIO SIGNAL PROCESS)	IC6001 (SYSTEM MICROCONTROLLER)	IC2002 (EEPROM)	CCD P.C.B.	Lens Unit	G sensor
Camera	CAM hall amplifier and Iris PWM	○									
	CAM Tracking and De-focus	○									
	CAM WB rough	○	○								
	CAM AWB 3100	○	○								
	CAM AWB 5100	○	○								
	CAM Revision CCD white scratch	○						○	○		
	CAM Revision CCD black scratch	○						○	○		
Video	VCR Luminance level	○			○	○		○			
	G sensor offset	○						○		○	

Note : ○ : Adjustment Item

- How to use the software.

Please reference help of the TATSUJIN software.

Set-up manual for SD/HDD Video Camera

1. Installation of USB-SERIAL Driver

Execute the "Setup.exe" file in "Com Mass" folder by double clicking to install the USB-SERIAL driver.

2. Set-Up

- Remove the SD card from this unit.
- While keep pressing the "iA" button and "DEL" button, hold left the "zoom lever" towards to "W" position for more than 3 seconds until the "COM" is displayed on LCD.

3. Release of COM mode (It is necessary for normal mode.)

Retry above 2-b, then "COM" is disappeared.

10 Maintenance

10.1. Cleaning Lens and LCD Panel

Do not touch the surface of the lens and LCD Panel with your hand.

When cleaning the lens, use air-Blower to blow off the dust.

When cleaning the LCD Panel, dampen the lens cleaning paper with lens cleaner, and the gently wipe the their surface.

Note:

A lens cleaning paper and lens cleaner are available at local camera shops and market place.

11 Factory Setting

11.1. How to turn on the factory setting?

1. Indication method of the service menu

Set the mode switch "  Recording" mode.

2. While keep pressing the "Intelligent auto/Manual" button and "Menu" button, hold left the Zoom Lever towards to "[W]" position for more than 3 seconds until the top screen of the Service Menu being displayed.

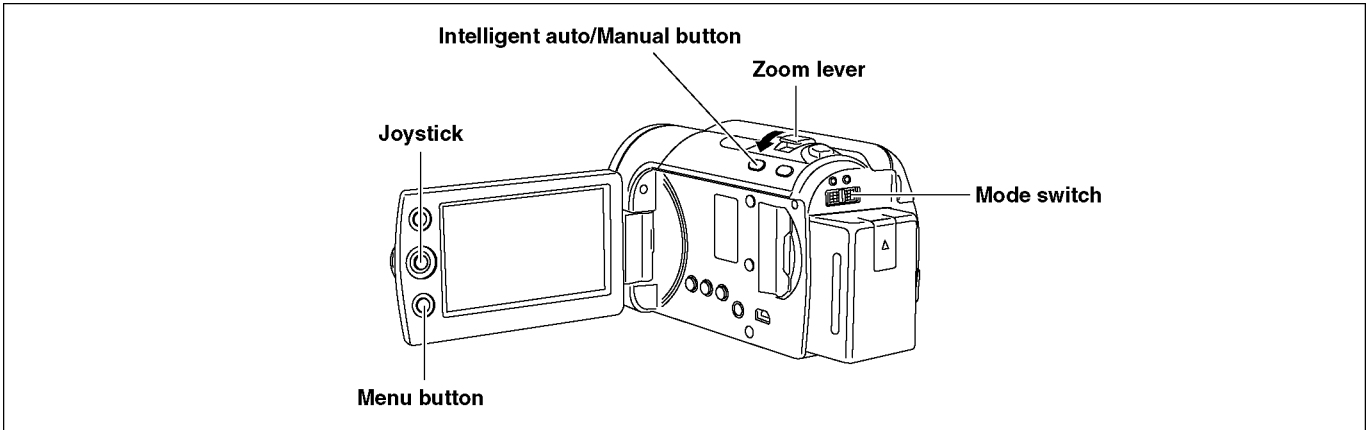

3. Under the condition of the Item No."1" is yellow high lighted, press the "[RIGHT >] of joystick" button.
4. By pressing the "[UP ^] of joystick" button, then press the "[center] of joystick" button.
5. After few seconds "END" is displayed on LCD monitor. Cutting of battery connection or AC power supply connection as a completion of the "FACTORY SETTINGS".

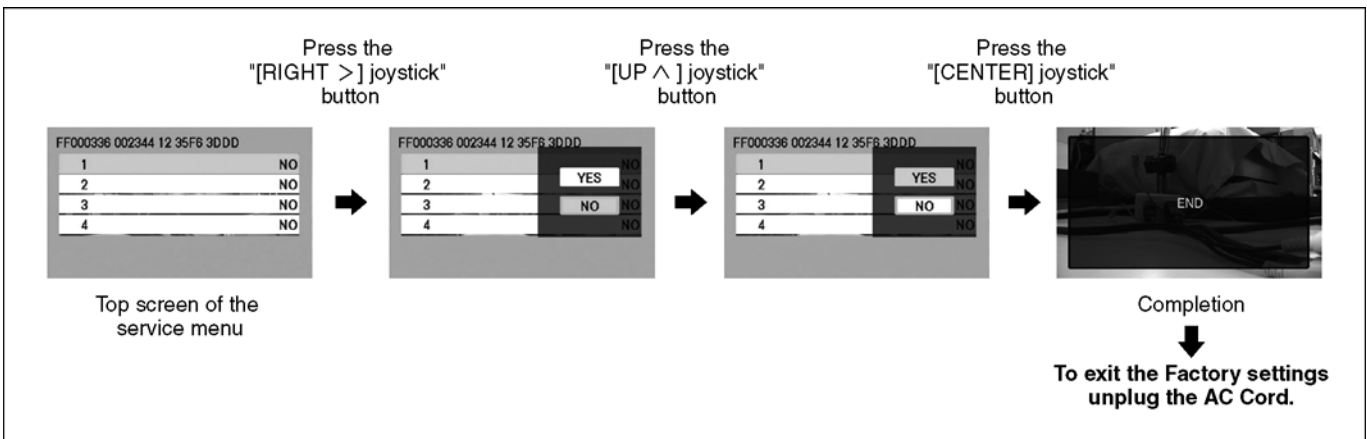



11.2. What is the factory settings?

The factory settings clean up and/or refresh the following settings.

1. MENU, MODE, ADJUSTMENT VALUE.
2. SD card format.
3. Reset the folder number and file number of still pictures.
(Setting the folder number is 100, and file number is 0.)
4. Clear the mechanism lock information.
5. Clear the service mode information contents.
6. Clear the date.
7. Initialize the VIERA Link Physical Address.
8. Confirm the data area of HDD is cleared.

The setting position of factory settings:

Name	Setting position
Mode switch	
Open/close switch	

Service Manual

Diagrams and Replacement Parts List

SD / HDD Video Camera

Model No.

SDR-H85P	SDR-H85EP	SDR-H86PR
SDR-H85PC	SDR-H85GA	SDR-H86PU
SDR-H85EB	SDR-H85GC	SDR-H95EE
SDR-H85EC	SDR-H85GK	SDR-H95GA
SDR-H85EE	SDR-H85GN	SDR-H95GC
SDR-H85EF	SDR-H85GT	
SDR-H85EG	SDR-H86EB	

Vol. 1

Colour

- (K).....Black Type (except SDR-H86EB)
- (S).....Silver Type (only SDR-H85P/EC/EE/EG/EP/GA/GC/GK, H86PU)
- (A).....Blue Type (only SDR-H85P/PC/GT)
- (R).....Red Type (only SDR-H85PC/EC/EF/EG/EP/GA/GC/GK/GT, H86PU)
- (H).....Gray Type (only SDR-H86EB)

Table of contents

<p>S1. About Indication of The Schematic Diagram..... S-1</p> <p>S1.1. Important Safety Notice..... S-1</p> <p>S2. Voltage Chart S-2</p> <p>S2.1. Rear P.C.B. S-2</p> <p>S2.2. Monitor P.C.B. S-2</p> <p>S3. Block Diagram..... S-3</p> <p>S3.1. Overall Block Diagram S-3</p> <p>S4. Schematic Diagram..... S-4</p> <p>S4.1. Interconnection Diagram S-4</p> <p>S4.2. Rear Schematic Diagram S-5</p> <p>S4.3. CCD Schematic Diagram S-6</p> <p>S4.4. EMC Schematic Diagram..... S-6</p> <p>S4.5. DC BATT OP FPC Schematic Diagram S-7</p> <p>S4.6. HDD FPC Schematic Diagram..... S-8</p> <p>S4.7. MONI FPC Schematic Diagram S-8</p> <p>S4.8. Monitor Schematic Diagram..... S-9</p> <p>S4.9. LED Light Schematic Diagram S-10</p>	<p>S5. Print Circuit Board..... S-11</p> <p>S5.1. Rear P.C.B. S-11</p> <p>S5.2. CCD P.C.B. S-11</p> <p>S5.3. EMC FPC P.C.B. S-12</p> <p>S5.4. DC BATT OP FPC P.C.B..... S-12</p> <p>S5.5. HDD FPC P.C.B. S-14</p> <p>S5.6. MONI FPC P.C.B..... S-14</p> <p>S5.7. Monitor P.C.B. S-18</p> <p>S5.8. LED Light P.C.B. S-19</p> <p>S6. Replacement Parts List..... S-21</p> <p>S7. Exploded View S-27</p> <p>S7.1. Frame and Casing Section..... S-27</p> <p>S7.2. LCD Section S-28</p> <p>S7.3. Lens Section S-29</p> <p>S7.4. Packing Parts and Accessories Section..... S-30</p>
---	---

S1. About Indication of The Schematic Diagram

S1.1. Important Safety Notice

COMPONENTS IDENTIFIED WITH THE MARK \triangle HAVE THE SPECIAL CHARACTERISTICS FOR SAFETY. WHEN REPLACING ANY OF THESE COMPONENTS USE ONLY THE SAME TYPE.

1. Although reference number of the parts is indicated on the P.C.B. drawing and/or schematic diagrams, it is NOT mounted on the P.C.B. when it is displayed with "\$" mark.
2. It is only the "Test Round" and no terminal (Pin) is available on the P.C.B. when the TP (Test Point) indicated as "●" mark.
3. The voltage being indicated on the schematic diagram is measured in "Standard-Playback" mode when there is no specify mode is mentioned.
4. Although the voltage and waveform available on here is measured with standard frame, it may be differ from actual measurement due to modification of circuit and so on.
5. The voltage being indicated here may be include observational-error (deviation) due to internal-resistance and/or reactance of equipment. Therefore, handle the value indicated on here as reference.
6. Use the parts number indicated on the Replacement Parts List .
7. Indication on Schematic diagrams:

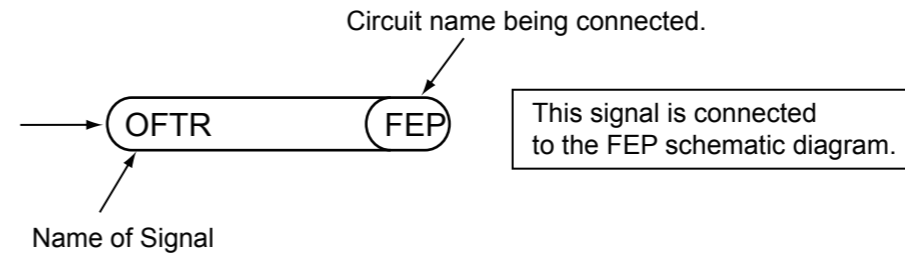

S2. Voltage Chart

Note) Indicated voltage values are the standard values for the unit measured by the DC electronic circuit tester (high-impedance) with the chassis taken as standard.
Therefore, there may exist some errors in the voltage values, depending on the internal impedance of the DC circuit tester.

S2.1. Rear P.C.B.

S2.2. Monitor P.C.B.

REF No.	PIN No.	REC	PB	EE
IC3901	1	1.4	1.4	1.4
IC3901	2	0	0	0
IC3901	3	3	3	3
IC3901	4	1.4	1.4	1.4
IC3902	1	1.4	1.4	1.4
IC3902	2	0	0	0
IC3902	3	3	3	3
IC3902	4	1.4	1.4	1.4
Q3901	E	3.1	3.1	3.1
Q3901	C	0	0	0
Q3901	B	3.1	3.1	3.1

REF No.	PIN No.	REC	PB	EE
Q901	E	1.4	1.4	1.4
Q901	C	0	0	0
Q901	B	0.8	0.8	0.8

S3. Block Diagram

S3.1. Overall Block Diagram

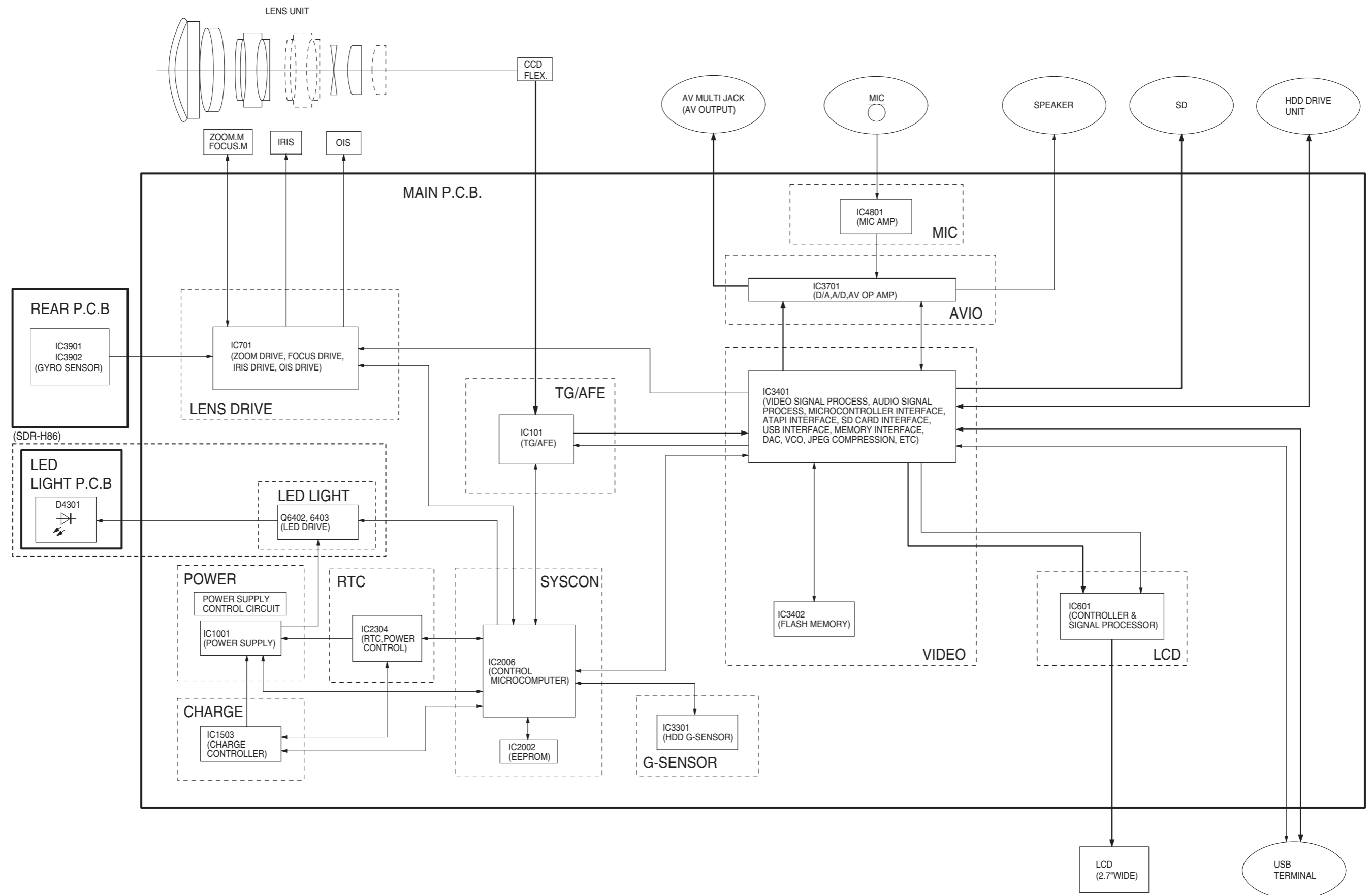

SDR-H85/H86/H95
OVERALL SCHEMATIC DIAGRAM

S4. Schematic Diagram

S4.1. Interconnection Diagram

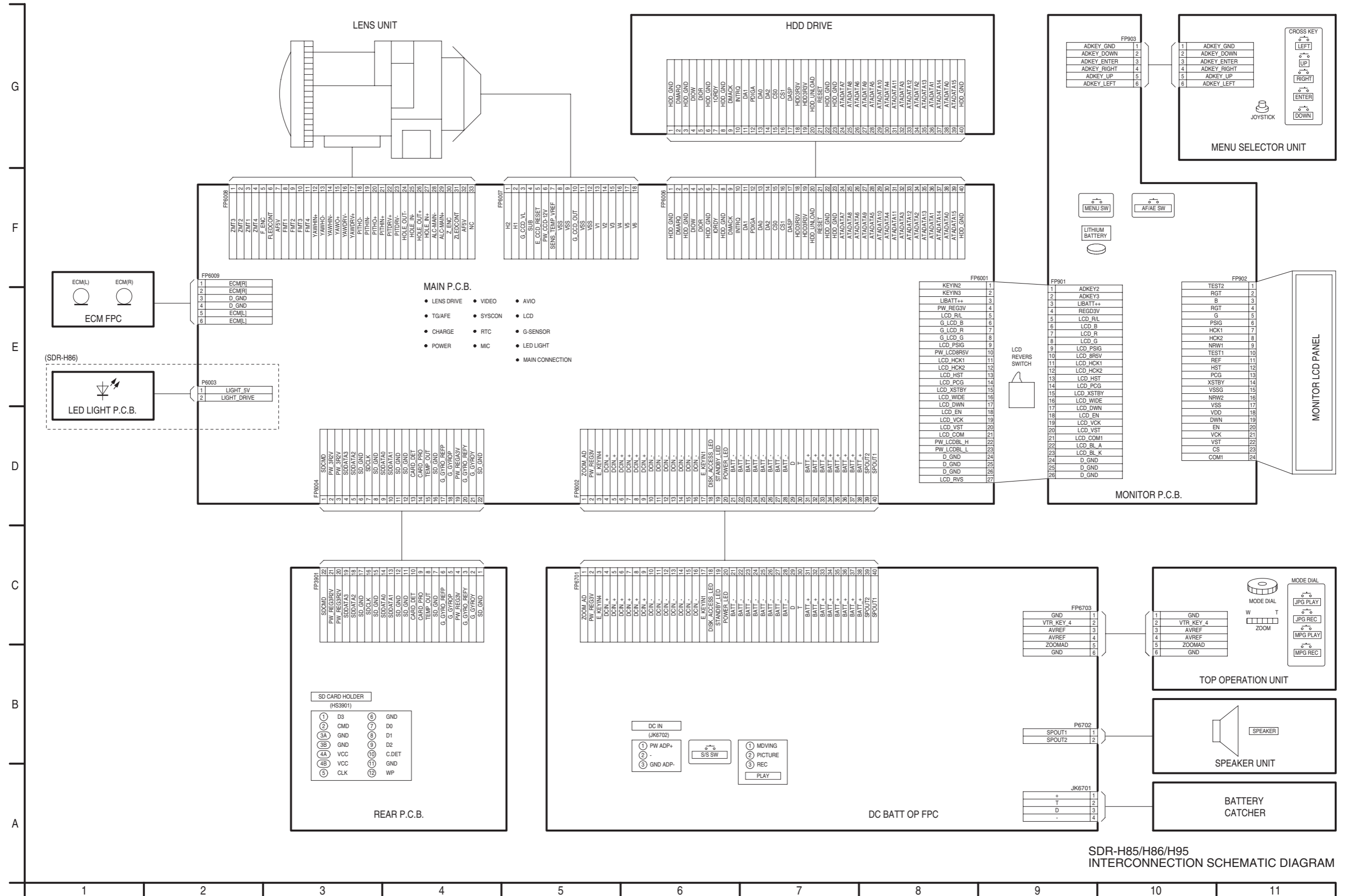

SDR-H85/H86/H95 INTERCONNECTION SCHEMATIC DIAGRAM

S4.2. Rear Schematic Diagram

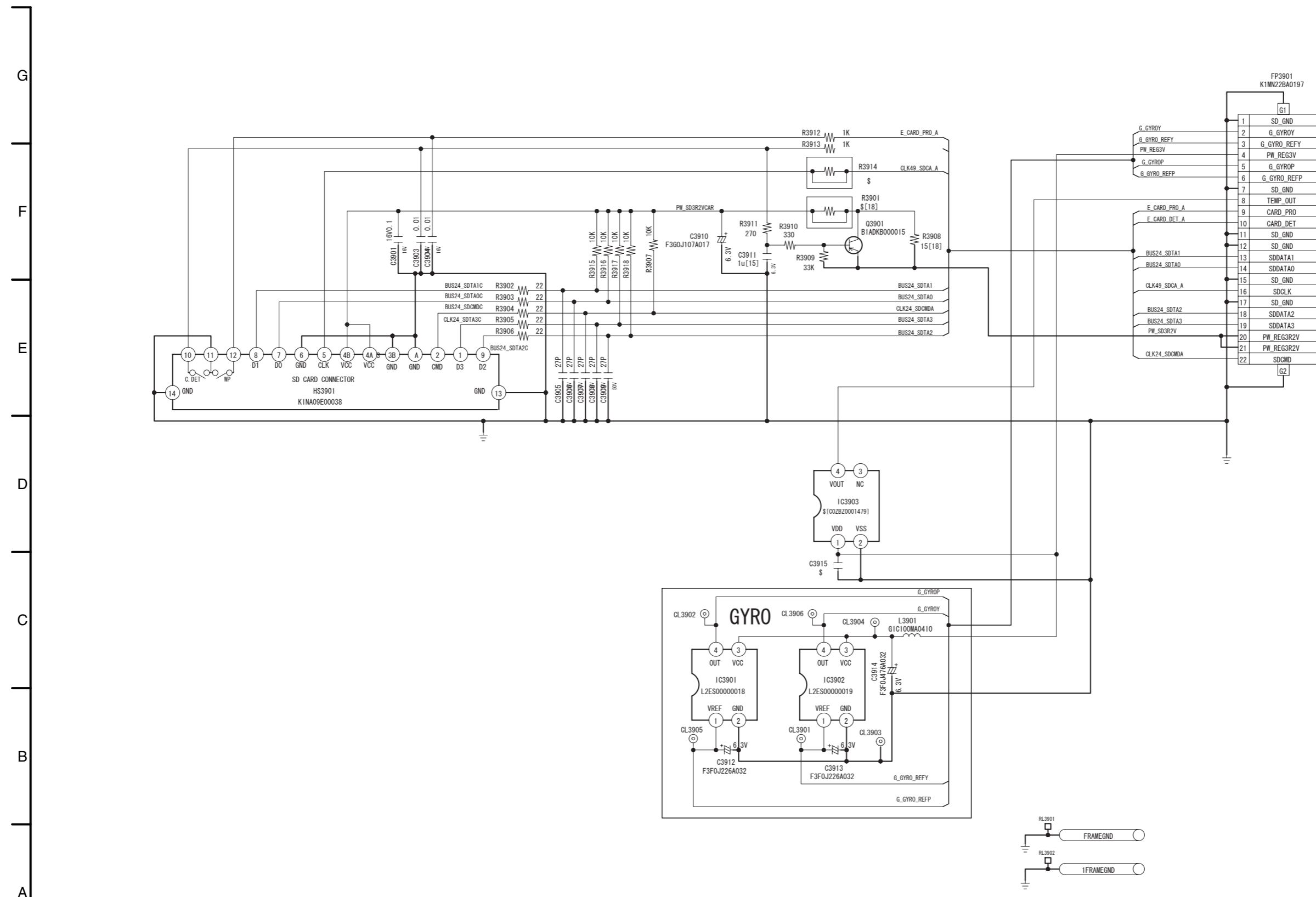

SDR-H85/H86/H95
Rear
Schematic Diagram

S4.3. CCD Schematic Diagram / S4.4. EMC Schematic Diagram

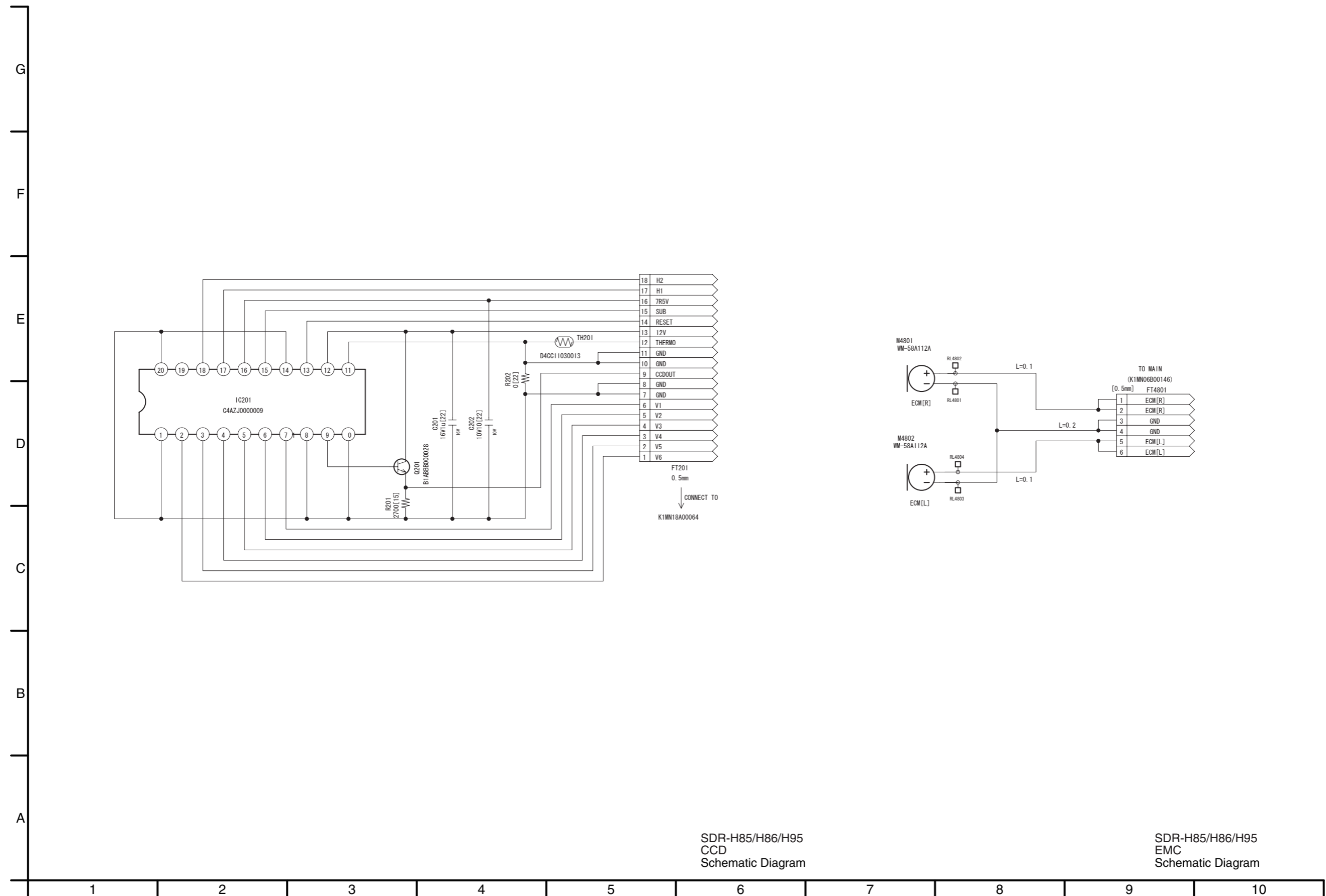

SDR-H85/H86/H95
CCD
Schematic Diagram

SDR-H85/H86/H95
EMC
Schematic Diagram

S4.5. DC BATT OP FPC Schematic Diagram

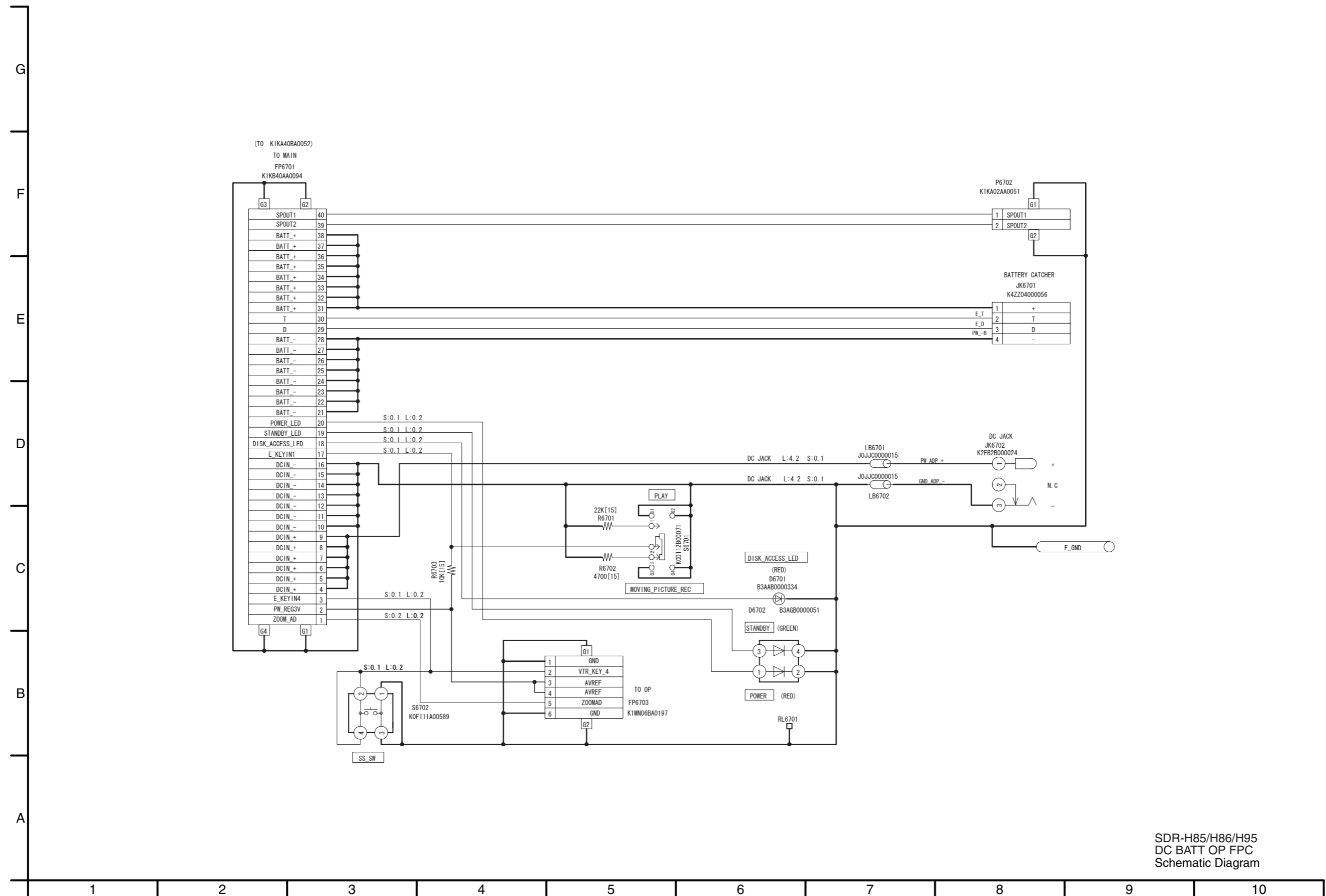

SDR-H85/H86/H95
DC BATT OP FPC
Schematic Diagram

S4.6. HDD FPC Schematic Diagram / S4.7. MONI FPC Schematic Diagram

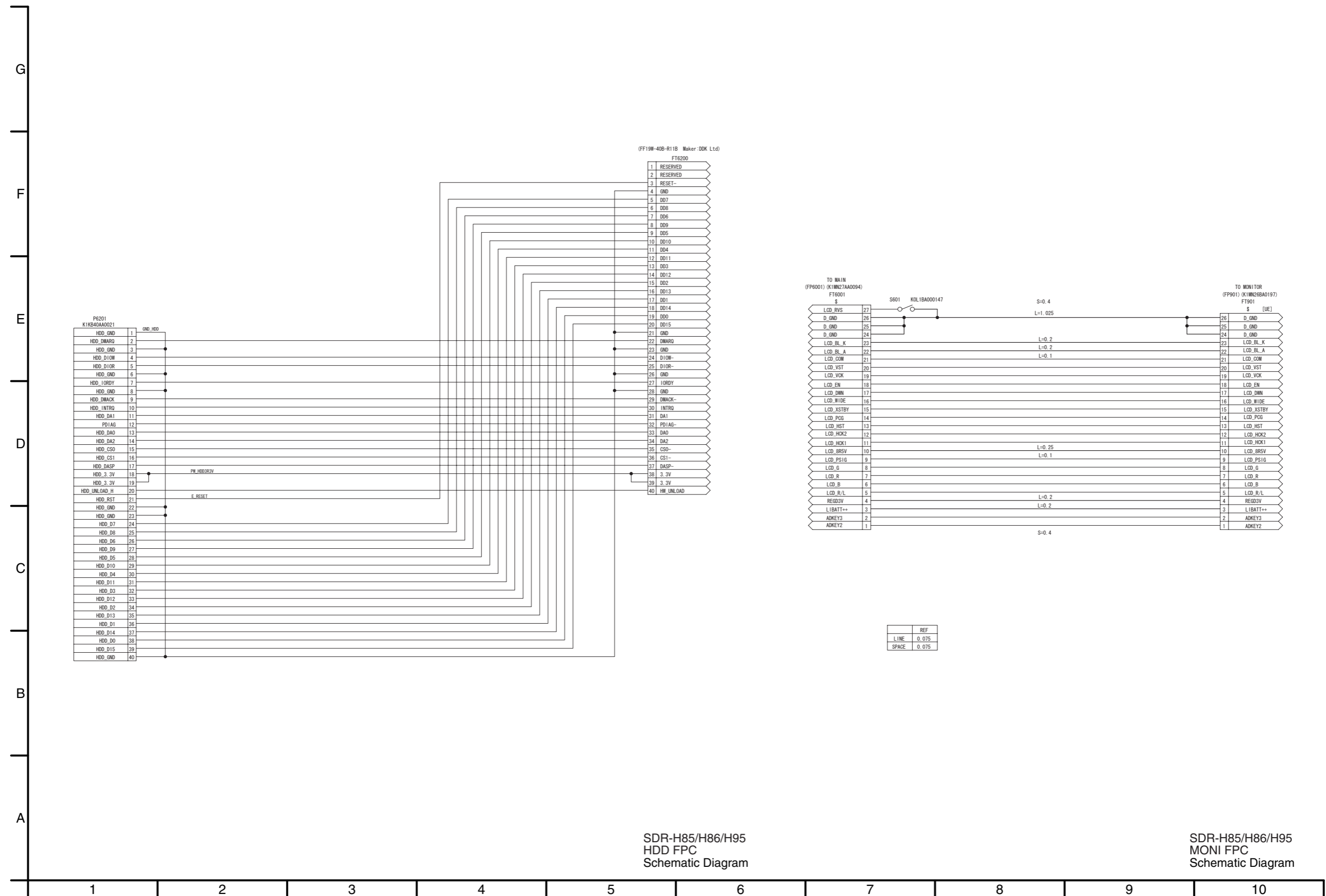

SDR-H85/H86/H95
HDD FPC
Schematic Diagram

SDR-H85/H86/H95
MONI FPC
Schematic Diagram

S4.8. Monitor Schematic Diagram

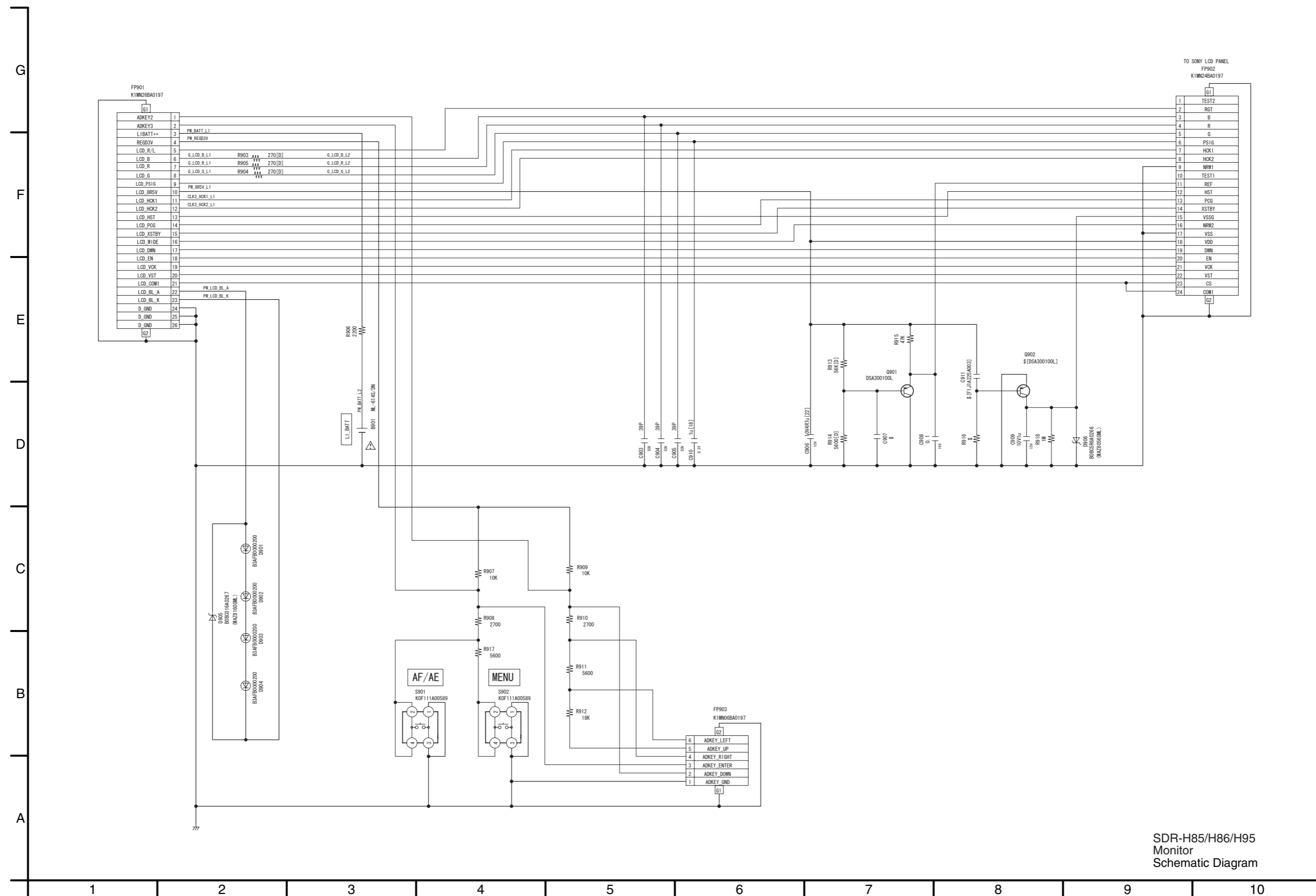

SDR-H85/H86/H95
Monitor
Schematic Diagram

S4.9. LED Light Schematic Diagram

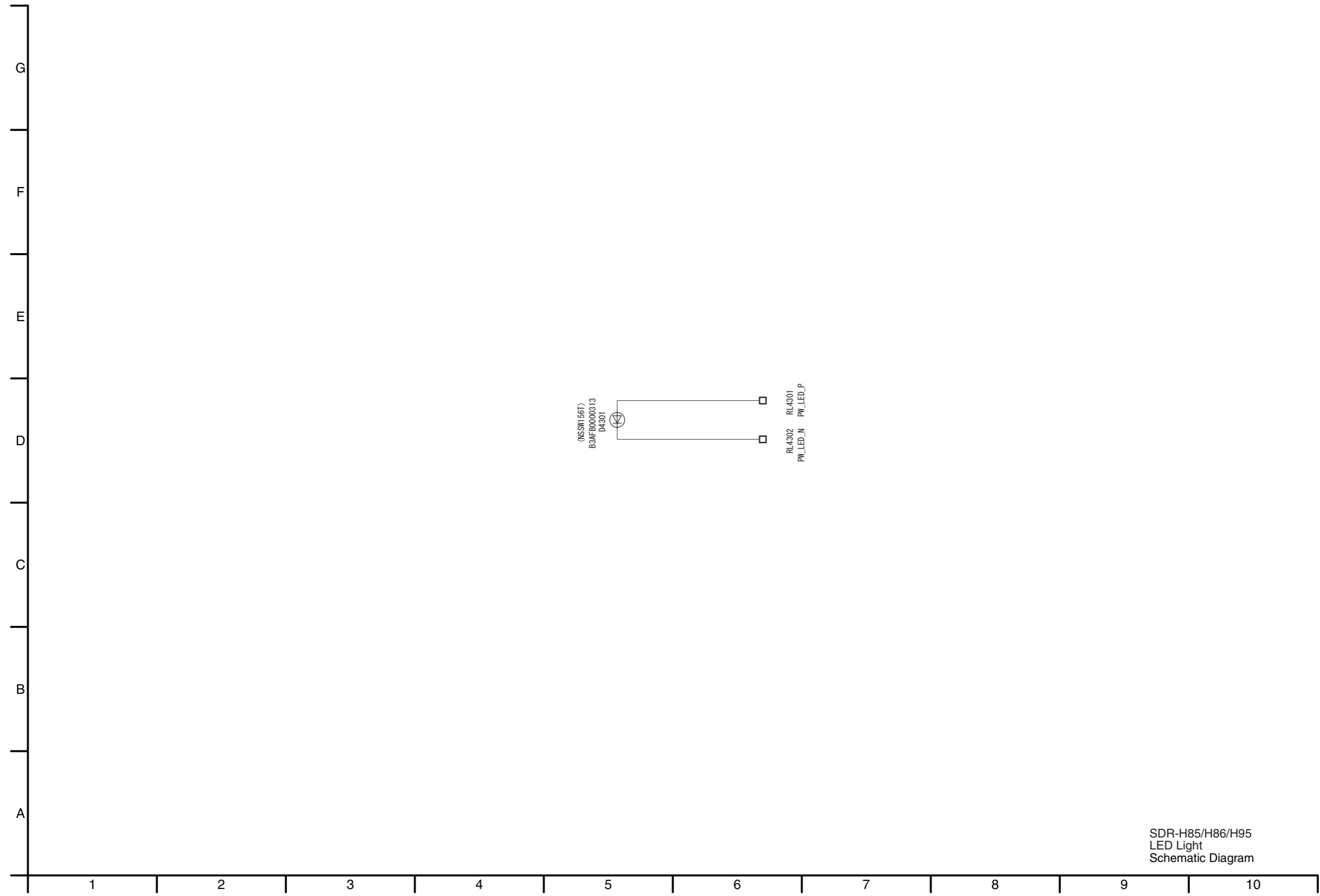

SDR-H85/H86/H95
LED Light
Schematic Diagram

S5. Print Circuit Board

S5.1. Rear P.C.B. / S5.2. CCD P.C.B.

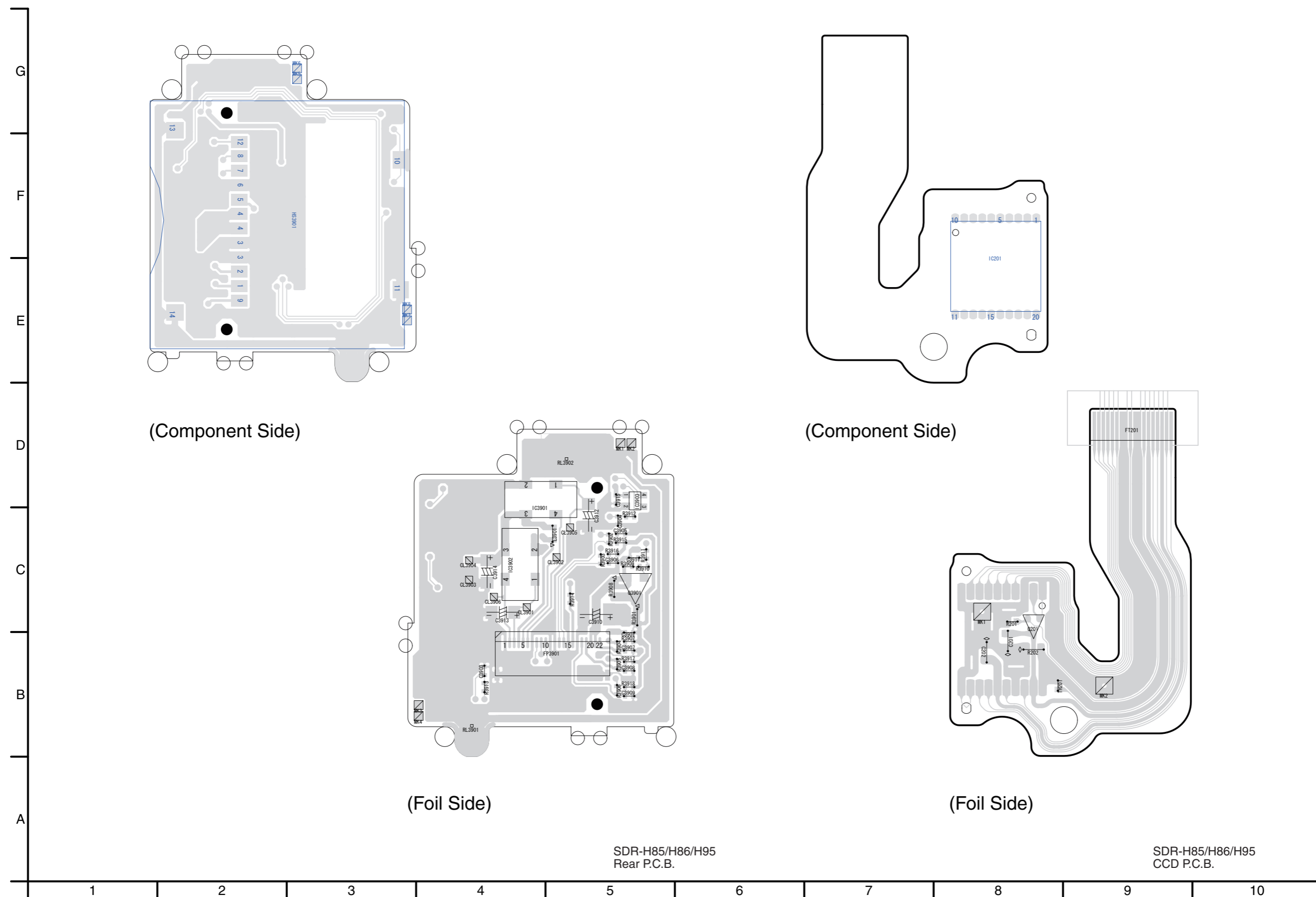

SDR-H85/H86/H95
Rear P.C.B.

SDR-H85/H86/H95
CCD P.C.B.

S5.3. EMC FPC P.C.B. / S5.4. DC BATT OP FPC P.C.B.

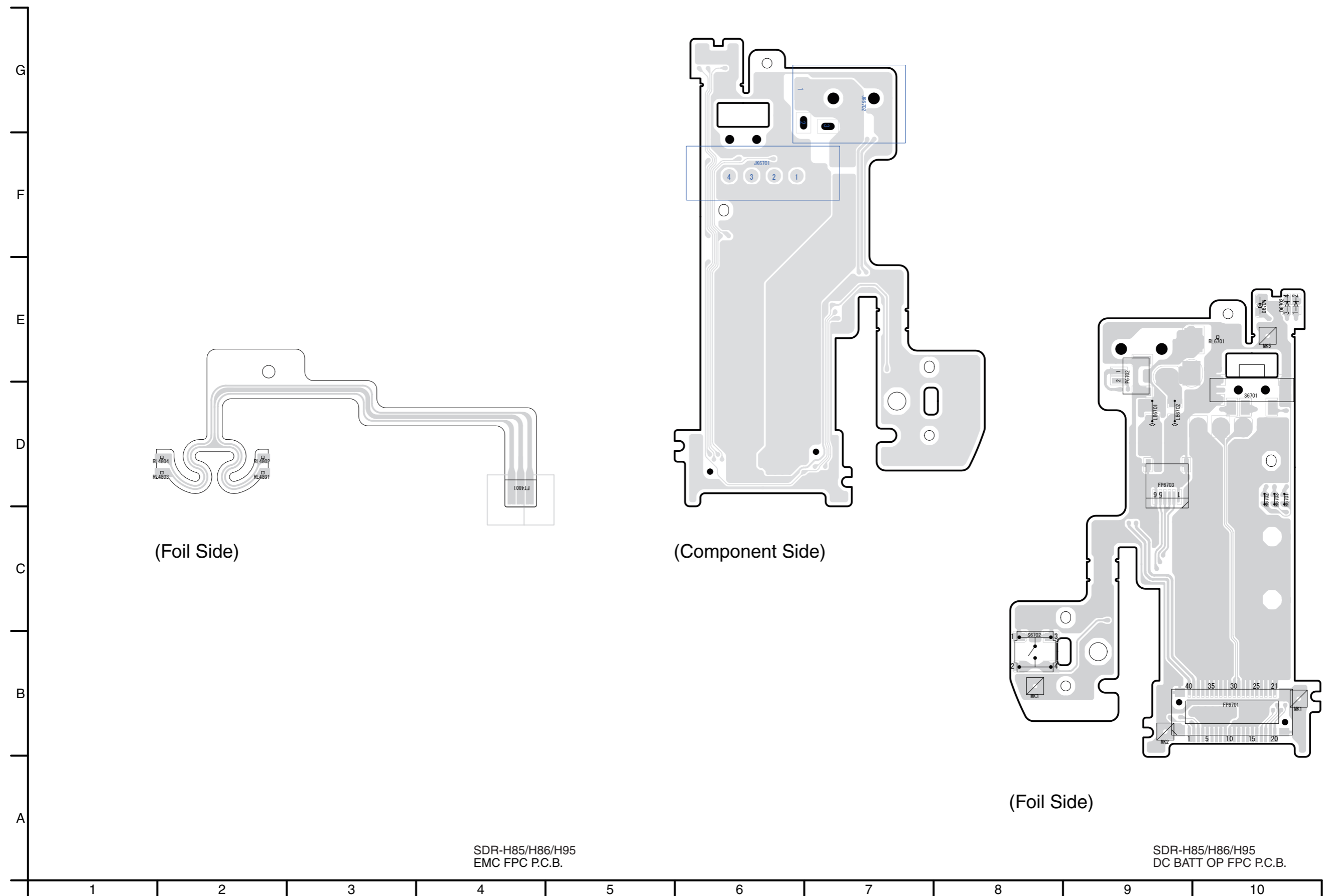

S5.5. HDD FPC P.C.B. / S5.6. MONI FPC P.C.B.

1/4	

SDR-H85/H86/H95
HDD FPC P.C.B.

N
M
L
K
J
I
H
G

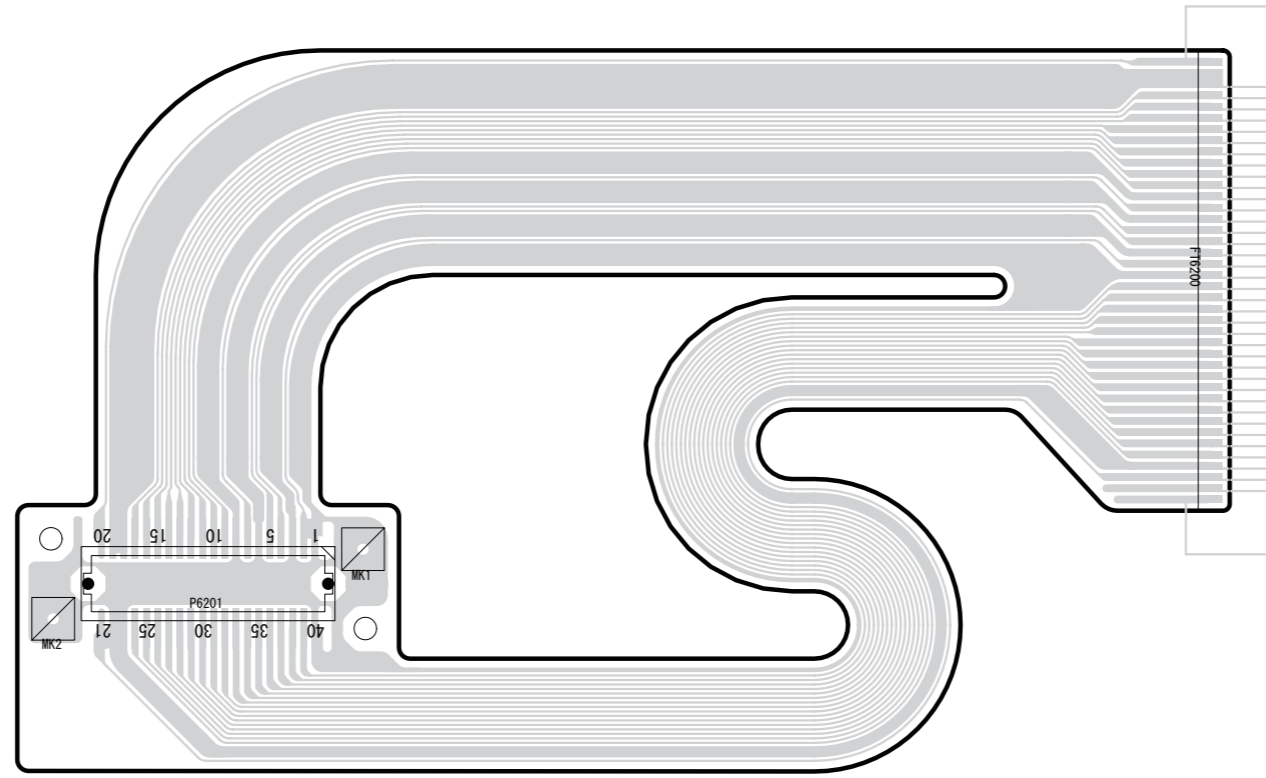

(Foil Side)



	2/4

SDR-H85/H86/H95
MONI FPC P.C.B.

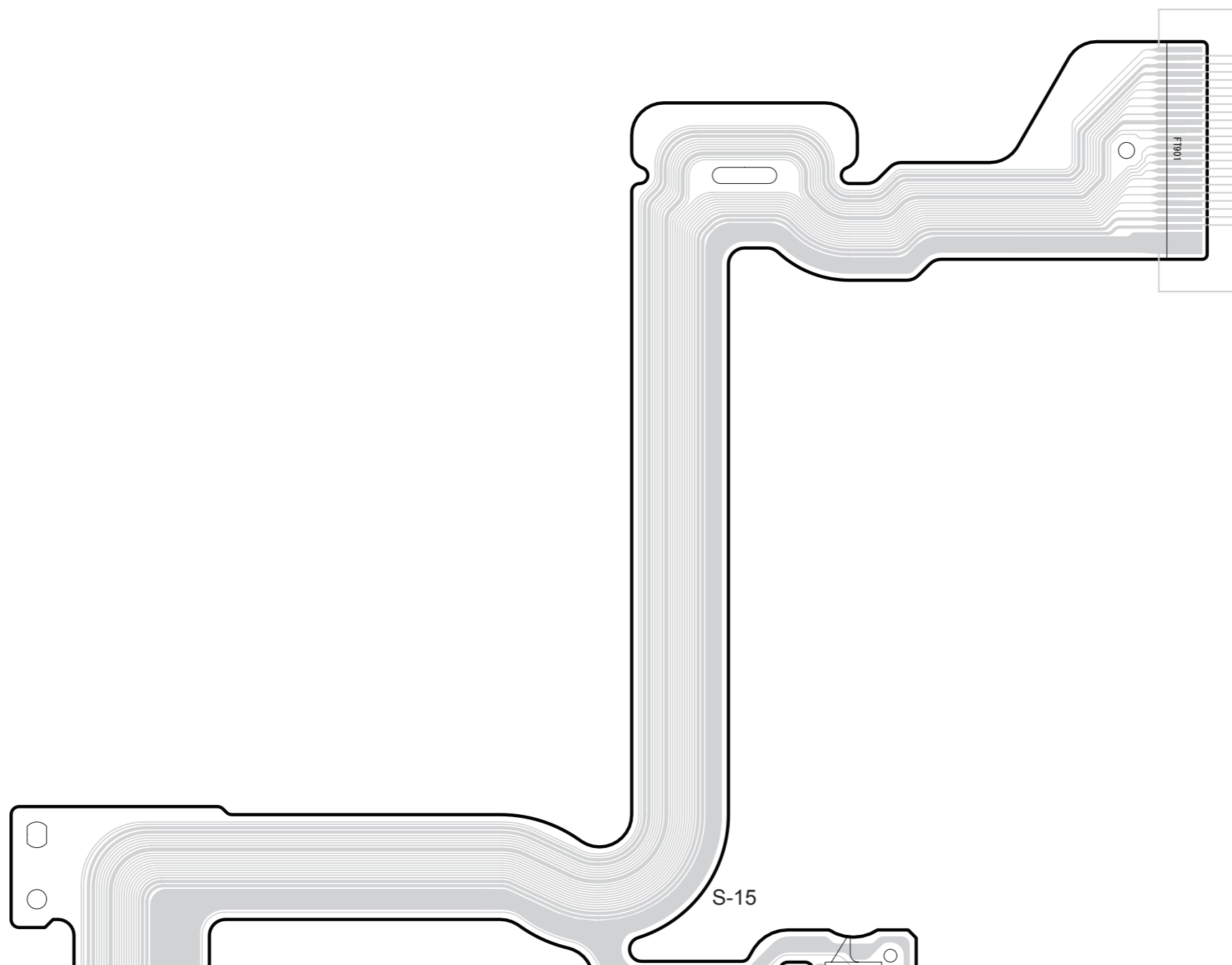

H

G

F

E

D

C

B

A

1

2

3

4

5

6

7

8

9

10

11

3/4	

SDR-H85/H86/H95
MONI FPC P.C.B.

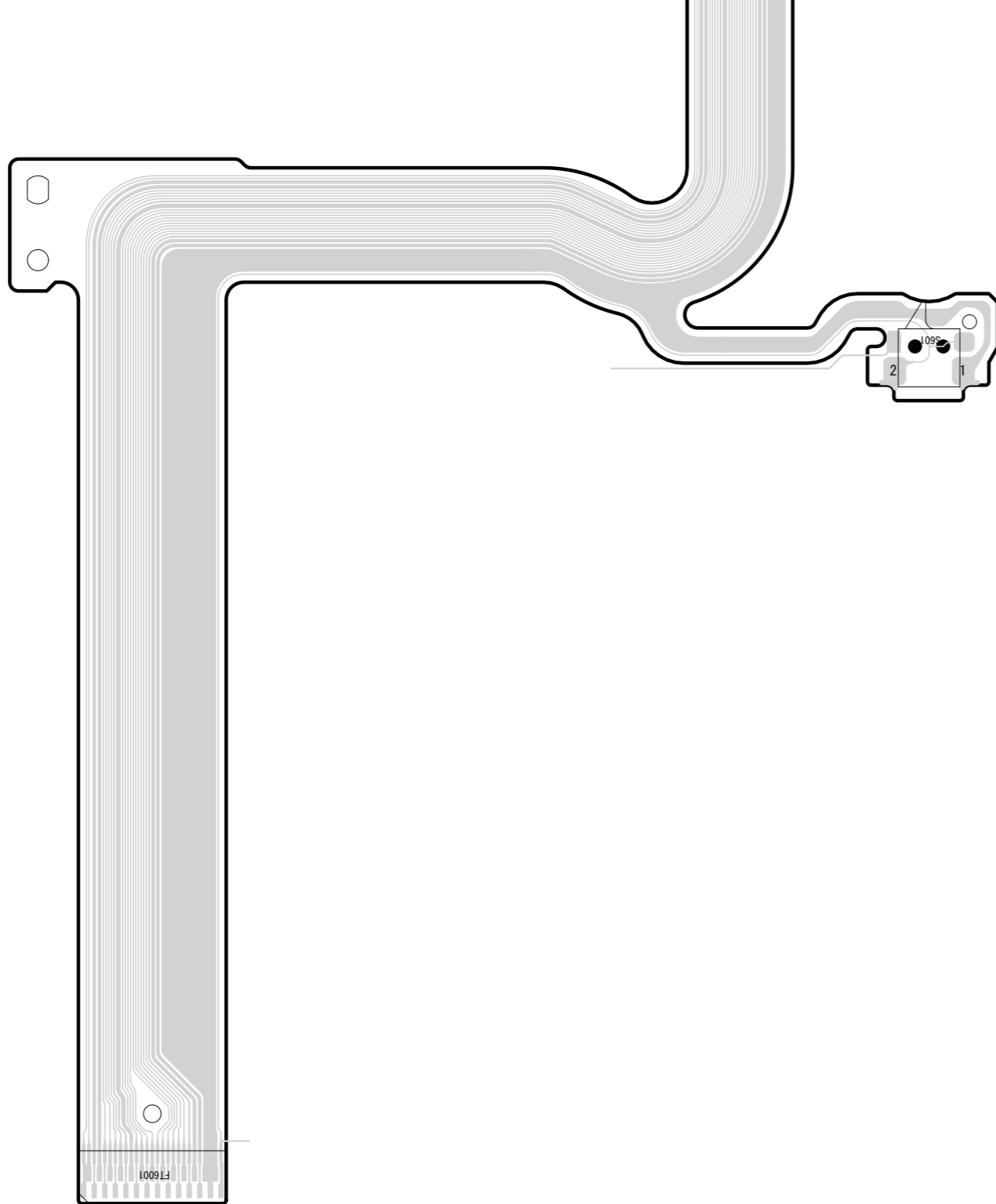

(Foil Side)

	4/4

SDR-H85/H86/H95
MONI FPC P.C.B.

11

12

13

14

15

16

17

18

19

20

21



S5.7. Monitor P.C.B.

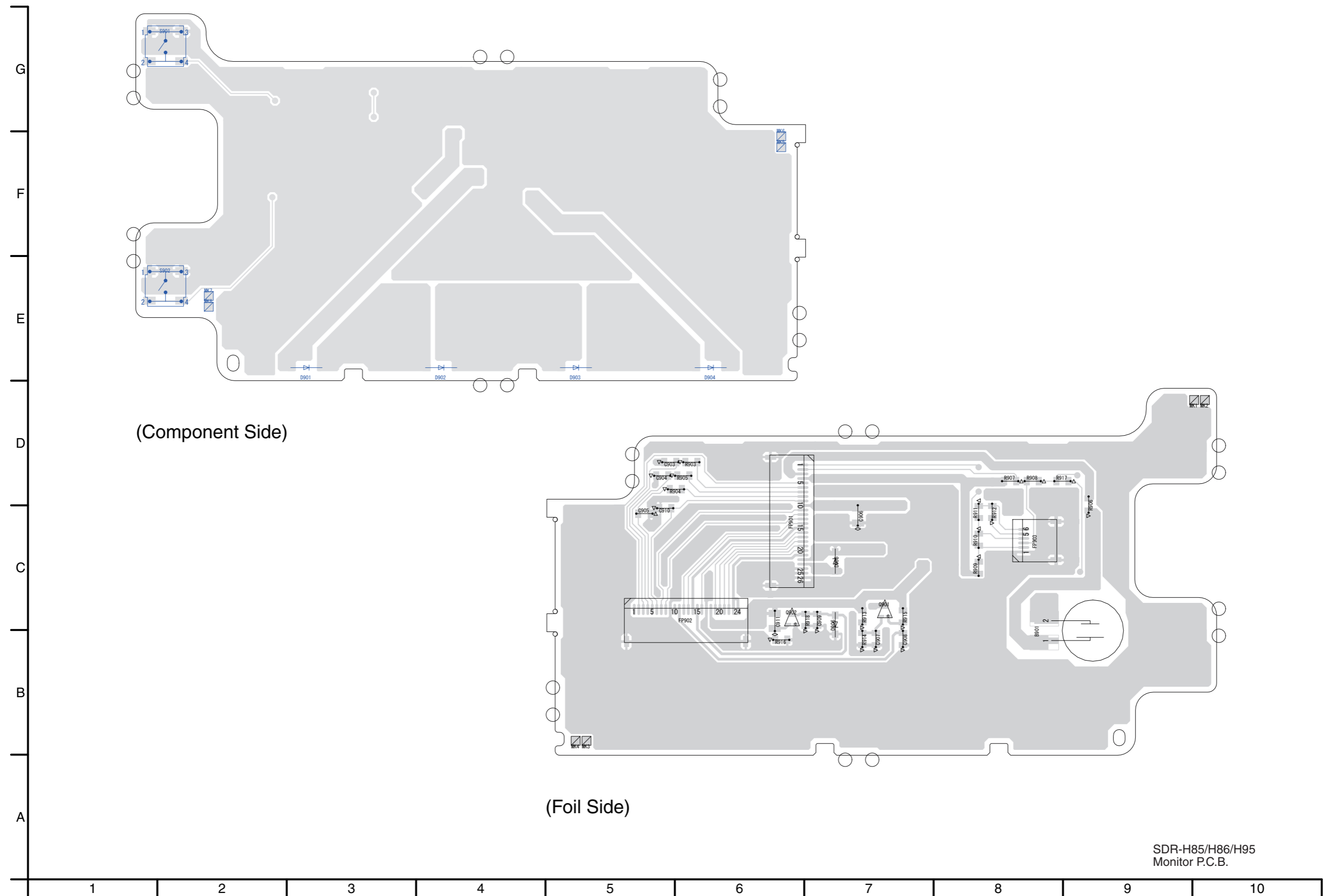

SDR-H85/H86/H95
Monitor P.C.B.

S5.8. LED Light P.C.B.

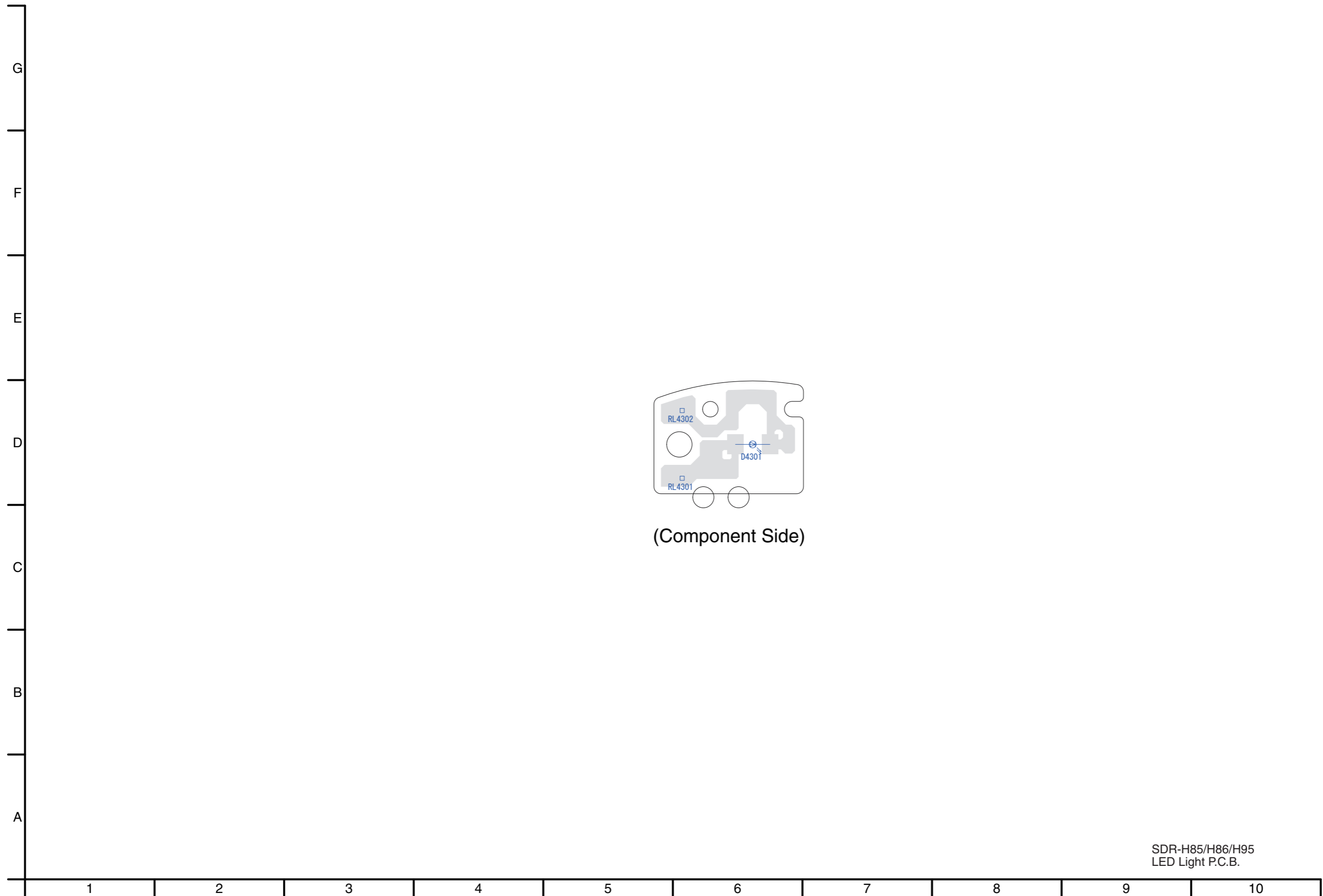

(Component Side)

S6. Replacement Parts List

- Note:
- * Be sure to make your orders of replacement parts according to this list.
 - IMPORTANT SAFETY NOTICE
Components identified with the mark \triangle have the special characteristics for safety.
When replacing any of these components, use only the same type.
 - Unless otherwise specified,
All resistors are in OHMS, K=1,000 OHMS. All capacitors are in MICRO-FARADS (uf), P=uuF.
 - The marking (RTL) indicates the retention time is limited for this item. After the discontinuation of this assembly in production, it will no longer be available.

E.S.D. standards for Electrostatically Sensitive Devices, refer to “PREVENTION OF ELECTROSTATIC DISCHARGE (ESD) TO ELECTROSTATICALLY SENSITIVE (ES) DEVICES” section.

SDR-H85EG-K vol.1

Ref.No.	Part No.	Part Name & Description	Pcs	Remarks
##	VEP02584A	REAR P.C.B.	1	(RTL) E.S.D.
##	VEP21310A	DC BATT OP FPC	1	(RTL) E.S.D.
##	VEP26326A	MONITOR P.C.B.	1	(RTL) E.S.D.
##	VEP20C83A	LED LIGHT P.C.B.	1	(SDR-H86) (RTL) E.S.D.
##	VEP02584A	REAR P.C.B.		(RTL) E.S.D.
C3901	F1G1C104A080	C.CAPACITOR CH 16V 0.1U	1	
C3903	ECJ0EB1C103K	C.CAPACITOR CH 16V 0.01U	1	
C3904	ECJ0EB1C103K	C.CAPACITOR CH 16V 0.01U	1	
C3905	ECJ0EC1H270J	C.CAPACITOR CH 50V 27P	1	
C3906	ECJ0EC1H270J	C.CAPACITOR CH 50V 27P	1	
C3907	ECJ0EC1H270J	C.CAPACITOR CH 50V 27P	1	
C3908	ECJ0EC1H270J	C.CAPACITOR CH 50V 27P	1	
C3909	ECJ0EC1H270J	C.CAPACITOR CH 50V 27P	1	
C3910	F3G0J107A017	C.CAPACITOR CH 6.3V 100U	1	
C3911	F1G0J1050007	C.CAPACITOR CH 6.3V 1U	1	
C3912	F3F0J226A032	T.CAPACITOR CH 6.3V 22U	1	
C3913	F3F0J226A032	T.CAPACITOR CH 6.3V 22U	1	
C3914	F3F0J476A032	E.CAPACITOR CH 6.3V 47U	1	
FP3901	K1MN22BA0197	CONNECTOR 22P	1	
HS3901	K1NA09E00038	CONNECTOR 9P	1	
IC3901	L2ES00000018	IC	1	E.S.D.
IC3902	L2ES00000019	IC	1	E.S.D.
L3901	G1C100MA0410	CHIP INDUCTOR 10UH	1	
Q3901	B1ADKB000015	TRANSISTOR	1	E.S.D.
R3902	ERJ2GEJ220	M.RESISTOR CH 1/16W 22	1	
R3903	ERJ2GEJ220	M.RESISTOR CH 1/16W 22	1	
R3904	ERJ2GEJ220	M.RESISTOR CH 1/16W 22	1	
R3905	ERJ2GEJ220	M.RESISTOR CH 1/16W 22	1	
R3906	ERJ2GEJ220	M.RESISTOR CH 1/16W 22	1	
R3907	ERJ2GEJ103	M.RESISTOR CH 1/10W 10K	1	
R3908	D0GB150JA057	M.RESISTOR CH 1/10W 15	1	
R3909	ERJ2GEJ333	M.RESISTOR CH 1/16W 33K	1	
R3910	ERJ2GEJ331	M.RESISTOR CH 1/16W 330	1	
R3911	ERJ2GEJ271	M.RESISTOR CH 1/10W 270	1	
R3912	ERJ2GEJ102X	M.RESISTOR CH 1/16W 1K	1	
R3913	ERJ2GEJ102X	M.RESISTOR CH 1/16W 1K	1	
R3915	ERJ2GEJ103	M.RESISTOR CH 1/10W 10K	1	
R3916	ERJ2GEJ103	M.RESISTOR CH 1/10W 10K	1	
R3917	ERJ2GEJ103	M.RESISTOR CH 1/10W 10K	1	
R3918	ERJ2GEJ103	M.RESISTOR CH 1/10W 10K	1	
##	VEP21310A	DC BATT OP FPC		(RTL) E.S.D.
D6701	B3AAB0000334	LED	1	E.S.D.
D6702	B3AGB0000051	LED	1	E.S.D.
FP6701	K1KB40AA0094	CONNECTOR 40P	1	
FP6703	K1MN06BA0197	CONNECTOR 6P	1	
JK6701	K4ZZ04000056	JK, BATTERY	1	
JK6702	K2EB2B000024	JK, DC IN	1	
LB6701	J0JJC0000015	FILTER	1	
LB6702	J0JJC0000015	FILTER	1	
P6702	K1KA02AA0051	CONNECTOR 2P	1	
R6701	D0GA223JA015	M.RESISTOR CH 1/16W 22K	1	
R6702	ERJ2GEJ472	M.RESISTOR CH 1/10W 4.7K	1	
R6703	D0GA103JA015	M.RESISTOR CH 1/16W 10K	1	
S6701	K0D112B00145	SWITCH	1	
S6702	K0F111A00589	SWITCH	1	

Ref.No.	Part No.	Part Name & Description	Pcs	Remarks
##	VEP26326A	MONITOR P.C.B.		(RTL) E.S.D.
△ B901	ML-614S/DN	BUTTON BATTERY	1	
C903	ECJ1VC1H390J	C.CAPACITOR CH 50V 39P	1	
C904	ECJ1VC1H390J	C.CAPACITOR CH 50V 39P	1	
C905	ECJ1VC1H390J	C.CAPACITOR CH 50V 39P	1	
C906	F1J1A475A023	C.CAPACITOR CH 10V 4.7U	1	
C908	F1H1C104A071	C.CAPACITOR CH 16V 0.1U	1	
C909	ECJ1VB1A105K	C.CAPACITOR CH 10V 1U	1	
C910	ECJ1VB0J105K	C.CAPACITOR CH 6.3V 1U	1	
D901	B3AFB0000200	LED	1	E.S.D.
D902	B3AFB0000200	LED	1	E.S.D.
D903	B3AFB0000200	LED	1	E.S.D.
D904	B3AFB0000200	LED	1	E.S.D.
D905	B0BC016A0267	DIODE	1	E.S.D.
D906	B0BC5R6A0266	DIODE	1	E.S.D.
FP901	K1MN26BA0197	CONNECTOR 26P	1	
FP902	K1MN24BA0197	CONNECTOR 24P	1	
FP903	K1MN06BA0197	CONNECTOR 6P	1	
Q901	DSA300100L	TRANSISTOR	1	E.S.D.
R903	ERJ3RBD271	M.RESISTOR CH 1/10W 270	1	
R904	ERJ3RBD271	M.RESISTOR CH 1/10W 270	1	
R905	ERJ3RBD271	M.RESISTOR CH 1/10W 270	1	
R906	D0GB222JA041	M.RESISTOR CH 1/10W 2.2K	1	
R907	D0GB103JA057	M.RESISTOR CH 1/10W 10K	1	
R908	D0GB272JA041	M.RESISTOR CH 1/10W 2.7K	1	
R909	D0GB103JA057	M.RESISTOR CH 1/10W 10K	1	
R910	D0GB272JA041	M.RESISTOR CH 1/10W 2.7K	1	
R911	D0GB562JA041	M.RESISTOR CH 1/10W 5.6K	1	
R912	D0GB183JA057	M.RESISTOR CH 1/10W 18K	1	
R913	ERJ3RBD563V	M.RESISTOR CH 1/10W 56K	1	
R914	ERJ3RBD562	M.RESISTOR CH 1/10W 5.6K	1	
R915	D0GB473JA041	M.RESISTOR CH 1/10W 47K	1	
R917	D0GB562JA041	M.RESISTOR CH 1/10W 5.6K	1	
R918	D0GB105JA057	M.RESISTOR CH 1/10W 1M	1	
S901	K0F111A00589	SWITCH	1	
S902	K0F111A00589	SWITCH	1	
##	VEP20C83A	LED LIGHT P.C.B.		(SDR-H86) (RTL) E.S.D.
D4301	B3AFB0000313	LED	1	(SDR-H86) E.S.D.

SDR-H85EG-K vol.1

Ref.No.	Part No.	Part Name & Description	Pcs	Remarks	Ref.No.	Part No.	Part Name & Description	Pcs	Remarks
1	VEP02584A	REAR P.C.B.	1	(RTL) E.S.D.	B9	XQN16+B4FJK	SCREW	1	
2	LSKF0753	REAR COVER	1		B10	XQN16+B4FJK	SCREW	1	
3	LSGK1050	FRONT CASE	1	(-K,-H)	B11	XQN16+B4FJK	SCREW	1	
3	LSGK1042	FRONT CASE	1	(-S,-R,-A)	B12	XQN16+B4FJK	SCREW	1	
4	LSYK2896	LENS PIECE U	1	(SDR-H85, SDR-H95)	B13	XQN16+B4FJK	SCREW	1	
4	LSYK2897	LENS PIECE U	1	(SDR-H86)	B14	XQN16+B4FJK	SCREW	1	
5	LSYK2901	FRONT PANEL U	1		B15	XQN16+B4FJK	SCREW	1	
6	LSGT0633	SHUTTER KNOB	1		B16	XQN16+B4FJK	SCREW	1	
7	VDL2468	LED LIGHT LENS	1	(SDR-H86)	B18	XQN16+BJ5FJK	SCREW	1	
8	VEP20C83A	LED LIGHT P.C.B.	1	(SDR-H86) (RTL) E.S.D.	B19	LSHD0132	SCREW	1	
9	LSMG0199	LENS DAMPER	1		B20	LSHD0132	SCREW	1	
10	LSKM1993	GRIP COVER(HDD)	1		B21	XQN16+BJ4FN	SCREW	1	
11	LSMA1064	STRAP ANGLE	1		B22	XQN16+BJ4FN	SCREW	1	
12	LSMA1064	STRAP ANGLE	1		B23	XQN16+BJ5FJK	SCREW	1	
13	LSGQ0371	GRIP BELT U	1		B24	XQN16+BJ5FN	SCREW	1	
14	LSYK2927	JACK COVER (HDD) U	1		B25	XQN16+B4FJK	SCREW	1	
22	VEP03H83AP	MAIN P.C.B.	1	H85EG,EB,EC,EF,EP (RTL) E.S.D.	B30	XQN16+B4FJK	SCREW	1	
22	VEP03H83AQ	MAIN P.C.B.	1	H85EE,GA,GK,GN,GC, H95EE, GA,GC (RTL) E.S.D.	B31	XQN16+B4FJK	SCREW	1	
22	VEP03H83AN	MAIN P.C.B.	1	H85GT,P,PC (RTL) E.S.D.	B32	XQN16+BJ5FJK	SCREW	1	
22	VEP03H83AR	MAIN P.C.B.	1	H86EB (RTL) E.S.D.	B33	XQN16+B4FJK	SCREW	1	
22	VEP03H83AM	MAIN P.C.B.	1	H86PR,PU (RTL) E.S.D.	B34	XQN16+B4FN	SCREW	1	
23	LSKM1990	REAR CASE	1		B35	XQN16+B4FN	SCREW	1	
24	LSGT0630	BATTERY RELEASE KNOB	1		B36	XQN16+BJ5FJK	SCREW	1	
25	LSMB0369	BATTERY RELEASE SPRING	1		B37	XQN16+BJ4FN	SCREW	1	
26	LSMD1117	BATTERY RELEASE HOLDER	1		B38	XQN16+BJ4FN	SCREW	1	
27	LSGT0631	MODE SELECT KNOB	1		B39	XQN16+BJ4FN	SCREW	1	
28	LSGL1553	LED PANEL(REAR)	1		B40	XQN16+BJ4FN	SCREW	1	
29	LSSC1111	EARTH PLATE(MODE)	1		B41	XQN16+B4FN	SCREW	1	
30	LSGT0632	S/S BUTTON	1		B42	XQN16+B4FN	SCREW	1	
31	VEP21310A	DC BATT OP FPC	1	(RTL) E.S.D.	B43	XQN16+B4FN	SCREW	1	
32	LSSC1112	EARTH PLATE (REAR)	1		B44	XQN16+B4FJK	SCREW	1	
35	LSYK2834	SIDE CASE R U	1	H85EG,EB,EC,EE,EF,EP,GA, GK,GN,GC, H95EE,GA,GC	B45	XQN16+B4FJK	SCREW	1	
35	LSYK2833	SIDE CASE R U	1	H85GT,P,PC					
35	LSYK2836	SIDE CASE R U	1	H86EB					
35	LSYK2835	SIDE CASE R U	1	H86PR,PU					
36	LSKM2010	TOP CASE	1	(-K)					
36	LSKM1997	TOP CASE	1	(-S)					
36	LSKM2012	TOP CASE	1	(-R)					
36	LSKM2011	TOP CASE	1	(-A)					
36	LSKM2065	TOP CASE	1	(-H)					
37	LSGU0779	TOP BUTTON	1						
38	LSGK1047	DECO. PIECE (TOP)	1	(-K,-H)					
38	LSGK1039	DECO. PIECE (TOP)	1	(-S,-R,-A)					
39	LSYK2810	TOP OPERATION U	1						
40	L0AA01A00049	SPEAKER	1						
41	LSMC0178	SPEAKER ANGLE	1						
42	LSMA1169	MAIN FRAME	1						
43	LSHN0021	TRIPOD FRAME	1						
44	LSKM1991	SHUTTER GUIDE	1						
45	LSML0386	SHUTTER ARM	1						
46	LSKF0749	SHUTTER PANEL	1						
47	LSGF0561	SHUTTER COVER	1						
48	LSMB0370	SHUTTER SPRING	1						
49	LSEQ0874	MIC U	1						
50	RFKV0219HDKT	HDD (80GB)	1	(SDR-H85, H86)					
50	RFKV0220HDKT	HDD (120GB)	1	(SDR-H95)					
51	VEP79257A	HDD FPC	1						
52	VMG1922	HDD DAMPER	1						
53	VMG1922	HDD DAMPER	1						
54	VEE1H20	LIGHT WIRE	1	(SDR-H86)					
55	LSGK1045	GRIP PIECE	1						
56	VWJ2129	REAR F.P.C.	1						
57	LSGL1555	LED PANEL(REAR/HDD)	1						
58	LSSC1110	SIDE L ANGLE	1						
B1	XQN16+BJ4FN	SCREW	1						
B2	XQN16+BJ4FN	SCREW	1						
B3	XQN16+BJ4FN	SCREW	1						
B4	XQN16+BJ5FN	SCREW	1						
B5	XQN16+BJ5FN	SCREW	1						
B6	XQN16+BJ5FN	SCREW	1	(SDR-H86)					
B7	XQN16+B4FJK	SCREW	1						
B8	XQN16+BJ5FJK	SCREW	1						

SDR-H85EG-K vol.1

Ref.No.	Part No.	Part Name & Description	Pcs	Remarks	Ref.No.	Part No.	Part Name & Description	Pcs	Remarks
401	LSXN0061	LENS U	1						
401-1	L6HA66NB0011	ZOOM MOTOR UNIT	1						
401-2	L6HA66NB0012	FOCUS MOTOR UNIT	1						
401-3	LSEM0118	AUTO IRIS UNIT	1						
402	VEP22409A	CCD P.C.B.	1	E.S.D.					
403	LSDW0141	CCD CASE	1						
404	LSFL0343	OPTICAL LPF	1						
405	LSMX0246	CCD CUSHION	1						
B401	LSHD0136	SCREW	1						
B402	LSHD0136	SCREW	1						
B403	XQN16+BJ4FN	SCREW	1						
B404	XQN16+BJ4FN	SCREW	1						
B405	XQN16+BJ4FN	SCREW	1						
B406	XQN16+BJ4FN	SCREW	1						
B407	XQN16+BJ4FN	SCREW	1						
B408	XQN16+BJ4FN	SCREW	1						

SDR-H85EG-K vol.1

Ref.No.	Part No.	Part Name & Description	Pcs	Remarks
501	VYQ5309	PACKING CASE U	1	H85EGS,ECS,EES,EPS,GAS
501	VYQ5315	PACKING CASE U	1	H85EGR,EGR,EFR,EPR,GAR
501	VYQ5183	PACKING CASE U	1	H85GKK
501	VYQ5310	PACKING CASE U	1	H85GKS
501	VYQ5316	PACKING CASE U	1	H85GKR
501	VYQ5312	PACKING CASE U	1	H85GCS
501	VYQ5317	PACKING CASE U	1	H85GCR
501	VYQ5188	PACKING CASE U	1	H85GTK
501	VYQ5597	PACKING CASE U	1	H85GTR
501	VYQ5596	PACKING CASE U	1	H85GTA
501	VYQ5308	PACKING CASE U	1	H85PS
501	VYQ5313	PACKING CASE U	1	H85PA,PCA
501	VYQ5314	PACKING CASE U	1	H85PCR
501	VYQ5535	PACKING CASE U	1	H86PUS
501	VYQ5536	PACKING CASE U	1	H86PUR
502	VPF1294	POLYETHYLENE BAG	1	
503	VPF1388	PROTECT BAG	1	
504	K2KYYYYY00054	AV CABLE	1	
505	K1HY04YY0032	USB CABLE	1	
△ 506	K2CQ29A00002	AC CORD	1	H85EG,EC,EE,EF,EP,GA,GC, H95EE,GA,GC
△ 506	K2CT39A00002	AC CORD	1	H85EB,GA,GC, H86EB, H95GA,GC
△ 506	K2CA2YY00070	AC CORD	1	H85GK
△ 506	K2CJ29A00002	AC CORD	1	H85GN
△ 506	K2CA29A00021	AC CORD	1	H85GT
△ 506	K2CA2CA00025	AC CORD	1	H85P,PC, H86PU
△ 506	K2CJ29A00003	AC CORD	1	H86PR
△ 507	VSK0712	AC ADAPTER CHARGER	1	H85EG,EBK,EC,EE,EF,EP, GA,GN,GC, H86EB,PR,PU, H95EE,GA,GC
△ 507	VSK0713	AC ADAPTER CHARGER	1	H85GK
△ 507	VSK0714	AC ADAPTER CHARGER	1	H85GT
△ 507	VSK0711	AC ADAPTER CHARGER	1	H85P,PC
508	VPN6972	PAD	1	
508	VPN6994	PAD	1	H85GC, H95GC
509		CD-ROM	1	H85EG,EB,EC,EE,EF,EP,GA, GN,GC,GT,P,PC, H86EB, PR,PU, H95EE,GA,GC
509		CD-ROM	1	H85GK
△ 510	VQT2L19	O/I	1	H85EG GERMAN/FRENCH
△ 510	VQT2L20	O/I	1	H85EG ITALIAN/DUTCH
△ 510	VQT2L21	O/I	1	H85EG TURKISH
△ 510	VQT2L28	O/I	1	H85EB ENGLISH
△ 510	VQT2L23	O/I	1	H85EC PORTUGUESE/SPANISH
△ 510	VQT2L24	O/I	1	H85EC SWEDISH/DANISH
△ 510	VQT2L25	O/I	1	H85EC FINNISH
△ 510	VQT2L33	O/I	1	H85EE, H95EE RUSSIAN
△ 510	VQT2L34	O/I	1	H85EE, H95EE UKRAINIAN
△ 510	VQT2L22	O/I	1	H85EF FRENCH
△ 510	VQT2L26	O/I	1	H85EP ENGLISH/POLISH
△ 510	VQT2L27	O/I	1	H85EP CZECH/HUNGARIAN
△ 510	VQT2L31	O/I	1	H85GA, H95GA ENGLISH/CHINESE(TRADITIONAL)
△ 510	VQT2L32	O/I	1	H85GA, H95GA THAI/HINDI
△ 510	VQT2L36	O/I	1	H85GK CHINESE(SIMPLIFIED)
△ 510	VQT2L35	O/I	1	H85GN ENGLISH
△ 510	VQT2L29	O/I	1	H85GC, H95GC ENGLISH
△ 510	VQT2L30	O/I	1	H85GC, H95GC ARABIC/PERSIAN

Ref.No.	Part No.	Part Name & Description	Pcs	Remarks
△ 510	VQT2L18	O/I	1	H85GT CHINESE(TRADITIONAL)
△ 510	VQT2L14	O/I	1	H85P,PC ENGLISH
△ 510	VQT2L15	O/I	1	H85PC CANADIAN FRENCH
△ 510	VQT2N67	O/I	1	H86EB ENGLISH
△ 510	VQT2L17	O/I	1	H86PR,PU SPANISH
△ 510	VQT2L16	O/I	1	H86PU ENGLISH
△ 511	VFF0568	CD-ROM(O/I)	1	H85EG,EC,EP
△ 511	VFF0570	CD-ROM(O/I)	1	H85GA, H95GA
△ 511	VFF0569	CD-ROM(O/I)	1	H85GC, H95GC

S7. Exploded View

S7.1. Frame and Casing Section

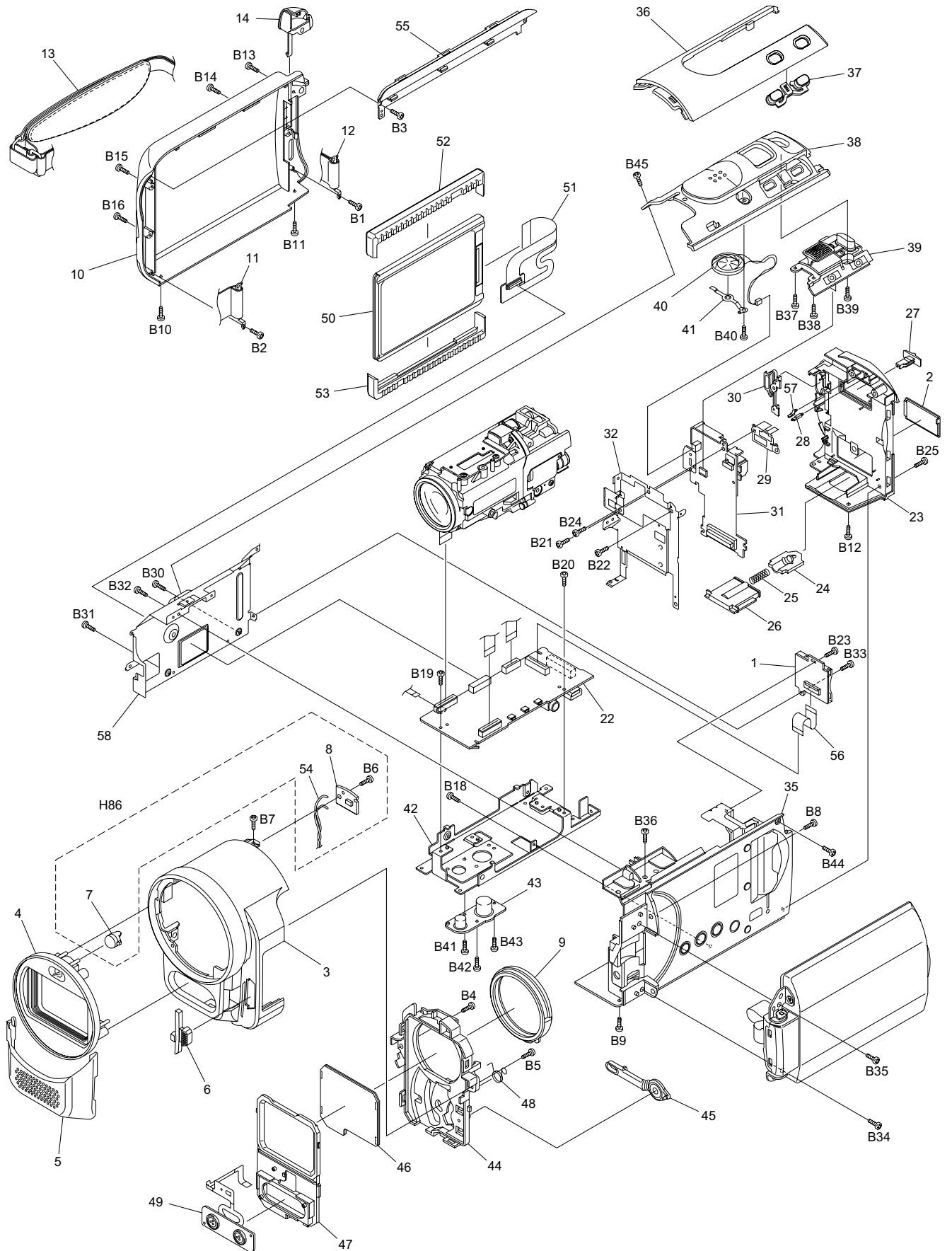

S7.2. LCD Section

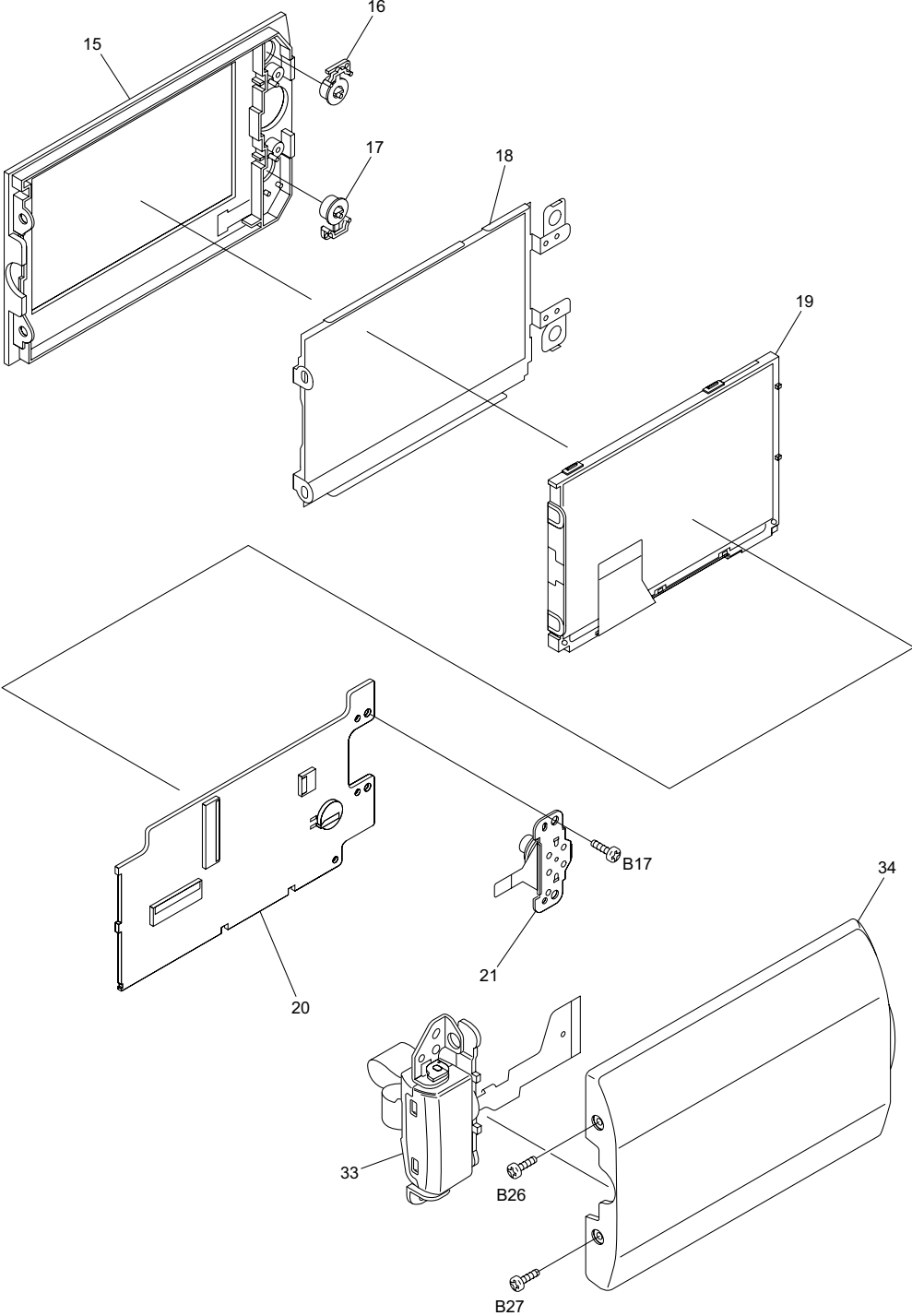

S7.3. Lens Section

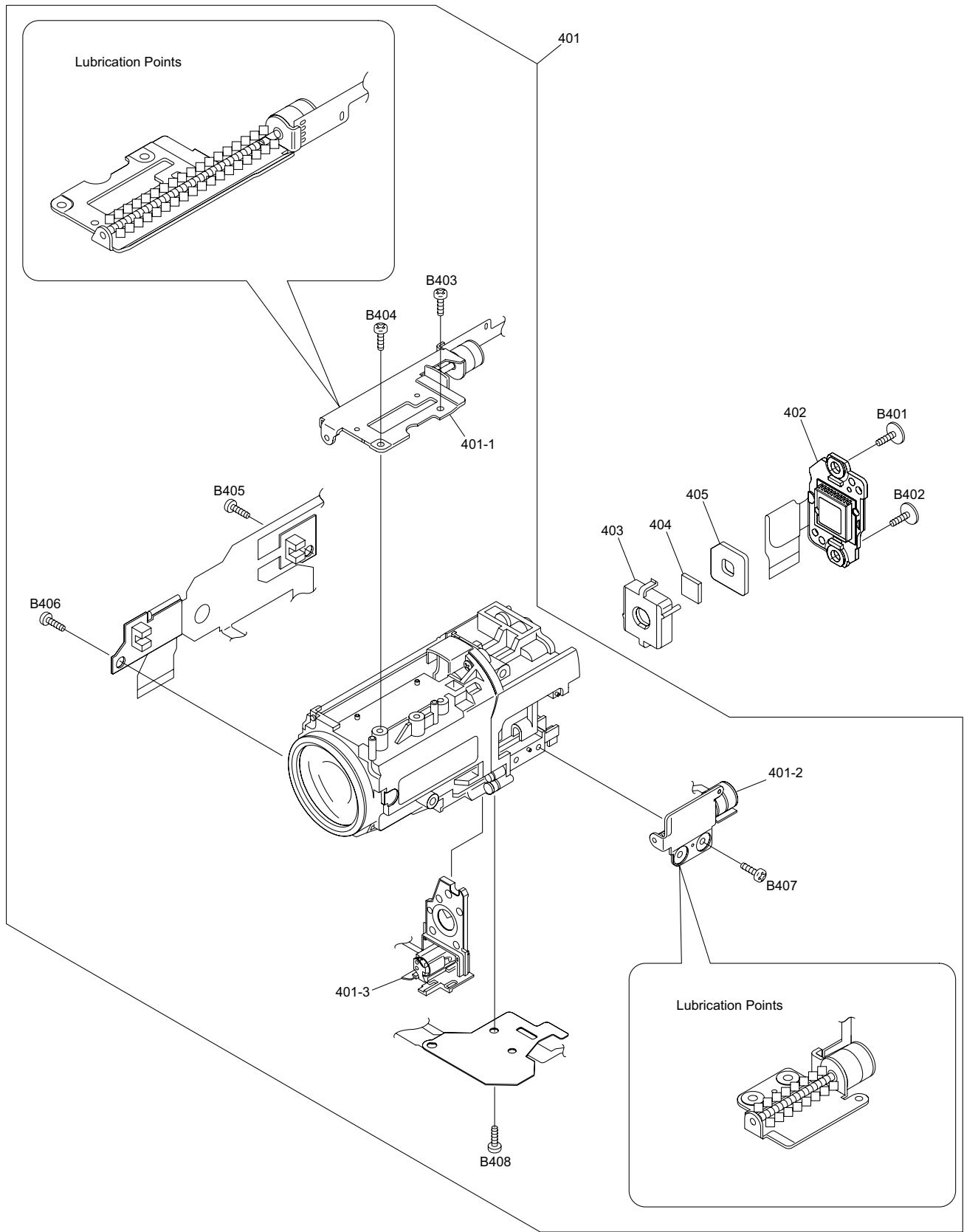

S7.4. Packing Parts and Accessories Section

