

Service Manual

Digital Camera

LUMIX

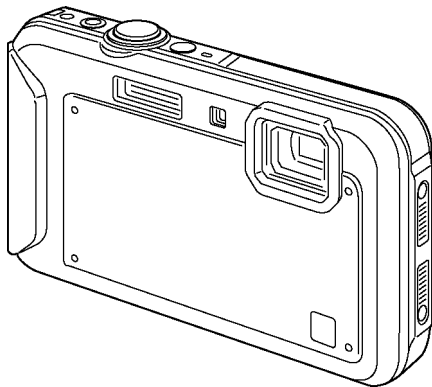

Model No. **DMC-FT20EB**
DMC-FT20EE
DMC-FT20EF
DMC-FT20EG
DMC-FT20EP
DMC-FT20GA
DMC-FT20GC
DMC-FT20GF
DMC-FT20GN
DMC-TS20P
DMC-TS20PC
DMC-TS20PU
DMC-TS20PB
DMC-TS20GH
DMC-TS20GK
DMC-TS20GT

Colours

- (A).....Blue Type (Except DMC-FT20EF, DMC-TS20GT)
- (D).....Orange Type (Except DMC-FT20EE, DMC-TS20PU/PB/GK)
- (K).....Black Type (Except DMC-FT20EF, DMC-TS20PC/PB/GH/GK)
- (R).....Red Type (Except DMC-FT20EE)

⚠ **WARNING**

This service information is designed for experienced repair technicians only and is not designed for use by the general public. It does not contain warnings or cautions to advise non-technical individuals of potential dangers in attempting to service a product. Products powered by electricity should be serviced or repaired only by experienced professional technicians. Any attempt to service or repair the product or products dealt with in this service information by anyone else could result in serious injury or death.

TABLE OF CONTENTS

	PAGE		PAGE
1 Safety Precautions -----	3		
1.1. General Guidelines -----	3		
1.2. Leakage Current Cold Check -----	3		
1.3. Leakage Current Hot Check (See Figure 1) -----	3		
1.4. How to Discharge the Capacitor on Flash P.C.B. -----	4		
2 Warning -----	5		
2.1. Prevention of Electrostatic Discharge (ESD) to Electrostatic Sensitive (ES) Devices -----	5		
2.2. How to Recycle the Lithium Ion Battery (U.S. Only) -----	5		
2.3. Caution for AC Cord (For EB/GC/GH) -----	6		
2.4. How to Replace the Lithium Battery -----	7		
3 Service Navigation -----	9		
3.1. Introduction -----	9		
3.2. Air-leak test (inspection) -----	9		
3.3. Replacing the waterproof packing (waterproof seal) -----	9		
3.4. Camera Lens Unit -----	9		
3.5. General Description About Lead Free Solder (PbF) -----	10		
3.6. How to Define the Model Suffix (NTSC or PAL model) -----	11		
4 Specifications -----	15		
5 Location of Controls and Components -----	20		
6 Service Mode -----	22		
6.1. Error Code Memory Function -----	22		
6.2. ICS (Indication of additional Camera Settings when picture was taken) function -----	25		
7 Troubleshooting Guide -----	27		
7.1. Service and Check Procedures -----	27		
7.2. Air-leak Test -----	30		
8 Service Fixture & Tools -----	32		
8.1. Service Fixture and Tools -----	32		
8.2. When Replacing the Main P.C.B. -----	33		
8.3. Service Position -----	33		
9 Disassembly and Assembly Instructions -----	34		
9.1. Disassembly Flow Chart -----	34		
9.2. P.C.B. Location -----	34		
9.3. Disassembly Procedures -----	35		
10 Measurements and Adjustments -----	44		
10.1. Introduction -----	44		
10.2. Before Disassembling the unit -----	44		
10.3. Details of Electrical Adjustment -----	46		
10.4. After Adjustment -----	50		
11 Maintenance -----	51		
11.1. Cleaning Lens and LCD Panel -----	51		
12 Block Diagram -----	53		
12.1. Overall Block Diagram -----	53		
12.2. System Control Block Diagram -----	54		
12.3. Video/Audio Signal Process Block Diagram -----	55		
12.4. Sensor Block Diagram -----	56		
		12.5. Lens Drive Block Diagram -----	57
		12.6. Power Block Diagram -----	58
		13 Wiring Connection Diagram -----	59
		13.1. Interconnection Diagram -----	59

1 Safety Precautions

1.1. General Guidelines

1. IMPORTANT SAFETY NOTICE

There are special components used in this equipment which are important for safety. These parts are marked by  in the Schematic Diagrams, Circuit Board Layout, Exploded Views and Replacement Parts List. It is essential that these critical parts should be replaced with manufacturer's specified parts to prevent X-RADIATION, shock fire, or other hazards. Do not modify the original design without permission of manufacturer.

2. An Isolation Transformer should always be used during the servicing of AC Adaptor whose chassis is not isolated from the AC power line. Use a transformer of adequate power rating as this protects the technician from accidents resulting in personal injury from electrical shocks. It will also protect AC Adaptor from being damaged by accidental shorting that may occur during servicing.
3. When servicing, observe the original lead dress. If a short circuit is found, replace all parts which have been overheated or damaged by the short circuit.
4. After servicing, see to it that all the protective devices such as insulation barriers, insulation papers shields are properly installed.
5. After servicing, make the following leakage current checks to prevent the customer from being exposed to shock hazards.

1.2. Leakage Current Cold Check

1. Unplug the AC cord and connect a jumper between the two prongs on the plug.
2. Measure the resistance value, with an ohmmeter, between the jumpered AC plug and each exposed metallic cabinet part on the equipment such as screwheads, connectors, control shafts, etc. When the exposed metallic part has a return path to the chassis, the reading should be between $1M\Omega$ and $5.2M\Omega$. When the exposed metal does not have a return path to the chassis, the reading must be infinity.

1.3. Leakage Current Hot Check (See Figure 1)

1. Plug the AC cord directly into the AC outlet. Do not use an isolation transformer for this check.
2. Connect a $1.5k\Omega$, 10 W resistor, in parallel with a $0.15\mu F$ capacitor, between each exposed metallic part on the set and a good earth ground, as shown in Figure 1.
3. Use an AC voltmeter, with $1 k\Omega/V$ or more sensitivity, to measure the potential across the resistor.
4. Check each exposed metallic part, and measure the voltage at each point.
5. Reverse the AC plug in the AC outlet and repeat each of the above measurements.
6. The potential at any point should not exceed 0.75 V RMS. A leakage current tester (Simpson Model 229 or equivalent) may be used to make the hot checks, leakage current must not exceed $1/2$ mA. In case a measurement is outside of the limits specified, there is a possibility of a shock hazard, and the equipment should be repaired and rechecked before it is returned to the customer.

Hot-Check Circuit

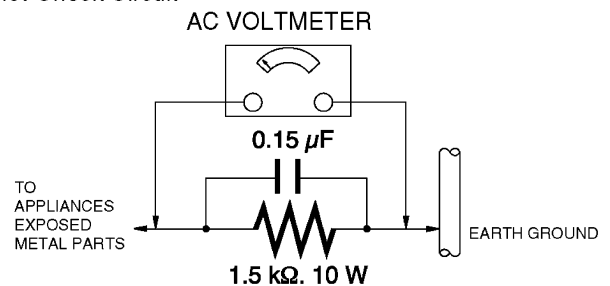

Figure 1

1.4. How to Discharge the Capacitor on Flash P.C.B.

- This unit equipped with two pieces of capacitors as flash charging capacitors.
"Either one of the capacitor discharging operation" makes discharging for others as well.

CAUTION:

1. **Be sure to discharge the capacitor on Flash P.C.B.**
2. **Be careful of the high voltage circuit on Flash P.C.B. when servicing.**

[Discharging Procedure]

1. Refer to the disassemble procedure and remove the necessary parts/unit.
2. Put the insulation tube onto the lead part of Resistor (ERG5SJ102:1k Ω /5W).
(An equivalent type of resistor may be used.)
3. Put the resistor between both terminals of capacitor on Flash P.C.B. for approx. 5 seconds.
4. After discharging confirm that the capacitor voltage is lower than 10V using a voltmeter.

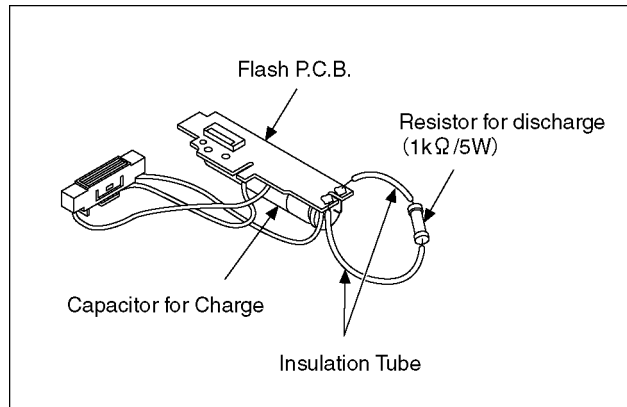

Fig. F1

2 Warning

2.1. Prevention of Electrostatic Discharge (ESD) to Electrostatic Sensitive (ES) Devices

Some semiconductor (solid state) devices can be damaged easily by static electricity. Such components commonly are called Electrostatically Sensitive (ES) Devices.

Examples of typical ES devices are CCD image sensor, IC (integrated circuits) and some field-effect transistors and semiconductor "chip" components.

The following techniques should be used to help reduce the incidence of component damage caused by electrostatic discharge (ESD).

1. Immediately before handling any semiconductor component or semiconductor-equipped assembly, drain off any ESD on your body by touching a known earth ground. Alternatively, obtain and wear a commercially available discharging ESD wrist strap, which should be removed for potential shock reasons prior to applying power to the unit under test.
2. After removing an electrical assembly equipped with ES devices, place the assembly on a conductive surface such as aluminum foil, to prevent electrostatic charge buildup or exposure of the assembly.
3. Use only a grounded-tip soldering iron to solder or unsolder ES devices.
4. Use only an antistatic solder removal device. Some solder removal devices not classified as **antistatic (ESD protected)** can generate electrical charge sufficient to damage ES devices.
5. Do not use freon-propelled chemicals. These can generate electrical charges sufficient to damage ES devices.
6. Do not remove a replacement ES device from its protective package until immediately before you are ready to install it. (Most replacement ES devices are packaged with leads electrically shorted together by conductive foam, aluminum foil or comparable conductive material).
7. Immediately before removing the protective material from the leads of a replacement ES device, touch the protective material to the chassis or circuit assembly into which the device will be installed.

CAUTION:

Be sure no power is applied to the chassis or circuit, and observe all other safety precautions.

8. Minimize bodily motions when handling unpackaged replacement ES devices. (Otherwise harmless motion such as the brushing together of your clothes fabric or the lifting of your foot from a carpeted floor can generate static electricity (ESD) sufficient to damage an ES device).

2.2. How to Recycle the Lithium Ion Battery (U.S. Only)

ENGLISH



A lithium ion/polymer battery that is recyclable powers the product you have purchased. Please call 1-800-8-BATTERY for information on how to recycle this battery.

FRANÇAIS



L'appareil que vous vous êtes procuré est alimenté par une batterie au lithium-ion/polymère recyclable. Pour des renseignements sur le recyclage de la batterie, veuillez composer le 1-800-8-BATTERY.

2.3. Caution for AC Cord (For EB/GC/GH)

2.3.1. Information for Your Safety

IMPORTANT

Your attention is drawn to the fact that recording of pre-recorded tapes or discs or other published or broadcast material may infringe copyright laws.

WARNING

To reduce the risk of fire or shock hazard, do not expose this equipment to rain or moisture.

CAUTION

To reduce the risk of fire or shock hazard and annoying interference, use the recommended accessories only.

FOR YOUR SAFETY

DO NOT REMOVE THE OUTER COVER

To prevent electric shock, do not remove the cover. No user serviceable parts inside. Refer servicing to qualified service personnel.

2.3.2. Caution for AC Mains Lead

For your safety, please read the following text carefully.

This appliance is supplied with a moulded three-pin mains plug for your safety and convenience.

A 5-ampere fuse is fitted in this plug.

Should the fuse need to be replaced please ensure that the replacement fuse has a rating of 5 amperes and it is approved by ASTA or BSI to BS1362

Check for the ASTA mark or the BSI mark on the body of the fuse.



If the plug contains a removable fuse cover you must ensure that it is refitted when the fuse is replaced.

If you lose the fuse cover, the plug must not be used until a replacement cover is obtained.

A replacement fuse cover can be purchased from your local Panasonic Dealer.

If the fitted moulded plug is unsuitable for the socket outlet in your home then the fuse should be removed and the plug cut off and disposed of safely.

There is a danger of severe electrical shock if the cut off plug is inserted into any 13-ampere socket.

If a new plug is to be fitted please observe the wiring code as shown below.

If in any doubt, please consult a qualified electrician.

2.3.2.1. Important

The wires in this mains lead are coloured in accordance with the following code:

Blue	Neutral
Brown	Live

As the colours of the wires in the mains lead of this appliance may not correspond with the coloured markings identifying the terminals in your plug, proceed as follows:

The wire which is coloured BLUE must be connected to the terminal in the plug which is marked with the letter N or coloured BLACK.

The wire which is coloured BROWN must be connected to the terminal in the plug which is marked with the letter L or coloured RED.

Under no circumstances should either of these wires be connected to the earth terminal of the three pin plug, marked with the letter E or the Earth Symbol.

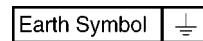

2.3.2.2. Before Use

remove the Connector Cover as follows.

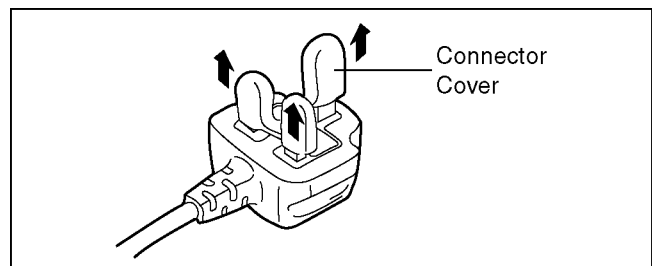

2.3.2.3. How to Replace the Fuse

1. Remove the Fuse Cover with a screwdriver.

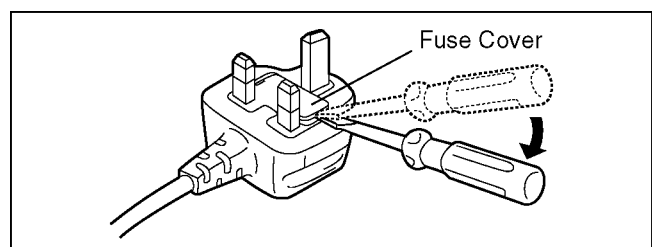

2. Replace the fuse and attach the Fuse cover.

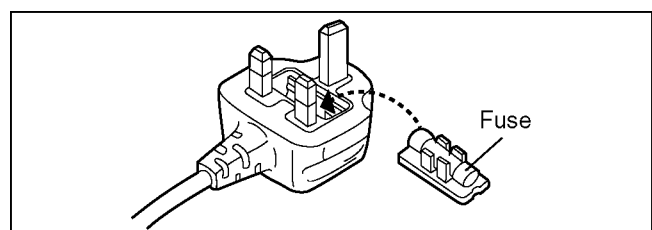

2.4. How to Replace the Lithium Battery

2.4.1. Replacement Procedure

1. Remove the Main P.C.B. (Refer to Disassembly Procedures.)
2. Unsolder the Lithium battery (Ref. No. **B9101** at foil side of Main P.C.B.) and then replace it into new one.

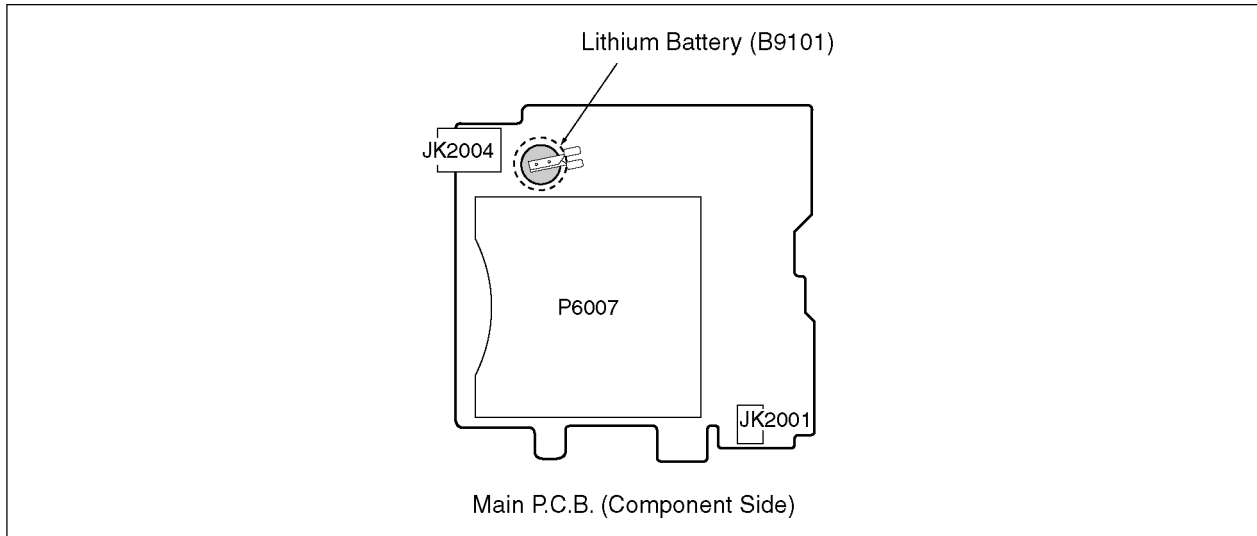

CAUTION

Danger of explosion if battery is incorrectly replaced.
Replace only with the same or equivalent type.

CAUTION

The battery used in this device may present a risk of fire or chemical burn if mistreated.
Do not recharge, disassemble, heat above 100 °C (212 °F), or incinerate.
Replace battery with Panasonic part number ML-421S/DN only.
Use of another battery may present a risk of fire or explosion.
Dispose of used battery promptly.
Keep away from children.
Do not disassemble and do not dispose of in fire.

Note:

The lithium battery is a critical component.

(Type No.: ML-421S/DN **Manufactured by Energy Company, Panasonic Corporation**)

It must never be subjected to excessive heat or discharge.

It must therefore only be fitted in equipment designed specifically for its use.

Replacement batteries must be of the same type and manufacture.

They must be fitted in the same manner and location as the original battery, with the correct polarity contacts observed.

Do not attempt to re-charge the old battery or re-use it for any other purpose.

It should be disposed of in waste products destined for burial rather than incineration.

(For English)

CAUTION

Danger of explosion if battery is incorrectly replaced.
Replace only with the same or equivalent type recommended by the manufacturer.
Dispose of used batteries according to the manufacturer's instructions.

(For German)

ACHTUNG

Explosionsgefahr bei falschem Anbringen der Batterie. Ersetzen Sie nur mit einem äquivalentem vom Hersteller empfohlenem Typ.
Behandeln Sie gebrauchte Batterien nach den Anweisungen des Herstellers.

(For French)

MISE EN GARDE

Une batterie de remplacement inappropriée peut exploser. Ne remplacez qu'avec une batterie identique ou d'un type recommandé par le fabricant. L'élimination des batteries usées doit être faite conformément aux instructions du fabricant.

Note:

Above caution is applicable for a battery pack which is for DMC-FT20 and DMC-TS20 series, as well.
Danger of explosion if battery is incorrectly replaced.
Replace only with the same or equivalent type recommended by the manufacturer.
Dispose of used batteries according to the manufacturer's instructions.

3 Service Navigation

3.1. Introduction

This service manual contains technical information, which will allow service personnel's to understand and service this model. Please place orders using the parts list and not the drawing reference numbers. If the circuit is changed or modified, the information will be followed by service manual to be controlled with original service manual.

3.2. Air-leak test (inspection)

Waterproof/Dustproof Performance
This camera's waterproof/dustproof rating complies with the "IPX8" and "IP6X" ratings. Provided the care and maintenance guidelines described in this document are strictly followed, this camera can operate underwater, to a depth not exceeding 5 m (16 feet) for a time not exceeding 60 minutes. (*1)

Anti-shock Performance
This camera also complies with "MIL-STD 810F Method 516.5-Shock". The camera has cleared a drop test from a height of 1.5 m (5 feet) onto 3 cm (0.1 feet) thick plywood. In most cases this camera should not sustain any damage if dropped from a height not exceeding 1.5 m (5 feet). (*2)

This does not guarantee no destruction, no malfunction, or waterproofing in all conditions.

*1 This means that the camera can be used underwater for specified time in specified pressure in accordance with the handling method established by Panasonic.

*2 "MIL-STD 810F Method 516.5-Shock" is the test method standard of the U.S. Defense Department, which specifies performing drop tests from a height of 122 cm (4 feet), at 26 orientations (8 corners, 12 ridges, 6 faces) using 5 sets of devices, and passing the 26 orientation drops within 5 devices. (If failure occurs during the test, a new set is used to pass the drop orientation test within a total of 5 devices)

Panasonic's test method is based on the above "MIL-STD 810F Method 516.5-Shock". However, the drop height was changed from 122 cm (4.0 feet) to 150 cm (5 feet) dropping onto 3 cm (0.1 feet) thick plywood. This drop test was passed. (Disregarding appearance change such as loss of paint or distortion of the part where drop impact is applied.)

- Due to the above characteristics of the products, perform the air-leak test (inspection) using Air -leak tester (Part No.:RFKZ0528) before/after servicing including assembly and/or assembly process.

Note:

The purpose of the air-leak test before servicing is that whether the malfunction occurred due to air-leak or not.

- When servicing, refer to the "7.Troubleshooting" section for details.

3.3. Replacing the waterproof packing (waterproof seal)

- The integrity of the waterproof packing may decrease about 1 year, with use and age. (We recommend end users to replace the waterproof packing (waterproof seal) at least once each year described in the operating instructions.)
- As for replacement procedure, refer to the 7.1.2. Periodical maintenance (Packing replacement) flow for details.

3.4. Camera Lens Unit

- Since the lens unit for this model is assembled with high accuracy manufacturing technologies, it is not allowed to disassemble/assemble the lens unit, in terms of performance retention. When servicing, it has to be handled the "Camera Lens Unit" as the smallest part size. Confirm the replacement part list and exploded views for details.

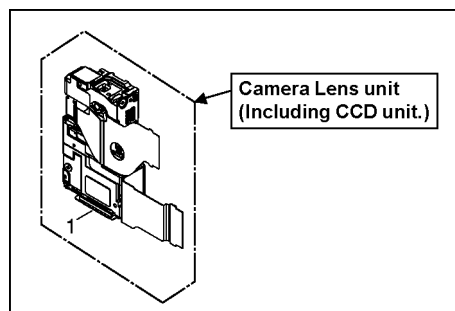

3.5. General Description About Lead Free Solder (PbF)

The lead free solder has been used in the mounting process of all electrical components on the printed circuit boards used for this equipment in considering the globally environmental conservation.

The normal solder is the alloy of tin (Sn) and lead (Pb). On the other hand, the lead free solder is the alloy mainly consists of tin (Sn), silver (Ag) and Copper (Cu), and the melting point of the lead free solder is higher approx.30 °C (86 °F) more than that of the normal solder.

Definition of P.C.B. Lead Free Solder being used

The letter of PbF is printed either foil side or components side on the P.C.B. using the lead free solder. (See right figure)	PbF
---	------------

Service caution for repair work using Lead Free Solder (PbF)

- The lead free solder has to be used when repairing the equipment for which the lead free solder is used.
- (Definition: The letter of **PbF** is printed on the P.C.B. using the lead free solder.)
- To put lead free solder, it should be well molten and mixed with the original lead free solder.
- Remove the remaining lead free solder on the P.C.B. cleanly for soldering of the new IC.
- Since the melting point of the lead free solder is higher than that of the normal lead solder, it takes the longer time to melt the lead free solder.
- Use the soldering iron (more than 70W) equipped with the temperature control after setting the temperature at 350±30 degrees C (662±86 °F).

Recommended Lead Free Solder (Service Parts Route.)

- The following 3 types of lead free solder are available through the service parts route.
 - RFKZ03D01KS------(0.3mm 100g Reel)
 - RFKZ06D01KS------(0.6mm 100g Reel)
 - RFKZ10D01KS------(1.0mm 100g Reel)

Note

* Ingredient: tin (Sn) 96.5%, silver (Ag) 3.0%, Copper (Cu) 0.5%, Cobalt (Co) / Germanium (Ge) 0.1 to 0.3%

3.6. How to Define the Model Suffix (NTSC or PAL model)







There are eight kinds of DMC-FT20/TS20, regardless of the colours.

- a) DMC-FT20 (Japan domestic model.)
- b) DMC-TS20P/PC
- c) DMC-FT20EB/EF/EG/EP
- d) DMC-FT20EE
- e) DMC-TS20GT
- f) DMC-FT20GN
- g) DMC-TS20GK
- h) DMC-FT20GA/GC/GF, DMC-TS20GH/PB/PU

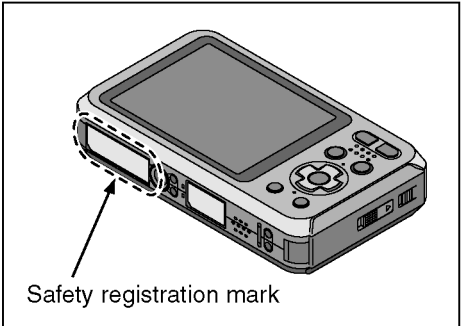
What is the difference is that the "INITIAL SETTINGS" data which is stored in Flash ROM mounted on Main P.C.B.

3.6.1. Defining methods

To define the model suffix to be serviced, refer to the nameplate which is putted on the bottom side of the Unit.

<p>a) DMC-FT20 (Japan domestic model) The nameplate for this model shows the following Safety registration mark.</p> 	 <p>Safety registration mark</p>
<p>b) DMC-TS20P/PC The nameplate for these models show the following Safety registration mark.</p> 	
<p>c) DMC-FT20EB/EF/EG/EP The nameplate for these models show the following Safety registration mark.</p> 	<p>f) DMC-FT20GN The nameplate for this model show the following Safety registration mark.</p> 
<p>d) DMC-FT20EE The nameplate for this model show the following Safety registration mark.</p> 	<p>g) DMC-TS20GK The nameplate for this model show the following Safety registration mark.</p> 
<p>e) DMC-TS20GT The nameplate for this model show the following Safety registration mark.</p> 	<p>h) DMC-FT20GA/GC/GF, DMC-TS20GH/PB/PU The nameplate for these models do not show any above safety registration mark.</p>

Note:

After replacing the Main P.C.B., be sure to achieve adjustment.

The Maintenance software (DIAS) is available at "software download" on the "Support Information from NWBG/VDBG-AVC" web-site in "TSN system".

3.6.2. INITIAL SETTINGS:

After replacing the Main P.C.B., be sure to perform the initial settings after achieving the adjustment by ordering the following procedure in accordance with model suffix of the unit.

1. IMPORTANT NOTICE:

Before proceeding Initial settings, be sure to read the following CAUTIONS.

CAUTION 1:(INITIAL SETTINGS)

---AFTER REPLACING THE MAIN P.C.B. ---

*.The model suffix can be chosen **JUST ONE TIME.**

(Model suffix : DMC-FT20; "EB/EE/EF/EG/EP/GA/GC/GF/GN", DMC-TS20; "P/PC/PU/PB/GH/GK/GT")

*.Once one of the model suffix has been chosen, the model suffix lists will not be displayed, thus, it can not be changed.

[Note:Only for "EG, EF, EB and EP" models]

*.When one of the "EG, EF, EB and EP" has been chosen, only "EG, EF, EB and EP" are displayed from second times.

CAUTION 2:(Stored picture image data in the unit)

This unit employs "Built-in Memory" for picture image data recording.(Approx.70MB)

After proceeding "INITIAL SETTINGS", the picture image data stored in the unit is erased.

2. PROCEDURES:

- Precautions: Read the above "CAUTION 1" and "CAUTION 2", carefully
- Preparation:
 1. Attach the Battery to the unit.
 2. Set to NORMAL PICTURE mode by operating the mode button.

Note:

If the picture mode is other than NORMAL PICTURE mode, it does not display the initial settings menu.

• Step 1. The temporary cancellation of "INITIAL SETTINGS":

While keep pressing "UP of Cursor button" and MOTION PICTURE button simultaneously, turn the Power on.

• Step 2. The cancellation of "INITIAL SETTINGS":

Press the PLAYBACK button.

Press "UP of Cursor button" and MOTION PICTURE button simultaneously, then turn the Power off.

• Step 3. Turn the Power on:

Turn the Power on.

• Step 4. Display the "INITIAL SETTINGS" menu:

While keep pressing MENU/SET and "RIGHT of Cursor button" simultaneously, turn the Power off.

The "INITIAL SETTINGS" menu is displayed.

There are two kinds of "INITIAL SETTINGS" menu form as follows:

[CASE 1. After replacing Main P.C.B.]

When Main P.C.B. has just been replaced, the following model suffix list is displayed as follows. (Six pages in total)

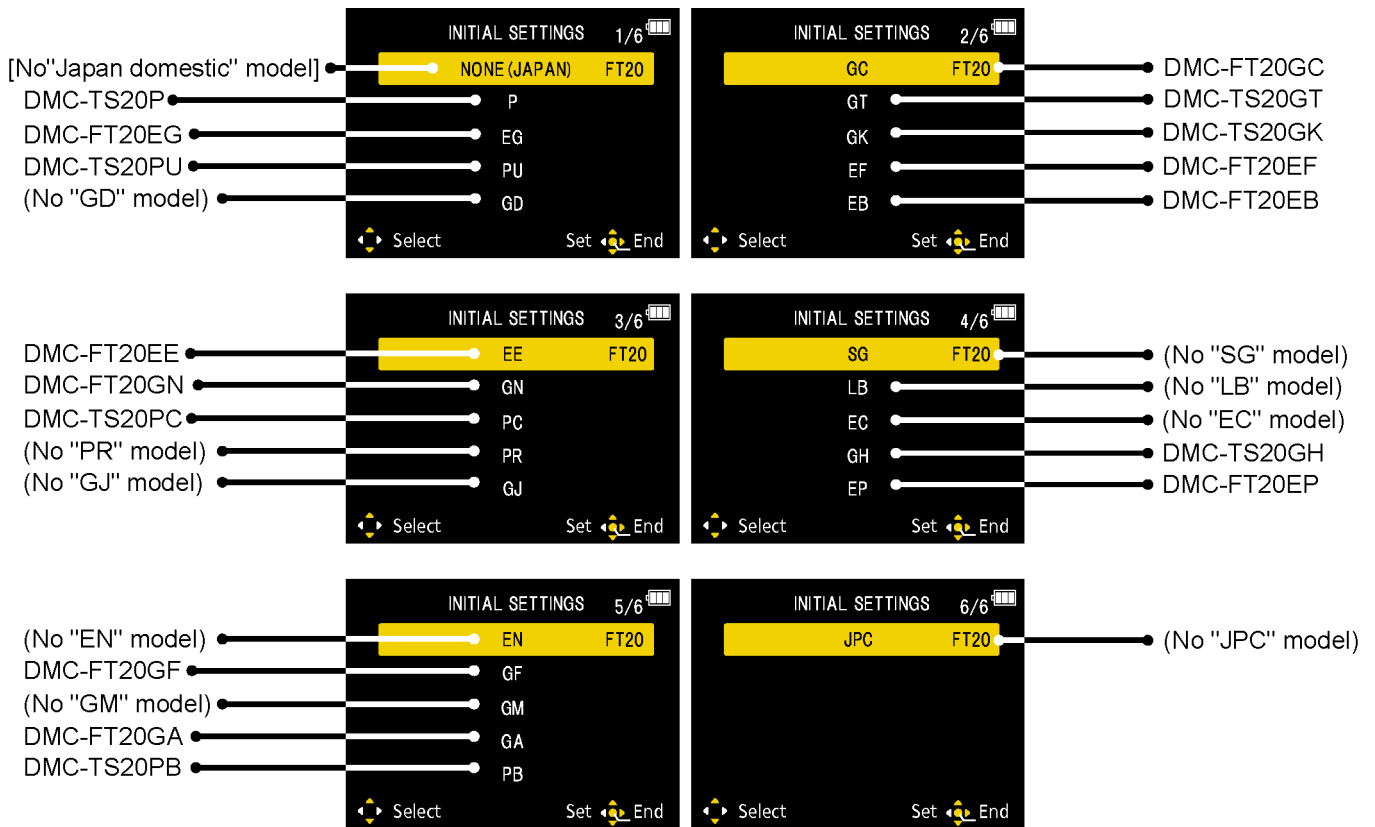

[CASE 2. Other than "After replacing Main P.C.B."]

< Other than "EG/EF/EB/EP" models >

< Only "EG/EF/EB/EP" models >

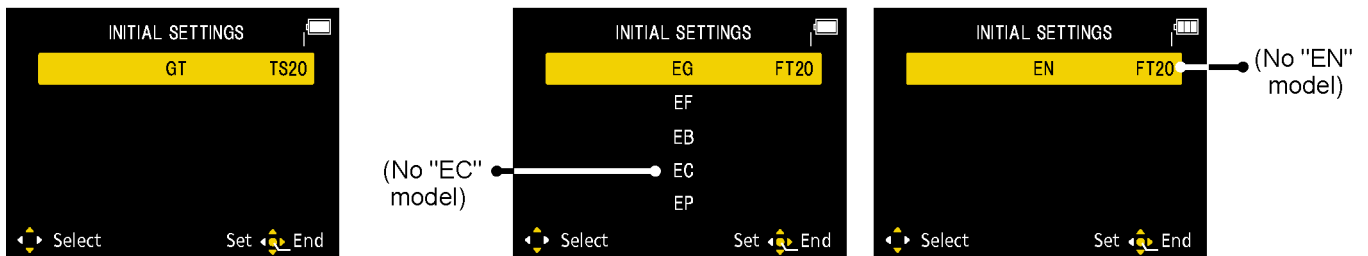

• Step 5. Choose the model suffix in "INITIAL SETTINGS": (Refer to "CAUTION 1")

[Caution: After replacing Main P.C.B.]

(Especially, other than "EG, EF, EB and EP" models)

The model suffix can be chosen, JUST ONE TIME.

Once one of the model suffix have been chosen, the model suffix lists will not be displayed, thus, it can be changed.

Therefore, select the area carefully.

Select the area with pressing "UP / DOWN of Cursor buttons".

• Step 6. Set the model suffix at "INITIAL SETTINGS":

Press the "RIGHT" of Cursor buttons".

The only set area is displayed. Press the "RIGHT" of Cursor buttons" after confirmation.

(The unit is powered off automatically.)

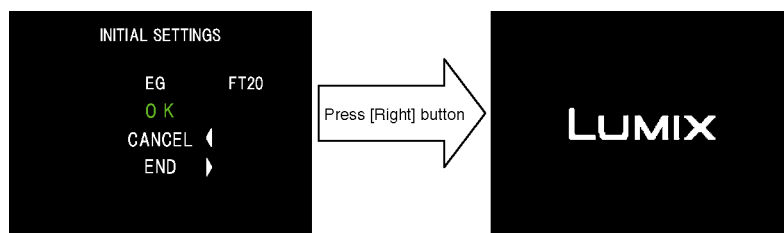

• **Step 7. CONFIRMATION:**

Confirm the display of "PLEASE SET THE CLOCK" in concerned language when the unit is turned on again.

When the unit is connected to PC with USB cable, it is detected as removable media.

1) As for your reference, major default setting condition is as shown in the following table.

Default setting (After "INITIAL SETTINGS")

	MODEL	VIDEO OUTPUT	LANGUAGE	DATE	REMARKS
a)	DMC-FT20(Japan domestic model)	NTSC	Japanese	Year/Month/Date	
b)	DMC-FT20EB	PAL	English	Date/Month/Year	
c)	DMC-FT20EE	PAL	Russian	Date/Month/Year	
d)	DMC-FT20EF	PAL	French	Date/Month/Year	
e)	DMC-FT20EG	PAL	English	Date/Month/Year	
f)	DMC-FT20EP	PAL	English	Date/Month/Year	
g)	DMC-FT20GA	PAL	English	Date/Month/Year	
h)	DMC-FT20GC	PAL	English	Date/Month/Year	
i)	DMC-FT20GF	PAL	English	Date/Month/Year	
j)	DMC-FT20GN	PAL	English	Date/Month/Year	
k)	DMC-TS20GH	PAL	English	Date/Month/Year	
l)	DMC-TS20GK	PAL	Chinese (Simplified)	Year/Month/Date	
m)	DMC-TS20GT	NTSC	Chinese (Traditional)	Year/Month/Date	
n)	DMC-TS20P	NTSC	English	Date/Month/Year	
o)	DMC-TS20PC	NTSC	English	Date/Month/Year	
p)	DMC-TS20PU	NTSC	Spanish	Date/Month/Year	
q)	DMC-TS20PB	NTSC	Spanish	Date/Month/Year	

4 Specifications

Digital Camera:
Information for your safety

Power Source:	DC 5.1 V	
Power Consumption:	1.0 W (When recording) 0.6 W (When playing back)	
Camera effective pixels	16,100,000 pixels	
Image sensor	1/2.33" CCD, total pixel number 16,600,000 pixels, Primary color filter	
Lens	Optical 4× zoom, f=4.5 mm to 18 mm (35 mm film camera equivalent: 25 mm to 100 mm)/F3.9 (Wide) to F5.7 (Tele)	
Image stabilizer	Optical method	
Focus range	Normal	50 cm (1.6 feet) (Wide)/1 m (3.3 feet) (Tele) to ∞
	Macro/ Intelligent auto/ Motion picture	5 cm (0.16 feet) (Wide)/1 m (3.3 feet) (Tele) to ∞
	Scene Mode	There may be differences in the above settings.
Shutter system	Electronic shutter+Mechanical shutter	
Minimum Illumination	Approx. 14 lx (when i-low light is used, the shutter speed is 1/30th of a second)	
Shutter speed	8 seconds to 1/1300th of a second	
Exposure (AE)	Auto (Program AE)	
Metering mode	Multiple	
LCD monitor	2.7" TFT LCD (4:3) (Approx. 230,000 dots) (field of view ratio about 100%)	

Microphone	Monaural
Speaker	Monaural
Recording media	Built-in Memory (Approx. 70 MB)/SD Memory Card/ SDHC Memory Card/SDXC Memory Card
Recording file format	
Still Picture	JPEG (based on "Design rule for Camera File system", based on "Exif 2.3" standard)/DPOF corresponding
Motion pictures	MP4
Audio compression format	AAC
Interface	
Digital	"USB 2.0" (High Speed)
Analog video	NTSC
Audio	Audio line output (monaural)
Terminal	
[AV OUT/DIGITAL]	Dedicated jack (8 pin)
Dimensions (excluding the projecting parts)	Approx. 101 mm (W)×58.3 mm (H)×19.2 mm (D) [3.98"(W)×2.3"(H)×0.76"(D)]
Mass (weight)	Approx. 142 g/0.313 lb (with card and battery) Approx. 123 g/0.271 lb (excluding card and battery)
Operating temperature	-10 °C* to 40 °C (14 °F* to 104 °F) * The performance of the battery (number of recordable pictures/operating time) may decrease temporarily when using in a temperature between -10 °C and 0 °C (14 °F and 32 °F) (cold places such as ski resorts or places at high altitude).
Operating humidity	10%RH to 80%RH
Language select	[ENGLISH]/[ESPAÑOL]
Waterproof performance	Equivalent to IEC 60529 "IPX8" [Usable for 60 minutes in 5 m (16 feet) water depth]

Crash resistance performance	<p>The test method of the camera is in compliance with "MIL-STD 810F Method 516.5-Shock"*.</p> <p>* "MIL-STD 810F Method 516.5-Shock" is the test method standard of the U.S. Defense Department, which specifies performing drop tests from a height of 122 cm (4 feet), at 26 orientations (8 corners, 12 ridges, 6 faces) using 5 sets of devices, and passing the 26 orientation drops within 5 devices.</p> <p>(If failure occurs during the test, a new set is used to pass the drop orientation test within a total of 5 devices)</p> <p>• Panasonic's test method is based on the above "MIL-STD 810F Method 516.5-Shock". However, the drop height was changed from 122 cm (4 feet) to 150 cm (5 feet) dropping onto 3 cm (0.1 feet) thick plywood. This drop test was passed. (Disregarding appearance change such as loss of paint or distortion of the part where drop impact is applied.)</p> <p>There is no guarantee of not breaking or malfunctioning under all conditions.</p>
Dustproof performance	Equivalent to IEC 60529 "IP6X".

Battery Charger (Panasonic DE-A91B):
Information for your safety

Input:	~ 110 V to 240 V, 50/60 Hz, 0.2 A
Output:	=== 4.2 V, 0.43 A
Operating temperature:	0 °C* to 40 °C (32 °F* to 104 °F)
	* The battery cannot be recharged in a temperature less than 0 °C (32 °F). (The [CHARGE] indicator blinks when the battery cannot be recharged.)

Equipment mobility:
Movable

Battery Pack (lithium-ion) (Panasonic DMW-BCK7PP):
Information for your safety

Voltage/capacity:	3.6 V/680 mAh
--------------------------	---------------

Note:

*Above specification is for DMC-TS20P. Some of the specification may differ depends on model suffix.

[1] Only for "EB/EF/EG/EP" models:

1). [Interface Digital:]

- Data from the PC can not be written to the camera using the USB connection cable.

[2] Others:

1). [Analog video/audio:]

NTSC -----(Only "P/PC" models)

NTSC/PAL Composite (Switched by menu) -----(Except "P/PC" models)

(Important) About the Waterproof/Dustproof and Anti-shock Performance of the Camera

Waterproof/Dustproof Performance

This camera's waterproof/dustproof rating complies with the "IPX8" and "IP6X" ratings. Provided the care and maintenance guidelines described in this document are strictly followed, this camera can operate underwater, to a depth not exceeding 5 m (16 feet) for a time not exceeding 60 minutes. (*1)

Anti-shock Performance

This camera also complies with "MIL-STD 810F Method 516.5-Shock". The camera has cleared a drop test from a height of 1.5 m (5 feet) onto 3 cm (0.1 feet) thick plywood. In most cases this camera should not sustain any damage if dropped from a height not exceeding 1.5 m (5 feet). (*2)

This does not guarantee no destruction, no malfunction, or waterproofing in all conditions.

- *1 This means that the camera can be used underwater for specified time in specified pressure in accordance with the handling method established by Panasonic.
- *2 "MIL-STD 810F Method 516.5-Shock" is the test method standard of the U.S. Defense Department, which specifies performing drop tests from a height of 122 cm (4 feet), at 26 orientations (8 corners, 12 ridges, 6 faces) using 5 sets of devices, and passing the 26 orientation drops within 5 devices. (If failure occurs during the test, a new set is used to pass the drop orientation test within a total of 5 devices)
Panasonic's test method is based on the above "MIL-STD 810F Method 516.5-Shock". However, the drop height was changed from 122 cm (4 feet) to 150 cm (5 feet) dropping onto 3 cm (0.1 feet) thick plywood. This drop test was passed.
(Disregarding appearance change such as loss of paint or distortion of the part where drop impact is applied.)

■ Handling of the camera

- Waterproofing is not guaranteed if the unit is subject to an impact as a result of being hit or dropped, etc. If an impact to the camera occurs, it should be inspected (subject to a fee) by a Panasonic's Service Center to verify that the waterproofing is still effective.
- When the camera is splashed with detergent, soap, hot spring, bath additive, sun oil, sun screen, chemical, etc., wipe it off immediately.
- Waterproof function of the camera is for sea water and fresh water only.
- Any malfunction caused by customer misuse, or mishandling will not be covered by the warranty.
- The inside of this unit is not waterproof. Water leakage will cause malfunction.
- Supplied accessories are not waterproof (excluding Hand Strap).
- Card and battery are not waterproof. Do not handle with a wet hand. Also, do not insert wet card or battery into the camera.
- Do not leave the camera for a long period of time in places where temperature is very low (at ski resorts or at high altitude, etc.) or very high [above 40 °C (104 °F)], inside a car under strong sunlight, close to a heater, on the beach, etc. Waterproof performance may be degraded.

■ About the [Precautions] demonstration display ([Requirements for Underwater use])

- [Precautions] is displayed when the power is turned on for the first time after purchase, with the side door completely closed.
- Please check beforehand to maintain the waterproof performance.

1 Press ◀ to select [Yes], and press [MENU/SET].

- It will automatically skip to the clock setting screen if [No] is selected before it starts.

2 Press ◀/▶ to select the picture.

◀: Return to the previous screen

▶: View the next screen

- It can be forcefully ended by pressing [MENU/SET].
- When it is forcefully ended while checking by turning the unit off or pressing [MENU/SET], [Precautions] is displayed every time the power is turned on.

3 After the final screen (12/12), press [MENU/SET] to finish.

- When [MENU/SET] is pressed after the final screen (12/12), [Precautions] is not displayed from the next time the power is turned on.
- This can also be viewed from [Precautions] in the [Setup] menu.

Check before using underwater

Do not open or close the side door in places with sand and dust, close to water, or with wet hands. Sand or dust adhering may cause water leaks.

1 Check that there are no foreign objects on the inner side of the side door.

- (A) Brush (supplied)
- (B) Side door

- If there is any foreign object, such as lint, hair, sand, etc., on the surrounding area, water will leak within a few seconds causing malfunction.
- Wipe it off with a dry soft cloth if there is any liquid.

It may cause water leaks and malfunction if you use the camera with liquid adhered.

- If there is any foreign material, remove with supplied brush.
- Be extremely careful to remove any sand, etc. that may adhere to the sides and corners of the rubber seal.
- Remove large foreign objects, wet sand, etc., using the shorter (harder) side of the brush.

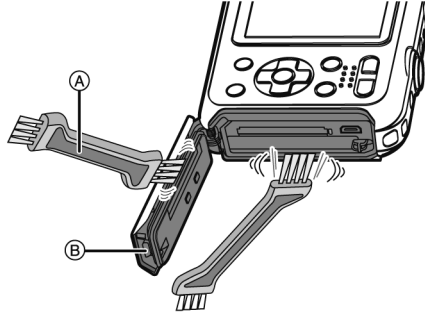

2 Check for cracks and deformation of the rubber seal on the side door.

- The integrity of the rubber seals may decrease after about 1 year, with use and age. To avoid permanently damaging the camera the seals should be replaced once each year. Please contact Panasonic's Service Center for related costs and other information.

3 Close the side door securely.

- (C) [LOCK] switch (gray part)
- (D) Red part
- (E) Released state
- (F) Locked state

- Lock the [LOCK] switch securely until the red part is no longer visible.
- To prevent water seeping into the camera, be careful not to trap foreign objects such as liquids, sand, hair or dust, etc.

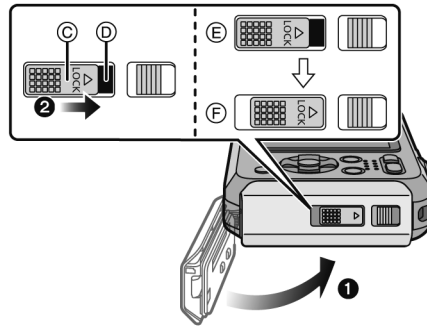

Using the camera underwater

- Use the camera underwater to 5 m (16 feet) with the water temperature between 0 °C and 40 °C (32 °F and 104 °F).
- Do not use for scuba diving (Aqualung).
- Do not use the camera at a depth of over 5 m (16 feet).
- Do not use it in hot water over 40 °C (104 °F) (in the bath or hot spring).
- Do not use the camera underwater for longer than 60 minutes continuously.
- Do not open or close the side door underwater.
- Do not apply shock to the camera underwater. (Waterproof performance may not be maintained, and there is a chance of water leak.)
- Do not dive into the water holding the camera. Do not use the camera in a location where the water will splash strongly, such as rapid flow or waterfall. (Strong water pressure may be applied, and it may cause malfunction.)
- The camera will sink in the water. Take care not to drop the camera and lose it underwater by securely placing the strap around your wrist or similar measure.

Caring of the camera after using it underwater

Do not open or close the side door until the sand and dust is removed by rinsing the camera with water.

Make sure to clean the camera after using it.

- Thoroughly wipe off any water droplets, sand, and saline matter on your hands, body, hair, etc.
- It is recommended to clean the camera indoors, avoiding places where water spray or sand may fall.

After using it underwater, always clean the camera rather than leaving it in a dirty state.

- Leaving the camera with foreign objects or saline matter on it may cause damage, discoloration, corrosion, unusual odour, or deterioration of the waterproof performance.

1 Rinse with water with the side door closed.

- After use at the seaside or underwater, soak the unit in fresh water pooled in a shallow container for 10 minutes or less.
- If the zoom button or camera [ON/OFF] button do not move smoothly, it may be caused by an adhesion of foreign objects. Using in such a state may cause malfunctions, such as locking up, so wash off any foreign objects by shaking the camera in fresh water.
- Bubbles may come out of the drainage hole when you immerse the camera in water, but this is not a malfunction.



2 Drain water by holding the camera upside-down (A) and the right way up (B) and shaking it lightly a few times.

- After using the camera at the beach or in water, or after washing it, water may remain around the speaker and microphone for a while and may cause a drop in volume or sound distortion.
- Fasten the strap firmly to prevent the camera from dropping.

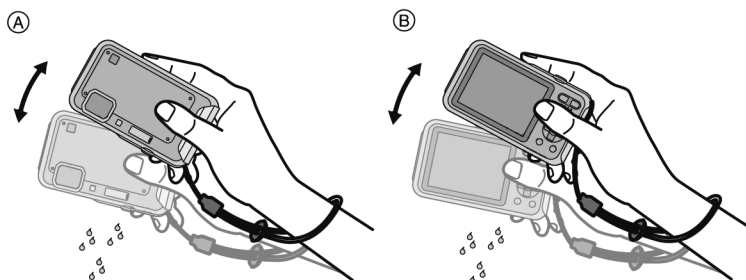

3 Wipe off water drops on the camera with a soft, dry cloth and dry the camera in a shaded area which is well ventilated.

- Dry the camera by standing it on a dry cloth. This unit incorporates drain design, draining water in gaps in the camera [ON/OFF] button and zoom button, etc.
- Do not dry the camera with hot air from dryer or similar. Waterproof performance will deteriorate due to deformation.
- Do not use chemicals such as benzine, thinner, alcohol or cleanser, soap or detergents.



4 Confirm that there are no water droplets, open the side door, and wipe off any water droplets or sand left inside using a soft, dry cloth.

- Water droplets may adhere to the card or battery when the side door is opened without thoroughly drying. Also, water may accumulate in the gap around the card/battery slot or the terminal connector. Be sure to wipe any water off with a soft, dry cloth.
- The water droplets may seep into the camera when the side door is closed while it is still wet, causing condensation or failure.

5 Location of Controls and Components

- 1 Flash
- 2 Motion picture button
- 3 Shutter button
- 4 Camera [ON/OFF] button
- 5 Microphone
- 6 Self-timer indicator/
AF Assist Lamp
- 7 Lens

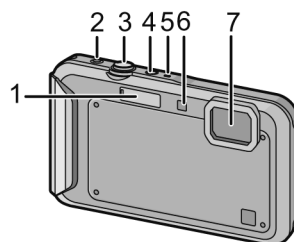

- 8 LCD monitor
- 9 [MODE] button
- 10 Zoom button
- 11 Strap eyelet
 - Be sure to attach the strap when using the camera to ensure that you will not drop it.
- 12 Release lever
- 13 [LOCK] switch
- 14 Side door
- 15 [▶] (Playback) button
- 16 [Q.MENU]/[⏏/⏏] (Delete/Cancel) button
- 17 [DISPLAY] button
- 18 [MENU/SET] button

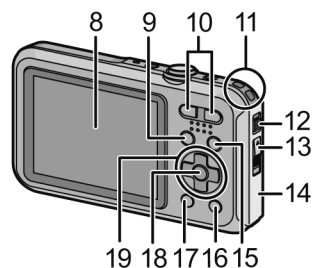

- 19 Cursor buttons
 - (A): ▲/Exposure compensation
Auto Bracket
 - (B): ▼/Macro Mode
AF Tracking
 - (C): ◀/Self-timer
 - (D): ▶/Flash setting

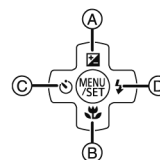

In this Owner's Manual, the cursor buttons are described as shown in the figure below or described with ▲/▼/◀/▶.
e.g.: When you press the ▼ (down) button

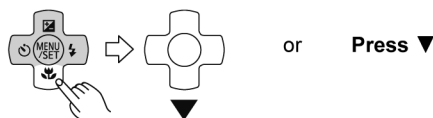



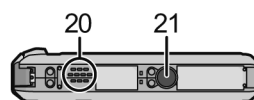



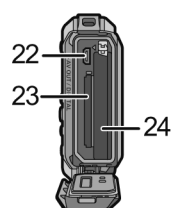

- 20 Speaker
 - Be careful not to cover the speaker with your finger.
Doing so may make sound difficult to hear.
- 21 Tripod receptacle



- 22 [AV OUT/DIGITAL] socket
- 23 Card slot
- 24 Battery slot



■ List of Recording Modes

 Intelligent Auto Mode
The subjects are recorded using settings automatically selected by the camera.
 Normal Picture Mode
The subjects are recorded using your own settings.
 Sports Mode
Use this mode to take pictures of sporting events, etc.
 Snow Mode
This allows you to take pictures that show the snow as white as possible at a ski resort or a snow-covered mountain.
 Beach & Surf Mode
This mode is optimal for taking pictures to 3 m (10 feet) underwater and at the beach.
 Underwater Mode
This mode is optimal for taking pictures at depths of 3 m (10 feet) to 5 m (16 feet).
 Miniature Effect Mode
This is an imaging effect which defocuses the surroundings to make it look like a diorama. (also known as Tilt Shift Focus)
 Scene Mode
This allows you to take pictures that match the scene being recorded.

Note

- When the mode has been switched from Playback Mode to Recording Mode, the previously set Recording Mode will be set.

6 Service Mode

6.1. Error Code Memory Function

1. General description

This unit is equipped with history of error code memory function, and can be memorized 16 error codes in sequence from the latest. When the error is occurred more than 16, the oldest error is overwritten in sequence.

The error code is not memorized when the power supply is shut down forcibly (i.e., when the unit is powered on by the battery, the battery is pulled out) The error code is memorized to FLASH ROM when the unit has just before powered off.

2. How to display

The error code can be displayed by ordering the following procedure:

• Preparation:

1. Attach the Battery to the unit.

Note:

- *Since this unit has built-in memory, it can be performed without inserting SD memory card.
- *Select the mode other than "3D" mode (such as normal picture / iA / Sports / Snow / SCN) to display the error code.

• Step 1. The temporary cancellation of "INITIAL SETTINGS":

While keep pressing "UP" of Cursor button" and MOTION PICTURE button simultaneously, turn the Power on.

• Step 2. Execute the error code display mode:

Press the "LEFT" of Cursor button", MENU/SET button and MOTION PICTURE button simultaneously.

The display is changed as shown below when the above buttons are pressed simultaneously.

Normal display → Error code display → CAMERA INFO → Normal display →

Example of Error Code Display

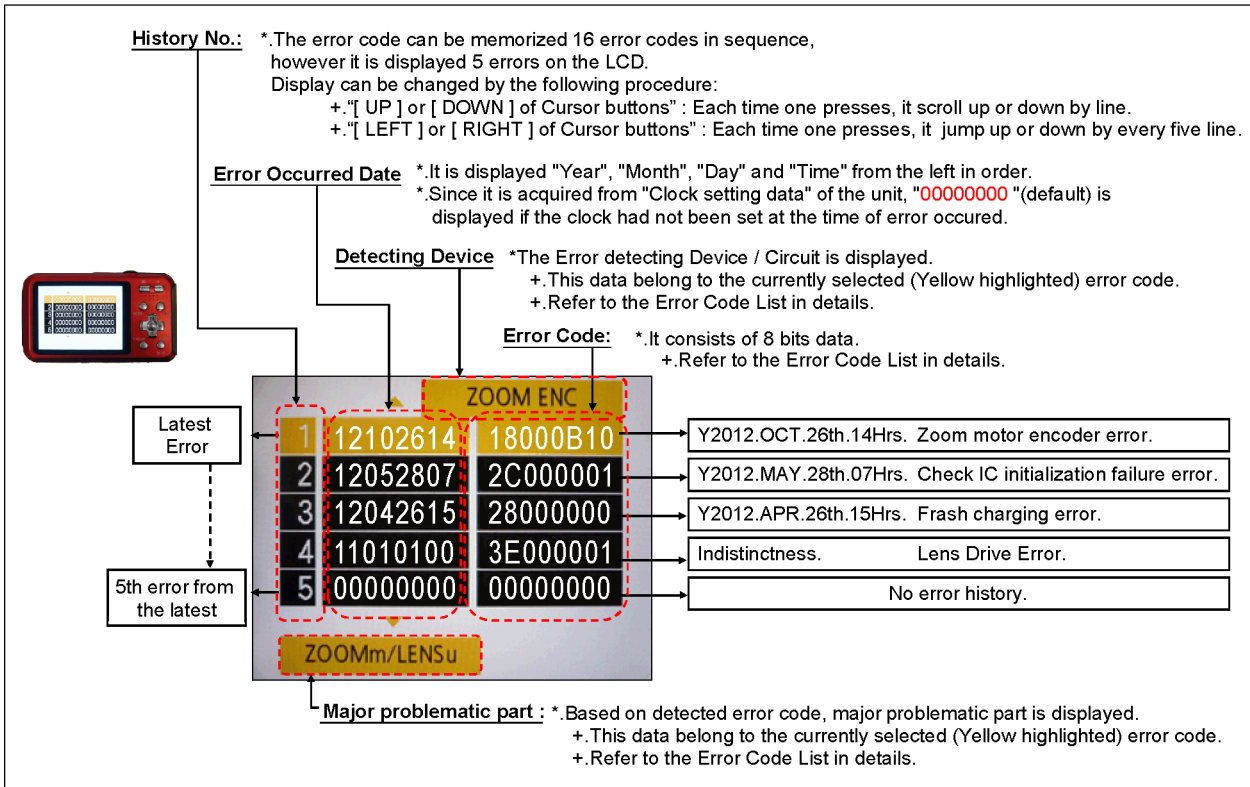

3. Error Code List

The error code consists of 8 bits data and it shows the following information.

Attribute	Main item	Sub item	Error code		Contents (Upper)	Error Indication		
			High 4bits	Low 4 bits	Check point (Lower)	Detecting device	Part/Circuit	
LENS	Lens drive	OIS	18*0	1000	PSD (X) error. Hall element (X axis) position detect error in OIS unit. OIS Unit	OIS X	LENSu NG	
				2000	PSD (Y) error. Hall element (Y axis) position detect error in OIS unit. OIS Unit	OIS Y		
			3000	GYRO (X) error. Gyro (IC7101) detect error on Main P.C.B. IC7101 (Gyro element) or IC6001 (VENUS ENGINE)	GYRO X	GYRO NG		
				4000	GYRO (Y) error. Gyro (IC7101) detect error on Main P.C.B. IC6302 (Gyro element) or IC6001 (VENUS ENGINE)		GYRO Y	
			5000	MREF error (Reference voltage error). IC9101 (LENS DRIVE) or IC6001 (VENUS ENGINE)	OIS REF	LENSSd/DSP NG		
				6000	Drive voltage (X) error. LENS Unit, LENS flex breaks, IC6001(VENUS ENGINE) AD value error, etc.		OISX REF	LENSu/LENS FPC
			7000		Drive voltage (Y) error. LENS Unit, LENS flex breaks, IC6001(VENUS ENGINE) AD value error, etc.	OISY REF		
				Zoom	0?10	Collapsible barrel Low detect error (Collapsible barrel encoder always detects Low.) Mechanical lock, FP9003-(2) signal line or IC6001 (VENUS ENGINE)	ZOOM L	ZOOMm/LENSu
			0?20			Collapsible barrel High detect error (Collapsible barrel encoder always detects High.) Mechanical lock, FP9003-(2) signal line or IC6001 (VENUS ENGINE)	ZOOM H	
			0?60			The zoom position jump is detected due to the impact (i.e. drop.) to the camera occurs. Lens unit	(No indication)	(No indication)
			Focus	0?01	HP High detect error (Focus encoder always detects High, and not becomes Low) Mechanical lock, FP9003-(40) signal line or IC6001 (VENUS ENGINE)	FOCUS L	LENS FPC/DSP	
					0?02	HP Low detect error (Focus encoder always detects Low, and not becomes High) Mechanical lock, FP9002-(40) signal line or IC6001 (VENUS ENGINE)		FOCUS H
			Lens	18*1	0000	Power ON time out error. Lens drive system	LENS DRV	LENSu
					18*2	0000		
		Adj.History	OIS	19*0	2000	OIS adj. Yaw direction amplitude error (small)	OIS ADJ	OIS ADJ
					3000	OIS adj. Pitch direction amplitude error (small)		
					4000	OIS adj. Yaw direction amplitude error (large)		
					5000	OIS adj. Pitch direction amplitude error (large)		
					6000	OIS adj. MREF error		
					7000	OIS adj. time out error		
					8000	OIS adj. Yaw direction off set error		
					9000	OIS adj. Pitch direction off set error		
					A000	OIS adj. Yaw direction gain error		
					B000	OIS adj. Pitch direction gain error		
					C000	OIS adj. Yaw direction position sensor error		
					D000	OIS adj. Pitch direction position sensor error		
					E000	OIS adj. other error		

Attribute	Main item	Sub item	Error code		Contents (Upper)	Error Indication		
			High 4bits	Low 4 bits	Check point (Lower)	Detecting device	Part/Circuit	
HARD	VENUS A/D	Flash	28*0	0000	Flash charging error.	STRB CHG	FLASH P.C.B./FPC	
					IC6001-(AC16) signal line or Flash charging circuit			
	FLASH ROM (EEPROM Area)	FLASH ROM (EEPROM Area)	2B*0	0001 0003 0004	EEPROM read error	FROM RE	FROM	
					IC6002 (FLASH ROM)			
					EEPROM write error			FROM WR
					IC6002 (FLASH ROM)			
					0005	Firmware version up error	(No indication)	(No indication)
					0008	Replace the firmware file in the SD memory card.		
	0009	SDRAM error						
	SYSTEM	RTC	2C*0	0001	SDRAM Mounting defective			
SYSTEM IC initialize failure error					SYS INIT	MAIN P.C.B.		
SOFT	CPU	Reset	30*0	0001 0007	NMI reset	NMI RST	MAIN P.C.B.	
					Non Mask-able Interrupt (30000001-30000007 are caused by factors)			
	Card	Card	31*0	0001	Card logic error	SD CARD	SD CARD/DSP	
					SD memory card data line or IC6001 (VENUS ENGINE)			
					Card physical error			
					0002	SD memory card data line or IC6001 (VENUS ENGINE)	SD WRITE	
					0004	Write error		
	39*0	0005	Format error	INMEMORY	FROM			
	CPU, ASIC hard	Stop	38*0	0001	Camera task finish process time out.	LENS COM	LENSu/DSP	
					Communication between Lens system and IC6001 (VENUS ENGINE)			
					0002	Camera task invalid code error.	DSP	DSP
					0100	IC6001 (VENUS ENGINE)		
					0200	File time out error in recording motion image		
					0300	IC6001 (VENUS ENGINE)		
					0300	File data cue send error in recording motion image		
	0300	IC6001 (VENUS ENGINE)						
	Memory area	Memory area	3A*0	0008	Single or burst recording brake time out.	(No indication)	(No indication)	
					USB work area partitioning failure			
	Operation	Power on	3B*0	0000	USB dynamic memory securing failure when connecting	INIT	(No indication)	
					FLASHROM processing early period of camera during movement.			
Zoom	Zoom	3C*0	0000	Imperfect zoom lens processing	ZOOM	ZOOMm/LENSu		
				Zoom lens				
		35*0	0000 FFFF	Software error (0-7bit : command, 8-15bit : status)	DSP	DSP		
				Though record preprocessing is necessary, it is not called.				
35*1	0000	Though record preprocessing is necessary, it is not completed.	(No indication)	(No indication)				
35*2	0000	Though record preprocessing is necessary, it is not completed.						

1) About "*" indication:

The third digit from the left is different as follows.

In case of 0 (example: 18 0 01000)

When the third digit from the left shows "0", this error occurred under the condition of INITIAL SETTINGS has been completed.

It means that this error is occurred basically at user side.

In case of 8 (example: 18 8 01000)

When the third digit from the left shows "8", this error occurred under the condition of INITIAL SETTINGS has been released.

(Example; Factory assembling-line before unit shipment, Service mode etc.)

It means that this error is occurred at service side.

2) About "?" indication: ("18*0 0?01" to "18*0 0?50"):

The third digit from the right shows one of the hexadecimal ("0" to "F") character.

4. How to returned to Normal Display:

Turn the power off and on, to exit from Error code display mode.

Note:

The error code can not be initialized.

6.2. ICS (Indication of additional Camera Settings when picture was taken) function

1. General description

This unit is equipped with ICS (ICS : Indication of additional Camera Settings when picture was taken) function by playing back the concerned picture on the LCD display.

(This function is achieved by utilizing "maker note" data stored in Exif data area of recorded picture file.)

To proceed failure diagnosis, use this ICS function together with "displaying the recorded picture with picture information" function.

Note:

- *.The ICS function operates with a picture which is only taken with the same model. (It may not be displayed when the picture was taken with other model.)
- *.Since Exif data is not available after the picture is edited by PC, the ICS function may not be activated.

2. How to display

The ICS data is displayed by ordering the following procedure:

• Preparation:

- 1.Attach the Battery to the unit.

Note:

*Select the mode other than "3D "mode (such as normal picture / iA / Sports / Snow / SCN) to display the ICS data.

• Step 1. The temporary cancellation of "INITIAL SETTINGS":

While keep pressing "UP of Cursor button" and MOTION PICTURE button simultaneously, turn the Power on.

• Step 2. Execute the ICS display mode:

Press the PLAYBACK button.

Select the concerned picture by pressing the "LEFT and RIGHT of Cursor button".

Press the MENU/SET button, "LEFT of Cursor button" and MOTION PICTURE button simultaneously.

Press the DISPLAY button, 3 times.

The display condition is changed as shown below when the DISPLAY button is pressed.

Code display → Code + Picture display (1) → Code + Picture display (2) → ICS display →

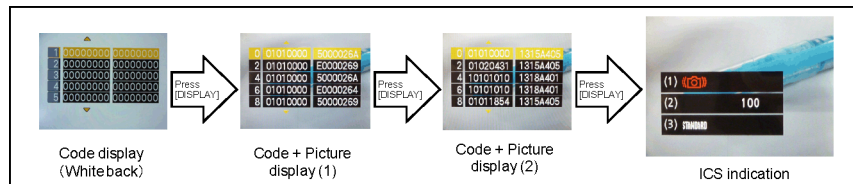

3. How to read

(1). Jitter alert was displayed or not:
 This part shows that the "Jitter alert" mark was displayed or not when the picture has just before been taken.
 +.With "Jitter alert" mark : The "Jitter alert" mark was displayed.
 +.Without "Jitter alert" mark: The "Jitter alert" mark was not displayed.
 [About "Jitter alert" mark]
 Due to lacking the enough light amount etc, shooting condition prone to make a "hand jitter", the "Jitter alert" mark is displayed.
 [Reference Guide]
 (Applicable settings : Normal picture mode, ISO100, WIDE edge, Flash OFF)
 +.The "Jitter alert" mark is displayed when the shutter speed is 1/15th and below.

(2). ISO Sensitivity Setting condition:
 This part shows that the "ISO Sensitivity" setting condition when the picture had been taken.
 (Note: The [i ISO] is displayed when the "Intelligent ISO " was selected.)
 For instance, when the recorded picture information shows [ISO100], it can be confirmed the ISO setting condition ; [AUTO], [INTELLIGENT ISO] or [ISO100](Fixed: set by user).
 [Point for Confirmation]
 *The symptom is "Picture with "hand jitter". Subject is not clearly stopped." in darker scene, does the picture was taken with lower ISO setting mode?
 *The symptom is "Noisy picture. Rough picture image" in brighter scene, does the picture was taken with higher ISO setting mode?

(3). Color mode Setting condition:
 This part shows that the "Color mode" setting condition when the picture had been taken.
 [Point for Confirmation]
 *The symptom is "Color is strange. The picture is bluish (Yellowish) ", does the picture was taken with [SEPIA] / [COOL] / [WARM] settings?
 NOTE: As for the symptom related with the color, confirm the picture information which is displayed in normal playback screen as well.
 (In normal playback screen, the setting condition of "White balance" and "WB Adjustment" can be confirmed.)

[Reference Guide : Settings "When taking picture"]

<ISO SENSITIVITY>
 *This allows the sensitivity to light (ISO sensitivity) to be set. Setting to a higher figure enables pictures to be taken even in dark places without the resulting pictures coming out dark.
 *In this unit, it can be set one of the [i ISO], [100], [200], [400], [800] and [1600] in "Normal Picture Mode".
 ***[iISO]** (Intelligent ISO sensitivity control)
 The camera detects movement of the subject and then automatically sets the optimum ISO sensitivity and shutter speed to suit the movement of the subject and brightness of the scene to minimize the jitter of the subject.
 *The ISO sensitivity is automatically set under the following conditions.
 - When recording motion pictures
 - When [Burst] in the [Rec] menu is set to [] or []

Settings	Description of settings
[iISO] ([i.iISO])	The ISO sensitivity is adjusted according to the movement of the subject and the brightness. • Maximum [1600]
[100]	The ISO sensitivity is fixed to various settings.
[200]	
[400]	
[800]	
[1600]	

	[100] ←	→ [1600]
Recording location (recommended)	When it is light (outdoors)	When it is dark
Shutter speed	Slow	Fast
Noise	Less	Increased
Jitter of the subject	Increased	Less

<COLOR MODE>
 *Using these modes, the pictures can be made sharper or softer, the colors of the pictures can be turned into sepia colors or other color effects can be achieved.
 *In this unit, it can be set one of the following effects in "Intelligent Auto Mode" and "Normal Picture Mode".

Settings	Description of settings
[STANDARD]	This is the standard setting.
[Happy] *1	Image with enhanced brightness and vividness.
[VIVID] *2	The picture becomes sharper.
[B&W]	The picture becomes black and white.
[SEPIA]	The picture becomes sepia.

* 1 This can be set only when Intelligent Auto Mode is set.
 * 2 This can be set only during Normal Picture Mode.

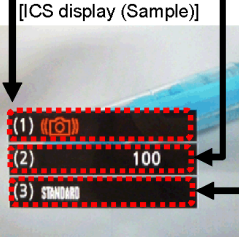
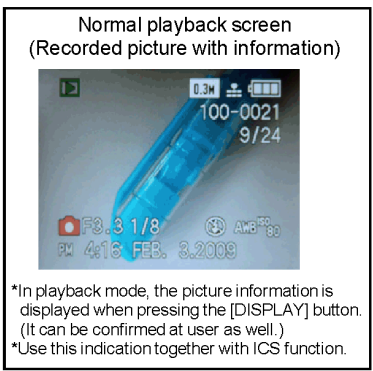

4. How to exit

Simply, turn the power off. (Since ICS function is executed under the condition of temporary cancellation of "INITIAL SETTINGS", it wake up with normal condition when turn off the power.)

7 Troubleshooting Guide

7.1. Service and Check Procedures

7.1.1. Servicing flow

- The following is the servicing procedure including assembly/disassembly process.
- As for the air-leak test, refer to "7.2. Air-leak Test".

< Note >

Air-leak test (inspection) before taking service measure:

- When the first inspection, do not perform cleaning (removal of foreign objects caught etc.) of the waterproof packing parts (battery door and Jack door) from the viewpoint of the cause investigation at NG of test (inspection) result.
- When the test (inspection) result was NG, perform test again after cleaning of waterproof packing parts.

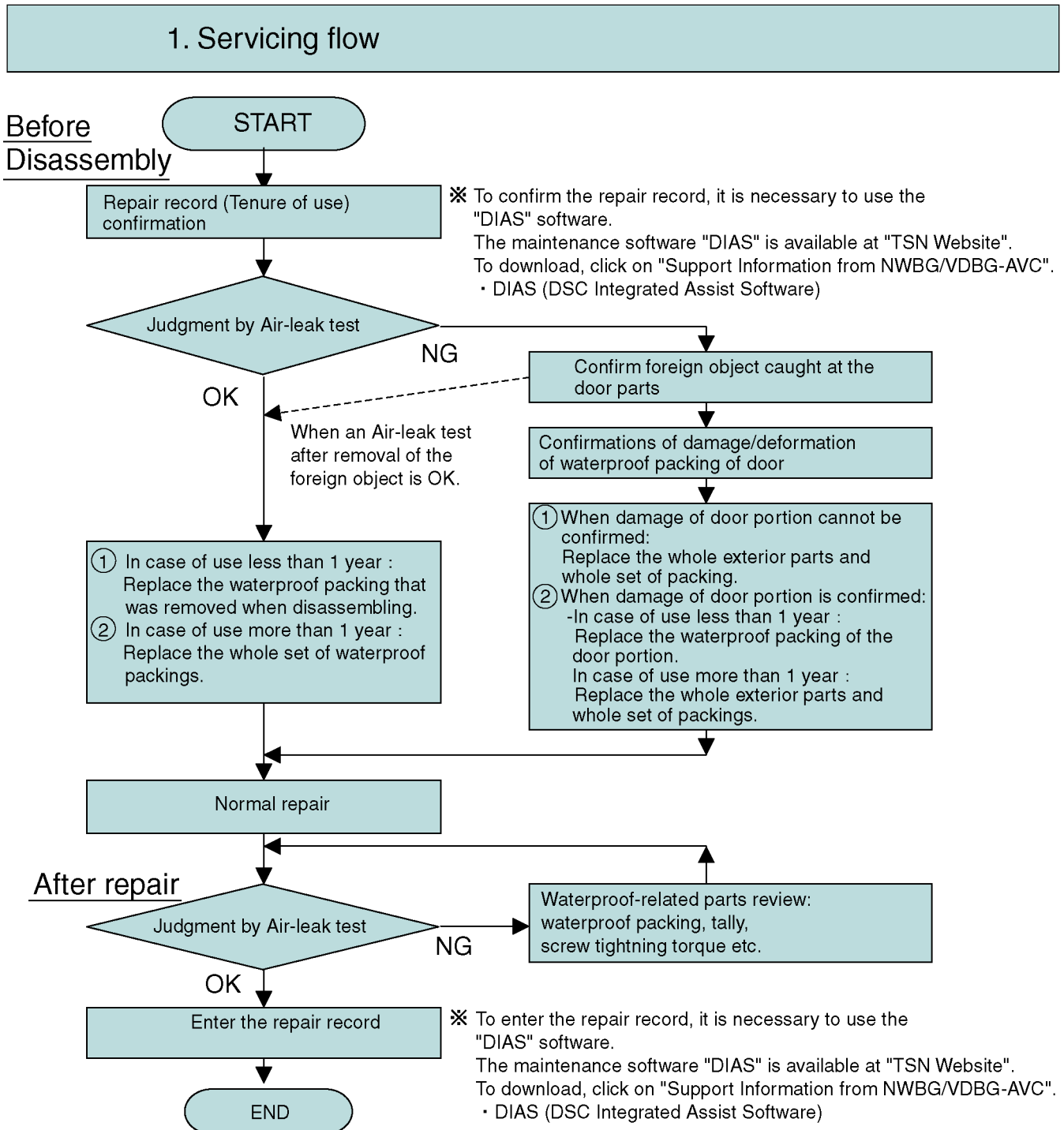

7.1.2. Periodical maintenance (Packing replacement) flow

- The integrity of the waterproof packings may decrease about 1 year, with use and age.
(We recommend end-users to replace the waterproof packing at least once each year described in the operating instructions.)
- Please use waterproof packing kit (Part No.: VUMG2032). (5 types, 6 packings in total are included)
- Do not touch the waterproof packings directly by the hand.
- Do not perform cleaning of waterproof packings by the solvent of alcohol etc. or by blowing air.
- Take care not to put any foreign objects (garbage and dust).
- As for the air-leak test, refer to "7.2. Air-leak Test".

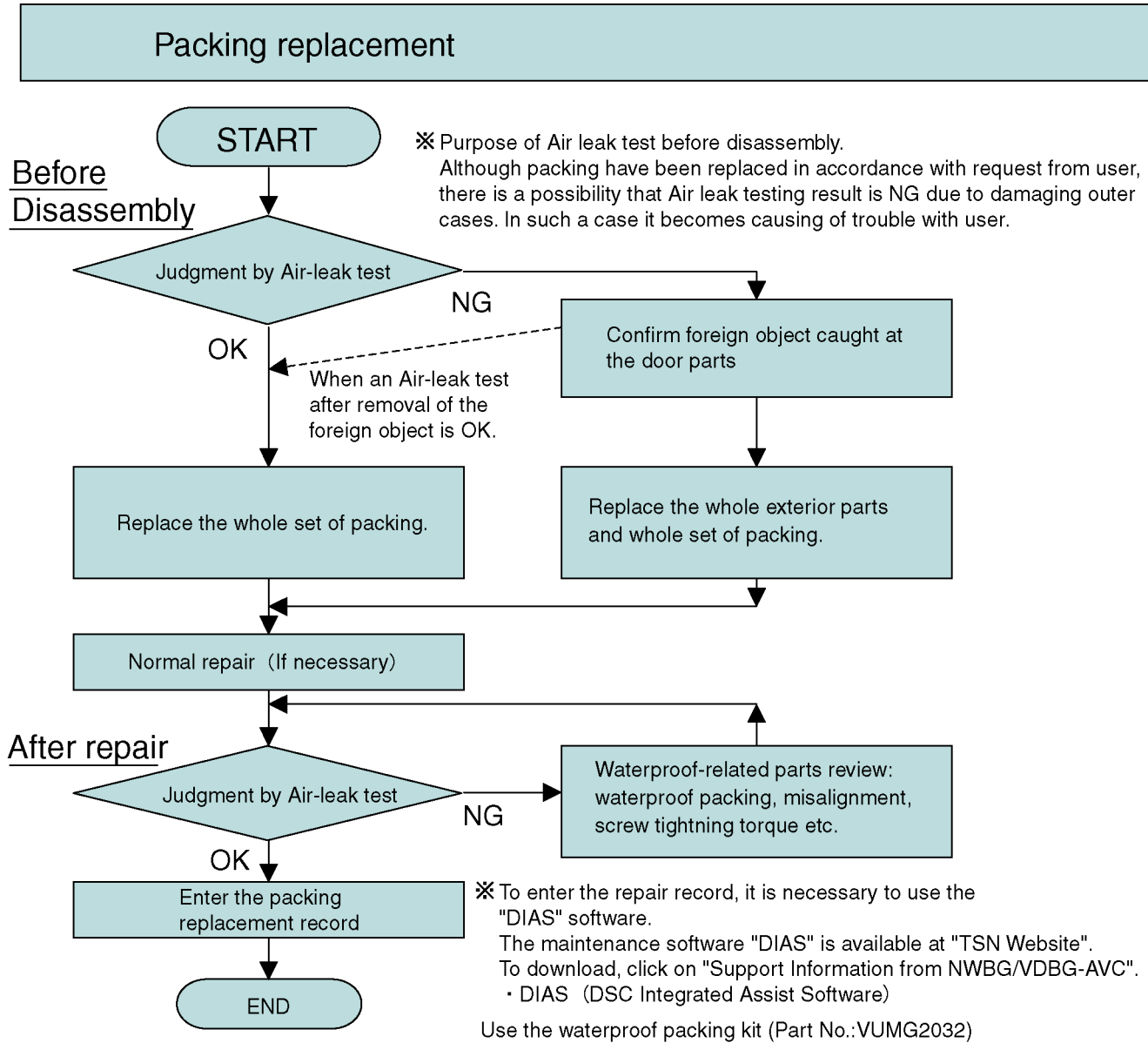

Replacing the waterproof packing

- The location of waterproof packing are shown at right. (5 types, 6 packings in total)
- Waterproof packings are supplied as Waterproof packing kit (Part No.: VUMG2032).

< Note for replacement >

- Do not touch the waterproof packings directly by the hand.
- Do not perform cleaning of waterproof packings by the solvent of alcohol etc. or by blowing air.
- Take care not to put any foreign objects (garbage and dust).
- Use the silicon chips (Part No.: RFKZ0478) when replacing the Case O-ring.

From Ref No. "P-1" to "P-6" are supplied as a "waterproof packing kit" (Part No. VUMG2032), and are Not supplied individually. ("P-6" is also included in Ref.37.)

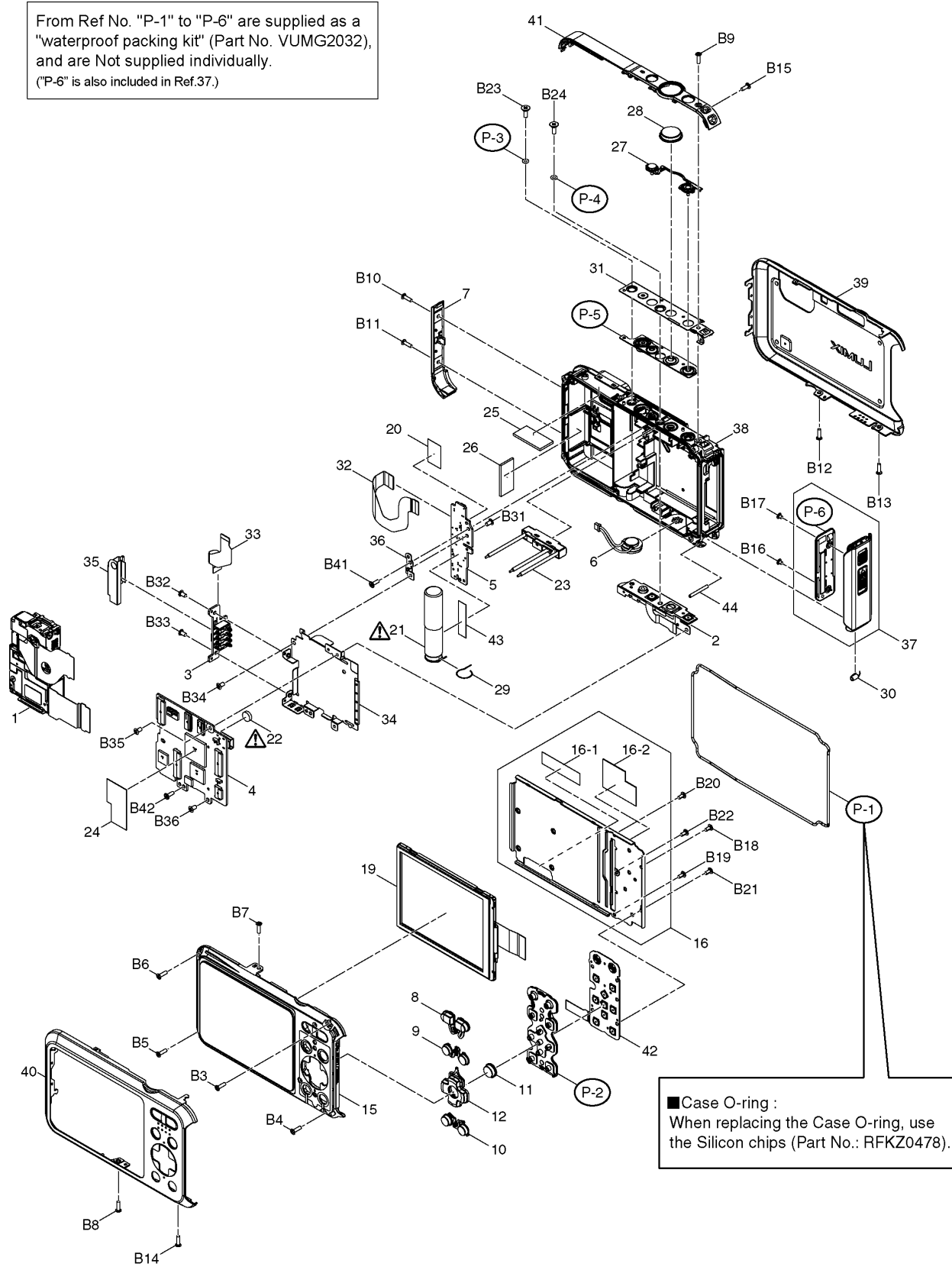

7.2. Air-leak Test

Due to the waterproof performance retention, perform the air-leak test using Air-leak tester (Part No.:RFKZ0528) before/after servicing when disassembling and assembling the unit.

*The Air-leak test before servicing is necessary to be performed to check whether the malfunction occurred due to air-leak or not.

1. Preparation:

- 1) By referring the "9.3. Disassembly procedures", remove the side ornament R and front almi case unit.
- 2) Confirm that no foreign objects at the side door, and it is firmly closed.



2. Air-leak Test (Inspection):

*Perform the air-leak test by referring the following procedure.

Note:

As for the detail instruction of air-leak tester, refer to the operating guide (attached to the product).

[Preparation]

1. Put the camera with the top case facing upward condition.
2. Set the following measurement pressure value on the air-leak tester. (Part No.:RFKZ0528).

[Measurement pressure value] :- 33 k P a

*About the Setting methods, refer to the operating guide for air-leak tester.

3. Attach "L" size of absorption pad to the tip of the hose of the air-leak tester.
4. Put the absorption pad of air-leak tester vertically on the Inspection point.

Note:

- Keep firmly hold above condition until the measurement is completed.
- Once pad is tilted/misaligned from the test hole during testing process, start it from this step.

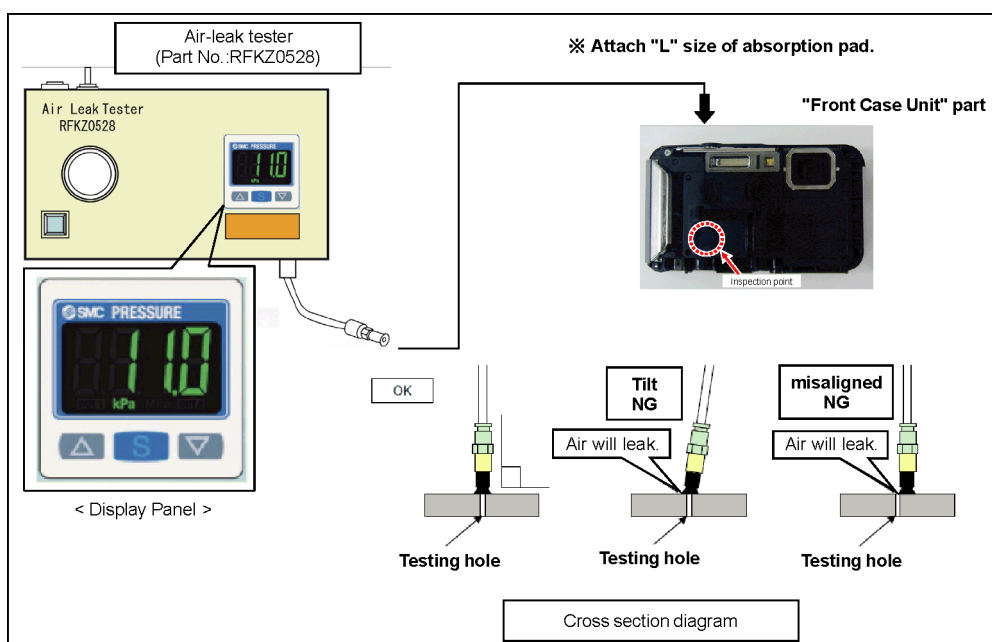

■ Measuring condition (For DMC-FT20, DMC-TS20)

Item	Specifications	Remarks
Setting pressure	- 33 kPa	
Setting stand value	- 30 kPa	
Exhausted period	90sec.	
Stand-by period	15sec.	
Measuring time*1 (Period)	30sec.	
Testing*1 Specification	Stabilization	Between -30kPa and -33kPa
	Deviation	±0.2kPa
		*1 It must be stabilized between -30kPa and -33kPa, with a deviation of +/- 0.2kPa, within 30 seconds.

*Attach "L" size of absorption pad.

[Exhaust Air]

5. Operate the measurement switch of the air-leak tester to exhaust air inside the product for 90 seconds.

[Stand-by]

6. After a laps of 15 seconds, take a note (Record) that the pressure value indicated on the indication panel.

[Measurement]

7. Confirm that the pressure value fluctuations during measurement process are within the testing specification.

[Measuring time] : 30 seconds
 [Testing Specification] : Stabilization : Between -30kPa and -33kPa
 Deviation : ± 0.2kPa

The air-leak test is now completed.

3. Packing replacement record input:

- To enter the repair record, it is necessary to use the "DIAS" software. The maintenance software "DIAS" is available at "TSN Website".

To download, click on "Support Information from NWBG/VDBG-AVC".

*DIAS (DSC Integrated Assist Software)

8 Service Fixture & Tools

8.1. Service Fixture and Tools

The following Service Fixture and tools are used for checking and servicing this unit.

Related to waterproof				
Waterproof packing kit (For waterproof packing replacement) VUMG2032				
Air-leak test jig (For Waterproof property test) RFKZ0528				
	Part No.	Usage	Spec.	Remarks
	RFKZ0536	DC/banana conversion cable	For power supply	Optional goods (1 piece supplied with RFKZ0528)
	RFKZ0533	Vacuum pad (2 included)	For power supply	Optional goods (1 piece supplied with RFKZ0528)
	RFKZ0537	Air-leak test tube (without pad)	For air-leak test	Optional goods (1 piece supplied with RFKZ0528)
Torque driver RFKZ0542	Silicon chips RFKZ0478		Diffuser RFKZ0591	
<p>(For tightening screws with the torque) RFKZ0456 (Shorter shank version) may be used.</p>	<p>(For replacing the packings/ For prevention sticking of dust when replacing the packings)</p>			
Resistor for Discharging (1k Ω/5W) ERG5SJ102	COLLIMATOR (with Focus Chart) VFK1164TCM02		LIGHT BOX (with DC Cable) RFKZ0523	
<p>An equivalent type of Resistor may be used.</p>	<p>※ RFKZ0422 may be used. ※ VFK1164TCM03 may be used.</p>		<p>※ VFK1164TDVLB may be used.</p>	
TR Chart RFKZ0443	Lens Cleaning Kit VFK1900BK		ND Filter RFKZ0513(ND0.3)	

8.2. When Replacing the Main P.C.B.

After replacing the Main P.C.B., be sure to achieve adjustment.

The Maintenance software (DIAS) is available at "software download" on the "Support Information from NWBG/VDBG-AVC" website in "TSN system".

8.3. Service Position

This Service Position is used for checking and replacing parts. Use the original cables for servicing.

8.3.1. Extension Cable Connections

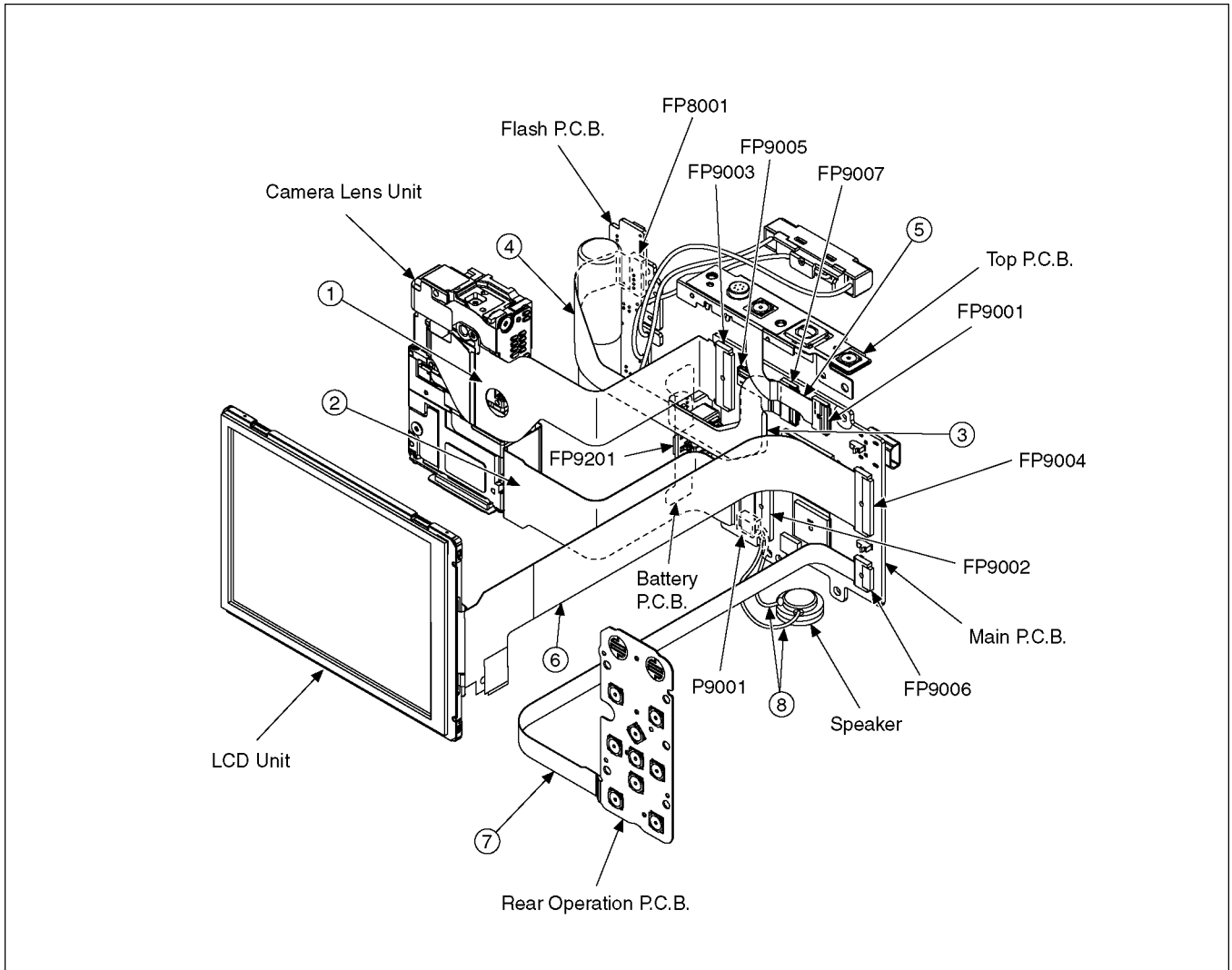

CAUTION-1. (When servicing Flash P.C.B.)

1. Be sure to discharge the capacitor on Flash P.C.B.

Refer to "HOW TO DISCHARGE THE CAPACITOR ON FLASH P.C.B."

The capacitor voltage is not lowered soon even if the AC Cord is unplugged or the battery is removed.

2. Be careful of the high voltage circuit on Flash P.C.B.
3. DO NOT allow other parts to touch the high voltage circuit on Flash P.C.B.

9 Disassembly and Assembly Instructions

9.1. Disassembly Flow Chart

- Make sure to perform air-leak test (refer to "7.1. Service and Check Procedures" before disassembly and after assembly for check of waterproof property.
- Do not touch the waterproof packings directly by the hand.
- Do not perform cleaning of waterproof packings by the solvent of alcohol etc. or by blowing air .
- Take care not to put any foreign object (garbage and dust).
- When replacing the case O-ring, use Silicon chips (RFKZ0478).
- When tightening screws, follow the specifications when the torque is specified .

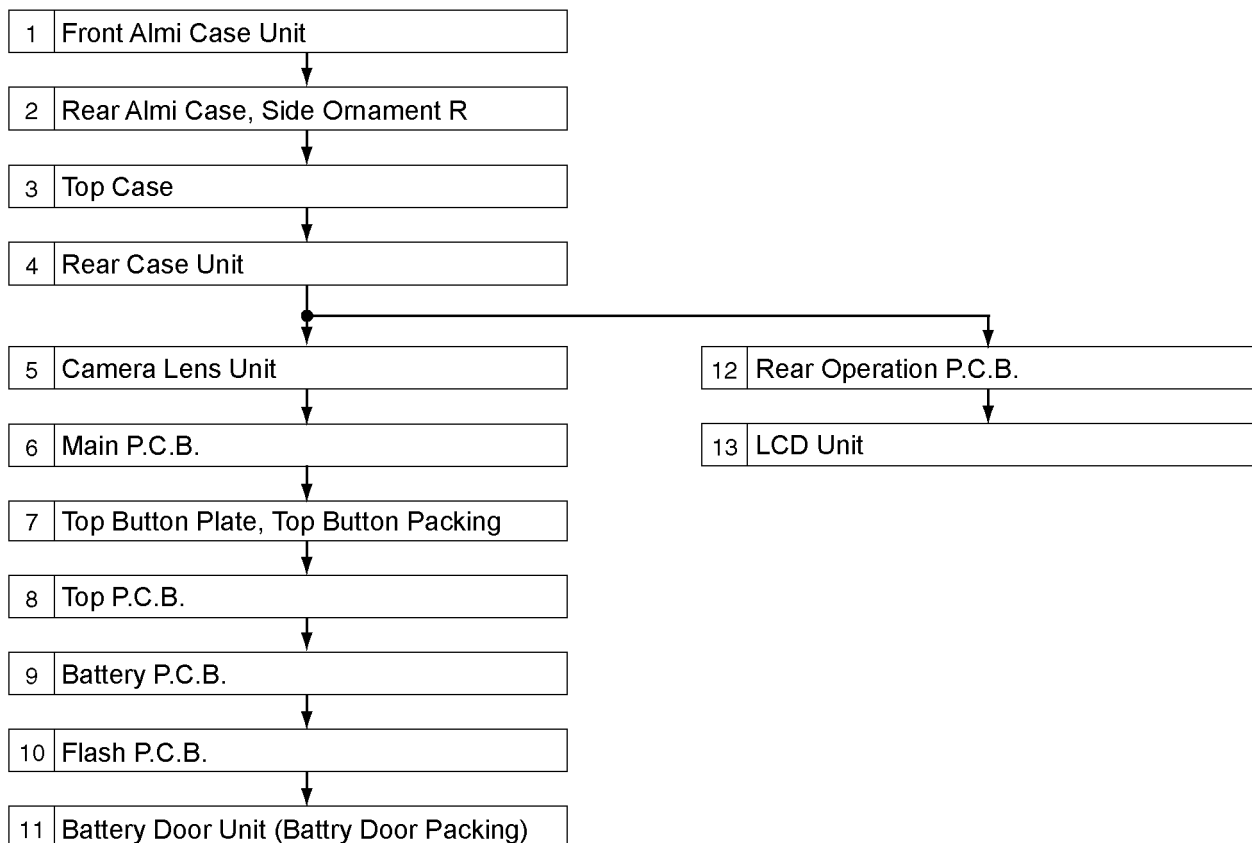

9.2. P.C.B. Location

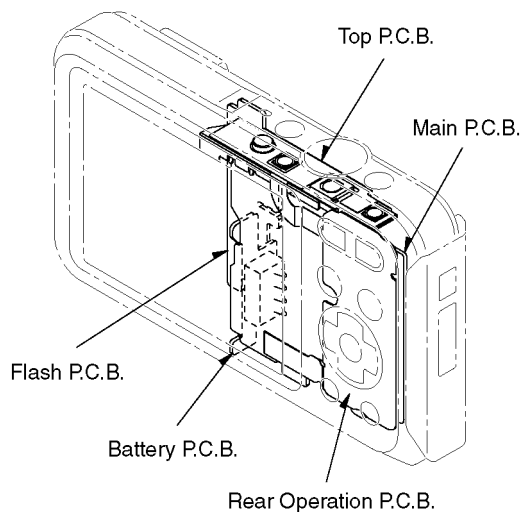

9.3. Disassembly Procedures

No.	Item	Fig.	Removal
1	Front Almi Case Unit	Fig. D1	5 Screws (A) Front Almi Case Unit
2	Rear Almi Case/ Side Ornament R	Fig. D2	2 Screws (B) Rear Aluminum Case Side Ornament R
3	Top Case	Fig. D3	1 Screw (C) 2 Locking tabs Shutter Button POWER/REC Button Top Case
4	Rear Case Unit	Fig. D4	5 Screws (D) FP9004 (Flex) FP9006 (Flex) 2 Locking tabs Rear Case Unit
		Fig. D5	Note:(When attaching Rear Case Unit)
5	Camera Lens Unit	Fig. D6	FP9002 (Flex) FP9003 (Flex) Camera Lens Unit
6	Main P.C.B.	Fig. D7	2 Screws (E) 1 Screw (F) DPR Sheet Speaker FP9001 (Flex) FP9005 (Flex) FP9007 (Flex) P9001 (Connector) Main P.C.B.
			2 Screws (G) 1 Locking tab 2 Screw O Rings Top Button Plate Top Button Packing
			Top P.C.B.
			3 Screws (H) FP9201 (Flex) Battery Case Battery Barrier Sheet Battery P.C.B.
			Note:(When attaching Battery P.C.B.)
			1 Screw (I) FP8001 (Flex) LCD FPC Sheet Flash P.C.B.
			2 Screws (J) Battery Door Shaft Battery Door Spring Battery Door Unit (Battery Door Packing)
			5 Screws (K) 2 Locking tabs Frame Plate Unit
			Rear Operation P.C.B.
			2 Locking tabs (A) 2 Locking tabs (B) LCD Barrier Sheet CCD FPC Spacer Sheet LCD Unit

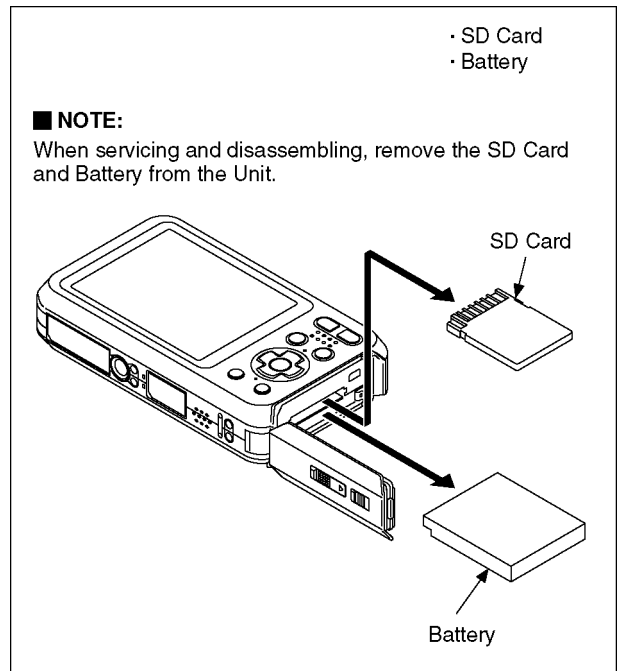

9.3.1. Removal of Front Almi Case Unit

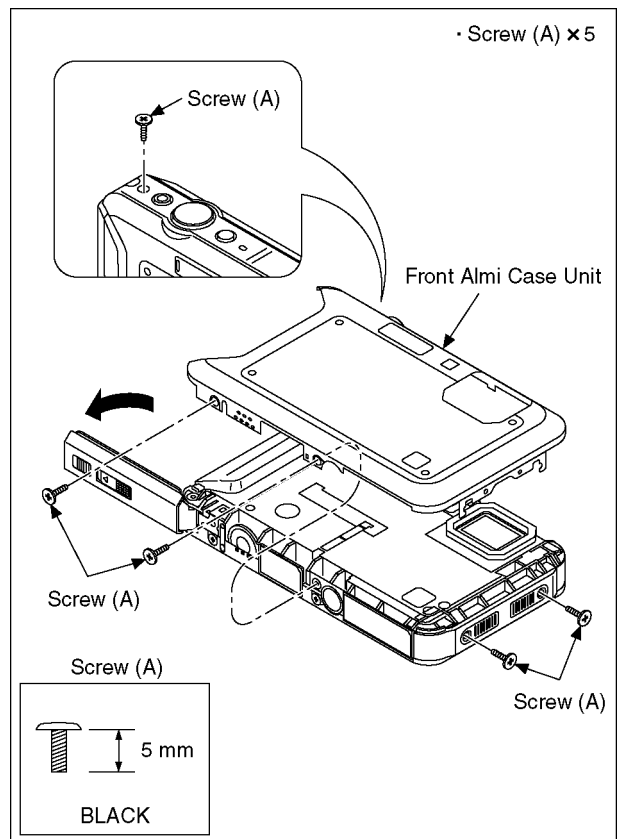

Fig. D1

9.3.2. Removal of Rear Almi Case/Side Ornament R

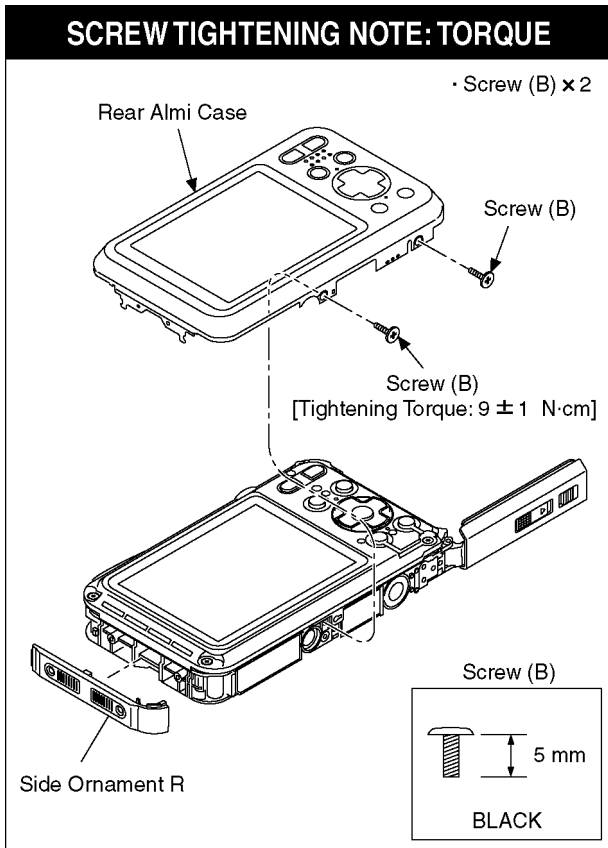

Fig. D2

9.3.3. Removal of Top Case

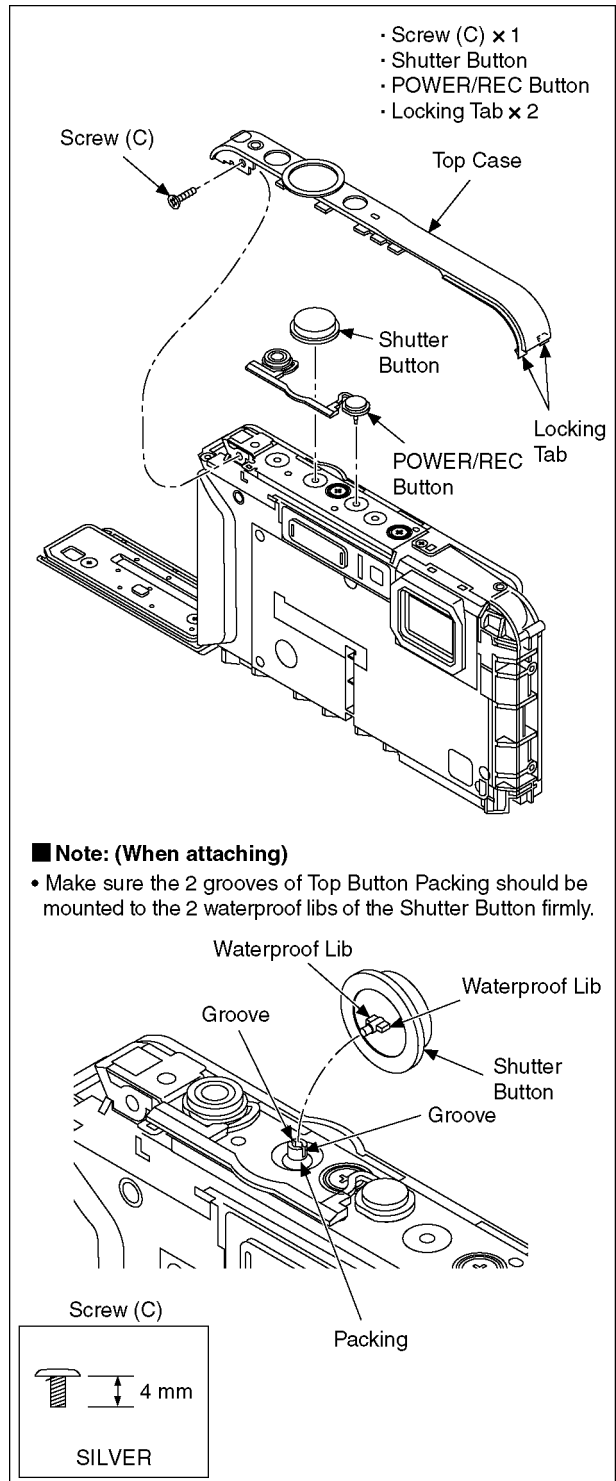

Fig. D3

9.3.4. Removal of Rear Case Unit

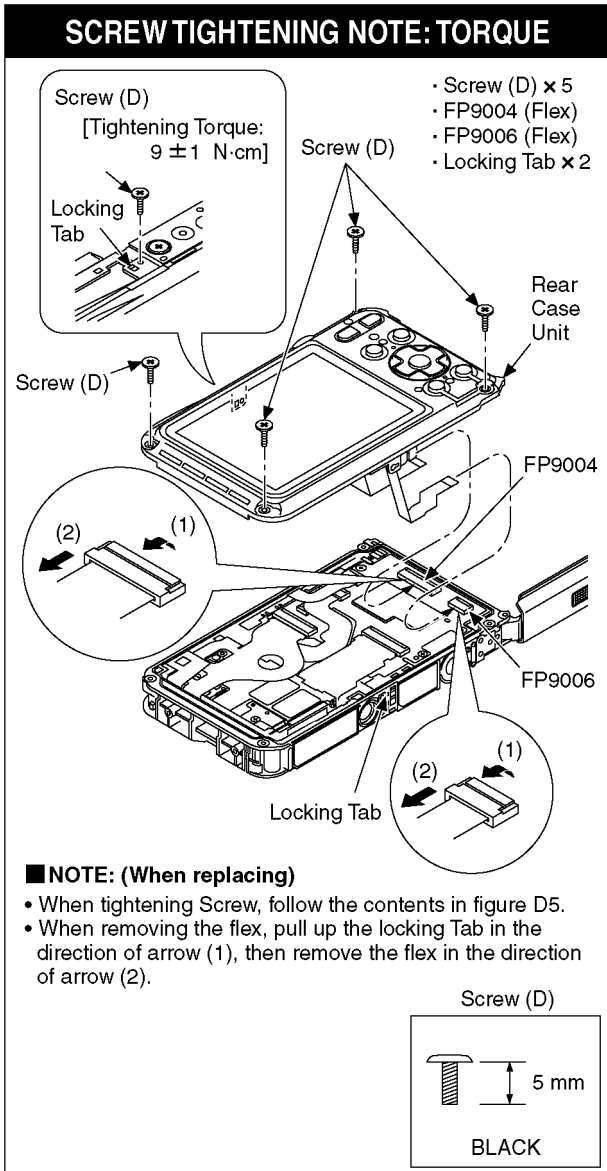
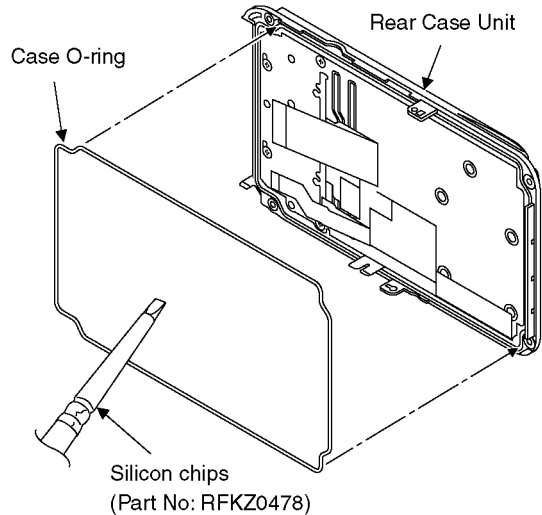

Fig. D4

SCREW TIGHTENING NOTE: TAPE/ORDER/TORQUE

NOTE: (When attaching Rear Case Unit)

- Do not insert the Flex from any slanted angle.
- Make sure the connector is firmly locked.
- When attaching case O-ring, use Silicon chips (Part No. : RFKZ0478).
- Make sure the O-ring of rear case dose not come off.
- Make sure foreign objects are not attached to the O-ring the waterproof lib of the front case.
- When tighten the screws, use Torque screwdriver (Part No. RFKZ0542) and tighten by the specified torque.
- Tighten the screws in the order of (1) to (4) as shown below.
- To keep waterproof property, not to be stripped thread or stuffed thread.



< Order of tightening screws/ tightening torque >

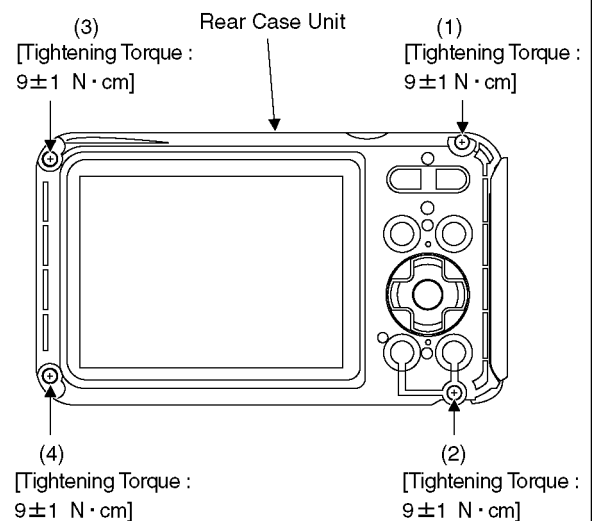

Fig. D5

9.3.5. Removal of Camera Lens Unit

Note: (When Disassembling/Assembling)

1. When dust stuck, use air-Blower to blow off the dust.
2. Do not touch the surface of lens by your hand.
3. Use Lens Cleaning KIT; VFK1900BK (Only supplied as 10 set/Box) is available as Service Aid.

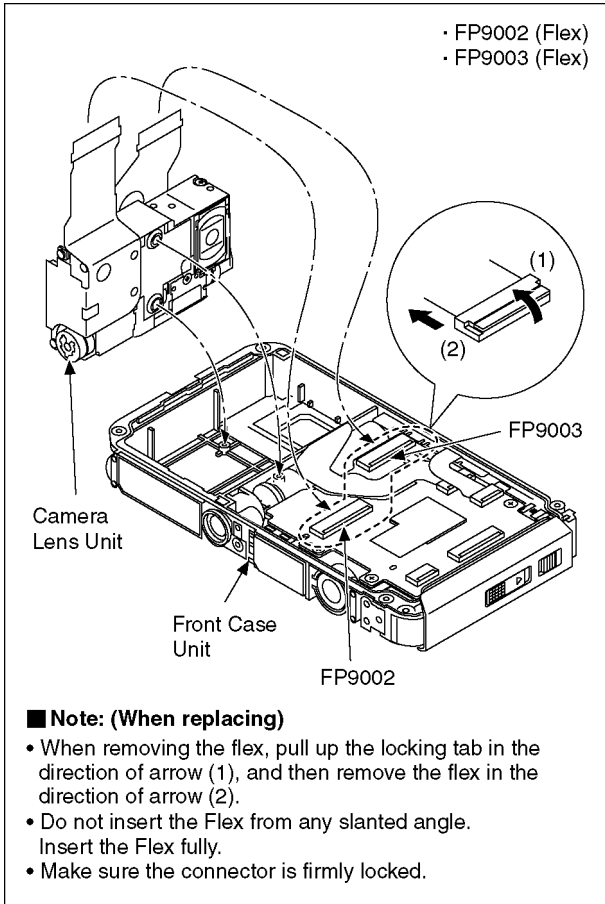

Fig. D6

9.3.6. Removal of Main P.C.B.

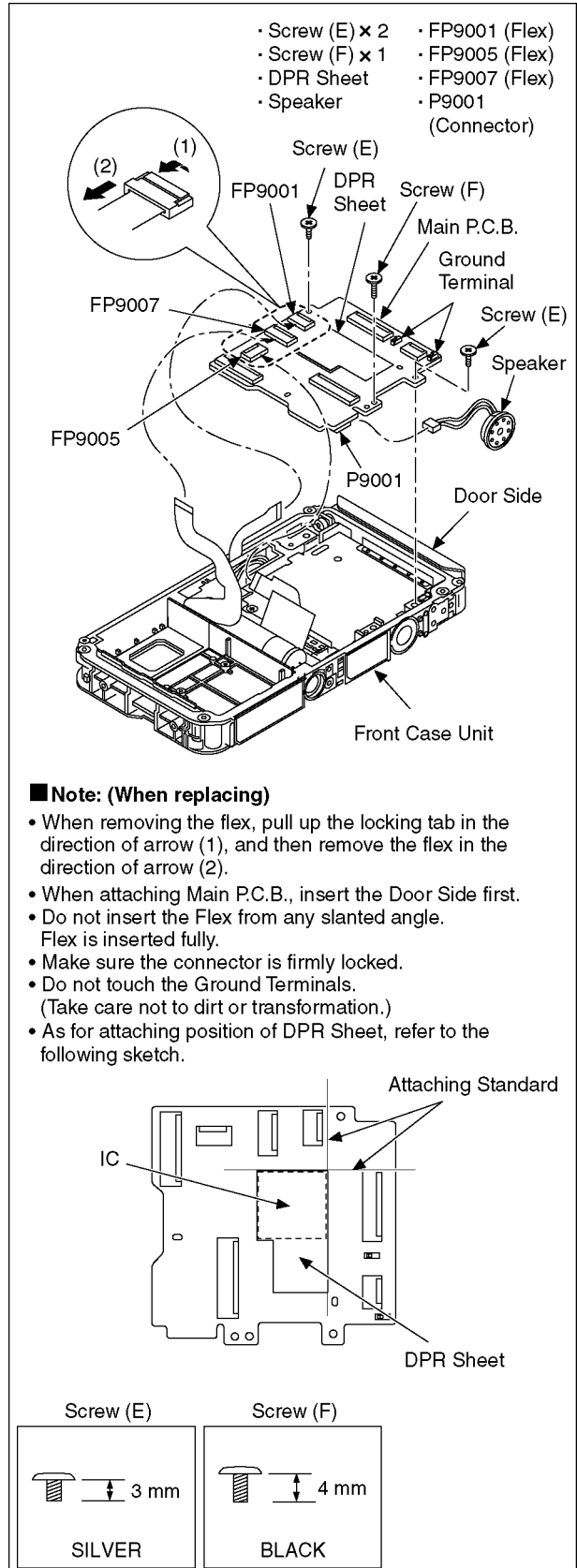

Fig. D7

9.3.7. Removal of Top Button Plate/Top Button Packing

SCREW TIGHTENING NOTE: ORDER/TORQUE

- Screw (G) × 2
- Screw O Ring × 2
- Locking Tab × 1

■ Note: (When attaching)

- Make sure the grooves of Top Button Packing should be mounted to the waterproof libs of the Front Case Unit firmly.
- Make sure foreign objects are not attached to the Top Button Packing and Front Case Unit.
- Take Care not to damage the grooves and waterproof libs.

<Order of tightening screws/ tightening torque>

(1) [Tightening Torque: 10 ± 1.0 N·cm]

(2) [Tightening Torque: 10 ± 1.0 N·cm]

Screw (G)

SILVER

Fig. D8

9.3.8. Removal of Top P.C.B.

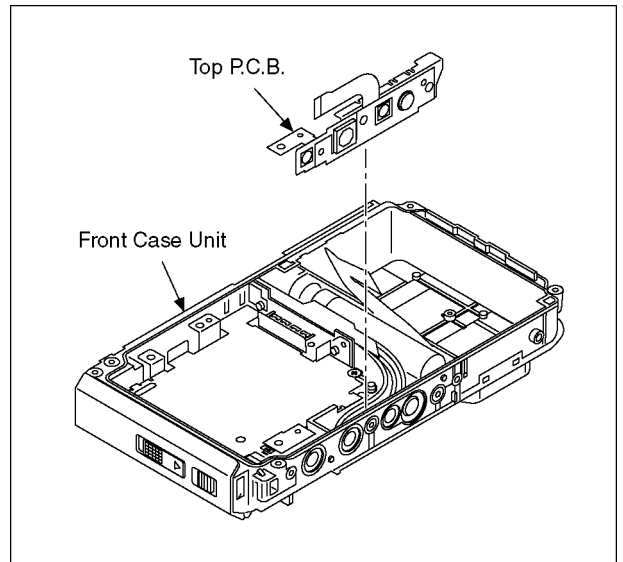

Fig. D9

9.3.9. Removal of Battery P.C.B.

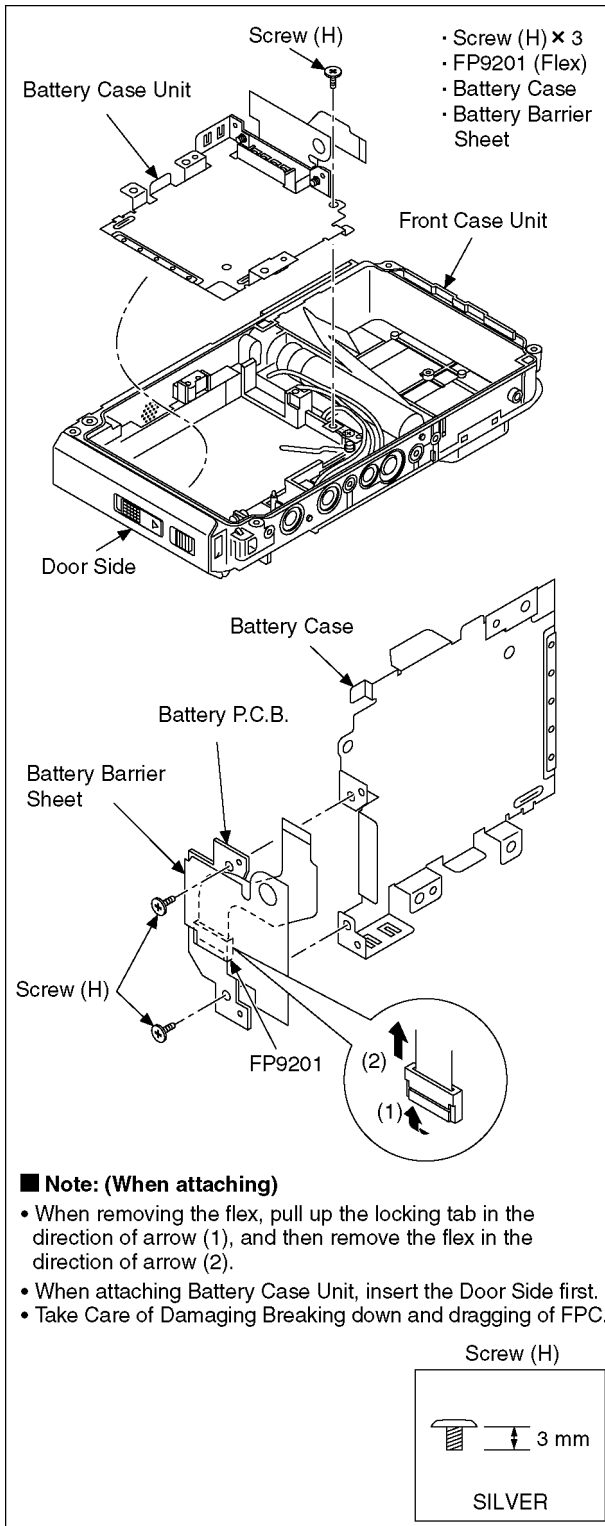

Fig. D10

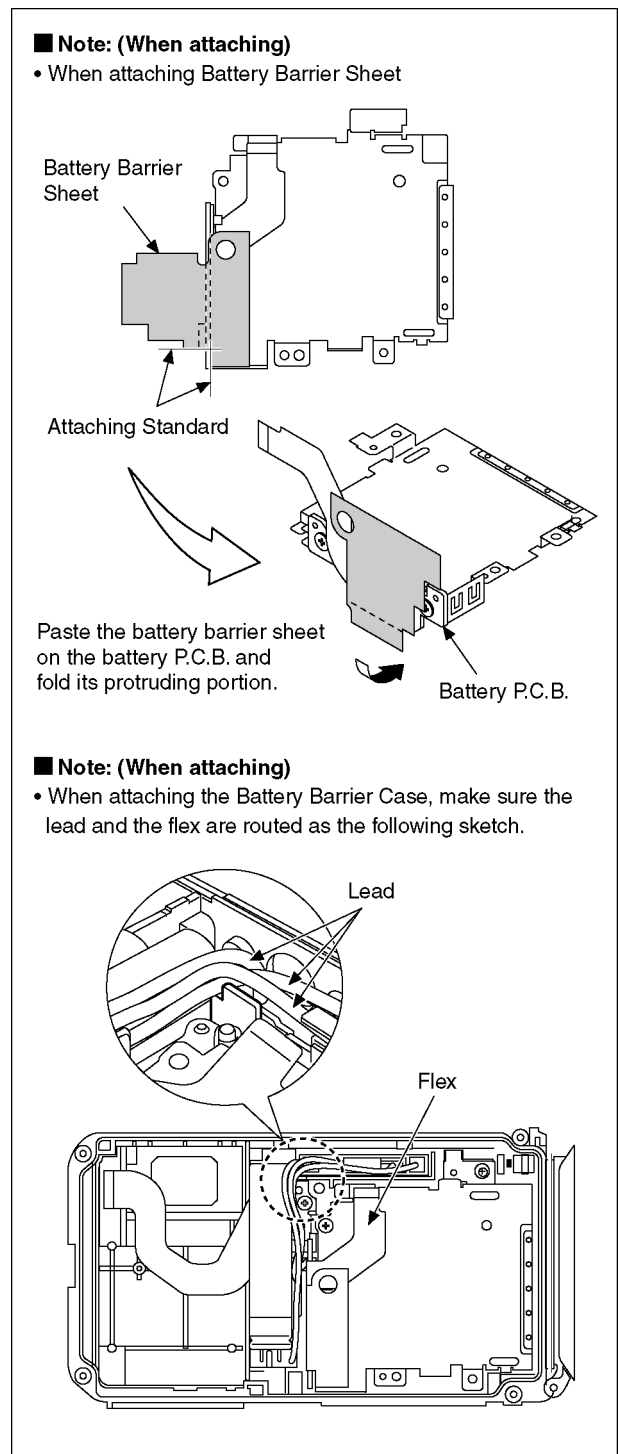

Fig. D11

9.3.10. Removal of Flash P.C.B.

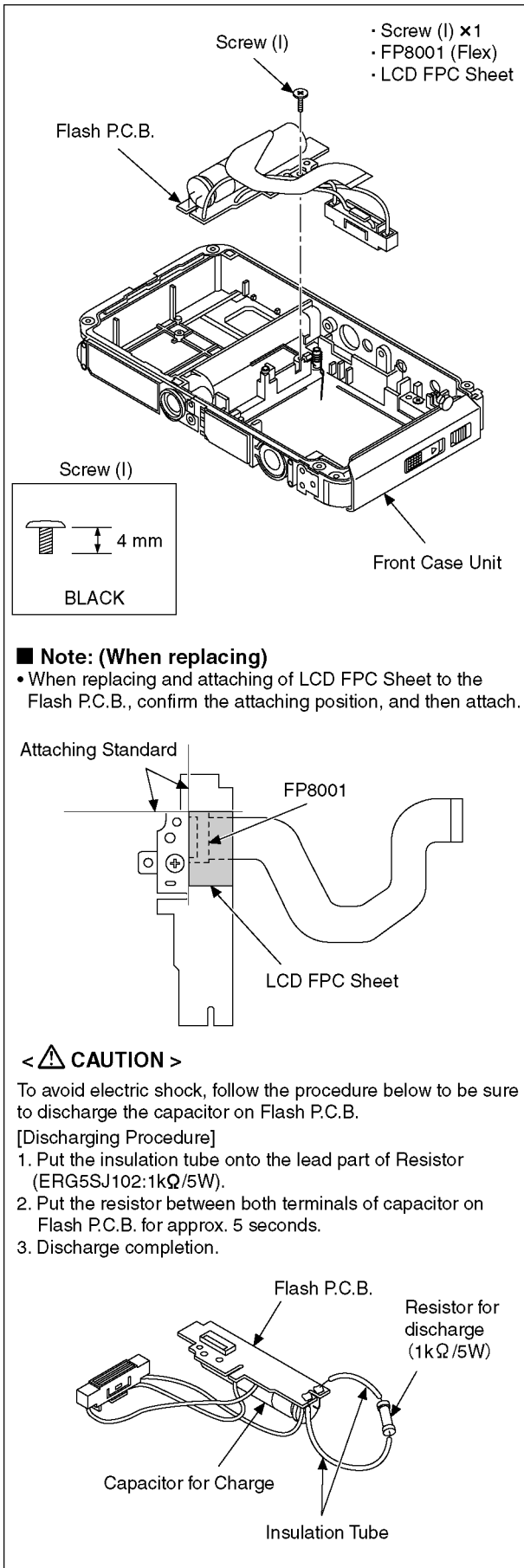

Fig. D12

9.3.11. Removal of Battery Door Unit (Battery Door Packing)

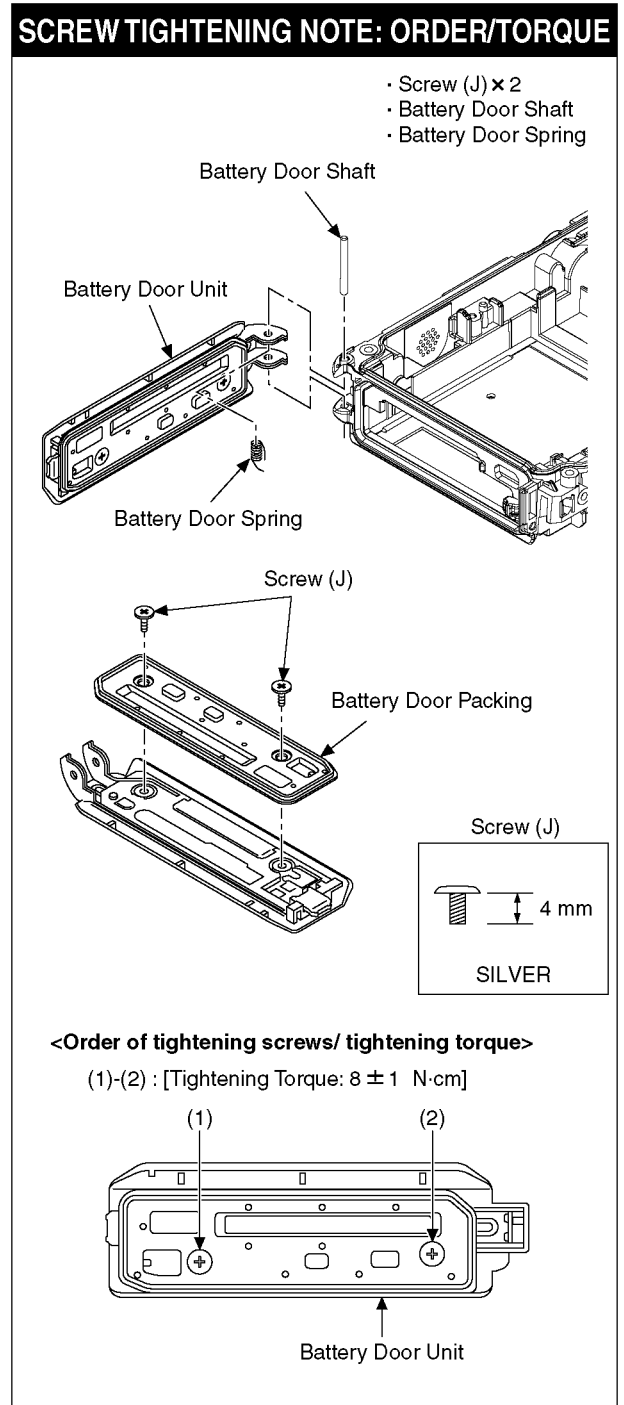
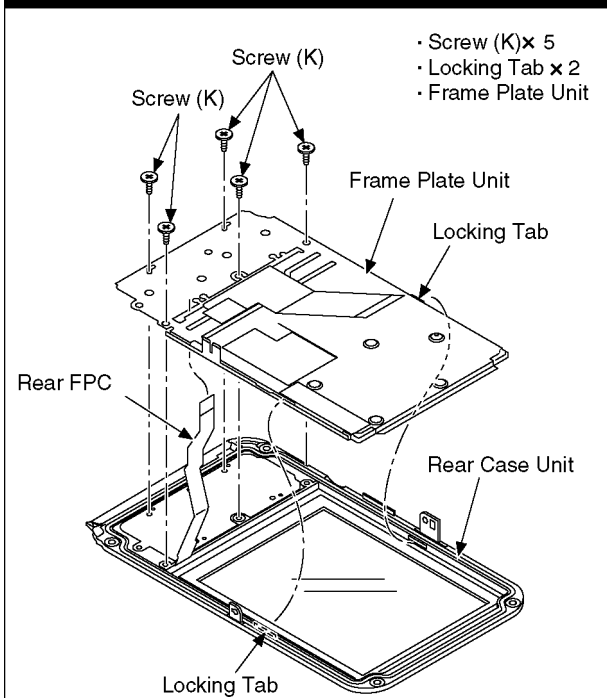

Fig. D13

9.3.12. Removal of Rear Operation P.C.B.

SCREW TIGHTENING NOTE: ORDER/TORQUE



■ Note: (When attaching)

- Pass the REAR FPC through the hole of Rear FPC Plate (above).
- If the Rear FPC Plate is floating, screws tend to become loose. Avoid floating of Rear FPC Plate when tightening screws.

<Order of tightening screws/ tightening torque>

(1)-(5) : [Tightening Torque : 12 ± 1.0 N·cm]

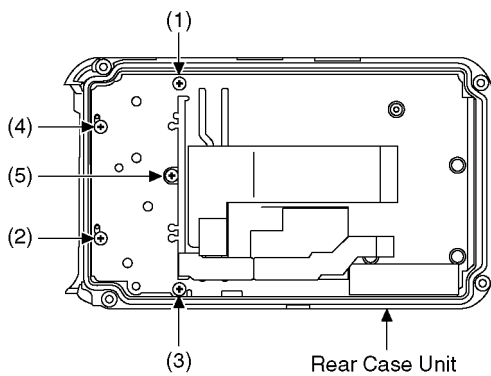

Screw (K)

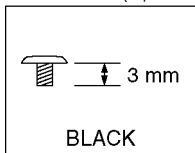
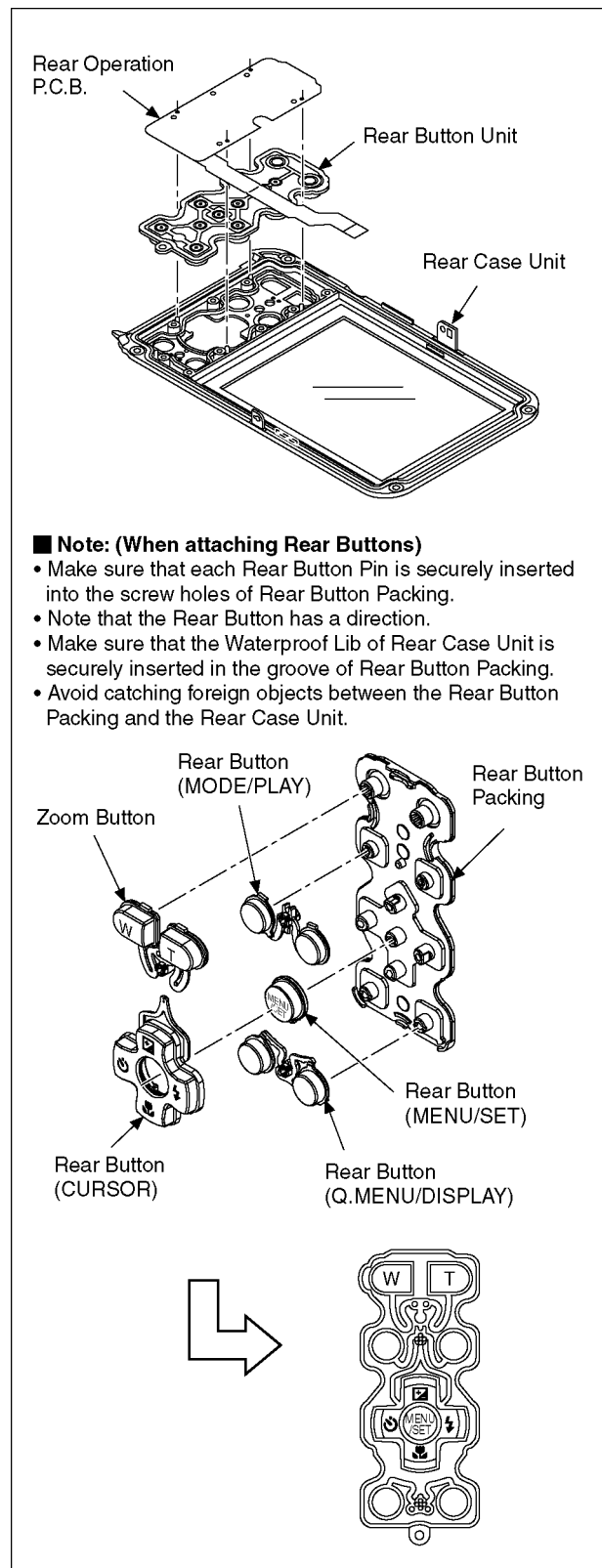

Fig. D14



■ Note: (When attaching Rear Buttons)

- Make sure that each Rear Button Pin is securely inserted into the screw holes of Rear Button Packing.
- Note that the Rear Button has a direction.
- Make sure that the Waterproof Lib of Rear Case Unit is securely inserted in the groove of Rear Button Packing.
- Avoid catching foreign objects between the Rear Button Packing and the Rear Case Unit.

Fig. D15

9.3.13. Removal of LCD Unit

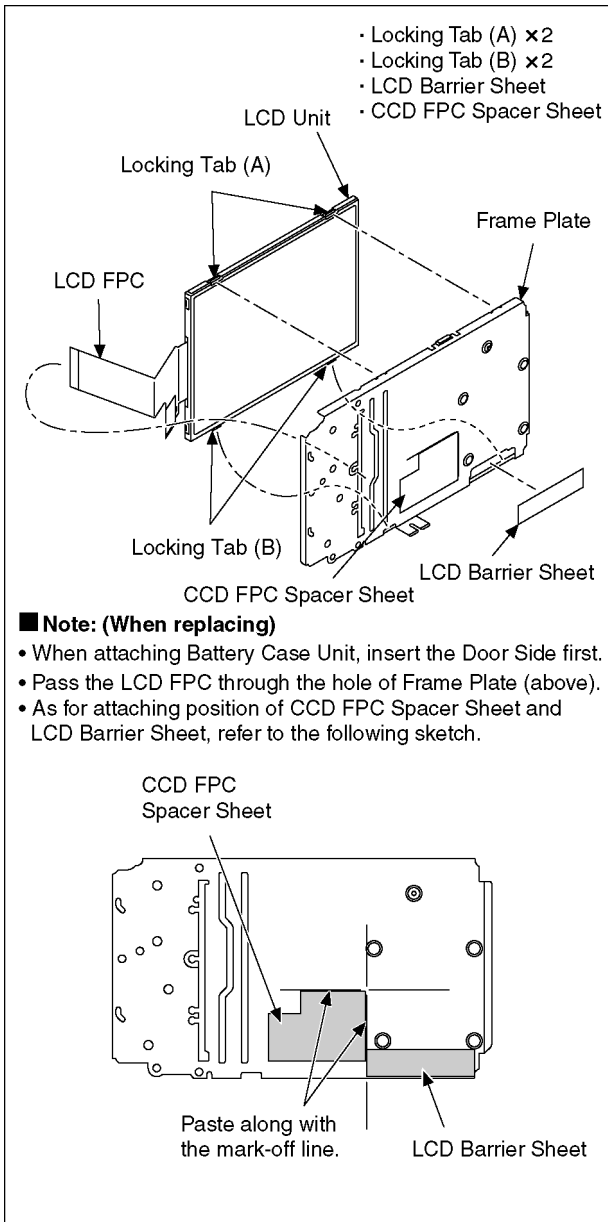

Fig. D16

10 Measurements and Adjustments

10.1. Introduction

When servicing this unit, make sure to perform the adjustments necessary based on the part(s) replaced.
Before disassembling the unit, it is recommended to back up the camera data stored in flash-rom as a data file.

IMPORTANT NOTICE (After replacing the Main P.C.B.)

After replacing the Main P.C.B., it is necessary to use the "DIAS" software to allow the release of adjustment flag(s).
The Adjustment software "DIAS" is available at "TSN Website". To download, click on "Support Information from NWBG/VDBG-AVC".

*DIAS (DSC Integrated Assist Software)

10.2. Before Disassembling the unit

10.2.1. Initial Setting Release

The cameras specification are initially set in accordance with model suffix (such as EB, EG, GC, and so on.).
Unless the initial setting is not released, an automatic alignment software in the camera is not able to be executed when the alignment is carried out.

Note:
The initial setting should be again done after completing the alignment. Otherwise, the camera may not work properly.
Therefore as a warning, the camera display a warning symbol " ! " on the LCD monitor every time the camera is turned off.
Refer to the procedure described in "3.6.2. INITIAL SETTINGS" for details.

[How to Release the camera initial setting]

Preparation:

Attach the Battery to the unit.
Set to Normal picture mode by operating the mode button.

Step 1. Temporary cancellation of "INITIAL SETTINGS":

While pressing the UP of Cursor button and MOTION PICTURE button simultaneously, turn the Power on.

Step 2. Cancellation of "INITIAL SETTINGS":

Press the PLAYBACK switch.
While pressing UP of Cursor button and MOTION PICTURE button simultaneously, turn the Power off. (The warning symbol " ! " is displayed on the LCD monitor.)

10.2.2. Flash-Rom Data Backup

When trouble occurs, it is recommended to backup the Flash-rom data before disassembling the unit. There are two kinds of Flash-rom data backup methods:

[ROM_BACKUP (Method of Non-PC backup)]

1. Insert the SD-card into the camera.
2. Set the camera to "Temporary cancellation of the initial settings".
3. Select the "SETUP" menu.
From the "SETUP" menu, select "ROM BACKUP".

Note:

This item is not listed on the customer's "SET UP" menu.

4. When this "ROM_BACKUP" item is selected, the following submenus are displayed.



Item	Function	Details
DSC → SD	Save all the DSC's Flash-rom data to SD-CARD	<ul style="list-style-type: none"> • DSC's Flash-rom data is saved to the SD-CARD as a data file by the same format as the TATSUJIN software for the previous models. (DATA BACKUP) -File location: ROOT DIRECTORY in SD-CARD. -File Name: <ol style="list-style-type: none"> 1) User Setup Information data : <Model Number>U.txt [Example: DMC-FX66 : "FX66U.txt"] 2) Optical Adjustment data : <Model Number>F.txt [Example: DMC-FX66 : "FX66F.txt"] • If the concerned file already exists, "OVERWRITE?" message is displayed.
SDALL → DSC (ID CHECK)	Write the all data to DSC's Flash-rom from SD-CARD	<ul style="list-style-type: none"> • The backup data being stored in the SD card is transferred to DSC unit. • ID CHECK: When the model ID is different, data is not transferred.
SDALL → DSC (FORCE)	Write the all data to DSC's Flash-rom from SD-CARD	<ul style="list-style-type: none"> • FORCE: Even if the model ID is different, data is transferred. * If the main PCB is replaced, select "SDALL → DSC (FORCE)".
SDUSER → DSC (FORCE)	Only "User setup information" is written from the saved file in the SD-CARD to DSC's Flash-rom.	<ul style="list-style-type: none"> • Only the user's "setup" setting condition is transferred to DSC unit. • FORCE: Even if the model ID is different, the data is transferred.
I → LUMIX	Shipping set without initializing "User setup information"	<ul style="list-style-type: none"> • Initial setting is executed without initializing the user's set up setting condition. * The initial setting must be perform while the Self-timer LED is blinking, * The picture data stored in the built-in memory of the DSC is not erased, with this operation.

[DSC Integrated Assist Software (Method of Using PC)]

Same as TATSUJIN software for previous models.

10.2.3. Light Box

If using VFK1164TDVLB Light Box, remove the lens connection ring by loosening three hexagon screws.

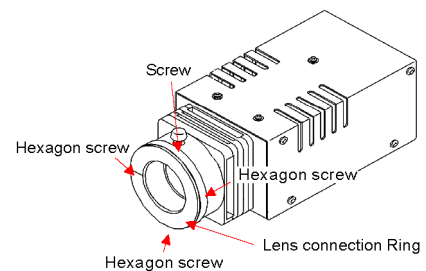

10.3. Details of Electrical Adjustment

10.3.1. How to execute the Electrical Adjustment

It is not necessary to connect the camera to a PC to perform adjustments.

"Flag reset operation" and "Initial setting operation" are required when carrying out the alignment, follow the procedure below.

10.3.1.1. Startup Electrical Adjustment mode

1. Release the initial settings.
2. Insert a recordable SD card.
(Without a SD card, the automatic adjustment can not executed.)
3. Procedure to set the camera into adjustment mode:
 - a. Set to Normal picture mode by operating the mode button.
 - b. Turn the Power off.
 - c. Turn the Power on pressing MOTION PICTURE and MENU/SET simultaneously.
LCD monitor displays "SERVICE MODE".
(Refer to Fig.F3-1)

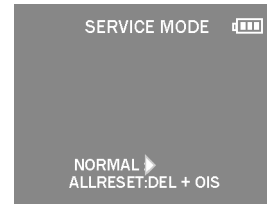

Fig. 3-1

10.3.1.2. Status Adjustment Flag Setting

Reset (Not yet adjusted) the status flag condition.

1. After pressing the DISPLAY button, the LCD monitor displays the Flag status screen (Refer to Fig.3-2.)
2. Select item by pressing the cross keys. (Gray cursor is moved accordingly.)
3. Press the DELETE button.

Note:

The selected item's flag has been changed from "F (green)" to "0 (yellow)".

*(Refer to Fig. 3-3)

*Flag conditions:

F (green)

means that the alignment has been completed and the status flag condition is set. In this case, the flag condition should be reset, if you try to carry out the automatic alignment.

0 (yellow)

means that the alignment has been not "completed" and the status flag condition is "reset". In this case, automatic alignment is available.

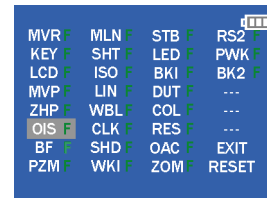

Fig. 3-2

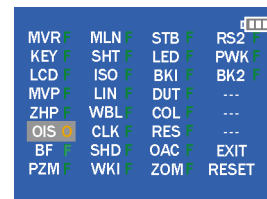

Fig. 3-3

< Example: OIS flag is reset. >

- In case of setting the status flag into set condition again without completion of the alignment, the status flag should be SET by using PC, or UNDO by using ROM BACKUP function.

10.3.1.3. Execute Adjustment

1. Perform step "10.3.1.1." to "10.3.1.2.", to reset the OIS flag status "F" (Set) to "0" (Reset).
2. Press DISPLAY button after Flag reset.
OIS Adjustment screen is displayed on the LCD panel.
(Refer to Fig.3-4)
3. Press the shutter button. The adjustment will start automatically.
4. When the adjustment is completed successfully, adjustment report menu appears with Green OK on the LCD monitor. (Refer to Fig.3-5)



Fig. 3-4

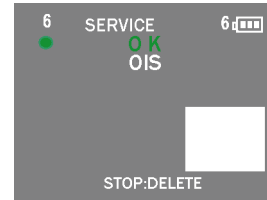

Fig. 3-5

10.3.1.4. Attention point during Adjustment

1. Step "10.3.1.3." procedure shows OIS adjustment as an example. To perform the adjustment, refer to the "10.3.2. Adjustment Specifications" table which shows key point for each adjustment.
2. Do not move the light box, the camera or the chart while adjusting. If one of these is moved accidentally, start the adjustment again.
3. Do not press any buttons/keys until the default menu (Fig.3-6) is displayed on the LCD monitor. Otherwise, adjustment data may not be stored properly.
4. If the adjustment is interrupted accidentally, the alignment data may not be properly saved in the Flash-rom.

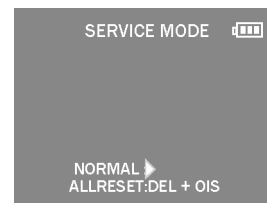

Fig. 3-6

10.3.1.5. Finalizing the Adjustment

1. Several adjustment flags can be reset ("F" into "0") at the same time. In this case, when the adjustment has been completed, the screen will change showing the adjustment for the next item until all reset items are completed.
Also, when the shutter button is pressed, the screen jump to the next adjustment item.
2. To cancel the adjustment mode while in the process of performing the adjustment, follow this procedures.
(1) Press "Right of cross key" button.

Note:

- *.If adjustment is cancelled with above procedure, adjustment is not completed. Make sure to adjust it later.
- *.Adjustment software "DIAS" is able to control the status of the adjustment flags.

10.3.2. Adjustment Specifications

The following matrix table shows the relation between the replaced part and the Necessary Adjustment.

When a part is replaced, make sure to perform the necessary adjustment(s) in the order indicated.

The table below shows all the information necessary to perform each adjustment.

Adjustment order	Adjustment Item	FLAG	Purpose	Replacing Parts				JIG/TOOLS	SET UP	How to Operate	
				MAIN PCB/ VENUS ENGINE (IC6001)/ F-ROW (IC6002)	Lens Parts (include CCD U)	MIC UNIT	FLASH UNIT				LCD UNIT
1	LCD flickering	LCD	Minimize the LCD flickering	○	-	-	-	○	NONE	NONE	1) No flickering, just press the shutter Button. 2) There are 5 LCD modes. (The position of green ● mark is different.) Select LCD modes with less flicking by pressing the left/right cursor buttons. 3) Press the shutter button. 4) After completed, the "OK" menu appears.
2	Zoom Home Position	ZHP	Zoom Home Position inspection and Microphone check	○	○	○	-	-	NONE	Right before pressing the shutter button, enter the continuous sounds (voice) to the microphone for about 5 seconds.	1) Press Shutter Button. 2) After completed, the "OK" menu appears.
3	OIS sensor	OIS	OIS sensor output level adjustment	○	○	-	-	-	NONE	NONE	1) Press Shutter Button. (Do not apply any shock and vibration for the camera while adjusting) 2) After completed, the "OK" menu appears.
4	Backfocus / GYRO	BF	To have the focus tracking curve be appropriate shape and GYRO sensor adjustment	○	○	-	-	-	-	1) Set the camera in front of collimator so that the distance from collimator to camera becomes about 1 cm as shown in Fig. A. 2) Set the camera angle so that the center of the chart comes to the center of the LCD monitor. [IMPORTANT] The adjustment "NG" might be happened with the following conditions: - Do not put the black colored stuff at the back side of collimator near hunching chart. It needs to get some certain brightness. - Make sure the hunching chart has no dust and dirty condition. - Do not connect a USB cable during adjustment.	1) Press Shutter Button. (Do not apply any shock and vibration for the camera while adjusting) (The green ● mark is displayed on LCD). 2) Press Shutter Button again. 3) After completed, the "OK" menu appears.
5	Venus Zoom	PZM	Venus Zoom Inspection	○	-	-	-	-	NONE	NONE	1) Press Shutter Button. 2) After completed, the "OK" menu appears.
6	Monitor Linearity	MLN	Monitor Linearity adjustment	○	○	-	-	-	-	1) Set the camera in front of LIGHT BOX so that the distance from LIGHT BOX to camera becomes about 1.5 cm as shown in Fig. B. 2) Aim the LIGHTBOX and make the frame detail alignment so that the entire LCD screen becomes fully "white". (No dark area).	1) Press Shutter Button. 2) After completed, the "OK" menu appears.
7	Shutter	SHT	Shutter speed adjustment	○	○	-	-	-	-	1) Set the camera in front of LIGHT BOX so that the distance from LIGHT BOX to camera becomes about 9 cm as shown in Fig. B. 2) Aim the LIGHTBOX so that the entire LCD screen becomes fully "white". (No dark area).	1) Press Shutter Button 2) After completed, the "OK" menu appears.
8	ISO	ISO	ISO sensitivity adjustment	○	○	-	-	-	-	1) Prepare the LIGHTBOX (RFKZ0523). (The LIGHTBOX "VFK1164TDVLB" can be used if the front hood of VFK1164TDVLB is removed.) 2) Set ND FILTER (RFKZ0513 (ND0.3)) to the LIGHTBOX. 3) Set ND FILTER and Camera unit so that distance becomes about 8 cm (Fig. B) 4) Aim the LIGHTBOX so that the entire LCD screen becomes fully "white". (No dark area).	1) Press Shutter Button. 2) After completed, the "OK" menu appears.
9	High brightness coloration	LIN	High brightness coloration adjustment	○	○	-	-	-	-	1) Press Shutter Button. 2) After completed, the "OK" menu appears.	1) Press Shutter Button. 2) After completed, the "OK" menu appears.

10	White Balance	WBL	White balance adjustment under various color temperature	○	○	-	-	-	<ul style="list-style-type: none"> • LIGHT BOX (RFKZ0523 or • VFK1164TDVLB) • TR CHART (RFKZ0443) 	<p>1) Insert the TR chart into the slot of LIGHT BOX.</p> <p>2) Set the camera in front of LIGHT BOX so that the distance from the TR chart to camera becomes about 15 cm as shown in Fig. B.</p> <p>3) Set the camera angle so that the center of the chart comes to the center of the LCD monitor.</p> <p>[IMPORTANT]</p> <p>The adjustment "NG" might be happened with the following conditions:</p> <ul style="list-style-type: none"> - Do not put the black colored stuff at the back side of collimator near hunching chart. It needs to get some certain brightness. - Make sure the hunching chart has no dust and dirty condition. - Do not connect a USB cable during adjustment. 	<p>1) Press Shutter Button.</p> <p>2) After completed, the "OK" menu appears.</p>
11	*1 CCD Missing Pixels (White)	WKL	Compensation of CCD Missing Pixels (White)	○	○	-	-	-	NONE	NONE	<p>1) Press Shutter Button.</p> <p>2) After completed, the "OK" menu appears.</p>
12	Flash	STB	Flash Inspection	○	-	-	○	-	NONE	NONE	<p>1) Press Shutter Button and check that Flash is emitted. (The number of emissions differs depending on the model.) If Flash is not emitted, Flash Unit may be damaged.</p> <p>2) If the inspection result shows "NG", use "DIAS" and rewrite STB to confirm it is adjusted. The result may show "NG" if the inspection is performed on sites other than the specific environment (factory). However, if the flash emission is visible, there is no problem.</p> <p>3) After completed, the "OK" menu appears.</p>
13	Color reproduction inspection and Microphone check	COL	Color reproduction inspection and Microphone check	○	○	-	-	-	NONE	No need to enter the continuous sounds (voice) to the microphone as usual.	<p>1) Press Shutter Button.</p> <p>2) After completed, the "OK" menu appears.</p>
14	OAC Act	OAC	OIS performance /ghost (flare) inspection	○	○	-	-	-	NONE	Set the Camera on a horizontal plane.	<p>1) Press Shutter Button. (Do not apply any shock and vibration for the camera while adjusting)</p> <p>2) After completed, the "OK" menu appears.</p>
		BKI	Do not use "BK1" adjustment flag for this unit. Use "BK2" adjustment flag, instead. (In case of most DSC models, the adjustment flag for CCD Missing Pixels is "BK1". But, in this model, "BK1" the adjustment flag for CCD Missing Pixels.)								
15	*2 CCD Missing Pixels (Black)	BK2	Compensation of CCD Missing Pixels (Black)	○	○	-	-	-	<ul style="list-style-type: none"> • LIGHT BOX (RFKZ0523 or • VFK1164TDVLB) • DIFFUSER (RFKZ0591) 	<p>1) Prepare the LIGHTBOX (RFKZ0523). (The LIGHTBOX "VFK1164TDVLB" can be used if the front hood of VFK1164TDVLB is removed.)</p> <p>2) Set the Diffuser (RFKZ0591) to the LIGHTBOX.</p> <p>3) Set the LIGHTBOX and Camera unit so that distance becomes about 2 cm in Fig. B.</p> <p>NOTE Do not use "BK1" adjustment flag for this unit. Use "BK2" adjustment flag, instead.</p>	<p>1) Set the LIGHTBOX and Camera unit so that the distance becomes about 2 cm (Refer to Fig. B)</p> <p>2) Press Shutter Button. (The green●mark is displayed on LCD.)</p> <p>3) Aim the LIGHTBOX and make the frame detail alignment so that the entire LCD screen becomes fully "white". (No dark area). Press the Shutter Button. (The green●mark is displayed on LCD.)</p> <p>4) Press Shutter Button. (The adjustment is executed, and then green●mark is displayed on LCD.)</p> <p>5) Press Shutter Button. (The green●mark is displayed on LCD.)</p> <p>6) Press Shutter Button. (The adjustment is executed, and then green●mark is displayed on LCD.)</p> <p>7) Press Shutter Button. (The green●mark is displayed on LCD.)</p> <p>8) Press Shutter Button. (The adjustment is executed, then "OK" mark is displayed on LCD when the adjustment has been completed successfully.)</p>

*1 :White missing pixels means that the pixel which is always active (lit) although shading (Dark) condition.

*2 :Black missing pixels means that the pixel which is always non-active (off) although high-intensity light is coming.

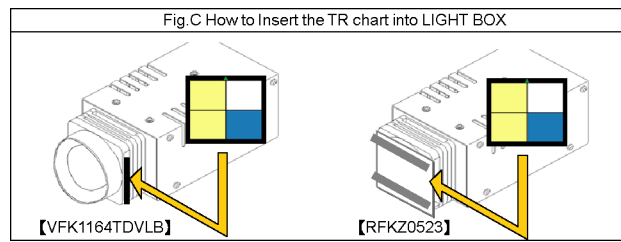
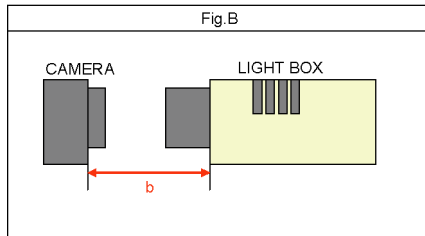
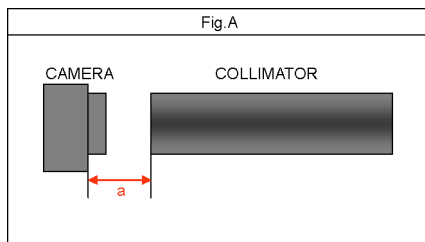

■ **IMPORTANT NOTICE (After replacing the MAIN P.C.B.)**
 After replacing the MAIN P.C.B., make sure to perform the "INITIAL SETTINGS" first, then release the "INITIAL SETTINGS" in order to proceed the electrical adjustment.

Note:

1. If electrical adjustment or data re-writing is executed before "INITIAL SETTINGS", suffix code list is never displayed, and it cannot be chosen suitable suffix code.
2. Never remove the battery during initial setting in process.

10.4. After Adjustment

10.4.1. Initial Setting

Since the initial setting has been released to execute the built-in adjustment software, it should be set up again before shipping the camera to the customer.

Refer to the procedure described in "3.6.2. INITIAL SETTINGS" for details.

[IMPORTANT]

1. The initial setting should be done again after completing the alignment. Otherwise, the camera will not work properly.
 Therefore as a warning, the camera display a warning symbol "!" on the LCD monitor every time the camera is turned off.
2. Confirm that status of all adjustment flag show "F". Even if one of the adjustment flag shows "0", initial setting programmed is never executed.
3. Adjustment software "DIAS" is able to control the status of the adjustment flags.
 The Adjustment software "DIAS" is available at "TSN Website", therefore, access to "TSN Website" at "Support Information from NWBG/VDBG-AVC".

11 Maintenance

11.1. Cleaning Lens and LCD Panel

Do not touch the surface of lens and LCD Panel with your hand.

When cleaning the lens, use air-Blower to blow off the dust.

When cleaning the LCD Panel, dampen the lens cleaning paper with lens cleaner, and the gently wipe the their surface.

Note:

The Lens Cleaning KIT; VFK1900BK (Only supplied as 10 set/Box) is available as Service Aid.

12 Block Diagram

12.1. Overall Block Diagram

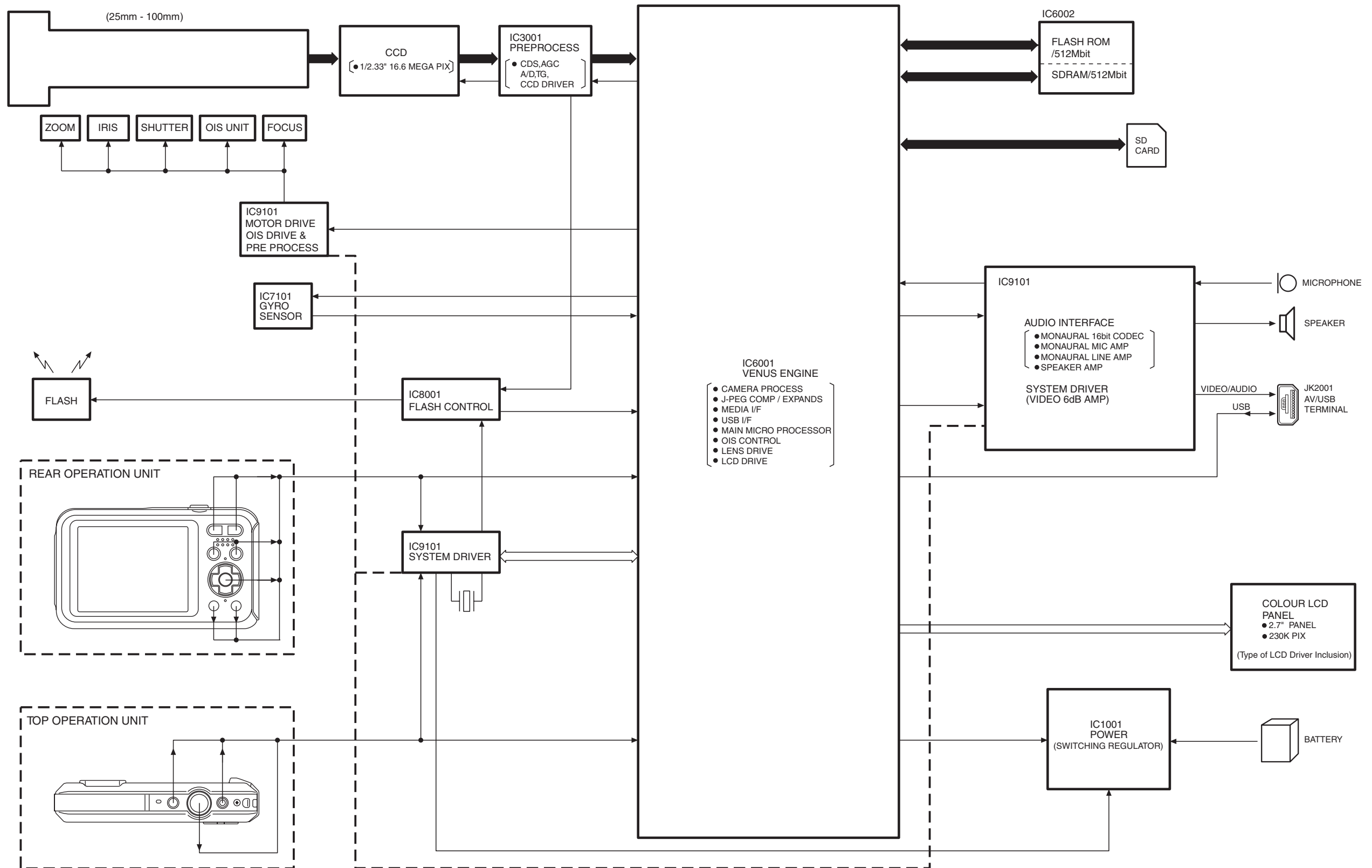

DMC-FT20/TS20 OVERALL BLOCK DIAGRAM

12.2. System Control Block Diagram

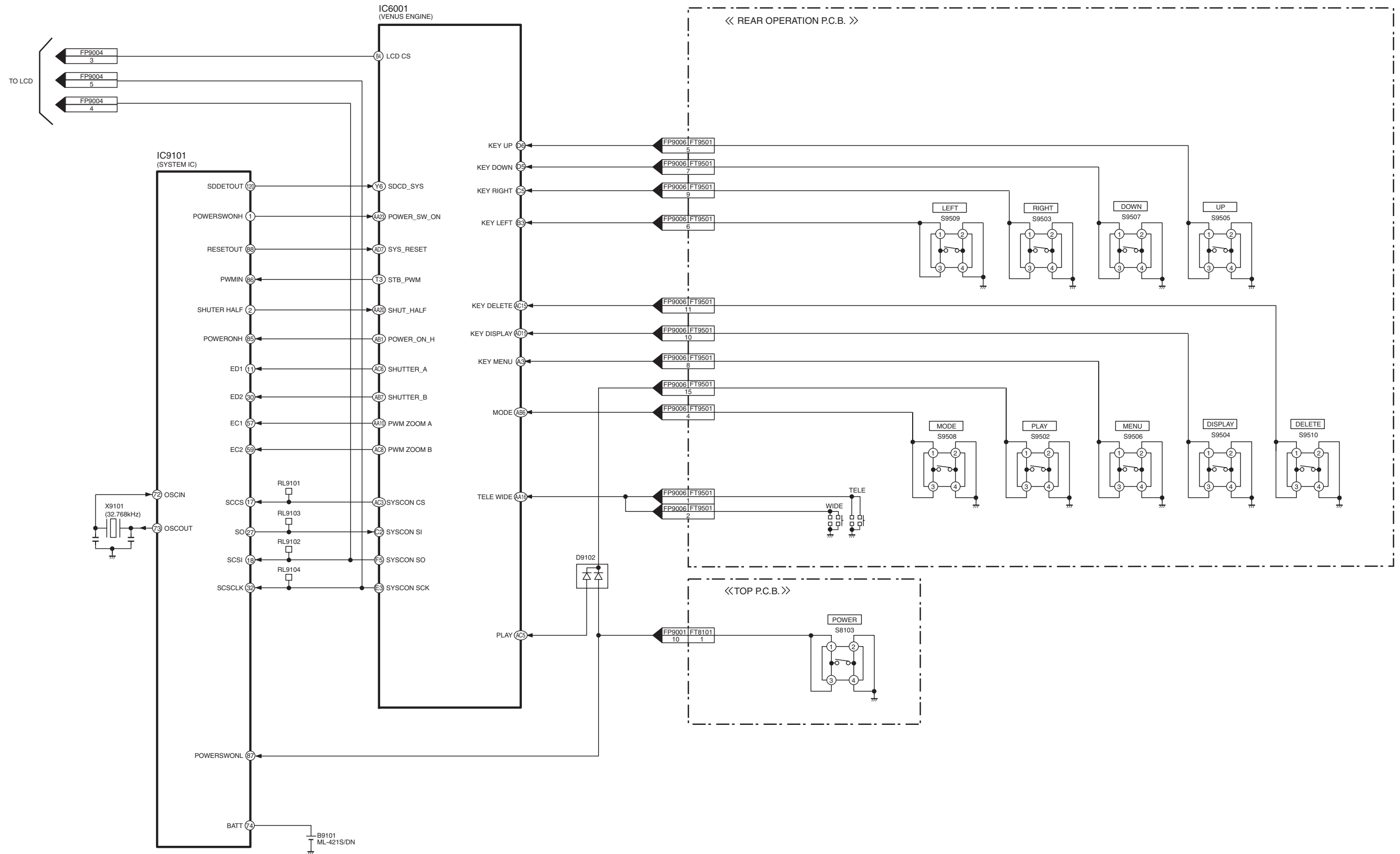

DMC-FT20/TS20 SYSTEM CONTROL BLOCK DIAGRAM

12.3. Video/Audio Signal Process Block Diagram

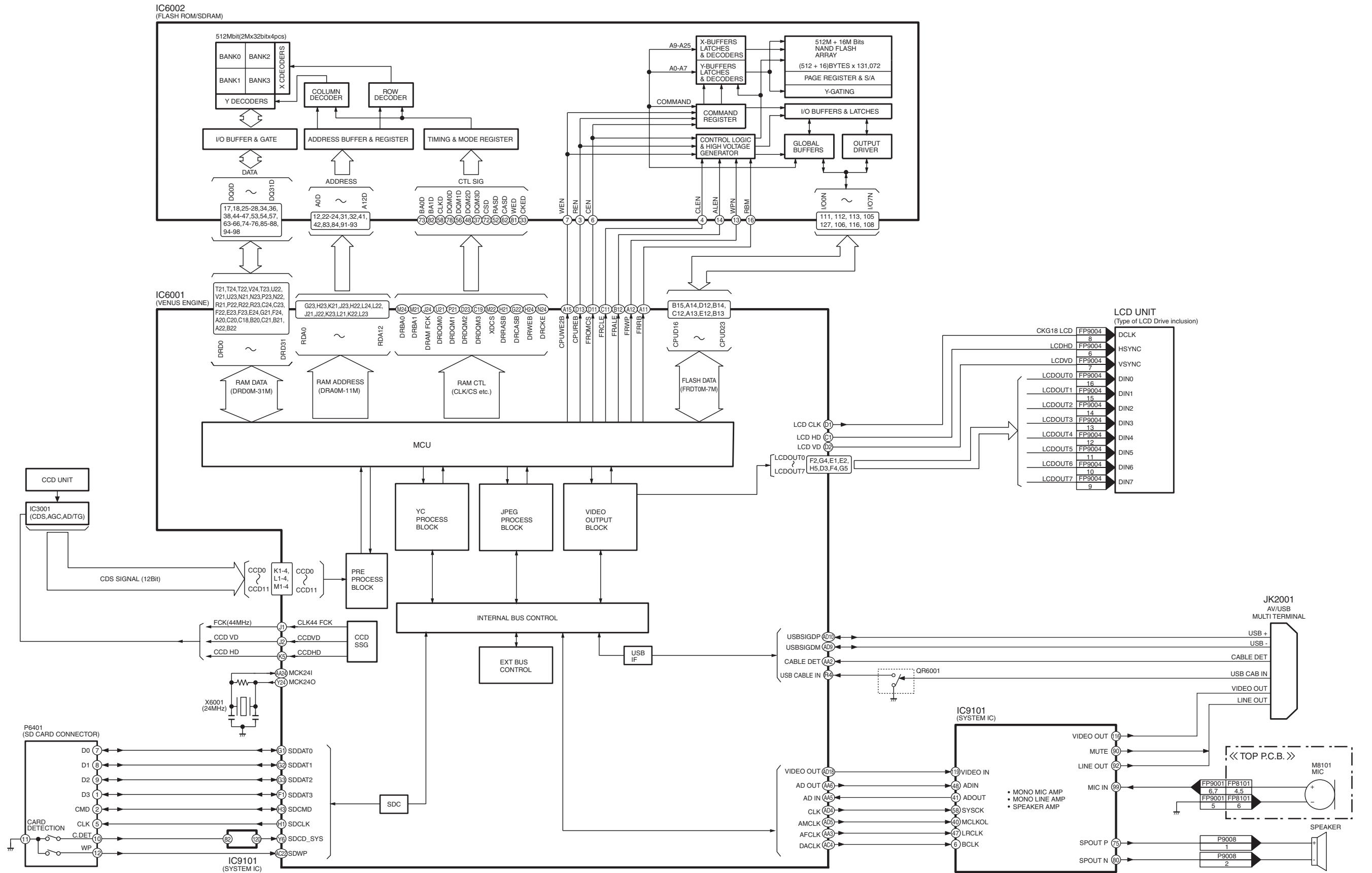

DMC-FT20/TS20 VIDEO/AUDIO PROCESS BLOCK DAIGRAM

12.4. Sensor Block Diagram

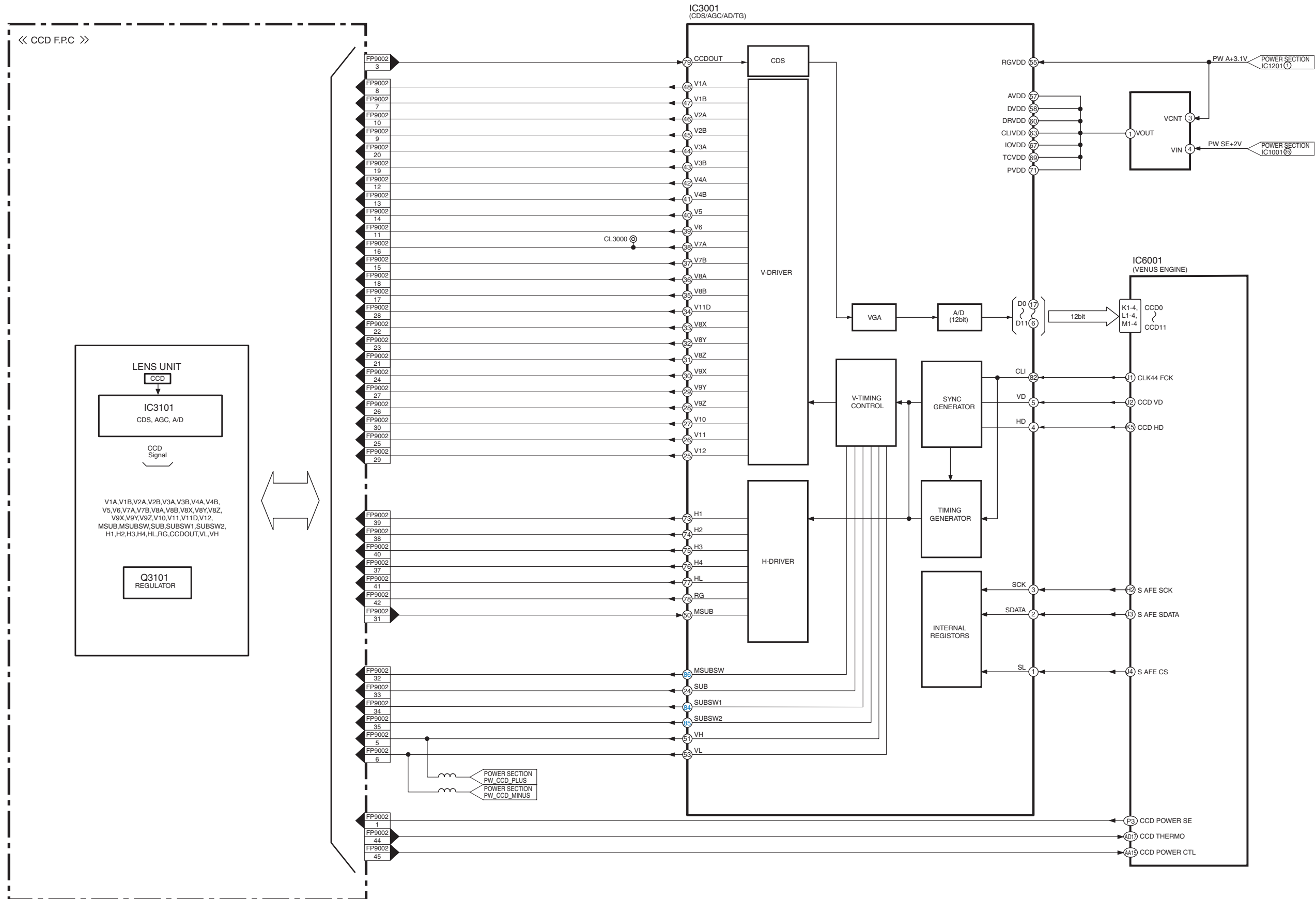

DMC-FT20/TS20 SENSOR BLOCK DIAGRAM

12.5. Lens Drive Block Diagram

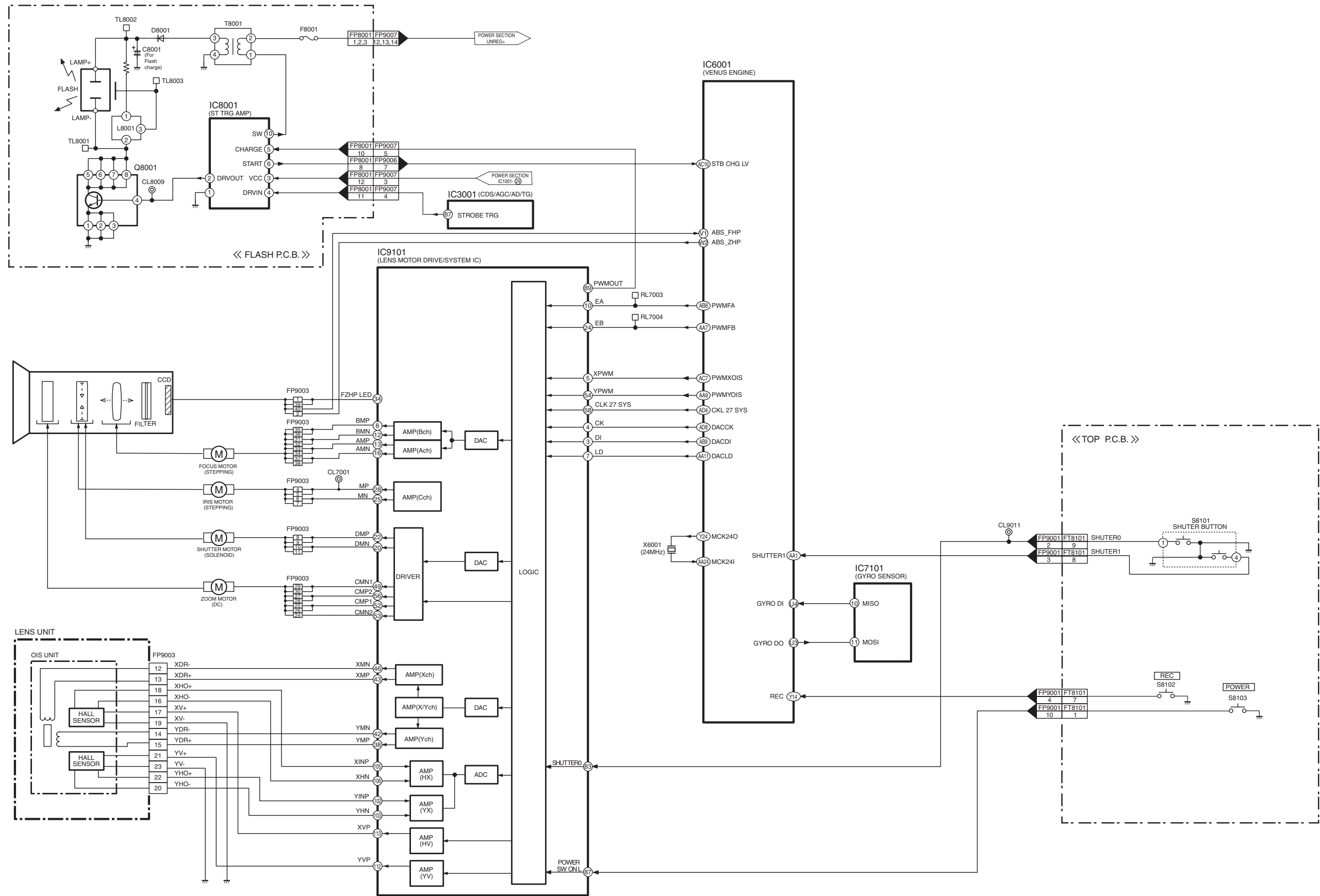

DMC-FT20/TS20 LENS DRIVE BLOCK DIAGRAM

12.6. Power Block Diagram

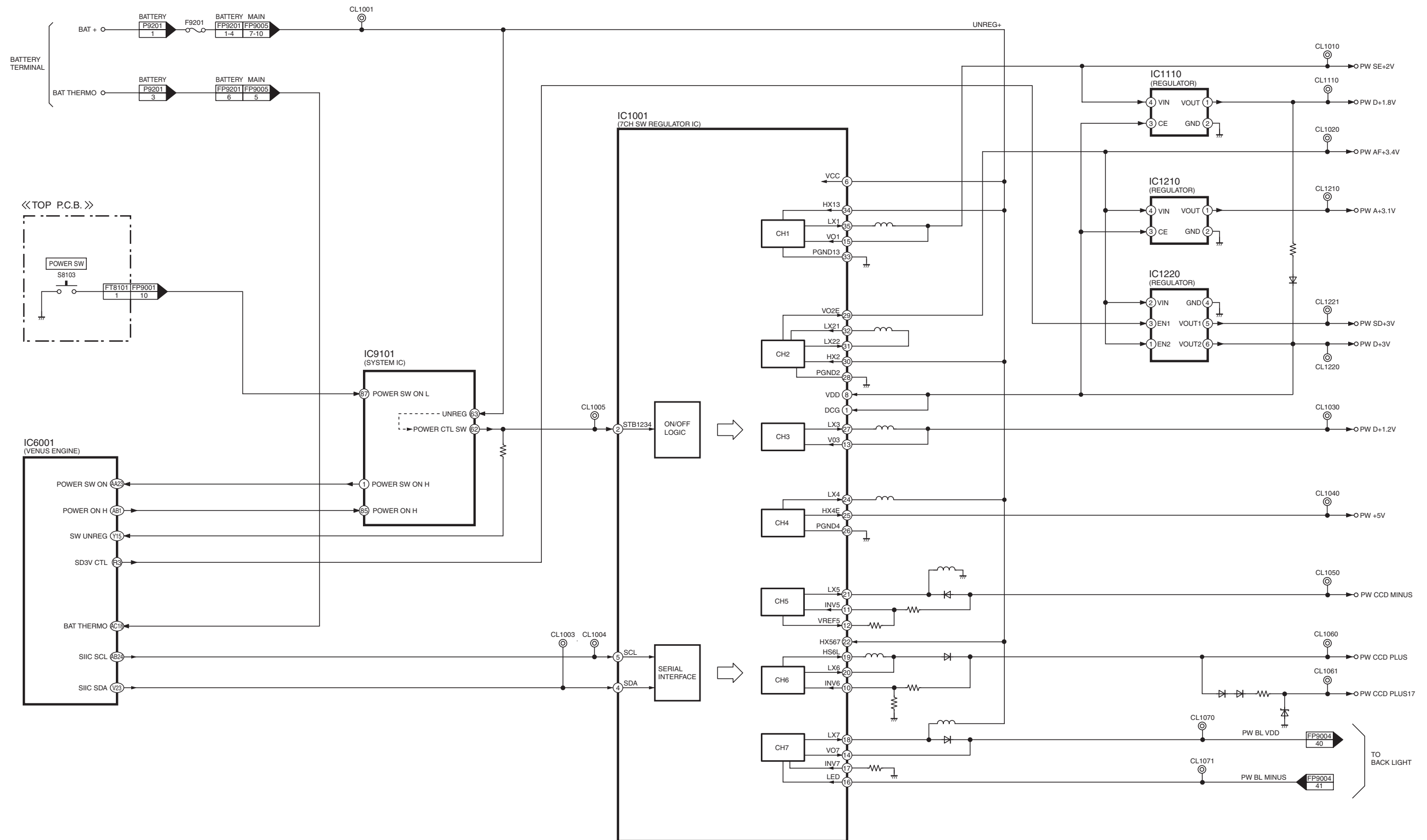

DMC-FT20/TS20 POWER BLOCK DIAGRAM

13 Wiring Connection Diagram

13.1. Interconnection Diagram

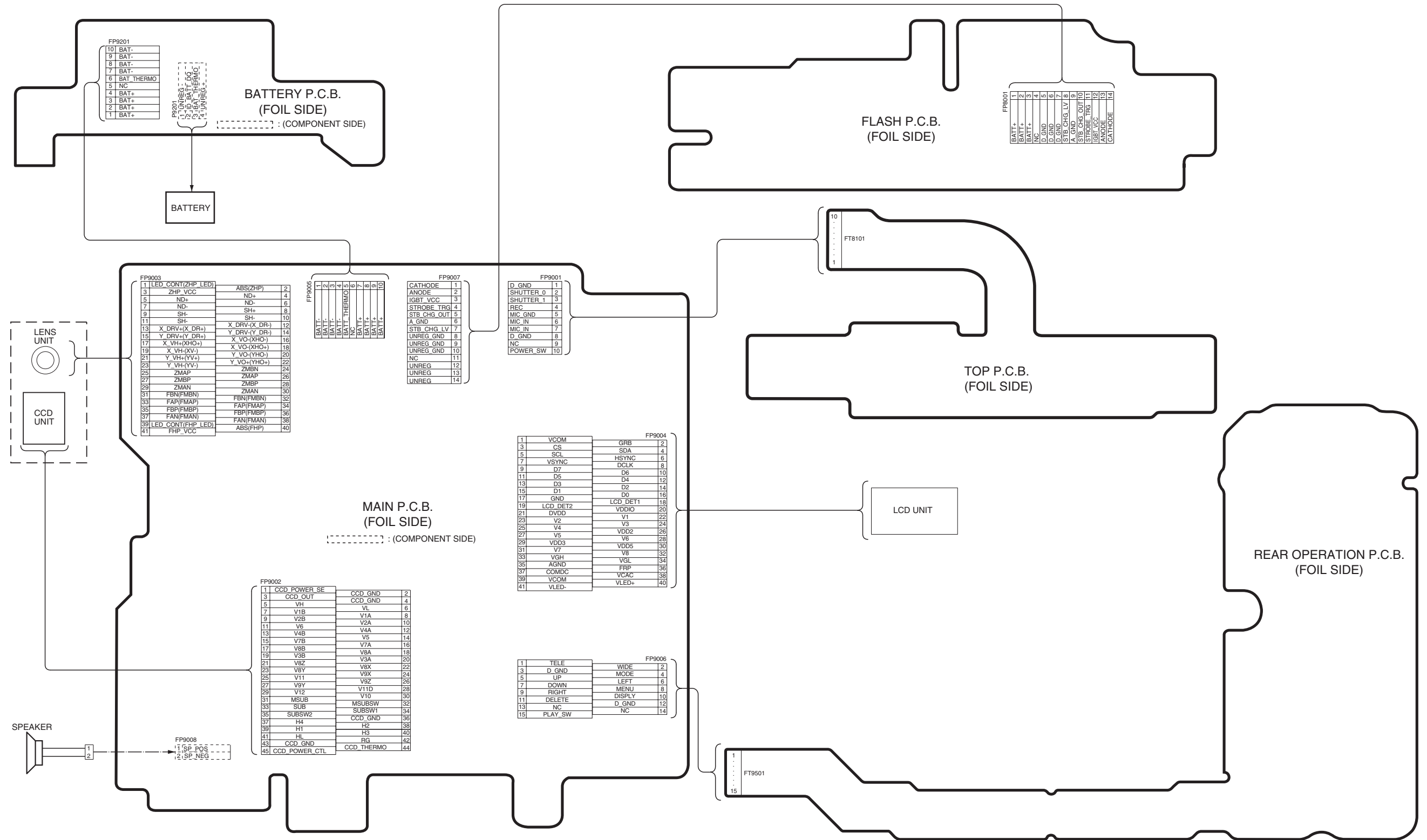

DMC-FT20/TS20
INTERCONNECTION
SCHEMATIC DIAGRAM

IMPORTANT SAFETY NOTICE:

COMPONENTS IDENTIFIED WITH THE MARK  HAVE THE SPECIAL CHARACTERISTICS FOR SAFETY. WHEN REPLACING ANY OF THESE COMPONENTS USE ONLY THE SAME TYPE.

1. Although reference number of the parts is indicated on the P.C.B. drawing and/or schematic diagrams, it is NOT mounted on the P.C.B. when it is displayed with "\$" mark.
2. It is only the "Test Round" and no terminal (Pin) is available on the P.C.B. when the TP (Test Point) indicated as "●" mark.
3. Use the parts number indicated on the Replacement Parts List .
4. Indication on Schematic diagrams:

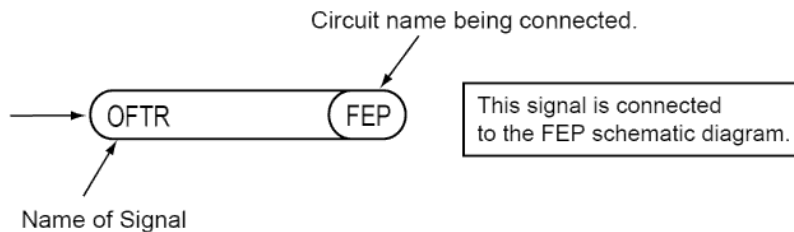

5. It might be taking time for display and/or access of the Schematic Diagrams & P. C. B having the heavy data volume.

Model No. : DMC-FT20/TS20 Parts List Note

- Note:
- * Be sure to make your orders of replacement parts according to this list.
 - IMPORTANT SAFETY NOTICE
Components identified with the mark \triangle have the special characteristics for safety.
When replacing any of these components, use only the same type.
 - Unless otherwise specified,
All resistors are in OHMS, K=1,000 OHMS. All capacitors are in MICRO-FARADS (uf), P=uuF.
 - The marking (RTL) indicates the retention time is limited for this item. After the discontinuation of this assembly in production, it will no longer be available.
 - Supply of CD-ROM, in accordance with license protection, is allowable as replacement parts only for customers who accidentally damaged or lost their own.

E.S.D. standards for Electrostatically Sensitive Devices, refer to "PREVENTION OF ELECTROSTATIC DISCHARGE (ESD) TO ELECTROSTATICALLY SENSITIVE (ES) DEVICES" section.

Definition of Parts supplier:

- Parts marked with [ENERGY] in the remarks column are supplied from Panasonic Corporation Energy Company.
- Parts marked with [SPC] in the remarks column are supplied from AVC-CSC-SPC. Others are supplied from PAVCX.

POWER (Main P.C.B.)

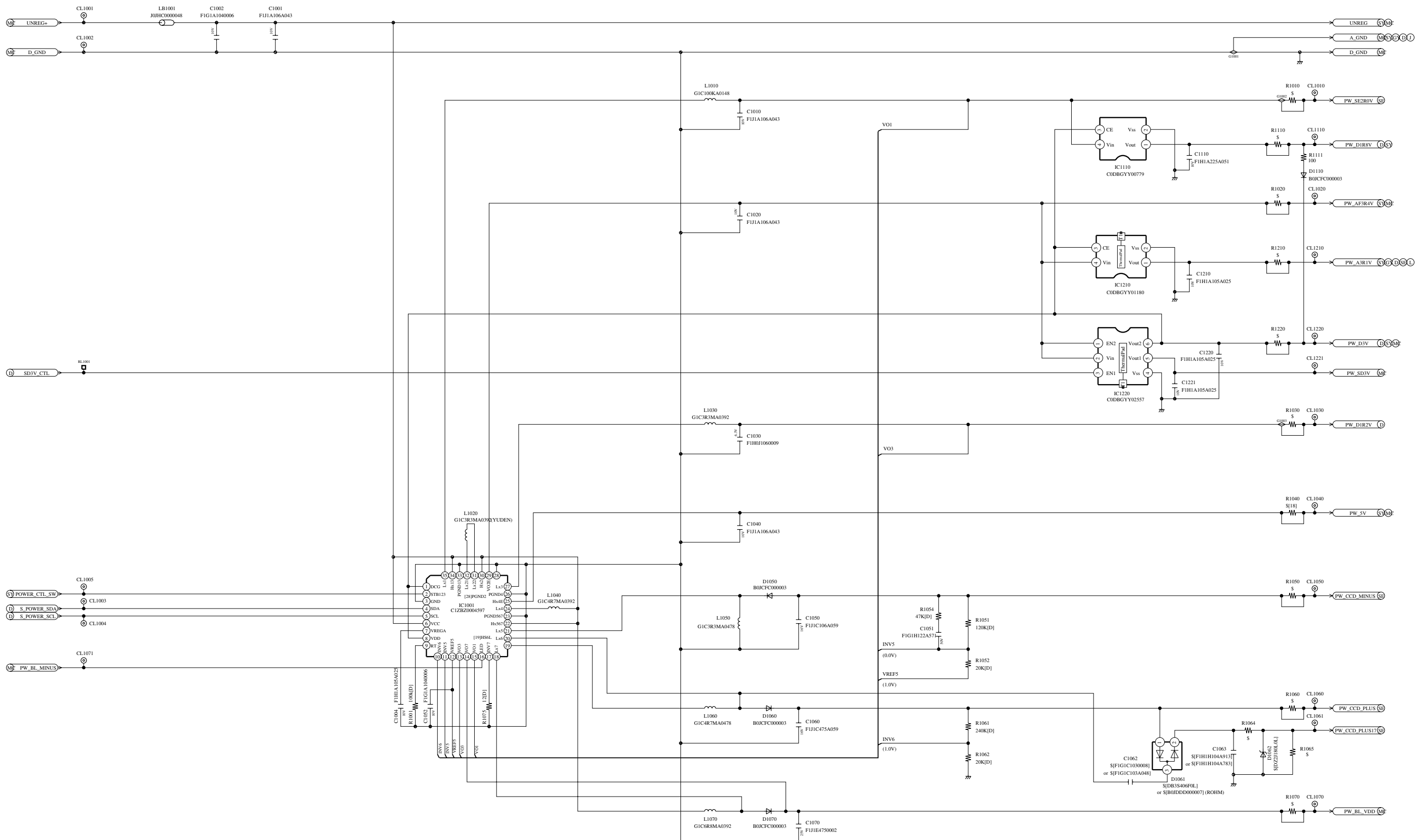

JACK (Main P.C.B.)

CAUTION: FOR CONTINUED PROTECTION AGAINST FIRE HAZARD,
REPLACE ONLY WITH THE SAME TYPE 1.5A 32V FUSE.
ATTENTION: POUR UNE PROTECTION CONTINUE LES RISQUES
D' INCENDIE N' UTILISER QUE DES FUSIBLE DE MÊME TYPE 1.5A 32V.

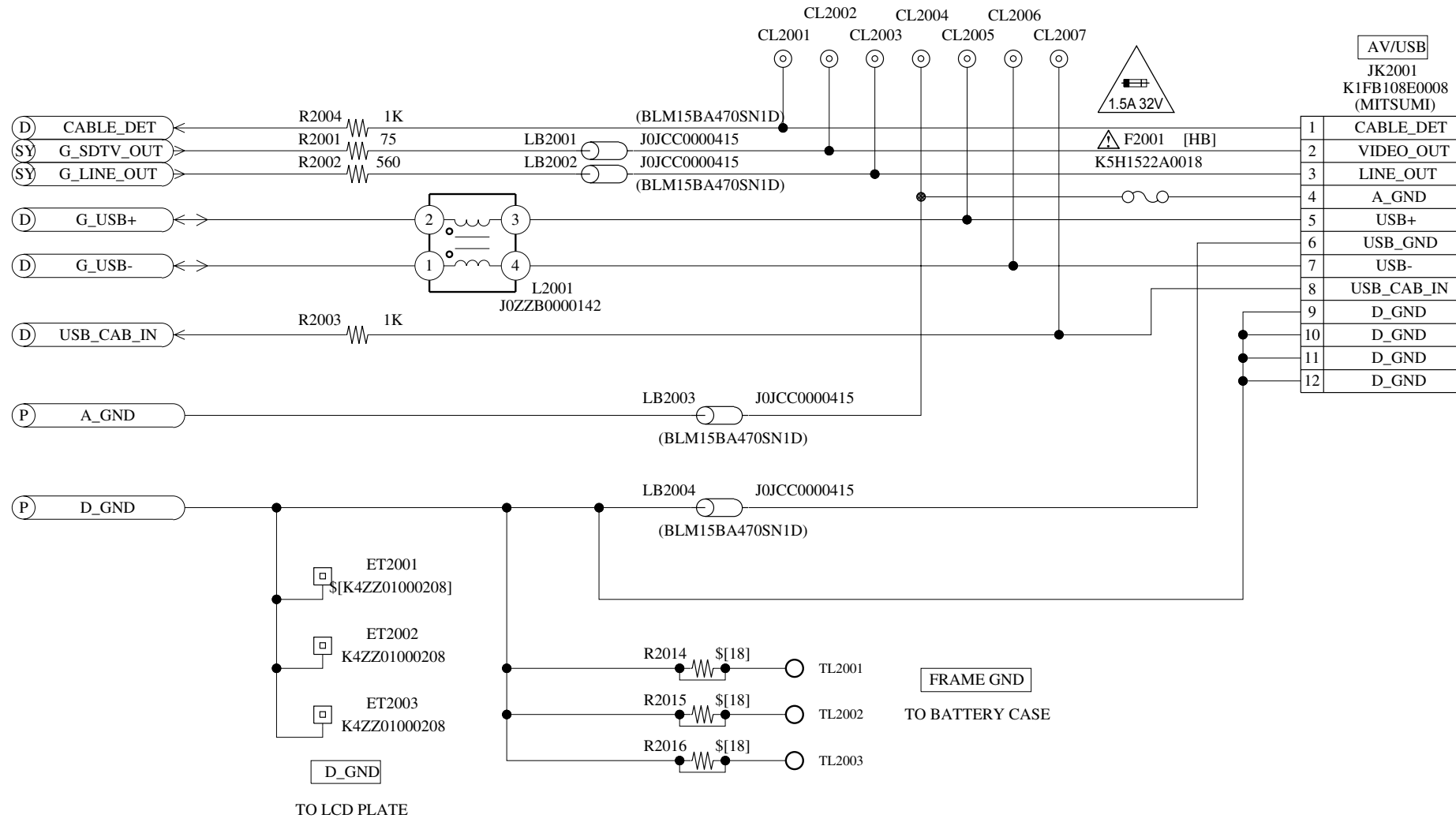

A

B

C

D

E

F

G

H

A3

SENSOR (Main P.C.B.)

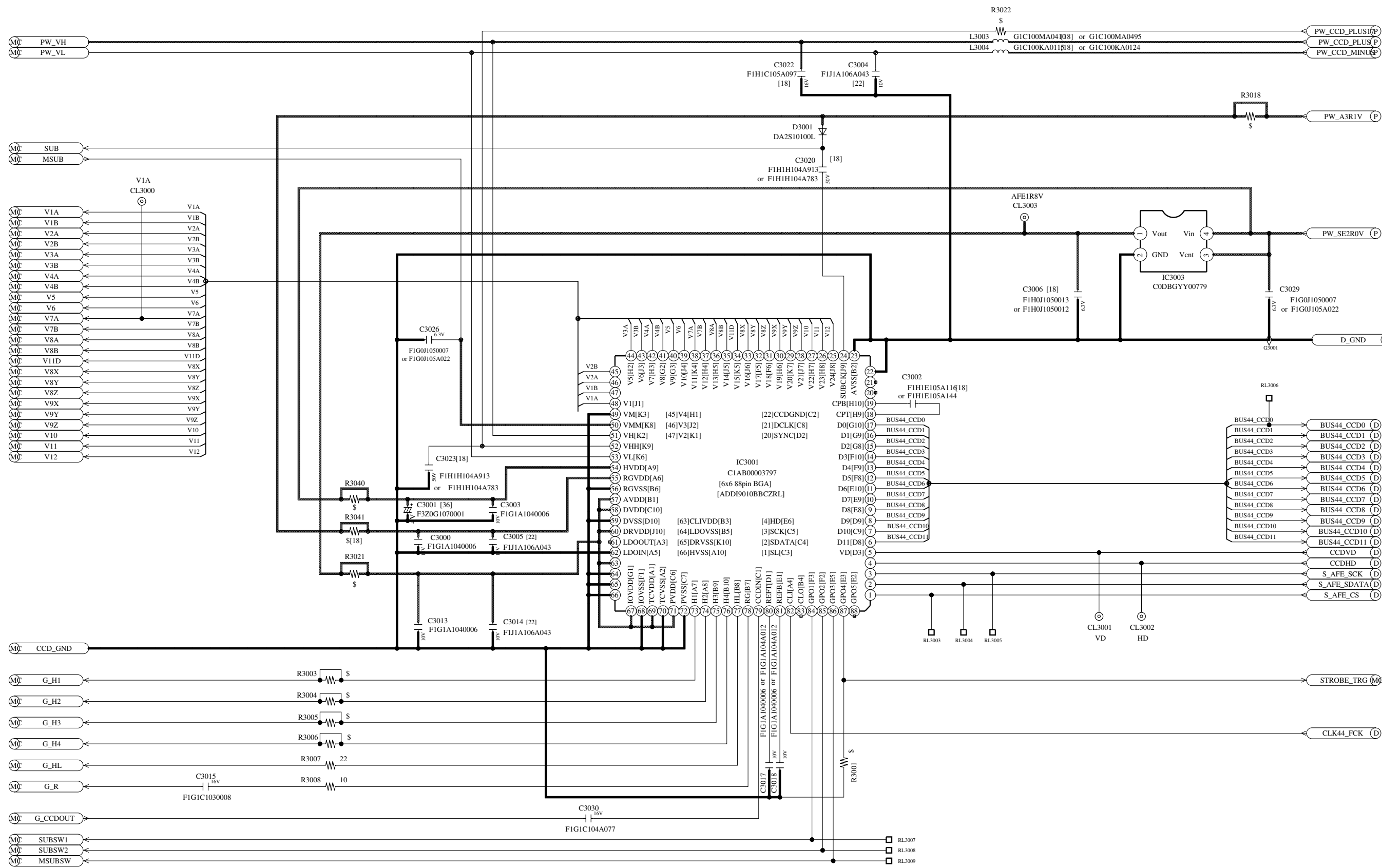

1
2
3
4
5
6
7
8

A

B

C

D

E

F

LCD (Main P.C.B.)

1

1

2

2

3

3

4

4

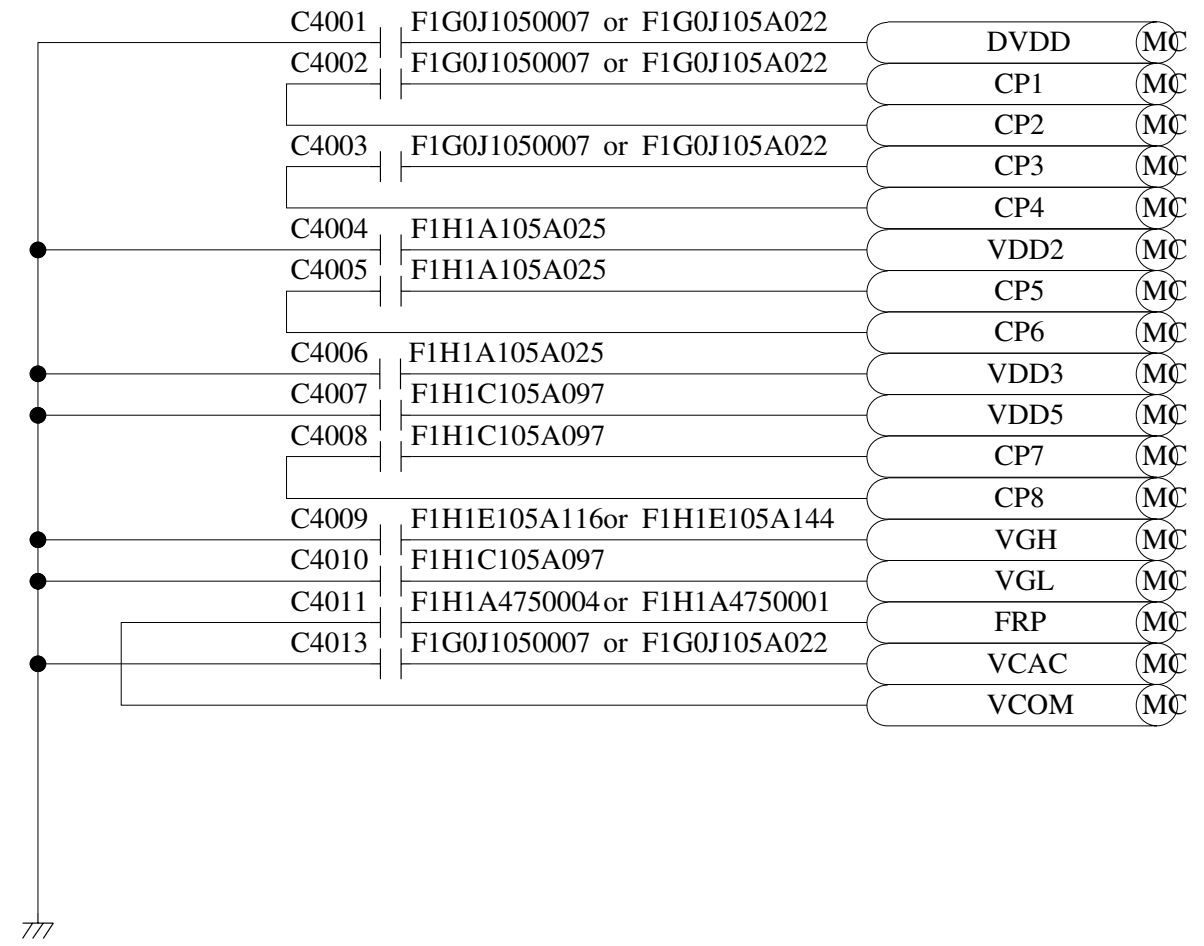

A

B

C

D

E

F

A4

DIGITAL (Main P.C.B.)

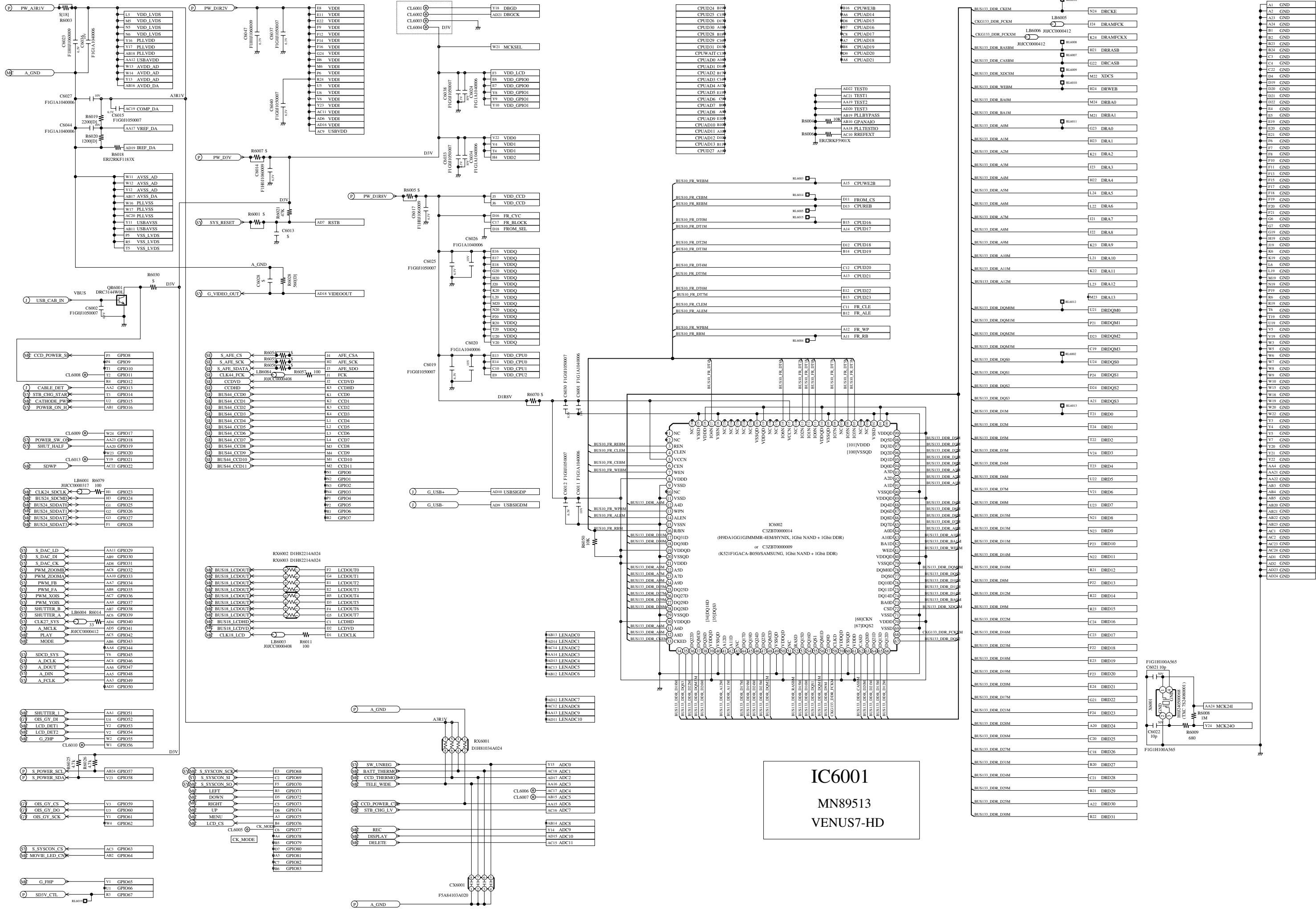

IC6001
MN89513
VENUS7-HD

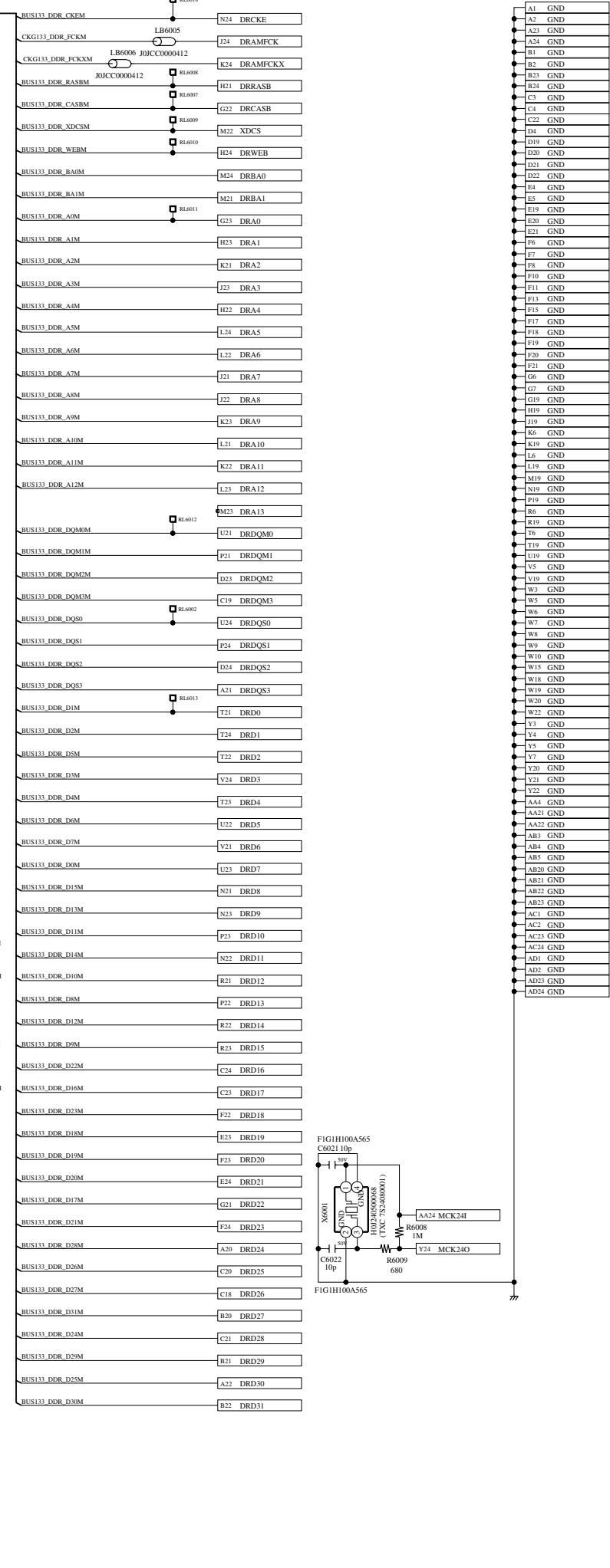
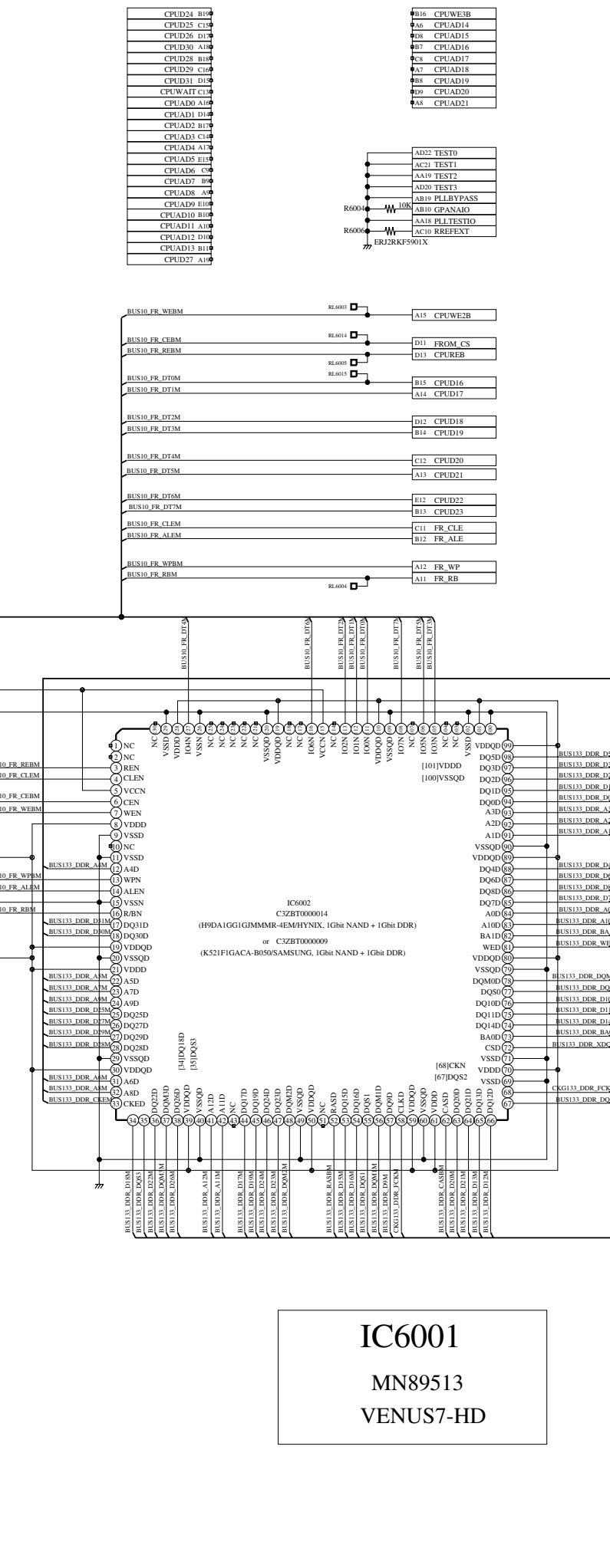
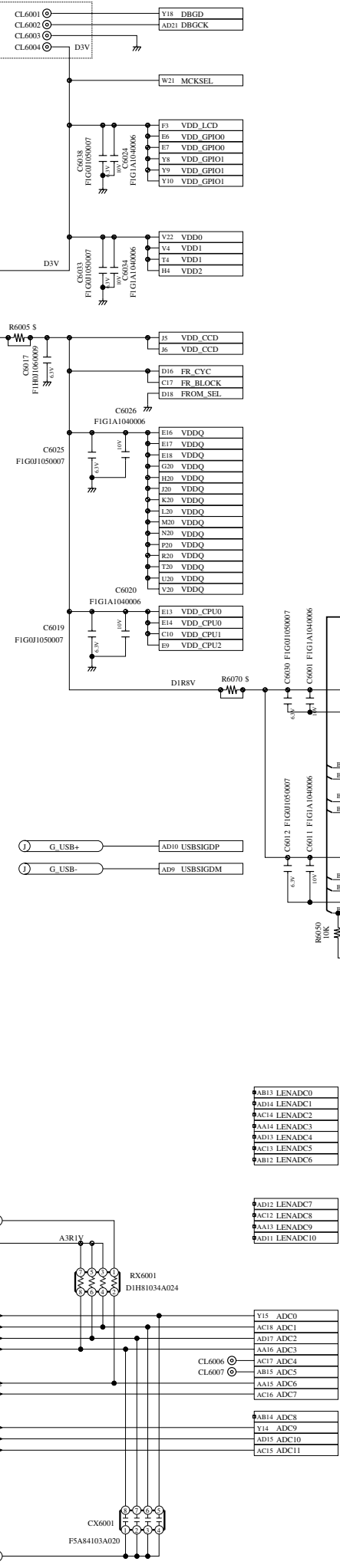
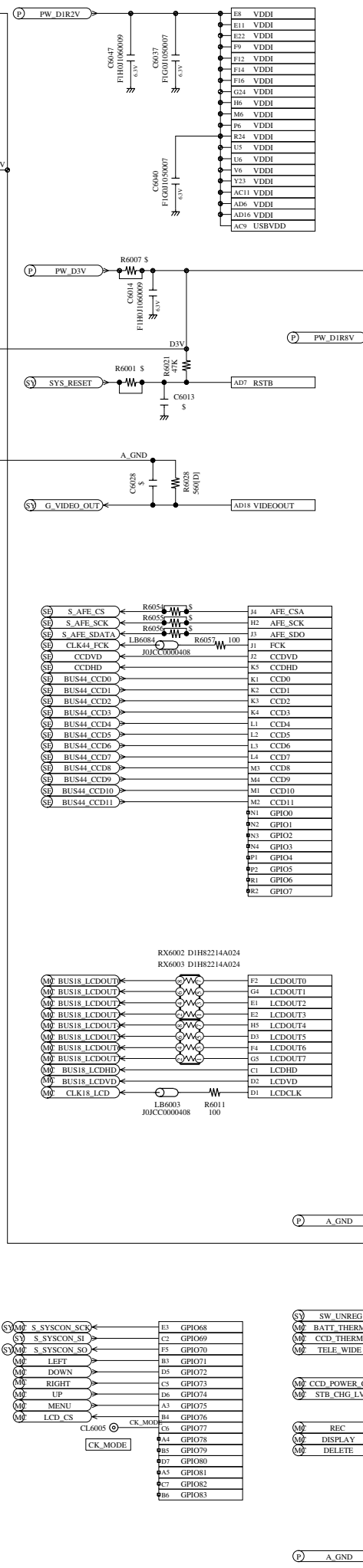
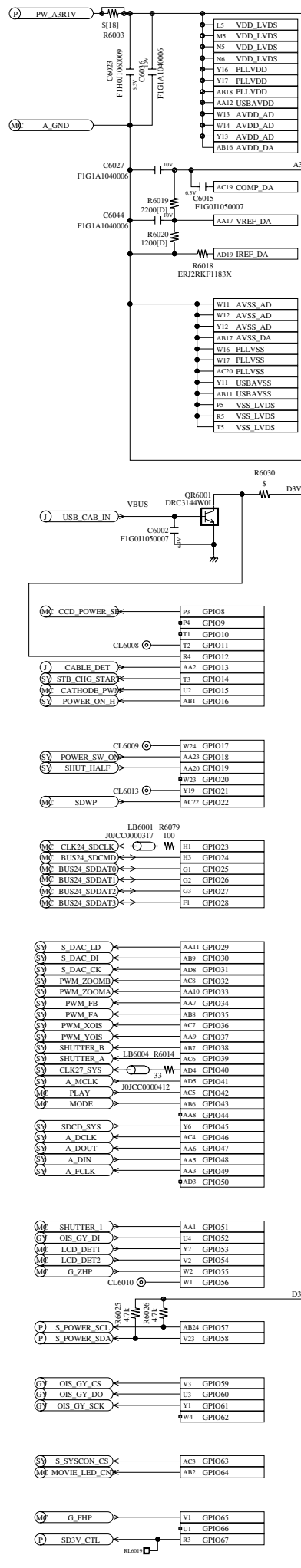

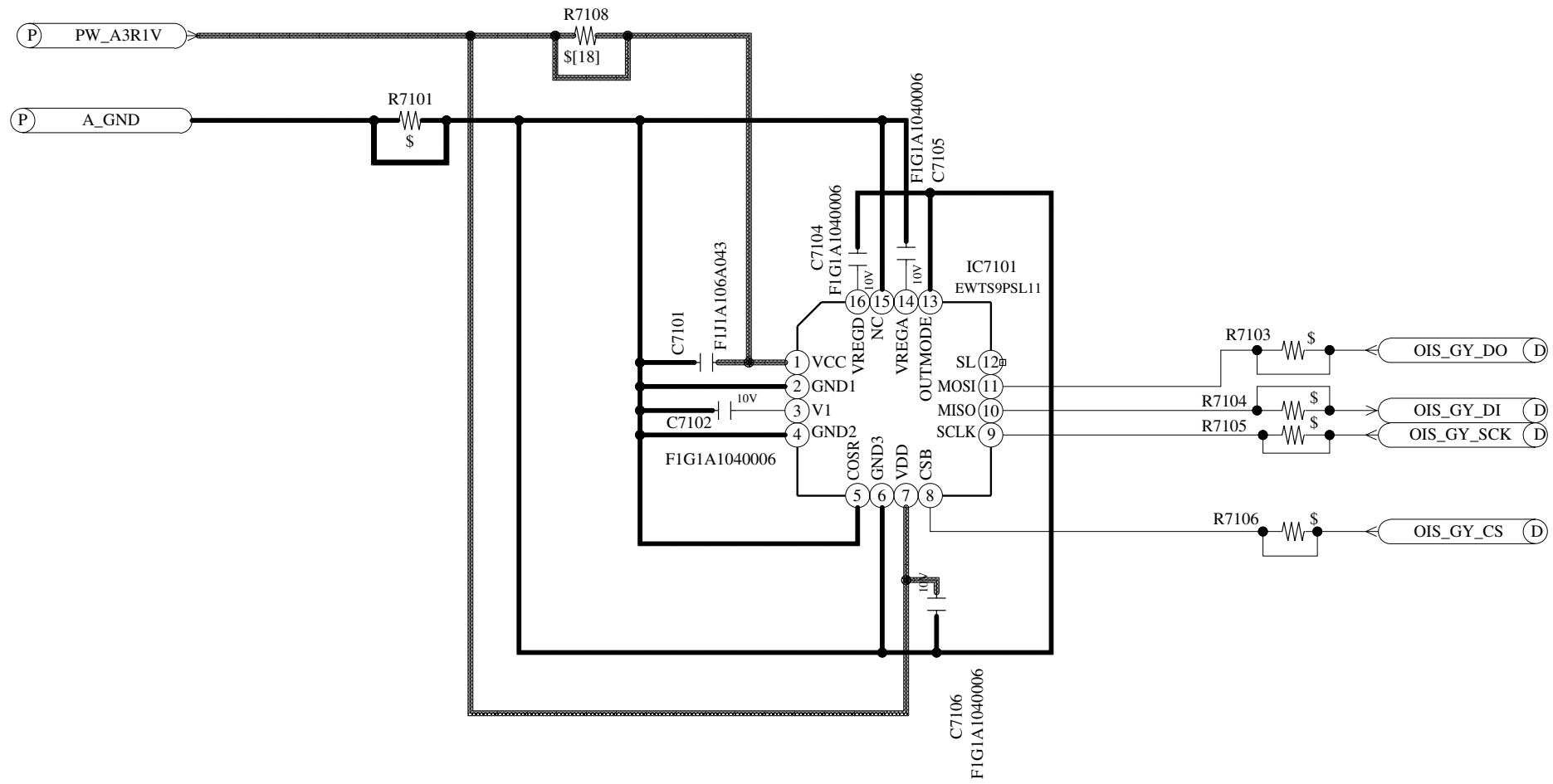

SYSTEM DRIVER (Main P.C.B.)

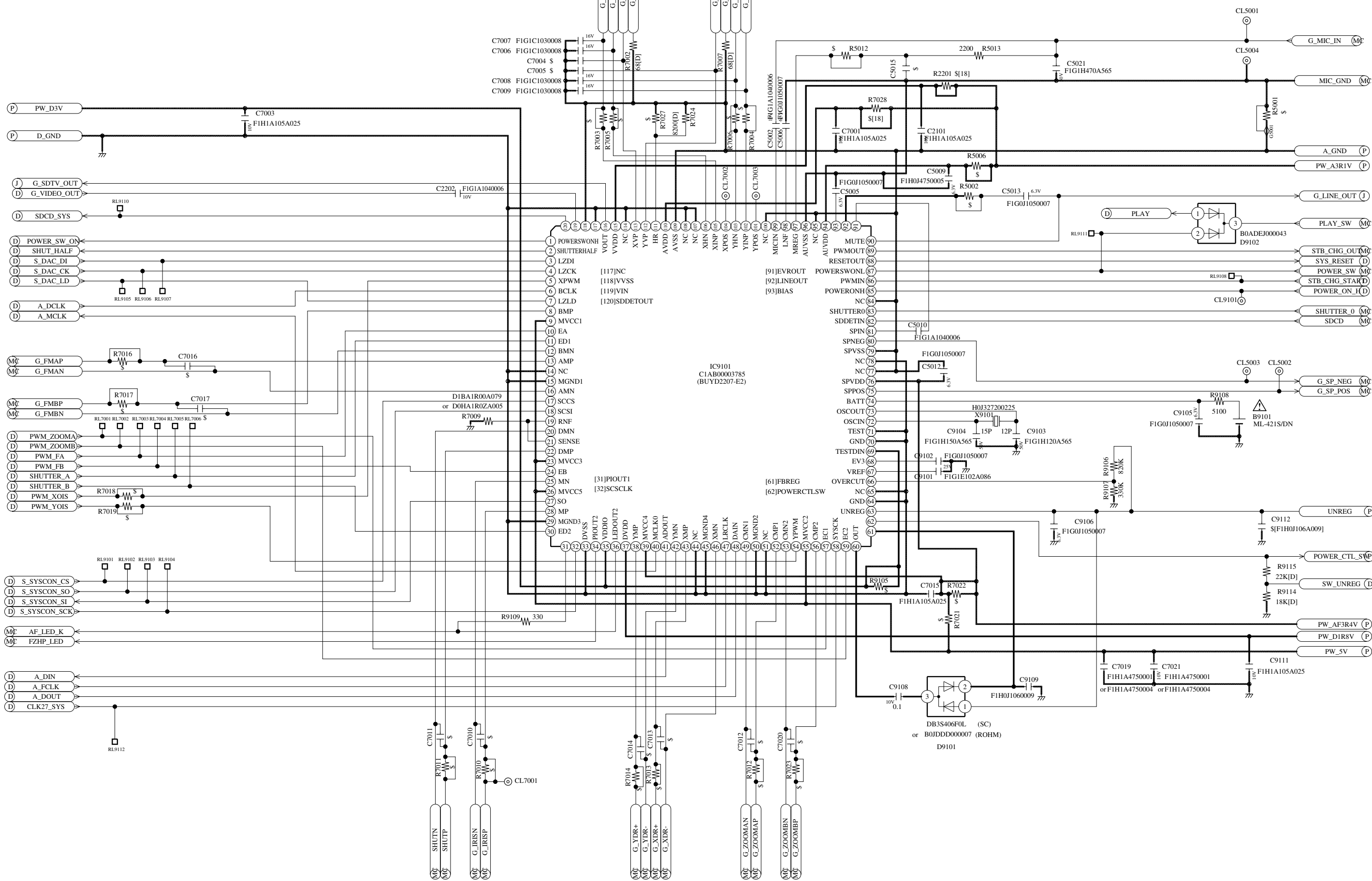

MAIN CN (Main P.C.B.)

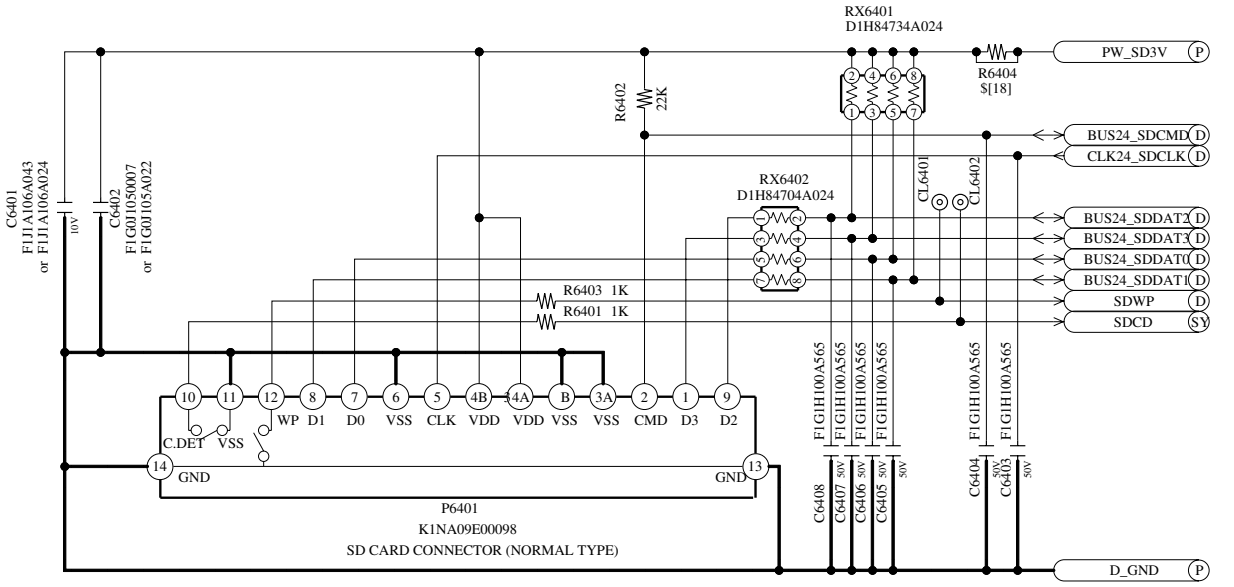
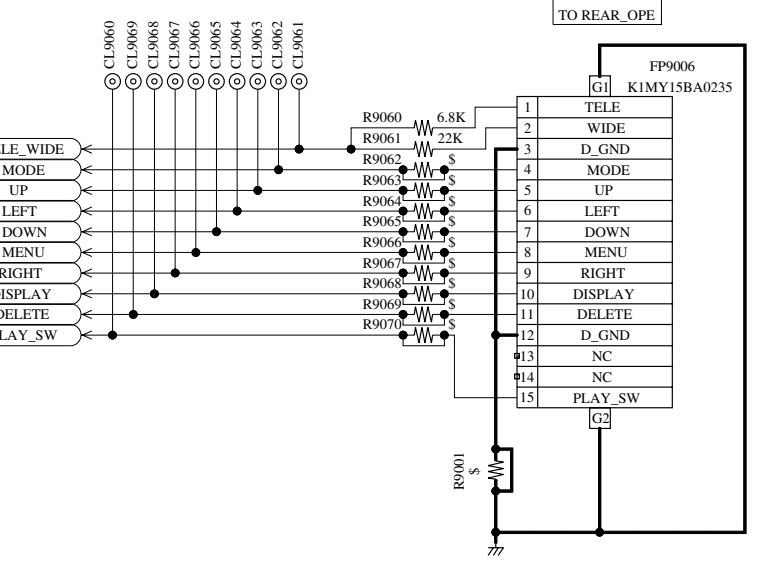
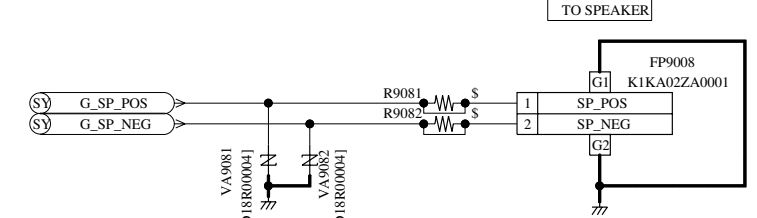
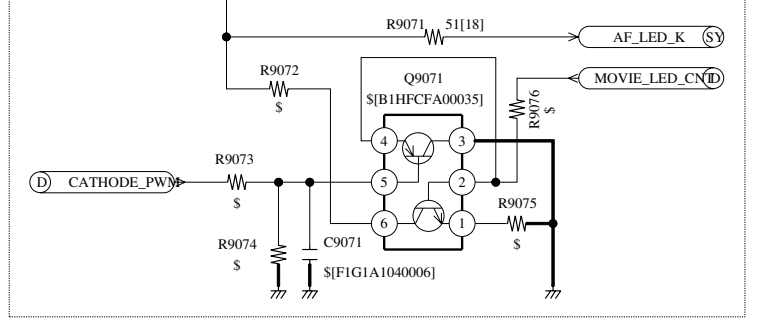
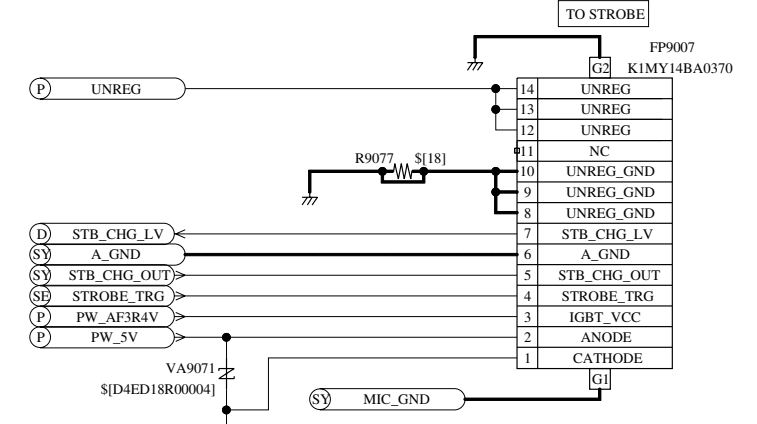
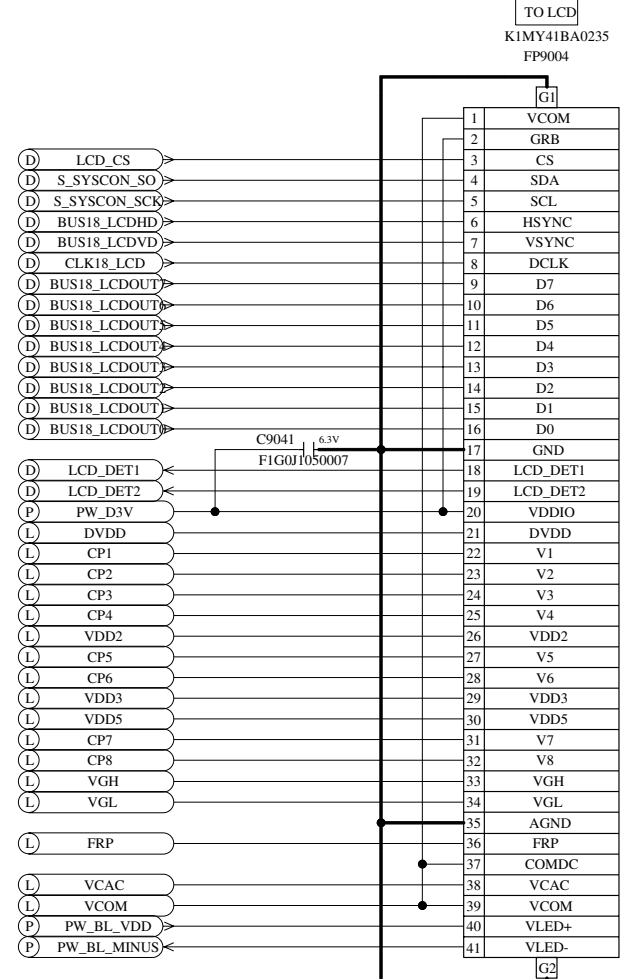
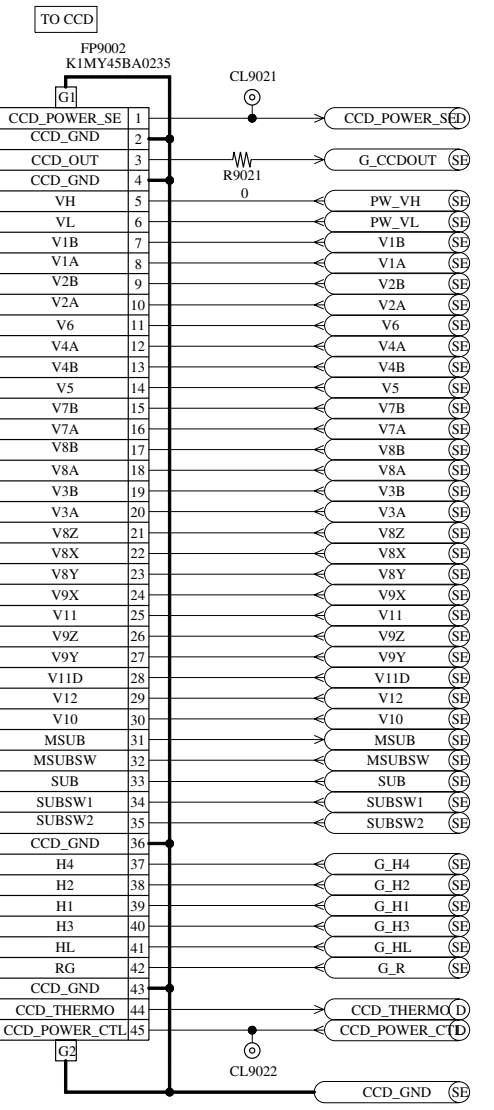
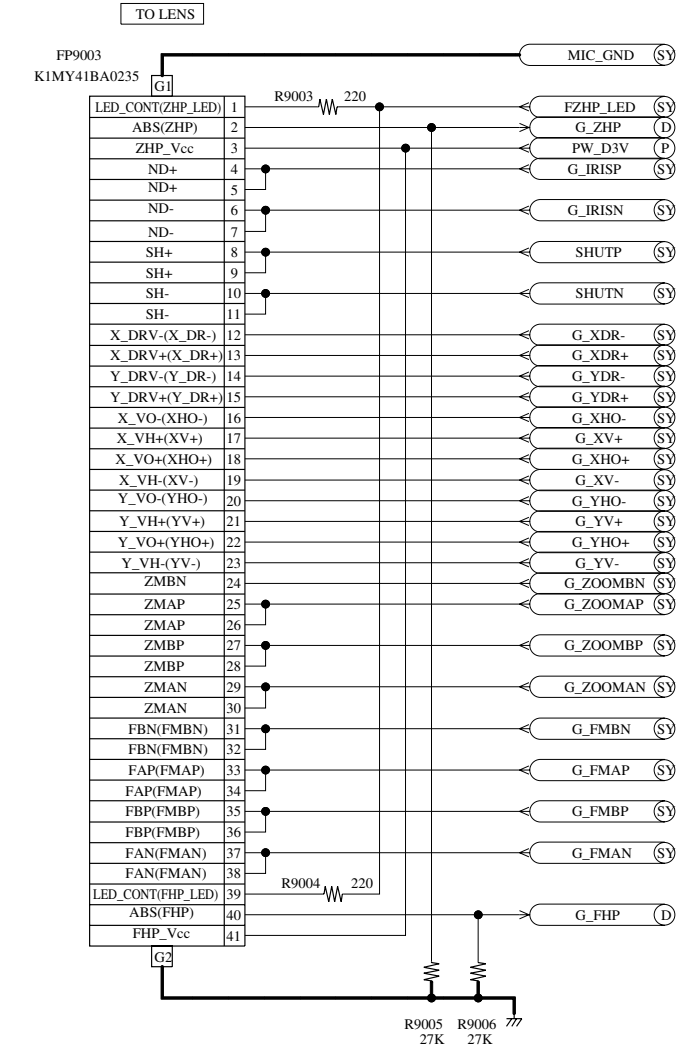
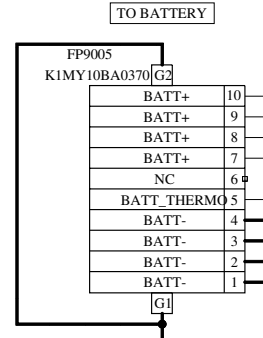
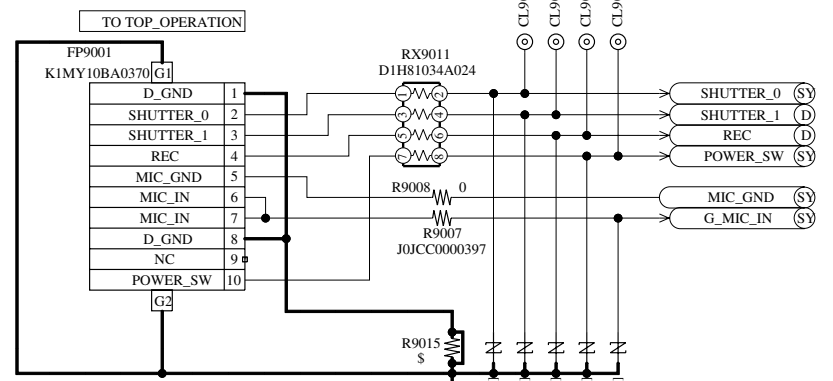

REAR OPERATION (Rear Operation P.C.B.)

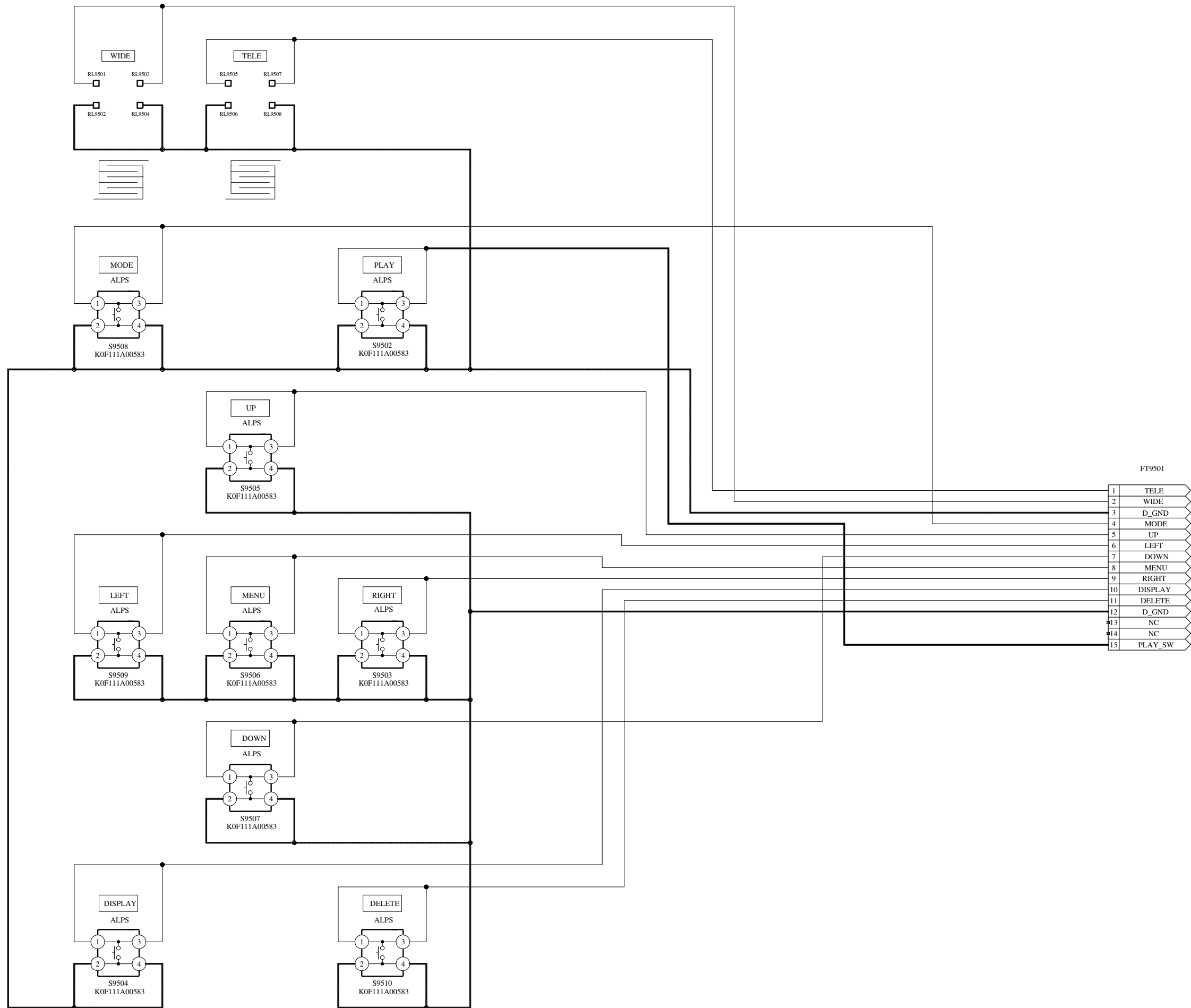

FT9501
TO MAIN PCB
0.3 PITCH CONNECTOR
KIMY15BA0255

CAUTION: FOR CONTINUED PROTECTION AGAINST FIRE HAZARD, REPLACE ONLY WITH THE SAME TYPE 1.25A 32V FUSE.
 ATTENTION: POUR UNE PROTECTION CONTINUE LES RISQUES D'INCENDIE N'UTILISER QUE DES FUSIBLES DE MÊME TYPE 1.25A 32V.

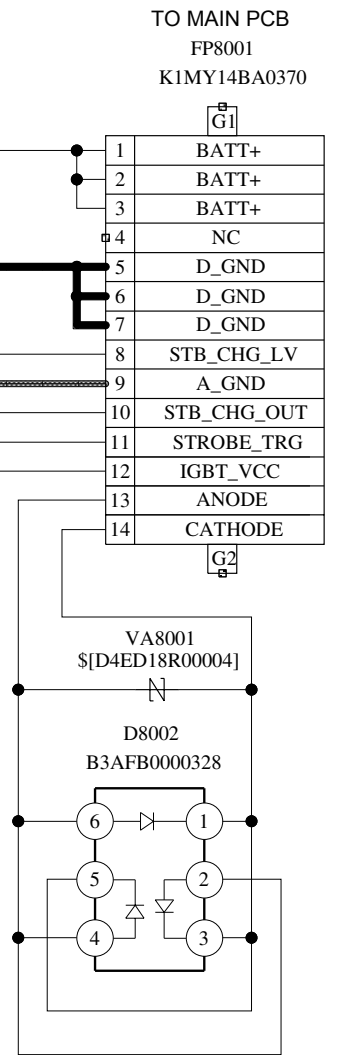
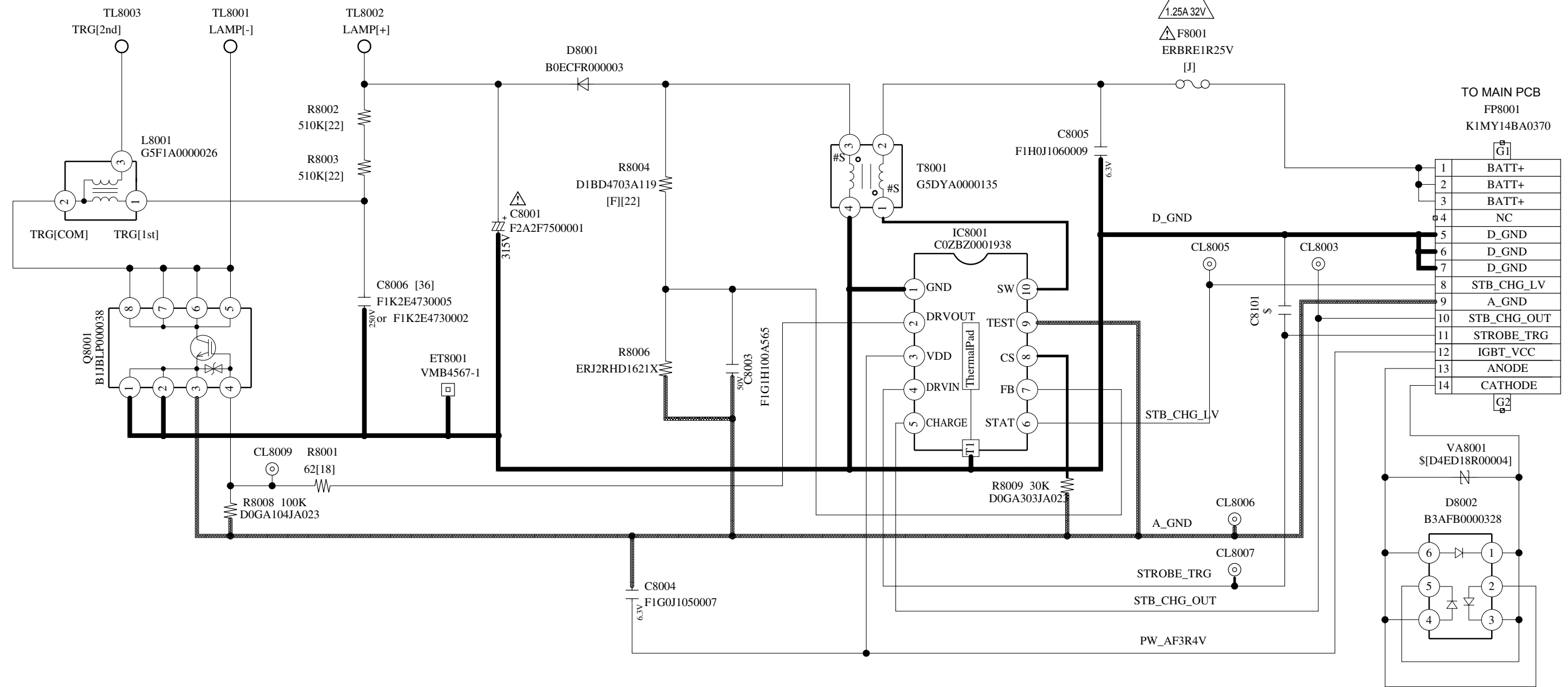

BATTERY (Battery P.C.B.)

CAUTION: FOR CONTINUED PROTECTION AGAINST FIRE HAZARD,
REPLACE ONLY WITH THE SAME TYPE 2.0A 32V FUSE.
ATTENTION: POUR UNE PROTECTION CONTINUE LES RISQUES
D'INCENDIE N'UTILISER QUE DES FUSIBLE DE MÊME TYPE 2.0A 32V.

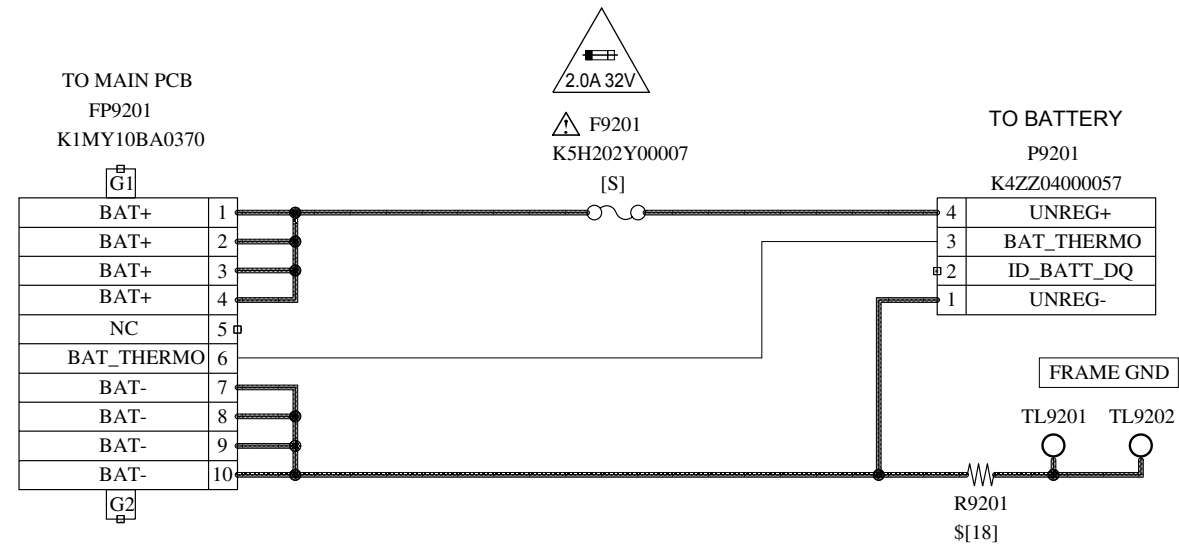

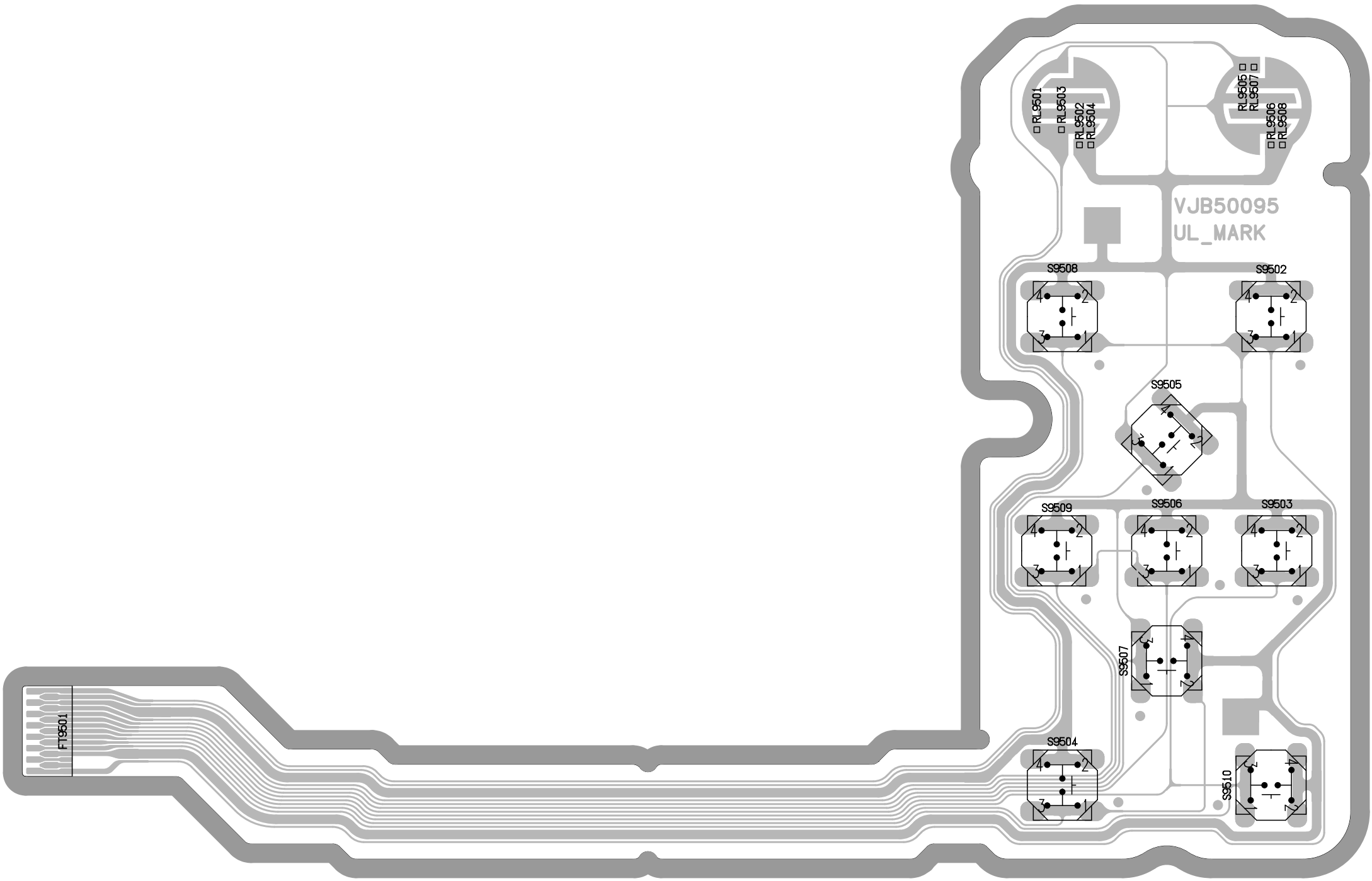

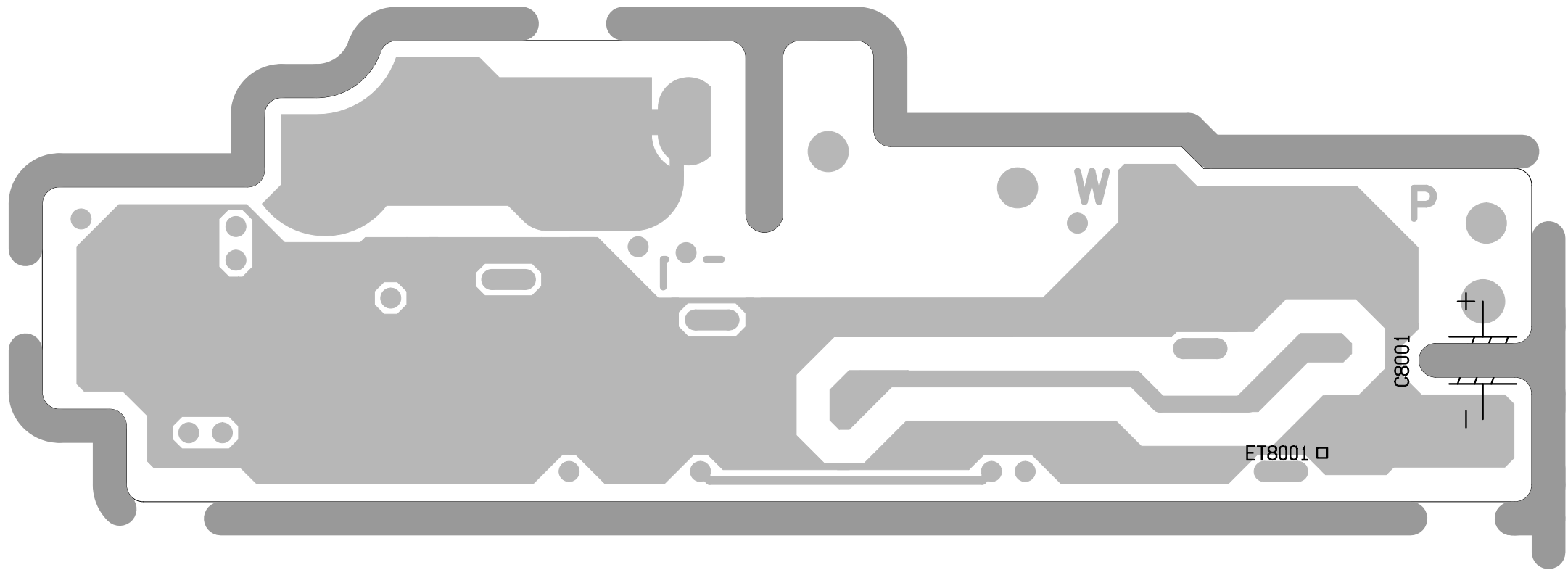

W

P

C8001

ET8001 □

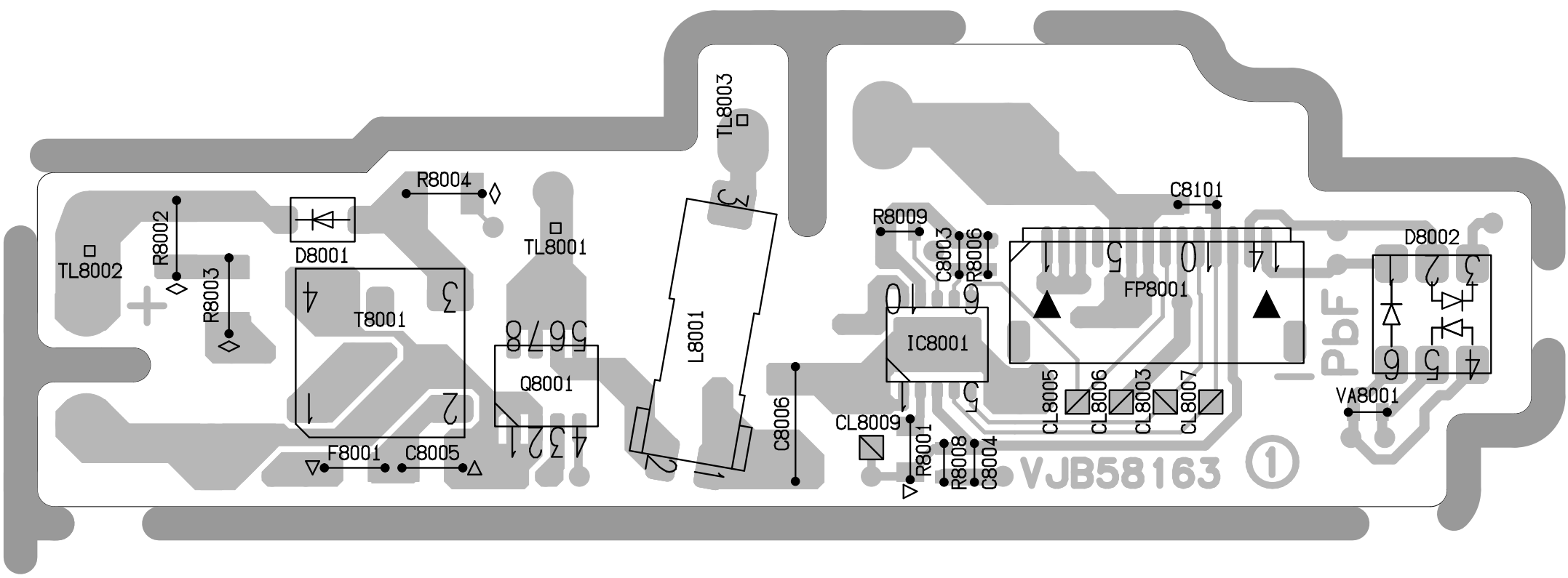

TL8002

R8002

R8003

D8001

T8001

F8001

R8004

TL8001

Q8001
5678
1080

L8001

TL8003

C8006

CL8009

R8009

C8003

R8001

R8008

C8004

IC8001

CL8005

CL8006

CL8003

CL8007

FP8001

C8101

VA8001

D8002

VJB58163

①

PbF

VEP51030

P9201

F9201

4

3

2

1

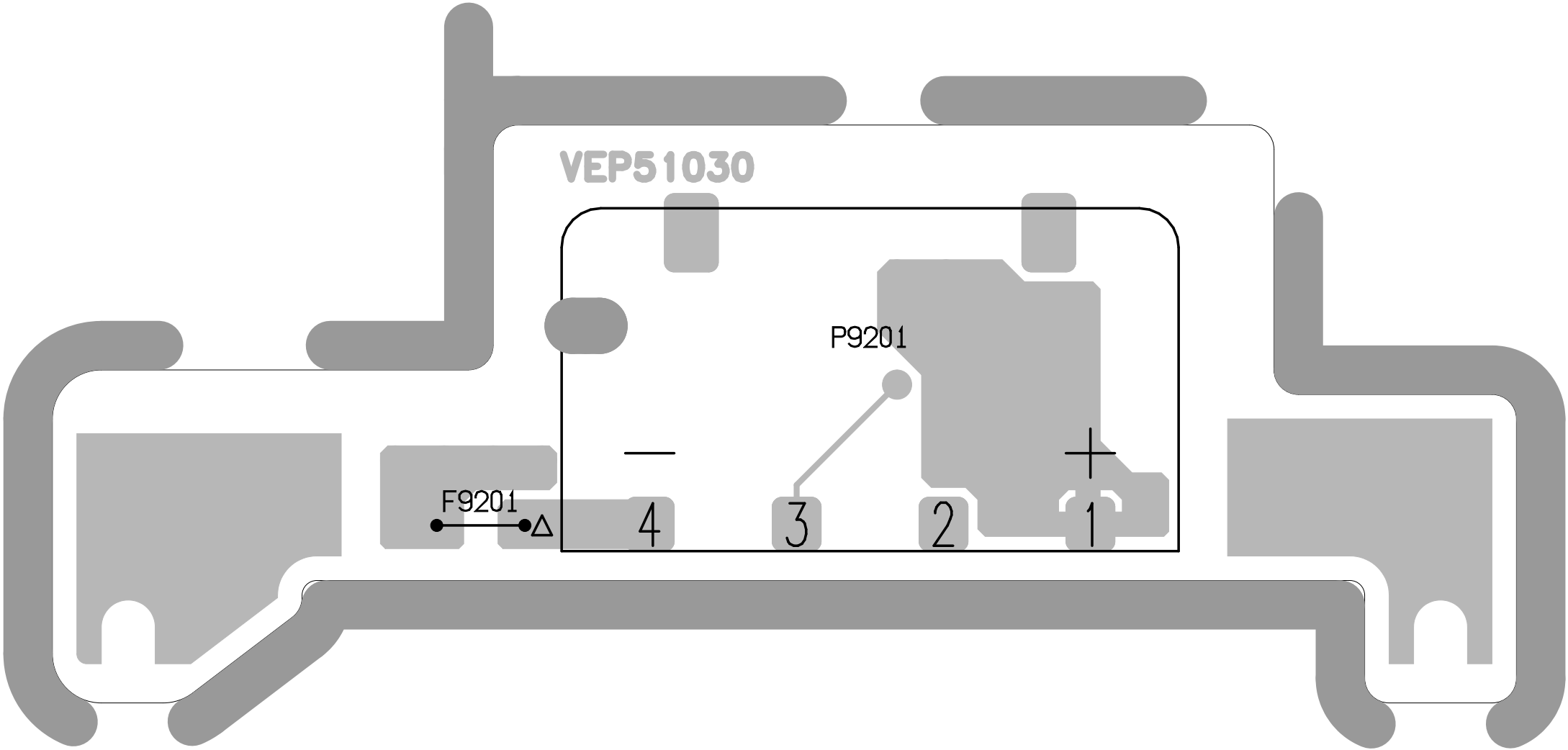

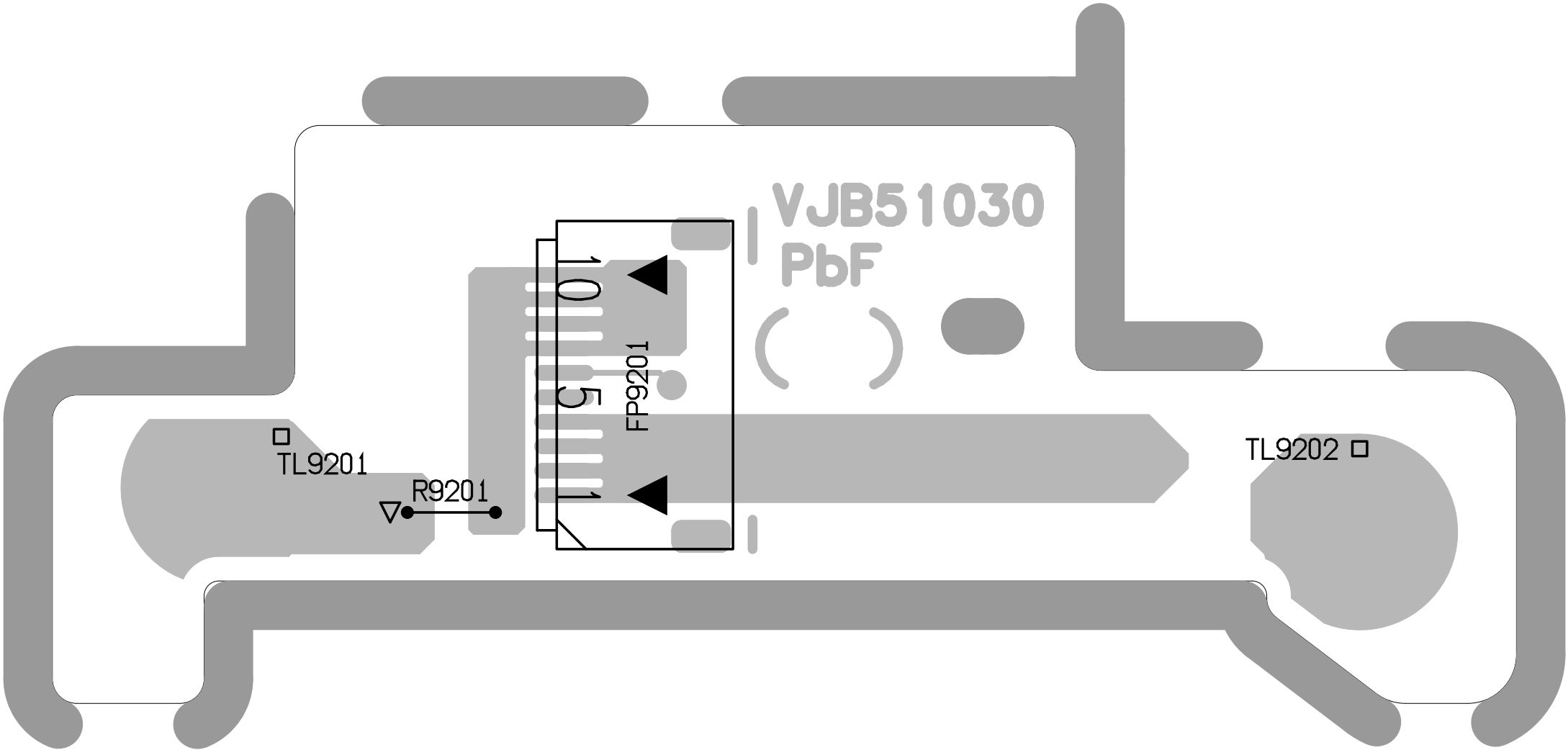

VJB51030
PbF

FP9201

TL9201

R9201

TL9202

Model No. : DMC-FT20/TS20 Parts List

Safety	Ref. No.	Part No.	Part Name & Description	Q'ty	Remarks
	C1001	FIJ1A106A043	C.CAPACITOR CH 10V 10U	1	
	C1002	FIG1A1040006	C.CAPACITOR CH 10V 0.1U	1	
	C1004	FIH1A105A025	C.CAPACITOR CH 10V 1U	1	
	C1010	FIJ1A106A043	C.CAPACITOR CH 10V 10U	1	
	C1020	FIJ1A106A043	C.CAPACITOR CH 10V 10U	1	
	C1030	FIH0J1060009	C.CAPACITOR CH 6.3V 10U	1	
	C1040	FIJ1A106A043	C.CAPACITOR CH 10V 10U	1	
	C1050	FIJ1C106A059	C.CAPACITOR CH 16V 10U	1	
	C1051	FIG1H122A571	C.CAPACITOR CH 50V 1200P	1	
	C1052	FIG1A1040006	C.CAPACITOR CH 10V 0.1U	1	
	C1060	FIJ1C475A059	C.CAPACITOR CH 16V 4.7U	1	
	C1070	FIJ1E4750002	C.CAPACITOR CH 25V 4.7U	1	
	C1110	FIH1A225A051	C.CAPACITOR CH 10V 2.2U	1	
	C1210	FIH1A105A025	C.CAPACITOR CH 10V 1U	1	
	C1220	FIH1A105A025	C.CAPACITOR CH 10V 1U	1	
	C1221	FIH1A105A025	C.CAPACITOR CH 10V 1U	1	
	C2101	FIH1A105A025	C.CAPACITOR CH 10V 1U	1	
	C2202	FIG1A1040006	C.CAPACITOR CH 10V 0.1U	1	
	C3000	FIG1A1040006	C.CAPACITOR CH 10V 0.1U	1	
	C3001	F3Z0E1070001	CAPACITOR	1	
	C3002	FIH1E105A144	C.CAPACITOR CH 25V 1U	1	
	C3003	FIG1A1040006	C.CAPACITOR CH 10V 0.1U	1	
	C3004	FIJ1A106A043	C.CAPACITOR CH 10V 10U	1	
	C3005	FIJ1A106A043	C.CAPACITOR CH 10V 10U	1	
	C3006	FIH0J1050013	C.CAPACITOR CH 6.3V 1U	1	
	C3013	FIG1A1040006	C.CAPACITOR CH 10V 0.1U	1	
	C3014	FIJ1A106A043	C.CAPACITOR CH 10V 10U	1	
	C3015	FIG1C1030008	C.CAPACITOR CH 16V 0.01U	1	
	C3017	FIG1A1040006	C.CAPACITOR CH 10V 0.1U	1	
	C3018	FIG1A1040006	C.CAPACITOR CH 10V 0.1U	1	
	C3020	FIH1H104A913	C.CAPACITOR CH 50V 0.1U	1	
	C3022	FIH1C105A097	C.CAPACITOR CH 16V 1U	1	
	C3023	FIH1H104A913	C.CAPACITOR CH 50V 0.1U	1	
	C3026	FIG0J1050007	C.CAPACITOR CH 6.3V 1U	1	
	C3029	FIG0J1050007	C.CAPACITOR CH 6.3V 1U	1	
	C3030	FIG1C104A077	C.CAPACITOR CH 16V 0.1U	1	
	C4001	FIG0J1050007	C.CAPACITOR CH 6.3V 1U	1	
	C4002	FIG0J1050007	C.CAPACITOR CH 6.3V 1U	1	
	C4003	FIG0J1050007	C.CAPACITOR CH 6.3V 1U	1	
	C4004	FIH1A105A025	C.CAPACITOR CH 10V 1U	1	
	C4005	FIH1A105A025	C.CAPACITOR CH 10V 1U	1	
	C4006	FIH1A105A025	C.CAPACITOR CH 10V 1U	1	
	C4007	FIH1C105A097	C.CAPACITOR CH 16V 1U	1	
	C4008	FIH1C105A097	C.CAPACITOR CH 16V 1U	1	
	C4009	FIH1E105A144	C.CAPACITOR CH 25V 1U	1	
	C4010	FIH1C105A097	C.CAPACITOR CH 16V 1U	1	
	C4011	FIH1A4750004	C.CAPACITOR CH 10V 4.7U	1	
	C4013	FIG0J1050007	C.CAPACITOR CH 6.3V 1U	1	
	C5002	FIG1A1040006	C.CAPACITOR CH 10V 0.1U	1	
	C5005	FIG0J1050007	C.CAPACITOR CH 6.3V 1U	1	
	C5006	FIG0J1050007	C.CAPACITOR CH 6.3V 1U	1	
	C5009	FIH0J4750005	C.CAPACITOR CH 6.3V 4.7U	1	
	C5010	FIG1A1040006	C.CAPACITOR CH 10V 0.1U	1	
	C5012	FIG0J1050007	C.CAPACITOR CH 6.3V 1U	1	
	C5013	FIG0J1050007	C.CAPACITOR CH 6.3V 1U	1	
	C5021	FIG1H470A565	C.CAPACITOR CH 50V 47P	1	
	C6001	FIG1A1040006	C.CAPACITOR CH 10V 0.1U	1	
	C6002	FIG0J1050007	C.CAPACITOR CH 6.3V 1U	1	
	C6011	FIG1A1040006	C.CAPACITOR CH 10V 0.1U	1	
	C6012	FIG0J1050007	C.CAPACITOR CH 6.3V 1U	1	
	C6014	FIH0J1060009	C.CAPACITOR CH 6.3V 10U	1	
	C6015	FIG0J1050007	C.CAPACITOR CH 6.3V 1U	1	

Model No. : DMC-FT20/TS20 Parts List

Safety	Ref. No.	Part No.	Part Name & Description	Q'ty	Remarks
	C6017	F1H0J1060009	C.CAPACITOR CH 6.3V 10U	1	
	C6019	F1G0J1050007	C.CAPACITOR CH 6.3V 1U	1	
	C6020	F1G1A1040006	C.CAPACITOR CH 10V 0.1U	1	
	C6021	F1G1H100A565	C.CAPACITOR CH 50V 10P	1	
	C6022	F1G1H100A565	C.CAPACITOR CH 50V 10P	1	
	C6023	F1H0J1060009	C.CAPACITOR CH 6.3V 10U	1	
	C6024	F1G1A1040006	C.CAPACITOR CH 10V 0.1U	1	
	C6025	F1G0J1050007	C.CAPACITOR CH 6.3V 1U	1	
	C6026	F1G1A1040006	C.CAPACITOR CH 10V 0.1U	1	
	C6027	F1G1A1040006	C.CAPACITOR CH 10V 0.1U	1	
	C6030	F1G0J1050007	C.CAPACITOR CH 6.3V 1U	1	
	C6033	F1G0J1050007	C.CAPACITOR CH 6.3V 1U	1	
	C6034	F1G1A1040006	C.CAPACITOR CH 10V 0.1U	1	
	C6036	F1G1A1040006	C.CAPACITOR CH 10V 0.1U	1	
	C6037	F1G0J1050007	C.CAPACITOR CH 6.3V 1U	1	
	C6038	F1G0J1050007	C.CAPACITOR CH 6.3V 1U	1	
	C6040	F1G0J1050007	C.CAPACITOR CH 6.3V 1U	1	
	C6044	F1G1A1040006	C.CAPACITOR CH 10V 0.1U	1	
	C6047	F1H0J1060009	C.CAPACITOR CH 6.3V 10U	1	
	C6401	F1J1A106A043	C.CAPACITOR CH 10V 10U	1	
	C6402	F1G0J1050007	C.CAPACITOR CH 6.3V 1U	1	
	C6403	F1G1H100A565	C.CAPACITOR CH 50V 10P	1	
	C6404	F1G1H100A565	C.CAPACITOR CH 50V 10P	1	
	C6405	F1G1H100A565	C.CAPACITOR CH 50V 10P	1	
	C6406	F1G1H100A565	C.CAPACITOR CH 50V 10P	1	
	C6407	F1G1H100A565	C.CAPACITOR CH 50V 10P	1	
	C6408	F1G1H100A565	C.CAPACITOR CH 50V 10P	1	
	C7001	F1H1A105A025	C.CAPACITOR CH 10V 1U	1	
	C7003	F1H1A105A025	C.CAPACITOR CH 10V 1U	1	
	C7006	F1G1C1030008	C.CAPACITOR CH 16V 0.01U	1	
	C7007	F1G1C1030008	C.CAPACITOR CH 16V 0.01U	1	
	C7008	F1G1C1030008	C.CAPACITOR CH 16V 0.01U	1	
	C7009	F1G1C1030008	C.CAPACITOR CH 16V 0.01U	1	
	C7015	F1H1A105A025	C.CAPACITOR CH 10V 1U	1	
	C7019	F1H1A4750004	C.CAPACITOR CH 10V 4.7U	1	
	C7021	F1H1A4750004	C.CAPACITOR CH 10V 4.7U	1	
	C7101	F1J1A106A043	C.CAPACITOR CH 10V 10U	1	
	C7102	F1G1A1040006	C.CAPACITOR CH 10V 0.1U	1	
	C7104	F1G1A1040006	C.CAPACITOR CH 10V 0.1U	1	
	C7105	F1G1A1040006	C.CAPACITOR CH 10V 0.1U	1	
	C7106	F1G1A1040006	C.CAPACITOR CH 10V 0.1U	1	
	C8003	F1G1H100A565	C.CAPACITOR CH 50V 10P	1	
	C8004	F1G0J1050007	C.CAPACITOR CH 6.3V 1U	1	
	C8005	F1H0J1060009	C.CAPACITOR CH 6.3V 10U	1	
	C8006	F1K2E4730005	C.CAPACITOR 250V 0.047U	1	
	C8101	F1G1H101A557	C.CAPACITOR CH 50V 100P	1	
	C9041	F1G0J1050007	C.CAPACITOR CH 6.3V 1U	1	
	C9101	F1G1E102A086	C.CAPACITOR CH 25V 1000P	1	
	C9102	F1G0J1050007	C.CAPACITOR CH 6.3V 1U	1	
	C9103	F1G1H120A565	C.CAPACITOR CH 50V 12P	1	
	C9104	F1G1H150A565	C.CAPACITOR CH 50V 15P	1	
	C9105	F1G0J1050007	C.CAPACITOR CH 6.3V 1U	1	
	C9106	F1G0J1050007	C.CAPACITOR CH 6.3V 1U	1	
	C9108	F1G1A1040006	C.CAPACITOR CH 10V 0.1U	1	
	C9109	F1H0J1060009	C.CAPACITOR CH 6.3V 10U	1	
	C9111	F1H1A105A025	C.CAPACITOR CH 10V 1U	1	
	CX6001	F5A84103A020	CAPACITOR	1	
	D1050	B0JCFC000003	DIODE	1	E.S.D.
	D1060	B0JCFC000003	DIODE	1	E.S.D.
	D1070	B0JCFC000003	DIODE	1	E.S.D.
	D1110	B0JCFC000003	DIODE	1	E.S.D.
	D3001	DA2S10100L	DIODE	1	E.S.D.

Model No. : DMC-FT20/TS20 Parts List

Safety	Ref. No.	Part No.	Part Name & Description	Q'ty	Remarks
	D8001	B0ECFR000003	DIODE	1	E.S.D.
	D8002	B3AFB0000328	DIODE	1	E.S.D.
	D9101	DB3S406F0L	DIODE	1	E.S.D.
	D9102	B0ADDH000014	DIODE	1	E.S.D.
	ET2002	K4ZZ01000208	EARTH TERMINAL	1	
	ET2003	K4ZZ01000208	EARTH TERMINAL	1	
⚠	F2001	K5H1522A0018	FUSE 32V 1.5A	1	
⚠	F8001	ERBRE1R25V	FUSE 32V 1.25A	1	
⚠	F9201	K5H202Y00007	FUSE 32V 2.0A	1	
	FP8001	K1MY14BA0370	CONNECTOR 14P	1	
	FP9001	K1MY10BA0370	CONNECTOR 10P	1	
	FP9002	K1MY45BA0235	CONNECTOR 45P	1	
	FP9003	K1MY41BA0235	CONNECTOR 41P	1	
	FP9004	K1MY41BA0235	CONNECTOR 41P	1	
	FP9005	K1MY10BA0370	CONNECTOR 10P	1	
	FP9006	K1MY15BA0235	CONNECTOR 15P	1	
	FP9007	K1MY14BA0370	CONNECTOR 14P	1	
	FP9008	K1KA02ZA0001	CONNECTOR 2P	1	
	FP9201	K1MY10BA0370	CONNECTOR 10P	1	
	IC1001	C1ZBZ0004597	IC	1	E.S.D.
	IC1110	C0DBGYY00779	IC	1	E.S.D.
	IC1210	C0DBGYY01180	IC	1	E.S.D.
	IC1220	C0DBGYY02557	IC	1	E.S.D.
	IC3001	C1AB00003797	IC	1	E.S.D.
	IC3003	C0DBGYY00779	IC	1	E.S.D.
	IC6001	MN89513	IC	1	E.S.D.
	IC6002	RS10312	IC	1	E.S.D.
	IC7101	EWTS9PSL1A	IC	1	[SPC] E.S.D.
	IC8001	C0ZBZ0001938	IC	1	E.S.D.
	IC9101	C1AB00003785	IC	1	E.S.D.
	JK2001	K1FB108E0008	JACK, AV/USB	1	
	L1010	G1C100KA0148	CHIP INDUCTOR 10UH	1	
	L1020	G1C3R3MA0392	CHIP INDUCTOR 3.3UH	1	
	L1030	G1C3R3MA0392	CHIP INDUCTOR 3.3UH	1	
	L1040	G1C4R7MA0392	CHIP INDUCTOR 4.7UH	1	
	L1050	G1C3R3MA0478	CHIP INDUCTOR 3.3UH	1	
	L1060	G1C4R7MA0478	CHIP INDUCTOR 4.7UH	1	
	L1070	G1C6R8MA0392	CHIP INDUCTOR 6.8UH	1	
	L2001	J0ZZB0000142	FILTER	1	
	L3003	G1C100MA0410	CHIP INDUCTOR 10UH	1	
	L3004	G1C100KA0115	CHIP INDUCTOR 10UH	1	
	L8001	G5F1A0000026	CHIP INDUCTOR	1	
	LB1001	J0JHC0000048	FILTER	1	
	LB2001	J0JCC0000415	FILTER	1	
	LB2002	J0JCC0000415	FILTER	1	
	LB2003	J0JCC0000415	FILTER	1	
	LB2004	J0JCC0000415	FILTER	1	
	LB6001	J0JCC0000317	FILTER	1	
	LB6003	J0JCC0000408	FILTER	1	
	LB6004	J0JCC0000412	FILTER	1	
	LB6005	J0JCC0000412	FILTER	1	
	LB6006	J0JCC0000412	FILTER	1	
	LB6084	J0JCC0000408	FILTER	1	
	P6401	K1NA09E00098	SD CARD CONNECTOR	1	
	P9201	K4ZZ04000059	CONNECTOR 4P	1	
	Q8001	B1JBLP000038	TRANSISTOR	1	E.S.D.
	QR6001	DRC3144W0L	TRANSISTOR-RESISTOR	1	E.S.D.
	R1001	ERJ2RHD104X	M.RESISTOR CH 1/16W 100K	1	
	R1051	ERJ2RKD124X	M.RESISTOR CH 1/16W 120K	1	
	R1052	ERJ2RHD203X	M.RESISTOR CH 1/16W 20K	1	
	R1054	ERJ2RHD473X	M.RESISTOR CH 1/16W 47K	1	
	R1061	ERJ2RKD244X	M.RESISTOR CH 1/16W 240K	1	

Model No. : DMC-FT20/TS20 Parts List

Safety	Ref. No.	Part No.	Part Name & Description	Q'ty	Remarks
	R1062	ERJ2RHD203X	M.RESISTOR CH 1/16W 20K	1	
	R1075	ERJ2RKD120X	M.RESISTOR CH 1/16W 12	1	
	R1111	D0GA101JA023	M.RESISTOR CH 1/10W 100	1	
	R2001	D0GA750JA023	M.RESISTOR CH 1/10W 75	1	
	R2002	D0GA561JA023	M.RESISTOR CH 1/10W 560	1	
	R2003	D0GA102JA023	M.RESISTOR CH 1/10W 1K	1	
	R2004	D0GA102JA023	M.RESISTOR CH 1/10W 1K	1	
	R3007	D0GA220JA023	M.RESISTOR CH 1/10W 22	1	
	R3008	D0GA100JA023	M.RESISTOR CH 1/10W 10	1	
	R5013	D0GA222JA023	M.RESISTOR CH 1/10W 2.2K	1	
	R6004	D0GA103JA023	M.RESISTOR CH 1/10W 10K	1	
	R6006	ERJ2RKF5901X	M.RESISTOR CH 1/16W 5.9K	1	
	R6008	D0GA105JA023	M.RESISTOR CH 1/10W 1M	1	
	R6009	D0GA681JA023	M.RESISTOR CH 1/10W 680	1	
	R6011	D0GA101JA023	M.RESISTOR CH 1/10W 100	1	
	R6014	D0GA330JA023	M.RESISTOR CH 1/10W 33	1	
	R6018	ERJ2RKF1183X	M.RESISTOR CH 1/16W 118K	1	
	R6019	ERJ2RHD222X	M.RESISTOR CH 1/16W 2.2K	1	
	R6020	ERJ2RHD122X	M.RESISTOR CH 1/16W 1.2K	1	
	R6021	D0GA473JA023	M.RESISTOR CH 1/10W 47K	1	
	R6025	D0GA472JA023	M.RESISTOR CH 1/10W 4.7K	1	
	R6026	D0GA472JA023	M.RESISTOR CH 1/10W 4.7K	1	
	R6028	ERJ2RHD561X	M.RESISTOR CH 1/16W 560	1	
	R6050	D0GA103JA023	M.RESISTOR CH 1/10W 10K	1	
	R6057	D0GA101JA023	M.RESISTOR CH 1/10W 100	1	
	R6079	D0GA101JA023	M.RESISTOR CH 1/10W 100	1	
	R6401	D0GA102JA023	M.RESISTOR CH 1/10W 1K	1	
	R6402	D0GA223JA023	M.RESISTOR CH 1/10W 22K	1	
	R6403	D0GA102JA023	M.RESISTOR CH 1/10W 1K	1	
	R7002	ERJ2RKD680X	M.RESISTOR CH 1/16W 68	1	
	R7007	ERJ2RKD680X	M.RESISTOR CH 1/16W 68	1	
	R7009	D1BA1R00A079	RESISTOR	1	
	R7024	ERJ2RHD822X	M.RESISTOR CH 1/16W 8.2K	1	
	R8001	D0GB620JA065	RESISTOR	1	
	R8002	ERJ6GEYJ514V	M.RESISTOR CH 1/8W 510K	1	
	R8003	ERJ6GEYJ514V	M.RESISTOR CH 1/8W 510K	1	
	R8004	D1BD4703A119	RESISTOR	1	
	R8006	ERJ2RHD1621X	M.RESISTOR CH 1/16W 1620	1	
	R8008	D0GA104JA023	M.RESISTOR CH 1/10W 100K	1	
	R8009	D0GA303JA023	M.RESISTOR CH 1/10W 30K	1	
	R9003	D0GA221JA023	M.RESISTOR CH 1/10W 220	1	
	R9004	D0GA221JA023	M.RESISTOR CH 1/10W 220	1	
	R9005	D0GA273JA023	M.RESISTOR CH 1/10W 27K	1	
	R9006	D0GA273JA023	M.RESISTOR CH 1/10W 27K	1	
	R9007	J0JCC0000397	FILTER	1	
	R9008	D0GAR00J0005	RESISTOR	1	
	R9021	D0GAR00J0005	RESISTOR	1	
	R9060	D0GA682JA023	M.RESISTOR CH 1/10W 6.8K	1	
	R9061	D0GA223JA023	M.RESISTOR CH 1/10W 22K	1	
	R9071	ERJ3GEYJ510V	M.RESISTOR CH 1/10W 51	1	
	R9106	D0GA824JA023	M.RESISTOR CH 1/10W 820K	1	
	R9107	D0GA334JA023	M.RESISTOR CH 1/10W 330K	1	
	R9108	D0GA512JA023	M.RESISTOR CH 1/10W 5.1K	1	
	R9109	D0GA331JA023	M.RESISTOR CH 1/10W 330	1	
	R9114	ERJ2RHD183X	M.RESISTOR CH 1/16W 18K	1	
	R9115	ERJ2RHD223X	M.RESISTOR CH 1/16W 22K	1	
	RX6001	D1H81034A024	RESISTOR ARRAY	1	
	RX6002	D1H82214A024	RESISTOR ARRAY	1	
	RX6003	D1H82214A024	RESISTOR ARRAY	1	
	RX6401	D1H84734A024	RESISTOR ARRAY	1	
	RX6402	D1H84704A024	RESISTOR ARRAY	1	
	RX9011	D1H81034A024	RESISTOR ARRAY	1	

Model No. : DMC-FT20/TS20 Parts List

Safety	Ref. No.	Part No.	Part Name & Description	Q'ty	Remarks
	S9502	K0F111A00581	SWITCH	1	
	S9503	K0F111A00581	SWITCH	1	
	S9504	K0F111A00581	SWITCH	1	
	S9505	K0F111A00581	SWITCH	1	
	S9506	K0F111A00581	SWITCH	1	
	S9507	K0F111A00581	SWITCH	1	
	S9508	K0F111A00581	SWITCH	1	
	S9509	K0F111A00581	SWITCH	1	
	S9510	K0F111A00581	SWITCH	1	
	T8001	G5DYA0000135	TRANSFORMER	1	
	X6001	H0J240500068	CRYSTAL OSCILLATOR	1	
	X9101	H0J327200225	CRYSTAL OSCILLATOR	1	

Model No. : DMC-FT20/TS20 Frame and Casing Section

From Ref No. "P-1" to "P-6" are supplied as a "waterproof packing kit" (Part No. VUMG2032), and are Not supplied individually. ("P-6" is also included in Ref.37.)

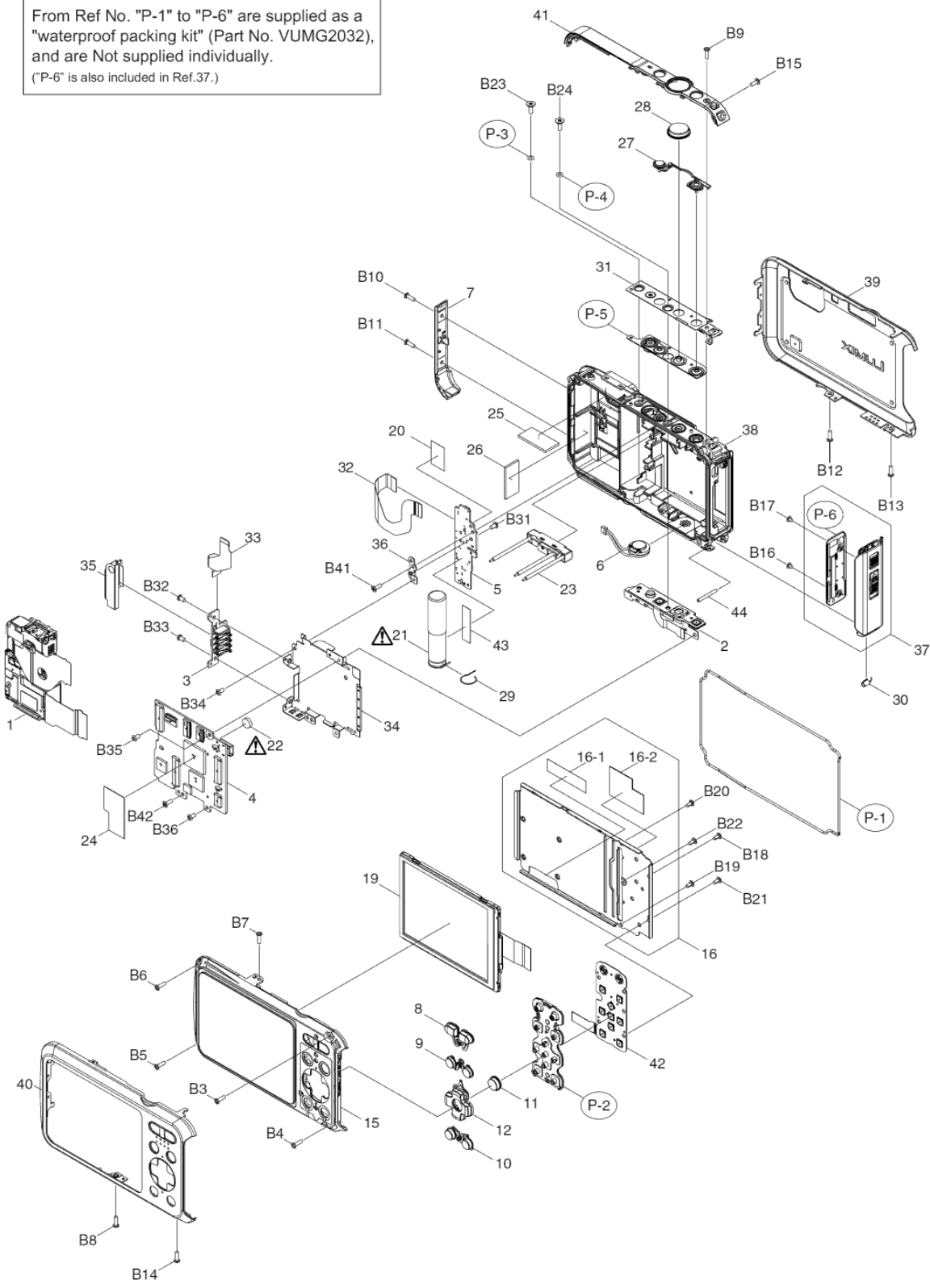

Model No. : DMC-FT20/TS20 Packing Parts and Accessories Section (1)

< Except for P / PC / PU >

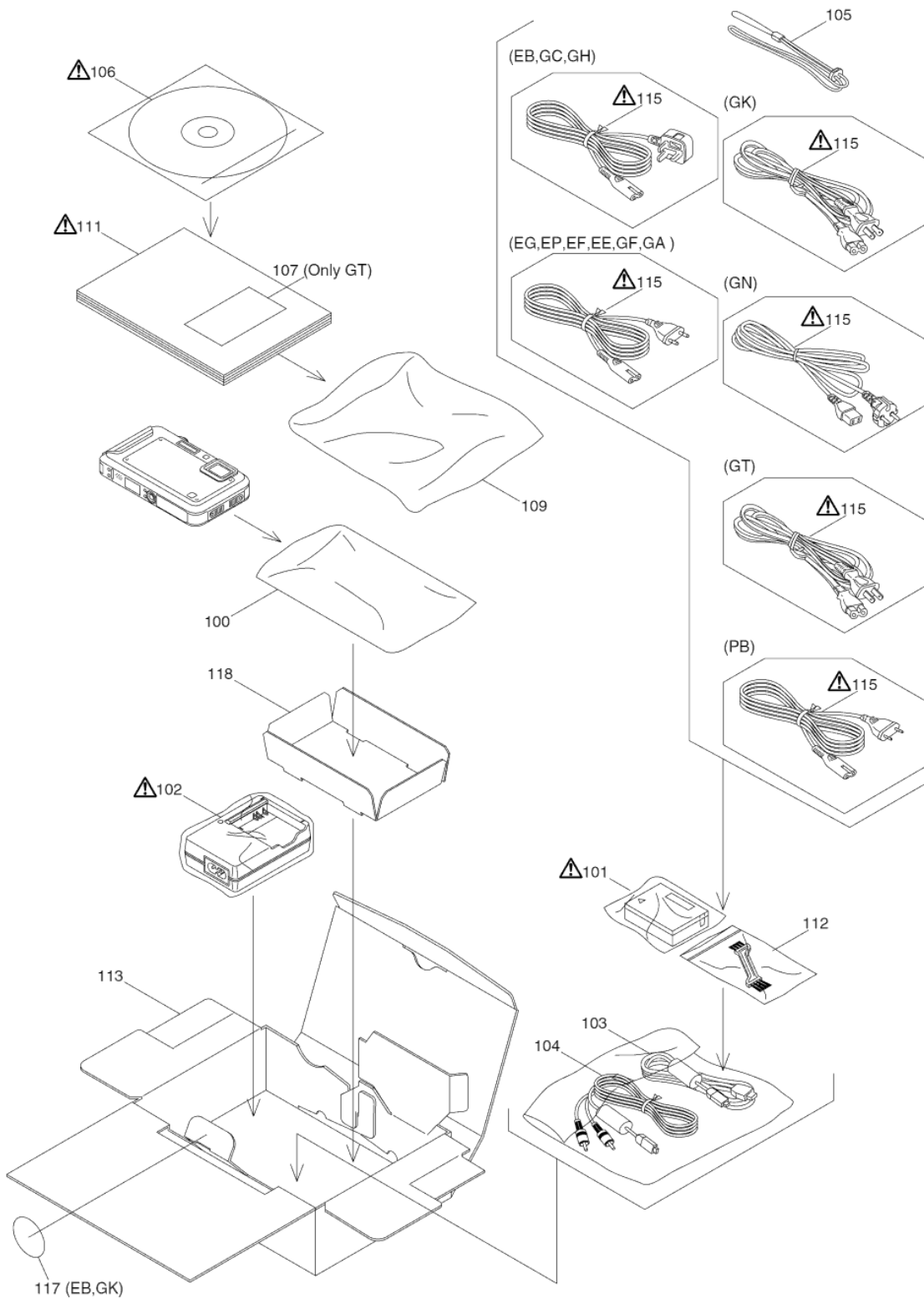





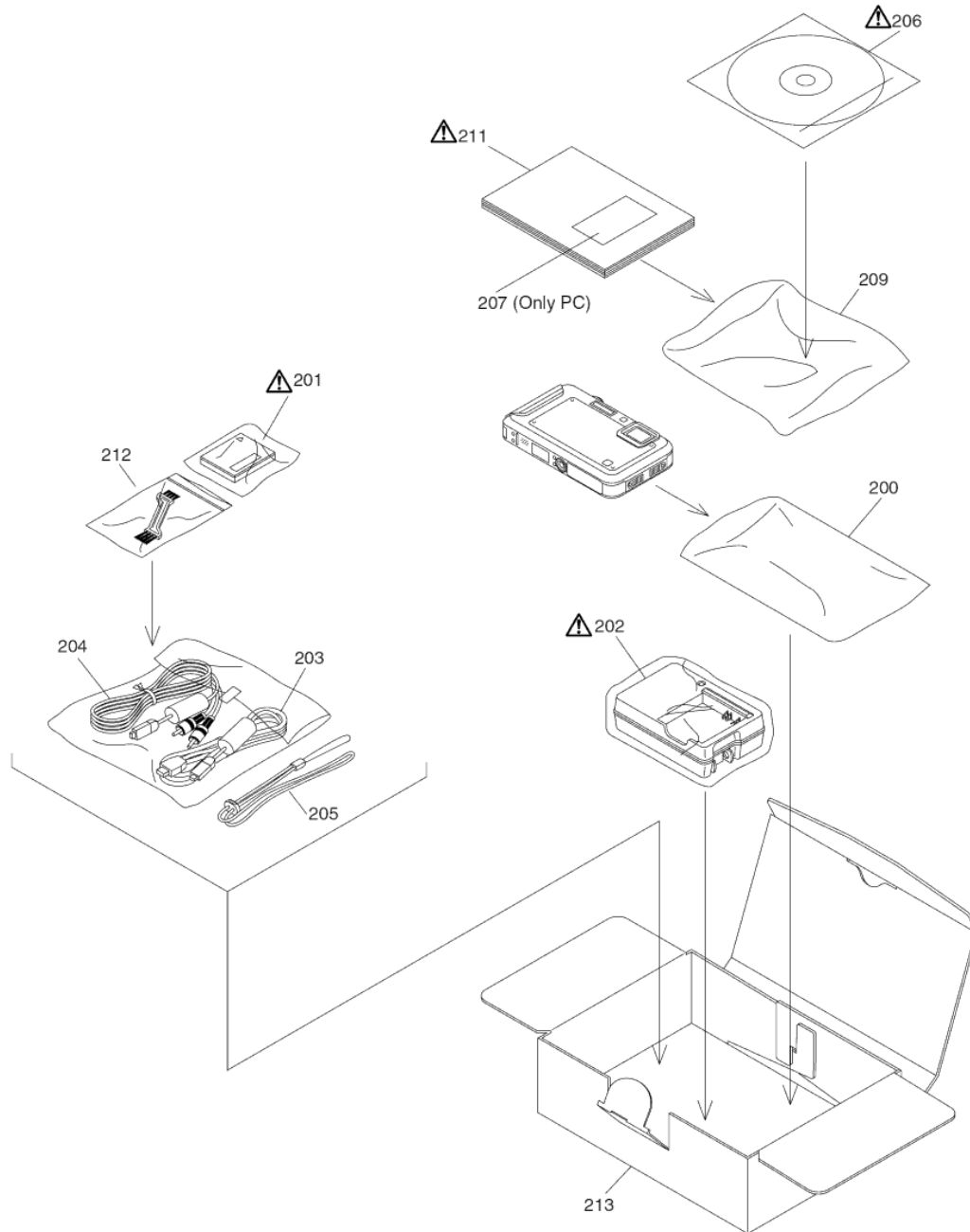

Model No. : DMC-FT20/TS20 Packing Parts and Accessories Section (2)

< Only P / PC / PU >



Model No. : DMC-FT20/TS20 Parts List

Safety	Ref. No.	Part No.	Part Name & Description	Q'ty	Remarks
	1	VXW1426	CAMERA LENS UNIT	1	
	2	VXK2017	TOP P.C.B. UNIT	1	
	3	VEP51030A	BATTERY P.C.B.	1	(RTL)
	4	VEP56146A	MAIN P.C.B.	1	(RTL) E.S.D.
	5	VEP58163A	FLASH P.C.B.	1	(RTL) E.S.D.
	6	L0AA01A00125	SPEAKER	1	
	7	VKM9729	SIDE ORNAMENT R	1	
	8	VGU0L04	ZOOM BUTTON	1	
	9	VGU0L05	REAR BUTTON (MODE/PLAY)	1	
	10	VGU0L06	REAR BUTTON (Q.MENU/DISPLAY)	1	
	11	VGU0L07	REAR BUTTON (MENU/SET)	1	
	12	VGU0L08	REAR BUTTON (CURSOR)	1	
	15	VYK5R43	REAR CASE UNIT	1	
	16	VXK2007	FRAME PLATE UNIT	1	
	16-1	VGQ1D17	LCD BARRIER SHEET	1	
	16-2	VMZ3929	CCD FPC SPACER SHEET	1	
	19	VYK5R42	LCD UNIT	1	
	20	VGQ0X00	LCD FPC SHEET	1	
	21	F2A2F7500001	FLASH CHRQ CAPACITOR	1	(C8001)
	22	ML-421S/DN	BUTTON BATTERY	1	[ENERGY] (B9101)
	23	VEK0R44	FLASH U	1	
	24	VGQ1A58	DPR SHEET	1	
	27	VGU0L02	POWER/REC BUTTON	1	
	28	VGU0L03	SHUTTER BUTTON	1	
	29	VMB4567	EARTH SPRING	1	(ET8001)
	30	VMB4574	BATTERY DOOR SPRING	1	
	31	VXK2016	TOP BUTTON PLATE	1	
	32	VWJ2312	FLASH-MAIN FPC	1	
	33	VWJ2316	BATTERY-MAIN FPC	1	
	34	VMP0B94	BATTERY CASE	1	
	35	VMZ3924	BATTERY BARRIER SHEET	1	
	36	VMP0C00	FL EARTH PLATE	1	
	37	VYF3474	BATTERY DOOR UNIT	1	
	38	VYK5V84	FRONT CASE UNIT	1	
	39	VYK5R84	FRONT ALMI CASE UNIT	1	EG-K, EP-K, EB-K, EE-K, GC-K, GF-K, GA-K, GN-K, PU-K, GT-K
	39	VYK5R88	FRONT ALMI CASE UNIT	1	EG-A, EP-A, EB-A, EE-A, GC-A, GF-A, GA-A, GN-A, PC-A, PU-A, PB-A, GH-A, GK-A
	39	VYK5R92	FRONT ALMI CASE UNIT	1	EG-D, EP-D, EF-D, EB-D, GC-D, GF-D, GA-D, GN-D, PC-D, GH-D, GT-D
	39	VYK5R87	FRONT ALMI CASE UNIT	1	EG-R, EP-R, EF-R, EB-R, GC-R, GF-R, GA-R, GN-R, PC-R, PU-R, PB-R, GH-R, GT-R, GK-R
	39	VYK5R86	FRONT ALMI CASE UNIT	1	P-K
	39	VYK5R91	FRONT ALMI CASE UNIT	1	P-A
	39	VYK5R89	FRONT ALMI CASE UNIT	1	P-D
	39	VYK5R90	FRONT ALMI CASE UNIT	1	P-R
	40	VKM9725	REAR ALMI CASE	1	(-K)
	40	VKM9857	REAR ALMI CASE	1	(-A)
	40	VKM9858	REAR ALMI CASE	1	(-D)
	40	VKM9856	REAR ALMI CASE	1	(-R)
	41	VKM9728	TOP CASE	1	EG, EP, EF, EB, EE, GC, GF, GA, GN
	41	VKM9859	TOP CASE	1	P, PC, PU, PB, GH, GT, GK
	42	VEP50095A	REAR OPERATION P.C.B.	1	(RTL)
	43	VGQ0S42	CAPACITOR SHEET	1	
	44	VMS8228	BATT DOOR SHAFT	1	
	100	VFF1301-A	CAMERA BAG	1	EG, EP, EF, EB, EE, GC, GF, GA, GN, PB, GH, GT, GK
	101	-----	BATTERY PACK	1	EG, EP, EF, EB, EE, GC, GF, GA, GN, PB, GH, GT, GK (NOT SUPPLIED)
	102	DE-A92AB/SX	BATTERY CHARGER	1	EG, EP, EF, EB, EE, GN, PB
	102	DE-A92BB/SX	BATTERY CHARGER	1	GC, GF, GA, GH, GK
	102	DE-A92CA/SX	BATTERY CHARGER	1	GT
	103	K1HY08YY0025	USB CABLE	1	EG, EP, EF, EB, EE, GC, GF, GA, GN, PB, GH, GT, GK

Model No. : DMC-FT20/TS20 Parts List

Safety	Ref. No.	Part No.	Part Name & Description	Q'ty	Remarks
	104	K1HY08YY0026	AV CABLE	1	EG, EP, EF, EB, EE, GC, GF, GA, GN, PB, GH, GT, GK
	105	VFC4393	HAND STRAP	1	EG, EP, EF, EB, EE, GC, GF, GA, GN, PB, GH, GT, GK
⚠	106	VFF0961-S	CD-ROM(SOFT/INSTRUCTION BOOK)	1	EG [SPC] See "Notes"
⚠	106	VFF0962-S	CD-ROM(SOFT/INSTRUCTION BOOK)	1	EP, EF, EB [SPC] See "Notes"
⚠	106	VFF0963-S	CD-ROM(SOFT/INSTRUCTION BOOK)	1	EE [SPC] See "Notes"
⚠	106	VFF0964-S	CD-ROM(SOFT/INSTRUCTION BOOK)	1	GC, GF, GA, GN, GH [SPC] See "Notes"
⚠	106	VFF0965-S	CD-ROM(SOFT/INSTRUCTION BOOK)	1	GT [SPC] See "Notes"
⚠	106	VFF0966-S	CD-ROM(SOFT/INSTRUCTION BOOK)	1	GK [SPC] See "Notes"
⚠	106	VFF0960-S	CD-ROM(SOFT/INSTRUCTION BOOK)	1	PB [SPC] See "Notes"
	107	VQL2C68-1A	OPERATING LABEL	1	GT
	109	VFF1378	POLYETHYLENE BAG	1	EG, EP, EF, EB, EE, GC, GF, GA, GN, PB, GH, GT, GK
⚠	111	VQT4A83	BASIC O/I (GERMAN/FRENCH)	1	EG
⚠	111	VQT4A84	BASIC O/I (ITALIAN/DUTCH)	1	EG
⚠	111	VQT4A85	BASIC O/I (SPANISH/PORTUGUESE)	1	EG
⚠	111	VQT4A86	BASIC O/I (TURKISH)	1	EG
⚠	111	VQT4A87	BASIC O/I (SWEDISH/DANISH)	1	EP
⚠	111	VQT4A88	BASIC O/I (POLISH/CZECH)	1	EP
⚠	111	VQT4A89	BASIC O/I (HUNGARIAN/FINNISH)	1	EP
⚠	111	VQT4A90	BASIC O/I (FRENCH)	1	EF
⚠	111	VQT4A91	BASIC O/I (ENGLISH)	1	EB
⚠	111	VQT4A92	BASIC O/I (RUSSIAN/UKRAINIAN)	1	EE
⚠	111	VQT4A93	BASIC O/I (ENGLISH/CHINESE (TRADITIONAL))	1	GC, GF, GA, GH
⚠	111	VQT4A94	BASIC O/I (ARABIC/PERSIAN)	1	GC, GF
⚠	111	VQT4A95	BASIC O/I (VIETNAMESE)	1	GA
⚠	111	VQT4A98	BASIC O/I (ENGLISH)	1	GN
⚠	111	VQT4A82	BASIC O/I (SPANISH/PORTUGUESE)	1	PB
⚠	111	VQT4A96	BASIC O/I (CHINESE (TRADITIONAL))	1	GT
⚠	111	VQT4A97	BASIC O/I (CHINESE (SIMPLIFIED))	1	GK
	112	VYC1013	BRUSH U	1	EG, EP, EF, EB, EE, GC, GF, GA, GN, PB, GH, GT, GK
	113	VYQ7485	PACKING CASE U	1	EG-K, EP-K, EB-K, EE-K, GC-K, GA-K, GN-K
	113	VYQ7499	PACKING CASE U	1	EG-A, EP-A, EB-A, EE-A, GC-A, GA-A, GN-A
	113	VYQ7504	PACKING CASE U	1	EG-D, EP-D, EF-D, EB-D, GC-D, GA-D, GN-D
	113	VYQ7491	PACKING CASE U	1	EG-R, EP-R, EF-R, EB-R, GC-R, GA-R, GN-R
	113	VYQ7487	PACKING CASE U	1	GF-K
	113	VYQ7501	PACKING CASE U	1	GF-A
	113	VYQ7507	PACKING CASE U	1	GF-D
	113	VYQ7494	PACKING CASE U	1	GF-R
	113	VYQ7500	PACKING CASE U	1	PB-A, GH-A
	113	VYQ7492	PACKING CASE U	1	PB-R, GH-R, GT-R
	113	VYQ7505	PACKING CASE U	1	GH-D, GT-D
	113	VYQ7486	PACKING CASE U	1	GT-K
	113	VYQ7502	PACKING CASE U	1	GK-A
	113	VYQ7495	PACKING CASE U	1	GK-R
⚠	115	K2CQ2YY00082	AC CORD	1	EG, EP, EF, EE, GF, GA
⚠	115	K2CT3YY00034	AC CORD	1	EB, GC, GH
⚠	115	K2CJ2YY00052	AC CORD	1	GN
⚠	115	K2CR2YY00047	AC CORD	1	PB
⚠	115	K2CA2YY00129	AC CORD	1	GT
⚠	115	K2CA2YY00130	AC CORD	1	GK
	117	VQL1S65	LABEL	1	EB, GK
	118	VPN7343	CUSHION	1	EG, EP, EF, EB, EE, GC, GF, GA, GN, PB, GH, GT, GK
	200	VFF1458	CAMERA BAG	1	P, PC, PU
⚠	201	-----	BATTERY PACK	1	P, PC, PU (NOT SUPPLIED)
⚠	202	DE-A91BA/SX	BATTERY CHARGER	1	P, PC, PU
	203	K1HY08YY0025	USB CABLE	1	P, PC, PU
	204	K1HY08YY0026	AV CABLE	1	P, PC, PU
	205	VFC4393	HAND STRAP	1	P, PC, PU
⚠	206	VFF0960-S	CD-ROM(SOFT/INSTRUCTION BOOK)	1	P, PC, PU [SPC] See "Notes"
	207	VQL2C67	OPERATING LABEL	1	PC
	209	VFF1378	POLYETHYLENE BAG	1	P, PC, PU
⚠	211	VQT4A80	BASIC O/I (ENGLISH/SPANISH)	1	P
⚠	211	VQT4A81	BASIC O/I (ENGLISH/CANADIAN FRENCH)	1	PC

Model No. : DMC-FT20/TS20 Parts List

Safety	Ref. No.	Part No.	Part Name & Description	Q'ty	Remarks
	211	VQT4A82	BASIC O/I (SPANISH/PORTUGUESE)	1	PU
	212	VYC1013	BRUSH U	1	P, PC, PU
	213	VYQ7484	PACKING CASE U	1	PU-K
	213	VYQ7498	PACKING CASE U	1	PU-A
	213	VYQ7490	PACKING CASE U	1	PU-R
	213	VYQ7497	PACKING CASE U	1	P-A, PC-A
	213	VYQ7503	PACKING CASE U	1	P-D, PC-D
	213	VYQ7483	PACKING CASE U	1	P-K
	213	VYQ7489	PACKING CASE U	1	P-R, PC-R
	B3	VHD2235	SCREW	1	
	B4	VHD2235	SCREW	1	
	B5	VHD2235	SCREW	1	
	B6	VHD2235	SCREW	1	
	B7	VHD2235	SCREW	1	
	B8	VHD2235	SCREW	1	
	B9	VHD2235	SCREW	1	
	B10	VHD2235	SCREW	1	
	B11	VHD2235	SCREW	1	
	B12	VHD2235	SCREW	1	
	B13	VHD2235	SCREW	1	
	B14	VHD2235	SCREW	1	
	B15	VHD2322	SCREW	1	
	B16	VHD2322	SCREW	1	
	B17	VHD2322	SCREW	1	
	B18	VHD1909	SCREW	1	
	B19	VHD1909	SCREW	1	
	B20	VHD1909	SCREW	1	
	B21	VHD1909	SCREW	1	
	B22	VHD1909	SCREW	1	
	B23	VHD2378	SCREW	1	
	B24	VHD2378	SCREW	1	
	B31	VHD2019	SCREW	1	
	B32	VHD2019	SCREW	1	
	B33	VHD2019	SCREW	1	
	B34	VHD2019	SCREW	1	
	B35	VHD2019	SCREW	1	
	B36	VHD2019	SCREW	1	
	B41	XQN14+BJ4FJK	SCREW	1	
	B42	XQN14+BJ4FJK	SCREW	1	
	P	VUMG2032	WATER PROOF PACKING KIT	1	(Including in "P-1 to P-6")
	P-1	-----	CASE O-RING	1	(Included in "VUMG2032")
	P-2	-----	REAR BUTTON PACKING	1	(Included in "VUMG2032")
	P-3	-----	SCREW O RING	1	(Included in "VUMG2032")
	P-4	-----	SCREW O RING	1	(Included in "VUMG2032")
	P-5	-----	TOP BUTTON PACKING	1	(Included in "VUMG2032")
	P-6	-----	BATTERY DOOR PACKING	1	(Included in "VUMG2032")