

Service Manual

Digital Camera

LUMIX

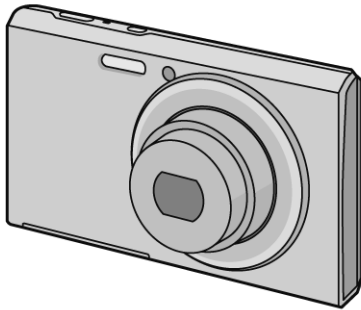

Model No. **DMC-FH10P**
DMC-FH10PC
DMC-FH10PU
DMC-FH10GA
DMC-FH10GC
DMC-FH10GF
DMC-FH10GK
DMC-FH10GN
DMC-FH10GT
DMC-FS50EB
DMC-FS50EE
DMC-FS50EF
DMC-FS50EG
DMC-FS50EP

Colour

[DMC-FH10]

(S).....Silver Type (except P/PC)
(K).....Black Type
(P).....Pink Type (except PC/GN)
(V).....Violet Type (except P/PC/GT)

[DMC-FS50]

(S).....Silver Type
(K).....Black Type
(P).....Pink Type (only EE)
(V).....Violet Type (only EE)

WARNING

This service information is designed for experienced repair technicians only and is not designed for use by the general public. It does not contain warnings or cautions to advise non-technical individuals of potential dangers in attempting to service a product. Products powered by electricity should be serviced or repaired only by experienced professional technicians. Any attempt to service or repair the product or products dealt with in this service information by anyone else could result in serious injury or death.

Panasonic[®]

© Panasonic Corporation 2013 Unauthorized copying and distribution is a violation of law.

TABLE OF CONTENTS

	PAGE	PAGE
1 Safety Precautions	3	
1.1. General Guidelines	3	
1.2. Leakage Current Cold Check	3	
1.3. Leakage Current Hot Check (See Figure. 1)	3	
1.4. How to Discharge the E.Capacitor on Flash Top P.C.B.	4	
2 Warning	5	
2.1. Prevention of Electrostatic Discharge (ESD) to Electrostatically Sensitive (ES) Devices	5	
2.2. How to Recycle the Lithium Ion Battery (U.S. Only)	5	
3 Service Navigation	6	
3.1. Introduction	6	
3.2. Important Notice	6	
3.3. General Description About Lead Free Solder (PbF)	7	
3.4. How to Define the Model Suffix (NTSC or PAL model)	8	
4 Specifications	12	
5 Location of Controls and Components	13	
6 Service Mode	15	
6.1. Error Code Memory Function	15	
7 Service Fixture & Tools	18	
7.1. Service Fixture and Tools	18	
7.2. When Replacing the Main P.C.B.	18	
7.3. Service Position	19	
8 Disassembly and Assembly Instructions	20	
8.1. Disassembly Flow Chart	20	
8.2. P.C.B. Location	20	
8.3. Disassembly Procedure	21	
8.4. Removal of the CCD FPC Unit	27	
9 Measurements and Adjustments	28	
9.1. Introduction	28	
9.2. Before Disassembling the unit	28	
9.3. Details of Electrical Adjustment	30	
9.4. After Adjustment	34	
10 Maintenance	35	
10.1. Cleaning Lens and LCD Panel	35	
11 Block Diagram	36	
11.1. Overall Block Diagram	36	
11.2. Flash / Top Block Diagram	37	
11.3. Sub Operation Block Diagram	37	
12 Wiring Connection Diagram	38	
12.1. Interconnection Diagram	38	

1 Safety Precautions

1.1. General Guidelines

1. IMPORTANT SAFETY NOTICE

There are special components used in this equipment which are important for safety. These parts are marked by

 in the Schematic Diagrams, Circuit Board Layout, Exploded Views and Replacement Parts List. It is essential that these critical parts should be replaced with manufacturer's specified parts to prevent X-RADIATION, shock, fire, or other hazards. Do not modify the original design without permission of manufacturer.

2. An Isolation Transformer should always be used during the servicing of AC Adaptor whose chassis is not isolated from the AC power line. Use a transformer of adequate power rating as this protects the technician from accidents resulting in personal injury from electrical shocks. It will also protect AC Adaptor from being damaged by accidental shorting that may occur during servicing.
3. When servicing, observe the original lead dress. If a short circuit is found, replace all parts which have been overheated or damaged by the short circuit.
4. After servicing, see to it that all the protective devices such as insulation barriers, insulation papers shields are properly installed.
5. After servicing, make the following leakage current checks to prevent the customer from being exposed to shock hazards.

1.2. Leakage Current Cold Check

1. Unplug the AC cord and connect a jumper between the two prongs on the plug.
2. Measure the resistance value, with an ohmmeter, between the jumpered AC plug and each exposed metallic cabinet part on the equipment such as screwheads, connectors, control shafts, etc. When the exposed metallic part has a return path to the chassis, the reading should be between $1\text{ M}\Omega$ and $5.2\text{ M}\Omega$. When the exposed metal does not have a return path to the chassis, the reading must be infinity.

1.3. Leakage Current Hot Check (See Figure. 1)

1. Plug the AC cord directly into the AC outlet. Do not use an isolation transformer for this check.
2. Connect a $1.5\text{ k}\Omega$, 10 W resistor, in parallel with a $0.15\text{ }\mu\text{F}$ capacitor, between each exposed metallic part on the set and a good earth ground, as shown in Figure. 1.
3. Use an AC voltmeter, with $1\text{ k}\Omega/\text{V}$ or more sensitivity, to measure the potential across the resistor.
4. Check each exposed metallic part, and measure the voltage at each point.
5. Reverse the AC plug in the AC outlet and repeat each of the above measurements.
6. The potential at any point should not exceed 0.75 V RMS . A leakage current tester (Simpson Model 229 or equivalent) may be used to make the hot checks, leakage current must not exceed $1/2\text{ mA}$. In case a measurement is outside of the limits specified, there is a possibility of a shock hazard, and the equipment should be repaired and rechecked before it is returned to the customer.

Hot-Check Circuit

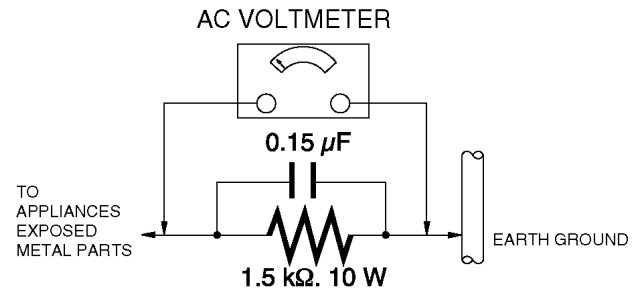

Figure. 1

1.4. How to Discharge the E.Capacitor on Flash Top P.C.B.

CAUTION:

- Be sure to discharge the E.Capacitor on Flash Top P.C.B. before disassembling.
- Be careful of the high voltage circuit on Flash Top P.C.B. when servicing.

[Discharging Procedure]

1. Put the insulation tube on the lead part of resistor (ERG5SJ102:1k Ω /5W).
(An equivalent type of resistor may be used.)
2. Put the resistor between both terminals of E.Capacitor on the Flash Top P.C.B. for approx. 5 seconds.
3. After discharging, confirm that the E.Capacitor voltage is lower than 10V by using a voltmeter.

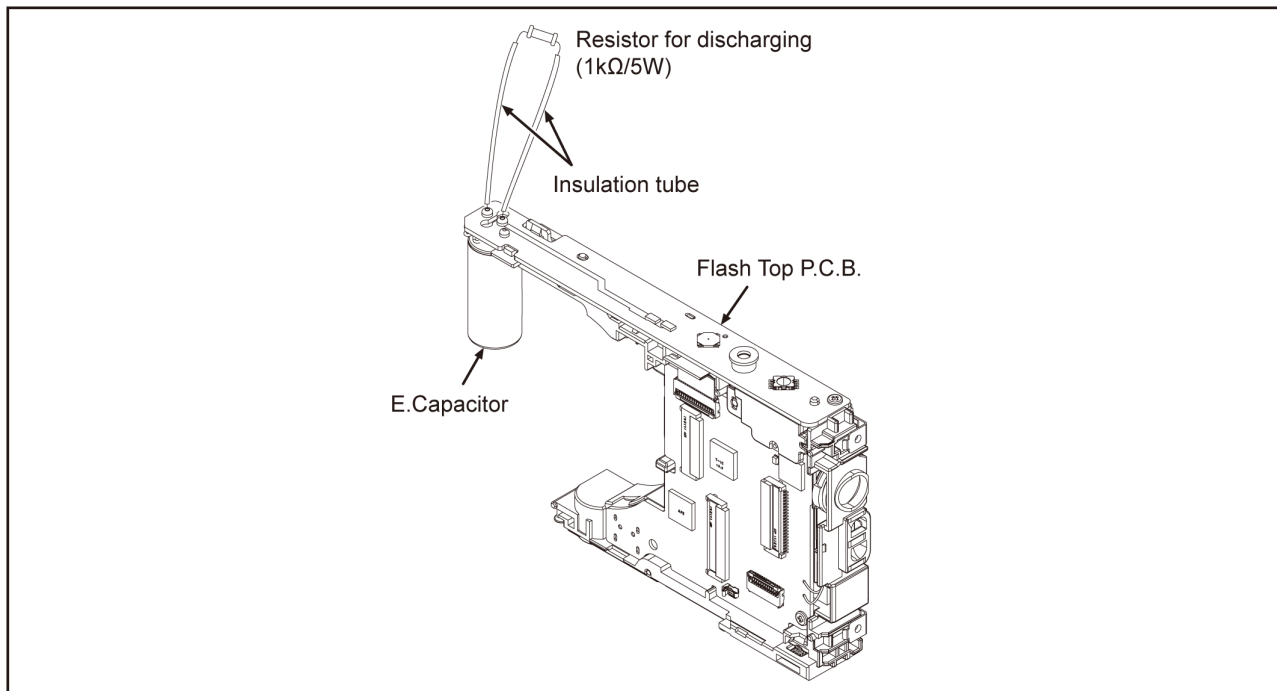

Fig. F1

2 Warning

2.1. Prevention of Electrostatic Discharge (ESD) to Electrostatically Sensitive (ES) Devices

Some semiconductor (solid state) devices can be damaged easily by static electricity. Such components commonly are called Electrostatically Sensitive (ES) Devices.

Examples of typical ES devices are IC (integrated circuits) and some field-effect transistors and semiconductor “chip” components.

The following techniques should be used to help reduce the incidence of component damage caused by electrostatic discharge (ESD).

1. Immediately before handling any semiconductor component or semiconductor-equipped assembly, drain off any ESD on your body by touching a known earth ground. Alternatively, obtain and wear a commercially available discharging ESD wrist strap, which should be removed for potential shock reasons prior to applying power to the unit under test.
2. After removing an electrical assembly equipped with ES devices, place the assembly on a conductive surface such as aluminum foil, to prevent electrostatic charge buildup or exposure of the assembly.
3. Use only a grounded-tip soldering iron to solder or unsolder ES devices.
4. Use only an antistatic solder removal device. Some solder removal devices not classified as “antistatic (ESD protected)” can generate electrical charge sufficient to damage ES devices.
5. Do not use freon-propelled chemicals. These can generate electrical charges sufficient to damage ES devices.
6. Do not remove a replacement ES device from its protective package until immediately before you are ready to install it. (Most replacement ES devices are packaged with leads electrically shorted together by conductive foam, aluminum foil or comparable conductive material).
7. Immediately before removing the protective material from the leads of a replacement ES device, touch the protective material to the chassis or circuit assembly into which the device will be installed.

CAUTION :

Be sure no power is applied to the chassis or circuit, and observe all other safety precautions.

8. Minimize bodily motions when handling unpackaged replacement ES devices. (Otherwise harmless motion such as the brushing together of your clothes fabric or the lifting of your foot from a carpeted floor can generate static electricity (ESD) sufficient to damage an ES device).

2.2. How to Recycle the Lithium Ion Battery (U.S. Only)

ENGLISH



A lithium ion battery that is recyclable powers the product you have purchased. Please call 1-800-8-BATTERY for information on how to recycle this battery.

FRANÇAIS



L'appareil que vous vous êtes procuré est alimenté par une batterie au lithium-ion recyclable. Pour des renseignements sur le recyclage de la batterie, veuillez composer le 1-800-8-BATTERY.

3 Service Navigation

3.1. Introduction

This service manual contains technical information, which allow service personnel's to understand and service this model.

Please place orders using the parts list and not the drawing reference numbers.

If the circuit is changed or modified, the information will be followed by service manual to be controlled with original service manual.

3.2. Important Notice

3.2.1. CCD FPC UNIT:

- The image sensor (CCD FPC) unit which are connected to the lens unit with 3 screws. These screws are adjusted for the Optical tilt. During servicing, if one of CCD FPC fixing screws are loosened, the Optical tilt adjustment must be performed. About the Optical tilt adjustment, refer to the "9.3.2. Adjustment Specifications" for details.

3.2.2. P.C.B.:

- In order to remove Main P.C.B., it is necessary to remove the solder (3 points) of the battery terminal. It is judged that the analysis of the Main P.C.B. which the battery terminal separated is difficult. So the Main P.C.B. is unit exchange. Please fix individually about the Flash Top P.C.B..

3.2.3. LENS UNIT:

The minimum replacement part size of the Lens part is as shown below.

When servicing, replace the following numbered replacement part size as the smallest size.

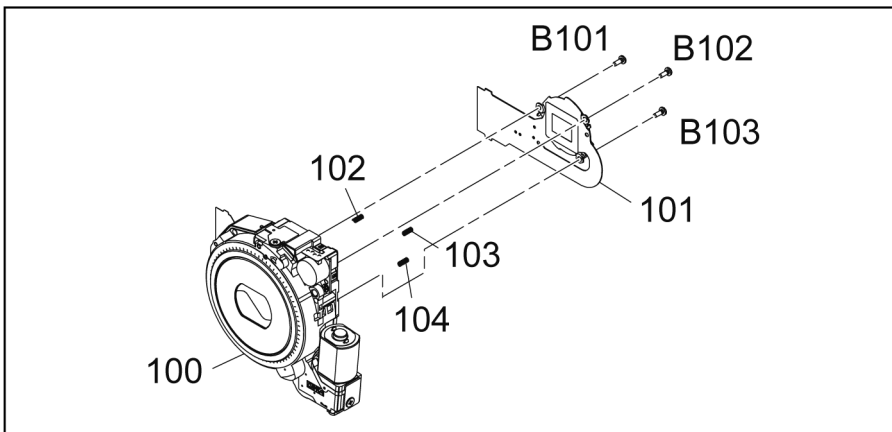

3.2.4. About Flexible Cable and Connector

Do not touch carelessly so that the foreign body should not adhere to the terminal part of flexible cable and connector. Wipe off with a clean cloth and the cotton bud, etc. when the terminal part is dirty.

3.3. General Description About Lead Free Solder (PbF)

The lead free solder has been used in the mounting process of all electrical components on the printed circuit boards used for this equipment in considering the globally environmental conservation.

The normal solder is the alloy of tin (Sn) and lead (Pb). On the other hand, the lead free solder is the alloy mainly consists of tin (Sn), silver (Ag) and Copper (Cu), and the melting point of the lead free solder is higher approx.30°C (86°F) more than that of the normal solder.

Distinction of P.C.B. Lead Free Solder being used

The letter of "PbF" is printed either foil side or components side on the P.C.B. using the lead free solder.(See right figure)	PbF
--	-----

Service caution for repair work using Lead Free Solder (PbF)

- The lead free solder has to be used when repairing the equipment for which the lead free solder is used.
(Definition: The letter of "PbF" is printed on the P.C.B. using the lead free solder.)
- To put lead free solder, it should be well molten and mixed with the original lead free solder.
- Remove the remaining lead free solder on the P.C.B. cleanly for soldering of the new IC.
- Since the melting point of the lead free solder is higher than that of the normal lead solder, it takes the longer time to melt the lead free solder.
- Use the soldering iron (more than 70W) equipped with the temperature control after setting the temperature at 350±30°C (662±86°F).

Recommended Lead Free Solder (Service Parts Route.)

- The following 3 types of lead free solder are available through the service parts route.
RFKZ03D01KS-----(0.3mm 100g Reel)
RFKZ06D01KS-----(0.6mm 100g Reel)
RFKZ10D01KS-----(1.0mm 100g Reel)

Note

* Ingredient: tin (Sn) 96.5%, silver (Ag) 3.0%, Copper (Cu) 0.5%, Cobalt (Co) / Germanium (Ge) 0.1 to 0.3%

3.4. How to Define the Model Suffix (NTSC or PAL model)







There are seven kinds of DMC-FH10 and DMC-FS50, regardless of the colours.

- a) DMC-FH10 (Japan domestic model)
- b) DMC-FH10P/PC
- c) DMC-FS50EB/EF/EG/EP
- d) DMC-FS50EE
- e) DMC-FH10GT
- f) DMC-FH10GN
- g) DMC-FH10PU/GA/GC/GF/GK

What is the difference is that the "INITIAL SETTINGS" data which is stored in Flash-ROM mounted on Main P.C.B..

3.4.1. Defining methods:

To define the model suffix to be serviced, refer to the nameplate which is putted on the bottom side of the Unit.

<p>a) DMC-FH10 (Japan domestic model) The nameplate for this model shows the following Safety registration mark.</p> 
<p>b) DMC-FH10P/PC The nameplate for these models show the following Safety registration mark.</p> 
<p>c) DMC-FS50EB/EF/EG/EP The nameplate for these models show the following Safety registration mark.</p> 
<p>d) DMC-FS50EE The nameplate for this model shows the following Safety registration mark.</p> 
<p>e) DMC-FH10GT The nameplate for this model shows the following Safety registration mark.</p> 
<p>f) DMC-FH10GN The nameplate for this model shows the following Safety registration mark.</p> 
<p>g) DMC-FH10PU/GA/GC/GF/GK The nameplate for these models does not show any above Safety registration mark.</p>

NOTE:

After replacing the Main P.C.B., be sure to achieve adjustment.
The service software is available at "TSN Website".

3.4.2. INITIAL SETTINGS:

After replacing the Main P.C.B., make sure to perform the initial settings after achieving the adjustment by ordering the following procedure in accordance with model suffix of the unit.

1. IMPORTANT NOTICE:

Before proceeding Initial settings, make sure to read the following CAUTIONS.

CAUTION 1:(INITIAL SETTINGS)

--- AFTER REPLACING THE Main P.C.B. and/or Flash-ROM ---

*. The model suffix can be chosen JUST ONE TIME.

*. Once one of the model suffix has been chosen, the model suffix lists will not be displayed, thus, it can not be changed.

CAUTION 2:(Stored picture image data in the unit)

This unit employs "Built-in Memory" for picture image data recording. (Approx.90MB)
After proceeding "INITIAL SETTINGS", the picture image data stored in the unit is erased.

2. PROCEDURES:

• Precautions: Read the above "CAUTION 1" and "CAUTION 2", carefully.

• Preparation:

- Attach the Battery.

(Since this unit has built-in memory, it can be performed without inserting memory card.)

1. Turn the Power on.

2. Press the [MODE] button, and select the [NORMAL PICTURE] mode by Cursor buttons, then press the [MENU/SET] button.

3. Turn the Power off.

(If the unit is other than [NORMAL PICTURE] mode, it does not display the initial settings menu.)

• **Step 1. The temporary cancellation of "INITIAL SETTINGS":**

Press the [PLAYBACK] button, "[UP] of Cursor button" and "[W] side of Zoom button" simultaneously, turn the Power on.

• **Step 2. The cancellation of "INITIAL SETTINGS":**

Press the [PLAYBACK] button in order to enter the [PLAYBACK] mode.

Press the [MENU/SET] button and "[LEFT] of Cursor button" simultaneously, turn the Power off.

The LCD displays the "!" mark before the unit powers down.

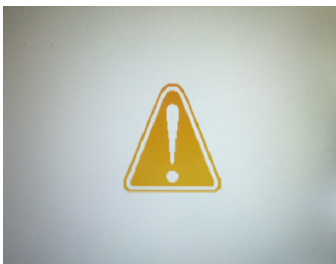

• **Step 3. Turn the Power on:**

Turn the Power on.

• **Step 4. Display the INITIAL SETTING:**

While pressing [MENU/SET] button and “[RIGHT] of Cursor button” simultaneously, turn the Power off.

The “INITIAL SETTINGS” menu is displayed.

There are two kinds of “INITIAL SETTINGS” menu form as follows:

[CASE 1. After replacing Main P.C.B.]

When MAIN P.C.B. has just been replaced, all of the model suffix is displayed as follows. (Five pages in total)

The following table summarizes the model suffix options shown in the screenshots:

Page	Selected Suffix	Other Suffixes
1/5	NONE(JAPAN)	FH10, P, EG, PU, GD
2/5	GC	FH10, GT, GK, EF, EB
3/5	EE	FS50, GN, PC, PR, GJ
4/5	SG	FH10, LB, EC, GH, EP
5/5	EN	FS50, GF, GM, GA, EA

[CASE 2. Other than “After replacing Main P.C.B.”]

< Other than “EG/EF/EB/EP” models >

INITIAL SETTINGS 1/2
GN FH10
Select Set End

< Only “EG/EF/EB/EP” models >

INITIAL SETTINGS 1/2
EG FS50
EF
EB
EC
EP
Select Set End

INITIAL SETTINGS 1/2
EN FS50
Select Set End

• **Step 5. Choose the model suffix in “INITIAL SETTINGS”: (Refer to “CAUTION 1”)**

[Caution: After replacing Main P.C.B.]

The model suffix can be chosen, **JUST ONE TIME**.

Once one of the model suffix have been chosen, the model suffix lists will not be displayed, thus, it can not be changed.

Therefore, select the area carefully.

Select the area with pressing “[UP] / [DOWN] of Cursor buttons”.

• **Step 6. Set the model suffix in “INITIAL SETTINGS”:**

Press the “[RIGHT] of Cursor buttons”.

The only set area is displayed, and then press the “[RIGHT] of Cursor buttons” after confirmation.

(The unit is powered off automatically.)

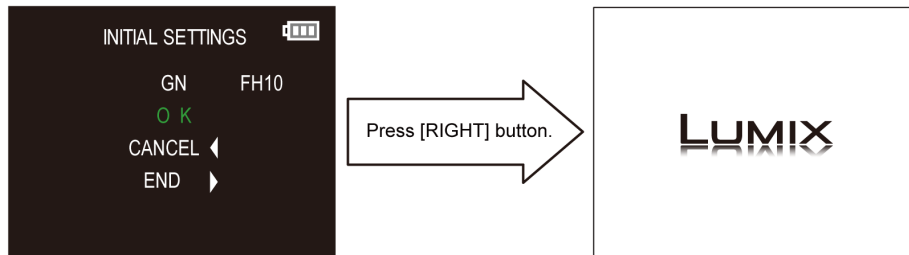

• **Step 7. CONFIRMATION:**

Confirm the display of “PLEASE SET THE CLOCK” in concerned language when the unit is turned on again.

When the unit is connected to PC with USB cable, it is detected as removable media.

(When the “GK” or “GT” model suffix is selected, the display shows “PLEASE SET THE CLOCK” in Chinese.)

1) As for your reference, major default setting condition is as shown in the following table.

• **Default setting (After “INITIAL SETTINGS”)**

	MODEL	VIDEO OUTPUT	LANGUAGE	DATE	REMARKS
a)	DMC-FH10(Japan domestic model)	NTSC	Japanese	Year/Month/Date	
b)	DMC-FH10P	NTSC	English	Month/Date/Year	
c)	DMC-FH10PC	NTSC	English	Month/Date/Year	
d)	DMC-FH10PU	NTSC	Spanish	Month/Date/Year	
e)	DMC-FH10GA	PAL	English	Date/Month/Year	
f)	DMC-FH10GC	PAL	English	Date/Month/Year	
g)	DMC-FH10GF	PAL	English	Date/Month/Year	
h)	DMC-FH10GK	PAL	Chinese (simplified)	Year/Month/Date	
i)	DMC-FH10GN	PAL	English	Date/Month/Year	
j)	DMC-FH10GT	NTSC	Chinese (traditional)	Year/Month/Date	
k)	DMC-FS50EB	PAL	English	Date/Month/Year	
l)	DMC-FS50EE	PAL	Russian	Date/Month/Year	
m)	DMC-FS50EF	PAL	French	Date/Month/Year	
n)	DMC-FS50EG	PAL	English	Date/Month/Year	
o)	DMC-FS50EP	PAL	English	Date/Month/Year	

4 Specifications

The following specification is for DMC-XS1P/DMC-FH10P.

Some specifications may differ depending on model suffix.

Digital Camera: Information for your safety

Power Source:	DC 5 V	
Power Consumption:	1.1 W (When recording) 0.6 W (When playing back)	
Camera effective pixels	16,100,000 pixels	
Image sensor	1/2.33" CCD, total pixel number 16,600,000 pixels, Primary color filter	
Lens	Optical 5× zoom, f=4.3 mm to 21.5 mm (35 mm film camera equivalent: 24 mm to 120 mm)/F2.8 (Wide) to F6.9 (Tele)	
Image stabilizer	Optical method	
Focus range	Normal/ Intelligent auto	5 cm (0.16 feet) (Wide)/ 1 m (3.3 feet) (Tele) to ∞
	Scene Mode	There may be differences in the above settings.
Shutter system	Electronic shutter+Mechanical shutter	
Shutter speed	8 seconds to 1/1600th of a second [Starry Sky] Mode: 15 seconds, 30 seconds, 60 seconds	
Exposure (AE)	Auto (Program AE)	
Metering mode	Multiple	
LCD monitor	2.7" TFT LCD (4:3) (Approx. 230,000 dots) (field of view ratio about 100%)	
Microphone	Monaural	
Speaker	Monaural	
Recording media	Built-in Memory (Approx. 90 MB)/microSD Memory Card/microSDHC Memory Card	
Recording file format		
Still Picture	JPEG (based on "Design rule for Camera File system", based on "Exif 2.3" standard)	
Motion pictures	"QuickTime Motion JPEG" (motion pictures with audio)	
Interface		
Digital	"USB 2.0" (High Speed)	
Analog video	NTSC	
Audio	Audio line output (monaural)	
Terminal		
[AV OUT/DIGITAL]	Dedicated jack (8 pin)	
Dimensions (excluding the projecting parts)	DMC-XS1 Approx. 93.8 mm (W)×53.5 mm (H)×17.6 mm (D) [3.69"(W)×2.11"(H)×0.69"(D)] DMC-FH10 Approx. 93.0 mm (W)×54.6 mm (H)×18.0 mm (D) [3.66"(W)×2.15"(H)×0.71"(D)]	
Mass (weight)	DMC-XS1 Approx. 103 g/0.23 lb (with card and battery) Approx. 88 g/0.19 lb (excluding card and battery) DMC-FH10 Approx. 100 g/0.22 lb (with card and battery) Approx. 85 g/0.19 lb (excluding card and battery)	
Operating temperature	0°C to 40°C (32°F to 104°F)	
Operating humidity	10%RH to 80%RH	
Language select	[ENGLISH]/[ESPAÑOL]	

AC Adaptor (Panasonic VSK0768):

Information for your safety

Input:	~ 110 V to 240 V, 50/60 Hz, 0.2 A
Output:	=== 5 V, 800 mA

Battery Pack (lithium-ion) (Panasonic DMW-BCL7PP):

Information for your safety

Voltage/capacity:	3.6 V/690 mAh
--------------------------	---------------

5 Location of Controls and Components

The following description is for DMC-FH10P.

Some descriptions may differ depending on model suffix.

- 1 Flash (P50)
- 2 Self-timer indicator (P54)
- 3 Lens (P5, 110)

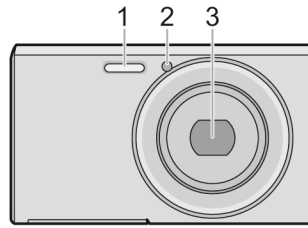

- 4 LCD monitor (P45, 107, 110)
- 5 [MODE] button (P25, 82)
- 6 Charging lamp (P13)
- 7 Zoom button (P47)
- 8 Motion picture button (P32)
- 9 [MENU/SET] button (P38)
- 10 [▶] (Playback) button (P34)
- 11 [⏏/↵] (Delete/Cancel) button (P37)

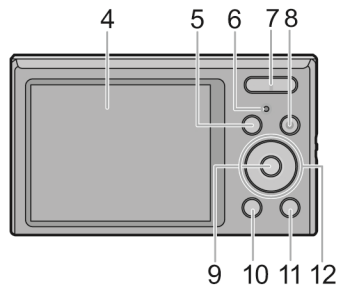

- 12 Cursor buttons
 - (A): ▲/Exposure compensation (P55)
 - (B): ▼/[DISP.] (P45)
 - (C): ◀/Self-timer (P54)
 - (D): ▶/Flash setting (P50)

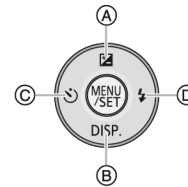

In this Owner's Manual, the cursor buttons are described as shown in the figure below or described with ▲/▼/◀/▶.
 e.g.: When you press the ▼ (down) button

or
Press ▼

-
- 13 Speaker (P41)
 - Be careful not to cover the speaker with your finger. Doing so may make sound difficult to hear.
 - 14 Lens barrel
 - 15 Strap eyelet (P24)
 - Be sure to attach the strap when using the camera to ensure that you will not drop it.
-

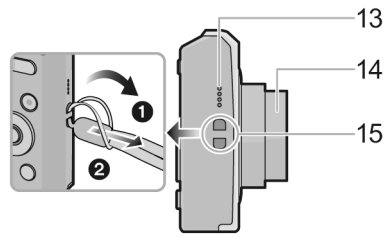

- 16 Camera [ON/OFF] button (P22)
 - 17 Microphone
 - Be careful not to cover the microphone with your finger.
 - 18 Shutter button (P26, 29)
-

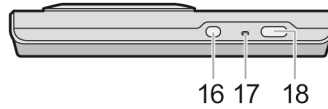

- 19 Tripod mount
 - A tripod with a screw length of 5.5 mm (0.22 inch) or more may damage this unit if attached.
 - 20 [AV OUT/DIGITAL] socket (P13, 96, 100, 102)
 - This socket is also used when charging the battery.
 - Take care not to subject the socket with water or other liquids.
 - 21 Card/Battery door (P12, 18)
 - 22 Release lever (P12, 18)
-

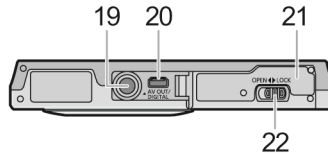

6 Service Mode

6.1. Error Code Memory Function

1. General description

This unit is equipped with history of error code memory function, and can be memorized 16 error codes in sequence from the latest. When the error is occurred more than 16, the oldest error is overwritten in sequence.

The error code is not memorized when the power supply is shut down forcibly (i.e., when the unit is powered on by the battery, the battery is pulled out) The error code is memorized to Flash-ROM when the unit has just before powered off.

2. How to display

The error code can be displayed by ordering the following procedure:

- Preparation
 - Attach the Battery.
 - (Since this unit has built-in memory, it can be performed without inserting memory card.)
- 1. Turn the Power on.
- 2. Press the [MODE] button, and select the [NORMAL PICTURE] mode by Cursor buttons, then press the [MENU/SET] button.
- 3. Turn the Power off.
- (If the unit is other than [NORMAL PICTURE] mode, it does not display the initial settings menu.)
- **Step 1. The temporary cancellation of “INITIAL SETTINGS”:**
Press the [PLAYBACK] button , “[UP] of Cursor button” and “[W] side of Zoom button” simultaneously, turn the Power on.
- **Step 2. Execute the error code display mode:**
Press the [PLAYBACK] button in order to enter the [PLAYBACK] mode.
Press in order of [PLAYBACK] button, [SHUTTER BUTTON] fully, and “[LEFT] of Cursor button”.
Finally those states are press simultaneously.
The display is changed as shown below when the above buttons are pressed simultaneously.
Normal display → Error code display → Operation history display → Normal display →.....

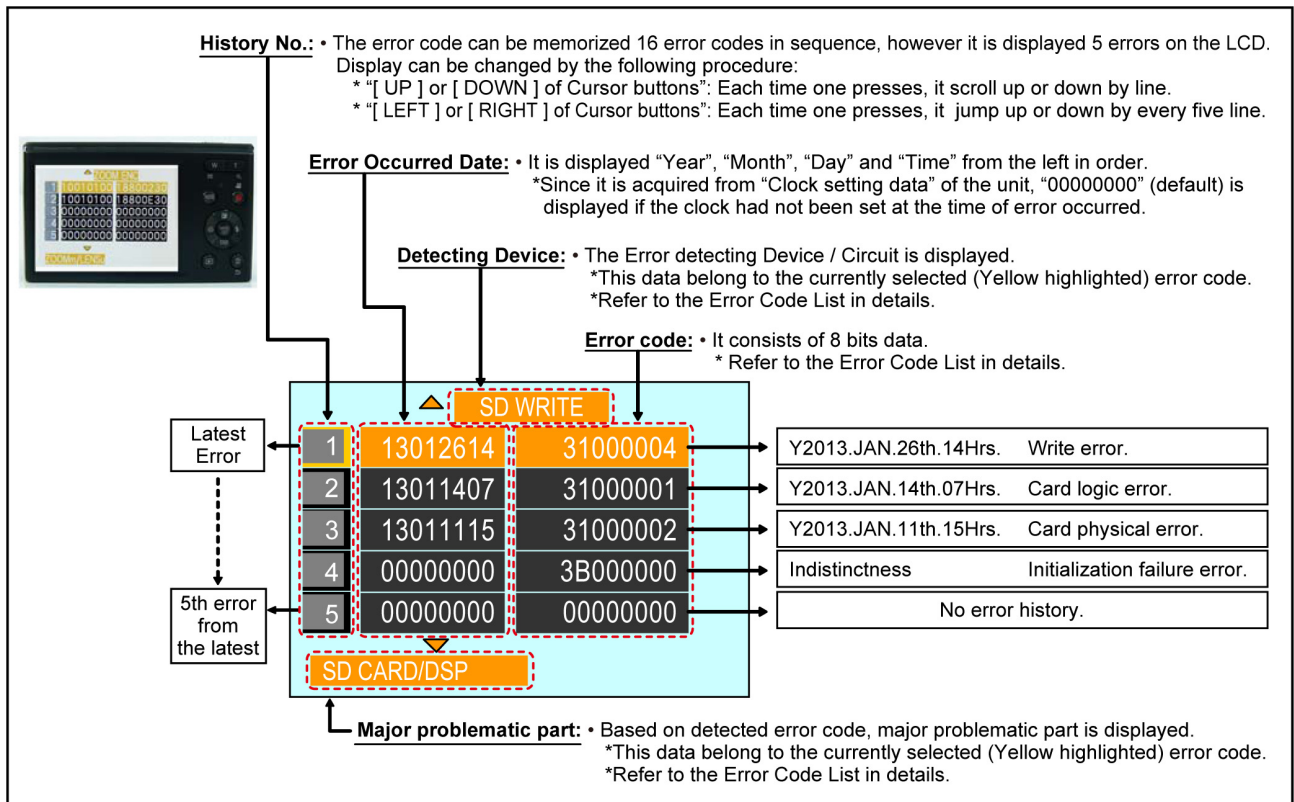

Example of Error Code Display

Error Code List

The error code consists of 8 bits data and it shows the following information.

Attribute	Main item	Sub item	Error code		Contents (Upper line)		Error Indication	
			High 4 bits	Low 4 bits	Problematic Part & Check point (Lower line)		Detecting device	Problematic Part/Circuit
LENS	Lens drive	Focus	18*0	0701	HP Low detect error (Focus encoder always detects High, and not becomes Low)	FOCUS L	LENS FPC/ DSP	
					Mechanical lock or IC6001 (DSP)			
			18*0	0702	HP High detect error (Focus encoder always detects Low, and not becomes High)	FOCUS H	LENS FPC/ DSP	
					Mechanical lock or IC6001 (DSP)			
			Zoom	18*0	0710	Collapsible barrel Low detect error (Collapsible barrel encoder always detects Low.)	ZOOM L	ZOOMm/ LENSu
						Mechanical lock or IC6001 (DSP)		
				18*0	0720	Collapsible barrel High detect error (Collapsible barrel encoder always detects High.)	ZOOM H	ZOOMm/ LENSu
						Mechanical lock or IC6001 (DSP)		
		18*0		0730	Zoom motor sensor error.	ZOOM ENC	ZOOMm/ LENSu	
					Mechanical lock or IC6001 (DSP)			
		18*0		0740	Zoom motor sensor error. (During monitor mode.)	ZOOM ENC	ZOOMm/ LENSu	
					Mechanical lock or IC6001 (DSP)			
		OIS	18*0	1000	PSD (X) error. Hall element (X axis) position detect error in OIS unit.	OIS X	LENSu NG	
					OIS Unit			
			18*0	2000	PSD (Y) error. Hall element (Y axis) position detect error in OIS unit.	OIS Y	LENSu NG	
					OIS Unit			
			18*0	3000	GYRO (X) error. Gyro (IC7101: X axis) detect error on MAIN P.C.B..	JYRO X	JYRO NG	
					IC7101 (Gyro element) or IC6001 (DSP)			
			18*0	4000	GYRO (Y) error. Gyro (IC7101: Y axis) detect error on MAIN P.C.B..	JYRO Y	JYRO NG	
					IC7101 (Gyro element) or IC6001 (DSP)			
		Lens	18*0	5000	GYRO (R) error. Gyro (IC7101: R axis) detect error on MAIN P.C.B..	JYRO R	JYRO NG	
					IC7101 (Gyro element) or IC6001 (DSP)			
			18*0	6000	Drive voltage (X) error.	OISX REF	LENSu/LENS FPC	
					LENS Unit, LENS flex breaks, IC6001 (DSP) AD value error, etc.			
			18*0	7000	Drive voltage (Y) error.	OISY REF	LENSu/LENS FPC	
					LENS Unit, LENS flex breaks, IC6001 (DSP) AD value error, etc.			
			18*0	8000	OIS GYRO-Digital communication error	(No indication)	(No indication)	
					IC7101(Gyro element) or IC6001(DSP)			
		Adj. History	OIS	10*8	0000	Lens cap error	(No indication)	(No indication)
						Zoom motor,Zoom pulse encoder2		
				18*1	0000	Power ON time out error.	LENS DRV	LENSu
						Lens drive system		
	18*2			0000	Power OFF time out error.	LENS DRV	LENSu	
					Lens drive system			
	10*8			0000	Lens cap error	(No indication)	(No indication)	
					Zoom motor,Zoom pulse encoder2			
	19*0			2000	OIS adj. Yaw direction amplitude error (small)	OIS ADJ	OIS ADJ	
					OIS adj. Pitch direction amplitude error (small)	OIS ADJ	OIS ADJ	
	19*0			4000	OIS adj. Yaw direction amplitude error (large)	OIS ADJ	OIS ADJ	
					OIS adj. Pitch direction amplitude error (large)	OIS ADJ	OIS ADJ	
19*0	8000			OIS adj. Yaw direction off set error	OIS ADJ	OIS ADJ		
				OIS adj. Pitch direction off set error	OIS ADJ	OIS ADJ		
19*0	A000			OIS adj. Yaw direction gain error	OIS ADJ	OIS ADJ		
				OIS adj. Pitch direction gain error	OIS ADJ	OIS ADJ		
19*0	C000	OIS adj. Yaw direction position sensor error	OIS ADJ	OIS ADJ				
		OIS adj. Pitch direction position sensor error	OIS ADJ	OIS ADJ				
19*0	E000	OIS adj. other error	OIS ADJ	OIS ADJ				
HARD	FLASH	Flash	28*0	0000	Flash charging error.	STRB CHG	STRB PCB/ FPC	
					IC6001-(U13) signal line or Flash charging circuit			
			2000	0000	Flash charging error.	STRB CHG	STRB PCB/ FPC	
					IC6001-(U13) signal line or Flash charging circuit			
	FLASH ROM (EEPROM Area)	FLASH ROM (EEPROM Area)	2B*0	0001	EEPROM read error	FROM RE	FROM	
					IC6002 (FLASH ROM)			
			2B*0	0002	EEPROM write error	FROM WR	FROM	
				IC6002 (FLASH ROM)				
		2B*0	0005	Firmware version up error	(No indication)	(No indication)		
				Replace the firmware file in the memory card.				
SYSTEM	RTC	RTC	2C*0	0001	SYSTEM IC initialize failure error	SYS INIT	MAIN PCB	
					Communication between IC6001 (DSP)			

Attribute	Main item	Sub item	Error code		Contents (Upper line) Problematic Part & Check point (Lower line)	Error Indication	
			High 4 bits	Low 4 bits		Detecting device	Problematic Part/Circuit
SOFT	CPU	Reset	30*0	0000 0007	NMI reset Non Mask-able Interrupt (30000001-30000007 are caused by factors)	NMI RST	MAIN PCB
	CPU, ASIC hard	Stop	38*0	0001	Camera task finish process time out.	LENS COM	LENSu/DSP
					Communication between Lens system and IC6001 (DSP)		
			38*0	0002	Camera task invalid code error.	DSP	DSP
					IC6001 (DSP)		
			38*0	0100	File time out error in recording motion image	DSP	DSP
					IC6001 (DSP)		
	38*0	0200	File data cue send error in recording motion image	DSP	DSP		
			IC6001 (DSP)				
	Memory Area	3A00	0008	USB work area partitioning failure	(No indication)	(No indication)	
				USB dynamic memory securing failure when connecting	(No indication)	(No indication)	
	Operation	Power on	3B*0	0000	FLASHROM processing early period of camera during movement.	INIT	(No indication)
	Zoom	Zoom	3C*0	0000	Inperfect zoom lens processing	ZOOM	ZOOMm/ LENSu
					Zoom lens		
35*0			0000 FFFF	Change to the dummy processing (=Illegal command) (0-7bit : command, 8-15bit : status)	DSP	DSP	
				Though record preprocessing is necessary, it is not called.	(No indication)	(No indication)	
35*2	0000	Though record preprocessing is necessary, it is not completed.	(No indication)	(No indication)			

Important notice about “Error Code List”

1) About “*” indication:

The third digit from the left is different as follows.

- In case of 0 (example: 1801000)

When the third digit from the left shows “0”, this error occurred under the condition of INITIAL SETTINGS has been completed.

It means that this error is occurred basically at user side.

- In case of 8 (example: 1881000)

When the third digit from the left shows “8”, this error occurred under the condition of INITIAL SETTINGS has been released.

(Example; Factory assembling-line before unit shipment, Service mode etc.)

It means that this error is occurred at service side.

2) About “?” indication: (“18*0 0?01” to “18*0 0?60”):

The third digit from the right shows one of the hexadecimal (“0” to “F”) character.

• Step 3. How to exit from Error Code display mode:

Simply, turn the power off. (Since Error code display mode is executed under the condition of temporary cancellation of “INITIAL SETTINGS”, it wake up with normal condition when turn off the power.)





NOTE:

The error code can not be initialized.

7 Service Fixture & Tools

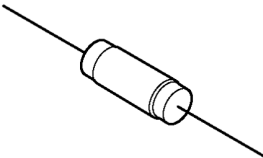
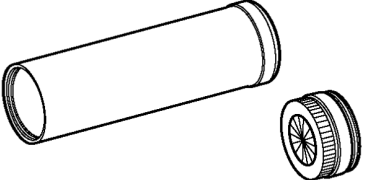
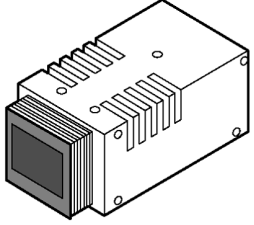
7.1. Service Fixture and Tools

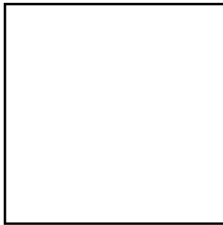
The following Service Fixture and tools are used for checking and servicing this unit.

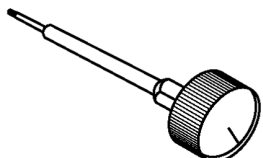
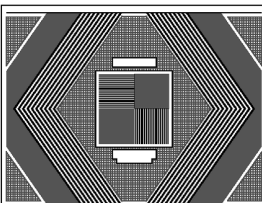
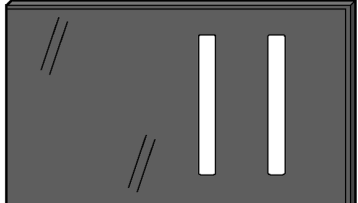
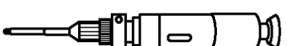
Resistor for Discharging (1k Ω /5W) ERG5SJ102	Collimator (with Focus Chart) VFK1164TCM02	LIGHT BOX (with DC Cable) RFKZ0523
 <p>* An equivalent type of Resistor may be used.</p>	 <p>* VFK1164TCM03 can be used. * RFKZ0422 can be used.</p>	 <p>* VFK1164TDVLB can be used.</p>
Lens Cleaning Kit (BK) VFK1900BK	ND FILTER (ND0.3) RFKZ0513	Diffuser RFKZ0591
 <p>* Only supplied 10 set/box.</p>		
Driver (for optical axis adjustment) RFKZ0609	Optical axis adjustment chart RFKZ0570	Camera stand RFKZ0333J
 <p>* T3 Torx type</p>		
Torque Driver RFKZ0542		
		

7.2. When Replacing the Main P.C.B.

After replacing the Main P.C.B., be sure to achieve adjustment.

The service software is available at "TSN Website".

7.3. Service Position

Check the Flash Top P.C.B., when servicing this DSC.(Refer to the following.)

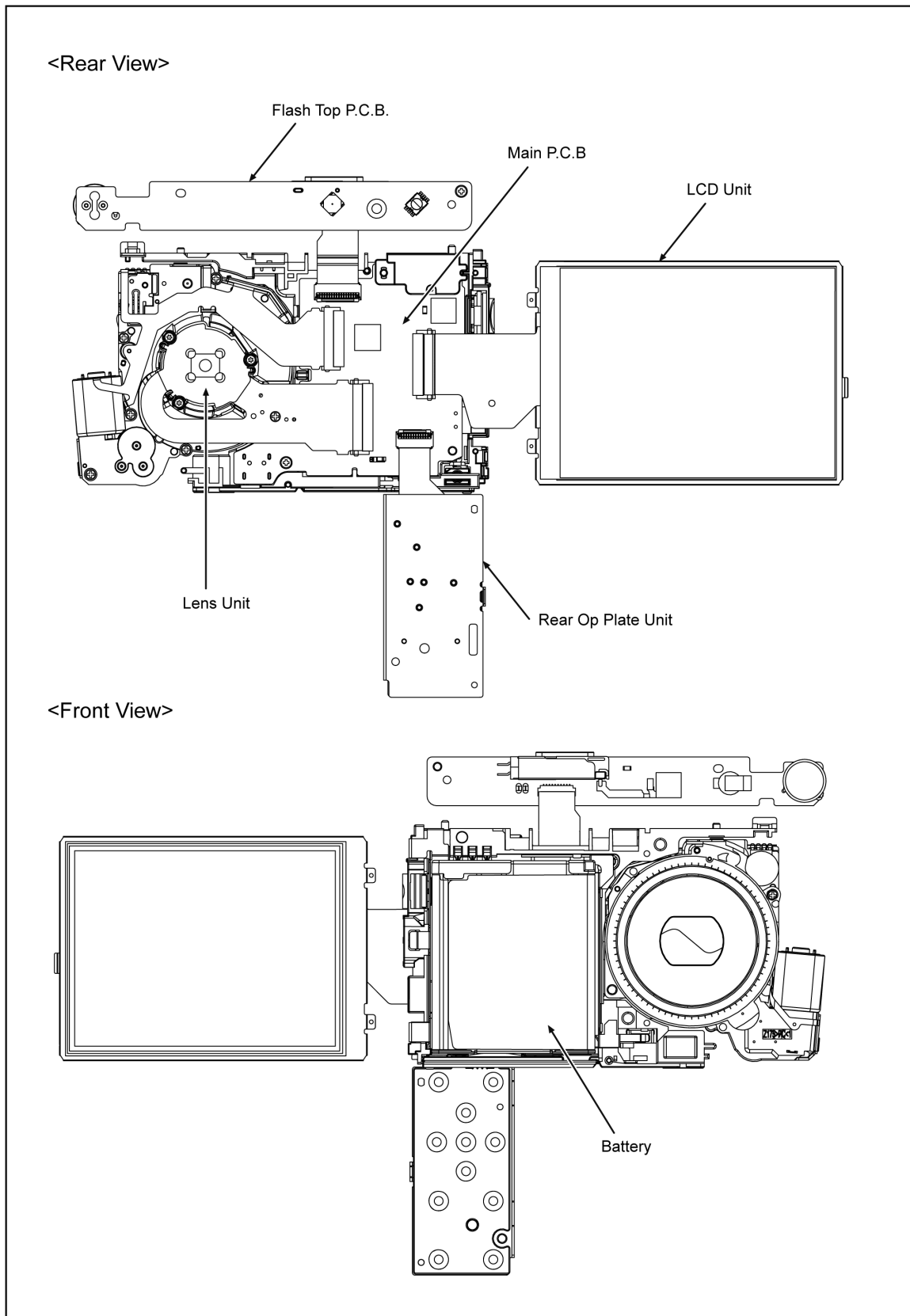

CAUTION. (When servicing Flash Top P.C.B.)

1. Be sure to discharge the E.Capacitor on Flash Top P.C.B..
Refer to "How to Discharge the E.Capacitor on Flash Top P.C.B.".
The E.Capacitor voltage is not lowered soon even if the AC Cord is unplugged or the battery is removed.
2. Be careful of the high voltage circuit on Flash Top P.C.B..
3. DO NOT allow other parts to touch the high voltage circuit on Flash Top P.C.B..

8 Disassembly and Assembly Instructions

8.1. Disassembly Flow Chart

This is a disassembling chart.

When assembling, perform this chart conversely.

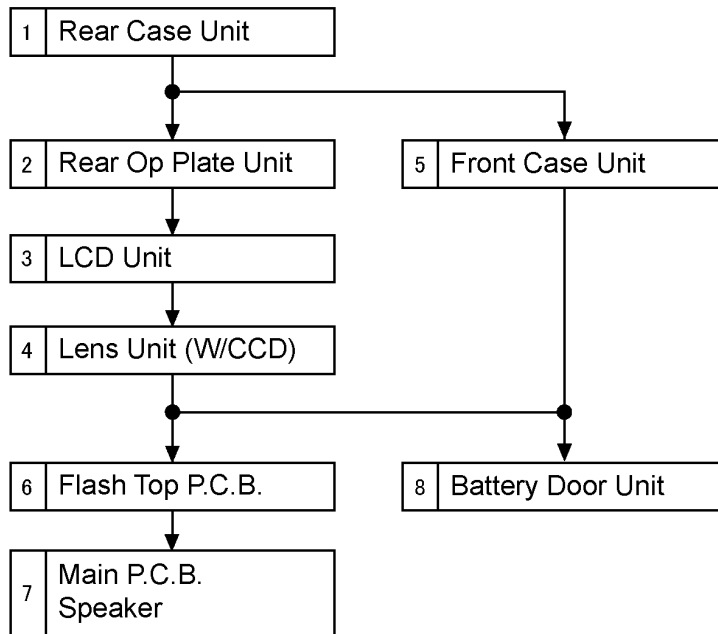

8.2. P.C.B. Location

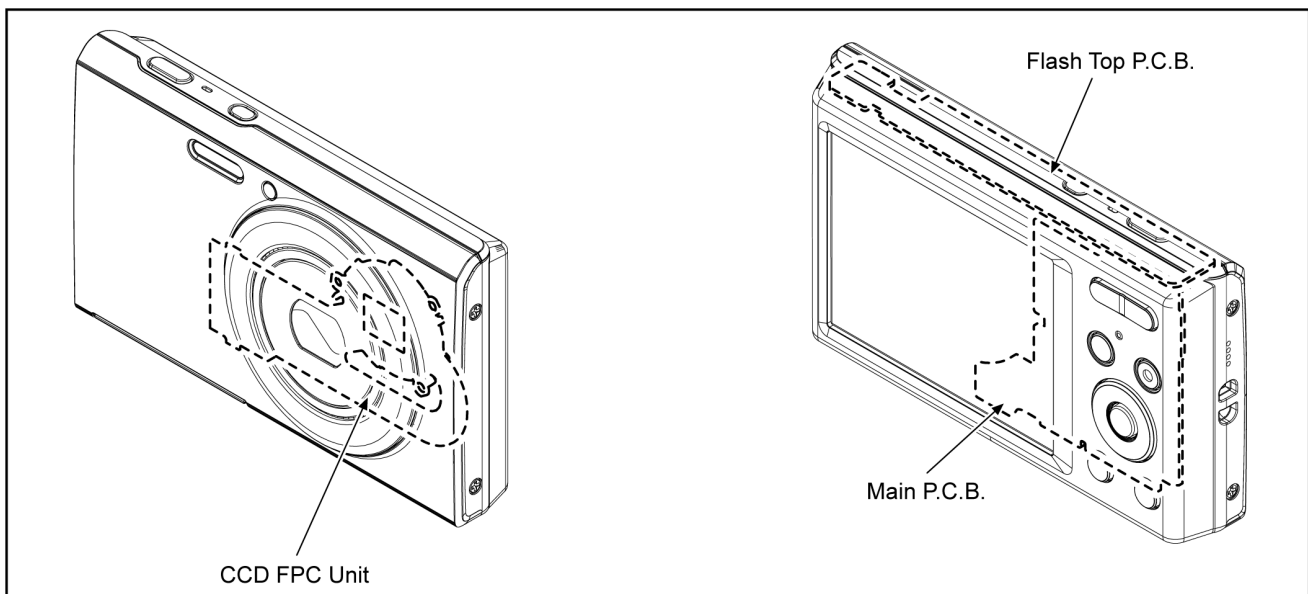

8.3. Disassembly Procedure

No.	Item	Fig	Removal	
1	Rear Case Unit	(Fig. D1)	Memory Card	
			Battery	
		(Fig. D2)	1 Screws (A)	
			4 Screws (B)	
2	Rear Op Plate Unit	(Fig. D3)	3 Locking tabs	
			Rear Case Unit	
			1 Screw (C)	
			1 Locking tab	
			2 Convexes	
			Connector (A)	
3	LCD Unit	(Fig. D4)	Rear Op Plate Unit	
			1 Locking tab	
			2 Convexes	
			Connector (B)	
4	Lens Unit (W/CCD)	(Fig. D5)	LCD Unit	
			1 Screw (D)	
			1 Screw (E)	
			3 Locking tabs	
			2 Convexes	
			Frame Plate	
			Connector (C)	
			Connector (D)	
			Lens Unit (W/CCD)	
5	Front Case Unit	(Fig. D6)	Front Case Unit	
			(Discharge the E.Capacitor)	
6	Flash Top P.C.B.	(Fig. D8)	Connector (E)	
			(Fig. D9)	1 Screw (F)
				1 Locking tab
				2 Convexes
7	Main P.C.B. Speaker	(Fig. D10)	Flash Top P.C.B.	
			Terminal Cover	
			3 Solders	
			1 Screw (G)	
			1 Convex	
			Main P.C.B.	
			2 Solders	
			Speaker	
8	Battery Door Unit	(Fig. D11)	Battery Door Unit	
			Battery Door Spring	
			Battery Door Shaft	
			AF Panel Light	
			Battery Door Unit	

8.3.1. Removal of the Rear Case Unit

NOTE:

When servicing and reassembling, remove the memory card and battery from the unit.

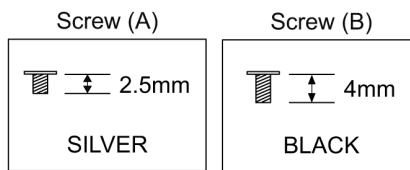
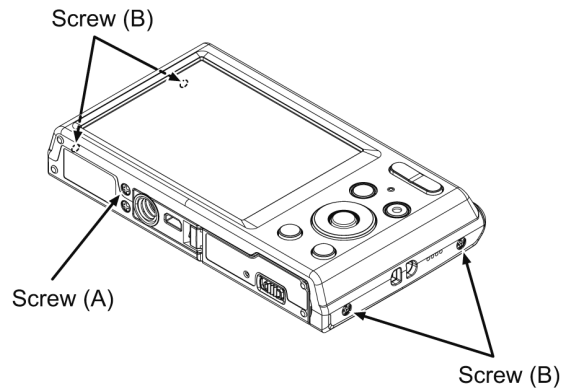
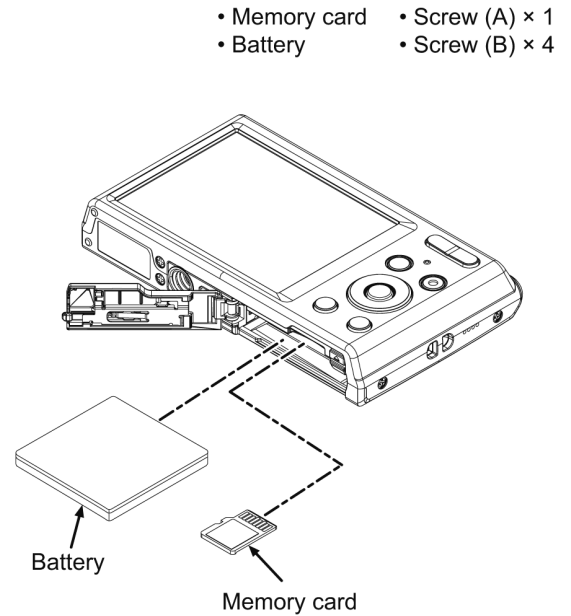

(Fig. D1)

8.3.2. Removal of the Rear Op Plate Unit

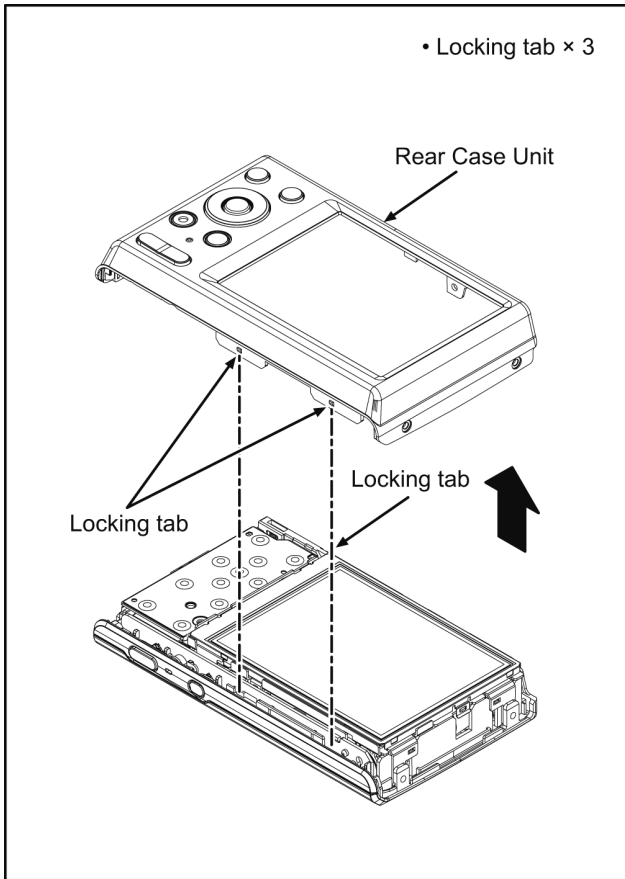

(Fig. D2)

NOTE: (When Installing)

- When install the Rear Op Plate Unit, align the convex and the hole of Rear Op Plate Unit.

- Screw (C) × 1
- Convex × 2
- Locking tab × 1
- Connector (A)

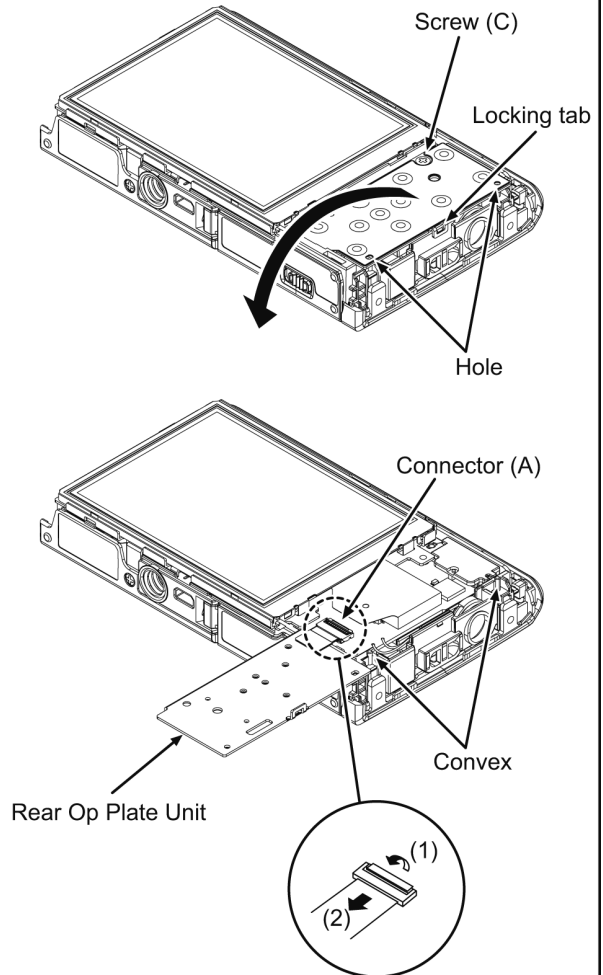

NOTE: (When Replacing)

- When remove the Rear Op Plate Unit, remove the locking tab and half rotated in the direction of arrow.
- When remove the flex, pull up the locking tab in the direction of arrow (1), and then remove the flex in the direction of arrow (2).
- Take care not to damage the flex.

Screw (C)

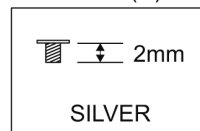

(Fig. D3)

8.3.3. Removal of the LCD Unit

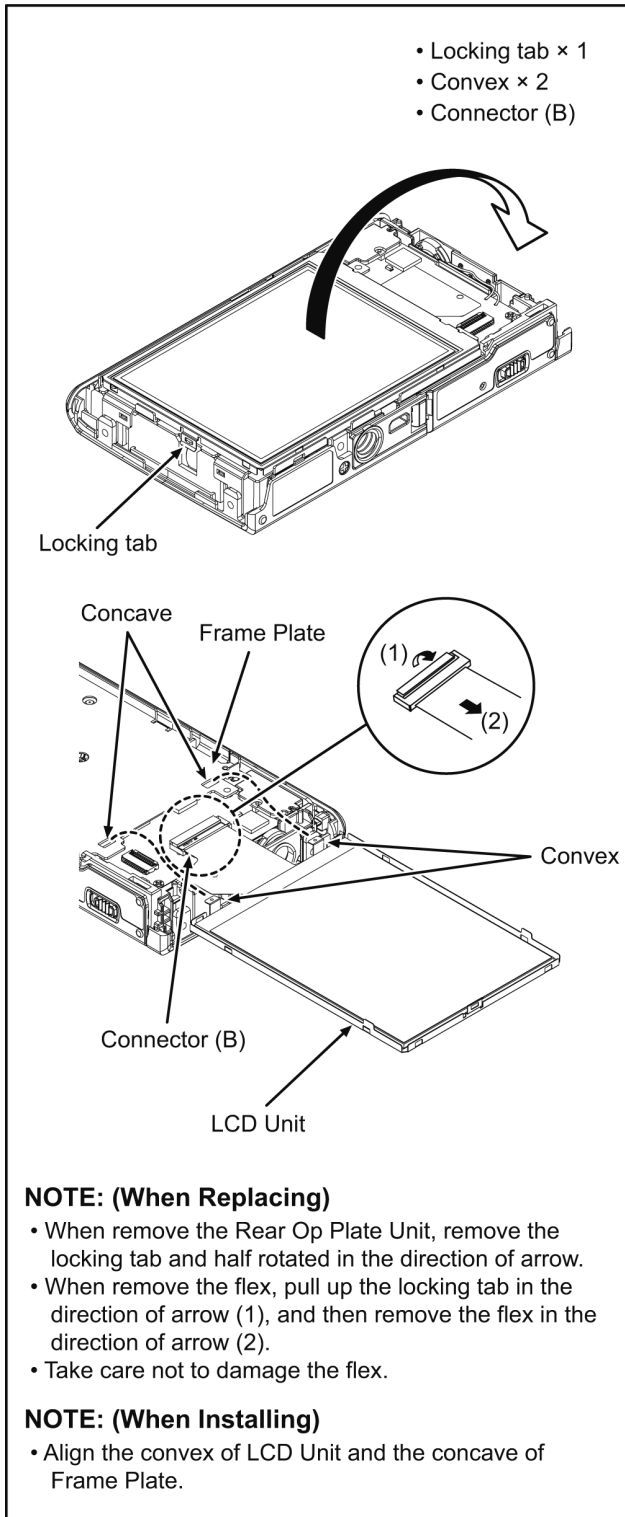

(Fig. D4)

8.3.4. Removal of the Lens Unit (W/CCD)

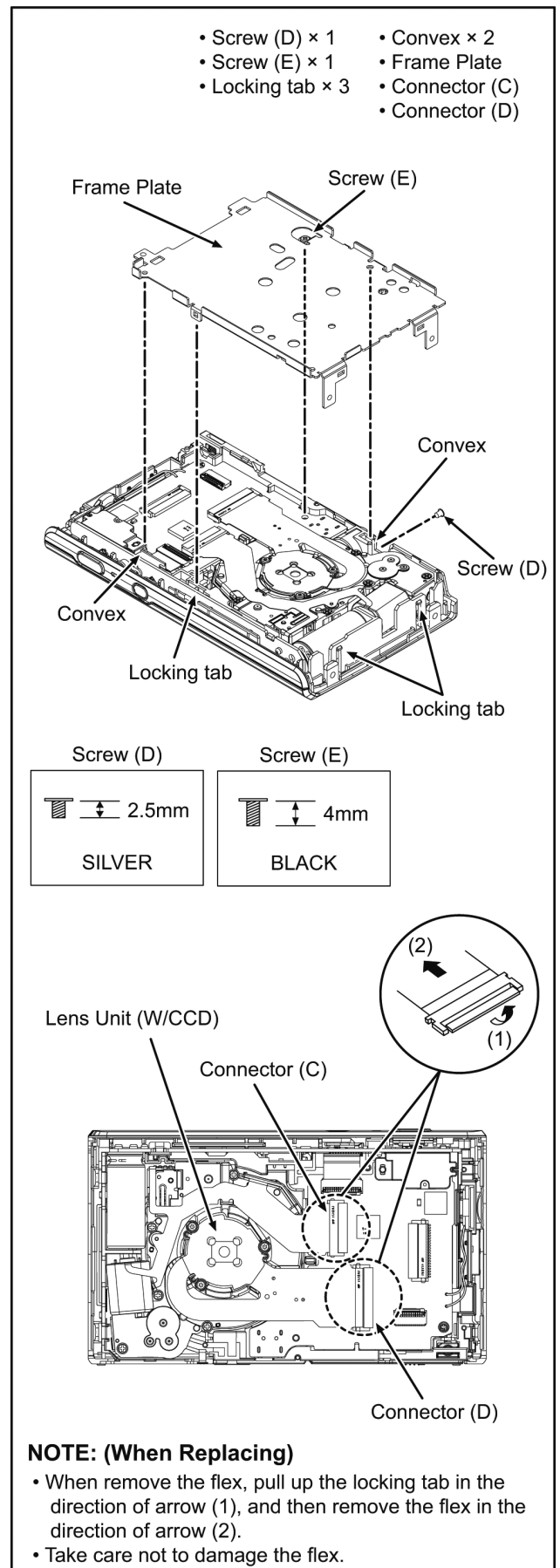

(Fig. D5)

8.3.5. Removal of the Front Case Unit

IMPORTANT NOTICE:

- Take care not apply any bending load to the charging E.Capacitor.
It brings about the possibility of Flash Top P.C.B. and /or component damage on the Flash Top P.C.B..

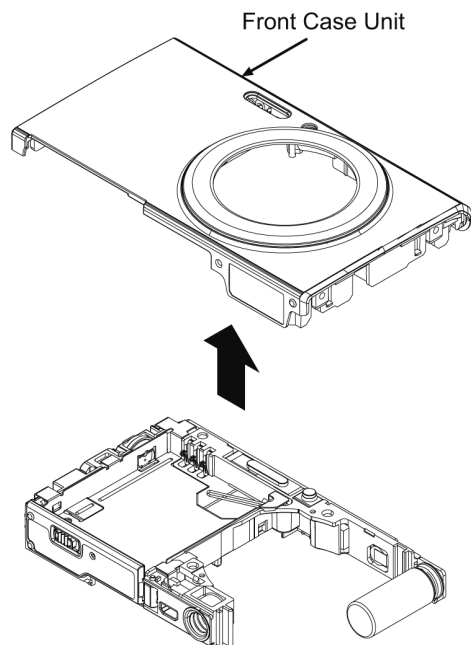

(Fig. D6)

IMPORTANT NOTICE:

- Take care not apply any bending load to the charging E.Capacitor.
It brings about the possibility of Flash Top P.C.B. and /or component damage on the Flash Top P.C.B..

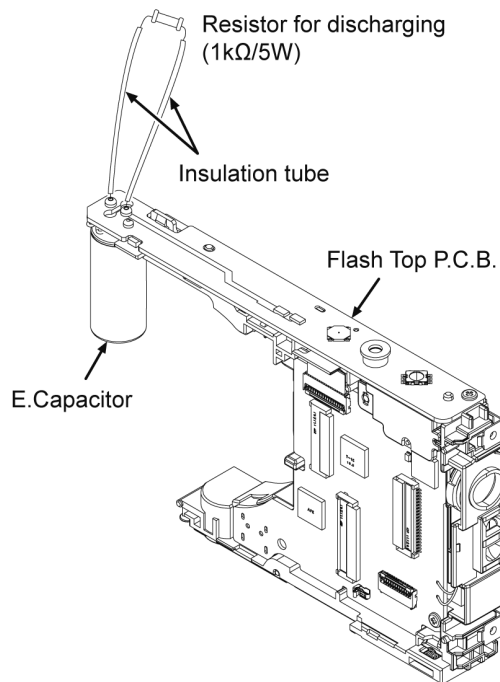

⚠ CAUTION

- Be sure to discharge the E.Capacitor on Flash Top P.C.B. before disassembling.
 - Be careful of the high voltage circuit on Flash Top P.C.B. when servicing.
1. Put the insulation tube on the lead part of resistor (ERG5SJ102: 1kΩ / 5W).
(An equivalent type of resistor may be used.)
 2. Put the resistor between both terminals of E.Capacitor on the Flash Top P.C.B. for approx. 5 seconds.
 3. After discharging, confirm that the E.Capacitor voltage is lower than 10V by using a voltmeter.

(Fig. D7)

8.3.6. Removal of the Flash Top P.C.B.

IMPORTANT NOTICE:

- Take care not apply any bending load to the charging E.Capacitor. It brings about the possibility of Flash Top P.C.B. and /or component damage on the Flash Top P.C.B..

• Connector (E)

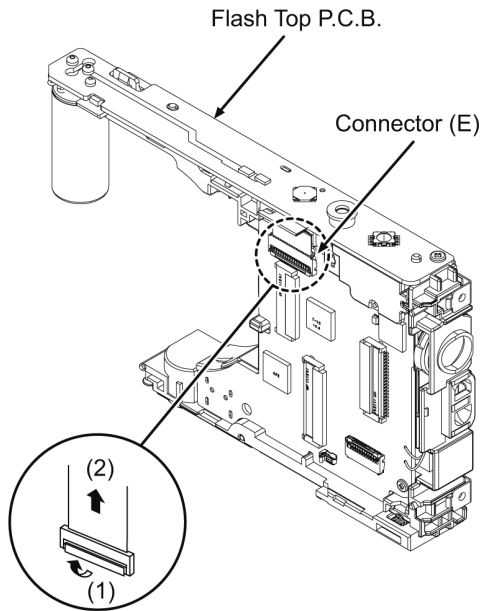

NOTE: (When Replacing)

- When remove the flex, pull up the locking tab in the direction of arrow (1), and then remove the flex in the direction of arrow (2).
- Take care not to damage the flex.

(Fig. D8)

IMPORTANT NOTICE:

- Take care not apply any bending load to the charging E.Capacitor. It brings about the possibility of Flash Top P.C.B. and /or component damage on the Flash Top P.C.B..

- Screw (F) × 1
- Locking tab × 1
- Convex × 2

NOTE: (When Installing)

- When install the Flash Top P.C.B., align the convex and the hole of Flash Top P.C.B..

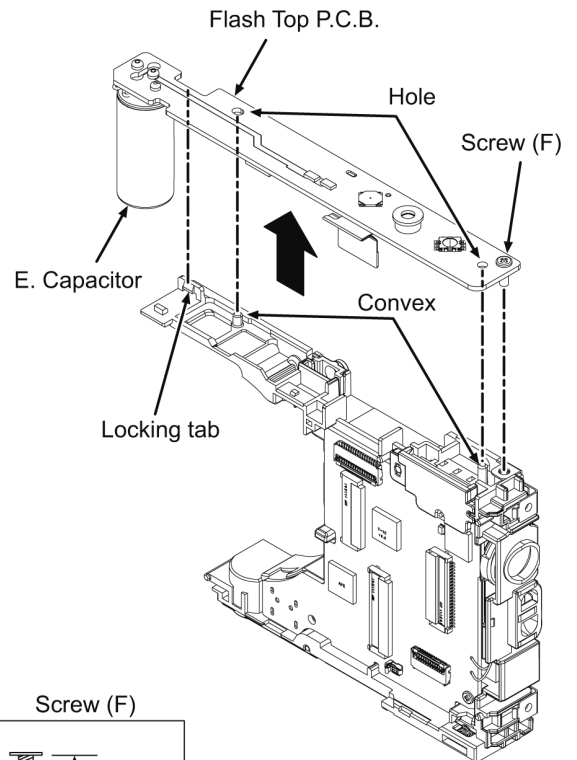

Screw (F)



BLACK

(Fig. D9)

8.3.7. Removal of the Main P.C.B. and Speaker

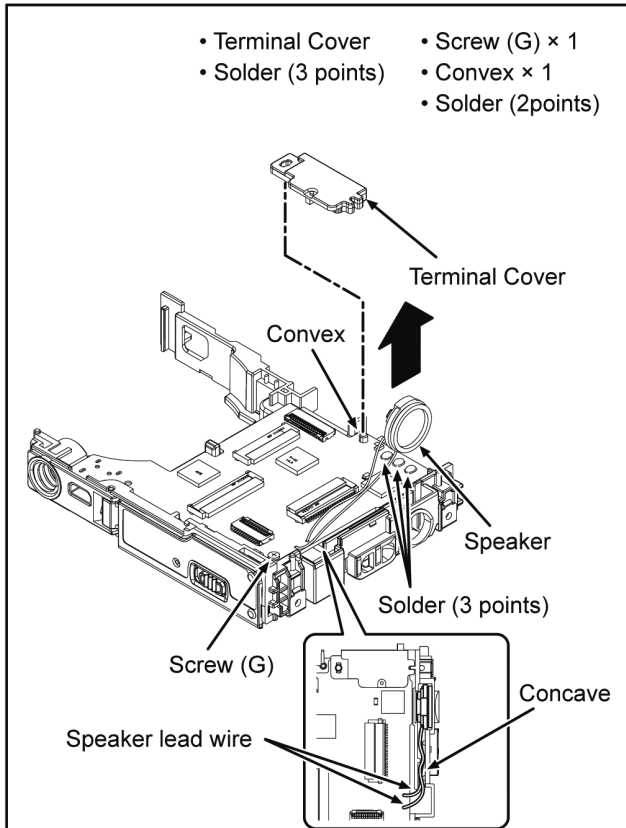

NOTE: (When Installing)

- Wiring the speaker lead wire to concave.

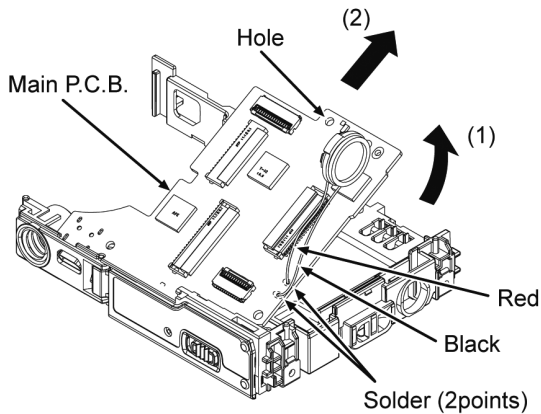

NOTE: (When Replacing)

- Lift the Main P.C.B. in the direction of arrow (1), and then remove in the direction of arrow (2).

Screw (G)

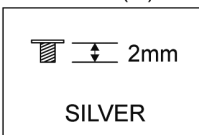

(Fig. D10)

[When Installing]

CATION: Before soldering the Terminal A (Connecting part of Main P.C.B. and Frame Unit).

Before soldering the Terminal A, make sure to tighten the "Screw (G)" first in order to eliminate the gap between Main P.C.B. and Frame Unit. Otherwise, soldered terminal A part may be damaged after assembling.

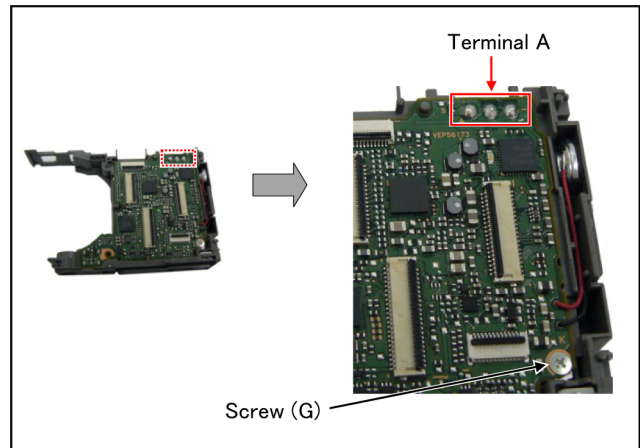

8.3.8. Removal of the Battery Door Unit

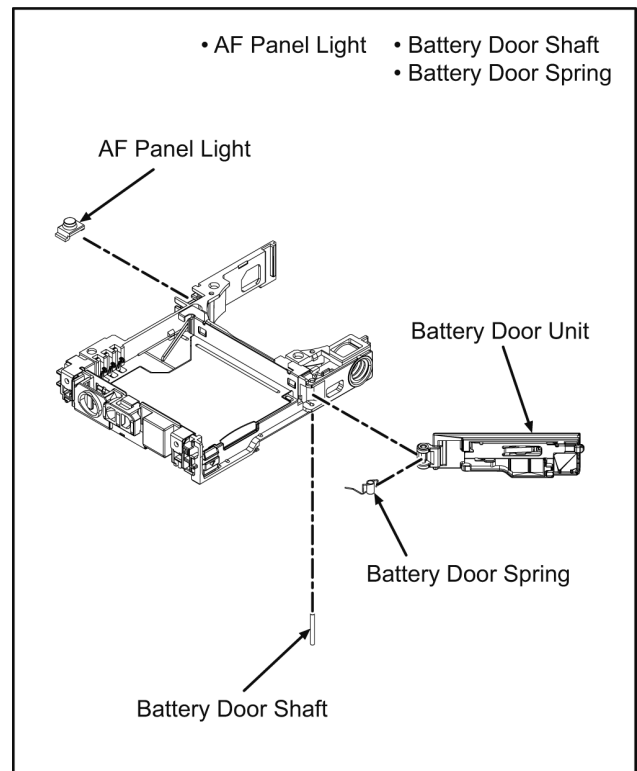

(Fig. D11)

NOTE: (When Installing)

Make sure to confirm the following points when installing:

- The Screw is tightened enough.
- Installing conditions are fine. (No distortion, no abnormal-space.)
- No dust and/or dirt on Lens surfaces.
- LCD image is fine. (No dust and dirt on it, and no gradient images.)

8.4. Removal of the CCD FPC Unit

When remove the CCD FPC unit once (the screw (H) is loosened even a little), the optical tilt adjustment is required.

When loosen the screw (H), necessary the optical tilt adjustment at the end of assembling. (Refer to item "9.3.2.")

To prevent the CCD FPC unit from catching the dust and dirt, do not remove the CCD FPC unit except for replacing.

■ CAUTION

- The screw (H) is fixed by the screw locking glue with the optical tilt adjustment finished. When remove the CCD FPC Unit, wipe the screw locking glue away carefully.
- Don't reuse the screw (H) that the screw locking glue adheres to keep dust or dirt away from the CCD FPC Unit. (When installing, use new screw (H).)

• Screw (H) × 3 • Tilt Spring × 3

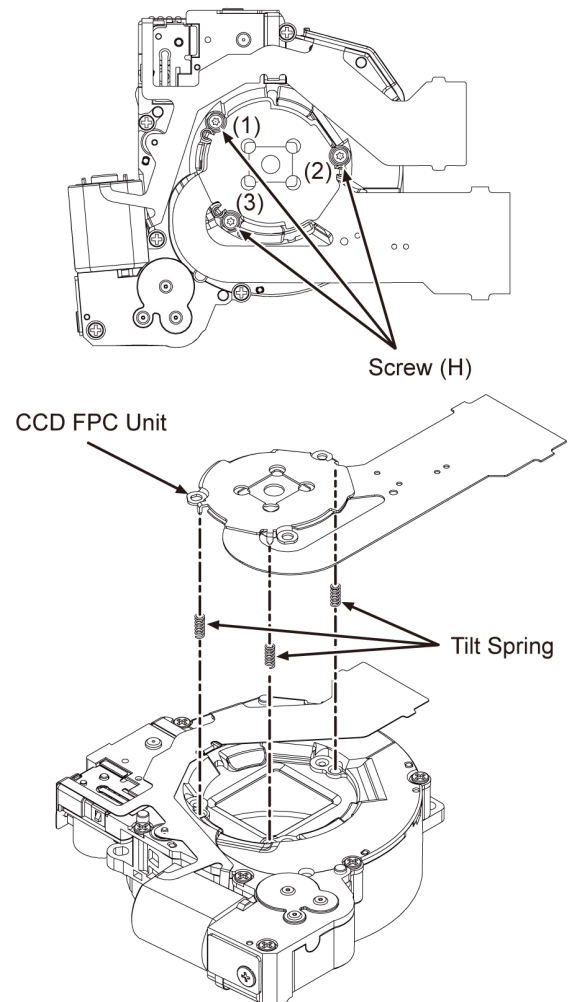

NOTE: (When Installing)

- Take new screw.
(Don't reuse the screw that the screw locking glue adheres.)
- Tighten the 3 special screws according to the following.
* Set the bit of adjustment driver (RFKZ0609) to the torque driver (RFKZ0542).
[Screw order]: (2)→(1)→(3).
[Screw torque]: 5 ± 1 N·cm.
- Be sure to execute the optical tilt adjustment with the screw (1), (2) and (3).
- After the adjustment is finished, the screw locking glue is unnecessary.

Screw (H)

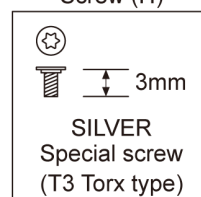

(Fig. D12)

9 Measurements and Adjustments

9.1. Introduction

When servicing this unit, make sure to perform the adjustments necessary based on the part(s) replaced.

Before disassembling the unit, it is recommended to back up the camera data stored in Flash-ROM as a data file.

IMPORTANT NOTICE (After replacing the Main P.C.B.)

After replacing the Main P.C.B., it is necessary to use the “DIAS” software to allow the release of adjustment flag(s).

The Adjustment software “DIAS” is available at “TSN Website”.

*DIAS (DSC Integrated Assist Software)

NOTE: (When replacing the Lens unit and CCD FPC unit)

- When the CCD FPC unit is unavoidably removed for Lens unit and CCD FPC unit replaced, an optical tilt adjustment is necessary after parts are exchanged.
- The adjustment software (DSC_Tilt) is necessary to execute an optical tilt adjustment.
- The adjustment software “DSC_Tilt” is available at “TSN Website”.

NOTE: (When replacing the Main P.C.B.)

- Number of necessary adjustment items decreases by copying the backup data to new Main P.C.B. when adjustment data in old Main P.C.B. can be read by ROM_BACKUP “DSC→SD” in “9.2.2. Flash-ROM Data Backup”.
- For more details, please refer an item “Main P.C.B. (to which the backup data was copied)” in the table of “9.3.2. Adjustment Specifications”.

9.2. Before Disassembling the unit

9.2.1. Initial Setting Release

The cameras specification are initially set in accordance with model suffix (such as EB/EG/GK/GC and so on.).

Unless the initial setting is not released, an automatic alignment software in the camera is not able to be executed when the alignment is carried out.

Note:

The initial setting should be again done after completing the alignment. Otherwise, the camera may not work properly.

Therefore as a warning, the camera display a warning symbol “ ! ” on the LCD monitor every time the camera is turned off.

Refer to the procedure described in “3.4.2. INITIAL SETTINGS” for details.

[How to Release the camera initial setting]

Preparation:

- Attach the Battery.

(Since this unit has built-in memory, it can be performed without inserting memory card.)

1. Turn the Power on.
2. Press the [MODE] button, and select the [NORMAL PICTURE] mode by Cursor buttons, then press the [MENU/SET] button.
3. Turn the Power off.

(If the unit is other than [NORMAL PICTURE] mode, it does not display the initial settings menu.)

Step 1. The temporary cancellation of “INITIAL SETTINGS”:

Press the [PLAYBACK] button, “[UP] of Cursor button” and “[W] side of Zoom button” simultaneously, turn the Power on.

Step 2. Cancellation of “INITIAL SETTINGS”:

Press the [PLAYBACK] button in order to enter the [PLAYBACK] mode.

Press the [MENU/SET] button and “[LEFT] of Cursor button” simultaneously, turn the Power off.

The LCD displays the “ ! ” mark before the unit powers down.

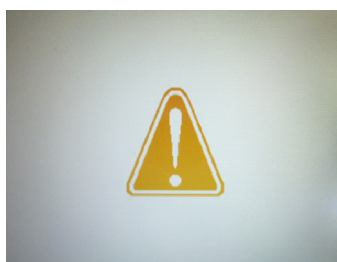

9.2.2. Flash-ROM Data Backup

Number of necessary adjustment items decreases by copying the backup data to new Main P.C.B. when adjustment data in old Main P.C.B. is usually read by ROM_BACKUP “DSC→SD”.

It is recommended to backup the Flash-ROM data as the way of return when trouble occurs before disassembling the unit depending on each case.

[ROM_BACKUP (Method of Non-PC backup)]

1. Insert the memory card into the camera.
2. Set the camera to “Temporary cancellation of the initial settings”.
3. Select the “SETUP” menu.

From the “SETUP” menu, select “ROM_BACKUP”.

NOTE:

This item is not listed on the customer's “SETUP” menu.

4. When this “ROM_BACKUP” item is selected, the following submenus are displayed.

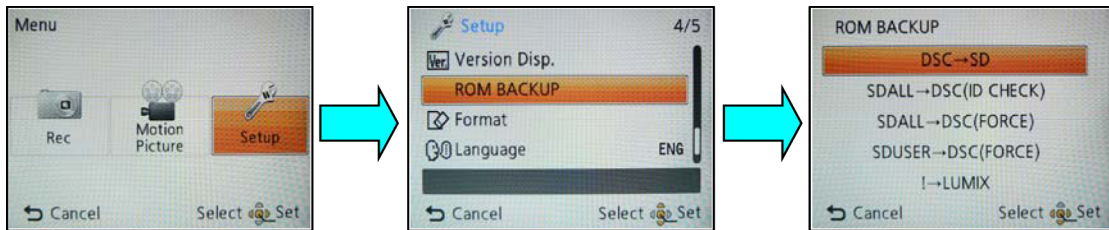

Fig.2-1

Item	Function	Details
DSC → SD	Save all the DSC's Flash-rom data to Memory Card	<ul style="list-style-type: none"> • DSC's Flash-rom data is saved to the Memory Card as a data file. (DATA BACKUP) - File location: ROOT DIRECTORY in Memory Card. - File Name: <ol style="list-style-type: none"> 1) User Setup Information data: <Model No.>U.TXT [Depending on the model, more than one file may be generated (e.g. <Model No.>U.TXT and <Model No.>U3.TXT).] 2) Electrical Adjustment data: <Model No.>F.TXT [Depending on the model, more than one file may be generated (e.g. <Model No.>F.TXT and <Model No.>F3.TXT).] • If the concerned file already exists, "OVERWRITE?" message is displayed.
SDALL → DSC (ID CHECK)	Write the all data to DSC's Flash-rom from Memory Card	<ul style="list-style-type: none"> • The backup data stored in the Memory Card is transferred to DSC unit. - ID CHECK: When the model ID is different, data is not transferred. - FORCE: Even if the model ID is different, data is transferred. * If the main P.C.B. is replaced, select "SDALL→DSC(FORCE)".
SDALL → DSC (FORCE)	Write the all data to DSC's Flash-rom from Memory Card	
SDUSER → DSC (FORCE)	Only "User setup information" is written from the saved file in the Memory Card to DSC's Flash-rom	<ul style="list-style-type: none"> • Only the user's "setup" setting condition is transferred to DSC unit. • FORCE: Even if the model ID is different, the data is not transferred.
! → LUMIX	Shipping set without initializing "User setup information"	<ul style="list-style-type: none"> • Initial setting is executed without initializing the user's set up setting condition. * The initial setting must be performed while the Self-timer LED is blinking. * The picture data stored in the built-in memory of the DSC is not erased, with this operation.

[DSC Integrated Assist Software (Method of Using PC)]

Same as TATSUJIN software for previous models.

9.2.3. Light Box

If using VFK1164TDVLB Light Box, remove the lens connection ring by loosening three hexagon screws.

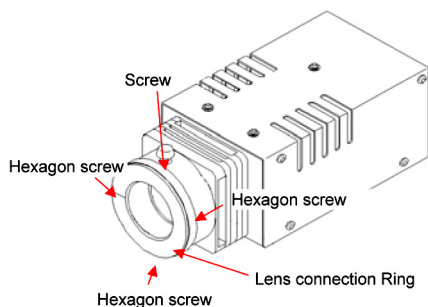

Fig.2-2

9.3. Details of Electrical Adjustment

9.3.1. How to execute the Electrical Adjustment

It is not necessary to connect the camera to a PC to perform adjustments.

“Flag reset operation” and “Initial setting operation” are required when carrying out the alignment, follow the procedure below.

9.3.1.1. Startup Electrical Adjustment mode

1. Release the initial settings.
2. Insert a recordable memory card (32MB or more).
(Without a memory card, the automatic adjustment can not executed.)
3. Procedure to set the camera into adjustment mode:
 - a. Turn the Power on.
 - b. Press the [MODE] button, and select the [NORMAL PICTURE] mode by Cursor button, then press the [MENU/SET] button.
 - c. Turn the Power off.
 - d. Turn the Power on pressing [MENU/SET] and [MOTION PICTURE] simultaneously.
LCD monitor displays “SERVICE MODE”.(Refer to Fig. 3-1)

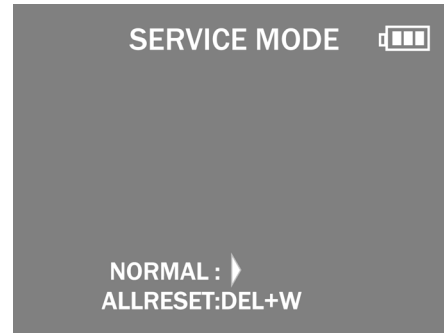

Fig.3-1

9.3.1.2. Status Adjustment Flag Setting

Reset (Not yet adjusted) the status flag condition.

1. After pressing the “[W] side of Zoom button”, the LCD monitor displays the Flag status screen (Refer to Fig.3-2)
2. Select item by pressing the Cursor buttons. (Gray cursor is moved accordingly.)
3. Press the [Delete/Cancel] button.

NOTE:

The selected item’s flag has been changed from “F (green)” to “0 (yellow)”.

*Flag conditions:

F (green)

means that the alignment has been completed and the status flag condition is set. In this case, the flag condition should be reset, if you try to carry out the automatic alignment.

0 (yellow)

means that the alignment has been not “completed” and the status flag condition is “reset”. In this case, automatic alignment is available.

- In case of setting the status flag into set condition again without completion of the alignment, the status flag should be SET by using PC, or UNDO by using ROM BACKUP function.

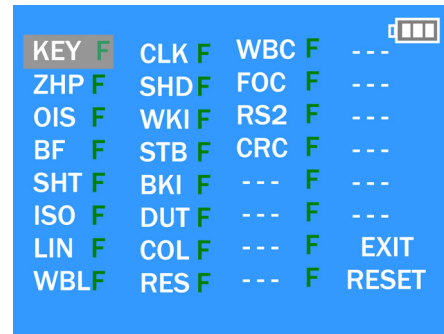

Fig.3-2

9.3.1.3. Execute Adjustment (In case of “OIS Adjustment”)

1. Perform step “9.3.1.1.” to “9.3.1.2.”, to reset the OIS flag status “F” (Set) to “0” (Reset)
2. Press “[W] side of the Zoom button” after Flag reset. OIS Adjustment screen is displayed on the LCD panel. (Refer to Fig.3-3)
3. Press the [Shutter] button. The adjustment will start automatically.



Fig.3-3

4. When the adjustment is completed successfully, adjustment report menu appears with Green OK on the LCD monitor. (Refer to Fig.3-4)

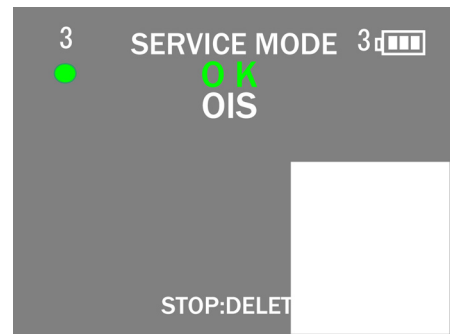

Fig.3-4

9.3.1.4. Attention point during Adjustment

1. Step “9.3.1.3.” procedure shows OIS adjustment as an example. To perform the adjustment, refer to the “9.3.2. Adjustment Specifications” table which shows key point for each adjustment.
2. Do not move the light box, the camera or the chart while adjusting. If one of these is moved accidentally, start the adjustment again.
3. Do not press any buttons/keys until the default menu (Refer to Fig.3-5) is displayed on the LCD monitor. Otherwise, adjustment data may not be stored properly.
4. If the adjustment is interrupted accidentally, the alignment data may not be properly saved in the Flash-ROM.

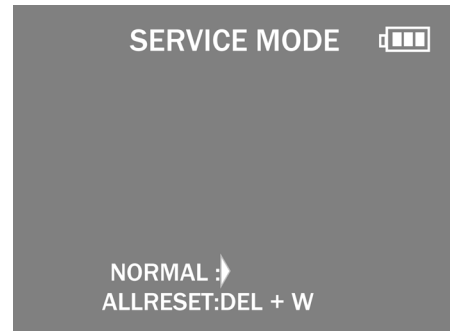

Fig.3-5

9.3.1.5. Finalizing the Adjustment

1. Several adjustment flags can be reset (“F” into “0”) at the same time. In this case, when the adjustment has been completed, the screen will change showing the adjustment for the next item until all reset items are completed. Also, when the [Shutter] button is pressed, the screen jump to the next adjustment item.
2. To cancel the adjustment mode while in the process of performing the adjustment, follow this procedures.
3. Operate the following, when escaping the Electrical Adjustment mode on the way.
 - (1) Press “[Delete/Cancel] button”.
 - (2) Press “[RIGHT] of Cursor button”.

NOTE:

- If adjustment is cancelled with above procedure, adjustment is not completed. Make sure to adjust it later.
- Adjustment software “DIAS” is able to control the status of the adjustment flags.

9.3.2. Adjustment Specifications

The following matrix table shows the relation between the replaced part and the Necessary Adjustment.

When a part is replaced, make sure to perform the necessary adjustment(s) in the order indicated.

The table below shows all the information necessary to perform each adjustment.

Adjustment order	Adjustment Item	FLAG	Purpose	Replacing Parts						JIG/TOOLS	SETUP	How to Operate
				MAIN P.C.B.	MAIN P.C.B. (When written the Backup data)	Lens part (Excluding Image Sensor)	Image Sensor	MIC	Flash part			
1	Optical Tilt	-	Adjustment of CCD FPC installation angle to the Lens	-	-	○	○	-	-	NOTE: It is necessary to use the "DSC_Tilt" software to allow the "Optical tilt adjustment". The Adjustment software "DSC_Tilt" is available at "TSN Website". • Optical Axis Adjustment Driver RFKZ0609 : T3 • Optical Axis Adjustment Chart RFKZ0570 • Camera Stand RFKZ0333J • Torque Driver RFKZ0542 * The screw locking glue is unnecessary, after adjustment.		
2	Zoom Home Position and Microphone check	ZHP	Zoom Home Position adjustment	○	-	○	○	○	-	NONE	NONE	1) Change the flag into the "0", and then proceed to the adjustment mode. 2) Press the shutter button fully. 3) Utter the voice for about 5 seconds into the microphone, just before pushing a shutter release. * Comparatively high voice is Ideal. (Standard:about 1Khz)
3	OIS sensor	OIS	OIS sensor output level adjustment	○	-	○	○	-	-	NONE	NONE	1) Change the flag into the "0", and then proceed to the adjustment mode. 2) Press the shutter button fully.
4	Backfocus	BF	To have the focus tracking curve be appropriate shape	○	○	○	○	*1	-	• COLLIMATOR (VFK1164TCM02 or VFK1164TCM03 or RFKZ0422)	Set the camera in front of Collimator so that the distance between Collimator and Camera becomes 2.5 cm as shown in Fig.A. (It is not distance between lens barrel and Camera.)	1) Change the flag into the "0", and then proceed to the adjustment mode. 2) Set the camera angle so that the star chart is displayed to the center, and press the shutter button fully. * The lens carries out zoom and stops, and green ● mark is displayed on LCD. 3) Confirm the camera angle so that the star chart is displayed to the center, and press the shutter button fully, again.
5	Shutter	SHT	Shutter speed adjustment	○	-	○	○	-	-	• LIGHTBOX RFKZ0523 (VFK1164TDVLB)	Set the camera in front of Lightbox so that the distance between diffusing surface of Lightbox and Camera becomes 9 cm as shown in Fig.B. (It is not distance between lens barrel and Camera.)	1) Change the flag into the "0", and then proceed to the adjustment mode. 2) Set the camera angle so that the diffusing surface of Lightbox is displayed on the center of LCD monitor, and press the shutter button fully.
6	High brightness coloration	LIN	High brightness coloration adjustment	○	-	○	○	-	-	• LIGHTBOX RFKZ0523 (VFK1164TDVLB) • ND FILTER RFKZ0513 (ND0.3)	Set the ND Filter to the Lightbox. (The Lightbox "VFK1164TDVLB" can be used if the front hood of VFK1164TDVLB is removed.) Set the camera in front of Lightbox so that the distance between ND Filter and Camera becomes 9 cm as shown in Fig.C. (It is not distance between lens barrel and Camera.)	1) Change the flag into the "0", and then proceed to the adjustment mode. 2) Set the camera angle so that the diffusing surface of Lightbox is displayed on the full of LCD monitor, and press the shutter button fully. * TR Chart is not using.
7	Shading	SHD	Shading compensation adjustment	○	-	○	○	-	-	• LIGHTBOX RFKZ0523 (VFK1164TDVLB) • DIFFUSER RFKZ0591	Set the Diffuser to the Lightbox. (The Lightbox "VFK1164TDVLB" can be used if the front hood of VFK1164TDVLB is removed.) Set the camera in front of Lightbox so that the distance between Diffuser and Camera becomes 3 cm as shown in Fig.D. (It is not distance between lens barrel and Camera.)	1) Change the flag into the "0", and then proceed to the adjustment mode. 2) Set the camera angle so that the diffusing surface of Lightbox is displayed on the full of LCD monitor, and press the shutter button fully.
8	CCD Missing Pixels (White) *2	WKI	Compensation of CCD Missing Pixels (White)	○	-	-	○	*1	-	NONE	NONE	1) Change the flag into the "0", and then proceed to the adjustment mode. 2) Press the shutter button fully. CAUTION When you execute this adjustment, change the next flag conditions into the "0" at the same time. And executing the adjustment successively. WKI → BKI → DUT → WBC

Adjustment order	Adjustment Item	FLAG	Purpose	Replacing Parts						JIG/TOOLS	SETUP	How to Operate
				MAIN P.C.B.	MAIN P.C.B. (When written the Backup data)	Lens part (Excluding Image Sensor)	Image Sensor	MIC	Flash part			
9	Flash adjustment	STB	Flash adjustment	○	○	-	-	-	○	NONE	NONE	1) Change the flag into the "0". 2) Press the shutter button fully. 3) Check that a flash shines. (It is different for every model how many times it shines.) * When a flash does not shine, there is a possibility that the flash unit is out of order. 4) Check a test result. * Results of the tests are usually NG. (When a result is OK, it is the completion of an inspection.) 5) When a result is NG, rewrite STB flag to an adjustment using DIAS. * The flag "STB" is an item which checks shines operation of a flash automatically at a Manufacturing facility. For this reason, except environment for exclusive use, a result will be NG, but it is no problem if shines operation can be checked visually.
10	CCD Missing Pixels (Black) *3	BKI	Compensation of CCD Missing Pixels (Black)	○	-	○	○	-	-	• LIGHTBOX RFKZ0523 (VFK1164TDVLB)	Set the camera in front of Lightbox so that the distance between diffusing surface of Lightbox and Camera becomes 3 cm as shown in Fig.B. (It is not distance between lens barrel and Camera.)	1) Change the flag into the "0", and then proceed to the adjustment mode. 2) Set the camera angle so that the diffusing surface of Lightbox is displayed on the full of LCD monitor, and press the shutter button fully. CAUTION When you execute this adjustment, change the next flag conditions into the "0" at the same time. And executing the adjustment successively. WKI → BKI → DUT → WBC
11	Lens Dust	DUT	Lens Dust inspection and make the compensation data of CCD Missing Pixels	○	-	○	○	-	-	• LIGHTBOX RFKZ0523 (VFK1164TDVLB)	Set the camera in front of Lightbox so that the distance between diffusing surface of Lightbox and Camera becomes 3 cm as shown in Fig.B. (It is not distance between lens barrel and Camera.)	1) Change the flag into the "0", and then proceed to the adjustment mode. 2) Set the camera angle so that the diffusing surface of Lightbox is displayed on the full of LCD monitor, and press the shutter button fully. CAUTION When you execute this adjustment, change the next flag conditions into the "0" at the same time. And executing the adjustment successively. WKI → BKI → DUT → WBC
12	Color reproduction inspection	COL	Color reproduction inspection	○	-	○	○	-	-	NONE	NONE	1) Change the flag into the "0", and then proceed to the adjustment mode. 2) Press the shutter button fully. (It is unnecessary to utter voice.)
13	Write the compensation data of CCD Missing Pixels	WBC	Write the compensation data of CCD Missing Pixels	○	-	○	○	-	-	NONE	NONE	1) Change the flag into the "0", and then proceed to the adjustment mode. 2) Press the shutter button fully. * It is about 25 seconds, until the adjustment end. CAUTION When you execute this adjustment, change the next flag conditions into the "0" at the same time. And executing the adjustment successively. WKI → BKI → DUT → WBC

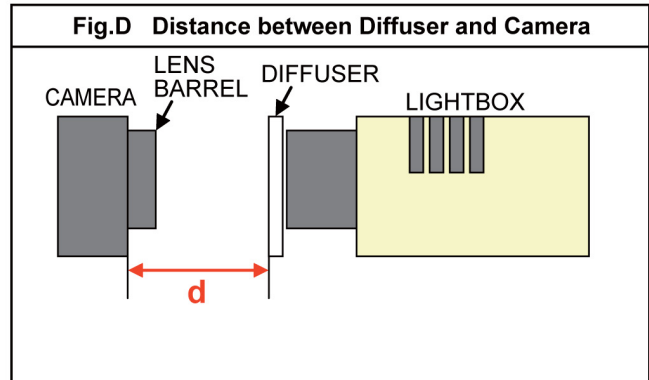
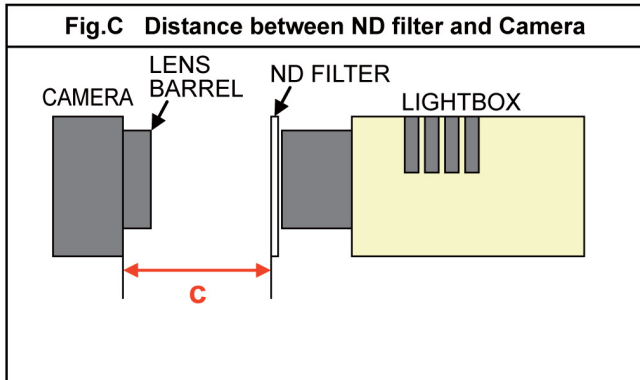
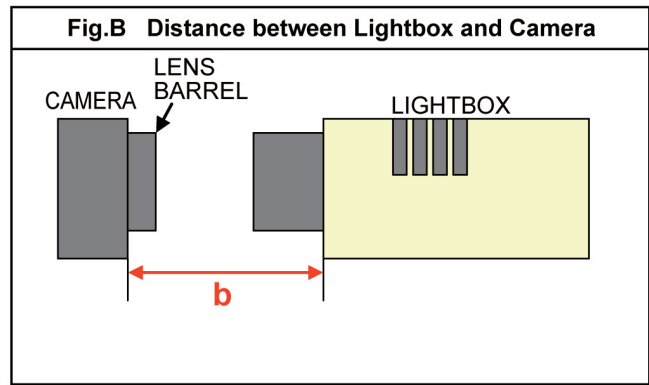
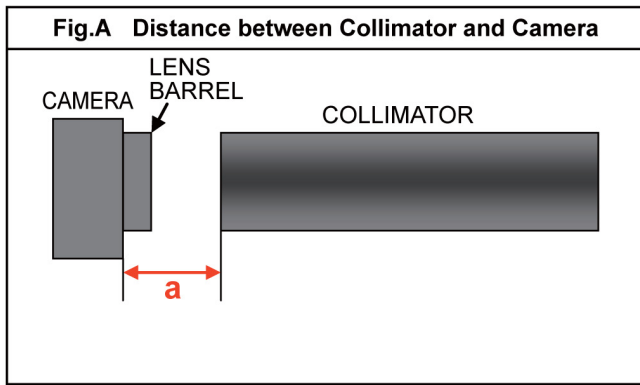

* 1: This adjustment must be performed not only replacing the CCD FPC unit, but also simply removing the CCD FPC unit.

* 2: The pixel that always lights while shaded is called a white wound.

* 3: The pixel that does not light while complete exposed is called a black wound.

IMPORTANT NOTICE: (After replacing the MAIN P.C.B.)

After replacing the MAIN P.C.B., make sure to perform the "INITIAL SETTINGS" first, then release the "INITIAL SETTINGS" in order to proceed the electrical adjustment.

NOTE:

1) If electrical adjustment or data re-writing is executed before "INITIAL SETTINGS", suffix code list is never displayed, and it cannot be chosen suitable suffix code.

2) Never remove the battery during initial setting in process.

9.4. After Adjustment

9.4.1. Initial Setting

Since the initial setting has been released to execute the built-in adjustment software, it should be set up again before shipping the camera to the customer.

Refer to the procedure described in "3.4.2. INITIAL SETTINGS" for details.

[IMPORTANT]

1. The initial setting should be done again after completing the alignment. Otherwise, the camera will not work properly.

Therefore as a warning, the camera display a warning symbol "!" on the LCD monitor every time the camera is turned off.

2. Confirm that status of all adjustment flag show "F". Even if one of the adjustment flag shows "0", initial setting programmed is never executed.

10 Maintenance

10.1. Cleaning Lens and LCD Panel

Do not touch the surface of lens and LCD Panel with your hand.

When cleaning the lens, use air-Blower to blow off the dust.

When cleaning the LCD Panel, dampen the lens cleaning paper with lens cleaner, and the gently wipe the its surface.

Note:

The Lens Cleaning KIT ; VFK1900BK (Only supplied as 10 set/Box) is available as Service Aid.

11 Block Diagram

11.1. Overall Block Diagram

OVERALL BLOCK DIAGRAM

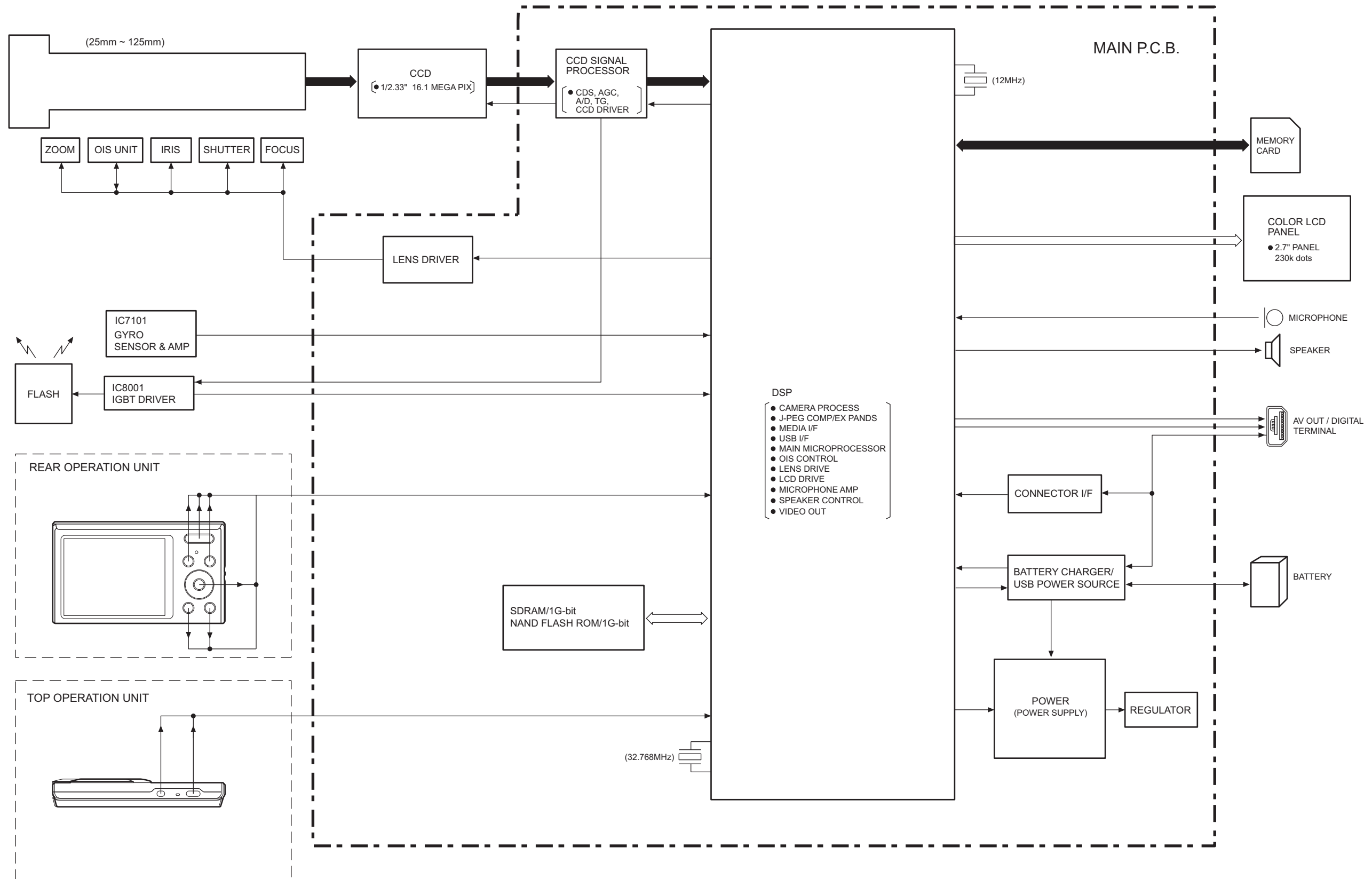

11.2. Flash / Top Block Diagram

◆ FLASH TOP BLOCK DIAGRAM

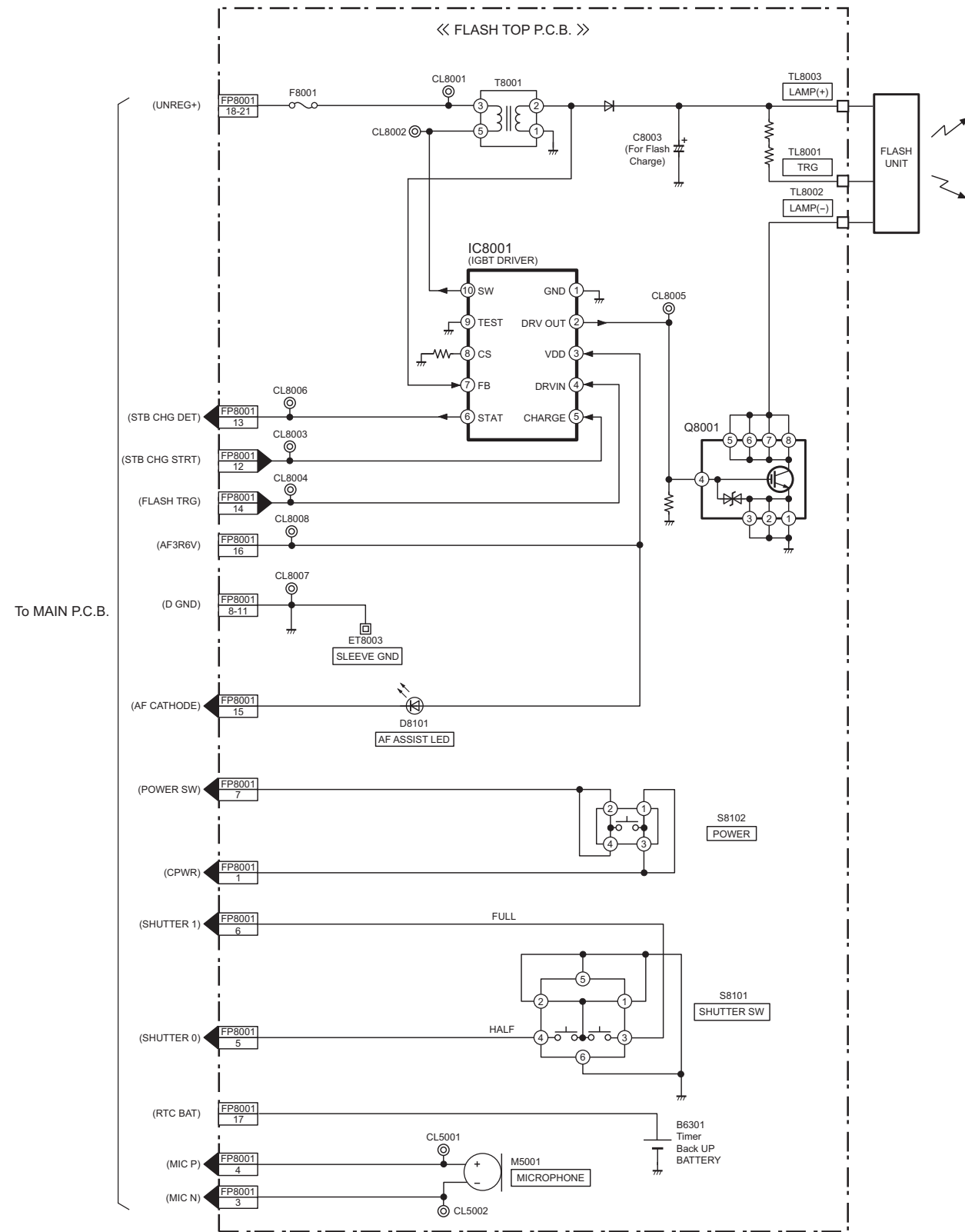

DMC-FH10/FS50 FLASH TOP BLOCK DIAGRAM

11.3. Sub Operation Block Diagram

◆ SUB OPERATION BLOCK DIAGRAM

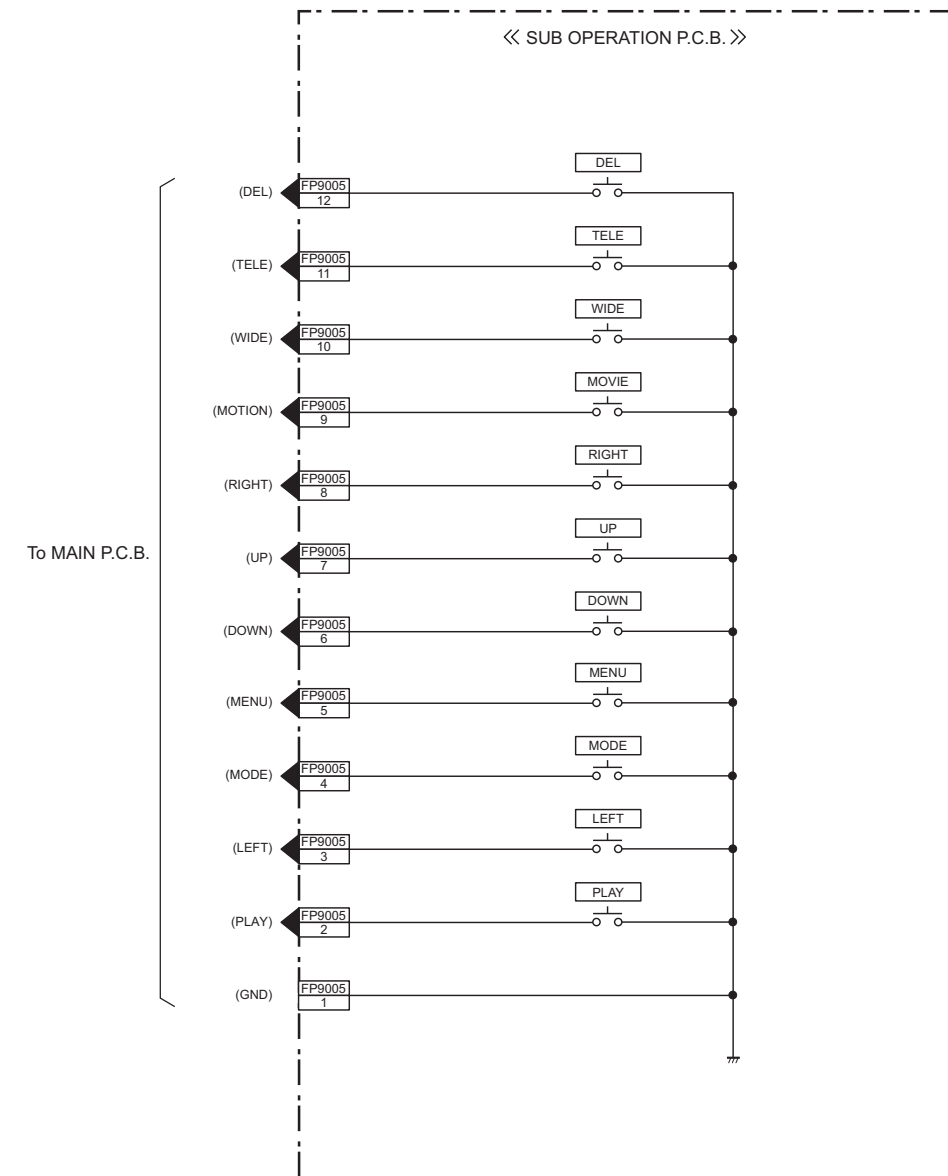

DMC-FH10/FS50 SUB OPERATION BLOCK DIAGRAM

12 Wiring Connection Diagram

12.1. Interconnection Diagram

INTERCONNECTION DIAGRAM

