

## Ceiling Concealed Chilled Water Fan Coil Unit (60Hz)

Models: MCW200 MCW300 MCW400  
MCW600 MCW800 MCW1000  
MCW1200

Air Flow: 112~2040m<sup>3</sup>/h

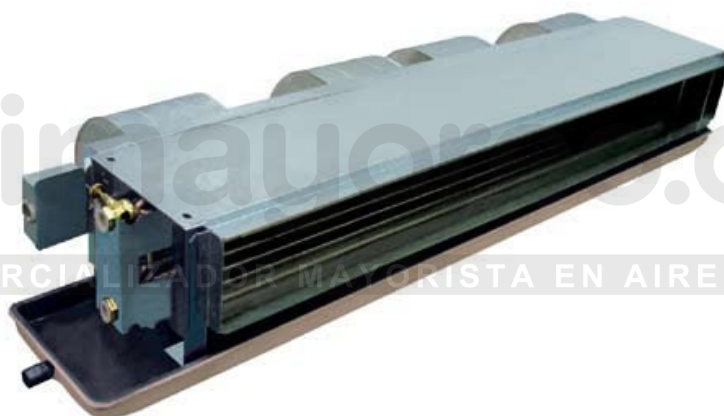

climauor.com

COMERCIALIZADOR MAYORISTA EN AIRE ACONDICIONADO



*Engineered for flexibility and performance.™*

**McQuay**<sup>®</sup>  
Air Conditioning

# Contents

Nomenclature .....	2
Features .....	3
Electric Heater Power .....	3
Specifications .....	4
Sound Data .....	8
Performance Data-Cooling .....	9
Performance Data-Heating .....	18
Air Flow vs ESP Curve .....	21
Operating Limits .....	22
Water Flow Rate vs Pressure Drop Chart .....	23
Outlines and Dimensions .....	25
Electrical Data .....	27
Wiring Diagrams .....	29
Installation .....	31
Exploded View & Part List .....	33
Guide Specifications .....	36

**NOTE:** Installation and maintenance are to be performed only by qualified personnel who are familiar with local codes and regulations, and experienced with this type of equipment.

**Caution:** Sharp edges and coil surfaces are a potential injury hazard. Avoid contact with them.

**Warning:** Moving machinery and electrical power hazard. May cause severe personal injury or death. Disconnect and lock off power before servicing equipment.

“McQuay” is a registered trademark of McQuay International. All rights reserved throughout the world.

© 2008 McQuay International

“Bulletin illustrations cover the general appearance of McQuay International products at the time of publication and we reserve the right to make changes in design and construction at any time without notice.”

# Nomenclature

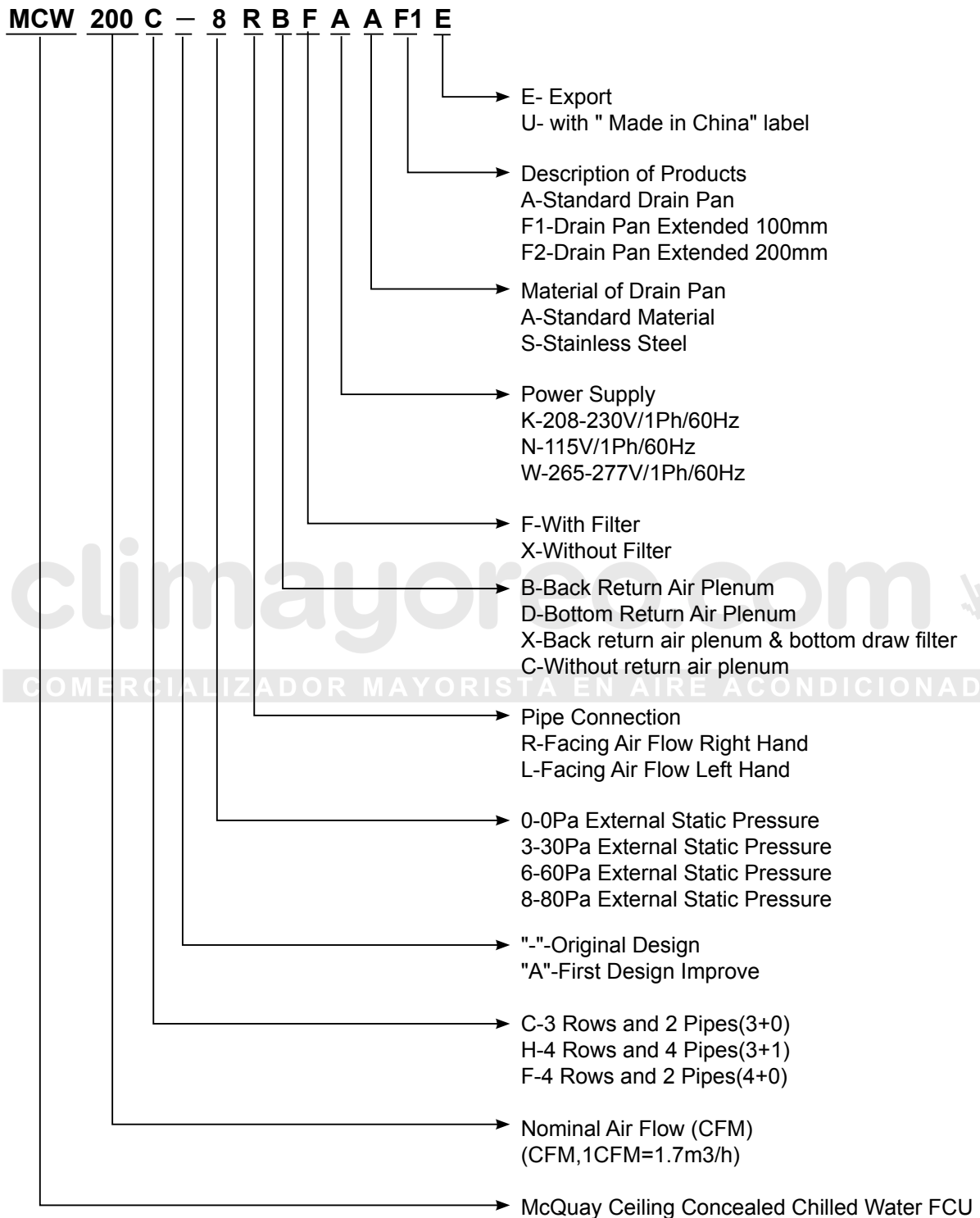

# Features

## Extra Low Noise Design

Enlarged fan wheels design allows lower fan RPM selection for the same external static pressure and airflow requirement. Thereby, noise level is significantly reduced.

## Flexibility

Water connection side can be changed easily in the field by changing positions of fan-motor assembly or the supply air flange assembly. Fan-motor assembly is not cased allowing back return or bottom return installations.

## High Efficiency Heat Exchanger

A boundary layer film of air adhering to the fin surface will insulate the fin surface and severely reduces the heat exchange efficiency. Mcquay slit fin design eliminates this boundary layer of air and creates continuous for best heat exchange efficiency.

## Variable External Static Pressure

Four types of external static pressure are available for every unit: 0Pa, 30Pa, 60Pa, 80Pa.

## Compact Design

This series of fan coil units are designed to suit most ceiling concealed installations. Unit height is only 251mm across the entire model range. The feature also maximizes provisions for drain fall requirements.

New design realizes all the filters removal both from the side and bottom (Option).

climayoreo.com 

COMERCIALIZADOR MAYORISTA EN AIRE ACONDICIONADO

# Specifications

## General Data

### MCW-C

MODEL			MCW200	MCW300	MCW400	MCW600	MCW800	MCW1000	MCW1200	
Air Flow	HIGH	m <sup>3</sup> /h	390	530	760	1040	1420	1620	2040	
		CFM	229	312	447	612	835	953	1200	
	MEDIUM	m <sup>3</sup> /h	260	370	490	780	1090	1140	1500	
		CFM	153	218	288	459	641	671	882	
	LOW	m <sup>3</sup> /h	190	240	340	500	740	830	1020	
		CFM	112	141	200	294	435	488	600	
EXTERNAL STATIC PRESSURE		Pa	0,30,60,80							
		in.wg	0,0.12,0.24,0.32							
TOTAL COOLING CAPACITY		W	2200	3200	4390	6160	7810	8830	10700	
		Btu/h	7507	10919	14979	21019	26649	30129	36510	
SENSIBLE COOLING CAPACITY		W	1738	2359	3242	4401	6040	6409	7763	
		Btu/h	5930	8049	11062	15017	20609	21868	26488	
TOTAL HEATING CAPACITY		W	3500	5100	7300	9960	13080	14780	19170	
		Btu/h	11942	17402	24909	33985	44631	50431	65411	
WATER FLOW RATE		m <sup>3</sup> /h	0.4	0.6	0.8	1.1	1.4	1.6	1.9	
		USGPM	1.8	2.5	3.4	4.8	6.1	6.9	8.5	
HEAD LOSS (COOLING)		kPa	14.6	12.0	21.6	38.2	18.4	21.0	32.7	
		in.wg.	58.4	48.0	86.4	152.8	73.6	84.0	130.8	
DIMENSIONS	UNIT DIMENSIONS	HEIGHT	mm	251	251	251	251	251	251	
		WIDTH	mm	714	884	1014	1214	1464	1564	1824
		DEPTH	mm	556	556	556	556	556	556	556
	PACKING DIMENSION	HEIGHT	mm	260	260	260	260	260	260	260
		WIDTH	mm	724	894	1024	1224	1474	1574	1834
		DEPTH	mm	570	570	570	570	570	570	570
UNIT WEIGHT (Without plenum)		kg	19.0	20.0	26.0	30.0	41.0	44.0	46.0	
		lb	41.9	44.1	57.3	66.1	90.4	97.0	101.4	
UNIT GROSS WEIGHT (Without plenum)		kg	21.7	24.8	29.5	33.6	44.0	47.8	51.2	
		lb	47.8	54.7	65.0	74.1	97.0	105.4	112.9	
UNIT WEIGHT (With plenum)		kg	20.0	24.0	28.0	33.0	44.0	47.0	50.0	
		lb	44.1	52.9	61.7	72.8	97.0	103.6	110.2	
UNIT GROSS WEIGHT (With plenum)		kg	22.7	28.8	31.5	36.6	47.0	50.8	55.2	
		lb	50.0	63.5	69.4	80.7	103.6	112.0	121.7	
CONDENSATE DRAIN PIPE SIZE			R3/4							

#### NOTES:

- 1) ALL SPECIFICATIONS ARE SUBJECTED TO CHANGE BY THE MANUFACTURER WITHOUT PRIOR NOTICE.
- 2) ALL THE UNITS ARE BEING TESTED UNDER FOLLOWING CONTITION:
  - a) COOLING: 27°C DB/19.5°C WB INDOOR AND WATER INLET 7°C OUTLET 12°C
  - b) HEATING: 21°C DB INDOOR AND WATER 60°C INLET.WATER FLOW:SAME WITH COOLING CONDITION.

## MCW-H

MODEL			MCW200	MCW300	MCW400	MCW600	MCW800	MCW1000	MCW1200	
Air Flow	HIGH	m <sup>3</sup> /h	360	510	750	1010	1380	1570	2000	
		CFM	212	300	441	594	812	924	1176	
	MEDIUM	m <sup>3</sup> /h	250	350	470	770	1070	1110	1470	
		CFM	147	206	276	453	629	653	865	
	LOW	m <sup>3</sup> /h	180	230	330	490	720	820	1010	
		CFM	106	135	194	288	424	482	594	
EXTERNAL STATIC PRESSURE		Pa	0,30,60,80							
		in.wg	0,0.12,0.24,0.32							
TOTAL COOLING CAPACITY		W	2130	3100	4260	5980	7580	8570	10380	
		Btu/h	7268	10578	14536	20405	25864	29242	35418	
SENSIBLE COOLING CAPACITY		W	1683	2285	3146	4272	5862	6220	7531	
		Btu/h	5742	7798	10735	14578	20002	21224	25696	
TOTAL HEATING CAPACITY (1 ROW)		W	1350	2280	3210	4290	5120	6940	8490	
		Btu/h	4606	7780	10953	14638	17470	23680	28969	
WATER FLOW RATE (3 ROWS)		m <sup>3</sup> /h	0.4	0.6	0.8	1.1	1.4	1.6	1.9	
		USGPM	1.8	2.5	3.4	4.8	6.1	6.9	8.5	
WATER FLOW RATE (1 ROW)		m <sup>3</sup> /h	0.2	0.2	0.2	0.2	0.2	0.5	0.5	
		USGPM	1.1	1.1	1.1	1.1	1.1	2.2	2.2	
HEAD LOSS (COOLING) (3 ROWS)		KPa	12.0	21.6	38.2	18.4	21.0	32.7	12.0	
		in.wg.	58.4	48.0	86.4	152.8	73.6	84.0	130.8	
DIMENSIONS	UNIT DIMENSIONS	HEIGHT	mm	251	251	251	251	251	251	
		WIDTH	mm	714	884	1014	1214	1464	1564	1824
		DEPTH	mm	556	556	556	556	556	556	556
	PACKING DIMENSION	HEIGHT	mm	260	260	260	260	260	260	260
		WIDTH	mm	724	894	1024	1224	1474	1574	1834
		DEPTH	mm	570	570	570	570	570	570	570
HEAD LOSS (HEATING) (1 ROW)		KPa	12.0	13.5	14.8	20.7	4.0	12.8	14.6	
		in.wg.	48	54	59	83	16	51	59	
UNIT WEIGHT (Without plenum)		kg	20.0	24.0	28.0	32.0	44.0	47.0	49.0	
		lb	44.1	52.9	61.7	70.5	97.0	103.6	108.0	
UNIT GROSS WEIGHT (Without plenum)		kg	22.7	26.8	31.5	35.6	47.0	50.8	54.2	
		lb	50.0	59.1	69.4	78.5	103.6	112.0	119.5	
UNIT WEIGHT (With plenum)		kg	22.0	27.0	31.0	36.0	48.0	52.0	56.0	
		lb	48.5	59.5	68.3	79.4	105.8	114.6	123.5	
UNIT GROSS WEIGHT (With plenum)		kg	24.7	29.8	34.5	39.6	51.0	55.8	61.2	
		lb	54.5	65.7	76.1	87.3	112.4	123.0	134.9	
CONDENSATE DRAIN PIPE SIZE			R3/4							

### NOTES:

- 1) ALL SPECIFICATIONS ARE SUBJECTED TO CHANGE BY THE MANUFACTURER WITHOUT PRIOR NOTICE.
- 2) ALL THE UNITS ARE BEING TESTED UNDER FOLLOWING CONTITION:
  - a) COOLING: 27°C DB/19.5°C WB INDOOR AND WATER INLET 7°C OUTLET 12°C
  - b) HEATING: 21°C DB INDOOR AND WATER 60°C INLET.WATER FLOW:SAME WITH COOLING CONDITION.

## MCW-F

MODEL			MCW200	MCW300	MCW400	MCW600	MCW800	MCW1000	MCW1200	
Air Flow	HIGH	m <sup>3</sup> /h	360	510	750	1010	1380	1570	2000	
		CFM	212	300	441	594	812	924	1176	
	MEDIUM	m <sup>3</sup> /h	250	350	470	770	1070	1110	1470	
		CFM	147	206	276	453	629	653	865	
	LOW	m <sup>3</sup> /h	180	230	330	490	720	820	1010	
		CFM	106	135	194	288	424	482	594	
EXTERNAL STATIC PRESSURE		kPa	0,30,60,80							
		in.wg	0,0.12,0.24,0.32							
TOTAL COOLING CAPACITY		W	2622	3418	5277	7185	8691	10261	12791	
		Btu/h	8948	11661	18007	24517	29653	35013	43644	
SENSIBLE COOLING CAPACITY		W	1783	2406	3536	5047	6365	7297	9382	
		Btu/h	6085	8210	12066	17222	21719	24899	32011	
TOTAL HEATING CAPACITY		W	4196	5468	8444	11496	13905	16418	20465	
		Btu/h	14317	18658	28811	39227	47445	56020	69830	
WATER FLOW RATE		m <sup>3</sup> /h	0.5	0.6	0.9	1.3	1.5	1.8	2.3	
		USGPM	2.0	2.7	4.1	5.5	6.8	8.0	10.1	
HEAD LOSS (COOLING)		kPa	1.3	6.0	1.3	27.0	8.8	12.0	20.0	
		in.wg.	5.2	24.1	5.2	108.3	35.3	48.1	80.2	
DIMENSIONS	UNIT DIMENSIONS	HEIGHT	mm	251	251	251	251	251	251	251
		WIDTH	mm	714	884	1014	1214	1464	1564	1824
		DEPTH	mm	556	556	556	556	556	556	556
	PACKING DIMENSION	HEIGHT	mm	260	260	260	260	260	260	260
		WIDTH	mm	724	894	1024	1224	1474	1574	1834
		DEPTH	mm	570	570	570	570	570	570	570
UNIT WEIGHT (Without plenum)		kg	20.0	24.0	28.0	32.0	44.0	47.0	49.0	
		lb	44.1	52.9	61.7	70.5	97.0	103.6	108.0	
UNIT GROSS WEIGHT (Without plenum)		kg	22.7	26.8	31.5	35.6	47.0	50.8	54.2	
		lb	50.0	59.1	69.4	78.5	103.6	112.0	119.5	
UNIT WEIGHT (With plenum)		kg	22.0	27.0	31.0	36.0	48.0	52.0	56.0	
		lb	48.5	59.5	68.3	79.4	105.8	114.6	123.5	
UNIT GROSS WEIGHT (With plenum)		kg	24.7	29.8	34.5	39.6	51.0	55.8	61.2	
		lb	54.5	65.7	76.1	87.3	112.4	123.0	134.9	
CONDENSATE DRAIN PIPE SIZE			R3/4							

### NOTES:

- 1) ALL SPECIFICATIONS ARE SUBJECTED TO CHANGE BY THE MANUFACTURER WITHOUT PRIOR NOTICE.
- 2) ALL THE UNITS ARE BEING TESTED UNDER FOLLOWING CONTITION:
  - a) COOLING: 27°C DB/19.5°C WB INDOOR AND WATER INLET 7°C OUTLET 12°C
  - b) HEATING: 21°C DB INDOOR AND WATER 60°C INLET.WATER FLOW:SAME WITH COOLING CONDITION.

## Components Data

### MCW-C/H/F

			MCW200	MCW300	MCW400	MCW600	MCW800	MCW1000	MCW1200	
FAN	TYPE		CENTRIFUGAL (BLADE: FORWARD)							
	QUANTITY		1		2		3		4	
	MATERIAL		GALVANIZED STEEL							
	DRIVE		DIRECT DRIVE							
	DIAMETER	mm	160							
		in	6.25							
LENGTH	mm	200								
	in	7.875								
MOTOR	TYPE		SINGLE PHASE CAPACITOR RUNNING							
	QUANTITY		1				2			
	IP/INSULATION GRADE		IP20/E							
COIL	TUBE	MATERIAL		COPPER						
		DIAMETER	mm	9.52						
			in	3/8						
		THICK-NESS	mm	0.30						
	in		0.012							
	FIN	MATERIAL		HYDROPHILIC ALUMINUM						
		THICK-NESS	mm	0.11						
			in	0.0043						
		FACE AREA	m <sup>2</sup>	0.09	0.13	0.15	0.19	0.24	0.26	0.32
			ft <sup>2</sup>	0.98	1.35	1.64	2.07	2.62	2.84	3.41
		ROW	C	3						
H/F	4									
FIN PER INCH		11								
AIR FILTER (Option)	TYPE		NYLON/ALUMINIUM FRAME							
	SIZE	LENGTH	mm	462	632	762	962	1212	1311	1572
			in	18.19	24.88	30.00	37.87	47.72	51.61	61.89
		WIDTH	mm	205						
			in	8.07						
	THICK-NESS	mm	8							
in		0.31								

**NOTES:**

ALL SPECIFICATIONS ARE SUBJECTED TO CHANGE BY THE MANUFACTURER WITHOUT PRIOR NOTICE.



# Sound Data

## MCW-C/H/F

ESP		0Pa								30Pa									
Unit	Speed	1/1 Octave Sound pressure level (dBA, ref 20µPa)								Total dB (A)	1/1 Octave Sound pressure level (dBA, ref 20µPa)								Total dB (A)
		63	125	250	500	1k	2k	4k	8k		63	125	250	500	1k	2k	4k	8k	
200	High	15	19	23	28	28	23	14	13	33	15	19	24	28	29	24	15	13	33
	Medium	14	18	19	24	24	19	14	13	29	12	17	22	26	26	23	15	13	31
	Low	13	14	17	20	18	14	13	13	25	15	18	18	20	20	15	12	13	26
300	High	16	21	26	32	34	30	19	14	37	16	21	26	32	34	30	19	14	37
	Medium	15	19	23	28	28	23	14	13	33	12	17	22	26	26	23	15	13	31
	Low	15	15	19	23	23	18	11	11	28	14	18	19	24	24	19	14	13	29
400	High	14	20	25	31	32	28	16	14	36	16	21	28	33	34	31	20	13	38
	Medium	12	17	22	26	26	23	15	13	31	13	20	26	29	31	27	18	14	35
	Low	15	18	18	20	20	15	12	13	26	15	19	24	28	29	24	15	13	33
600	High	15	25	30	35	37	33	25	18	41	16	28	32	36	39	37	30	21	43
	Medium	14	24	28	33	35	32	22	16	39	14	24	28	33	35	32	22	16	39
	Low	15	19	23	28	28	23	14	13	33	14	18	23	27	28	23	15	13	32
800	High	14	23	29	34	37	32	21	15	40	15	25	30	35	37	33	25	18	41
	Medium	16	21	28	33	34	31	20	13	38	16	21	28	33	34	31	20	13	38
	Low	14	18	23	27	28	23	15	13	32	15	19	24	28	29	24	15	13	33
1000	High	15	25	30	35	37	33	25	18	41	16	28	32	36	39	37	30	21	43
	Medium	16	21	28	33	34	31	20	13	38	16	21	26	32	34	30	19	14	37
	Low	15	19	23	28	28	23	14	13	33	14	20	23	28	30	27	16	13	34
1200	High	16	28	32	36	39	37	30	21	43	17	28	32	37	41	38	28	21	44
	Medium	14	23	29	34	37	32	21	15	40	14	24	28	33	35	32	22	16	39
	Low	13	20	26	29	31	27	18	14	35	15	19	24	28	29	24	15	13	33
ESP		60Pa								80Pa									
Unit	Speed	1/1 Octave Sound pressure level (dBA, ref 20µPa)								Total dB(A)	1/1 Octave Sound pressure level (dBA, ref 20µPa)								Total dB(A)
		63	125	250	500	1k	2k	4k	8k		63	125	250	500	1k	2k	4k	8k	
200	High	16	21	26	32	34	30	19	14	37	16	21	28	33	34	31	20	13	38
	Medium	14	20	23	28	30	27	16	13	34	13	20	26	29	31	27	18	14	35
	Low	12	17	22	26	26	23	15	13	31	14	18	23	27	28	23	15	13	32
300	High	16	21	28	33	34	31	20	13	38	14	24	28	33	35	32	22	16	39
	Medium	13	20	26	29	31	27	18	14	35	14	20	25	31	32	28	16	14	36
	Low	12	17	22	26	26	23	15	13	31	14	18	23	27	28	23	15	13	32
400	High	15	25	30	35	37	33	25	18	41	16	30	34	38	42	38	29	22	45
	Medium	14	20	25	31	32	28	16	14	36	15	25	30	35	37	33	25	18	41
	Low	15	19	23	28	28	23	14	13	33	13	20	26	29	31	27	18	14	35
600	High	19	36	36	41	43	40	30	26	47	19	35	40	43	46	43	34	31	50
	Medium	17	28	32	37	41	38	28	21	44	18	34	35	40	42	39	31	20	46
	Low	16	21	28	33	34	31	20	13	38	18	26	31	36	38	35	27	16	42
800	High	19	36	36	41	43	40	30	26	47	18	34	39	42	45	43	34	30	49
	Medium	17	28	32	37	41	38	28	21	44	19	36	36	41	43	40	30	26	47
	Low	14	24	28	33	35	32	22	16	39	17	28	32	37	41	38	28	21	44
1000	High	18	34	39	42	45	43	34	30	49	18	34	39	42	45	43	34	30	49
	Medium	18	34	35	40	42	39	31	20	46	18	32	38	40	44	42	36	29	48
	Low	14	23	29	34	37	32	21	15	40	16	30	34	38	42	38	29	22	45
1200	High	18	34	39	42	45	43	34	30	49	18	34	39	42	45	43	34	30	49
	Medium	16	30	34	38	42	38	29	22	45	18	32	38	40	44	42	36	29	48
	Low	18	26	31	36	38	35	27	16	42	16	30	34	38	42	38	29	22	45

**NOTES:**

- 1) ALL SPECIFICATIONS ARE SUBJECTED TO CHANGE BY THE MANUFACTURER WITHOUT PRIOR NOTICE.
- 2) SOUND PRESSURE LEVELS ARE TESTED IN SEMI-ANECHOIC ROOM, WITH BACKGROUND LEVEL: 11.5dB(A), MICROPHONE POSITION OF THE MEASUREMENT POINT IS 1m IN FRONT AND 1m BELOW THE UNIT.

# Performance Data-Cooling

## MCW-C

MODEL	WATER FLOW (m <sup>3</sup> /h)	W.P.D (kPa)	ENTERING AIR: DB27°C, WB19.5°C									
			ENTERING WATER TEMPERATURE°C									
			6		7		8		9		10	
			TOTAL	SENSIBLE	TOTAL	SENSIBLE	TOTAL	SENSIBLE	TOTAL	SENSIBLE	TOTAL	SENSIBLE
	W	W	W	W	W	W	W	W	W	W	W	
MCW200	0.24	5.6	1940	1420	1820	1400	1720	1370	1590	1310	1400	1260
	0.33	9.7	2190	1600	2080	1560	1940	1550	1800	1520	1660	1480
	0.42	14.8	2370	1740	2210	1700	2080	1660	1940	1640	1790	1610
	0.51	21.6	2500	1830	2270	1800	2190	1750	2030	1700	1880	1680
MCW300	0.36	4.0	2910	2150	2730	2100	2510	2050	2300	2020	2250	1990
	0.48	9.2	3230	2380	3020	2330	2820	2300	2600	2270	2520	2220
	0.6	13.2	3480	2550	3240	2490	3020	2450	2780	2410	2680	2390
	0.72	18.7	3660	2700	3420	2630	3170	2600	2920	2550	2820	2490
MCW400	0.42	7.3	3650	2660	3410	2600	3200	2550	2950	2510	2570	2460
	0.6	13.8	4190	2970	3940	3040	3690	3010	3410	2990	3130	2930
	0.78	21.6	4580	3360	4390	3320	3980	3280	3710	3240	3410	3200
	0.96	31.0	4850	3510	4530	3490	4230	3450	3900	3410	3590	3380
MCW600	0.72	18.7	5850	4260	5480	4220	5100	4180	4670	4110	4270	3970
	0.9	32.7	6310	4410	5890	4360	5460	4260	5070	4200	4650	4110
	1.08	38.2	6670	4660	6160	4460	5780	4400	5330	4360	4900	4350
	1.26	50.0	6970	4830	6490	4780	6030	4700	5560	4680	5090	4600
MCW800	1.14	12.5	7780	5720	7300	5630	6740	5570	6060	5450	5530	5320
	1.44	18.7	8410	5880	7900	5800	7370	5750	6820	5700	6220	5680
	1.74	26.2	8920	6320	8340	6250	7750	6200	7200	6120	6620	5980
	2.04	34.5	9320	6520	8710	6460	8100	6410	7500	6370	6910	6220
MCW1000	1.2	13.6	8610	5710	8040	6190	7410	6300	6820	6140	6280	6030
	1.5	20.1	9280	6550	8710	6440	8080	6410	7460	6340	6780	6240
	1.8	26.5	9850	6890	9190	6780	8520	6720	7900	6710	7230	6690
	2.1	33.7	10300	7210	9610	7080	8920	7010	8210	6970	7550	6940
MCW1200	1.56	21.5	10710	7490	10010	7400	9280	7360	8490	7270	7740	7190
	1.92	32.7	11480	8470	10700	8240	9970	8140	9170	8070	8380	7710
	2.28	40.7	12110	8710	11290	8650	10460	8580	9610	8460	8820	8120
	2.64	54.3	12600	8950	11750	8810	10890	8710	10020	8620	9140	8410

### NOTES:

- 1) THE COOLING CAPACITY IS TESTED UNDER HIGH SPEED. THE CAPACITY UNDER MEDIUM AND LOW FAN SPEED MUST MULTIPLY A CORRECTION FACTOR.
- 2) W.P.D: WATER PRESSURE DROP

**TOTAL:** TOTAL COOLING CAPACITY      **SENSIBLE:** SENSIBLE COOLING CAPACITY

### Cooling Capacity Correction Factors:

MODEL		MCW200C	MCW300C	MCW400C	MCW600C	MCW800C	MCW1000C	MCW1200C
MEDIUM	TOTAL	0.85	0.82	0.84	0.84	0.87	0.85	0.86
	SENSIBLE	0.78	0.75	0.78	0.80	0.80	0.80	0.80
LOW	TOTAL	0.66	0.60	0.65	0.65	0.68	0.70	0.71
	SENSIBLE	0.58	0.55	0.58	0.60	0.62	0.63	0.66

MODEL	WATER FLOW (m <sup>3</sup> /h)	W.P.D (kPa)	ENTERING AIR: DB28°C, WB21°C							
			ENTERING WATER TEMPERATURE°C							
			6		7		8		9	
			TOTAL	SENSIBLE	TOTAL	SENSIBLE	TOTAL	SENSIBLE	TOTAL	SENSIBLE
			W	W	W	W	W	W	W	W
MCW200	0.24	5.6	2160	1580	2020	1560	1910	1520	1770	1460
	0.33	9.7	2430	1780	2310	1730	2160	1720	2000	1690
	0.42	14.8	2630	1930	2460	1890	2310	1840	2160	1820
	0.51	21.6	2780	2030	2740	2000	2430	1940	2260	1890
MCW300	0.36	4	3230	2390	3030	2330	2790	2280	2560	2240
	0.48	9.2	3590	2640	3360	2590	3130	2560	2890	2520
	0.6	13.2	3870	2830	3600	2770	3360	2720	3090	2680
	0.72	18.7	4070	3000	3800	2920	3520	2890	3240	2830
MCW400	0.42	7.3	4060	2960	3790	2890	3560	2830	3280	2790
	0.6	13.8	4660	3300	4380	3380	4100	3340	3790	3320
	0.78	21.6	5090	3730	4880	3690	4420	3640	4120	3600
	0.96	31	5390	3900	5030	3880	4700	3830	4330	3790
MCW600	0.72	18.7	6500	4730	6090	4690	5670	4640	5190	4570
	0.9	32.7	7010	4900	6540	4840	6070	4730	5630	4670
	1.08	38.2	7410	5180	6840	4960	6420	4890	5920	4840
	1.26	50	7740	5370	7210	5310	6700	5220	6180	5200
MCW800	1.14	12.5	8640	6360	8110	6260	7490	6190	6730	6060
	1.44	18.7	9340	6530	8780	6440	8190	6390	7580	6330
	1.74	26.2	9910	7020	9270	6940	8610	6890	8000	6800
	2.04	34.5	10360	7240	9680	7180	9000	7120	8330	7080
MCW1000	1.2	13.6	9570	6340	8930	6880	8230	7000	7580	6820
	1.5	20.1	10310	7280	9680	7160	8980	7120	8290	7040
	1.8	26.5	10940	7660	10210	7530	9470	7470	8780	7460
	2.1	33.7	11440	8010	10680	7870	9910	7790	9120	7740
MCW1200	1.56	21.5	11900	8320	1120	8220	10310	8180	9430	8080
	1.92	32.7	12760	9410	11890	9160	11080	9040	10190	8970
	2.28	40.7	13460	9680	12540	9610	11620	9530	10680	9400
	2.64	54.3	14000	9940	13060	9790	12100	9680	1130	9580

**NOTES:**

- 1) THE COOLING CAPACITY IS TESTED UNDER HIGH SPEED.THE CAPACITY UNDER MEDIUM AND LOW FAN SPEED MUST MULTIPLY A CORRECTION FACTOR.
- 2) W.P.D:WATER PRESSURE DROP

**TOTAL:** TOTAL COOLING CAPACITY      **SENSIBLE:**SENSIBLE COOLING CAPACITY

**Cooling Capacity Correction Factors:**

MODEL		MCW200C	MCW300C	MCW400C	MCW600C	MCW800C	MCW1000C	MCW1200C
MEDIUM	TOTAL	0.85	0.82	0.84	0.84	0.87	0.85	0.86
	SENSIBLE	0.78	0.75	0.78	0.80	0.80	0.80	0.80
LOW	TOTAL	0.66	0.60	0.65	0.65	0.68	0.70	0.71
	SENSIBLE	0.58	0.55	0.58	0.60	0.62	0.63	0.66

MODEL	WATER FLOW (m <sup>3</sup> /h)	W.P.D (kPa)	ENTERING AIR: DB25°C, WB18°C									
			ENTERING WATER TEMPERATURE°C									
			6		7		8		9		10	
			TOTAL	SENSIBLE	TOTAL	SENSIBLE	TOTAL	SENSIBLE	TOTAL	SENSIBLE	TOTAL	SENSIBLE
W	W	W	W	W	W	W	W	W	W			
MCW200	0.24	5.6	1750	1280	1640	1260	1550	1230	1430	1180	1260	1130
	0.33	9.7	1970	1440	1870	1400	1750	1400	1620	1370	1490	1330
	0.42	14.8	2130	1570	1990	1530	1870	1490	1750	1480	1610	1450
	0.51	21.6	2250	1650	2220	1620	1970	1580	1830	1530	1690	1510
MCW300	0.36	4	2620	1940	2460	1890	2260	1850	2070	1820	2030	1790
	0.48	9.2	2910	2140	2720	2100	2540	2070	2340	2040	2270	2000
	0.6	13.2	3130	2300	2920	2240	2720	2210	2500	2170	2410	2150
	0.72	18.7	3290	2430	3080	2370	2850	2340	2630	2300	2540	2240
MCW400	0.42	7.3	3290	2390	3070	2340	2880	2300	2660	2260	2310	2210
	0.6	13.8	3770	2670	3550	2740	3320	2710	3070	2690	2820	2640
	0.78	21.6	4120	3020	3950	2990	3580	2950	3340	2920	3070	2880
	0.96	31	4370	3160	4080	3140	3810	3110	3510	3070	3230	3040
MCW600	0.72	18.7	5270	3830	4930	3800	4590	3760	4200	3700	3840	3570
	0.9	32.7	5680	3970	5300	3920	4910	3830	4560	3780	4190	3700
	1.08	38.2	6000	4190	5540	4010	5200	3960	4800	3920	4410	3920
	1.26	50	6270	4350	5840	4300	5430	4230	5000	4210	4580	4140
MCW800	1.14	12.5	7000	5150	6570	5070	6070	5010	5450	4910	4980	4790
	1.44	18.7	7570	5290	7110	5220	6630	5180	6140	5130	5600	5110
	1.74	26.2	8030	5690	7510	5630	6980	5580	6480	5510	5960	5380
	2.04	34.5	8390	5870	7840	5810	7290	5770	6750	5730	6220	5600
MCW1000	1.2	13.6	7750	5140	7240	5570	6670	5670	6140	5530	5650	5430
	1.5	20.1	8350	5900	7840	5800	7270	5770	6710	5710	6100	5620
	1.8	26.5	8870	6200	8270	6100	7670	6050	7110	6040	6510	6020
	2.1	33.7	9270	6490	8650	6370	8030	6310	7390	6270	6800	6250
MCW1200	1.56	21.5	9640	6740	9010	6660	8350	6620	7640	6540	6970	6470
	1.92	32.7	10330	7620	9630	7420	8970	7330	8250	7260	7540	6940
	2.28	40.7	10900	7840	10160	7790	9410	7720	8650	7610	7940	7310
	2.64	54.3	11340	8060	10580	7930	9800	7840	9020	7760	8230	7570

**NOTES:**

1) THE COOLING CAPACITY IS TESTED UNDER HIGH SPEED. THE CAPACITY UNDER MEDIUM AND LOW FAN SPEED MUST MULTIPLY A CORRECTION FACTOR.

2) W.P.D: WATER PRESSURE DROP

TOTAL: TOTAL COOLING CAPACITY      SENSIBLE: SENSIBLE COOLING CAPACITY

**Cooling Capacity Correction Factors:**

MODEL		MCW200C	MCW300C	MCW400C	MCW600C	MCW800C	MCW1000C	MCW1200C
MEDIUM	TOTAL	0.85	0.82	0.84	0.84	0.87	0.85	0.86
	SENSIBLE	0.78	0.75	0.78	0.80	0.80	0.80	0.80
LOW	TOTAL	0.66	0.60	0.65	0.65	0.68	0.70	0.71
	SENSIBLE	0.58	0.55	0.58	0.60	0.62	0.63	0.66

## MCW-H

MODEL	WATER FLOW (m <sup>3</sup> /h)	W.P.D (kPa)	ENTERING AIR: DB27°C, WB19.5°C									
			ENTERING WATER TEMPERATURE°C									
			6		7		8		9		10	
			TOTAL	SENSIBLE	TOTAL	SENSIBLE	TOTAL	SENSIBLE	TOTAL	SENSIBLE	TOTAL	SENSIBLE
			W	W	W	W	W	W	W	W	W	W
MCW200	0.24	5.6	1882	1377	1765	1358	1668	1329	1542	1271	1358	1222
	0.33	9.7	2124	1552	2018	1513	1882	1504	1746	1474	1610	1436
	0.42	14.8	2299	1688	2144	1649	2018	1610	1882	1591	1736	1562
	0.51	21.6	2425	1775	2202	1746	2124	1698	1969	1649	1824	1630
MCW300	0.36	4	2823	2086	2648	2037	2435	1989	2231	1959	2183	1930
	0.48	9.2	3133	2309	2929	2260	2735	2231	2522	2202	2444	2153
	0.6	13.2	3376	2474	3143	2415	2929	2377	2697	2338	2600	2318
	0.72	18.7	3550	2619	3317	2551	3075	2522	2832	2474	2735	2415
MCW400	0.42	7.3	3541	2580	3308	2522	3104	2474	2862	2435	2493	2386
	0.6	13.8	4064	2881	3822	2949	3579	2920	3308	2900	3036	2842
	0.78	21.6	4443	3259	4258	3220	3861	3182	3599	3143	3308	3104
	0.96	31	4705	3405	4394	3385	4103	3347	3783	3308	3482	3279
MCW600	0.72	18.7	5675	4132	5316	4093	4947	4055	4530	3987	4142	3851
	0.9	32.7	6121	4278	5713	4229	5296	4132	4918	4074	4511	3987
	1.08	38.2	6470	4520	5975	4326	5607	4268	5170	4229	4753	4220
	1.26	50	6761	4685	6295	4637	5849	4559	5393	4540	4937	4462
MCW800	1.14	12.5	7547	5548	7081	5461	6538	5403	5878	5287	5364	5160
	1.44	18.7	8158	5704	7663	5626	7149	5578	6615	5529	6033	5510
	1.74	26.2	8652	6130	8090	6063	7518	6014	6984	5936	6421	5801
	2.04	34.5	9040	6324	8449	6266	7857	6218	7275	6179	6703	6033
MCW1000	1.2	13.6	8352	5539	7799	6004	7188	6111	6615	5956	6092	5849
	1.5	20.1	9002	6354	8449	6247	7838	6218	7236	6150	6577	6053
	1.8	26.5	9555	6683	8914	6577	8264	6518	7663	6509	7013	6489
	2.1	33.7	9991	6994	9322	6868	8652	6800	7964	6761	7324	6732
MCW1200	1.56	21.5	10389	7265	9710	7178	9002	7139	8235	7052	7508	6974
	1.92	32.7	1136	8216	10379	7993	9671	7896	8895	7828	8129	7479
	2.28	40.7	11747	8449	10951	8391	10146	8323	9322	8206	8555	7876
	2.64	54.3	12222	8682	11398	8546	10563	8449	9719	8361	8866	8158

### NOTES:

- 1) THE COOLING CAPACITY IS TESTED UNDER HIGH SPEED. THE CAPACITY UNDER MEDIUM AND LOW FAN SPEED MUST MULTIPLY A CORRECTION FACTOR.
- 2) W.P.D: WATER PRESSURE DROP

TOTAL: TOTAL COOLING CAPACITY      SENSIBLE: SENSIBLE COOLING CAPACITY

### Cooling Capacity Correction Factors:

MODEL		MCW200H	MCW300H	MCW400H	MCW600H	MCW800H	MCW1000H	MCW1200H
MEDIUM	TOTAL	0.85	0.82	0.84	0.84	0.87	0.85	0.86
	SENSIBLE	0.78	0.75	0.78	0.80	0.80	0.80	0.80
LOW	TOTAL	0.66	0.60	0.65	0.65	0.68	0.70	0.71
	SENSIBLE	0.58	0.55	0.58	0.60	0.62	0.63	0.66

MODEL	WATER FLOW (m <sup>3</sup> /h)	W.P.D (kPa)	ENTERING AIR: DB28°C, WB21°C									
			ENTERING WATER TEMPERATURE°C									
			6		7		8		9		10	
			TOTAL	SENSIBLE	TOTAL	SENSIBLE	TOTAL	SENSIBLE	TOTAL	SENSIBLE	TOTAL	SENSIBLE
			W	W	W	W	W	W	W	W	W	W
MCW200	0.24	5.6	2095	1533	1959	1513	1853	1474	1717	1416	1513	1358
	0.33	9.7	2357	1727	2241	1678	2095	1668	1940	1639	1785	1591
	0.42	14.8	2551	1872	2386	1833	2241	1785	2095	1765	1930	1736
	0.51	21.6	2697	1969	2658	1940	2357	1882	2192	1833	2027	1814
MCW300	0.36	4	3133	2318	2939	2260	2706	2212	2483	2173	2425	2144
	0.48	9.2	3482	2561	3259	2512	3036	2483	2803	2444	2716	2396
	0.6	13.2	3754	2745	3492	2687	3259	2638	2997	2600	2891	2580
	0.72	18.7	3948	2910	3686	2832	3414	2803	3143	2745	3036	2687
MCW400	0.42	7.3	3938	2871	3676	2803	3453	2745	3182	2706	2774	2648
	0.6	13.8	4520	3201	4249	3279	3977	3240	3676	3220	3376	3162
	0.78	21.6	4937	3618	4734	3579	4287	3531	3996	3492	3676	3453
	0.96	31	5228	3783	4879	3764	4559	3715	4200	3676	3870	3647
MCW600	0.72	18.7	6305	4588	5907	4549	5500	4501	5034	4433	4598	4278
	0.9	32.7	6800	4753	6344	4695	5888	4588	5461	4530	5015	4433
	1.08	38.2	7188	5025	6635	4811	6227	4743	5742	4695	5277	4685
	1.26	50	7508	5209	6994	5151	6499	5063	5995	5044	5490	4957
MCW800	1.14	12.5	8381	6169	7867	6072	7265	6004	6528	5878	5956	5733
	1.44	18.7	9060	6334	8517	6247	7944	6198	7353	6140	6703	6121
	1.74	26.2	9613	6809	8992	6732	8352	6683	7760	6596	7139	6441
	2.04	34.5	10049	7023	9390	6965	8730	6906	8080	6868	7450	6703
MCW1000	1.2	13.6	9283	6150	8662	6674	7983	6790	7353	6615	6771	6499
	1.5	20.1	10001	7062	9390	6945	8711	6906	8041	6829	7304	6722
	1.8	26.5	10612	7430	9904	7304	9186	7246	8517	7236	7789	7207
	2.1	33.7	11097	7770	10360	7634	9613	7556	8846	7508	8138	7479
MCW1200	1.56	21.5	11543	8070	10786	7973	10001	7935	9147	7838	8342	7750
	1.92	32.7	12377	9128	11533	8885	10748	8769	9884	8701	9031	8313
	2.28	40.7	13056	9390	12164	9322	11271	9244	10360	9118	9506	8749
	2.64	54.3	13580	9642	12668	9496	11737	9390	10796	9293	9855	9060

**NOTES:**

- 1) THE COOLING CAPACITY IS TESTED UNDER HIGH SPEED. THE CAPACITY UNDER MEDIUM AND LOW FAN SPEED MUST MULTIPLY A CORRECTION FACTOR.
- 2) W.P.D: WATER PRESSURE DROP

**TOTAL:** TOTAL COOLING CAPACITY      **SENSIBLE:** SENSIBLE COOLING CAPACITY

**Cooling Capacity Correction Factors:**

MODEL		MCW200H	MCW300H	MCW400H	MCW600H	MCW800H	MCW1000H	MCW1200H
MEDIUM	TOTAL	0.85	0.82	0.84	0.84	0.87	0.85	0.86
	SENSIBLE	0.78	0.75	0.78	0.80	0.80	0.80	0.80
LOW	TOTAL	0.66	0.60	0.65	0.65	0.68	0.70	0.71
	SENSIBLE	0.58	0.55	0.58	0.60	0.62	0.63	0.66

MODEL	WATER FLOW (m <sup>3</sup> /h)	W.P.D (kPa)	ENTERING AIR: DB25°C, WB18°C									
			ENTERING WATER TEMPERATURE°C									
			6		7		8		9		10	
			TOTAL	SENSIBLE	TOTAL	SENSIBLE	TOTAL	SENSIBLE	TOTAL	SENSIBLE	TOTAL	SENSIBLE
W	W	W	W	W	W	W	W	W	W			
MCW200	0.24	5.6	1698	1242	1591	1222	1504	1193	1387	1145	1222	1096
	0.33	9.7	1911	1397	1814	1358	1698	1358	1571	1329	1445	1290
	0.42	14.8	2066	1523	1930	1484	1814	1445	1698	1436	1562	1407
	0.51	21.6	2183	1601	2153	1571	1911	1533	1775	1484	1639	1465
MCW300	0.36	4	2541	1882	2386	1833	2192	1795	2008	1765	1969	1736
	0.48	9.2	2823	2076	2638	2037	2464	2008	2270	1979	2202	1940
	0.6	13.2	3036	2231	2832	2173	2638	2144	2425	2105	2338	2086
	0.72	18.7	3191	2357	2988	2299	2765	2270	2551	2231	2464	2173
MCW400	0.42	7.3	3191	2318	2978	2270	2794	2231	2580	2192	2241	2144
	0.6	13.8	3657	2590	3444	2658	3220	2629	2978	2609	2735	2561
	0.78	21.6	3996	2929	3832	2900	3473	2862	3240	2832	2978	2794
	0.96	31	4239	3065	3958	3046	3696	3017	3405	2978	3133	2949
MCW600	0.72	18.7	5112	3715	4782	3686	4452	3647	4074	3589	3725	3463
	0.9	32.7	5510	3851	5141	3802	4763	3715	4423	3667	4064	3589
	1.08	38.2	5820	4064	5374	3890	5044	3841	4656	3802	4278	3802
	1.26	50	6082	4220	5665	4171	5267	4103	4850	4084	4443	4016
MCW800	1.14	12.5	6790	4996	6373	4918	5888	4860	5287	4763	4831	4646
	1.44	18.7	7343	5131	6897	5063	6431	5025	5956	4976	5432	4957
	1.74	26.2	7789	5519	7285	5461	6771	5413	6286	5345	5781	5219
	2.04	34.5	8138	5694	7605	5636	7071	5597	6548	5558	6033	5432
MCW1000	1.2	13.6	7518	4986	7023	5403	6470	5500	5956	5364	5481	5267
	1.5	20.1	8100	5723	7605	5626	7052	5597	6509	5539	5917	5451
	1.8	26.5	8604	6014	8022	5917	7440	5869	6897	5859	6315	5839
	2.1	33.7	8992	6295	8391	6179	7789	6121	7168	6082	6596	6063
MCW1200	1.56	21.5	9351	6538	8740	6460	8100	6421	7411	6344	6761	6276
	1.92	32.7	10020	7391	9341	7197	8701	7110	8003	7042	7314	6732
	2.28	40.7	10573	7605	9855	7556	9128	7488	8391	7382	7702	7091
	2.64	54.3	11000	7818	10263	7692	9506	7605	8749	7527	7983	7343

**NOTES:**

- 1) THE COOLING CAPACITY IS TESTED UNDER HIGH SPEED. THE CAPACITY UNDER MEDIUM AND LOW FAN SPEED MUST MULTIPLY A CORRECTION FACTOR.
- 2) W.P.D: WATER PRESSURE DROP

**TOTAL:** TOTAL COOLING CAPACITY      **SENSIBLE:** SENSIBLE COOLING CAPACITY

**Cooling Capacity Correction Factors:**

MODEL		MCW200H	MCW300H	MCW400H	MCW600H	MCW800H	MCW1000H	MCW1200H
MEDIUM	TOTAL	0.85	0.82	0.84	0.84	0.87	0.85	0.86
	SENSIBLE	0.78	0.75	0.78	0.80	0.80	0.80	0.80
LOW	TOTAL	0.66	0.60	0.65	0.65	0.68	0.70	0.71
	SENSIBLE	0.58	0.55	0.58	0.60	0.62	0.63	0.66



## MCW-F

MODEL	WATER FLOW (m <sup>3</sup> /h)	W.P.D (kPa)	ENTERING AIR: DB27°C, WB19.5°C									
			ENTERING WATER TEMPERATURE°C									
			6		7		8		9		10	
			TOTAL	SENSIBLE	TOTAL	SENSIBLE	TOTAL	SENSIBLE	TOTAL	SENSIBLE	TOTAL	SENSIBLE
			W	W	W	W	W	W	W	W	W	
MCW200	0.24	0.51	2134	1562	2000	1500	1900	1400	1800	1400	1540	1300
	0.33	0.96	2400	1700	2200	1600	2100	1584	1900	1596	1800	1495
	0.42	1.56	2600	1849	2400	1700	2200	1696	2100	1722	1900	1626
	0.51	2.29	2700	1944	2500	1800	2400	1788	2200	1785	2000	1697
MCW300	0.36	2.19	3201	2365	3000	2250	2773	2095	2604	2159	2475	2053
	0.48	3.89	3540	2529	3194	2390	3053	2350	2744	2384	2733	2242
	0.6	6.08	3818	2709	3519	2490	3194	2504	3009	2531	2845	2414
	0.72	8.76	3953	2869	3767	2630	3474	2657	3165	2678	3000	2515
MCW400	0.42	3.08	4015	2926	3747	2786	3535	2606	3340	2682	2827	2538
	0.6	6.29	4592	3156	4167	3118	3994	3076	3599	3140	3394	2959
	0.78	10.6	5024	3570	4767	3320	4210	3352	4016	3402	3620	3232
	0.96	16.1	5238	3729	4989	3490	4636	3526	4227	3581	3819	3414
MCW600	0.72	10.04	6435	4686	6022	4521	5634	4272	5287	4392	4697	4096
	0.9	15.69	6915	4686	6230	4472	5910	4353	5352	4410	5042	4151
	1.08	22.59	7317	4951	6690	4460	6113	4496	5770	4578	5201	4394
	1.26	30.75	7528	5132	7148	4780	6608	4803	6026	4914	5415	4646
MCW800	1.14	5.53	8558	6292	8022	6032	7445	5692	6860	5824	6083	5489
	1.44	8.83	9216	6248	8356	5949	7978	5876	7199	5985	6745	5737
	1.74	12.89	9786	6715	9057	6250	8197	6336	7794	6426	7027	6040
	2.04	17.72	10066	6928	9593	6460	8877	6550	8128	6689	7351	6282
MCW1000	1.2	6.44	9471	6281	8835	6632	8185	6438	7721	6562	6908	6221
	1.5	10.1	10170	6959	9213	6605	8746	6550	7874	6657	7352	6302
	1.8	14.49	10806	7321	9980	6780	9012	6867	8552	7046	7674	6757
	2.1	19.72	1124	7661	10584	7080	9775	7164	8898	7319	8032	7009
MCW1200	1.56	11.21	11781	8239	11000	7929	10251	7521	9611	7769	8514	7418
	1.92	16.98	12581	8999	11317	8451	10792	8318	9679	8474	9087	7787
	2.28	23.94	13285	9254	12261	8650	11063	8768	10403	8883	9362	8201
	2.64	32.1	13608	9509	12941	8810	11934	8901	10859	9051	9723	8494

### NOTES:

- 1) THE COOLING CAPACITY IS TESTED UNDER HIGH SPEED. THE CAPACITY UNDER MEDIUM AND LOW FAN SPEED MUST MULTIPLY A CORRECTION FACTOR.
- 2) W.P.D: WATER PRESSURE DROP

TOTAL: TOTAL COOLING CAPACITY      SENSIBLE: SENSIBLE COOLING CAPACITY

### Cooling Capacity Correction Factors:

MODEL		MCW200F	MCW300F	MCW400F	MCW600F	MCW800F	MCW1000F	MCW1200F
MEDIUM	TOTAL	0.85	0.82	0.84	0.84	0.87	0.85	0.86
	SENSIBLE	0.78	0.75	0.78	0.80	0.80	0.80	0.80
LOW	TOTAL	0.66	0.60	0.65	0.65	0.68	0.70	0.71
	SENSIBLE	0.58	0.55	0.58	0.60	0.62	0.63	0.66



MODEL	WATER FLOW (m <sup>3</sup> /h)	W.P.D (kPa)	ENTERING AIR: DB28°C, WB21°C									
			ENTERING WATER TEMPERATURE°C									
			6		7		8		9		10	
			TOTAL	SENSIBLE	TOTAL	SENSIBLE	TOTAL	SENSIBLE	TOTAL	SENSIBLE	TOTAL	SENSIBLE
			W	W	W	W	W	W	W	W	W	W
MCW200	0.24	0.51	2376	1738	2220	1671	2110	1553	2004	1560	1716	1444
	0.33	0.96	2663	1891	2443	1774	2338	1758	211	1775	1995	1656
	0.42	1.56	2885	2051	2671	1890	2443	1880	2338	1911	2112	1808
	0.51	2.29	3002	2157	3018	2000	2663	1982	2449	1985	2223	1889
MCW300	0.36	2.19	3553	2629	3330	2496	3082	2330	2898	2394	2750	2280
	0.48	3.89	3934	2805	3554	2656	3388	2616	3051	2646	3036	2495
	0.6	6.08	4246	3007	3910	2770	3554	2780	3345	2814	3163	2687
	0.72	8.76	4396	3188	4185	2920	3858	2953	3511	2972	3330	2798
MCW400	0.42	3.08	4466	3256	4165	3096	3933	2892	3713	2982	3146	2817
	0.6	6.29	5107	3506	4633	3467	4438	3413	4001	3486	3773	3293
	0.78	10.6	5584	3963	5300	3690	4675	3720	4460	3780	4023	3596
	0.96	16.1	5821	4144	5540	3880	5151	3914	4693	3980	4245	3798
MCW600	0.72	10.04	7150	5203	6692	5025	6263	4742	5875	4884	5214	4550
	0.9	15.69	7682	5206	6917	4964	6571	4834	5943	4904	5606	4616
	1.08	22.59	8129	5504	7428	4960	6790	4997	6408	5082	5774	4878
	1.26	30.75	8359	5706	7941	5310	7342	5334	6698	5460	6021	5161
MCW800	1.14	5.53	9504	6996	8912	6707	8274	6326	7619	6476	6754	6098
	1.44	8.83	10236	6938	9287	6605	8865	6530	8001	6647	7493	6373
	1.74	12.89	10872	7459	10067	6940	9107	7041	8660	7140	7812	6706
	2.04	17.72	1189	7693	10661	7180	9863	7276	9028	7434	8170	6979
MCW1000	1.2	6.44	10527	6974	9813	7371	9091	7153	8581	7289	7678	6913
	1.5	10.1	11299	7735	10238	7344	9721	7276	8751	7392	8165	6999
	1.8	14.49	12002	8139	11088	7530	10016	7634	9504	7833	8523	7504
	2.1	19.72	12355	8511	11762	7870	10860	7961	9884	8127	8926	7787
MCW1200	1.56	11.21	13090	9152	12220	8807	11389	8359	10675	8635	9460	8244
	1.92	16.98	13984	9998	12576	9395	11994	9238	10756	9419	10095	8656
	2.28	23.94	14766	10285	13618	9610	12290	9739	11561	9870	10402	9110
	2.64	32.1	15120	10561	14383	9790	13260	9892	12062	10059	10809	9433

**NOTES:**

- 1) THE COOLING CAPACITY IS TESTED UNDER HIGH SPEED.THE CAPACITY UNDER MEDIUM AND LOW FAN SPEED MUST MULTIPLY A CORRECTION FACTOR.
- 2) W.P.D:WATER PRESSURE DROP

**TOTAL:** TOTAL COOLING CAPACITY      **SENSIBLE:**SENSIBLE COOLING CAPACITY

**Cooling Capacity Correction Factors:**

MODEL		MCW200F	MCW300F	MCW400F	MCW600F	MCW800F	MCW1000F	MCW1200F
MEDIUM	TOTAL	0.85	0.82	0.84	0.84	0.87	0.85	0.86
	SENSIBLE	0.78	0.75	0.78	0.80	0.80	0.80	0.80
LOW	TOTAL	0.66	0.60	0.65	0.65	0.68	0.70	0.71
	SENSIBLE	0.58	0.55	0.58	0.60	0.62	0.63	0.66

MODEL	WATER FLOW (m³/h)	W.P.D (kPa)	ENTERING AIR: DB25°C, WB18°C									
			ENTERING WATER TEMPERATURE°C									
			6		7		8		9		10	
			TOTAL	SEN-SIBLE	TOTAL	SEN-SIBLE	TOTAL	SEN-SIBLE	TOTAL	SEN-SIBLE	TOTAL	SEN-SIBLE
	W	W	W	W	W	W	W	W	W	W	W	
MCW200	0.24	0.51	1925	1408	1802	1350	1712	1257	1619	1261	1386	1166
	0.33	0.96	2159	1530	1978	1436	1894	1431	1710	1439	1616	1343
	0.42	1.56	2337	1668	2161	1530	1978	1523	1894	1554	1709	1465
	0.51	2.29	2430	1753	2445	1620	2159	1615	1983	1607	1798	1525
MCW300	0.36	2.19	2882	2134	2703	2025	2497	1891	2343	1945	2233	1847
	0.48	3.89	3189	2274	2877	2154	2749	2115	2470	2142	2461	2020
	0.6	6.08	3434	2444	3171	2240	2877	2258	2706	2279	2558	2172
	0.72	8.76	3553	2582	3392	2370	3123	2391	2850	2415	2702	2262
MCW400	0.42	3.08	3619	2629	3374	2507	3181	2350	3011	2415	2541	2280
	0.6	6.29	4132	2837	3755	2810	3594	2769	3241	2825	3058	2666
	0.78	10.6	4520	3209	4290	2990	3787	3015	3615	3066	3259	2909
	0.96	16.1	4720	3358	4493	3140	4175	3178	3804	3224	3436	3070
MCW600	0.72	10.04	5797	4213	5418	4071	5070	3842	4755	3954	4224	3683
	0.9	15.69	6225	4218	5606	4021	5315	3914	4813	3969	4543	3737
	1.08	22.59	6582	4452	6016	4010	5500	4047	5196	4116	4681	3959
	1.26	30.75	6772	4622	6432	4300	5951	4323	5419	4421	4872	4181
MCW800	1.14	5.53	7700	5665	7220	5432	6705	5120	6170	5247	5478	4942
	1.44	8.83	8296	5621	7520	5354	7177	5293	6481	5387	6072	5161
	1.74	12.89	8809	6046	8156	5630	7383	5702	7014	5786	6326	5434
	2.04	17.72	9061	6237	8634	5810	7989	5896	7315	6017	6617	5656
MCW1000	1.2	6.44	8525	5654	7956	5968	7368	5794	6951	5910	6215	5602
	1.5	10.1	9151	6269	8292	5949	7870	5896	7083	5996	6614	5676
	1.8	14.49	9731	6588	8981	6100	8113	6182	7696	6342	6910	6080
	2.1	19.72	10012	6896	9526	6370	8800	6448	8009	6584	7234	6313
MCW1200	1.56	11.21	10604	7414	9901	7136	9224	6765	8649	6989	7667	6675
	1.92	16.98	11321	8096	10186	7610	9710	7491	8708	7623	8176	7009
	2.28	23.94	11958	8330	11033	7790	9953	7889	9363	7991	8428	7383
	2.64	32.1	12247	8564	11652	7930	10740	8012	9775	8148	8755	7646

**NOTES:**

- 1) THE COOLING CAPACITY IS TESTED UNDER HIGH SPEED. THE CAPACITY UNDER MEDIUM AND LOW FAN SPEED MUST MULTIPLY A CORRECTION FACTOR.
- 2) W.P.D: WATER PRESSURE DROP

**TOTAL:** TOTAL COOLING CAPACITY      **SENSIBLE:** SENSIBLE COOLING CAPACITY

**Cooling Capacity Correction Factors:**

MODEL		MCW200F	MCW300F	MCW400F	MCW600F	MCW800F	MCW1000F	MCW1200F
MEDIUM	TOTAL	0.85	0.82	0.84	0.84	0.87	0.85	0.86
	SENSIBLE	0.78	0.75	0.78	0.80	0.80	0.80	0.80
LOW	TOTAL	0.66	0.60	0.65	0.65	0.68	0.70	0.71
	SENSIBLE	0.58	0.55	0.58	0.60	0.62	0.63	0.66

# Performance Data-Heating

## MCW-C

MODEL	WATER FLOW (m³/h)	W.P.D (kpa)	ENTERING AIR: DB21°C								
			ENTERING WATER TEMPERATURE°C								
			40	45	50	55	60	65	70	75	80
			W	W	W	W	W	W	W	W	W
MCW200	0.24	4.5	1560	1970	2380	2790	3190	3600	4020	4420	4830
	0.33	7.8	1670	2110	2550	2990	3430	3860	4300	4740	5190
	0.42	11.8	1740	2200	2650	3110	3580	4030	4490	4940	5410
	0.51	17.3	1790	2260	2730	3190	3670	4140	4610	5080	5550
MCW300	0.36	3.2	2160	2720	3300	3870	4440	5010	5570	6140	6700
	0.48	7.4	2410	3050	3690	4330	4970	5600	6230	6880	7520
	0.6	10.6	2520	3180	3850	4520	5170	5830	6510	7150	7810
	0.72	15.0	2590	3270	3960	4630	5310	6000	6670	7360	8050
MCW400	0.42	5.8	3150	3970	4810	5620	6460	7290	8110	8940	9770
	0.6	11.0	3410	4400	5200	6100	7000	7890	8780	9680	10570
	0.78	17.3	3550	4500	5430	6470	7300	8240	9180	10120	11040
	0.96	24.8	3660	4620	5590	6550	7520	8480	9450	10400	11370
MCW600	0.72	15.0	4510	5710	6900	8090	9280	10460	11650	12840	14030
	0.9	26.2	4710	5960	7200	8440	9680	10920	12160	13410	14640
	1.08	30.6	4850	6130	7410	8690	9960	11250	12510	13800	15070
	1.26	40.0	4960	6270	7570	8870	10180	11480	12790	14090	15400
MCW800	1.14	10.0	6140	7770	9400	11030	12660	14290	15920	17550	19190
	1.44	15.0	6400	8120	9820	11520	13220	14920	16620	18330	20030
	1.74	21.0	6600	8350	10110	11860	13610	15360	17120	18870	20620
	2.04	27.6	6740	8530	10320	12110	13900	15690	17490	19270	21060
MCW1000	1.2	10.9	6860	8700	10530	12370	14210	16050	17880	19720	21560
	1.5	16.1	7180	9100	11020	12940	14860	16790	18710	20630	22550
	1.8	21.2	7410	9390	11370	13350	15330	17310	19290	21270	23250
	2.1	27.0	7580	9600	11630	13660	15680	17700	19730	21770	23740
MCW1200	1.56	17.2	8560	10850	13150	15780	17760	20070	21390	24670	26970
	1.92	26.2	9490	11910	14330	16750	19170	21590	24020	26450	28870
	2.28	32.6	9780	12280	14780	17270	19770	22270	24760	27260	29750
	2.64	43.4	10010	12570	15120	17670	20220	22780	25330	27880	30440

### NOTES:

- 1) THE HEATING CAPACITY IS TESTED UNDER HIGH SPEED. THE CAPACITY UNDER MEDIUM AND LOW FAN SPEED MUST MULTIPLY A CORRECTION FACTOR.
- 2) W.P.D: WATER PRESSURE DROP

### Heating Capacity Correction Factors:

MODEL	MCW200C	MCW300C	MCW400C	MCW600C	MCW800C	MCW1000C	MCW1200C
MEDIUM	0.80	0.78	0.78	0.81	0.83	0.80	0.81
LOW	0.58	0.56	0.57	0.58	0.62	0.60	0.61

## MCW-H

MODEL	WATER FLOW (m³/h)	W.P.D (kpa)	ENTERING AIR: DB21°C								
			ENTERING WATER TEMPERATURE°C								
			40	45	50	55	60	65	70	75	80
			W	W	W	W	W	W	W	W	W
MCW200	0.12	3.2	430	540	690	830	950	1180	1370	1820	1980
	0.18	7.3	530	680	780	940	1160	1360	1800	1980	2180
	0.24	12.0	620	760	920	1170	1350	1780	1930	2160	2460
	0.36	21.9	800	910	1150	1250	1730	1900	2150	2440	2640
MCW300	0.12	3.7	790	980	1180	1380	1580	1780	1970	2170	2360
	0.18	8.2	1000	1240	1490	1740	1990	2240	2490	2740	2980
	0.24	13.5	1140	1420	1700	1990	2280	2560	2850	3130	3420
	0.36	25.0	1340	1660	1990	2340	2660	3000	3330	3660	3990
MCW400	0.12	5.2	1170	1430	1760	2040	2340	2620	2910	3190	3490
	0.18	10.0	1430	1790	2860	2500	2860	3210	3580	3930	4280
	0.24	14.8	1610	2010	2410	2790	3210	3600	4030	4420	4820
	0.36	29.0	1900	2370	2830	3320	3790	4270	4740	5210	5630
MCW600	0.12	8.2	1570	1980	2380	2760	3140	3570	3990	4370	4770
	0.18	14.0	1890	2390	2890	3350	3790	4220	4800	5240	5730
	0.24	20.7	2120	2700	3240	3790	4290	4870	5450	5990	6530
	0.36	36.0	2520	3200	3850	4540	5180	5860	6530	7120	7830
MCW800	0.12	2.4	1890	2350	2830	3290	3770	4240	4720	5180	5650
	0.18	4.8	2270	2840	3400	3970	4540	5100	5660	6240	6800
	0.24	7.8	2570	3200	3840	4480	5120	5760	6400	7050	7690
	0.36	11.5	3040	3810	4560	5320	6080	6840	7600	8360	9130
MCW1000	0.3	5.5	2070	2600	3290	3800	4360	4790	6070	6440	7430
	0.4	8.8	2830	3300	4240	4400	5660	6350	7090	7610	9290
	0.5	12.8	3610	4090	5180	5400	6940	7550	9230	9620	10550
	0.6	18.5	4060	4900	5290	6340	8510	9370	10150	11300	12380
MCW1200	0.3	6.0	2980	3540	4210	5230	5970	6440	7650	8270	9250
	0.4	9.9	3650	4270	5650	6350	7150	7980	9414	10280	11080
	0.5	14.6	4300	5200	6490	7580	8490	9400	10900	11900	12980
	0.6	20.0	4830	5910	7660	8790	10420	11200	12380	13610	14850

### NOTES:

- 1) THE HEATING CAPACITY IS TESTED UNDER HIGH SPEED. THE CAPACITY UNDER MEDIUM AND LOW FAN SPEED MUST MULTIPLY A CORRECTION FACTOR.
- 2) W.P.D: WATER PRESSURE DROP

### Heating Capacity Correction Factors:

MODEL	MCW200H	MCW300H	MCW400H	MCW600H	MCW800H	MCW1000H	MCW1200H
MEDIUM	0.80	0.78	0.78	0.81	0.83	0.80	0.81
LOW	0.58	0.56	0.57	0.58	0.62	0.60	0.61

## MCW-F

MODEL	WATER FLOW (m <sup>3</sup> /h)	W.P.D (kpa)	ENTERING AIR: DB21°C								
			ENTERING WATER TEMPERATURE°C								
			40	45	50	55	60	65	70	75	80
			W	W	W	W	W	W	W	W	W
MCW200	0.24	0.4	1701	2148	2595	3042	3478	3925	4383	4819	5267
	0.33	0.8	1821	2301	2780	3260	3740	4209	4689	5168	5659
	0.42	1.2	1897	2399	2890	3391	3904	4394	4896	5386	5899
	0.51	1.8	1952	2464	2977	3478	4002	4514	5027	5539	6052
MCW300	0.36	1.8	2252	2836	3441	4035	4629	5223	5807	6402	6986
	0.48	3.1	2513	3180	3847	4515	5182	5839	6495	7173	7840
	0.6	4.9	2627	3316	4014	4713	5390	6078	6787	7455	8143
	0.72	7.0	2700	3409	4129	4827	5536	6256	6954	7674	8393
MCW400	0.42	2.5	3266	4116	4987	5827	6697	7558	8408	9269	10129
	0.6	5.0	3535	4562	5391	6324	7257	8180	9103	10036	10958
	0.78	8.5	3680	4665	5630	6708	7568	8543	9517	10492	11446
	0.96	12.9	3795	4790	5795	6791	7796	8792	9797	10782	11788
MCW600	0.72	8.0	4770	6039	7298	8556	9815	11063	12321	13580	14839
	0.9	12.6	4981	6304	7615	8926	10238	11549	12861	14183	15484
	1.08	18.1	5130	6483	7837	9191	10534	11898	13231	14595	15939
	1.26	24.6	5246	6631	8006	9381	10767	12142	13527	14902	16288
MCW800	1.14	4.4	6768	8565	10362	12158	13955	15752	17549	19345	21153
	1.44	7.1	7055	8951	10825	12699	14572	16446	18320	20205	22079
	1.74	10.3	7275	9204	11144	13073	15002	16931	18871	20801	22730
	2.04	14.2	7430	9403	11376	13349	15322	17295	19279	21241	23215
MCW1000	1.2	5.2	6768	8565	10362	12158	13955	15752	17549	19345	21153
	1.5	8.1	7055	8951	10825	12699	14572	16446	18320	20205	22079
	1.8	11.6	7275	9204	11144	13073	15002	16931	18871	20801	22730
	2.1	15.8	7430	9403	11376	13349	15322	17295	19279	21241	23215
MCW1200	1.56	9.0	8808	1164	13531	16237	18275	20641	22010	25385	27752
	1.92	13.6	9765	12255	14745	17235	19726	22216	24716	27217	29707
	2.28	19.2	10063	12636	15208	17771	20343	22915	25478	28050	30612
	2.64	25.7	10300	12934	15558	18182	20806	23440	26064	28688	31322

### NOTES:

- 1) THE HEATING CAPACITY IS TESTED UNDER HIGH SPEED. THE CAPACITY UNDER MEDIUM AND LOW FAN SPEED MUST MULTIPLY A CORRECTION FACTOR.
- 2) W.P.D.: WATER PRESSURE DROP

### Heating Capacity Correction Factors:

MODEL	MCW200F	MCW300F	MCW400F	MCW600F	MCW800F	MCW1000F	MCW1200F
MEDIUM	0.80	0.78	0.78	0.81	0.83	0.80	0.81
LOW	0.58	0.56	0.57	0.58	0.62	0.60	0.61

# Air Flow vs ESP Curve

1-0Pa 2-30Pa 3-60Pa 4-80Pa

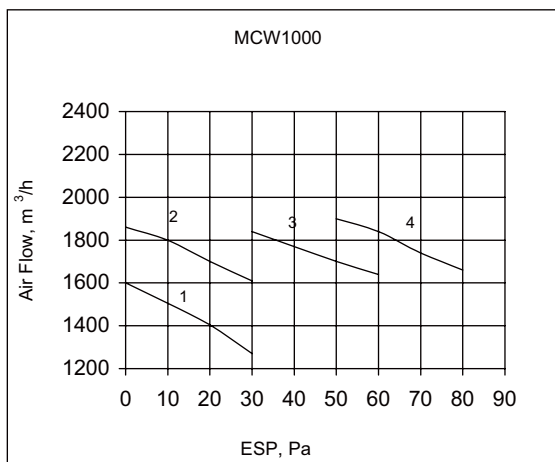
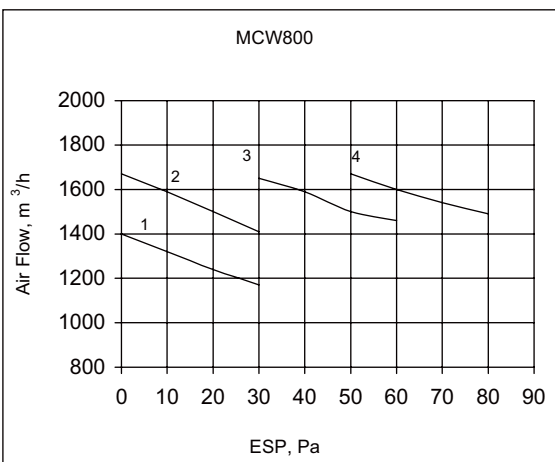
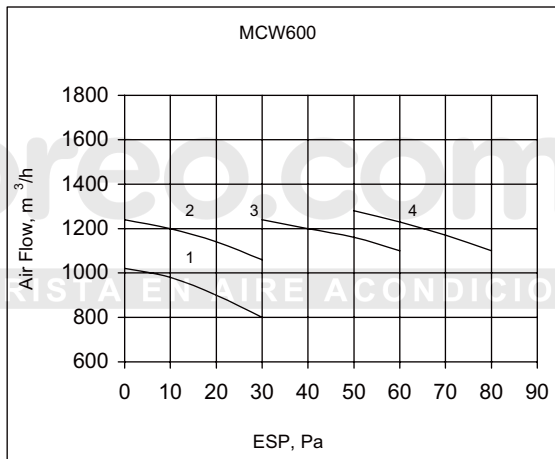
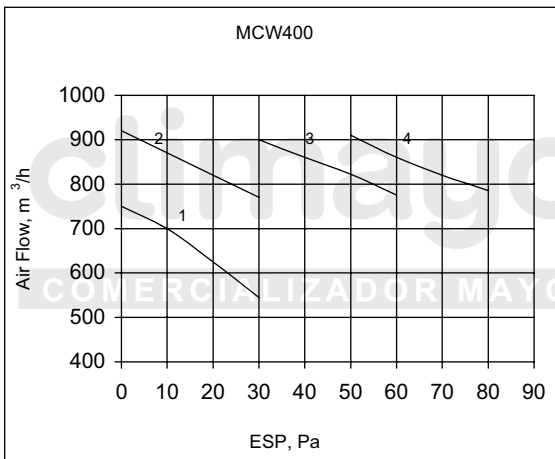
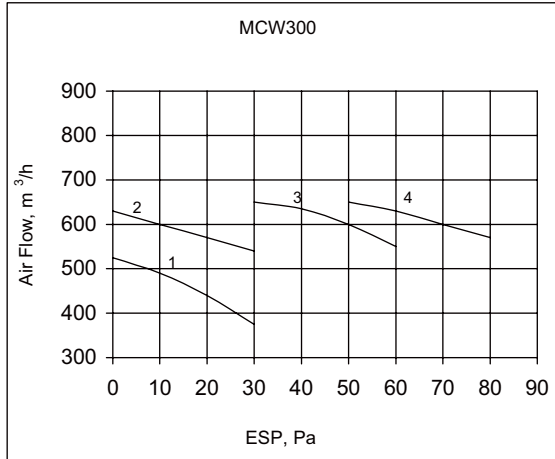
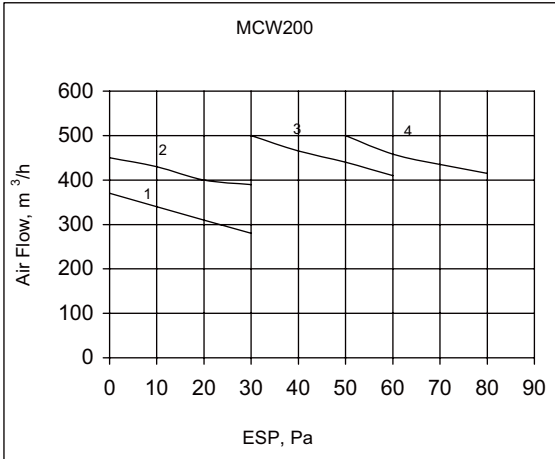

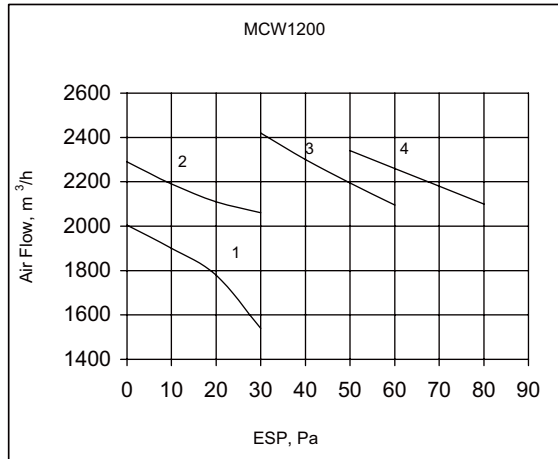

## Operating Limits

Operating Limits	MCW-C/H/F
<b>Water Circuit</b>	
Max. Water side pressure	1.6MPa
Min. Entering water temperature	3°C (cooling)
Max. Entering water temperature	80°C (heating)
<b>Power supply</b>	
Operating voltage limits	± 0% Volt
Operating frequency limits	±2Hz

# Water Flow Rate vs Pressure Drop Chart

## MCW-C

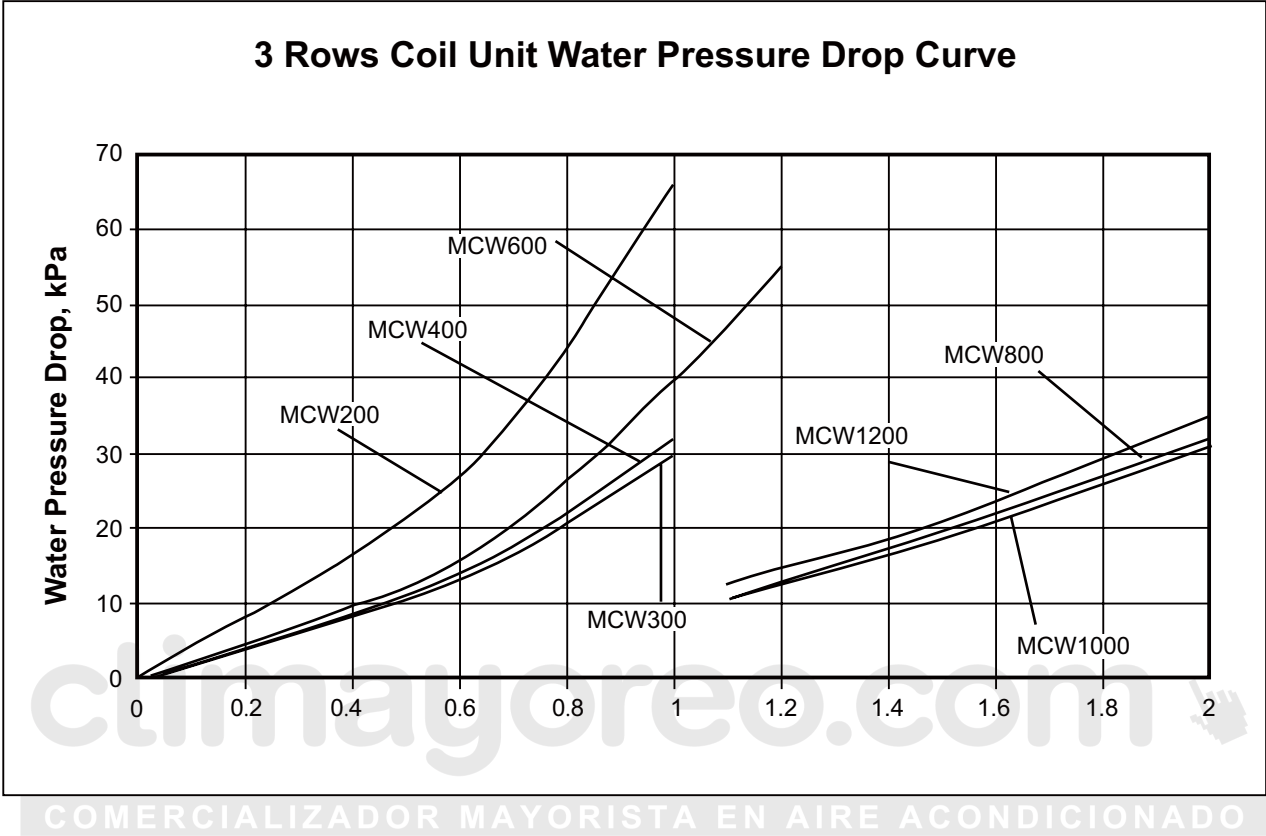

## MCW-H

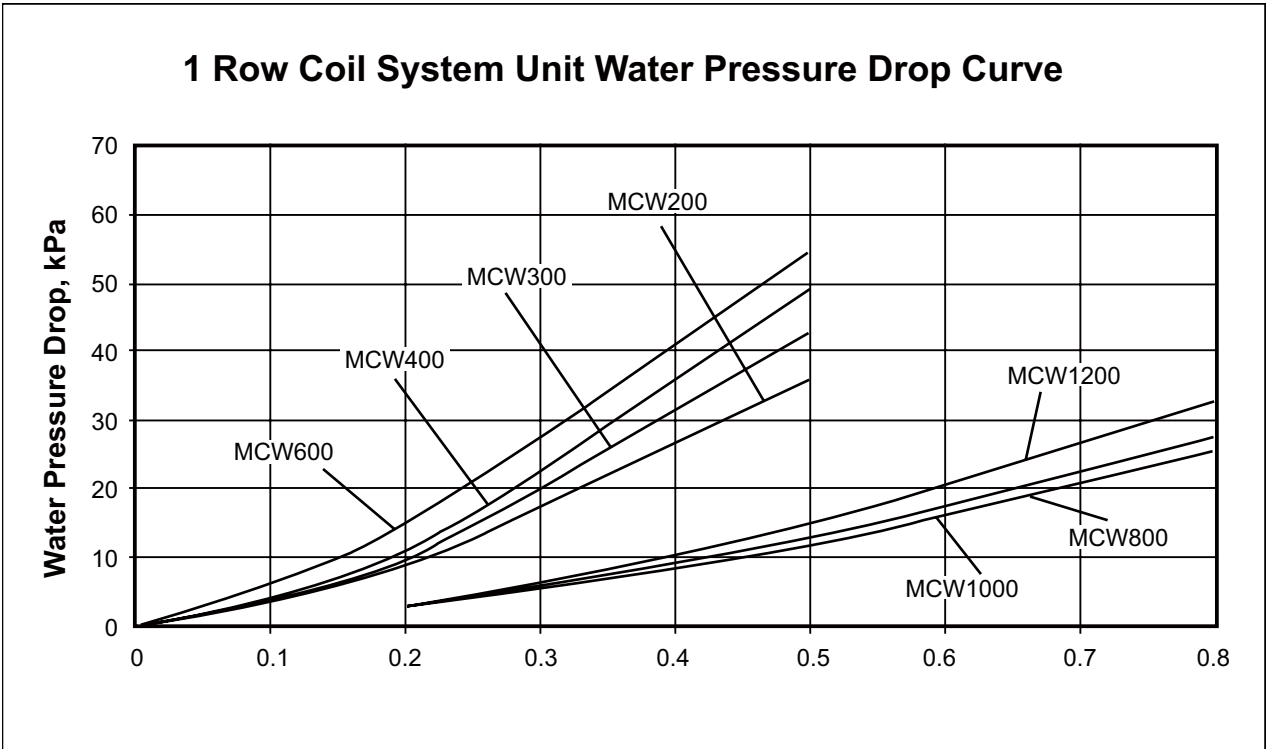



**MCW-F**

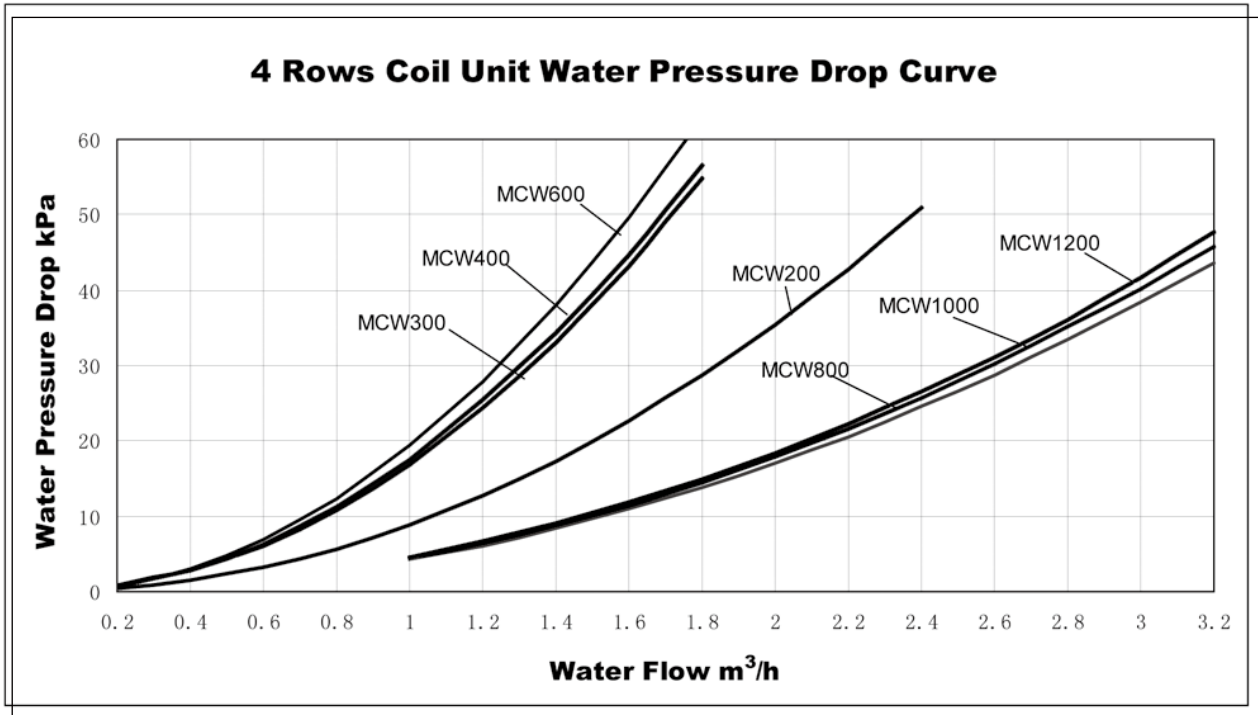

**climayoreo.com** 

COMERCIALIZADOR MAYORISTA EN AIRE ACONDICIONADO

# Outlines and Dimensions

## MCW-C/H/F

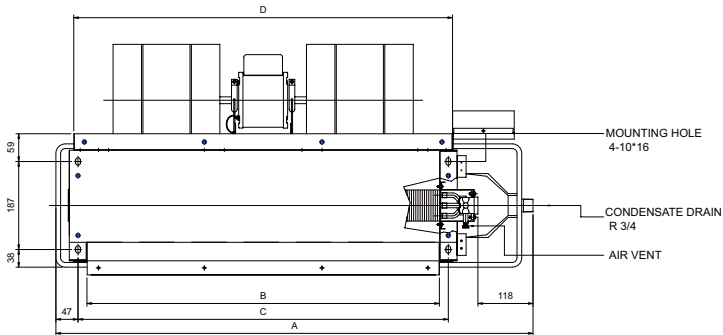

UNIT SIZE	A		B	C	D	Number of Fans
	Standard Drain pan	100mm extension drain pan				
MCW200C	714	814	448	487	505	1
MCW300C	884	984	618	657	675	1
MCW400C	1014	1114	748	787	805	2
MCW600C	1214	1314	948	987	1005	2
MCW800C	1464	1564	1198	1237	1255	3
MCW1000C	1564	1664	1298	1337	1355	3
MCW1200C	1824	1924	1558	1597	1615	4

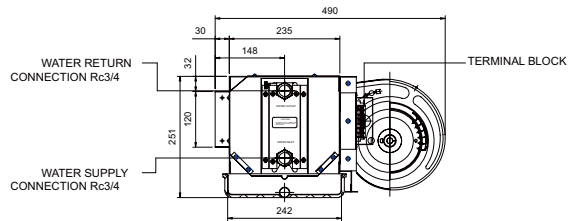
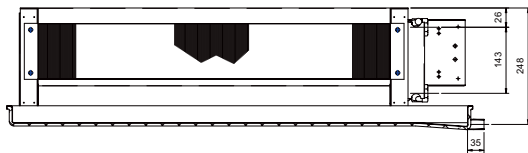

UNIT SIZE	DIMENSION	
	A	B
MCW200C	507	467
MCW300C	677	637
MCW400C	807	767
MCW600C	1007	967
MCW800C	1257	1217
MCW1000C	1357	1317
MCW1200C	1617	1577

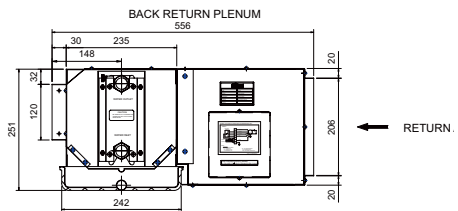
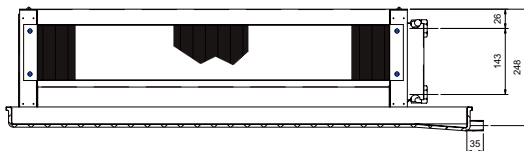
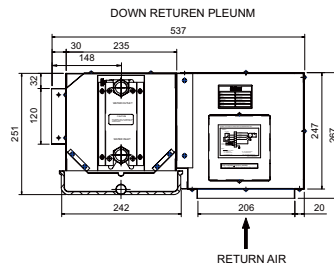
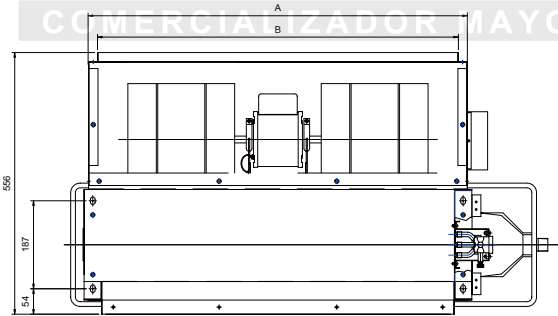

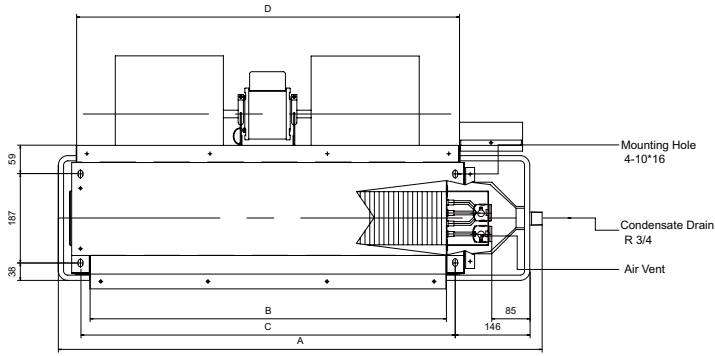

UNIT	A		B	C	D	Number of Fans
	Standard Drain pan	100mm extension Drain pan				
MCW200H	714	814	448	487	505	1
MCW300H	884	984	618	657	675	1
MCW400H	1014	1114	748	787	805	2
MCW600H	1214	1314	948	987	1005	2
MCW800H	1464	1564	1198	1237	1255	3
MCW1000H	1564	1664	1298	1337	1355	3
MCW1200H	1824	1924	1558	1597	1615	4

Note: INLET  
 OUTLET  
 CONNECTION PIPE Rc3/4

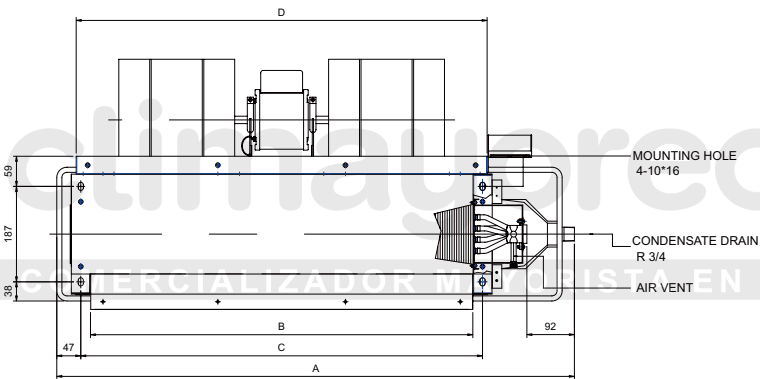
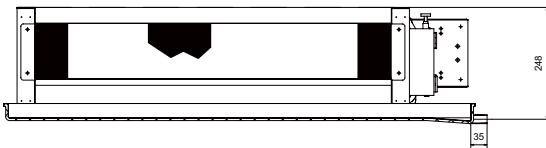
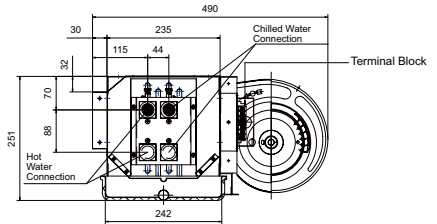

UNIT SIZE	A		B	C	D	Number of Fans
	Standard Drain pan	100mm extension Drain pan				
MCW200F	714	814	448	487	505	1
MCW300F	884	984	618	657	675	1
MCW400F	1014	1114	748	787	805	2
MCW600F	1214	1314	948	987	1005	2
MCW800F	1464	1564	1198	1237	1255	3
MCW1000F	1564	1664	1298	1337	1355	3
MCW1200F	1824	1924	1558	1597	1615	4

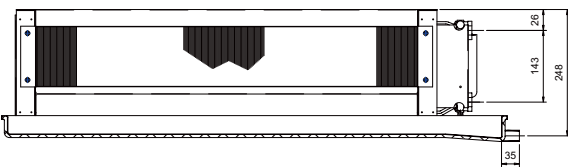
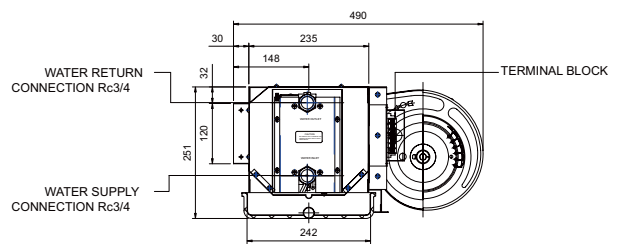

**NOTES:**

- 1) ALL DIMENSIONS ARE IN mm.
- 2) ALL STANDARD UNITS ARE WITHOUT BACK AIR PLENUM AND BOTTOM REMOVEAL FILTERS.
- 3) A1 IS THE DIMENSION FOR 100mm EXTENDED DRAIN PAN UNITS.
- 4) RIGHT HAND COIL CONNECTION SHOWN.
- 5) WIRING CONNECTION SIDE IS THE SAME AS COIL AND DRAIN CONNECTIONS.

# Electrical Data

## MCW-C/H/F

115V/1Ph/60Hz

MODEL			MCW200	MCW300	MCW400	MCW600	MCW800	MCW1000	MCW1200
0Pa MOTOR	INSULATION GRADE/IP		E/20						
	POWER SOURCE	V/Ph/Hz	115/1/60						
	RATED INPUT POWER	W	35	47	56	88	115	132	173
	RATED RUNNING CURRENT	A	0.30	0.41	0.49	0.77	1.00	1.15	1.50
	POLES		6						
30Pa MOTOR	INSULATION GRADE/IP		E/20						
	POWER SOURCE	V/Ph/Hz	115/1/60						
	RATED INPUT POWER	W	54	73	100	143	196	210	276
	RATED RUNNING CURRENT	A	0.47	0.63	0.87	1.24	1.70	1.83	2.40
	POLES		4						
60Pa MOTOR	INSULATION GRADE/IP		E/20						
	POWER SOURCE	V/Ph/Hz	115/1/60						
	RATED INPUT POWER	W	63	97	111	183	263	281	353
	RATED RUNNING CURRENT	A	0.55	0.84	0.97	1.59	2.29	2.44	3.07
	POLES		4						
80Pa MOTOR	INSULATION GRADE/IP		E/20						
	POWER SOURCE	V/Ph/Hz	115/1/60						
	RATED INPUT POWER	W	72	107	125	187	253	283	353
	RATED RUNNING CURRENT	A	0.63	0.93	1.09	1.63	2.20	2.46	3.07
	POLES		4						

208~230V/1Ph/60Hz

MODEL			MCW200	MCW300	MCW400	MCW600	MCW800	MCW1000	MCW1200
80Pa MOTOR	INSULATION GRADE/IP		E/20						
	POWER SOURCE	V/Ph/Hz	265~277/1/60						
	RATED INPUT POWER	W	75	97	125	175	248	270	335
	RATED RUNNING CURRENT	A	0.36	0.47	0.60	0.84	1.19	1.30	1.61
	POLES		4						

265~277V/1Ph/60Hz

MODEL			MCW200	MCW300	MCW400	MCW600	MCW800	MCW1000	MCW1200
80Pa MOTOR	INSULATION GRADE/IP		E/20						
	POWER SOURCE	V/Ph/Hz	265~277/1/60						
	RATED INPUT POWER	W	74	97	124	180	245	269	343
	RATED RUNNING CURRENT	A	0.28	0.37	0.47	0.68	0.92	1.02	1.29
	POLES		4						

### NOTES:

- 1) ALL SPECIFICATIONS ARE SUBJECTED TO CHANGE BY THE MANUFACTURER WITHOUT PRIOR NOTICE.
- 2) ALL ELECTRIC DATA ARE BEING TESTED UNDER HIGH SPEED.

## Power Input and Current of Medium and Low Speed

### 115V/1Ph/60Hz

MODEL				MCW200	MCW300	MCW400	MCW600	MCW800	MCW1000	MCW1200
0Pa MOTOR	POWER INPUT	MEDIUM	W	59	79	109	157	237	237	309
		LOW	W	51	67	93	145	221	217	287
	CURRENT	MEDIUM	A	0.54	0.73	0.96	1.38	2.06	2.09	2.71
		LOW	A	0.48	0.64	0.85	1.26	1.92	1.92	2.53
30Pa MOTOR	POWER INPUT	MEDIUM	W	57	76	104	150	223	225	286
		LOW	W	49	65	89	136	210	211	272
	Current	MEDIUM	A	0.53	0.71	0.92	1.33	1.96	2.00	2.58
		LOW	A	0.46	0.62	0.82	1.20	1.84	1.85	2.46
60Pa MOTOR	POWER INPUT	MEDIUM	W	55	73	99	141	215	217	279
		LOW	W	47	61	85	129	203	197	261
	Current	MEDIUM	A	0.51	0.69	0.89	1.24	1.89	1.93	2.45
		LOW	A	0.44	0.60	0.79	1.15	1.79	1.77	2.30
80Pa MOTOR	POWER INPUT	MEDIUM	W	53	69	93	135	209	211	265
		LOW	W	45	57	81	123	193	187	247
	Current	MEDIUM	A	0.49	0.67	0.86	1.20	1.84	1.85	2.33
		LOW	A	0.43	0.57	0.76	1.10	1.69	1.70	2.20

### 208~230V/1Ph/60Hz

MODEL				MCW200	MCW300	MCW400	MCW600	MCW800	MCW1000	MCW1200
80Pa MOTOR	POWER INPUT	MEDIUM	W	81	102	126	182	258	285	320
		LOW	W	69	88	109	147	181	230	260
	Current	MEDIUM	A	0.35	0.47	0.55	0.80	1.13	1.33	1.30
		LOW	A	0.31	0.42	0.49	0.66	0.90	1.25	1.10

### 265~277V/1Ph/60Hz

MODEL				MCW200	MCW300	MCW400	MCW600	MCW800	MCW1000	MCW1200
80Pa MOTOR	POWER INPUT	MEDIUM	W	55	81	109	147	195	243	293
		LOW	W	47	58	81	118	153	196	244
	Current	MEDIUM	A	0.24	0.36	0.42	0.59	0.78	1.02	1.13
		LOW	A	0.20	0.28	0.35	0.51	0.62	0.82	1.06

**NOTES:**

ALL SPECIFICATIONS ARE SUBJECTED TO CHANGE BY THE MANUFACTURER WITHOUT PRIOR NOTICE.

# Wiring Diagrams

## Wiring(C/H/F)

Electrical wiring connection must be done according to the wiring diagram on the unit.

The unit must be GROUNDED to the earth system of the building.

All field wiring must be installed in accordance with the national wiring regulation and Fire Department regulation.

### FOR MODEL: MCW200 MCW300 MCW400 MCW600 (0Pa and 30Pa)

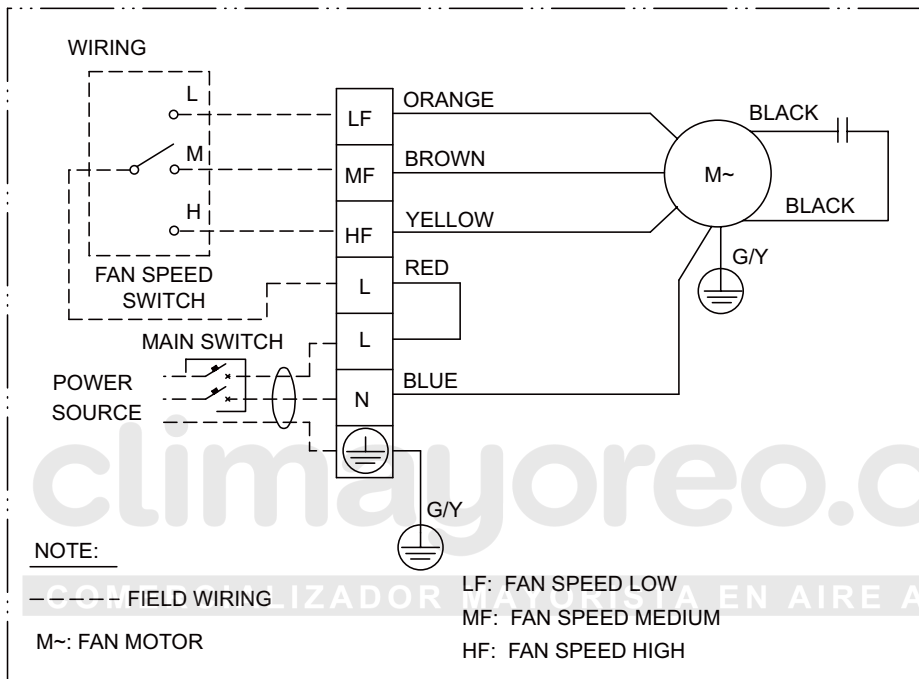

### FOR MODEL: MCW800 MCW1000 MCW1200 (0Pa and 30Pa)

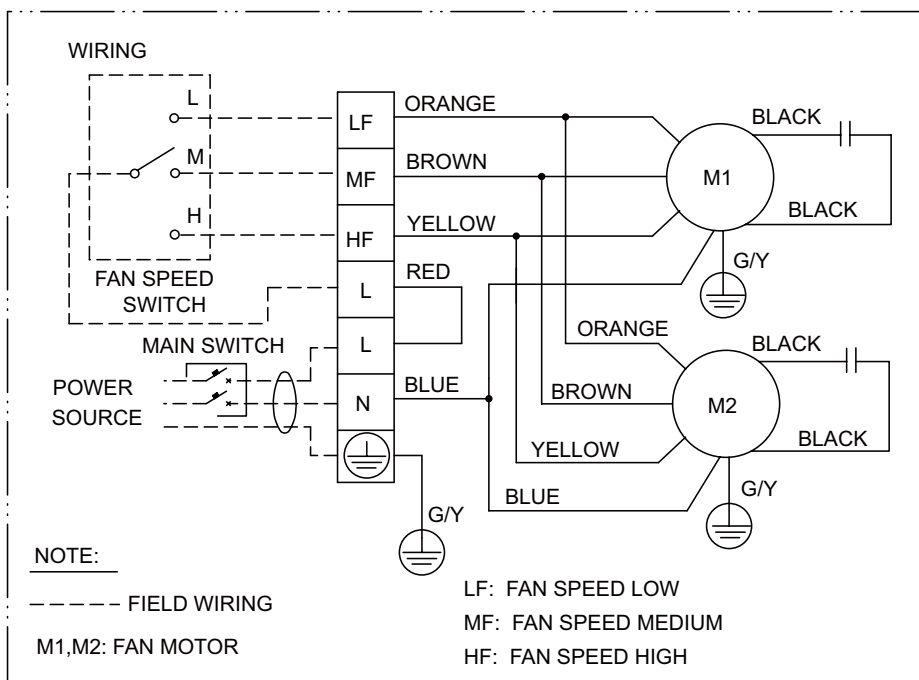

**FOR MODEL: MCW200 MCW300 MCW400 MCW600 (60Pa and 80Pa)**

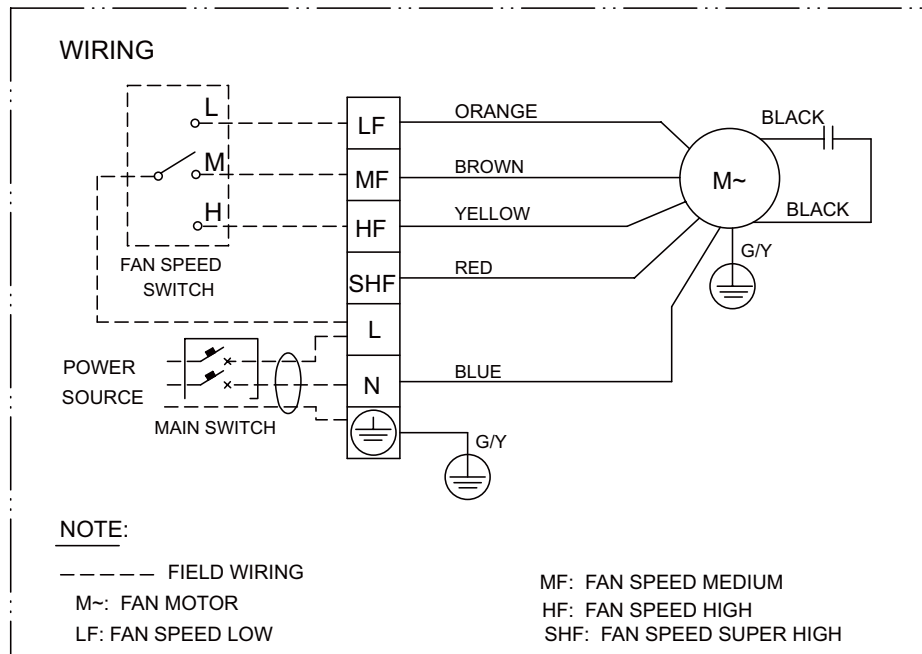

60Pa: LF—Low Speed MF—Medium Speed HF—High Speed  
 80Pa: MF—Low Speed HF—Medium Speed SHF—High Speed

**FOR MODEL: MCW800 MCW1000 MCW1200 (60Pa and 80Pa)**

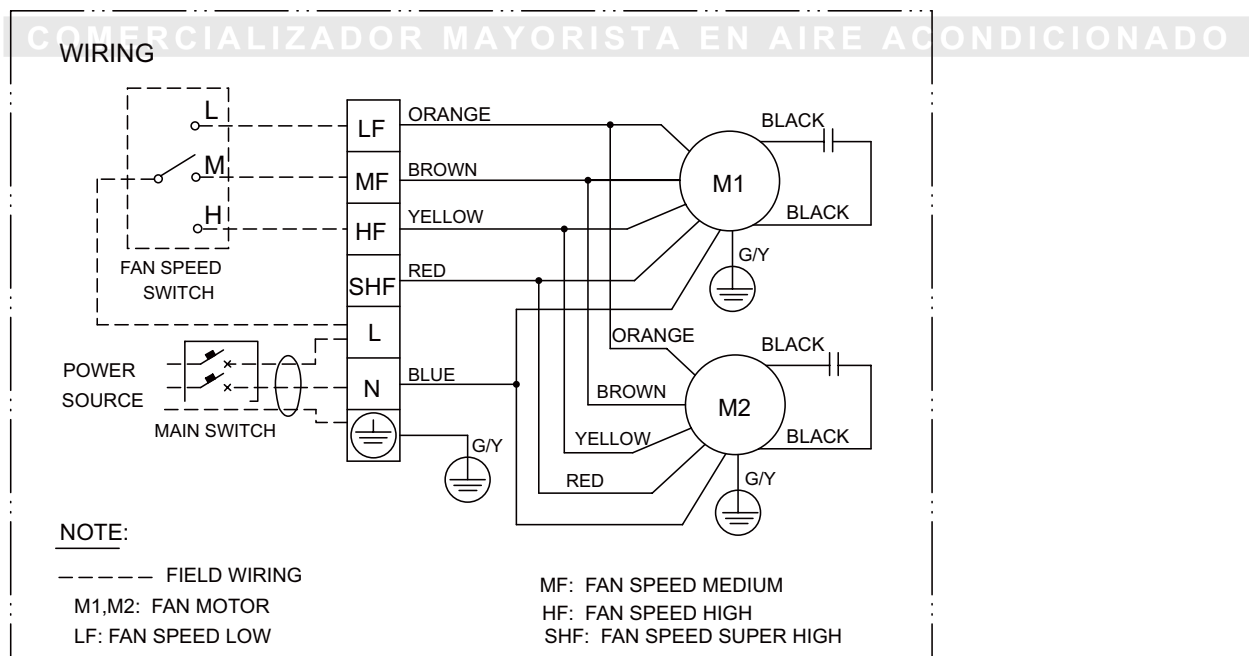

60Pa: LF—Low Speed MF—Medium Speed HF—High Speed  
 80Pa: MF—Low Speed HF—Medium Speed SHF—High Speed

# Installation

## Receiving

All units leaving the McQuay plant have been inspected to ensure the shipment of high quality products and reasonable means are utilized to properly pack the fan coil units to protect them in transit.

Carefully inspect all shipments immediately upon delivery. When damage is visible, note this fact on the carrier's freight bill and request that the carrier sends a representative to inspect the damage. This may be done by telephone or in person, but should always be confirmed in writing.

The shipment should be unpacked in the presence of the agent so that the damage or loss can be determined.

The carrier's agent will make an inspection report and a copy will be given to the consignee for forwarding to the carrier with a formal claim.

## Location

Before installation, please check the following:

There must be enough space for unit installation and maintenance. Please refer to the unit's drawings and dimensions and fig.1 for the minimum distance between the unit and obstacle.

Please ensure enough space for piping connection and electrical wiring.

Please make sure that the hanging rods can support weight of the unit.

## Installation

The unit is designed for concealed ceiling installation.

There are holes on the top of the unit for hanging. Please refer to Fig.1, Fig.2 and Fig.3.

Make sure that the top of the unit is level.

## Insulation

- 1) Use proper insulation material only
- 2) Chilled water pipes and all parts on the pipes should be insulated
- 3) It is also necessary to insulated air ducted
- 4) Adhesive for insulation should work under range 0°F(-18°C) to 200°F(93.3°C).

Fig.1

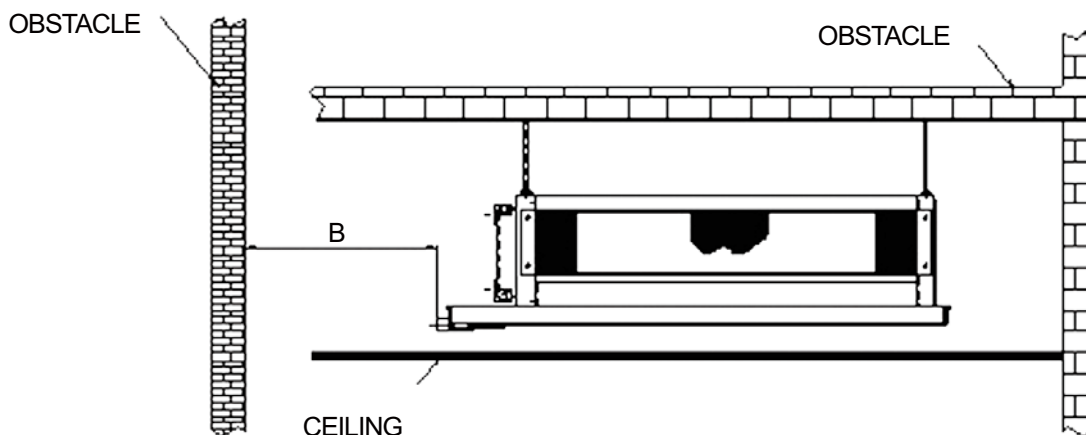

$B \geq 400\text{MM}$



**Fig.2 WITH AND WITHOUT PLENUM FORM:**

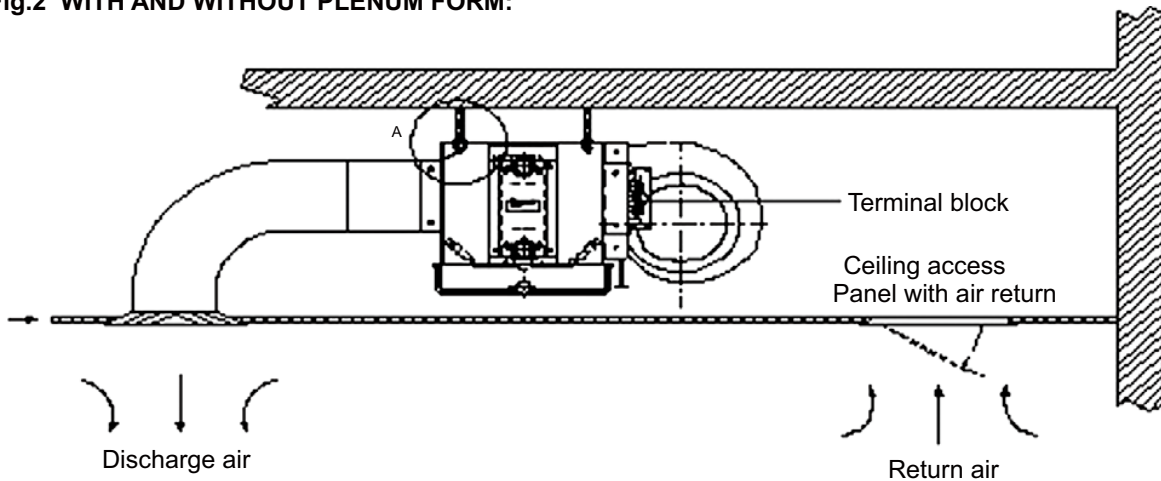

**Fig.3 DETAIL A:**

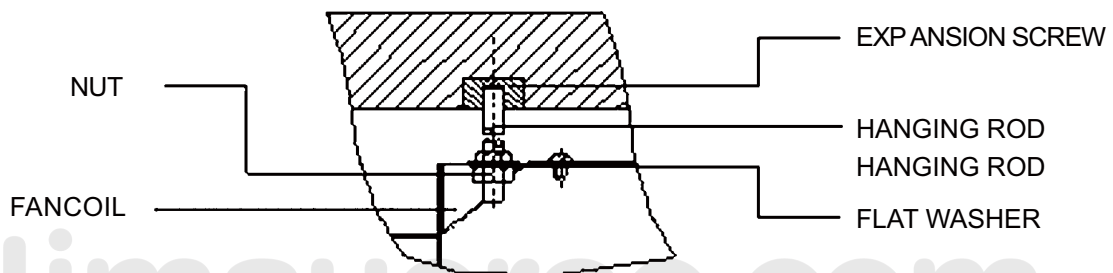

climayoreo.com

COMERCIALIZADOR MAYORISTA EN AIRE ACONDICIONADO

**Air Duct Connection**

Circulatory air pressure drop should be within External Static Pressure  
 Galvanized steel air ducts are suitable  
 Make sure there is no leak of air.  
 Air duct should be fireproof, refer to concerned country national and local regulations.

**Pipe Connection**

Using suitable fittings as water pipe connections. Refer to the specification  
 The water inlet is on the bottom while outlet on top.  
 The connection must be concealed with rubberized fabric to avoid leakage.  
 Drainpipe can be PVC or steel.  
 The suggested slope of the drainpipe is at least 1:50.

**Wiring**

- 1) Wiring connection must be done according to the wiring diagram on the unit.
- 2) The unit must be GROUNDED well.
- 3) An appropriate strain relief device must be used to attach the power wires to the terminal box.
- 4) A 7/8" knockout hole is designed on the terminal box for field installation of the strain relief device.
- 5) Field wiring must be complied with the national security regulations.

# Exploded View & Part List

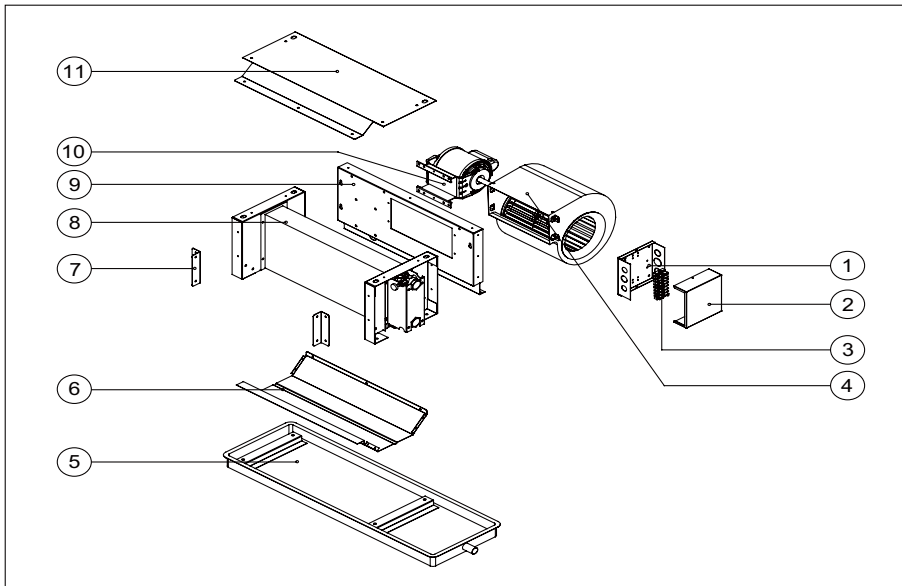

NO.	PART NUMBER	DESCRIPTION	MODEL SELECTION	QTY
1	M50014063206	TERMINAL BOX SUPPORT	TMCW200-1200C/F/H	1
2	M50064063434	TERMINAL BOX COVER	MCW200-1200C/F/H	1
3	A04114012928	TERMINAL BLOCK	MCW200-1200C/F/H	1
4	need selection	BLOWER CENTRIFUGAL	need selection	need selection
5	need selection	DRIANPAN	need selection	1
6	M01014060309	DRAIN GUIDE PLATE	MCW200C/H/F	1
	M01014060312	DRAIN GUIDE PLATE	MCW300C/H/F	1
	M01014060315	DRAIN GUIDE PLATE	MCW400C/H/F	1
	M01014060318	DRAIN GUIDE PLATE	MCW600C/H/F	1
	M01014060321	DRAIN GUIDE PLATE	MCW800C/H/F	1
	M01014060324	DRAIN GUIDE PLATE	MCW1000C/H/F	1
	M01014060327	DRAIN GUIDE PLATE	MCW1200C/H/F	1
7	M01014060304	DUCT PLATE	MCW200-1200C/H/F	2
8	need selection	ASSY.,COIL	need selection	1
9	M01014060310	FAN DECK PLATE	MCW200C/H/F	1
	M01014060313	FAN DECK PLATE	MCW300C/H/F	1
	M01014060316	FAN DECK PLATE	MCW400C/H/F	1
	M01014060319	FAN DECK PLATE	MCW600C/H/F	1
	M01014060322	FAN DECK PLATE	MCW800C/H/F	1
	M01014060325	FAN DECK PLATE	MCW1000C/H/F	1
	M01014060328	FAN DECK PLATE	MCW1200C/H/F	1
10	need selection	MOTOR	need selection	need selection
11	M01014060308	TOP PLATE	MCW200C/H/F	1
	M01014060311	TOP PLATE	MCW300C/H/F	1
	M01014060314	TOP PLATE	MCW400C/H/F	1
	M01014060317	TOP PLATE	MCW600C/H/F	1
	M01014060320	TOP PLATE	MCW800C/H/F	1
	M01014060323	TOP PLATE	MCW 000C/H/F	1
	M01014060326	TOP PLATE	MCW 200C/H/F	1

NOTE: "NEED SELECTION" PARTS PLEASE FIND THE REFERENCMENT MATERIAL MARKED AS FOLLOWING:

## Item4.Blower Centrifugal

P/N	DESCRIPTION	MODEL & QUANTITY SELECTION						
		MCW200 C/H/F	MCW300 C/H/F	MCW400 C/H/F	MCW600 C/H/F	MCW800 C/H/F	MCW1000 C/H/F	MCW1200 C/H/F
M03029000980	BLOWER CENTRIFUGAL SYP 60/200J-L	1	1	1	1	2	2	2
M03029000981	BLOWER CENTRIFUGAL SYP 60/200J-R	-	1	1	1	1	2	2

P/N	DESCRIPTION
M03029000980	BLOWER CENTRIFUGAL SYP 60/200J-L
M03029000981	BLOWER CENTRIFUGAL SYP 60/200J-R

### Item5.Drain pan

P/N	DESCRIPTION	NOTE	MODEL SELECTION	QUANTITY
M50014063167	DRAINPAN	STANDARD LENGTH.PE INSULATION	MCW200C/H/F	1
M50014063168	DRAINPAN	STANDARD LENGTH.PE INSULATION	MCW300C/H/F	1
M50014063169	DRAINPAN	STANDARD LENGTH.PE INSULATION	MCW400C/H/F	1
M50014063170	DRAINPAN	STANDARD LENGTH.PE INSULATION	MCW600C/H/F	1
M50014063171	DRAINPAN	STANDARD LENGTH.PE INSULATION	MCW800C/H/F	1
M50014063172	DRAINPAN	STANDARD LENGTH.PE INSULATION	MCW1000C/H/F	1
M50014063173	DRAINPAN	STANDARD LENGTH.PE INSULATION	MCW1200C/H/F	1
M50014063738	DRAINPAN	LENGTH EXTENDED100mm.PE INSULATION	MCW200C/H/F	1
M50014063739	DRAINPAN	LENGTH EXTENDED100mm.PE INSULATION	MCW300C/H/F	1
M50014063740	DRAINPAN	LENGTH EXTENDED100mm.PE INSULATION	MCW400C/H/F	1
M50014063741	DRAINPAN	LENGTH EXTENDED100mm.PE INSULATION	MCW600C/H/F	1
M50014063742	DRAINPAN	LENGTH EXTENDED100mm.PE INSULATION	MCW800C/H/F	1
M50014063743	DRAINPAN	LENGTH EXTENDED100mm.PE INSULATION	MCW1000C/H/F	1
M50014063744	DRAINPAN	LENGTH EXTENDED100mm.PE INSULATION	MCW1200C/H/F	1

### Item8.Assy coil

P/N	DESCRIPTION	NOTE	MODEL SELECTION	QUANTITY
M50024063540	ASSY.,COIL	3ROWS*8TH*11FPI	MCW200C	1
M50024063541	ASSY.,COIL	3ROWS*8TH*11FPI	MCW300C	1
M50024063542	ASSY.,COIL	3ROWS*8TH*11FPI	MCW400C	1
M50024063543	ASSY.,COIL	3ROWS*8TH*11FPI	MCW600C	1
M50024063544	ASSY.,COIL	3ROWS*8TH*11FPI	MCW800C	1
M50024063545	ASSY.,COIL	3ROWS*8TH*11FPI	MCW1000C	1
M50024063546	ASSY.,COIL	3ROWS*8TH*11FPI	MCW1200C	1
M50024063869	ASSY.,COIL	4ROWS*8TH*11FPI	RIGHT MCW200H	1
M50024063870	ASSY.,COIL	4ROWS*8TH*11FPI	LEFT MCW200H	1
M50024063871	ASSY.,COIL	4ROWS*8TH*11FPI	RIGHT MCW300H	1
M50024063872	ASSY.,COIL	4ROWS*8TH*11FPI	LEFT MCW300H	1
M50024063873	ASSY.,COIL	4ROWS*8TH*11FPI	RIGHT MCW400H	1
M50024063874	ASSY.,COIL	4ROWS*8TH*11FPI	LEFT MCW400H	1
M50024063875	ASSY.,COIL	4ROWS*8TH*11FPI	RIGHT MCW600H	1
M50024063876	ASSY.,COIL	4ROWS*8TH*11FPI	LEFT MCW600H	1
M50024063877	ASSY.,COIL	4ROWS*8TH*11FPI	RIGHT MCW800H	1
M50024063878	ASSY.,COIL	4ROWS*8TH*11FPI	LEFT MCW800H	1
M50024063879	ASSY.,COIL	4ROWS*8TH*11FPI	RIGHT MCW 000H	1
M50024063880	ASSY.,COIL	4ROWS*8TH*11FPI	LEFT MCW 000H	1
M50024063881	ASSY.,COIL	4ROWS*8TH*11FPI	RIGHT MCW 200H	1
M50024063882	ASSY.,COIL	4ROWS*8TH*11FPI	LEFT MCW 200H	1
M50024063917	ASSY.,COIL	4ROWS*8TH*11FPI	MCW200F	1
M50024061183	ASSY.,COIL	4ROWS*8TH*11FPI	MCW300F	1
M50024063822	ASSY.,COIL	4ROWS*8TH*11FPI	MCW400F	1
M50024063349	ASSY.,COIL	4ROWS*8TH*11FPI	MCW600F	1
M50024063821	ASSY.,COIL	4ROWS*8TH*11FPI	MCW800F	1
M50024063845	ASSY.,COIL	4ROWS*8TH*11FPI	MCW1000F	1
M50024063846	ASSY.,COIL	4ROWS*8TH*11FPI	MCW1200F	1

## Item 10.Motor

**MOTOR: 115v/1ph/60Hz**

MODEL	STATIC PRES-SURRE	P/N	DESCRIPTION	P/N	DESCRIPTION
MCW200 C/H/F	0 Pa	M03034065050	YDK7-6T	/	/
	30 Pa	M03034065054	YDK10-4T	/	/
	60/80 Pa	M03034065058	YDK22-4T	/	/
MCW300 C/H/F	0 Pa	M03034065051	YDK10-6T	/	/
	30 Pa	M03034065055	YDK16-4T	/	/
	60/80 Pa	M03034065059	YDK32-4T	/	/
MCW400 C/H/F	0 Pa	M03034065052	YDK16-6T	/	/
	30 Pa	M03034065056	YSK20-4T4	/	/
	60/80 Pa	M03034065060	YSK35-4T	/	/
MCW600 C/H/F	0 Pa	M03034065053	YDK25-6T	/	/
	30 Pa	M03034065030	YSK30-4T	/	/
	60/80 Pa	M03034065061	YSK75-4T	/	/
MCW800 C/H/F	0 Pa	M03034065050	YDK7-6T	M03034065053	YDK25-6T
	30 Pa	M03034065054	YDK10-4T	M03034065057	YSK30-4T
	60/80 Pa	M03034065058	YDK22-4T	M03034065061	YSK75-4T
MCW1000 C/H/F	0 Pa	M03034065051	YDK10-6T	M03034065053	YDK25-6T
	30 Pa	M03034065055	YDK16-4T	M03034065057	YSK30-4T
	60/80 Pa	M03034065059	YDK32-4T	M03034065061	YSK75-4T
MCW1200 C/H/F	0 Pa	M03034065053	YDK25-6T	M03034065053	YDK25-6T
	30 Pa	M03034065055	YDK16-4T	M03034065057	YSK30-4T
	60/80 Pa	M03034065061	YSK75-4T	M03034065061	YSK75-4T

COMERCIALIZADOR MAYORISTA EN AIRE ACONDICIONADO

# Guide Specifications

## Unit Description

Factory-assembled, horizontal, blow-thru type, galvanized casing, ceiling ducted fan coil unit is complete with water coil, fans, motors, drain pan, filters and all required wiring, with full access to internal components.

## Quality Assurance

Each coil is factory tested for leakage at 3.3MPa air pressure with coil submerged in water. Each unit and its moving components (fans and motors) are factory computer-tested and recorded after unit is complete and before it is packed.

## Component Specifications

### 1. Casing:

Construction is of 0.8mm thickness galvanized steel, lined on the inside with 5mm PE thermal and acoustical insulation. Return air plenum is lined with 5mm PE foam and has a 30mm collar for return duct connection. Supply duct connection also has a 30mm long collar. Removable bottom panel is provided for access to the fan/motor assembly.

### 2. Coil:

Standard unit is equipped with a 3-row (C series), 4-row (F series) or 3+1 rows (H series) coil for installation in a 2-pipe (C and F series) or 4-pipe (H series) system. Coil has 3/8 inch seamless copper tubes, slit type fins hydrophilic aluminum bonded to the tubes by mechanical expansion. Each coil has a manual air vent and two Rc3/4 water pipe connections with a working pressure of 1.6MPa.

### 3. Fan:

Direct-driven centrifugal fan wheel has forward-curved blades which are statically and dynamically balanced.

The fan housing and blades are constructed of high quality hot-galvanized steel.

### 4. Motor:

Fan motor is 3-speed permanent split-capacitor type with ball bearing and build-in automatic reset thermal overload protection. The motor's insulation is class E.

### 5. Drain pan

The drain pan plate body is constructed of cold-rolled steel by way of integral cupping. Both its sides are sprayed with plastic coating. And its outer wall is lined with 7mm heat insulating PE foam and high quality adhesive by way of integral adhering and pressing. It extends under the full length and width of the coils and is pitched for positive drainage with features of high anti-corrosion, anti-condensation and high fire reluctance.

### 6. Filter

Filter is with washable type nylon media in 8mm thickness aluminum frame.

# climayoreo.com

COMERCIALIZADOR MAYORISTA EN AIRE ACONDICIONADO



9601019  
ISO9001:2000



EMS 80362  
ISO14001



CNAS L0778

©2007 McQuay International +1 (800) 432-1342 [www.mcquay.com](http://www.mcquay.com)

While utmost care is taken in ensuring that all details in the publication are correct at the time of going to press, we are constantly striving for improvement and therefore reserve the right to alter model specifications and equipment without notice.

Details of specifications and equipment are also subject to change to suit local conditions and requirements and not all models are available in every market.