

**New!**  
30 l/s oil interceptor with by-pass  
and coalescing filter

**Pe** HydroPE

Oil interceptors  
**POLYETHYLENE**

1 t o 5 0 l / s

# Pe POLYETHYLENE

Oil interceptor range

A complete range, from 1 to 50 l/s.

## Contents

● Introduction.....	2
● Operation.....	3
● How to choose?.....	4
● General installation.....	5
● Specific installations.....	6
● Options: Alarms.....	7
Extension shafts, cast iron covers and anchoring belts.....	8
● Oil interceptors:	
<b>ELLIPSE Range</b> and <b>ARONDE Range</b>	
<b>EH05</b> and <b>DHFE</b> with sludge trap and coalescing filter.....	9
<b>EH10</b> and <b>DHLFE</b> with sludge trap, coalescing filter and by-pass.....	10
<b>EH15-EH16</b> and <b>GDHFE</b> with coalescing filter and "Big Size" sludge trap.....	11
<b>EH20</b> and <b>HFE</b> with coalescing filter.....	12
<b>EH25</b> and <b>DHE</b> with sludge trap.....	13
<b>EH30</b> and <b>DHLE</b> with sludge trap and by-pass.....	14
<b>EH35-EH36</b> and <b>GDHE</b> with "Big Size" sludge trap.....	15
<b>EH40</b> and <b>HE</b> .....	16
● Other ranges:	
<b>ED</b> and <b>DE</b> Sludge trap.....	17
<b>EN</b> and <b>CNE</b> Battery acid neutralisation tank.....	18
<b>Models of oil interceptors with a pumping trap at the outlet</b> .....	19
● <b>Form</b> .....	20

*Techneau site, 4 production units over more than 30 000 m<sup>2</sup>*



Due to a policy of continuous improvement, **Techneau** reserves the right to alter all dimensions.

# Introduction

## Oil interceptor

*Our skills serving the environment*

### Why?

- **Pollution** from insoluble liquids (oil, grease hydrocarbons) floating on water, results in a **significant reduction in atmospheric oxygen transfer**.

*It is therefore our duty to preserve the biological quality of runoff water.*

### How?

- In order to **trap sludge, solids and oil** contained in runoff water, **Techneau** have developed a complete range of **polyethylene** oil interceptors. Our interceptors work in the following way:
  - **Gravity separation** of solids ("sludge")
  - **Oil flotation**, improved by the addition of a coalescing filter.

Thanks to the **Engineering Department** and **Testing Centre** integrated into our **assembly line**, we can guarantee a product that fulfils your firm's needs perfectly as well as complying with current Standards.



Test base: checking the performances of an oil interceptor

### Standards

- Oil-interceptor production is covered by various Standards, in particular **French Standard NF EN 858**,
  - **NF EN 858-1:**  
"Principles of product design, performance and testing, marking and quality control"
  - **NF EN 858-2:**  
"Separator systems for light liquids (for example, oil and petrol)  
Part 2: selection of nominal size, installation, operation and maintenance"

**CE marking** is compulsory for oil interceptors. Therefore, any equipment will comply with the annexe ZA of the **NF EN 1825-1** standard requirements.

This Standard defines two levels of discharge:

- **Class I: < 5 mg/l**
- **Class II: < 100 mg/l**

See page 4 for the calculation method.



### Manufacture

- The **rotational moulding** technique is used to produce hollow bodies in polyethylene, with extremely thick walls, making them extremely strong. The units are seamless, and there is therefore no risk of leaking. Polyethylene is corrosion resistant.



# Operation

## Oil interceptor

*Constant innovation for optimal operation*

### General remarks

● The **oil interceptor** is a piece of apparatus designed to trap oil and settleable solids present in runoff water. It usually comprises two compartments: a sludge trap and an interceptor. An automatic closing valve prevents any oil discharge.

*There are two classes of interceptor:*

#### Class 1:

Residual content below **5 mg/l**, in accordance with test protocol in NF EN 858-1  
Model **with coalescing filter**

#### Class 2:

Residual content below **100 mg/l**, in accordance with test protocol in NF EN 858-1  
Model **without coalescing filter**

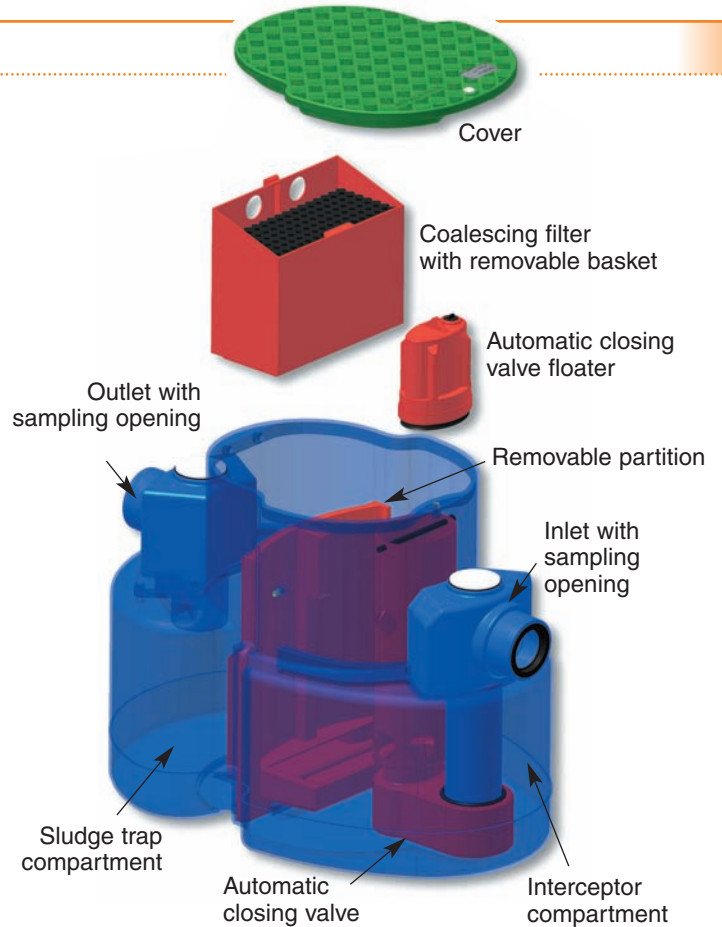

### Oil interceptor with by-pass

● The **oil interceptor with by-pass** fulfils the same functions as a standard interceptor but is able to deal with greater flow rates in storm conditions, up to five times its nominal capacity. The water entering the interceptor compartment is limited. Thus, when the flow rate is above the permissible level, the level in the inlet rises and goes into the by-passes, without affecting the interceptor's operation.

#### ELLIPSE range

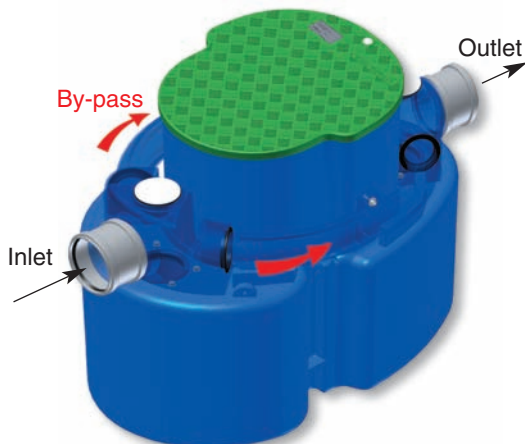

#### ARONDE range



# How to choose?

## Oil interceptor

A complete range to meet all your needs

### The following elements are used for defining an interceptor:

- 1 • Peak flow rate,
- 2 • Pollution load to be treated,
- 3 • Oil density
- 4 • Discharge level laid down

The flow rate usually depends on the type of areas to be covered. There are three:

- A • Covered areas
- B • Uncovered areas
- C • Areas involved in fuel filling or distribution.

### A • COVERED AREAS

The interceptor flow rate will be calculated using the number of taps, floor drains, and the total oil-polluted residue. For covered car parks, please refer to the following chart to select the appropriate unit.

m <sup>2</sup> Covered areas	Number of parking places	Capa- city l/s	Interceptor + sludge trap		Interceptor + sludge trap + pump	
			< 5 mg/l.	< 100 mg/l.	< 5 mg/l.	< 100 mg/l.
1 -> 500	1 -> 10	1,5	EH0501_	EH2501_	EH0501_ + PU423CE	EH2501_ + PU423CE
501 -> 1500	11 -> 50	3	EH0503_	EH2503_	EH0503_ + PU423CE	EH2503_ + PU423CE
1501 -> 3000	51 -> 125	6	EH0506_	EH2506_	EH0506_ + PU425CE	EH2506_ + PU425CE
3001 -> 4000	126 -> 150	8	EH0508_	EH2508_	EH0508_ + PU425CE	EH2510_ + PU425CE
4001 -> 5000	151 -> 200	10	EH0510_	EH2510_	EH0510_ + PO1326T	EH0510_ + PO1326T
5001 -> 8000	201 -> 320	15	_DHF115E	_DH115E	Please consult our engineering department	
8001 -> 15000	321 -> 600	20	_DHF130E	_DH120E	Please consult our engineering department	
15001 -> 22500	601 -> 900	30	_DHF130E	_DH130E	Please consult our engineering department	

### B • UNCOVERED AREAS

The peak flow rate depends on the area to be treated and the rainfall in the region involved (**ZONE 1, 2** ou **3** as shown below for France, to be adapted to the local rainfall in other countries). For areas below 10,000m<sup>2</sup>, the calculation method, in accordance with NF EN 752-4, is as follows:

$$Q = \Psi \times I \times A$$

**Q** : Peak flow rate (litres/second)

**Ψ** : Runoff coefficient (depending on type of surface: 0.9 for concrete or road coating material)

**I** : Precipitation Intensity (litres/second/hectare) corresponding in France to three main geographical zones (ten yearly rainfall):

**ZONE 1** : 300 l/s/ha - **ZONE 2** : 400 l/s/ha - **ZONE 3** : 500 l/s/ha

**A** : Uncovered area (hectares)

ZONE 1 (m <sup>2</sup> )	ZONE 2 (m <sup>2</sup> )	ZONE 3 (m <sup>2</sup> )	Capacity l/s	< 5 mg/l	< 100 mg/l
1 to 90	1 to 65	1 to 55	1,5	EH0501_	EH2501_
91 to 145	66 to 110	56 to 85	3	EH0503_	EH2503_
146 to 255	111 to 190	86 to 155	6	EH0506_	EH2506_
256 to 330	191 to 250	156 to 200	8	EH0508_	EH2508_
331 to 405	251 to 300	201 to 265	10	EH0510_	EH2510_
406 to 630	301 to 470	266 to 375	15	_DHF115E	_DH115E
631 to 810	471 to 610	376 to 485	20	_DHF130E	_DH120E
811 to 1140	611 to 880	486 to 710	30	_DHF130E	_DH130E
1 to 415	1 to 310	1 to 250	1,5	EH1001_	EH3001_
416 to 830	311 to 620	251 to 500	3	EH1003_	EH3003_
831 to 1185	621 to 888	501 to 711	6	EH1006_	EH3006_
1186 to 1555	889 to 1166	712 to 933	8	EH1008_	EH3008_
1556 to 2310	1167 to 1730	934 to 1385	10	EH1010_	EH3010_
2311 to 3230	1731 to 2430	1386 to 1940	15	_DHLF115E	_DHL115E
3231 to 4160	2431 to 3120	1941 to 2500	20	_DHLF120E	_DHL120E
4161 to 5080	3121 to 3820	2501 to 3050	25	_DHLF125E	_DHL125E
5081 to 6000	3821 to 4500	3051 to 3600	30	_DHLF130E	_DHL130E

- Without by-pass: Total inflow treated
- With by pass: Inflow partially treated

### C • AREAS INVOLVED IN FUEL FILLING OR DISTRIBUTION

**Caution!** The use of interceptors with by-passes is prohibited for this type of area.

The size of pre-treatment apparatus for areas involved in fuel filling or distribution is defined in France by the law of 7th January 2003. The law sets the flow rate unit as **45 l/h/m<sup>2</sup>** for uncovered areas. A factor of **0.5** is applied for covered areas (roofed over).

#### Example:

A fuel distribution zone with a **total area of 550 m<sup>2</sup>**, of which 200 m<sup>2</sup> are under cover.

The following calculation is applied:  $Q = (350 + (200 \times 0.5)) \times 45 = 20,250$  l/h, that is a flow rate in l/s of 5.625.

A **size 6 Interceptor** will therefore be installed.

Finally, the law also states that effluent from the washing area should go through a pre-treatment unit separate from the one used for the fuel distribution area.

# Standard installation

## Oil interceptor

To facilitate installation, our interceptors are supplied with installation instructions

### Precautions and recommendations

- Interceptors must be installed underground (see following page for interceptors installed above ground).
- They are put in a horizontal position on stable ground (sand or lean concrete),
- Connect the inlet and outlet to the piping,
- Connect the ventilation,
- Add the extension if appropriate, and adjust its height depending on the terrain,
- Fill the interceptor with clean water,
- Lift the floater and release it when the water level has stabilised,
- Fill in with sand or gravel.
- Standard interceptors have a polyethylene cover able to withstand pedestrian traffic. Refer to the following page if an interceptor is going to be installed in an area with vehicular traffic.

## Non throughway installation

### -> Installation **outside** a water table area

The maximum depth (P) for installing without a raft is:  
**2.5 metres** for the **ELLIPSE range**,  
**2 metres** for the **ARONDE range**.

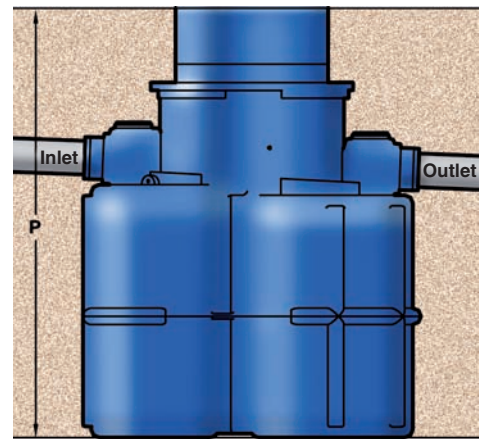

### -> Installation **in** a water table area

**Only for the ELLIPSE range.** The interceptors from the **ARONDE range** should never be installed in a water table area.

When the cover is at ground level, the maximum water table height (H) should not exceed **0.75 metres**. If the interceptor is to be buried at a greater depth, please contact our engineering department, who will determine the value of H.

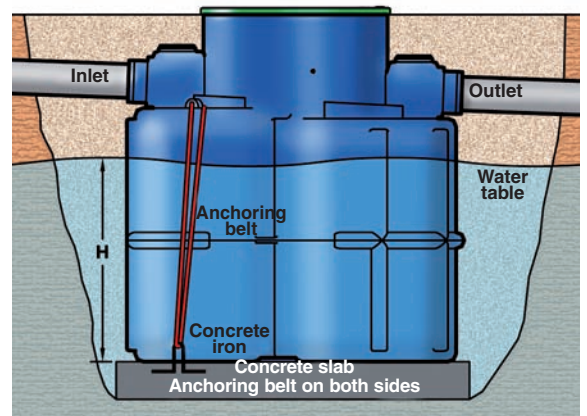
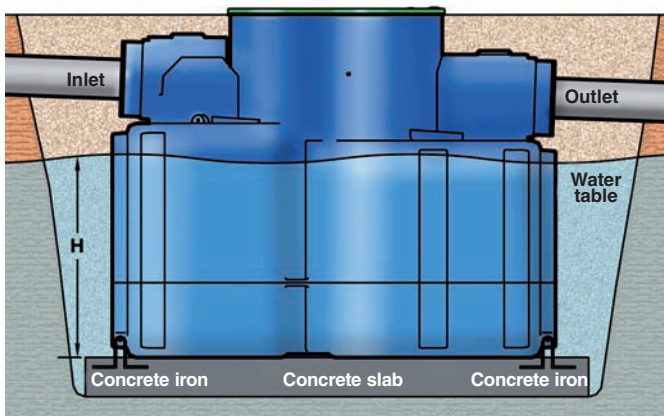

The tank will be anchored on a concrete slab by concrete irons set in both anchoring plates at the lower part of the tank. When no anchoring plate is provided, each hoisting device will be connected to the concrete slab with anchoring belts (for optional devices, see ref. SA107).

# Specific installation

## Oil interceptor

Solutions for dealing with your project constraints

### 2 types of installation

### Installation with vehicular traffic or installation at great depth (ELLIPSE range: $P > 2.5$ m - ARONDE range: $P > 2$ m)

When the excavation is filled in, great care should be taken (Caution! the interceptor should be filled with water before this operation).

If a concrete extension is to be used to raise the interceptor, it will rest on a concrete slab.

The dimensions of the protective slab will be calculated taking into account the different types of stress to which it is going to be exposed:

- Height of the earth,
- Mass of concrete extension,
- Vehicular traffic.

For installations with vehicular traffic, the frames of cast iron covers should be embedded in a concrete slab designed by a specialised engineering department.

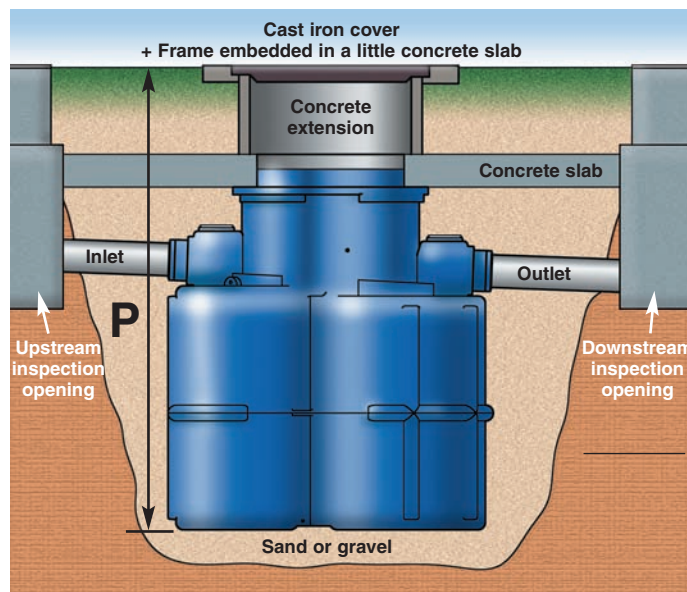

### Above ground installation

To avoid the tank being deformed and any risk of being damaged by a machine, it is indispensable to protect the interceptor by building a wall around it.

The space between the wall and the interceptor will be filled in with sand.

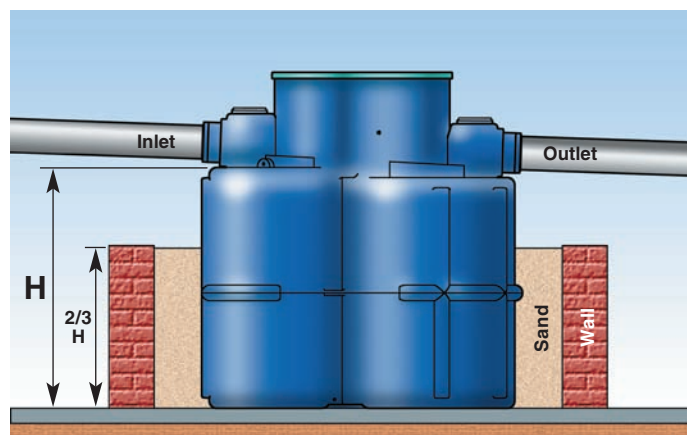

## MAINTENANCE

- Interceptors should be stripped regularly; the interval between emptying operations depends on the quantity of polluted water processed.
- The sludge trap compartment should be emptied regularly, at least twice a year; the complete interceptor should be emptied every two years.
- If there has been no accidental oil spillage, the interceptor compartment should be emptied once a year. When this is done, the floater will be cleaned, and also the coalescing filter if there is one. The closing valve seal will be checked, and replaced if necessary

-> **Caution!** Fill the interceptor with water each time it is stripped and raise the floater.

# Options

## Oil interceptor

### Alarms

#### Visual and audible alarm for OIL: : AH or AH8

The visual and audible alarm is used to detect a maximum oil level in the interceptor before the system becomes blocked. A density-difference detector fitted inside the interceptor detects the level of the oil layer. When the maximum level is reached, the visual and audible alarm is triggered.

According to the paragraph 6.5.4 of the **NF EN 858-1** standard: "Oil interceptors must be equipped with an alarm"

#### 2 possible types of power supply:

- **Ref. AH:** Mains, 230V
- **Ref. AH8:** Autonomous, using solar panel, 24V

As the alarm is usually installed in risk-prone areas, it has a **fail-safe safety device and is ATEX certified**.

#### Control cabinet:

- IP67 rated (dimensions: 180 x 130, depth: 60 mm)
- On the front panel:
  - “On” light and switch fault visual and audible alarm,
  - Test and reset push button
- Buzzer, numbered terminals, dry contact for alarm transfer

#### Sensor:

- IP68 rated, supplied with 2 metres of 2 x 0.5 mm<sup>2</sup> cable and connection unit for an extension,
- 316 stainless steel body; the floater is rated for maximum oil density
- Inductive proximity sensor.

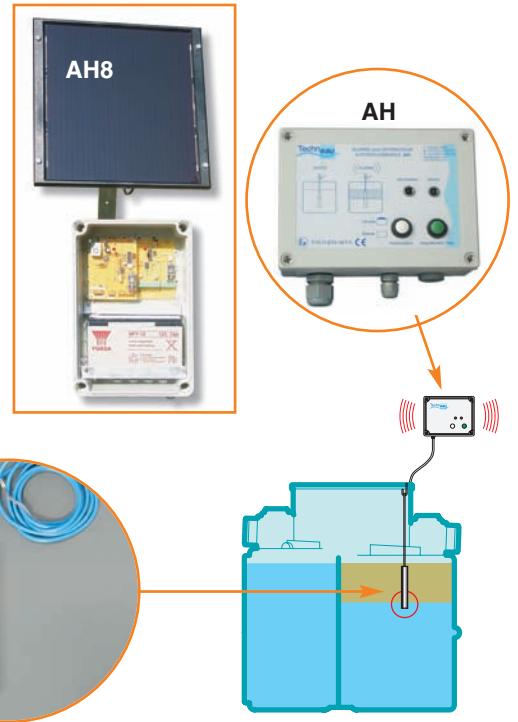

#### Visual and audible SLUDGE alarm: AB\_\_

The sludge-level alarm is used to detect sludge deposit in the sludge trap. A pulsating-infrared detector, detects a sludge blanket at a given height and triggers a visual and audible alarm.

#### Control cabinet:

- IP67 rated (dimensions: 180 x 130, depth: 60 mm)
- On front panel: "Energised" and "Fault" indicator lamp
  - Visual or audible alarm switch,
  - Test and reset push button
  - Potentiometer for adjusting detection threshold,
  - Buzzer, numbered terminals, dry contact for alarm transfer

#### Sensor:

- IP68 rated, in Ø 25 PVC tube,
- supplied with 5 metres of shielded cable. See table.

Reference	Length of cable
AB010	10 m
AB020	20 m
AB030	30 m
AB040	40 m
AB050	50 m

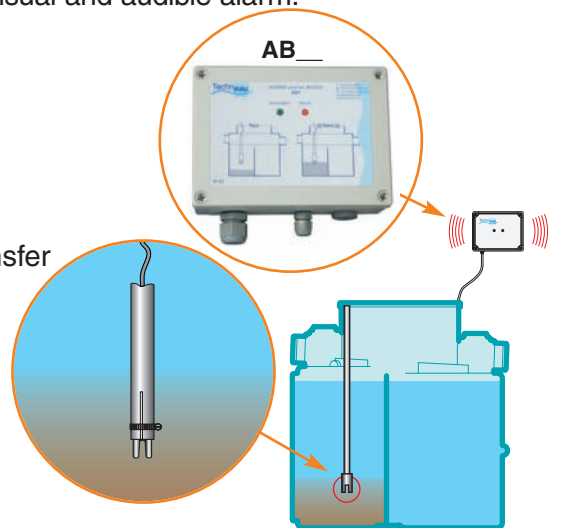

Oil and sludge alarms can be installed in a single cabinet, on request.



# Options

## Oil interceptor

Fixed or adjustable extensions and anchoring belts

### Cover extensions and cast iron covers

#### ELLIPSE Range



Vertically adjustable, used to position the cover at ground level; the top can be cut down

#### Extensions



Ref.	Length	Width	Height	Weight
RE107	850	765	700	11
RE207	1080	1060	700	18
RE210	1080	1060	1050	25

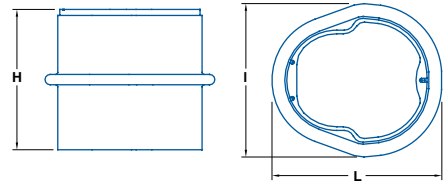

#### Extensions with cast iron covers



Ref.	Length	Width	Height	Weight
TCRE107	850	765	820	65
TCRE207	1080	1060	830	131
TCRE210	1080	1060	1180	138

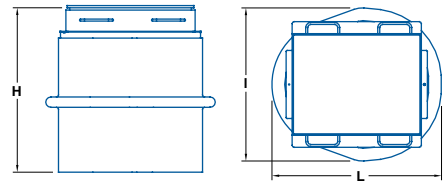

#### ARONDE Range

Fixed or telescopic extensions, type E, for Aronde range

#### Type E extensions



	Ref.	Diameter	Height	Weight
Fixed	R47EF	812	490	8
	R65EF	812	660	11
Telescopic	R47ET	812	250 to 450	8
	R65ET	812	430 to 600	11

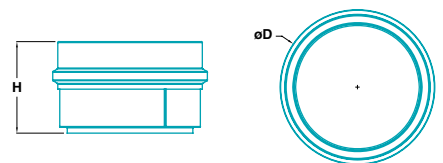

#### Type E extensions with galvanised steel frames and 250 Kn cast iron covers

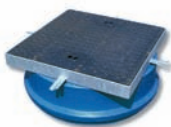

	Ref.	Diameter	Height	Weight
Fixed	TCR47EF	892	560	84
	TCR65EF	892	730	88
Telescopic	TCR47ET	892	320 to 520	84
	TCR65ET	892	500 to 670	88

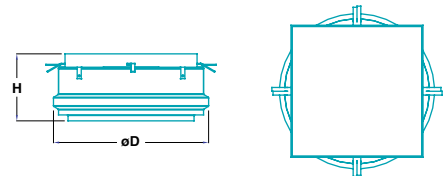

### Polyester anchoring belts

Ref. SA107 : polyester anchoring belts

ELLIPSE ref. EH0501\_, EH0503\_, EH1001\_, EH1003\_, EH1501\_, EH2003\_, EH2006\_, EH2501\_, EH2503\_, EH3001\_, EH3003\_, EH3501\_, EH4003\_, EH4006\_, ED0340\_, ED0480\_, and ED0720\_.

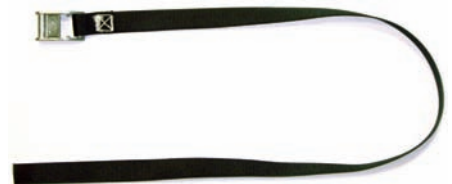

# Pe OIL INTERCEPTOR

with sludge trap and coalescing filter

Class 1  
Discharge < 5 mg/l 

## EH05 ELLIPSE Range

1,5 • 3 • 6 • 8 • 10 l/s

Registered and patented design



- Polyethylene tank produced by rotational moulding, with anchor rings,
- Polyethylene inlet and outlet with nitrile rubber seal,
- Removable polyethylene partition, with filter holder and coalescing filter,
- Automatic vertical closing floater in polyethylene, rated 0.85 (other ratings on request),
- Polyethylene cover (C) for pedestrian traffic, with stainless steel screws, or inspection opening (D).



OPTIONS (see pages 7 & 8):

- Cover extension RE107 - RE207 - RE210
- Visual and audible alarm AH - AH8 - AB

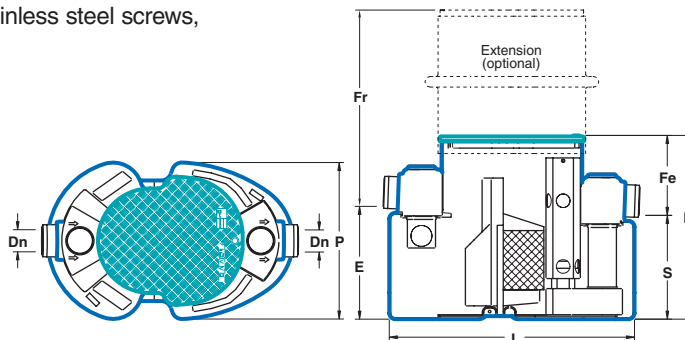

Ref. EH05	Capacity l/s	L	P	H	E	S	Fe	Dn	Volume		Weight	Optional extension			
									Sludge trap	Interceptor		H 700	Fr min - max	H 1000	Fr min - max
EH0501C or D	1,5	1220	780	914	573	528	386	110	150	190	50	RE107	660 - 960	-	-
EH0503C or D	3	1282	780	1346	1005	960	386	110	300	350	75				
EH0506C or D	6	1882	1160	1475	1085	1005	470	160	630	770	150				
<b>New</b> EH0508C or D	8	1882	1160	1985	1600	1520	465	160	980	1420	184	RE207	610 - 1010	RE210	960 - 1360
EH0510C or D	10	1882	1160	1985	1600	1520	465	160	1080	1320	194				

Dimensions are in millimetres, weights in kilograms, volumes in litres (useful volume)

## DHFE ARONDE Range

15 • 30 l/s

- Polyethylene tank produced by rotational moulding,
- Polyethylene cover, for pedestrian traffic, held on by quarter turn bolt or stainless steel screws,
- Inlet and outlet connections with PVC sleeve,
- Polyethylene partition with coalescing filter,
- Automatic pendulum closing floater in polyethylene, rated 0.85 (other ratings on request).

OPTIONS (see pages 7 & 8):

- Fixed or adjustable extensions, type E,
- Extensions, type E, with galvanised steel frame and 250 Kn cast iron cover,
- Visual and audible alarm

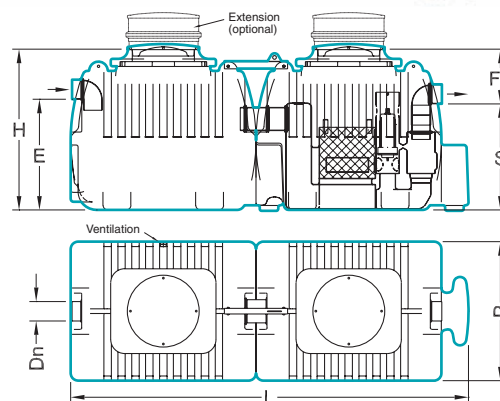
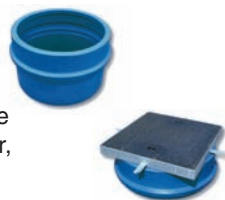

Ref. DHFE	Capacity l/s	L	P	H	E	S	Fe	Dn	Volume		Weight	Extensions type E Numbers
									Sludge trap	Interceptor		
AD* or DHF115E	15	2930	1400	1370	845	835	535	200	1525	1675	200	2
AD* or DHF130E	30	4292	1500	1730	1200	1150	580	200	3000	3200	310	

\* ADH\_\_E: model without cover

Dimensions are in millimetres, weights in kilograms, volumes in litres (useful volume)

## EH10

### ELLIPSE Range

1,5 • 3 • 6 • 8 • 10 l/s

Registered and patented design



- Polyethylene **tank** produced by rotational moulding, with anchor rings,
- **Inlet device** with overflow blade and siphon partition for by-pass feed,
- Polyethylene **outlet device** with nitrile rubber seal,
- **Removable polyethylene partition**, with filter holder and coalescing filter,
- **Automatic vertical closing floater** in polyethylene, rated 0.85\*,
- **Polyethylene cover (C)**, for pedestrian traffic, with stainless steel screws, or **inspection opening (D)**.



OPTIONS (see pages 7 & 8):

- **Cover extension** RE107 - RE207 - RE210
- Visual and audible **alarm** AH - AH8 - AB

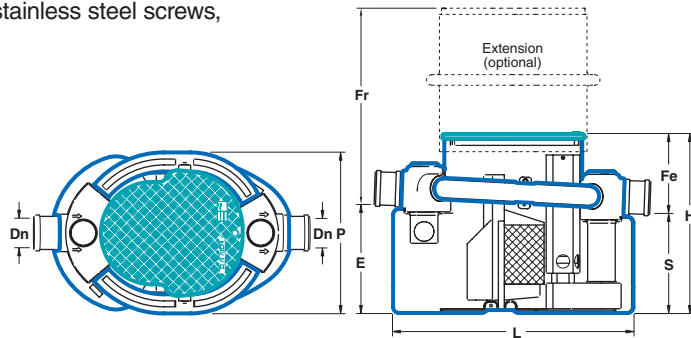

Ref. EH10	Capacity l/s	L	P	H	E	S	Fe	Dn	Volume		Weight	Optional extension			
									Sludge trap	Interceptor		H 700	Fr min - max	H 1000	Fr min - max
EH1001C or D	1,5	1220	817	914	556	511	403	160	150	190	52	RE107	840 - 980	-	-
EH1003C or D	3	1282	817	1346	988	943	403	160	300	350	77				
EH1006C or D	6	1882	1195	1475	1065	985	490	200	630	770	158	RE207	860 - 1030	RE210	1210 - 1380
<b>New</b> EH1008C or D	8	1882	1195	1985	1525	1445	540	315	980	1420	190	RE207	910 - 1080	RE210	1260 - 1430
EH1010C or D	10	1882	1195	1985	1525	1445	540	315	1080	1320	200				

Dimensions are in millimetres, weights in kilograms, volumes in litres (useful volume)

## DHLFE

### ARONDE Range

15 • 20 • 25 • 30 l/s



- Polyethylene **tank** produced by rotational moulding,
- Polyethylene **cover**, for pedestrian traffic, with stainless steel screws,
- **Inlet and outlet connections with PVC sleeve**,
- Polyethylene **partition** with coalescing filter,
- **Automatic pendulum closing floater** in polyethylene, rated 0.85 (other ratings on request).

OPTIONS (see pages 7 & 8):

- Fixed or adjustable **extensions**, type E,
- **Extensions**, type E, with galvanised steel frame and 250 Kn cast iron cover,
- Visual and audible **alarm**

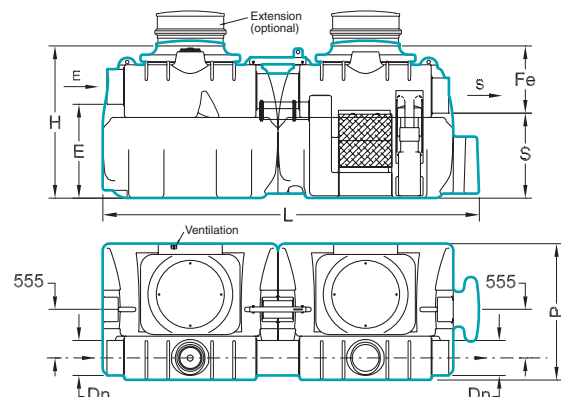

Ref. DHLFE	Capacity l/s	L	P	H	E	S	Fe	Dn	Volume		Weight	Extensions type E	
									Sludge trap	Interceptor		Numbers	
AD* or DHLF115E	15	3300	1400	1370	815	740	630	300	1500	1500	200	2	
AD* or DHLF120E	20	4292	1500	1730	1070	970	760	400	2500	2700	340		
AD* or DHLF125E	25	4300	1555	1730	1080	980	750	400	2500	2700	350		
<b>New</b> AD* or DHLF130E	30	4960	1880	1730	1200	1150	580	400	3000	3200	370		

\* ADHLF\_\_E: model without cover

Dimensions are in millimetres, weights in kilograms, volumes in litres (useful volume)

# Pe OIL INTERCEPTOR

with coalescing filter and "big size" sludge trap

Class 1  
Discharge < 5 mg/l 

## EH15-EH16 ELLIPSE Range

1,5 • 3 • 4 • 6 l/s

Registered and patented design



Special for washing areas

- Polyethylene **tank** produced by rotational moulding, with anchor rings,
- Polyethylene **inlet and outlet device** with nitrile rubber seal,
- **Removable** polyethylene **partition**, with filter holder and coalescing filter,
- **Automatic** vertical **closing floater** in polyethylene, rated 0.85 (other ratings on request),
- Polyethylene **cover (C)** for pedestrian traffic, with stainless steel screws, or **inspection opening (D)**



**OPTIONS** (see pages 7 & 8):

- **Cover extension** RE107 - RE207 - RE210
- Visual and audible **alarm** AH - AH8 - AB

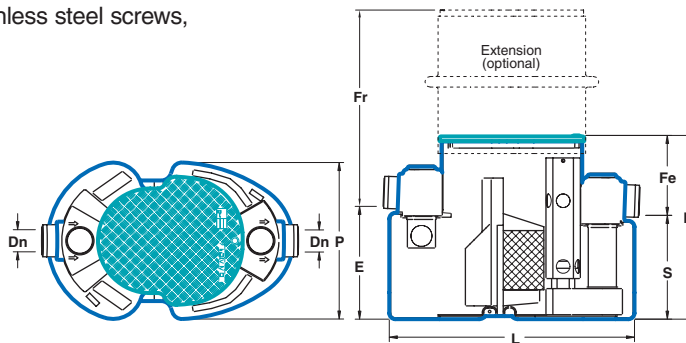

Ref. EH15-EH16	Capacity l/s	L	P	H	E	S	Fe	Dn	Volume		Weight	Optional extension			
									Sludge trap	Interceptor		H 700	Fr min - max	H 1000	Fr min - max
EH1501C or D	1,5	1282	780	1346	1005	960	386	110	300	350	75	RE107	660 - 960	-	-
EH1603C or D	3	1882	1160	1475	1015	925	550	110	900	500	150	RE207	670 - 1070	RE210	1030 - 1430
EH1504C or D	4	1882	1160	1475	1015	925	550	110	800	400	150	RE207	610 - 1010	RE210	960 - 1360
EH1506C or D	6	1882	1160	1985	1600	1520	465	160	1200	800	194	RE207	610 - 1010	RE210	960 - 1360

Dimensions are in millimetres, weights in kilograms, volumes in litres (useful volume)

## GDHFE ARONDE Range

6 • 8 • 10 l/s



Special for washing areas

- Polyethylene **tank** produced by rotational moulding,
- Polyethylene **cover**, for pedestrian traffic, held on by quarter turn bolt or by stainless steel screws,
- **Inlet and outlet** connections with PVC sleeve,
- Polyethylene **partition** with coalescing filter,
- **Automatic closing floater** with pendulum, in polyethylene, rated 0.85 (other ratings on request).

**OPTIONS** (see pages 7 & 8):

- Fixed or adjustable **extensions**, type E,
- **Extensions**, type E, with galvanised steel frame and 250 Kn cast iron cover,
- Visual and audible **alarm**

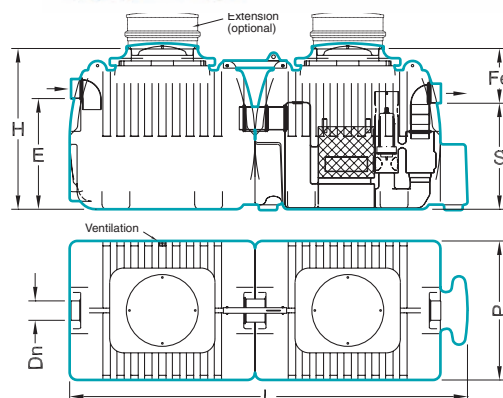
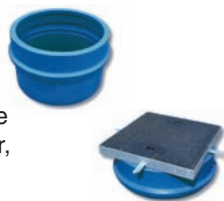

Ref. GDHFE	Capacity l/s	L	P	H	E	S	Fe	Dn	Volume		Weight	Extensions type E Numbers
									Sludge trap	Interceptor		
GDHF306E	6	2930	1400	1370	885	875	495	160	1800	1000	180	2
GDHF208E	8	2930	1400	1370	885	875	495	160	1950	1150	180	
GDHF510E	10	4292	1500	1730	1200	1150	580	160	5000	1200	310	

Dimensions are in millimetres, weights in kilograms, volumes in litres (useful volume)

## EH20 ELLIPSE Range

3 • 6 • 10 • 15 l/s

- Polyethylene **tank** produced by rotational moulding, with anchor rings,
- Polyethylene **inlet and outlet device** with nitrile rubber seal,
- **Removable** polyethylene **partition**, with filter holder and coalescing filter,
- **Automatic** vertical **closing floater** in polyethylene, rated 0.85 (other ratings on request),
- Polyethylene **cover (C)** for pedestrian traffic, with stainless steel screws, or **inspection opening (D)**.



**OPTIONS** (see pages 7 & 8):

- **Cover extension** RE107 - RE207 - RE210
- Visual and audible **alarm** AH - AH8 - AB

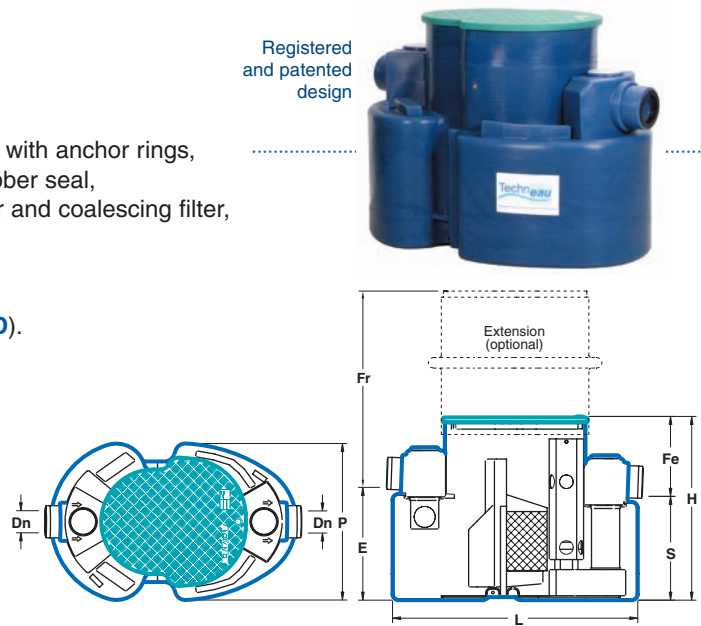

Ref. EH20	Capacity l/s	L	P	H	E	S	Fe	Dn	Volume Sludge trap	Weight	Optional extension			
											H 700	Fr min - max	H 1000	Fr min - max
EH2003C or D	3	1220	780	914	573	528	386	110	340	50	RE107	660 - 960	-	-
EH2006C or D	6	1282	780	1346	988	943	403	160	650	75	RE207	610 - 1010	RE210	960 - 1360
EH2010C or D	10	1882	1160	1475	1085	1005	470	160	1400	150	RE207	630 - 1030	RE210	980 - 1380
EH2015C or D	15	1882	1160	1985	1580	1500	485	200	2400	194	RE207	630 - 1030	RE210	980 - 1380

Dimensions are in millimetres, weights in kilograms, volumes in litres (useful volume)

## HFE ARONDE Range

20 • 30 • 50 l/s

- Polyethylene **tank** produced by rotational moulding,
- Polyethylene **cover**, for pedestrian traffic, held on by stainless steel screws,
- **Inlet and outlet** connections with PVC sleeve,
- Polyethylene **partition** with coalescing filter,
- **Automatic closing floater** with pendulum, in polyethylene, rated 0.85 (other ratings on request).

**OPTIONS** (see pages 7 & 8):

- Fixed or adjustable **extensions**, type E,
- **Extensions**, type E, with galvanised steel frame and 250 Kn cast iron cover,
- Visual and audible **alarm**

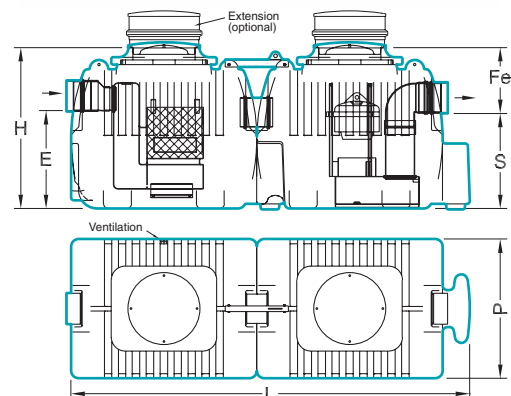
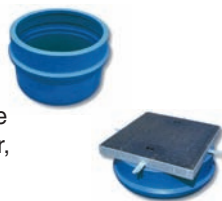

Ref. HFE	Capacity l/s	L	P	H	E	S	Fe	Dn	Volume Sludge trap	Weight	Extensions type E	
											Numbers	
HF120E	20	2930	1400	1370	845	835	535	200	3050	180	2	
HF130E	30	2292	1500	1730	1085	1065	665	200	3100	190	1	
HF150E	50	4292	1500	1730	1055	1035	695	300	5700	320	2	

Dimensions are in millimetres, weights in kilograms, volumes in litres (useful volume)

# Pe OIL INTERCEPTOR

with sludge trap

Class 2  
Discharge < 100 mg/l 

## EH25 ELLIPSE Range

1,5 • 3 • 6 • 8 • 10 l/s

Registered and patented design



- Polyethylene **tank** produced by rotational moulding, with anchor rings,
- Polyethylene **inlet and outlet device** with nitrile rubber seal,
- **Removable** polyethylene **partition**, with filter holder and coalescing filter,
- **Automatic** vertical **closing floater** in polyethylene, rated 0.85 (other ratings on request),
- **Polyethylene cover (C)** for pedestrian traffic, with stainless steel screws, or inspection opening (**D**).



**OPTIONS** (see pages 7 & 8):

- **Cover extension** RE107 - RE207 - RE210
- Visual and audible **alarm** AH - AH8 - AB

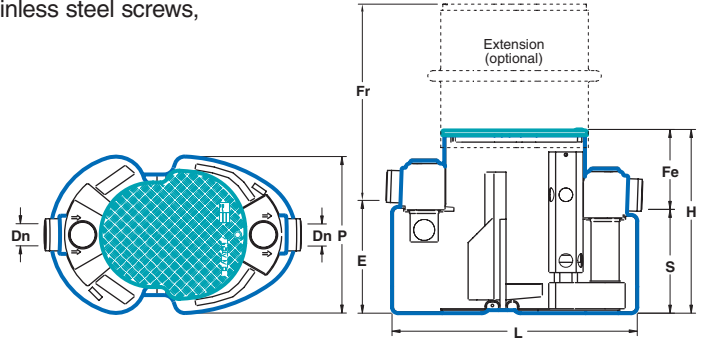

Ref. EH25	Capacity l/s	L	P	H	E	S	Fe	Dn	Volume		Weight	Optional extension			
									Sludge trap	Interceptor		H 700	Fr min - max	H 1000	Fr min - max
EH2501C or D	1,5	1220	780	914	573	528	386	110	150	190	47	RE107	660 - 960	-	-
EH2503C or D	3	1282	780	1346	1005	960	386	110	300	350	70				
EH2506C or D	6	1882	1160	1475	1085	1005	470	160	630	770	145				
<b>New</b> EH2508C or D	8	1882	1160	1985	1600	1520	465	160	980	1420	177	RE207	610 - 1010	RE210	960 - 1360
EH2510C or D	10	1882	1160	1985	1600	1520	465	160	1080	1320	186				

Dimensions are in millimetres, weights in kilograms, volumes in litres (useful volume)

## DHE ARONDE Range

15 • 20 • 30 l/s

- Polyethylene **tank** produced by rotational moulding,
- Polyethylene **cover**, for pedestrian traffic, held on by stainless steel screws,
- **Inlet and outlet connections** with PVC sleeve
- Polyethylene **partition** with coalescing filter,
- **Automatic** polyethylene **closing floater**, rated 0.85 (other ratings on request).

**OPTIONS** (see pages 7 & 8):

- Fixed or adjustable **extensions**, type E,
- **Extensions**, type E, with galvanised steel frame and 250 Kn cast iron cover,
- Visual and audible **alarm**

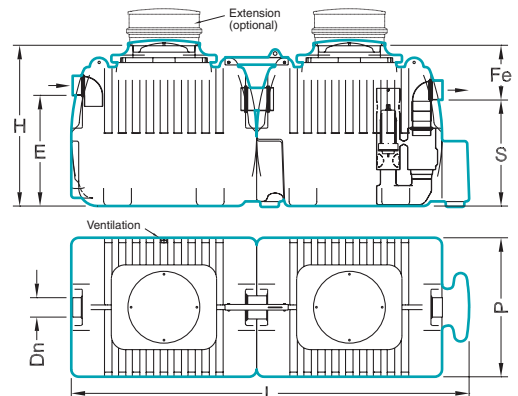

Ref. DHE	Capacity l/s	L	P	H	E	S	Fe	Dn	Volume		Weight	Extensions type E Numbers
									Sludge trap	Interceptor		
AD* or DH115E	15	2292	1500	1730	1200	1150	580	200	1500	1400	150	1
AD* or DH120E	20	2930	1400	1370	845	835	535	200	1525	1525	170	2
AD* or DH130E	30	4292	1500	1730	1200	1150	580	200	3000	3200	290	2

\* ADH\_\_E: model without cover

Dimensions are in millimetres, weights in kilograms, volumes in litres (useful volume)

## EH30 ELLIPSE Range

1,5 • 3 • 6 • 8 • 10 l/s

Registered and patented design



- Polyethylene **tank** produced by rotational moulding, with anchor rings,
- **Inlet device** with overflow blade and siphon partition for by-pass feed,
- Polyethylene **outlet device** with nitrile rubber seal,
- **Removable** polyethylene **partition**, with filter holder and coalescing filter,
- Automatic vertical closing floater in polyethylene, rated 0.85 (other ratings on request),
- **Polyethylene cover (C)** for pedestrian traffic, with stainless steel screws, or **inspection opening (D)**



**OPTIONS** (see pages 7 & 8):

- **Cover extension** RE107 - RE207 - RE210
- Visual and audible **alarm** AH - AH8 - AB

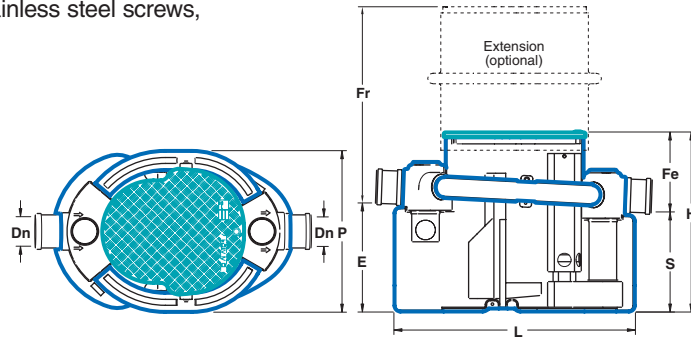

Ref. EH30	Capacity l/s	L	P	H	E	S	Fe	Dn	Volume		Weight	Optional extension			
									Sludge trap	Interceptor		H 700	Fr min - max	H 1000	Fr min - max
EH3001C or D	1,5	1220	817	914	556	511	403	160	150	190	49	RE107	840 - 980	-	-
EH3003C or D	3	1282	817	1346	988	943	403	160	300	350	72				
EH3006C or D	6	1882	1195	1475	1065	985	490	200	630	770	152	RE207	860 - 1030	RE210	1210 - 1380
<b>New</b> EH3008C or D	8	1882	1195	1985	1525	1445	540	315	980	1420	183	RE207	910 - 1080	RE210	1260 - 1430
EH3010C or D	10	1882	1195	1985	1525	1445	540	315	1080	1320	193				

\* Other ratings on request

Dimensions are in millimetres, weights in kilograms, volumes in litres (useful volume)

## DHLE ARONDE Range

15 • 20 • 25 • 30 l/s



- Polyethylene **tank** produced by rotational moulding,
- Polyethylene **cover**, for pedestrian traffic, held on by stainless steel screws,
- **Inlet and outlet connections** with PVC sleeve
- Polyethylene **partition** with coalescing filter,
- **Automatic** polyethylene **closing floater**, rated 0.85 (other ratings on request).

**OPTIONS** (see pages 7 & 8):

- Fixed or adjustable **extensions**, type E,
- **Extensions**, type E, with galvanised steel frame and 250 Kn cast iron cover,
- Visual and audible **alarm**

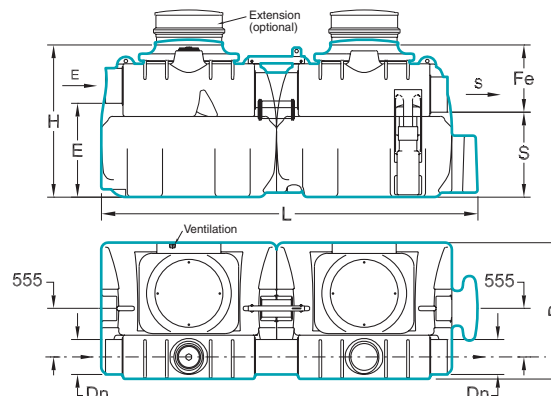
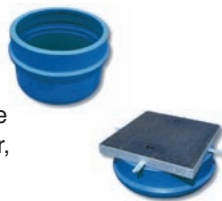

Ref. DHLE	Capacity l/s	L	P	H	E	S	Fe	Dn	Volume		Weight	Extensions type E	
									Sludge trap	Interceptor		Numbers	
AD* or DHL115E	15	3300	1400	1370	815	740	630	300	1500	1500	180	2	
AD* or DHL120E	20	4292	1500	1730	1070	970	760	400	2500	2700	320		
AD* or DHL125E	25	4300	1555	1730	1080	980	750	400	2500	2700	330		
<b>New</b> AD* or DHL130E	30	4960	1880	1730	1200	1150	580	400	3000	3200	350		

Dimensions are in millimetres, weights in kilograms, volumes in litres (useful volume)

# Pe OIL INTERCEPTOR

with "Big Size" sludge trap

Class 2   
Discharge < 100 mg/l

## EH35-EH36 ELLIPSE Range

1,5 • 3 • 4 • 6 l/s

Registered and patented design



Special for washing areas

- Polyethylene tank produced by rotational moulding, with anchor rings,
- Polyethylene inlet and outlet device with nitrile rubber seal,
- Removable polyethylene partition,
- Automatic vertical closing floater in polyethylene, rated 0.85 (other ratings on request),
- **Polyethylene cover (C)** for pedestrian traffic, with stainless steel screws, or **inspection opening (D)**

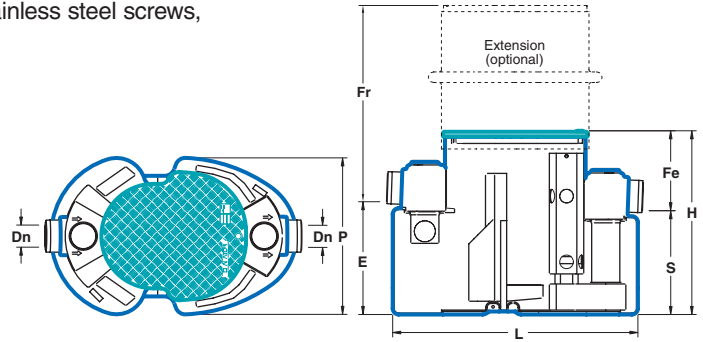

**OPTIONS** (see pages 7 & 8):

- **Cover extension** RE107 - RE207 - RE210
- Visual and audible **alarm** AH - AH8 - AB

Ref. EH35-EH36	Capacity l/s	L	P	H	E	S	Fe	Dn	Volume		Weight	Optional extension			
									Sludge trap	Interceptor		H 700	Fr min - max	H 1000	Fr min - max
EH3501C or D	1,5	1282	780	1346	1005	960	386	110	300	350	66	RE107	660 - 960	-	-
EH3603C or D	3	1882	1160	1475	1015	925	550	110	900	400	144	RE207	680 - 1080	RE210	1030 - 1430
EH3504C or D	4	1882	1160	1475	1015	925	550	110	800	500	144	RE207	610 - 1010	RE210	960 - 1360
EH3506C or D	6	1882	1160	1985	1600	1520	465	160	1200	800	186	RE207	610 - 1010	RE210	960 - 1360

Dimensions are in millimetres, weights in kilograms, volumes in litres (useful volume)

## GDHE ARONDE Range

6 • 8 • 10 l/s



Special for washing areas

- Polyethylene tank produced by rotational moulding,
- Polyethylene cover, for pedestrian traffic, held on by quarter turn bolt or stainless steel screws,
- **Inlet and outlet connections** with PVC sleeve,
- Polyethylene partition,
- **Automatic closing floater** with pendulum, in polyethylene, rated 0.85 (other ratings on request).

**OPTIONS** (see pages 7 & 8):

- Fixed or adjustable **extensions**, type E,
- **Extensions**, type E, with galvanised steel frame and 250 Kn cast iron cover,
- Visual and audible **alarm**

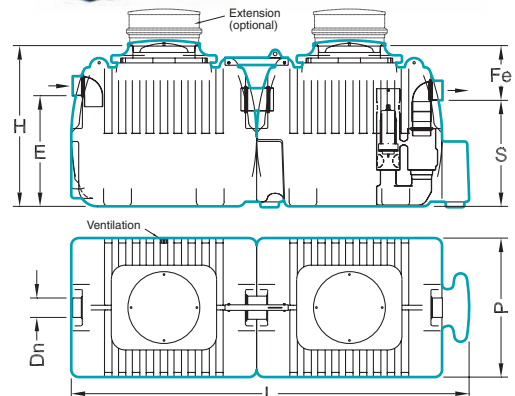

Ref. GDHE	Capacity l/s	L	P	H	E	S	Fe	Dn	Volume		Weight	Extensions type E Numbers
									Sludge trap	Interceptor		
GDH306E	6	2930	1400	1370	885	875	495	160	1800	1000	170	2
GDH208E	8	2930	1400	1370	885	875	495	160	1950	1150	170	2
GDH210E	10	2292	1500	1730	1200	1150	580	160	2000	1200	150	1
GDH510E	10	4292	1500	1730	1200	1150	580	160	5000	1200	290	2

Dimensions are in millimetres, weights in kilograms, volumes in litres (useful volume)



## EH40 ELLIPSE Range

3 • 6 • 10 • 15 l/s

- Polyethylene **tank** produced by rotational moulding, with anchor rings,
- Polyethylene **Inlet and outlet device** with nitrile rubber seal,
- **Automatic vertical closing floater** in polyethylene, rated 0.85 (other ratings on request),
- **Polyethylene cover (C)** for pedestrian traffic, with stainless steel screws, or **inspection opening (D)**.

Registered and patented design



**OPTIONS** (see pages 7 & 8):

- **Cover extension** RE107 - RE207 - RE210
- Visual and audible **alarm** AH - AH8 - AB

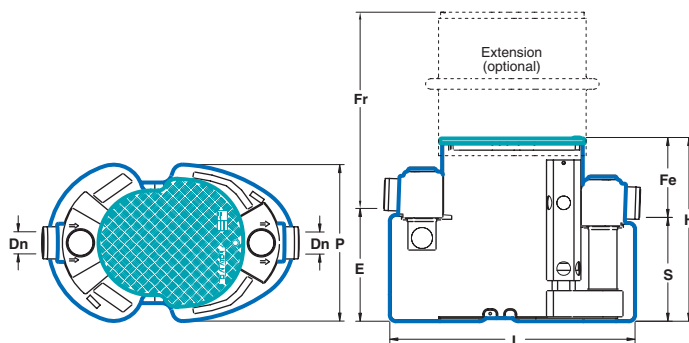

Ref. EH40	Capacity l/s	L	P	H	E	S	Fe	Dn	Volume Interceptor	Weight	Optional extension			
											H 700	Fr min - max	H 1000	Fr min - max
EH4003C or D	3	1220	780	914	573	528	386	110	340	47	RE107	660 - 960	-	-
EH4006C or D	6	1282	780	1346	988	943	403	160	650	66	RE107	680 - 980	-	-
EH4010C or D	10	1882	1160	1475	1085	1005	470	160	1400	138	RE207	610 - 1010	RE210	960 - 1360
EH4015C or D	15	1882	1160	1985	1580	1500	485	200	2400	176	RE207	630 - 1030	RE210	980 - 1380

Dimensions are in millimetres, weights in kilograms, volumes in litres (useful volume)

## HE ARONDE Range

25 • 30 • 50 l/s

- Polyethylene **tank** produced by rotational moulding,
- Polyethylene **cover**, for pedestrian traffic, held on by stainless steel screws,
- **Inlet and outlet connections** with PVC sleeve,
- Polyethylene **partition**,
- **Automatic closing floater**, in polyethylene, rated 0.85 (other ratings on request).

**OPTIONS** (see pages 7 & 8):

- Fixed or adjustable **extensions**, type E,
- **Extensions**, type E, with galvanised steel frame and 250 Kn cast iron cover,
- Visual and audible **alarm**

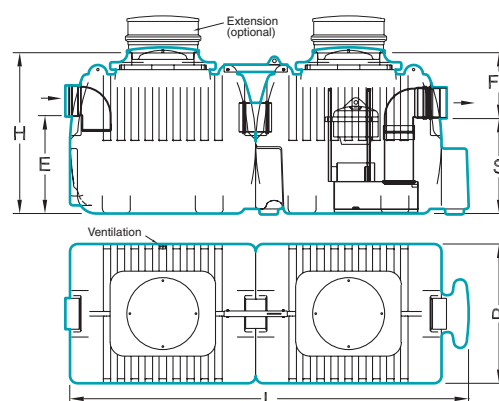

Ref. HE	Capacity l/s	L	P	H	E	S	Fe	Dn	Volume Interceptor	Weight	Extensions type E Numbers
H125E	25	2930	1400	1370	845	835	535	200	3050	170	2
H130E	30	2292	1500	1730	1200	1150	580	200	3100	170	1
H150E	50	4292	1500	1730	1055	1035	695	300	5700	300	2

Dimensions are in millimetres, weights in kilograms, volumes in litres (useful volume)

# Pe SLUDGE TRAP

340 to 6,000 litres

## ED ELLIPSE Range 340 to 2,400 litres

Registered and patented design



- Polyethylene tank produced by rotational moulding, with anchor rings,
- Polyethylene Inlet device with nitrile rubber seal,
- PVC outlet device,
- Polyethylene cover (C) for pedestrian traffic, with stainless steel screws, or inspection opening (D).



OPTIONS (see page 8):

- Cover extension  
RE107 - RE207 - RE210

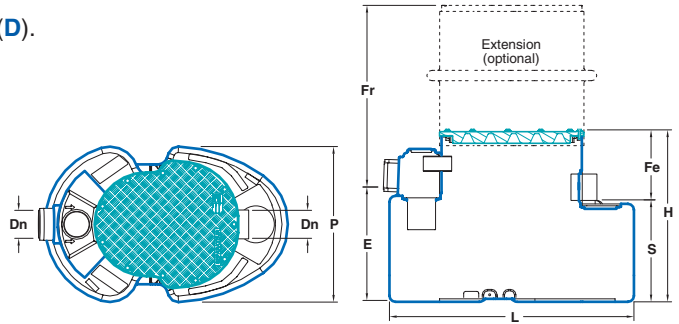

Ref. ED	L	P	H	E	S	Fe	Dn	Volume	Weight	Optional extension			
										H 700	Fr min - max	H 1000	Fr min - max
ED0340C or D	1220	780	858	573	528	330	110	340	36	RE107	860 - 900	-	-
ED0480C or D	1220	780	1093	808	763	330	110	480	42				
ED0720C or D	1251	780	1290	1005	960	330	110	720	53				
ED1000C or D	1882	1160	1245	785	695	550	110	1000	98	RE207	680 - 1080	RE210	1030 - 1430
ED1500C or D	1882	1160	1475	1015	925	550	110	1500	111	RE207	610 - 1010	RE210	960 - 1360
ED1700C or D	1882	1160	1625	1240	1160	465	160	1700	119				
ED2400C or D	1882	1160	1985	1600	1520	465	160	2400	140				

Dimensions are in millimetres, weights in kilograms, volumes in litres (useful volume)

## DE ARONDE Range 3,000 & 6,000 litres

- Polyethylene tank produced by rotational moulding,
- Inlet and outlet connections with PVC sleeve,
- Polyethylene cover (C) for pedestrian traffic, with stainless steel screws

OPTIONS (see page 8):

- Cover extensions  
R47EF - R47ET - R65EF - R65ET

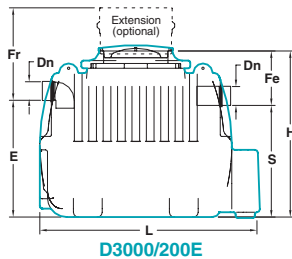

D3000/200E

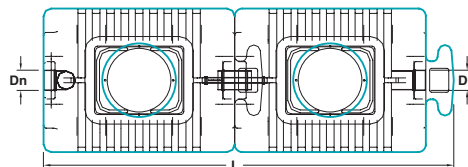

D6000/200E

Ref. DE	L	P	H	E	S	Fe	Dn	Volume	Weight	Optional extension			
										H 470	Fr	H 660	Fr
D3000/200E	2292	1500	1730	1200	1180	550	200	3000	140	R47EF	1080	R65EF	1250
D2850/300E	2292	1500	1730	1085	1035	695	300	2850	145				
D6000/200E	4292	1500	1730	1200	1150	580	200	6000	280	R47EF (X2)	1080	R65EF (X2)	1250
D5700/300E	4292	1500	1730	1085	1035	695	300	5700	290				

Dimensions are in millimetres, weights in kilograms, volumes in litres (useful volume)

## EN & CNE

ELLIPSE Range

150 – 340 – 500 - 1,000 liters

This equipment is intended to neutralise battery acids that are discharged into the network.

It is specially adapted to treat waste water from battery storage or maintenance shops.

It includes a polyethylene tank, a marble filtre that enables to neutralise battery acids.

- Polyethylene **tank** produced by rotational moulding, with anchor rings,
- Polyethylene **Inlet and outlet device** with nitrile rubber seal,
- 1 or 2 neutralisation column(s) in high-density polyethylene, comprising removable baskets filled with marble gravel
- **Polyethylene cover (C)** for pedestrian traffic, with stainless steel screws, or **inspection opening (D)**.



Registered and patented design

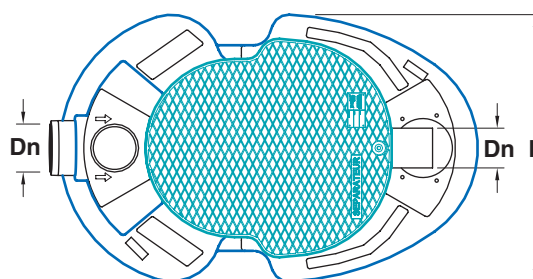

Models EN0304, EN0500 and EN1000

**OPTIONS** (see page 8):

- **Cover extension** RE107 - RE207 - RE210 only for EN models

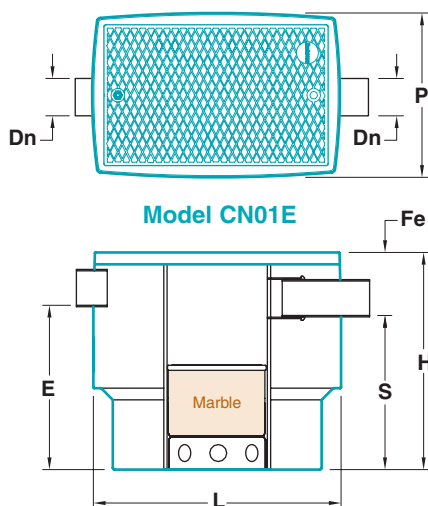

Model CN01E

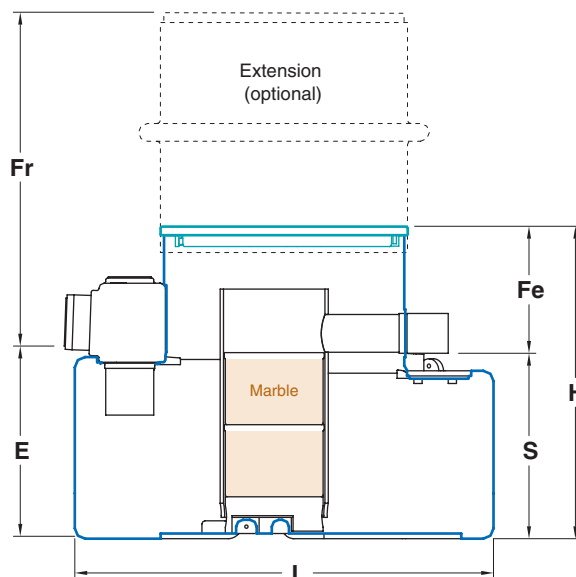

Ref. CNE & EN	Volume liters	L	P	H	E	S	Fe	Dn	Weight (with marble)	Optional extension			
										H 700	Fr min - max	H 1000	Fr min - max
CN01E	150	730	480	640	464	434	206	110	35	-	-	-	-
EN0340C or D	340	1220	780	914	573	543	371	110	78	RE107	660 - 960	-	-
EN0500C or D	500	1220	780	1149	808	778	371	110	107				
EN1000C or D	1000	1882	1160	1258	872	842	416	160	232	RE207	610 - 1010	RE210	960 - 1360

Dimensions are in millimetres, weights in kilograms

# Installation of a pumping trap at the outlet

## OF THE OIL INTERCEPTOR

3 installation examples of *Techneau* pumping traps equipped with 2 pumps

### Oil interceptor, 1.5 and 3 l/s with PU423CE, 1-phase 230 V

- This equipment is given as an indication since water head is to be checked. Caution: the peak water head should be considered for the interceptors with built-in by-pass. Consult our engineering department.

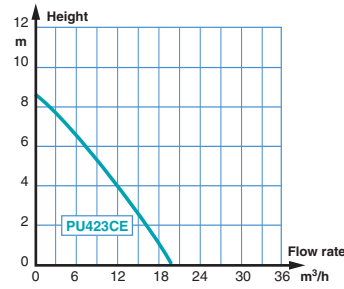
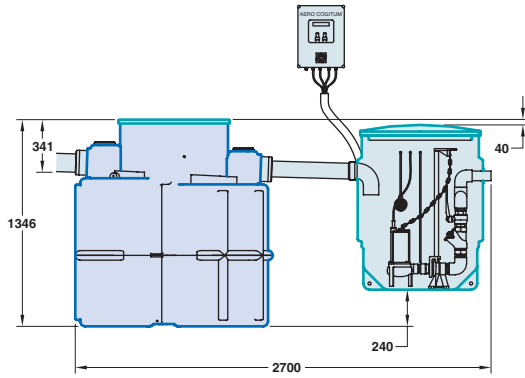

### Oil interceptor, 6 l/s with PU425CE, 1-phase 230 V

- This equipment is given as an indication since water head is to be checked. Caution: the peak water head should be considered for the interceptors with built-in by-pass. Consult our engineering department.

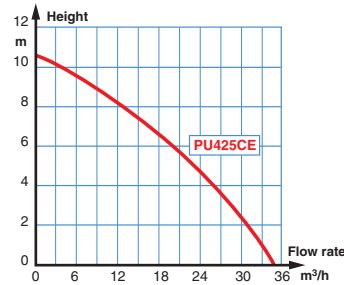
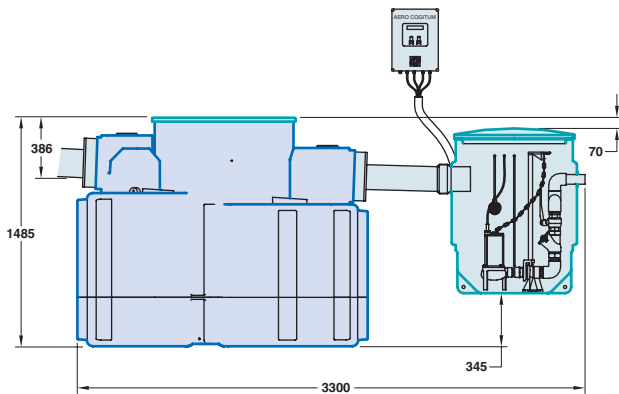

### Oil interceptor, 10 l/s with PO1326T, 3-phase 400 V

- This equipment is given as an indication since water head is to be checked. Caution: the peak water head should be considered for the interceptors with built-in by-pass. Consult our engineering department.

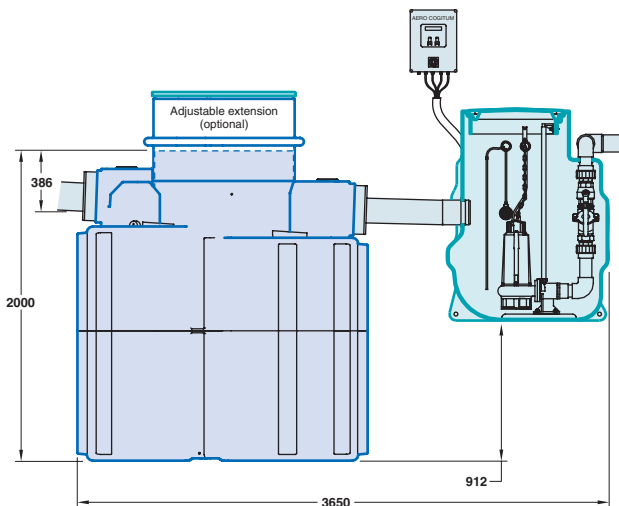

**Ask for our pumping stations catalogue STAR**

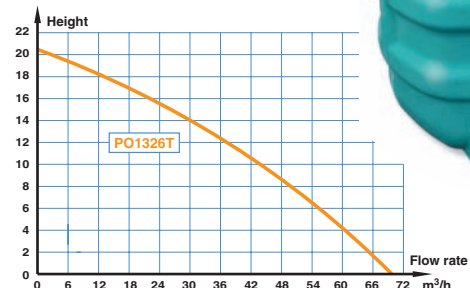

# Form

## OIL INTERCEPTOR REQUIREMENTS

Please photocopy this questionnaire, fill it in and fax it to **+33 (0)2 33 56 61 93**

### Your contact details

Date: ...../...../ 200.....

Company name: ..... Person to contact: .....

Complete address: .....

Telephone: ..... Fax: ..... E-mail: .....

### Type of project

Tender  Site  Study - Reference: ..... Country: .....

### Information about the study

#### • Parameters for calculations: Rainfall - Flow rate:

Total area of catchment area to be covered: ..... m<sup>2</sup>

of which:

• Waterproofed area(s): ..... m<sup>2</sup>

• Non-waterproofed area(s): ..... m<sup>2</sup>

• Roofed area(s): ..... m<sup>2</sup>

Type of terrain: .....

Average slope (defect value: 1%): ..... %

Treatment required:  Q<sub>2 months</sub> (20% Q<sub>10</sub>)  
 Q<sub>1 month</sub> (12% Q<sub>10</sub>)  
 Q<sub>10 years</sub>  
 other: .....

or

Peak flow rate: ..... l/s

Treatment flow rate: ..... l/s

#### • Technical characteristics of the site:

DN of network connection: ..... mm

Gravity feed

Density of oil to be retrieved (defect value: 0.85):  
.....

Concentration of oil at inlet:  
..... mg/l

Outflow:  Rainwater system  
 Waste water system  
 Natural environment  
 Process

Fuel distribution or transfer area

Washing area -> Number of lanes: .....

#### • Parameters for interceptor positioning:

Installation above ground

Water table  Sea water

Installation includes concrete extensions

Value of Fe (see diagram opposite): ..... mm

Quantity of sludge produced:  Low

Medium

High

Concentration of suspended solids allowed at outlet:  
..... mg/l

Concentration of suspended solids at inlet:  
..... mg/l

Fall velocity: ..... m/h

Trapping capacity: ..... μ

Industrial process water

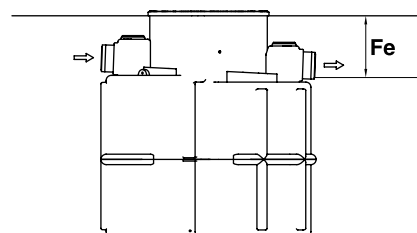

# "BIG SIZE" OIL INTERCEPTORS

Flow rates from 20 l/s

A tailor-made manufacture to meet your project requirements

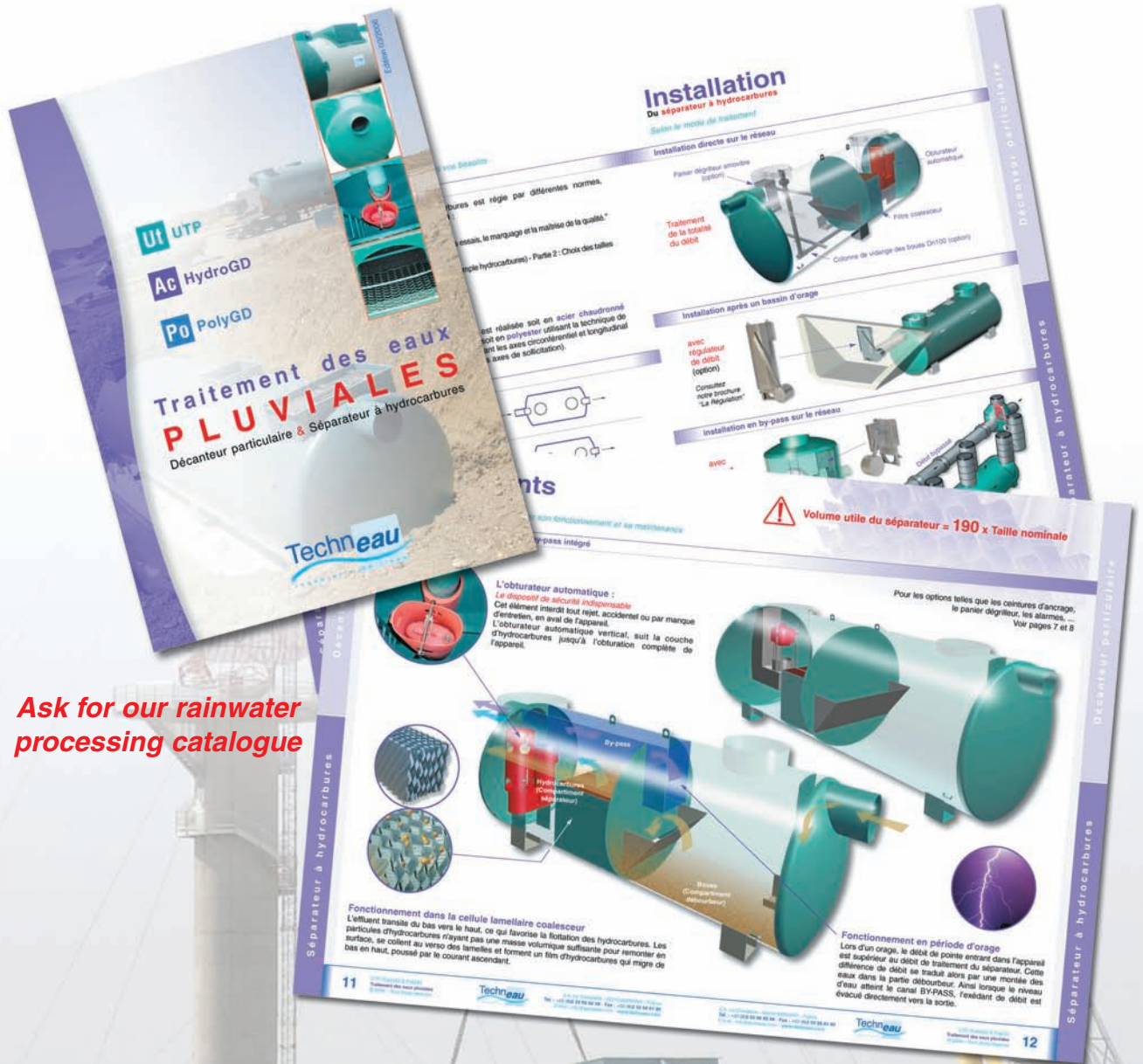

Ask for our rainwater processing catalogue

A model of installation: the A380 Airbus construction site at Toulouse

## WATER PRE-TREATMENT



### Oil interceptors

1.5 to 1,000 l/s  
Steel, polyethylene or polyester

### Grease and starch interceptors

Size 1 to 30 - Stainless steel, polyethylene or polyester

### Particle sludge traps

10 to 500 l/s  
Steel or polyester

### Sewage treatment plant

Small communities  
From 51 to 400 EH - Polyester

## WATER PUMPING



### For private homes

160 to 400 litres  
1 pump - polyethylene

### For small communities

Height: 1.3 to 2.2 m  
1 or 2 pumps - polyethylene

### For communities

Ø 1 to 3 m - 1, 2 or 3 pumps  
Polyethylene or polyester

## HYDRAULIC EQUIPMENTS

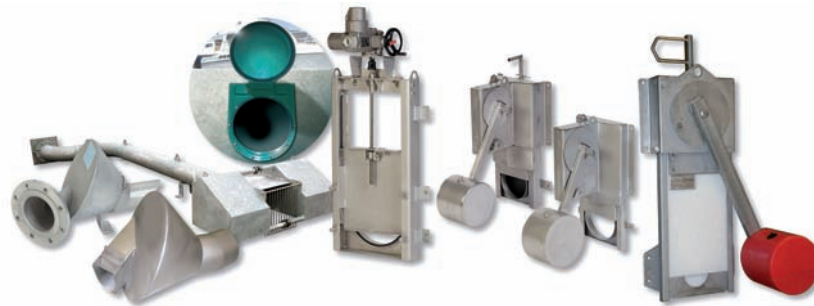

### Flow controllers

4 to 360 l/s  
Stainless steel or galvanised steel

### Flow controllers with Vortex effect

0.5 to 500 l/s - Stainless steel

### Penstocks

Ø 200 to 1,200 - Stainless steel or galvanised steel

### Flap valves

Dn 315, 400 or 500  
Polyester

## GROUND EQUIPMENT

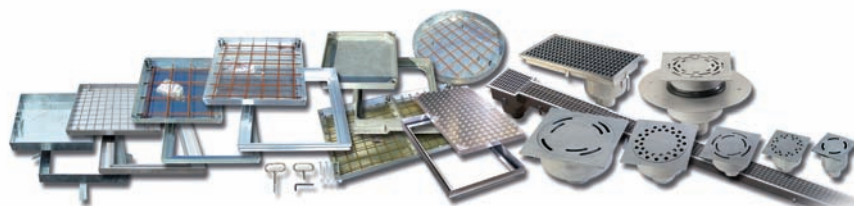

### Floor access covers

30 x 30 to 80 x 80 cm - Aluminium, stainless steel or galvanised steel

### Ground siphons

Ø 40 to 100 mm  
Stainless steel

### Grid or groove channels

From 400 mm long  
Stainless steel



[www.techneau.com](http://www.techneau.com)



**WATER MANAGEMENT**

Tel: +33 (0)2 33 56 62 08 – Fax: +33 (0)2 33 56 61 93

- **WATER PRE-TREATMENT**
  - Oil interceptors
  - Grease and starch interceptors
- **WATER TREATMENT**
  - Lamellar particle sludge traps
  - Sewage treatment plant
- **HYDRAULIC EQUIPMENTS**
  - Flow regulators and controllers
    - Penstocks
    - Flap valves
- **WATER PUMPING**
  - For small communities
  - For communities

**GROUND EQUIPMENT**

Tel: +33 (0)2 33 05 36 14 – Fax: +33 (0)2 33 77 71 01

- **INSPECTION COVERS**
- **SIPHONS AND CHANNELS**



Z.A. La Chevalerie  
 50570 MARIGNY - France  
 Tel.: +33 (0)2 33 56 62 08  
 Fax: +33 (0)2 33 56 61 93  
 E-mail: [info@techneau.com](mailto:info@techneau.com)  
[www.techneau.com](http://www.techneau.com)

Your distributor