

AllSky Camera Assembly Instructions



New Mexico State University

Las Cruces, New Mexico

February 2013

Version: 0.1.0

Table of Contents

List of Figures	iii
1 Introduction	2
2 Parts List	5
3 Housing	7

List of Figures

Figure	Page
1.1 Images of NMSU1 and NMSU2, on the roof of Thomas Brown Building, on the NMSU campus	2
1.1 Previous version	3
1.2 Current version	4
3.1 Step 1	7
3.2 Step 2	8
3.3 Step 3	9
3.4 Step 4	10
3.5 Step 5	11
3.6 Step 6	12
3.7 Step 6	13
3.8 Step 6	14
3.9 Step 7	15
3.10 Step 8	16
3.11 Step 9	17
3.12 Step 10	18
3.13 Step 11	19
3.14 Step 12	20
3.15 Step 13	21
3.16 Step 13	22

3.17 Step 14	23
3.18 Step 14	24
3.19 Step 15	26
3.20 Step 15	27
3.21 Step 16	28

Disclaimer

Fabricating this camera unit will involve the use of mechanical hand/electrical tools, which may be dangerous in their use. A clear understanding of these tools and their safe use are to be followed. Use of certain chemicals, adhesives, and the health risks involved with their application are to be understood and proper safety precautions followed. Mention of certain tools, chemical adhesives, etc. are only suggested by NMSU and is in no way responsible for misuse or abuse, or injury as a result of the use of the mentioned tools/chemicals.

1 Introduction

The main components of the system include a Sony black and white CCD video camera, camera lens, 12 Volt DC power adapter, resistive heaters, thermostat, DC fan, a video capture card, and a weatherproof optical dome and housing. The housing consists of PVC pipe and flanges. It is a requirement for the AllSky Camera system to be operational 24 hours a day, 365 days a year, therefore, it must be able to work in all weather conditions. The heaters, thermostat, and fan are to maintain a reasonable thermal environment for the camera system to operate within. This thermal environment is mainly to help ensure that the dome remains condensation free no matter what the moisture level is outside the housing.

The camera mounting is the responsibility of the host user, since we have no control over the cameras physical mounting location. At NMSU, the cameras were mounted on all-weather simulated wood. This allowed for a flat surface to mount the camera by the flanges using lag screws. Attaching the cameras to the platform made it easy to install the camera at almost any location utilizing a couple of bricks. This is a simple method that is cost effective and doesnt require drilling to the actual roof surface and can be relocated easily.



(d)

(e)

Figure 1.1: Images of NMSU1 and NMSU2, on the roof of Thomas Brown Building, on the NMSU campus

Below in Figures 1.1 and 1.2 are cut-away views of the camera and the environmental electronics. There are no user serviceable parts inside. There are two versions of the AllSky Camera Systems that have been distributed, they are slightly different, but both are functionally the same.

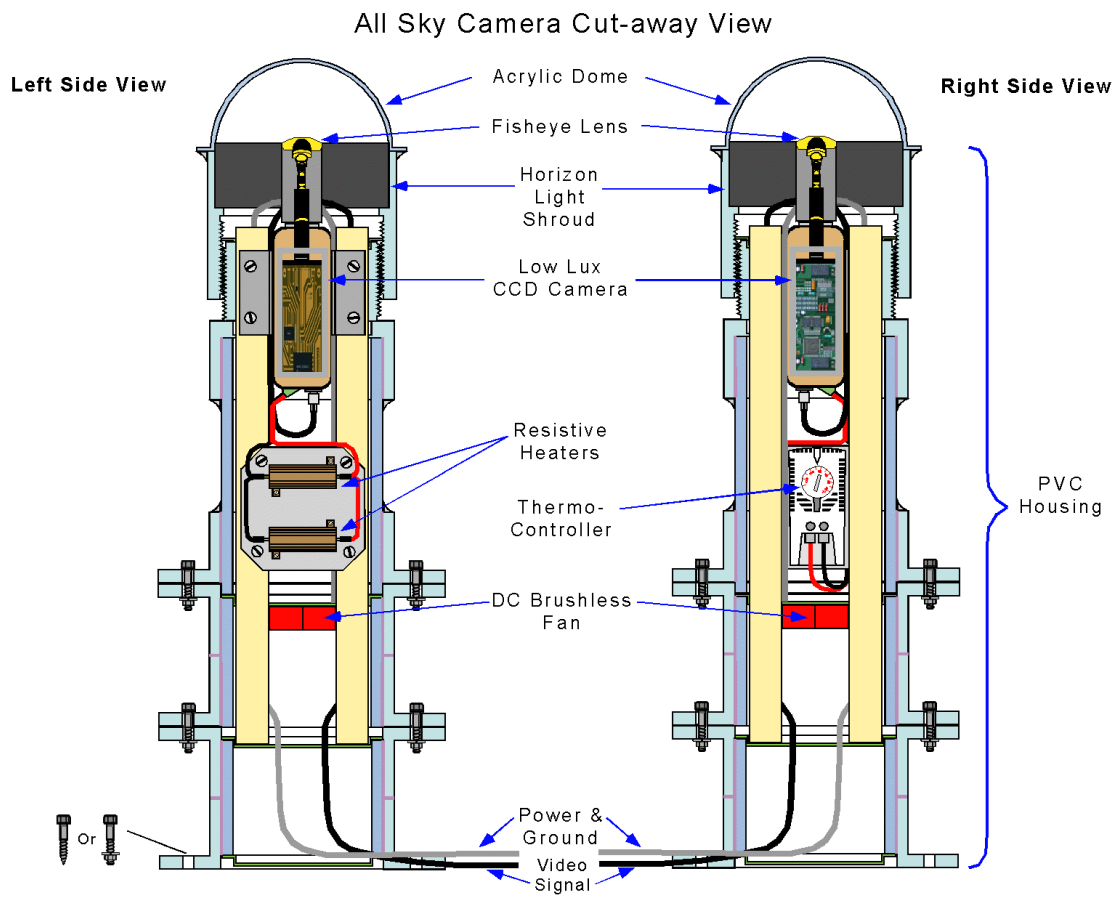

Figure 1.1: Previous version

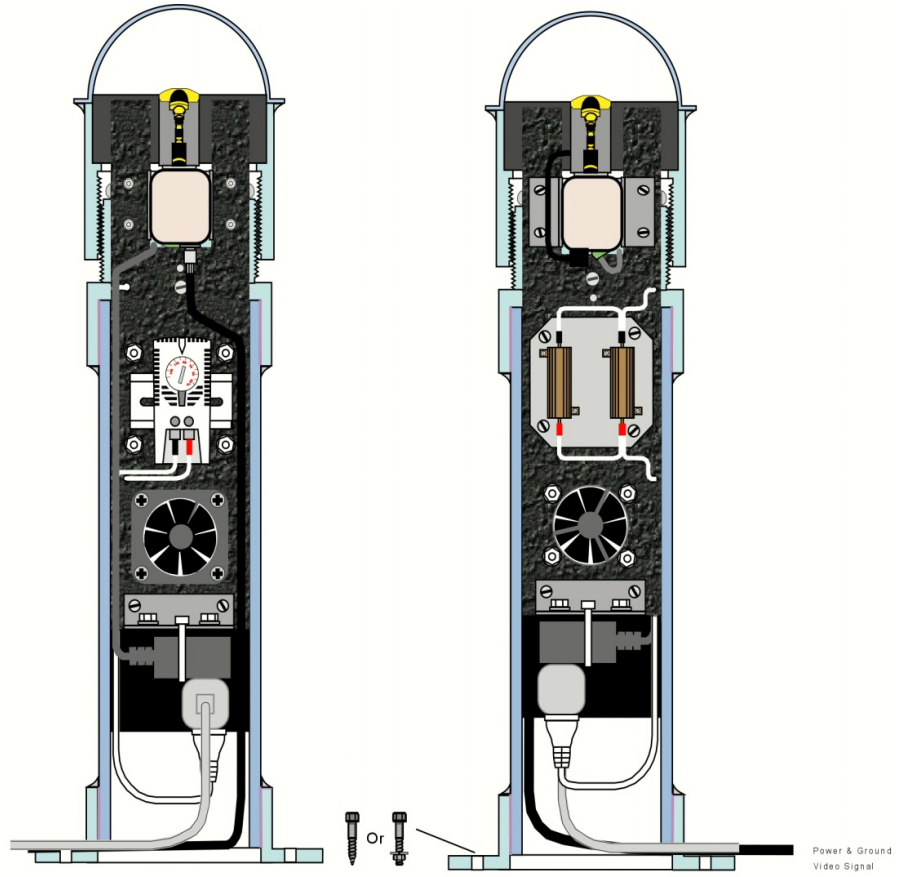

Figure 1.2: Current version

2 Parts List

- **Electrical**

- HB-710E Star Light B/W CCD Camera (1)
- L163VDC4P Rainbow Camera Lens (1), Fujinon YV22X14ASA Lens (1)
- Dale RH-50 50W resister/ heater (2)
- Fully Regulated 12 Volt DC 500Ma Adapter (1)
- Flight LT Brushless DC Fan (1)
- Plannenbergl 30°F - 140°F Thermostat (1)
- Hauppauge ImpactVCB 64900, Model 188 Frame Grabber Board (1), or USB-Live2 video capture RCA interface
- 3' 75 ohm BNC Coaxial Cable (1)
- 3' 125V-15Amp Extension Cord(2)

- **Housing**

- 1/8" X 4 1/4" Dia. X 2 1/8" High W/1/4" Flange Acrylic Dome, Global Plastics
- 4" Cap (SCH 40) (2)
- 17 1/4" x 4" PVC section (SCH 40) (1)
- 4" closet flange (5)
- 4" male adapter Hub x MPT (1)

- **Other Materials**

- Cutting board (1)
- #4-40 Pan Head Machine Screws, 3" (4)
- #6-32 Pan Head Wood Screws, 3/4" (4)
- #8-32 Pan Head Machine Screws, 1" (8)
- #8-32 Pan Head Machine Screw, 3 1/2" (2)
- Box of 4-40 Washers (1)
- Box of 4-40 Lock-washers (1)
- Box of 4-40 Nuts (1)

- Box of 8-32 Washers (1)
- Box of 8-32 Lock-washers (1)
- Box of 8-32 Nuts (1)
- Reel of Weather Stripping (1)
- Tube of White Caulking (1)
- Roll of 22 AWG. Stranded Wire Red (1)
- Roll of 22 AWG. Stranded Wire Black (1)
- 10 or 12 inch Zip-Tie (6)
- 1 inch Heat Shrink (4)

3 Housing

Step 1: Cut the 4" PVC pipe 17¹/₄" long, making sure the edge is as perpendicular as possible. See Figure 3.1.

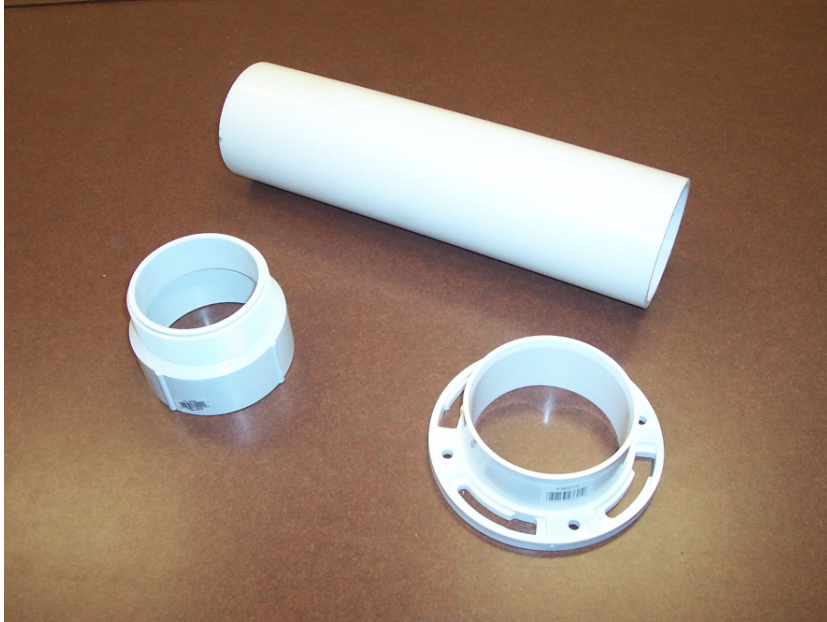

Figure 3.1: Step 1

Step 2: Using PVC Primer and Cement, prime the ends of the tube and the insides of the toilet flange and coupler. Then apply the cement on one end of the PVC tube and insert into the toilet flange, give it a small twist at the end to ensure a spreading of the cement and thus a good seal. Then cement the threaded coupler at the other end following the same method. Allow to dry and set. See Figure 3.2.

Note: PVC Primer and Cement vapors can be irritating or harmful to some persons. A well-ventilated area, mask, and gloves should be used while applying these chemicals. **See product warning label.**



(a)



(b)

Figure 3.2: Step 2

Step 3: Drill a 1/4" hole and slot at the bottom of the flange/tube to allow the BNC cable and power cord to pass to the outside of the unit. Some filing may be needed to make the hole/slot clean and uniform. See Figure 3.3.

Note: PVC dust should not be inhaled. It can be irritating or harmful to persons with allergies, a mask should be used as a precaution.



(a)

(b)

Figure 3.3: Step 3

Step 4: Attach the acrylic dome to the 4" female coupler using clear or white RTV cement. Be cautious to not get any on the dome. Apply to the rim of the coupler, then lower the dome onto the coupler evenly. Center as well as possible. See Figure 3.4.

Note: RTV Cement vapors can be irritating or harmful to some persons. A well-ventilated area, mask, and gloves should be used while applying this chemical adhesive. **See product warning label.**



Figure 3.4: Step 4

Step 5: The environmental control components are held in a webbing material. This is simply a cutting board. This material was selected because it can handle the high operating temperatures without burning, melting, or deforming. Cut out the inner web to hold the environmental control components using a bandsaw or other cutting equipment as indicated in the drawing. See **Safety Warning Label**. See Figure 3.5



Figure 3.5: Step 5

Step 6: Drill out the inner web to hold the environmental control components using a drillpress or hand drill as indicated in the drawing. **See Safety Warning Label.** See Figures 3.6, 3.7, 3.8.



(a)



(b)

Figure 3.6: Step 6

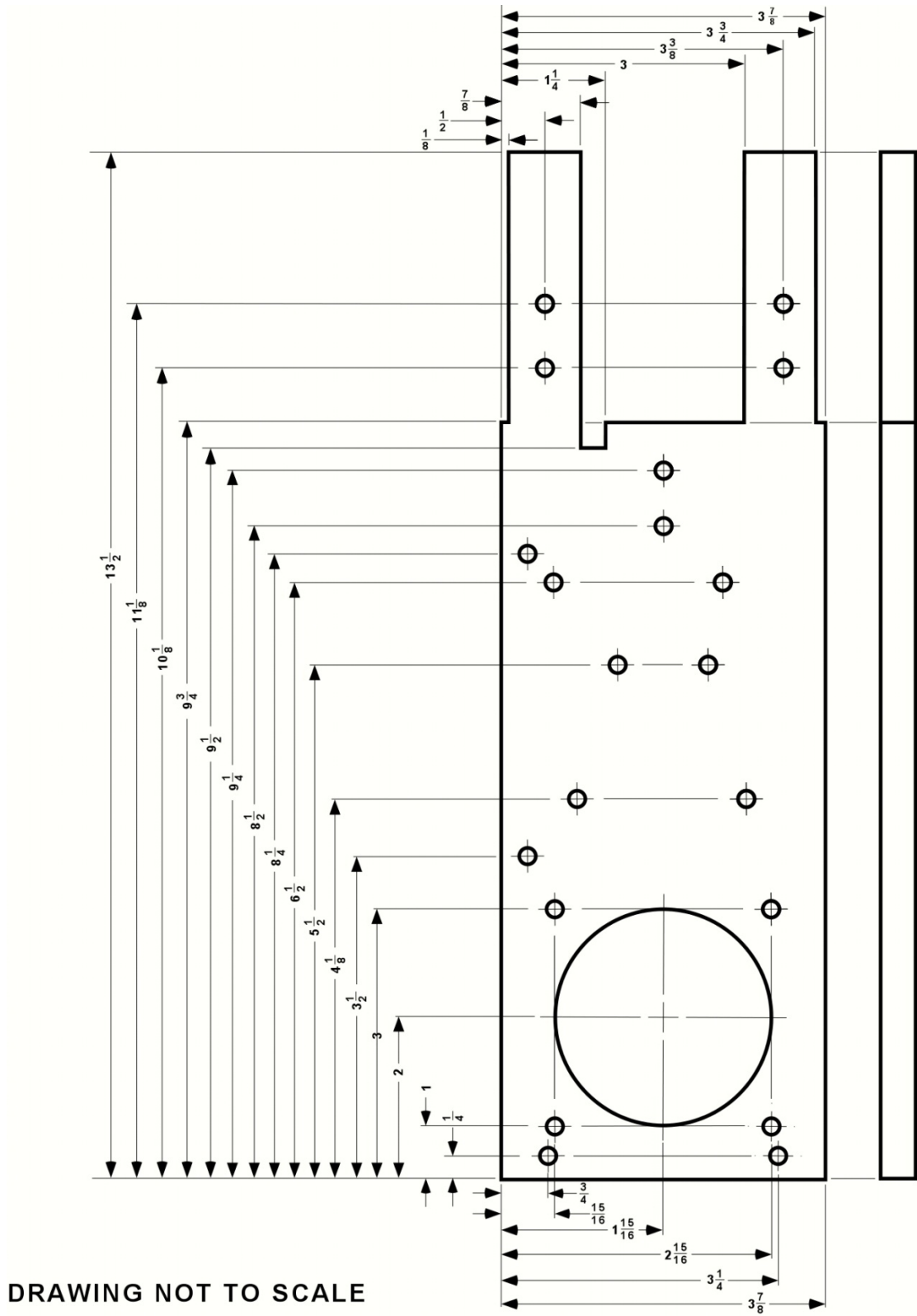
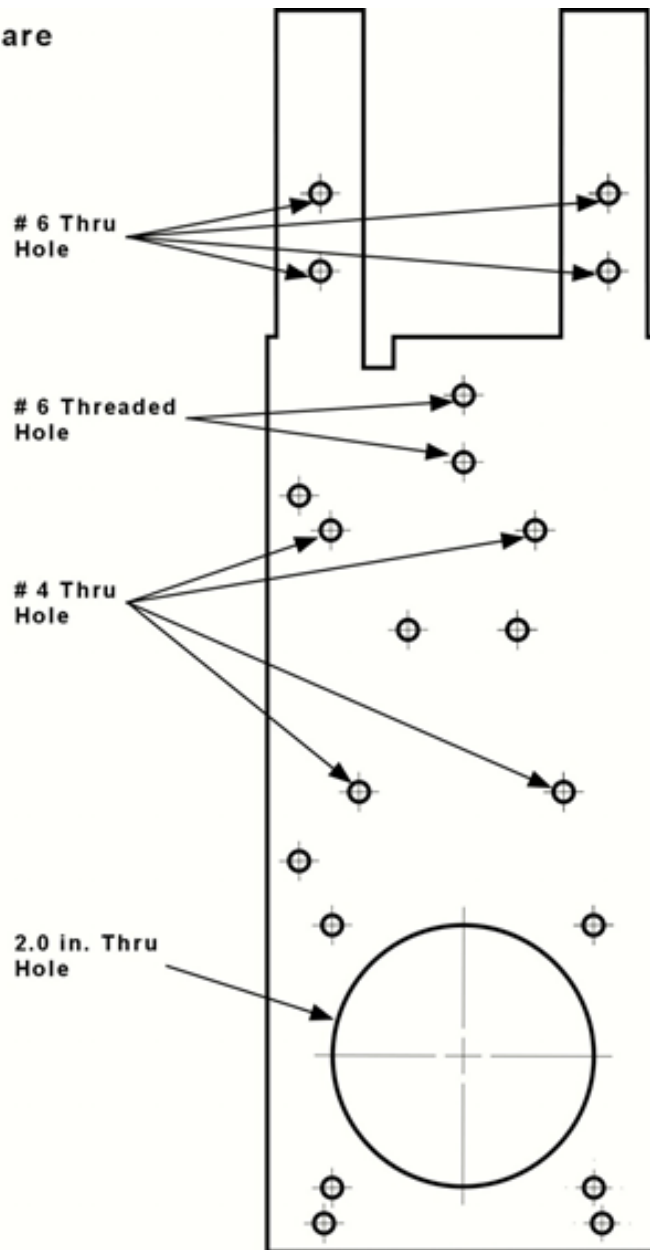

Figure 3.7: Step 6

All Mounting Holes are
#8 Thru Holes,
Unless Indicated



DRAWING NOT TO SCALE

Figure 3.8: Step 6

Step 7: Gather the internal components to be mounted.



Figure 3.9: Step 7

Step 8: Mount the brushless fan to the four mounting holes with the 2" hole cutout. Be sure to place the fan such that the wires are closest to the hole immediately above and to the side of the four fan mounting holes. See Figure 3.10.

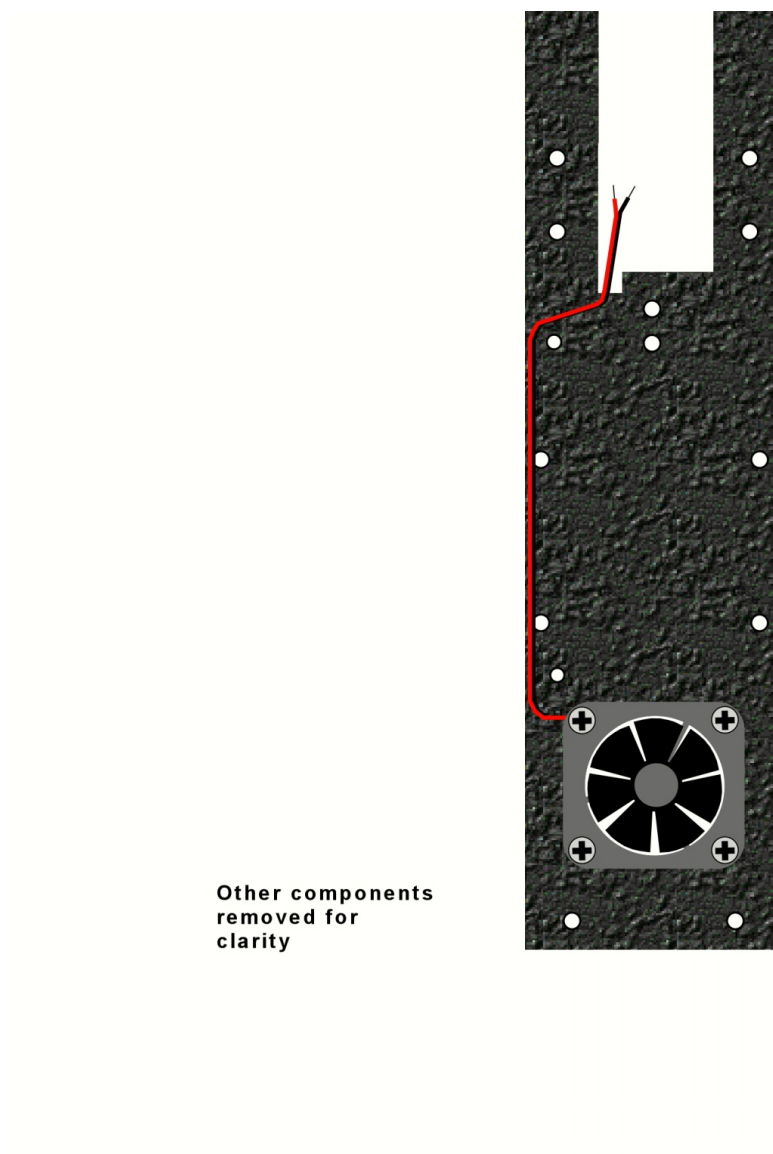

Figure 3.10: Step 8

Step 9: Mount the bracket to hold the thermostat using two 8-32 $\frac{3}{4}$ " machine screws with lock-washer, washer, and nut. Then snap connect the thermostat to the bracket. See Figure 3.11.

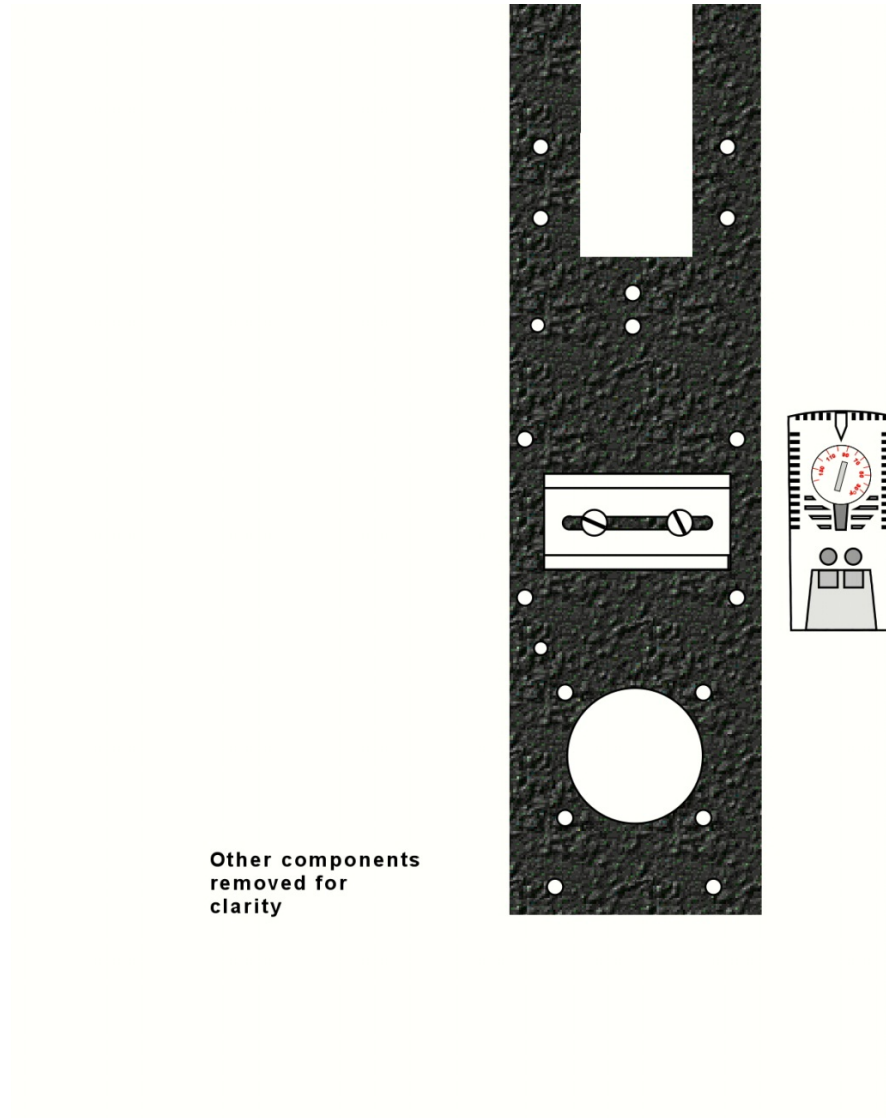

Figure 3.11: Step 9

Step 10: Mount the heat resistors/metal plate using four 4-40 2" machine screws with lock-washer, washer, and nut. Then solder the wires from the thermostat to the resistors as shown. See Figure 3.12.

Additional wiring instructions for the resistors/thermostat are shown in Figure 3.16.

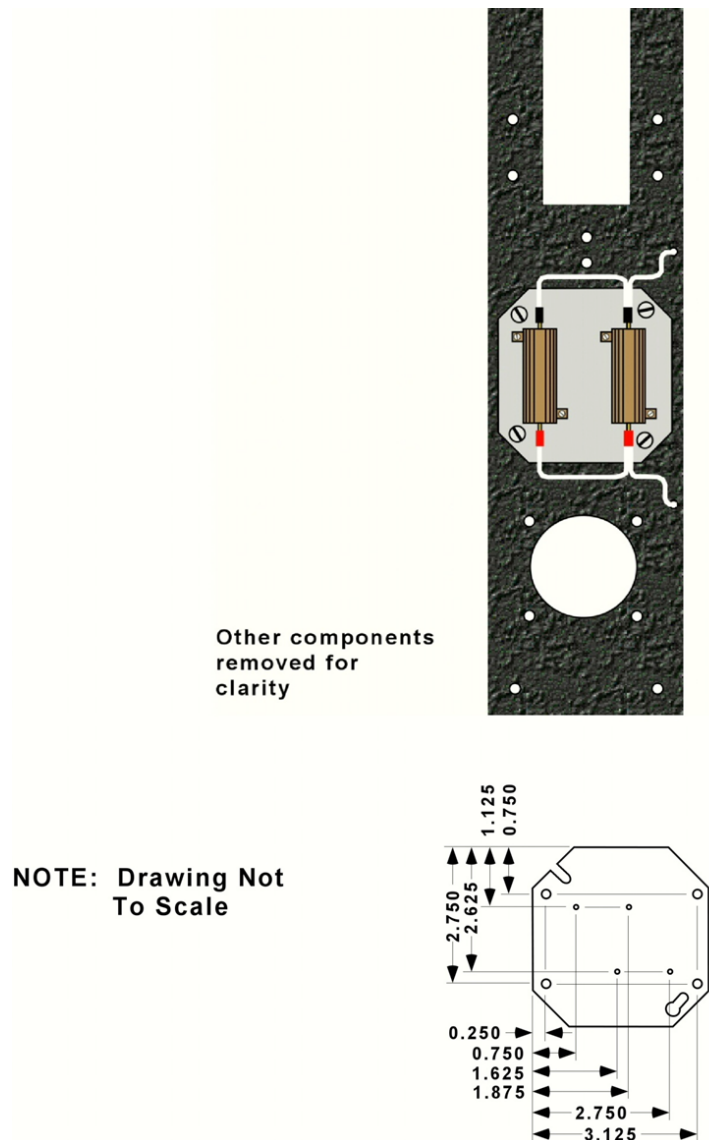
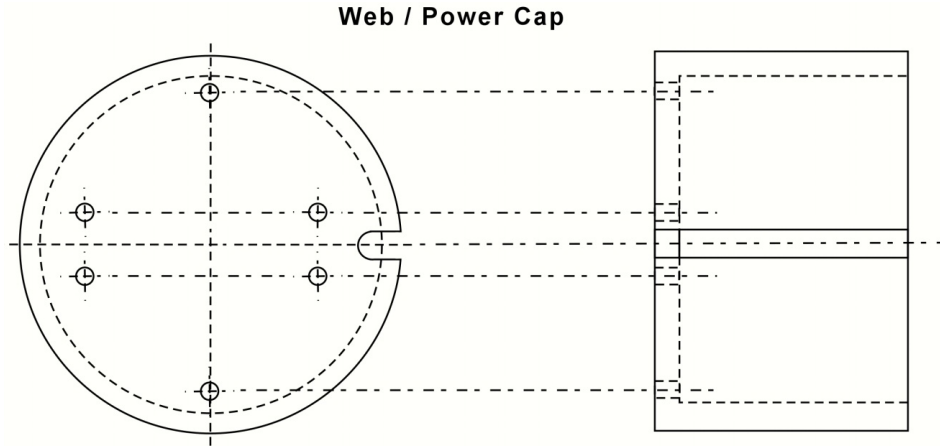
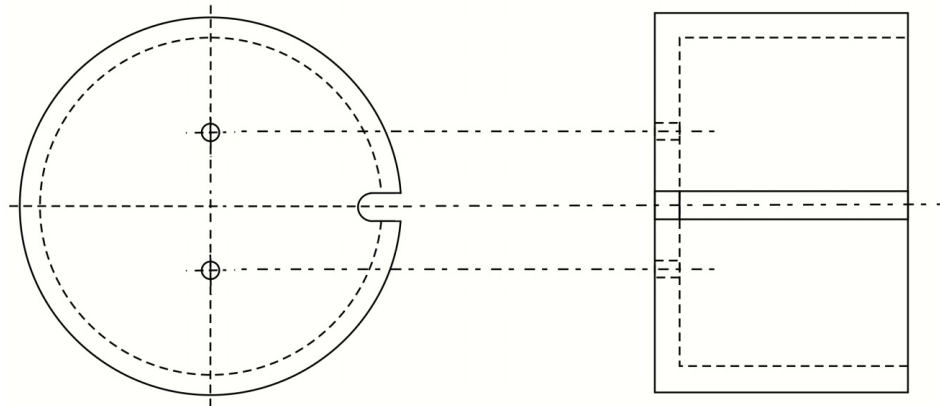

Figure 3.12: Step 10

Step 11: Modify the caps with a hole/slot to allow for the wires from the power supply and camera to pass and exit the bottom of the camera housing. Use the brackets as guides to make mounting holes. See Figure 3.13



NOTE: Drawings Not To Scale



Bottom Close Out Cap

Figure 3.13: Step 11

Step 12: Mount the power supply for the camera as shown in Figure 3.14 and Figure 3.15. Make sure to mount so that the wire will enter the hole/slot in the cap. Secure using a zip tie. Then run the wire up the side of the web backing till you reach the area where the camera will be mounted. Cut the wires at about 15 inches long, and strip the insulation so that you can connect the camera power supply connector.

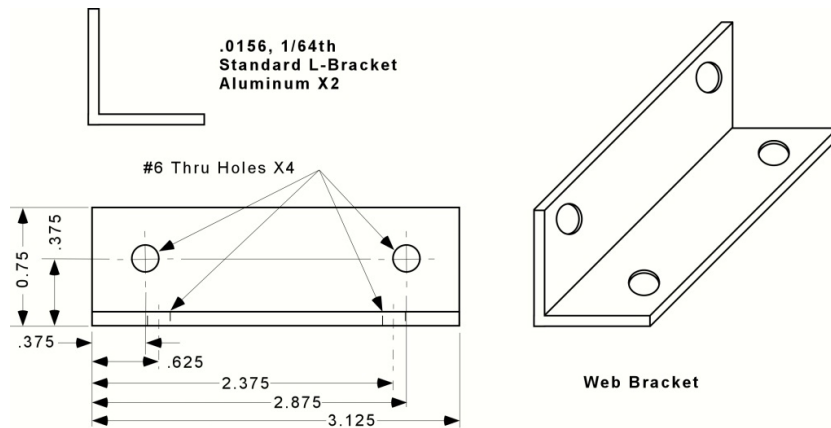

NOTE: Drawings Not To Scale

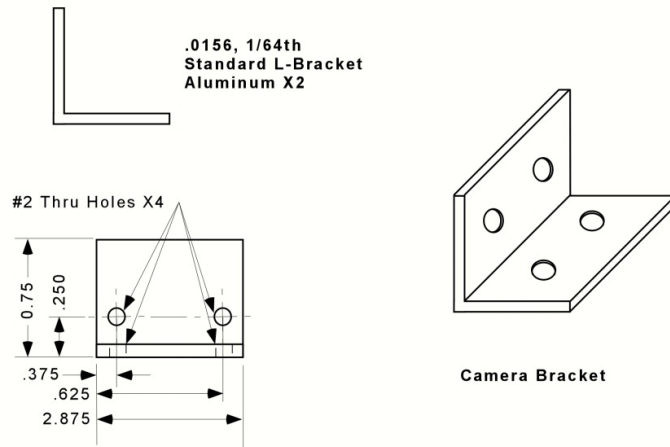

Figure 3.14: Step 12

Step 13: The 120V AC/DC power adapter is attached to the inside of the close out cap using a 10 or 12 inch zip ties. The cord runs along the side with the other wires to the top area of the assembly with the fan power line. Measure the ends of the fan power cord and the AC/DC power adapter to the same length and cut the end off of the AC/DC adapter and discard. Then split the wires about 1½ inches and strip the individual wires. See Figure 3.15.



Figure 3.15: Step 13

Note: Wire with “White Dash,” and the red wire from the fan power, are to be connected in the “inner” screw hole on the camera power connector (green). The two remaining black wires connect to the outside of the camera power connector (green). Figure 3.16.

Cut a 13A heavy duty power cord so that it can run from the extension cord up to the hole for the top and bottom resistors. Split the cord so that one end goes to the thermostat, #1 and screw it in. The other end to the top of the resistors through the hole just beside the resistor plate. Then cut from the excess wire and connect from #2 on the thermostat, to the bottom of the resistors, in the hole just above the fan. See Figure 3.16.

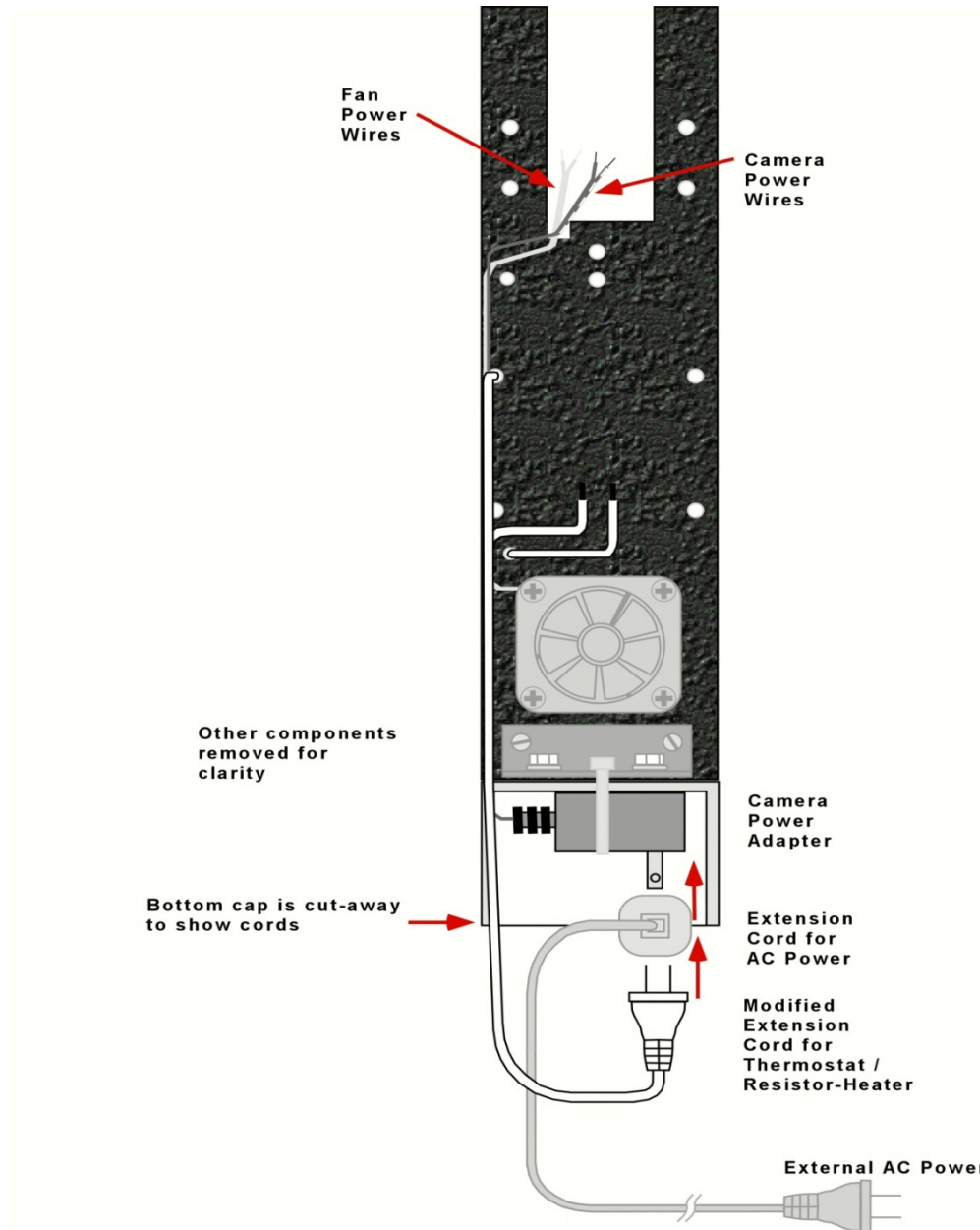
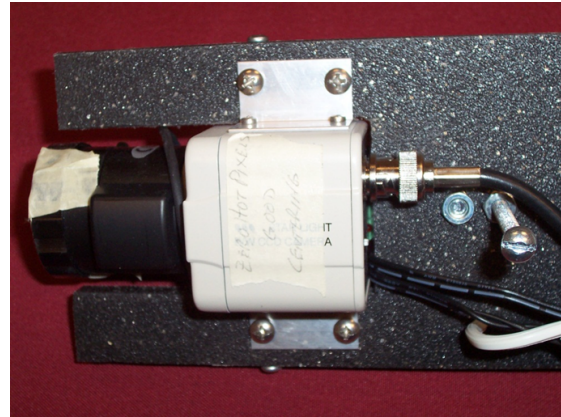

Figure 3.16: Step 13

Step 14: Mount the camera onto the camera brackets. The edge of the connector should line up along the middle of the camera housing. Then mount the camera onto the webbing and connect the power for the fan and the camera. Connect the BNC cable for the camera output. See Figures 3.17 and 3.18.



(a) Camera



(b) Camera Connection

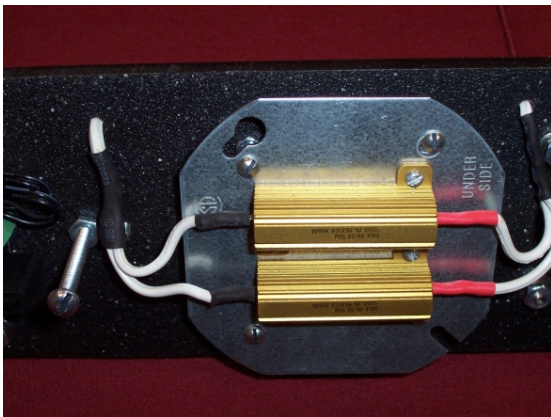

(c) Resistor Connection

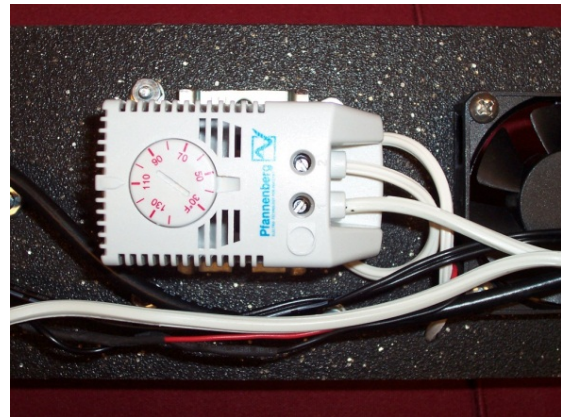

(d) Thermometer Connection

Figure 3.17: Step 14

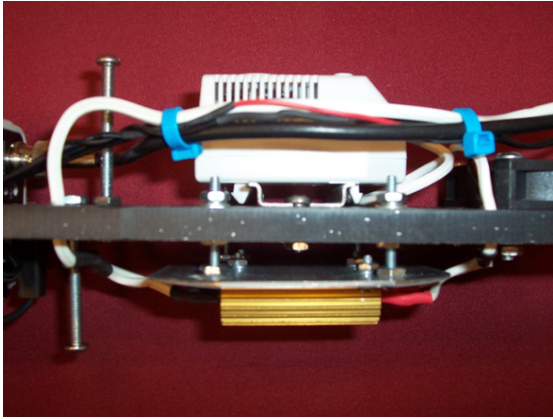

(a)

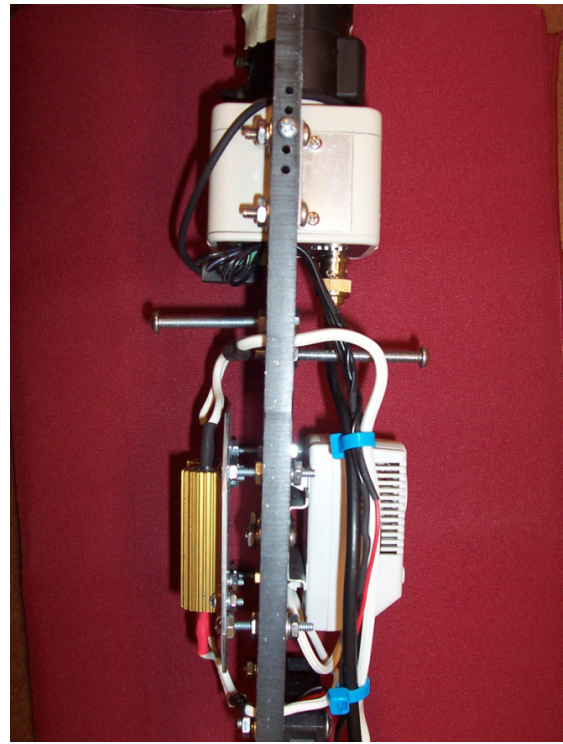

(b)

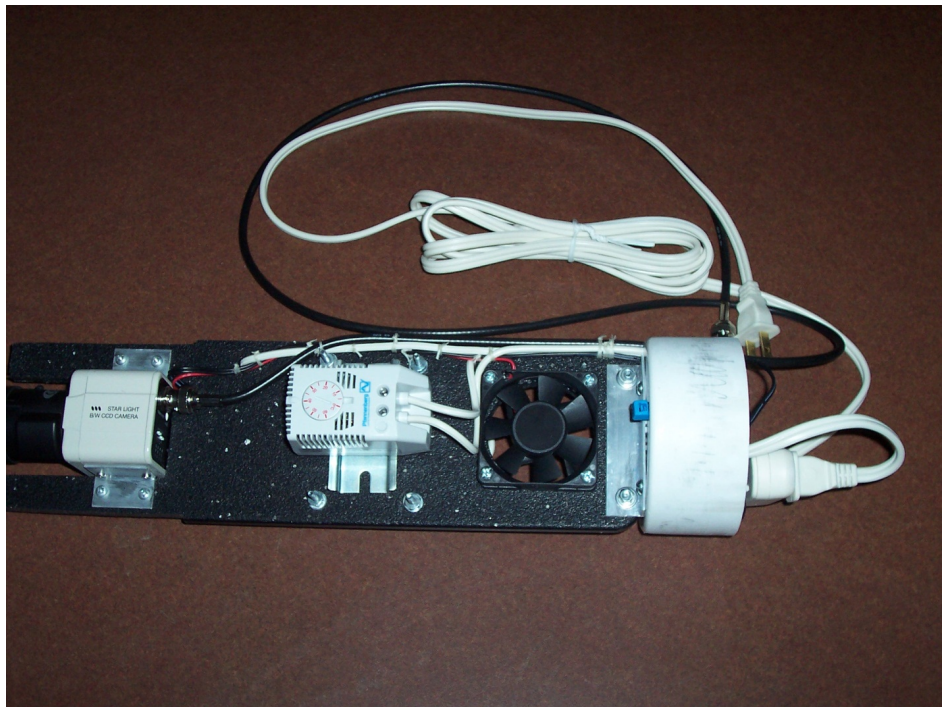

(c)

Figure 3.18: Step 14

Step 15: The internal components on the webbing are then inserted into the tube housing until the camera lens is just above the distortions on the dome from the bend of the flange at the bottom. Make note of its physical location. Drill a pilot hole for the small pan screw. This will hold the camera lens/internal components on the webbing at the correct height. See Figures 3.19 and 3.20.

AllSky Camera Cut-away

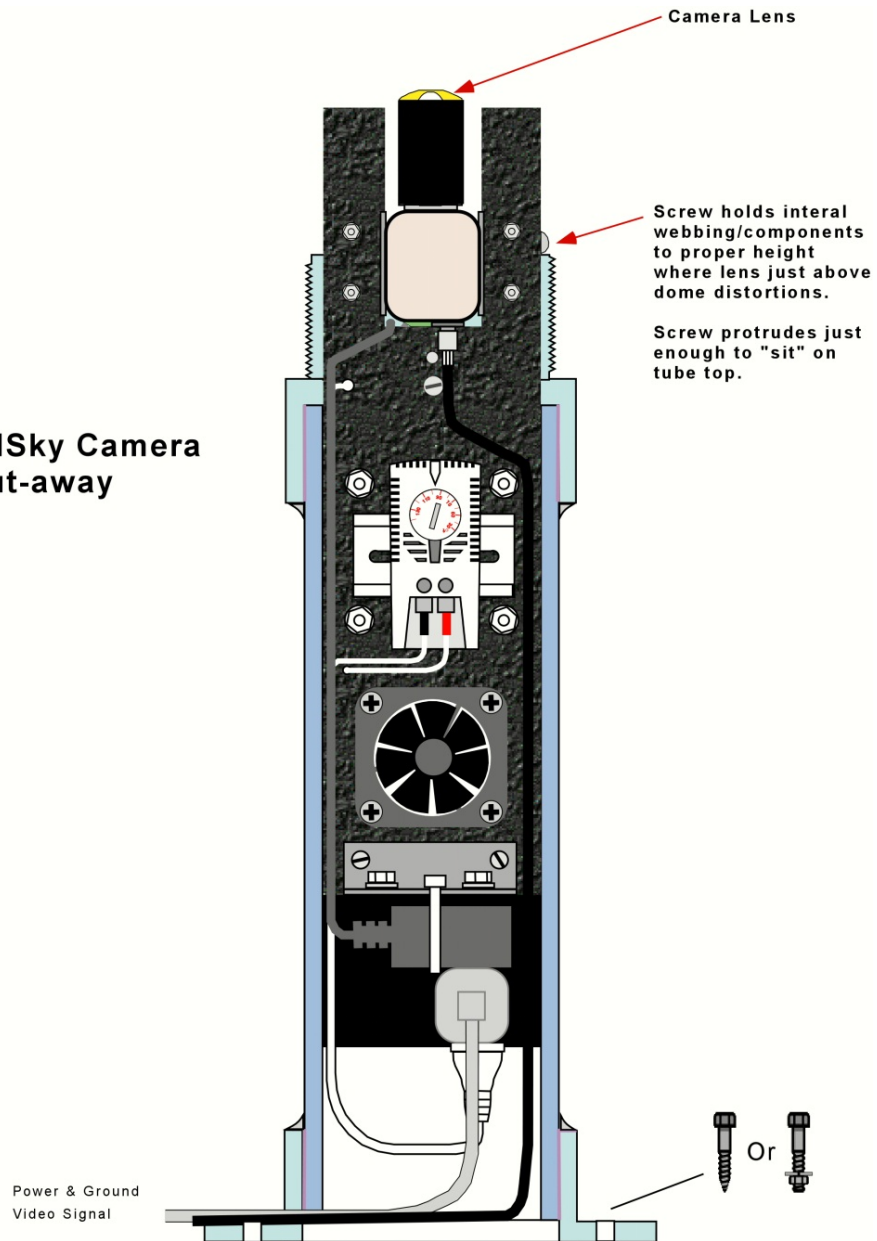

Figure 3.19: Step 15

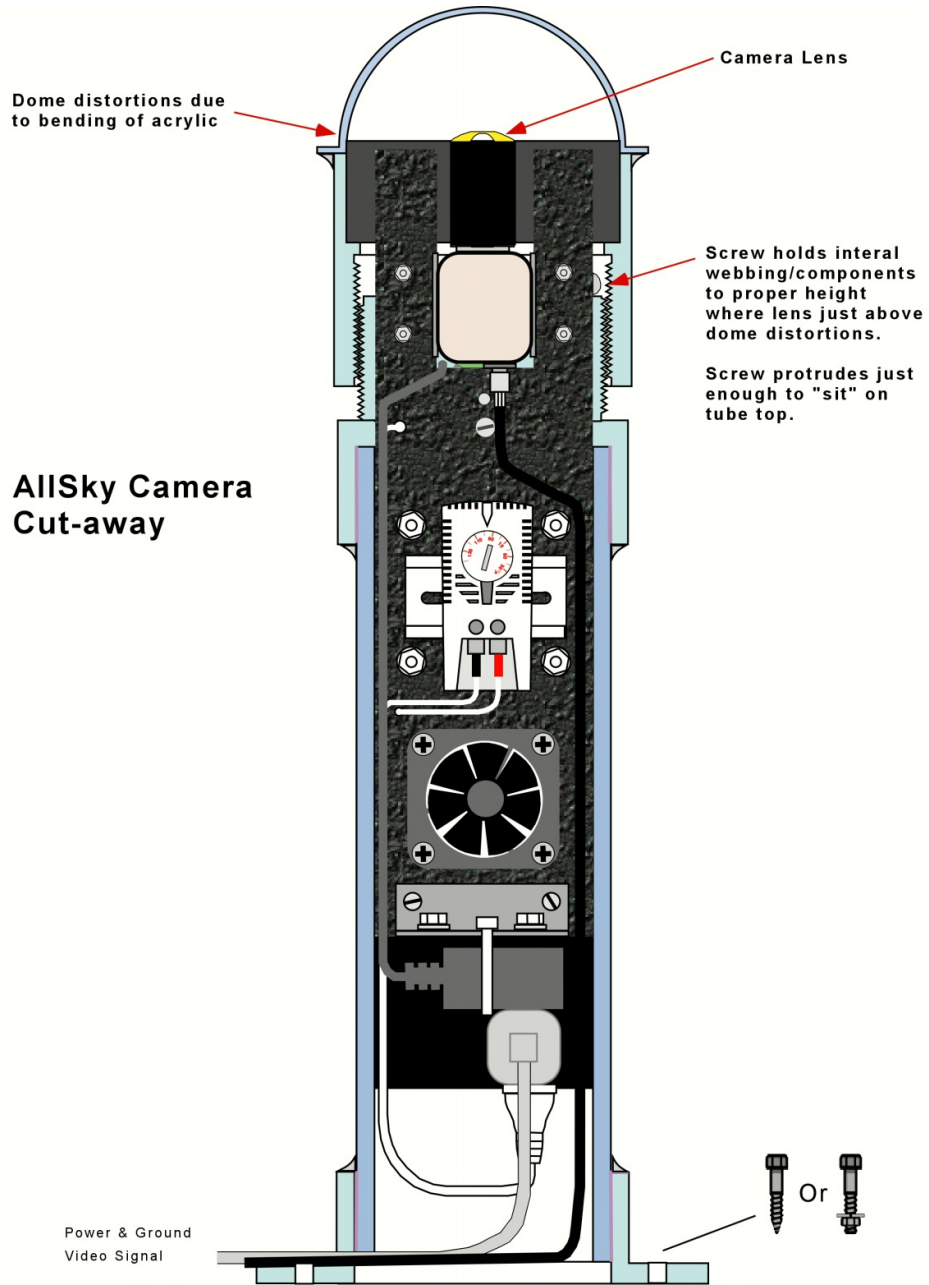

Figure 3.20: Step 15

Step 16: Insert the end cap and secure with a screw on the side. A piece of weatherstripping can be used to fill the hole made to allow the wires to pass. This will prevent water, dust, bugs, etc. from entering the camera housing. See Figure 3.21.



(a)



(b)



(c)

Figure 3.21: Step 16