



Ergotron® LAN Organizer™ 3000

Organize your network environment



Orderguide

LAN Organizer™ 3000

Table of Contents

Pre-configured Systems	1
Sample Configurations	3
How to Configure a Custom System	6
Base Unit Components	7
DuraFrames®	7
Legs (w/ Glides, Casters & Security Brackets)	7
Worksurfaces	8
Linear Worksurfaces	8
Corner System	9
Freestanding System	9
Storage Options	10
Tower Shelves	10
Pull-out Tower Holders	10
Suspension Shelves	11
Security Cabinets	11
Server Shelves	12
Tilt Server Shelves	12
Server Shelf Extensions	13
Shelf Backstops	13
Organizer Drawer	13
Keyboard Riser	14
Pedestal File Cabinet	14
Monitor Mounting Solutions	15
CRT Under-Shelf Mounts	15
CRT Lift Arm	15
Flat Panel Under-Shelf Mounts	16
Flat Panel Arms: Desk Mount	16
Frame Mount Brackets (for CRT & Flat Panel Monitors)	16
Keyboard Mounting Solutions	17
Keyboard Holders, Trays & Arms	17
Cable Management	18
Quik-Touch® Cable Management	18
Cable Channel Accessories	18
Rack Mount Solutions	19
19" Rack Mount Brackets	19
Monitor Drawers for 19" Racks	19
19" Rack Add-on	20
Power Accessories	20
Task Lights	20
Power Strips/Surge Suppressor	20
Notes	21

Pre-configured Systems

Order these complete solutions with one part number. Add components according to your needs.

Note: You may not remove or substitute parts included in pre-configured systems.

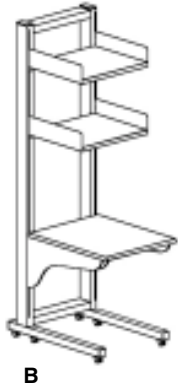

B

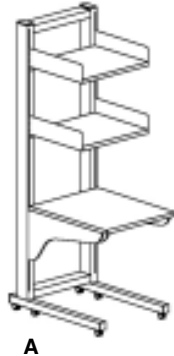

A

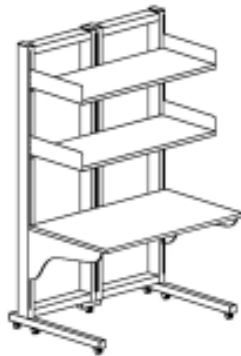

C

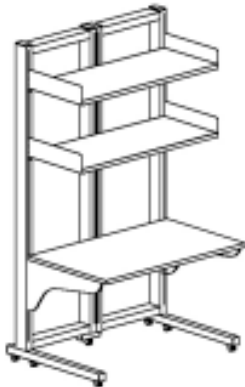

D



E

A. 27-212-100-998

24" W x 77" H Pre-configured System includes:

- (1) 10-087-100, 24" x 77" DuraFrame
- (1) 17-040-100, 34" Legs (two)
- (1) 72-022, Casters, set of 6
- (1) 55-005-998, 24" W x 30" D Worksurface
- (1) 65-069-100, Cantilever Bracing for single Frame
- (2) 50-116-100, 24" W x 20" D Server Shelf

Note: To order this system without a Worksurface, order number 27-222-100.

B. 27-213-100-998

24" W x 84" H Pre-configured System includes:

- (1) 10-088-100, 24" x 84" DuraFrame
- (1) 17-040-100, 34" Legs (two)
- (1) 72-022, Casters, set of 6
- (1) 55-005-998, 24" W x 30" D Worksurface
- (1) 65-069-100, Cantilever Bracing for single Frame
- (2) 50-116-100, 24" W x 20" D Server Shelf

Note: To order this system without a Worksurface, order number 27-223-100.

C. 27-214-100-998

48" W x 77" H Pre-configured System includes:

- (2) 10-087-100, 24" x 77" DuraFrame
- (1) 17-040-100, 34" Legs (two)
- (1) 17-041-100, 6" Center Leg (one) for dual Frame
- (1) 72-022, Casters, set of 6
- (1) 72-003, Caster (one)
- (1) 55-086-998, 48" W x 30" D Worksurface
- (1) 65-070-100, Cantilever Bracing for dual Frame
- (2) 50-104-100, 48" W x 20" D Server Shelf

Note: To order this system without a Worksurface, order number 27-226-100.

D. 27-215-100-998

48" W x 84" H Pre-configured System includes:

- (2) 10-088-100, 24" x 84" DuraFrame
- (1) 17-040-100, 34" Legs (two)
- (1) 17-041-100, 6" Center Leg (one) for dual Frame
- (1) 72-022, Casters, set of 6
- (1) 72-003, Caster (one)
- (1) 55-086-998, 48" W x 30" D Worksurface
- (1) 65-070-100, Cantilever Bracing for dual Frame
- (2) 50-104-100, 48" W x 20" D Server Shelf

Note: To order this system without a Worksurface, order number 27-227-100.

E. 27-220-100-998

72" W x 77" H Pre-configured System includes:

- (1) 10-063-100, 30" x 77" DuraFrame
- (1) 10-065-100, 42" x 77" DuraFrame
- (1) 17-040-100, 34" Legs (two)
- (1) 17-041-100, 6" Center Leg (one) for dual Frame
- (1) 72-022, Casters, set of 6
- (1) 72-003, Caster (one)
- (1) 55-015-998, 72" W x 30" D Worksurface
- (1) 65-070-100, Cantilever Bracing for dual Frame
- (2) 50-051-100, 72" W x 20" D Server Shelf

Pre-configured Systems

Order these complete solutions with one part number. Add components according to your needs.

Note: You may not remove or substitute parts included in pre-configured systems.

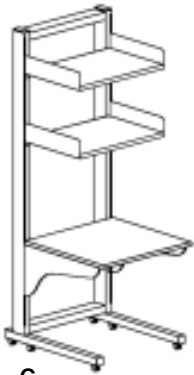

G

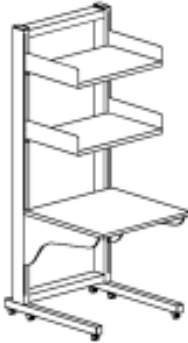

F



H

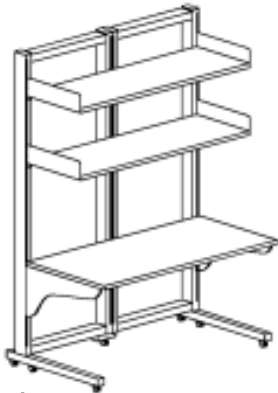

I

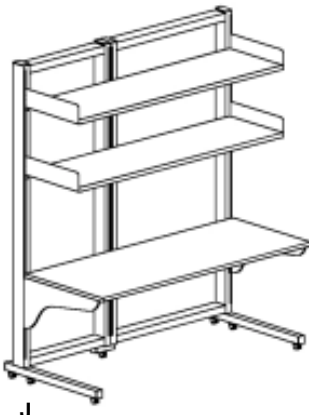

J

F. 27-216-100-998

30" W x 77" H Pre-configured System includes:

- (1) 10-063-100, 30" x 77" DuraFrame
- (1) 17-040-100, 34" Legs (two)
- (1) 72-022, Casters, set of 6
- (1) 55-008-998, 30" W x 30" D Worksurface
- (1) 65-069-100, Cantilever Bracing for single Frame
- (2) 50-048-100, 30" W x 20" D Server Shelf

Note: To order this system without a Worksurface, order number 27-224-100.

G. 27-217-100-998

30" W x 84" H Pre-configured System includes:

- (1) 10-095-100, 30" x 84" DuraFrame
- (1) 17-040-100, 34" Legs (two)
- (1) 72-022, Casters, set of 6
- (1) 55-008-998, 30" W x 30" D Worksurface
- (1) 65-069-100, Cantilever Bracing for single Frame
- (2) 50-048-100, 30" W x 20" D Server Shelf

Note: To order this system without a Worksurface, order number 27-225-100.

H. 27-218-100-998

60" W x 77" H Pre-configured System includes:

- (2) 10-063-100, 30" x 77" DuraFrame
- (1) 17-040-100, 34" Legs (two)
- (1) 17-041-100, 6" Center Leg (one) for dual Frame
- (1) 72-022, Casters, set of 6
- (1) 72-003, Caster (one)
- (1) 55-013-998, 60" W x 30" D Worksurface
- (1) 65-070-100, Cantilever Bracing for dual Frame
- (2) 50-050-100, 60" W x 20" D Server Shelf

I. 27-219-100-998

60" W x 84" H Pre-configured System includes:

- (2) 10-095-100, 30" x 84" DuraFrame
- (1) 17-040-100, 34" Legs (two)
- (1) 17-041-100, 6" Center Leg (one) for dual Frame
- (1) 72-022, Casters, set of 6
- (1) 72-003, Caster (one)
- (1) 55-013-998, 60" W x 30" D Worksurface
- (1) 65-070-100, Cantilever Bracing for dual Frame
- (2) 50-050-100, 60" W x 20" D Server Shelf

J. 27-221-100-998

72" W x 84" H Pre-configured System includes:

- (1) 10-095-100, 30" x 84" DuraFrame
- (1) 10-096-100, 42" x 84" DuraFrame
- (1) 17-040-100, 34" Legs (two)
- (1) 17-041-100, 6" Center Leg (one) for dual Frame
- (1) 72-022, Casters, set of 6
- (1) 72-003, Caster (one)
- (1) 55-015-998, 72" W x 30" D Worksurface
- (1) 65-070-100, Cantilever Bracing for dual Frame
- (2) 50-051-100, 72" W x 20" D Server Shelf

Sample Configurations

Configure your own solution with Ergotron's modular components. Examples listed here are some common configurations.

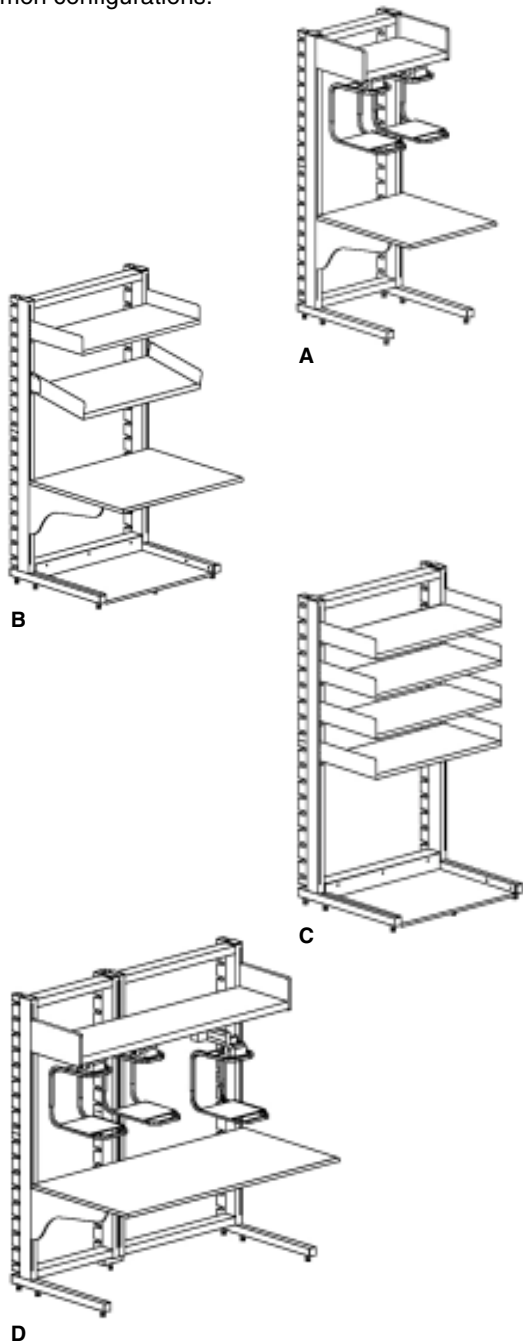

- A. 30" W x 77" H Suspension Configuration includes:**
- (1) 10-063-100, 30" x 77" DuraFrame
 - (1) 17-040-100, 34" Legs (two)
 - (1) 72-021, Glides, set of 6
 - (1) 55-019-998, 30" W x 36" D Worksurface
 - (1) 65-069-100, Cantilever Bracing for single Frame
 - (1) 53-062-100, 30" Suspension Shelf
 - (2) 42-020-100, Suspension Truck
 - (2) 40-002-100, Type 2 Monitor Caddy*
 - (4) 70-067-099, 36" Quik-Touch Cable Management

- B. 42" W x 77" H Configuration includes:**
- (1) 10-065-100, 42" x 77" DuraFrame
 - (1) 99-045-100, Hook Spacer Kit
 - (1) 17-040-100, 34" Legs (two)
 - (1) 72-021, Glides, set of 6
 - (1) 72-008, Glide (one)
 - (1) 55-020-998, 42" W x 36" D Worksurface
 - (1) 65-069-100, Cantilever Bracing for single Frame
 - (1) 50-079-100, 42" Tower Shelf
 - (1) 50-049-100, 42" W x 20" D Server Shelf
 - (1) 50-112-100, 42" Tilt Server Shelf
 - (4) 70-067-099, 36" Quik-Touch Cable Management

- C. 42" W x 77" H Configuration includes:**
- (1) 10-065-100, 42" x 77" DuraFrame
 - (1) 99-045-100, Hook Spacer Kit
 - (1) 17-040-100, 34" Legs (two)
 - (1) 72-021, Glides, set of 6
 - (1) 72-008, Glide (one)
 - (1) 50-079-100, 42" Tower Shelf
 - (4) 50-049-100, 42" W x 20" D Server Shelf
 - (4) 70-067-099, 36" Quik-Touch Cable Management

- D. 72" W x 77" H Configuration includes:**
- (1) 10-063-100, 30" x 77" DuraFrame
 - (1) 10-065-100, 42" x 77" DuraFrame
 - (1) 17-040-100, 34" Legs (two)
 - (1) 17-041-100, 6" Center Leg (one) for dual Frame
 - (1) 72-021, Glides, set of 6
 - (1) 72-008, Glide (one)
 - (1) 55-026-998, 72" W x 36" D Worksurface
 - (1) 65-070-100, Cantilever Bracing for dual Frame
 - (1) 53-065-100, 72" Suspension Shelf
 - (1) 44-323-100, "B" Suspension Arm*
 - (2) 42-020-100, Suspension Truck
 - (3) 40-002-100, Type 2 Monitor Caddy*
 - (8) 70-067-099, 36" Quik-Touch Cable Management

* For samples showing Arms or Caddies, specify "A", "B" or "C" Arms based on monitor weight. Specify Caddy size (Type 2, 3, 4 or 5) based on monitor dimensions. See Page 15 for more information concerning Arms and Caddies.

Sample Configurations

Configure your own solution with Ergotron's modular components. Examples listed here are some common configurations.

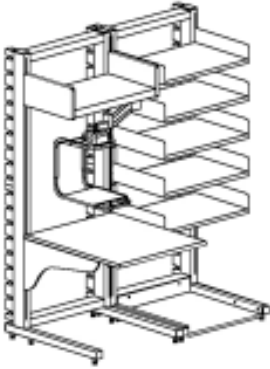

E

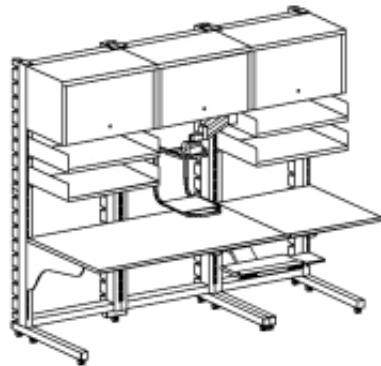

F

E. 60" W x 77" H Configuration includes:

- (2) 10-063-100, 30" x 77" DuraFrame
- (1) 99-045-100, Hook Spacer Kit
- (2) 17-040-100, 34" Legs (two)
- (2) 72-021, Glides, set of 6
- (1) 55-019-998, 30" W x 36" D Worksurface
- (1) 65-069-100, Cantilever Bracing for single Frame
- (1) 50-078-100, 30" Tower Shelf
- (1) 53-062-100, 30" Suspension Shelf
- (5) 50-048-100, 30" W x 20" D Server Shelf
- (1) 44-323-100, "B" Suspension Arm*
- (1) 40-002-100, Type 2 Monitor Caddy*
- (8) 70-067-099, 36" Quik-Touch Cable Management

F. 90" W x 77" H Configuration includes:

- (3) 10-063-100, 30" x 77" DuraFrame
- (1) 99-045-100, Hook Spacer Kit
- (2) 17-040-100, 34" Legs (two)
- (1) 17-041-100, 6" Center Leg (one) for dual Frame
- (2) 72-022, Casters, set of 6
- (1) 72-003, Caster (one)
- (1) 55-019-998, 30" W x 36" D Worksurface
- (1) 55-024-998, 60" W x 36" D Worksurface
- (1) 65-069-100, Cantilever Bracing for single Frame
- (1) 65-070-100, Cantilever Bracing for dual Frame
- (3) 95-011-100, 30" Security Cabinet
- (4) 50-048-100, 30" W x 20" D Server Shelf
- (1) 44-323-100, "B" Suspension Arm*
- (1) 40-002-100, Type 2 Monitor Caddy*
- (1) 75-038, Keyboard Arm
- (1) 77-026-098, Keyboard and Mouse Tray for Keyboard Arm, black
- (1) 85-008-098, Wrist Rest, Tray Mount, for 77-026-098, black
- (12) 70-067-099, 36" Quik-Touch Cable Management

* For samples showing Arms or Caddies, specify "A", "B" or "C" Arms based on monitor weight. Specify Caddy size (Type 2, 3, 4 or 5) based on monitor dimensions. See Page 15 for more information concerning Arms and Caddies.

Sample Configurations

Configure your own solution with Ergotron's modular components. Examples listed here are some common configurations.

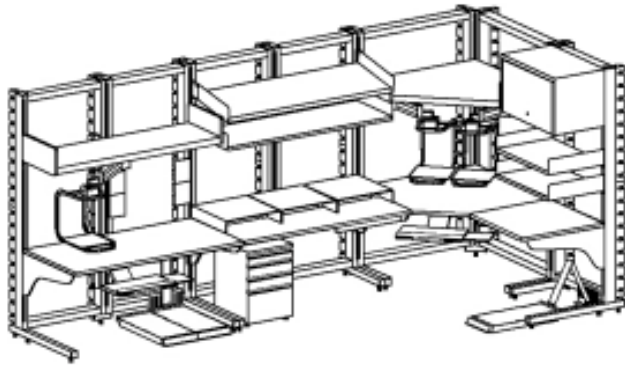

G

G. Corner Configuration includes:

- (5) 10-063-100, 30" x 77" DuraFrame
- (2) 10-065-100, 42" x 77" DuraFrame
- (2) 17-040-100, 34" Legs (two)
- (2) 17-041-100, 6" Center Leg (one) for dual Frame
- (3) 72-021, Glides, set of 6
- (5) 72-008, Glide (one)
- (1) 55-008-998, 30" W x 30" D Worksurface
- (2) 55-013-998, 60" W x 30" D Worksurface
- (1) 65-069-100, Cantilever Bracing for single Frame
- (2) 65-070-100, Cantilever Bracing for dual Frame
- (1) 53-002-100, Corner Suspension Shelf and Bracket
- (1) 55-077-998, Corner Worksurface, Laminated
- (1) 65-072-100, Corner Worksurface Mounting Hardware
- (1) 17-006-100, 22" Legs (two)
- (1) 80-065-100, 12" Pull-out Tower Holder
- (1) 80-071-100, For 30" W Frame, (2) 12" Pull-out Tower Holders
- (2) 60-160-100, 12" L-Bracket/Slide
- (2) 70-065, Cable Routing Management
- (1) 53-064-100, 60" Suspension Shelf
- (1) 95-011-100, 30" Security Cabinet
- (2) 50-048-100, 30" W x 20" D Server Shelf
- (1) 50-050-100, 60" W x 20" D Server Shelf
- (1) 50-113-100, 60" Tilt Server Shelf
- (1) 68-007-098, Organizer Drawer, black
- (3) 99-015, Keyboard Riser, acrylic
- (1) 68-114-100, File Cabinet with Casters, 3 drawers
- (3) 44-323-100, "B" Suspension Arm*
- (3) 40-002-100, Type 2 Monitor Caddy*
- (1) 75-038, Keyboard Arm
- (1) 75-039, Extended Keyboard Arm (for Corner Systems)
- (2) 77-026-098, Keyboard and Mouse Tray for Keyboard Arm, black
- (2) 85-008-098, Wrist Rest, Tray Mount, for 77-026-098, black
- (28) 70-067-099, 36" Quik-Touch Cable Management
- (2) 60-110-100, 19" Rack Mount Brackets
- (1) 83-025-100, 8-outlet Horizontal Mount Power Strip

* For samples showing Arms or Caddies, specify "A", "B" or "C" Arms based on monitor weight. Specify Caddy size (Type 2, 3, 4 or 5) based on monitor dimensions. See Page 15 for more information concerning Arms and Caddies.

How to Configure a Custom System

A

Select Base Unit Components.

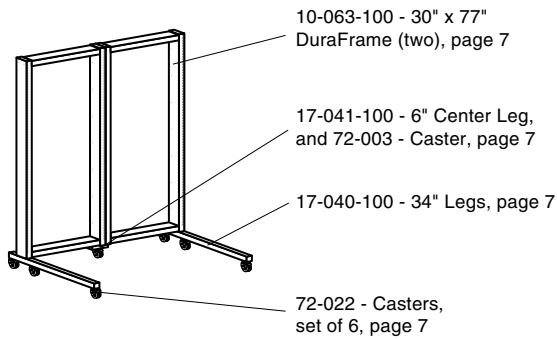

D

Select a Monitor Mounting Solution.

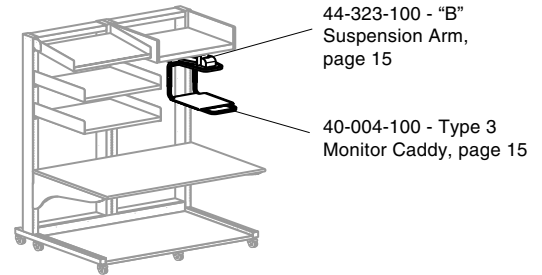

B

Select a Worksurface.

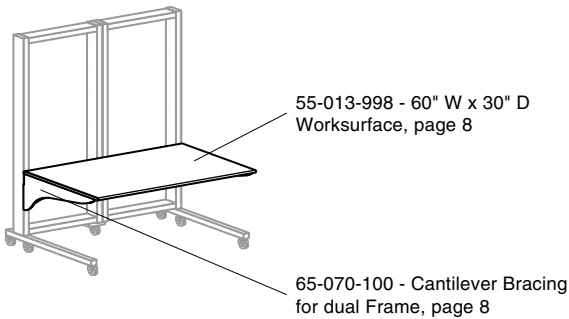

E

Select Keyboard Solutions.

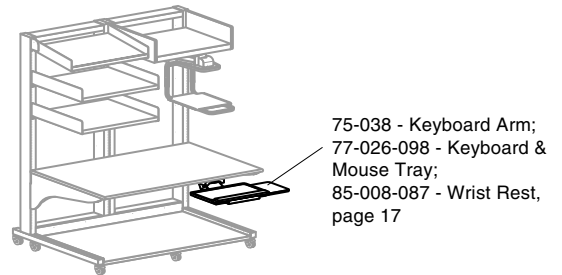

C

Select Storage Options.

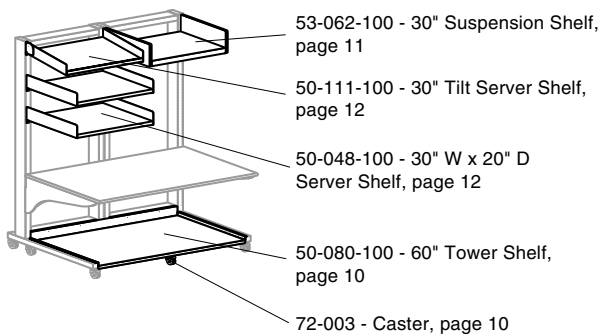

F

Select Cable Management, Rack Mount Solutions and Power Accessories.

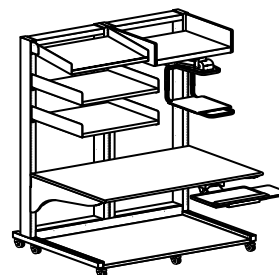

Base Unit Components

DuraFrames®

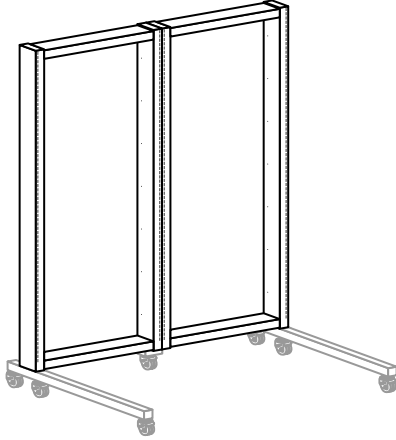

60" module containing two 30" x 77" DuraFrames, 10-063-100

Ergotron's 2" x 4" DuraFrame is capable of holding up to 3500 lbs (1589 kg) of weight per module*. Combine individual Frames to form 48", 60" and 72" wide modules.

Part Number	Description	Dimensions W x H	Height With Legs & Glides	Height With Legs & Casters
10-087-100	24" X 77" DuraFrame	24" x 73-5/8" (610 x 1870 mm)	77-3/16" (1961 mm)	79-3/16" (2011 mm)
10-088-100	24" X 84" DuraFrame	24" x 80-5/8" (610 x 2048 mm)	84-3/16" (2138 mm)	86-3/16" (2189 mm)
10-063-100	30" X 77" DuraFrame	30" x 73-5/8" (762 x 1870 mm)	77-3/16" (1961 mm)	79-3/16" (2011 mm)
10-095-100	30" X 84" DuraFrame	30" x 80-5/8" (762 x 2048 mm)	84-3/16" (2138 mm)	86-3/16" (2189 mm)
10-065-100	42" X 77" DuraFrame	42" x 73-5/8" (1067 x 1870 mm)	77-3/16" (1961 mm)	79-3/16" (2011 mm)
10-096-100	42" X 84" DuraFrame	42" x 80-5/8" (1067 x 2048 mm)	84-3/16" (2138 mm)	86-3/16" (2189 mm)
99-045-100	Hook Spacer Kit, 6 per pair			

* Module is 1 Leg set with 1 or 2 joined Frames.

Note: Six (6) Hook Spacers or 3 pairs of Hook Spacers provided with each Frame.

Note: Maximum weight capacity of module* depends on which components are used in configuration.

Legs

(w/ Glides, Casters & Security Brackets)

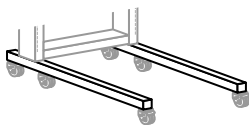

One set of 34" Legs, 17-040-100

Glide, 72-008

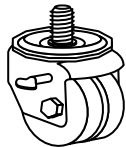

Caster, 72-003

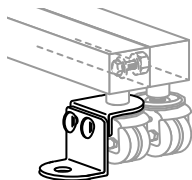

Caster Mount Security Brackets, 97-058-100

These 2" x 2" Legs provide a sturdy base for any racking system. To configure a stationary system, order Glides. To add mobility to the system, order Casters.

Part Number	Description	Length in front and behind Frame	Mounts for Glides/Caster
17-040-100	34" Legs (two)	27", 3" (686, 76 mm)	6 per Leg
17-041-100	6" Center Leg (one) for dual Frame		1 per Leg
17-039-100	58" "T" Legs (two)	27", 27" (686, 686 mm)	10 per Leg
72-021	Glides, set of 6		
72-022	Castors, set of 6		
72-008	Glide (one)		
72-003	Caster (one)		
60-001-100	Glide Mount Security Brackets, 4 pieces		
97-058-100	Caster Mount Security Brackets, set of 2		

Leg height with Glides and Casters fully inserted: Glides: 3-3/16" (81 mm), Casters: 5-3/16" (132 mm)

Glide height: 13/16" (21 mm)

Diameter of Glides: 1-3/8" (35 mm)

Height adjustment: 1/2" (13 mm)

Caster height: 2-3/4" (70 mm)

Diameter of Casters: 2" (51 mm)

Weight capacity per Caster: 250 lbs (113.6 kg)

Worksurfaces

Linear Worksurfaces

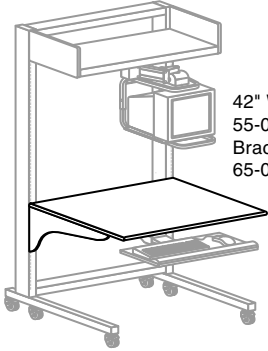

42" W x 36" D Worksurface, 55-020-998, and Cantilever Bracing for single Frame, 65-069-100

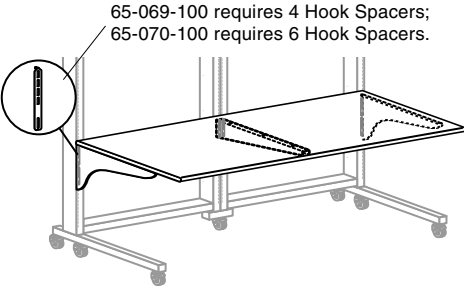

65-069-100 requires 4 Hook Spacers; 65-070-100 requires 6 Hook Spacers.

60" W x 36" D Worksurface, 55-024-998, and Cantilever Bracing for dual Frame, 65-070-100

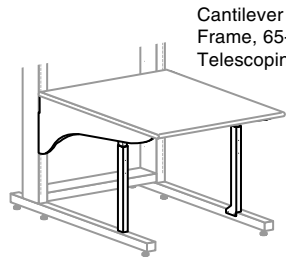

Cantilever Bracing for single Frame, 65-069-100 with Telescoping Leg Kit, 65-071-100

Ergotron Worksurfaces combine aesthetics and heavy-duty strength. To increase weight capacity to 1000 lbs, order the Telescoping Leg Kit. Standard laminate is Grey Millstone.

Part Number	Description	Dimensions W x D	Weight Capacity
55-005-998	24" W x 30" D Worksurface	24" x 30" (610 x 762 mm)	
55-008-998	30" W x 30" D Worksurface	30" x 30" (762 x 762 mm)	
55-009-998	42" W x 30" D Worksurface	42" x 30" (1067 x 762 mm)	
55-086-998	48" W x 30" D Worksurface	48" x 30" (1219 x 762 mm)	
55-013-998	60" W x 30" D Worksurface	60" x 30" (1524 x 762 mm)	
55-015-998	72" W x 30" D Worksurface	72" x 30" (1829 x 762 mm)	
55-025-998	24" W x 36" D Worksurface	24" x 36" (610 x 914 mm)	
55-019-998	30" W x 36" D Worksurface	30" x 36" (762 x 914 mm)	
55-020-998	42" W x 36" D Worksurface	42" x 36" (1067 x 914 mm)	
55-068-998	48" W x 36" D Worksurface	48" x 36" (1219 x 914 mm)	
55-024-998	60" W x 36" D Worksurface	60" x 36" (1524 x 914 mm)	
55-026-998	72" W x 36" D Worksurface	72" x 36" (1829 x 914 mm)	
65-069-100	Cantilever Bracing for single Frame (requires 4 Hook Spacers)		500 lbs (227 kg)
65-070-100	Cantilever Bracing for dual Frame (requires 6 Hook Spacers)		500 lbs (227 kg)
65-128-100	Underbracing Kit for (3) 24" Frames, 72" W System*		500 lbs (227 kg)
65-071-100	Telescoping Leg Kit for cantilevered Worksurface		1000 lbs (454 kg)

* Cantilever Bracing for dual Frame (65-070-100) is required when using the Underbracing Kit (65-128-100).

Vertical space required on Frame: 15" (381 mm)

Note: Each Cantilever Brace has a safety screw that locks the Worksurface assembly to the Frame.

Note: Six (6) Hook Spacers or 3 pairs of Hook Spacers provided with each Frame.

Corner System

Freestanding System

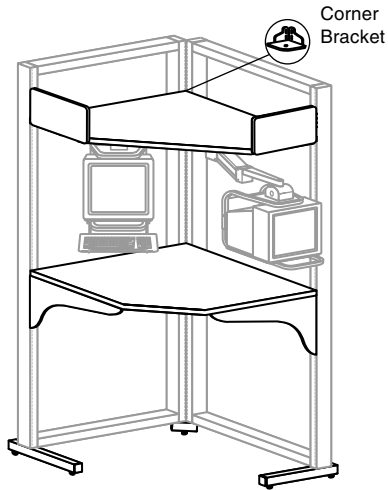

The Freestanding Corner System may be connected to another LAN Organizer 3000 module or installed as an independent unit. Requires two 42" Frames.

Part Number	Description	Dimensions	Depth	Use with...	Weight Capacity
53-002-100	Corner Suspension Shelf and Bracket	33-1/8" x 41" (841 x 1041 mm)			500 lbs (227 kg)
55-077-998	Corner Worksurface, Laminated	17" front width (432 mm)	50" (1270 mm)	30" D Worksurfaces	500 lbs (227 kg)
55-078-998	Corner Worksurface, Laminated	9" front width (229 mm)	54" (1372 mm)	36" D Worksurfaces	500 lbs (227 kg)
65-072-100*	Corner Worksurface Mounting Hardware				
17-006-100**	22" Legs (two) – requires 4 Glides/Casters				
72-015	Glides, set of 4				
72-016	Casters, set of 4				
72-008	Glide (one)				
72-003	Caster (one)				

* Corner Worksurface Mounting Hardware includes (order Glides/Casters and Hook Spacers separately):
22" Legs (two) – requires 4 Glides/Casters; Cantilever Bracing (two) – requires 4 Hook Spacers;
Center Leg – requires 1 Glide/Caster; Frame Brackets; Worksurface Bracket

** 22" Legs (17-006-100) can be ordered to replace the 34" Legs of an adjacent LO3000 module's Legs.
These will match the 22" Corner Legs (65-072-100) and increase leg room under the corner. May not be used with fixed Tower Shelves.

Vertical Frame space required for Shelf: 9" (229 mm)

Note: Six (6) Hook Spacers or 3 pairs of Hook Spacers provided with each Frame for Worksurfaces & Shelves.

Note: Corner Suspension Shelf has safety screws that lock the Suspension Shelf to the Frame.

Storage Options

Tower Shelves

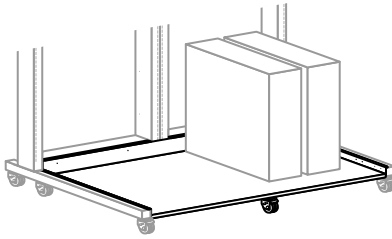

60" Tower Shelf, 50-080-100

Tower Shelves hold CPUs and other computer peripherals underneath the Worksurface.

Part Number	Description	Dimensions D x W (ID)	Weight Capacity*	# of REQUIRED Casters/Glides**
50-020-100	24" Tower Shelf	27" x 19-5/16" (686 x 491 mm)	1300 lbs (591 kg)	0
50-078-100	30" Tower Shelf	27" x 25-5/16" (686 x 643 mm)	1300 lbs (591 kg)	0
50-079-100	42" Tower Shelf	27" x 37-5/16" (686 x 948 mm)	1300 lbs (591 kg)	1
50-021-100	48" Tower Shelf	27" x 43-5/16" (686 x 1100 mm)	1500 lbs (682 kg)	1
50-080-100	60" Tower Shelf	27" x 55-5/16" (686 x 1405 mm)	1500 lbs (682 kg)	1
50-081-100	72" Tower Shelf	27" x 67-5/16" (686 x 1710 mm)	1500 lbs (682 kg)	2
72-008	Glide (one)			
72-003	Caster (one)			

* Total weight load on Frames, Legs and Tower Shelves cannot exceed total weight capacity of Casters: 250 lbs per Caster.

** Optional Caster(s) or Glide(s) can be added to the rear of the Shelf to increase the weight capacity.

Height above floor: Casters: 4" (102 mm); Glides: 2" (51 mm)

Pull-out Tower Holders

18" L-Bracket/Slide,
60-161-100

Cable Routing
Management,
70-065

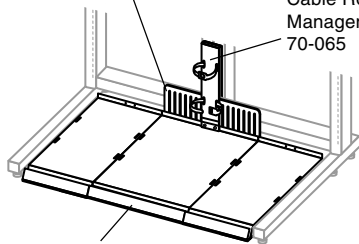

48" Pull-out Tower Holder,
80-073-100

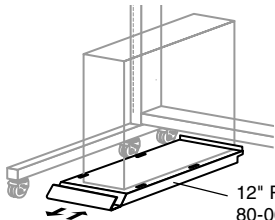

12" Pull-out Tower Holder,
80-065-100

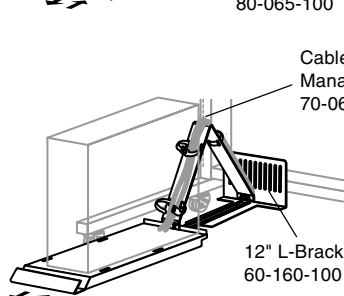

12" L-Bracket/Slide,
60-160-100

Pull-out Tower Holders hold CPUs and other computer peripherals underneath the Worksurface. They roll in and out to provide access to mounted equipment. Bracket Slides can be ordered to attach to the Frame and stop the Holder from pulling out too far.

Part Number	Description	Dimensions W x D (OD) x H	Weight Capacity
80-065-100	12" Pull-out Tower Holder	12" x 26-3/4" x 3-1/8" (305 x 679 x 79 mm)	500 lbs (227 kg)
80-064-100	For 24" W Frame, 18" Pull-out Tower Holder	18" x 26-3/4" x 3-1/8" (457 x 679 x 79 mm)	750 lbs (341 kg)
80-071-100	For 30" W Frame, (2) 12" Pull-out Tower Holders	24" x 26-3/4" x 3-1/8" (610 x 679 x 79 mm)	1000 lbs (454 kg)
80-072-100	For 42" W Frame, (2) 18" Pull-out Tower Holders	36" x 26-3/4" x 3-1/8" (914 x 679 x 79 mm)	1500 lbs (682 kg)
80-073-100	For 48" W Frame, (2) 12" & (1) 18" Pull-out Tower Holder	42" x 26-3/4" x 3-1/8" (1067 x 679 x 79 mm)	1750 lbs (795 kg)
80-074-100	For 60" W Frame, (3) 18" Pull-out Tower Holders	54" x 26-3/4" x 3-1/8" (1372 x 679 x 79 mm)	2250 lbs (1023 kg)
80-075-100	For 72" W Frame, (4) 12" & (1) 18" Pull-out Tower Holder	66" x 26-3/4" x 3-1/8" (1676 x 679 x 79 mm)	2750 lbs (1250 kg)
60-160-100	12" L-Bracket/Slide	11-3/4" x 24-1/2" x 7" (298 x 622 x 178 mm)	
60-161-100	18" L-Bracket/Slide	17-3/4" x 24-1/2" x 7" (451 x 622 x 178 mm)	
70-065	Cable Routing Management	34-1/4" x 3-3/8" (870 x 86 mm)	

Mounting Options: Mount at any point along lower Frame using Bracket/Slide. When mounting directly to middle of adjoining frames, use the 18" Bracket/Slide.

Mounting Combinations: Tower Holders may be attached together side by side. Order Holders in any combination.

Shelf Extension: With L-Bracket/Slide from front of Frame 27-1/2" to 51" (699 to 1295 mm)
Shelf Depth (ID): 24-1/2" (622 mm)

Storage Options

Suspension Shelves

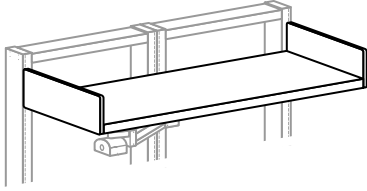

60" Suspension Shelf, 53-064-100

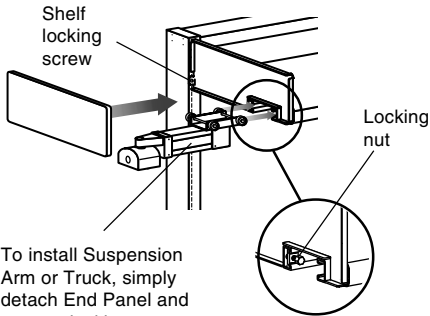

To install Suspension Arm or Truck, simply detach End Panel and remove locking nut.

Security Cabinets hold CPUs, peripherals or other supplies and equipment. Monitor Mounting Solutions may be suspended underneath.

Part Number	Description	Dimensions W(ID) x D	Weight Capacity
53-075-100	24" Suspension Shelf	22" x 18" (559 x 457 mm)	500 lbs (227 kg)
53-062-100	30" Suspension Shelf	28" x 18" (711 x 457 mm)	500 lbs (227 kg)
53-063-100	42" Suspension Shelf	40" x 18" (1016 x 457 mm)	500 lbs (227 kg)
53-078-100	48" Suspension Shelf	46" x 18" (1168 x 457 mm)	500 lbs (227 kg)
53-064-100	60" Suspension Shelf	58" x 18" (1473 x 457 mm)	500 lbs (227 kg)
53-065-100	72" Suspension Shelf	70" x 18" (1778 x 457 mm)	500 lbs (227 kg)

Vertical Frame space required: 9" (229 mm)

Note: Two (2) Hook Spacers or 1 pair of Hook Spacers required per slot mounted shelf. Six (6) Hook Spacers or 3 pairs of Hook Spacers provided with each Frame.

Note: Suspension Shelf has safety screws that lock the Suspension Shelf to the Frame.

Security Cabinets

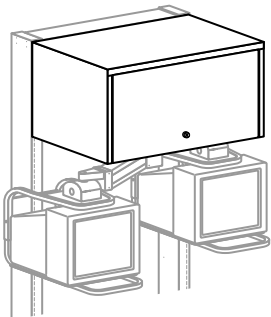

30" Security Cabinet, 95-011-100

Lockable Security Cabinets hold CPUs, peripherals or other supplies and equipment. Monitor Mounting Solutions may be suspended underneath.

Part Number	Description	Dimensions (ID) W x H x D	Weight Capacity
95-013-100	24" Security Cabinet	21-15/16" x 13-1/2" x 17" (557 x 343 x 432 mm)	250 lb (113 kg)
95-011-100	30" Security Cabinet	27-15/16" x 13-1/2" x 17" (710 x 343 x 432 mm)	250 lb (113 kg)
95-014-100	42" Security Cabinet	39-15/16" x 13-1/2" x 17" (1014 x 343 x 432 mm)	250 lb (113 kg)

Note: Vertical Frame space required: 18" (457 mm)

Note: Security Cabinets have locking mechanisms which lock them securely to the Frame.

Storage Options

Server Shelves

(20" & 27" Deep Shelves)

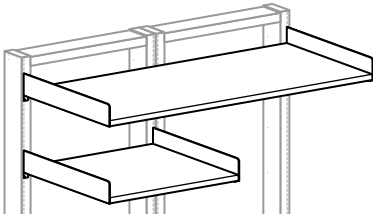

20" Deep Server Shelves -
60" Server Shelf (top), 50-050-100
and 30" Server Shelf, 50-048-100

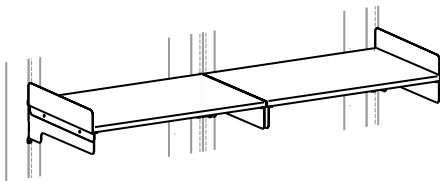

27" Deep Server Shelves -
(2) 42" Server Shelves, 50-171-100
(2) Side Panels, 60-353-100

The Server Shelf is a steel shelf that accommodates servers, CPUs or peripheral storage.

Part Number	Description	Dimensions W(ID) x D	Weight Capacity
50-116-100	24" W x 20" D Server Shelf	22-7/8" x 20" (581 x 508 mm)	500 lbs (227 kg)
50-048-100	30" W x 20" D Server Shelf	28-7/8" x 20" (733 x 508 mm)	500 lbs (227 kg)
50-049-100	42" W x 20" D Server Shelf	40-7/8" x 20" (1038 x 508 mm)	500 lbs (227 kg)
50-104-100	48" W x 20" D Server Shelf	46-7/8" x 20" (1191 x 508 mm)	500 lbs or 800 lbs* (227 kg or 363 kg)
50-050-100	60" W x 20" D Server Shelf	58-7/8" x 20" (1495 x 508 mm)	500 lbs or 800 lbs* (227 kg or 363 kg)
50-051-100	72" W x 20" D Server Shelf	70-7/8" x 20" (1800 x 508 mm)	500 lbs or 800 lbs* (227 kg or 363 kg)
60-042-100	Center Support Brace for 48"W, 60"W and 72"W Server Shelves*		
50-169-100	24" W x 27" D Server Shelf	23-3/4" x 27" (603 x 686 mm)	500 lbs (227 kg)
50-170-100	30" W x 27" D Server Shelf	29-3/4" x 27" (756 x 686 mm)	500 lbs (227 kg)
50-171-100	42" W x 27" D Server Shelf	41-3/4" x 27" (1060 x 686 mm)	500 lbs (227 kg)
60-353-100	Side Panels for 27" Deep Shelves (one per kit)		

* Weight capacity increases to 800 lbs (363 kg) when Center Support Brace (60-042-100) is installed.

Vertical Space on Frame required for 20" Deep Shelves: 7" (178 mm)

Vertical Space on Frame required for 27" Deep Shelves w/ end panel: 13-1/4" (337 mm)

Vertical Space on Frame required for 27" Deep Shelves w/o end panel: 9-3/8" (238 mm)

Maximum 20" Deep Shelves per Frame: 77"(H) Frame = 10, 84"(H) Frame = 11

Note: Server Shelf has safety screws that lock the Shelf to the Frame.

Tilt Server Shelves

Tilt Server Shelves angle down at 5°, 10°, 15°. A front flange extends up 1/2" from the Shelf surface, acting as a safety rail. Each Shelf includes two Ergolock Kits (adhesive clamps) to hold equipment in place.

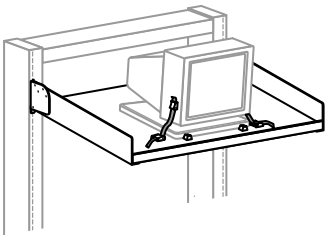

30" Tilt Server Shelf, 50-111-100

Part Number	Description	Dimensions W(ID) x D	Weight Capacity
50-088-100	24" Tilt Server Shelf with Strap Kits	22-7/8" x 20" (581 x 508 mm)	500 lbs (227 kg)
50-111-100	30" Tilt Server Shelf with Strap Kits	28-7/8" x 20" (733 x 508 mm)	500 lbs (227 kg)
50-112-100	42" Tilt Server Shelf with Strap Kits	40-7/8" x 20" (1038 x 508 mm)	500 lbs (227 kg)
50-089-100	48" Tilt Server Shelf with Strap Kits	46-7/8" x 20" (1191 x 508 mm)	500 lbs (227 kg)
50-113-100	60" Tilt Server Shelf with Strap Kits	58-7/8" x 20" (1495 x 508 mm)	500 lbs (227 kg)
50-025-100	72" Tilt Server Shelf with Strap Kits	70-7/8" x 20" (1800 x 508 mm)	500 lbs (227 kg)

Vertical space required on Frame for Tilt Shelf: at 0° tilt=6" (152 mm) at 10° tilt=8-1/4" (210 mm)
at 5° tilt=6-1/2" (165 mm) at 15° tilt=9-3/4" (248 mm)

Maximum Shelves per Frame: 77"(H) Frame = 10, 84"(H) Frame = 11

Note: Two (2) Hook Spacers or 1 pair of Hook Spacers required per slot mounted shelf. Six (6) Hook Spacers or 3 pairs of Hook Spacers provided with each frame.

Note: Tilt Server Shelf has safety screws that lock the Shelf to the Frame.

Note: Two Hold-down Strap Kits are included with each Tilt Server Shelf. Hold-down Straps should be used on equipment tilted beyond 5°.

Note: Additional Hold-down Strap Kits, 97-069, may be ordered.

Storage Options

Server Shelf Extensions

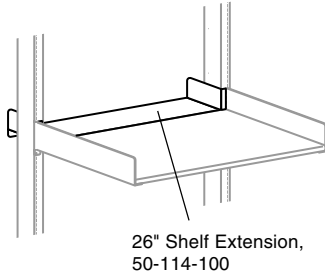

An Extension adds 6-1/4" of depth to the back of a Server Shelf.

Part Number	Description	Dimensions W x D x H	Mounts to:
50-138-100	20" Shelf Extension	19-5/8" x 6-1/4" x 3-5/8" (498 x 159 x 92 mm)	24" Server Shelf
50-114-100	26" Shelf Extension	25-5/8" x 6-1/4" x 3-5/8" (651 x 159 x 92 mm)	30" Server Shelf
50-115-100	38" Shelf Extension	37-5/8" x 6-1/4" x 3-5/8" (956 x 159 x 92 mm)	42" Server Shelf

Note: The Shelf Extension does not increase weight capacity of the Shelf.

Shelf Backstops

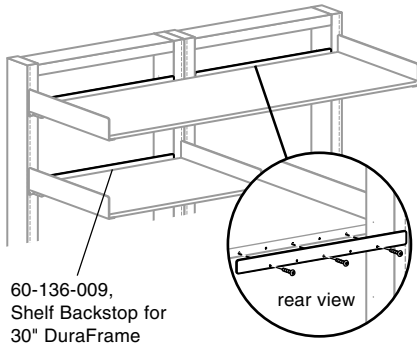

Mount Shelf Backstops behind Server and Suspension Shelves to prevent items from slipping off the back of the LAN Organizer.

Part Number	Description	Dimensions W x H
60-135-009	Shelf Backstop for 24" DuraFrames	22" x 2-11/32" (559 x 60 mm)
60-136-009	Shelf Backstop for 30" DuraFrames	28" x 2-11/32" (711 x 60 mm)
60-137-009	Shelf Backstop for 42" DuraFrames	40" x 2-11/32" (1016 x 60 mm)

Organizer Drawer

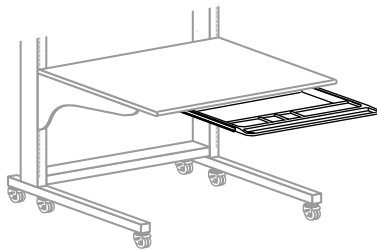

This shallow, space saving drawer attaches under the Worksurface. Pulls out smoothly on ball-bearing slides.

Part Number	Description	Dimensions W x D x H
68-007-098	Organizer Drawer, black	(OD) 21-15/32" x 16-9/64" x 1-31/32" (545 x 410 x 50 mm) (ID) 19-3/32" x 15-3/4" x 1-49/64" (485 x 400 x 45 mm)

Note: Not compatible with 24" W modules or Freestanding Corner Systems.

Storage Options

Keyboard Riser

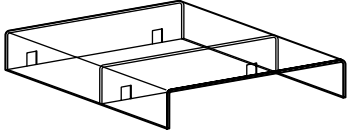

The Keyboard Riser sits on the Worksurface and raises the monitor 4-1/4" from the surface while allowing the keyboard to be stored underneath.

Part Number	Description	Dimensions W x H x D
99-015	Keyboard Riser, acrylic	20" x 4-1/4" x 19" (508 x 108 x 483 mm)

Pedestal File Cabinet

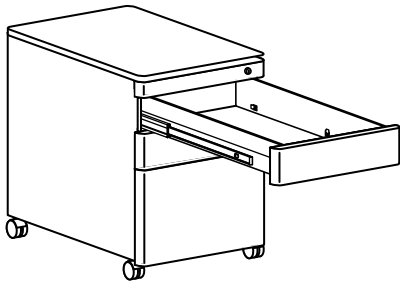

Painted steel construction, available in grey. A lock and key secure a drawer for standard-size files. Two more utility drawers provide extra storage space.

Part Number	Description	Dimensions W x D x H
68-114-100	File Cabinet with Casters, 3 drawers	15-1/4" x 21-3/4" x 27" (387 x 552 x 686 mm)

Inside dimension of drawers: Width 12-1/8" (308 mm) x Depth 18-3/4" (476 mm) x Height 10-1/2" or 4-1/2" (267 or 114 mm)

Note: When Casters are removed, height of unit is 25-1/8" (638 mm).

Note: Outside face of File drawer is 12" (305 mm) tall and the other two drawers are 6" (152 mm) tall.

Note: File Cabinet's footprint is 2.3 ft² (.214 m²).

Note: One key locks all drawers; lock is core removable.

68-114-100, File Cabinet with Casters

Monitor Mounting Solutions

CRT Under-Shelf Mounts

Mount a CRT monitor below a Suspension Shelf or Security Cabinet with a Suspension Arm or Truck. Both slide across a shelves/cabinets underside track and provide monitor tilt and rotation. Arms also add 6" of height adjustment.

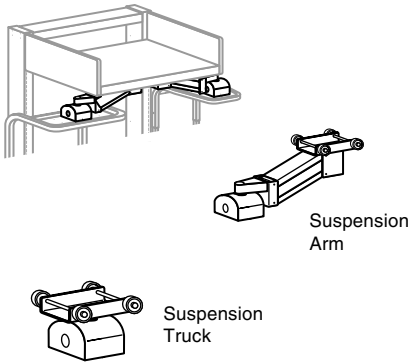

Part Number	Description	Weight Capacity	Horizontal Length (Pivot-point to pivot-point)
44-322-100	"A" Suspension Arm	15–35 lbs (6.8–16 kg)	13" (330 mm)
44-323-100	"B" Suspension Arm	35–65 lbs (16–30 kg)	13" (330 mm)
44-324-100	"C" Suspension Arm	65–100 lbs (30–45 kg)	13" (330 mm)
42-020-100	Suspension Truck	≤ 100 lbs (≤ 45 kg)	

Tilt / rotate adjustment: 20° / 360° Vertical adjustment for Arms: 6" (152 mm)

Order a Caddy along with a Suspension Arm or Truck. Choose a Caddy based on the size and weight of the monitor it will hold.

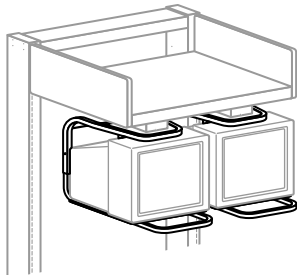

Type 2 Monitor Caddies, 40-002-100 mounted to Suspension Trucks

Part Number	Description	Height Adjustment	Monitor Depth*	Monitor Width*	Monitor Weight*
40-002-100	Type 2 Monitor Caddy	12"–15-1/2" (305–394 mm)	16-1/2" (419 mm)	—	40 lbs (18 kg)
40-004-100	Type 3 Monitor Caddy	13-1/2"–18-1/2" (343–470 mm)	19" (483 mm)	—	65 lbs (29 kg)
40-008-100	Type 4 Monitor Caddy	16-1/2"–22" (419–559 mm)	22" (559 mm)	—	70 lbs (32 kg)
40-013-100	Type 5 Monitor Caddy	16-1/2"–22" (419–559 mm)	—	16-1/4"*** (413 mm)	120 lbs (54 kg)

* Monitor depth, width and weight specifications are all listed as maximum measurements.

** For wide-backed monitors; maximum rear monitor width is 16-1/4", measured 15" from front of monitor.

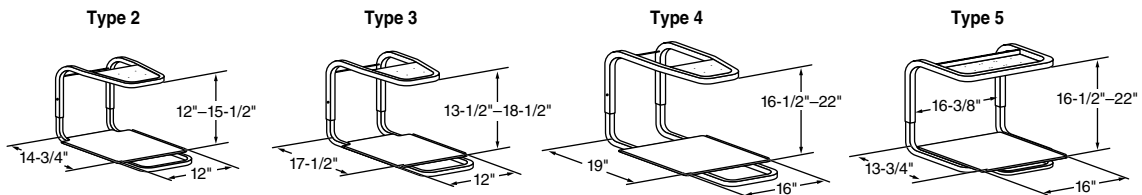

CRT Lift Arm

The 10" Lift Arm features height adjustability, swing and rotation for optimum ergonomic positioning. Quick-release tabs securely clamp the monitor in place. Optional Wire Keyboard Holders pull out for quick keypad access.

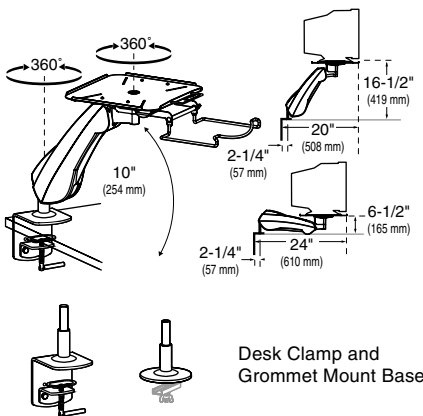

Part Number	Description	Weight Capacity	Attaches to...
44-343-100	10" Lift Arm	20–60 lbs (9.1–27.3 kg)	
60-257-100	Desk Clamp		Worksurface edge ≤ 3" (76 mm) thick
33-269-100	Grommet Mount		Worksurface through hole 3/8"–3-1/2" (10-89 mm) wide, ≤ 4" (102 mm) thick
75-064-009	Wire Keyboard Holder, 2" Drop		10" Lift Arm under platform
75-065-009	Wire Keyboard Holder, 4" Drop		10" Lift Arm under platform

Monitor Mounting Solutions

Flat Panel Under-Shelf Mounts

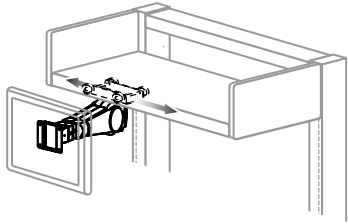

Ergotron's 400 Series Horizontal Mount Arm provides monitor height-adjustment, tilt, rotation, and portrait/landscape screen adjustment. The Arm suspends below a Suspension Shelf or Security Cabinet. Slide it along shelf's/cabinet's underside rack.

Part Number	Description	Weight Capacity
45-014-099	400 Series Arm, Horizontal Mount, Suspend Rotate, Double Pivot with P/L	23 lbs (10.4 kg)
42-021-100	Shelf Mount Truck	

Note: Monitor interfaces that are not VESA FDMI compliant require a separately ordered, adapter bracket. Contact your Sales Representative for more information.

Flat Panel Arms: Desk Mount

Desk Mounts attach to worksurfaces with either the Desk Clamp or the Grommet Mount. Desk Clamps attach to the edge of worksurfaces $\leq 2\text{-}1/8"$ (54 mm) thick. Grommet Mounts attach through a hole in the worksurface $3/8"$ to $3"$ (10 to 76 mm) wide, up to $4"$ (102 mm) thick. The DS100 Grommet Mount Base works with worksurfaces up to $3\text{-}1/4"$ (83 mm) thick. Free Standing bases require no bolting or clamping to surface. See the Flat Panel Monitor Mounting Solutions Orderguide (#870-03-005) for complete product offering.

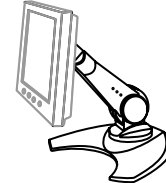
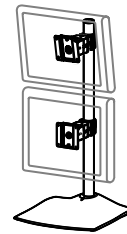
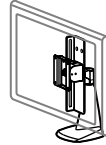
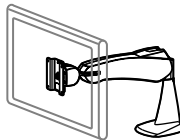
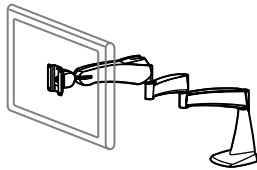

Frame Mount Brackets

(For CRT and Flat Panel Monitors)

Arm Mount Kit, 60-233-100, with 12" CRT Arm attached to front of two LO3000 DuraFrames

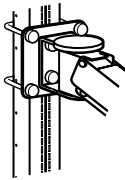

Frame Brackets attach CRT Arms or Flat Panel Arms directly to the Frame.

Part Number	Description	Application
60-231-100	Arm Mount Kit	Mounts Arm to front of one LO3000 DuraFrame
60-230-100	Arm Mount Kit	Mounts Arm to inside of one LO3000 DuraFrame
60-233-100	Arm Mount Kit	Mounts Arm to front or inside of two LO3000 DuraFrames

Note: Use only with 0", 6", 10" & 12" CRT Arms or 200, 300, 400 Series Flat Panel Arms. See the CRT Orderguide (870-03-018), Flat Panel Monitor Mounting Solutions Orderguide (870-03-005), or consult your Ergotron Sales Representative.

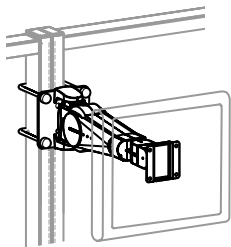

Arm Mount Kit, 60-233-100, with 400 Series Arm attached to front of two LO3000 DuraFrames

CRT Arms:

0" Vertical Movement

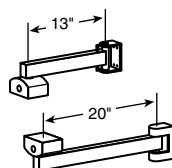

6" Vertical Movement

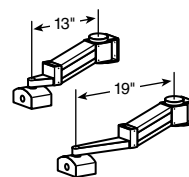

10" Vertical Movement

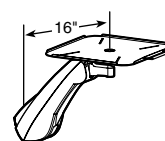

12" Vertical Movement

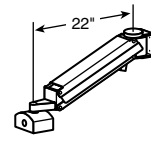

Keyboard Mounting Solutions

Keyboard Holders, Trays & Arms

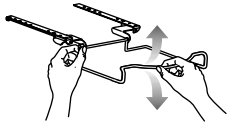

75-052-009

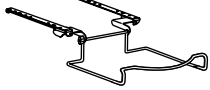

75-053-009



75-054-009

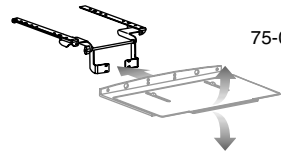

75-055-009

77-049-180

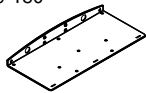

77-050-180

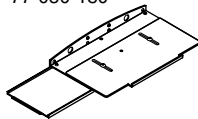

85-014-180

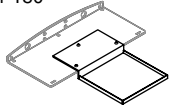

77-076-180

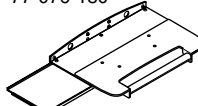

85-024-180

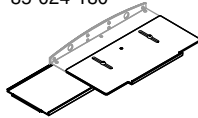

85-033, Wrist Rest



85-025-079, Mouse Pad

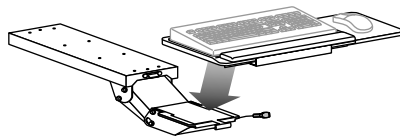

Articulating Keyboard Arm, Keyboard Tray w/ Sliding Mouse Tray, and Wrist Rest

Wire Keyboard Holders: Attach under Server Shelves or Monitor Caddies.

Part Number	Description	Dimensions W x D x H	Weight Capacity
75-052-009	Wire Keyboard Holder 2" drop, pull-out	12-7/8" x 23-1/2" x 4-1/2" (327 x 597 x 114 mm)	15 lbs (6.8 kg)
75-053-009	Wire Keyboard Holder 4" drop, pull-out	12-7/8" x 23-1/2" x 6-1/2" (327 x 597 x 165 mm)	15 lbs (6.8 kg)

Adjustable Keyboard Tray Holders: Use with separately-ordered Keyboard/Mouse Trays (see below). Attach under Server Shelves or Monitor Caddies.

Part Number	Description	Dimensions W x D x H	Weight Capacity
75-054-009	Adjustable Keyboard Tray Holder, 2.5" drop, pull-out	12-7/8" x 18-3/8" x 4" (327 x 467 x 102 mm)	15 lbs (6.8 kg)
75-055-009	Adjustable Keyboard Tray Holder, 5" drop, pull-out	12-7/8" x 18-3/8" x 7-1/2" (327 x 467 x 191 mm)	15 lbs (6.8 kg)

Keyboard/Mouse Trays & Accessories

Part Number	Description	Dimensions W x D x H	Use with...
77-001-100	Steel Keyboard/Mouse Tray	26" x 8-1/4" (660 x 210 mm)	75-052-009 or 75-053-009
77-049-180	Keyboard Tray	16-1/2" x 7-1/4" x 2" (419 x 184 x 51 mm)	75-054-009 or 75-055-009
77-050-180	Keyboard Tray w/ Sliding Mouse Tray & Wrist Rest Holder	17-1/2" x 9 to 12" x 2-1/2" (445 x 229 to 305 x 64 mm)	75-054-009 or 75-055-009
77-076-180	Keyboard Tray w/ Handle and Sliding Mouse Tray	17-1/2" x 12-1/2" x 3-3/8" (445 x 318 x 86 mm)	75-054-009 or 75-055-009
85-014-180	Front Mouse Tray	7-1/4" x 7-1/8" x 1" (184 x 181 x 25 mm)	77-049-180
85-024-180*	Sliding Mouse Tray & Wrist Rest Holder		77-049-180
85-033	Wrist Rest, black	19" x 3" (483 x 76 mm)	
85-010-087	Wrist Rest, grey, premium, easy-clean	19" x 3" (483 x 76 mm)	
85-025-079	Mouse Pad	7" x 7" (178 x 178 mm)	

* 85-024-180 converts 77-049-180 into 77-050-180.

Keyboard Arms & Tray: Arms offer full ergonomic adjustment.

Part Number	Description	Slide Track Length	360° Arm Rotation
75-037	Keyboard Arm, w/ Adjustment Knob	17-1/16" (433 mm)	no
75-038	Keyboard Arm w/ Adjustment Lever	16-13/16" (427 mm)	yes
75-039	Ext. Kybd. Arm (for Corner Systems), w/ Adjustment Lever	21-13/16" (554 mm)	yes
77-026-098	Keyboard & Mouse Tray for Keyboard Arm, black		
85-008-098	Wrist Rest, Tray Mount, for 77-026-098, black		

Cable Management

Quik-Touch® Cable Management

Organize and route equipment cables with Ergotron's patented Quik-Touch. Individually hinged sections provide one-touch access to cables and wires along a non-conductive channel. Attach Quik-Touch to the DuraFrame, on the back of Shelves, or under the Worksurface.

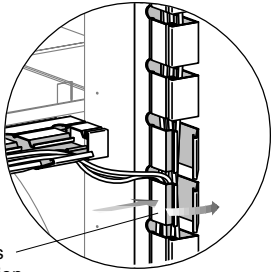

One-touch opens the channel section

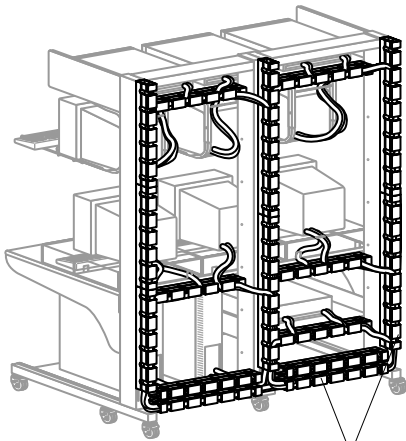

70-068-099

Part Number	Description	Dimensions L x W x D
70-069-099	18" Quik-Touch Cable Management, grey	18" x 2" x 3" (457 x 51 x 76 mm)
70-068-099	24" Quik-Touch Cable Management, grey	24" x 2" x 3" (610 x 51 x 76 mm)
70-067-099	36" Quik-Touch Cable Management, grey	36" x 2" x 3" (914 x 51 x 76 mm)

Cable Channel Accessories

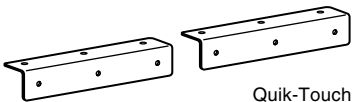

Quik-Touch Mounting Bracket (two), 97-004-100

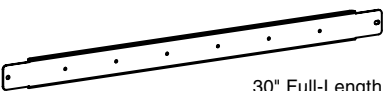

30" Full-Length Quik-Touch Mounting Bracket, 60-268-100

Part Number	Description	Dimensions L x W x H	Application
97-004-100	Quik-Touch Mounting Bracket (two)	10" x 1-1/2" x 2" (254 x 38 x 51 mm)	Mounts Quik-Touch below Worksurface or to rear of lower Frame member
60-267-100	24" Full-Length Quik-Touch Mounting Bracket	24" x 3/8" x 2" (610 x 10 x 51 mm)	Mounts Quik-Touch anyplace on 24" Frame
60-268-100	30" Full-Length Quik-Touch Mounting Bracket	30" x 3/8" x 2" (762 x 10 x 51 mm)	Mounts Quik-Touch anyplace on 30" Frame
60-269-100	42" Full-Length Quik-Touch Mounting Bracket	42" x 3/8" x 2" (1067 x 10 x 51 mm)	Mounts Quik-Touch anyplace on 42" Frame
97-020	Cable Routing Kit (Clips, Ties)		Helps organize cables and wires in easy-to-identify groupings
97-048	Cable Identification Kit		Makes identification of cables easy

Rack Mount Solutions

19" Rack Mount Brackets

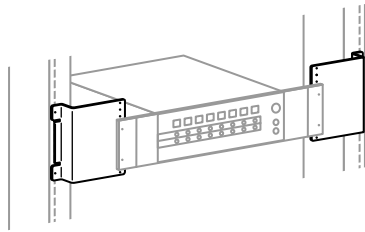

19" Rack Mounting Brackets, 60-194-100

The 19" Rack Mount Brackets allow rack components to be mounted between a Frame's uprights. Extended Brackets allow rack components up to 15-1/2" deep to clear wall when mounted.

Part Number	Description	Mounts to Slots of...
60-194-100	19" Rack Mount Brackets	24" Frame
60-195-100	19" Rack Mount Brackets – Extended	24" Frame
60-110-100	19" Rack Mount Brackets	30" Frame
60-112-100	19" Rack Mount Brackets – Extended	30" Frame
60-111-100	19" Rack Mount Brackets	42" Frame
60-113-100	19" Rack Mount Brackets – Extended	42" Frame

Maximum number of 7" high Brackets: 77" (H) Frame = 10, 84" (H) Frame = 11

Number of Mounting Holes: 12

Distance Between Mounting Holes (ANSI): 18-5/16" (465 mm)

Note: One set of Hook Spacers required per set of Rack Mount Brackets

Monitor Drawers for 19" Racks

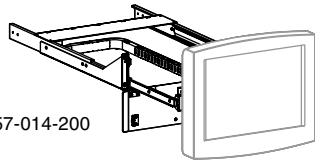

57-014-200

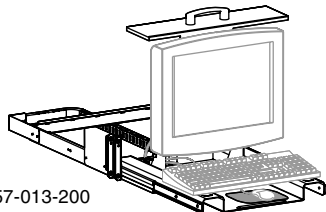

57-013-200

Monitor Drawers (MD Series) securely integrate your flat panel monitor and/or keyboard into a 19" rack-mount frame or enclosure. Store your flat panel folded down horizontally, ready to be pulled out for viewing. The MD101 accepts monitors up to 17-1/4" W x 16-1/2" H x 3" D; the MD102 up to 17-1/4" W x 14-1/8" H x 3" D. Features quick and easy installation to front rails of rack – no rear-rail attachment necessary! The monitor and/or keyboard are not included so you get to choose the model and make that you want. Drawers require only 3U of rack space.

Part Number	Description	Max. Monitor Weight	Shipping Weight
57-014-200	MD Series, MD101 Monitor-Only Drawer, black	25 lbs (11.4 kg)	14 lbs (6.4 kg)
57-013-200	MD Series, MD102 Monitor/Keyboard Drawer, black	25 lbs (11.4 kg)	25 lbs (11.4 kg)

Note: Monitor interfaces that are not VESA FDMI compliant require a separately ordered, adapter bracket. Contact your Sales Representative for more information.

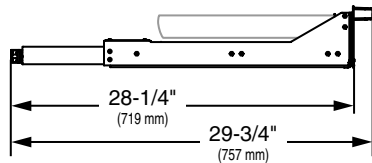

MD101 pulls out from storage position when needed. Monitor tilts up/down 180°. Screen adjusts 360° portrait/landscape.

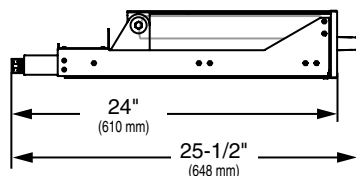

MD102 pulls out from storage position when needed. Holds monitor and keyboard.

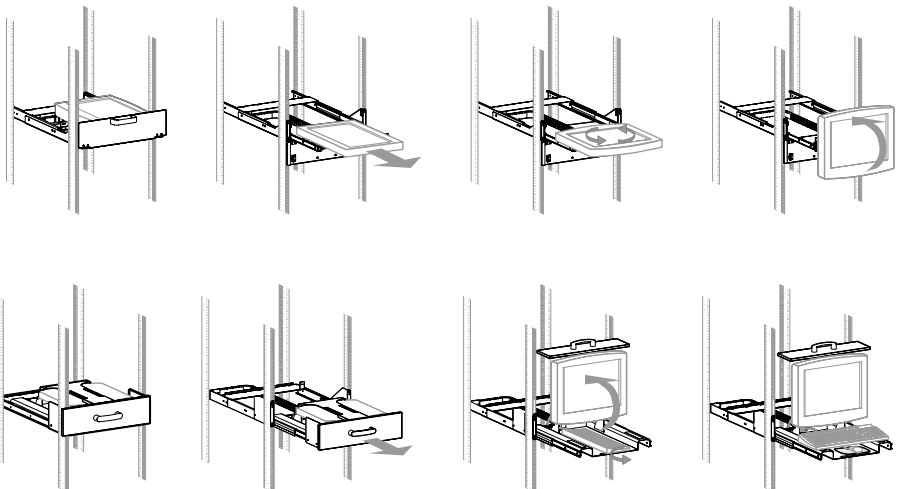

Rack Mount Solutions

19" Rack Add-on

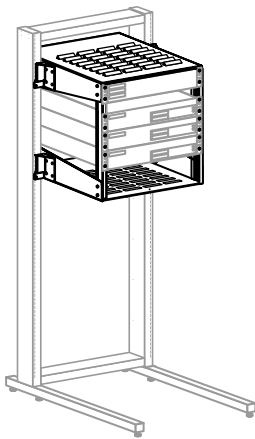

The 19" Rack Add-on is a low-cost alternative to enclosures. It seamlessly integrates 19" components into new or existing LAN Organizer systems.

Part Number	Description	Dimensions W x D x H	Use with...
57-002-100	19" Rack Add-on 30" Wide, 14U*	19-1/2" x 27" x 26-3/8" (495 x 686 x 670 mm)	LO3000 30" Frame
57-004-100	19" Rack Add-on 30" Wide, 18U*	19-1/2" x 27" x 33-3/8" (495 x 686 x 848 mm)	LO3000 30" Frame
97-137-100	M6 Retainer Nuts (25)		
97-138-100	10/32 Retainer Nuts & Screws (25)		

* 14U @ 26" High, 18U @ 33" High (1U = 1-3/4"); 31 Retainer Nuts & Screws (#10-32) for mounting components to Rack are included. For extra screws and/or nuts, order Kits listed above.

Power Accessories

Task Lights

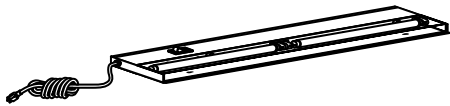

Add fluorescent light to your LAN Organizer configuration. Housing color is grey.

Part Number	Description
82-004-100	24" Task Light – mounts under Security Cabinets, Server and Suspension Shelves
82-005-100	33" Task Light – mounts under Security Cabinets, Server and Suspension Shelves

Note: Not compatible with 24"-Wide Shelves.

Note: Not recommended for use with Suspension Shelves and Security Cabinets that have a Monitor Mounting Solution installed.

Power Strips/Surge Suppressor

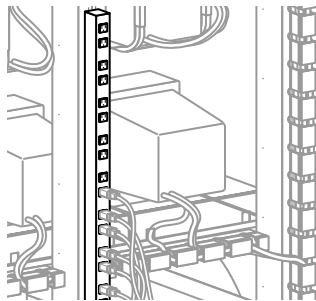

16-outlet Power Strip, 83-001

Ergotron Power Strips and Surge Suppressors can be mounted to any LAN Organizer system. Power Products feature sturdy aluminum housing and a 15' cord.

Part Number	Description	Length	Protection	Circuit	Response Time
83-001	16-outlet Power Strip	48" (1219 mm)	Office grade	15 amp	N/A
83-002	6-outlet Power Strip	12" (305 mm)	Office grade	15 amp	N/A
83-008*	10-outlet Power Strip	48" (1219 mm)	Office grade	20 amp	N/A
83-006	6-outlet Surge Suppressor	14" (356 mm)	Computer grade surge	2-stage, 15 amp	One nanosecond
83-025-100	8-outlet Horizontal Mount Power Strip	24" (610 mm)	Office grade	15 amp	N/A
83-026-100	12-outlet Horizontal Mount Power Strip	36" (914 mm)	Office grade	15 amp	N/A

* Requires a 20 amp receptacle/outlet.

Notes

Maximize the effectiveness of your computer systems with Ergotron Products



Since 1982, Ergotron has designed and engineered products specifically for improving the human interface with computers. Innovative engineering concepts incorporate the human factor into each and every product. With our patented Monitor Suspension technology as the core, Ergotron designs Mounting Solutions that consistently meet the ever changing needs of our customers.

Our experienced Sales Representatives will work with you to define your requirements and custom configure standard components to cost-effectively meet those requirements. If you do not see a product that meets your requirements, call us and we will tailor a solution to your needs.

© 2004 Ergotron, Inc.
rev. 10/14/04 870-03-006

Ergotron, Inc.: St. Paul, MN; (800) 888-8458;
www.ergotron.com; sales@ergotron.com

Ergotron Europe: Amsterdam, The Netherlands;
Tel. +31 20 312.29.39; info.eu@ergotron.com

Ergotron Canada: Calgary, Alberta;
(800) 267-9912; info.ca@ergotron.com

